

WARREN CO.
PCC PAVEMENT-GRADE AND REPLACE
NHSX-092-5(51)--3H-91

LETTING DATE
 10-21-2014

INDEX OF SHEETS	
No.	DESCRIPTION
A Sheets	Title Sheets
A.1	Title Sheet
A.2	Location Map Sheet
B Sheets	Typical Cross Sections and Details
B.1 - 12	Typical Cross Sections and Details
C Sheets	Quantities and General Information
C.1	Project Description
C.1 - 2	Estimated Project Quantities
C.2 - 6	Estimate Reference Information
C.6	Index of Tabulations
C.6	Standard Road Plans
C.7	Pollution Prevention Plan
C.8	General Notes
C.8 - 27	Tabulations
CH Sheets	Hydraulics Information
CH.1	Hydraulics Tabulation
CS Sheets	Soils Information
CS.1 - 5	Soils Tabulations
D Sheets	Mainline Plan and Profile Sheets
* D.1	Plan & Profile Legend & Symbol Information Sheet
* D.2 - 29	IA 92 Mainline
E Sheets	Side Road Plan and Profile Sheets
* E.1	Kennedy Street
* E.2	R-57
* E.3	90th Ave
* E.4	R-63
* E.5	Y Street
* E.6	Access 258
* E.7	Entrance 359
F Sheets	Detour or Temporary Pavement Sheets
* F.1	County Road R-57
* F.2	County Road R-63
* F.3 - 5	Y Street
* F.6 - 7	IA 92 North Side East End
* F.8	IA 92 South Side East End
* F.9	Spruce Street
G Sheets	Survey Sheets
G.1 - 5	Reference Ties and Bench Marks
G.6 - 11	Horizontal Control Tab. & Super for all Alignments
H Sheets	Right-of-Way Mainline Sheets
H.1 - 15	Ia. 92 Mainline Sheets
HE Sheets	Right-of-Way Side Road Sheets
HE.1 - 6	Side Road ROW Sheets
J Sheets	Traffic Control and Staging Sheets
* J.1	Traffic Control Plan
* J.1	Pedestrian Path Closures
* J.1	Coordinated Operations
* J.2 - 3	Staging Notes
* J.4	Traffic Control & Staging Legend & Symbol Info.
* J.5 - 12	Detour Signing Sheets
* J.13 - 23	Staging Typical
* J.24 - 34	Staging Lay-out Sheets
* J.35 - 42	Traffic Control Details
L Sheets	Geometric, Staking and Jointing Sheets
L.1 - 5	Geometric Details of Co. Rd. R-57, R-63, 'Y' St.
L.6 - 11	Geometric Details of E. End of Ia. 92, Temp. Detours
L.12 - 14	Staking Details of Co. Rd. R-57, R-63, 'Y' ST.
L.15 - 22	Staking Details of E. End of Ia. 92, Temp. Detours
L.23 - 25	Edge Profiles of Co. Rd. R-57, R-63, 'Y' ST.
L.26 - 27	Edge Profiles of E. End of Ia. 92, Temp. Detours
L.28 - 30	Jointing Details of Co. Rd. R-57, R-63, 'Y' ST.



Highway Division

PLANS OF PROPOSED IMPROVEMENT ON THE

PRIMARY ROAD SYSTEM

WARREN COUNTY

PCC PAVEMENT-GRADE AND REPLACE

Ia. 92 From Just West Of Co. Rd. R-57
 East To Just East of South 'N' Street In Indianola

SCALES: As Noted

Refer to the Proposal Form for list of applicable specifications.

Value Engineering Saves. Refer to Article 1105.15 of the Specifications.



For Project Location Map
 Refer to Sheet A.2

DESIGN DATA RURAL				DESIGN DATA URBAN			
2014	AADT	6500	V.P.D.	2014	AADT	9500	V.P.D.
2034	AADT	11000	V.P.D.	2034	AADT	16000	V.P.D.
2034	DHV	1130	V.P.H.	2034	DHV	1650	V.P.H.
	TRUCKS	8	%		TRUCKS	8	%
	Total				Total		
	Design ESALs	8,300,000			Design ESALs	11,500,000	

INDEX OF SEALS		
SHEET NO.	NAME	TYPE
A.1	Jason M. Holst	Primary Signature Block
CH.1	David R. Claman	Hydraulic Signature Block
CS.1	Robert L. Stanley	Geotechnical Signature
J.5	Zachary Abrams	Signing Design Signature

REVISIONS

TOTAL
00
PROJECT IDENTIFICATION NUMBER
04-91-092-010-01
PROJECT NUMBER
NHSX-092-5(51)--3H-91
R.O.W. PROJECT NUMBER
STPN-092-5(50)--2J-91

INDEX OF SHEETS	
No.	DESCRIPTION
M Sheets	Storm Sewer Sheets
M.1 - 3	Storm Sewer Tabulations
M.4	Storm Sewer Legend & Symbol Information Sheet
M.5 - 18	Storm Sewer Plan Sheets
M.19 - 30	Storm Sewer Profile Sheets
Q Sheets	Soils Sheets
Q.1	Soils Legend & Symbol Information Sheet
Q.2 - 32	Soils Sheets Ia. 92 Mainline
S Sheets	Sidewalk Sheets
* S.1	Sidewalk Legend & Symbol Information Sheet
* S.2 - 6	Sidewalk Plan Sheets
* S.7 - 10	Sidewalk Tabulations
T Sheets	Earthwork Quantity Sheets
T.1 - 23	Earthwork Quantity Sheets
U Sheets	500 Series, Mod.Stds. and Detail Sheets
U.1 - 18	Removal Detail Sheets
U.19 - 28	Pavement Marking Detail Sheets
U.29	Modified Details Of Mailbox Turnouts
W Sheets	Mainline Cross Sections
W.1	Cross Sections Legend & Symbol Information Sheet
W.2 - 158	IA 92 Cross Sections - Rural Section
W.160 - 206	IA 92 Cross Sections - Urban Section
W.207 - 231	IA 92 Cross Sections - Widening Section
X Sheets	Side Road Cross Sections
X.1 - 3	Kennedy St
X.4 - 10	R-57
X.12 - 21	90th
X.22 - 26	R-63
X.27 - 34	Y Street
X.35 - 48	R-57 Detour
X.48 - 60	Entrance 259
X.61 - 72	R-63 Detour
X.73 - 90	Y Street Detours
X.91 - 100	IA 92 North Side East End Detour
X.101 - 104	IA 92 South Side East End Detour
X.105 - 106	Spruce Street Detour
	* Color Plan Sheets

ROADWAY DESIGN

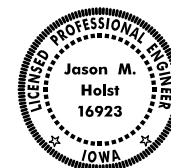

I hereby certify that this engineering document was prepared by me or under my direct personal supervision and that I am a duly licensed Professional Engineer under the laws of the State of Iowa.

Signature: *Jason M. Holst* Date: _____
 Jason M. Holst
 Printed or Typed Name
 My license renewal date is December 31, 2015

Pages or sheets covered by this seal: A.1-A.2; B.1-B.12; C.1-C.27; D.1-D.29; E.1-E.7; F.1-F.9; G.1-G.11; H.1-H.15; HE.1-HE.6; J.1-J.4; J.13-J.42; L.1-L.30; M.1-M.30; S.1-S.10; T.1-T.23; U.1-U.29; W.1-W.231; X.1-X.106

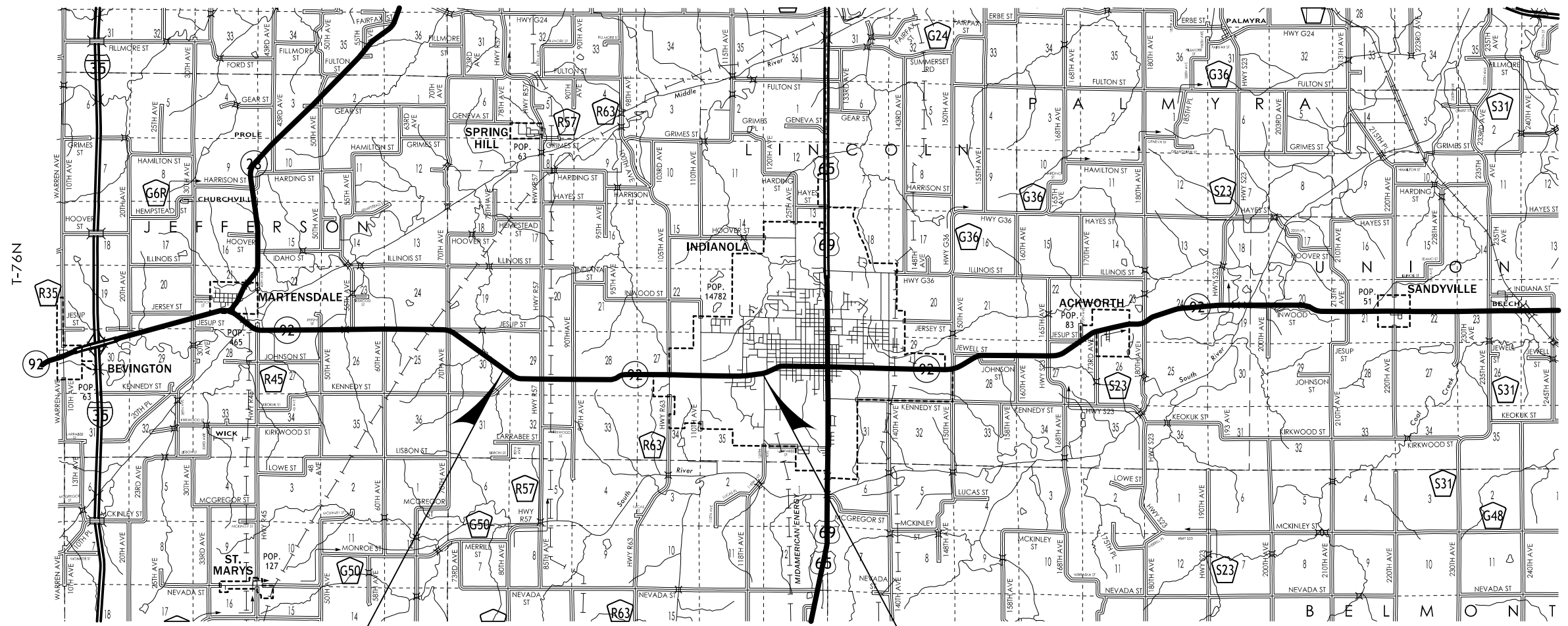

R-25W

R-24W

R-23W

R-22W

STA. 256+50.00
BEGIN PROJECT
M.P. 125.97

STA. 465+03.68
END PROJECT
M.P. 129.92

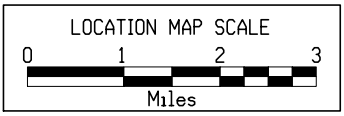
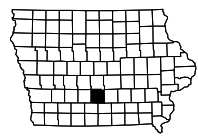

LOCATION MAP SHEET

Paved Shoulder Alternates

PCC Shoulder Jointing:
 Longitudinal joint: BT-1 or BT-3
 Transverse joints: C at 20' spacing
 HMA Shoulder Jointing:
 Longitudinal joint: B

2_P_ALT_10-19-10		
STATION TO STATION	(P)	Feet
256+50.00	282+86.00	8
291+18.00	390+19.00	8

Paved Shoulder Alternates

PCC Shoulder Jointing:
 Longitudinal joint: BT-1 or BT-3
 Transverse joints: C at 20' spacing
 HMA Shoulder Jointing:
 Longitudinal joint: B

2_P_ALT_10-19-10		
STATION TO STATION	(P)	Feet
257+70.00	279+39.00	8
284+80.50	286+70.00	8

Auxiliary Lane

Paved Shoulder Alternates

Auxiliary Lane

Longitudinal joint: L or KT
 Transverse joint: Match Mainline

PCC Shoulder Jointing:
 Longitudinal joint: BT-1 or BT-3
 Transverse joints: C at 20' spacing
 HMA Shoulder Jointing:
 Longitudinal joint: B

2_AuxLane_PCC_10-19-10		2_AL_Shldr_ALT_10-19-10	
STATION TO STATION	(AL) Feet	(P)	Feet
284+48.00	289+38.00	10	6
289+38.00	292+08.00	10-0	6-0

Auxiliary Lane Paved Shoulder Alternates

Auxiliary Lane

Longitudinal joint: L or KT
 Transverse joint: Match Mainline

PCC Shoulder Jointing:
 Longitudinal joint: BT-1 or BT-3
 Transverse joints: C at 20' spacing
 HMA Shoulder Jointing:
 Longitudinal joint: B

2_AuxLane_PCC_10-19-10		2_AL_Shldr_ALT_10-19-10	
STATION TO STATION	(AL) Feet	(P)	Feet
279+39.00	281+19.00	0-10	0-6
281+19.00	282+94.00	10	6
386+70.00	388+50.00	0-10	0-6
388+50.00	390+25.00	10	6

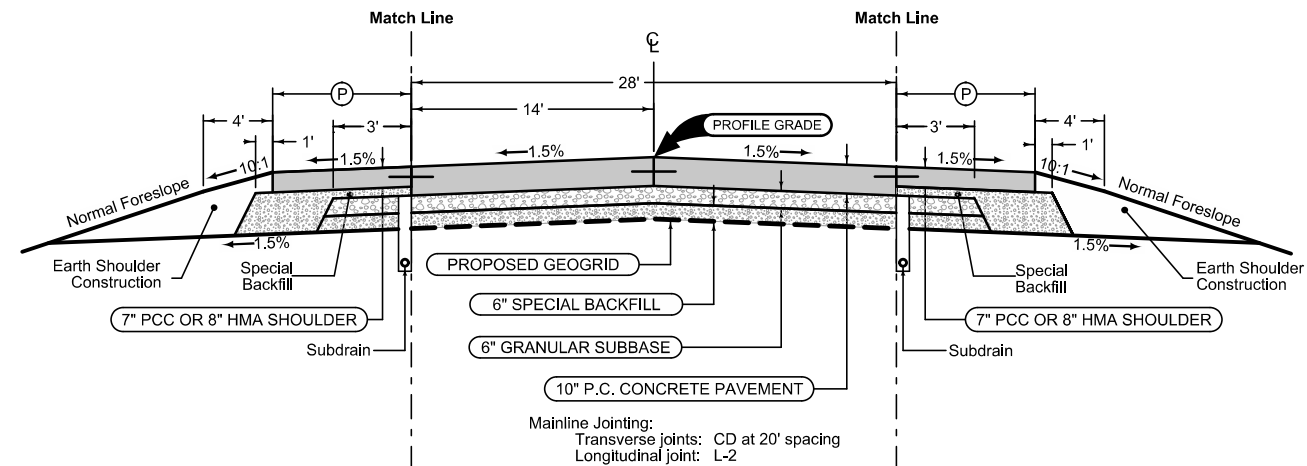

Mainline Jointing:
 Transverse joints: CD at 20' spacing
 Longitudinal joint: L-2

2P_10-19-10		
STATION TO STATION	(P)	Feet
256+50.00	391+00.00	

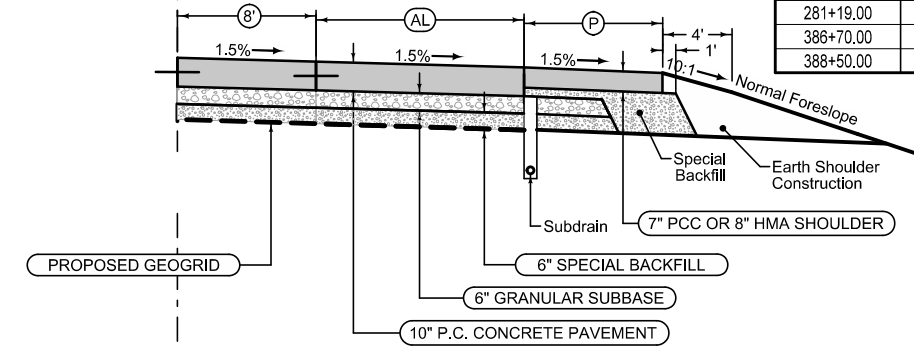
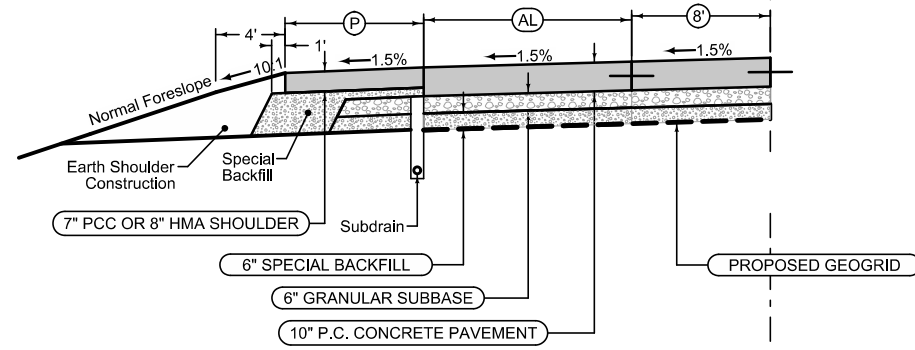

Paved Shoulder Alternates With Adjacent Granular Shoulder

PCC Shoulder Jointing:
 Longitudinal joint: BT-1 or BT-3
 Transverse joints: C at 20' spacing
 HMA Shoulder Jointing:
 Longitudinal joint: B

2_P_ALT_10-19-10			
STATION TO STATION	(P)	(G)	Feet
256+50.00	257+70.00	4	2-4

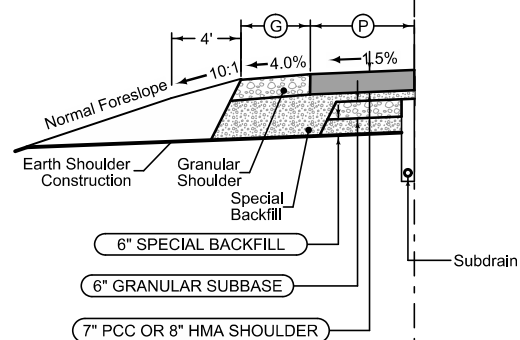

Paved Shoulder Alternates With Adjacent Granular Shoulder

PCC Shoulder Jointing:
 Longitudinal joint: BT-1 or BT-3
 Transverse joints: C at 20' spacing
 HMA Shoulder Jointing:
 Longitudinal joint: B

2_P_ALT_10-19-10			
STATION TO STATION	(P)	(G)	Feet
256+50.00	257+70.00	4	2-4

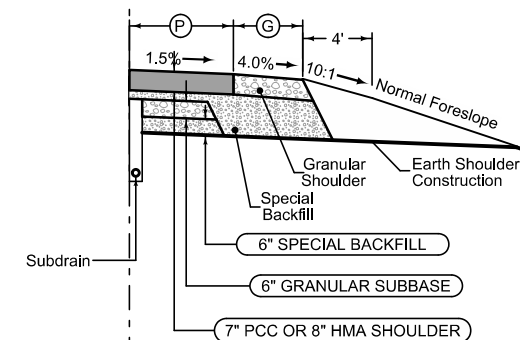

See Tab 100-24 for pavement quantities.
 See Tab 112-9 for shoulder quantities.

Curbed Shoulder

Shoulder Jointing:
Longitudinal joint: L-2
Staged: KT-2
Transverse: CD at 20' spacing

Single pour: L-2
Staged: KT-2
Transverse: CD at 20' spacing

2_Curb_MODIFIED			
STATION TO STATION	(P) Feet	Curb Type See PV-102	
391+00.00	443+18.01	3	6" Standard

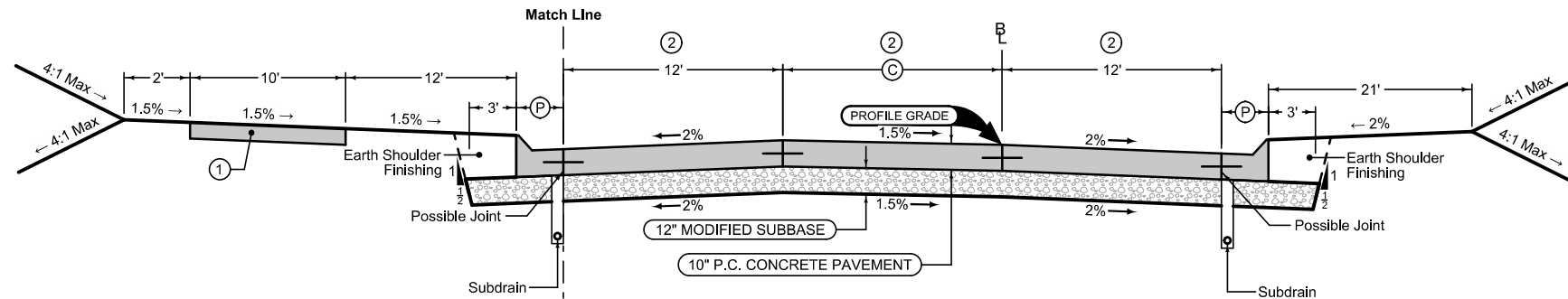

Mainline Jointing:
Transverse joints: CD at 20' spacing
Longitudinal joint: L-2

2P_TWLTL_10-19-10		
STATION TO STATION	(C) Feet	
391+00.00	441+27.50	16
441+27.50	443+18.01	16-12

Curbed Shoulder

Shoulder Jointing:
Longitudinal joint: L-2
Staged: KT-2
Transverse: CD at 20' spacing

Single pour: L-2
Staged: KT-2
Transverse: CD at 20' spacing

2_Curb_MODIFIED			
STATION TO STATION	(P) Feet	Curb Type See PV-102	
391+00.00	443+18.01	3	6" Standard

Auxiliary Lane

Longitudinal joint: L or KT
Transverse joint: Match Mainline

4_AuxLane_PCC_MODIFIED			
Direction of Travel	BEGIN STATION	END STATION	(AL) Feet
WEST	391+92.00	396+82.00	13

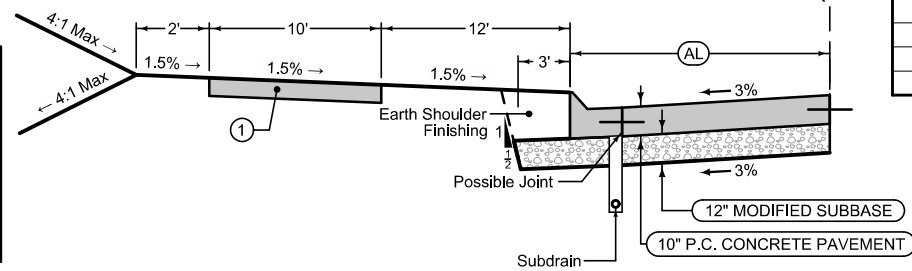

See Tab 100-24 for pavement quantities.

- ① Recreational Trail - Refer to Typ. 7402 for additional information.
- ② Refer to L-Sheets for transition areas.

IOWA 92 - URBAN

Curbed Shoulder

Shoulder Jointing:
Longitudinal: BT-2
Transverse: C at 20' spacing

2_Curb_MODIFIED			
STATION TO STATION	(P) Feet	Curb Type See PV-102	
443+18.01	464+92.00	2.5	6" Standard

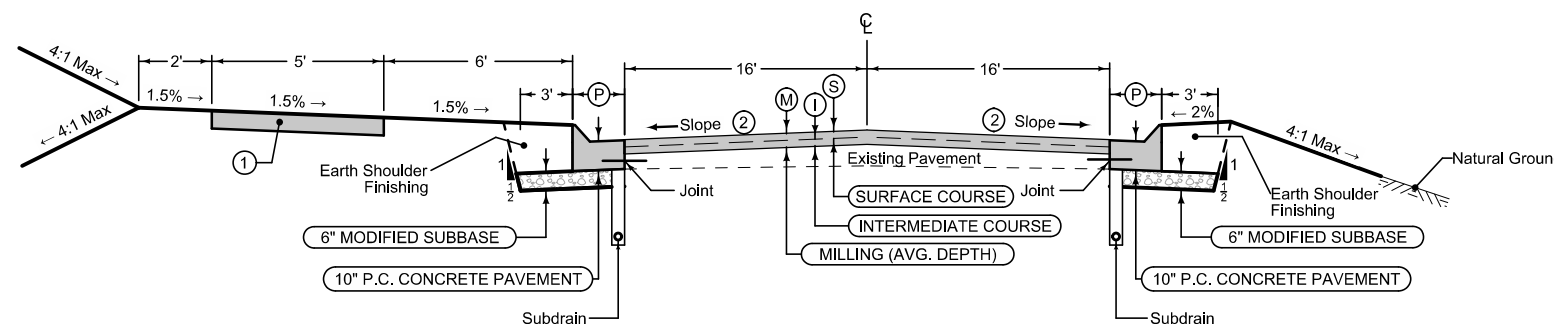

HMA RESURFACING

LOCATION					
ROAD IDENTIFICATION	STATION TO STATION	(M) Inches	(S) Inches	(I) Inches	
la. 92	443+18.01	465+01.01	3	1.5	1.5

Curbed Shoulder

Shoulder Jointing:
Longitudinal: BT-2
Transverse: C at 20' spacing

2_Curb_MODIFIED			
STATION TO STATION	(P) Feet	Curb Type See PV-102	
443+18.01	464+92.00	2.5	6" Standard

- ① Recreational Trail - Refer to Typ. 7402 for additional information. See Tab 100-24 for pavement quantities.
- ② Match finished slope to existing pavement, except the the maximum allowable slope is 3.0%, minimum allowable slope is 2.0%. Section may be modified as directed by the Engineer through areas of special shaping.
- ③ Refer to Plan and Profile sheets for Curb Form Grade.

IOWA 92 - WIDENING & RESURFACE

Granular Shoulder

2_G_ 10-19-10

ROAD IDENTIFICATION	STATION TO STATION		Ⓞ Feet
R-57	1280+60.00	1283+41.23	6
R-57	1384+16.17	1386+06.00	6
R-63	3388+60.00	3390+71.41	6
R-63	3391+41.99	3393+05.00	6

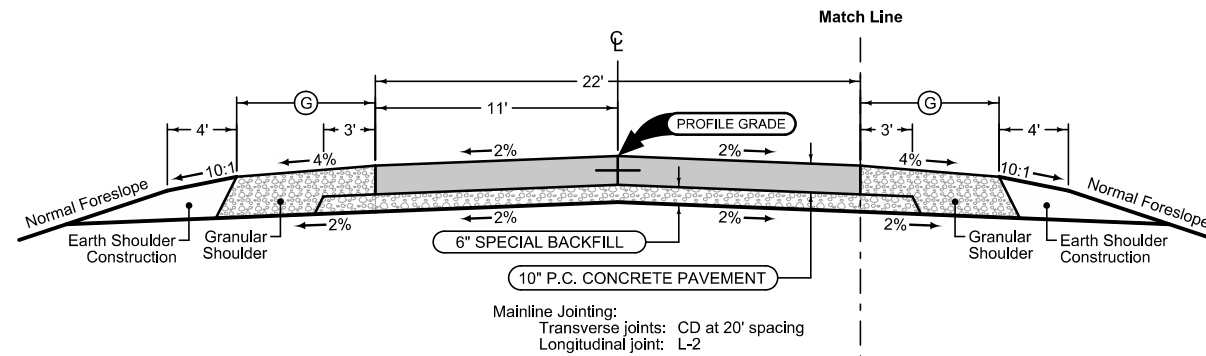

2P_ 10-19-10

ROAD IDENTIFICATION	STATION TO STATION	
R-57	1280+60.00	1283+41.23
R-57	1384+16.17	1386+06.00
R-63	3388+60.00	3390+71.41
R-63	3391+41.99	3393+05.00

Granular Shoulder

2_G_ 10-19-10

ROAD IDENTIFICATION	STATION TO STATION		Ⓞ Feet
R-57	1280+60.00	1283+41.23	6
R-57	1384+16.17	1386+06.00	6
R-63	3388+60.00	3390+71.41	6
R-63	3391+41.99	3393+05.00	6

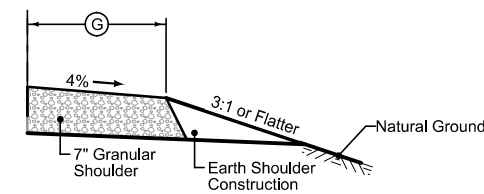

Granular Shoulder *

2_G_ 10-19-10

ROAD IDENTIFICATION	STATION TO STATION		Ⓞ Feet
R-57	1277+35.00	1279+25.00	6
R-57	1387+86.00	1389+68.00	6
R-63	3385+50.00	3386+82.00	6
R-63	3394+93.00	3396+25.00	6

*After removal of Detour

R-57 & R-63

Curbed Shoulder

Shoulder Jointing:
 Longitudinal joint not required when distance from back of curb to nearest joint is less than 15':

Single pour: L-2
 Staged : KT-2
 Transverse:C at 20' spacing

STATION TO STATION		(P) Feet	Curb Type See PV-102
4414+15.00	4417+25.32	1.5	6" Standard
4417+64.40	4422+60.00	1.5	6" Standard

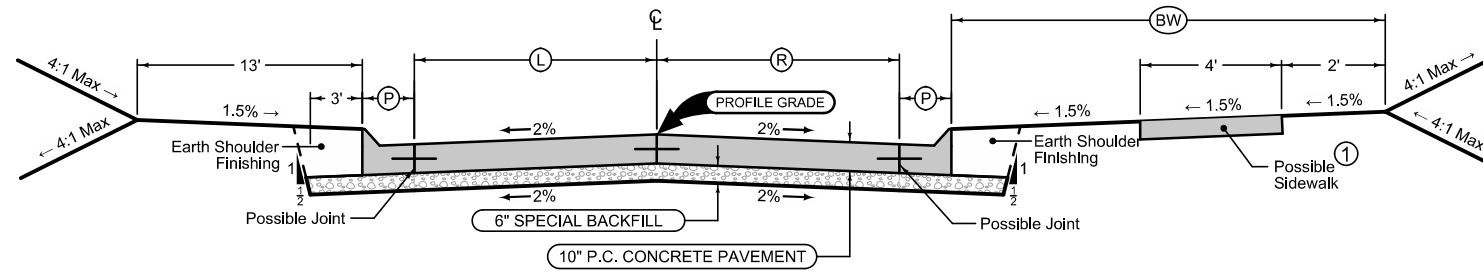

Curbed Shoulder

Shoulder Jointing:
 Longitudinal joint not required when distance from back of curb to nearest joint is less than 15':

Single pour: L-2
 Staged : KT-2
 Transverse:C at 20' spacing

STATION TO STATION		(P) Feet	Curb Type See PV-102	(BW) Feet
4414+15.00	4417+25.32	1.5	6" Standard	18
4417+64.40	4422+60.00	1.5	6" Standard	13

Mainline Jointing:
 Transverse joints: C at 20' spacing
 Longitudinal joint: L-2

STATION TO STATION		(L) Feet	(R) Feet
4414+15.00	4417+25.32	11	11
4417+64.40	4422+60.00	14	14

① Refer to S-sheets for Add. info
 See Tab 100-24 for pavement quantities.
 See Tab 112-9 for shoulder quantities.

Y ST

Curbed Shoulder

Shoulder Jointing:
 Longitudinal: BT-2
 Transverse: C at 20' spacing

STATION TO STATION		(P) Feet	Curb Type See PV-102
4410+73.00 Lt	4411+62.00 Lt	1.5	6" Standard
4414+91.00 Rt	4415+37.00 Rt	1.5	6" Standard
4424+96.00 Lt	4425+66.00 Lt	1.5	6" Standard

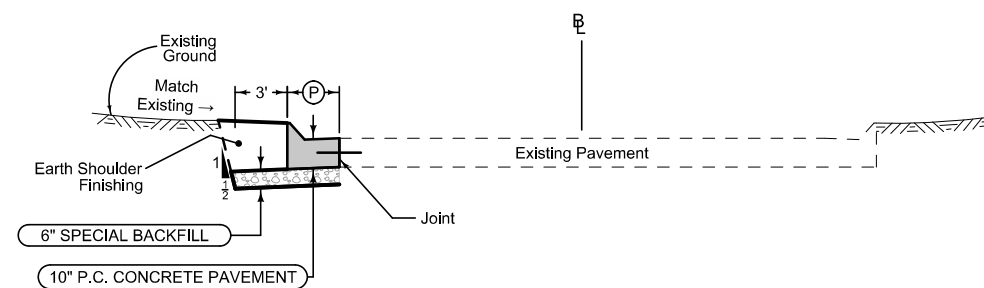

① Recreational Trail - Refer to Typ. 7402 for additional information.
 See Tab 100-24 for pavement quantities.

Y ST

Curbed Shoulder

Shoulder Joining:
Longitudinal joint not required when distance from back of curb to nearest joint is less than 15':

Single pour: L-2
Staged : KT-2
Transverse:C at 20' spacing

		2_Curb_MODIFIED		
STATION TO STATION	P Feet	Curb Type		
		See PV-102		
SPRUCE ST	0	31.4	2	6" Standard
SOUTH 'R' ST	0	27.5	3.5	6" Standard
KENWOOD BLVD.	0	33.4	2	6" Standard
SOUTH 'P' ST-SOUTH	0	36.7	2	6" Standard
SOUTH 'P' ST-NORTH	0	33.7	2	6" Standard
SOUTH 'N' ST	0	16.1	6	6" Standard

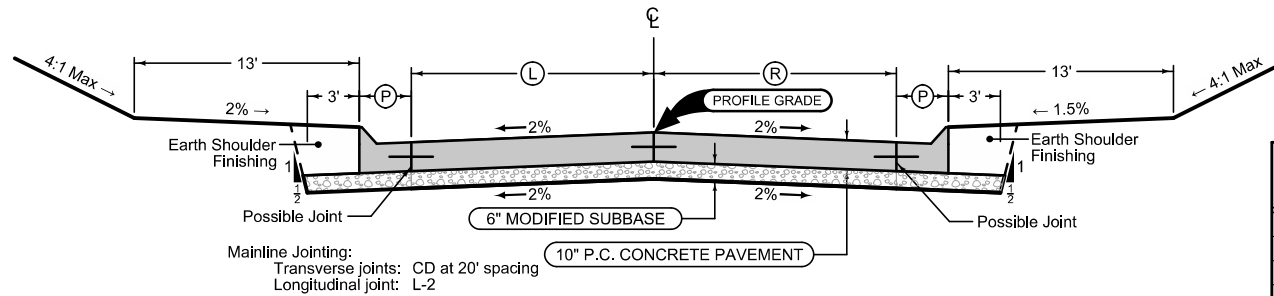

Mainline Joining:
Transverse joints: CD at 20' spacing
Longitudinal joint: L-2

	STATION TO STATION	L Feet	R Feet
SPRUCE ST	0	31.4	10.5
SOUTH 'R' ST	0	27.5	12
KENWOOD BLVD.	0	33.4	18.5
SOUTH 'P' ST-SOUTH	0	36.7	13
SOUTH 'P' ST-NORTH	0	33.7	11
SOUTH 'N' ST	0	16.1	10

Curbed Shoulder

Shoulder Joining:
Longitudinal joint not required when distance from back of curb to nearest joint is less than 15':

Single pour: L-2
Staged : KT-2
Transverse:C at 20' spacing

		2_Curb_MODIFIED		
STATION TO STATION	P Feet	Curb Type		
		See PV-102		
SPRUCE ST	0	31.4	2	6" Standard
SOUTH 'R' ST	0	27.5	3.5	6" Standard
KENWOOD BLVD.	0	33.4	2	6" Standard
SOUTH 'P' ST-SOUTH	0	36.7	2	6" Standard
SOUTH 'P' ST-NORTH	0	33.7	2	6" Standard
SOUTH 'N' ST	0	16.1	6	6" Standard

Refer to 'L' Sheets.
See Tab 100-24 for pavement quantities.
Curb shoulder quantities included with mainline pavement.

- ① Station based on distance from edge of mainline pavement.
- ② Use staking details for profile. Refer to L-Sheets.

TYPICAL URBAN INTERSECTION

7402
MODIFIED

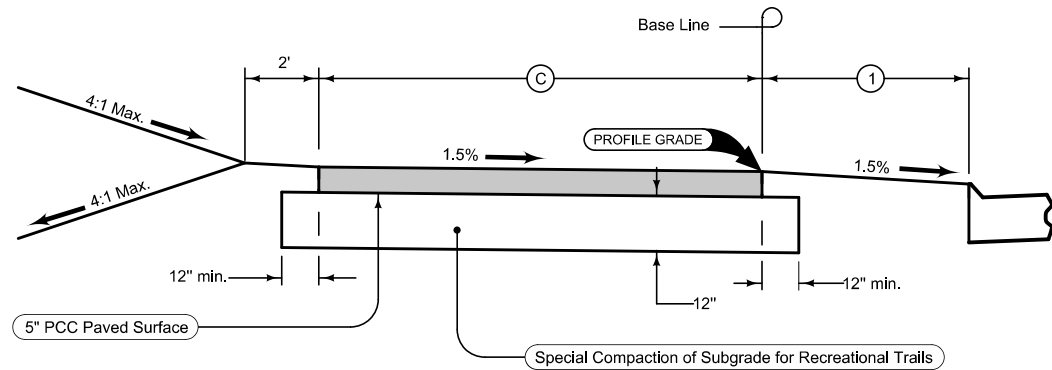

STATION TO STATION	PAVEMENT TYPE	C Feet	
391+20.00	441+21.07	PCC	10

- Notes:
- ① Refer to other detail typicals and cross sections for distance from edge of Recreational Trail to back of curb.

Refer to Tab 113-1 on C-sheets.

Contract bid items:
'Recreational Trail, Portland Cement Concrete, 5 in.'
'Special Compaction of Subgrade for Recreational Trail'

TYPICAL CROSS SECTION RECREATIONAL TRAIL PAVED SURFACE

7149M
MODIFIED

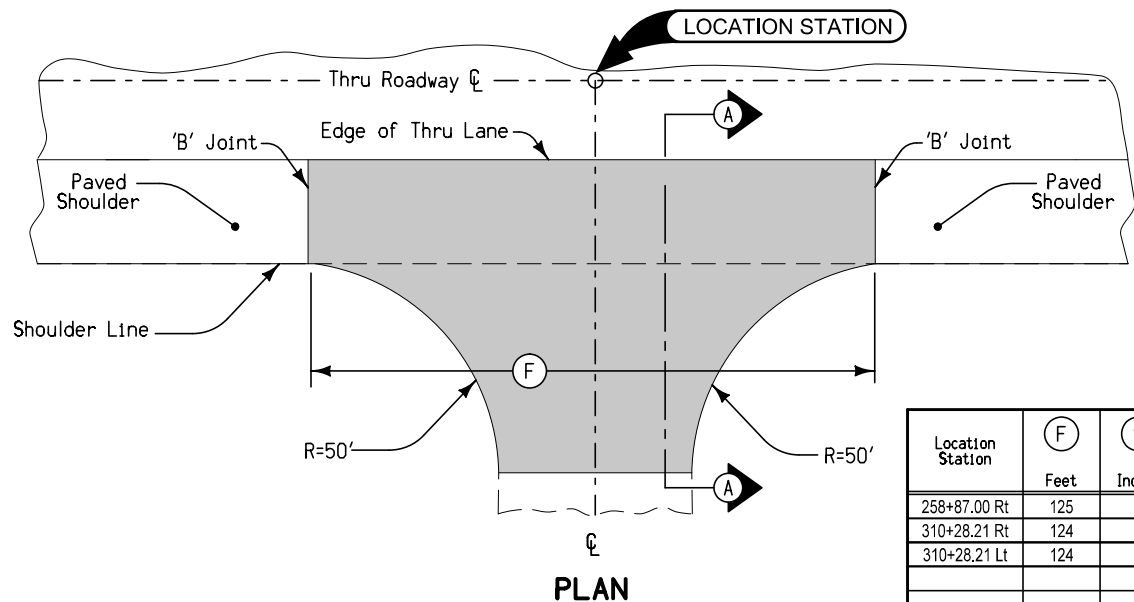

Location Station	F Feet	S Inches	T Inches	L (50' min.) Feet	Remarks
258+87.00 Rt	125	6	8	69.3	See Tab. 100-24, KENNEDY ST.
310+28.21 Rt	124	6	8	57.4	See Tab. 100-24, 90TH AVE.
310+28.21 Lt	124	6	8	58.6	See Tab. 100-24, 90TH AVE.

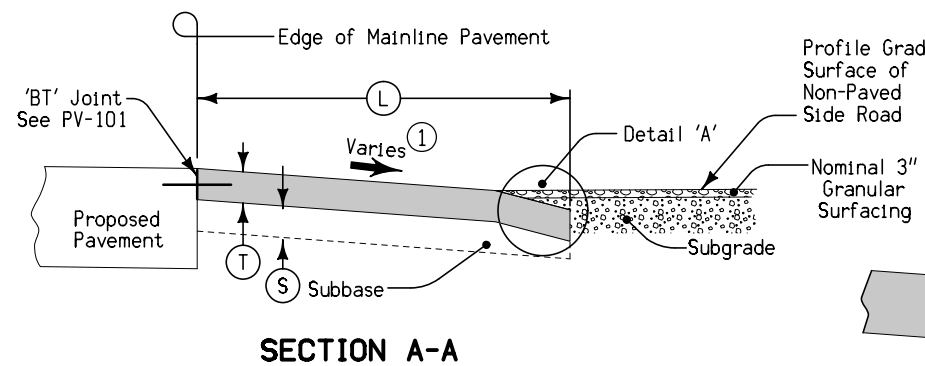

Special shaping of existing surface prior to placement of fillet or fillet extension may be required by the Engineer and is incidental to other work on the project.

- ① Profile grade of Side Road

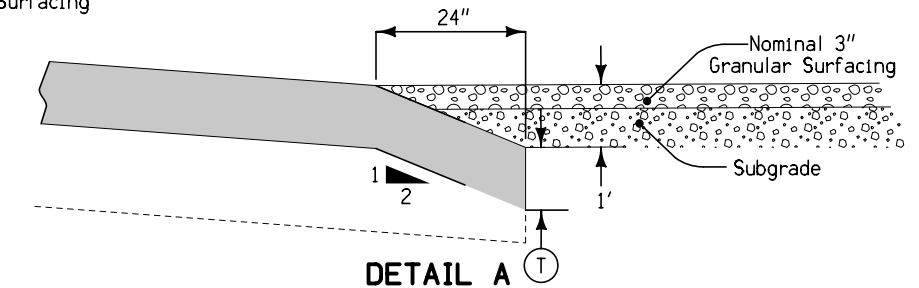

FILLET EXTENSION FOR NON-PAVED SIDE ROADS

ROAD IDENTIFICATION	LOCATION		DIMENSIONS							Quantities	
	STATION TO STATION		Ⓛ Feet	Ⓡ Feet	Ⓜ Feet	Ⓜ Feet	FS	BS	Ⓧ Feet	Length Mile	Granular Surfacing Tons
KENNEDY ST	1257+45.00	1258+68.00	15	15	12	12	3	3	5	0.023	54.7
90TH AVE	2305+85.00	2307+00.00	12-13	12-13	12	12	2.5-3	2.5-3	0	0.022	51.2
90TH AVE	2307+00.00	2308+00.00	13	13	12	12	3	3	0-5	0.019	44.5
90TH AVE	2308+00.00	2310+06.21	13	13	12	12	3	3	5	0.047	111.4
90TH AVE	2310+50.21	2313+85.00	13	13	12	12	3	3	5	0.063	149.0
Accessway 258	1259+09.00	1259+38.00	13	13-20	12	12	3	3	0	0.005	12.9
Accessway 258	1259+38.00	1259+90.00	13	20	12	12	3	3	0	0.010	23.1
Accessway 258	1259+90.00	1260+30.00	13	20-13	12	12	3	3	0	0.008	17.8
Accessway 258	1260+30.00	1261+20.00	13	13	12	12	3	3	0	0.017	40.1
Kirkwood St.	0+00.00	26+40.00	U.A.C.	U.A.C.	8	8	U.A.C.	U.A.C.	U.A.C.	0.500	1175.0
Detour Y St. SW	14409+91.69	14417+13.53	10	10	10	10	3	3	5	0.137	321.3
Detour Y St SE	24415+20.54	24418+46.15	10	10	10	10	3	3	5	0.061	144.5
Detour Y St NW	14416+96.30	14424+85.76	10	10	10	10	3	3	5	0.150	351.4
Detour Spruce St	19441+06.00	19442+36.05	12	12	10	10	3	2.5	5	0.025	57.9

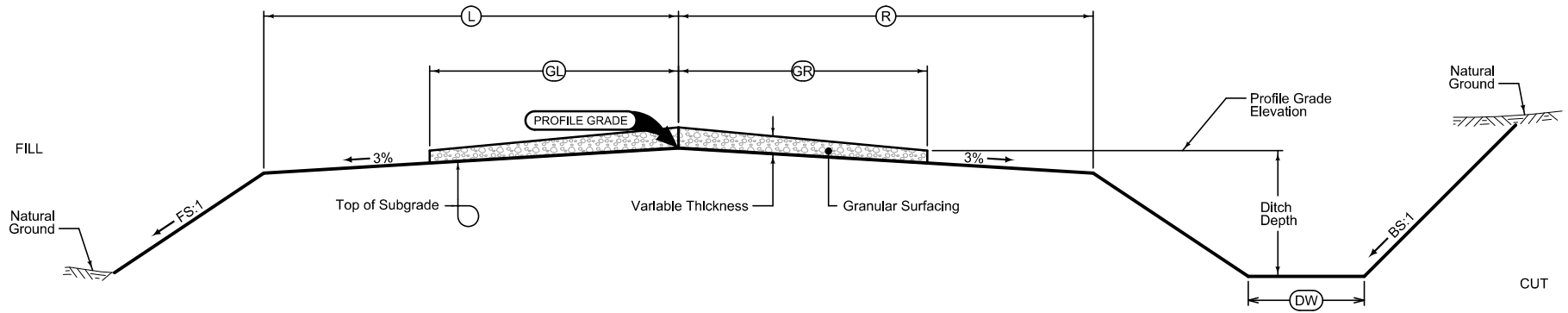

Normal section shown may be modified appropriately in areas of superelevated curves or other locations specifically designated by the Engineer.

See plan & profile sheets and cross sections for additional details of ditches and backslopes.

Place Granular Surfacing as follows:
Grade-Pave design application rate is 2330 tons per mile.

GRADING AND GRANULAR SURFACING

2117
04-15-08

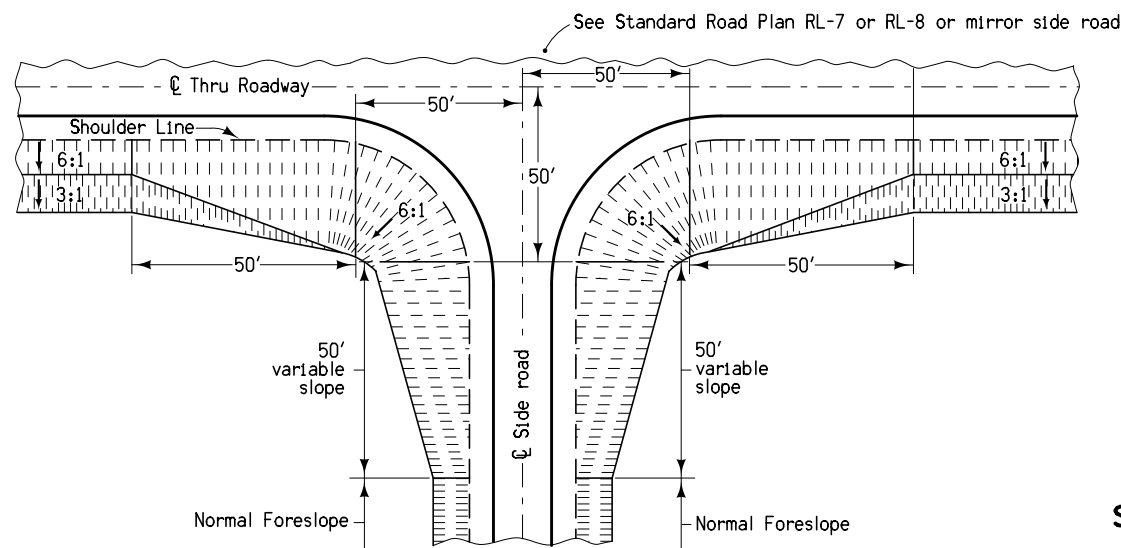

**SIDE ROAD GRADING
(BARNROOF)**

LOCATION		DIMENSIONS				Quantities		
ROAD IDENTIFICATION	STATION TO STATION		HMA		PCC		Detour Pavement SY	Special Backfill Tons
			(T) Inches	(SGW) Feet	(T) Inches	(SGW) Feet		
IA 92 NE Tie-in	439+07.95	444+99.72	9	VARI	8	VARI	798.6	543.8
IA 92 SE Tie-in	441+22.91	441+23.02	9	VARI	8	VARI	163.8	119.8
Totals							962.4	663.6

Quantity calculations based on vertical pavement edges.
 Normal section shown may be modified appropriately in areas of superelevated curves or other locations specifically designated by the Engineer.
 Refer to L-Sheets.

- ① 6" Granular Shoulder
- ② Possible 1:1 slope

2_Detour
MODIFIED

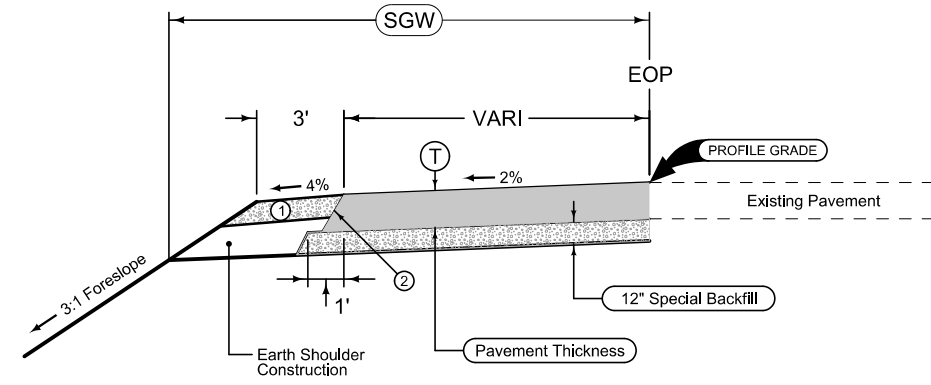

1 LANE DETOUR PAVING

LOCATION		DIMENSIONS				Quantities		
ROAD IDENTIFICATION	STATION TO STATION		HMA		PCC		Detour Pavement SY	Special Backfill Tons
			(T) Inches	(SGW) Feet	(T) Inches	(SGW) Feet		
R-57	11277+89.54	11283+98.25	8	35	7	34.5	1254.3	432.6
R-57	11284+92.87	11290+40.39	8	35	7	34.5	1092.3	376.9
R-63	18386+48.19	18392+53.75	8	35	7	34.5	1476.2	506.0
R-63	18392+77.34	18397+71.90	8	35	7	34.5	1179.8	402.9
Totals							5002.6	1688.4

Quantity calculations based on vertical pavement edges.
 Normal section shown may be modified appropriately in areas of superelevated curves or other locations specifically designated by the Engineer.
 Refer to L-Sheets.

- ① 6" Granular Shoulder
- ② Possible 1:1 slope

2_Detour
MODIFIED

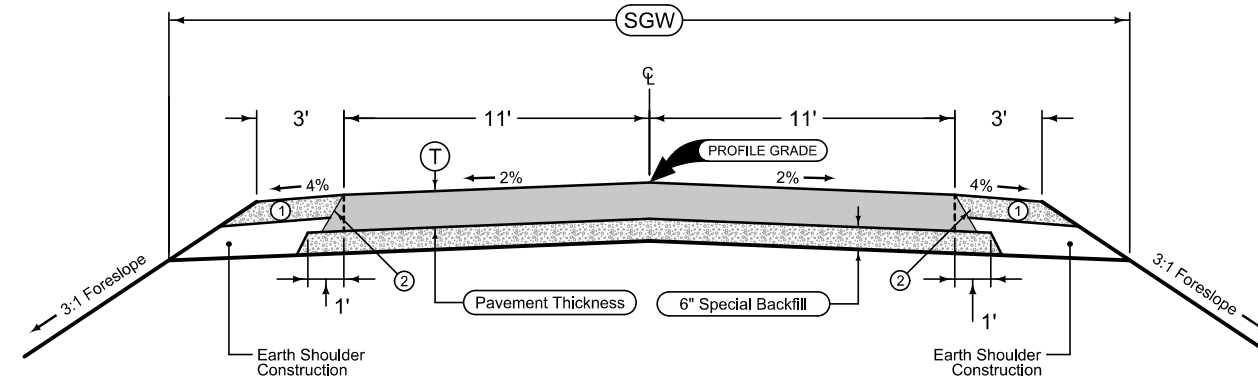

2 LANE DETOUR PAVING

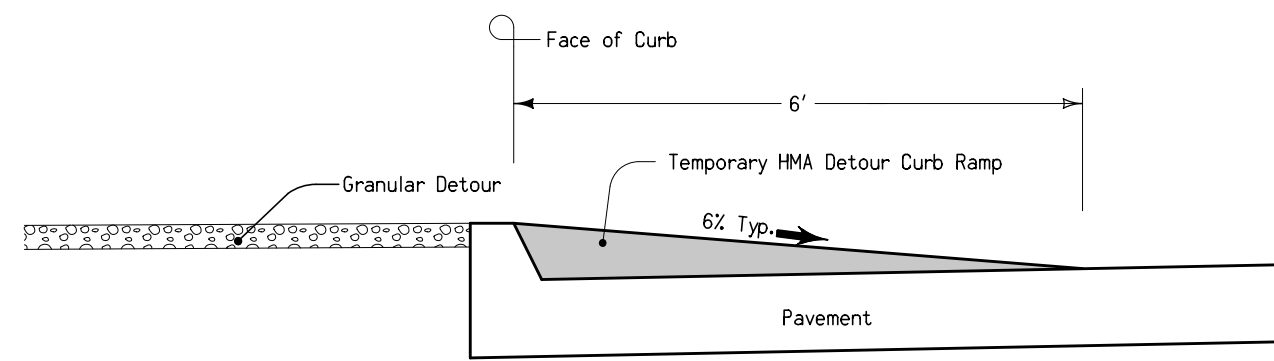
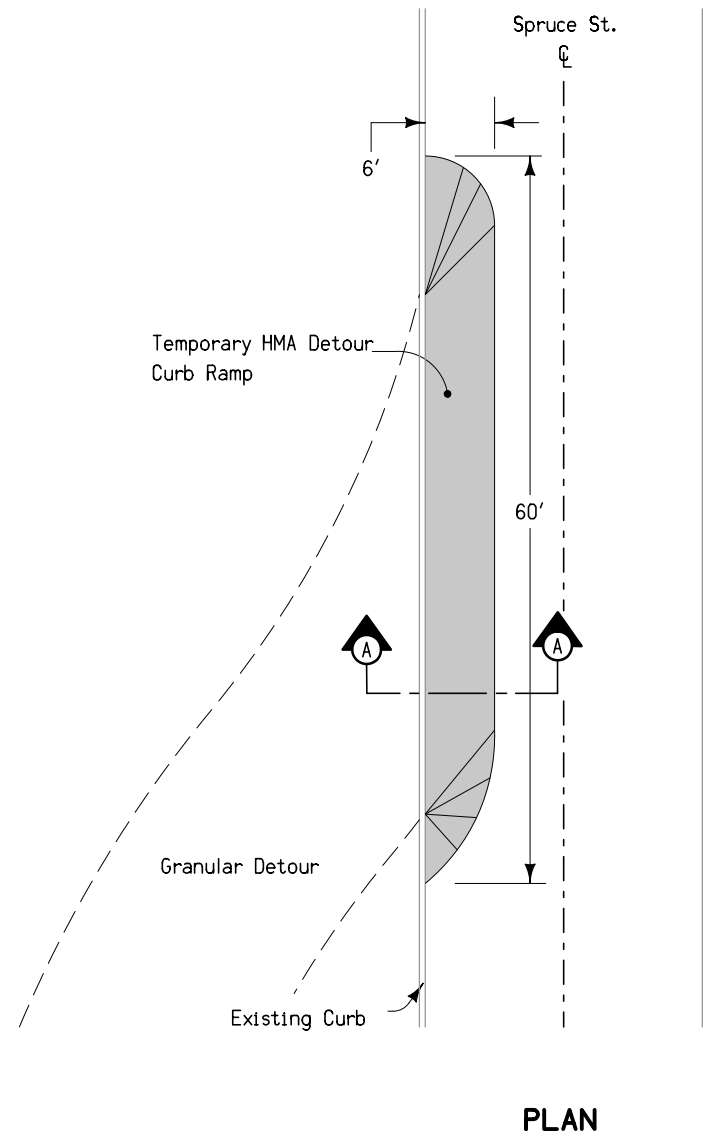

SECTION A-A

Bid as Temporary Pavement.
Removal of temporary HMA Detour Curb Ramp is incidental to Temporary Pavement.
Temporary Pavement area is 6.7 square yards.

TEMPORARY HMA DETOUR CURB RAMP

7154B
10-20-09

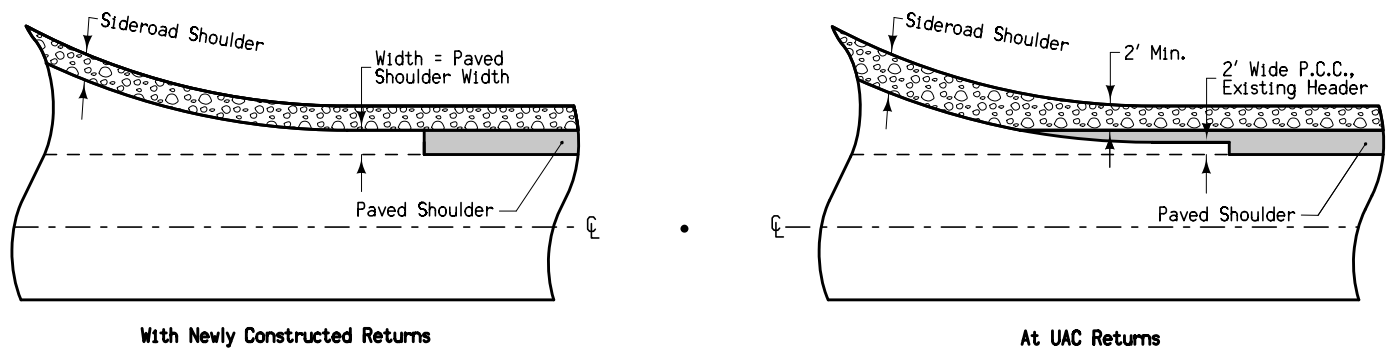

PAVED SHOULDER
DETAIL AT RETURNS

7154A
10-20-09

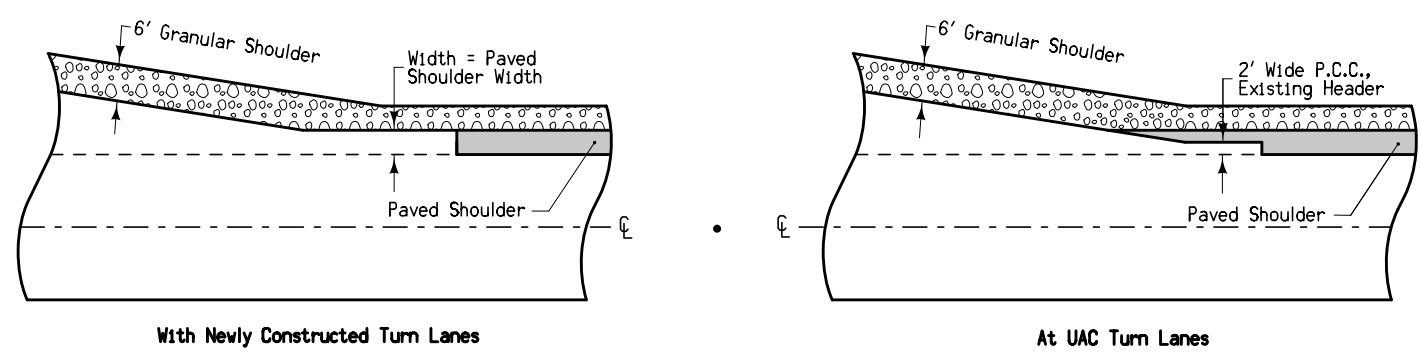

PAVED SHOULDER
DETAIL AT
TURN LANES

7101
10-19-10

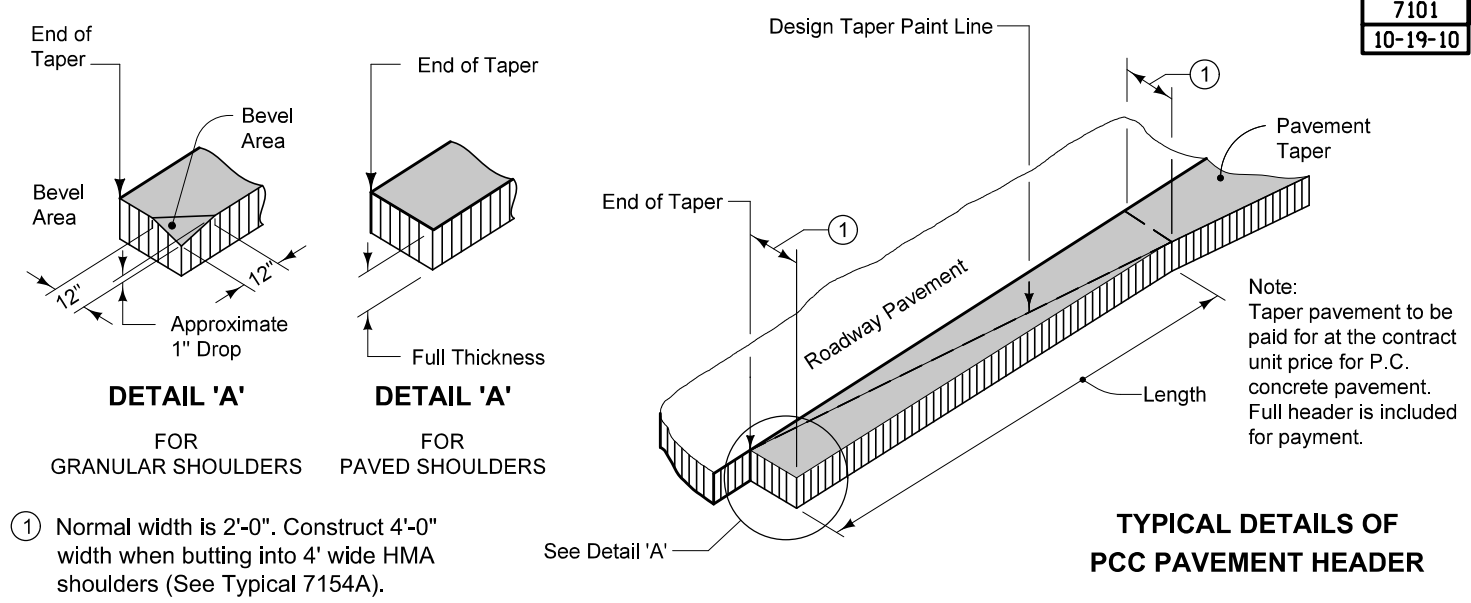

TYPICAL DETAILS OF
PCC PAVEMENT HEADER

9503
07-15-97

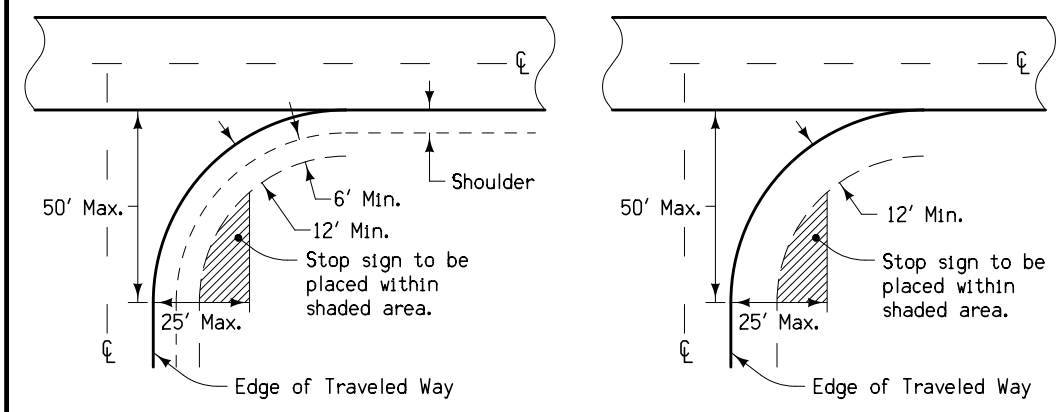

NOTES:
Stop signs should be confined to the shaded areas, but as close to the approach roadway as possible to provide the motorist with the best visual impact.
If possible, stop signs should be placed at the point where vehicles are to stop or as near as practical.
In rural areas, the lateral clearance should not be closer than 6' from the edge of a usable shoulder, or if none, 12' from edge of the traveled way.
In urban areas, stop signs should be placed a minimum of 6' from the near edge of the intersected street or a minimum of 4' in advance of the near edge of a marked crosswalk. Lateral clearance may be reduced to a minimum of 2' from the face of a curb.
Where the approach roadway consists of two lanes of traffic, a second stop sign should be placed where it is visible to traffic in the inner lane.
At channelized intersections, the additional stop sign may be placed on a channelized island or median.

CASE 'A'
WITH SHOULDER

CASE 'B'
WITHOUT SHOULDER

STOP SIGN PLACEMENT

TURNAROUND
NEW

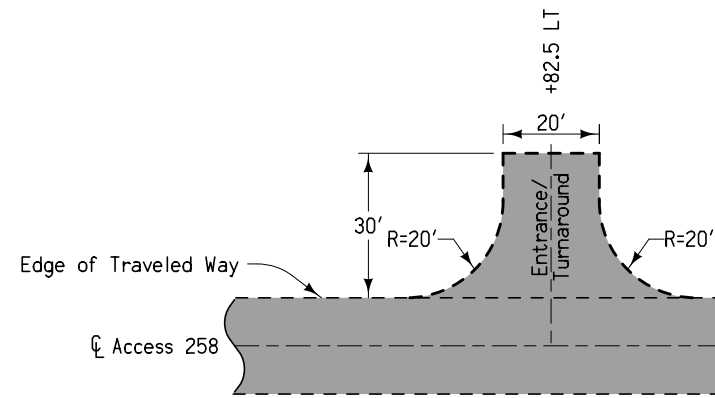

NOTES:
Refer to Plan and Profile sheets for profile of Entrance.

**MAINTENANCE
TURNAROUND DETAIL
ACCESSWAY 258**

ENT359
NEW

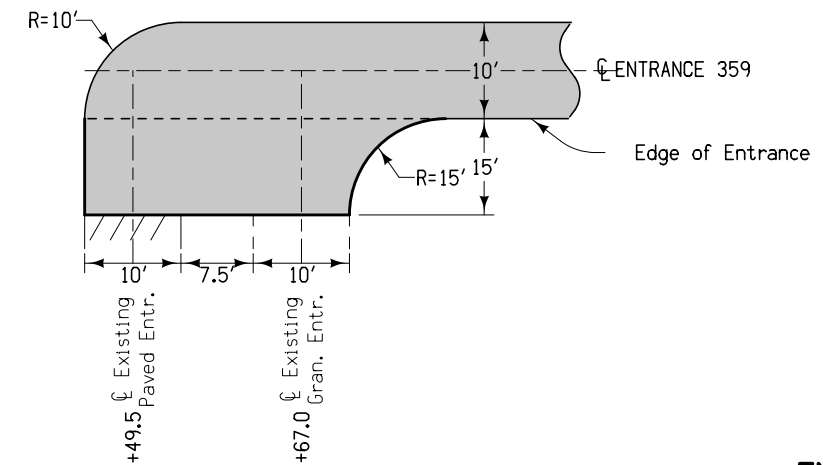

NOTES:
Refer to Plan and Profile sheets for profile of Entrance.

**ENTRANCE 359
TERMINAL DETAIL**

ENT419
NEW

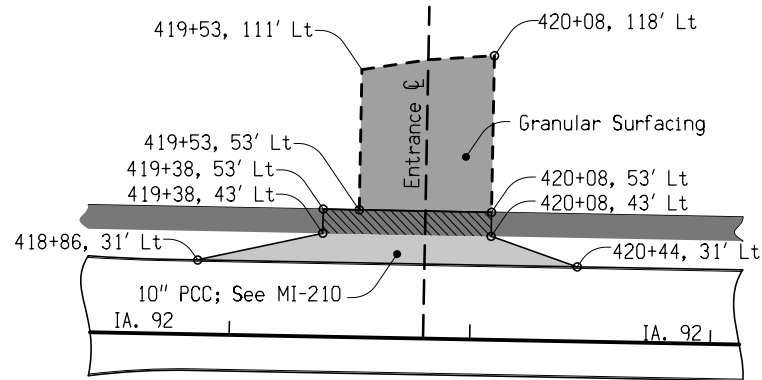

NOTES:
Refer to Tab. 102-3 for quantities.
Refer to MI-210 for additional details.
Refer to Plan and Profile sheets for profile of Entrance.

**ENTRANCE 419
CONSTRUCTION LIMITS**

ENT423
NEW

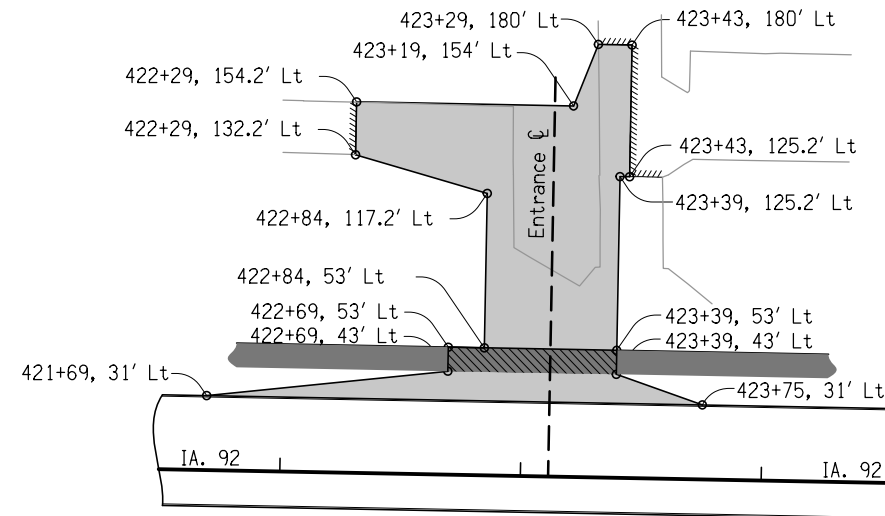

NOTES:
Refer to Tab. 102-3 for quantities.
Refer to MI-210 for additional details.
Refer to Plan and Profile sheets for profile of Entrance.

**ENTRANCE 423
CONSTRUCTION LIMITS**

4309
Modified

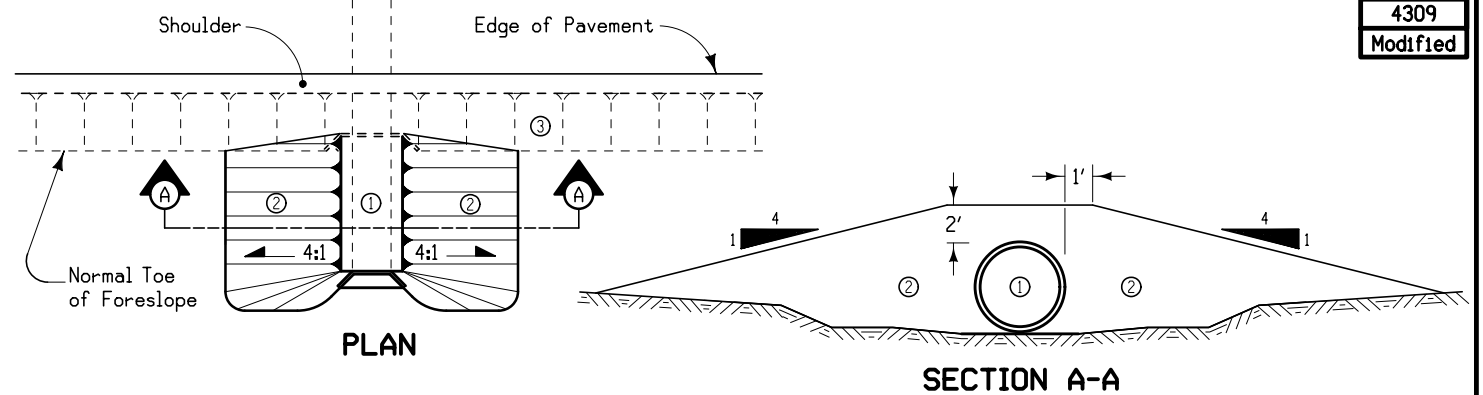

STATION	SIDE	Cu. Yds.
4414+30	Rt.	40
426+59	Rt.	110

- Notes:
- ① Storm Sewer Outlet
 - ② Proposed Embankment
 - ③ Adjacent Foreslope

**PLACEMENT OF EMBANKMENT
AT STORM SEWER OUTLET**

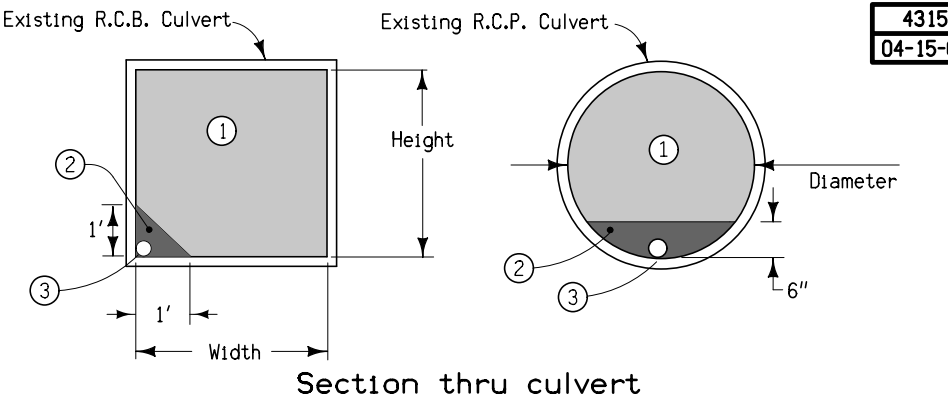
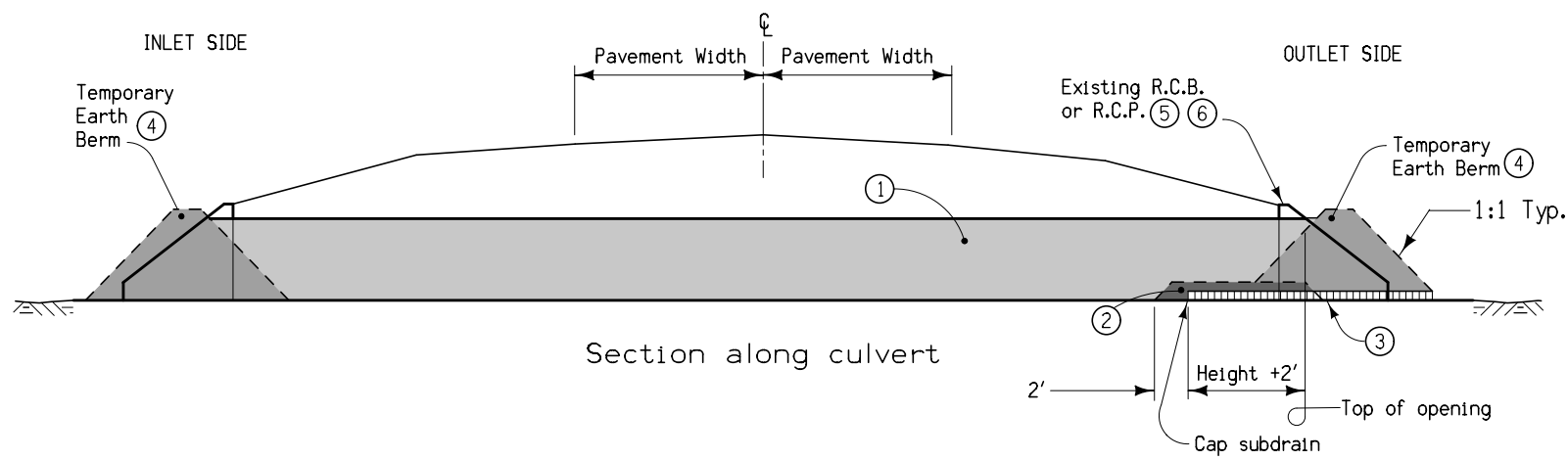
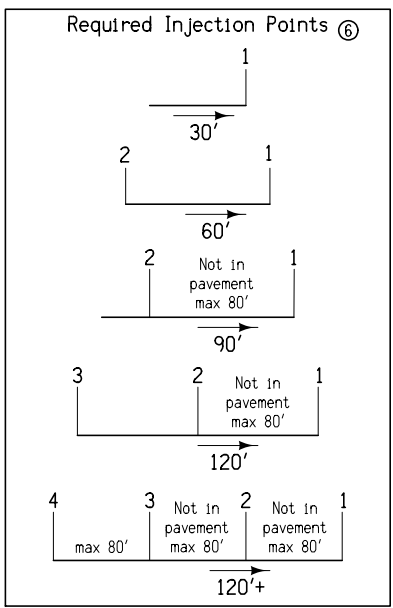

- ① Flowable Mortar.
- ② Granular Backfill.
- ③ 4" subdrain at flowline elevation of culvert shall be extended into the culvert a distance of 2' plus the height of the culvert. Granular Backfill covers subdrain and extends an additional 2'. Subdrain and granular backfill are incidental to flowable mortar.
- ④ Ends of culvert shall be plugged sufficiently to retain flowable mortar. Temporary earth berms are incidental to flowable mortar.
- ⑤ Removal of headwalls may be required.
- ⑥ Outlet shall be filled first. See injection point detail for additional information.

DETAILS OF CULVERT ABANDONMENT WITH FLOWABLE MORTAR
(Rectangular structures less than 8' in either height or width.
Circular structures less than 10' Dia.)

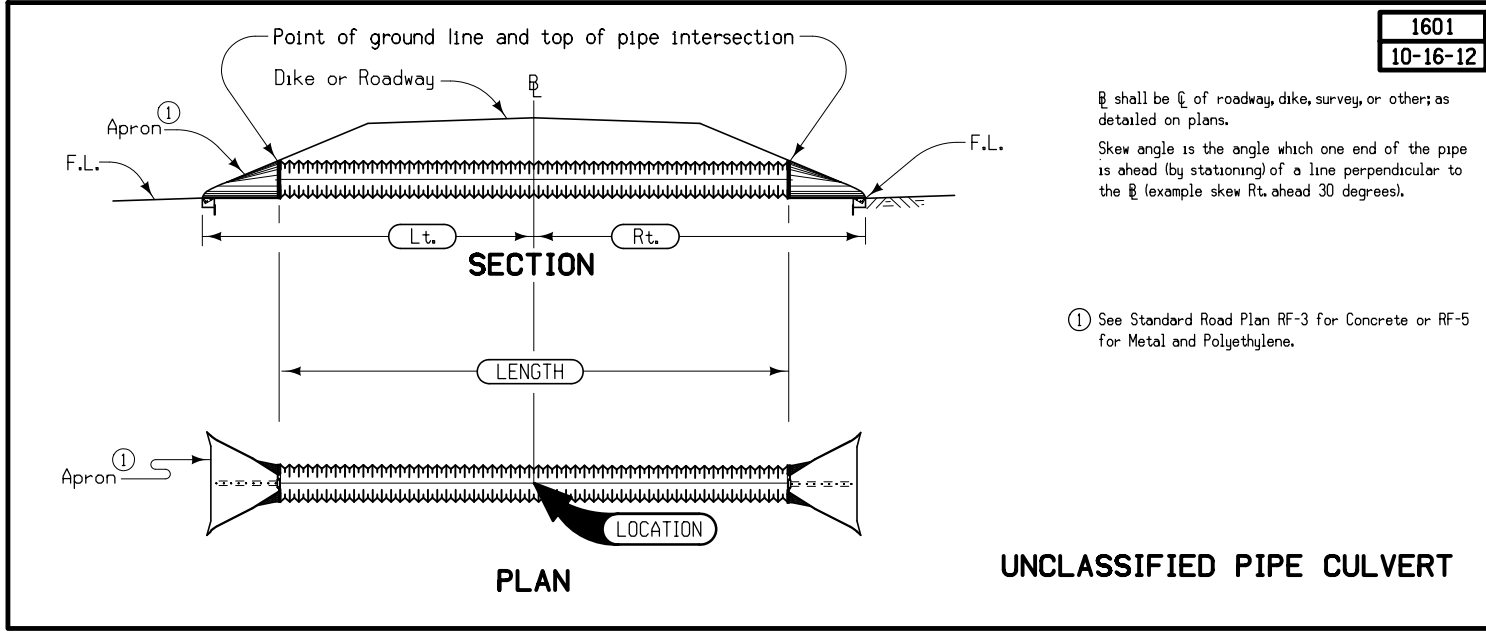
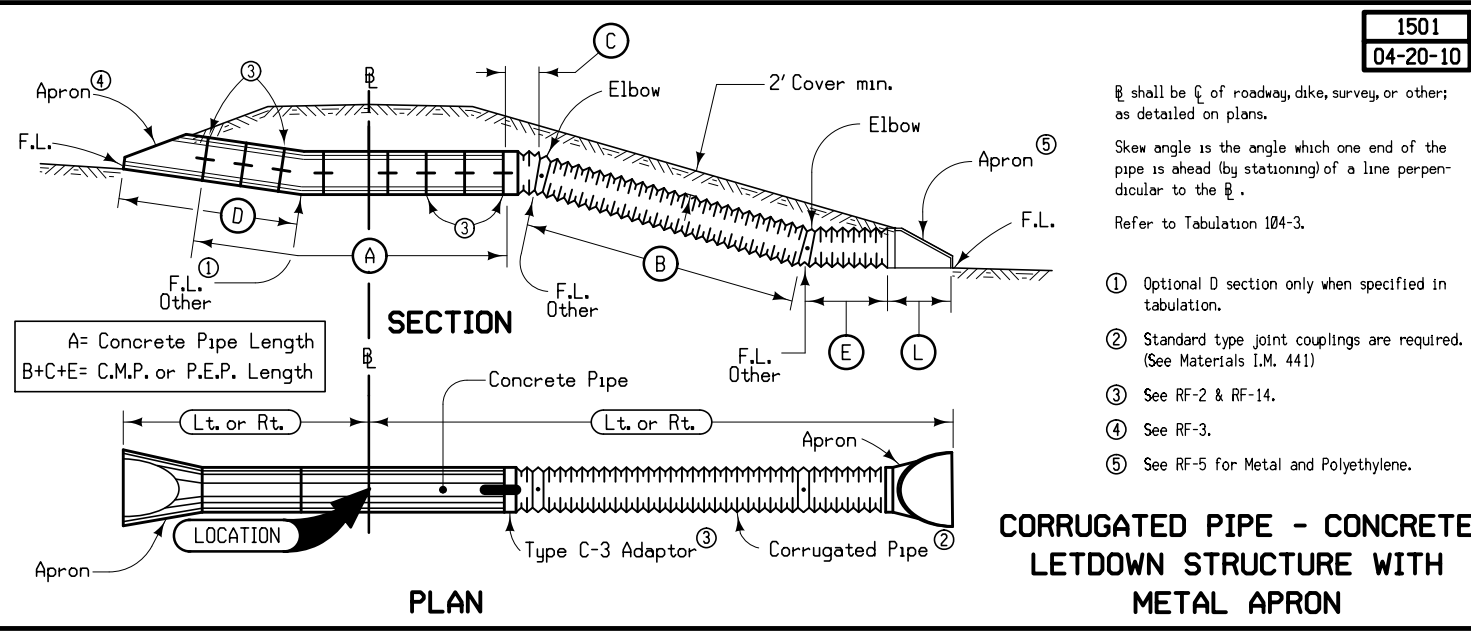
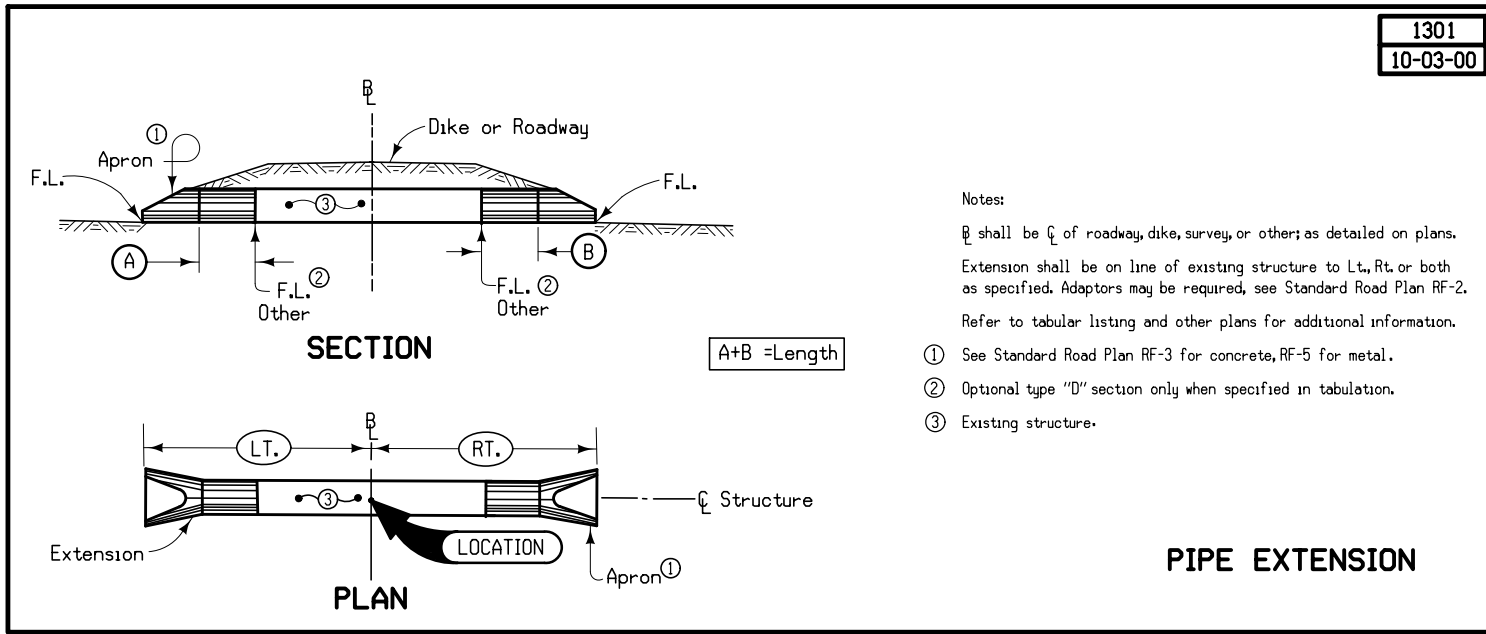
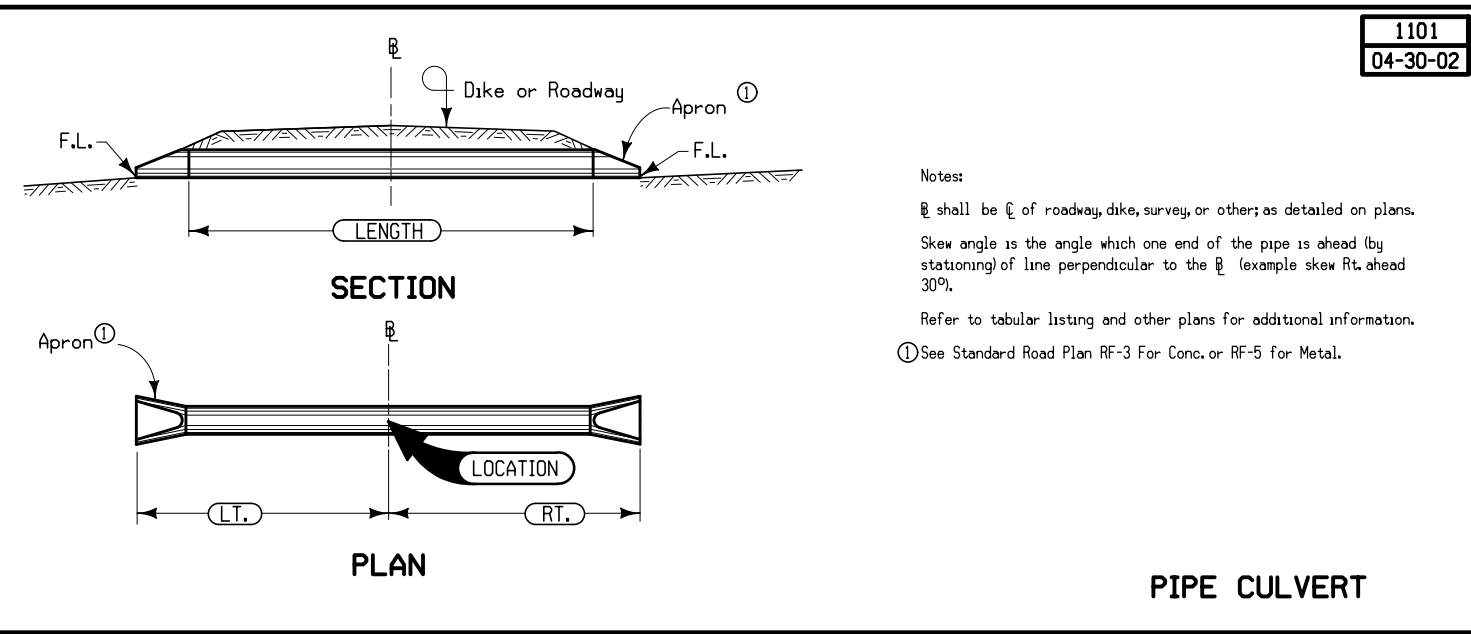

PROJECT DESCRIPTION

This project involves the reconstruction of IA 92 from west of Kennedy Street to east of 'N' Street in Indianola. The project is divided into a rural and an urban section.

The rural section extends from west of Kennedy Street easterly 2.5 miles to County Road R-63. This section of IA 92 west of Co. Rd. R-63 will be closed to thru traffic and detoured off site. Access to private properties will be maintained during construction. Traffic on Co. Rd. R-57, Co. Rd. R-63, and 'Y' St. will be also be maintained during construction. Traffic on Co. Rd. R-63 will be maintained except for the construction of the IA 92/R-63 intersection.

The urban section extends from Co. Rd. R-63 to just east of 'N' Street, a total distance of approximately 1.5 miles. It will include reconstruction from Co. Rd. R-63 to just east of Spruce Street; then a curb and gutter widening to the end of project where it meets the existing curb and gutter section. The traffic in the urban section will be maintained via staging. The reconstruction will consist of a 46' back-to-back curbed roadway including a 16' wide continuous center turn lane. The curb and gutter widening will be 37' back-to-back and UAC existing pavement.

Also, the project includes the construction of a 10' wide shared use path constructed on the north side of the roadway from Co. Rd. R-63 east to Spruce Street and a 5' wide sidewalk will be constructed on the north side of the roadway from Spruce Street east to South 'M' Street.

**ESTIMATED PROJECT QUANTITIES
(1 DIVISION PROJECT)**

Item No.	Item Code	Item	Unit	Total	As Built Qty.
33	2402-2720100	EXCAVATION, CLASS 20, FOR ROADWAY PIPE CULVERT	CY	4,206.9	
34	2416-0100015	APRONS, CONCRETE, 15 IN. DIA.	EACH	13	
35	2416-0100018	APRONS, CONCRETE, 18 IN. DIA.	EACH	5	
36	2416-0100021	APRONS, CONCRETE, 21 IN. DIA.	EACH	1	
37	2416-0100024	APRONS, CONCRETE, 24 IN. DIA.	EACH	24	
38	2416-0100030	APRONS, CONCRETE, 30 IN. DIA.	EACH	7	
39	2416-0100036	APRONS, CONCRETE, 36 IN. DIA.	EACH	2	
40	2416-1180018	CULVERT, CONCRETE ROADWAY PIPE, 18 IN. DIA.	LF	128	
41	2416-1180024	CULVERT, CONCRETE ROADWAY PIPE, 24 IN. DIA.	LF	1254	
42	2416-1180030	CULVERT, CONCRETE ROADWAY PIPE, 30 IN. DIA.	LF	304	
43	2416-1180036	CULVERT, CONCRETE ROADWAY PIPE, 36 IN. DIA.	LF	118	
44	2417-0225024	APRONS, METAL, 24 IN. DIA.	EACH	1	
45	2417-1060024	CULVERT, CORRUGATED METAL ROADWAY PIPE, 24 IN. DIA.	LF	64	
46	2422-0360018	APRONS, UNCLASSIFIED, 18 IN. DIA.	EACH	54	
47	2422-0360024	APRONS, UNCLASSIFIED, 24 IN. DIA.	EACH	2	
48	2422-0360036	APRONS, UNCLASSIFIED, 36 IN. DIA.	EACH	4	
49	2422-1722018	CULVERT, UNCLASSIFIED ENTRANCE PIPE, 18 IN. DIA.	LF	2138	
50	2422-1722024	CULVERT, UNCLASSIFIED ENTRANCE PIPE, 24 IN. DIA.	LF	74	
51	2422-1722036	CULVERT, UNCLASSIFIED ENTRANCE PIPE, 36 IN. DIA.	LF	102	
52	2422-1723018	CULVERT, UNCLASSIFIED ROADWAY PIPE, 18 IN. DIA.	LF	212	
53	2422-1723024	CULVERT, UNCLASSIFIED ROADWAY PIPE, 24 IN. DIA.	LF	98	
54	2422-1723030	CULVERT, UNCLASSIFIED ROADWAY PIPE, 30 IN. DIA.	LF	44	
55	2435-0140200	MANHOLE, STORM SEWER, SW-402	EACH	1	
56	2435-0250800	INTAKE, SW-508	EACH	77	
57	2435-0251000	INTAKE, SW-510	EACH	17	
58	2435-0251224	INTAKE, SW-512, 24 IN.	EACH	1	
59	2435-0600010	MANHOLE ADJUSTMENT, MINOR	EACH	0	
60	2435-0600020	MANHOLE ADJUSTMENT, MAJOR	EACH	0	
61	2502-4388050	INTAKE, STANDPIPE, AS PER PLAN	EACH	2	
62	2502-8212034	SUBDRAIN, LONGITUDINAL, (SHOULDER) 4 IN. DIA.	LF	44,699.7	
63	2502-8215110	SUBDRAIN, CORRUGATED METAL PIPE, 10 IN. DIA.	LF	257	
64	2502-8220193	SUBDRAIN OUTLET (RF-19C)	EACH	166	
65	2502-8220196	SUBDRAIN OUTLET, RF-19E	EACH	124	
66	2502-8220197	SUBDRAIN OUTLET (RF-19F)	EACH	4	
67	2503-0114215	STORM SEWER GRAVITY MAIN, TRENCHED, REINFORCED CONCRETE PIPE (RCP), 2000D (CLASS III), 15 IN.	LF	1,382.0	
68	2503-0114218	STORM SEWER GRAVITY MAIN, TRENCHED, REINFORCED CONCRETE PIPE (RCP), 2000D (CLASS III), 18 IN.	LF	4,378.0	
69	2503-0114221	STORM SEWER GRAVITY MAIN, TRENCHED, REINFORCED CONCRETE PIPE (RCP), 2000D (CLASS III), 21 IN.	LF	1,005.0	
70	2503-0114224	STORM SEWER GRAVITY MAIN, TRENCHED, REINFORCED CONCRETE PIPE (RCP), 2000D (CLASS III), 24 IN.	LF	1,245.0	
71	2503-0114230	STORM SEWER GRAVITY MAIN, TRENCHED, REINFORCED CONCRETE PIPE (RCP), 2000D (CLASS III), 30 IN.	LF	274.0	
72	2503-0114236	STORM SEWER GRAVITY MAIN, TRENCHED, REINFORCED CONCRETE PIPE (RCP), 2000D (CLASS III), 36 IN.	LF	19.0	
73	2503-0124215	STORM SEWER GRAVITY MAIN, TRENCHLESS, REINFORCED CONCRETE PIPE (RCP), 2000D (CLASS III), 15 IN.	LF	160.0	
74	2503-0124218	STORM SEWER GRAVITY MAIN, TRENCHLESS, REINFORCED CONCRETE PIPE (RCP), 2000D (CLASS III), 18 IN.	LF	118.0	
75	2503-0124224	STORM SEWER GRAVITY MAIN, TRENCHLESS, REINFORCED CONCRETE PIPE (RCP), 2000D (CLASS III), 24 IN.	LF	56.0	
76	2503-0200036	REMOVE STORM SEWER PIPE LESS THAN OR EQUAL TO 36 IN.	LF	650	
77	2503-0200341	STORM SEWER ABANDONMENT, FILL AND PLUG, LESS THAN OR EQUAL TO 36 IN. DIA.	LF	149	
78	2506-4984000	FLOWABLE MORTAR	CY	104.6	
79	2510-6745850	REMOVAL OF PAVEMENT	SY	65,344.1	
80	2510-6750600	REMOVAL OF INTAKES AND UTILITY ACCESSES	EACH	6	
81	2511-0302500	RECREATIONAL TRAIL, PORTLAND CEMENT CONCRETE, 5 IN.	SY	4,957.8	
82	2511-0310100	SPECIAL COMPACTION OF SUBGRADE FOR RECREATIONAL TRAIL	STA	50.00	
83	2511-6745900	REMOVAL OF SIDEWALK	SY	230.4	
84	2511-7526004	SIDEWALK, P.C. CONCRETE, 4 IN.	SY	1,373.3	
85	2511-7526006	SIDEWALK, P.C. CONCRETE, 6 IN.	SY	517.1	
86	2511-7526010	SIDEWALK, P.C. CONCRETE, 10 IN.	SY	155.6	
87	2511-7528101	DETECTABLE WARNINGS	SF	264	
88	2512-1725156	CURB AND GUTTER, P.C. CONCRETE, 1.5 FT.	LF	205.0	
89	2512-1725256	CURB AND GUTTER, P.C. CONCRETE, 2.5 FT.	LF	4,126.0	
90	2512-1750006	CURB AND GUTTER, P.C. CONCRETE, AS PER PLAN	LF	70.0	
91	2515-2475006	DRIVEWAY, P.C. CONCRETE, 6 IN.	SY	3,038.7	
92	2515-2475008	DRIVEWAY, P.C. CONCRETE, 8 IN.	SY	516.7	
93	2515-6745600	REMOVAL OF PAVED DRIVEWAY	SY	4,578.4	
94	2518-6910000	SAFETY CLOSURE	EACH	114	
95	2519-4200140	REMOVAL OF FENCE, FIELD	LF	16,922.0	
96	2519-4200190	REMOVAL OF FENCE, WOOD	LF	1,005.0	
97	2520-3350010	FIELD LABORATORY	EACH	1	
98	2526-8285000	CONSTRUCTION SURVEY	LS	1.00	
99	2527-8400065	TEMPORARY DELINEATORS	EACH	161	
100	2527-9263109	PAINTED PAVEMENT MARKING, WATERBORNE OR SOLVENT-BASED	STA	631.15	
101	2527-9263131	WET RETROREFLECTIVE REMOVABLE TAPE MARKINGS	STA	18.79	
102	2527-9263137	PAINTED SYMBOLS AND LEGENDS, WATERBORNE OR SOLVENT-BASED	EACH	78	
103	2527-9263180	PAVEMENT MARKINGS REMOVED	STA	33.66	
104	2528-8400157	TEMPORARY FLOODLIGHTING LUMINAIRE	EACH	10	

**ESTIMATED PROJECT QUANTITIES
(1 DIVISION PROJECT)**

Item No.	Item Code	Item	Unit	Total	As Built Qty.
1	2101-0850001	CLEARING AND GRUBBING	ACRE	81.3	
2	2102-0425070	SPECIAL BACKFILL	TON	26,397.9	
3	2102-2625001	EMBANKMENT-IN-PLACE, CONTRACTOR FURNISHED	CY	64,648.0	
4	2102-2710070	EXCAVATION, CLASS 10, ROADWAY AND BORROW	CY	127,386.0	
5	2102-2712015	EXCAVATION, CLASS 12, BOULDERS OR ROCK FRAGMENTS	CY	305.0	
6	2102-4560000	LOCATING TILE LINES	STA	803.00	
7	2105-8425015	TOPSOIL, STRIP, SALVAGE AND SPREAD	CY	62,950.0	
8	2107-0875100	COMPACTION WITH MOISTURE CONTROL	CY	153,818.0	
9	2107-3825025	GRANULAR MATERIAL FOR BLANKET AND SUBDRAIN	CY	290.0	
10	2111-8174100	GRANULAR SUBBASE	SY	60,553.4	
11	2113-0001100	SUBGRADE STABILIZATION MATERIAL, POLYMER GRID	SY	100,414.0	
12	2115-0100000	MODIFIED SUBBASE	CY	10,550.1	
13	2121-7425010	GRANULAR SHOULDERS, TYPE A	TON	904.4	
14	2123-7450000	SHOULDER CONSTRUCTION, EARTH	STA	283.30	
15	2123-7450020	SHOULDER FINISHING, EARTH	STA	160.00	
16	2212-0475095	CLEANING AND PREPARATION OF BASE	MILE	0.5	
17	2213-7100400	RELOCATION OF MAIL BOXES	EACH	42	
18	2214-5145150	PAVEMENT SCARIFICATION	SY	7,762.0	
19	2301-1033080	STANDARD OR SLIP FORM PORTLAND CEMENT CONCRETE PAVEMENT, CLASS C, CLASS 3 DURABILITY, 8 IN.	SY	1,125.2	
20	2301-1033100	STANDARD OR SLIP FORM PORTLAND CEMENT CONCRETE PAVEMENT, CLASS C, CLASS 3 DURABILITY, 10 IN.	SY	86,454.3	
21	2301-4875006	MEDIAN, P.C. CONCRETE, 6 IN.	SY	126.4	
22	2301-6911722	PORTLAND CEMENT CONCRETE PAVEMENT SAMPLES	LS	1.00	
23	2303-0042500	HOT MIX ASPHALT MIXTURE (3,000,000 ESAL), INTERMEDIATE COURSE, 1/2 IN. MIX	TON	968.5	
24	2303-0043502	HOT MIX ASPHALT MIXTURE (3,000,000 ESAL), SURFACE COURSE, 1/2 IN. MIX, FRICTION L-2	TON	673.9	
25	2303-0245828	ASPHALT BINDER, PG 58-28	TON	98.6	
26	2304-0100000	DETOUR PAVEMENT	SY	5,965.0	
27	2304-0101000	TEMPORARY PAVEMENT	SY	6.7	
28	2312-8260051	GRANULAR SURFACING ON ROAD, CLASS A CRUSHED STONE	TON	2,554.7	
29	2314-8257000	DUST CONTROL SURFACE TREATMENT	STA	0.00	
30	2315-8275025	SURFACING, DRIVEWAY, CLASS A CRUSHED STONE	TON	1,823.8	
31	2401-6745650	REMOVAL OF EXISTING STRUCTURES	LS	1.00	
32	2402-0425040	FLOODED BACKFILL	CY	3,095.2	

**ESTIMATED PROJECT QUANTITIES
(1 DIVISION PROJECT)**

Item No.	Item Code	Item	Unit	Total	As Built Qty.
105	2528-8445110	TRAFFIC CONTROL	LS	1.00	
106	2528-8445113	FLAGGERS	EACH	See Proposal	
107	2529-2242320	CT JOINT	EACH	8	
108	2529-5070110	PATCHES, FULL-DEPTH FINISH, BY AREA	SY	363.0	
109	2529-5070120	PATCHES, FULL-DEPTH FINISH, BY COUNT	EACH	12	
110	2529-8174010	SUBBASE (PATCHES)	SY	363.0	
111	2529-8202000	RUMBLE STRIP PANEL (IN FULL DEPTH PATCH)	EACH	8	
112	2533-4980005	MOBILIZATION	LS	1.00	
113	2538-6975110	SEALING WELLS	EACH	3	
114	2548-0000200	MILLED SHOULDER RUMBLE STRIPS, PCC SURFACE	STA	249.6	
115	2548-0000320	MILLED CENTERLINE RUMBLE STRIPS, PCC SURFACE	STA	123.5	
116	2554-0214000	FIRE HYDRANT ADJUSTMENT	EACH	8	
117	2590-0000020	PROJECT MANAGEMENT	LS	1.00	
118	2599-9999005	('EACH' ITEM) REMOVAL OF SILT BASINS	EACH	69	
119	2599-9999018	('SQUARE YARDS' ITEM) DRIVEWAY, P.C. CONCRETE, 10 IN.	SY	1,196.3	
120	2601-2633100	MOWING	ACRE	72.9	
121	2601-2634100	MULCHING	ACRE	58.1	
122	2601-2634105	MULCHING, BONDED FIBER MATRIX	ACRE	14.8	
123	2601-2642100	STABILIZING CROP - SEEDING AND FERTILIZING	ACRE	58.1	
124	2601-2642120	STABILIZING CROP - SEEDING AND FERTILIZING (URBAN)	ACRE	14.8	
125	2602-0000020	SILT FENCE	LF	1,988.0	
126	2602-0000030	SILT FENCE FOR DITCH CHECKS	LF	7,671.0	
127	2602-0000050	SILT BASINS	EACH	138	
128	2602-0000101	MAINTENANCE OF SILT FENCE OR SILT FENCE FOR DITCH CHECK	LF	670.4	
129	2602-0000312	PERIMETER AND SLOPE SEDIMENT CONTROL DEVICE, 12 IN. DIA.	LF	7,500.0	
130	2602-0000320	PERIMETER AND SLOPE SEDIMENT CONTROL DEVICE, 20 IN. DIA.	LF	1,200.0	
131	2602-0000350	REMOVAL OF PERIMETER AND SLOPE SEDIMENT CONTROL DEVICE	LF	2,400.0	
132	2602-0010010	MOBILIZATIONS, EROSION CONTROL	EACH	1	
133	2602-0010020	MOBILIZATIONS, EMERGENCY EROSION CONTROL	EACH	1	
		ALTERNATE AA OPTION 1-PCC			
134	2102-0425071	SPECIAL BACKFILL	CY	15,153.7	
135	2122-5190007	PAVED SHOULDER, P.C. CONCRETE, 7 IN.	SY	22,581.8	
		ALTERNATE AA OPTION 2-HMA			
136	2102-0425071	SPECIAL BACKFILL	CY	13,620.0	
137	2122-5500080	PAVED SHOULDER, HOT MIX ASPHALT MIXTURE, 8 IN.	SY	22,581.8	

ESTIMATE REFERENCE INFORMATION

Item No.	Item Code	Description
1	2101-0850001	CLEARING AND GRUBBING Item is for the Clearing and Grubbing within construction need limits. Areas of Clearing and Grubbing within the construction need limits has been subtracted out. Item also includes the removal of existing shrubs except as noted in the Removal Details, see U-sheets for more information. Removal of field fence within the construction need limits is bid seperately.
-	-	-
2	2102-0425070	SPECIAL BACKFILL Refer to Typical on B-sheets for additional details. Item includes 22985.9 Tons for PCC Pavement. Refer to Tab 100-24 on C-sheets. Item includes 663.6 Tons for 1 Lane Detour Paving. Refer to Typical B-sheets. Item includes 1688.4 Tons for 2 Lane Detour Paving. Refer to Typical B-sheets. Item includes 33.1 Tons for Curb and Gutter. Refer to Tab 112-9C on C-sheets. Item includes 1026.9 Tons for Driveways. Refer to Tab 102-3 on C-sheets.
-	-	-
3	2102-2625001	EMBANKMENT-IN-PLACE, CONTRACTOR FURNISHED Refer to Tab. 107-29 in 'T' sheets.
-	-	-
4	2102-2710070	EXCAVATION, CLASS 10, ROADWAY AND BORROW Item includes 127,386 CY from Template Quantities. Refer to Tab. 107-29 on the T-sheets. T-sheet quantities include Plowing and Shaping. Refer to Tab 107-31 on the CS-sheets for locations. Overhaul will not be measured or paid for, but shall be considered incidental to roadway excavation on this project. Item includes 150 CY for Embankment at Storm Sewer Outlets. Refer to Typ 4309 on the B-sheets.
-	-	-
5	2102-2712015	EXCAVATION, CLASS 12, BOULDERS OR ROCK FRAGMENTS Includes an estimated 200 CY of Boulders. Refer to Tab. 103-7 on CS-sheets. Item includes the removal of 105 CY of existing rip-rap revetment at culvert outlets. Refer to Removal Details on the U-sheets for locations. Dispose of excess material according to Article 1106.07 of the current specifications. Overhaul will not be measured or paid for, but shall be considered incidental to roadway excavation on this project.
-	-	-
6	2102-4560000	LOCATING TILE LINES Estimated at two times the project length.
-	-	-
7	2105-8425015	TOPSOIL, STRIP, SALVAGE AND SPREAD Refer to Tab. 103-4 on C-sheets for depths and locations.
-	-	-
8	2107-0875100	COMPACTION WITH MOISTURE CONTROL Cubic yards shown on the contract documents as determined by the template fill volume. Shrinkage will not be included in moisture control quantity. Refer to CS-sheets for application.
-	-	-
9	2107-3825025	GRANULAR MATERIAL FOR BLANKET AND SUBDRAIN Refer to Q-sheets for location details. Refer to Tab 104-5C on CS-sheets.
-	-	-
10	2111-8174100	GRANULAR SUBBASE Refer to Typical on B-sheets for additional details. Item includes 60553.4 Tons for PCC Pavement. Refer to Tab 100-24 on C-sheets.
-	-	-
11	2113-0001100	SUBGRADE STABILIZATION MATERIAL, POLYMER GRID Geogrid shall be installed beneath Special Backfill to standard width and only to the edge of pavement in area of new subdrains. Refer to Tab. 104-9 on the CS-sheets for subdrain locations. Refer to Typical on B-sheets for location details.
-	-	-
12	2115-0100000	MODIFIED SUBBASE Refer to Typical on B-sheets for additional details. Item includes 10120.7 CY for PCC Pavement. Refer to Tab 100-24 on C-sheets. Item includes 429.4 Tons for Curb and Gutter. Refer to Tab 112-9C on C-sheets.
-	-	-
13	2121-7425010	GRANULAR SHOULDERS, TYPE A Refer to Typical on B-sheets for details. Refer to Tab. 112-9 on C-sheets.

ESTIMATE REFERENCE INFORMATION

Item No.	Item Code	Description
-	-	-
14	2123-7450000	SHOULDER CONSTRUCTION, EARTH Includes 13138 CY of earth shoulder fill material including 4 inches of topsoil (___ cu. yds.). Strip 8 inches of topsoil at the edge of the shoulder for use as 4 inches of topsoil.
-	-	-
15	2123-7450020	SHOULDER FINISHING, EARTH Refer to 'B' Sheets for details. Item includes xxxx STA for mainline. Item includes 42.3 STA for Curb and Gutter. Refer to Tab 112-9C on C-sheets. No payment for overhaul allowed for this material.
-	-	-
16	2212-0475095	CLEANING AND PREPARATION OF BASE This bid item is for the Resurfacing location of this project Sta. 441+18.01 to 465+01.01
-	-	-
17	2213-7100400	RELOCATION OF MAIL BOXES Refer to Tab MAILBOX on C-sheets for locations. The Contractor is responsible for coordinating the relocation schedule with property owners and the US Post Office. If necessary, the Contractor is to provide temporary mailboxes until the permanent mailboxes can be reinstalled. METHOD OF MEASUREMENT: The quantity for Relocation of Mail Boxes will be measured by counting the number of mailboxes removed, temporarily relocated, and reinstalled. BASIS OF PAYMENT: The Contractor will be paid the contract unit price per each mailbox removed, temporarily relocated, and reinstalled.
-	-	-
18	2214-5145150	PAVEMENT SCARIFICATION Refer to Tab 100-25 on C-sheets.
-	-	-
19	2301-1033080	STANDARD OR SLIP FORM PORTLAND CEMENT CONCRETE PAVEMENT, CLASS C, CLASS 3 DURABILITY, 8 IN. Item is for fillet extensions for non-paved side roads. Refer to Typ 7149M for on B-sheets for additional details. Refer to Tab 100-24 on C-sheets.
-	-	-
20	2301-1033100	STANDARD OR SLIP FORM PORTLAND CEMENT CONCRETE PAVEMENT, CLASS C, CLASS 3 DURABILITY, 10 IN. Refer to Typicals on B-sheets. Refer to Tab 100-24 on C-sheets.
-	-	-
21	2301-4875006	MEDIAN, P.C. CONCRETE, 6 IN. Item is for Raised Islands at side road intersections. Refer to Standard Road Plan PV-20 for additional details. Refer to Tab. 112-4 on C-sheets.
-	-	-
22	2301-6911722	PORTLAND CEMENT CONCRETE PAVEMENT SAMPLES - -
-	-	-
23	2303-0042500	HOT MIX ASPHALT MIXTURE (3,000,000 ESAL), INTERMEDIATE COURSE, 1/2 IN. MIX Refer to Tab 100-25 on C-sheets. Quantity includes 280.5 Ton for leveling. Refer to HMA thickness bar on D-sheets for estimation of total HMA Thickness. Quantity includes 5% for irregularities.
-	-	-
24	2303-0043502	HOT MIX ASPHALT MIXTURE (3,000,000 ESAL), SURFACE COURSE, 1/2 IN. MIX, FRICTION L-2 Refer to Tab 100-25 on C-sheets. Quantity includes 5% for irregularities.
-	-	-
25	2303-0245828	ASPHALT BINDER, PG 58-28 Estimated at a rate of 6%. Refer to Tab 100-25 on C-sheets.
-	-	-
26	2304-0100000	DETOUR PAVEMENT Item is for temporary detour pavements as shown on the F-sheets. Refer to Detour Typicals on B-sheets. Item includes 962.4 SY for 1 Lane Detour Paving Item includes 5002.6 SY for 2 Lane Detour Paving
-	-	-
27	2304-0101000	TEMPORARY PAVEMENT Item is for Temporary HMA Detour Curb Ramp used at Spruce Street. Refer to Typ DETRAMP on B-sheets for details. DESCRIPTION. Furnish, place, and remove HMA surface used to carry traffic during construction of permanent pavement. MATERIALS.

ESTIMATE REFERENCE INFORMATION

Item No.	Item Code	Description
-	-	-
-	-	Use HMA 1,000,000 ESAL surface or intermediate course, 1/2 inch (12.5 mm) or 3/4 inch (19 mm), with PG 64-22 asphalt binder.
-	-	CONSTRUCTION. A. HMA Paving. 1. Meet the requirements of Section 2303. 2. Place pavement in such a manner that it may be removed without damaging existing pavement surface. B. Pavement Removal Remove temporary pavement and replace, at no additional cost to the Contracting Authority, all concrete broken or damaged under or adjacent to temporary pavement during operations of placement and removal of temporary pavement.
-	-	METHOD OF MEASUREMENT. Temporary Pavement constructed, in square yards will be the quantity shown in the contract documents.
-	-	BASIS OF PAYMENT. A. Payment for Temporary Pavement will be the contract unit price per square yard. B. Payment is full compensation for furnishing material, equipment, and labor to construct and remove the temporary pavement in accordance with the contract documents.
-	-	-
28	2312-8260051	GRANULAR SURFACING ON ROAD, CLASS A CRUSHED STONE Refer to Grading and Granular Surfacing typical on B-sheets.
-	-	-
29	2314-8257000	DUST CONTROL SURFACE TREATMENT Check with District regarding quantity. Double check with District that Calcium Chloride bid items should or shouldn't be used.
-	-	-
30	2315-8275025	SURFACING, DRIVEWAY, CLASS A CRUSHED STONE Refer to Tab 102-3 on C-sheets.
-	-	-
31	2401-6745650	REMOVAL OF EXISTING STRUCTURES Refer to Tab 110-2 on C-sheets. Refer to U-sheets for Removal Details.
-	-	-
32	2402-0425040	FLOODED BACKFILL
33	2402-2720100	EXCAVATION, CLASS 20, FOR ROADWAY PIPE CULVERT Refer to Tab 104-3 on CH-sheet.
-	-	-
34	2416-0100015	APRONS, CONCRETE, 15 IN. DIA. Includes 13 aprons for Storm Sewer. Refer to M-sheets for locations.
-	-	-
35	2416-0100018	APRONS, CONCRETE, 18 IN. DIA. Includes 3 aprons for storm sewer. Refer to M-sheets for locations. Includes 2 aprons for roadway culverts. Refer to Tab 104-3 on CH-sheets.
-	-	-
36	2416-0100021	APRONS, CONCRETE, 21 IN. DIA. Includes 1 apron for storm sewer. Refer to M-sheets for location.
-	-	-
37	2416-0100024	APRONS, CONCRETE, 24 IN. DIA. Includes 2 aprons for storm sewer. Refer to M-sheets for locations. Includes 22 aprons for roadway culverts. Refer to Tab 104-3 on CH-sheets.
-	-	-
38	2416-0100030	APRONS, CONCRETE, 30 IN. DIA. Includes 3 aprons for storm sewer. Refer to M-sheets for locations. Includes 4 aprons for roadway culverts. Refer to Tab 104-3 on CH-sheets.
-	-	-
39	2416-0100036	APRONS, CONCRETE, 36 IN. DIA. Includes 2 aprons for roadway culverts. Refer to Tab 104-3 on CH-sheets.
-	-	-
40	2416-1180018	CULVERT, CONCRETE ROADWAY PIPE, 18 IN. DIA.
41	2416-1180024	CULVERT, CONCRETE ROADWAY PIPE, 24 IN. DIA.
42	2416-1180030	CULVERT, CONCRETE ROADWAY PIPE, 30 IN. DIA.
43	2416-1180036	CULVERT, CONCRETE ROADWAY PIPE, 36 IN. DIA.
44	2417-0225024	APRONS, METAL, 24 IN. DIA.
45	2417-1060024	CULVERT, CORRUGATED METAL ROADWAY PIPE, 24 IN. DIA. Refer to Tab 104-3 on CH-sheet.
-	-	-
46	2422-0360018	APRONS, UNCLASSIFIED, 18 IN. DIA.
47	2422-0360024	APRONS, UNCLASSIFIED, 24 IN. DIA.
48	2422-0360036	APRONS, UNCLASSIFIED, 36 IN. DIA.
49	2422-1722018	CULVERT, UNCLASSIFIED ENTRANCE PIPE, 18 IN. DIA.
50	2422-1722024	CULVERT, UNCLASSIFIED ENTRANCE PIPE, 24 IN. DIA.
51	2422-1722036	CULVERT, UNCLASSIFIED ENTRANCE PIPE, 36 IN. DIA. Refer to Tab 102-3 on the C-sheets.
-	-	-
52	2422-1723018	CULVERT, UNCLASSIFIED ROADWAY PIPE, 18 IN. DIA.
53	2422-1723024	CULVERT, UNCLASSIFIED ROADWAY PIPE, 24 IN. DIA.
54	2422-1723030	CULVERT, UNCLASSIFIED ROADWAY PIPE, 30 IN. DIA.

ESTIMATE REFERENCE INFORMATION

Item No.	Item Code	Description
-	-	Refer to Tab 104-3 on CH-sheet.
55	2435-0140200	MANHOLE, STORM SEWER, SW-402
56	2435-0250800	INTAKE, SW-508
57	2435-0251000	INTAKE, SW-510
58	2435-0251224	INTAKE, SW-512, 24 IN. Refer to Tab 104-5B on M-sheets for additional information.
59	2435-0600010	MANHOLE ADJUSTMENT, MINOR
60	2435-0600020	MANHOLE ADJUSTMENT, MAJOR ... needs to be calculated
61	2502-4388050	INTAKE, STANDPIPE, AS PER PLAN Refer to Tab. 104-5T on the C-sheets. Refer to D-sheets for additional location information.
62	2502-8212034	SUBDRAIN, LONGITUDINAL, (SHOULDER) 4 IN. DIA. Refer to Tab 104-9 on CS-sheets.
63	2502-8215110	SUBDRAIN, CORRUGATED METAL PIPE, 10 IN. DIA. Refer to Tab. 104-5T on the C-sheets.
64	2502-8220193	SUBDRAIN OUTLET (RF-19C)
65	2502-8220196	SUBDRAIN OUTLET, RF-19E Refer to Tab 104-9 on CS-sheets.
66	2502-8220197	SUBDRAIN OUTLET (RF-19F) Refer to Tab. 104-5T on the C-sheets.
67	2503-0114215	STORM SEWER GRAVITY MAIN, TRENCHED, REINFORCED CONCRETE PIPE (RCP), 2000D (CLASS III), 15 IN.
68	2503-0114218	STORM SEWER GRAVITY MAIN, TRENCHED, REINFORCED CONCRETE PIPE (RCP), 2000D (CLASS III), 18 IN.
69	2503-0114221	STORM SEWER GRAVITY MAIN, TRENCHED, REINFORCED CONCRETE PIPE (RCP), 2000D (CLASS III), 21 IN.
70	2503-0114224	STORM SEWER GRAVITY MAIN, TRENCHED, REINFORCED CONCRETE PIPE (RCP), 2000D (CLASS III), 24 IN.
71	2503-0114230	STORM SEWER GRAVITY MAIN, TRENCHED, REINFORCED CONCRETE PIPE (RCP), 2000D (CLASS III), 30 IN.
72	2503-0114236	STORM SEWER GRAVITY MAIN, TRENCHED, REINFORCED CONCRETE PIPE (RCP), 2000D (CLASS III), 36 IN.
73	2503-0124215	STORM SEWER GRAVITY MAIN, TRENCHLESS, REINFORCED CONCRETE PIPE (RCP), 2000D (CLASS III), 15 IN.
74	2503-0124218	STORM SEWER GRAVITY MAIN, TRENCHLESS, REINFORCED CONCRETE PIPE (RCP), 2000D (CLASS III), 18 IN.
75	2503-0124224	STORM SEWER GRAVITY MAIN, TRENCHLESS, REINFORCED CONCRETE PIPE (RCP), 2000D (CLASS III), 24 IN. Refer to Tab 104-5B on M-sheets for additional information.
76	2503-0200036	REMOVE STORM SEWER PIPE LESS THAN OR EQUAL TO 36 IN.
77	2503-0200341	STORM SEWER ABANDONMENT, FILL AND PLUG, LESS THAN OR EQUAL TO 36 IN. DIA. Refer to Tab 110-14 on C-sheets.
78	2506-4984000	FLOWABLE MORTAR Item includes 70.2 CY for Culvert Abandonment. Silt inside existing culverts need not be removed prior to placing flowable mortar. Refer to Typ 4315 on B-sheets and Tab 110-9 on C-sheets. Item includes 34.4 CY per Tab 104-3 on the CH-sheet.
79	2510-6745850	REMOVAL OF PAVEMENT Refer to Tab 110-1 on the C-sheets. Refer to Tab 102-5 on the C-sheets for pavement type information. Refer to the U-sheets for additional details. Item is to become the property of the Contractor.
80	2510-6750600	REMOVAL OF INTAKES AND UTILITY ACCESSES Refer to Tab 110-15 on the C-sheets.
81	2511-0302500	RECREATIONAL TRAIL, PORTLAND CEMENT CONCRETE, 5 IN.
82	2511-0310100	SPECIAL COMPACTION OF SUBGRADE FOR RECREATIONAL TRAIL Refer to Typical 7402 on B-sheets for details. Refer to Tab 113-1 on C-sheets.
83	2511-6745900	REMOVAL OF SIDEWALK Refer to Tab 110-5 on the C-Sheets. Item includes 28 LF of full depth saw cut. Refer to Tab 113-2 for location of Pedestrian Path Closures.
84	2511-7526004	SIDEWALK, P.C. CONCRETE, 4 IN.
85	2511-7526006	SIDEWALK, P.C. CONCRETE, 6 IN. Refer to Tab 113-1 on C-sheets. Refer to tabulations on S-sheets for additional information. See sheet J.1 for Pedestrian Path Closures.
86	2511-7526010	SIDEWALK, P.C. CONCRETE, 10 IN. Item is for sidewalk thru entrances Lt. at Sta. 419+80.63 and Sta. 423+11.51. Refer to Tab 113-1 on C-sheets. Refer to tabulations on S-sheets for additional information.

ESTIMATE REFERENCE INFORMATION

Item No.	Item Code	Description
-	-	Requires 12" Modified Subbase which will be paid for seperately.
87	2511-7528101	DETECTABLE WARNINGS Refer to Tab 113-1 on C-sheets. Refer to tabulations on S-sheets for additional information. See sheet J.1 for Pedestrian Path Closures.
88	2512-1725156	CURB AND GUTTER, P.C. CONCRETE, 1.5 FT. Refer to Typical Y St. on B-sheets. Refer to Tab 112-9C on C-sheets.
89	2512-1725256	CURB AND GUTTER, P.C. CONCRETE, 2.5 FT. Refer to Typical 'IOWA 92-Widening & Resurface' on B-sheets. Refer to Tab 112-9C on C-sheets.
90	2512-1750006	CURB AND GUTTER, P.C. CONCRETE, AS PER PLAN Item is for Raised Islands at side road intersections. Refer to Standard Road Plans PV-20 and PV-102 for additional details. Refer to Tab. 112-4 on C-sheets.
91	2515-2475006	DRIVEWAY, P.C. CONCRETE, 6 IN. Refer to Tab 102-3 on C-sheets.
92	2515-2475008	DRIVEWAY, P.C. CONCRETE, 8 IN. Refer to Tab 102-3 on C-sheets. Entrance 359 requires 6" special backfill that will be paid for seperately.
93	2515-6745600	REMOVAL OF PAVED DRIVEWAY Refer to Tab. 110-8 on the C-sheets. Item includes 768 LF of full depth saw cut.
94	2518-6910000	SAFETY CLOSURE Item includes 30 Road Closures and 84 Safety Closures. Refer to Tab. 108-13A on C-heets.
95	2519-4200140	REMOVAL OF FENCE, FIELD
96	2519-4200190	REMOVAL OF FENCE, WOOD Refer to Tab 100-17R on C-sheets. Refer to Removal Details on the U-sheets.
97	2520-3350010	FIELD LABORATORY
98	2526-8285000	CONSTRUCTION SURVEY
99	2527-8400065	TEMPORARY DELINEATORS Refer to Standard Road Plan TC-253 and J-sheets for layout information. Item includes 42 delineators for R-57 Detour. Item includes 48 delineators for R-63 Detour. Item includes 33 delineators for SW Y St. Detour. Item includes 48 delineators for NW Y St. Detour.
100	2527-9263109	PAINTED PAVEMENT MARKING, WATERBORNE OR SOLVENT-BASED
101	2527-9263131	WET RETROREFLECTIVE REMOVABLE TAPE MARKINGS Refer to Tab 108-22 on C-sheets. Refer to U-sheets for additional details.
102	2527-9263137	PAINTED SYMBOLS AND LEGENDS, WATERBORNE OR SOLVENT-BASED Refer to Tab 108-29 on C-sheets.
103	2527-9263180	PAVEMENT MARKINGS REMOVED Refer to Tab 108-22 on C-sheets.
104	2528-8400157	TEMPORARY FLOODLIGHTING LUMINAIRE Refer to Tab 108-27 on C-sheets.
105	2528-8445110	TRAFFIC CONTROL
106	2528-8445113	FLAGGERS
107	2529-2242320	CT JOINT
108	2529-5070110	PATCHES, FULL-DEPTH FINISH, BY AREA
109	2529-5070120	PATCHES, FULL-DEPTH FINISH, BY COUNT
110	2529-8174010	SUBBASE (PATCHES)

ESTIMATE REFERENCE INFORMATION

Item No.	Item Code	Description
111	2529-8202000	RUMBLE STRIP PANEL (IN FULL DEPTH PATCH) Item includes Rumble Strip Panels in adjacent county roads. Refer to Tab 112-7 and Tab 102-6C for additional information.
	2529-5070110	PATCHES, FULL-DEPTH FINISH, BY AREA Item includes patches on existing IA 92. Refer to Tab 102-6C on C-sheets.
	2529-8174010	SUBBASE (PATCHES) Item includes patches on existing IA 92. Refer to Tab 102-6C on C-sheets.
112	2533-4980005	MOBILIZATION - -
113	2538-6975110	SEALING WELLS Includes wells: Sta. 270+16, 12' Rt (Parcel 7) Sta. 282+55, 71' Lt (Parcel 12) Sta. 282+65, 120' Rt (Parcel 13) All locations are approximate.
114	2548-0000200	MILLED SHOULDER RUMBLE STRIPS, PCC SURFACE
115	2548-0000320	MILLED CENTERLINE RUMBLE STRIPS, PCC SURFACE Refer to Tab 112-10 on C-sheets.
116	2554-0214000	FIRE HYDRANT ADJUSTMENT - -
117	2590-0000020	PROJECT MANAGEMENT - -
118	2599-9999005	('EACH' ITEM) REMOVAL OF SILT BASINS Fill the silt basin with Class 10 material and a minimum of 4 inches of topsoil. Furnish Class 10 material according to Section 2107 of the Standard Specifications and compact the material by driving over the material a minimum of two times. Furnish and place topsoil according to Section 2105 of the Standard Specifications. Smooth the surface of the topsoil and leave in a finished condition so it will drain properly. This will be incidental to the bid item. METHOD OF MEASUREMENT: The Engineer will count the number of silt basins removed. BASIS OF PAYMENT: Payment will be the contract unit price for each silt basin removed. Payment is full compensation for providing, preparing, transporting, and placing the Class 10 material and topsoil. The Contractor has the option, at no additional cost to the Contracting Authority, of stripping and stockpiling the Class 10 material and topsoil from constructing silt basins for later use in silt basin removal. Overhaul will not be paid for this item.
119	2599-9999018	('SQUARE YARDS' ITEM) DRIVEWAY, P.C. CONCRETE, 10 IN. Item is for entrances Lt. at Sta. 419+80.63 (in front of sidewalk only) and Sta. 423+11.51. 10" PCC Driveways will have 12" of Modified Subbase, which will be paid for separately. Refer to Tab 102-3 on C-sheets.
120	2601-2633100	MOWING Estimate based on one mowing of all seeded areas in October 2014. Areas inaccessible to field equipment shall be cut with appropriate hand equipment and kept current with the mowing of adjacent areas. Vegetation shall be mowed to between four and six inches in height.
121	2601-2634100	MULCHING Mulching per Article 2601.03, E, 2. Anchor mulch into the soil using mulch anchoring equipment with a minimum of two passes. Included for areas requiring reshaping and seedbed preparation. Mulch shall be Certified Noxious Weed Seed Free Mulch as certified by the Iowa Crop Improvement Association or adjacent states Crop Improvement Associations. Mulch Rate: 1 1/2 tons of dry cereal straw or native grass straw per acre.
122	2601-2634105	MULCHING, BONDED FIBRE MATRIX A Bonded Fibre Matrix shall be applied as the mulch for all areas designated as "Stabilizing Crop-Seeding and Fertilizing (Urban)". The seed and fertilizer for the area to be covered shall be applied before the Bonded Fibre Matrix Hydraulic Mulch application. Application rate shall be a minimum of 3000 lbs per acre.

ESTIMATE REFERENCE INFORMATION

Item No.	Item Code	Description
123	2601-2642100	STABILIZING CROP - SEEDING AND FERTILIZING Included for disturbed areas as directed by the Engineer. All rural disturbed areas shall be seeded and fertilizer per Article 2601.03, C, 1
124	2601-2642120	STABILIZING CROP - SEEDING AND FERTILIZING (URBAN) Included for disturbed areas as directed by the Engineer. All urban disturbed areas shall be seeded and fertilizer per Article 2601.03, C, 2.
125	2602-0000020	SILT FENCE Refer to Tab 100-17 on C-sheets. The tabulation includes estimated locations for placement of "Silt Fence" to address erosion to be encountered during construction. Verify the specific locations with the Engineer prior to beginning placement. Bid item includes 25% additional quantity for field adjustments and replacements.
126	2602-0000030	SILT FENCE FOR DITCH CHECKS Refer to Tab 100-18 on C-sheets. The tabulation includes estimated locations for placement of "Silt Fence for Ditch Checks" to address erosion to be encountered during construction. Verify the specific locations with the Engineer prior to beginning placement. Bid item includes 50% additional quantity for field adjustments and replacements.
127	2602-0000050	SILT BASINS Refer to Tab 100-14 on C-sheets. The tabulation includes estimated locations for placement of "Silt Basins" to address erosion to be encountered during construction. Verify the specific locations with the Engineer prior to beginning placement. Bid item includes 100% additional quantity for field adjustments and maintenance.
128	2602-0000101	MAINTENANCE OF SILT FENCE OR SILT FENCE FOR DITCH CHECK This item is included for clean-out and repair of the silt fence and silt fence for ditch checks during the grading project. Refer to Tabulations 100-17 and 100-18.
129	2602-0000312	PERIMETER AND SLOPE SEDIMENT CONTROL DEVICE, 12 IN. DIA. Item is included for temporary perimeter sediment control, inlet protection, and water velocity reduction on slopes or ditches at locations to be determined during construction. Verify specific locations with the Engineer prior to beginning placement. Perimeter and Slope Sediment Control Devices will be required to be constructed out of wood excelsior. Quantity includes 6300 LF for protection of 126 intakes calculated at an average of 50 LF per intake.
130	2602-0000320	PERIMETER AND SLOPE SEDIMENT CONTROL DEVICE, 20 IN. DIA. Item is included for temporary perimeter sediment control, inlet protection, and water velocity reduction on slopes or ditches at locations to be determined during construction. Verify specific locations with the Engineer prior to beginning placement. Perimeter and Slope Sediment Control Devices will be required to be constructed out of wood excelsior.
131	2602-0000350	REMOVAL OF PERIMETER AND SLOPE SEDIMENT CONTROL DEVICE Included for removal of perimeter and sediment control devices. All material shall become the property of the contractor and removed from the project within 24 hours.
132	2602-0010010	MOBILIZATIONS, EROSION CONTROL - -
133	2602-0010020	MOBILIZATIONS, EMERGENCY EROSION CONTROL - -

ESTIMATE REFERENCE INFORMATION

100-4A
10-29-02

Item No.	Item Code	Description
		ALTERNATE AA OPTION 1-PCC
134	2102-0425071	SPECIAL BACKFILL
135	2122-5190007	PAVED SHOULDER, P.C. CONCRETE, 7 IN. Refer to Typical on B-sheets for details. Refer to Tab. 112-9 on C-sheets.
-	-	-
		ALTERNATE AA OPTION 2-HMA
136	2102-0425071	SPECIAL BACKFILL
137	2122-5500080	PAVED SHOULDER, HOT MIX ASPHALT MIXTURE, 8 IN. Refer to Typical on B-sheets for details. Refer to Tab. 112-9 on C-sheets.
-	-	-

INDEX OF TABULATIONS

111-25
10-18-11

Tabulation	Tabulation Title	Sheet No.
C Sheets		
100-1A	ESTIMATED PROJECT QUANTITIES (1 DIVISION PROJECT)	C.1 - C.2
100-1D	PROJECT DESCRIPTION	C.1
100-4A	ESTIMATE REFERENCE INFORMATION	C.2 - C.6
100-14	SILT BASINS	C.10
100-MAIL	TABULATION OF MAILBOX TURNOUTS	C.11
100-17	TABULATION OF SILT FENCES	C.10
100-17R	TABULATION OF FENCE REMOVAL	C.10
100-18	TABULATION OF SILT FENCES FOR DITCH CHECKS	C.9 - C.9
100-24	PCC PAVEMENT	C.15 - C.16
100-25	HMA PAVEMENT	C.17
102-3	ACCESS POINTS AND SAFETY RAMPS	C.21 - C.22
102-5	EXISTING PAVEMENT	C.11
102-6C	FULL-DEPTH PATCHES	C.18
103-4	TABULATION OF SPREADING TOPSOIL	C.14
104-5T	LIST OF SUBDRAIN WORK	C.14
104-10	ADJUSTMENT OF FIXTURES	C.13 - C.13
105-4	STANDARD ROAD PLANS	C.6
108-13A	SAFETY CLOSURES	C.8 - C.8
108-22	PAVEMENT MARKING LINE TYPES	C.24 - C.26
108-27	TEMPORARY FLOODLIGHTING LUMINAIRES	C.8
108-29	PAVEMENT MARKING SYMBOLS AND LEGENDS	C.27
110-1	REMOVAL OF PAVEMENT	C.11
110-2	REMOVAL OF EXISTING STRUCTURES	C.12
110-5	SIDEWALK REMOVAL	C.11
110-8	REMOVAL OF CONCRETE DRIVES	C.11
110-9	CULVERT ABANDONMENT	C.12
110-12A	POLLUTION PREVENTION PLAN	C.7 - C.7
110-14	SANITARY OR STORM SEWER ABANDONMENT OR REMOVAL	C.12
110-15	REMOVAL OF INTAKES AND UTILITY ACCESSES	C.12
111-25	INDEX OF TABULATIONS	C.6
112-04	CURBS AND ISLANDS	C.19
112-7	RUMBLE STRIP PANELS	C.18
112-9	SHOULDERS	C.20
112-9C	Curb and Gutter	C.19
112-10	MILLED RUMBLE STRIPS	C.18
113-1	SIDEWALKS	C.23 - C.23
213-3	SUBSOIL TILLAGE	C.8
262-5	UTILITIES (POINT 25 PROJECT)	C.8
281-1	SECTION 404 PERMIT AND CONDITIONS	C.8

STANDARD ROAD PLANS

105-4
10-18-11

The following Standard Road Plans apply to construction work on this project.		
Number	Date	Title
EC-101	04-20-10	Wood Excelsior Mat for Ditch Protection
EC-102	04-20-10	Sod for Ditch Protection
EC-103	04-20-10	Wood Excelsior Mat for Slope Protection
EC-201	04-20-10	Silt Fence
EC-202	10-21-14	Floating Silt Curtain
EC-204	10-16-12	Perimeter and Slope Sediment Control Devices
EW-101	04-19-11	Embankment and Rebuilding Embankments
EW-102	10-21-14	Allowable Placement of Unsuitable Soil in Embankments
EW-110	10-15-13	Ditch Blocks and Dikes
EW-403	10-15-13	Temporary Erosion Control Measures
EW-501	10-15-13	Rural Entrance
LI-130	10-21-14	Temporary Floodlighting Luminaires
MI-210	10-15-13	PCC Driveways and Alleys
MI-220	10-16-12	Detectable Warnings and Pedestrian Ramp
PM-110	04-16-13	Line Types
PM-111	10-16-12	Symbols and Legends
PM-120	10-21-14	Stop Lines and Islands
PM-210	10-18-11	Separation in Two-Lane Roadway
PM-520	04-19-11	Two-Lane Roadway with no Turn Lanes (Two-Way Stop Condition)
PM-521	04-19-11	Two-Lane Roadway with Right Turn Lanes
PM-522	10-16-12	Two-Lane Roadway with Left Turn Lanes
PM-550	04-19-11	Two-Lane Roadway with Two-Way Left Turn Lane
PR-102	10-21-14	Full Depth PCC Patch without Dowels
PR-103	10-21-14	Full Depth PCC Patch with Dowels
PR-140	10-21-14	Subbase Patches
PV-10	04-19-11	Rumble Strip Panel for Intersection Approach
PV-11	04-20-10	Structural Rumble Strips
PV-12	04-17-12	Milled Shoulder Rumble Strips
PV-13	04-19-11	Milled Centerline Rumble Strips
PV-20	10-21-14	Paved Islands
PV-101	10-21-14	Joints
PV-102	04-15-14	PCC Curb Details
PV-103	04-19-11	Manhole Boxouts in PCC Pavement
PV-301	04-19-11	Superelevation Details Two Lane Roadway
RF-3	10-15-13	Concrete Aprons
RF-5	04-16-13	Metal Pipe Aprons and Beveled Ends
RF-13	10-18-11	Pipe Bends and Half Pipe
RF-14	04-16-13	Connected Pipe Joints
RF-19B	04-17-12	Subdrains Standard (Farm Tile Replacement)
RF-19C	10-16-12	Subdrains (Longitudinal)
RF-19E	10-21-14	Outlets for Longitudinal, Transverse and Backslope Subdrains
RF-19F	10-16-12	Subdrain Outlets (Standard Subdrain, Pressure Release and Special)
RF-21	10-18-11	Culvert Pipe Tee Sections
RF-26	10-15-13	Pipe Apron Guard
RF-30A	04-15-14	Pipe Culvert (Bedding and Backfill)
RF-30B	10-19-10	Pipe Culvert (Cover and Camber)
RF-30C	04-16-13	Pipe Culvert (Installation Details)
RF-30D	10-21-14	Box Culvert (Backfill)
RF-31	03-28-95	Depth of Cover Tables for Concrete Pipe
RF-32	10-19-10	Depth of Cover Tables for Corrugated Pipe
SI-101	04-21-09	Locations - Type 'A' Signs
SI-102	10-20-09	Locations - Type 'B' Signs
SI-131	10-18-11	Installation - Type 'A' Signs
SI-132	04-20-10	Installation - Type 'B' Signs
SI-881	10-15-13	Special Signs for Workzones
SW-101	04-21-09	Trench Bedding and Backfill Zones
SW-102	04-21-09	Rigid Gravity Pipe Trench Bedding
SW-105	10-20-09	Miscellaneous Pipe Bedding
SW-211	10-16-12	Special Pipe Connections for Storm Sewer
SW-402	04-21-09	Rectangular Storm Sewer Manhole
SW-508	10-21-14	Single Open-Throat Intake, Large Box
SW-510	10-21-14	Double Open-Throat Curb Intake, Large Box
SW-512	10-21-14	Circular Area Intake
SW-602	04-15-14	Castings for Storm Sewer Manholes
SW-604	10-20-09	Castings for Area Intakes
TC-1	04-16-13	Work Not Affecting Traffic (Two-Lane or Multi-Lane)
TC-202	10-15-13	Shoulder Closure (One Lane)
TC-213	04-17-12	Lane Closure with Flaggers
TC-228	10-15-13	Lane Closure Involving TWLTL
TC-251	04-17-12	Temporary Road Closure
TC-252	04-17-12	Routes Closed to Traffic
TC-253	10-21-14	Paved On-Site Detour
TC-273	04-20-10	Construction Site Entrance
TC-282	04-19-11	Uneven Lanes

POLLUTION PREVENTION PLAN

This Base Pollution Prevention Plan (PPP) includes information on Roles and Responsibilities, Project Site Description, Controls, Maintenance Procedures, Inspection Requirements, Non-Storm Water Controls, Potential Sources of Off Right-of-Way Pollution, and Definitions. This plan references other documents rather than repeating the information contained in the documents. A copy of this Base Pollution Prevention Plan, amended as needed per plan revisions or by contract modification, will be readily available for review.

All contractors shall conduct their operations in a manner that controls pollutants, minimizes erosion, and prevents sediments from entering waters of the state and leaving the highway right-of-way. The prime contractor shall be responsible for compliance and

implementation of the PPP for their entire contract. This responsibility shall be further shared with subcontractors whose work is a source of potential pollution as defined in this PPP.

I. ROLES AND RESPONSIBILITIES**A. Designer:**

1. Prepares Base PPP included in the project plan.
2. Prepares Notice of Intent (NOI) submitted to Iowa DNR.
3. Signature authority on the Base PPP and NOI.

B. Contractor/Subcontractor:

1. Affected contractors/subcontractors are co-permittees with the IDOT and will sign a certification statement adhering to the requirements of the NPDES permit and this PPP plan. All co-permittees are legally required under the Clean Water Act and the Iowa Administrative Code to ensure compliance with the terms and conditions of this PPP.
2. Submit a detailed schedule according to Article 2602 of the Specifications and any additional plan notes.
3. Install and maintain appropriate controls.
4. Supervise and implement good housekeeping practices.
5. Conduct joint required inspections of the site with inspection staff.
6. Signature authority on Co-Permittee Certification Statements and storm water inspection reports.

C. RCE/Inspector:

1. Update PPP whenever there is a change in design, construction, operation or maintenance, which has a significant effect on the discharge of pollutants from the project.
2. Maintain an up-to-date list that identifies contractors and subcontractors as co-permittees.
3. Make these plans available to the DNR upon their request.
4. Conduct joint required inspections of the site with the contractor/subcontractor.
5. Complete an inspection report after each inspection.
6. Signature authority on storm water inspection reports and Notice of Discontinuation (NOD).

II. PROJECT SITE DESCRIPTION

- A. This Pollution Prevention Plan (PPP) is for the construction of highway 92 in Warren county.
- B. This PPP covers approximately 103 acres with an estimated 81 acres being disturbed. The portion of the PPP covered by this contract has 81 acres disturbed.
- C. The PPP is located in an area of one (1) soil association (Sharpsburg - Shelby - Adair). The estimated average SCS runoff curve number for this PPP after completion will be 69.0.
- D. Storm Water Site Map - Multiple sources of information comprise the base storm water site map including:
 1. Drainage patterns - Plan and Profile sheets and Situation plans.
 2. Proposed Slopes - Cross Sections.
 3. Areas of Soil Disturbance - construction limits shown on Plan and Profile sheets.
 4. Location of Structural Controls - Tabulations on C sheets.
 5. Locations of Non-structural Controls - Tabulations on C sheets.
 6. Locations of Stabilization Practices - generally within construction limits shown on Plan and Profile sheets.
 7. Surface Waters (including wetlands) - Plan and Profile sheets.
 8. Locations where storm water is discharged - Plan and Profile sheets.
- E. The base site map is amended by contract modifications and progress payments of completed erosion control work.
- F. Runoff from this work will flow into various ditches and tributaries to Middle River, and South River.

III. CONTROLS

- A. The contractor's work plan and sequence of operations specified in Article 2602.03 for accomplishment of storm water controls should clearly describe the intended sequence of major activities and for each activity define the control measure and the timing during the construction process that the measure will be implemented.
- B. Preserve vegetation in areas not needed for construction.
- C. Section 2601 and 2602 of the Standard Specifications define requirements to implement erosion and sediment control measures. Actual quantities used may vary from the Base PPP and amendment of the plan will be documented via fieldbook entries or by contract modification. Additional erosion and sediment control items may be required as determined by the inspector and/or contractor during storm water monitoring inspections. If the work involved is not applicable to any contract items, the work will be paid for according to Article 1109.03 paragraph B.
 1. EROSION AND SEDIMENT CONTROLS
 - a. Stabilization Practices
 - 1) Site plans will ensure that existing vegetation is preserved where attainable and disturbed portions of the site will be stabilized.
 - 2) Stabilization measures shall be initiated as soon as practicable in portions of the site where construction activities have temporarily or permanently ceased.
 - 3) Temporary stabilizing seeding shall be completed as the disturbed areas are constructed. If construction activity is not planned to occur in a disturbed area for at least 21 days, the area shall be stabilized by temporary seeding or mulching within 14 days. Other stabilizing methods shall be used outside the seeding time period.
 - 4) Stabilization measures to be used for this project are located in the Estimated Project Quantities (100-1A) and Estimate Reference Information (100-4A) located on the C sheets of the plan. Additional items may be found in the Inspector's Daily Reports (IDR) or Contract Modifications.
 - b. Structural Practices
 - 1) Structural practices will be implemented to divert flows from exposed soils and detain or otherwise limit runoff and the discharge of pollutants from exposed areas of the site.
 - 2) Structural items to be used for this project are located in the Estimated Project Quantities (100-1A) and Estimate Reference Information (100-4A) located on the C sheets of the plan, as well as all other item specific Tabulations. Typical drawings detailing construction of the devices to be used on this project can be found on the B sheets of the plan or are referenced in the Standard Road Plans Tabulation.
 - c. Storm Water Management
 - 1) Measures shall be installed during the construction process to control pollutants in storm water discharges that will

POLLUTION PREVENTION PLAN

occur after construction operations have been completed. The installation of these devices may be subject to Section 404 of the Clean Water Act.

2. OTHER CONTROLS

- a. Contractor disposal of unused construction materials and construction material wastes shall comply with applicable state and local waste disposal, sanitary sewer, or septic system regulations. In the event of a conflict with other governmental laws, rules and regulations, the more restrictive laws, rules or regulations shall apply.
 - 1) Vehicle Entrances and Exits - Construct and maintain entrances and exits to prevent tracking of sediments onto roadways.
 - 2) Material Delivery, Storage and Use - Implement practices to prevent discharge of construction materials during delivery, storage, and use.
 - 3) Stockpile Management - Install controls to reduce or eliminate pollution of storm water from stockpiles of soil and paving.
 - 4) Waste Disposal - Do not discharge any materials, including building materials, into waters of the state, except as authorized by a Section 404 permit.
 - 5) Spill Prevention and Control - Implement procedures to contain and clean-up spills and prevent material discharges to the storm drain system and waters of the state.
 - 6) Concrete Residuals and Washout Wastes - Designate temporary concrete washout facilities for rinsing out concrete trucks. Provide directions to truck drivers where designated washout facilities are located.
 - 7) Vehicle and Equipment Cleaning - Employ washing practices that prevent contamination of surface and ground water from wash water.
 - 8) Vehicle and Equipment Fueling and Maintenance - Perform on site fueling and maintenance in accordance with all environment laws such as proper storage of onsite fuels and proper disposal of used engine oil or other fluids on site.
 - 9) Litter Management - Ensure employees properly dispose of litter.

3. APPROVED STATE OR LOCAL PLANS

During the course of this construction, it is possible that situations will arise where unknown materials will be encountered. When such situations are encountered, they will be handled according to all federal, state, and local regulations in effect at the time.

IV. MAINTENANCE PROCEDURES

The contractor is required to maintain all temporary erosion and sediment control measures in proper working order, including cleaning, repairing, or replacing them throughout the contract period. This shall begin when the features have lost 50% of their capacity.

V. INSPECTION REQUIREMENTS

- A. Inspections shall be made jointly by the contractor and the contracting authority at least once every seven calendar days. Storm water monitoring inspections will include:
 1. Date of the inspection.
 2. Summary of the scope of the inspection.
 3. Name and qualifications of the personnel making the inspection.
 4. Rainfall amount.
 5. Review erosion and sediment control measures within disturbed areas for the effectiveness in preventing impacts to receiving waters.
 6. Major observations related to the implementation of the PPP.
 7. Identify corrective actions required to maintain or modify erosion and sediment control measures.
- B. Include storm water monitoring inspection reports in the Amended PPP. Incorporate any additional erosion and sediment control measures determined as a result of the inspection. Immediately begin corrective actions on all deficiencies found and complete all actions within 3 calendar days of the inspection.

VI. NON-STORM WATER DISCHARGES

This includes subsurface drains (i.e. longitudinal and standard subdrains) and slope drains. The velocity of the discharge from these features may be controlled by the use of patio blocks, Class A stone, erosion stone or other appropriate materials.

VII. POTENTIAL SOURCES OF OFF RIGHT-OF-WAY (ROW) POLLUTION

Silts, sediment, and other forms of pollution may be transported onto highway right-of-way (ROW) as a result of a storm event. Potential sources of pollution located outside highway ROW are beyond the control of this PPP. Pollution within highway ROW will be conveyed and controlled per this PPP.

VIII. DEFINITIONS

- A. Base PPP - Initial Pollution Prevention Plan.
- B. Amended PPP - May include Plan Revisions or Contract Modifications for new items and fieldbook entries made by the inspector.
- C. IDR - Inspector's Daily Report - this contains the inspector's daily diary and item postings.
- D. Controls - Methods, practices, or measures to minimize or prevent erosion, control sedimentation, control storm water, or minimize contaminants from other types of waste or materials.
- E. Signature Authority - Representative from Designer, Contractor/Subcontractor, or RCE/Inspector authorized to sign various storm water documents.

213-3
04-15-14

SUBSOIL TILLAGE

All stockpile areas, haul roads, and areas used for equipment on this project require subsoil tillage to an average depth of 16 to 20 inches prior to placement of topsoil and/or stabilizing crop seeding. Complete this tillage at 3 foot maximum centers and at right angles to the finished slope.

Use tillage equipment equipped with an arrowhead type shoe that will provide lateral displacement and limit the movement of the subsoil to the surface. Obtain the Engineer's approval for the equipment. This work is incidental to other work on the project.

Following the subsoil tillage, the area is to remain in a "loosened" condition. Additional compaction or the operation of heavy equipment, other than required for topsoil placement and shaping, will not be allowed on areas which have received subsoil tillage.

262-5
10-18-05

UTILITIES (POINT 25 PROJECT)

This is a POINT 25 project and is subject to the provisions of IAC 761-115.25.

281-1
10-15-13

SECTION 404 PERMIT AND CONDITIONS

Construct this project according to the requirements of U.S. Army Corps of Engineers NWP 14-Linear Transportation Projects, , Permit No. 2013-813.
A copy of this permit is available from the Iowa DOT website (<http://envpermits.iowadot.gov/CMEPortalENV/Home.aspx>). The U.S. Army Corps of Engineers reserves the right to visit the site without prior notice.

108-13A
08-01-08

SAFETY CLOSURES

Refer to Section 2518 of the Standard Specifications

Station	Closure Type		Remarks
	Road Qty.	Hazard Qty.	
Roads			
Stage 2A			
283+90	1		Ia 92
309+80	1		Ia 92
4412+50	1		Y Street (So.)
4417+60	1		Y Street
Stage 2B			
256+00	1		Ia 92
1257+35	1		Kennedy Drive
284+15	1		Ia 92
284+55	1		Ia 92
1279+85	1		R-57 (So.)
1283+75	1		R-57 (No.)
2307+65	1		90th Street (1)
2312+85	1		90th Street (1)
391+95	1		Ia 92 (1)
3387+30	1		R-63 (So.) (1)
3394+45	1		R-63 (No.) (1)
416+20	1		Ia 92 (1)
416+60	1		Ia 92 (1)
4412+50	1		Y Street (So.) (1)
4417+60	1		Y Street (1) (2)
443+52	1		Ia 92 (EB Lane Only)
Stage 2C			
284+00	1		Ia 92
418+65	1		Ia 92 (2)
419+35	1		Ia 92 (2)
Stage 2D			
391+30	1		Ia 92
416+80	1		Ia 92
Stage 3A			
391+50	1		Ia 92 (WB Lane Only) (3)
4417+48	1		Y Street (3)
Stage 3B			
441+36	1		Ia 92 (85' Lt. on Spruce)
Stage 3C			
4424+15	1		Y Street (No.)
Stage 3D			
417+90	1		Ia 92 (WB Lane Only)
Entrances			
Stage 2			
270+56 Lt		2	
270+56 Rt		2	
276+46 Lt		2	
291+80 Lt		2	
219+80 Rt		2	
297+08 Lt		2	
297+08 Rt		2	
305+08 Rt		2	
312+60 Rt		2	Existing until removed
315+00 Rt		2	New
324+07 Lt		2	
324+07 Rt		2	
334+27 Rt		2	
341+03 Lt		2	
341+03 Rt		2	
352+40 Lt		2	
352+40 Rt		2	
356+60 Rt		2	Existing until removed
359+18 Lt		2	New
359+18 Rt		2	
359+90 Lt		2	Existing until removed
361+85 Lt		2	Existing until removed
363+75 Lt		2	Existing until removed
365+37 Lt		2	New
365+37 Rt		2	
375+45 Lt		2	
375+45 Rt		2	
407+00 Rt		2	
430+78 Rt		2	
433+47 Rt		2	
440+48 Rt		2	
442+23 Rt		2	

108-13A
08-01-08

SAFETY CLOSURES

Refer to Section 2518 of the Standard Specifications

Station	Closure Type		Remarks
	Road Qty.	Hazard Qty.	
Stage 3			
398+16 Lt		2	
407+00 Lt		2	
419+80 Lt		2	
423+11 Lt		2	
425+99 Lt		2	
427+53 Lt		2	
429+54 Lt		2	
431+96 Lt		2	
433+46 Lt		2	
438+08 Lt		2	
Totals	30	84	
(1) To remain in place for Stage 2C. (2) To remain in place for Stage 2D. (3) To remain in place for Stages 3B and 3C.			

108-27
10-16-12

TEMPORARY FLOODLIGHTING LUMINAIRES

No.	Location Station	Offset	Number Lumin.	Remarks
1	11278+10	30' Rt	1	R-57 South Detour
2	11283+70	30' Rt	1	R-57 South Detour
3	11285+20	30' Rt	1	R-57 North Detour
4	11290+20	30' Rt	1	R-57 North Detour
5	18386+70	30' Rt	1	R-63 South Detour
6	18392+20	30' Rt	1	R-63 South Detour
7	18393+05	30' Rt	1	R-63 North Detour
8	18397+50	30' Rt	1	R-63 North Detour
9	14410+10	30' Lt	1	Y St. South Detour
10	14425+05	30' Lt	1	Y St. North Detour
Total			10	

TABULATION OF SILT FENCES
FOR DITCH CHECKS

Refer to EC-201

Table with 4 columns: Location Station, Side, Length LF, Remarks. Rows include stationing from 256+45.00 to 389+00.00.

TABULATION OF SILT FENCES
FOR DITCH CHECKS

Refer to EC-201

Table with 4 columns: Location Station, Side, Length LF, Remarks. Rows include stationing from 257+75.00 to 334+00.00.

TABULATION OF SILT FENCES
FOR DITCH CHECKS

Refer to EC-201

Table with 4 columns: Location Station, Side, Length LF, Remarks. Rows include stationing from 334+25.00 to 11286+80.00.

TABULATION OF SILT FENCES
FOR DITCH CHECKS

Refer to EC-201

Table with 4 columns: Location Station, Side, Length LF, Remarks. Rows include stationing from 11287+20.00 to 14417+71.00, including a subtotal and total row.

100-14 10-15-13		
SILT BASINS		
Refer to EW-403		
Location Station	Side	Remarks
257+80.00	48'Rt	
258+20.00	51'Rt	
257+80.00	107'Lt	
258+05.00	108'Lt	
257+40.00	190'Lt	
257+60.00	214'Lt	
258+70.00	212'Rt	
265+00.00	101'Rt	
277+60.00	119'Lt	
277+90.00	119'Lt	
277+60.00	73'Rt	
277+90.00	73'Rt	
287+20.00	68'Rt	
288+50.00	66'Rt	
291+30.00	112'Rt	
292+50.00	73'Lt	
292+90.00	73'Lt	
307+20.00	76'Lt	
307+60.00	76'Lt	
307+90.00	86'Rt	
308+40.00	86'Rt	
315+90.00	58'Lt	
316+20.00	58'Lt	
316+40.00	96'Rt	
316+70.00	96'Rt	
329+70.00	92'Rt	
330+00.00	92'Rt	
329+70.00	65'Lt	
330+05.00	65'Lt	
332+60.00	105'Rt	
332+90.00	102'Rt	
332+90.00	73'Lt	
333+20.00	71'Lt	
340+60.00	149'Rt	
341+60.00	142'Rt	
341+80.00	114'Rt	
342+10.00	82'Lt	
342+40.00	77'Lt	
357+90.00	69'Rt	
358+20.00	69'Rt	
357+90.00	63'Lt	
358+20.00	63'Lt	
379+40.00	80'Rt	
379+80.00	80'Rt	
379+70.00	57'Lt	
379+90.00	57'Lt	
390+20.00	81'Lt	
390+50.00	101'Lt	
394+80.00	64'Rt	
395+20.00	64'Rt	
395+30.00	82'Lt	
395+60.00	82'Lt	
426+20.00	161'Rt	
436+30.00	81'Lt	
436+60.00	81'Lt	
436+50.00	79'Rt	
1280+70.00	35'Lt	R-57
1386+00.00	40'Lt	R-57
1388+60.00	36'Rt	R-57
2305+40.00	25'Rt	90th Ave
2305+85.00	17'Lt	90th Ave
3385+60.00	47'Rt	R-63
3388+10.00	47'Lt	R-63
4414+30.00	134'Rt	Y' St.
14413+75.00	40'Rt	Y' St. Detour
14413+75.00	25'Lt	Y' St. Detour
14414+00.00	25'Lt	Y' St. Detour
14418+00.00	37'Lt	Y' St. Detour
14418+50.00	37'Lt	Y' St. Detour
Subtotal	69	
+100%	69	
Total	138	

100-17 04-20-10				
TABULATION OF SILT FENCES				
Refer to EC-201				
Location			Length LF	Remarks
Begin Station	End Station	Side		
Hwy. 92				
257+50.00	259+25.00	Lt	175	
276+75.00	278+75.00	Lt	200	
278+75.00	279+50.00	Lt	75	
265+25.00	267+25.00	Rt	200	
267+25.00	269+25.00	Rt	200	
269+25.00	271+25.00	Rt	200	
292+00.00	292+25.00	Rt	25	
R-57				
1280+60.00	1282+25.00	Rt	165	R-57
1385+00.00	1386+00.00	Lt	100	R-57
90th St				
2308+75.00	2309+50.00	Lt	75	90th St.
2308+75.00	2309+50.00	Rt	75	90th St.
R-63				
3389+00.00	3390+00.00	Rt	100	R-63
Subtotal			1590	
+25%			398	
Total			1988	

100-17R MODIFIED				
TABULATION OF FENCE REMOVAL				
Location			Length LF	Remarks
Begin Station	End Station	Side		
256+23.9, 133.4'Lt	258+34.1, 197'Lt		410	Field
256+49.4, 50.0'Lt	258+31.56, 50.3'Lt		182	Field
258+61.6, 199.0'Lt	261+46.0, 47.2'Lt		369	Field
260+45.7, 50.5'Lt	260+46.0, 145.0'Lt		95	Field
262+18.3, 45.3'Lt	266+52.2, 71.2'Lt		420	Field
268+55.0, 63.5'Lt	269+72.0, 73.0'Lt		117	Field
263+27.8, 95.0'Rt	267+38.2, 6.5'Rt		447	Field
265+28.8, 28.8'Rt	265+45.3, 133.8'Rt		106	Field
265+44.4, 128.4'Rt	267+74.4, 133.0'Rt		266	Field
266+75.5, 108.7'Rt	268+71.0, 3.3'Rt		273	Field
267+25.2, 58.1'Rt	267+46.5, 104.6'Rt		54	Wood
268+70.5, 100.6'Rt	269+35.8, 120.5'Rt		80	Field
270+51.8, 29.1'Rt	270+48.1, 202.7'Rt		182	Wood
270+47.8, 225'Rt	270+48.1, 202.7'Rt		22	Field
270+52.0, 29.0'Rt	278+64.0, 35.0'Rt		812	Field
287+75.9, 115.0'Lt	290+86.1, 115.0'Lt		413	Field
292+27.8, 60.7'Lt	302+87.7, 72.0'Lt		1060	Field
307+28.0, 26.0'Rt	307+42.9, 25.8'Rt		199	Wood
307+42.9, 25.8'Rt	310+00, 25.6'Rt		257	Field
314+17.1, 61.8'Lt	323+53.7, 76'Lt		938	Field
318+45.0, 25.0'Rt	323+56.1, 26.2'Rt		511	Field
323+56.1, 9.6'Rt	323+56.7, 110.0'Rt		100	Field
323+72.3, 86.5'Lt	339+52.6, 90.9'Lt		1613	Field
326+86.6, 110.3'Rt	327+71.6, 8.5'Rt		187	Field
327+86.9, 9.6'Rt	334+26.8, 8.7'Rt		640	Field
334+26.8, 8.7'Rt	334+28.9, 105.6'Rt		97	Field
334+26.8, 8.7'Rt	342+44.4, 52.2'Rt		826	Field
341+82.5, 41.4'Lt	350+97.6, 53.8'Lt		916	Field
342+44.4, 52.2'Rt	342+62.6, 110.3'Rt		69	Wood
342+80, 114.3'Rt	343+08.8, 68.6'Rt		67	Wood
343+08.8, 68.6'Rt	344+66.6, 128.2'Rt		178	Field
354+56.5, 76.7'Lt	355+90.2, 16.4'Lt		196	Field
355+06.8, 90.0'Rt	355+10.1, 60.3'Rt		30	Wood
356+81.1, 135.1'Rt	361+82.5, 58.2'Rt		560	Field
359+75.1, 103.6'Lt	359+78.4, 23.0'Lt		81	Wood
361+83.6, 95.0'Rt	363+00, 56.0'Rt		152	Field
365+77.4, 95.0'Lt	375+07.4, 58.1'Lt		980	Field
373+62.0, 91.8'Lt	373+63.7, 66.9'Lt		25	Wood
374+80.0, 91.3'Lt	374+80.7, 70.8'Lt		21	Wood
375+06.9, 91.1'Lt	375+07.4, 58.1'Lt		33	Wood
376+46.0, 100.0'Rt	377+70.0, 110.0'Rt		254	Field
377+65.1, 95.0'Lt	387+33.9, 71.8'Lt		1008	Field
377+67.2, 38.5'Rt	384+86.3, 1.2'Lt		744	Field
461+55.0, 52.8'Lt	464+00.0, 52.3'Lt		245	Wood
R-57				
1280+46.4, 50.6'Lt	1281+66.1, 69.6'Lt		145	Field
1385+84.1, 50.7'Rt	1389+96.5, 49.3'Rt		412	Field
90th Ave.				
2305+50.0, 36.72'Rt	2306+07.0, 55.0'Rt		77	Field
2305+50.0, 25.4'Lt	2310+03.0, 28.6'Lt		453	Field
Totals				
Field			16320	
Wood			1005	

EXISTING PAVEMENT

No.	Location					Year	Type	Project Number	Surface		Base		Subbase		Removal		Coarse Aggregate			Reinforcement	Remarks
	County	Route	Dir. of Travel	Begin Milepost	End Milepost				Type	Depth IN	Type	Depth IN	Type	Depth IN	Type	Depth IN	Source	Type	Durability Class		
1	Warren	Ia.92	EB & WB	120.85	129.91	1992		FN-92-5(31)--21-91	AAC	3				AAC	0.5	University		Gravel			AAC=Type A Asphalt Cement Concrete
2	"	"	"	"	"	1983		FN-92-5(20)--21-91	BSC												BSC=Bituminous Seal Coat
3	"	"	"	"	"	1952		P-1023W	BAC	1.5	TBB	1.5									BAC=Type B Asphalt Cement Concrete
4	"	"	"	"	"	1930		P-569	PC7	7	PC7					Earlham		Gravel	1		PC7=10"-7"-10" PCC Concrete Slab

REMOVAL OF PAVEMENT

110-1
04-16-13

Refer to Tabulation 102-5

* Not a Bid Item

Begin Station	End Station	Side	Pavement Type	Area	Saw Cut*	Remarks
				SY	LF	
256+50.00	259+85.60	EB & WB	HMA, PCC	894.9	24.0	Ia. 92
259+85.60	266+94.70	EB & WB	HMA, PCC	2048.5		Ia. 92
266+94.70	440+60.00	EB & WB	HMA, PCC	46307.5		Ia. 92
440+60.00	443+18.01	EB & WB	HMA, PCC	863.6	35.0	Ia. 92 - width 24' to 35'
443+18.01	465+01.01	Lt	HMA, PCC	453.8	2183.0	Pavement edge removal for widening
443+18.01	465+01.01	Rt	HMA, PCC	472.6	2183.0	Pavement edge removal for widening
284+24.95	287+27.07	WB	HMA, PCC	313.8		Turning Lane at R-57
256+50.00	390+00.00	Lt & Rt	HMA	621.1		21 Driveway fillets, 2 Sideroad fillets (90th Ave.)
441+21.63		45' Lt-57' Lt	PCC	1.0	12.0	Spruce St. curb to be removed for detour const.
441+44.68		38' Lt-59' Lt	PCC	1.6	21.0	Spruce St. curb to be removed for detour const.
440+88.94	441+58.58	Lt	PCC	105.7	25.0	Remaining Spruce St. pavement and returns
443+40.85	444+24.64	Rt	PCC	128.1	14.0	"R" St. pavement and returns
451+47.64	452+39.61	Lt	PCC	186.3	60.0	S. Kenwood Blvd. Pavement & Returns
453+92.98	454+76.86	Rt	PCC	174.3	25.0	S. "P" St. pavement and returns
455+28.84	456+00.00	Lt	PCC	123.8	64.0	S. "P" St. pavement and returns
461+86.25	462+60.36	Rt	PCC	33.7	28.0	S. "N" St. returns
R-57						
1280+60.00	1283+81.10	NB & SB	HMA	786.2	22.0	R-57 South
1384+00.43	1386+06.00	NB & SB	HMA	501.1	22.0	R-57 North
		NB & SB	HMA	592.5		R-57 returns
284+24.95	287+27.07	WB	HMA, PCC	313.8		Turning Lane at R-57
R-63						
3389+00.00	3391+35.75	NB & SB	HMA	672.5	22.0	R-63 South
3391+60.00	3393+05.00	NB & SB	HMA	356.5	22.0	R-63 North
		NB & SB	HMA	519.3		R-63 returns
Y Street						
4414+15.00	4417+73.13	NB & SB	PCC	1124.7	31.0	Y St. South, Pavement & Returns
4417+90.70	4422+60.00	NB & SB	PCC	1795.3	31.0	Y St. North, Pavement & Returns
4410+73.00	4411+62.00	NB	PCC	14.8	92.0	Y St. Curb at Detour
4414+91.00	4415+37.00	SB	PCC	7.7	49.0	Y St. Curb at Detour
4424+96.00	4425+66.00	NB	PCC	11.7	73.0	Y St. Curb at Detour
DETOURS						
439+07.78	441+22.33	Lt	HMA	200.9		Mainline Detour Paving at East End Tie-In
441+45.03	445+00.00	Lt	HMA	600.5		Mainline Detour Paving at East End Tie-In
441+22.97	443+48.00	Rt	HMA	86.0		Mainline Detour Paving at East End Tie-In
11277+89.54	11283+98.25	NB & SB	HMA	1270.8		Co.Rd. R-57 Detour Pavement
11284+92.87	11289+34.28	NB & SB	HMA	1109.1		Co.Rd. R-57 Detour Pavement
18386+48.19	18392+53.72	NB & SB	HMA	1472.8		Co.Rd. R-63 Detour Pavement
18392+77.35	18397+71.90	NB & SB	HMA	1177.7		Co.Rd. R-63 Detour Pavement
			Totals =	65344.1	5038.0	

SIDEWALK REMOVAL

110-5
08-01-08

Begin Station	End Station	Area SY	Remarks
417+68.00	Rt	114.0	270' South along 'Y' St.
441+44.50	Lt	8.8	East side of Spruce St.
451+72.06	Lt	7.6	West side of S. Kenwood St.
452+26.29	Lt	8.0	East side of S. Kenwood St.
454+14.44	Rt	10.5	West side of S. 'P' St.
454+66.22	Rt	11.0	East side of S. 'P' St.
454+70.00	Lt	53.3	East to S. 'P' St. and north
455+79.30	Lt	17.2	East side of S. 'P' St.
Totals =		230.4	

REMOVAL OF CONCRETE DRIVES

110-8
08-01-08

Location Station	Side	Area SY	Remarks
324+07.61	Rt	113.9	
356+56.57	Rt	84.5	
398+16.98	Lt	196.1	
423+11.51	Lt	911.7	Removal as directed by Engineer
425+99.40	Lt	136.5	
427+53.90	Lt	108.7	
429+54.16	Lt	149.8	
430+78.41	Rt	339.5	
431+96.41	Lt	100.5	
433+46.06	Lt	35.7	
433+47.85	Rt	775.2	Includes parking lot
440+48.56	Rt	125.7	
442+23.75	Rt	192.1	
446+48.51	Rt	181.9	
446+56.51	Lt	134.7	
447+68.44	Rt	173.8	
448+17.01	Lt	203.8	
448+54.51	Rt	168.4	
449+42.01	Lt	185.9	
458+76.10	Lt	85.6	
460+15.20	Lt	108.8	
461+34.29	Lt	65.8	
Total =		4578.4	

TABULATION OF MAILBOX TURNOUTS

MAILBOX

Location Station	Side	Remarks
Mainline 92		
262+00.00	Lt.	1
269+50.00	Lt.	2
271+40.00	Lt.	1
276+25.00	Lt.	6
281+90.00	Rt.	1
285+30.00	Lt.	1
291+60.00	Lt.	1
297+05.00	Lt.	1
305+30.00	Lt.	1
90th Ave.		
2313+25.00	Rt.	1
2308+00.00	Rt.	1
Mainline 92		
324+25.00	Lt.	1
341+10.00	Lt.	1
353+00.00	Lt.	2
356+75.00	Lt.	1
361+70.00	Lt.	1
363+90.00	Lt.	1
365+50.00	Lt.	2
375+40.00	Lt.	3
422+80.00	Lt.	1
423+75.00	Lt.	1
427+30.00	Lt.	1
431+75.00	Lt.	1
432+25.00	Lt.	1
433+90.00	Lt.	1
433+90.00	Rt.	1
437+80.00	Lt.	1
438+40.00	Lt.	1
442+80.00	Rt.	1
446+75.00	Lt.	1
448+40.00	Lt.	2
Total = 42 Mailboxes		

TABULATION OF SPREADING TOPSOIL

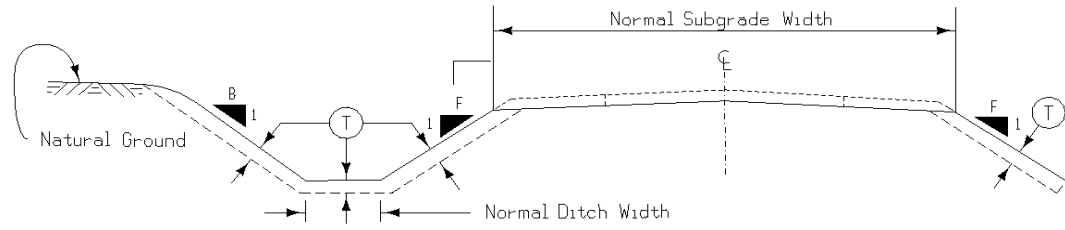

Perform this work according to Section 2105. Prior to placing topsoil on any cohesive soil, scarify the area to be covered to a minimum depth of 3 inches.

Appropriate adjustments have been made in the template quantities to reflect the placement of topsoil on foreslope, backslope and ditch bottom as detailed hereon.

Placement Description							Topsoil Excavation Available From				
Area	Quantity	Location		Side	Slope	(T)	Remarks	Amount Reserved	Station to Station		Remarks
No.	CY	Station to Station		L. or R.	B. or F.	IN		CY			
1	43274.0	256+00.00	390+00.00	Both	Both	8.0	ML092:Rural	52952.0	256+00.00	390+00.00	ML092:Rural
2	10534.0	390+25.00	443+18.00	Both	Both	8.0	ML092: Urban STG1B and STG2B	9301.0	390+25.00	443+18.00	ML092: Urban STG1B and STG2B
3	1792.0	443+23.01	464+92.00	Both	Both	8.0	ML092: Widening	126.0	443+23.01	464+92.00	ML092: Widening
4	133.0	1257+10.00	1258+50.00	Both	Both	8.0	Kennedy	0.0	1257+10.00	1258+50.00	Kennedy
5	703.0	1280+60.00	1283+50.00	Both	Both	8.0	R57S	0.0	1280+60.00	1283+50.00	R57S
6	303.0	1384+25.00	1386+06.00	Both	Both	8.0	R57N	0.0	1384+25.00	1386+06.00	R57N
7	1231.0	2305+85.00	2313+85.00	Both	Both	8.0	90th	0.0	2305+85.00	2313+85.00	90th
8	699.0	3388+60.00	3390+75.00	Both	Both	8.0	R63S	0.0	3388+60.00	3390+75.00	R63S
9	251.0	3391+31.95	3393+05.00	Both	Both	8.0	R63N	0.0	3391+31.95	3393+05.00	R63N
10	422.0	4414+15.00	4417+25.32	Both	Both	8.0	YSTS	0.0	4414+15.00	4417+25.32	YSTS
11	754.0	4417+64.40	4422+60.00	Both	Both	8.0	YSTN	0.0	4417+64.40	4422+60.00	YSTN
12	1735.0	11277+89.54	11290+40.39	Both	Both	8.0	DET R57	0.0	11277+89.54	11290+40.39	Detour R57
13	1119.0	18388+00.00	18396+25.00	Both	Both	8.0	DET R63	0.0	18388+00.00	18396+25.00	R63
TOTAL	62950.0						TOTAL	62379.0			

LIST OF SUBDRAIN WORK

Refer to Standard Road Plans RF-3, RF-5, RF-14, RF-19A, RF-19B, RF-19C, RF-19E and RF-19F

* Not a bid item

No.	Location		Type of Installation	Pipe			Aprons		Outlets		Connected Pipe Joints (RF-14)*	Trench Drain	Granular Material	Porous Backfill*	Class "A" Crushed Stone*	Remarks	
	Station to Station	Type of Installation		Concrete C.M.P., C.M.P. Coated, or Plastic	Dia.	Length	RF-3	RF-5	RF-19E	RF-19F							
										Type							No.
1	292+04 90' Rt	292+75.00 80' Rt	Case 'B'	C.M.P. Coated	10.0	72										Install Intake, Standpipe I-1 @ Sta 292+75, 80' Rt at inlet end	
2	307+71 109' Lt	307+62 91' Lt	Case 'C'	C.M.P. Coated	10.0	22			A	1							
3	308+04.00 91' Rt	307+98 108' Rt	Case 'A'	C.M.P. Coated	10.0	18										Install Intake, Standpipe I-2 @ Sta 308+04, 91' Rt at inlet end	
4A	1388+80 73' Rt		Case 'C'						A	1						(A)	
4B	1388+80 73' Rt	1388+77 49' Rt	Cases 'A' and 'C'	C.M.P. Coated	10.0	23			A	1						(B)	
5A	4414+58 154' Lt		Case 'C'						A	1						(A)	
5B	4414+58 154' Lt	4414+34 34' Lt	Case 'A'	C.M.P. Coated	10.0	122										(B) Outlet into Intake I-219 Refer to Tab. 104-5B in M-sheets	
			Totals		10.0	257				4						Intake, Standpipe quantity = 2 each	

(A) Outlet only; Replace existing tile with RF-19F outlet at detour ditch location.
(B) Remove outlet and extend tile line after removal of detour.

PCC PAVEMENT

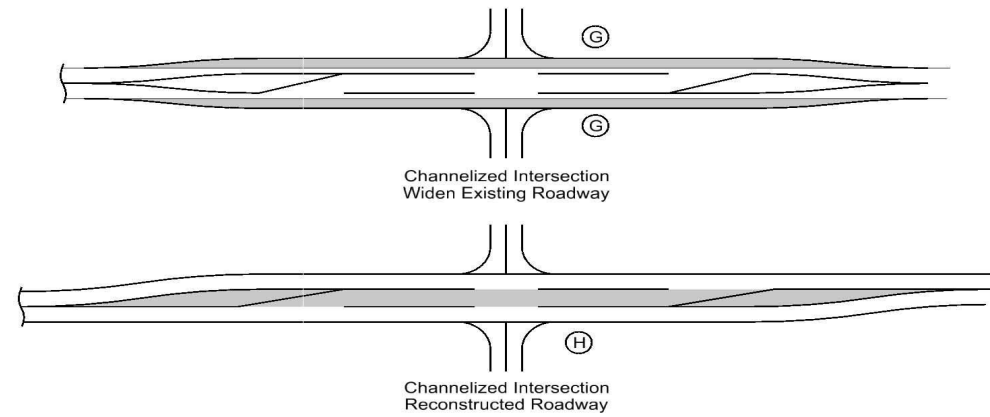
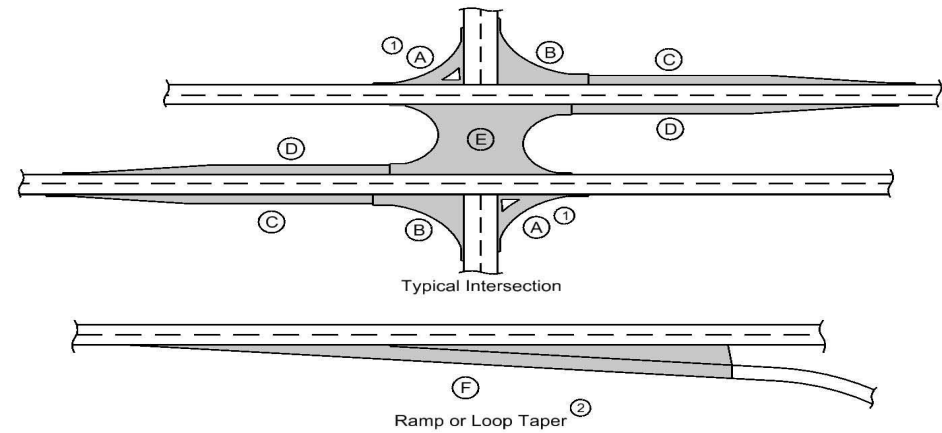

- ① Does not include island area or curb. Refer to tabulation 112-4 for quantities.
- ② Refer to PV-410, PV-411, PV-412, and PV-414.
- ③ Quantity includes Pavement Header.

Road Identification	Location		Mainline			Area (3)								Total Area By Pavement Thickness		Special Backfill	Modified Subbase	Granular Subbase	Remarks	
	Direction of Travel	Station to Station	Width	Length	Area	A	B	C	D	E	F	G	H	SY						
														10 IN	8 IN					
														TONS	CY					
FT	FT	SY	SY	SY	SY	SY	SY	SY	SY	SY	SY	SY	10 IN	8 IN	TONS	CY	SY			
IA 92	WB	256+50.00	271+47.79	14.0	1497.8	2329.9									2329.9		904.3		2912.4	
IA 92	EB	256+50.00	271+47.79	14.0	1497.8	2329.9									2329.9		904.3		2919.4	
IA 92	WB	271+47.79	301+54.21	14.0	3006.4	4676.7									4676.7		1815.1		5845.9	
IA 92	EB	271+47.79	301+54.21	14.0	3006.4	4676.7									4676.7		1815.1		5845.9	
IA 92	Both	271+47.79	301+54.21	Varies	3006.4							3786.7		3786.7		1192.8		3786.7	Center Turn Lane & Channelized Area	
IA 92 - E.B. Turn Lane	EB	279+39.00	282+94.00	Varies	355.0			567.8						567.8		178.8		567.8	Rt. Turn Lane at Co. Rd. R-57	
IA 92 - W.B. Turn Lane	WB	284+48.00	292+08.00	Varies	760.0			1306.7						1306.7		411.6		1306.7	Rt. Turn Lane at Co. Rd. R-57	
IA 92	WB	301+54.21	378+78.79	14.0	7724.6	#####								12016.0		4663.8		15019.8		
IA 92	EB	301+54.21	378+78.79	14.0	7724.6	#####								12016.0		4663.8		15019.8		
IA 92	WB	378+78.79	391+00.00	14.0	1221.2	1899.7								1899.7		737.3		2374.6		
IA 92	EB	378+78.79	391+00.00	14.0	1221.2	1899.7								1899.7		737.3		2374.6		
IA 92	EB	378+78.79	391+00.00	Varies	1221.2							1392.1		1392.1		438.5		1397.8	Center Turn Lane & Channelized Area	
IA 92	EB	386+70.00	390+25.00	Varies	355.0			567.9						567.9		178.9		567.9	Rt. Turn Lane at Co. Rd. R-63	
IA 92	WB	391+92.00	398+19.88	Varies	627.9			614.3						614.3		193.5		614.3	Rt. Turn Lane at Co. Rd. R-63	
IA 92	WB	391+00.00	441+09.29	15.0	5009.3	8348.8								8348.8			3385.9			
IA 92	EB	391+00.00	441+09.29	15.0	5009.3	8348.8								8348.8			3385.9			
IA 92	Both	391+00.00	441+27.50	16.0	5027.5	8937.8								8937.8			2979.3		Center Turn Lane	
IA 92	WB	441+09.29	443+18.01	Varies	208.7	345.8								345.8			138.9			
IA 92	EB	441+09.29	443+18.01	Varies	208.7	306.0								306.0			124.1			
IA 92	Both	441+27.50	443+18.01	Varies	190.5	320.0								320.0			106.7		Center Turn Lane	
Kennedy St.	NB & SB	1258+03.53	1258+72.80	24.0	69.3	399.8										399.8	132.1		Typical 7149M	
R-57	NB & SB	1280+60.00	1283+59.24	22.0	299.2	731.5								731.5		293.3			Mainline	
R-57	NB & SB	1383+98.17	1386+06.00	22.0	207.8	508.0								508.0		203.6			Mainline	
R-57	NB	1383+98.17	1386+06.00	Varies	207.8			462.6						462.6		172.9			Return #1-NE Quad. Of Intersection	
R-57	SB	1383+98.17	1385+36.60	Varies	138.4		398.8							398.8		151.7			Return #2-NW Quad. Of Intersection	
R-57	SB	1281+54.45	1283+59.24	Varies	204.8			456.8						456.8		170.8			Return #3-SW Quad. Of Intersection	
R-57	NB	1282+22.45	1283+59.24	Varies	136.8		402.0							402.0		152.6			Return #4-SE Quad. Of Intersection	
90th St.	NB & SB	2309+56.83	2310+14.21	24.0	57.4	153.0									153.0	48.2			Typical 7149M	
90th St.	NB & SB	2310+42.21	2311+00.84	24.0	58.6	156.3									156.3	49.2			Typical 7149M	
90th St.	NB	2309+56.83	2310+14.21	Varies	57.4		104.0							104.0		35.5			Typical 7149M	
90th St.	SB	2309+56.83	2310+14.21	Varies	57.4			104.0						104.0		35.5			Typical 7149M	
90th St.	SB	2310+42.21	2311+00.84	Varies	58.6		104.0							104.0		35.5			Typical 7149M	

PCC PAVEMENT

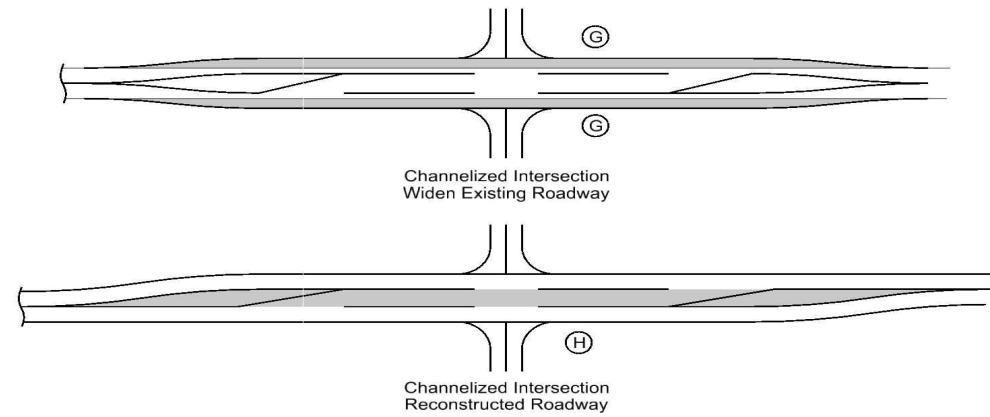
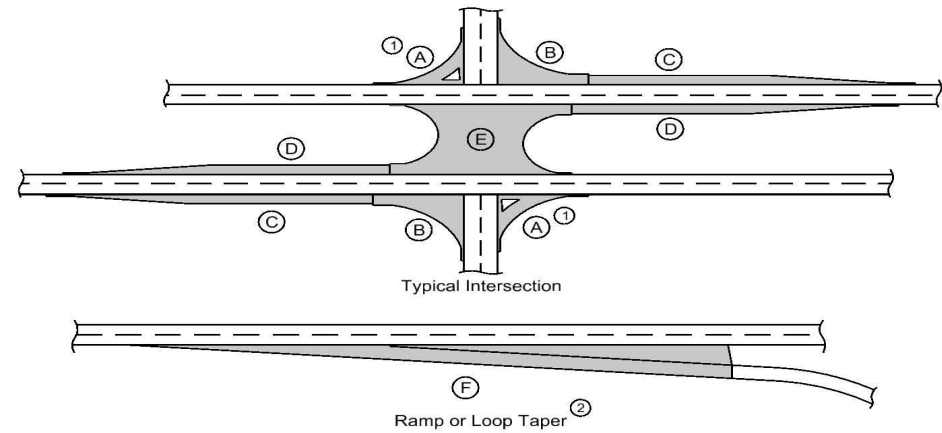

- ① Does not include island area or curb. Refer to tabulation 112-4 for quantities.
- ② Refer to PV-410, PV-411, PV-412, and PV-414.
- ③ Quantity includes Pavement Header.

Road Identification	Location		Mainline			Area (3)								Total Area By Pavement Thickness		Special Backfill	Modified Subbase	Granular Subbase	Remarks	
	Direction of Travel	Station to Station		Width	Length	Area	A	B	C	D	E	F	G	H	SY					
		FT	FT												SY					10 IN
90th St.	NB	2310+42.21	2311+00.84	Varies	58.6											104.0	35.5		Typical 7149M	
R-63	NB & SB	3388+60.00	3390+88.93	22.0	228.9	559.6									559.6		224.3		Mainline	
R-63	NB & SB	3391+34.46	3393+05.00	22.0	170.5	416.9									416.9		167.1		Mainline	
R-63	NB	3391+34.46	3393+02.01	Varies	167.5										364.3		137.2		Return #1-NE Quad. Of Intersection	
R-63	SB	3391+34.46	3392+50.13	Varies	115.7										372.1		142.7		Return #2-NW Quad. Of Intersection	
R-63	SB	3389+14.04	3390+88.93	Varies	174.9										442.6		162.7		Return #3-SW Quad. Of Intersection	
R-63	NB	3389+77.13	3390+88.93	Varies	111.8										278.1		109.3		Return #4-SE Quad. Of Intersection	
Y Street	NB & SB	4414+15.00	4417+25.21	25.0	310.2	861.7									861.7		336.6		Mainline; See Note (1) below	
Y Street	NB & SB	4417+64.32	4422+60.00	31.0	495.7	1707.3									1707.3		641.9		Mainline	
Y Street	NB	4417+64.32	4419+15.98	Varies	151.7										232.6		97.7		Return #1-NE Quad. Of Intersection	
Y Street	SB	4417+64.32	4418+93.99	Varies	129.7										256.9		106.8		Return #2-NW Quad. Of Intersection	
Y Street	SB	4415+71.91	4417+25.21	Varies	153.3										201.7		85.8		Return #3-SW Quad. Of Intersection	
Y Street	NB	4416+01.51	4417+25.21	Varies	123.7										227.7		93.8		Return #4-SE Quad. Of Intersection	
Spruce St.						102.0									102.0		39.1		Includes 70.6' of curb	
R St.						138.4									138.4		51.4		Includes 78.5' of curb	
S. Kenwood Blvd						197.9									197.9		71.3		Includes 90.4' of curb	
South P St. (South)						194.2									194.2		71.7		Includes 104.9' of curb	
South P St. (North)						163.7									163.7		61.5		Includes 98.9' of curb	
South N St.						89.7									89.7		33.5		Includes 54.9' of curb	
Totals=															86454.3	1125.2	22985.9	10120.7	60553.4	

Notes:
(1) Quantities do not include Curb and Gutter on right side from Sta. 4414+91 to 4415+37 due to Detour Construction. Refer to Tab 112-9C.

MILLED RUMBLE STRIPS

See PV-12 and PV-13.

112-10
04-19-11

* Calculated at 18" width for Shoulder.

Location		Length		Type (Centerline, Rt or Lt Shoulder)	Fog Seal* (Milled Rumble Strip) Shoulder GAL	Effective Shoulder Width			Remarks
Road Identification	Station to Station	PCC	HMA			PCC Paved	HMA Paved	Granular\Earth	
		STA	STA						
Iowa 92 Mainline	256+50.00	380+00.00	123.50	Centerline	0.0				
Iowa 92 Mainline	256+50.00	281+94.00	25.44	Left Shoulder	0.0				
Iowa 92 Mainline	291+50.00	389+14.00	97.64	Left Shoulder	0.0				
Iowa 92 Mainline	256+50.00	280+39.00	23.89	Right Shoulder	0.0				
Iowa 92 Mainline	284+40.00	387+00.00	102.60	Right Shoulder	0.0				
Total Centerline =			123.50						
Total Shoulder =			249.57						

RUMBLE STRIP PANELS

Refer to Standard Road Plan PV-10.

112-7
10-19-10

Location		Pavement		Remarks
Road Ident.	Station	Side	New Existing	
Co. Rd. R-57	1277+43	Rt.	X	in Patch
South	1280+43	Rt.	X	in Patch
Co. Rd. R-57	1387+14	Lt.	X	in Patch
North	1390+14	Lt.	X	in Patch
Co. Rd. R-63	3384+35	Rt.	X	in Patch
South	3387+35	Rt.	X	in Patch
Co. Rd. R-63	3394+92	Lt.	X	in Patch
North	3397+92	Lt.	X	in Patch

FULL-DEPTH PATCHES

Refer to Standard Roads Plans PR-101, PR-102, PR-103, PR-104 and PR-140.

102-6C
10-21-14

Count	Location		Dimension			PCC Patches			HMA Patches	Composite HMA	Subbase Patches	Subbase Patch w/ 'EF' Joint	Patch Subdrain	'CD' Joints	'CT' Joints	'EF' Joints	Anchor Lugs Removal	Remarks
	Station or Milepost	Lane	Length	Width	Patch Thickness	With Dowels	Without Dowels	C R C										
	L, R, or B	FT	FT	IN	PR-103	PR-102	PR-104											
1	451+75	R	6.0	12.0	11.0	8.0				8.0								
1	451+75	L	6.0	12.0	11.0	8.0				8.0								
1	460+35	R	20.0	12.0	11.0	26.7				26.7								
1	461+06	R	20.0	12.0	11.0	26.7				26.7								
1	1277+43	R	30.0	11.0	7.4		36.7			36.7					1			See Tab 112-7
1	1280+43	R	30.0	11.0	7.4		36.7			36.7					1			See Tab 112-7
1	1387+14	L	30.0	11.0	7.4		36.7			36.7					1			See Tab 112-7
1	1390+14	L	30.0	11.0	7.4		36.7			36.7					1			See Tab 112-7
1	3384+35	R	30.0	11.0	7.4		36.7			36.7					1			See Tab 112-7
1	3387+35	R	30.0	11.0	7.4		36.7			36.7					1			See Tab 112-7
1	3394+92	L	30.0	11.0	7.4		36.7			36.7					1			See Tab 112-7
1	3397+92	L	30.0	11.0	7.4		36.7			36.7					1			See Tab 112-7
12	Totals					69.4	293.6			363.0								

Curb and Gutter

Refer to PV-102 and 6000 Detail Series.

- ① Lane(s) to which the curb is adjacent.
- ② Bid Item
- ③ Applies only for curbs constructed on project with existing granular shoulders.
- ④ Does not include shrink.

Road Identification	Direction Of Traffic	Location			Curb Type	Pavement Thickness	Width	Length	Quantities					Remarks		
		Station to Station	Side	IN					FT	Class 13 Excavation	Special Backfill	Modified Subbase	Earth Shoulder Finishing			
													FT		CY ②	TON ②
IA 92	WB	443+18.01	451+46.61	Lt	6" Standard	10	2.5	828.6				86.2	8.3	154.7		
IA 92	WB	452+38.91	455+21.32	Lt	6" Standard	10	2.5	282.4				29.4	2.8	52.7		
IA 92	WB	456+11.24	465+01.01	Lt	6" Standard	10	2.5	889.8				92.6	8.9	166.1		
IA 92	EB	441+22.91	443+41.50	Rt	6" Standard	10	2.5	218.6				22.7	2.2			
IA 92	EB	444+22.50	453+91.57	Rt	6" Standard	10	2.5	969.1				100.9	9.7	180.9		
IA 92	EB	454+86.45	461+85.60	Rt	6" Standard	10	2.5	699.2				72.8	7.0	130.5		
IA 92	EB	462+62.57	465+01.01	Rt	6" Standard	10	2.5	238.4				24.8	2.4	44.5		
Y Street	SB	4410+73.00	4411+62.00	Lt	6" Standard	10	1.5	89.0	14.4	16.2			0.9	16.6	after removal of detour	
Y Street	NB	4414+91.00	4415+37.00	Rt	6" Standard	10	1.5	46.0	7.4	16.2			0.5	8.6	after removal of detour	
Y Street	SB	4424+96.00	4425+66.00	Lt	6" Standard	10	1.5	70.0	11.3	16.2			0.7	13.1	after removal of detour	
Totals												33.1		429.4	43.3	
Curb							1.5	205.0								
Curb							2.5	4126.0								

CURBS AND ISLANDS

Refer to PV-20, PV-102, and 6000s Detail Series.

Point No.	Station	Offset	Island Interior Area SY ①	Curb and Gutter			Remarks
				Curb Type	Gutter Width	Length ①	
					FT	LF	
A	283+53.81	41.0' Lt.					
	1384+09.30	14.0' Lt.					
B	283+40.37	41.0' Lt.					
C	1384+19.19	15.0' Lt.	63.2	6" Sloped PCC		33.8	Refer to Modified PV-20 Detail in the 'U' Sheets
A	283+87.71	25.0' Rt.					
	1283+47.97	14.0' Rt.					
B	284+01.84	25.0' Rt.					
C	1283+37.33	15.0' Rt.	63.2	6" Sloped PCC		36.2	Refer to Modified PV-20 Detail in the 'U' Sheets
Totals =			126.4			70.0	

SHOULDERS

- ① Lane(s) to which the shoulder is adjacent.
- ② Bid Item
- ③ Applies only for Paved Shoulders constructed on project with existing granular shoulders.
- ④ Does not include shrink.

Calculations assume a HMA unit weight (lbs/cf) of 145, a Special Backfill unit weight (lbs/cf) of 140, and a Granular Shoulder unit weight (lbs/cf) of 140.

Road Identification	Direction Of Traffic	Location			Quantities																		Remarks	
		Station to Station		Side	P Width FT	G Width FT	L Length FT	Class 13 Excavation CY ②	Hot Mix Asphalt		Binder TONS	Paved Shoulder SY ②	Reinforced Paved Shoulder SY ②	Special Backfill				Modified Subbase CY ②	Granular Shoulder		Earth Shoulder Construction Alternates			
		Station to Station							HMA Alternate					PCC Alternate		TON/STA			TON/STA		STA ②	HMA CY ④		PCC CY ④
		Start	End	TON	TON/STA	TON	TON/STA	TON	TON/STA	TON	TON/STA	TON	TON/STA	TON	TON/STA	TON	TON/STA	TON	TON/STA					
Ia 92	WB	256+50.00	257+70.00	Lt	4.0	2 to 4	120.0	23.2	19.4	1.4	53.3		51.0	42.5	56.3	46.9		15.0	12.5	1.2	47.3	47.3		
"	EB	256+50.00	257+70.00	Rt	4.0	2 to 4	120.0	23.2	19.4	1.4	53.3		51.0	42.5	56.3	46.9		15.0	12.5	1.2	47.3	48.0		
"	WB	257+70.00	281+93.58	Lt	8.0		2423.6	936.5	38.6	56.2	2154.3		1302.9	53.8	1448.8	59.8				24.2	1578.0	1585.2		
"	EB	257+70.00	258+12.03	Rt	8.0		42.0	16.2	38.6	1.0	37.4		22.6	53.8	25.1	59.8				0.4	32.1	32.2		
"	EB	259+36.67	279+39.00	Rt	8.0		2002.3	773.8	38.6	46.4	1779.8		1076.5	53.8	1197.0	59.8				20.0	1527.0	1532.9		
"	WB	281+93.58	282+79.35	Lt	0 to 6		85.8	12.4	14.5	0.7	28.6		11.1	13.0	13.4	15.6				0.9	17.6	17.6		
"	WB	282+79.35	283+22.95	Lt	6.0		43.6	12.6	29.0	0.8	29.1		16.3	37.5	18.3	41.9				0.4	17.6	17.6	portion of R-5	
"	EB	279+39.00	280+39.00	Rt	0 to 6		100.0	14.5	14.5	0.9	33.3		13.0	13.0	15.6	15.6				1.0	54.4	55.0		
"	EB	280+39.00	283+15.78	Rt	6.0		276.8	80.3	29.0	4.8	184.5		103.7	37.5	115.9	41.9				2.8	142.8	145.4	portion of R-5	
"	EB	284+18.63	284+61.62	Rt	6.0		43.0	12.5	29.0	0.7	28.7		16.1	37.5	18.0	41.9				0.4	22.9	23.1		
"	EB	284+61.62	285+41.84	RT	6.0	0.0	80.2	11.6	14.5	0.7	26.7		10.4	13.0	12.5	15.6				0.8	32.1	33.0		
"	WB	284+27.41	290+88.00	Lt	6.0		660.6	191.6	29.0	11.5	440.4		247.4	37.5	276.5	41.9				6.6	282.6	285.0		
"	WB	290+88.00	291+55.36	Lt	6 to 1.5		67.4	13.0	19.4	0.8	28.1		14.2	21.1	16.7	24.8				0.7	28.1	28.3		
"	EB	285+41.84	309+67.10	Rt	8.0		2425.3	937.2	38.6	56.2	2155.8		1303.8	53.8	1449.8	59.8				24.3	1124.6	1127.3		
"	EB	310+91.11	386+70.00	Rt	8.0		7578.9	2928.7	38.6	175.7	6736.8		4074.4	53.8	4530.7	59.8				75.8	3514.4	3522.8		
"	WB	292+08.00	309+65.31	Lt	8.0		1757.3	679.1	38.6	40.7	1562.1		944.7	53.8	1050.5	59.8				17.6	814.2	816.8		
"	WB	310+89.32	389+20.00	Lt	8.0		7830.7	3026.0	38.6	181.6	6960.6		4209.8	53.8	4681.2	59.8				78.3	3628.2	3639.8		
"	EB	386+70.00	387+70.00	Rt	0 to 6		100.0	14.5	14.5	0.9	33.3		13.0	13.0	15.6	15.6				1.0	41.7	42.0		
"	EB	387+70.00	390+48.62	Rt	6.0		278.6	80.8	29.0	4.8	185.7		104.3	37.5	116.6	41.9				2.8	113.8	114.6	portion of R-6	
"	WB	389+20.00	390+13.50	Lt	0 to 6		93.5	13.6	14.5	0.8	31.2		12.1	13.0	14.6	15.6				0.9	37.4	35.2		
"	WB	390+13.50	390+71.72	Lt	6.0		58.2	16.9	29.0	1.0	38.8		21.8	37.5	24.4	41.9				0.6	24.3	24.4	portion of R-6	
Co. Rd. R-57																								
"	NB	1277+35.00	1279+25.00	Rt		6.0	190.0											48.9	25.8	1.9	2.9	2.9	Detour removal	
"	NB	1280+60.00	1283+25.78	Rt		6.0	265.8											125.6	47.3	2.7				
"	NB	1384+34.94	1386+06.00	Rt		6.0	171.1											80.8	47.3	1.7				
"	NB	1387+86.00	1389+68.00	Rt		6.0	182.0											46.9	25.8	1.8	2.8	2.8	Detour removal	
"	SB	1280+60.00	1283+22.61	Lt		6.0	262.6											124.1	47.3	2.6				
"	SB	1384+35.03	1386+06.00	Lt		6.0	171.0											80.8	47.3	1.7				
Co. Rd. R-63																								
"	NB	3385+50.00	3386+82.00	Rt		6.0	132.0											34.0	25.8	1.3	2.0	2.0	Detour removal	
"	NB	3388+60.00	3390+53.08	Rt		6.0	193.1											91.2	47.3	1.9				
"	NB	3391+77.07	3393+05.00	Rt		6.0	127.9											60.4	47.3	1.3				
"	NB	3394+93.00	3396+25.00	Rt		6.0	132.0											34.0	25.8	1.3	2.0	2.0	Detour removal	
"	SB	3388+60.00	3390+50.73	Lt		6.0	190.7											90.1	47.3	1.9				
"	SB	3391+83.39	3393+05.00	Lt		6.0	121.6											57.5	47.3	1.2				

ACCESS POINTS AND SAFETY RAMPS

Refer to Cross-Sections

Length of unclassified pipe calculated is based on using Reinforced Concrete Pipe.

① Refer to MI-210

② Refer to EW-501.

③ Refer to EW-501 or EW-502.

*Predetermined for access point not constructed with this project.

Station	Side	Location	Type	Length of Opening ①			Pipe Culvert ③						Aprons	Driveway Surface Area		Driveway Surfacing Material	Remarks				
				Case	1½" Dropped Curb	3" Dropped Curb	W	PR	SR	H	Size	Pipe Length		Lt.	Rt.			No.	HMA	PCC	TON
270+56.00	Lt	Jt. C					30.0		15.0	3.7	18.0	76.0	47.0	41.2	2			29.500	ENT270		
							14.0		15.0	2.4	18.0	46.0	34.4	23.8	2			163.000	ENT269 - Jt. w/ENT270		
270+56.00	RT	Jt. C				30.0		15.0	7.0	18.0	134.0	63.6	82.5	2			70.000	ENT270			
276+46.00	Lt	Jt. C				24.0		15.0	6.4	18.0	112.0	55.2	68.6	2			54.000	ENT275 & ENT276			
291+80.00	Lt	C				20.0		15.0	2.9	18.0	62.0	34.2	40.0	2			23.000	ENT291			
291+80.00	Rt	C				20.0		15.0	4.0	18.0	74.0	48.0	38.2	2			37.000	ENT291			
297+08.00	Lt	Jt. C				30.0		15.0	2.1	18.0	60.0	37.9	34.3	2			21.000	ENT297			
297+08.00	Rt	Jt. C				30.0		15.0	4.4	18.0	92.0	44.4	59.9	2			58.500	ENT298			
						12.0		-	1.8	18.0	18.0	12.4	17.8	2			24.000	ENT297 - Jt. w/ENT298			
305+31.00	Rt	C				20.0		15.0	3.1	18.0	68.0	48.7	31.5	2			25.500	ENT305			
315+00.00	Rt	C				24.0		15.0	4.0	18.0	112.0	76.0	48.0	2			140.000	ENT315			
324+07.61	Lt	C				24.0		15.0	3.5	18.0	80.0	40.5	51.7	2			29.000	ENT323			
324+07.61	Rt	C				24.0		20.0								155.9		ENT323: 6" PCC Driveway			
334+27.00	Rt	C				24.0		15.0	4.6	18.0	82.0	42.4	51.8	2			38.000	ENT334			
341+03.00	Lt	Jt. C				35.0		15.0									44.000	ENT341			
341+03.00	Rt	C				24.0		15.0	8.9	36.0	86.0	50.1	48.1	2			203.000	ENT341			
352+40.00	Lt	C				24.0		15.0									53.520	ENT352			
352+40.00	Rt	C				24.0		15.0	1.9	18.0	50.0	32.7	29.5	2			20.000	ENT352			
359+18.00	Lt	C				24.0		15.0	3.3	18.0	72.0	44.3	39.8	2			125.000	ENT359			
359+18.00	Rt	Jt. C				24.0		15.0	4.9	18.0	92.0	50.0	42.0	2		516.7		ENT359: 8" PCC and 6" Spec Backfill (171.9 Ton); Refer to Typ. ENT359; Req. RCP			
						10.0		15.0	1.6	36.0	16.0	7.0	9.0	2					ENT359: Align pipe with ML draw at Sta. 358+05; Requires RCP		
365+37.00	Lt	B				30.0		15.0	3.9	18.0	86.0	49.9	48.3	2			88.800	ENT365			
365+37.00	Rt	C				24.0		15.0	3.8	18.0	80.0	43.4	48.8	2			47.870	ENT365			
375+45.00	Lt	C				24.0		15.0	3.3	18.0	72.0	40.5	43.7	2			25.200	ENT375			
375+45.00	Rt	C				24.0		15.0	5.4	18.0	106.0	61.6	56.5	2			39.200	ENT375			
387+95.00	Lt	Safety Ramp				36.0															
398+16.98	Lt	B			1	52.0		37.0									228.4				
407+00.00	Lt	C			1	38.5		24.0									165.2				
407+00.00	Rt	C			1	38.5		24.0									83.3				
419+80.63	Lt	Jt. B			2 Mod.	155.3		70.0									151.9	80.000	Refer to Typ. ENT419; 10" PCC and 12" Spec Backfill (144.7 Ton); 4" Gran Surface		
423+11.51	Lt	Jt. B			2 Mod.	206.0		70.0									1044.4		Refer to Typ. ENT423; 10" PCC and 12" Special Backfill (710.3 Ton)		
425+99.40	Lt	B			1	42.0		24.0									162.1				
427+53.90	Lt	B			1	42.0		24.0									144.9				
429+54.16	Lt	B			1	50.0		32.0									181.6				
430+78.41	Rt	B			1	42.0		24.0									151.7				
431+96.41	Lt	Jt. B			1	43.0		25.0									114.1				
433+46.06	Lt	B			1	44.5		26.5									78.3				
433+47.85	Rt	B			1	42.0		24.0									138.3				
438+08.06	Lt	B			1	42.0		24.0									71.7				
440+48.56	Rt	B			1	42.4		24.0									70.8				
442+23.75	Rt	B			1	63.5		51.3									157.7				
446+48.51	Rt	Jt. B			1	62.0		44.0									164.4				
446+56.51	Lt	B			1	41.0		35.0									196.7				
447+68.44	Rt	B			1	63.0		33.0									115.0				
448+17.01	Lt	B			1	36.0		30.0									168.9				
448+54.51	Rt	B			1	51.0		33.0									115.0				
449+42.01	Lt	B			1	44.0		38.0									150.0				
448+76.10	Lt	B			1	38.0		24.0									72.4				
460+15.20	Lt	B			1	38.0		24.0									85.9				
461+34.29	Lt	B			1	38.0		24.0									66.2				
ACCESS 258																					
1259+82.50	Lt	Jt. C				12.0		15.0	8.5	24.0	74.0	32.6	46.6	2			139.400		ENT258A		
1259+82.50	Lt	Jt. C				10.0		15.0									63.800		ENT258B		
1260+80.00	Lt	C				20.0		20.0									12.000		ENT258C		
1261+20.00	CL	C				12.0											46.000		ENT258D		
Co. Rd. R-57																					
1281+92.00	Lt	C				20.0		15.0	2.3	18.0	60.0	38.0	34.0	2			16.680		ENT1281		
1281+92.00	Rt	C				20.0		15.0	3.5	18.0	94.0	36.0	70.0	2			19.240		ENT1281		
1386+92.00	Rt	C				24.0		15.0	4.5	18.0	138.0	114.0	36.0	2			31.520		ENT1386		
90th AVE																					
2306+07.14	Rt	C				24.0		15.0	4.1	18.0	70.0	36.0	46.0	2			10.400		ENT2306		
2307+80.00	Rt	C				20.0		15.0	4.0	18.0	92.0	42.0	62.0	2			17.200		ENT2307		
2313+08.00	Rt	C				20.0		15.0	2.5	18.0	60.0	40.0	32.0	2			12.000		ENT2313		
Co. Rd. R-63																					
3388+79.00	Lt	C				24.0		15.0		18.0	50.0	36.2	26.0	2			16.480				

SIDEWALKS
See MI-220 and S Sheets

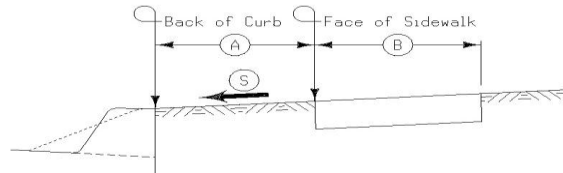

Road Id	Station to Station		Side	A	B	S	4" PCC Sidewalk	6" PCC Sidewalk	Other	Detectable Warnings	Remarks	
				FT	FT	%	SY	SY	SY	SF		
IA 92	391+36.28	391+47.85	Lt	Varies	10.00	2.00%		12.9		26		
	391+47.85	392+48.17		Varies	10.00	2.00%			111.5		5" Rec Trail	
	392+48.17	397+98.46		12.00	10.00	2.00%			611.4		5" Rec Trail	
	397+98.46	398+35.48		12.00	10.00			41.1			Driveway	
	398+35.48	406+88.00		12.00	10.00	2.00%			947.2		5" Rec Trail	
	406+88.00	407+12.00		12.00	10.00			26.7			Driveway	
	407+12.00	415+53.57		12.00	10.00	2.00%			935.1		5" Rec Trail	
	415+53.57	416+54.85		Varies	10.00	2.00%			112.5		5" Rec Trail	
	416+54.85	416+80.98		Varies	10.00	2.00%		29.0			48	
	417+80.98	417+95.59		Varies	10.00	2.00%		19.5			34	
	417+95.59	418+71.33		Varies	10.00	2.00%			84.2			5" Rec Trail
	418+71.33	419+38.13		12.00	10.00	2.00%			74.2			5" Rec Trail
	419+38.13	420+08.13		12.00	10.00				77.8			10" Sidewalk (1)
	420+08.13	422+69.01		12.00	10.00	2.00%			289.9			5" Rec Trail
	422+69.01	423+39.01		12.00	10.00				77.8			10" Sidewalk (1)
	423+39.01	425+87.40		12.00	10.00	2.00%			276.0			5" Rec Trail
	425+87.40	426+11.40		12.00	10.00			26.7				Driveway
	426+11.40	427+41.90		12.00	10.00	2.00%			145.0			5" Rec Trail
	427+41.90	427+65.90		12.00	10.00			26.7				Driveway
	427+65.90	429+38.16		12.00	10.00	2.00%			191.4			5" Rec Trail
	429+38.16	429+70.16		12.00	10.00			35.6				Driveway
	429+70.16	431+83.91		12.00	10.00	2.00%			237.5			5" Rec Trail
	431+83.91	432+08.91		12.00	10.00			27.8				Driveway
	432+08.91	433+32.81		12.00	10.00	2.00%			137.7			5" Rec Trail
	433+32.81	433+59.31		12.00	10.00			29.4				Driveway
	433+59.31	437+96.06		12.00	10.00	2.00%			485.3			5" Rec Trail
	437+96.06	438+20.47		12.00	10.00			27.1				Driveway
	438+20.47	441+07.59		12.00	10.00	2.00%			319.0			5" Rec Trail
	441+07.59	441+21.92		Varies	10.00	2.00%		15.9				20
	441+21.92	441+56.71		Varies	5.00	2.00%		6.1				10
	441+56.71	441+64.44		14.50	5.00	2.00%		4.3				
	441+64.44	442+53.92		Varies	5.00	2.00%		49.7				
	442+53.92	446+39.01		6.00	5.00	2.00%		213.9				
	446+39.01	446+74.01		6.00	5.00				19.4			
	446+74.01	448+01.91		6.00	5.00	2.00%		71.1				
	448+01.91	448+32.10		6.00	5.00				16.8			
	448+32.10	449+22.88		6.00	5.00	2.00%		50.4				
	449+22.88	449+61.13		6.00	5.00				21.3			
	449+61.13	451+46.61		6.00	5.00	2.00%		103.0				
	451+46.61	451+58.50		Varies	5.00	2.00%		6.6				
	451+58.50	451+67.49		Varies	5.00	2.00%			5.0			10
	451+67.49	452+25.56		Varies	5.00	2.00%			4.2			
	452+25.56	452+38.91		Varies	5.00	2.00%		7.4				
	452+38.91	455+21.28		6.00	5.00	2.00%		156.9				
	455+21.28	455+38.76		Varies	5.00	2.00%		9.7				
	455+38.76	455+45.43		Varies	5.00	2.00%			3.7			16
	455+45.43	455+98.09		Varies	5.00	2.00%			6.1			
	455+98.09	456+11.24		Varies	5.00	2.00%		7.3				
456+11.24	458+64.96	6.00	5.00	2.00%		141.0						
458+64.96	458+89.04	6.00	5.00				13.4					
458+89.04	460+03.93	6.00	5.00	2.00%		63.8						
460+03.93	460+27.99	6.00	5.00				13.4					
460+27.99	461+22.29	6.00	5.00	2.00%		52.4						
461+22.29	461+46.29	6.00	5.00				13.3					
461+46.29	464+98.64	6.00	5.00	2.00%		195.7						
464+98.64	465+03.64	6.00	5.00	2.00%		2.8						
391+40.71	391+56.60	Rt	Varies	10.00	2.00%		17.7					
391+56.60	391+80.78	Rt	Varies	10.00	2.00%		26.9					
R-63S	3390+62.10	3390+75.53	Rt	Varies	10.00	2.00%		14.9		20		
R-63N	3391+45.10	3391+65.87	Rt	Varies	10.00	2.00%		23.1		20		
Y St.	4414+15.00	4416+01.51	Rt	12.00	4.00	2.00%	82.9					
	4416+01.51	4416+63.61		Varies	4.00	2.00%	27.6					
	4416+99.20	4417+04.26		Varies	5.00	2.00%	2.8					
	4417+04.26	4417+12.60		Varies	5.00	2.00%	4.6			10		
Y St.												
Ret. 4	+64.49	1+15.76	Rt	6.00	4.00	2.00%	22.8					
Ret. 4	1+15.76	1+24.20		Varies	4.00	2.00%	3.8					

SIDEWALKS
See MI-220 and S Sheets

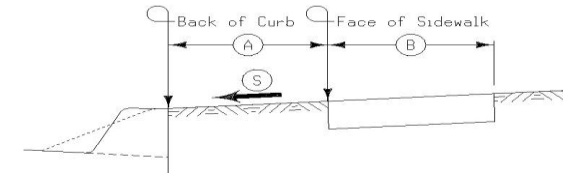

Road Id	Station to Station		Side	A	B	S	4" PCC Sidewalk	6" PCC Sidewalk	Other	Detectable Warnings	Remarks
				FT	FT	%	SY	SY	SY	SF	
Y St.	4417+68.19	4417+74.97	Rt	Varies	5.00	2.00%		3.8		10	
Spruce St.							3.8				
S Kenwood Blvd			Lt				8.4				
			Rt				4.5				
South P St.											
Ret. 1							13.6				
Ret. 2							15.6				
Ret. 3							12.8				
								3.9		10	
Ret. 4							11.9				
IA 92 Crossing								4.8		20	
								3.3		10	
Totals							1373.3	517.1	4957.8	264	5" Rec Trail
									155.6		10" Sidewalk (1)
(1) Matches 10" Driveway Pavement. Requires 12" Special Backfill that is tabulated with driveway pavement (Tab 102-3)											

PAVEMENT MARKING LINE TYPES

See PM-110

***MNY4 - Factor of 1.00 as value includes number of 4-inch passes to cover median nose area.

*BCY4 - Place on the same side of the roadway to match existing markings near the project.

**NPY4 - For estimating purposes only. No Passing Zone Lines will be located in the field.

BCY4: Broken Centerline (Yellow) @ 0.25

DCY4: Double Centerline (Yellow) @ 2.00

NPY4: No Passing Zone Line (Yellow) @ 1.25

BLW4: Broken Lane Line (White) @ 0.25

ELW4: Edge Line Right (White) @ 1.00

ELY4: Edge Line Left (Yellow) @ 1.00

Road ID	Station to Station		Dir. of Travel	Location Marking Type	Side			Length by Line Type (Unfactored)										Remarks				
					L	C	R	BCY4*	DCY4	NPY4**	BLW4	ELW4	ELY4									
								STA	STA	STA	STA	STA	STA	STA	STA	STA	STA		STA	STA	STA	STA
STAGE 2B																						
R-57 Detour	11277+89.54	11279+38.20	SB	Wet Retroreflective Removable Tape			X							1.49						Right Edge Line		
R-57 Detour	11279+38.20	11288+91.65	SB	Waterborne/Solvent Paint			X							9.53						Right Edge Line		
R-57 Detour	11288+91.65	11290+40.39	SB	Wet Retroreflective Removable Tape			X							1.49						Right Edge Line		
R-57 Detour	11277+89.54	11278+95.60	NB	Wet Retroreflective Removable Tape	X					1.06										Centerline (Solid)		
R-57 Detour	11278+95.60	11289+34.28	NB	Waterborne/Solvent Paint	X					10.39										Centerline (Solid)		
R-57 Detour	11289+34.28	11290+40.39	NB	Wet Retroreflective Removable Tape	X					1.06										Centerline (Solid)		
R-57 Detour	11277+89.54	11290+40.39	NB	Waterborne/Solvent Paint			X							12.51						Right Edge Line		
R-57 (So.)	1277+35.33	1279+85.00	NB	Removal of Paint	X				2.50		2.50									Existing Centerline Removal		
R-57 (No.)	1387+25.00	1389+67.34	NB	Removal of Paint	X				2.42		2.42									Existing Centerline Removal		
R-63 Detour	18386+48.19	18387+71.41	SB	Wet Retroreflective Removable Tape			X							1.23						Right Edge Line		
R-63 Detour	18387+71.41	18396+47.81	SB	Waterborne/Solvent Paint			X							8.76						Right Edge Line		
R-63 Detour	18396+47.81	18397+71.90	SB	Wet Retroreflective Removable Tape			X							1.24						Right Edge Line		
R-63 Detour	18386+48.19	18387+39.83	NB	Wet Retroreflective Removable Tape	X					0.92										Centerline (Solid)		
R-63 Detour	18387+39.83	18392+05.00	NB	Waterborne/Solvent Paint	X					4.65										Centerline (Solid)		
R-63 Detour	18393+20.00	18396+78.99	NB	Waterborne/Solvent Paint	X					3.59										Centerline (Solid)		
R-63 Detour	18396+78.99	18397+71.90	NB	Wet Retroreflective Removable Tape	X					0.93										Centerline (Solid)		
R-63 Detour	18386+48.19	18392+53.30	NB	Waterborne/Solvent Paint			X							6.92						Right Edge Line		
R-63 Detour	18392+77.34	18397+71.90	NB	Waterborne/Solvent Paint			X							5.26						Right Edge Line		
R-63 (So.)	3385+50.00	3387+30.00	NB	Removal of Paint	X				1.80		1.80									Existing Centerline Removal		
R-63 (No.)	3394+45.00	3396+25.00	NB	Removal of Paint	X				1.80		1.80									Existing Centerline Removal		
Ia 92	439+07.78	441+22.23	WB	Removal of Paint	X					2.14										Existing Centerline Removal		
Ia 92	441+46.19	445+00.00	WB	Removal of Paint	X					3.54										Existing Centerline Removal		
Ia 92	439+07.78	441+22.23	WB	Removal of Paint			X							2.14						Existing Right Edge Line Removal		
Ia 92	441+46.19	445+00.00	WB	Removal of Paint			X							3.54						Existing Right Edge Line Removal		
Ia 92	439+07.78	441+22.23	WB	Waterborne/Solvent Paint			X							2.26						Right Edge Line		
Ia 92	441+46.19	445+00.00	WB	Waterborne/Solvent Paint			X							3.66						Right Edge Line		
Ia 92	439+07.78	441+10.85	EB	Waterborne/Solvent Paint	X					2.09										Centerline (Solid)		
Ia 92	441+57.60	445+00.00	EB	Waterborne/Solvent Paint	X					3.45										Centerline (Solid)		
Ia 92	439+07.78	443+38.00	EB	Waterborne/Solvent Paint			X							4.40						Right Edge Line		
STAGE 2C																						
R-57 Detour	11277+89.54	11279+38.20	SB	Removal of Removable Tape			X							1.49						Right Edge Line Tape Removal		
R-57 Detour	11277+89.54	11278+95.60	NB	Removal of Removable Tape	X					1.06										Centerline Tape Removal		
R-57 Detour	11283+90.53	11284+99.76	NB	Removal of Paint	X									1.09						Edge Line Removal on new pavement		
R-57 Detour	11283+98.10	11284+92.87	NB	Removal of Paint			X			0.95										Centerline Removal on new pavement		
R-57 Detour	11284+03.66	11284+88.26	NB	Removal of Paint			X							0.85						Edge Line Removal on new pavement		
R-57 Detour	11288+91.65	11290+40.39	SB	Removal of Removable Tape			X							1.49						Edge Line Removal on new pavement		
R-57 Detour	11289+34.28	11290+40.39	NB	Removal of Removable Tape	X					1.06										Centerline Tape Removal		
Ia 92	256+50.00	271+47.79	EB	Waterborne/Solvent Paint			X			14.98										Centerline (Dashed)		
Ia 92	256+50.00	258+12.30	EB	Waterborne/Solvent Paint			X							1.62						Right Edge Line		
Ia 92	256+50.00	258+45.63	WB	Waterborne/Solvent Paint			X							1.96						Right Edge Line		
Ia 92	259+37.19	282+74.15	EB	Waterborne/Solvent Paint			X							23.37						Right Edge Line		
Ia 92	259+30.97	282+80.60	WB	Waterborne/Solvent Paint			X							23.50						Right Edge Line		
Ia 92	265+45.59	271+47.79	EB	Waterborne/Solvent Paint			X				6.02									Centerline (Solid)		
Ia 92	271+47.79	282+94.00	BOTH	Waterborne/Solvent Paint			X							27.40						Channelizing (Includes Diagonals)		
Ia 92	279+48.41	281+19.00	EB	Waterborne/Solvent Paint			X													Bike Lane, Left Edge Line (Dotted)		
Ia 92	280+19.00	281+19.00	EB	Waterborne/Solvent Paint			X													Bike Lane, Right Edge Line (Dotted)		
Ia 92	281+19.00	282+94.00	EB	Waterborne/Solvent Paint			X							1.75						Bike Lane, Left Edge Line (Solid)		
Ia 92	281+19.00	282+94.00	EB	Waterborne/Solvent Paint			X							1.75						Bike Lane, Right Edge Line (Solid)		
Ia 92	281+44.00	282+94.00	EB	Waterborne/Solvent Paint			X							1.50						Left Turn Lane, Right Edge Line		
R-57 (So.)	1283+50.11		NB	Waterborne/Solvent Paint			X													Stop Line		
R-57 (So.)	1283+35.76	1283+49.97	NB	Waterborne/Solvent Paint			X													Curb of Stop Island		
R-57 (So.)	1280+60.00	1283+36.28	BOTH	Waterborne/Solvent Paint			X							6.34						Right Edge Lines (Includes Returns)		
R-57 (So.)	1280+60.00	1283+50.11	SB	Waterborne/Solvent Paint			X			2.90										Centerline (Dashed)		
R-57 (So.)	1280+60.00	1283+50.11	NB	Waterborne/Solvent Paint			X													Centerline (Solid)		
R-57 (No.)	1384+10.19		NB	Waterborne/Solvent Paint			X													Stop Line		
R-57 (No.)	1384+10.19	1384+19.41	NB	Waterborne/Solvent Paint			X													Curb of Stop Island		
R-57 (No.)	1384+08.94	1386+06.00	BOTH	Waterborne/Solvent Paint			X							4.93						Right Edge Line (Includes Returns)		
R-57 (No.)	1384+10.19	1386+06.00	SB	Waterborne/Solvent Paint			X			1.96										Centerline (Dashed)		
R-57 (No.)	1384+10.19	1386+06.00	NB	Waterborne/Solvent Paint			X													Centerline (Solid)		
STAGE 2D																						
Ia 92	284+48.00	301+54.00	BOTH	Waterborne/Solvent Paint			X							43.06						Channelizing (Includes Diagonals)		
Ia 92	284+48.00	289+38.00	EB	Waterborne/Solvent Paint			X													Bike Lane, Right Edge Line (Solid)		
Ia 92	284+48.00	289+38.00	EB	Waterborne/Solvent Paint			X							4.90						Bike Lane, Left Edge Line (Solid)		
Ia 92	289+38.00	291+03.48	EB	Waterborne/Solvent Paint			X													Bike Lane, Right Edge Line (Dotted)		
Ia 92	289+38.00	292+08.00	EB	Waterborne/Solvent Paint			X													Bike Lane, Left Edge Line (Dotted)		
Ia 92	284+48.00	285+98.00	EB	Waterborne/Solvent Paint			X							1.50						Left Turn Lane, Right Edge Line		

PAVEMENT MARKING LINE TYPES

See PM-110

***MNY4 - Factor of 1.00 as value includes number of 4-inch passes to cover median nose area.

*BCY4 - Place on the same side of the roadway to match existing markings near the project.

**NPY4 - For estimating purposes only. No Passing Zone Lines will be located in the field.

BCY4: Broken Centerline (Yellow) @ 0.25

DCY4: Double Centerline (Yellow) @ 2.00

NPY4: No Passing Zone Line (Yellow) @ 1.25

BLW4: Broken Lane Line (White) @ 0.25

ELW4: Edge Line Right (White) @ 1.00

ELY4: Edge Line Left (Yellow) @ 1.00

Road ID	Station to Station	Dir. of Travel	Location			Length by Line Type (Unfactored)														Remarks	
			Marking Type	Side			BCY4*	DCY4	NPY4**	BLW4	ELW4	ELY4									
				L	C	R	STA	STA	STA	STA	STA	STA	STA	STA	STA	STA	STA	STA	STA		STA
			Factored Total: Waterborne/Solvent Paint			61.75	51.34	185.96	-	332.10	-	-	-	-	-	-	-	-	-		
			Factored Total: Wet Retroreflective Removable Tape			-	11.54	-	-	7.25	-	-	-	-	-	-	-	-	-		
			Factored Total: Removal of Paint			2.13	13.26	10.65	-	7.62	-	-	-	-	-	-	-	-	-		
			Factored Total: Removal of Removable Tape			-	7.94	-	-	5.45	-	-	-	-	-	-	-	-	-		
			Bid Quantity: Painted Pavement Markings, Waterborne or Solvent-Based							631.15											
			Bid Quantity: Wet Retroreflective Removable Tape Markings							18.79											
			Bid Quantity: Pavement Markings Removed							33.66											
			Incidental Removal of Removable Tape							13.39											

PAVEMENT MARKING SYMBOLS AND LEGENDS

Refer to PM-111

Road Identification	Location		STAW	RTAW	LTAW	CSRW	CSLW	CSTW	CRLW	FERW	LLRW	RLRW	RRCW	BLSW	WCSW	WPSB	SCLW	XNGW	STPW	AHDW	ONLW	BIKW	LANW	XITW	Groove Cuts EACH	Remarks
	Station	Side																								
STAGE 2C																										
Ia 92 at R-57	283+68.17		1		2																	1				WB Left Turn Lane (PM-522)
Ia 92 at R-57	283+68.17																									WB Center Lane (PM-522)
Ia 92 at R-57	283+68.17													2												WB Bike Lane
Ia 92 at R-57	283+68.17			2																						WB Right Turn Lane (PM-522)
STAGE 2D																										
Ia 92 at R-57	283+73.24				2																	1				EB Left Turn Lane (PM-522)
Ia 92 at R-57	283+73.24		1																							EB Center Lane (PM-522)
Ia 92 at R-57	283+73.24													2												EB Bike Lane
Ia 92 at R-57	283+73.24			2																						EB Right Turn Lane (PM-522)
STAGE 3D																										
Ia 92 at R-63	391+03.42				2																	1				EB Left Turn Lane (PM-522)
Ia 92 at R-63	391+03.42		1																							EB Center Lane (PM-522)
Ia 92 at R-63	391+03.42													2												EB Bike Lane
Ia 92 at R-63	391+03.42			2																						EB Right Turn Lane (PM-522)
Ia 92 at R-63	391+03.95				2																	1				WB Left Turn Lane (PM-522)
Ia 92 at R-63	391+03.95		1																							WB Center Lane (PM-522)
Ia 92 at R-63	391+03.95			2																						WB Right Turn Lane (PM-522)
Ia 92	393+70.00			1	1																					Center Lane (PM-550)
Ia 92	398+20.00			1	1																					Center Lane (PM-550)
Ia 92	402+70.00			1	1																					Center Lane (PM-550)
Ia 92	407+20.00			1	1																					Center Lane (PM-550)
Ia 92	411+70.00			1	1																					Center Lane (PM-550)
STAGE 4A																										
Ia 92	416+20.00			1	1																					Center Lane (PM-550)
Ia 92	418+50.00			1	1																					Center Lane (PM-550)
Ia 92	423+00.00			1	1																					Center Lane (PM-550)
Ia 92	427+50.00			1	1																					Center Lane (PM-550)
Ia 92	432+00.00			1	1																					Center Lane (PM-550)
Ia 92	436+50.00			1	1																					Center Lane (PM-550)
STAGE 4C																										
Ia 92	440+80.00			1	1																					Center Lane (PM-550)
Ia 92	441+80.00			1	1																					Center Lane (PM-550)
Ia 92	443+00.00			1	1																					Center Lane (PM-550)
Ia 92	444+40.00			1	1																					Center Lane (PM-550)
Ia 92	448+90.00			1	1																					Center Lane (PM-550)
Ia 92	451+30.00			1	1																					Center Lane (PM-550)
Ia 92	452+50.00			1	1																					Center Lane (PM-550)
Ia 92	453+90.00			1	1																					Center Lane (PM-550)
Ia 92	455+00.00			1	1																					Center Lane (PM-550)
Ia 92	456+20.00			1	1																					Center Lane (PM-550)
Ia 92	460+50.00			1	1																					Center Lane (PM-550)
Ia 92	461+80.00			1	1																					Center Lane (PM-550)
Ia 92	462+70.00			1	1																					Center Lane (PM-550)
Totals			4	32	32	0	0	0	0	0	0	0	0	6	0	0	0	0	0	0	0	4	0	0	0	0
Bid Total			78																							

LONGITUDINAL SUBDRAIN SHOULDER AND BACKSLOPE

Refer to Soils Sheets

① Refer to EW-203, EW-204, or EW-211.
*Not a bid item

Line No.	Road or Lane Ident.	Location		Side	Longitudinal Subdrain (RF-19C)							Subdrain Outlet			Porous* Backfill CY	Class "A"* Crushed Stone CY	Remarks	
		Station to Station			Depth D	Shoulder		Backslope		Bridge Berm ①			RF-19C, RF-19E, or RF-19F					
		IN	FT			Size IN	Length FT	Size IN	Length FT	Size IN	Type	Length FT	Station	Size IN				Standard Road Plan and Type
15	IA 92	315+00.00	320+00.00	RT	42.0	4.0	540.0						315+00.00	6.0	RF-19E	50.0		
16	IA 92	320+00.00	325+00.00	RT	42.0	4.0	540.0						320+00.00	6.0	RF-19E	50.0	0.2	
17	IA 92	325+00.00	329+00.00	RT	42.0	4.0	440.0						325+00.00	6.0	RF-19E	40.7	0.2	
18	IA 92	329+00.00	331+75.00	RT	42.0	4.0	315.0						329+00.00	6.0	RF-19E	29.2	0.2	
19	IA 92	331+75.00	335+00.00	RT	42.0	4.0	365.0						331+75.00	6.0	RF-19E	33.8	0.2	
20	IA 92	335+00.00	340+00.00	RT	42.0	4.0	540.0						335+00.00	6.0	RF-19E	50.0	0.2	
21	IA 92	340+00.00	345+00.00	RT	42.0	4.0	540.0						340+00.00	6.0	RF-19E	50.0	0.2	
22	IA 92	345+00.00	350+50.00	RT	42.0	4.0	590.0						345+00.00	6.0	RF-19E	54.6	0.2	
23	IA 92	350+50.00	356+75.00	RT	42.0	4.0	665.0						350+50.00	6.0	RF-19E	61.6	0.2	
24	IA 92	356+75.00	361+00.00	RT	42.0	4.0	465.0						356+75.00	6.0	RF-19E	43.1	0.2	
25	IA 92	361+00.00	365+00.00	RT	42.0	4.0	440.0						361+00.00	6.0	RF-19E	40.7	0.2	
26	IA 92	365+00.00	370+00.00	RT	42.0	4.0	540.0						365+00.00	6.0	RF-19E	50.0	0.2	
27	IA 92	370+00.00	375+00.00	RT	42.0	4.0	540.0						370+00.00	6.0	RF-19E	50.0	0.2	
28	IA 92	375+00.00	380+00.00	RT	42.0	4.0	540.0						375+00.00	6.0	RF-19E	50.0	0.2	
29	IA 92	380+00.00	386+70.00	RT	42.0	4.0	710.0						380+00.00	6.0	RF-19E	65.7	0.2	
30	IA 92	386+70.00	390+55.00	RT	42.0	4.0	445.0						386+70.00	6.0	RF-19E	41.2	0.2	
31	IA 92	391+36.00	393+50.00	RT	24.0	4.0	256.0						391+36.00	6.0	RF-19E	11.9	0.1	OUTLET ALONG TURN RADIUS
32	IA 92	393+50.00	393+89.83	RT	24.0	4.0	43.8						393+50.00	6.0	RF-19C	2.0	0.0	INTAKE 104
33	IA 92	393+89.83	394+30.00	RT	24.0	4.0	44.2						393+89.83	6.0	RF-19C	2.0	0.0	INTAKE 107
34	IA 92	394+30.00	395+35.95	RT	24.0	4.0	109.9						394+30.00	6.0	RF-19C	5.1	0.0	INTAKE 108
35	IA 92	395+35.95	397+00.00	RT	24.0	4.0	168.1						395+35.95	6.0	RF-19C	7.8	0.0	INTAKE 111
36	IA 92	397+00.00	399+00.00	RT	24.0	4.0	204.0						397+00.00	6.0	RF-19C	9.4	0.0	INTAKE 102
37	IA 92	399+00.00	404+50.00	RT	24.0	4.0	554.0						399+00.00	6.0	RF-19C	25.6	0.0	INTAKE 101
38	IA 92	404+50.00	407+39.00	RT	24.0	4.0	293.0						404+50.00	6.0	RF-19C	13.6	0.0	INTAKE 201
39	IA 92	407+39.00	409+50.00	RT	24.0	4.0	215.0						407+39.00	6.0	RF-19C	10.0	0.0	INTAKE 203
40	IA 92	409+50.00	411+70.00	RT	24.0	4.0	224.0						409+50.00	6.0	RF-19C	10.4	0.0	INTAKE 205
41	IA 92	411+70.00	413+85.00	RT	24.0	4.0	219.0						411+70.00	6.0	RF-19C	10.1	0.0	INTAKE 207
42	IA 92	413+85.00	415+95.00	RT	24.0	4.0	214.0						413+85.00	6.0	RF-19C	9.9	0.0	INTAKE 209
43	IA 92	415+95.00	4416+06.96	RT	24.0	4.0	240.0						415+95.00	6.0	RF-19C	11.1	0.0	INTAKE 211
44	IA 92	4416+07.00	421+00.00	RT	24.0	4.0	460.0						4416+07.00	6.0	RF-19C	21.3	0.0	INTAKE 216
45	IA 92	421+00.00	422+61.70	RT	24.0	4.0	165.7						421+00.00	6.0	RF-19C	7.7	0.0	INTAKE 213
46	IA 92	422+61.70	425+30.00	RT	24.0	4.0	272.3						422+61.70	6.0	RF-19C	12.6	0.0	INTAKE 301
47	IA 92	425+30.00	426+35.00	RT	24.0	4.0	109.0						425+30.00	6.0	RF-19C	5.0	0.0	INTAKE 303
48	IA 92	426+35.00	426+67.15	RT	24.0	4.0	36.2						426+35.00	6.0	RF-19C	1.7	0.0	INTAKE 305
49	IA 92	426+67.15	427+00.00	RT	24.0	4.0	36.8						426+67.15	6.0	RF-19C	1.7	0.0	INTAKE 307
50	IA 92	427+00.00	428+00.00	RT	24.0	4.0	104.0						427+00.00	6.0	RF-19C	4.8	0.0	INTAKE 315
51	IA 92	428+00.00	431+15.00	RT	24.0	4.0	319.0						428+00.00	6.0	RF-19C	14.8	0.0	INTAKE 313
52	IA 92	431+15.00	435+57.00	RT	24.0	4.0	446.0						431+15.00	6.0	RF-19C	20.6	0.0	INTAKE 311
53	IA 92	435+57.00	436+00.00	RT	24.0	4.0	47.0						435+57.00	6.0	RF-19C	2.2	0.0	INTAKE 309

LONGITUDINAL SUBDRAIN SHOULDER AND BACKSLOPE

Refer to Soils Sheets

① Refer to EW-203, EW-204, or EW-211.
*Not a bid item

Line No.	Road or Lane Ident.	Location Station to Station		Side	Longitudinal Subdrain (RF-19C)							Subdrain Outlet			Porous* Backfill CY	Class "A"* Crushed Stone CY	Remarks	
					Depth D	Shoulder		Backslope		Bridge Berm ①			RF-19C, RF-19E, or RF-19F					
						Size	Length	Size	Length	Size	Type	Length	Station	Size				Standard Road Plan and Type
						IN	FT	IN	FT	IN		FT	IN					
54	IA 92	436+00.00	436+45.00	RT	24.0	4.0	49.0						436+00.00	6.0	RF-19C	2.3	0.0	INTAKE 403
													436+00.00	6.0	RF-19C			INTAKE 403
													436+45.00	6.0	RF-19C		0.0	INTAKE 413
55	IA 92	436+45.00	437+72.04	RT	24.0	4.0	131.0						436+45.00	6.0	RF-19C	6.1	0.0	INTAKE 413
													437+72.04	6.0	RF-19C			INTAKE 412
56	IA 92	437+72.04	439+20.00	RT	24.0	4.0	152.0						437+72.04	6.0	RF-19C	7.0	0.0	INTAKE 412
													439+20.00	6.0	RF-19C			INTAKE 411
57	IA 92	439+20.00	441+02.00	RT	24.0	4.0	186.0						439+20.00	6.0	RF-19C	8.6	0.0	INTAKE 411
													441+02.00	6.0	RF-19C			INTAKE 409
58	IA 92	441+02.00	442+62.95	RT	24.0	4.0	164.9						441+02.00	6.0	RF-19C	7.6	0.0	INTAKE 409
													442+62.95	6.0	RF-19C			INTAKE 407
59	IA 92	442+62.95	444+30.00	RT	24.0	4.0	171.1						442+62.95	6.0	RF-19C	7.9	0.0	INTAKE 407
													444+30.00	6.0	RF-19C			INTAKE 501
60	IA 92	444+30.00	445+80.00	RT	24.0	4.0	154.0						444+30.00	6.0	RF-19C	7.1	0.0	INTAKE 501
													445+80.00	6.0	RF-19C			INTAKE 610
61	IA 92	445+80.00	447+20.00	RT	24.0	4.0	144.0						445+80.00	6.0	RF-19C	6.7	0.0	INTAKE 610
													447+20.00	6.0	RF-19C			INTAKE 615
62	IA 92	447+20.00	448+95.00	RT	24.0	4.0	179.0						447+20.00	6.0	RF-19C	8.3	0.0	INTAKE 615
													448+95.00	6.0	RF-19C			INTAKE 620
63	IA 92	448+95.00	450+30.00	RT	24.0	4.0	139.0						448+95.00	6.0	RF-19C	6.4	0.0	INTAKE 620
													450+30.00	6.0	RF-19C			INTAKE 625
64	IA 92	450+30.00	451+70.00	RT	24.0	4.0	144.0						450+30.00	6.0	RF-19C	6.7	0.0	INTAKE 625
													451+70.00	6.0	RF-19C			INTAKE 630
65	IA 92	451+70.00	453+77.00	RT	24.0	4.0	211.0						451+70.00	6.0	RF-19C	9.8	0.0	INTAKE 630
													453+77.00	6.0	RF-19C			INTAKE 635
66	IA 92	453+77.00	456+25.00	RT	24.0	4.0	252.0						453+77.00	6.0	RF-19C	11.7	0.0	INTAKE 635
													456+25.00	6.0	RF-19C			INTAKE 640
67	IA 92	456+25.00	458+40.00	RT	24.0	4.0	219.0						456+25.00	6.0	RF-19C	10.1	0.0	INTAKE 640
													458+40.00	6.0	RF-19C			INTAKE 645
68	IA 92	458+40.00	459+75.00	RT	24.0	4.0	139.0						458+40.00	6.0	RF-19C	6.4	0.0	INTAKE 645
													459+75.00	6.0	RF-19C			INTAKE 650
69	IA 92	459+75.00	461+00.00	RT	24.0	4.0	129.0						459+75.00	6.0	RF-19C	6.0	0.0	INTAKE 650
													461+00.00	6.0	RF-19C			INTAKE 655
70	IA 92	461+00.00	461+75.00	RT	24.0	4.0	79.0						461+00.00	6.0	RF-19C	3.7	0.0	INTAKE 655
													461+75.00	6.0	RF-19C			INTAKE 760
71	IA 92	461+75.00	463+90.00	RT	24.0	4.0	219.0						461+75.00	6.0	RF-19C	10.1	0.0	INTAKE 760
													463+90.00	6.0	RF-19C			INTAKE 770
72	IA 92	463+90.00	464+95.00	RT	24.0	4.0	109.0						463+90.00	6.0	RF-19C	5.0	0.0	INTAKE 770
													464+95.00	6.0	RF-19C			INTAKE 775
73	IA 92	256+50.00	260+00.00	LT	42.0	4.0	390.0						256+50.00	6.0	RF-19E	36.1	0.2	
													260+00.00	6.0	RF-19E			
74	IA 92	260+00.00	265+00.00	LT	42.0	4.0	540.0						260+00.00	6.0	RF-19E	50.0	0.2	
													265+00.00	6.0	RF-19E			
75	IA 92	265+00.00	270+00.00	LT	42.0	4.0	540.0						265+00.00	6.0	RF-19E	50.0	0.2	
													270+00.00	6.0	RF-19E			
76	IA 92	270+00.00	275+00.00	LT	42.0	4.0	540.0						270+00.00	6.0	RF-19E	50.0	0.2	
													275+00.00	6.0	RF-19E			
77	IA 92	275+00.00	279+00.00	LT	42.0	4.0	440.0						275+00.00	6.0	RF-19E	40.7	0.2	
													279+00.00	6.0	RF-19E			
78	IA 92	279+00.00	281+91.00	LT	42.0	4.0	331.0						279+00.00	6.0	RF-19E	30.6	0.2	
													281+91.00	6.0	RF-19E			
79	IA 92	281+91.00	283+25.00	LT	42.0	4.0	194.0						281+91.00	6.0	RF-19E	18.0	0.2	
													283+25.00	6.0	RF-19E			
80	IA 92	284+20.00	288+00.00	LT	42.0	4.0	440.0						284+20.00	6.0	RF-19E	40.7	0.2	OUTLET ALONG TURN RADIUS
													288+00.00	6.0	RF-19E			OUTLET ALONG TURN RADIUS
81	IA 92	288+00.00	292+08.00	LT	42.0	4.0	448.0						288+00.00	6.0	RF-19E	41.5	0.2	
													292+08.00	6.0	RF-19E			
82	IA 92	292+08.00	295+00.00	LT	42.0	4.0	332.0						292+08.00	6.0	RF-19E	30.7	0.2	
													295+00.00	6.0	RF-19E			
83	IA 92	295+00.00	300+00.00	LT	42.0	4.0	540.0						295+00.00	6.0	RF-19E	50.0	0.2	
													300+00.00	6.0	RF-19E			
84	IA 92	300+00.00	305+00.00	LT	42.0	4.0	540.0						300+00.00	6.0	RF-19E	50.0	0.2	
													305+00.00	6.0	RF-19E			
85	IA 92	305+00.00	311+25.00	LT	42.0	4.0	665.0						305+00.00	6.0	RF-19E	61.6	0.2	
													311+25.00	6.0	RF-19E			
86	IA 92	311+25.00	315+00.00	LT	42.0	4.0	415.0						311+25.00	6.0	RF-19E	38.4	0.2	
													315+00.00	6.0	RF-19E			
87	IA 92	315+00.00	320+00.00	LT	42.0	4.0	540.0						315+00.00	6.0	RF-19E	50.0	0.2	
													320+00.00	6.0	RF-19E			
88	IA 92	320+00.00	325+00.00	LT	42.0	4.0	540.0						320+00.00	6.0	RF-19E	50.0	0.2	
													325+00.00	6.0	RF-19E			
89	IA 92	325+00.00	329+00.00	LT	42.0	4.0	440.0						325+00.00	6.0	RF-19E	40.7	0.2	
													329+00.00	6.0	RF-19E			
90	IA 92	329+00.00	331+75.00	LT	42.0	4.0	315.0						329+00.00	6.0	RF-19E	29.2	0.2	
													331+75.00	6.0	RF-19E			
91	IA 92	331+75.00	335+00.00	LT	42.0	4.0	365.0						331+75.00	6.0	RF-19E	33.8	0.2	
													335+00.00	6.0	RF-19E			

LONGITUDINAL SUBDRAIN SHOULDER AND BACKSLOPE

Refer to Soils Sheets

① Refer to EW-203, EW-204, or EW-211.
*Not a bid item

Line No.	Road or Lane Ident.	Location		Side	Longitudinal Subdrain (RF-19C)							Subdrain Outlet			Porous* Backfill CY	Class "A"* Crushed Stone CY	Remarks		
		Station to Station			Depth D	Shoulder		Backslope		Bridge Berm ①			RF-19C, RF-19E, or RF-19F						
		IN	FT			IN	FT	IN	FT	IN	Type	Length FT	Station	IN				Standard Road Plan and Type	
																			IN
92	IA 92	335+00.00	340+00.00	LT	42.0	4.0	540.0							335+00.00	6.0	RF-19E	50.0		
														340+00.00	6.0	RF-19E		0.2	
93	IA 92	340+00.00	345+00.00	LT	42.0	4.0	540.0							340+00.00	6.0	RF-19E	50.0		
														345+00.00	6.0	RF-19E		0.2	
94	IA 92	345+00.00	350+50.00	LT	42.0	4.0	590.0							345+00.00	6.0	RF-19E	54.6		
														350+50.00	6.0	RF-19E		0.2	
95	IA 92	350+50.00	356+75.00	LT	42.0	4.0	665.0							350+50.00	6.0	RF-19E	61.6		
														356+75.00	6.0	RF-19E		0.2	
96	IA 92	356+75.00	361+00.00	LT	42.0	4.0	465.0							356+75.00	6.0	RF-19E	43.1		
														361+00.00	6.0	RF-19E		0.2	
97	IA 92	361+00.00	365+00.00	LT	42.0	4.0	440.0							361+00.00	6.0	RF-19E	40.7		
														365+00.00	6.0	RF-19E		0.2	
98	IA 92	365+00.00	370+00.00	LT	42.0	4.0	540.0							365+00.00	6.0	RF-19E	50.0		
														370+00.00	6.0	RF-19E		0.2	
99	IA 92	370+00.00	375+00.00	LT	42.0	4.0	540.0							370+00.00	6.0	RF-19E	50.0		
														375+00.00	6.0	RF-19E		0.2	
100	IA 92	375+00.00	380+00.00	LT	42.0	4.0	540.0							375+00.00	6.0	RF-19E	50.0		
														380+00.00	6.0	RF-19E		0.2	
101	IA 92	380+00.00	385+00.00	LT	42.0	4.0	540.0							380+00.00	6.0	RF-19E	50.0		
														385+00.00	6.0	RF-19E		0.2	
102	IA 92	385+00.00	389+12.00	LT	42.0	4.0	452.0							385+00.00	6.0	RF-19E	41.9		
														389+12.00	6.0	RF-19E		0.2	
103	IA 92	389+12.00	390+68.00	LT	42.0	4.0	216.0							389+12.00	6.0	RF-19E	20.0		
														390+68.00	6.0	RF-19E		0.2	OUTLET ALONG TURN RADIUS
104	IA 92	391+32.00	393+50.00	LT	24.0	4.0	260.0							391+32.00	6.0	RF-19E	12.0		OUTLET ALONG TURN RADIUS
														393+50.00	6.0	RF-19C		0.1	INTAKE 103
105	IA 92	393+50.00	393+89.83	LT	24.0	4.0	43.8							393+50.00	6.0	RF-19C	2.0		INTAKE 103
														393+89.83	6.0	RF-19C		0.0	INTAKE 106
106	IA 92	393+89.83	394+30.00	LT	24.0	4.0	44.2							393+89.83	6.0	RF-19C	2.0		INTAKE 106
														394+30.00	6.0	RF-19C		0.0	INTAKE 105
107	IA 92	394+30.00	395+36.30	LT	24.0	4.0	110.3							394+30.00	6.0	RF-19C	5.1		INTAKE 105
														395+36.30	6.0	RF-19C		0.0	INTAKE 110
108	IA 92	395+36.30	399+00.00	LT	24.0	4.0	367.7							395+36.30	6.0	RF-19C	17.0		INTAKE 110
														399+00.00	6.0	RF-19C		0.0	INTAKE 100
109	IA 92	399+00.00	404+50.00	LT	24.0	4.0	554.0							399+00.00	6.0	RF-19C	25.6		INTAKE 100
														404+50.00	6.0	RF-19C		0.0	INTAKE 200
110	IA 92	404+50.00	407+39.00	LT	24.0	4.0	293.0							404+50.00	6.0	RF-19C	13.6		INTAKE 200
														407+39.00	6.0	RF-19C		0.0	INTAKE 202
111	IA 92	407+39.00	409+55.00	LT	24.0	4.0	220.0							407+39.00	6.0	RF-19C	10.2		INTAKE 202
														409+55.00	6.0	RF-19C		0.0	INTAKE 204
112	IA 92	409+55.00	411+70.00	LT	24.0	4.0	219.0							409+55.00	6.0	RF-19C	10.1		INTAKE 204
														411+70.00	6.0	RF-19C		0.0	INTAKE 206
113	IA 92	411+70.00	413+85.00	LT	24.0	4.0	219.0							411+70.00	6.0	RF-19C	10.1		INTAKE 206
														413+85.00	6.0	RF-19C		0.0	INTAKE 208
114	IA 92	413+85.00	416+95.00	LT	24.0	4.0	314.0							413+85.00	6.0	RF-19C	14.5		INTAKE 208
														416+95.00	6.0	RF-19C		0.0	INTAKE 210
115	IA 92	416+95.00	4418+45.06	LT	24.0	4.0	220.0							416+95.00	6.0	RF-19C	10.2		INTAKE 210
														4418+45.06	6.0	RF-19C		0.0	INTAKE 233
116	IA 92	4418+45.00	418+71.33	LT	24.0	4.0	140.0							4418+45.00	6.0	RF-19C	6.5		INTAKE 232
														418+71.33	6.0	RF-19C		0.0	INTAKE 299
117	IA 92	418+71.33	421+00.00	LT	24.0	4.0	232.7							418+71.33	6.0	RF-19C	10.8		INTAKE 299
														421+00.00	6.0	RF-19C		0.0	INTAKE 300
118	IA 92	421+00.00	423+82.00	LT	24.0	4.0	286.0							421+00.00	6.0	RF-19C	13.2		INTAKE 300
														423+82.00	6.0	RF-19C		0.0	INTAKE 302
119	IA 92	423+82.00	425+30.00	LT	24.0	4.0	152.0							423+82.00	6.0	RF-19C	7.0		INTAKE 302
														425+30.00	6.0	RF-19C		0.0	INTAKE 304
120	IA 92	425+30.00	426+35.00	LT	24.0	4.0	109.0							425+30.00	6.0	RF-19C	5.0		INTAKE 304
														426+35.00	6.0	RF-19C		0.0	INTAKE 306
121	IA 92	426+35.00	426+67.15	LT	24.0	4.0	36.2							426+35.00	6.0	RF-19C	1.7		INTAKE 306
														426+67.15	6.0	RF-19C		0.0	INTAKE 314
122	IA 92	426+67.15	427+00.00	LT	24.0	4.0	36.8							426+67.15	6.0	RF-19C	1.7		INTAKE 314
														427+00.00	6.0	RF-19C		0.0	INTAKE 312
123	IA 92	427+00.00	428+00.00	LT	24.0	4.0	104.0							427+00.00	6.0	RF-19C	4.8		INTAKE 312
														428+00.00	6.0	RF-19C		0.0	INTAKE 310
124	IA 92	428+00.00	431+15.00	LT	24.0	4.0	319.0							428+00.00	6.0	RF-19C	14.8		INTAKE 310
														431+15.00	6.0	RF-19C		0.0	INTAKE 308
125	IA 92	431+15.00	435+57.00	LT	24.0	4.0	446.0							431+15.00	6.0	RF-19C	20.6		INTAKE 308
														435+57.00	6.0	RF-19C		0.0	INTAKE 400
126	IA 92	435+57.00	436+00.00	LT	24.0	4.0	47.0							435+57.00	6.0	RF-19C	2.2		INTAKE 400
														436+00.00	6.0	RF-19C		0.0	INTAKE 402
127	IA 92	436+00.00	436+45.00	LT	24.0	4.0	49.0							436+00.00	6.0	RF-19C	2.3		INTAKE 402
														436+45.00	6.0	RF-19C		0.0	INTAKE 405
128	IA 92	436+45.00	437+72.00	LT	24.0	4.0	131.0							436+45.00	6.0	RF-19C	6.1		INTAKE 405
														437+72.00	6.0	RF-19C		0.0	INTAKE 415
129	IA 92	437+72.00	439+20.00	LT	24.0	4.0	152.0							437+72.00	6.0	RF-19C	7.0		INTAKE 415
														439+20.00	6.0	RF-19C		0.0	INTAKE 410
130	IA 92	439+20.00	441+19.00	LT	24.0	4.0	203.0							439+20.00	6.0	RF-19C	9.4		INTAKE 410

LONGITUDINAL SUBDRAIN SHOULDER AND BACKSLOPE

Refer to Soils Sheets

① Refer to EW-203, EW-204, or EW-211.
*Not a bid item

Line No.	Road or Lane Ident.	Location		Side	Longitudinal Subdrain (RF-19C)							Subdrain Outlet			Porous* Backfill CY	Class "A"* Crushed Stone CY	Remarks		
		Station to Station	Depth D		Shoulder		Backslope		Bridge Berm ①			RF-19C, RF-19E, or RF-19F							
					Size	Length	Size	Length	Size	Type	Length	Station	Size	Standard Road Plan and Type					
																		IN	FT
131	IA 92	441+19.00	443+23.00	LT	24.0	4.0	208.0						441+19.00	6.0	RF-19C	9.6	0.0	INTAKE 408	
													441+19.00	6.0	RF-19C			INTAKE 408	
													443+23.00	6.0	RF-19C		0.0	INTAKE 703	
132	IA 92	443+23.00	444+50.00	LT	24.0	4.0	131.0						443+23.00	6.0	RF-19C	6.1		INTAKE 703	
													444+50.00	6.0	RF-19C		0.0	INTAKE 702	
133	IA 92	444+50.00	445+80.00	LT	24.0	4.0	134.0						444+50.00	6.0	RF-19C	6.2		INTAKE 702	
													445+80.00	6.0	RF-19C		0.0	INTAKE 701	
134	IA 92	445+80.00	447+40.00	LT	24.0	4.0	164.0						445+80.00	6.0	RF-19C	7.6		INTAKE 701	
													447+40.00	6.0	RF-19C		0.0	INTAKE 715	
135	IA 92	447+40.00	448+80.00	LT	24.0	4.0	144.0						447+40.00	6.0	RF-19C	6.7		INTAKE 715	
													448+80.00	6.0	RF-19C		0.0	INTAKE 714	
136	IA 92	448+80.00	450+30.00	LT	24.0	4.0	154.0						448+80.00	6.0	RF-19C	7.1		INTAKE 714	
													450+30.00	6.0	RF-19C		0.0	INTAKE 713	
137	IA 92	450+30.00	453+77.00	LT	24.0	4.0	351.0						450+30.00	6.0	RF-19C	16.3		INTAKE 713	
													453+77.00	6.0	RF-19C		0.0	INTAKE 753	
138	IA 92	453+77.00	455+10.00	LT	24.0	4.0	137.0						453+77.00	6.0	RF-19C	6.3		INTAKE 753	
													455+10.00	6.0	RF-19C		0.0	INTAKE 754	
139	IA 92	455+10.00	456+25.00	LT	24.0	4.0	119.0						455+10.00	6.0	RF-19C	5.5		INTAKE 754	
													456+25.00	6.0	RF-19C		0.0	INTAKE 755	
140	IA 92	456+25.00	458+40.00	LT	24.0	4.0	219.0						456+25.00	6.0	RF-19C	10.1		INTAKE 755	
													458+40.00	6.0	RF-19C		0.0	INTAKE 756	
141	IA 92	458+40.00	459+75.00	LT	24.0	4.0	139.0						458+40.00	6.0	RF-19C	6.4		INTAKE 756	
													459+75.00	6.0	RF-19C		0.0	INTAKE 757	
142	IA 92	459+75.00	461+00.00	LT	24.0	4.0	129.0						459+75.00	6.0	RF-19C	6.0		INTAKE 757	
													461+00.00	6.0	RF-19C		0.0	INTAKE 758	
143	IA 92	461+00.00	461+75.00	LT	24.0	4.0	79.0						461+00.00	6.0	RF-19C	3.7		INTAKE 758	
													461+75.00	6.0	RF-19C		0.0	INTAKE 759	
144	IA 92	461+75.00	463+90.00	LT	24.0	4.0	219.0						461+75.00	6.0	RF-19C	10.1		INTAKE 759	
													463+90.00	6.0	RF-19C		0.0	INTAKE 769	
145	IA 92	463+90.00	464+95.00	LT	24.0	4.0	109.0						463+90.00	6.0	RF-19C	5.0		INTAKE 769	
													464+95.00	6.0	RF-19C		0.0	INTAKE 768	
Totals							44699.7									290	3421.0	12.4	
NOTE: LONGITUDINAL SUBDRAINS 1 - 30 AND 73 - 103 ARE TYPE 7b WITH PCC OR TYPE 8b WITH HMA (ACC).																			
NOTE: LONGITUDINAL SUBDRAINS 31 - 72 AND 104 - 145 ARE TYPE 12.																			
NOTE: THERE ARE 124 RF-19E OUTLETS AND 166 RF-19C OUTLETS.																			

SURVEY SYMBOLS

- TDC Tree Deciduous
- PPA Power Pole Co. 1
- FWD Wood Fence
- LUM Luminaire
- TEV Evergreen Tree
- LP L.P. Tank
- D Centerline Draw or Stream (Down)
- RET Retaining Walls
- SI Sign
- SHR Shrub
- SI Sign
- EW Edge of Water
- DIK Centerline of Dike or Dam
- FLG Flag Poles
- WM Wind Mill
- FCL Chain Link and Security Fence
- HDG Hedge Row
- TV Satellite TV Dish
- RT Radio Tower
- INB Storm Sewer Beehive Intake
- WV Water Valve
- FHD Fire Hydrants
- WEL Well
- MH Utility Access (Manhole)
- LUM Luminaire
- MIS Miscellaneous
- TPD Telephone Pedestal
- EB Electrical Box
- UB Utility Box
- PR Electric Riser Pole
- FW Wire Fence
- GP Guard Post (Less Than 4 Posts)
- IN Storm Sewer Intake
- TLN Treeline
- TVP TV Pedestal
- SEP Septic Tank
- OUT Tile Outlet
- TIL Tile Line
- UST Underground Tank
- GV Gas Valve
- DU Centerline Draw or Stream (Up)
- BNK Stream Bank
- BL Topo Breakline
- RIP Rip-Rap

- St.S. STA Storm Sewer Line Co. 1
- F03 FOC Underground Fiber Optic Co. 3
- F05 FOE Underground Fiber Optic Co. 5
- F02 FOB Underground Fiber Optic Co. 2
- San. SAA Sanitary Sewer Line Co. 1
- T1 TLA Underground Telephone Line Co. 1
- E1 ELA Underground Electric Line Co. 1
- G GLA Underground Gas Line Co. 1
- TV TVA Underground TV Cable Co. 1
- W WLA Underground Water Line Co. 1
- F0 FOA Underground Fiber Optic Co. 1
- E2 ELB Underground Electric Line Co. 2
- San.2 SAB Sanitary Sewer Line Co. 2
- G2 GLB Underground Gas Line Co. 2
- F04 FOD Underground Fiber Optic Co. 4
- W2 WLB Underground Water Line Co. 2

UTILITY LEGEND

- F0 FOA Paetac Iowa Communications Network
- F02 FOB Lightcore (Digital Teleport)
- F03 FOC Iowa Network Service
- F04 FOD Indianola Municipal Utilities
- F05 FOE MCI
- T1 TLA Qwest
- E1 ELA Mid-American
- E2 ELB Indianola Municipal Utilities
- TV TVA Mediacom
- W WLA Indianola Municipal Utilities
- W2 WLB Warren Rural Water
- San. SAA City of Indianola
- San.2 SAB Private
- G GLA Mid-American
- G2 GLB Kinder Morgan
- St.S. STA City of Indianola
- PPA Mid-American

PLAN VIEW COLOR LEGEND OF PLAN AND PROFILE SHEETS

LINEWORK	Design Color No.	Description
Green	(2)	Existing Topographic Features and Labels
Blue	(1)	Proposed Alignment, Stationing, Tic Marks, and Alignment Annotation
Magenta	(5)	Existing Utilities
SHADING		
Design Color No.		
Yellow	(4)	Highlight for Critical Notes or Features
Red	(3)	Delineates Restricted Areas
Lavender	(9)	Temporary Pavement Shading
Gray, Light	(48)	Proposed Pavement Shading
Gray, Med	(80)	Proposed Granular Shading
Gray, Dark	(112)	Proposed Grade and Pave Shading
Brown, Light	(236)	Grading Shading
Tan	(8)	Proposed Sidewalk Shading
Blue, Light	(230)	Proposed Sidewalk Landing Shading
Pink	(11)	Proposed Sidewalk Ramp Shading
Green, Light	(225)	Existing Pavement Shading

PROFILE VIEW COLOR LEGEND OF PLAN AND PROFILE SHEETS

LINEWORK	Design Color No.	Description
Green	(2)	Existing Ground Line Profile
Blue	(1)	Proposed Profile and Annotation
Magenta	(5)	Existing Utilities
Blue, Light	(230)	Proposed Ditch Grades, Left
Black	(0)	Proposed Ditch Grades, Median
Rust	(14)	Proposed Ditch Grades, Right

Reference Point

Station

Section Corner

Ground Line Intercept

Saw Cut

Guardrail

Clearing & Grubbing Area

Pavement Removal

RIGHT-OF-WAY LEGEND

- Proposed Right-of-Way
- Existing and Proposed Right-of-Way
- Easement and Existing Right-of-Way
- Borrow
- Easement (Temporary)
- Easement
- Excess
- Access Control

PLAN AND PROFILE LEGEND AND SYMBOL INFORMATION SHEET

(COVERS SHEET SERIES D, E, F, & K)

Lincoln TWP.
T-76N R-24W
SEC. 29

Curve Data (Survey)
 $\Delta = 34^\circ 40' 53.90''$ (LT)
 $T = 357.80$
 $L = 693.62$
 $E = 1,145.89$
 $E = 54.56$

Curve Data
 $\Delta = 29^\circ 11' 23.92''$ (LT)
 $T = 398.39$
 $L = 779.48$
 $R = 1,530.00$
 $E = 51.02$

SCS PI Sta 264+10.92
 $\Delta = 35^\circ 10' 54.09''$ (LT)
 $\text{Theta} = 2^\circ 59' 45.09''$
 $L_s = 160.00$
 $T_s = 565.29$
 $E_s = 75.79$
 $P = 0.70$
 $K = 79.99$
 $X_c = 159.96$
 $Y_c = 2.79$
 $LT = 106.68$
 $ST = 53.35$
 $LC = 159.98$

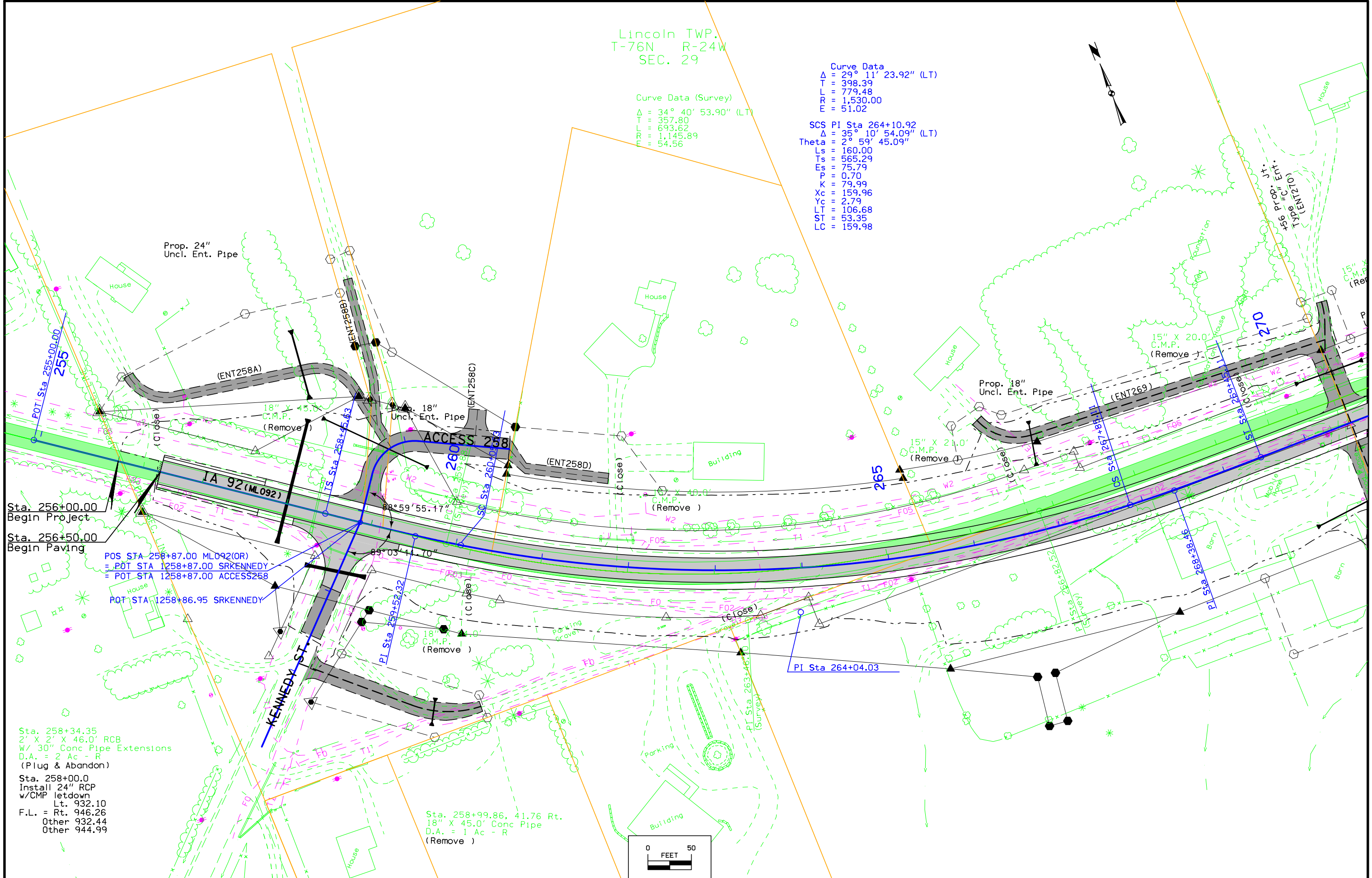

Sta. 256+00.00
Begin Project

Sta. 256+50.00
Begin Paving

POS STA 258+87.00 MLO92(OR)
 = POT STA 1258+87.00 SRKENNEDY
 = POT STA 1258+87.00 ACCESS258

POT STA 1258+86.95 SRKENNEDY

Sta. 258+34.35
 2' X 2' X 46.0' RCB
 w/ 30" Conc Pipe Extensions
 D.A. = 2 Ac - R
 (Plug & Abandon)

Sta. 258+00.0
 Install 24" RCP
 w/CMP letdown
 Lt. 932.10
 F.L. = Rt. 946.26
 Other 932.44
 Other 944.99

Sta. 258+99.86, 41.76 Rt.
 18" X 45.0' Conc Pipe
 D.A. = 1 Ac - R
 (Remove)

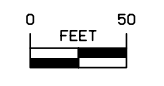

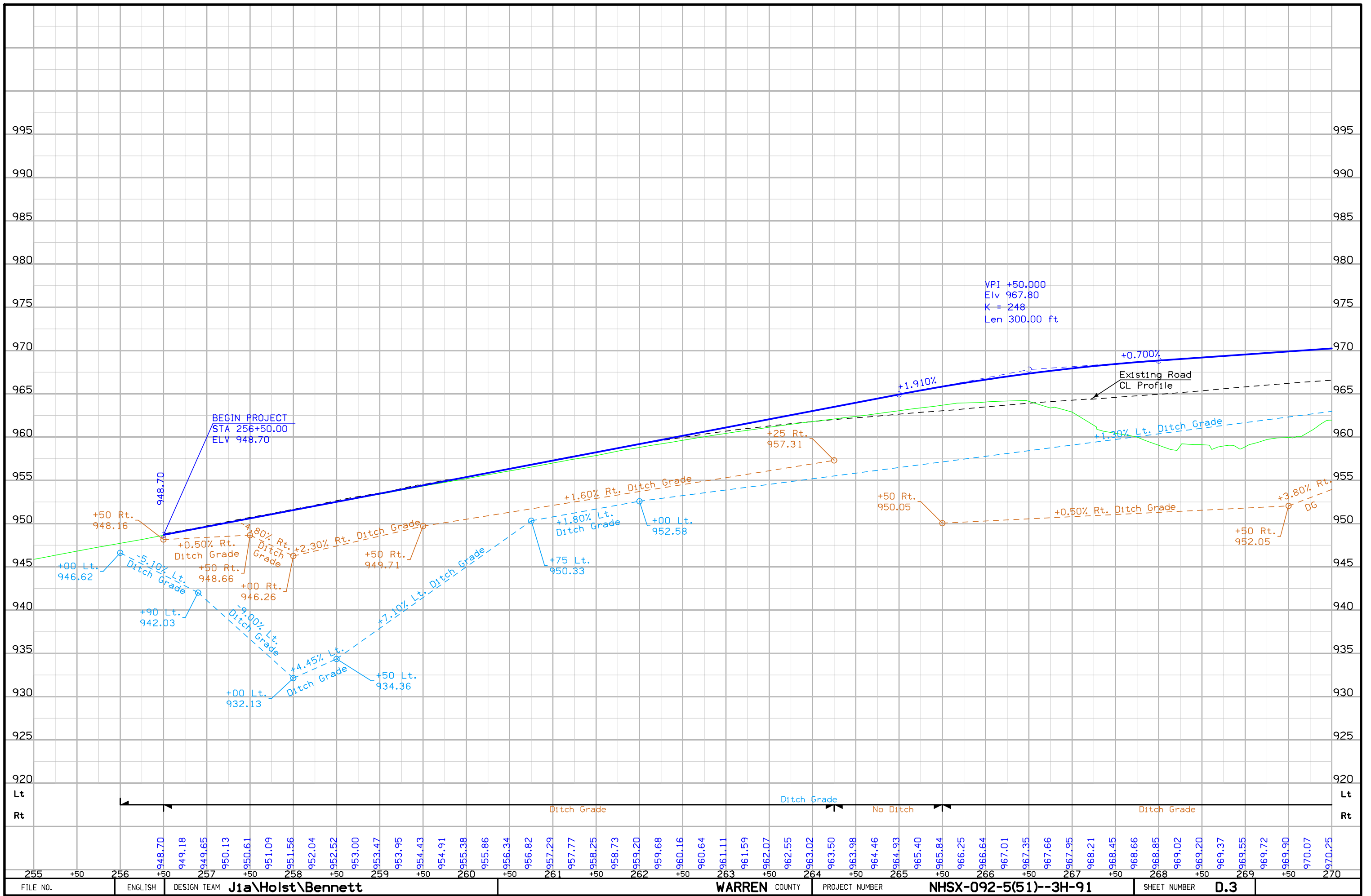

Lincoln TWP.
T-76N R-24W
SEC. 29

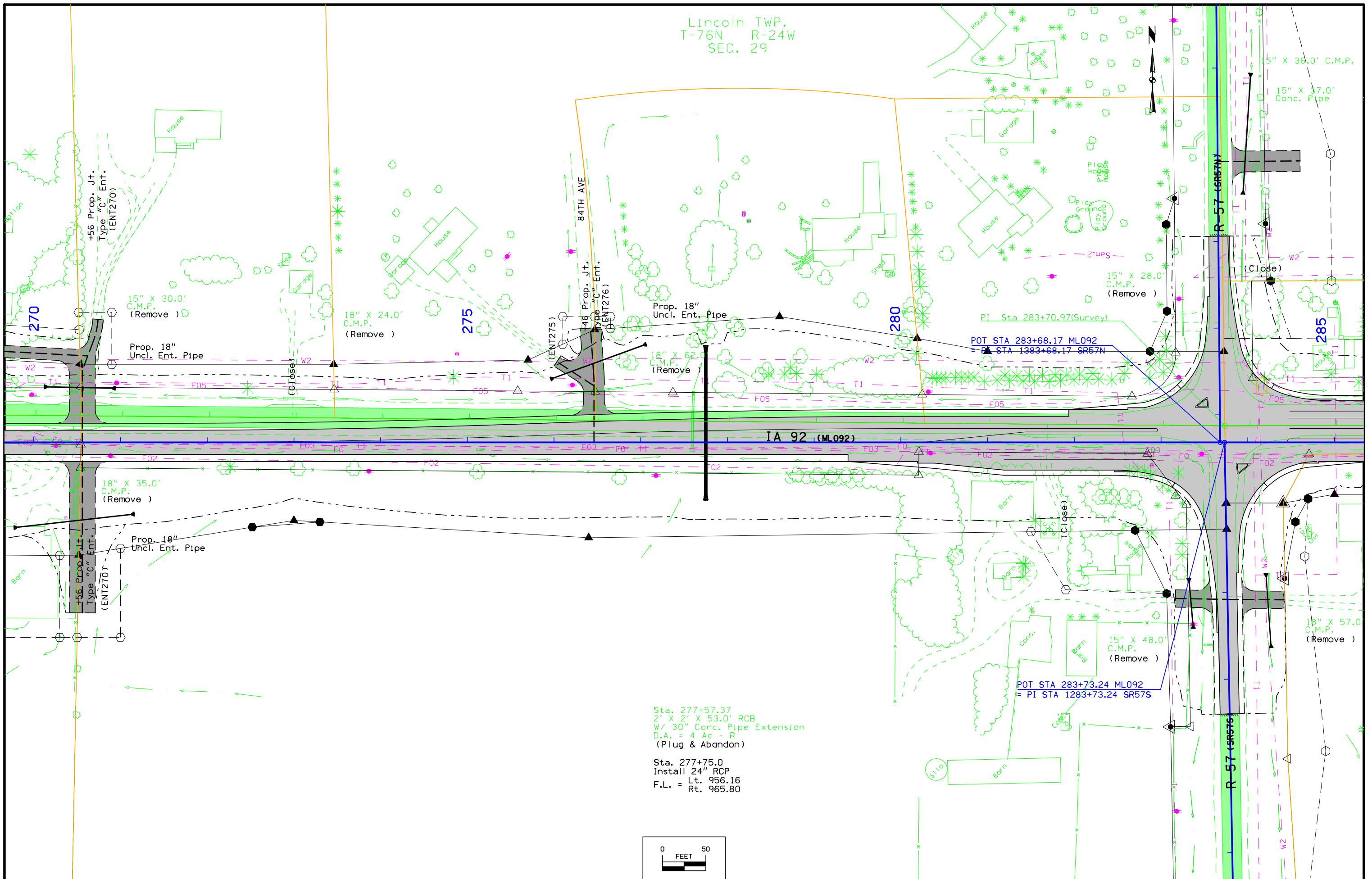

Sta. 277+57.37
2' X 2' X 53.0' RCB
W/ 30" Conc. Pipe Extension
D.A. = 4 Ac - R
(Plug & Abandon)

Sta. 277+75.0
Install 24" RCP
F.L. = Lt. 956.16
Rt. 965.80

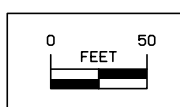

Lincoln TWP.
T-76N R-24W
SEC. 29

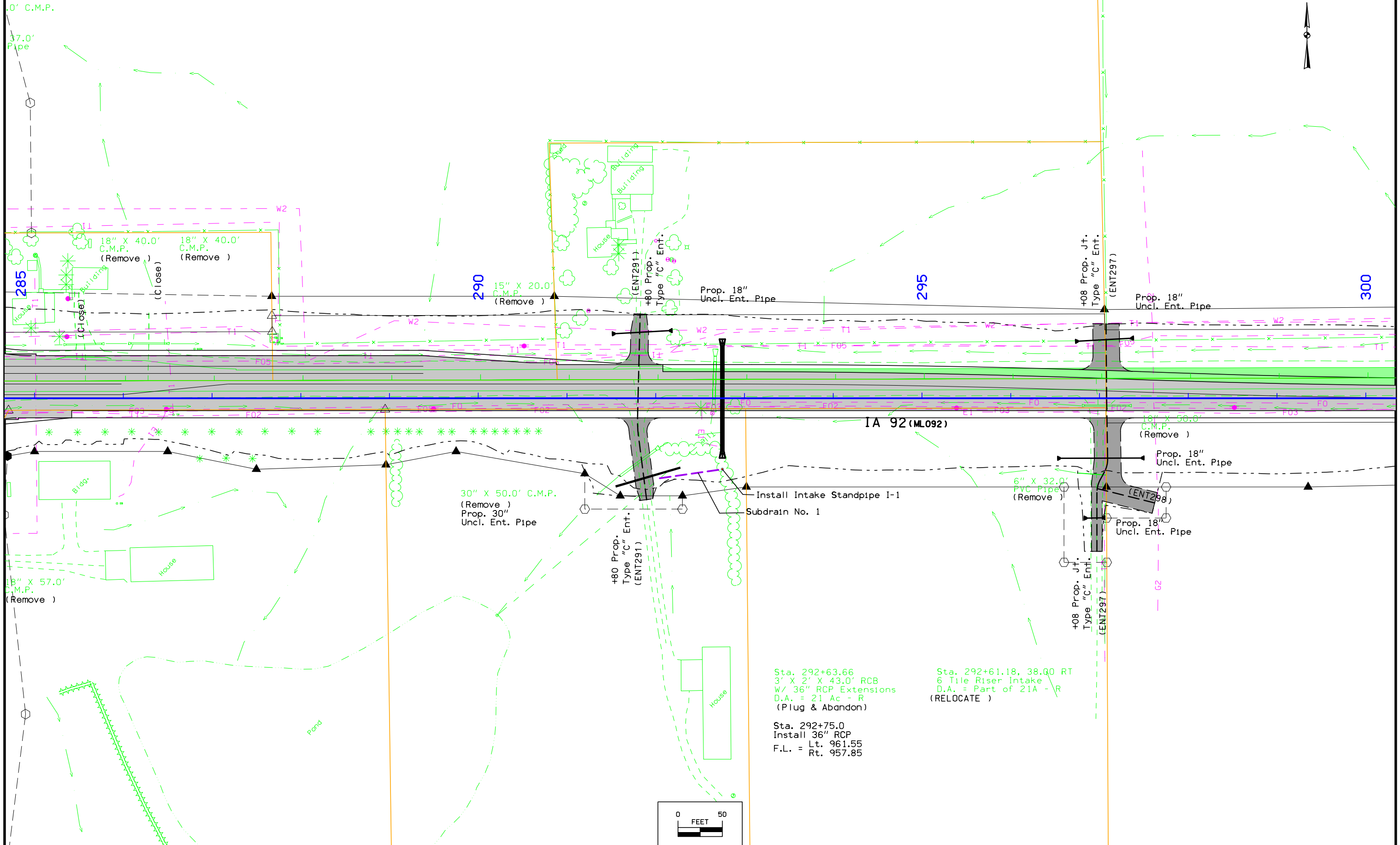

Sta. 292+63.66
3' X 2' X 43.0' RCB
W/ 36\"/>

Sta. 292+61.18, 38.00 RT
6 Tile Riser Intake
D.A. = Part of 21A - R
(RELOCATE)

Sta. 292+75.0
Install 36\"/>

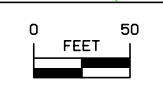

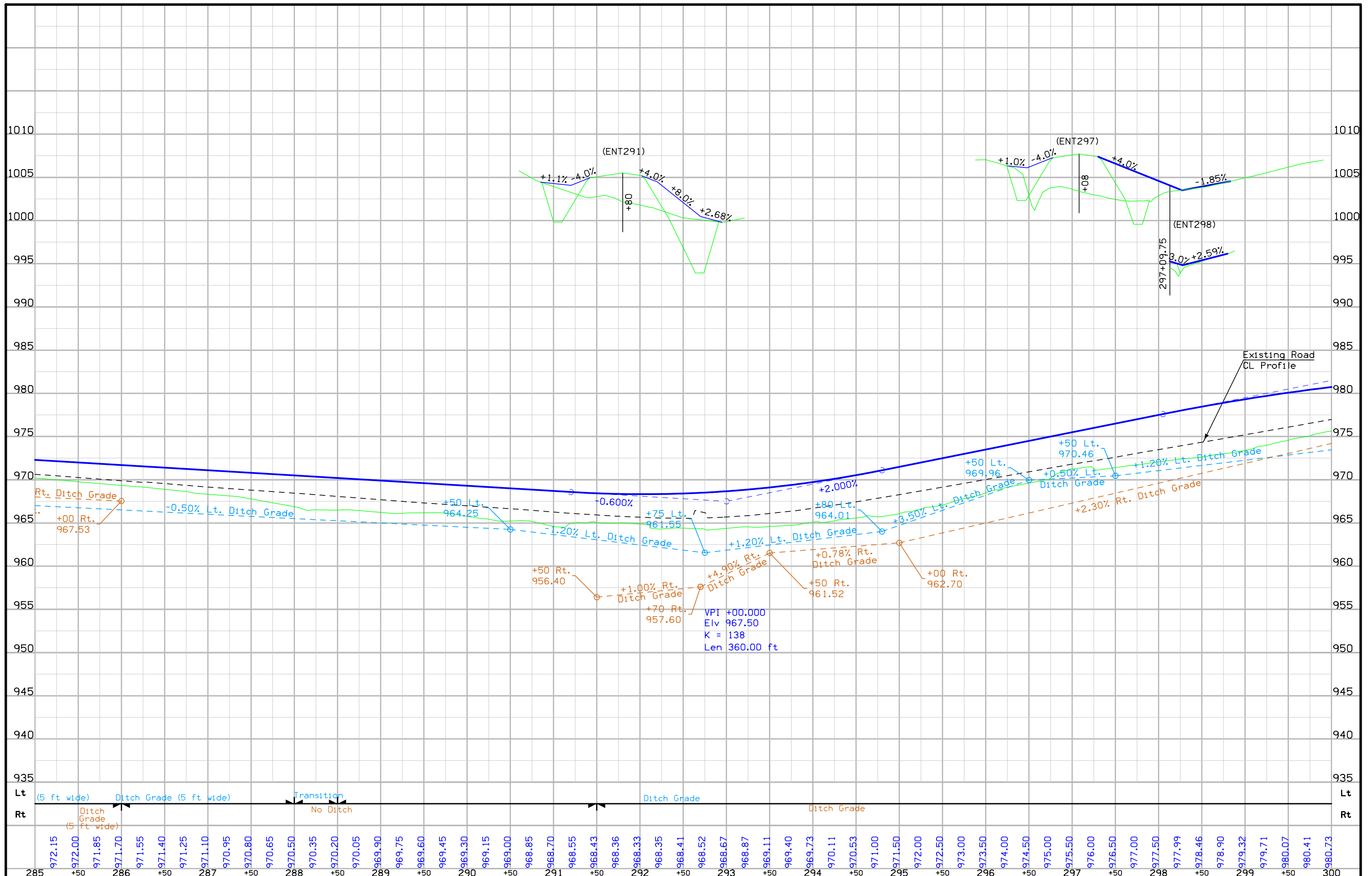

FILE NO.	ENGLISH	DESIGN TEAM	J1a\Holst\Bennett	WARREN COUNTY	PROJECT NUMBER	NHSX-092-5(51)--3H-91	SHEET NUMBER	D.7
----------	---------	-------------	-------------------	---------------	----------------	-----------------------	--------------	-----

Lincoln TWP.
T-76N R-24W
SEC. 29

Lincoln TWP.
T-76N R-24W
SEC. 28

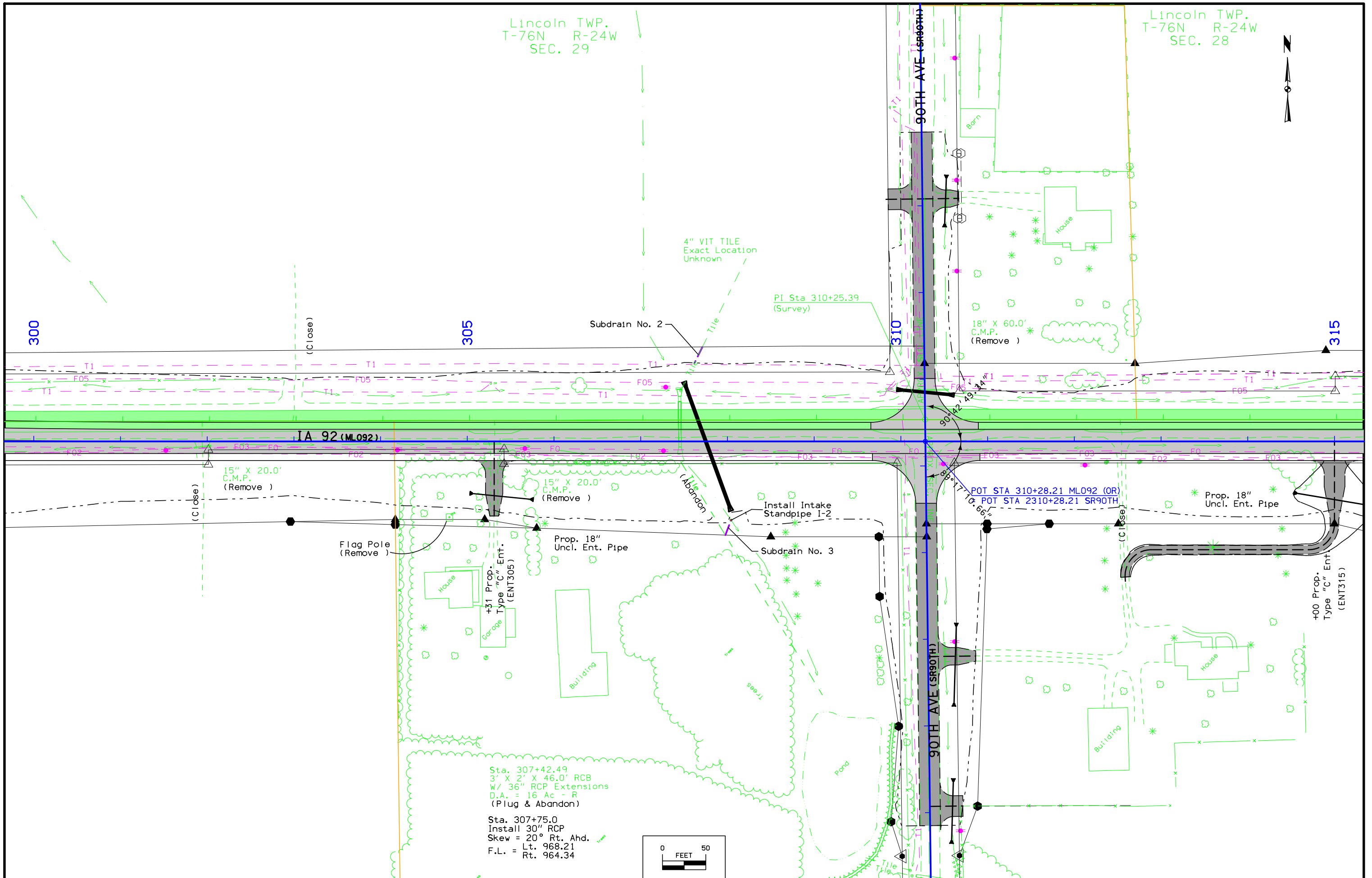

Sta. 307+42.49
3' X 2' X 46.0' RCB
W/ 36" RCP Extensions
D.A. = 16 Ac - R
(Plug & Abandon)

Sta. 307+75.0
Install 30" RCP
Skew = 20° Rt. Ahd.
F.L. = Lt. 968.21
Rt. 964.34

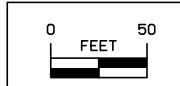

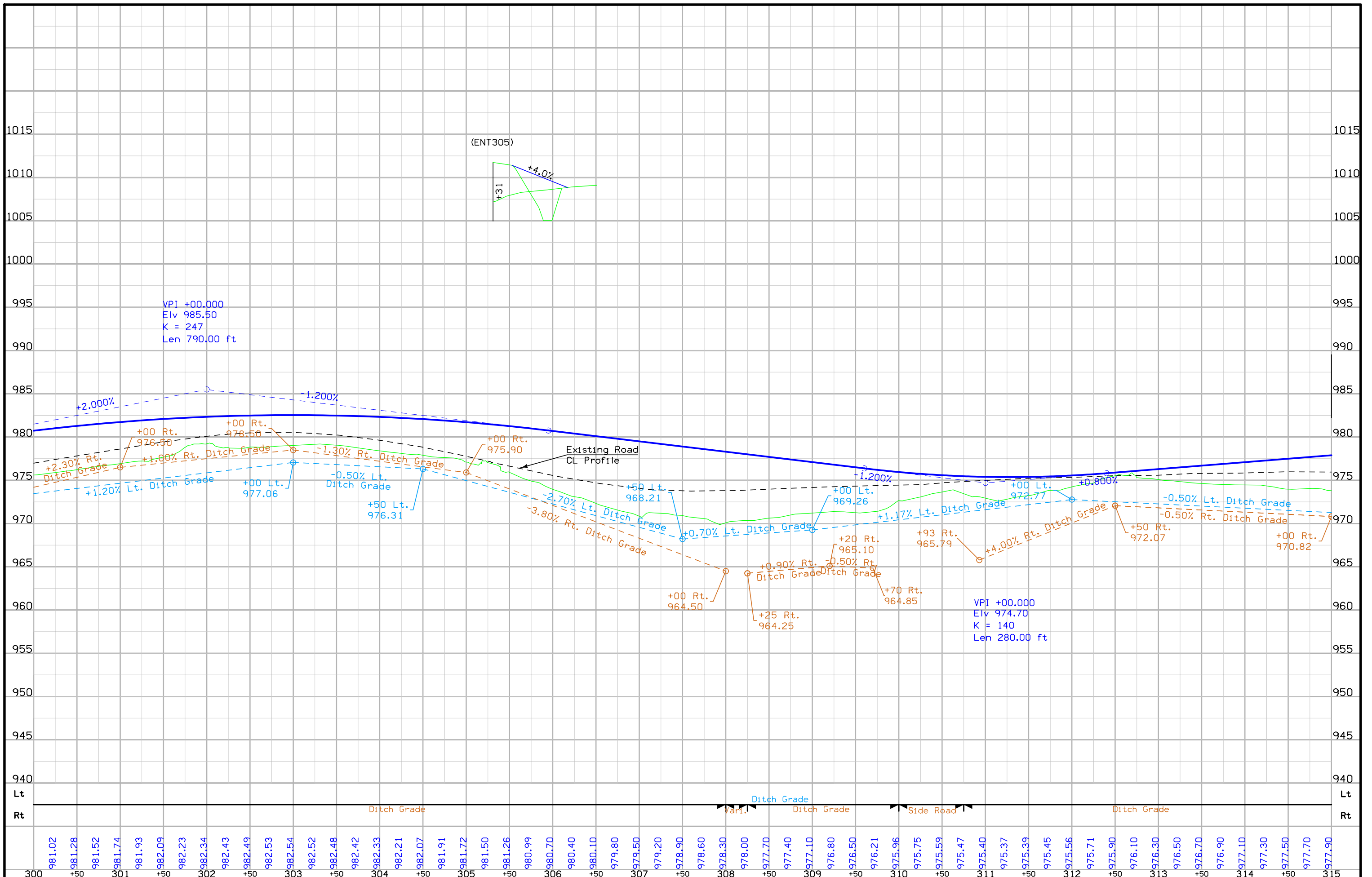

FILE NO.	ENGLISH	DESIGN TEAM	J1a\Holst\Bennett	WARREN COUNTY	PROJECT NUMBER	NHSX-092-5(51)--3H-91	SHEET NUMBER	D.9
----------	---------	-------------	-------------------	---------------	----------------	-----------------------	--------------	-----

Lincoln TWP.
T-76N R-24W
SEC. 28

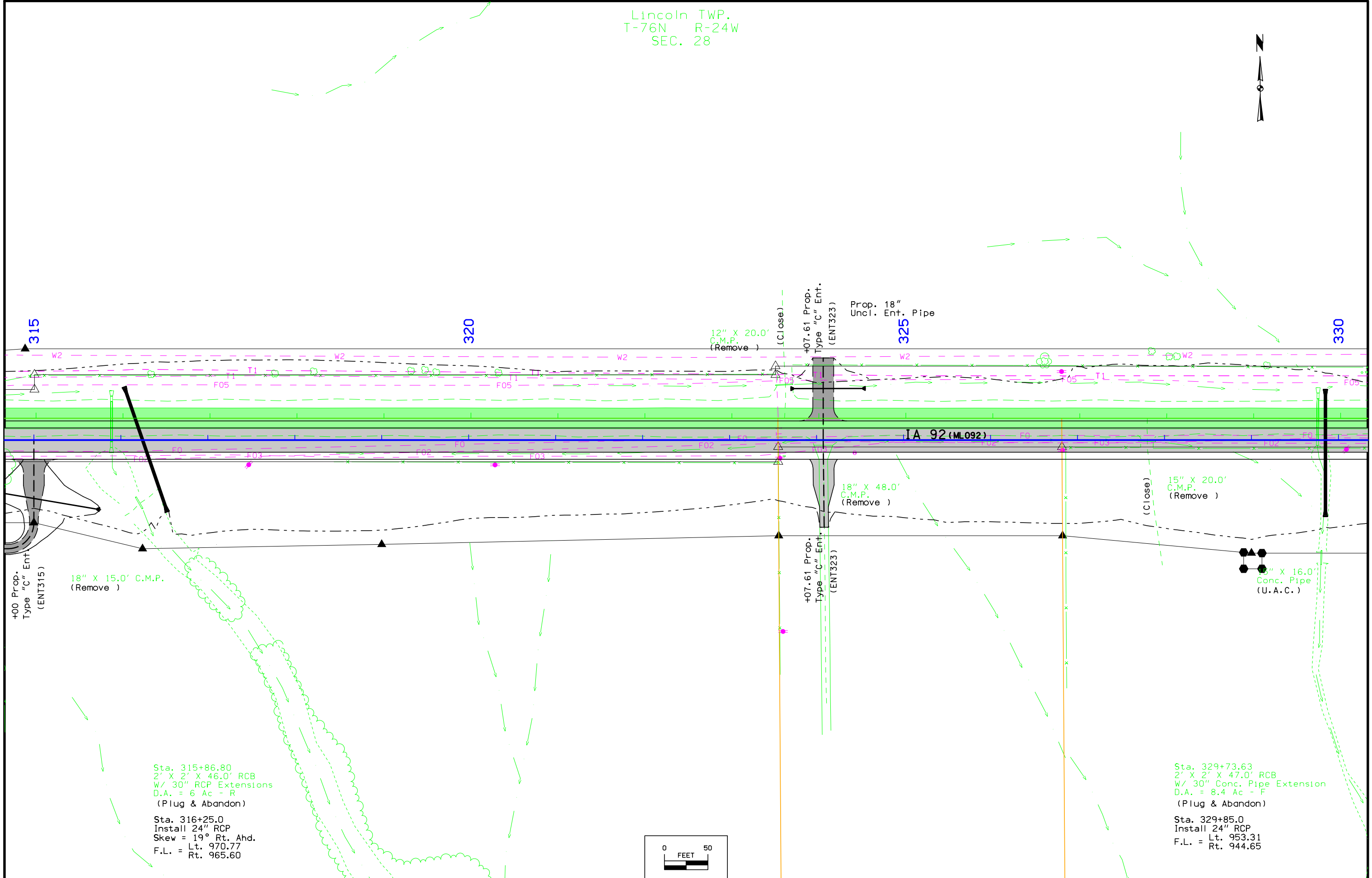

+00 Prop.
Type "C" Ent.
(ENT315)

18" X 15.0' C.M.P.
(Remove)

Sta. 315+86.80
2' X 2' X 46.0' RCB
W/ 30" RCP Extensions
D.A. = 6 Ac - R
(Plug & Abandon)
Sta. 316+25.0
Install 24" RCP
Skew = 19° Rt. Ahd.
Lt. 970.77
Rt. 965.60

+07.61 Prop.
Type "C" Ent.
(ENT323)

18" X 48.0'
C.M.P.
(Remove)

15" X 20.0'
C.M.P.
(Remove)

18" X 16.0'
Conc. Pipe
(U.A.C.)

Sta. 329+73.63
2' X 2' X 47.0' RCB
W/ 30" Conc. Pipe Extension
D.A. = 8.4 Ac - F
(Plug & Abandon)
Sta. 329+85.0
Install 24" RCP
Lt. 953.31
Rt. 944.65

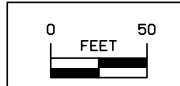

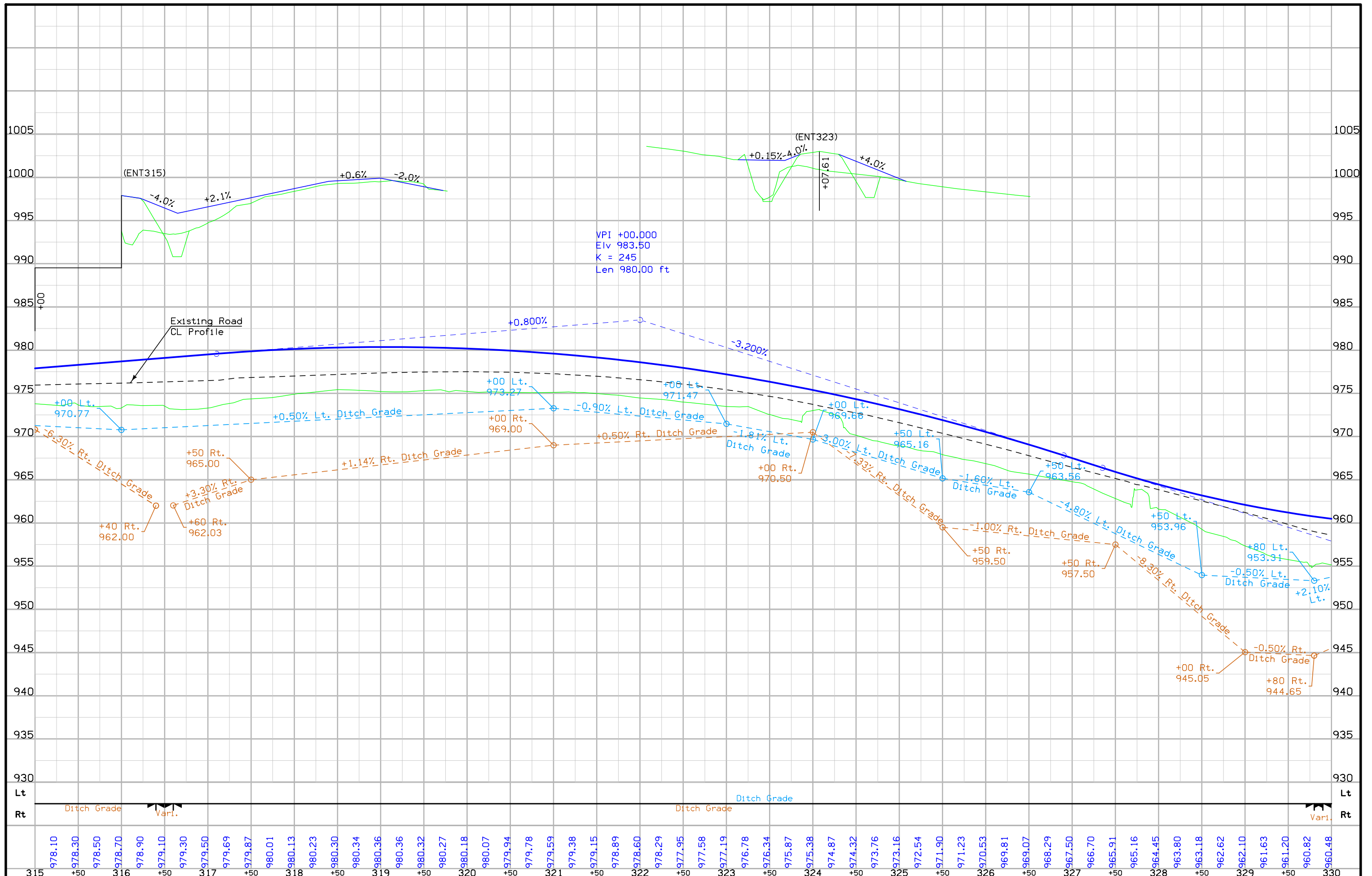

FILE NO.	ENGLISH	DESIGN TEAM	J1a\Holst\Bennett	WARREN COUNTY	PROJECT NUMBER	NHSX-092-5(51)--3H-91	SHEET NUMBER	D.11
----------	---------	-------------	-------------------	---------------	----------------	-----------------------	--------------	------

Lincoln TWP.
T-76N R-24W
SEC. 28

Curve Data
 $\Delta = 21^\circ 58' 51.50''$ (LT)
 $T = 297.14$
 $R = 586.97$
 $E = 1,530.00$
 $F = 28.59$
 SCS PI Sta 342+33.59
 $\Delta = 27^\circ 58' 21.68''$ (LT)
 $\text{Theta} = 2^\circ 59' 45.09''$
 $L_s = 160.00$
 $T_s = 461.25$
 $E_s = 47.46$
 $P = 0.70$
 $K = 79.99$
 $X_c = 159.96$
 $Y_c = 2.79$
 $L_T = 106.68$
 $ST = 53.35$
 $LC = 159.98$

Curve Data (Survey)
 $\Delta = 32^\circ 51' 54.10''$ (LT)
 $T = 337.60$
 $R = 656.58$
 $E = 1,144.67$
 $F = 48.75$

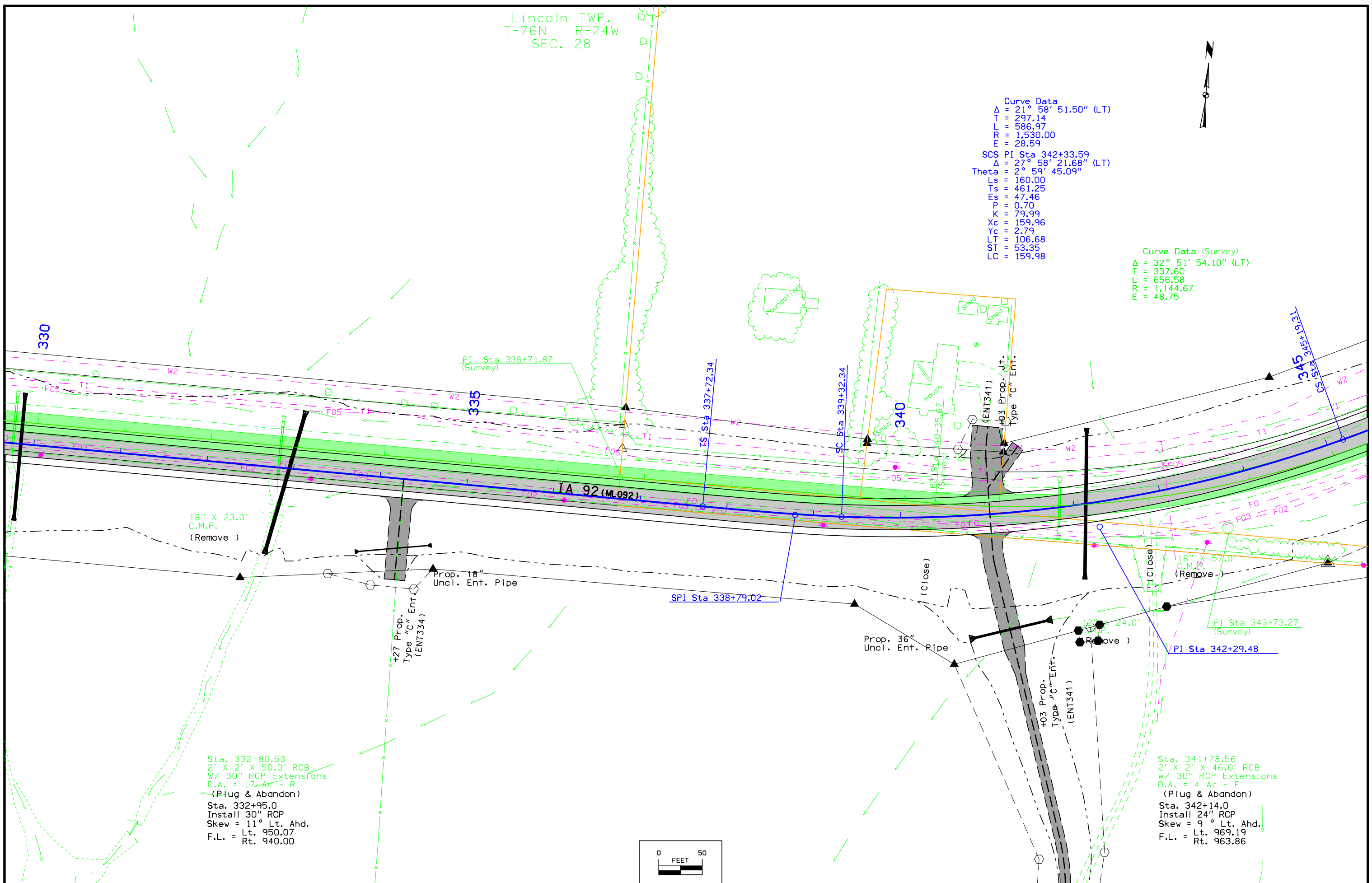

18" X 23.0'
C.M.P.
(Remove)

Prop. 18"
Uncl. Ent. Pipe

SPI Sta 338+79.02

Prop. 36"
Uncl. Ent. Pipe

18" X 57.0'
C.M.P.
(Remove)

PI Sta 343+73.27
(Survey)

PI Sta 342+29.48

Sta. 332+80.53
2' X 2' X 50.0' RCB
W/ 30" RCP Extensions
D.A. = 17' Ac = R
(Plug & Abandon)
Sta. 332+95.0
Install 30" RCP
Skew = 11° Lt. Ahd.
F.L. = Lt. 950.07
Rt. 940.00

Sta. 341+78.56
2' X 2' X 46.0' RCB
W/ 30" RCP Extensions
D.A. = 4' Ac = F
(Plug & Abandon)
Sta. 342+14.0
Install 24" RCP
Skew = 9° Lt. Ahd.
F.L. = Lt. 969.19
Rt. 963.86

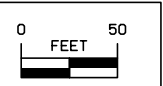

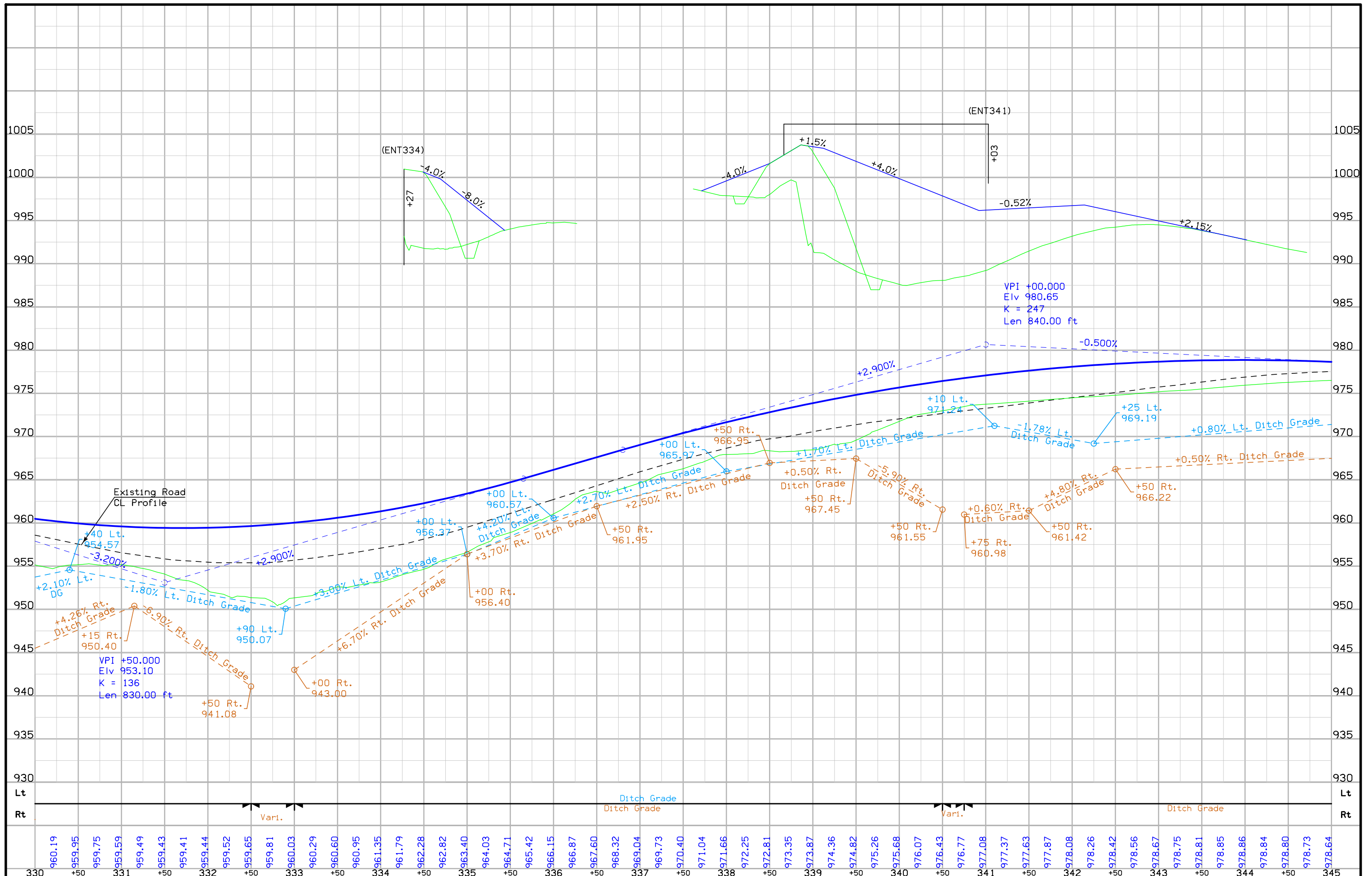

FILE NO.	ENGLISH	DESIGN TEAM	J1a\Holst\Bennett	WARREN COUNTY	PROJECT NUMBER	NHSX-092-5(51)--3H-91	SHEET NUMBER	D.13
----------	---------	-------------	-------------------	---------------	----------------	-----------------------	--------------	------

Lincoln TWP.
T-76N R-24W
SEC. 28

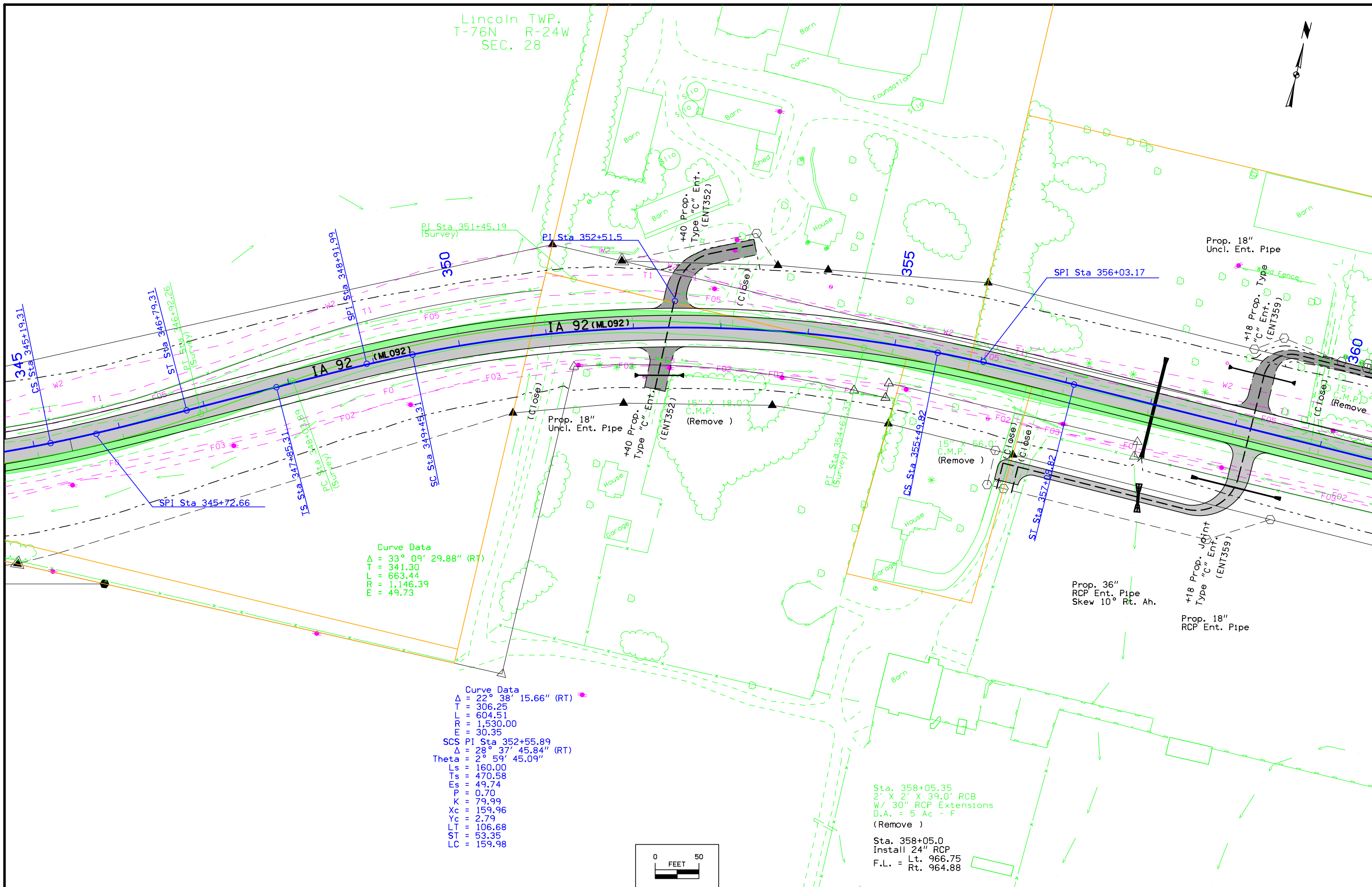

Curve Data
 $\Delta = 33^\circ 09' 29.88''$ (RT)
 $T = 341.30$
 $L = 663.44$
 $R = 1,146.39$
 $E = 49.73$

Curve Data
 $\Delta = 22^\circ 38' 15.66''$ (RT)
 $T = 306.25$
 $L = 604.51$
 $R = 1,530.00$
 $E = 30.35$
 SCS PI Sta 352+55.89
 $\Delta = 28^\circ 37' 45.84''$ (RT)
 Theta = $2^\circ 59' 45.09''$
 $L_s = 160.00$
 $T_s = 470.58$
 $E_s = 49.74$
 $P = 0.70$
 $K = 79.99$
 $X_c = 159.96$
 $Y_c = 2.79$
 $L_T = 106.68$
 $ST = 53.35$
 $LC = 159.98$

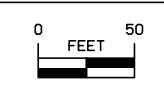

Sta. 358+05.35
 2' X 2' X 39.0' RCB
 W/ 30" RCP Extensions
 D.A. = 5 Ac - F
 (Remove)
 Sta. 358+05.0
 Install 24" RCP
 F.L. = Lt. 966.75
 Rt. 964.88

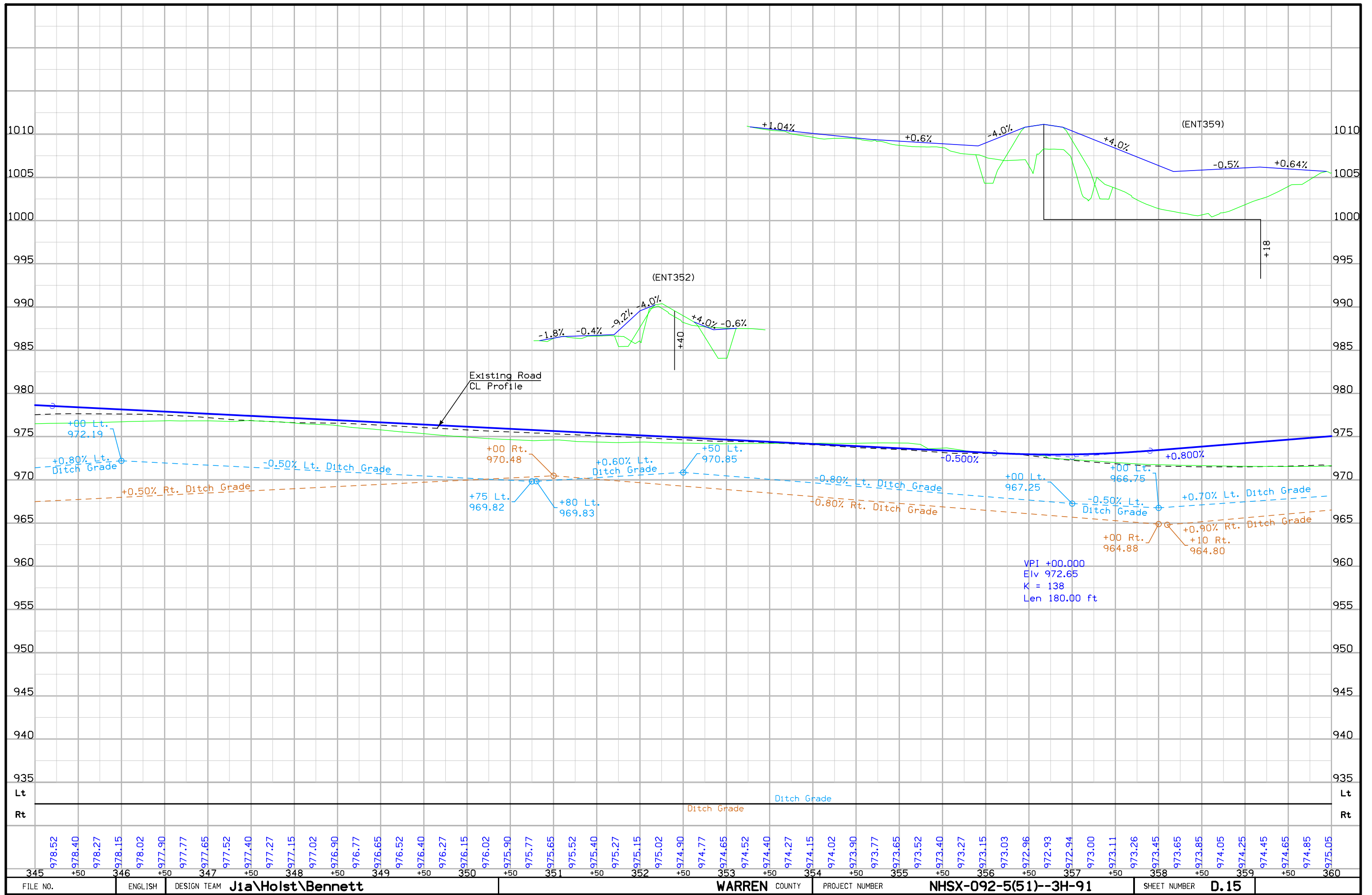

Lincoln TWP.
T-76N R-24W
SEC. 28

Lincoln TWP.
T-76N R-24W
SEC. 27

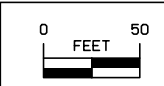
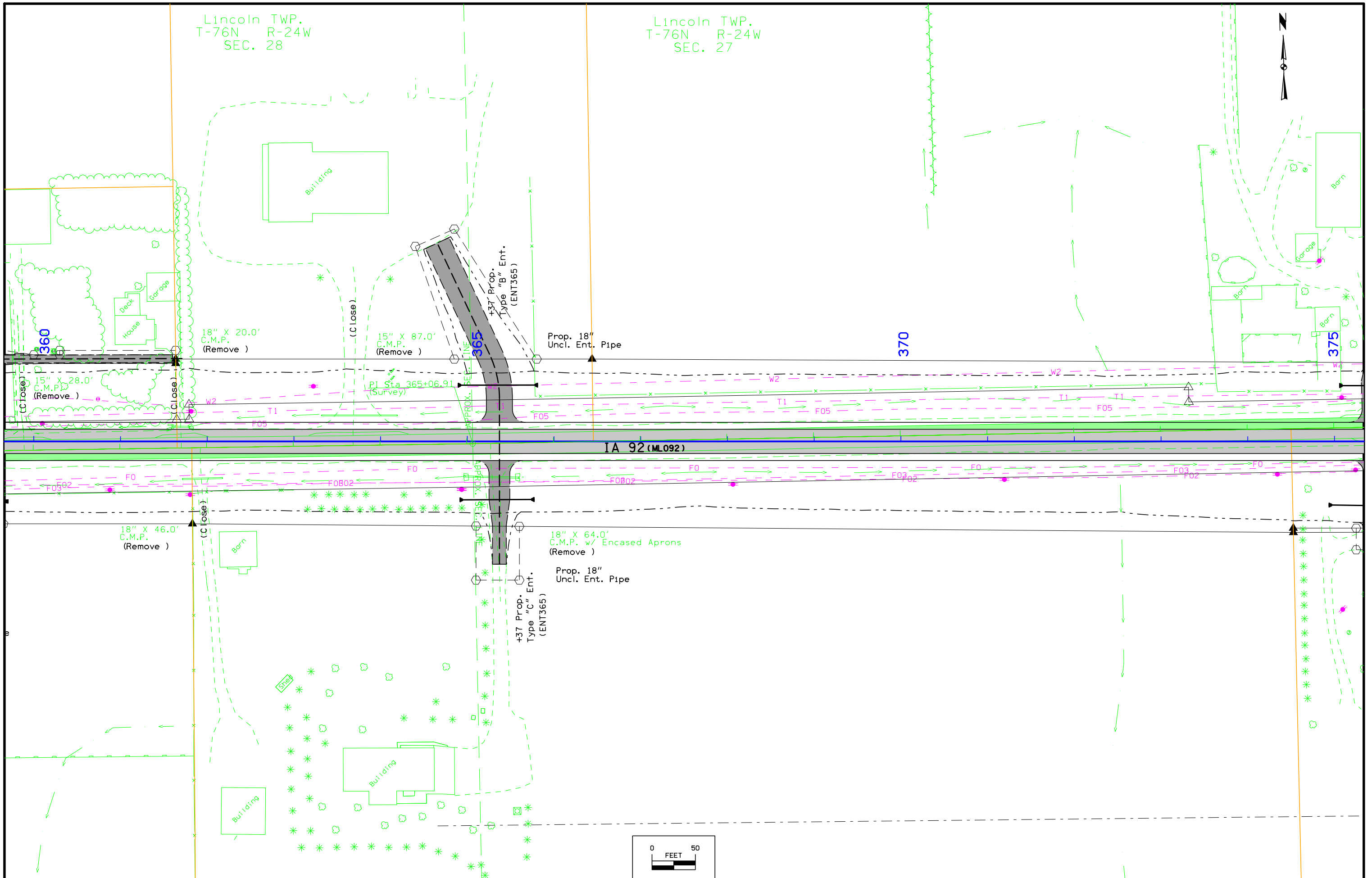

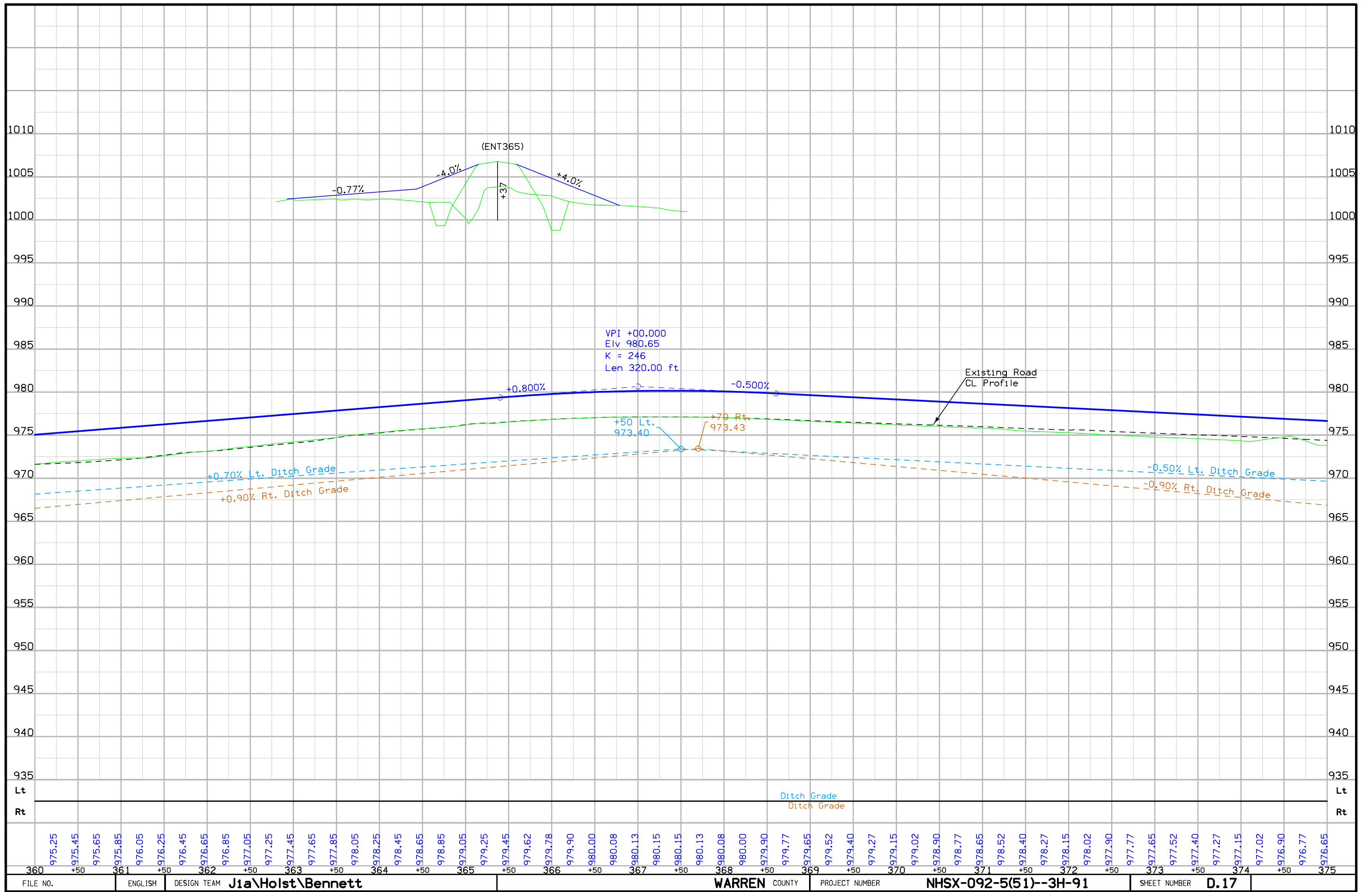

FILE NO.	ENGLISH	DESIGN TEAM	J1a\Holst\Bennett	WARREN COUNTY	PROJECT NUMBER	NHSX-092-5(51)--3H-91	SHEET NUMBER	D.17
----------	---------	-------------	-------------------	---------------	----------------	-----------------------	--------------	------

Lincoln TWP.
T-76N R-24W
SEC. 27

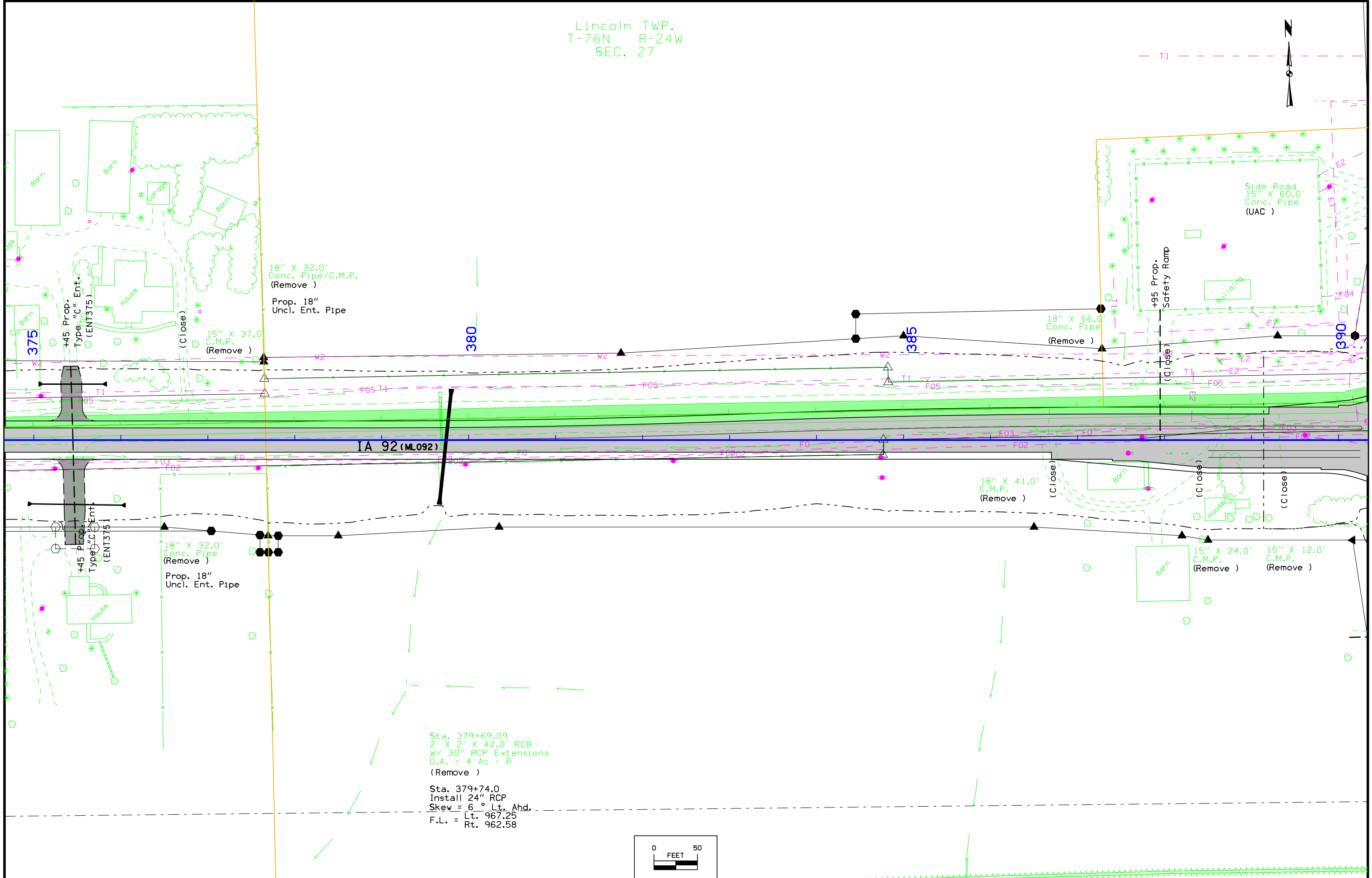

Sta. 379+69.09
2' X 2' X 42.0' RCB
W/ 30" RCP Extensions
D.A. = 4 Ac - R
(Remove)
Sta. 379+74.0
Install 24" RCP
Skew = 6° Lt. Ahd.
F.L. = Lt. 967.25
Rt. 962.58

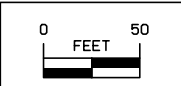

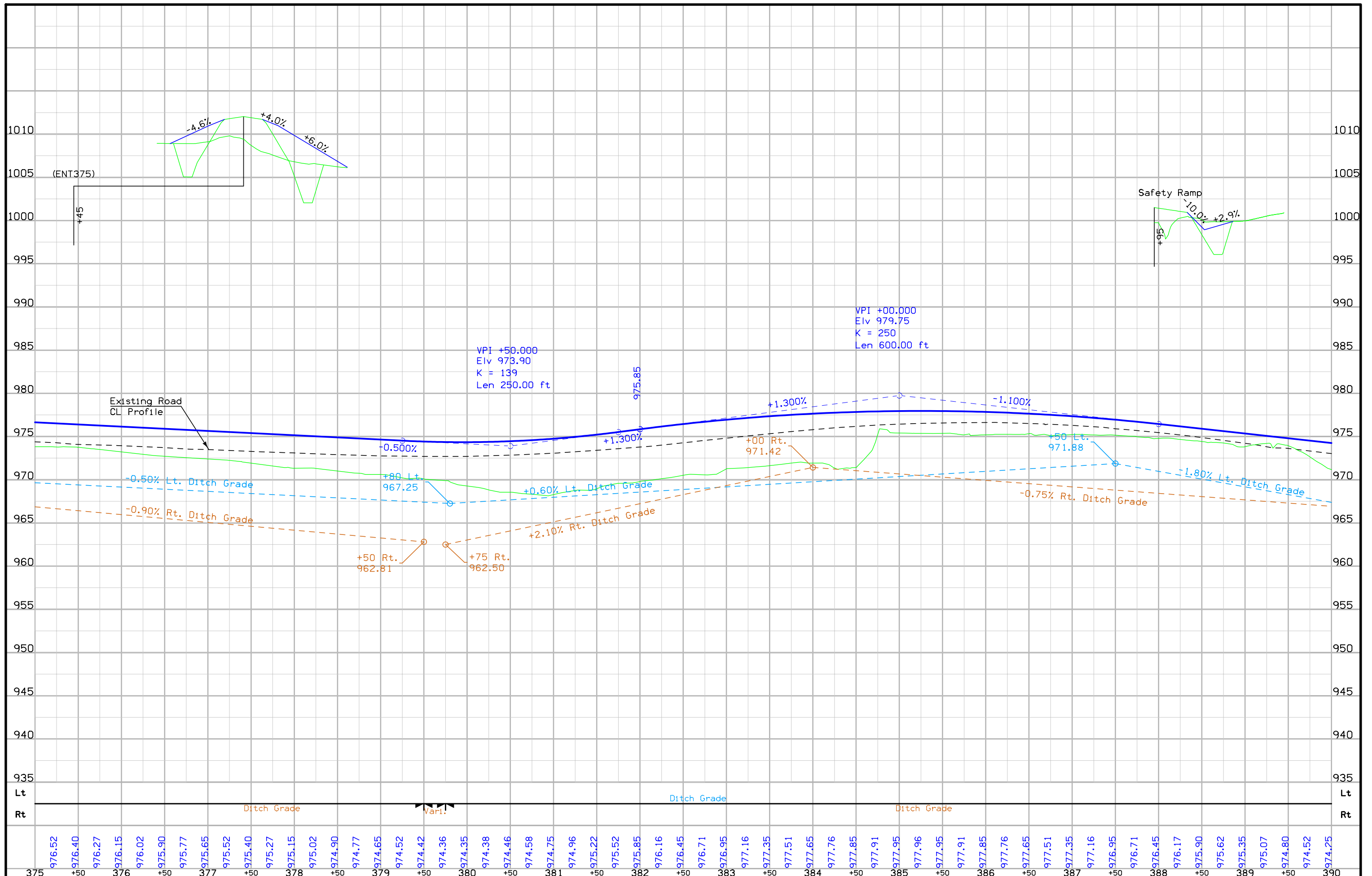

FILE NO.	ENGLISH	DESIGN TEAM	J1a\Holst\Bennett	WARREN COUNTY	PROJECT NUMBER	NHSX-092-5(51)--3H-91	SHEET NUMBER	D.19
----------	---------	-------------	-------------------	---------------	----------------	-----------------------	--------------	------

Lincoln TWP.
T-76N R-24W
SEC. 27

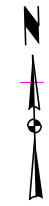

Curve Data
 $\Delta = 0^\circ 19' 35.74''$ (RT)
 $PT = 34.20$
 $PI = 68.40$
 $PC = 12,000.00$
 $E = 0.05$

Side Road
 $15'' \times 43.0'$
 C.M.P.
 (UAC)

PI Sta 391+01.81
 (Survey)

PI Sta 391+01.93

$18'' \times 243.0'$
 Conc. Pipe
 (UAC)

$24'' \times 88.0'$
 Conc. Pipe
 (UAC)

$15'' \times 30.0'$
 Conc. Pipe
 (Remove)

$15'' \times 48.0'$
 Conc. Pipe
 (UAC)

$24'' \times 80.0'$
 Conc. Pipe
 (UAC)

+16.98 Prop.
 Type "B" Ent.

400

405

IA 92 (ML092)

Side Road
 $15'' \times 28.0'$
 C.M.P.
 (Remove)

Side Road
 $15'' \times 56.0'$
 C.M.P.
 (Remove)

Sta. 390+78.55
 $2' \times 2' \times 132.0'$ RCB
 W/ 30" RCP Extensions
 D.A. = 7 Ac - R
 (Remove)

Sta. 391+07.0
 Install 24" RCP
 Skew = 37° Rt. Ahd.
 Lt. 966.73
 Rt. 963.79

Sta. 395+43.91
 $2' \times 2' \times 43.0'$ RCB
 W/ 30" RCP Extensions
 D.A. = 9 Ac - R
 (Remove)

Sta. 391+29.59, 61.89 Lt.
 $24'' \times 60.0'$ Conc Pipe
 D.A. = 3 Ac - R
 (Remove)



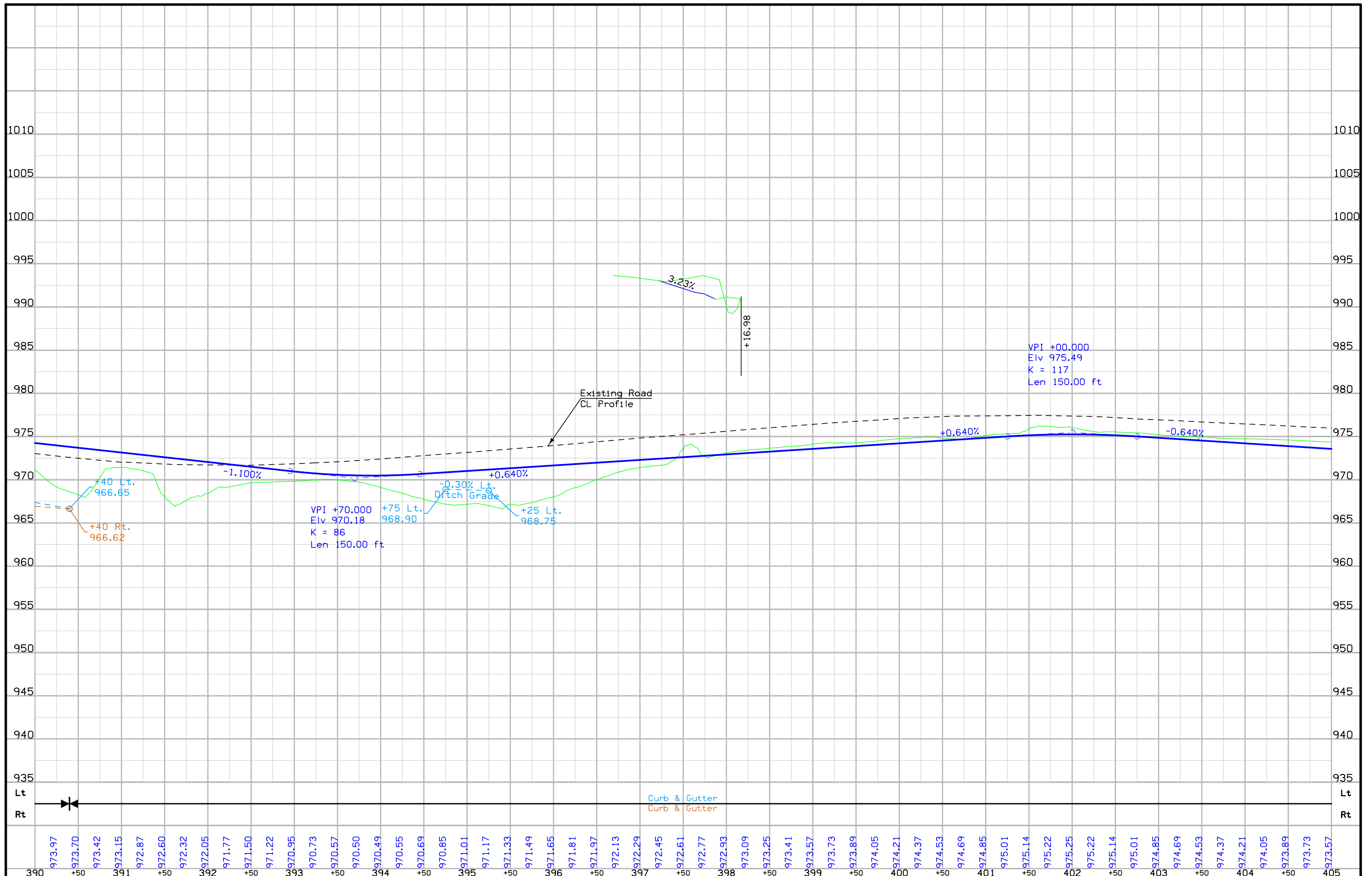

FILE NO.	ENGLISH	DESIGN TEAM	J1a\Holst\Bennett	WARREN COUNTY	PROJECT NUMBER	NHSX-092-5(51)--3H-91	SHEET NUMBER	D.21
----------	---------	-------------	-------------------	---------------	----------------	-----------------------	--------------	------

4:12:36 PM 7/11/2014 jholst pw:\projectwise.dot.int.lan:PWMain\Documents\Projects\9109201004\Design\91092051002.sht

Lincoln TWP.
T-76N R-24W
SEC. 27

Sta. 417+03.73, 37.07 Lt.
22' X 14" X 60.0' Arch Conc Pipe
D.A. = 4 Ac - r
(Remove)

Curve Data
 $\Delta = 0^\circ 25' 37.45''$ (LT)
T = 44.72
L = 89.45
R = 12,000.00
E = 0.08

PI Sta 417+36.67
(Survey)

15" X 148.0
C.M.P.
(Remove)

+80.63 Prop. Jt.
Type "B" Ent.

+00 Prop.
Type "C" Ent.

15" X 24.0'
C.M.P.
(Remove)

+00 Prop.
Type "C" Ent.

410

415

420

IA 92 (ML092)

PC Sta 416+90.59

PI Sta 417+35.31

PT Sta 417+80.03

Sta. 412+66.92, 247.41 RT
6 Tile Riser Intake
D.A. = 5A - R
(U.A.C.)

Sta. 414+54.06, 307.09 RT
6 Tile Riser Intake
D.A. = 2A - R
(U.A.C.)

Sta. 417+30.31, 350.36 Rt
30" X 44.0' CMP
D.A. = 16 Ac - R
(Remove)

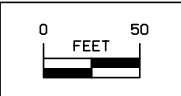

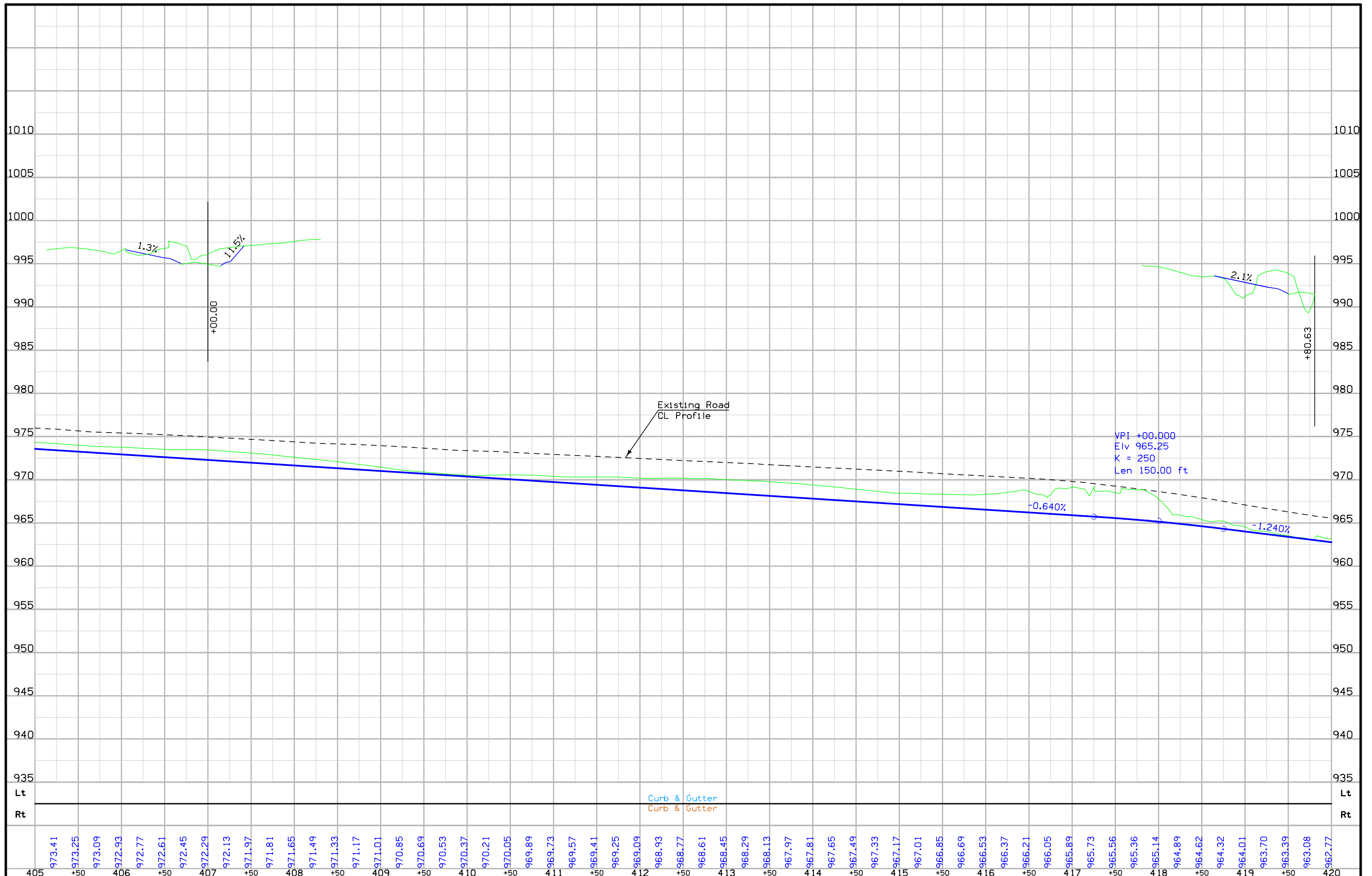

FILE NO.	ENGLISH	DESIGN TEAM	J1a\Holst\Bennett	WARREN COUNTY	PROJECT NUMBER	NHSX-092-5(51)--3H-91	SHEET NUMBER	D.23
----------	---------	-------------	-------------------	---------------	----------------	-----------------------	--------------	------

Lincoln TWP.
T-76N R-24W
SEC. 26

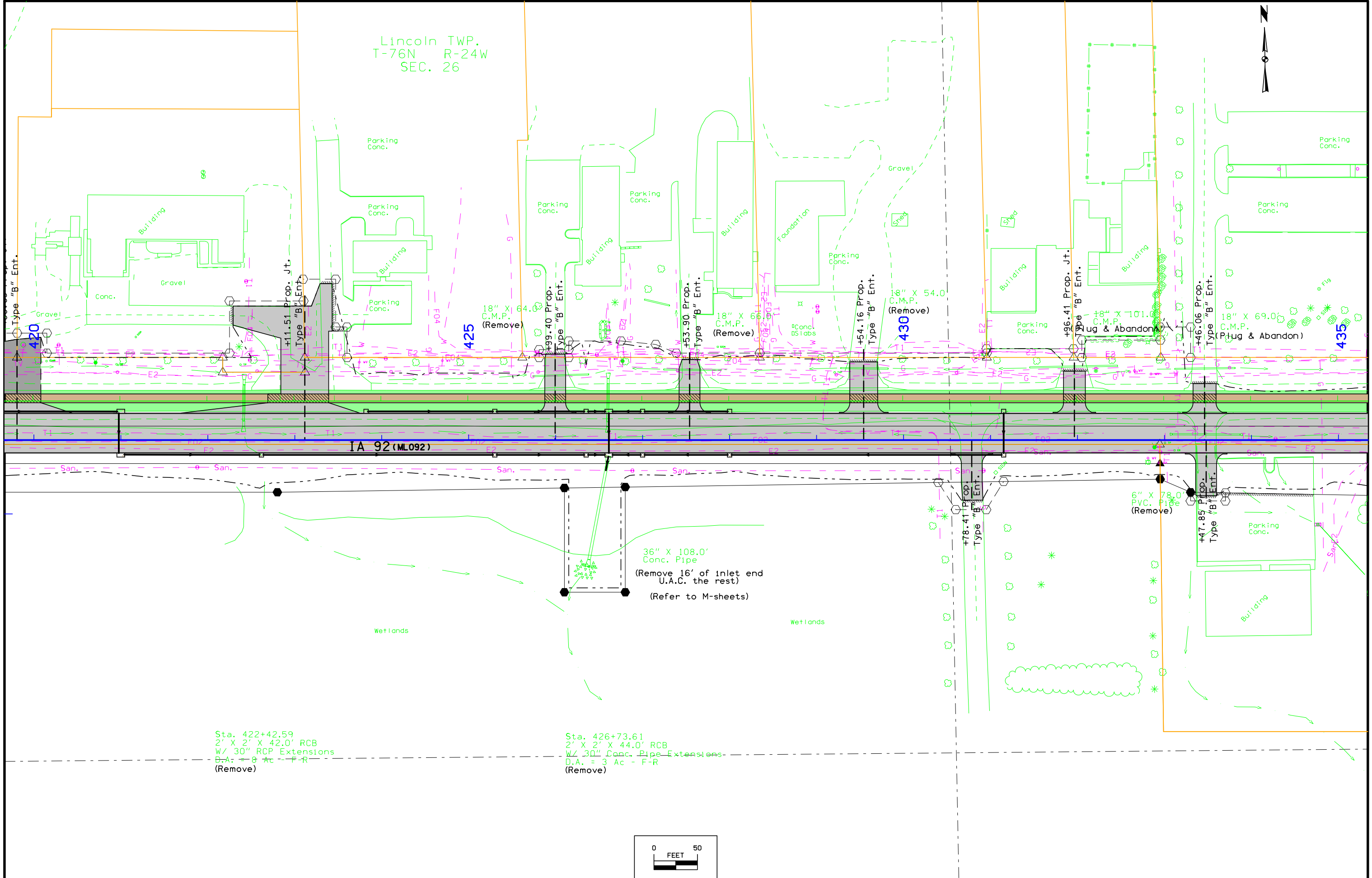

Sta. 422+42.59
2' X 2' X 42.0' RCB
W/ 30" RCP Extensions
D.A. = 8 Ac - F-R
(Remove)

Sta. 426+73.61
2' X 2' X 44.0' RCB
W/ 30" Conc. Pipe Extensions
D.A. = 3 Ac - F-R
(Remove)

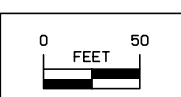

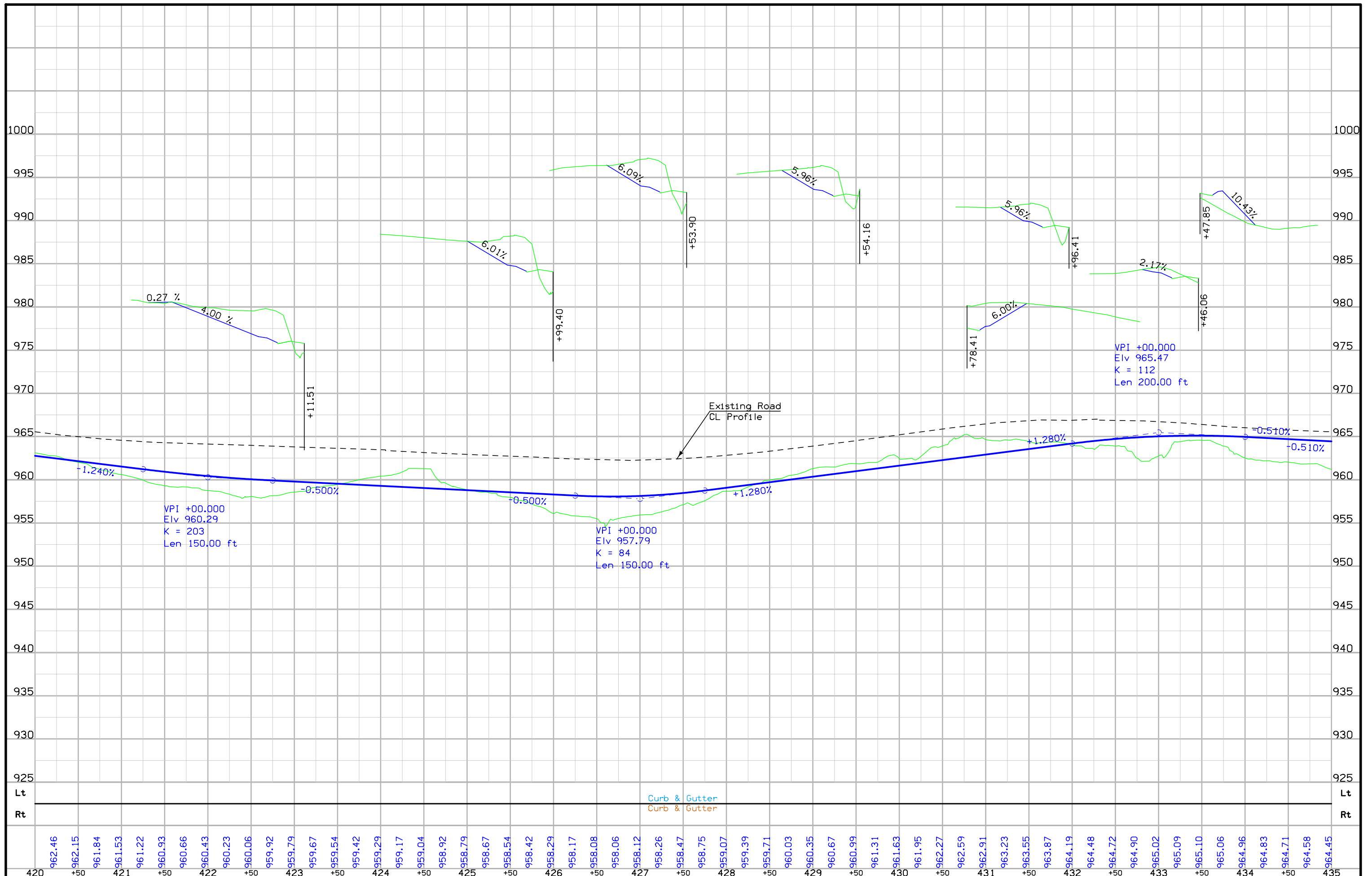

FILE NO.	ENGLISH	DESIGN TEAM	J1a\Holst\Bennett	WARREN COUNTY	PROJECT NUMBER	NHSX-092-5(51)--3H-91	SHEET NUMBER	D.25
----------	---------	-------------	-------------------	---------------	----------------	-----------------------	--------------	------

4:12:46 PM 7/11/2014 jholst pw:\projectwise.dot.int.lan:PWMain\Documents\Projects\9109201004\Design\91092051002.sht

Lincoln TWP.
T-76N R-24W
SEC. 26

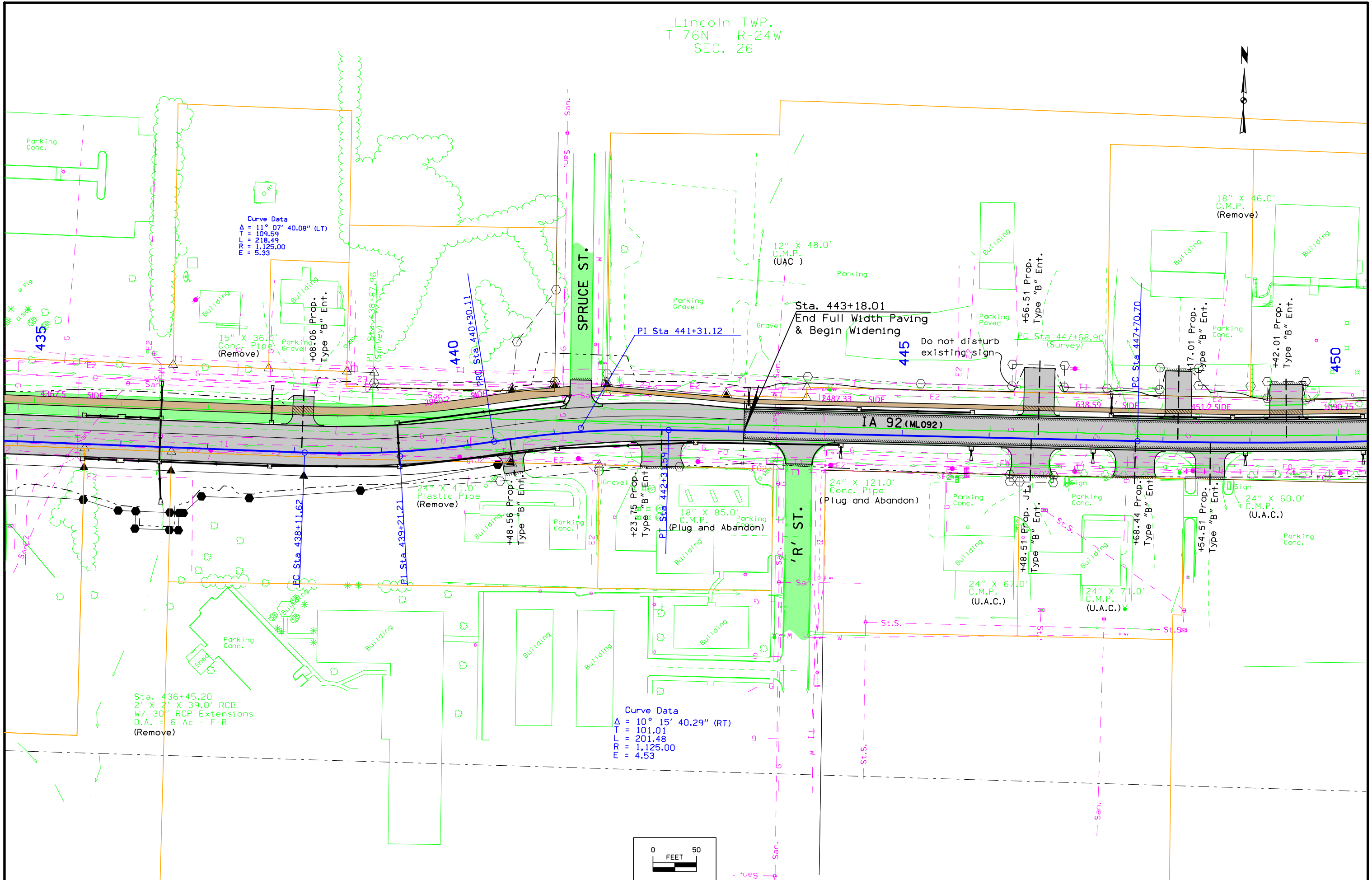

Curve Data
Δ = 11° 07' 40.08" (LT)
T = 109.59
L = 218.49
R = 1,125.00
E = 5.33

Curve Data
Δ = 10° 15' 40.29" (RT)
T = 101.01
L = 201.48
R = 1,125.00
E = 4.53

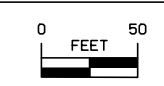

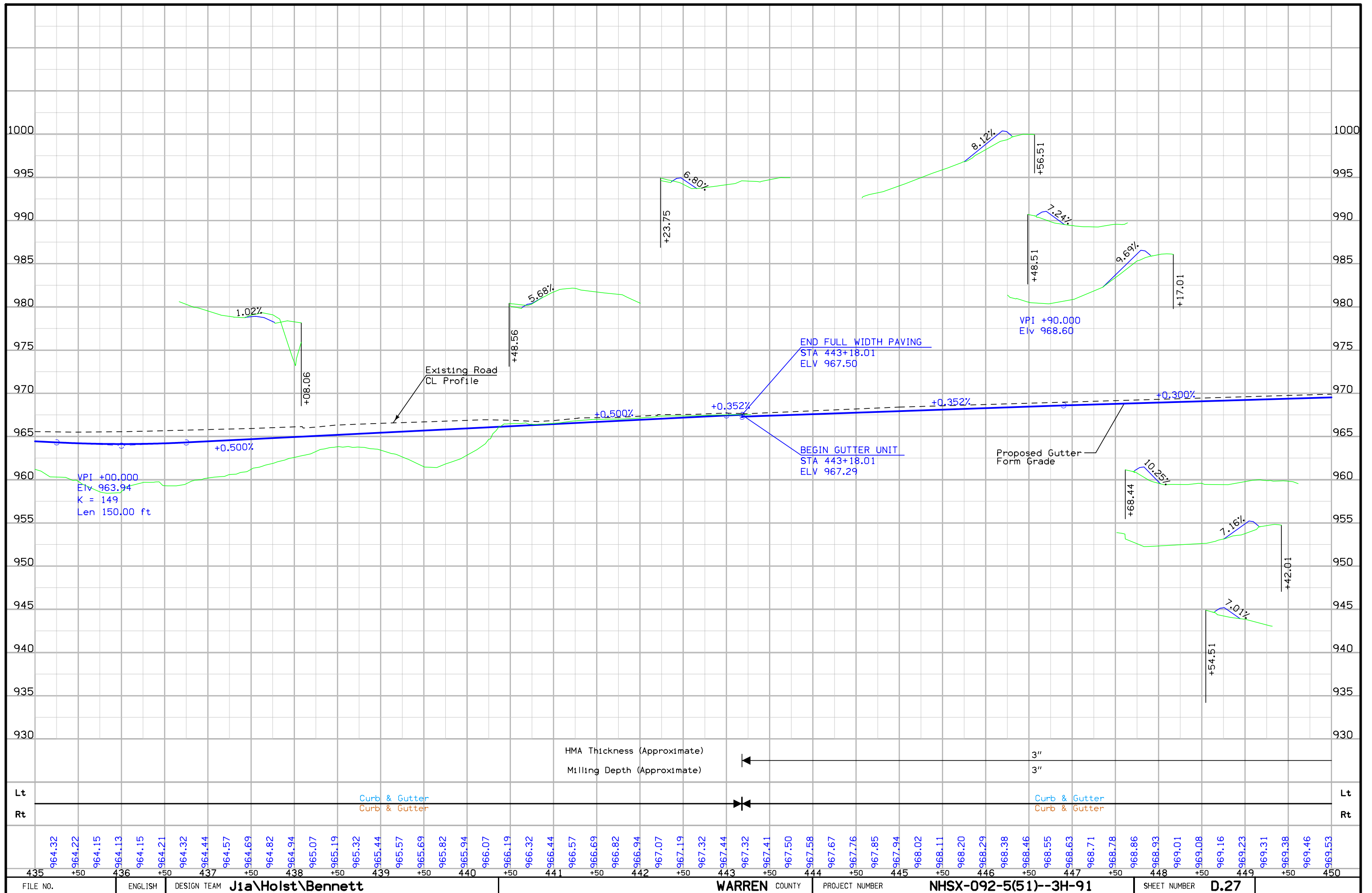

HMA Thickness (Approximate) 3"
 Milling Depth (Approximate) 3"

Lt Curb & Gutter Rt
 Rt Curb & Gutter Lt

964.32	964.22	964.15	964.13	964.15	964.21	964.32	964.44	964.57	964.69	964.82	964.94	965.07	965.19	965.32	965.44	965.57	965.69	965.82	965.94	966.07	966.19	966.32	966.44	966.57	966.69	966.82	966.94	967.07	967.19	967.32	967.44	967.32	967.41	967.50	967.58	967.67	967.76	967.85	967.94	968.02	968.11	968.20	968.29	968.38	968.46	968.55	968.63	968.71	968.78	968.86	968.93	969.01	969.08	969.16	969.23	969.31	969.38	969.46	969.53
435	+50	436	+50	437	+50	438	+50	439	+50	440	+50	441	+50	442	+50	443	+50	444	+50	445	+50	446	+50	447	+50	448	+50	449	+50	450																													

Lincoln TWP.
T-76N R-24W
SEC. 26

Curve Data
Δ = 6° 59' 27.10" (LT)
T = 351.79
L = 702.70
R = 5,759.23
E = 10.73

Curve Data (Survey)
Δ = 6° 59' 27.10" (LT)
T = 351.30
L = 701.73
R = 5,751.23
E = 10.72

Sta. 455+27.49, 27.81 Lt
18" X 72.0 Conc. Pipe
D.A. = .3 Ac - F
(Plug & Abandon)

Sta. 462+04.63
18" X 60.0' Conc. Pipe
D.A. = 2 Ac - F
(Plug & Abandon)

Sta. 465+03.68
End Project

Sta. 465+01.01
End Widening

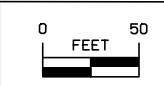
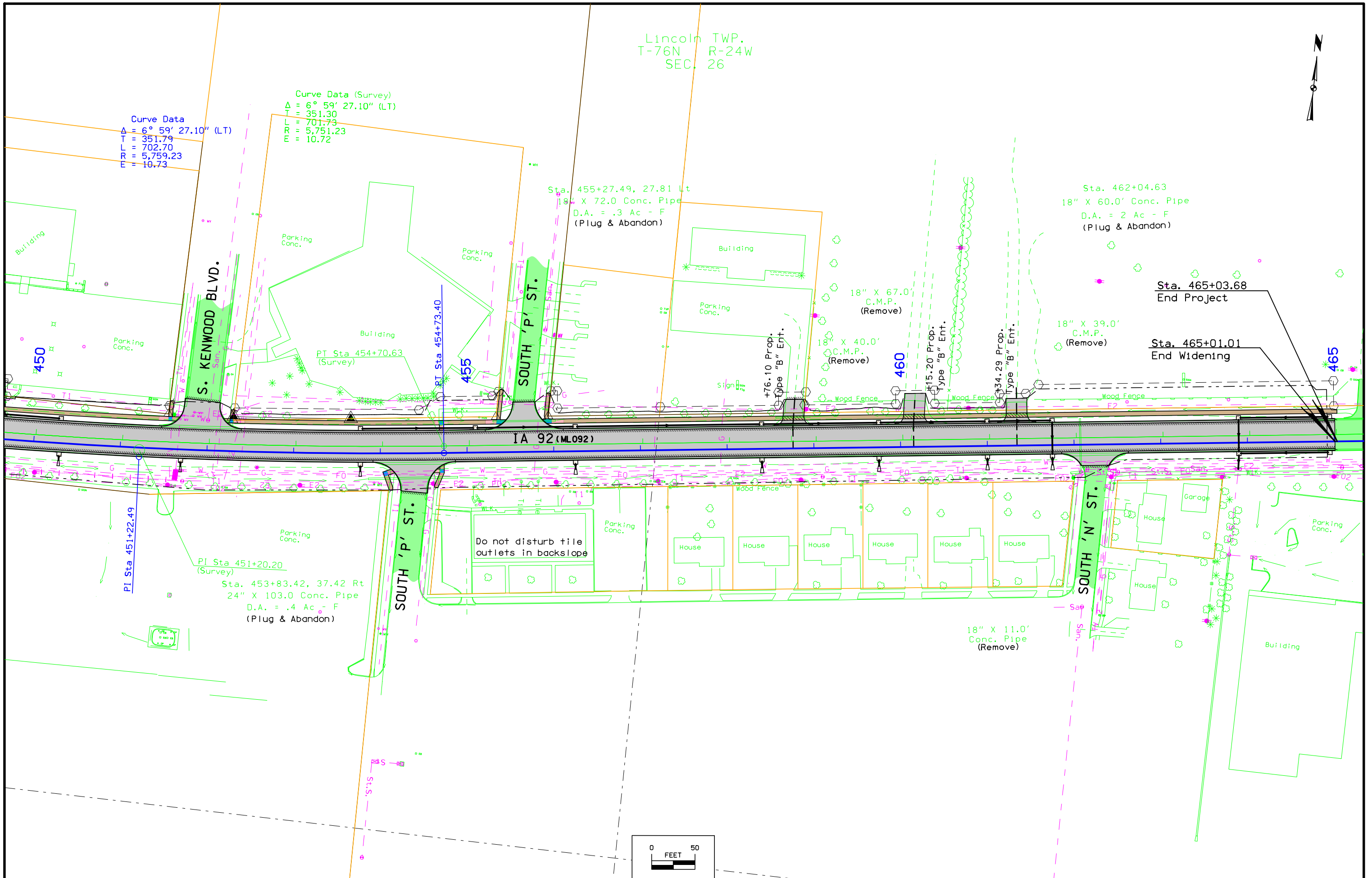

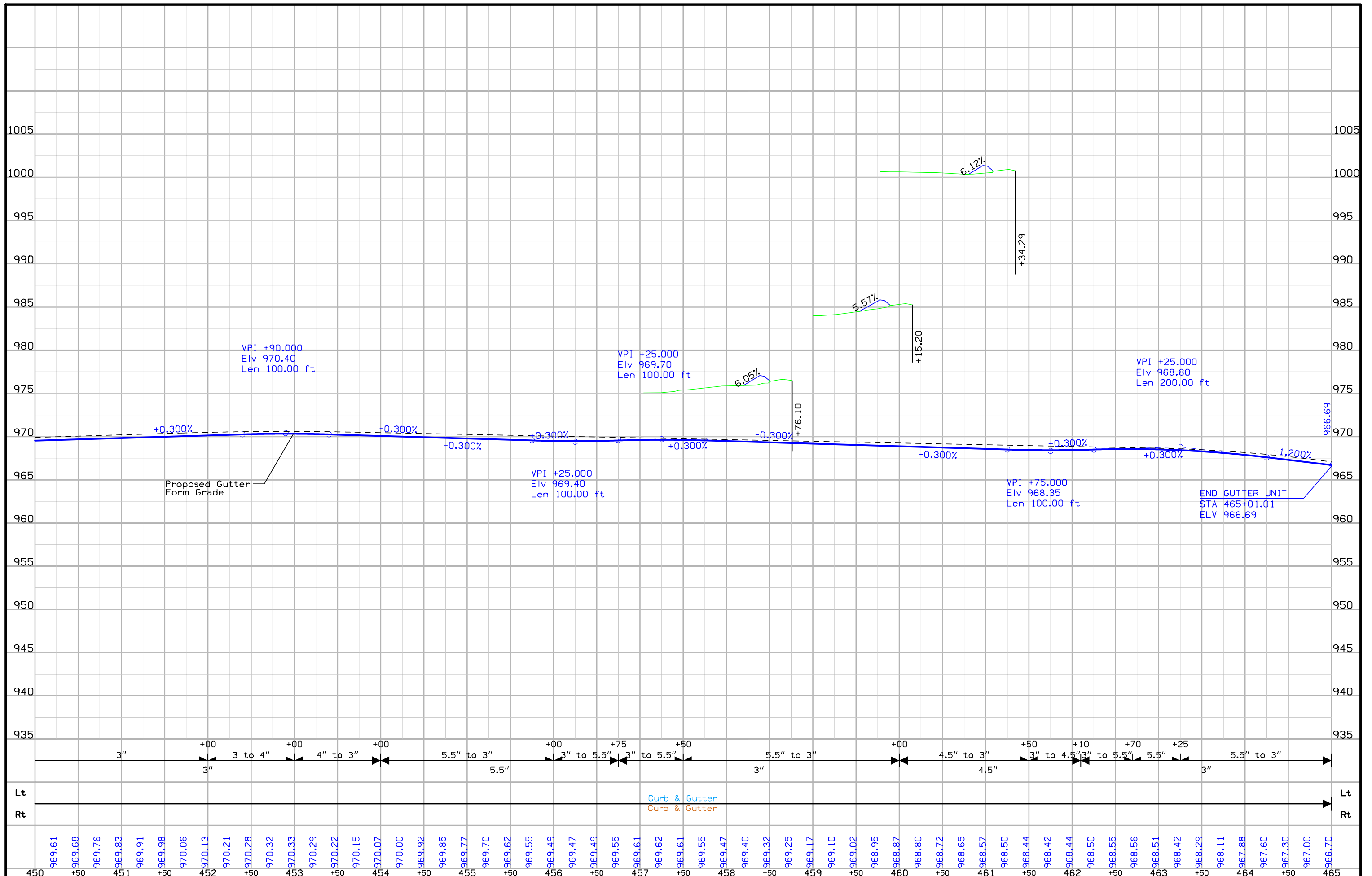

FILE NO.	ENGLISH	DESIGN TEAM	J1a\Holst\Bennett	WARREN COUNTY	PROJECT NUMBER	NHSX-092-5(51)--3H-91	SHEET NUMBER	D.29
----------	---------	-------------	-------------------	---------------	----------------	-----------------------	--------------	------

Lincoln TWP.
T-76N R-24W
SEC. 30

Lincoln TWP.
T-76N R-24W
SEC. 29

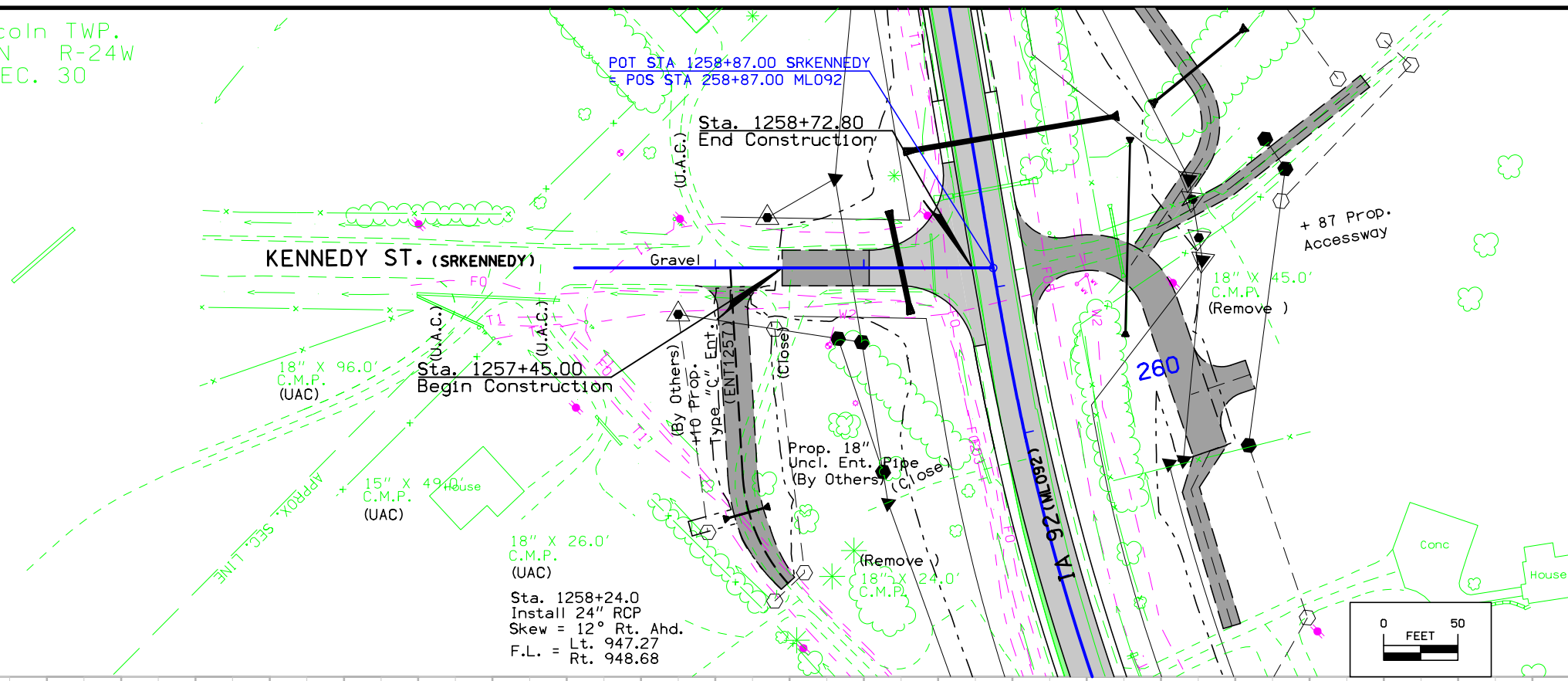

KENNEDY ST

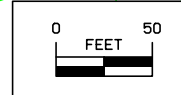

Sta. 1258+24.0
Install 24" RCP
Skew = 12° Rt. Ahd.
F.L. = Lt. 947.27
Rt. 948.68

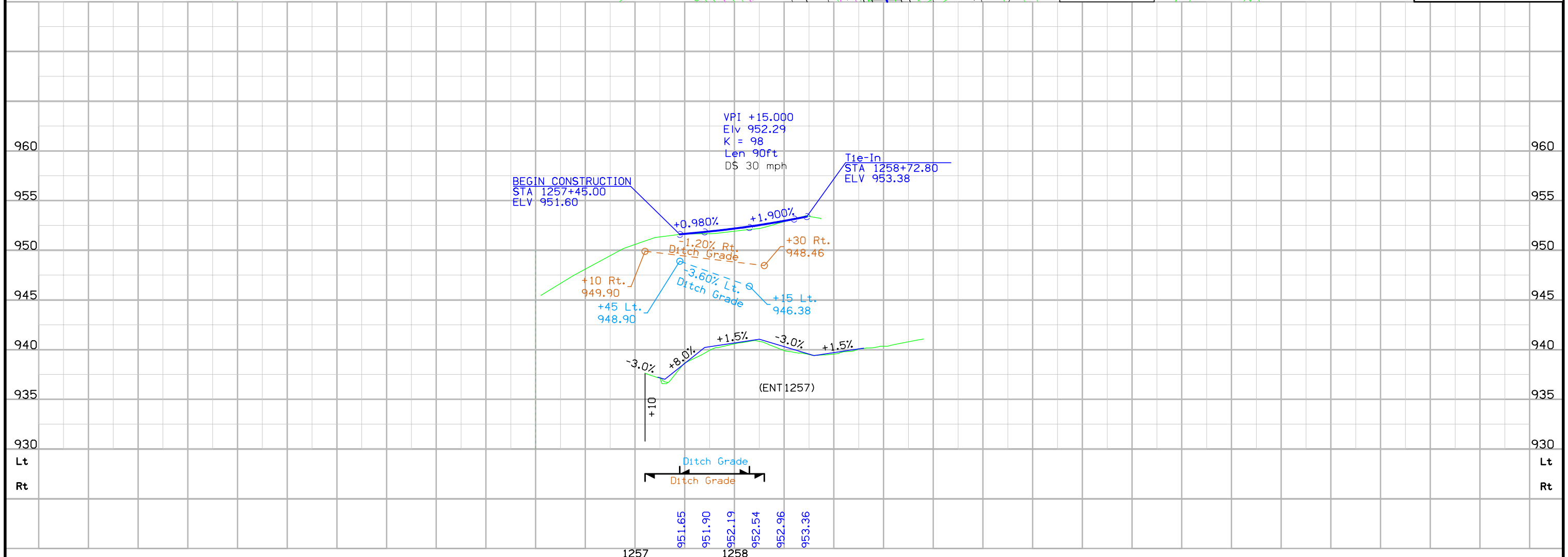

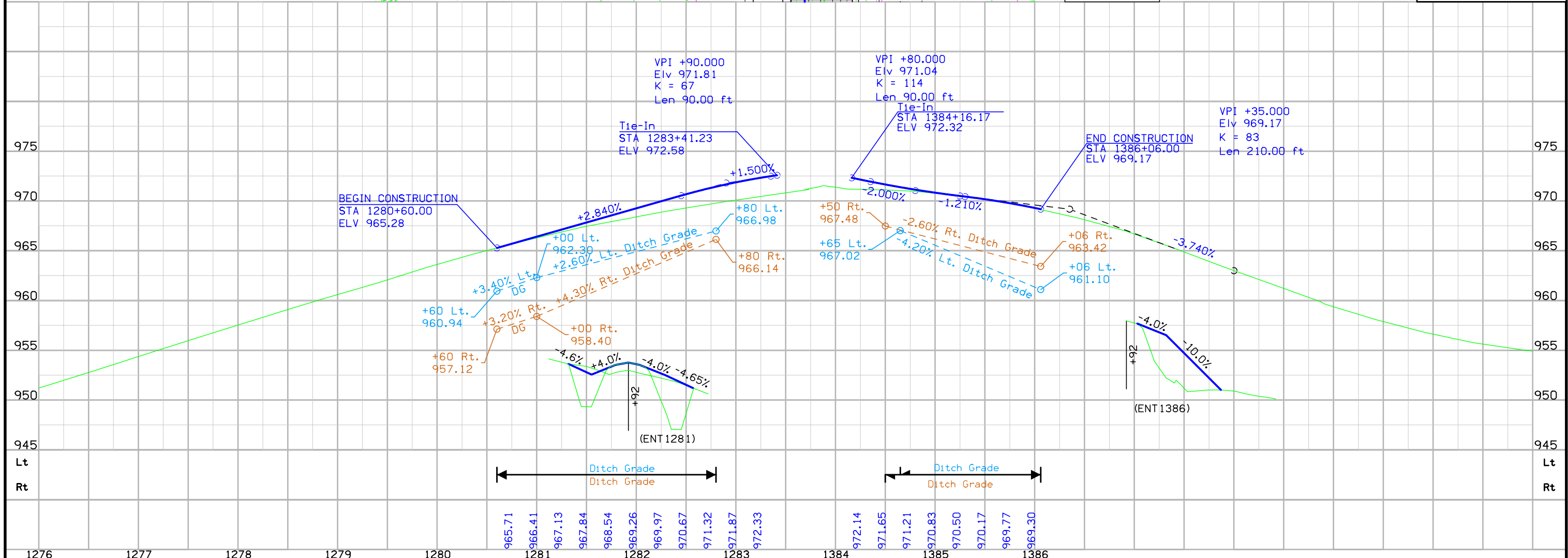
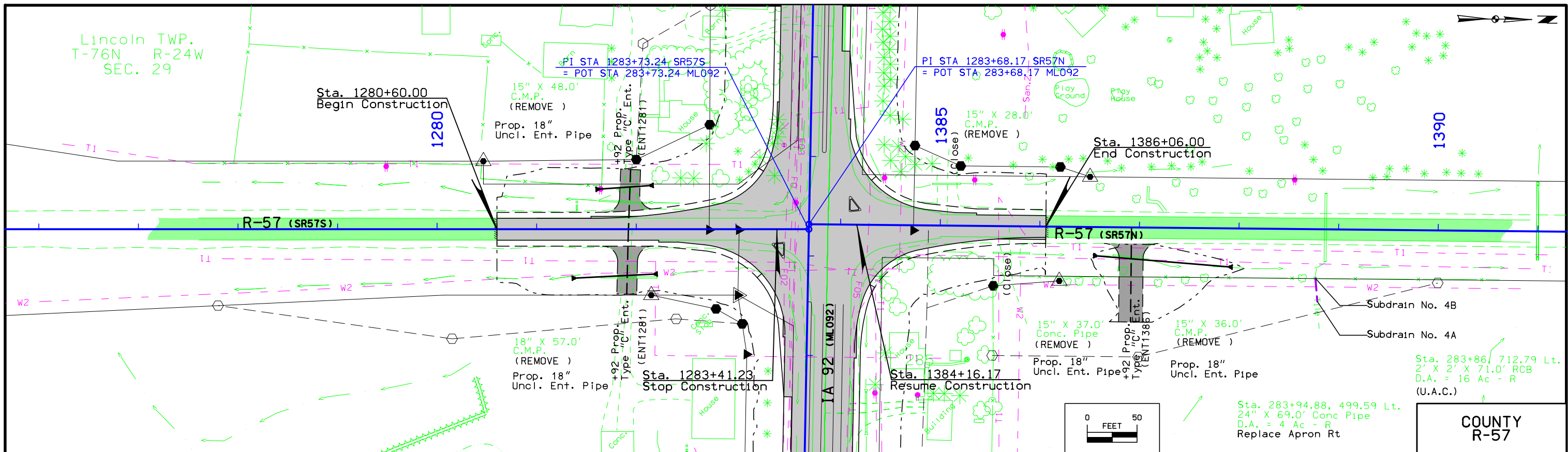

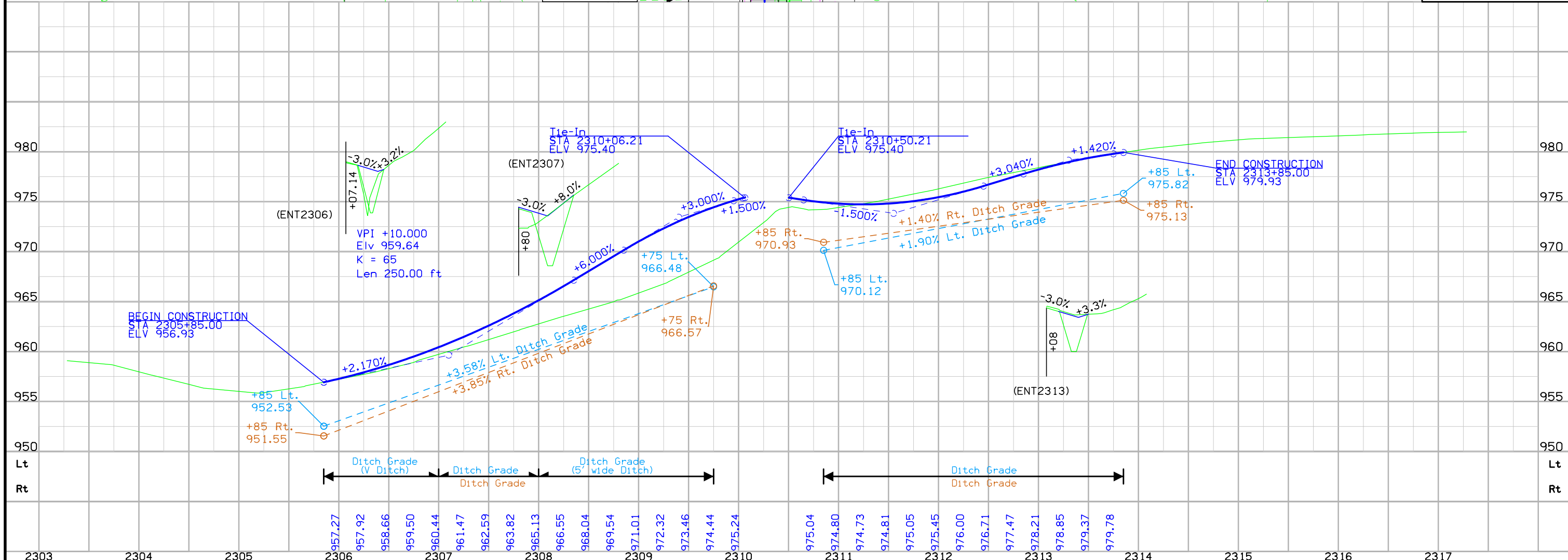
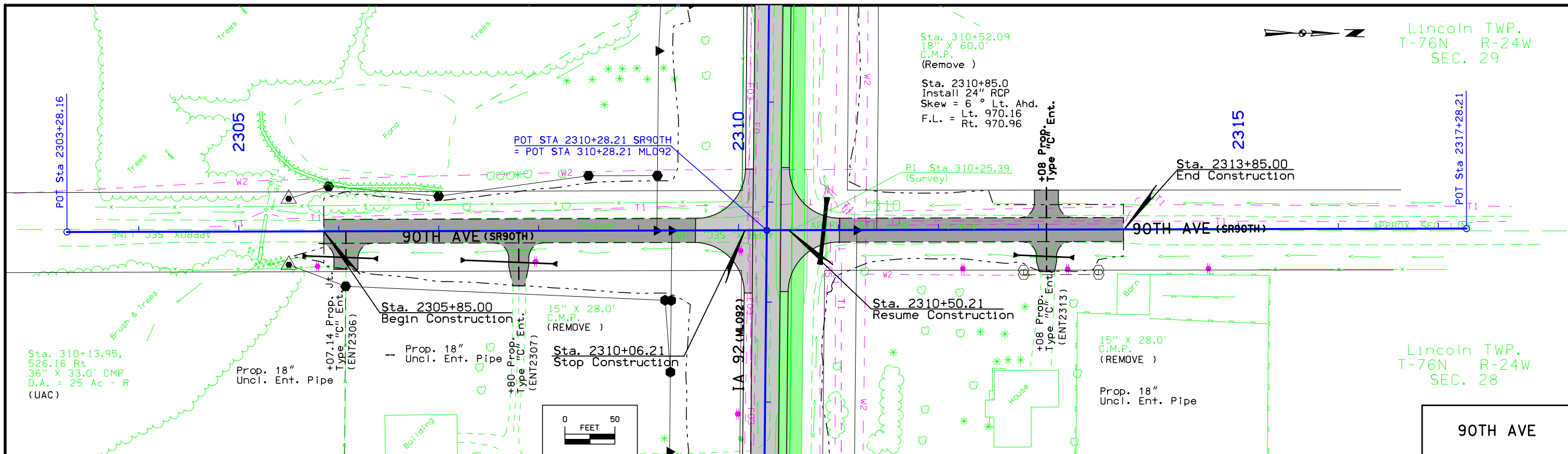

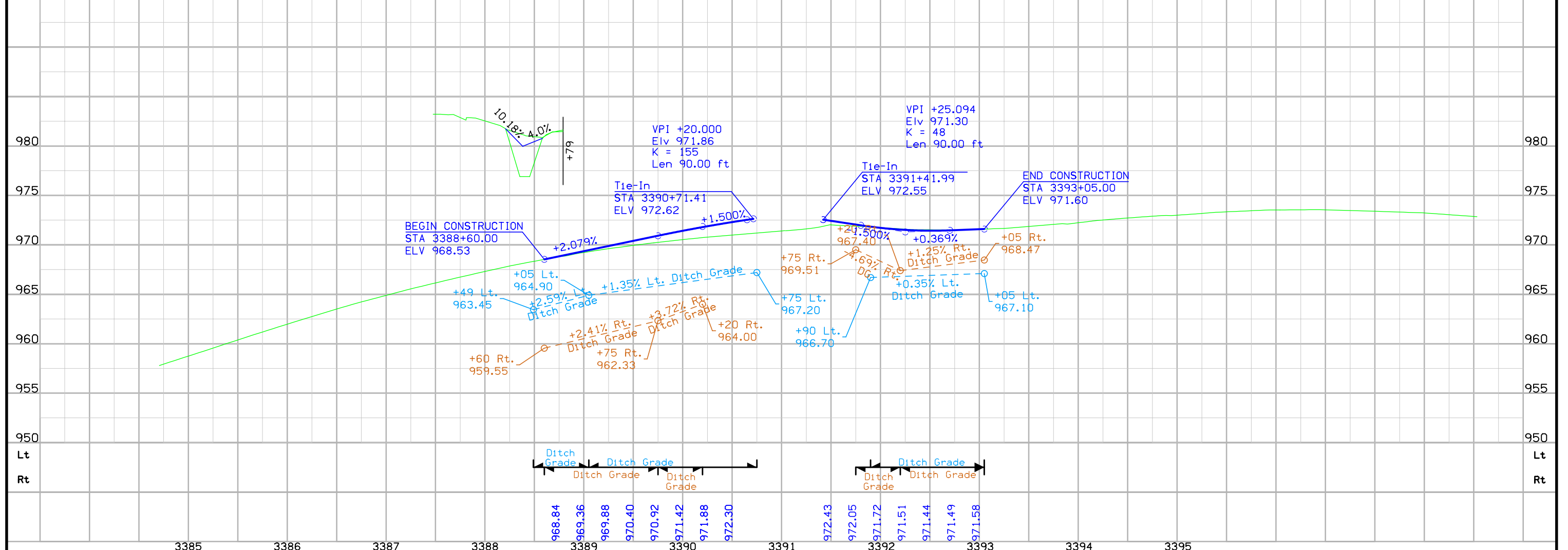
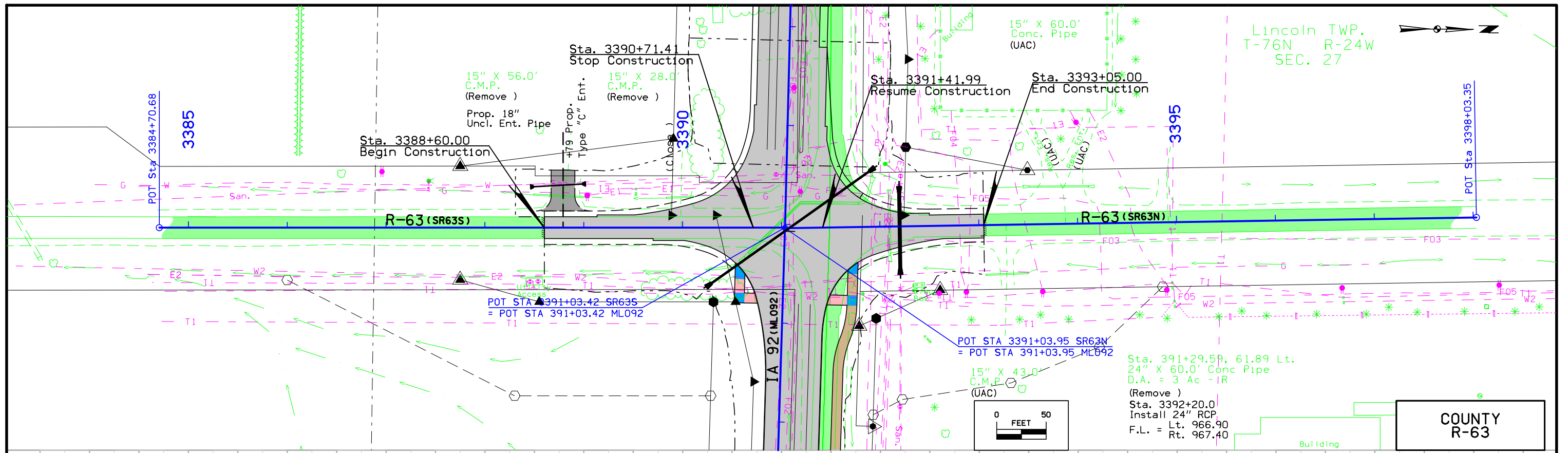

FILE NO.	ENGLISH	DESIGN TEAM	J1a\Holst\Bennett	WARREN COUNTY	PROJECT NUMBER	NHSX-092-5(51)--3H-91	SHEET NUMBER	E.4
----------	---------	-------------	-------------------	---------------	----------------	-----------------------	--------------	-----

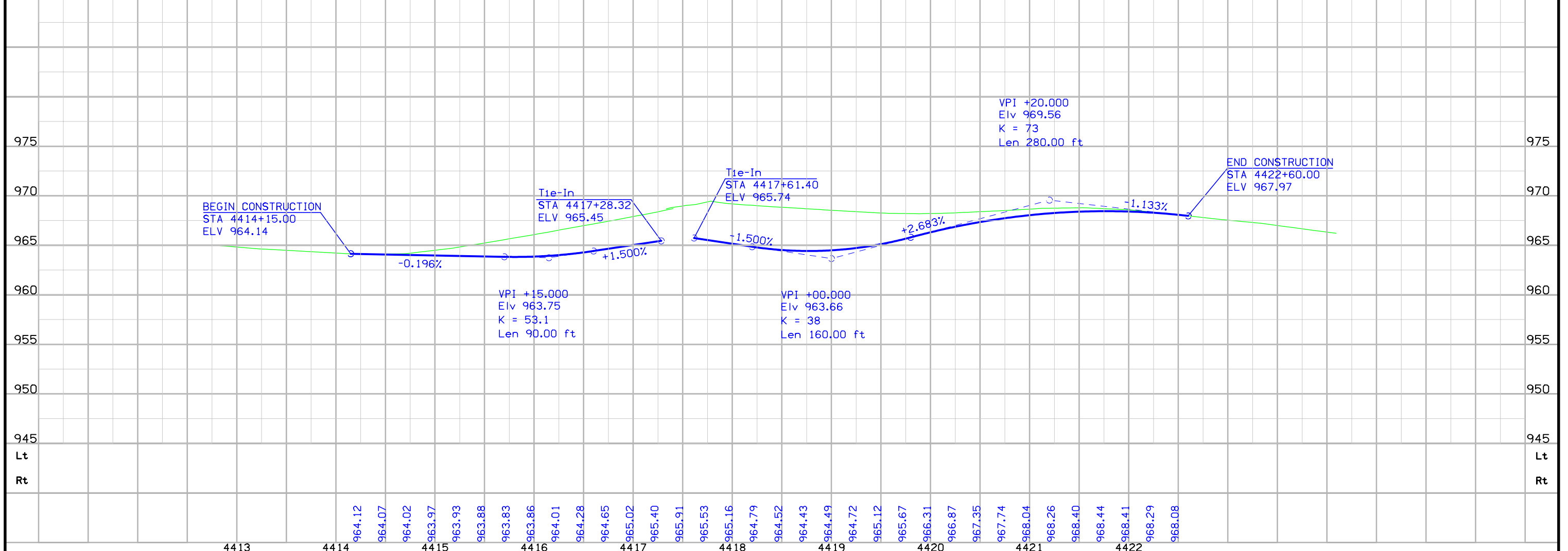
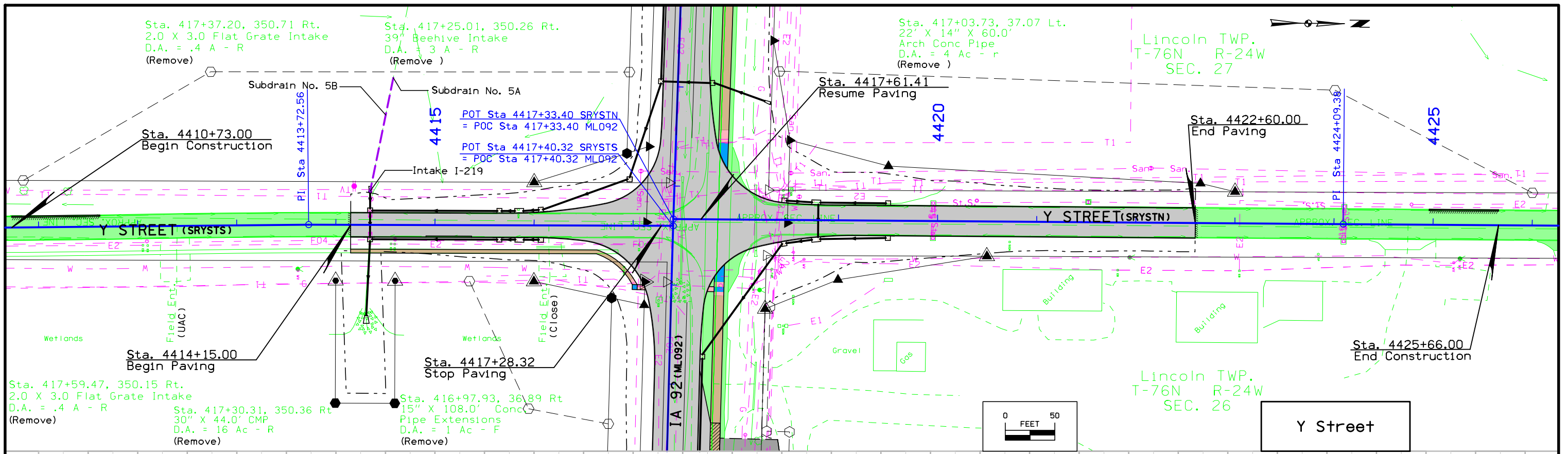

FILE NO.	ENGLISH	DESIGN TEAM	J1a\Holst\Bennett	WARREN COUNTY	PROJECT NUMBER	NHSX-092-5(51)--3H-91	SHEET NUMBER	E.5
----------	---------	-------------	-------------------	---------------	----------------	-----------------------	--------------	-----

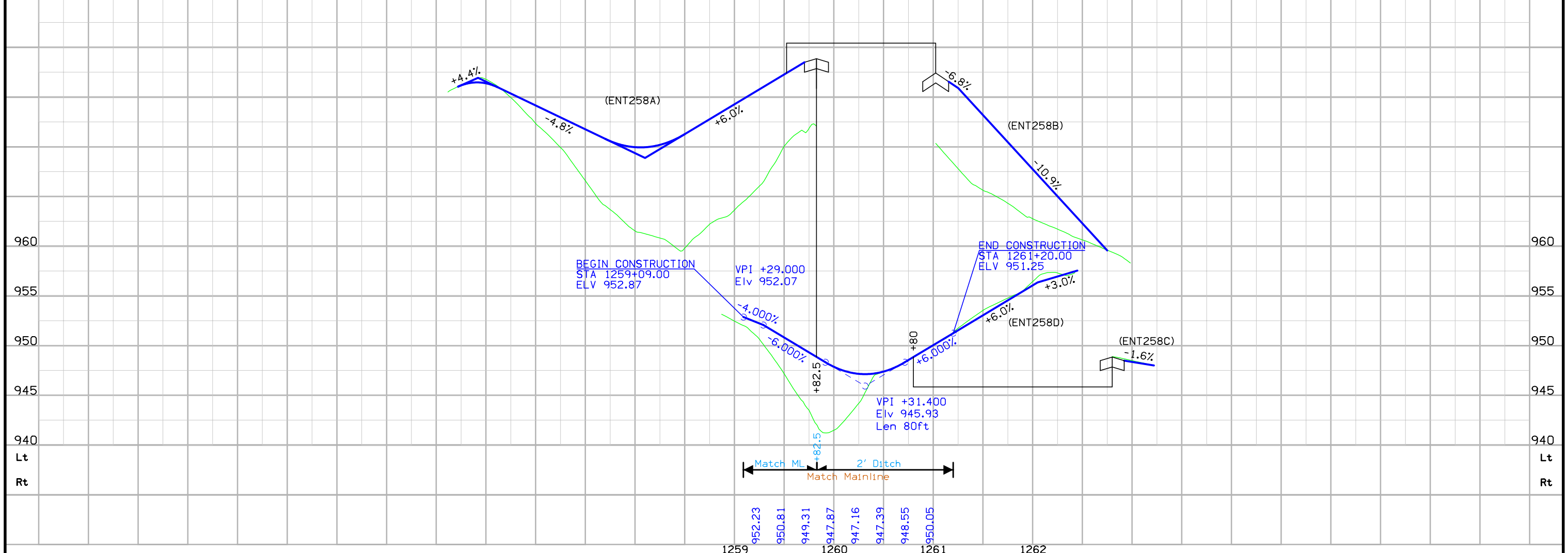
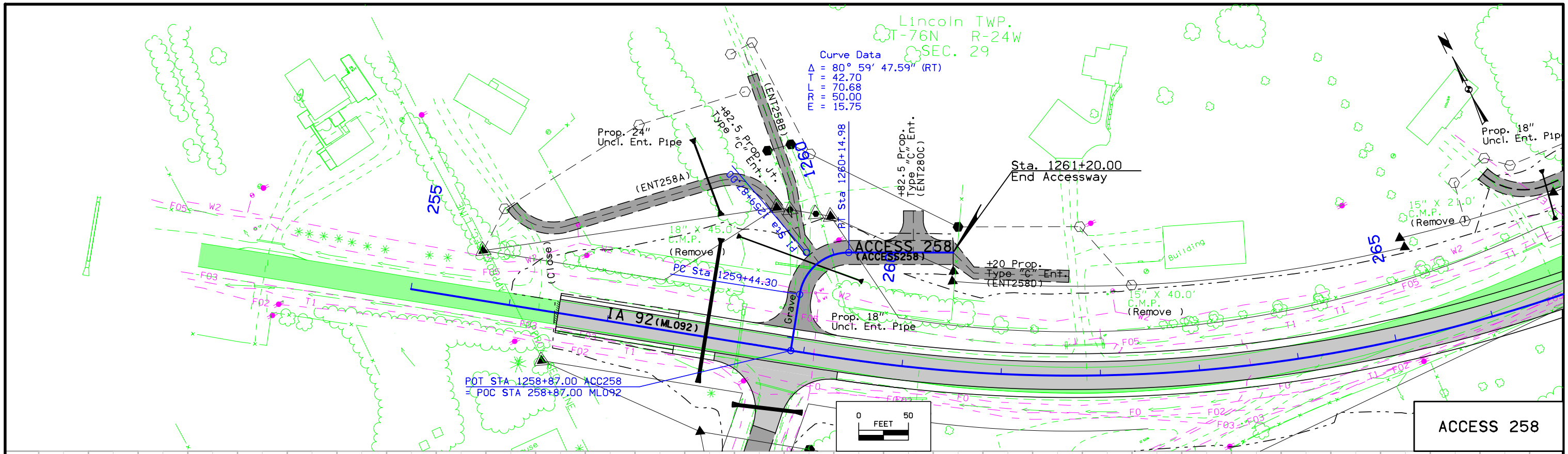

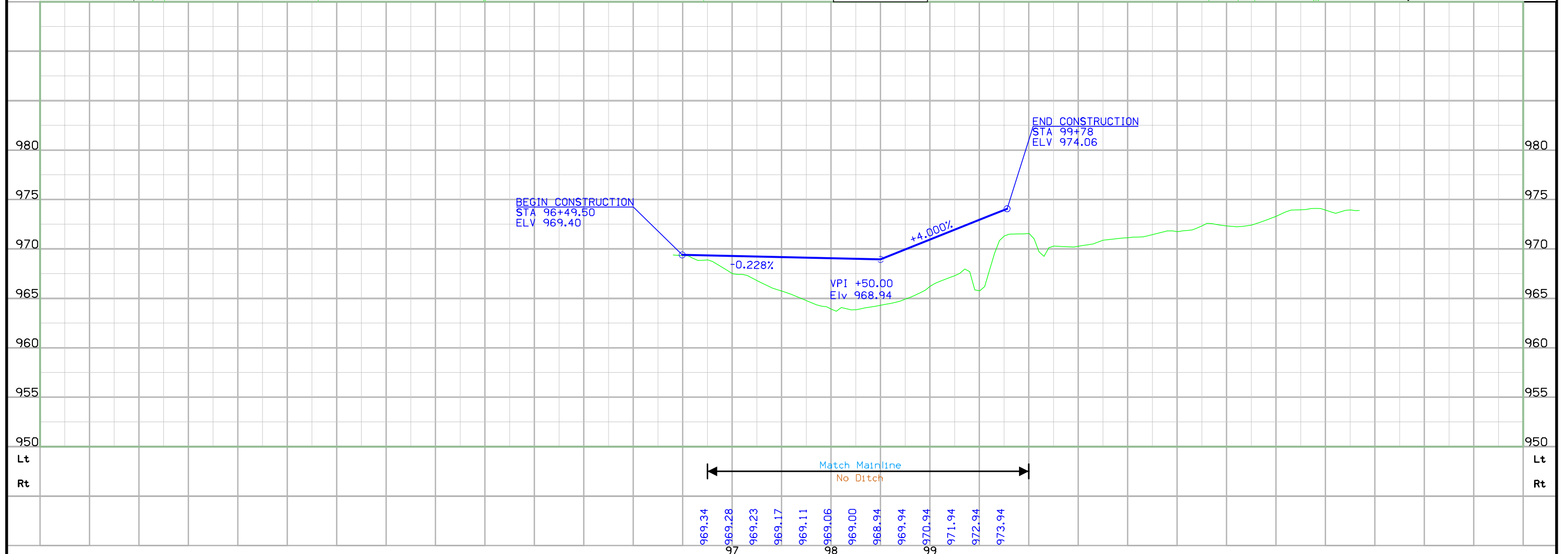
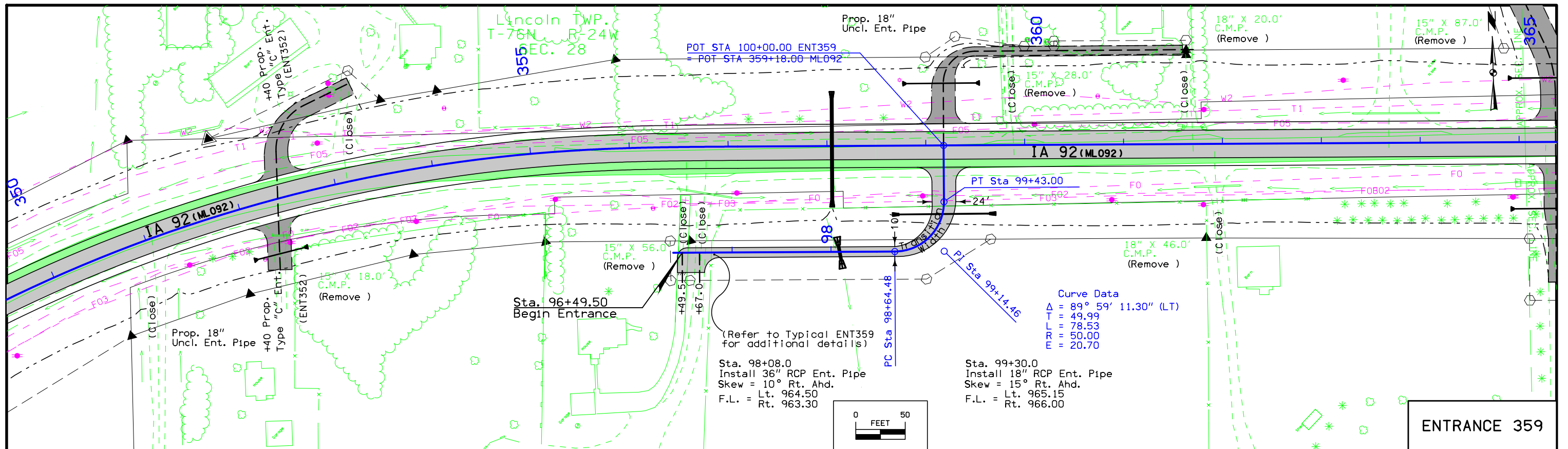

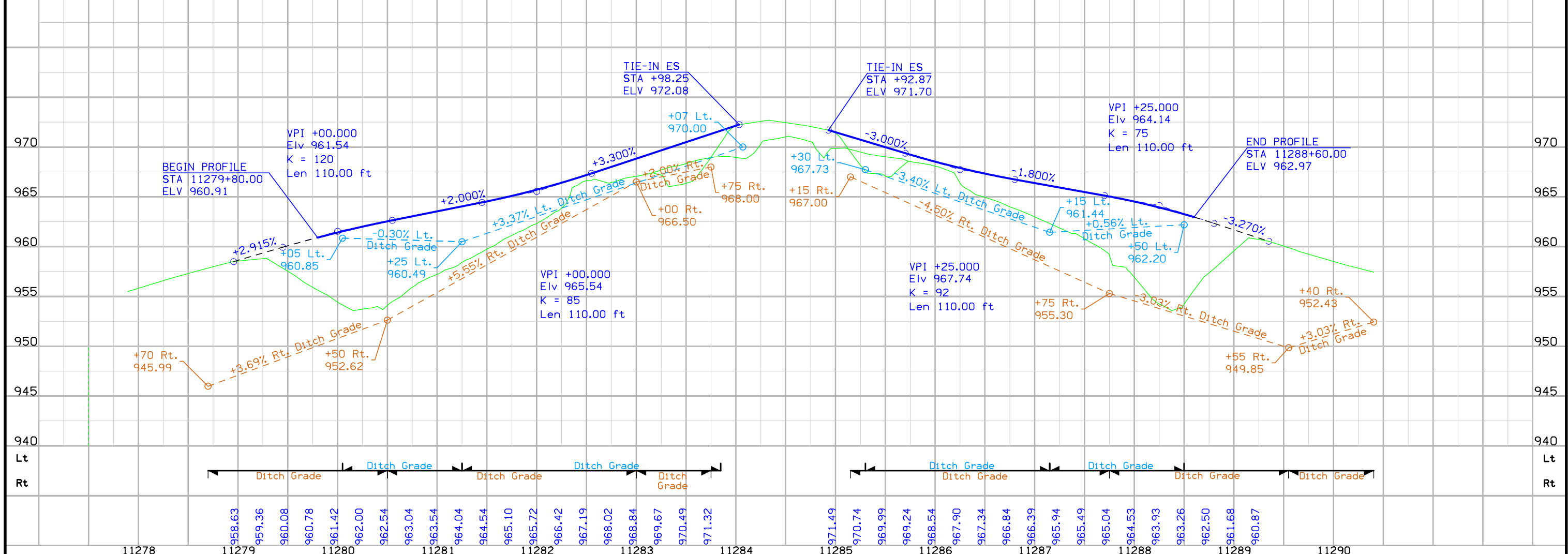
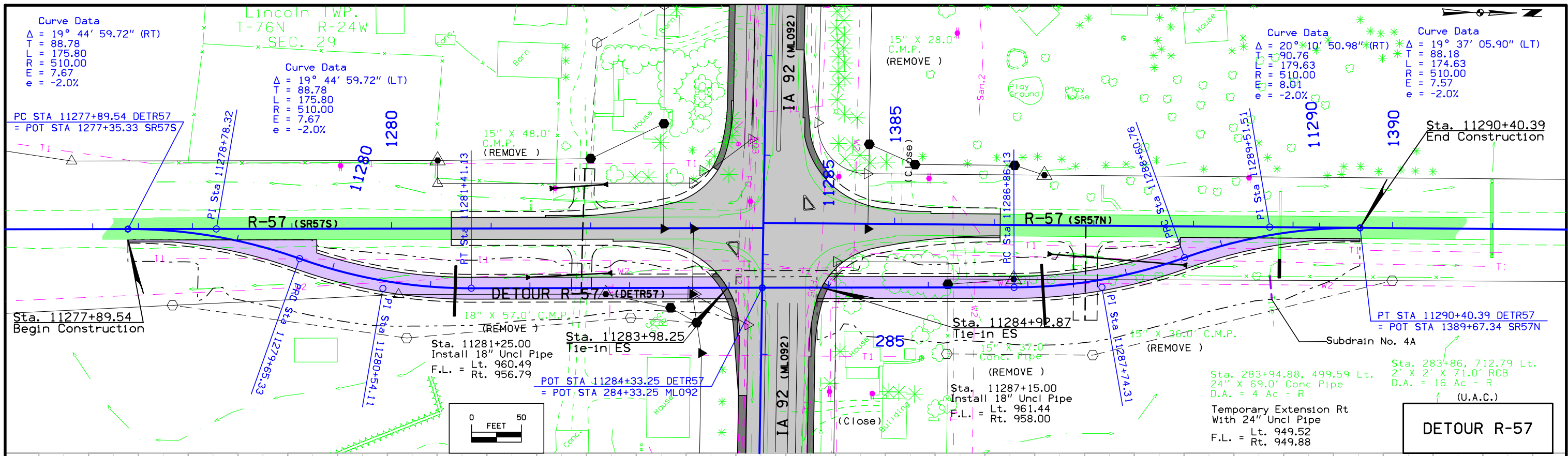

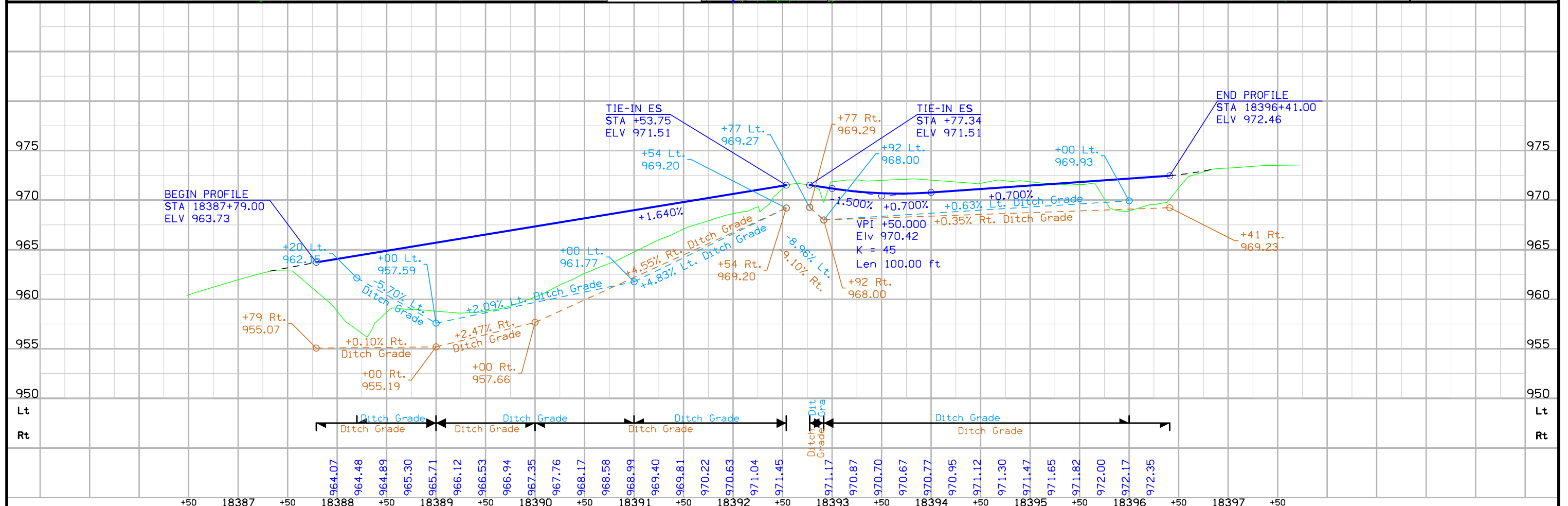
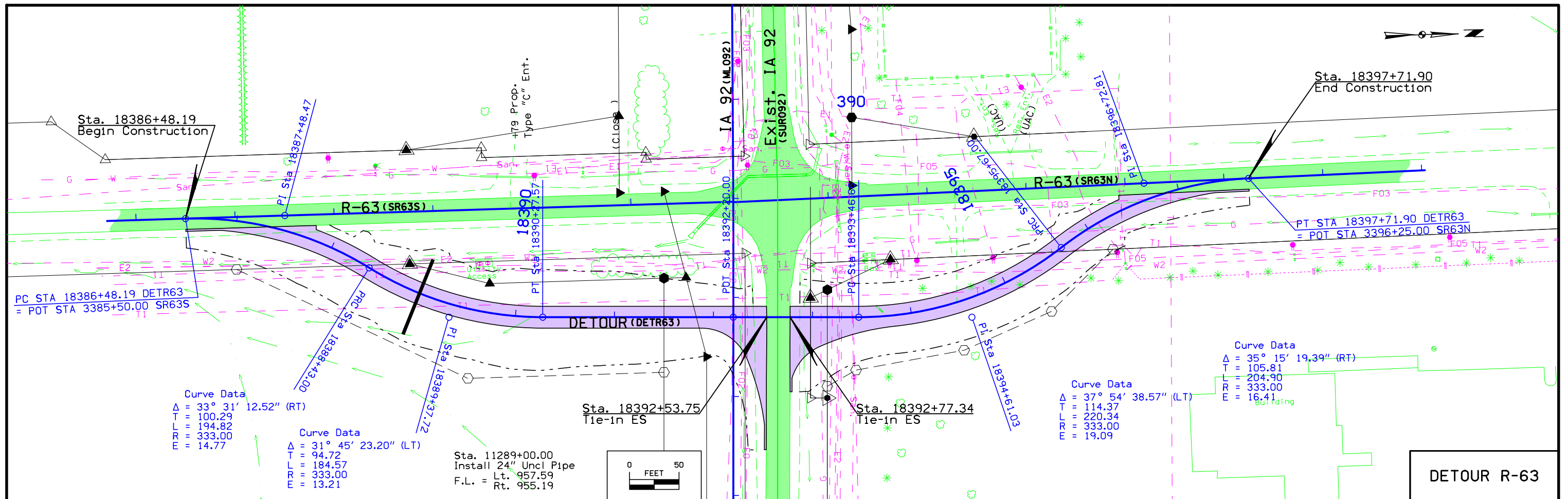

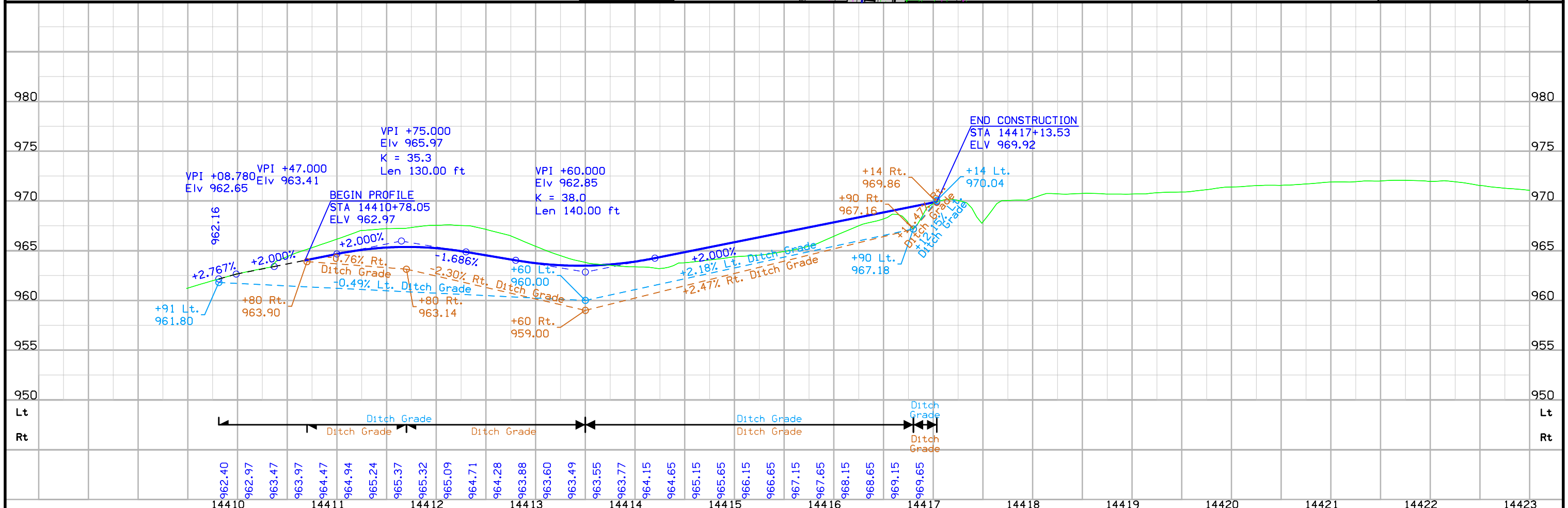
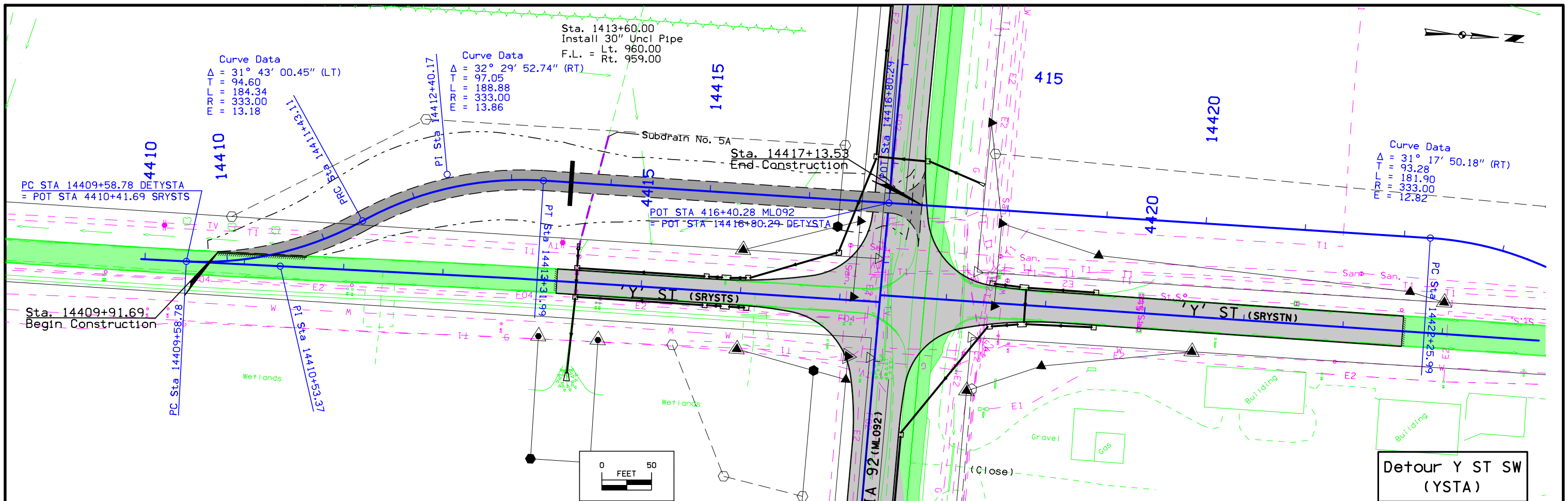

FILE NO.	ENGLISH	DESIGN TEAM	J1a\Holst\Bennett	WARREN COUNTY	PROJECT NUMBER	NHSX-092-5(51)--3H-91	SHEET NUMBER	F.3
----------	---------	-------------	-------------------	---------------	----------------	-----------------------	--------------	-----

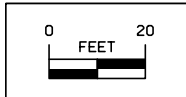
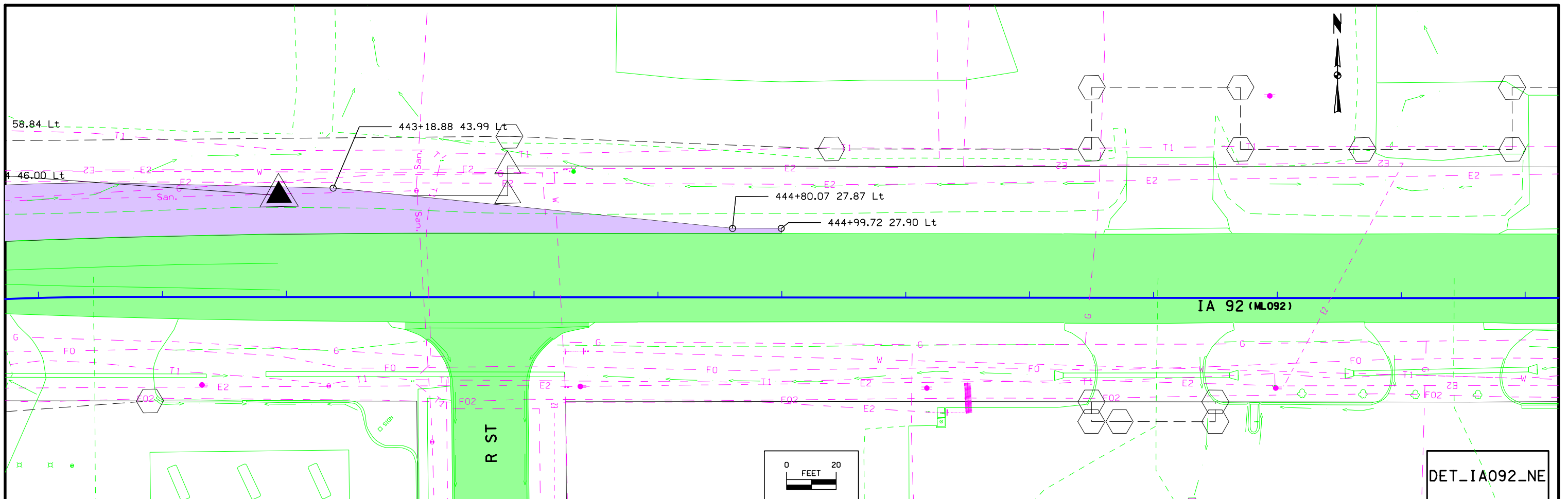

DET_IA092_NE

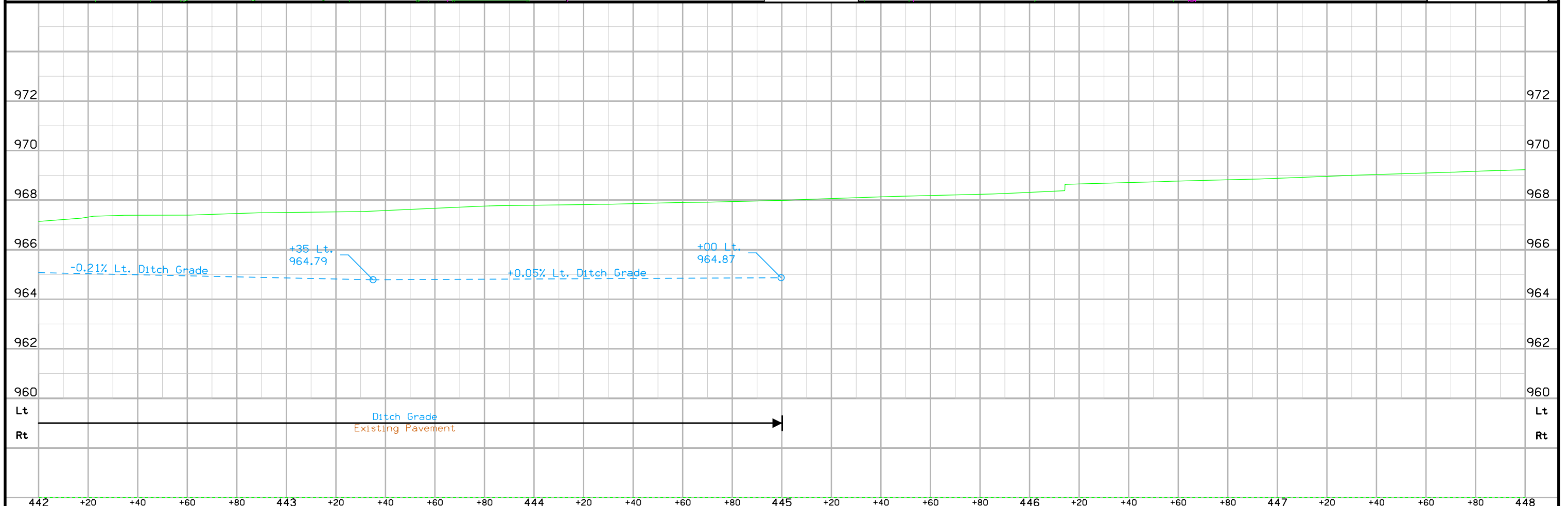

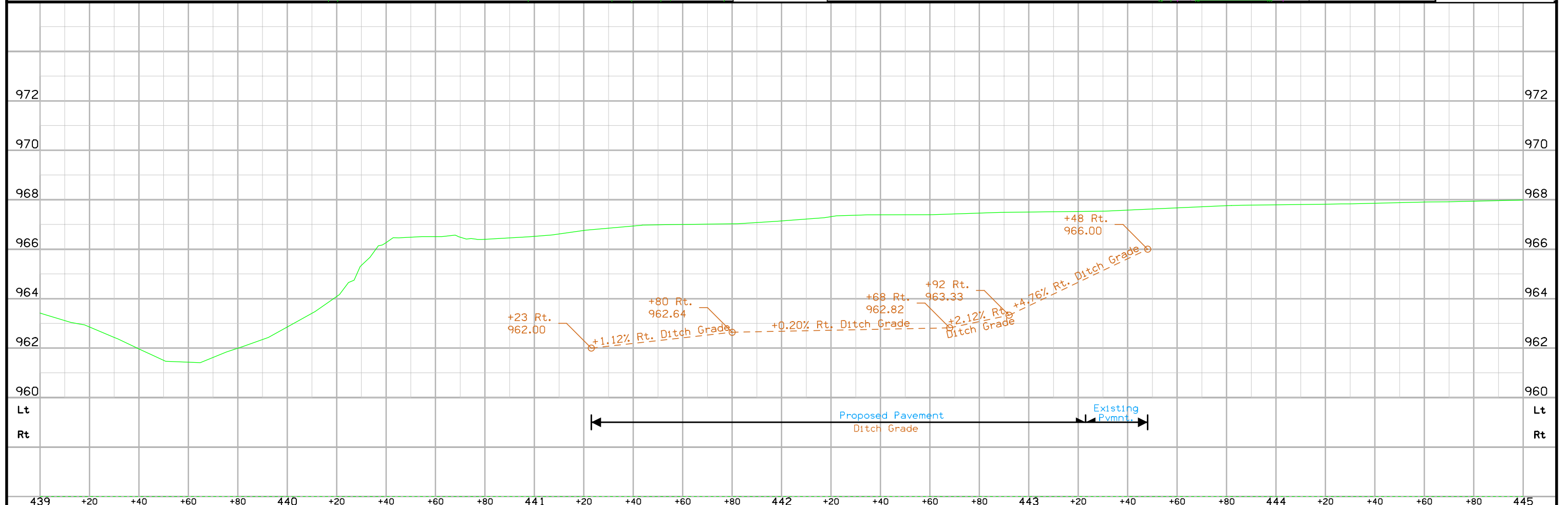
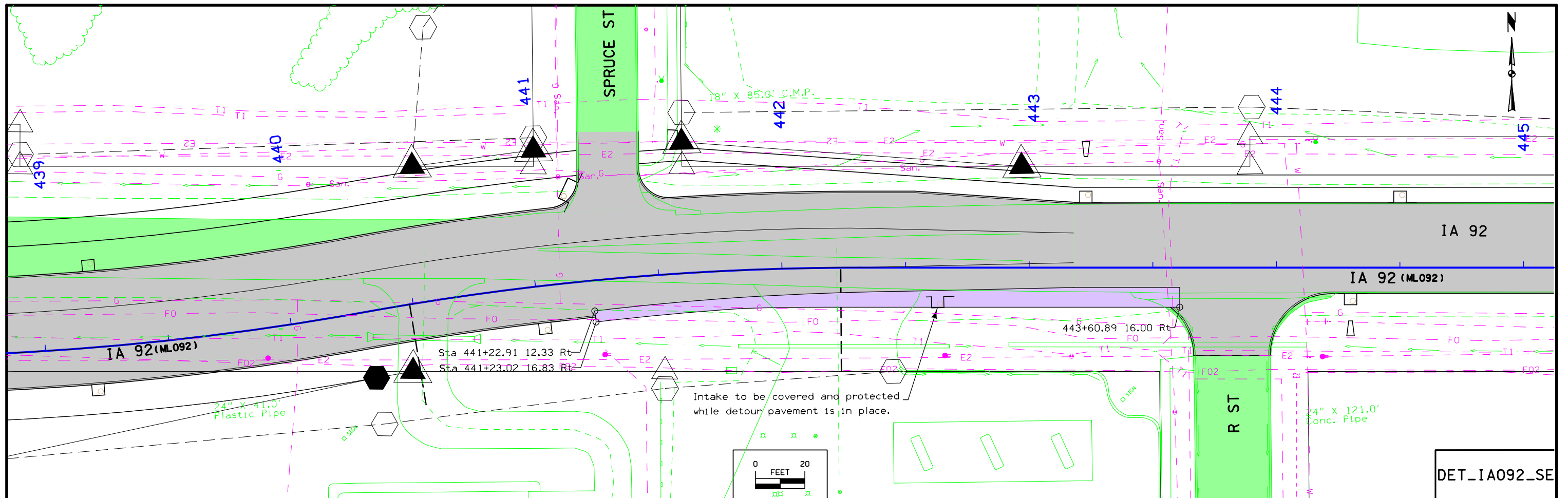

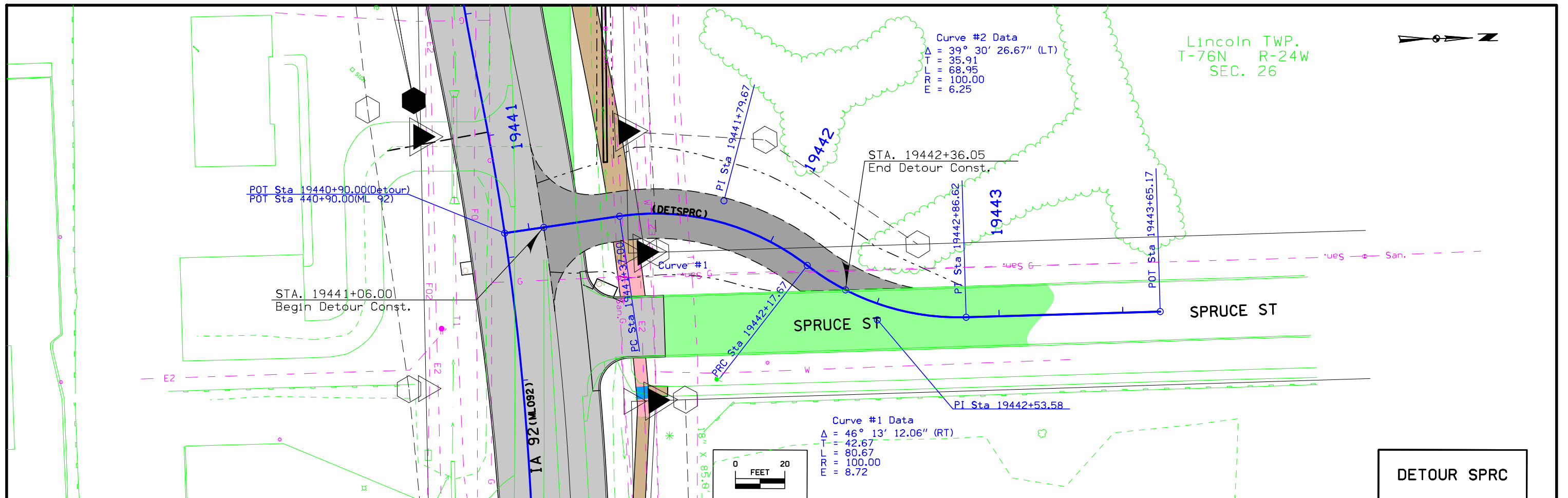

DETOUR SPRC

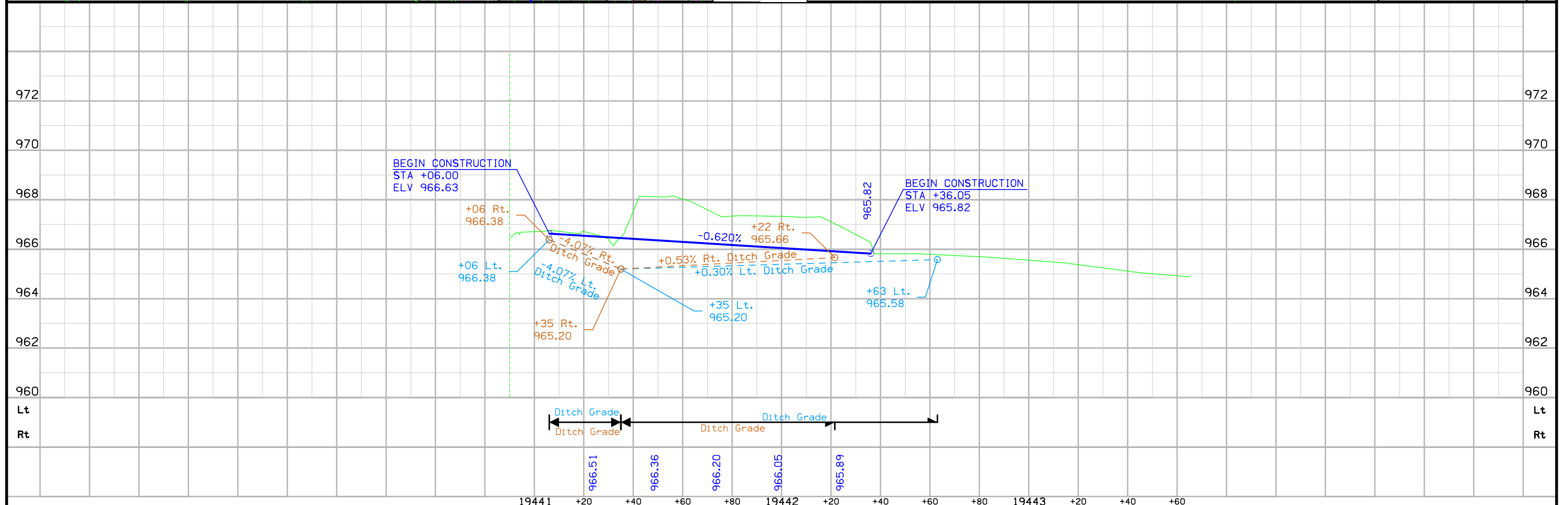

Survey Information

Warren County
 STP-092-5(46)--2C-91
 IA 92 From Just W. of Co. Rd. R-57
 To S. Kenwood Blvd. in Indianola
 04-91-092-010-01
 Sap-0482.2

General Information

Measurement units for this survey are US survey feet. This survey is for improvements on IA 2 in Warren County. This field survey was to obtain roadway and drainage features and break lines. The entire digital terrain model and topography in the corridor will be completed by supplemental aerial photography..

Vertical Control

This survey control is relative to NAVD88 Datum in accordance with 3rd. order vertical accuracy. NAVD88 height was transferred to the project at CP # 25 & CP # 35 using averaging redundant IARTN observations applying Geoid 2009. Iowa RTN reference stations are relative vertically to highly accurate National Geodetic Survey (NGS) Reference Stations that are used by NGS for reporting heights relative to NAVD88 datum. A 3-wire level loop was run from CP # 25 through the project benchmarks and ended at CP # 35. The loop error was allowable and the error was distributed proportionately among the project marks

Vertical equations are as follows:

Datum Benchmarks

CP # 25 this survey, elevation 958.76=
 G025 Project # STP-092-5(46)--2C-91, elevation 958.86

CP # 35 this survey, elevation 967.18=
 G035 Project # STP-092-5(46)--2C-91, elevation 967.14

Horizontal Control

The GPS Network along this project was collected by IDOT Preliminary Survey Crews. Information about that network can be found in the 0482gpspoints.rep file included with this survey in NAD83(1996) Datum.. Iowa State Plane Coordinates were transformed to project coordinates using the following information.

General Information for GPS Project : STP-092-5(46)--2C-91 SAP 482
 State Plane Coordinate Zone 1402 (Iowa South Lambert)

Average Project Latitude = 41 21 46.06621
 Resulting Radius = 6363322.382 (Meters)
 Mean Project Elevation = 279.990 (Meters)
 Sea Level Factor = 0.999956001
 Average Project Scale Factor = 0.999953270
 Combined Factor (Grid) = 0.999909273
 1 / Grid = 1.000090735
 Vertical Datum = NAVD 88 <> Horizontal Datum = NAD 83 (1996)

Local Project Plane Coordinate Conversion Equation:

- a. Local Project Coord y = [(State Plane y - hold point y) 1/grid factor] + hold point y
- b. Local Project Coord x = [(State Plane x - hold point x) 1/grid factor] + hold point x

Alignment Information

The horizontal alignment for this survey is a retrace of As-built Plans No. P-569 Survey stationing was equated to the plans at PI Sta. 263+46.7 and carried back and ahead with no equation throughout the survey.

Equations are as follows:

PI Sta. 263+46.7 This Survey
 = PI Sta. 263+46.7 As-built Plans Project No. P-569

PI Sta. 283+70.97 This Survey
 = PI Sta. 283+72.3 As-built Plans Project No. P-569

PI Sta. 310+25.39 This Survey
 = PI Sta. 310+27.4 As-built Plans Project No. P-569

PI Sta. 336+71.87 This Survey
 = PI Sta. 336+75.5 As-built Plans Project No. P-569

PI Sta. 343+73.27 This Survey
 = PI Sta. 343+76.9 As-built Plans Project No. P-569

PI Sta. 351+45.19 This Survey
 = PI Sta. 351+50.8 As-built Plans Project No. P-569

PI Sta. 365+06.91 This Survey
 = PI Sta. 365+11.5 As-built Plans Project No. P-569

PI Sta. 391+01.81 This Survey
 = PI Sta. 391+06.4 As-built Plans Project No. P-569

PI Sta. 417+36.67 This Survey
 = PI Sta. 417+43.4 As-built Plans Project No. P-569

PI Sta. 438+87.96 This Survey
 = PI Sta. 438+94.7 As-built Plans Project No. P-569

PI Sta. 451+20.2 This Survey
 = PI Sta. 451+26.0 As-built Plans Project No. P-569

VERTICAL CONTROL

Point	North	East	Elevation	Station	Offset	Description
659	494848.786	1597094.294	932.179	246+17.65	45.909	SETRRR SPK E SIDE 1ST POWER POLE
660	494140.746	1598099.141	950.571	258+46.84	34.474	SETRRR SPK E SIDE POWER POLE
661	493843.985	1598916.852	962.955	267+16.92	26.062	SETRRR SPK N SIDE POWER POLE
662	493790.182	1599914.401	969.535	277+15.27	62.083	SETRRR SPK N SIDE POWER POLE
663	493809.495	1600544.970	971.893	283+45.39	31.540	SETRRR SPK N SIDE POWER POLE
664	493801.002	1601735.334	967.621	295+35.44	31.666	SETRRR SPK N SIDE POWER POLE
665	493793.570	1602616.804	980.958	304+16.94	33.113	SETRRR SPK N SIDE POWER POLE
666	493774.151	1603186.184	970.300	309+86.44	48.666	CONC MONUMENT
667	493761.377	1604526.042	975.070	323+26.48	49.186	CONC MONUMENT
668	493764.357	1605810.055	968.332	336+10.41	34.374	SETRRR SPK S SIDE POWER POLE
669	493952.361	1606901.909	974.072	347+14.74	48.102	SETRRR SPK W SIDE POWER POLE
670	494182.094	1608008.803	966.556	358+97.50	39.449	SETRRR SPK N SIDE POWER POLE
671	494163.385	1609230.603	974.025	371+19.20	53.216	SETRRR SPK S SIDE POWER POLE
672	494181.064	1610588.817	975.829	384+77.37	32.550	CUT X ON R.O.W. RAIL
673	494255.767	1611520.232	974.200	394+07.47	-51.566	CUT X NW BOLT 1ST FIRE HYDRANT
674	494225.721	1612685.096	976.154	405+72.72	-52.100	CUT X ON NW BOLT FIRE HYDRANT
675	494186.822	1613914.713	967.557	418+03.27	-44.989	CUT X ON NW BOLT FIRE HYDRANT
676	494060.801	1615399.101	965.440	432+89.77	53.111	CUT X ON NE BOLT FIRE HYDRANT
677	494169.002	1616259.880	969.058	441+49.41	-67.303	CUT X ON SW BOLT FIRE HYDRANT
678	494142.697	1617266.587	971.521	451+58.64	-31.568	CUT X ON S BOLT FIRE HYDRANT
679	494179.247	1618305.076	967.642	461+96.05	46.333	CUT X ON SE BOLT FIRE HYDRANT
680	494489.398	1619450.029	968.177	Off Chain	Off Chain	NE BOLT FIRE HYDRANT

CP STA OFF CHAIN
 CP No. 10, Fd. Rebar
 N=496175.910, E=1561565.170

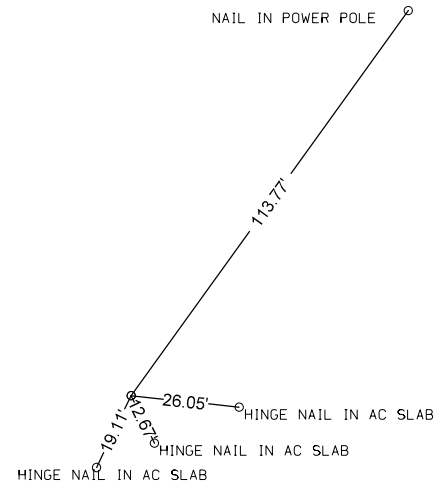

CP STA OFF CHAIN
 CP No. 12, Fd. Feno Monument
 N=497203.940, E=1565343.760

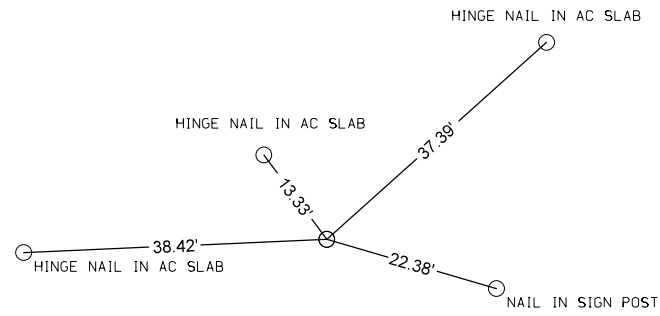

CP STA OFF CHAIN
 CP No. 13, Fd. Rebar
 N=498065.040, E=1568426.330,

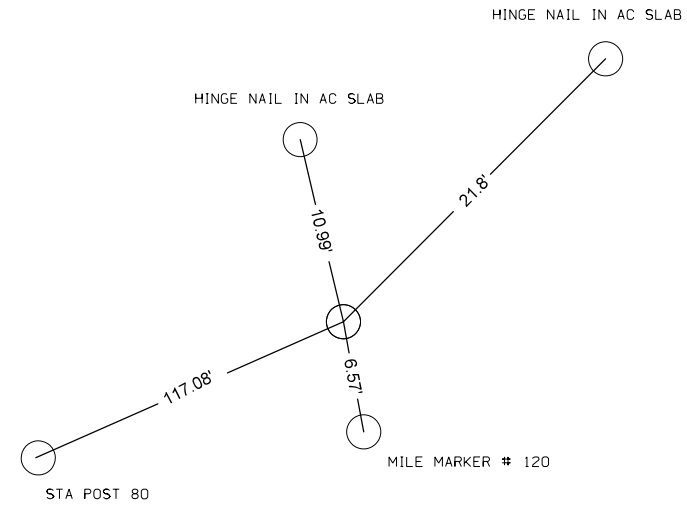

CP STA OFF CHAIN
 CP No. 14, Fd. Rebar
 N=498911.550, E=1571561.620,

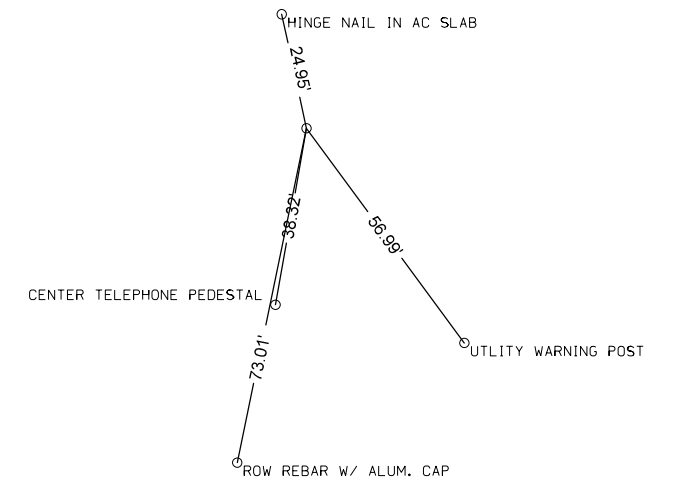

CP STA 3+91.63, 180.71 Rt.
 CP No. 15, Fd. Rebar
 N=499571.430, E=1574333.310,

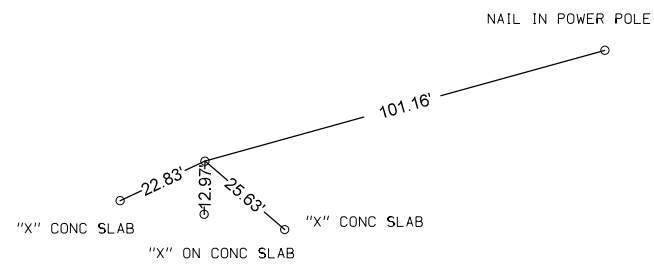

CP STA 23+47.79, 21.90 Lt.
 CP No. 16, Fd. Rebar
 N=498516.240, E=1575992.890,

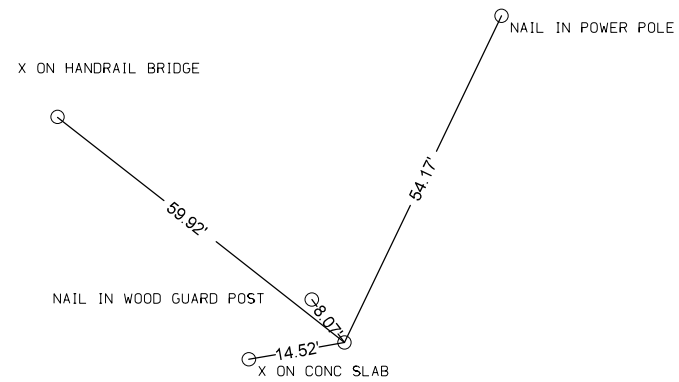

CP STA 36+16.39, 19.13 Rt.
 CP No. 17, Fd. Rebar
 N=497895.020, E=1577077.580,

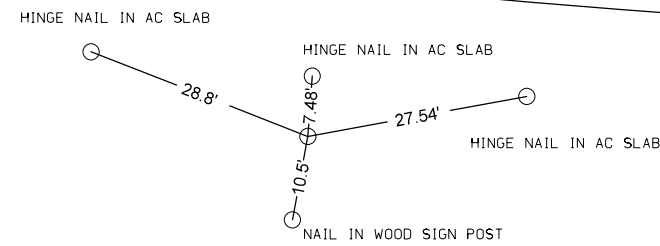

CP STA 68+34.41, 21.89 Rt.
 CP No. 18, Fd. Rebar
 N=497914.250, E=1580297.290,

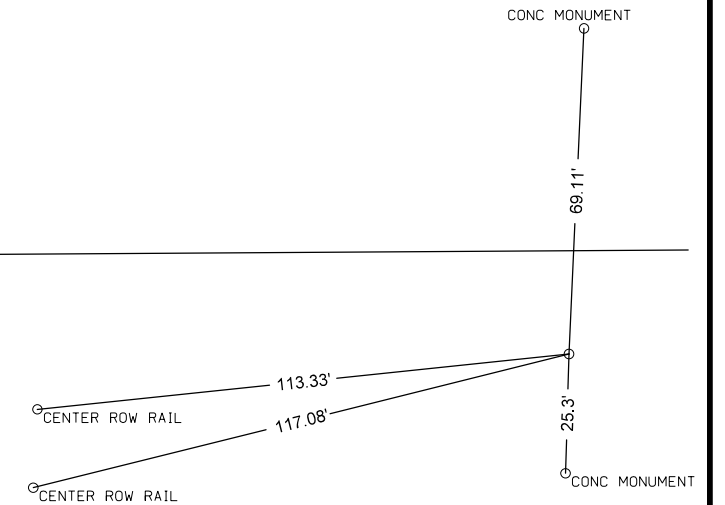

CP STA 97+35.35, 21.36 Lt.
 CP No. 19, Fd. Rebar
 N=497982.600, E=1583197.690,

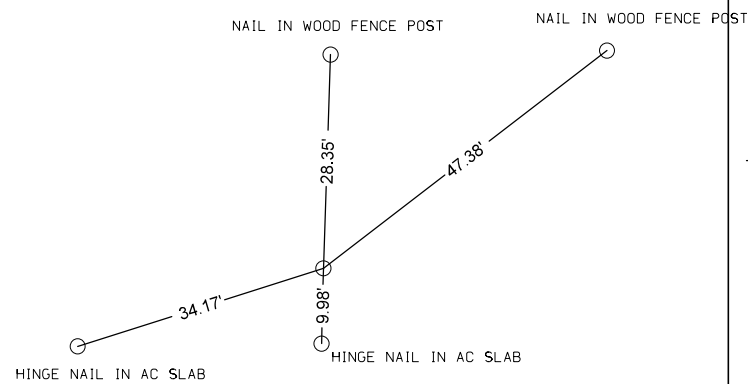

CP STA 139+97.21, 22.08 Lt.
 CP No. 20, Fd. Rebar
 N=498040.020, E=1587459.150,

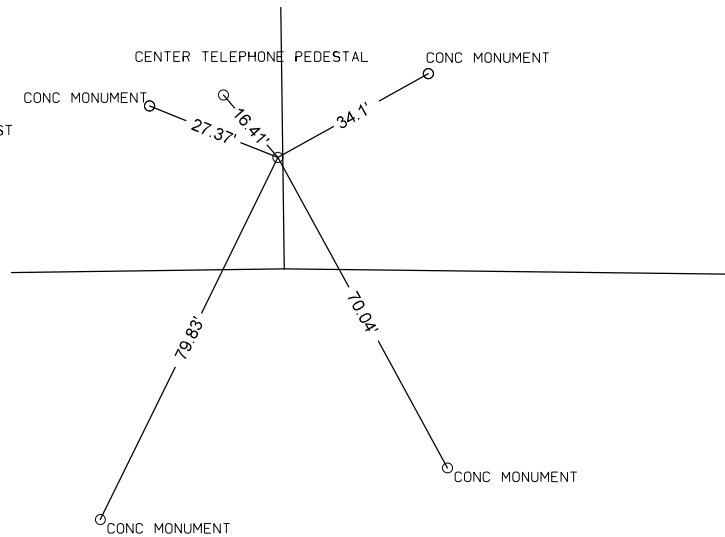

CP STA 183+66.82, 19.52 Rt.
 CP No. 21, Fd. Rebar
 N=497943.610, E=1591828.450,

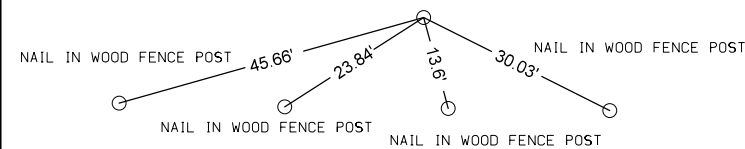

CP STA 192+66.29, 69.52 Lt.
 CP No. 22, Fd. Rebar
 N=497982.890, E=1592741.290,

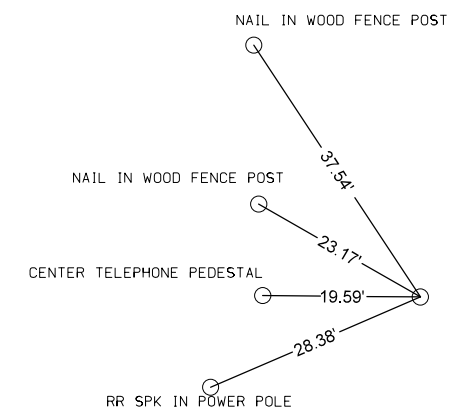

CP STA 202+26.65, 23.77 Lt.
 CP No. 23, Fd. Rebar
 N=497467.850, E=1593569.210,

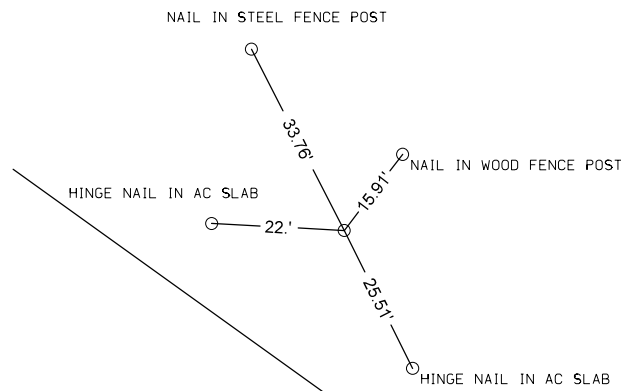

CP STA 212+27.42, 25.52 Lt.
 CP No. 24, Fd. Rebar
 N=496885.250, E=1594382.920,

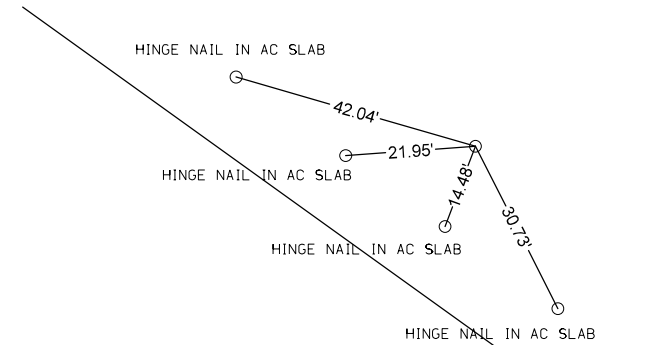

CP STA 246+74.28, 15.78 Lt.
 CP No. 324, Fd. Iron Pin
 N=494865.830, E=1597176.285,

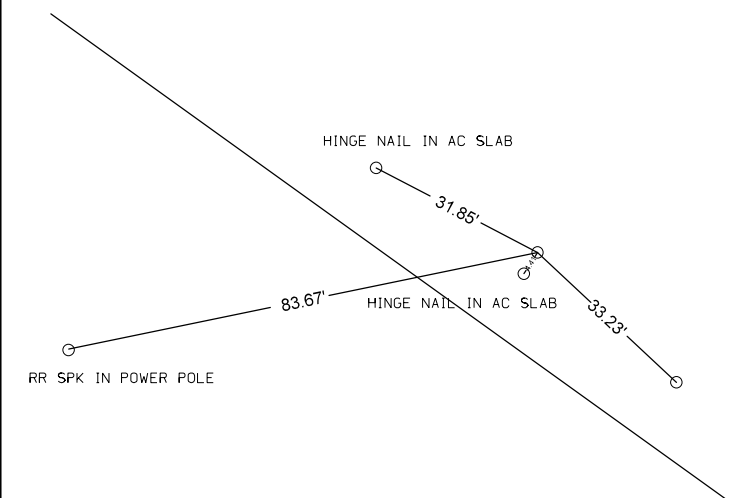

CP STA 257+09.95, 23.63 Rt.
 CP No. 325, Fd. Iron Pin
 N=494229.441, E=1597994.308,

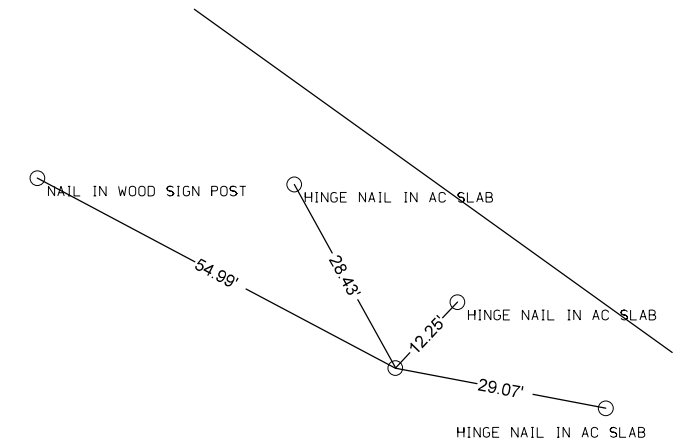

CP STA 263+35.7, 54.56 Rt.
 CP No. 25, Fd. Rebar
 N=493877.030, E=1598525.180,

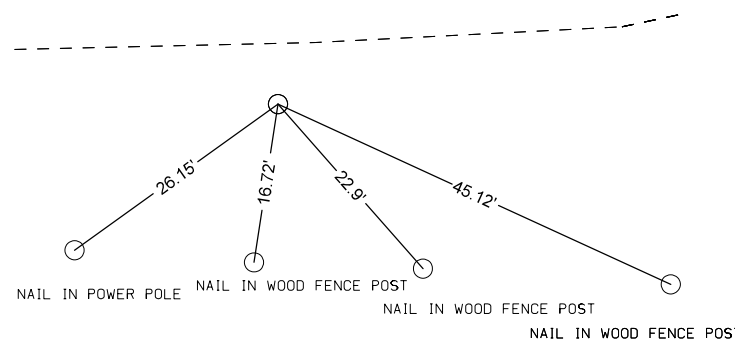

CP STA 275+00.55, 17.59 Rt.
 CP No. 26, Fd. Rebar
 N=493838.490, E=1599700.510,

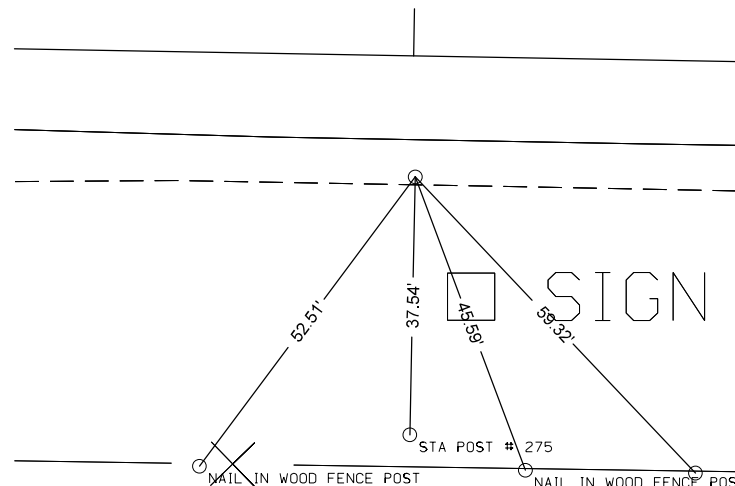

CP STA 283+29.75, 47.72 Lt.
 CP No. 326, Fd. Iron Pin
 N=493889.024, E=1600530.738,

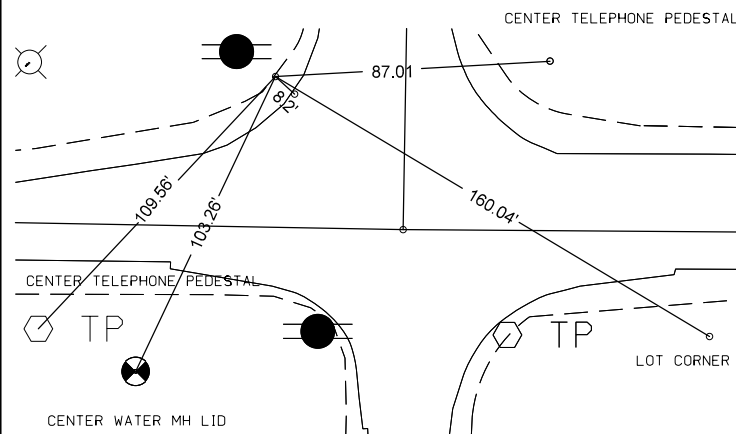

CP STA 293+73.67, 19.02 Rt.
 CP No. 327, Fd. Iron Pin
 N=493814.742, E=1601573.649,

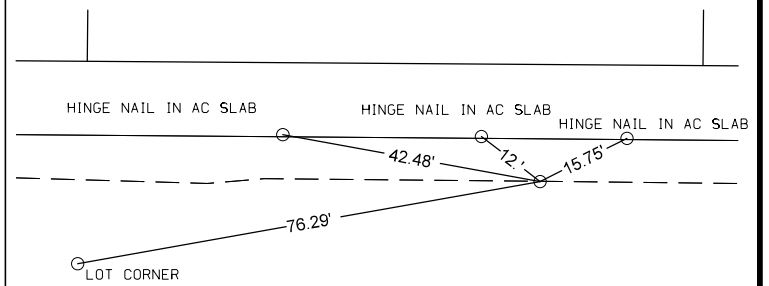

CP STA 302+85.88, 26.47 Lt.
 CP No. 27, Fd. Rebar
 N=493854.040, E=1602486.150,

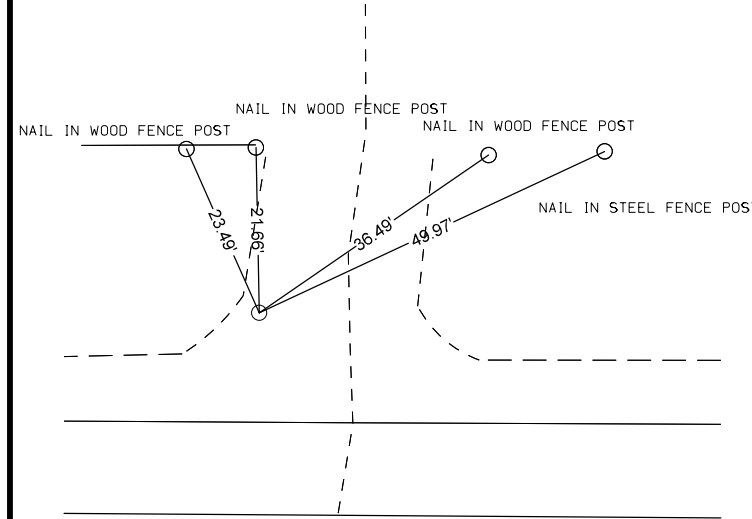

CP STA 310+51.04, 27.19 Rt.
 CP No. 328, Fd. Iron Pin
 N=493795.126, E=1603250.863,

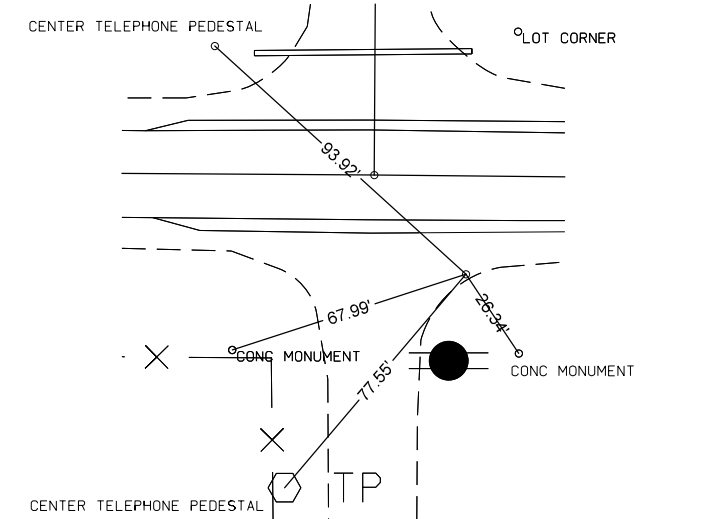

CP STA 323+51.93, 27.54 Lt.
 CP No. 28, Fd. Rebar
 N=493837.870, E=1604552.200,

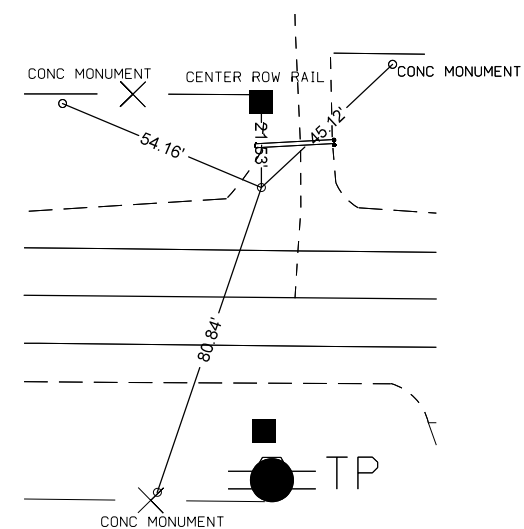

CP STA 331+33.48, 20.40 Lt.
 CP No. 329, Fd. Iron Pin
 N=493823.519, E=1605333.648,

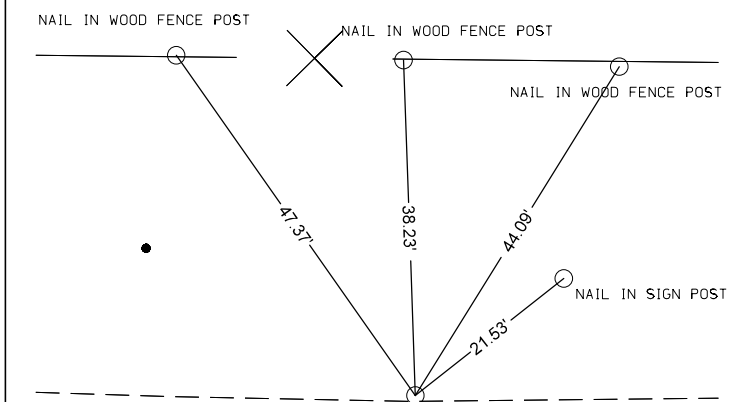

CP STA 342+98.08, 21.90 Rt.
 CP No. 29, Fd. Rebar
 N=493806.250, E=1606500.740,

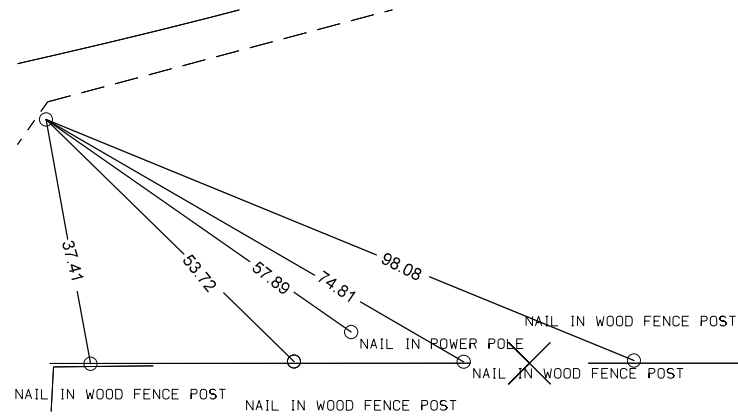

CP STA 350+95.08, 20.57 Lt.
 CP No. 30, Fd. Rebar
 N=494185.860, E=1607206.330,

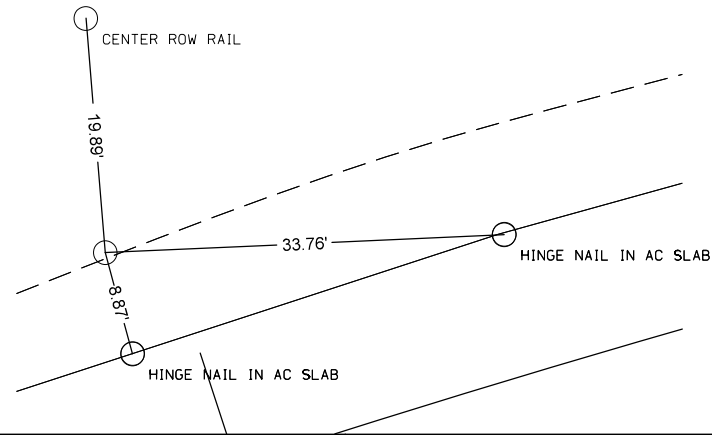

CP STA 359+87.72, 18.85 Lt.
 CP No. 330, Fd. Iron Pin
 N=494202.157, E=1608099.134,

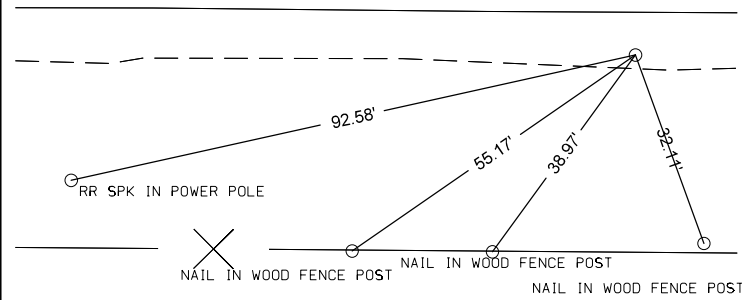

CP STA 368+07.83, 46.84 Lt.
 CP No. 31, Fd. Rebar
 N=494264.130, E=1608919.450,

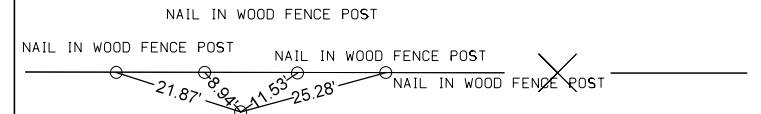

CP STA 377+81.08, 17.74 Lt.
 CP No. 331, Fd. Iron Pin
 N=494232.887, E=1609892.640,

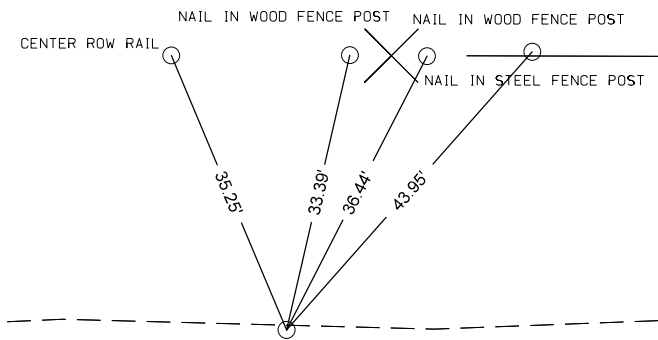

CP STA 386+82.38, 22.31 Rt.
 CP No. 32, Fd. Rebar
 N=494190.850, E=1610793.850,

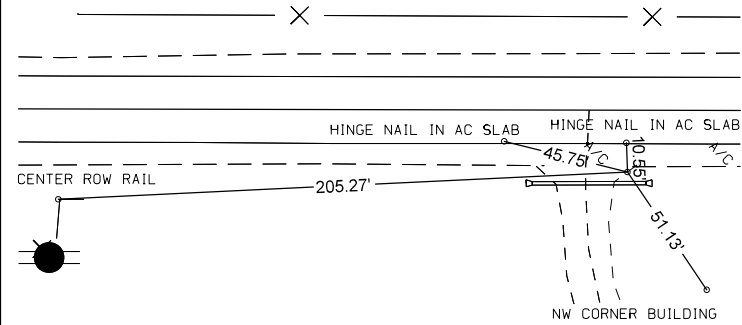

CP STA 391+45.71, 33.75 Lt.
 CP No. 332, Fd. Iron Pin
 N=494244.830, E=1611258.092,

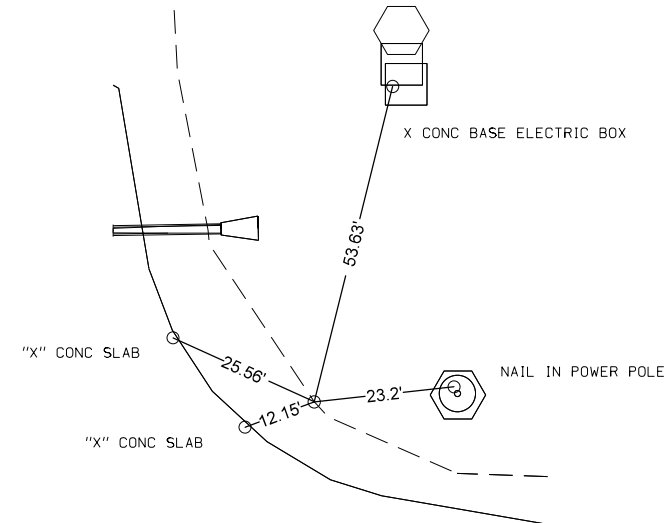

CP STA 401+75.95, 36.08 Rt.
 CP No. 33, Fd. Rebar
 N=494147.980, E=1612286.150,

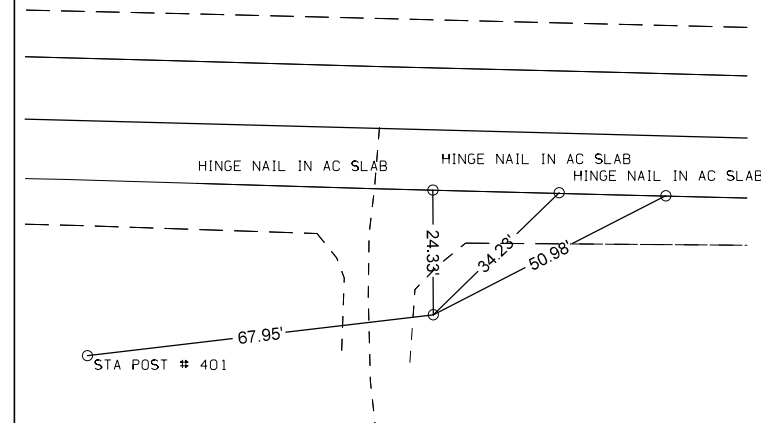

CP STA 408+86.04, 20.70 Lt.
 CP No. 333, Fd. Iron Pin
 N=494186.113, E=1612997.486,

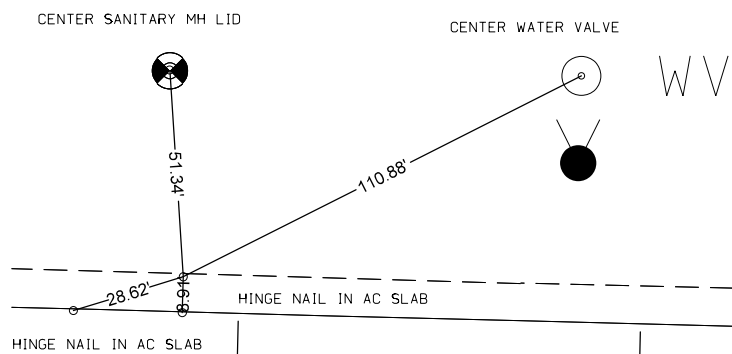

CP STA 417+02.74, 28.34 Rt.
 CP No. 334, Fd. Iron Pin
 N=494115.651, E=1613812.612,

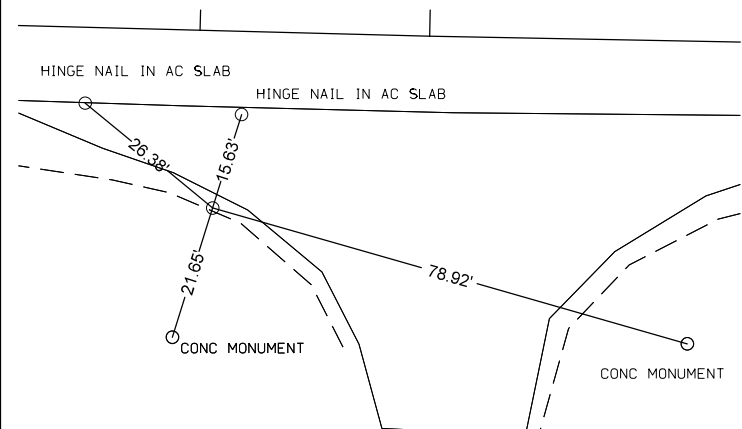

CP STA 425+26.32, 19.97 Rt.
 CP No. 335, Fd. Iron Pin
 N=494108.283, E=1614636.408,

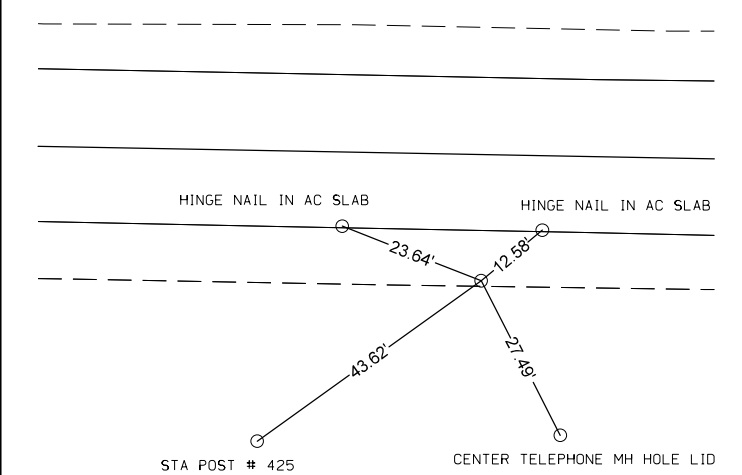

CP STA 433+23.93, 28.04 Rt.
 CP No. 34, Fd. Rebar
 N=494085.230, E=1615433.730,

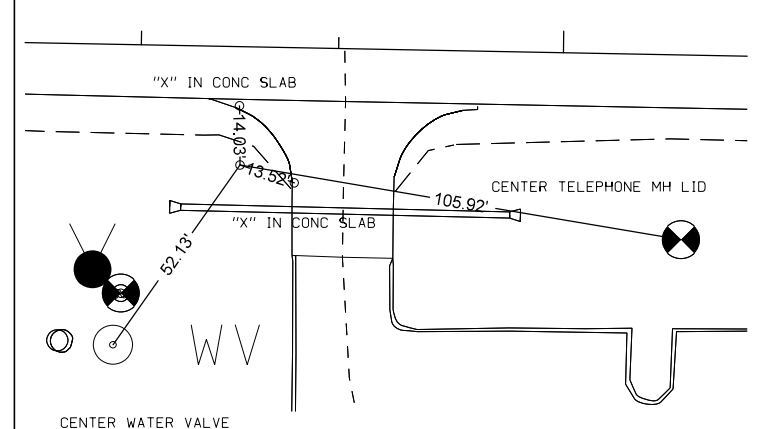

CP STA 441+70.77, 24.95, 24.95 Rt.
 CP No. 336, Fd. Iron Pin
 N=494076.672, E=1616280.908,

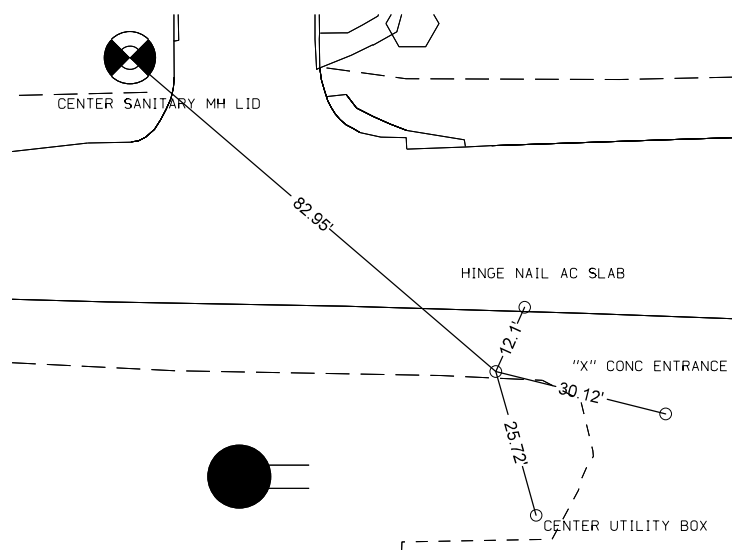

CP STA 449+71.11, 35.09 Rt.
 CP No. 35, Fd. Feno Monument
 N=494067.160, E=1617082.410,

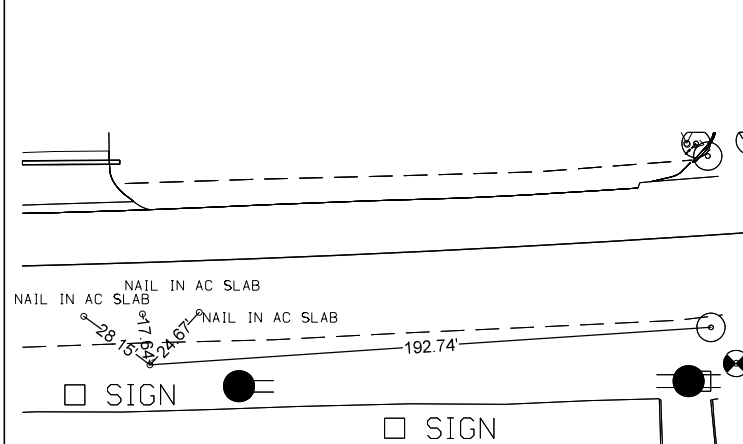

CP STA 455+71.13, 24.86 Rt.
 CP No. 337, Fd. Iron Pin
 N=494126.788, E=1617681.998,

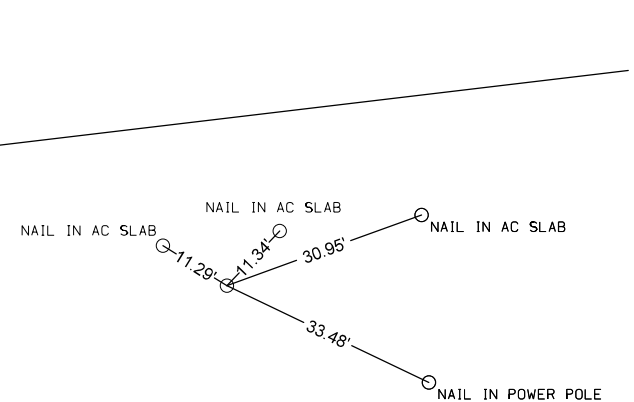

CP STA 462+35.77, 23.50 Lt.
 CP No. 338, Fd. Iron Pin
 N=494253.285, E=1618336.278,

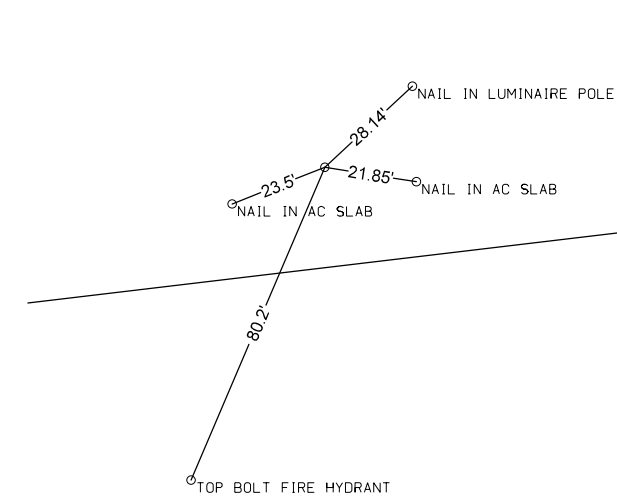

CP STA Off Chain
 CP No. 339, Fd. Iron Pin

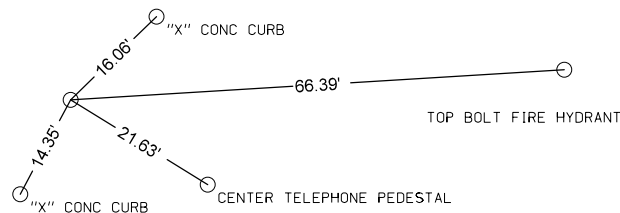

ALIGNMENT COORDINATES

101-16
10-20-09

Name	Location	Point on Tangent			Begin Spiral			Begin Curve			Simple Curve PI or Master PI of SCS			End Curve			End Spiral		
		Station	Coordinates		Station	Coordinates		Station	Coordinates		Station	Coordinates		Station	Coordinates		Station	Coordinates	
			Y (Northing)	X (Easting)		Y (Northing)	X (Easting)		Y (Northing)	X (Easting)		Y (Northing)	X (Easting)		Y (Northing)	X (Easting)		Y (Northing)	X (Easting)
20001	ML092	255+00.00	494,371.15	1,597,837.61															
20006	ML092				258+45.63	494,169.44	1,598,118.28	260+05.63	494,078.36	1,598,249.80	264+10.92	493,839.55	1,598,577.33	267+85.11	493,838.66	1,598,982.67	269+45.11	493,834.41	1,599,142.60
20015	ML092				337+72.34	493,772.36	1,605,969.55	339+32.34	493,773.69	1,606,129.52	342+33.59	493,768.17	1,606,430.78	345+19.31	493,909.54	1,606,696.86	346+79.31	493,980.80	1,606,840.09
20022	ML092				347+85.31	494,029.67	1,606,934.15	349+45.31	494,100.94	1,607,077.39	352+55.89	494,246.61	1,607,351.75	355+49.82	494,237.44	1,607,662.25	357+09.82	494,236.94	1,607,822.23
20028	ML092							390+67.33	494,167.94	1,611,179.03	391+01.53	494,167.24	1,611,213.23	391+35.73	494,166.34	1,611,247.42			
20032	ML092							416+90.59	494,099.28	1,613,801.39	417+35.31	494,098.11	1,613,846.10	417+80.03	494,097.27	1,613,890.81			
20036	ML092							438+11.62	494,059.08	1,615,922.04	439+21.21	494,057.02	1,616,031.61	440+30.11	494,076.15	1,616,139.52			
20038	ML092							440+30.11	494,076.15	1,616,139.52	441+31.12	494,093.78	1,616,238.98	442+31.59	494,093.40	1,616,339.99			
20043	ML092							447+70.70	494,091.42	1,616,879.10	451+22.49	494,090.13	1,617,230.88	454+73.40	494,131.67	1,617,580.21			
20046	ML092	466+80.72	494,274.21	1,618,779.08															
31000	SRKENNEDY	1256+05.14	493,946.86	1,597,951.77															
31002	SRKENNEDY	1258+87.00	494,145.34	1,598,151.90															
30000	SR57S	1273+87.78	492,836.02	1,600,580.14															
30003	SR57S	1283+73.24	493,821.43	1,600,570.67															
30010	SR57N	1383+68.17	493,821.48	1,600,565.60															
30013	SR57N	1394+41.91	494,895.22	1,600,565.83															
40000	SR90TH	2303+28.16	493,097.25	1,603,227.88															
40002	SR90TH	2310+28.21	493,797.30	1,603,225.53															
40004	SR90TH	2317+28.21	494,497.30	1,603,223.17															
50000	SR63S	3384+70.68	493,534.41	1,611,217.98															
50001	SR63S	3391+03.42	494,167.15	1,611,215.11															
50010	SR63N	3391+03.95	494,167.14	1,611,215.64															
50011	SR63N	3398+03.35	494,866.40	1,611,201.59															
60011	SRYSTS	4412+74.33	493,632.11	1,613,854.33															
60012	SRYSTS	4413+22.77	493,680.54	1,613,853.53															
60013	SRYSTS	4413+72.56	493,730.32	1,613,852.79															
60015	SRYSTS	4417+40.32	494,098.08	1,613,851.11															
60000	SRYSTN	4417+33.40	494,098.23	1,613,844.19															
60001	SRYSTN	4424+09.38	494,774.21	1,613,843.99															

ALIGNMENT COORDINATES

101-16
10-20-09

Name	Location	Point on Tangent			Begin Spiral			Begin Curve			Simple Curve PI or Master PI of SCS			End Curve			End Spiral		
		Station	Coordinates		Station	Coordinates		Station	Coordinates		Station	Coordinates		Station	Coordinates		Station	Coordinates	
			Y (Northing)	X (Easting)		Y (Northing)	X (Easting)		Y (Northing)	X (Easting)		Y (Northing)	X (Easting)		Y (Northing)	X (Easting)		Y (Northing)	X (Easting)
90000	ENT258	98+68.14	494,052.48	1,598,058.28															
90001		100+00.00	494,145.34	1,598,151.90															
90002								100+71.65	494,203.67	1,598,193.51	101+46.98	494,265.00	1,598,237.26	102+17.98	494,340.28	1,598,239.84			
90004		103+14.58	494,436.82	1,598,243.15															
90005	ENT259	100+00.00	494,381.81	1,597,968.42															
90005								101+20.00	494,358.92	1,598,086.21	101+76.66	494,348.11	1,598,141.83	102+30.43	494,309.73	1,598,183.52			
90007								104+30.43	494,174.26	1,598,330.65	104+62.64	494,152.44	1,598,354.35	104+94.30	494,139.17	1,598,383.70			
90009		105+70.41	494,107.81	1,598,453.04															
90014	ENT269	95+33.10	494,037.37	1,598,836.03															
90015								95+80.40	493,993.49	1,598,853.66	96+24.58	493,952.49	1,598,870.14	96+59.22	493,949.72	1,598,914.24			
90017		100+00.00	493,928.40	1,599,254.34															
90010	ENT270	97+80.00	493,613.42	1,599,251.48															
90011		100+00.00	493,833.41	1,599,253.48															
90011								101+06.87	493,940.27	1,599,254.45	101+71.34	494,004.74	1,599,255.04	102+31.60	494,056.73	1,599,293.16			
90013		102+59.60	494,079.31	1,599,309.72															
90025	ENT275	100+00.00	493,893.24	1,599,844.05															
90026		100+69.23	493,931.57	1,599,786.40															
90020	ENT276	100+00.00	493,828.04	1,599,843.46															
90021								100+70.21	493,898.25	1,599,844.10	100+74.35	493,902.39	1,599,844.13	100+78.48	493,906.52	1,599,843.89			
90023		101+40.15	493,968.08	1,599,840.20															
90030	ENT291	98+59.16	493,673.99	1,601,388.99															
90031								99+59.01	493,773.16	1,601,377.36	99+68.08	493,782.16	1,601,376.30	99+77.11	493,791.22	1,601,376.61			
90032		100+00.00	493,814.10	1,601,377.39															
90033		101+20.04	493,934.07	1,601,381.48															
90040	ENT297	97+18.87	493,529.41	1,601,891.83															
90041								97+48.87	493,559.41	1,601,892.10	97+70.37	493,580.92	1,601,892.30	97+91.72	493,601.89	1,601,897.06			
90042								98+11.72	493,621.39	1,601,901.49	98+34.91	493,644.01	1,601,906.62	98+57.89	493,667.20	1,601,906.45			
90043		100+00.00	493,809.30	1,601,905.37															
90044		101+20.00	493,929.31	1,601,905.46															
90047	ENT298	100+00.00	493,704.35	1,601,906.17															
90049		100+62.11	493,688.74	1,601,966.28															
90050	ENT305	98+80.00	493,681.83	1,602,727.25															
90051		100+00.00	493,801.82	1,602,728.34															
90066	ENT322	98+93.56	493,663.11	1,604,456.15															
90067		100+00.00	493,710.24	1,604,551.58															
90060	ENT323	96+84.92	493,484.75	1,604,605.53															
90061								97+64.92	493,564.74	1,604,606.26	97+98.08	493,597.90	1,604,606.56	98+28.46	493,623.33	1,604,585.28			
90063								98+48.46	493,638.66	1,604,572.44	98+81.62	493,664.09	1,604,551.16	99+12.00	493,697.25	1,604,551.46			
90064		100+00.00	493,785.24	1,604,552.26															
90065		102+00.00	493,985.23	1,604,554.08															
90070	ENT331	98+00.00	493,578.34	1,605,310.41															
90071		100+00.00	493,778.33	1,605,312.23															
90080	ENT341	94+00.70	493,209.61	1,606,415.14															
90081								95+27.63	493,336.37	1,606,421.62	95+73.99	493,382.68	1,606,423.99	96+19.31	493,426.75	1,606,409.60			
90083								99+40.16	493,731.74	1,606,310.00	99+49.84	493,740.94	1,606,306.99	99+59.47	493,750.50	1,606,305.50			
90084		100+00.00	493,790.55	1,606,299.26															
90085								100+61.11	493,850.92	1,606,289.84	100+71.04	493,860.74	1,606,288.31	100+80.93	493,870.67	1,606,288.41			
90087		101+10.51	493,900.25	1,606,288.72															
90090	ENT352	98+95.18	494,091.62	1,607,356.71															
90091		100+00.00	494,196.43	1,607,355.69															
90092								100+47.55	494,243.97	1,607,355.23	100+79.97	494,276.40	1,607,354.91	101+05.08	494,289.91	1,607,384.39			
90093		101+62.97	494,314.04	1,607,437.01															
90100	ENT359	96+73.79	494,137.73	1,607,780.69															
90101								98+71.48	494,133.71	1,607,978.33	99+21.46	494,132.70	1,608,028.31	99+50.00	494,182.68	1,608,029.34			
90102		100+00.00	494,232.66	1,608,030.37															
90103								100+90.00	494,322.64	1,608,032.22	101+80.00	494,412.62	1,608,034.07	102+31.37	494,410.77	1,608,124.05			
90105		103+43.37	494,408.47	1,608,236.02															

ALIGNMENT COORDINATES

101-16
10-20-09

Name	Location	Point on Tangent			Begin Spiral			Begin Curve			Simple Curve PI or Master PI of SCS			End Curve			End Spiral		
		Station	Coordinates		Station	Coordinates		Station	Coordinates		Station	Coordinates		Station	Coordinates		Station	Coordinates	
			Y (Northing)	X (Easting)		Y (Northing)	X (Easting)		Y (Northing)	X (Easting)		Y (Northing)	X (Easting)		Y (Northing)	X (Easting)		Y (Northing)	X (Easting)
90115	ENT364	96+63.00	494,026.91	1,608,308.20															
90116		100+00.00	494,019.98	1,608,645.13															
90110	ENT365	97+80.00	493,999.99	1,608,644.72															
90111		100+00.00	494,219.94	1,608,649.24															
90111							100+49.55	494,269.48	1,608,650.25	100+76.37	494,296.30	1,608,650.81	101+02.33	494,320.80	1,608,639.89				
90113		102+56.34	494,461.47	1,608,577.18															
90120	ENT367	98+79.96	494,079.19	1,609,657.56															
90121		100+00.00	494,199.23	1,609,657.02															
90122		101+00.04	494,299.27	1,609,656.08															
31201	ENT1257 (KENNEDY)	100+00.00	494,020.70	1,598,026.23															
31203							101+39.30	493,927.84	1,598,130.06	101+82.50	493,899.04	1,598,162.26	102+22.23	493,897.37	1,598,205.43				
31204		102+80.29	493,895.13	1,598,263.44															
30201	ENT1281 (R-53)	99+19.94	493,642.43	1,600,492.39															
30202		100+00.00	493,640.20	1,600,572.41															
30203		100+80.02	493,638.97	1,600,652.43															
40201	ENT2307 (90TH)	100+00.00	493,549.09	1,603,226.36															
40202		101+00.00	493,549.43	1,603,326.36															
40205	ENT2313 (90TH)	100+00.00	494,077.09	1,603,224.59															
40206		101+00.00	494,077.43	1,603,324.58															

SPIRAL OR CIRCULAR CURVE DATA

101-17
04-19-11

Name	Location	Δ_{scs}	Horizontal Alignment Data													Remarks
			Spiral Data						Curve Data							
			θ_s	Ls	Ts	Es	Xc	Yc	L.T.	S.T.	Δ_c	T	L	R	E	
20006		35° 10' 54.09" LT	2° 59' 45.09"	-160.00'	TS	53.35'	159.96'	2.79'	106.68'	53.35'	29° 11' 23.92" LT	398.39'	779.48'	1,530.00'	51.02'	
20015		27° 58' 21.68" LT	2° 59' 45.09"	-160.00'	TS	53.35'	159.96'	2.79'	106.68'	53.35'	21° 58' 51.50" LT	297.14'	586.97'	1,530.00'	28.59'	
20022		28° 37' 45.84" RT	2° 59' 45.09"	160.00'	TS	53.35'	159.96'	2.79'	106.68'	53.35'	22° 38' 15.66" RT	306.25'	604.51'	1,530.00'	30.35'	
20028											0° 19' 35.74" RT	34.20'	68.40'	12,000.00'	0.05'	
20032											0° 25' 37.45" LT	44.72'	89.45'	12,000.00'	0.08'	
20036											11° 07' 40.08" LT	109.59'	218.49'	1,125.00'	5.33'	
20038											10° 15' 40.29" RT	101.01'	201.48'	1,125.00'	4.53'	
20043											6° 59' 27.10" LT	351.79'	702.70'	5,759.23'	10.73'	
10001			19° 44' 59.72" RT	11° 14' 04.08"		510.00'	88.78'	175.80'	7.67'							

ALIGNMENT COORDINATES

101-16
10-20-09

Name	Location	Point on Tangent			Begin Spiral			Begin Curve			Simple Curve PI or Master PI of SCS			End Curve			End Spiral		
		Station	Coordinates		Station	Coordinates		Station	Coordinates		Station	Coordinates		Station	Coordinates		Station	Coordinates	
			Y (Northing)	X (Easting)		Y (Northing)	X (Easting)		Y (Northing)	X (Easting)		Y (Northing)	X (Easting)		Y (Northing)	X (Easting)		Y (Northing)	X (Easting)
SR57N_RET_1																			
30015																			
30016					0+00.00	494,059.22	1,600,576.65	0+64.51	493,994.71	1,600,576.64	1+28.53	493,931.67	1,600,590.34						
30017					1+28.53	493,931.67	1,600,590.34	1+74.21	493,887.03	1,600,600.04	2+10.58	493,875.17	1,600,644.15						
30018					2+10.58	493,875.17	1,600,644.15	2+36.09	493,868.54	1,600,668.77	2+61.32	493,868.31	1,600,694.28						
SR57N_RET_2																			
30026					0+00.00	493,860.45	1,600,459.51	0+82.18	493,859.70	1,600,541.69	1+33.20	493,941.47	1,600,549.88						
30025								1+80.88	493,988.91	1,600,554.64									
SR57N_RET_3																			
30035								0+00.00	493,790.59	1,600,443.07									
30036					0+00.00	493,790.59	1,600,443.07	0+25.50	493,790.36	1,600,468.58	0+50.73	493,783.74	1,600,493.20						
30037					0+50.73	493,783.74	1,600,493.20	0+95.90	493,772.00	1,600,536.83	1+32.05	493,727.96	1,600,546.85						
30038					1+32.05	493,727.96	1,600,546.85	1+96.56	493,665.05	1,600,561.17	2+60.58	493,600.54	1,600,561.79						
SR57N_RET_4																			
30045								0+00.00	493,670.76	1,600,583.12									
30046					0+45.99	493,716.56	1,600,587.25	1+28.98	493,799.21	1,600,594.72	1+80.07	493,798.46	1,600,677.71						

SUPERELEVATION DATA

See PV-300 Series

Road Identification	Circular Curve or Spiral Curve Name	Radius	Superelevation Data			Standard Road Plan	Section A-A	Section B-B	Section C-C	Section D-D	Section E-E	Section F-F	Case A	Case B	Case C	Case S	Case T	Case U	Remarks
			e	L	x														
			FT	%	FT														
IA 92	20006	1530	6.0	160	53	PV-301	257+92.63	258+45.63	258+98.63	260+05.63			260+05.63			259+52.30	259+52.30		
							269+98.11	269+45.11	268+92.11	267+85.11			267+85.11			268+38.44	268+38.44		
IA 92	20015	1530	6.0	160	53	PV-301	337+19.34	337+72.34	338+25.34	339+32.34			339+32.34			338+79.01	338+79.01		
							347+32.31	346+79.31	346+26.31	345+19.31			345+19.31			345+72.64	345+72.64		
IA 92	20022	1530	6.0	160	53	PV-301	347+32.31	347+85.31	348+38.31	349+45.31			349+45.31			348+91.98	348+91.98		
							357+62.82	357+09.82	356+56.82	355+49.82			355+49.82			356+03.15	356+03.15		

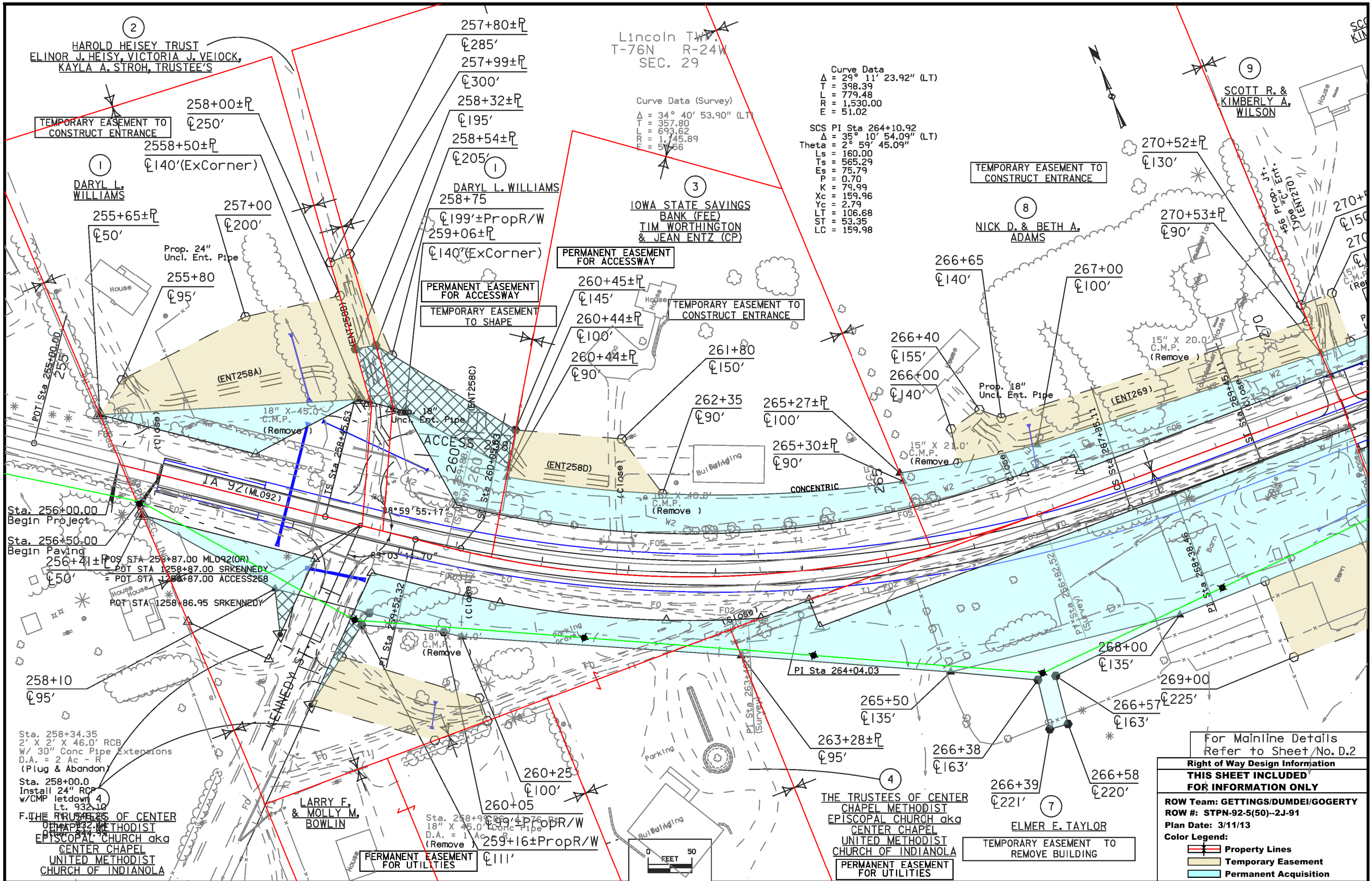

Lincoln Twp
T-76N R-24W
SEC. 29

Curve Data (Survey)
 $\Delta = 34^\circ 40' 53.90''$ (LT)
 $T = 357.80$
 $L = 693.62$
 $E = 1,745.89$
 $S = 57.56$

Curve Data
 $\Delta = 29^\circ 11' 23.92''$ (LT)
 $T = 398.39$
 $L = 779.48$
 $R = 1,530.00$
 $E = 51.02$

SCS PI Sta 264+10.92
 $\Delta = 35^\circ 10' 54.09''$ (LT)
 $\text{Theta} = 2^\circ 59' 45.09''$
 $L_s = 160.00$
 $T_s = 565.29$
 $E_s = 75.79$
 $P = 0.70$
 $K = 79.99$
 $X_c = 159.96$
 $Y_c = 2.79$
 $LT = 106.68$
 $ST = 53.35$
 $LC = 159.98$

For Mainline Details Refer to Sheet No. D.2	
Right of Way Design Information	
THIS SHEET INCLUDED FOR INFORMATION ONLY	
ROW Team: GETTINGS/DUMDEI/GOGERTY	
ROW #: STPN-92-5(50)--2J-91	
Plan Date: 3/11/13	
Color Legend:	
	Property Lines
	Temporary Easement
	Permanent Acquisition

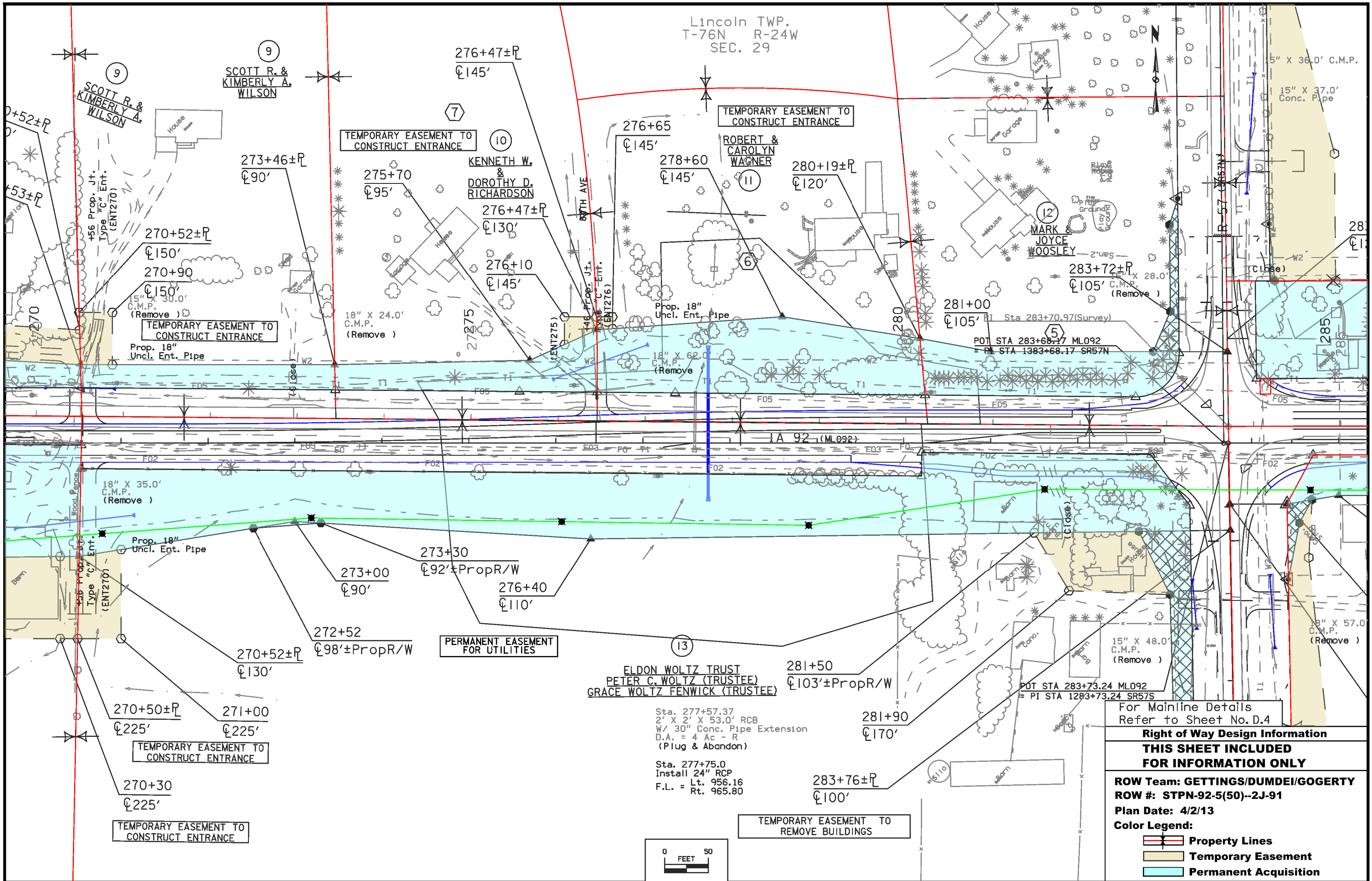

Lincoln TWP.
T-76N R-24W
SEC. 29

9
SCOTT R. &
KIMBERLY A.
WILSON

9
SCOTT R. &
KIMBERLY A.
WILSON

TEMPORARY EASEMENT TO
CONSTRUCT ENTRANCE

10
KENNETH W.
&
DOROTHY D.
RICHARDSON

TEMPORARY EASEMENT TO
CONSTRUCT ENTRANCE

ROBERT &
CAROLYN
WAGNER

12
MARK &
JOYCE
WOOSLEY

13
ELDON WOLTZ TRUST
PETER C. WOLTZ (TRUSTEE)
GRACE WOLTZ FENWICK (TRUSTEE)

Sta. 277+57.37
2' X 2' X 53.0' RCB
W/ 30" Conc. Pipe Extension
D.A. = 4 Ac - R
(Plug & Abandon)

Sta. 277+75.0
Install 24" RCP
F.L. = Lt. 956.16
Rt. 965.80

For Mainline Details
Refer to Sheet No. D.4

Right of Way Design Information

**THIS SHEET INCLUDED
FOR INFORMATION ONLY**

ROW Team: GETTINGS/DUMDEI/GOGERTY

ROW #: STPN-92-5(50)--2J-91

Plan Date: 4/2/13

Color Legend:

- Property Lines
- Temporary Easement
- Permanent Acquisition

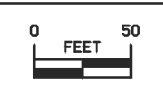

Lincoln TWP.
T-76N R-24W
SEC. 29

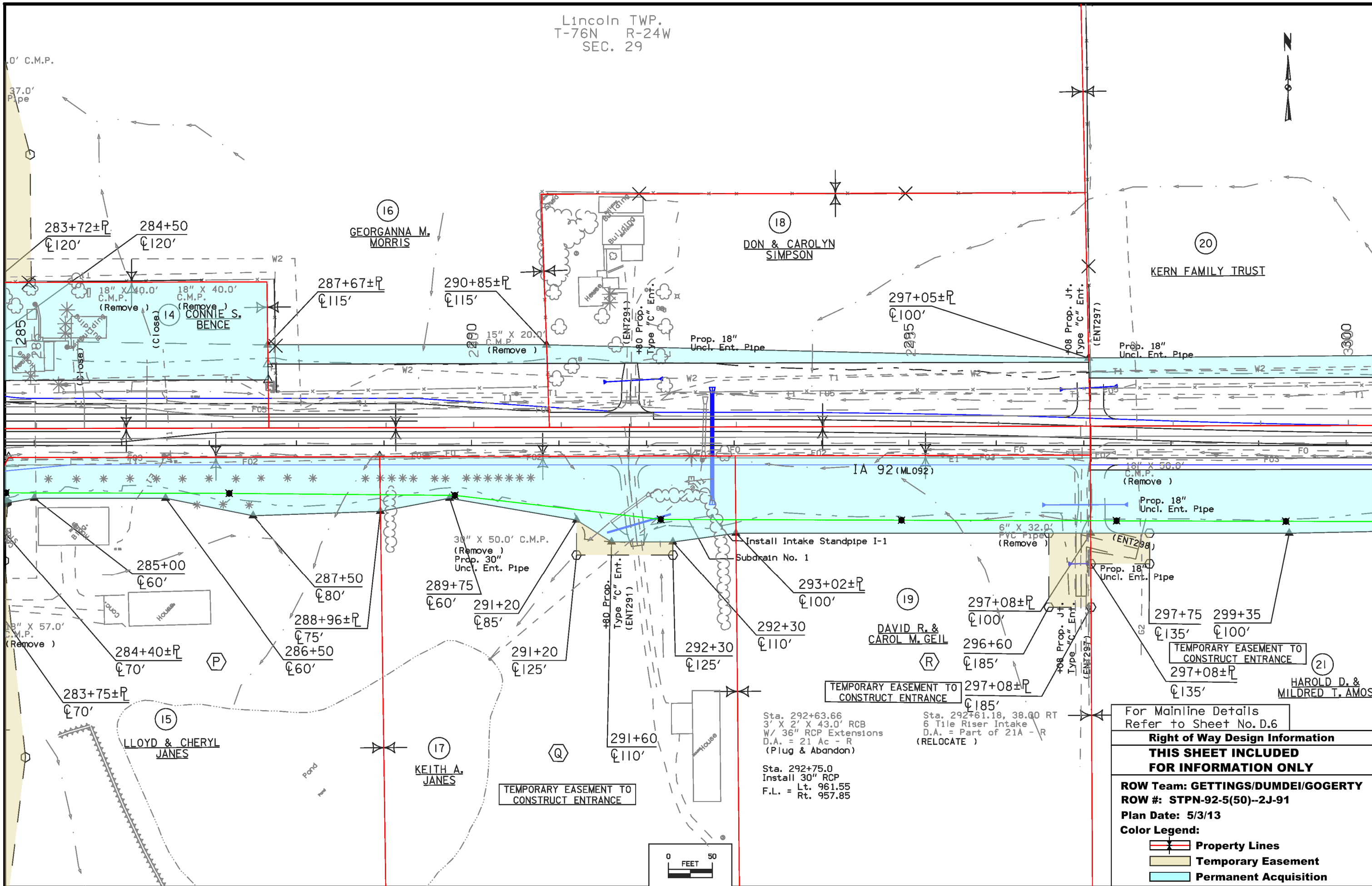

For Mainline Details Refer to Sheet No. D.6
Right of Way Design Information
THIS SHEET INCLUDED FOR INFORMATION ONLY
ROW Team: GETTINGS/DUMDEI/GOGERTY
ROW #: STPN-92-5(50)--2J-91
Plan Date: 5/3/13
Color Legend:
Property Lines
Temporary Easement
Permanent Acquisition

Lincoln TWP.
T-76N R-24W
SEC. 29

Lincoln TWP.
T-76N R-24W
SEC. 28

(20)
KERN FAMILY TRUST

(25)
DWIGHT T.
MC CORMICK

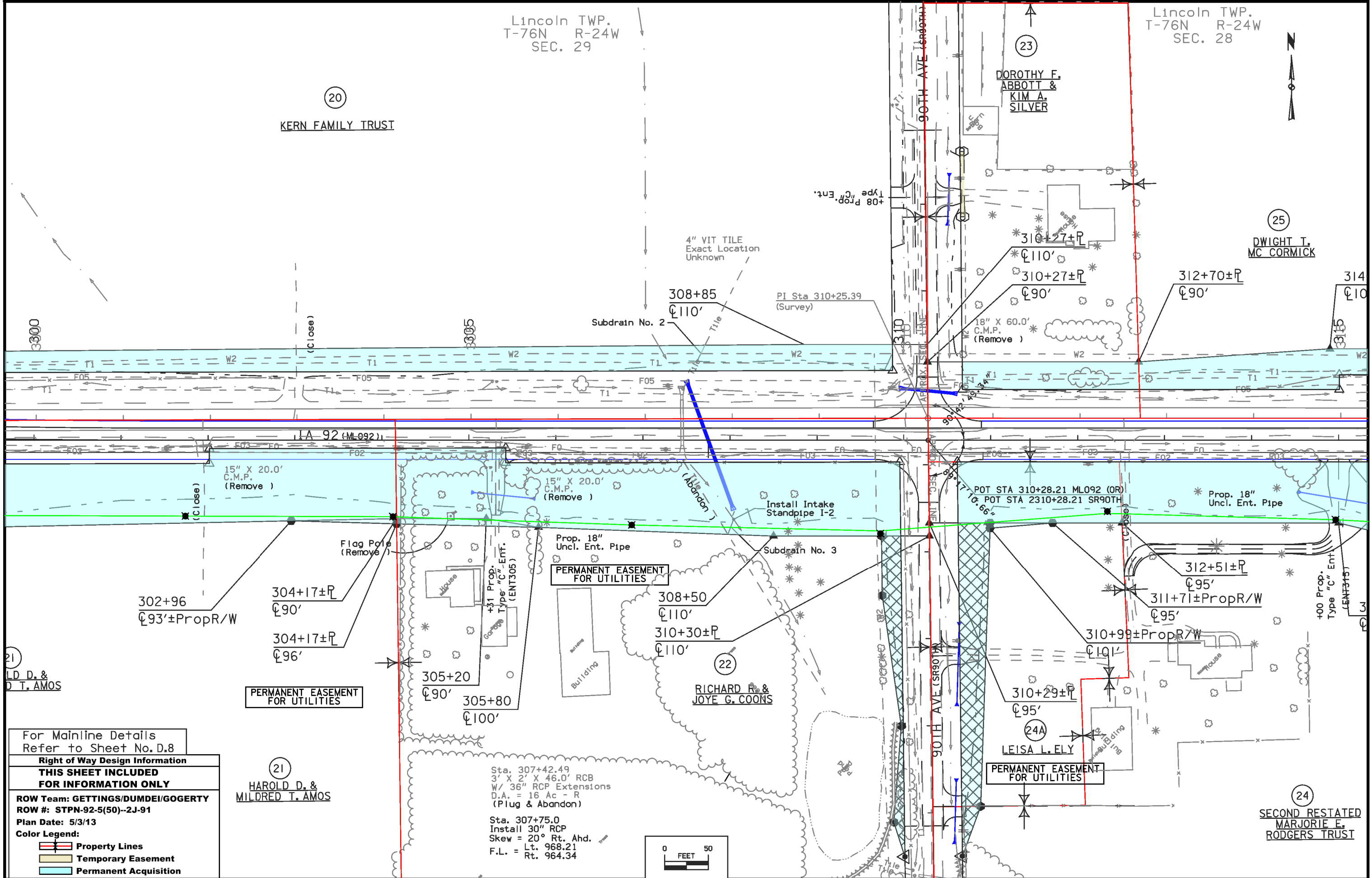

For Mainline Details
Refer to Sheet No. D.8

Right of Way Design Information

THIS SHEET INCLUDED FOR INFORMATION ONLY

ROW Team: GETTINGS/DUMDEI/GOGERTY
ROW #: STPN-92-5(50)--2J-91
Plan Date: 5/3/13

Color Legend:

- Property Lines
- Temporary Easement
- Permanent Acquisition

(21)
HAROLD D. &
MILDRED T. AMOS

Sta. 307+42.49
3' X 2' X 46.0' RCB
W/ 36" RCP Extensions
D.A. = 16 Ac - R
(Plug & Abandon)

Sta. 307+75.0
Install 30" RCP
Skew = 20° Rt. Ahd.
F.L. = Lt. 968.21
Rt. 964.34

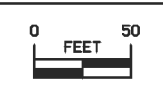

(22)
RICHARD R. &
JOYE G. COONS

(24A)
LEISA L. ELY

(24)
SECOND RESTATED
MARJORIE E.
RODGERS TRUST

Lincoln TWP.
T-76N R-24W
SEC. 28



(25) DWIGHT T.
MC CORMICK

(25) DWIGHT T.
MC CORMICK

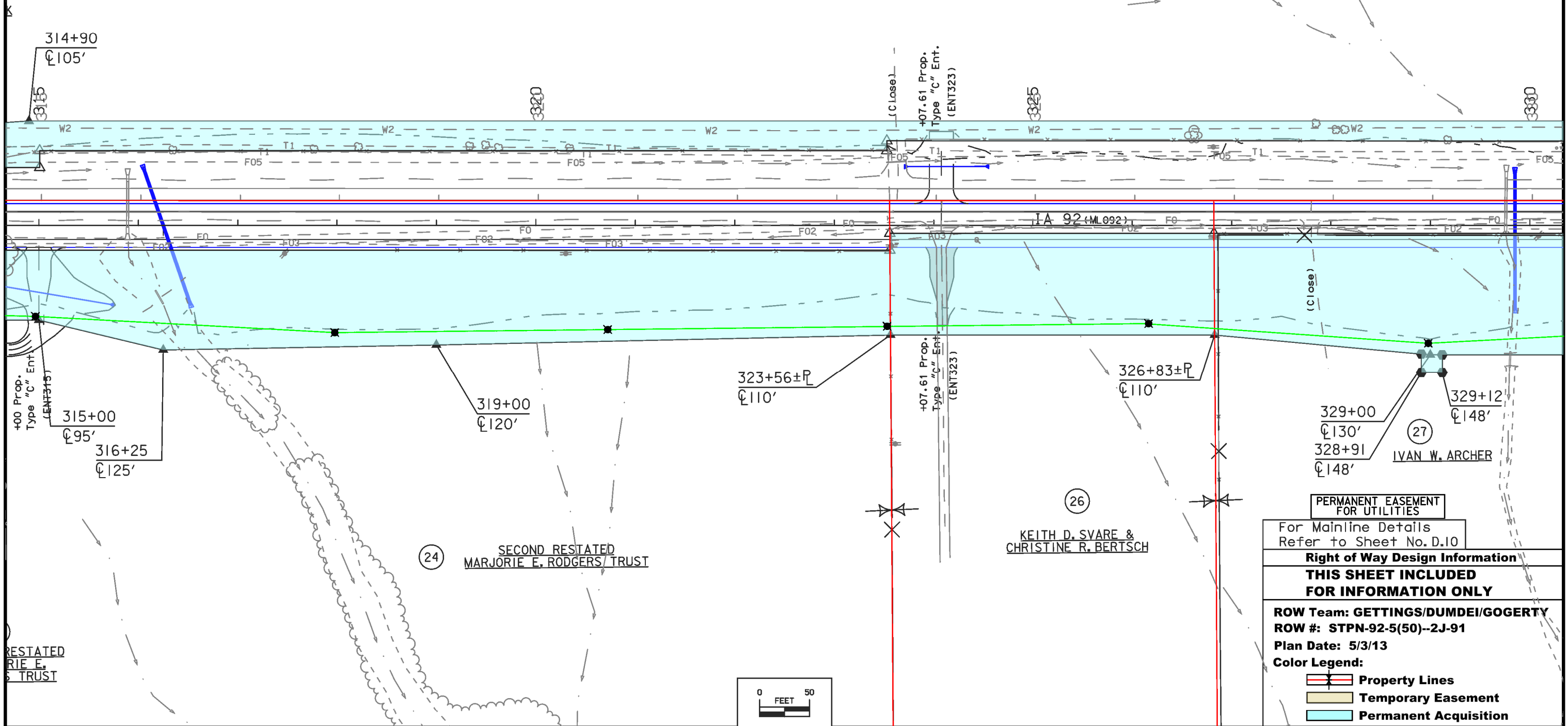

(24) SECOND RESTATED
MARJORIE E. RODGERS TRUST

(26) KEITH D. SVARE &
CHRISTINE R. BERTSCH

(27) IVAN W. ARCHER

PERMANENT EASEMENT FOR UTILITIES

For Mainline Details Refer to Sheet No. D.10

Right of Way Design Information

THIS SHEET INCLUDED FOR INFORMATION ONLY

ROW Team: GETTINGS/DUMDEI/GOGERTY
ROW #: STPN-92-5(50)--2J-91
Plan Date: 5/3/13

Color Legend:

- Property Lines
- Temporary Easement
- Permanent Acquisition

Right of Way Design Information
THIS SHEET INCLUDED
FOR INFORMATION ONLY

ROW Team: **GETTINGS/DUMDEI/GOGERTY**
ROW #: **STPN-92-5(50)--2J-91**
Plan Date: **5/3/13**
Color Legend:

- Property Lines
- Temporary Easement
- Permanent Acquisition

For Mainline Details
Refer to Sheet No. D.12

L = 297.14
L = 586.97
R = 1,530.00
E = 28.59
SCS PI Sta 342+33.59
Δ = 27° 58' 21.68" (LT)
Theta = 2° 59' 45.09"
Ls = 160.00
Ts = 461.25
Es = 47.46
P = 0.70
K = 79.99
Curve Data (Survey)
T = 32° 51' 54.10" (LT)
L = 337.60
E = 656.58
P = 1,144.67
R = 48.75
ST = 53.35
LC = 159.98

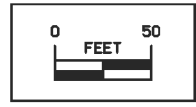
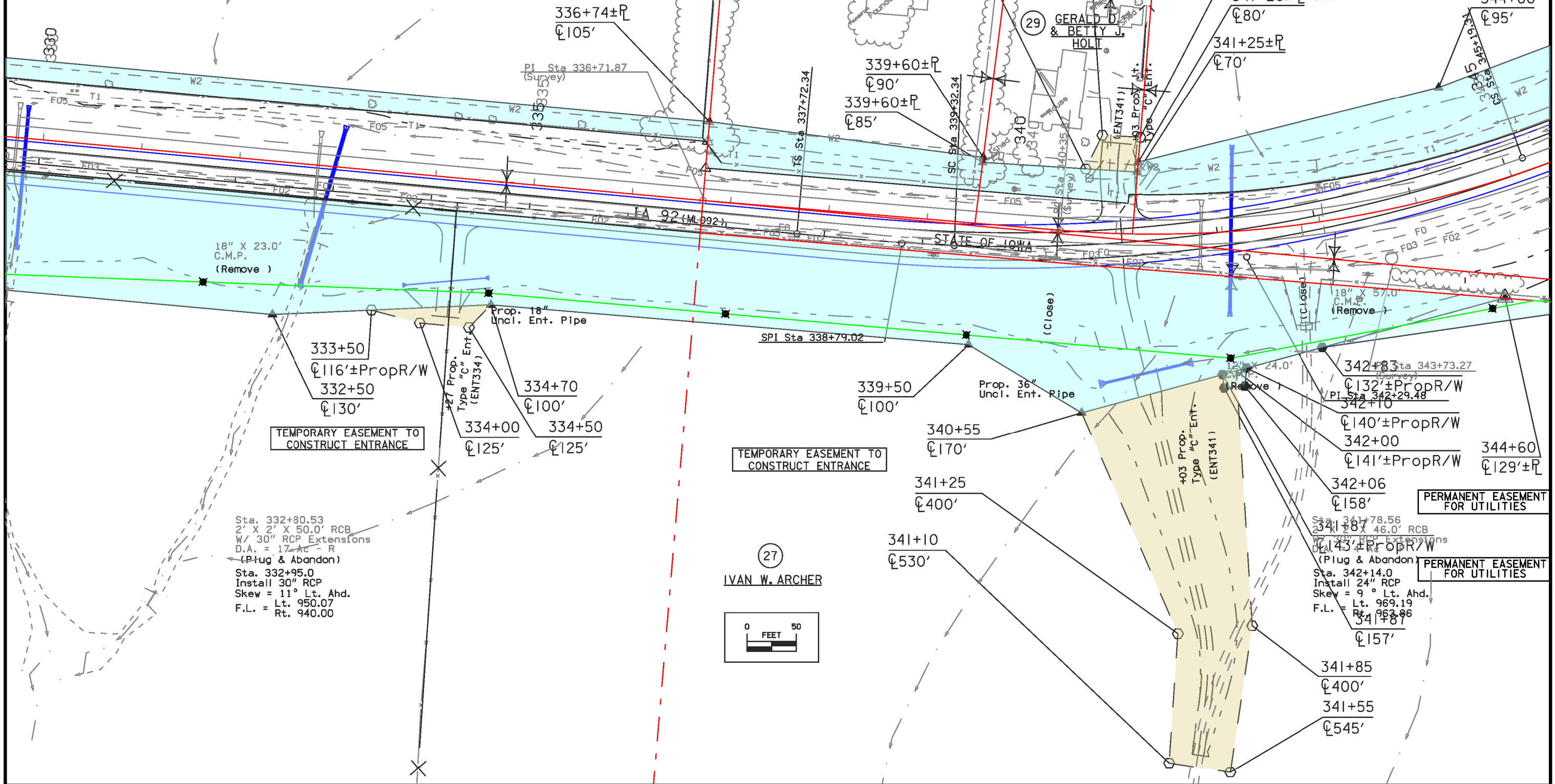

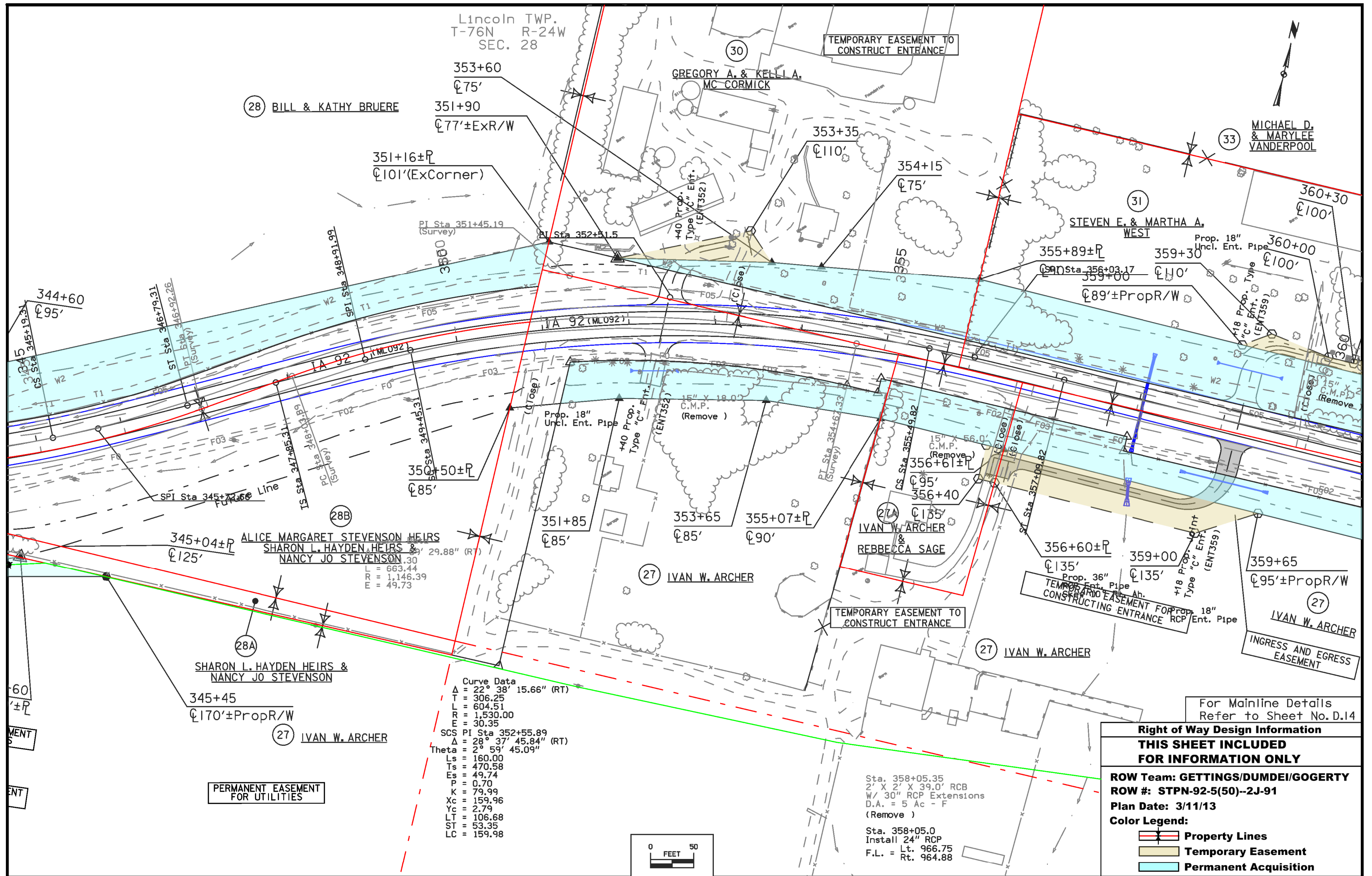

Curve Data
 $\Delta = 22^\circ 38' 15.66''$ (RT)
 $T = 306.25$
 $L = 604.51$
 $R = 1,530.00$
 $E = 30.35$
 SCS PI Sta 352+55.89
 $\Delta = 28^\circ 37' 45.84''$ (RT)
 $\text{Theta} = 2^\circ 59' 45.09''$
 $L_s = 160.00$
 $T_s = 470.58$
 $E_s = 49.74$
 $P = 0.70$
 $K = 79.99$
 $X_c = 159.96$
 $Y_c = 2.79$
 $LT = 106.68$
 $ST = 53.35$
 $LC = 159.98$

Sta. 358+05.35
 2' X 2' X 39.0' RCB
 W/ 30" RCP Extensions
 D.A. = 5 Ac - F
 (Remove)
 Sta. 358+05.0
 Install 24" RCP
 F.L. = Lt. 966.75
 Rt. 964.88

For Mainline Details
 Refer to Sheet No. D.14

Right of Way Design Information

THIS SHEET INCLUDED FOR INFORMATION ONLY

ROW Team: GETTINGS/DUMDEI/GOGERTY
ROW #: STPN-92-5(50)--2J-91
Plan Date: 3/11/13

Color Legend:

- Property Lines
- Temporary Easement
- Permanent Acquisition

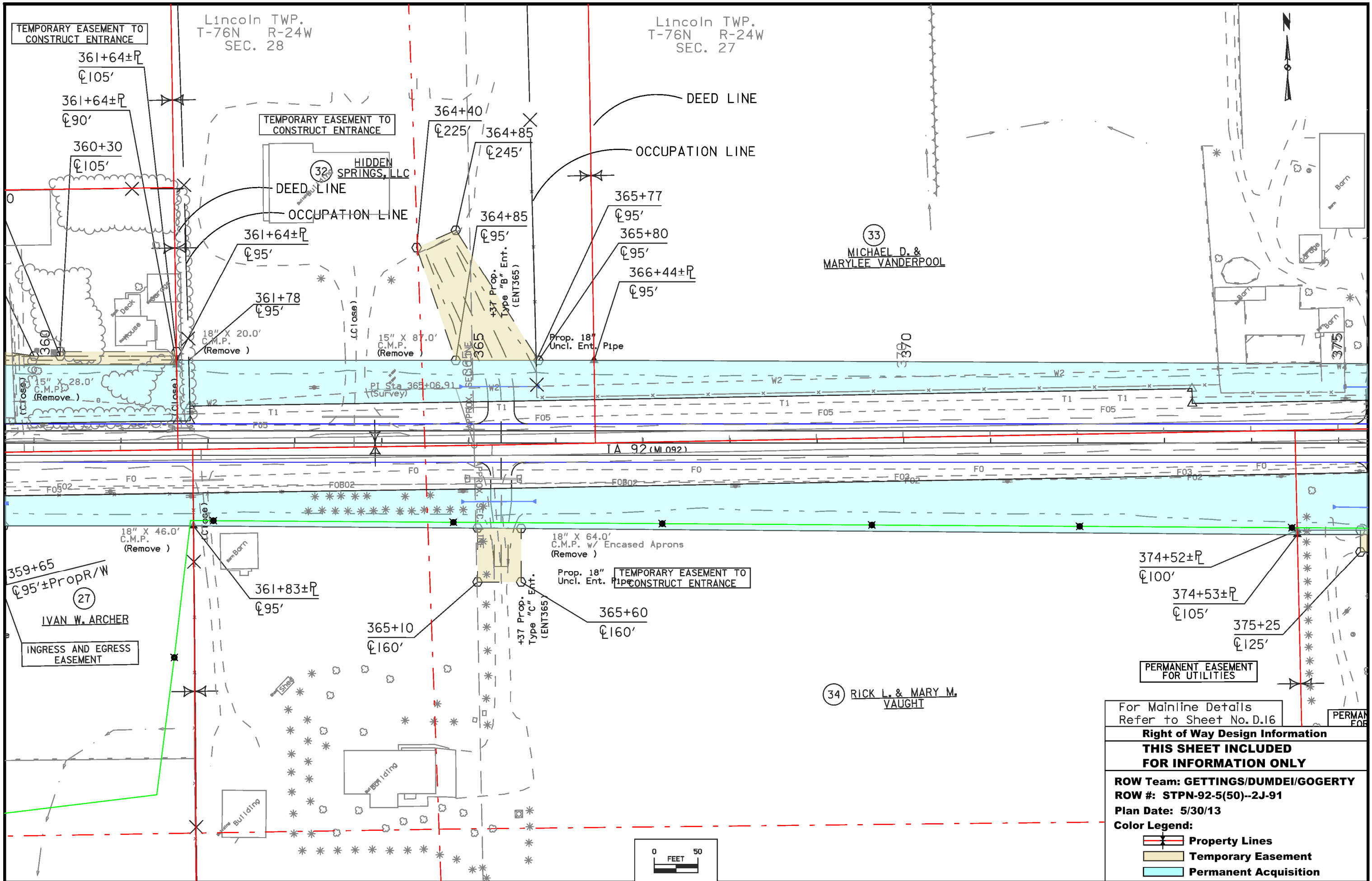

For Mainline Details Refer to Sheet No. D.16

Right of Way Design Information

THIS SHEET INCLUDED FOR INFORMATION ONLY

ROW Team: GETTINGS/DUMDEI/GOGERTY
 ROW #: STPN-92-5(50)--2J-91
 Plan Date: 5/30/13

Color Legend:

- Property Lines
- Temporary Easement
- Permanent Acquisition

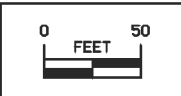

Lincoln TWP.
T-76N R-24W
SEC. 27

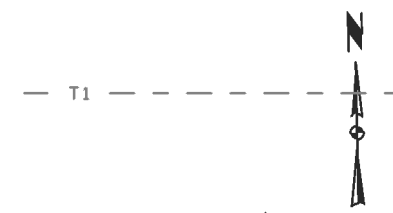

33
MICHAEL D. &
MARYLEE VANDERPOOL

36
MAYNARD J.V. HAYDEN (LE)
LORI J. HAYDEN, CHRISTI L. HAYDEN
AND STEVEN J. HAYDEN (REM)

38
CITY OF
INDIANOLA &
INDIANOLA MUNICIPAL
UTILITIES

37 HIDDEN SPRING LLC

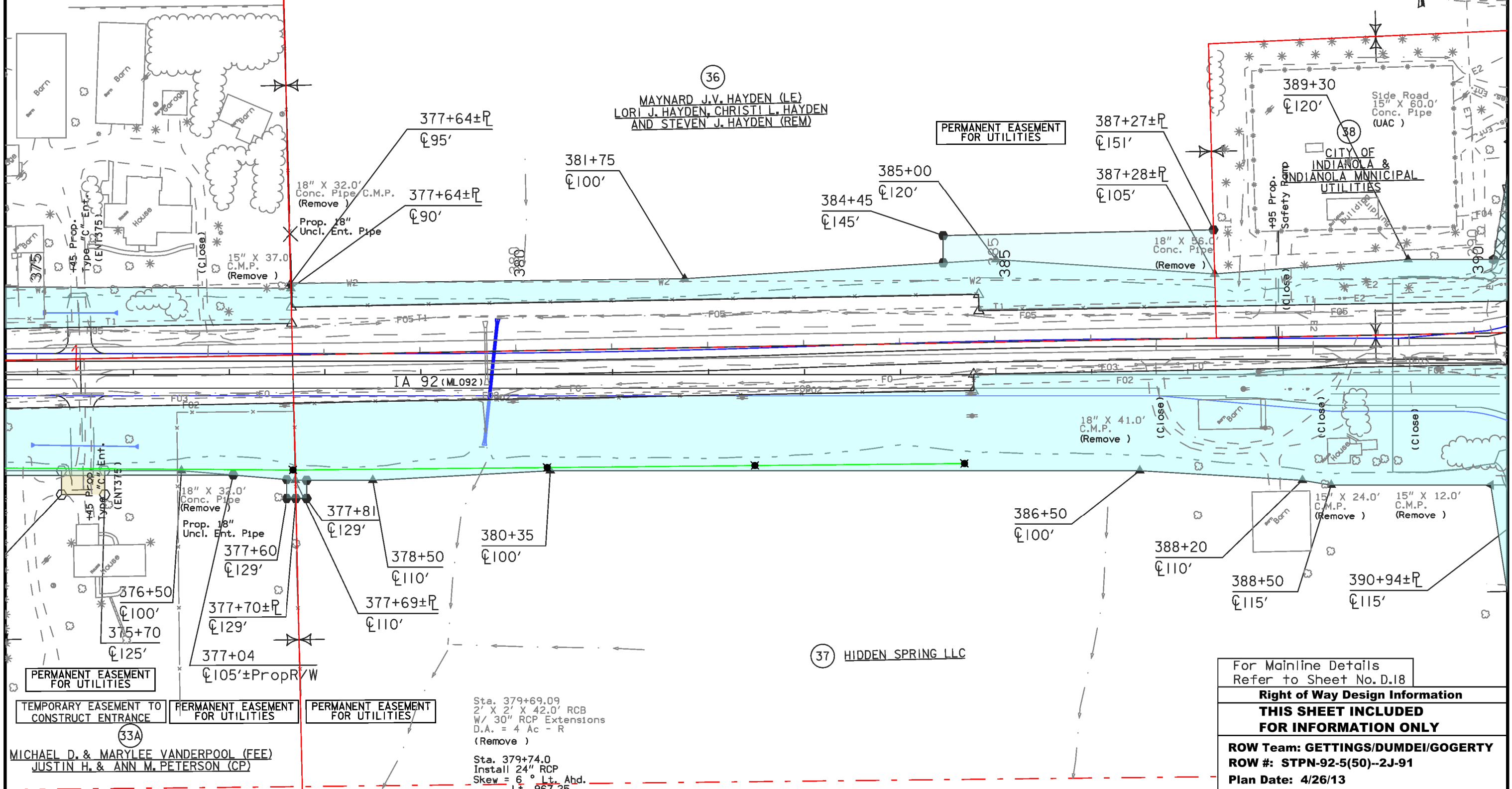

Sta. 379+69.09
2' X 2' X 42.0' RCB
W/ 30" RCP Extensions
D.A. = 4 Ac - R
(Remove)

Sta. 379+74.0
Install 24" RCP
Skew = 6° Lt. Ahd.
F.L. = Lt. 967.25
Rt. 962.58

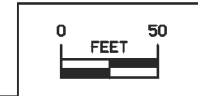

For Mainline Details
Refer to Sheet No. D.18

Right of Way Design Information

**THIS SHEET INCLUDED
FOR INFORMATION ONLY**

ROW Team: GETTINGS/DUMDEI/GOGERTY
ROW #: STPN-92-5(50)--2J-91
Plan Date: 4/26/13

Color Legend:

- Property Lines
- Temporary Easement
- Permanent Acquisition

Lincoln TWP.
T-76N R-24W
SEC. 27

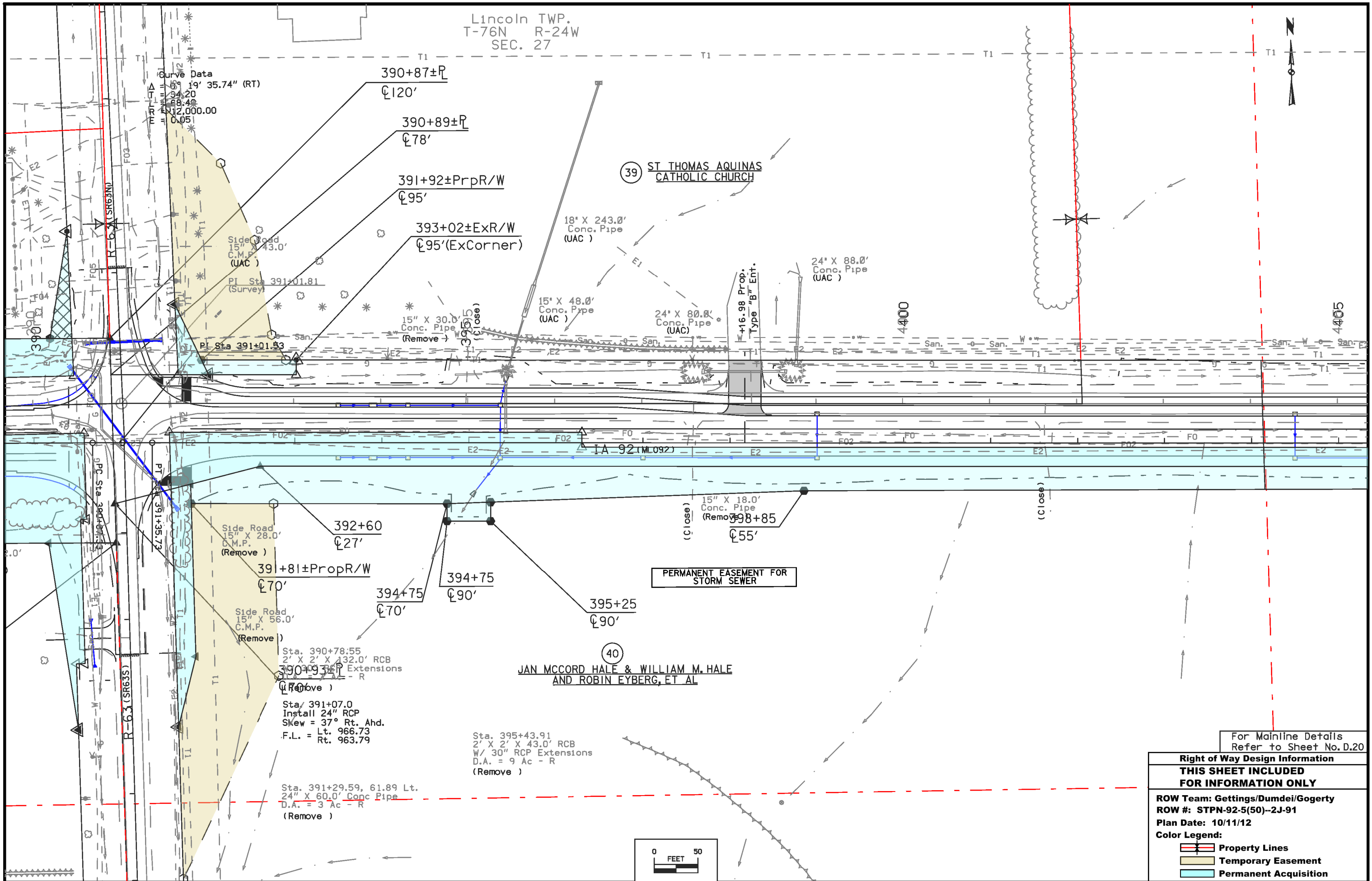

For Mainline Details
Refer to Sheet No. D.20

Right of Way Design Information	
THIS SHEET INCLUDED FOR INFORMATION ONLY	
ROW Team: Gettings/Dumdei/Gogerty	
ROW #: STPN-92-5(50)--2J-91	
Plan Date: 10/11/12	
Color Legend:	
	Property Lines
	Temporary Easement
	Permanent Acquisition

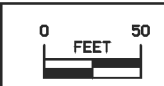

Lincoln TWP.
T-76N R-24W
SEC. 27

Sta. 417+03.73, 37.07 Lt.
22' X 14" X 60.0' Arch Conc Pipe
D.A. = 4 Ac - r
(Remove)

Curve Data
Δ = 0° 25' 37.45" (LT)
T = 44.72
L = 89.45
R = 12,000.00
E = 0.08 417+34±R

40
JAN MCCORD HALE & WILLIAM M. HALE
AND ROBIN R. EYBERG

41
M & W FARM
SERVICE CO

TEMPORARY EASEMENT TO
SHAPE & CONSTRUCT ENTRANCE

15" X 24.0'
C.M.P.
(Remove)

15" X 24.0'
C.M.P.
(Remove)

40
JAN MCCORD HALE & WILLIAM M. HALE
AND ROBIN R. EYBERG

Sta. 412+66.92, 247.41 RT
6 Tile Riser Intake
D.A. = 5A - R
(U.A.C.)

Sta. 414+54.06, 307.09 RT
6 Tile Riser Intake
D.A. = 2A - R
(U.A.C.)

Sta. 417+30.31, 350.36 Rt
30" X 44.0' CMP
D.A. = 16 Ac - R
(Remove)

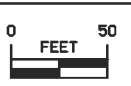

For Mainline Details
Refer to Sheet No. D.22

Right of Way Design Information

THIS SHEET INCLUDED FOR INFORMATION ONLY

ROW Team: GETTINGS/DUMDEI/GOGERTY

ROW #: STPN-92-5(50)--2J-91

Plan Date: 5/3/13

Color Legend:

- Property Lines
- Temporary Easement
- Permanent Acquisition

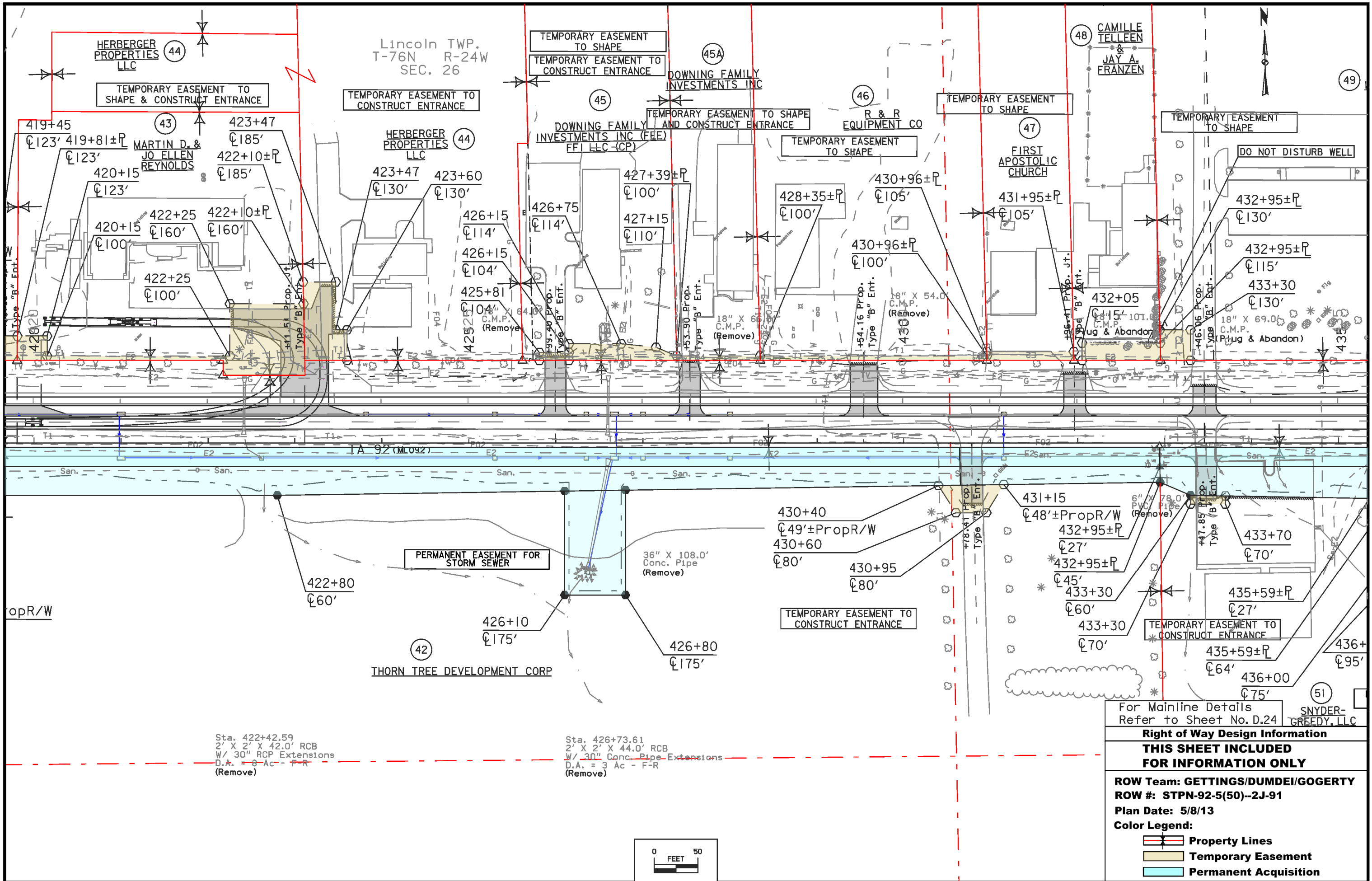

For Mainline Details
Refer to Sheet No. D.24

Right of Way Design Information

THIS SHEET INCLUDED FOR INFORMATION ONLY

ROW Team: GETTINGS/DUMDEI/GOGERTY
ROW #: STPN-92-5(50)--2J-91
Plan Date: 5/8/13

Color Legend:

- Property Lines
- Temporary Easement
- Permanent Acquisition

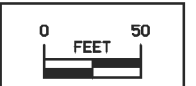

Lincoln TWP.
T-76N R-24W
SEC. 26

49 CITY OF INDIANOLA

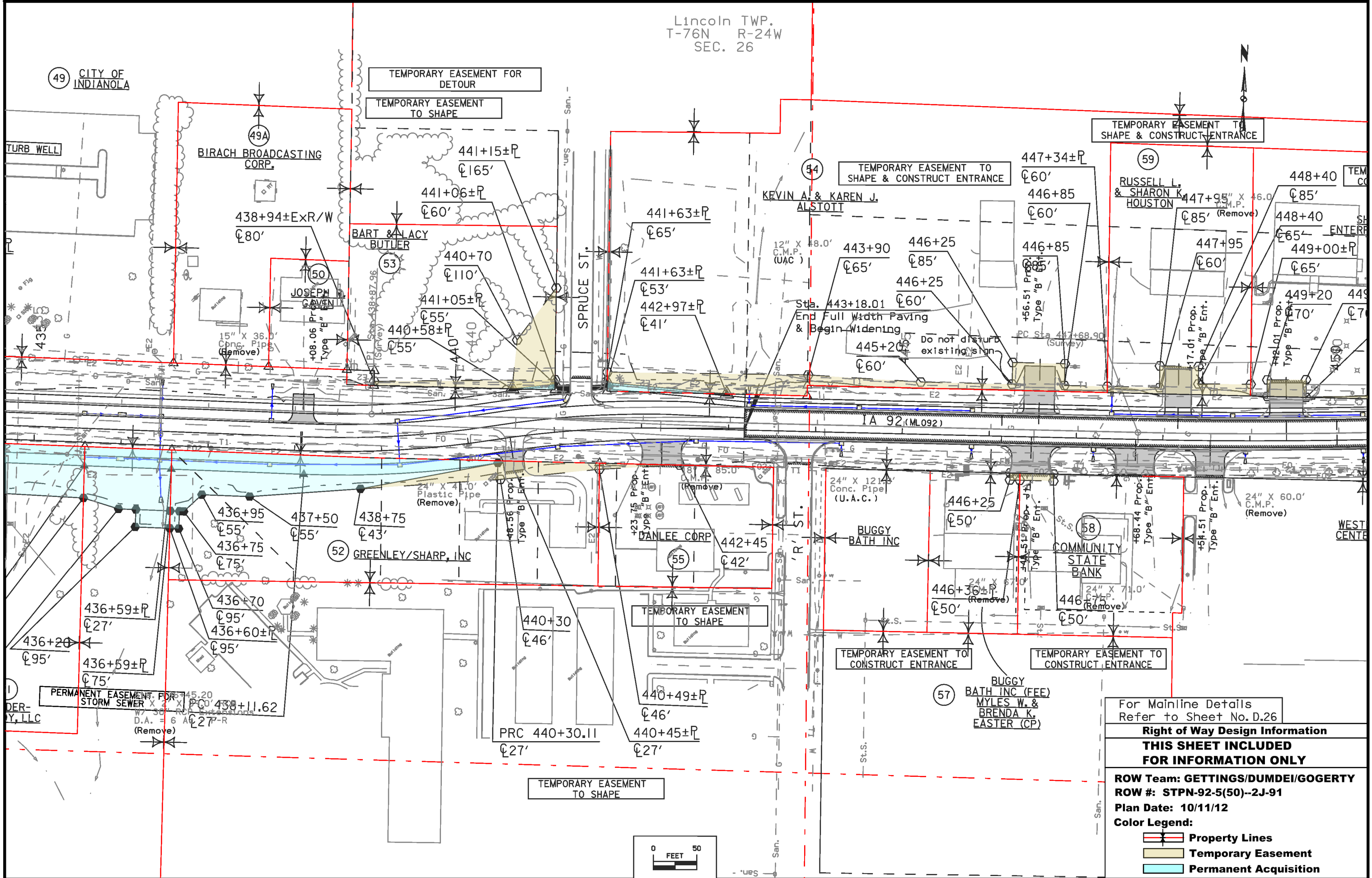

For Mainline Details
Refer to Sheet No. D.26

Right of Way Design Information

THIS SHEET INCLUDED FOR INFORMATION ONLY

ROW Team: GETTINGS/DUMDEI/GOGERTY
ROW #: STPN-92-5(50)--2J-91
Plan Date: 10/11/12
Color Legend:

- Property Lines
- Temporary Easement
- Permanent Acquisition

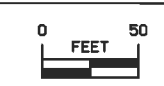

Lincoln TWP.
T-76N R-24W
SEC. 26

CPD I CONDOMINIUMS ATTORNEY-IN-FACT
FOR JANICE WESTERLY, MARJORIE L. BARNETT,
SHIRLEY A. ANDREW AND LOWELL G. &
PATRICIA J. WILKINSON

Curve Data (Survey)
Δ = 6° 59' 27.10" (LT)
T = 351.30
L = 701.79
R = 5,751.23
E = 10.72

Curve Data
Δ = 6° 59' 27.10" (LT)
T = 351.79
L = 702.70
R = 5,759.23
E = 10.73

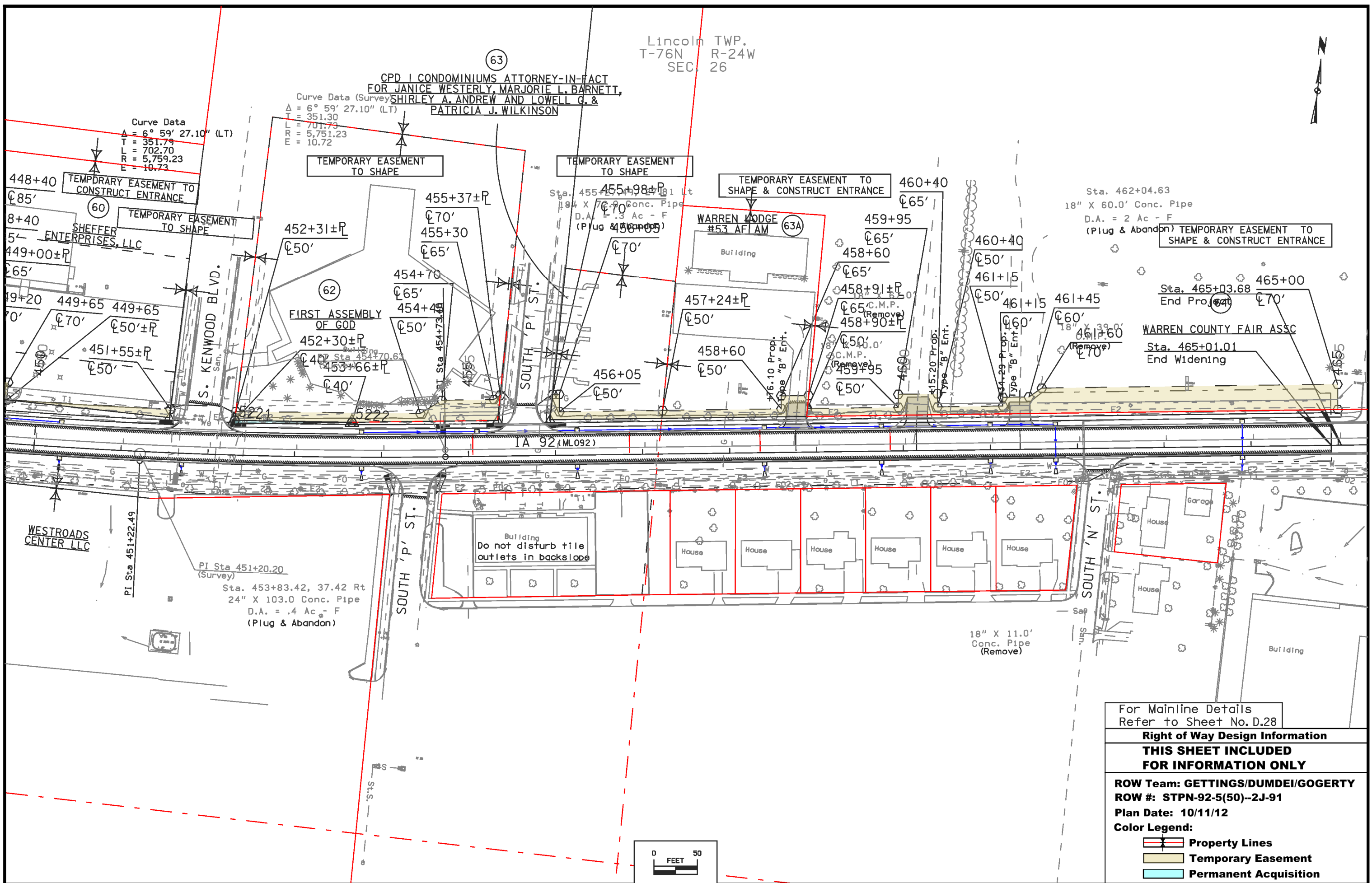

For Mainline Details
Refer to Sheet No. D.28

Right of Way Design Information

**THIS SHEET INCLUDED
FOR INFORMATION ONLY**

ROW Team: GETTINGS/DUMDEI/GOGERTY
ROW #: STPN-92-5(50)--2J-91
Plan Date: 10/11/12

Color Legend:

- Property Lines
- Temporary Easement
- Permanent Acquisition

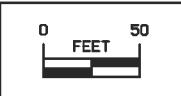

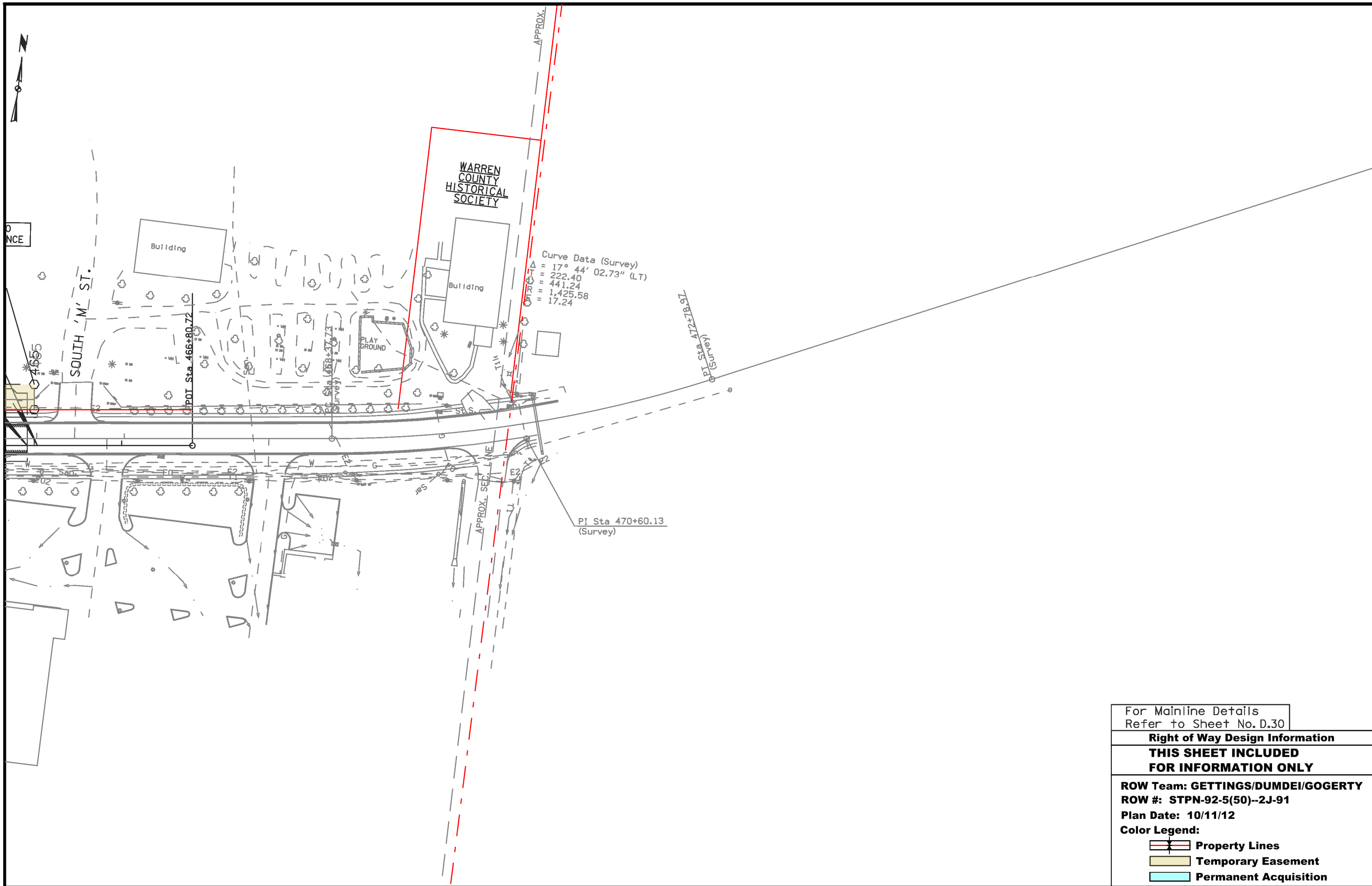

For Mainline Details
Refer to Sheet No. D.30

Right of Way Design Information

**THIS SHEET INCLUDED
FOR INFORMATION ONLY**

ROW Team: GETTINGS/DUMDEI/GOGERTY
ROW #: STPN-92-5(50)--2J-91
Plan Date: 10/11/12

Color Legend:

- Property Lines
- Temporary Easement
- Permanent Acquisition

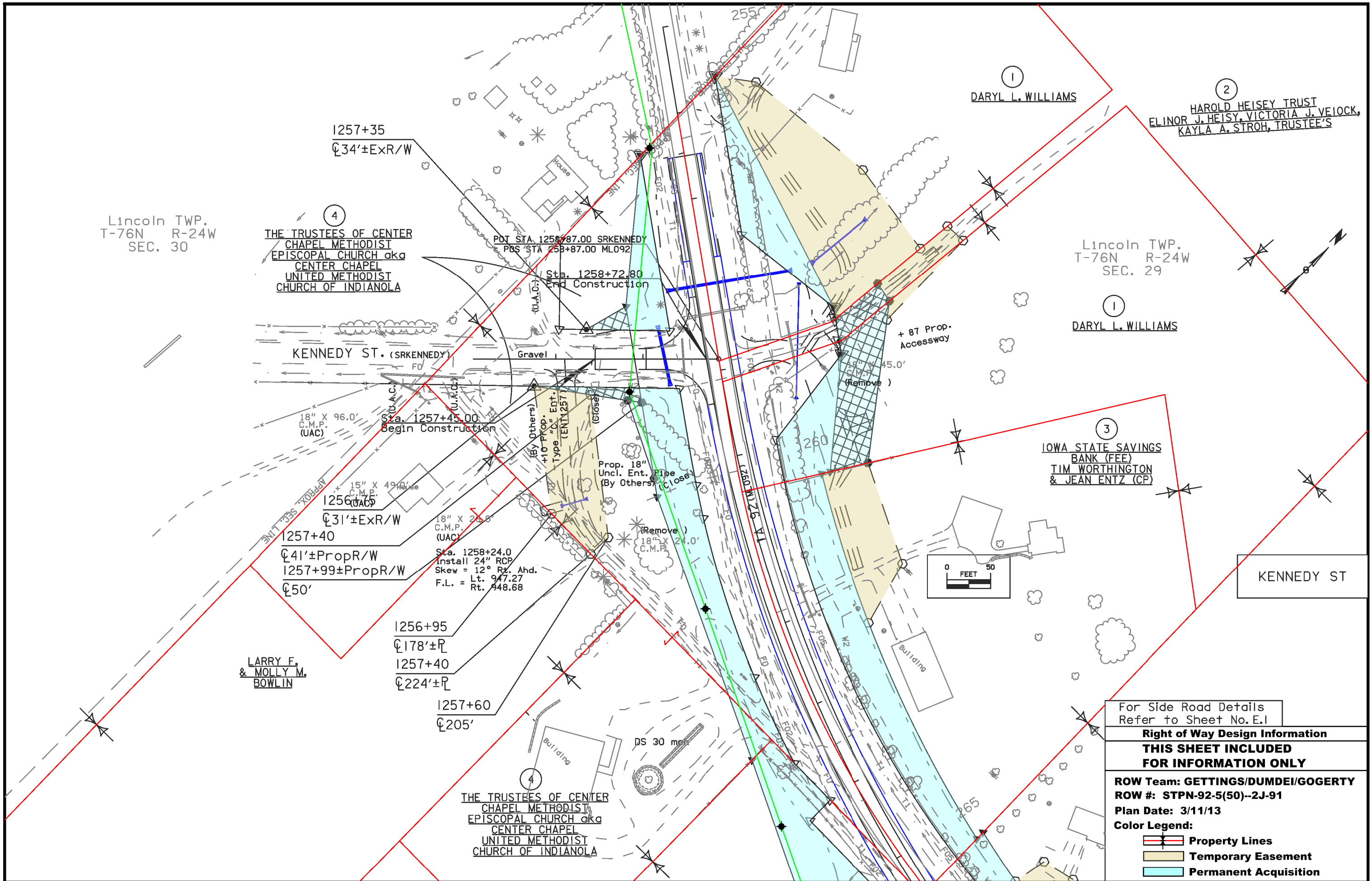

Lincoln TWP.
T-76N R-24W
SEC. 30

Lincoln TWP.
T-76N R-24W
SEC. 29

4
THE TRUSTEES OF CENTER
CHAPEL METHODIST
EPISCOPAL CHURCH aka
CENTER CHAPEL
UNITED METHODIST
CHURCH OF INDIANOLA

4
THE TRUSTEES OF CENTER
CHAPEL METHODIST
EPISCOPAL CHURCH aka
CENTER CHAPEL
UNITED METHODIST
CHURCH OF INDIANOLA

1
DARYL L. WILLIAMS

2
HAROLD HEISEY TRUST
ELINOR J. HEISY, VICTORIA J. VELOCK,
KAYLA A. STROH, TRUSTEE'S

1
DARYL L. WILLIAMS

3
IOWA STATE SAVINGS
BANK (FEE)
TIM WORTHINGTON
& JEAN ENTZ (CP)

LARRY F.
& MOLLY M.
BOWLIN

KENNEDY ST



For Side Road Details
Refer to Sheet No. E.1

Right of Way Design Information

**THIS SHEET INCLUDED
FOR INFORMATION ONLY**

ROW Team: GETTINGS/DUMDEI/GOGERTY
ROW #: STPN-92-5(50)--2J-91
Plan Date: 3/11/13

Color Legend:

- Property Lines
- Temporary Easement
- Permanent Acquisition

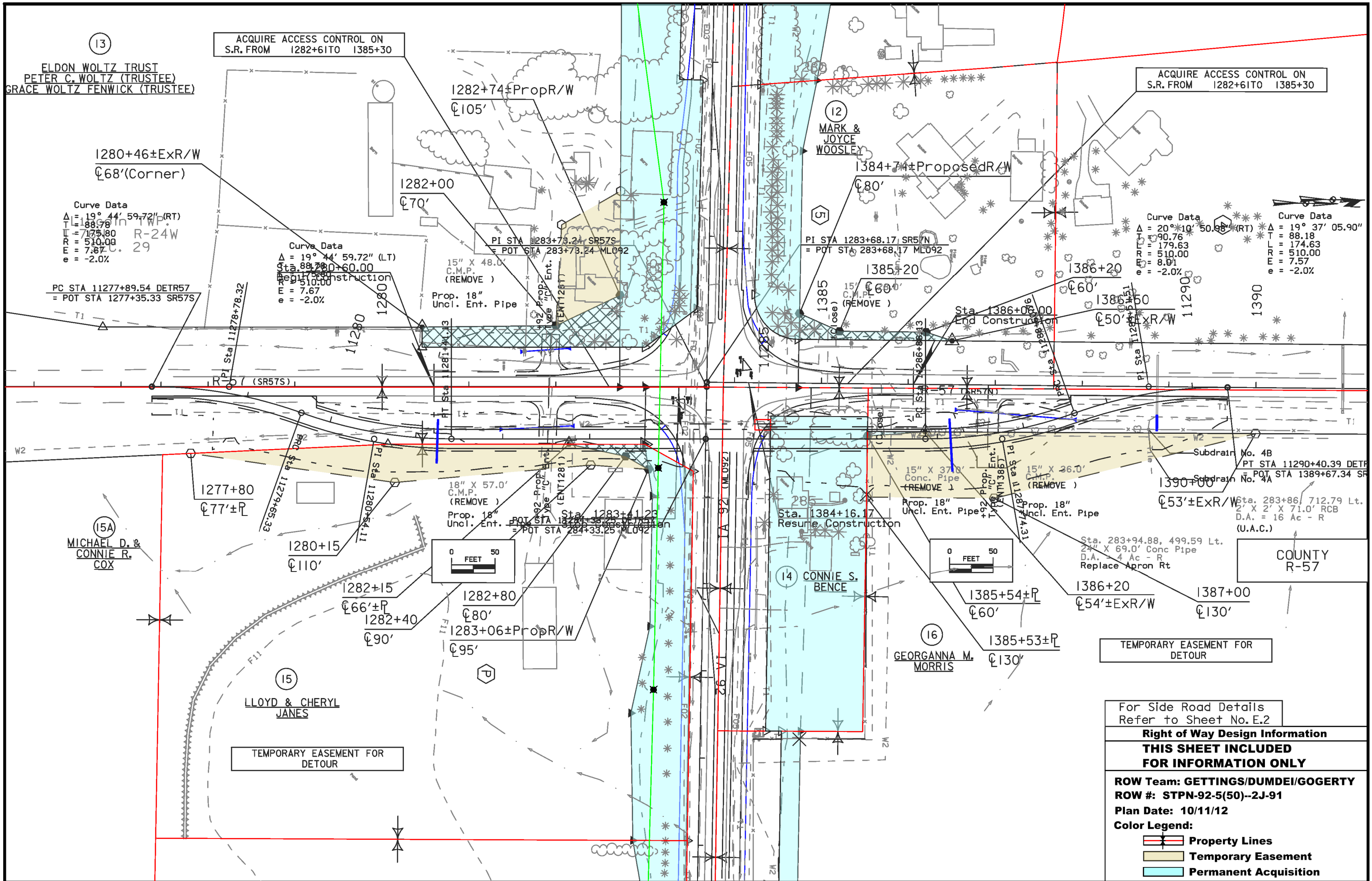

13
 ELDON WOLTZ TRUST
 PETER C. WOLTZ (TRUSTEE)
 GRACE WOLTZ FENWICK (TRUSTEE)

ACQUIRE ACCESS CONTROL ON
 S.R. FROM 1282+61 TO 1385+30

ACQUIRE ACCESS CONTROL ON
 S.R. FROM 1282+61 TO 1385+30

Curve Data
 $\Delta = 19^\circ 44' 59.72''$ (RT)
 $T = 188.78$
 $L = 7175.80$
 $R = 510.00$
 $E = 7.87$
 $e = -2.0\%$

Curve Data
 $\Delta = 19^\circ 44' 59.72''$ (LT)
 $T = 188.78$
 $L = 7175.80$
 $R = 510.00$
 $E = 7.87$
 $e = -2.0\%$

Curve Data
 $\Delta = 20^\circ 10' 50.96''$ (RT)
 $T = 90.76$
 $L = 179.63$
 $R = 510.00$
 $E = 8.91$
 $e = -2.0\%$



For Side Road Details
 Refer to Sheet No. E.2

Right of Way Design Information

**THIS SHEET INCLUDED
 FOR INFORMATION ONLY**

ROW Team: GETTINGS/DUMDEI/GOGERTY
ROW #: STPN-92-5(50)--2J-91
Plan Date: 10/11/12

Color Legend:

- Property Lines
- Temporary Easement
- Permanent Acquisition

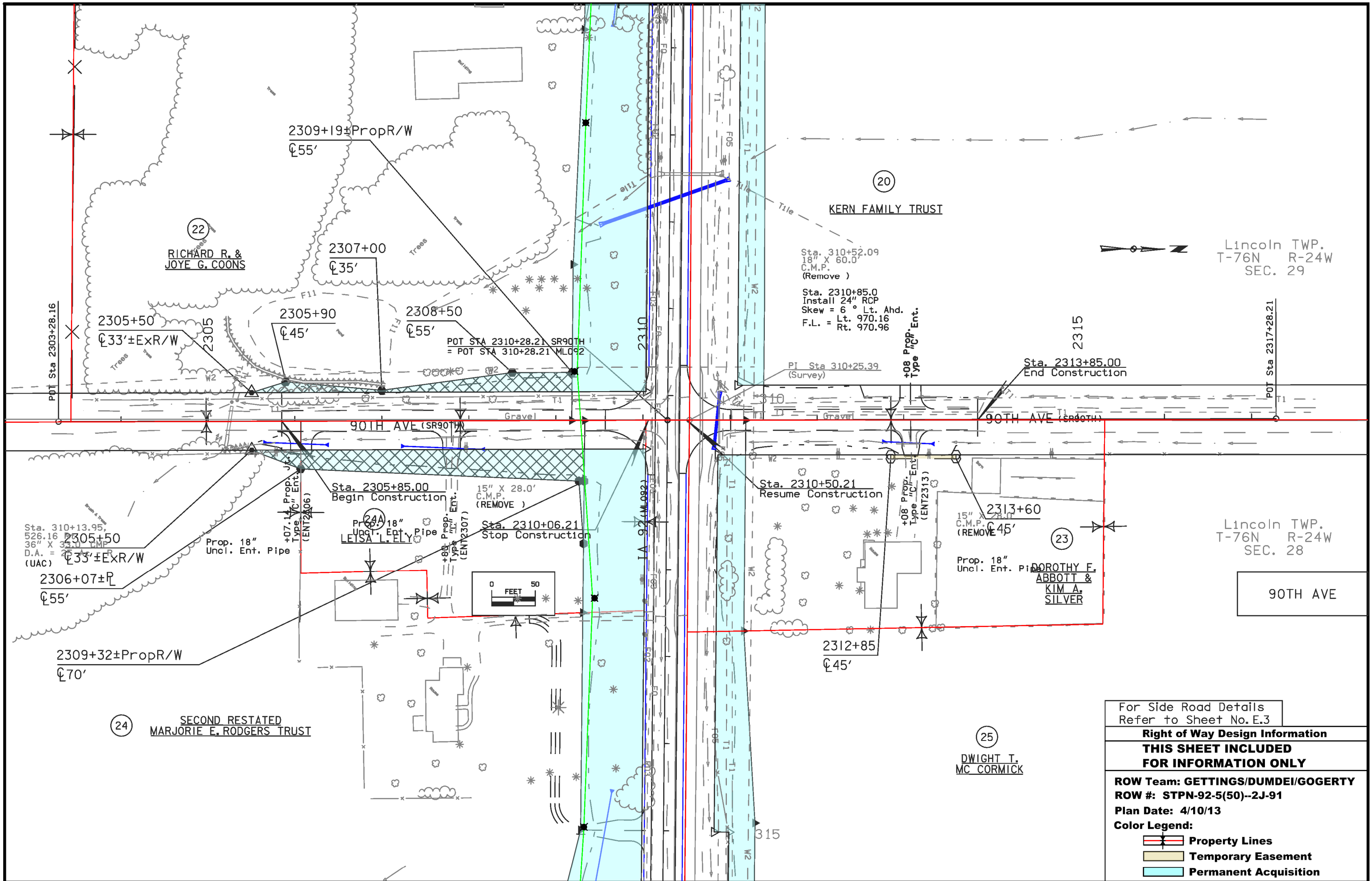

Lincoln TWP.
T-76N R-24W
SEC. 29

Lincoln TWP.
T-76N R-24W
SEC. 28

For Side Road Details Refer to Sheet No.E.3	
Right of Way Design Information	
THIS SHEET INCLUDED FOR INFORMATION ONLY	
ROW Team: GETTINGS/DUMDEI/GOGERTY	
ROW #: STPN-92-5(50)--2J-91	
Plan Date: 4/10/13	
Color Legend:	
	Property Lines
	Temporary Easement
	Permanent Acquisition

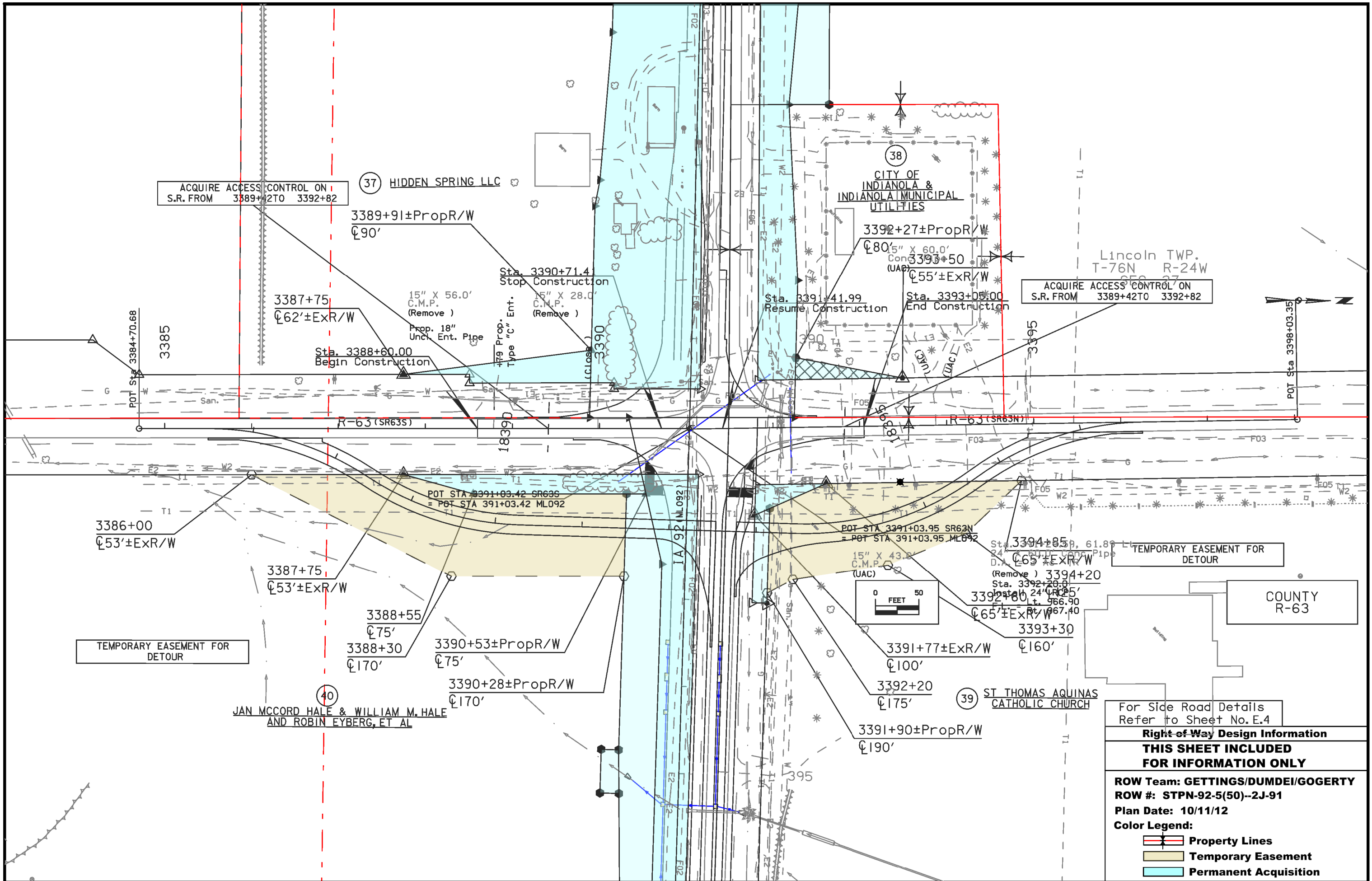

For Side Road Details
Refer to Sheet No. E.4

Right of Way Design Information

THIS SHEET INCLUDED FOR INFORMATION ONLY

ROW Team: GETTINGS/DUMDEI/GOGERTY
ROW #: STPN-92-5(50)--2J-91
Plan Date: 10/11/12

Color Legend:

- Property Lines
- Temporary Easement
- Permanent Acquisition

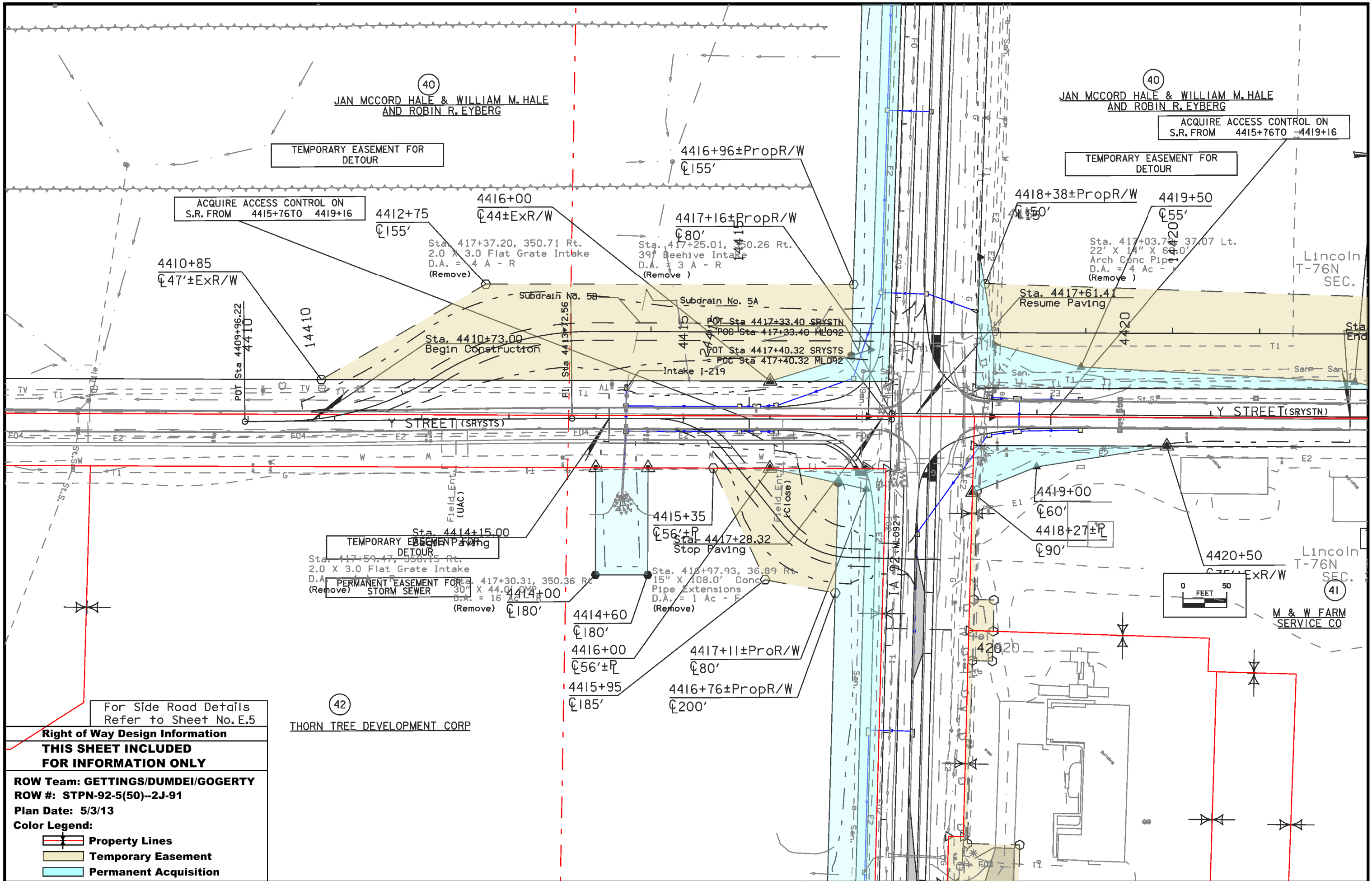

ACQUIRE ACCESS CONTROL ON S.R. FROM 4415+76 TO 4419+16

TEMPORARY EASEMENT FOR DETOUR

JAN MCCORD HALE & WILLIAM M. HALE AND ROBIN R. EYBERG

ACQUIRE ACCESS CONTROL ON S.R. FROM 4415+76 TO 4419+16

TEMPORARY EASEMENT FOR DETOUR

4410+85
447'±ExR/W

4412+75
155'

4416+00
44±ExR/W

4417+16±PropR/W
80'

4418+38±PropR/W
150'

4419+50
55'

Sta. 4410+73.00
Begin Construction

POT Sta 4417+33.40 SRYSTN
POC Sta 4417+33.40 ML092

Sta. 4417+61.41
Resume Paving

Sta. 4414+15.00
Begin Paving

4415+35
56'±P
Sta. 4417+28.32
Stop Paving

4419+00
60'

4418+27±P
90'

PERMANENT EASEMENT FOR STORM SEWER

4414+60
180'

4416+00
56'±P

4415+95
185'

4417+11±ProR/W
80'

4416+76±PropR/W
200'

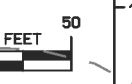

For Side Road Details Refer to Sheet No. E.5

THORN TREE DEVELOPMENT CORP

Right of Way Design Information	
THIS SHEET INCLUDED FOR INFORMATION ONLY	
ROW Team: GETTINGS/DUMDEI/GOGERTY	
ROW #: STPN-92-5(50)--2J-91	
Plan Date: 5/3/13	
Color Legend:	
	Property Lines
	Temporary Easement
	Permanent Acquisition

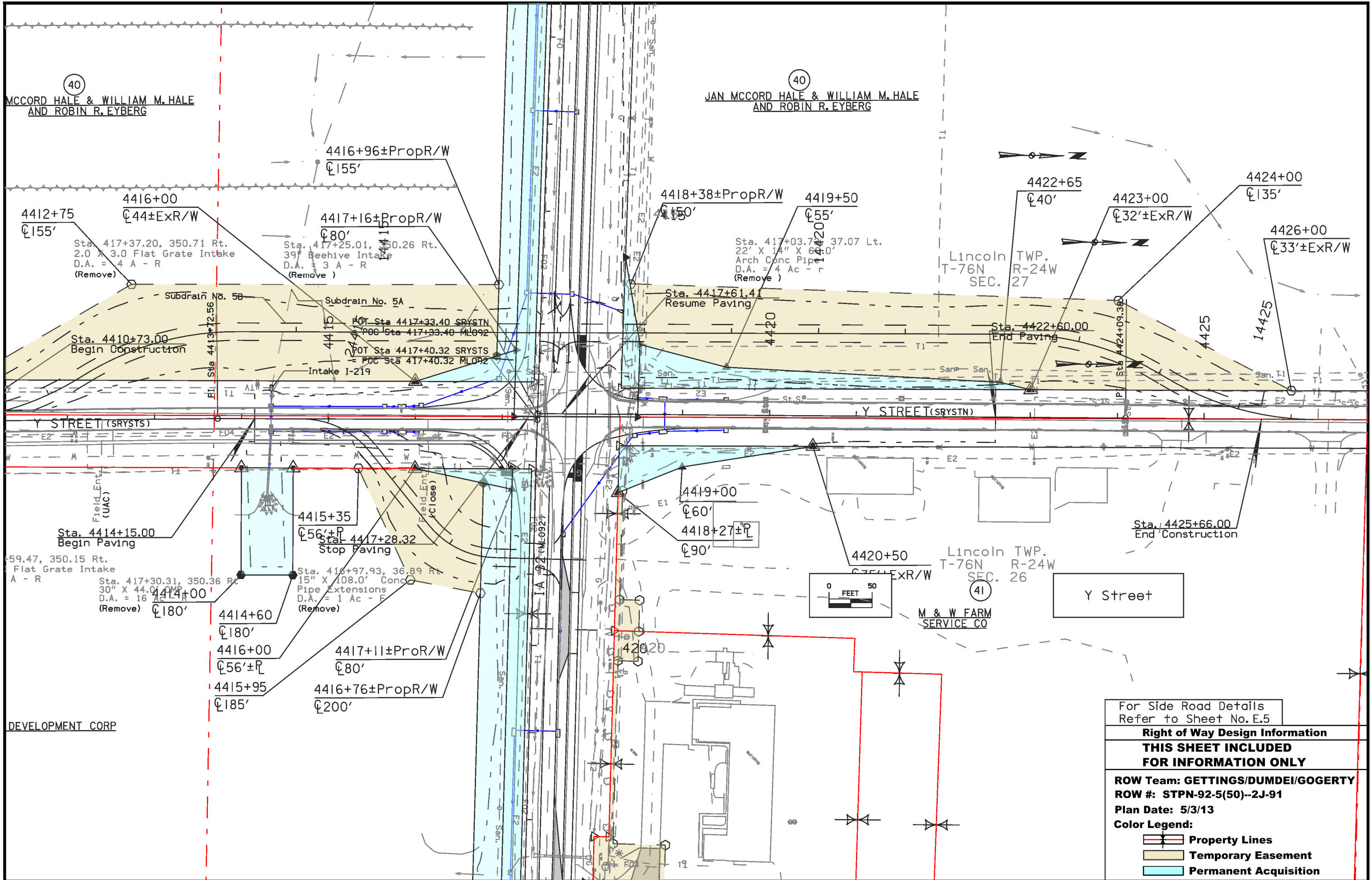

For Side Road Details Refer to Sheet No. E.5	
Right of Way Design Information	
THIS SHEET INCLUDED FOR INFORMATION ONLY	
ROW Team: GETTINGS/DUMDEI/GOGERTY	
ROW #: STPN-92-5(50)--2J-91	
Plan Date: 5/3/13	
Color Legend:	
	Property Lines
	Temporary Easement
	Permanent Acquisition

TRAFFIC CONTROL PLAN

IA 92
Traffic on IA 92 will be maintained one lane in each direction at all times except as follows:
IA 92 will be closed from the BOP to R-63 during Stage 2. Thru traffic will be detoured north in Martensdale on IA 28, east on IA 5, and south on US 65/US 69.
Access to all entrances will be maintained at all times.

R-57
Traffic will be maintained in both directions at all times.

90th Avenue (North of IA 92)
Road will be closed to thru traffic during closure of IA 92 from BOP to R-63. Local traffic will access 90th St. via local roads Illinois St. and Indiana/Inwood Streets.

90th Ave. (South of IA 92)
Road will be closed to thru traffic during closure of IA 92 from BOP to R-63. Local traffic will access 90th St. from R-57 via Kirkwood St.

R-63
Traffic will be maintained in both directions at all times.

Y St. (North of IA 92)
Traffic will be maintained in both directions at all times.

Y St. (South of IA 92)
Traffic will be maintained in both directions at all times.

South Spruce St.
Traffic will be maintained in both directions at all times.

R St.
Street will be closed during construction of the R Street intersection with IA 92. R Street will not be closed at the same time as South P Street on the south side of IA 92.

South Kenwood Blvd.
Street will be closed during construction of the South Kenwood Blvd. intersection with IA 92. South Kenwood Blvd will not be closed at the same time as South P St. on the north side of IA 92.

South P St. (North of IA 92)
Street will be closed during construction of the South P St. intersection with IA 92. South P St. north of IA 92 will not be closed at the same time as South Kenwood Blvd.

South P St. (South of IA 92)
Street will be closed during construction of the South P St. intersection with IA 92. South P St. south of IA 92 will not be closed at the same time as R St. or South N St. on the south side of IA 92.

South N St.
Street will be closed during construction of the N St. intersection with IA 92. R St. will not be closed at the same time as South P St. on the south side of IA 92.

PEDESTRIAN PATH CLOSURES

Refer to TC-601.

*Assumes 6 foot wide barricade.
Closures may need to be removed and re-established.

Location	Side	Type III Barricades*	Remarks
		No.	
Sta 4410+73; East side of Y St., South of IA 92	Rt	1	Closed for Stages 1 and 2
Station 441+60; East side of Spruce St.	Lt	1	Closed for Stages 1 thru 4
Station 454+10; West side of South P St., South of IA 92	Rt	1	Closed for Stage 4
Station 454+65; East side of South P St., South of IA 92	Rt	1	Closed for Stage 4
Station 451+60; West side of S. Kenwood Blvd, North of IA 92	Lt	1	Closed for Stage 4
Station 452+30; East side of S. Kenwood Blvd, North of IA 92	Lt	1	Closed for Stage 4
Station 455+40; West side of South P Street, North of IA 92	Lt	1	Closed for Stage 4
Station 455+95; East side of South P Street, North of IA 92	Lt	1	Closed for Stage 4
Sta 465+85	Lt	1	Closed for Stages 1 thru 4

COORDINATED OPERATIONS

Other work in progress during the same period of time will include the construction of the projects listed. Coordinate operations with those of other contractors working within the same area.

Project	Type of Work
NHSX-092-5(55)--3H-91	Lighting
NHSX-092-5(54)--3H-91	Traffic Signs

STAGING NOTES

- Stage 1
 - Traffic Control
 - IA 92
 - Maintain traffic on existing IA 92 from beginning of project to end of project
 - Sideroads
 - Maintain traffic on all existing sideroads
 - Construction
 - IA 92
 - Construct temporary pavement on north side of IA 92 at the Spruce Street intersection
 - Sideroads
 - Construct the SW temporary granular detour for Y Street south of IA 92
 - Place granular surface on Kirkwood Street between R-57 and 90th Street
- Stage 2A
 - Traffic Control
 - IA 92
 - Detour IA 92 thru traffic as shown on sheets J.5-J.12
 - Maintain IA 92 local traffic on existing pavement from BOP to R-57
 - Close IA 92 local traffic from R-57 to 90th Street
 - Maintain IA 92 local traffic on existing pavement from 90th Street to EOP
 - Sideroads
 - Maintain traffic on R-57
 - Access to 90th Street south of IA 92 shall be maintained from R-57 via Kirkwood Street
 - Access to 90th Street north of IA 92 shall utilize local roads Illinois Street and Indiana/Inwood Streets
 - Maintain traffic on R-63
 - Maintain traffic on Y Street north of IA 92
 - Close Y Street south of IA 92 and use the SW temporary granular detour for Y Street south of IA 92
 - Construction
 - IA 92
 - Grade and Pave IA 92 from R-57 (Sta 284+00) east 150'
 - Sideroads
 - Construct the NE and SE temporary paved detours for R-57 north and south of IA 92
 - Construct the NE and SE temporary paved detours for R-63 north and south of IA 92
- Stage 2B
 - Traffic Control
 - IA 92
 - Continue to detour thru traffic for IA 92 as shown on sheets J.5-J.12
 - Close IA 92 from BOP east to just east of R-63 (Sta 391+80)
 - Traffic on R-57 shall be allowed to cross the new IA 92 pavement at the temporary detour pavement
 - Maintain local entrance access only
 - Maintain local traffic on existing pavement of IA 92 as one-lane in each direction between R-63 and EOP while utilizing temporary pavement at Spruce Street
 - Sideroads
 - Maintain traffic on R-57 via detour pavement
 - Close 90th Street
 - Maintain traffic on R-63 via detour pavement
 - Maintain traffic on Y Street north of IA 92
 - Maintain traffic on SW temporary granular detour pavement for Y Street south of IA 92
 - Construction
 - IA 92
 - Grade and Pave IA 92 from BOP to just east of the R-57 intersection (Sta 284+00)
 - Grade and Pave IA 92 from just east of R-57 (Sta 285+50) to just east of R-63 intersection (Sta 391+80)
 - Grade and Pave new EB and center turn lanes of IA 92 from just east of R-63 (Sta 393+30) to just west of SW temporary granular detour for Y Street (Sta 416+15)
 - Grade and Pave new EB and center turn lanes of IA 92 from just east of SW temporary granular detour for Y Street (Sta 416+64) to just west of R Street (Sta 443+18)
 - Place temporary pavement with curb on south side of new IA 92 pavement from Sta 441+15.20 to the SW return of R Street. Place steel cover over storm sewer well at Sta. 442+63 (Right) prior to placing temporary pavement
 - Sideroads
 - Construct Access 258
 - Grade and Pave south and north legs of R-57
 - Grade and Pave south and north legs of R-63
 - Grade and Pave south leg of Y St.
 - Construct as much as possible of the NW temporary granular detour for Y Street north of existing IA 92.
- Stage 2C
 - Traffic Control
 - IA 92
 - Continue to detour thru traffic for IA 92 as shown on sheets J.5-J.12
 - Maintain IA 92 local traffic from BOP to R-57
 - Maintain closure of IA 92 from just east of R-57 (Sta 285+50) to just east of R-63 (Sta 391+80); maintain local access only
 - Maintain local traffic on existing pavement of IA 92 as two-lane, two-way traffic between R-63 and EOP while utilizing temporary pavement at Spruce St.
 - Sideroads
 - Place traffic on R-57
 - Maintain closure of 90th Street
 - Maintain traffic on R-63 by utilizing the NE and SE temporary paved detours
 - Maintain traffic on Y Street north of IA 92

STAGING NOTES

- Maintain traffic on the SW temporary granular detour for Y Street south of IA 92
- Construction
 - IA 92
 - Finish Grading and Paving from just east of R-57 (Sta 285+50) to just east of R-63 (Sta 391+80)
 - Sideroads
 - Remove the NE and SE temporary detours of R-57
 - Construct temporary granular detour in the southeast quadrant of the IA 92/Y St. intersection; Place granular surfacing across the top of new IA 92 pavement as part of detour due to the grade difference
- Stage 2D
 - Traffic Control
 - IA 92
 - Continue to detour thru traffic for IA 92 as shown on sheets J.5-J.12
 - Maintain IA 92 local traffic from BOP to R-63
 - Close IA 92 from just east of R-63 (Sta 391+80) to Y Street
 - Maintain local traffic on existing pavement of IA 92 between Y Street and EOP while utilizing temporary pavement at Spruce Street
 - Sideroads
 - Open R-57 to normal traffic
 - Open 90th Street to normal traffic
 - Place traffic on R-63
 - Place traffic on the SE temporary granular detour for Y Street south of IA 92
 - Construction
 - IA 92
 - Grade and Pave the gapped areas of the EB and left turn lane of IA 92 between R-63 and Y Street
 - Sideroads
 - Remove the NE and SE temporary paved detours of R-63
 - Construct the remainder of the NW temporary granular detour of Y Street to tie into the new IA 92 pavement
- Stage 3A
 - Traffic Control
 - IA 92
 - Open IA 92 to thru traffic
 - Maintain normal operation from from BOP to R-63
 - Place traffic on the new EB and left turn lane of IA 92 from R-63 to just east of Spruce Street (Sta 443+18) to maintain traffic as one lane in each direction
 - Sideroads
 - Place traffic on the NW temporary granular detour for Y Street north of IA 92
 - Open traffic on Y Street south of IA 92
 - Maintain traffic on all other sideroads
 - Construction
 - IA 92
 - Remove temporary pavement on the north side of IA 92 from just west to just east of Spruce Street (Sta 445+00)
 - Sideroads
 - Remove the SE temporary granular detour for Y Street south of IA 92
 - Construct the NW temporary granular detour for Spruce Street north of IA 92
- Stage 3B
 - Traffic Control
 - IA 92
 - Same as Stage 3A
 - Sideroads
 - Maintain traffic on NW temporary granular detour for Y Street north of IA 92
 - Place Spruce Street traffic on the NW temporary granular detour for Spruce Street
 - Maintain traffic on all other sideroads
 - Construction
 - IA 92
 - Construct WB lane with curb on the north side of IA 92 from just west of Spruce Street (Sta 441+10) to Sta 443+18
 - Sideroads
 - Construct Spruce Street intersection
- Stage 3C
 - Traffic Control
 - IA 92
 - Same as Stage 3B
 - Sideroads
 - Maintain traffic on NW temporary granular detour for Y Street north of IA 92
 - Open Spruce Street at intersection of IA 92
 - Maintain traffic on all other sideroads
 - Construction
 - IA 92
 - Grade and Pave WB lane of IA 92 from just east of R-63 (Sta 391+80) to just west of Spruce Street (441+10); gap construction for the NW temporary granular detour for Y Street
 - Sideroads
 - Grade and Pave the north leg of Y Street
 - Remove the NW temporary granular detour for Spruce Street north of IA 92

STAGING NOTES

- Stage 3D
- Traffic Control
 - IA 92
 - Same as Stage 3C
 - Sideroads
 - Maintain traffic on all sideroads
 - Construction
 - IA 92
 - Grade and Pave the gapped area of the WB lane of IA 92 just west of Y Street after removal of the NW temporary granular detour
 - Sideroads
 - Remove the NW temporary granular detour for Y Street north of IA 92

- Stage 4A
- Traffic Control
 - IA 92
 - Maintain thru traffic on IA 92; shift traffic north from 800' west of Spruce Street to EOP; use existing left turn lane (center lane) for EB traffic
 - Sideroads
 - Close R St., South P St., and South N St. south of IA 92
 - NOTE: Closure of R St. and South P St. south of IA 92 shall not occur simultaneously
 - Maintain traffic on all other sideroads
 - Construction
 - IA 92
 - Remove temporary pavement on the south side of IA 92 from Spruce Street to the SW return at R Street
 - Construct the curb and gutter on the south side of IA 92 from Spruce Street to EOP
 - Mill and Resurface EB lane of IA 92
 - Sideroads
 - Construct intersections of R Street, South P Street, and South N Street south of IA 92

- Stage 4B
- Traffic Control
 - IA 92
 - Maintain thru traffic on IA 92; close existing left turn lane (center lane)
 - Sideroads
 - Maintain traffic on all sideroads
 - Construction
 - IA 92
 - Mill and resurface left turn lane (center lane) of IA 92
 - Sideroads
 - None









- Stage 4C
- Traffic Control
 - IA 92
 - Maintain thru traffic on IA 92; shift traffic south from 800' west of Spruce Street to EOP; use existing left turn lane (center lane) for WB traffic
 - Sideroads
 - Close South Kenwood Blvd and South P Street north of IA 92
 - NOTE: Closure of South Kenwood Blvd and South P Street north of IA 92 shall not occur simultaneously
 - Maintain traffic on all other sideroads
 - Construction
 - IA 92
 - Remove temporary pavement on the north side of IA 92 from Sta 443+18 to Sta 445+00
 - Construct the curb and gutter on the north side of IA 92 from Sta 443+18 to EOP
 - Mill and Resurface WB lane of IA 92
 - Sideroads
 - Construct intersections of South Kenwood Blvd and South P St. north of IA 92

- Stage 4D
- Traffic Control
 - Open IA 92 and sideroads to full operation

**CROSS SECTION VIEW COLOR LEGEND
OF TRAFFIC CONTROL AND STAGING SHEETS**

SHADING	Design Color No.	
Green, Light	(225)	Existing Pavement Shading
Gray, Light	(48)	Previously Constructed Pavement Shading
Gray, Med	(80)	Previously Constructed Granular Surface Shading
Blue, Light	(230)	Proposed Pavement Shading
Lavender	(9)	Temporary Pavement Shading
Brown, Med	(237)	Future Proposed Pavement Shading

**CROSS SECTION VIEW PATTERN AND SYMBOL LEGEND
OF TRAFFIC CONTROL AND STAGING SHEETS**



















	Pavement Removal		Proposed Granular Shoulder
	Proposed Granular Subbase		Temporary Shoulder
	Proposed Special Backfill		Existing Shoulder Strengthening
	Temporary Barrier Rail		Permanent Barrier Rail
			Channelizing Device

PLAN VIEW COLOR LEGEND OF TRAFFIC CONTROL AND STAGING SHEETS

LINEWORK	Design Color No.	
Green	(2)	Existing Topographic Features and Labels
Magenta	(5)	Pavement Marking Call Outs
Blue	(1)	Proposed Alignment, Stationing, Tic Marks, and Alignment Annotation
Yellow	(4)	Pavement Markings, Yellow
Off White	(254)	Pavement Markings, White

SHADING	Design Color No.	
Green, Light	(225)	Existing Pavement Shading
Gray, Light	(48)	Previously Constructed Pavement Shading
Gray, Med	(80)	Previously Constructed Granular Surface Shading
Blue, Light	(230)	Proposed Pavement Shading
Lavender	(9)	Temporary Pavement Shading
Brown, Light	(236)	Proposed Grading Limits Shading
Pink, Dark	(13)	Proposed MSE or CIP Wall Shading
Red	(3)	Proposed Bridge Shading and Sign Trusses
Black w/Gray, Light Fill	(0,48)	Previously Constructed Structure

**PLAN VIEW PATTERN AND SYMBOL LEGEND
OF TRAFFIC CONTROL AND STAGING SHEETS**

	Channelizing Device		Crash Cushion
	Drum		Traffic Signal
	Temporary Lane Separator		Flagger
	Tubular Marker		Temporary Floodlighting
	Channelizer Marker		Traffic Sign
	Concrete Barrier Marker		Type III Barricade
	Delineator		Type A Warning Light
	Temporary Barrier Rail		Direction of Traffic
	Pavement Removal		Safety Closure

NOTE: Device spacing according to Standard Road Plans unless specifically dimensioned.

**TRAFFIC CONTROL
AND
STAGING
LEGEND AND SYMBOL
INFORMATION SHEET**

(COVERS SHEET SERIES J)

**RESERVED FOR
DETOUR SIGN DETAILS SHEET
Zach's Signature**

POLK COUNTY

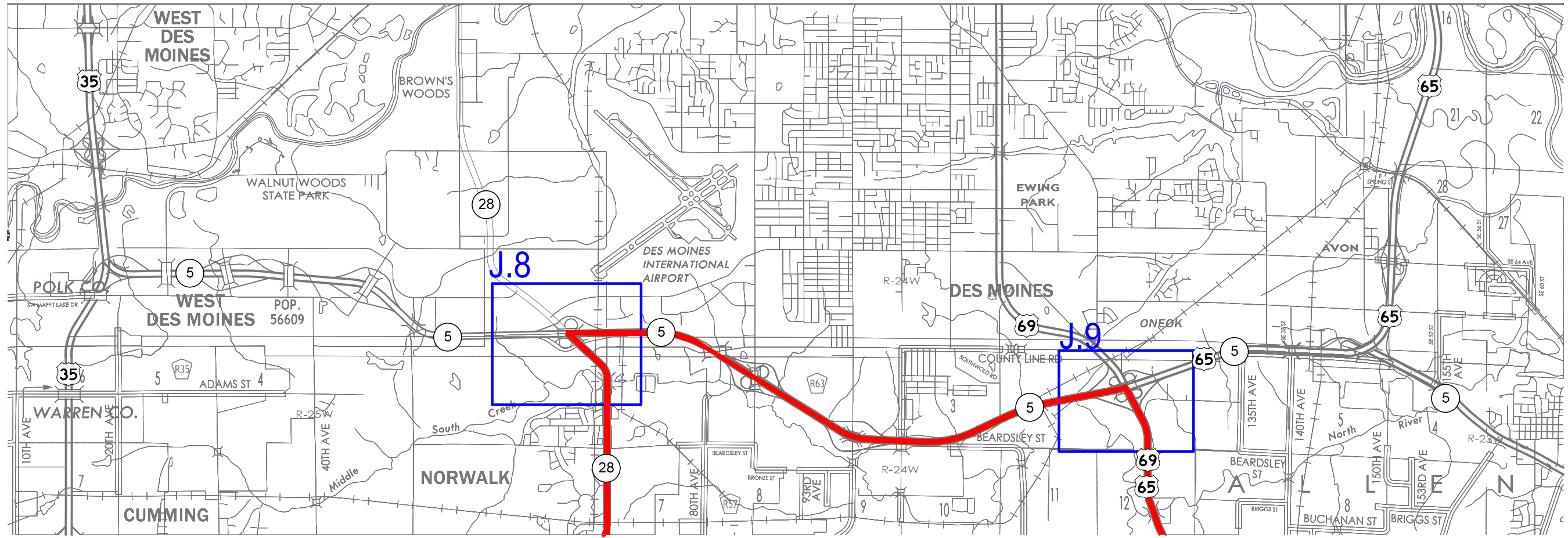

WARREN COUNTY

SIGN/DEVICE	SIGN NO.	COLOR	SIZE InchxInch
	M1-4	BLACK ON WHITE	24X24
	M3-2	BLACK ON WHITE	24X12
	M3-4	BLACK ON WHITE	24X12
	M4-8	BLACK ON ORANGE	24X12
	M4-8a	BLACK ON ORANGE	24X18
	M6-3	BLACK ON WHITE	21X15
	M5-1R	BLACK ON WHITE	21X15

SIGN/DEVICE	SIGN NO.	COLOR	SIZE InchxInch
	M5-1L	BLACK ON WHITE	21X15
	M5-2	BLACK ON WHITE	21X15
	M6-1R	BLACK ON WHITE	21X15
	M6-1L	BLACK ON WHITE	21X15
	R11-3a	BLACK ON WHITE	60X30
	R11-2	BLACK ON WHITE	48X30
	R11-4	BLACK ON WHITE	60X30

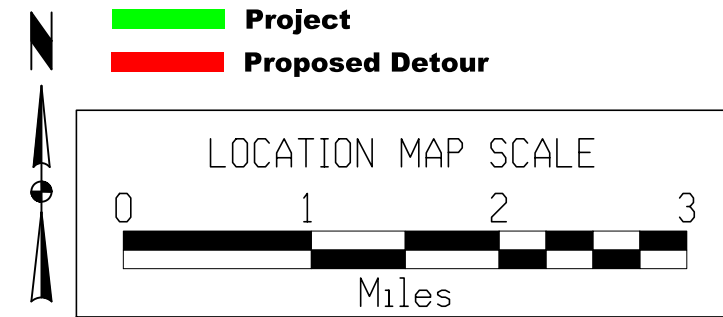

SIGN/DEVICE	SIGN NO.	COLOR	SIZE InchxInch
	W20-3	BLACK ON ORANGE	48X48
	W20-3	BLACK ON ORANGE	48X48
	TYPE III		

DETOUR LAYOUT DETAILS
(Sheet 1 of 8)

WARREN COUNTY

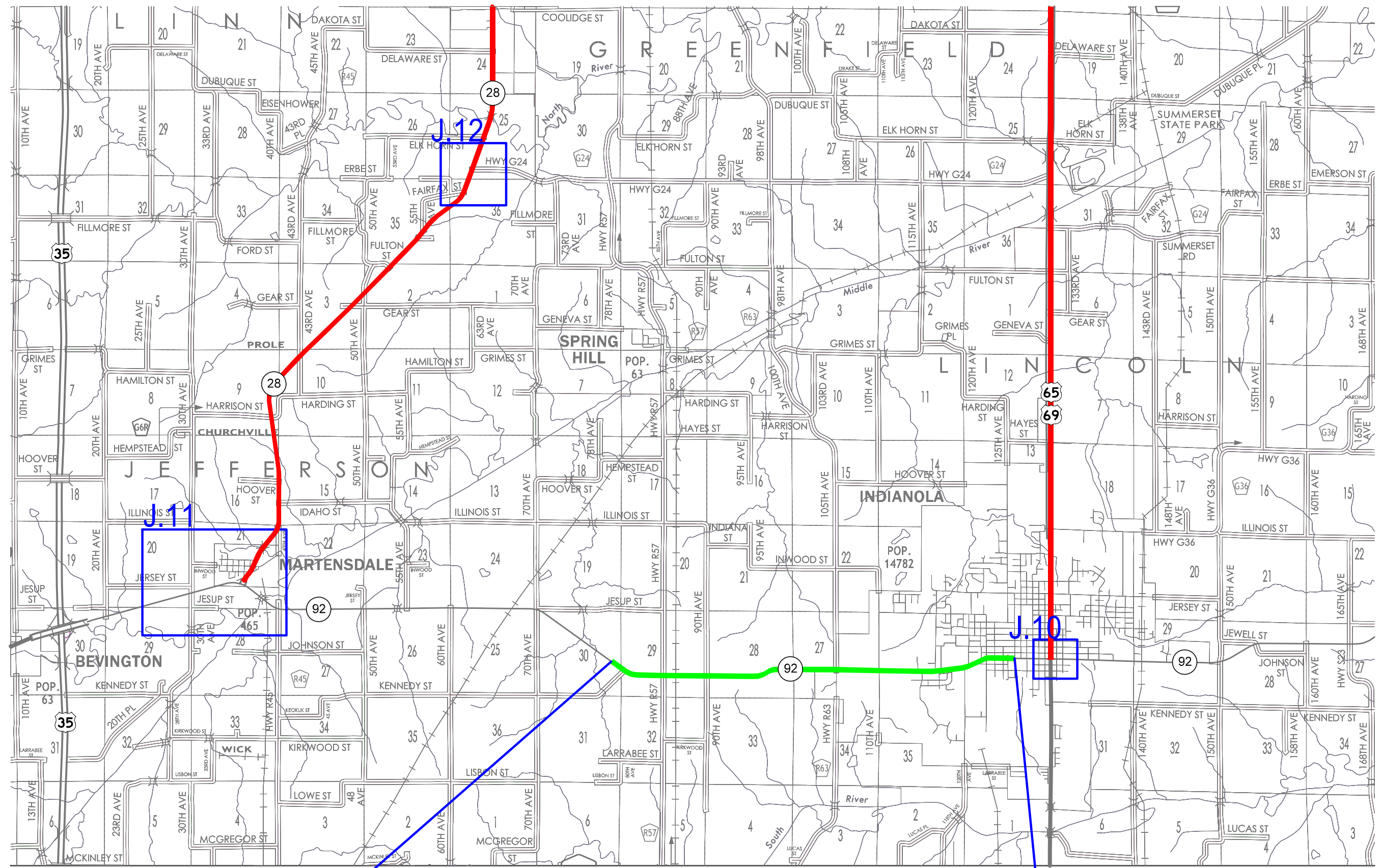

 **Project**
 **Proposed Detour**

BEGIN PROJECT

END PROJECT

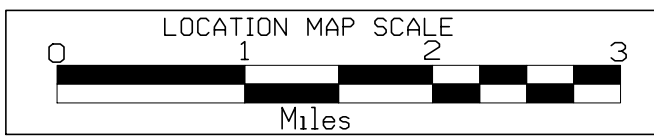

DETOUR LAYOUT DETAILS
 (Sheet 2 of 8)

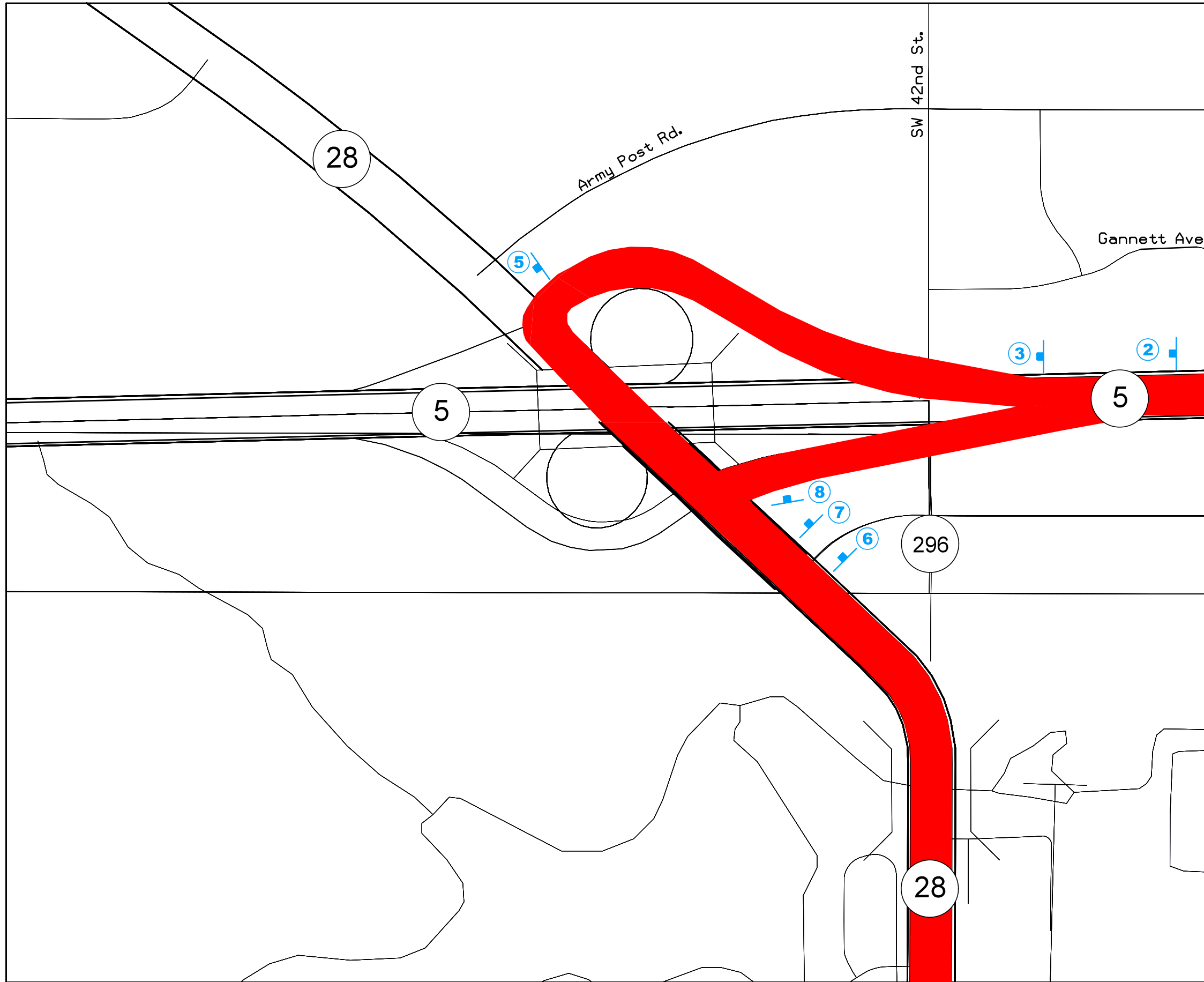

2	3	5	6
DETOUR	DETOUR	DETOUR	DETOUR
WEST	WEST	WEST	EAST
92	92	92	92
Right Turn	Right Arrow	Left Arrow	Up Arrow

7	8
DETOUR	DETOUR
EAST	EAST
92	92
Right Turn	Right Arrow

NOT TO SCALE

LEGEND

Sign

Detour Route



DETOUR LAYOUT DETAILS
(Sheet 3 of 8)

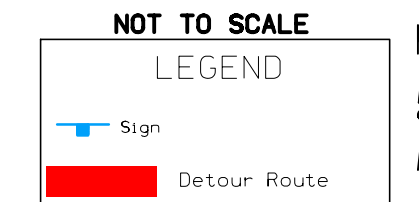
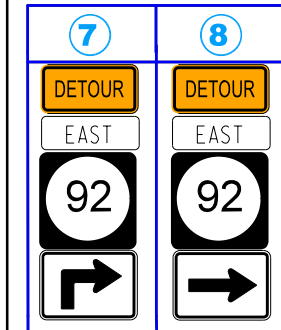
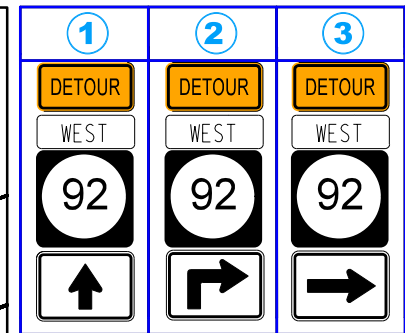
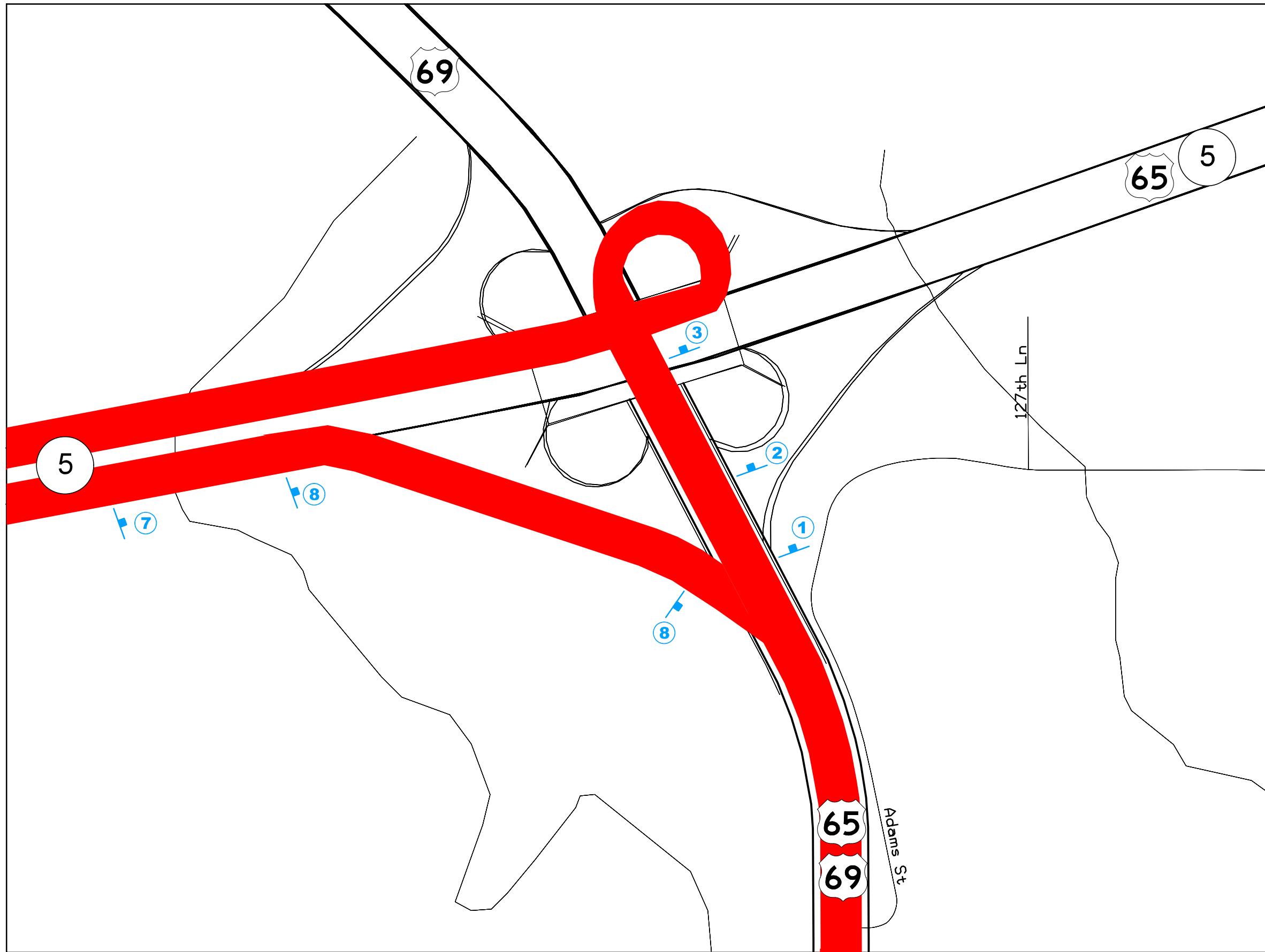

DETOUR LAYOUT DETAILS
(Sheet 4 of 8)

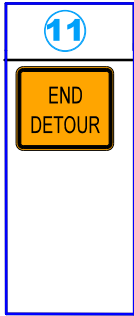
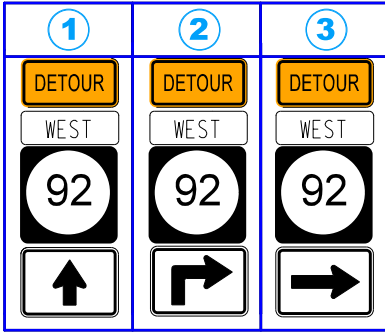
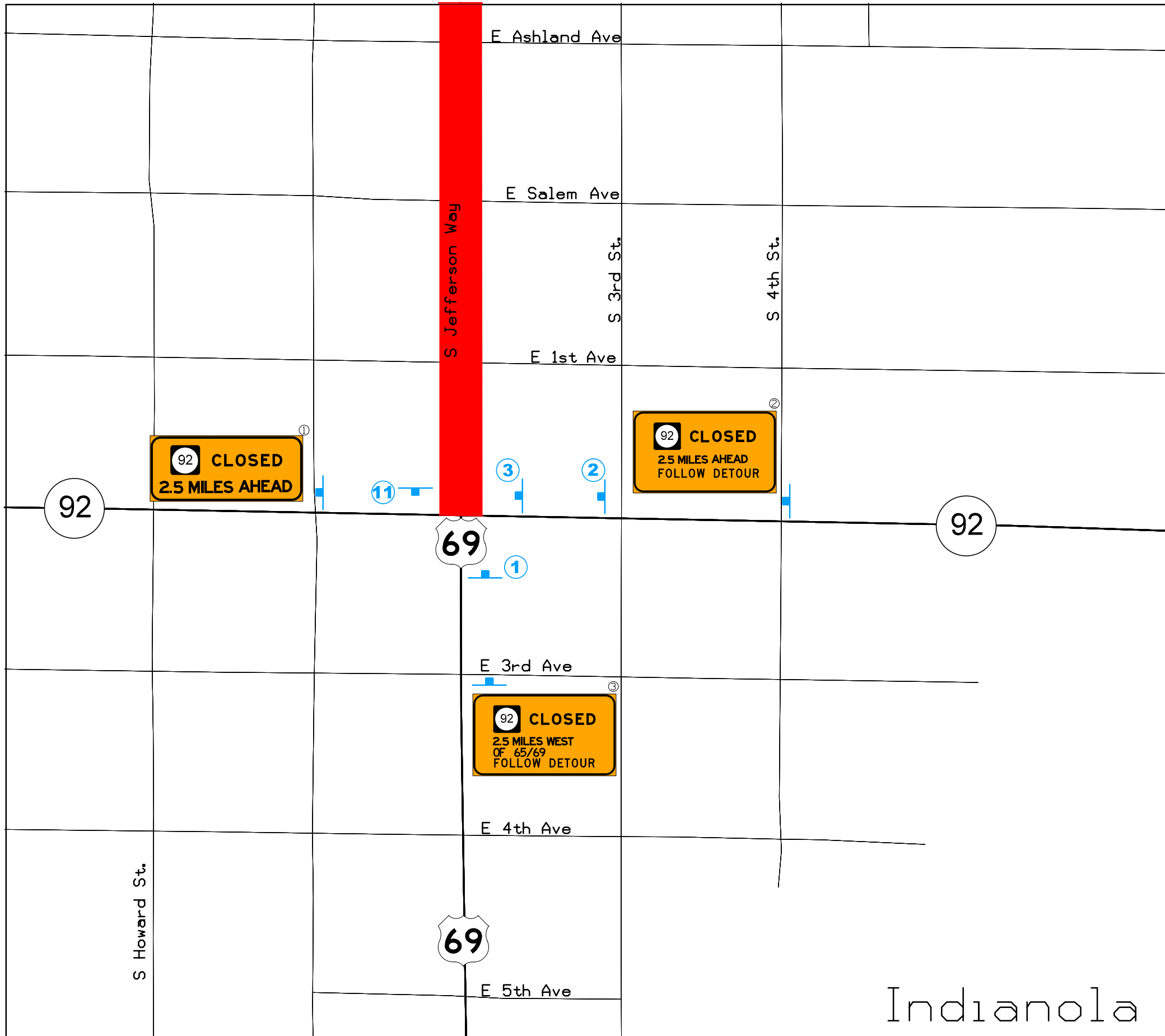

- ① See Detour Guide Sign #1 on Sheet J.8 for signing details.
- ② See Detour Guide Sign #2 on Sheet J.8 for signing details.
- ③ See Detour Guide Sign #3 on Sheet J.8 for signing details.

NOT TO SCALE

LEGEND

Sign

Detour Route

DETOUR LAYOUT DETAILS
(Sheet 5 of 8)

Martensdale

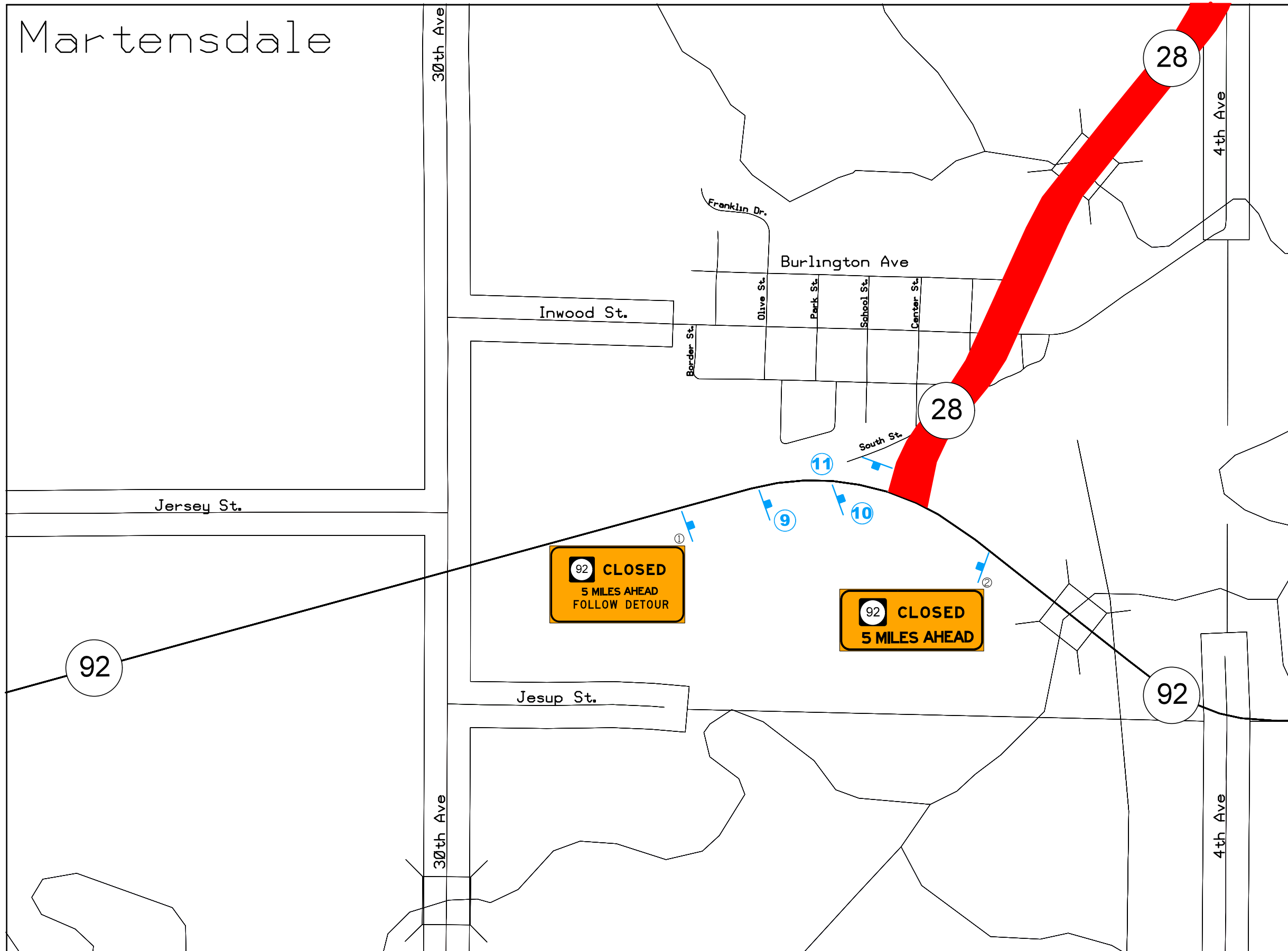

9	10
DETOUR	DETOUR
EAST	EAST
92	92
←	←

11
END DETOUR

① See Detour Guide Sign #4 on Sheet J.8 for signing details.
 ② See Detour Guide Sign #5 on Sheet J.8 for signing details.

NOT TO SCALE

LEGEND

←	Sign
█	Detour Route

DETOUR LAYOUT DETAILS
(Sheet 6 of 8)

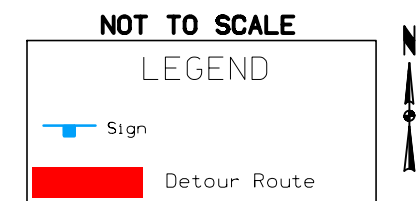
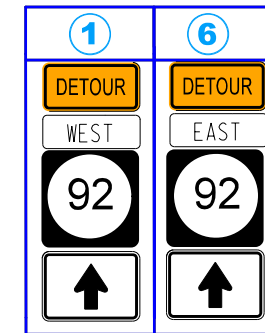
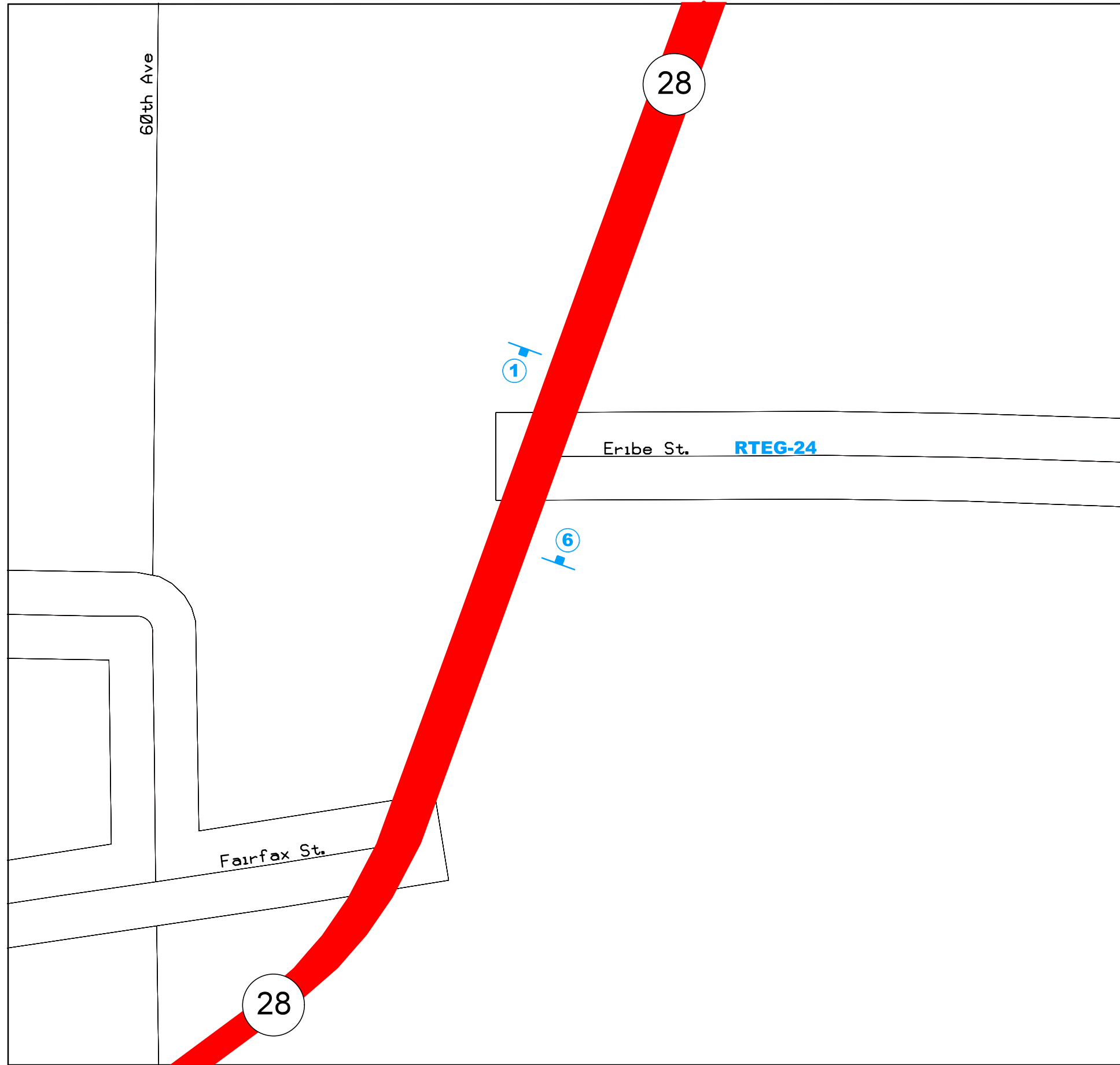

DETOUR LAYOUT DETAILS
(Sheet 7 of 8)

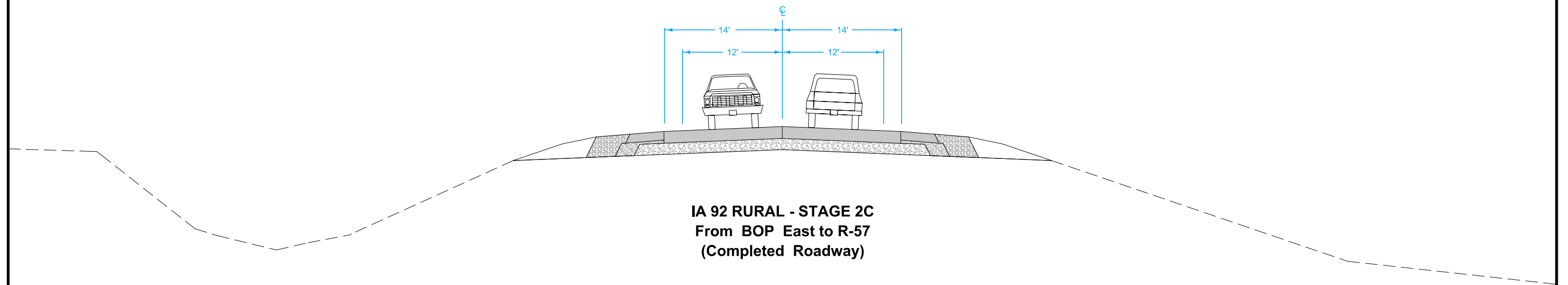
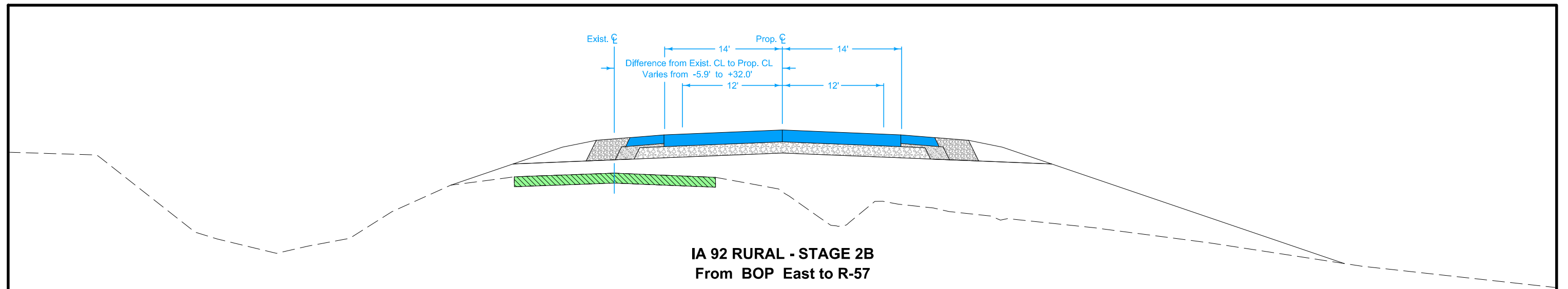

STAGING TYPICAL
IA 92 RURAL
B.O.P. TO R-57

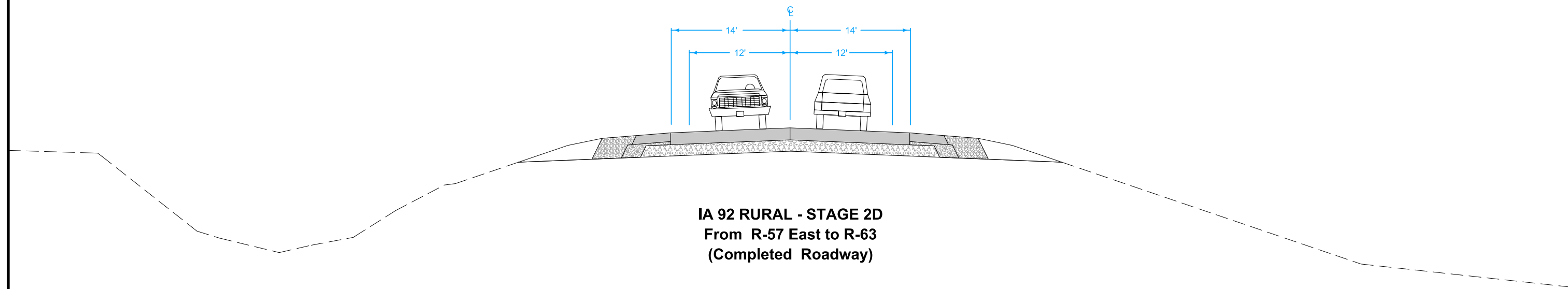
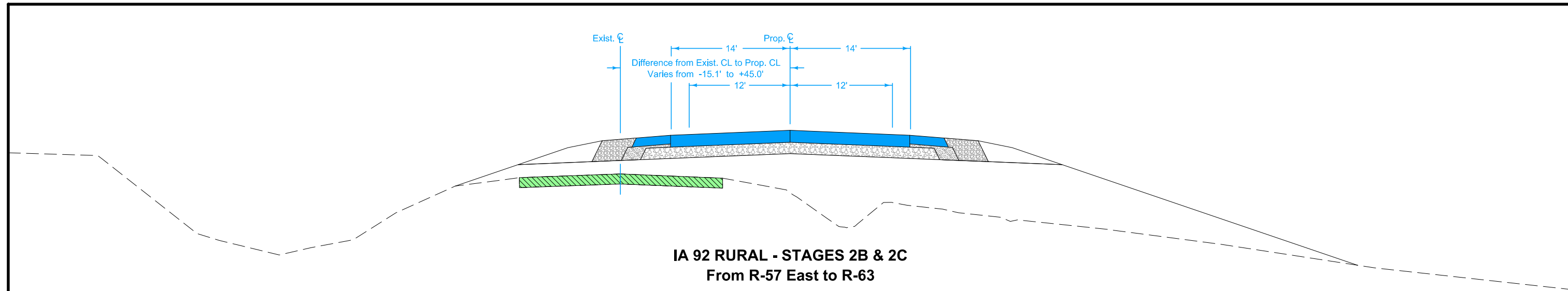

STAGING TYPICAL
IA 92 RURAL
R-57 TO R-63

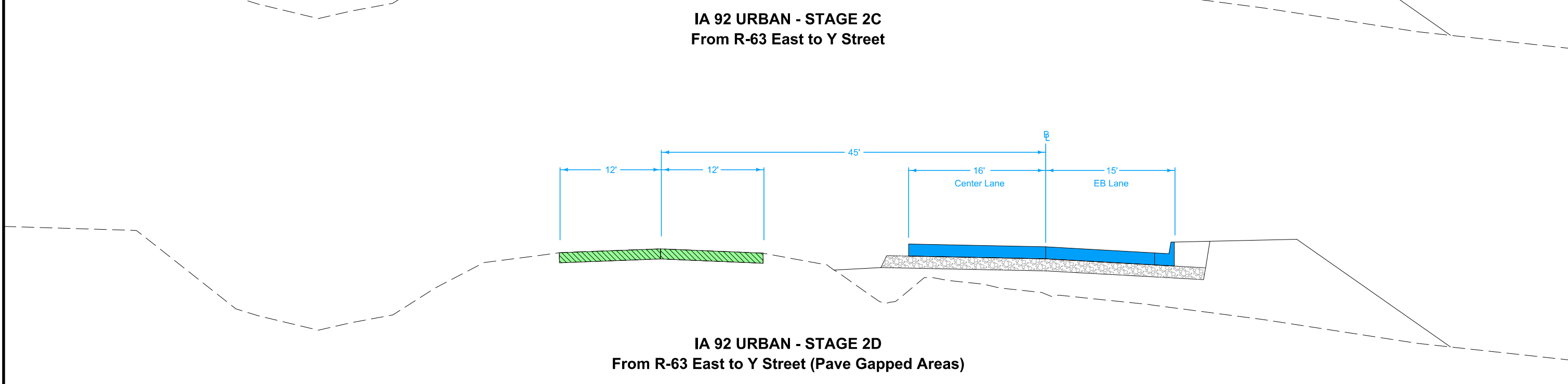
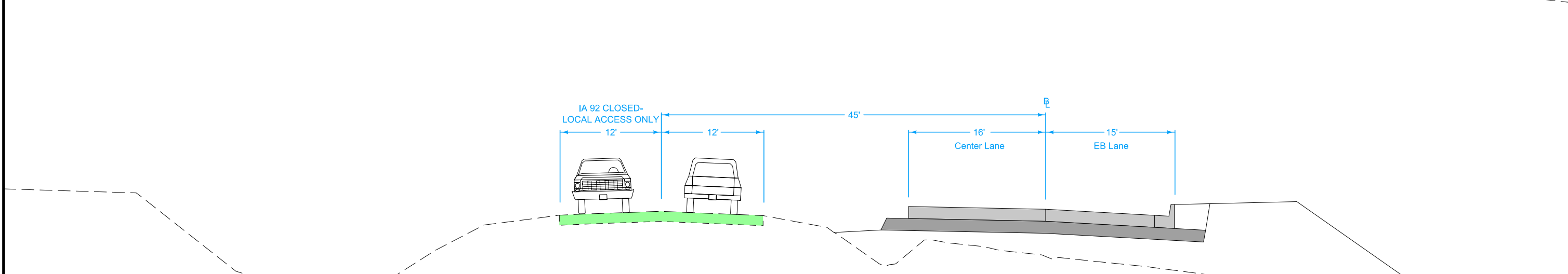
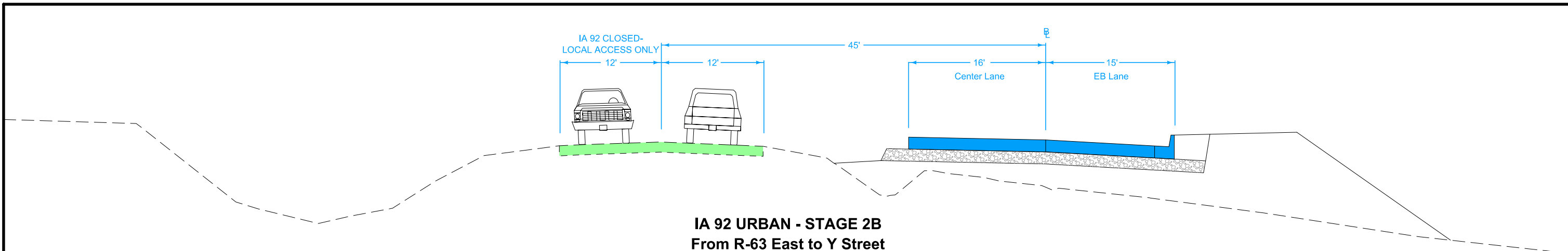

STAGING TYPICAL
IA 92 URBAN
R-63 TO Y STREET

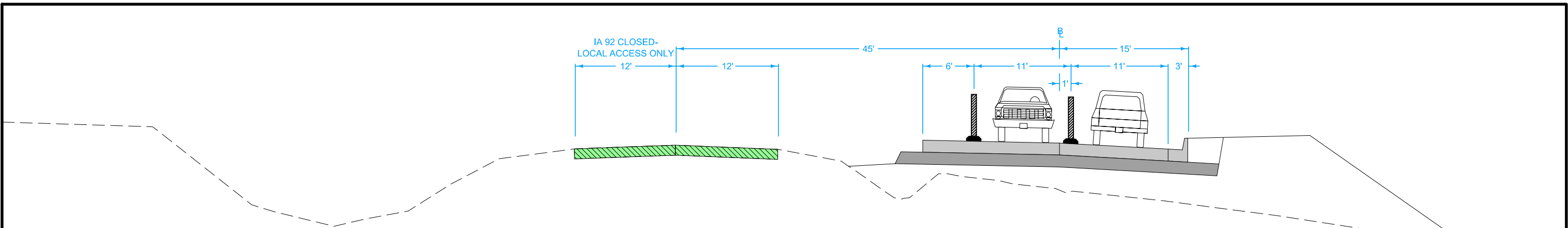

IA 92 URBAN - STAGES 3A & 3B
From R-63 East to Y Street

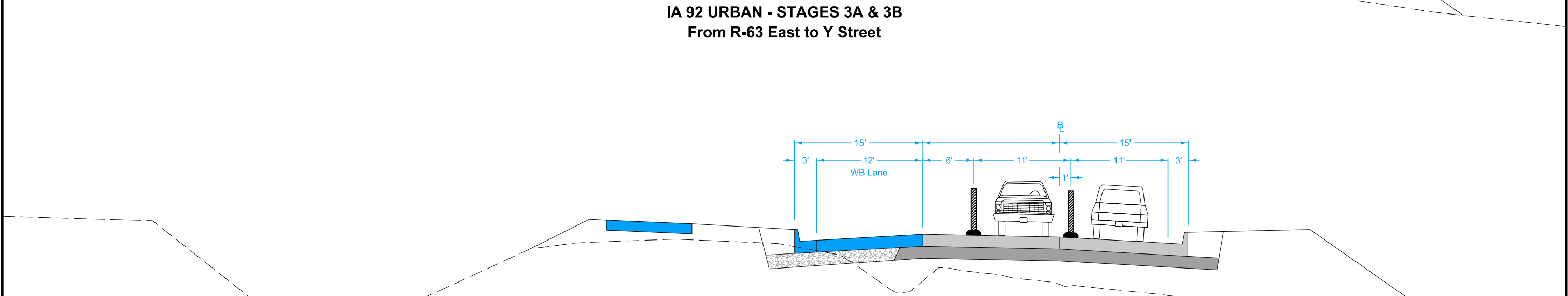

IA 92 URBAN - STAGE 3C
From R-63 East to Y Street
Gap for NW Detour at Y Street

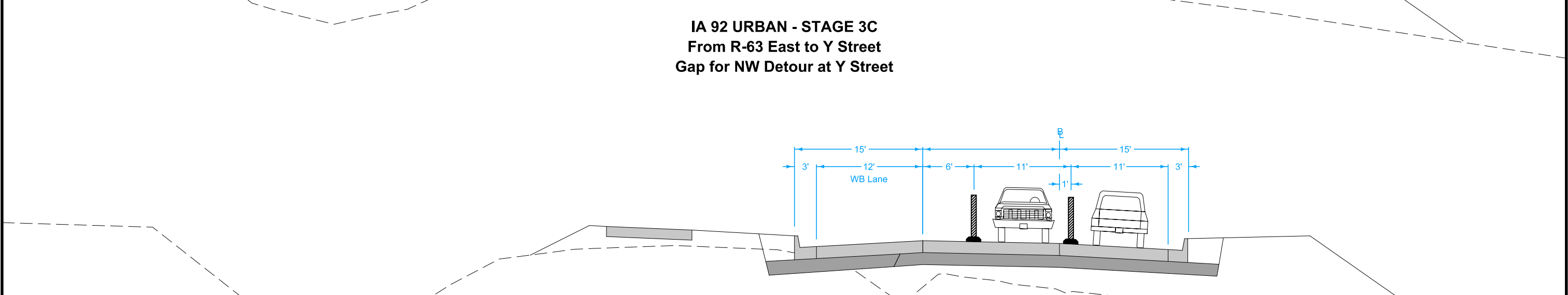

IA 92 URBAN - STAGE 3D
From R-63 East to Y Street
Pave Gapped Area after NW Detour Removal
(Completed Roadway)

STAGING TYPICAL
IA 92 URBAN
R-63 TO Y STREET

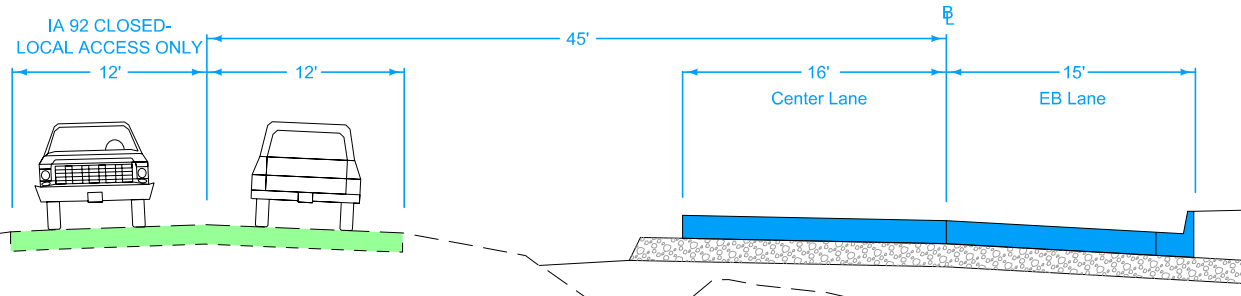

IA 92 URBAN - STAGE 2B
From Y Street East to Sta 438+11.20

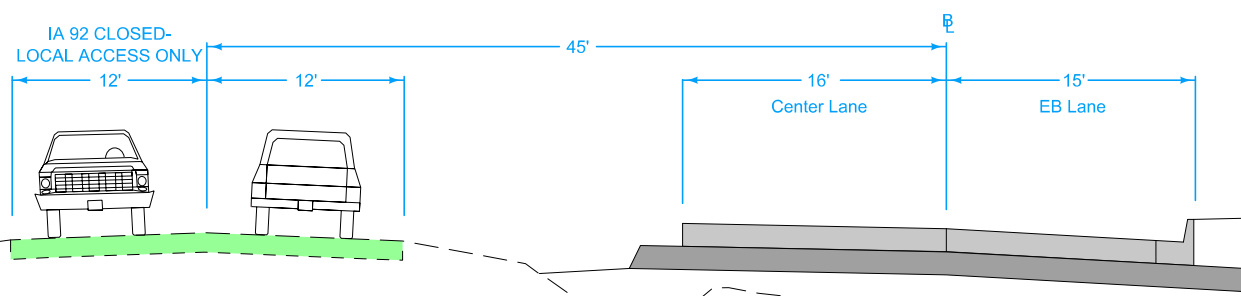

IA 92 URBAN - STAGE 2C & 2D
From Y Street East to Sta 438+11.20

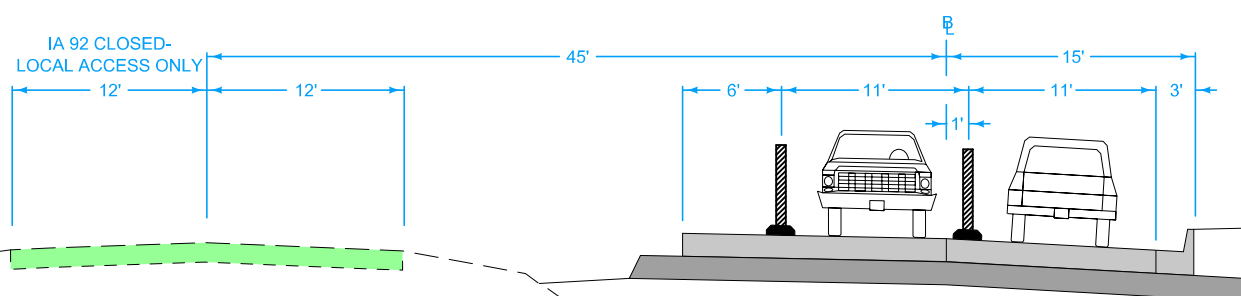

IA 92 URBAN - STAGES 3A & 3B
From Y Street East to Sta 438+11.20

STAGING TYPICAL
IA 92 URBAN
Y ST TO STA 438+11.20

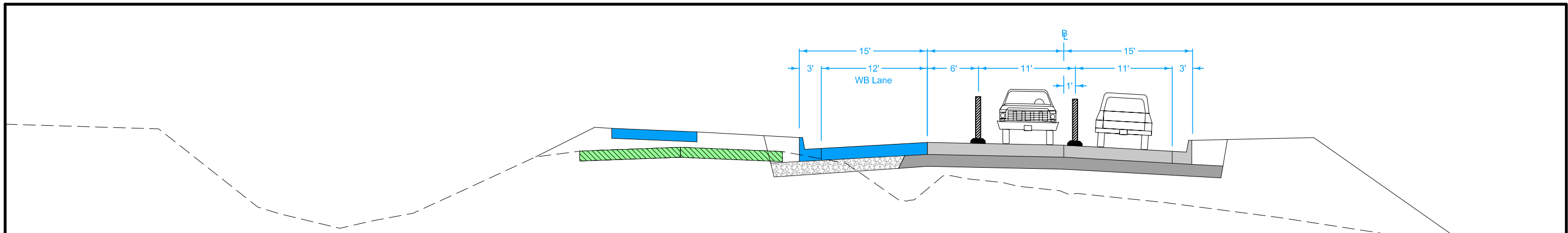

IA 92 URBAN - STAGE 3C
From Y Street East to Sta 438+11.20

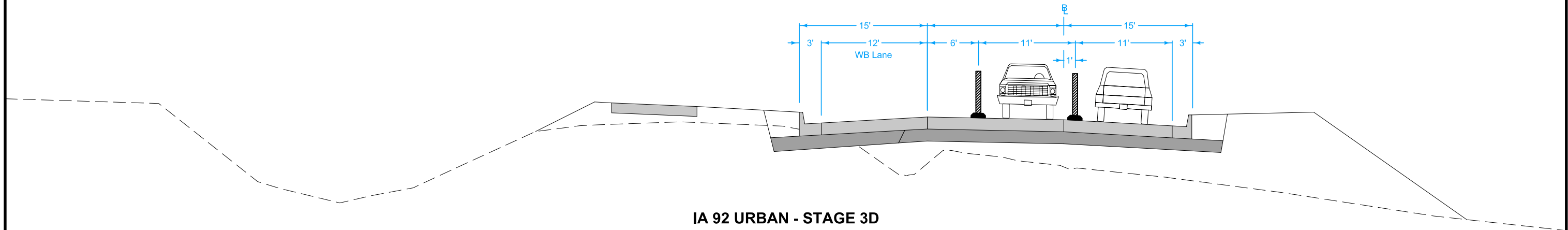

IA 92 URBAN - STAGE 3D
From Y Street East to Sta 438+11.20
(Completed Paving - Keep Traffic off WB Lane)

STAGING TYPICAL
IA 92 URBAN
Y ST TO STA 438+11.20

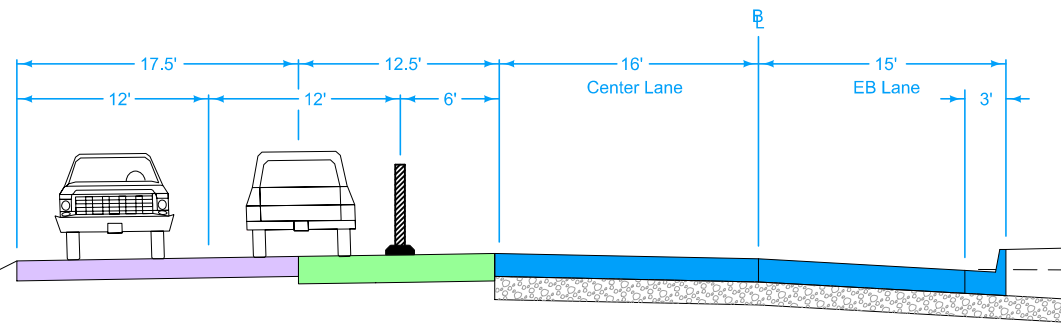

IA 92 URBAN - STAGE 2B
STA 441+15.50

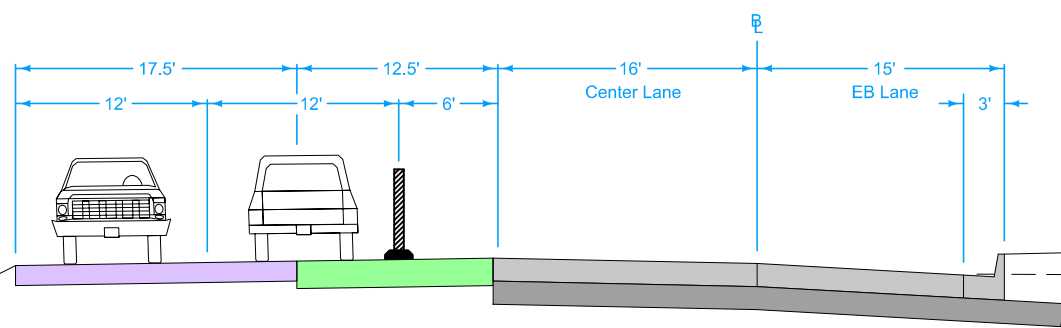

IA 92 URBAN - STAGES 2C & 2D
STA 441+15.50

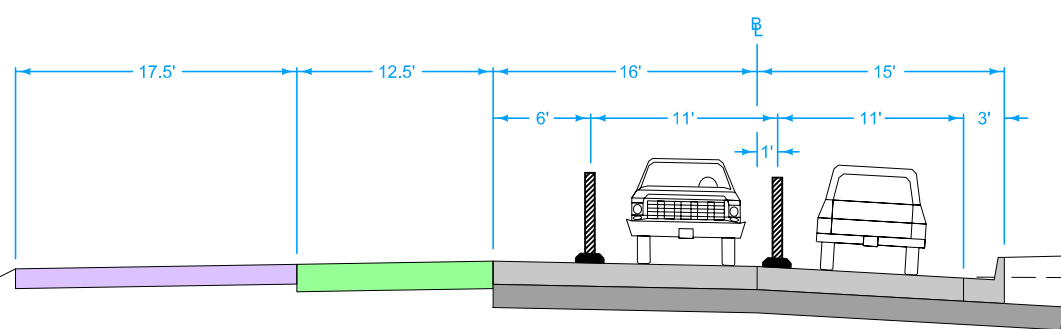

IA 92 URBAN - STAGE 3A
STA 441+15.50

STAGING TYPICAL
IA 92 URBAN
STA 441+15.50

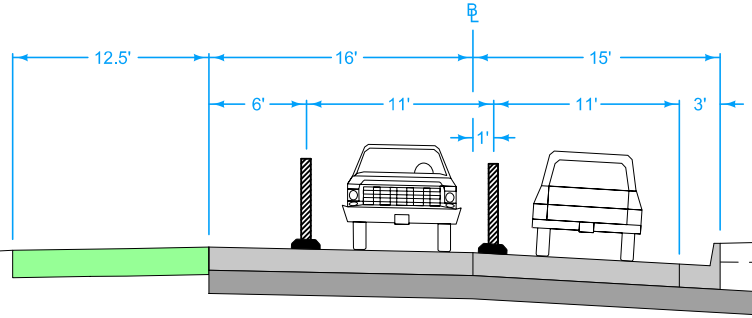

IA 92 URBAN - STAGE 3B
STA 441+15.50

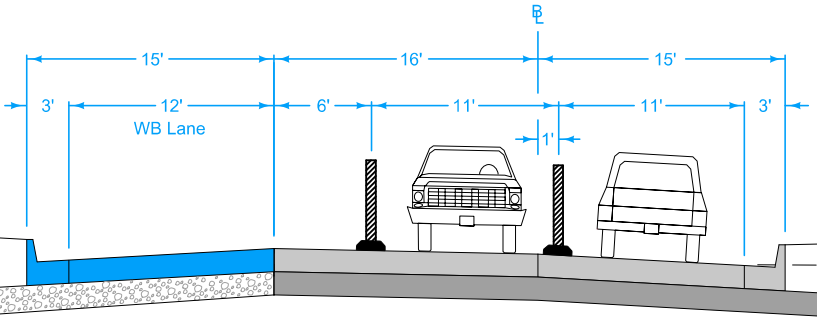

IA 92 URBAN - STAGE 3C
STA 441+15.50

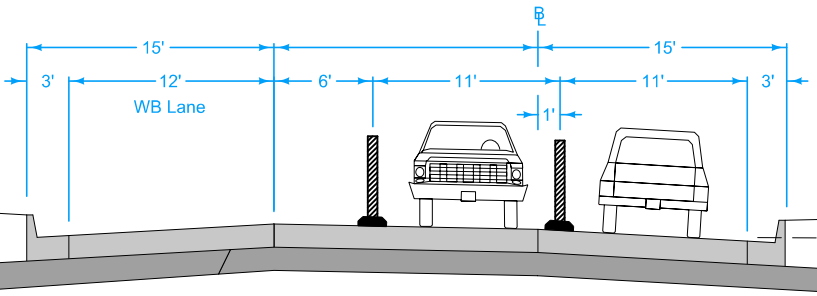

IA 92 URBAN - STAGE 3D
STA 441+15.50
(Completed Paving - Keep Traffic off WB Lane)

STAGING TYPICAL
IA 92 URBAN
STA 441+15.50

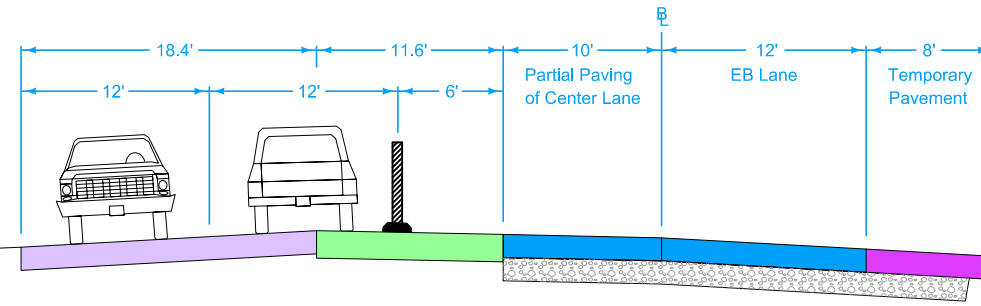

IA 92 URBAN - STAGE 2B
STA 443+18.00

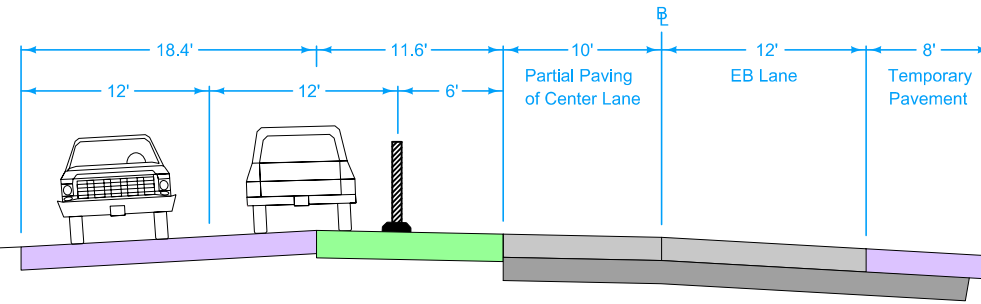

IA 92 URBAN - STAGES 2C & 2D
STA 443+18.00

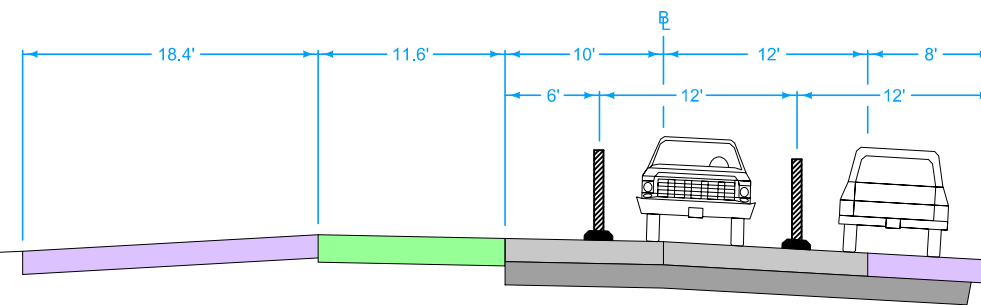

IA 92 URBAN - STAGE 3A
STA 443+18.00

STAGING TYPICAL
IA 92 URBAN
STA 443+18.00

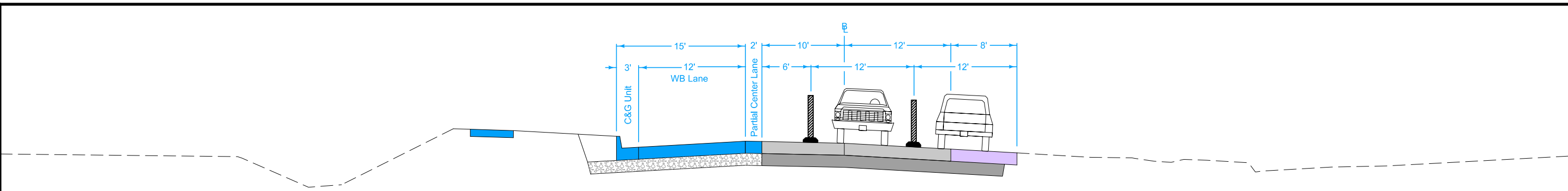

IA 92 URBAN - STAGE 3B
STA 443+18.00

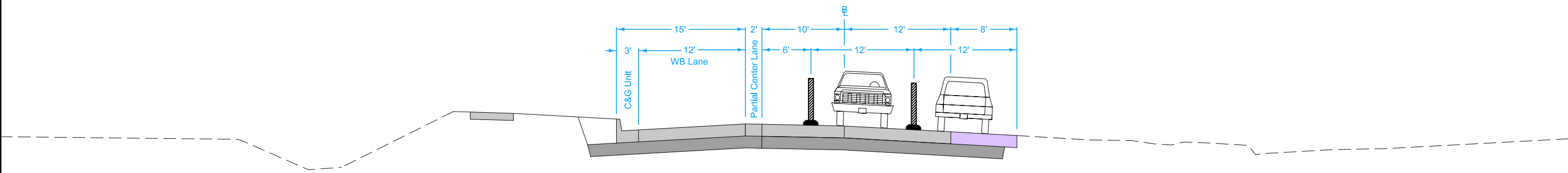

IA 92 URBAN - STAGES 3C & 3D
STA 443+18.00

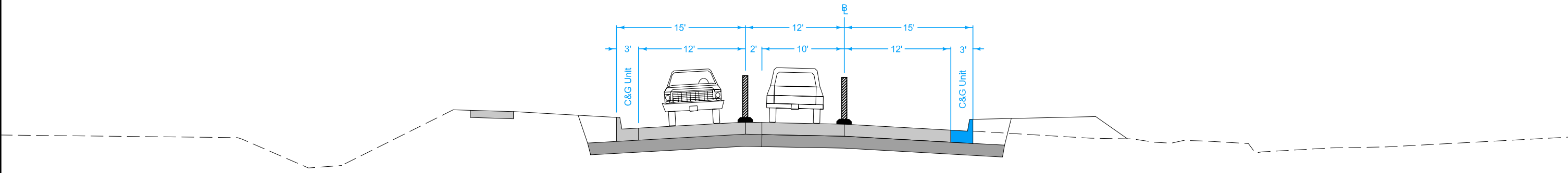

IA 92 URBAN - STAGE 4A
STA 443+18.00

STAGING TYPICAL
IA 92 URBAN
STA 443+18.00

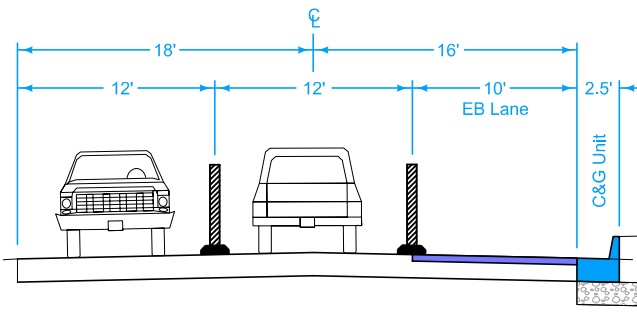

IA 92 URBAN - STAGE 4A
FROM STA 443+18 TO STA 464+92

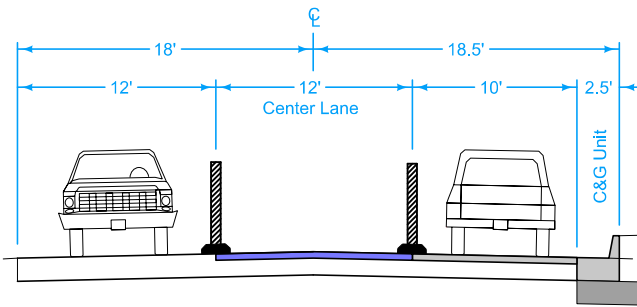

IA 92 URBAN - STAGE 4B
FROM STA 443+18 TO STA 464+92

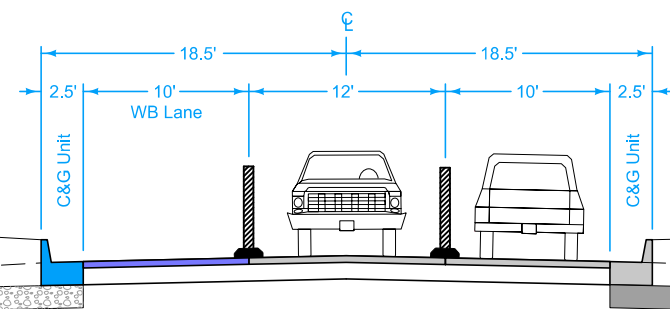

IA 92 URBAN - STAGE 4C
FROM STA 443+18 TO STA 464+92

STAGING TYPICAL
IA 92 URBAN
STA 443+18.00 TO E.O.P.

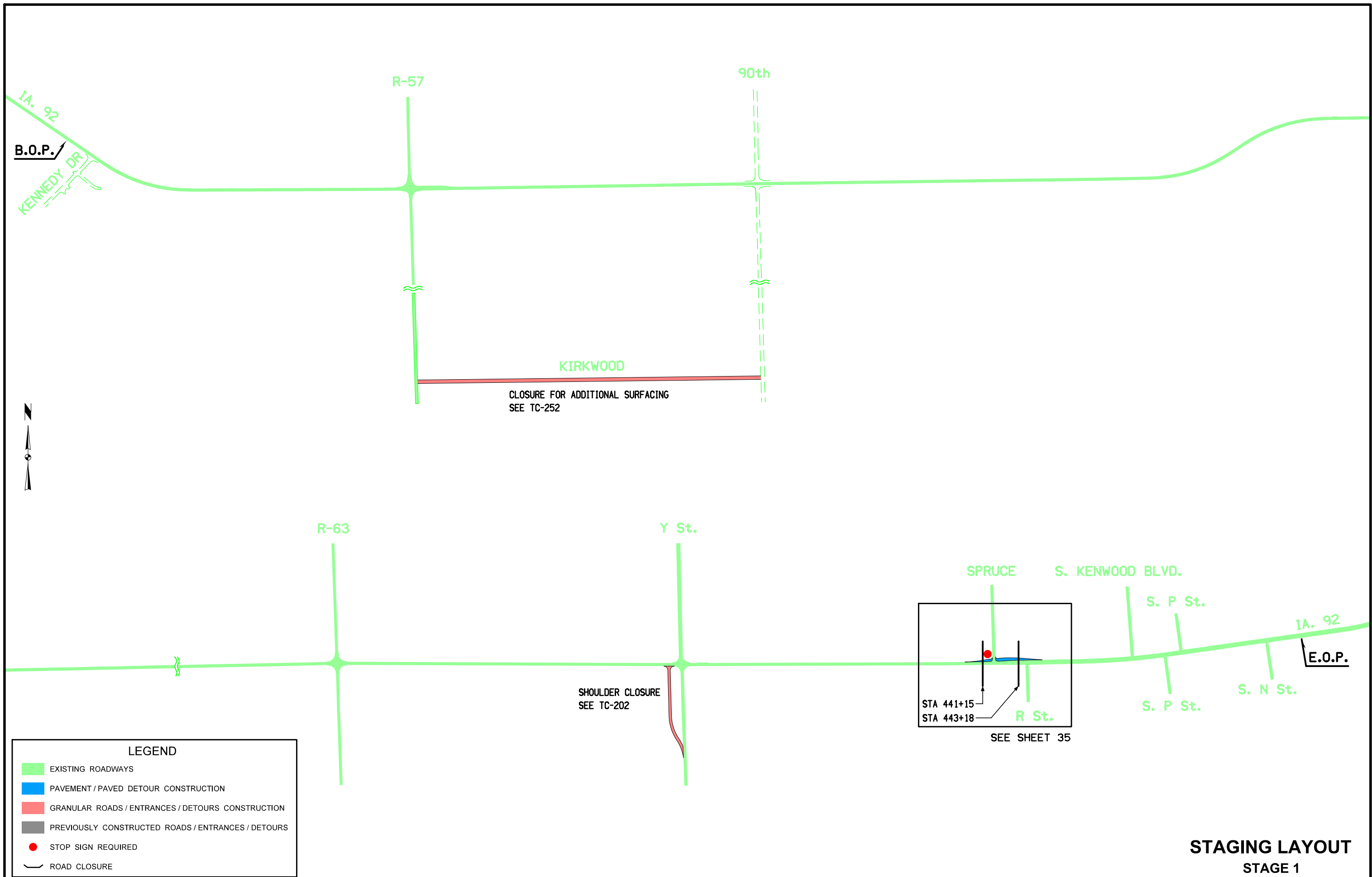

CLOSURE FOR ADDITIONAL SURFACING
SEE TC-252

SHOULDER CLOSURE
SEE TC-202

STA 441+15
STA 443+18
SEE SHEET 35

LEGEND

- EXISTING ROADWAYS
- PAVEMENT / PAVED DETOUR CONSTRUCTION
- GRANULAR ROADS / ENTRANCES / DETOURS CONSTRUCTION
- PREVIOUSLY CONSTRUCTED ROADS / ENTRANCES / DETOURS
- STOP SIGN REQUIRED
- ROAD CLOSURE

**STAGING LAYOUT
STAGE 1**

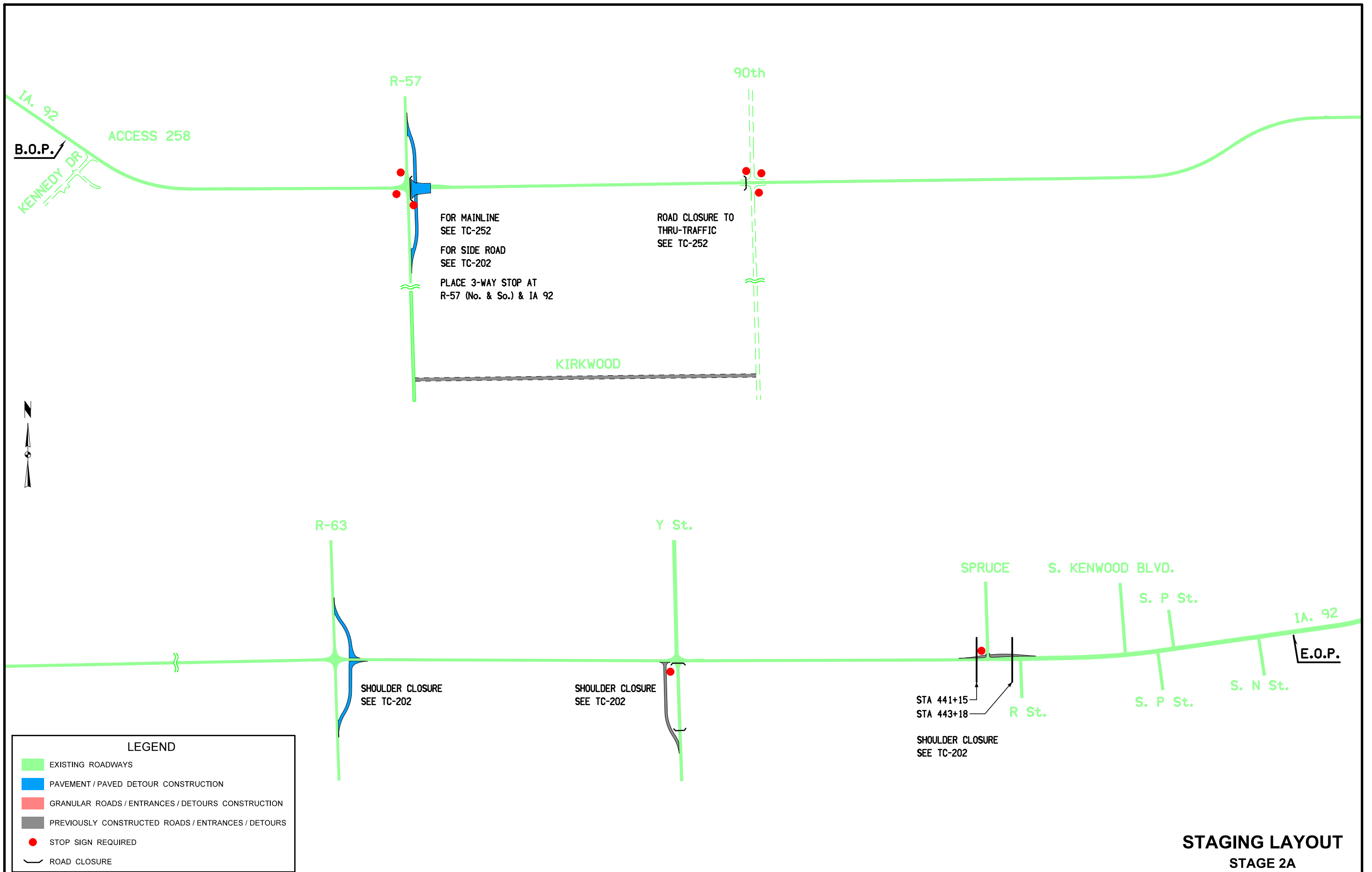

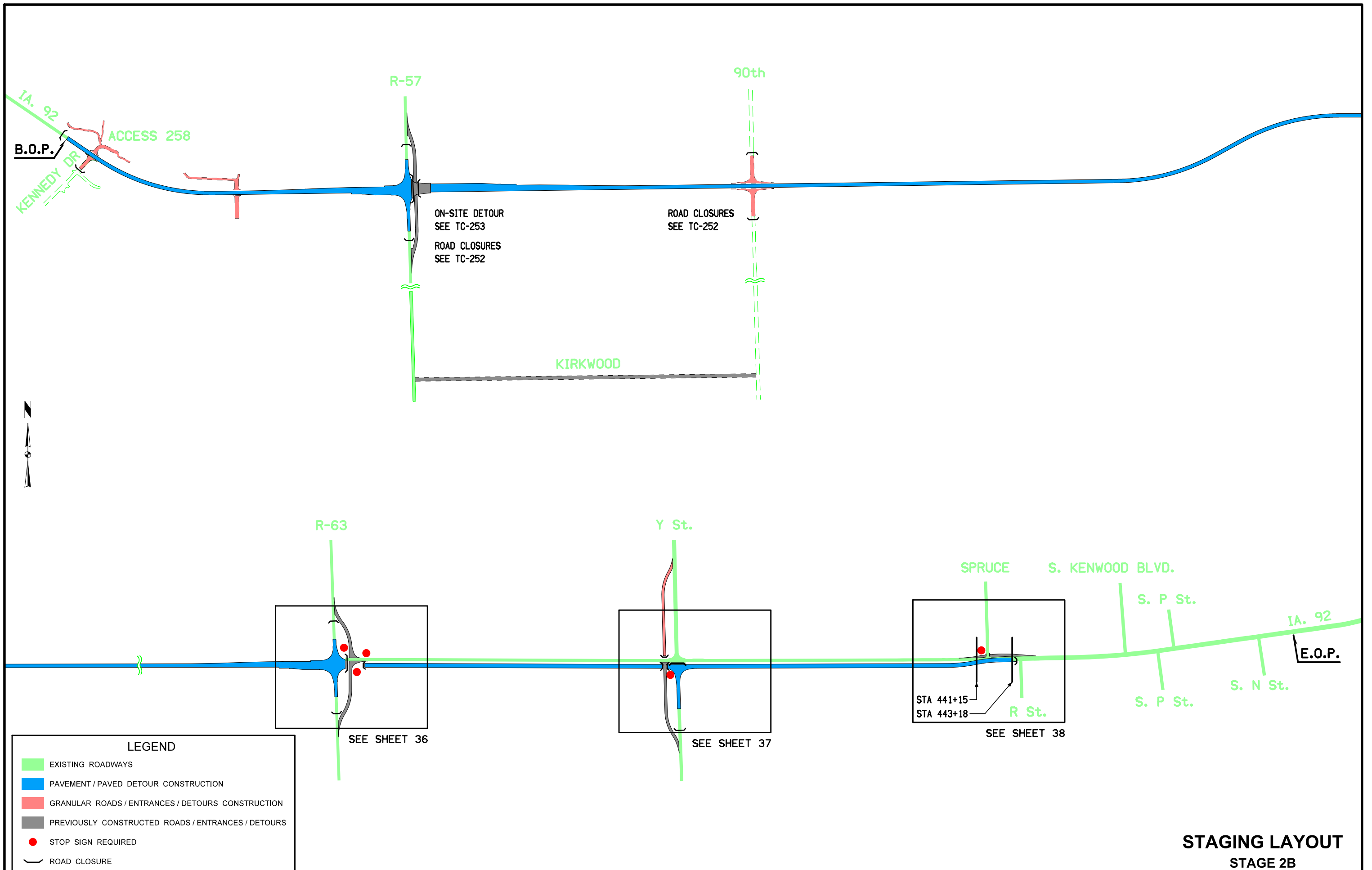

LEGEND

	EXISTING ROADWAYS
	PAVEMENT / PAVED DETOUR CONSTRUCTION
	GRANULAR ROADS / ENTRANCES / DETOURS CONSTRUCTION
	PREVIOUSLY CONSTRUCTED ROADS / ENTRANCES / DETOURS
	STOP SIGN REQUIRED
	ROAD CLOSURE

**STAGING LAYOUT
STAGE 2B**

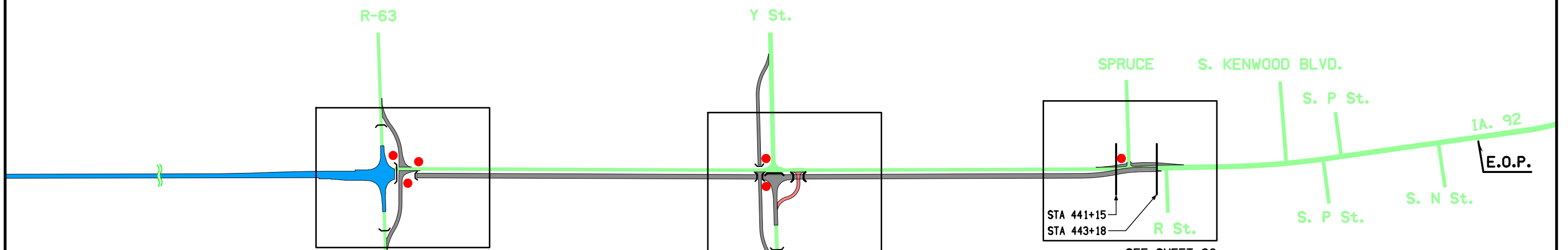
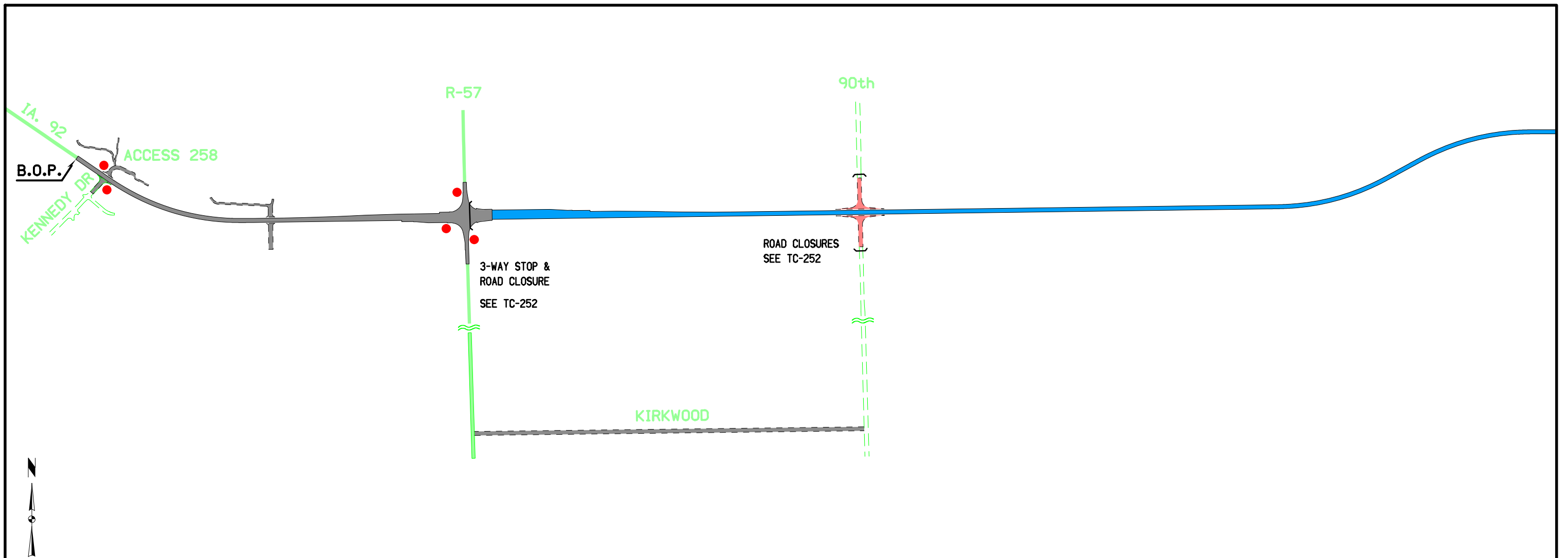

LEGEND

	EXISTING ROADWAYS
	PAVEMENT / PAVED DETOUR CONSTRUCTION
	GRANULAR ROADS / ENTRANCES / DETOURS CONSTRUCTION
	PREVIOUSLY CONSTRUCTED ROADS / ENTRANCES / DETOURS
	STOP SIGN REQUIRED
	ROAD CLOSURE

**STAGING LAYOUT
STAGE 2C**

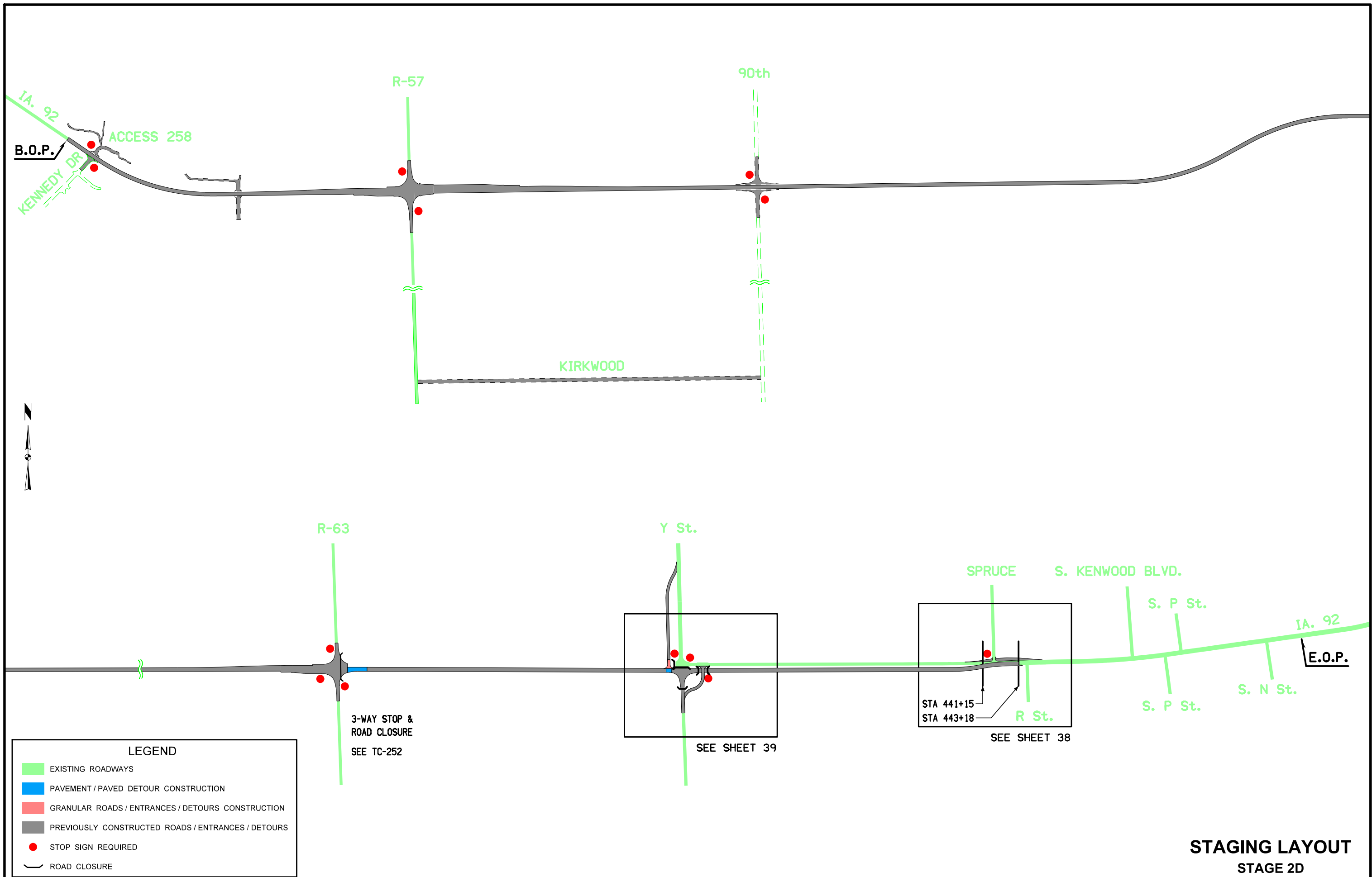

LEGEND	
	EXISTING ROADWAYS
	PAVEMENT / PAVED DETOUR CONSTRUCTION
	GRANULAR ROADS / ENTRANCES / DETOURS CONSTRUCTION
	PREVIOUSLY CONSTRUCTED ROADS / ENTRANCES / DETOURS
	STOP SIGN REQUIRED
	ROAD CLOSURE

**STAGING LAYOUT
STAGE 2D**

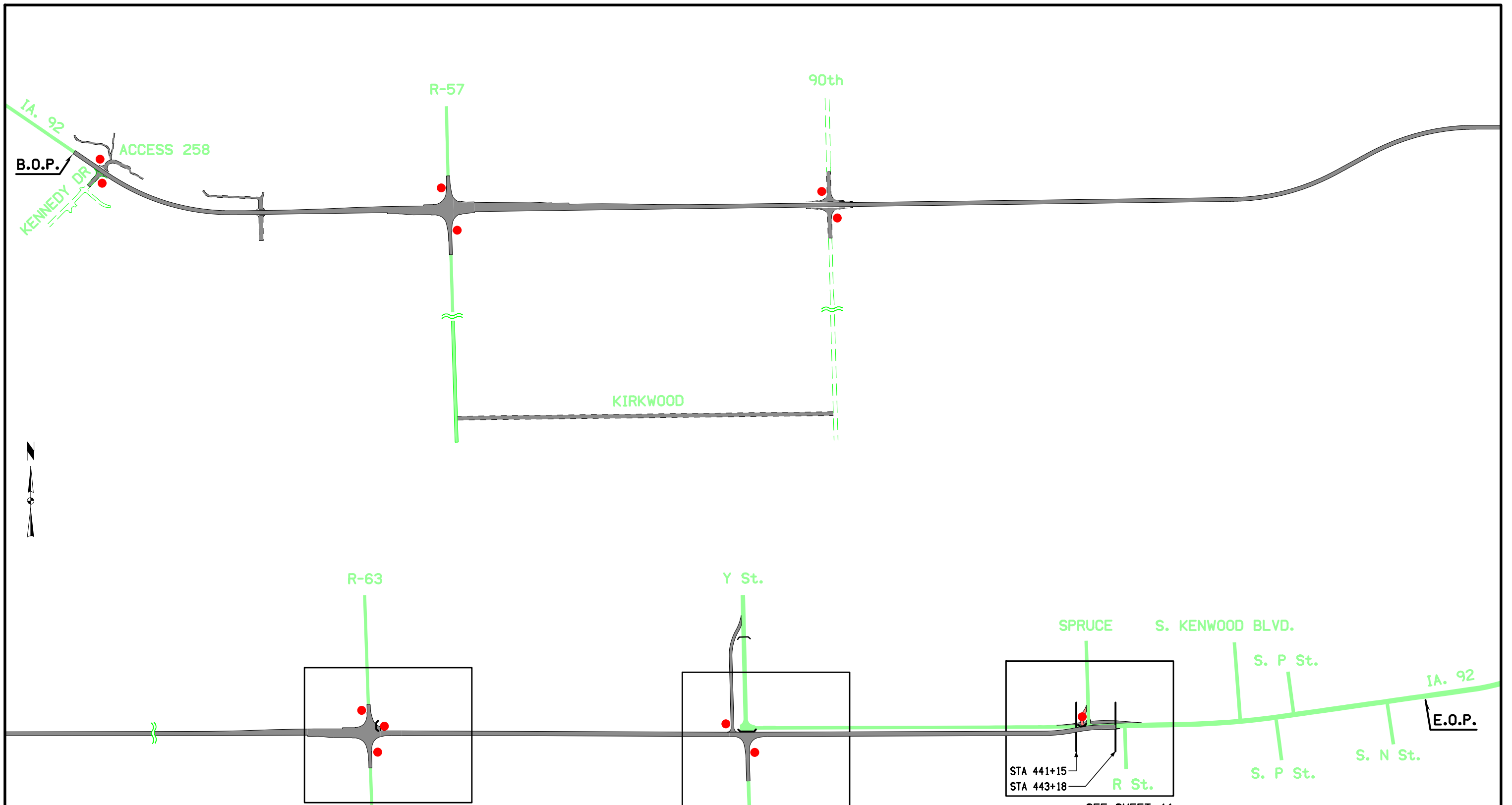

LEGEND

	EXISTING ROADWAYS
	PAVEMENT / PAVED DETOUR CONSTRUCTION
	GRANULAR ROADS / ENTRANCES / DETOURS CONSTRUCTION
	PREVIOUSLY CONSTRUCTED ROADS / ENTRANCES / DETOURS
	STOP SIGN REQUIRED
	ROAD CLOSURE

**STAGING LAYOUT
STAGE 3A**

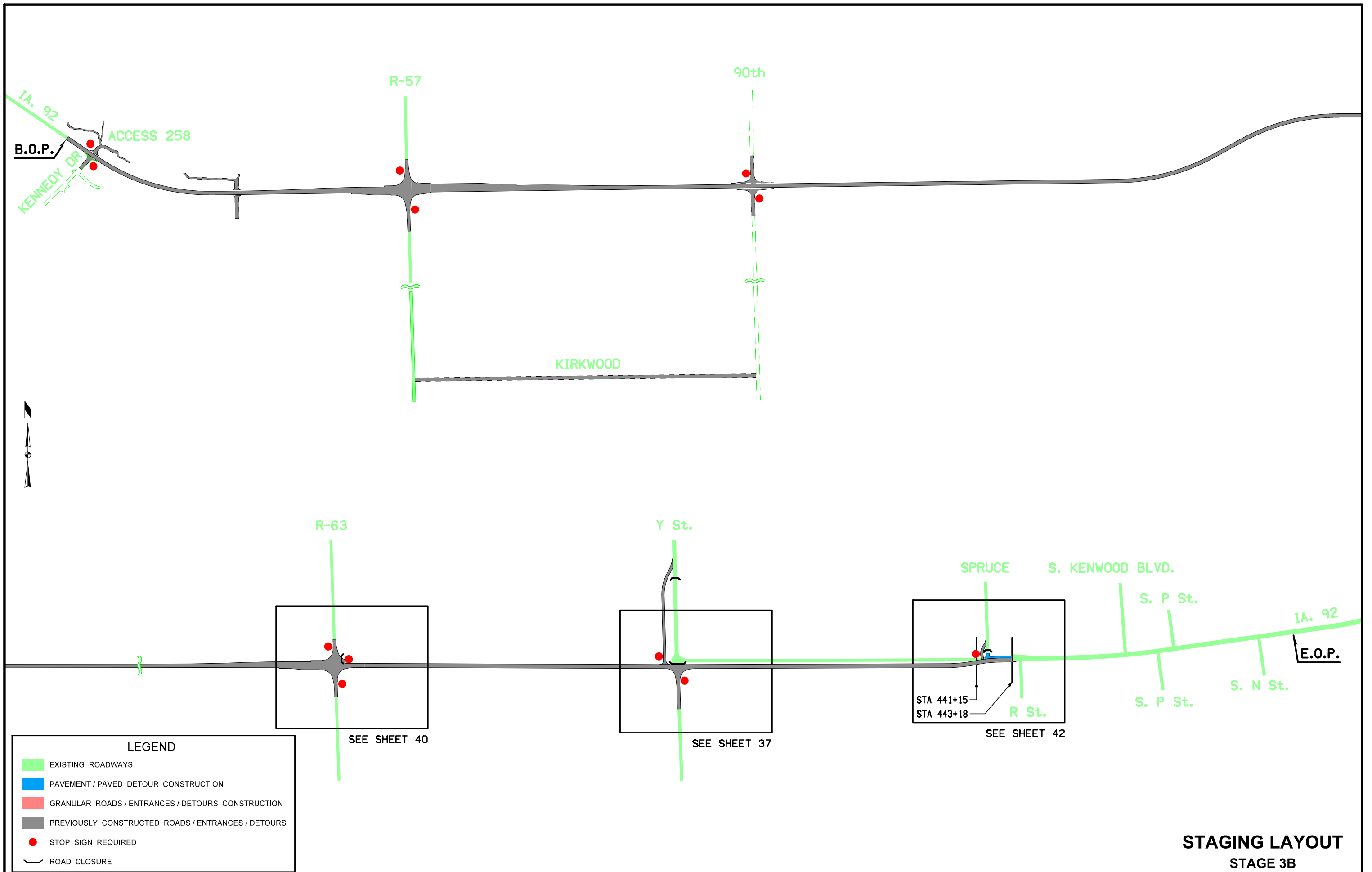

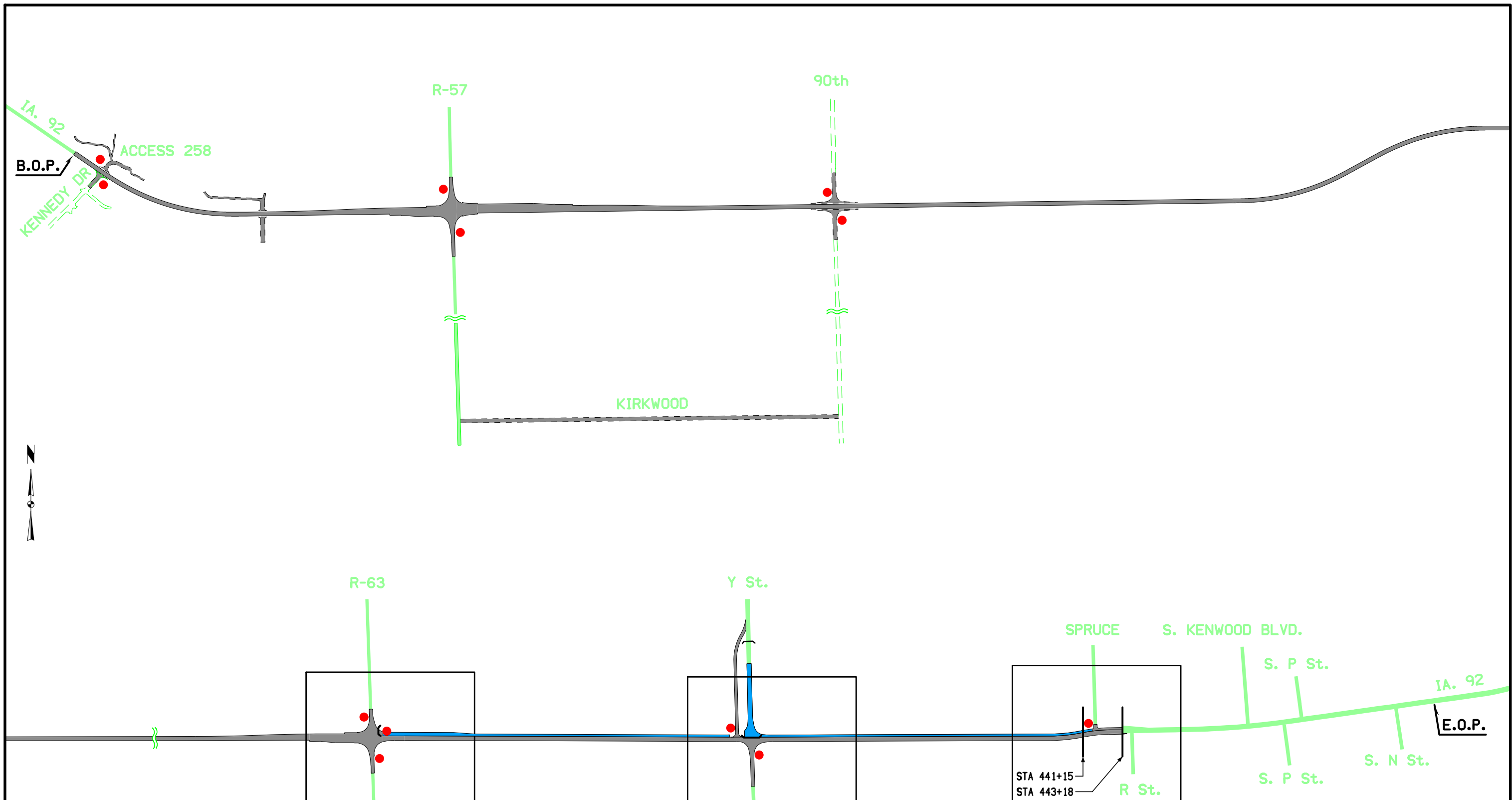

LEGEND	
	EXISTING ROADWAYS
	PAVEMENT / PAVED DETOUR CONSTRUCTION
	GRANULAR ROADS / ENTRANCES / DETOURS CONSTRUCTION
	PREVIOUSLY CONSTRUCTED ROADS / ENTRANCES / DETOURS
	STOP SIGN REQUIRED
	ROAD CLOSURE

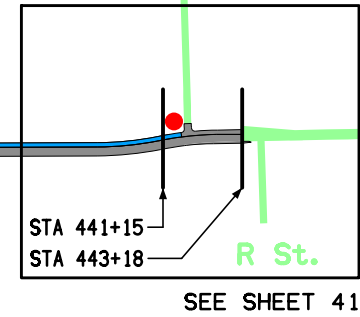
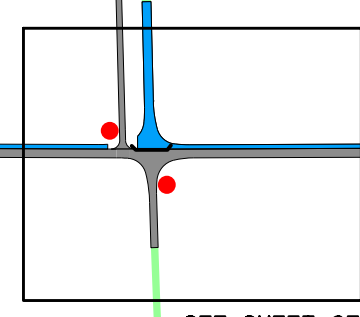
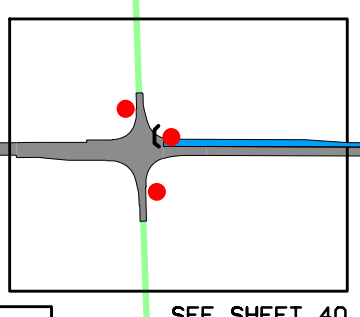

STAGING LAYOUT
STAGE 3C

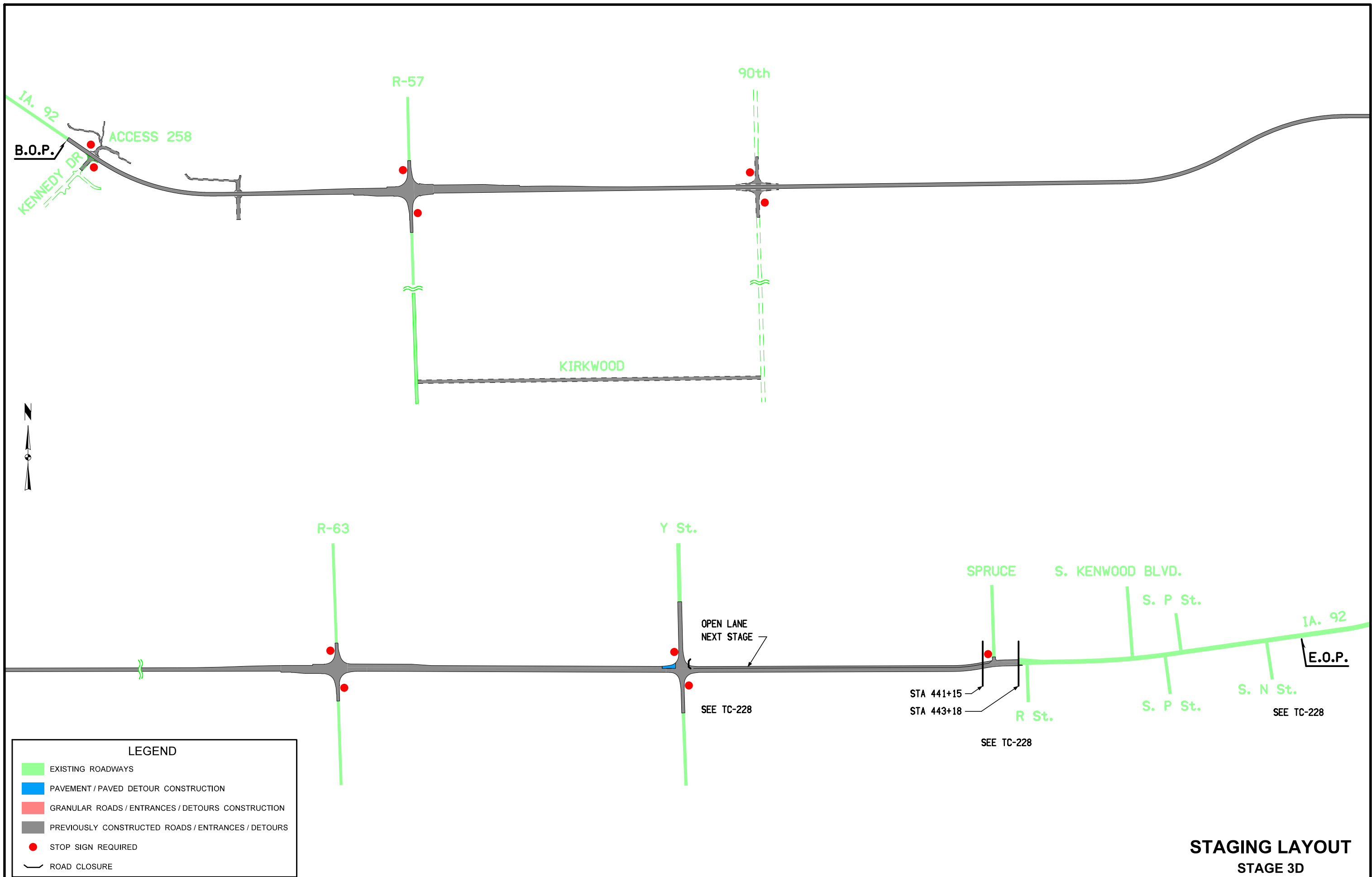

LEGEND

- EXISTING ROADWAYS
- PAVEMENT / PAVED DETOUR CONSTRUCTION
- GRANULAR ROADS / ENTRANCES / DETOURS CONSTRUCTION
- PREVIOUSLY CONSTRUCTED ROADS / ENTRANCES / DETOURS
- STOP SIGN REQUIRED
- ROAD CLOSURE

**STAGING LAYOUT
STAGE 3D**

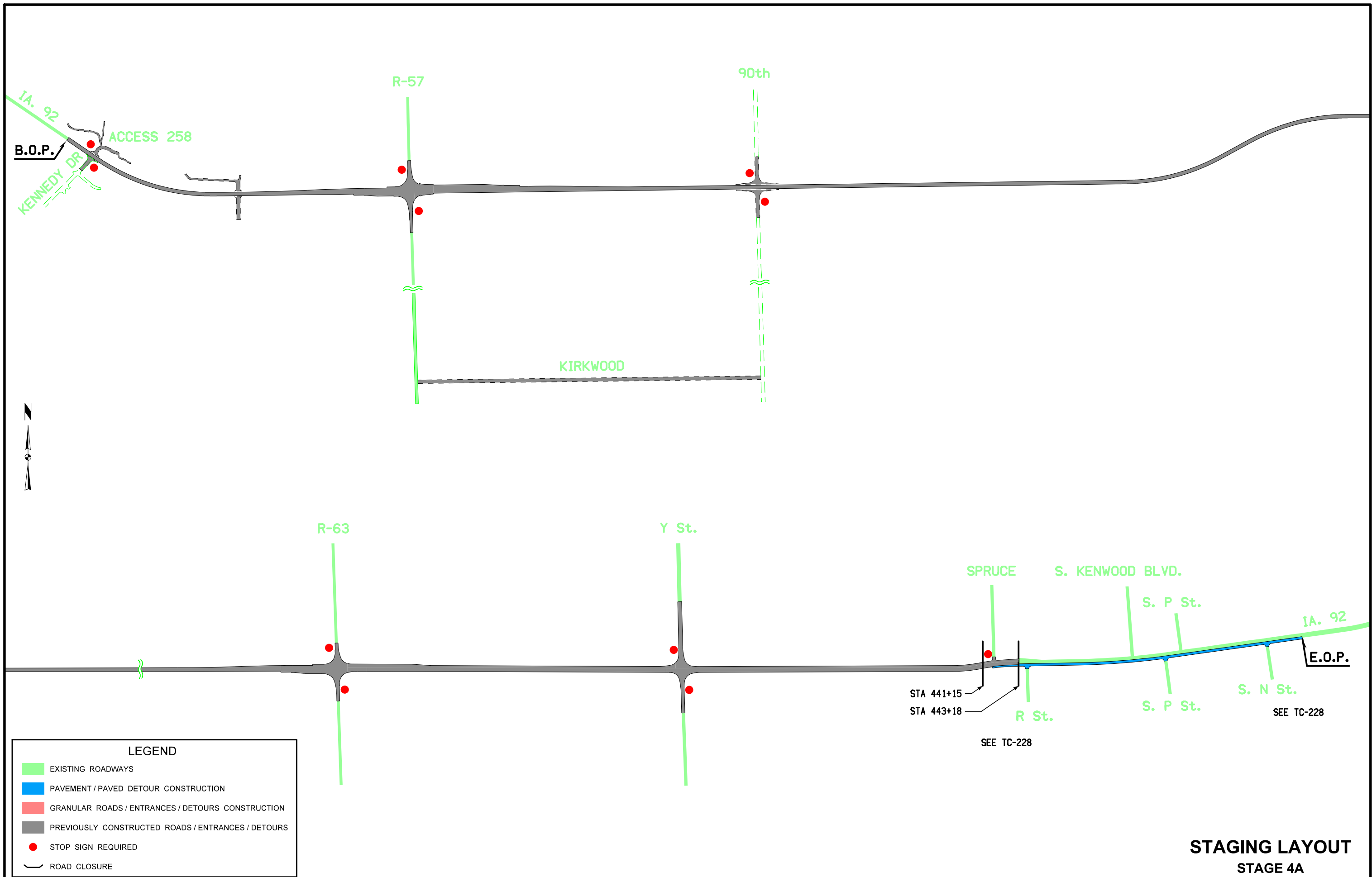

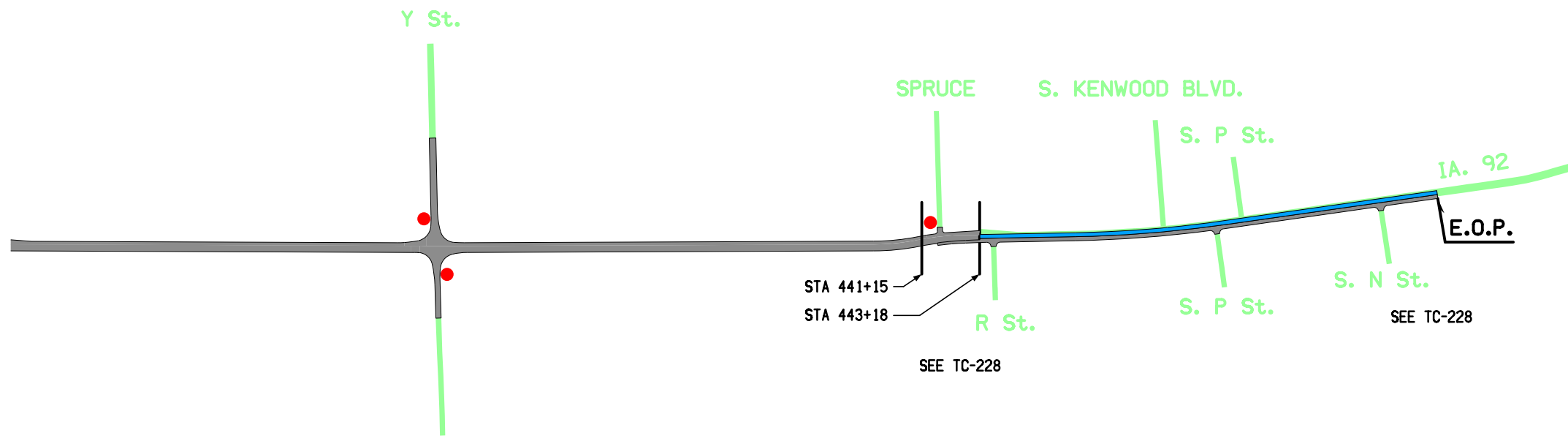

STAGE 4B

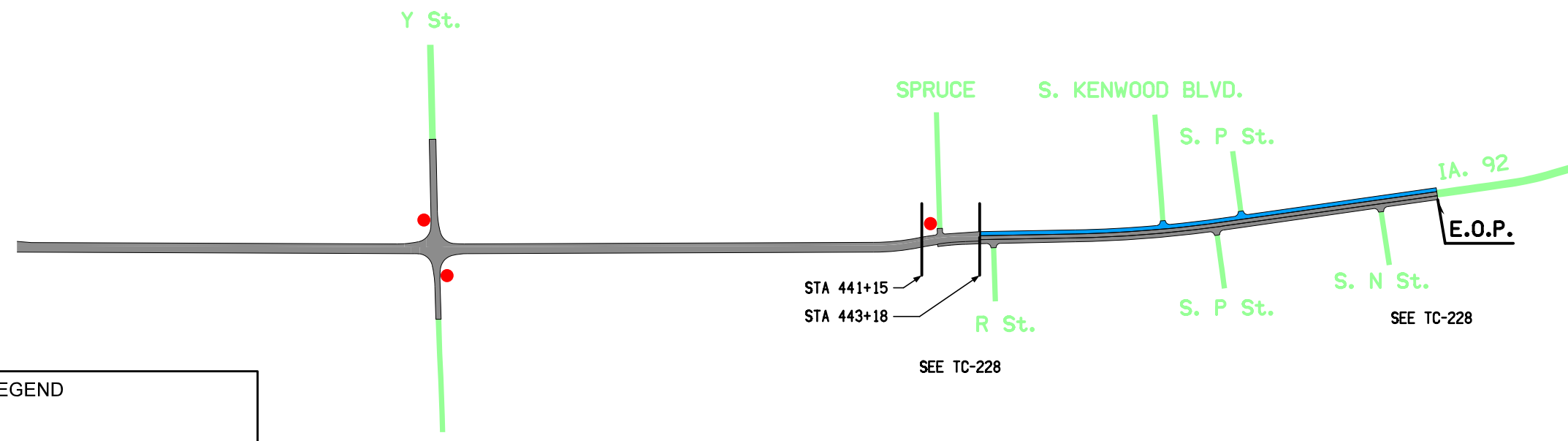

STAGE 4C

LEGEND

- EXISTING ROADWAYS
- PAVEMENT / PAVED DETOUR CONSTRUCTION
- GRANULAR ROADS / ENTRANCES / DETOURS CONSTRUCTION
- PREVIOUSLY CONSTRUCTED ROADS / ENTRANCES / DETOURS
- STOP SIGN REQUIRED
- ROAD CLOSURE

STAGING LAYOUT
STAGES 4B & 4C

THREE-LANE TO TWO-LANE

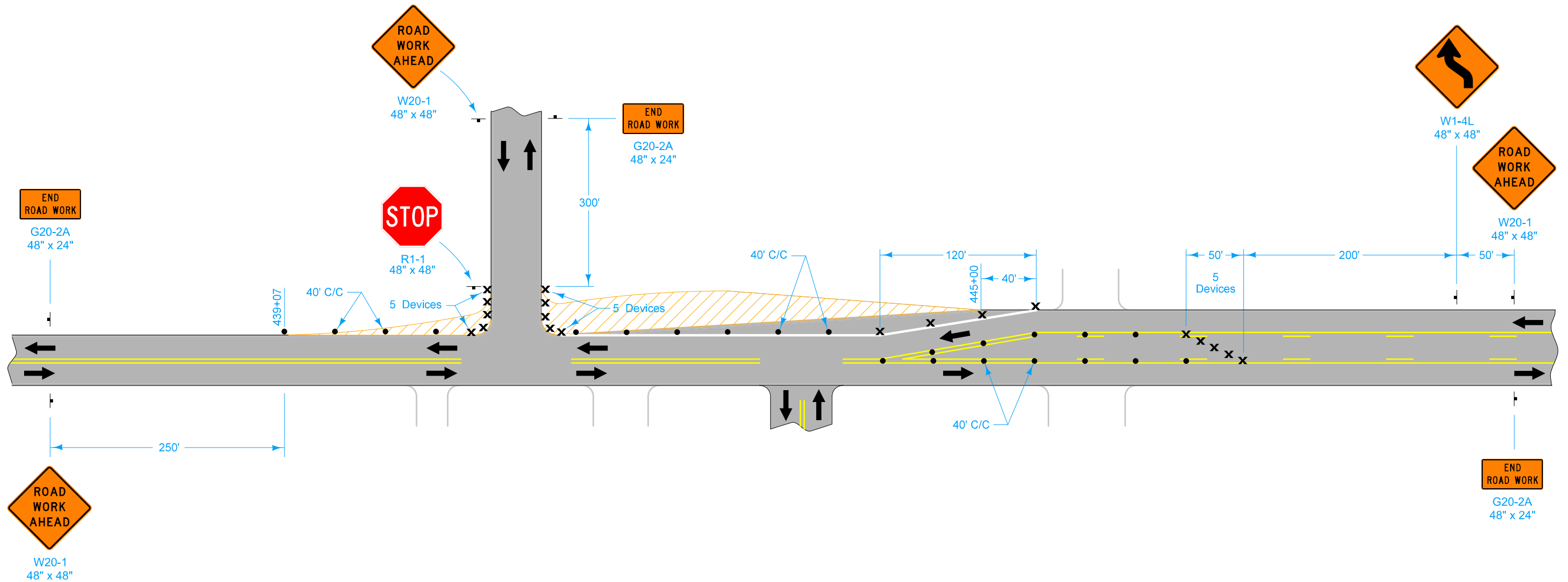

LEGEND

⊥	Traffic Sign
•	42' Channelizer
x	Drum
▨	Possible Work Area
←	Direction of Traffic

Contract Items:
 Pavement Marking Items
 Pavement Markings Removed
 Traffic Control

Tabulations:
 108-22

**LANE CLOSURE AT
 THREE-LANE TO TWO-LANE TRANSITION**

TWO-LANE DETOUR WITH INTERSECTION

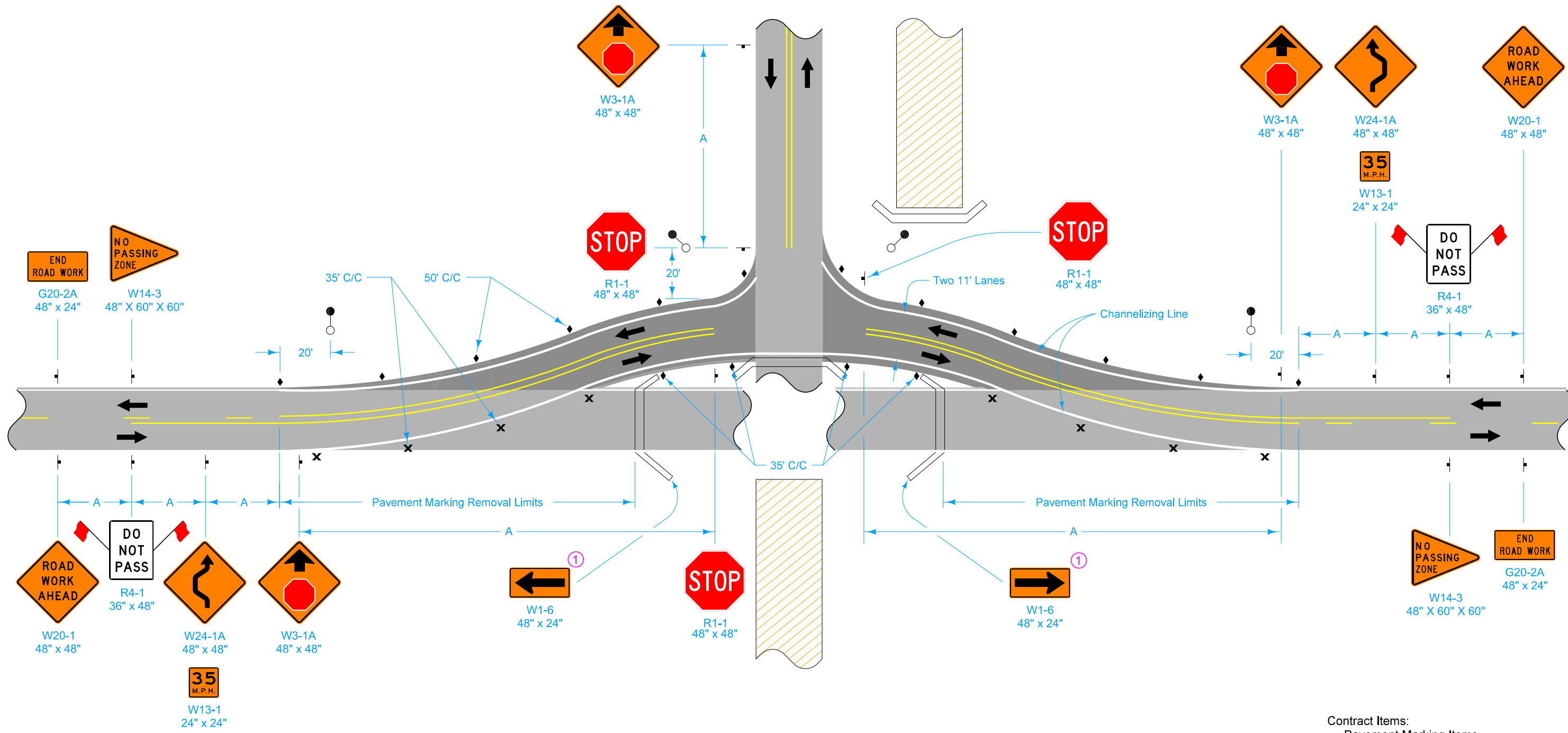

LEGEND

- ← Direction of Traffic
- x Drum
- ◆ Single White Delineators (mount back to back)
- ⎓ Road Closure
- Temporary Floodlighting
- ⊥ Traffic Sign
- ▨ Possible Work Area

SPEED LIMIT (mph)	A
35 or less	250'
40 - 45	350'
50 or greater	500'

① Add below ROAD CLOSED (R11-2) sign already included in Safety Closure.

- Contract Items:**
- Pavement Marking Items
 - Pavement Markings Removed
 - Safety Closures
 - Temporary Floodlighting
 - Temporary Delineators
 - Traffic Control

- Tabulations:**
- 108-13A
 - 108-22
 - 108-27

UTILIZING PAVED ON-SITE DETOUR WITH 3-WAY STOP

TWO-LANE GRAVEL DETOUR INTERSECTION

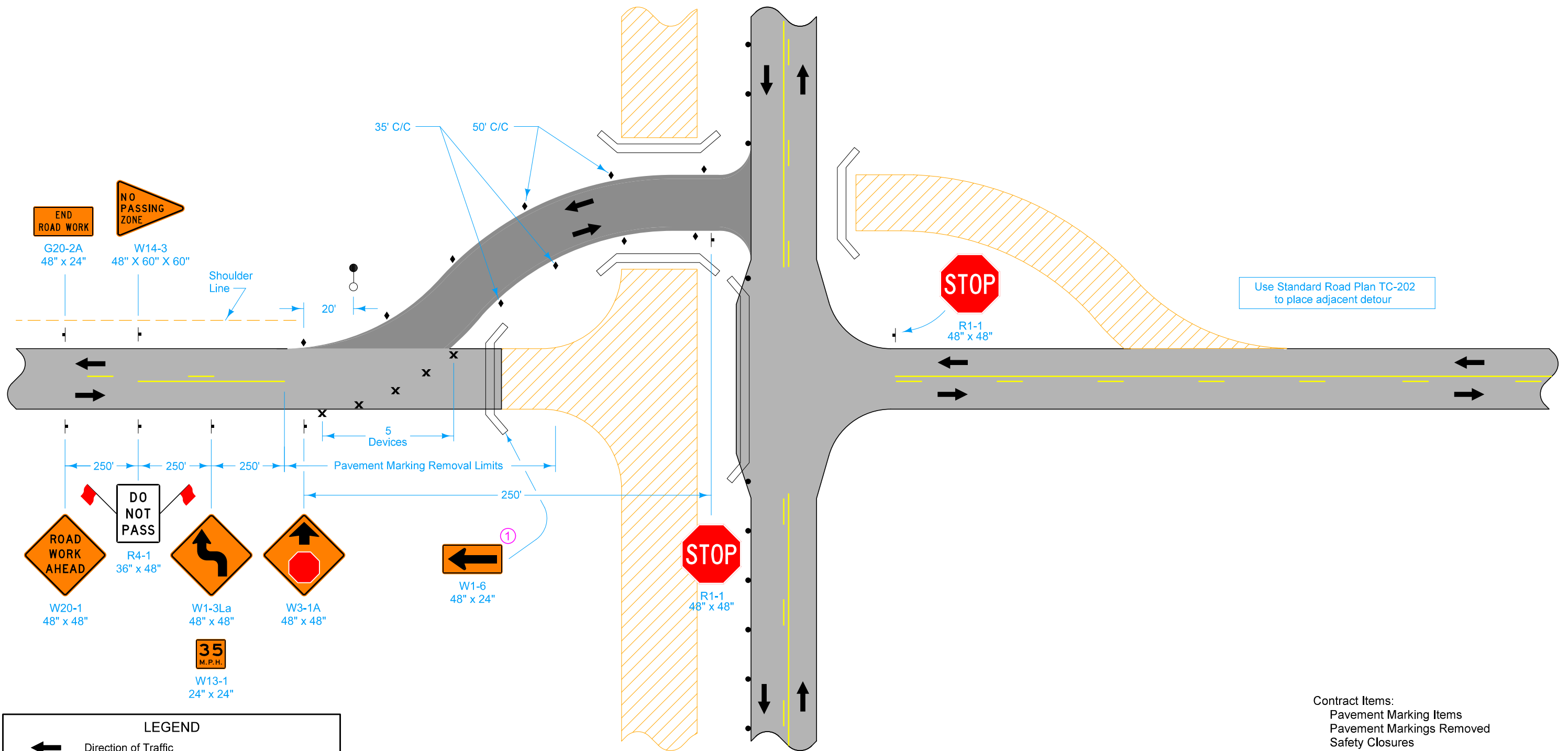

- W20-1 48" x 48" ROAD WORK AHEAD
- DO NOT PASS
- R4-1 36" x 48"
- W1-3La 48" x 48"
- W3-1A 48" x 48"
- W13-1 24" x 24" 35 M.P.H.
- W1-6 48" x 24"
- R1-1 48" x 48"

LEGEND

- ← Direction of Traffic
- x Drum
- ◆ Single White Delineators (mount back to back)
- 42" Channelizer
- ⎓ Road Closure
- Temporary Floodlighting
- ⊥ Traffic Sign
- ▨ Possible Work Area

- Contract Items:
- Pavement Marking Items
 - Pavement Markings Removed
 - Safety Closures
 - Temporary Floodlighting
 - Temporary Delineators
 - Traffic Control

- Tabulations:
- 108-13A
 - 108-22
 - 108-27

① Add below ROAD CLOSED (R11-2) sign already included in Safety Closure.

**UTILIZING GRAVEL ON-SITE DETOUR
WITH STOP AT THRU-WAY**

TWO-LANE TO THREE-LANE TEMPORARY PAVEMENT

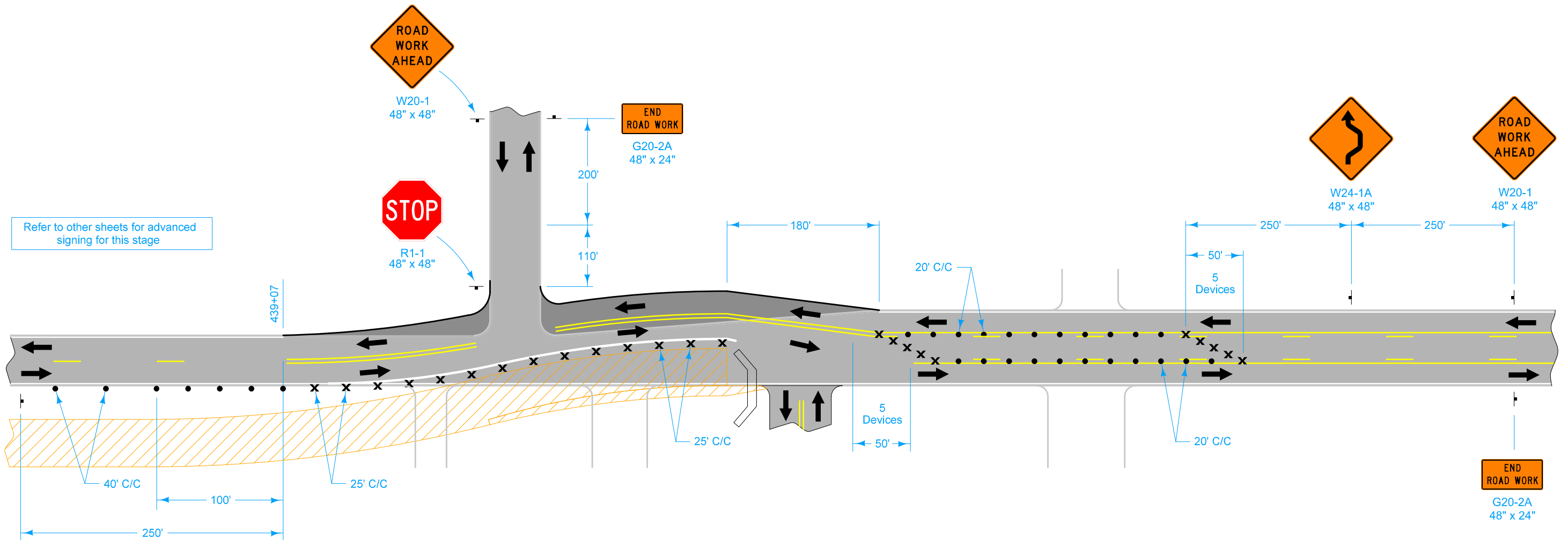

Refer to other sheets for advanced signing for this stage



W24-1A
48" x 48"

LEGEND	
←	Direction of Traffic
⊥	Traffic Sign
•	42' Channelizer
x	Drum
⎓	Road Closure
▨	Possible Work Area

Contract Items:
 Pavement Marking Items
 Pavement Markings Removed
 Safety Closures
 Traffic Control

Tabulations:
 108-13A
 108-22

**UTILIZING TEMPORARY PAVEMENT FOR
 TWO-LANE TO THREE-LANE TRANSITION**

TWO-LANE GRAVEL DETOUR CONSTRUCTION

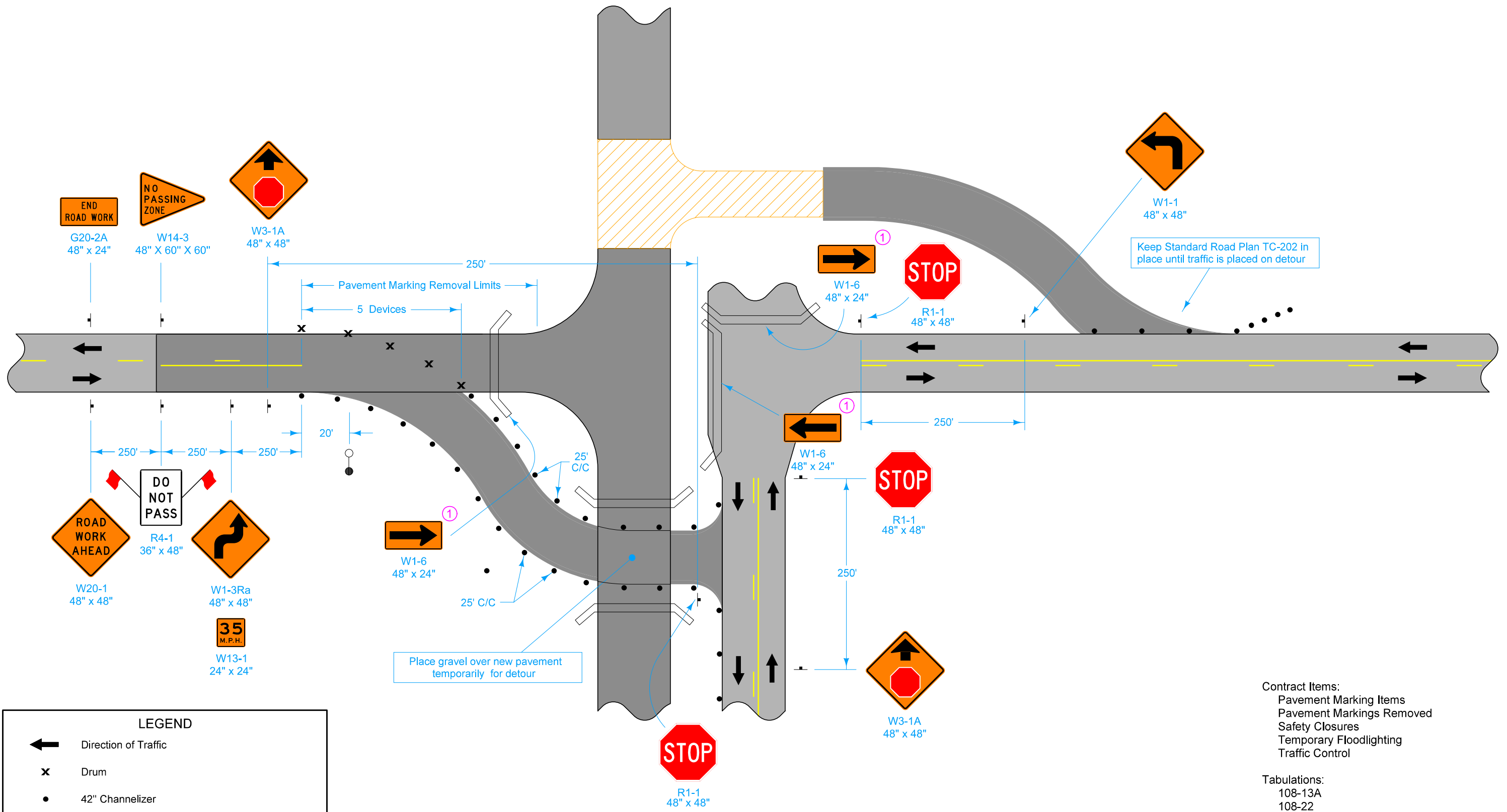

- W20-1 48" x 48"
- R4-1 36" x 48"
- W13-1 24" x 24"
- 35 M.P.H.
- W1-3Ra 48" x 48"
- DO NOT PASS
- 250'
- 250'
- 250'
- 20'

LEGEND

- ← Direction of Traffic
- x Drum
- 42" Channelizer
- ⎓ Road Closure
- Temporary Floodlighting
- ⊥ Traffic Sign
- ▨ Possible Work Area

Contract Items:
 Pavement Marking Items
 Pavement Markings Removed
 Safety Closures
 Temporary Floodlighting
 Traffic Control

Tabulations:
 108-13A
 108-22
 108-27

**UTILIZING GRAVEL ON-SITE DETOUR
 WITH STOP AT THRU-WAY**

① Add below ROAD CLOSED (R11-2) sign already included in Safety Closure.

INTERSECTION WITH 4-WAY STOP

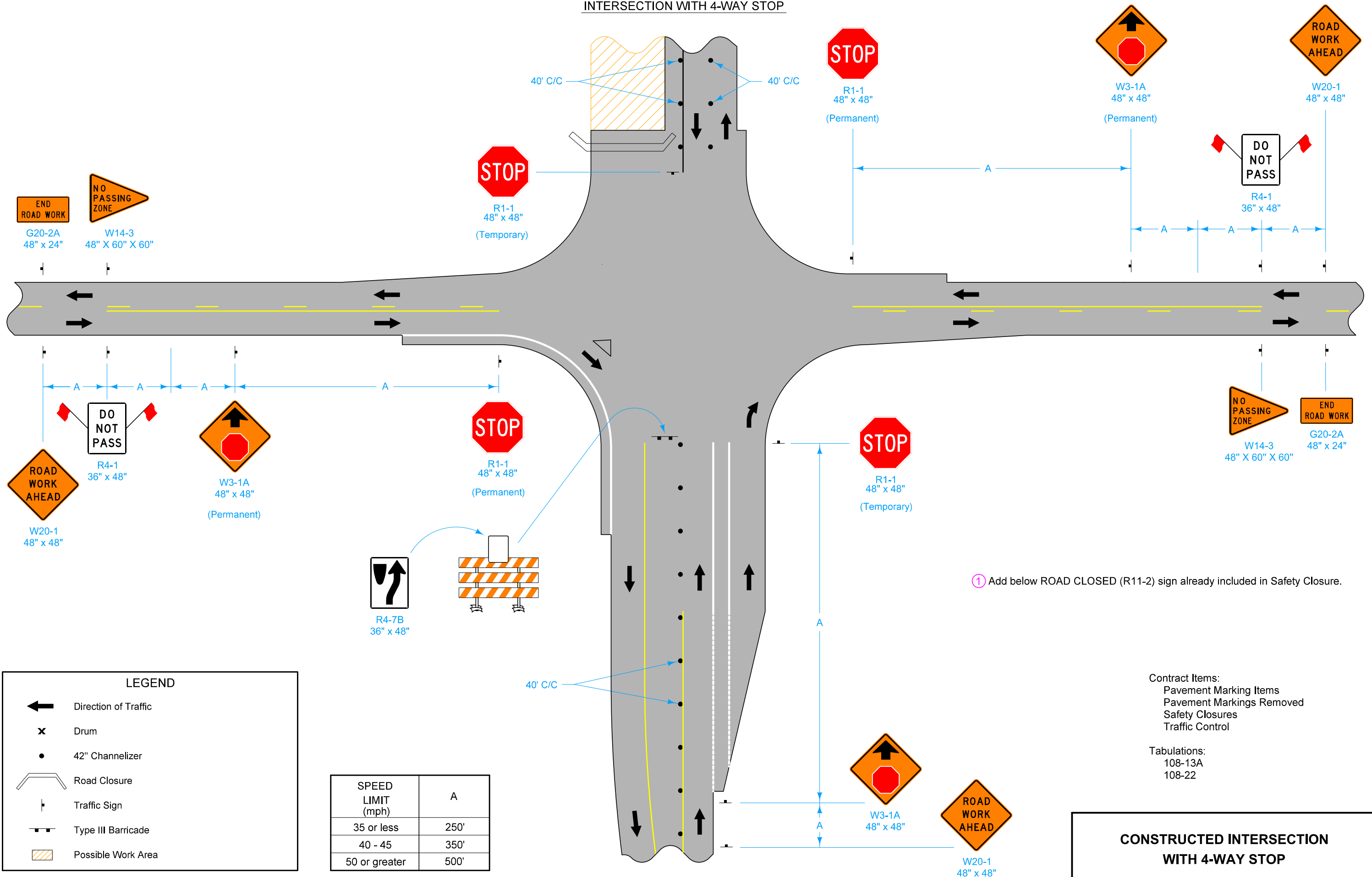

LEGEND

- Direction of Traffic
- Drum
- 42" Channelizer
- Road Closure
- Traffic Sign
- Type III Barricade
- Possible Work Area

SPEED LIMIT (mph)	A
35 or less	250'
40 - 45	350'
50 or greater	500'

① Add below ROAD CLOSED (R11-2) sign already included in Safety Closure.

Contract Items:
 Pavement Marking Items
 Pavement Markings Removed
 Safety Closures
 Traffic Control

Tabulations:
 108-13A
 108-22

CONSTRUCTED INTERSECTION WITH 4-WAY STOP

WB LANE COMPLETION

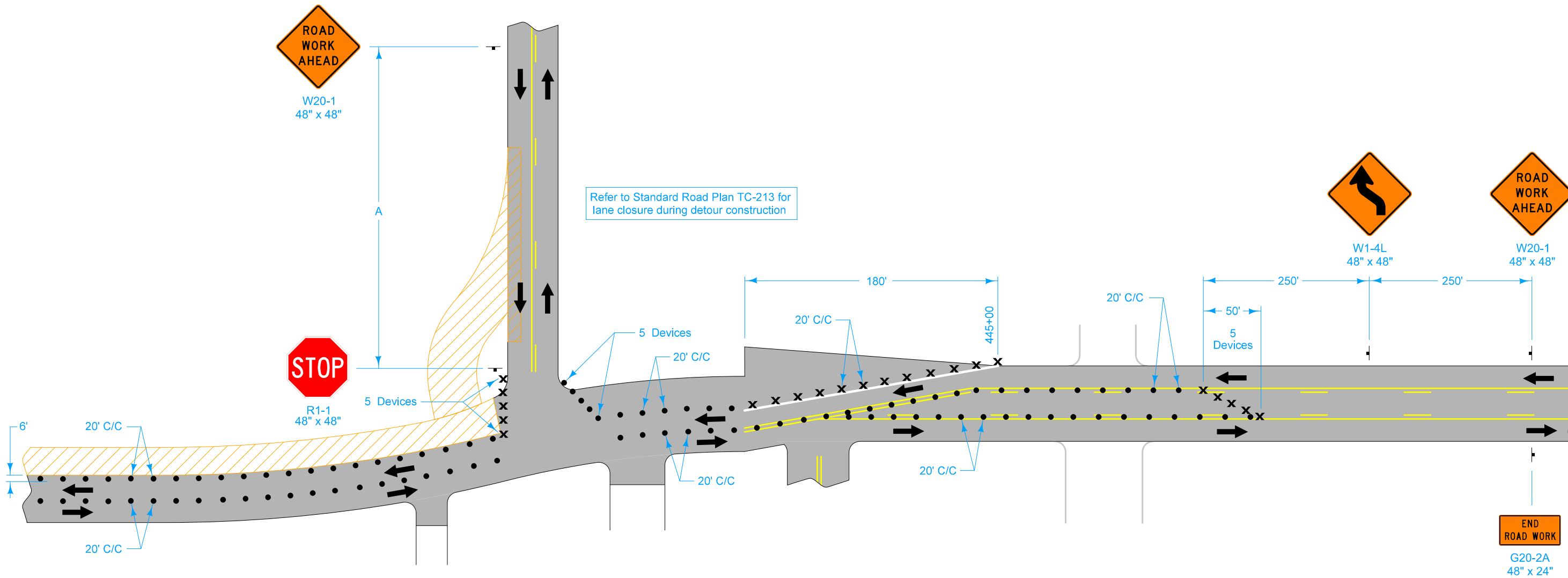

LEGEND

←	Direction of Traffic
⊥	Traffic Sign
•	42' Channelizer
x	Drum
▭ (hatched)	Road Closure
▭ (hatched)	Possible Work Area

Contract Items:
 Pavement Marking Items
 Pavement Markings Removed
 Traffic Control

Tabulations:
 108-22

**CONSTRUCT REMAINDER OF WB-LANE
 BETWEEN SIDE STREETS**

TWO-LANE TO THREE-LANE PAVEMENT WITH DETOUR

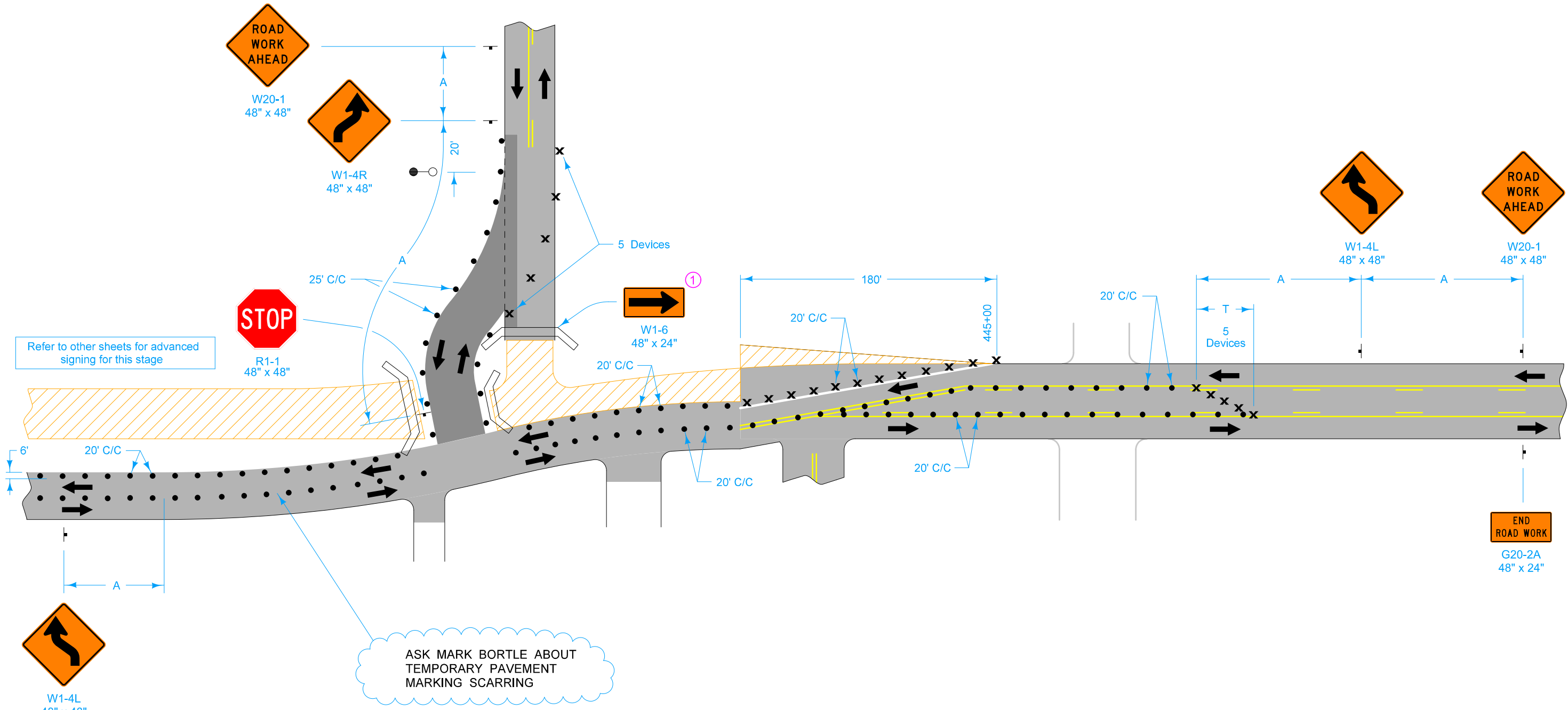

Refer to other sheets for advanced signing for this stage

ASK MARK BORTLE ABOUT TEMPORARY PAVEMENT MARKING SCARRING

LEGEND

- ← Direction of Traffic
- ⊥ Traffic Sign
- 42' Channelizer
- x Drum
- Temporary Floodlighting
- ⎓ Road Closure
- ▨ Possible Work Area

SPEED LIMIT (mph)	A	T
35 or less	250'	50'
40 - 45	350'	100'
50 or greater	500'	100'

① Add below ROAD CLOSED (R11-2) sign already included in Safety Closure.

Contract Items:
 Pavement Marking Items
 Pavement Markings Removed
 Safety Closures
 Temporary Floodlighting
 Traffic Control

Tabulations:
 108-13A
 108-22
 108-27

UTILIZING GRAVEL ON-LINE DETOUR FOR SIDE STREET PAVING CONNECTION

Lincoln TWP.
T-76N R-24W
SEC. 29

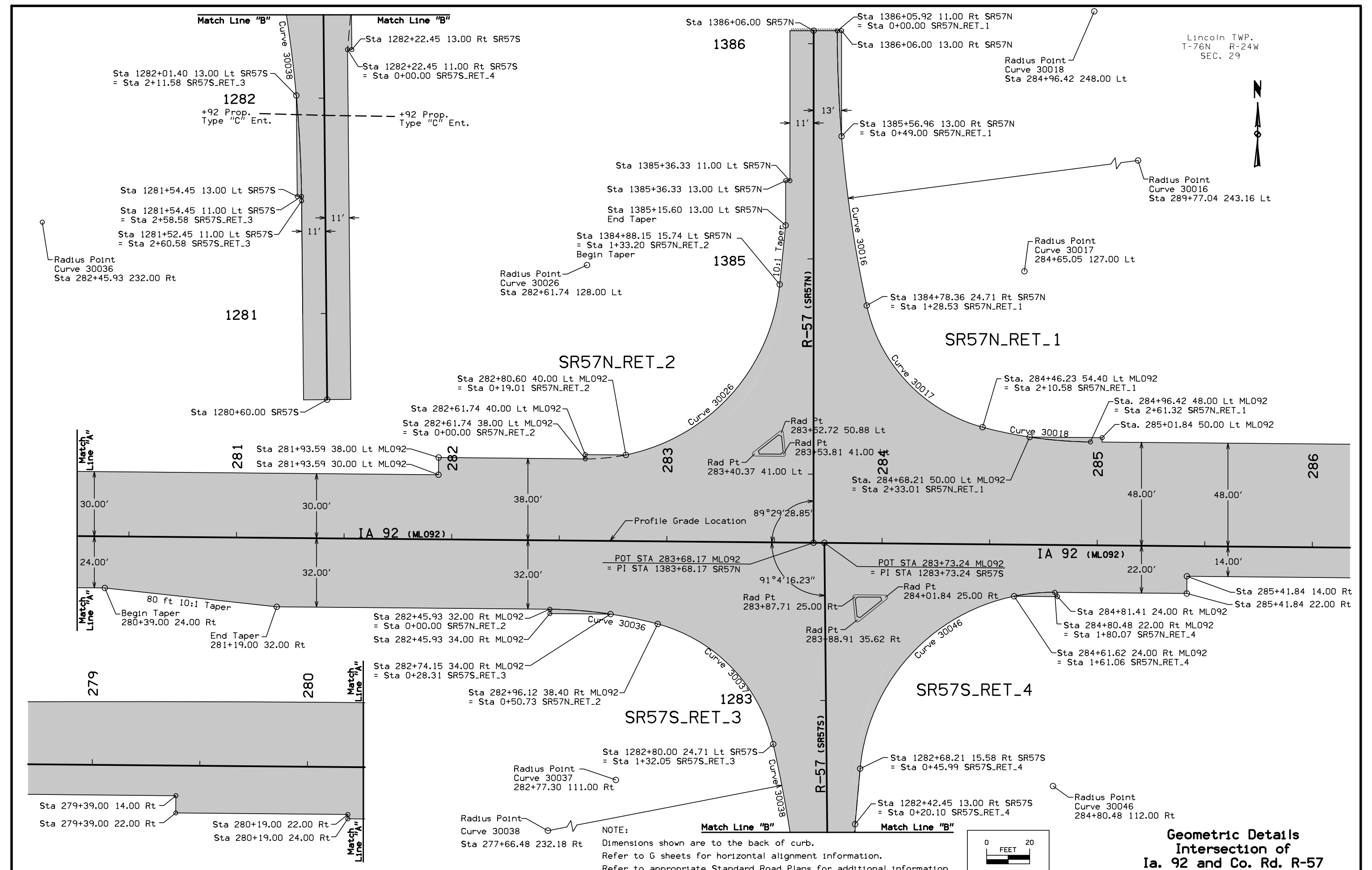

NOTE:
Dimensions shown are to the back of curb.
Refer to G sheets for horizontal alignment information.
Refer to appropriate Standard Road Plans for additional information.

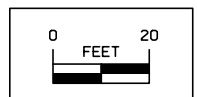

**Geometric Details
Intersection of
Ia. 92 and Co. Rd. R-57**

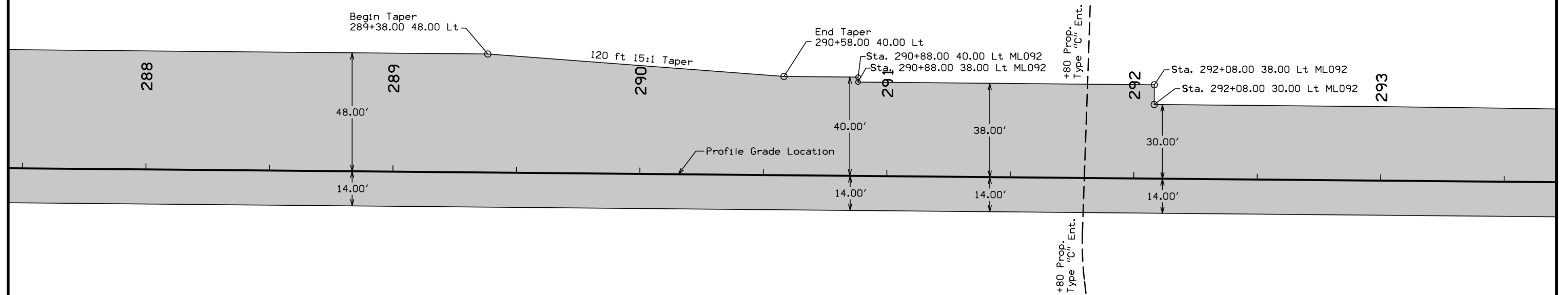

NOTE:
Dimensions shown are to the back of curb.
Refer to G sheets for horizontal alignment information.
Refer to appropriate Standard Road Plans for additional information,

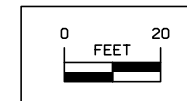

Geometric Details
Ia. 92

Lincoln TWP.
T-76N R-24W
SEC. 27

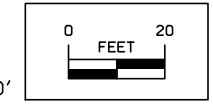
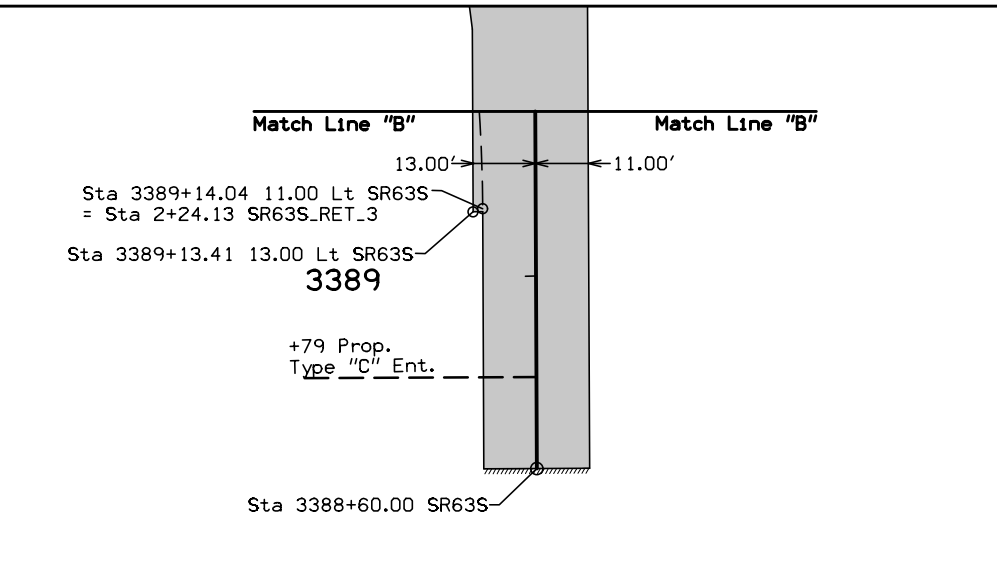
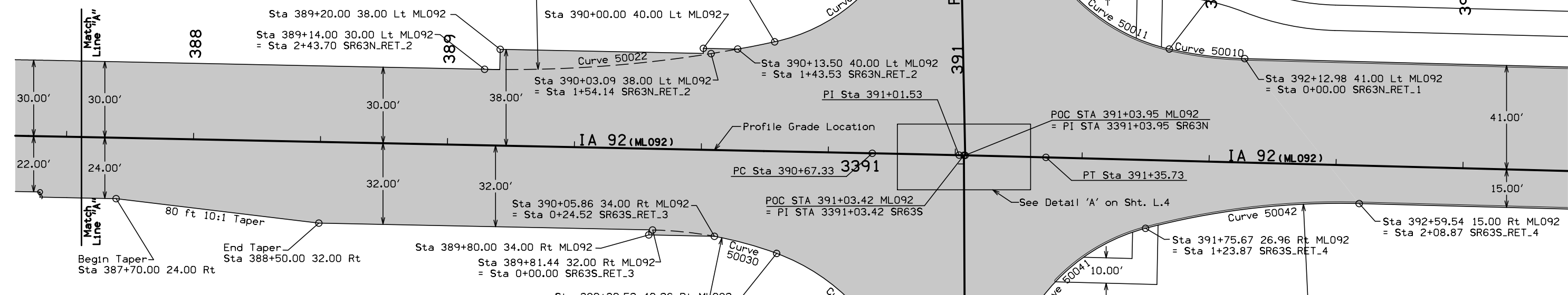
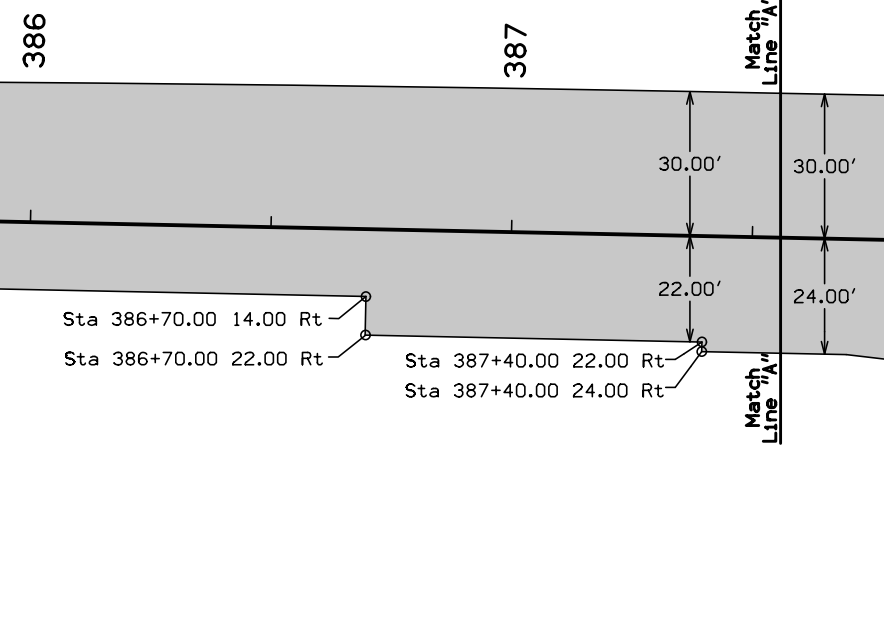

**Geometric Details
Intersection of
Ia. 92 and Co. Rd. R-63**

NOTE:
Dimensions shown are to the back of curb.
Refer to G sheets for horizontal alignment information.
Refer to appropriate Standard Road Plans for additional information.

Lincoln TWP.
T-76N R-24W
SEC. 27

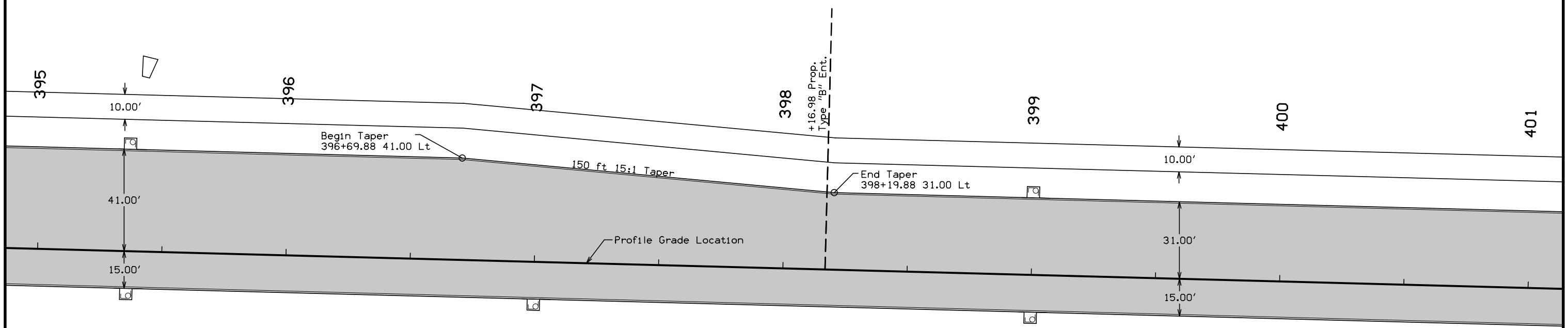

Detail 'A'
(Do Not Scale)

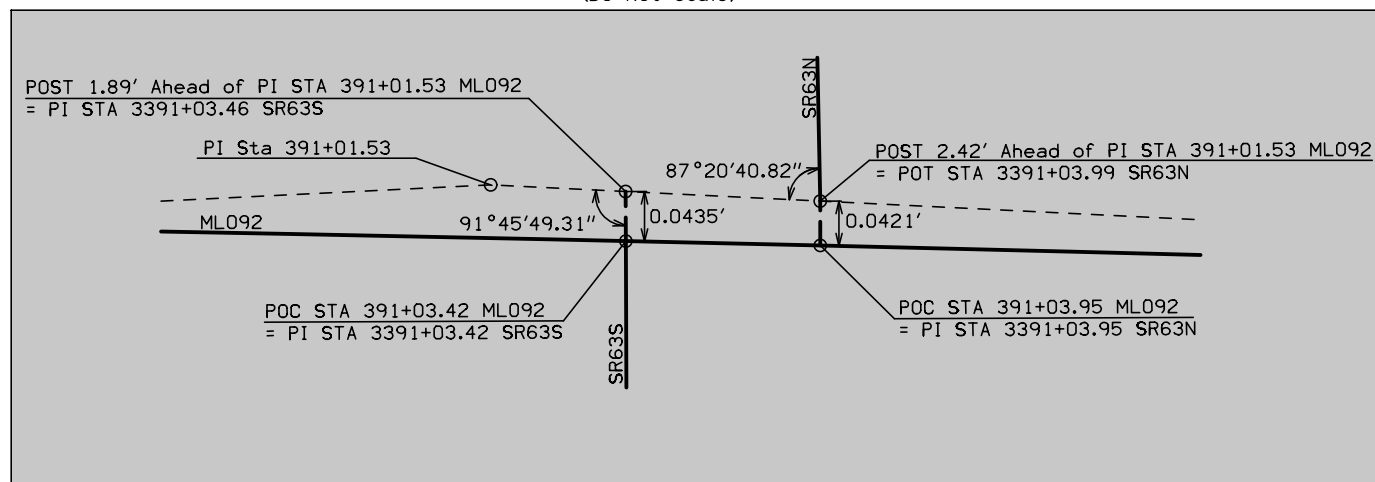

NOTE:
Dimensions shown are to the back of curb.
Refer to G sheets for horizontal alignment information.
Refer to appropriate Standard Road Plans for additional information.

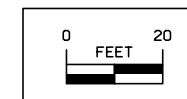

**Geometric Details
Ia. 92**

Lincoln TWP.
T-76N R-24W
SEC. 27

Lincoln TWP.
T-76N R-24W
SEC. 26

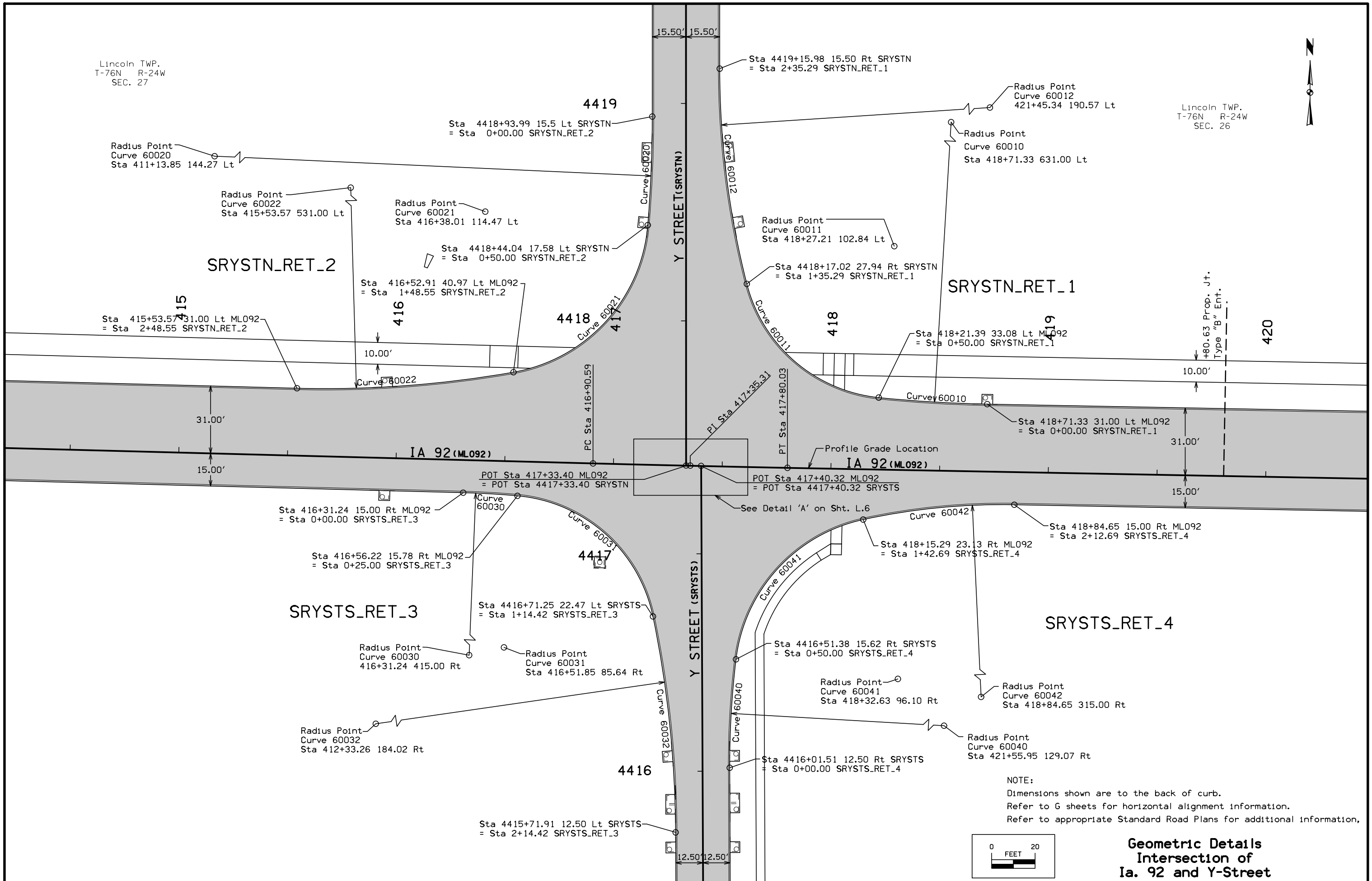

NOTE:
 Dimensions shown are to the back of curb.
 Refer to G sheets for horizontal alignment information.
 Refer to appropriate Standard Road Plans for additional information.

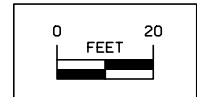

**Geometric Details
 Intersection of
 Ia. 92 and Y-Street**

Lincoln TWP.
T-76N R-24W
SEC. 26

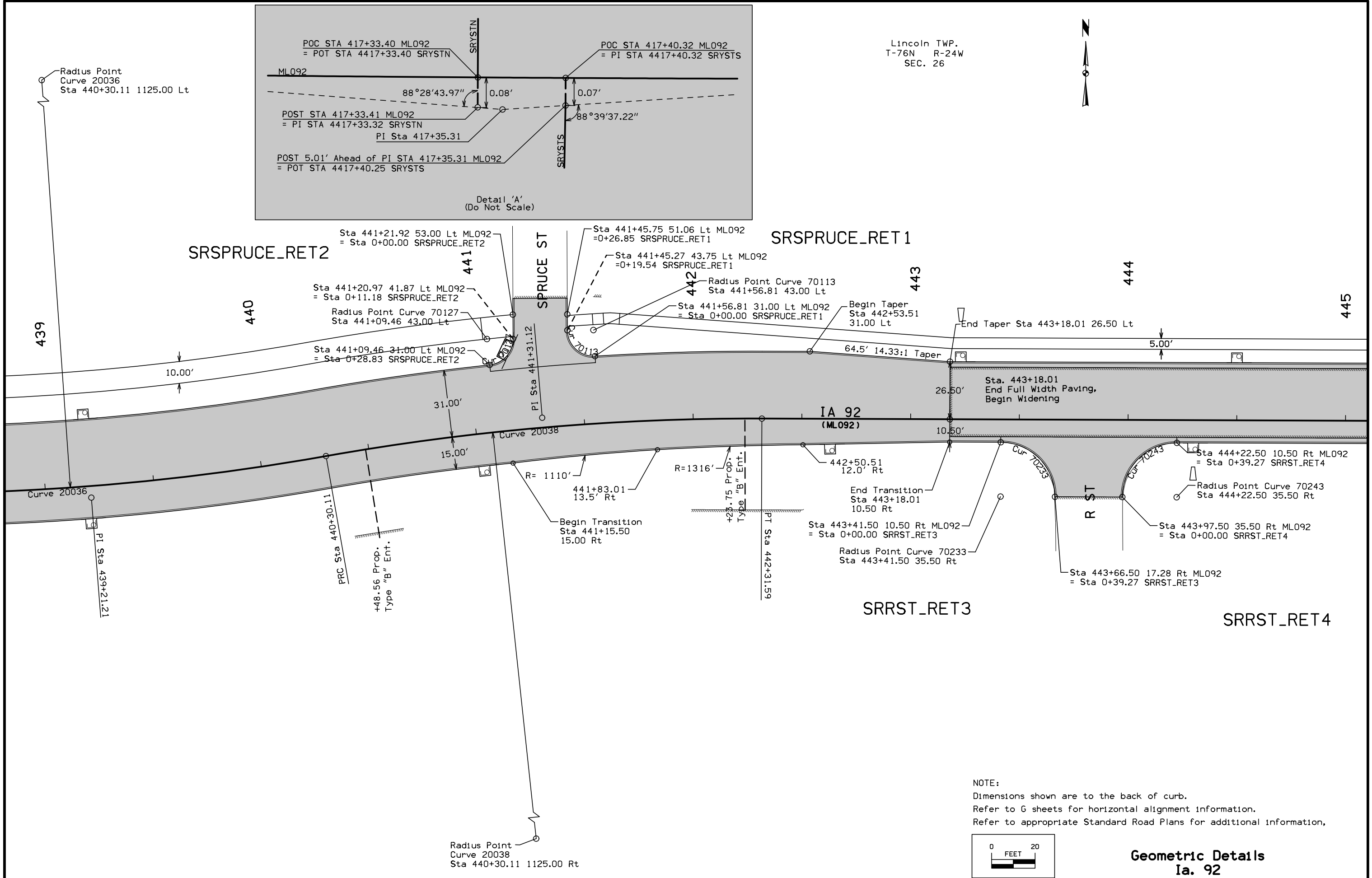
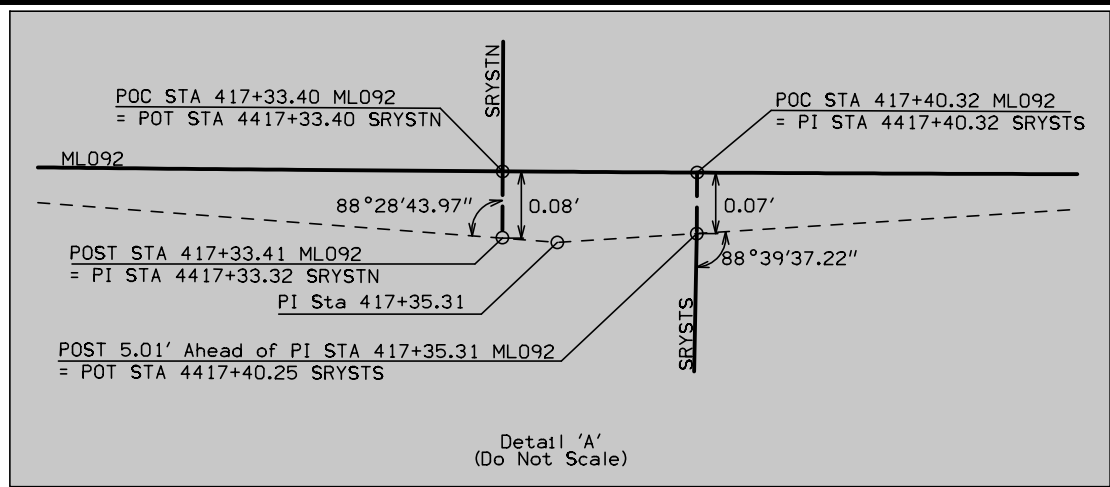

NOTE:
Dimensions shown are to the back of curb.
Refer to G sheets for horizontal alignment information.
Refer to appropriate Standard Road Plans for additional information,

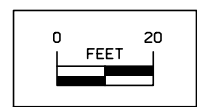

Geometric Details
Ia. 92



SRKENWOOD_RET2

SRKENWOOD_RET1

SRPST_RET2

SRPST_RET1

Sta 451+72.27 55.52 Lt ML092
= Sta 0+00.00 SRKENWOOD_RET2

Sta 451+71.70 49.40 Lt ML092
= Sta 0+06.17 SRKENWOOD_RET2

Radius Point Curve 70327
Sta 451+46.57 51.50 Lt

451

Sta 451+46.60 26.50 Lt ML092
= Sta 0+43.31 SRKENWOOD_RET2

S KENWOOD BLVD

Sta 452+13.95 55.52 Lt ML092
= Sta 0+43.31 SRKENWOOD_RET1

Sta 452+13.80 53.80 Lt ML092
= Sta 0+41.60 SRKENWOOD_RET1

Radius Point Curve 70313
Sta 452+38.92 51.50 Lt

452

Sta 452+38.90 26.50 Lt ML092
= Sta 0+00.00 SRKENWOOD_RET1

Sta 455+21.30 26.50 Lt ML092
= Sta 0+49.46 SRPST_RET2

454

Sta 455+53.30 57.70 Lt ML092
= Sta 0+00.00 SRPST_RET2

SOUTH P ST

Sta 455+79.25 57.70 Lt ML092
= Sta 0+49.48 SRPST_RET1

Radius Point Curve 70513
Sta 456+11.24 58.50 Lt

456

Sta 456+11.25 26.50 Lt ML092
= Sta 0+00.00 SRPST_RET1

Sta 453+91.57 10.50 Rt ML092
= Sta 0+00.00 SRPST_RET3

Radius Point Curve 70433
Sta 453+91.57 42.50 Rt

Sta 454+16.67 22.83 Rt ML092
= Sta 0+29.01 SRPST_RET3

SRPST_RET3

SOUTH P ST

Sta 454+86.45 10.50 Rt ML092
= Sta 0+29.06 SRPST_RET4

Radius Point Curve 70443
Sta 454+86.45 42.50 Rt

Sta 454+61.27 22.83 Rt ML092
= Sta 0+00.00 SRPST_RET4

SRPST_RET4

461

+34.29 Prop.
Type "B" Ent.

462

463

Sta 461+85.60 10.50 Rt ML092
= Sta 0+00.00 SRNST_RET3

Radius Point Curve 70633
Sta 461+85.60 35.50 Rt

Sta 462+07.85 24.10 Rt ML092
= Sta 0+27.43 SRNST_RET3

SRNST_RET3

SOUTH N ST

Sta 462+62.60 10.50 Rt ML092
= Sta 0+27.48 SRNST_RET4

Radius Point Curve 70643
Sta 462+62.55 35.50 Rt

Sta 462+40.30 24.10 Rt ML092
= Sta 0+00.00 SRNST_RET4

SRNST_RET4

NOTE:
Dimensions shown are to the back of curb.
Refer to G sheets for horizontal alignment information.
Refer to appropriate Standard Road Plans for additional information,

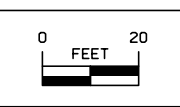

Geometric Details
Ia. 92

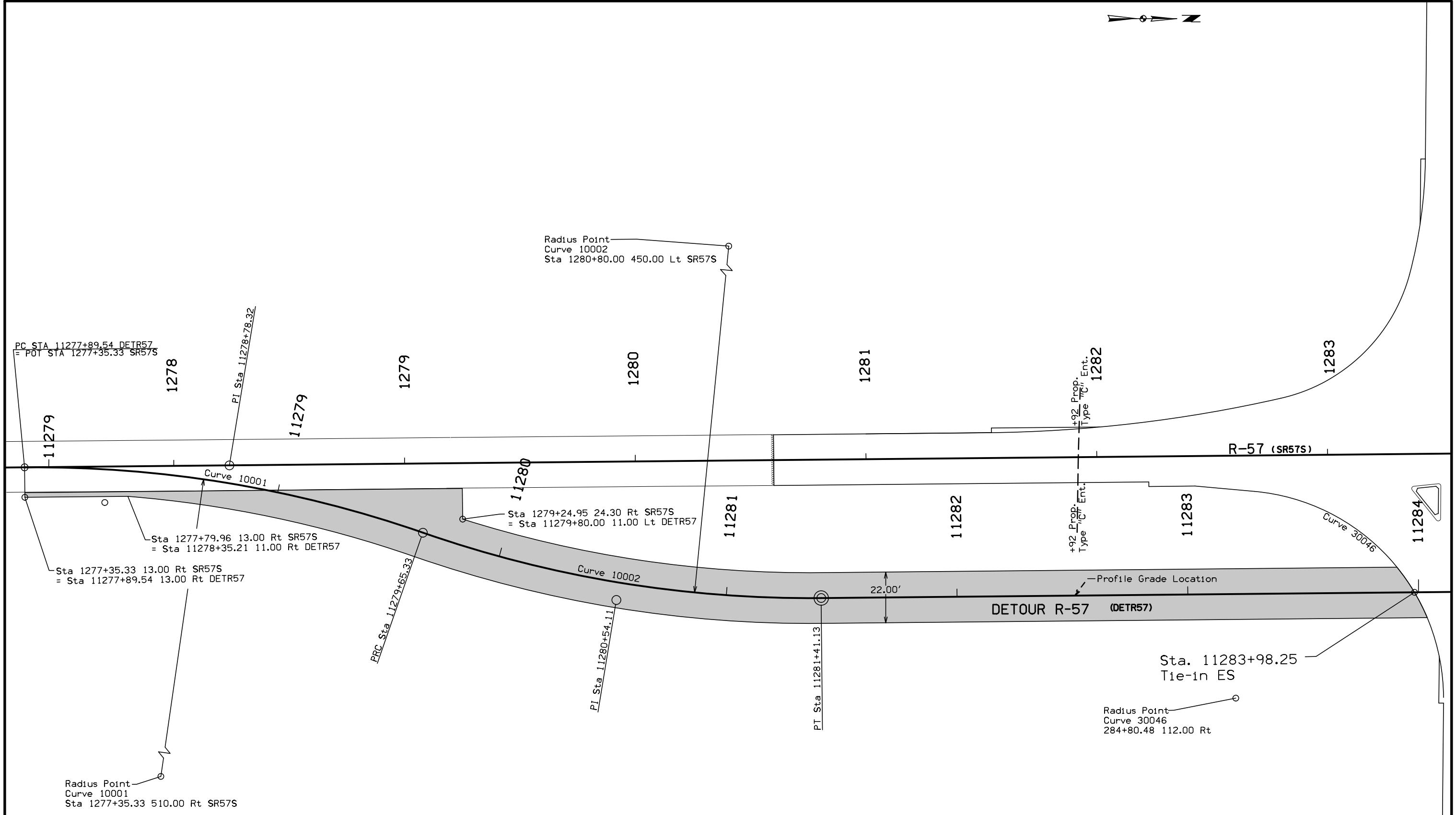
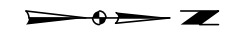

NOTE:
 Dimensions shown are to the back of curb.
 Refer to G sheets for horizontal alignment information.
 Refer to appropriate Standard Road Plans for additional information.

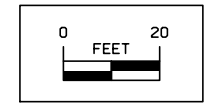

**Geometric Details
 Detour - R57 South**

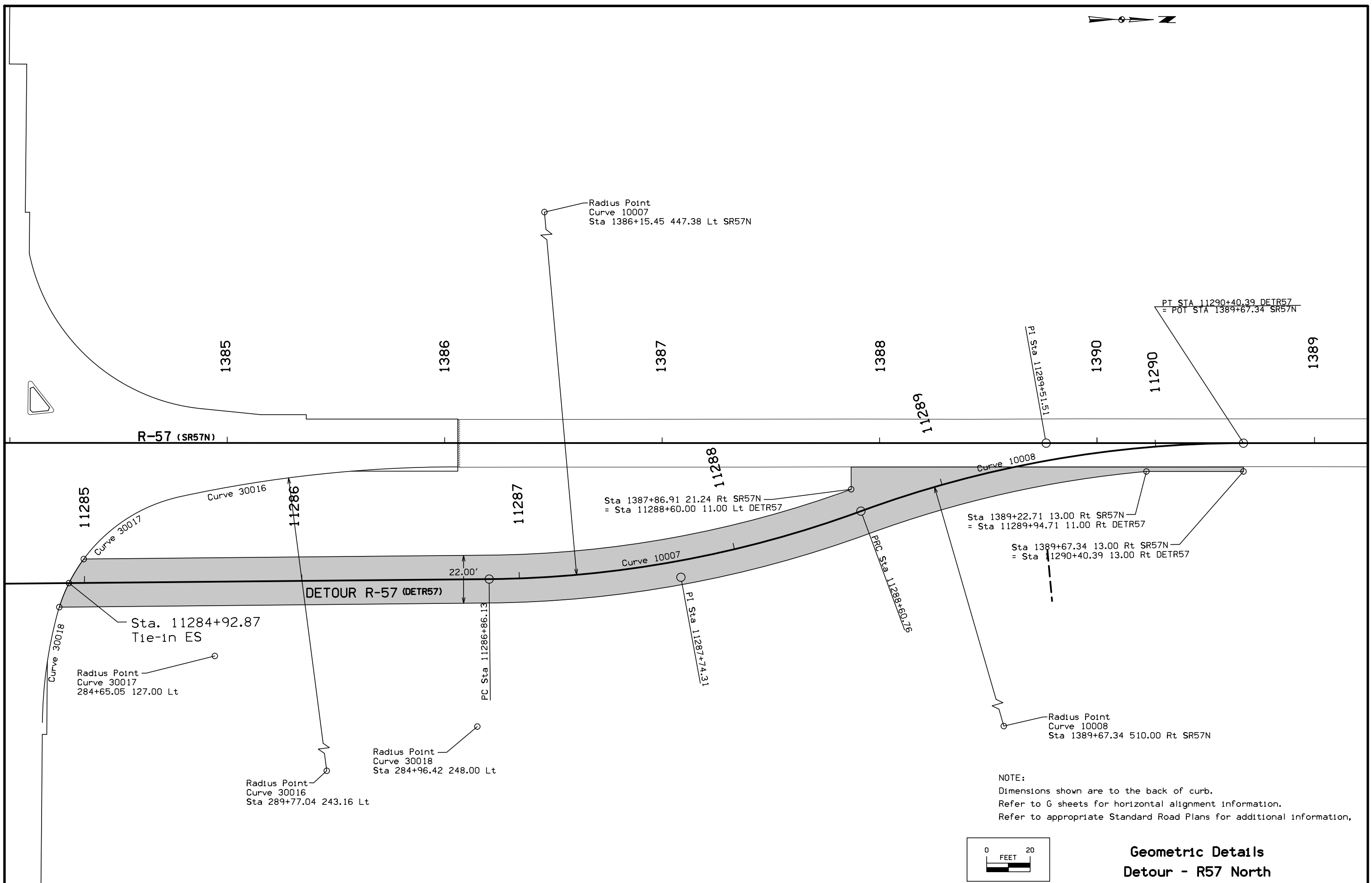
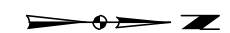

NOTE:
 Dimensions shown are to the back of curb.
 Refer to G sheets for horizontal alignment information.
 Refer to appropriate Standard Road Plans for additional information.

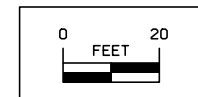

Geometric Details
Detour - R57 North

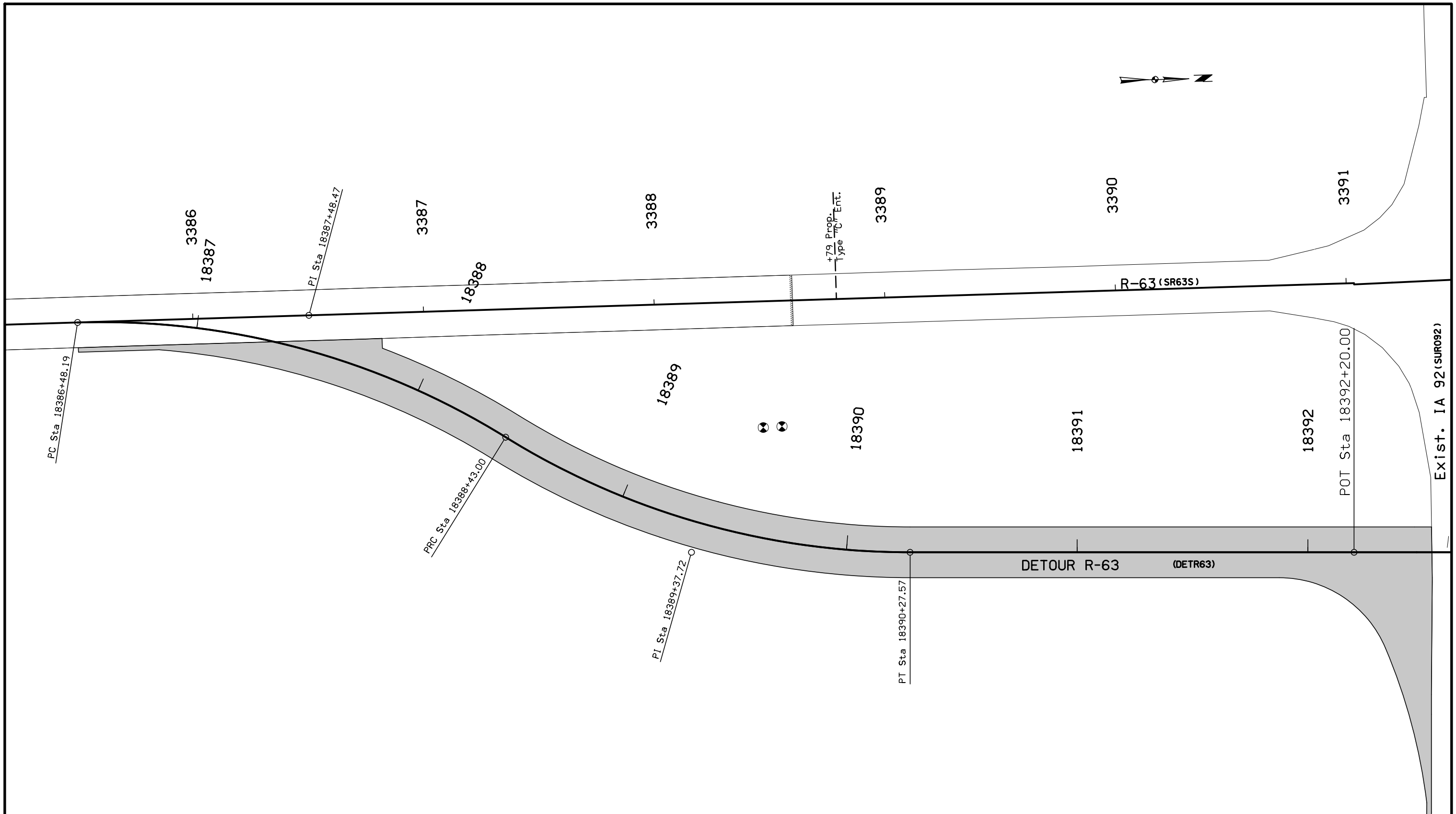

NOTE:
 Dimensions shown are to the back of curb.
 Refer to G sheets for horizontal alignment information.
 Refer to appropriate Standard Road Plans for additional information,

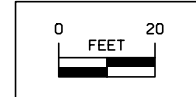

**Geometric Details
 Detour - R63 South**

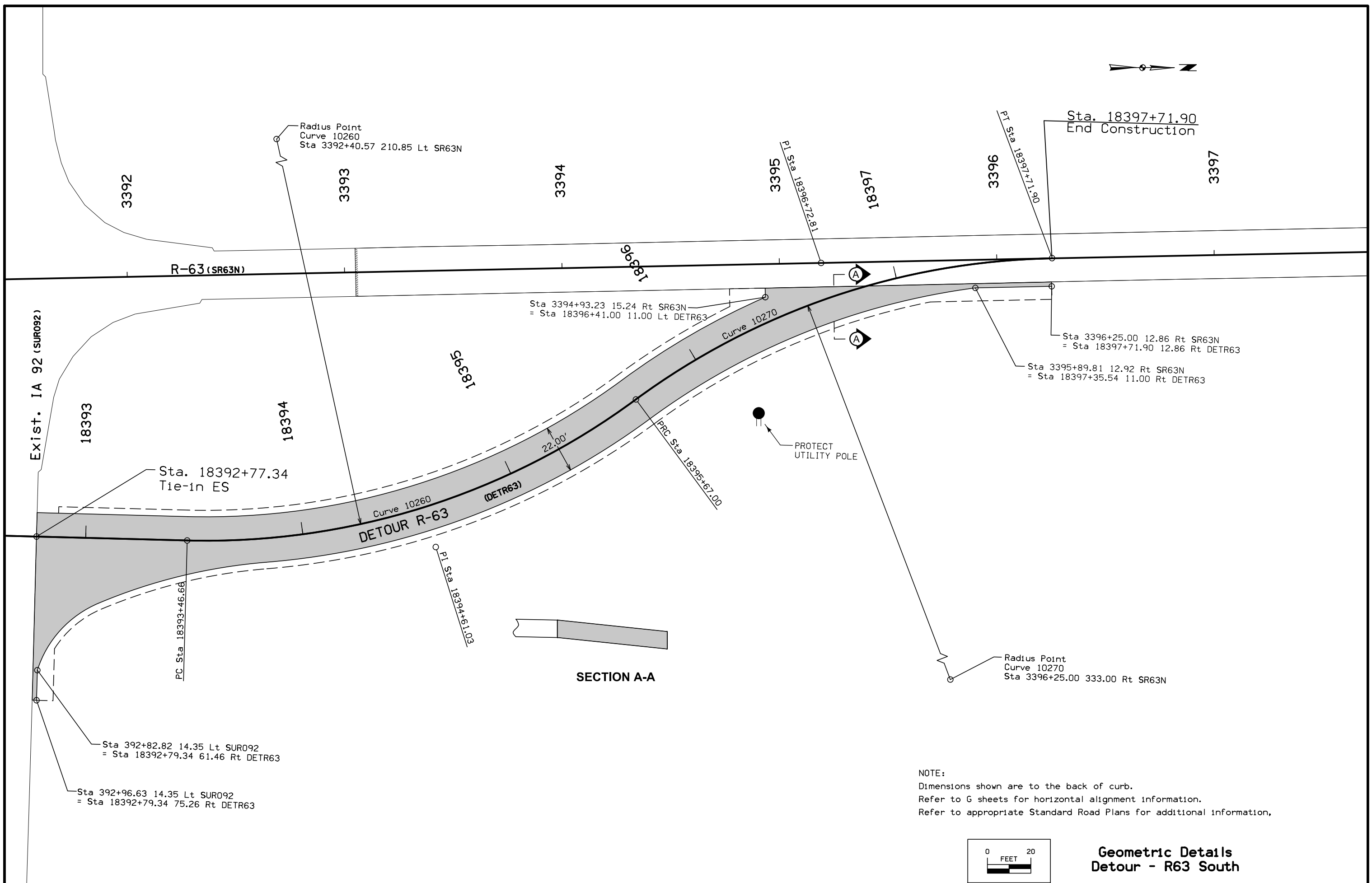
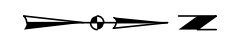

SECTION A-A

NOTE:
 Dimensions shown are to the back of curb.
 Refer to G sheets for horizontal alignment information.
 Refer to appropriate Standard Road Plans for additional information,

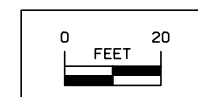

**Geometric Details
 Detour - R63 South**

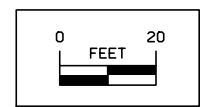
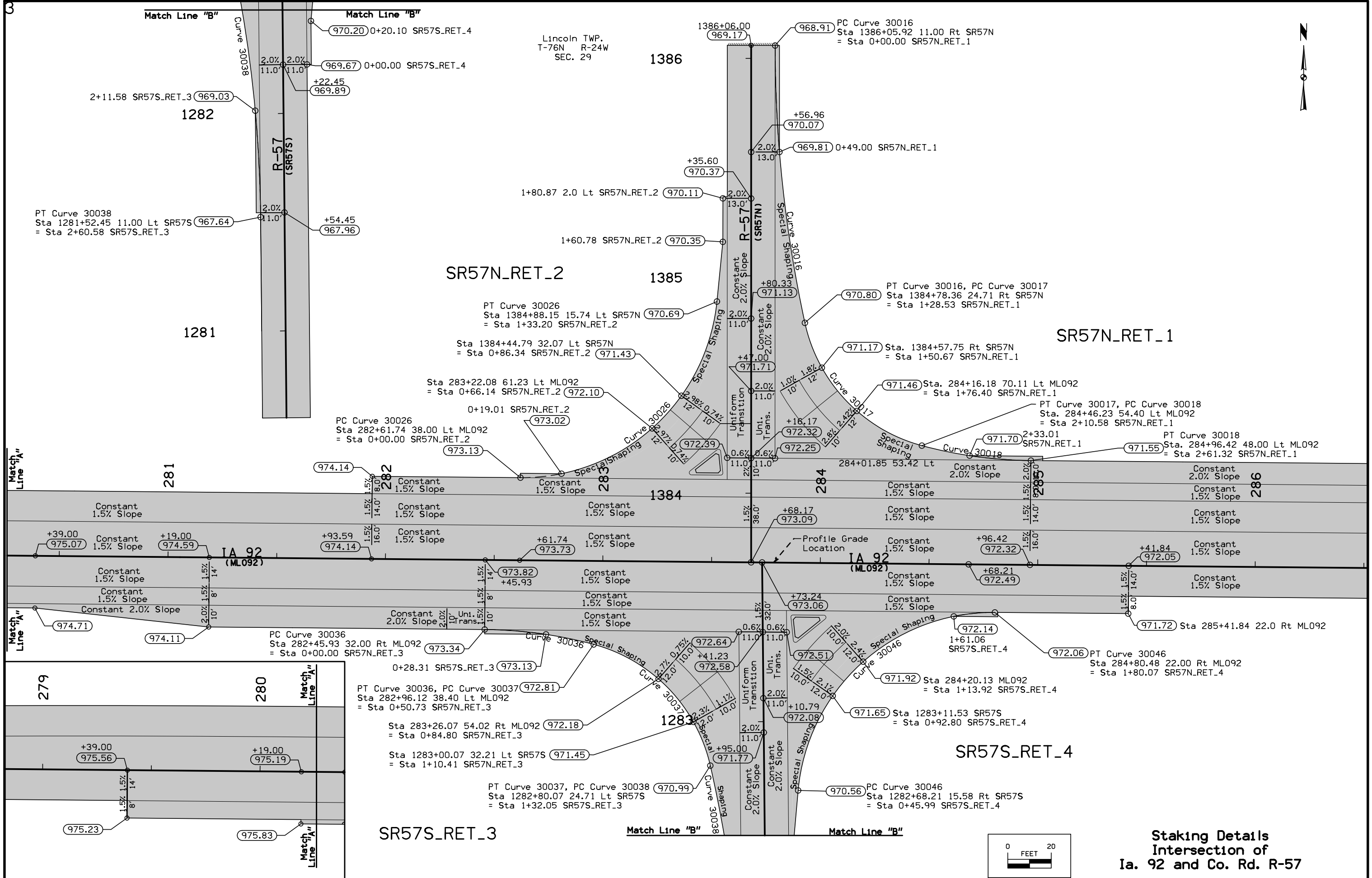

Staking Details
Intersection of
Ia. 92 and Co. Rd. R-57

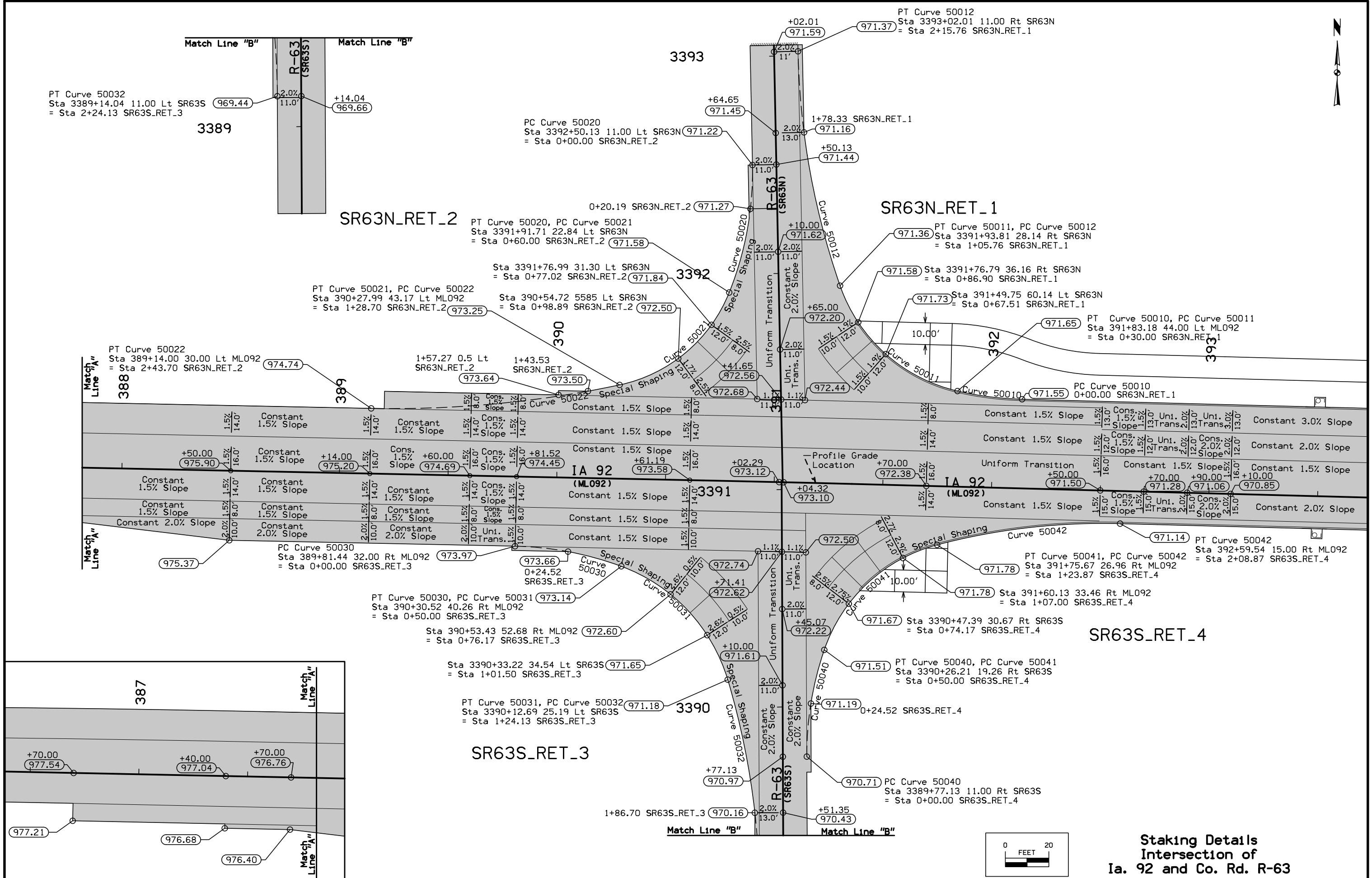

Staking Details
Intersection of
Ia. 92 and Co. Rd. R-63

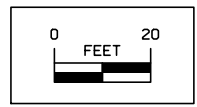



See Detail 'B'
on Sht. L.17

SRSRUCE_RET2

SRSRUCE_RET1

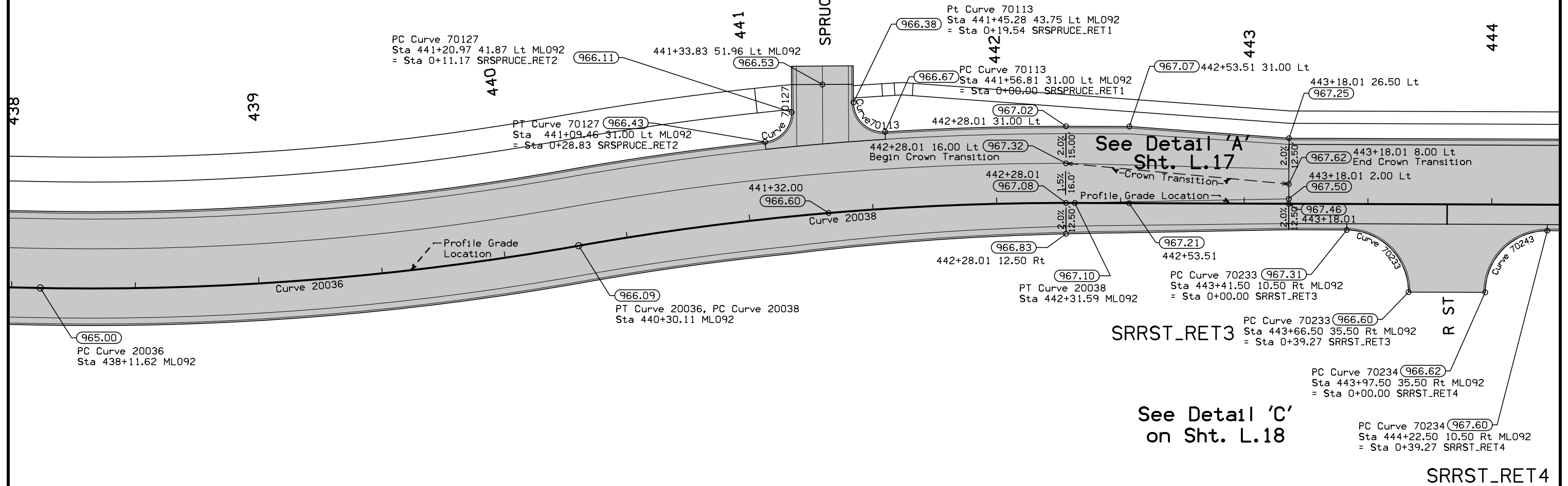

See Detail 'A'
Sht. L.17

See Detail 'C'
on Sht. L.18

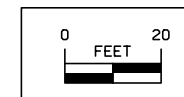

Staking Details
Intersection of
Ia. 92 and Spruce
and R Streets

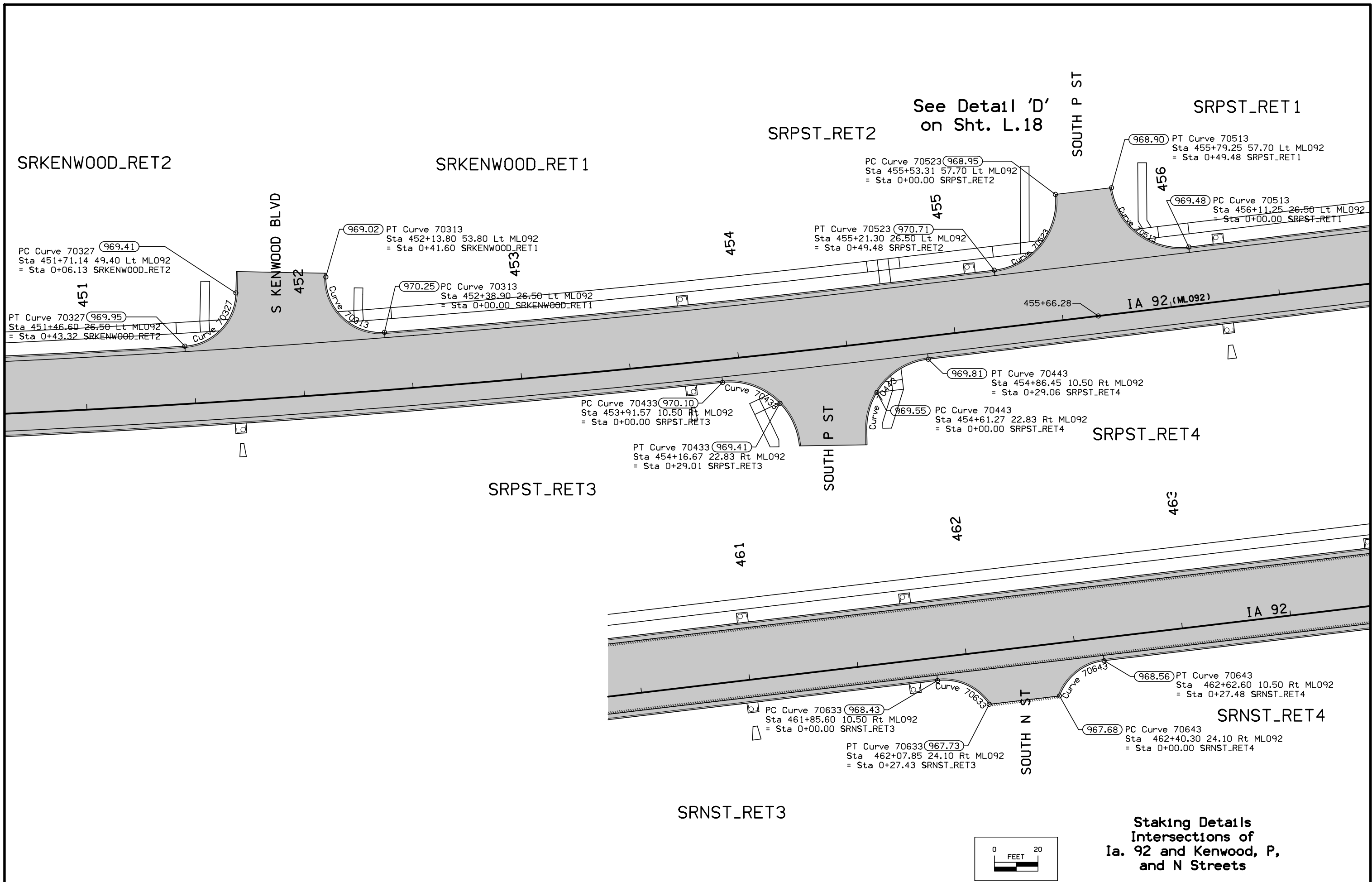

FILE NO.	ENGLISH	DESIGN TEAM	J1a\Holst\Bennett	WARREN COUNTY	PROJECT NUMBER	NHSX-092-5(51)--3H-91	SHEET NUMBER	L.16
----------	---------	-------------	-------------------	---------------	----------------	-----------------------	--------------	------

10:14:37 AM 6/24/2014 jholst pw:\projectwise.dot.int.lan:PWMain\Documents\Projects\9109201004\Design\91092051L01.sht

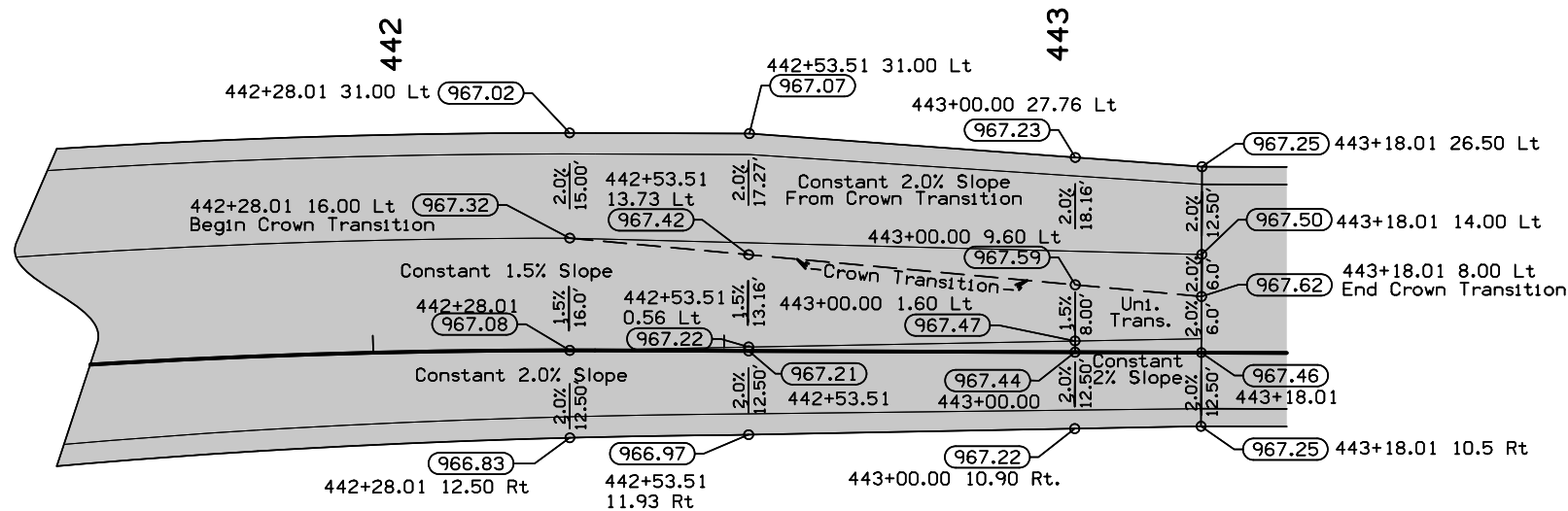

Detail 'A'
End Full Width Paving-Begin Widening
(Not To Scale)

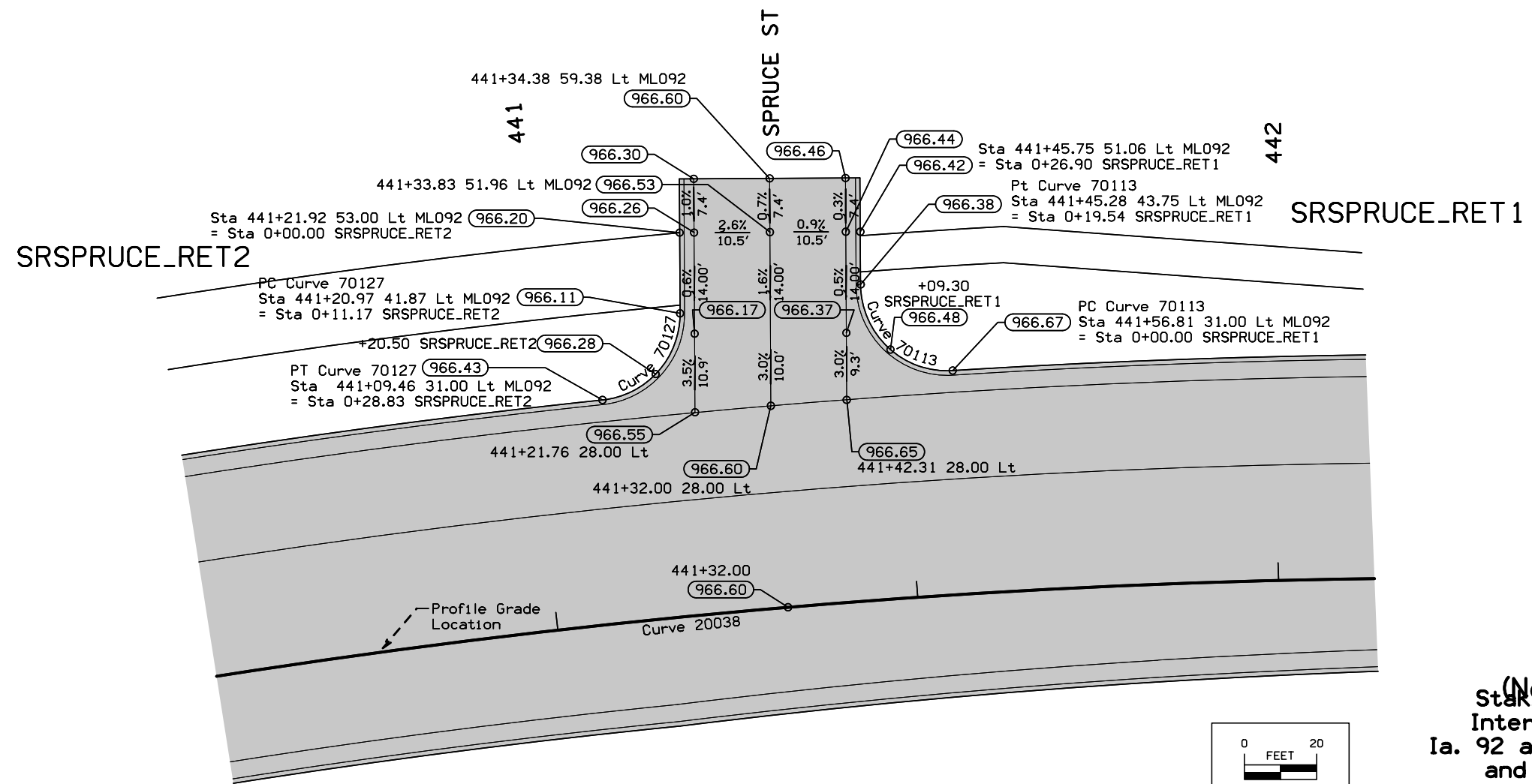

Detail 'B'
Spruce St.
(Not To Scale)
Staking Details
Intersections of
Ia. 92 and Kenwood, P,
and N Streets

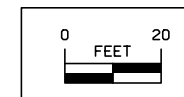

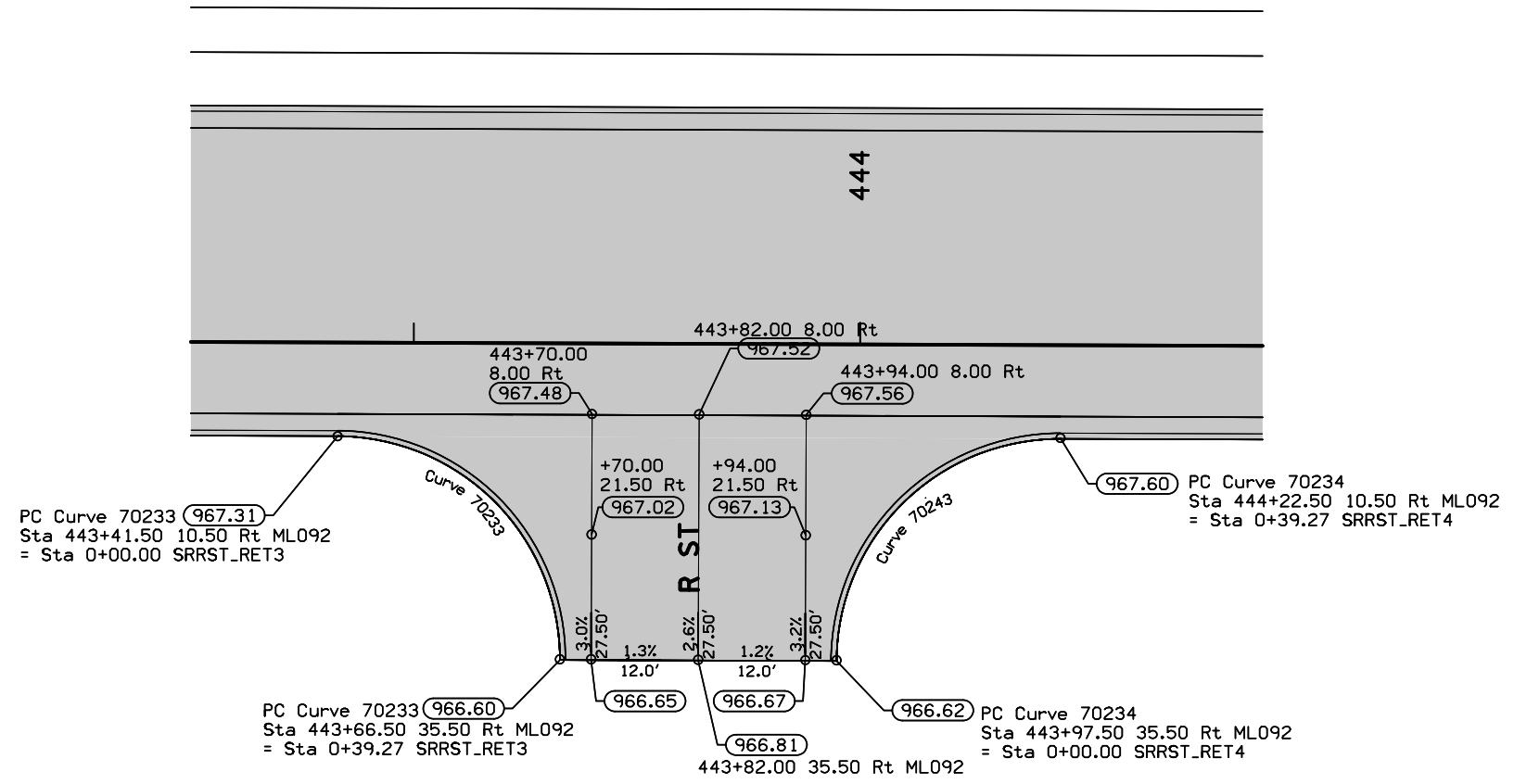

Detail 'C'
R Street
(Not To Scale)

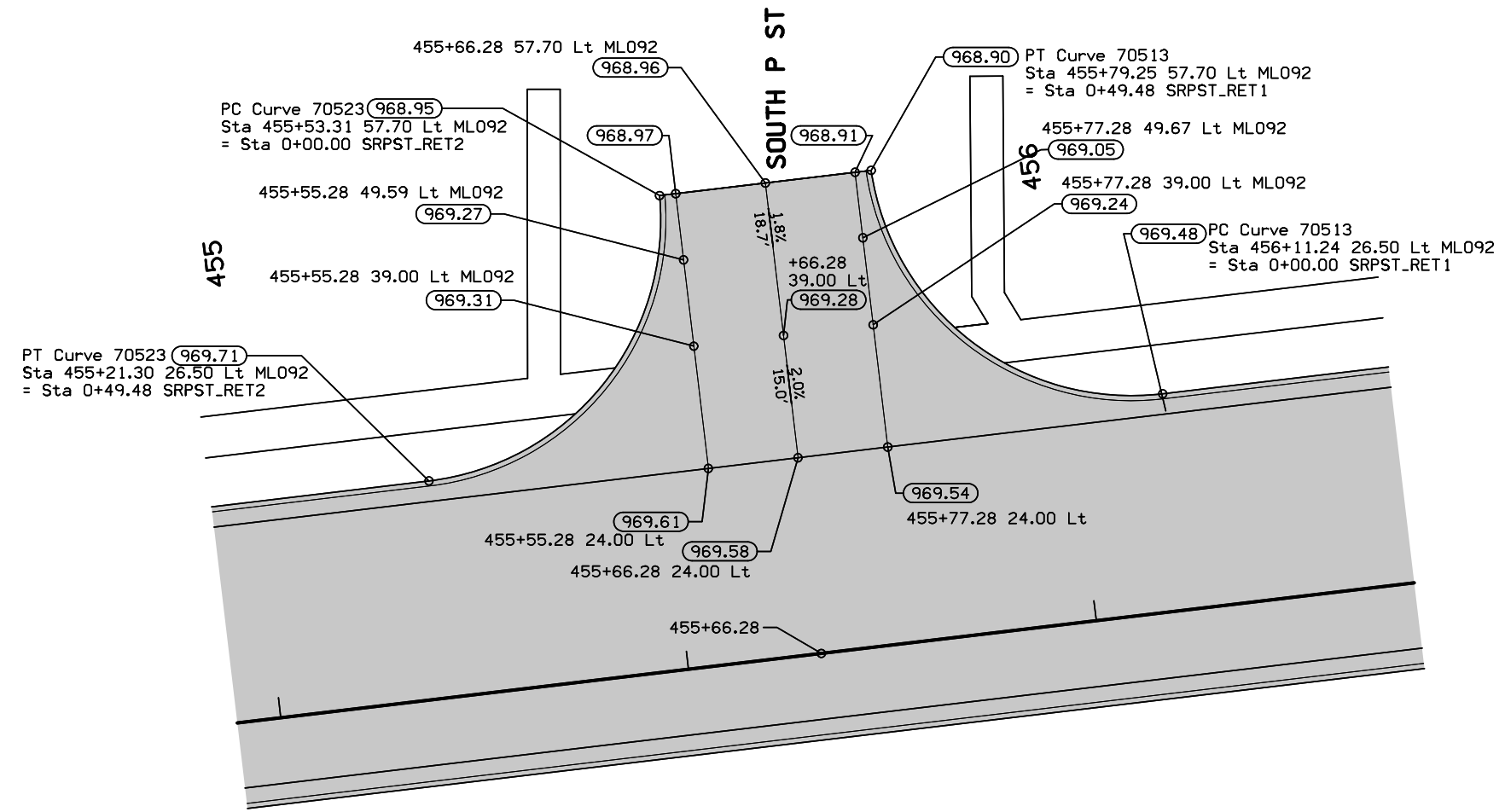

Detail 'D'
South P St.
(Not To Scale)

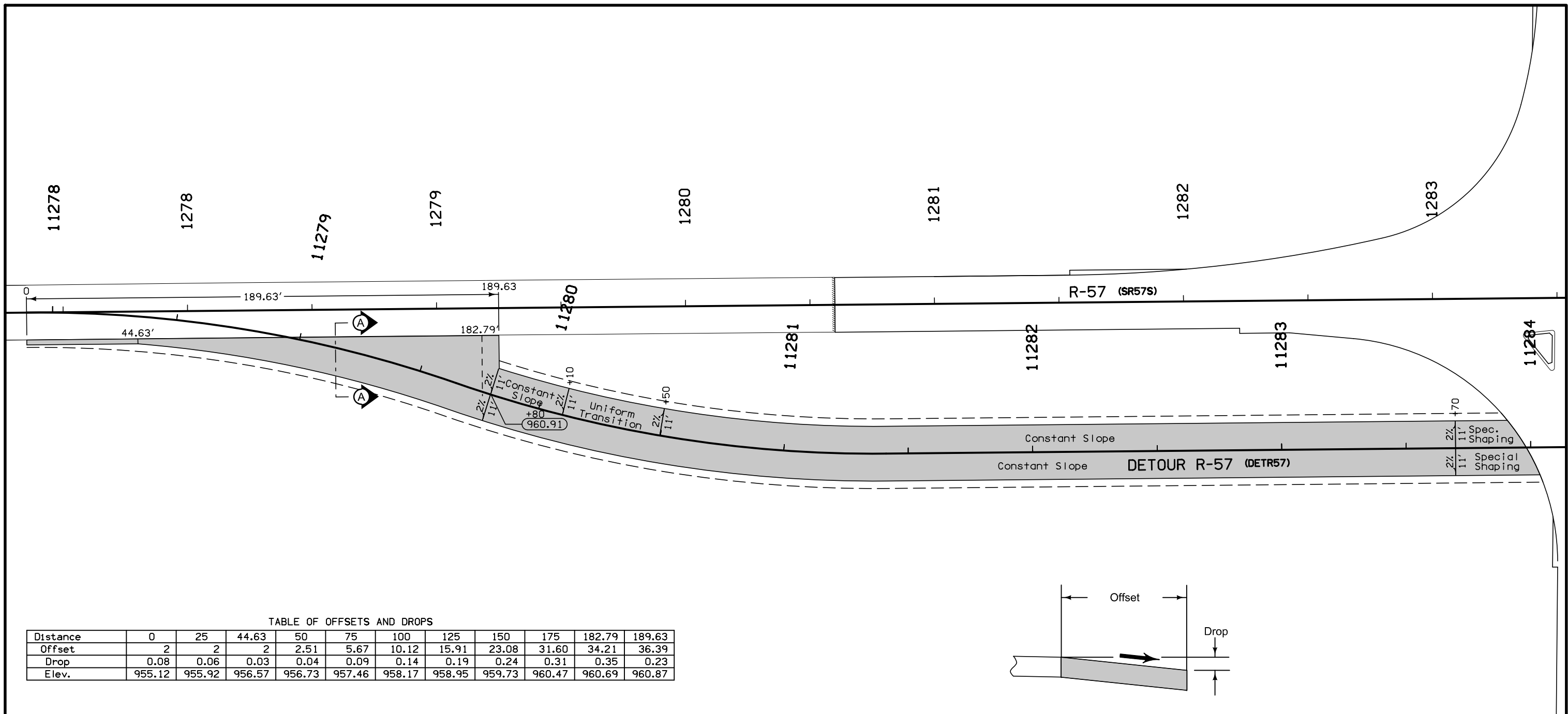
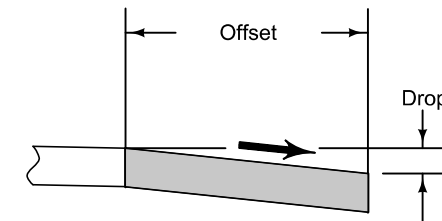
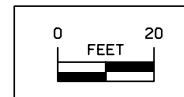

TABLE OF OFFSETS AND DROPS

Distance	0	25	44.63	50	75	100	125	150	175	182.79	189.63
Offset	2	2	2	2.51	5.67	10.12	15.91	23.08	31.60	34.21	36.39
Drop	0.08	0.06	0.03	0.04	0.09	0.14	0.19	0.24	0.31	0.35	0.23
Elev.	955.12	955.92	956.57	956.73	957.46	958.17	958.95	959.73	960.47	960.69	960.87



SECTION A-A



Staking Details
Detour R-57
South

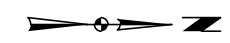

283
1384
1385
1386
1387
1388
1389
11290

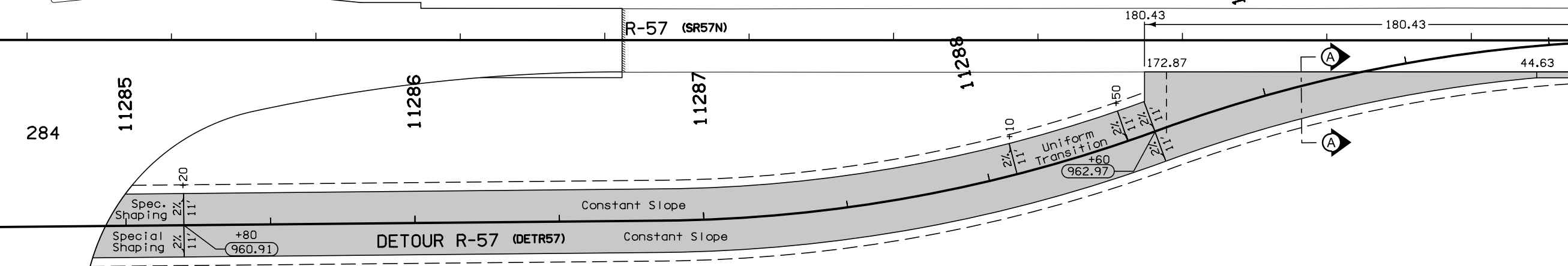

284
11285
11286
11287
11288
11289
285
286

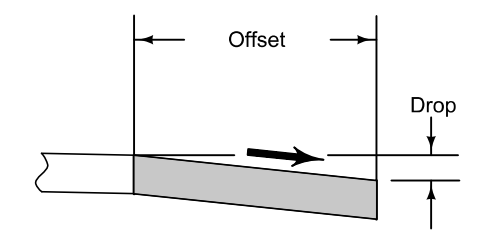

SECTION A-A

TABLE OF OFFSETS AND DROPS

Distance	180.43	172.87	150	125	100	75	50	44.63	25	0
Offset	33.60	30.90	23.07	15.91	10.12	5.67	2.51	2	2	2
Drop	0.28	0.27	0.22	0.18	0.14	0.09	0.04	0.03	0.06	0.07
Elev.	969.98	962.75	961.97	961.10	960.25	959.53	958.78	958.62	957.96	957.15

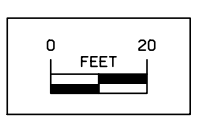

Staking Details
Detour R-57
North

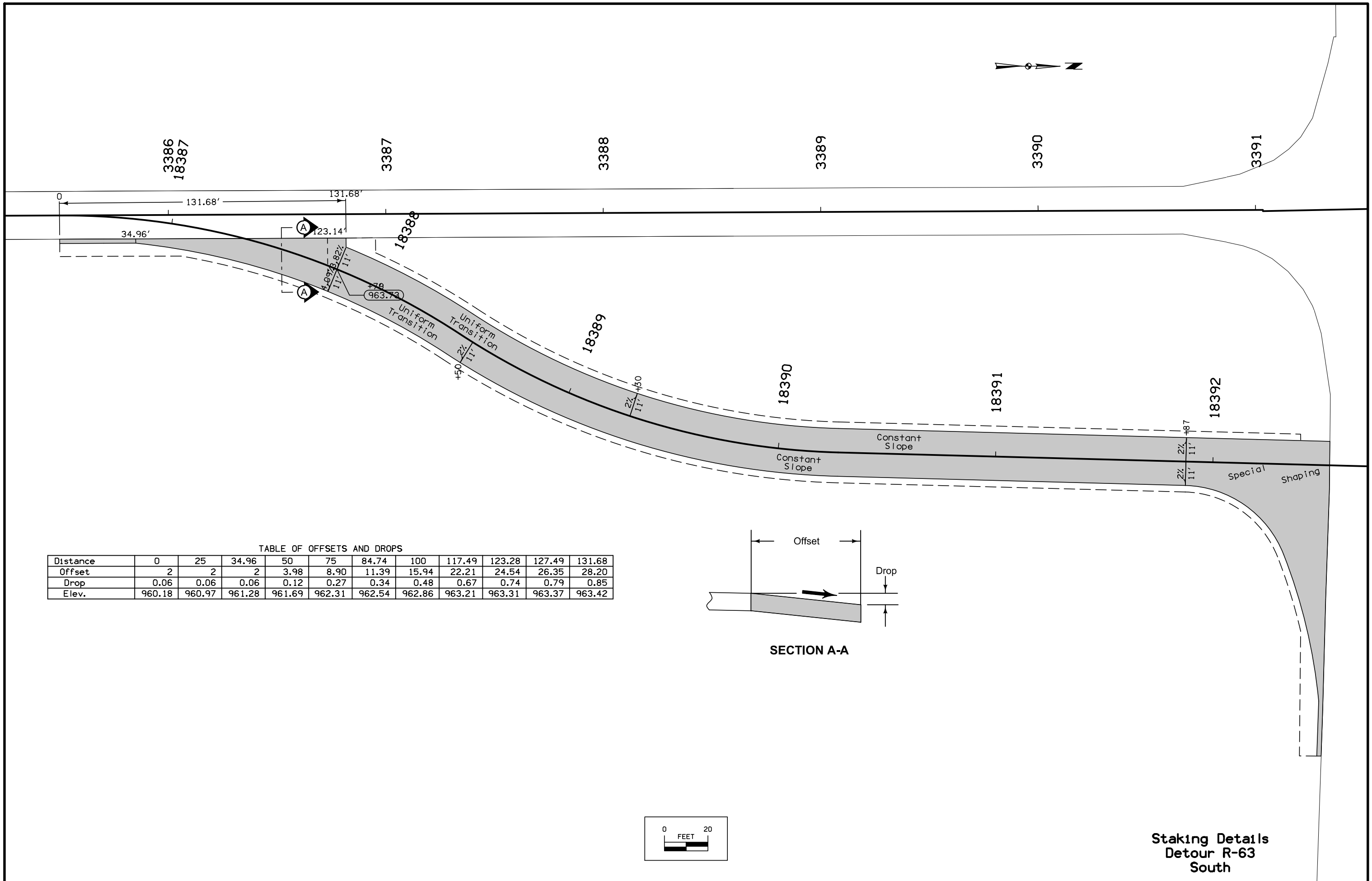
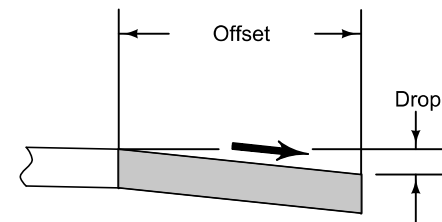
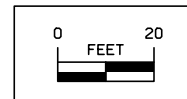

TABLE OF OFFSETS AND DROPS

Distance	0	25	34.96	50	75	84.74	100	117.49	123.28	127.49	131.68
Offset	2	2	2	3.98	8.90	11.39	15.94	22.21	24.54	26.35	28.20
Drop	0.06	0.06	0.06	0.12	0.27	0.34	0.48	0.67	0.74	0.79	0.85
Elev.	960.18	960.97	961.28	961.69	962.31	962.54	962.86	963.21	963.31	963.37	963.42



SECTION A-A



Staking Details
Detour R-63
South

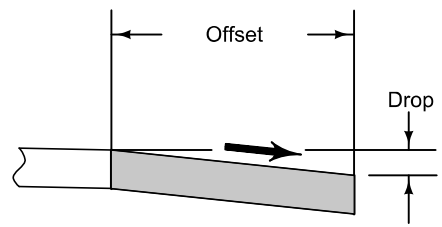
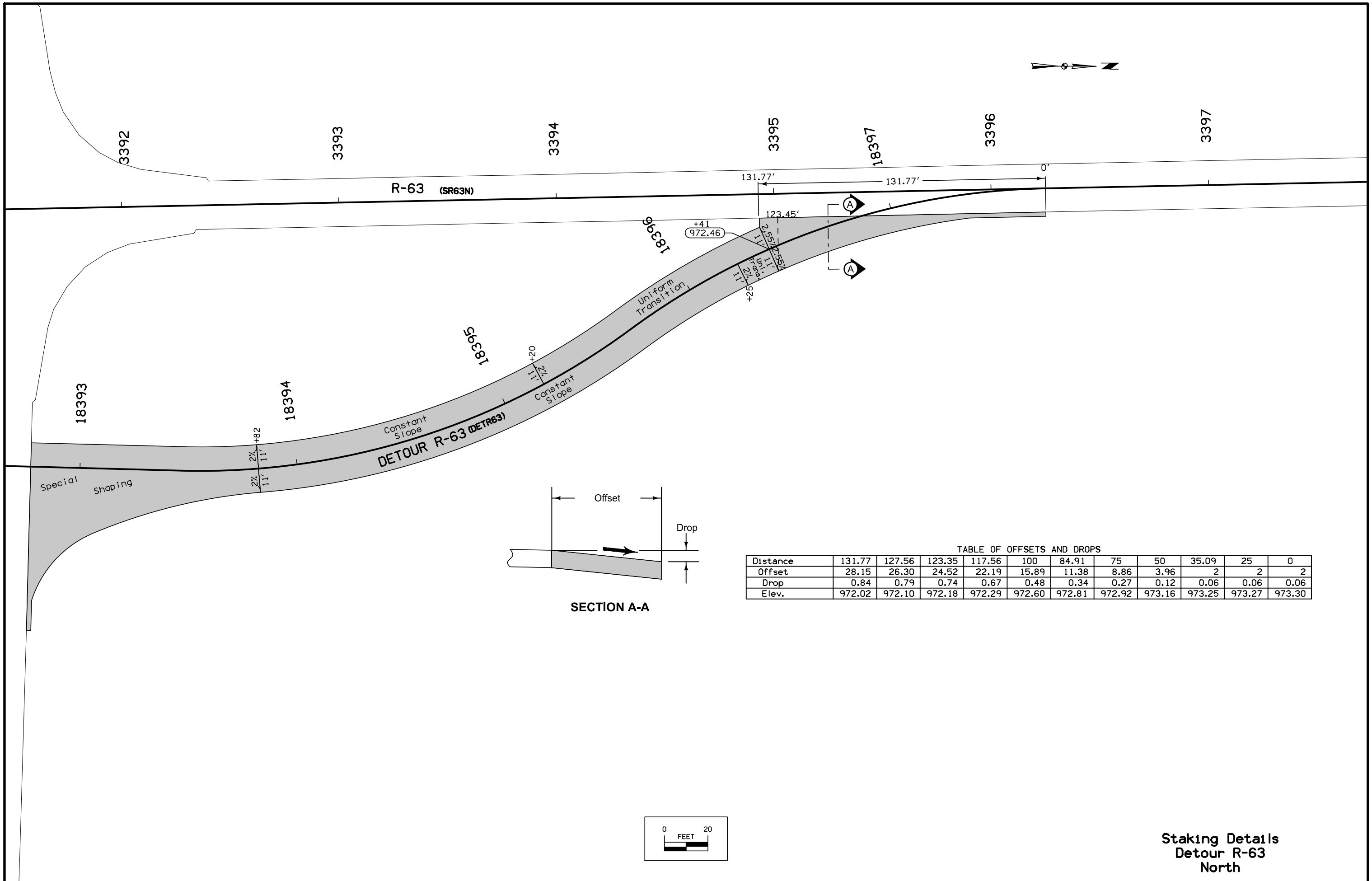

SECTION A-A

TABLE OF OFFSETS AND DROPS

Distance	131.77	127.56	123.35	117.56	100	84.91	75	50	35.09	25	0
Offset	28.15	26.30	24.52	22.19	15.89	11.38	8.86	3.96	2	2	2
Drop	0.84	0.79	0.74	0.67	0.48	0.34	0.27	0.12	0.06	0.06	0.06
Elev.	972.02	972.10	972.18	972.29	972.60	972.81	972.92	973.16	973.25	973.27	973.30

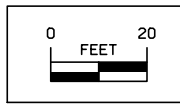

Staking Details
Detour R-63
North

SR57N_RET_2

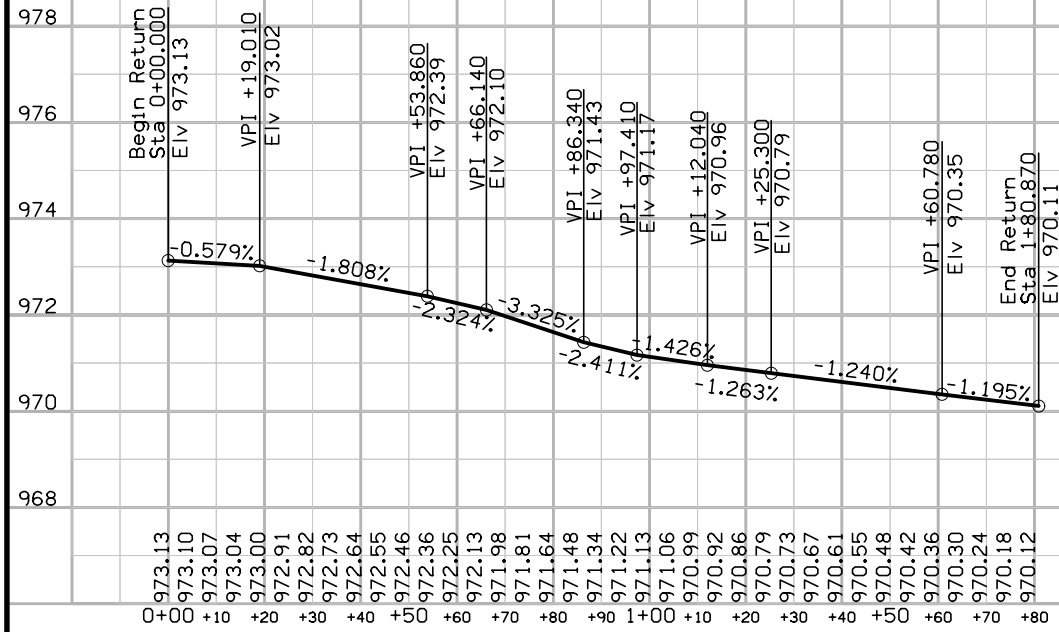

SR57N_RET_1

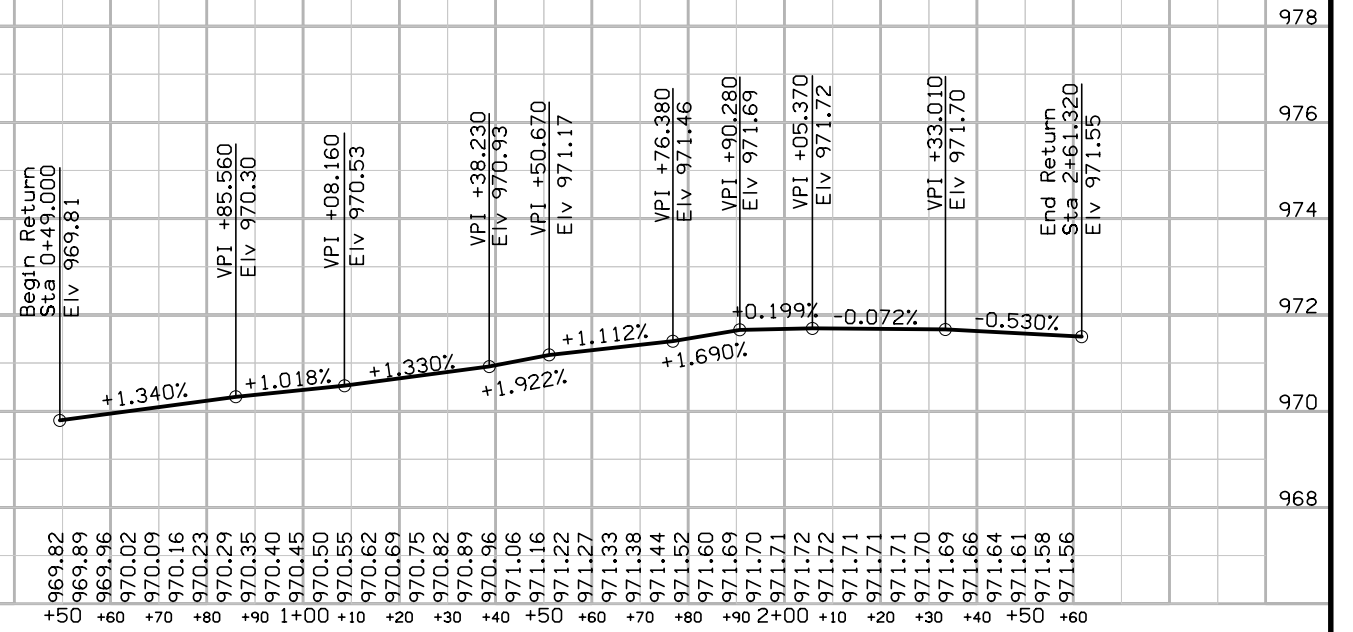

SR57S_RET_3

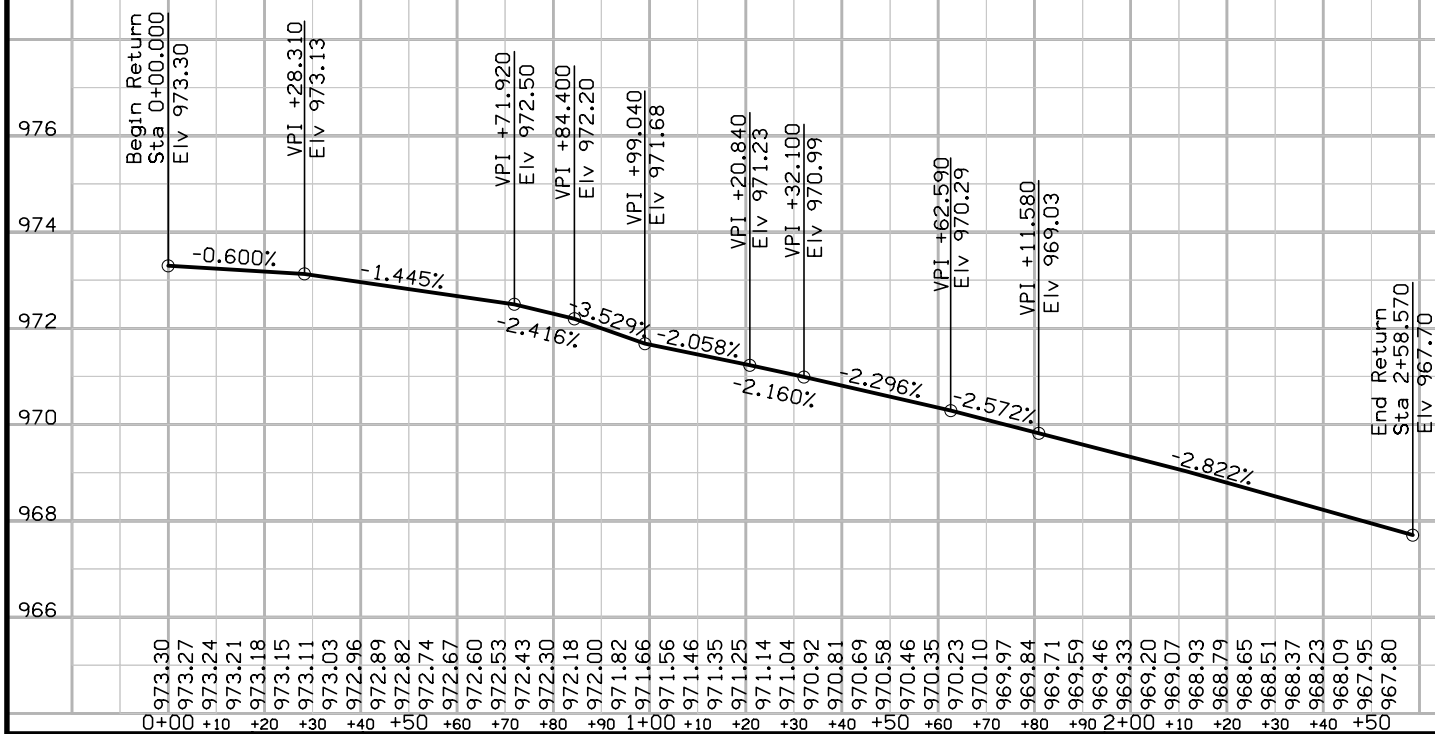

SR57S_RET_4

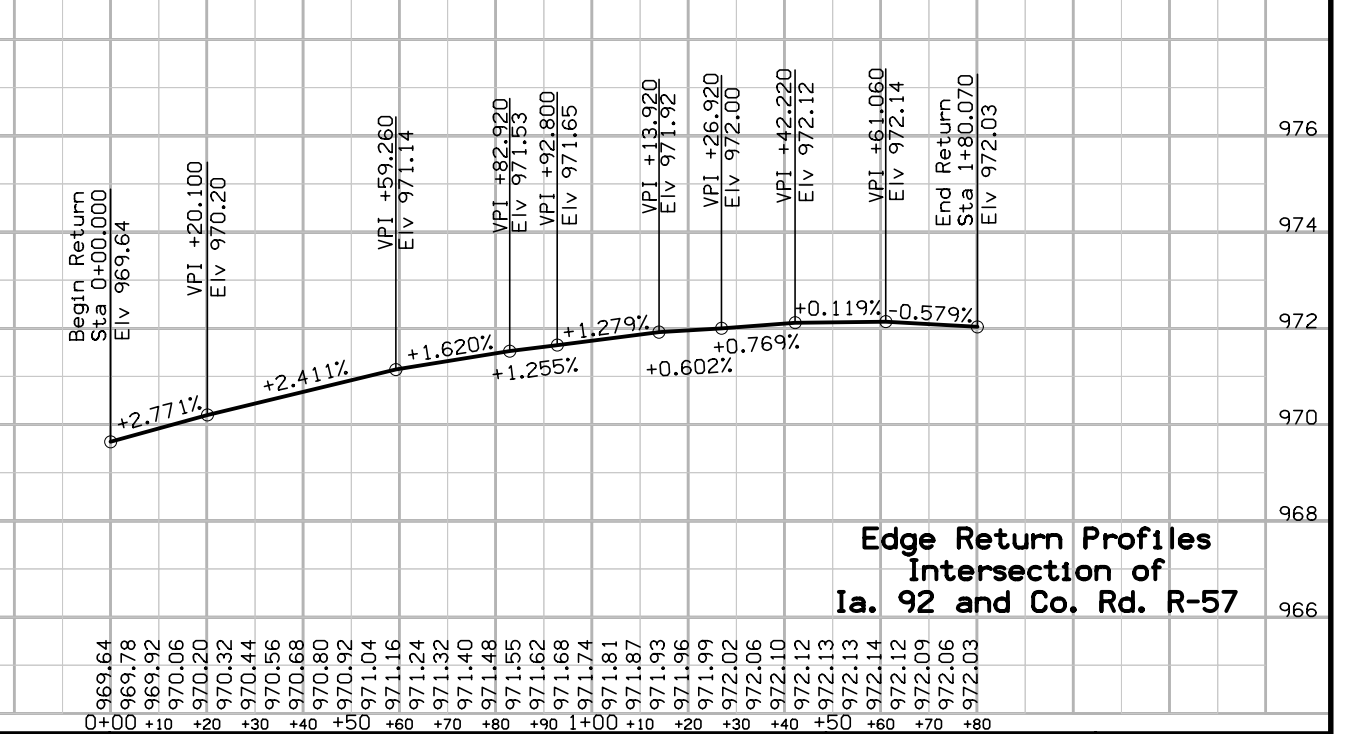

Edge Return Profiles
Intersection of
Ia. 92 and Co. Rd. R-57

SR63N_RET_2

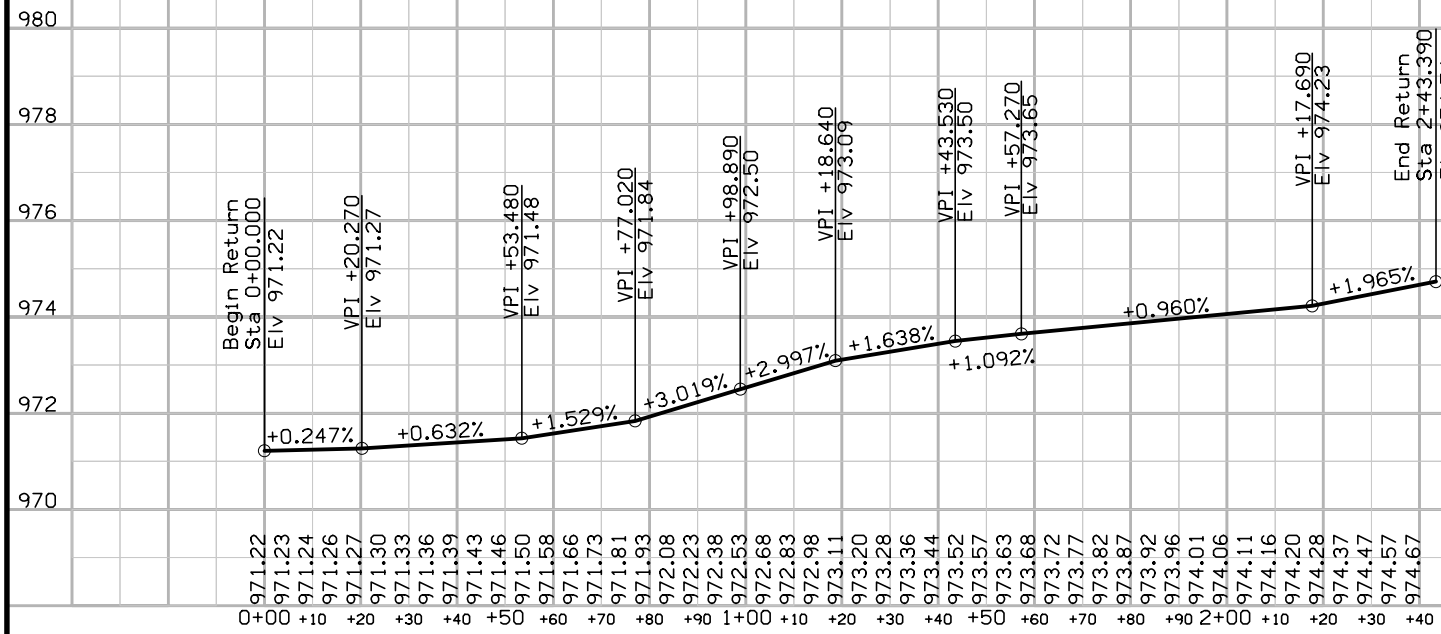

SR63N_RET_1

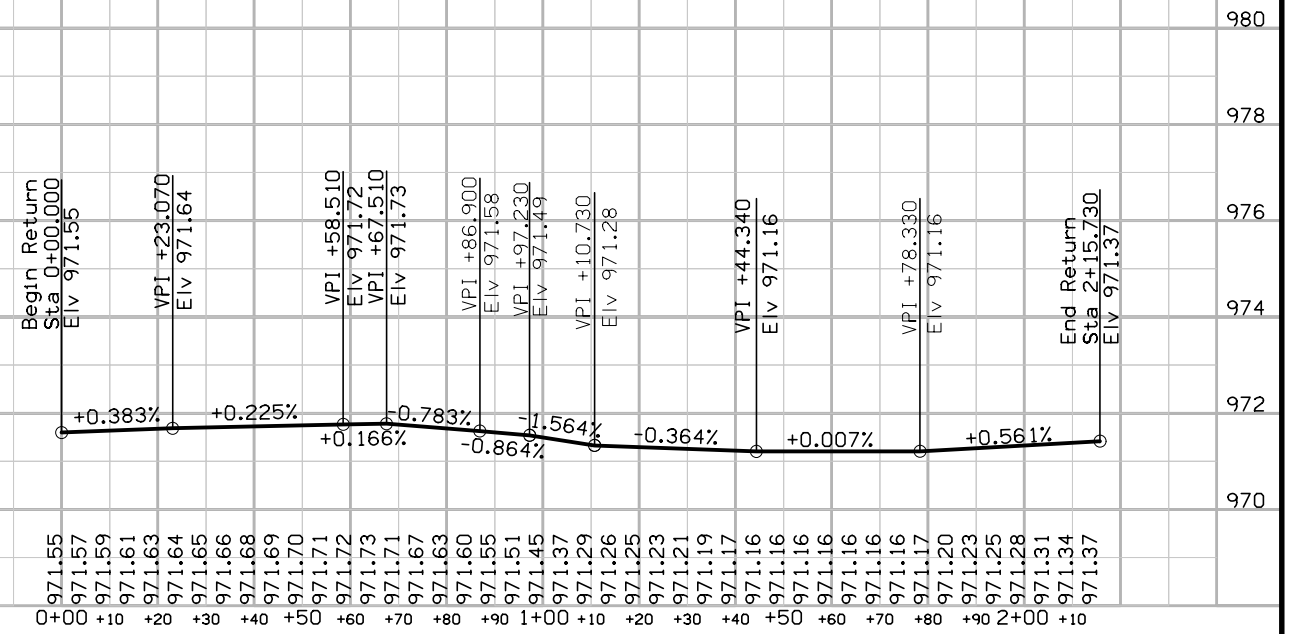

SR63S_RET_3

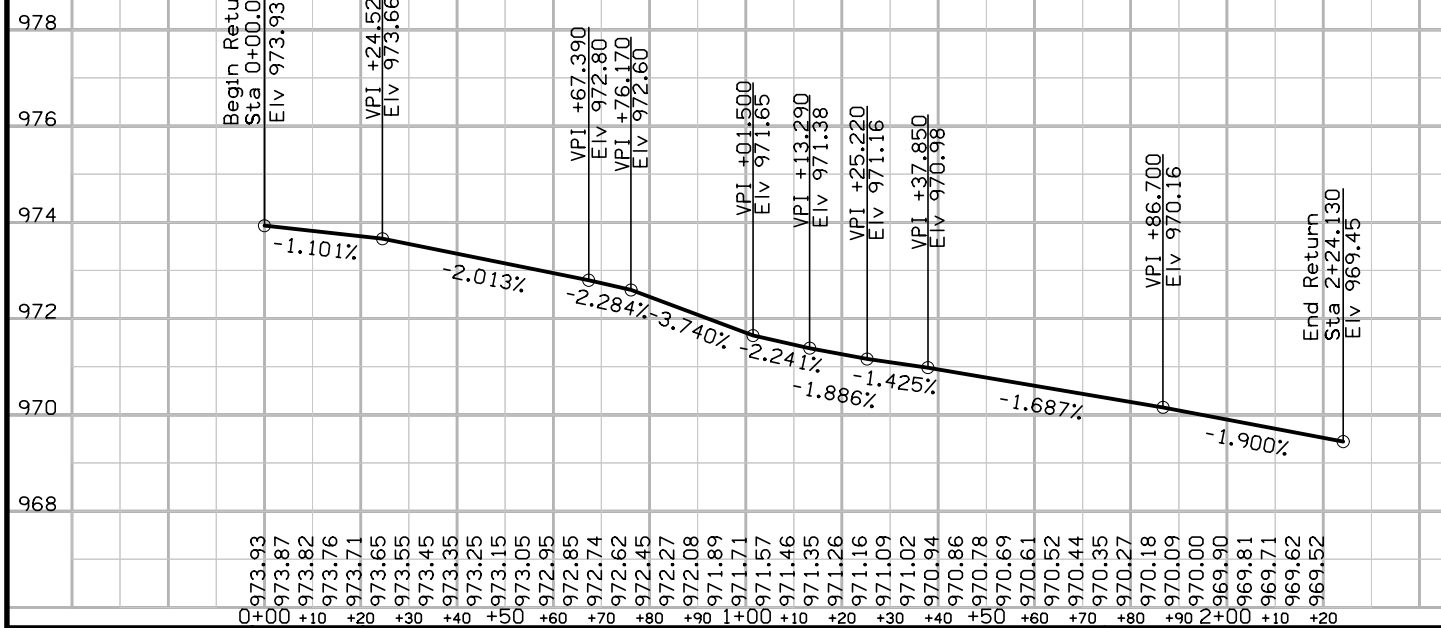

SR63S_RET_4

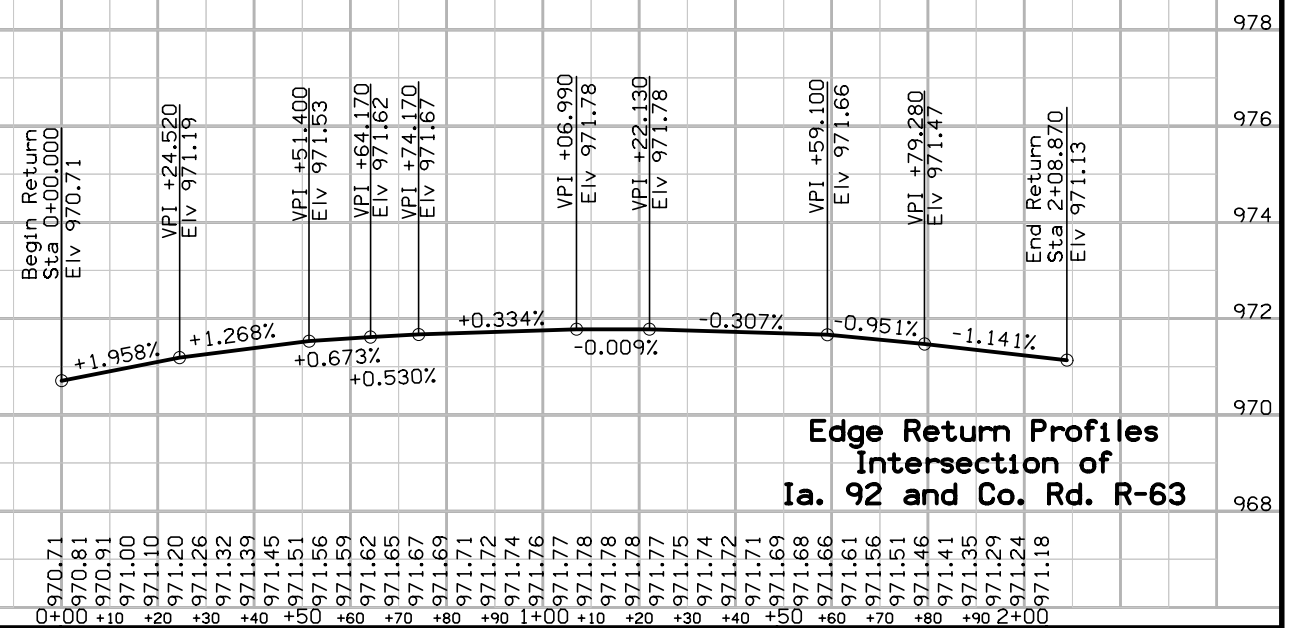

Edge Return Profiles
Intersection of
Ia. 92 and Co. Rd. R-63

SRYSTN_RET 2

SRYSTN_RET_1

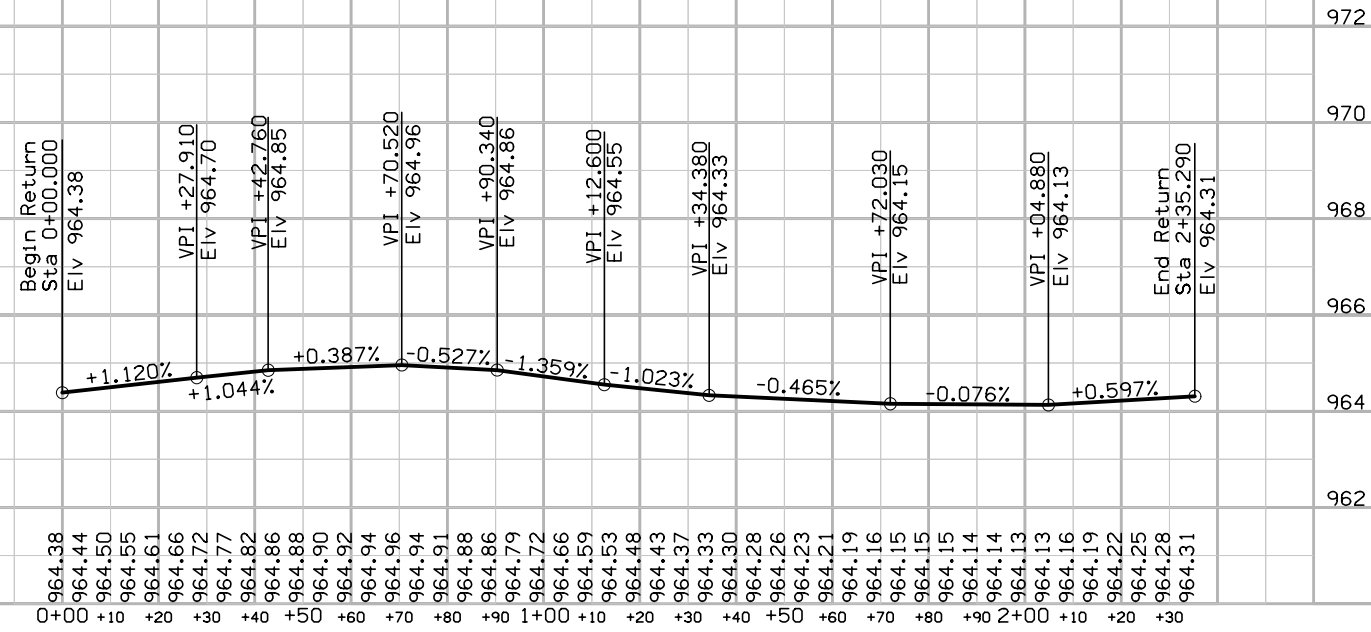
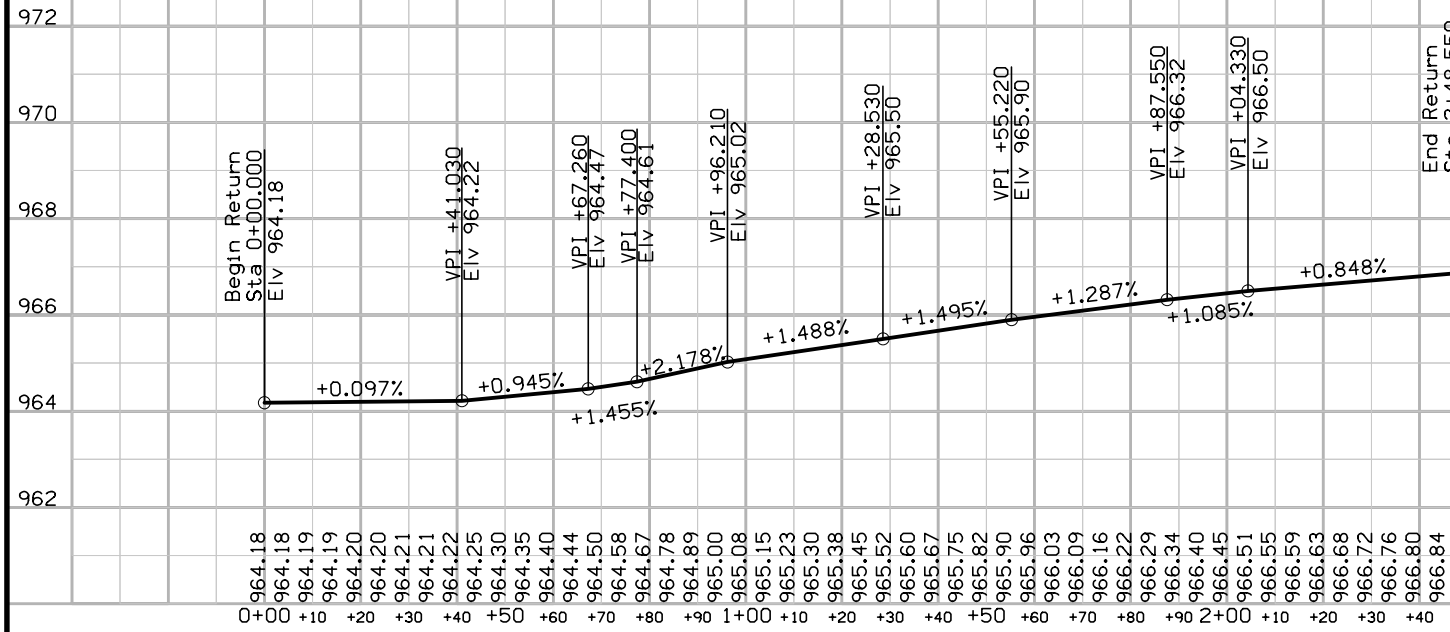

SRYSTS_RET_3

SRYSTS_RET_4

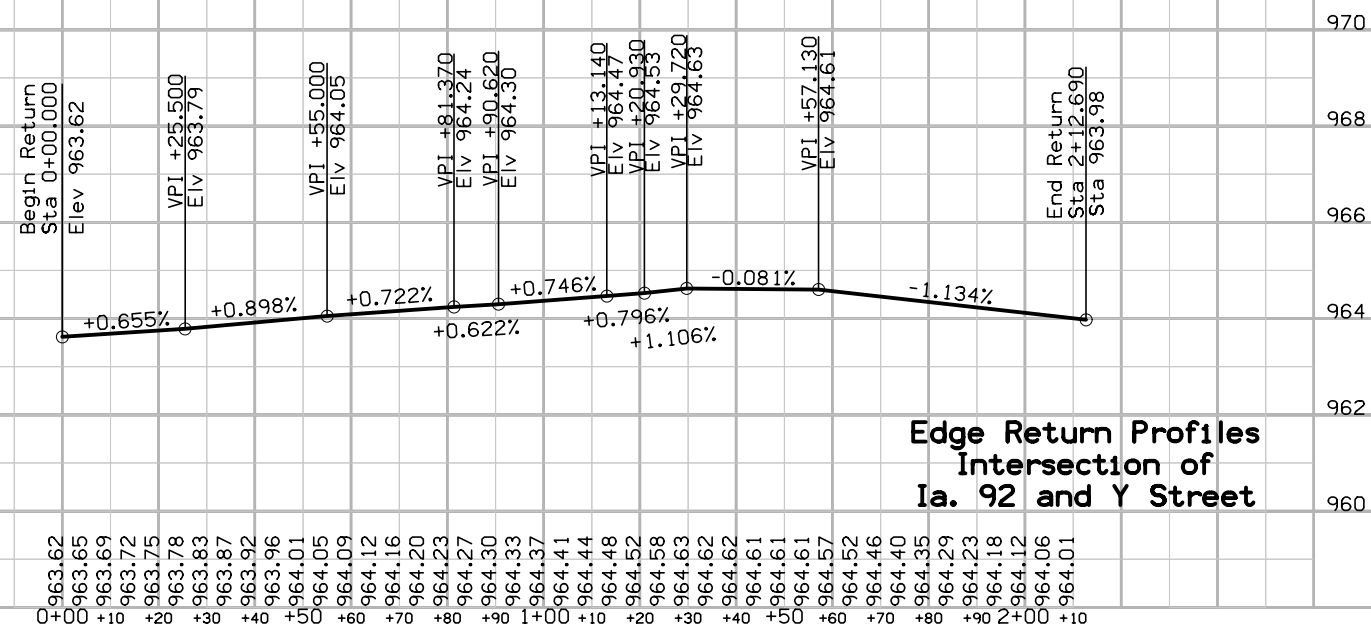
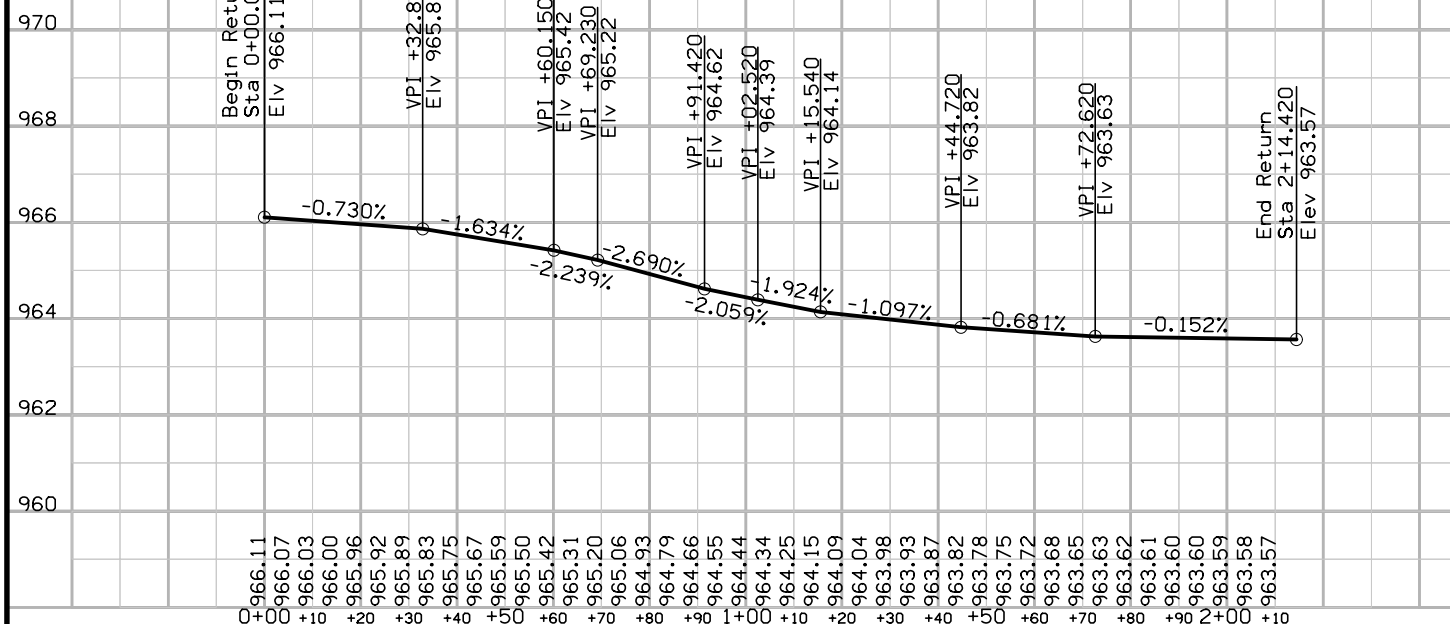

Edge Return Profiles
Intersection of
Ia. 92 and Y Street

SRSRUCE_RET_1

SRRST_RET_3

SRKENWOOD_RET_1

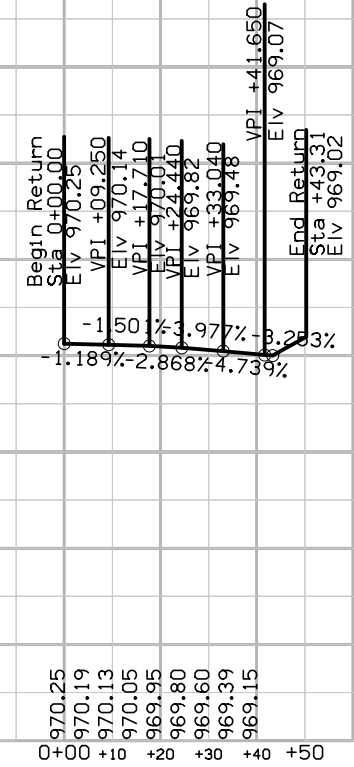
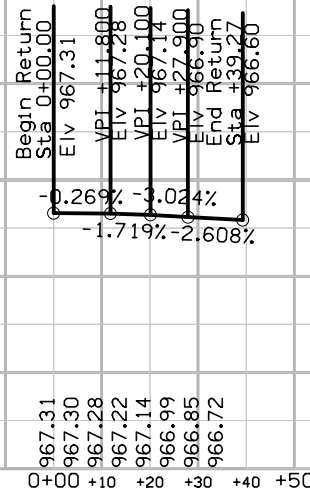
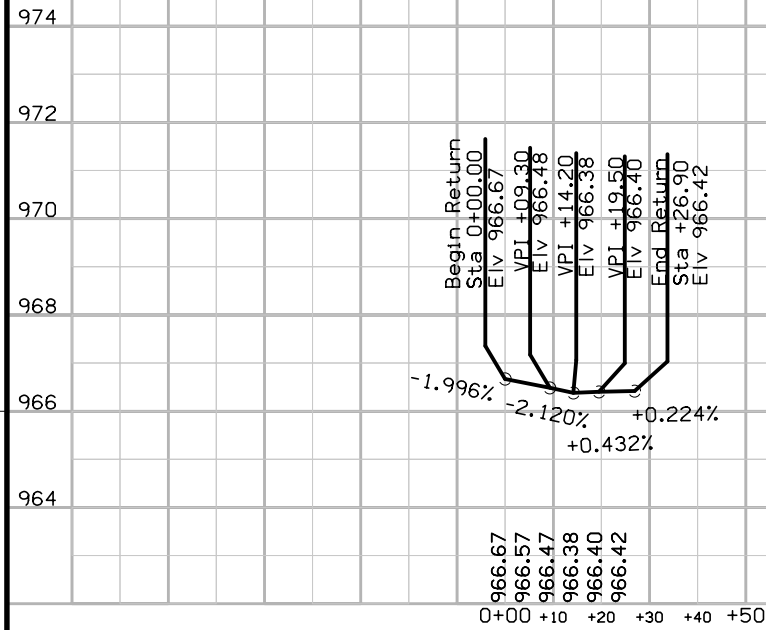

SRSRUCE_RET 2

SRRST_RET_4

SRKENWOOD_RET_2

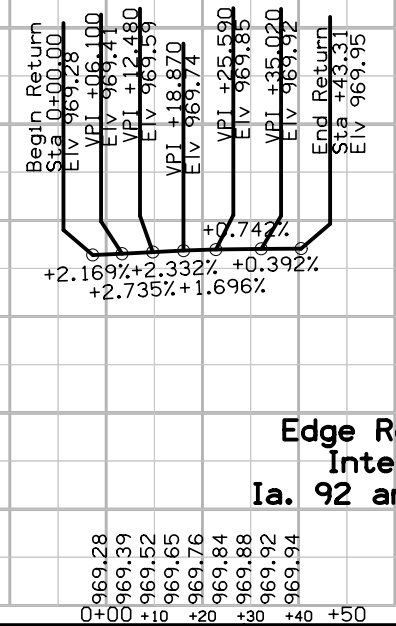
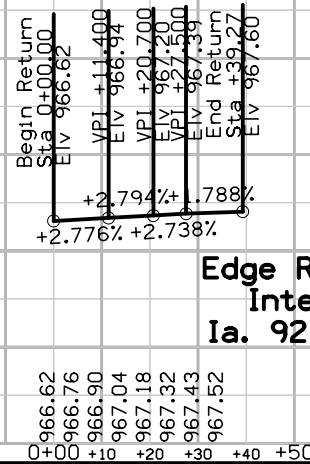
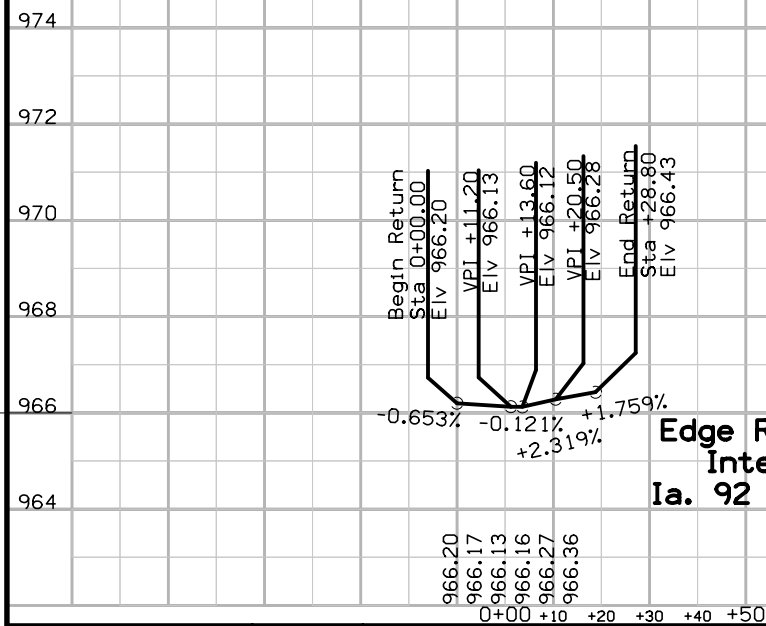

**Edge Return Profiles
Intersection of
Ia. 92 and Spruce St.**

**Edge Return Profiles
Intersection of
Ia. 92 and R Street**

**Edge Return Profiles
Intersection of
Ia. 92 and Kenwood Ave.**

SRPST_RET 2

SRPST_RET_1

SRNST_RET_3

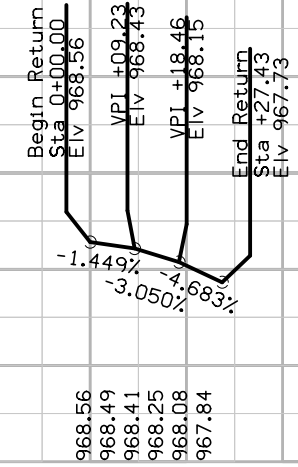
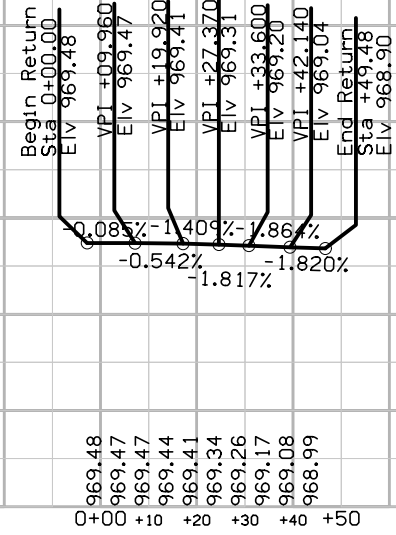
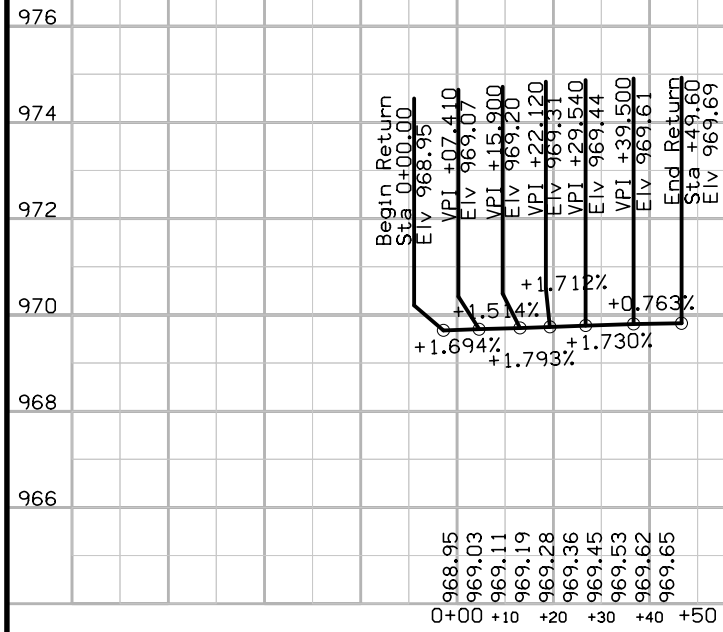

SRPST_RET_3

SRPST_RET_4

SRNST_RET_4

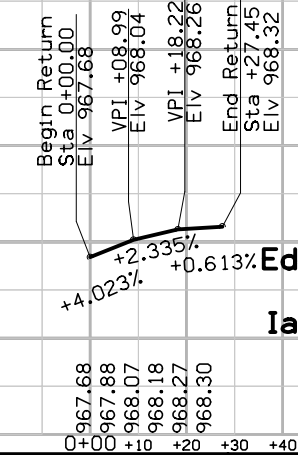
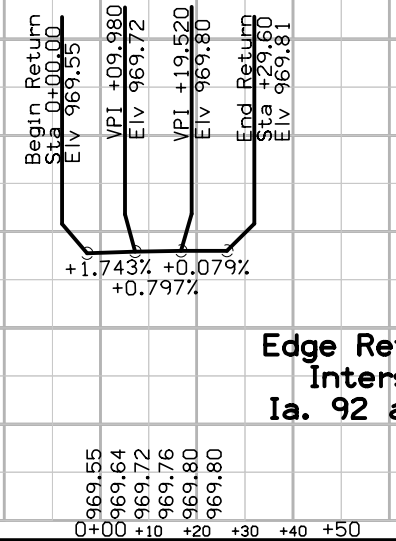
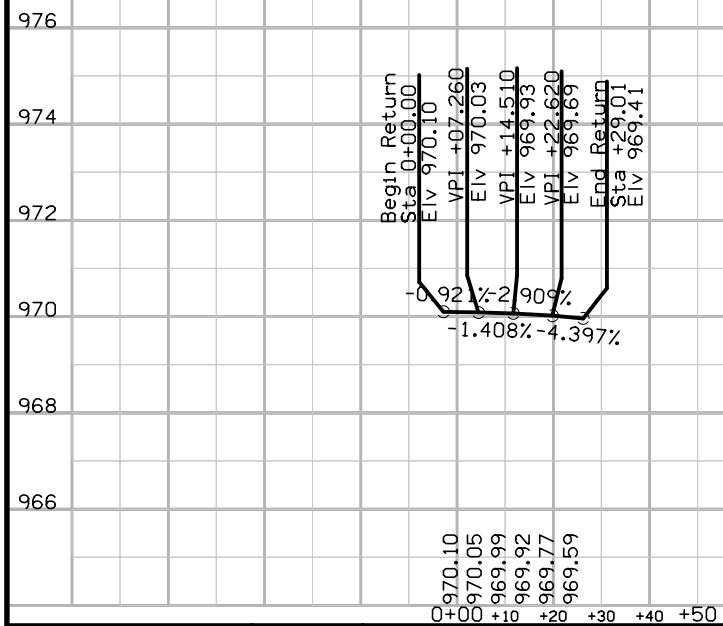

Edge Return Profiles
Intersection of
Ia. 92 and P Street

Edge Return Profiles
Intersection of
Ia. 92 and N Street

Lincoln TWP.
T-76N R-24W
SEC. 29

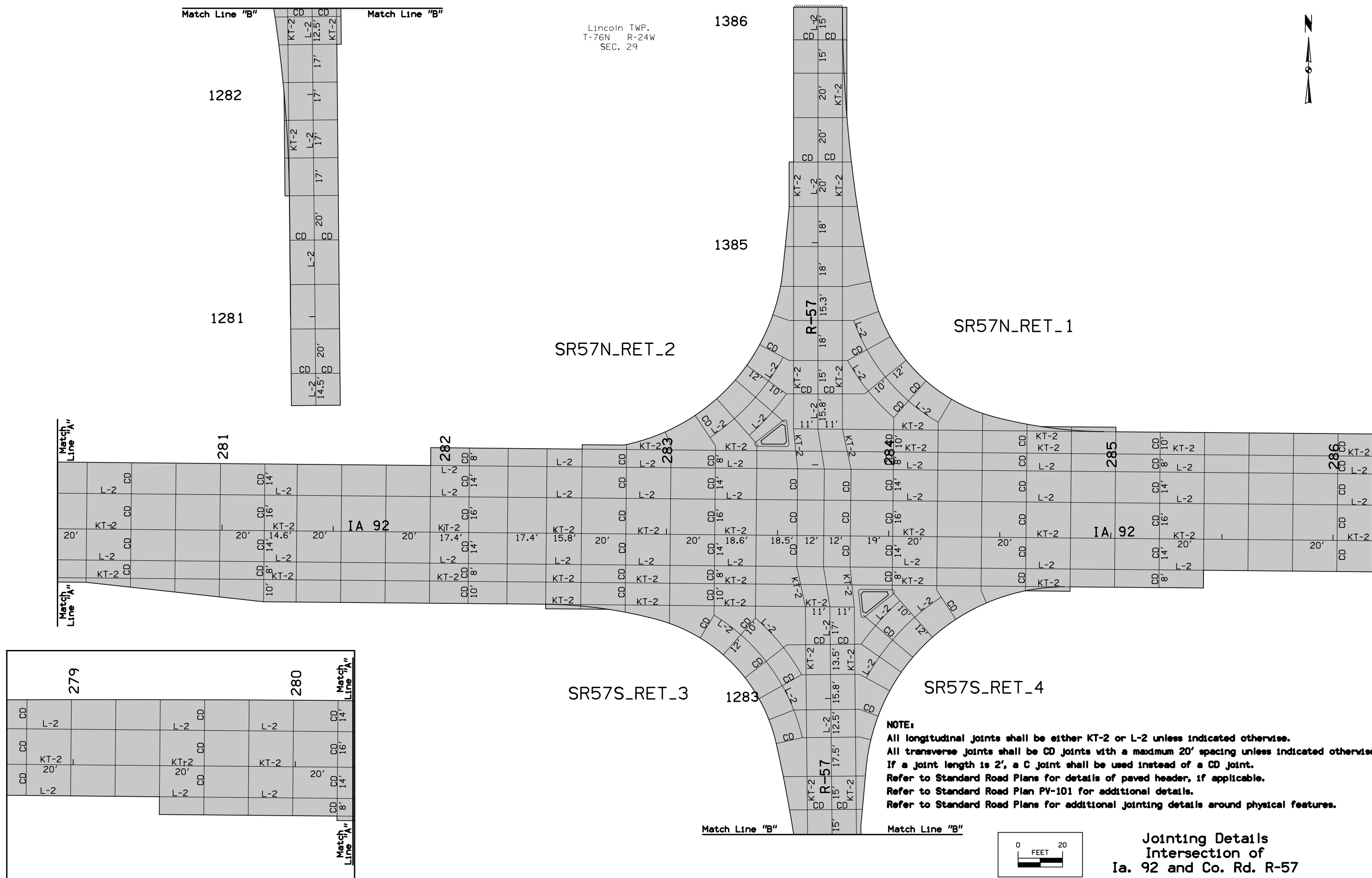

NOTE:
 All longitudinal joints shall be either KT-2 or L-2 unless indicated otherwise.
 All transverse joints shall be CD joints with a maximum 20' spacing unless indicated otherwise.
 If a joint length is 2', a C joint shall be used instead of a CD joint.
 Refer to Standard Road Plans for details of paved header, if applicable.
 Refer to Standard Road Plan PV-101 for additional details.
 Refer to Standard Road Plans for additional jointing details around physical features.

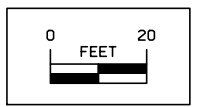

Jointing Details
 Intersection of
 Ia. 92 and Co. Rd. R-57

Lincoln TWP.
T-76N R-24W
SEC. 27

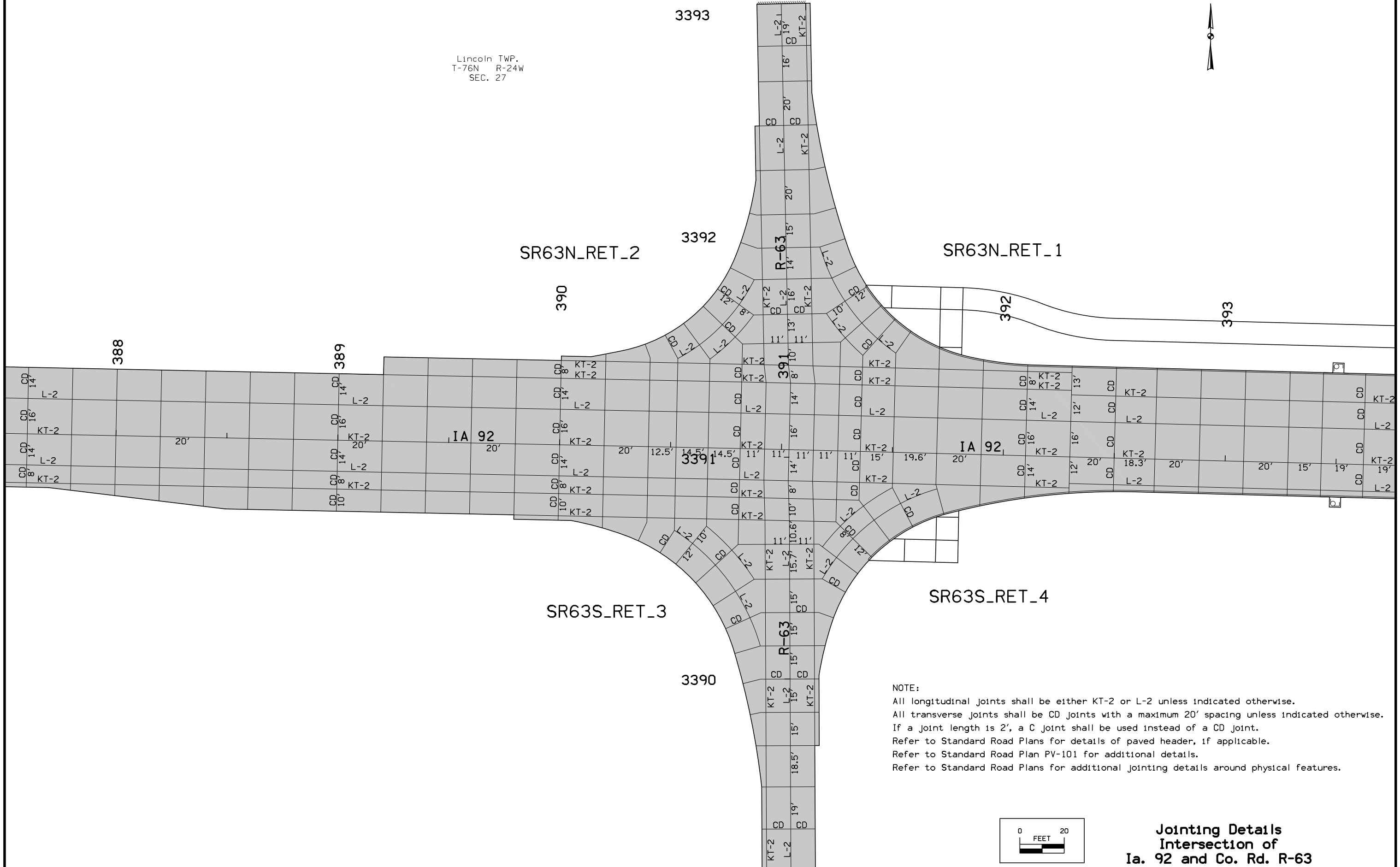

NOTE:
All longitudinal joints shall be either KT-2 or L-2 unless indicated otherwise.
All transverse joints shall be CD joints with a maximum 20' spacing unless indicated otherwise.
If a joint length is 2', a C joint shall be used instead of a CD joint.
Refer to Standard Road Plans for details of paved header, if applicable.
Refer to Standard Road Plan PV-101 for additional details.
Refer to Standard Road Plans for additional jointing details around physical features.

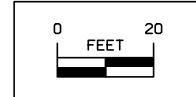

Jointing Details
Intersection of
Ia. 92 and Co. Rd. R-63

FILE NO.	ENGLISH	DESIGN TEAM	J1a\Holst\Bennett	WARREN COUNTY	PROJECT NUMBER	NHSX-092-5(51)--3H-91	SHEET NUMBER	L.29
----------	---------	-------------	-------------------	---------------	----------------	-----------------------	--------------	------

Lincoln TWP.
T-76N R-24W
SEC. 27

Lincoln TWP.
T-76N R-24W
SEC. 26

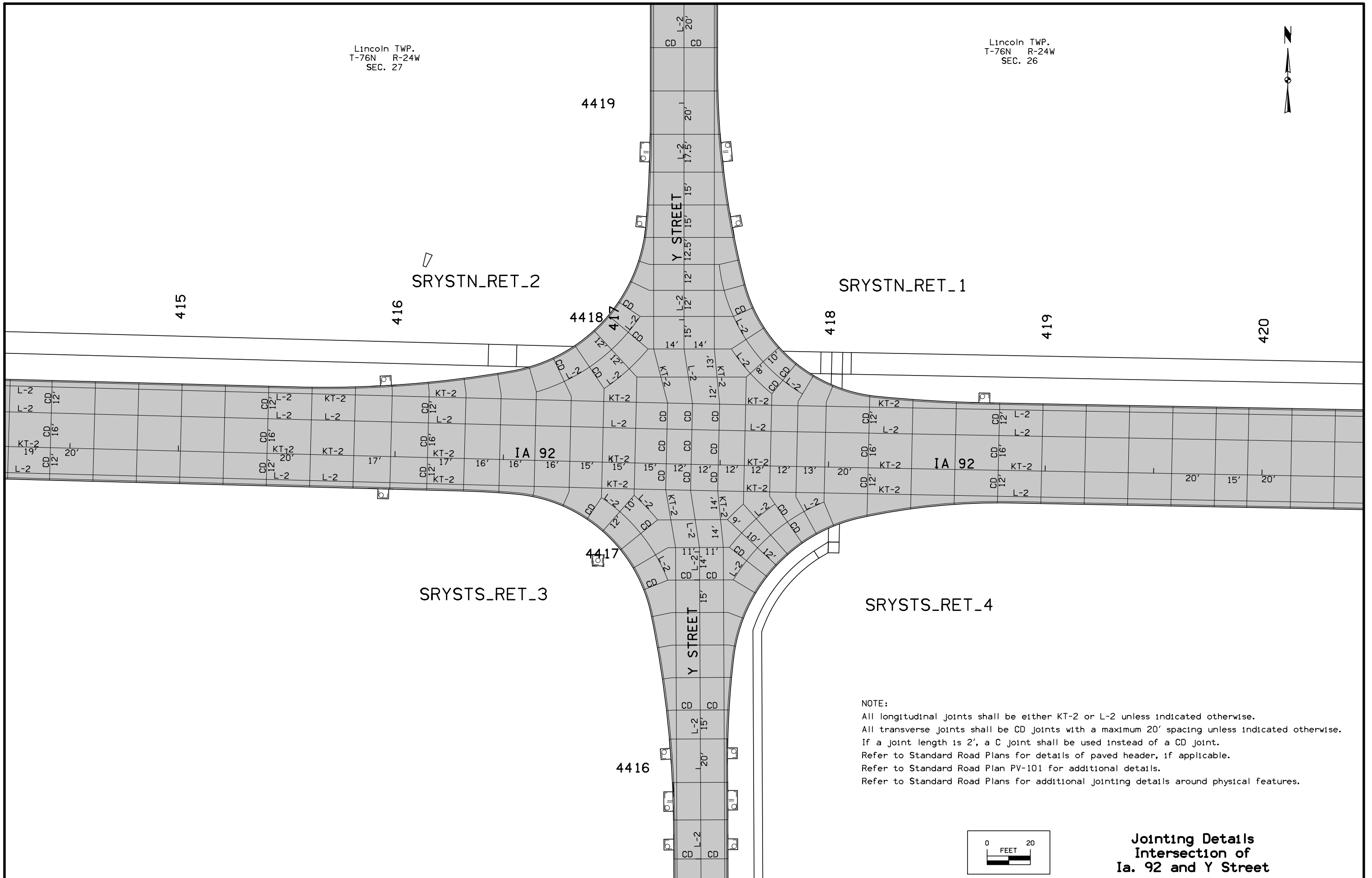

NOTE:
All longitudinal joints shall be either KT-2 or L-2 unless indicated otherwise.
All transverse joints shall be CD joints with a maximum 20' spacing unless indicated otherwise.
If a joint length is 2', a C joint shall be used instead of a CD joint.
Refer to Standard Road Plans for details of paved header, if applicable.
Refer to Standard Road Plan PV-101 for additional details.
Refer to Standard Road Plans for additional jointing details around physical features.

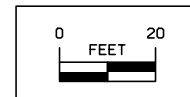

**Jointing Details
Intersection of
Ia. 92 and Y Street**

STORM SEWER

① Diameter or equivalent diameter

* Bid Item
** For SW-545

INTAKES AND UTILITY ACCESSES							PIPES												
							Design Length, Slope, and Flowlines are calculated from inside wall to inside wall along CL of pipe. An additional 3 ft length is added to each side of the Design Length to account for estimated length to center of structures.												
No.	Location Station and Offset	*Type or Standard Road Plan	Form Grade	Bottom Well	Extension Length**	Notes	Line Number	Intake/Utility Access No.		Class 'D'	Pipe Size	Bid* Length	Design Length	Slope %	Flow Lines			Pipe Profile Sheet No.	Notes
			Elev.	Elev.	FT			From	To		IN				FT	FT	Inlet Elev.		
I-400	435+57.00, -31	SW-508	964.13	960.13			P-400	I-400	I-402	2000	18	49	43.00	0.60	961.13	960.87		M.26	
I-401	435+57.00, 15	SW-508	963.89	959.89			P-401	I-401	I-403	2000	18	43	37.00	0.95	960.98	960.63		M.26	
I-402	436+00.00, -31	SW-510	964.07	960.07			P-402	I-402	I-405	2000	18	45	39.00	1.62	960.57	959.94		M.26	
I-403	436+00.00, 15	SW-510	963.83	959.83			P-403	I-403	I-413	2000	18	45	39.00	0.95	960.33	959.96		M.26	
I-404	436+45.20, -75	RF-3 (30")	960.73			30" Apron Guard, RF-26	P-404	I-404	I-405	2000	30	37	33.92	4.66	960.45	958.90		M.26	
I-405	436+45.00, -31	SW-508	964.14	958.10			P-405	I-405	I-413	2000	30	52	46.00	2.00	958.60	957.68		M.26	
I-407	442+62.95, 11.72	SW-508	967.01	961.25			P-407	I-407	I-409	2000	24	162	155.11	0.50	961.75	960.98		M.27	(6)
I-408	441+19.00, -36.15	SW-510	966.12	961.32			P-408	I-408	I-410	2000	18	198	191.92	0.44	961.82	960.98		M.26	
I-409	441+02.00, 15	SW-508	966.15	960.18			P-409	I-409	I-411	2000	24	185	178.52	0.50	960.68	959.78		M.27	
I-410	439+20.00, -31	SW-508	965.73	960.18			P-410	I-410	I-411	2000	18	52	46.00	1.00	960.68	960.22		M.26	
I-411	439+20.00, 15	SW-508	965.24	958.98			P-411	I-411	I-412	2000	24	152	145.53	0.75	959.48	958.39		M.27	
I-412	437+72.04, 15	SW-508	964.50	957.59			P-412	I-412	I-413	2000	21	130	123.04	0.54	958.09	957.42		M.27	
I-413	436+45.00, 15	SW-508	963.90	956.17			P-413	I-413	I-414	2000	30	44	40.67	0.53	956.67	956.45		M.27	Requires 6 RF-14 Joints; (4)
I-501	444+30.00, 10.5	SW-508	967.67	962.37			P-501	I-501	I-407	2000	24	167	163.01	0.50	962.87	962.05		M.27	56' of Trenchless
I-501A	444+30.00, 27.6	RF-3 (24")	963.43			24" Apron Guard, RF-26	P-501A	I-501A	I-501	2000	24	13	7.00	2.00	963.31	963.17		M.27	
O-414	436+48.67, 65.67	RF-3 (18")	956.42																
I-415	437+72.00, -31	SW-508	964.74	960.74			P-415	I-415	O-416	2000	15	38	34.30	1.00	961.90	961.56		M.26	Requires 5 RF-14 Joints; (4)
O-416	437+72.00, -75.3	RF-3 (15")	961.50																
I-610	445+80.00, 10.5	SW-508	968.22	964.22			P-610	I-610	O-610	2000	15	9	6.00	2.25	964.72	964.59		M.28	Requires 2 RF-14 Joints; (4)
O-610	445+80.00, 26.5	RF-3 (15")	964.45																
I-615	447+20.00, 10.5	SW-508	968.69	964.69			P-615	I-615	O-615	2000	15	9	6.00	1.00	965.42	965.36		M.28	Requires 2 RF-14 Joints; (4)
O-615	447+20.00, 26.5	RF-3 (15")	965.30																
I-620	448+95.00, 10.5	SW-508	969.22	965.22			P-620	I-620	O-620	2000	15	8	4.50	1.00	966.83	966.78		M.28	Requires 1 RF-14 Joints; (4)
O-620	448+95.00, 25.0	RF-3 (15")	966.72																
I-625	450+30.00, 10.5	SW-508	969.62	965.62			P-625	I-625	O-625	2000	15	8	4.50	1.00	967.23	967.18		M.29	Requires 1 RF-14 Joints; (4)
O-625	450+30.00, 26.5	RF-3 (15")	967.12																
I-630	451+70.00, 10.5	SW-508	970.04	966.04			P-630	I-630	O-630	2000	15	8	4.50	1.00	967.65	967.60		M.29	Requires 1 RF-14 Joints; (4)
O-630	451+70.00, 25.0	RF-3 (15")	967.54																
I-635	453+77.00, 10.5	SW-508	970.14	966.14			P-635	I-635	O-635	2000	15	9	6.00	4.08	966.64	966.40		M.29	Requires 2 RF-14 Joints; (4)
O-635	453+77.00, 26.5	RF-3 (15")	966.15																
I-640	456+25.00, 10.5	SW-510	969.48	965.48			P-640	I-640	O-640	2000	15	9	6.00	1.33	965.98	965.90		M.29	Requires 2 RF-14 Joints; (4)
O-640	456+25.00, 26.5	RF-3 (15")	965.82																
I-645	458+40.00, 10.5	SW-508	969.35	965.35			P-645	I-645	O-645	2000	15	10	7.00	1.85	965.85	965.72		M.29	Requires 2 RF-14 Joints; (4)
O-645	458+40.00, 27.5	RF-3 (15")	965.61																
I-650	459+75.00, 10.5	SW-508	968.95	964.95			P-650	I-650	O-650	2000	15	10	7.00	1.77	965.45	965.33		M.29	Requires 2 RF-14 Joints; (4)
O-650	459+75.00, 27.5	RF-3 (15")	965.22																
I-655	461+00.00, 10.5	SW-508	968.57	964.57			P-655	I-655	O-655	2000	15	10	7.00	5.54	965.07	964.68		M.29	Requires 2 RF-14 Joints; (4)
O-655	461+00.00, 27.5	RF-3 (15")	964.35																
I-701	445+80.00, -26.5	SW-508	968.22	964.22			P-701	I-701	I-702	2000	15	132	126.00	0.30	965.72	965.34		M.28	
I-702	444+50.00, -26.5	SW-508	967.76	963.76			P-702	I-702	I-703	2000	15	129	123.00	0.30	965.24	964.92		M.28	
I-703	443+23.00, -26.5	SW-508	967.31	963.31			P-703	I-703	O-703	2000	15	18	14.50	0.10	964.82	964.81		M.28	Requires 3 RF-14 Joints; (4)
O-703	443+23.00, -51.0	RF-3 (15")	964.80																
I-713	450+30.00, -26.5	SW-508	969.62	965.62			P-713	I-713	I-714	2000	15	152	146.00	0.40	966.70	966.12		M.28	
I-714	448+80.00, -26.5	SW-508	969.17	965.17			P-714	I-714	I-715	2000	15	142	136.00	0.40	966.02	965.50		M.28	48' of Trenchless
I-715	447+40.00, -26.5	SW-508	968.75	964.75			P-715	I-715	O-715	2000	15	21	18.00	0.40	965.40	965.32		M.28	Requires 3 RF-14 Joints; (4)
O-715	447+40.00, -54.5	RF-3 (15")	965.30																

STORM SEWER

① Diameter or equivalent diameter

* Bid Item
** For SW-545

INTAKES AND UTILITY ACCESSES							PIPES												
							Design Length, Slope, and Flowlines are calculated from inside wall to inside wall along CL of pipe. An additional 3 ft length is added to each side of the Design Length to account for estimated length to center of structures.												
No.	Location Station and Offset	*Type or Standard Road Plan	Form Grade	Bottom Well	Extension Length**	Notes	Line Number	Intake/Utility Access No.		Class 'D'	Pipe Size	Bid* Length	Design Length	Slope %	Flow Lines			Pipe Profile Sheet No.	Notes
			Elev.	Elev.	FT			From	To		IN				FT	FT	Inlet Elev.		
I-753	453+77.00, -26.5	SW-508	970.14	966.14			P-753	I-753	I-754	2000	15	135	129.00	0.60	967.64	966.87		M.30	
I-754	455+10.00, -26.5	SW-508	969.74	965.74			P-754	I-754	I-755	2000	15	117	111.00	0.30	966.77	966.43		M.30	72' of Trenchless
I-755	456+25.00, -26.5	SW-510	969.48	965.48			P-755	I-755	I-756	2000	15	217	211.00	0.30	966.33	965.70		M.30	
I-756	458+40.00, -26.5	SW-508	969.35	965.05			P-756	I-756	I-757	2000	15	137	131.00	0.20	965.60	965.34		M.30	40' of Trenchless
I-757	459+75.00, -26.5	SW-508	968.95	964.53			P-757	I-757	I-758	2000	18	127	121.00	0.20	965.09	964.85		M.30	
I-758	461+00.00, -26.5	SW-508	968.57	964.18			P-758	I-758	I-759	2000	18	77	71.00	0.30	964.75	964.56		M.30	
I-759	461+75.00, -26.5	SW-510	968.42	963.94			P-759	I-759	I-760	2000	18	43	37.00	0.50	964.46	964.28		M.30	37' of Trenchless
I-760	461+75.00, 10.5	SW-510	968.42	963.53			P-760	I-760	O-760	2000	21	11	8.00	0.20	964.03	964.01		M.30	Requires 2 RF-14 Joints; (4)
O-760	461+75.00, 28.5	RF-3 (21")	964.00																
I-768	464+95.00, -26.5	SW-508	966.75	962.75			P-768	I-768	I-769	2000	15	107	101.00	0.60	964.00	963.39		M.29	
I-769	463+90.00, -26.5	SW-508	967.97	962.59			P-769	I-769	I-770	2000	18	43	37.00	1.00	963.09	963.06		M.29	37' of Trenchless
I-770	463+90.00, 10.5	SW-508	967.97	962.26			P-770	I-770	E-770	2000	18	17	14.00	2.60	962.76	962.40		M.29	
E-770	463+89.00, 30.5	SW-211																	
I-775	464+95.00, 10.5	SW-508	966.75	962.75			P-775	I-775	I-770	2000	15	107	101.00	0.60	963.91	963.31		M.29	
Notes:																			
(1) For temporary drainage of Detour. Remove when Detour is removed.																			
(2) Construct after removal of I-219A																			
(3) Connect with Subdrain No. 5B; Refer to Tab 104-5T in C-sheets																			
(4) Number of connected joints based on 8' pipe segments																			
(5) Connect to P-219																			
(6) At proposed entrance location, use backfill material complying with Article 2552.02, C of the Standard Specifications. Place and compact backfill according to Article 2552.03, E, 3, of the Standard Specifications.																			
Totals:																			
							Trenched Totals: Size Qty												
							15 1382												
							18 4378												
							21 1005												
							24 1245												
							30 274												
							36 19												
							Trenchless Totals: Size Qty												
							15 160												
							18 118												
							24 56												

SURVEY SYMBOLS

- TDC Tree Deciduous
- PPA Power Pole Co. 1
- FWD Wood Fence
- LUM Luminaire
- TEV Evergreen Tree
- LP L.P. Tank
- D Centerline Draw or Stream (Down)
- RET Retaining Walls
- SI Sign
- SHR Shrub
- SI Sign
- EW Edge of Water
- DIK Centerline of Dike or Dam
- FLG Flag Poles
- WM Wind Mill
- FCL Chain Link and Security Fence
- HDG Hedge Row
- TV Satellite TV Dish
- RT Radio Tower
- INB Storm Sewer Beehive Intake
- WV Water Valve
- FHD Fire Hydrants
- WEL Well
- MH Utility Access (Manhole)
- LUM Luminaire
- MIS Miscellaneous
- TPD Telephone Pedestal
- EB Electrical Box
- UB Utility Box
- PR Electric Riser Pole
- FW Wire Fence
- GP Guard Post (Less Than 4 Posts)
- IN Storm Sewer Intake
- TLN Treeline
- TVP TV Pedestal
- SEP Septic Tank
- OUT Tile Outlet
- TIL Tile Line
- UST Underground Tank
- GV Gas Valve
- DU Centerline Draw or Stream (Up)
- BNK Stream Bank
- BL Topo Breakline
- RIP Rip-Rap

- St.S. STA Storm Sewer Line Co. 1
- F03 FOC Underground Fiber Optic Co. 3
- F05 F0E Underground Fiber Optic Co. 5
- F02 FOB Underground Fiber Optic Co. 2
- San. SAA Sanitary Sewer Line Co. 1
- T1 TLA Underground Telephone Line Co. 1
- E1 ELA Underground Electric Line Co. 1
- G GLA Underground Gas Line Co. 1
- W WLA Underground Water Line Co. 1
- F0 FOA Underground Fiber Optic Co. 1
- E2 ELB Underground Electric Line Co. 2
- San.2 SAB Sanitary Sewer Line Co. 2
- GLB Underground Gas Line Co. 2
- F04 FOD Underground Fiber Optic Co. 4
- WLB Underground Water Line Co. 2

UTILITY LEGEND

- F0 FOA Paetac Iowa Communications Network
- F02 FOB Lightcore (Digital Teleport)
- F03 FOC Iowa Network Service
- F04 FOD Indianola Municipal Utilities
- F05 F0E MCI
- T1 TLA Qwest
- E1 ELA Mid-American
- E2 ELB Indianola Municipal Utilities
- W WLA Indianola Municipal Utilities
- WLB Warren Rural Water
- San. SAA City of Indianola
- San.2 SAB Private
- G GLA Mid-American
- GLB Kinder Morgan
- St.S. STA City of Indianola
- PPA Mid-American

PLAN VIEW COLOR LEGEND OF STORM SEWER SHEETS

LINEWORK	Design Color No.	Description
Green	(2)	Existing Topographic Features and Labels
Blue	(1)	Proposed Alignment, Stationing, Tic Marks, and Alignment Annotation
Magenta	(5)	Existing Utilities
SHADING		
Design Color No.	Description	
Yellow	(4)	Highlight for Critical Notes or Features
Red	(3)	Delineates Restricted Areas
Lavender	(9)	Temporary Pavement Shading
Gray, Light	(48)	Proposed Pavement Shading
Gray, Med	(80)	Proposed Granular Shading
Gray, Dark	(112)	Proposed Grade and Pave Shading
Brown, Light	(236)	Grading Shading
Tan	(8)	Proposed Sidewalk Shading
Blue, Light	(230)	Proposed Sidewalk Landing Shading
Pink	(11)	Proposed Sidewalk Ramp Shading
Green, Light	(225)	Existing Pavement Shading

PROFILE VIEW COLOR LEGEND OF STORM SEWER SHEETS

LINEWORK	Design Color No.	Description
Gray, Dark	(112)	Existing Ground Line Profile and Existing Utilities Information
Black	(17)	Proposed Pipes and Intakes

PLAN VIEW LINE STYLE LEGEND OF STORM SEWER SHEETS

- Plug and Abandon Existing Pipe or Structure
- Removal of Existing Pipe or Structure
- Previously Constructed Pipe or Structure
- Direction of Pipe Flow

PROFILE VIEW LINE STYLE LEGEND OF STORM SEWER SHEETS

- Existing Ground
- Proposed Ground
- Previously Constructed Pipe or Structure
- Proposed Pipe or Structure

- Reference Point
- Station
- Survey Line
- Section Corner
- Ground Line Intercept
- Saw Cut
- Guardrail
- Clearing & Grubbing Area
- Pavement Removal

RIGHT-OF-WAY LEGEND

- Proposed Right-of-Way
- Existing and Proposed Right-of-Way
- Easement and Existing Right-of-Way
- Borrow
- Easement (Temporary)
- Easement
- Excess
- Access Control

STORM SEWER LEGEND AND SYMBOL INFORMATION SHEET

(COVERS SHEET SERIES M)

Lincoln TWP.
T-76N R-24W
SEC. 27

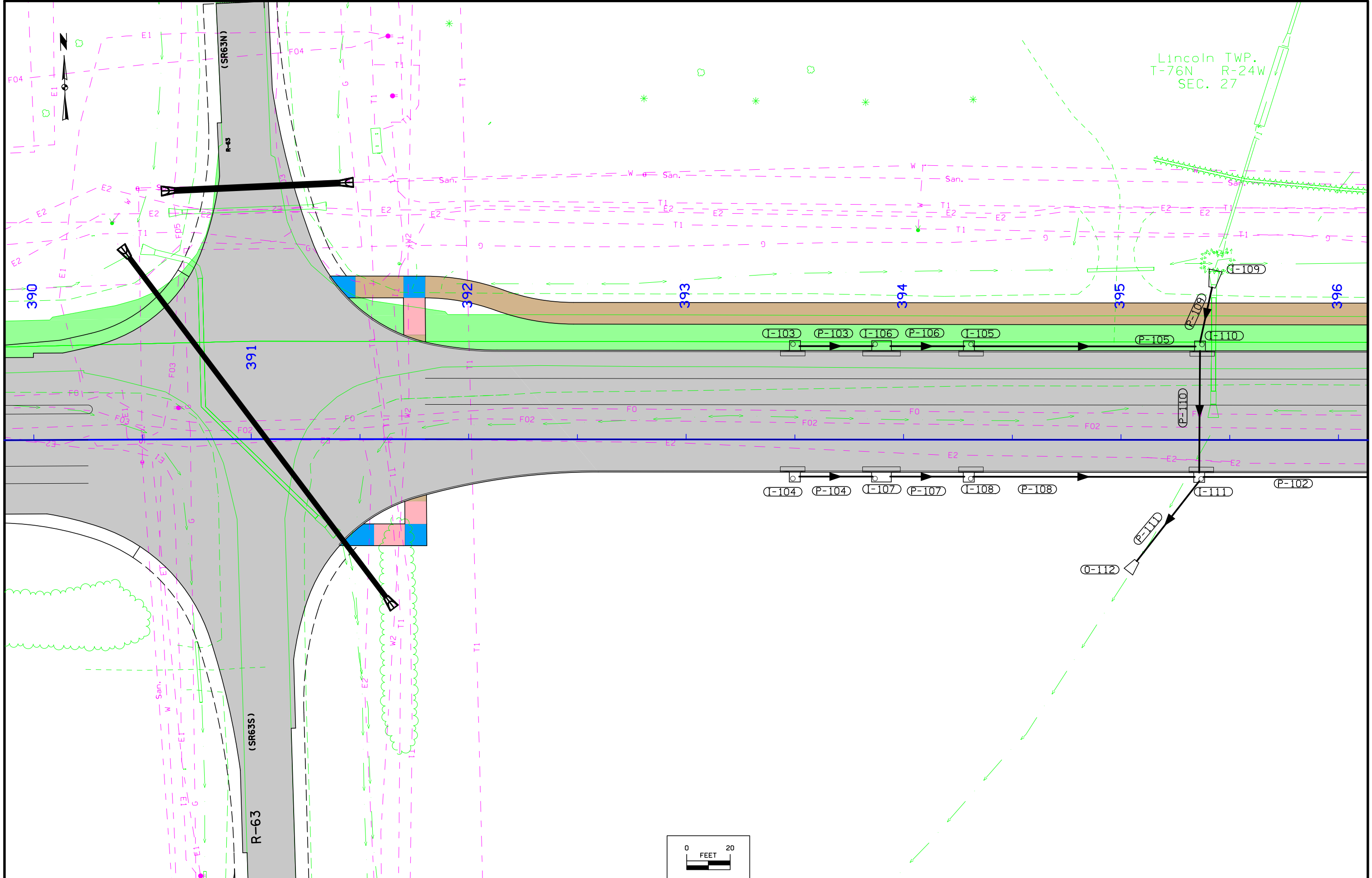

Lincoln TWP.
T-76N R-24W
SEC. 27

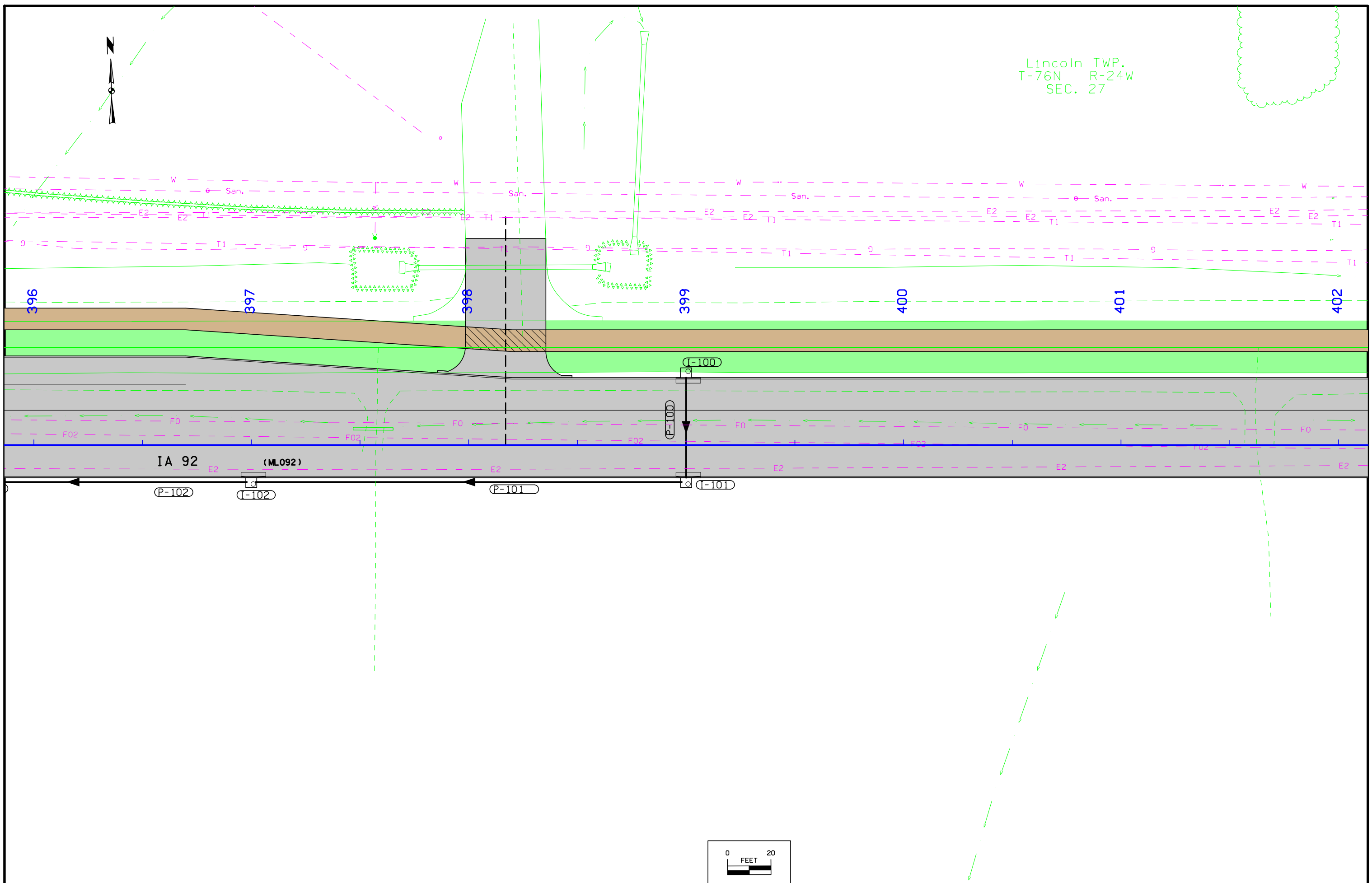

Lincoln TWP.
T-76N R-24W
SEC. 27

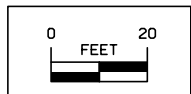
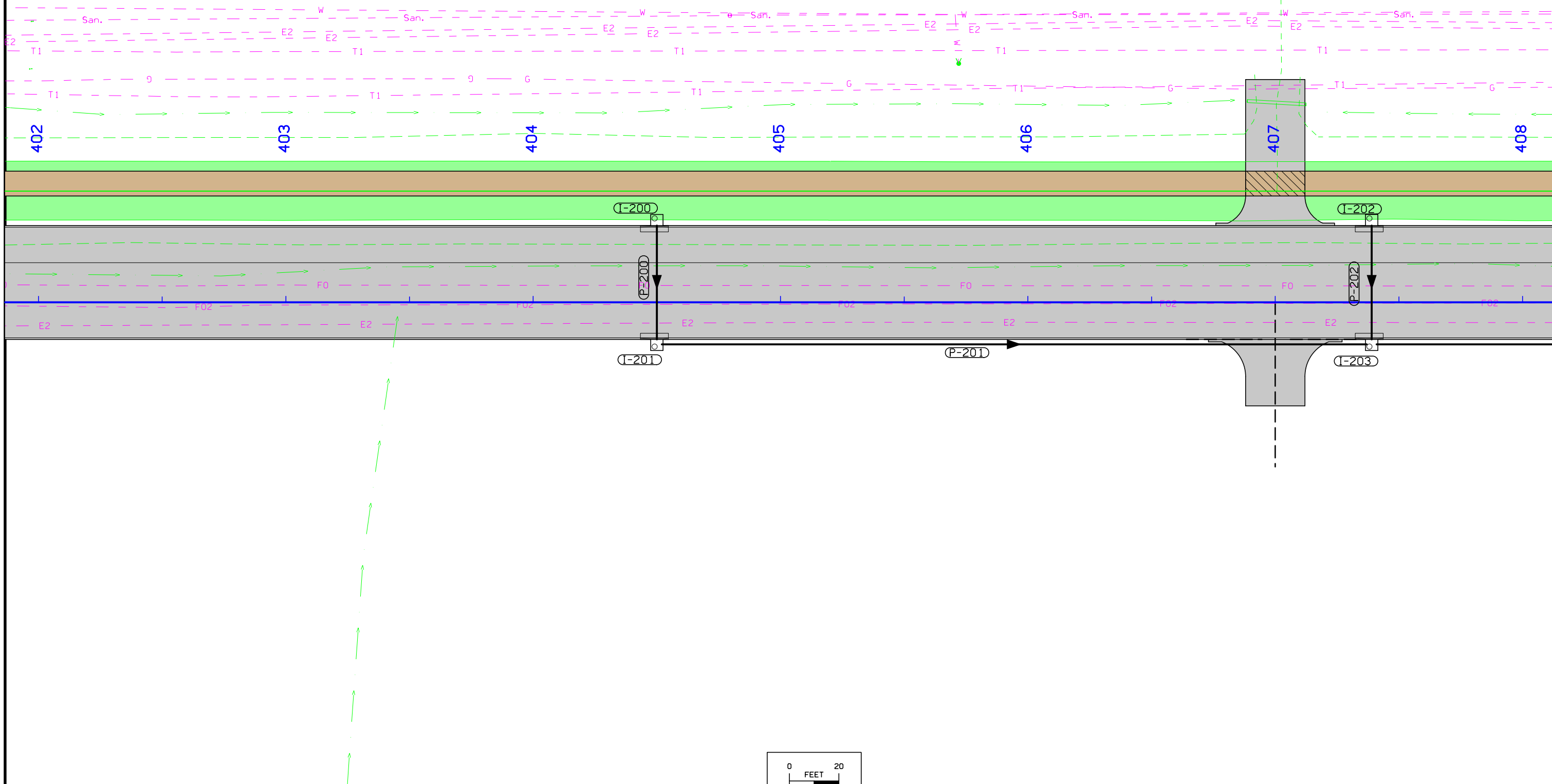



Lincoln TWP.
T-76N R-24W
SEC. 27

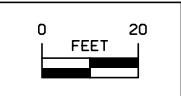
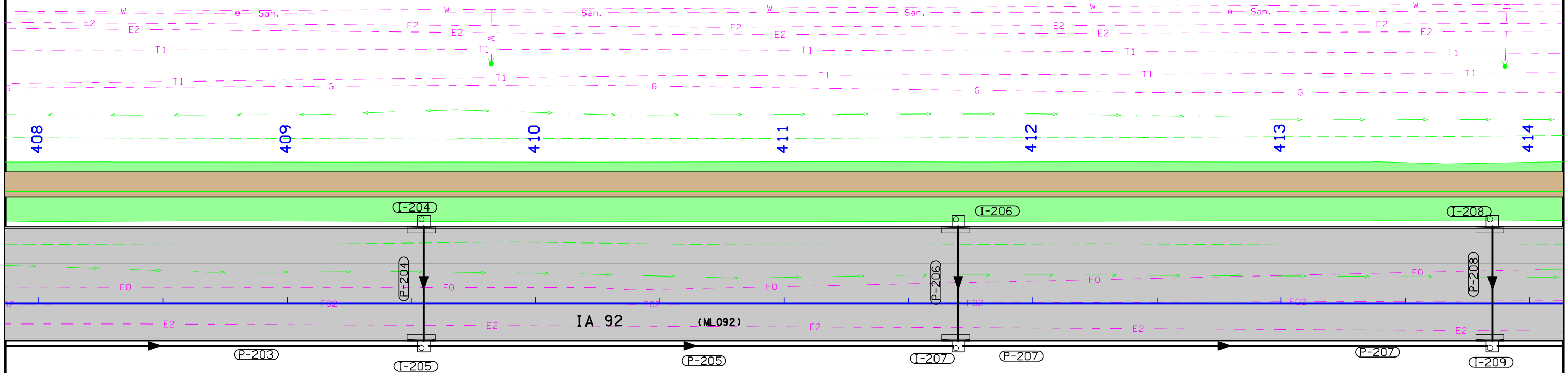

Lincoln TWP.
T-76N R-24W
SEC. 26

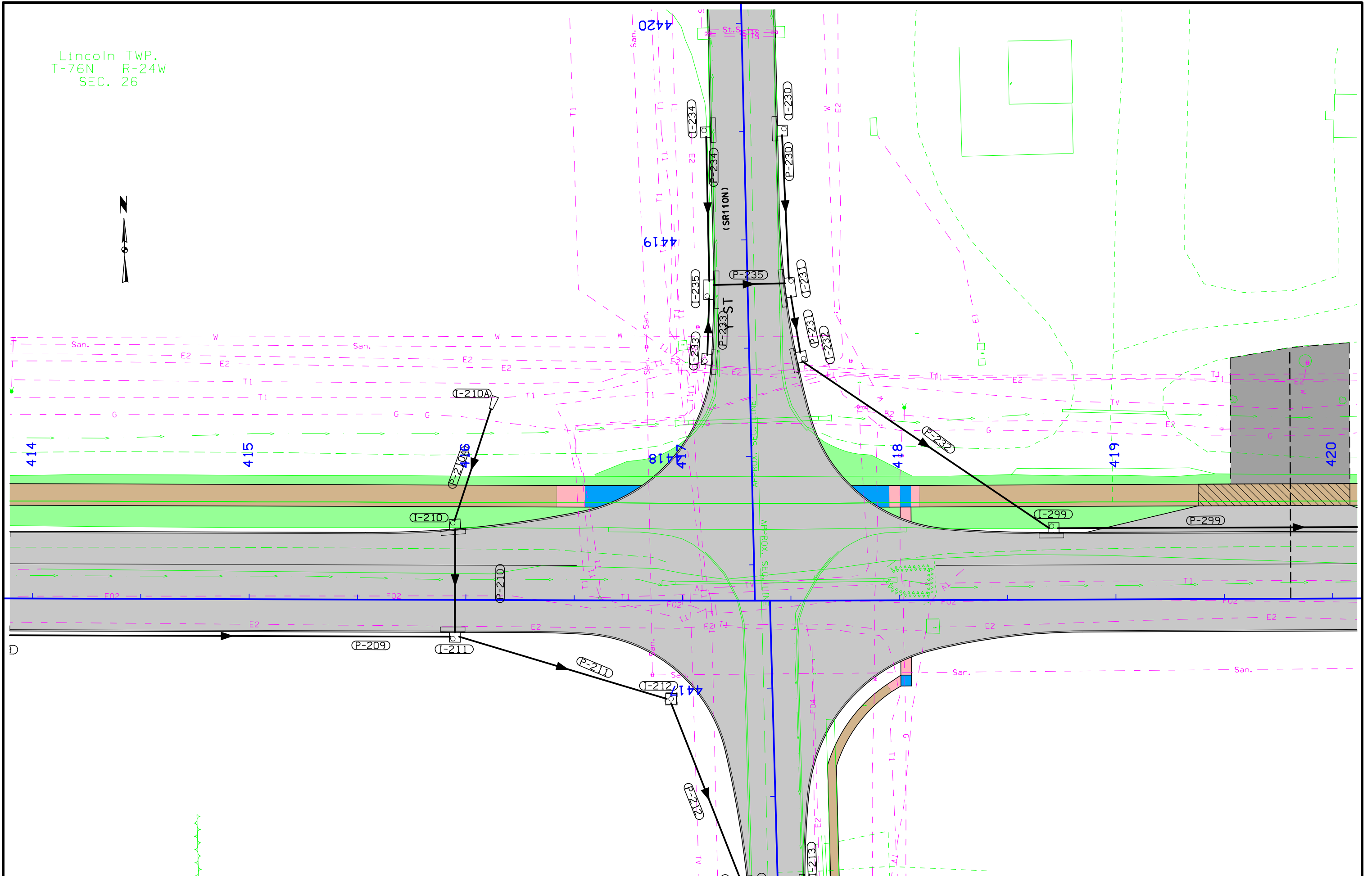

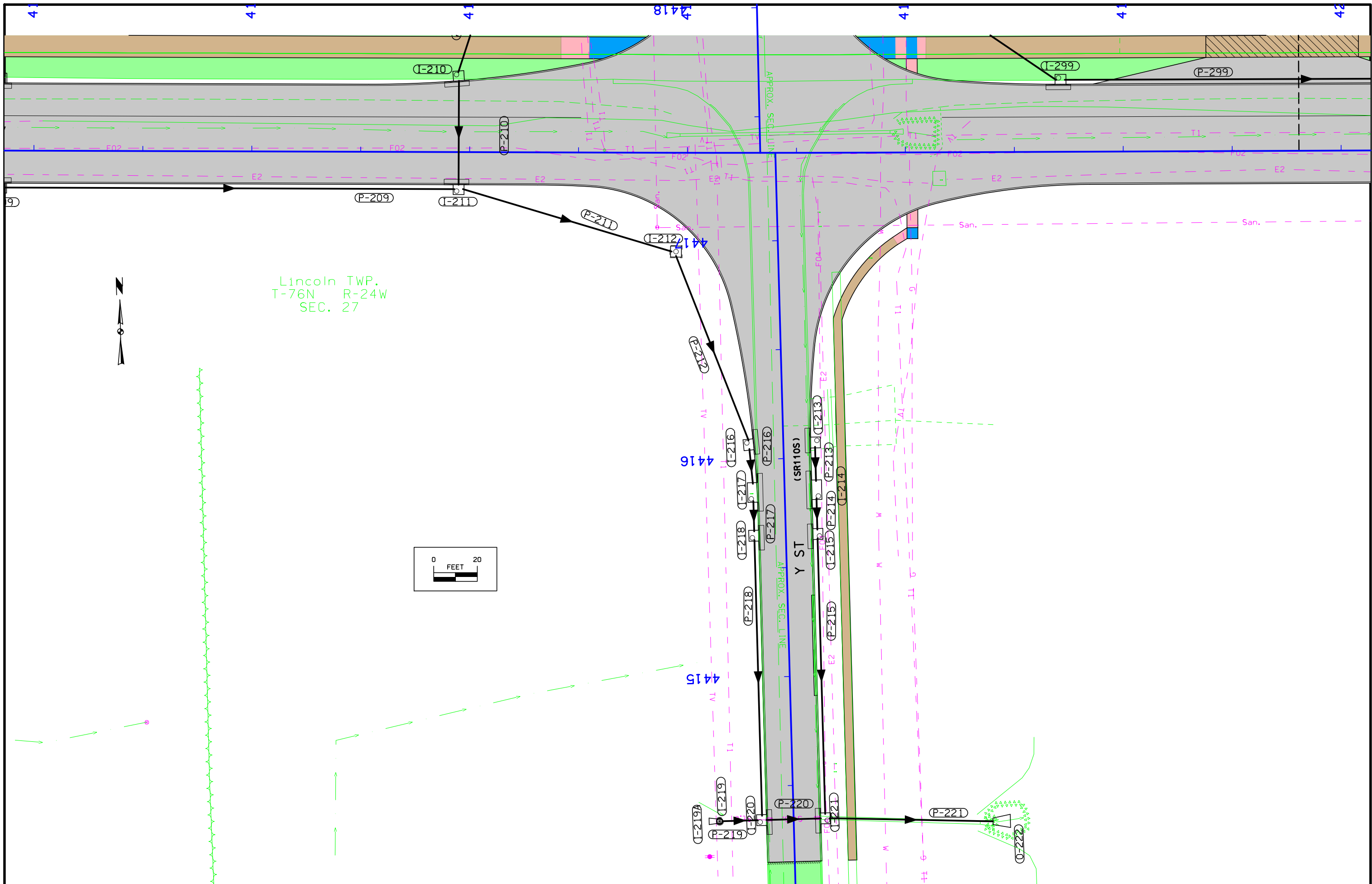

Lincoln TWP.
T-76N R-24W
SEC. 27

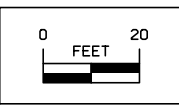

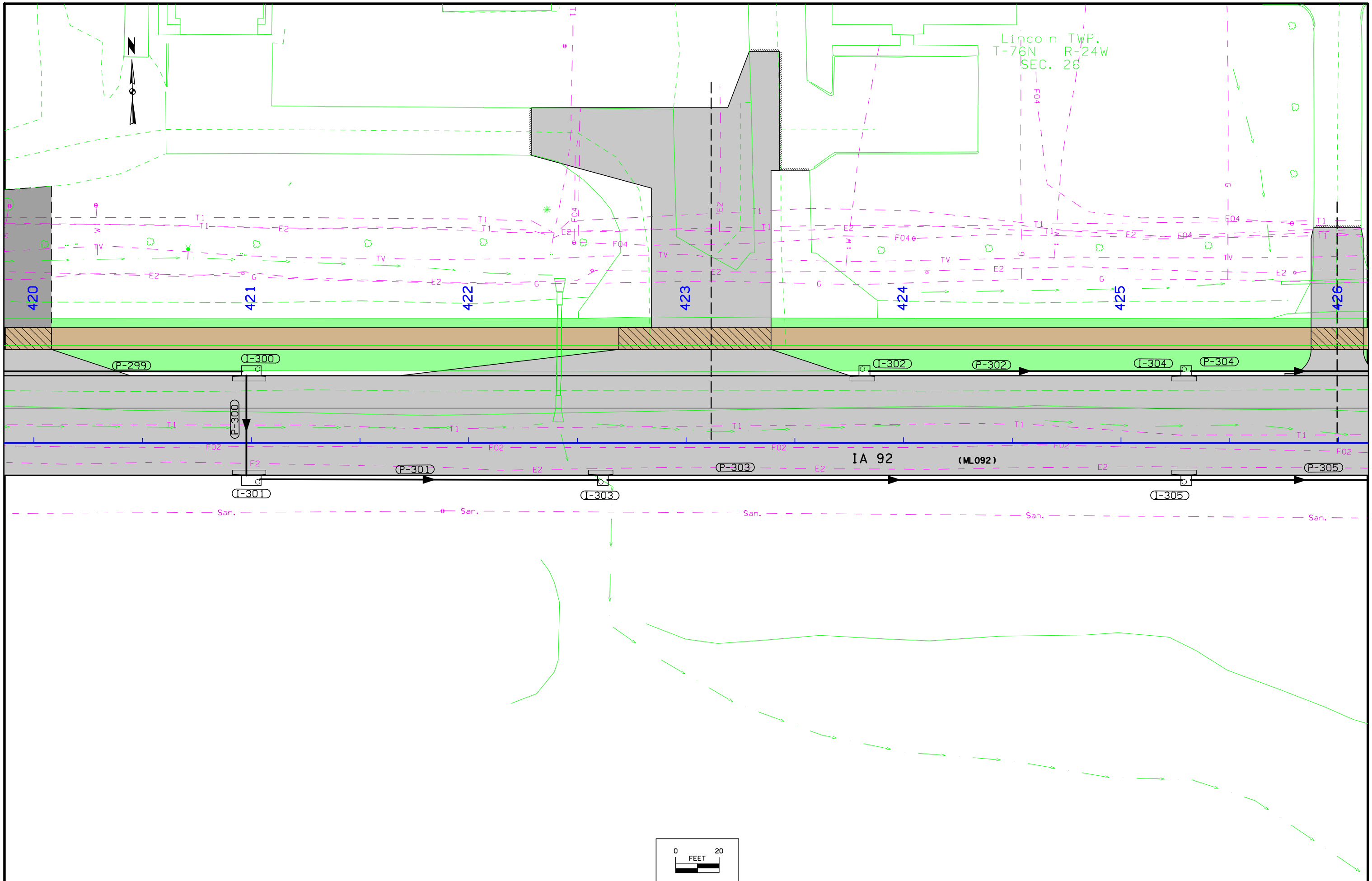

Lincoln TWP.
T-76N R-24W
SEC. 26

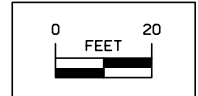
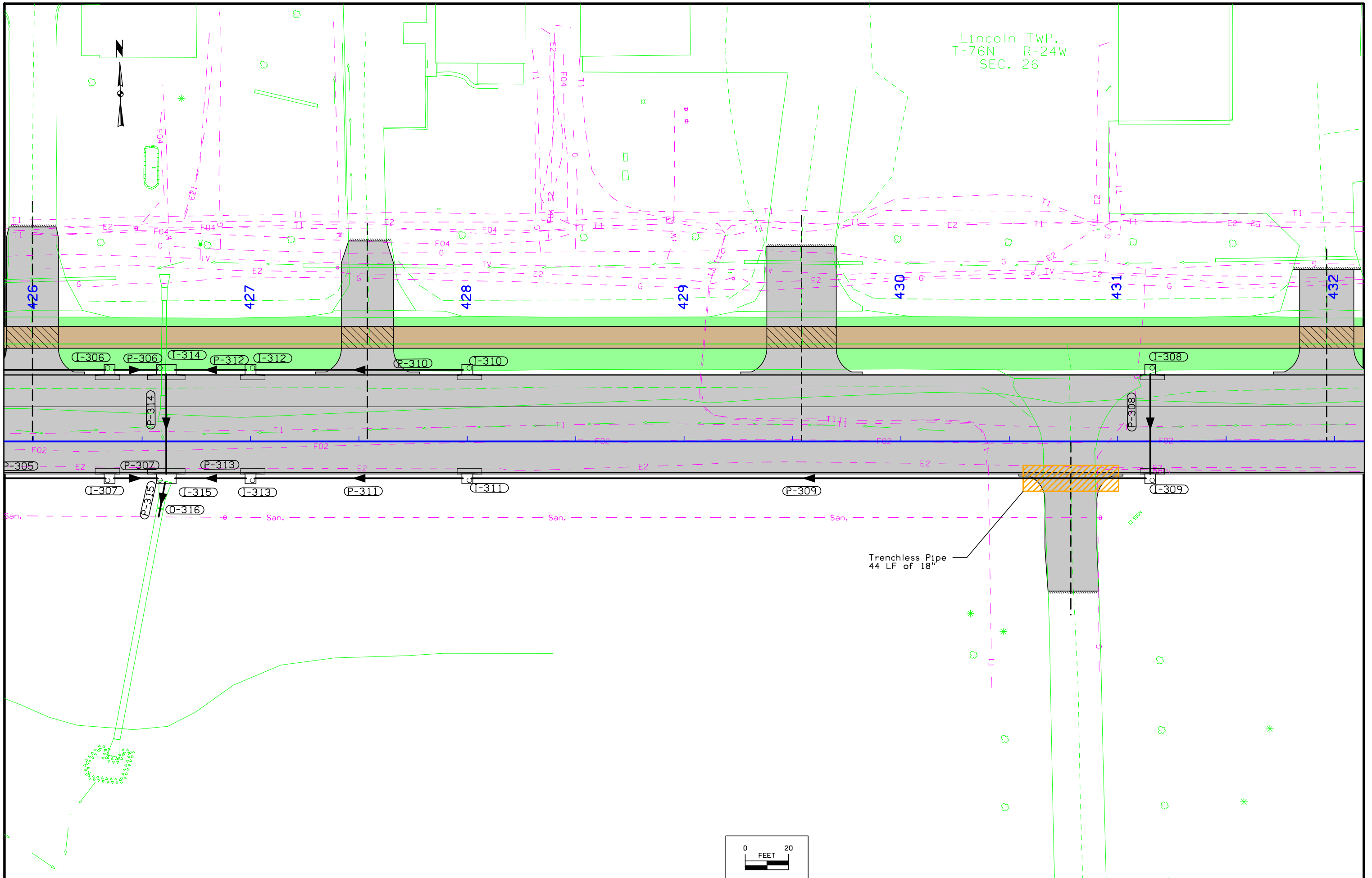

Lincoln TWP.
T-76N R-24W
SEC. 26

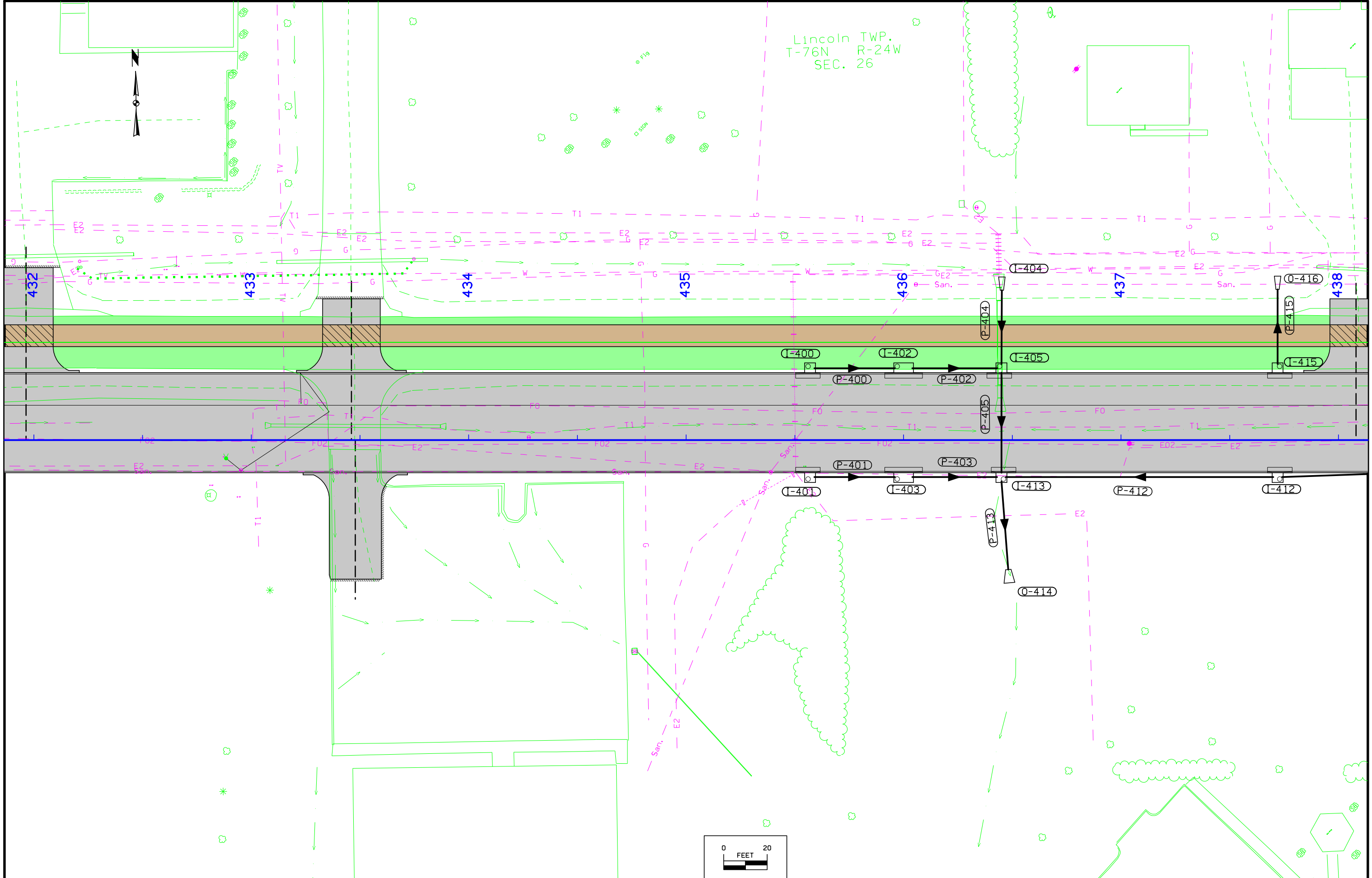

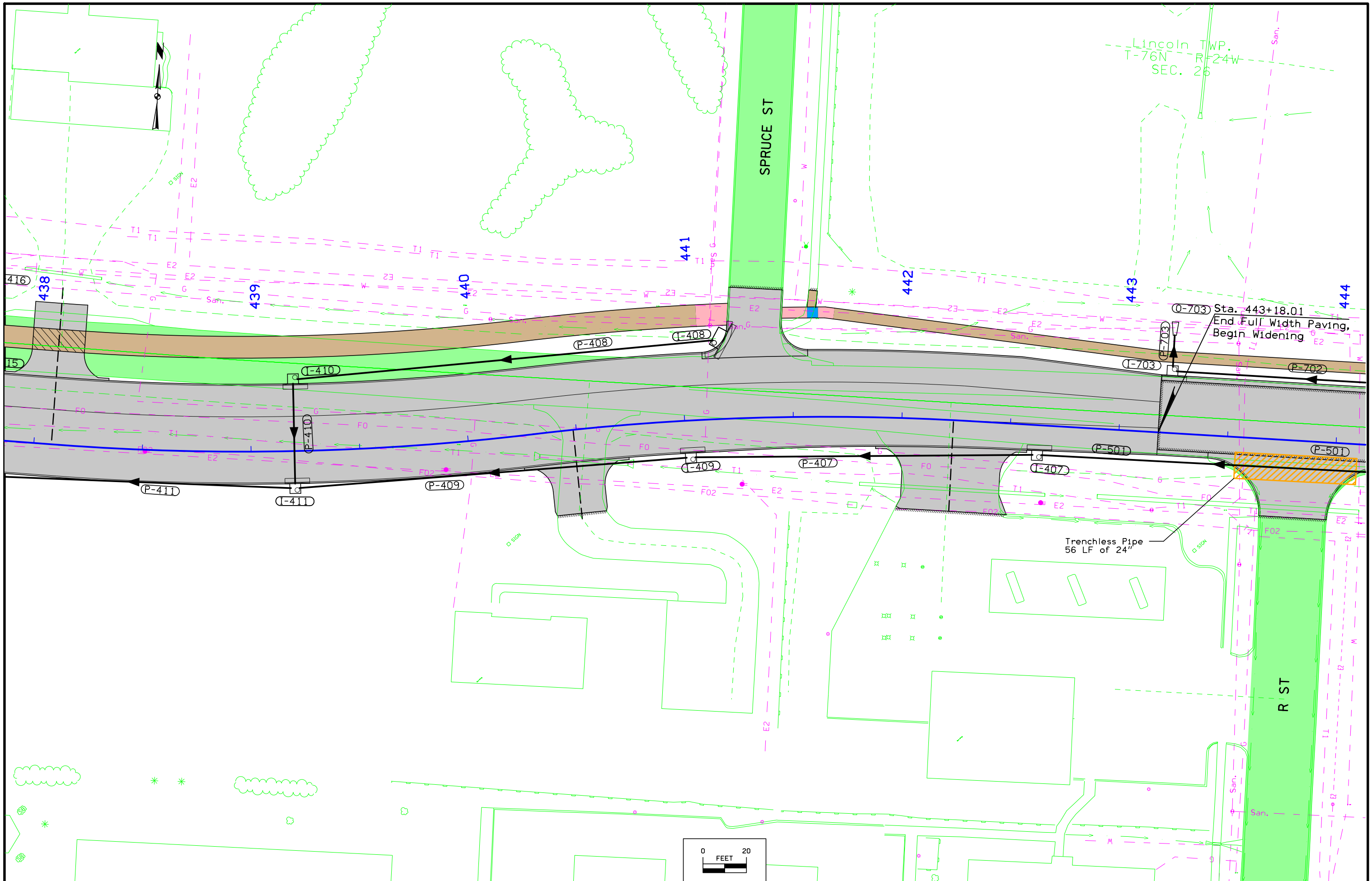

Lincoln TWP.
T-76N R-24W
SEC. 26

SPRUCE ST

R ST

Sta. 443+18.01
End Full Width Paving,
Begin Widening

Trenchless Pipe
56 LF of 24"

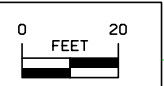



Lincoln TWP.
T-76N R-24W
SEC. 26

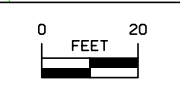
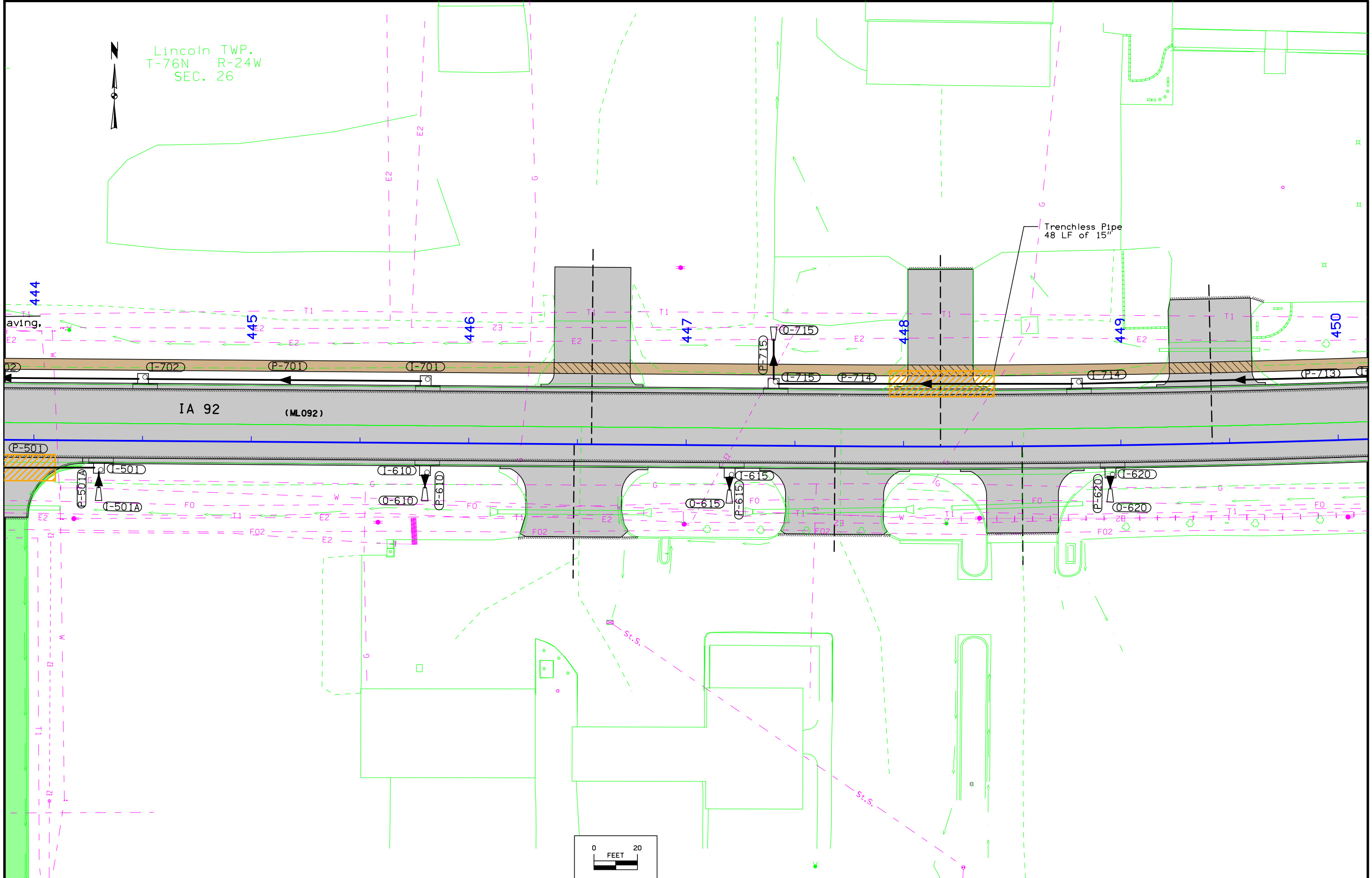

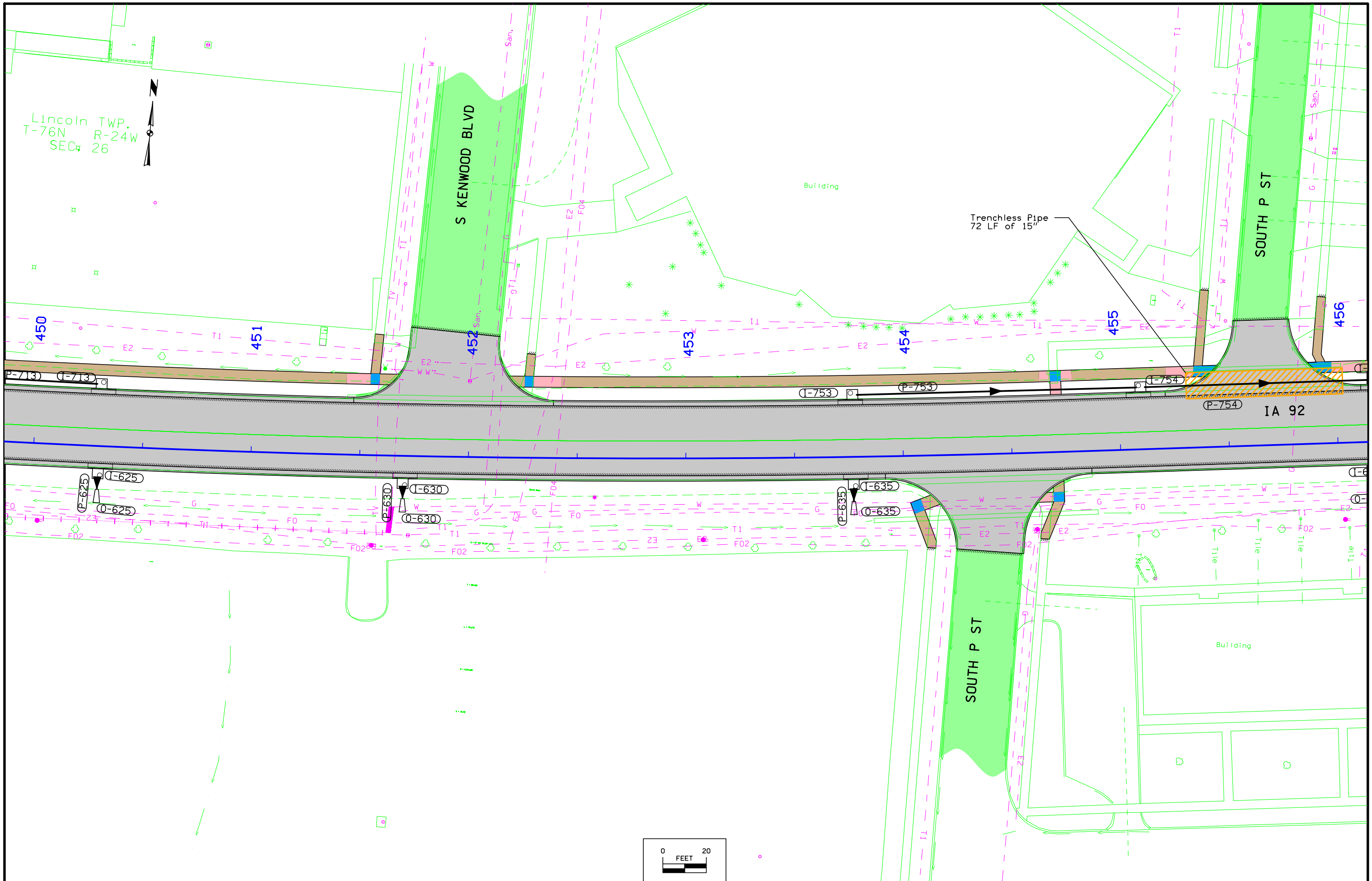

Lincoln TWP.
T-76N R-24W
SEC. 26

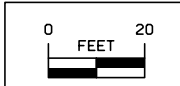
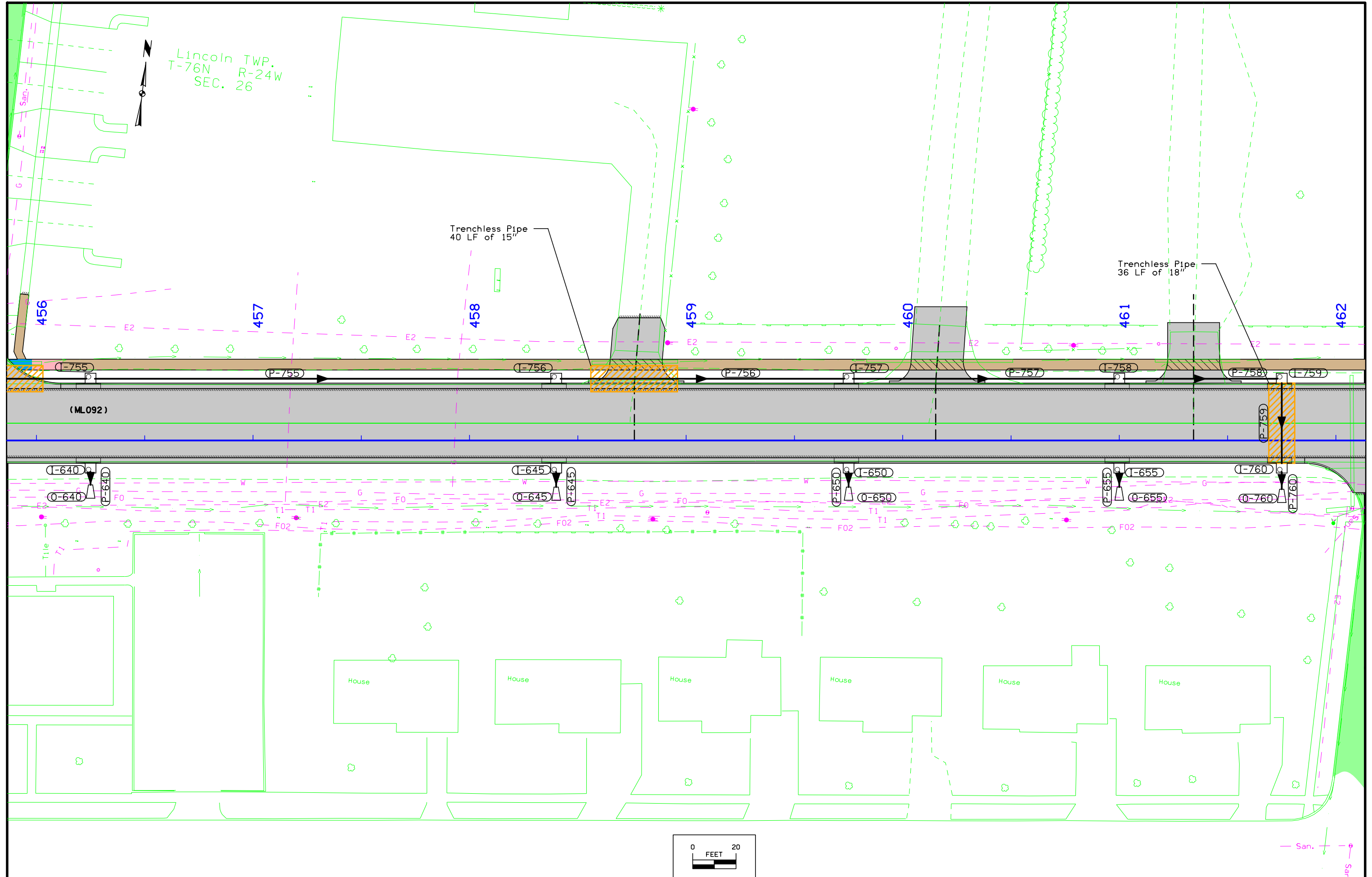

Lincoln TWP.
T-76N R-24W
SEC. 26

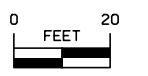
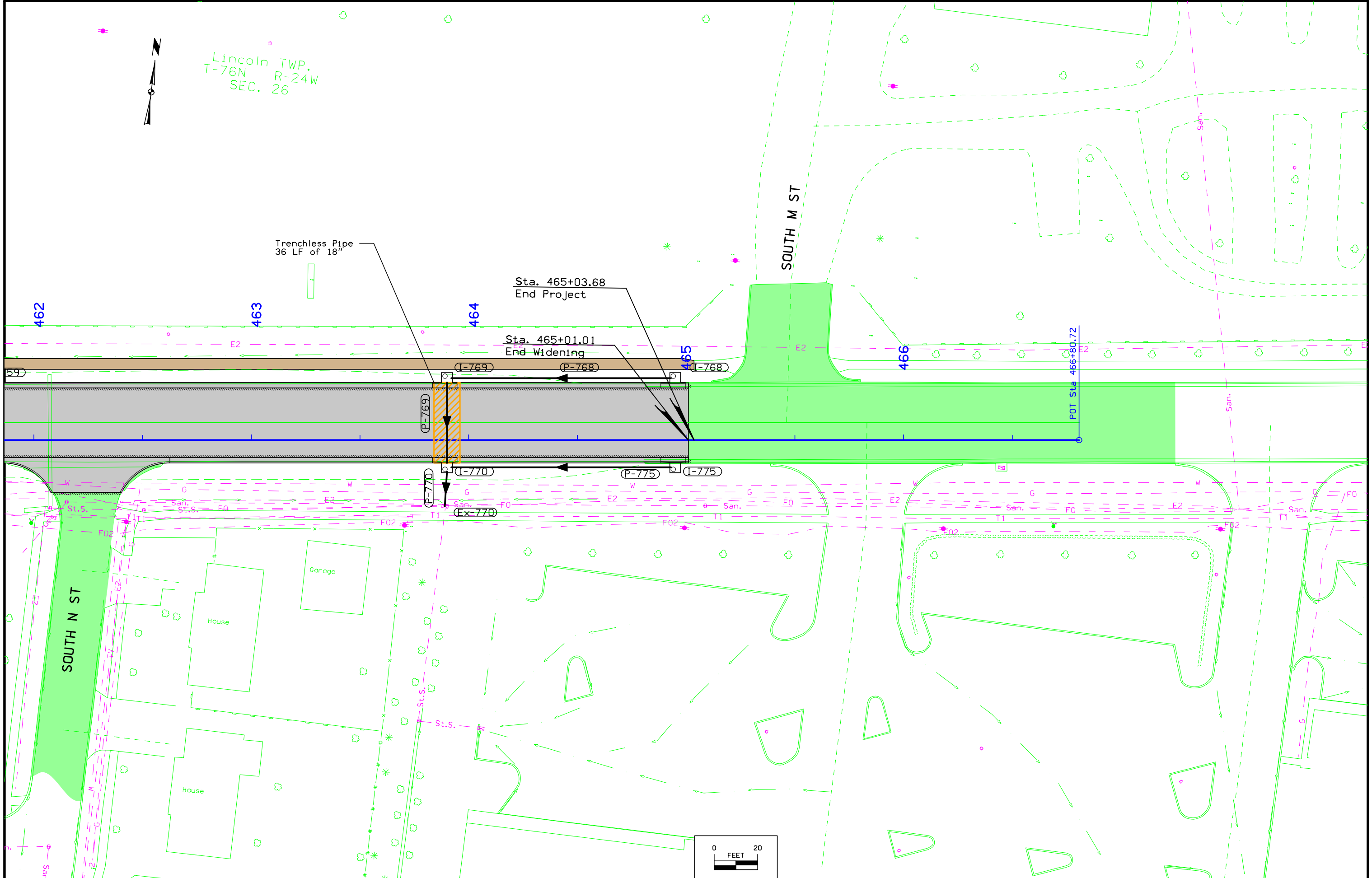

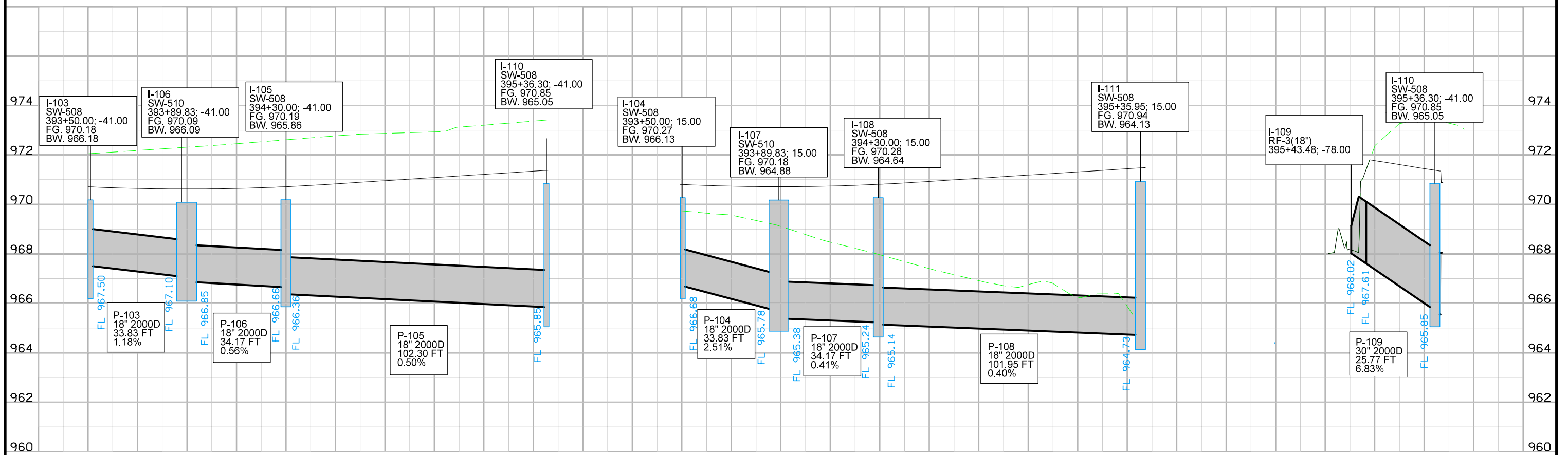
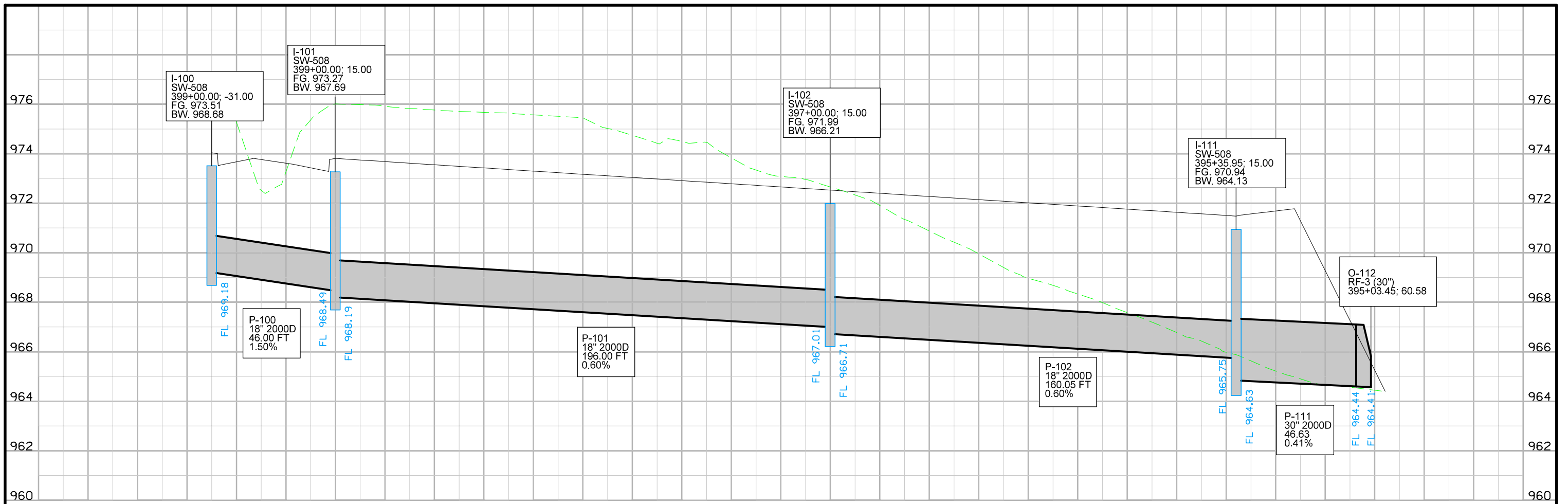

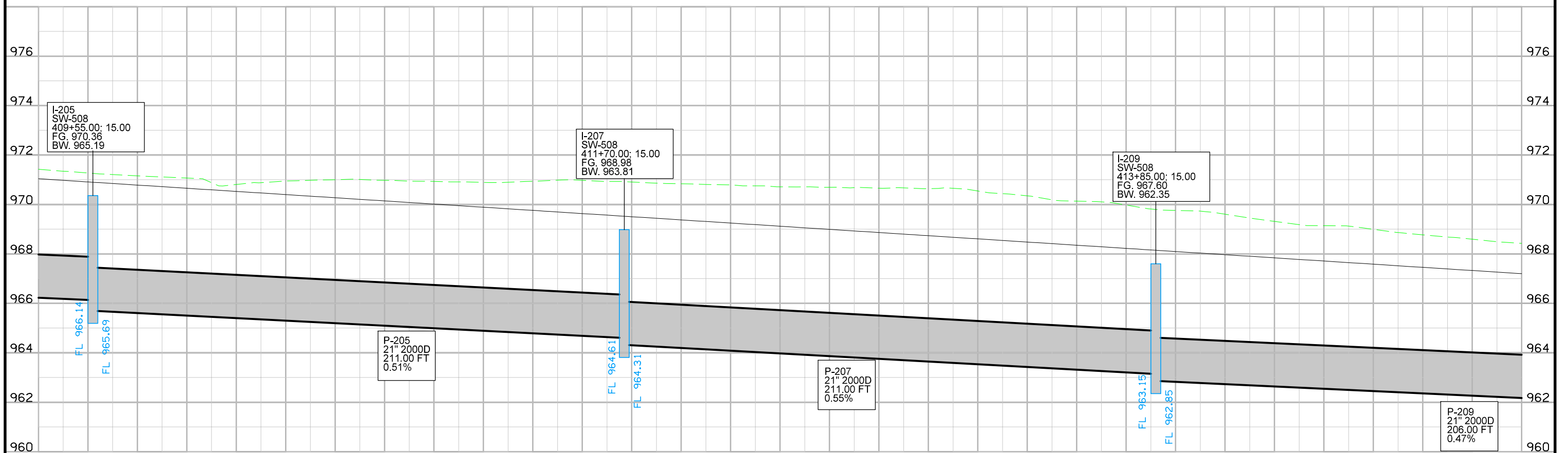
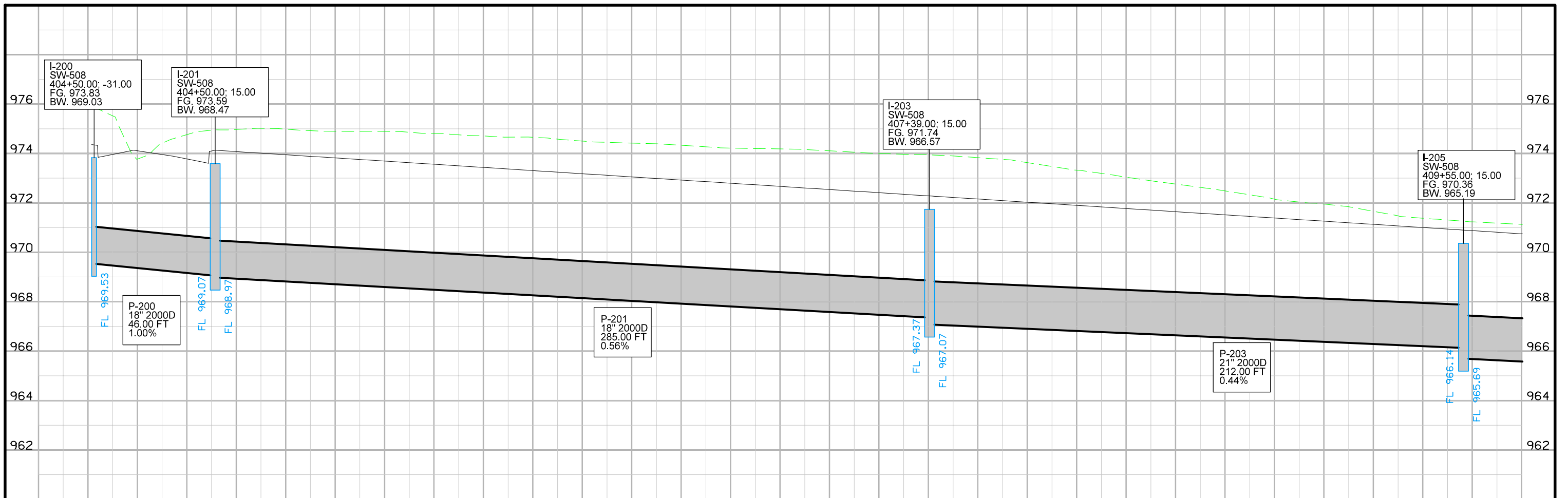

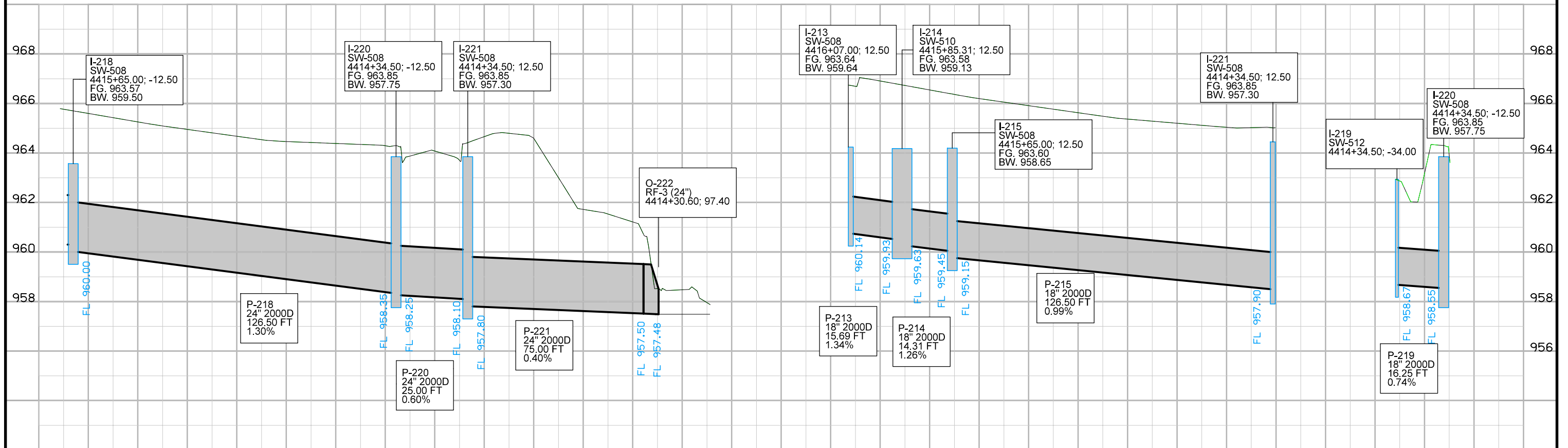
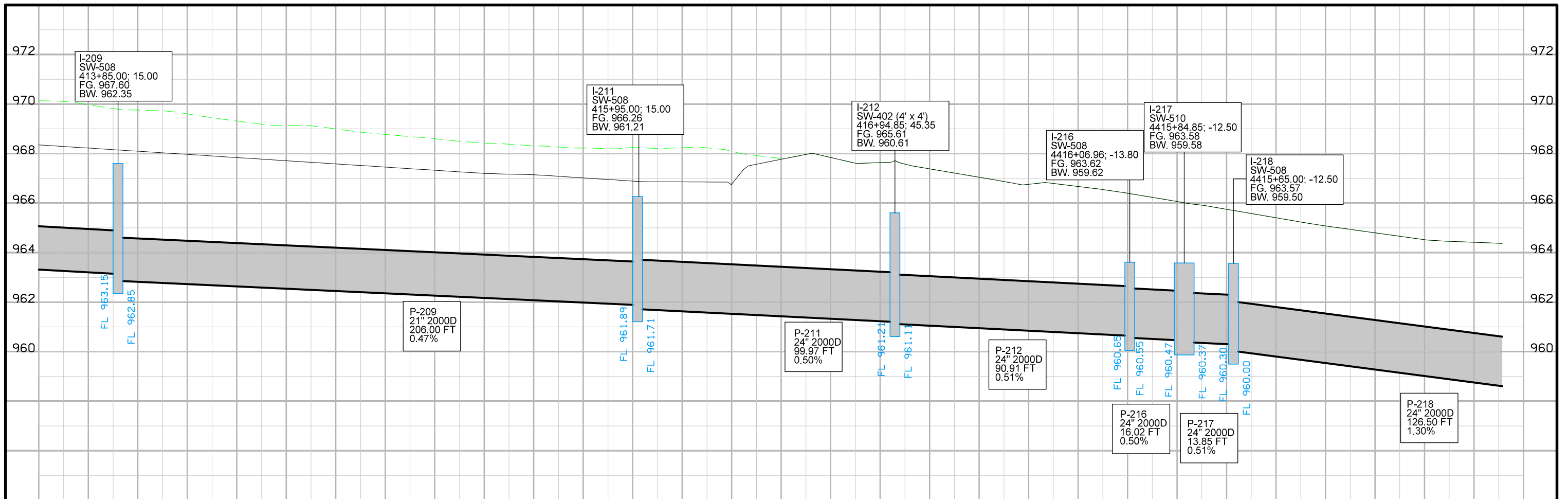

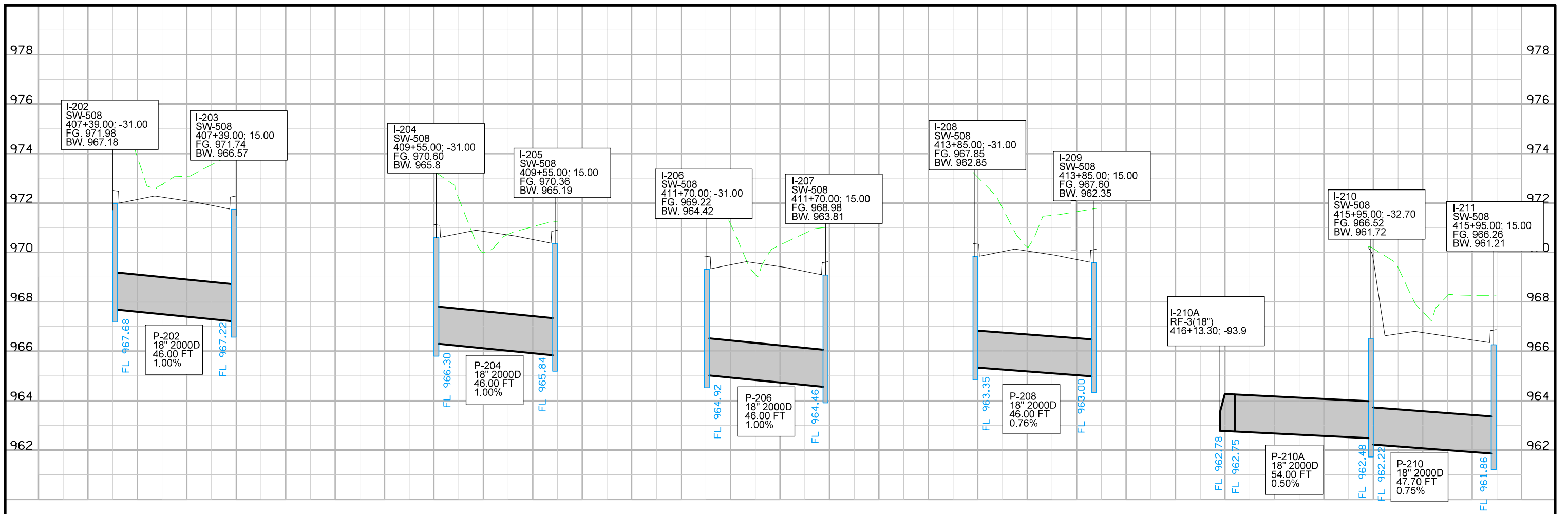

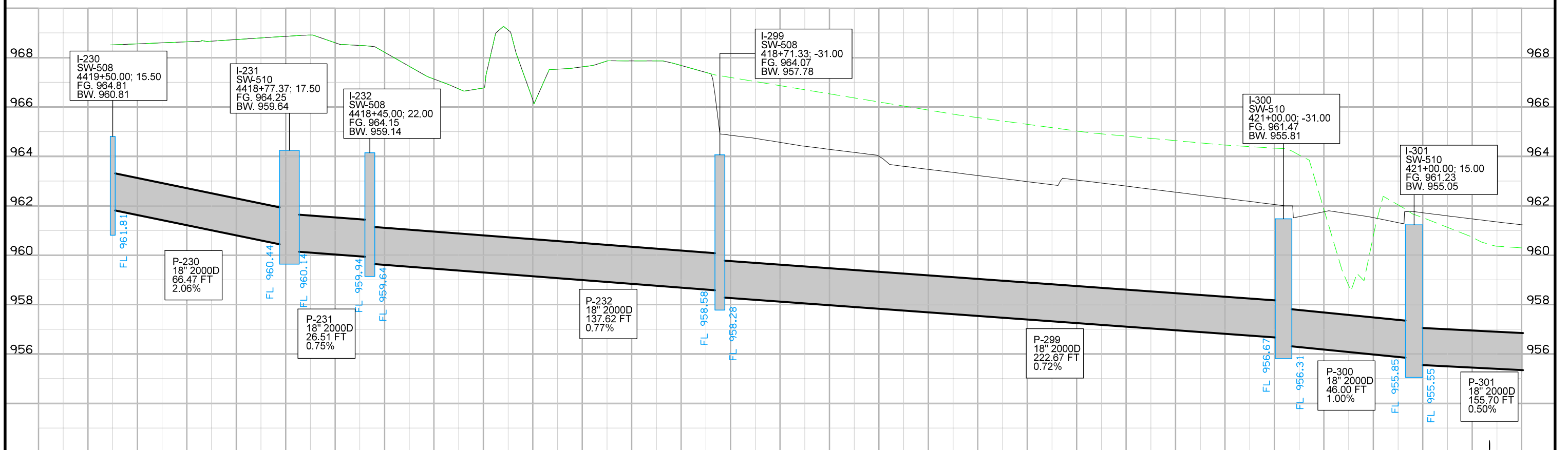
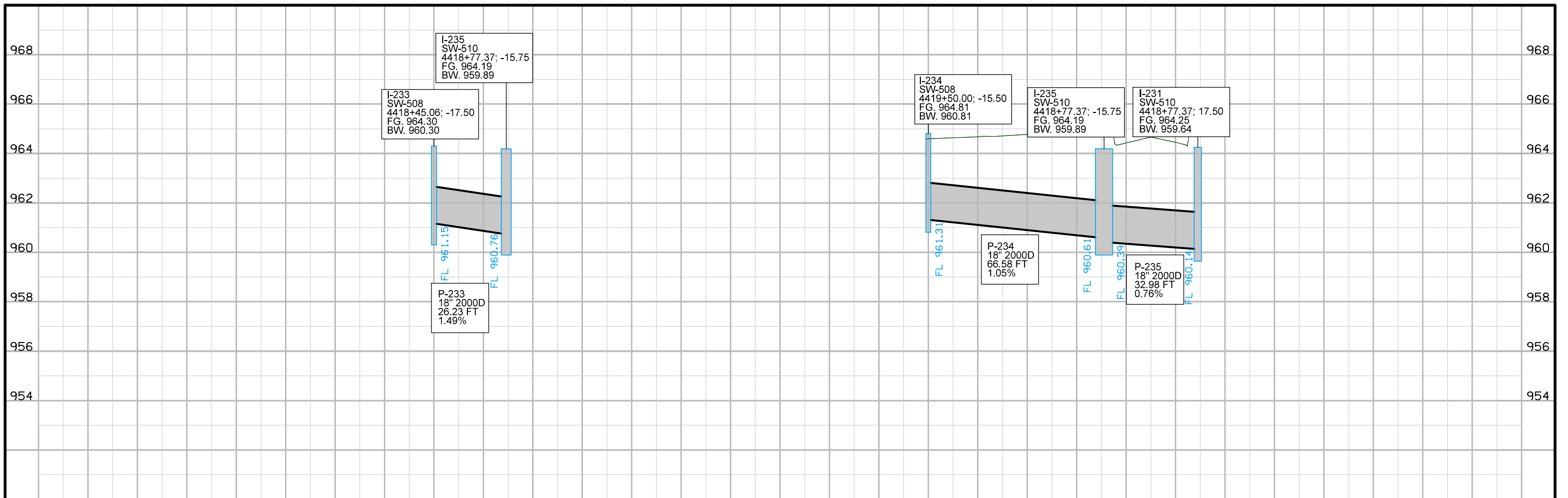

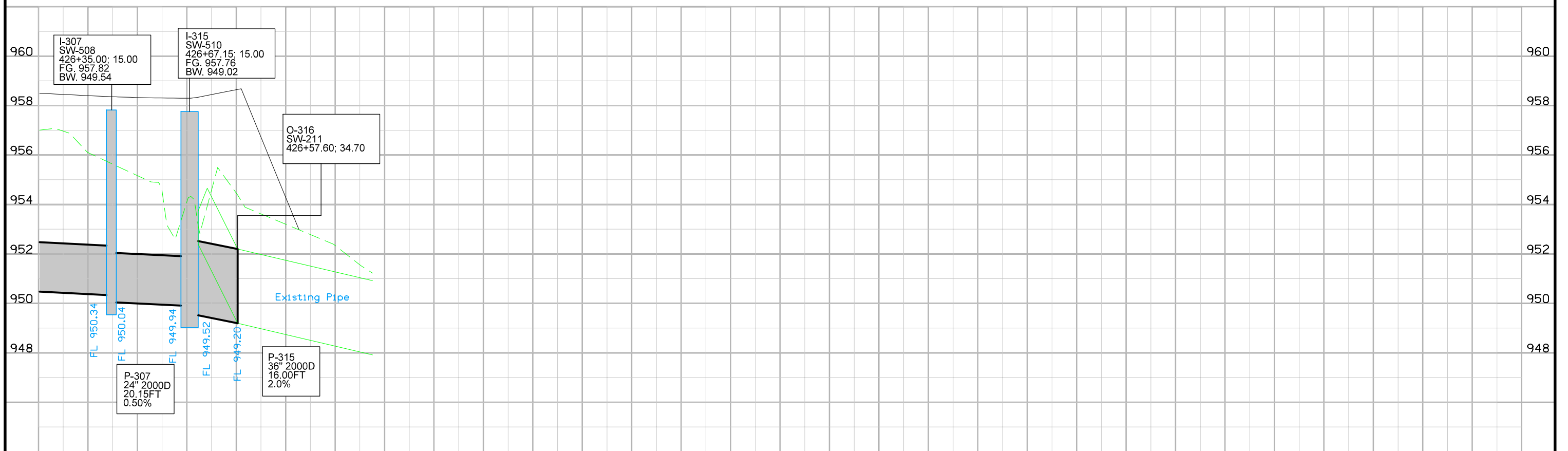
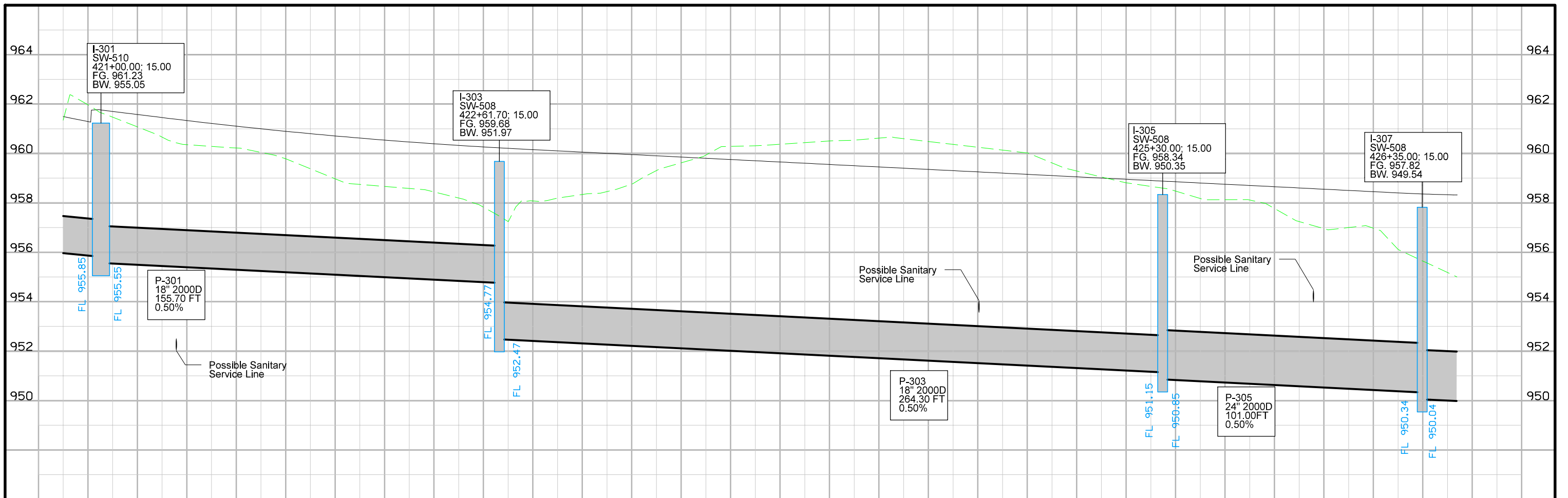

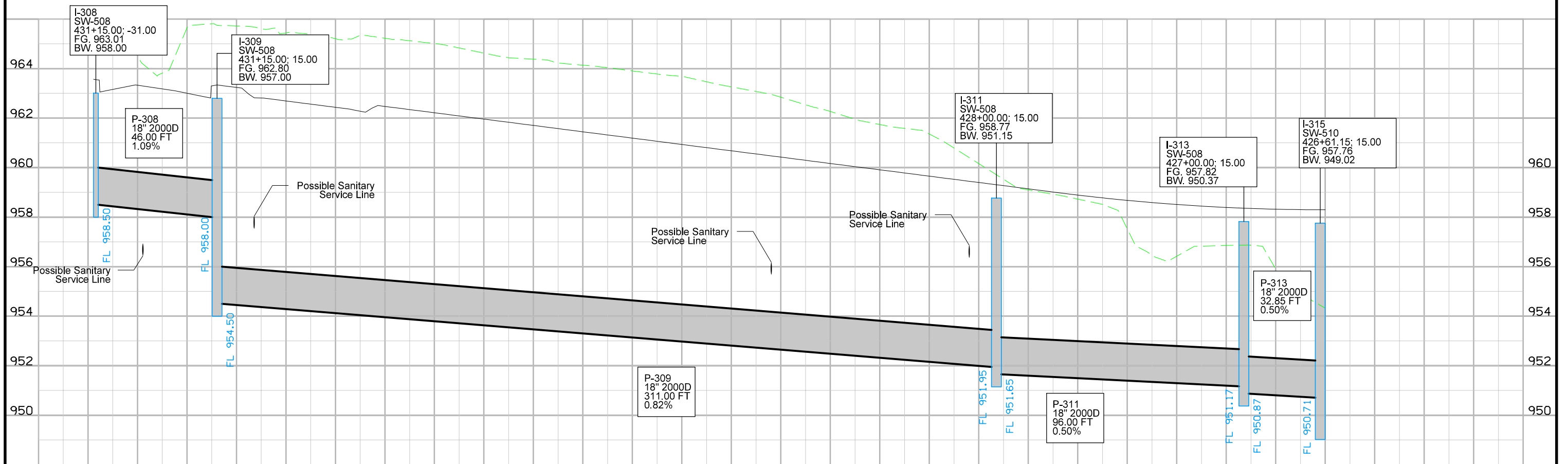
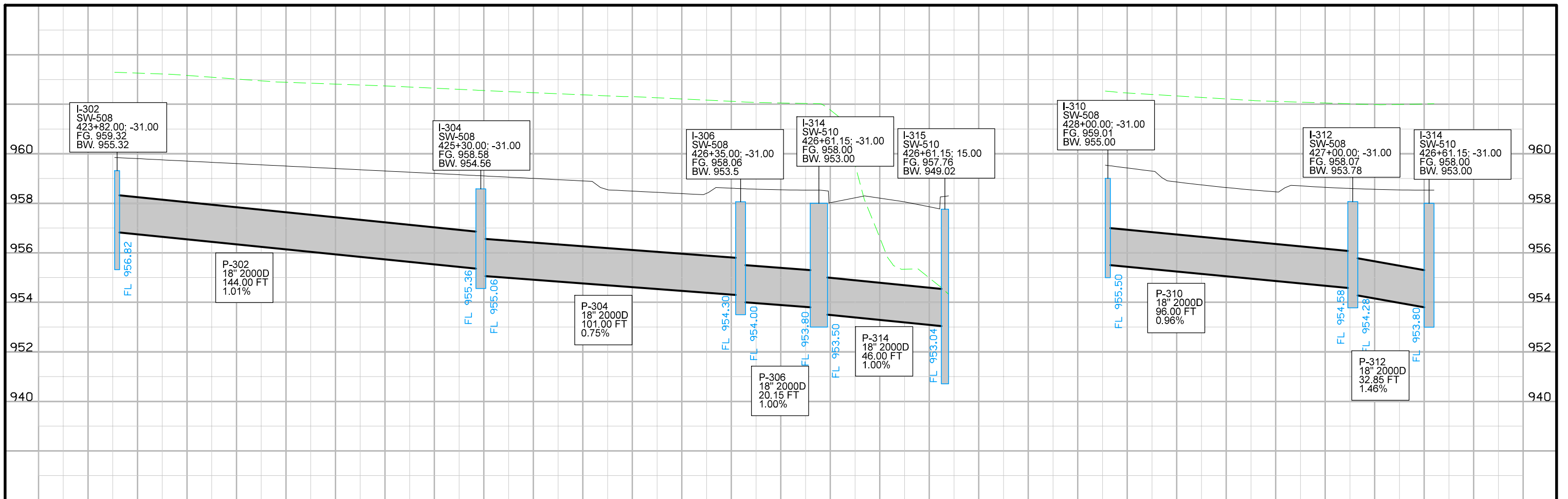

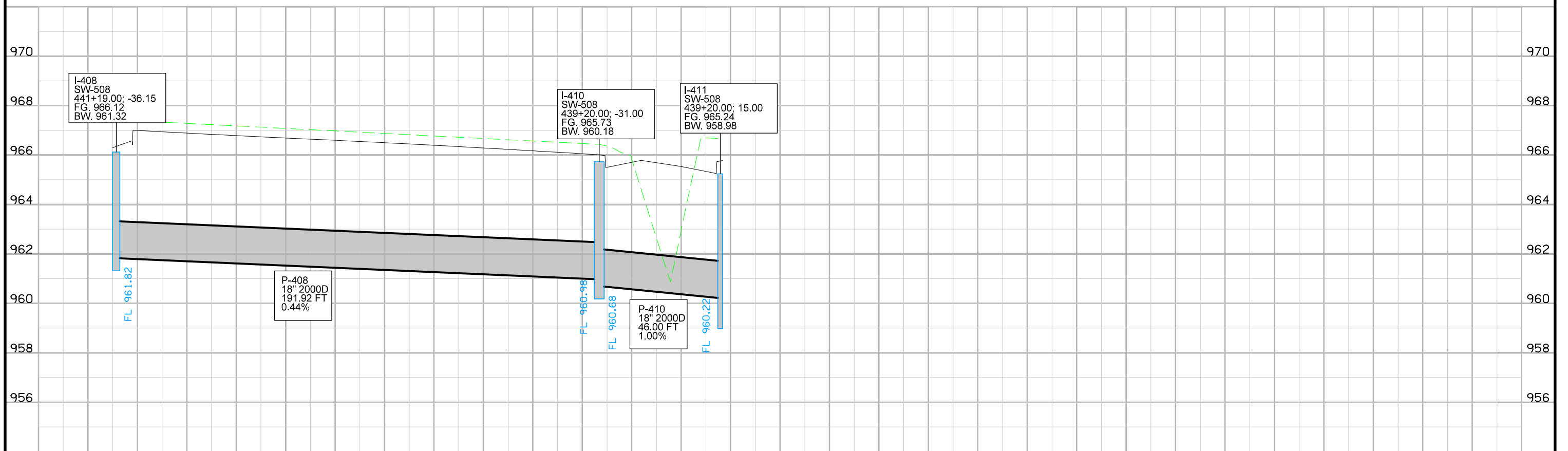
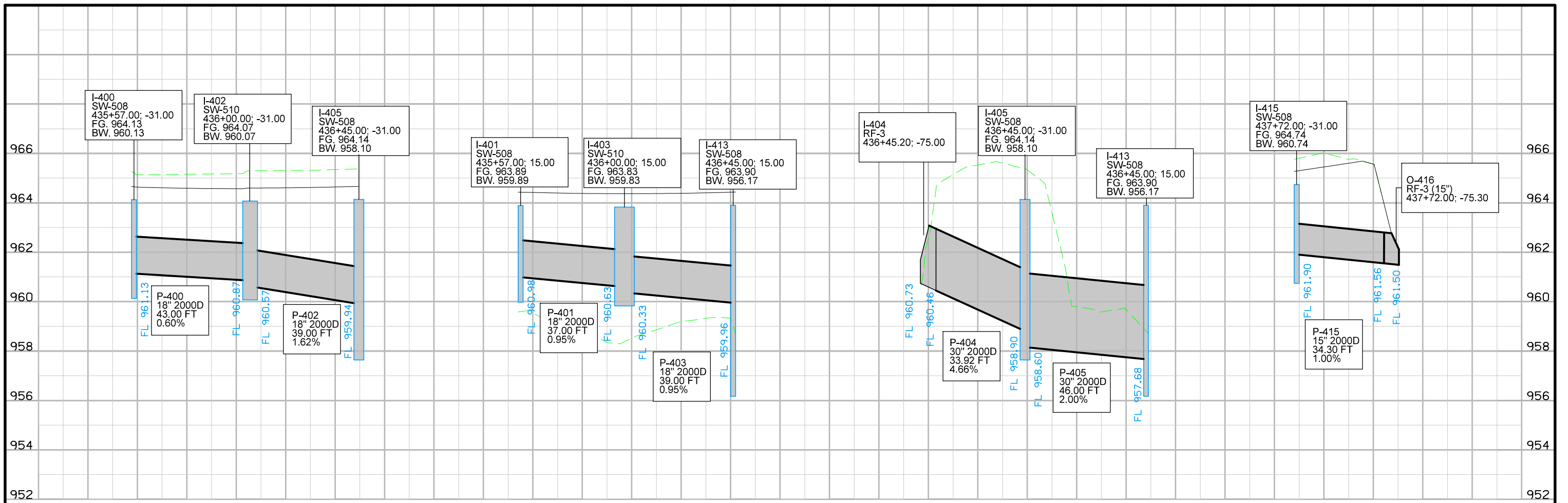

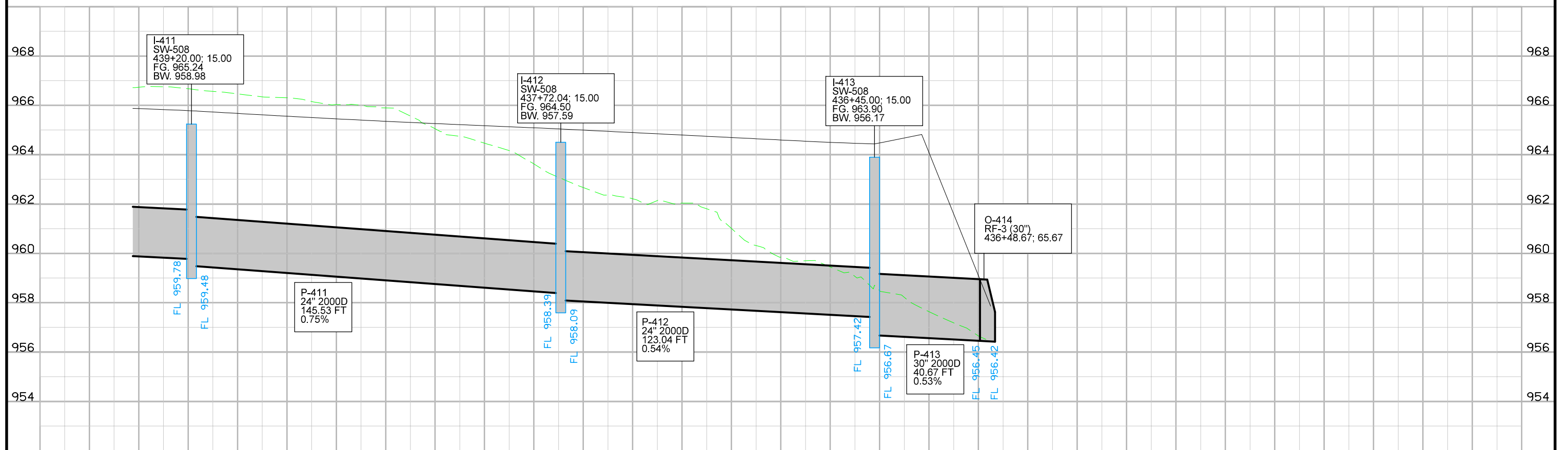
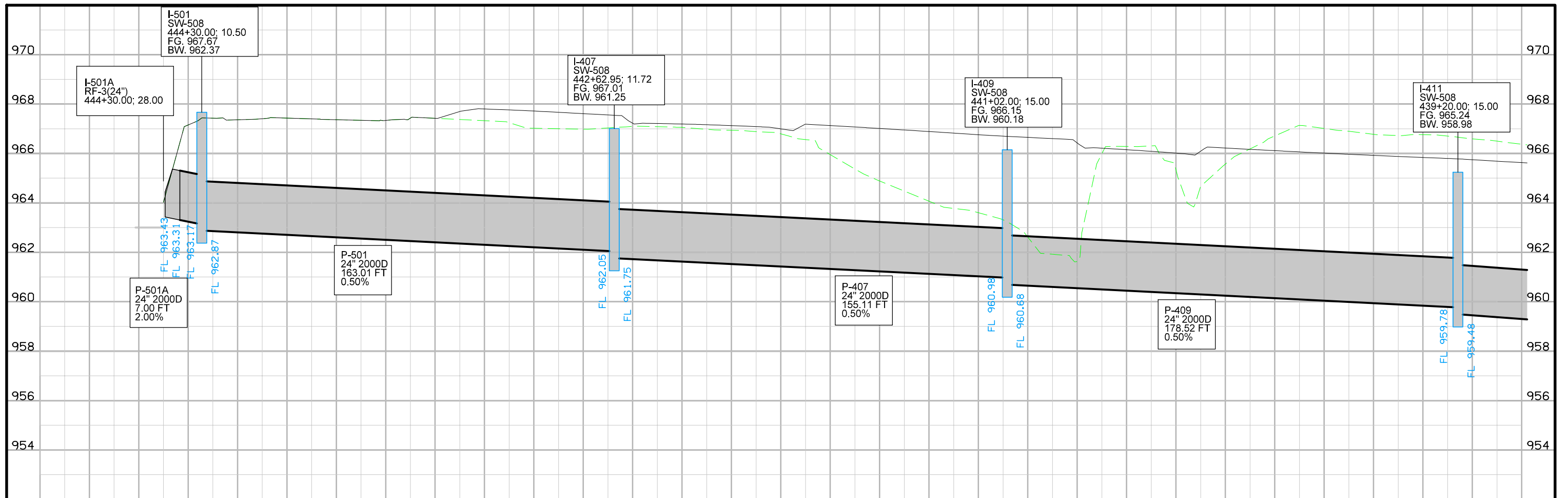

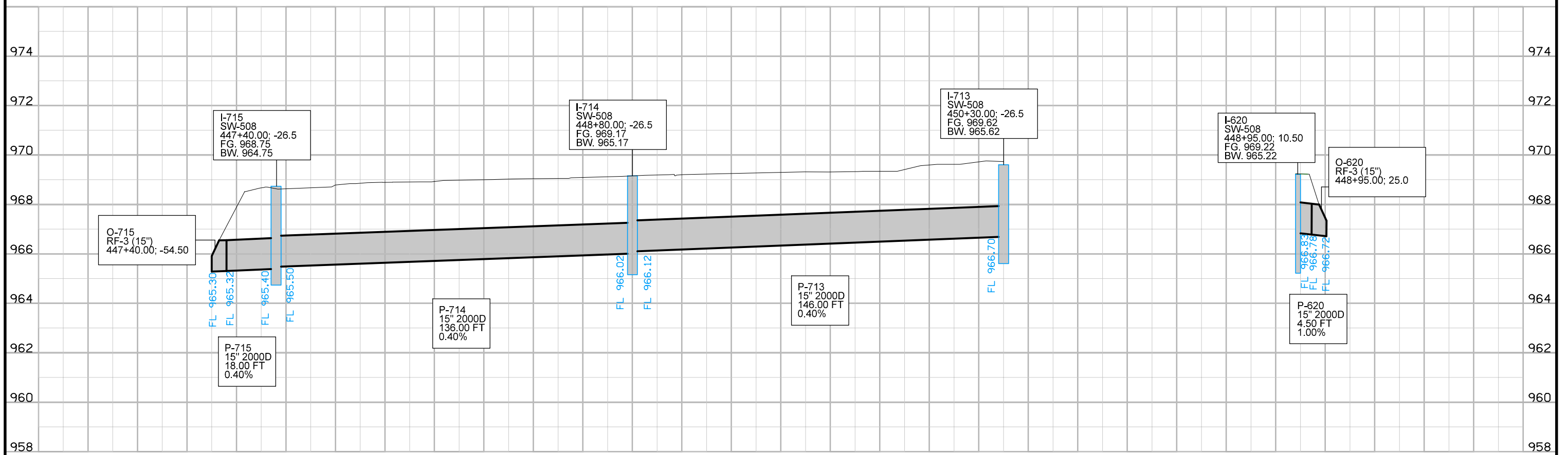
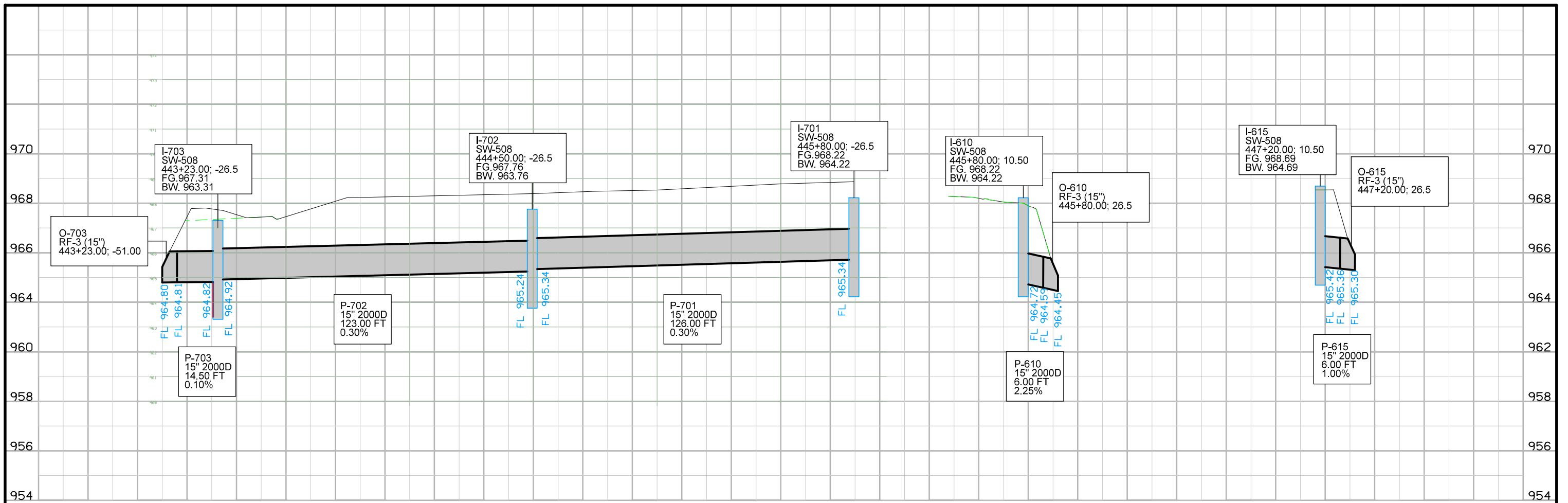

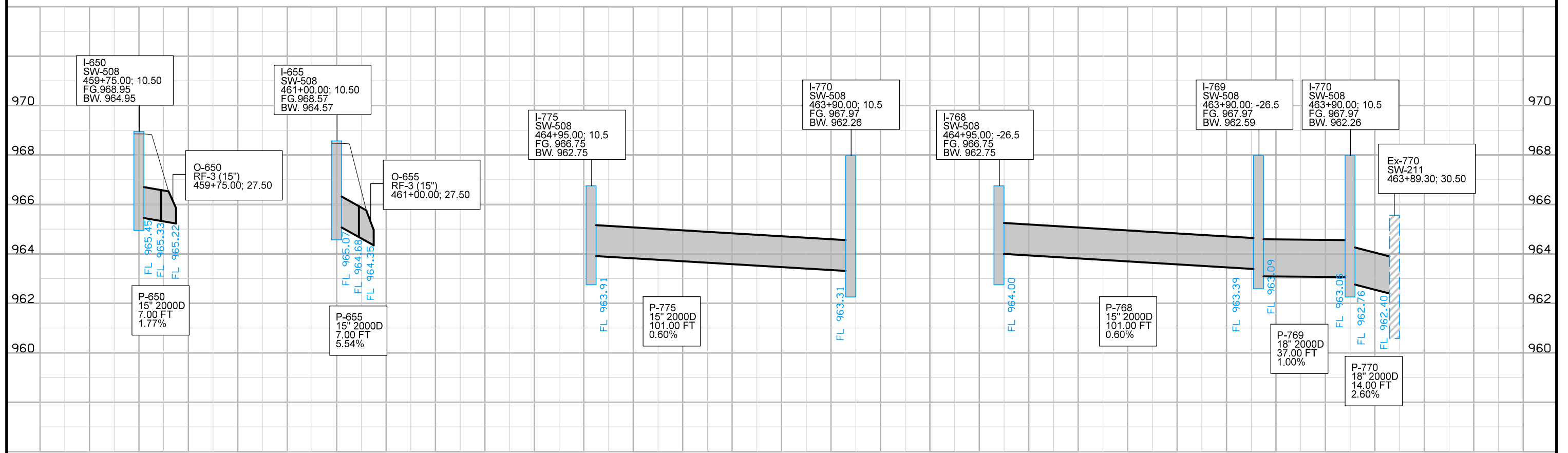
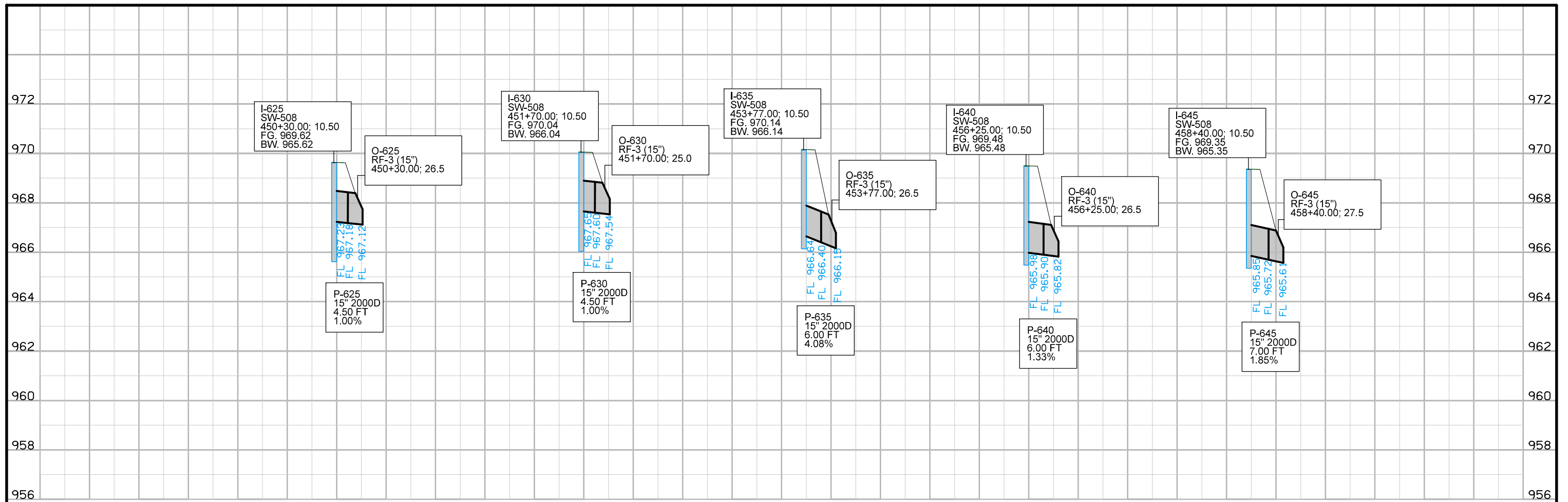

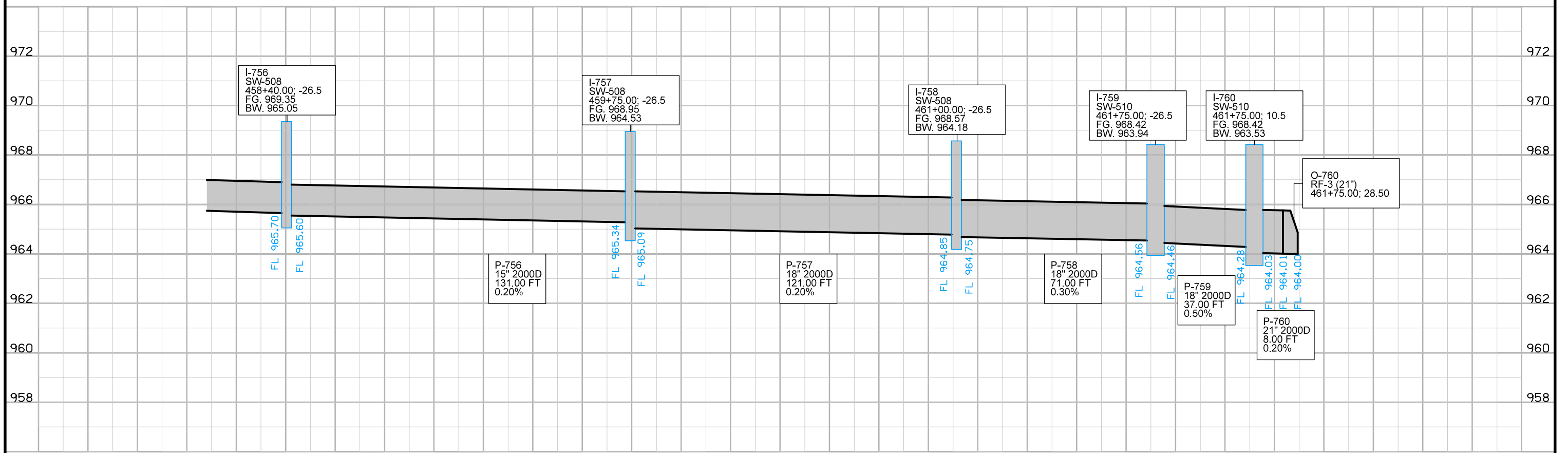
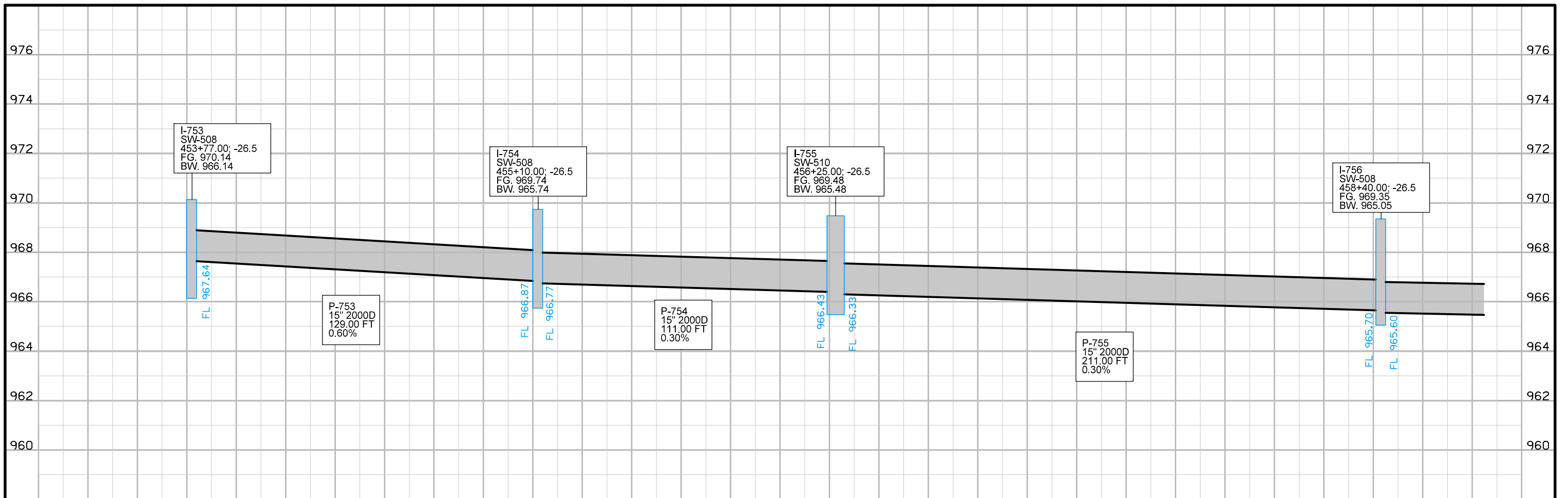

SURVEY SYMBOLS

UTILITY LEGEND

PLAN VIEW COLOR LEGEND OF SOILS SHEETS

LINEWORK	Design Color No.	
Green	(2)	Existing Topographic Features and Labels
Purple (Halo)	(15)	Backslope Drains
Blue	(1)	Proposed Alignment, Stationing, Tic Marks, and Alignment Annotation
SHADING	Design Color No.	
Brown, Light	(236)	Core Out

PROFILE VIEW COLOR LEGEND OF SOILS SHEETS

LINEWORK	Design Color No.	
Blue	(1)	Proposed Alignment, Stationing, and Alignment Annotation
Green	(2)	Existing Ground Line Profile
Green, Med	(227)	Class 10 Topsoil
Green, M.Light	(226)	Unsuitable A Topsoil
Green, Light	(225)	Unsuitable B Topsoil
Green, V.Light	(224)	Unsuitable C Topsoil
Orange	(6)	Loam
Brown, Dark	(238)	Class 10
Brown, Med	(237)	Sand
Red	(3)	Unsuitable A
Pink, Dark	(13)	Unsuitable B
Pink	(11)	Unsuitable C
Red	(3)	Shale
Red	(3)	Waste
Gray, Light	(48)	Broken and Weathered Rock
Gray, Med	(80)	Rock
Gray, V.Dark	(128)	Boulders

PATTERN AND SYMBOL LEGEND OF SOILS SHEETS

Soils Book No.	Date(s) Drilled		
Water	Dry	Treatment	Unsuitable A Topsoil
Sample	Plugged	Sand Blanket	Unsuitable B Topsoil
Moisture	Shelby	Soil Remediation Area	Unsuitable C Topsoil
Blow Count	Dens. Core	Select Soil	Unsuitable A
		Select Sand	Unsuitable B
		Shale	Unsuitable C
		Broken and Weathered Rock	Sandy Soil
		Rock	Boulders
		Sandstone	

Reference Point	Survey Line
Station	Section Corner
Ground Line Intercept	Saw Cut
Guardrail	Clearing & Grubbing Area
Pavement Removal	

RIGHT-OF-WAY LEGEND	
	Proposed Right-of-Way
	Existing and Proposed Right-of-Way
	Easement and Existing Right-of-Way
	Borrow
	Easement (Temporary)
	Easement
	Excess
	A/C Access Control

NOTE: Sounding and test boring data shown in the plans were accumulated for designing and estimating purposes. Their appearance on the plans does not constitute a guarantee that conditions other than those indicated will be encountered. Details and notes shown elsewhere shall be used for roadway and structure construction.

SOILS LEGEND AND SYMBOL INFORMATION SHEET

(COVERS SHEET SERIES Q & R)

Lincoln TWP.
T-76N R-24W
SEC. 29

Special attention should be given to Section 2107.03.C, Standard Specification Series of 2012, on this project.

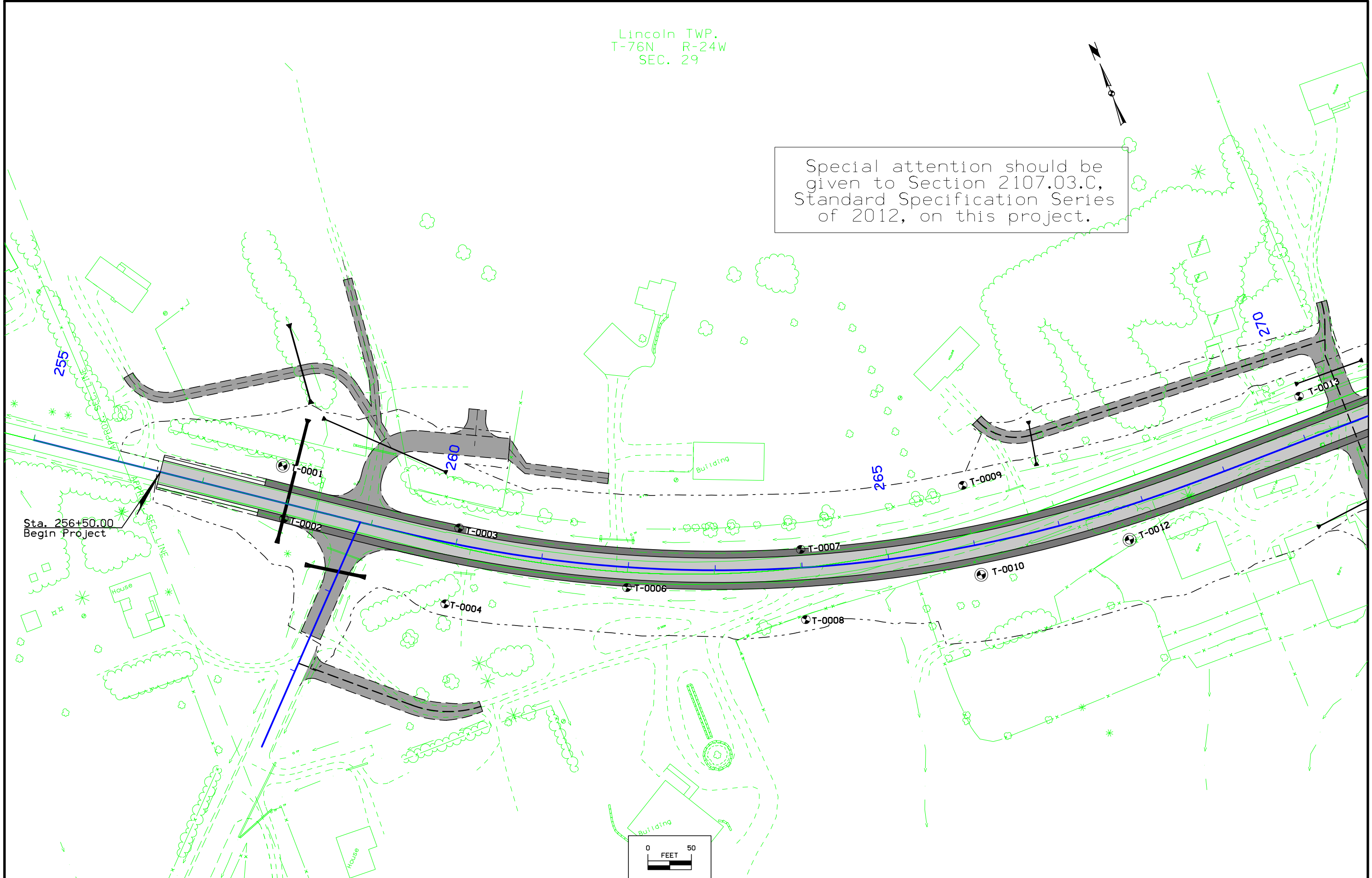

CUT MOISTURE
CUT DENSITY (lb/ft³)
PLASTIC LIMIT

20,27,22
102,94,104
20,23,16

24
96
22

23,30,25
96,88,96
21,21,16

28
Disturbed

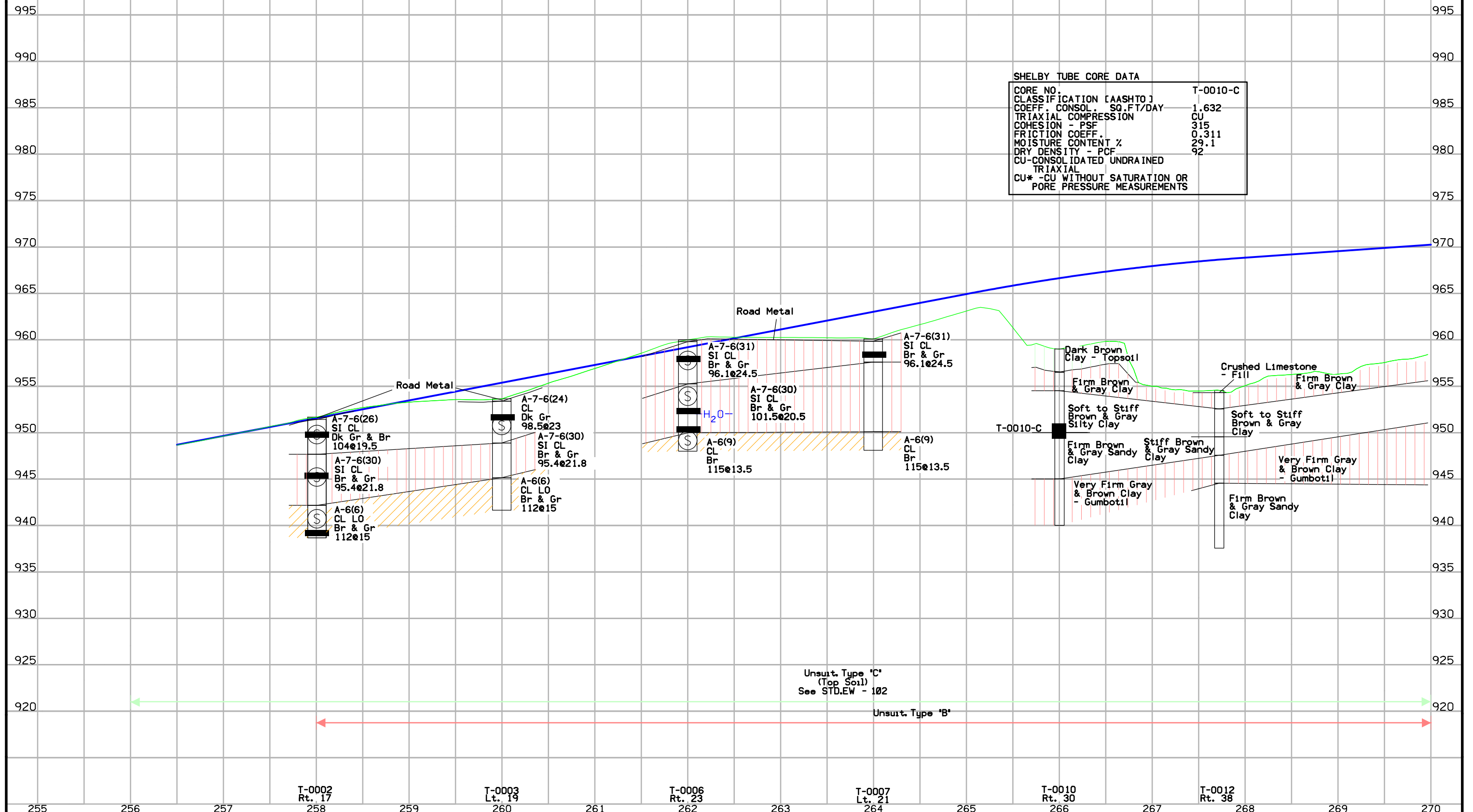

Lincoln TWP.
T-76N R-24W
SEC. 29

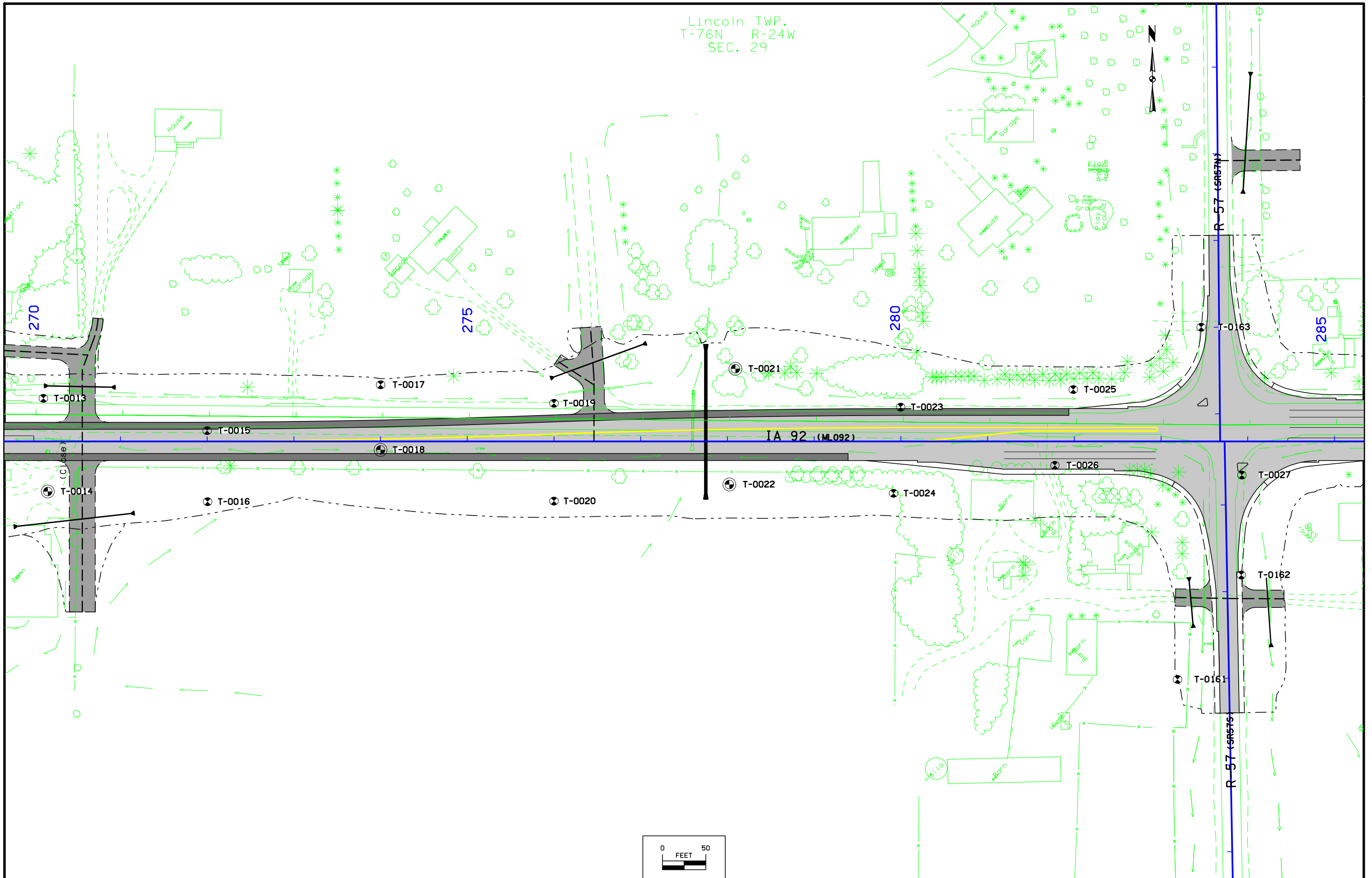

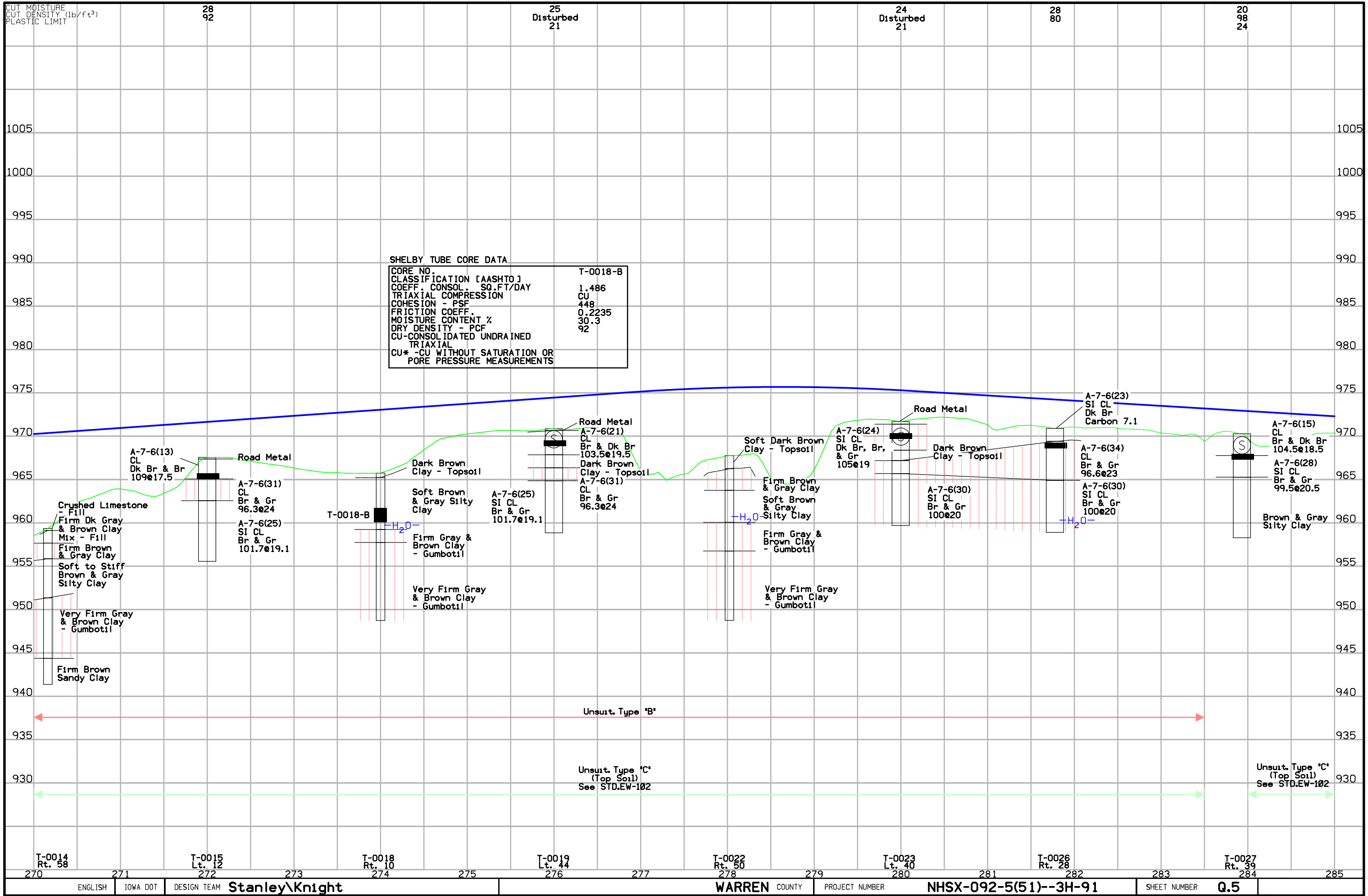

Lincoln TWP.
T-76N R-24W
SEC. 29

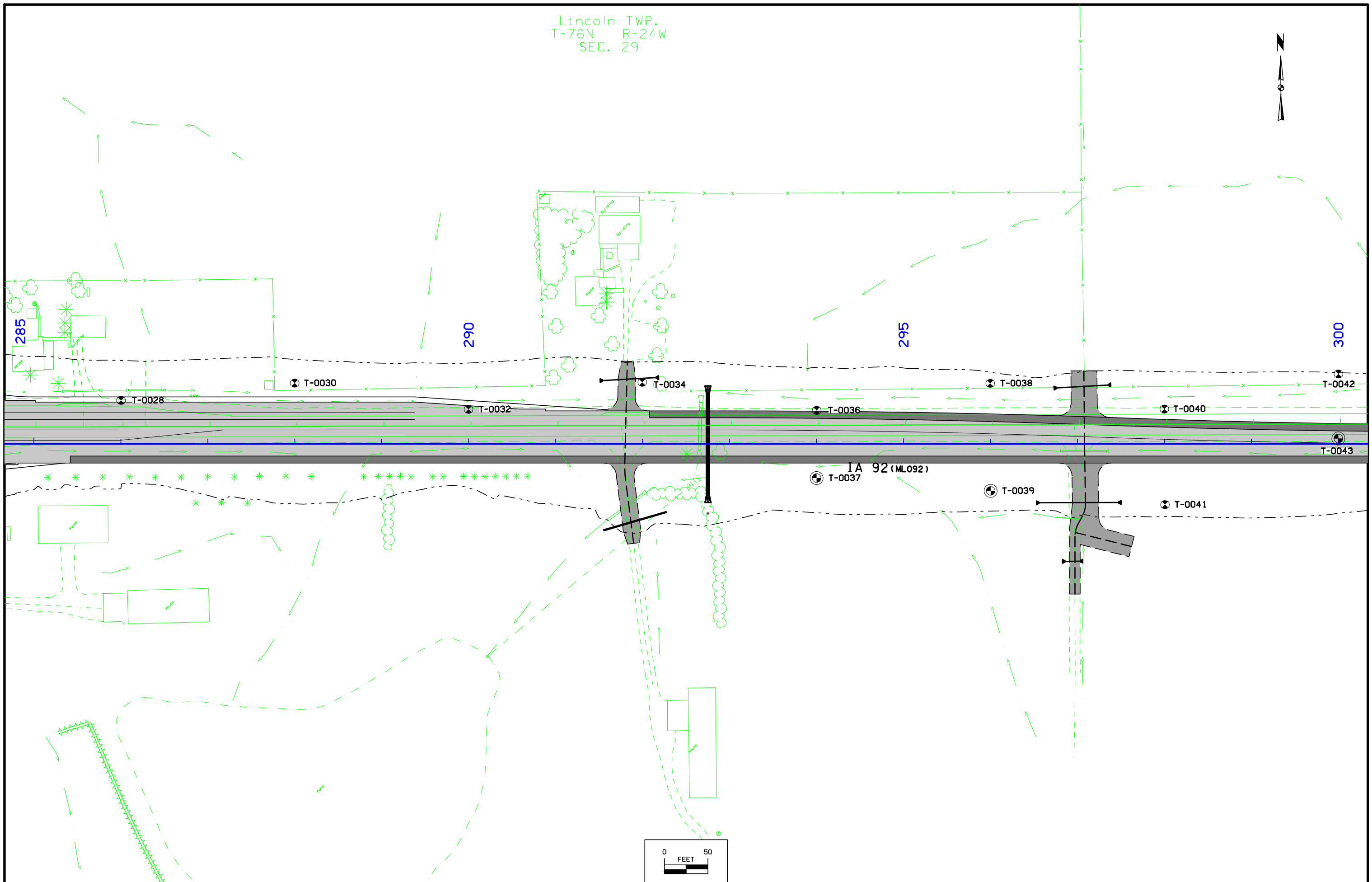

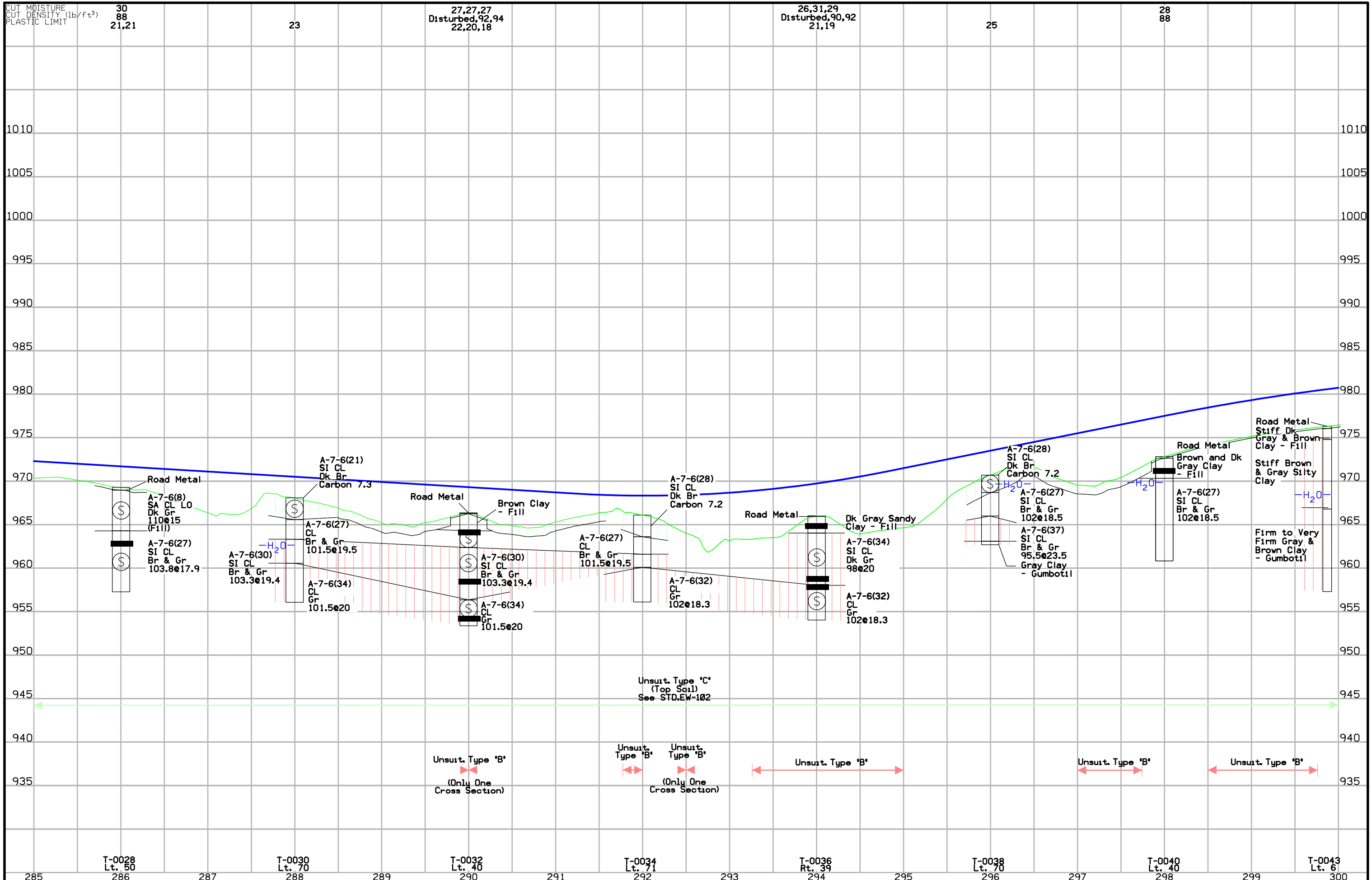

Lincoln TWP.
T-76N R-24W
SEC. 29

Lincoln TWP.
T-76N R-24W
SEC. 28

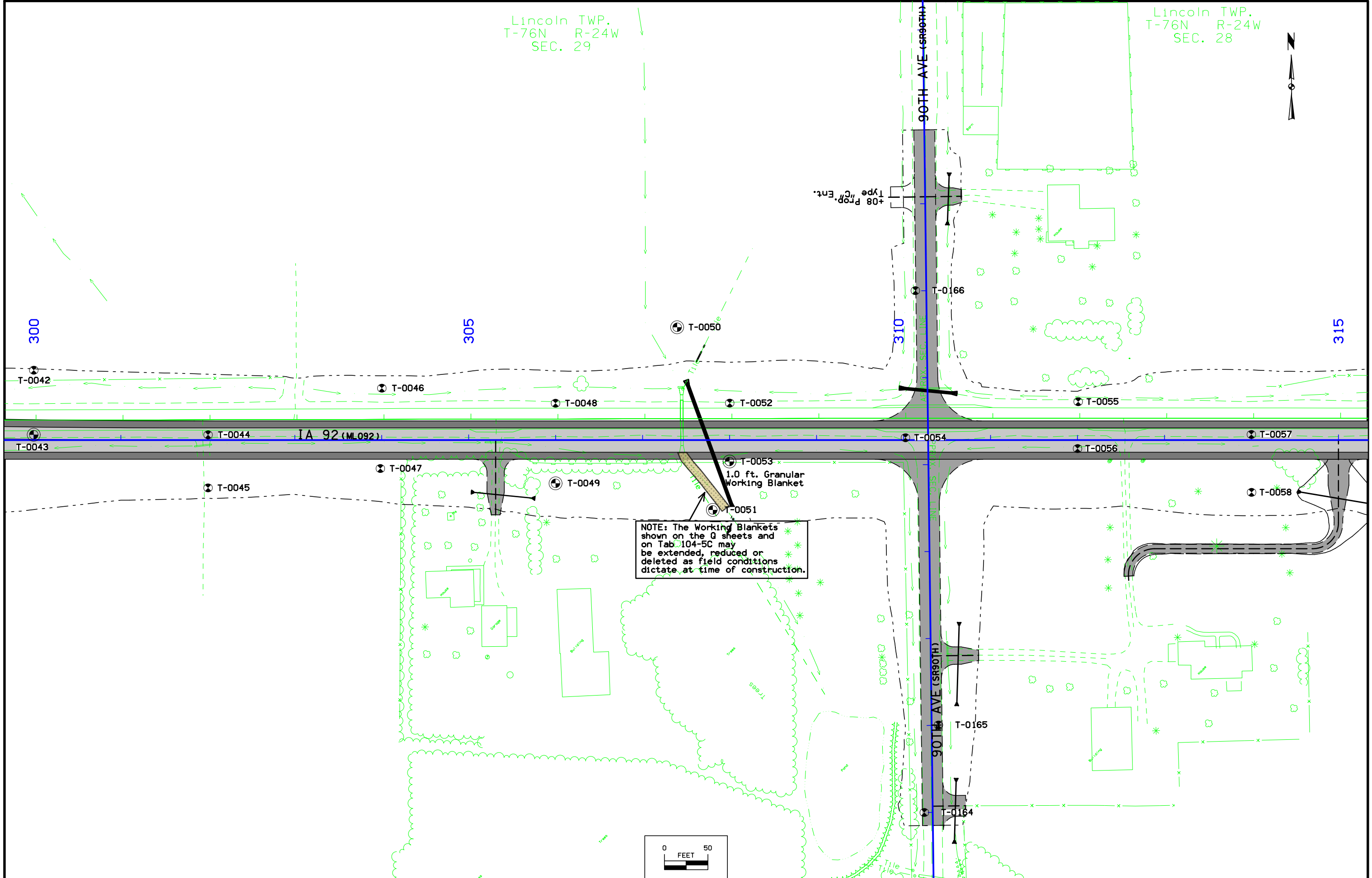

NOTE: The Working Blankets shown on the Q sheets and on Tab 104-5C may be extended, reduced or deleted as field conditions dictate at time of construction.

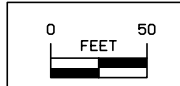

CUT MOISTURE
CUT DENSITY (lb/ft³)
PLASTIC LIMIT

26
93
22

30
84

25
81
25

29
93
20

26.26
94.97
17

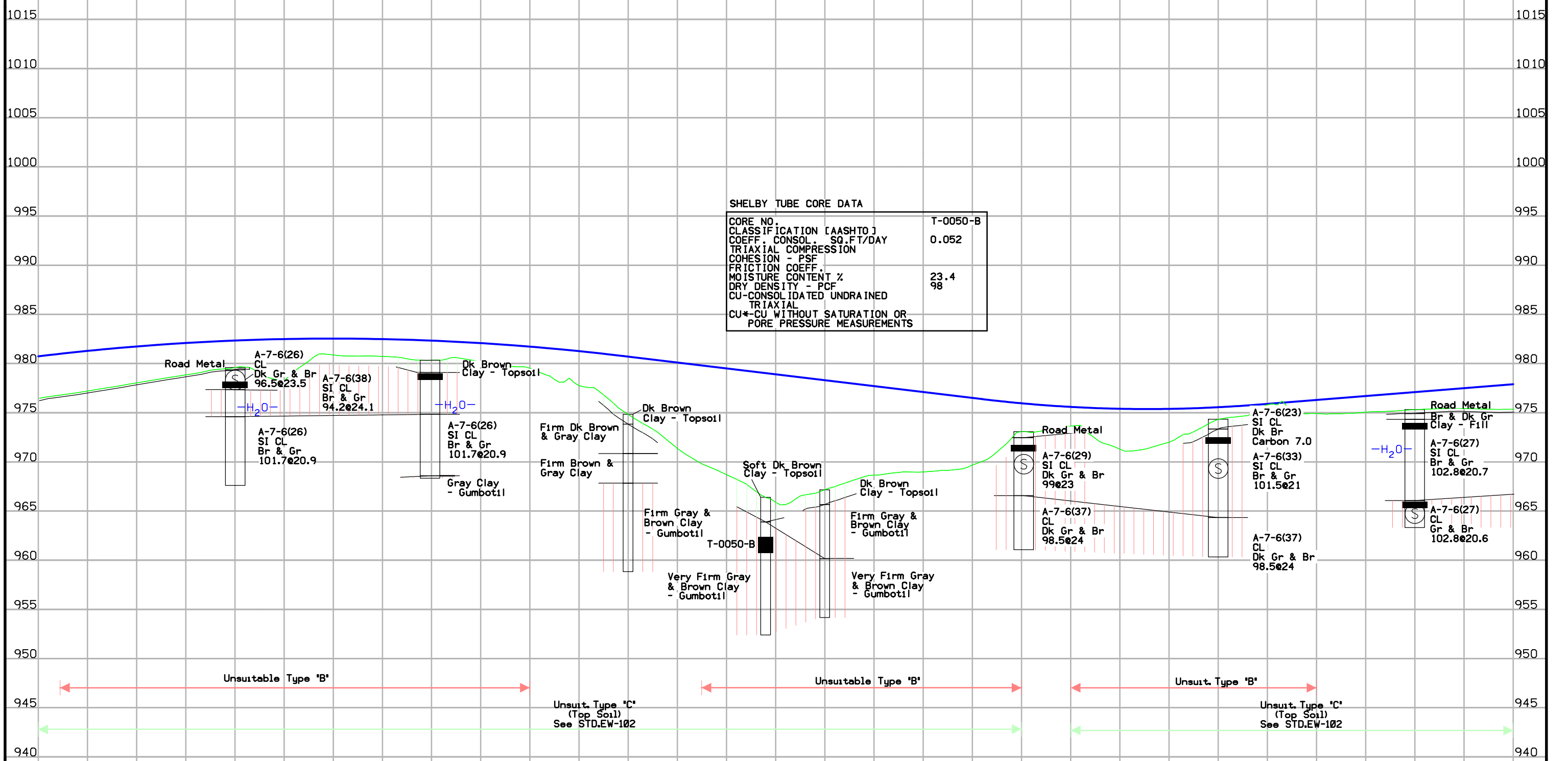

T-0044 Lt. 6 T-0047 Rt. 33 T-0049 Rt. 50 T-0050 Lt. 130 T-0053 Rt. 25 T-0054 Lt. 3 T-0056 Rt. 10 T-0057 Lt. 6

ENGLISH IOWA DOT DESIGN TEAM **Stanley\Knight** WARREN COUNTY PROJECT NUMBER **NHSX-092-5(51)--3H-91** SHEET NUMBER **Q.9**

Lincoln TWP.
T-76N R-24W
SEC. 28

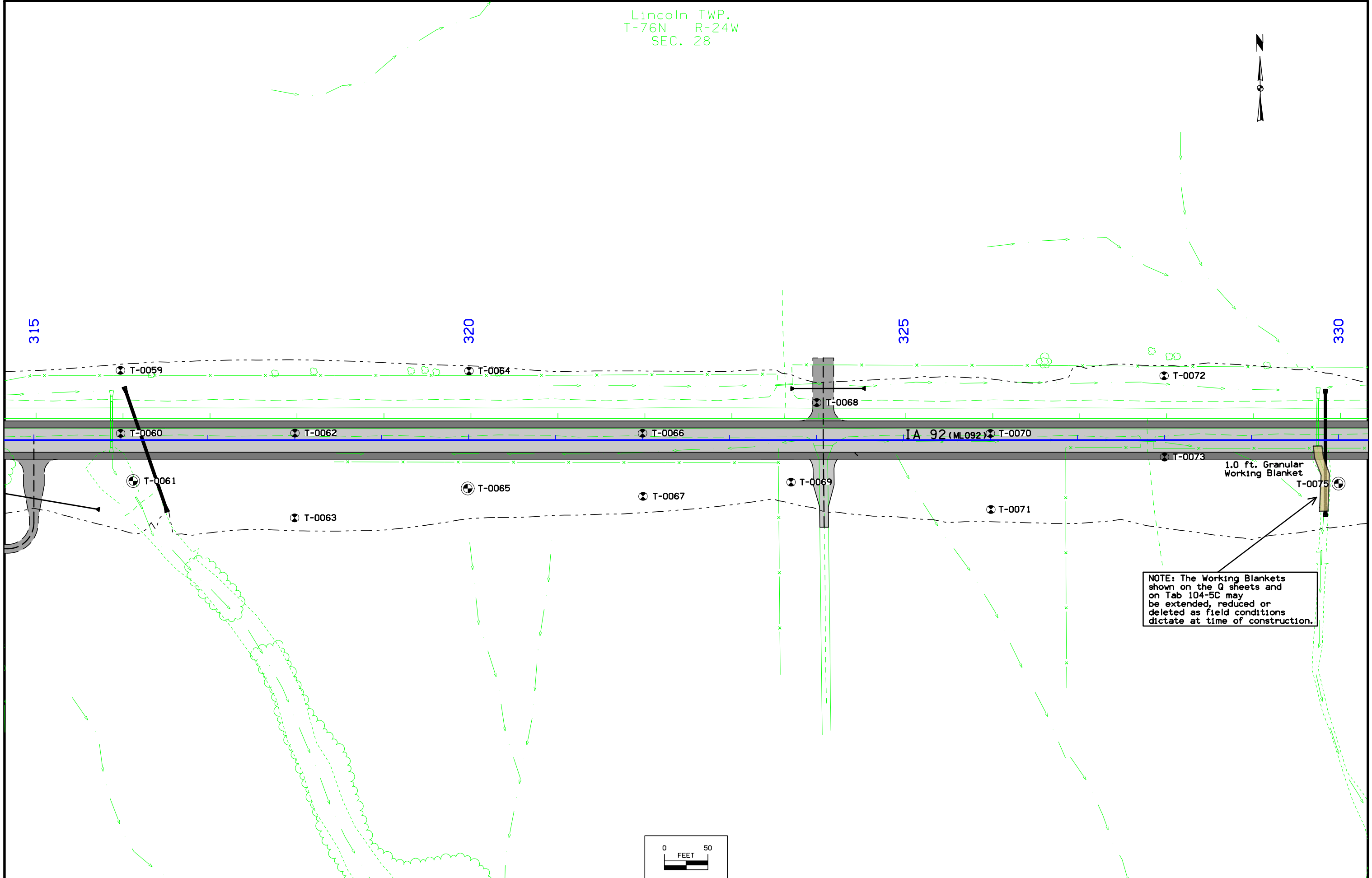

NOTE: The Working Blankets shown on the Q sheets and on Tab 104-5C may be extended, reduced or deleted as field conditions dictate at time of construction.

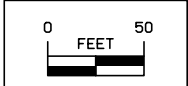

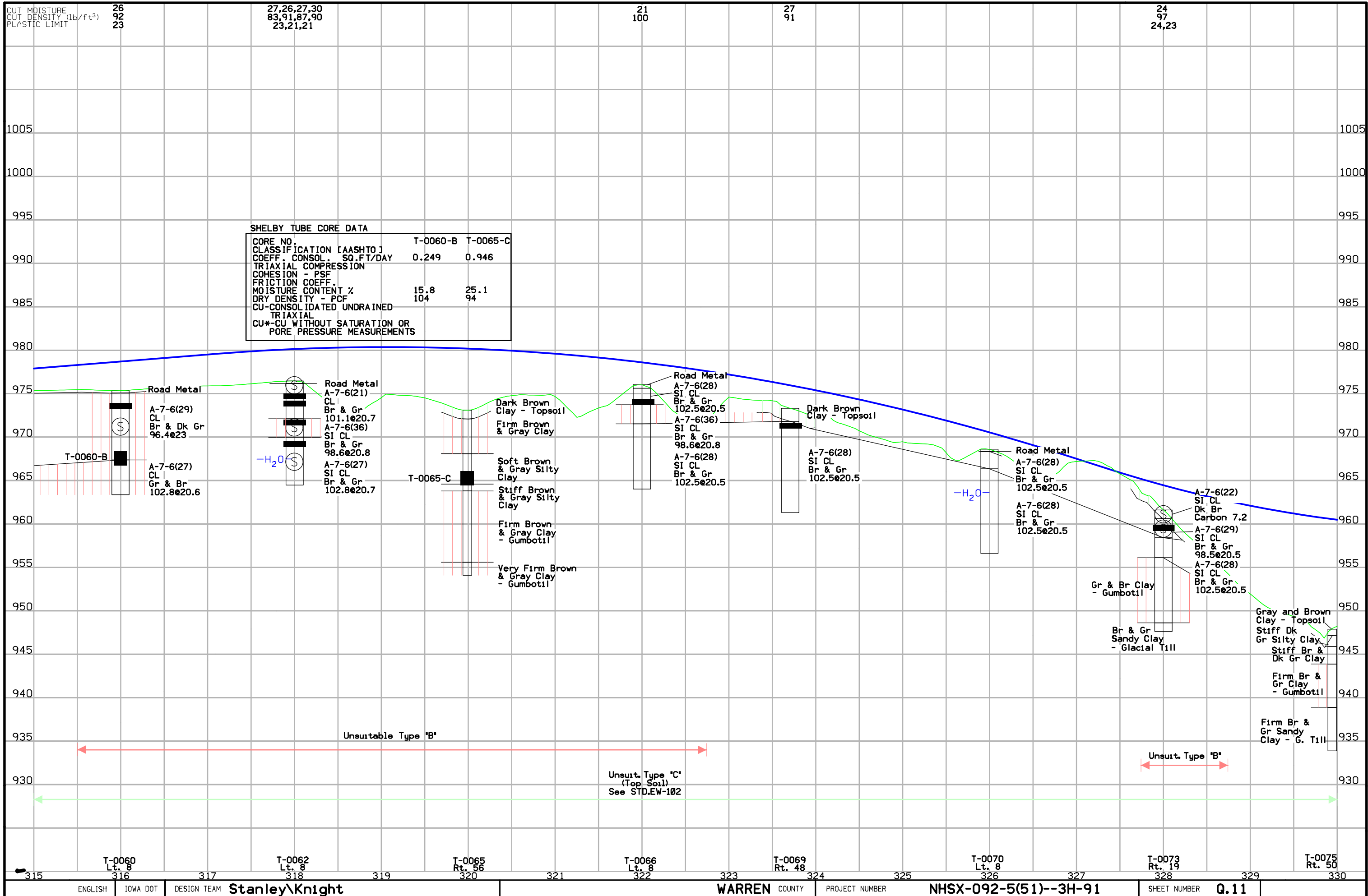

Lincoln TWP.
T-76N R-24W
SEC. 28

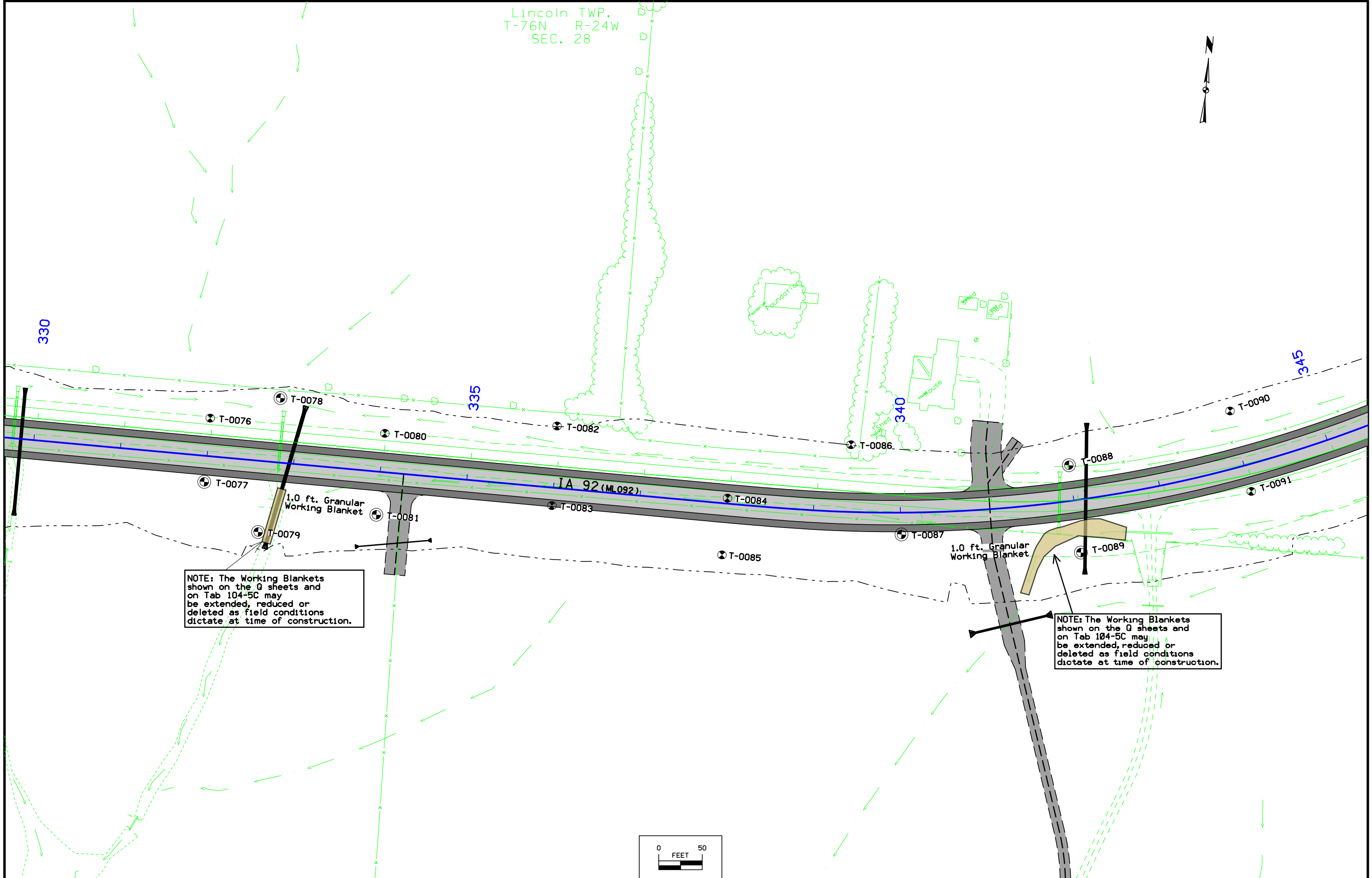

NOTE: The Working Blankets shown on the Q sheets and on Tab 104-5C may be extended, reduced or deleted as field conditions dictate at time of construction.

NOTE: The Working Blankets shown on the Q sheets and on Tab 104-5C may be extended, reduced or deleted as field conditions dictate at time of construction.

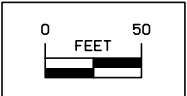

CUT MOISTURE
CUT DENSITY (lb/ft³)
PLASTIC LIMIT

28
89
24

24,28
95,97
22

27

24,25,31,33
93,90,86,85
24,21

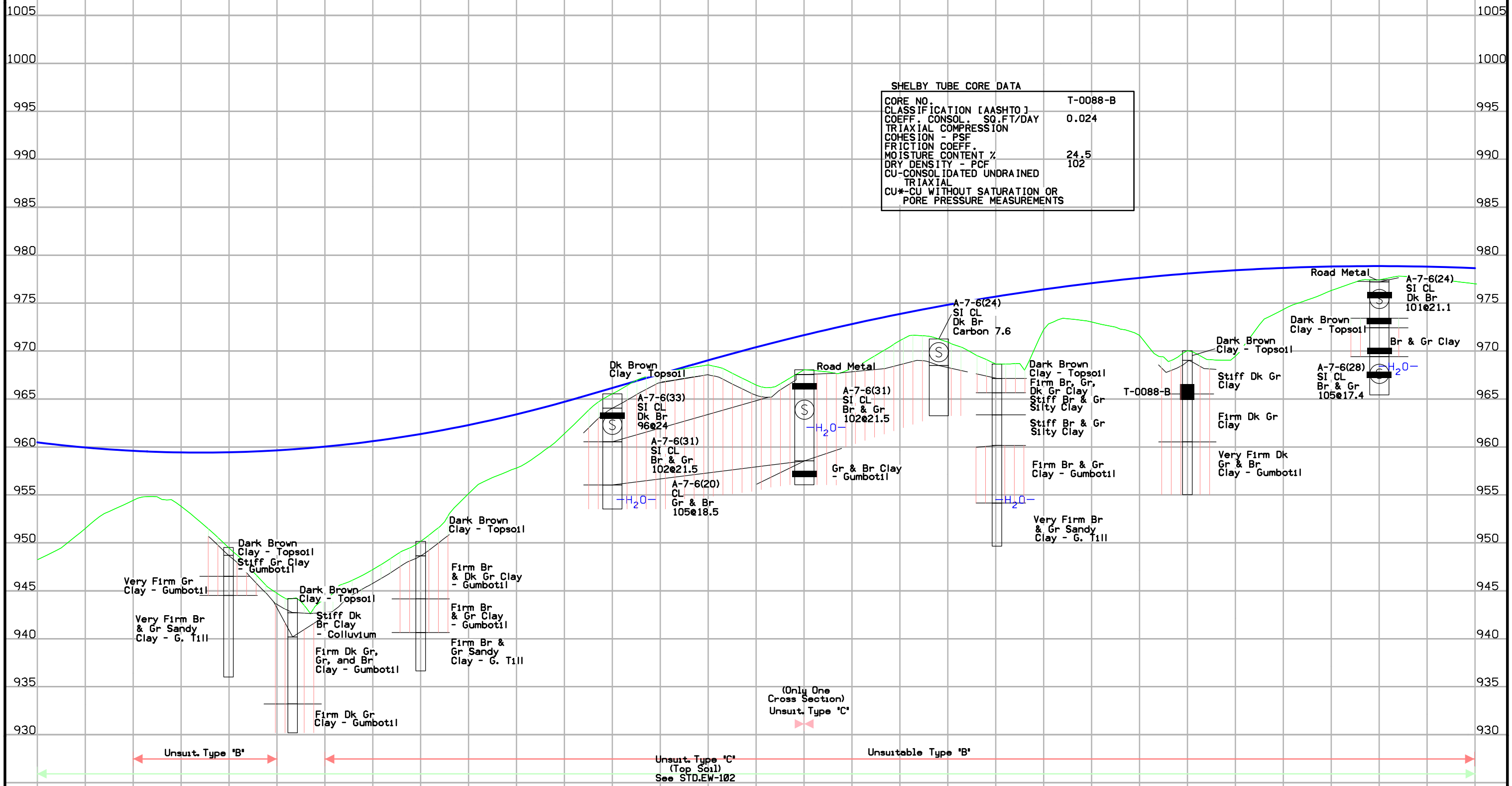

T-0077 Rt. 30 T-0079 Rt. 82 T-0081 Rt. 50 T-0083 Rt. 21 T-0084 Lt. 6 T-0086 Lt. 77 T-0087 Rt. 25 T-0088 Lt. 41 T-0091 Rt. 31

ENGLISH IOWA DOT DESIGN TEAM **Stanley\Knight** WARREN COUNTY PROJECT NUMBER **NHSX-092-5(51)--3H-91** SHEET NUMBER **Q.13**

Lincoln TWP.
T-76N R-24W
SEC. 28

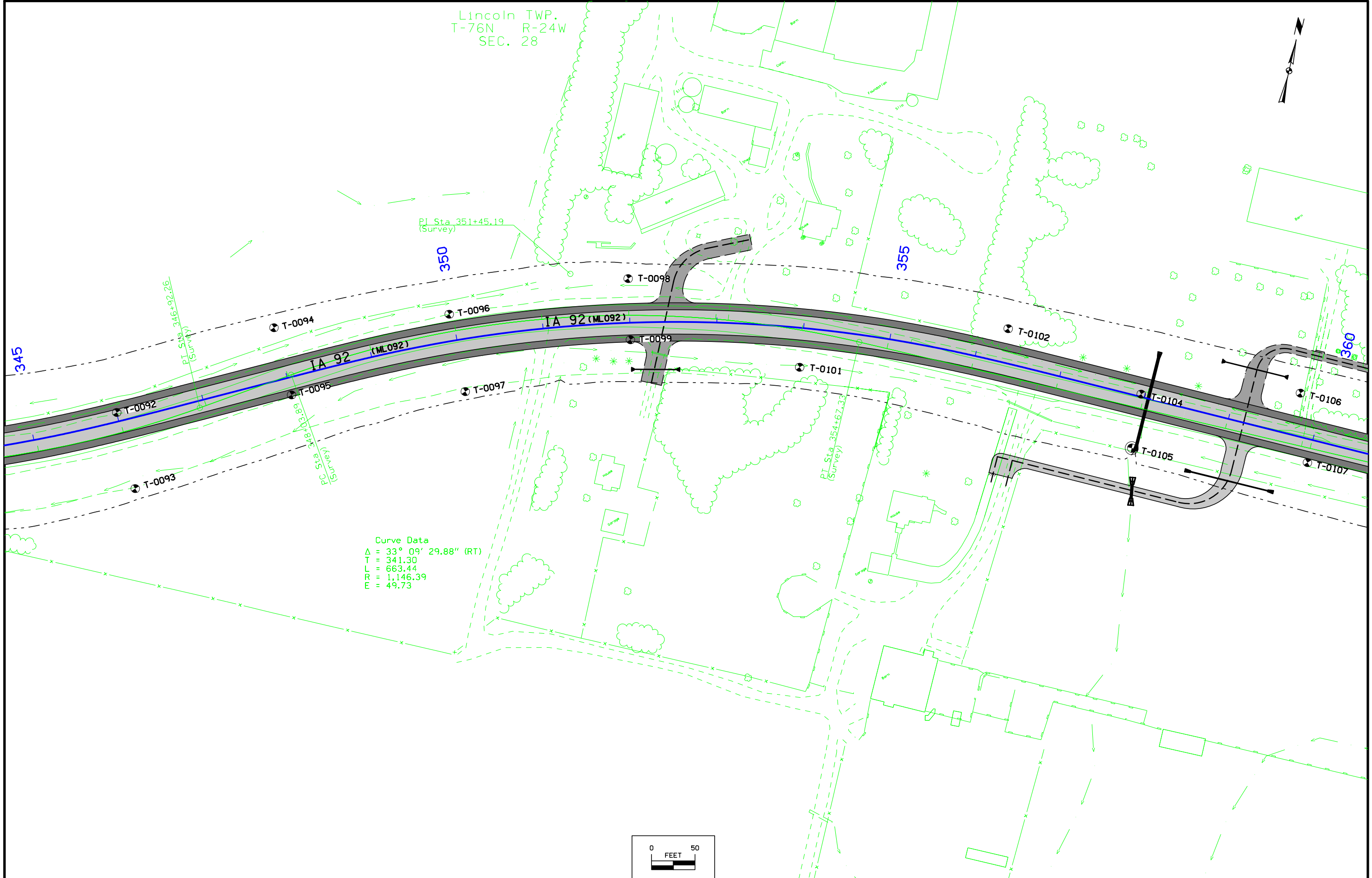

Curve Data
 $\Delta = 33^\circ 09' 29.88''$ (RT)
T = 341.30
L = 663.44
R = 1,146.39
E = 49.73

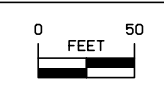

Lincoln TWP.
T-76N R-24W
SEC. 28

Lincoln TWP.
T-76N R-24W
SEC. 27

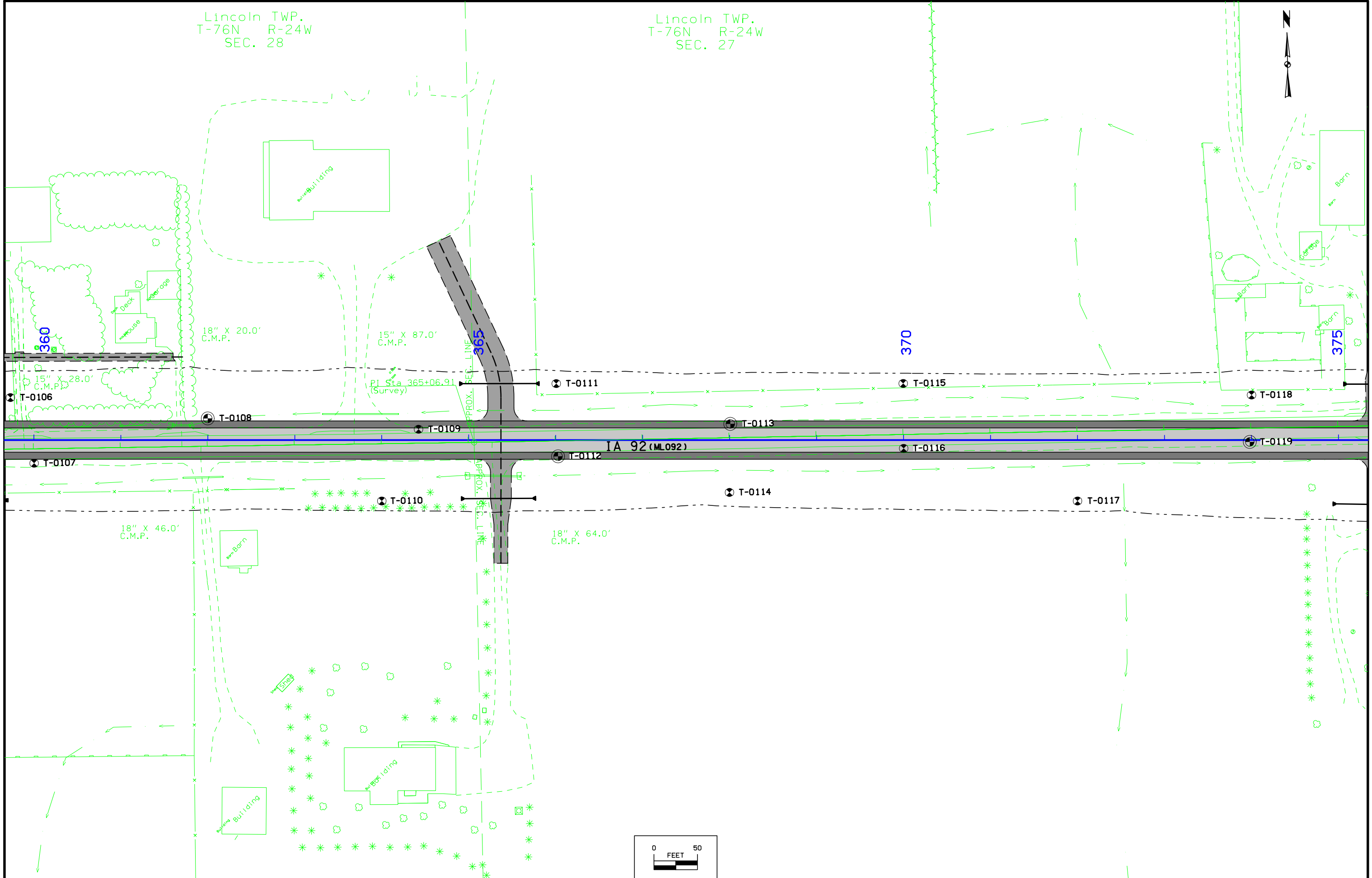

CUT MOISTURE
CUT DENSITY (lb/ft³)
PLASTIC LIMIT

25
88

10,25,34
110,99,84
20,23,21,20

24

SHELBY TUBE CORE DATA			
CORE NO.	T-0108-C	T-0113-E	T-0119-F
CLASSIFICATION [AASHTO]			
COEFF. CONSOL. SQ.FT/DAY		0.904	0.809
TRIAxIAL COMPRESSION	CU	CU	CU
COHESION - PSF	382	267	358
FRICTION COEFF.	0.198	0.227	0.236
MOISTURE CONTENT %	33.8	35.3	32.6
DRY DENSITY - PCF	89.7	85.8	86.7
CU-CONSOLIDATED UNDRAINED TRIAXIAL			
CU*-CU WITHOUT SATURATION OR PORE PRESSURE MEASUREMENTS			

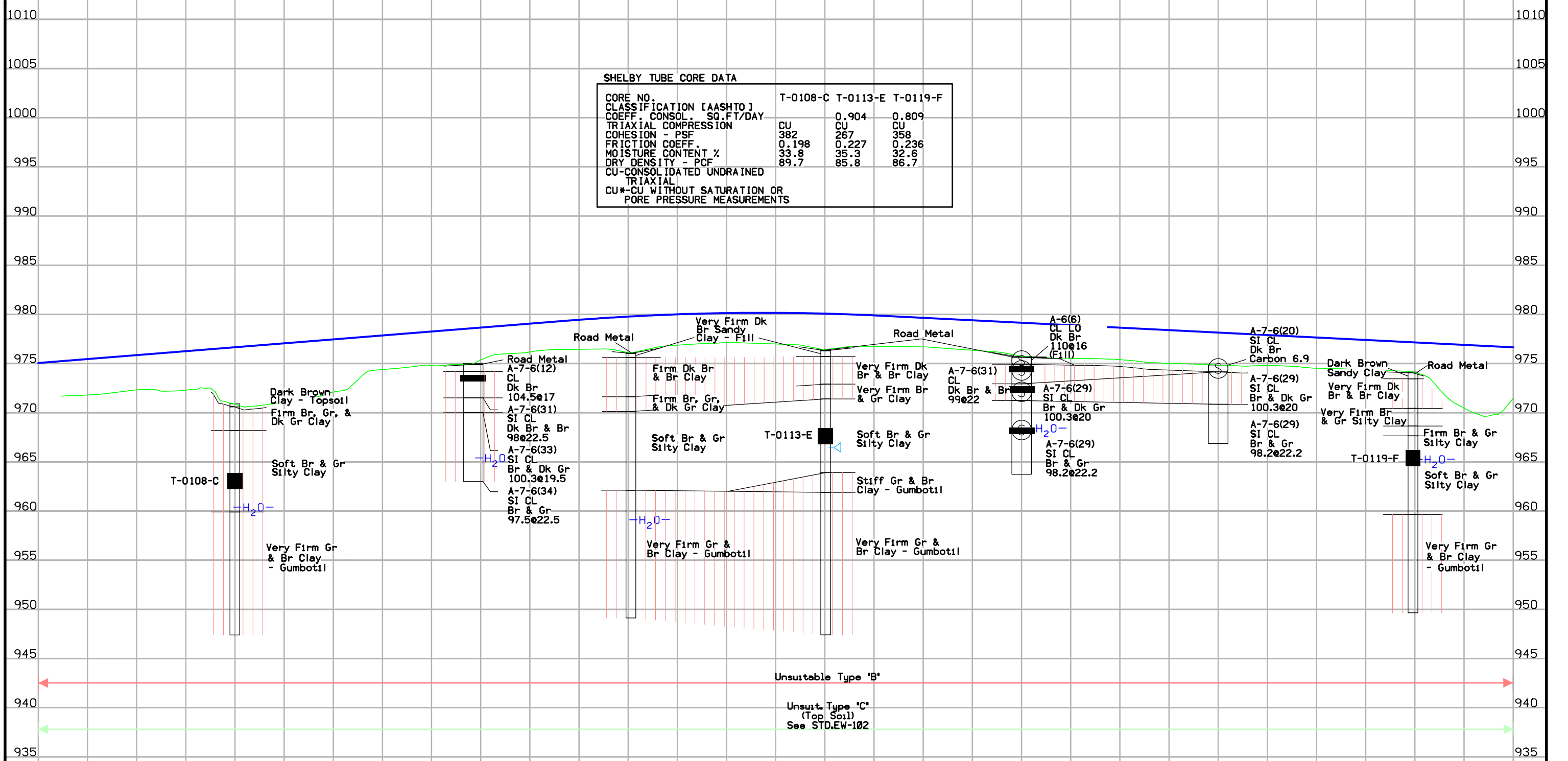

T-0108 Lt. 25 T-0109 Lt. 12 T-0112 Rt. 19 T-0113 Lt. 19 T-0116 Rt. 10 T-0117 Rt. 70 T-0119 Rt. 2

Lincoln TWP.
T-76N R-24W
SEC. 27

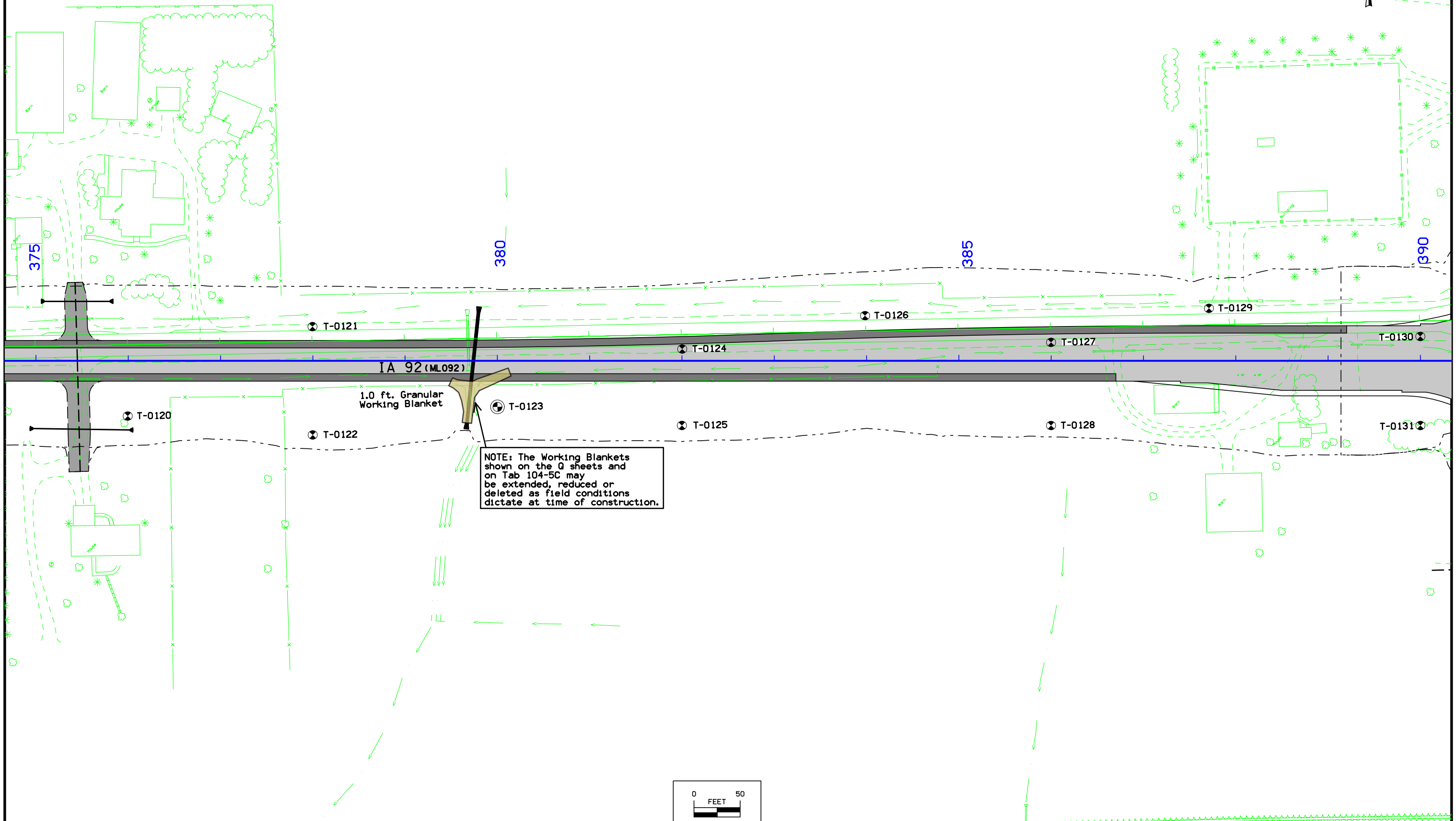

NOTE: The Working Blankets shown on the Q sheets and on Tab 104-5C may be extended, reduced or deleted as field conditions dictate at time of construction.

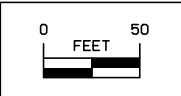

CUT MOISTURE
CUT DENSITY (lb/ft³)
PLASTIC LIMIT

27,31,32	25	26,28,33,26	24
93,89,88	92	92,89,87,97	96
20,25,22,19		22,22,20,18	

SHELBY TUBE CORE DATA

CORE NO.	T-0123-B
CLASSIFICATION [AASHTO]	
COEFF. CONSOL. SQ.FT/DAY	0.116
TRIAxIAL COMPRESSION	
COHESION - PSF	
FRICTION COEFF.	
MOISTURE CONTENT %	22.9
DRY DENSITY - PCF	103
CU-CONSOLIDATED UNDRAINED TRIAXIAL	
CU*-CU WITHOUT SATURATION OR PORE PRESSURE MEASUREMENTS	

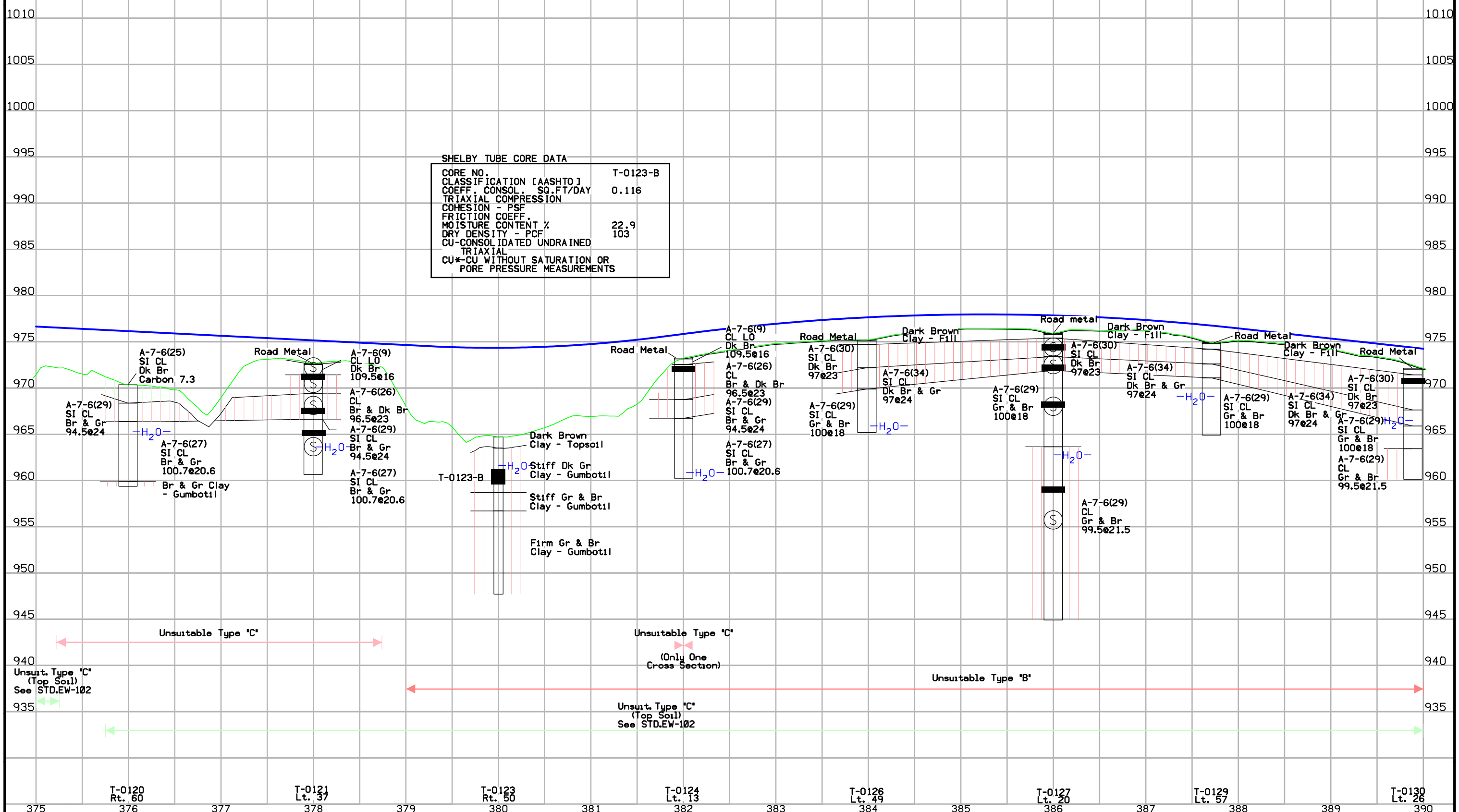

T-0120 Rt. 60 T-0121 Lt. 37 T-0123 Rt. 50 T-0124 Lt. 13 T-0126 Lt. 49 T-0127 Lt. 20 T-0129 Lt. 57 T-0130 Lt. 26

ENGLISH IOWA DOT DESIGN TEAM **Stanley\Knight** WARREN COUNTY PROJECT NUMBER **NHSX-092-5(51)--3H-91** SHEET NUMBER **Q.19**

Lincoln TWP.
T-76N R-24W
SEC. 27

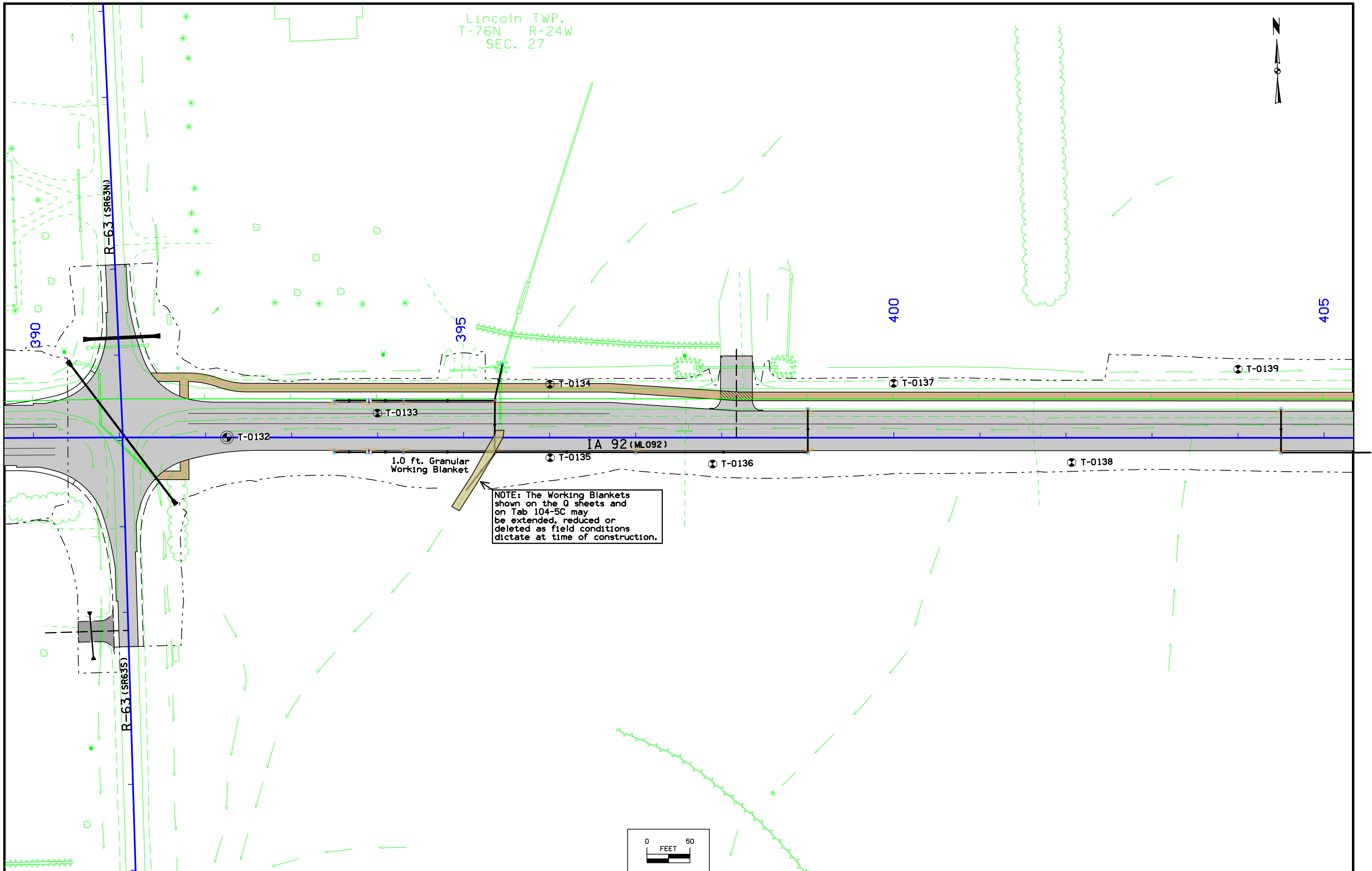

NOTE: The Working Blankets shown on the Q sheets and on Tab 104-5C may be extended, reduced or deleted as field conditions dictate at time of construction.

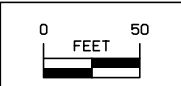

CUT MOISTURE
CUT DENSITY (lb/ft³)
PLASTIC LIMIT

24
94

26
96
23

24
93

29,28
89,93
22,20,21

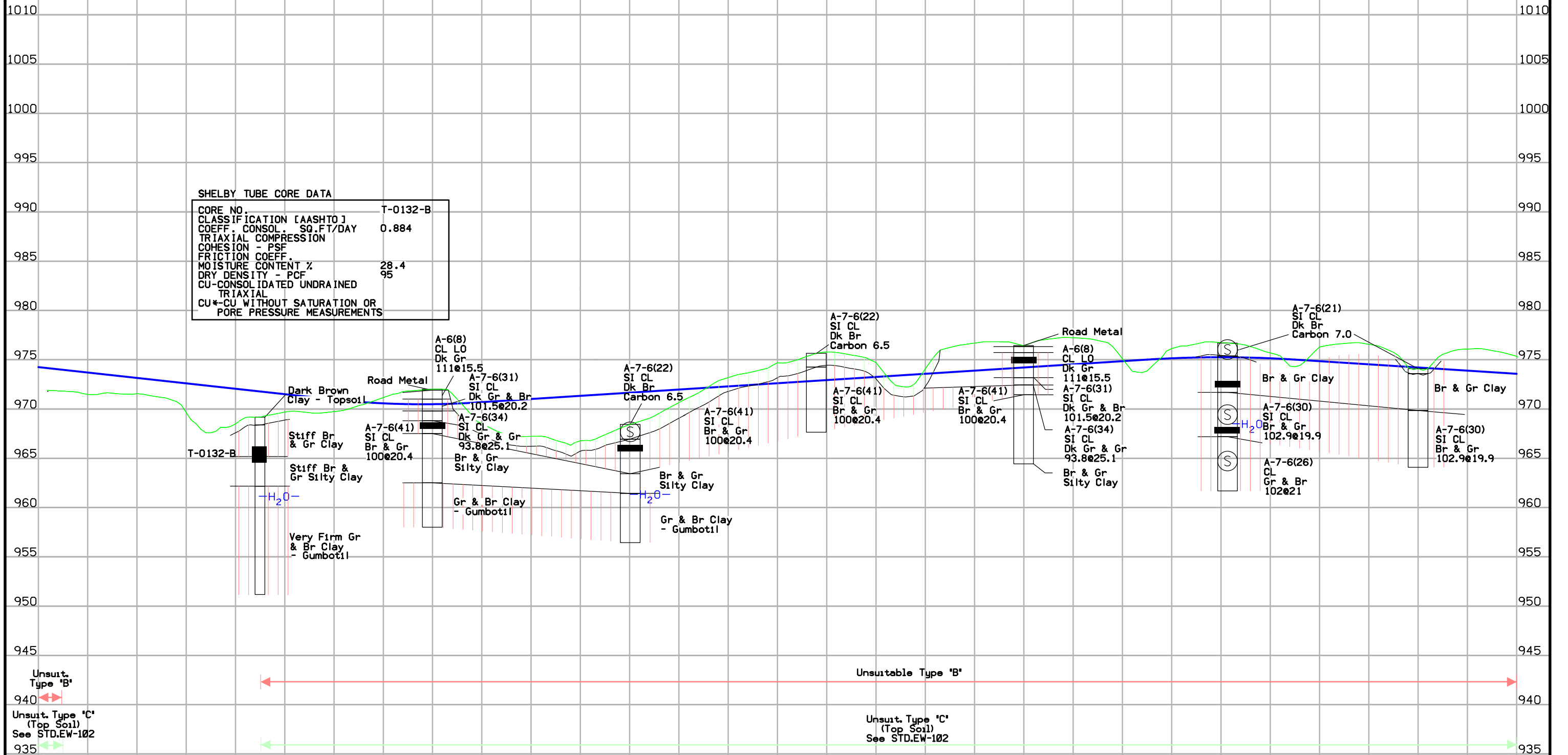

SHELBY TUBE CORE DATA

CORE NO.	T-0132-B
CLASSIFICATION [AASHTO]	
COEFF. CONSOL. SQ.FT/DAY	0.884
COHESION - PSF	
TRIAXIAL COMPRESSION	
FRICTION COEFF.	
MOISTURE CONTENT %	28.4
DRY DENSITY - PCF	95
CU-CONSOLIDATED UNDRAINED TRIAXIAL	
CU*-CU WITHOUT SATURATION OR PORE PRESSURE MEASUREMENTS	

T-0132 CL T-0133 Lt. 28 T-0135 Rt. 23 T-0136 Rt. 31 T-0137 Lt. 63 T-0138 Rt. 29 T-0139 Lt. 80

Lincoln TWP.
T-76N R-24W
SEC. 27

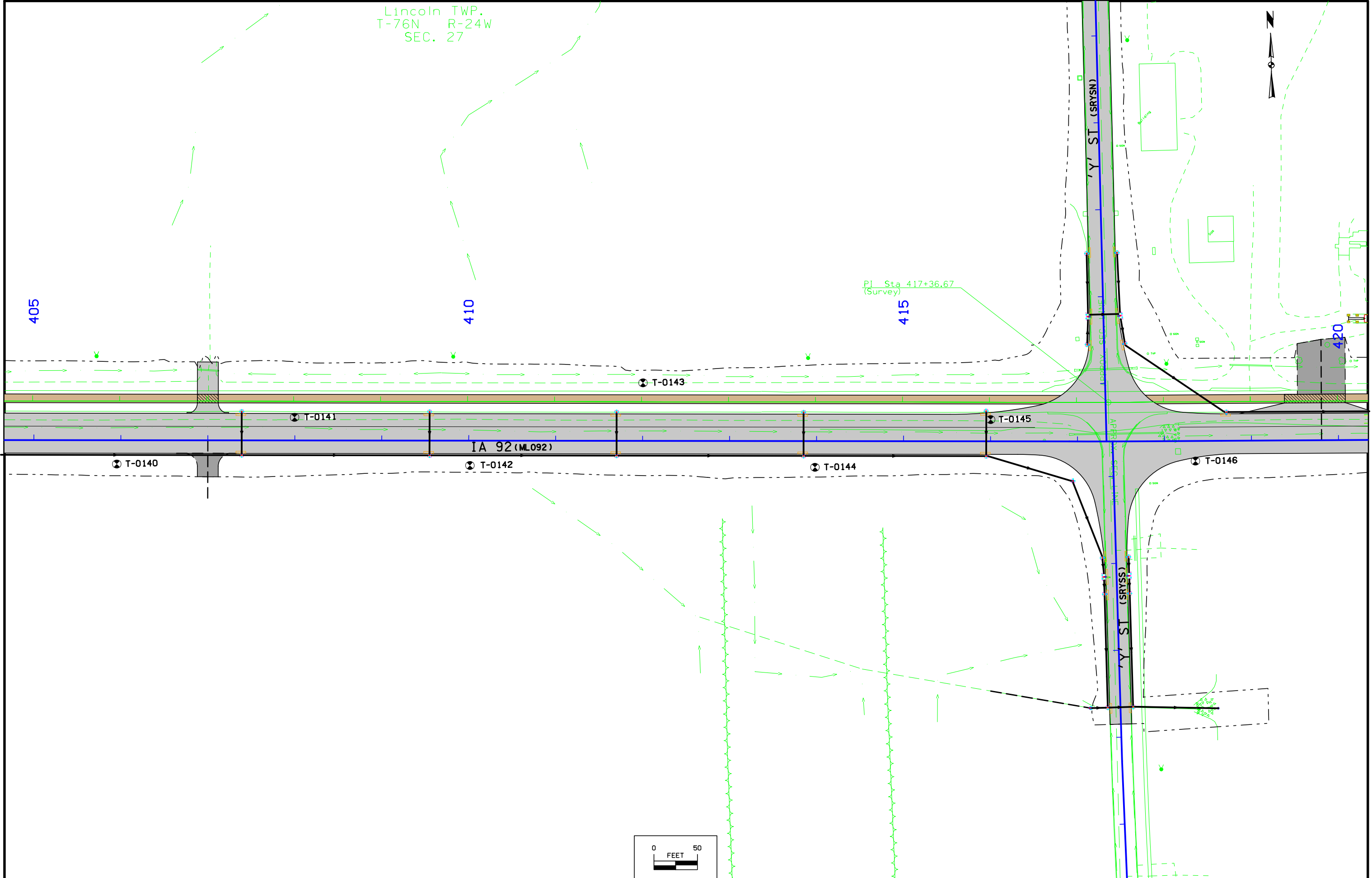

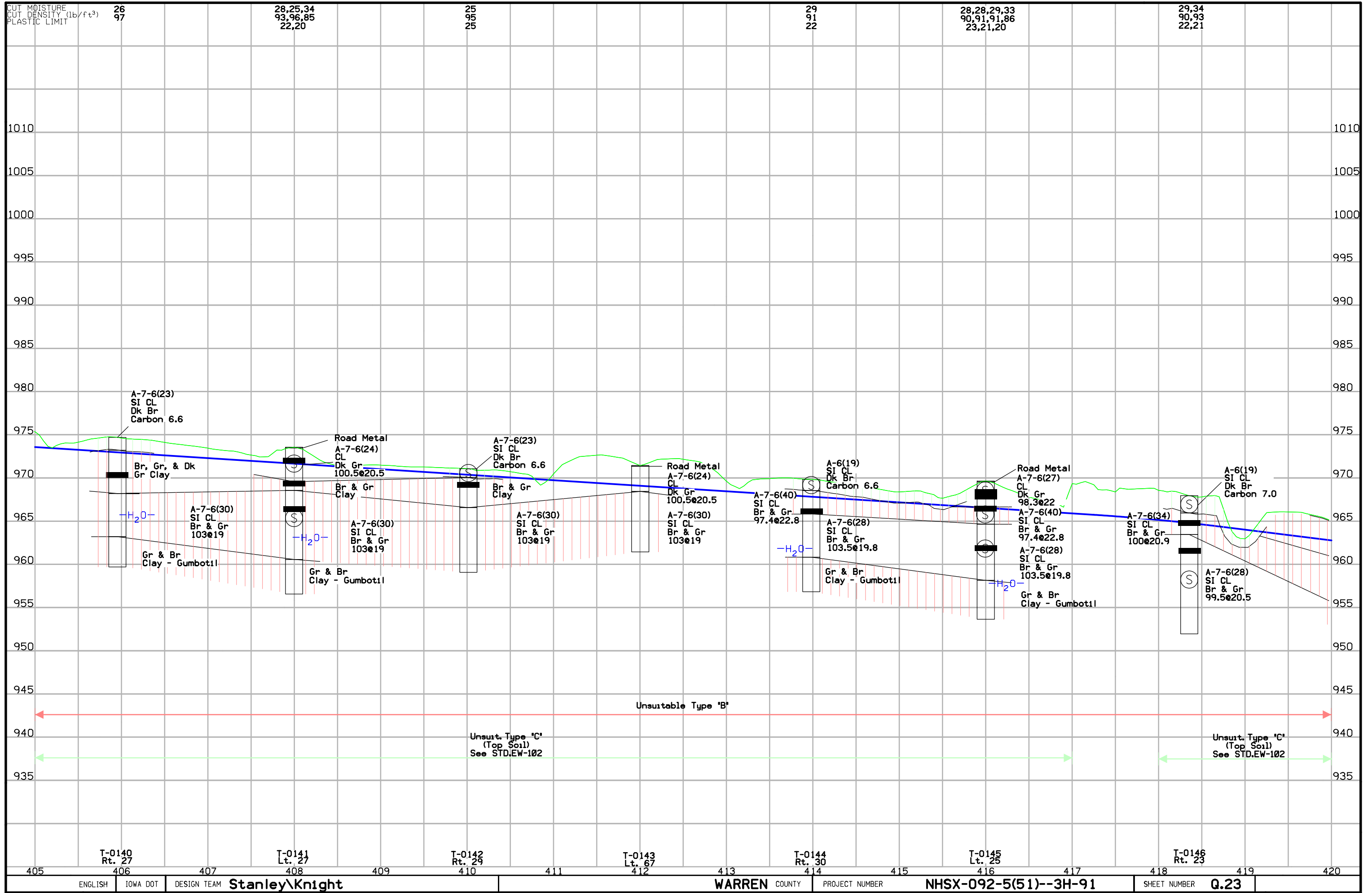

Lincoln TWP.
T-76N R-24W
SEC. 26

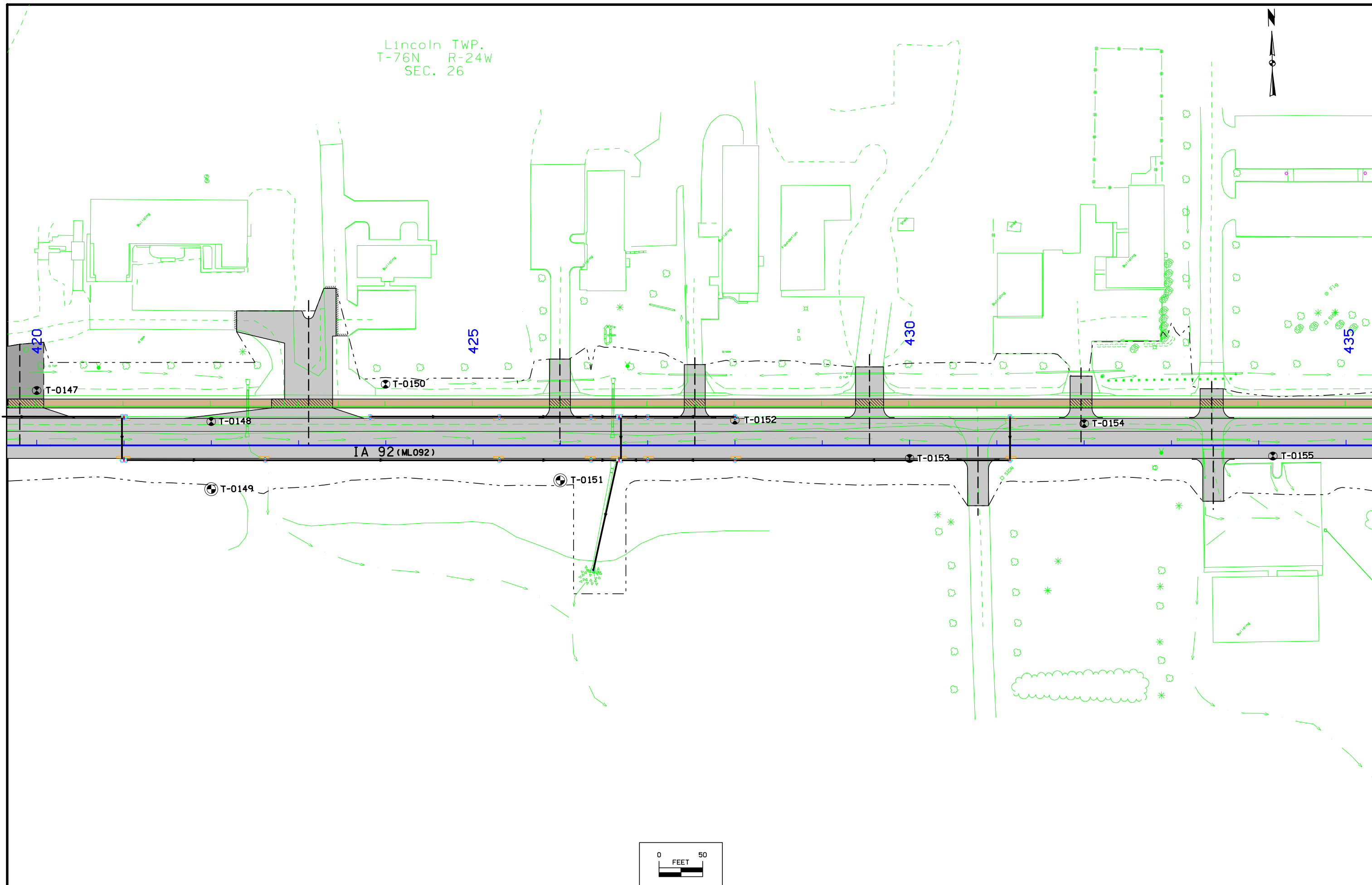

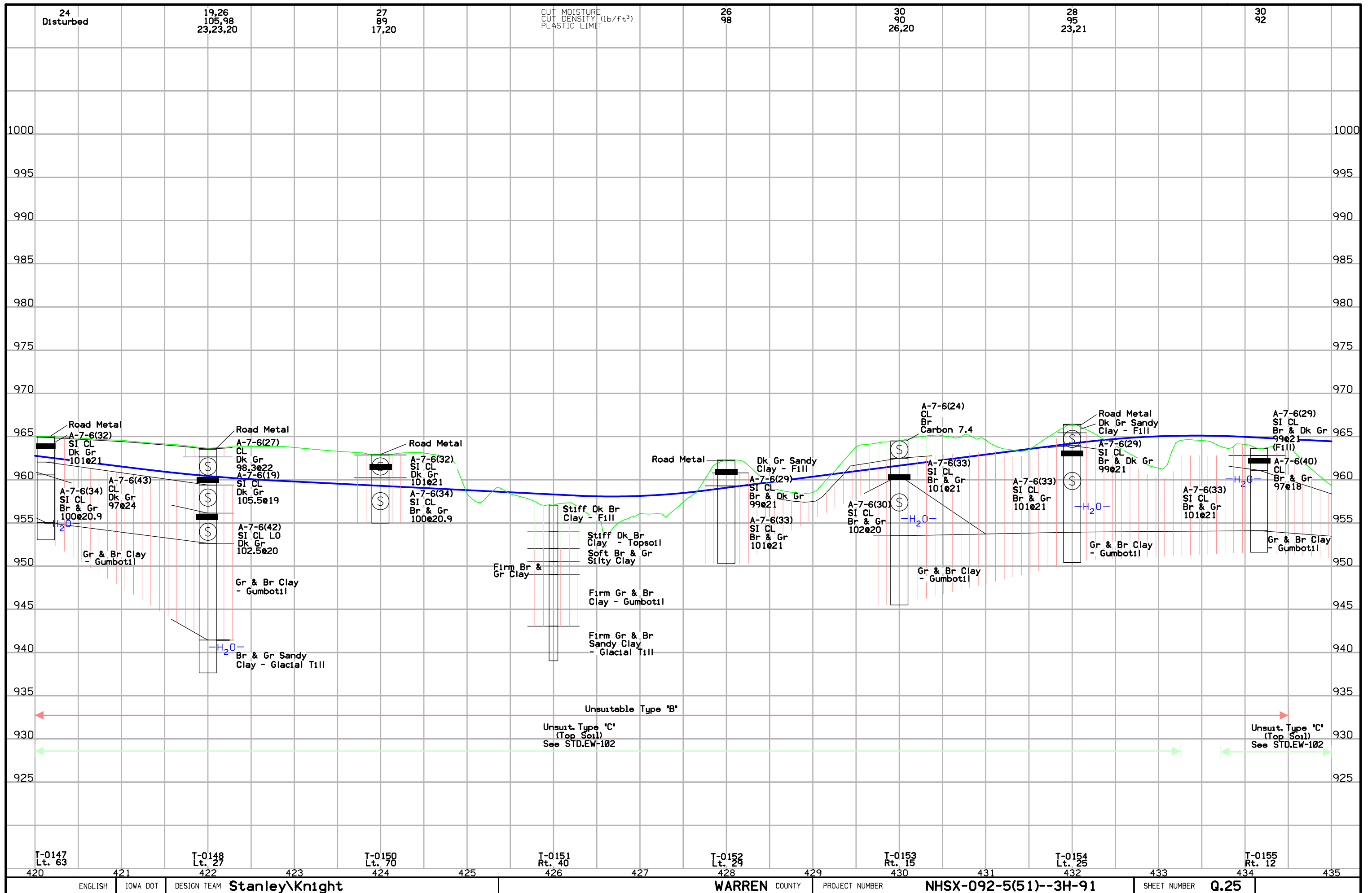

Lincoln TWP.
T-76N R-24W
SEC. 26



No soil borings performed through widening area.

Sta. 443+18.01
End Full Width Paving
& Begin Widening

PC Sta. 447+68.90
(Survey)

SPRUCE ST.

'R' ST.

IA 92 (ML092)

1.0 ft. Granular Working Blanket

NOTE: The Working Blankets shown on the Q sheets and on Tab 104-5C may be extended, reduced or deleted as field conditions dictate at time of construction.



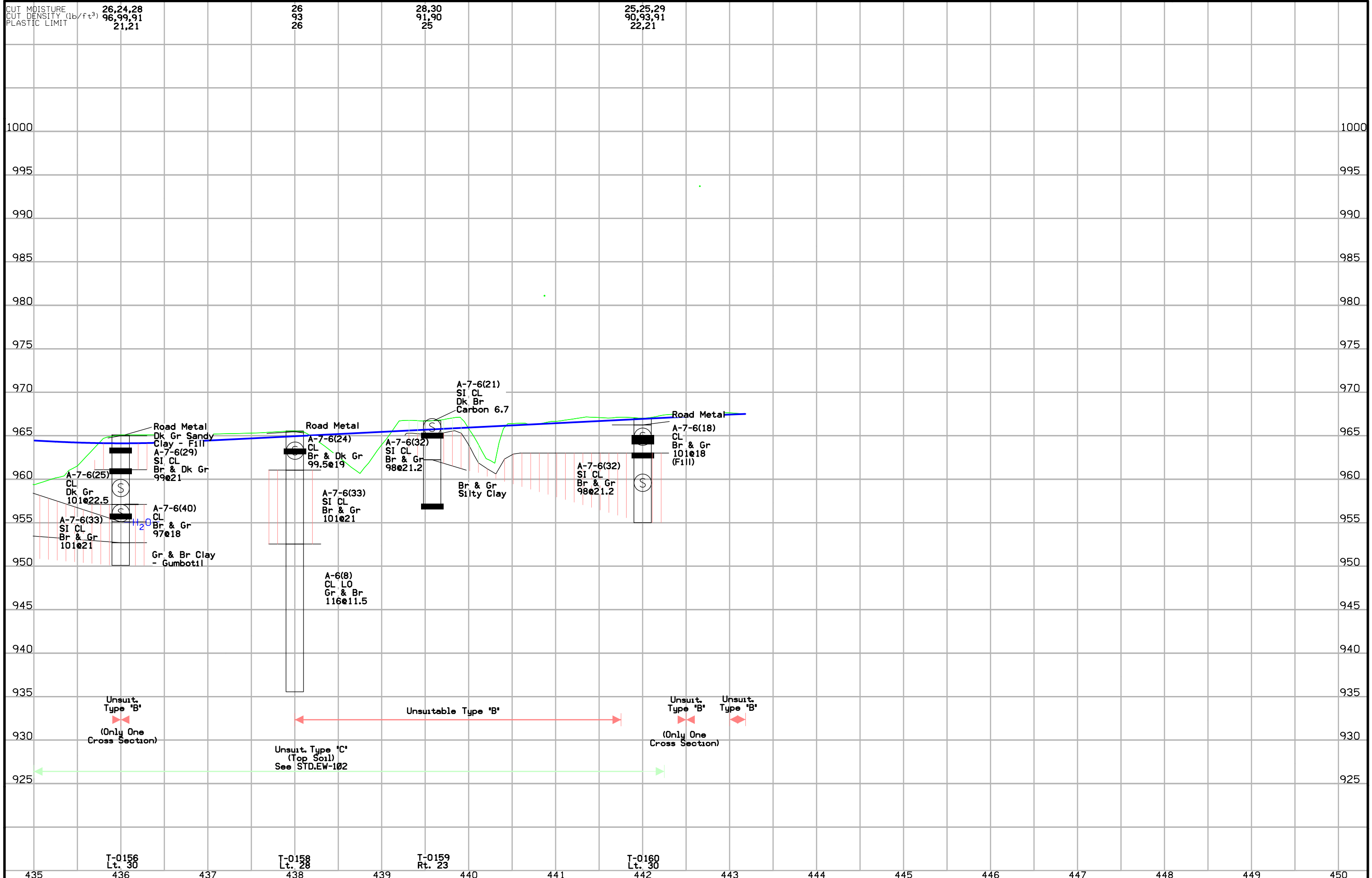

Lincoln TWP.
T-76N R-24W
SEC. 30

Lincoln TWP.
T-76N R-24W
SEC. 29

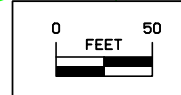
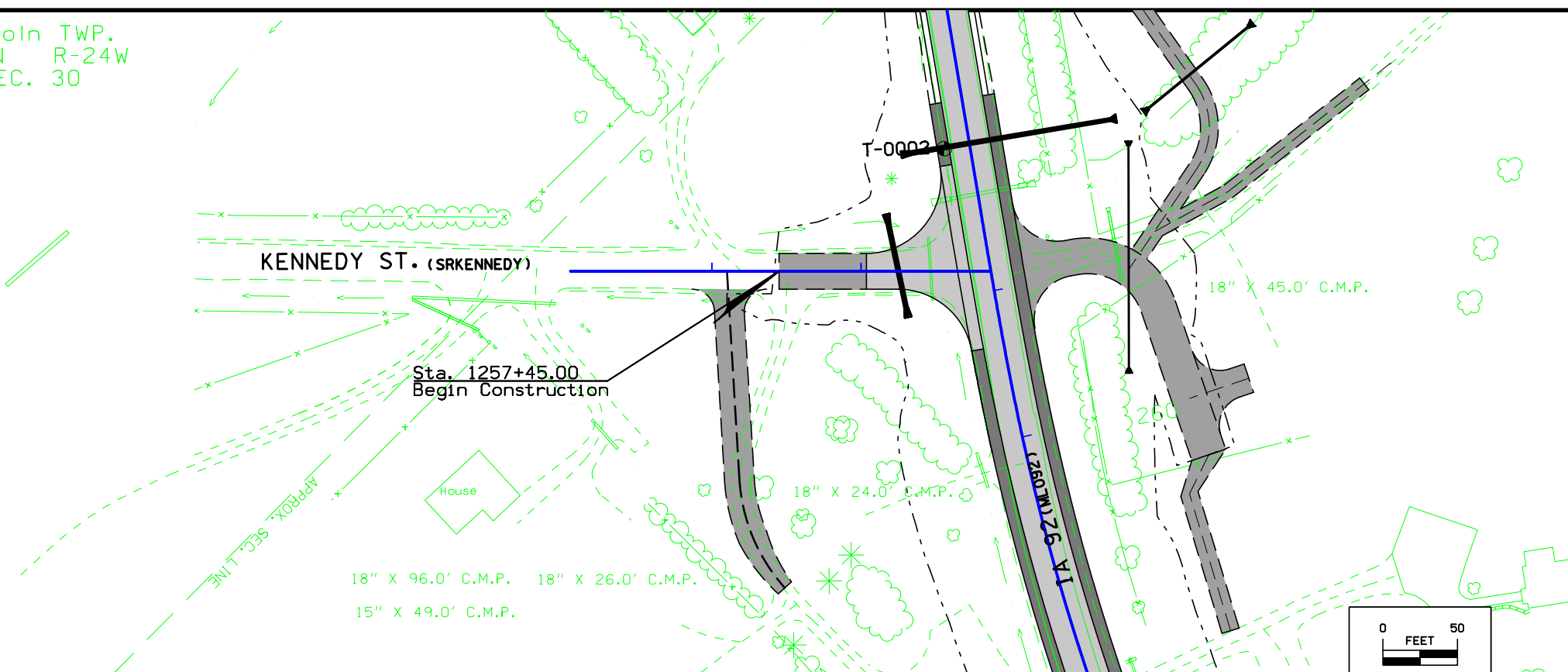
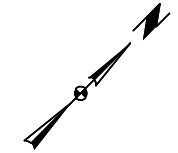

KENNEDY ST

CUT MOISTURE
CUT DENSITY (lb/ft³)
PLASTIC LIMIT

20,22,15
104,95,112
20,23,16

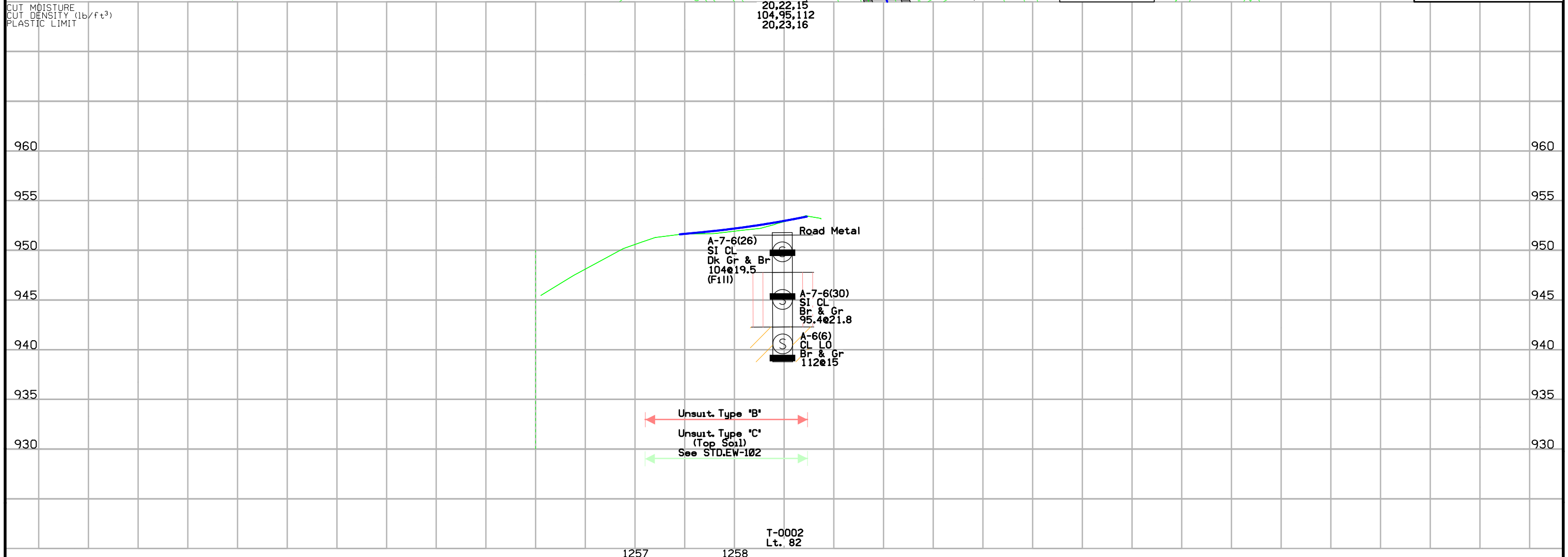

Road Metal
A-7-6(26)
SI CL
Dk Gr & Br
104@19.5
(Fill)
A-7-6(30)
SI CL
Br & Gr
95.4@21.8
A-6(6)
CL LO
Br & Gr
112@15

Unsuit. Type "B"
Unsuit. Type "C"
(Top Soil)
See STD.EW-102

T-0002
Lt. 82

Lincoln TWP.
T-76N R-24W
SEC. 29

Sta. 1280+60.00
Begin Construction

Sta. 1386+06.00
End Construction

R-57 (SR57S)

R-57 (SR57N)

IA 92 (ML092)

COUNTY
R-57

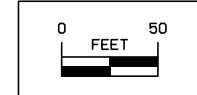

CUT MOISTURE
CUT DENSITY (lb/ft³)
PLASTIC LIMIT

22

19,28,26
104,88,97
20,23,18

16,24
107,99
18,20

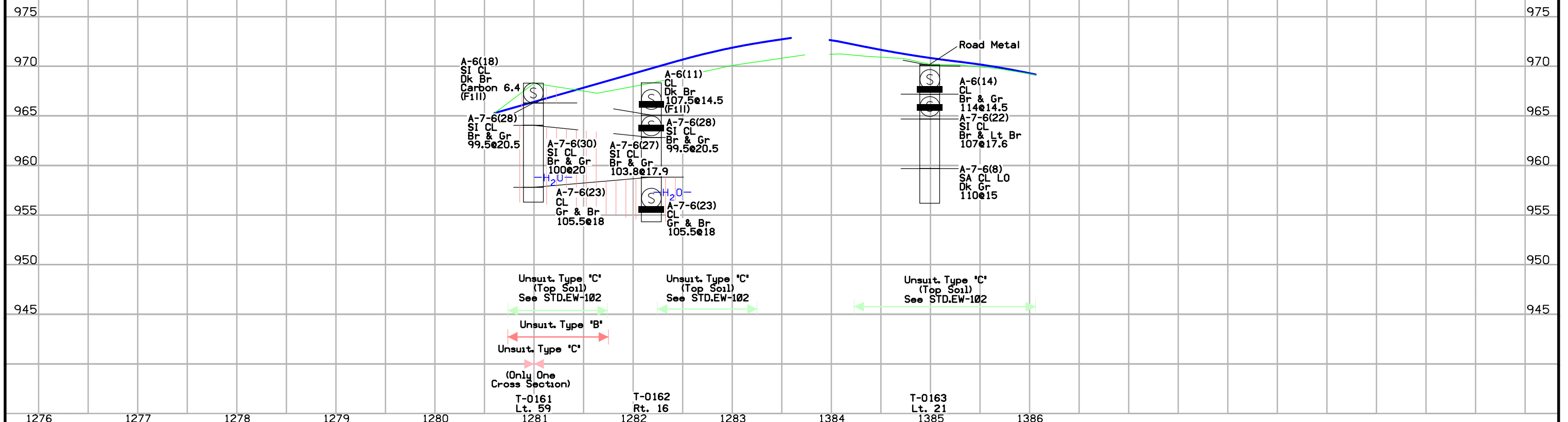

Lincoln TWP.
T-76N R-24W
SEC. 29

Lincoln TWP.
T-76N R-24W
SEC. 28

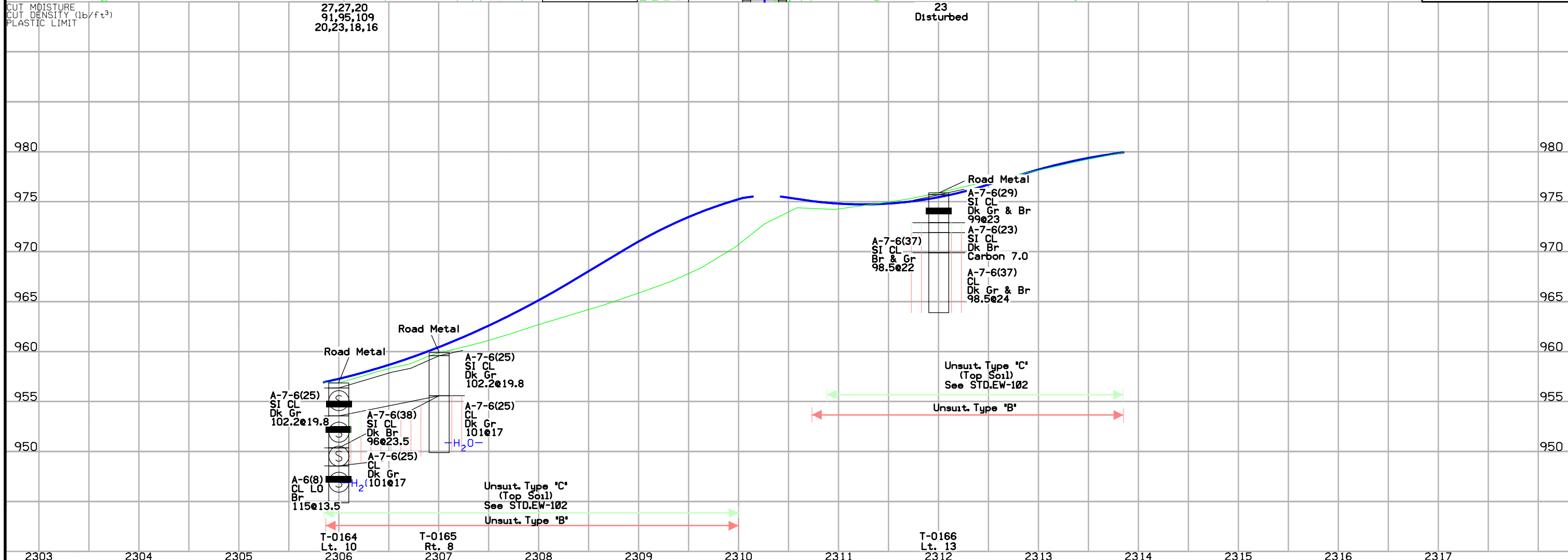
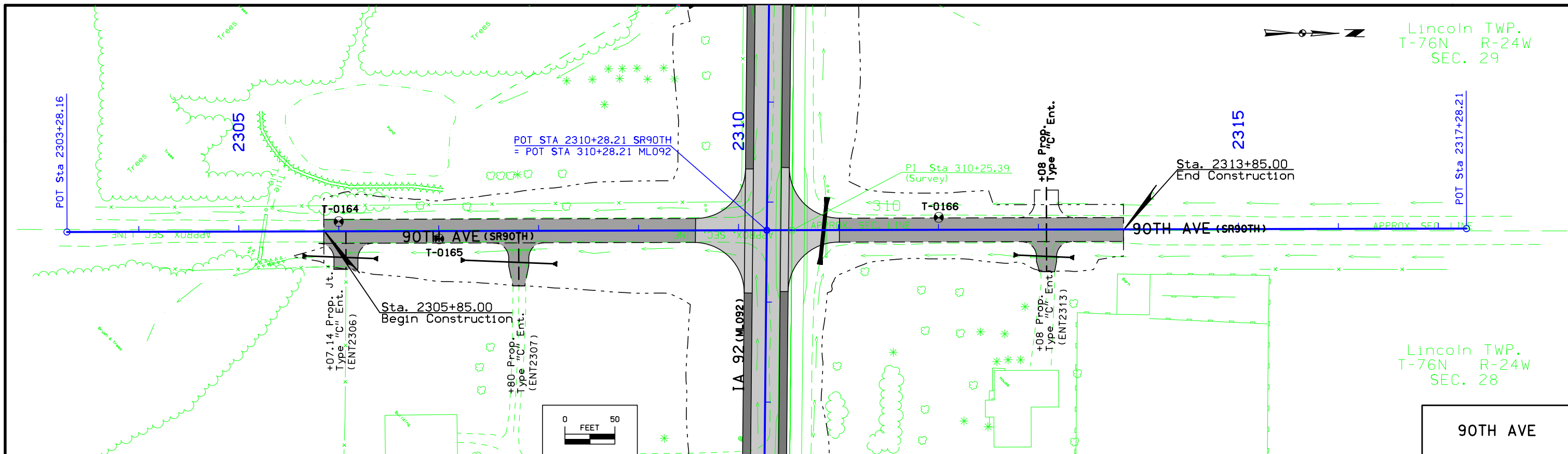

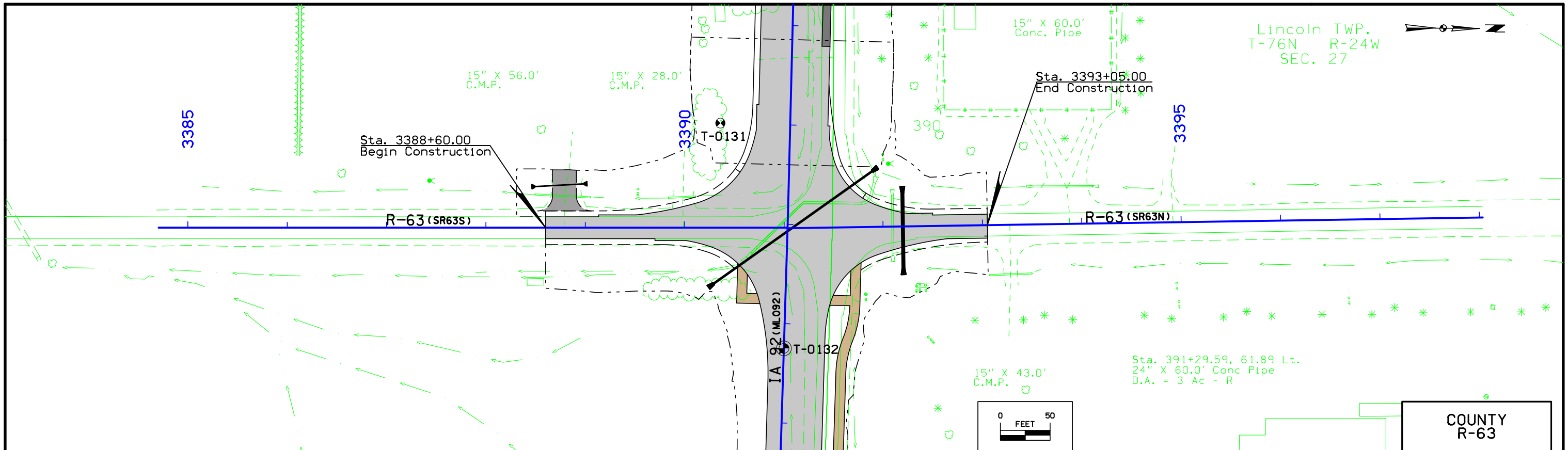

CUT MOISTURE
CUT DENSITY (lb/ft³)
PLASTIC LIMIT

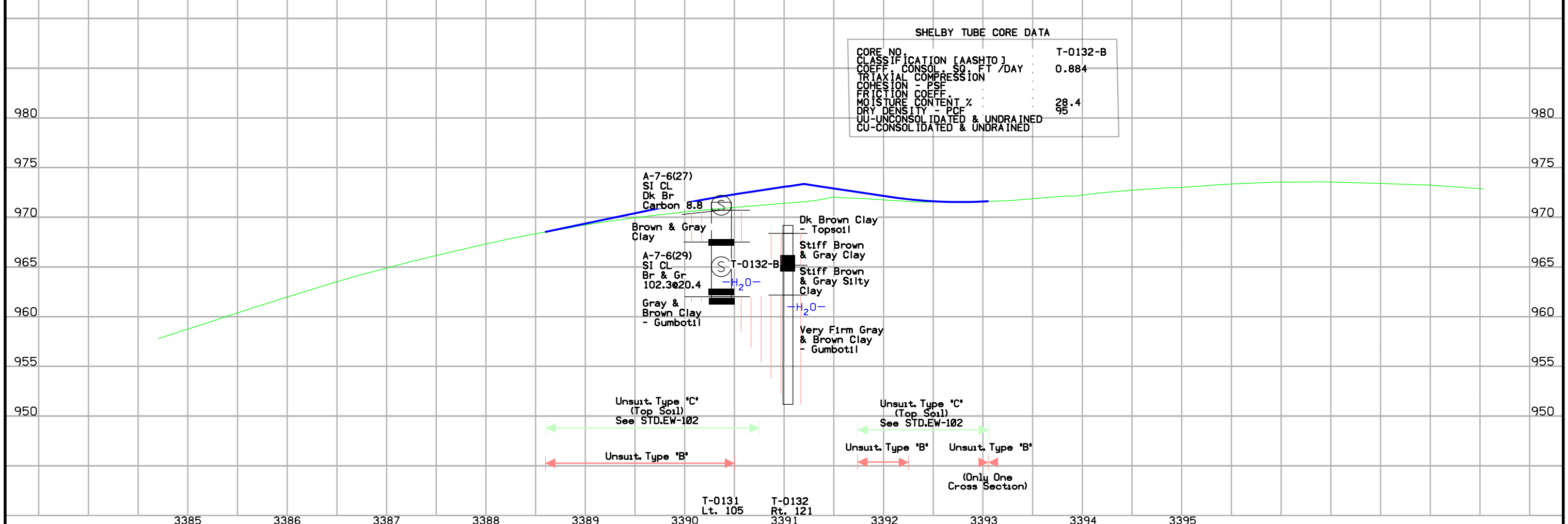

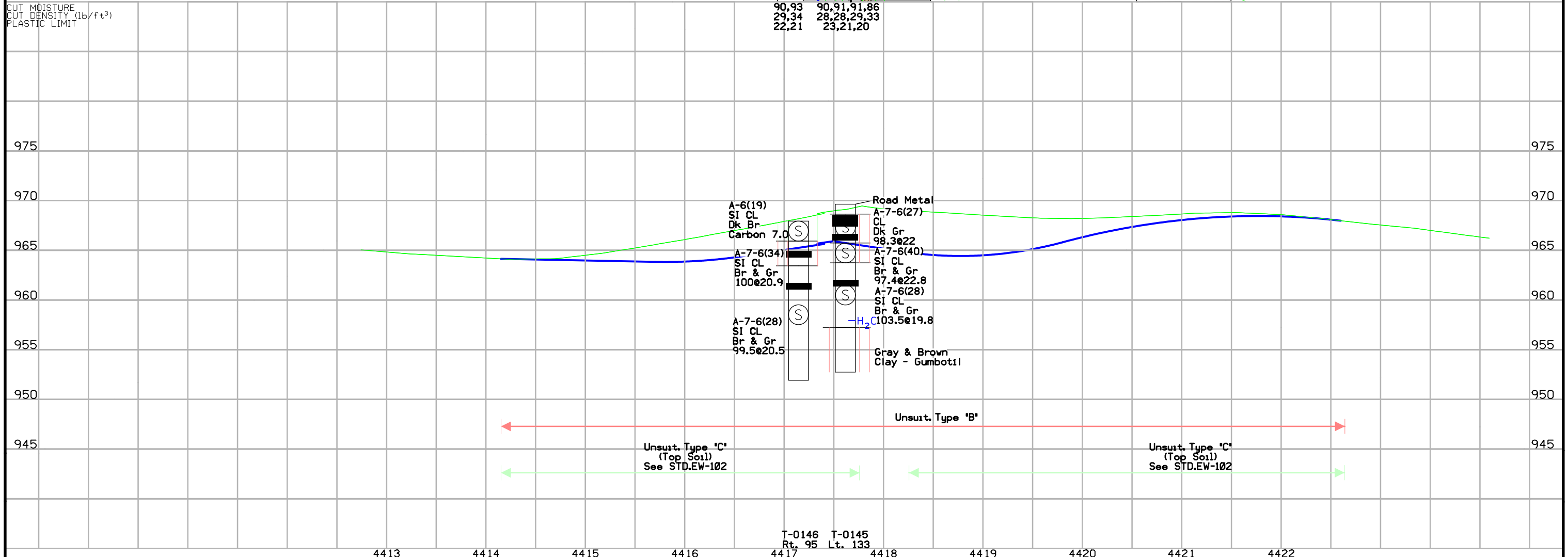
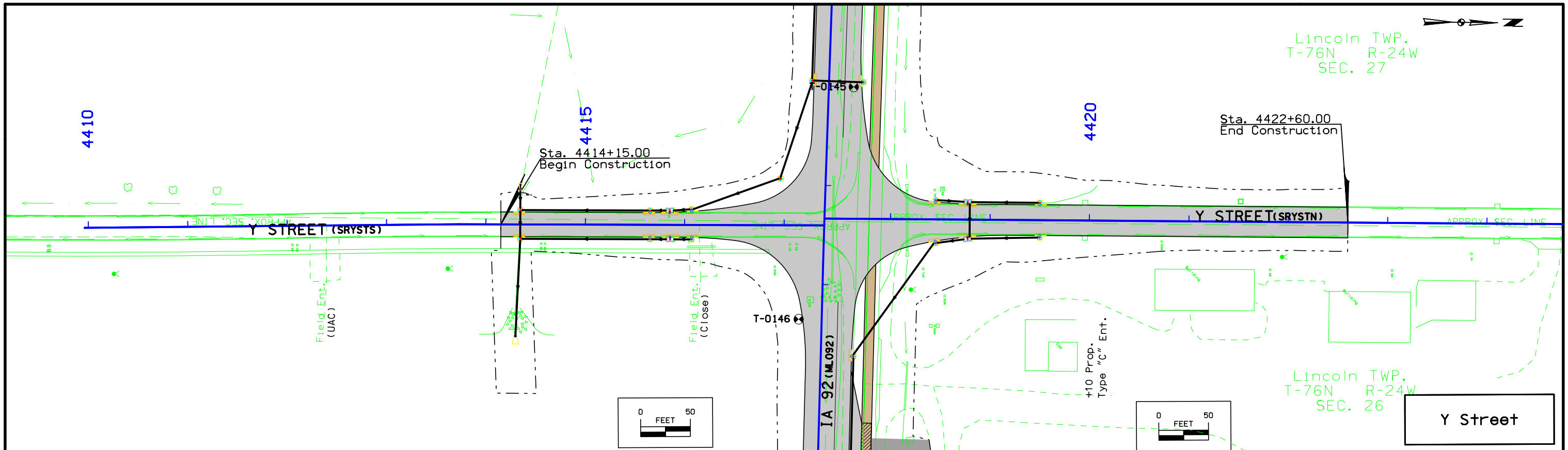

SURVEY SYMBOLS

- TDC Tree Deciduous
- PPA Power Pole Co. 1
- FWD Wood Fence
- LUM Luminaire
- TEV Evergreen Tree
- LP L.P. Tank
- D Centerline Draw or Stream (Down)
- RET Retaining Walls
- SI Sign
- SHR Shrub
- SI Sign
- EW Edge of Water
- DIK Centerline of Dike or Dam
- FLG Flag Poles
- WM Wind Mill
- FCL Chain Link and Security Fence
- HDG Hedge Row
- TV Satellite TV Dish
- RT Radio Tower
- INB Storm Sewer Beehive Intake
- WV Water Valve
- FHD Fire Hydrants
- WEL Well
- MH Utility Access (Manhole)
- LUM Luminaire
- MIS Miscellaneous
- TPD Telephone Pedestal
- EB Electrical Box
- UB Utility Box
- PR Electric Riser Pole
- FW Wire Fence
- GP Guard Post (Less Than 4 Posts)
- IN Storm Sewer Intake
- TLN Treeline
- TVP TV Pedestal
- SEP Septic Tank
- OUT Tile Outlet
- TIL Tile Line
- UST Underground Tank
- GV Gas Valve
- DU Centerline Draw or Stream (Up)
- BNK Stream Bank
- BL Topo Breakline
- RIP Rip-Rap

- St.S. STA Storm Sewer Line Co. 1
- F03 FOC Underground Fiber Optic Co. 3
- F05 FOE Underground Fiber Optic Co. 5
- F02 FOB Underground Fiber Optic Co. 2
- San. SAA Sanitary Sewer Line Co. 1
- T1 TLA Underground Telephone Line Co. 1
- E1 ELA Underground Electric Line Co. 1
- G GLA Underground Gas Line Co. 1
- W WLA Underground Water Line Co. 1
- F0 FOA Underground Fiber Optic Co. 1
- E2 ELB Underground Electric Line Co. 2
- San.2 SAB Sanitary Sewer Line Co. 2
- GLB Underground Gas Line Co. 2
- F04 FOD Underground Fiber Optic Co. 4
- WLB Underground Water Line Co. 2

UTILITY LEGEND

- F0 FOA Paetac Iowa Communications Network
- F02 FOB Lightcore (Digital Teleport)
- F03 FOC Iowa Network Service
- F04 FOD Indianola Municipal Utilities
- F05 FOE MCI
- T1 TLA Qwest
- E1 ELA Mid-American
- E2 ELB Indianola Municipal Utilities
- W WLA Indianola Municipal Utilities
- San. SAA City of Indianola
- San.2 SAB Private
- G GLA Mid-American
- GLB Kinder Morgan
- St.S. STA City of Indianola
- PPA Mid-American

PLAN VIEW COLOR LEGEND OF PLAN AND PROFILE SHEETS

LINEWORK		Design Color No.	
Green	(2)		Existing Topographic Features and Labels
Blue	(1)		Proposed Alignment, Stationing, Tic Marks, and Alignment Annotation
Magenta	(5)		Existing Utilities
SHADING		Design Color No.	
Tan	(8)		Proposed Sidewalk Shading
Blue, Light	(230)		Proposed Sidewalk Landing Shading
Pink	(11)		Proposed Sidewalk Ramp Shading
Yellow	(4)		Highlight for Critical Notes or Features
Red	(3)		Delineates Restricted Areas
Lavender	(9)		Temporary Pavement Shading
Gray, Light	(48)		Proposed Pavement Shading
Gray, Med	(80)		Proposed Granular Shading
Gray, Dark	(112)		Proposed Grade and Pave Shading
Brown, Light	(236)		Grading Shading

Reference Point

Survey Line

Station

Section Corner

Ground Line Intercept

Saw Cut

Guardrail

Clearing & Grubbing Area

Pavement Removal

RIGHT-OF-WAY LEGEND

- Proposed Right-of-Way
- Existing and Proposed Right-of-Way
- Easement and Existing Right-of-Way
- Borrow
- Easement (Temporary)
- Easement
- Excess
- Access Control

SIDEWALK LEGEND AND SYMBOL INFORMATION SHEET

(COVERS SHEET SERIES S)

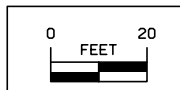
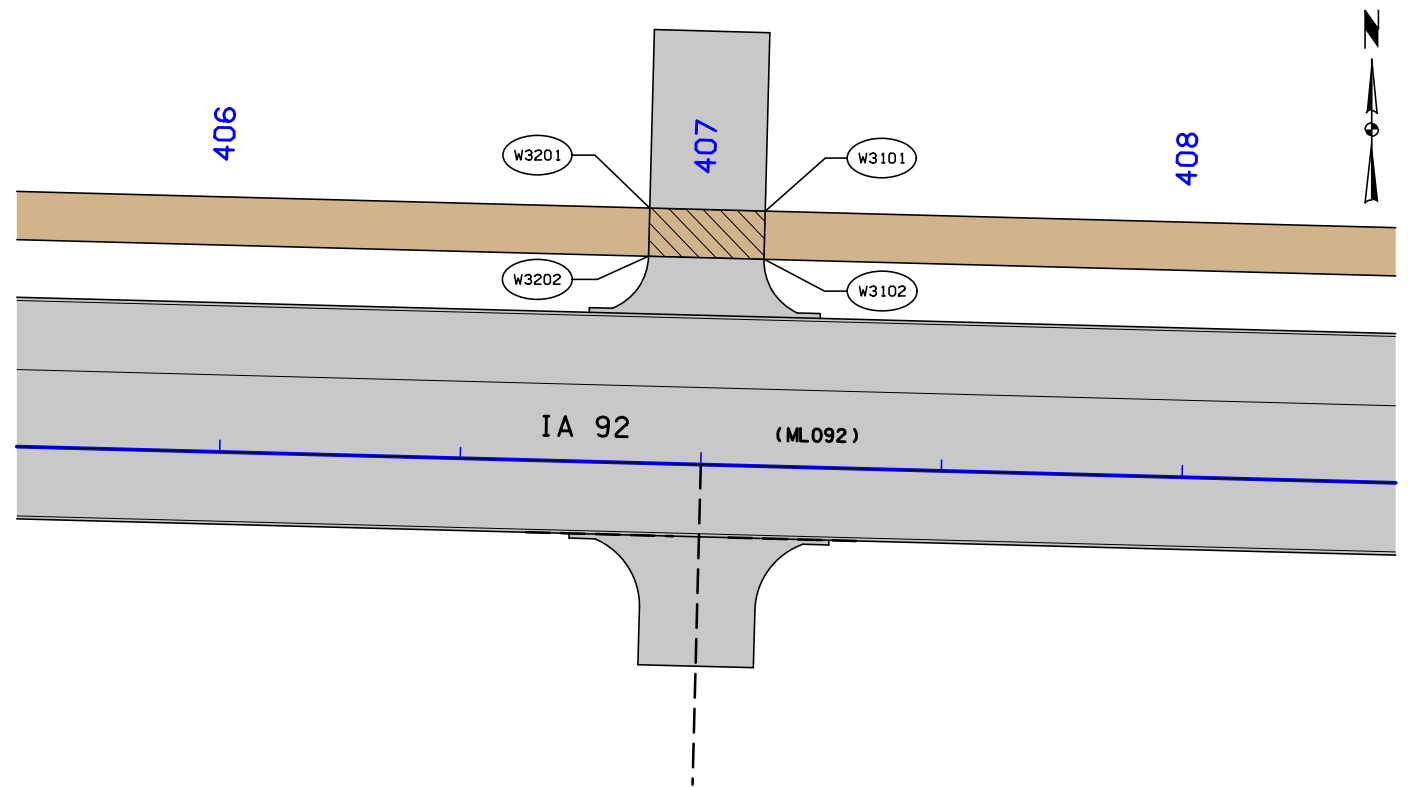
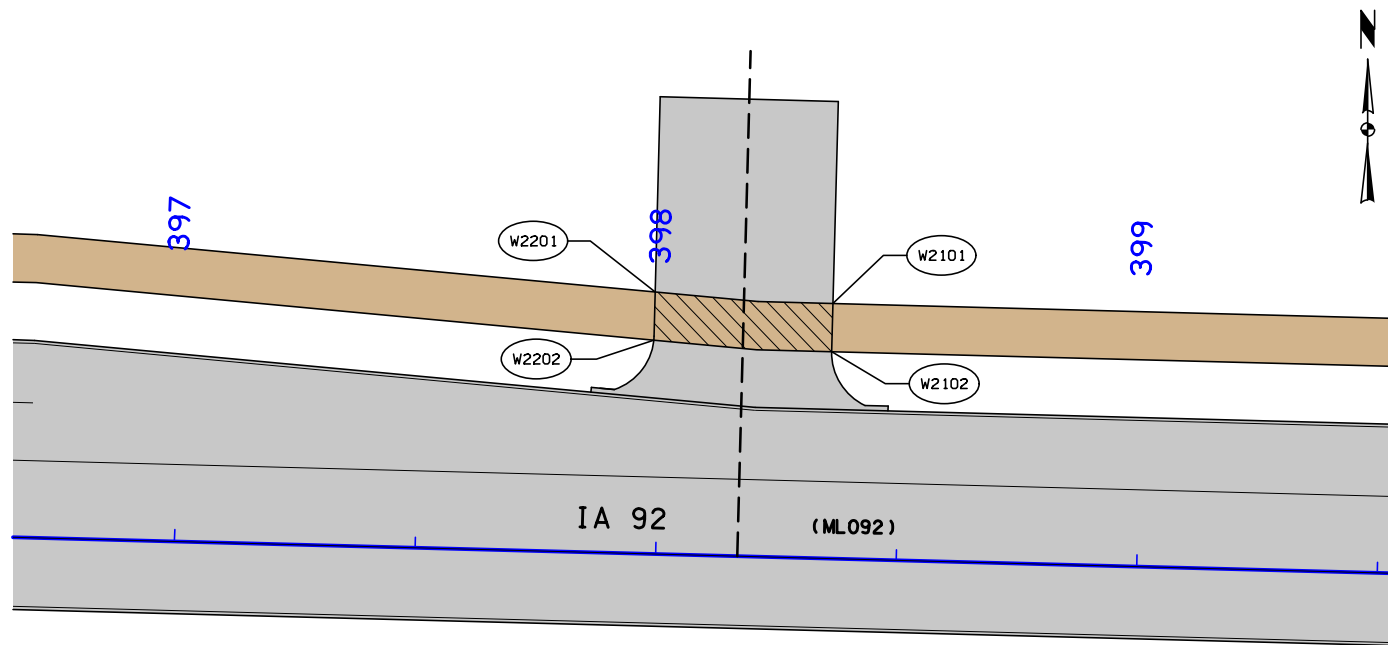
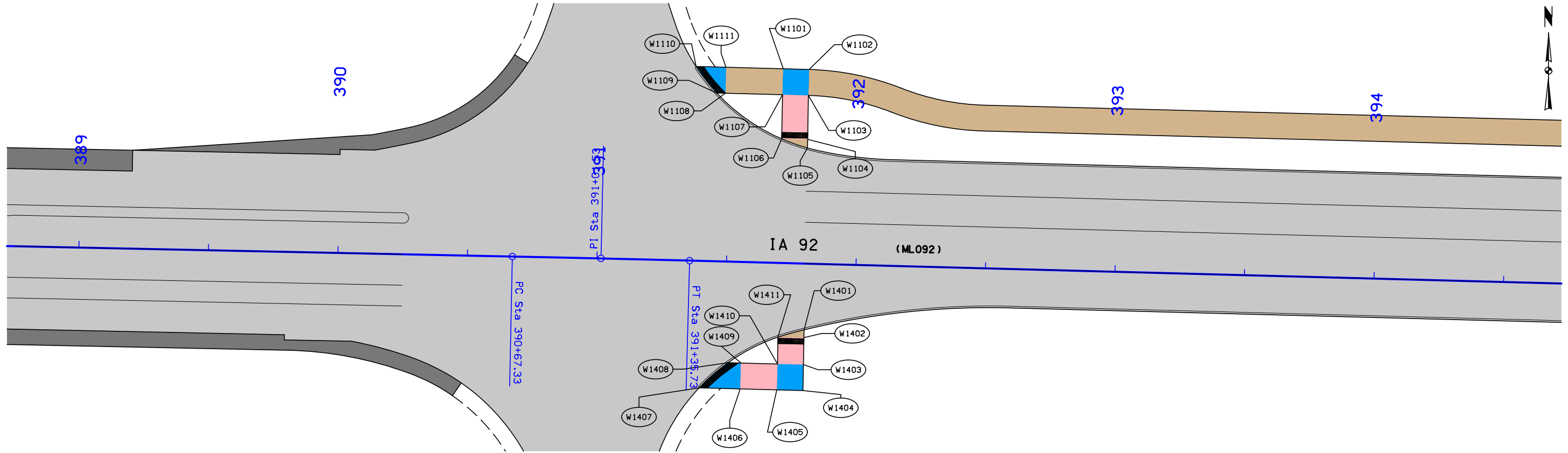

SIDEWALK LAYOUT
(Sheet 1 of 5)

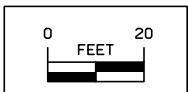
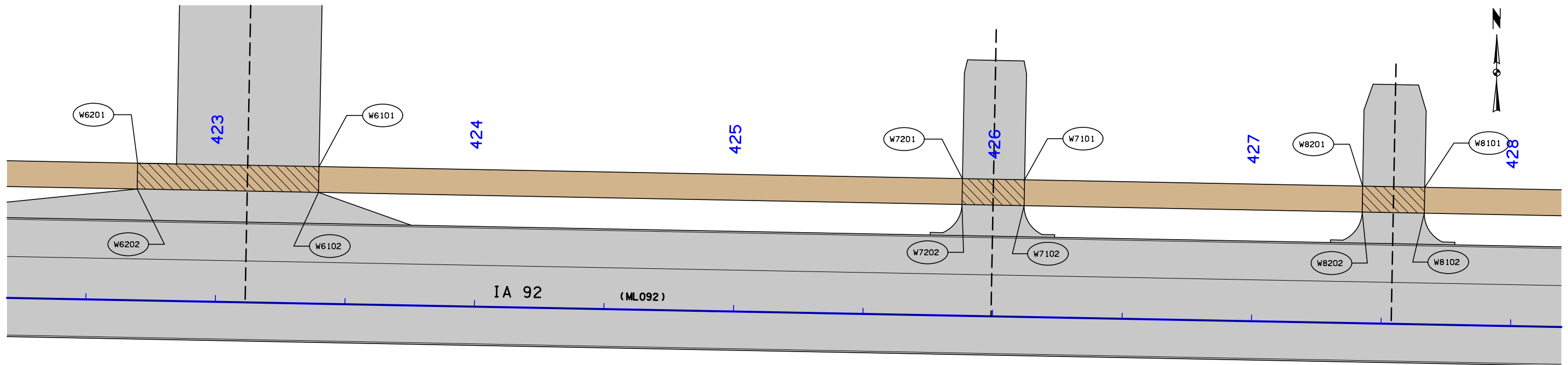
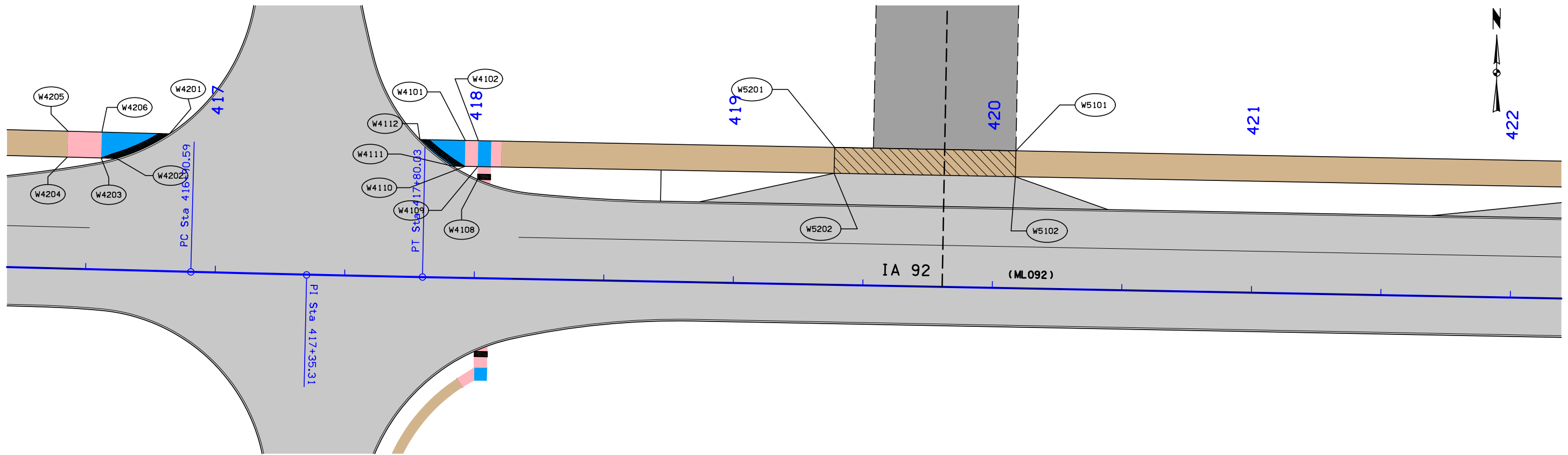

SIDEWALK LAYOUT
(Sheet 2 of 5)

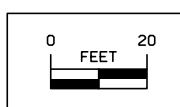
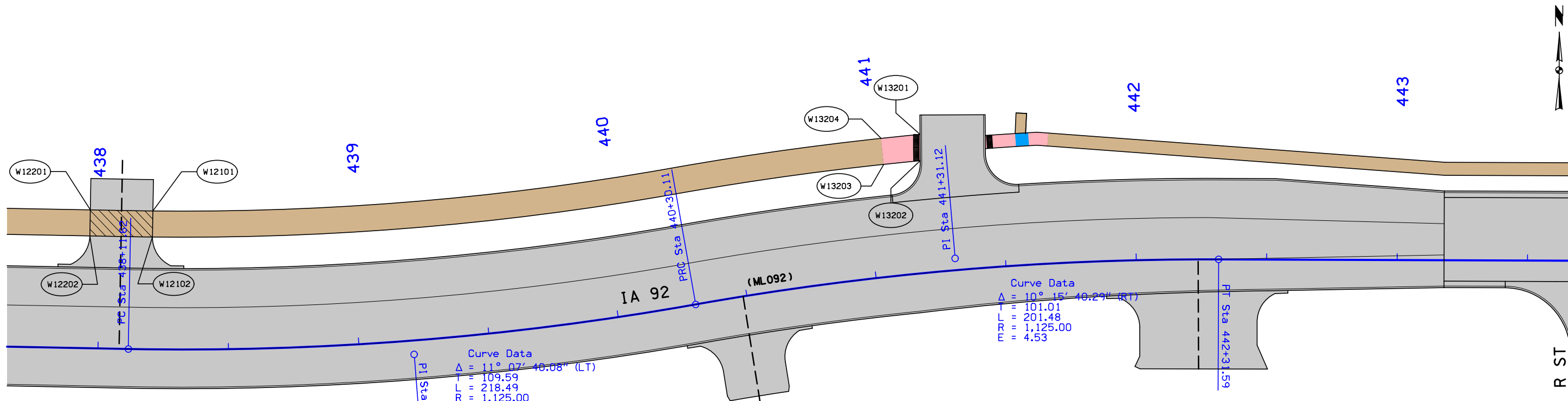
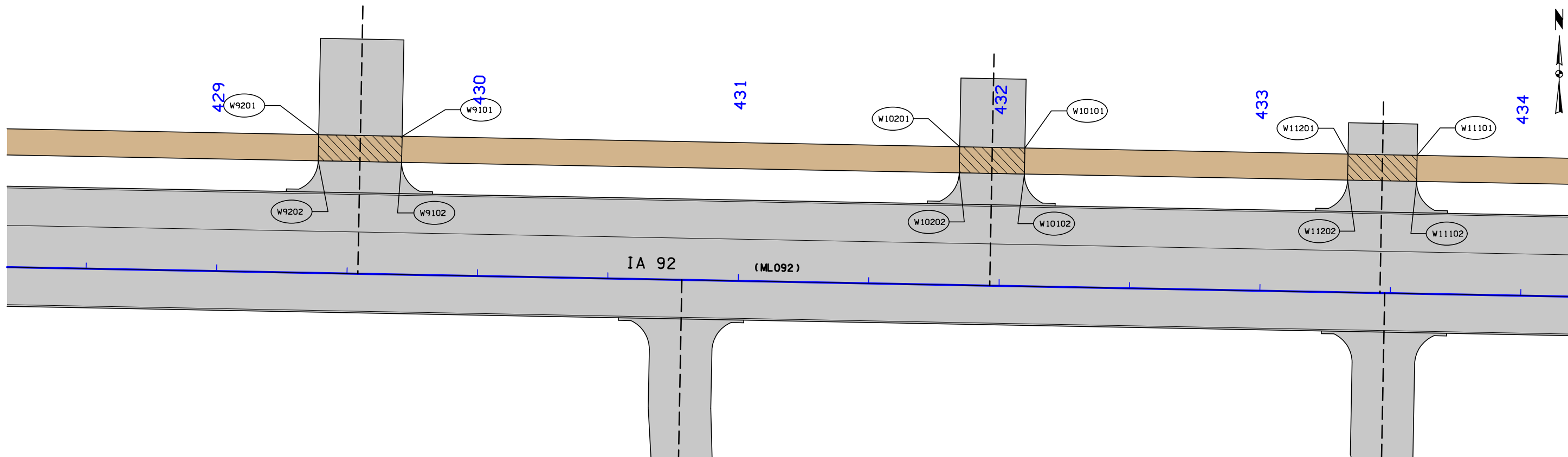

SIDEWALK LAYOUT
(Sheet 3 of 5)

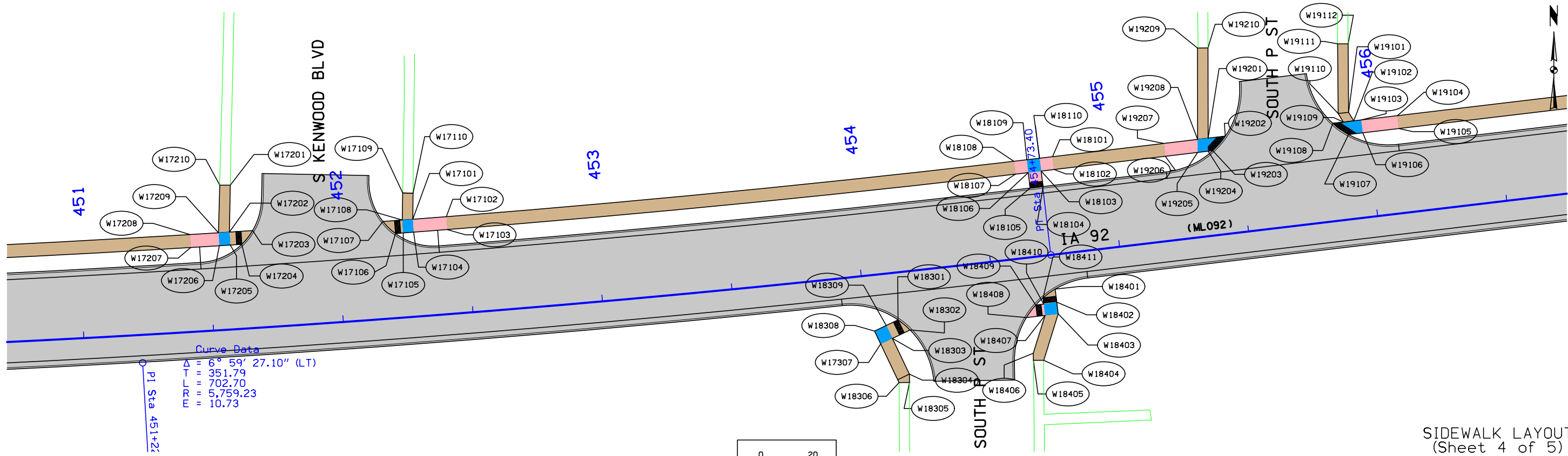
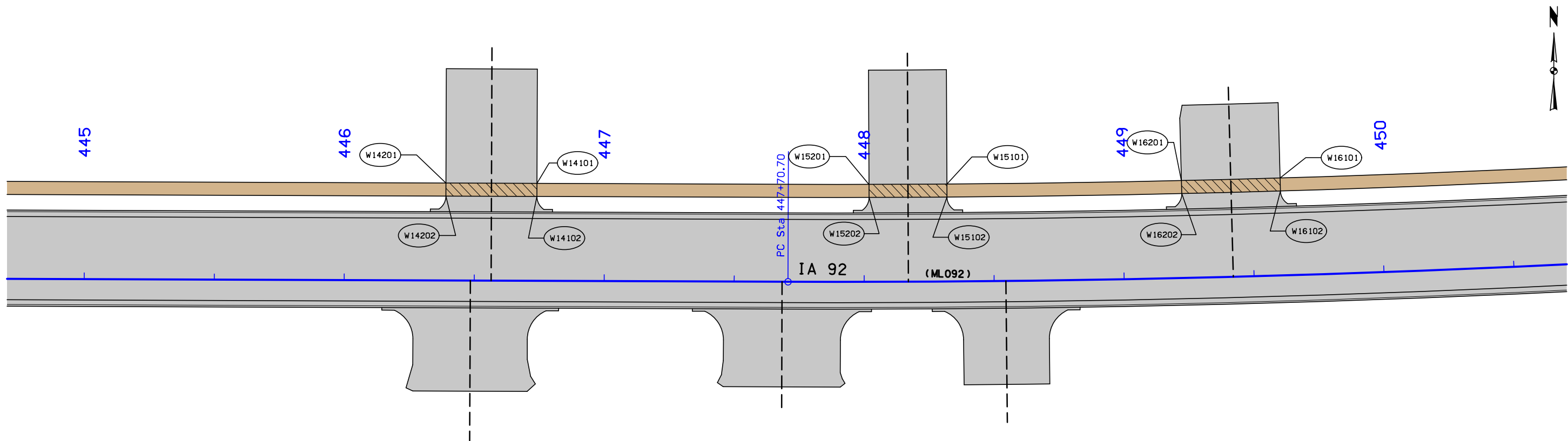

Curve Data
 $\Delta = 6^\circ 59' 27.10''$ (LT)
 T = 351.79
 L = 702.70
 E = 5,759.23
 R = 10.73

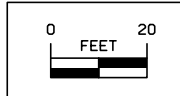

SIDEWALK LAYOUT
 (Sheet 4 of 5)

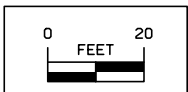
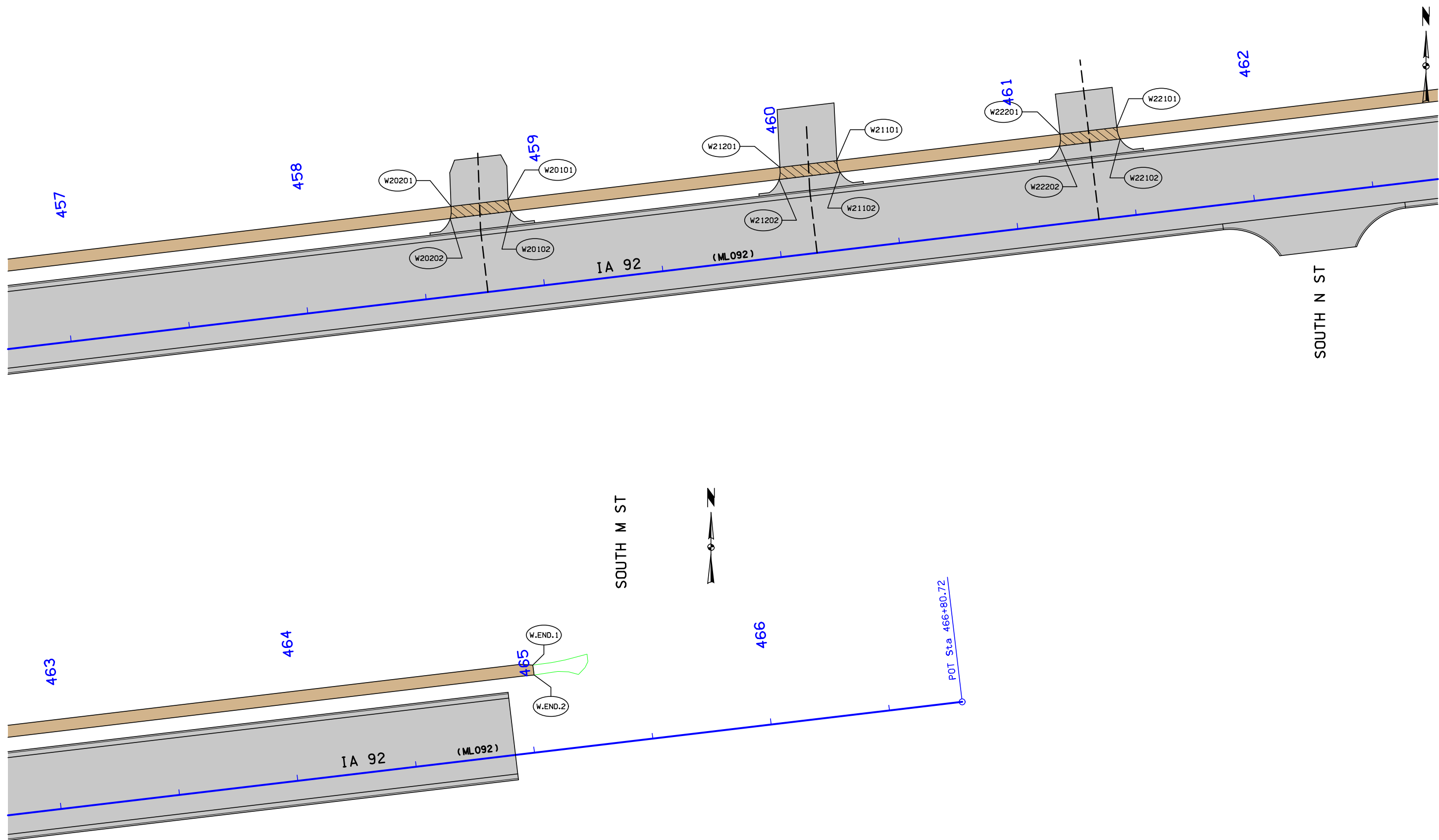

SIDEWALK LAYOUT
(Sheet 5 of 5)

SIDEWALK COMPLIANCE

See S Sheets

* Does not include curb
 ① Staking required by Contracting Authority per Article 2511.03 of the Standard Specifications.

Point to Point	Sidewalk Designation	Distance*	Δ Elevation	Slope	Acceptable Constructed Range	Staking Required on this Quadrant?	Measured Slope	Initials	Remarks	FOR INFORMATION ONLY: VALUES USED TO DETERMINE DESIGNED SLOPES			
										Point	Station	Offset	Elevation
										W1101	W1102	Landing/Turning Space	10.00
W1102	W1103	Landing/Turning Space	10.00	-0.15	-1.5%	0.1% to 2.0%				W1102			972.39
W1103	W1107	Landing/Turning Space	10.00	0.03	0.3%	0.1% to 2.0%				W1103			972.24
W1107	W1101	Landing/Turning Space	10.00	0.15	1.5%	0.1% to 2.0%				W1104			971.65
W1110	W1111	Landing/Turning Space	13.00	0.17	1.3%	0.1% to 2.0%				W1105	391+80.08	44.69	971.60
W1111	W1108	Landing/Turning Space	10.00	-0.08	-0.8%	0.1% to 2.0%				W1106	918+70.06	47.93	971.59
W1108	W1109	Landing/Turning Space	5.03	-0.07	-1.4%	0.1% to 2.0%				W1107			972.27
W1111	W1101	Sidewalk Running Slope	20.65	0.72	3.5%	0.5% to 5.0%				W1108			971.62
W1108	W1107	Sidewalk Running Slope	20.39	0.65	3.2%	0.5% to 5.0%				W1109			971.55
W1106	W1107	Sidewalk Running Slope	17.08	0.68	4.0%	0.5% to 5.0%				W1110			971.53
W1105	W1104	Sidewalk Running Slope	3.31	0.05	1.4%	0.5% to 5.0%				W1111			971.70
W1104	W1103	Sidewalk Running Slope	17.00	0.59	3.5%	0.5% to 5.0%							
W1106	W1104	Sidewalk Cross Slope	10.00	0.06	0.6%	0.5% to 2.0%							
W1110	W1109	Crosswalk Cross Slope - Yield Condition	12.95	0.02	0.1%	0.0% to 2.0%							
W1410	W1403	Landing/Turning Space	10.00	-0.10	-1.0%	0.1% to 2.0%				W1401	391+80.61	25.57	970.96
W1403	W1404	Landing/Turning Space	10.00	0.15	1.5%	0.1% to 2.0%				W1402			971.00
W1404	W1405	Landing/Turning Space	10.00	0.10	1.0%	0.1% to 2.0%				W1403			971.25
W1405	W1410	Landing/Turning Space	10.00	-0.15	-1.5%	0.1% to 2.0%				W1404			971.40
W1408	W1409	Landing/Turning Space	5.00	0.07	1.4%	0.1% to 2.0%				W1405			971.50
W1409	W1406	Landing/Turning Space	10.00	0.12	1.2%	0.1% to 2.0%				W1406			971.10
W1406	W1407	Landing/Turning Space	15.89	-0.22	-1.4%	0.1% to 2.0%				W1407			970.88
W1409	W1410	Sidewalk Running Slope	12.84	0.37	2.9%	0.5% to 5.0%				W1408			970.91
W1406	W1405	Sidewalk Running Slope	12.84	0.40	3.1%	0.5% to 5.0%				W1409			970.98
W1411	W1410	Sidewalk Running Slope	10.37	0.41	3.9%	0.5% to 5.0%				W1410			971.35
W1401	W1402	Sidewalk Running Slope	2.98	0.04	1.3%	0.5% to 5.0%				W1411	391+70.63	28.63	970.94
W1402	W1403	Sidewalk Running Slope	10.45	0.25	2.4%	0.5% to 5.0%							
W1411	W1402	Sidewalk Cross Slope	10.00	0.06	0.6%	0.5% to 2.0%							
W2201	W2202	Sidewalk Cross Slope	10.00	-0.15	-1.5%	0.5% to 2.0%				W2101			973.93
W2101	W2102	Sidewalk Cross Slope	10.00	-0.15	-1.5%	0.5% to 2.0%				W2102			973.78
W2201	W2101	Sidewalk Running Slope	37.05	0.26	0.7%	0.5% to 5.0%				W2201			973.66
W2202	W2102	Sidewalk Running Slope	37.08	0.26	0.7%	0.5% to 5.0%				W2202			973.51
W3201	W3202	Sidewalk Cross Slope	10.00	-0.15	-1.5%	0.5% to 2.0%				W3101			972.98
W3101	W3102	Sidewalk Cross Slope	10.00	-0.15	-1.5%	0.5% to 2.0%				W3102			972.83
W3201	W3101	Sidewalk Running Slope	24.00	-0.15	-0.6%	0.5% to 5.0%				W3201			973.14
W3202	W3102	Sidewalk Running Slope	24.00	-0.15	-0.6%	0.5% to 5.0%				W3202			972.99
W4206	W4201	Landing/Turning Space	29.13	-0.45	-1.5%	0.1% to 2.0%				W4201	416+80.98	53.00	965.38
W4203	W4202	Landing/Turning Space	5.90	-0.08	-1.4%	0.1% to 2.0%				W4202	416+60.74	43.00	965.73
W4206	W4203	Landing/Turning Space	10.00	-0.02	-0.2%	0.1% to 2.0%				W4203			965.81
W4205	W4206	Ramp Running Slope	5.00	-0.22	-4.4%	0.5% to 8.3%				W4204			965.90
W4204	W4203	Ramp Running Slope	5.00	-0.09	-1.8%	0.5% to 8.3%				W4205			966.05
W4205	W4204	Sidewalk Cross Slope	10.00	-0.15	-1.5%	0.5% to 2.0%				W4206			965.83
W4106	W4101	Landing/Turning Space	19.54	0.23	1.2%	0.1% to 2.0%				W4101			964.95
W4101	W4104	Landing/Turning Space	10.00	-0.04	-0.4%	0.1% to 2.0%				W4102			965.20
W4104	W4105	Landing/Turning Space	6.71	-0.02	-0.3%	0.1% to 2.0%				W4103			965.05
W4101	W4102	Ramp Running Slope	5.00	0.25	5.0%	0.5% to 8.3%				W4104			964.91
W4104	W4103	Ramp Running Slope	5.00	0.14	2.8%	0.5% to 8.3%				W4105	417+90.89	53.00	964.89
W4102	W4103	Sidewalk Cross Slope	10.00	-0.15	-1.5%	0.5% to 2.0%				W4106	417+78.05	43.00	964.72
W5101	W5102	Sidewalk Cross Slope	10.00	-0.15	-1.5%	0.5% to 2.0%				W5101	420+08.13	53.00	963.44
W5201	W5202	Sidewalk Cross Slope	10.00	-0.15	-1.5%	0.5% to 2.0%				W5102	420+08.13	43.00	963.29
W5102	W5202	Sidewalk Running Slope	70.00	0.87	1.2%	0.5% to 5.0%				W5202	419+38.13	43.00	964.16
W5201	W5101	Sidewalk Running Slope	70.00	-0.87	-1.2%	0.5% to 5.0%				W5201	419+38.13	54.00	964.31
W6101	W6102	Sidewalk Cross Slope	10.00	-0.15	-1.5%	0.5% to 2.0%				W6101	423+39.01	53.00	960.42
W6201	W6202	Sidewalk Cross Slope	10.00	-0.15	-1.5%	0.5% to 2.0%				W6102	423+39.01	43.00	960.27
W6102	W6202	Sidewalk Running Slope	70.00	0.30	0.4%	0.5% to 5.0%				W6202	422+69.01	43.00	960.57
W6201	W6101	Sidewalk Running Slope	70.00	-0.30	-0.4%	0.5% to 5.0%				W6201	422+69.01	53.00	960.72
W7101	W7102	Sidewalk Cross Slope	10.00	-0.15	-1.5%	0.5% to 2.0%				W7101	426+11.40	53.00	959.00
W7201	W7202	Sidewalk Cross Slope	10.00	-0.15	-1.5%	0.5% to 2.0%				W7102	426+11.40	43.00	958.85
W7102	W7202	Sidewalk Running Slope	24.00	0.12	0.5%	0.5% to 5.0%				W7202	425+87.40	43.00	958.97
W7201	W7101	Sidewalk Running Slope	24.00	-0.12	-0.5%	0.5% to 5.0%				W7201	425+87.40	53.00	959.12
W8101	W8102	Sidewalk Cross Slope	10.00	-0.15	-1.5%	0.5% to 2.0%				W8101	427+65.90	53.00	959.41
W8201	W8202	Sidewalk Cross Slope	10.00	-0.15	-1.5%	0.5% to 2.0%				W8102	427+65.90	43.00	959.26
W8102	W8202	Sidewalk Running Slope	24.00	-0.25	-1.0%	0.5% to 5.0%				W8202	427+41.90	43.00	959.01
W8201	W8101	Sidewalk Running Slope	24.00	0.25	1.0%	0.5% to 5.0%				W8201	427+41.90	53.00	959.16
W9101	W9102	Sidewalk Cross Slope	10.00	-0.15	-1.5%	0.5% to 2.0%				W9101	429+70.16	53.00	962.02
W9201	W9202	Sidewalk Cross Slope	10.00	-0.15	-1.5%	0.5% to 2.0%				W9102	429+70.16	43.00	961.87
W9102	W9202	Sidewalk Running Slope	32.00	-0.41	-1.3%	0.5% to 5.0%				W9202	429+38.16	43.00	961.46
W9201	W9101	Sidewalk Running Slope	32.00	0.41	1.3%	0.5% to 5.0%				W9201	429+38.16	53.00	961.61

SIDEWALK COMPLIANCE

See S Sheets

* Does not include curb
 ① Staking required by Contracting Authority per Article 2511.03 of the Standard Specifications.

Point to Point	Sidewalk Designation	Distance*	Δ Elevation	Slope	Acceptable Constructed Range	Staking Required on this Quadrant?	Measured Slope	Initials	Remarks	FOR INFORMATION ONLY: VALUES USED TO DETERMINE DESIGNED SLOPES			
										Point	Station	Offset	Elevation
										W10101	W10102	Sidewalk Cross Slope	10.00
W10201	W10202	Sidewalk Cross Slope	10.00	-0.15	-1.5%	0.5% to 2.0%				W10102	432+08.91	43.00	964.92
W10102	W10202	Sidewalk Running Slope	25.00	-0.32	-1.3%	0.5% to 5.0%				W10202	431+83.91	43.00	964.61
W10201	W10101	Sidewalk Running Slope	25.00	0.32	1.3%	0.5% to 5.0%				W10201	431+83.91	53.00	964.76
W11101	W11102	Sidewalk Cross Slope	10.00	-0.15	-1.5%	0.5% to 2.0%				W11101	433+59.31	53.00	965.86
W11201	W11202	Sidewalk Cross Slope	10.00	-0.15	-1.5%	0.5% to 2.0%				W11102	433+59.31	43.00	965.71
W11102	W11202	Sidewalk Running Slope	26.50	0.01	0.0%	0.5% to 5.0%				W11202	433+32.81	43.00	965.72
W11201	W11101	Sidewalk Running Slope	26.50	-0.01	0.0%	0.5% to 5.0%				W11201	433+32.81	53.00	965.87
W12101	W12102	Sidewalk Cross Slope	10.00	-0.15	-1.5%	0.5% to 2.0%				W12101	438+20.43	53.00	965.81
W12201	W12202	Sidewalk Cross Slope	10.00	-0.15	-1.5%	0.5% to 2.0%				W12102	438+20.43	43.00	965.66
W12102	W12202	Sidewalk Running Slope	24.00	-0.12	-0.5%	0.5% to 5.0%				W12202	437+96.06	43.00	965.54
W12201	W12101	Sidewalk Running Slope	24.00	0.12	0.5%	0.5% to 5.0%				W12201	437+96.06	53.00	965.69
W13104	W13103	Crosswalk Cross Slope - Yield Condition	5.00	-0.01	-0.3%	0.0% to 2.0%				W13101			967.48
W13101	W13102	Sidewalk Cross Slope	5.00	-0.08	-1.5%	0.5% to 2.0%				W13102			967.40
W13104	W13101	Ramp Running Slope	16.00	1.06	6.6%	0.5% to 8.3%				W13103			966.41
W13103	W13102	Ramp Running Slope	16.29	1.00	6.1%	0.5% to 8.3%				W13104			966.42
W13204	W13203	Sidewalk Cross Slope	10.00	-0.15	-1.5%	0.5% to 2.0%				W13201			966.20
W13201	W13202	Crosswalk Cross Slope - Yield Condition	10.04	-0.06	-0.6%	0.0% to 2.0%				W13202			966.14
W13204	W13201	Ramp Running Slope	15.50	-1.05	-6.7%	0.5% to 8.3%				W13203			967.10
W13203	W13202	Ramp Running Slope	14.50	-0.96	-6.6%	0.5% to 8.3%				W13204			967.25
						0							
W14101	W14102	Sidewalk Cross Slope	5.00	-0.08	-1.5%	0.5% to 2.0%				W14101	446+74.01	37.50	969.22
W14201	W14202	Sidewalk Cross Slope	5.00	-0.08	-1.5%	0.5% to 2.0%				W14102	446+74.01	32.50	969.14
W14102	W14202	Sidewalk Running Slope	35.00	-0.11	-0.3%	0.5% to 5.0%				W14202	446+39.01	32.50	969.03
W14201	W14101	Sidewalk Running Slope	35.00	0.11	0.3%	0.5% to 5.0%				W14201	446+39.01	37.50	969.11
W15101	W15102	Sidewalk Cross Slope	5.00	-0.08	-1.5%	0.5% to 2.0%				W15101	448+32.10	37.50	969.76
W15201	W15202	Sidewalk Cross Slope	5.00	-0.07	-1.5%	0.5% to 2.0%				W15102	448+32.10	32.50	969.68
W15102	W15202	Sidewalk Running Slope	30.00	-0.06	-0.2%	0.5% to 5.0%				W15202	448+01.92	32.50	969.62
W15201	W15101	Sidewalk Running Slope	30.00	0.06	0.2%	0.5% to 5.0%				W15201	448+01.92	37.50	969.70
W16101	W16102	Sidewalk Cross Slope	5.00	-0.08	-1.5%	0.5% to 2.0%				W16101	449+61.13	37.50	970.15
W16201	W16202	Sidewalk Cross Slope	5.00	-0.08	-1.5%	0.5% to 2.0%				W16102	449+61.13	32.50	970.08
W16102	W16202	Sidewalk Running Slope	38.00	-0.12	-0.3%	0.5% to 5.0%				W16202	449+22.89	32.50	969.96
W16201	W16101	Sidewalk Running Slope	38.00	0.12	0.3%	0.5% to 5.0%				W16201	449+22.89	37.50	970.03
W17108	W17101	Landing/Turning Space	4.00	0.06	1.5%	0.1% to 2.0%				W17101			970.06
W17101	W17104	Landing/Turning Space	5.00	0.05	1.0%	0.1% to 2.0%				W17102			970.98
W17105	W17104	Landing/Turning Space	4.00	0.06	1.5%	0.1% to 2.0%				W17103			970.91
W17108	W17105	Landing/Turning Space	5.00	0.05	1.0%	0.1% to 2.0%				W17104			970.11
W17107	W17108	Sidewalk Running Slope	7.47	0.29	3.9%	0.5% to 5.0%				W17105			970.05
W17106	W17105	Sidewalk Running Slope	2.99	0.04	1.3%	0.5% to 5.0%				W17106			970.01
W17107	W17106	Crosswalk Cross Slope - Yield Condition	6.71	0.30	4.5%	0.0% to 5.5%			Not inside scope of project to fix (ROW limits)	W17107			969.71
W17101	W17102	Ramp Running Slope	13.00	0.92	7.1%	0.5% to 8.3%				W17108			970.00
W17104	W17103	Ramp Running Slope	13.00	0.80	6.1%	0.5% to 8.3%				W17109			970.06
W17102	W17103	Sidewalk Cross Slope	5.00	-0.08	-1.5%	0.5% to 2.0%				W17110			970.00
W17108	W17109	Sidewalk Running Slope	10.04	0.06	0.6%	0.5% to 5.0%							
W17101	W17110	Sidewalk Running Slope	10.04	-0.06	-0.6%	0.5% to 5.0%							
W17109	W17110	Match Existing Cross Slope	3.98	-0.06	-1.6%	Match Existing							
W17209	W17202	Landing/Turning Space	4.21	-0.06	-1.5%	0.1% to 2.0%				W17201			970.16
W17206	W17205	Landing/Turning Space	4.21	-0.06	-1.5%	0.1% to 2.0%				W17202			969.97
W17209	W17206	Landing/Turning Space	5.00	-0.02	-0.4%	0.1% to 2.0%				W17203			969.61
W17202	W17205	Landing/Turning Space	5.00	-0.02	-0.4%	0.1% to 2.0%				W17204			969.84
W17202	W17203	Sidewalk Running Slope	8.93	-0.36	-4.0%	0.5% to 5.0%				W17205			969.95
W17205	W17204	Sidewalk Running Slope	4.46	-0.11	-2.5%	0.5% to 5.0%				W17206			970.02
W17204	W17203	Crosswalk Cross Slope - Yield Condition	6.71	-0.23	-3.4%	0.0% to 4.4%			Not inside scope of project to fix	W17207			970.69
W17208	W17209	Ramp Running Slope	11.00	-0.73	-6.7%	0.5% to 8.3%				W17208			970.77
W17207	W17206	Ramp Running Slope	11.00	-0.68	-6.2%	0.5% to 8.3%				W17209			970.04
W17208	W17207	Sidewalk Cross Slope	5.00	-0.08	-1.5%	0.5% to 2.0%				W17210			970.20
W17201	W17202	Sidewalk Running Slope	18.07	-0.19	-1.1%	0.5% to 5.0%							
W17210	W17209	Sidewalk Running Slope	18.34	-0.16	-0.9%	0.5% to 5.0%							
W17210	W17201	Match Existing Cross Slope	5.00	-0.04	-0.7%	Match Existing							
W18308	W18309	Landing/Turning Space	5.00	0.07	1.4%	0.1% to 2.0%				W18301			969.66
W18307	W18303	Landing/Turning Space	5.00	0.07	1.4%	0.1% to 2.0%				W18302			969.37
W18308	W18307	Landing/Turning Space	5.50	-0.08	-1.5%	0.1% to 2.0%				W18303			969.61
W18309	W18303	Landing/Turning Space	5.50	-0.08	-1.5%	0.1% to 2.0%				W18304			969.39
W18309	W18301	Sidewalk Running Slope	5.03	-0.03	-0.6%	0.5% to 5.0%				W18305			969.37
W18303	W18302	Sidewalk Running Slope	7.55	-0.24	-3.2%	0.5% to 5.0%				W18306			969.34
W18301	W18302	Crosswalk Cross Slope - Yield Condition	6.05	-0.29	-4.8%	0.0% to 5.8%			Not inside scope of project to fix	W18307			969.54

SIDEWALK COMPLIANCE

See S Sheets

* Does not include curb
 (1) Staking required by Contracting Authority per Article 2511.03 of the Standard Specifications.

Point to Point	Sidewalk Designation	Distance*	Δ Elevation	Slope	Acceptable Constructed Range	Staking Required on this Quadrant?	Measured Slope	Initials	Remarks	FOR INFORMATION ONLY: VALUES USED TO DETERMINE DESIGNED SLOPES			
										Point	Station	Offset	Elevation
W18307	W18306	Sidewalk Running Slope	16.47	-0.20	-1.2%	0.5% to 5.0%				W18308			969.62
W18303	W18304	Sidewalk Running Slope	15.23	-0.22	-1.4%	0.5% to 5.0%				W18309			969.69
W18304	W18305	Sidewalk Running Slope	3.40	-0.02	-0.7%	0.5% to 5.0%							
W18306	W18305	Match Existing Cross Slope	4.00	0.03	0.6%	Match Existing							
W18410	W18407	Landing/Turning Space	4.42	0.03	0.7%	0.1% to 2.0%				W18401			969.71
W18402	W18403	Landing/Turning Space	4.42	0.05	1.1%	0.1% to 2.0%				W18402			969.62
W18410	W18402	Landing/Turning Space	5.08	0.02	0.4%	0.1% to 2.0%				W18403			969.67
W18407	W18403	Landing/Turning Space	5.08	0.04	0.8%	0.1% to 2.0%				W18404			969.06
W18408	W18409	Crosswalk Cross Slope - Yield Condition	5.98	0.24	4.0%	0.0% to 5%			Not inside scope of project to fix	W18405			968.97
W18409	W18410	Ramp Running Slope	3.12	0.20	6.3%	0.5% to 8.3%				W18406			969.03
W18408	W18407	Ramp Running Slope	7.22	0.47	6.5%	0.5% to 8.3%				W18407			969.63
W18411	W18401	Crosswalk Cross Slope - No Yield Condition	5.77	0.15	2.6%	0.0% to 5.0%				W18408			969.16
W18411	W18410	Sidewalk Running Slope	2.40	0.04	1.7%	0.5% to 5.0%				W18409			969.40
W18401	W18402	Sidewalk Running Slope	5.12	-0.09	-1.8%	0.5% to 5.0%				W18410			969.60
W18407	W18406	Sidewalk Running Slope	15.26	-0.60	-3.9%	0.5% to 5.0%				W18411			969.56
W18403	W18404	Sidewalk Running Slope	18.70	-0.61	-3.2%	0.5% to 5.0%							
W18406	W18405	Sidewalk Running Slope	2.75	-0.06	-2.4%	0.5% to 5.0%							
W18405	W18404	Match Existing Cross Slope	4.00	0.10	2.5%	Match Existing							
W18109	W18110	Landing/Turning Space	5.00	-0.01	-0.2%	0.1% to 2.0%				W18101			970.79
W18106	W18103	Landing/Turning Space	5.00	-0.01	-0.2%	0.1% to 2.0%				W18102			970.71
W18109	W18106	Landing/Turning Space	5.00	-0.06	-1.3%	0.1% to 2.0%				W18103			970.45
W18110	W18103	Landing/Turning Space	5.00	-0.06	-1.3%	0.1% to 2.0%				W18104			970.13
W18106	W18105	Ramp Running Slope	6.00	-0.32	-5.4%	0.5% to 8.3%				W18105			970.14
W18103	W18104	Ramp Running Slope	6.00	-0.32	-5.4%	0.5% to 8.3%				W18106			970.46
W18104	W18104	Crosswalk Cross Slope - No Yield Condition	5.00	0.00	0.0%	0.0% to 5.0%				W18107			970.73
W18108	W18109	Ramp Running Slope	5.00	-0.28	-5.7%	0.5% to 8.3%				W18108			970.81
W18107	W18106	Ramp Running Slope	5.00	-0.27	-5.5%	0.5% to 8.3%				W18109			970.53
W18108	W18107	Sidewalk Cross Slope	5.00	-0.08	-1.5%	0.5% to 2.0%				W18110			970.52
W18110	W18101	Ramp Running Slope	5.00	0.27	5.4%	0.5% to 8.3%							
W18103	W18102	Ramp Running Slope	5.00	0.26	5.2%	0.5% to 8.3%							
W18101	W18102	Sidewalk Cross Slope	5.00	-0.08	-1.5%	0.5% to 2.0%							
W19108	W19109	Landing/Turning Space	4.11	0.02	0.5%	0.1% to 2.0%				W19101			969.51
W19109	W19102	Landing/Turning Space	4.01	0.02	0.5%	0.1% to 2.0%				W19102			969.60
W19102	W19103	Landing/Turning Space	2.88	0.01	0.3%	0.1% to 2.0%				W19103			969.61
W19107	W19106	Landing/Turning Space	5.50	-0.08	-1.5%	0.1% to 2.0%				W19104			970.51
W19103	W19106	Landing/Turning Space	5.00	0.01	0.2%	0.1% to 2.0%				W19105			970.43
W19108	W19107	Crosswalk Cross Slope - Yield Condition	7.43	0.14	1.9%	0.0% to 2.0%				W19106			969.62
W19103	W19104	Ramp Running Slope	14.00	0.89	6.4%	0.5% to 8.3%				W19107	+19.92		969.70
W19106	W19105	Ramp Running Slope	14.00	0.81	5.8%	0.5% to 8.3%				W19108	+27.58		969.56
W19104	W19105	Sidewalk Cross Slope	5.00	-0.08	-1.6%	0.5% to 2.0%	Yes			W19109			969.58
W19111	W19110	Sidewalk Running Slope	26.82	-0.04	-0.2%	0.5% to 5.0%				W19110			969.45
W19112	W19101	Sidewalk Running Slope	26.38	0.02	0.1%	0.5% to 5.0%				W19111			969.49
W19110	W19109	Sidewalk Running Slope	3.86	0.13	3.4%	0.5% to 5.0%				W19112			969.49
W19101	W19102	Sidewalk Running Slope	3.85	0.09	2.3%	0.5% to 5.0%							
W19111	W19112	Match Existing Cross Slope	4.00	0.00	0.0%	Match Existing							
W19110	W19101	Sidewalk Cross Slope	4.03	0.06	1.5%	0.5% to 2.0%							
W19208	W19201	Landing/Turning Space	4.03	-0.06	-1.5%	0.1% to 2.0%				W19201			969.76
W19205	W19204	Landing/Turning Space	4.04	-0.04	-1.0%	0.1% to 2.0%				W19202	+22.12		969.65
W19208	W19205	Landing/Turning Space	5.04	-0.01	-0.2%	0.1% to 2.0%				W19203	+29.54		969.80
W19201	W19204	Landing/Turning Space	5.04	0.01	0.2%	0.1% to 2.0%				W19204			969.77
W19201	W19202	Sidewalk Running Slope	6.68	-0.11	-1.6%	0.5% to 5.0%				W19205			969.81
W19204	W19203	Sidewalk Running Slope	1.80	0.03	1.7%	0.5% to 5.0%				W19206			970.63
W19202	W19203	Crosswalk Cross Slope - Yield Condition	7.40	0.15	2.0%	0.0% to 2.0%				W19207			970.70
W19207	W19208	Ramp Running Slope	13.09	-0.88	-6.7%	0.5% to 8.3%				W19208			969.82
W19206	W19205	Ramp Running Slope	12.50	-0.82	-6.5%	0.5% to 8.3%				W19209			969.03
W19207	W19206	Sidewalk Cross Slope	5.00	-0.08	-1.5%	0.5% to 2.0%				W19210			969.01
W19209	W19208	Sidewalk Running Slope	35.21	0.79	2.2%	0.5% to 5.0%							
W19210	W19201	Sidewalk Running Slope	34.74	0.75	2.1%	0.5% to 5.0%							
W19209	W19210	Match Existing Cross Slope	4.00	-0.02	-0.5%	Match Existing							
W.END.1	W.END.2	Match Existing Cross Slope	4.21	0.02	0.5%	Match Existing				W.END.1			967.59
										W.END.2			967.61
W20101	W20102	Sidewalk Cross Slope	5.00	-0.08	-1.5%	0.5% to 2.0%				W20101	458+89.04	37.50	969.84
W20201	W20202	Sidewalk Cross Slope	5.00	-0.08	-1.5%	0.5% to 2.0%				W20102	458+89.83	32.50	969.77
W20102	W20202	Sidewalk Running Slope	25.82	0.11	0.4%	0.5% to 5.0%				W20202	458+65.01	32.50	969.88
W20201	W20101	Sidewalk Running Slope	24.08	-0.11	-0.5%	0.5% to 5.0%				W20201	458+64.96	37.50	969.95
W21101	W21102	Sidewalk Cross Slope	5.00	-0.08	-1.5%	0.5% to 2.0%				W21101	460+27.99	37.50	969.60
W21201	W21202	Sidewalk Cross Slope	5.00	-0.07	-1.5%	0.5% to 2.0%				W21102	460+28.77	32.50	969.53
W21102	W21202	Sidewalk Running Slope	35.77	0.04	0.1%	0.5% to 5.0%				W21202	460+03.00	32.50	969.57
W21201	W21101	Sidewalk Running Slope	24.06	-0.04	-0.1%	0.5% to 5.0%				W21201	460+03.93	37.50	969.64

SIDEWALK COMPLIANCE

See S Sheets

* Does not include curb
 ① Staking required by Contracting Authority per Article 2511.03 of the Standard Specifications.

Point to Point	Sidewalk Designation	Distance*	Δ Elevation	Slope	Acceptable Constructed Range	Staking Required on this Quadrant?	Measured Slope	Initials	Remarks	FOR INFORMATION ONLY: VALUES USED TO DETERMINE DESIGNED SLOPES				
										Point	Station	Offset	Elevation	
W22101	W22102	Sidewalk Cross Slope	5.00	-0.08	-1.5%	0.5% to 2.0%					W22101	461+46.29	37.50	969.42
W22201	W22202	Sidewalk Cross Slope	5.00	-0.07	-1.5%	0.5% to 2.0%					W22102	461+47.12	32.50	969.34
W22102	W22202	Sidewalk Running Slope	25.60	0.05	0.2%	0.5% to 5.0%					W22202	461+21.45	32.50	969.39
W22201	W22101	Sidewalk Running Slope	24.00	-0.05	-0.2%	0.5% to 5.0%					W22201	461+22.29	37.50	969.47

TABULATION OF TEMPLATE QUANTITIES AND ADJUSTMENTS

Refer to Standard Road Plans EW-101 and EW-102.

STATION	TOTAL CUT	TOPSOIL TYPE B SAVED -C	TOPSOIL TYPE C SAVED -C	UNSUIT TYPE B CUT	UNSUIT TYPE C CUT	CLASS 10 SUITABLE CUT	ADJUSTED CLASS 10 TOTAL	TOTAL FILL	CLASS 10 SUITABLE + 30% SHRINK	TOTAL FILL WITH SHRINK																		
256+00.00	36		15			21	21																					
256+25.00	96		34			62	62																					
256+50.00	151		49			102	102																					
256+75.00	164		58			106	106	1	1	1																		
257+00.00	132		53			79	79	16	21	21																		
257+25.00	116		51			65	65	65	85	85																		
257+50.00	124		54			70	70	137	178	178																		
257+75.00	100		47			53	53	129	168	168																		
257+92.00	55		24	11		20	31	68	88	88																		
258+00.00	131		46	41		44	85	247	321	321																		
258+25.00	31		10	6		15	21	94	122	122																		
258+34.00	68		21	19		28	47	121	157	157																		
258+50.00	203		55	18		130	148	65	85	85																		
258+75.00	142		37	34		71	105																					
258+87.00	140		38	62		40	102																					
259+00.00	171		49	67		55	122	48	62	62																		
259+25.00	153		46	68		39	107	100	130	130																		
259+50.00	226		68	102		56	158	84	109	109																		
259+75.00	297		72	165		60	225	41	53	53																		
260+00.00	362		84	235		43	278	12	16	16																		
260+25.00	374		99	234		41	275	2	3	3																		
260+50.00	346		98	208		40	248																					
260+75.00	344		96	208		40	248																					
261+00.00	371		97	235		39	274																					
261+25.00	367		96	234		37	271	1	1	1																		
261+50.00	354		98	219		37	256	1	1	1																		
261+75.00	356		102	234		20	254																					
262+00.00	373		98	269		6	275																					
262+25.00	401		92	290		19	309	1	1	1																		
262+50.00	393		90	285		18	303	2	3	3																		
262+75.00	366		88	270		8	278	4	5	5																		
263+00.00	352		89	256		7	263	5	7	7																		
263+25.00	342		87	247		8	255	9	12	12																		
263+50.00	321		83	231		7	238	14	18	18																		
263+75.00	275		80	190		5	195	18	23	23																		
264+00.00	222		65	154		3	157	38	49	49																		
264+25.00	185		46	138		1	139	83	108	108																		
264+50.00	164		39	124		1	125	138	179	179																		
264+75.00	148		37	111			111	202	263	263																		
265+00.00	135		35	99		1	100	260	338	338																		
265+25.00	155		46	108		1	109	296	385	385																		
265+50.00	168		56	112			112	327	425	425																		
265+75.00	152		64	88			88	358	465	465																		
266+00.00	147		63	84			84	396	515	515																		
266+25.00	145		53	92			92	433	563	563																		
266+50.00	133		55	78			78	506	658	658																		
266+75.00	113		52	60		1	61	606	788	788																		
267+00.00	99		48	49		2	51	688	894	894																		
267+25.00	90		46	41		3	44	734	954	954																		
267+50.00	91		36	47		8	55	755	982	982																		
267+75.00	112		38	66		8	74	749	974	974																		
268+00.00	149		53	89		7	96	725	943	943																		
268+25.00	157		54	94		9	103	721	937	937																		
268+50.00	143		54	82		7	89	718	933	933																		
268+75.00	116		50	59		7	66	715	930	930																		
269+00.00	89		45	33		11	44	691	898	898																		
269+25.00	89		45	26		18	44	639	831	831																		
269+50.00	103		46	37		20	57	592	770	770																		
269+75.00	98		44	40		14	54	542	705	705																		
270+00.00	94		38	28		28	56	454	590	590																		
270+25.00	129		33	58		38	96	354	460	460																		
270+50.00	40		7	21		12	33	76	99	99																		
270+56.00	115		32	57		26	83	258	335	335																		
270+75.00	122		52	64		6	70	352	458	458																		
271+00.00	124		50	68		6	74	340	442	442																		
271+25.00																												

TABULATION OF TEMPLATE QUANTITIES AND ADJUSTMENTS

Refer to Standard Road Plans EW-101 and EW-102.

STATION	TOTAL CUT	TOPSOIL TYPE B SAVED -C	TOPSOIL TYPE C SAVED -C	UNSUIT TYPE B CUT	UNSUIT TYPE C CUT	CLASS 10 SUITABLE CUT	ADJUSTED CLASS 10 TOTAL	TOTAL FILL	CLASS 10 SUITABLE + 30% SHRINK	TOTAL FILL WITH SHRINK																									
271+25.00	135		52	77		6	83	318	413	413																									
271+50.00	147		54	88		5	93	289	376	376																									
271+75.00	154		46	103		5	108	260	338	338																									
272+00.00	157		48	104		5	109	233	303	303																									
272+25.00	164		59	99		6	105	214	278	278																									
272+50.00	164		61	96		7	103	205	267	267																									
272+75.00	151		59	86		6	92	201	261	261																									
273+00.00	157		59	92		6	98	196	255	255																									
273+25.00	180		63	112		5	117	191	248	248																									
273+50.00	194		65	126		3	129	188	244	244																									
273+75.00	200		71	127		2	129	186	242	242																									
274+00.00	209		73	126		10	136	186	242	242																									
274+25.00	230		72	143		15	158	187	243	243																									
274+50.00	251		76	169		6	175	191	248	248																									
274+75.00	261		77	182		2	184	199	259	259																									
275+00.00	261		77	183		1	184	210	273	273																									
275+25.00	249		75	174			174	226	294	294																									
275+50.00	224		71	153			153	243	316	316																									
275+75.00	192		73	118		1	119	268	348	348																									
276+00.00	217		77	134		6	140	292	380	380																									
276+25.00	244		67	152		25	177	265	345	345																									
276+46.00	52		14	30		8	38	54	70	70																									
276+50.00	242		71	137		34	171	392	510	510																									
276+75.00	138		55	76		7	83	530	689	689																									
277+00.00	102		46	51		5	56	649	844	844																									
277+25.00	76		39	34		3	37	730	949	949																									
277+50.00	30		15	14		1	15	324	421	421																									
277+60.00	42		19	22		1	23	495	644	644																									
277+75.00	71		39	32			32	811	1054	1054																									
278+00.00	94		50	44			44	784	1019	1019																									
278+25.00	117		50	67			67	722	939	939																									
278+50.00	144		55	88		1	89	647	841	841																									
278+75.00	177		62	115			115	563	732	732																									
279+00.00	200		67	133			133	481	625	625																									
279+25.00	219		66	143		10	153	413	537	537																									
279+50.00	228		64	145		19	164	348	452	452																									
279+75.00	225		76	135		14	149	272	354	354																									
280+00.00	222		79	133		10	143	195	254	254																									
280+25.00	216		68	135		13	148	155	202	202																									
280+50.00	195		63	117		15	132	146	190	190																									
280+75.00	164		57	93		14	107	130	169	169																									
281+00.00	146		54	82		10	92	112	146	146																									
281+25.00	141		53	78		10	88	100	130	130																									
281+50.00	126		58	56		12	68	97	126	126																									
281+75.00	110		56	38		16	54	100	130	130																									
282+00.00	109		47	46		16	62	98	127	127																									
282+25.00	70		32	30		8	38	68	88	88																									
282+50.00	14		9	4		1	5	46	60	60																									
282+75.00								51	66	66																									
283+00.00								54	70	70																									
283+25.00								56	73	73																									
283+50.00								36	47	47																									
283+75.00								30	39	39																									
284+00.00								43	56	56																									
284+25.00								42	55	55																									
284+50.00								41	53	53																									
284+75.00								48	19	72																									
285+00.00	48		19			29	29	55	72	72																									
285+25.00	89		37			52	52	77	100	100																									
285+50.00	75		35			40	40	76	99	99																									
285+75.00	64		33			31	31	68	88	88																									
286+00.00	64		33			31	31	71	92	92																									
286+25.00	59		32			27	27	71	92	92																									
286+50.00	54		29			25	25	77	100	100																									
286+75.00	60		29			31	31	100	130	130																									
287+00.00	68		30			38	38	131	170	170																									

TABULATION OF TEMPLATE QUANTITIES AND ADJUSTMENTS

Refer to Standard Road Plans EW-101 and EW-102.

STATION	TOTAL CUT	TOPSOIL TYPE B SAVED -C	TOPSOIL TYPE C SAVED -C	UNSUIT TYPE B CUT	UNSUIT TYPE C CUT	CLASS 10 SUITABLE CUT	ADJUSTED CLASS 10 TOTAL	TOTAL FILL	CLASS 10 SUITABLE + 30% SHRINK	TOTAL FILL WITH SHRINK																										
302+25.00	124		62	55		7	62	46	68	68																										
302+50.00	127		64	55		8	63	41	53	53																										
302+75.00	139		63	64		12	76	42	55	55																										
303+00.00	137		63	62		12	74	43	56	56																										
303+25.00	130		66	55		9	64	42	55	55																										
303+50.00	136		66	62		8	70	47	61	61																										
303+75.00	157		63	66		28	94	78	101	101																										
304+00.00	168		65	78		25	103	88	114	114																										
304+25.00	151		63	86		2	88	78	101	101																										
304+50.00	148		59	88		1	89	94	122	122																										
304+75.00	159		59	100			100	112	146	146																										
305+00.00	157		58	53		46	99	139	181	181																										
305+25.00	36		14			22	22	40	52	52																										
305+31.00	118		43			75	75	141	183	183																										
305+50.00	163		57			106	106	228	296	296																										
305+75.00	149		53			96	96	304	395	395																										
306+00.00	116		46			70	70	386	502	502																										
306+25.00	97		42			55	55	458	595	595																										
306+50.00	86		40	20		26	46	527	685	685																										
306+75.00	79		40	39			39	583	758	758																										
307+00.00	79		40	39			39	624	811	811																										
307+25.00	64		32	32			32	548	712	712																										
307+45.00	16		8	8			8	144	187	187																										
307+50.00	33		15	18			18	281	365	365																										
307+60.00	52		23	28		1	29	415	540	540																										
307+75.00	86		37	49			49	667	867	867																										
308+00.00	100		40	60			60	600	780	780																										
308+25.00	135		48	87			87	510	663	663																										
308+50.00	167		53	113		1	114	435	566	566																										
308+75.00	183		55	126		2	128	388	504	504																										
309+00.00	182		55	123		4	127	352	458	458																										
309+25.00	164		55	104		5	109	323	420	420																										
309+50.00	96		38	55		3	58	295	384	384																										
309+75.00	43		21	20		2	22	272	354	354																										
310+00.00	76		10	28		38	66	182	237	237																										
310+25.00	73		9	25		39	64	132	172	172																										
310+50.00	42		18	11		13	24	133	173	173																										
310+75.00	94		30	25		39	64	82	107	107																										
311+00.00	177		51	65		61	126	44	57	57																										
311+25.00	248		63	121		64	185	21	27	27																										
311+50.00	314		71	179		64	243	9	12	12																										
311+75.00	367		75	227		65	292	2	3	3																										
312+00.00	413		82	260		71	331																													
312+25.00	418		88	248		82	330																													
312+50.00	447		96	253		98	351																													
312+75.00	532		103	301		128	429																													
313+00.00	581		104	162		315	477																													
313+25.00	604		104			500	500	3	4	4																										
313+50.00	594		105			489	489	7	9	9																										
313+75.00	545		125			420	420	13	17	17																										
314+00.00	482		122			360	360	21	27	27																										
314+25.00	400		95			305	305	35	46	46																										
314+50.00	299		83			216	216	54	70	70																										
314+75.00	203		67			136	136	91	118	118																										
315+00.00	152		59			93	93	152	198	198																										
315+25.00	148		58	41		49	90	228	296	296																										
315+50.00	189		59	88		42	130	369	480	480																										
315+75.00	108		33	52		23	75	280	364	364																										
315+89.00	72		29	40		3	43	238	309	309																										
316+00.00	156		64	85		7	92	517	672	672																										
316+25.00	131		47	75		9	84	474	616	616																										
316+50.00	154		53	94		7	101	455	592	592																										
316+75.00	187		66	116		5	121	431	560	560																										
317+00.00	188		66	117		5	122	393	511	511																										
317+25.00	195		68	122		5	127	349	454	454																										

TABULATION OF TEMPLATE QUANTITIES AND ADJUSTMENTS

Refer to Standard Road Plans EW-101 and EW-102.

STATION	TOTAL CUT	TOPSOIL TYPE B SAVED -C	TOPSOIL TYPE C SAVED -C	UNSUIT TYPE B CUT	UNSUIT TYPE C CUT	CLASS 10 SUITABLE CUT	ADJUSTED CLASS 10 TOTAL	TOTAL FILL	CLASS 10 SUITABLE + 30% SHRINK	TOTAL FILL WITH SHRINK																		
332+50.00	25	15		5		5	10	525	683	683																		
332+65.00	14	7				7	7	380	494	494																		
332+75.00	12	6				6	6	329	428	428																		
332+83.00	33	19		8		6	14	658	855	855																		
333+00.00	53	34		18		1	19	813	1057	1057																		
333+25.00	39	30		9			9	723	940	940																		
333+50.00	34	28		6			6	651	846	846																		
333+75.00	36	28		8			8	579	753	753																		
334+00.00	45	31		14			14	500	650	650																		
334+25.00	68	38		30			30	403	524	524																		
334+50.00	81	41		40			40	322	419	419																		
334+75.00	76	39		37			37	275	358	358																		
335+00.00	88	42		46			46	231	300	300																		
335+25.00	123	51		72			72	173	225	225																		
335+50.00	166	62		103		1	104	121	157	157																		
335+75.00	221	95		125		1	126	94	122	122																		
336+00.00	270	107		162		1	163	84	109	109																		
336+25.00	310	97		212		1	213	78	101	101																		
336+50.00	353	103		248		2	250	75	98	98																		
336+75.00	392	107		282		3	285	73	95	95																		
337+00.00	402	107		291		4	295	71	92	92																		
337+25.00	387	106		276		5	281	69	90	90																		
337+50.00	361	104		253		4	257	67	87	87																		
337+75.00	323	105		169	45	4	218	64	83	83																		
338+00.00	286	97		139	45	5	189	64	83	83																		
338+25.00	256	80		170		6	176	64	83	83																		
338+50.00	231	70		155		6	161	72	94	94																		
338+75.00	212	65		140		7	147	90	117	117																		
339+00.00	184	61		117		6	123	115	150	150																		
339+25.00	144	66		74		4	78	156	203	203																		
339+50.00	107	60		45		2	47	218	283	283																		
339+75.00	91	50		41			41	287	373	373																		
340+00.00	87	47		39		1	40	356	463	463																		
340+25.00	82	41		41			41	423	550	550																		
340+50.00	72	39		33			33	482	627	627																		
340+75.00	60	28		25		7	32	525	683	683																		
341+00.00	7	2		3		2	5	65	85	85																		
341+03.00	43	21		15		7	22	489	636	636																		
341+25.00	46	31		15			15	591	768	768																		
341+50.00	46	30		16			16	601	781	781																		
341+75.00	15	10		5			5	190	247	247																		
341+83.00	33	23		10			10	382	497	497																		
342+00.00	59	36		22		1	23	503	654	654																		
342+25.00	117	46		71			71	436	567	567																		
342+50.00	229	35		111		83	194	314	408	408																		
342+75.00	255	37		136		82	218	248	322	322																		
343+00.00	209	56		153			153	291	378	378																		
343+25.00	213	56		136		21	157	307	399	399																		
343+50.00	219	58		110		51	161	262	341	341																		
343+75.00	203	55		90		58	148	213	277	277																		
344+00.00	175	60		76		39	115	166	216	216																		
344+25.00	157	63		76		18	94	122	159	159																		
344+50.00	163	62		91		10	101	87	113	113																		
344+75.00	177	71		91		15	106	63	82	82																		
345+00.00	189	78		78		33	111	48	62	62																		
345+25.00	193	79		71		43	114	38	49	49																		
345+50.00	187	75		78		34	112	30	39	39																		
345+75.00	181	67		77		37	114	25	33	33																		
346+00.00	183	67		73		43	116	25	33	33																		
346+25.00	193	74		91		28	119	24	31	31																		
346+50.00	196	75		95		26	121	22	29	29																		
346+75.00	191	74		84		33	117	23	30	30																		
347+00.00	187	73		88		26	114	26	34	34																		
347+25.00	191	71		94		26	120	30	39	39																		
347+50.00	189	68		91		30	121	32	42	42																		
347+75.00																												

TABULATION OF TEMPLATE QUANTITIES AND ADJUSTMENTS

Refer to Standard Road Plans EW-101 and EW-102.

STATION	TOTAL CUT	TOPSOIL TYPE B SAVED -C	TOPSOIL TYPE C SAVED -C	UNSOILT TYPE B CUT	UNSOILT TYPE C CUT	CLASS 10 SUITABLE CUT	ADJUSTED CLASS 10 TOTAL	TOTAL FILL	CLASS 10 SUITABLE + 30% SHRINK	TOTAL FILL WITH SHRINK	APPROX. FILL VOLUME BELOW 3 FT	APPROX. FILL VOLUME BELOW 5 FT																		
362+75.00	122		51	71			71	234	304	304																				
363+00.00	128		52	75		1	76	226	294	294																				
363+25.00	163		58	94		11	105	197	256	256																				
363+50.00	198		43	113		42	155	172	224	224																				
363+75.00	189		45	112		32	144	170	221	221																				
364+00.00	161		61	99		1	100	196	255	255																				
364+25.00	144		55	89			89	227	295	295																				
364+50.00	135		53	82			82	230	299	299																				
364+75.00	131		52	79			79	215	280	280																				
365+00.00	151		39	93		19	112	184	239	239																				
365+25.00	81		12	51		18	69	80	104	104																				
365+37.00	85		22	54		9	63	91	118	118																				
365+50.00	159		58	101			101	202	263	263																				
365+75.00	164		63	98		3	101	228	296	296																				
366+00.00	158		61	93		4	97	233	303	303																				
366+25.00	149		55	94			94	233	303	303																				
366+50.00	147		55	92			92	234	304	304																				
366+75.00	155		54	86		15	101	248	322	322																				
367+00.00	144		52	77		15	92	246	320	320																				
367+25.00	117		49	68			68	229	298	298																				
367+50.00	112		48	64			64	231	300	300																				
367+75.00	120		52	68			68	234	304	304																				
368+00.00	129		53	76			76	237	308	308																				
368+25.00	135		52	83			83	238	309	309																				
368+50.00	136		52	84			84	238	309	309																				
368+75.00	136		52	84			84	240	312	312																				
369+00.00	134		52	82			82	242	315	315																				
369+25.00	132		51	81			81	242	315	315																				
369+50.00	131		51	80			80	242	315	315																				
369+75.00	129		62	67			67	242	315	315																				
370+00.00	129		62	67			67	242	315	315																				
370+25.00	126		50	76			76	240	312	312																				
370+50.00	124		49	75			75	238	309	309																				
370+75.00	121		49	72			72	238	309	309																				
371+00.00	118		48	70			70	237	308	308																				
371+25.00	115		47	68			68	235	306	306																				
371+50.00	113		47	66			66	233	303	303																				
371+75.00	113		43	70			70	232	302	302																				
372+00.00	113		43	70			70	232	302	302																				
372+25.00	104		44	60			60	228	296	296																				
372+50.00	112		46	66			66	218	283	283																				
372+75.00	132		50	81		1	82	209	272	272																				
373+00.00	149		54	90		5	95	203	264	264																				
373+25.00	166		59	99		8	107	198	257	257																				
373+50.00	186		64	112		10	122	194	252	252																				
373+75.00	206		72	119		15	134	191	248	248																				
374+00.00	218		74	136		8	144	184	239	239																				
374+25.00	226		70	156			156	173	225	225																				
374+50.00	228		70	157		1	158	160	208	208																				
374+75.00	230		71	158		1	159	155	202	202																				
375+00.00	239		72	80	74	13	167	150	195	195																				
375+25.00	198		29		117	52	169	95	124	124																				
375+45.00	50				30	20	50	19	25	25																				
375+50.00	236		34		140	62	202	131	170	170																				
375+75.00	211		70		120	21	141	176	229	229																				
376+00.00	190		67		116	7	123	195	254	254																				
376+25.00	170		59		111		111	212	276	276																				
376+50.00	164		39		103	22	125	221	287	287																				
376+75.00	139		34		83	22	105	236	307	307																				
377+00.00	110		46		64		64	254	330	330																				
377+25.00	127		49		74	4	78	250	325	325																				
377+50.00	169		57		106	6	112	232	302	302																				
377+75.00	195		59		127	9	136	211	274	274																				
378+00.00	202		60		127	15	142	193	251	251																				
378+25.00	203		63		128	12	140	190	247	247																				
378+50.00																														

TABULATION OF TEMPLATE QUANTITIES AND ADJUSTMENTS

Refer to Standard Road Plans EW-101 and EW-102.

STATION	TOTAL CUT	TOPSOIL TYPE B SAVED -C	TOPSOIL TYPE C SAVED -C	UNSUITS TYPE B CUT	UNSUITS TYPE C CUT	CLASS 10 SUITABLE CUT	ADJUSTED CLASS 10 TOTAL	TOTAL FILL	CLASS 10 SUITABLE + 30% SHRINK	TOTAL FILL WITH SHRINK																					
378+50.00	179	58			107	14	121	205	267	267																					
378+75.00	136	52	27		44	13	84	234	304	304																					
379+00.00	103	48	46			9	55	274	356	356																					
379+25.00	84	43	31			10	41	317	412	412																					
379+50.00	15	7	5			3	8	69	90	90																					
379+55.00	38	17	14			7	21	189	246	246																					
379+68.00	22	11	8			3	11	101	131	131																					
379+75.00	18	9	6			3	9	69	90	90																					
379+80.00	66	35	21			10	31	265	345	345																					
380+00.00	75	42	22			11	33	327	425	425																					
380+25.00	79	44	24			11	35	326	424	424																					
380+50.00	85	46	28			11	39	311	404	404																					
380+75.00	94	48	36			10	46	290	377	377																					
381+00.00	105	50	46			9	55	263	342	342																					
381+25.00	116	51	55			10	65	237	308	308																					
381+50.00	128	53	67			8	75	213	277	277																					
381+75.00	73	28	41			4	45	104	135	135																					
381+88.00	71	26	41		1	3	45	94	122	122																					
382+00.00	153	55	90		2	6	98	191	248	248																					
382+25.00	160	57	96			7	103	181	235	235																					
382+50.00	172	60	106			6	112	172	224	224																					
382+75.00	177	61	109			7	116	165	215	215																					
383+00.00	177	62	110			5	115	158	205	205																					
383+25.00	177	62	108			7	115	154	200	200																					
383+50.00	171	61	101			9	110	148	192	192																					
383+75.00	162	59	90			13	103	141	183	183																					
384+00.00	172	61	96			15	111	131	170	170																					
384+25.00	206	68	122			16	138	116	151	151																					
384+50.00	263	78	164			21	185	75	98	98																					
384+75.00	297	83	187			27	214	47	61	61																					
385+00.00	294	82	185			27	212	51	66	66																					
385+25.00	286	81	183			22	205	48	62	62																					
385+50.00	268	78	161			29	190	53	69	69																					
385+75.00	261	79	147			35	182	57	74	74																					
386+00.00	265	80	163			22	185	49	64	64																					
386+25.00	265	76	171			18	189	36	47	47																					
386+50.00	259	74	162			23	185	35	46	46																					
386+75.00	262	75	155			32	187	33	43	43																					
387+00.00	285	77	168			40	208	28	36	36																					
387+25.00	280	76	173			31	204	20	26	26																					
387+50.00	293	76	189			28	217	11	14	14																					
387+75.00	248	51	159			38	197	9	12	12																					
387+93.00	101	18	63			20	83	3	4	4																					
388+00.00	373	76	235			62	297	9	12	12																					
388+25.00	394	63	249			82	331	7	9	9																					
388+50.00	415	88	263			64	327	3	4	4																					
388+75.00	432	131	280			21	301	6	8	8																					
389+00.00	362	116	230			16	246	22	29	29																					
389+25.00	281	104	167			10	177	37	48	48																					
389+50.00	262	91	147			24	171	48	62	62																					
389+75.00	125	39	67			19	86	69	90	90																					
390+00.00																															
Stage 1B																															
390+25.00	2					2	2	135	176	176																					
390+50.00	1					1	1	115	150	150																					
390+75.00								55	72	72																					
391+00.00	2					2	2	4	5	5																					
391+07.00	6					6	6	3	4	4																					
391+25.00	4					4	4	35	46	46																					
391+50.00	4					4	4	67	87	87																					
391+75.00								60	78	78																					
392+00.00								35	46	46																					
392+25.00								12	16	16																					
392+50.00	6	6						18	23	23																					
392+75.00	19	19						28	36	36																					
393+00.00																															

TABULATION OF TEMPLATE QUANTITIES AND ADJUSTMENTS

Refer to Standard Road Plans EW-101 and EW-102.

STATION	TOTAL CUT	TOPSOIL TYPE B SAVED -C	TOPSOIL TYPE C SAVED -C	UNSUIT TYPE B CUT	UNSUIT TYPE C CUT	CLASS 10 SUITABLE CUT	ADJUSTED CLASS 10 TOTAL	TOTAL FILL	CLASS 10 SUITABLE + 30% SHRINK	TOTAL FILL WITH SHRINK	APPROX. FILL VOLUME BELOW 3 FT	APPROX. FILL VOLUME BELOW 5 FT																												
408+50.00	119		57	60		2	62	3	4	4																														
408+75.00	109		56	51		2	53	3	4	4																														
409+00.00	99		55	42		2	44	3	4	4																														
409+25.00	90		53	34		3	37	3	4	4																														
409+50.00	87		52	32		3	35	3	4	4																														
409+75.00	89		53	33		3	36	3	4	4																														
410+00.00	93		53	37		3	40	3	4	4																														
410+25.00	99		54	42		3	45	3	4	4																														
410+50.00	104		54	49		1	50	3	4	4																														
410+75.00	109		55	54			54	3	4	4																														
411+00.00	117		56	60		1	61	3	4	4																														
411+25.00	126		57	68		1	69	3	4	4																														
411+50.00	135		58	76		1	77	3	4	4																														
411+75.00	142		58	82		2	84	3	4	4																														
412+00.00	148		58	86		4	90	3	4	4																														
412+25.00	154		58	93		3	96	3	4	4																														
412+50.00	163		59	101		3	104	3	4	4																														
412+75.00	172		61	109		2	111	3	4	4																														
413+00.00	174		61	110		3	113	3	4	4																														
413+25.00	170		61	106		3	109	3	4	4																														
413+50.00	167		60	103		4	107	3	4	4																														
413+75.00	165		62	99		4	103	3	4	4																														
414+00.00	162		62	92		8	100	3	4	4																														
414+25.00	157		59	91		7	98	3	4	4																														
414+50.00	154		59	90		5	95	3	4	4																														
414+75.00	151		59	87		5	92	3	4	4																														
415+00.00	149		58	87		4	91	3	4	4																														
415+25.00	148		58	88		2	90	3	4	4																														
415+50.00	148		57	88		3	91	3	4	4																														
415+75.00	152		56	90		6	96	3	4	4																														
416+00.00	164		57	101		6	107	3	4	4																														
416+25.00	145		45	96		4	100	1	1	1																														
416+50.00	117		31	79		7	86																																	
416+75.00	140		30	104		6	110																																	
417+00.00	153		14	128		11	139																																	
417+25.00	133			116		17	133																																	
417+50.00	145			118		27	145																																	
417+75.00	144		15	108		21	129																																	
418+00.00	113		31	66		16	82																																	
418+25.00	98		33	40		25	65																																	
418+50.00	90		33	39		18	57																																	
418+75.00	127		46	68		13	81	1	1	1																														
419+00.00	165		58	99		8	107	3	4	4																														
419+25.00	155		56	96		3	99	3	4	4																														
419+50.00	140		52	84		4	88	3	4	4																														
419+75.00	29		6	9		14	23	1	1	1																														
419+80.63	93		18	26		49	75	4	5	5																														
420+00.00	105		46	58		1	59	6	8	8																														
420+25.00	91		44	45		2	47	7	9	9																														
420+50.00	79		42	35		2	37	9	12	12																														
420+75.00	63		35	27		1	28	10	13	13																														
421+00.00	48		28	17		3	20	15	20	20																														
421+25.00	41		27	10		4	14	21	27	27																														
421+50.00	41		28	8		5	13	23	30	30																														
421+75.00	36		25	4		7	11	29	38	38																														
422+00.00	31		21	4		6	10	37	48	48																														
422+25.00	19		7	1		11	12	29	38	38																														
422+41.02	10		3	1		6	7	20	26	26																														
422+50.00	32		18	3		11	14	54	70	70																														
422+75.00	40		27			13	13	42	55	55																														

TABULATION OF TEMPLATE QUANTITIES AND ADJUSTMENTS

Refer to Standard Road Plans EW-101 and EW-102.

STATION	TOTAL CUT	TOPSOIL TYPE B SAVED -C	TOPSOIL TYPE C SAVED -C	UNSUIT TYPE B CUT	UNSUIT TYPE C CUT	CLASS 10 SUITABLE CUT	ADJUSTED CLASS 10 TOTAL	TOTAL FILL	CLASS 10 SUITABLE + 30% SHRINK	TOTAL FILL WITH SHRINK	APPROX. FILL VOLUME BELOW 3 FT	APPROX. FILL VOLUME BELOW 5 FT															
424+00.00	135	54	80			1	81	3	4	4																	
424+25.00	156	54	102				102	3	4	4																	
424+50.00	138	51	86			1	87	3	4	4																	
424+75.00	94	46	48				48	4	5	5																	
425+00.00	75	39	36				36	10	13	13																	
425+25.00	62	35	27				27	16	21	21																	
425+50.00	49	31	15			3	18	18	23	23																	
425+75.00	34	25	5			4	9	22	29	29																	
425+99.41	1	1						1	1	1																	
426+00.00	22	17				5	5	29	38	38																	
426+25.00	21	13	2			6	8	59	77	77																	
426+50.00	8	5	2			1	3	49	64	64																	
426+59.60	13	8	2			3	5	68	88	88																	
426+75.00	25	17	3			5	8	34	44	44																	
427+00.00	24	17	2			5	7	16	21	21																	
427+25.00	32	24	6			2	8	11	14	14																	
427+50.00	7	5	2				2	1	1	1																	
427+53.91	46	29	13			4	17	4	5	5																	
427+75.00	68	39	28			1	29	5	7	7																	
428+00.00	94	45	48			1	49	5	7	7																	
428+25.00	118	49	68			1	69	4	5	5																	
428+50.00	132	51	81				81	4	5	5																	
428+75.00	149	53	96				96	3	4	4																	
429+00.00	162	56	106				106	3	4	4																	
429+25.00	168	58	110				110	3	4	4																	
429+50.00	29	10	19				19																				
429+54.16	141	49	92				92	2	3	3																	
429+75.00	171	71	99			1	100	3	4	4																	
430+00.00	179	73	105			1	106	3	4	4																	
430+25.00	202	64	136			2	138	3	4	4																	
430+50.00	234	32	150			52	202	2	3	3																	
430+75.00	34		22			12	34																				
430+78.41	187	18	131			38	169	1	1	1																	
431+00.00	181	50	126			5	131	2	3	3																	
431+25.00	163	60	102			1	103	3	4	4																	
431+50.00	140	57	82			1	83	3	4	4																	
431+75.00	103	45	58				58	2	3	3																	
431+96.41	16	7	8			1	9																				
432+00.00	94	47	46			1	47	5	7	7																	
432+25.00	73	41	30			2	32	8	10	10																	
432+50.00	43	28	15				15	15	20	20																	
432+75.00	22	17	5				5	21	27	27																	
433+00.00	38	28	10				10	17	22	22																	
433+25.00	40	16	11			13	24	20	26	26																	
433+46.06	3		1			2	3	3	4	4																	
433+47.86	4		1			3	4	3	4	4																	
433+50.00	36	13	7			16	23	52	68	68																	
433+75.00	21	19	1			1	2	90	117	117																	
434+00.00	13	7	6				6	115	150	150																	
434+25.00	10	4	5			1	6	121	157	157																	
434+50.00	7	6				1	1	129	168	168																	
434+75.00	3	3						114	148	148																	
435+00.00	1	1						113	147	147																	
435+25.00	1	1						164	213	213																	
435+50.00	1	1						223	290	290																	
435+75.00	1	1						275	358	358																	
436+00.00	1	1						278	361	361																	
436+25.00	1	1						211	274	274																	
436+44.70								59	77	77																	
436+50.00	1	1						250	325	325																	
436+75.00	2	2						159	207	207																	
437+00.00	1	1						89	116	116																	
437+25.00	1	1						90	117	117																	
437+50.00	5	5						82	107	107																	
437+75.00	16	13	3				3	58	75	75																	
438+00.00																											

TABULATION OF TEMPLATE QUANTITIES AND ADJUSTMENTS

Refer to Standard Road Plans EW-101 and EW-102.

STATION	TOTAL CUT	TOPSOIL TYPE B SAVED -C	TOPSOIL TYPE C SAVED -C	UNSUIT TYPE B CUT	UNSUIT TYPE C CUT	CLASS 10 SUITABLE CUT	ADJUSTED CLASS 10 TOTAL	TOTAL FILL	CLASS 10 SUITABLE + 30% SHRINK	TOTAL FILL WITH SHRINK																										
433+00.00	70		3	11		56	67	35	46	46																										
433+25.00	47			18		29	47	2	3	3																										
433+46.06	2			2			2																													
433+47.86	3			2		1	3																													
433+50.00	32		1	17		14	31	3	4	4																										
433+75.00	31		3	6		22	28	4	5	5																										
434+00.00	28		4			24	24	3	4	4																										
434+25.00	27		4			23	23	3	4	4																										
434+50.00	27		3			24	24	2	3	3																										
434+75.00	28		3			25	25	3	4	4																										
435+00.00	31		4			27	27	3	4	4																										
435+25.00	35		4			31	31	3	4	4																										
435+50.00	39		4			35	35	3	4	4																										
435+75.00	42		4	9		29	38	3	4	4																										
436+00.00	44		5	9		30	39	3	4	4																										
436+25.00	35		4			31	31	2	3	3																										
436+44.70	9		1			8	8	1	1	1																										
436+50.00	43		4			39	39	3	4	4																										
436+75.00	40		4			36	36	3	4	4																										
437+00.00	38		5			33	33	3	4	4																										
437+25.00	36		5			31	31	3	4	4																										
437+50.00	35		5			30	30	3	4	4																										
437+75.00	36		4			32	32	2	3	3																										
438+00.00	12		1			11	11	1	1	1																										
438+08.06	26		3			23	23	3	4	4																										
438+25.00	39		5	4		30	34	14	18	18																										
438+50.00	37		5	4		28	32	17	22	22																										
438+75.00	36		3	1		32	33	15	20	20																										
439+00.00	34		1			33	33	18	23	23																										
439+25.00	32		1	5		26	31	20	26	26																										
439+50.00	29			15		14	29	20	26	26																										
439+75.00	32		4	20		8	28	21	27	27																										
440+00.00	36		8	20		8	28	22	29	29																										
440+25.00	29		3	14		12	26	21	27	27																										
440+48.56	2			1		1	2	1	1	1																										
440+50.00	26			6		20	26	24	31	31																										
440+75.00	25			2		23	25	25	33	33																										
441+00.00	17			3		14	17	14	18	18																										
441+25.00	11			2		9	11	1	1	1																										
441+50.00	19			3		16	19	6	8	8																										
441+75.00	28		8	2		18	20	10	13	13																										
442+00.00	28		8			20	20	5	7	7																										
442+23.76	1					1	1																													
442+25.00	30		2			28	28	3	4	4																										
442+50.00	29		2			27	27	3	4	4																										
442+75.00	27		1			26	26	3	4	4																										
443+00.00	18		1	8		9	17	2	3	3																										
443+18.00																																				
Widening																																				
443+23.01	2					2	2	1	1	1																										
443+25.00	18		2			16	16	6	8	8																										
443+50.00	14		2			12	12	6	8	8																										
443+75.00	13		1			12	12	11	14	14																										
444+00.00	16		1			15	15	20	26	26																										
444+25.00	19		1			18	18	27	35	35																										
444+50.00	19		1			18	18	32	42	42																										
444+75.00	18		1			17	17	36	47	47																										
445+00.00	18		1			17	17	32	42	42																										
445+25.00	18		1			17	17	27	35	35																										
445+50.00	18		1			17	17	28	36	36																										
445+75.00	18		1			17	17	29	38	38																										
446+00.00	18		1			17	17	32	42	42																										
446+25.00	16					16	16	34	44	44																										
446+48.51	1					1	1	2	3	3																										
446+50.00	4					4	4	10	13	13																										
446+56.51																																				

TABULATION OF TEMPLATE QUANTITIES AND ADJUSTMENTS

Refer to Standard Road Plans EW-101 and EW-102.

STATION	TOTAL CUT	TOPSOIL TYPE B SAVED -C	TOPSOIL TYPE C SAVED -C	UNSUITS TYPE B CUT	UNSUITS TYPE C CUT	CLASS 10 SUITABLE CUT	ADJUSTED CLASS 10 TOTAL	TOTAL FILL	CLASS 10 SUITABLE + 30% SHRINK	TOTAL FILL WITH SHRINK																														
461+25.00	7					7	7	5	4	4																														
461+34.29	12					12	12	5	7	7																														
461+50.00	21		3			18	18	16	21	21																														
461+75.00	20		5			15	15	25	33	33																														
462+00.00	17		5			12	12	23	30	30																														
462+25.00	16		5			11	11	20	26	26																														
462+50.00	19		5			14	14	19	25	25																														
462+75.00	22		4			18	18	19	25	25																														
463+00.00	22		3			19	19	21	27	27																														
463+25.00	22		4			18	18	23	30	30																														
463+50.00	23		5			18	18	22	29	29																														
463+75.00	23		5			18	18	20	26	26																														
464+00.00	23		5			18	18	20	26	26																														
464+25.00	24		5			19	19	18	23	23																														
464+50.00	25		7			18	18	14	18	18																														
464+75.00	19		5			14	14	6	8	8																														
464+92.00																																								
Kennedy																																								
1257+10.00	7					7	7																																	
1257+25.00	25					25	25																																	
1257+45.00	10					10	10																																	
1257+50.00	56					56	56	2	3	3																														
1257+75.00	55					55	55	4	5	5																														
1258+00.00	43					43	43	11	14	14																														
1258+25.00																																								
1258+25.10	4					4	4	4	5	5																														
1258+27.00	27					27	27	62	81	81																														
1258+50.00																																								
R57																																								
1280+60.00	53					53	53																																	
1280+75.00	126					126	126	5	7	7																														
1281+00.00	151					151	151	13	17	17																														
1281+25.00	157					157	157	12	16	16																														
1281+50.00	150					150	150	3	4	4																														
1281+75.00	107					107	107																																	
1281+92.00	50					50	50																																	
1282+00.00	99					99	99	3	4	4																														
1282+25.00	28					28	28	8	10	10																														
1282+50.00								14	18	18																														
1282+75.00								18	23	23																														
1283+00.00								23	30	30																														
1283+25.00								31	40	40																														
1283+50.00																																								
1384+25.00																																								
1384+50.00	86					86	86	42	55	55																														
1384+75.00	151					151	151	21	27	27																														
1385+00.00	155					155	155	8	10	10																														
1385+07.00	47					47	47	2	3	3																														
1385+25.00	106					106	106	6	8	8																														
1385+30.00	25					25	25	2	3	3																														
1385+50.00	92					92	92	12	16	16																														
1385+72.00	102					102	102	16	21	21																														
1385+75.00	15					15	15	2	3	3																														
1386+00.00	95					95	95	19	25	25																														
1386+06.00	16					16	16	6	8	8																														
90th St																																								
2305+85.00	21					21	21	4	5	5																														
2306+00.00	13					13	13	2	3	3																														
2306+07.14	41					41	41	7	9	9																														
2306+25.00	71					71	71	12	16	16																														
2306+50.00	81					81	81	15	20	20																														
2306+75.00																																								

Lincoln TWP.
T-76N R-24W
SEC. 29



Fence removed on previous project.
Sta 266+70.0 Lt - Sta 268+55.0 Lt
Sta 269+72.0 Lt - Sta 270+40.0 Lt
245.0 LF

Clearing & Grubbing completed
on previous project.
0.37 acre

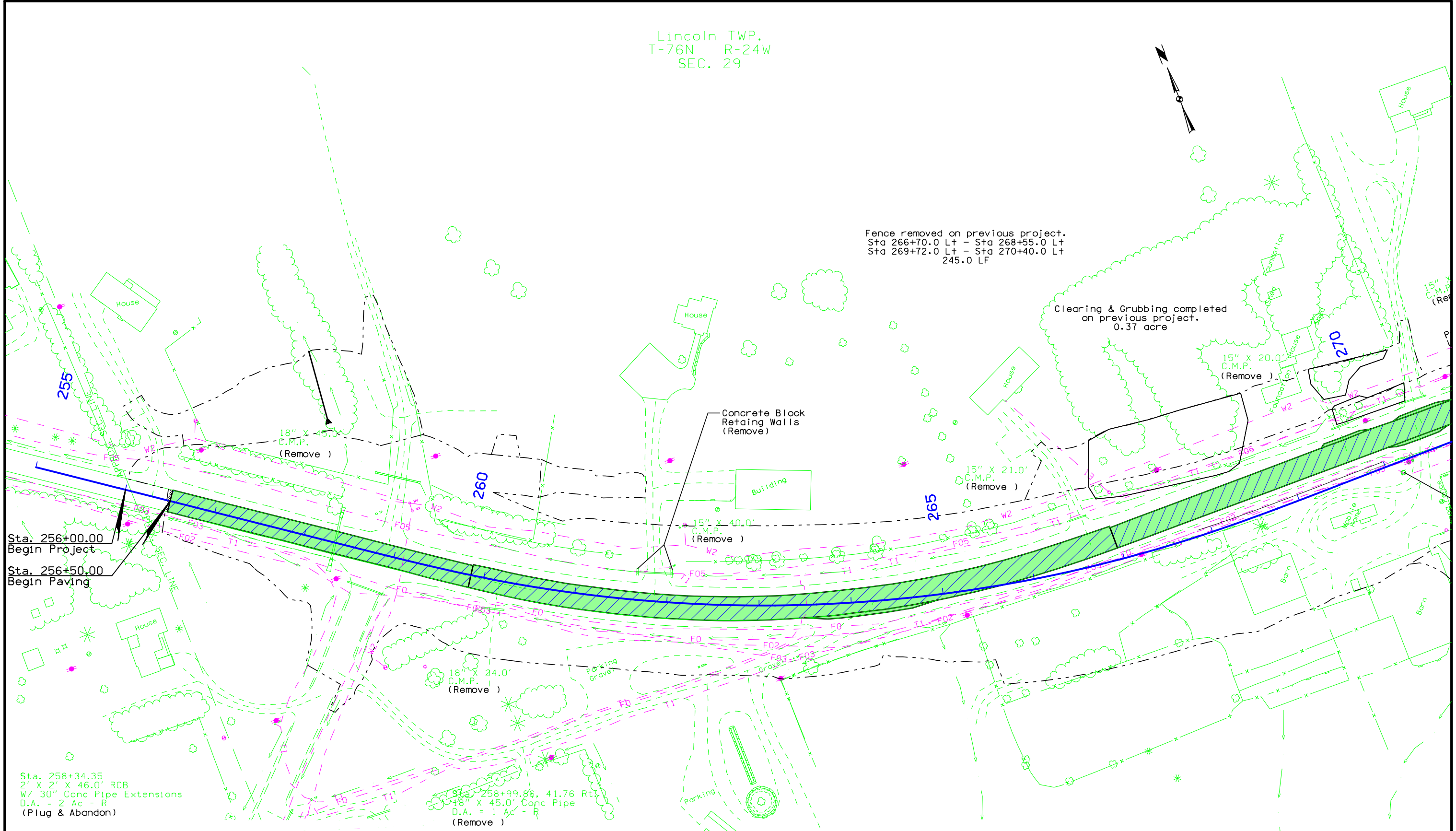

Sta. 256+00.00
Begin Project
Sta. 256+50.00
Begin Paving

Sta. 258+34.35
2' X 2' X 46.0' RCB
W/ 30" Conc Pipe Extensions
D.A. = 2 Ac - R
(Plug & Abandon)

Sta. 258+99.86, 41.76 Rt.
18" X 45.0' Conc Pipe
D.A. = 1 Ac - R
(Remove)

- Pavement Removal (General)
- Paved Entrance Removal
- Detour Pavement Removal
- Sidewalk Removal

NOTE:
Removal Detail Sheets are for general
removal details only.
Refer also to Tabulations and
Staging Detail Sheets elsewhere
in these plans.

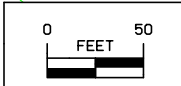

Removal Details
Sheet
1 of 18

Lincoln TWP.
T-76N R-24W
SEC. 29

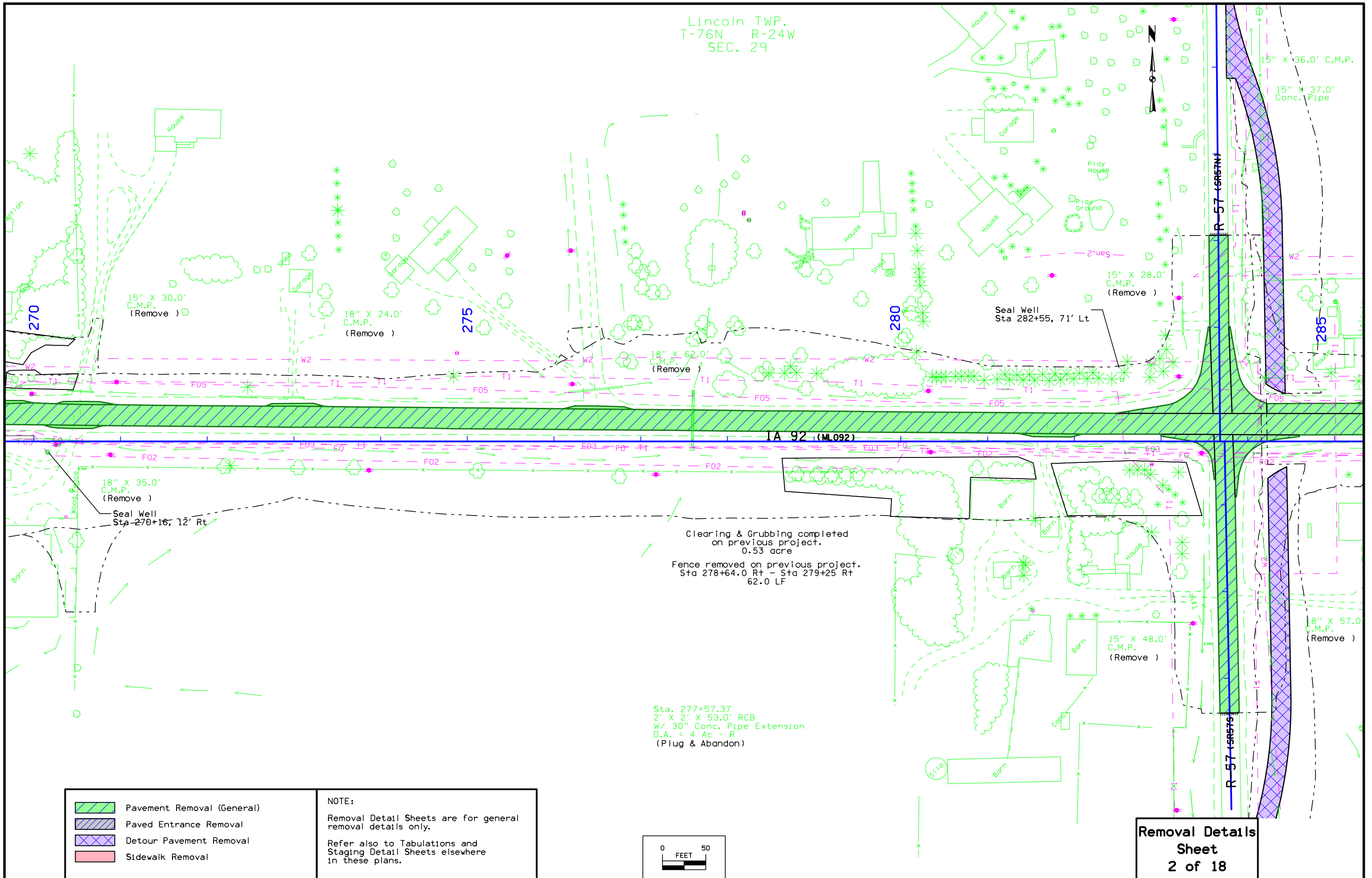

	Pavement Removal (General)
	Paved Entrance Removal
	Detour Pavement Removal
	Sidewalk Removal

NOTE:
Removal Detail Sheets are for general removal details only.
Refer also to Tabulations and Staging Detail Sheets elsewhere in these plans.

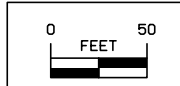

**Removal Details
Sheet
2 of 18**

Lincoln TWP.
T-76N R-24W
SEC. 29

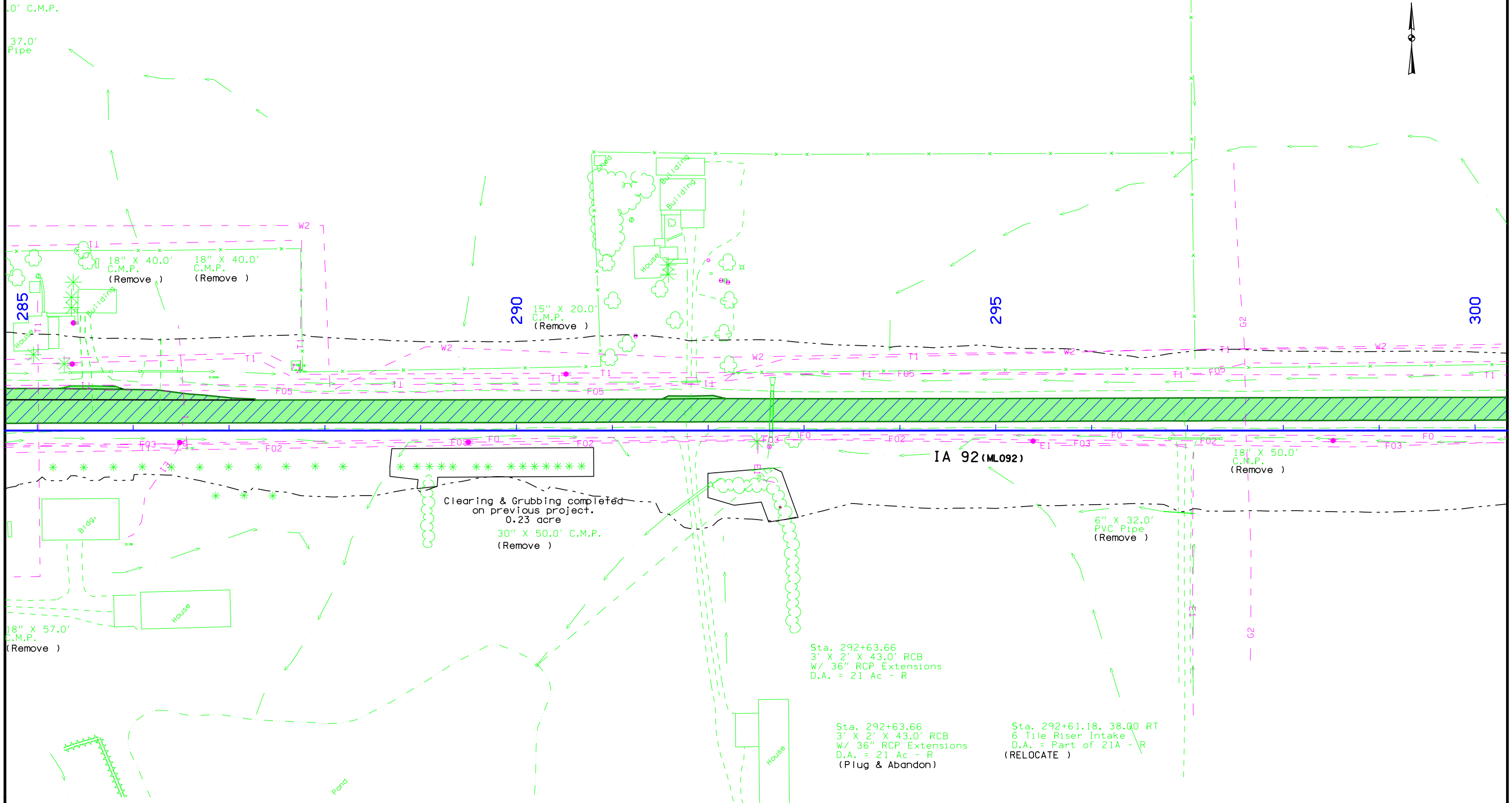

Clearing & Grubbing completed on previous project.
0.23 acre
30" X 50.0' C.M.P.
(Remove)

Sta. 292+63.66
3' X 2' X 43.0' RCB
W/ 36" RCP Extensions
D.A. = 21 Ac - R

Sta. 292+63.66
3' X 2' X 43.0' RCB
W/ 36" RCP Extensions
D.A. = 21 Ac - R
(Plug & Abandon)

Sta. 292+61.18, 38.00 RT
6 Tile Riser Intake
D.A. = Part of 21A - R
(RELOCATE)

6" X 32.0'
PVC Pipe
(Remove)

18" X 50.0'
C.M.P.
(Remove)

	Pavement Removal (General)
	Paved Entrance Removal
	Detour Pavement Removal
	Sidewalk Removal

NOTE:
Removal Detail Sheets are for general removal details only.
Refer also to Tabulations and Staging Detail Sheets elsewhere in these plans.

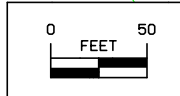

Removal Details
Sheet
3 of 18

Lincoln TWP.
T-76N R-24W
SEC. 29

Lincoln TWP.
T-76N R-24W
SEC. 28

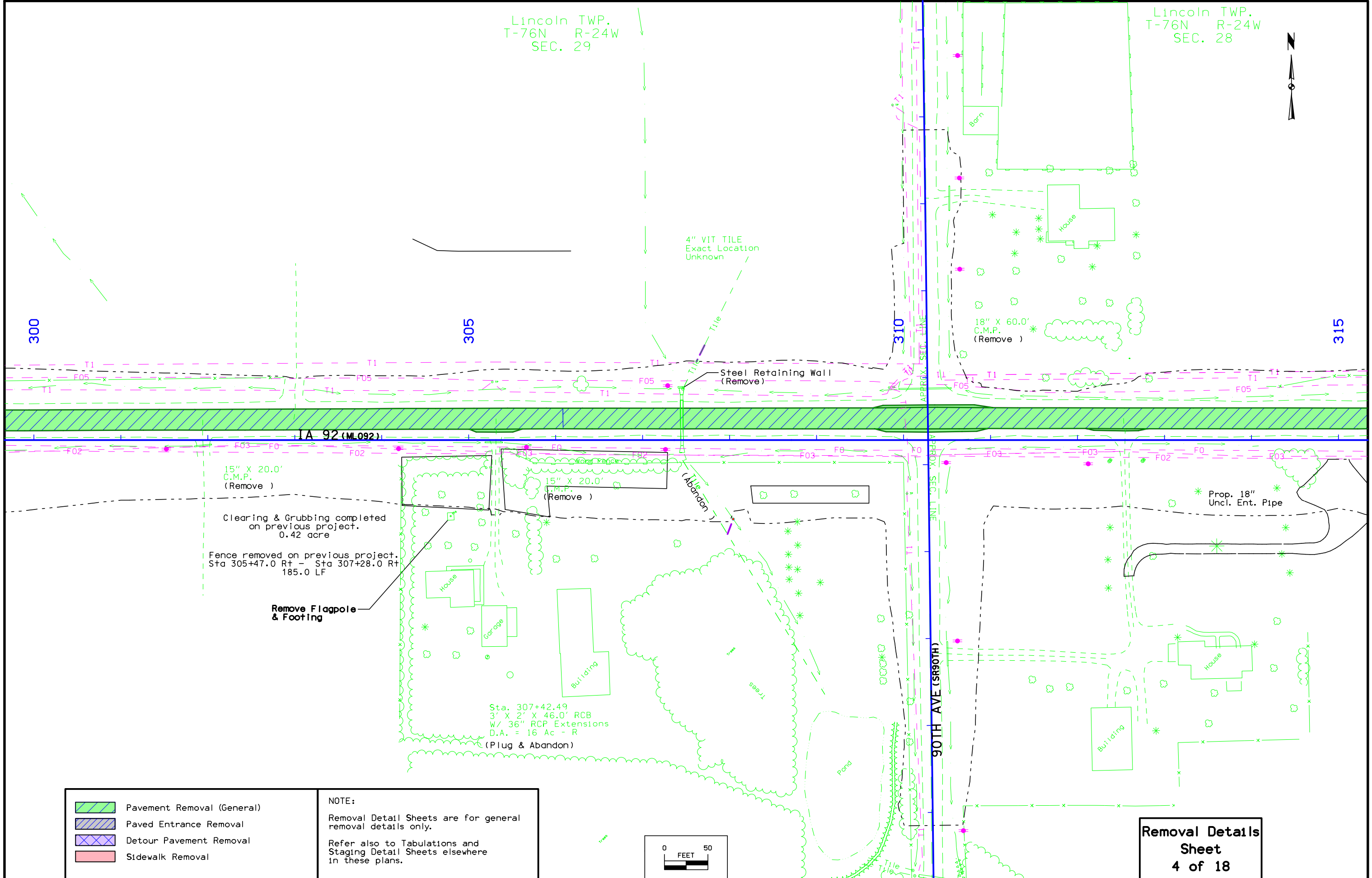

	Pavement Removal (General)
	Paved Entrance Removal
	Detour Pavement Removal
	Sidewalk Removal

NOTE:
Removal Detail Sheets are for general removal details only.
Refer also to Tabulations and Staging Detail Sheets elsewhere in these plans.

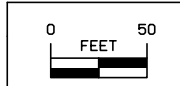

Removal Details
Sheet
4 of 18

Lincoln TWP.
T-76N R-24W
SEC. 28

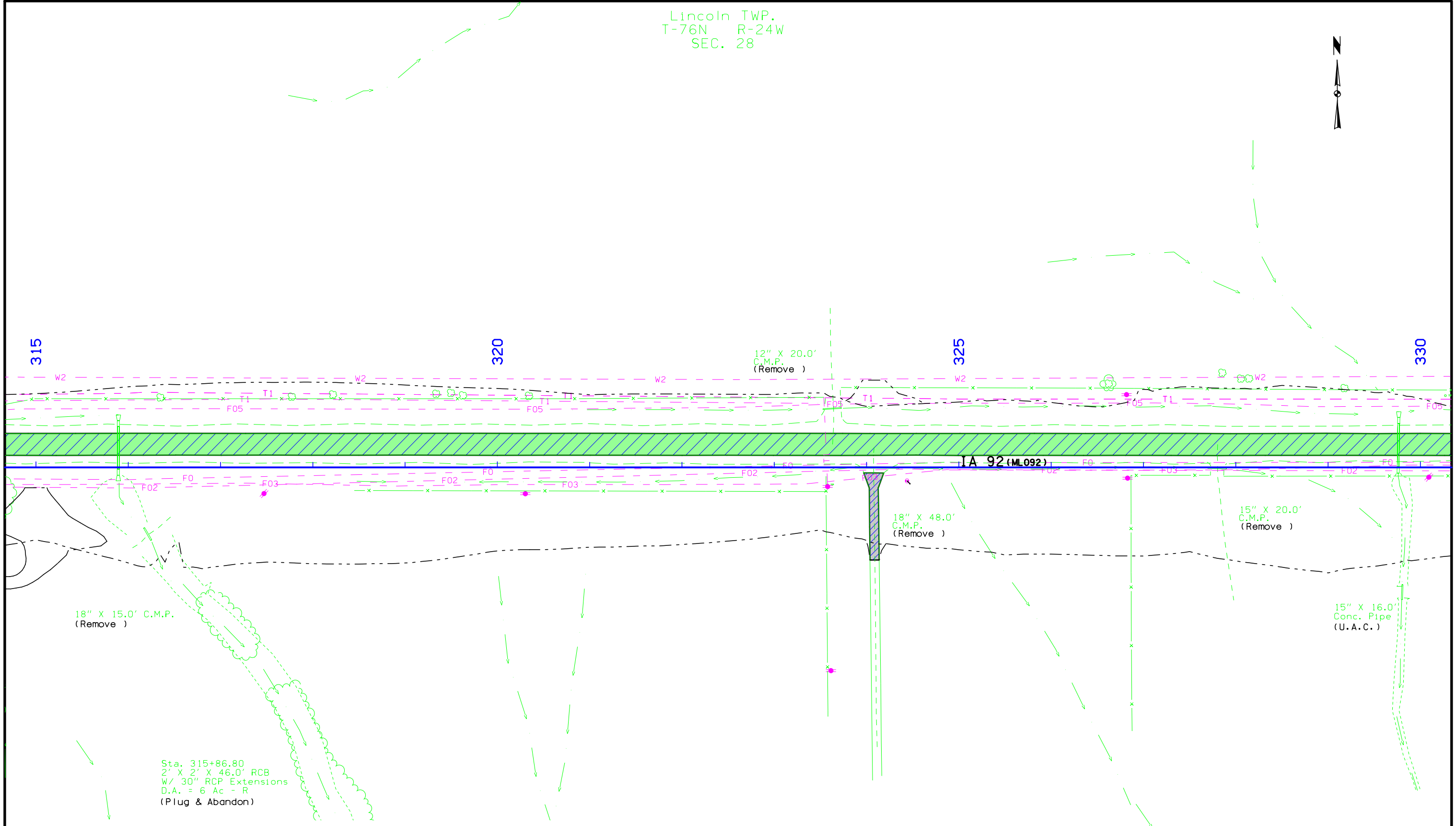

	Pavement Removal (General)
	Paved Entrance Removal
	Detour Pavement Removal
	Sidewalk Removal

NOTE:
Removal Detail Sheets are for general removal details only.
Refer also to Tabulations and Staging Detail Sheets elsewhere in these plans.

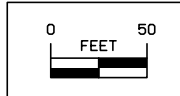

Removal Details
Sheet
5 of 18

Lincoln TWP.
T-76N R-24W
SEC. 28

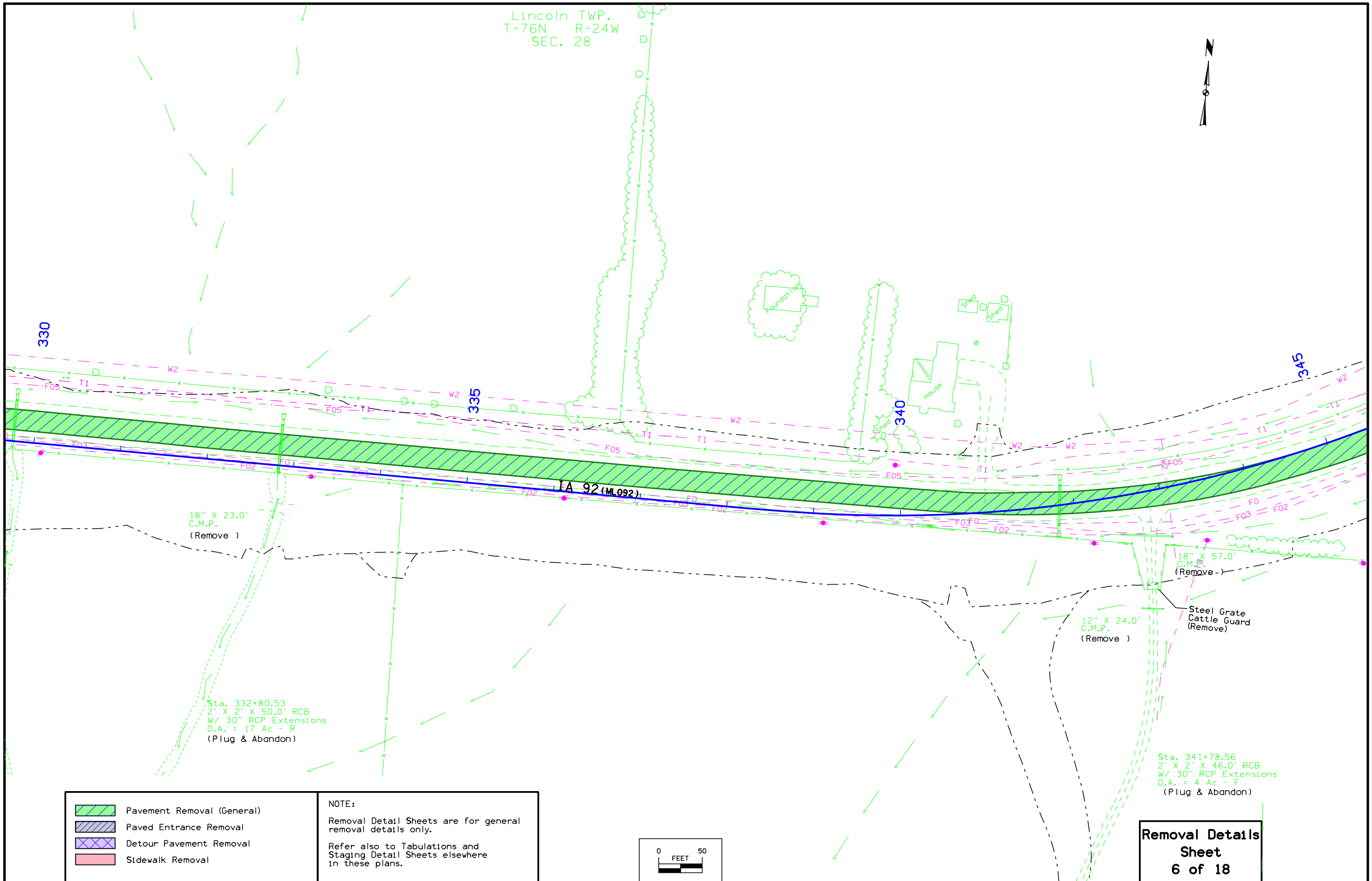

	Pavement Removal (General)
	Paved Entrance Removal
	Detour Pavement Removal
	Sidewalk Removal

NOTE:
Removal Detail Sheets are for general removal details only.
Refer also to Tabulations and Staging Detail Sheets elsewhere in these plans.

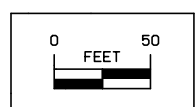

**Removal Details
Sheet
6 of 18**

Lincoln TWP.
T-76N R-24W
SEC. 28

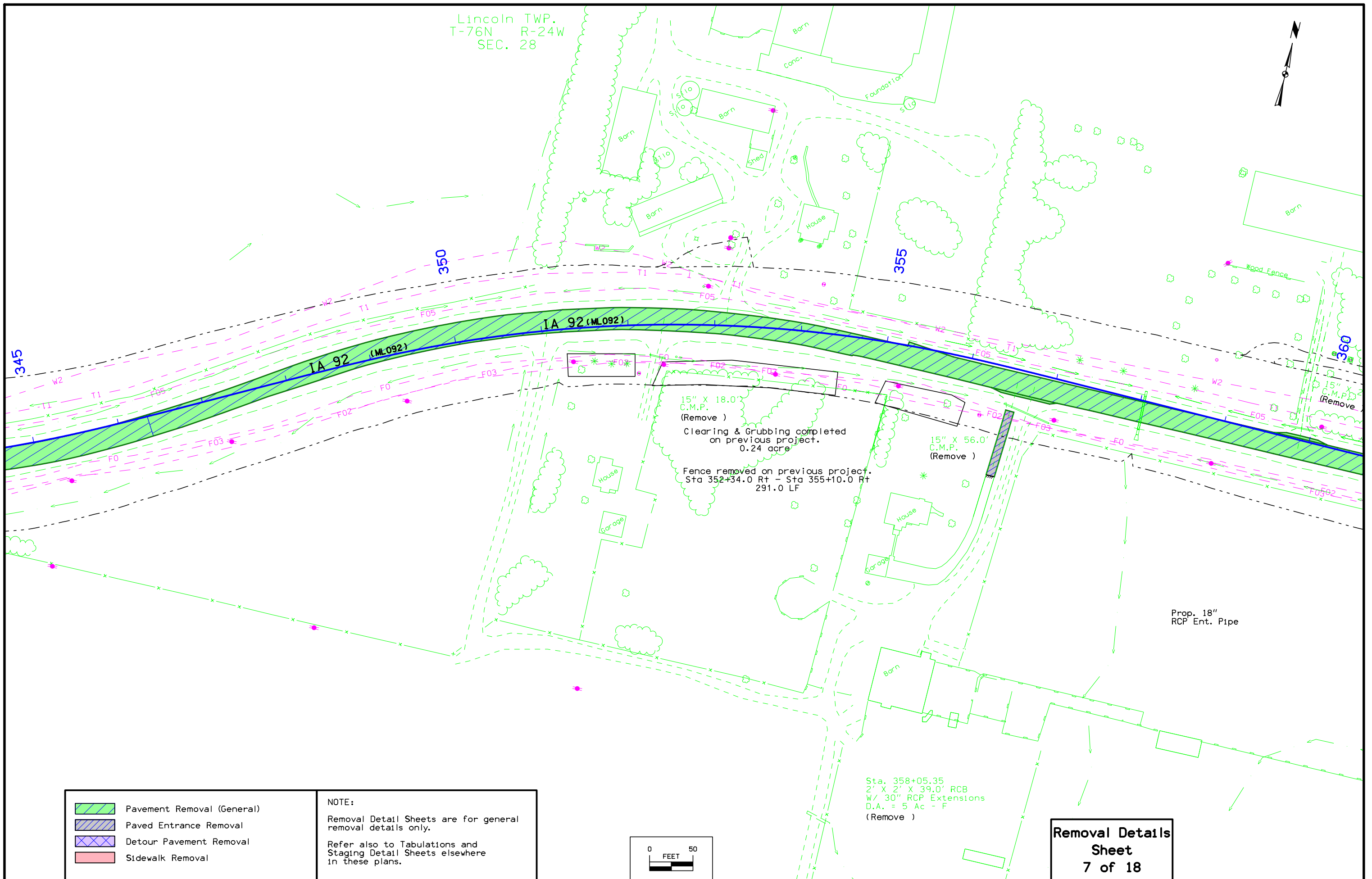

	Pavement Removal (General)
	Paved Entrance Removal
	Detour Pavement Removal
	Sidewalk Removal

NOTE:
Removal Detail Sheets are for general removal details only.
Refer also to Tabulations and Staging Detail Sheets elsewhere in these plans.

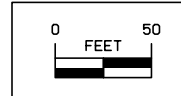

**Removal Details
Sheet
7 of 18**

Lincoln TWP.
T-76N R-24W
SEC. 28

Lincoln TWP.
T-76N R-24W
SEC. 27

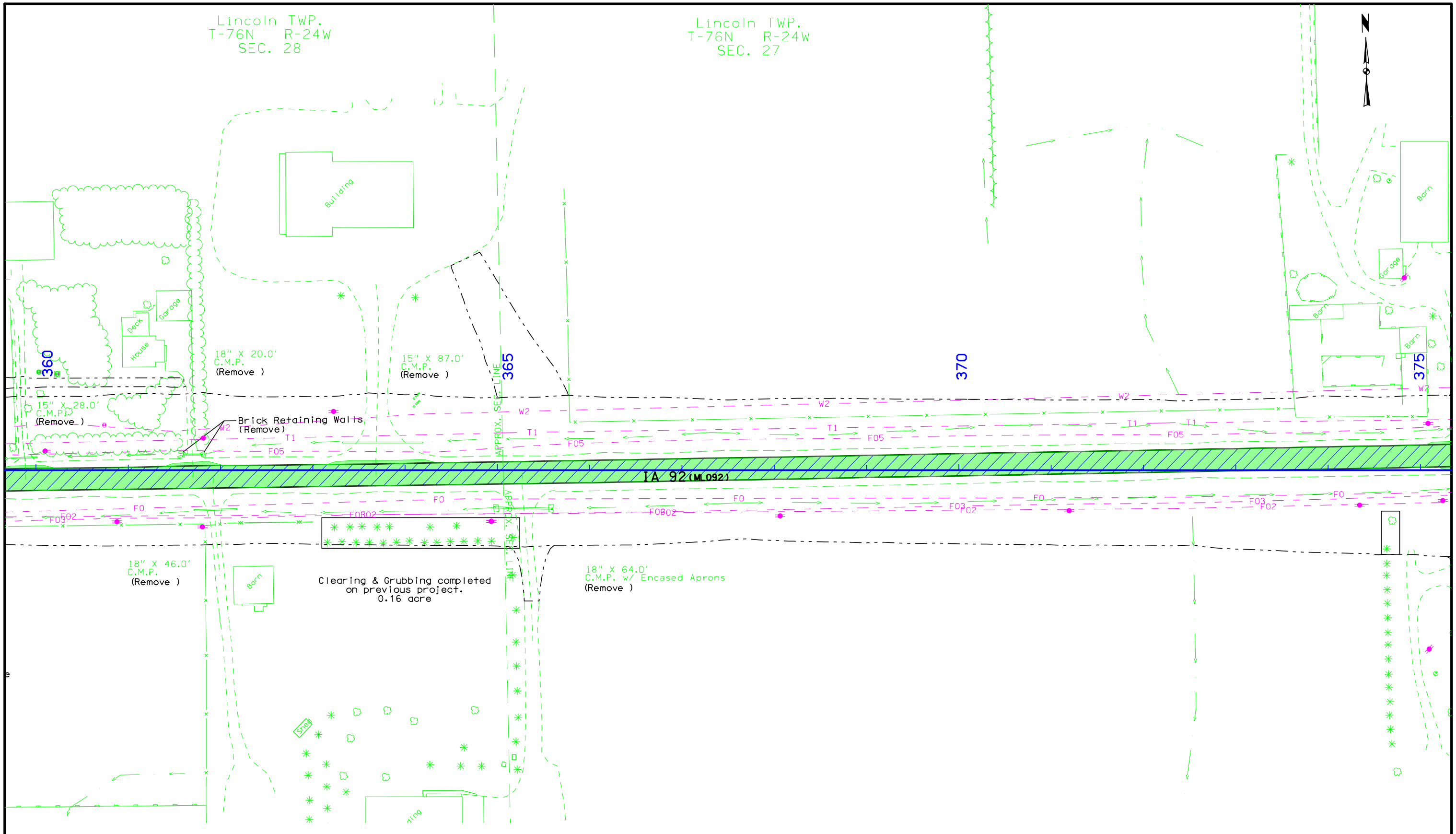

- Pavement Removal (General)
- Paved Entrance Removal
- Detour Pavement Removal
- Sidewalk Removal

NOTE:
Removal Detail Sheets are for general removal details only.
Refer also to Tabulations and Staging Detail Sheets elsewhere in these plans.

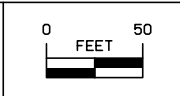

Removal Details
Sheet
8 of 18

Lincoln TWP.
T-76N R-24W
SEC. 27

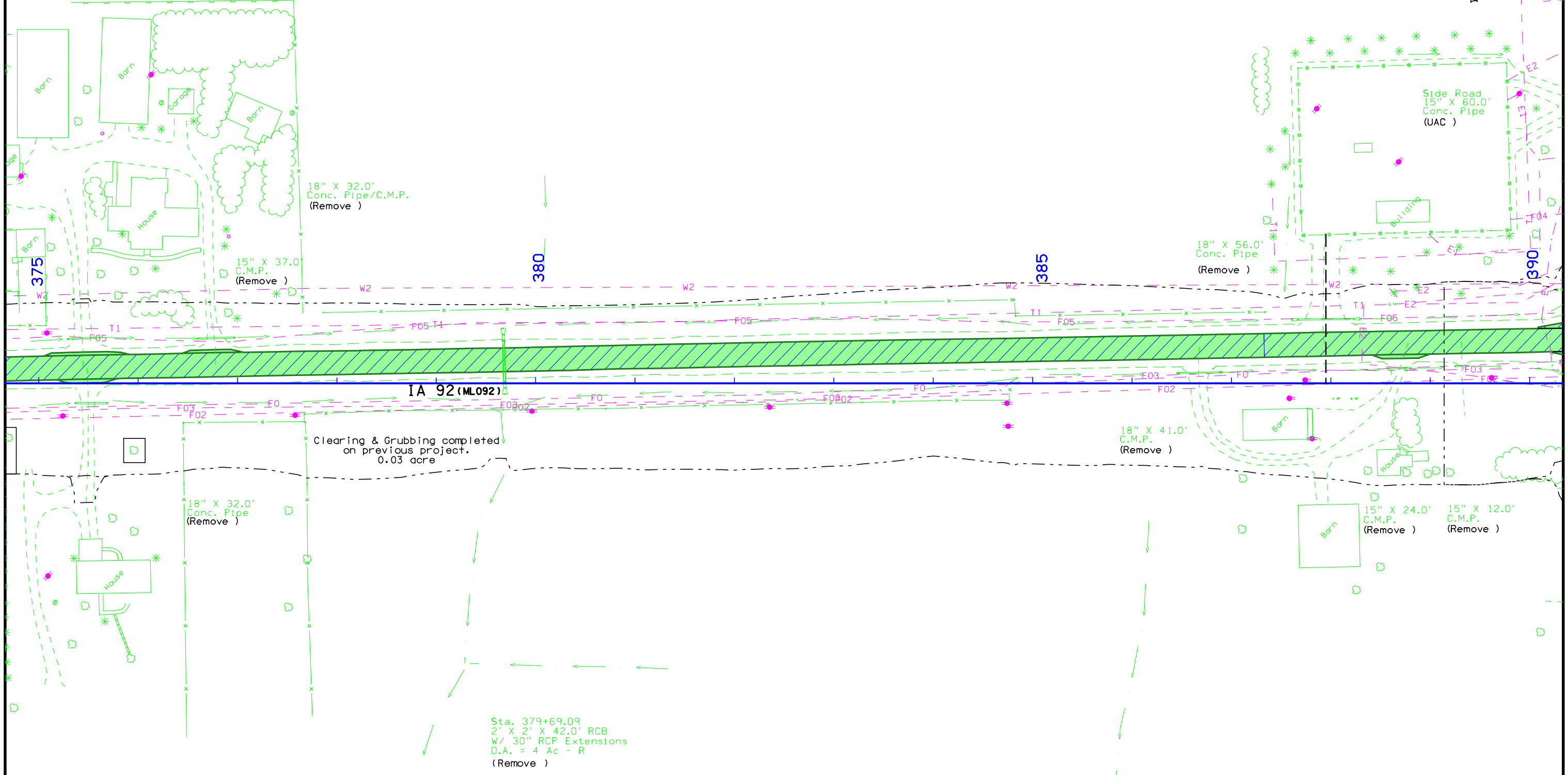

Clearing & Grubbing completed
on previous project.
0.03 acre

Sta. 379+69.09
2' X 2' X 42.0' RCB
W/ 30\"/>

	Pavement Removal (General)
	Paved Entrance Removal
	Detour Pavement Removal
	Sidewalk Removal

NOTE:
Removal Detail Sheets are for general
removal details only.

Refer also to Tabulations and
Staging Detail Sheets elsewhere
in these plans.

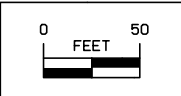

Removal Details
Sheet
9 of 18

Lincoln TWP.
T-76N R-24W
SEC. 27

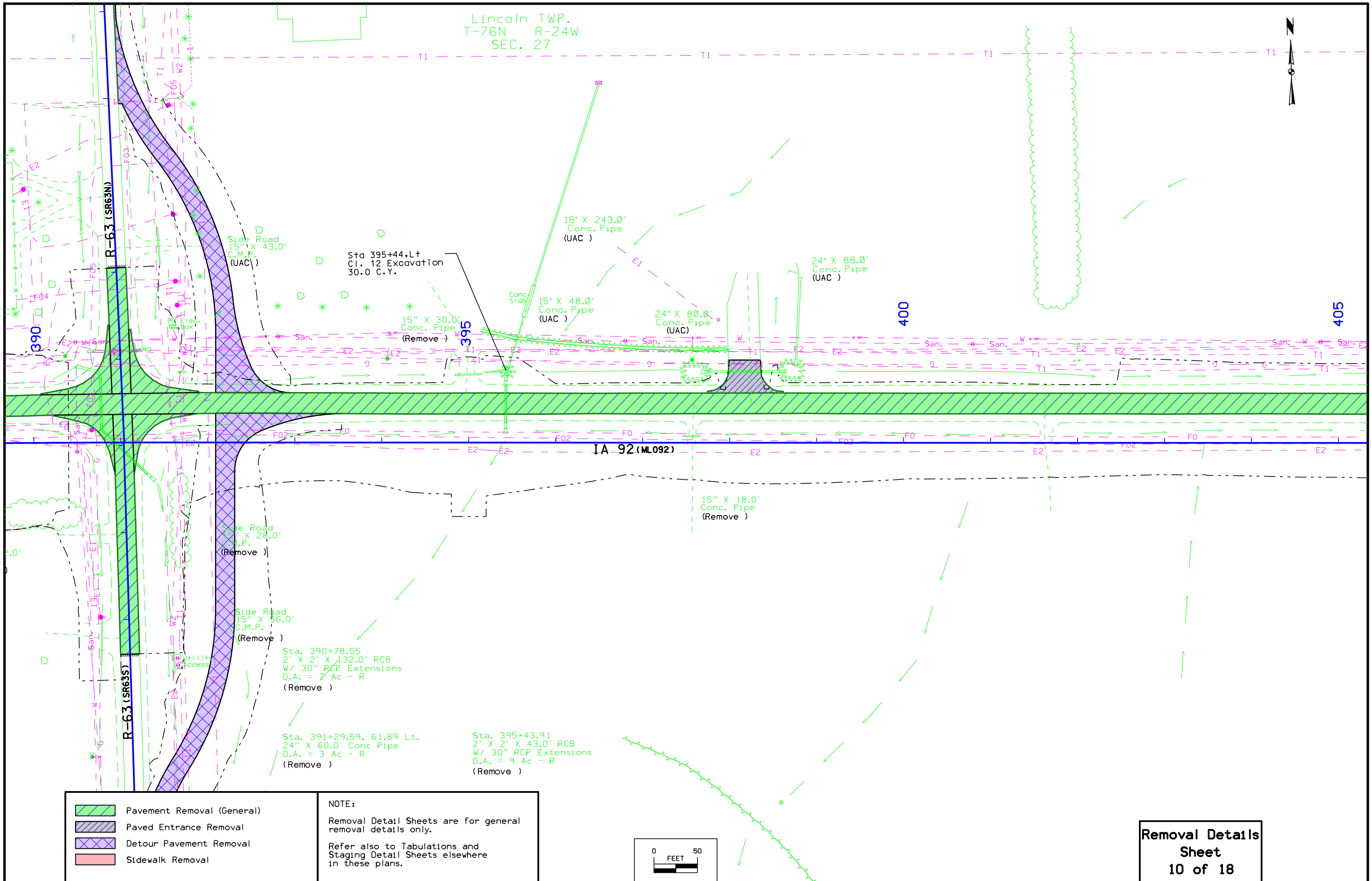
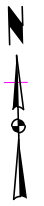

	Pavement Removal (General)
	Paved Entrance Removal
	Detour Pavement Removal
	Sidewalk Removal

NOTE:
Removal Detail Sheets are for general removal details only.
Refer also to Tabulations and Staging Detail Sheets elsewhere in these plans.

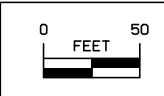

Removal Details
Sheet
10 of 18

Lincoln TWP.
T-76N R-24W
SEC. 27

PLUG & ABANDON
Storm Sewer
Sta. 4422+60 to 4424+08.3

Sta. 417+03.73, 37.07 Lt.
22' X 14" X 60.0' Arch Conc Pipe
D.A. = 4 Ac - R
(Remove)

REMOVE
Storm Sewer & Intakes
Sta. 4419+96 to 4422+60



405

15" X 24.0'
C.M.P.
(Remove)

410

415

15" X 148.0'
C.M.P.
(Remove)

420

IA 92 (ML092)

Sta. 416+97.93, 36.89 Rt
15" X 108.0' Conc.
Pipe Extensions
D.A. = 1 Ac - F
(Remove)

Sta. 417+25.01, 350.26 Rt.
39" Beehive Intake
D.A. = 3 A - R
(Remove)

Sta. 417+37.20, 350.71 Rt.
2.0 X 3.0 Flat Grate Intake
D.A. = .4 A - R
(Remove)

Sta 418+08.Rt
Cl. 12 Excavation
30.0 C.Y.

Sta. 417+59.47, 350.15 Rt.
2.0 X 3.0 Flat Grate Intake
D.A. = .4 A - R
(Remove)

Sta. 412+66.92, 247.41 RT
6 Tile Riser Intake
D.A. = 5A - R
(U.A.C.)

REMOVE
Storm Sewer Pipe
Sta. 4414+35

Sta 418+44.Rt
Cl. 12 Excavation
30.0 C.Y.

Sta. 414+54.06, 307.09 RT
6 Tile Riser Intake
D.A. = 2A - R
(U.A.C.)

Sta. 417+30.31, 350.36 Rt
30" X 44.0' CMP
D.A. = 16 Ac - R
(Remove)

Removal Details
Sheet
11 of 18

-  Pavement Removal (General)
-  Paved Entrance Removal
-  Detour Pavement Removal
-  Sidewalk Removal

NOTE:
Removal Detail Sheets are for general removal details only.
Refer also to Tabulations and Staging Detail Sheets elsewhere in these plans.

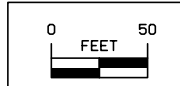

Lincoln TWP.
T-76N R-24W
SEC. 26

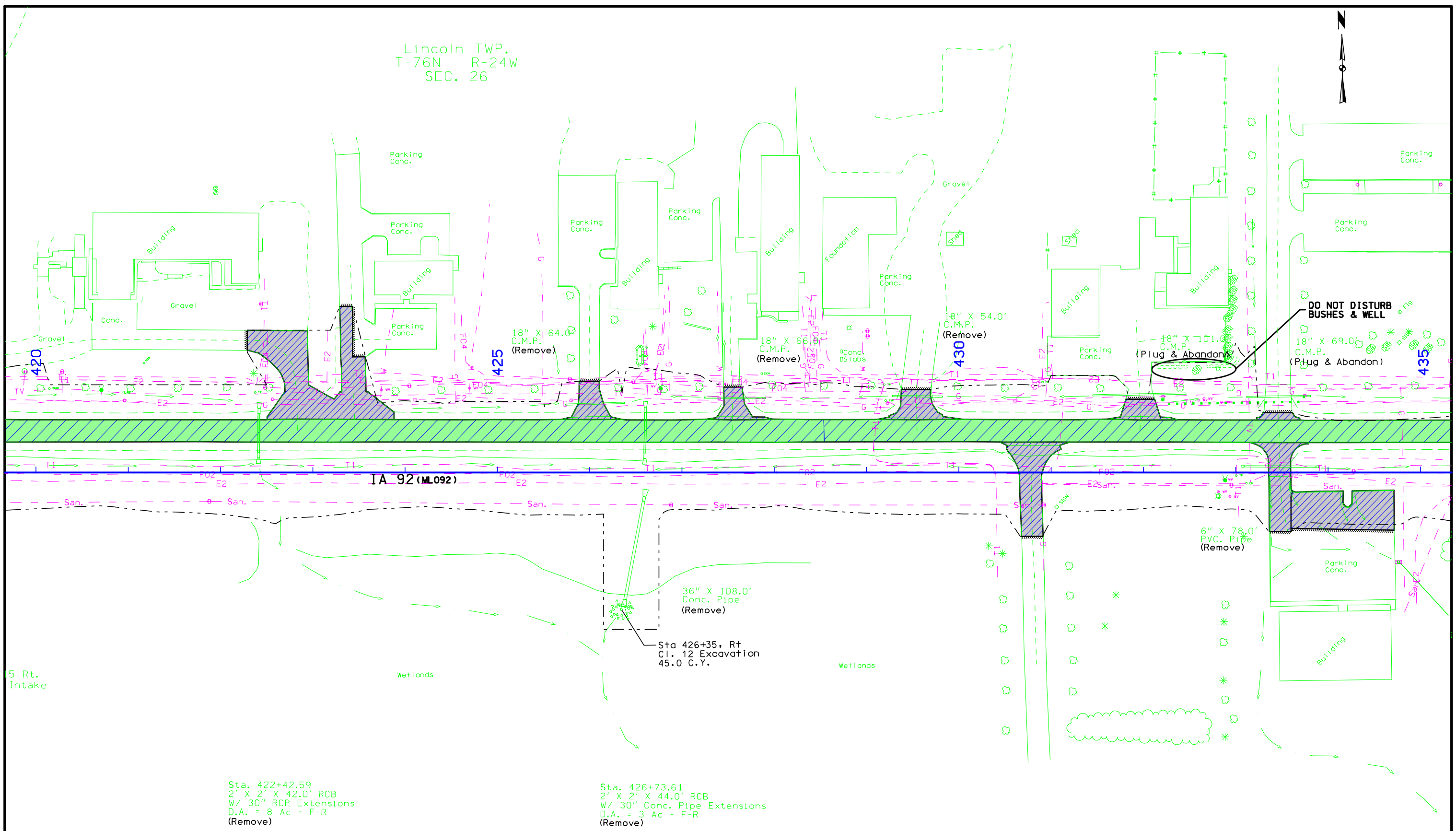

	Pavement Removal (General)
	Paved Entrance Removal
	Detour Pavement Removal
	Sidewalk Removal

NOTE:
Removal Detail Sheets are for general removal details only.
Refer also to Tabulations and Staging Detail Sheets elsewhere in these plans.

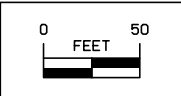

**Removal Details
Sheet
12 of 18**

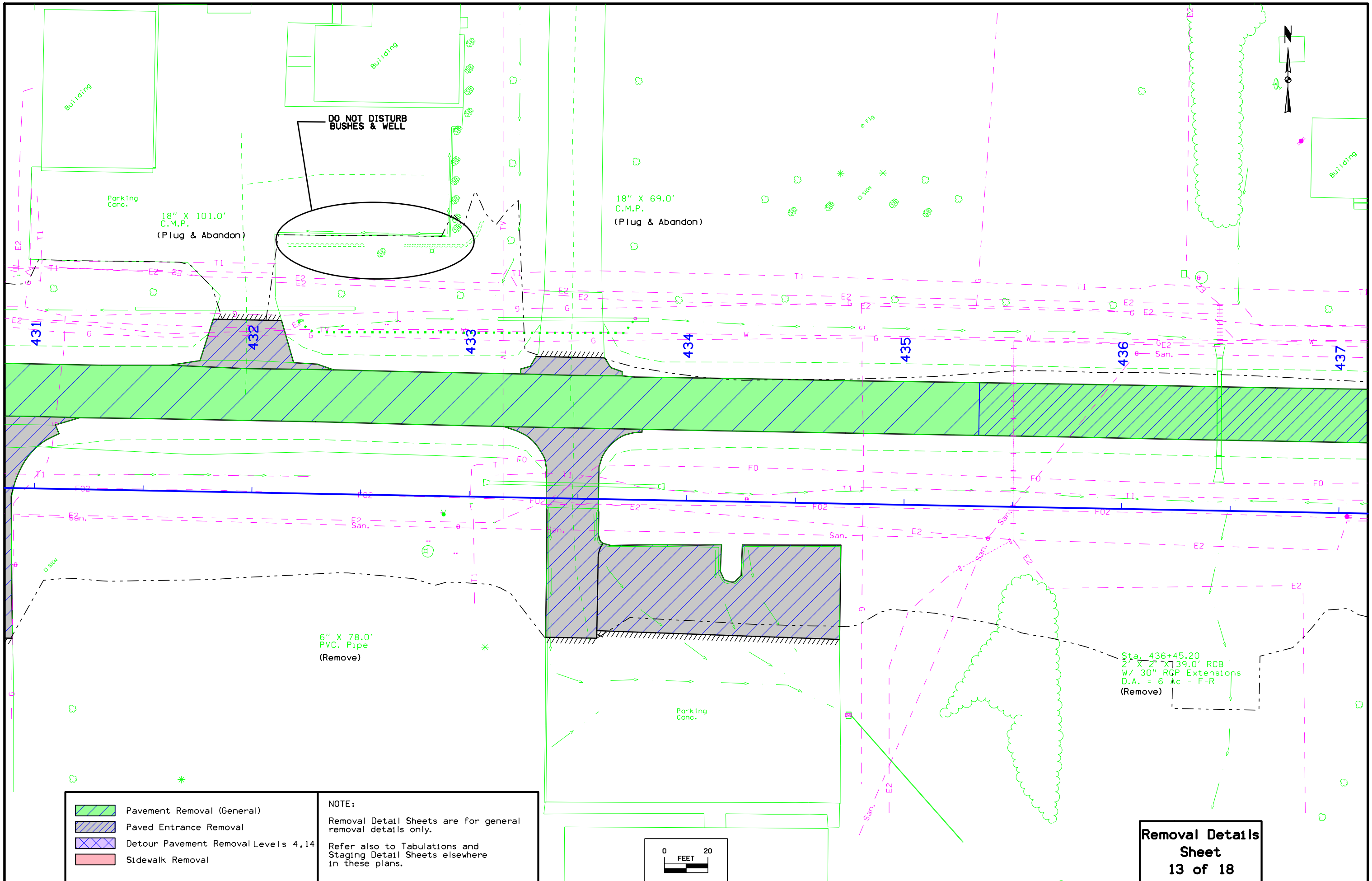

- Pavement Removal (General)
- Paved Entrance Removal
- Detour Pavement Removal Levels 4,14
- Sidewalk Removal

NOTE:
 Removal Detail Sheets are for general removal details only.
 Refer also to Tabulations and Staging Detail Sheets elsewhere in these plans.

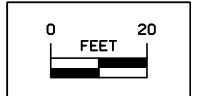

Removal Details
Sheet
13 of 18

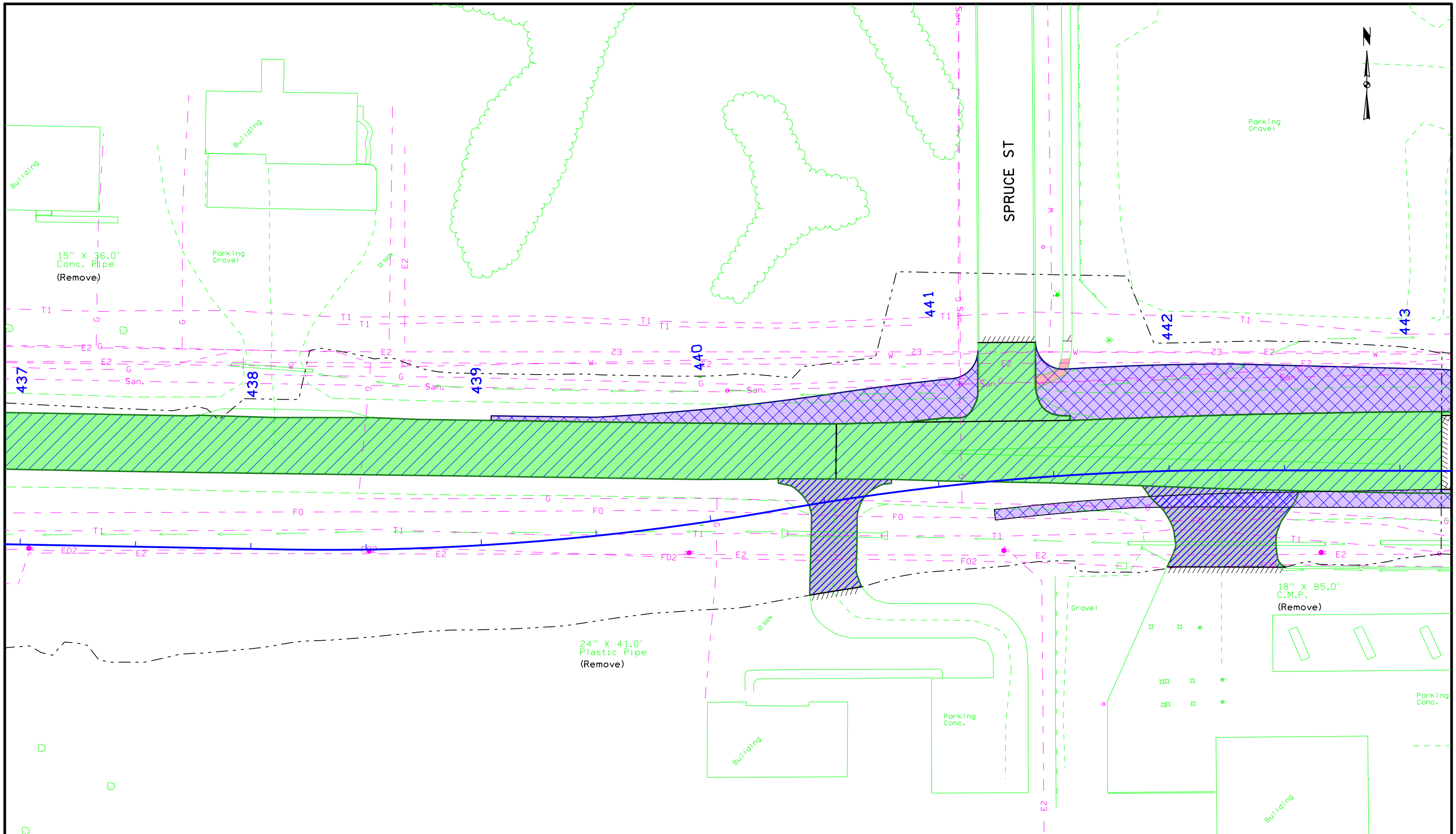

- Pavement Removal (General)
- Paved Entrance Removal
- Detour Pavement Removal Levels 4,14
- Sidewalk Removal

NOTE:
 Removal Detail Sheets are for general removal details only.
 Refer also to Tabulations and Staging Detail Sheets elsewhere in these plans.

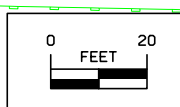

Removal Details
Sheet
14 of 18

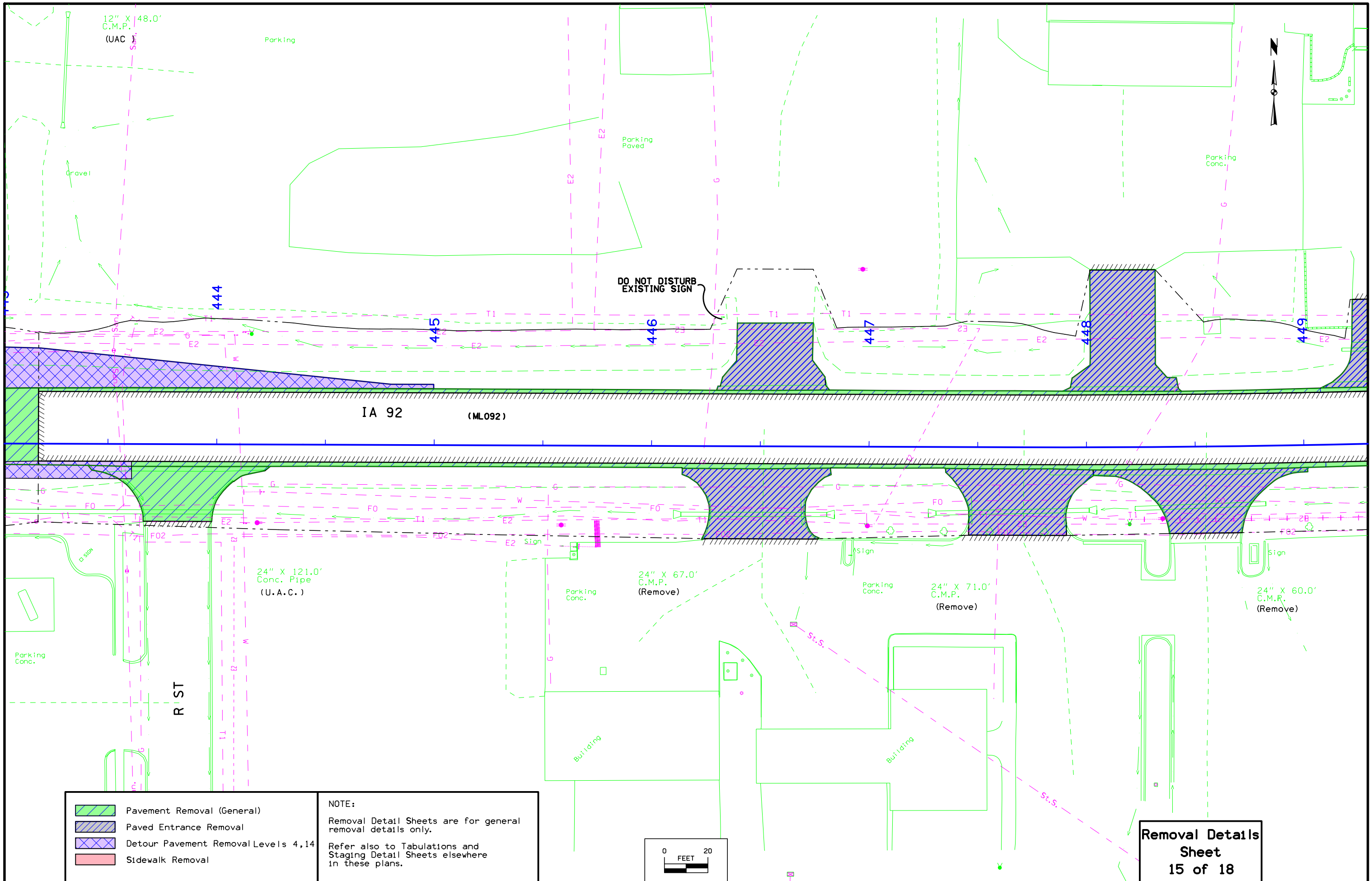

- Pavement Removal (General)
- Paved Entrance Removal
- Detour Pavement Removal Levels 4, 14
- Sidewalk Removal

NOTE:
 Removal Detail Sheets are for general removal details only.
 Refer also to Tabulations and Staging Detail Sheets elsewhere in these plans.

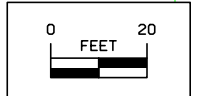

**Removal Details
 Sheet
 15 of 18**

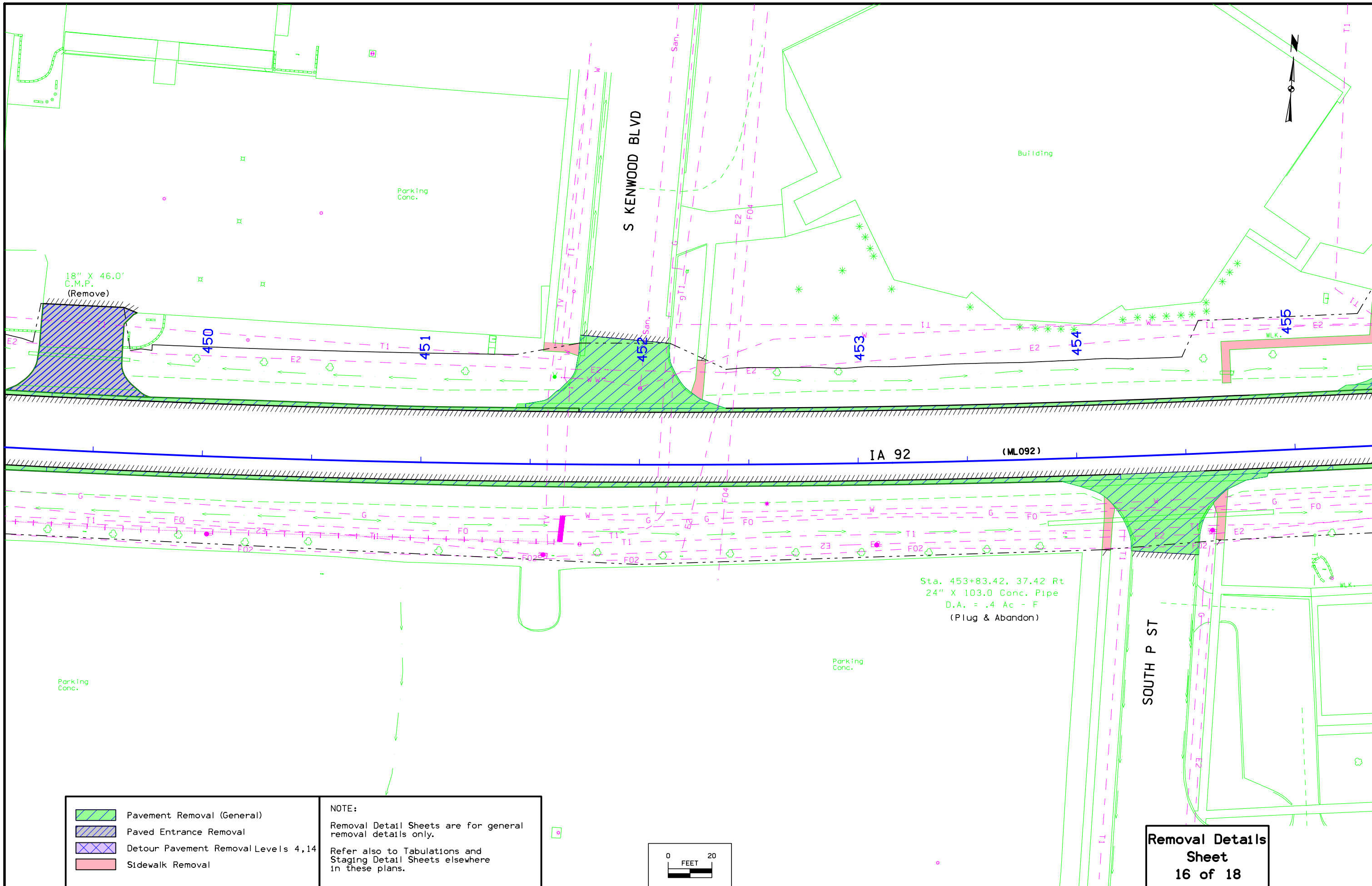

Sta. 453+83.42, 37.42 Rt
 24" X 103.0 Conc. Pipe
 D.A. = .4 Ac - F
 (Plug & Abandon)

- Pavement Removal (General)
- Paved Entrance Removal
- Detour Pavement Removal Levels 4,14
- Sidewalk Removal

NOTE:
 Removal Detail Sheets are for general removal details only.
 Refer also to Tabulations and Staging Detail Sheets elsewhere in these plans.

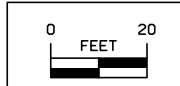

Removal Details
Sheet
16 of 18

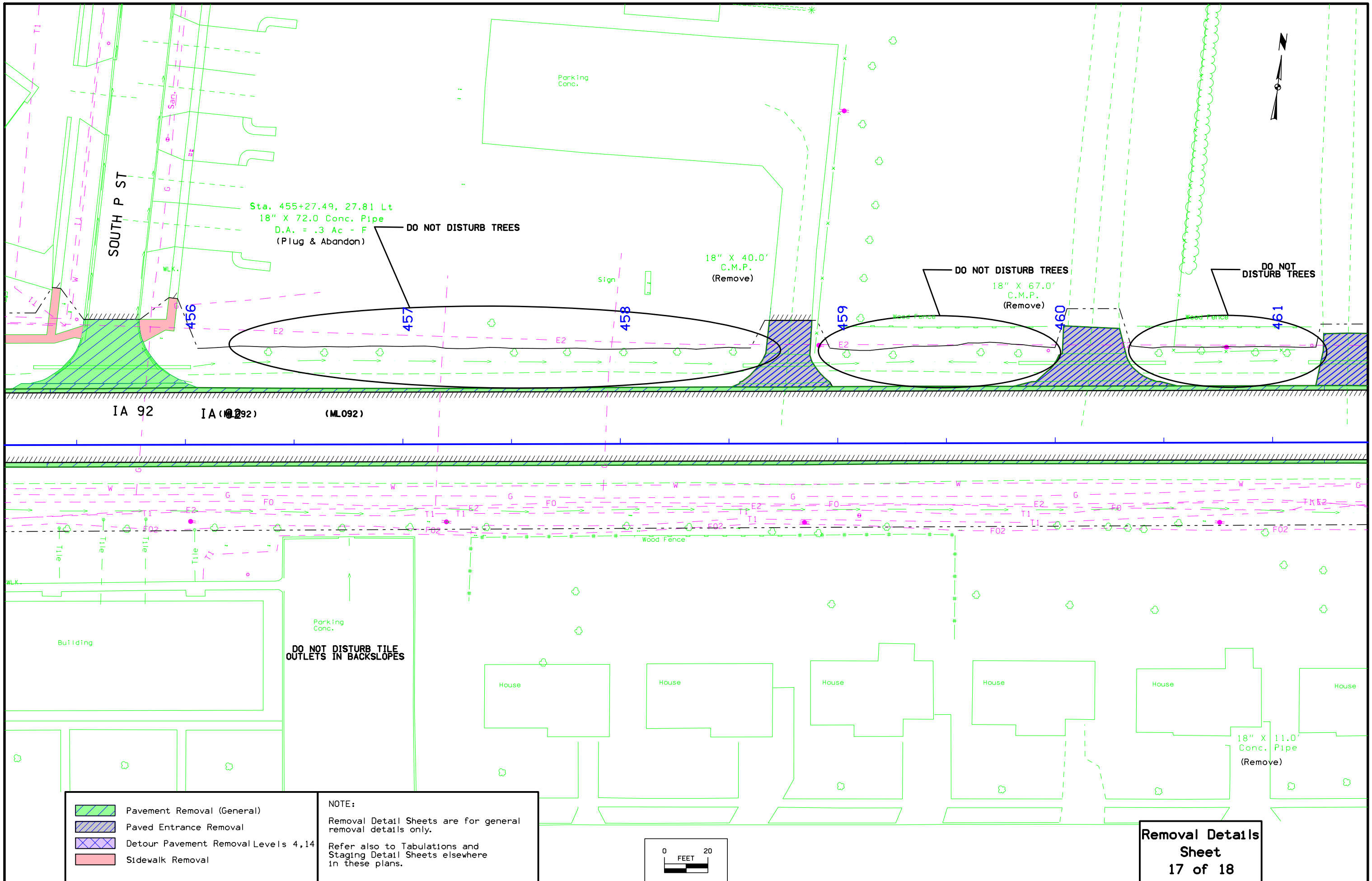

- Pavement Removal (General)
- Paved Entrance Removal
- Detour Pavement Removal Levels 4, 14
- Sidewalk Removal

NOTE:
 Removal Detail Sheets are for general removal details only.
 Refer also to Tabulations and Staging Detail Sheets elsewhere in these plans.

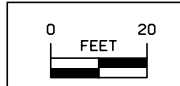

**Removal Details
 Sheet
 17 of 18**

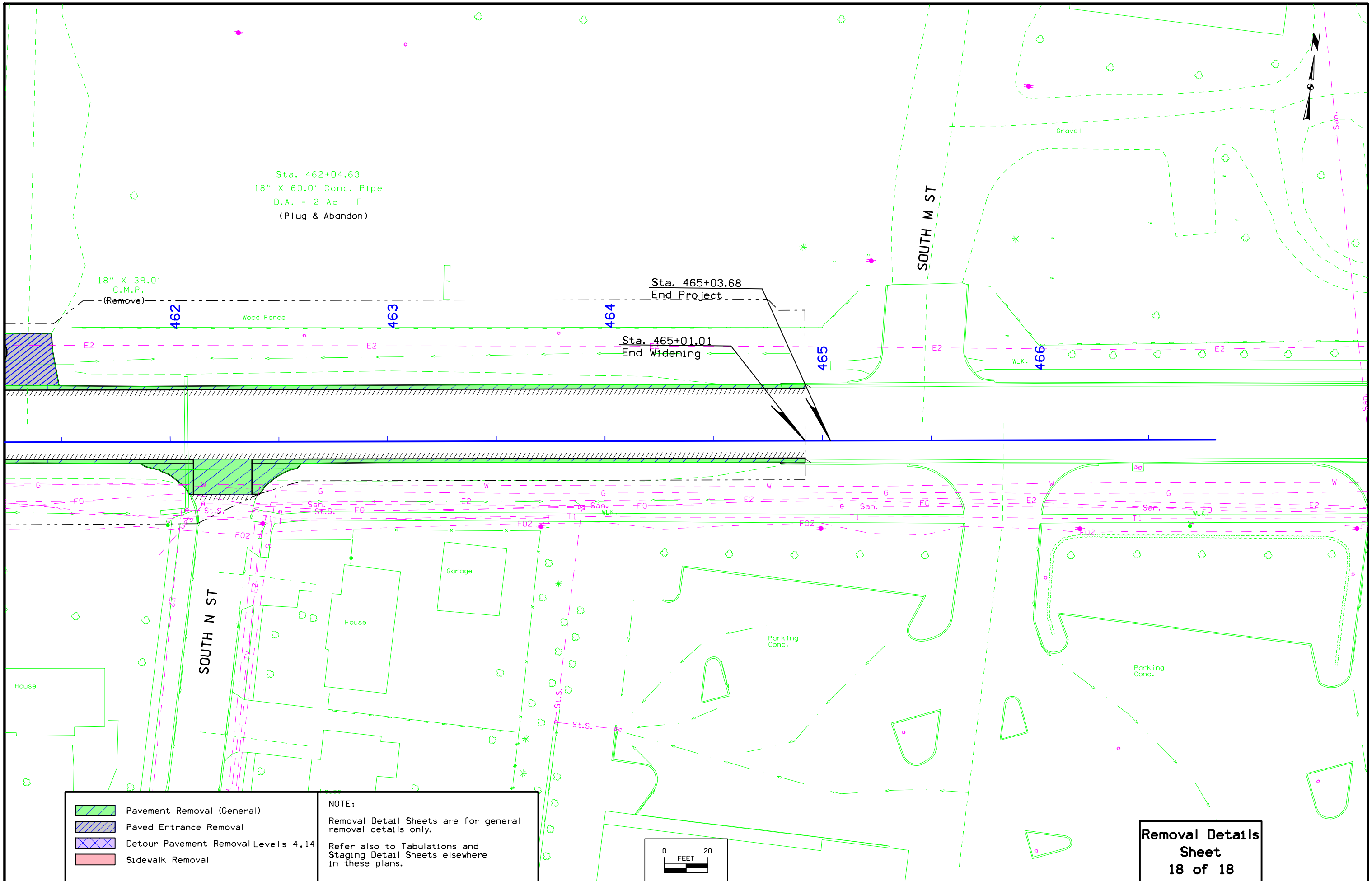

Sta. 462+04.63
 18" X 60.0' Conc. Pipe
 D.A. = 2 Ac - F
 (Plug & Abandon)

18" X 39.0'
 C.M.P.
 (Remove)

Sta. 465+03.68
 End Project

Sta. 465+01.01
 End Widening

- Pavement Removal (General)
- Paved Entrance Removal
- Detour Pavement Removal Levels 4, 14
- Sidewalk Removal

NOTE:
 Removal Detail Sheets are for general removal details only.
 Refer also to Tabulations and Staging Detail Sheets elsewhere in these plans.

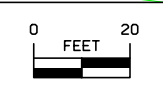

Removal Details
Sheet
18 of 18

Lincoln TWP.
T-76N R-24W
SEC. 29

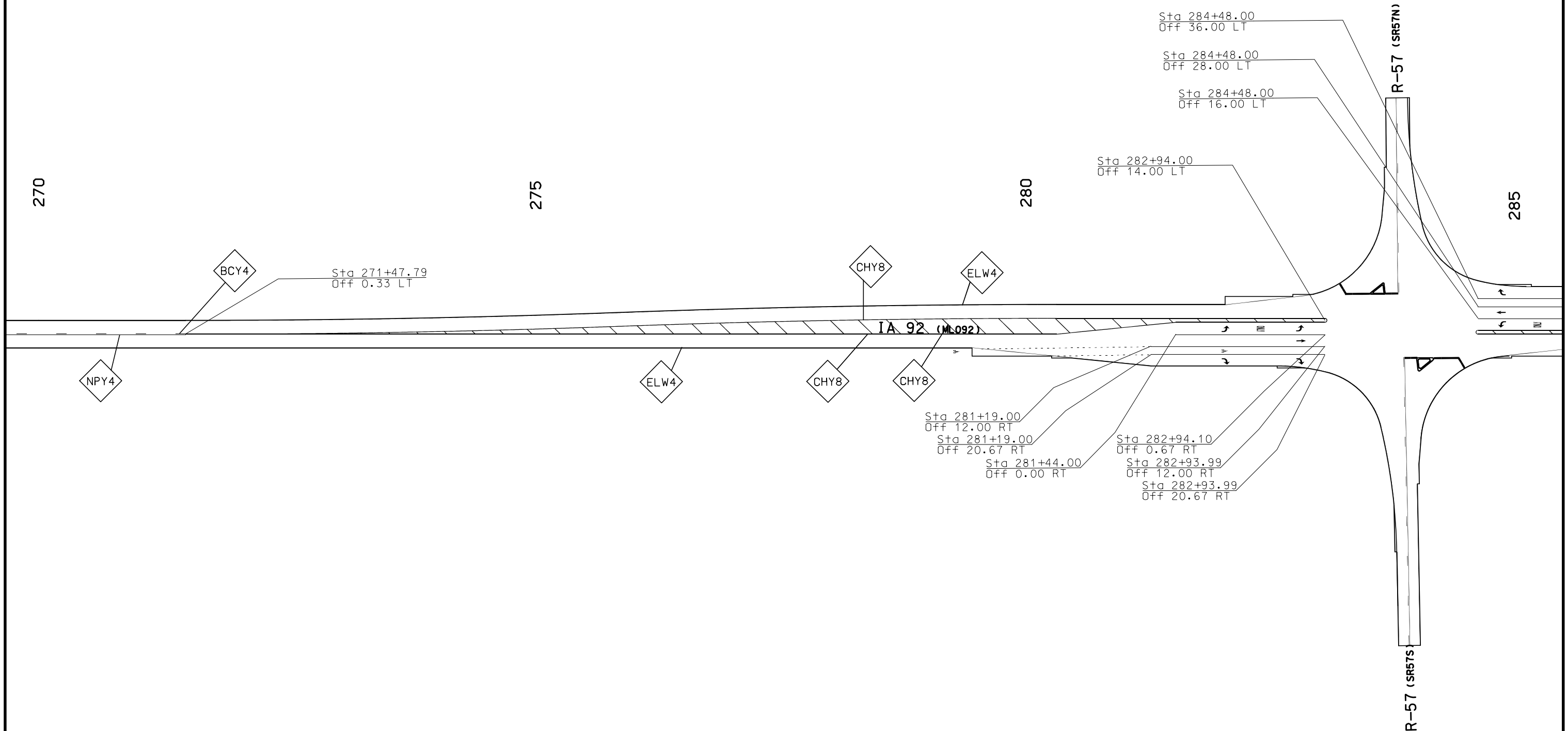

Final Pavement Marking Details

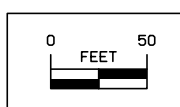

Lincoln TWP.
T-76N R-24W
SEC. 29

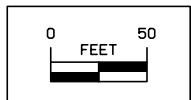
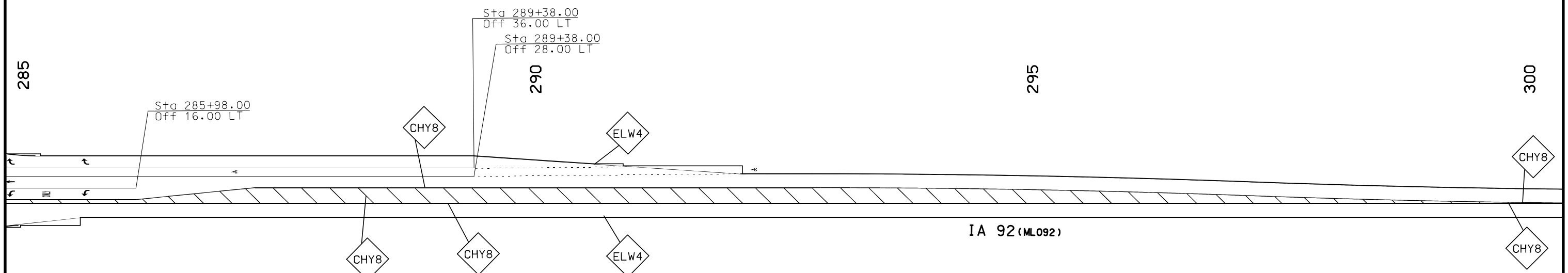

Final Pavement Marking Details

Lincoln TWP.
T-76N R-24W
SEC. 29

Lincoln TWP.
T-76N R-24W
SEC. 28

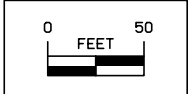
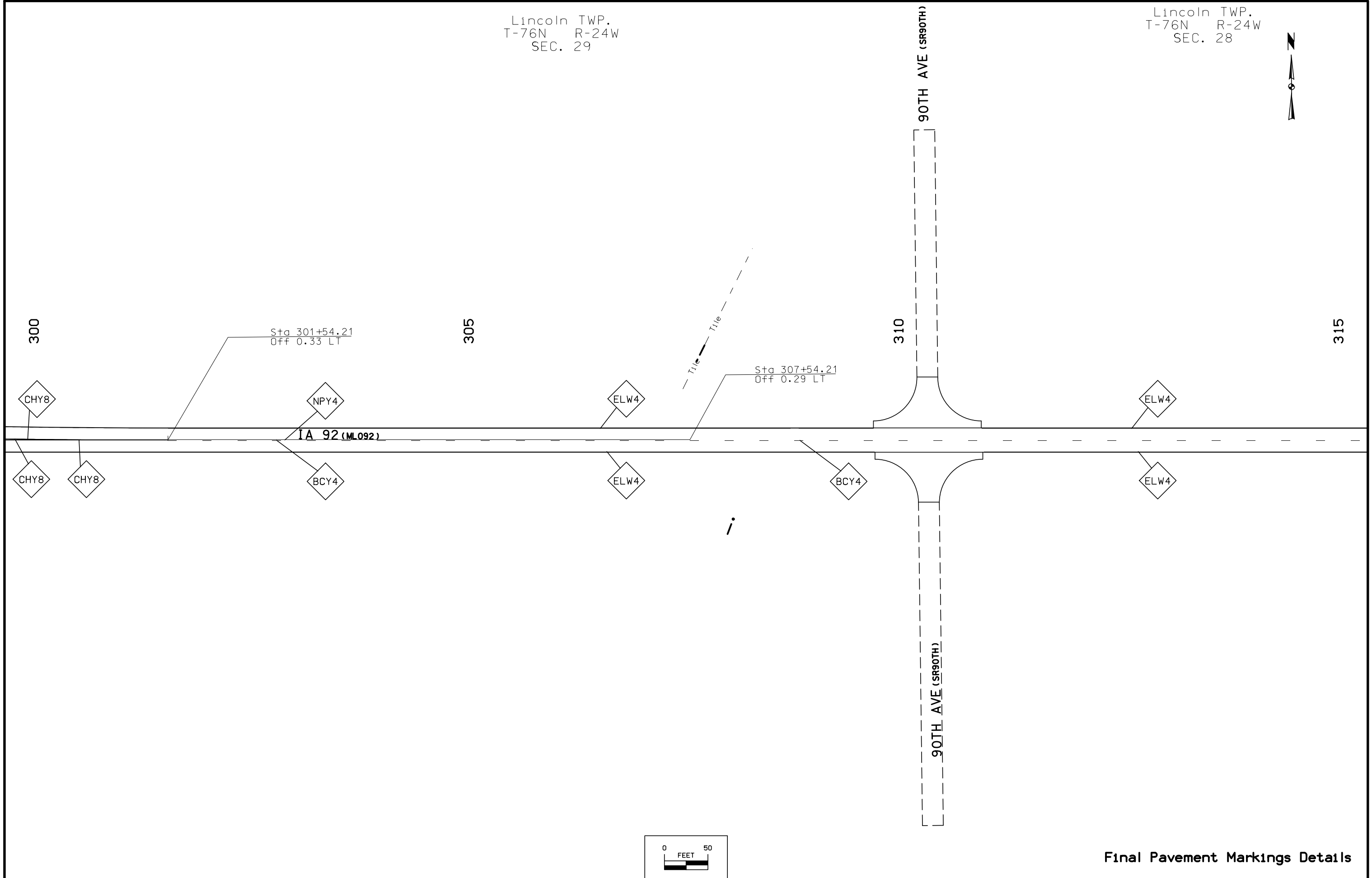

Final Pavement Markings Details

Lincoln TWP.
T-76N R-24W
SEC. 27



375

380

385

390

BCY4

ELW4

CHY8

NPY4

ELW4

CHY8

CHY8

IA 92 (ML092)

Sta 378+78.79
Off 0.33 RT

Sta 388+50.00
Off 12.67 RT

Sta 388+50.00
Off 20.67 RT

Sta 388+75.00
Off 0.67 RT

Sta 390+25.00
Off 0.00 RT

Sta 390+25.00
Off 12.67 RT

Sta 390+25.00
Off 20.00 RT

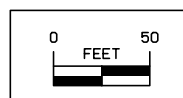

Final Pavement Marking Details

FILE NO.

ENGLISH

DESIGN TEAM J1a\Holst\Bennett

WARREN COUNTY

PROJECT NUMBER

NHSX-092-5(51)--3H-91

SHEET NUMBER

U.22

Lincoln TWP.
T-76N R-24W
SEC. 27



339E

390

R-63 (SR63N)

Sta 391+79.93
Off 28.00 LT
Sta 391+79.92
Off 14.99 LT

Sta 393+29.11
Off 15.00 LT

395

Sta 396+69.88
Off 28.00 LT

400

405

BCY4

NPY4

BCY4

NPY4

BCY4

NPY4

BCY4

NPY4

IA 92 (ML092)

Sta 391+79.93
Off 0.00 RT

06E
00 RT
+25.00
00 RT

R-63 (SR63S)

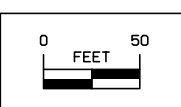

Final Pavement Marking Details

Lincoln TWP.
T-76N R-24W
SEC. 27

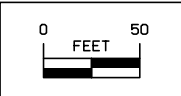
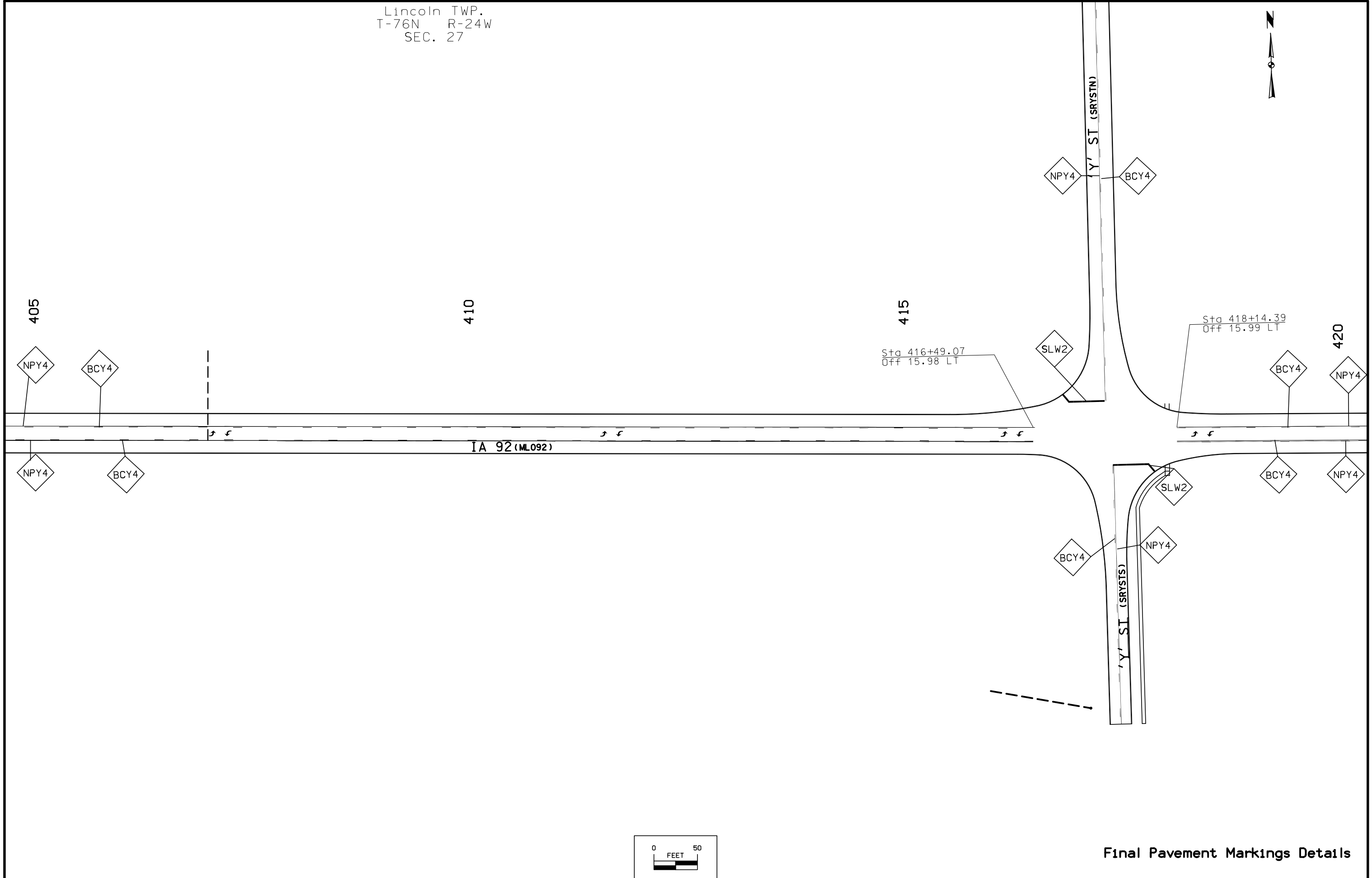

Final Pavement Markings Details

Lincoln TWP.
T-76N R-24W
SEC. 26



420



425

430

435



IA 92 (ML092)

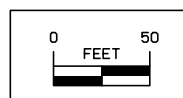

Final Pavement Markings Details

Lincoln TWP.
T-76N R-24W
SEC. 26

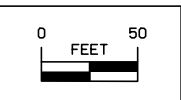
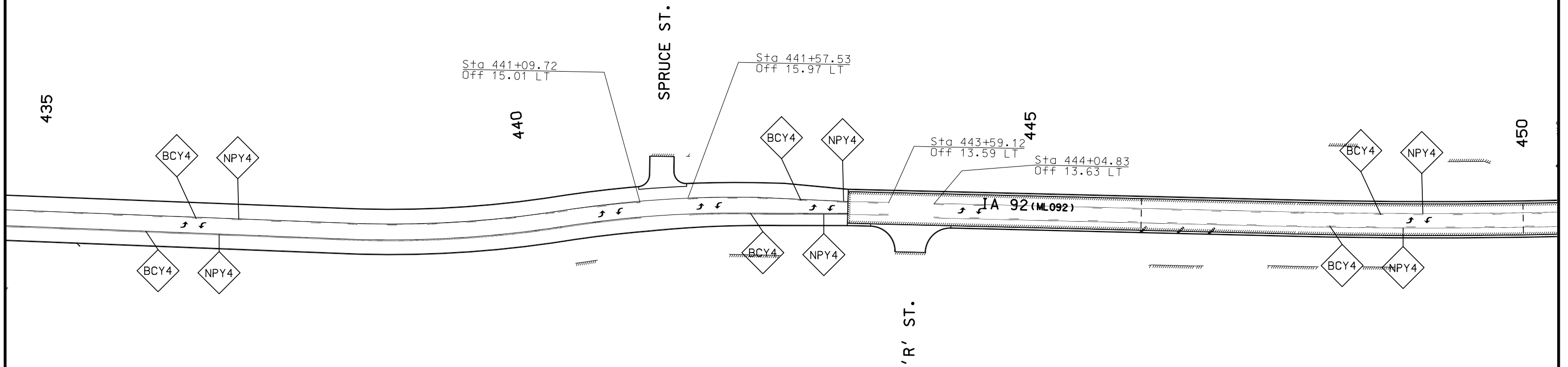

Final Pavement Markings Details

FILE NO.	ENGLISH	DESIGN TEAM J1a\Holst\Bennett	WARREN COUNTY	PROJECT NUMBER NHSX-092-5(51)--3H-91	SHEET NUMBER U.26
----------	---------	--------------------------------------	----------------------	---	--------------------------

Lincoln TWP.
T-76N R-24W
SEC. 26

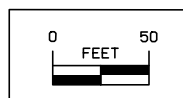
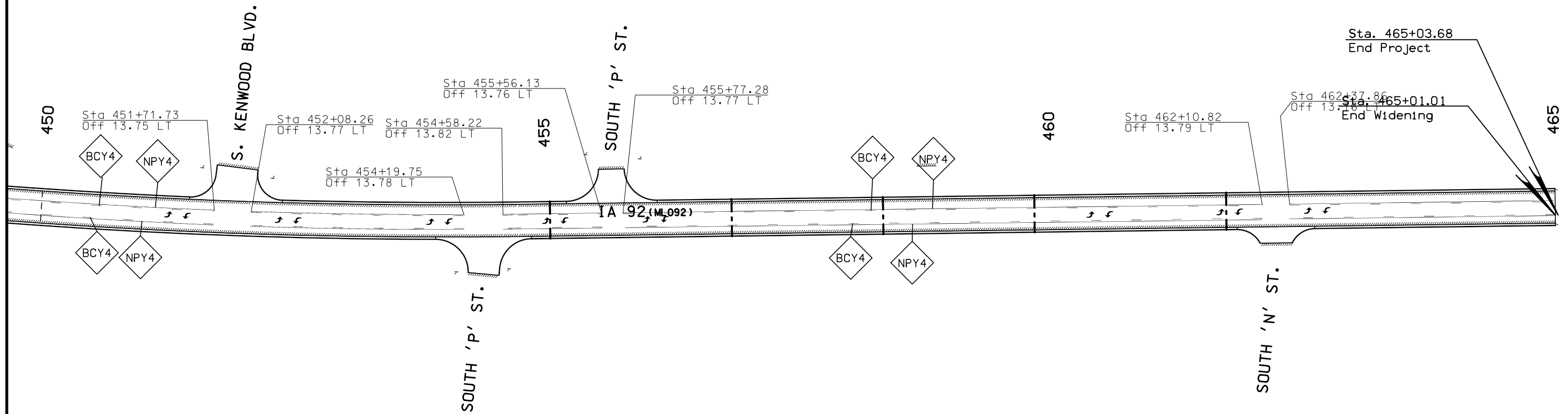

Final Pavement Markings Details

FILE NO.	ENGLISH	DESIGN TEAM J1a\Holst\Bennett	WARREN COUNTY	PROJECT NUMBER NHSX-092-5(51)--3H-91	SHEET NUMBER U.27
----------	---------	-------------------------------	---------------	--------------------------------------	-------------------

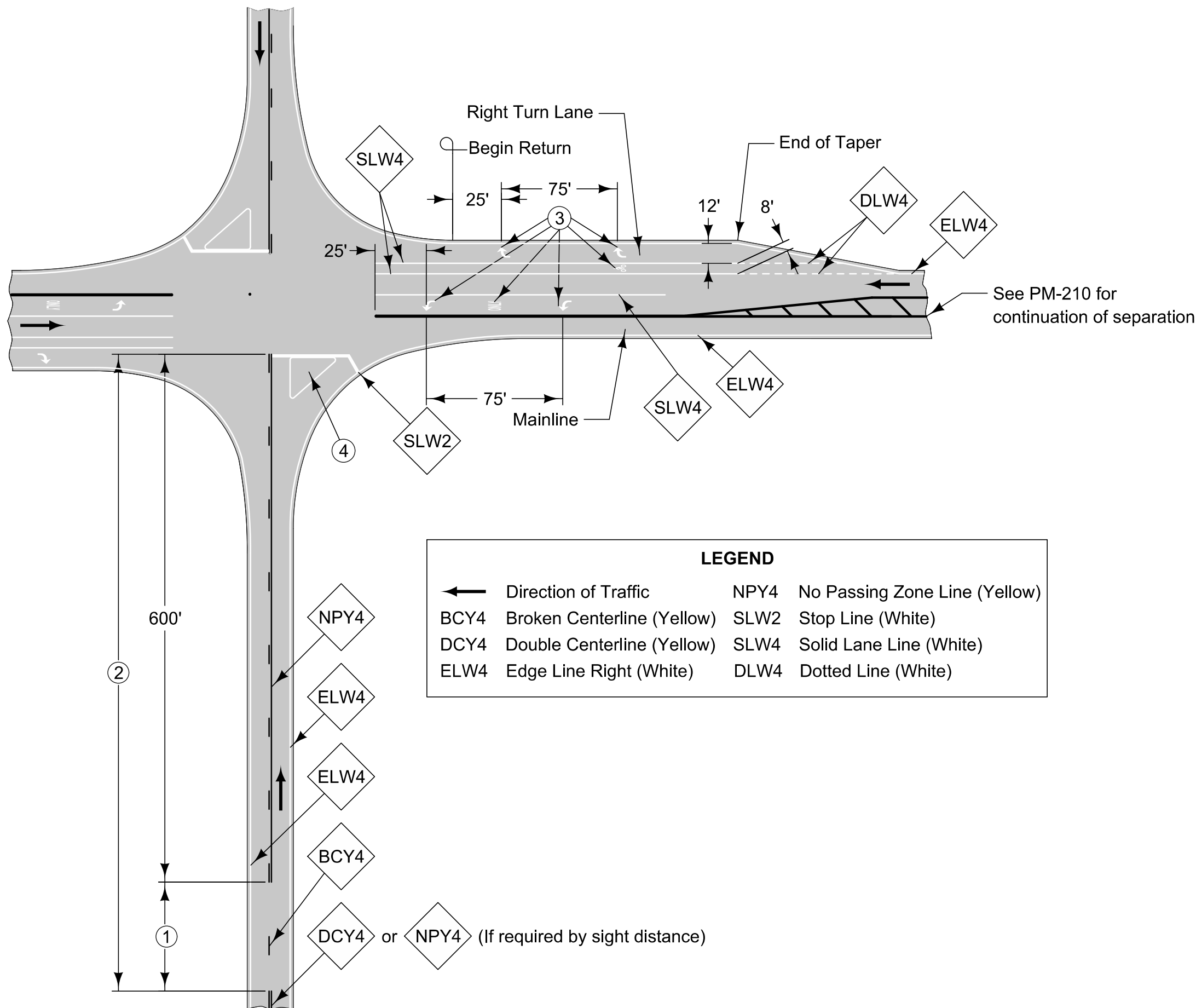

Terminate all mainline centerline markings at the edge of the thru lanes of the side road.

Start Solid Lane Line for Right Turn Lane at end of taper.

For line information, see PM-110.

For symbol and legend information, see PM-111.

① If less than 400 feet, join Yellow Lines.

② If less than 1000 feet, extend Yellow Line to Stop Line.

③ Symbol and Legend (when listed in 108-29).

④ For Island information, see PM-120.

Possible Contract Items:
 Pavement Marking Line Items
 Pavement Marking Symbol and Legend Items

Possible Tabulations:
 108-22
 108-29

LEGEND			
	Direction of Traffic	NPY4	No Passing Zone Line (Yellow)
	Broken Centerline (Yellow)	SLW2	Stop Line (White)
	Double Centerline (Yellow)	SLW4	Solid Lane Line (White)
	Edge Line Right (White)	DLW4	Dotted Line (White)

**FINAL PAVEMENT MARKINGS
FOR TURN LANES**

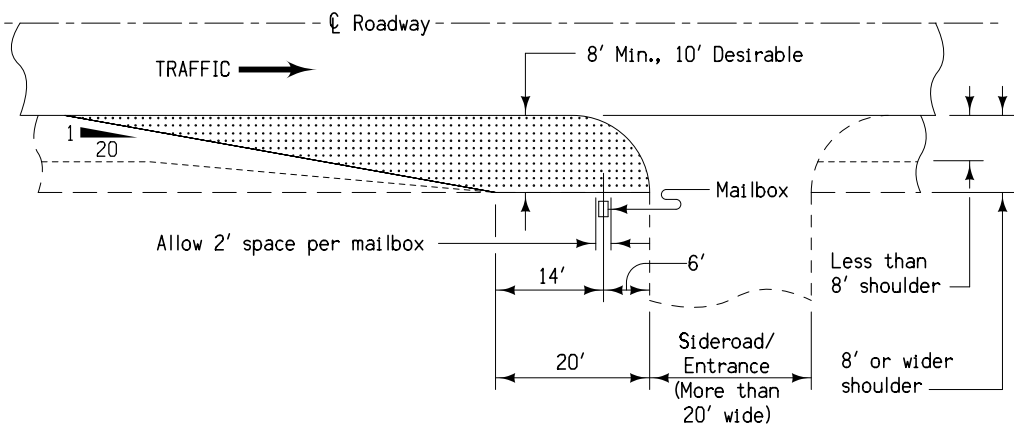

PLAN VIEW
Approach Side of Entrance

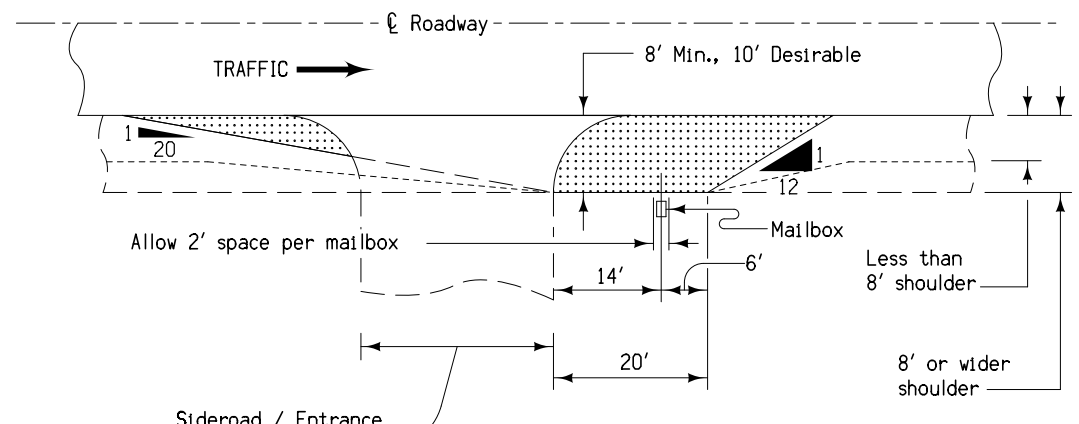

PLAN VIEW
Trailing Side of Entrance

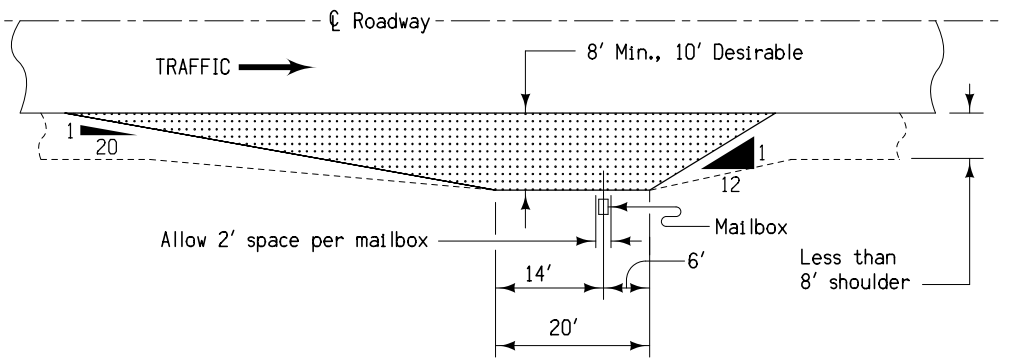

PLAN VIEW
Shoulder Width Less than 8'

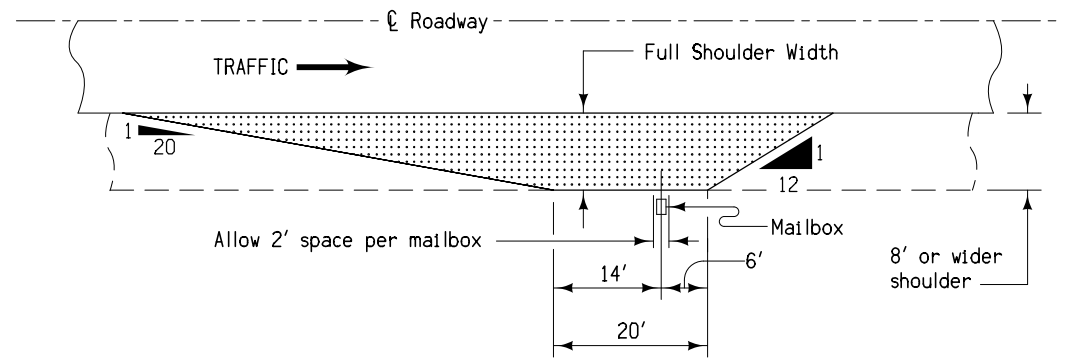

PLAN VIEW
Shoulder Width 8' or More

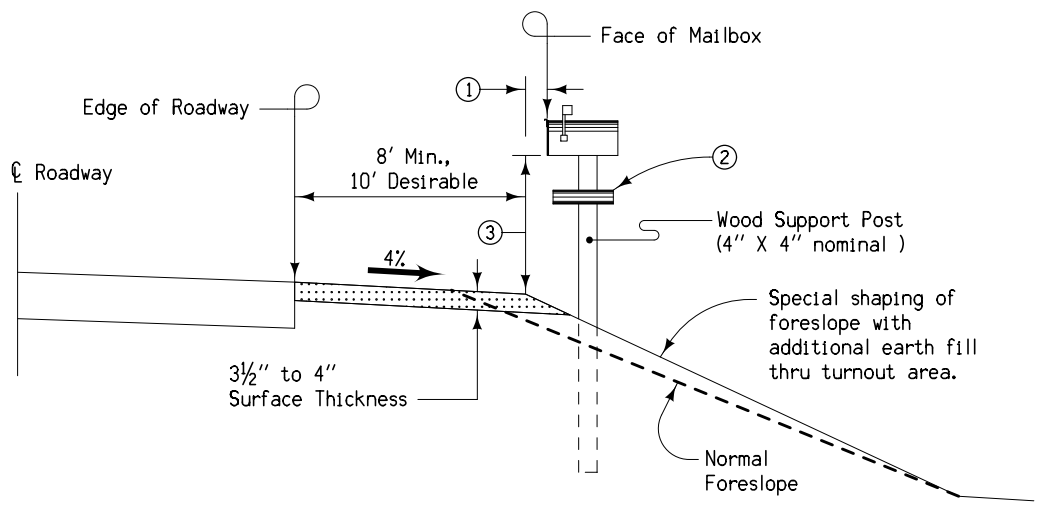

TYPICAL SECTION
Shoulder Width Less than 8'

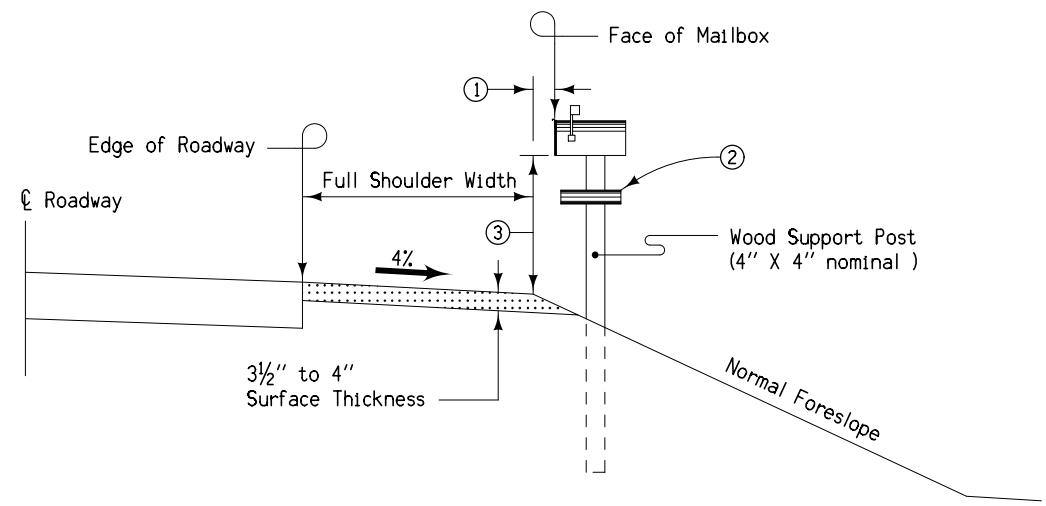

TYPICAL SECTION
Shoulder Width 8' or More

GENERAL NOTES:

Refer to "Policies and Procedures Manual", Policy 610.09, Mailboxes and Newspaper Receptacles on Primary Roads.

Mailbox turnouts shall be full shoulder width with a minimum width of 8 feet. On shoulders less than 8 feet, build fillet to obtain a minimum width of 8 feet.

For multiple mailbox installations in one turnout, the taper dimensions will remain the same. The dimensions from centerline of mailbox located at either end will remain the same and 2 feet will be allowed for each mailbox in the installation.

When the mailbox owner's driveway is on the right hand side of the road, as the mail carrier travels, the box would preferably be placed near the driveway as shown on this sheet. With these types of placement, the driveway will serve as part of the mailbox turnout.

Requests, by the property owner, for the location of mailbox turnouts other than at driveways shall be approved by the Engineer in charge of construction and the U.S. Postal Authorities.

Mailbox(s) shall be installed with the face (door) no closer to the roadway than the shoulder line. Support post shall be in the foreslope with the inside edge at least one (1) foot outward from the shoulder line.

SURFACING QUANTITY

Surfacing of mailbox turnouts is based on a 5 inch design depth (loose volume) which will, under normal conditions, compact to 3.5" to 4" actual depth. A width of 8 feet will require approximately 18.3 cubic yards and 10 foot width will require approximately 27.8 cubic yards of surfacing. Quantities are given for a single mailbox installation 276 to 340 feet in length. Where multiple installations or installations at driveways are encountered, quantities will vary as directed by the Engineer.

Payment for construction of mailbox turnouts will be as specified elsewhere in the contract documents.

- ① 8" to 12" preferred, 0" minimum.
- ② Metal tube / box for delivery of local advertisements, newspapers etc.
- ③ Mounting height per U.S. Postal Regulations (42" to 48" above mail stop surface).

<i>Project Development Division</i>		
DETAIL SHEET	560-2	
REVISION: Place in CADD	REVISION NO.	REVISION DATE
	1	03-28-95
DETAILS OF MAILBOX TURNOUTS (GRANULAR SURFACED)		