

LETTING DATE
01-20-2021

BRIDGE REPLACEMENT-PPCB
BRF-002-9(32)--38-56

LEE CO.



Highway Division

PLANS OF PROPOSED IMPROVEMENT ON THE

PRIMARY ROAD SYSTEM
LEE COUNTY
BRIDGE REPLACEMENT-PPCB

Sugar Creek 1.8 mi W of US 218

SCALES: As Noted

Refer to the Proposal Form for list of applicable specifications.

Value Engineering Saves. Refer to Article 1105.14 of the Specifications.



REVISIONS

TOTAL

26

PROJECT IDENTIFICATION NUMBER

16-56-002-010

PROJECT NUMBER

BRF-002-9(32)--38-56

R.O.W. PROJECT NUMBER

STPN-002-9(33)--2J-56

INDEX OF SHEETS

No.	DESCRIPTION
A Sheets	Title Sheets
A.1	Title Sheet
A.1	Location Map Sheet
B Sheets	Typical Cross Sections and Details
B.1 - 4	Typical Cross Sections and Details
C Sheets	Quantities and General Information
C.1	Access Points and Safety Ramps
D Sheets	Mainline Plan and Profile Sheets
* D.1	Plan & Profile Legend & Symbol Information Sheet
* D.2	IA 2
G Sheets	Survey Sheets
G.1	Reference Ties and Bench Marks
G.2	Control Point Vicinity Map
G.3	Horizontal Control Tab. & Super for all Alignments
G.4	Alignment Coordinates
J Sheets	Traffic Control and Staging Sheets
J.1	Traffic Control Plan
J.1	511 Travel Restrictions
J.1	Coordinated Operations
V Sheets	Bridge and Culvert Situation Plans
* V.1 - 2	Bridge and Culvert Situation Plans
W Sheets	Mainline Cross Sections
W.1 - 11	Mainline Cross Sections
	* Color Plan Sheets

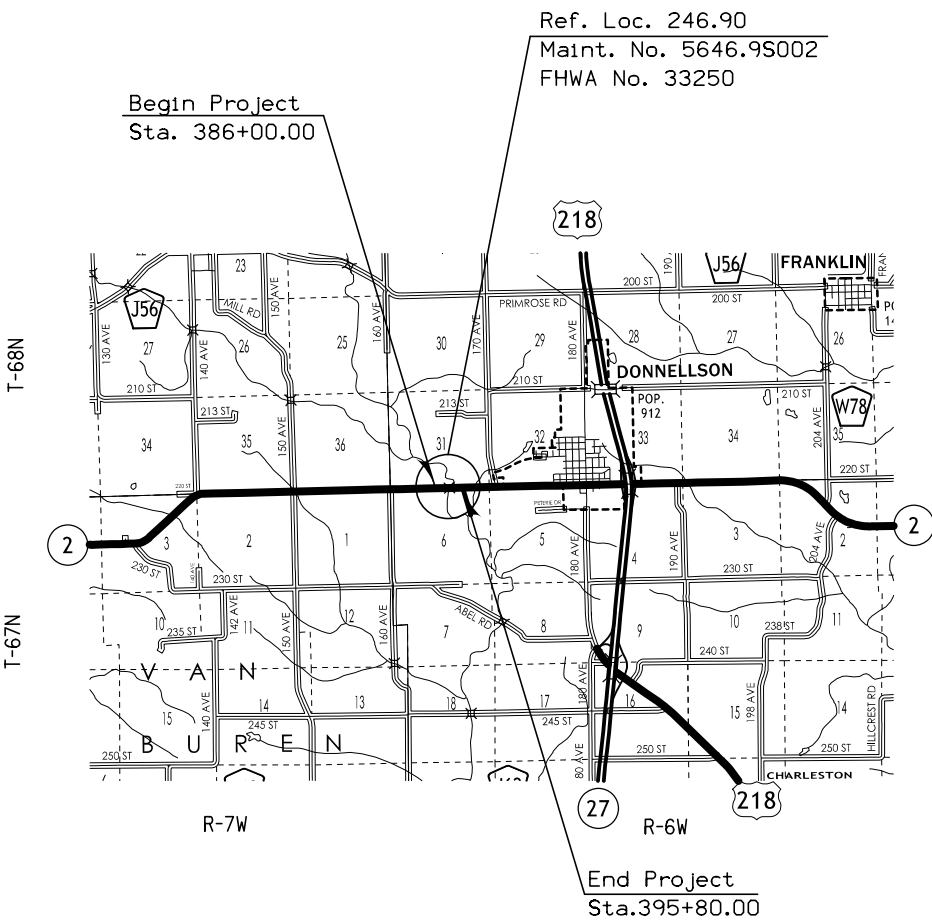

DESIGN DATA RURAL

2021	AADT	1900	V.P.D.
2041	AADT	2100	V.P.D.
20--	DHV	--	V.P.H.
	TRUCKS	8	%
	Total		
	Design ESALs	--	

LOCATION MAP SCALE

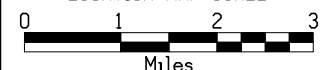

INDEX OF SEALS

SHEET NO.	NAME	TYPE
A.1	X	Primary Signature Block
X	X	X

PRELIMINARY PLANS

Subject to change by final design.

D5 PLAN - Date: 8-16-2019

Combination Shoulder

Shoulder Jointing:
 Longitudinal joint: L-2 or KT-2
 Transverse joints: C at 17' spacing

STATION TO STATION		2_C_ 10-15-13	
		(P) Feet	(G) Feet
386+00.00	389+47.11	4	4
392+94.11	395+80.00	4	4

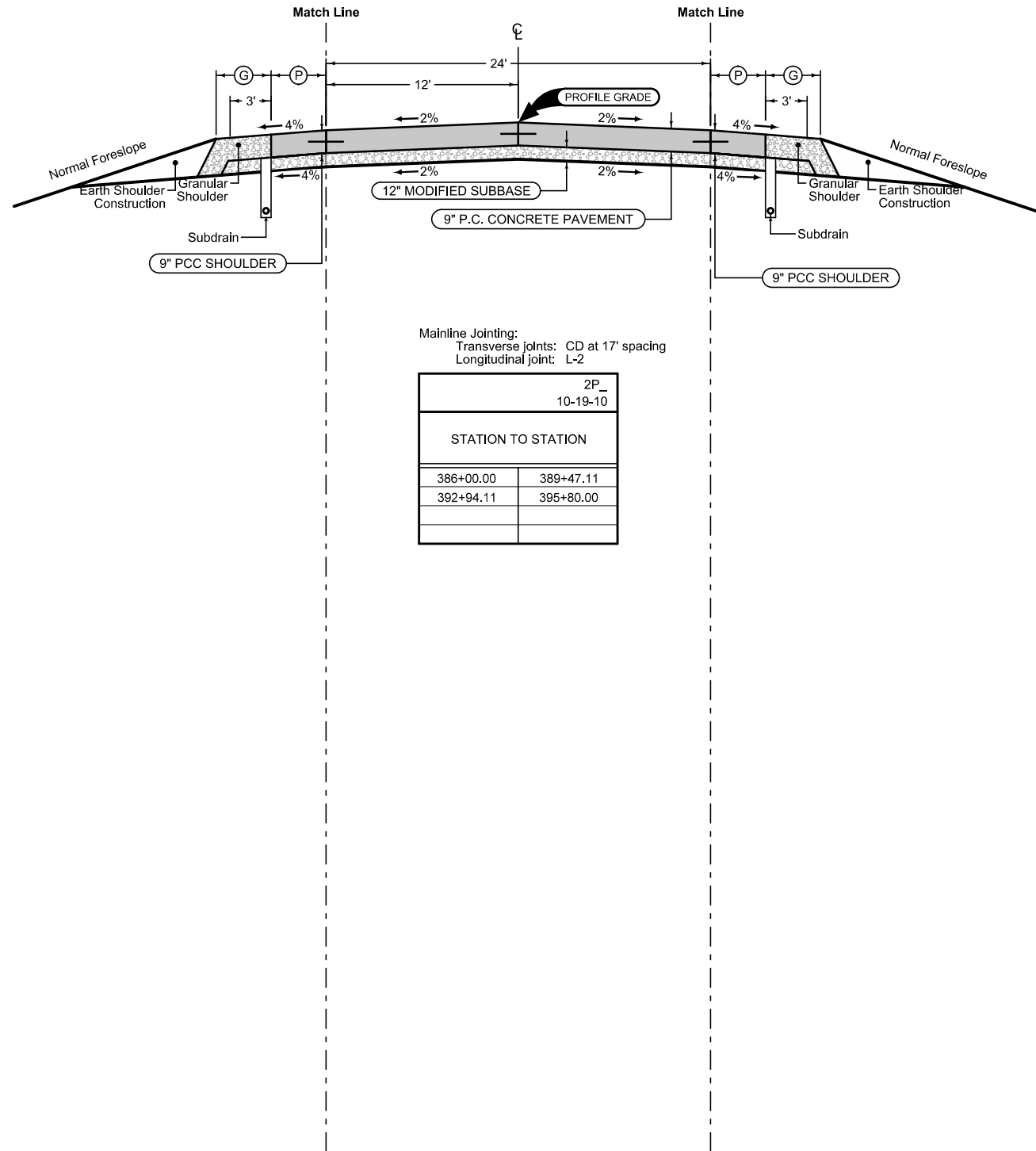

Mainline Jointing:
 Transverse joints: CD at 17' spacing
 Longitudinal joint: L-2

STATION TO STATION		2P_ 10-19-10	
386+00.00	389+47.11		
392+94.11	395+80.00		

Combination Shoulder

Shoulder Jointing:
 Longitudinal joint: L-2 or KT-2
 Transverse joints: C at 17' spacing

STATION TO STATION		2_C_ 10-15-13	
		(P) Feet	(G) Feet
386+00.00	389+47.11	4	4
392+94.11	395+80.00	4	4

See Tab 100-24 or 100-25 for pavement quantities.
 See Tab 112-9 for shoulder quantities.

Shoulder at Bridge Approach

Shoulder Jointing:
 Longitudinal joint: L-2 or KT-2
 Transverse joints: C at 17' spacing

2_P_FullPCC_10-19-10		
STATION TO STATION		(P) Feet
389+47.11	390+17.11	8
392+24.11	392+94.11	8

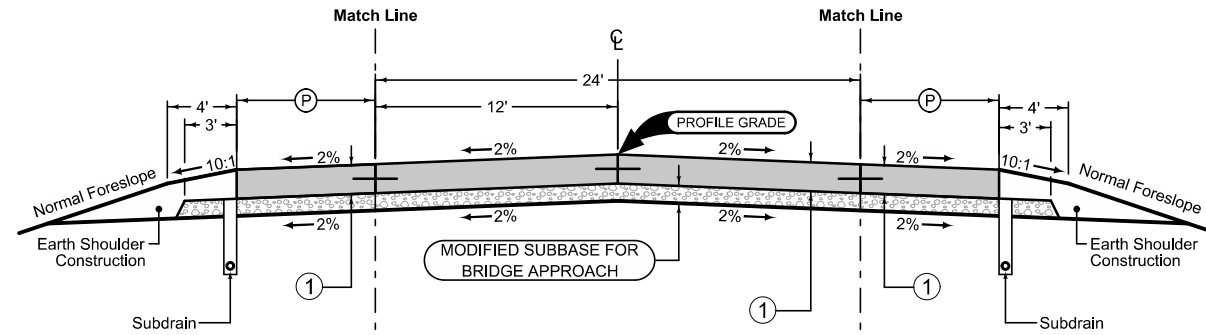

Mainline Jointing:
 Transverse joints: CD at 17' spacing
 Longitudinal joint: L-2

2P_10-19-10		
STATION TO STATION		(P) Feet
389+47.11	390+17.11	8
392+24.11	392+94.11	8

Shoulder at Bridge Approach

Shoulder Jointing:
 Longitudinal joint: L-2 or KT-2
 Transverse joints: C at 17' spacing

2_P_FullPCC_10-19-10		
STATION TO STATION		(P) Feet
389+47.11	390+17.11	8
392+24.11	392+94.11	8

① 12" Bridge Approach Pavement

See Tab 112-6 for bridge approach.

IA 2 at Bridge Approach

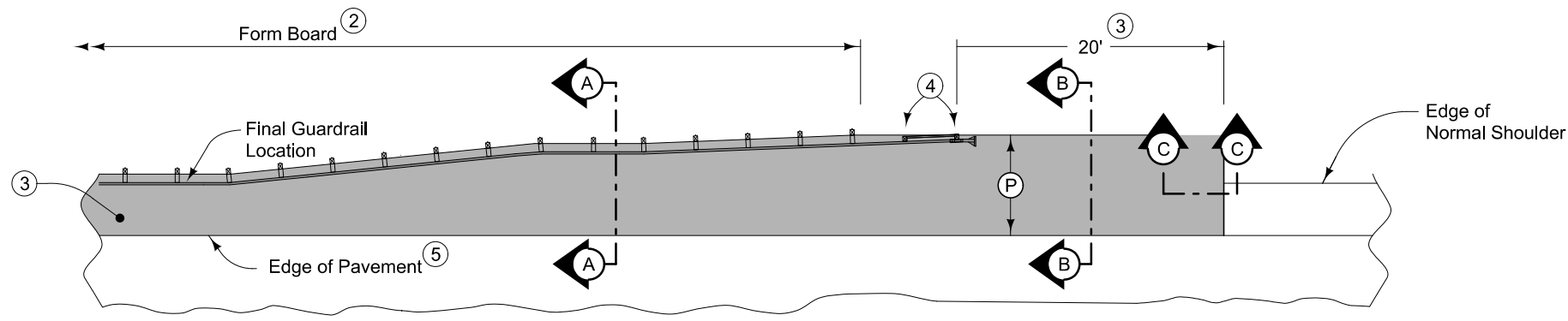

PLAN VIEW

9" PCC Paved Shoulder at guardrail with the following jointing layout:

Match mainline pavement joint spacing. When mainline pavement is 8" or greater in thickness, place additional transverse 'C' joints in shoulder at mid-panel of the mainline pavement. Place longitudinal 'C' joint at P/2 from edge of mainline pavement when P is greater than 10' wide. Terminate longitudinal joint at transverse joint less than 10' in length.

Refer to Tabulation 112-9 for shoulder quantities.

- ① 12" Modified Subbase.
- ② When guardrail posts are installed prior to construction of PCC paved shoulder, fasten form board to the face of guardrail posts for the length shown. Refer to note 4 for final 2 posts.
- ③ Continue paved shoulder to existing paved shoulder or 20 feet beyond the center of the first post.
- ④ Shoulder may be notched for final 2 posts or post sleeves may be installed through pavement. Do not drive posts through pavement.
- ⑤ 'KT-1 joint for PCC shoulder.

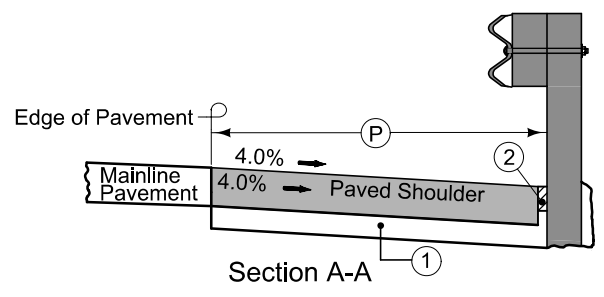

Section A-A

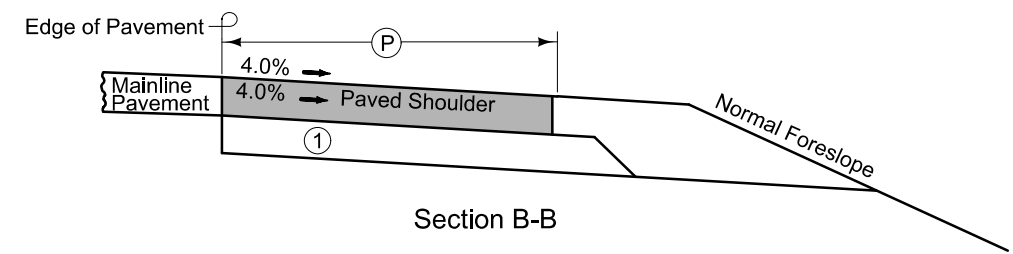

Section B-B

NEW CONSTRUCTION

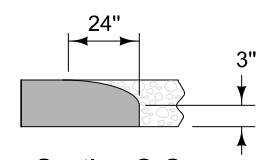

Section C-C
Roll down at granular shoulder or earth.

PAVED SHOULDER AT GUARDRAIL

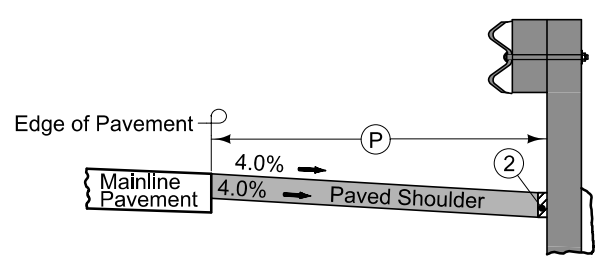

Section A-A

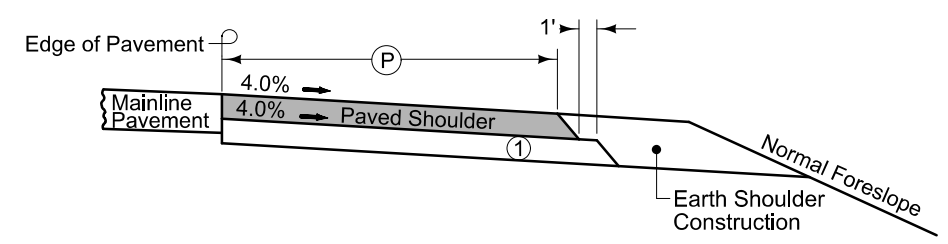

Section B-B

EXISTING SHOULDER

ACCESS POINTS AND SAFETY RAMPS

Refer to Cross-Sections















Length of Unclassified Pipe calculated is based on using Corrugated Metal Pipe.

- ① Refer to MI-210
- ② Refer to EW-501.
- ③ Refer to EW-501 or EW-502.





*Predetermined for access point not constructed with this project.

Location		Type	Length of Opening ①			Pipe Culvert ③			Pipe Culvert ③			Aprons	Driveway Surface Area		Driveway Surfacing Material	Remarks		
Station	Side	A, B, C, Safety Ramp, or Predetermined*	Case	1½" Dropped Curb	3" Dropped Curb	W	① PR	② SR	H	Size	Pipe Length	Lt.	Rt.	No.	HMA		PCC	TON
			1 or 2	LF	LF	FT	FT	FT	FT	IN	LF	LF	LF	SY	SY			
386+73.17	Rt	C				20.0		20.0	4.1	24.0	85.4	38.7	81.1	2				
386+86.98	Lt	C				20.0		20.0	2.7	24.0	61.7	34.8	62.0	2				













SURVEY SYMBOLS

-  FENO FENO Monument
-  PCT Photo Control Target
-  TW Top of Water
-  PPA Power Pole Co. 1
-  BM Bench Mark
-  SNP Unpaved Shoulder
-  FO1D Fiber Optic Co. 1 - Quality D
-  TPD Telephone Pedestal
-  TL1D Telephone Line Co. 1 - Quality D
-  SI Sign
-  WL1D Water Line Co. 1 - Quality D
-  WW Water Valve
-  SCR Section Corner
-  REF Reference Tie Point







UTILITY LEGEND











-  FO1D Fiber Optic Windstream Communications - Quality D
-  TL1D Telephone Line Windstream Communications - Quality D
Kelly Eggers
101 West Madison
Mt. Pleasant, IA 52641
kelly.a.eggers@windstream.com
(319) 385-5004
-  PPA Power Pole Alliant Energy
Heather Dee
200 1st St. SE
Cedar Rapids, IA 52401
REROW@alliantenergy.com
(319) 786-8196
-  WL1D Water Line Rathbun Regional Water - Quality D
Jim Hopp
1677 Salem Rd.
Salem, IA 52544
hopprwa@gmail.com
(319) 258-2103

PLAN VIEW COLOR LEGEND OF PLAN AND PROFILE SHEETS







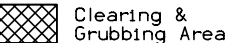

LINEWORK	Design Color No.	
Green	(2)	 Existing Topographic Features and Labels
Blue	(1)	 Proposed Alignment, Stationing, Tic Marks, and Alignment Annotation
Magenta	(5)	 Existing Utilities
SHADING	Design Color No.	
Yellow	(4)	 Highlight for Critical Notes or Features
Red	(3)	 Delineates Restricted Areas
Lavender	(9)	 Temporary Pavement Shading
Gray, Light	(48)	 Proposed Pavement Shading
Gray, Med	(80)	 Proposed Granular Shading
Gray, Dark	(112)	 Proposed Grade and Pave Shading "In conjunction with a paving project"
Brown, Light	(236)	 Grading Shading
Tan	(8)	 Proposed Sidewalk Shading
Blue, Light	(230)	 Proposed Sidewalk Landing Shading
Pink	(11)	 Proposed Sidewalk Ramp Shading

PROFILE VIEW COLOR LEGEND OF PLAN AND PROFILE SHEETS

LINEWORK	Design Color No.	
Green	(2)	 Existing Ground Line Profile
Blue	(1)	 Proposed Profile and Annotation
Magenta	(5)	 Existing Utilities
Blue, Light	(230)	 Proposed Ditch Grades, Left
Black	(0)	 Proposed Ditch Grades, Median
Rust	(14)	 Proposed Ditch Grades, Right

-  Reference Point
-  Station
-  Survey Line
-  Section Corner
-  Ground Line Intercept
-  Saw Cut
-  Guardrail
-  Trench Drain
-  HighTension Cable Guardrail
-  Sheet Pile
-  Pavement Removal
-  Clearing & Grubbing Area

RIGHT-OF-WAY LEGEND

-  Proposed Right-of-Way
-  Existing Right of Way
-  Existing and Proposed Right-of-Way
-  Easement and Existing Right-of-Way
-  Easement (Temporary)
-  Easement
-  Access Control
-  Property Line

PLAN AND PROFILE LEGEND AND SYMBOL INFORMATION SHEET

(COVERS SHEET SERIES D, E, F, & K)

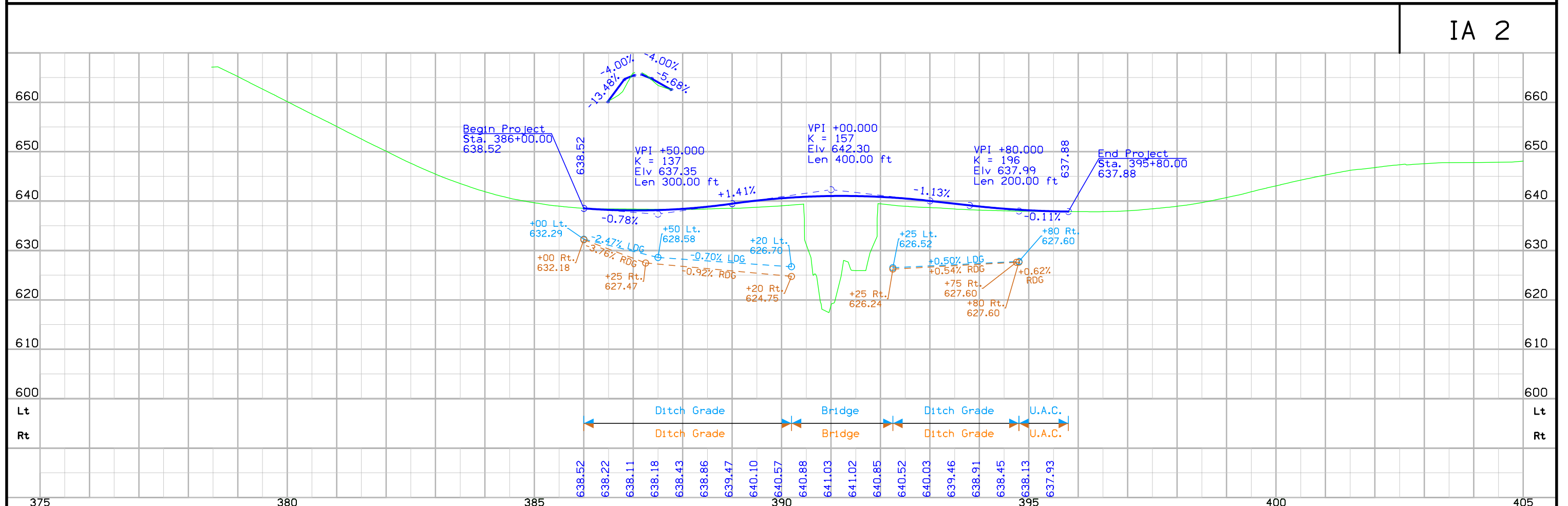
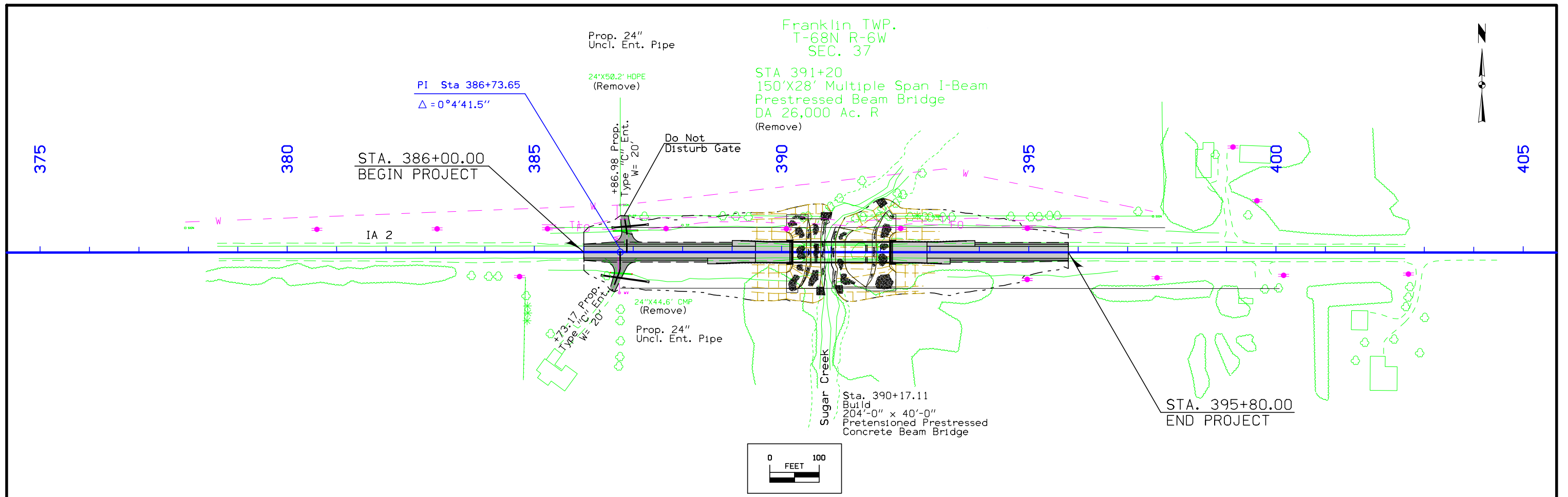

Survey Information

County: Lee
 SAP 758.1
 PIN: 16-56-002-010
 Project Number: BRFN-002-9(32)--39-56
 Location: Sugar Creek 1.8 mi W of US 218
 Type of Work: Bridge-Unspecified
 Project Directory: 5600201016
 IaRCS Zone 14

General Information

Measurement units for this survey are US survey feet. This survey is for proposed Bridge reconstruction and reconstruction of State Road 2 over Sugar Creek. Project datum and control information is provided by Design Survey Office. This is a partial terrain field survey with aerial image acquired terrain added in the Photogrammetry section of the Design Office. This survey request was for the Hwy 2 corridor only.

Vertical Control

Vertical datum for this survey is NAVD88 (Computed using Geoid12A). Benchmarks were placed throughout the project using post processed static observations relative to IaRTN Base Network. A minimum of 6hrs of data was simultaneously collected on each of these primary control points.

Three local existing control points were observed to ensure that the Donnellson reference station broadcast position is within acceptable tolerance of the positions on the datasheet.

A122 is a NGS vertical control monument. It was checked only for vertical tolerance.

The difference of +0.13 ft. is within acceptable tolerance when comparing passive control to active control. The strategy is to keep project heights relative to the IaRTN broadcast height from the Donnellson reference station to enable future IaRTN network RTK observations so the published height on A122 is used only to prove the broadcast height is within acceptable tolerance.

B122 RESET is a NGS vertical control monument. It was checked only for vertical tolerance. The difference of -0.09 ft. is within acceptable tolerance. B 122 RESET could not be checked with GPS due to obstructions. CP1 and CP2 were used to determine and check a location of B122 RESET with a total station.

Horizontal Control

The project coordinate system for this survey is IaRCS Zone 14 (U.S. Survey Feet). This survey control is relative to IaRTN reference stations. IaRTN Reference Station coordinates are relative to the National Reference Station network datum: NAD83 (2011) for Epoch 2010.00.

Lee County Control Pt. 11 is checked for vertical and horizontal tolerance. The horizontal difference is about 0.06 ft. and the vertical difference is 0.03 ft.

Name	Northing	Easting	Elevation	Feature
100	6344770.92	24412324.23	728.09	CP Donnellson reference station broadcast position.
101	6341876.68	24403336.58	688.98	FENO Monument stamped #1 1364ft E of gravel road 160th and 49ft S of centerline of Hwy 2 set 4in's below the surface.
102	6341946.16	24407594.00	681.38	FENO Monument stamped #2 150ft W of centerline gravel road 170th Ave and 36.6ft N of the centerline of Hwy 2 set 4in's below the surface.
11	6341855.43	24401937.42	665.29	CP 5/8" dia driven aluminum rod with a 2-1/2" dia aluminum cap and permanent magnet encased in a 5" dia PVC pipe with an aluminum access cover. 70ft S of Hwy 2, 30ft W of 160th Ave near the NE Cor of Sec 1 T67N R7W.
B122 RESET	6342695.86	24407697.75	667.91	CP BM Disk set in top of concrete monument. 1-mile W of the intersection of Hwy 2 and Hwy 218 in Donnellson then N on gravel road, 170th Ave, 0.15 miles the E of the centerline of road 44.3ft.

Alignment Information

The horizontal alignment for this survey was provided by the IDOT District 5 Land Survey office.

CONTROL POINT VICINITY MAP

This map is a guide to the vicinity of the primary project control points
 Primary control is for use with RTK base stations and for RTN validation.
 Future surveys will use primary project control to establish temporary control as needed for construction or other surveying applications.

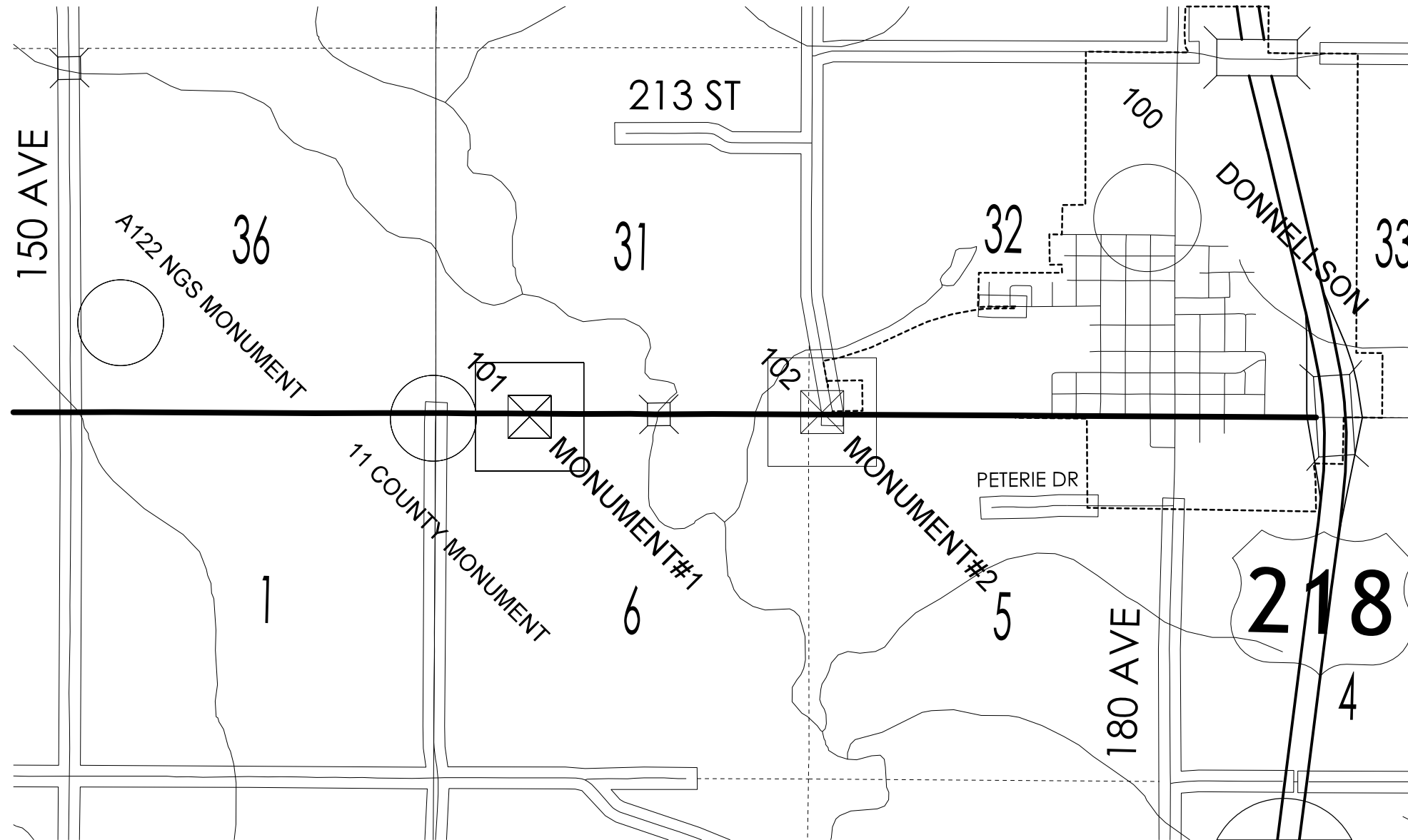

HORIZ. DATUM: NAD83(2011) EPOCH 2010.00

VERT. DATUM: NAVD88

1a. Regional Coordinate System Zone 14

Coordinate listing from next sheet will be used with 1aRTN for monument recovery. No other reference ties are given.

HORIZONTAL AND VERTICAL PROJECT CONTROL COORDINATE LISTING

HORIZ. DATUM: NAD83(2011) EPOCH 2013.00

VERT. DATUM: NAVD88

Ia. Regional Coordinate System Zone 14

Name	Northing	Easting	Elevation	Feature
100	6344770.92	24412324.23	728.09	CP Donnellson reference station broadcast position.
101	6341876.68	24403336.58	688.98	FENO Monument stamped #1 1364ft E of gravel road 160th Ave and 49ft S of centerline of hwy 2. Set 4in's below the surface.
102	6341946.16	24407594.00	681.38	FENO Monument stamped #2 150ft W of centerline gravel road 170th Ave and 36.6ft N of the centerline of hwy2. Set 4in's below the surface.
11	6341855.43	24401937.42	665.29	CP 5/8" dia driven aluminum rod with a 2-1/2" dia aluminum cap and permanent magnet encased in a 5" dia PVC pipe with an aluminum access cover. 70ft S of hwy 2, 30ft W of 160th Ave near the NE Cor of Sec 1 T67N R7W.
B122 RESET	6342695.86	24407697.75	667.91	CP BM Disk set in top of concrete monument . 1 mile W of the intersection of hwy 2 and hwy 218 in Donnellson then N on gravel road, 170th Ave, 0.15 miles then E of the centerline of road 44.3ft.

ALIGNMENT COORDINATES

Name	Location	Point on Tangent			Begin Spiral			Begin Curve			Simple Curve PI or Master PI of SCS			End Curve			End Spiral		
		Station	Coordinates		Station	Coordinates		Station	Coordinates		Station	Coordinates		Station	Coordinates		Station	Coordinates	
			Y (Northing)	X (Easting)		Y (Northing)	X (Easting)		Y (Northing)	X (Easting)		Y (Northing)	X (Easting)		Y (Northing)	X (Easting)		Y (Northing)	X (Easting)
1	ML002	358+75.17 R1	6341928.83	24401966.83															
2	ML002	386+73.65 R1	6341919.49	24404765.30															
2	ML002	466+30.88 R1	6341882.09	24412722.44															
1	ENT L	0+00.00	6341919.45	24404773.21															
2	ENT L	0+73.69	6341993.14	24404773.91															
2	ENT L	0+73.77	6341993.22	24404773.91															
1	ENT R	0+00.00	6341919.49	24404765.30															
2	ENT R						0+25.72	6341893.78	24404765.64		0+39.06	6341880.43	24404765.81		0+51.98	6341868.27	24404760.31		
3	ENT R	0+80.24	6341842.52	24404748.67															

NO ACCESS RIGHTS ARE TO BE ACQUIRED ON THIS PROJECT.

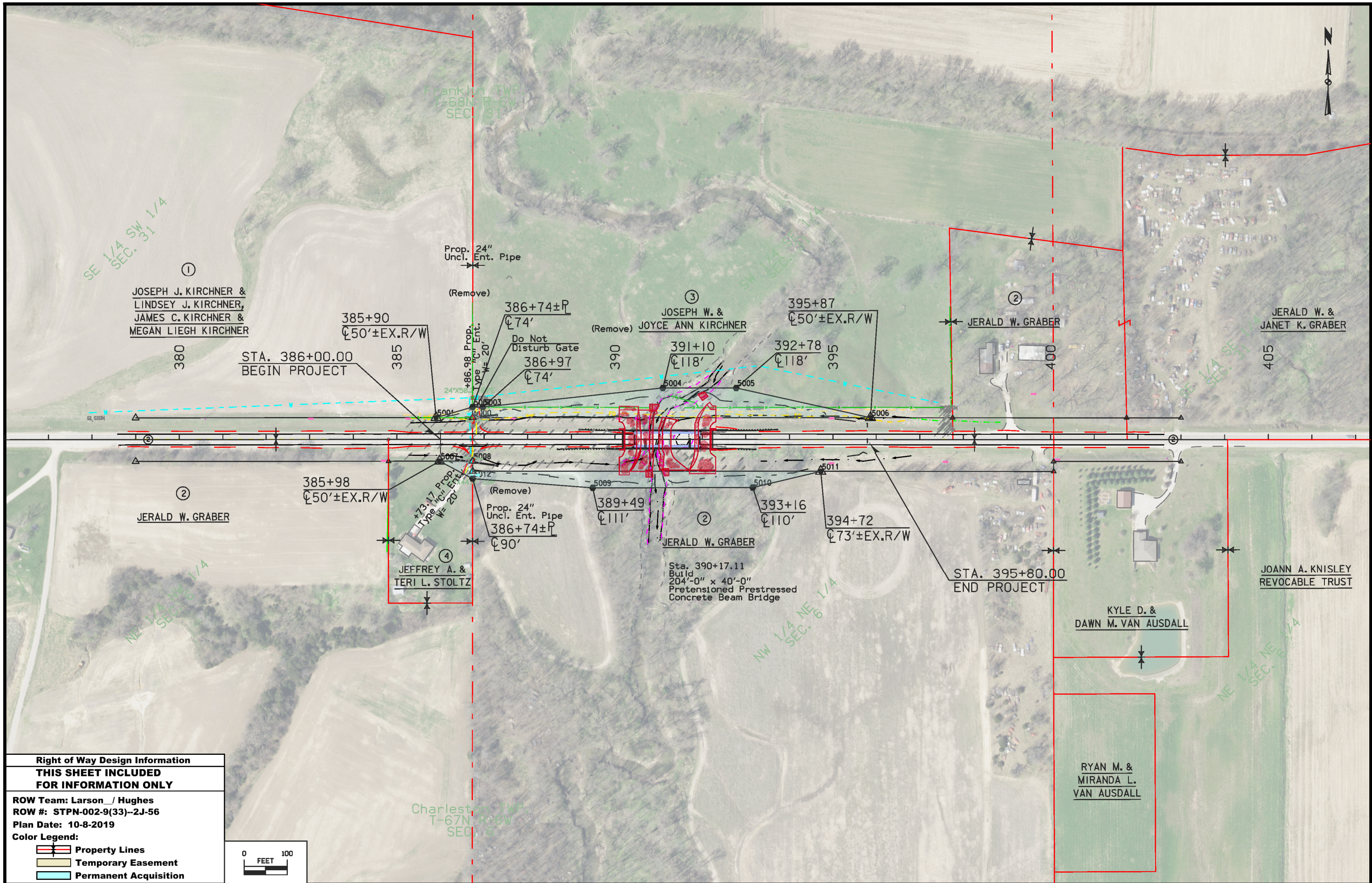

Right of Way Design Information
THIS SHEET INCLUDED FOR INFORMATION ONLY

ROW Team: Larson / Hughes
 ROW #: STPN-002-9(33)--2J-56
 Plan Date: 10-8-2019

Color Legend:

- Property Lines
- Temporary Easement
- Permanent Acquisition

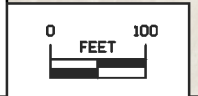

108-23A
08-01-08

TRAFFIC CONTROL PLAN

IA 2 traffic shall be maintained at all times by an off-site detour. Contractor shall maintain access at all times to residences.

NOTES:
 TL-4 BRIDGE RAILING PROPOSED.
 TOP OF BRIDGE DECK CROWN 0.03' BELOW PROFILE GRADE

CP 101 N 6341876.68, E 24403336.58, FENO MONUMENT STAMPED #1, 1,364' EAST OF 160TH AVE AND 49' SOUTH OF IA 2 CENTERLINE. SET 4 INCHES BELOW GROUND SURFACE, ELEV. 688.98

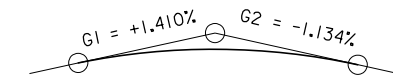

VPC STA = 389+00.00 VPT STA = 393+00.00
 VPC ELEV = 639.48 VPT ELEV = 640.03
 VPI STA = 391+00.00 VC = 400'
 VPI ELEV = 642.30

PROPOSED PROFILE GRADE IA 2

HYDRAULIC DATA

DRAINAGE AREA = 41.4 SQ. MI.
 STREAM SLOPE = 4.8 FT./MI.
 AVG. LOW WATER STAGE = 620.0

Q₅₀ = 11,700 CFS
 STAGE = 635.00
 REGULATORY LOW BEAM = 636.79
 BACKWATER = 1.05 FT.
 AVG. BRIDGE VELOCITY = 6.2 FPS

Q₁₀₀ = 14,100 CFS
 STAGE = 635.81
 OPERATIONAL LOW BEAM = 636.49
 BACKWATER = 1.37 FT.
 AVG. BRIDGE VELOCITY = 6.9 FPS

Q₂₀₀ = 16,800 CFS
 STAGE = 636.59
 CALCULATED DESIGN SCOUR = 601.33

Q₅₀₀ = 19,900 CFS
 STAGE = 637.50
 AVG. BRIDGE VELOCITY = 9.2 FPS
 CALCULATED CHECK SCOUR = 598.01

ROADWAY OVERTOP 637.69
 STA. 395+91.17
 EXTREME HW STAGE = 632
 DATE = UNKNOWN

LOCATION

IA 2 OVER SUGAR CREEK
 T-68N R-6W
 SECTION 31
 FRANKLIN TOWNSHIP
 LEE COUNTY
 BRIDGE MAINT. NO. 5646.9S002
 FHWA NO. 33251
 LATITUDE 40.639035°
 LONGITUDE 91.591528°

TRAFFIC ESTIMATE

2021 AADT	1,900	V.P.D.
2041 AADT	2,100	V.P.D.
202 DHV		V.P.H.
TRUCKS	8	%
TOTAL DESIGN ESALs		

PRELIMINARY

DESIGN FOR 0° SKEW
**204'-0" X 40'-0" PRETENSIONED
 PRESTRESSED CONCRETE BEAM BRIDGE**
 51'-0" END SPANS 102'-0" CENTER SPAN
SITUATION PLAN
 STATION 391+20.61 BTB BEAMS JULY 2019
LEE COUNTY
 IOWA DEPARTMENT OF TRANSPORTATION - HIGHWAY DIVISION
 DESIGN SHEET NO. 1 OF 2 FILE NO. 31795 DESIGN NO. 221

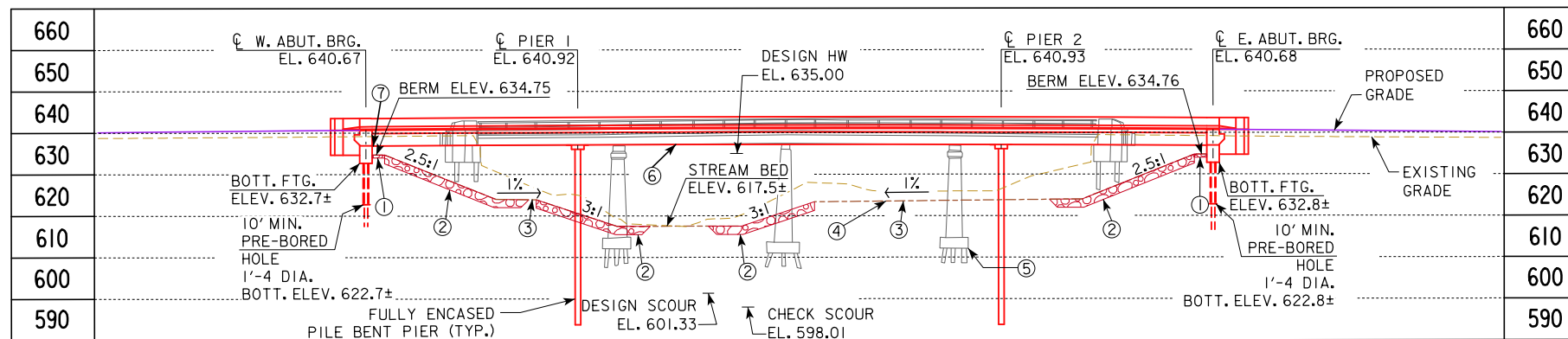

LONGITUDINAL SECTION ALONG C APPROACH ROADWAY

UTILITIES LEGEND:

- FO - FIBER OPTIC - WINDSTREAM COMMUNICATIONS
 - - POWER POLE - ALLIANT ENERGY
 - TI - TELEPHONE - WINDSTREAM COMMUNICATIONS
 - W - WATER - RATHBUN REGIONAL WATER
- UTILITIES SHOWN ON THIS SHEET ARE FOR INFORMATION ONLY, SEE ROAD DESIGN SHEETS FOR FINAL UTILITY INFORMATION.

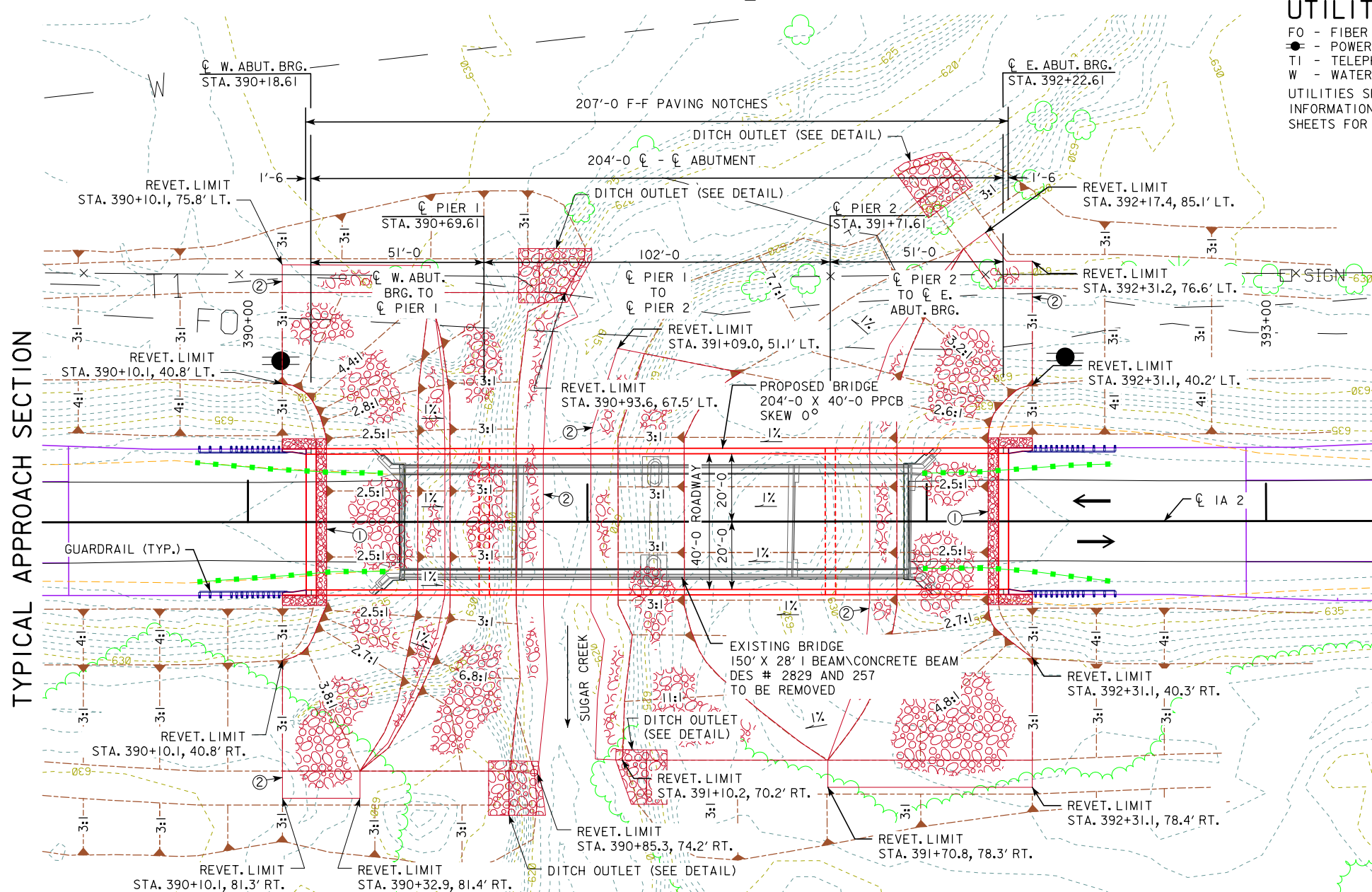

TYPICAL APPROACH SECTION

TYPICAL BRIDGE SECTION

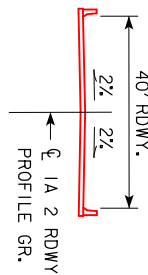

SITUATION PLAN

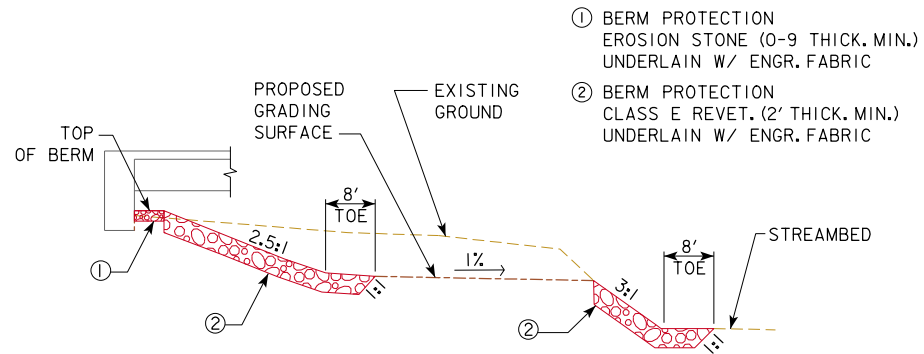

TYPICAL SECTION AT BRIDGE BERM REVETMENT PROTECTION

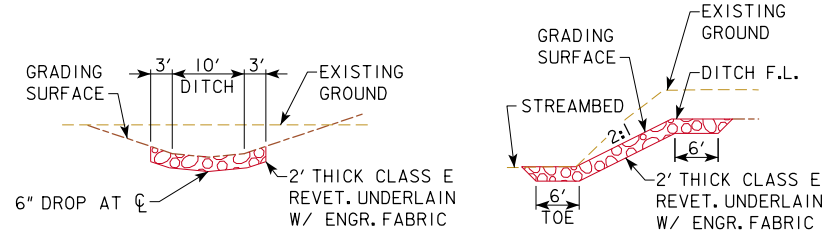

TYPICAL SECTIONS AT DITCH OUTLET

BERM SLOPE LOCATION TABLE

	WEST ABUTMENT			EAST ABUTMENT		
	STATION	OFFSET	ELEV	STATION	OFFSET	ELEV
A1	390+49.98	24.58' LT	624.00	391+91.21	24.58' LT	624.00
A2	390+49.98	0	624.00	391+91.21	0	624.00
A3	390+49.98	24.58' RT	624.00	391+91.21	24.58' RT	624.00
A4	390+59.55	24.58' LT	623.90	391+28.55	24.58' LT	623.37
A5	390+59.55	0	623.90	391+28.55	0	623.37
A6	390+59.55	24.58' RT	623.90	391+28.55	24.58' RT	623.37
A7	390+79.05	24.58' LT	617.50	391+09.05	24.58' LT	617.50
A8	390+79.05	0	617.50	391+09.05	0	617.50
A9	390+79.05	24.58' RT	617.50	391+09.05	24.58' RT	617.50
B1	390+23.11	24.58' LT	634.75	392+18.11	24.58' LT	634.76
B2	390+23.11	0	634.75	392+18.11	0	634.76
B3	390+23.11	24.58' RT	634.75	392+18.11	24.58' RT	634.76
G1	390+10.13	40.16' LT	634.75	392+31.13	40.18' LT	634.76
G2	390+10.17	77.61' LT	626.77	392+31.13	78.64' LT	626.55
G3	390+10.17	67.61' LT	626.77	392+31.13	68.64' LT	626.55
G4	390+53.91	77.56' LT	624.00	392+19.03	86.22' LT	624.16
G5	390+53.91	67.56' LT	624.00	392+10.95	80.34' LT	624.16
G6	390+85.88	77.52' LT	623.00	392+07.62	101.89' LT	622.00
G7	390+85.88	67.52' LT	623.00	391+99.54	96.00' LT	622.00
G8	390+99.22	77.52' LT	619.00	392+04.09	106.74' LT	620.00
G9	390+93.60	67.52' LT	619.00	391+94.06	103.53' LT	620.00
G10	390+50.29	38.85' LT	624.00	391+99.58	60.01' LT	624.00
G11	390+58.98	40.53' LT	623.91	391+16.85	49.54' LT	619.50
G12	390+80.00	41.23' LT	617.00	391+50.49	78.24' LT	620.00
G13	390+10.13	40.16' RT	634.75	391+85.21	84.04' LT	622.00
G14	390+10.13	73.34' RT	624.84	391+45.23	43.94' LT	623.53
G15	390+10.13	83.34' RT	624.84	391+90.75	72.45' LT	623.85
G16	390+32.92	73.36' RT	624.21	392+31.13	40.18' RT	634.76
G17	390+32.92	83.36' RT	624.21	392+31.13	70.35' RT	626.27
G18	390+76.82	73.41' RT	623.00	392+31.13	80.35' RT	626.27
G19	390+76.82	83.41' RT	623.00	391+70.80	70.29' RT	624.00
G20	390+84.25	73.42' RT	619.00	391+80.80	80.29' RT	624.00
G21	390+85.05	83.42' RT	619.00	391+17.40	70.23' RT	622.00
G22	390+45.45	46.11' RT	624.00	391+17.40	80.23' RT	622.00
G23	390+50.84	49.40' RT	623.94	391+10.24	70.22' RT	620.00
G24	390+80.15	46.19' RT	620.04	391+14.13	80.22' RT	620.00
G25				391+44.95	50.83' RT	623.57
G26				391+10.88	52.98' RT	620.50
W1	390+10.13	24.58' LT	639.96	391+31.13	24.58' LT	639.98
W2	390+10.13	24.58' RT	639.96	391+31.13	24.58' RT	639.98

W - END WING / EROSION STONE
 BERM SLOPE TABLE ELEVATIONS REFLECT GRADING SURFACE
 GRADING CONTROL:
 WEST BERM: POINTS A7, A8, A9, G12 AND G24 ARE BERM GRADING CONTROL LINE
 EAST BERM: POINTS A7, A8, A9, G11 AND G26 ARE BERM GRADING CONTROL LINE

ESTIMATED BERM ARMORING QUANTITIES

LOCATION	REVTMENT CL. E (TON)	EROSION STONE (TON)	ENGINEERING FABRIC (SY)	EXCAVATION (CY)
BANK\BERM LINING - WEST ABUTMENT	1,340	7	1,450	829
BANK\BERM LINING - EAST ABUTMENT	1,344	7	1,460	835
DITCH OUTLETS - WEST ABUTMENT	74		97	45
DITCH OUTLETS - EAST ABUTMENT	63		85	39
TOTALS	2,821	14	3,092	1,748

EXCAVATION QUANTITY CALCULATED FROM GRADING SURFACE.

PRELIMINARY
 DESIGN FOR 0° SKEW
**204'-0 X 40'-0 PRETENSIONED
 PRESTRESSED CONCRETE BEAM BRIDGE**
 51'-0 END SPANS 102'-0 CENTER SPAN
SITUATION PLAN-SITE
 STATION 391+20.61 BTB BEAMS JULY 2019
LEE COUNTY
 IOWA DEPARTMENT OF TRANSPORTATION - HIGHWAY DIVISION
 DESIGN SHEET NO. 2 OF 2 FILE NO. 31795 DESIGN NO. 221

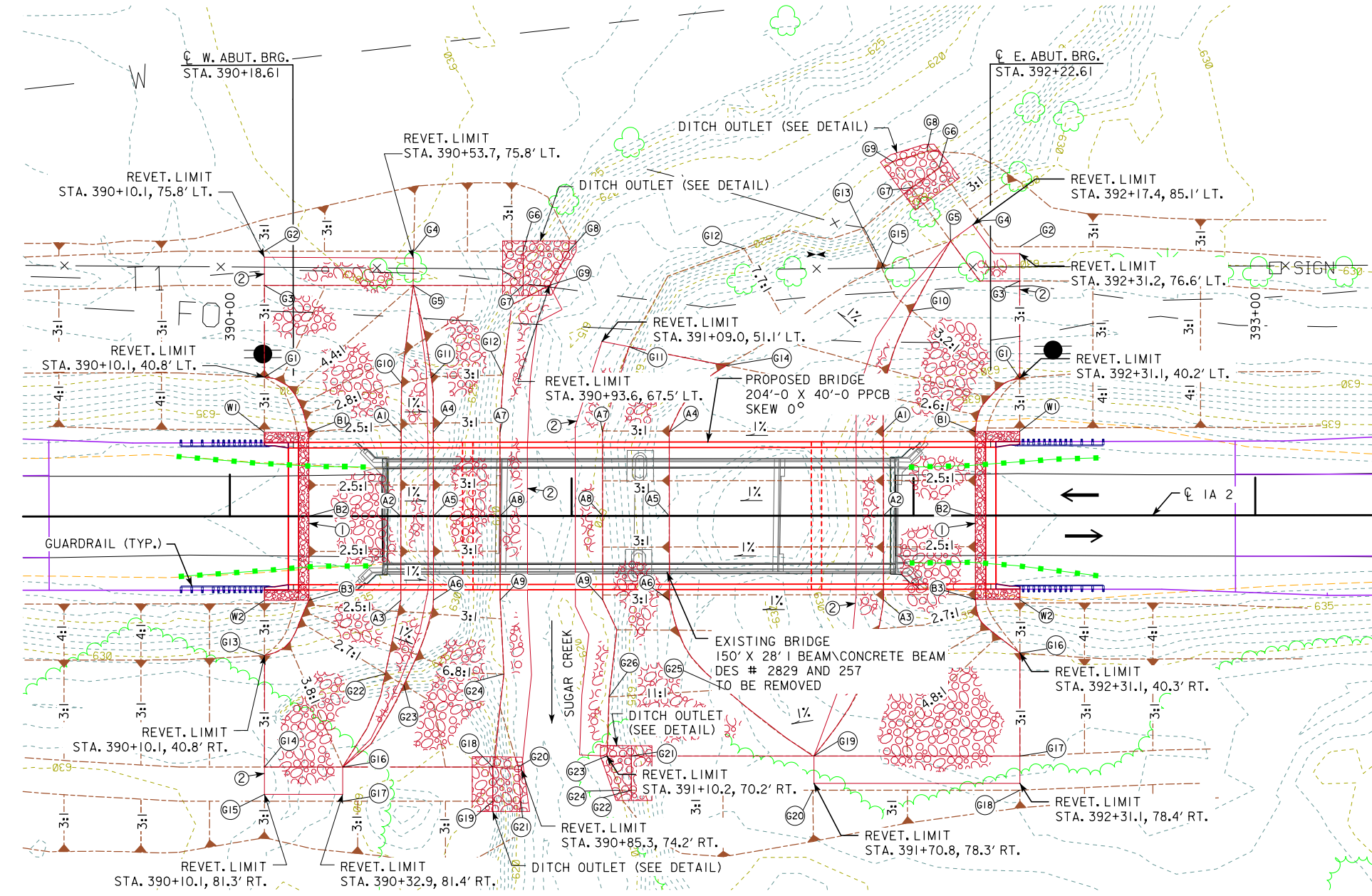

SITE PLAN



IA 2 Preliminary

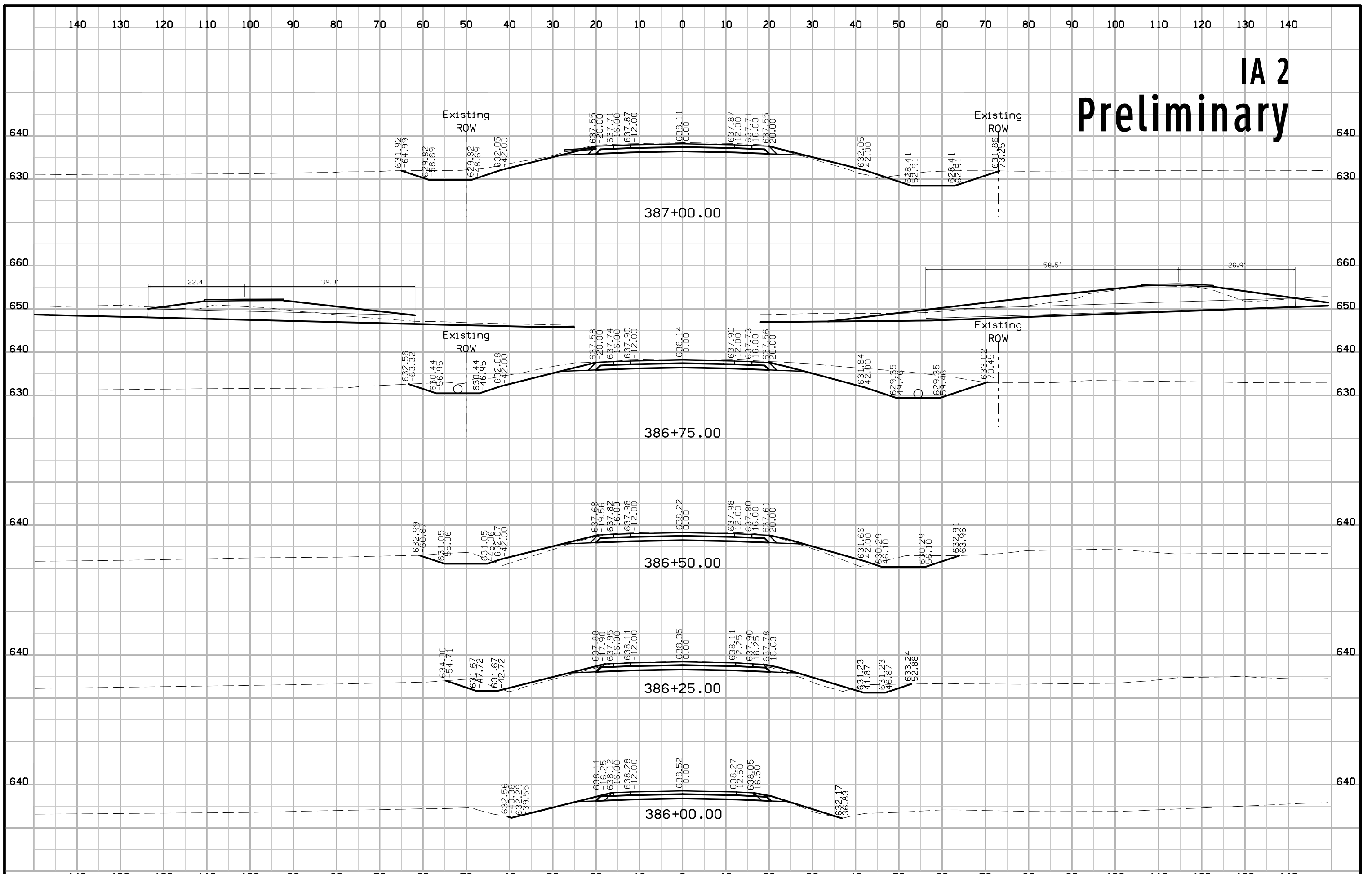

IA 2 Preliminary

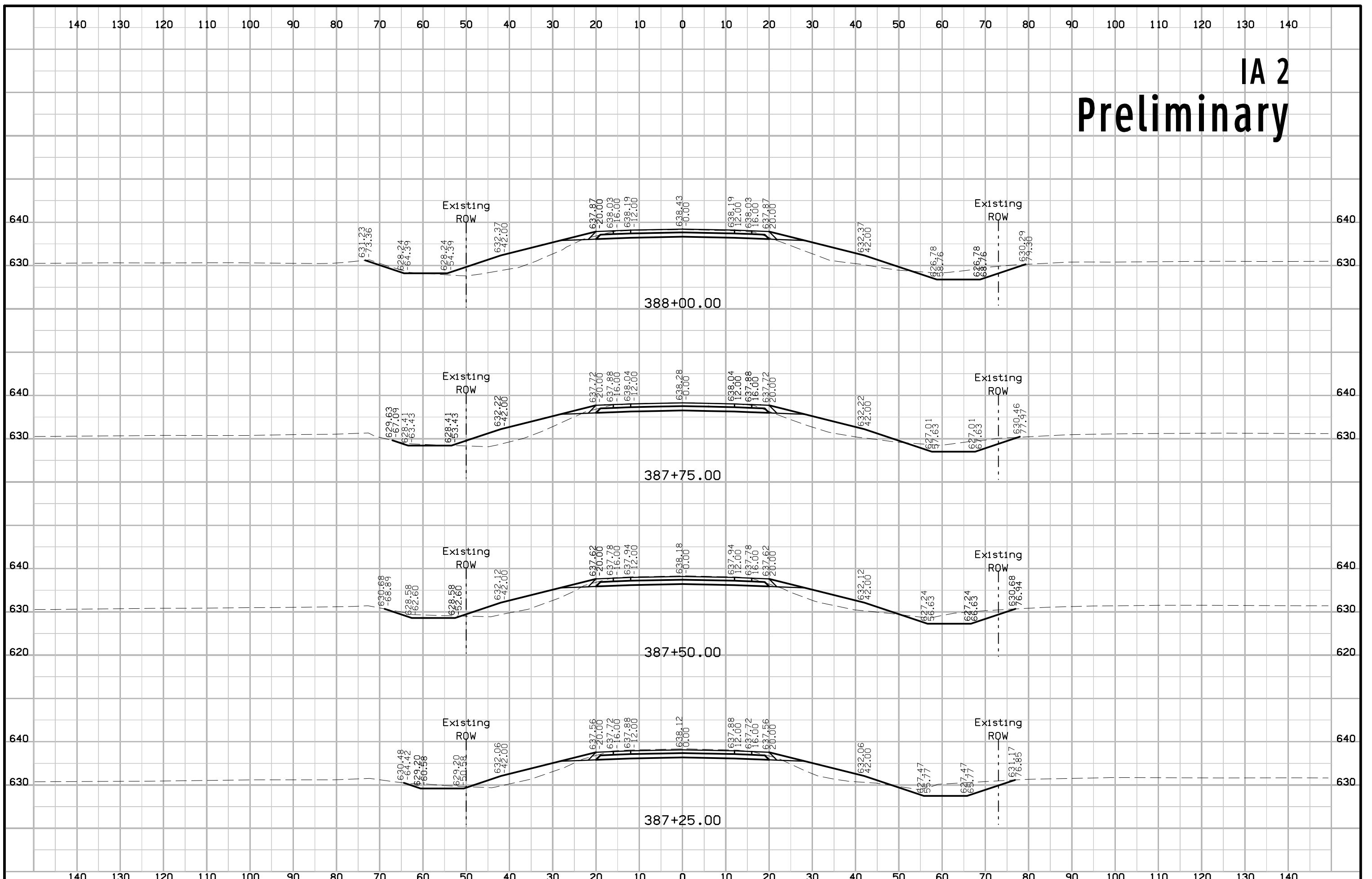

IA 2 Preliminary

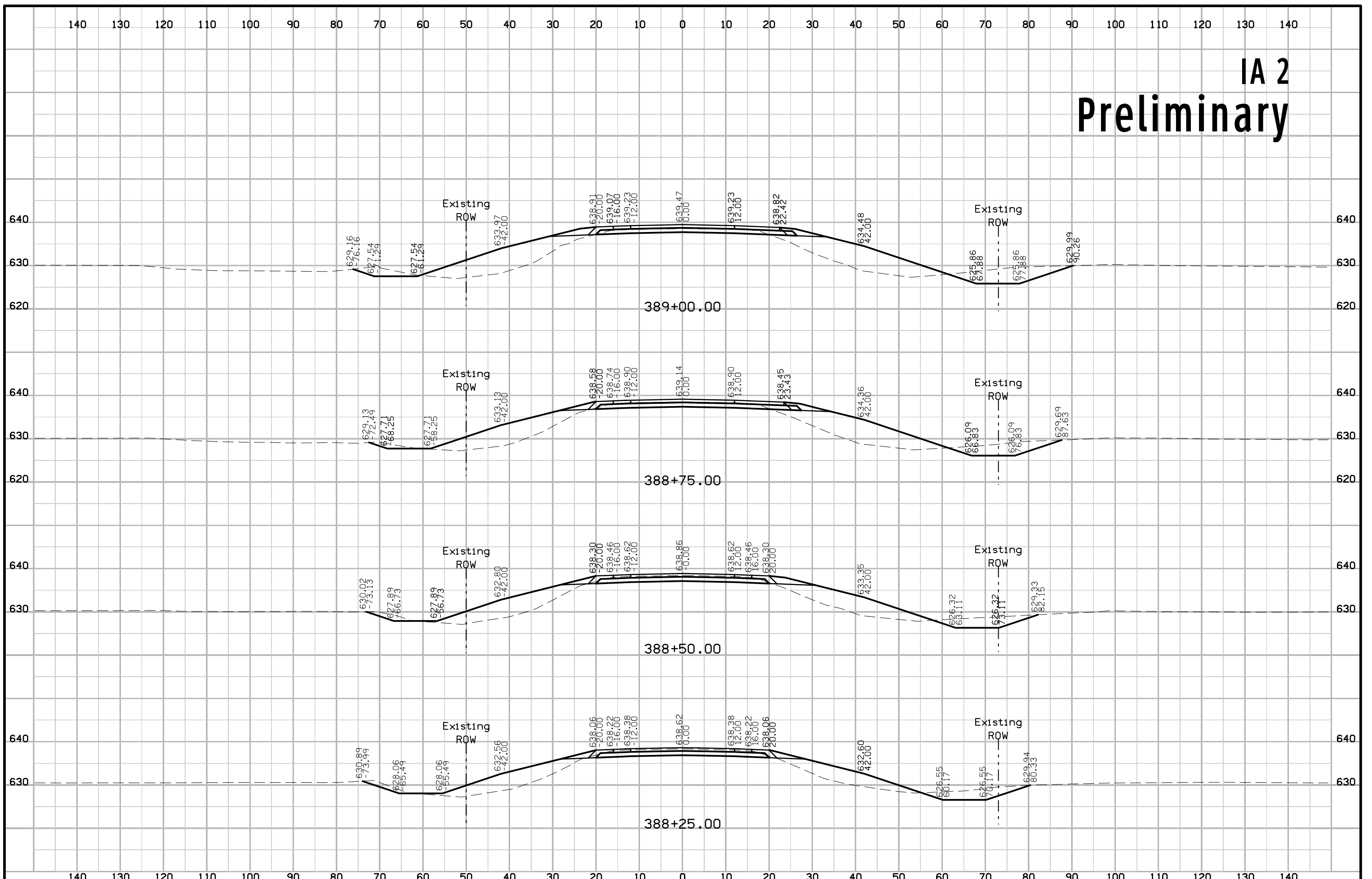

IA 2 Preliminary

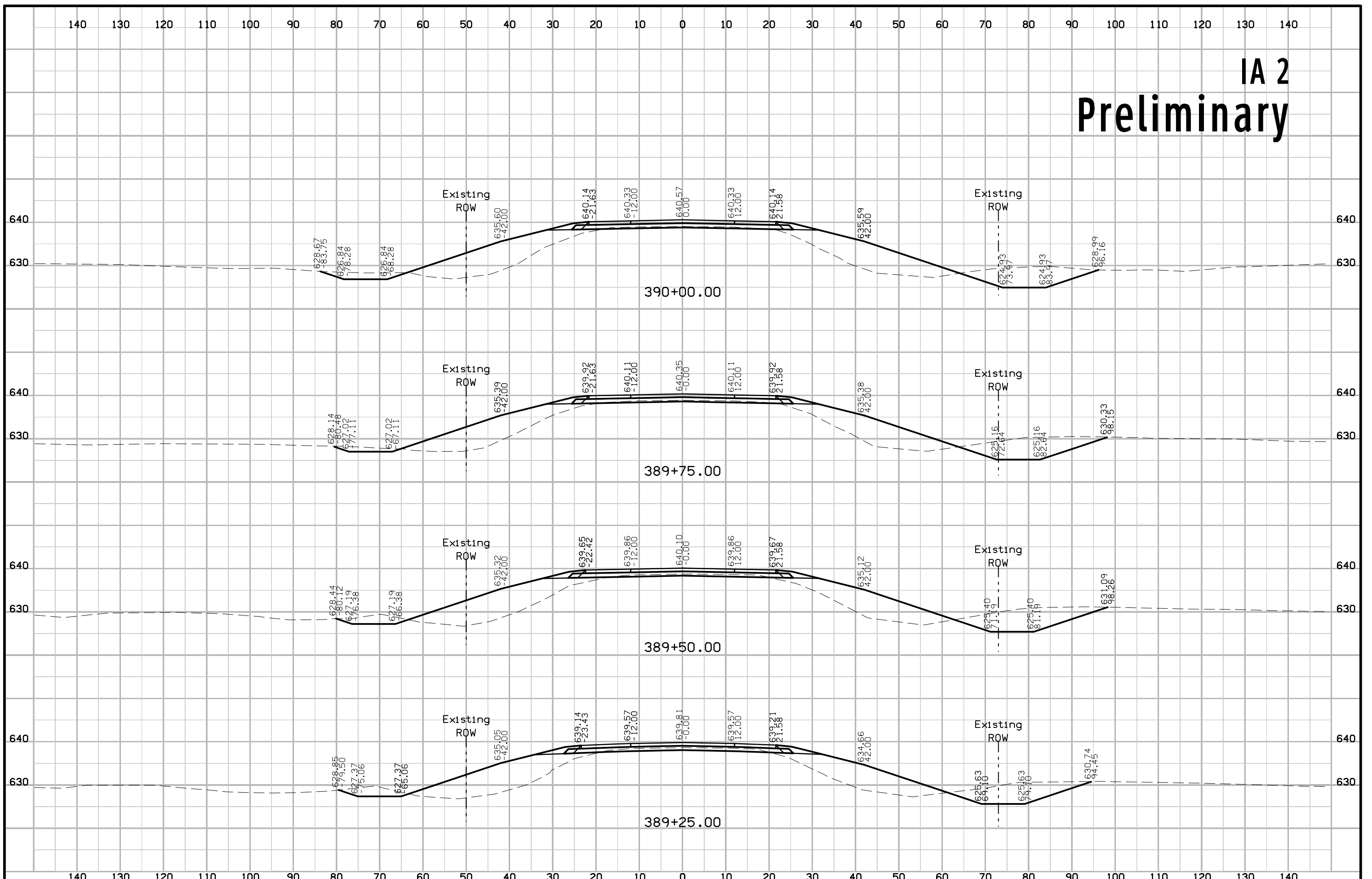

IA 2 Preliminary

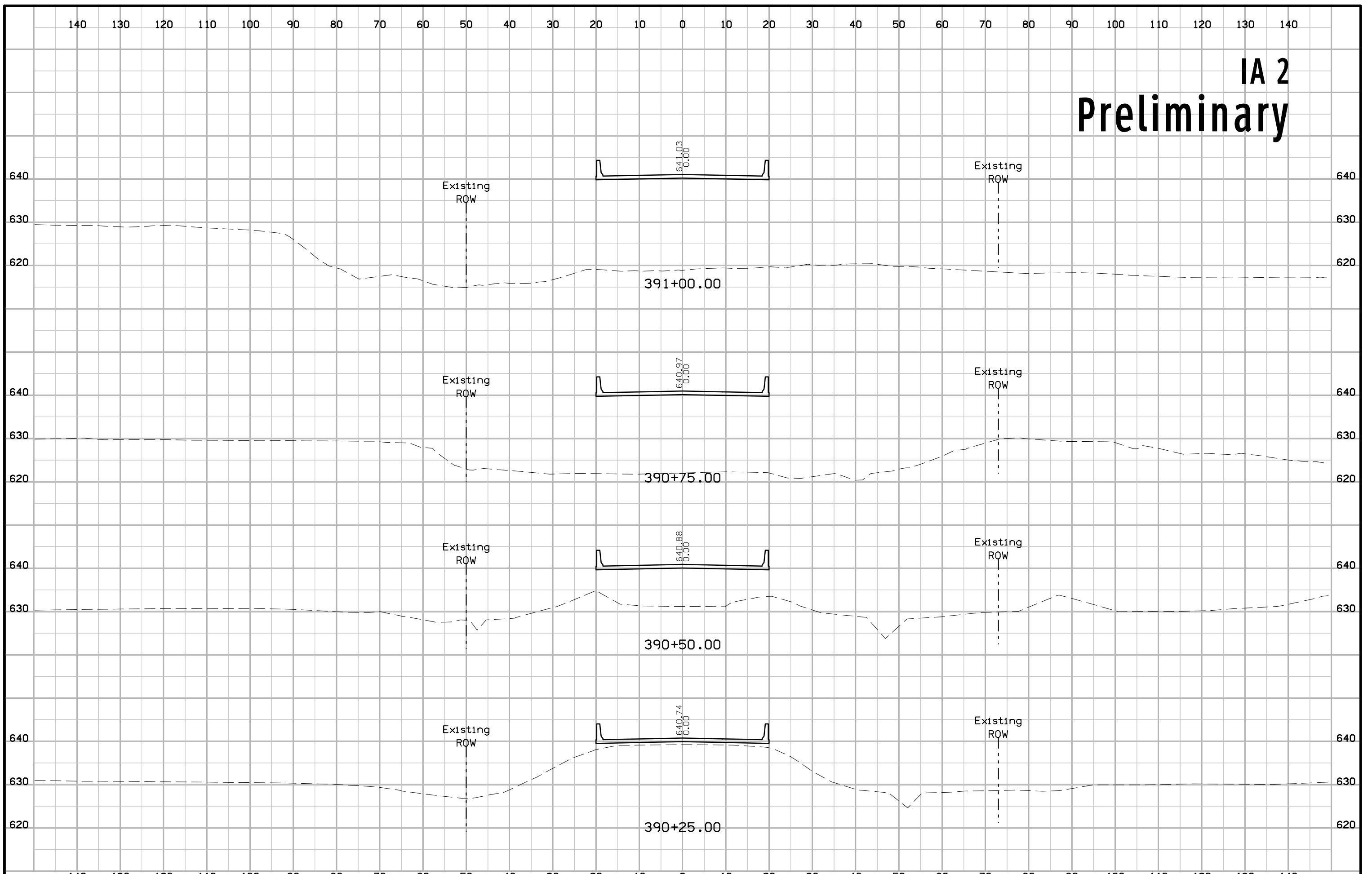

IA 2 Preliminary

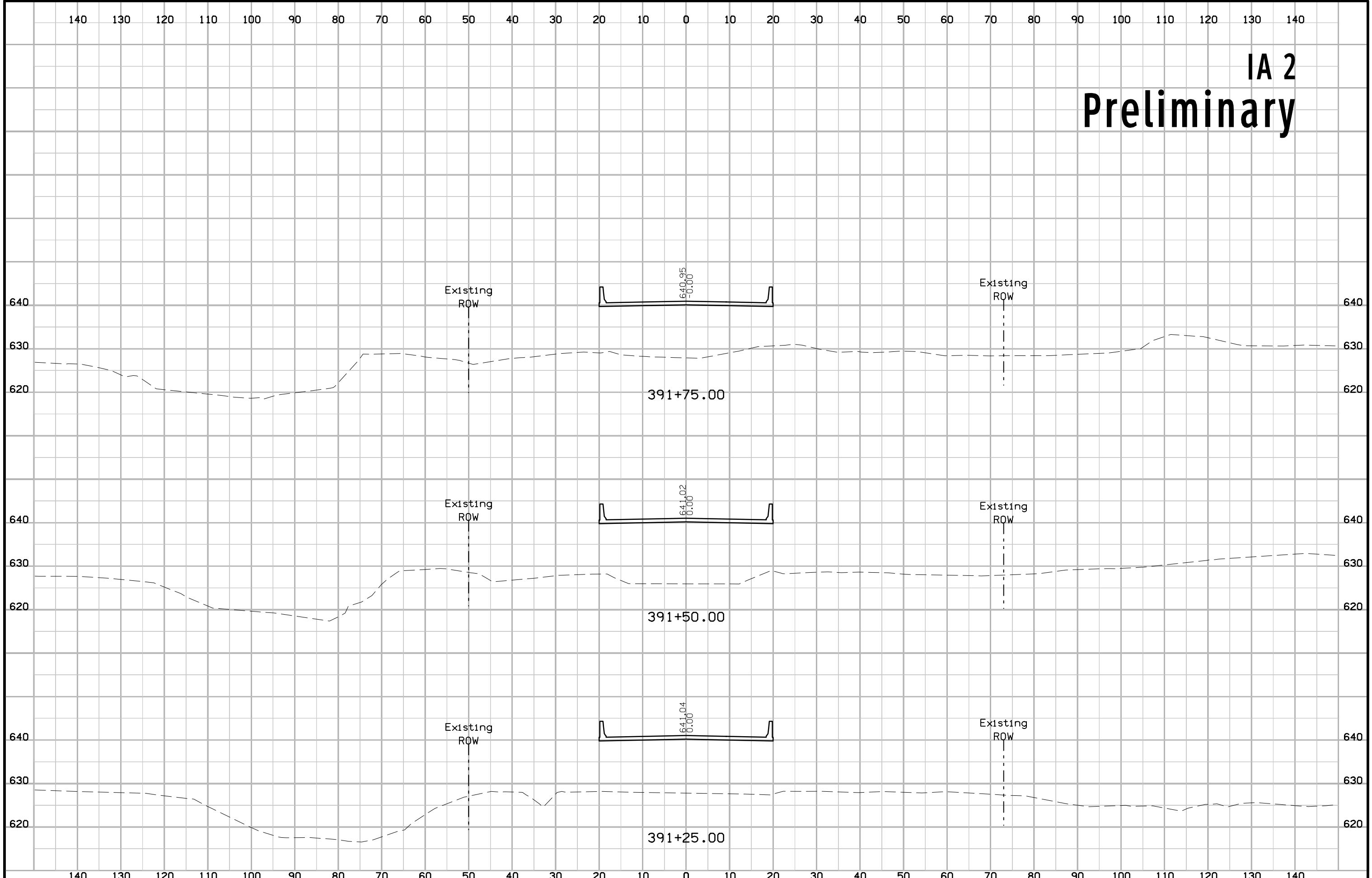

IA 2 Preliminary

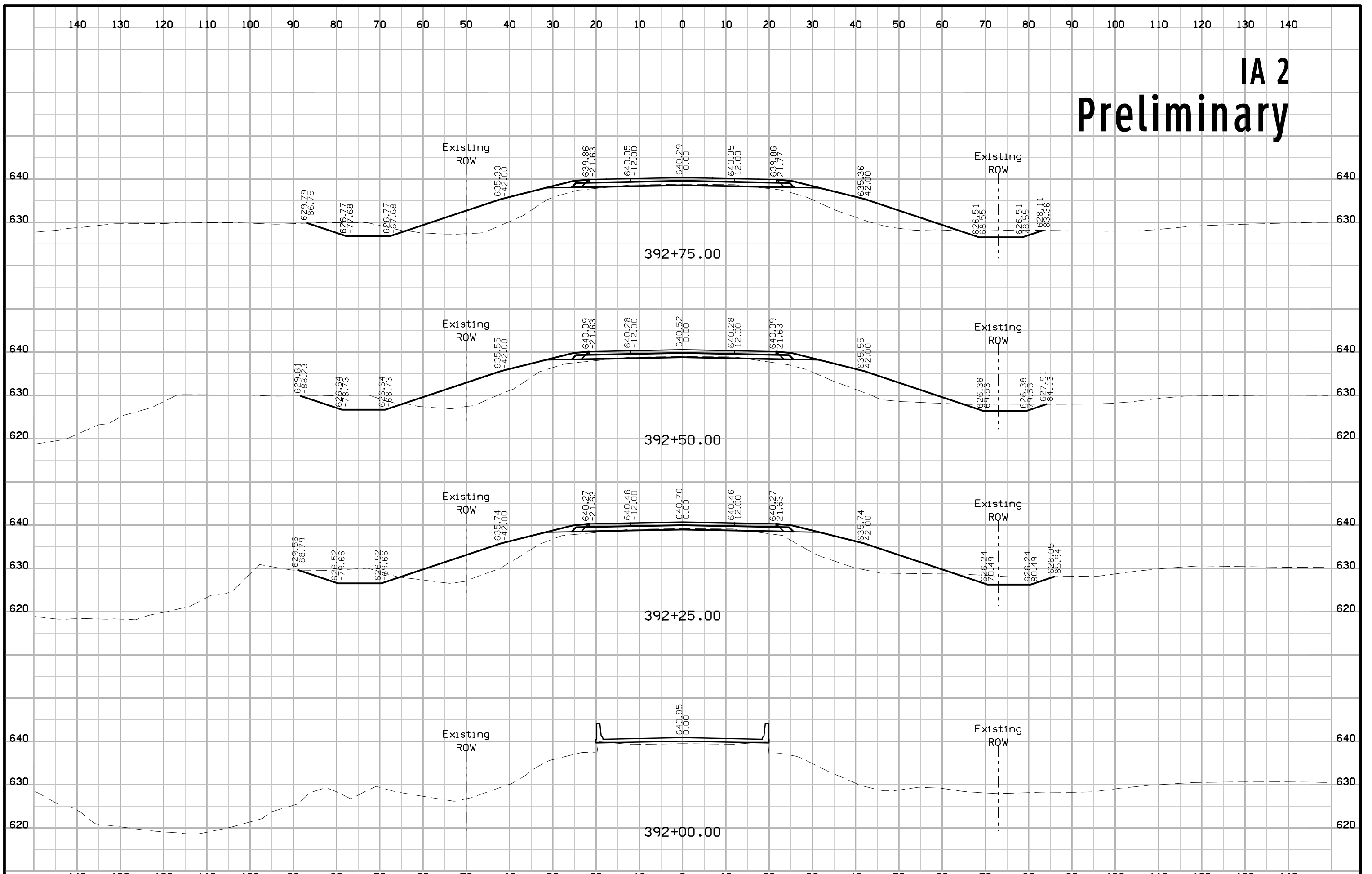

IA 2 Preliminary

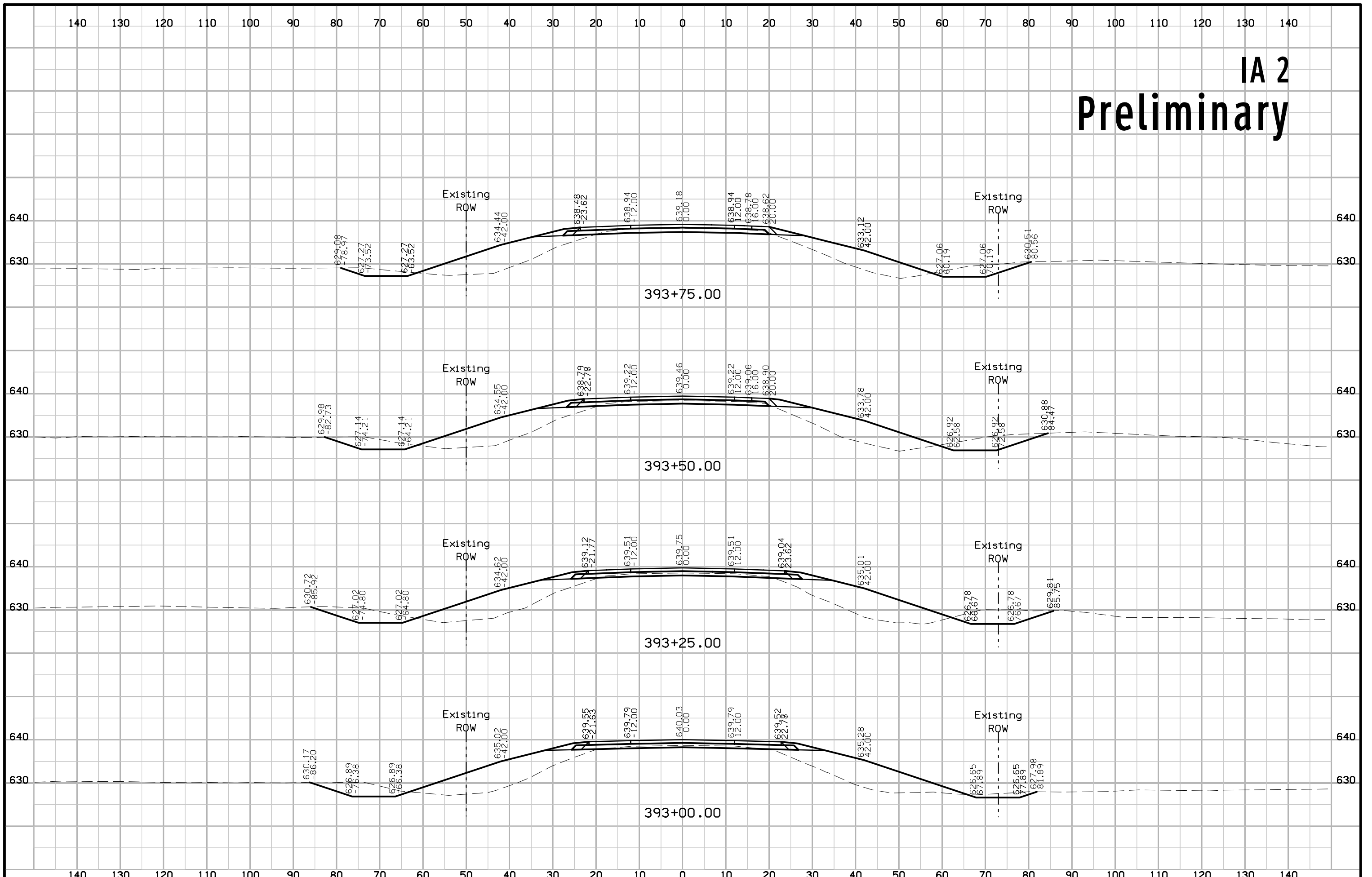

IA 2 Preliminary

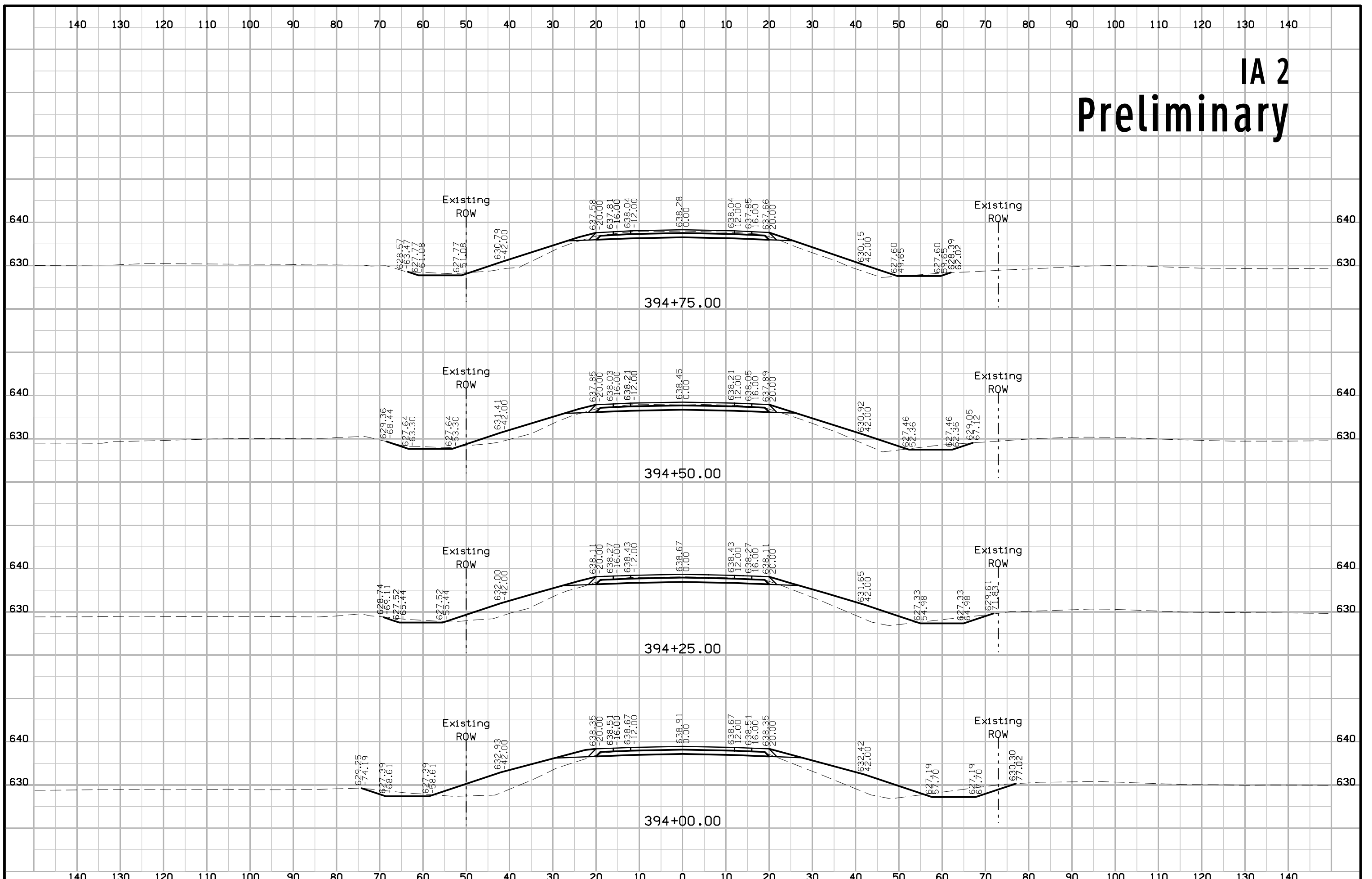

IA 2 Preliminary

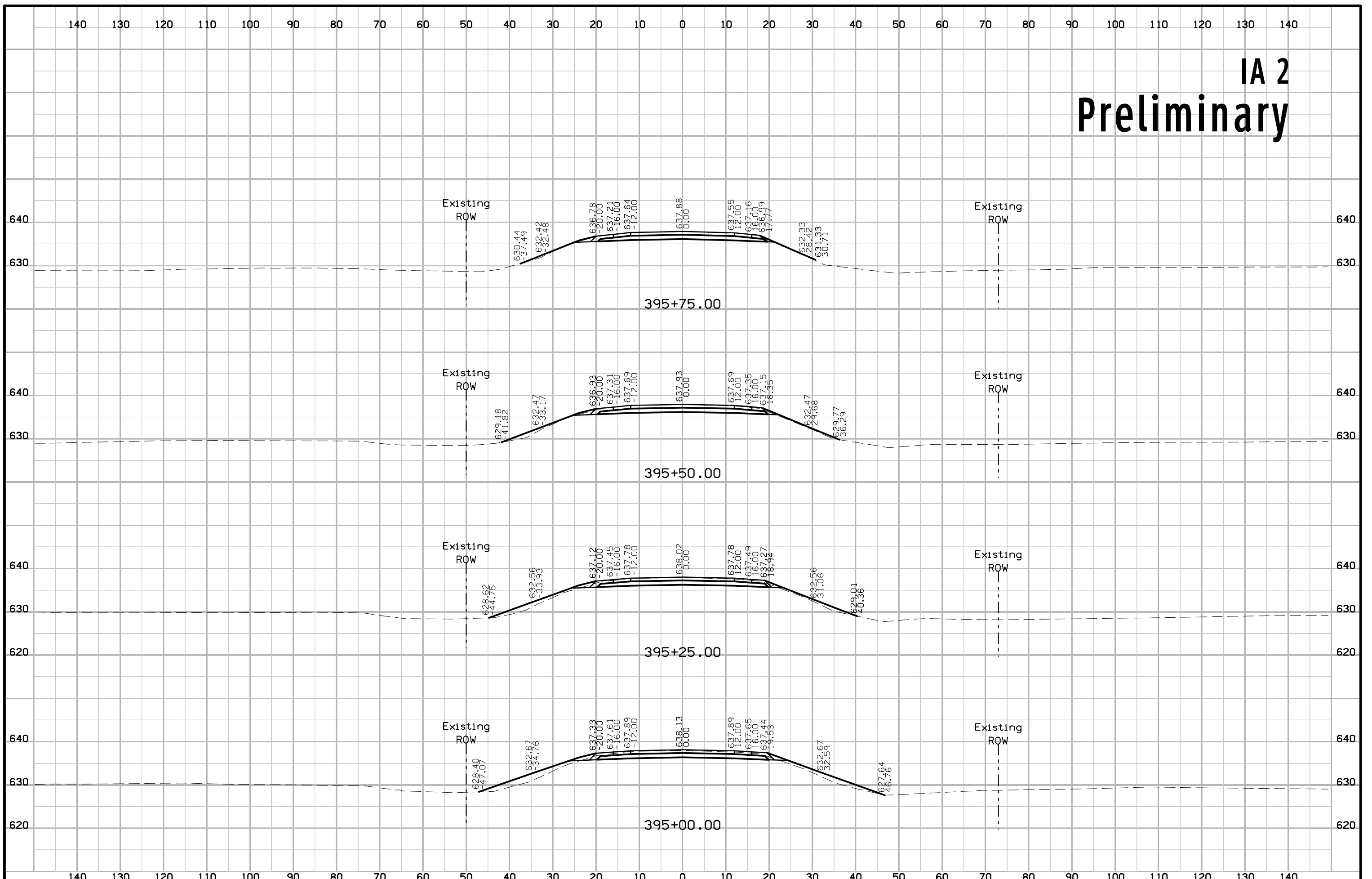

IA 2 Preliminary

