

LETTING DATE
12-21-2021

BRIDGE REPLACEMENT-PPCB
BRF-028-2(45)--38-77

POLK CO.



Highway Division

PLANS OF PROPOSED IMPROVEMENT ON THE

PRIMARY ROAD SYSTEM

POLK COUNTY
BRIDGE REPLACEMENT-PPCB

Raccoon River 3.7 mi N of IA 5 (SB)

SCALES: As Noted

Refer to the Proposal Form for list of applicable specifications.

Value Engineering Saves. Refer to Article 1105.14 of the Specifications.

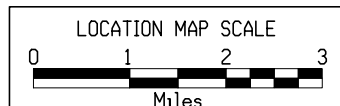
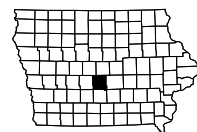
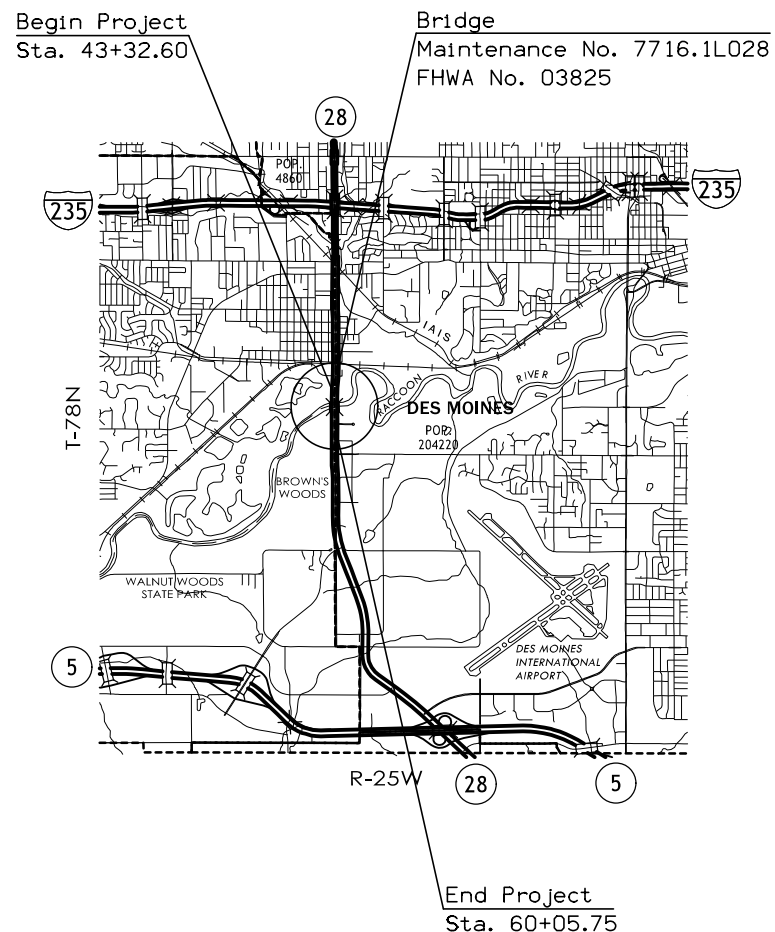

DESIGN DATA RURAL			
2022	AADT	27,100	V.P.D.
2042	AADT	34,000	V.P.D.
20--	DHV	--	V.P.H.
	TRUCKS	3	%
	Total		
	Design ESALs	--	

INDEX OF SEALS		
SHEET NO.	NAME	TYPE
A.1	X	Primary Signature Block
X	X	X

REVISIONS

TOTAL

34

PROJECT IDENTIFICATION NUMBER

17-77-028-010

PROJECT NUMBER

BRF-028-2(45)--38-77

R.O.W. PROJECT NUMBER

NHSN-028-2(46)--2R-77

INDEX OF SHEETS

No.	DESCRIPTION
A Sheets	Title Sheets
A.1	Title Sheet
A.1	Location Map Sheet
B Sheets	Typical Cross Sections and Details
B.1 - 5	Typical Cross Sections and Details
D Sheets	Mainline Plan and Profile Sheets
* D.1	Plan & Profile Legend & Symbol Information Sheet
* D.2 - 3	IA 28
G Sheets	Survey Sheets
G.1	Reference Ties and Bench Marks
G.2	Control Point Vicinity Map
G.3	Horizontal Control Tab. & Super for all Alignments
J Sheets	Traffic Control and Staging Sheets
J.1	Traffic Control Plan
J.1	511 Travel Restrictions
J.1	Coordinated Operations
J.1	Staging Notes
* J.2	Traffic Control and Staging Sheet Legend
* J.3 - 5	Staging and Traffic Control Sheets
U Sheets	500 Series, Mod.Stds. and Detail Sheets
* U.1 - 7	500 Series, Modified Standards and Detail Sheets
V Sheets	Bridge and Culvert Situation Plans
* V.1	Bridge and Culvert Situation Plans
W Sheets	Mainline Cross Sections
W.1 - 9	Mainline Cross Sections
	* Color Plan Sheets

PRELIMINARY PLANS

Subject to change by final design.

D5 PLAN - Date: 03-20-2020

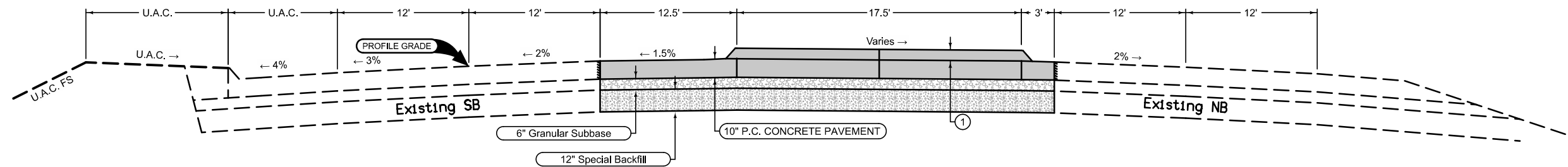

Mainline Jointing:
 Transverse joints: CD at 17' spacing
 Longitudinal joint: L-2

BEGIN STATION	END STATION	Curb Type See PV-102
43+32.60	48+42.62	6" Sloped
56+76.01	60+06.33	6" Sloped

See Tab 100-24 or 100-25 for pavement quantities.
 See Tab 112-9 for shoulder quantities.

IA 28

6150
06-15-93

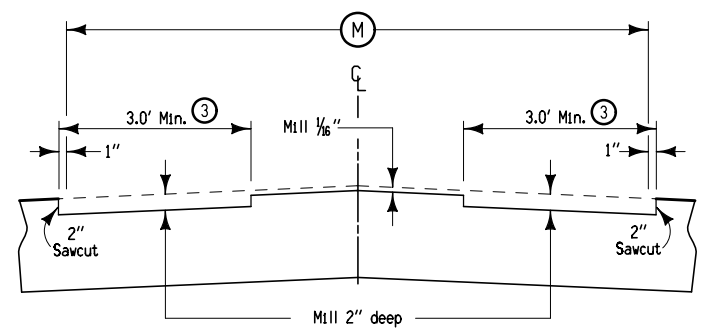

Details of Milling

Notes:
 This section may be appropriately modified in areas specifically designated by the Engineer.
 Use 'C' joints in the doweled median and match the location of all transverse and longitudinal joints to the joints in the existing pavement.
 Place tie bars at 24" C-C longitudinal spacing between joints in existing pavement. Drill 3/4" holes for tie bars and epoxy to new pavement. See Tabulation 112-5 for additional details. Epoxy material shall be as specified in Materials IM491.11, appendix C.

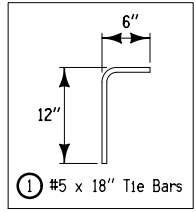

① #5 x 18" Tie Bars

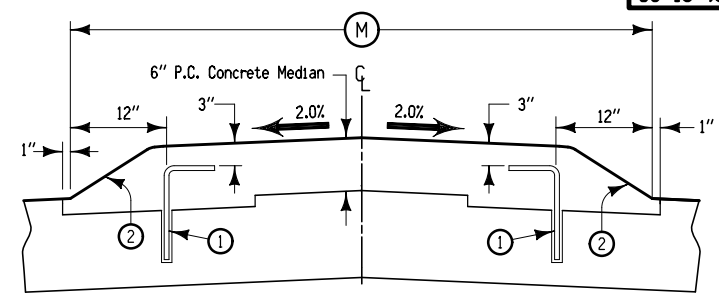

Details of Median Placement

- ② 6" Sloped Curb
- ③ The contractor has the option to mill 2" across the total width of 'M'.

DOWELED MEDIAN WITH SLOPED CURB

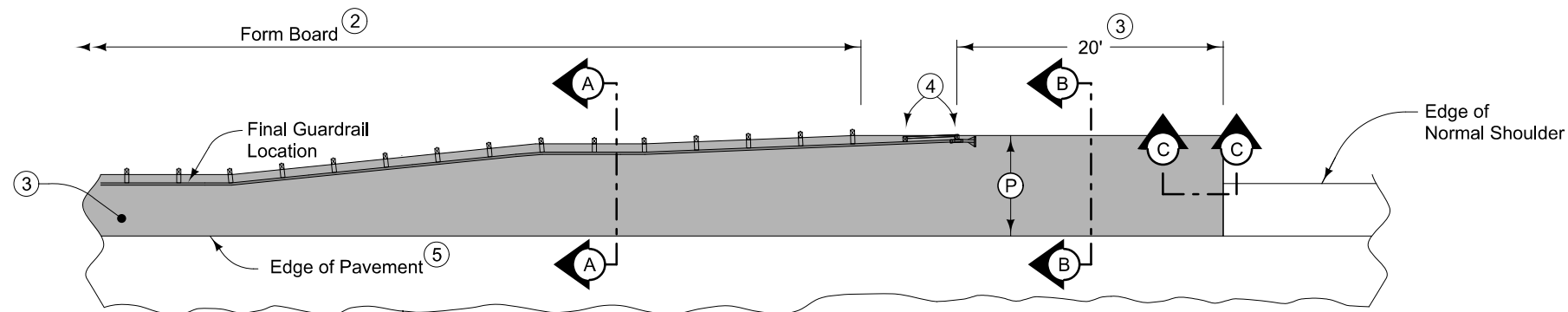

PLAN VIEW

9" HMA Paved Shoulder at guardrail. 8" PCC may be substituted with the following jointing layout:

Match mainline pavement joint spacing. When mainline pavement is 8" or greater in thickness, place additional transverse 'C' joints in shoulder at mid-panel of the mainline pavement. Place longitudinal 'C' joint at P/2 from edge of mainline pavement when P is greater than 10' wide. Terminate longitudinal joint at transverse joint less than 10' in length.

Compaction of HMA is required to face of guardrail post. Hand compaction will be allowed under guardrail. Removal and reinstallation of guardrail will be allowed with no additional payment.

Refer to Tabulation 112-9 for shoulder quantities.

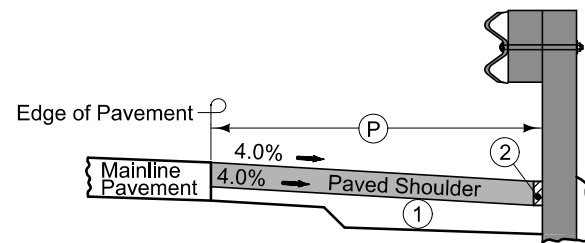

Section A-A

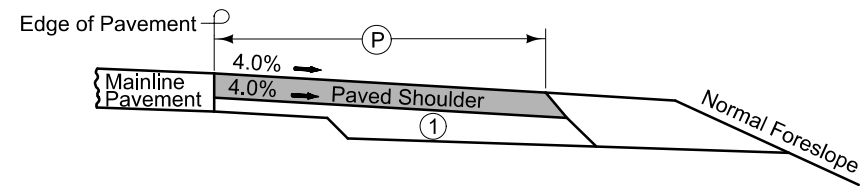

Section B-B

NEW CONSTRUCTION

- ① For subgrade treatment, refer to other details in the plan.
- ② PCC option only: When guardrail posts are installed prior to construction of PCC paved shoulder, fasten form board to the face of guardrail posts for the length shown. Refer to note 4 for final 2 posts.
- ③ Continue paved shoulder to existing paved shoulder or 20 feet beyond the center of the first post.
- ④ Shoulder may be notched for final 2 posts or post sleeves may be installed through pavement. Do not drive posts through pavement.
- ⑤ 'KT-1 joint for PCC shoulder.
'B' joint for HMA shoulder.

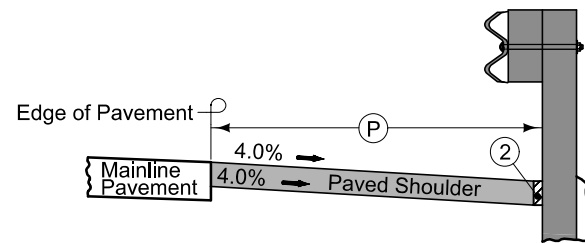

Section A-A

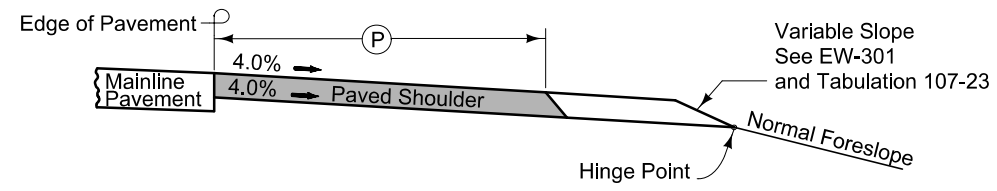

Section B-B

EXISTING SHOULDER

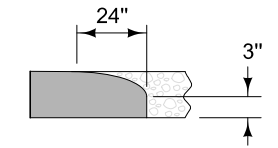

Section C-C
Roll down at granular shoulder or earth.

PAVED SHOULDER AT GUARDRAIL

3208A
11-04-92

Refer to other drawings for details of shoulder design and construction.

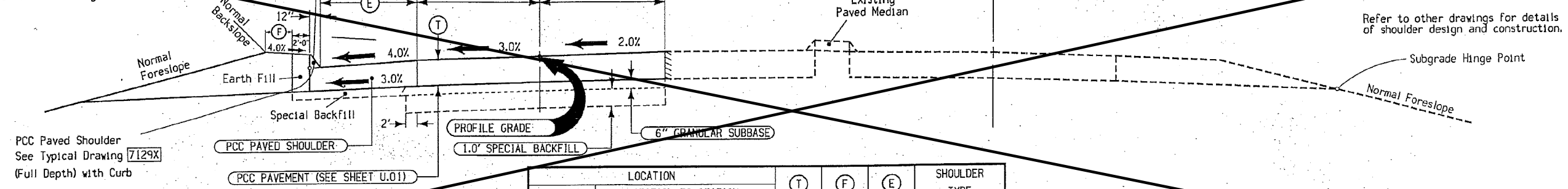

PCC Paved Shoulder
See Typical Drawing 7129X
(Full Depth) with Curb

NOTE: Normal section shown may be appropriately modified for areas specifically designated by the engineer such as intersections or superelevated curves.

- ① See Typical 6128 for details of 6" Sloped Curb.
- ② Vari. - See Cross Sections

LOCATION		T	F	E	SHOULDER TYPE
IDENT.	STATION TO STATION				
Left Lane	26+72.76 - 34+84.40	10" ✓	② ✓	10' ✓	Paved
	27+55'				

TYPICAL CROSS SECTION
4 LANE PCC PAVEMENT
WITH CURBED MEDIAN

3208B
11-04-92

Refer to other drawings for details of shoulder design and construction.

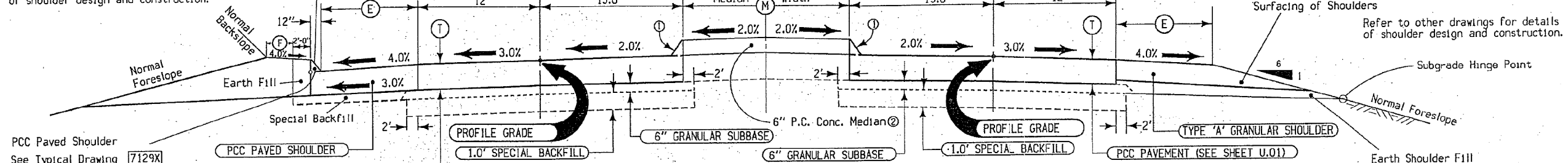

PCC Paved Shoulder
See Typical Drawing 7129X
(Full Depth) with Curb

NOTE: Normal section shown may be appropriately modified for areas specifically designated by the engineer such as intersections or superelevated curves.

- ① See Typical 6128 for details of 6" Sloped Curb.
- ② See Typical 6140 for details of median.
- ③ Vari. - See Cross Sections

LOCATION		T	M	E	F	SHOULDER TYPE
IDENT.	STATION TO STATION					
Left Lane	34+84.40 - 49+59.28	10" ✓	27' ✓	10' ✓	③ ✓	Paved ✓
Right Lane	34+84.40 - 49+60.00	10" ✓	27' ✓	10' ✓	—	Granular ✓

Type 'A' Granular Shoulder Full Depth
See Typical Drawing 7110

TYPICAL CROSS SECTION
4 LANE PCC PAVEMENT
WITH CURBED MEDIAN

For Information Only

TYPICAL CROSS SECTIONS

ROAD DESIGN • CADD • PRODUCED

STATE OF IOWA

FHWA REGION 7

FISCAL YEAR

POLK

COUNTY

PROJECT NUMBER

NHS-28-2(9)--19-77

SHEET NUMBER

B.01

3207D
11-04-92

- Notes:
- Normal sections shown may be appropriately modified for areas specifically designated by the engineer such as inter-sections or super elevated curves.
- Refer to other drawings for details of P.C. Conc. Median.
- ① Refer to other drawings for details of shoulder and possible sidewalk construction.
 - ② Excavate and backfill 2.0'
 - ③ Backfill
 - ④ 6" Integral Standard Curb
 - ⑤ See Typical [6139] for details of median.

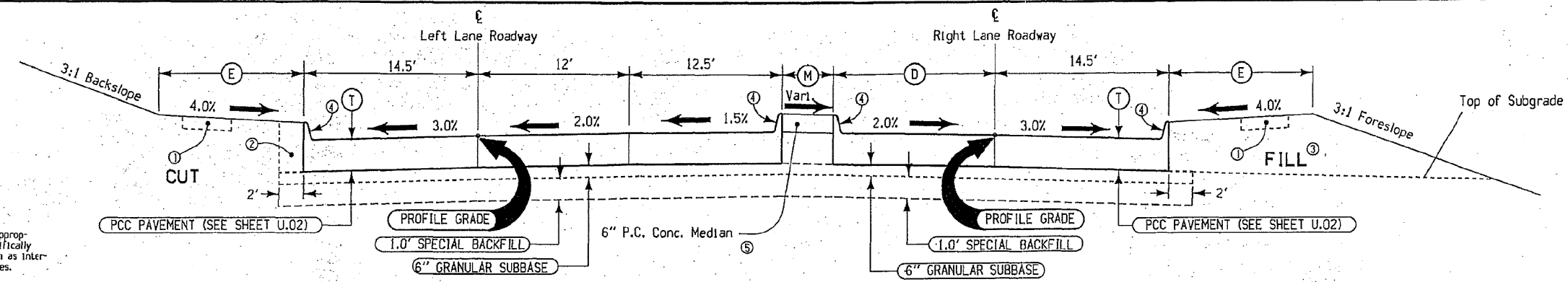

LOCATION		T	D	E	M		
IDENT.	STATION TO STATION						
Lt. Lane	34+25.00	35+75.00	10"	13.0'	12'	17'	*
Lt. Lane	43+49.00	44+99.00	10"	13.0'	12'	17'	*
Lt. Lane	61+10.00	62+10.00	10"	13.0'	12'	Varl.	*
Lt. Lane	69+95.00	71+20.00	10"	12.5'	12'	Varl.	*
Lt. Lane	77+55.00	78+30.00	10"	12.5'	12'	Varl.	*
Lt. Lane	83+50.00	85+00.00	10"	12.5'	12'	3'	
Lt. Lane	92+85.00	94+35.00	10"	12.5'	12'	3'	
Lt. Lane	99+57.00	101+07.00	10"	12.5'	12'	3'	
Lt. Lane	106+15.00	107+35.00	10"	12.5'	12'	3'	
Lt. Lane	109+48.78	110+68.78	10"	12.5'	12'	3'	
Lt. Lane	112+74.00	114+24.00	10"	12.5'	12'	3'	

* Median Curbs are 6" Sloped Curb (Typical [6128] and [6140]).

* See Geometric Sheets for Special Lane Widths.

TYPICAL CROSS SECTION
4 LANE PCC PAVEMENT
WITH CURBS
WITH LEFT TURN LANE

3207E
11-04-92

- Notes:
- Normal sections shown may be appropriately modified for areas specifically designated by the engineer such as inter-sections or super elevated curves.
- Refer to other drawings for details of shoulder design and construction.
- ① Refer to other drawings for details of shoulder and possible sidewalk construction.
 - ② Excavate and backfill 2.0'
 - ③ Backfill
 - ④ 6" Integral Standard Curb
 - ⑤ See Typical [6135] for details of median.

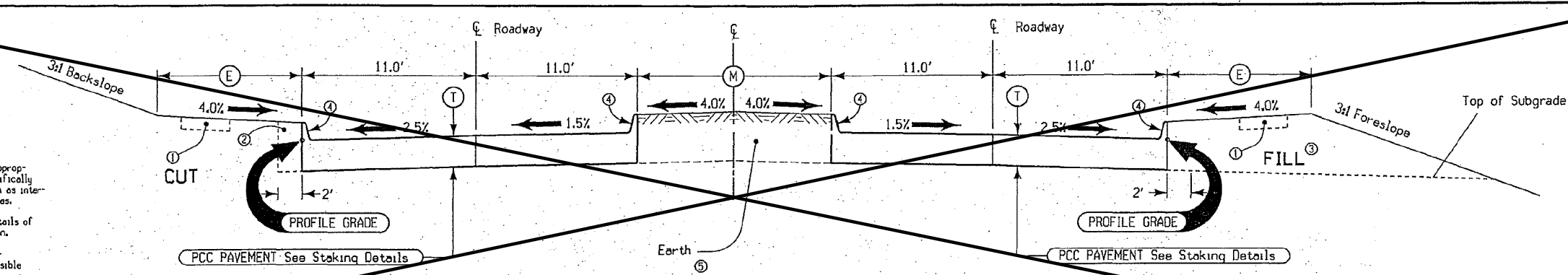

LOCATION		T	E	M	
ROAD IDENTIFICATION	STATION TO STATION	Inches	Feet	Feet	
Creston Ave.	1043+58.03	1046+58.00	10	10	20

TYPICAL CROSS SECTION
4 LANE PCC PAVEMENT
WITH CURBS

For Information Only

TYPICAL CROSS SECTIONS

SURVEY SYMBOLS

- W--- Existing Water Line
- W2--- Existing Water Line (Second Company)
- San.--- Existing Sanitary Sewer Line
- T--- Existing Telephone Line
- T2--- Existing Telephone Line (Second Company)
- F0-1--- Existing Fiber Optics Telephone Line
- St. S.--- Existing Storm Sewer Line
- G--- Existing Gas Line
- G-HP--- Existing High Pressure Gas Line
- G2--- Existing Gas Line (Second Company)
- G2-HP--- Existing High Pressure Gas Line (Second Company)
- E----- Existing Power Line
- E2----- Existing Power Line (Second Company)
- TV----- Cable Television Line
- ⊙ FP Filler Pipe
- ⊙ GV Gas Valve
- ⊙ WV Water Valve
- ⊙ SL Speed Limit Sign
- ⊙ MM Mile Marker Post
- SIGN Sign
- TCB Traffic Signal Control Box
- RRB Rail Road Signal Control Box
- TSB Telephone Switch Box
- EB Electric Box
- ~~~~~ Timber

UTILITY LEGEND

- F0-1--- Aureon Network Services
Jeff Klocko
7760 Office Plaza Drive South
West Des Moines IA 50266
jeff.klocko@aureon.com
(515) 830-0445
- F0-1--- Centurylink
Steve Parker
2103 E. University Ave.
Des Moines IA 50317
steven.parker4@centurylink.com
(515) 265-0968
- F0-1--- Consolidated Communications
Westen Grow
2859 99th St.
Urbandale IA 50322
weston.grow@eventis.com
(515) 867-4769
- F0-1--- City of Des Moines
Steve Naber
400 Robert D Ray Dr.
Des Moines IA 50309
snaber@dmgov.org
(515) 283-4920
- W--- Des Moines Water Works
Danny Klopfer
2201 George Flag Parkway
Des Moines IA 50321
dannyklopfer@dmww.com
(515) 283-8754
- TV--- Mediacom Communications Corp.
Paul May
2205 Ingersoll Ave.
Des Moines IA 50312
pmay@mediacomcc.com
(515) 246-2252
- G--- MidAmerican Electric Dist. & Gas
Tim Davis
3500 104th St.
Urbandale IA 50322
tldavis@midamerican.com
(515) 242-4224
- E--- MidAmerican Electric Trans.
William Schierbrock
106 East Second St.
Davenport IA 52801
wschierbrock@midamerican.com
(563) 333-8155
- F0-1--- Unite Private Networks
Clark Lundy
2320 Wakonda View Dr.
Des Moines IA 50321
clark.lundy@upnfiber.com
(515) 321-3336
- W--- West Des Moines Water Works
William Mabuice
4200 Mills Civic Parkway,
Suite 1D
West Des Moines IA 50265
william.mabuice@wdmww.com
(515) 222-3464
- F0-1--- Windstream Communications
Jim Wiand
115 S. 2nd Ave. W.
Newton IA 50208
james.wiand@windstream.com
(641) 787-2270

PLAN VIEW COLOR LEGEND OF PLAN AND PROFILE SHEETS

LINEWORK	Design Color No.	
Green	(2)	Existing Topographic Features and Labels
Blue	(1)	Proposed Alignment, Stationing, Tic Marks, and Alignment Annotation
Magenta	(5)	Existing Utilities
SHADING	Design Color No.	
Yellow	(4)	Highlight for Critical Notes or Features
Red	(3)	Delineates Restricted Areas
Lavender	(9)	Temporary Pavement Shading
Gray, Light	(48)	Proposed Pavement Shading
Gray, Med	(80)	Proposed Granular Shading
Gray, Dark	(112)	Proposed Grade and Pave Shading "In conjunction with a paving project"
Brown, Light	(236)	Grading Shading
Tan	(8)	Proposed Sidewalk Shading
Blue, Light	(230)	Proposed Sidewalk Landing Shading
Pink	(11)	Proposed Sidewalk Ramp Shading

PROFILE VIEW COLOR LEGEND OF PLAN AND PROFILE SHEETS

LINEWORK	Design Color No.	
Green	(2)	Existing Ground Line Profile
Blue	(1)	Proposed Profile and Annotation
Magenta	(5)	Existing Utilities
Blue, Light	(230)	Proposed Ditch Grades, Left
Black	(0)	Proposed Ditch Grades, Median
Rust	(14)	Proposed Ditch Grades, Right

Reference Point

- Station
- Survey Line
- Section Corner
- Ground Line Intercept
- Saw Cut
- Guardrail
- Trench Drain
- High Tension Cable Guardrail
- Sheet Pile
- Pavement Removal
- Clearing & Grubbing Area

RIGHT-OF-WAY LEGEND

- Proposed Right-of-Way
- Existing Right of Way
- Existing and Proposed Right-of-Way
- Easement and Existing Right-of-Way
- Easement (Temporary)
- Easement
- Access Control
- Property Line

PLAN AND PROFILE LEGEND AND SYMBOL INFORMATION SHEET

(COVERS SHEET SERIES D, E, F, & K)

Sta. 44+90
 15" X 116' RCP
 DA = 1.55 ACRES F-H
 (UAC)

Bloomfield TWP.
 T-78N R-25W
 SEC. 14

TEMPORARY EASEMENT FOR
 CLEARING AND GRUBBING

Sta. 52+59.86
 601.8'x28'
 Steel I Beam Bridge
 D.A.=3533 Sq. Mi. (Per Plans)
 (Remove)

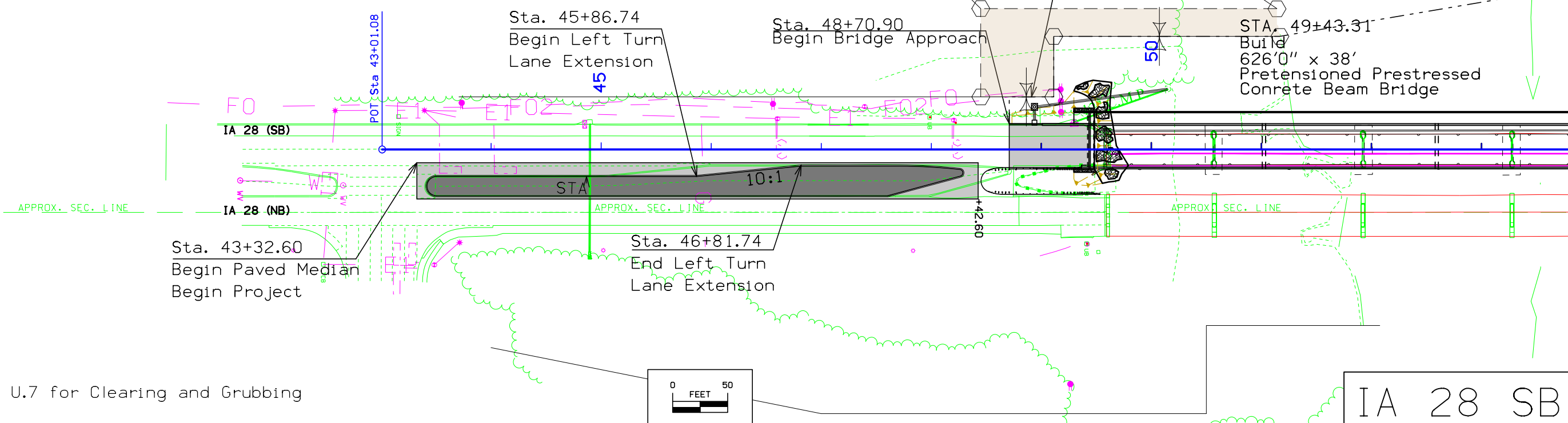

① See Sheet U.7 for Clearing and Grubbing

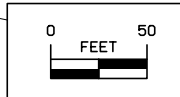

IA 28 SB

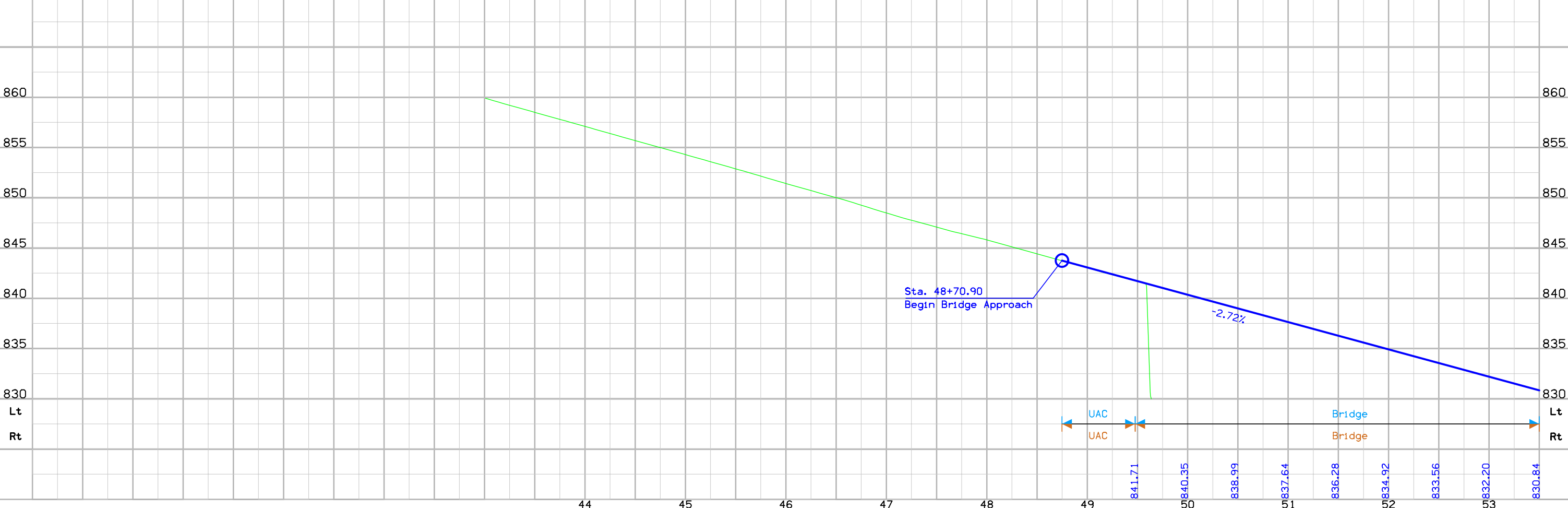

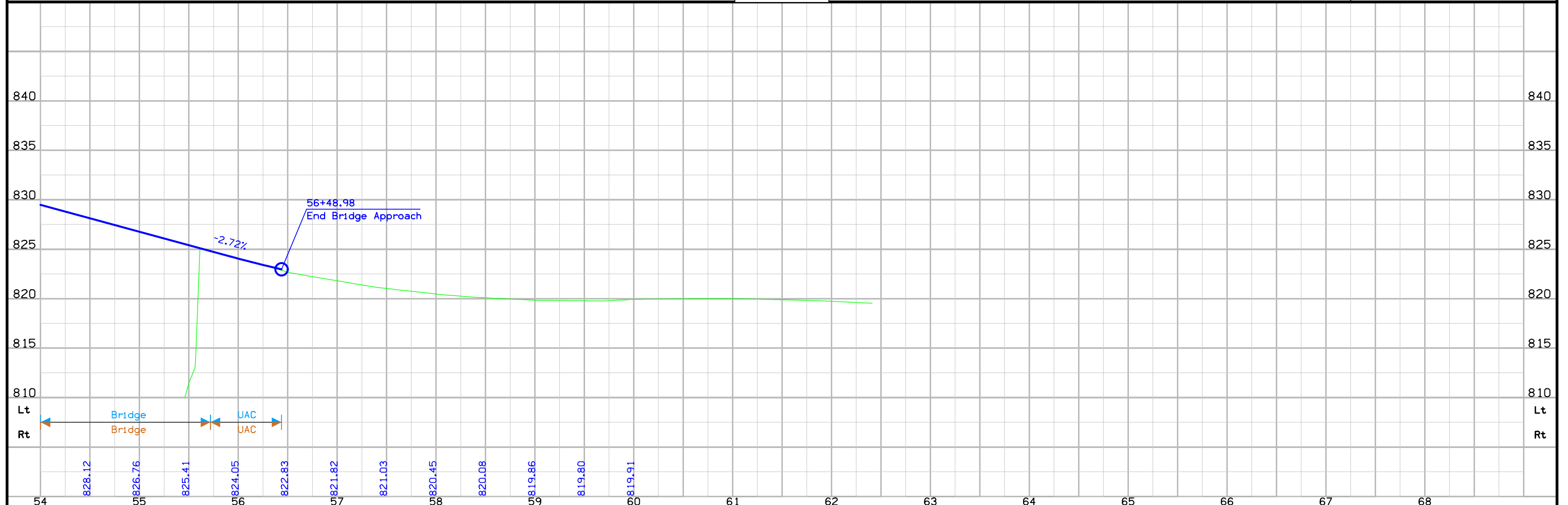
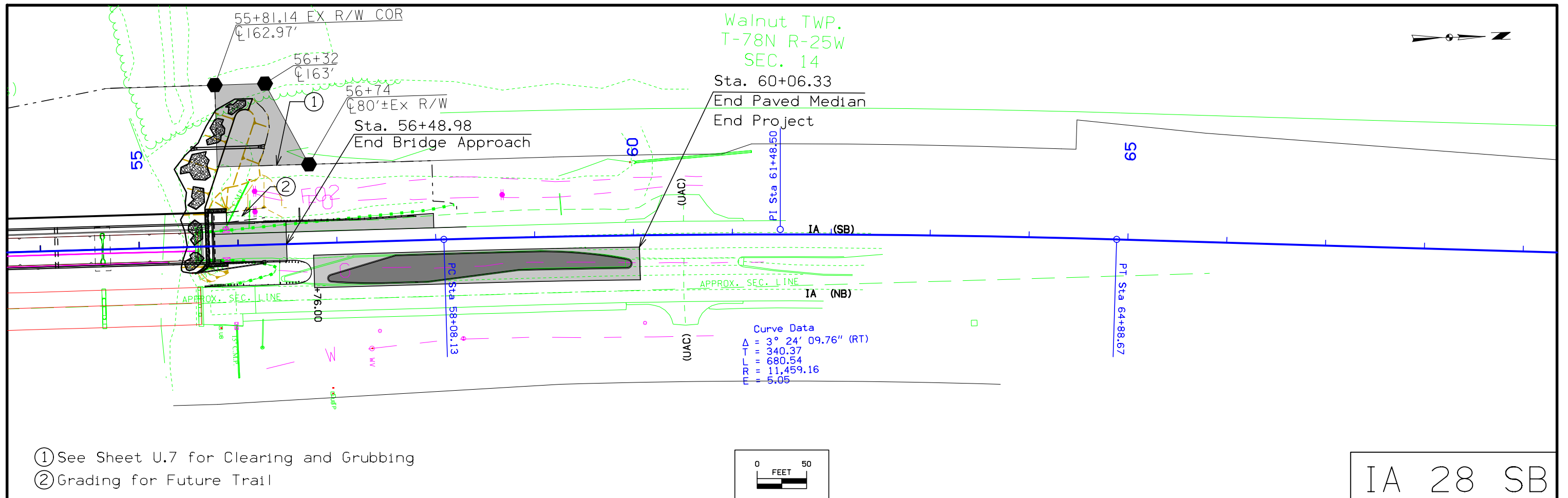

Survey Information

Polk County
BRFN-028-2(45)—39-77
SB IA 25 Bridge over Racoon River
PIN 17-77-028-010
Sap-0936

Party Personnel

Jeffrey Duncan- Party Chief
Paul Harry-Assistant Party Chief

Date(s) of Survey

Begin Date 04/15/2019
End Date 05/09/2019

General Information

Measurement units for this survey are US survey feet. This survey is for proposed bridge replacement along Iowa Highway 28 over the Racoon River. Project datum and control information is provided by Design Survey Office. This project is a Full DTM without Photo control.

Vertical Control

The vertical datum is NAVD88. Vertical Control was established on 3 monuments designated as points B117,WD55, and FENO1. These monuments are expected to hold vertical reasonably well. Datum was transferred from Iowa RTN reference stations to the projects monuments by using concurrent 6-hour static measurements and post processing connecting vectors. Geoid 12 B was used in processing. Additional control points were placed throughout the project using a GNSS Base-Rover setups.

This survey observed 1 NGS Control Monument with published NAVD88 heights to compare to local ground control:

NGS 2nd. order class Posted designated B117 has a published Elev. of 836.10
Survey Elev. = 836.211

This survey observed 1 City of West Des Moines Control Monument with published NAVD88 heights to compare to local ground control:

City of West Des Moines mark designated WD455 has a published Elev. Of 813.168
Survey Elev. = 813.168

Horizontal Control

The project coordinate system for this survey is Iowa RCS Zone 8 (U.S. Survey Feet). This survey control is relative to IaRTN reference stations. IaRTN Reference Station coordinate are relative to the National Reference Station network datum NAD83 (2011) for Epoch 2010.00. Coordinates were determined by using concurrent 6-hour static measurements and post processing connecting vectors. Additional control points were placed throughout the project using a GNSS Base-Rover setups.

Alignment Information

The horizontal alignment for this survey is provided by District 1 ROW.

CONTROL POINT VICINITY MAP

This map is a guide to the vicinity of the primary project control points
Primary control is for use with RTK base stations and for RTN validation.
Future surveys will use primary project control to establish temporary
control as needed for construction or other surveying applications.

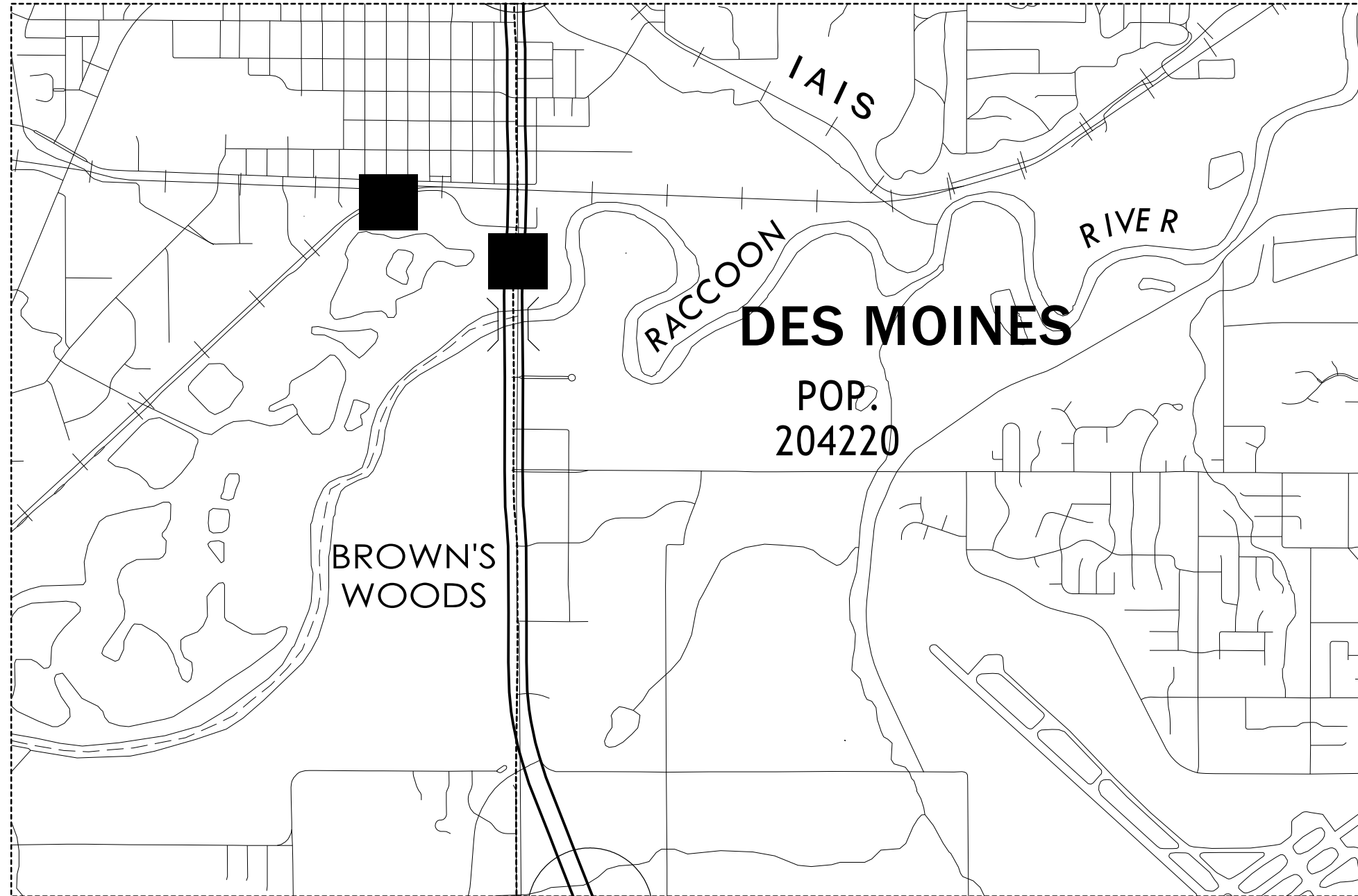

HORIZ. DATUM: NAD83(2011) EPOCH 2010.00

VERT. DATUM: NAVD88

1a. Regional Coordinate System Zone 8

Coordinate listing from next sheet will be used with 1aRTN for monument
recovery. No other reference ties are given.

HORIZONTAL AND VERTICAL PROJECT CONTROL COORDINATE LISTING

HORIZ. DATUM: NAD83(2011) EPOCH 2010.00

VERT. DATUM: NAVD88

Ia. Regional Coordinate System Zone 8

Point Name	North Coordinate	East Coordinate	Elevation	Feature Code-Description
B117	7470386.27	18510611.73	836.21	CP FOUND USGS BENCH MARK DISC SET IN TOP OF CURB AT THE SOUTHEAST CORNER OF BRIDGE ON MCKINLEY AVE. IN DES MOINES_ IA. MONUMENT IS 10.5FT SOUTH OF CENTERLINE 110.9FT WEST OF PK NAIL IN CENTER OF GREAT WESTERN TRAIL AT CENTERLINE OF MCKINLEY AVE. 5.2FT NW OF
WDMS5	7480430.723	18501413.56	813.17	CP FOUND WEST DES MOINES ALUMINUM CAP ON IRON PIN ENCASED IN 5FT PIPE WITH LID. 0.5 MILES WEST ALONG LINCOLN AVE. FROM THE INTERSECTION OF LINCOLN AVE. AND HWY 28 (63RD ST.) IN DES MOINES_ IA. AND 45.6FT SOUTH OF CENTERLINE LINCOLN AVE. MONUMENT IS 48.8FT NO
FENO1	7479386.994	18503682.21	815.76	FENO SET FENO MON 0.1 MILES S OF INT OF HWY 28 AND LINCOLN ST 12.8FT E OF PAVED SHOULDER EDGE 67.0FT N OF LUM POLE

Polk	ROW: NHSN-028-2(46)--2R-77			PIN 17-77-028-010																
	Raccoon River 3.7 mi N of IA 5 (SB)																			
		STATE		COUNTY		CITY			TEMP EASE	BORROW										
PARCEL NO.	OWNER NAME	FEE	EASE	FEE	EASE	FEE	EASE	EXCESS			FEE	T.E.	MITIGATION	OTHER	HOUSE	BUILDING(S)	A/C ONLY	TOTAL ACQ.		
1	Polk County Brown's Woods - Fee									10453 SF										
2	AFT, LLC - Fee		0.14 AC																	
2 Parcels	"TOTALS	0 AC	0.14 AC	0 AC	0 AC	0 AC	0 AC	0 AC	0 AC	0 AC	0 AC	0 AC	0 AC	0 AC						
		0 SF	0 SF	0 SF	0 SF	0 SF	0 SF	0 SF	0 SF	0 SF	0 SF	0 SF	0 SF	0 SF						

NO ACCESS RIGHTS ARE TO BE ACQUIRED ON THIS PROJECT.

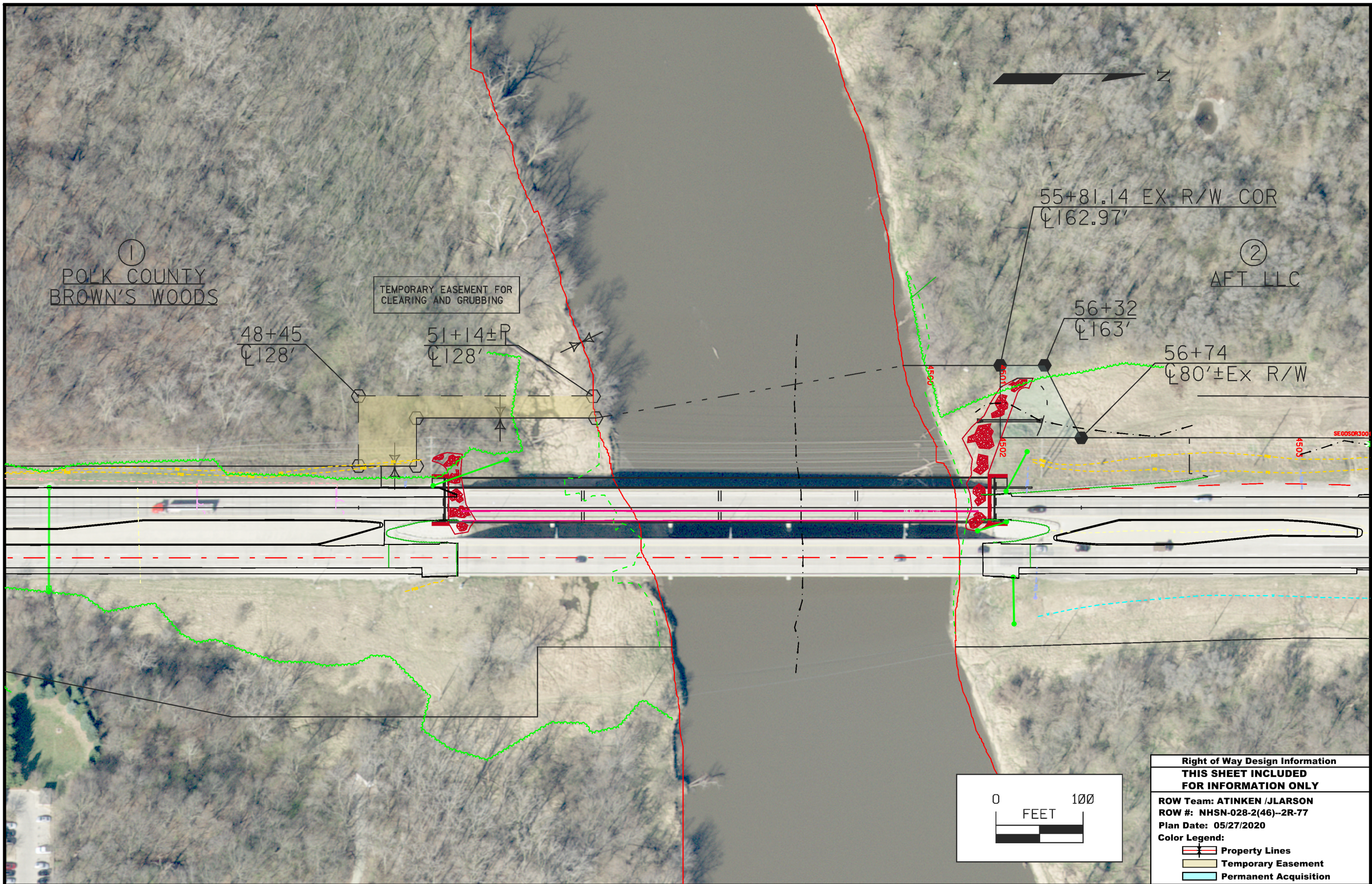

①
POLK COUNTY
BROWN'S WOODS

②
AFT LLC

TEMPORARY EASEMENT FOR
CLEARING AND GRUBBING

48+45
128'

51+14±P
128'

55+81.14 EX R/W COR
162.97'

56+32
163'

56+74
80'± EX R/W

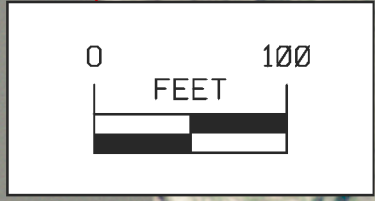

Right of Way Design Information	
THIS SHEET INCLUDED FOR INFORMATION ONLY	
ROW Team: ATINKEN /JLARSON	
ROW #: NHSN-028-2(46)--2R-77	
Plan Date: 05/27/2020	
Color Legend:	
	Property Lines
	Temporary Easement
	Permanent Acquisition

108-23A 08-01-08
TRAFFIC CONTROL PLAN
IA 28 SB traffic shall be maintained at all times by use of temporary median crossovers.

111-01 04-17-12						
COORDINATED OPERATIONS						
Other work in progress during the same period of time will include the construction of the projects listed. Coordinate operations with those of other contractors working within the same area.						
<table border="1" style="width: 100%;"> <tr> <th style="width: 50%;">Project</th> <th style="width: 50%;">Type of Work</th> </tr> <tr> <td>None Provided</td> <td></td> </tr> <tr> <td> </td> <td> </td> </tr> </table>	Project	Type of Work	None Provided			
Project	Type of Work					
None Provided						









108-26A 08-01-08
STAGING NOTES
<p>Stage Construction for PPCB Bridge</p> <p>Stage 1: Construction: Remove existing paved medians on both sides of the bridge and build median crossovers. Traffic: On existing outside lanes of both NB and SB directions.</p> <p>Stage 2: Construction: New SB PPCB bridge and approaches. Traffic: On median crossovers</p> <p>Stage 3 Construction: Left turn lane extension south of the bridge and paved medians. Traffic: On outside lanes of both NB and SB directions.</p>

108-25 10-21-14												
511 TRAVEL RESTRICTIONS												
Route	Direction	County	Location Description	Feature Crossed	Object Type	Maint. Bridge No., Structure ID, or FHWA No.	Type of Restriction	Existing Measurement	Construction Measurement	Construction Measurement as Signed	Projected As Built Measurement	Remarks
			No Restrictions									

**CROSS SECTION VIEW COLOR LEGEND
OF TRAFFIC CONTROL AND STAGING SHEETS**

SHADING	Design Color No.	
Green, Light	(225)	Existing Pavement Shading
Gray, Light	(48)	Previously Constructed Pavement Shading
Gray, Med	(80)	Previously Constructed Granular Surface Shading
Blue, Light	(230)	Proposed Pavement Shading
Lavender	(9)	Temporary Pavement Shading
Brown, Med	(237)	Future Proposed Pavement Shading

**CROSS SECTION VIEW PATTERN AND SYMBOL LEGEND
OF TRAFFIC CONTROL AND STAGING SHEETS**





















	Pavement Removal		Proposed Granular Shoulder
	Proposed Granular Subbase		Temporary Shoulder
	Proposed Special Backfill		Existing Shoulder Strengthening
	Temporary Barrier Rail		Permanent Barrier Rail
			Channelizing Device

PLAN VIEW COLOR LEGEND OF TRAFFIC CONTROL AND STAGING SHEETS

LINEWORK	Design Color No.	
Green	(2)	Existing Topographic Features and Labels
Magenta	(5)	Pavement Marking Call Outs
Blue	(1)	Proposed Alignment, Stationing, Tic Marks, and Alignment Annotation
Yellow	(4)	Pavement Markings, Yellow
Off White	(254)	Pavement Markings, White
Violet	(15)	Temporary barrier rail, Unpinned
Flush Orange	(228)	Temporary barrier rail, Pinned

SHADING	Design Color No.	
Green, Light	(225)	Existing Pavement Shading
Gray, Light	(48)	Previously Constructed Pavement Shading
Gray, Med	(80)	Proposed Granular Surface Shading
Gray, Med	(80)	Previously Constructed Granular Surface Shading
Blue, Light	(230)	Proposed Pavement Shading
Lavender	(9)	Temporary Pavement Shading
Brown, Light	(236)	Proposed Grading Limits Shading
Pink, Dark	(13)	Proposed MSE or CIP Wall Shading
Red	(3)	Proposed Bridge Shading and Sign Trusses
Black w/Gray, Light Fill	(0,48)	Previously Constructed Structure

**PLAN VIEW PATTERN AND SYMBOL LEGEND
OF TRAFFIC CONTROL AND STAGING SHEETS**

	Channelizing Device		Crash Cushion (Temp or Perm)
	Drum		Traffic Signal
	Temporary Lane Separator		Flagger
	Tubular Marker		Temporary Floodlighting
	Channelizer Marker		Traffic Sign
	Concrete Barrier Marker		Type III Barricade
	Delineator		Type A Warning Light
	Temporary Barrier Rail		Direction of Traffic
	Pavement Removal		Safety Closure
	Sand Barrel Layout		Lane Identification

NOTE: Device spacing according to Standard Road Plans unless specifically dimensioned.

**TRAFFIC CONTROL
AND
STAGING
LEGEND AND SYMBOL
INFORMATION SHEET**

(COVERS SHEET SERIES J)

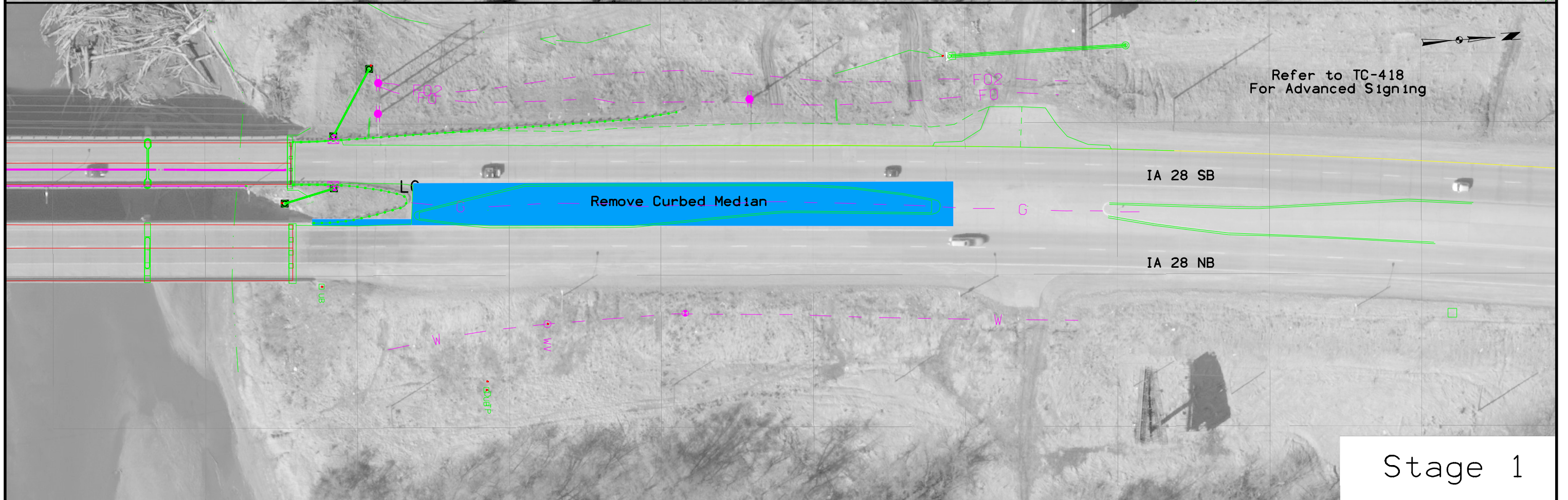
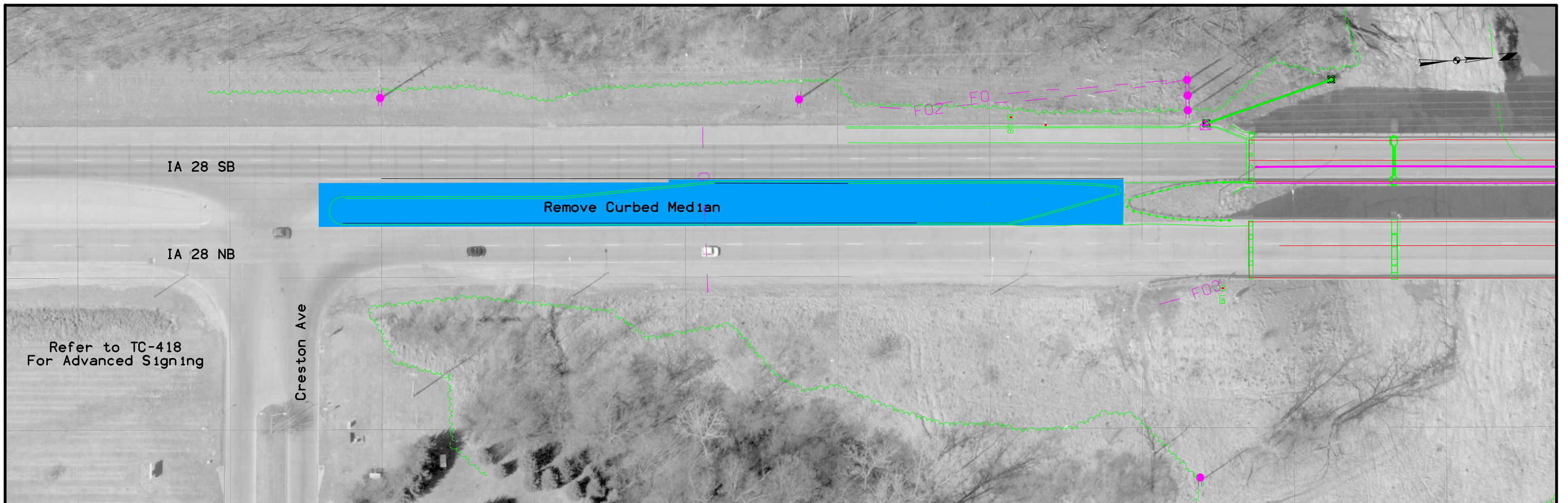

Stage 1

Refer to TC-418
For Advanced Signing
Advisory Speed Limit: 35 mph

IA 28 SB

IA 28 NB

Creston Ave

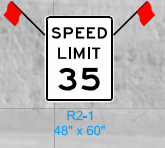
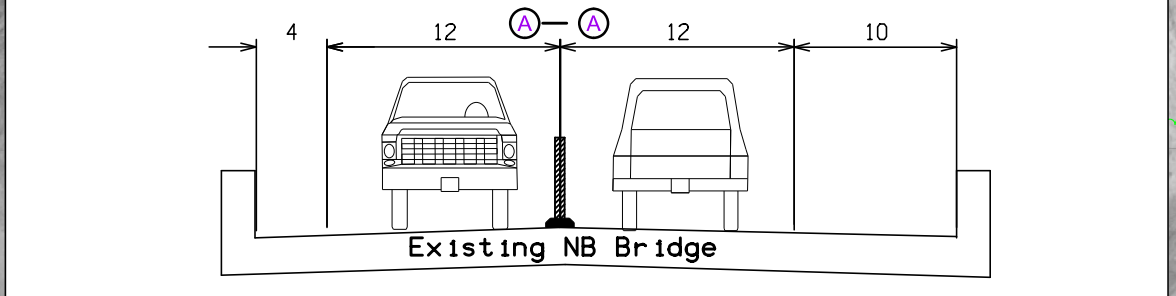
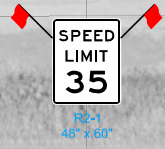

IA 28 SB

IA 28 NB

Refer to TC-418
For Advanced Signing
Advisory Speed Limit: 35 mph

Stage 2

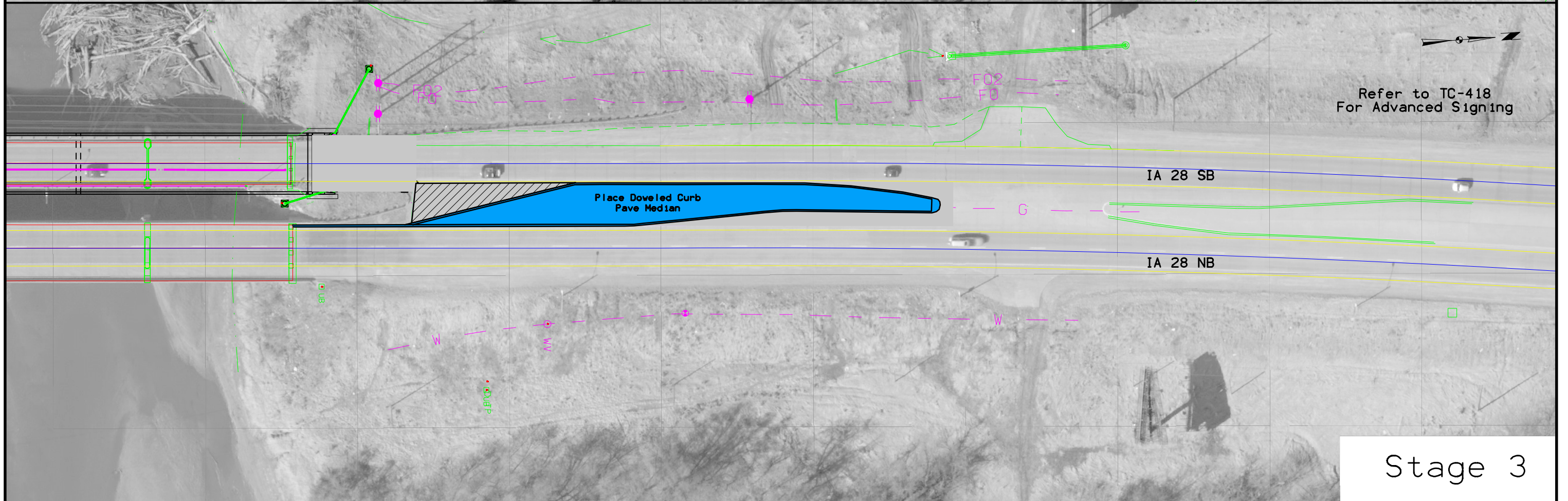
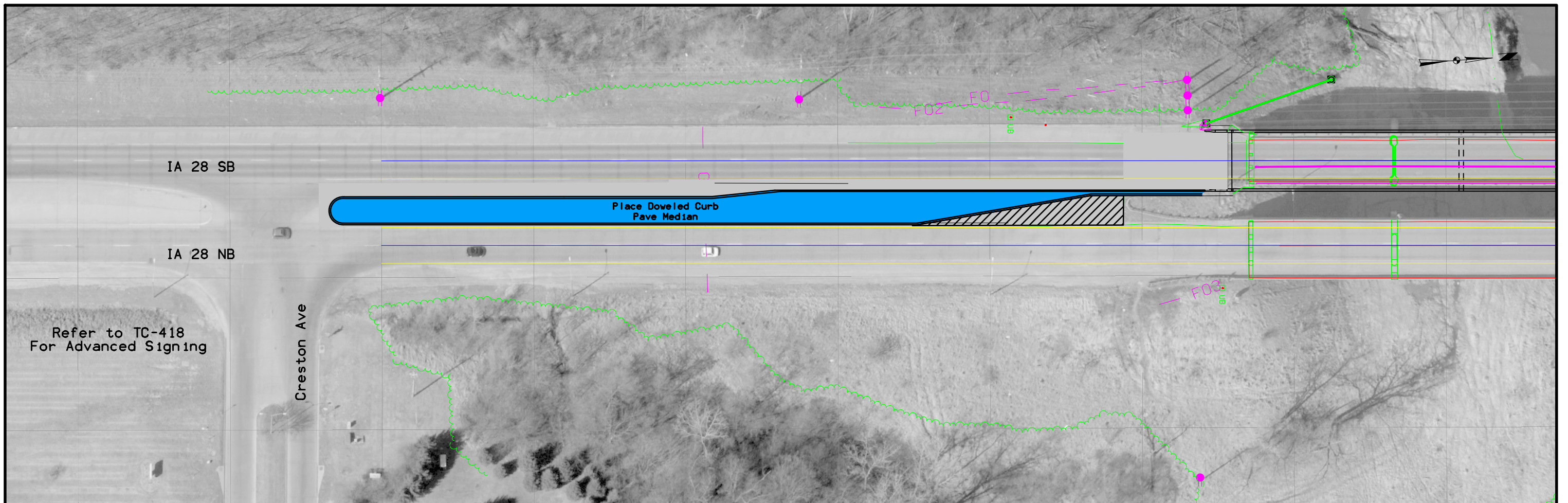

Stage 3

① Refer to table below for minimum distance between face of guardrail and edge of Shared-use Trail or Sidewalk.

Posted Speed Limit (mph)	Minimum Distance (feet)
<45	4
45 or greater	5

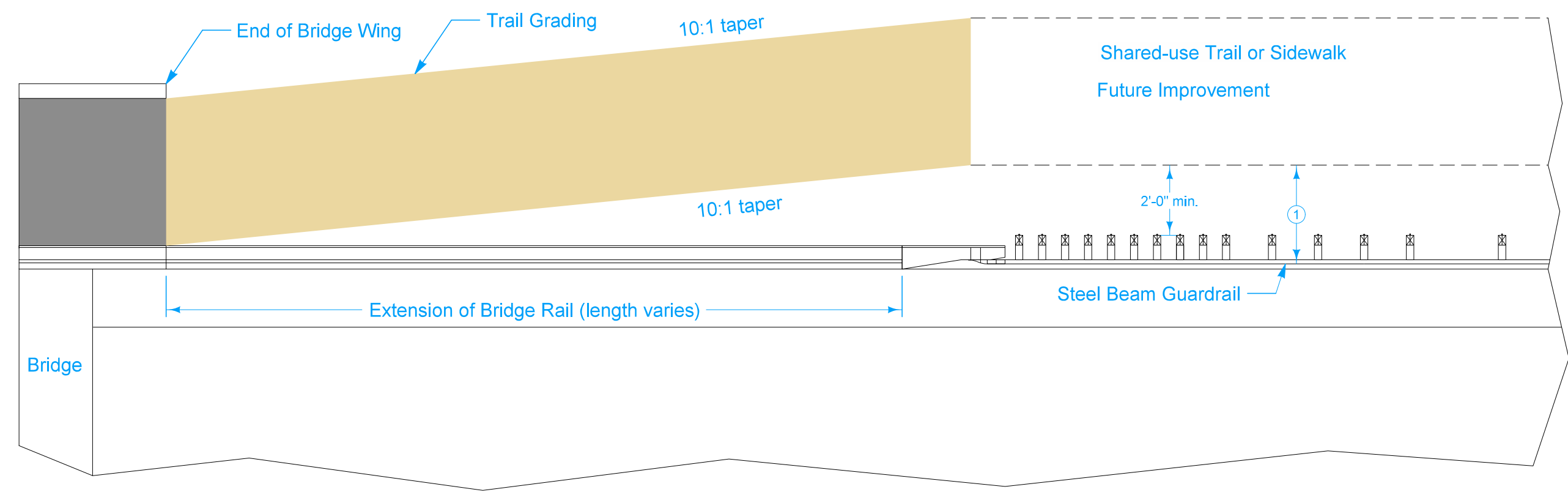

MODIFIED	REVISION	
	NEW	10-18-16
ROAD DESIGN DETAIL	560-6	
SHEET 1 of 1		
MODIFICATIONS: Changed Shared-use Trail or Sidewalk to Future Improvement.		
SHARED-USE TRAIL OR SIDEWALK BEHIND STEEL BEAM GUARDRAIL AT BRIDGE APPROACH		

Nose Cable with swaged end buttons attached by three sets of three $\phi 1/4"$ [6] U-bolts with 2 Nuts and Plate Washer at middle and quarter points.

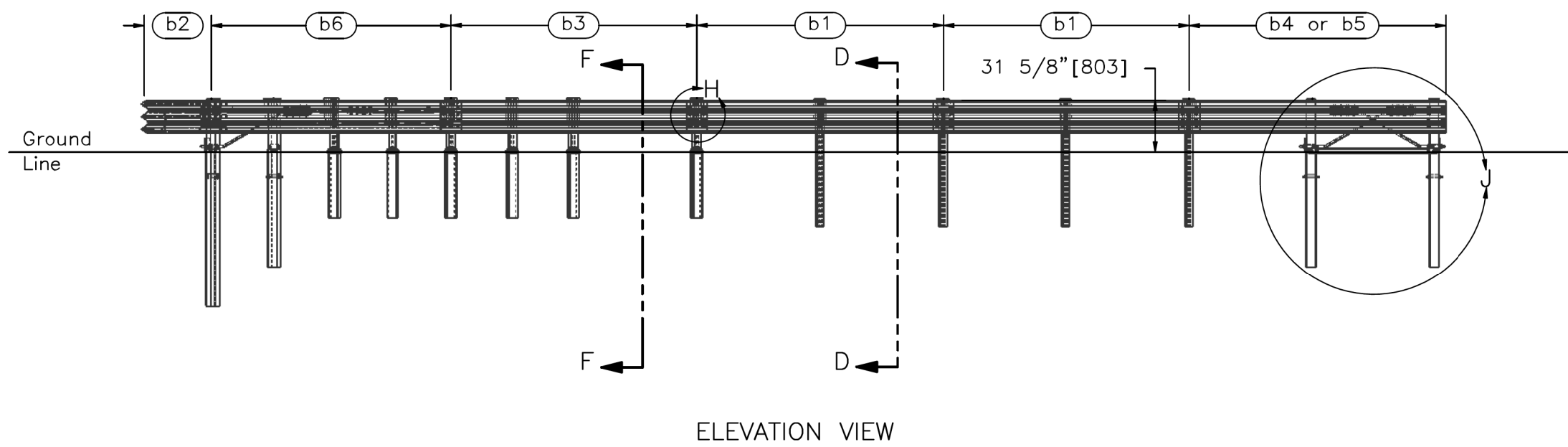
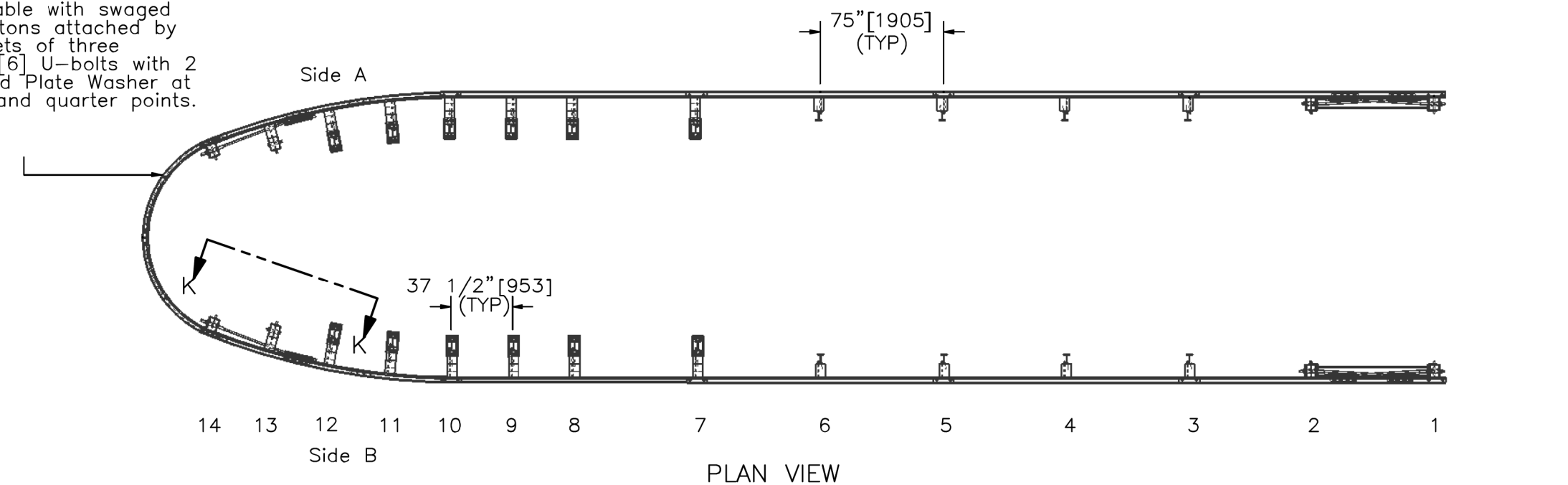

Midwest Roadside Safety Facility

MASH TL-3
Thrie-Beam Bullnose

System Layout

DWG. NAME:
Bullnose-Final_R0

SCALE: 1:100
UNITS: in.[mm]

SHEET:
1 of 24

DATE:
10/25/2019

DRAWN BY:
SBW

REV. BY:
-

Post No.	Side A				Side B			
	Rear Face-DS Edge		Rear Face-US Edge		Rear Face-DS Edge		Rear Face-US Edge	
	X	Y	X	Y	X	Y	X	Y
14	61'-10 7/8"	2'-3 1/8"	62'-4"	2'-5 1/8"	61'-10 7/8"	2'-3 1/8"	62'-4"	2'-5 1/8"
13	58'-9 3/4"	1'-11 1/4"	59'-3 1/8"	2'-0 3/4"	58'-9 3/4"	1'-11 1/4"	59'-3 1/8"	2'-0 3/4"
12	55'-10 1/4"	1'-9 3/8"	56'-2 1/8"	1'-10 1/8"	55'-10 1/4"	1'-9 3/8"	56'-2 1/8"	1'-10 1/8"
11	52'-11 1/4"	1'-4 3/8"	53'-3 1/8"	1'-4 3/4"	52'-11 1/4"	1'-4 3/8"	53'-3 1/8"	1'-4 3/4"
10	50'-0 3/4"	1'-2 3/8"	50'-4 3/4"	1'-2 3/8"	50'-0 3/4"	1'-2 3/8"	50'-4 3/4"	1'-2 3/8"
9	46'-11 1/4"	1'-2 3/8"	47'-3 1/4"	1'-2 3/8"	46'-11 1/4"	1'-2 3/8"	47'-3 1/4"	1'-2 3/8"
8	43'-9 3/4"	1'-2 3/8"	44'-1 3/4"	1'-2 3/8"	43'-9 3/4"	1'-2 3/8"	44'-1 3/4"	1'-2 3/8"
7	37'-6 3/4"	1'-2 3/8"	37'-10 3/4"	1'-2 3/8"	37'-6 3/4"	1'-2 3/8"	37'-10 3/4"	1'-2 3/8"
6	31'-3 3/4"	6 3/8"	31'-7 3/4"	6 3/8"	31'-3 3/4"	6 3/8"	31'-7 3/4"	6 3/8"
5	25'-0 3/4"	6 3/8"	25'-4 3/4"	6 3/8"	25'-0 3/4"	6 3/8"	25'-4 3/4"	6 3/8"
4	18'-9 3/4"	6 3/8"	19'-1 3/4"	6 3/8"	18'-9 3/4"	6 3/8"	19'-1 3/4"	6 3/8"
3	12'-6 3/4"	6 3/8"	12'-10 3/4"	6 3/8"	12'-6 3/4"	6 3/8"	12'-10 3/4"	6 3/8"
2	6'-3"	0"	6'-8 1/2"	0"	6'-3"	0"	6'-8 1/2"	0"
1	0"	0"	5 1/2"	0"	0"	0"	5 1/2"	0"

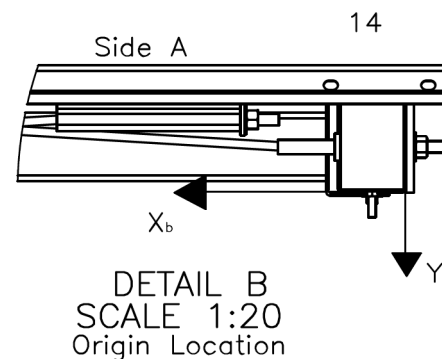
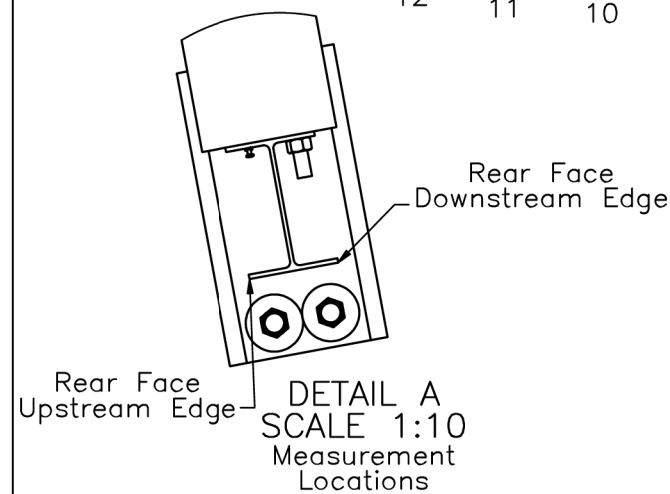
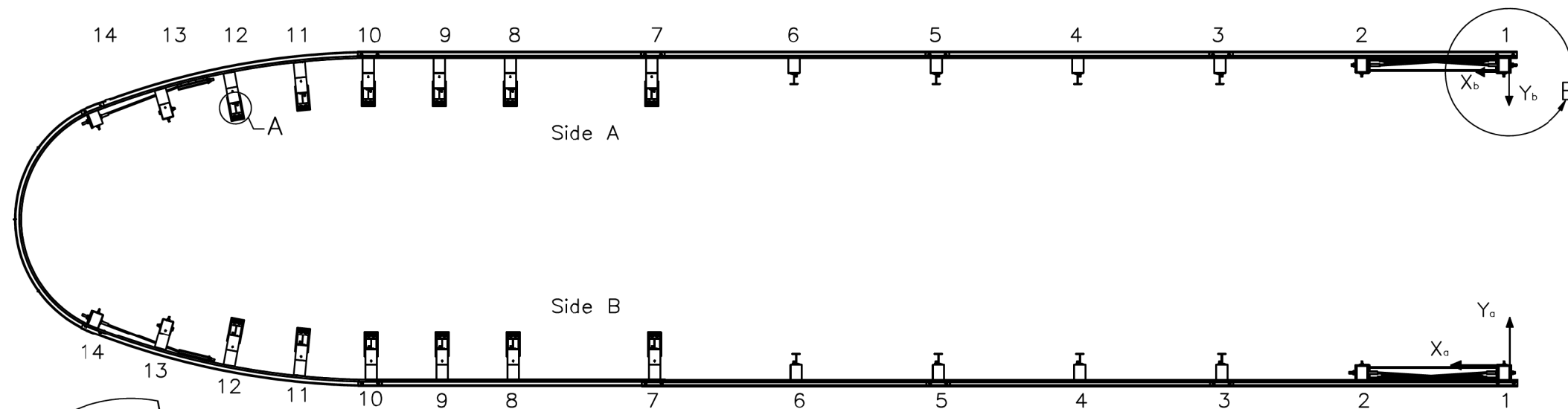

Note: All dimensions measured from the intersection of the rear face and downstream edge of post no. 1 on side B and post no. 1 on side A.

	MASH TL-3 Thrie-Beam Bullnose	SHEET: 2 of 24
	Layout for Post Locations	DATE: 10/25/2019
DWG. NAME: Bullnose-Final_RO	SCALE: 1:90 UNITS: in.[mm]	DRAWN BY: SBW
		REV. BY: -

Post No.	Rear Face-DS Edge		Rear Face-US Edge	
	X _a and X _b	Y _a and Y _b	X _a and X _b	Y _a and Y _b
14	11'-10 1/8"	1'-6 5/8"	12'-3 1/4"	1'-8 5/8"
13	8'-9"	1'-2 3/4"	9'-2 3/8"	1'-4 1/4"
12	5'-9 1/2"	1'-0 7/8"	6'-3 3/8"	1'-1 5/8"
11	2'-10 1/2"	7 7/8"	3'-2 3/8"	8 1/4"
10	0"	5 7/8"	4"	5 7/8"

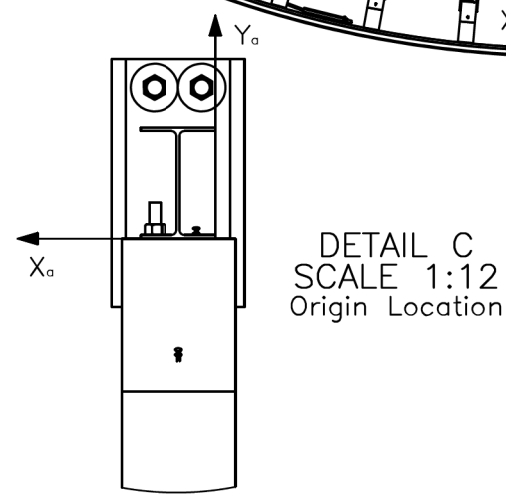
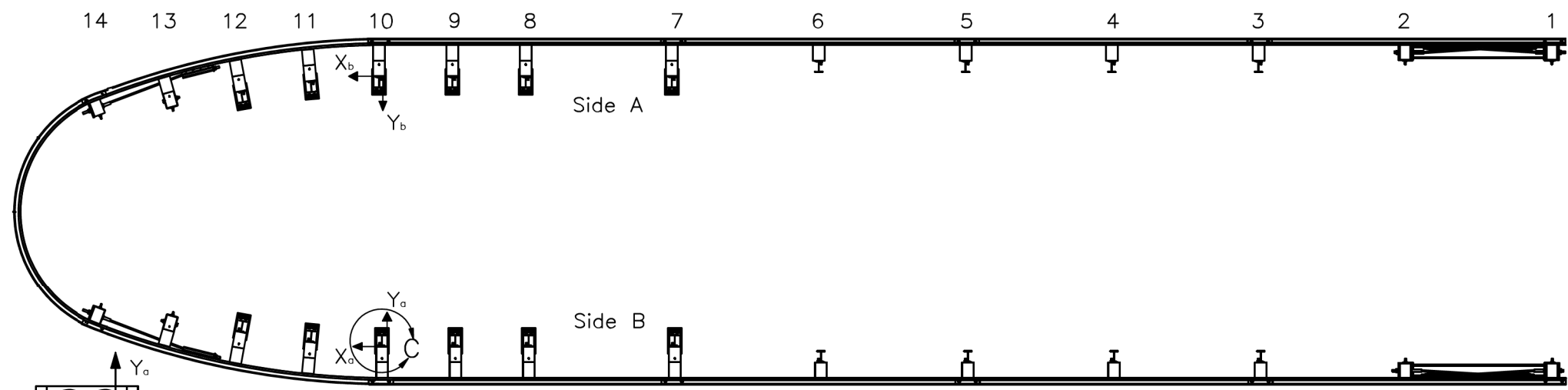

Note: All dimensions measured from the intersection of the front face and downstream edge of post no. 10 to each respective side.

	MASH TL-3 Thrie-Beam Bullnose	SHEET: 3 of 24
	Alternate Coordinate System for the Layout of Post Locations	DATE: 10/25/2019
DWG. NAME: Bullnose-Final_R0		DRAWN BY: SBW
	SCALE: 1:90 UNITS: in.[mm]	REV. BY: -

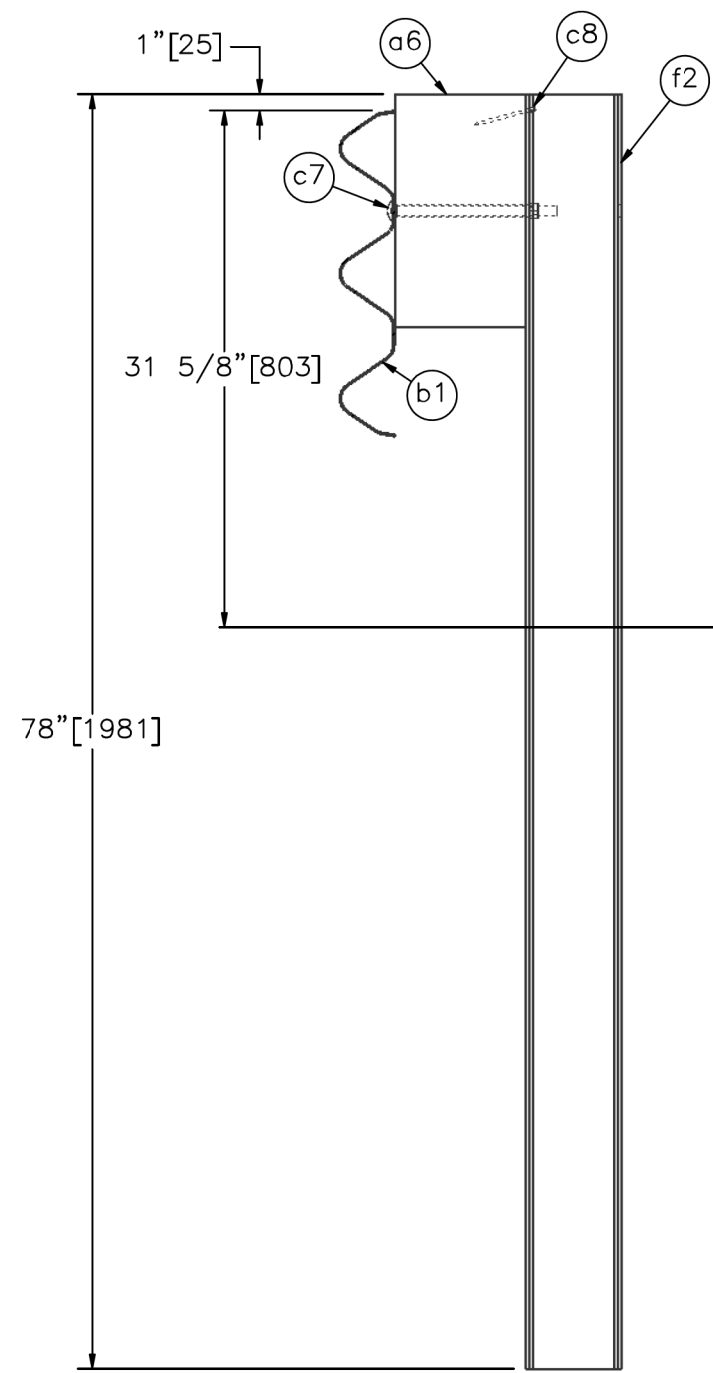

SECTION D-D
Post nos. 3-6

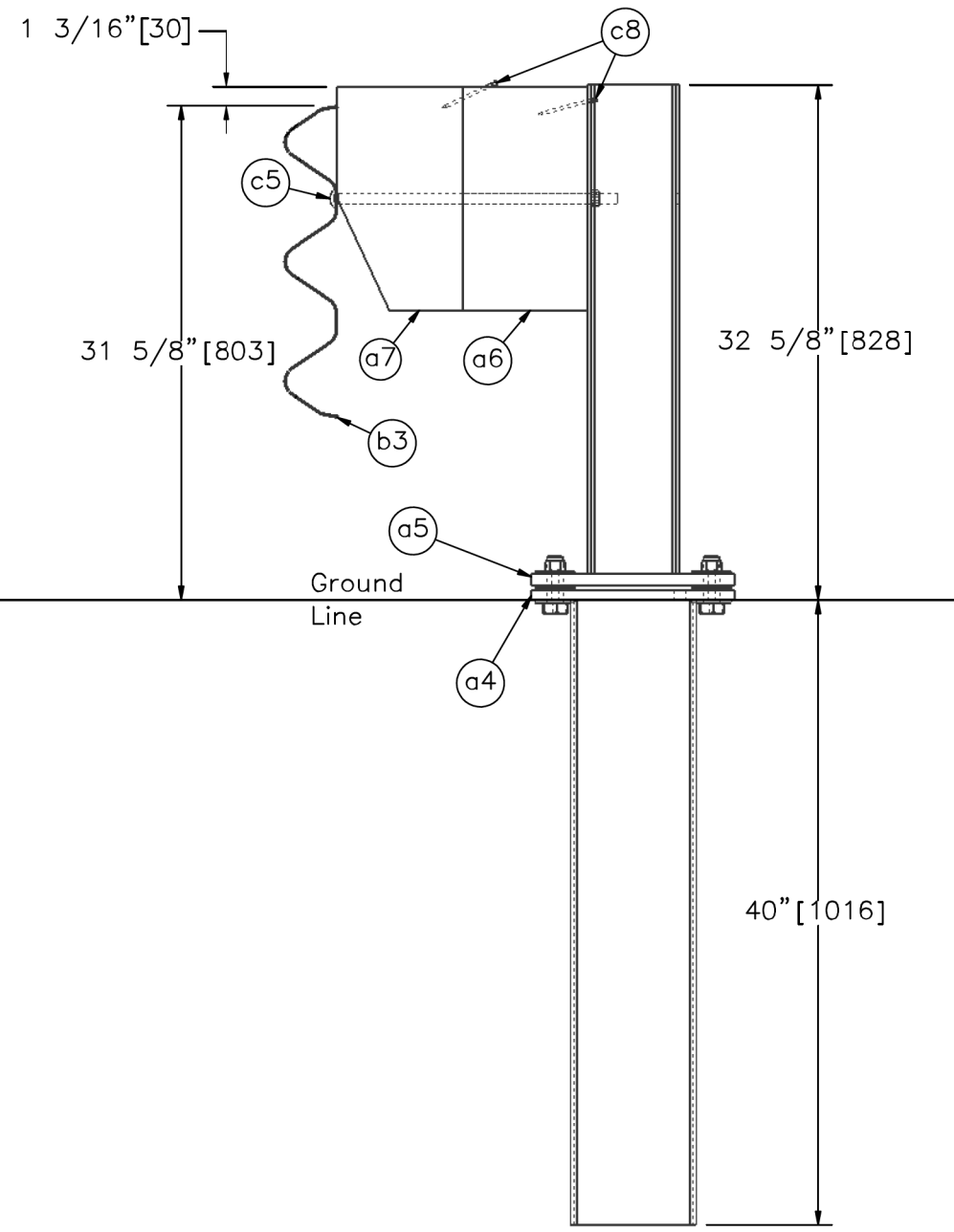

SECTION F-F
Post nos. 7-12



Midwest Roadside
Safety Facility

MASH TL-3
Thrie-Beam Bullnose

Post Nos. 3-6, 7-12 Details

DWG. NAME:
Bullnose-Final_R0

SCALE: 1:14
UNITS: in.[mm]

SHEET:
4 of 24

DATE:
10/25/2019

DRAWN BY:
SBW

REV. BY:
-

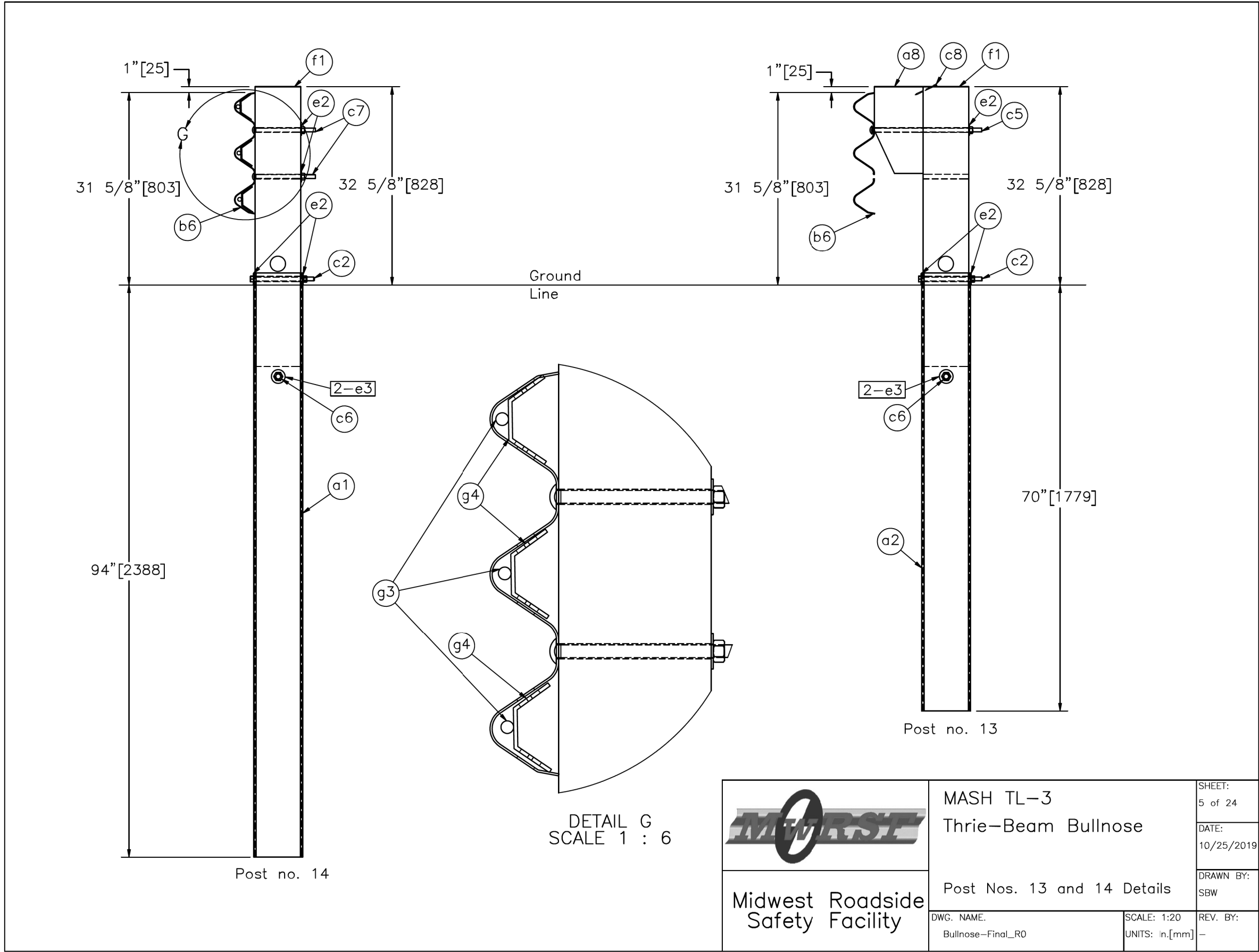

Midwest Roadside Safety Facility

MASH TL-3 Thrie-Beam Bullnose		SHEET: 5 of 24
Post Nos. 13 and 14 Details		DATE: 10/25/2019
DWG. NAME: Bullnose-Final_R0	SCALE: 1:20 UNITS: in.[mm]	DRAWN BY: SBW
		REV. BY: -

Bloomfield TWP.
T-78N R-25W
SEC. 14

Walnut TWP.
T-78N R-25W
SEC. 14

0.37 Acres

0.61 Acres

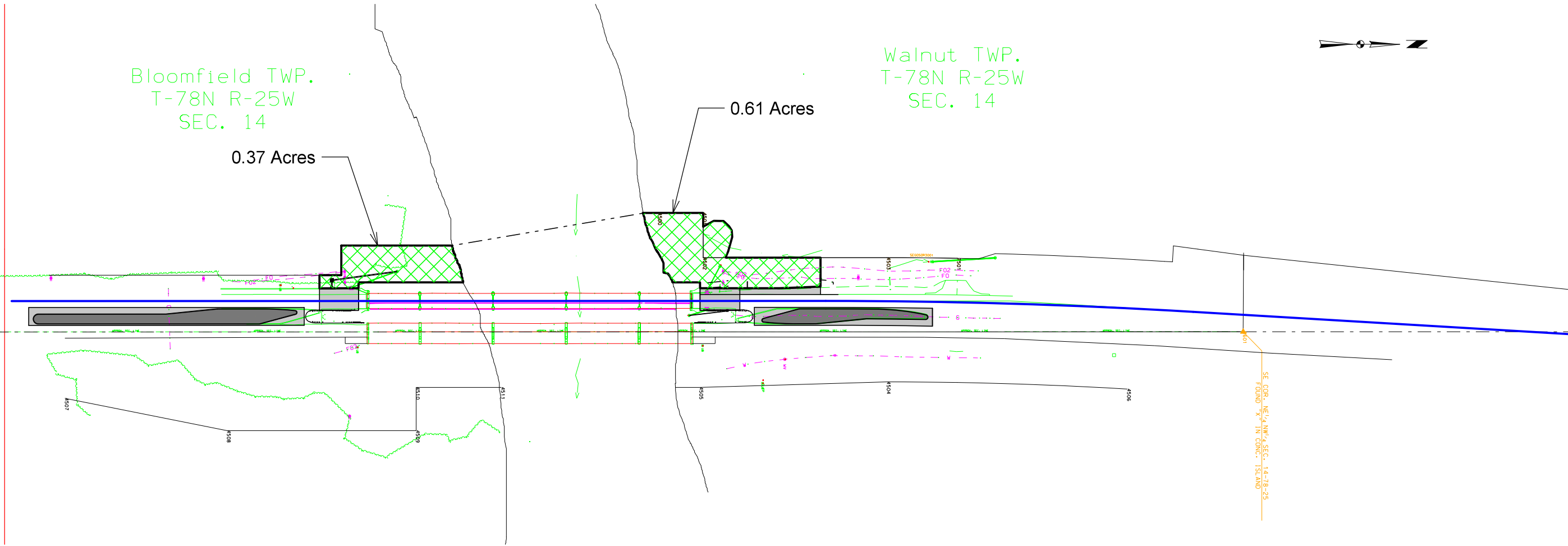
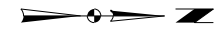

Clearing and Grubbing
Detail

IA 28 Preliminary

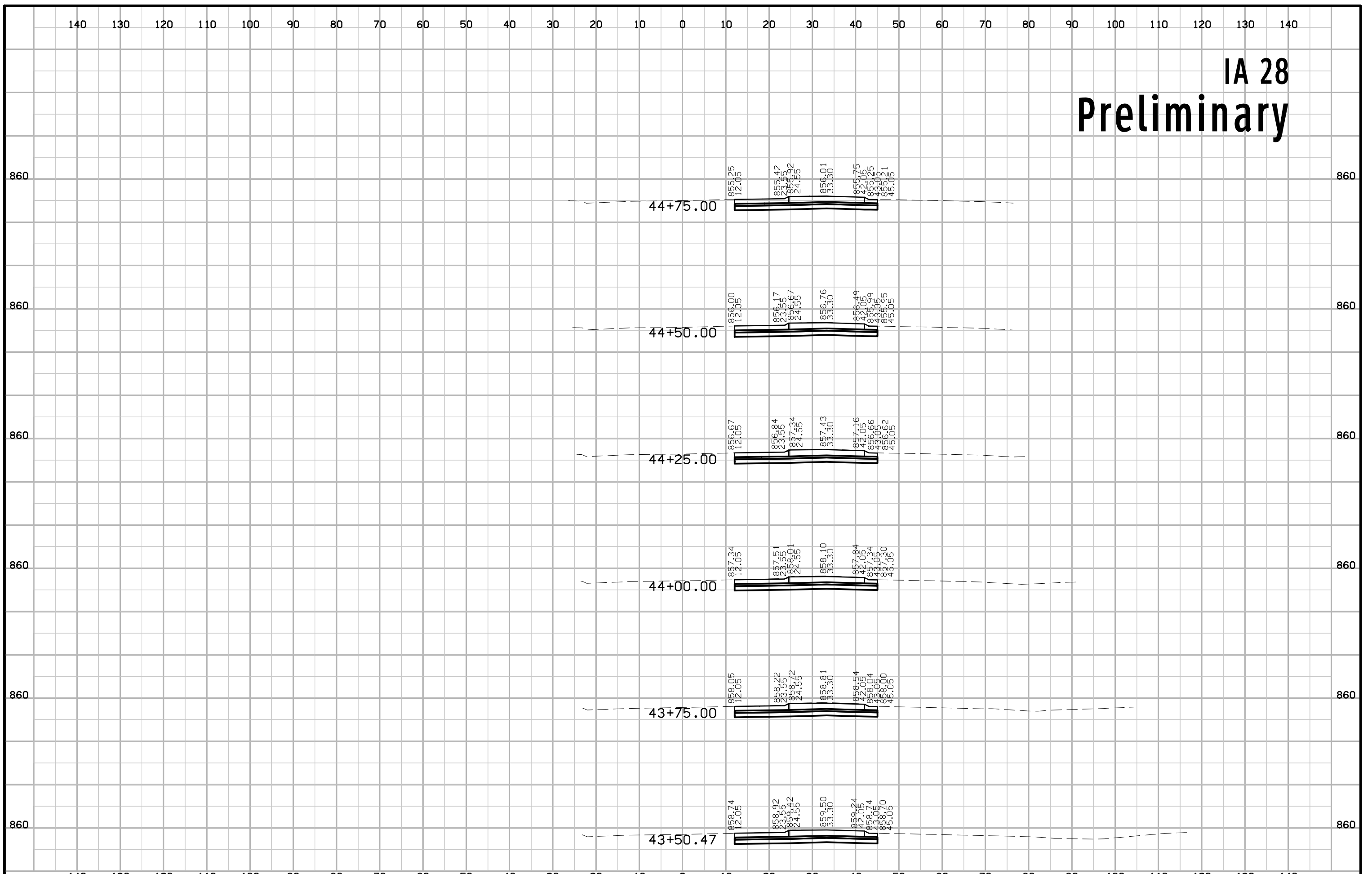

IA 28 Preliminary

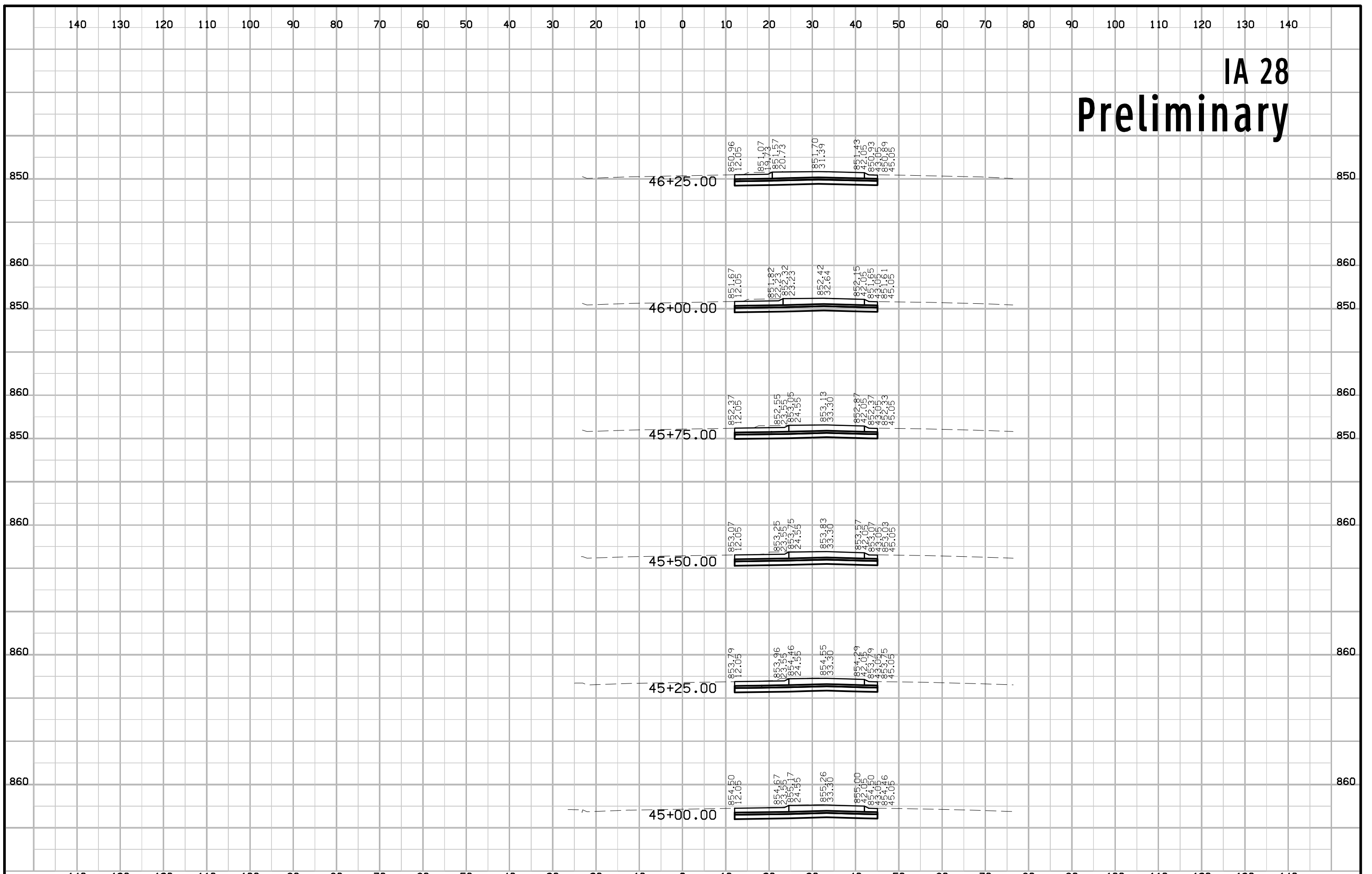

IA 28 Preliminary

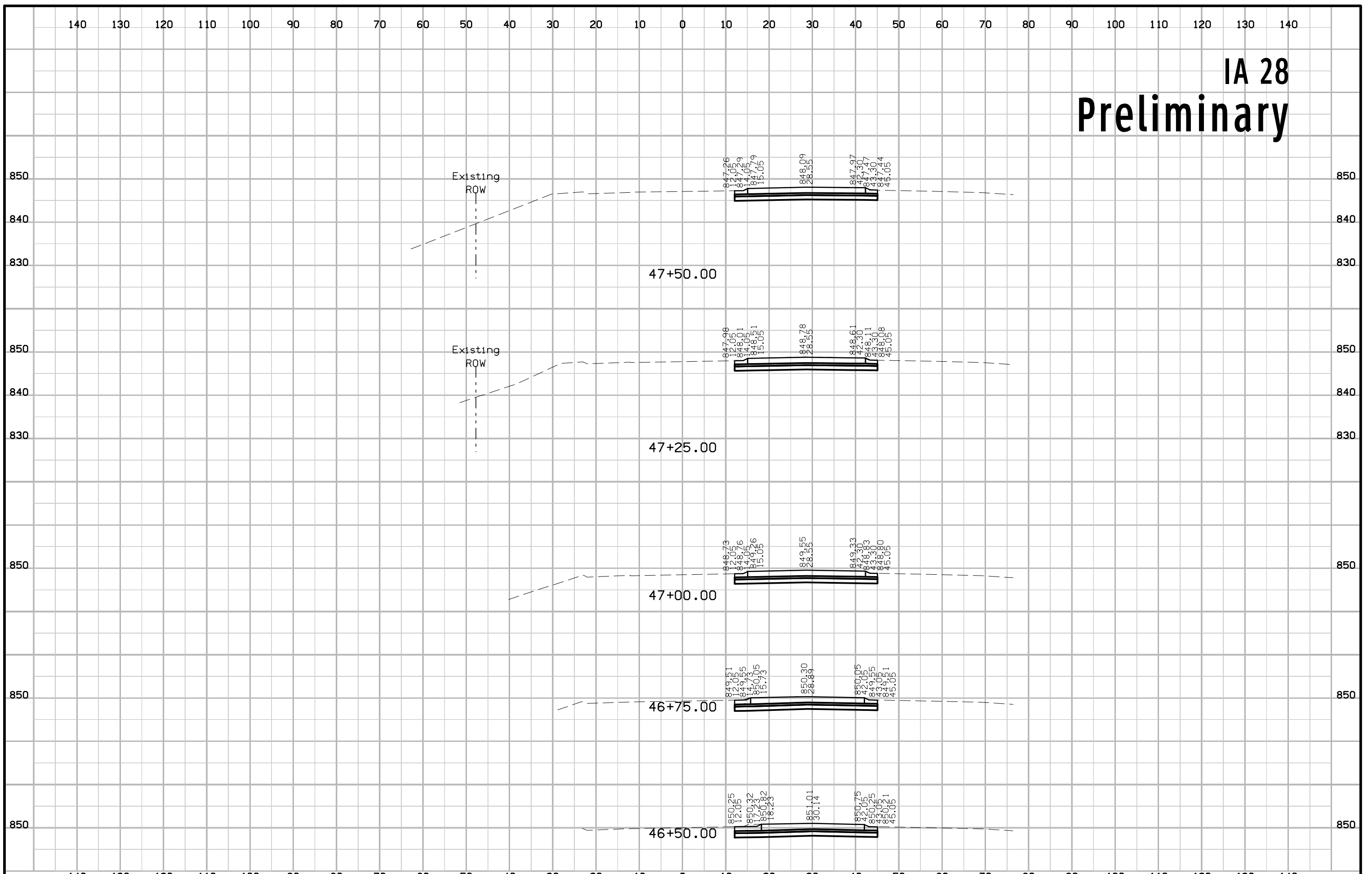

IA 28 Preliminary

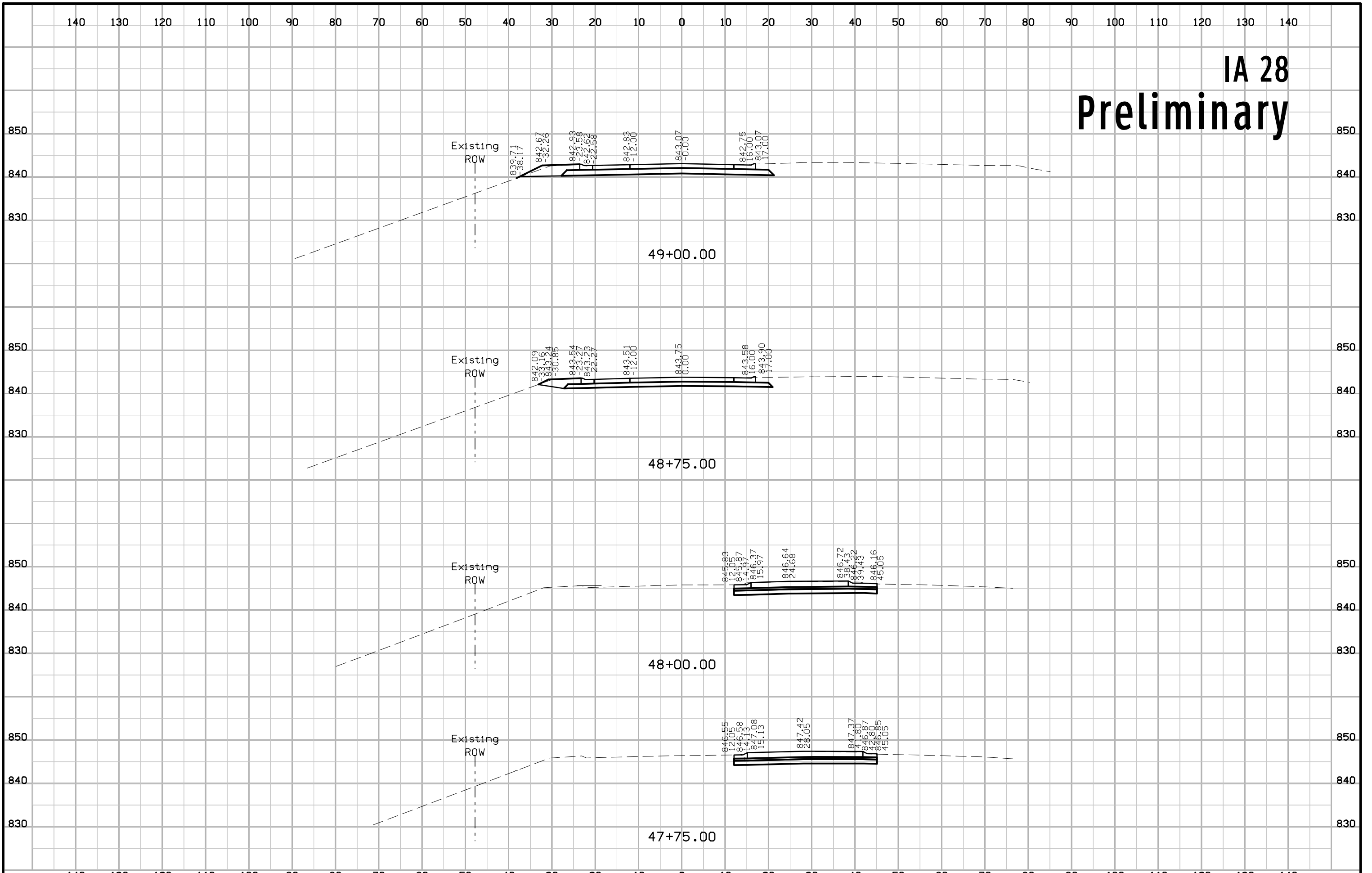

IA 28 Preliminary

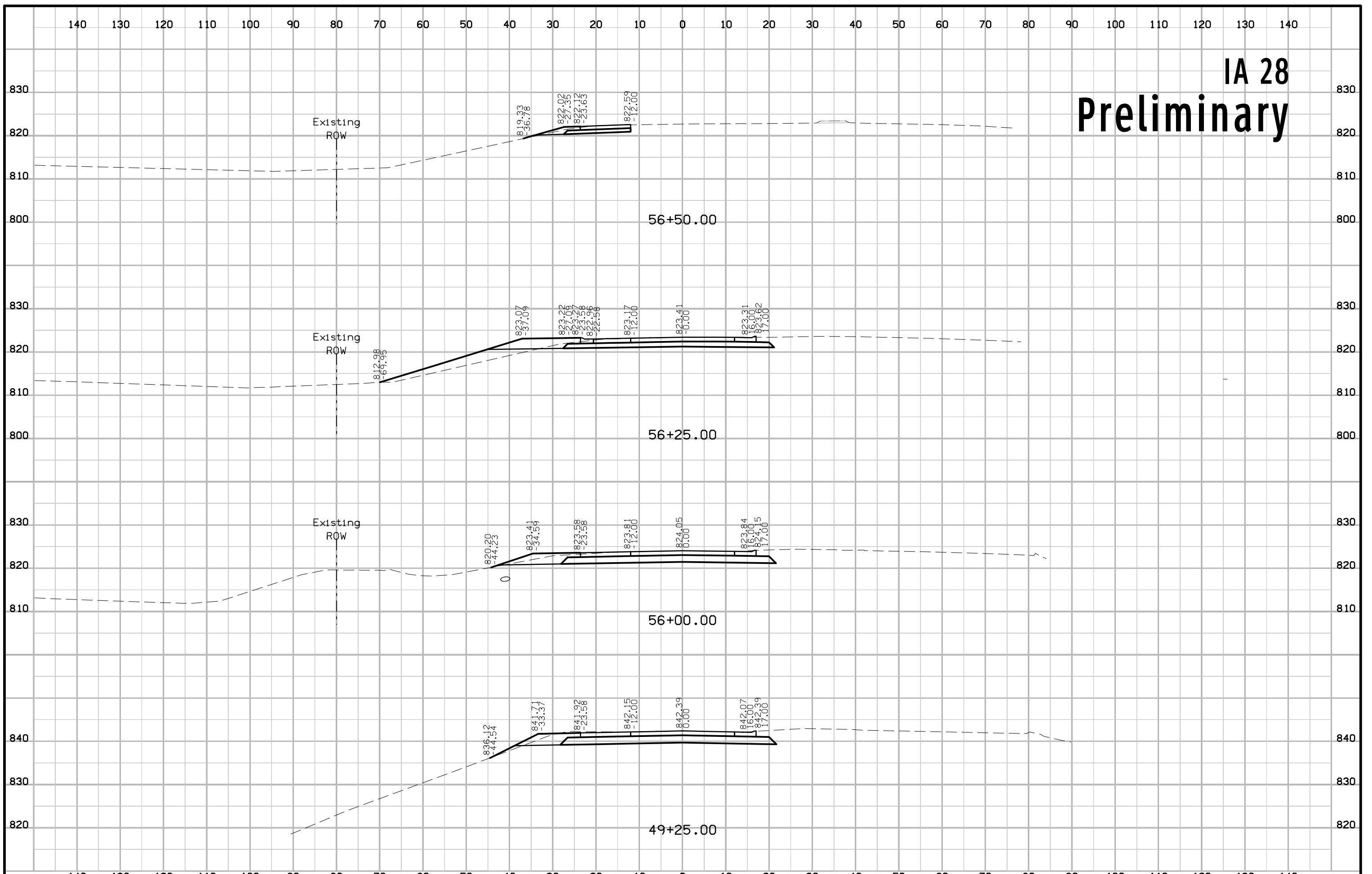

IA 28 Preliminary

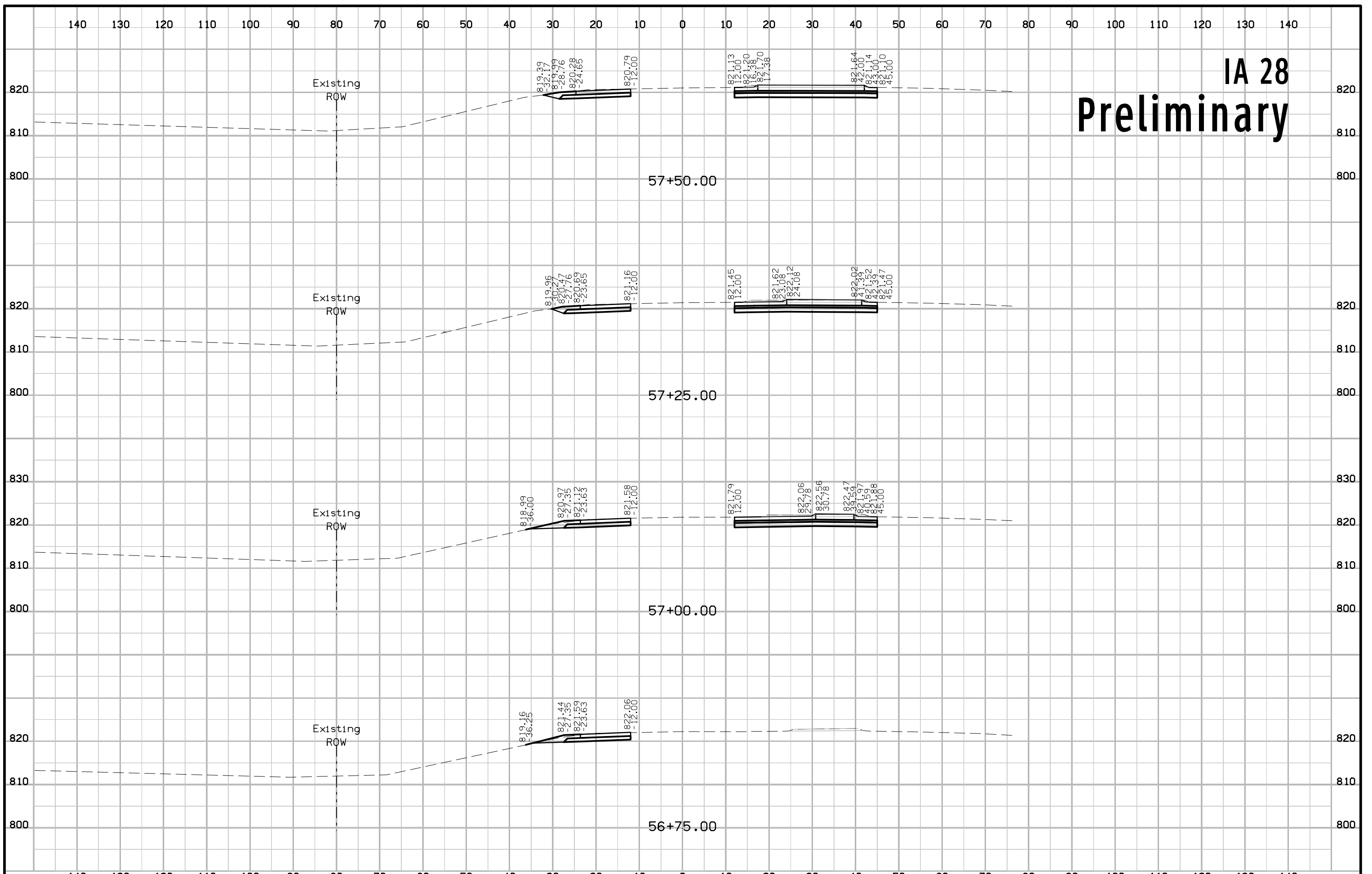

IA 28 Preliminary

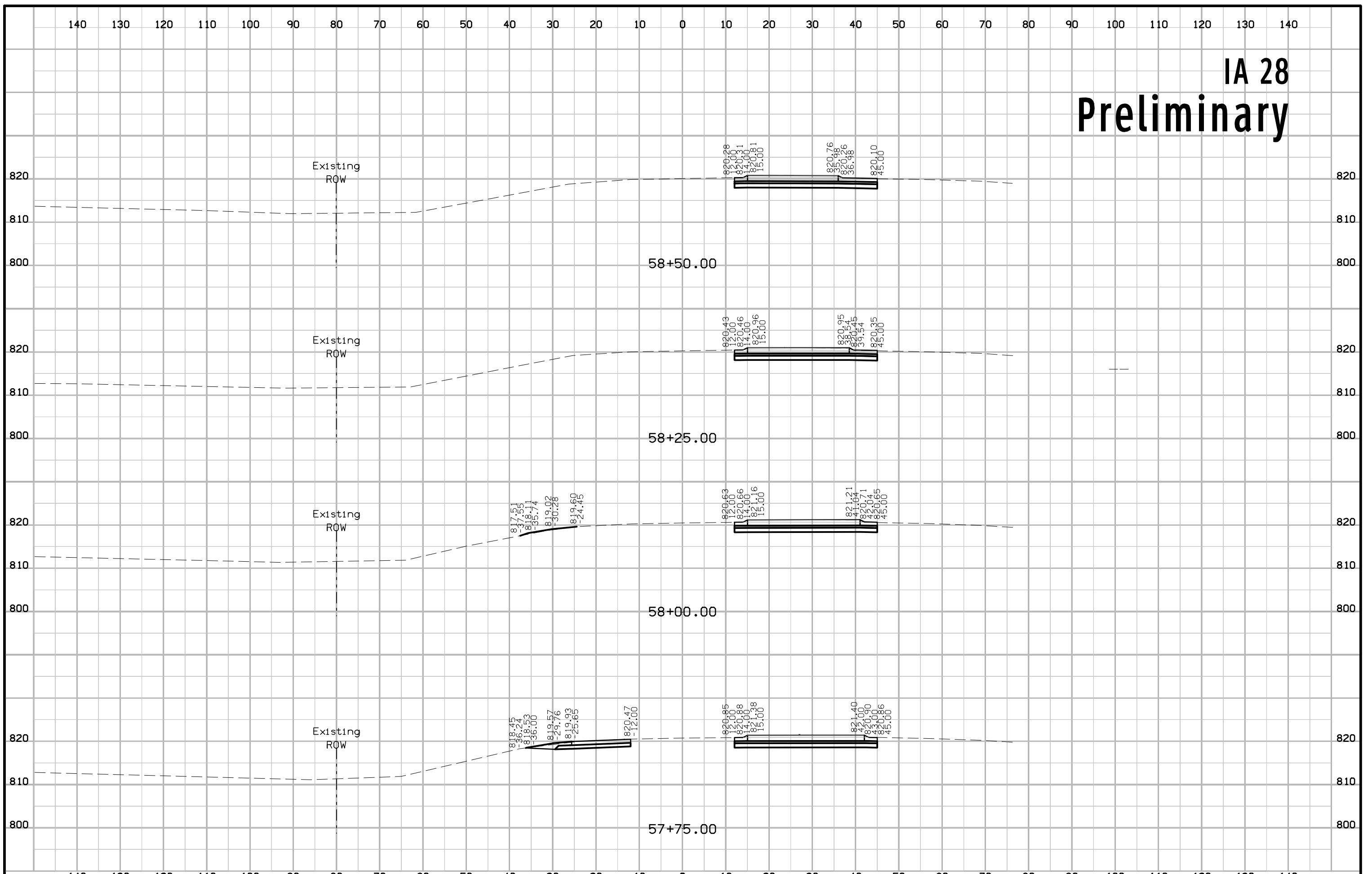

IA 28 Preliminary

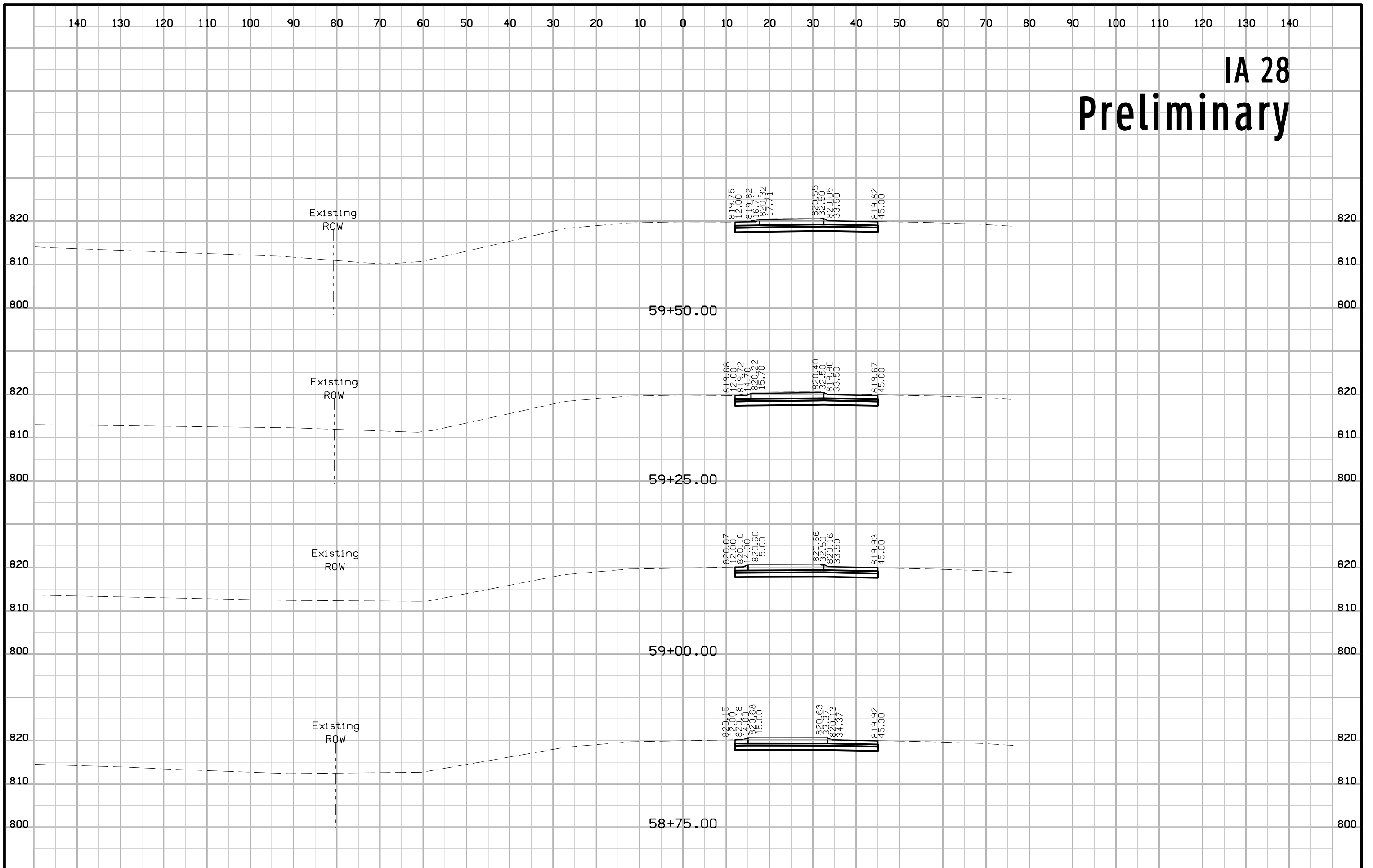

IA 28 Preliminary

