

BRIDGE REPLACEMENT-CCS  
 BRF-030-7(182)-38-57  
 LETTING DATE  
 01-01-2020

**LINN COUNTY**



**Highway Division**

PLANS OF PROPOSED IMPROVEMENT ON THE

**PRIMARY ROAD SYSTEM**

**LINN COUNTY**

**BRIDGE REPLACEMENT-PPCB**

US-30 OVER CEDAR RIVER  
 0.5 MILES W. OF E. JCT  
 US 151 (EB)

SCALES: As Noted

Refer to the Proposal Form for list of applicable specifications.

Value Engineering Saves. Refer to Article 1105.14 of the Specifications.

**IOWA ONE CALL**  
 1-800-292-8989  
 www.iowaonecall.com

REVISIONS

TOTAL

PROJECT IDENTIFICATION NUMBER	14-57-030-020
PROJECT NUMBER	BRF-030-7(182)-38.57
R.O.W. PROJECT NUMBER	

No.	DESCRIPTION
<b>A Sheets</b>	<b>Title Sheets</b>
* A.1	Title Sheet
<b>B Sheets</b>	<b>Typical Cross Sections and Details</b>
B.1 - 3	Typical Cross Sections and Details
<b>D Sheets</b>	<b>Mainline Plan and Profile Sheets</b>
* D.1	Plan & Profile Legend & Symbol Information Sheet
* D.2 - 7	US-30 Plan Sheets and Profile Sheets
<b>F Sheets</b>	<b>Detour or Temporary Pavement Sheets</b>
* F.1 - 2	Detour Plan and Profile Sheets
<b>G Sheets</b>	<b>Survey Sheets</b>
G.1 - 2	Reference Ties and Bench Marks
G.3	Horizontal Control Tab. and Super for all Alignments
<b>J Sheets</b>	<b>Traffic Control and Staging Sheets</b>
* J.1	Traffic Control Plan
* J.2	Traffic Control & Staging Legend & Symbol Info. Sheet
* J.3 - 9	Staging and Traffic Control Sheets Stage 2
<b>V Sheets</b>	<b>Bridge and Culvert Situation Plans</b>
* V.1 - 3	Bridge Situation Plans
* V.4	Bridge Site Plan
<b>W Sheets</b>	<b>Mainline Cross Sections</b>
W.1	Cross Sections Legend & Symbol Information Sheet
W.2 - 17	Mainline Cross Sections
<b>X Sheets</b>	<b>East Crossover Cross Sections</b>
X.1 - 6	East Crossover Sections
<b>Y Sheets</b>	<b>West Crossover Cross Sections</b>
Y.1 - 6	West Crossover Sections
	* Color Plan Sheets

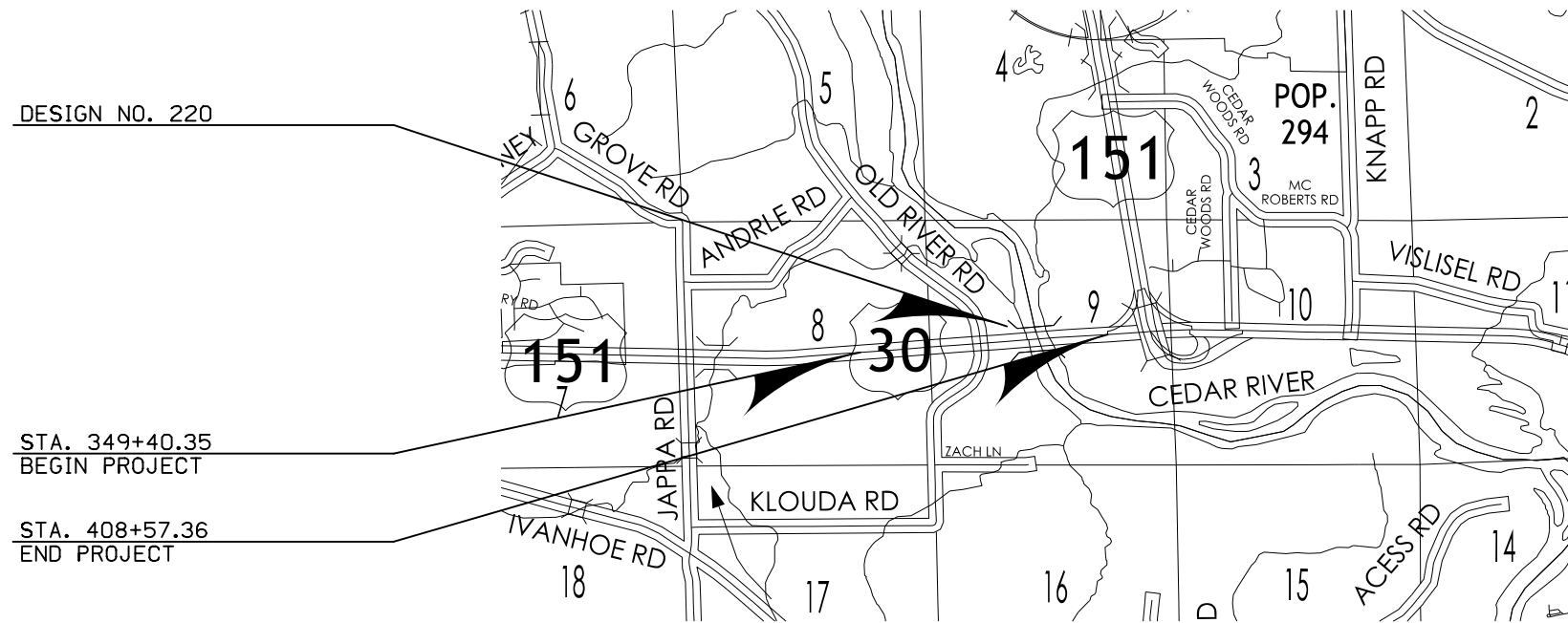

DESIGN NO. 220

STA. 349+40.35  
BEGIN PROJECT

STA. 408+57.36  
END PROJECT



Design Speed = 70 mph  
 Clear Zone = 34'

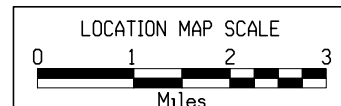
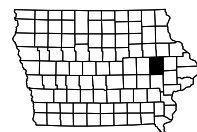

DESIGN DATA RURAL			
2020	AADT	27,700	V.P.D.
2040	AADT	39,800	V.P.D.
20--	DHV	--	V.P.H.
	TRUCKS	16	%
	Total Design ESALs	--	

INDEX OF SEALS		
SHEET NO.	NAME	TYPE
A.1	X	Primary Signature Block
X	X	X

**PRELIMINARY PLANS**

Subject to change by final design.

**D5 PLAN - Date: 6/2018**

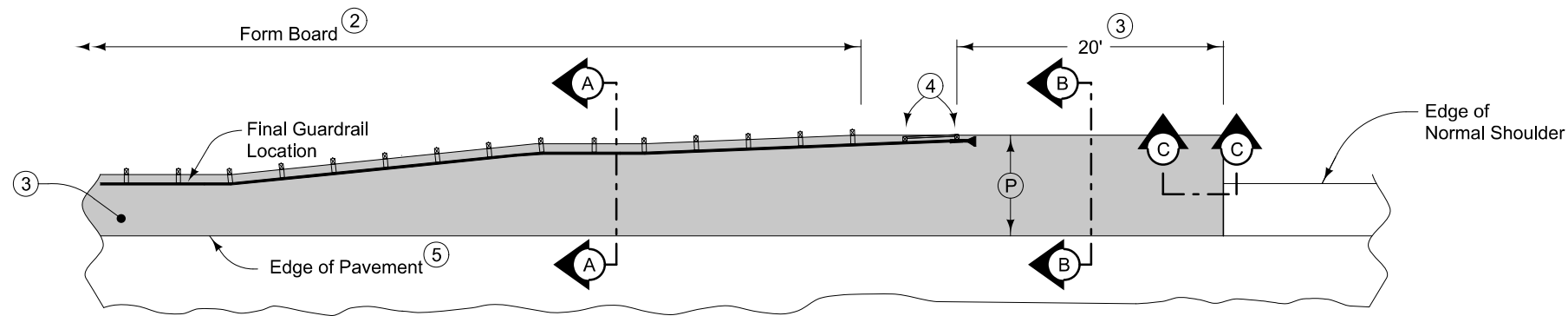

PLAN VIEW

9" HMA Paved Shoulder at guardrail. 8" PCC may be substituted with the following jointing layout:

Match mainline pavement joint spacing. When mainline pavement is 8" or greater in thickness, place additional transverse 'C' joints in shoulder at mid-panel of the mainline pavement. Place longitudinal 'C' joint at P/2 from edge of mainline pavement when P is greater than 10' wide. Terminate longitudinal joint at transverse joint less than 10' in length.

Compaction of HMA is required to face of guardrail post. Hand compaction will be allowed under guardrail. Removal and reinstallation of guardrail will be allowed with no additional payment.

Refer to Tabulation 112-9 for shoulder quantities.

- ① For subgrade treatment, refer to other details in the plan.
- ② PCC option only: When guardrail posts are installed prior to construction of PCC paved shoulder, fasten form board to the face of guardrail posts for the length shown. Refer to note 4 for final 2 posts.
- ③ Continue paved shoulder to existing paved shoulder or 20 feet beyond the center of the first post.
- ④ Shoulder may be notched for final 2 posts or post sleeves may be installed through pavement. Do not drive posts through pavement.
- ⑤ 'KT-1 joint for PCC shoulder.  
'B' joint for HMA shoulder.

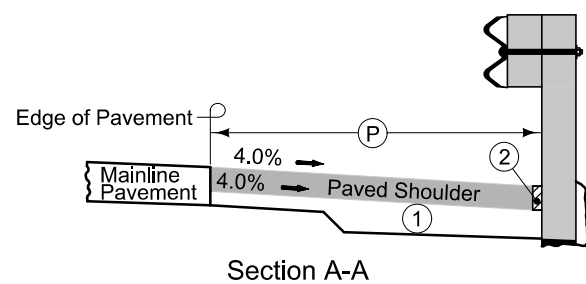

Section A-A

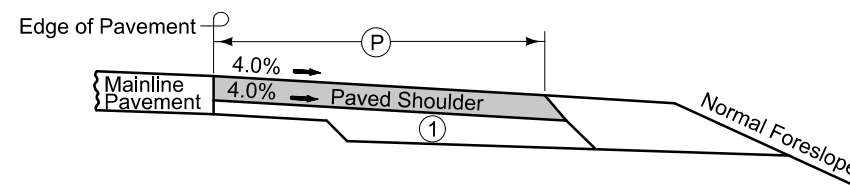

Section B-B

NEW CONSTRUCTION

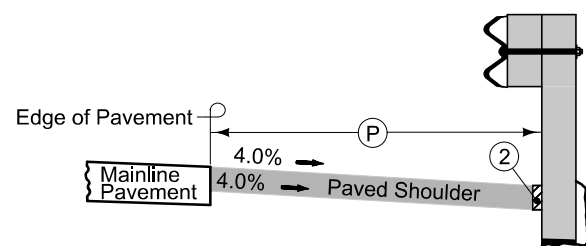

Section A-A

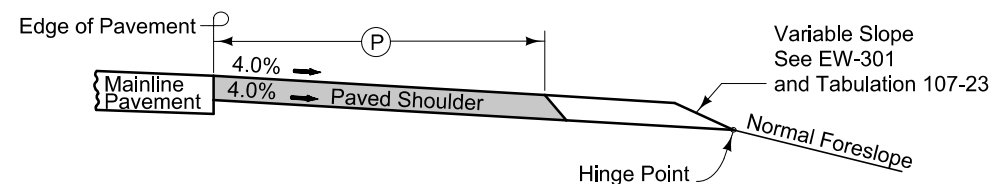

Section B-B

EXISTING SHOULDER

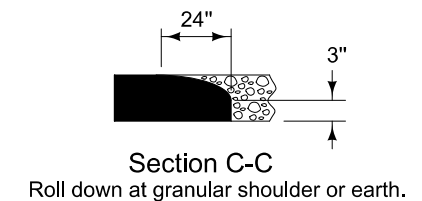

Section C-C  
Roll down at granular shoulder or earth.

PAVED SHOULDER AT GUARDRAIL

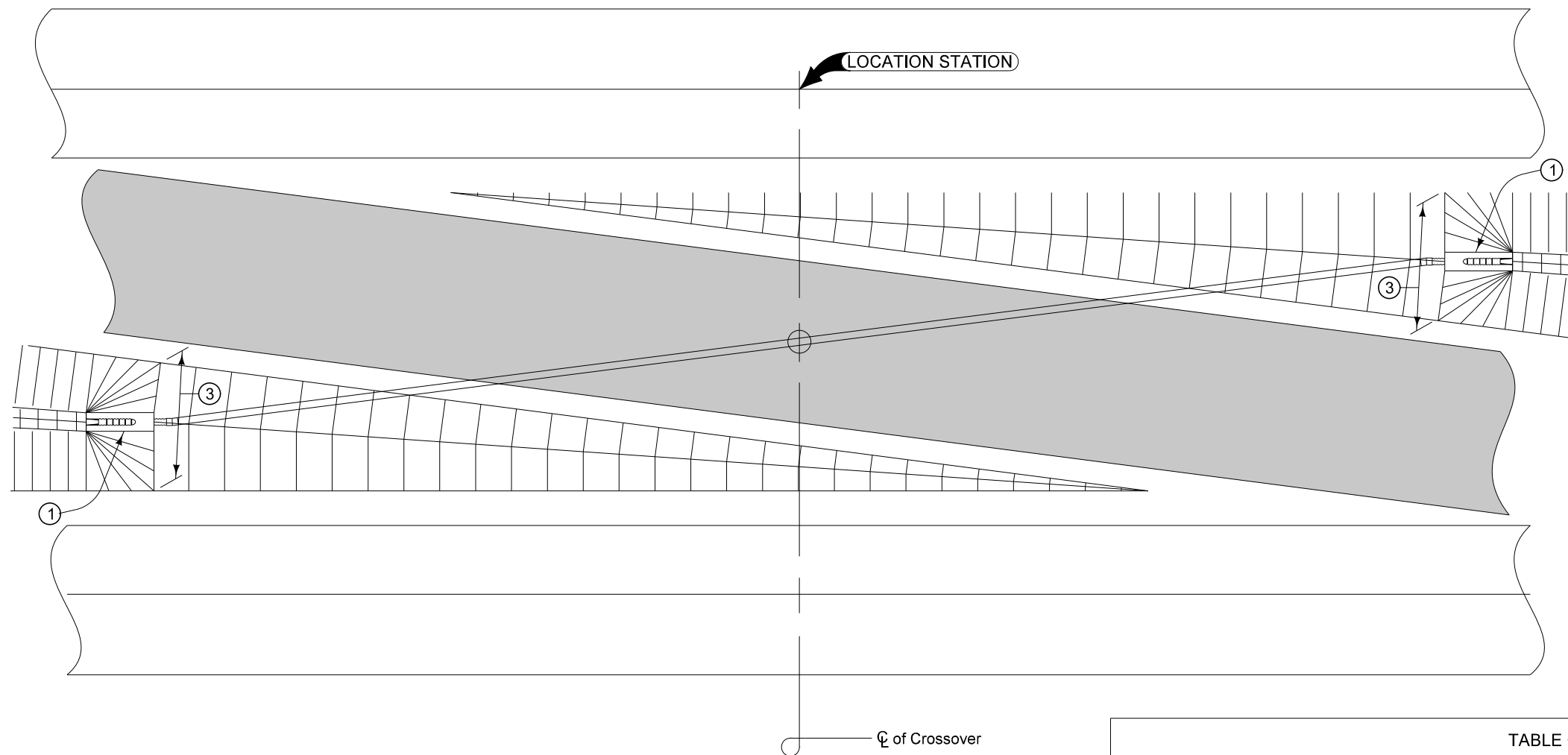

PLAN VIEW

- ① Beveled pipe and guard. See Standard Road Plan DR-212.
- ② Requires approximately 7 degree elbow.
- ③ Place the top edge of beveled pipe and guard at a point where the distance between the edges of the shoulders are approximately 22 feet apart.
- ④ Median ditch flow line.

TABLE OF QUANTITIES										
Standard Road Plan No.	PV-501	PV-502	PV-504	PV-505	PV-507	PV-508	PV-510	PV-511	PV-513	PV-514
Median Width	50.0'	50.0'	64.0'	64.0'	68.24'	68.24'	82.0'	82.0'	100.0'	100.0'
Crossover Pavement Width	16.0'	28.0'	16.0'	28.0'	16.0'	28.0'	16.0'	28.0'	16.0'	28.0'
Bid Item										
18" dia. Unclassified Entrance Pipe Culvert	250'	344'	112'	196'	82'	162'	56'	74'	148'	88'

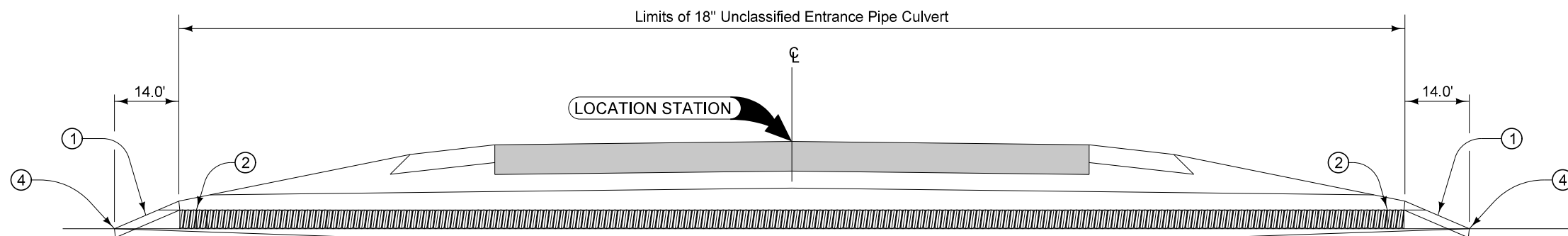

LONGITUDINAL SECTION AT PIPE CENTERLINE

Possible Contract Items:  
 Beveled Pipe and Guard.  
 Culvert, Unclassified Entrance Pipe, 18" Dia.  
 Embankment-In-Place  
 Excavation, Class 10, Roadway and Borrow  
 Special Backfill

Possible Tabulation:  
 112-8

7154B  
10-20-09

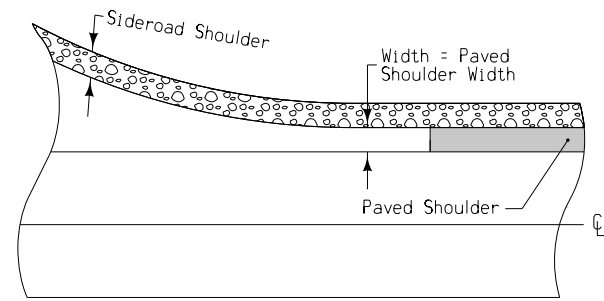

With Newly Constructed Returns

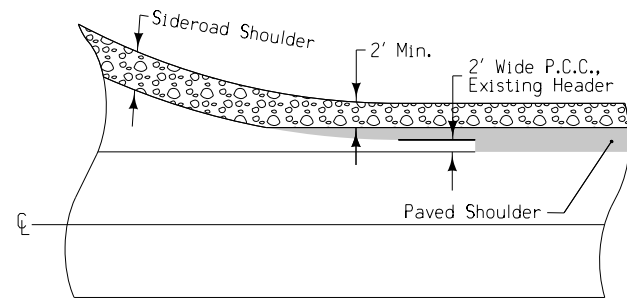

At UAC Returns

PAVED SHOULDER  
DETAIL AT RETURNS

### SURVEY SYMBOLS

-  U.S. Highway Symbol
-  Iowa Highway Symbol
-  Evergreen Tree
-  Deciduous Tree
-  Timber
-  Stump
-  Swamp
-  Revetment (Rip Rap)
-  Wire Fence
-  Earth Dam or Dike (Existing)
-  Tile Outlet
-  Edge of Water
-  Existing Drainage
-  Luminaire
-  TVP Television Pedestal
-  Power Pole
-  Power Riser Pole
-  Electrical Highline Tower (Metal or Concrete)
-  Existing Fiber Optics Telephone Line
-  Existing Power Line
-  Fiber Optic Hand Hole

### UTILITY OWNERS

ALLIANT ENERGY  
 Laura Barr  
 319-286-1315  
 locate\_IPL@alliantenergy.com

CENTURYLINK  
 Tom Sturmer  
 720-578-8090  
 Thomas.sturmer@centurylink.com

IOWA COMMUNICATIONS NETWORK  
 DOUG EBELSHEISER  
 515-725-4742  
 doug.ebelsheiser@iowa.gov













IOWA DEPARTMENT OF TRANSPORTATION  
 Johnny Shanahan  
 319-350-1764  
 johnny.shanahan@dot.iowa.us

LINN COUNTY REC  
 Johna Nunemaker  
 319-377-1587  
 nunemaker@linncountyrec.com







MEDIACOM  
 SHELLEY MARTIN OR DON COOK  
 319-395-9699  
 shmartin@mediacomcc.com, dcook@mediacomcc.com









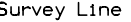

SOUTH SLOPE COOPERATIVE TELEPH  
 Brian Frese  
 319-227-7111  
 brian@southslope.com

### PLAN VIEW COLOR LEGEND OF PLAN AND PROFILE SHEETS

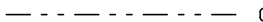
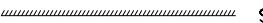
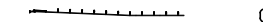

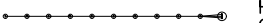





LINEWORK		Design Color No.	
Green	(2)		Existing Topographic Features and Labels
Blue	(1)		Proposed Alignment, Stationing, Tic Marks, and Alignment Annotation
Magenta	(5)		Existing Utilities
SHADING		Design Color No.	
Yellow	(4)		Highlight for Critical Notes or Features
Red	(3)		Delineates Restricted Areas
Lavender	(9)		Temporary Pavement Shading
Gray, Light	(48)		Proposed Pavement Shading
Gray, Med	(80)		Proposed Granular Shading
Gray, Dark	(112)		Proposed Grade and Pave Shading "In conjunction with a paving project"
Brown, Light	(236)		Grading Shading
Tan	(8)		Proposed Sidewalk Shading
Blue, Light	(230)		Proposed Sidewalk Landing Shading
Pink	(11)		Proposed Sidewalk Ramp Shading

### PROFILE VIEW COLOR LEGEND OF PLAN AND PROFILE SHEETS

LINEWORK		Design Color No.	
Green	(2)		Existing Ground Line Profile
Blue	(1)		Proposed Profile and Annotation
Magenta	(5)		Existing Utilities
Blue, Light	(230)		Proposed Ditch Grades, Left
Black	(0)		Proposed Ditch Grades, Median
Rust	(14)		Proposed Ditch Grades, Right

-  Reference Point
-  Station
-  Survey Line
-  Section Corner
-  Ground Line Intercept
-  Saw Cut
-  Guardrail
-  Trench Drain
-  HighTension Cable Guardrail
-  Sheet Pile
-  Pavement Removal
-  Rock Flume

### RIGHT-OF-WAY LEGEND

-  Proposed Right-of-Way
-  Existing Right of Way
-  Existing and Proposed Right-of-Way
-  Easement and Existing Right-of-Way
-  Easement (Temporary)
-  Easement
-  Access Control
-  Property Line

# PLAN AND PROFILE LEGEND AND SYMBOL INFORMATION SHEET

(COVERS SHEET SERIES D, E, F, & K)

Sta. 374+00.65, 139.60' LT CL30EB  
Remove Apron  
Install 9.0' - 24" C.M.P. Plus Apron  
F.L. = Lt.  
Ot.



Sta. 377+40 CL30EB  
Abandon 4' x 5.5' R.C.B. (Cattle Pass)

Sta. 377+42, 243.46' LT CL30EB  
Remove 24" x 46.43' C.M.P.

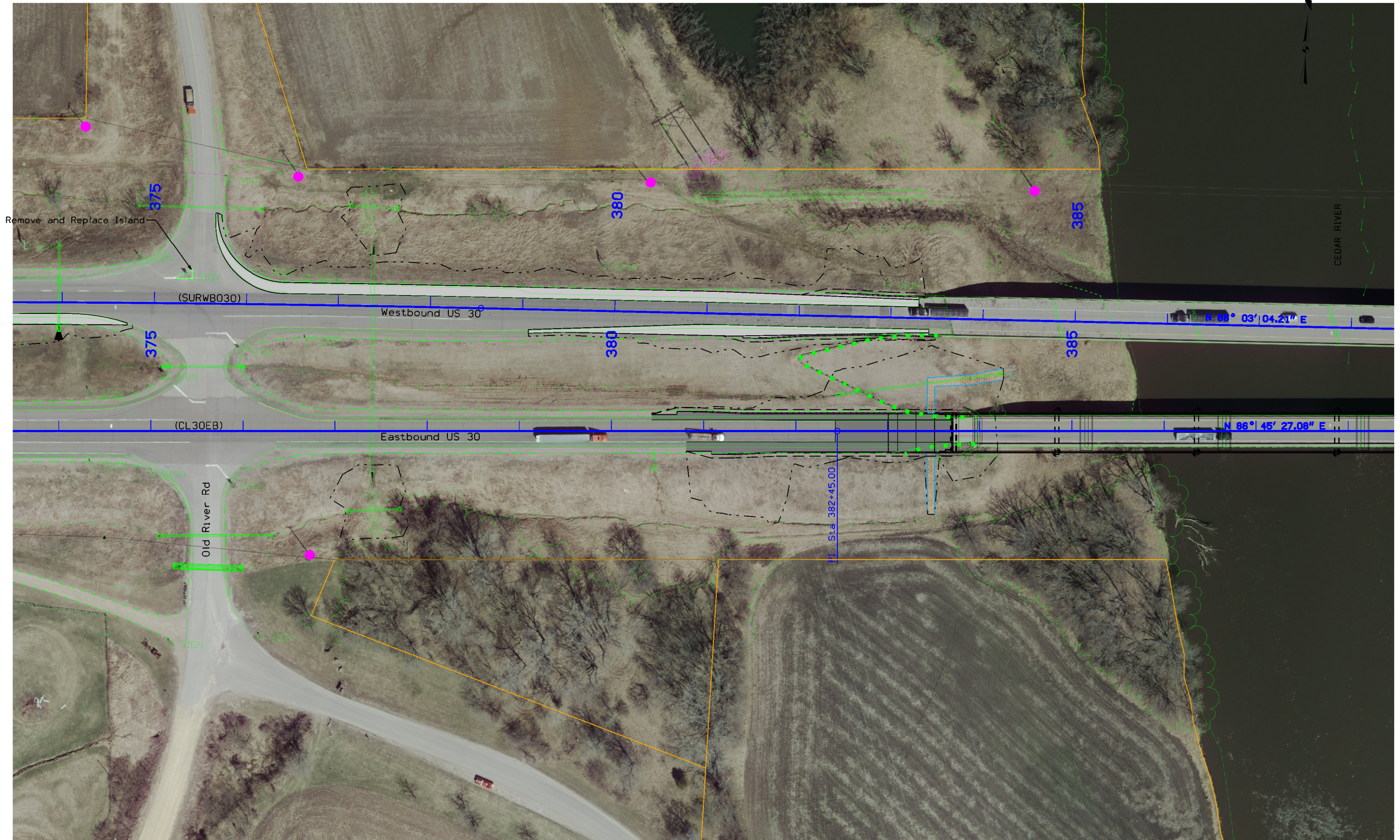

Sta. 377+42, 86' RT CL30EB  
Remove 24" x 52.21' C.M.P.  
Remove Aprons



Sta. 383+36, 51.03' LT CL30EB  
Remove 24" x 46.43' C.M.P.  
Remove Apron

For Bridge Replacement Details,  
Refer to Bridge Sheets

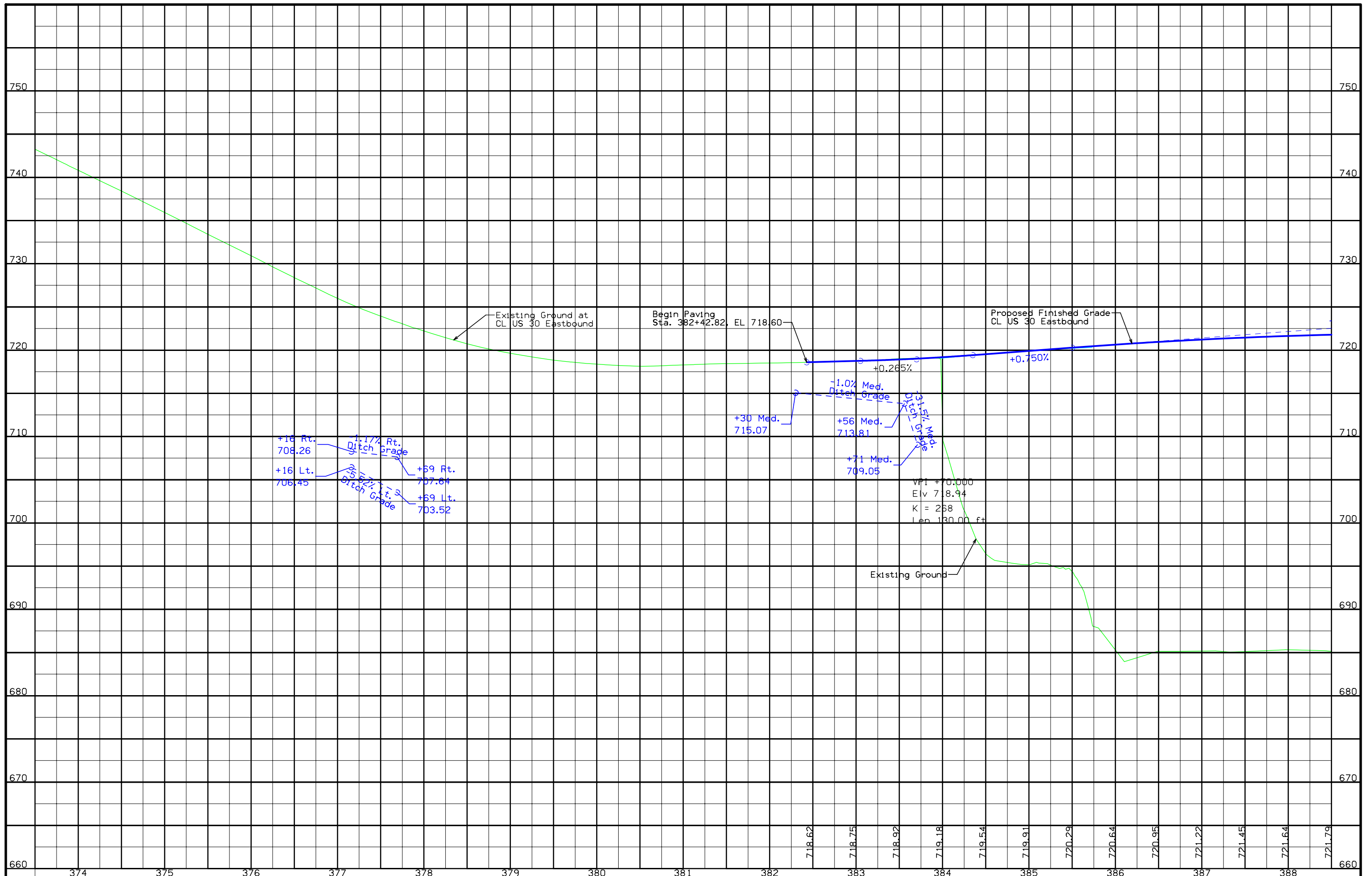





For Bridge Replacement Details,  
Refer to Bridge Sheets

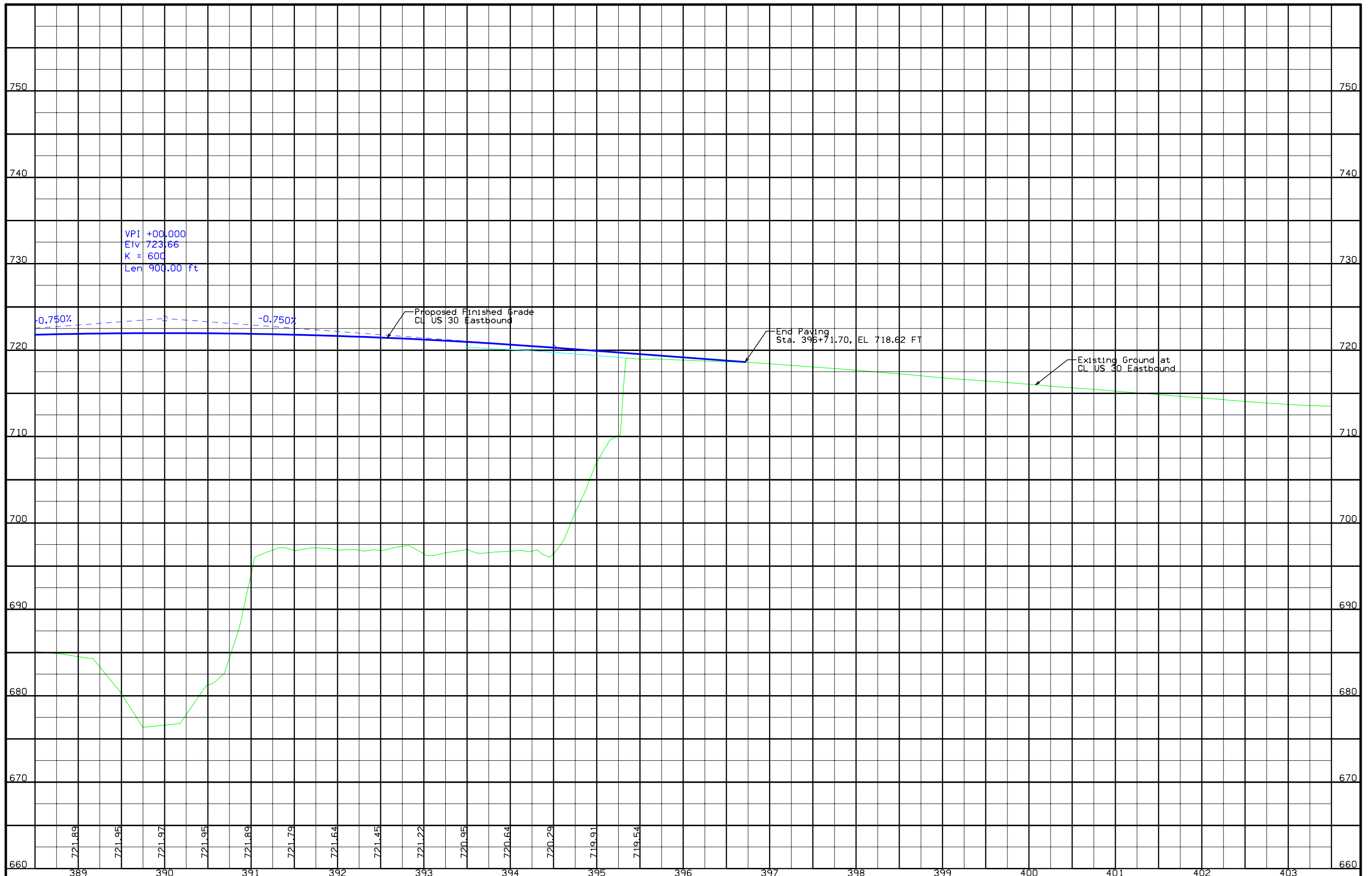

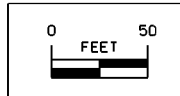
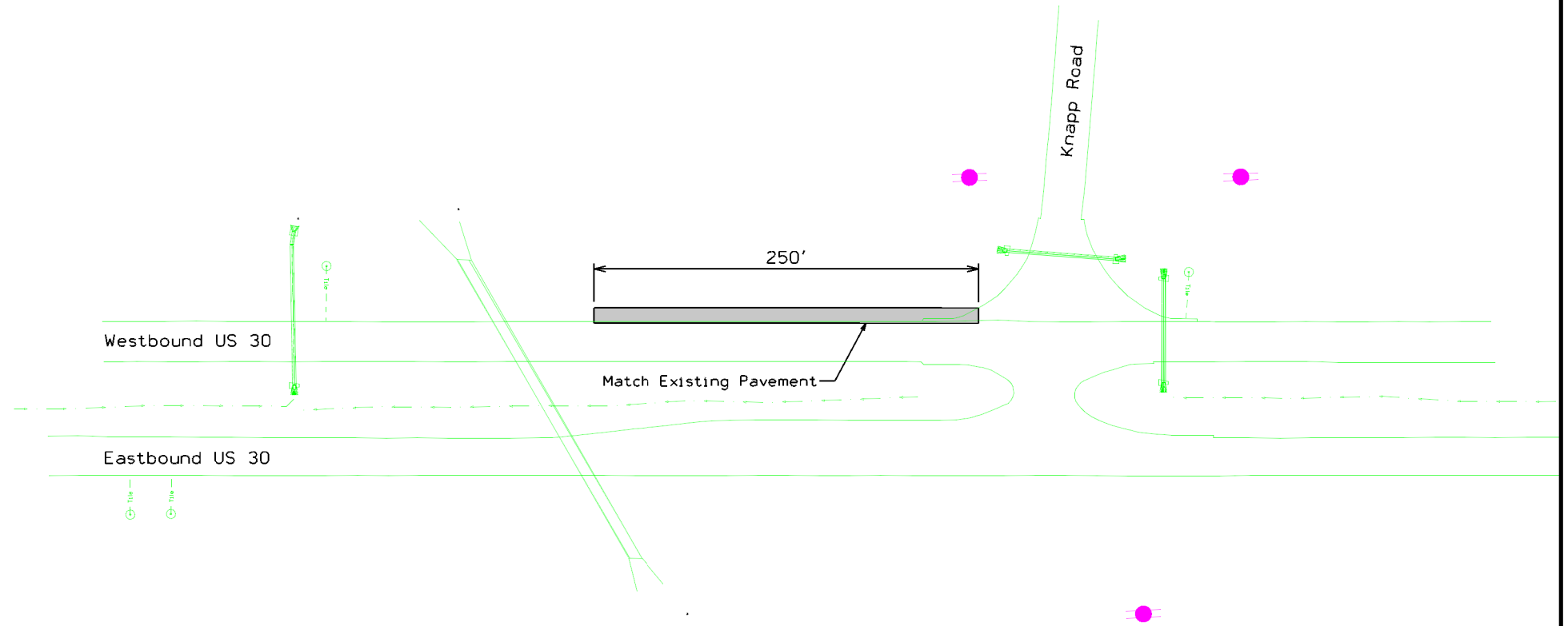

Sta. 9+37.84 WEST CROSSOVER  
 Install 308.0' - 24" C.M.P.  
 Rt. 798.25  
 Lt. 790.94

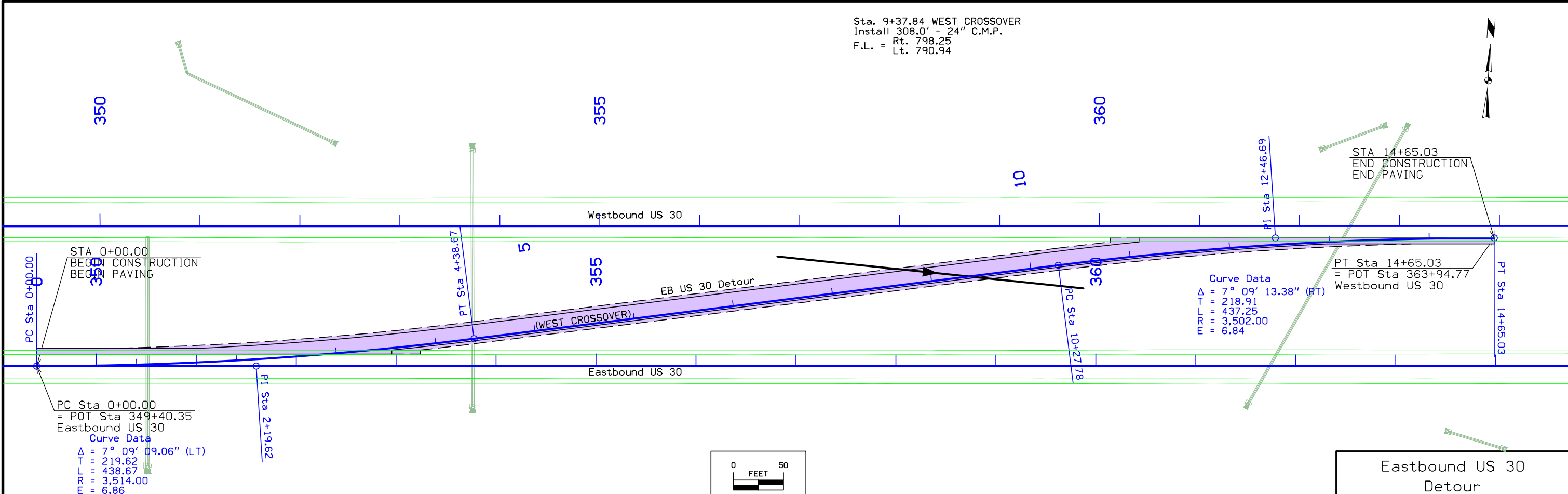

STA 0+00.00  
 BEGIN CONSTRUCTION  
 BEGIN PAVING

PC Sta 0+00.00  
 = POT Sta 349+40.35  
 Eastbound US 30  
 Curve Data  
 $\Delta = 7^\circ 09' 09.06''$  (LT)  
 T = 219.62  
 L = 438.67  
 E = 3,514.00  
 R = 6.86

Curve Data  
 $\Delta = 7^\circ 09' 13.38''$  (RT)  
 T = 218.91  
 L = 437.25  
 E = 3,502.00  
 R = 6.84

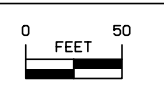

Eastbound US 30  
 Detour

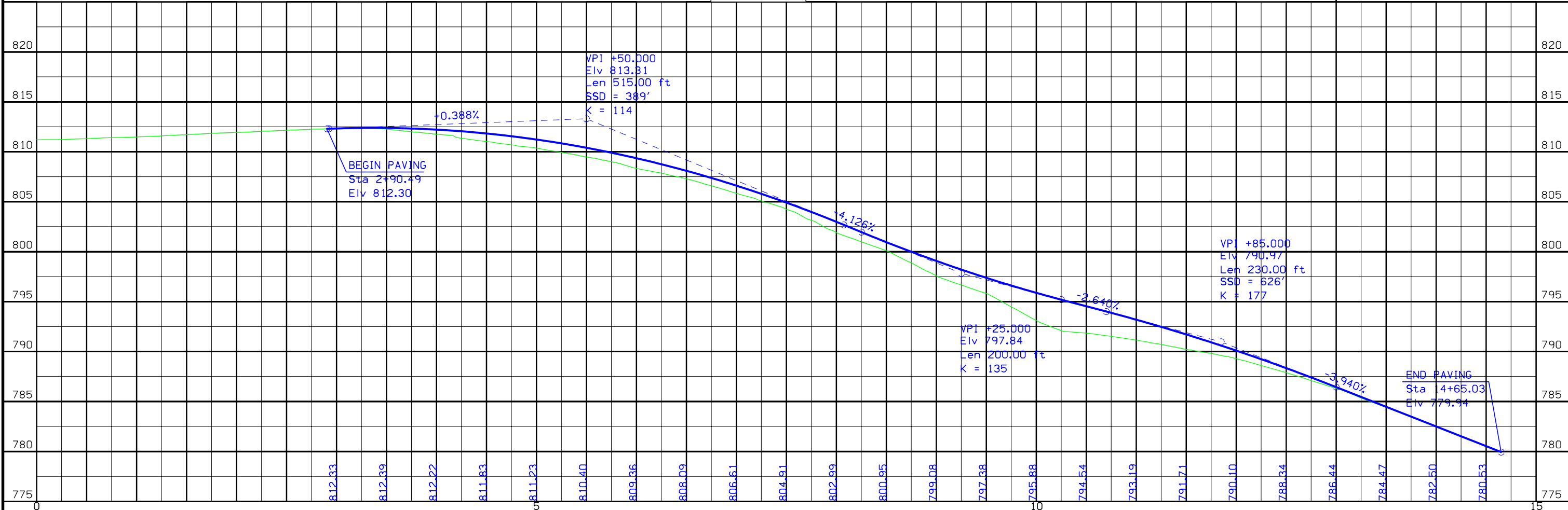

Sta. 4+11.81 EAST CROSSOVER  
 Install 210.6' - 24" C.M.P.  
 Rt. 713.41  
 F.L. = Ot. 710.47

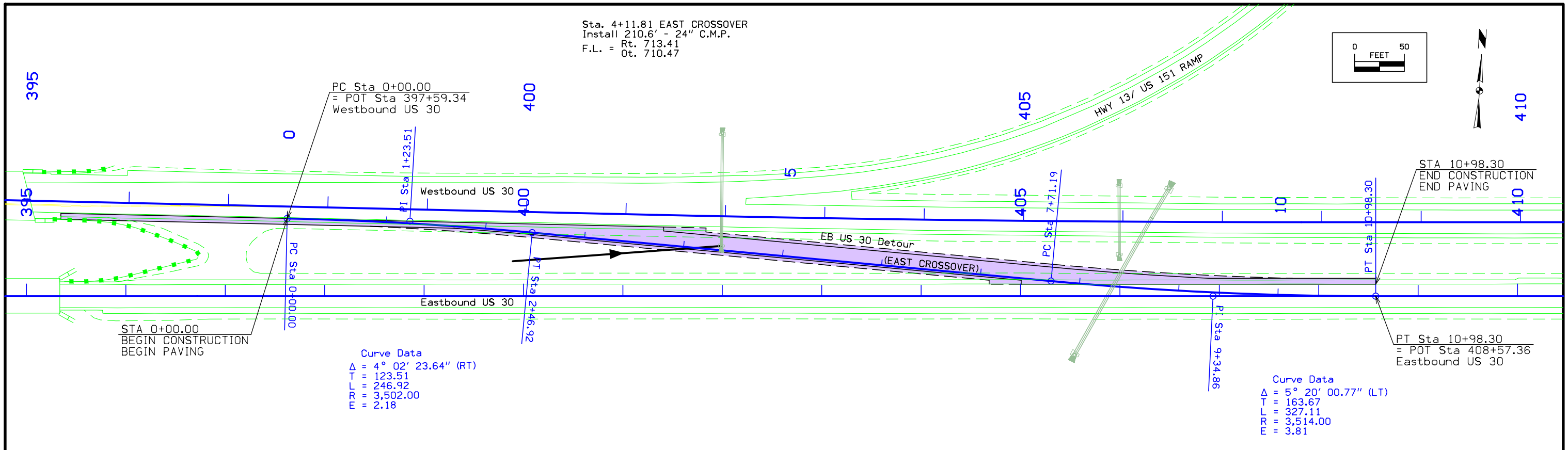
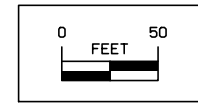

Curve Data  
 $\Delta = 4^\circ 02' 23.64''$  (RT)  
 T = 123.51  
 L = 246.92  
 R = 3,502.00  
 E = 2.18

Curve Data  
 $\Delta = 5^\circ 20' 00.77''$  (LT)  
 T = 163.67  
 L = 327.11  
 R = 3,514.00  
 E = 3.81

Eastbound US 30  
 Detour

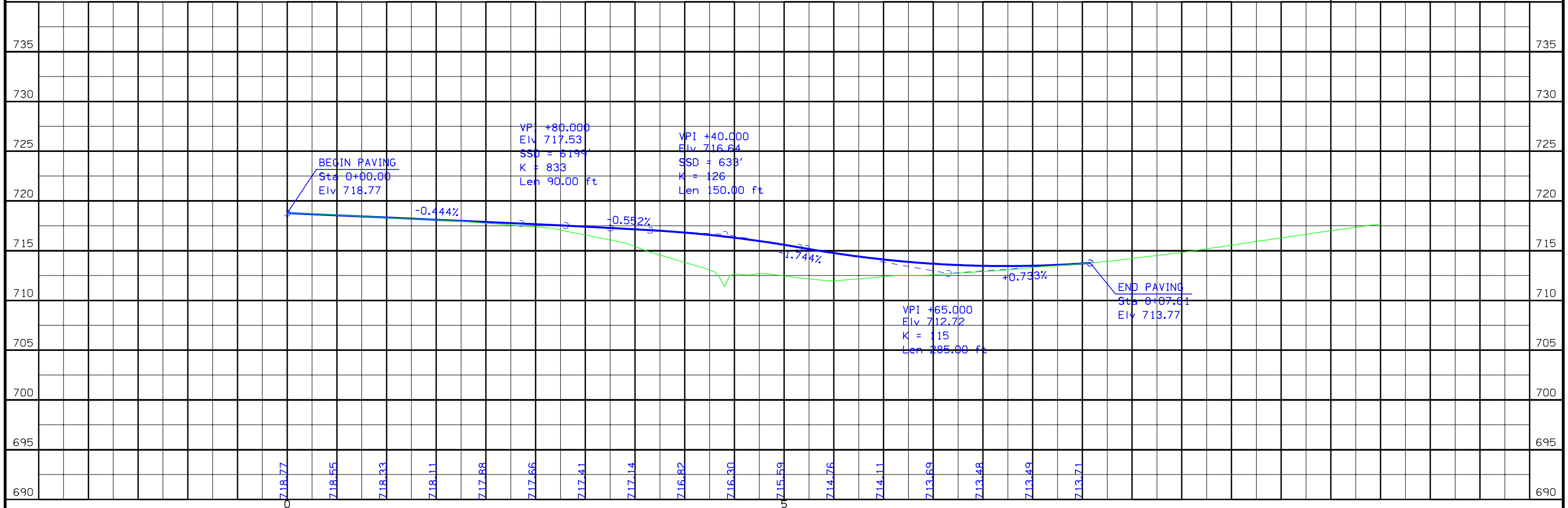

Survey Information

2017-07-20  
 BRF-030-7(182)--38-57  
 NAD83(2011) (EPOCH2010.00)  
 laRTN 2013 Adjustment  
 laRCS ZONE 10 US Feet  
 NAVD88 (Computed using Geoid12B)  
 Design Survey Office

Vertical Control

Point	North	East	Elevation	Description
321,	8033630.679,	20530416.940,	722.659,	FENO SET FENO MONUMENT
322,	8034138.474,	20533527.240,	726.916,	FENO SET FENO MONUMENT
323,	8034183.720,	20533960.030,	741.934,	CP 1/2 INCH REBAR ENCASED IN CONC MONU LEANING EAST
324,	8033702.091,	20538443.200,	717.637,	FENO SET FENO MONUMENT

Project Summary

Linn County BRF-030-7(182)--38-57 Cedar River 0.5 mi W of E Jct US 151 (EB) Project name: US 30 static.ttp  
 Surveyor: Jonathan Miranda  
 Comment: GPS network adjustment Marion Iartn position was held fixed for the network solution.  
 Linear unit: USFeet Projection: laRCS Zone 10 Geoid: g2012bu3 Adjustment Summary

Adjustment type: Plane + Height, Minimal constraint Confidence level: 95 %

Number of adjusted points: 9 Number of plane control points: 1 Number of used GPS vectors: 63

Number of rejected GPS vectors by plane: 2

A posteriori plane UWE: 0.9543276 , Bounds: ( 0.865455 , 1.134309 ) Number of height control points: 1

A posteriori height UWE: 0.8752673 , Bounds: ( 0.8134049 , 1.186162 )

GPS Observation Residuals

Name dN (USft)

CP321-CP323 553.038 dE (USft)  
 3543.087 dHt (USft) Horz RMS (USft) Vert RMS (USft)  
 19.243 0.002 0.004

CP321-IAAN65125.999 80836.896 132.234 0.035 0.061  
 CP321-IACI -78363.237 -14734.374 112.928 0.027 0.047  
 CP321-IAIN 189055.811 -88973.254 276.379 0.064 0.106  
 CP321-IAMN 38169.575 1616.461 138.294 0.013 0.023  
 CP321-IATA 16363.624 -271029.229 198.638 0.073 0.122  
 CP322-CP323 45.248 432.797 15.015 0.002 0.003  
 CP322-IAAN64618.177 77726.603 127.900 0.037 0.057  
 CP322-IACI -78871.035 -17844.651 108.846 0.028 0.047  
 CP322-IAIN 188548.001 -92083.528 271.988 0.067 0.105  
 CP322-IAMN 37661.744 -1493.839 134.042 0.014 0.022  
 CP322-IATA 15855.799 -274139.498 194.504 0.076 0.121

CP323-CP324 -481.629 4483.174 -24.343 0.003 0.004  
 CP323-IAAN64572.931 77293.854 112.937 0.036 0.058  
 CP323-IAAN64572.925 77293.802 112.888 0.035 0.058  
 CP323-IAAN64572.964 77293.803 113.011 0.034 0.059  
 CP323-IACI -78916.273 -18277.461 93.695 0.028 0.047  
 CP323-IACI -78916.287 -18277.447 93.833 0.028 0.047  
 CP323-IACI -78916.286 -18277.389 93.867 0.029 0.047  
 CP323-IAIN 188502.797 -92516.330 257.129 0.064 0.107  
 CP323-IAIN 188502.747 -92516.319 256.984 0.065 0.106  
 CP323-IAIN 188502.708 -92516.198 257.041 0.073 0.102  
 CP323-IAMN 37616.541 -1926.634 119.056 0.013 0.022  
 CP323-IAMN 37616.491 -1926.637 119.030 0.013 0.022  
 CP323-IAMN 37616.511 -1926.575 118.998 0.014 0.022  
 CP323-IATA 15810.548 -274572.294 179.505 0.074 0.122  
 CP323-IATA 15810.550 -274572.220 179.498 0.076 0.120  
 CP323-IATA 15810.613 -274572.322 179.410 0.075 0.121  
 CP324-IAAN65054.557 72810.672 137.284 0.035 0.056  
 CP324-IACI -78434.654 -22760.577 118.206 0.029 0.047  
 CP324-IAIN 188984.344 -96999.414 281.402 0.067 0.106  
 CP324-IAMN 38098.140 -6409.756 143.344 0.014 0.023  
 CP324-IATA 16292.185 -279055.403 203.839 0.077 0.121

IAAN-IACI -143489.228 -95571.262 -19.265 0.057 0.098  
 IAAN-IACI -143489.199 -95571.249 -19.113 0.056 0.098  
 IAAN-IACI -143489.209 -95571.250 -19.077 0.058 0.097  
 IAAN-IAIN 123929.830 -169810.136 144.163 0.063 0.108  
 IAAN-IAIN 123929.825 -169810.125 144.065 0.065 0.107  
 IAAN-IAIN 123929.802 -169810.105 144.129 0.061 0.109  
 IAAN-IAMN -26956.426 -79220.437 6.125 0.029 0.048  
 IAAN-IAMN -26956.414 -79220.431 6.072 0.029 0.048  
 IAAN-IAMN -26956.414 -79220.438 6.050 0.028 0.049  
 IAAN-IATA -48762.378 -351866.103 66.568 0.086 0.137  
 IAAN-IATA -48762.374 -351866.073 66.545 0.083 0.139  
 IAAN-IATA -48762.369 -351866.114 66.423 0.082 0.140  
 IACI-IAIN 267419.046 -74238.876 163.422 0.075 0.122  
 IACI-IAIN 267419.033 -74238.873 163.143 0.074 0.122  
 IACI-IAIN 267419.013 -74238.862 163.191 0.072 0.124  
 IACI-IAMN 116532.808 16350.821 25.333 0.040 0.068  
 IACI-IAMN 116532.783 16350.807 25.202 0.041 0.068

IACI-IAMN 116532.785 16350.818 25.189 0.040 0.068  
 IACI-IATA 94726.855 -256294.856 85.698 0.072 0.122  
 IACI-IATA 94726.831 -256294.854 85.640 0.074 0.121  
 IACI-IATA 94726.839 -256294.828 85.636 0.072 0.123  
 IAIN-IAMN -150886.240 90589.699 -138.107 0.058 0.098  
 IAIN-IAMN -150886.214 90589.673 -138.062 0.056 0.100  
 IAIN-IAMN -150886.254 90589.684 -137.927 0.059 0.098  
 IAIN-IATA -172692.201 -182055.979 -77.505 0.071 0.117  
 IAIN-IATA -172692.196 -182055.979 -77.726 0.071 0.116  
 IAIN-IATA -172692.166 -182055.967 -77.564 0.068 0.118  
 IAMN-IATA -21805.954 -272645.678 60.378 0.072 0.122  
 IAMN-IATA -21805.954 -272645.660 60.434 0.074 0.121  
 IAMN-IATA -21805.960 -272645.639 60.487 0.073 0.122

Control Points

Name Grid Northing (USft) Grid Easting (USft) Elevation (USft) Code  
 IAMN 8071800.231 20532033.431 860.432

Adjusted Points

Name Grid Northing (USft) Grid Easting (USft) Elevation (USft) Code  
 CP321 8033630.675 20530416.962 722.658 CP  
 CP322 8034138.470 20533527.253 726.916 CP  
 CP323 8034183.716 20533960.047 741.934 CP  
 CP324 8033702.087 20538443.214 717.637 CP

C.P. STA. 373+43.92, RT. 34.60' CL EASTBOUND US 30  
C.P. 321 FOUND FENO SET FENO MONUMENT  
N: 8033630.679, E: 20530416.940

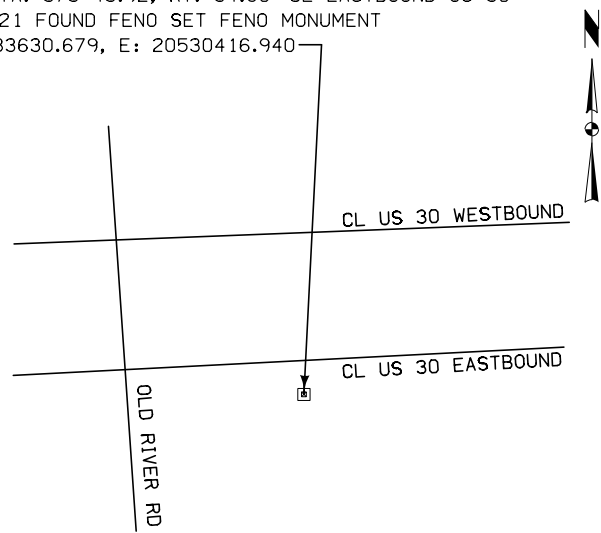

C.P. STA. 408+77.97, LT. 276.45' CL EASTBOUND US 30  
C.P. 322 FOUND FENO SET FENO MONUMENT  
N: 8034138.474, E: 20533527.240

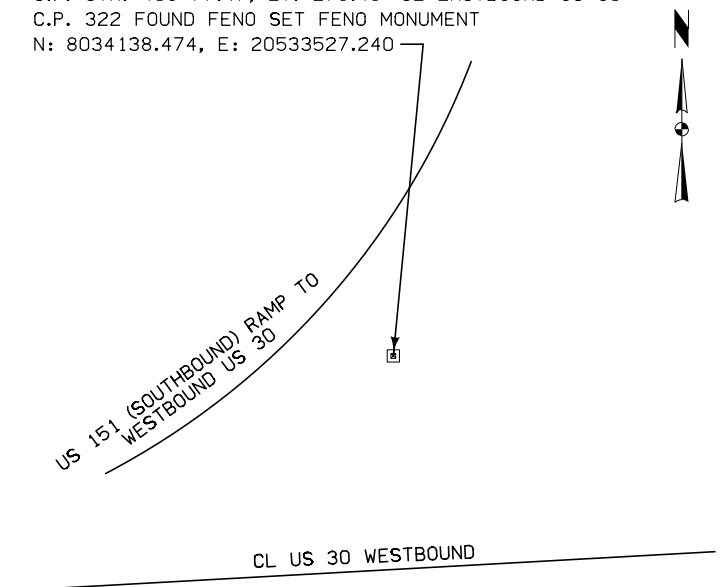

C.P. 323 CP 1/2 INCH REBAR ENCASED IN CONC.  
MONUMENT LEANING EAST  
N: 8034183.720, E: 20533960.030

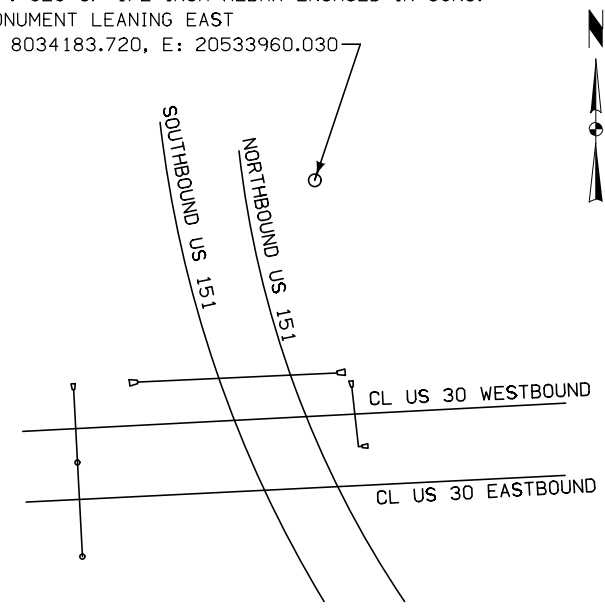

C.P. 324 FOUND FENO SET FENO MONUMENT  
N: 8033702.091, E: 20538443.200

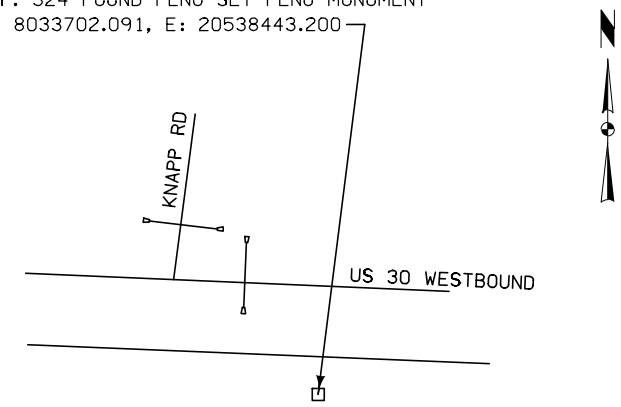

# ALIGNMENT COORDINATES

101-16  
10-20-09

Name	Location	Point on Tangent			Begin Spiral			Begin Curve			Simple Curve PI or Master PI of SCS			End Curve			End Spiral		
		Station	Coordinates		Station	Coordinates		Station	Coordinates		Station	Coordinates		Station	Coordinates		Station	Coordinates	
			Y (Northing)	X (Easting)		Y (Northing)	X (Easting)		Y (Northing)	X (Easting)		Y (Northing)	X (Easting)		Y (Northing)	X (Easting)		Y (Northing)	X (Easting)
CL30EB																			
CLEB01	EASTBOUND US 30	339+78.50	8,033,451.80	20,526,655.61															
CLEB02	EASTBOUND US 30	357+28.99	8,033,551.07	20,528,403.28															
CLEB03	EASTBOUND US 30	368+44.63	8,033,614.35	20,529,517.13															
CLEB06	EASTBOUND US 30	382+45.00	8,033,693.58	20,530,915.26															
CLEB05	EASTBOUND US 30	412+28.99	8,033,862.36	20,533,894.47															
SURWB030																			
WB3	WESTBOUND US 30	339+74.75	8,033,591.58	20,526,647.68															
C2	WESTBOUND US 30							372+54.31	8,033,777.48	20,529,921.97	375+54.60	8,033,794.50	20,530,221.76	378+54.85	8,033,804.72	20,530,521.87			
C3	WESTBOUND US 30							401+31.12	8,033,882.12	20,532,796.83	404+55.31	8,033,893.15	20,533,120.83	407+79.47	8,033,911.49	20,533,444.50			
WB2	WESTBOUND US 30	411+96.95	8,033,935.10	20,533,861.31															
WEST CROSSOVER																			
WEST_CR_1	WEST CROSSOVER							0+00.00	8,033,506.35	20,527,615.92	2+19.62	8,033,518.80	20,527,835.19	4+38.67	8,033,558.46	20,528,051.20			
WEST_CR_4	WEST CROSSOVER							10+27.78	8,033,664.84	20,528,630.62	12+46.69	8,033,704.37	20,528,845.93	14+65.03	8,033,716.78	20,529,064.49			
EAST CROSSOVER																			
EAST_CR_1	EAST CROSSOVER							0+00.00	8,033,857.49	20,532,425.67	1+23.51	8,033,861.69	20,532,549.11	2+46.92	8,033,857.18	20,532,672.54			
EAST_CR_4	EAST CROSSOVER							7+71.19	8,033,838.05	20,533,196.45	9+34.86	8,033,832.08	20,533,360.02	10+98.30	8,033,841.34	20,533,523.43			



108-23A  
08-01-08

### TRAFFIC CONTROL PLAN

1. Traffic will be maintained on US 30 at all times.
2. Traffic control on this project shall be in accordance with Standard Road Plans. For additional complementary information, refer to Part 6 of the Manual on Uniform Traffic Control Devices and the current Standard and Supplemental Specifications.
3. Left-turn access to and from Old River Road will be prohibited due to the use of a temporary lane separator system (TLSS). The TLSS needs to be extended from the west crossover, running the length of the work zone through the east crossover. In this area, the TLSS supercedes the centerline delineation shown in TC-61. Signage will be installed to guide traffic to the U-turn maneuvers past the project limits.

111-01  
04-17-12

### COORDINATED OPERATIONS

Other work in progress during the same period of time will include the construction of the projects listed. Coordinate operations with those of other contractors working within the same area.

Project	Type of Work
None provided	

108-26A  
08-01-08

### STAGING NOTES

Pre-Stage 1  
Pave westbound outside shoulders using TC-402 & TC-418:  
 -Between Old River Road and westbound bridge  
 -Between Knapp Road and approximately 250 feet west of Knapp Road  
 Construct median modifications using TC-418:  
 -East and west crossovers  
 -Right-turn lane for eastbound traffic traveling in westbound lanes at Old River Road  
 -Extension of existing westbound left-turn lane at Old River Road

Stage 1  
Traffic will be maintained in its existing configuration.  
Install the drilled shafts on the outsides of the existing eastbound bridge.

Stage 2  
Close the eastbound US 30 bridge by using TC-61.  
Eastbound traffic shifts to and from the inside westbound lane via the use of median crossovers.  
Implement detour signing for left-turning movements to and from Old River Road. See Sheet J.6.  
Remove the eastbound bridge and construct the new bridge pier caps, beams and decking.

Stage 3  
Return traffic to normal operation.  
Remove median crossovers.  
Use TC-418 when removing the crossovers.

102-15  
08-01-08









### TABULATION OF SPECIAL EVENTS

Event	Location	Date
None provided		

**CROSS SECTION VIEW COLOR LEGEND  
OF TRAFFIC CONTROL AND STAGING SHEETS**

SHADING	Design Color No.	
Green, Light	(225)	Existing Pavement Shading
Gray, Light	(48)	Previously Constructed Pavement Shading
Gray, Med	(80)	Previously Constructed Granular Surface Shading
Blue, Light	(230)	Proposed Pavement Shading
Lavender	(9)	Temporary Pavement Shading
Brown, Med	(237)	Future Proposed Pavement Shading

**CROSS SECTION VIEW PATTERN AND SYMBOL LEGEND  
OF TRAFFIC CONTROL AND STAGING SHEETS**





















	Pavement Removal		Proposed Granular Shoulder
	Proposed Granular Subbase		Temporary Shoulder
	Proposed Special Backfill		Existing Shoulder Strengthening
	Temporary Barrier Rail		Permanent Barrier Rail
			Channelizing Device

**PLAN VIEW COLOR LEGEND OF TRAFFIC CONTROL AND STAGING SHEETS**

LINEWORK	Design Color No.	
Green	(2)	Existing Topographic Features and Labels
Magenta	(5)	Pavement Marking Call Outs
Blue	(1)	Proposed Alignment, Stationing, Tic Marks, and Alignment Annotation
Yellow	(4)	Pavement Markings, Yellow
Off White	(254)	Pavement Markings, White
Violet	(15)	Temporary barrier rail, Unpinned
Flush Orange	(228)	Temporary barrier rail, Pinned

SHADING	Design Color No.	
Green, Light	(225)	Existing Pavement Shading
Gray, Light	(48)	Previously Constructed Pavement Shading
Gray, Med	(80)	Proposed Granular Surface Shading
Gray, Med	(80)	Previously Constructed Granular Surface Shading
Blue, Light	(230)	Proposed Pavement Shading
Lavender	(9)	Temporary Pavement Shading
Brown, Light	(236)	Proposed Grading Limits Shading
Pink, Dark	(13)	Proposed MSE or CIP Wall Shading
Red	(3)	Proposed Bridge Shading and Sign Trusses
Black w/Gray, Light Fill	(0,48)	Previously Constructed Structure

**PLAN VIEW PATTERN AND SYMBOL LEGEND  
OF TRAFFIC CONTROL AND STAGING SHEETS**

	Channelizing Device		Crash Cushion (Temp or Perm)
	Drum		Traffic Signal
	Temporary Lane Separator		Flagger
	Tubular Marker		Temporary Floodlighting
	Channelizer Marker		Traffic Sign
	Concrete Barrier Marker		Type III Barricade
	Delineator		Type A Warning Light
	Temporary Barrier Rail		Direction of Traffic
	Pavement Removal		Safety Closure
	Sand Barrel Layout		Lane Identification

NOTE: Device spacing according to Standard Road Plans unless specifically dimensioned.

**TRAFFIC CONTROL  
AND  
STAGING  
LEGEND AND SYMBOL  
INFORMATION SHEET**

(COVERS SHEET SERIES J)

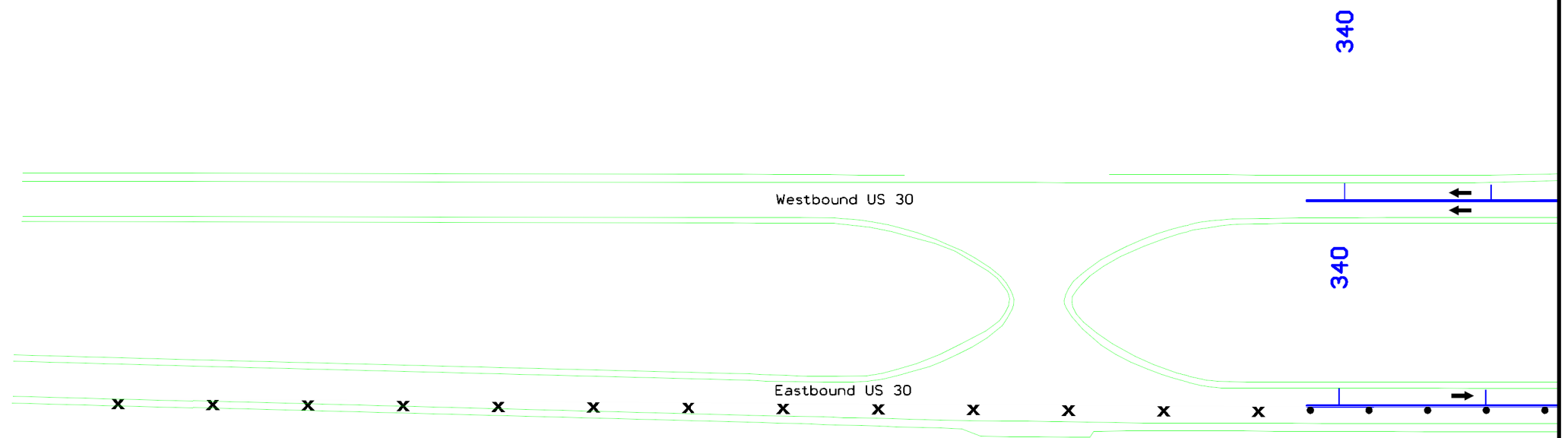

REFER TO TC-61

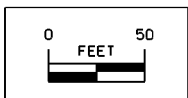



345

350

355

345

350

355

Westbound US 30

Eastbound US 30

TYPE III BARRICADES

REFER TO TC-61

12'

12'

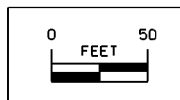

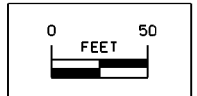
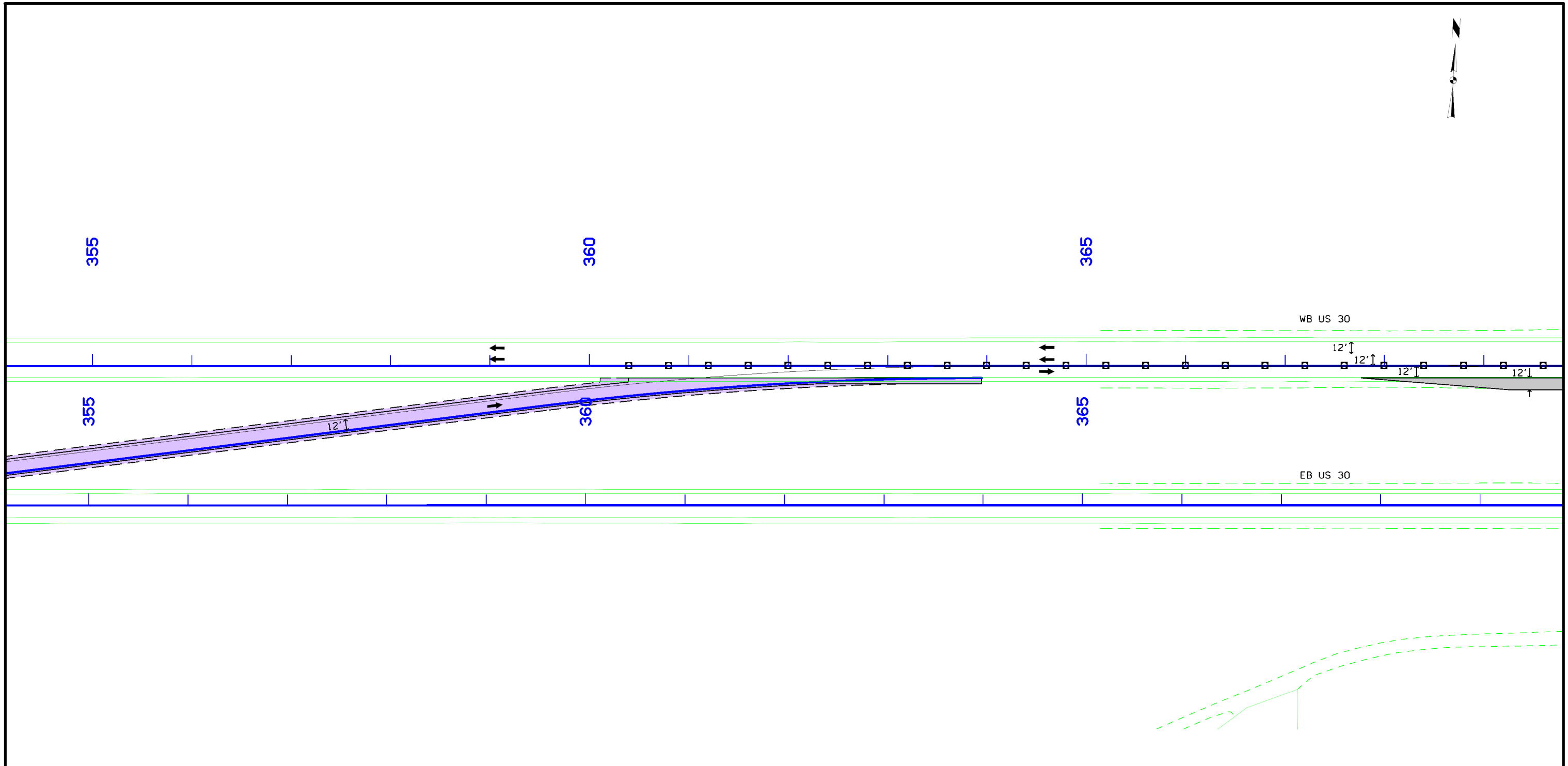

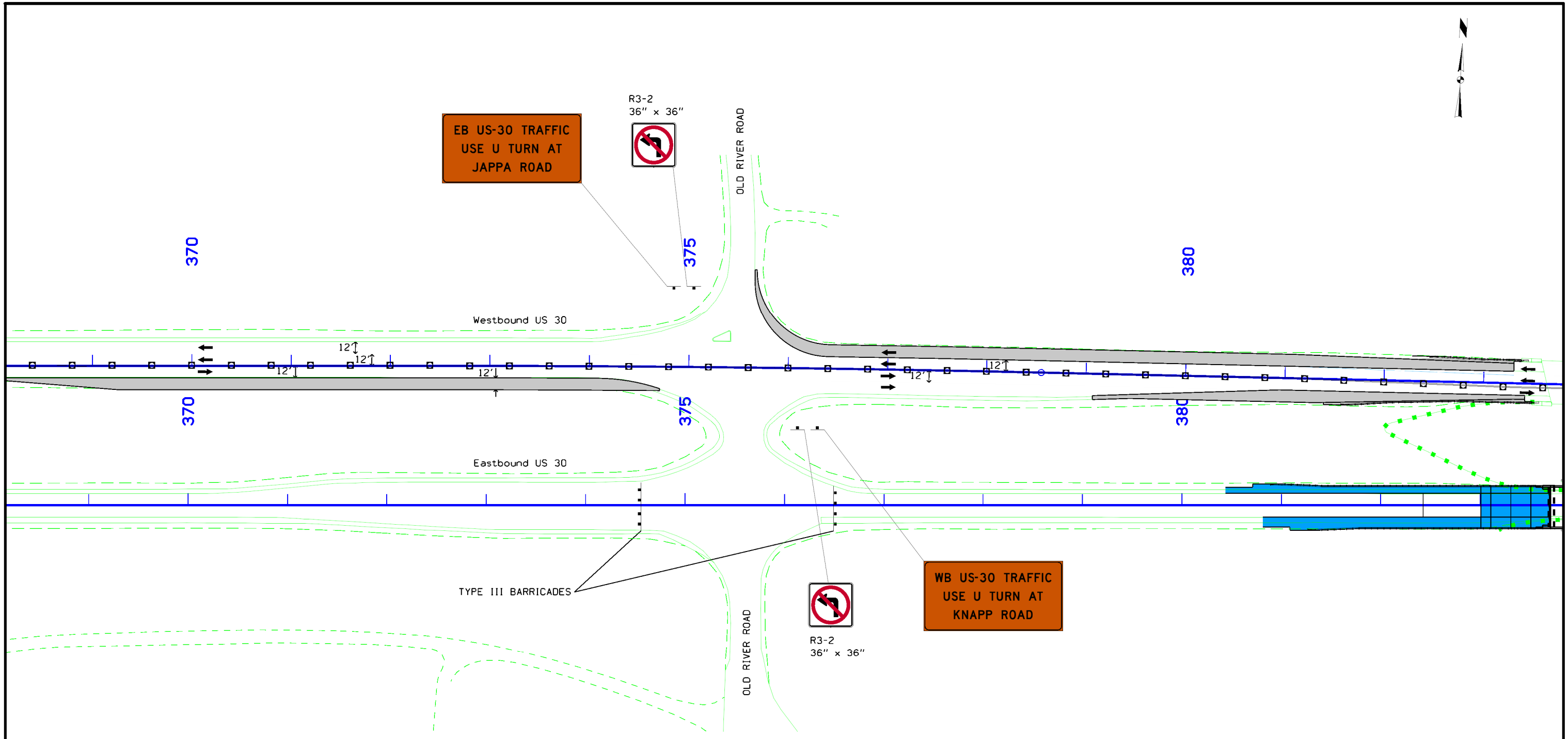

REFER TO TC-61

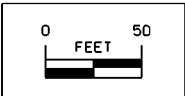

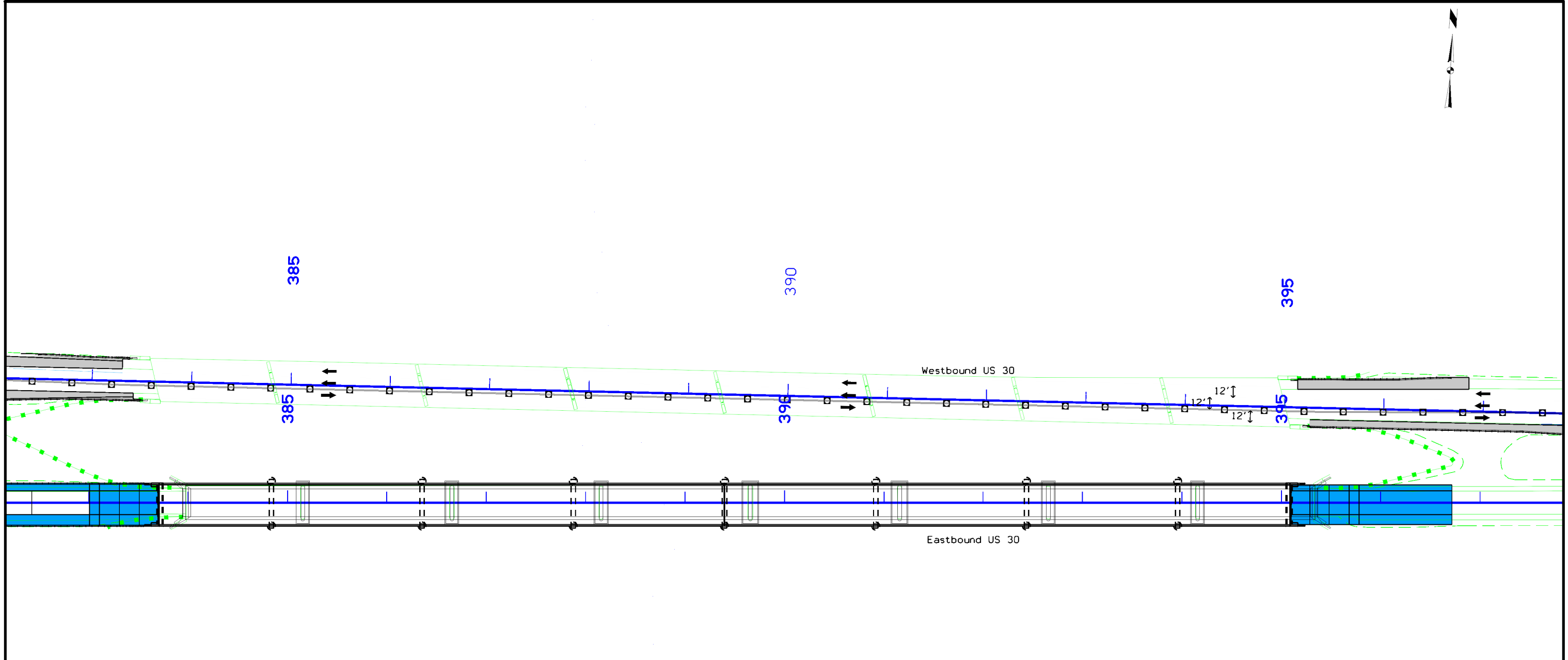

Westbound US 30

Eastbound US 30

385

390

395

385

390

395

12'  
12'

REFER TO TC-61

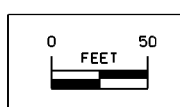

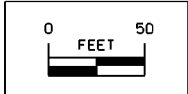
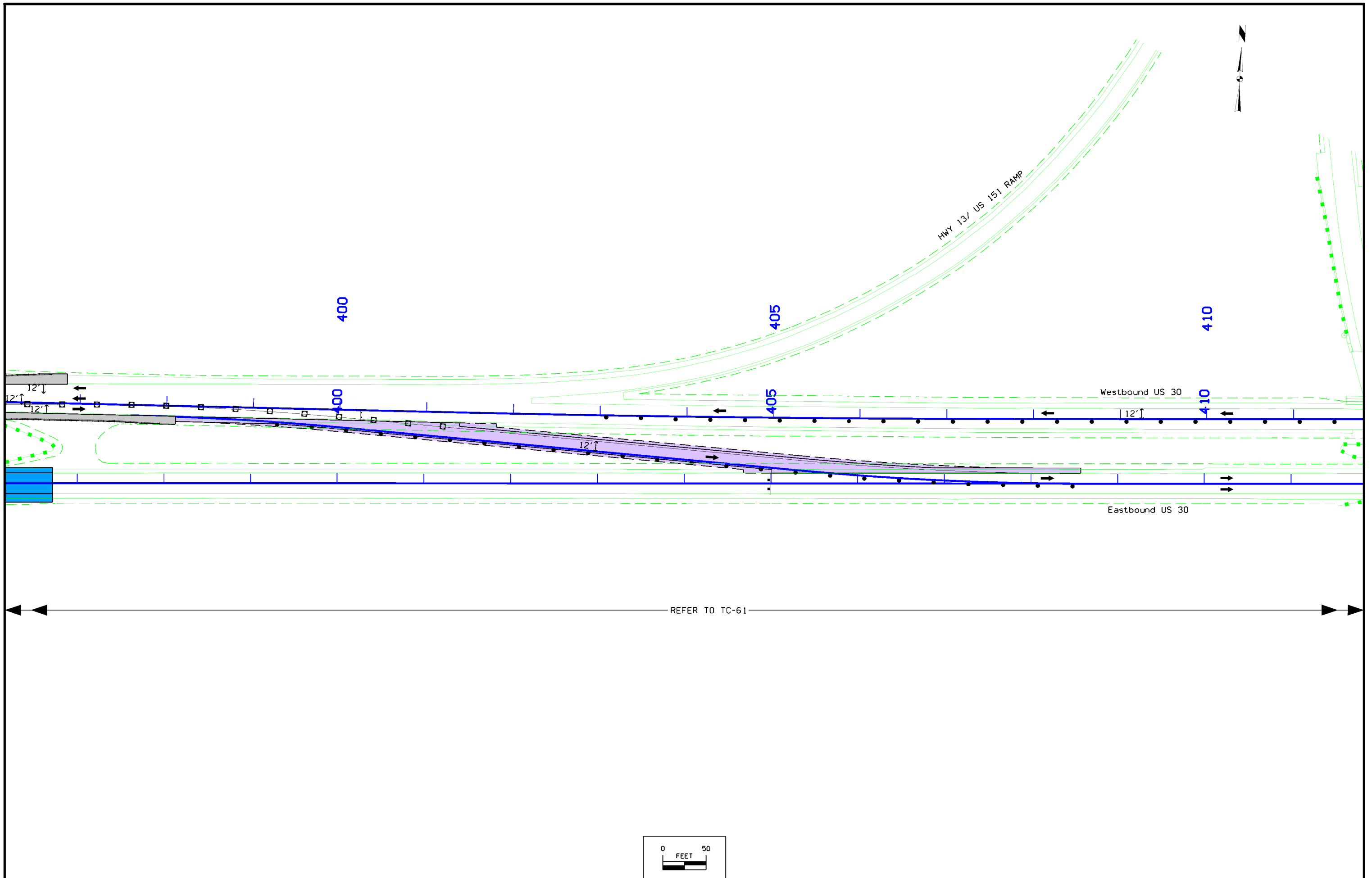



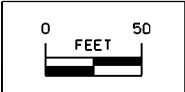
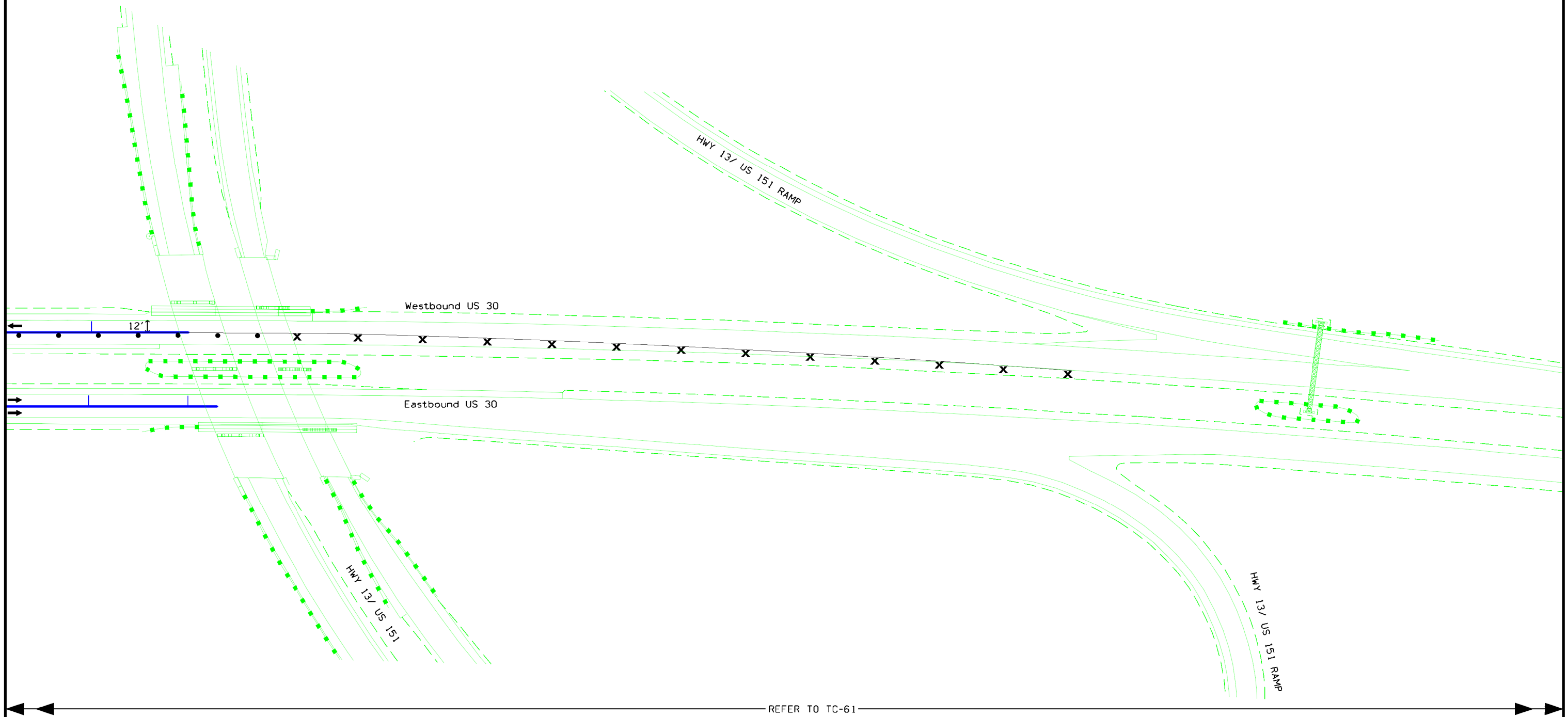

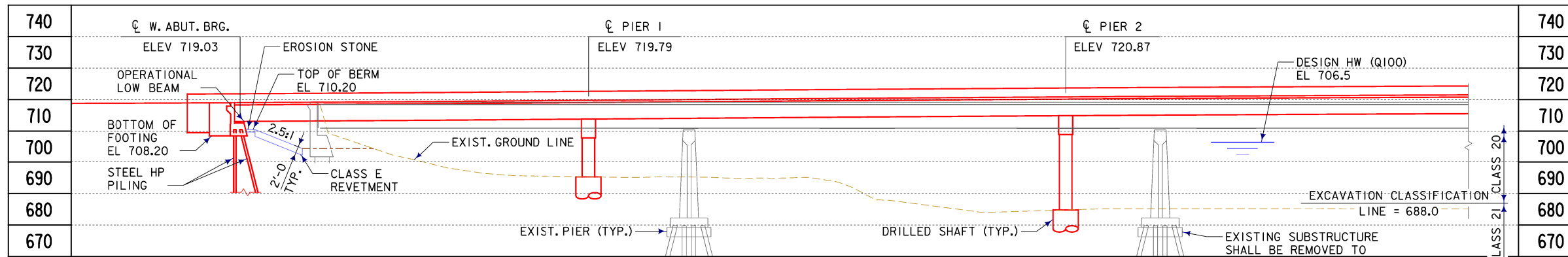

LONGITUDINAL SECTION ALONG  $\phi$  US 30 EB PROFILE GRADE

BENCH MARK NO. 1: 8033630.679N, 20530416.940E  
 CP-321 SET FENO MONUMENT  
 ELEV 722.66  
 BENCH MARK NO. 2: 8034138.474N, 20533527.240E  
 CP-322 SET FENO MONUMENT  
 ELEV 726.92  
 VPC STA = 383+05.00  
 VPC ELEV = 718.76  
 VPT STA = 384+35.00  
 VPT ELEV = 719.42

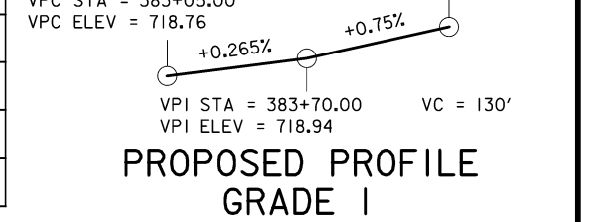

PROPOSED PROFILE GRADE 1

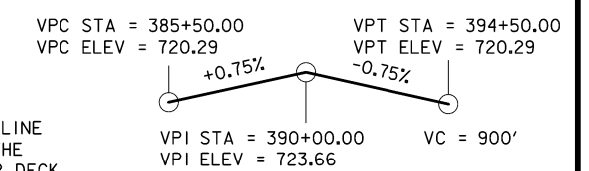

PROPOSED PROFILE GRADE 2

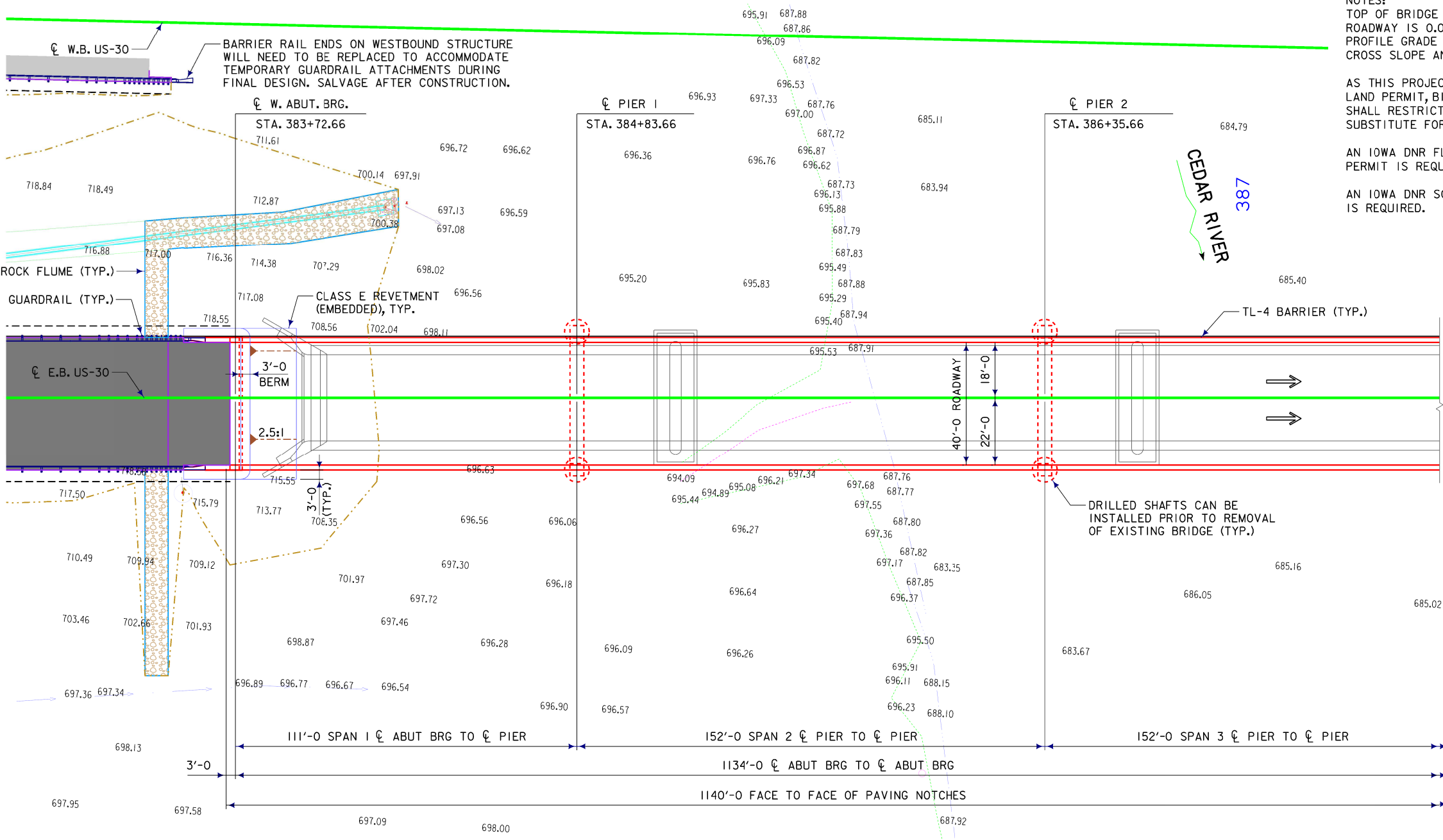

NOTES:  
 TOP OF BRIDGE DECK AT CENTERLINE ROADWAY IS 0.03 FEET BELOW THE PROFILE GRADE TO ACCOUNT FOR DECK CROSS SLOPE AND PARABOLIC CROWN.  
 AS THIS PROJECT REQUIRES A SOVEREIGN LAND PERMIT, BID ITEM REFERENCE NOTES SHALL RESTRICT BROKEN CONCRETE AS A SUBSTITUTE FOR REVETMENT.  
 AN IOWA DNR FLOOD PLAIN CONSTRUCTION PERMIT IS REQUIRED.  
 AN IOWA DNR SOVEREIGN LANDS PERMIT IS REQUIRED.

**HYDRAULIC DATA**  
 DRAINAGE AREA = 6951.0 SQ. MI.  
 STREAM SLOPE = 2.2 FT./MI.  
 AVG. LOW WATER STAGE = 688.0

Q<sub>50</sub> = 87,908 CFS  
 STAGE = 704.8  
 REGULATORY LOW BEAM = 715.2  
 BACKWATER = 0.3 FT.  
 AVG. BRIDGE VELOCITY = 5.9 FPS

Q<sub>100</sub> = 100,408 CFS  
 STAGE = 706.5  
 OPERATIONAL LOW BEAM = 712.6  
 BACKWATER = 0.4 FT.  
 AVG. BRIDGE VELOCITY = 6.0 FPS

Q<sub>200</sub> = 112,918 CFS  
 STAGE = 708.2  
 CALCULATED DESIGN SCOUR = 655.1

Q<sub>500</sub> = 129,241 CFS  
 STAGE = 709.4  
 AVG. BRIDGE VELOCITY = 6.5 FPS  
 CALCULATED CHECK SCOUR = 652.9

**UTILITIES LEGEND:**  
 NO KNOWN UTILITIES NEAR BRIDGE

**LOCATION**  
 EB US 30 OVER THE CEDAR RIVER  
 T-82N R-6W  
 SECTION 9  
 PUTNAM TOWNSHIP  
 LINN COUNTY  
 FHWA NO. 33471  
 BRIDGE MAINT. NO. 5758.9R030  
 LATITUDE 41.926005°  
 LONGITUDE -91.550627°

**TRAFFIC ESTIMATE**

Year	Mode	ADT	V.P.D.
2020	AADT	27,700	V.P.D.
2040	AADT	39,800	V.P.D.
2020	DHV	-	V.P.H.
	TRUCKS	16	%
	TOTAL DESIGN ESALS	-	



SITUATION PLAN

DESIGN FOR 0° SKEW  
**1,134'-0" X 40'-0" PRETENSIONED PRESTRESSED CONCRETE BEAM BRIDGE**  
 111' END SPANS (BTE BEAM TYPE) 152' INTERIOR SPAN  
**SITUATION PLAN**  
 STA. 389+39.66 FEBRUARY, 2018  
**LINN COUNTY**  
 IOWA DEPARTMENT OF TRANSPORTATION - HIGHWAY DIVISION  
 DESIGN SHEET NO. 1 OF 4 FILE NO. 31598 DESIGN NO. 220

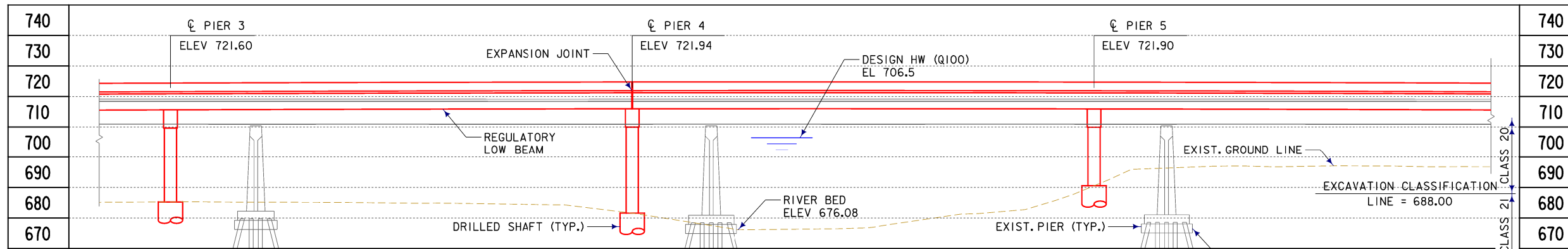

BENCH MARK NO. 1: 8033630.679N, 20530416.940E  
 CP-321 SET FENO MONUMENT  
 ELEV 722.66  
 BENCH MARK NO. 2: 8034138.474N, 20533527.240E  
 CP-322 SET FENO MONUMENT  
 ELEV 726.92

LONGITUDINAL SECTION ALONG CL US 30 EB PROFILE GRADE

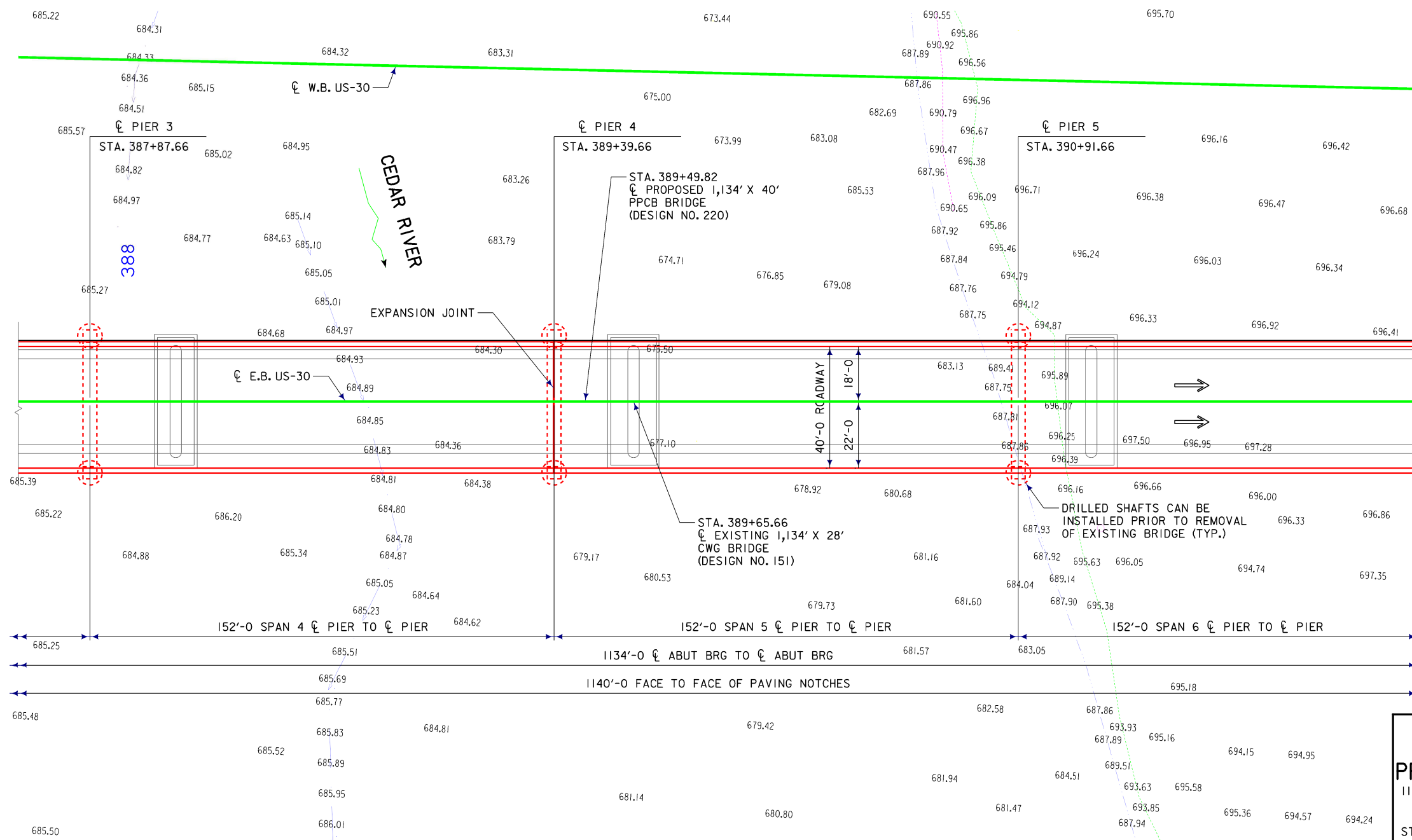

UTILITIES LEGEND:  
 NO KNOWN UTILITIES NEAR BRIDGE

DESIGN FOR 0° SKEW  
**1,134'-0" X 40'-0" PRETENSIONED  
 PRESTRESSED CONCRETE BEAM BRIDGE**  
 111' END SPANS (BTE BEAM TYPE) 152' INTERIOR SPAN  
**SITUATION PLAN**  
 STA. 389+39.66 FEBRUARY, 2018  
**LINN COUNTY**  
 IOWA DEPARTMENT OF TRANSPORTATION - HIGHWAY DIVISION  
 DESIGN SHEET NO. 2 OF 4 FILE NO. 31598 DESIGN NO. 220

SITUATION PLAN

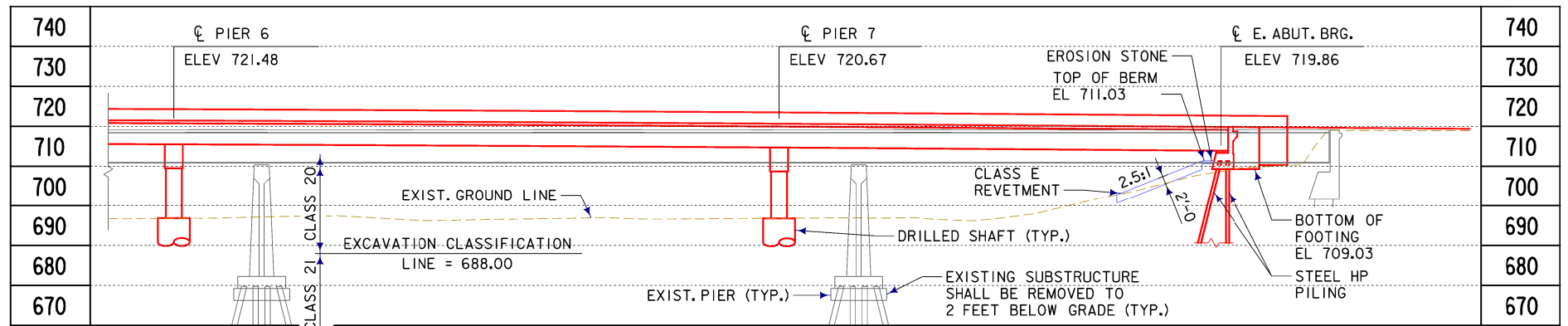

LONGITUDINAL SECTION ALONG  $\phi$  US 30 EB PROFILE GRADE

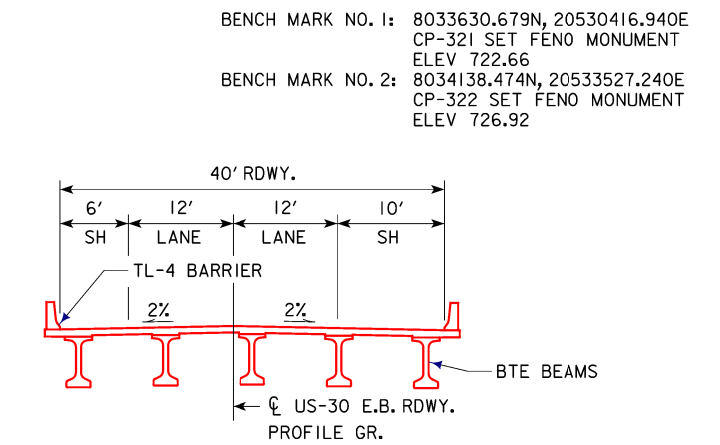

TYPICAL BRIDGE SECTION

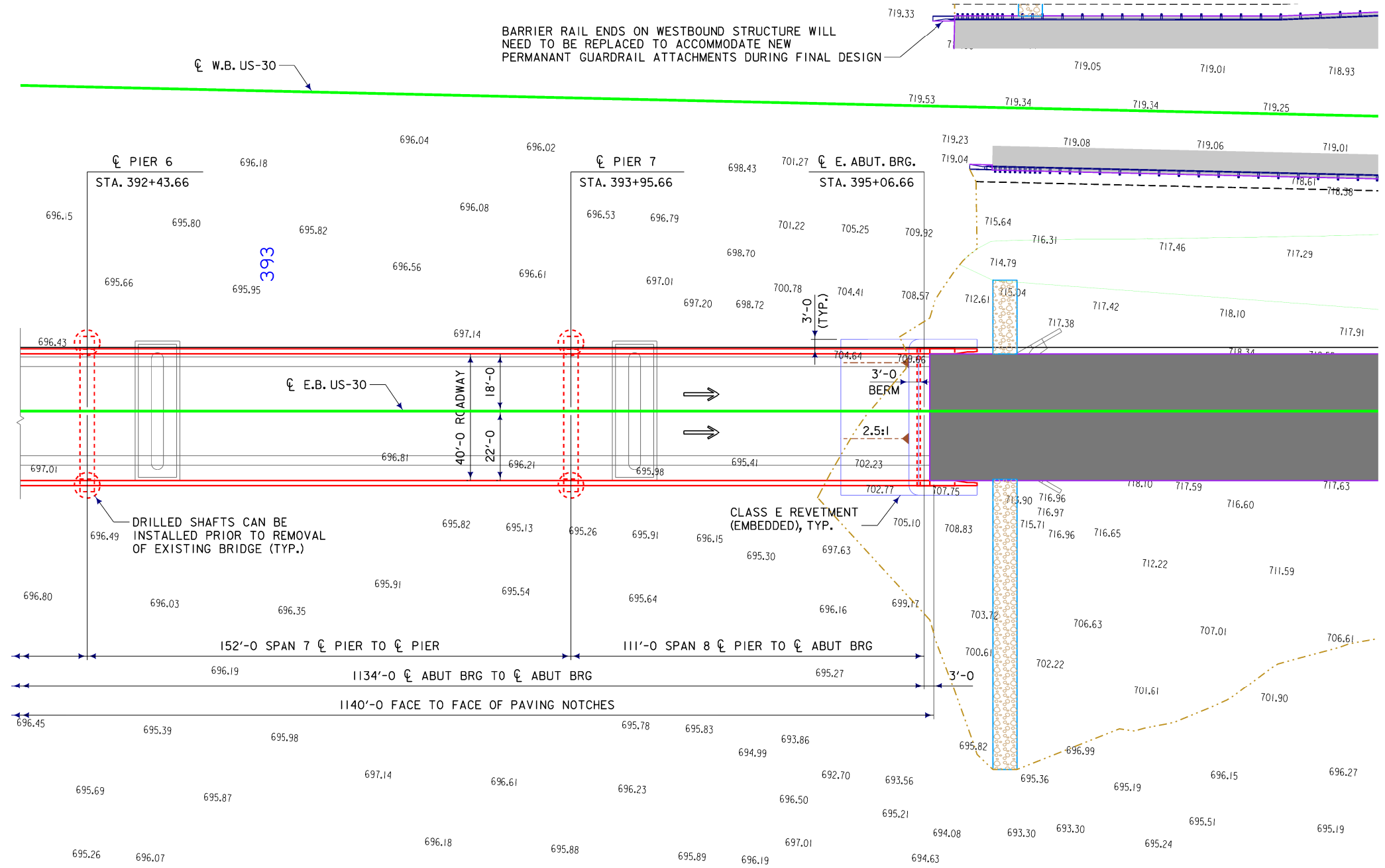

SITUATION PLAN

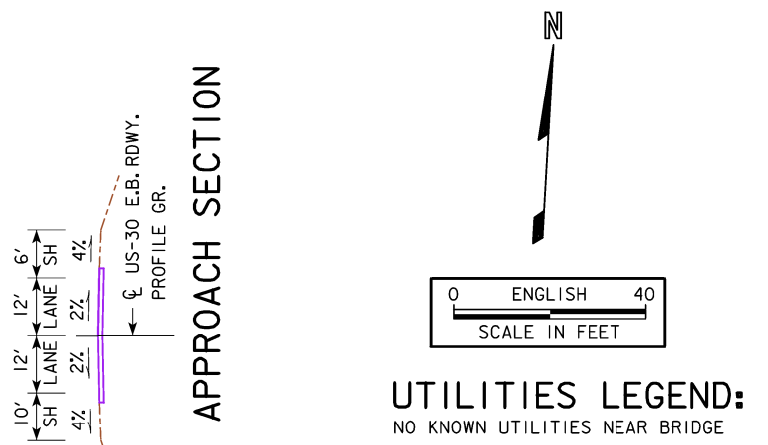

TYPICAL APPROACH SECTION

DESIGN FOR 0° SKEW  
**1,134'-0" X 40'-0" PRETENSIONED  
 PRESTRESSED CONCRETE BEAM BRIDGE**  
 111' END SPANS (BTE BEAM TYPE) 152' INTERIOR SPAN  
**SITUATION PLAN**  
 STA. 389+39.66 FEBRUARY, 2018  
**LINN COUNTY**  
 IOWA DEPARTMENT OF TRANSPORTATION - HIGHWAY DIVISION  
 DESIGN SHEET NO. 3 OF 4 FILE NO. 31598 DESIGN NO. 220

BENCH MARK NO. 321: STA. 373+43.92, 34.60' RT. SET FENO MON  
ELEV 722.66  
BENCH MARK NO. 322: STA. 408+77.97, 276.45' LT. SET FENO MON  
ELEV 726.92

### HYDRAULIC DESIGN



I hereby certify that this engineering document was prepared by me or under my direct personal supervision and that I am a duly licensed Professional Engineer under the laws of the State of Iowa.

Signature **Aaron D. Moore** Date \_\_\_\_\_

Printed or Typed Name

My license renewal date is December 31, **2018**

Pages or sheets covered by this seal: V.1, V.2, V.3 AND V.4

### SECTION THRU EMBEDDED REVETMENT BERM

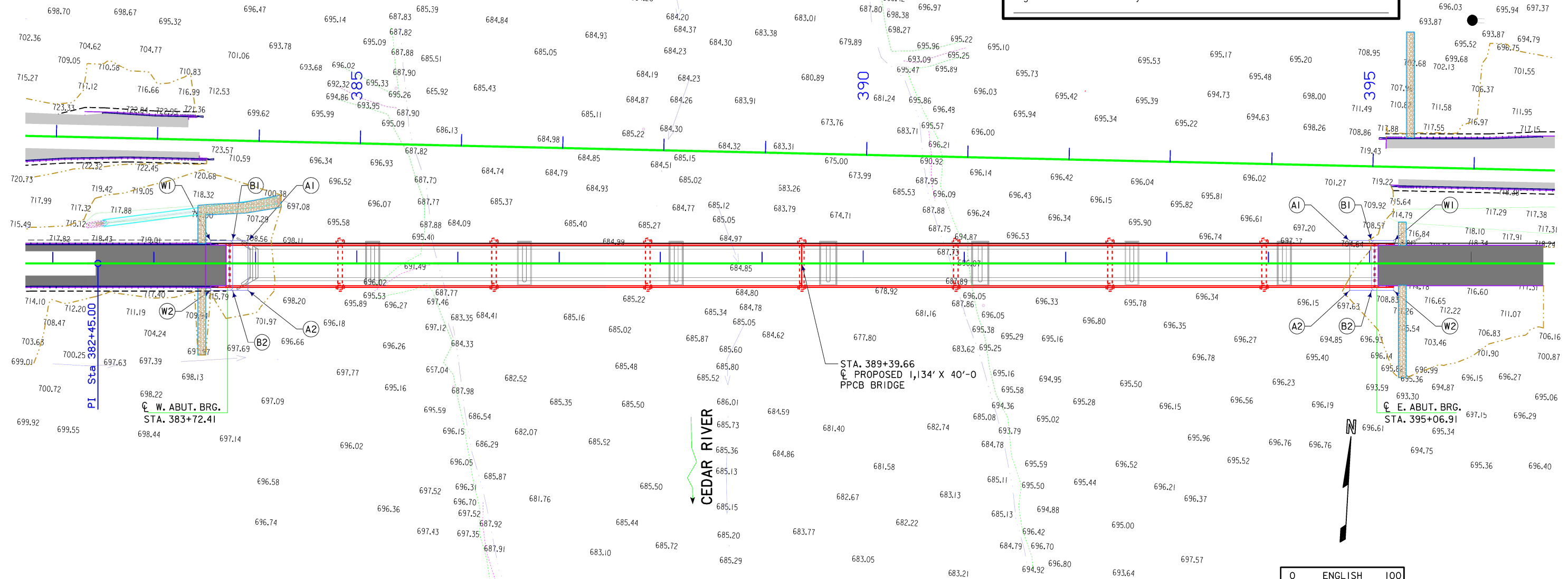
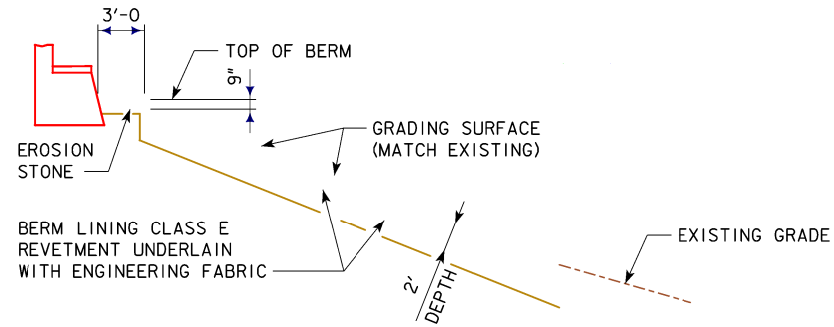

POINTS	W. ABUTMENT			E. ABUTMENT		
	STATION	OFFSET	ELEV.	STATION	OFFSET	ELEV.
A1	383+92.42	22.58' LT	704.20	394+80.54	22.58' LT	702.48
A2	383+92.42	26.58' RT	704.20	394+80.54	26.58' RT	702.48
B1	383+77.42	22.58' LT	710.20	395+01.91	22.58' LT	711.03
B2	383+77.42	26.58' RT	710.20	395+01.91	26.58' RT	711.03
W1	383+55.91	22.58' LT	718.56	395+23.41	22.58' LT	719.34
W2	383+55.91	26.58' RT	718.48	395+23.41	26.58' RT	719.26

BERM SLOPE ELEVATIONS REFLECT THE GRADING SURFACE

ESTIMATED BERM ARMORING QUANTITIES				
LOCATION	REVTMENT CL. E (TON)	EROSION STONE (TON)	ENGINEERING FABRIC (SY)	EXCAVATION (CY)
BERM LINING - WEST ABUTMENT	96.1	12.4	88.3	58.9
BERM LINING - EAST ABUTMENT	136.7	12.4	125.8	83.8
<b>TOTALS</b>	<b>232.8</b>	<b>24.8</b>	<b>214.0</b>	<b>142.7</b>

EXCAVATION QUANTITY CALCULATED FROM GRADING SURFACE.

### SITE PLAN

DESIGN FOR 0° SKEW  
**1,134'-0 X 40'-0 PRETENSIONED  
 PRESTRESSED CONCRETE BEAM BRIDGE**  
 111' END SPANS (BTE BEAM TYPE) 152' INTERIOR SPAN  
**SITE PLAN**  
 STA. 389+39.66 FEBRUARY, 2018  
**LINN COUNTY**  
 IOWA DEPARTMENT OF TRANSPORTATION - HIGHWAY DIVISION  
 DESIGN SHEET NO. 4 OF 4 FILE NO. 31598 DESIGN NO. 220

**LINE STYLE LEGEND OF CROSS SECTION SHEETS (ROAD)**

- - - - - - Existing Ground Line
- Proposed Template
- Proposed Topsoil Placement
- - - - - Additional Topsoil Removal
- Subgrade Treatment
- - - - - Granular Shoulder
- Pavement
- - - - - Existing Pipe\RCB
- Proposed Pipe\RCB
- Proposed Dike
- All Elements Associated with Proposed Entrances

**LINE STYLE LEGEND OF CROSS SECTION SHEETS (SOILS)**

- TS————— Topsoil (Class 10)
- SLOPE DRESSING — Slope Dressing Only
- CL 10————— Class 10 Materials
- SEL L0————— Select Loams And Clay-Loams
- SEL SA————— Select Sand
- UNS A————— Unsuitable Type A Disposal
- UNS B————— Unsuitable Type B Disposal
- UNS C————— Unsuitable Type C Disposal
- SHALE————— Shale
- WASTE————— Waste
- B&W LS————— Broken and Weathered Rock
- ROCK————— Solid Rock
- BLDRS————— Boulders

Note: All layer lines and descriptions identify layers above the line.

Note: Vertical or near vertical lines connecting soil layers at edges of cross sections are only for the purpose of calculating template quantities and do not depict soil stratification.

**SYMBOL LEGEND OF CROSS SECTION SHEETS**

- Existing  
ROW  
|  
Existing Right-of-Way Limit
- Proposed  
ROW  
|  
Proposed Right-of-Way Limit
- Temporary  
ROW  
|  
Temporary Right-of-Way Limit

**CROSS SECTIONS**

(COVERS SHEET SERIES W)

# WB US 30 Preliminary

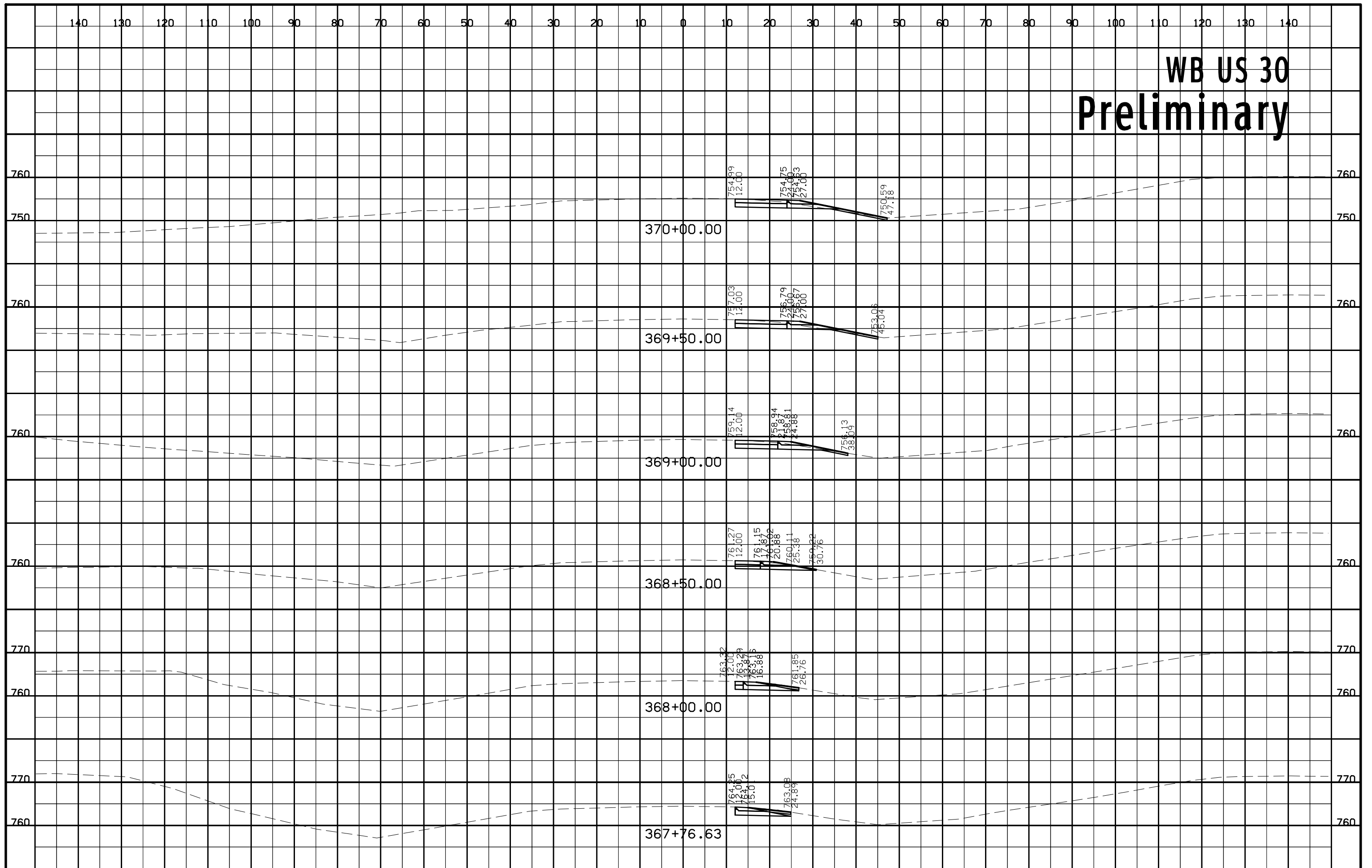

# WB US 30 Preliminary

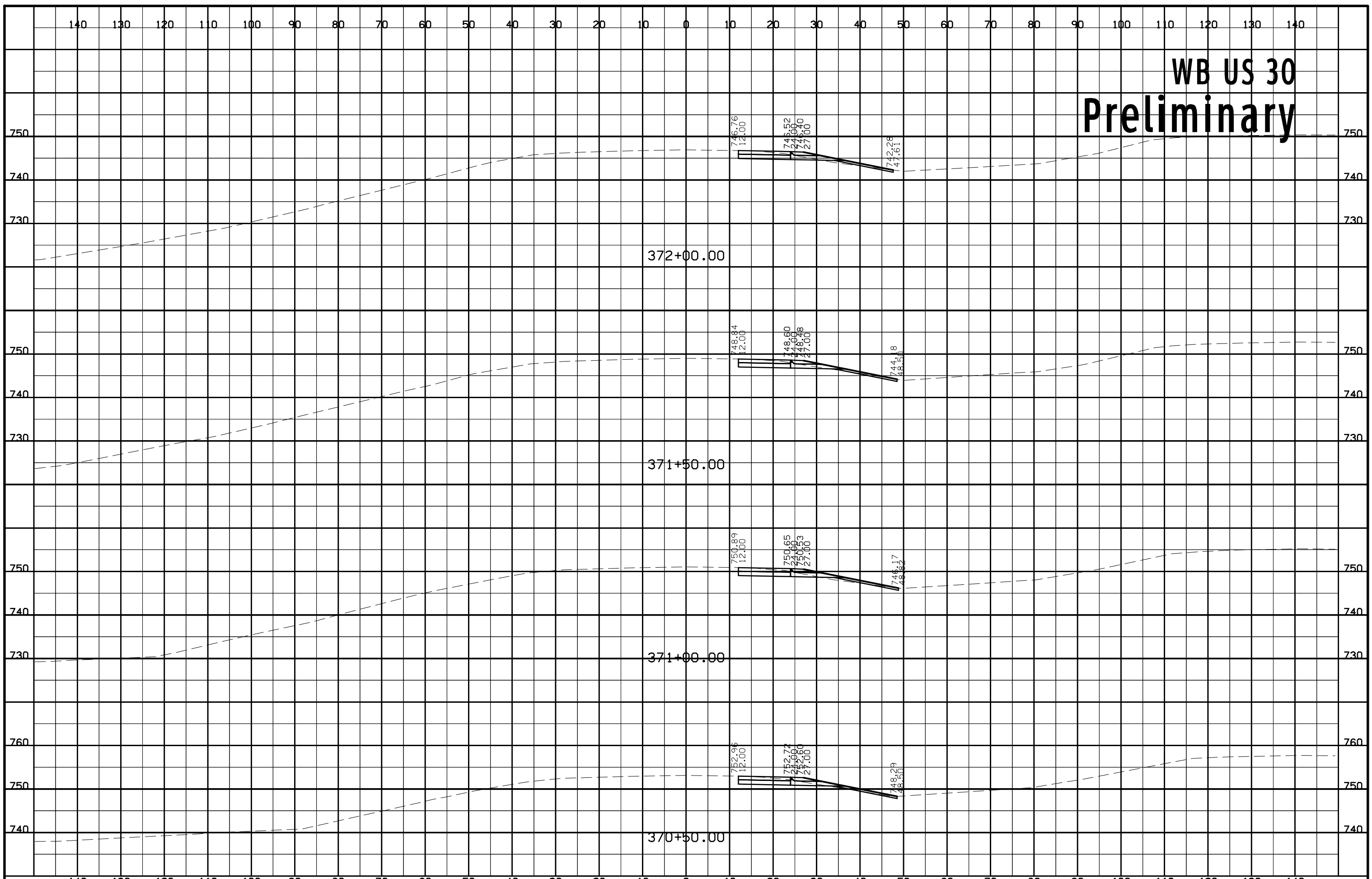



# WB US 30 Preliminary

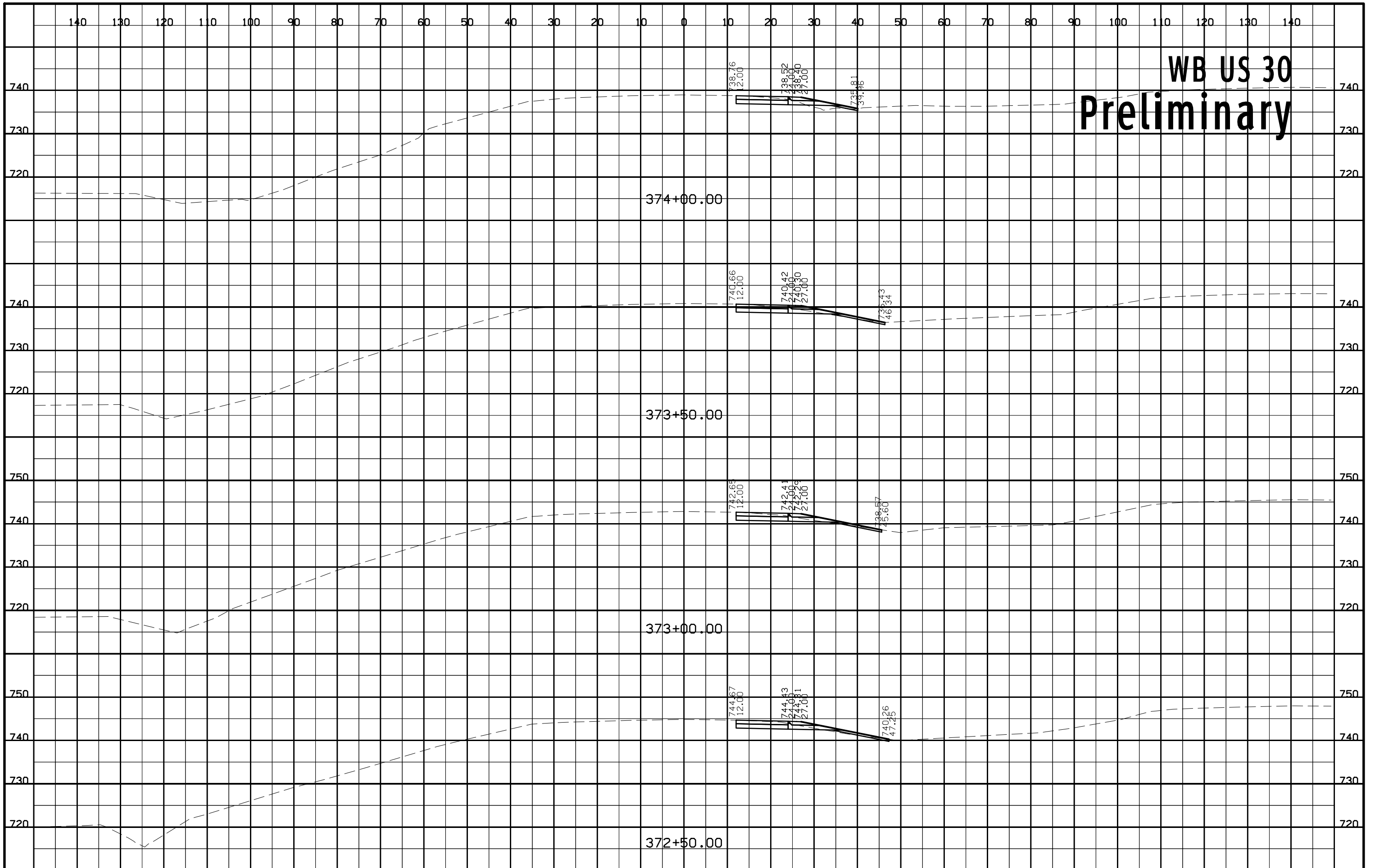

# WB US 30 Preliminary

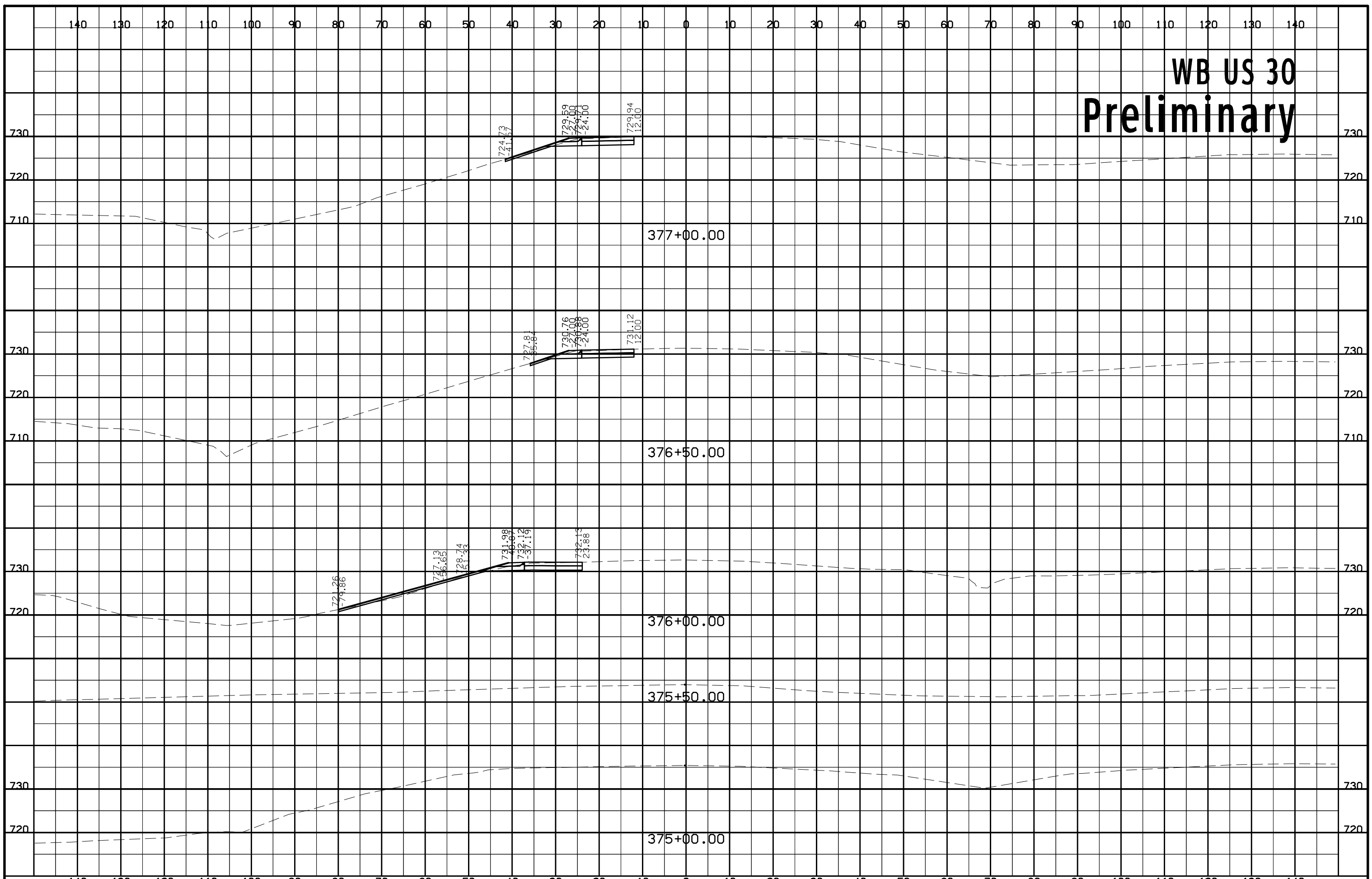

# WB US 30 Preliminary

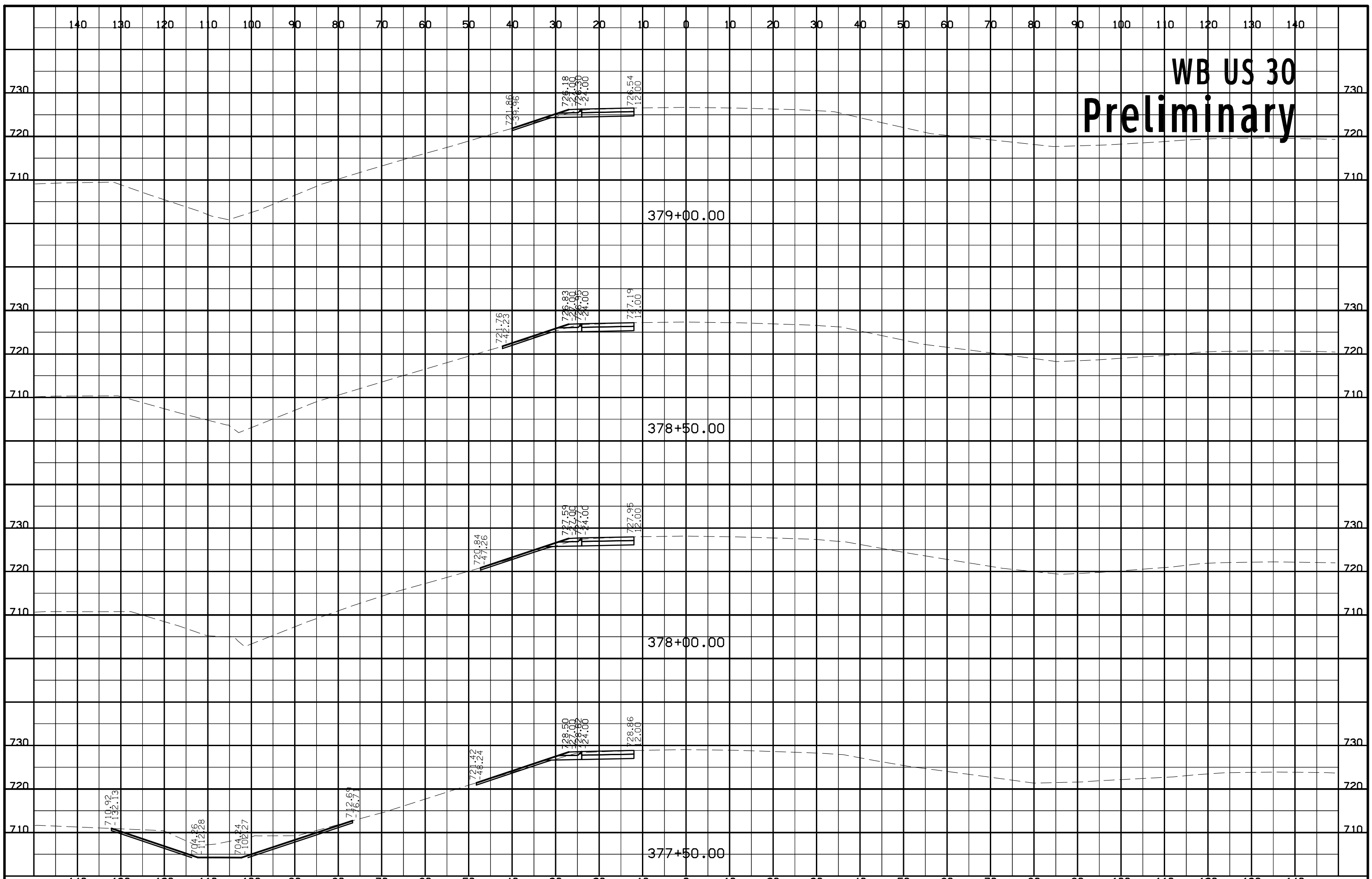

# WB US 30 Preliminary

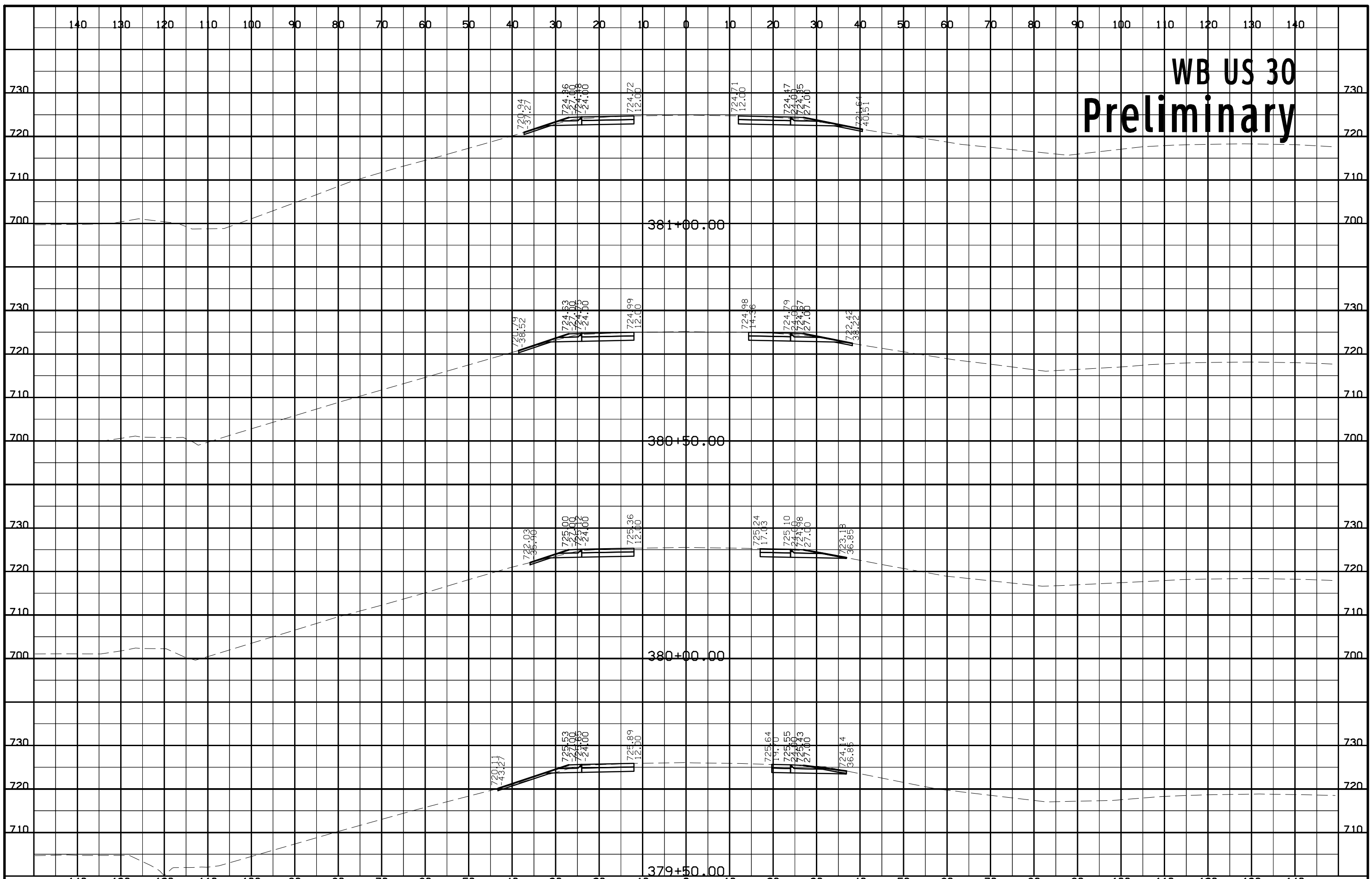

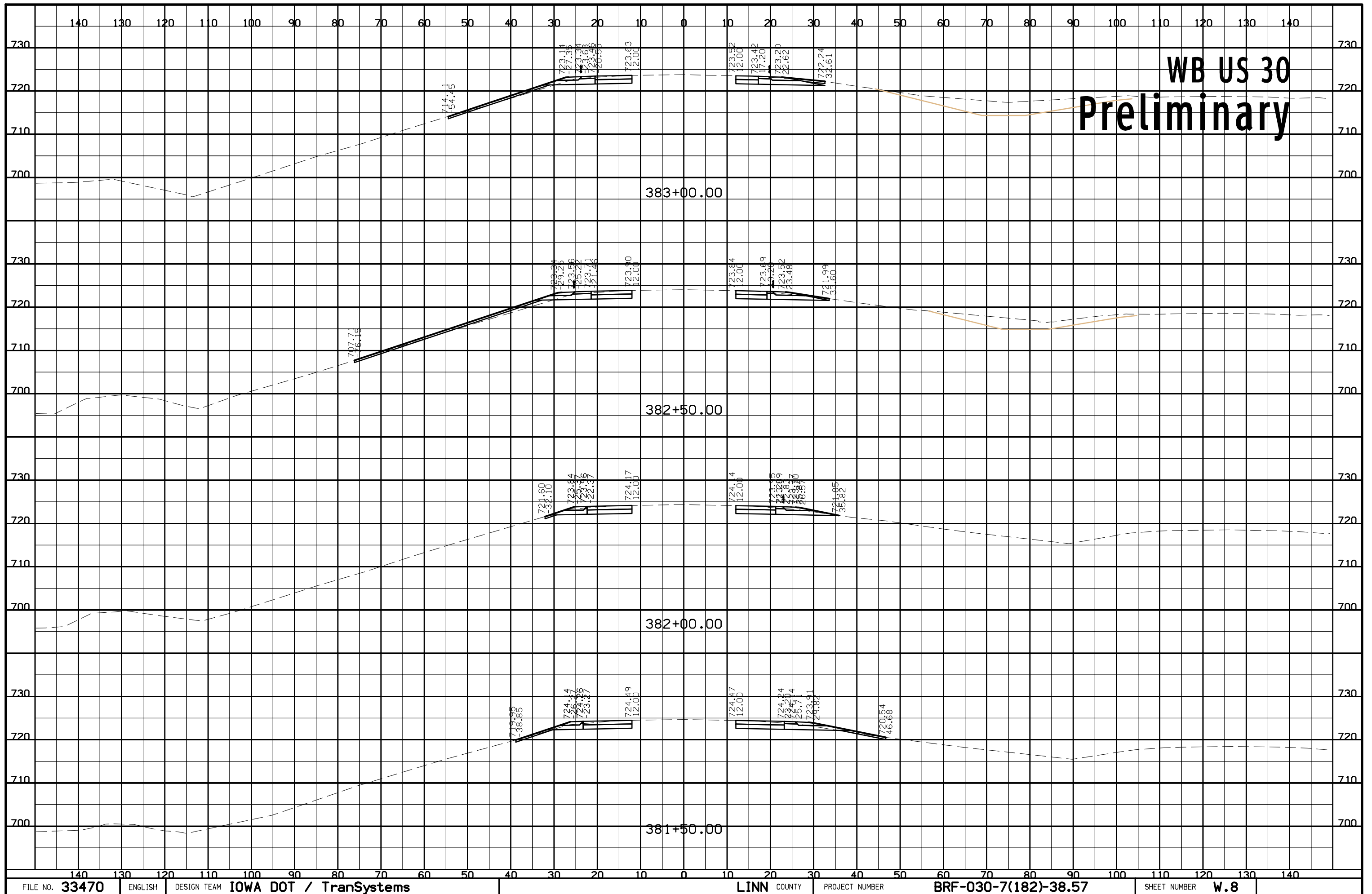

# WB US 30 Preliminary

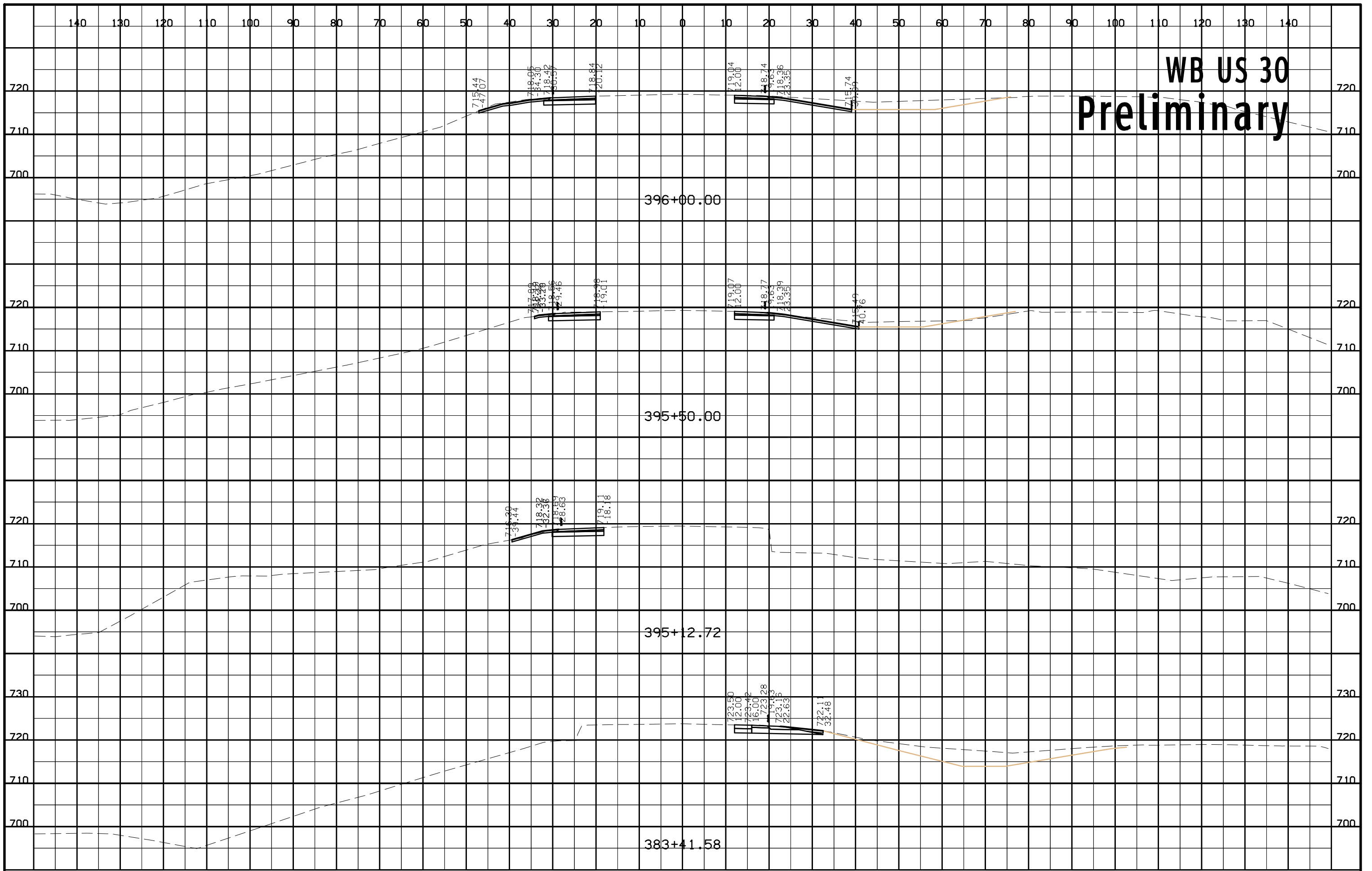

# WB US 30 Preliminary

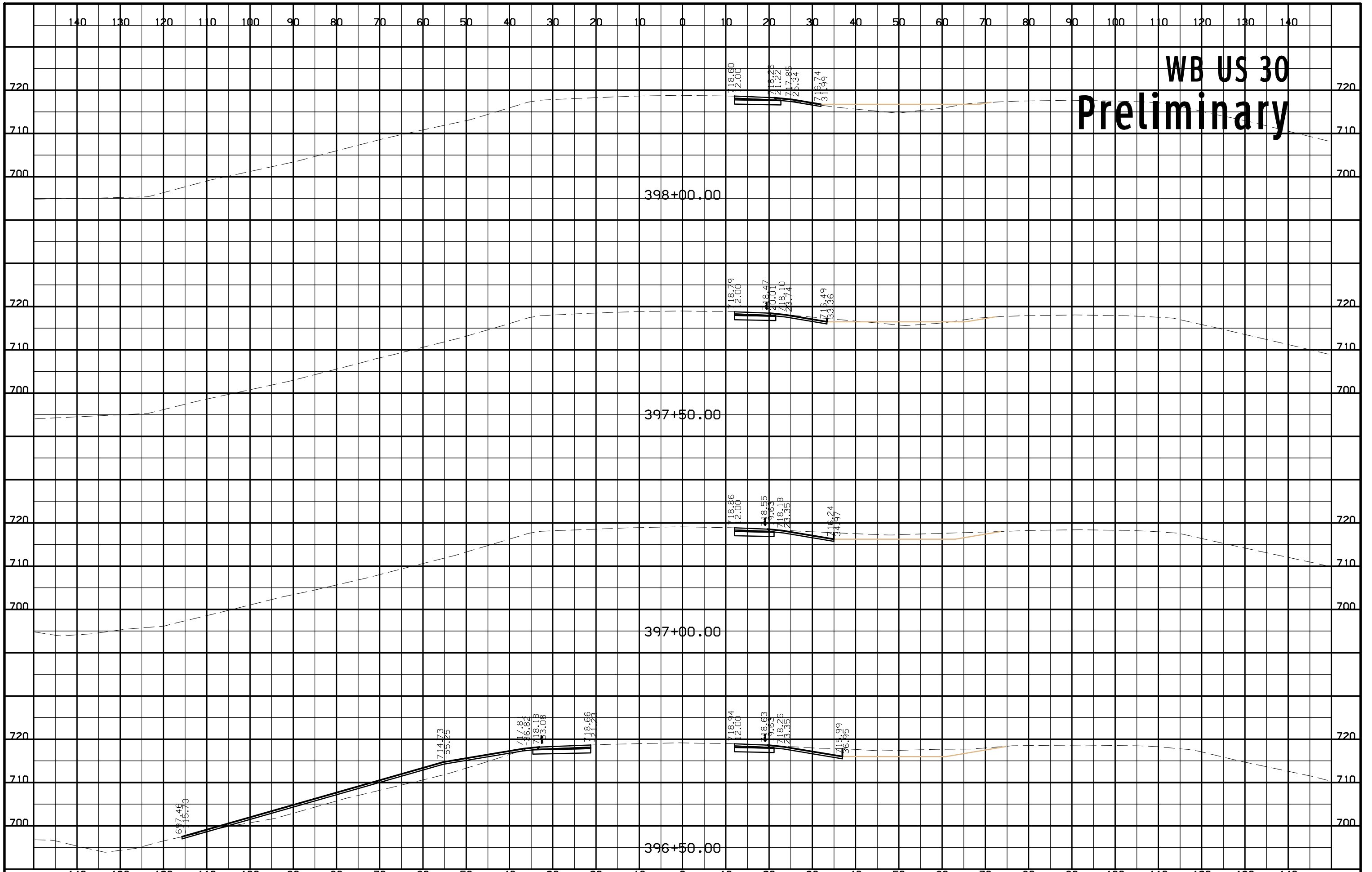

# WB US 30 Preliminary

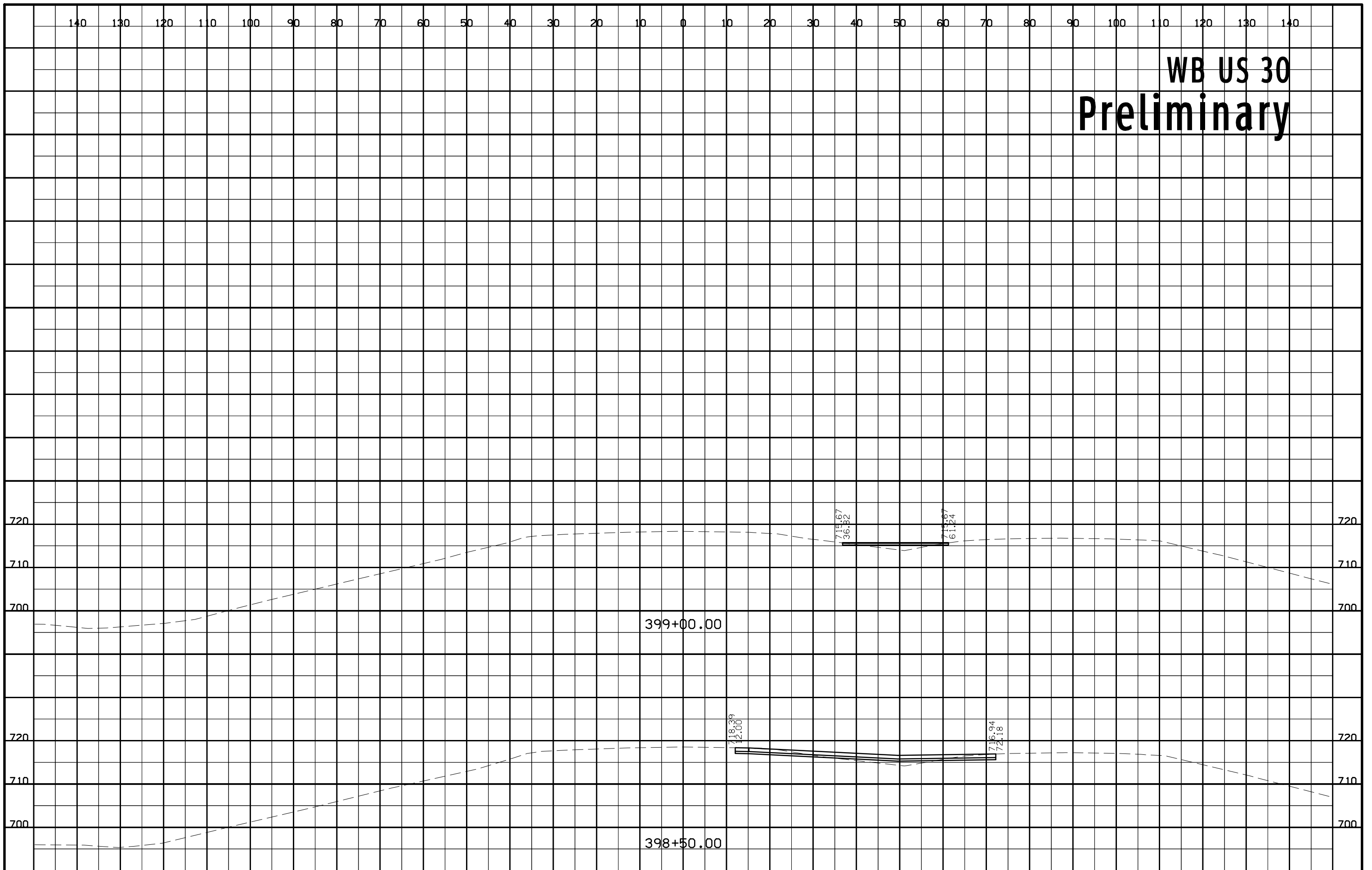



# EB US 30 Preliminary

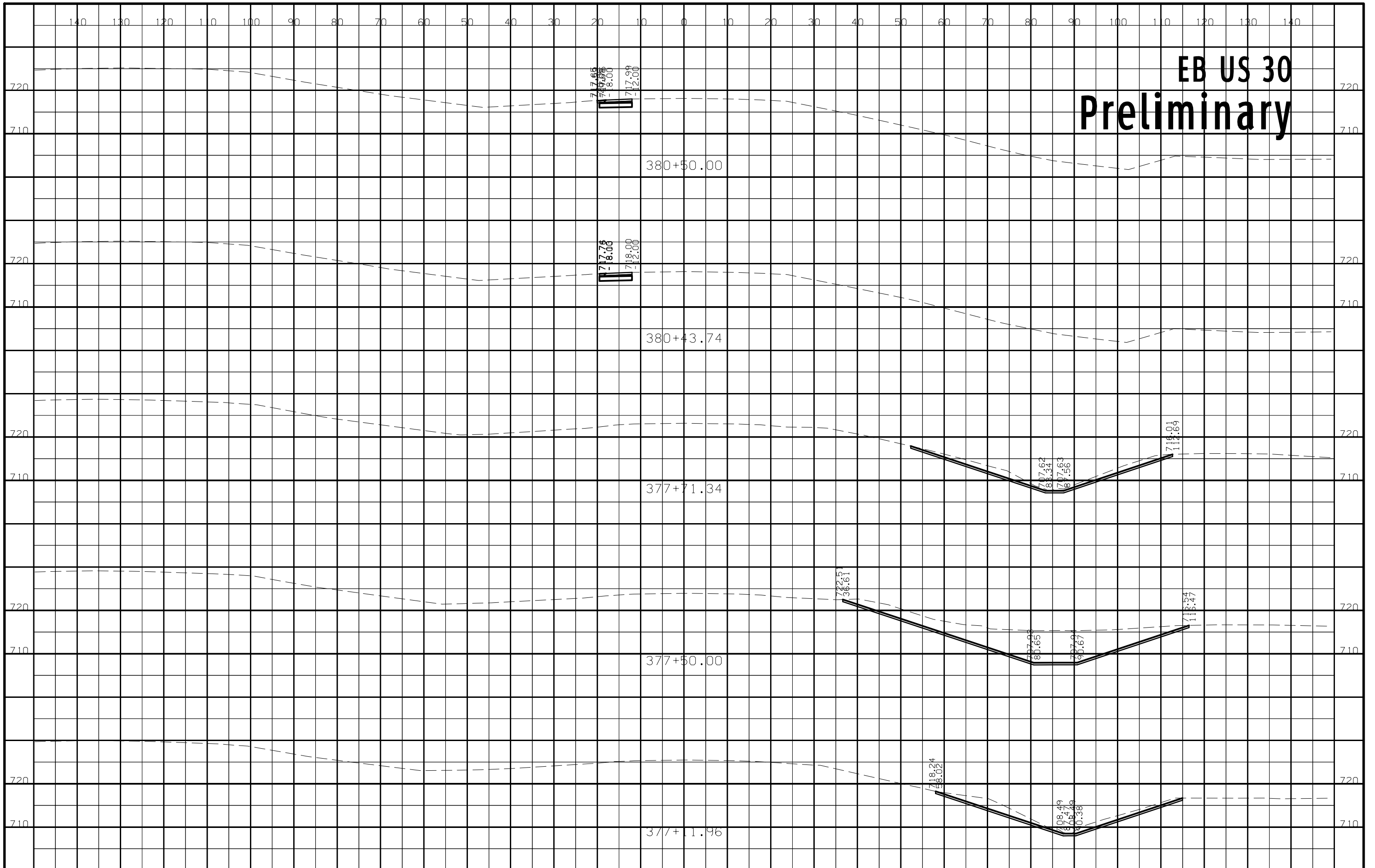

# EB US 30 Preliminary

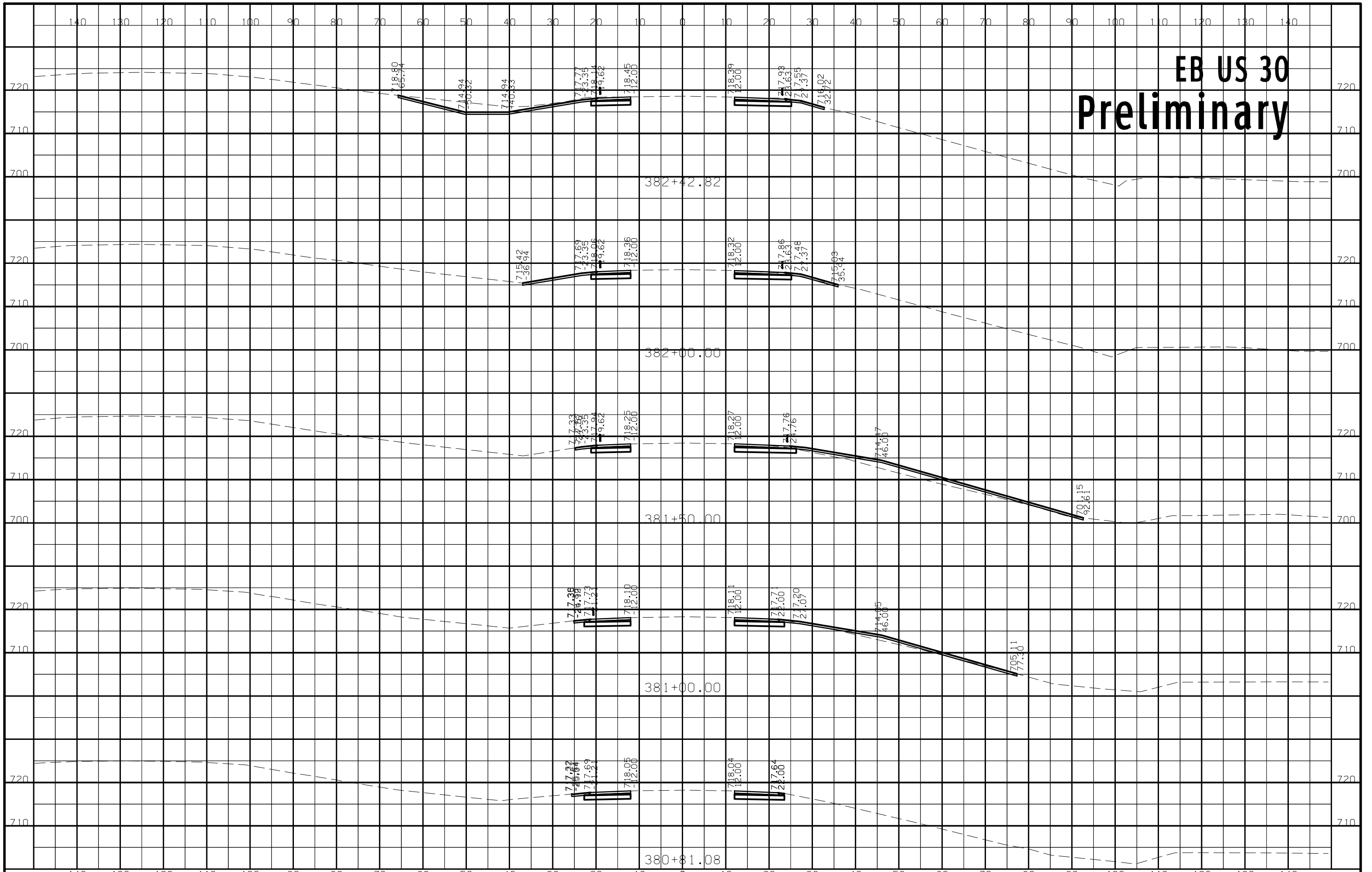

# EB US 30 Preliminary

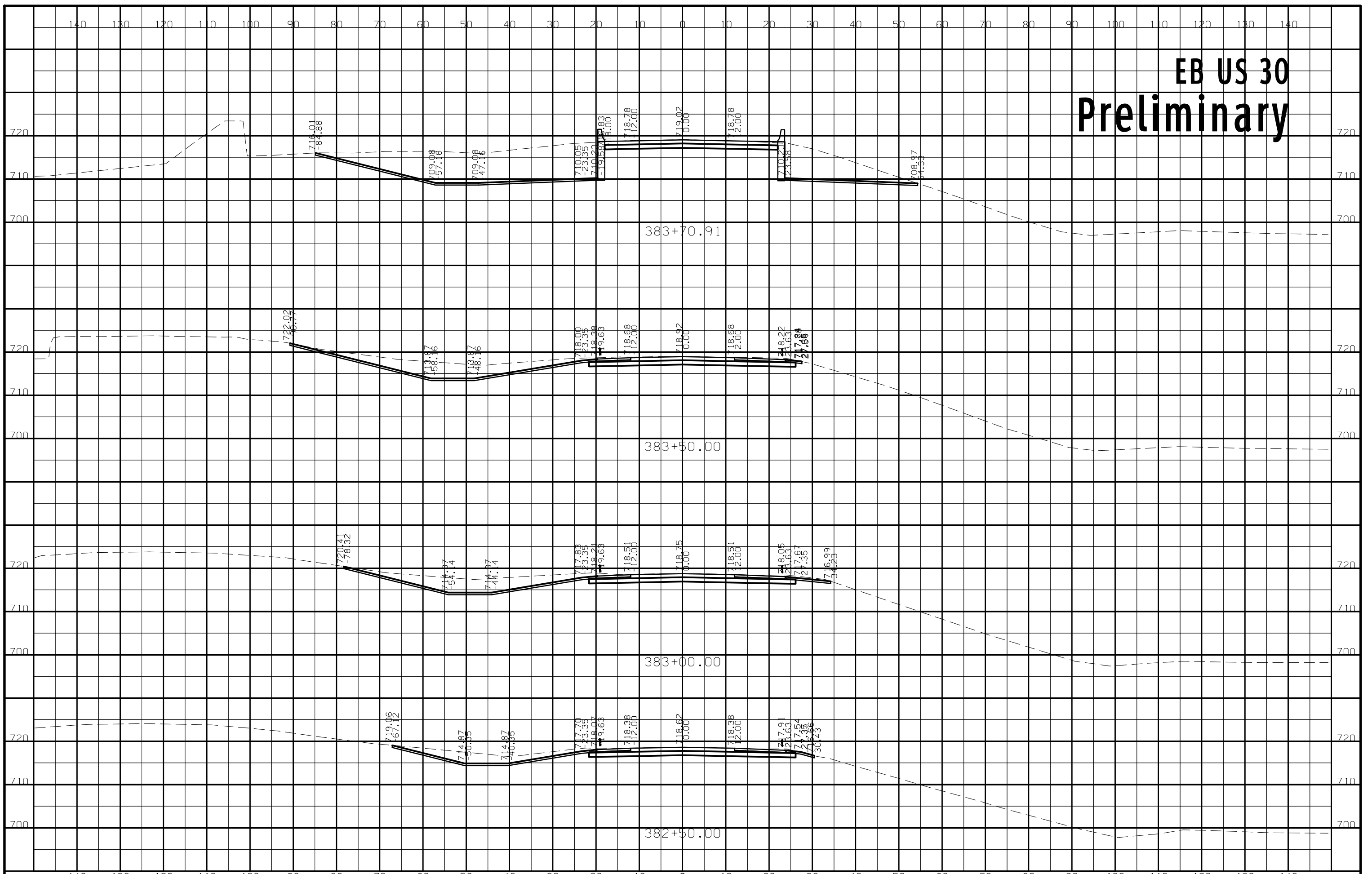

# EB US 30 Preliminary

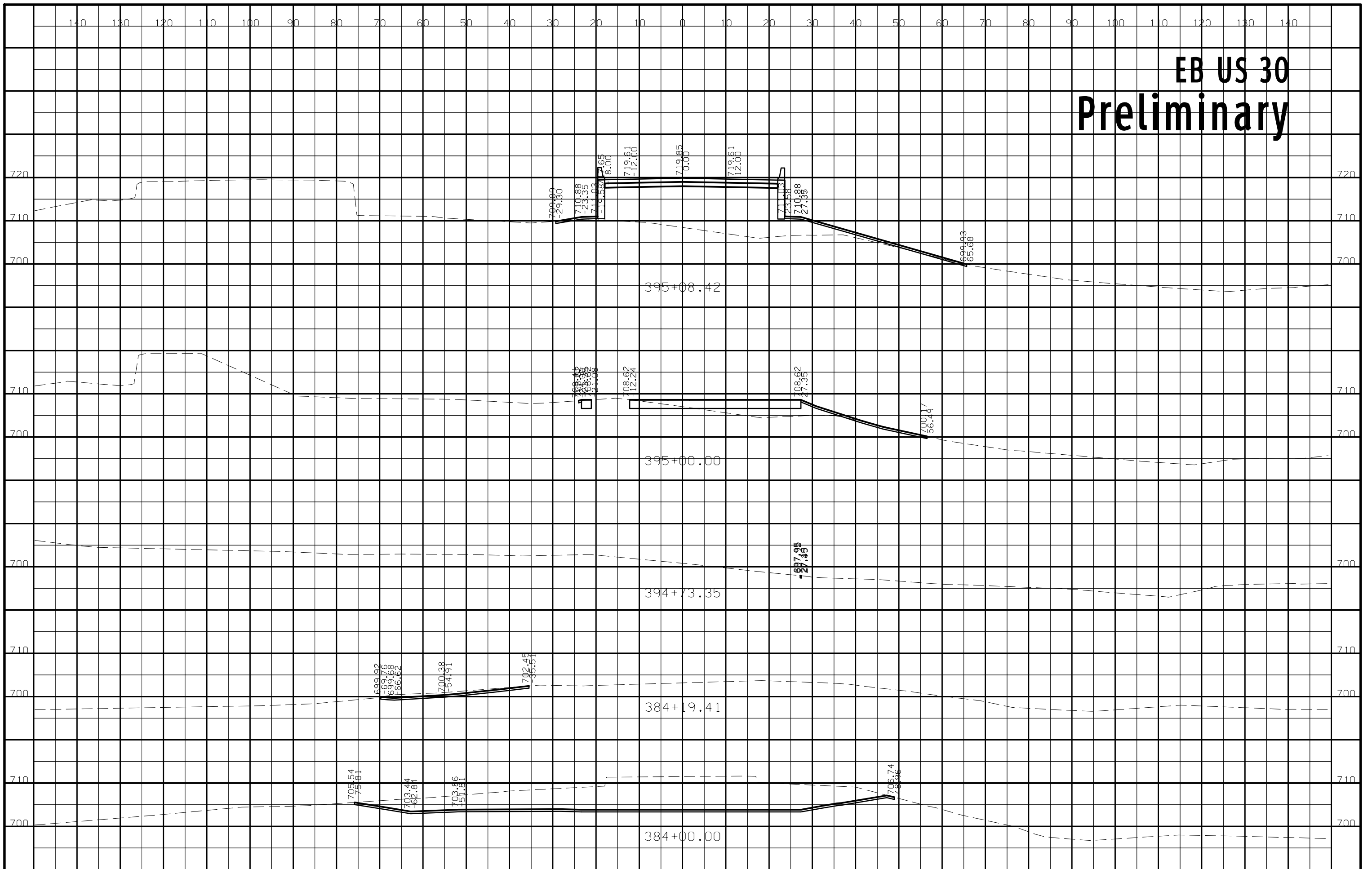

# EB US 30 Preliminary

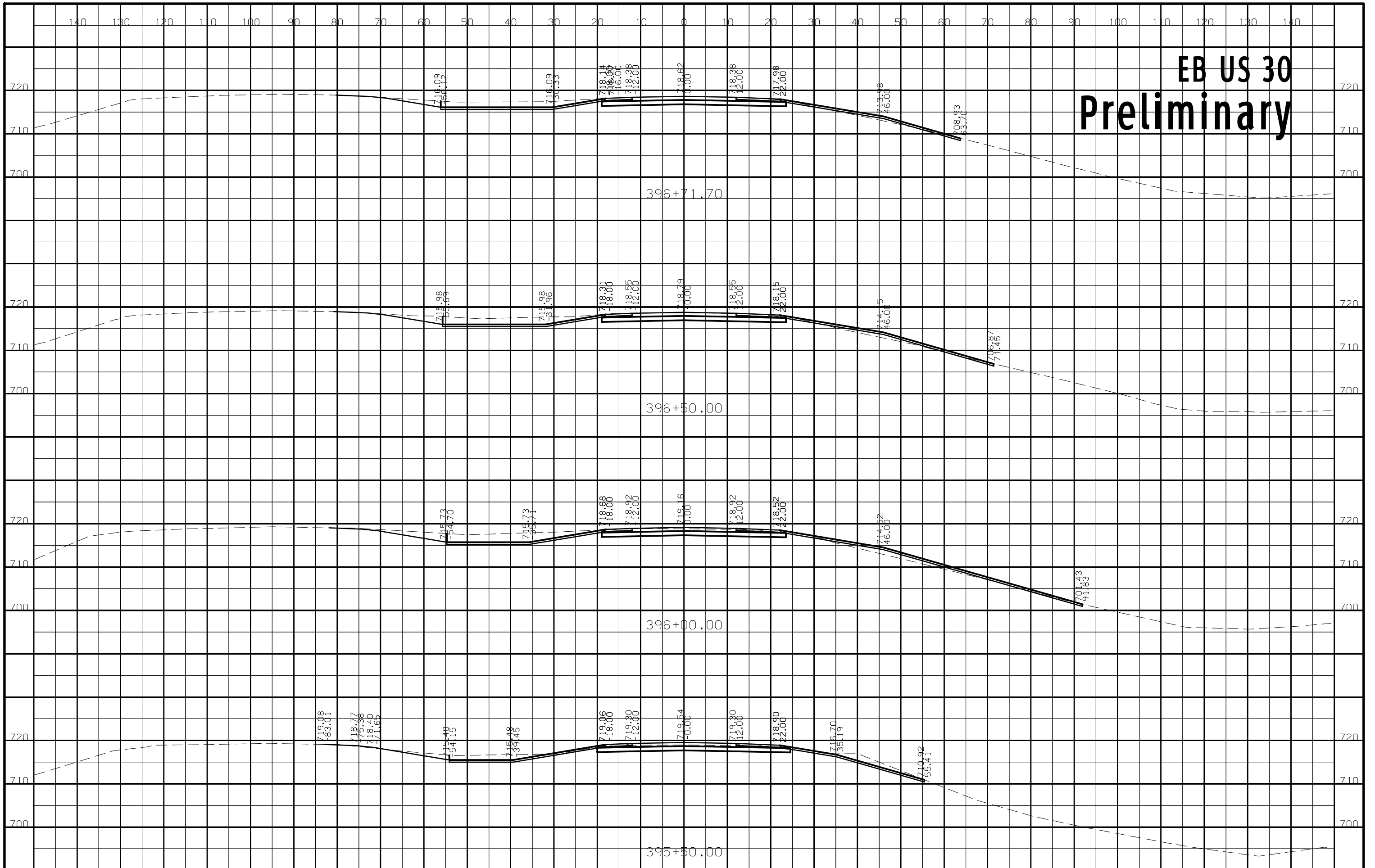

# EB US 30 Preliminary

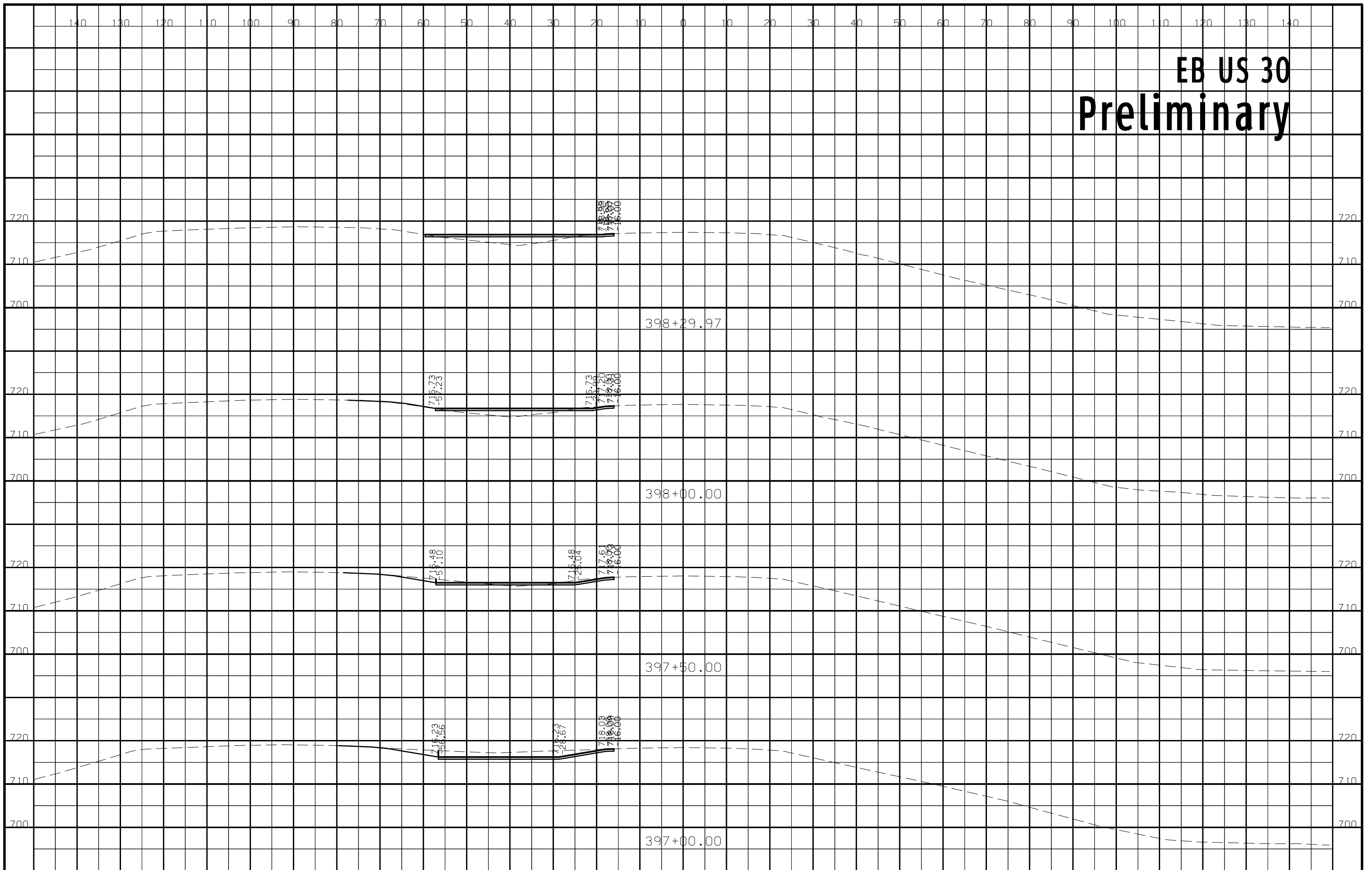

# WEST CROSSOVER Preliminary

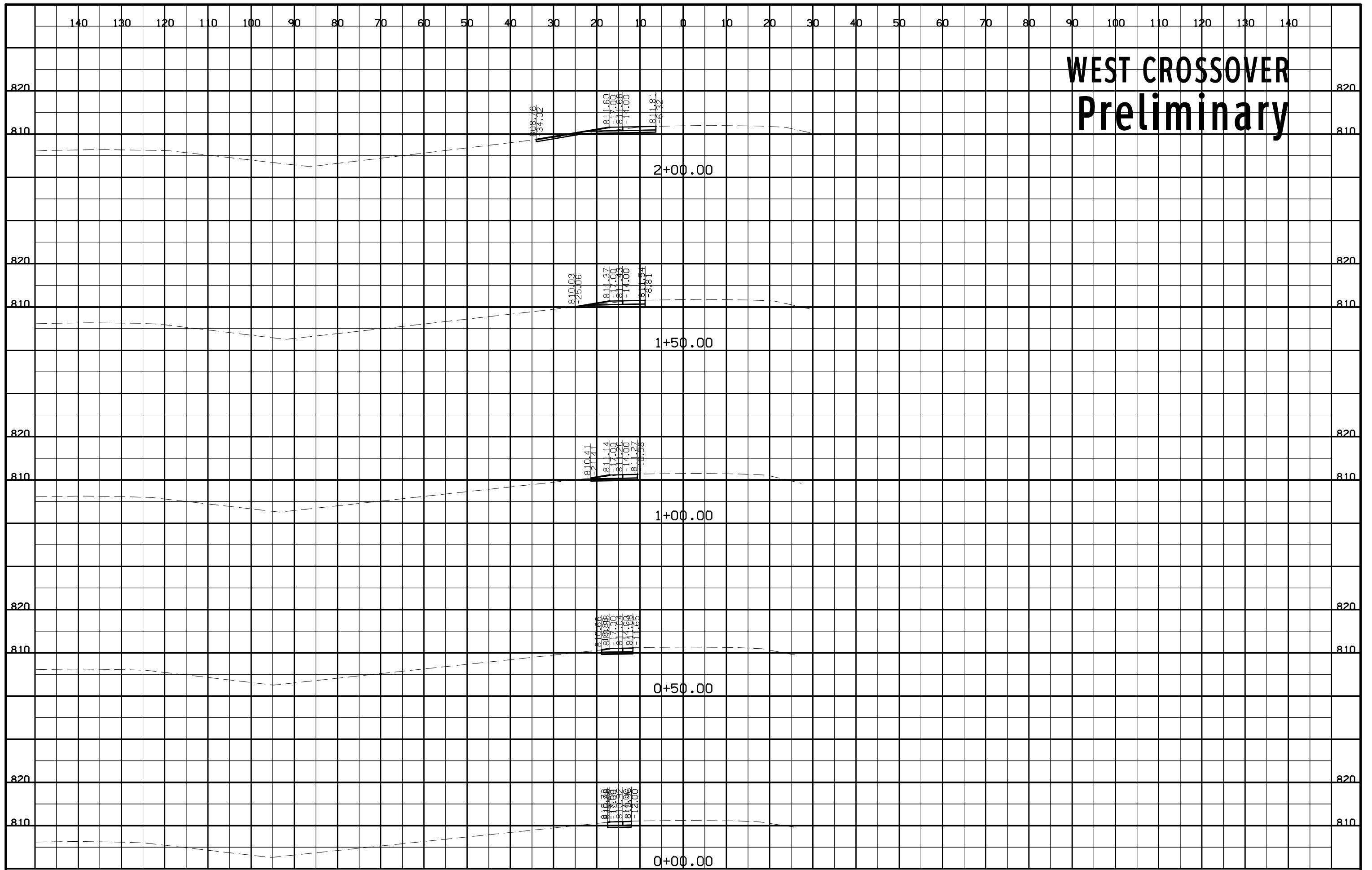

# WEST CROSSOVER Preliminary

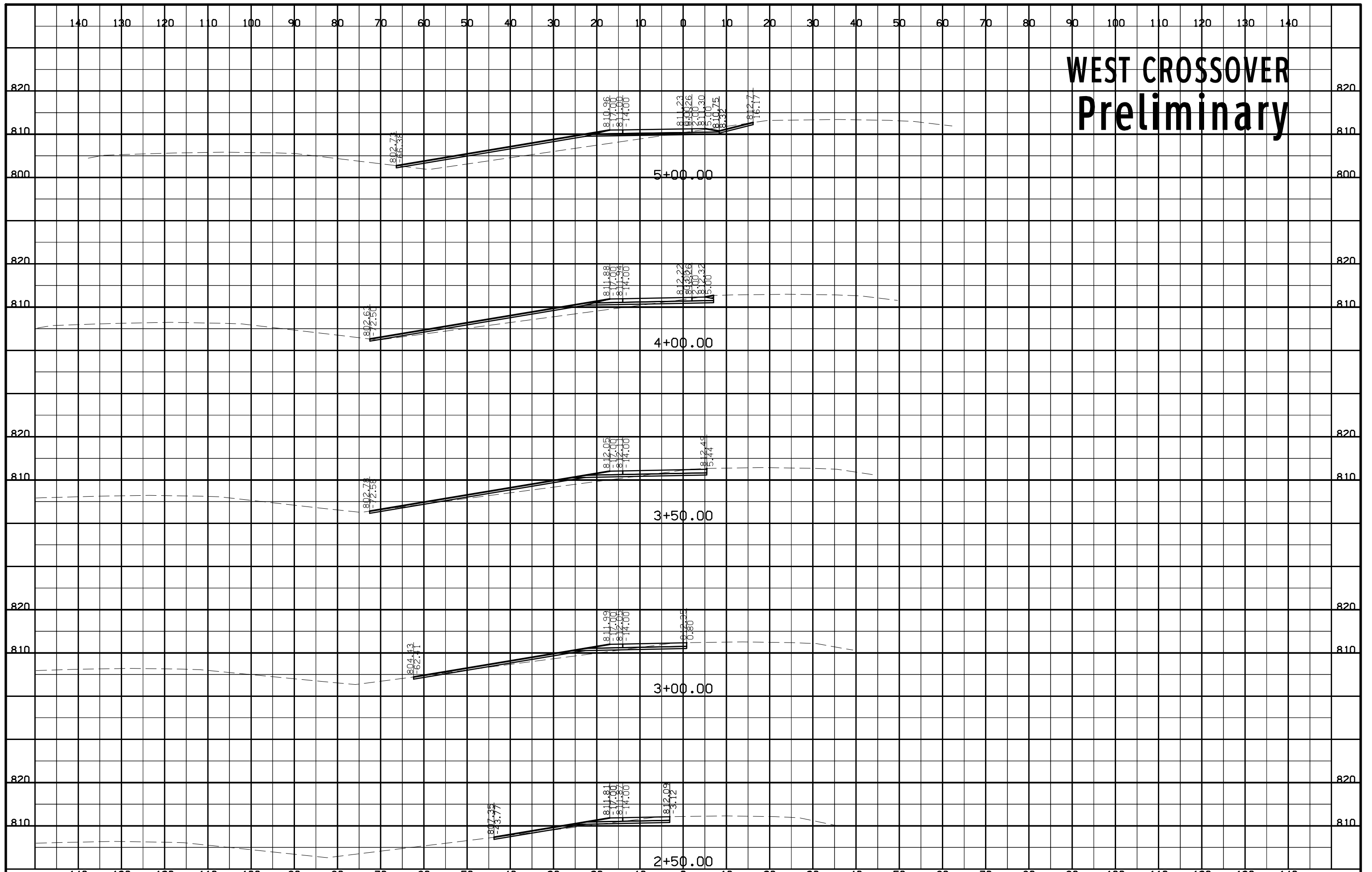



# WEST CROSSOVER Preliminary

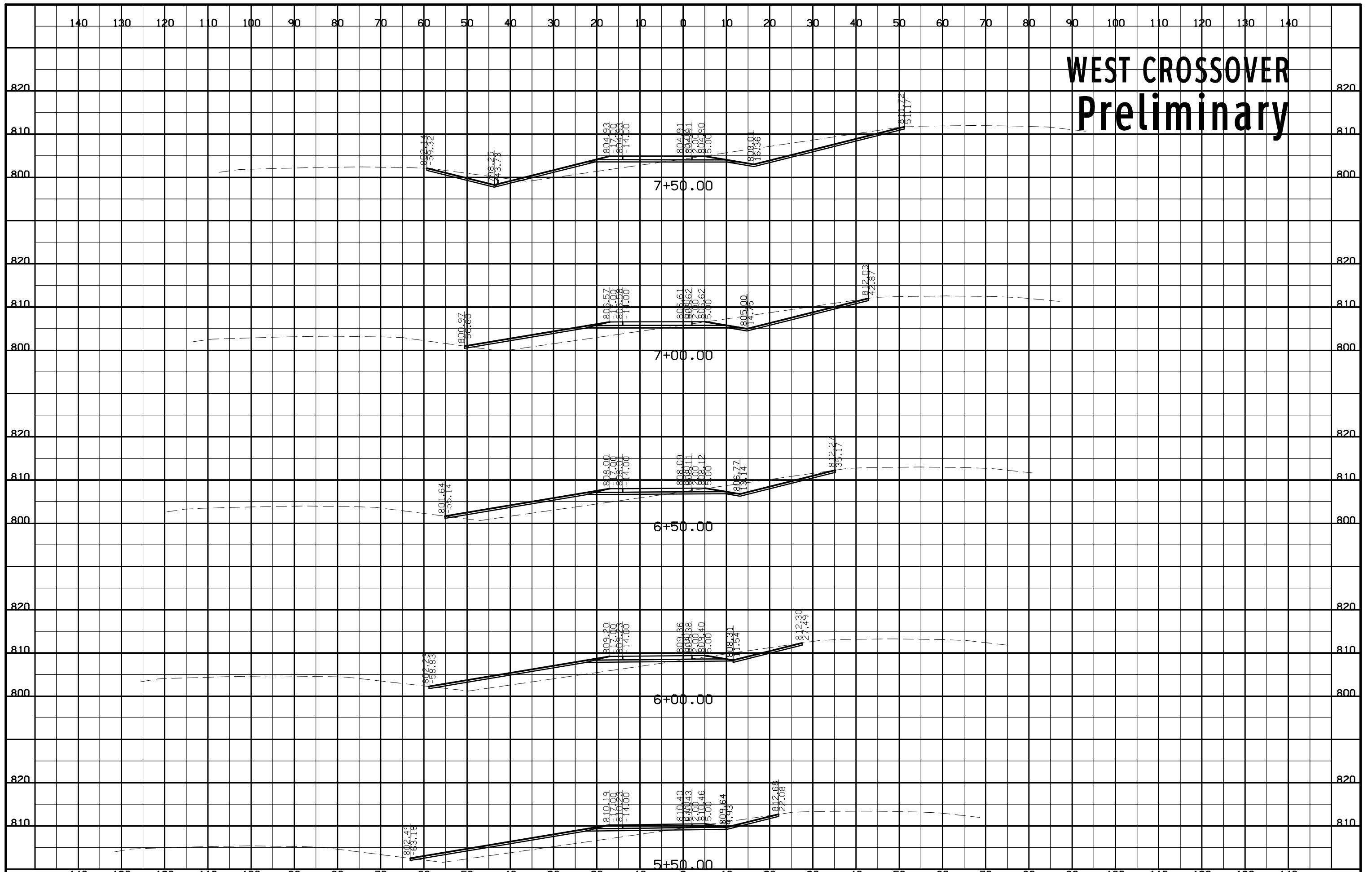

# WEST CROSSOVER Preliminary

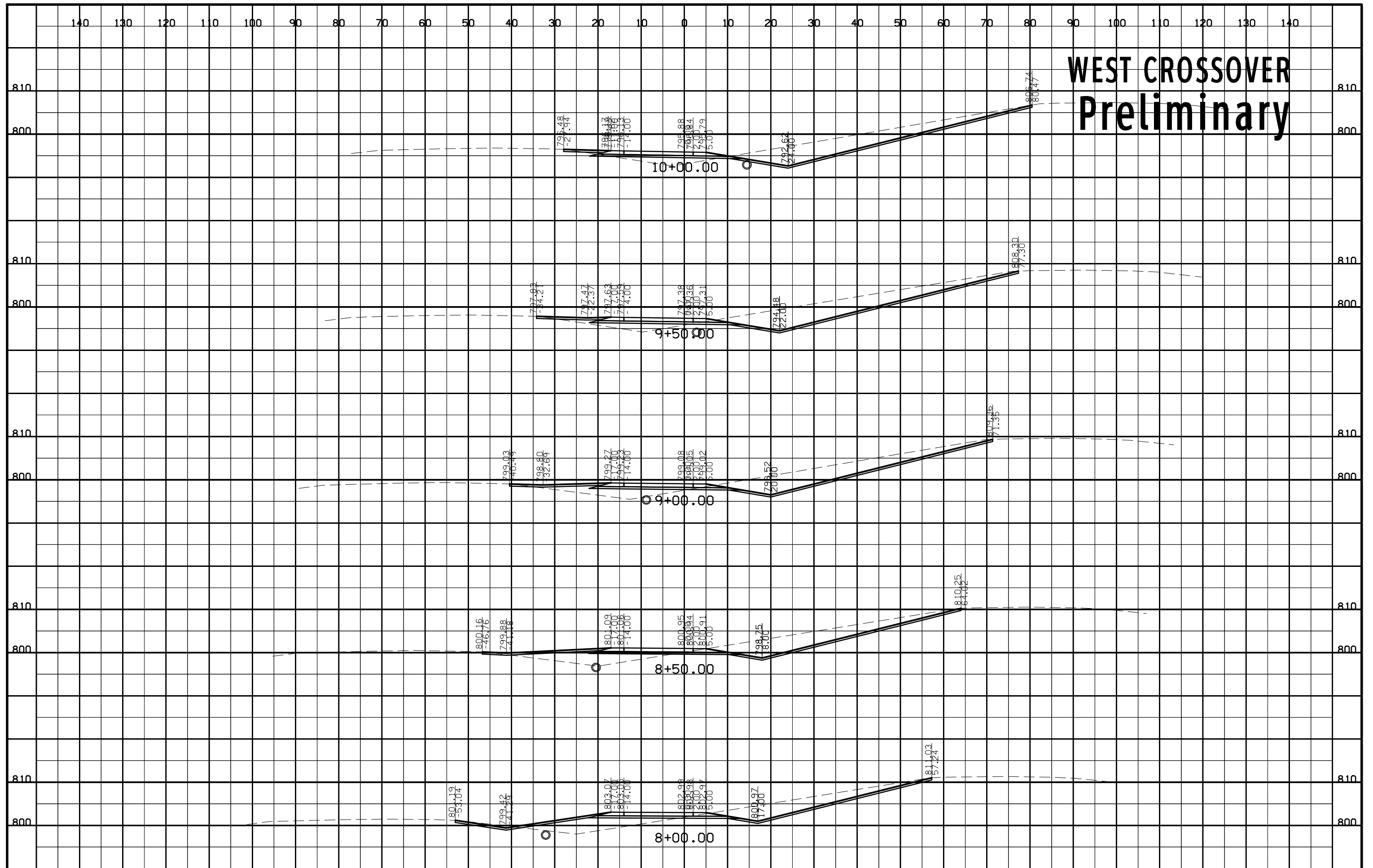

# WEST CROSSOVER Preliminary

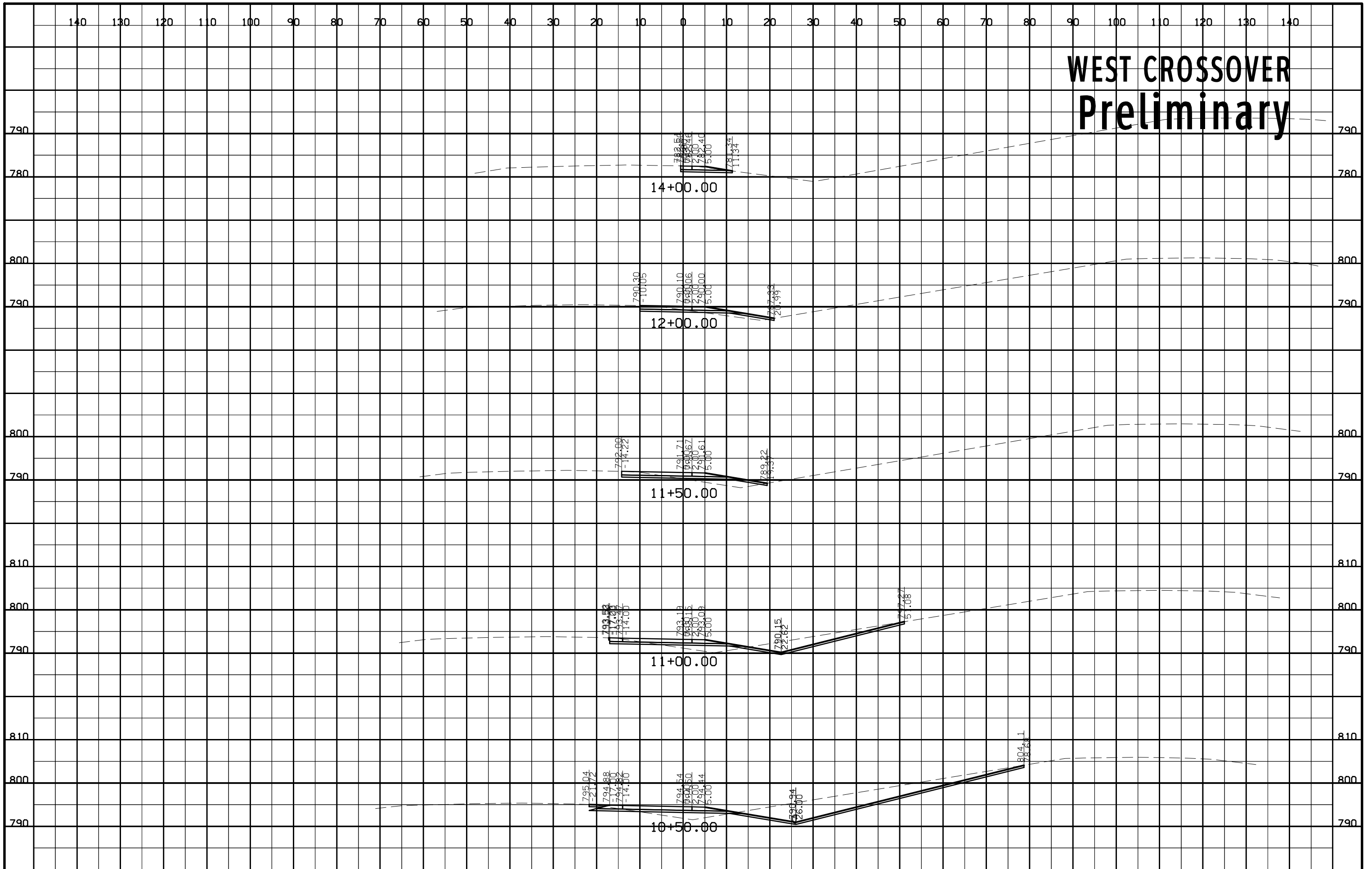

140 130 120 110 100 90 80 70 60 50 40 30 20 10 0 10 20 30 40 50 60 70 80 90 100 110 120 130 140

# WEST CROSSOVER Preliminary



# EAST CROSSOVER Preliminary

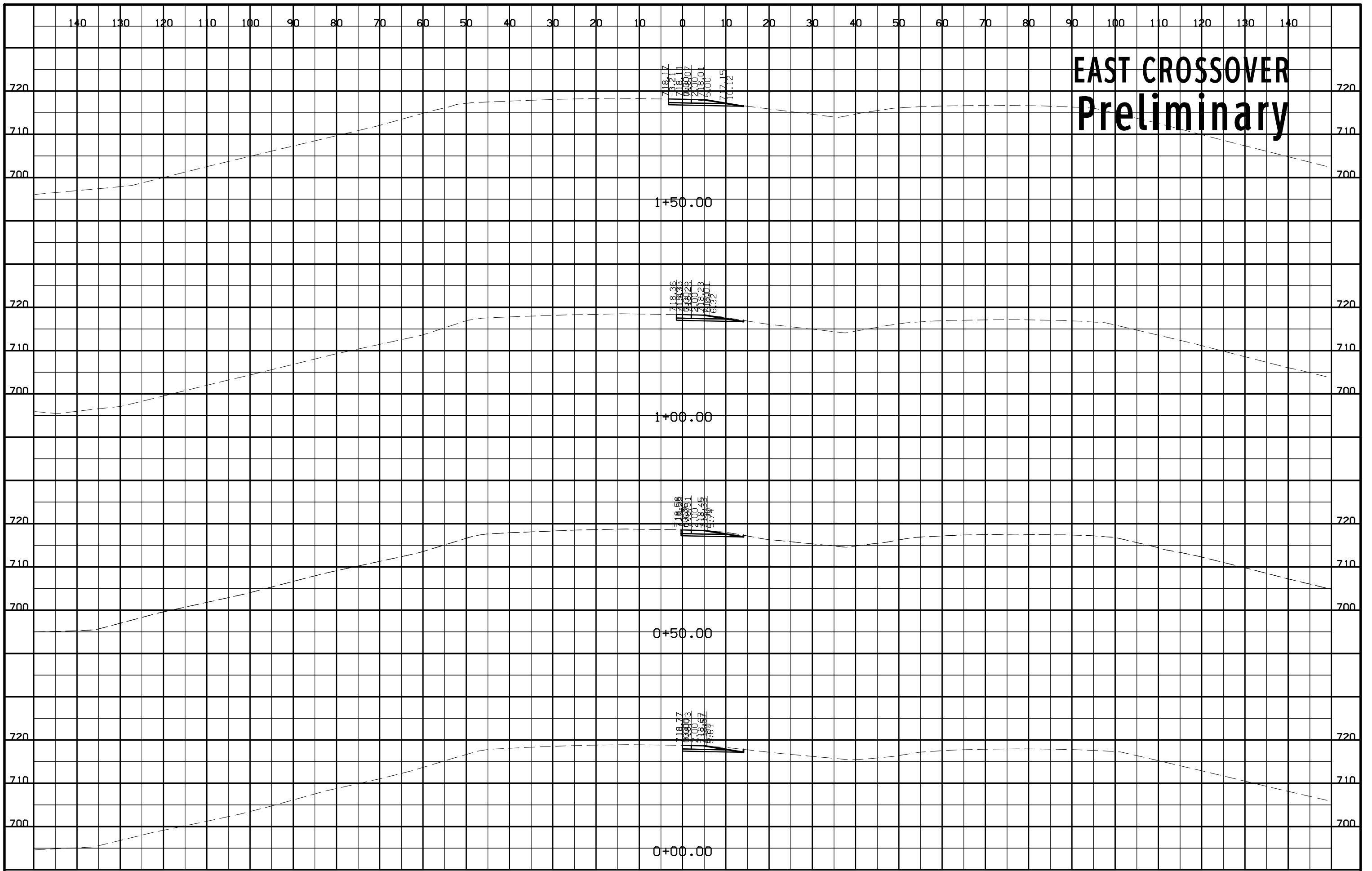

# EAST CROSSOVER Preliminary

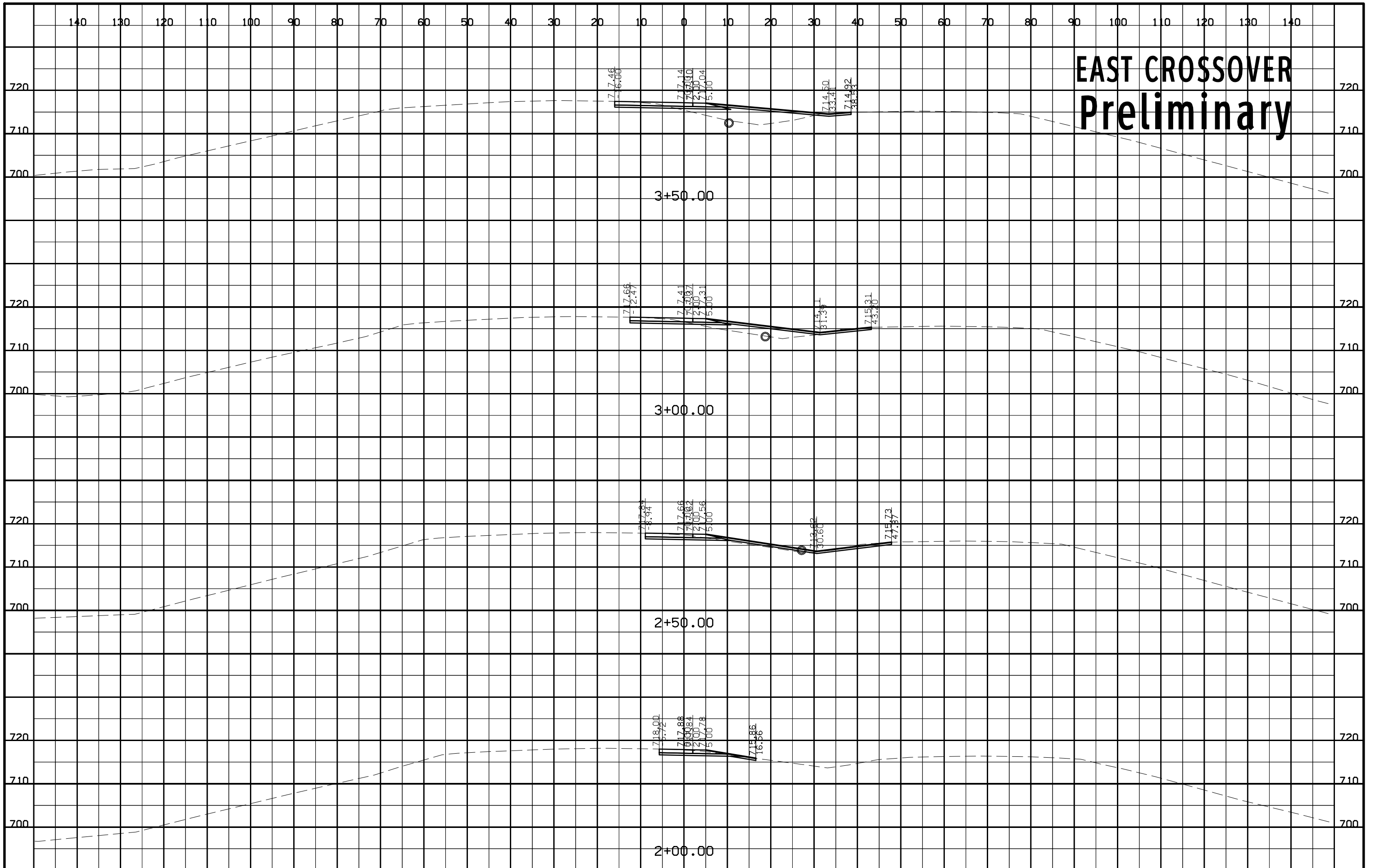

# EAST CROSSOVER Preliminary

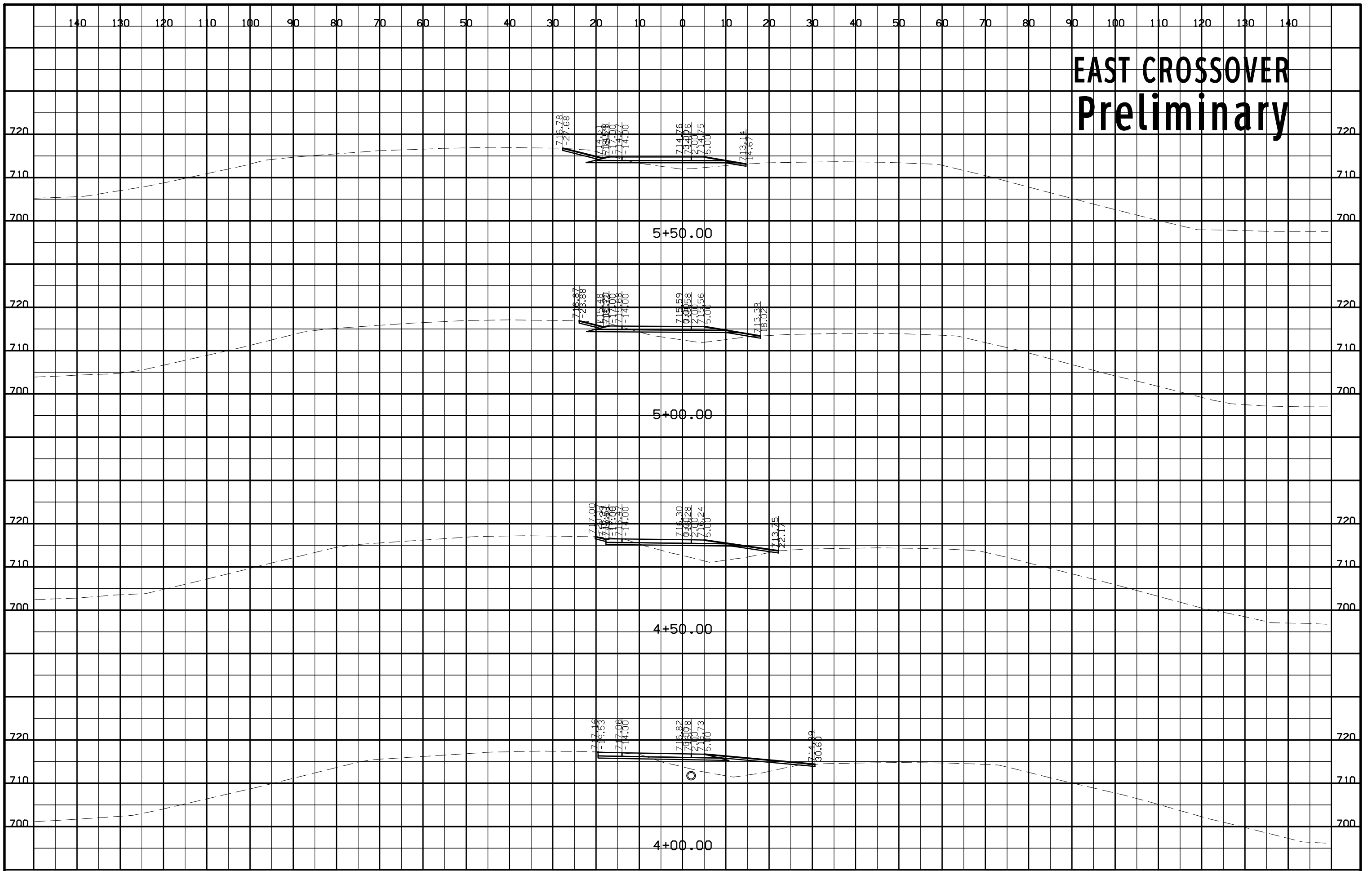

# EAST CROSSOVER Preliminary

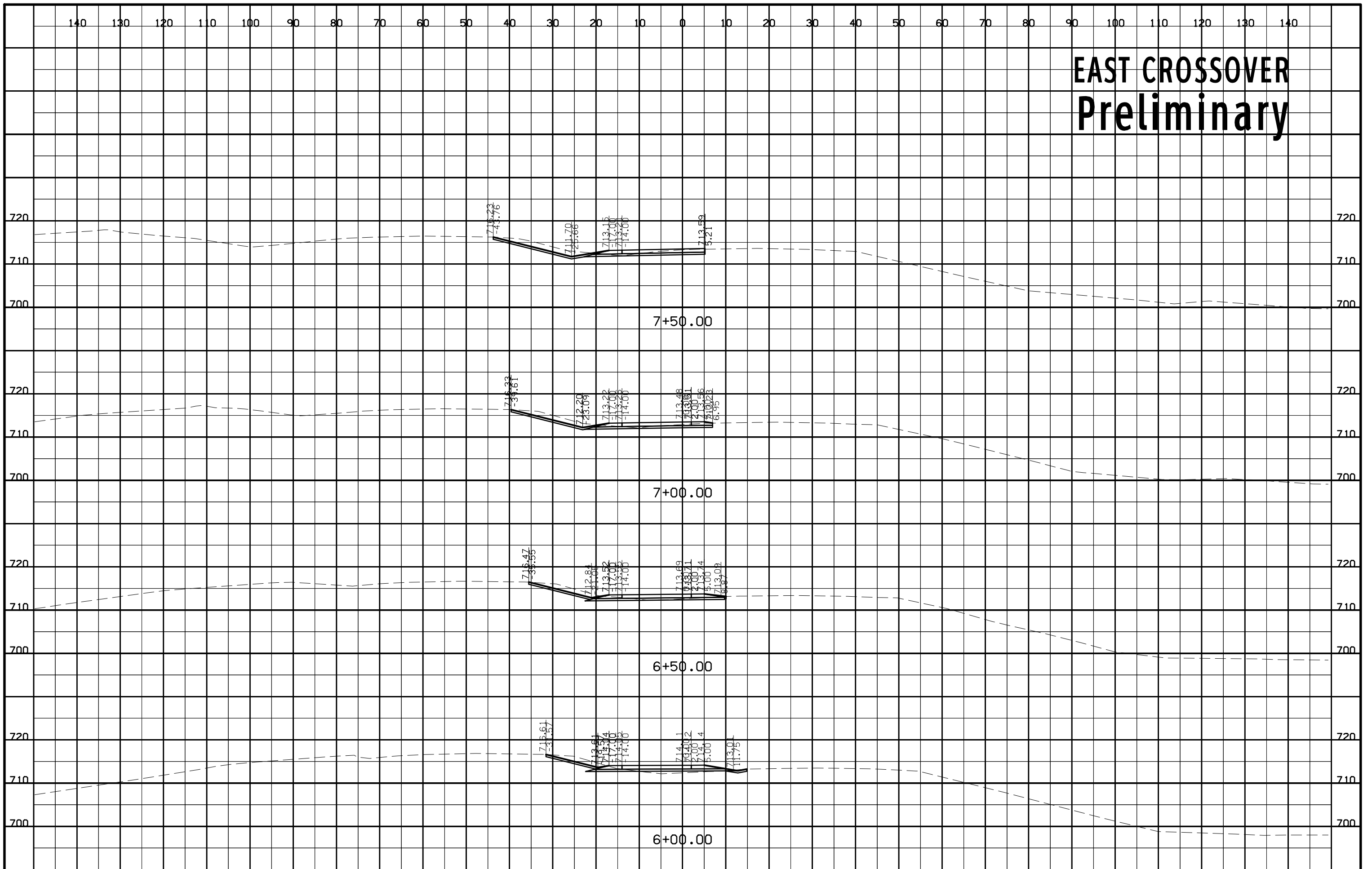



# EAST CROSSOVER Preliminary

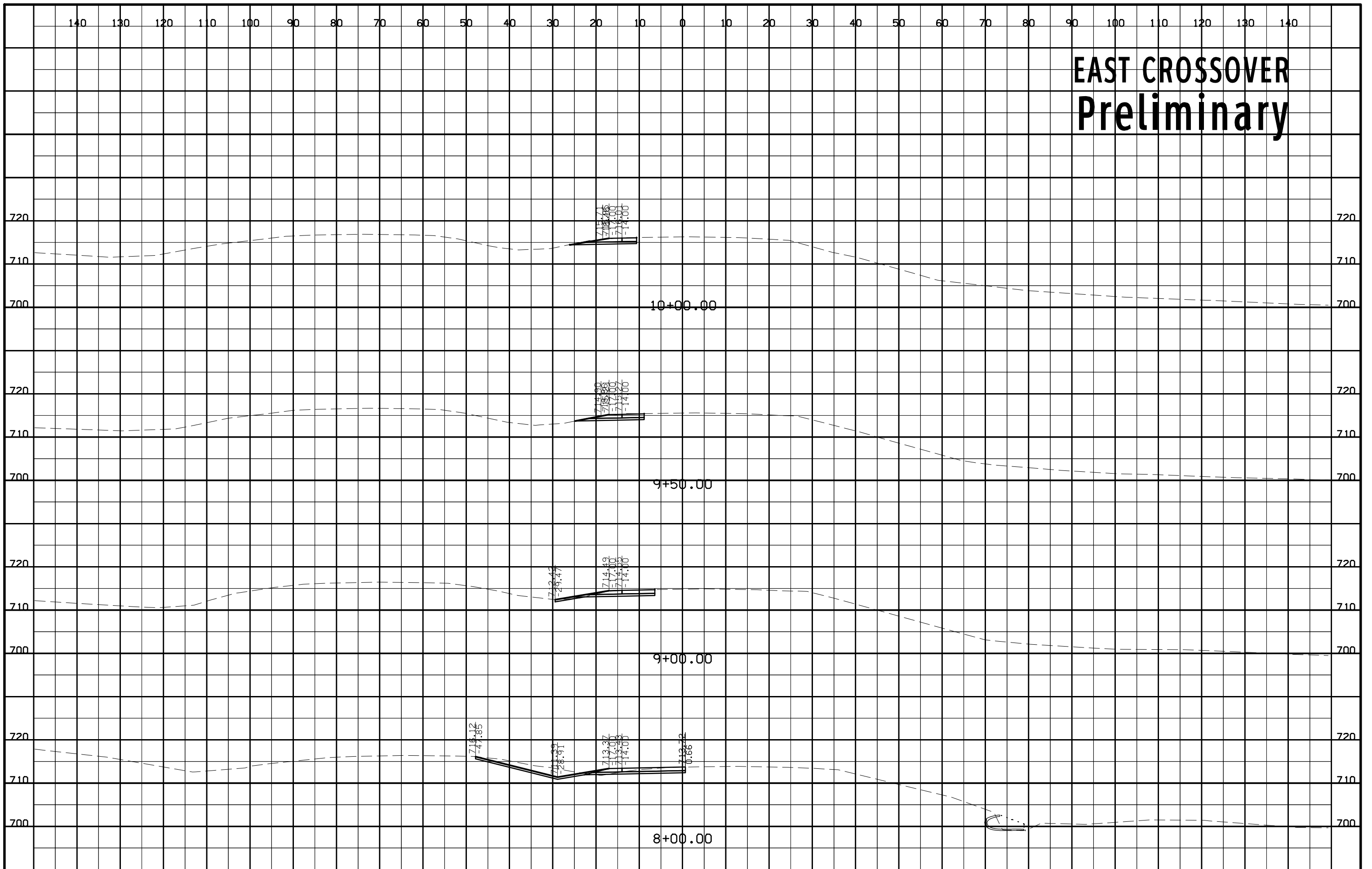

# EAST CROSSOVER Preliminary

