

WARREN COUNTY

Bridge Replacement
BRF-065-3(087)--38-91

LETTING DATE
Nov 17 2026



PLANS OF PROPOSED IMPROVEMENT ON THE
**PRIMARY ROAD SYSTEM
WARREN COUNTY**
Bridge Replacement
US 65 Bridge over Stream
0.2 miles N. of Co. Rd. G24 (NB)

SCALES: As Noted

Refer to the Proposal Form for list of applicable specifications.

Value Engineering Saves. Refer to Article 1105.14 of the Specifications.



REVISIONS

TOTAL

36

PROJECT IDENTIFICATION NUMBER

22-91-065-010

PROJECT NUMBER

BRF-065-3(087)--38-91

R.O.W. PROJECT NUMBER

NHSN-065-3(088)--2R-91

INDEX OF SHEETS	
No.	DESCRIPTION
A Sheets	Title Sheets
A.1	Title Sheet
B Sheets	Typical Cross Sections and Details
B.1 - 3	Typical Cross Sections and Details
D Sheets	Mainline Plan and Profile Sheets
* D.1	Plan & Profile Legend & Symbol Information Sheet
* D.2	ML65 Plan and Profile
G Sheets	Survey Sheets
G.1	Survey Information
G.2	Control Point Vacinity Map
G.3	Horizontal and Vertical Point Control
J Sheets	Traffic Control and Staging Sheets
J.1	Traffic Control Plan
J.2	Staging Notes
* J.3	Traffic Control & Staging Legend & Symbol Info. Sheet
* J.4 - 12	Staging and Traffic Control Sheets
V Sheets	Bridge and Culvert Situation Plans
* V.1	Bridge and Culvert Situation Plans
W Sheets	Mainline Cross Sections
* W.1	Cross Sections Legend & Symbol Information Sheet
* W.2 - W.14	Mainline Cross Sections
	* Color Plan Sheets

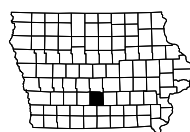
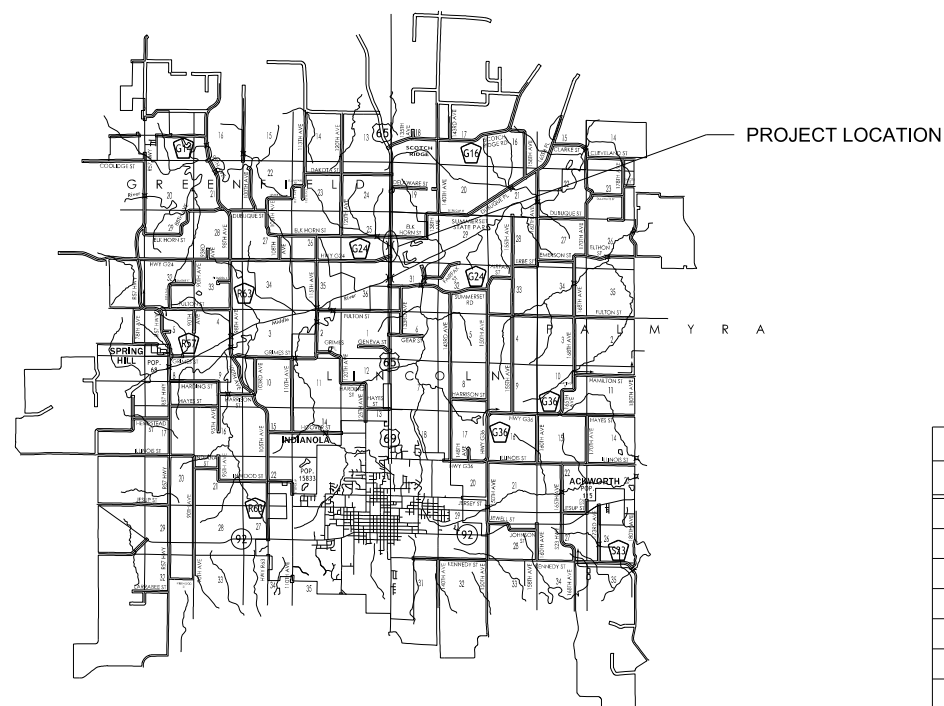

D5 PLAN - Date: 10-11-24
P9 PLAN - Date: 3-12-25
D4 PLAN - Date: 7-21-26

PRELIMINARY PLANS

Subject to change by final design.

D3 PLAN - Date: 6-7-24

INDEX OF SEALS			
SHEET NO.	NAME	TYPE	BID QUANTITY SHEETS
A.1	X	Primary Signature Block	X
X	X	X	X

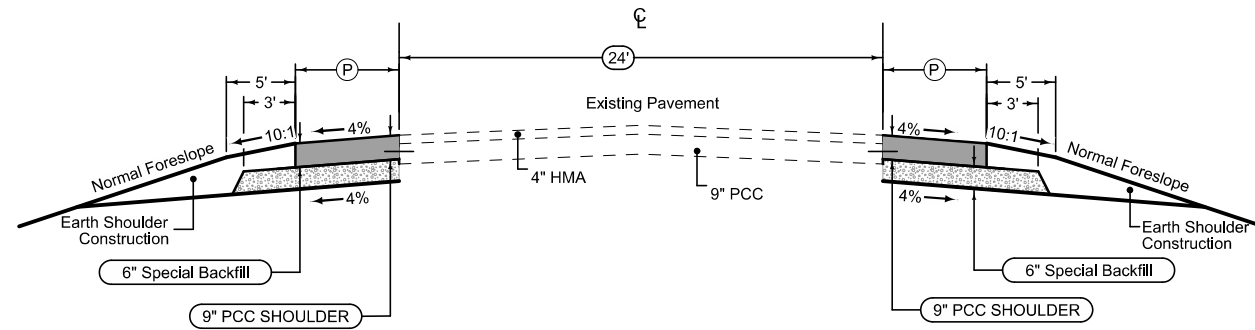

PCC SHOULDER

Shoulder Jointing:
 Longitudinal joint: BT-1 or BT-5
 Transverse Joint: C (match existing ML joint spacing)

4_P_PCC			
Direction of Travel	BEGIN STATION	END STATION	(P) Feet
NB	836+19.04	836+98.99	Varies
NB	836+98.99	838+79.40	7.6
NB	841+77.49	844+10.00	6

PCC SHOULDER

Shoulder Jointing:
 Longitudinal joint: BT-1 or BT-5
 Transverse Joint: C (match existing ML joint spacing)

4_P_PCC			
Direction of Travel	BEGIN STATION	END STATION	(P) Feet
NB	836+33.44	837+13.40	Varies
NB	837+16.40	838+79.40	11.6
NB	841+77.49	844+10.00	10

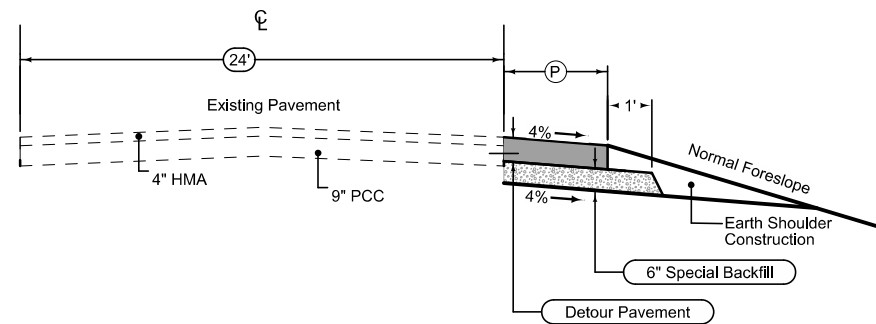

Detour Pavement

PCC Shoulder Jointing:
 Longitudinal joint: B
 Transverse joints: C
 HMA Shoulder Jointing
 Longitudinal joint: B

Custom				
Direction of Travel	BEGIN STATION	END STATION	(P) Feet	SPECIAL BACKFILL (CY)
NB	836+75.08	839+25.70	4	23.74
NB	839+25.70	839+47.18	Varies	1.64
NB	839+47.18	839+81.18	2	1.96
NB	840+67.75	844+07.50	4	32.19

U.S. 65

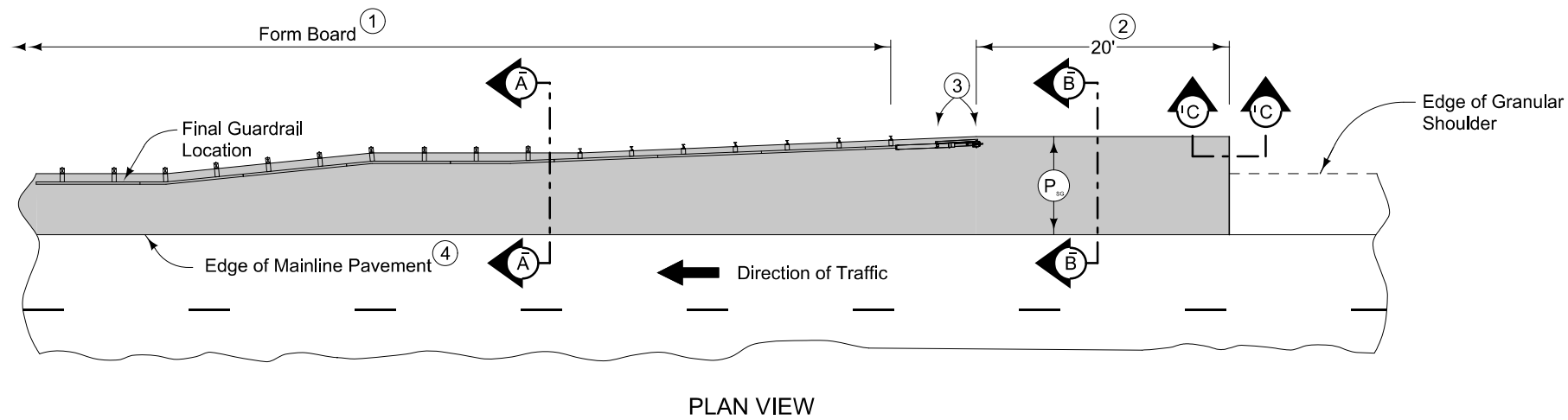

9" PCC Paved Shoulder at guardrail with the following jointing layout:

Match mainline pavement joint spacing. When mainline pavement is 8" or greater in thickness, place additional transverse 'C' joints in shoulder at mid-panel of the mainline pavement. Place longitudinal 'C' joint at P/2 from edge of mainline pavement when P is greater than 10' wide. Terminate longitudinal joint at transverse joint less than 10' in length.

Compaction of HMA is required to face of guardrail post. Hand compaction will be allowed under guardrail. Removal and reinstallation of guardrail will be allowed with no additional payment.

Refer to Tabulation 112-9 for shoulder quantities.

- ① PCC option only: When guardrail posts are installed prior to construction of PCC paved shoulder, fasten form board to the face of guardrail posts for the length shown.
- ② Continue paved shoulder 20 feet beyond the center of the first post.
- ③ Shoulder may be notched for first 2 posts or post sleeves may be installed through pavement. Do not drive posts through pavement.
- ④ 'KT' joint (per PV-101) for PCC shoulder. 'B' joint (per PV-101) for HMA shoulder.
- ⑤ Refer to other details in the plan.

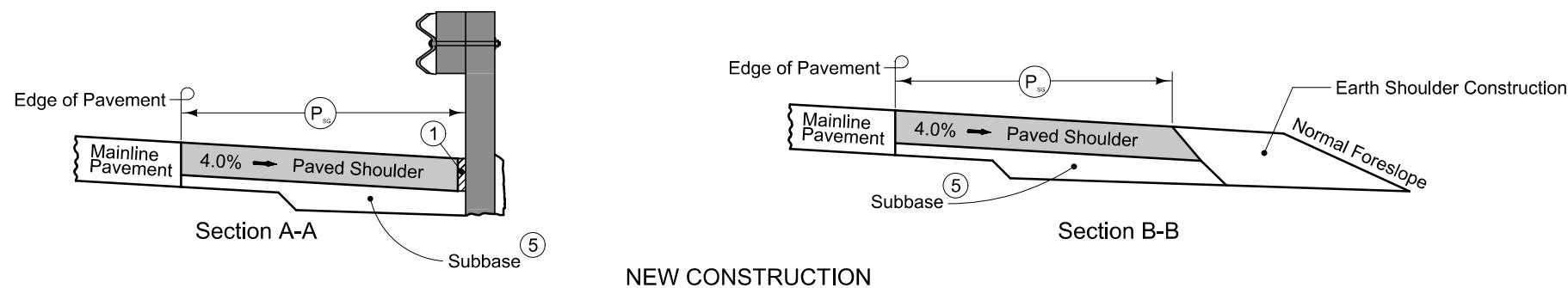

NEW CONSTRUCTION

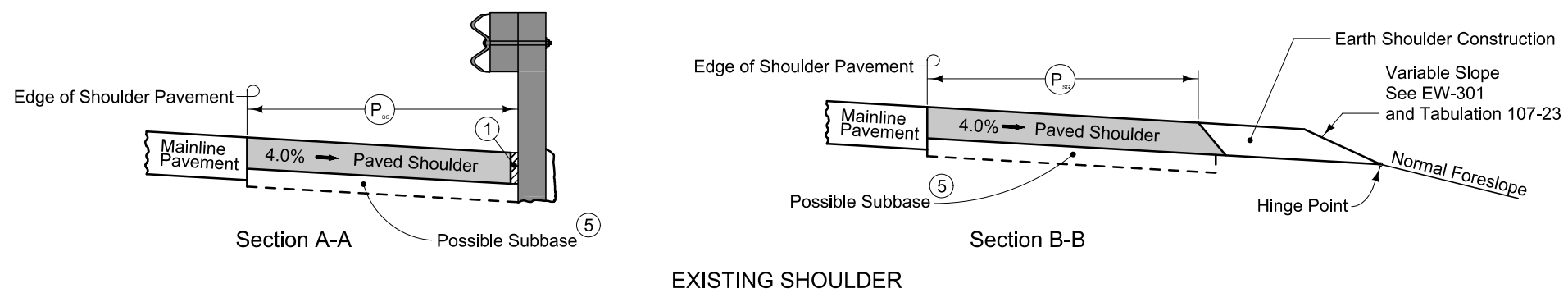

EXISTING SHOULDER

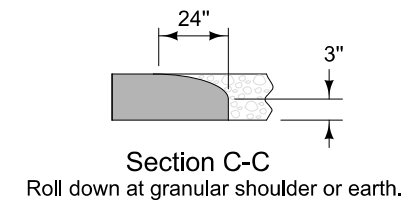

PAVED SHOULDER AT GUARDRAIL (GRANULAR SHOULDER ADJACENT TO MAINLINE)

8210
04-19-22

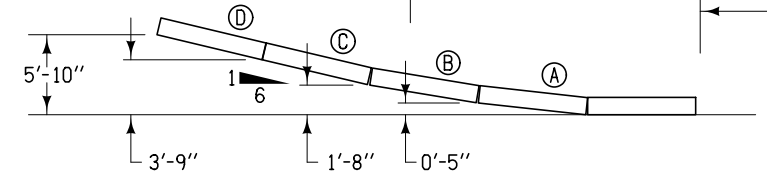
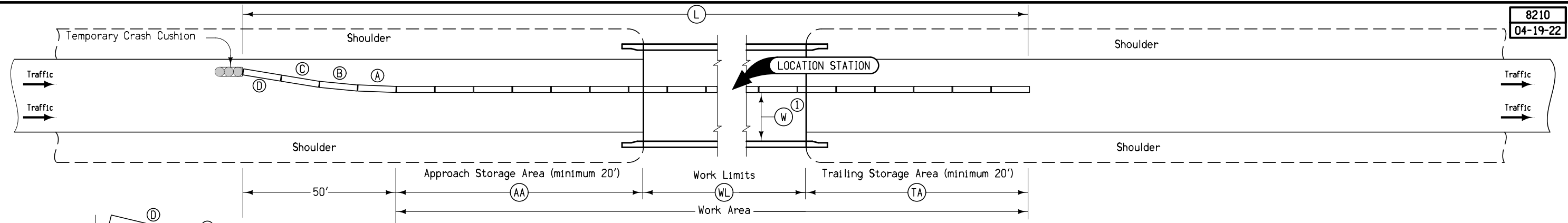

BARRIER OFFSETS FOR FLARE SECTIONS

Station	Side	AA	WL	TA	L	Anchored	W ^①	Remarks
		Feet	Feet	Feet	Feet	X	Ft-Inches	

① Where W is less than 15'-6", install restricted width signing as per Standard Road Plan TC-81.

**TEMPORARY CONCRETE BARRIER LAYOUT
for One-Way Traffic**

SURVEY SYMBOLS

- Interstate Highway Symbol
- U.S. Highway Symbol
- Iowa Highway Symbol
- County Road Highway Symbol
- Evergreen Tree
- Deciduous Tree
- Fruit Tree
- Shrub (Bushes)
- Timber
- Hedge
- Stump
- Swamp
- Rock Outcrop
- Broken Concrete
- Revetment (Rip Rap)
- Cemetery
- Grave
- Cave
- Sink Hole
- Board Fence
- Chain Link or Security Fence
- Wire Fence
- Terrace
- Earth Dam or Dike (Existing)
- Tile Outlet
- Edge of Water
- Existing Drainage
- Right of Way Rail or Lot Corner
- Concrete Monument
- Well
- Windmill
- Beehive Intake
- Existing Intake
- Existing Utility Access (Manhole)
- Fire Hydrant
- Water Hydrant (Rural)
- Septic Tank
- Cistern
- L.P. Gas Tank (No Footing)
- Underground Storage Tank
- Latrine
- Satellite TV Dish
- Water Hook Up
- Radio Tower
- Tower Anchor
- Guardrail (Beam or Cable)
- Guard Post (one or two)
- Guard Post (over two)
- Filler Pipe
- Gas Valve
- Water Valve
- Speed Limit Sign
- Mile Marker Post
- Sign
- Traffic Signal Control Box
- Rail Road Signal Control Box
- Telephone Switch Box
- Electric Box

UTILITY LEGEND

- PPA, MIDAMERICAN-ELEC
- FO1, CENTURYLINK - Quality D
- FO2, AUREON - Quality D
- FO3, WINDSTREAM - Quality D
- T1, CENTURYLINK - Quality D
- W, WARREN WATER DISTRICT - Quality D

PLAN VIEW COLOR LEGEND OF PLAN AND PROFILE SHEETS

LINEWORK		Design Color No.	
Green	(2)		Existing Topographic Features and Labels
Blue	(1)		Proposed Alignment, Stationing, Tic Marks, and Alignment Annotation
Magenta	(5)		Existing Utilities
SHADING		Design Color No.	Transparency
Lavender	(9)		Temporary Pavement Shading
Yellow	(4)		Proposed Pavement Shading
Orange	(6)		Proposed Granular Shading
Orange	(70)		Proposed Shoulder Granular Shading
Yellow	(68)		Proposed Shoulder Paved Full Depth Shading
Yellow	(132)		Proposed Shoulder Paved Partial Depth Shading
Violet	(15)		Proposed Grade and Pave Shading (In conjunction with a paving project)
Brown, Light	(236)		Grading Shading
Orange, Light	(134)		Proposed Granular Entrance Shading
Yellow	(220)		Proposed Paved Entrance Shading
Tan	(8)		Proposed Sidewalk Shading
Blue, Light	(230)		Proposed Sidewalk Landing Shading
Pink	(11)		Proposed Sidewalk Ramp Shading
Green, Light	(225)		Existing Pavement Shading
Red	(3)		Proposed Structure Shading
Red	(3)		Delineates Restricted Areas

PROFILE VIEW COLOR LEGEND OF PLAN AND PROFILE SHEETS

LINEWORK		Design Color No.	
Green	(10)		Existing Ground Line Profile
Blue	(1)		Proposed Profile and Annotation
Magenta	(5)		Existing Utilities
Blue, Light	(230)		Proposed Ditch Grades, Left
Black	(0)		Proposed Ditch Grades, Median
Rust	(14)		Proposed Ditch Grades, Right

- Reference Point
- Station
- Survey Line
- Section Corner
- Ground Line Intercept
- Saw Cut
- Guardrail
- Trench Drain
- HighTension Cable Guardrail
- Sheet Pile
- Pavement Removal
- Clearing & Grubbing Area

RIGHT-OF-WAY LEGEND

- Proposed Right-of-Way
- Existing Right of Way
- Existing and Proposed Right-of-Way
- Easement and Existing Right-of-Way
- Easement (Temporary)
- Easement
- Access Control
- Property Line

PLAN AND PROFILE LEGEND AND SYMBOL INFORMATION SHEET

(COVERS SHEET SERIES D, E, F, & K)

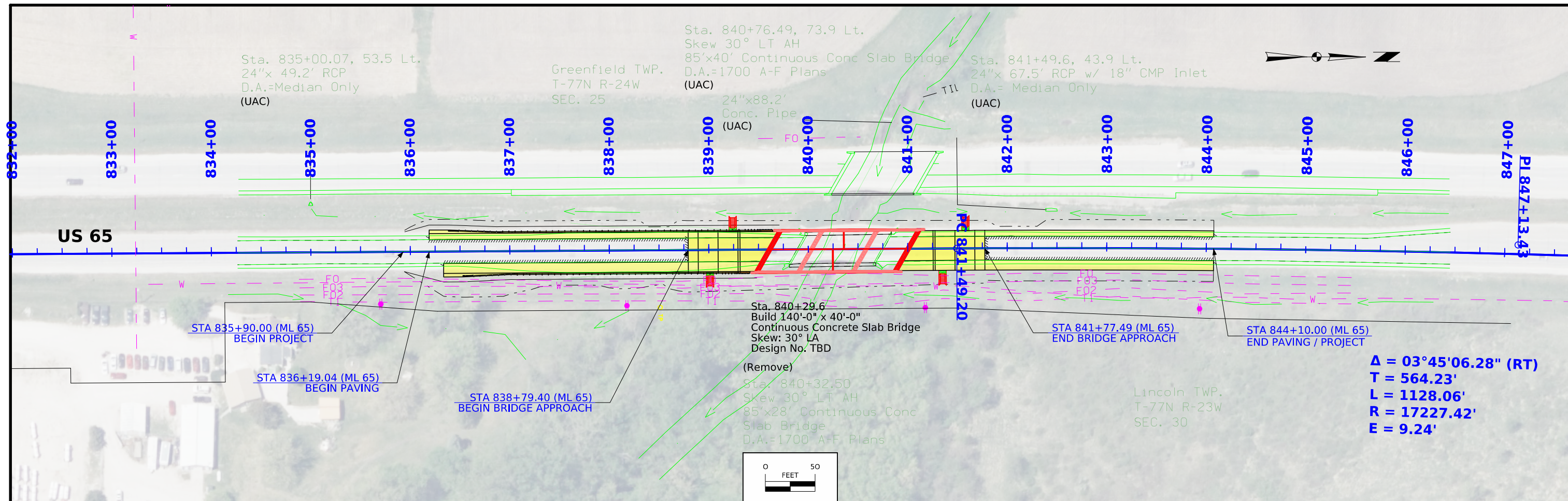

Sta. 840+76.49, 73.9 Lt.
 Skew 30° LT AH
 85'x40' Continuous Conc Slab Bridge
 D.A.=1700 A-F Plans
 (UAC)

Sta. 835+00.07, 53.5 Lt.
 24"x 49.2' RCP
 D.A.=Median Only
 (UAC)

Greenfield TWP.
 T-77N R-24W
 SEC. 25

Sta. 841+49.6, 43.9 Lt.
 24"x 67.5' RCP w/ 18" CMP Inlet
 D.A.= Median Only
 (UAC)

24"x88.2'
 Conc. Pipe
 (UAC)

Sta. 840+29.6
 Build 140'-0" x 40'-0"
 Continuous Concrete Slab Bridge
 Skew: 30° LA
 Design No. TBD
 (Remove)

Sta. 840+32.50
 Skew 30° LT AH
 85'x28' Continuous Conc
 Slab Bridge
 D.A.=1700 A-F Plans

Lincoln TWP.
 T-77N R-23W
 SEC. 30

$\Delta = 03^\circ 45' 06.28''$ (RT)
 T = 564.23'
 L = 1128.06'
 R = 17227.42'
 E = 9.24'

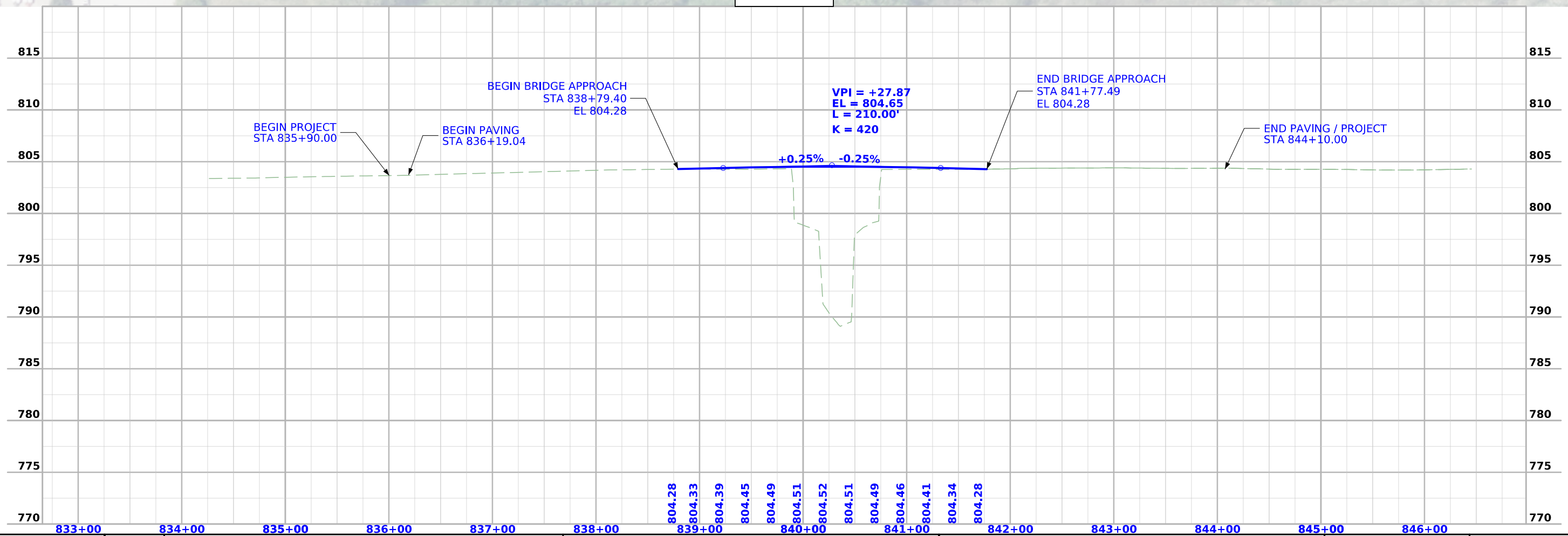
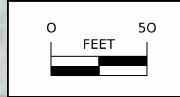

Survey Information

SURVEY INDEX

Warren County
Project Number: BRF-065-3(87)--38-91
Location: Stream 0.2 mi N of Co Rd G24 (NB)
PIN: 22-91-065-010
Type of Work: Bridge
Project Directory: 9106501022

Survey Personnel

Jason Arn – Survey Party Chief
Clayton Henningsen – Survey Party Chief

Date(s) of Survey

Begin Date 10/19/2023
End Date 02/03/2024

General Information

This survey is for US Hwy 65 northbound bridge 0.2 mi north of county road G24. This survey request was for the US Hwy 65 corridor only. This project is a Full Field DTM survey.

Utility Information

For logging data and other utility details see Utility Survey and Ownership Report in the Utility folder of the PrelimSurvey project directory.

Project Control

Coordinates were determined for primary project control points by conducting concurrent six-hour static observations. Post processing is constrained to nearby Iowa Real Time Network reference stations. For additional details of the control survey, contact the Preliminary Survey department.

PROJECT DATUM: NAD83(2011) for EPOCH 2010.00 (IaRTN 2019 ADJUSTMENT)
COORDINATE SYSTEM: IOWA REGIONAL COORDINATE SYSTEM ZONE 08
(U.S. SURVEY FOOT)
VERTICAL DATUM: NAVD88
GEOID MODEL: 2018u3

Alignment Information

Alignment was created by the District 1 Land Survey Office.

District 1 Notes:

The horizontal alignment for US 65/69 is a retrace of PCC Paving Plan FN-69-3(8)—21-91. Stationing was held at PI STA 822+67.40 (FN-69-3(8)—21-91) and was run ahead to PI STA 898+10.20 (FN-69-3(8)—21-91) with three (3) equation stations.

Begin Project

PI STA 822+67.40 (FN-69-3(8)—21-91) = PI STA 822+67.40 (this survey) (#8000) also is NE COR 36-77-24 Found PK Nail in centerline of asphalt northbound lane US 65/69.

Equation PC STA 841+48.56 (FN-69-3(8)—21-91) = PC STA 841+48.56 (this survey) (#3504) Computed Point – nothing found or set.

PI STA 847+12.79 (FN-69-3(8)—21-91) = PI STA 847+12.79 (this survey) (#3500) Computed Point – nothing found or set.

PI STA 858+40.76 (FN-69-3(8)—21-91) = PI STA 858+40.85 (this survey) (#3501) Computed Point – nothing found or set.

EQUATION PT STA 864+04.50 (FN-69-3(8)—21-91) = PT STA 864+04.67 (this survey) (#3502) Computed Point – nothing found or set.

EQUATION 74-foot offset PT 864+04.50 (FN-69-3(8)—21-91) = 74-foot offset PT 864+04.67 (this survey) (#3503) Computed Point – nothing found or set.

PI STA 898+10.20 (FN-69-3(8)—21-91) = PI STA 898+10.12 (this survey) (#3000) Set Bridge Spike in asphalt patch best fit from ties.
END PROJECT

CONTROL POINT VICINITY MAP

This map is a guide to the vicinity of the primary project control points. Primary control is for use with RTK base stations and for RTN validation. Future surveys will use primary project control to establish temporary control as needed for construction or other surveying applications.



HORIZ. DATUM: NAD83(2011) for EPOCH 2010.00 (IaRTN 2019 Adjustment) - Iowa RCS Zone 08 (U.S. Survey Foot)

VERT. DATUM: NAVD88 - Geoid Model: 2018u3

Coordinate listing from next sheet will be used with IaRTN for monument recovery. No other reference ties are given.

HORIZONTAL AND VERTICAL PROJECT CONTROL COORDINATE LISTING
 HORIZ. DATUM: NAD83(2011) for EPOCH 2010.00 (IaRTN 2019 Adjustment)
 Ia. Regional Coordinate System Zone 08 (U.S. Survey Foot)
 VERT. DATUM: NAVD88
 Geoid Model: 2018u3

<u>Point Name</u>	<u>Northing</u>	<u>Easting</u>	<u>Elevation</u>	<u>Feature Definition-Description</u>
CP1	7433687.11	18543244.62	798.75	CP SET FENO MONUMENT IN NW QUAD INTERSECTION US 65 & COUNTY HWY G24
CP2	7435569.86	18543242.04	800.61	CP CUT X ON ROW RAIL IN SW QUAD US 65 & ELK HORN ST
CP3	7439149.96	18543328.50	907.21	CP CONC MONUMENT ON WEST TOP OF BACKSLOPE APPROX. 0.3 MI SOUTH INTERSECTION US 65 & DELAWARE ST
GPS4	7445249.74	18543016.03	926.84	CP REBAR W/ CAP AS DESCRIBED IN GOOD CONDITION

108_23A
8/15/22

TRAFFIC CONTROL PLAN

One lane of traffic on US 65 shall be maintained at all times via temporary lane closure. Refer to J sheets for traffic control and staging plans. The contractor shall provide access to the east entrance at all times.

Close NB U.S. 65 access to and from G24 Hwy.

STAGING NOTES

STAGE 1

Traffic:

Shift U.S. 65 traffic to the inside lane via TBR. Refer to other J sheets for details.

G24 Hwy: Close NB U.S. 65 left turn lane to G24 Hwy and traffic from G24 Hwy to NB U.S 65.

Construction:

Construct detour pavement.

STAGE 2

Traffic:

Shift U.S. 65 traffic to the outside lane and the newly constructed outside shoulder and detour pavement via TBR. Refer to other J sheets for details.

G24 Hwy: Keep stage 1 configuration.

Construction:

(1) Construct 13'-6" of the bridge (west side) and the corresponding approach pavement.

(2) Construct inside shoulder and guardrail.

STAGE 3

Traffic:

Shift U.S. 65 traffic to the newly constructed pavement in stage 2 via TBR. Refer to other J sheets for details.

G24 Hwy: Keep stage 1 configuration.

Construction:









(1) Construct the rest of the bridge and approach pavement (east side).

(2) Construct outside shoulder and guardrail.

**CROSS SECTION VIEW COLOR LEGEND
OF TRAFFIC CONTROL AND STAGING SHEETS**

SHADING	Design Color No.	
Green, Light	(225)	Existing Pavement Shading
Gray, Light	(48)	Previously Constructed Pavement Shading
Gray, Med	(80)	Previously Constructed Granular Surface Shading
Blue, Light	(230)	Proposed Pavement Shading
Lavender	(9)	Temporary Pavement Shading
Brown, Med	(237)	Future Proposed Pavement Shading

**CROSS SECTION VIEW PATTERN AND SYMBOL LEGEND
OF TRAFFIC CONTROL AND STAGING SHEETS**





















	Pavement Removal		Proposed Granular Shoulder
	Proposed Granular Subbase		Temporary Shoulder
	Proposed Special Backfill		Existing Shoulder Strengthening
	Temporary Barrier Rail		Permanent Barrier Rail
			Channelizing Device

PLAN VIEW COLOR LEGEND OF TRAFFIC CONTROL AND STAGING SHEETS

LINEWORK	Design Color No.	
Green	(2)	Existing Topographic Features and Labels
Magenta	(5)	Pavement Marking Call Outs
Blue	(1)	Proposed Alignment, Stationing, Tic Marks, and Alignment Annotation
Yellow	(4)	Pavement Markings, Yellow
Off White	(254)	Pavement Markings, White
Violet	(15)	Temporary barrier rail, Unpinned
Flush Orange	(228)	Temporary barrier rail, Pinned

SHADING	Design Color No.	
Green, Light	(225)	Existing Pavement Shading
Gray, Light	(48)	Previously Constructed Pavement Shading
Gray, Med	(6)	Proposed Granular Surface Shading
Gray, Med	(80)	Previously Constructed Granular Surface Shading
Blue, Light	(230)	Proposed Pavement Shading
Lavender	(9)	Temporary Pavement Shading
Brown, Light	(236)	Proposed Grading Limits Shading
Pink, Dark	(13)	Proposed MSE or CIP Wall Shading
Red	(3)	Proposed Bridge Shading and Sign Trusses
Black w/Gray, Light Fill	(0,48)	Previously Constructed Structure

**PLAN VIEW PATTERN AND SYMBOL LEGEND
OF TRAFFIC CONTROL AND STAGING SHEETS**

	Channelizing Device		Crash Cushion (Temp or Perm)
	Drum		Traffic Signal
	Temporary Lane Separator		Flagger
	Tubular Marker		Temporary Floodlighting
	Channelizer Marker		Traffic Sign
	Concrete Barrier Marker		Type III Barricade
	Delineator		Type A Warning Light
	Temporary Barrier Rail		Direction of Traffic
	Pavement Removal		Safety Closure
	Sand Barrel Layout		Lane Identification

NOTE: Device spacing according to Standard Road Plans unless specifically dimensioned.

**TRAFFIC CONTROL
AND
STAGING
LEGEND AND SYMBOL
INFORMATION SHEET**

(COVERS SHEET SERIES J)

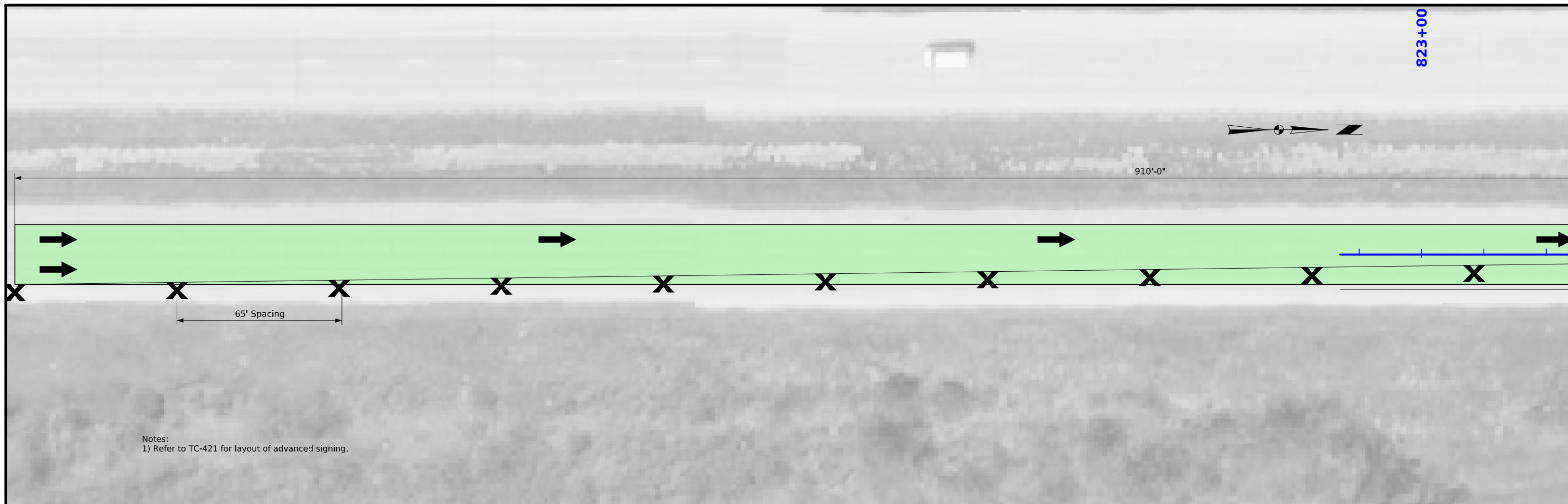

FILE NO.	ENGLISH	DESIGN TEAM Jia/Schoenrock/Evans	WARREN COUNTY	PROJECT NUMBER BRF-065-3(087)--38-91	SHEET NUMBER J.4
----------	---------	---	---------------	---	-------------------------

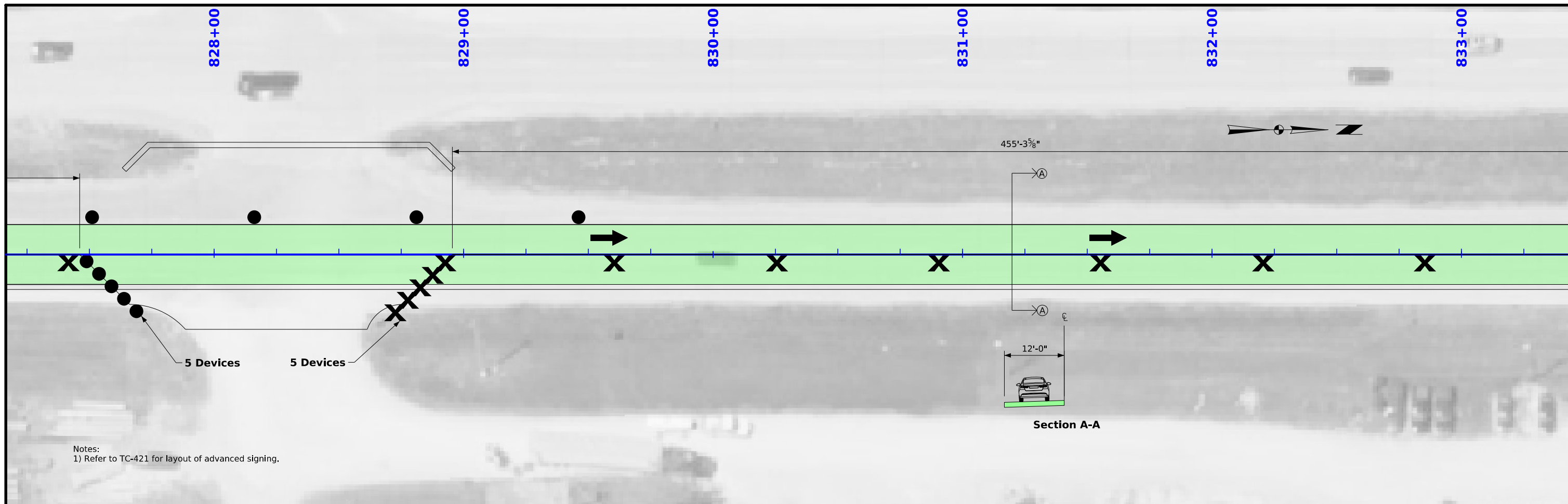

Section B-B
ML65 STAGE 1

FILE NO.	ENGLISH	DESIGN TEAM Jia/Schoenrock/Evans	WARREN COUNTY	PROJECT NUMBER BRF-065-3(087)--38-91	SHEET NUMBER J.5
----------	---------	---	---------------	---	-------------------------

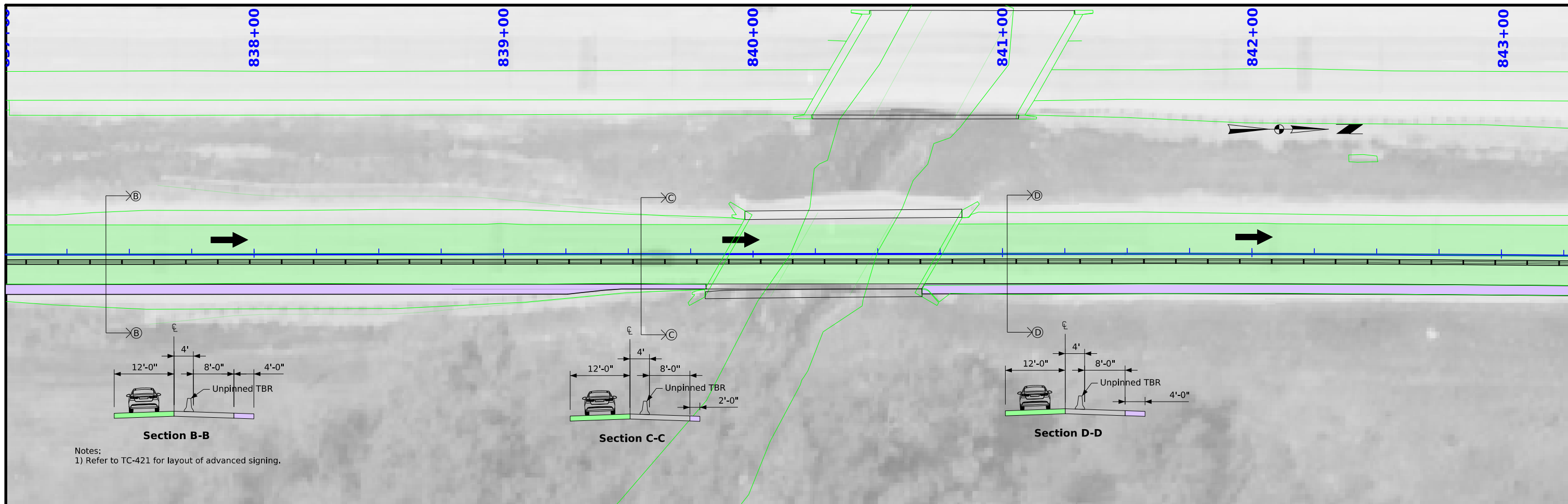

Notes:
1) Refer to TC-421 for layout of advanced signing.

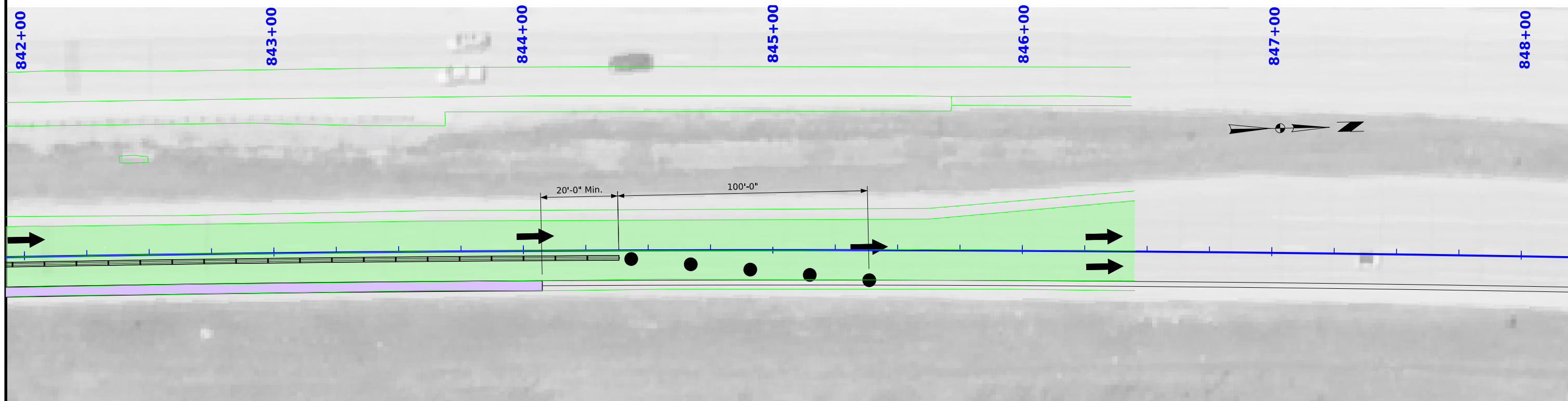

Notes:
1) Refer to TC-421 for layout of advanced signing.

ML65 STAGE 1

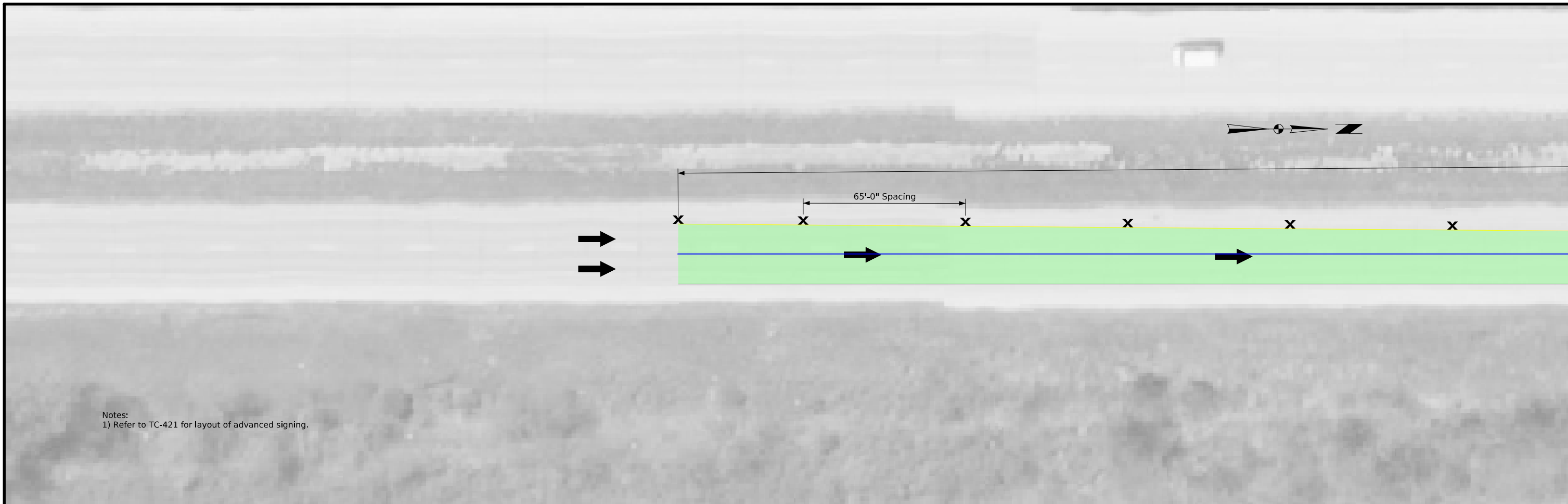

Notes:
1) Refer to TC-421 for layout of advanced signing.

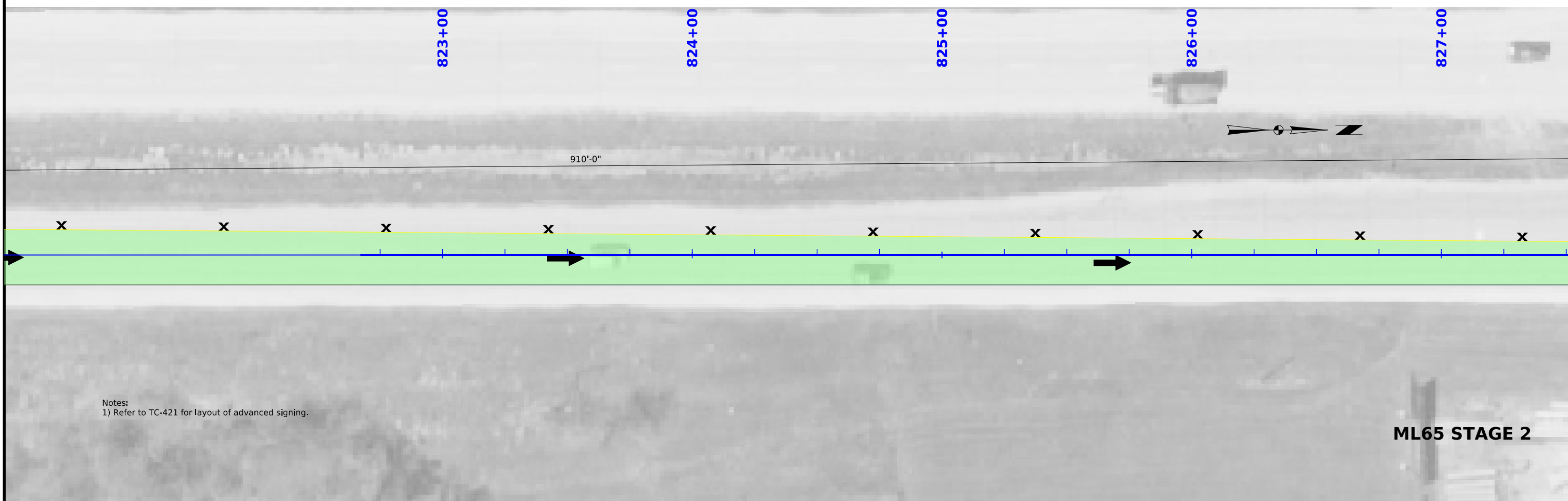

Notes:
1) Refer to TC-421 for layout of advanced signing.

ML65 STAGE 2

FILE NO.	ENGLISH	DESIGN TEAM Jia/Schoenrock/Evans	WARREN COUNTY	PROJECT NUMBER BRF-065-3(087)--38-91	SHEET NUMBER J.7
----------	---------	---	---------------	---	-------------------------

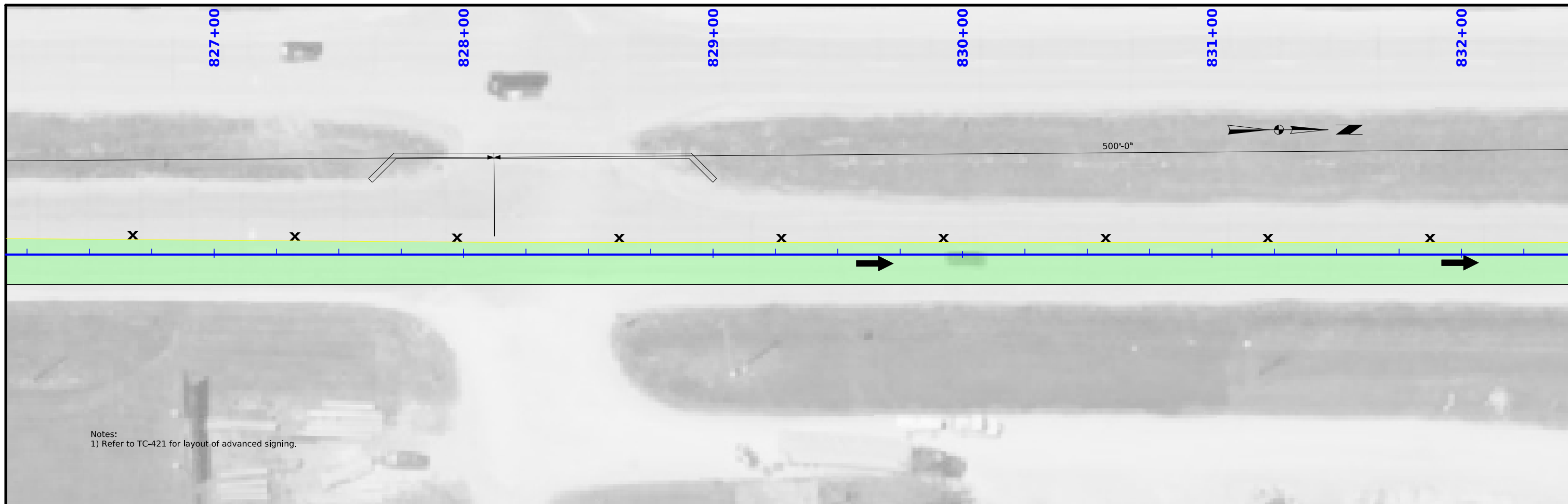

Notes:
1) Refer to TC-421 for layout of advanced signing.



ML65 STAGE 2

Notes:
1) Refer to TC-421 for layout of advanced signing.

FILE NO.	ENGLISH	DESIGN TEAM Jia/Schoenrock/Evans	WARREN COUNTY	PROJECT NUMBER BRF-065-3(087)--38-91	SHEET NUMBER J.8
----------	---------	---	---------------	---	-------------------------

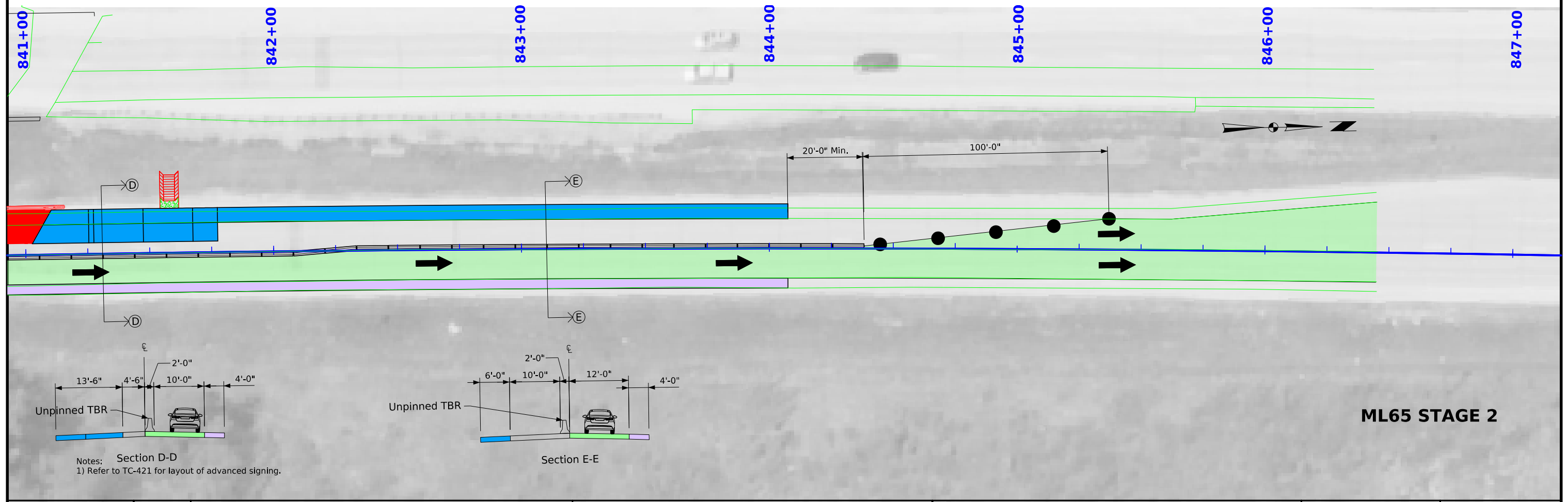
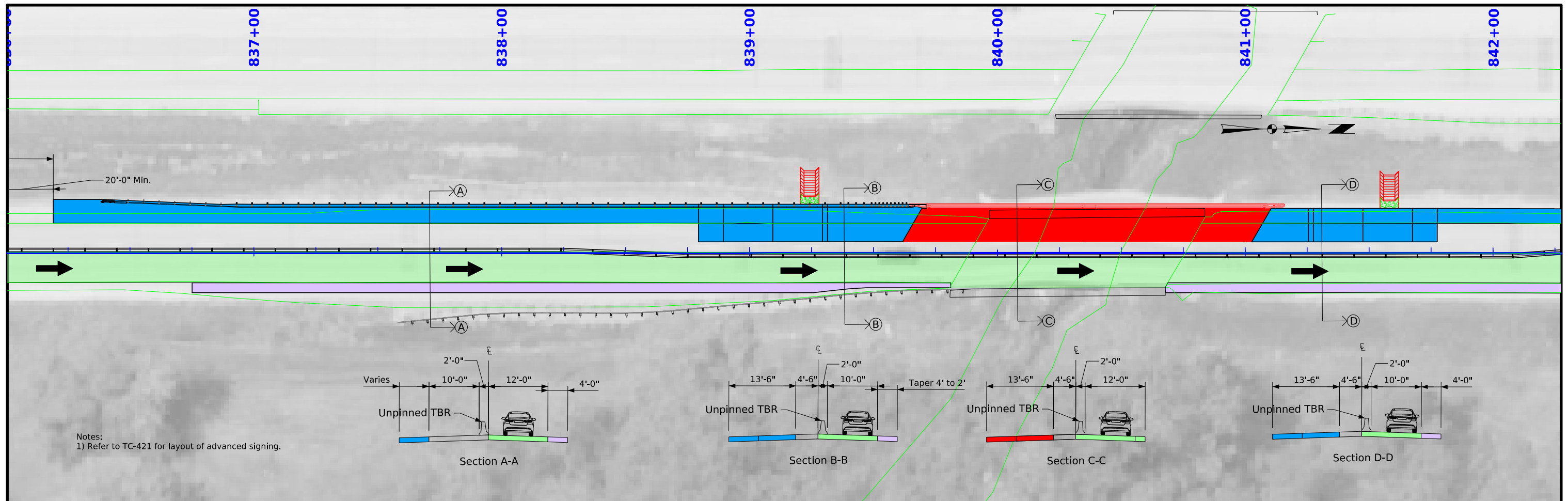

FILE NO.	ENGLISH	DESIGN TEAM	Jia/Schoenrock/Evans	WARREN COUNTY	PROJECT NUMBER	BRF-065-3(087)--38-91	SHEET NUMBER	J.9
----------	---------	-------------	----------------------	---------------	----------------	-----------------------	--------------	-----

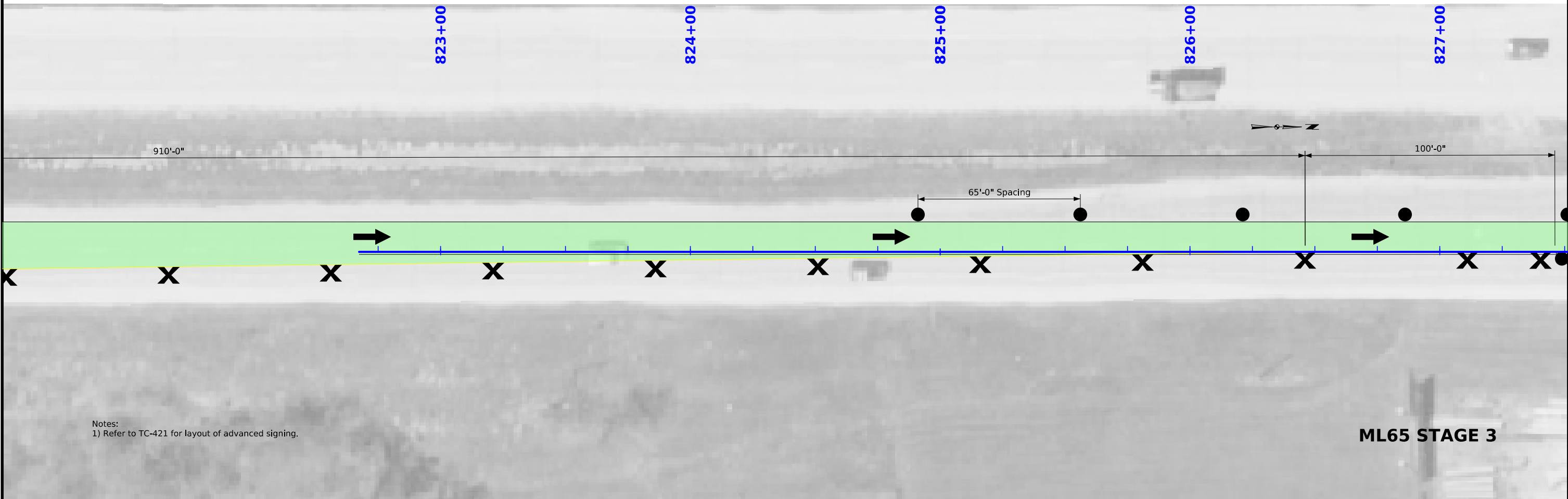
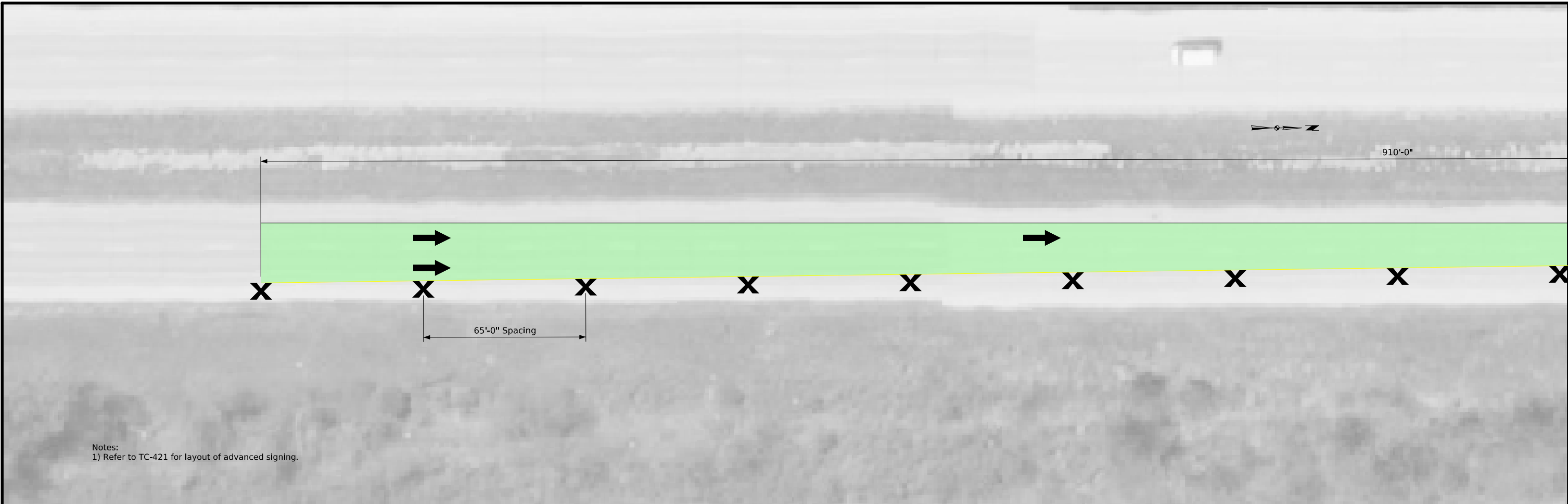

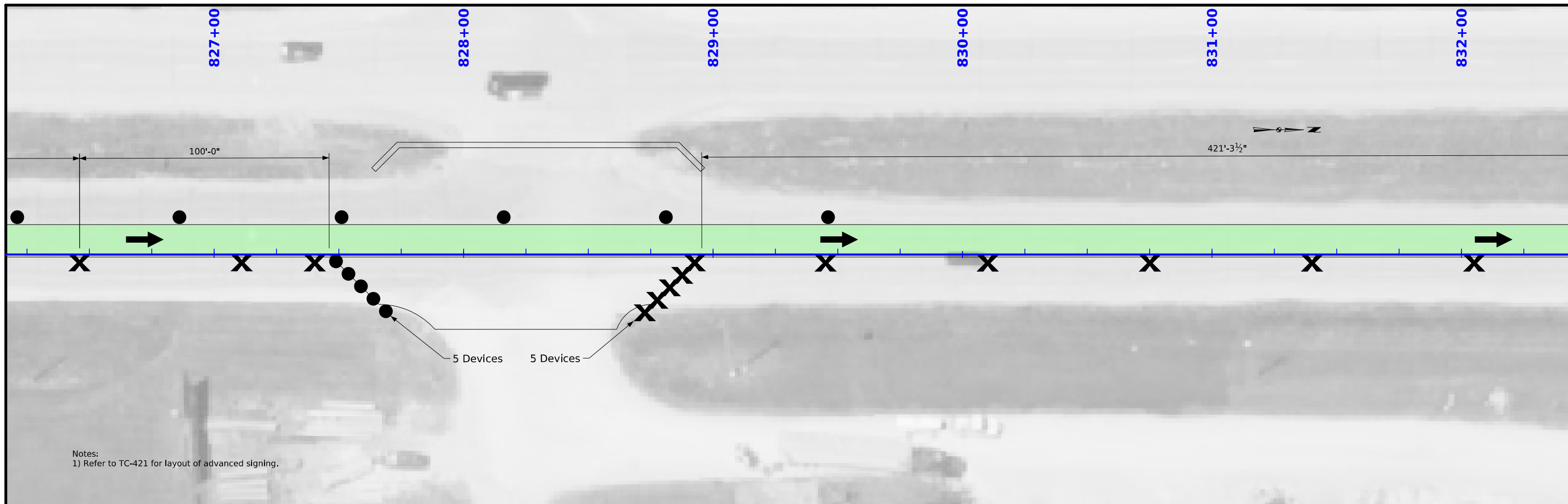

Notes:
1) Refer to TC-421 for layout of advanced signing.

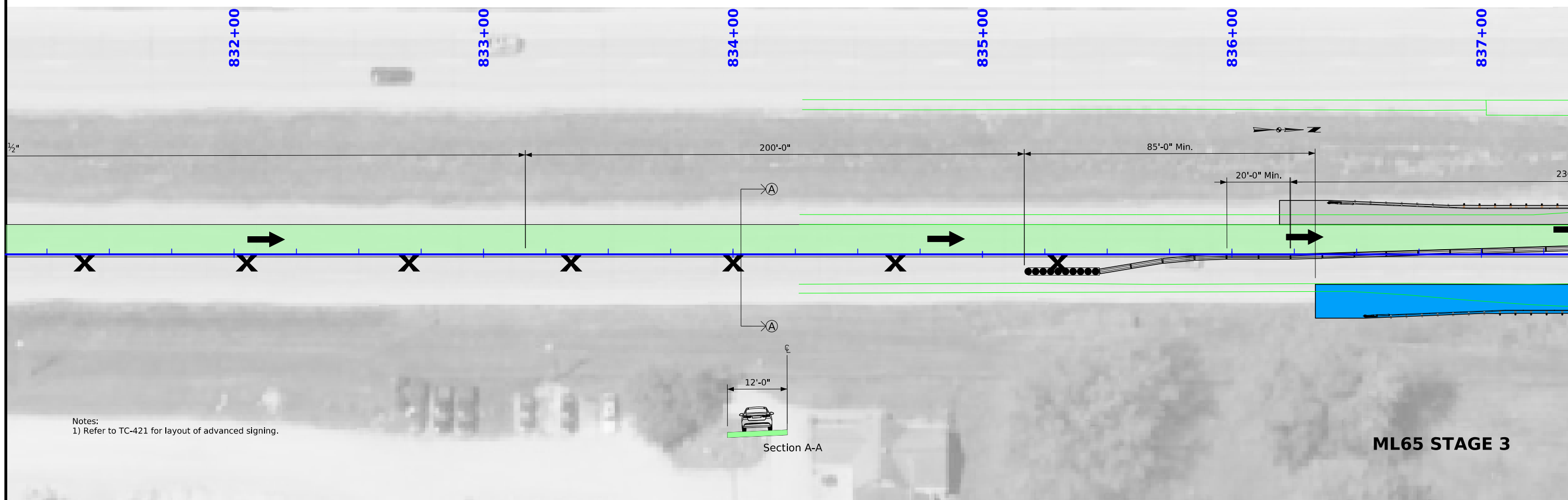

Notes:
1) Refer to TC-421 for layout of advanced signing.

ML65 STAGE 3

FILE NO.	ENGLISH	DESIGN TEAM Jia/Schoenrock/Evans	WARREN COUNTY	PROJECT NUMBER BRF-065-3(087)--38-91	SHEET NUMBER J.11
----------	---------	---	---------------	---	--------------------------

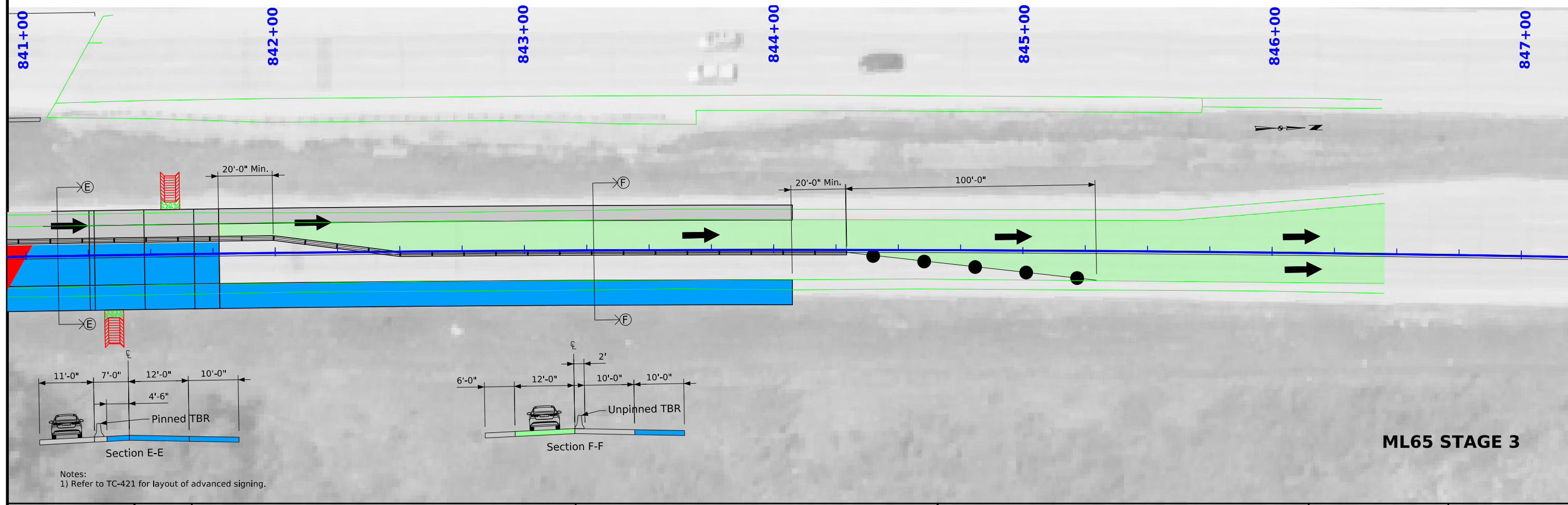
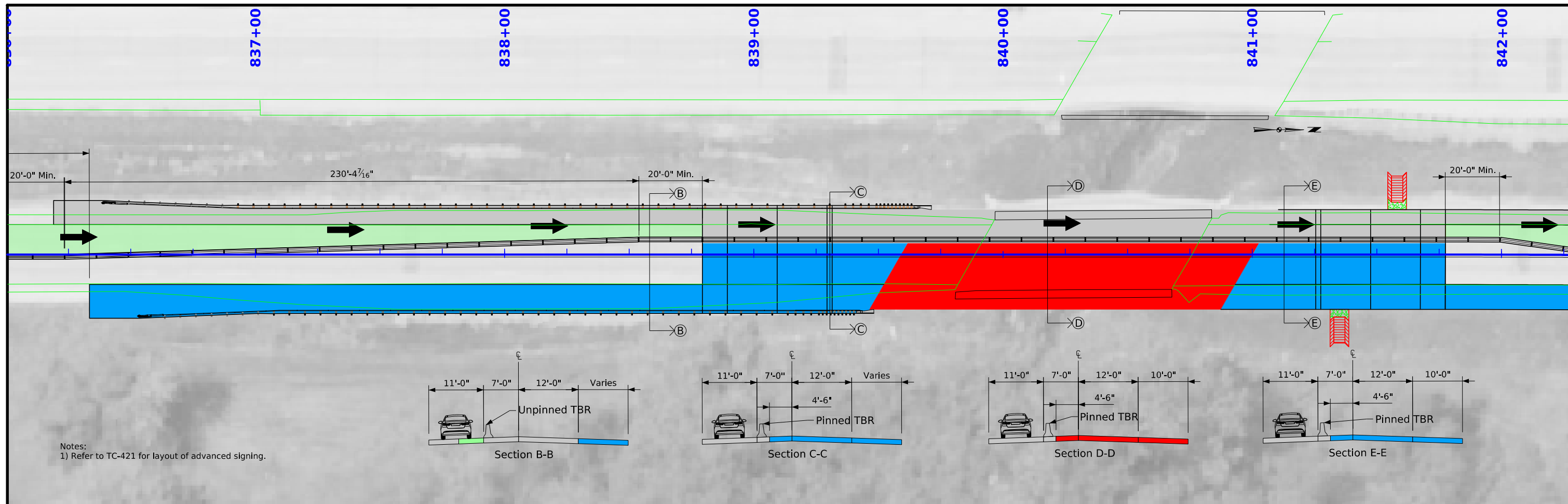

ML65 STAGE 3

FILE NO.	ENGLISH	DESIGN TEAM	Jia/Schoenrock/Evans	WARREN COUNTY	PROJECT NUMBER	BRF-065-3(087)--38-91	SHEET NUMBER	J.12
----------	---------	-------------	----------------------	---------------	----------------	-----------------------	--------------	------

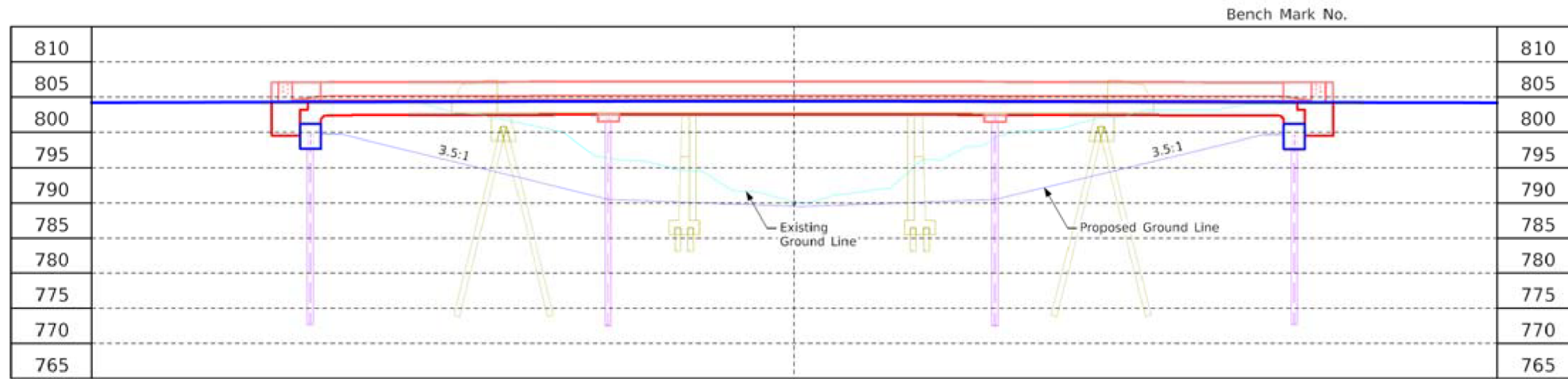

Longitudinal Section Along \bar{C} NB US 65 & 69



Situation Plan

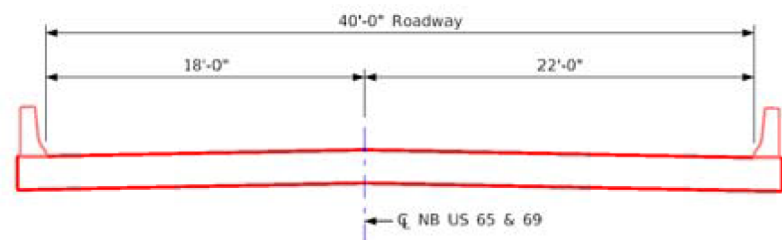

Typical Bridge Section
(Looking North)

Location

NB US 65 & 69 Over Stream
 T-77N R-24W & R-23W
 Section 25 & Section 30
 Greenfield & Lincoln Townships
 Warren County
 FHWA No. 050930
 Bridge Maint. No. 9164.6R065
 Latitude 41.443149°
 Longitude -93.558441°

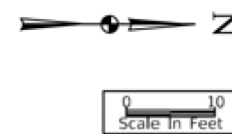

Design For 30° Skew (LA)
140'-0" x 40'-0" Continuous Concrete Slab Bridge
 42'-6" End Spans 55'-0" Interior Span
Situation Plan
 STA. 840+43.10 (NB US 65 & 69) September 2023
Warren County
 IOWA DEPARTMENT OF TRANSPORTATION
 Design No. TBD Design Sheet No. 1 of 1 FHWA No. 050930

FILE NO. TBD	ENGLISH	DESIGN TEAM Jacobs	Warren COUNTY	PROJECT NUMBER BRF-065-3(087)--38-91	SHEET NUMBER V.1
--------------	---------	--------------------	---------------	--------------------------------------	------------------

11:41:06 AM 10/20/2023 saavedj pw:\projectwise.dot.int.lan:PWM\In\Documents\Projects\9106501022\Bridge(87)_Bridge-Unspecified\SHT_91065087_JACOBS_50930_Z08.dgn

CROSS SECTION VIEW COLOR LEGEND

Design Color No.	Feature	Design Color No.	Feature
Aggregate			
(64)	Choke Stone	(8)	Behind Curb Cut
(42)	Engineering Fabric	(6)	Granular
(8)	Flooded Backfill	(13)	Granular Back Fill
(92)	Macadam Stone	(48)	Rock Undercut
(20)	Modified	(8)	Shoulder Earth Fill
(12)	Plowing Shaping	(2)	Side Slopes
(14)	Porous Backfill	(226)	Side Slopes Dressing
Grading			
(8)	Revetment Class A	(128)	Boulder
(6)	Revetment Class B	(209)	Boulder Removed
(62)	Revetment Class C	(48)	Broken Weathered
(188)	Revetment Class D	(210)	Broken Weathered Removed
(28)	Revetment Class E	(3)	Core Out
(12)	Shoulder Special Backfill	(115)	Core Out Remove Only
(12)	Special Backfill	(195)	Core Out Remove and Replace
(20)	Subbase	(203)	Existing Pavement
(20)	Subbase Lower	(184)	Existing Pavement Remove Only
(20)	Subbase Upper	(200)	Existing Pavement Remove and Replace
(118)	Subgrade Treatment	(6)	Loam
Substrata			
(207)	HMA Base Course	(211)	Loam Removed
(207)	HMA Interim Course	(80)	Rock
(207)	HMA Surface Course	(212)	Rock Removed
(0)	Bridge	(4)	Select Sand
(0)	Barrier Concrete	(214)	Select Sand Removed
(0)	Barrier Concrete Footing	(3)	Shale
(0)	Curb Gutter	(215)	Shale Removed
(48)	Flowable Mortar	(10)	Topsoil
(0)	Median Concrete	(2)	Topsoil Remove Only
(0)	PCC Pavement	(4)	Topsoil Remove and Replace
(0)	Sidewalk	Unsuitable / Waste	
(0)	Existing Pavement	(3)	Unsuitable Type A
(209)	Shoulder HMA	(216)	Unsuitable Type A Removed
(0)	Shoulder PCC	(13)	Unsuitable Type B
(6)	Shoulder Granular	(217)	Unsuitable Type B Removed
(112)	Noise Wall	(11)	Unsuitable Type C
(112)	Noise Wall Footing	(218)	Unsuitable Type C Removed
(112)	Retaining Wall Back	(3)	Waste
(112)	Retaining Wall Back Excavate	(219)	Waste Removed
(112)	Retaining Wall Face		
(112)	Retaining Wall Front Excavate		
(112)	Retaining Wall Front Footing		
(112)	Retaining Wall MSE Gutter		
(112)	Retaining Wall Reinforced Earth		
Asphalt			
Concrete			
Existing			
Shoulder			
Structural			

NOTES:

Text

NOTES:

Text

CROSS SECTIONS LEGEND AND INFORMATION SHEET

(COVERS SHEET SERIES W, X, Y, & Z)

ML - US65

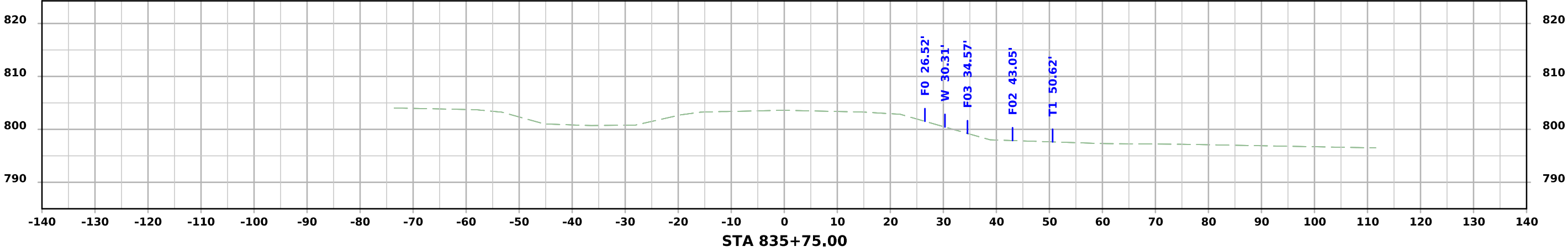
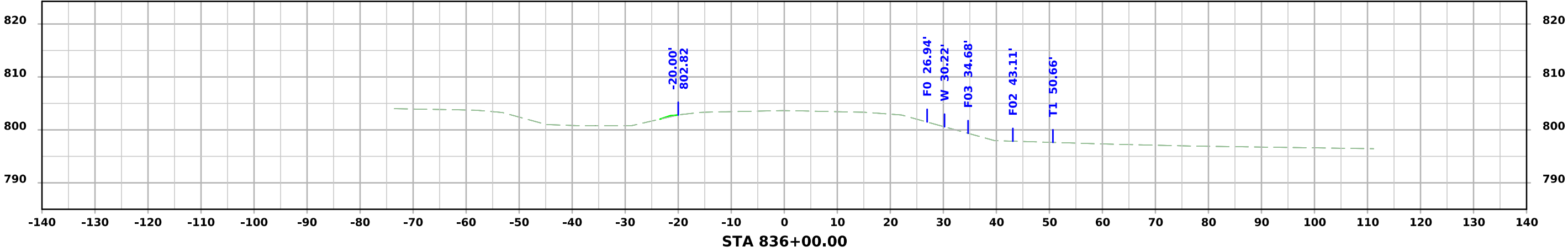
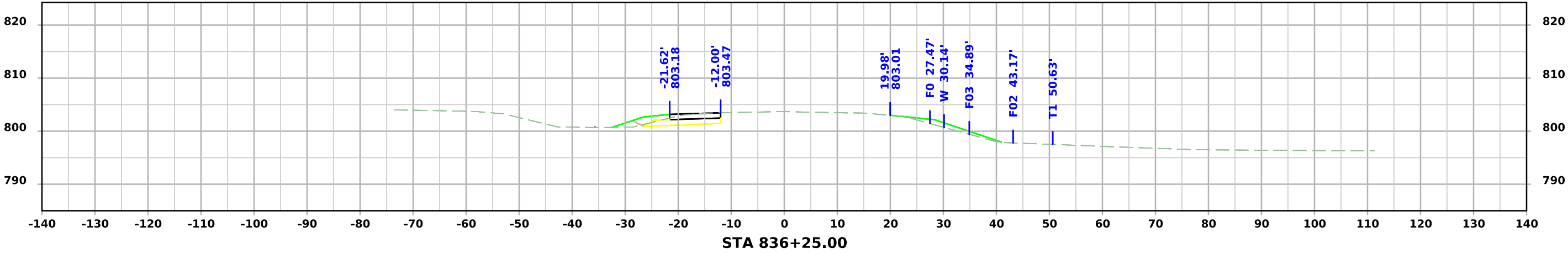

ML - US65

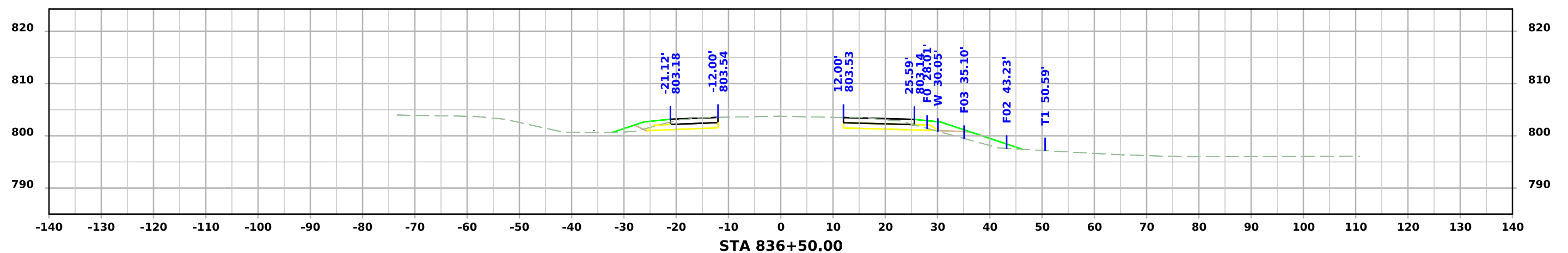
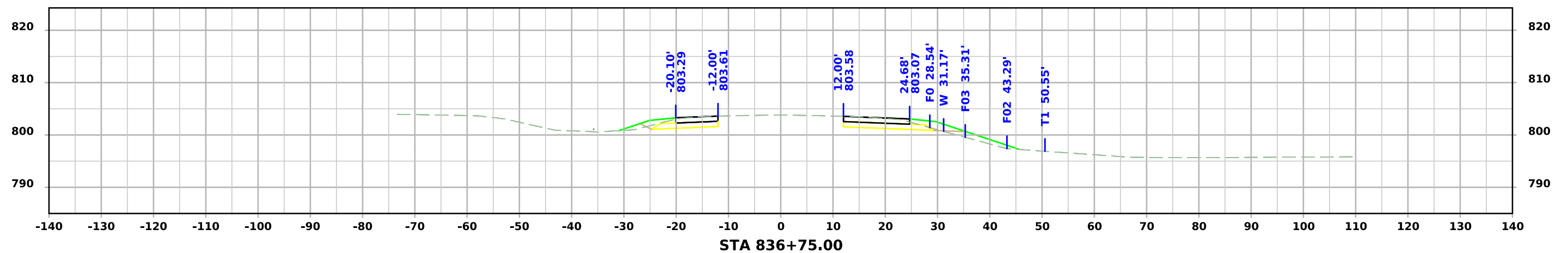
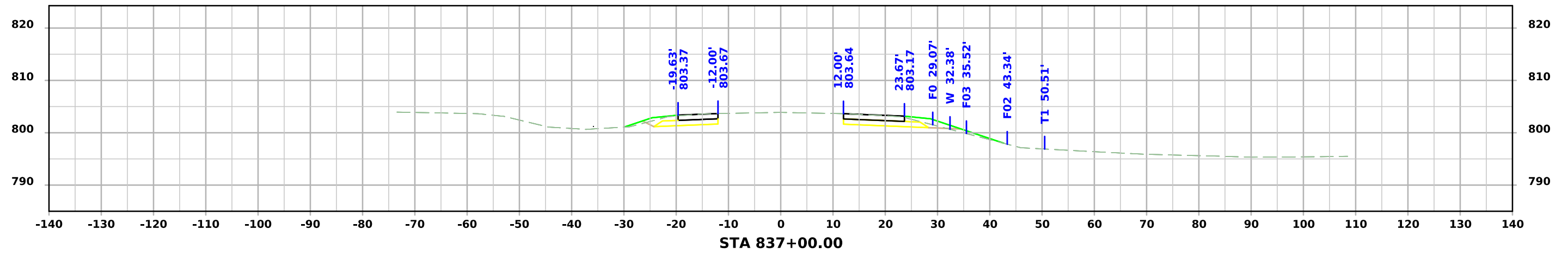

ML - US65

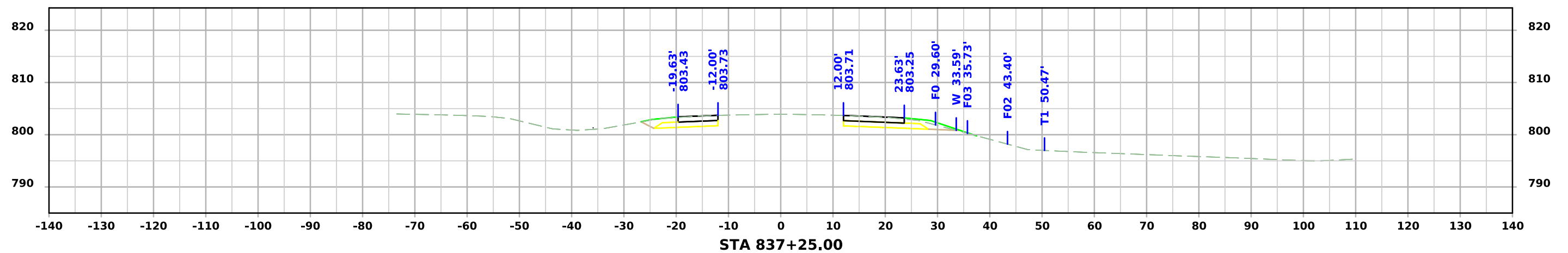
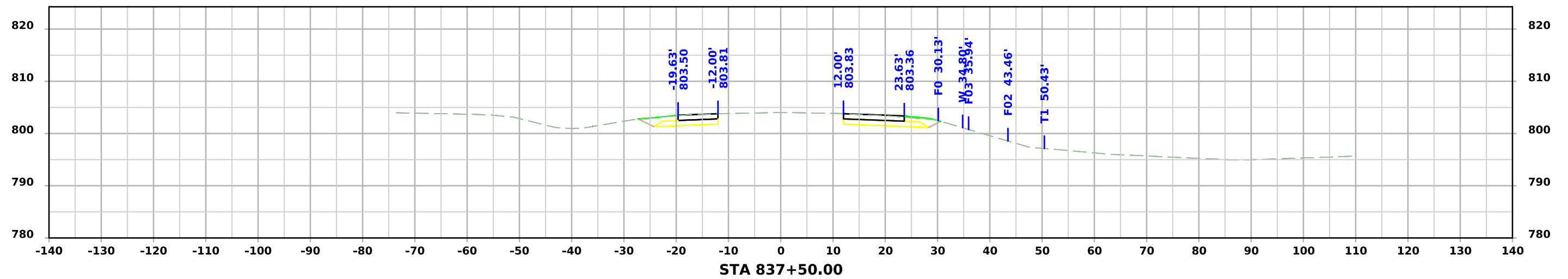
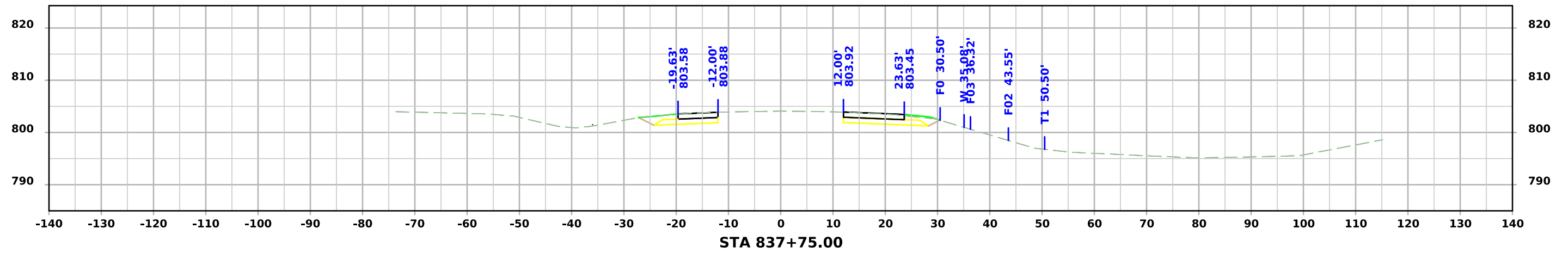

ML - US65

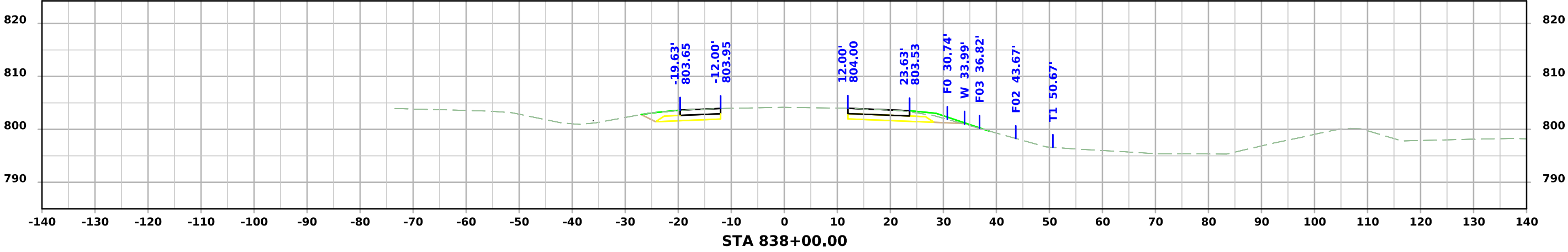
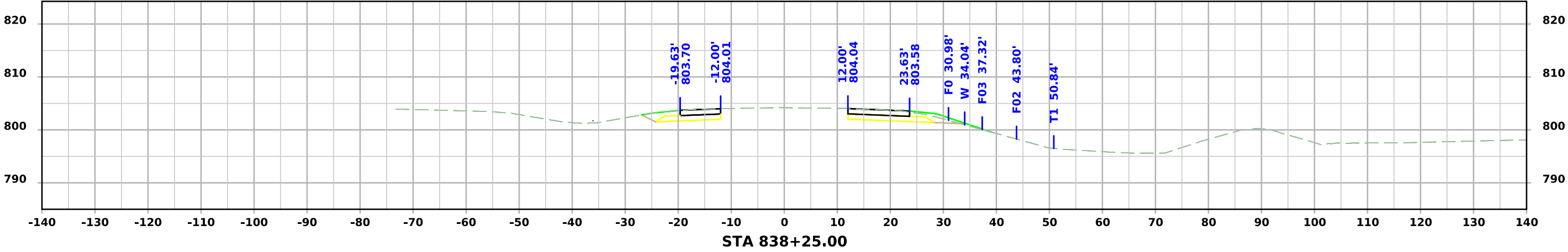
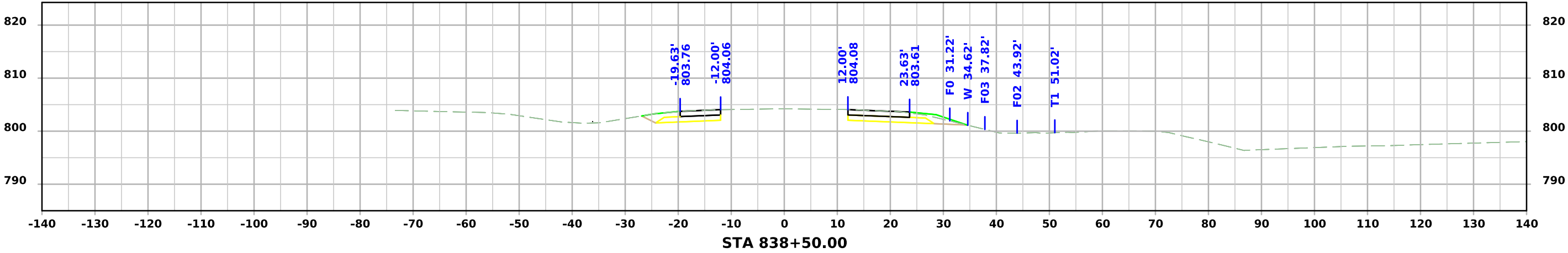

ML - US65

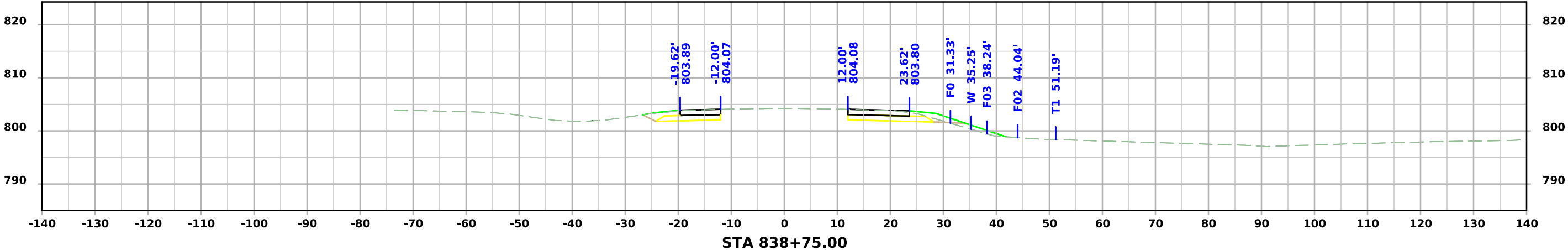
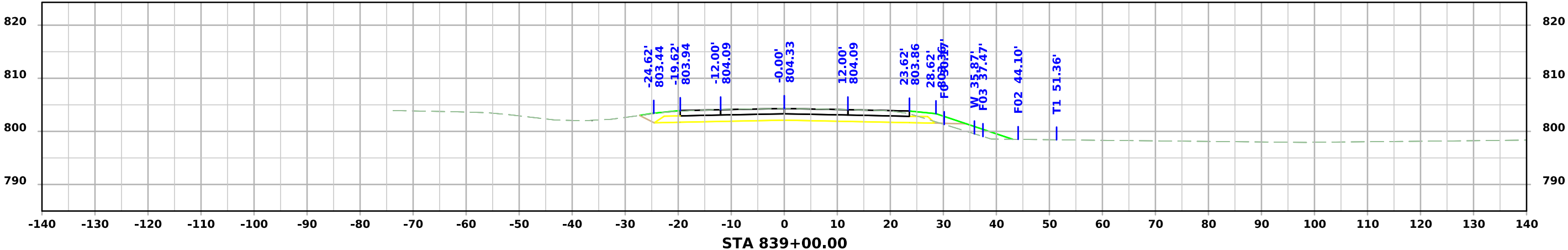
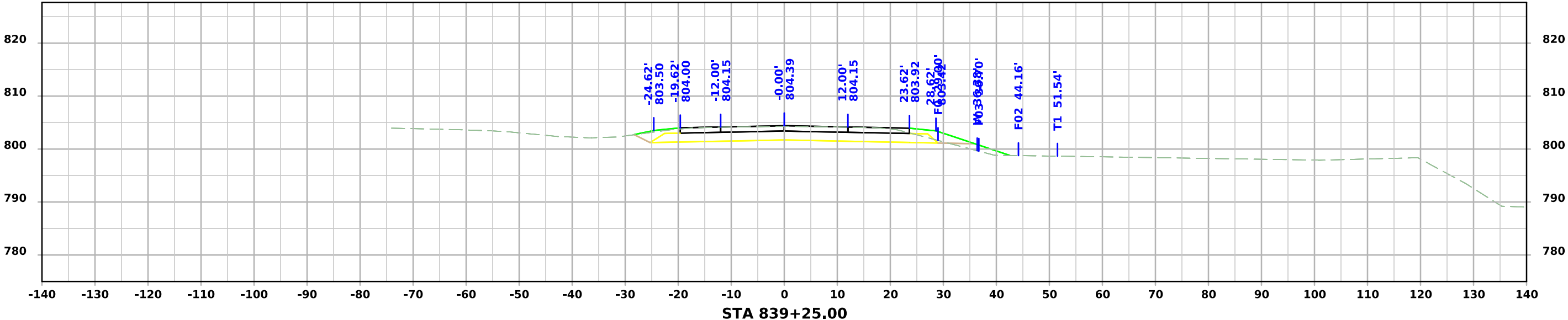

ML - US65

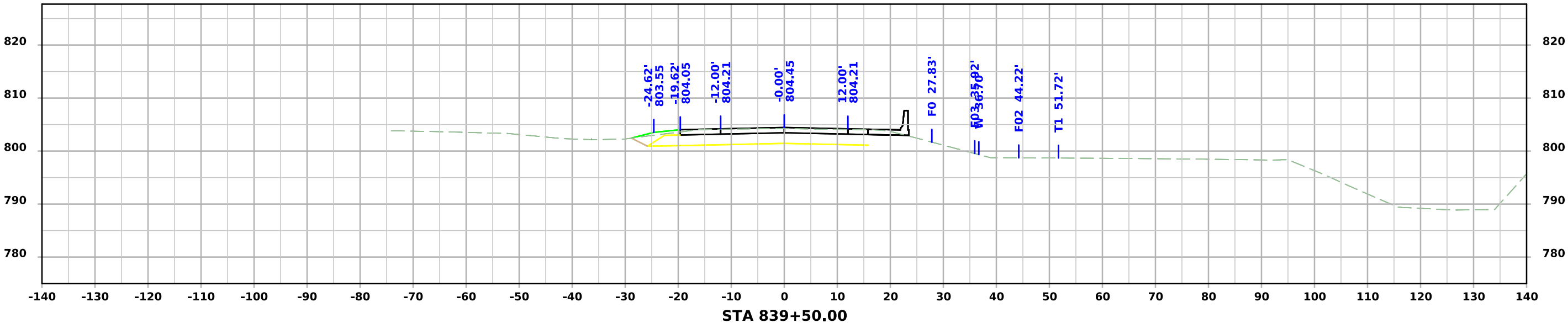
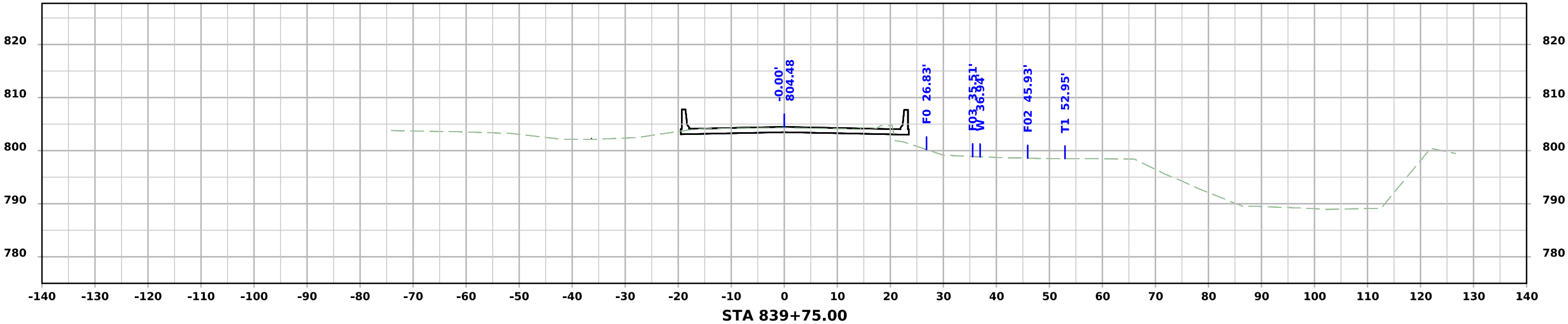

ML - US65

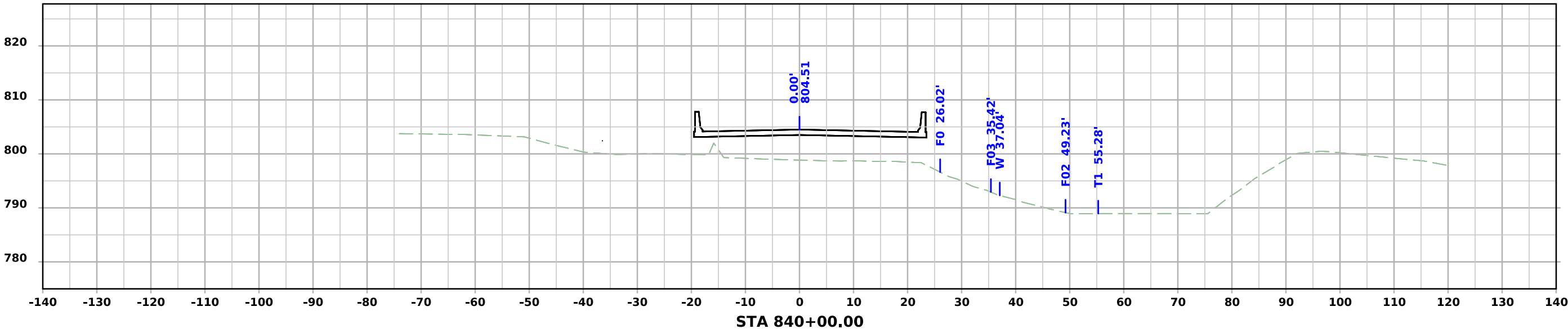
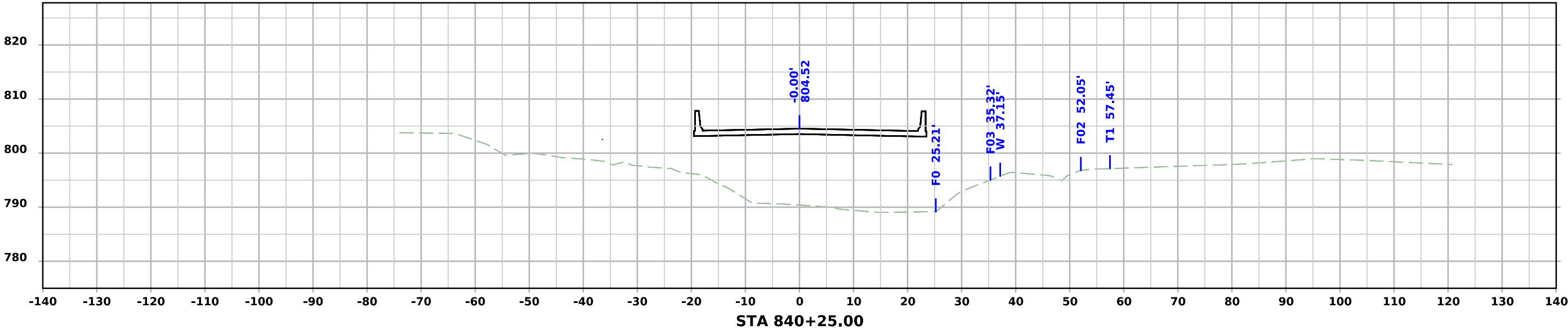

ML - US65

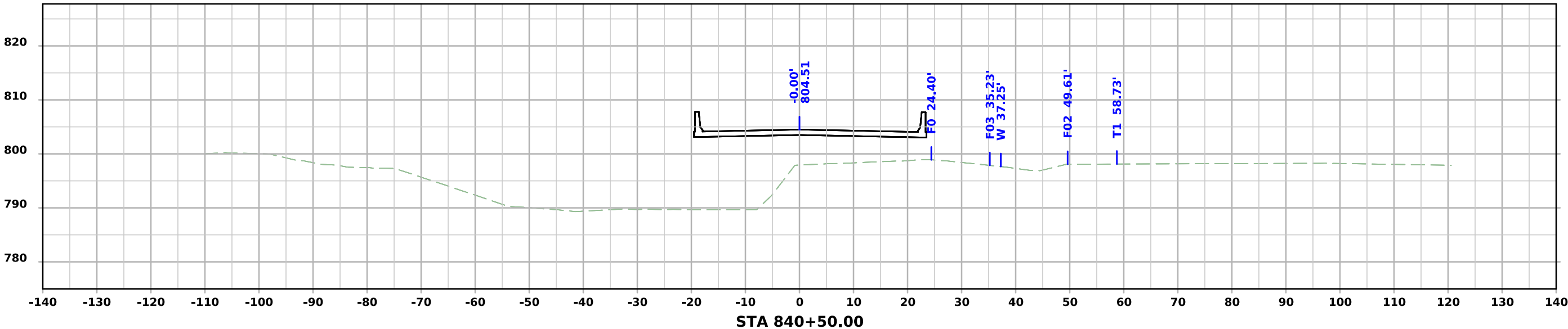
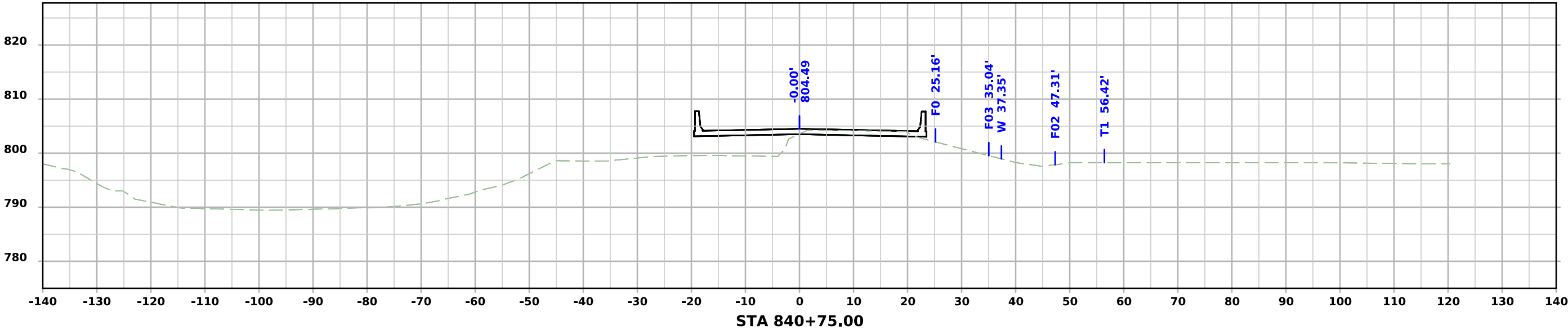

ML - US65

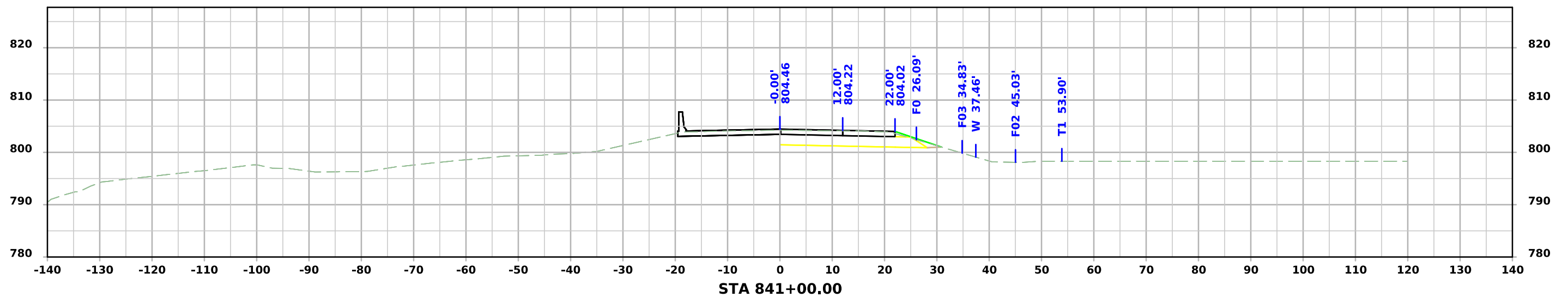
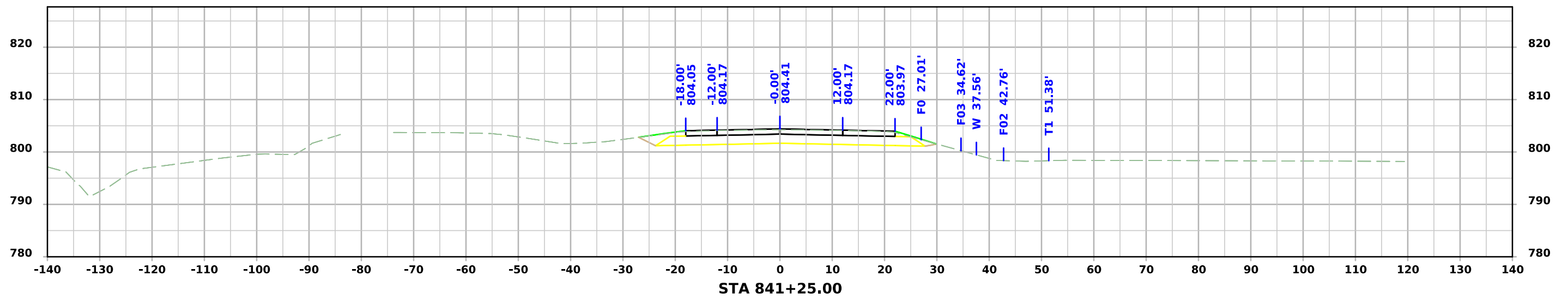
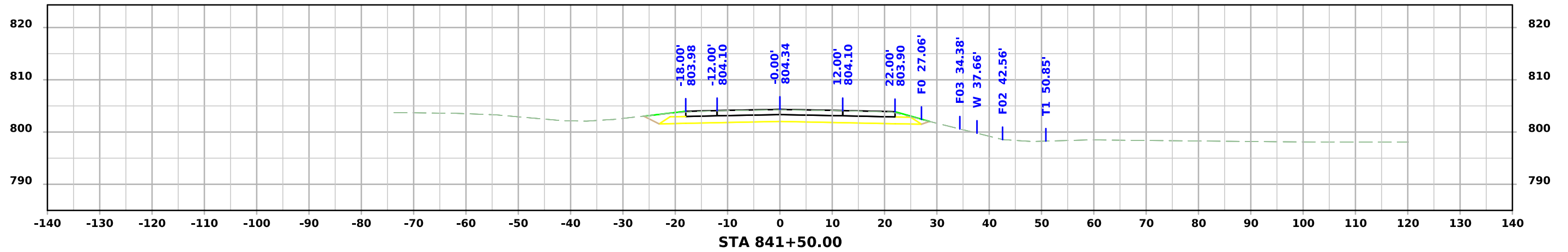

ML - US65

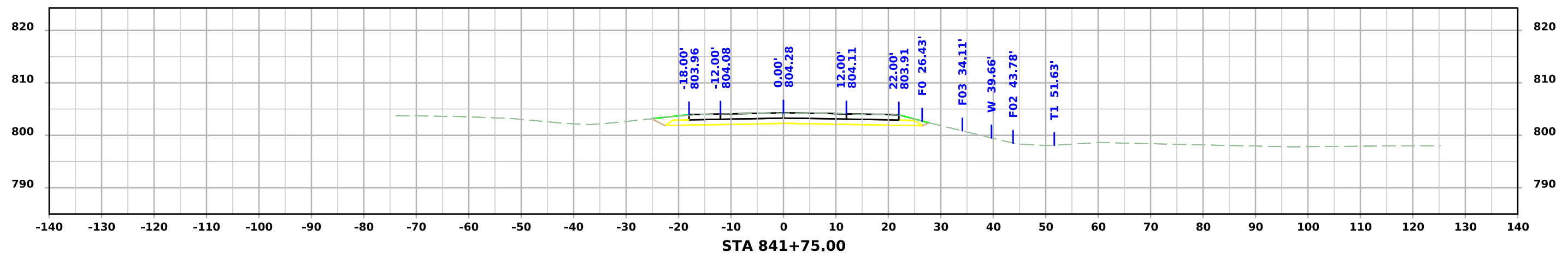
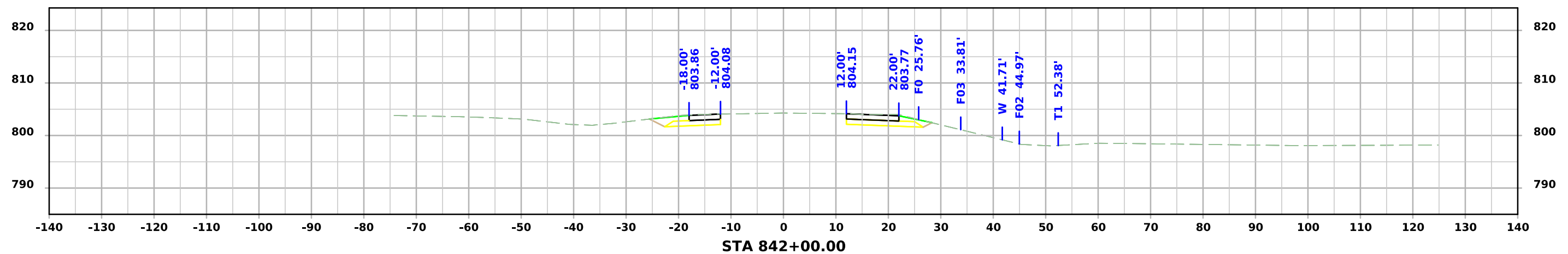
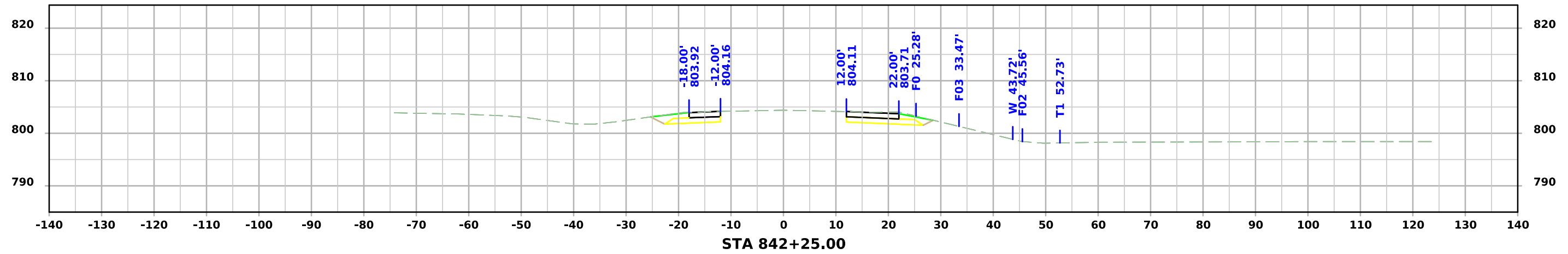

ML - US65

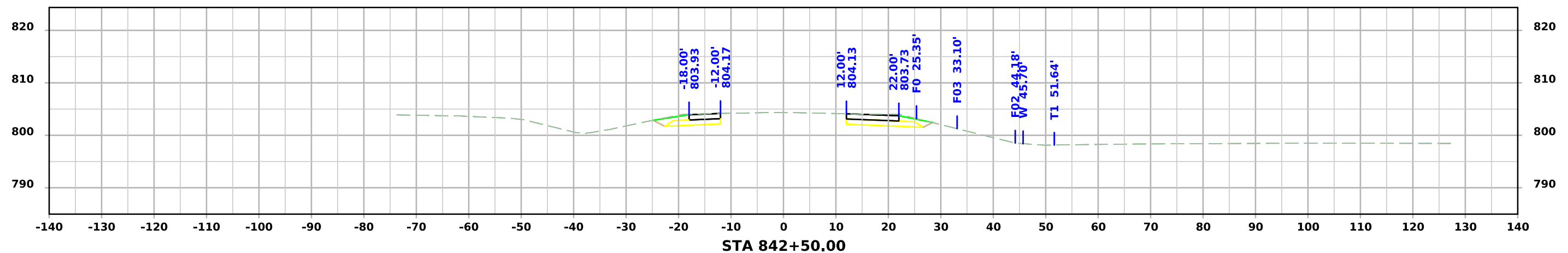
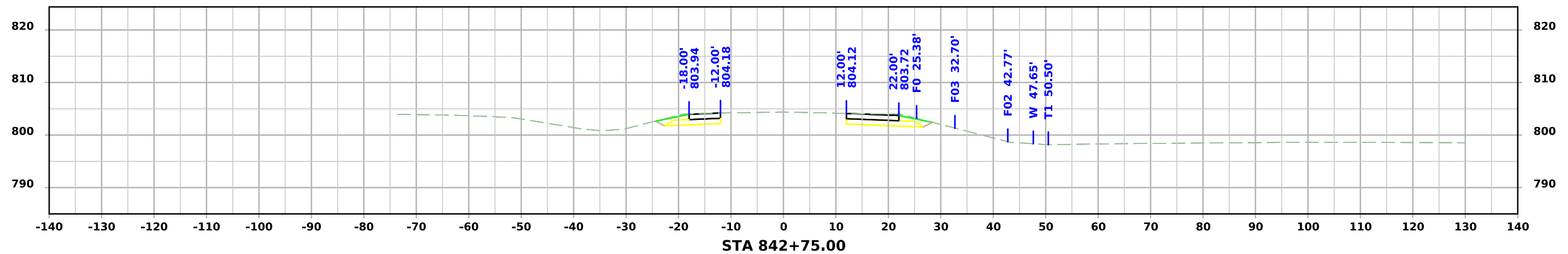
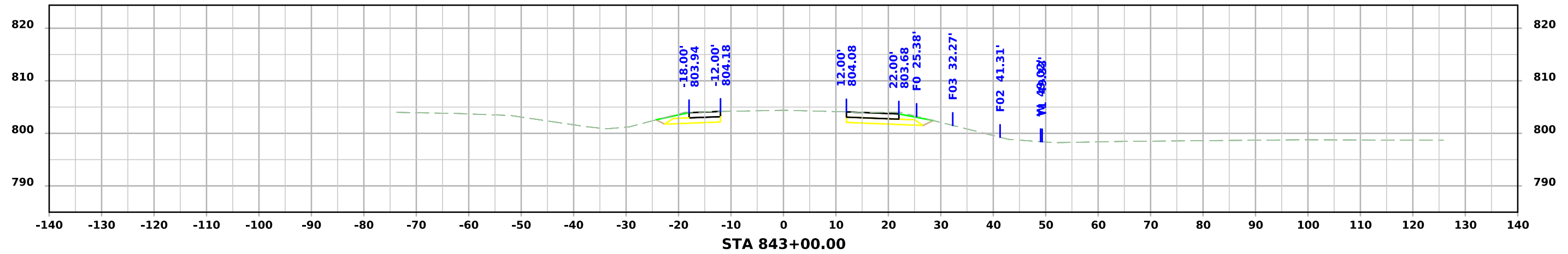

ML - US65

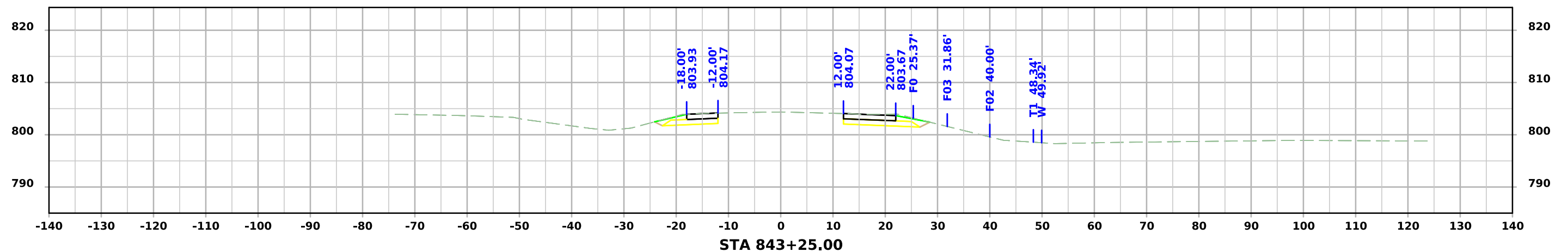
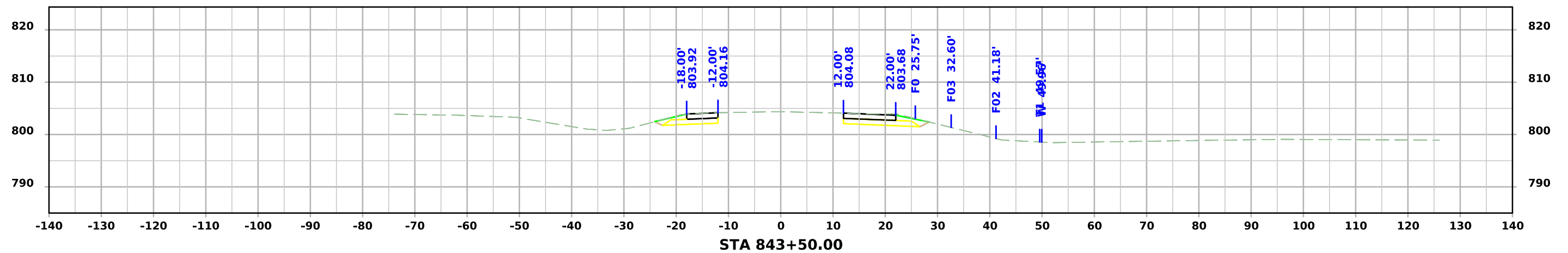
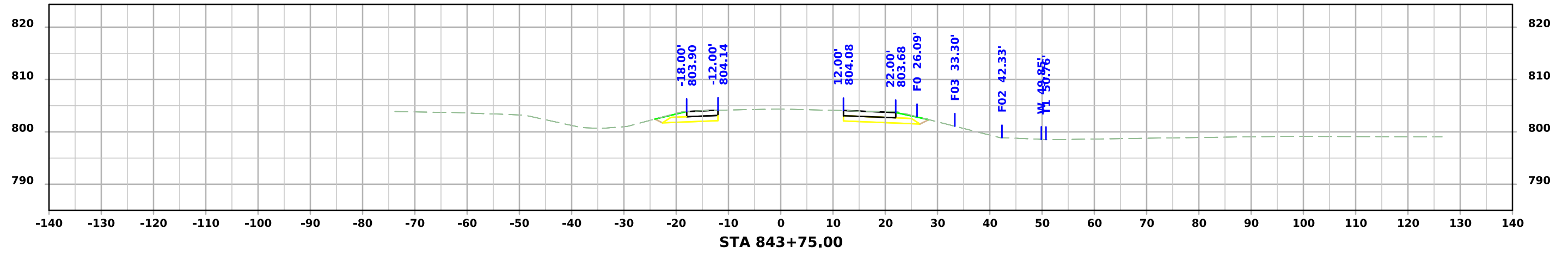

ML - US65

