

Index of Sheets	
No.	Description
Bridge Plan	
A.1	Title Sheet
A.2	Location Map Sheet
Road Plan	
V.1	Estimated Quantities - Design 0125
V.1 - V.6	Design 0125
Road Sheets	
C.1	Estimated Quantities - Road
C.2	Tabulations
J.1	Traffic Control



PLANS OF PROPOSED IMPROVEMENT ON THE
PRIMARY ROAD SYSTEM
DAVIS COUNTY
Culvert Repair - RCB
 US 63 over N. Chequest Creek
 0.6 Mi. N. of 160th St.

Revisions

TOTAL
11
PROJECT IDENTIFICATION NUMBER 20-26-063-020
CONTRACT ID NUMBER 26-0631-096
PROJECT NUMBER BRFN-063-1(96)--39-26
R.O.W. PROJECT NUMBER
PROJECT DIRECTORY NUMBER 2606302020

Refer to the Plan Sheets for list of applicable specifications.

Value Engineering Saves. Refer to Article 1105.13 of the Specifications.

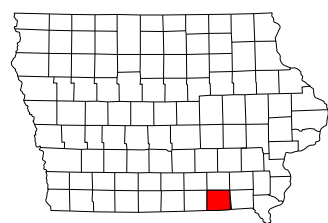

Standard Road Plans

Standard Road Plans are listed on C.2

Revisions to this Design Plan and/or Project Specifications should be submitted by _____

Design Data Rural

2021 AADT	5,800	V.P.D.
2040 AADT	--	V.P.D.
2040 DHV	--	V.P.H.
TRUCKS	10	%
Total Design ESALs	--	

Index Of Seals

Sheet No.	Name	Type
A.1	Sean E. Connor	Structural Design
A.1	Jacob M. Verry	Roadway Design

Roadway Design

I hereby certify that this engineering document was prepared by me or under my direct personal supervision and that I am a duly licensed Professional Engineer under the laws of the State of Iowa.

Signature: Jacob M. Verry Date: _____

Printed or Typed Name: Jacob M. Verry

My license renewal date is December 31, 2025

Pages or sheets covered by this seal: C.1 & J.1

Structural Design

I hereby certify that this engineering document was prepared by me or under my direct personal supervision and that I am a duly licensed Professional Engineer under the laws of the State of Iowa.

Signature: Sean E. Connor Date: _____

Printed or Typed Name: Sean E. Connor

My license renewal date is December 31, 2026

Pages or sheets covered by this seal: V.1-V.6

Design No. 0125
FHWA No. 022550

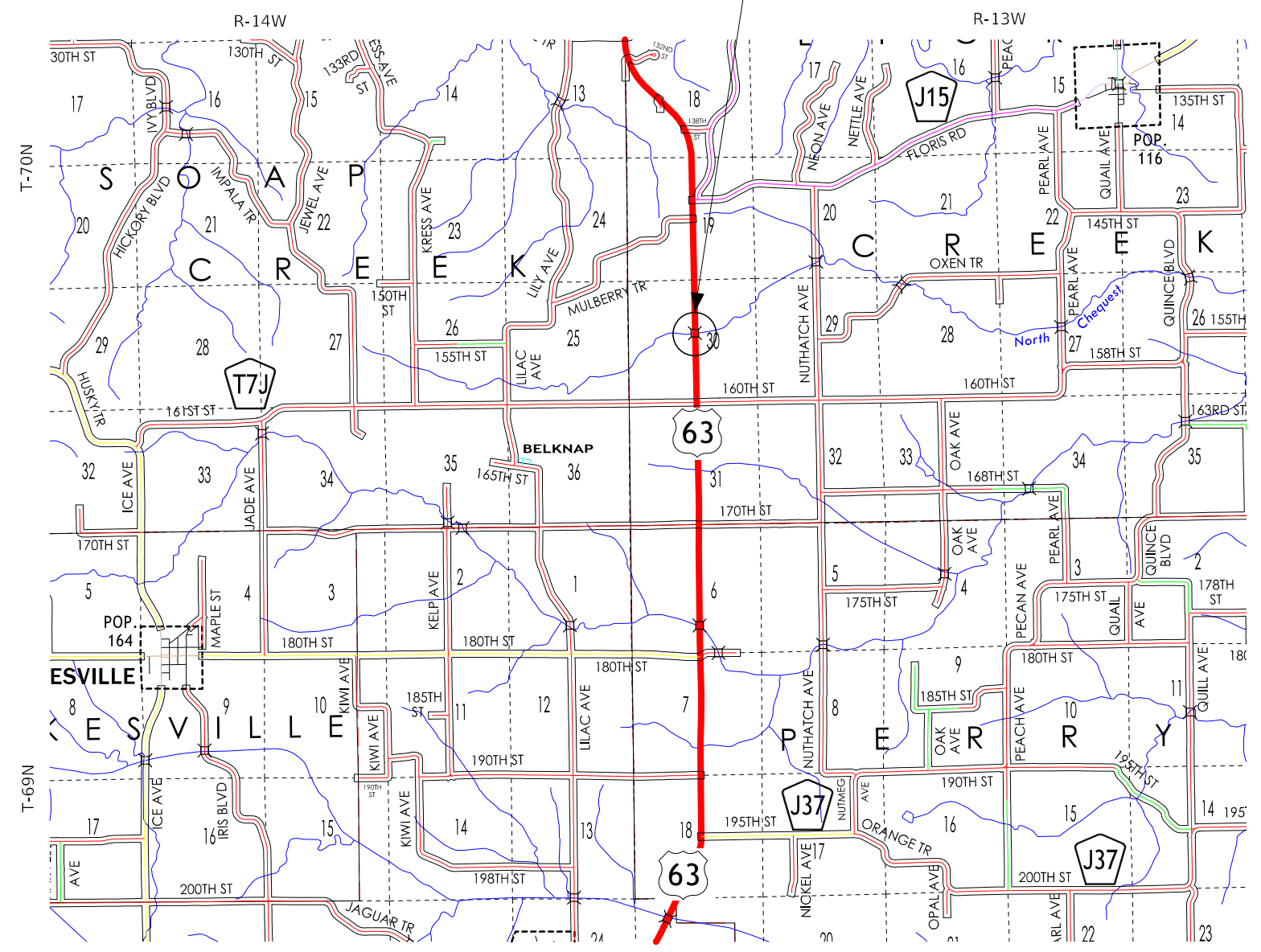

LEGEND	
INTERSTATE HIGHWAY	
PRIMARY HIGHWAY-DIVIDED	
PRIMARY HIGHWAY	
PORTLAND CEMENT CONCRETE ROAD	
ASPHALT ROAD	
BITUMINOUS ROAD	
GRAVEL ROAD	
EARTHEN ROAD	
INTERSTATE HIGHWAY	
UNITED STATES HIGHWAY	
STATE HIGHWAY	
COUNTY HIGHWAY	
RAILROAD	
PIPELINE	
AIRPORT	
HYDROLOGY	
BRIDGE	
STATE BOUNDARY	
COUNTY BOUNDARY	
CORPORATE BOUNDARY	
TOWNSHIP LINE	
SECTION LINE	
ROAD NAMES	
UNINCORPORATED PLACE	
ABBAY ROAD	
ELWOOD	

Davis County Location Map

Not To Scale

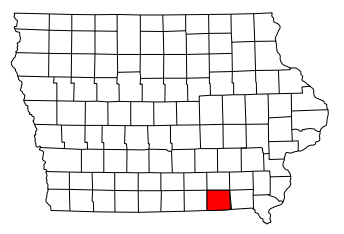

Estimated Culvert Quantities - Design 125

Item No.	Item Code	Item	Unit	Total	As Built Quantity
1	2104-2710020	Excavation, Class 10, Channel	C.Y.	376.8	
2	2426-6772016	Concrete Repair	S.F.	142.0	
3	2507-3250005	Engineering Fabric	S.Y.	348.0	
4	2507-6800061	Revetment, Class E	Ton	238.6	
5	2533-4980005	Mobilization	L.S.	1.0	

Item No.	Estimated Reference Information
1	For 10.7 CY excavation to regrade channel at west (upstream) end of culvert. Includes 217.1 CY excavation to remove sediment from culvert aprons and south barrel. Also includes excavation required to place revetment. All waste must be removed from project site.
3	Engineering fabric shall be material as specified for erosion control in accordance with article 4196.01,B,3 of sthe standard specifications. Installed below Class E revetment.
4	Estimated at 1.6 Ton/CY.

General Notes:

It is the intent of this design to repair the Twin 10'-0" x 12'-0" x 95'-0" Reinforced Concrete Box (RCB) Culvert, skewed 0°, on US 63 over North Chequest Creek. Project work will include wing repairs at both headwalls, clearing of sediment in the south barrel and placement of revetment stone at both ends of the culvert.

This design is for the repair of the existing RCB culvert, Design No. 162, with a year of construction of 1963. Electronic plans of the existing structure are available to the contractor as part of the e-files supplied with the contract. Dimensions shown on these plans are based on design plans (Original Design No. 162).

Faint lines on plans indicate existing structure.

Utility companies and municipalities whose facilities are shown on the plans or known to be within the construction limits shall be notified by the Contractor of the construction starting date.

All dimensions and details shown on these plans pertinent to new construction in relation to existing portions of the structure shall be verified in the field by the Contractor before starting construction.

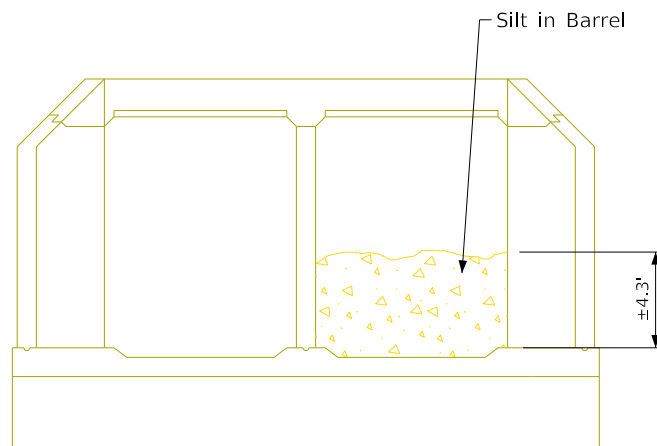

Typical Section
(Looking East)

Specifications:

Design:
AASHTO Series 2002.

Construction:
Iowa Department of Transportation Standard Specifications for Highway and Bridge Construction, series 2023, plus applicable General Supplemental Specifications, Developmental Specifications, Supplemental Specifications and Special Provisions shall apply to construction work on this project.

Design Stresses:

Design Stresses for the following materials are in accordance with the AASHTO Standard Specifications for Highway Bridges, Series 2002.

Reinforcing steel in accordance with Section 8, Grade 60.

Concrete in accordance with Section 8, f'c = 4.0 ksi.

Roadway quantities are included elsewhere in these plans.

Traffic Control Plan

The roadway will be open to thru traffic. Refer to the Traffic Control Plan shown elsewhere in these plans.

Design History at This Site

(Includes this Design)	
Des. No.	Type of Work
162	Original Design
125	Culvert Repairs



Design For 0° Skew
Twin 10'-0" x 12'-0"
Reinforced Concrete Box Repair
Estimated Quantities
STA. 308+90.00 (US 63) Turn-In Date: November 2024
Davis County
IOWA DEPARTMENT OF TRANSPORTATION
Design No. 0125 Design Sheet No. 1 of 6 Asset No. 022550

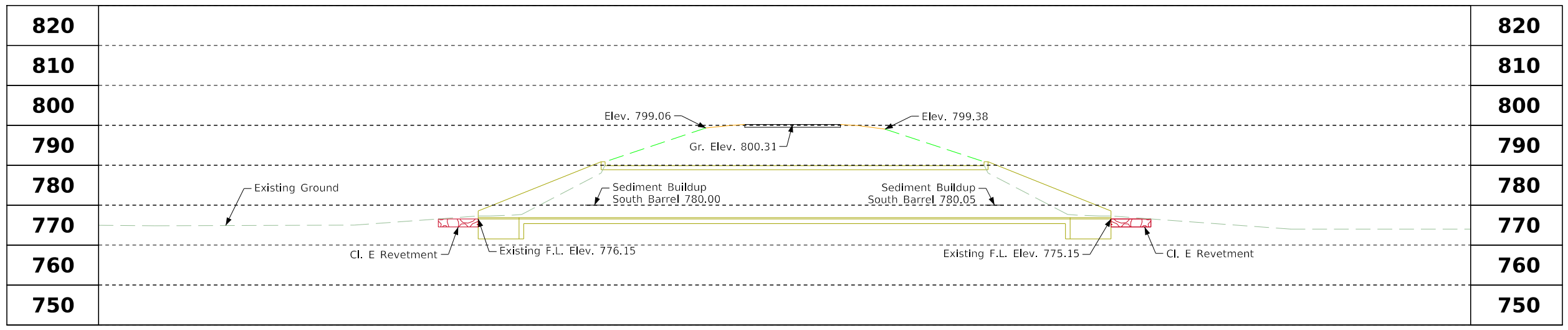

Control Point: No. 1; N=6173556.771,
E=22873778.170, Elev. 798.484, 3/8" Rebar w/ Pink
VNS Cap

Hydraulic Data
Drainage Area = 4.0 Sq. Mi.
Design Discharge = 1,500 CFS

Longitudinal Section along Centerline of Culvert

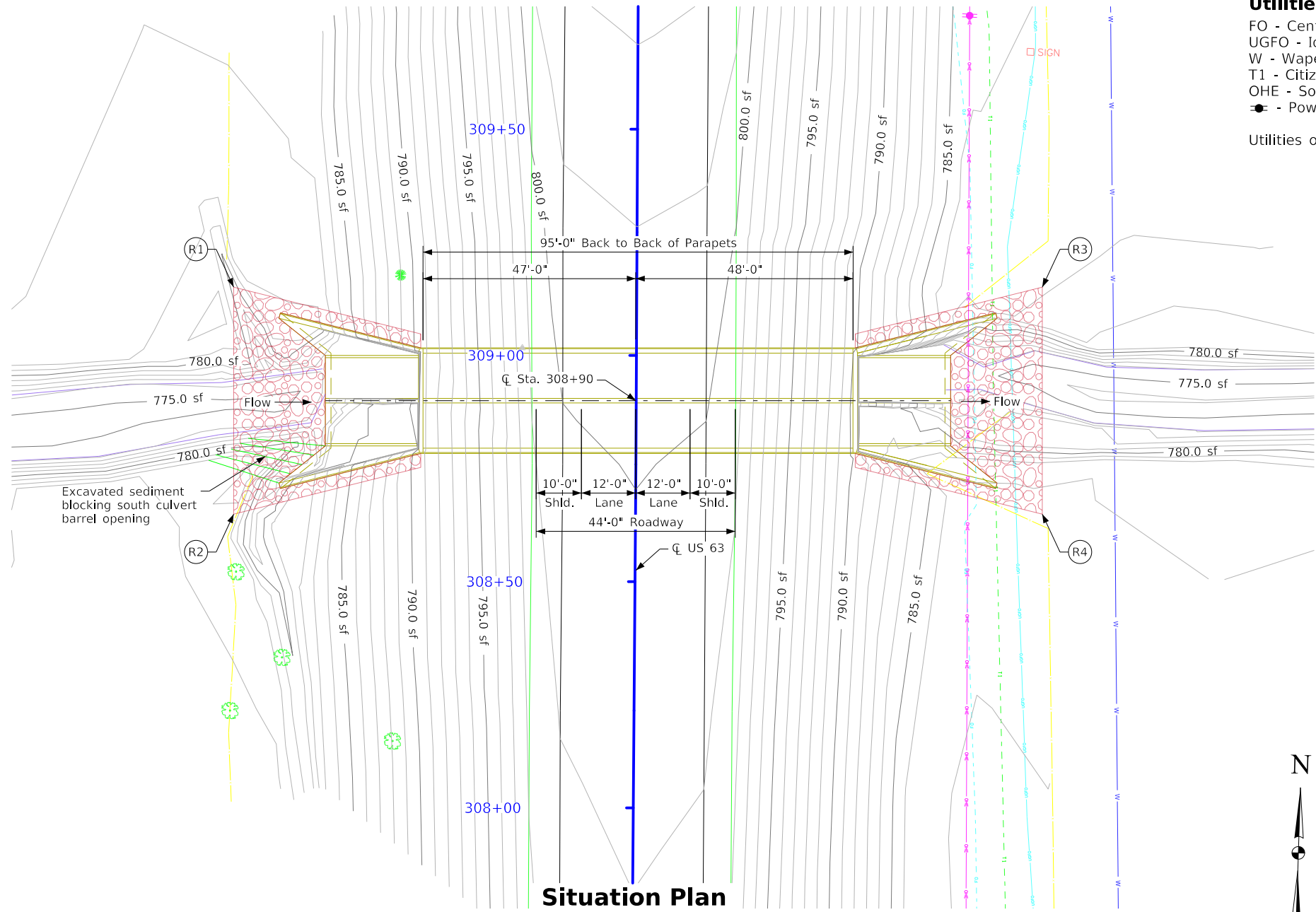

Utilities Legend

- FO - Century Link
- UGFO - Iowa Communications Network
- W - Wapello Rural Water Association
- T1 - Citizens Mutual Telephone
- OHE - Southern Iowa Electric
- - Power Pole, Southern Iowa Electric

Utilities on this sheet are for information only.

Location

US 63 Over North
Chequest Creek
T-70N R-13W
Section 30
Lick Creek Township
Davis County
FHWA No. 022550
Latitude 40.836082°
Longitude -92.399147°

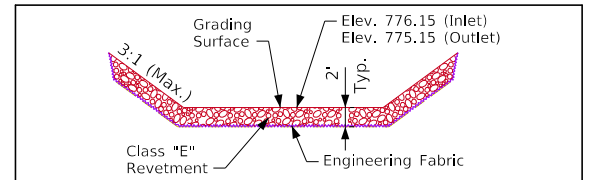

**Typical Channel Protection
Estimated Revetment
Quantities**

Location	Revetment CL. "E" (Ton)	Engineering Fabric (SY)	Excavation CL. 10 (CY)
Inlet	119.3	174.0	74.5
Outlet	119.3	174.0	74.5
Totals	238.6	348.0	149.0

Excavation quantity calculated from grading surface.

- (R1) 309+12.09, 88.83' Lt., Revetment Limits
- (R2) 308+64.91, 88.83' Lt., Revetment Limits
- (R3) 309+12.09, 89.83' Rt., Revetment Limits
- (R4) 308+64.91, 89.83' Rt., Revetment Limits



Design For 0° Skew
Twin 10'-0" x 12'-0"
Reinforced Concrete Box Repair
Situation Plan
STA. 308+90.00 (US 63) Turn-In Date: November 2024
Davis County
IOWA DEPARTMENT OF TRANSPORTATION
Design No. 0125 Design Sheet No. 2 of 6 Asset No. 022550

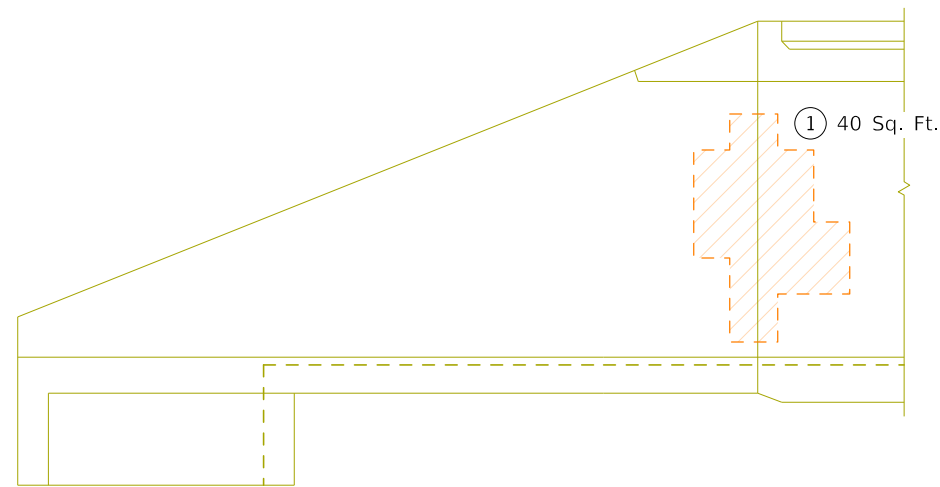

Northwest Wingwall

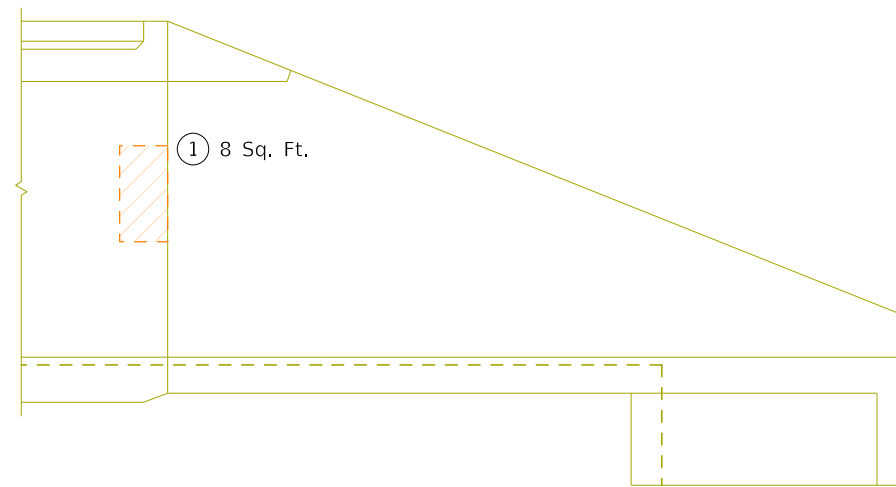

Northeast Wingwall

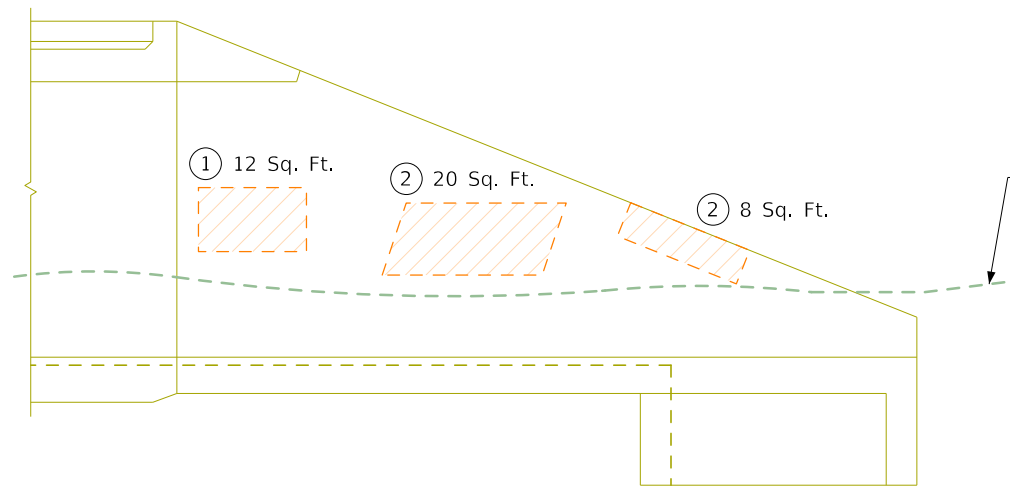

Southwest Wingwall

Existing Ground

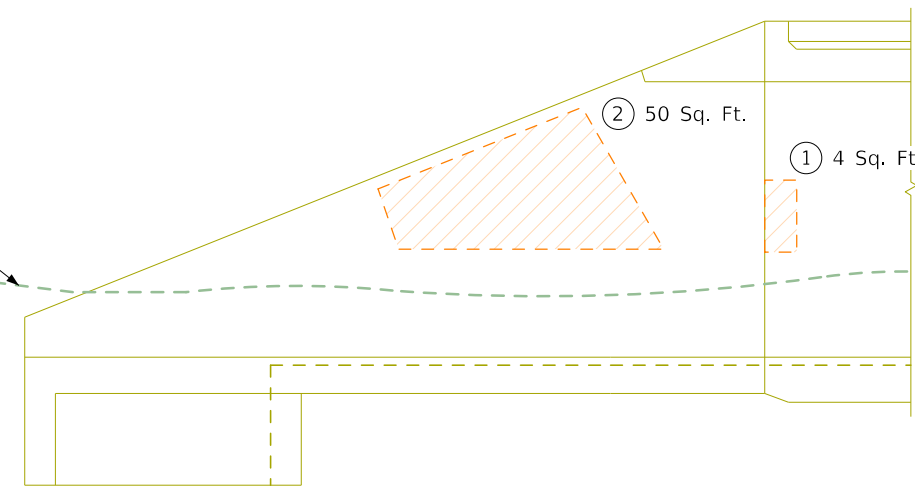

Southeast Wingwall

- ① Shallow Repair
- ② Regular Repair



Design For 0° Skew
Twin 10'-0" x 12'-0"
Reinforced Concrete Box Repair
Concrete Repair Details
 STA. 308+90.00 (US 63) Turn-In Date: November 2024
Davis County
 IOWA DEPARTMENT OF TRANSPORTATION
 Design No. 0125 Design Sheet No. 3 of 6 Asset No. 022550

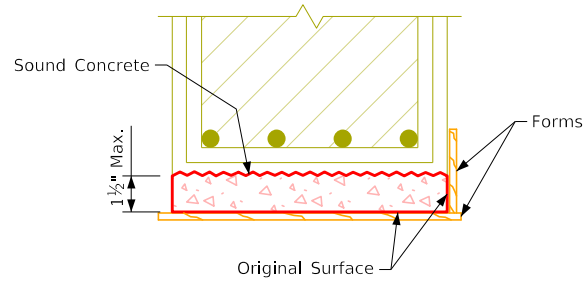

**Shallow Repair
Bottom Surface**

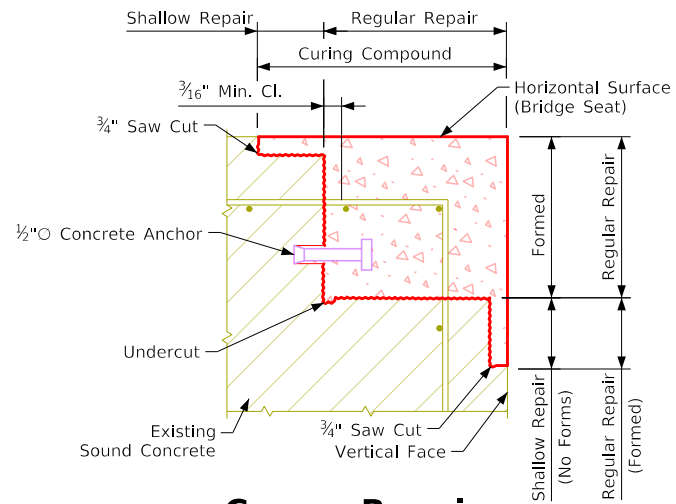

Corner Repair

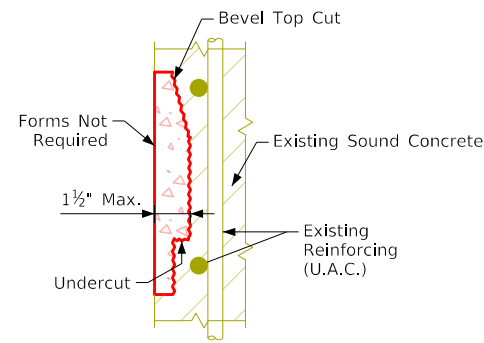

**Shallow Repair
Vertical Face**

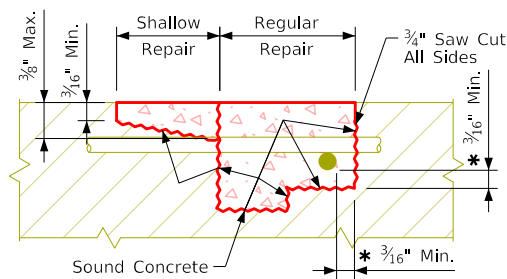

Repair Definition

* Indicates Clearance for an Un-Bonded Rebar.

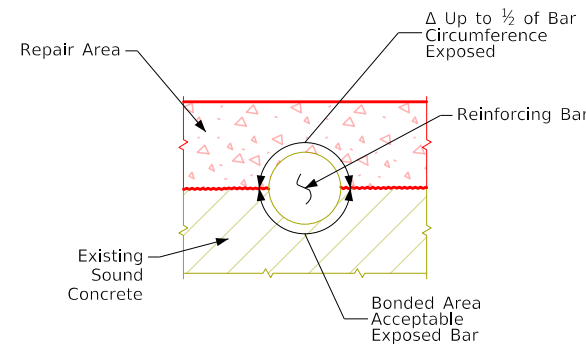

Δ If more than 1/2 of the rebar is exposed it shall be treated as an un-bonded rebar.

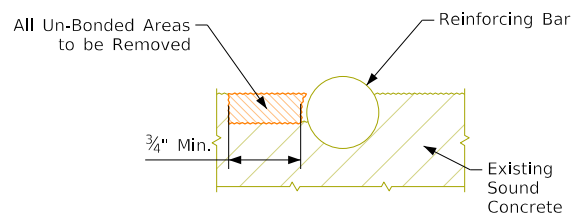

**Concrete Removal
Adjacent to Reinforcing**

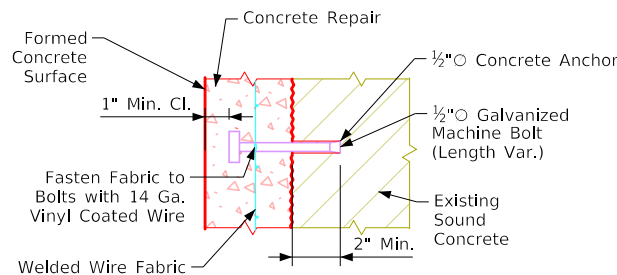

Anchor Detail

For Spacing and Use of Concrete Anchors and WWF See the Repair Notes.

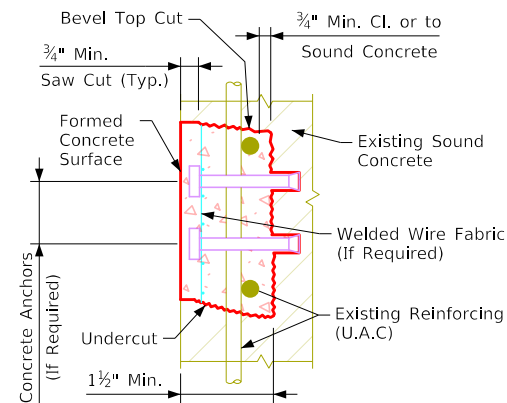

**Regular Repair
Vertical Face**

Repair Notes:

- The spalled and hollow areas of this bridge as noted and shown in these plans shall be repaired as follows:
- All the costs of equipment and materials required to repair the spalled and hollow areas of this bridge shall be included in the price bid for "Concrete Repair".
- The price bid for "Concrete Repair" shall include the cost of all concrete anchors and welded wire fabric required by the plans.
- The Engineer shall determine and outline by visual and audible inspection the actual areas of the concrete repairs. The Contractor shall be paid for the actual amount of repairs made on a square foot basis based on the price bid per square foot.
- All existing reinforcing bars that are exposed by the concrete removal shall be cleaned and carefully incorporated into the new work, except badly deteriorated existing reinforcing which shall be replaced as directed by the Engineer.
- The concrete anchors required shall have a minimum pull out of 5,000 lbs based on 4,000 psi concrete. An anchor meeting the requirements of Iowa D.O.T. Materials I.M. 453.09 and the pull out load above is required. The anchors shall be galvanized and shall be installed according to recommendations of the Manufacturer. The cost of furnishing and installing the concrete anchors shall be included in the price bid for "Concrete Repair".
- The welded wire fabric shall be ASTM A185 and galvanized as per ASTM A-641. The WWF wires shall be spaced 3x3 or 4x4 and the wires shall have a nominal area of 0.014 to 0.029 sq in inclusive, example "WWF 3x3 - W1.4xW2.9".
- Where reinforcement has been exposed and clearance around the periphery of the existing bar is provided, no supplemental reinforcing is required, except where existing reinforcement density and pattern are such that individual open spaces between bars are of 1.5 sq ft or larger. For this condition 1/2" concrete anchors and welded wire fabric shall be installed at the rate of one concrete anchor with WWF per each 1.5 sq ft of area within each open space.
- Repairing the structural concrete shall be in accordance with Section 2426, of the Standard Specifications.

Concrete Placement Quantities			
Mark	Type	Units	Quantity
①	Shallow repair	Sq. Ft.	64
②	Regular repair	Sq. Ft.	78
		Total (Sq. Ft.)	142

Estimated Concrete Repair Quantities		
Description	Units	Amount
Concrete Repair	Sq. Ft.	142

Design For 0° Skew
Twin 10'-0" x 12'-0"
Reinforced Concrete Box Repair
Concrete Repair Details (Cont.)
 STA. 308+90.00 (US 63) Turn-In Date: November 2024
Davis County
 IOWA DEPARTMENT OF TRANSPORTATION
 Design No. 0125 Design Sheet No. 4 of 6 Asset No. 022550

Revised 10-2014 - Deleted All References to Grout, Section 2426 Covers this Requirement and Doesn't Need to be Stated on the Plans.
 RepairRetrofitBridges.dgn - 2601255004 Repair2 - This Sheet Redrawn 09-27-1990.
 RepairRetrofitBridges.dgn - 2601255004 Repair2 - This Sheet Re-Issued 07-23.



Culvert Headwall View
(East Headwall looking West)



Culvert Headwall View
(West Headwall looking East)



Sediment Buildup
(South Culvert Barrel)



Typical Delamination
(Northwest Wing Shown)

Design For 0° Skew
Twin 10'-0" x 12'-0"
Reinforced Concrete Box Repair

Photos

STA. 308+90.00 (US 63) Turn-In Date: November 2024

Davis County
 IOWA DEPARTMENT OF TRANSPORTATION

Design No. 0125 Design Sheet No. 5 of 6 Asset No. 022550



ENGLISH:HRFDSIGNEDTWINCULVERTSFWH.DGN • TWEFWH 0-3-21 • THIS SHEET ISSUED 02-2021.

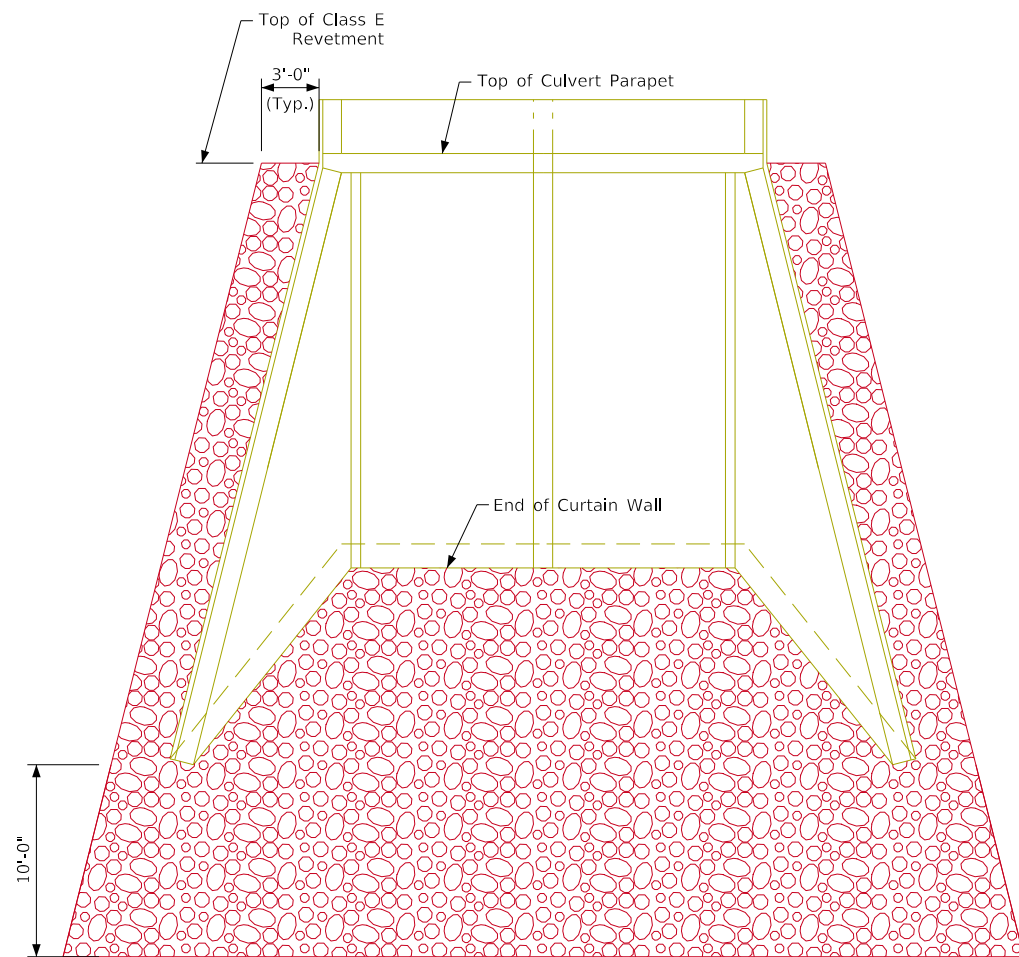

Plan View

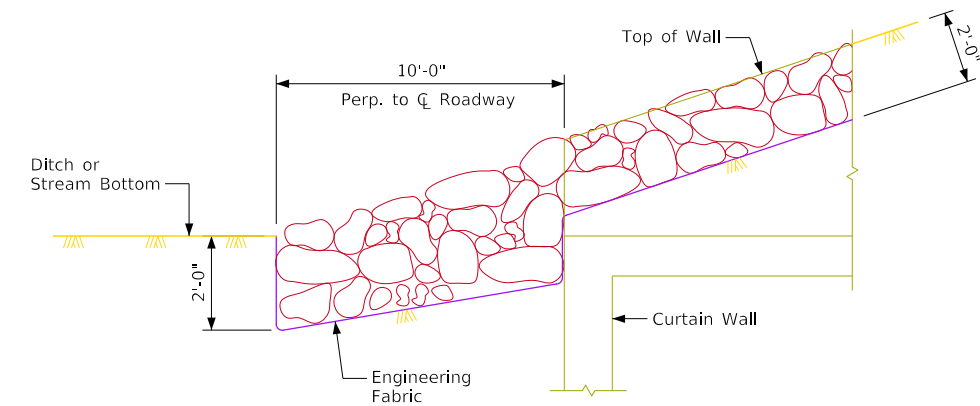

View B-B

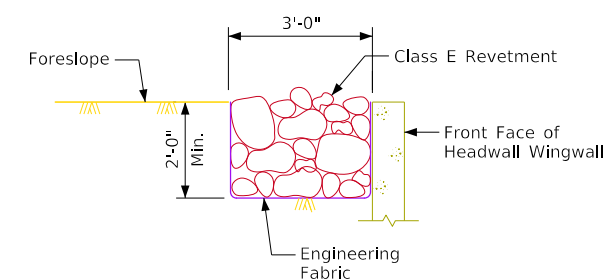

Section A-A

Typical Details

Construction Notes:

Class E Revetment shall be used and placed according to Article 2507.03, of the Standard Specifications. The engineering fabric shall meet the material requirements in accordance with Article 4196.01,B,3, of the Standard Specifications.

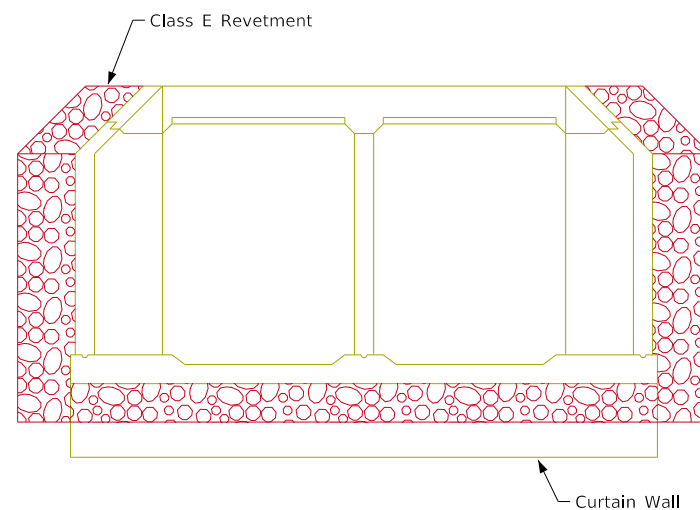

Elevation View



Design For 0° Skew
Twin 10'-0" x 12'-0"
Reinforced Concrete Box Repair
 Revetment Details
 STA. 308+90.00 (US 63) Turn-In Date: November 2024
Davis County
 IOWA DEPARTMENT OF TRANSPORTATION
 Design No. 0125 Design Sheet No. 6 of 6 Asset No. 022550

FILE NO. 32250	ENGLISH	DESIGN TEAM HR Green, Inc.	Modified Standard Sheet 1092	Davis COUNTY	PROJECT NUMBER BRFN-063-1(96)--39-26	SHEET NUMBER V.6
-----------------------	---------	-----------------------------------	-------------------------------------	---------------------	---	-------------------------

ESTIMATED PROJECT QUANTITIES AND REFERENCE NOTES

Roadway Items : Roadway Items

Item no.	Item Code	Item	Unit	Quantities		Estimate Reference Notes
				Estimated	Roadway Items	
1	2101-0850001	CLEARING AND GRUBBING	ACRE	0.1		<p>Refer to Sheet C.2. All material generated as a result of Clearing and Grubbing shall become the property of the contractor and must be disposed off site.</p> <p>All wood material must be disposed of according to Iowa Department of Agriculture and Land Stewardship Emerald Ash Borer Quarantine Order.</p> <p>For more information see www.iowatrepests.com.</p>
2	2528-8445110	TRAFFIC CONTROL	LS	1		Refer to Tab 108-23A on Sheet J.1 for details.
3	2602-0000320	PERIMETER AND SLOPE SEDIMENT CONTROL DEVICE, 20 IN. DIA.	LF	300		<p>Item is included for temporary perimeter sediment control, inlet protection, and water velocity reduction on slopes or ditches at locations to be determined during construction.</p> <p>Verify specific locations with the Engineer prior to beginning placement.</p> <p>Use Perimeter and Slope Sediment Control Devices fabricated using wood excelsior.</p>
4	2602-0000351	REMOVAL OF PERIMETER AND SLOPE OR DITCH CHECK SEDIMENT CONTROL DEVICE	LF	300		

STANDARD ROAD PLANS			105-4 10-18-11
The following Standard Road Plans apply to construction work on this project.			
Number	Date	Title	
TC-1	10-15-19	Work Not Affecting Traffic (Two-Lane or Multi-Lane)	
TC-202	04-18-23	Work Within 15 ft of Traveled Way	

PROJECT DESCRIPTION	100-1D 10-18-05
This project is a culvert repair project for the RCB culvert on US 63 over North Chequest Creek.	

INDEX OF TABULATIONS			111-25 10-18-11
Tabulation	Tabulation Title	Sheet No.	
C Sheets			
100-0A	ESTIMATED ROADWAY QUANTITIES	C.1	
100-1D	PROJECT DESCRIPTION	C.2	
105-04	STANDARD ROAD PLANS	C.2	
110-17	CLEARING AND GRUBBING	C.2	
111-25	INDEX OF TABULATIONS	C.2	
232-3A	EROSION CONTROL (RURAL SEEDING)	C.2	
262-06	UTILITIES (NOT A POINT 25 PROJECT)	C.2	
J Sheets			
108-23A	TRAFFIC CONTROL PLAN	J.1	
108-25	511 TRAVEL RESTRICTIONS	J.1	
111-01	COORDINATED OPERATIONS	J.1	

UTILITIES (NOT A POINT 25 PROJECT)	262-6 10-18-05
This is NOT a POINT 25 project and is not subject to the provisions of IAC 761-115.25.	

CLEARING AND GRUBBING																	110-17 04-18-17				
Location		Work and Material Type	Trees, Stumps, and Logs and Down Timber Material Diameters													All Other Materials		Estimated Quantities			Remarks
Station to Station or Ref. Loc. Sign to Ref. Loc. Sign or Description	Direction of Travel		3"-6"	>6"-9"	>9"-12"	>12"-15"	>15"-18"	>18"-24"	>24"-30"	>30"-36"	>36"-42"	>42"-48"	>48"-60"	>60"-72"	>72"	Length	Width	Units	Area	Herbicide Application	
			FT	FT	Units	Acres	Each														
US 63	NB/SB	Trees - Clearing and Grubbing																	0.1		
Total																			0.1		

EROSION CONTROL (RURAL SEEDING)	232-3A 10-19-21
<p>Area to be seeded is estimated to be less than 1 acre. If the contractor determines the area exceeds 2 acres, notify the Engineer. Approved quantity in excess of 2 acres will be paid for as extra work according to Article 1109.03,B of the Standard Specifications.</p> <p>Following the completion of work in a disturbed area and according to the seeding dates in Section 2601 of the Standard Specifications, place seed, fertilizer, and mulch on the disturbed area lying 8 feet adjacent to shoulder and median as follows:</p> <p>Place seed and fertilize according to the requirements of Article 2601.03,C,3 and Section 4169 of the Standard Specifications.</p> <p>Place mulch according to the requirements of Articles 2601.03,E,2,a and 4169.07,A of the Standard Specifications.</p> <p>Preparing the seedbed, furnishing and applying seed, fertilizer, and mulch are all incidental to mobilization and will not be paid for separately.</p>	

511 TRAVEL RESTRICTIONS

Route	Direction	County	Location Description	Feature Crossed	Object Type	Maint. Bridge No., Structure ID, or FHWA No.	Type of Restriction	Existing Measurement	Construction Measurement	Construction Measurement as Signed	Projected As Built Measurement	Remarks
US 63	NB/SB	Davis	RCB Culvert on US 63 over North Chequest Creek	No Travel Restriction Expected								

108-23A
08-01-08

TRAFFIC CONTROL PLAN

Maintain traffic on US 63 at all times in accordance with the Standard Road Plans listed on Tabulation 105-4. For additional information, refer to part 6 of the Manual on Uniform Traffic Control Devices and the Standard Specifications.

Permanent signing that conveys a message is not applicable to the working conditions shall be covered by the Contractor, as directed by the Engineer and stated in the Standard Specifications.

111-01
04-17-12

COORDINATED OPERATIONS

Other work in progress during the same period of time will include the construction of the projects listed. Coordinate operations with those of other contractors working within the same area.

Project	Type of Work
None Provided	