

POTTAWATTAMIE COUNTY

Bridge-Unspecified
BRFN-092-1(75)--39-78

LETTING DATE
Jan 22 2025



REVISIONS

TOTAL
24

PROJECT IDENTIFICATION NUMBER
20-78-092-010
PROJECT NUMBER
BRFN-092-1(75)--39-78
R.O.W. PROJECT NUMBER
STPN-092-1(76)--2J-78

No.	DESCRIPTION
A Sheets	Title Sheets
A.1	Title Sheet
A.2	Location Map
B Sheets	Typical Cross Sections and Details
B.1 - 4	Typical Cross Sections and Details
D Sheets	Mainline Plan and Profile Sheets
* D.1	Plan & Profile Legend & Symbol Information Sheet
* D.2	IA 92
E Sheets	Drainage Ditch
* E.1	N.E. ML Drainage Ditch
* E.2	S.W. ML Drainage Ditch
* E.3	S.E. ML Drainage Ditch
G Sheets	Survey Sheets
G.1	Survey Information
G.2	Control Point Vicinity Map
G.3	Horizontal and Vertical Project Control
G.4	Horizontal Control Tab
J Sheets	Traffic Control and Staging Sheets
J.1	Traffic Control Plan
V Sheets	Bridge and Culvert Situation Plans
V.1	RCB Situation Plan Sta 177+23.00
W Sheets	Mainline Cross Sections
* W.1	Cross Section Legend & Symbol Information Sheet
* W.2 - 7	Mainline Cross Sections
	* Color Plan Sheets

H Sheets

PLANS OF PROPOSED IMPROVEMENT ON THE
PRIMARY ROAD SYSTEM
POTTAWATTAMIE COUNTY
 Bridge-Unspecified
 Indian Creek 0.7 mi W of Co Rd M47

SCALES: As Noted

Refer to the Proposal Form for list of applicable specifications.

Value Engineering Saves. Refer to Article 1105.14 of the Specifications.

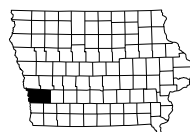

INDEX OF SEALS			
SHEET NO.	NAME	TYPE	BID QUANTITY SHEETS
A.1	Paul Flattery	Primary Signature Block	X

PRELIMINARY PLANS

Subject to change by final design.

D5 REVISION - 06/20/23

PROJECT LOCATION
 Ref.Loc. 36.86
 FHWA No. 43910
 Maint No. 7836.9S092

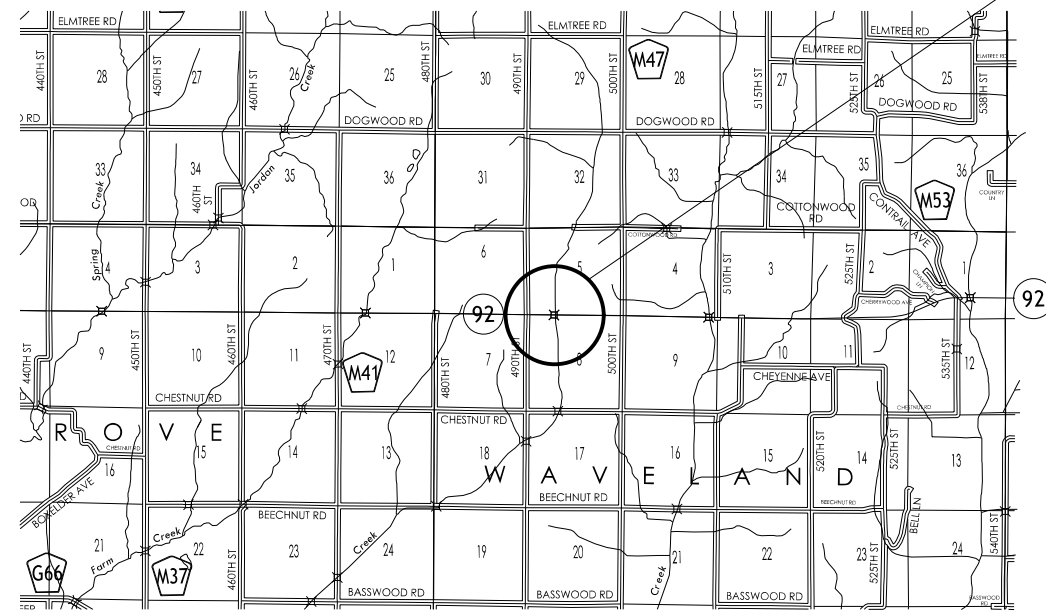

T-74N

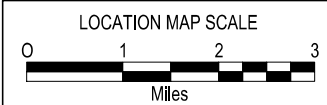

LOCATION		DIMENSIONS				
ROAD IDENTIFICATION	STATION TO STATION		(L)	(R)	(X)	FS
			Feet	Feet	Inches	
IA 9	175+44.94	178+88.60	(1)	(1)	6"	(1)
IA 9	175+53.47	179+05.22	(1)	(1)	6"	(1)
(1) See XS for Details						

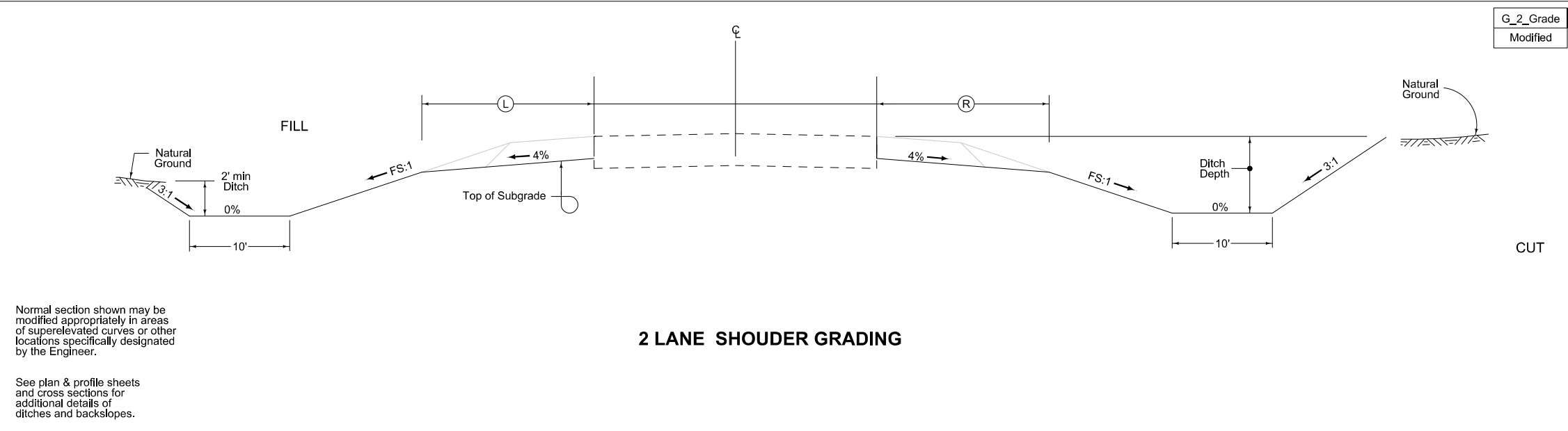

2E_10-19-10

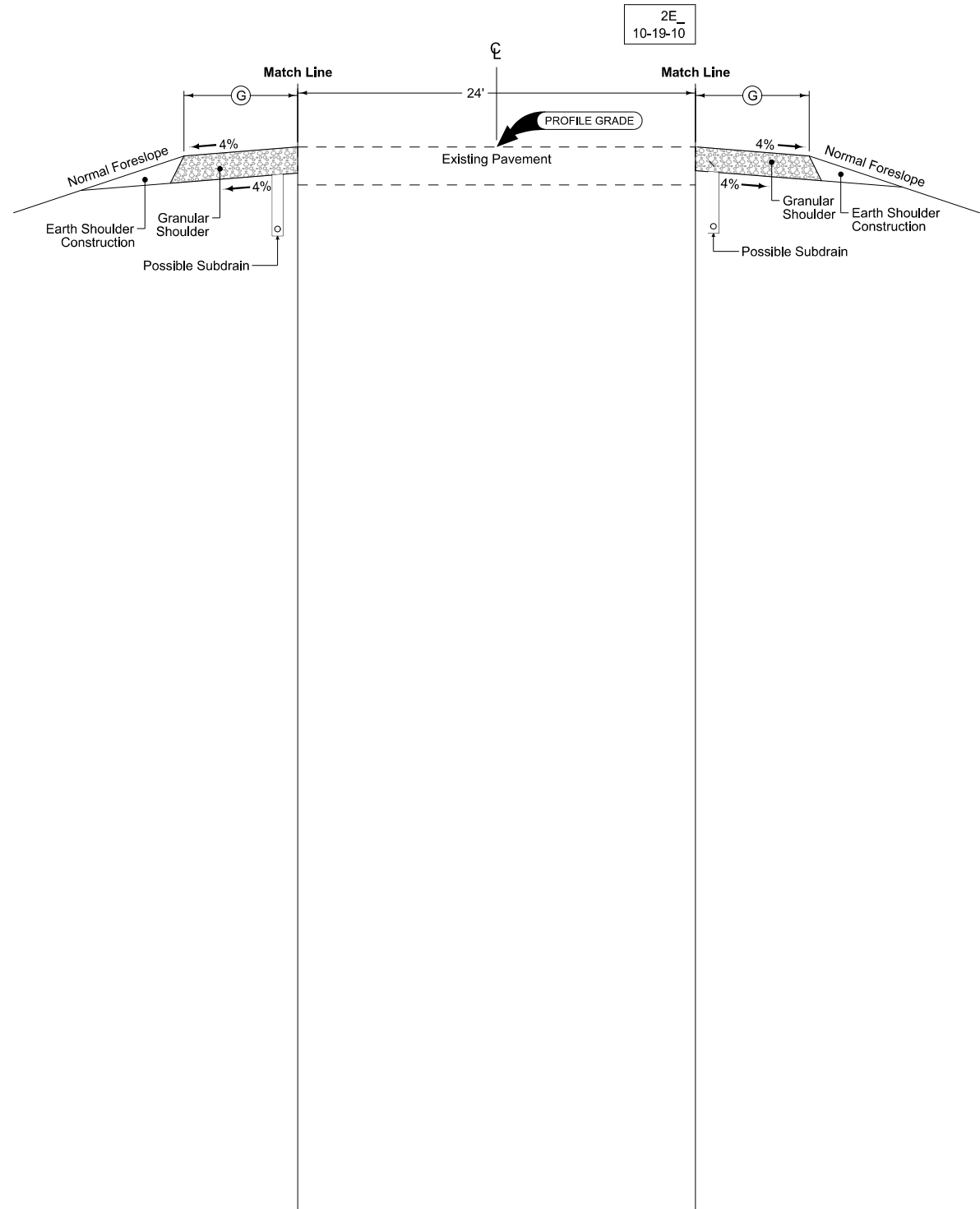

Granular Shoulder

1R_G_10-19-10		
BEGIN STATION	END STATION	Ⓞ Feet
175+44.94	178+88.60	10'

Granular Shoulder

1R_G_10-19-10		
BEGIN STATION	END STATION	Ⓞ Feet
175+53.47	179+05.22	10'

IA 92

See Tab 112-9 for shoulder quantities.

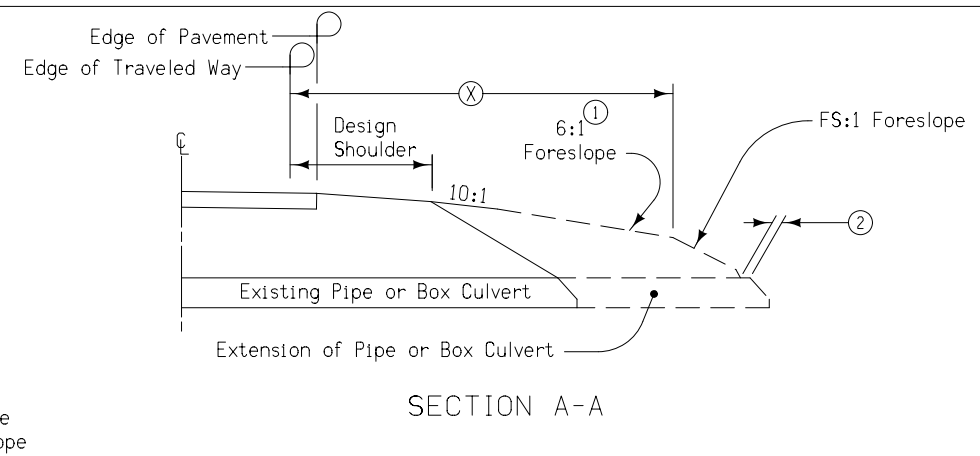
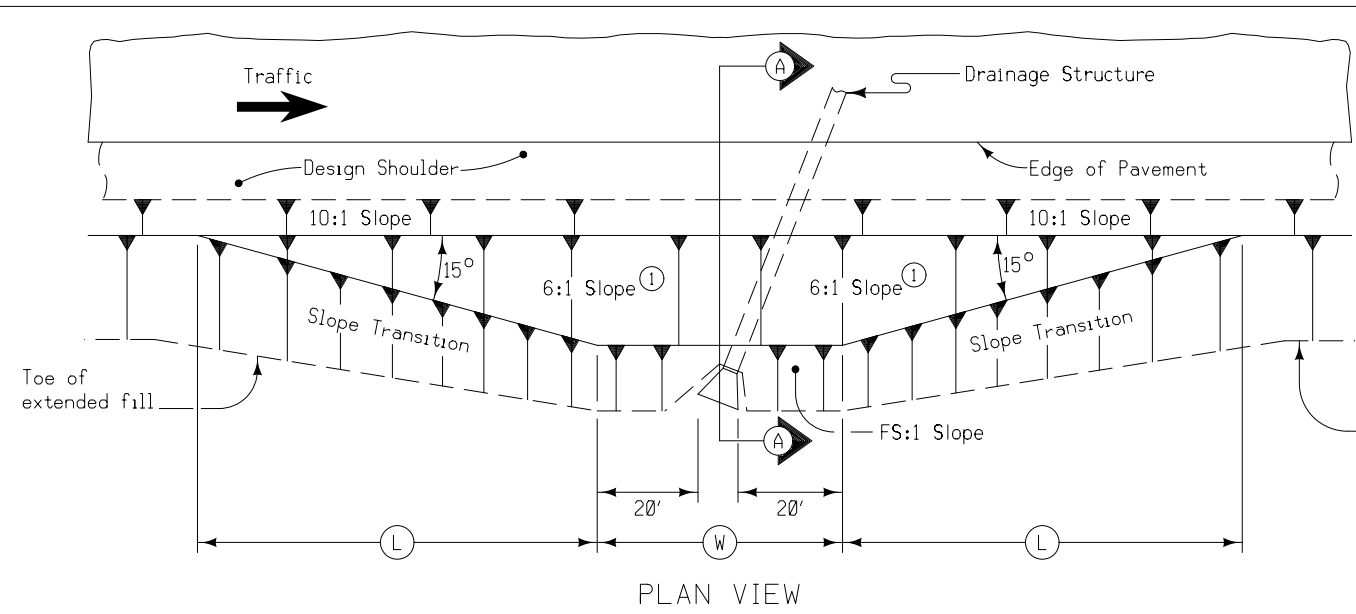

STRUCTURE LOCATION		W	L	X	FS
STATION ③	SIDE	Feet	Feet	Feet	
177+22.65	RT.	66.6	149.8	51.4	3
177+22.65	LT.	68.0	146.7	49.3	3

- At locations where an extended or newly constructed drainage structure extends beyond the normal foreslope cover, flatten as indicated so as to cover the structure. Minimum earth cover is 6 inches.
- ① Slope may be flatter than 6:1.
 - ② 6 inch minimum for pipe installations or to top of headwall on RCB.
 - ③ At \bar{C} of roadway.
 - Ⓜ = Pipe or RCB opening width plus 20 feet each side.

BARNROOF FORESLOPE AT SKEWED DRAINAGE STRUCTURE

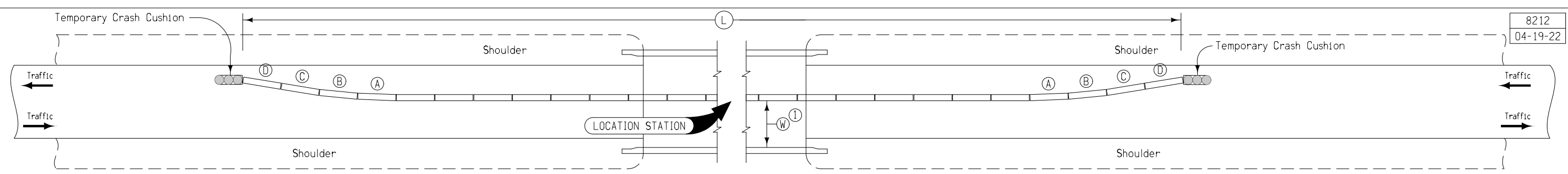

- ① Where Ⓜ is less than 15'-6", install restricted width signing as per Standard Road Plan TC-81.

TEMPORARY CONCRETE BARRIER LAYOUT for Two-Way Traffic

Station	Side	AA	WL	TA	L	Anchored	W ①	Remarks
		Feet	Feet	Feet	Feet	X	Ft-Inches	
177+23.80	Lt.	20	40	20	130		14	
177+23.80	Rt.	20	40	20	130		14	

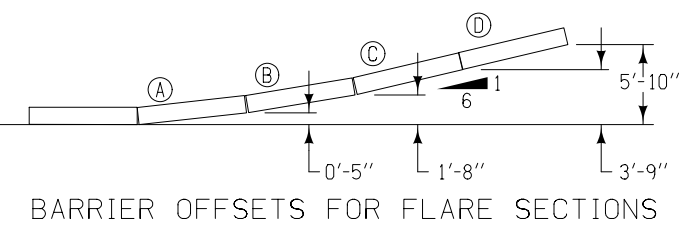

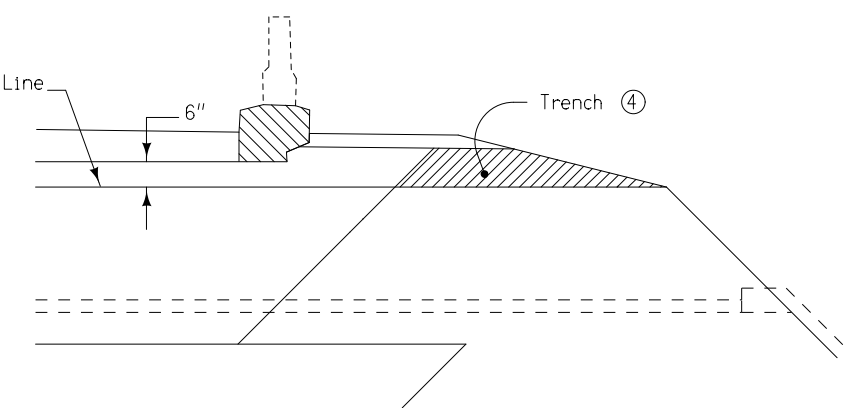
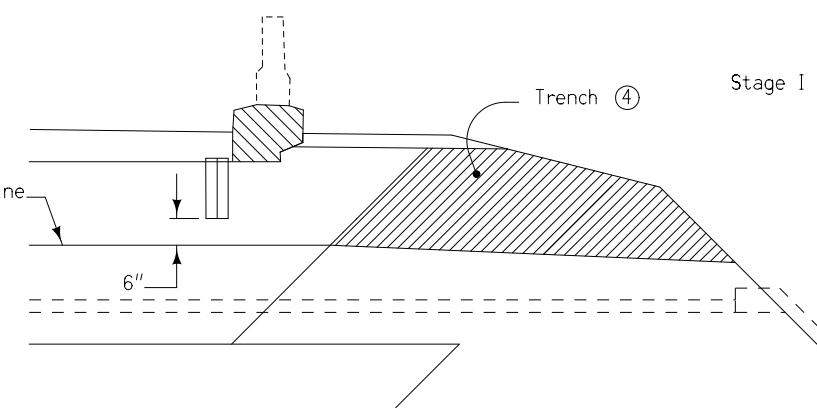
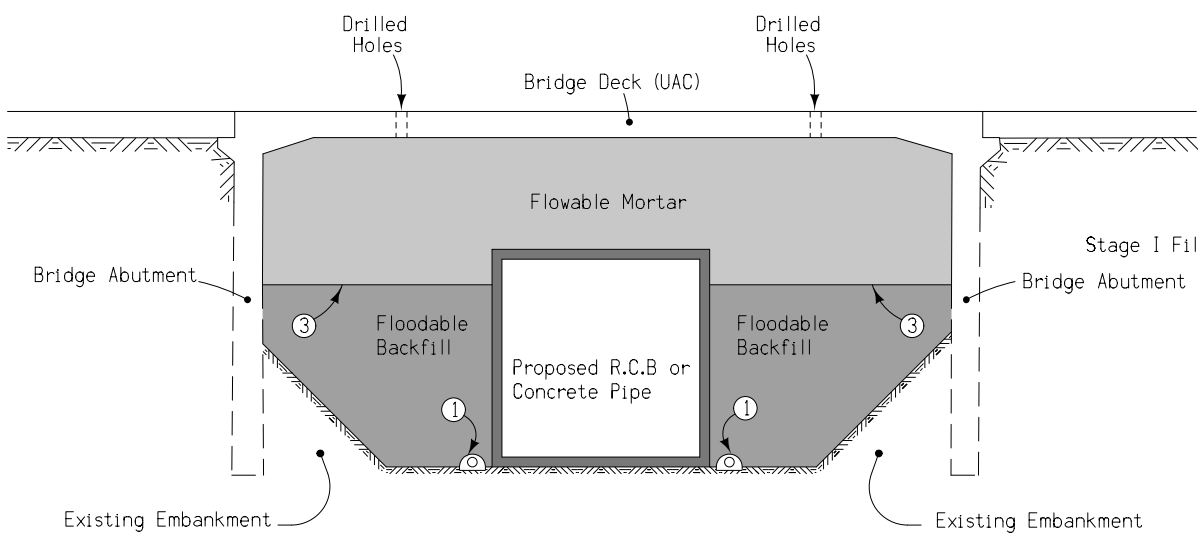
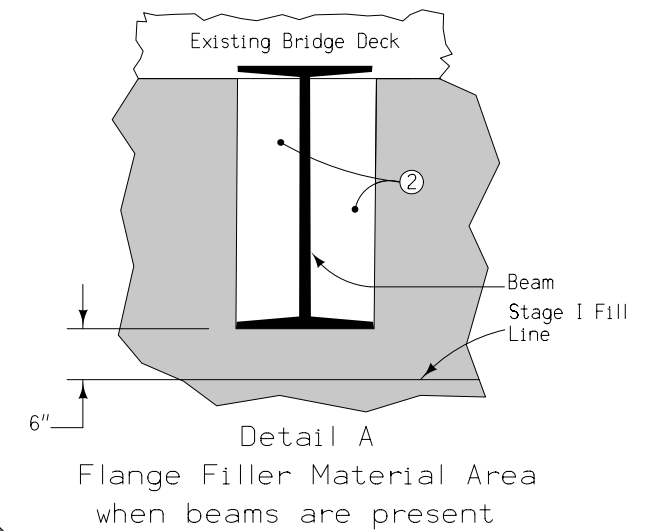
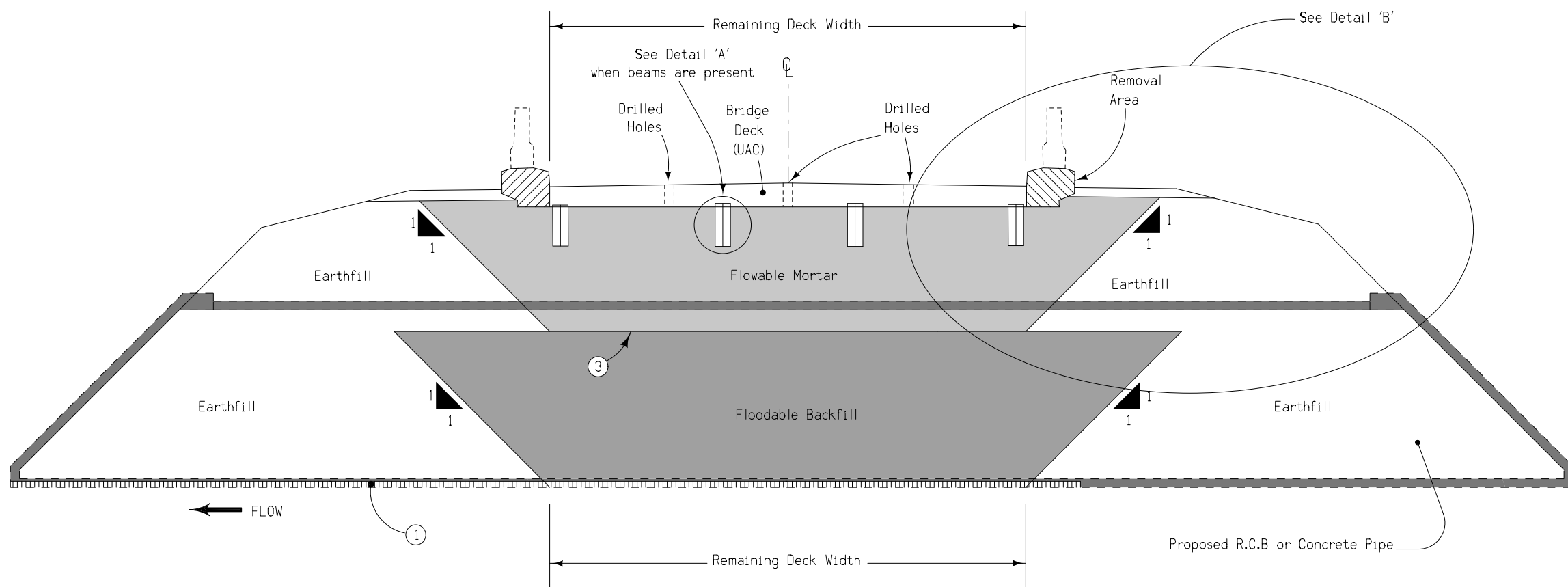

Detail B (Beam Bridge)

Detail B (Slab Bridge)

Section along Centerline

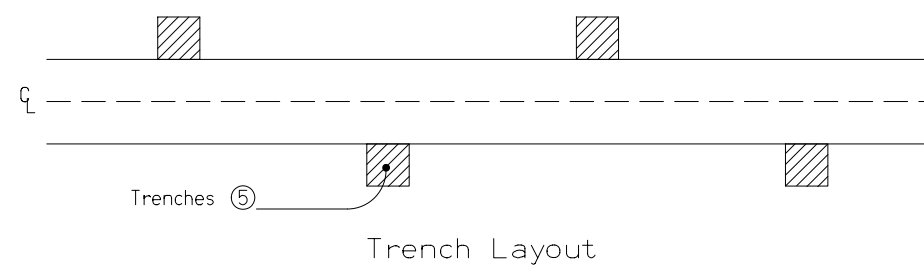

Trench Layout

- ① 4" Subdrain at flowline elevation of culvert with 4" cover of porous backfill.
- ② Place Flange Filler Material to fill pocket area between flanges to prevent flowable mortar from building up. Flange Filler Material is incidental to flowable mortar.
- ③ Fill void with the maximum amount of Floodable Backfill possible. Distance from Floodable Backfill to bridge beams (when present) or bridge deck shall not exceed 5'.
- ④ Cut trenches in the soil plug to provide drainage for the flowable mortar. Backfill the trenches with open graded crushed stone, gravel, or recycled PCC to allow water to drain. Backfill material is incidental to flowable mortar.
- ⑤ Place trenches at 20' spacing with a minimum of two trenches on each side of the roadway.

FILL FOR CULVERT USED IN BRIDGE REPLACEMENTS

Denotes pay limits for flowable mortar
Denotes pay limits for flooded backfill

SURVEY SYMBOLS

- Interstate Highway Symbol
- U.S. Highway Symbol
- Iowa Highway Symbol
- County Road Highway Symbol
- Evergreen Tree
- Deciduous Tree
- Fruit Tree
- Shrub (Bushes)
- Timber
- Hedge
- Stump
- Swamp
- Rock Outcrop
- Broken Concrete
- Revetment (Rip Rap)
- Cemetery
- Grave
- Cave
- Sink Hole
- Board Fence
- Chain Link or Security Fence
- Wire Fence
- Terrace
- Earth Dam or Dike (Existing)
- Tile Outlet
- Edge of Water
- Existing Drainage
- Right of Way Rail or Lot Corner
- Concrete Monument
- Well
- Windmill
- Beehive Intake
- Existing Intake
- Existing Utility Access (Manhole)
- Fire Hydrant
- Water Hydrant (Rural)
- Septic Tank
- Cistern
- L.P. Gas Tank (No Footing)
- Underground Storage Tank
- Latrine
- Satellite TV Dish
- Water Hook Up
- Radio Tower
- Tower Anchor
- Guardrail (Beam or Cable)
- Guard Post (one or two)
- Guard Post (over two)
- Filler Pipe
- Gas Valve
- Water Valve
- Speed Limit Sign
- Mile Marker Post
- Sign
- Traffic Signal Control Box
- Rail Road Signal Control Box
- Telephone Switch Box
- Electric Box

UTILITY LEGEND

- E1 - - - - ELID, Nishnabotna Valley REC - Quality D
- F0 - - - - FO1D, Centurylink - Quality D
- F02 - - - - FO2D, Griswold Cooperative Telephone - Quality D
- F03 - - - - FO3D, Aureon Network Services - Quality D

PLAN VIEW COLOR LEGEND OF PLAN AND PROFILE SHEETS

LINEWORK		Design Color No.	
Green	(2)		Existing Topographic Features and Labels
Blue	(1)		Proposed Alignment, Stationing, Tic Marks, and Alignment Annotation
Magenta	(5)		Existing Utilities
SHADING		Design Color No.	
Lavender	(9)		Temporary Pavement Shading
Yellow	(4)		Proposed Pavement Shading
Orange	(6)		Proposed Granular Shading
Orange	(70)		Proposed Shoulder Granular Shading
Yellow	(68)		Proposed Shoulder Paved Full Depth Shading
Yellow	(132)		Proposed Shoulder Paved Partial Depth Shading
Gray, Dark	(112)		Proposed Grade and Pave Shading "In conjunction with a paving project"
Brown, Light	(236)		Grading Shading
Orange, Light	(134)		Proposed Granular Entrance Shading
Yellow	(220)		Proposed Paved Entrance Shading
Tan	(8)		Proposed Sidewalk Shading
Blue, Light	(230)		Proposed Sidewalk Landing Shading
Pink	(11)		Proposed Sidewalk Ramp Shading
Green, Light	(225)		Existing Pavement Shading
Red	(3)		Proposed Structure Shading
Red	(3)		Delineates Restricted Areas

PROFILE VIEW COLOR LEGEND OF PLAN AND PROFILE SHEETS

LINEWORK		Design Color No.	
Green	(10)		Existing Ground Line Profile
Blue	(1)		Proposed Profile and Annotation
Magenta	(5)		Existing Utilities
Blue, Light	(230)		Proposed Ditch Grades, Left
Black	(0)		Proposed Ditch Grades, Median
Rust	(14)		Proposed Ditch Grades, Right

- Reference Point
- Station
- Section Corner
- Ground Line Intercept
- Saw Cut
- Guardrail
- Trench Drain
- HighTension Cable Guardrail
- Sheet Pile
- Pavement Removal
- Clearing & Grubbing Area

RIGHT-OF-WAY LEGEND

- Proposed Right-of-Way
- Existing Right of Way
- Existing and Proposed Right-of-Way
- Easement and Existing Right-of-Way
- Easement (Temporary)
- Easement
- Access Control
- Property Line

PLAN AND PROFILE LEGEND AND SYMBOL INFORMATION SHEET

(COVERS SHEET SERIES D, E, F, & K)

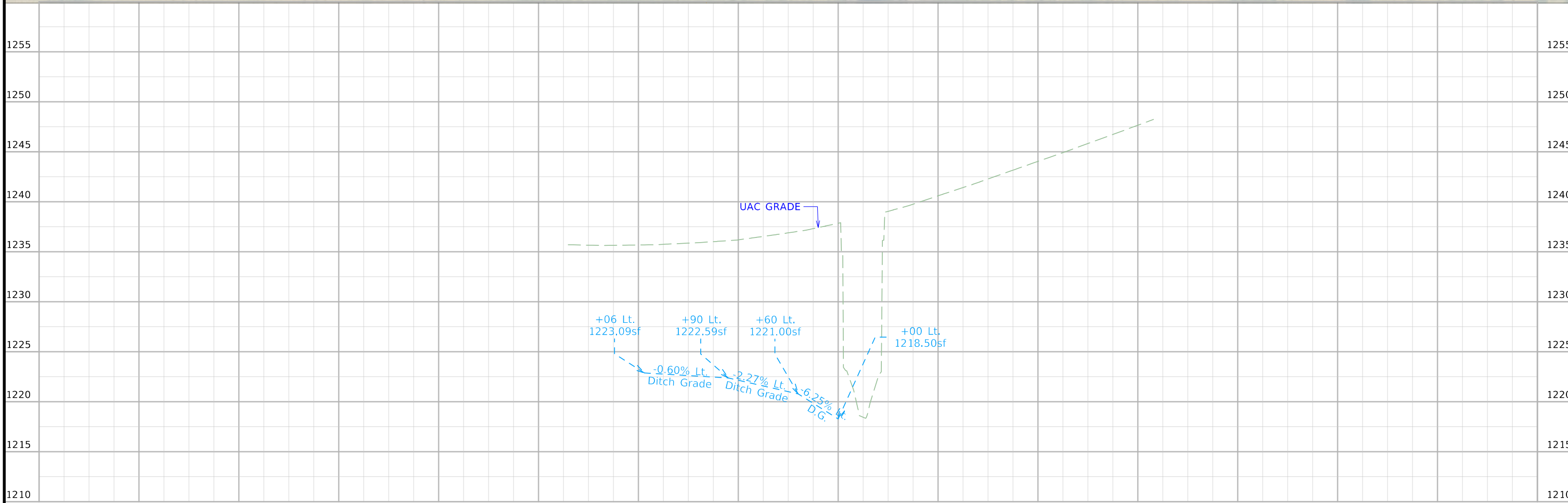
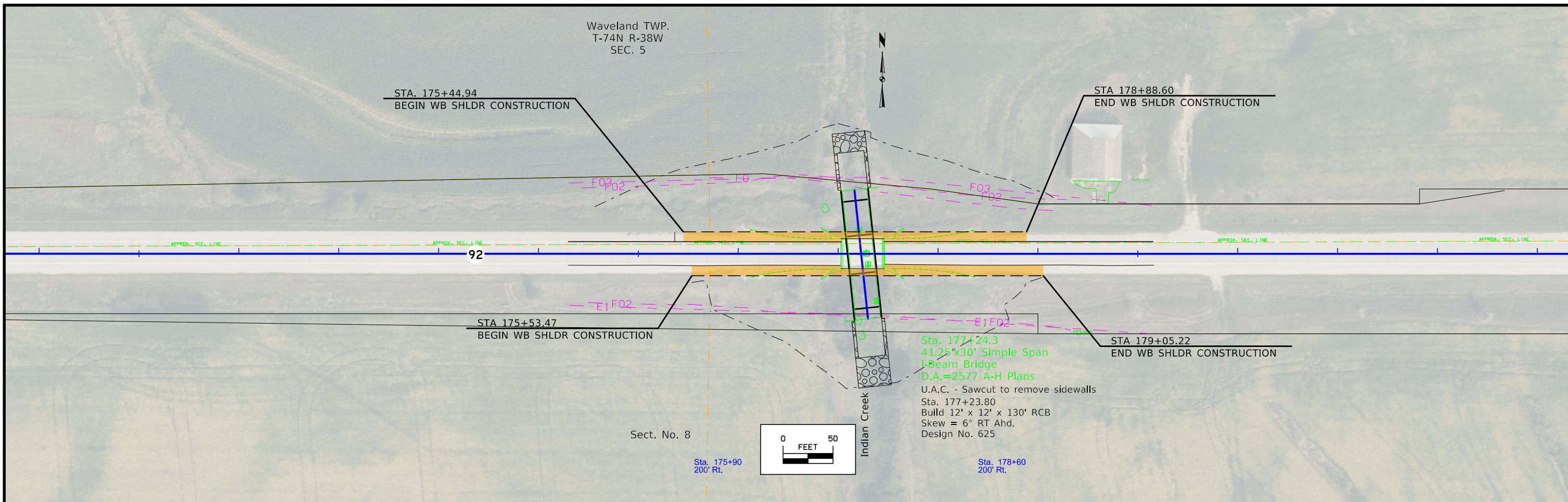

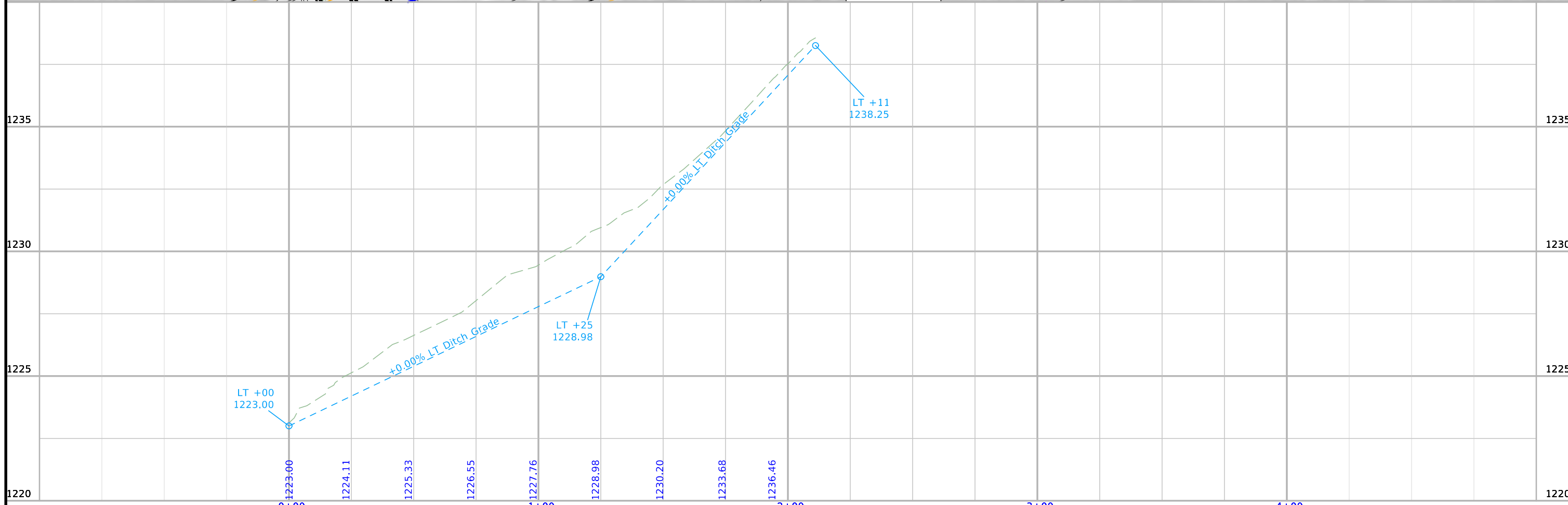
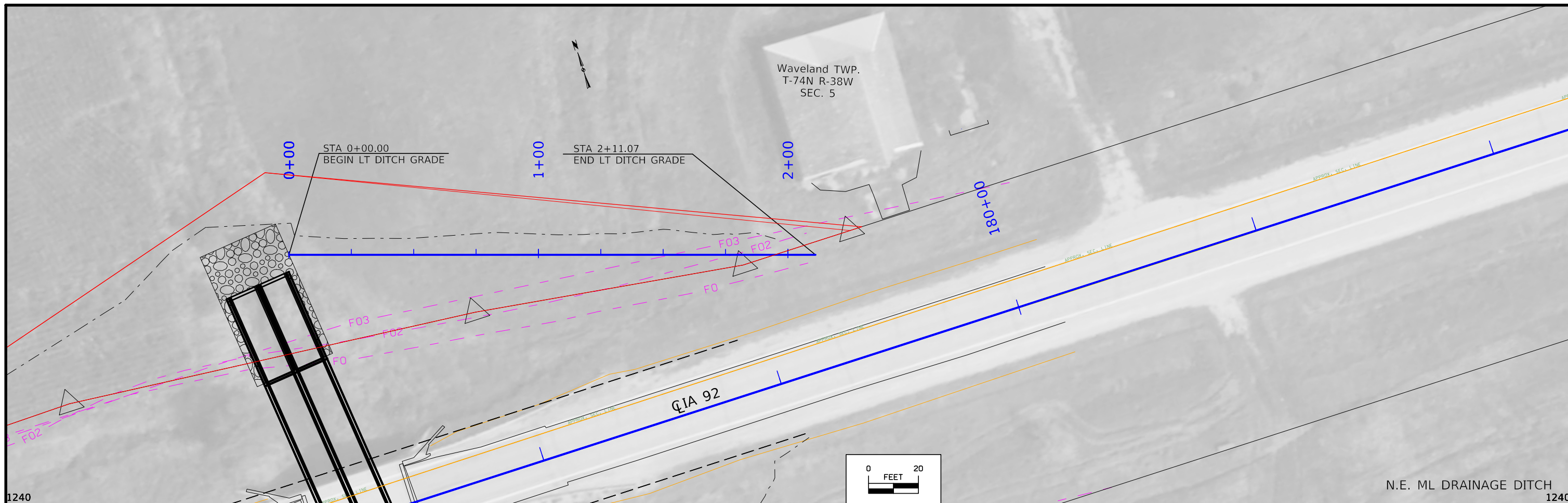

FILE NO.	ENGLISH	DESIGN TEAM	Flattery\Carlson	POTTAWATTAMIE COUNTY	PROJECT NUMBER	BRFN-092-1(75)--39-78	SHEET NUMBER	E.1
----------	---------	-------------	------------------	----------------------	----------------	-----------------------	--------------	-----

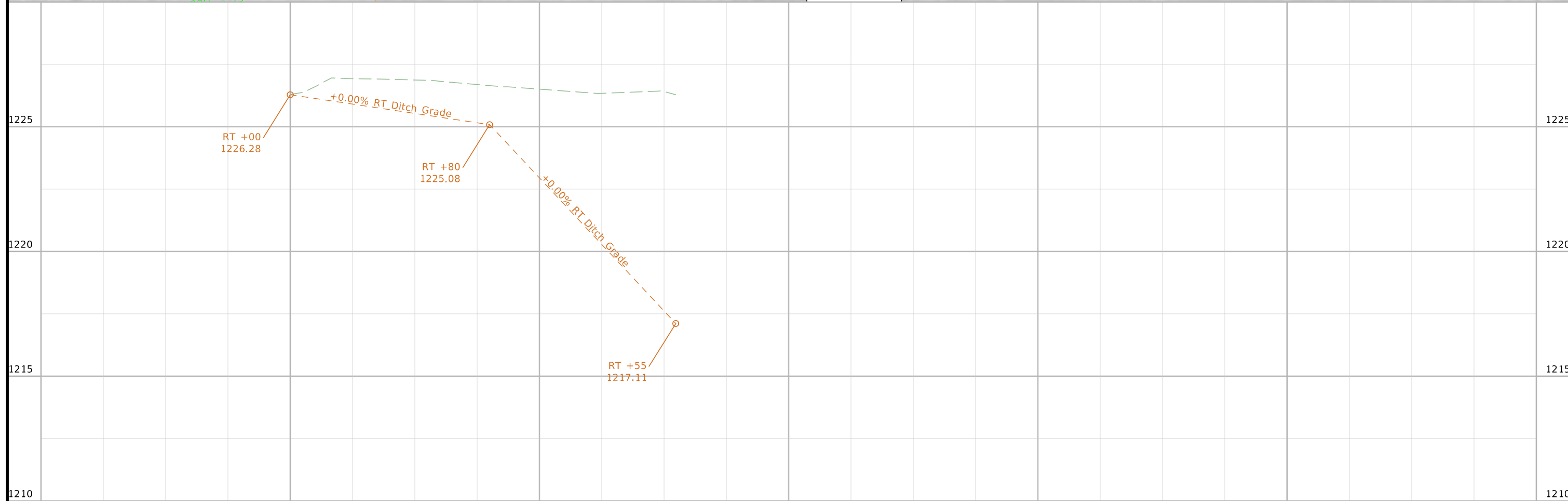

Waveland TWP.
T-74N R-38W
SEC. 5

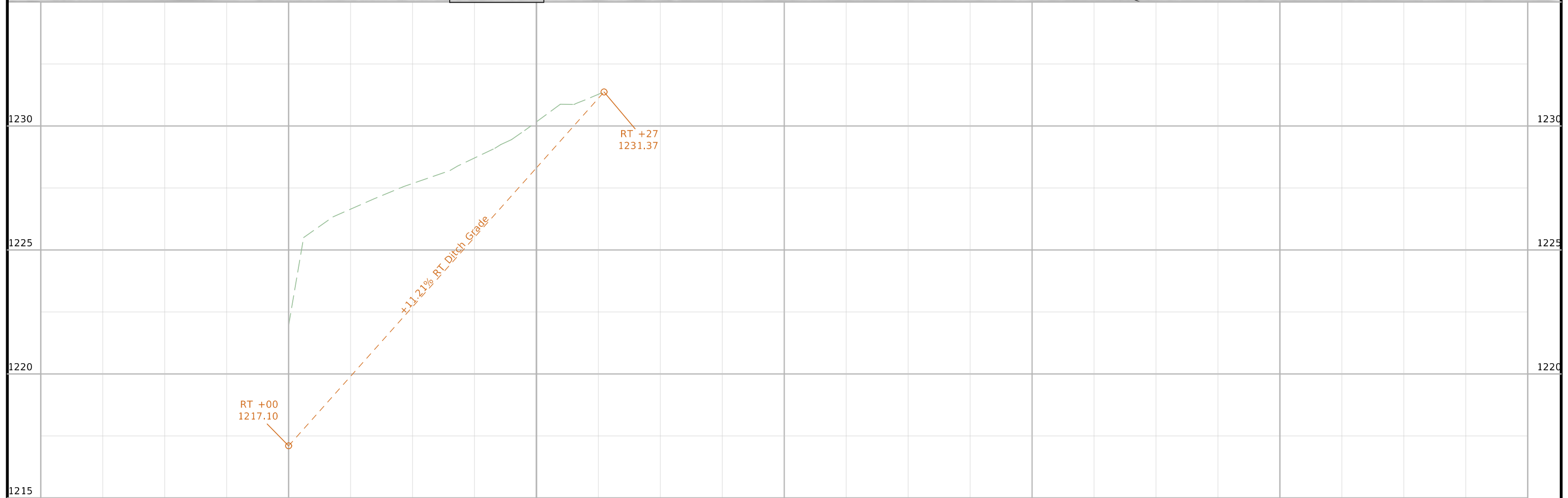
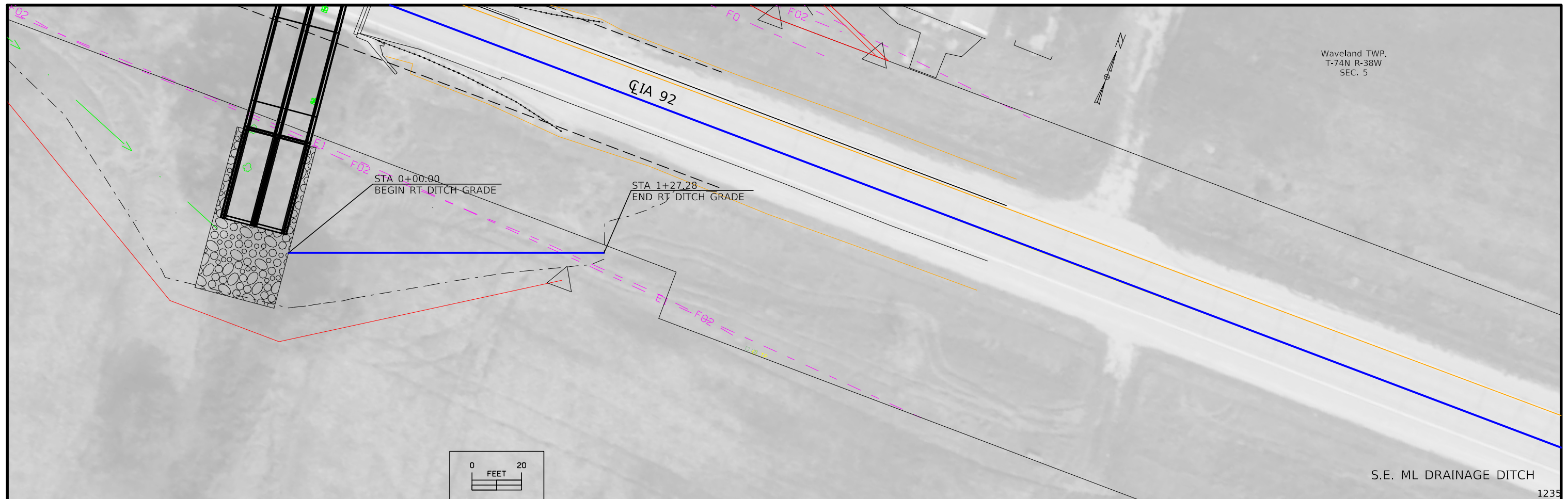

Survey Information

SURVEY INDEX

County: Pottawattamie
PIN: 20-78-092-010
Project Number: BRFN-092-1(75)--39-78
Location: Indian Creek 0.7 mi W of Co Rd M47
Type of Work: Bridge
Project Directory: 9417503020

Survey Personnel

Clayton Henningsen – Survey Party Chief
Jason Arn – Survey Party Chief
Robert Fredrickson – Assistant Survey Party Chief

Date(s) of Survey

Begin Date 12/01/2021
End Date 12/09/2021

General Information

Measurement units for this survey are US survey feet. This survey is for IA Hwy 92 bridge repair or replacement. Located over Indian Creek 0.7 mi west of county road M47. Survey is a full field.

Project Control

Coordinates were determined for primary project control points by conducting concurrent five-hour static observations. Post processing is constrained to nearby Iowa Real Time Network reference stations. For additional details of the control survey, contact the Preliminary Survey department.

PROJECT DATUM: NAD83(2011) EPOCH 2010.00
VERTICAL DATUM: NAVD88
COORDINATE SYSTEM: IOWA REGIONAL COORDINATE SYSTEM ZONE 6

Alignments Information

Alignment is a retrace of As-built Plan FN-92-1(15)—21-78. Stationing is held at POT 162+39.7 and carried ahead without equation.

Survey stationing relates to As-built plan stationing as follows:

POT Sta. 162+39.7 As Built Plans FN-92-1(15)—21-78
= Survey POT Sta. 162+39.7

PI Sta. 196+60.5 As Built Plans FN-92-1(15)—21-78
= Survey PI Sta. 196+60.33

Utility Information

For logging data and other utility details see Utility Survey and Ownership Report in the Utility folder of the PrelimSurvey project directory.

CONTROL POINT VICINITY MAP

This map is a guide to the vicinity of the primary project control points. Primary control is for use with RTK base stations and for RTN validation. Future surveys will use primary project control to establish temporary control as needed for construction or other surveying applications.

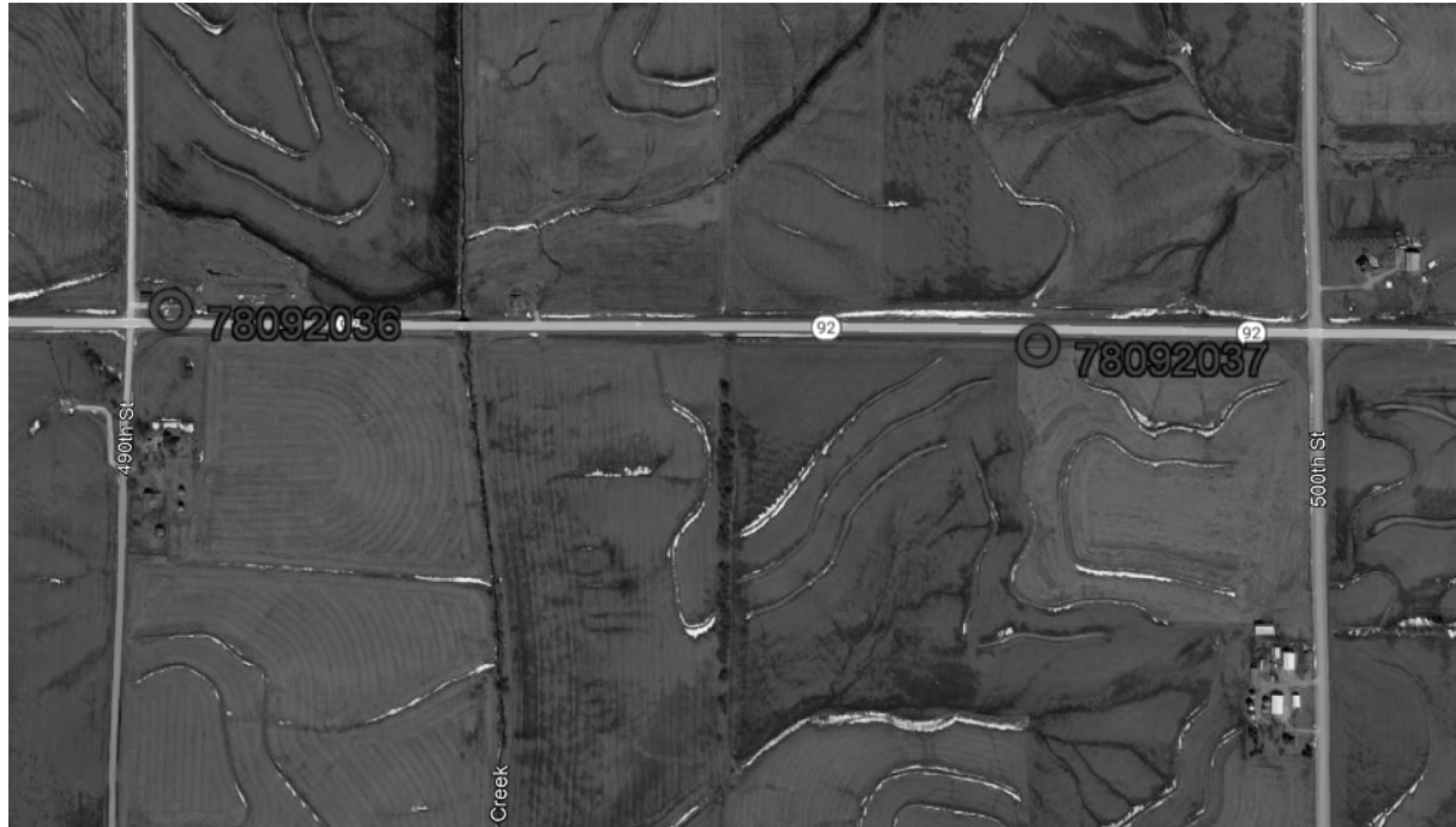

HORIZ. DATUM: NAD83(2011) EPOCH 2010.00 - Ia. RCS Zone 06
VERT. DATUM: NAVD88 - Geoid Model g2012bu3

Coordinate listing from next sheet will be used with IaRTN for monument recovery. No other reference ties are given.

HORIZONTAL AND VERTICAL PROJECT CONTROL COORDINATE LISTING

HORIZ. DATUM: NAD83(2011) EPOCH 2010.00
 1a. Regional Coordinate System Zone 06

VERT. DATUM: NAVD88
 Geoid Model g2012bu3
 Project Control Marks are Bench Marks

Point Name	Northing	Easting	Elevation	Feature Definition-Description
78092036	6958240.325	16632711.91	1259.978	CP 78092036 FROM THE INTERSECTION OF STATE HIGHWAY 92 AND STATE HIGHWAY 48 IN GRISWOLD GO WEST ALONG HWY 92 5.9 MILES A FENO TYPE MONUMENT 0.3 DEEP ALONGSIDE AN ENTRANCE ON NORTH SIDE 52 FEET N OF HWY 92 CENTERLINE 14 FEET NORTHEAST OF TOP CENTER INLET OF CMP 7 FEET SOUTH OF A CHAINLINK FENCE 22 FEET SOUTHEAST OF A LUM POLE
78092037	6958102.694	16635958.87	1293.754	CP 78092037 FROM THE INTERSECTION OF STATE HIGHWAY 92 AND STATE HIGHWAY 48 IN GRISWOLD GO WEST ALONG HWY 92 5.2 MILES A FOUND IRON PIN SET IN A CONC MONUMENT IN THE SOUTH DITCH 74 FEET SOUTH OF THE EDGE OF PAVEMENT 101 FEET EAST OF A WOOD FIBER OPTIC POST 117 FEET EAST OF STATION MARKER 195 0.6 FEET SOUTH OF A T POST

NOTE:

The first two digits in the control point name refer to the county number.
 The next 3 digits refer to the highway number.
 The next 3 digits refer to the highway milepost.
 The last digit refers to the distance from the referenced milepost to the nearest tenth of a mile.

ALIGNMENT COORDINATES

Name	Location	Point on Tangent			Begin Spiral			Begin Curve			Simple Curve PI or Master PI of SCS			End Curve			End Spiral		
		Station	Coordinates		Station	Coordinates		Station	Coordinates		Station	Coordinates		Station	Coordinates		Station	Coordinates	
			Y (Northing)	X (Easting)		Y (Northing)	X (Easting)		Y (Northing)	X (Easting)		Y (Northing)	X (Easting)		Y (Northing)	X (Easting)		Y (Northing)	X (Easting)
1	ML092	162+39.700	6958188.54	16632581.39															
2	ML092	196+60.333	6958188.41	16636002.02															

NO ACCESS RIGHTS ARE TO BE ACQUIRED ON THIS PROJECT.

WAVELAND TWP.
T-74N R-38W
SEC 5

1
FINO FARMS, LLC

2
HERITAGE FOX LTD

WAVELAND TWP.
T-74N R-38W
SEC 8

Right of Way Design Information	
THIS SHEET INCLUDED FOR INFORMATION ONLY	
ROW Team:	ATINKEN / JLARSON
ROW #:	STPN-092-1(76)--2J-78
Plan Date:	6-15-23
Color Legend:	
	Property Lines
	Temporary Easement
	Permanent Acquisition

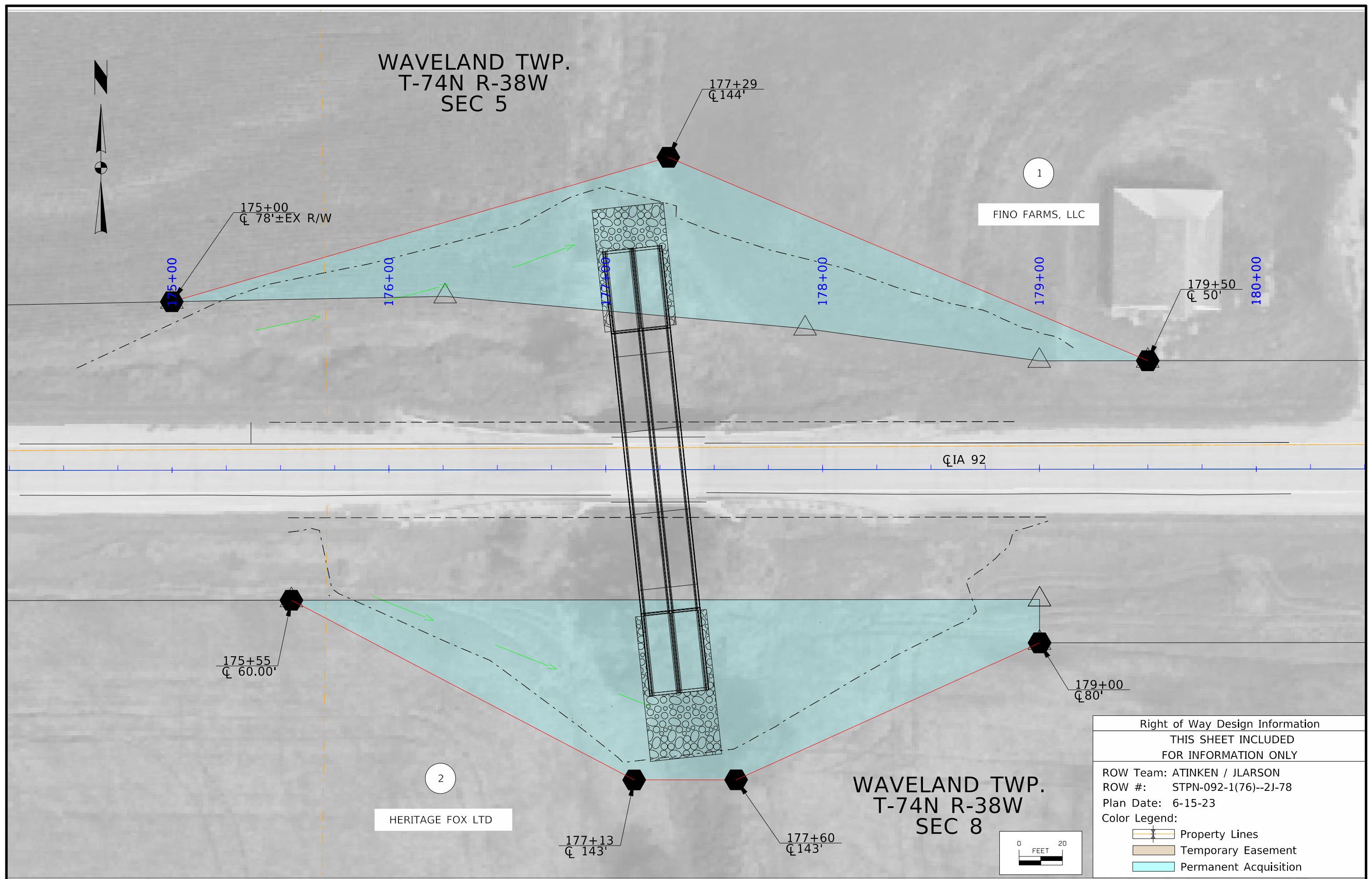
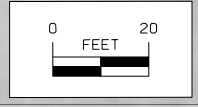

108-23A
08-01-08

TRAFFIC CONTROL PLAN

Traffic shall be maintained on IA 92 at all times. However, it will be necessary to reduce traffic down to one lane via use of TBR per Standard Road Plan TC-217 during the removal of the bridge rail, guardrail, deck patching, and placement of the flowable mortar.

108-25
10-21-14

511 TRAVEL RESTRICTIONS

Route	Direction	County	Location Description	Feature Crossed	Object Type	Maint. Bridge No., Structure ID, or FHWA No.	Type of Restriction	Existing Measurement	Construction Measurement	Construction Measurement as Signed	Projected As Built Measurement	Remarks
			No Travel Restrictions Expected									

Control Point 78092036: 6958240.325 N, 16632711.91 E, FENO monument 0.3' deep alongside an entrance on north side, 52 feet north of Hwy. 92 centerline, 14 feet northeast of top center inlet of CMP 7 feet south of a chainlink fence 22 feet southeast of a luminare pole, Elev. 1259.98

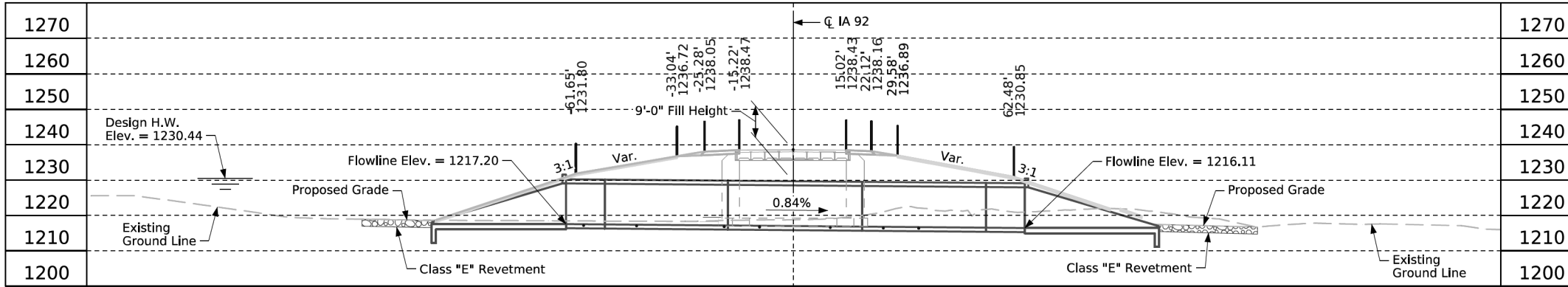

Longitudinal Section Along Centerline of Culvert

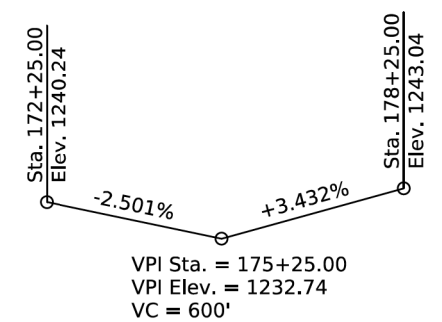

Proposed Profile Grade IA 92

Note: These elevations are based on the theoretical grade proposed on the original as-built plans (Design 256) and are not guaranteed for construction.

Traffic Estimate

2025 AADT	1300 V.P.D.
2045 AADT	1400 V.P.D.
TRUCKS	16 %

Location

IA 92 over Indian Creek
T-74N R-38W
Sections 5 & 6
Waveland Township
Pottawattamie County
FHWA No. 43911
Bridge Maint. No. 7836.9S092
Latitude 41.232065°
Longitude -95.245957°

Hydraulic Data

RIDB: Not Applicable
Drainage Area = 3.76 Sq.Mi.
Q₅₀ = 2780 cfs
HW Elev. (50-year) = 1230.44
Exit Velocity = 11.98 fps
Stream Slope = 31.43 Ft./Mi.
Q₁₀₀ = 3400 cfs
Q₅₀₀ = 4080 cfs

Utilities Legend:

- E1 - Nishnabotna Valley REC
- FO - Centurylink
- FO2 - Griswold Cooperative Telephone
- FO3 - Aureon Network Services

Utilities shown on this sheet are for information only, see road design sheets for final utility information.

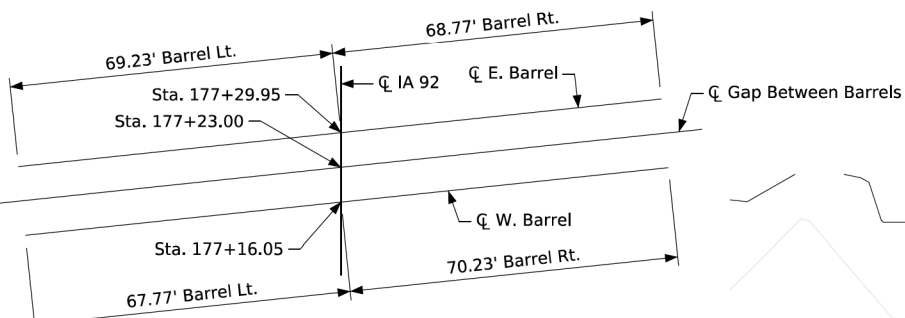
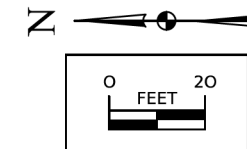

Precast Barrel Layout

Note: Lintel beam and curtain walls shall form one continuous line and shall not be staggered or offset.

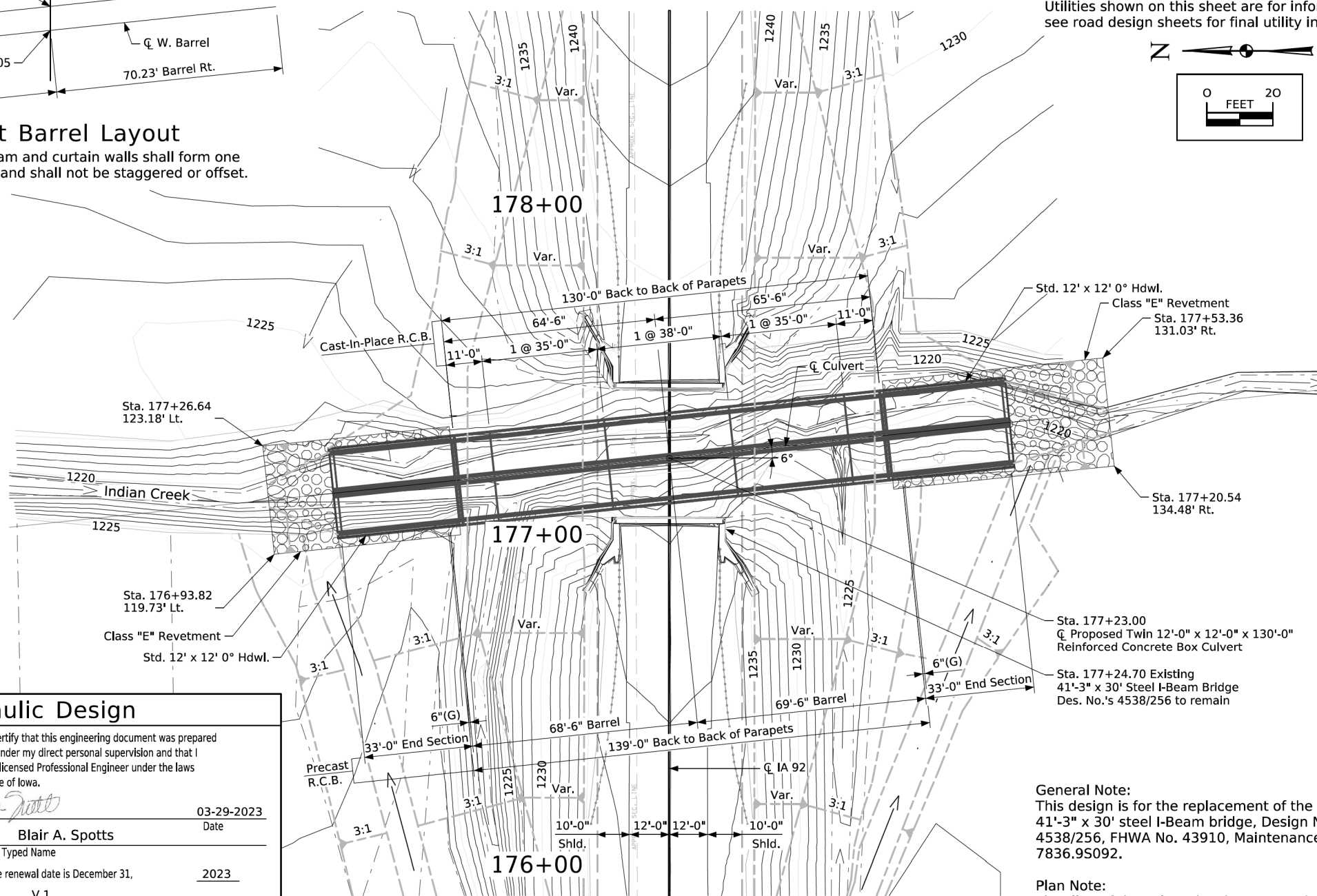

Situation Plan

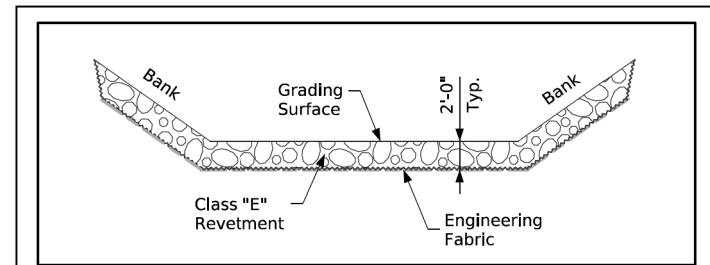

Typical Channel Protection

Estimated Revetment Quantities Included With Road Plans

Location	Revetment Class "E" (Ton)	Engineering Fabric (SY)	CL. 10 Channel Excavation (CY)
Inlet	104	97	65
Outlet	144	135	90
Totals	248	232	155

Excavation quantity calculated from grading surface. Excavation quantity is for embedded revetment core out only, and does not include excavation to the grading surface. Excavation quantity to the grading surface is determined by Road Design and included in the Road Plans. Quantities shown for information only. See Road Sheets.

Hydraulic Design

I hereby certify that this engineering document was prepared by me or under my direct personal supervision and that I am a duly licensed Professional Engineer under the laws of the State of Iowa.



Signature: *Blair A. Spotts* Date: 03-29-2023
Printed or Typed Name: Blair A. Spotts
My license renewal date is December 31, 2023

Pages or sheets covered by this seal: V.1

General Note: This design is for the replacement of the existing 41'-3" x 30' steel I-Beam bridge, Design No.'s 4538/256, FHWA No. 43910, Maintenance No. 7836.9S092.

Plan Note: Flow line of the culvert has been set 1' below streambed.

Design For 6 Degree (RA) Skew
Twin 12'-0" x 12'-0" x 130'-0" Reinforced Concrete Box Culvert
Situation Plan
STA. 177+23.00 (IA 92) Turn-in Date: Mar 2023
Pottawattamie County
IOWA DEPARTMENT OF TRANSPORTATION
Design No. 625 Sheet No. 1 of 1 FHWA/Asset 43911

CROSS SECTION VIEW COLOR LEGEND

Design Color No.	Feature	Design Color No.	Feature
Aggregate			
(64)	Choke Stone	(112)	Noise Wall
(42)	Engineering Fabric	(112)	Noise Wall Footing
(8)	Flooded Backfill	(112)	Retaining Wall Back
(92)	Macadam Stone	(112)	Retaining Wall Back Excavate
(20)	Modified	(112)	Retaining Wall Face
(12)	Plowing Shaping	(112)	Retaining Wall Front Excavate
(14)	Porous Backfill	(112)	Retaining Wall Front Footing
(8)	Revetment Class A	(112)	Retaining Wall MSE Gutter
(6)	Revetment Class B	(112)	Retaining Wall Reinforced Earth
(62)	Revetment Class C		
(188)	Revetment Class D	Grading	
(28)	Revetment Class E	(8)	Behind Curb Cut
(12)	Shoulder Special Backfill	(6)	Granular
(12)	Special Backfill	(13)	Granular Back Fill
(20)	Subbase	(48)	Rock Undercut
(20)	Subbase Lower	(8)	Shoulder Earth Fill
(20)	Subbase Upper	(2)	Side Slopes
(118)	Subgrade Treatment	(226)	Side Slopes Dressing
Asphalt			
(207)	HMA Base Course	Substrata	
(207)	HMA Interim Course	(128)	Boulder Substrata
(207)	HMA Surface Course	(48)	Broken Weathered Substrata
Concrete			
(0)	Barrier Concrete	(3)	Core Out Substrata
(0)	Barrier Concrete Footing	(203)	Existing Pavement Substrata
(0)	Curb Gutter	(6)	Loam Substrata
(48)	Flowable Mortar	(80)	Rock Substrata
(0)	Median Concrete	(4)	Select Sand Substrata
(0)	PCC Pavement	(3)	Shale Substrata
(0)	Sidewalk	(10)	Topsoil Substrata
Shoulder			
(209)	Shoulder HMA	Unsuitable / Waste	
(0)	Shoulder PCC	(3)	Unsuitable Type A
(6)	Shoulder Granular	(13)	Unsuitable Type B
		(11)	Unsuitable Type C
		(3)	Waste
Existing			
(0)	Existing Pavement		

NOTES:

Text

NOTES:

Text

CROSS SECTIONS LEGEND AND INFORMATION SHEET

(COVERS SHEET SERIES W, X, Y, & Z)

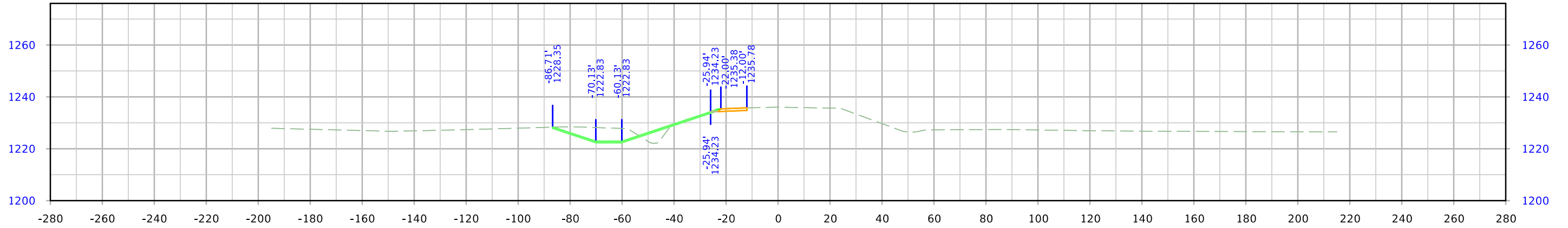

STA. 175+50.00

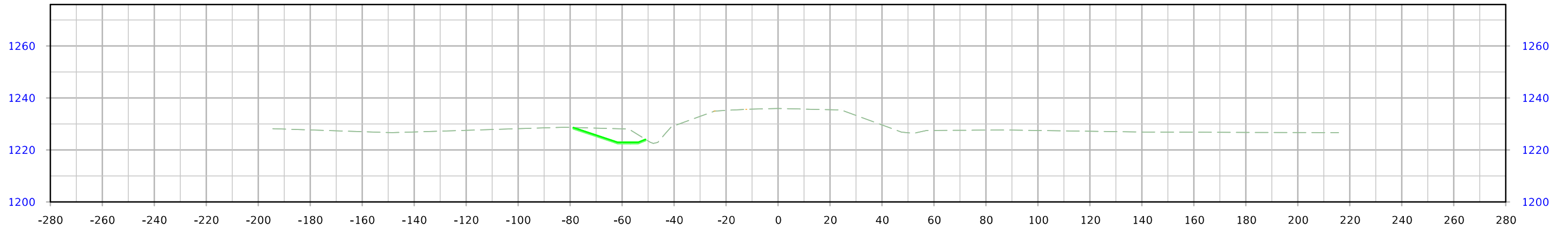

STA. 175+25.00

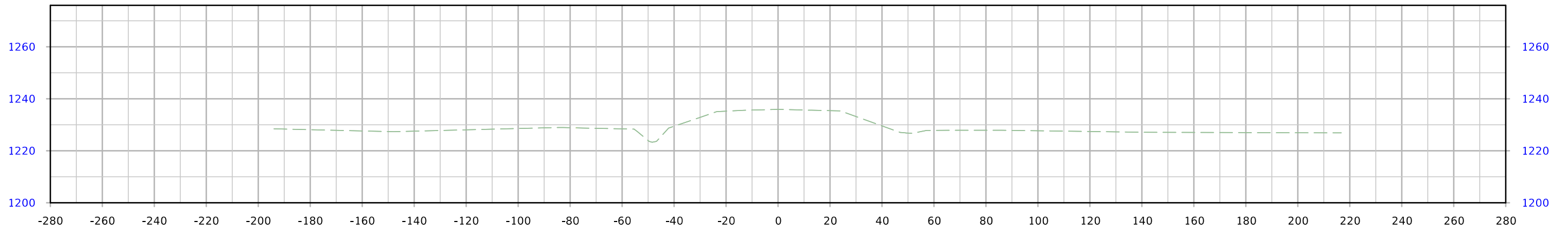

STA. 175+00.00

