

**LETTING DATE**  
 10-18-2022  
**PCC PVT WIDENING / HMA RESURFACING**  
 IM-NHS-080-7(134)266--03-16  
**CEDAR CO.**

INDEX OF SHEETS	
No.	DESCRIPTION
<b>A Sheets</b>	<b>Title Sheets</b>
* A.1	Title Sheet
* A.2	Location Map Sheet
<b>B Sheets</b>	<b>Typical Cross Sections and Details</b>
B.1 - 15	Typical Cross Sections
<b>D Sheets</b>	<b>Mainline Plan and Profile Sheets</b>
* D.1	Plan & Profile Legend & Symbol Information Sheet I-80
* D.2 - 47	
<b>E Sheets</b>	<b>Side Road Plan and Profile Sheets</b>
* E.1 - 2	306th St
* E.3 - 5	307th St
* E.6 - 7	Moscow Rd
* E.8 - 9	Pine Ave/Old Muscatine Rd
* E.10	306th St (B)
* E.11	East St
* E.12	Old Muscatine Rd
* E.13	Rose Ave
* E.14	Taylor Ave
* E.15	Vermont Ave
* E.16	Yankee Ave
<b>G Sheets</b>	<b>Survey Sheets</b>
G.1	Survey Information
G.2	Control Point Vicinity Map
G.3	Horizontal Control Tab.
<b>J Sheets</b>	<b>Traffic Control and Staging Sheets</b>
J.1 - 2	Staging Notes
* J.3	Traffic Control & Staging Legend & Symbol Info. Sheet
* J.4 - 9	Staging and Traffic Control Typical Section Sheets
* J.10 - 13	Bridge Reconstruction Detour Routes
<b>K Sheets</b>	<b>Interchange Sheets</b>
* K.1 - 2	Moscow Rd Interchange Layout
* K.3	Moscow Rd Ramp A
* K.4	Moscow Rd Ramp B
* K.5	Moscow Rd Ramp C
* K.6	Moscow Rd Ramp D
* K.7	Truck Parking Interchange Layout
* K.8	Truck Parking Ramp A
* K.9	Truck Parking Ramp B
* K.10	Truck Parking Ramp C
* K.11	Truck Parking Ramp D
* K.12 - 13	Rest Area Interchange Layout
* K.14	Rest Area Ramp A
* K.15	Rest Area Ramp B
* K.16	Rest Area Ramp C
* K.17	Rest Area Ramp D
* K.18 - 19	Rose Ave Interchange Layout
* K.20	Rose Ave Ramp A
* K.21	Rose Ave Ramp B
* K.22	Rose Ave Ramp C
* K.23	Rose Ave Ramp D
* K.24 - 25	Yankee Ave Interchange Layout
* K.26	Yankee Ave Ramp A
* K.27	Yankee Ave Ramp B
* K.28	Yankee Ave Ramp C
* K.29	Yankee Ave Ramp D
<b>M Sheets</b>	<b>Storm Sewer Sheets</b>
* M.1	Storm Sewer Legend & Symbol Information Sheet
* M.2 - 14	Storm Sewer Plan and Profile Sheets
<b>V Sheets</b>	<b>Bridge and Culvert Situation Plans</b>
* V.1 - 20	Bridge Situation Plans
* V.21 - 39	Culvert Situation Plans
* V.40 - 156	Culvert Plat Plans

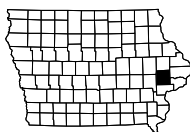

## Highway Division

PLANS OF PROPOSED IMPROVEMENT ON THE

INTERSTATE ROAD SYSTEM

# CEDAR COUNTY

## PCC PVT WIDENING / HMA RESURFACING

E of the Cedar River to approx 0.5 mi E of Co Rd Y26

SCALES: As Noted

Refer to the Proposal Form for list of applicable specifications.



For Project Location Map  
Refer to Sheet A.2

DESIGN DATA RURAL			
2020	AADT	41,185	V.P.D.
2040	AADT	75,580	V.P.D.
2040	DHV	--	V.P.H.
	TRUCKS	37	%
	Total		
	Design ESALs	--	

INDEX OF SEALS		
SHEET NO.	NAME	TYPE
A.1		Primary Signature Block

REVISIONS

TOTAL

1372

PROJECT IDENTIFICATION NUMBER

14-16-080-020

PROJECT NUMBER

IM-NHS-080-7(134)266--03-16

R.O.W. PROJECT NUMBER

IMN-080-7(132)266--0E-16

INDEX OF SHEETS	
No.	DESCRIPTION
<b>W Sheets</b>	<b>Mainline Cross Sections</b>
W.1	Cross Sections Legend & Symbol Information Sheet
W.2 - 386	I-80 Westbound
W.387 - 783	I-80 Eastbound
<b>X Sheets</b>	<b>Side Road Cross Sections</b>
X.1 - 17	306th St
X.18 - 51	307th St
X.52 - 72	Moscow Rd
X.73 - 96	Pine Ave/Old Muscatine Rd
X.97 - 98	306th St (B)
X.99 - 103	East St
X.104 - 106	Old Muscatine Rd
X.107 - 123	Rose Ave
X.124 - 137	Taylor Ave
X.138 - 150	Vermont Ave
X.151 - 168	Yankee Ave
<b>Y Sheets</b>	<b>Ramp Cross Sections</b>
Y.1 - 12	Moscow Rd Ramp A
Y.13 - 24	Moscow Rd Ramp B
Y.25 - 32	Moscow Rd Ramp C
Y.33 - 38	Moscow Rd Ramp D
Y.39 - 41	Truck Parking Ramp A
Y.42 - 45	Truck Parking Ramp B
Y.46 - 47	Truck Parking Ramp C
Y.48 - 50	Truck Parking Ramp D
Y.51 - 54	Rest Area Ramp C
Y.55 - 56	Rest Area Ramp D
Y.57 - 68	Rose Ave Ramp A
Y.69 - 79	Rose Ave Ramp B
Y.80 - 86	Rose Ave Ramp C
Y.87 - 94	Rose Ave Ramp D
Y.95 - 103	Yankee Ave Ramp A
Y.104 - 111	Yankee Ave Ramp B
Y.112 - 120	Yankee Ave Ramp C
Y.121 - 126	Yankee Ave Ramp D
	* Color Plan Sheets

# PRELIMINARY PLANS

Subject to change by final design.

D3 PLAN - Date: 8-16-19

FILE NO.

ENGLISH

DESIGN TEAM Iowa DOT \ HR Green

CEDAR COUNTY

PROJECT NUMBER

IM-NHS-080-7(134)266--03-16

SHEET NUMBER

A.1

7:13:26 AM 8/20/2019 mhahn

pw:\projectwise.dot.int.lan:PWMain\Documents\Projects\1608002014\Design\CADD\_Files\Sheet\_Files\SHT\_16080132\_A01.dgn

I-80 WB BRIDGE OVER SUGAR CREEK  
 FHWA BRIDGE No.: 18661  
 BRIDGE DESIGN No.: XXXX

RCB CULVERT - STA. 1072+26.10  
 FHWA BRIDGE No.: 18680  
 BRIDGE DESIGN No.: XXXX

RCB CULVERT - STA. 1220+13.82  
 FHWA BRIDGE No.: 18700  
 BRIDGE DESIGN No.: XXXX

RCB CULVERT - STA. 1349.59.32  
 FHWA BRIDGE No.: 18720  
 BRIDGE DESIGN No.: XXXX

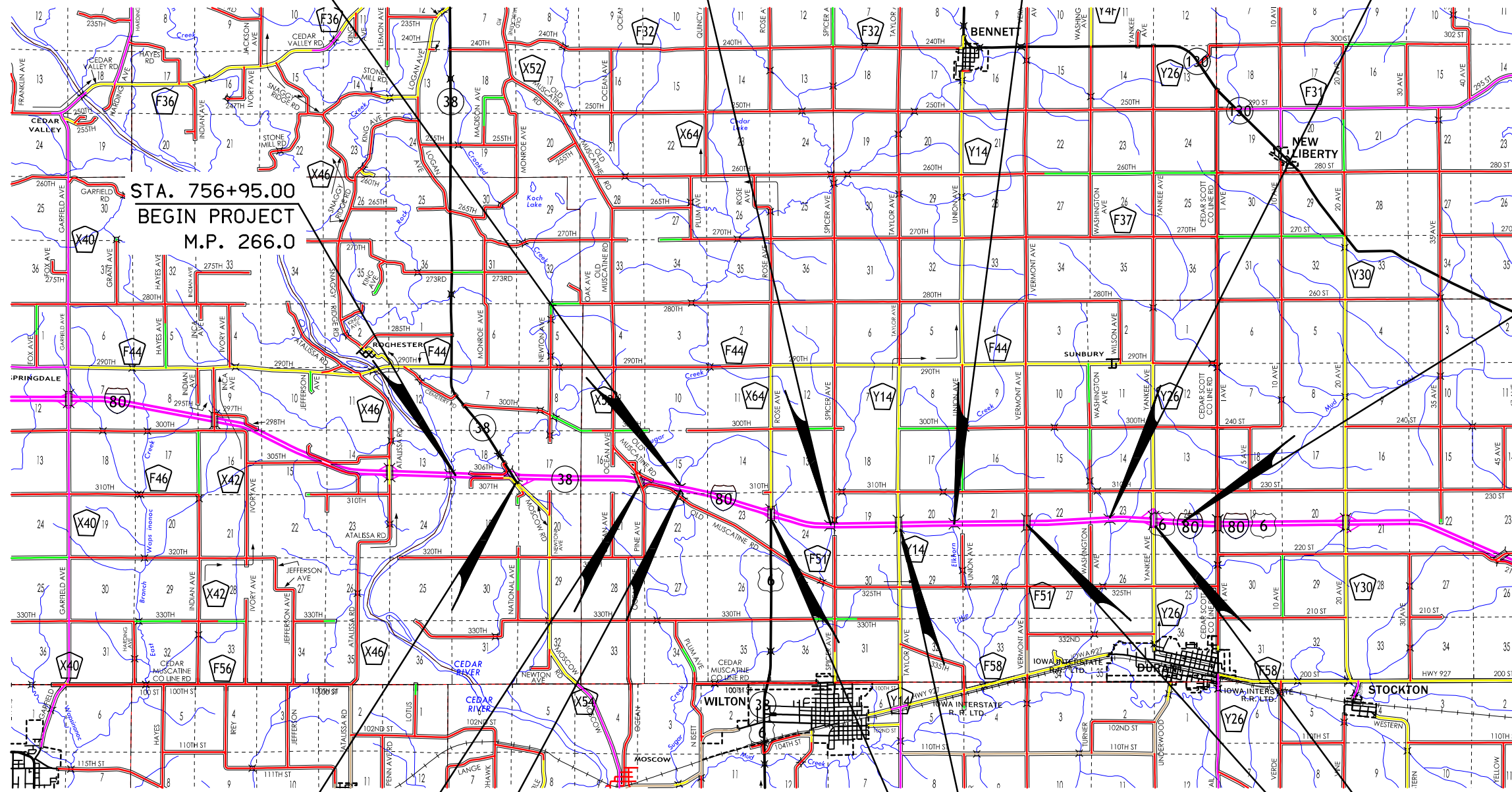

STA. 756+95.00  
 BEGIN PROJECT  
 M.P. 266.0

STA. 1424+00.00  
 END PROJECT  
 M.P. 277.8

MOSCOW ROAD BRIDGE OVER I-80  
 FHWA BRIDGE No.: 18331  
 BRIDGE DESIGN No.: XXXX

OLD MUSCATINE ROAD BRIDGE OVER I-80  
 FHWA BRIDGE No.: 18641  
 BRIDGE DESIGN No.: XXXX

I-80 EB BRIDGE OVER SUGAR CREEK  
 FHWA BRIDGE No.: 18651  
 BRIDGE DESIGN No.: XXXX

TAYLOR AVENUE BRIDGE OVER I-80  
 FHWA BRIDGE No.: 18691  
 BRIDGE DESIGN No.: XXXX

ROSE AVENUE BRIDGE OVER I-80  
 FHWA BRIDGE No.: 18321  
 BRIDGE DESIGN No.: XXXX

YANKEE AVENUE BRIDGE OVER I-80  
 FHWA BRIDGE No.: 18731  
 BRIDGE DESIGN No.: XXXX

VERMONT AVENUE BRIDGE OVER I-80  
 FHWA BRIDGE No.: 18711  
 BRIDGE DESIGN No.: XXXX

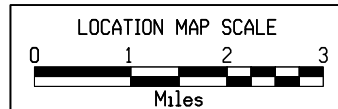
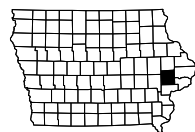



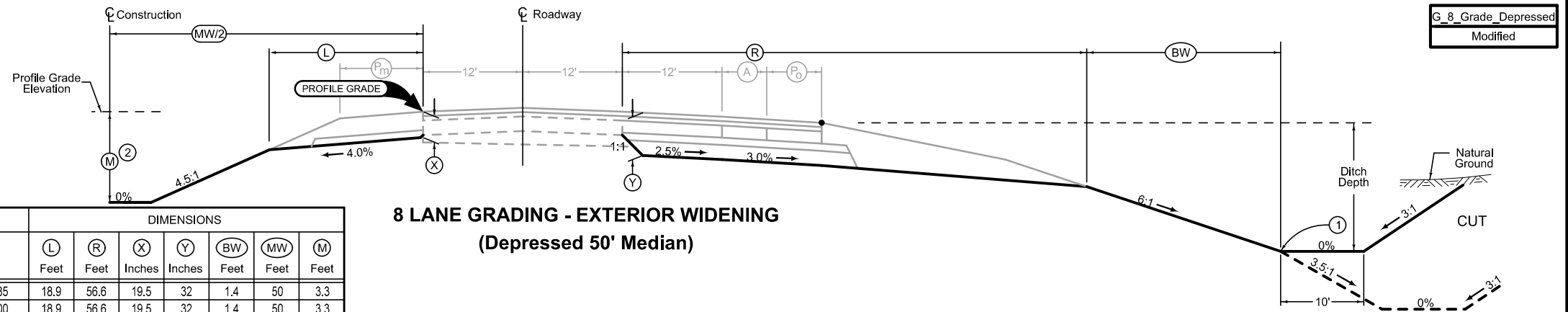

**8 LANE GRADING - EXTERIOR WIDENING  
(Depressed 50' Median)**

LOCATION		DIMENSIONS							
ROAD IDENTIFICATION	STATION TO STATION	L Feet	R Feet	X Inches	Y Inches	BW Feet	MW Feet	M Feet	
I-80 EASTBOUND	790+25.00	815+89.85	18.9	56.6	19.5	32	1.4	50	3.3
I-80 WESTBOUND	791+60.15	819+25.00	18.9	56.6	19.5	32	1.4	50	3.3
I-80 EASTBOUND	815+89.85	835+00.00	18.9	89.4-51	19.5	32	0-7	50	3.3
I-80 WESTBOUND	819+25.00	836+45.00	18.9	93.5-56.6	19.5	32	0-1.4	50	3.3
I-80 EASTBOUND	835+00.00	852+80.00	18.9	51	19.5	32	7	50	3.3
I-80 WESTBOUND	836+45.00	853+94.53	18.9	56.6	19.5	32	1.4	50	3.3
I-80 EASTBOUND	852+80.00	870+00.00	18.9	51-88	19.5	32	7-0	50	3.3
I-80 WESTBOUND	853+94.53	873+04.68	18.9	56.6-91.9	19.5	32	1.4-0	50	3.3
I-80 EASTBOUND	870+00.00	884+98.84	18.9	56.6	19.5	32	1.4	50	3.3
I-80 WESTBOUND	873+04.68	886+00.00	18.9	56.6	19.5	32	1.4	50	3.3
I-80 EASTBOUND	884+98.84	892+47.27	18.9	89-60.9	19.5	32	0	50	3.3
I-80 WESTBOUND	886+00.00	892+65.12	18.9	96.8-60.7	19.5	32	0	50	3.3
I-80 EASTBOUND	5892+47.27	5904+09.21	18.9	60.9-56.6	19.5	32	0-1.4	50	3.3
I-80 WESTBOUND	4892+65.12	4903+19.78	18.9	68.6-56.6	19.5	32	0-1.4	50	3.3
I-80 WESTBOUND	4903+19.78	4918+00.00	18.9	56.6	19.5	32	1.4	50	3.3
I-80 EASTBOUND	5904+09.21	5906+00.00	18.9	56.6	19.5	32	1.4	50	3.3
I-80 WESTBOUND	1005+50.00	1011+10.15	18.9	63-89.5	19.5	32	9.3-0	50	3.3
I-80 EASTBOUND	1004+96.21	1007+00.00	18.9	56.6-81	19.5	32	1.4-0	50	3.3
I-80 EASTBOUND	1007+00.00	1033+39.85	18.9	56.6	19.5	32	1.4	50	3.3
I-80 WESTBOUND	1011+10.15	1035+00.00	18.9	56.6	19.5	32	1.4	50	3.3
I-80 EASTBOUND	1033+39.85	1052+50.00	18.9	86.6-56.6	19.5	32	0-1.4	50	3.3
I-80 WESTBOUND	1035+00.00	1052+20.00	18.9	89.9-56.6	19.5	32	0-1.4	50	3.3
I-80 WESTBOUND	1052+20.00	1354+75.00	18.9	56.6	19.5	32	1.4	50	3.3
I-80 EASTBOUND	1052+50.00	1356+55.00	18.9	56.6	19.5	32	1.4	50	3.3
I-80 WESTBOUND	1354+75.00	1373+85.15	18.9	56.6-89.4	19.5	32	1.4	50	3.3
I-80 EASTBOUND	1356+55.00	1373+75.00	18.9	56.6-88	19.5	32	1.4-0	50	3.3
I-80 EASTBOUND	1373+75.00	1395+89.85	18.9	56.6	19.5	32	1.4	50	3.3
I-80 WESTBOUND	1373+85.15	1400+00.00	18.9	56.6	19.5	32	1.4	50	3.3
I-80 EASTBOUND	1395+89.85	1417+00.00	18.9	85.5-56.6	19.5	32	0-1.4	50	3.3
I-80 WESTBOUND	1400+00.00	1417+20.00	18.9	93-56.6	19.5	32	0-1.4	50	3.3
I-80 EASTBOUND	1417+00.00	1424+00.00	18.9	56.6	19.5	32	1.4	50	3.3
I-80 WESTBOUND	1417+20.00	1424+00.00	18.9	56.6	19.5	32	1.4	50	3.3

Normal section shown may be modified appropriately in areas of superelevated curves or other locations specifically designated by the Engineer.

See Plan & Profiles sheets and cross sections for additional details of ditches and backslopes.

① Refer to project plan and cross sections for specific location of foreslope change.

② Nominal Dimension. Varies due to split profile grades and split horizontal alignment.

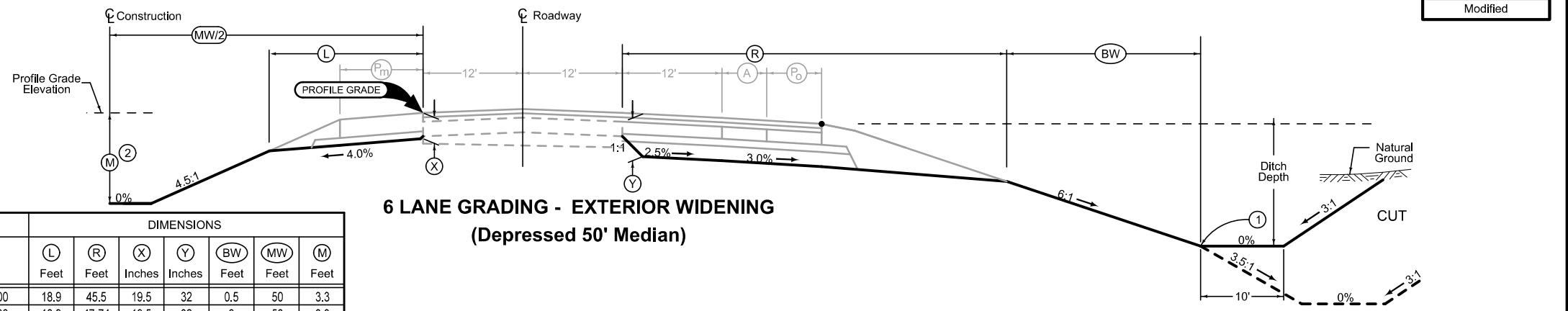

**6 LANE GRADING - EXTERIOR WIDENING  
(Depressed 50' Median)**

LOCATION		DIMENSIONS							
ROAD IDENTIFICATION	STATION TO STATION	L Feet	R Feet	X Inches	Y Inches	BW Feet	MW Feet	M Feet	
I-80 WESTBOUND	766+00.00	772+50.00	18.9	45.5	19.5	32	0.5	50	3.3
I-80 EASTBOUND	774+99.08	790+25.00	18.9	47-74	19.5	32	0	50	3.3
I-80 WESTBOUND	772+50.00	791+60.15	18.9	45.5-77.4	19.5	32	0.5-0	50	3.3

Normal section shown may be modified appropriately in areas of superelevated curves or other locations specifically designated by the Engineer.

See Plan & Profiles sheets and cross sections for additional details of ditches and backslopes.

① Refer to project plan and cross sections for specific location of foreslope change.

② Nominal Dimension. Varies due to split profile grades and split horizontal alignment.





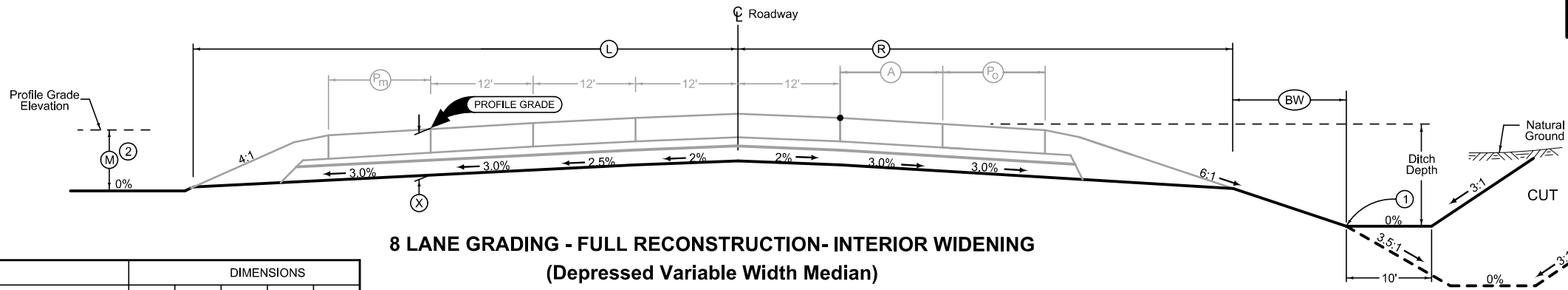

**8 LANE GRADING - FULL RECONSTRUCTION- INTERIOR WIDENING  
(Depressed Variable Width Median)**

LOCATION		DIMENSIONS				
ROAD IDENTIFICATION	STATION TO STATION	L Feet	R Feet	X Inches	BW Feet	M Feet
I-80 WESTBOUND	4938+75.00 - 4940+08.76	50.9	45.5	32	0.5	3
I-80 WESTBOUND	4942+96.77 - 4951+75.00	50.9	45.5	32	0.5	3
I-80 EASTBOUND	5939+00.00 - 5941+29.22	50.9	45.5	32	0.5	3
I-80 EASTBOUND	5944+38.25 - 5953+00.00	50.9	45.5	32	0.5	3

Normal section shown may be modified appropriately in areas of superelevated curves or other locations specifically designated by the Engineer.

See Plan & Profiles sheets and cross sections for additional details of ditches and backslopes.

- ① Refer to project plan and cross sections for specific location of foreslope change.
- ② Nominal Dimension. Varies due to split profile grades and split horizontal alignment.

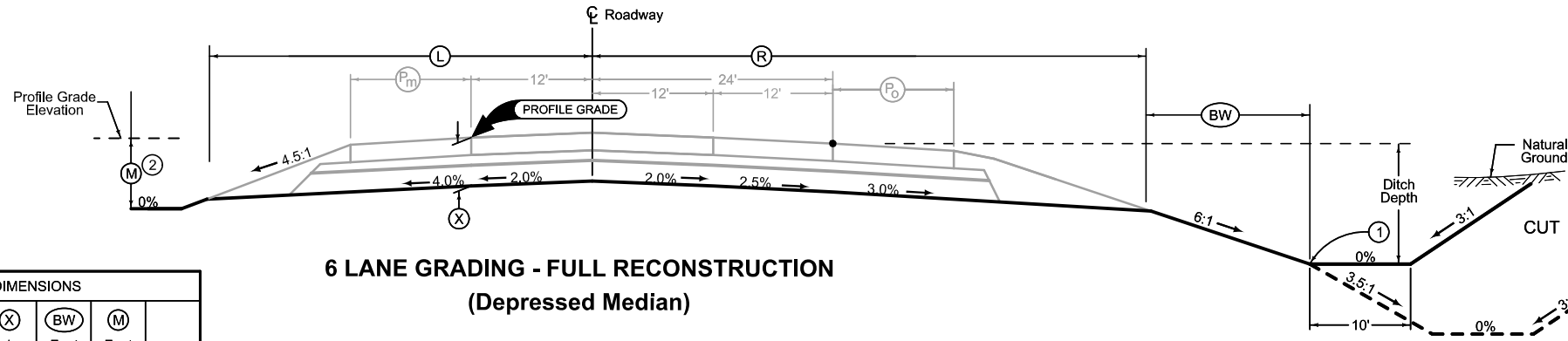

**6 LANE GRADING - FULL RECONSTRUCTION  
(Depressed Median)**

LOCATION		DIMENSIONS				
ROAD IDENTIFICATION	STATION TO STATION	L Feet	R Feet	X Inches	BW Feet	M Feet
I-80 WESTBOUND	56+95.00 - 66+00.09	28.4-36.7	57.5	30	0.5	3
I-80 EASTBOUND	57+62.00 - 73+05.93	26.6-38.5	57.5	30	0.5	3
I-80 EASTBOUND	73+08.93 - 75+00.00	28.5-30.7	57.5	30	0.5	3
I-80 EASTBOUND	5906+00.00 - 5920+50.00	37.6	57.5	32	12.5-0.5	3
I-80 WESTBOUND	4918+00.00 - 4926+40.09	37.6	57.5	32	12.5-0.5	3
I-80 EASTBOUND	5992+44.74 - 6004+76.96	36.9	63.5	32	3.5-6.9	3
I-80 WESTBOUND	4993+02.00 - 5005+92.76	50.9	51.5	32	0.5	3

Normal section shown may be modified appropriately in areas of superelevated curves or other locations specifically designated by the Engineer.

See Plan & Profiles sheets and cross sections for additional details of ditches and backslopes.

- ① Refer to project plan and cross sections for specific location of foreslope change.
- ② Nominal Dimension. Varies due to split profile grades and split horizontal alignment.

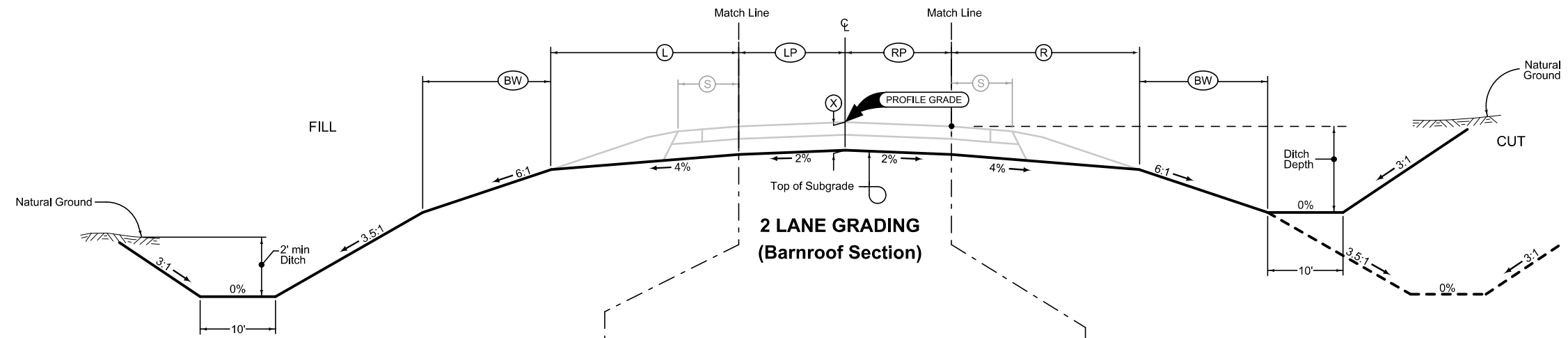

LOCATION		DIMENSIONS	
ROAD IDENTIFICATION	STATION TO STATION	(L) Feet	(BW) Feet
Moscow Rd	1781+75.00 - 1796+13.90	21.2	8.8
	1798+02.18 - 1800+72.92	21.2	8.8
	1804+68.38 - 1807+10.14	21.2	8.8
Rose Ave	165+20.00 - 171+32.30	23.0	7.0
	173+31.68 - 175+95.86	23.0	7.0
	178+90.99 - 181+65.75	23.0	7.0
	184+25.00 - 187+81.17	19.7	10.3

ROAD IDENTIFICATION	LOCATION		DIMENSIONS		
	STATION TO STATION	(LP) Feet	(RP) Feet	(X) Inches	
Moscow Rd	1781+75.00 - 1792+40.00	12	12	22	
	1792+40.00 - 1797+20.00	12-20	12-20	22	
	1797+20.00 - 1807+45.00	20	20	22	
	1807+45.00 - 1812+25.00	20-12	20-12	22	
Rose Ave	1812+25.00 - 1815+45.00	12	12	22	
	165+00.00 - 167+35.00	12	12	22	
	167+35.00 - 172+61.11	12-20	12-20	22	
	172+61.11 - 182+33.15	20	20	22	
	182+33.15 - 187+81.17	20-12	20-12	22	

LOCATION		DIMENSIONS	
ROAD IDENTIFICATION	STATION TO STATION	(R) Feet	(BW) Feet
Moscow Rd	1781+75.00 - 1793+20.00	21.2	8.8
	1797+86.77 - 1800+26.56	21.2	8.8
	1804+21.93 - 1806+92.49	21.2	8.8
Rose Ave	1809+67.66 - 1812+30.00	21.2	8.8
	165+00.00 - 165+20.00	23.0	7.0
	173+30.41 - 175+78.05	23.0	7.0
	178+73.18 - 181+72.97	23.0	7.0
	184+65.93 - 187+81.17	19.7	10.3

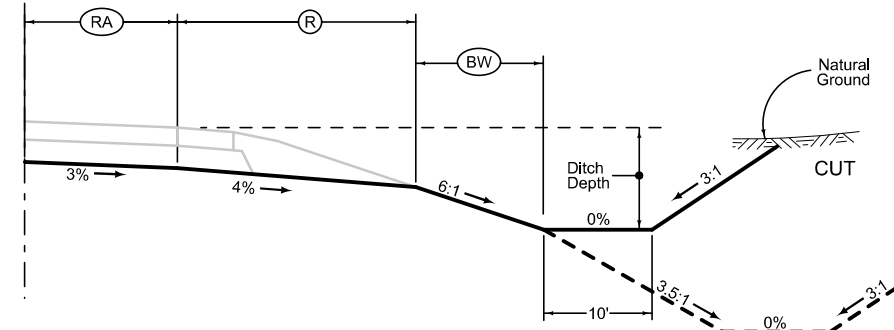
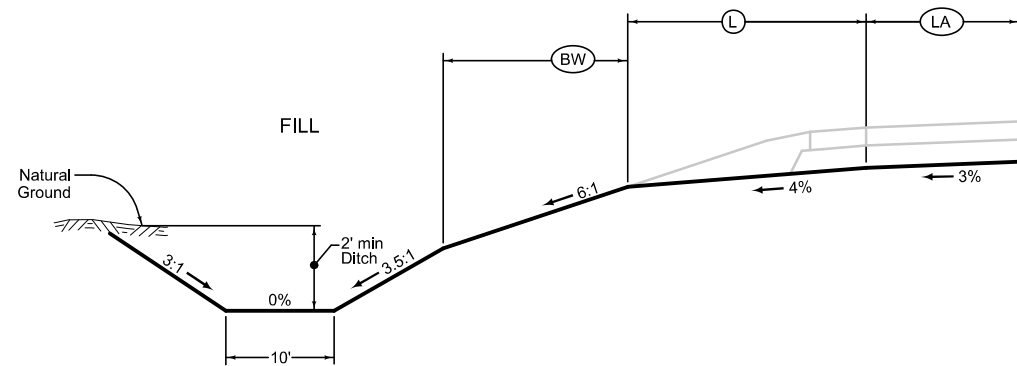

Normal section shown may be modified appropriately in areas of superelevated curves or other locations specifically designated by the Engineer.

See Plan & Profile sheets for additional details of ditches and back slopes.

LOCATION		DIMENSIONS		
ROAD IDENTIFICATION	STATION TO STATION	(LA) Feet	(L) Feet	(BW) Inches
Moscow Rd		12	19.8	12.2
		12-0	19.8-23.3	12.2-8.7

LOCATION		DIMENSIONS		
ROAD IDENTIFICATION	STATION TO STATION	(RA) Feet	(R) Feet	(BW) Feet
Moscow Rd	1793+20.00 - 1794+40.00	0-12	23.3-19.8	8.7-12.2
	1794+40.00 - 1795+88.25	12	19.8	12.2
	1812+30.00 - 1830+50.00	0-12	23.3-19.8	8.7-12.2
Rose Ave	1830+50.00 - 1815+50.00	12	19.8	12.2
	165+20.00 - 167+00.00	0-12	23.0-19.5	7.0-10.5
	167+00.00 - 171+78.91	12	19.5	10.5



LOCATION		DIMENSIONS					
ROAD IDENTIFICATION	STATION TO STATION	FS	BS	DW Feet	L Feet	R Feet	
306th St. at Moscow Rd.	11767+55.00 11802+05.00	3:1	3:1	10	14	14	
307th St.	10771+35.08 10796+17.26	3:1	3:1	6	12	12	
Old Muscatine Rd./Pine Ave.	1892+25.00 1921+00.00	3:1	3:1	10	14	14	
306th St. at Old Muscatine Rd.	50+79.01 52+08.25	3:1	3:1	10	14	14	
East St.	35+20.00 42+65.00	3:1	3:1	6	12	12	
Old Muscatine Rd.	60+24.49 64+11.49	3:1	3:1	10	14	14	
Vermont Ave.	2119+25.00 2139+25.00	3:1	3:1	10	14	14	

G\_2\_GradeGran  
Modified

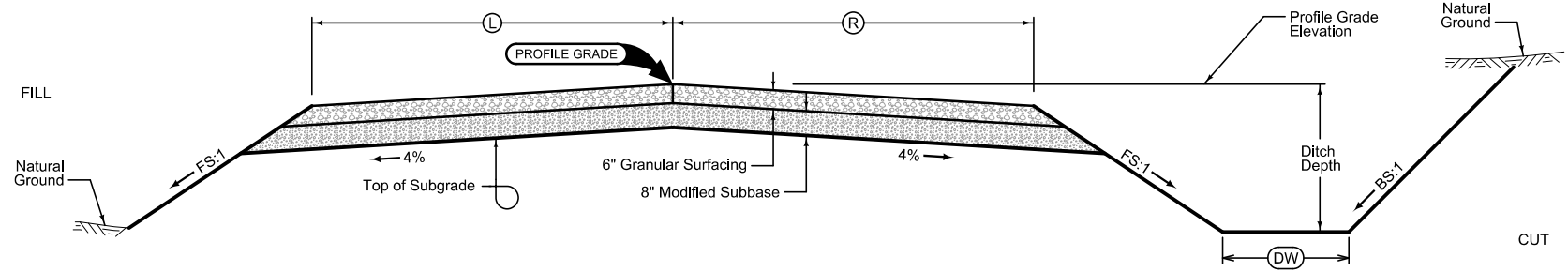

**GRADING AND GRANULAR SURFACING**

Normal section shown may be modified appropriately in areas of super-elevated curves or other locations specifically designated by the Engineer.

See plan & profile sheets and cross sections for additional details of ditches and backslopes.

LOCATION		DIMENSIONS			
ROAD IDENTIFICATION	STATION TO STATION	L Feet	R Feet	X Inches	FS
307th St. (SR307)	10796+17.26 10820+10.73	18.2	18.2	20	3:1
307th St. (SR307B)	10819+77.14 10822+05.40	18.2	18.2	20	3:1
Taylor Ave.	11+75.00 27+75.00	22.9	22.9	20	3:1
Yankee Ave.	2374+00.00 2402+00.00	26.6	26.6	20	4:1

G\_2\_Grade  
Modified

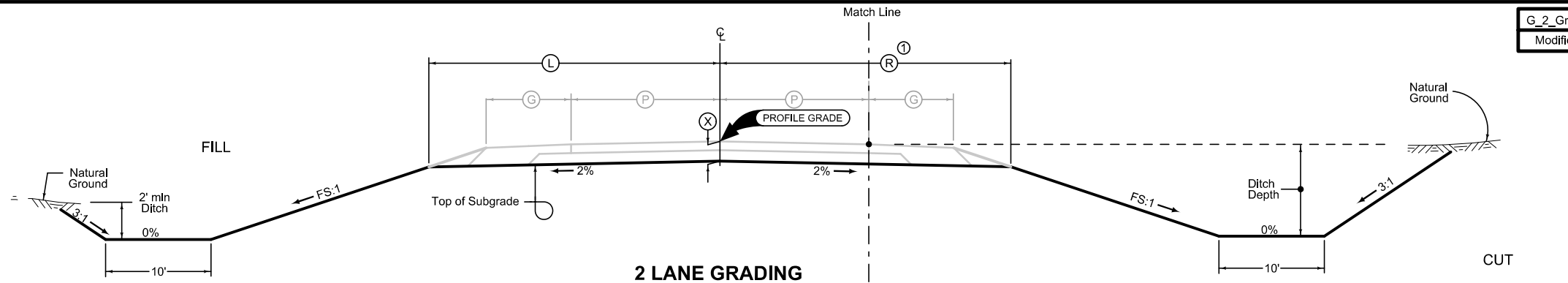

**2 LANE GRADING**

Normal section shown may be modified appropriately in areas of super-elevated curves or other locations specifically designated by the Engineer.

See plan & profile sheets and cross sections for additional details of ditches and backslopes.

① measurement is to the end of 2% subgrade slope. This measurement ends at the foreslope tie in for normal typical sections and at the edge of through travel way in areas of auxiliary lanes.

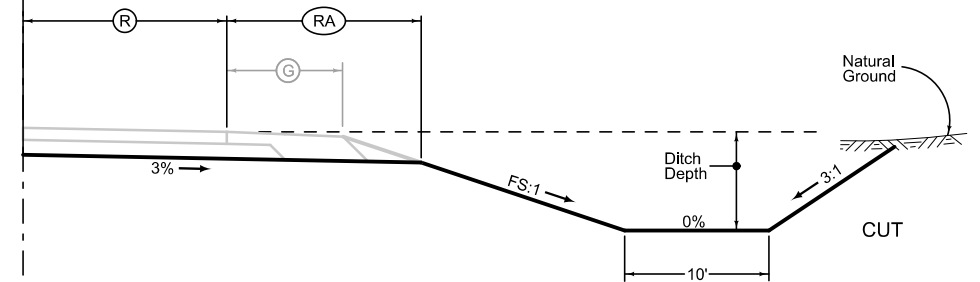

LOCATION		DIMENSIONS	
ROAD IDENTIFICATION	STATION TO STATION	R Feet	RA Feet
Yankee Ave.	2374+20.00 2376+00.00	0-12	16.1-14.2
	2376+00.00 2380+59.36	12	14.2

LOCATION				DIMENSIONS					
INTERCHANGE	RAMP	STATION TO STATION		(L) Feet	(R) Feet	(C) Feet	(X) Inches	(BW <sub>L</sub> ) Feet	(BW <sub>R</sub> ) Feet
Moscow Rd.	A	1599+86.21	1619+23.94	33.8	19.5	16	22	12.2	10.5
Moscow Rd.	B	2590+25.00	2608+09.87	33.8	19.5	16	22	6.2	4.5
Moscow Rd.	C	3545+58.92	3551+14.69	33.8	19.5	16	22	6.2	4.5
Moscow Rd.	D	4506+70.16	4515+91.09	33.8	19.5	16	22	12.2	10.5
I-80 P.O. Rest Area	A	1581+75.00	1586+00.00	33.8	19.5	16	22	0.2	0
I-80 P.O. Rest Area	B	2570+00.00	2576+75.00	33.8	19.5	16	22	0.2	0
I-80 P.O. Rest Area	C	3573+04.68	3575+00.00	33.8	19.5	16	22	.2	0
I-80 P.O. Rest Area	D	4580+50.00	4584+98.84	33.8	19.5	16	22	0.2	0
I-80 W.C. Rest Area	C	3557+54.38	3560+25.00	33.8	19.5	16	22	6.2	4.5
I-80 W.C. Rest Area	D	4580+25.00	4584+98.84	33.8	19.5	16	22	6.2	4.5
Rose Ave.	A	1519+74.35	1535+00.00	33.8	19.5	16	22	0.2	0
Rose Ave.	B	2507+00.00	2523+27.69	33.8	19.5	16	22	6.2	4.5
Rose Ave.	C	3511+08.92	3520+80.67	33.8	19.5	16	22	12.2	10.5
Rose Ave.	D	4522+61.74	4533+41.09	33.8	19.5	16	22	0.2	0
Yankee Ave.	A	1585+45.75	1600+00.00	33.8	19.5	16	22	6.2	4.5
Yankee Ave.	B	2573+75.00	2587+07.88	33.8	19.5	16	22	0.2	0
Yankee Ave.	C	3573+83.92	3586+43.32	33.8	19.5	16	22	0.2	0
Yankee Ave.	D	4586+03.35	4595+91.08	33.8	19.5	16	22	6.2	4.5

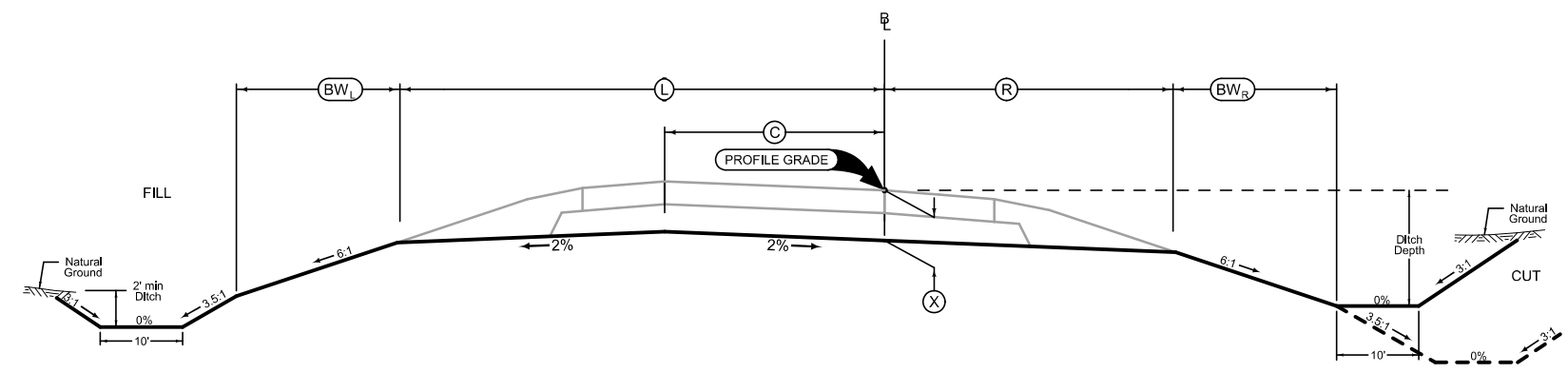

Section view is in direction of traffic.  
Normal sections shown may be appropriately modified for areas specifically designated by the Engineer such as intersections or superelevated curves.



**Full Depth HMA Shoulder**

Shoulder Jointing:  
Longitudinal joint: B

4_P_FullHMA_10-19-10			
Direction of Travel	BEGIN STATION	END STATION	(P) Feet
EB	790+25.00	892+47.27	10
EB	5892+47.27	5906+00.00	10
EB	1004+96.21	1424+00.00	10
WB	791+60.15	892+65.12	10
WB	4892+65.12	4918+00.00	10
WB	1005+50.00	1424+00.00	10

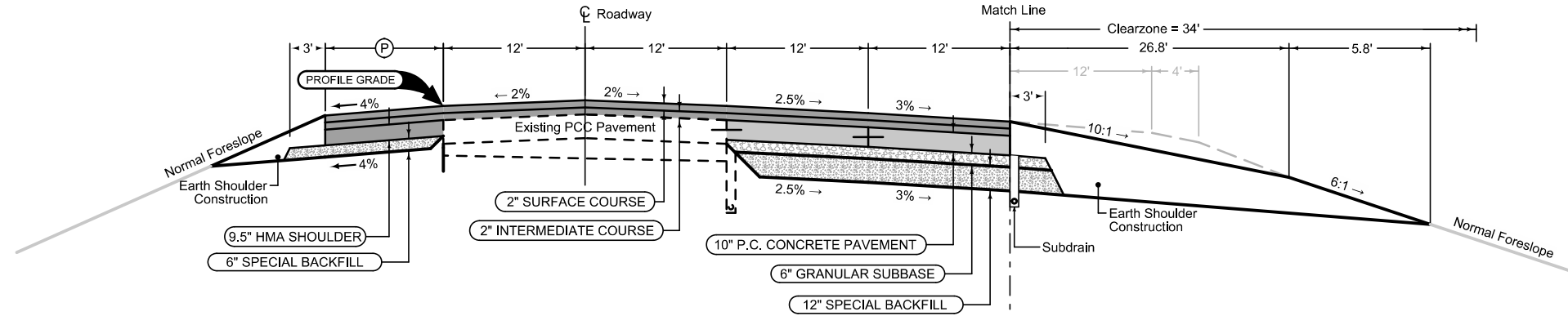

**6 LANE PAVING - EXTERIOR WIDENING FOR FUTURE 8 LANE (Depressed 50' Median)**

Section shown in the direction of traffic.  
Mainline Jointing:  
Transverse joints: CD at 20' spacing

8DP_Dprs_Modified		
Direction of Travel	BEGIN STATION	END STATION
EB	790+25.00	892+47.27
EB	5892+47.27	5906+00.00
EB	1004+96.21	1424+00.00
WB	791+60.15	892+65.12
WB	4892+65.12	4918+00.00
WB	1005+50.00	1424+00.00

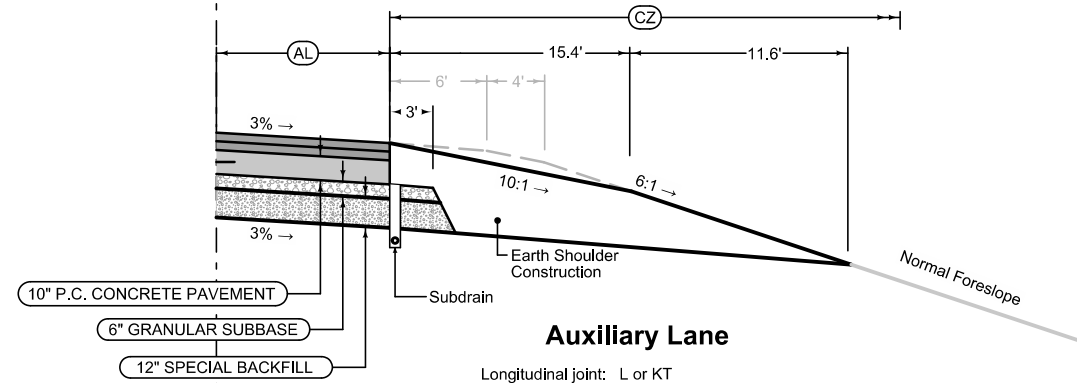

**Auxiliary Lane**

Longitudinal joint: L or KT  
Transverse joint: Match Mainline

2_AuxLane_PCC_10-18-16				
Direction of Travel	STATION TO STATION		(AL) Feet	(CZ) Feet
	EB	815+89.85	835+00.00	36.2-0
	852+80.00	870+00.00	0-40	22
	884+98.84	892+47.27	35-12	22
	5892+47.27	5904+09.21	12-0	22
	1004+96.21	1007+00.00	26.4-40	24
	1033+39.85	1052+50.00	36.2-0	22
	1356+55.00	1373+75.00	0-40	22
	1395+89.85	1415+00.00	36.2-0	24
WB	819+23.94	836+45.00	40-0	30
	853+94.53	873+04.68	0-35	22
	886+00.00	892+65.12	40-12	22
	4892+65.12	4903+19.78	12-0	22
	1005+50.00	1011+10.15	12-36.2	30
	1035+00.00	1052+20.00	40-0	22
	1354+75.00	1373+85.15	0-36.2	22
	1400+00.00	1417+20.00	40-0	24

**Full Depth PCC Shoulder**

Shoulder Jointing:  
Longitudinal joint: L-2 or KT-2  
Transverse joints: C at 20' spacing

6D_Closed_P_FullPCC_04-19-11		
Direction of Travel	BEGIN STATION	END STATION
EB	790+25.00	815+89.85
	835+00.00	852+80.00
	870+00.00	884+98.84
	5904+09.21	5906+00.00
	1007+00.00	1033+39.85
	1052+50.00	1356+55.00
	1373+75.00	1395+89.85
	1415+00.00	1424+00.00
WB	791+60.15	819+23.94
	836+45.00	853+94.53
	873+04.68	886+00.00
	4903+19.78	4918+00.00
	1011+10.15	1035+00.00
	1052+20.00	1354+75.00
	1373+85.15	1400+00.00
	1417+20.00	1424+00.00

### Full Depth HMA Shoulder

Shoulder Jointing:  
Longitudinal joint: B

4_P_FullHMA_10-19-10			
Direction of Travel	BEGIN STATION	END STATION	(P) Feet
EB	774+99.08	790+25.00	10
WB	766+00.00	791+60.15	10

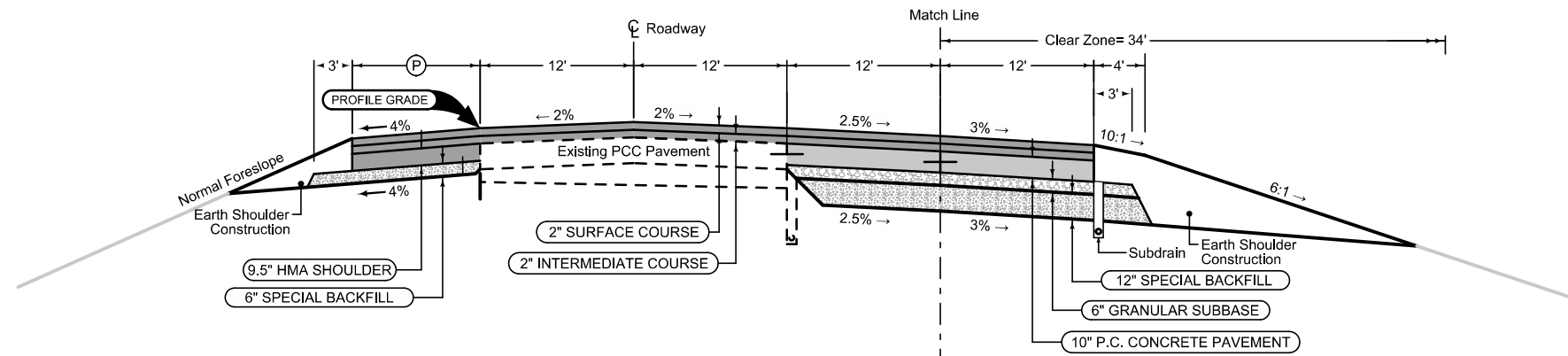

### Full Depth PCC Shoulder

Shoulder Jointing:  
Longitudinal joint: L-2 or KT-2  
Transverse joints: C at 20' spacing

6D_Closed_P_FullPCC_04-19-11		
Direction of Travel	BEGIN STATION	END STATION
WB	766+00.00	772+49.89

### 6 LANE PAVING - EXTERIOR WIDENING (Depressed 50' Median)

Section shown in the direction of traffic.

Mainline Jointing:  
Transverse joints: CD at 20' spacing

8DP_Dprs_Modified		
Direction of Travel	BEGIN STATION	END STATION
EB	774+99.08	790+25.00
WB	766+00.00	791+60.15

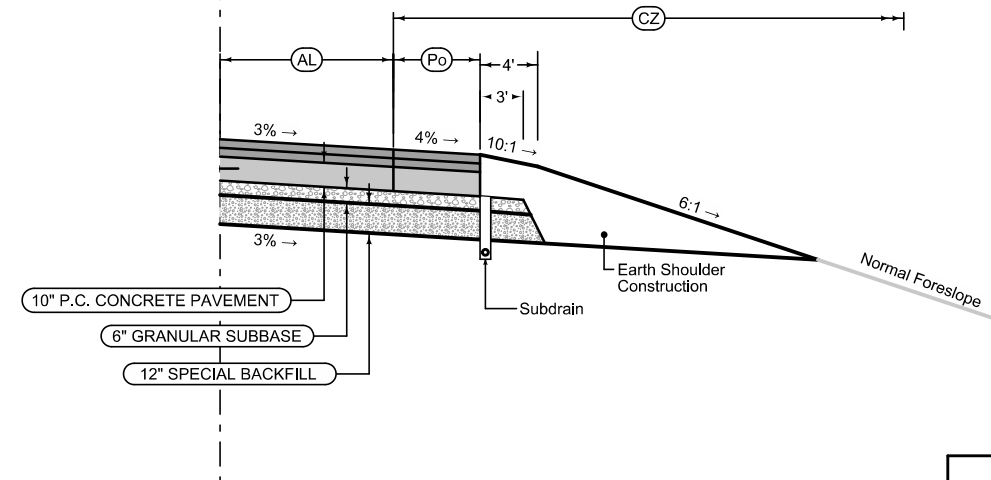

### Auxiliary Lane

Longitudinal joint: L or KT  
Transverse joint: Match Mainline

2_AuxLane_PCC_10-18-16				
Direction of Travel	STATION TO STATION		(AL) Feet	(CZ) Feet
	EB	774+99.08	776+05.00	7.8-12
	776+05.00	786+05.00	12	24
	786+05.00	790+25.00	12-40	24
WB	772+49.89	778+50.00	0-12	34-24
	778+50.00	788+50.00	12	24
	788+50.00	791+60.15	12-36.2	24



### Full Depth PCC Shoulder

Shoulder Jointing:  
 Longitudinal joint: L-2 or KT-2  
 Transverse joints: C at 20' spacing

6D_P_FullPCC_ Modified			
Direction of Travel	BEGIN STATION	END STATION	(P) Feet
EB	5920+50.00	5939+00.00	12
WB	4926+40.09	4938+75.00	12
WB	4951+75.00	4993+02.00	12
EB	5953+00.00	5992+44.74	12

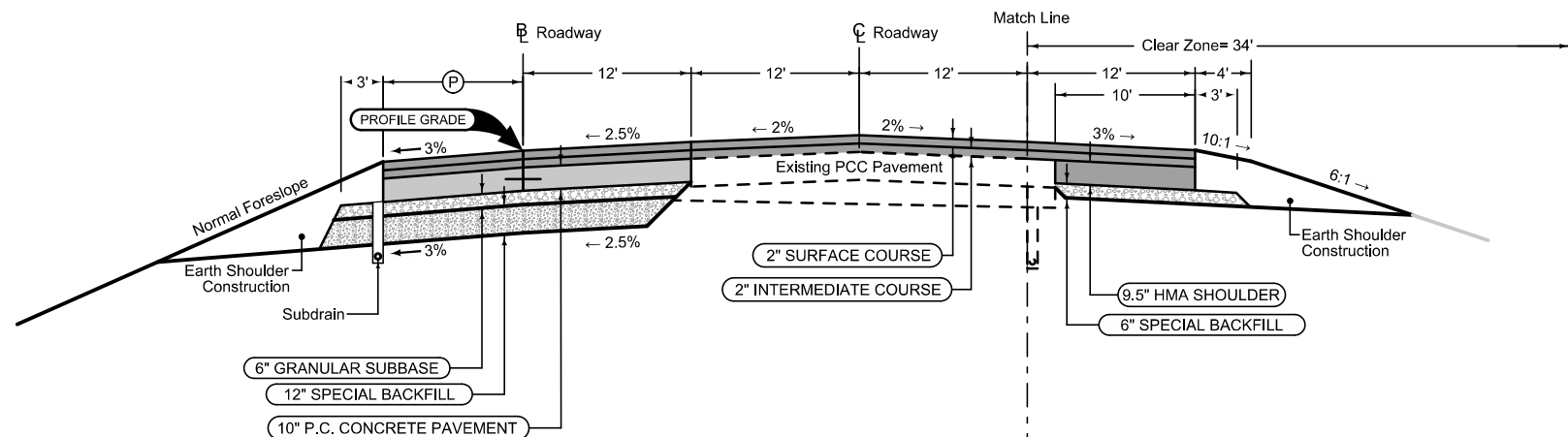

### Full Depth PCC Shoulder

Shoulder Jointing:  
 Longitudinal joint: L-2 or KT-2  
 Transverse joints: C at 20' spacing

6D_P_FullPCC_ Modified		
Direction of Travel	BEGIN STATION	END STATION
EB	5920+50.00	5939+00.00
WB	4926+40.00	4933+50.00
WB	4957+55.61	4976+86.47
EB	5960+60.59	5979+89.63

### 6 LANE PAVING - INTERIOR WIDENING (Depressed Variable Width Median)

Section shown in the direction of traffic.

Mainline Jointing:  
 Transverse joints: CD at 20' spacing

8DP_Dprs_ Modified		
Direction of Travel	BEGIN STATION	END STATION
EB	5920+50.00	5939+00.00
WB	4926+40.09	4938+75.00
WB	4951+75.00	4993+02.00
EB	5953+00.00	5992+44.74

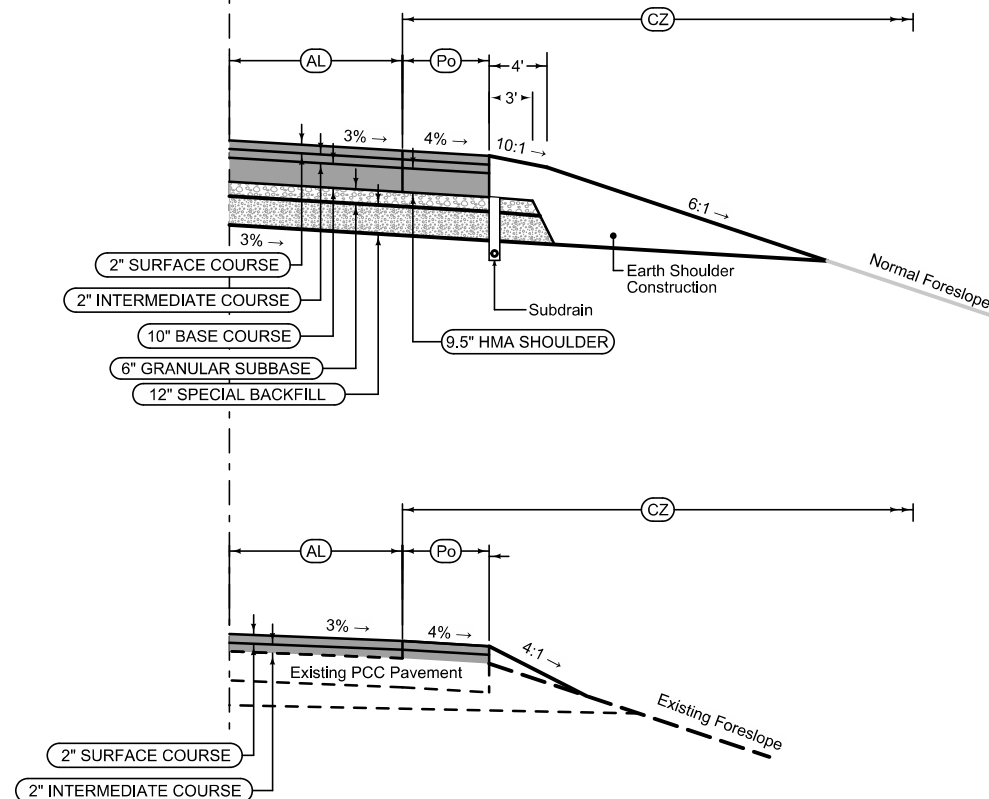

### Auxiliary Lane

Longitudinal joint: L or KT  
 Transverse joint: Match Mainline

2_AuxLane_HMA_ Modified				
Direction of Travel	STATION TO STATION	(AL) Feet	(CZ) Feet	
WB	4933+50.00	4938+75.00	2-10.5	34-24
WB	4951+75.00	4954+45.46	12	24
WB	4954+45.46	4957+55.61	12-36.2	24
EB	5953+00.00	5956+24.63	12	24
EB	5979+89.63	5982+99.78	36.2-12	24
EB	5982+99.78	5992+44.74	12	24
WB	4981+39.40	4993+02.00	12	24

### Auxiliary Lane Resurfacing

Longitudinal joint: L or KT  
 Transverse joint: Match Mainline

_AuxLane_Overlay_ New				
Direction of Travel	STATION TO STATION	(AL) Feet	(CZ) Feet	
EB	5956+24.63	5960+60.59	12-40	24
WB	4976+86.47	4981+39.40	40-12	24

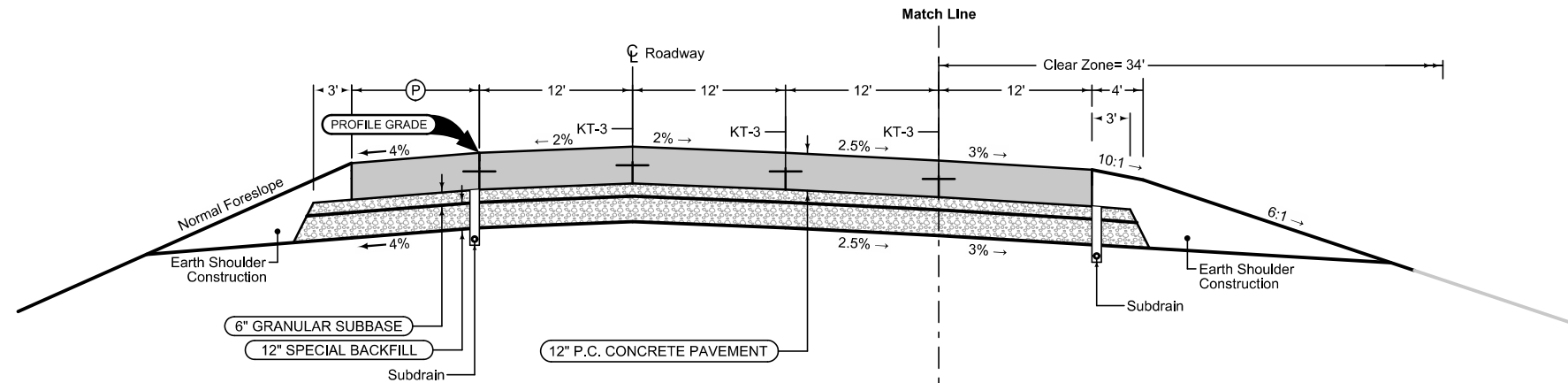

**6 LANE PAVING - FULL RECONSTRUCTION  
(Depressed 50' Median)**

Section shown in the direction of traffic.  
Mainline Jointing:  
Transverse joints: CD at 20' spacing

**Full Depth PCC Shoulder**

Shoulder Jointing:  
Longitudinal joint: L-2 or KT-2  
Transverse joints: C at 20' spacing

6D_Closed_P_FullPCC_04-19-11			
Direction of Travel	BEGIN STATION	END STATION	(P) Feet
EB	57+62.00	75+00.00	10
WB	56+95.00	66+00.09	10

8DP_Dprs Modified		
Direction of Travel	BEGIN STATION	END STATION
EB	57+62.00	75+00.00
WB	56+95.00	66+00.09

**Full Depth PCC Shoulder**

Shoulder Jointing:  
Longitudinal joint: L-2 or KT-2  
Transverse joints: C at 20' spacing

6D_Closed_P_FullPCC_04-19-11		
Direction of Travel	BEGIN STATION	END STATION
EB	57+62.00	73+05.93
WB	56+95.00	66+00.09

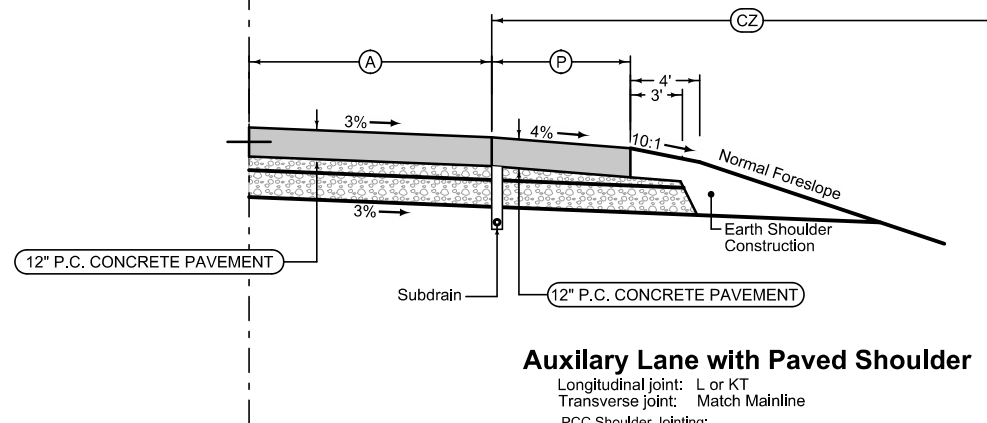

**Auxiliary Lane with Paved Shoulder**

Longitudinal joint: L or KT  
Transverse joint: Match Mainline  
PCC Shoulder Jointing:  
Longitudinal joint: L-2 or KT-2  
Transverse joints: C at 20' spacing  
HMA Shoulder Jointing:  
Longitudinal joint: B

2_AuxLane_PCC Modified					
ROAD IDENTIFICATION	STATION TO STATION	(A) Feet	(P) Feet	(CZ) Feet	
Eastbound I-80	73+05.93 - 73+54.78	2	10	24	
Eastbound I-80	73+54.78 - 75+00.00	2-7.8	10-6	24	

I-80

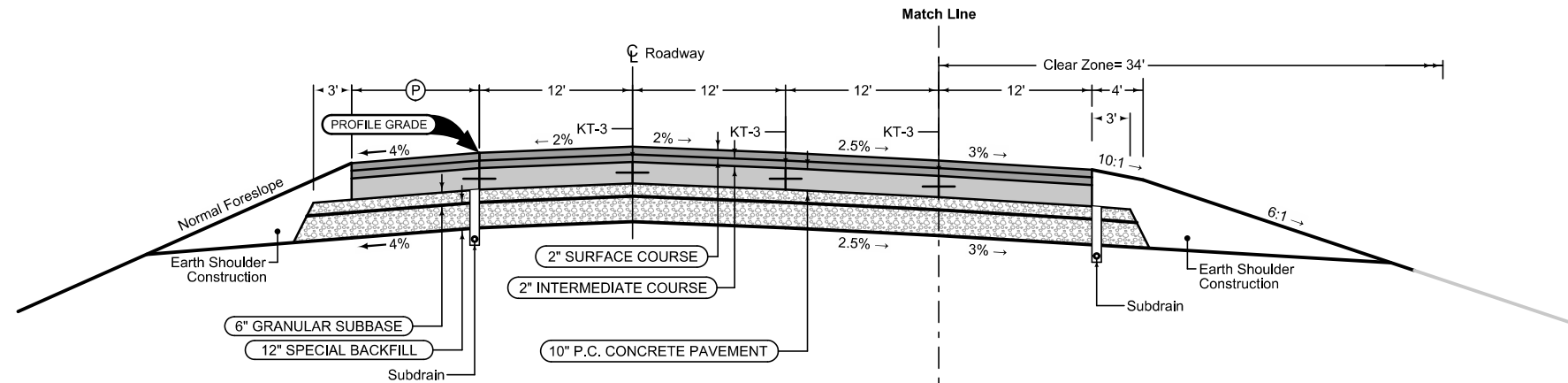

**6 LANE PAVING - FULL RECONSTRUCTION  
(Depressed 50' Median)**

Section shown in the direction of traffic.  
Mainline Jointing:  
Transverse joints: CD at 20' spacing

**Full Depth PCC Shoulder**

Shoulder Jointing:  
Longitudinal joint: L-2 or KT-2  
Transverse joints: C at 20' spacing

6D_Closed_P_FullPCC_04-19-11			
Direction of Travel	BEGIN STATION	END STATION	(P) Feet
EB	5906+00.00	5920+50.00	12
EB	5992+44.74	6004+76.96	12
WB	4918+00.00	4926+40.09	12
WB	4993+02.00	5005+92.76	12

8DP_Dprs Modified		
Direction of Travel	BEGIN STATION	END STATION
EB	5906+00.00	5920+50.00
EB	5992+44.74	6004+76.96
WB	4918+00.00	4926+40.09
WB	4993+02.00	5005+92.76

**Full Depth PCC Shoulder**

Shoulder Jointing:  
Longitudinal joint: L-2 or KT-2  
Transverse joints: C at 20' spacing

6D_Closed_P_FullPCC_04-19-11		
Direction of Travel	BEGIN STATION	END STATION
EB	5906+00.00	5920+50.00
WB	4918+00.00	4926+40.09

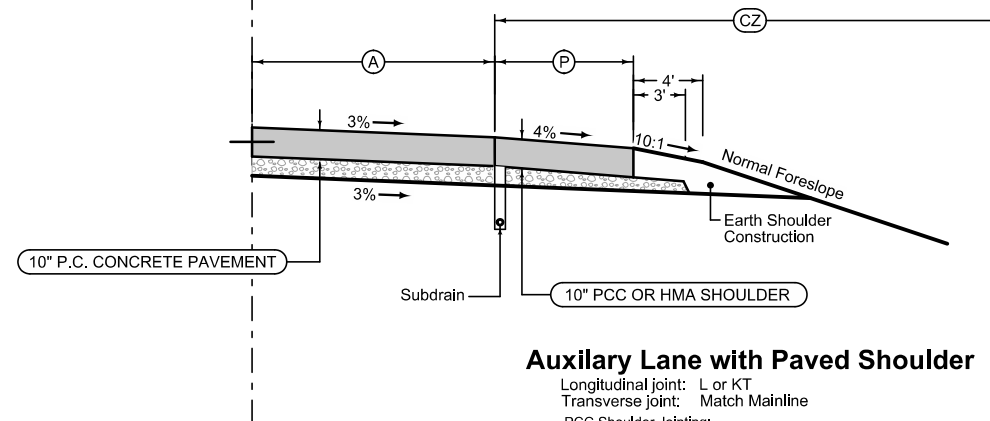

**Auxiliary Lane with Paved Shoulder**

Longitudinal joint: L or KT  
Transverse joint: Match Mainline  
PCC Shoulder Jointing:  
Longitudinal joint: L-2 or KT-2  
Transverse joints: C at 20' spacing  
HMA Shoulder Jointing:  
Longitudinal joint: B

2_AuxLane_PCC Modified					
ROAD IDENTIFICATION	STATION TO STATION	(A) Feet	(P) Feet	(CZ) Feet	
Eastbound I-80	5992+44.74 6000+80.74	12	6	24-34	
Eastbound I-80	6000+80.74 6004+76.96	14-38.4	6	34-24	
Westbound I-80	4993+02.00 5005+92.76	12	6	24	

I-80

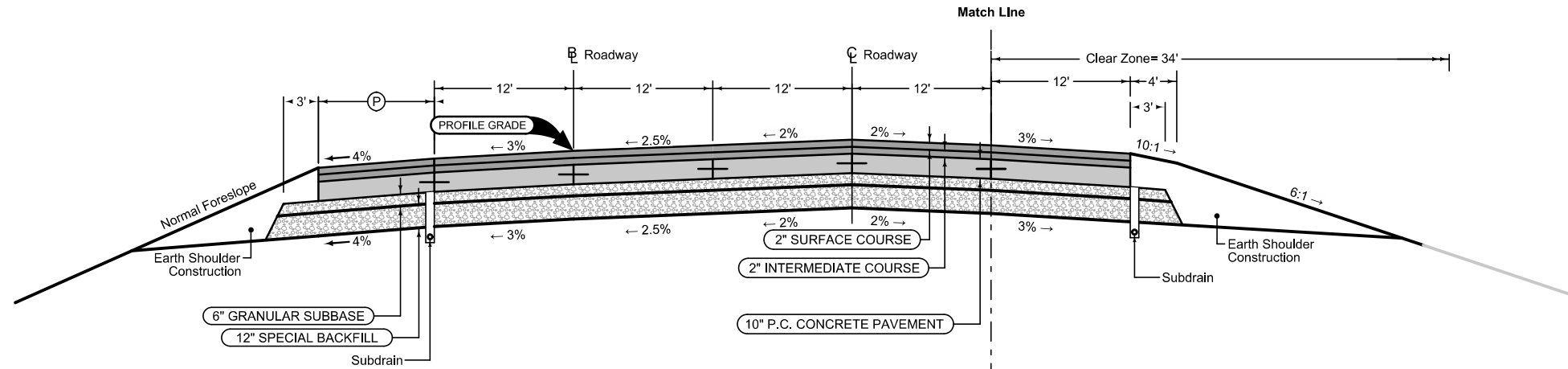

**8 LANE PAVING - FULL RECONSTRUCTION - INTERIOR WIDENING  
(Depressed Variable Width Median)**

Section shown in the direction of traffic.  
Mainline Jointing:  
Transverse joints: CD at 20' spacing

**Full Depth PCC Shoulder**

Shoulder Jointing:  
Longitudinal joint: L-2 or KT-2  
Transverse joints: C at 20' spacing

6D_Closed_P_FullPCC_04-19-11			
Direction of Travel	BEGIN STATION	END STATION	(P) Feet
WB	4938+75.00	4951+75.00	12
EB	5939+00.00	5953+00.00	12

8DP_Dprs_Modified			
Direction of Travel	BEGIN STATION	END STATION	
WB	4938+75.00	4951+75.00	
EB	5939+00.00	5953+00.00	

**Full Depth PCC Shoulder**

Shoulder Jointing:  
Longitudinal joint: L-2 or KT-2  
Transverse joints: C at 20' spacing

6D_Closed_P_FullPCC_04-19-11			
Direction of Travel	BEGIN STATION	END STATION	
EB	5939+00.00	5943+24.63	

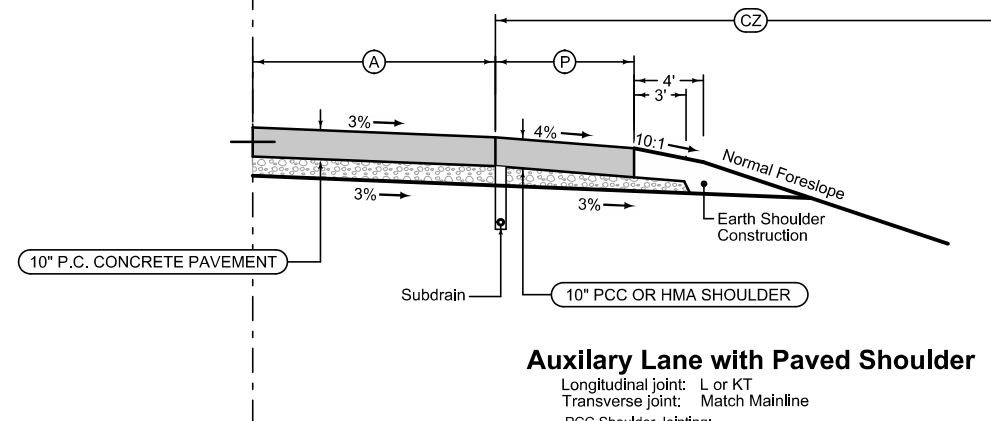

**Auxiliary Lane with Paved Shoulder**

Longitudinal joint: L or KT  
Transverse joint: Match Mainline  
PCC Shoulder Jointing:  
Longitudinal joint: L-2 or KT-2  
Transverse joints: C at 20' spacing  
HMA Shoulder Jointing:  
Longitudinal joint: B

2_AuxLane_PCC_Modified					
ROAD IDENTIFICATION	STATION TO STATION	(A) Feet	(P) Feet	(CZ) Feet	
WB	4938+75.00 - 4939+50.00	10.5-12	6	24	
WB	4939+50.00 - 4951+75.00	12	6	24	
EB	5943+24.63 - 5946+24.63	2-12	10-6	34-24	
EB	5946+24.63 - 5953+00.00	12	6	24	



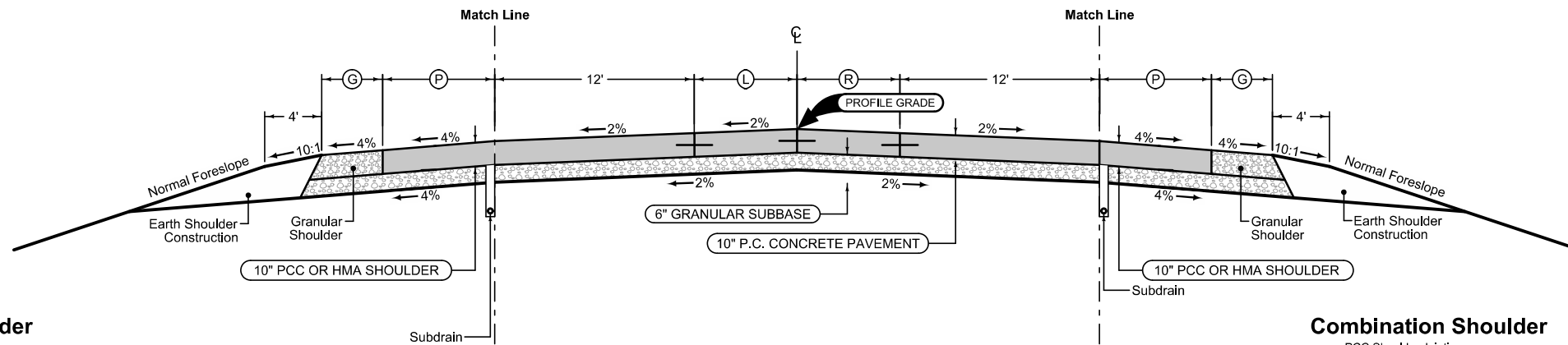

**Combination Shoulder**

PCC Shoulder Jointing:  
 Longitudinal joint: L-2 or KT-2  
 Transverse joints: C at 20' spacing  
 HMA Shoulder Jointing:  
 Longitudinal joint: B

		2_C_ Modified		
ROAD IDENTIFICATION	STATION TO STATION	G Feet	P Feet	
Moscow Rd.	1781+75.00	1796+13.90	4	6
	1798+02.18	1800+72.92	4	6
	1804+68.38	1807+10.14	4	6
Rose Ave.	165+20.00	171+32.30	4	6
	173+31.68	175+95.86	4	6
	178+90.99	181+65.75	4	6
	184+25.00	187+81.17	4	6

Mainline Jointing:  
 Transverse joints: CD at 20' spacing  
 Longitudinal joint: L-2

		2P_ Modified		
ROAD IDENTIFICATION	STATION TO STATION	L Feet	R Feet	
Moscow Rd.	1781+75.00	1792+40.00	0	0
	1792+40.00	1797+20.00	0-8	0-8
	1797+20.00	1807+45.00	8	8
	1807+45.00	1812+25.00	8-0	8-0
Rose Ave.	1812+25.00	1815+45.00	0	0
	165+00.00	167+35.00	0	0
	167+35.00	172+61.11	0-8	0-8
	172+61.11	182+33.15	8	8
	182+33.15	187+81.17	8-0	8-0

**Combination Shoulder**

PCC Shoulder Jointing:  
 Longitudinal joint: L-2 or KT-2  
 Transverse joints: C at 20' spacing  
 HMA Shoulder Jointing:  
 Longitudinal joint: B

		2_C_ Modified		
ROAD IDENTIFICATION	STATION TO STATION	G Feet	P Feet	
Moscow Rd.	1781+75.00	1793+20.00	4	6
	1797+86.77	1800+26.56	4	6
	1804+21.93	1806+92.49	4	6
	1809+67.66	1812+30.00	4	6
Rose Ave.	165+00.00	165+20.00	4	6
	173+30.41	175+78.05	4	6
	178+73.18	181+72.97	4	6
	184+65.93	187+81.17	4	6

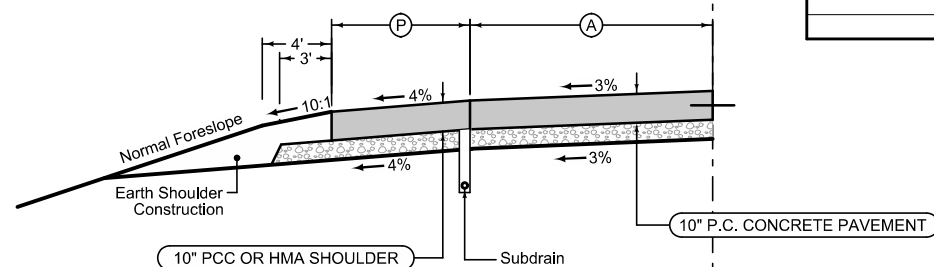

**Auxiliary Lane with Paved Shoulder**

Longitudinal joint: L or KT  
 Transverse joint: Match Mainline  
 PCC Shoulder Jointing:  
 Longitudinal joint: L-2 or KT-2  
 Transverse joints: C at 20' spacing  
 HMA Shoulder Jointing:  
 Longitudinal joint: B

		2_AuxLane_PCC_ Modified		
ROAD IDENTIFICATION	STATION TO STATION	A Feet	P Feet	
Moscow Rd.	1809+01.61	1813+65.00	0-12	6
	1813+65.00	1815+45.00	12	6

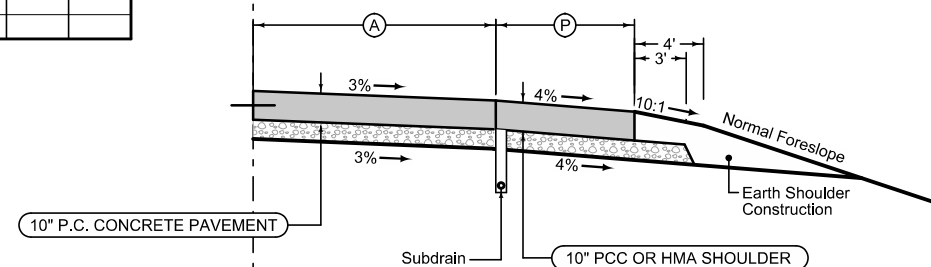

**Auxiliary Lane with Paved Shoulder**

Longitudinal joint: L or KT  
 Transverse joint: Match Mainline  
 PCC Shoulder Jointing:  
 Longitudinal joint: L-2 or KT-2  
 Transverse joints: C at 20' spacing  
 HMA Shoulder Jointing:  
 Longitudinal joint: B

		2_AuxLane_PCC_ Modified		
ROAD IDENTIFICATION	STATION TO STATION	A Feet	P Feet	
Moscow Rd.	1793+20.00	1794+40.00	0-12	6
	1794+40.00	1795+88.25	12	6
	1812+30.00	1830+50.00	0-12	6
Rose Ave.	1830+50.00	1815+50.00	12	6
	165+20.00	167+00.00	0-12	6
	167+00.00	171+78.91	12	6

Moscow Rd.  
 Rose Ave.

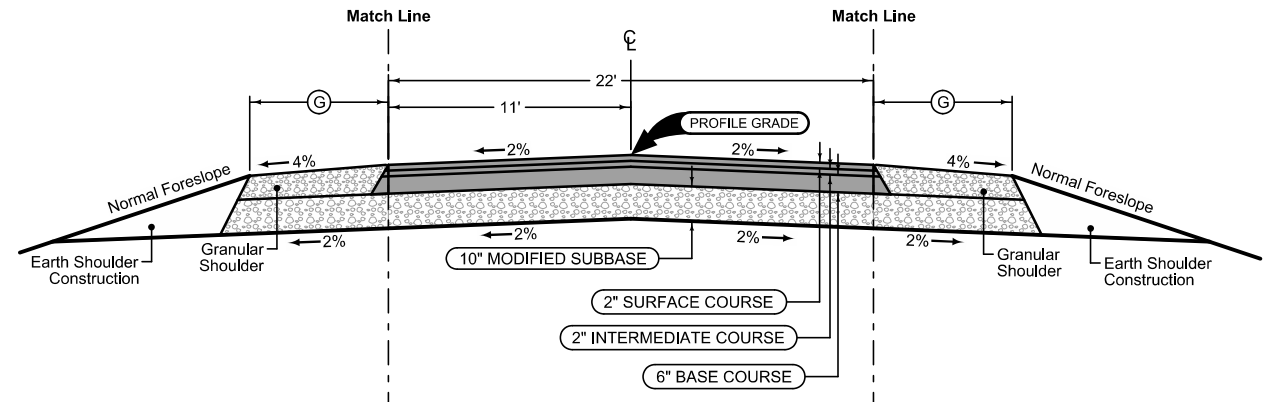

**Granular Shoulder**

			2_G_ Modified
ROAD IDENTIFICATION	STATION TO STATION		Ⓞ Feet
307th St. (SR307)	10796+17.26	10820+10.73	2
307th St. (SR307B)	10819+77.14	10822+05.40	2

			2H_ Modified
ROAD IDENTIFICATION	STATION TO STATION		
307th St. (SR307)	10796+17.26	10820+10.73	
307th St. (SR307B)	10819+77.14	10822+05.40	

**Granular Shoulder**

			2_G_ Modified
ROAD IDENTIFICATION	STATION TO STATION		Ⓞ Feet
307th St. (SR307)	10796+17.26	10820+10.73	2
307th St. (SR307B)	10819+77.14	10822+05.40	2

307th St.

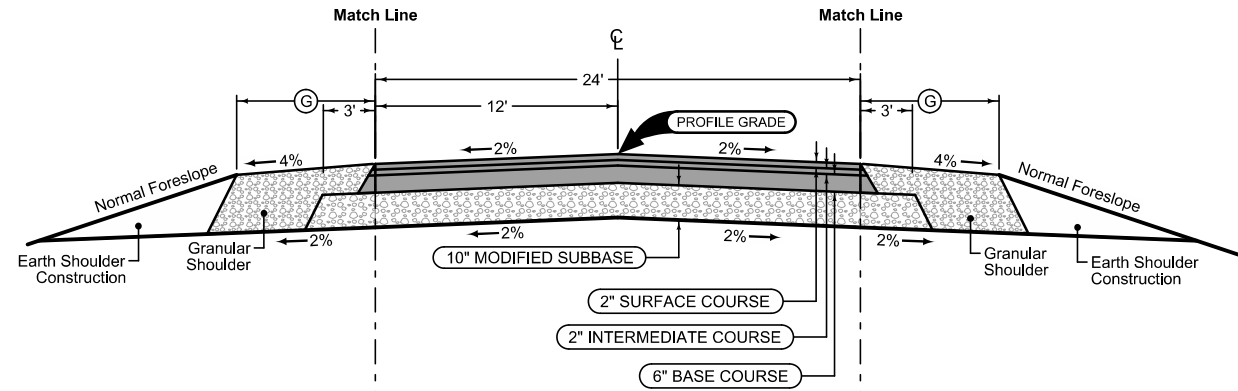

**Granular Shoulder**

2_G Modified			
ROAD IDENTIFICATION	STATION TO STATION		Ⓞ Feet
Taylor Ave.	11+75.00	27+75.00	6
Yankee Ave.	2374+00.00	2402+00.00	8

2H Modified			
ROAD IDENTIFICATION	STATION TO STATION		
Taylor Ave.	11+75.00	27+75.00	
Yankee Ave.	2374+00.00	2402+00.00	

**Granular Shoulder**

2_G Modified			
ROAD IDENTIFICATION	STATION TO STATION		Ⓞ Feet
Taylor Ave.	11+75.00	27+75.00	6
Yankee Ave.	2374+00.00	2374+20.00	8
	2380+59.36	2402+00.00	8

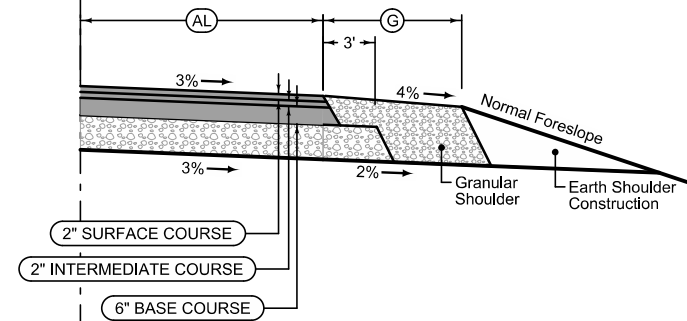

**Auxiliary Lane with Granular Shoulder**

2_G Modified				
ROAD IDENTIFICATION	STATION TO STATION		AL Feet	Ⓞ Feet
Yankee Ave.	2374+20.00	2376+00.00	0-12	4
	2376+00.00	2380+59.36	12	4

**Taylor Ave.  
Yankee Ave.**

**SHEET INTENTIONALLY LEFT BLANK**

### SURVEY SYMBOLS

- FENO Control Monument
- + TOP Top of Bridge Piers
- + REF reference tie points
- SOP Size of pipe
- + SBR size of bridge
- ⊕ CP Control Point Generic
- UB Misc utility vault
- PIP pipes(cast iron,steel,tile,etc)
- STOP ST stop sign
- PRO profile-r.r. rail,swk,abut
- ⊕ BM bench mark
- D cl of draw or stream
- TLNR tree line right
- × FW fence wire
- ⊕ TDC tree deciduous
- GDL guard rails
- SIGN Sl sign
- ⊕ PPC power pole, Owner C
- ⊕ PPB power pole, Owner B
- ⊕ TEV evergreen tree
- ⊕ ROW right of way rails
- ⊕ PPA power pole, Owner A
- ← DU cl of draw upstream
- ▲▲▲▲▲ RIP rip-rap
- ⊕ LUM luminaire
- + GR Ground Field Survey
- BNK stream bank
- TLNL tree line left
- ⊕ WC Wildcard
- ⊕ TW Top of Water
- SP Stream Profile
- EG edge of gravel road
- CON concrete or a/c slab
- + BD Bridge Deck
- ⊕ BLS Bridge Low Steel
- BCL bridge centerline
- BRG bridge
- C center of roadway
- EB electrical box
- ✂ PL Photo Location
- CUL culvert
- ⊕ INB intake-beehive
- ⊕ OUT tile outlet
- ⊕ STP stump
- GDC Cable Guardrail
- BB BB billboard or sign
- SIGN SL speed limit sign
- ⊕ MM MM mile marker post
- ⊕ TP TPD telephone pedestal
- ⊕ LC LC lot corner
- ⊕ MH Misc manhole
- ⊕ UE utility elevation
- ⊕ IN intake-grate, curb,umbrella
- LIN miscellaneous line
- CMP corrugated metal pipes
- ⊕ WH WHD water hydrant
- BLD foundation or building
- ⊕ SEP septic tank
- ⊕ SHR shrub
- ⊕ MIS miscellaneous
- ⊕ LP L.P. tank
- ⊕ TR Telephone Riser Pole
- ENU edge of unpaved entrance&parking
- CU curb or center island
- GU gutter
- UB UB Misc utility box
- CS concrete slab
- RET retaining walls
- FWD wood fence
- ROC rock outcropping
- TV tv dish
- ⊕ WV WW water valve
- EW edge of water
- FCL security & chain link
- ⊕ GP GP guard post / Bollard
- ⊕ S Soil sampling site

### UTILITY LEGEND

- ⊕ PPA power pole, Owner A
- E1(B) EL1B UG electric, Eastern Iowa Light & Power - Quality B
- E1(C) EL1C UG electric, Eastern Iowa Light & Power - Quality C
- F0(B) FO1B fiber optics, Iowa Communications Network - Quality B
- F0(C) FO1C fiber optics, Iowa Communications Network - Quality C
- F02(B) FO2B fiber optics, Aureon Network Services (INS) - Quality B
- F02(C) FO2C fiber optics, Aureon Network Services (INS) - Quality C
- F03(B) FO3B fiber optics, Windstream Communications - Quality B
- F03(C) FO3B fiber optics, Windstream Communications - Quality C
- F04(C) FO4C fiber optics, WTC Communications - Quality C
- F05(C) FO5C fiber optics, HWH Corporation - Quality C
- G(B) GL1B gas line, OneOK North System - Quality B
- G(C) GL1C gas line, OneOK North System - Quality C

### PLAN VIEW COLOR LEGEND OF PLAN AND PROFILE SHEETS

LINEWORK	Design Color No.	
Green	(2)	Existing Topographic Features and Labels
Blue	(1)	Proposed Alignment, Stationing, Tic Marks, and Alignment Annotation
Magenta	(5)	Existing Utilities
SHADING		
	Design Color No.	
Yellow	(4)	Highlight for Critical Notes or Features
Red	(3)	Delineates Restricted Areas
Lavender	(9)	Temporary Pavement Shading
Gray, Light	(48)	Proposed PCC Pavement with HMA Surfacing Shading
Gray, Med	(80)	Proposed Granular Shading
Gray, Dark	(112)	Proposed HMA Resurfacing Shading
Brown, Light	(236)	Grading Shading
Tan	(8)	Proposed Sidewalk Shading
Blue, Light	(230)	Proposed Sidewalk Landing Shading
Pink	(11)	Proposed Sidewalk Ramp Shading

### PROFILE VIEW COLOR LEGEND OF PLAN AND PROFILE SHEETS

LINEWORK	Design Color No.	
Green	(2)	Existing Ground Line Profile
Blue	(1)	Proposed Profile and Annotation
Magenta	(5)	Existing Utilities
Blue, Light	(230)	Proposed Ditch Grades, Left
Black	(0)	Proposed Ditch Grades, Median
Rust	(14)	Proposed Ditch Grades, Right

Reference Point

Station

Survey Line

Section Corner

Ground Line Intercept

Saw Cut

Guardrail

Trench Drain

HighTension Cable Guardrail

Sheet Pile

Pavement Removal

Clearing & Grubbing Area

### RIGHT-OF-WAY LEGEND

- ▲ Proposed Right-of-Way
- △ Existing Right of Way
- ▲ Existing and Proposed Right-of-Way
- ▲ Easement and Existing Right-of-Way
- Easement (Temporary)
- ⊕ Easement
- C/A Access Control
- Property Line

Existing Ditch Dike (U.A.C.)

## PLAN AND PROFILE LEGEND AND SYMBOL INFORMATION SHEET

(COVERS SHEET SERIES D, E, F, & K)

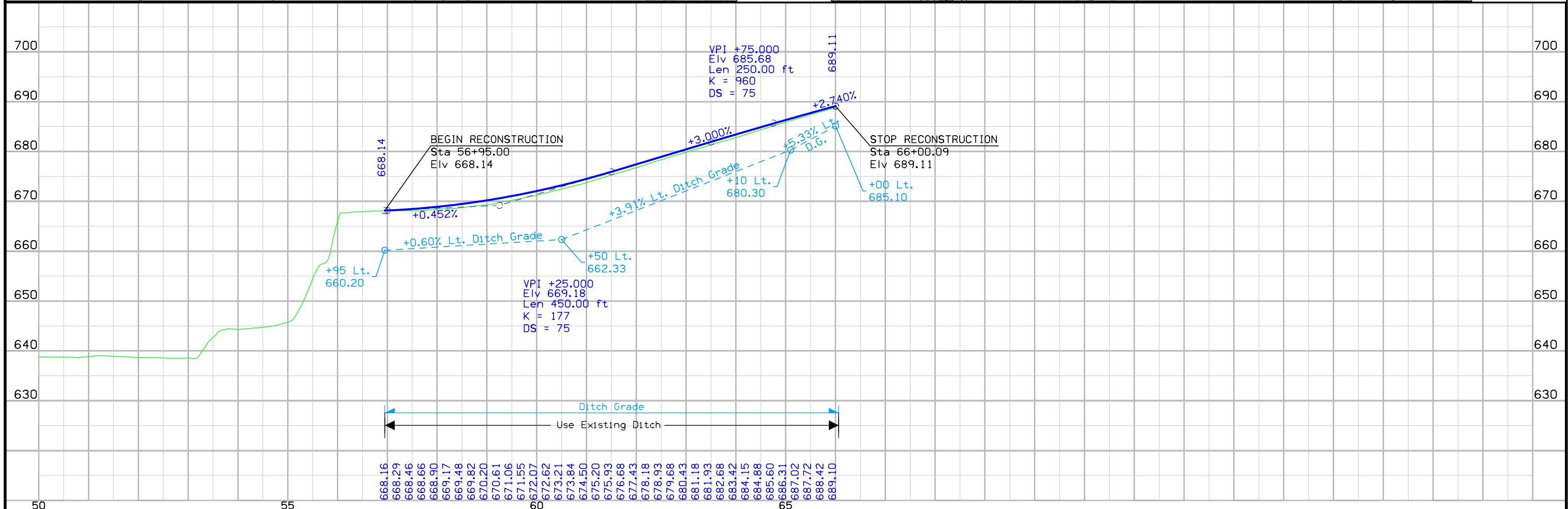
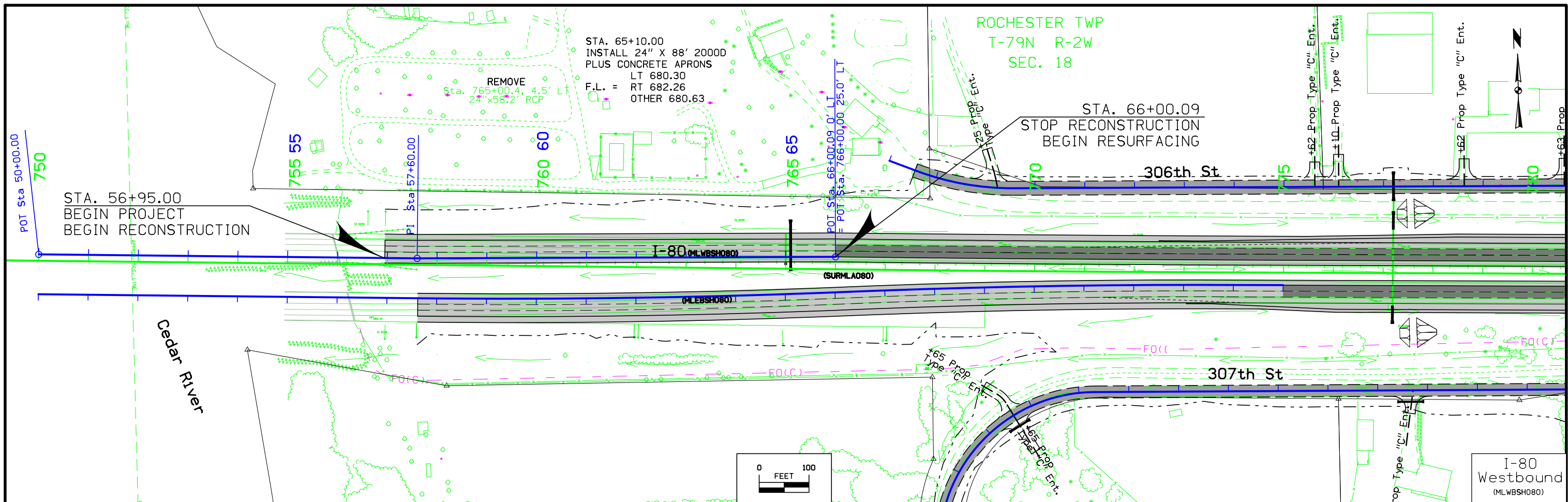

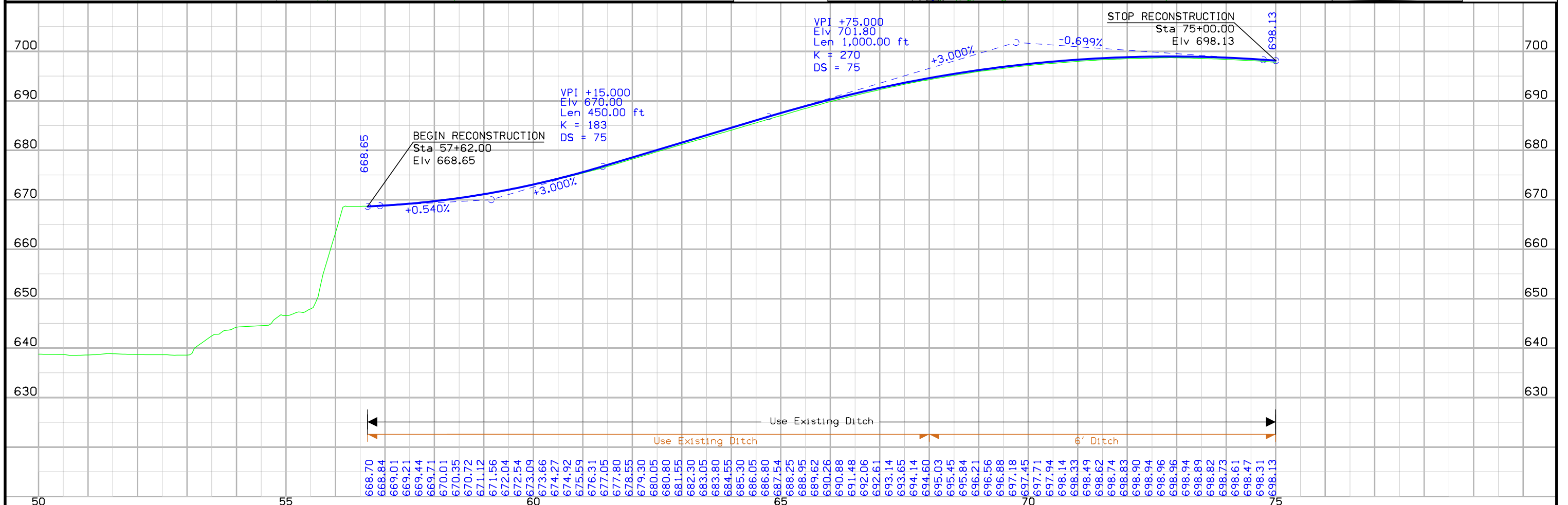
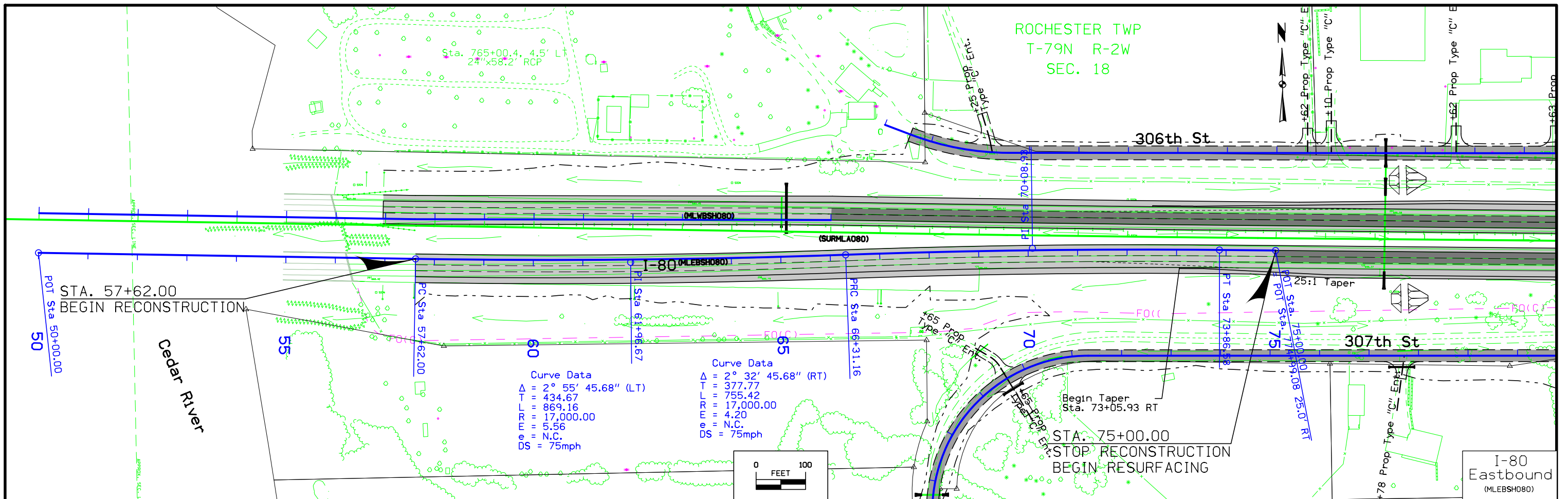

ROCHESTER TWP  
T-79N R-2W  
SEC. 18

Curve Data  
 $\Delta = 0^\circ 23' 00.00''$  (LT)  
 $T = 383.36$   
 $L = 766.72$   
 $R = 114,600.00$   
 $E = 0.64$   
 $e = N.C.$

REMOVE & EXTEND  
 Sta. 777+19.3  
 24" X 155.1' RCP  
 D.A.=2.0 A-R (Plans)  
 REMOVE APRONS LT & RT  
 INSTALL 24" X 28' 2000D LT  
 INSTALL 24" X 28' 2000D RT  
 PLUS CONCRETE APRONS  
 LT 683.67  
 RT 691.22  
 F.L. = OTHER 691.06  
 OTHER 685.85

STA. 756+95.00  
BEGIN CONSTRUCTION

STA. 766+00.00  
STOP WB RECONSTRUCTION  
BEGIN WB WIDENING  
AND RESURFACING

STA. 777+45 PROP.  
TYPE "M" DIKE  
ELEV. = 694.40

STA. 774+99.08  
STOP EB RECONSTRUCTION  
BEGIN EB WIDENING  
AND RESURFACING

750

755

760

765

770

775

Cedar River

(MWBSD80)

(MEBSD80)

I-80 (SURFLA080)

306th St

50:1 Taper

25:1 Taper

307th St

End Taper  
Sta. 776+05.00 RT

STA. 777+45 PROP.  
TYPE "M" DIKE  
ELEV. = 694.40

Begin Taper  
Sta. 772+49.89 LT

+65 Prop  
Type "C" Ent.

+62 Prop  
Type "C" Ent.

+62 Prop Type "C" Ent.

+10 Prop Type "C" Ent.

+78 Prop Type "C" Ent.

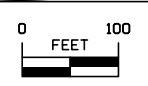



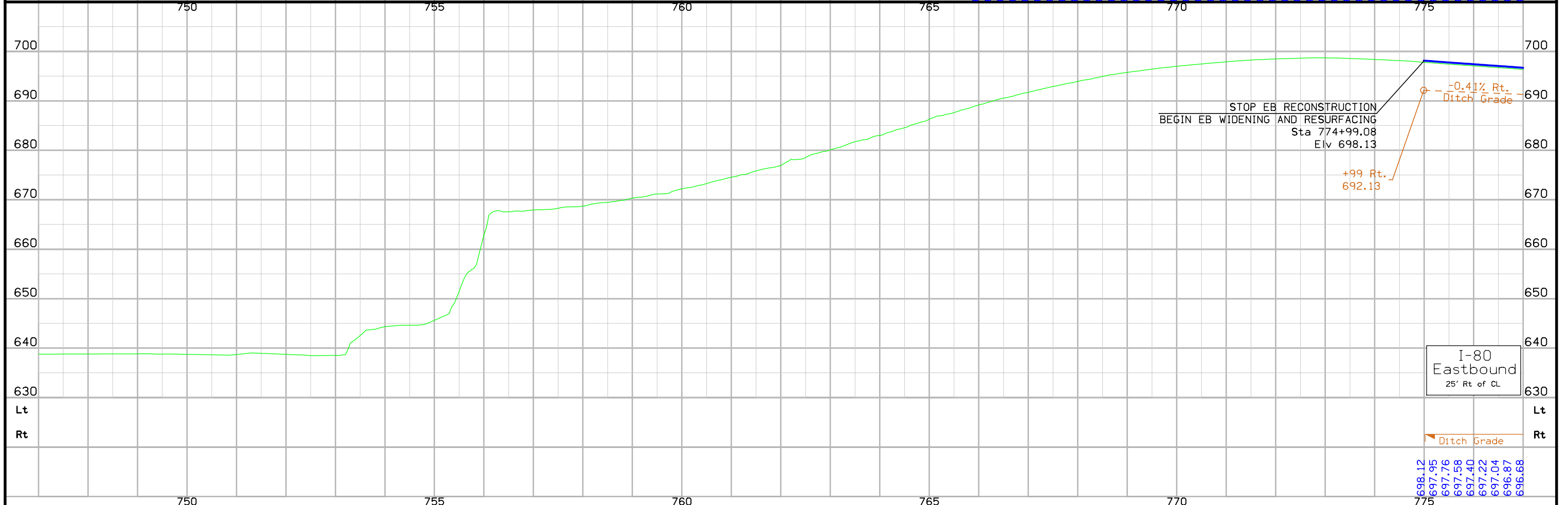
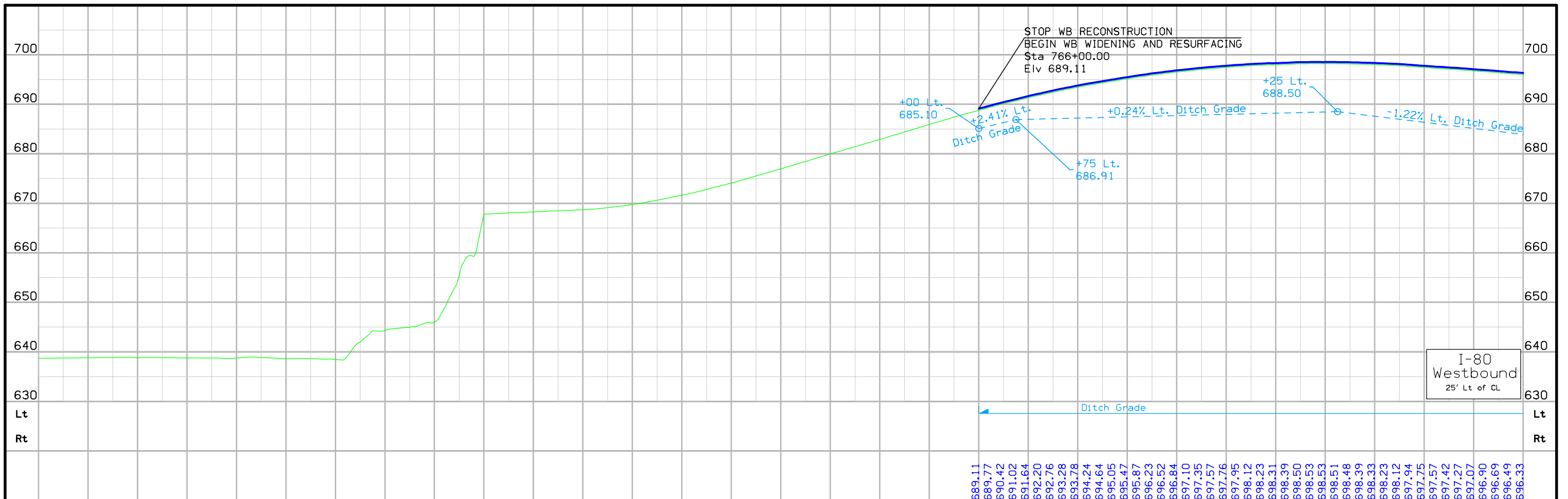

ROCHESTER TWP  
T-79N R-2W  
SEC. 18

REMOVE  
Sta. 788+99.9  
30"x170.4' RCP  
D.A.=8.0 A-R (Plans)

STA. 788+90.00  
INSTALL 36" X 226' 2000D  
PLUS CONCRETE APRONS  
F.L. = LT 677.21  
RT 679.84

POT Sta 803+90.39 (SURMLA080)  
= POT Sta 1802+49.94 (SRMOS)

(U.A.C.)  
Sta. 800+34.10  
15"x21.3' RCP &

(U.A.C.)  
Sta. 800+86.23  
15"x18.2' RCP

REMOVE  
Sta. 803+66.3  
24"x72.0' RCP

REMOVE  
Sta. 804+00.00  
18"x70.1' CMP

+52 Rt. Prop. Silt Berm

STA. 804+65.0  
INSTALL 24" X 96' 2000D  
PLUS CONCRETE APRONS  
F.L. = LT 679.65  
RT 681.76

POT Sta 3538+50.00 (RPCMOS)  
POT 788+50.00 (SURMLA080)

306th St

I-80 (SURMLA080)

307th St

POT Sta 2590+25.00 (RPBMOS)  
POT Sta 790+23.94 (SURMLA080)

STA. 783+00.00  
INSTALL 24" X 88' 2000D  
PLUS CONCRETE APRONS  
F.L. = LT 688.74  
RT 685.94  
OTHER 687.01

STA. 789+15 PROP.  
TYPE "M" DIKE  
ELEV. = 686.34

REMOVE & EXTEND  
Sta. 791+99.8  
24"x64.9' RCP  
REMOVE APRON RT  
INSTALL 24" X 74' 2000D RT  
PLUS CONCRETE APRON RT  
F.L. = RT 678.08  
OTHER 679.91

REMOVE & EXTEND  
Sta. 800+57.59, SKEW 45°  
TWIN 8'x8'x226.1' RCB CULVERT  
REMOVE HEADWALLS LT & RT  
INSTALL 8' X 8' X 37' PRECAST CONCRETE BOX LT  
INSTALL 8' X 8' X 37' PRECAST CONCRETE BOX RT  
F.L. = LT 670.13  
RT 671.83  
OTHER 670.34  
OTHER 671.61

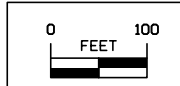

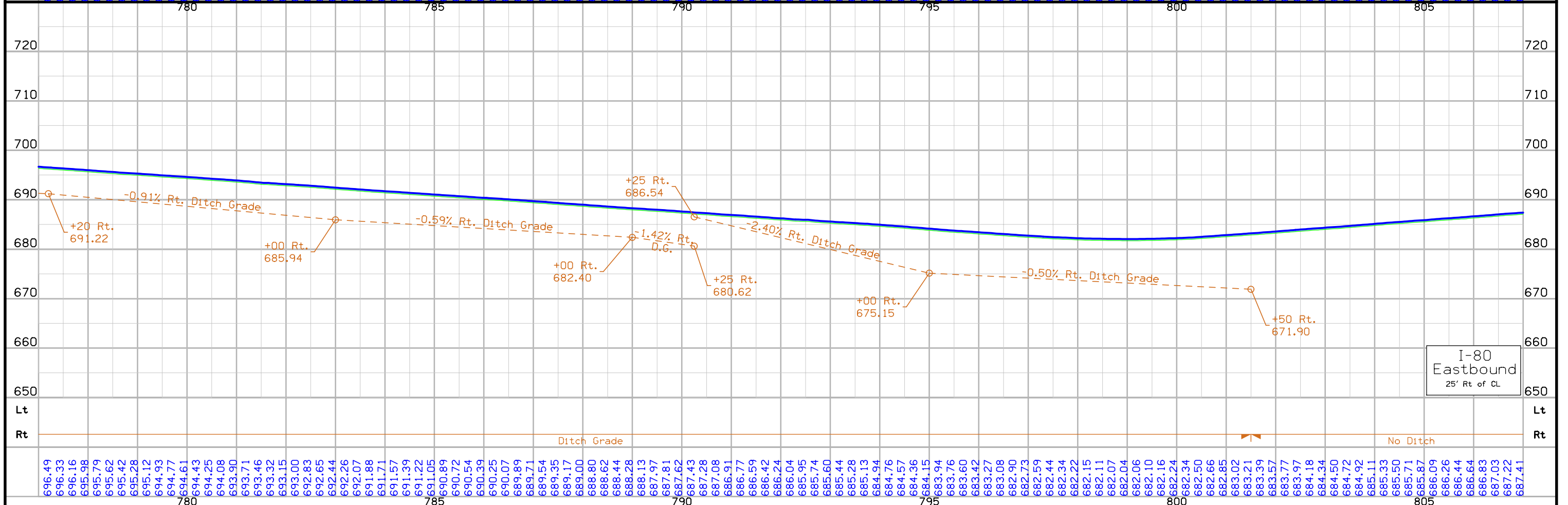
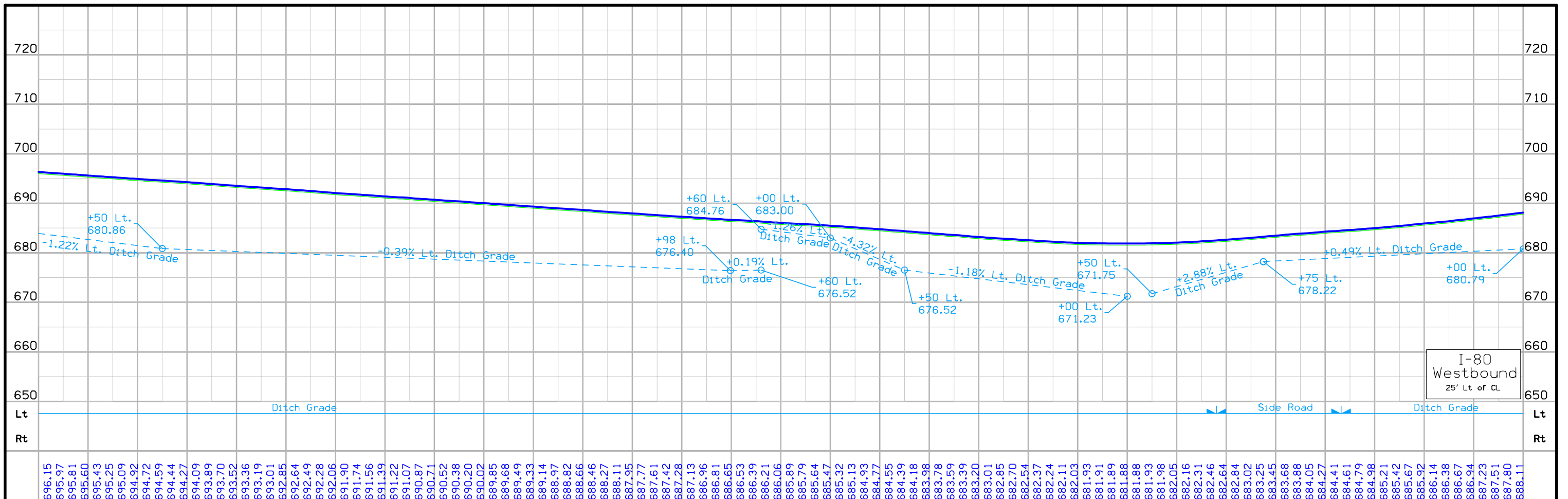

ROCHESTER TWP  
T-79N R-2W  
SEC. 17



REMOVE & EXTEND  
Sta. 824+00.23  
24"x70.7' RCP  
REMOVE APRON LT  
INSTALL 24" X 38' 2000D LT  
PLUS CONCRETE APRON LT  
F.L. = LT 695.07  
OTHER 695.96

POT Sta 1619+25.00 (RPAMOS)  
POT 819+26.06 112.93' LT (SURMLA080)

Begin Taper  
Sta. 836+45.00 LT  
End Taper  
Sta. 833+45.00 LT

835

25:1 Taper

I-80 (SURMLA080)

50:1 Taper

PT Sta 4519+00.00 (RPDMOS)  
POT Sta 819+00.00 85.00' RT (SURMLA080)

Begin Taper  
Sta. 829+00.00 RT

End Taper  
Sta. 835+00.00 RT

REMOVE & EXTEND  
Sta. 814+00.45  
24"x58.4' RCP  
REMOVE APRON RT  
INSTALL 24" X 112' 2000D RT  
PLUS CONCRETE APRON RT  
F.L. = RT 683.00  
OTHER 686.67

REMOVE & EXTEND  
Sta. 834+00.97  
24"x67.5' RCP  
REMOVE APRONS LT & RT  
INSTALL 24" X 32" 2000D LT  
INSTALL 24" X 2' 2000D RT  
PLUS CONCRETE APRONS  
F.L. = LT 707.87  
RT 706.47  
OTHER 707.77  
OTHER 706.47

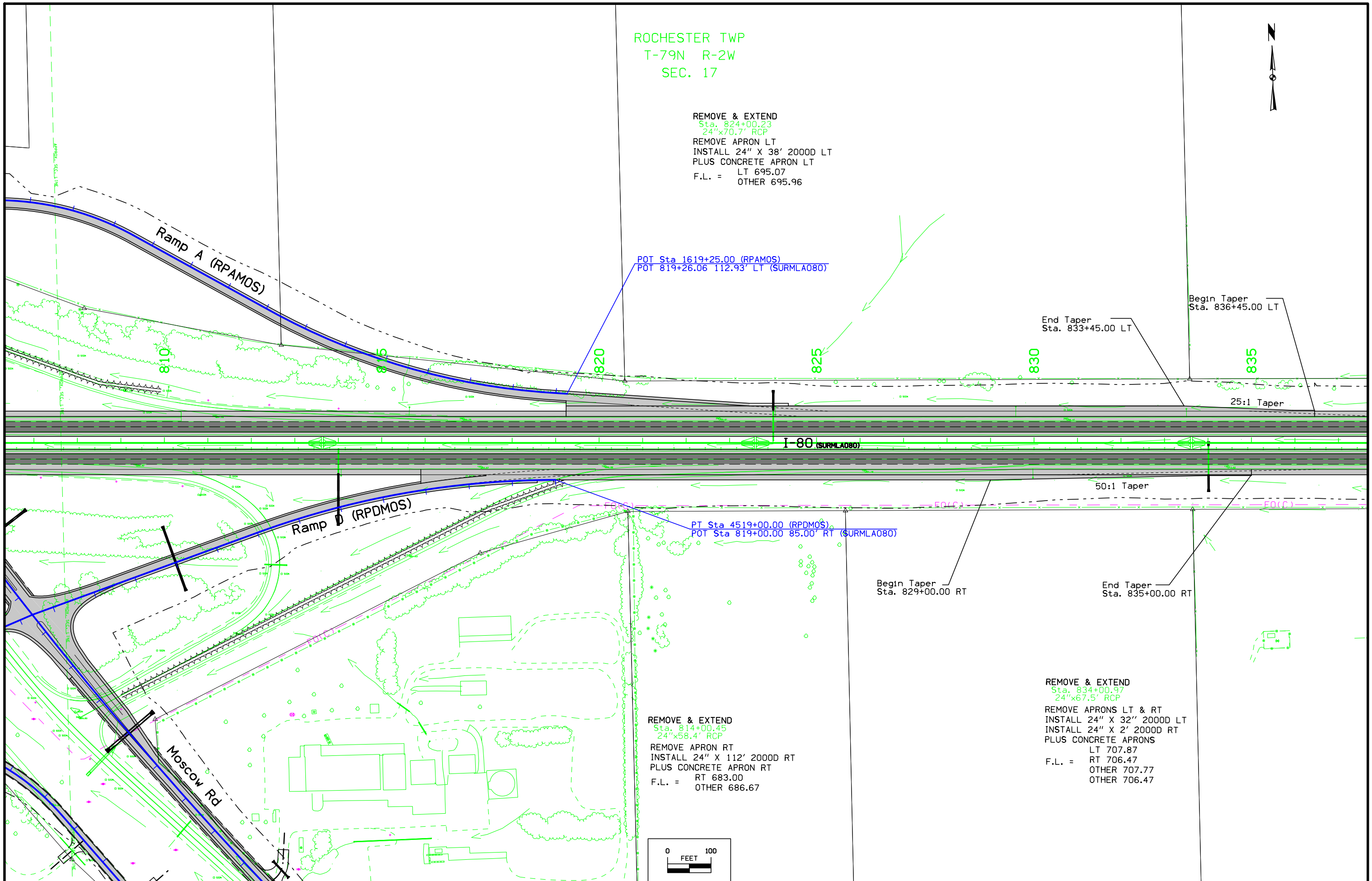
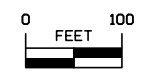



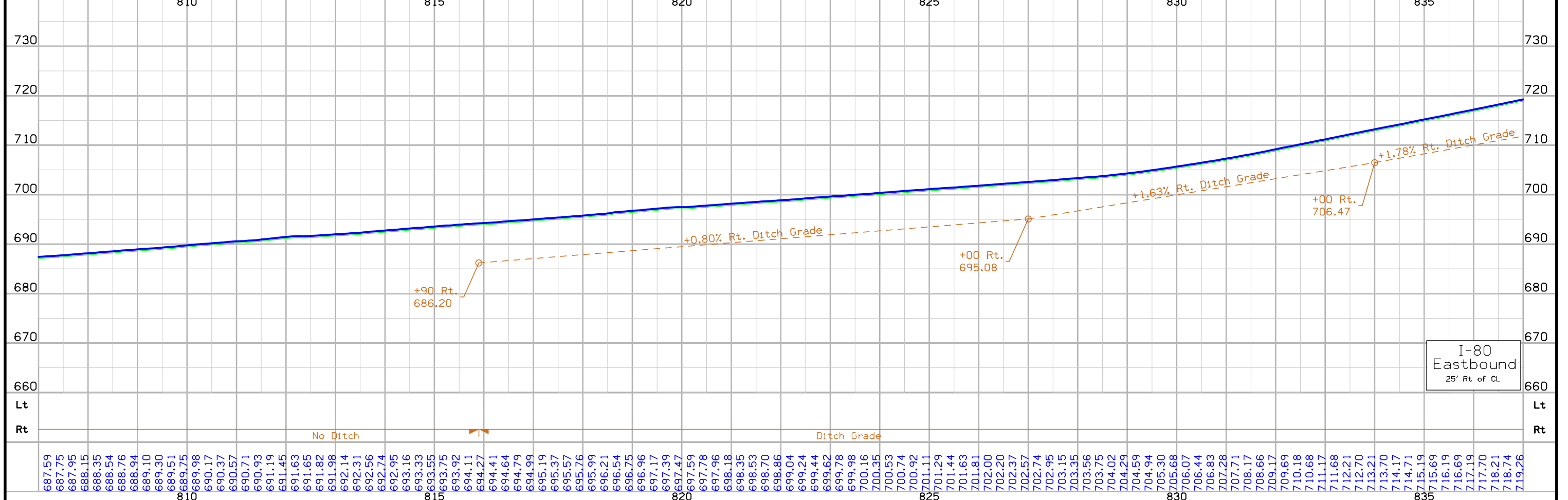
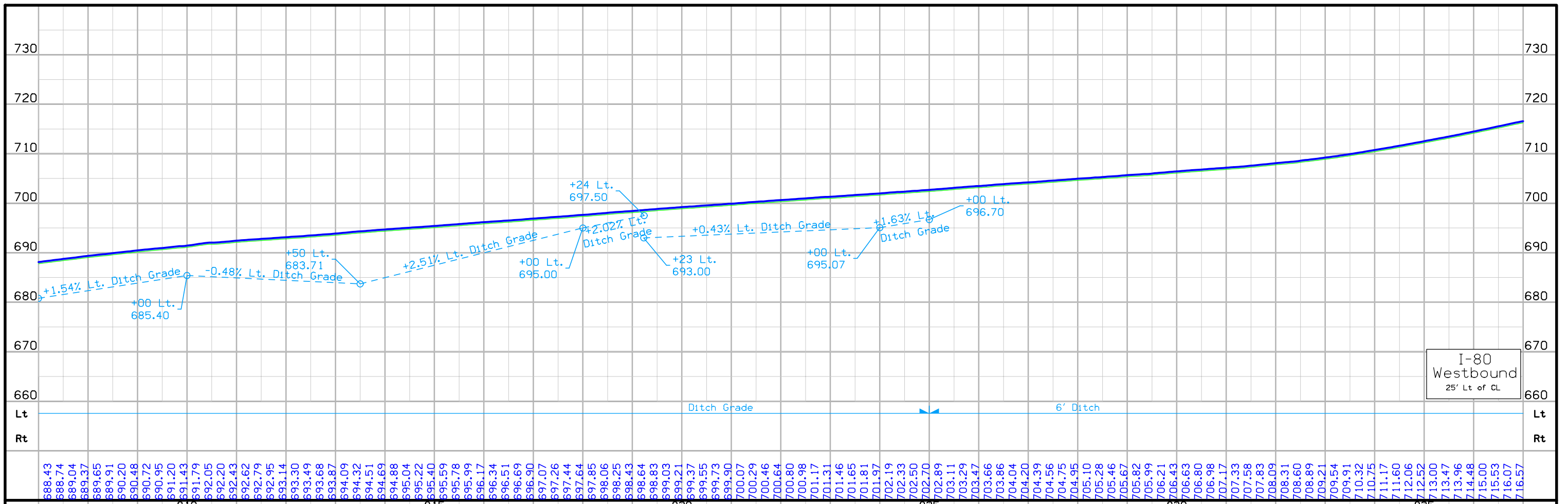

FILE NO.	ENGLISH	DESIGN TEAM	Iowa DOT \ HR Green	CEDAR COUNTY	PROJECT NUMBER	IM-NHS-080-7(134)266--03-16	SHEET NUMBER	D.9
----------	---------	-------------	---------------------	--------------	----------------	-----------------------------	--------------	-----

ROCHESTER TWP  
T-79N R-2W  
SEC. 17

SUGAR CREEK TWP  
T-79N R-2W  
SEC. 16



Curve Data  
 $\Delta = 1^\circ 23' 00.00''$  (LT)  
 T = 415.05  
 L = 830.06  
 R = 34,380.00  
 E = 2.51  
 e = N.C.  
 DS = 70mph

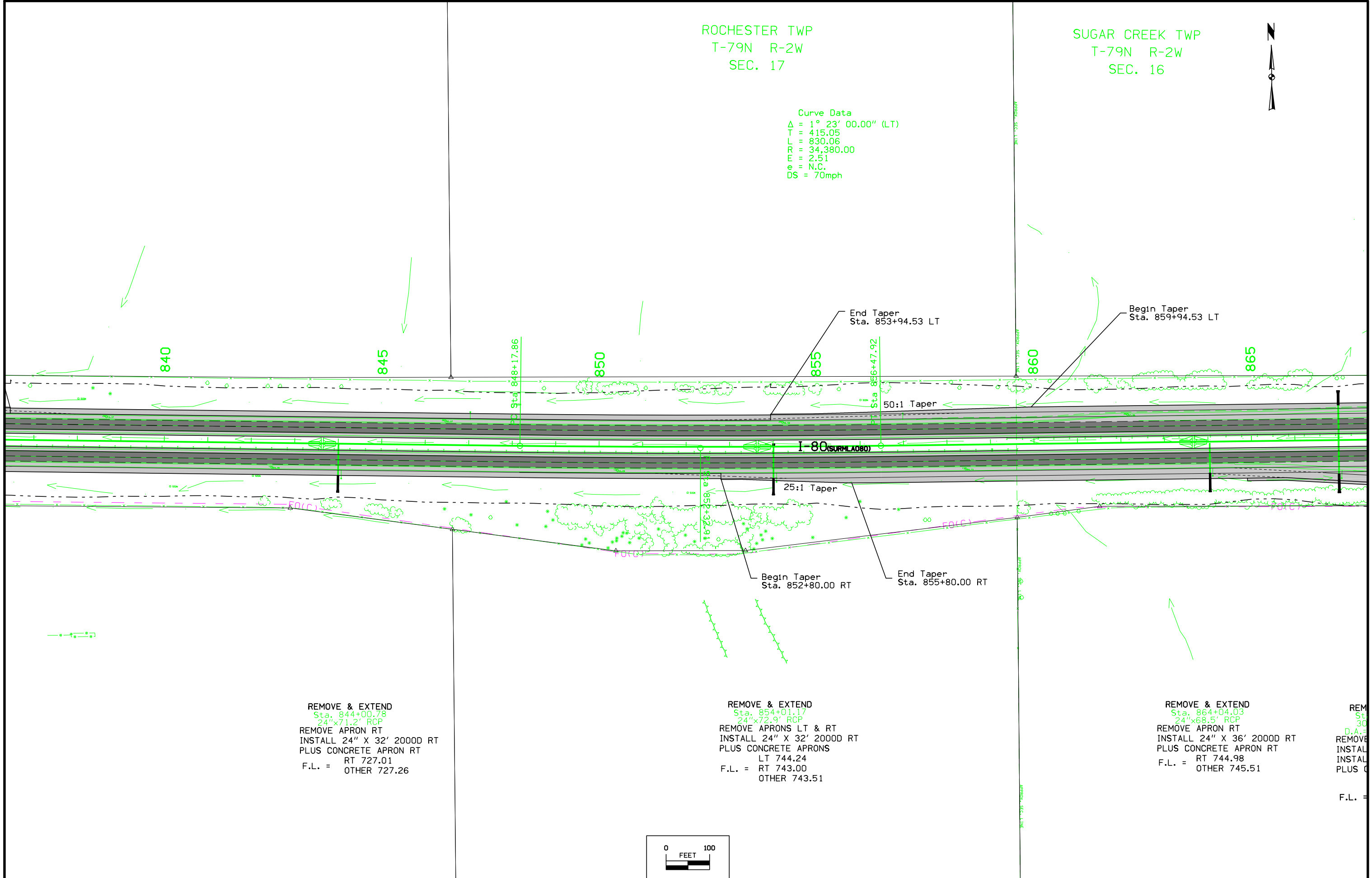

REMOVE & EXTEND  
 Sta. 844+00.78  
 24"x71.2' RCP  
 REMOVE APRON RT  
 INSTALL 24" X 32' 2000D RT  
 PLUS CONCRETE APRON RT  
 RT 727.01  
 F.L. = OTHER 727.26

REMOVE & EXTEND  
 Sta. 854+01.17  
 24"x72.9' RCP  
 REMOVE APRONS LT & RT  
 INSTALL 24" X 32' 2000D RT  
 PLUS CONCRETE APRONS  
 LT 744.24  
 F.L. = RT 743.00  
 OTHER 743.51

REMOVE & EXTEND  
 Sta. 864+04.03  
 24"x68.5' RCP  
 REMOVE APRON RT  
 INSTALL 24" X 36' 2000D RT  
 PLUS CONCRETE APRON RT  
 RT 744.98  
 F.L. = OTHER 745.51

REMOVE  
 STA. 864+04.03  
 24"x68.5' RCP  
 D.A. = 30'  
 REMOVE APRON RT  
 INSTALL 24" X 36' 2000D RT  
 PLUS CONCRETE APRON RT  
 RT 744.98  
 F.L. = OTHER 745.51

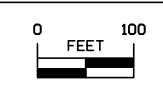

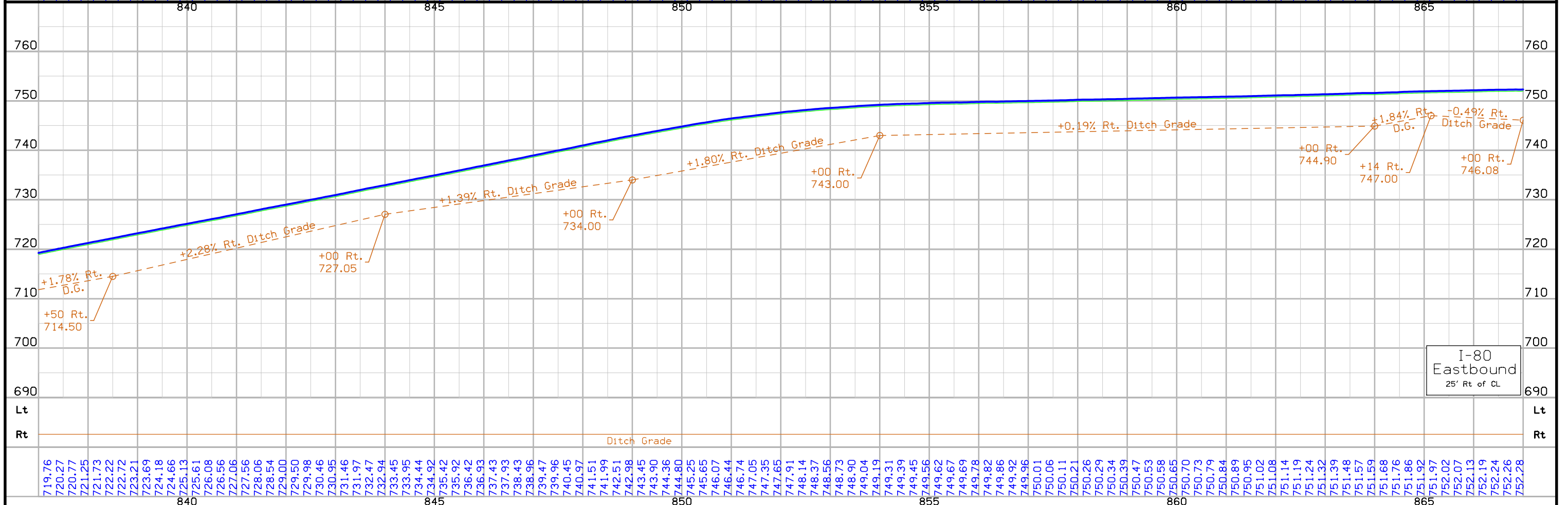
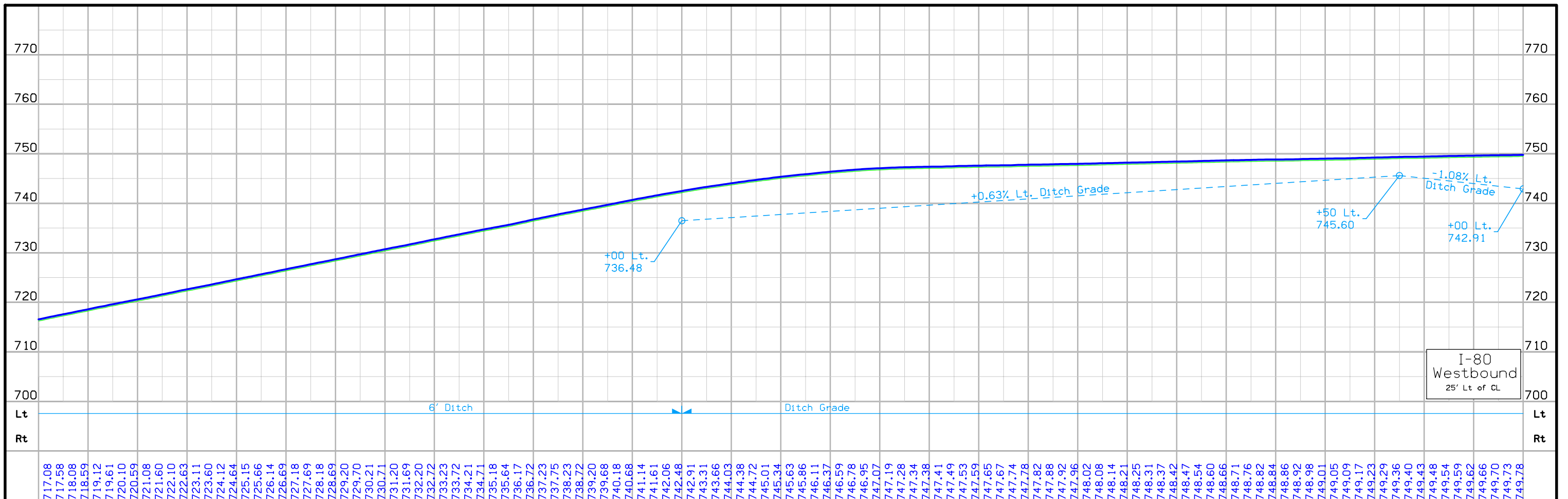

REMOVE & EXTEND  
 Sta. 874+75.91  
 Skew 10°  
 42"x227.0' RCP  
 D.A.=30.0 A-R (Plans)  
 REMOVE APRON LT & RT  
 INSTALL 42" X 8' 2000D LT  
 INSTALL 42" X 42' 2000D RT  
 TIE TO EXISTING  
 LT 738.40  
 RT 739.30  
 F.L. = OTHER 739.30  
 OTHER 743.33  
 OTHER 744.01

(U.A.C.)  
 Sta. 878+15.5, 229.7' LT  
 8"x109.3' CMP  
 STA. 871+70.00  
 INSTALL 24" X 102' 2000D  
 PLUS CONCRETE APRONS  
 LT 743.88  
 RT 747.47  
 F.L. = OTHER 745.67

SUGAR CREEK TWP  
 T-79N R-2W  
 SEC. 16

(U.A.C.)  
 Sta. 881+31.5, 308.3' LT  
 8"x101.7' CMP  
 REMOVE & EXTEND  
 Sta. 882+01.3, 4.9' LT  
 24"x60.6' RCP  
 REMOVE APRON LT & RT  
 INSTALL 24" X 32' 2000D LT  
 INSTALL 24" X 2' 2000D RT  
 PLUS CONCRETE ARPON RT  
 LT 743.09  
 RT 745.62  
 F.L. = OTHER 743.92  
 OTHER 745.41

REMOVE & EXTEND  
 Sta. 883+82.16  
 Skew 30°  
 24"x165.7' RCP  
 D.A.=3.0 A-R (Plans)  
 REMOVE APRONS LT & RT  
 INSTALL 24" X 110' 2000D LT  
 INSTALL 24" X 68' 2000D RT  
 PLUS CONCRETE ARPONS  
 LT 741.03  
 RT 744.50  
 F.L. = OTHER 744.17  
 OTHER 744.13

REMOVE  
 Sta. 888+22.10  
 24"x70.8' RCP  
 STA. 888+32.00  
 INSTALL 24" X 112' 2000D  
 PLUS CONCRETE APRONS  
 LT 743.18  
 RT 747.93  
 F.L. = OTHER 746.04

REMOVE  
 872+00.00 874+51.32, 90.7' LT  
 8"x21.0' RCP 24"x8.8' RCP  
 REMOVE  
 874+65.59, 88.4' LT  
 24"x5.3' RCP

POT Sta 892+65.12 25.01' LT (SURMLA080)  
 = PC Sta 4892+65.12 (MLWB080)  
 Sta. 892+65.12 (SURMLA080) BK  
 = Sta. 4892+65.12 (MLWB080) AHD  
 CONTINUE WB WIDENING  
 AND RESURFACING  
 POT Sta 1586+00.00 (RPATRU)  
 POT Sta 886+00.79 112.95' LT (SURMLA080)

PT Sta 4588+08.99 (RPATRU)  
 POT Sta 888+08.99 85.00' RT (SURMLA080)

POT Sta 2570+00.00 (RPBTRU)  
 POT Sta 869+98.94 112.93' RT (SURMLA080)

REMOVE  
 Sta. 871+90.6  
 Skew 30°  
 24"x248.6' RCP  
 D.A.=4.0 A-R (Plans)

REMOVE & EXTEND  
 Sta. 867+00.74  
 30"x159.8' RCP  
 D.A.=7.0 A-R (Plans)  
 REMOVE APRON LT & RT  
 INSTALL 30" X 26' 2000D LT  
 INSTALL 30" X 36' 2000D RT  
 PLUS CONCRETE APRONS  
 LT 742.91  
 RT 746.05  
 F.L. = OTHER 743.41  
 OTHER 745.84

STA. 871+55.00  
 INSTALL 24" X 316' 2000D  
 SKEW 35° RT AHD.  
 PLUS CONCRETE APRONS  
 LT 743.69  
 RT 745.33  
 F.L. =

(U.A.C.)  
 Sta. 879+85.1,  
 231.1' RT  
 8"x104.5' CMP

(U.A.C.)  
 Sta. 883+94.76  
 18"x19.9' RCP

REMOVE  
 Sta. 888+01.1  
 30"x164.2' RCP  
 D.A.=30.0 A-R (Plans)

STA. 888+11.00  
 INSTALL 42" X 224' 2000D  
 PLUS CONCRETE APRONS  
 F.L. = LT 743.06  
 RT 744.29

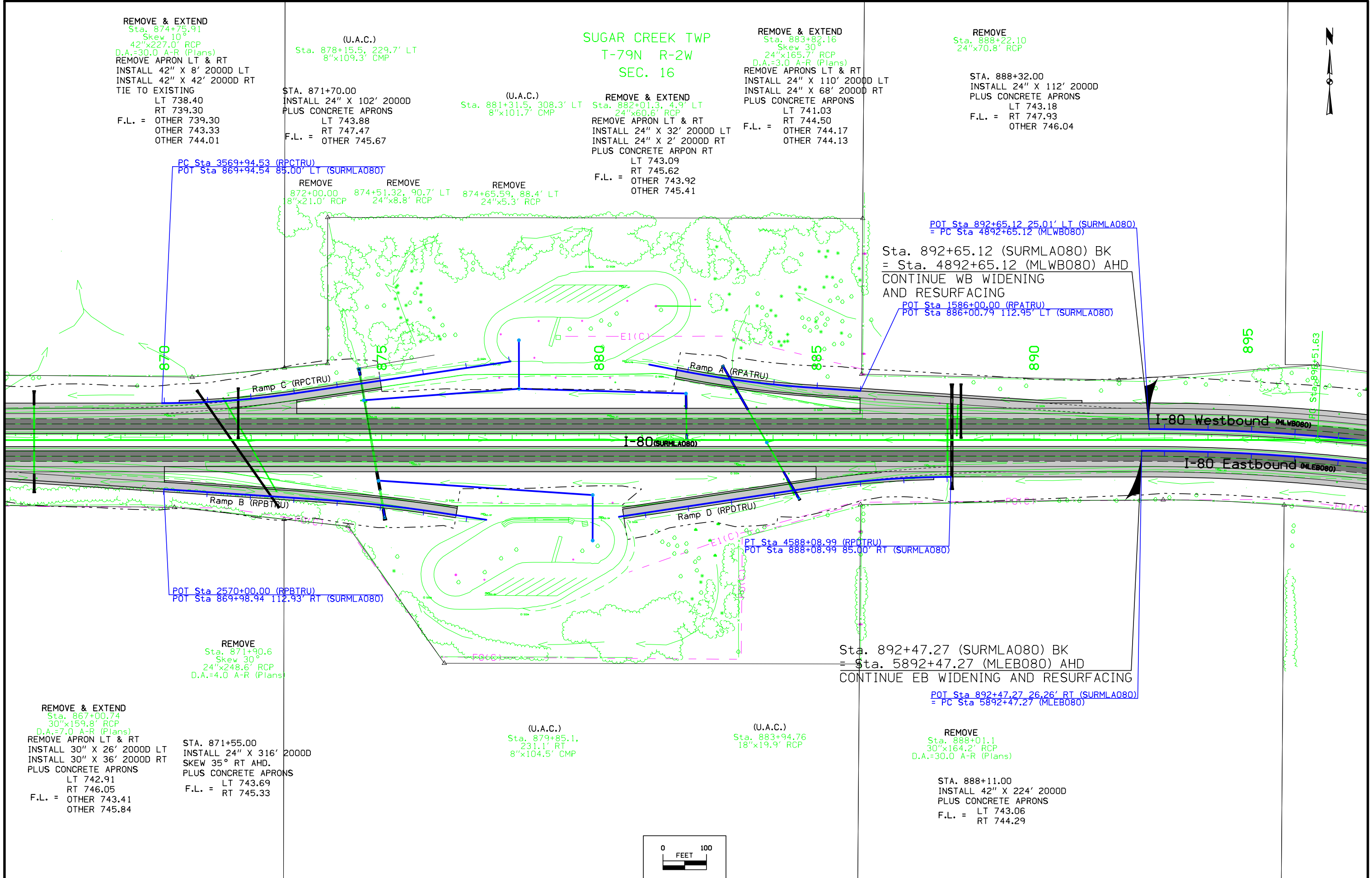
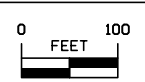



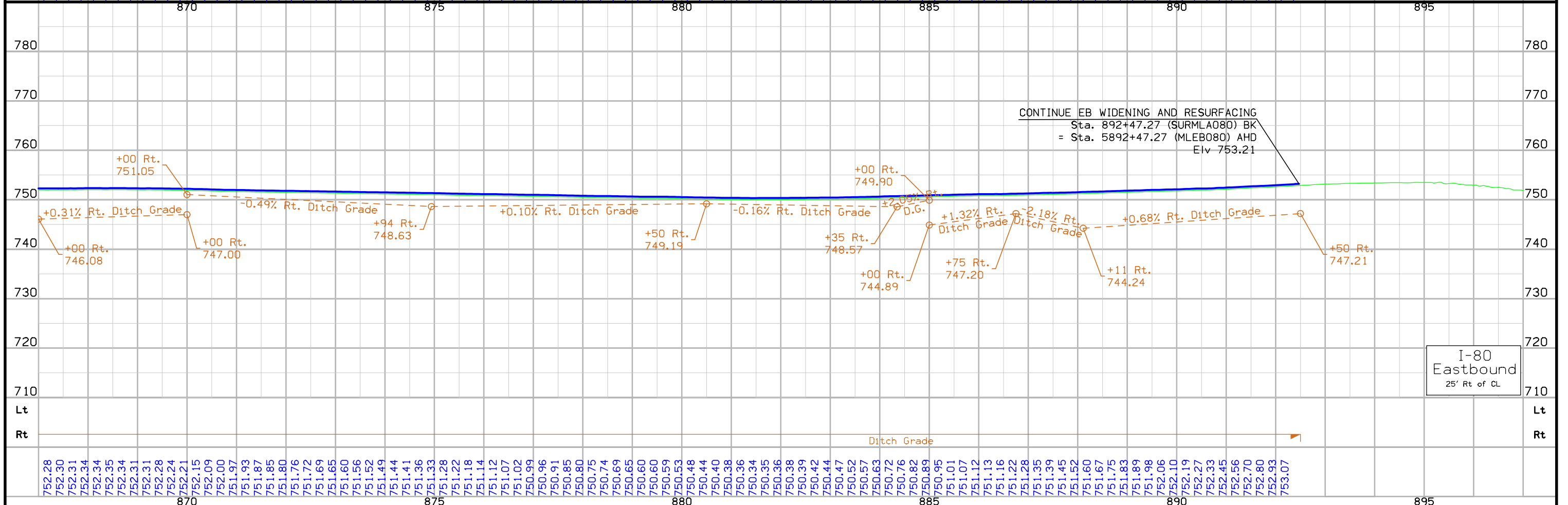
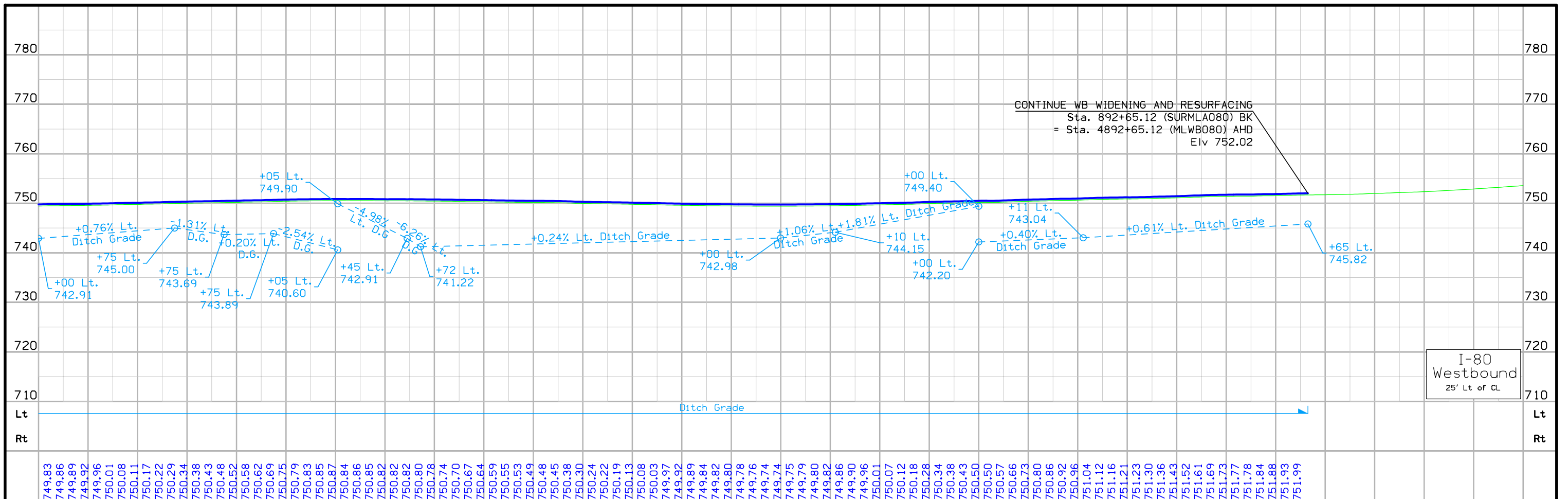

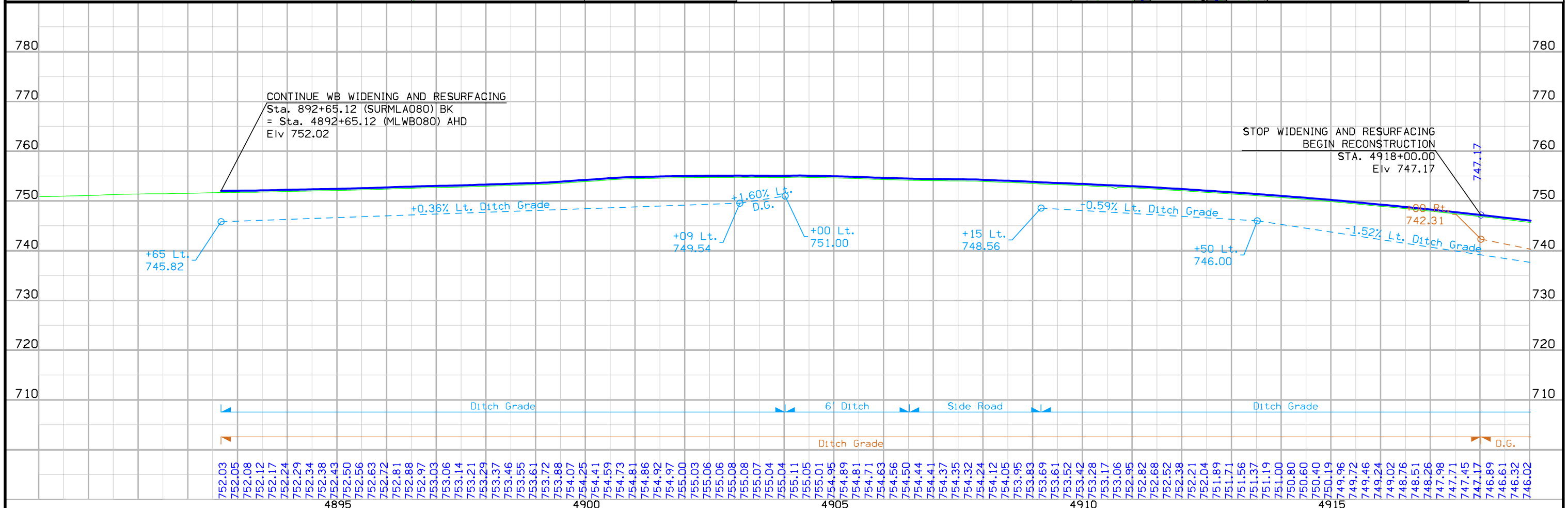
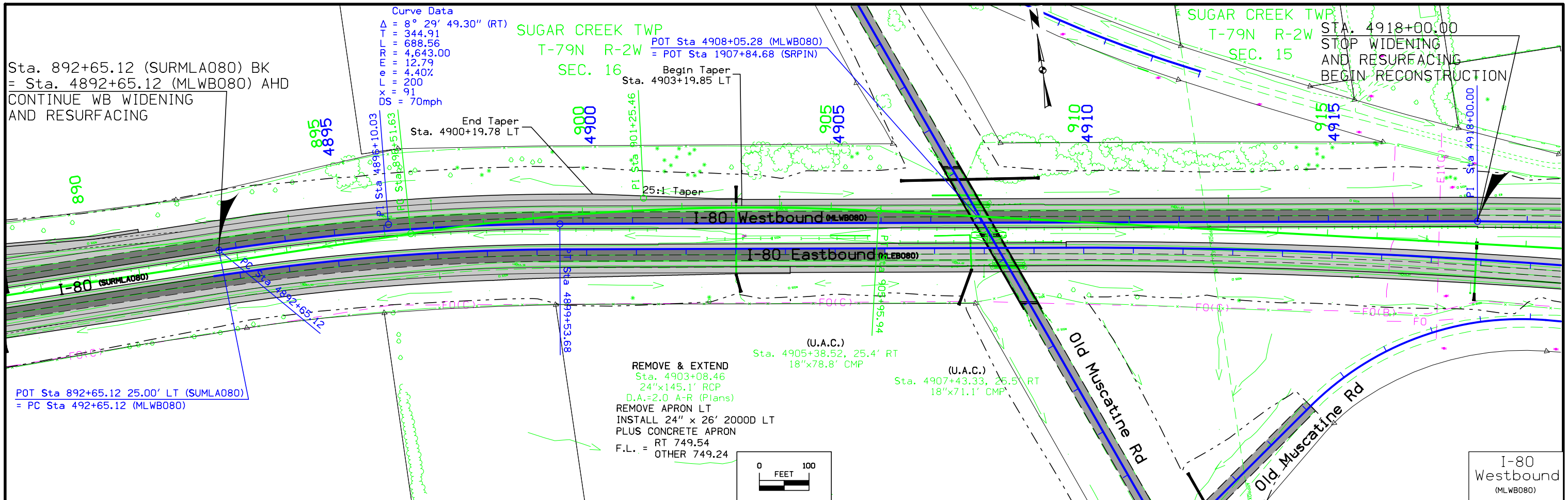

FILE NO.	ENGLISH	DESIGN TEAM	Iowa DOT \ HR Green	CEDAR COUNTY	PROJECT NUMBER	IM-NHS-080-7(134)266--03-16	SHEET NUMBER	D.14
----------	---------	-------------	---------------------	--------------	----------------	-----------------------------	--------------	------

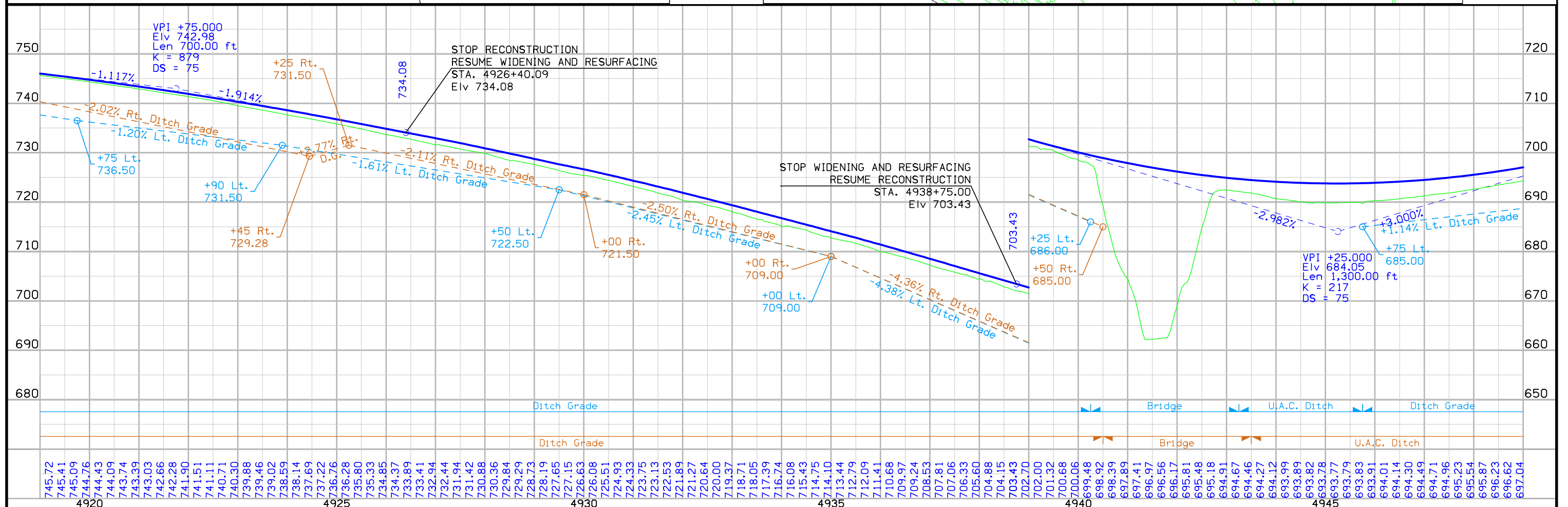
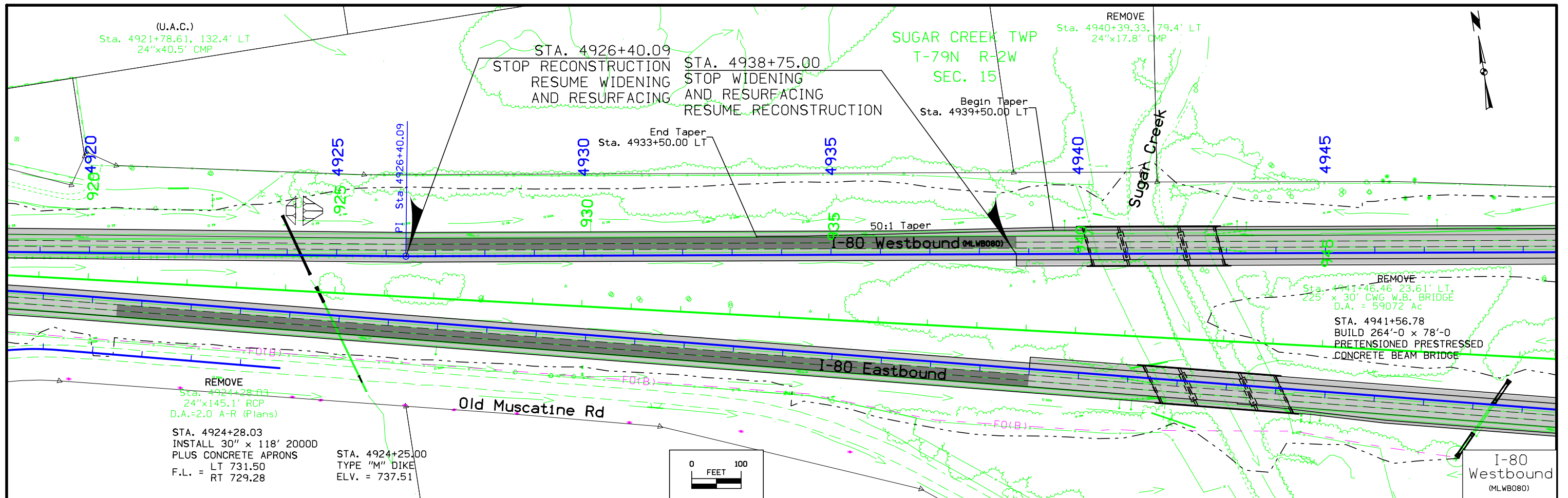



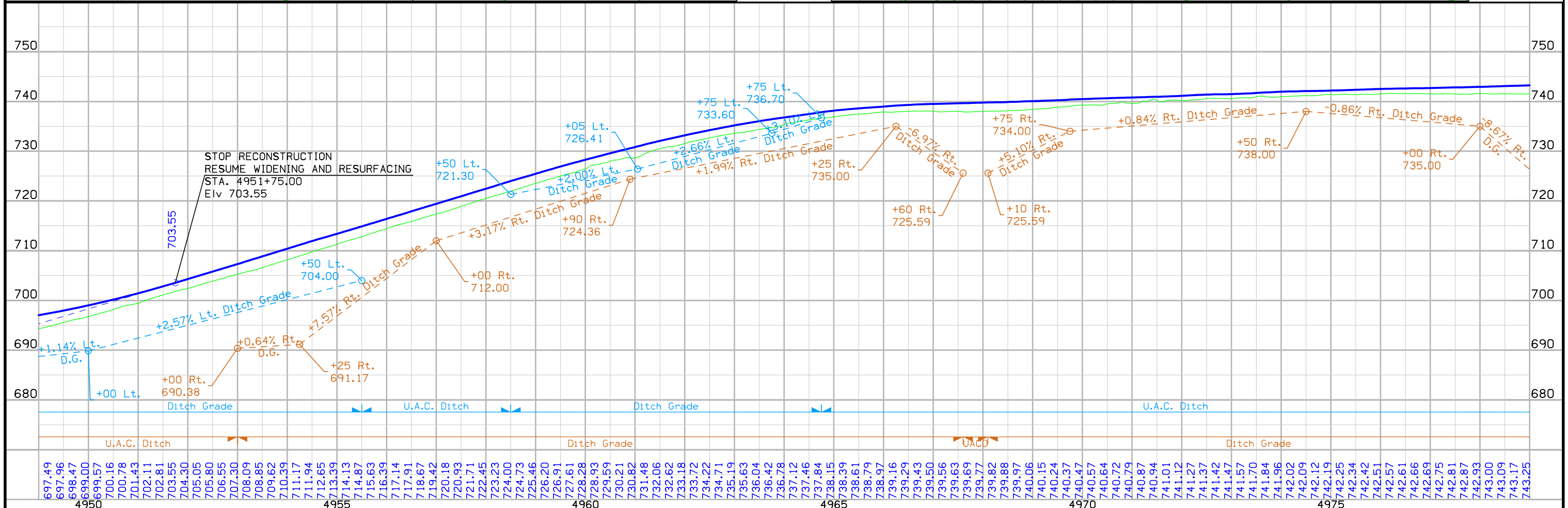
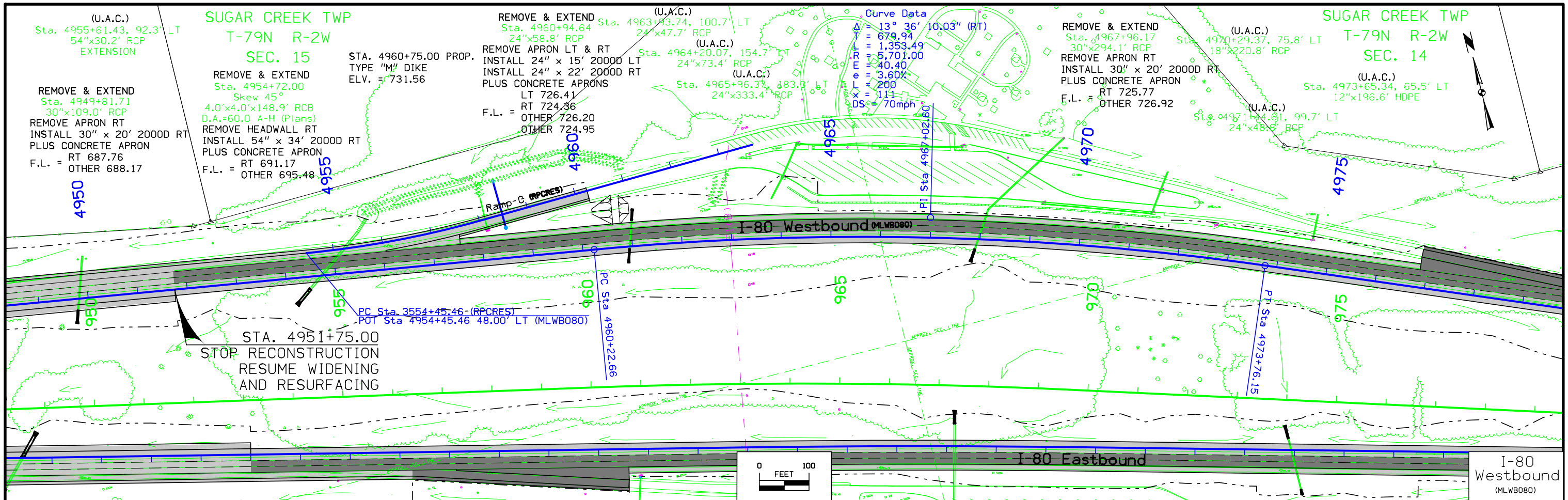

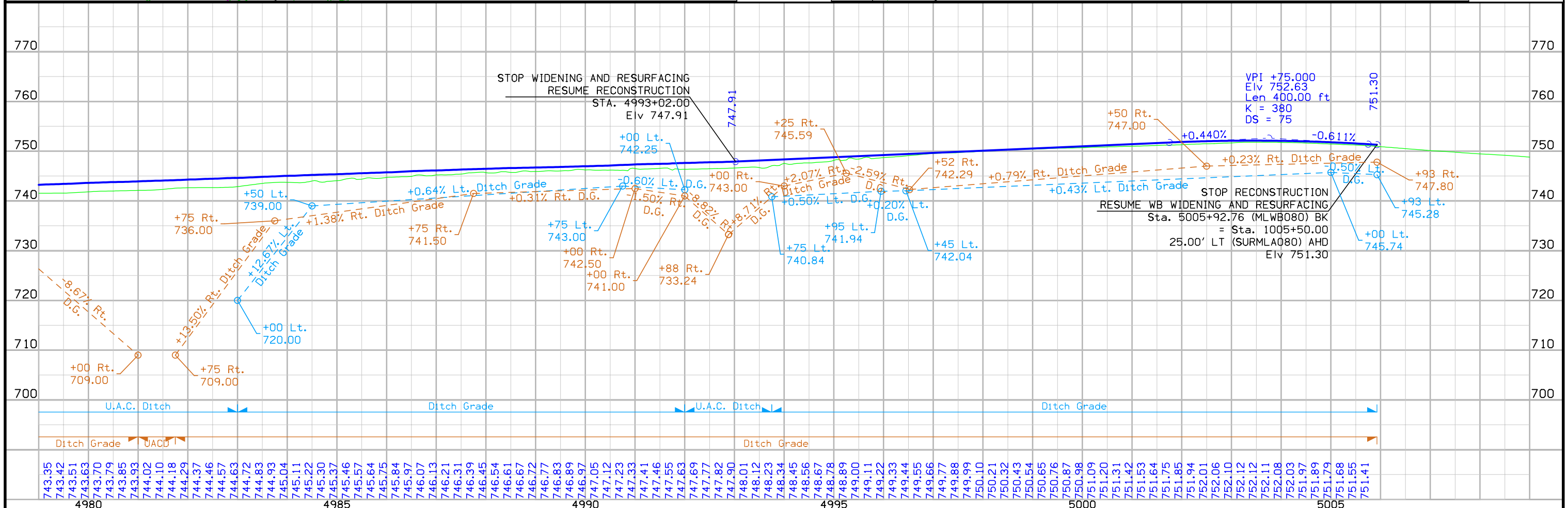
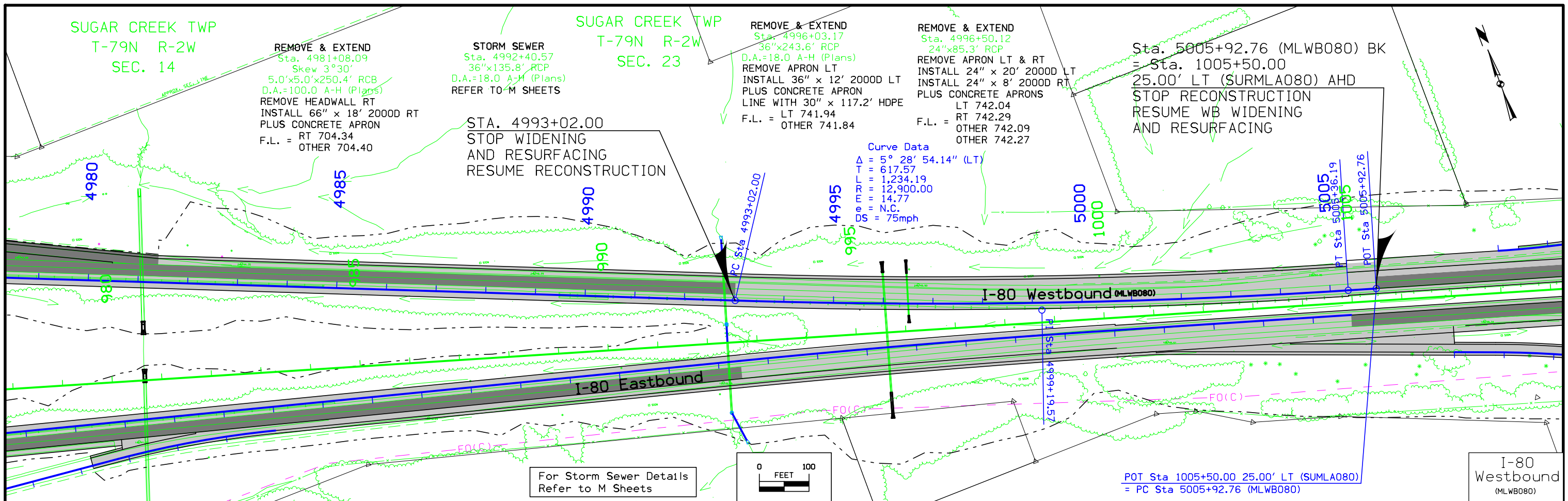

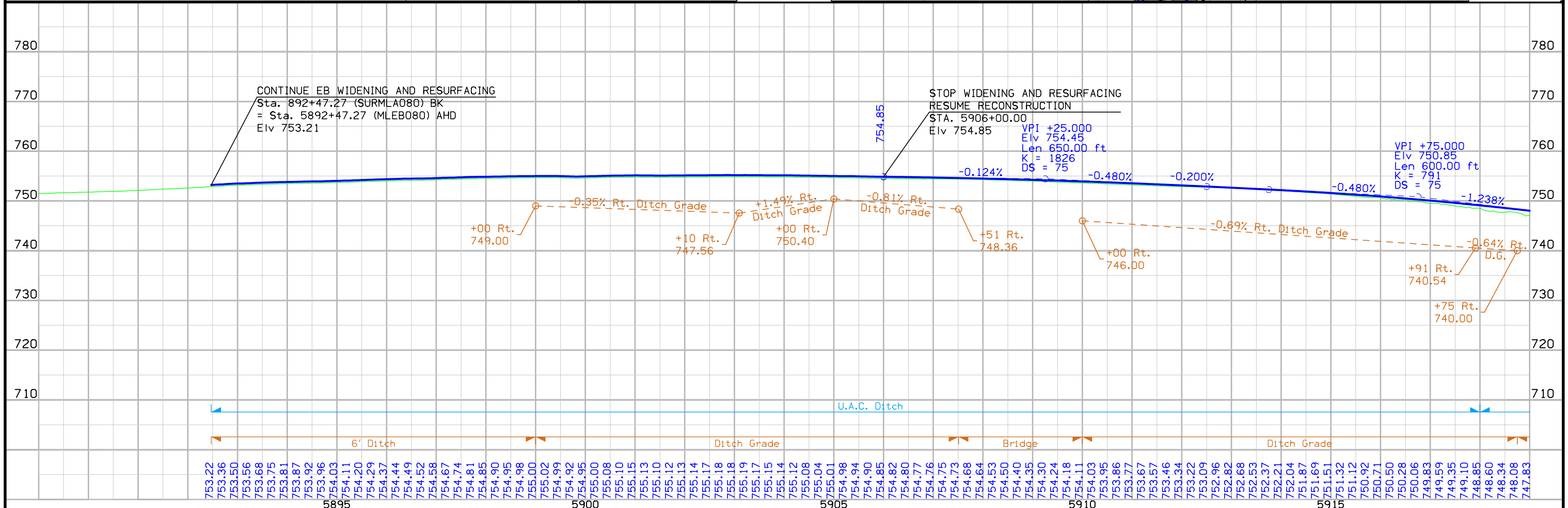
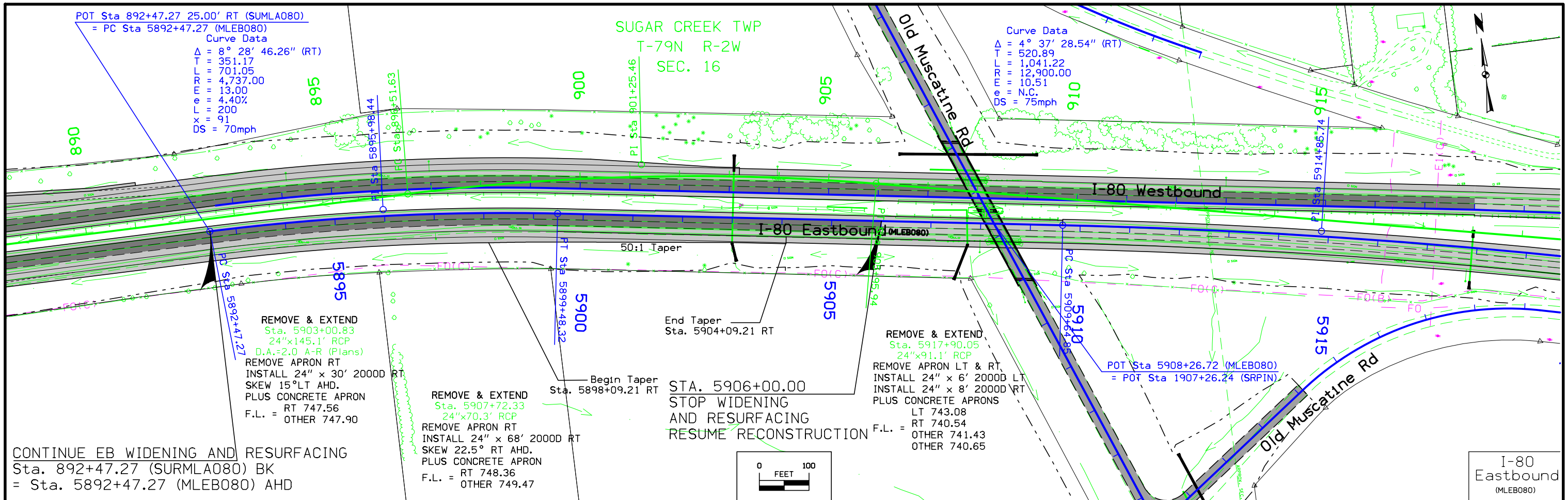



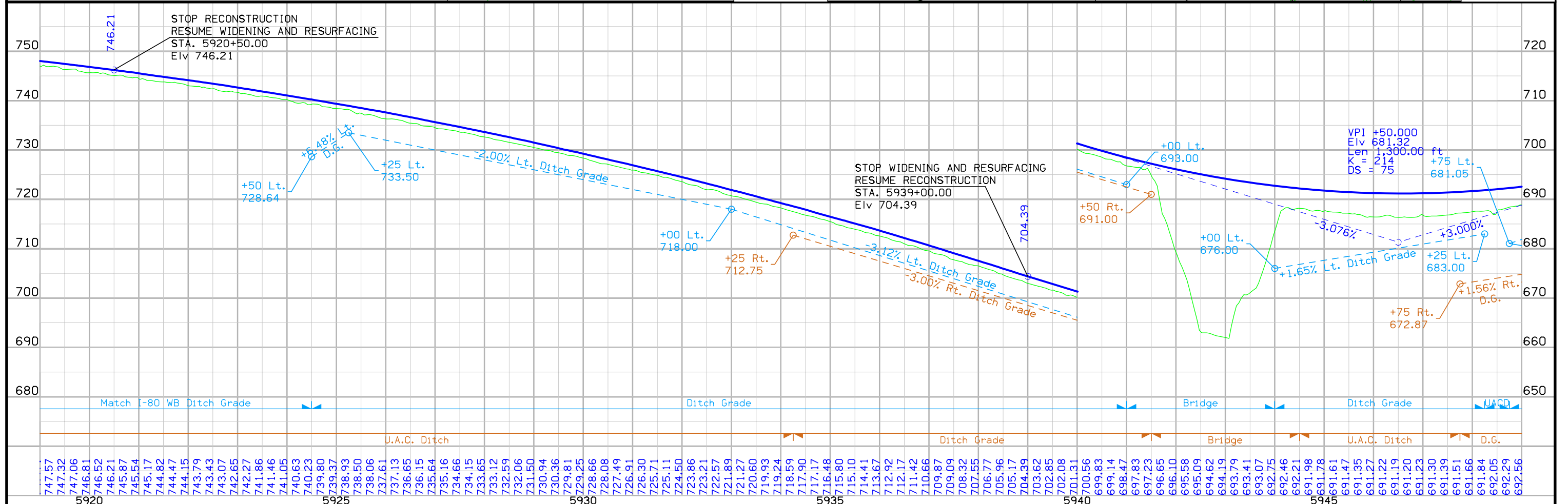
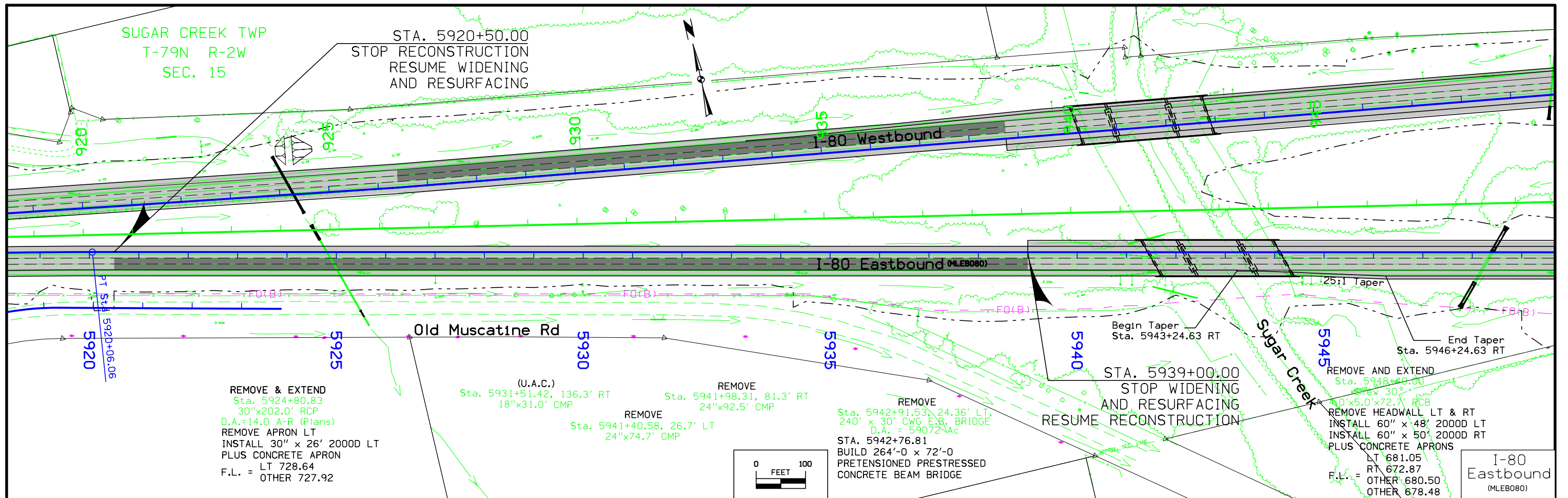

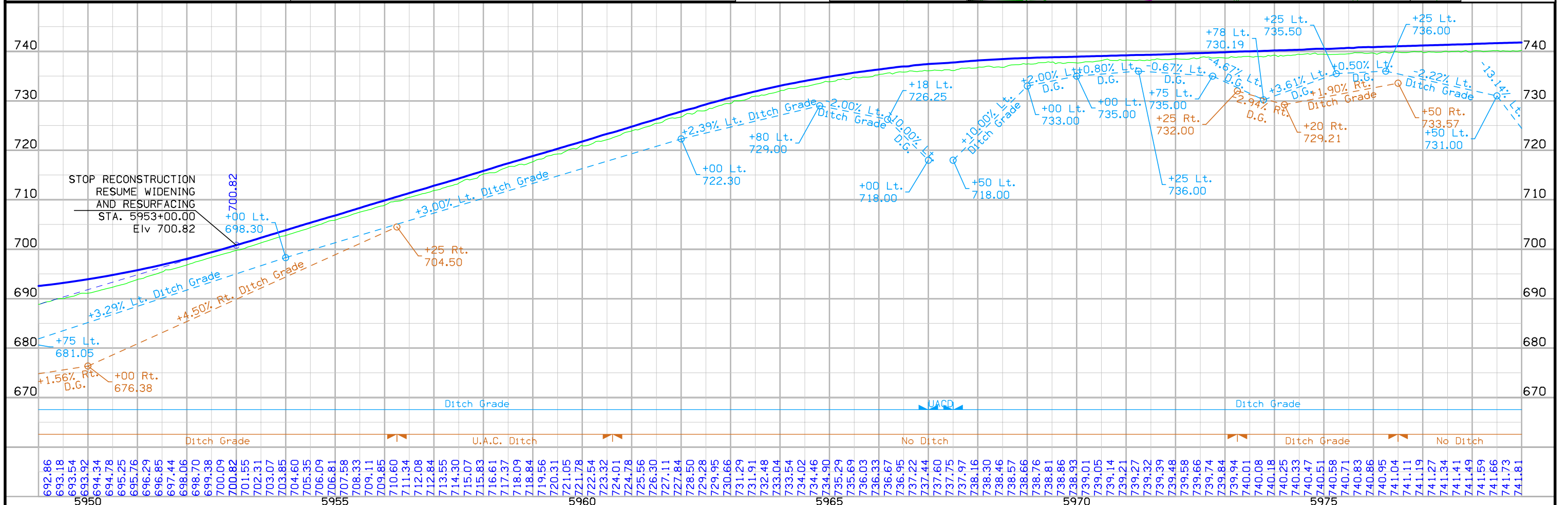
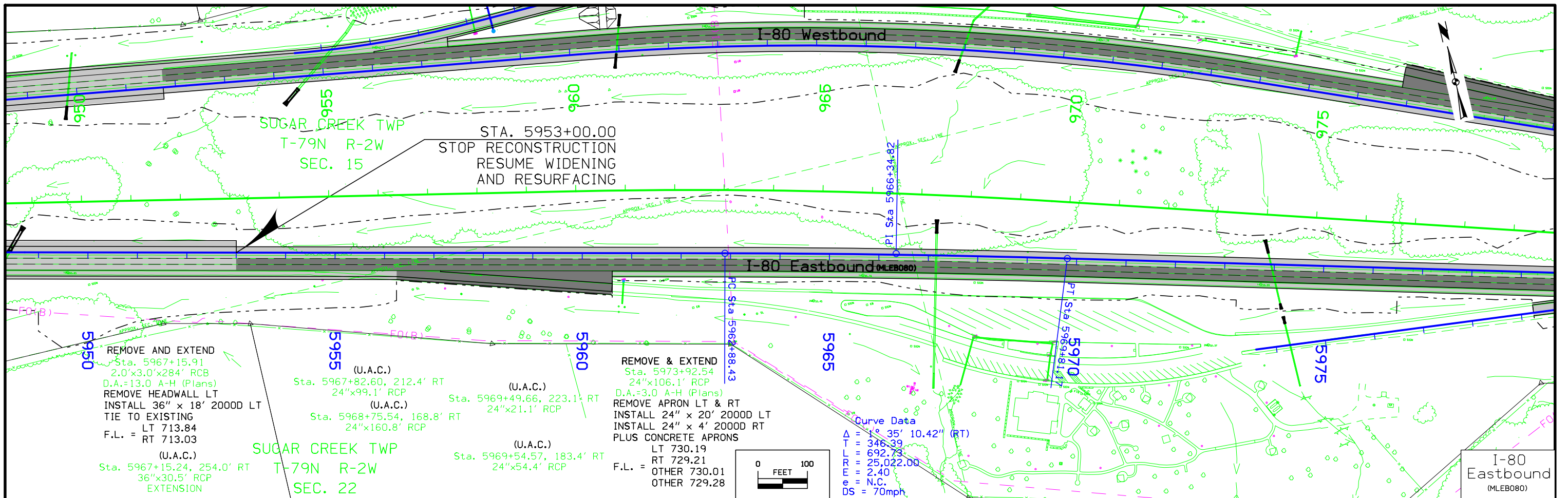

692.86	693.18	693.54	693.92	694.34	694.78	695.25	695.76	696.29	696.85	697.44	698.06	698.70	699.38	700.09	700.82	701.55	702.31	703.07	703.85	704.60	705.35	706.09	706.81	707.58	708.33	709.11	709.85	710.60	711.34	712.08	712.84	713.55	714.30	715.07	715.83	716.61	717.37	718.09	718.84	719.56	720.31	721.05	721.78	722.54	723.32	724.01	724.78	725.56	726.30	727.11	727.84	728.50	729.28	729.95	730.66	731.29	731.91	732.48	733.04	733.54	734.02	734.46	734.90	735.29	735.69	736.03	736.33	736.67	736.95	737.22	737.44	737.60	737.75	737.97	738.16	738.30	738.46	738.57	738.66	738.76	738.81	738.86	738.93	739.01	739.05	739.14	739.21	739.27	739.32	739.39	739.48	739.58	739.66	739.74	739.84	739.94	740.01	740.08	740.18	740.25	740.33	740.47	740.51	740.58	740.71	740.83	740.86	740.95	741.04	741.11	741.19	741.27	741.34	741.41	741.49	741.59	741.66	741.73	741.81
--------	--------	--------	--------	--------	--------	--------	--------	--------	--------	--------	--------	--------	--------	--------	--------	--------	--------	--------	--------	--------	--------	--------	--------	--------	--------	--------	--------	--------	--------	--------	--------	--------	--------	--------	--------	--------	--------	--------	--------	--------	--------	--------	--------	--------	--------	--------	--------	--------	--------	--------	--------	--------	--------	--------	--------	--------	--------	--------	--------	--------	--------	--------	--------	--------	--------	--------	--------	--------	--------	--------	--------	--------	--------	--------	--------	--------	--------	--------	--------	--------	--------	--------	--------	--------	--------	--------	--------	--------	--------	--------	--------	--------	--------	--------	--------	--------	--------	--------	--------	--------	--------	--------	--------	--------	--------	--------	--------	--------	--------	--------	--------	--------	--------	--------	--------	--------	--------	--------	--------





SUGAR CREEK TWP  
T-79N R-2W  
SEC. 23

SUGAR CREEK TWP  
T-79N R-2W  
SEC. 24

STA. 1018+12.00  
INSTALL 42" x 210' 2000D  
PLUS CONCRETE APRONS  
F.L. = LT 733.37  
RT 731.42

REMOVE & EXTEND  
Sta. 1026+99.42  
6.0'x8.0'x326.5' RCB  
REMOVE HEADWALL LT & RT  
INSTALL 6' x 8' x 8' PRECAST CONCRETE BOX LT  
INSTALL 6' x 8' x 47' PRECAST CONCRETE BOX RT OR  
BUILD 6' x 8' x 7' CAST-IN-PLACE CONCRETE BOX LT  
BUILD 6' x 8' x 41' CAST-IN-PLACE CONCRETE BOX RT  
PLUS CONCRETE HEADWALLS  
LT 719.05  
F.L. = RT 716.42  
OTHER 718.98  
OTHER 716.86

REMOVE  
Sta. 1018+02.00  
36"x129.4' RCP  
D.A.=2.0' A-H (Plans)

STA. 1018+37.00 PROP.  
TYPE "M" DIKE  
ELV. = 739.00

REMOVE  
Sta. 1020+50.10  
24"x146.8' RCP

STA. 1019+86.00  
INSTALL 24" x 232' 2000D  
PLUS CONCRETE APRONS  
F.L. = LT 731.69  
RT 730.48

POT Sta 1021+64.78 (SURMLA080)  
= POT Sta 177+34.52 (SRROS)

PC Sta 3508+00.00 (RPCROS)  
POT Sta 1008+00.00 85.00' LT (SURMLA080)

STOP RECONSTRUCTION  
RESUME WB WIDENING AND RESURFACING  
Sta. 5005+92.76 (MLWB080) BK  
= Sta. 1005+50.02 25.40'  
LT (SURMLA080) AHD

STOP RECONSTRUCTION  
RESUME EB WIDENING AND RESURFACING  
Sta. 6004+76.96 (MLEB080) BK  
= Sta. 1004+97.15 25.31'  
RT (SURMLA080) AHD

POT Sta 2507+00.00 (RPBROS)  
POT Sta 1006+98.94 112.93' RT (SURMLA080)

REMOVE  
Sta. 1017+92.00  
24"x19.9' RCP

REMOVE  
Sta. 1019+96.70  
18"x79.6' RCP

STA. 1017+77.00  
INSTALL 24" x 102' 2000D  
PLUS CONCRETE APRONS  
LT 733.74  
F.L. = RT 737.92  
OTHER 736.90

STA. 1018+02.00 PROP.  
TYPE "M" DIKE  
ELV. = 740.20

STA. 1020+07.00  
INSTALL 24" x 130' 2000D  
PLUS CONCRETE APRONS  
F.L. = LT 731.69  
RT 730.48

STA. 1020+32.00 PROP.  
TYPE "M" DIKE  
ELV. = 736.30

REMOVE  
Sta. 1026+00.00, 1.7' RT  
24"x79.2' RCP

STA. 1025+90.00  
INSTALL 24" x 118' 2000D  
PLUS CONCRETE APRONS  
F.L. = LT 722.60  
RT 729.78

REMOVE  
Sta. 1026+24.03, 92.0' LT  
24"x52.0' RCP

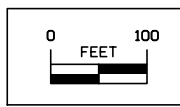

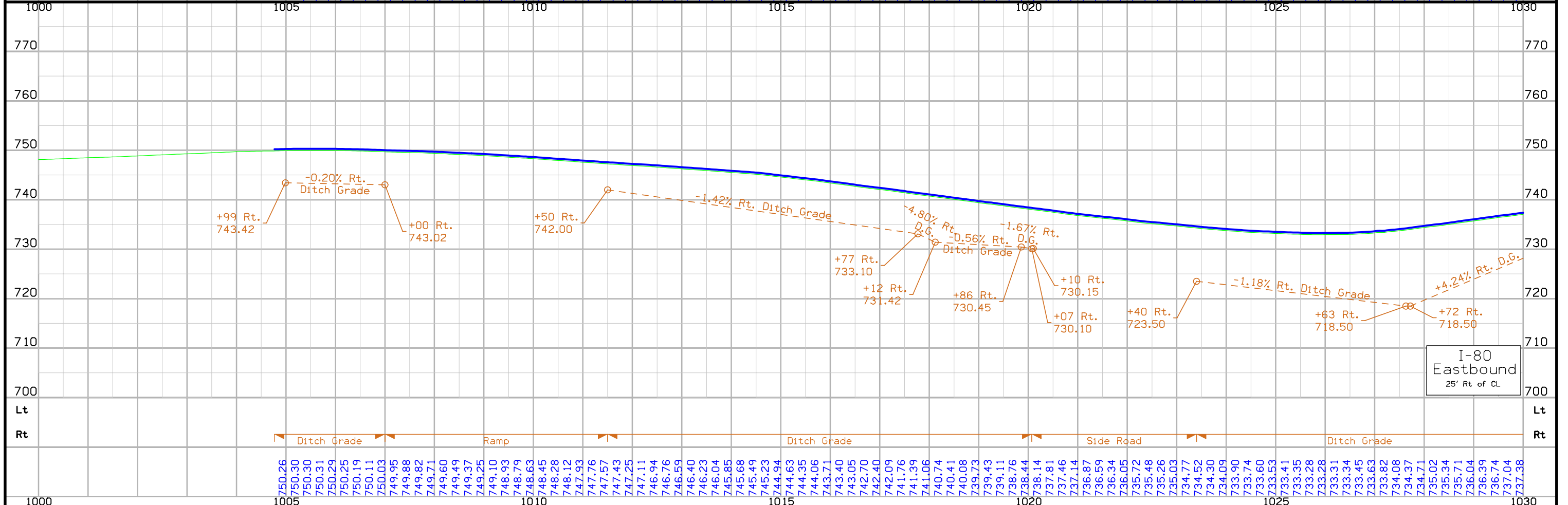
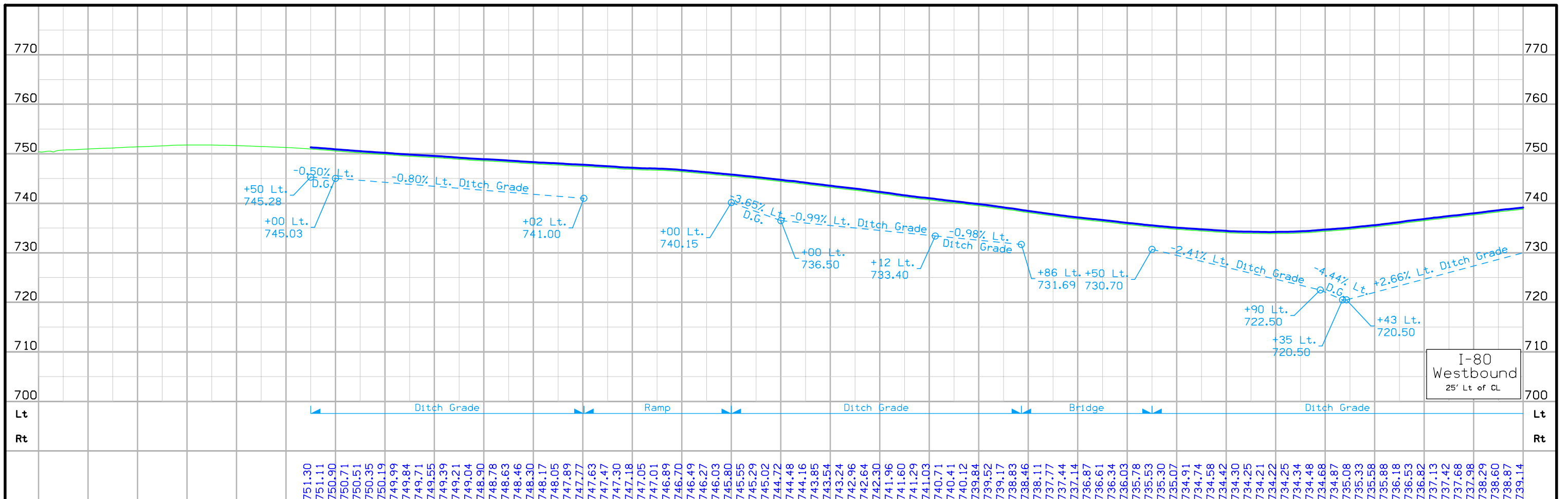



SUGAR CREEK TWP  
T-79N R-2W  
SEC. 24

Curve Data  
 $\Delta = 17^\circ 07' 01.39''$  (LT)  
 $T = 862.34$   
 $L = 1,711.83$   
 $R = 5,730.00$   
 $E = 64.53$   
 $e = 3.60\%$   
 $L = 200$   
 $x = 111$   
 $DS = 70$



REMOVE & EXTEND  
 Sta. 1061+19.00  
 24"x144.7' RCP

STA. 1061+44.0  
 TYPE "M" DIKE  
 ELV. = 731.10

STA. 1034+57.00 PROP.  
 TYPE "M" DIKE  
 ELV. = 739.30

STA. 1036+57.00 PROP.  
 TYPE "M" DIKE  
 ELV. = 743.40

REMOVE  
 Sta. 1034+70.70  
 24"x137.2' RCP  
 D.A.=2.0 A-H (Plans)

REMOVE & EXTEND  
 Sta. 1041+00.00, 3.8' LT  
 24"x56.7' RCP  
 REMOVE APRON LT & RT  
 INSTALL 24" x 50' 20000 LT  
 INSTALL 24" x 4' 20000 RT  
 PLUS CONCRETE APRONS  
 LT 742.97  
 RT 745.38  
 F.L. = OTHER 745.04  
 OTHER 745.35

REMOVE  
 Sta. 1055+00.50, 0.5' RT  
 24"x59.8' RCP

STA. 1055+10.00  
 INSTALL 24" x 100' 20000  
 PLUS CONCRETE APRONS  
 F.L. = LT 739.73  
 RT 743.18

REMOVE  
 Sta. 1034+77.35, 9.8' RT  
 18"x13.3' RCP

STA. 1034+81.00  
 INSTALL 24" x 254' 20000  
 PLUS CONCRETE APRONS  
 F.L. = LT 737.96  
 RT 734.04

STA. 1034+91.00  
 INSTALL 24" x 126' 20000  
 PLUS CONCRETE APRONS  
 LT 738.75  
 F.L. = RT 734.37  
 OTHER 737.77

STA. 1055+35.00 PROP.  
 TYPE "M" DIKE  
 ELV. = 743.50

POT Sta 1535+00.00 (RPAR05)  
 POT Sta 1035+01.06 112.93' LT (SURMLA080)

End Taper  
 Sta. 1049+20.00 LT

Begin Taper  
 Sta. 1052+20.00 LT

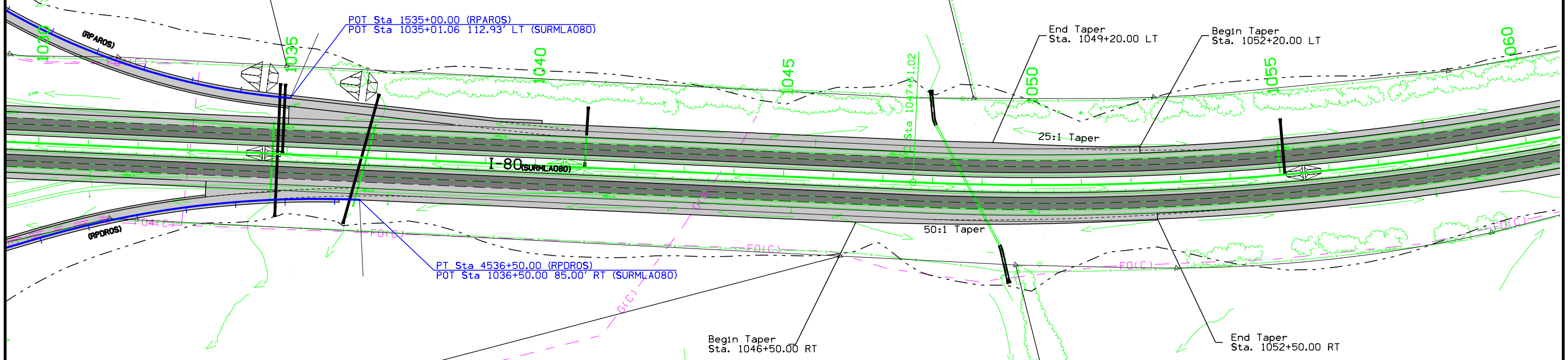

STA. 1034+66.00 PROP.  
 TYPE "M" DIKE  
 ELV. = 741.00

STA. 1036+50.00  
 INSTALL 24" x 258' 20000  
 SKEW 13° LT AHD.  
 PLUS CONCRETE APRONS  
 F.L. = LT 739.24  
 RT 730.80

REMOVE  
 Sta. 1036+60.30  
 Skew 13°  
 24"x170.6' RCP  
 D.A.=3.0 A-H (Plans)

REMOVE & EXTEND  
 Sta. 1048+70.30  
 Skew 30°  
 3.0'x4.0'x274.8' RCB  
 REMOVE HEADWALL LT & RT  
 INSTALL 48" x 62' 20000 LT  
 INSTALL 48" x 68' 20000 RT  
 PLUS CONCRETE APRONS  
 LT 726.12  
 RT 721.75  
 F.L. = OTHER 725.40  
 OTHER 722.54

Begin Taper  
 Sta. 1046+50.00 RT

End Taper  
 Sta. 1052+50.00 RT

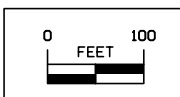

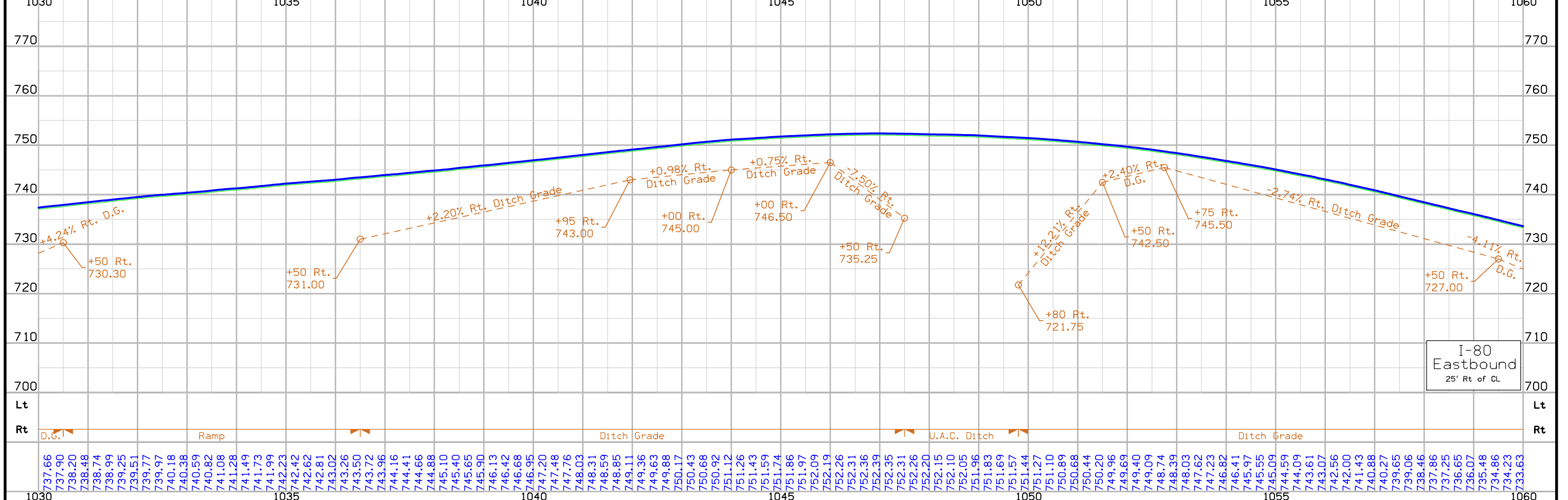
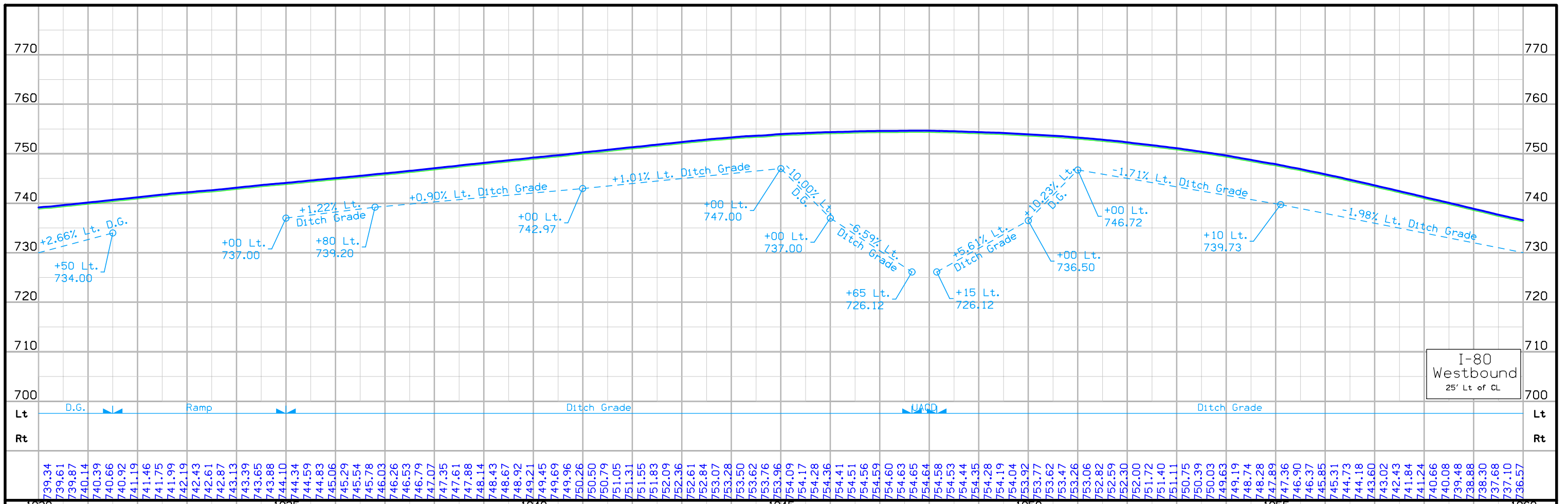

SUGAR CREEK TWP  
T-79N R-2W  
SEC. 24

FARMINGTON TWP  
T-79N R-1W  
SEC. 19



REMOVE & EXTEND  
Sta. 1061+19.00  
24"x144.7' RCP

STA. 1061+44.00  
TYPE "M" DIKE  
ELV. = 731.10

REMOVE & EXTEND  
Sta. 1064+11.38, 0.7' RT  
24"x59.1' RCP

PROP.

REMOVE APRON LT  
INSTALL 24" x 38' 2000D LT  
PLUS CONCRETE APRON  
RT 720.03  
F.L. = OTHER 720.47

REMOVE  
Sta. 1071+73.00, 2.7' RT  
18"x70.8' RCP

STA. 1071+32.00  
INSTALL 24" x 120' 2000D  
PLUS CONCRETE APRONS  
LT 696.96  
RT 705.04

REMOVE & EXTEND  
Sta. 1074+25.0, 3.3' LT  
24"x83.4' RCP

REMOVE APRON LT  
INSTALL 24" x 40' 2000D LT  
PLUS CONCRETE APRON  
LT 697.45  
F.L. = OTHER 698.75

REMOVE  
Sta. 1080+99.40, 3.2' LT  
24"x58.7' RCP

STA. 1081+10.00  
INSTALL 24" x 102' 2000D  
PLUS CONCRETE APRONS  
LT 708.19  
RT 711.77

REMOVE  
Sta. 1088+99.70  
30"x131.5' RCP

STA. 1089+10.00  
INSTALL 30" x 208' 2000D  
PLUS CONCRETE APRONS  
LT 714.46  
RT 716.66

REMOVE  
Sta. 1089+06.56, 4.0' LT  
24"x14.0' RCP

STA. 1089+20.00  
INSTALL 24" x 98' 2000D  
PLUS CONCRETE APRONS  
LT 718.69  
RT 716.71

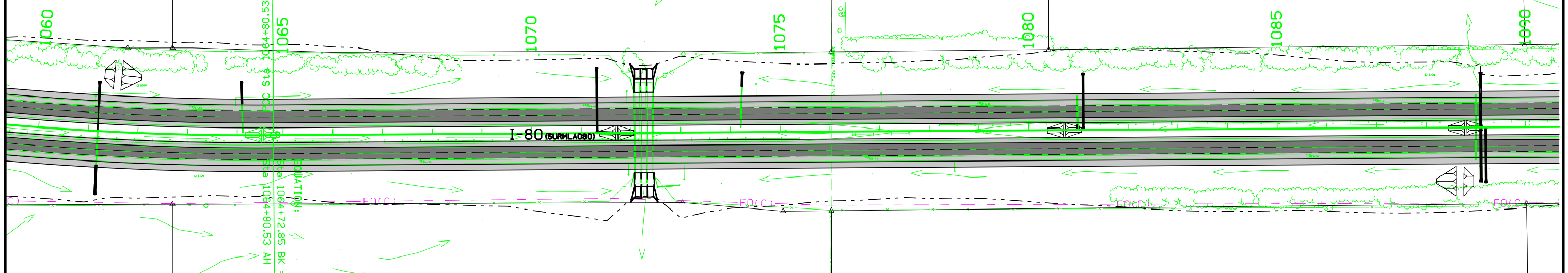

Curve Data  
Δ = 0° 00' 00.04" (LT)  
T = 0.00  
L = 0.00  
R = 5,730.00  
E = 0.00

STA. 1071+57.00 PROP.  
TYPE "M" DIKE  
ELV. = 706.30

REMOVE  
Sta. 1072+75.00, 107.2' RT  
24"x45.8' CMP

REMOVE & BUILD  
Sta. 1072+26.10  
TRIPLE 12"x10"x160' RCB  
REMOVE HEADWALL LT & RT  
BUILD 26' - TRIPLE 12' x 10' RCB LT  
BUILD 27' - TRIPLE 12' x 10' RCB RT  
PLUS CONCRETE HEADWALLS  
LT 691.63  
RT 690.41  
F.L. = OTHER 691.48  
OTHER 690.90

STA. 1080+85.00 PROP.  
TYPE "M" DIKE  
ELV. = 714.50

STA. 1088+95.00 PROP.  
TYPE "M" DIKE  
ELV. = 720.50

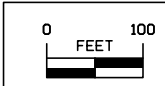

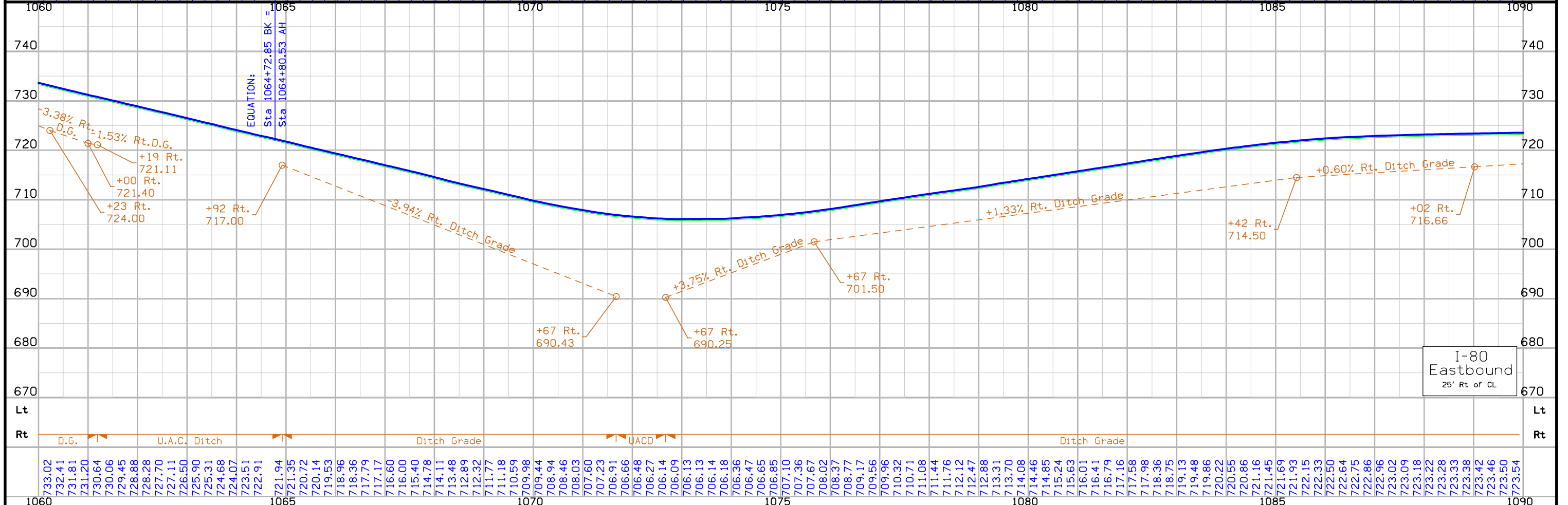
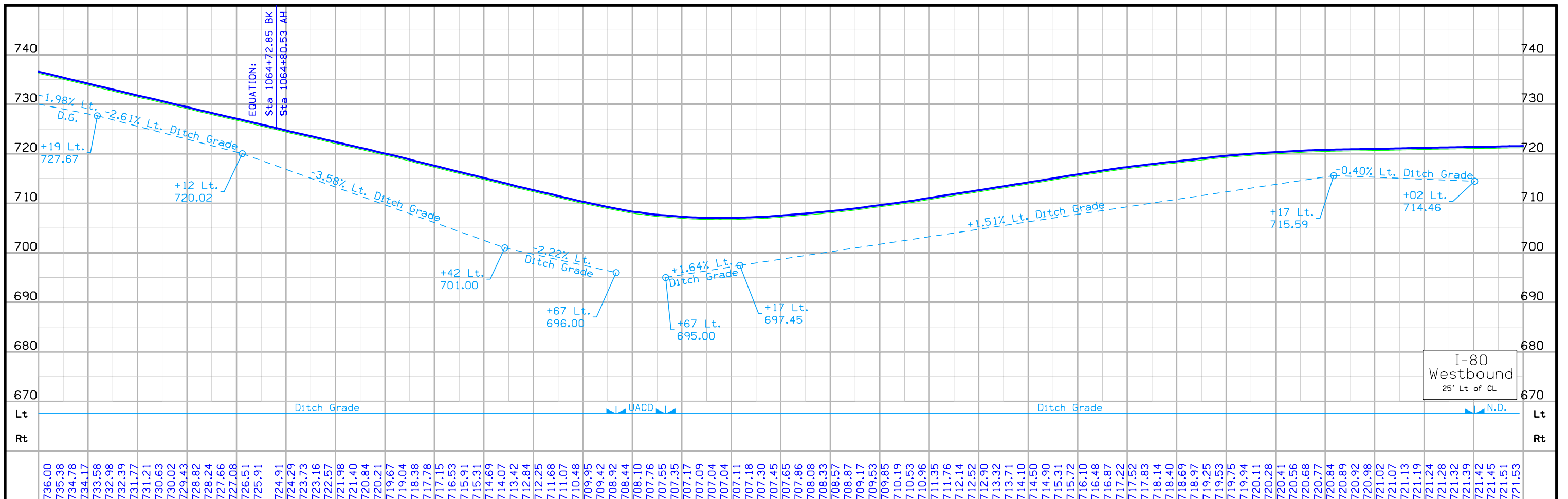

FILE NO.	ENGLISH	DESIGN TEAM	Iowa DOT \ HR Green	CEDAR COUNTY	PROJECT NUMBER	IM-NHS-080-7(134)266--03-16	SHEET NUMBER	D.27
----------	---------	-------------	---------------------	--------------	----------------	-----------------------------	--------------	------

FARMINGTON TWP  
T-79N R-1W  
SEC. 19



REMOVE  
Sta. 1094+98.80  
24"x144.9' RCP  
D.A.=5.0 A-R (Plans)

STA. 1095+09.00  
INSTALL 30" x 211' 20000  
PLUS CONCRETE APRONS  
F.L. = LT 714.00  
RT 718.00

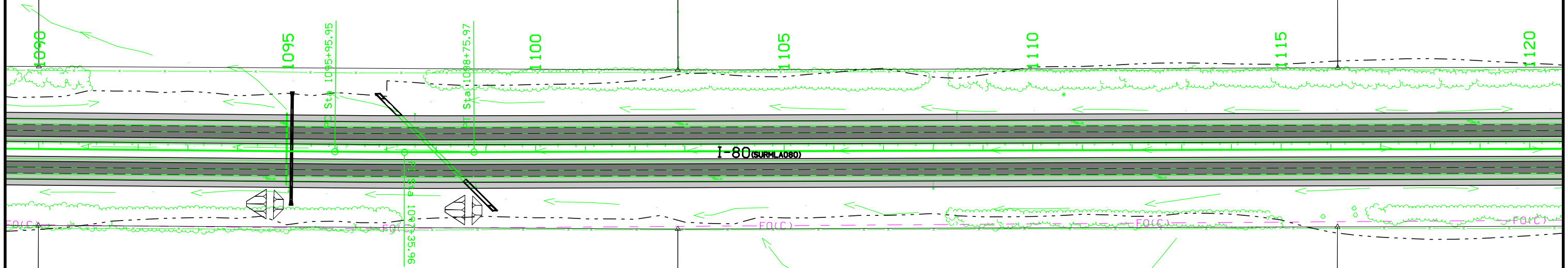

Curve Data  
 $\Delta = 0^\circ 42' 00.00''$  (LT)  
 T = 140.01  
 L = 280.02  
 R = 22,920.00  
 E = 0.43  
 e = N.C.  
 DS = 70

STA. 1094+84.00 PROP.  
TYPE "M" DIKE  
ELV. = 723.30

STA. 1098+99.00 PROP.  
TYPE "M" DIKE  
ELV. = 725.50

REMOVE & EXTEND  
Sta. 1097+99.99  
Skew 45°  
6.0'x3.0'x195.9' RCB  
D.A.=8.0 A-R (Plans)

REMOVE HEADWALL LT &  
INSTALL 6' x 3' x 44' PRECAST CONCRETE BOX RT OR  
INSTALL 6' x 3' x 67' PRECAST CONCRETE BOX RT OR  
BUILD 6' x 3' x 46' CAST-IN-PLACE CONCRETE BOX LT  
BUILD 6' x 3' x 71' CAST-IN-PLACE CONCRETE BOX RT  
PLUS CONCRETE HEADWALLS  
LT 715.33  
RT 722.01  
F.L. = OTHER 716.53  
OTHER 721.57

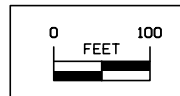



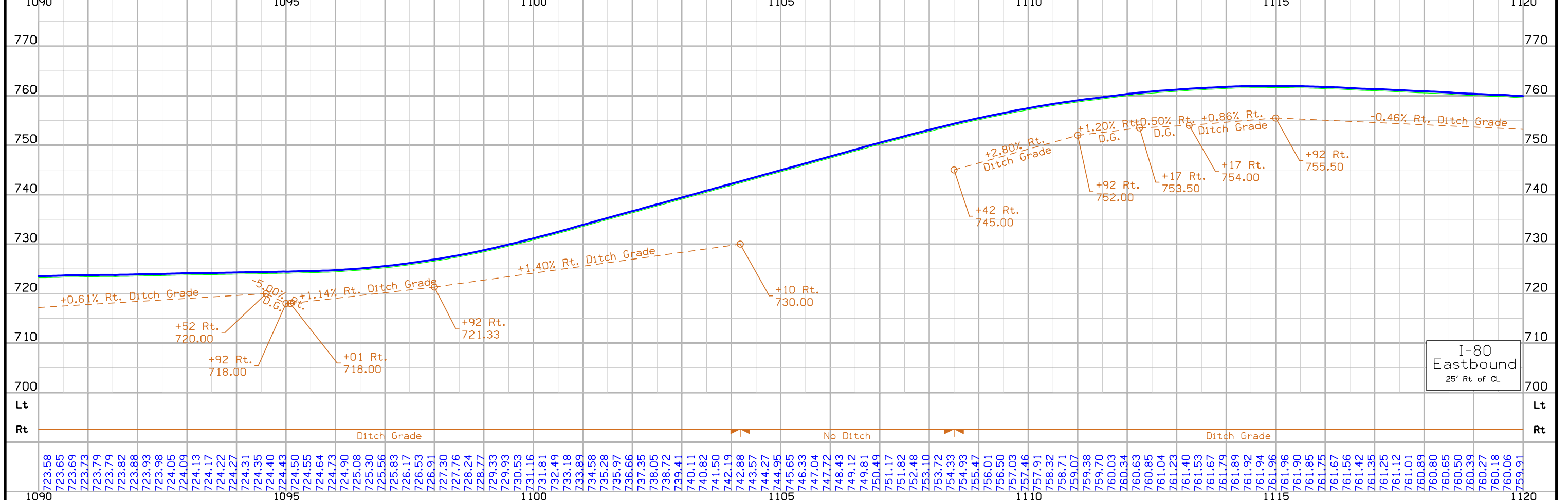
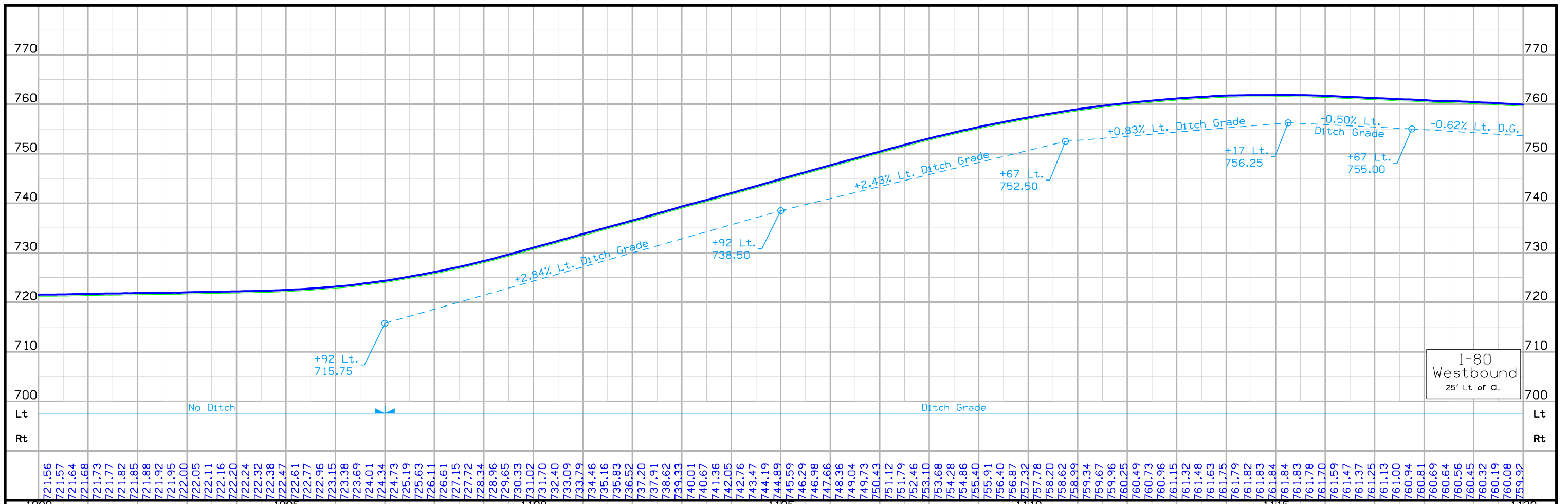

FILE NO.	ENGLISH	DESIGN TEAM	Iowa DOT \ HR Green	CEDAR COUNTY	PROJECT NUMBER	IM-NHS-080-7(134)266--03-16	SHEET NUMBER	D.29
----------	---------	-------------	---------------------	--------------	----------------	-----------------------------	--------------	------

FARMINGTON TWP  
T-79N R-1W  
SEC. 19

FARMINGTON TWP  
T-79N R-1W  
SEC. 20



REMOVE & EXTEND  
Sta. 1125+09.80, 3.3' LT  
24"x82.6' RCP  
REMOVE APRON & 16.0' EXISTING PIPE LT  
INSTALL 24" x 2000D LT  
PLUS CONCRETE APRON  
LT 748.63  
F.L.= OTHER 749.00

POT Sta 1129+36.01 (SURMLA080)  
= POT Sta 21+60.84 (SRROS)

REMOVE  
Sta. 1135+14.00  
24"x26.6' RCP

STA. 1135+20.00 PROP.  
TYPE "M" DIKE  
ELV. = 752.70

REMOVE  
Sta. 1135+27.00  
24"x7.2' RCP

(U.A.C.)  
Sta. 1135+27.00  
24"x77.5' CMP

STA. 1134+93.00  
INSTALL 24" x 96' 2000D  
PLUS CONCRETE APRONS  
LT 746.64  
F.L.= RT 749.87  
OTHER 748.01

STA. 1135+50.00 PROP.  
TYPE "M" DIKE  
ELV. = 751.90

REMOVE AND EXTEND  
Sta. 1144+40.00, 3.0' LT  
24"x81.9' RCP  
REMOVE APRON & 16.0' LT  
INSTALL 24" x 58' 2000D LT  
PLUS CONCRETE APRON  
LT 734.94  
F.L.= OTHER 735.22

STA. 1125+35.00 PROP.  
TYPE "M" DIKE  
ELV. = 756.60

STA. 1125+50.00  
INSTALL 42" x 226' 2000D LT  
PLUS CONCRETE APRONS  
LT 748.18  
F.L.= RT 745.96

REMOVE  
Sta. 1125+62.1  
36"x175.5' RCP  
D.A.=23.0' A-R (Plans)

REMOVE  
Sta. 1135+27.00  
24"x225.3' RCP  
D.A.=10.0' A-R (Plans)

STA. 1135+44.00  
INSTALL 24" x 216' 2000D  
SKEW 12° RT AHD.  
PLUS CONCRETE APRONS  
LT 746.88  
F.L.= RT 745.92

STA. 1144+60.00 PROP.  
TYPE "M" DIKE  
ELV. = 747.10

REMOVE & EXTEND  
Sta. 1144+76.90  
Skew 15°  
42"x199.2' RCP  
D.A.=35.0' A-R (Plans)  
REMOVE APRONS LT & RT  
INSTALL 42" x 44' 2000D LT  
INSTALL 42" x 52' 2000D RT  
PLUS CONCRETE APRONS  
LT 734.81  
F.L.= RT 726.07  
OTHER 733.30  
OTHER 727.72

Taylor Ave

I-80 (SURMLA080)

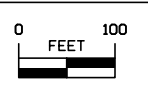

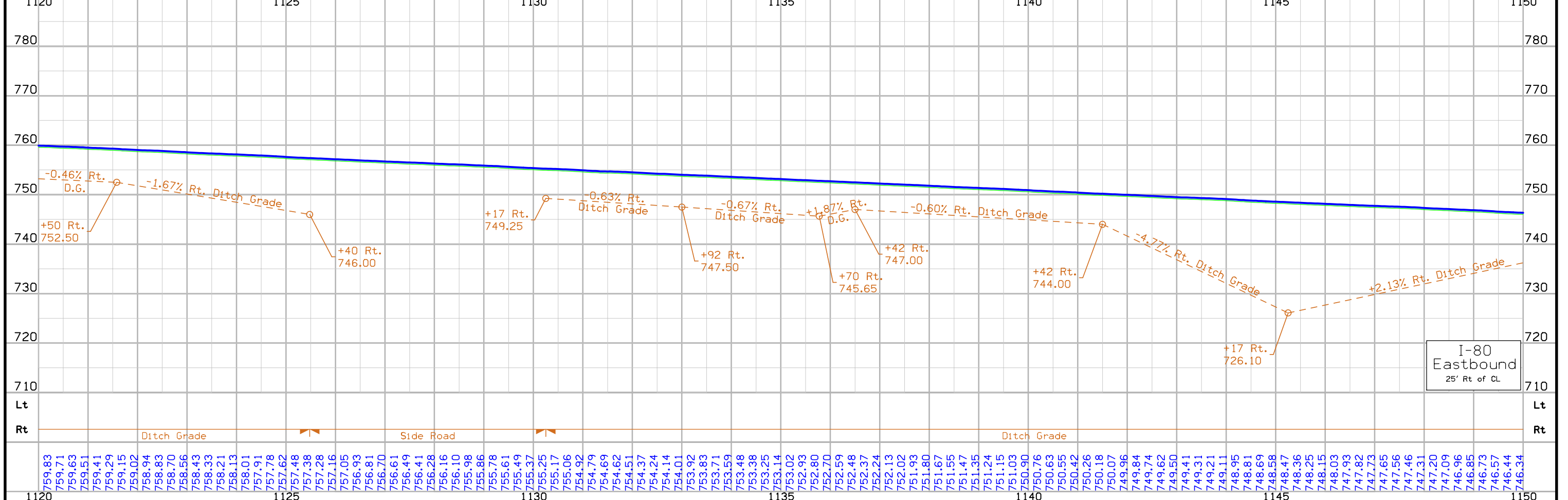
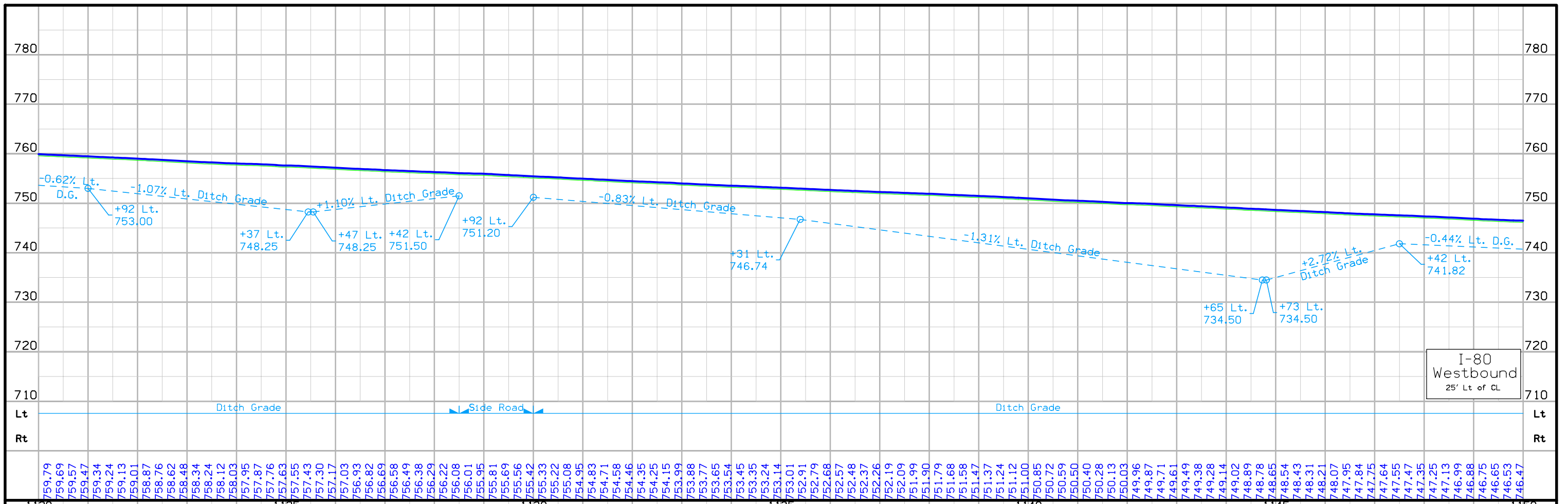

FARMINGTON TWP  
T-79N R-1W  
SEC. 20



STA. 1152+25.00 PROP.  
TYPE "M" DIKE  
ELV. = 744.60

REMOVE  
Sta. 1152+15.30, 3.0' LT  
18"x25.9' RCP

STA. 1151+96.00  
INSTALL 24" x 98' 2000D  
PLUS CONCRETE APRONS  
LT 739.84  
F.L.= RT 741.97  
OTHER 740.33

STA. 1153+25 PROP.  
TYPE "M" DIKE  
ELV. = 741.90

REMOVE  
Sta. 1205+02.50, 3.3' LT  
24"x57.9' RCP

STA. 1205+13.00  
INSTALL 24" x 98' 2000D  
PLUS CONCRETE APRONS  
LT 722.96  
F.L.= RT 726.22  
OTHER 724.38

REMOVE  
Sta. 1213+00.0, 3.6' LT  
24"x56.4' RCP

STA. 1213+10.00  
INSTALL 24" x 96' 2000D  
PLUS CONCRETE APRONS  
LT 705.38  
F.L.= RT 708.60  
OTHER 706.77

REMOVE  
Sta. 1219+85.90, 104.4' LT  
24"x48.2' CMP

REMOVE  
24"x40.4' CMP

REMOVE & EXTEND  
Sta. 1221+40.80, 1.6' LT  
24"x82.6' RCP  
REMOVE APRON LT  
INSTALL 24" x 26' 2000D LT  
PLUS CONCRETE APRON  
LT 690.95  
F.L.= OTHER 692.33

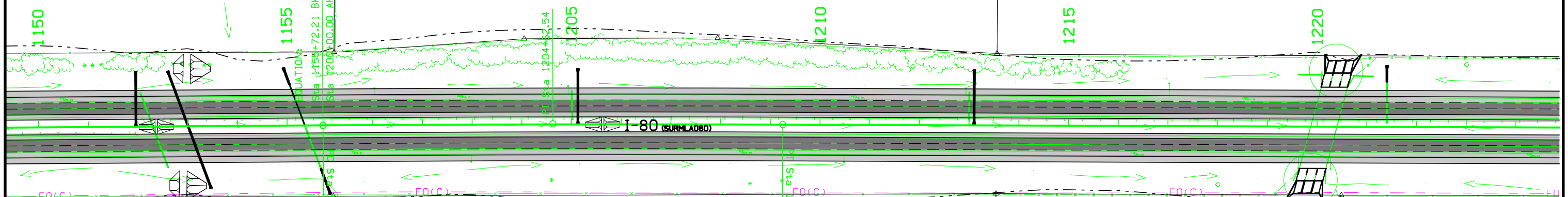

Curve Data  
Δ = 0° 37' 00.00" (RT)  
T = 462.54  
L = 925.07  
R = 85,950.00  
E = 1.24  
e = N.C.  
DS = 70mph

STA. 1152+85.00 PROP.  
TYPE "M" DIKE  
ELV. = 741.90

STA. 1205+25.00 PROP.  
TYPE "M" DIKE  
ELV. = 701.70

REMOVE  
Sta. 1152+29.90  
Skew 20°  
24"x160.6' RCP  
D.A.=5.0 A-R (Plans)

STA. 1153+00.00  
INSTALL 24" x 238' 2000D  
SKEW 20°RT AHD.  
PLUS CONCRETE APRONS  
LT 739.13  
F.L.= RT 733.51

REMOVE & EXTEND  
Sta. 1155+35.60  
Skew 20°  
24"x181.2' RCP  
D.A.=8.0 A-R (Plans)  
REMOVE APRONS LT & RT  
INSTALL 24" x 28' 2000D LT  
INSTALL 24" x 48' 2000D RT  
PLUS CONCRETE APRONS  
LT 734.28  
RT 726.37  
F.L.= OTHER 732.99  
OTHER 727.04

REMOVE & BUILD  
Sta. 1220+13.82  
SKEW 15°  
TRIPLE 15'-18'-15'x10.0'x166' RCB  
D.A. = 4877 AC  
REMOVE HEADWALL LT & RT  
BUILD 29' - 15'-18'-15'x10.0' RCB LT  
BUILD 25' - 15'-18'-15'x10.0' RCB RT  
PLUS CONCRETE HEADWALLS  
LT 686.66  
RT 684.04  
F.L.= OTHER 686.31  
OTHER 684.34

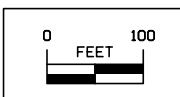

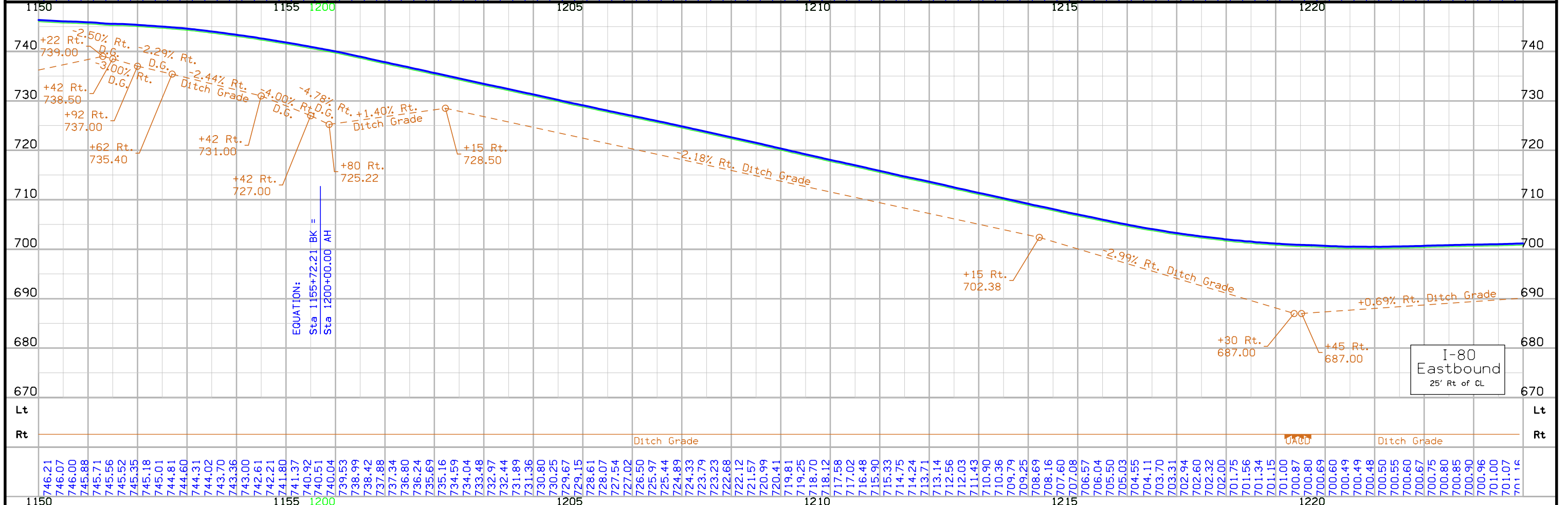
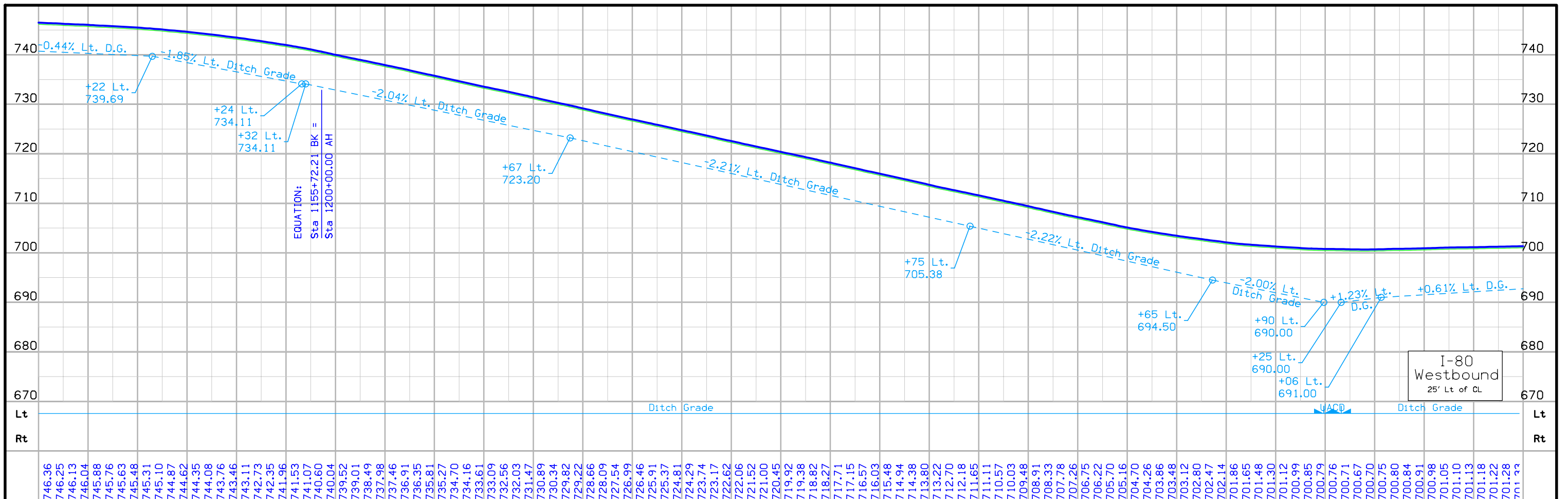

FILE NO.	ENGLISH	DESIGN TEAM	Iowa DOT \ HR Green	CEDAR COUNTY	PROJECT NUMBER	IM-NHS-080-7(134)266--03-16	SHEET NUMBER	D.33
----------	---------	-------------	---------------------	--------------	----------------	-----------------------------	--------------	------

FARMINGTON TWP  
T-79N R-1W  
SEC. 21



REMOVE  
Sta. 1228+98.70, 3.4' LT  
24"x60.2" RCP

REMOVE & EXTEND  
Sta. 1238+98.30, 3.5' LT  
24"x60.3" RCP  
REMOVE APRON LT  
INSTALL 24" x 36' 2000D LT  
PLUS CONCRETE APRON  
LT 698.65  
F.L.= OTHER 699.63

REMOVE  
Sta. 1248+99.20, 3.4' LT  
24"x66.2" RCP

STA. 1228+88.00  
INSTALL 24" x 98' 2000D  
PLUS CONCRETE APRONS  
LT 696.21  
F.L.= RT 698.71  
OTHER 696.97

STA. 1248+89.00  
INSTALL 24" x 100' 2000D  
PLUS CONCRETE APRONS  
LT 710.94  
F.L.= RT 715.91  
OTHER 713.85

1225

1230

1235

1240

1245

1250

I-80 (SURMLA080)

STA. 1228+75.00 PROP.  
TYPE "M" DIKE  
ELV. = 701.70

STA. 1238+75.00 PROP.  
TYPE "M" DIKE  
ELV. = 705.00

STA. 1248+75.00 PROP.  
TYPE "M" DIKE  
ELV. = 718.20

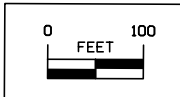



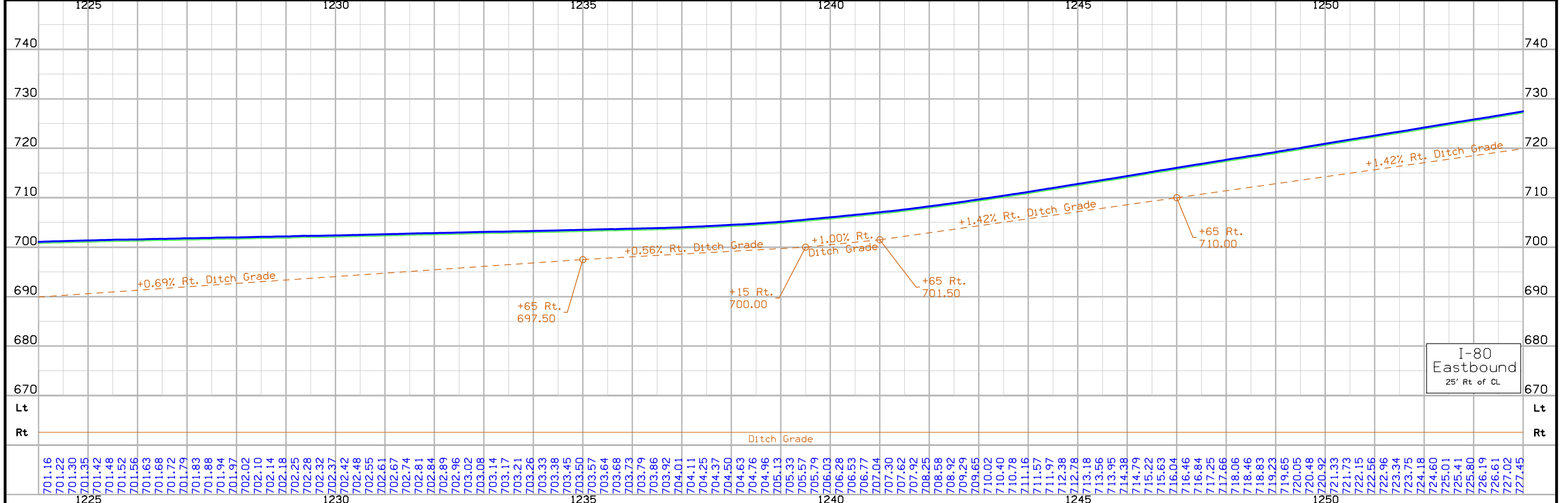
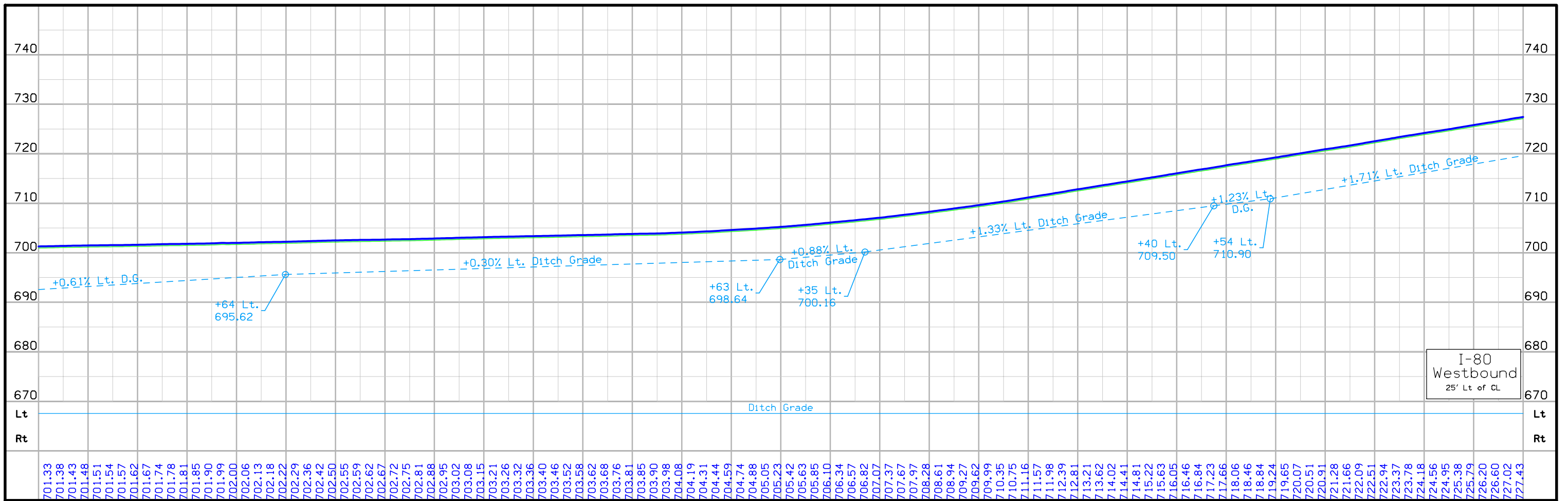

FILE NO.	ENGLISH	DESIGN TEAM	Iowa DOT \ HR Green	CEDAR COUNTY	PROJECT NUMBER	IM-NHS-080-7(134)266--03-16	SHEET NUMBER	D.35
----------	---------	-------------	---------------------	--------------	----------------	-----------------------------	--------------	------



FARMINGTON TWP  
T-79N R-1W  
SEC. 21



REMOVE  
Sta. 1256+99.30, 3.6' LT  
24"x60.0' RCP

Sta. 1256+89.00  
INSTALL 24" x 100' 2000D  
PLUS CONCRETE APRONS  
LT 724.59  
F.L.= RT 727.01  
OTHER 728.96

REMOVE  
Sta. 1271+99.6, 3.3' LT  
24"x60.5' RCP

STA. 1272+09.00  
INSTALL 24" x 94' 2000D  
PLUS CONCRETE APRONS  
LT 728.69  
F.L.= RT 732.13  
OTHER 730.27

REMOVE  
Sta. 1282+20.00, 7.1' LT  
18"x63.3' RCP

STA. 1282+30.00  
INSTALL 24" x 98' 2000D  
PLUS CONCRETE APRONS  
LT 717.09  
F.L.= RT 721.31  
OTHER 719.38

POT Sta 1280+57.52 (SURMLA080)  
= POT Sta 2129+39.12 (SRVER)

1255

1260

1265

1270

1275

1280

Vermont Ave

I-80 (SURMLA080)

STA. 1256+75.00 PROP.  
TYPE "M" DIKE  
ELV. = 731.80

STA. 1272+25.00 PROP.  
TYPE "M" DIKE  
ELV. = 735.10

REMOVE  
Sta. 1281+48.40  
ARCH 54"x88"x153.2' RCP

REMOVE & EXTEND  
Sta. 1278+92.00, 0.7' LT  
18"x71.1' RCP  
REMOVE APRON RT  
INSTALL 18" x 28' 2000D RT  
PLUS CONCRETE APRON  
RT 720.85  
F.L.= OTHER 721.33

STA. 1281+90.00  
INSTALL ARCH 54" x 88" x 208' 2000D  
PLUS CONCRETE APRONS  
LT 715.25  
F.L.= RT 714.87

REMOVE  
Sta. 2129+39.12,  
207'-1 x 24' PPCB BRIDGE  
Sta. 2129+39.12  
Build 272'-0 X 30'-0  
PRETENSIONED PRESTRESSED  
CONCRETE BEAM BRIDGE

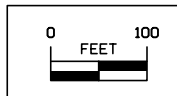

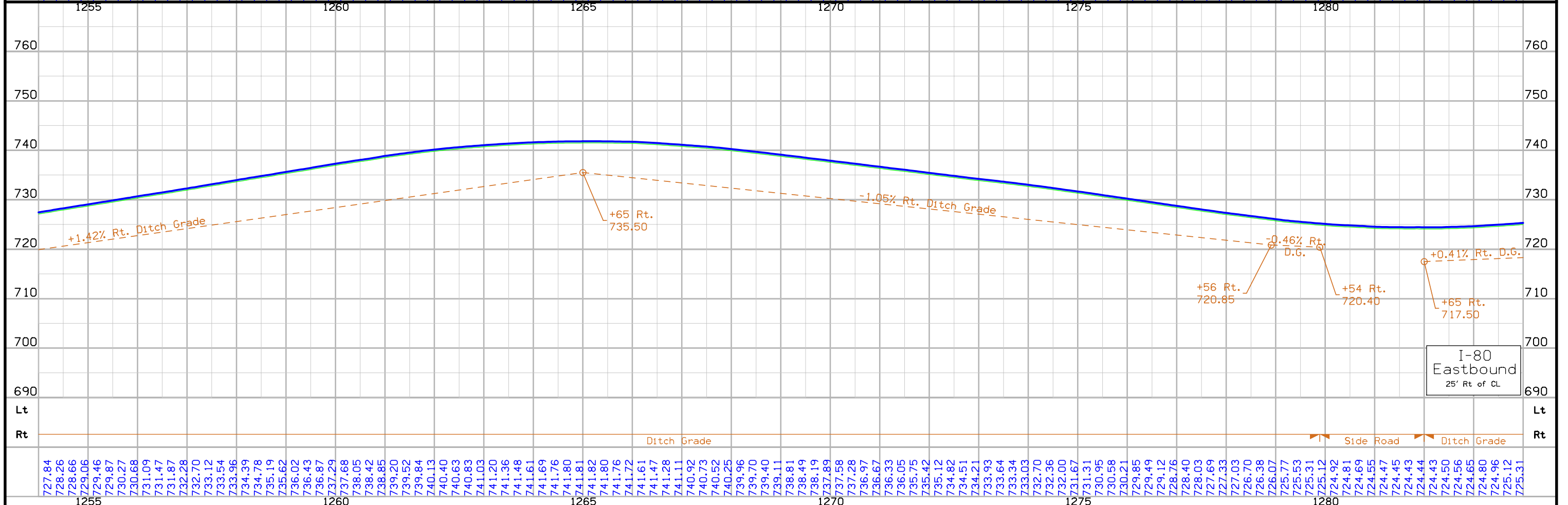
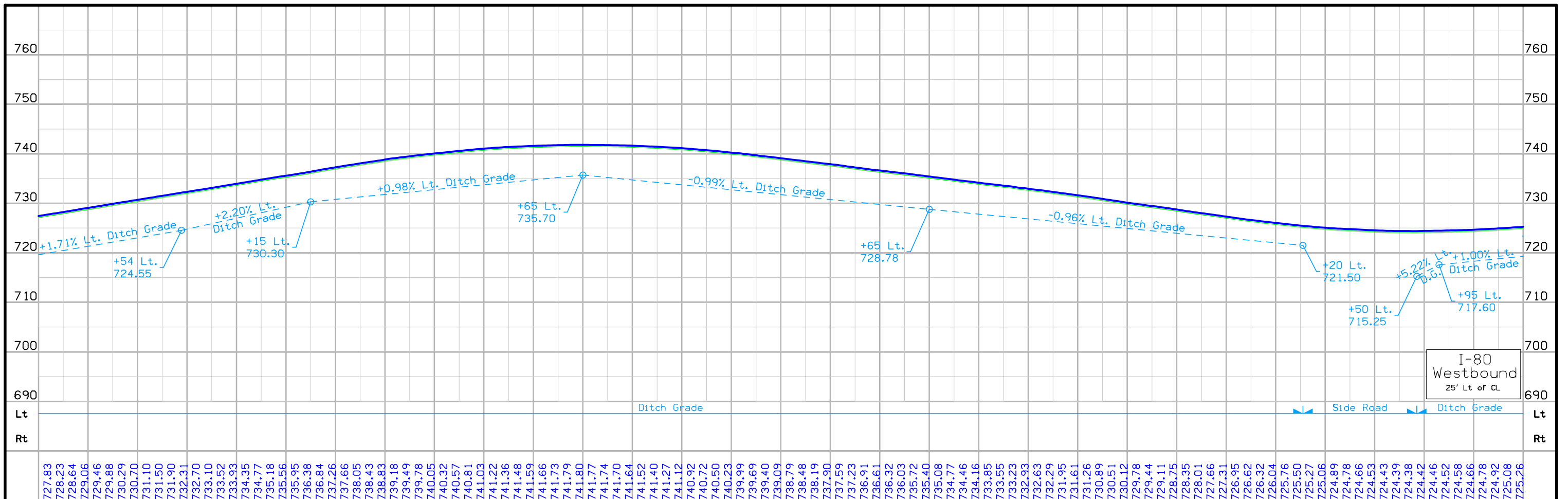

FILE NO.	ENGLISH	DESIGN TEAM	Iowa DOT \ HR Green	CEDAR COUNTY	PROJECT NUMBER	IM-NHS-080-7(134)266--03-16	SHEET NUMBER	D.37
----------	---------	-------------	---------------------	--------------	----------------	-----------------------------	--------------	------

FARMINGTON TWP  
T-79N R-1W  
SEC. 22



REMOVE & EXTEND  
Sta. 1287+79.00  
Skew 30°  
8.0'x5.0'x173.1' RCB  
REMOVE HEADWALL LT & RT  
INSTALL 8' x 5' x 40' PRECAST CONCRETE BOX LT  
INSTALL 8' x 5' x 35' PRECAST CONCRETE BOX RT OR  
BUILD 8' x 5' x 40' CAST-IN-PLACE CONCRETE BOX LT  
BUILD 8' x 5' x 35' CAST-IN-PLACE CONCRETE BOX RT  
PLUS CONCRETE HEADWALLS  
LT 721.05  
RT 716.75  
F.L.= OTHER 720.35  
OTHER 717.37

REMOVE & EXTEND  
Sta. 1289+99.00, 3.2' LT  
24"x64.5' RCP  
REMOVE APRON LT & RT  
INSTALL 24" x 34' 2000D LT  
PLUS CONCRETE APRONS  
LT 724.94  
F.L.= RT 728.92  
OTHER 726.27  
OTHER 728.40

REMOVE  
Sta. 1297+99.2, 2.7' LT  
24"x61.2' RCP

STA. 1297+89.00  
INSTALL 24" x 98' 2000D  
PLUS CONCRETE APRONS  
LT 735.73  
F.L.= RT 739.53  
OTHER 737.64

STA. 1297+75.00 PROP.  
TYPE "M" DIKE  
ELV. = 742.20

REMOVE  
Sta. 1306+54.10  
Skew 45°  
36"x209.6' RCP  
D.A.=22.0' A-R (Plans)

REMOVE  
Sta. 1306+73.40  
18"x21.6' RCP

STA. 1307+33.00  
INSTALL 36" X 214' 2000D  
PLUS CONCRETE APRONS  
LT 737.34  
F.L.= RT 739.75

STA. 1306+91.00  
INSTALL 24" X 104' 2000D  
PLUS CONCRETE APRONS  
LT 737.82  
F.L.= RT 743.65  
OTHER 741.63

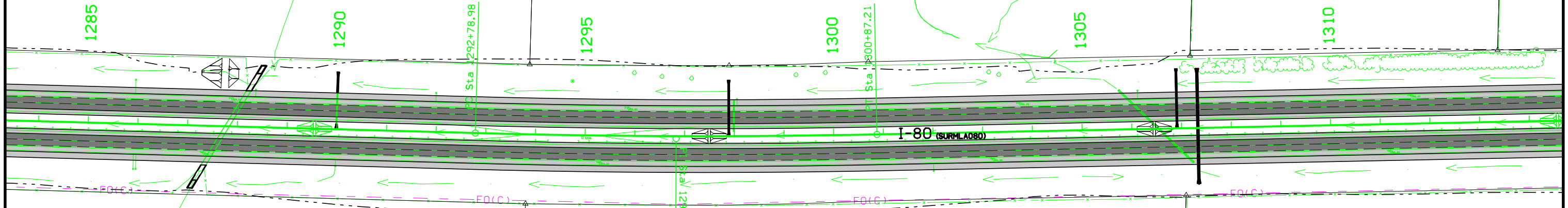

STA. 1289+75.00 PROP.  
TYPE "M" DIKE  
ELV. = 731.80

Curve Data  
Δ = 2° 41' 38.11" (LT)  
T = 404.19  
L = 808.24  
R = 17,190.00  
E = 4.75  
e = N.C.  
DS = 70mph

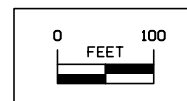

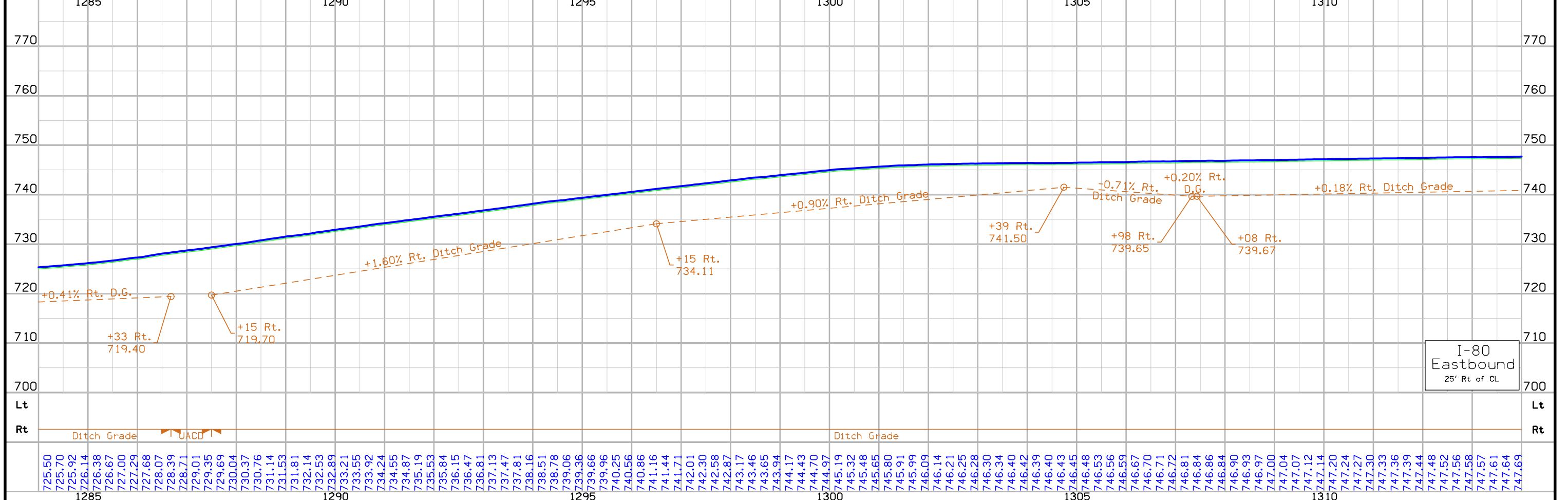
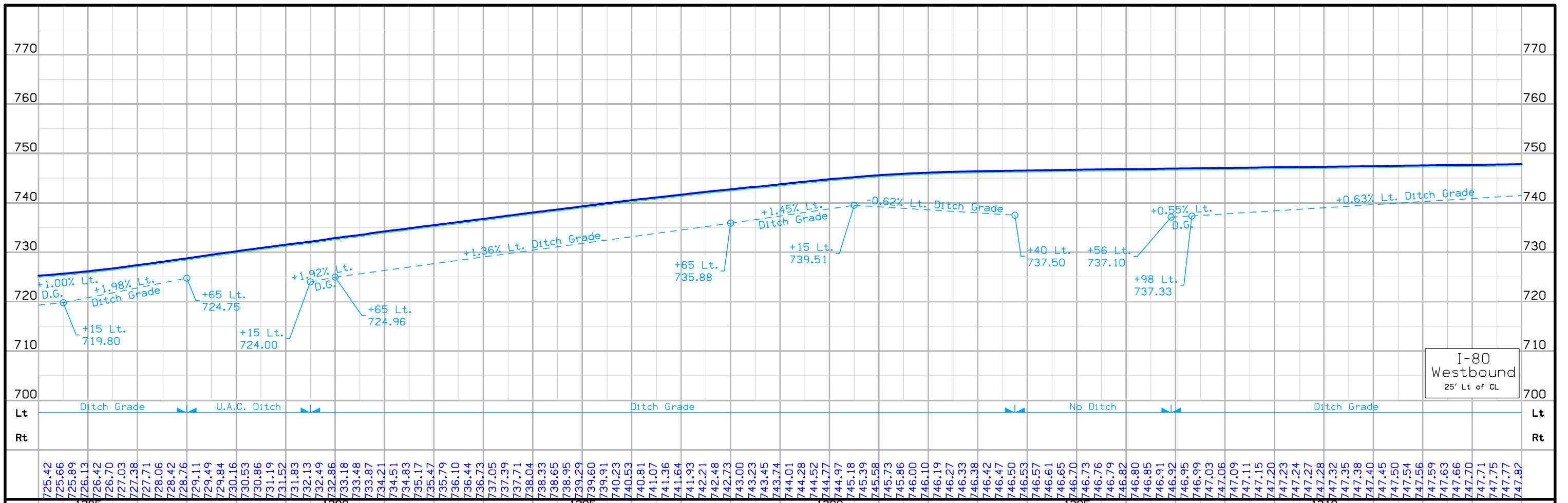

FARMINGTON TWP  
T-79N R-1W  
SEC. 22

FARMINGTON TWP  
T-79N R-1W  
SEC. 23



REMOVE & EXTEND  
Sta. 1321+99.7  
Skew 10°  
30"x181.6" RCP  
D.A.=8.0 A-R (Plans)  
REMOVE APRON LT & RT  
INSTALL 38' - 30" RCP LT  
INSTALL 10' - 30" RCP RT  
Plus Concrete Aprons  
F.L. = Lt. 735.13  
F.L. = Rt. 741.02  
F.L. = Other 735.18  
F.L. = Other 740.94

REMOVE & EXTEND  
Sta. 1332+09.8  
Skew 30°  
30"x217.6" RCP  
D.A.=7.0 A-R (Plans)  
REMOVE APRON LT & RT  
INSTALL 70' - 30" RCP LT  
INSTALL 46' - 30" RCP RT  
Plus Concrete Aprons  
F.L. = Lt. 725.03  
F.L. = Rt. 732.14  
F.L. = Other 725.14  
F.L. = Other 731.37

1315

1320

1325

1330

1335

1340

I-80 (SURMLA080)

REMOVE & EXTEND  
Sta. 1314+99.8, 2.8' RT  
24"x63.7' RCP  
REMOVE APRON RT  
INSTALL 32' - 24" RCP RT  
Plus Concrete Apron  
F.L. = Rt. 741.02  
F.L. = Other 742.15

REMOVE & EXTEND  
Sta. 1331+51.0, 1.0' RT  
24"x71.1' RCP  
REMOVE APRON RT  
INSTALL 34' - 24" RCP RT  
Plus Concrete Apron  
F.L. = Rt. 732.59  
F.L. = Other 732.94

REMOVE  
Sta. 1341+00.0, 3.2' RT  
24"x56.3' RCP

STA. 1341+10.00  
INSTALL 96' - 24" RCP RT  
Plus Concrete Aprons  
F.L. = Lt. 722.40  
F.L. = Rt. 719.00  
F.L. = Other 720.71

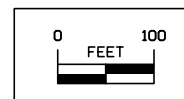



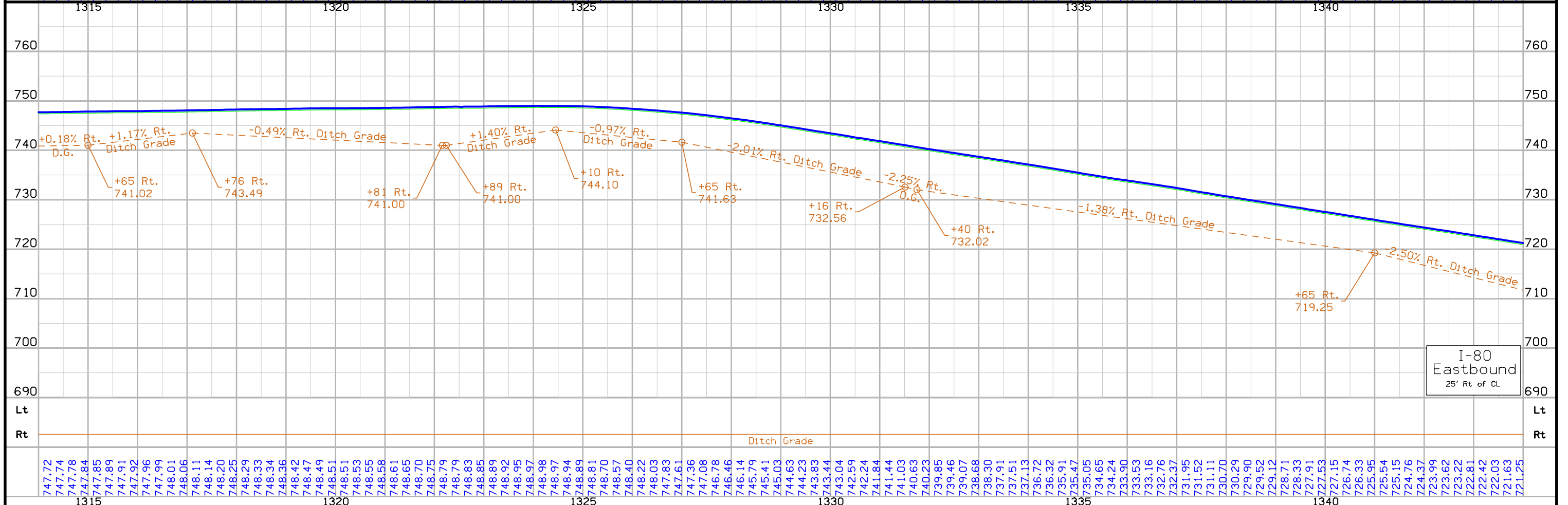
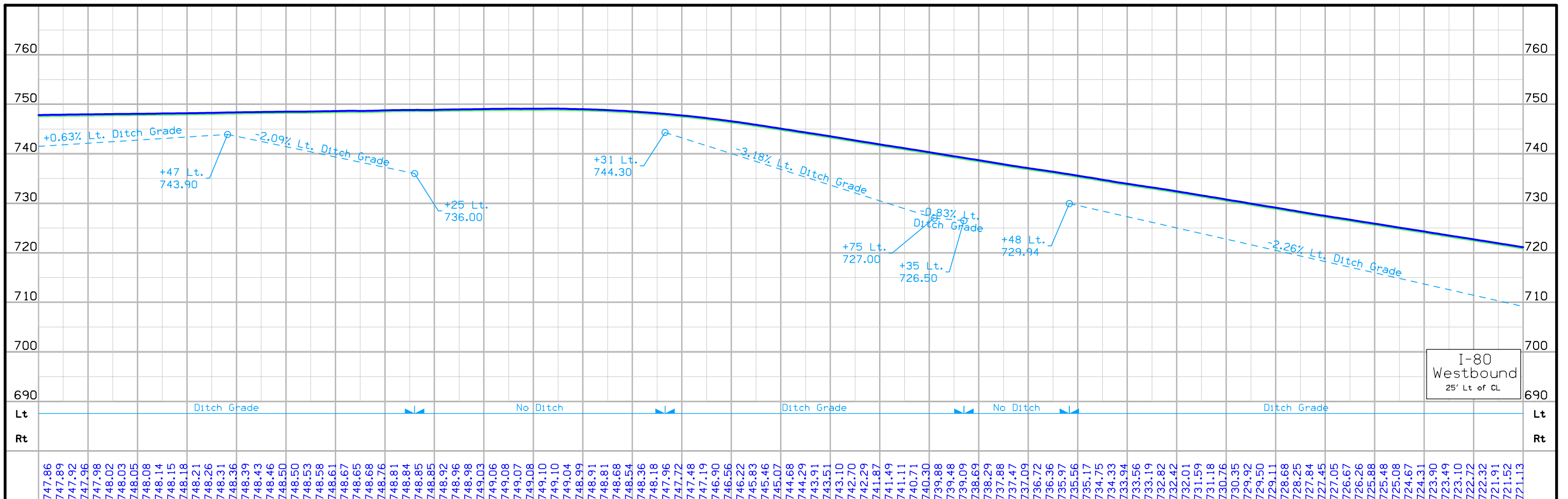

FARMINGTON TWP  
T-79N R-1W  
SEC. 23

Curve Data  
 $\Delta = 6^\circ 50' 21.32''$  (RT)  
 T = 456.53  
 L = 911.97  
 R = 7,640.00  
 E = 13.63  
 e = 2.80%  
 L = 200  
 x = 143  
 DS = 70



REMOVE & EXTEND  
 Sta. 1350+18.6, 3.7' LT  
 24"x92.1' RCP

Sta. 1350+18.6  
 INSTALL 36' - 24" RCP LT  
 INSTALL 2' - 24" RCP RT  
 Plus Concrete Aprons  
 F.L. = Lt. 698.04  
 F.L. = Rt. 710.28  
 F.L. = Other 700.10  
 F.L. = Other 709.33

REMOVE  
 Sta. 1356+99.3, 4.0' LT  
 24"x55.9' RCP

STA. 1356+89  
 INSTALL 100' - 24" RCP RT  
 Plus Concrete Aprons  
 F.L. = Lt. 711.77  
 F.L. = Rt. 714.99  
 F.L. = Other 713.17

REMOVE & EXTEND  
 Sta. 1364+99.1, 4.0' LT  
 24"x73.9' RCP

REMOVE APRON LT  
 INSTALL 48' - 24" RCP LT  
 Plus Concrete Apron  
 F.L. = Lt. 712.03  
 F.L. = Rt. 719.77  
 F.L. = Other 715.10

Sta. 1349+75.00  
 24"x63.0' CMP  
 REMOVED

Sta. 1348+61.00  
 24"x64.2' CMP  
 REMOVED

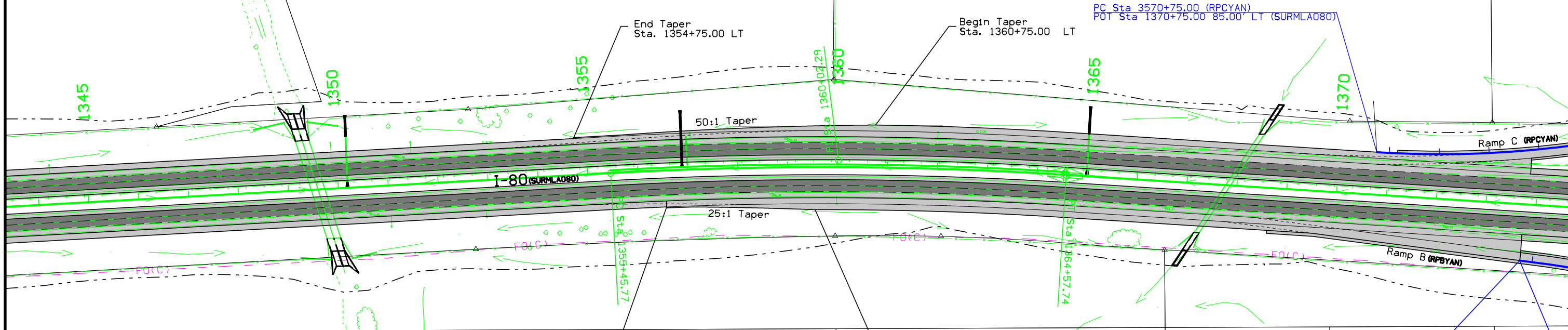

Begin Taper  
 Sta. 1356+55.00 RT

End Taper  
 Sta. 1359+55.00 RT

PC Sta 3570+75.00 (RPCYAN)  
 POT Sta 1370+75.00 85.00' LT (SURMLA080)

POT Sta 2573+75.00 (RPBYAN)  
 POT Sta 1373+73.94 112.95' RT (SURMLA080)

Sta. 1349+55.00  
 24"x59.1' CMP  
 REMOVED

Sta. 1350+45.00  
 24"x50.1' CMP  
 REMOVED

REMOVE & BUILD  
 Sta. 1349+59.32  
 SKEW 15°  
 TWIN 12'x14'x203' RCB  
 D.A. = 3034 AC  
 REMOVE APRON LT & RT  
 BUILD 24' - 12'x14' RCB LT  
 BUILD 26' - 12'x14' RCB RT  
 Plus Concrete Aprons  
 F.L. = Lt. 689.05  
 F.L. = Rt. 688.51  
 F.L. = Other 689.00  
 F.L. = Other 688.57

REMOVE & EXTEND  
 Sta. 1367+82.3  
 Skew 30°  
 8'x10'x233.9' RCB  
 D.A. = 600 A-R (Plans)  
 STA. 1367+82.22  
 BUILD 34' - 8' X 10' RCB LT  
 BUILD 42' - 8' X 10' RCB RT  
 Plus Concrete Aprons  
 F.L. = Lt. 711.77  
 F.L. = Rt. 714.99  
 F.L. = Other 713.17

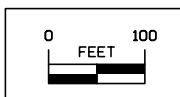

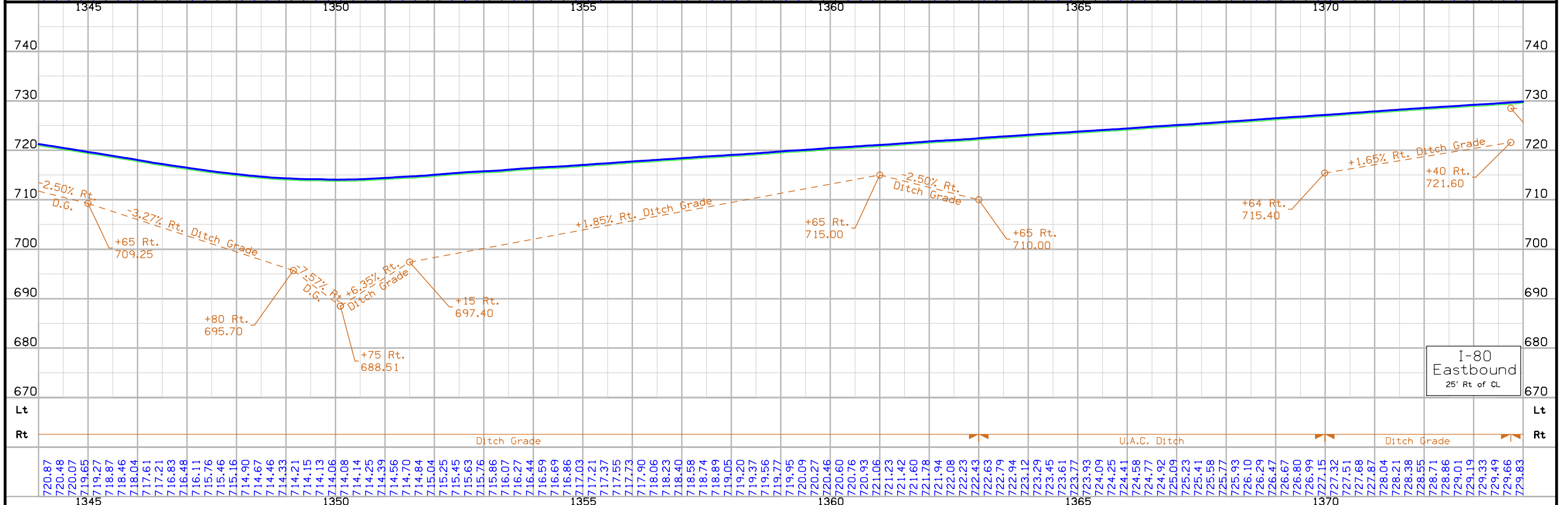
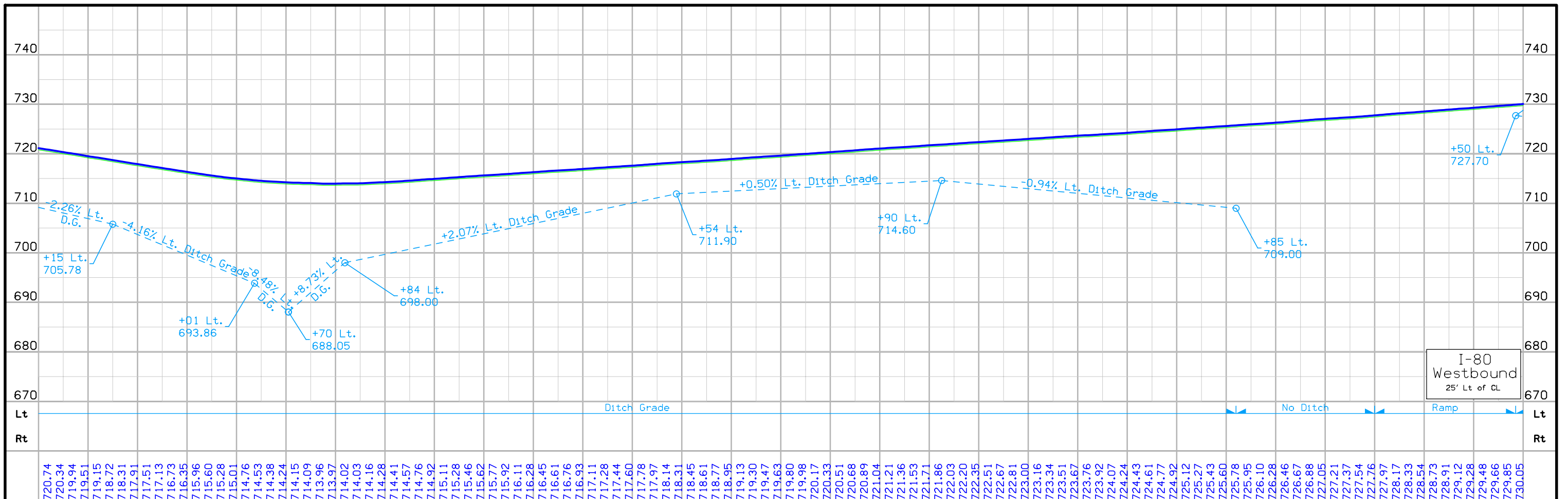

FILE NO.	ENGLISH	DESIGN TEAM	Iowa DOT \ HR Green	CEDAR COUNTY	PROJECT NUMBER	IM-NHS-080-7(134)266--03-16	SHEET NUMBER	D.43
----------	---------	-------------	---------------------	--------------	----------------	-----------------------------	--------------	------

FARMINGTON TWP  
T-79N R-1W  
SEC. 23

FARMINGTON TWP  
T-79N R-1W  
SEC. 24



REMOVE  
Sta. 1387+99.4, 5.3' LT  
18"x65.5' RCP

STA. 1388+50.00  
INSTALL 94' - 24" RCP  
Plus Concrete Aprons  
F.L. = Lt. 732.15  
F.L. = Rt. 735.52  
F.L. = Other 733.68

REMOVE  
Sta. 1401+99.5  
24"x139.2' RCP  
D.A.=5.0 A-R (Plans)

STA. 1402+15.00  
INSTALL 240' - 24" RCP  
Plus Concrete Aprons  
F.L. = Lt. 739.21  
F.L. = Rt. 737.95

REMOVE  
Sta. 1392+99.4, 3.1' LT  
24"x56.6' RCP

STA. 1393+10.00  
INSTALL 96' - 24" RCP  
Plus Concrete Aprons  
F.L. = Lt. 736.24  
F.L. = Rt. 739.45  
F.L. = Other 737.63

POT Sta 1386+29.87 (SURMLA080)  
= POT Sta 2386+30.16 (SRYAN)

POT Sta 1600+00.00 (RPAYAN)  
POT Sta 1400+01.06 122.93' LT (SURMLA080)

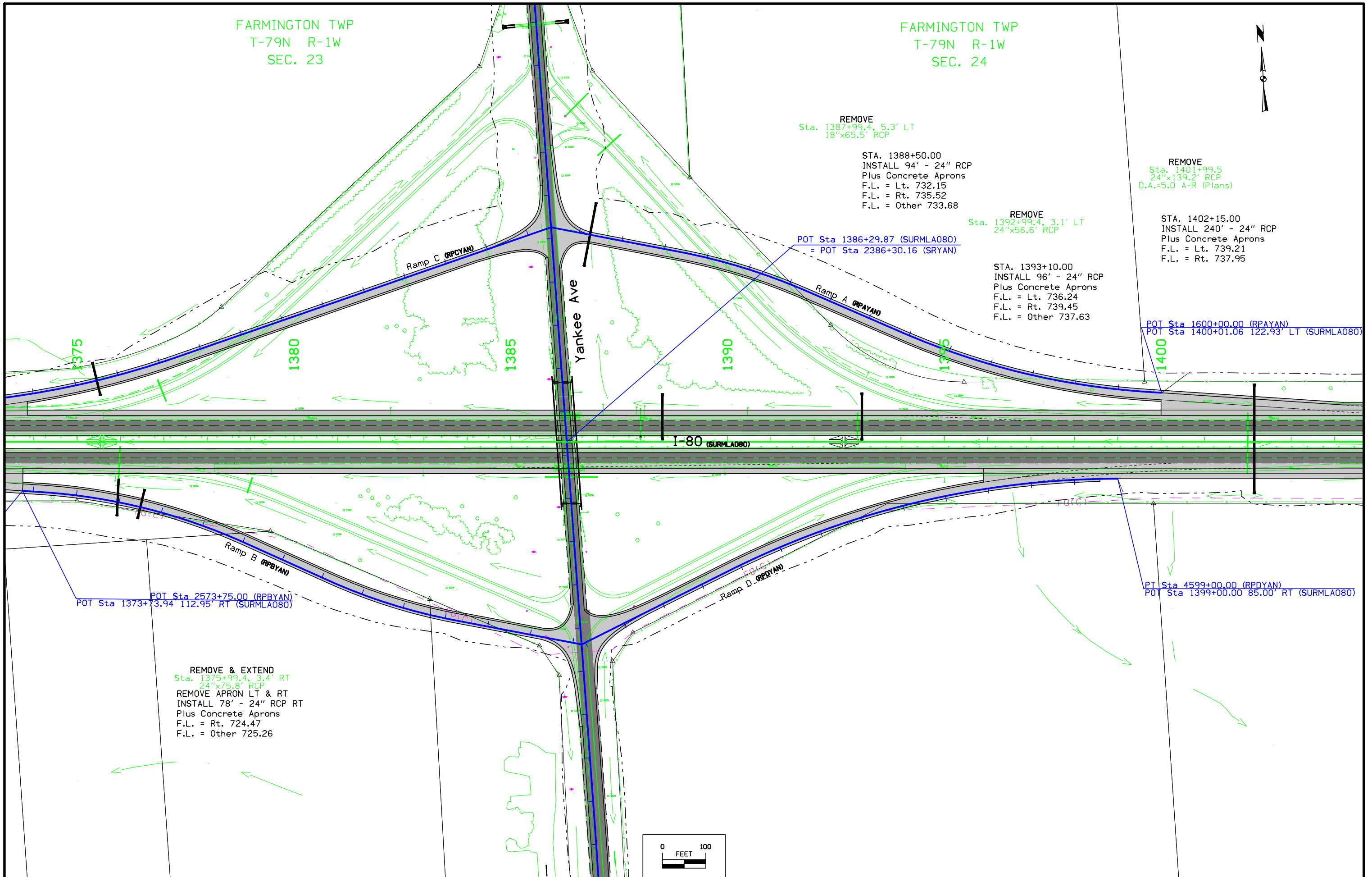

POT Sta 2573+75.00 (RPBYAN)  
POT Sta 1373+73.94 112.95' RT (SURMLA080)

REMOVE & EXTEND  
Sta. 1375+99.4, 3.4' RT  
24"x75.8' RCP  
REMOVE APRON LT & RT  
INSTALL 78' - 24" RCP RT  
Plus Concrete Aprons  
F.L. = Rt. 724.47  
F.L. = Other 725.26

PT Sta 4599+00.00 (RPDYAN)  
POT Sta 1399+00.00 85.00' RT (SURMLA080)

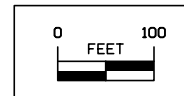

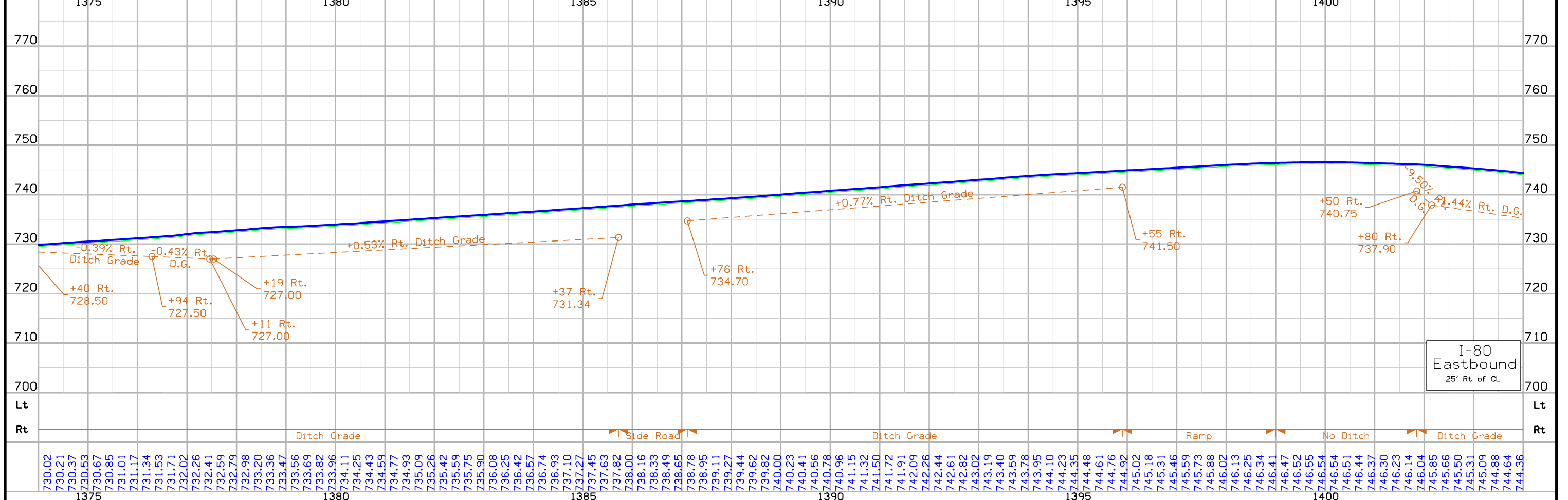
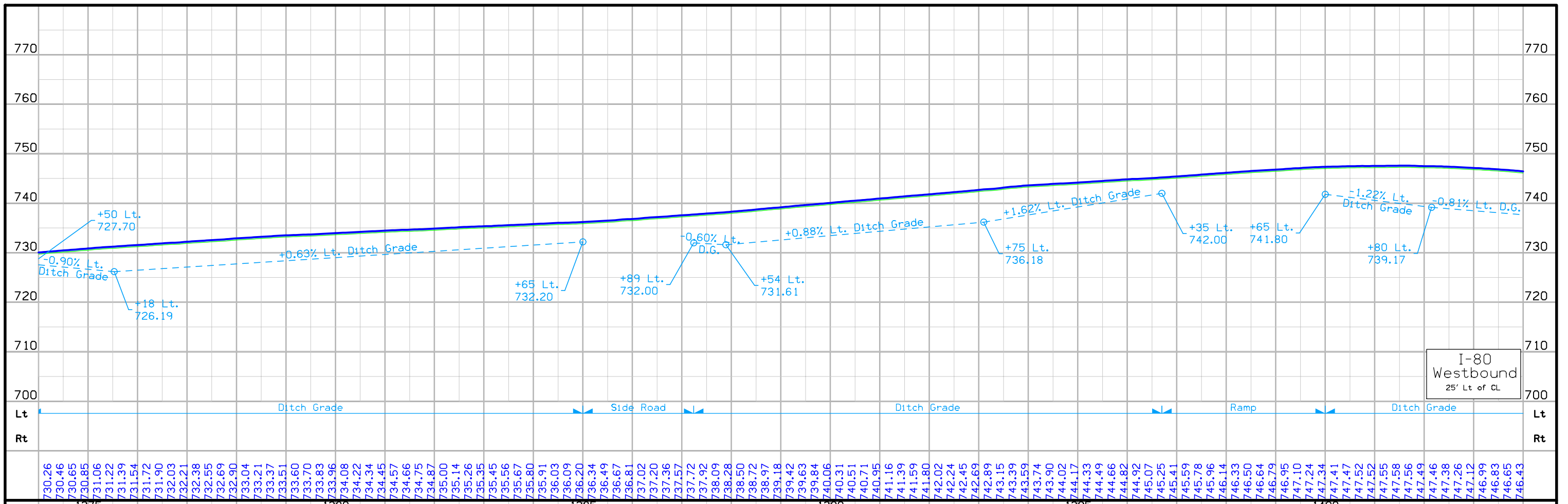



FARMINGTON TWP  
T-79N R-1W  
SEC. 24



Curve Data  
 $\Delta = 4^\circ 14' 41.66''$  (LT)  
 $T = 424.72$   
 $L = 849.04$   
 $R = 11,460.00$   
 $E = 7.87$   
 $e = 2.00\%$   
 $L = 200$   
 $x = 200$   
 $DS = 70\text{mph}$

REMOVE & EXTEND  
 Sta. 1409+98.7, 1.5' RT  
 24"x70.8' RCP  
 REMOVE APRON LT  
 INSTALL 36' - 24" RCP LT  
 Plus Concrete Apron  
 F.L. = Lt. 732.80  
 F.L. = Other 733.62

REMOVE & EXTEND  
 Sta. 1412+84.4  
 30"x168.90' RCP  
 D.A.=15.0 A-R (Plans)  
 REMOVE APRON LT & RT  
 INSTALL 36' - 30" RCP LT  
 INSTALL 32' - 30" RCP RT  
 Plus Concrete Aprons  
 F.L. = Lt. 729.51  
 F.L. = Rt. 722.46  
 F.L. = Other 728.31  
 F.L. = Other 723.54

REMOVE & EXTEND  
 Sta. 1425+39.5, 4.6' LT  
 24"x70.6' RCP  
 REMOVE APRON LT & RT  
 INSTALL 40' - 24" RCP LT  
 INSTALL 4' - 24" RCP RT  
 Plus Concrete Aprons  
 F.L. = Lt. 715.89  
 F.L. = Rt. 723.68  
 F.L. = Other 718.74  
 F.L. = Other 723.05

STA 1424+00.00  
 END PROJECT  
 END WIDENING AND  
 RESURFACING

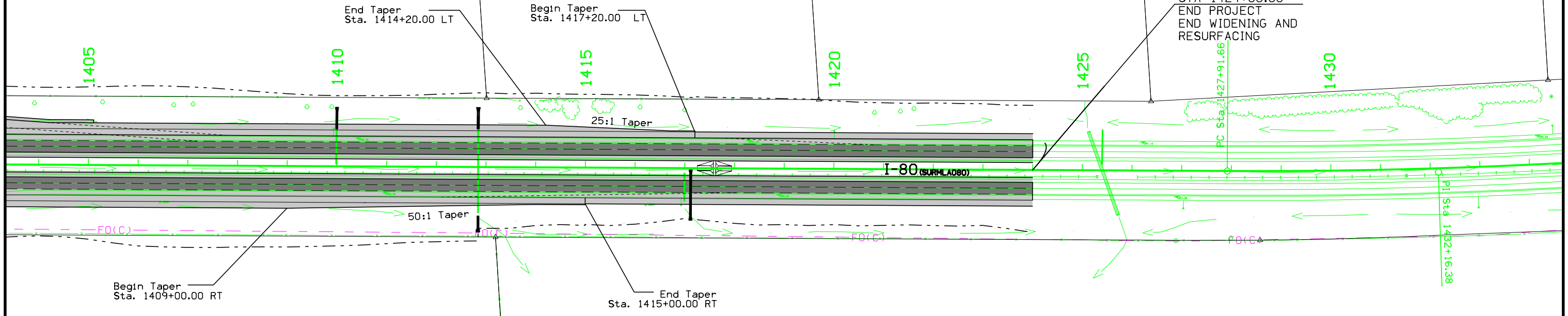

REMOVE  
 Sta. 1416+99.2, 3.5' RT  
 24"x56.4' RCP

STA. 1417+12.00  
 INSTALL 88' - 24" RCP  
 Plus Concrete Aprons  
 F.L. = Lt. 727.59  
 F.L. = Rt. 725.19  
 F.L. = Other 726.00

REMOVE & EXTEND  
 Sta. 1425+40.2  
 60"x177.4' RCP  
 D.A.=105.0 A-R (Plans)  
 REMOVE APRON LT & RT  
 INSTALL 32' - 60" RCP LT  
 INSTALL 26' - 60" RCP RT  
 Plus Concrete Aprons  
 F.L. = Lt. 717.57  
 F.L. = Rt. 714.99  
 F.L. = Other 717.20  
 F.L. = Other 715.39

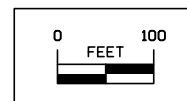

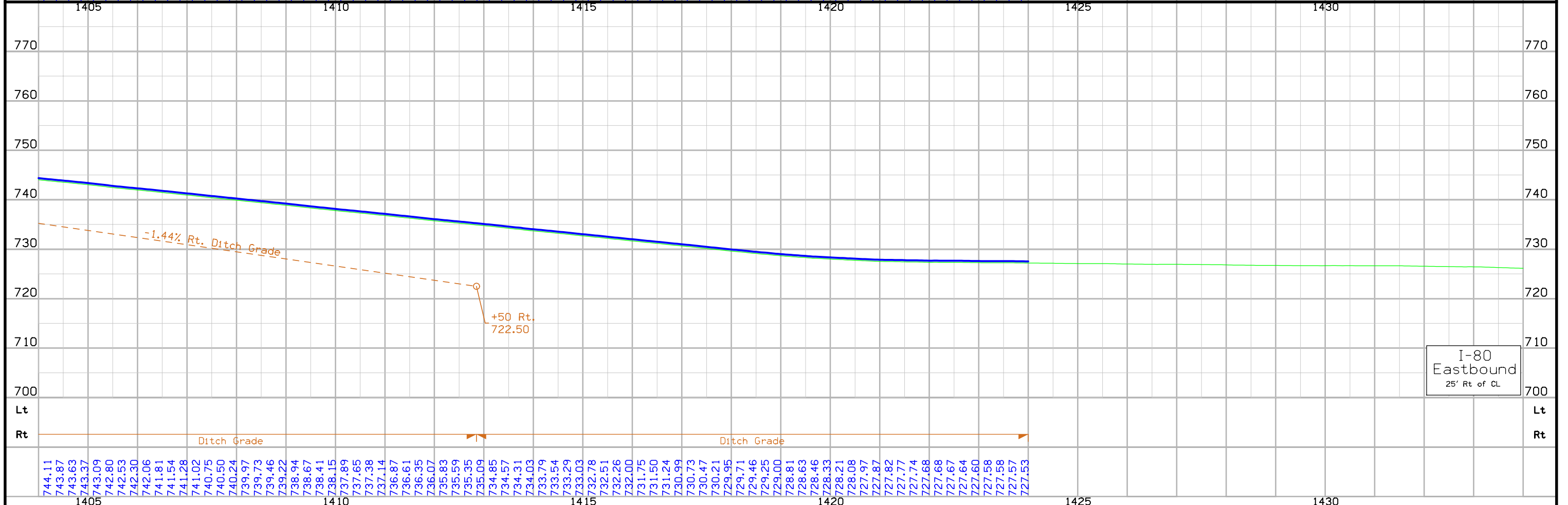
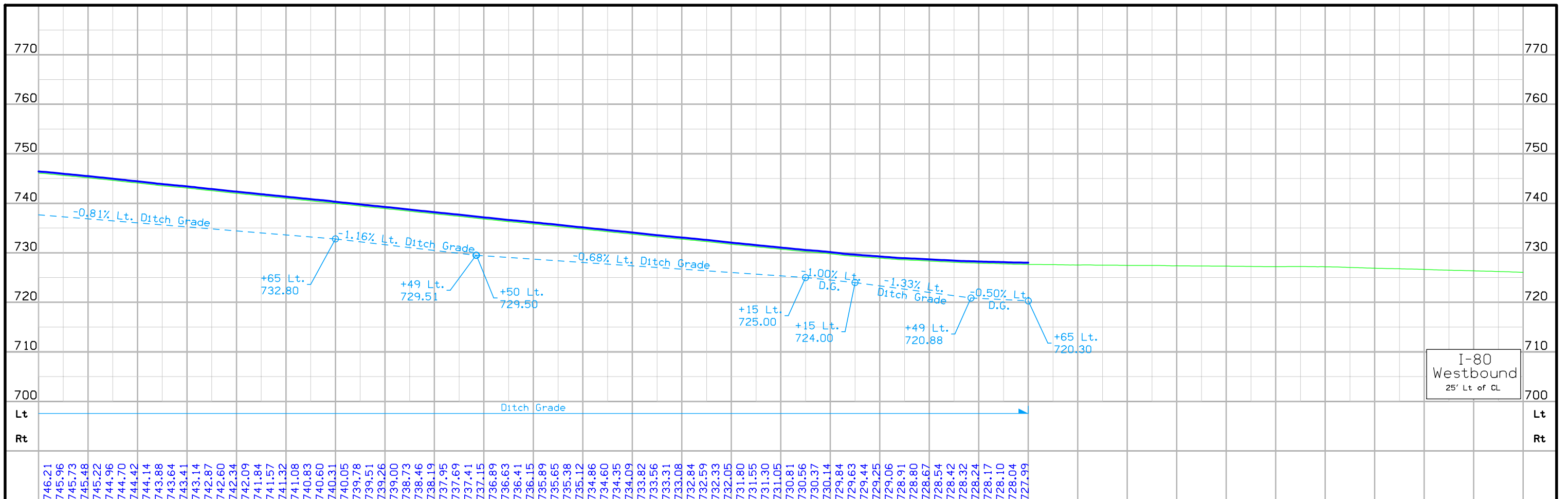

FILE NO.	ENGLISH	DESIGN TEAM	Iowa DOT \ HR Green	CEDAR COUNTY	PROJECT NUMBER	IM-NHS-080-7(134)266--03-16	SHEET NUMBER	D.47
----------	---------	-------------	---------------------	--------------	----------------	-----------------------------	--------------	------

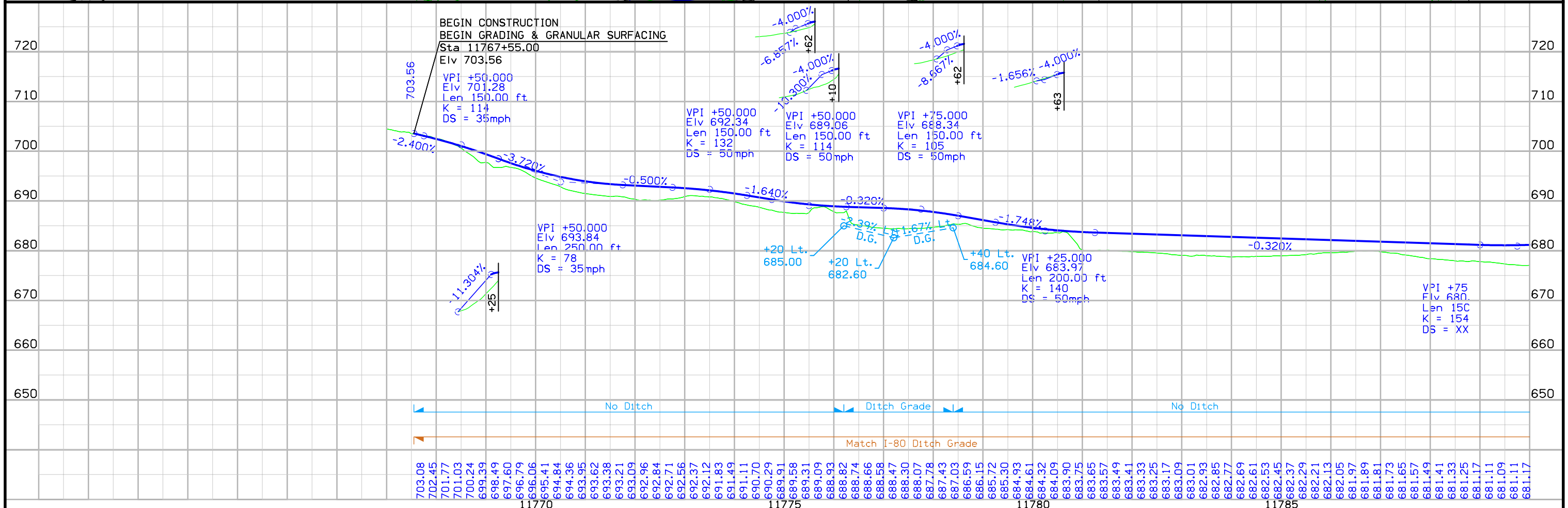
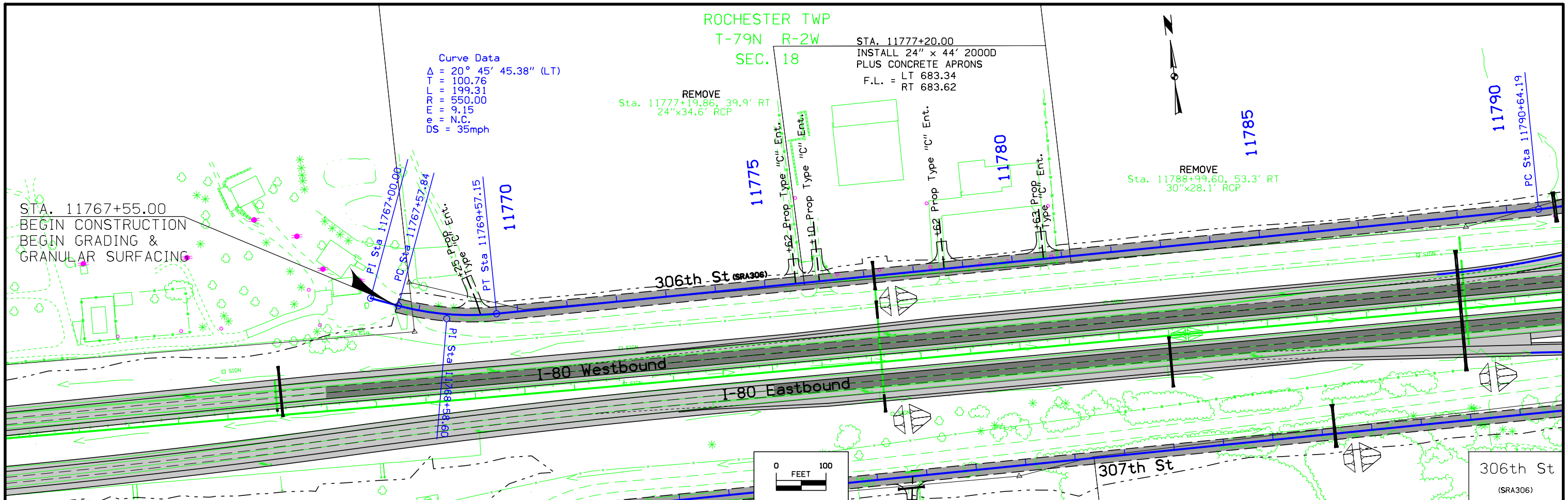

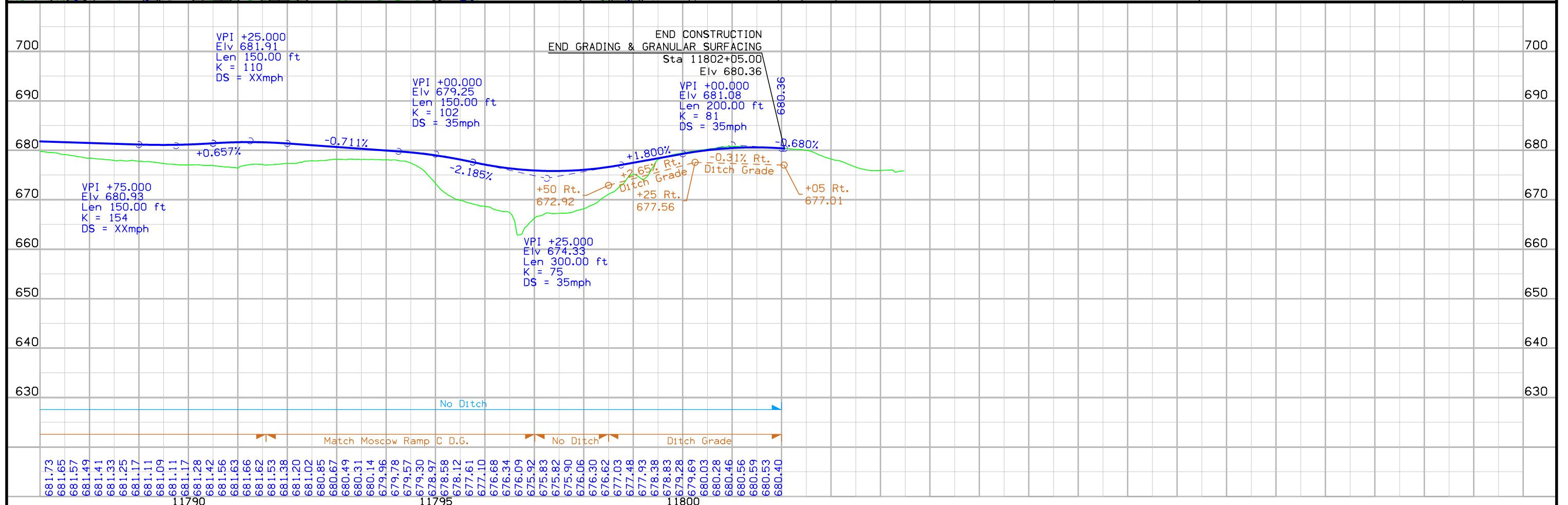
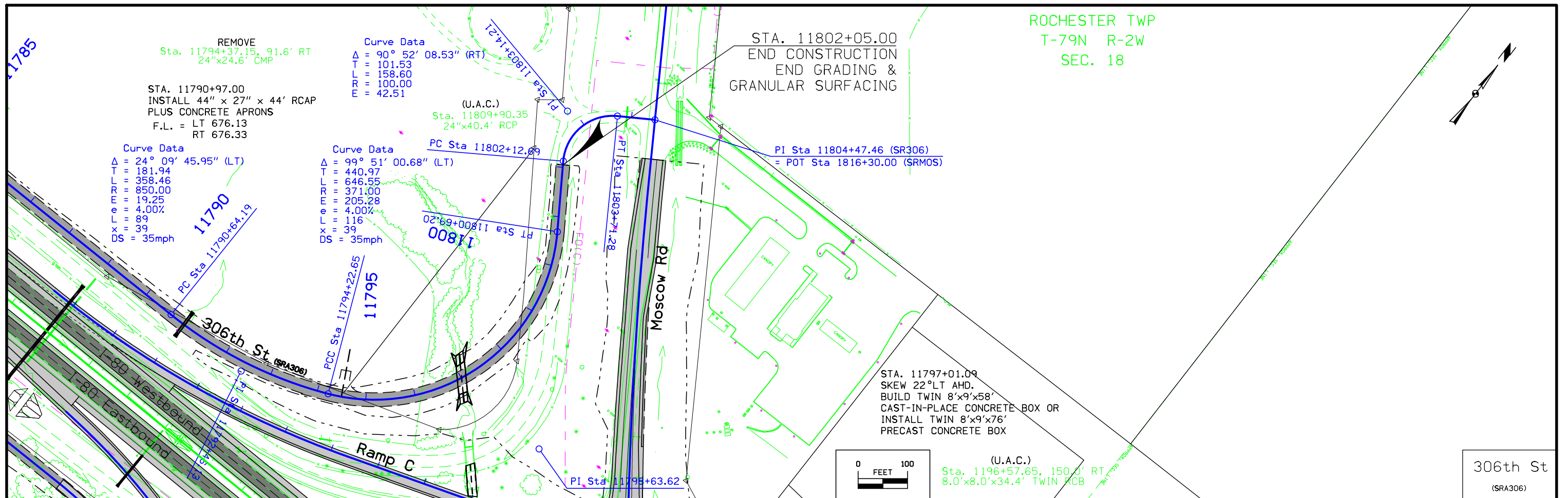



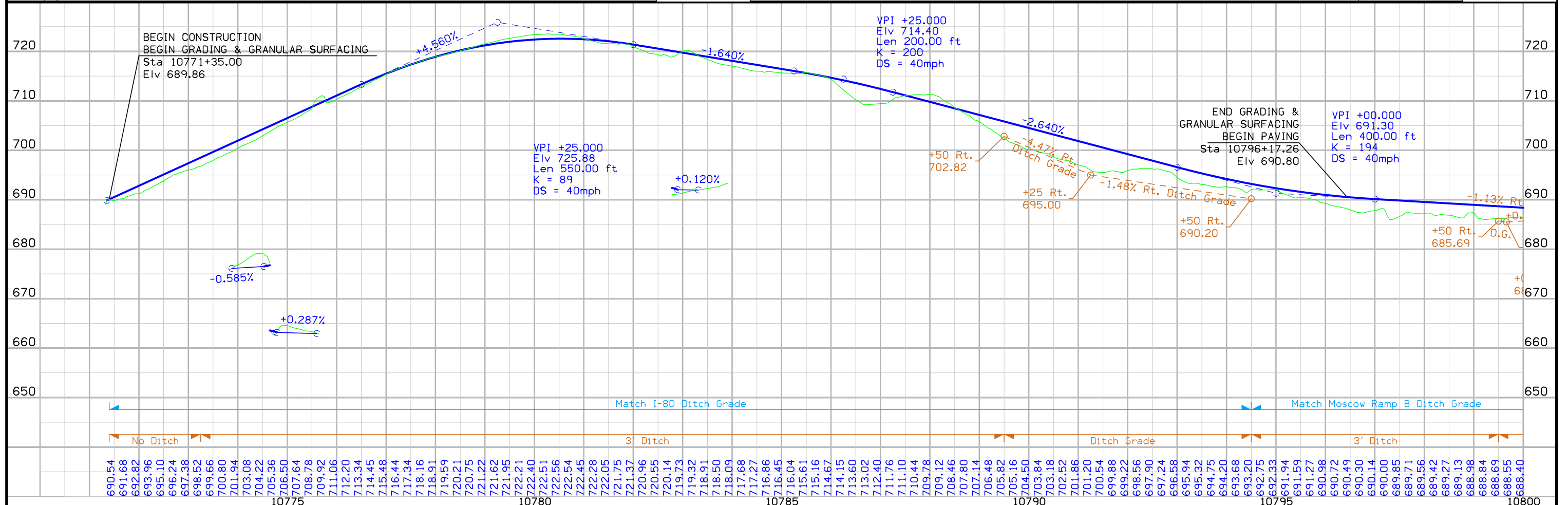
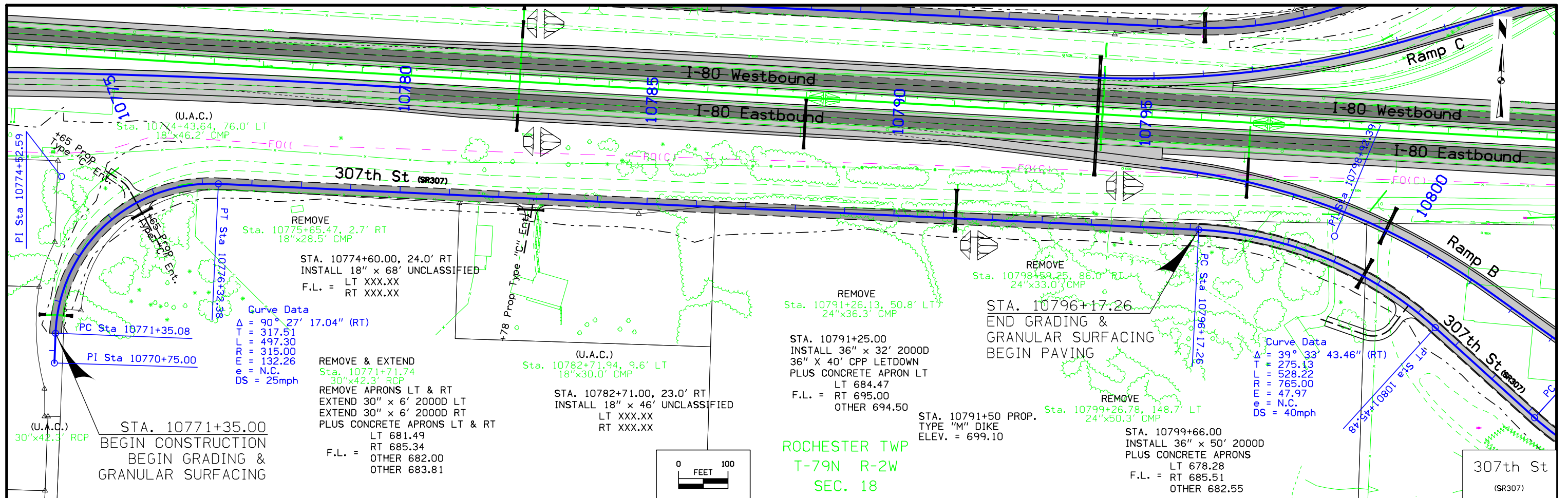

FILE NO.	ENGLISH	DESIGN TEAM	COUNTY	PROJECT NUMBER	SHEET NUMBER
					<b>E.3</b>

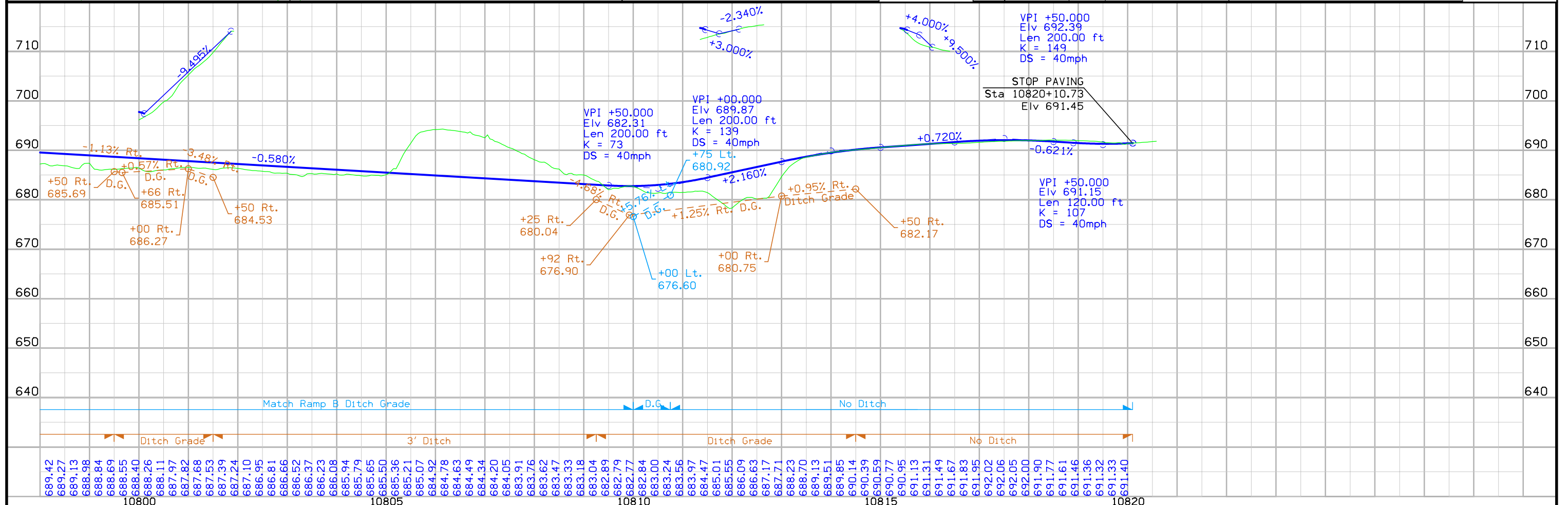
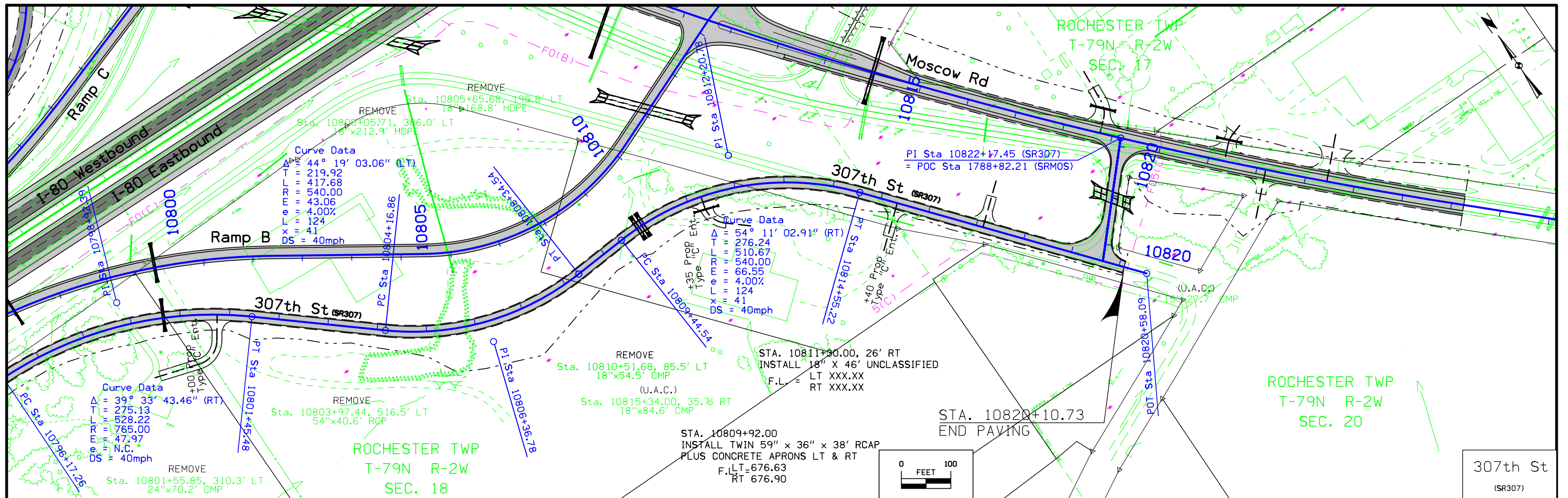

FILE NO.	ENGLISH	DESIGN TEAM	Iowa DOT \ HR Green	CEDAR COUNTY	PROJECT NUMBER	IM-NHS-080-7(134)266--03-16	SHEET NUMBER	E.4
----------	---------	-------------	---------------------	--------------	----------------	-----------------------------	--------------	-----



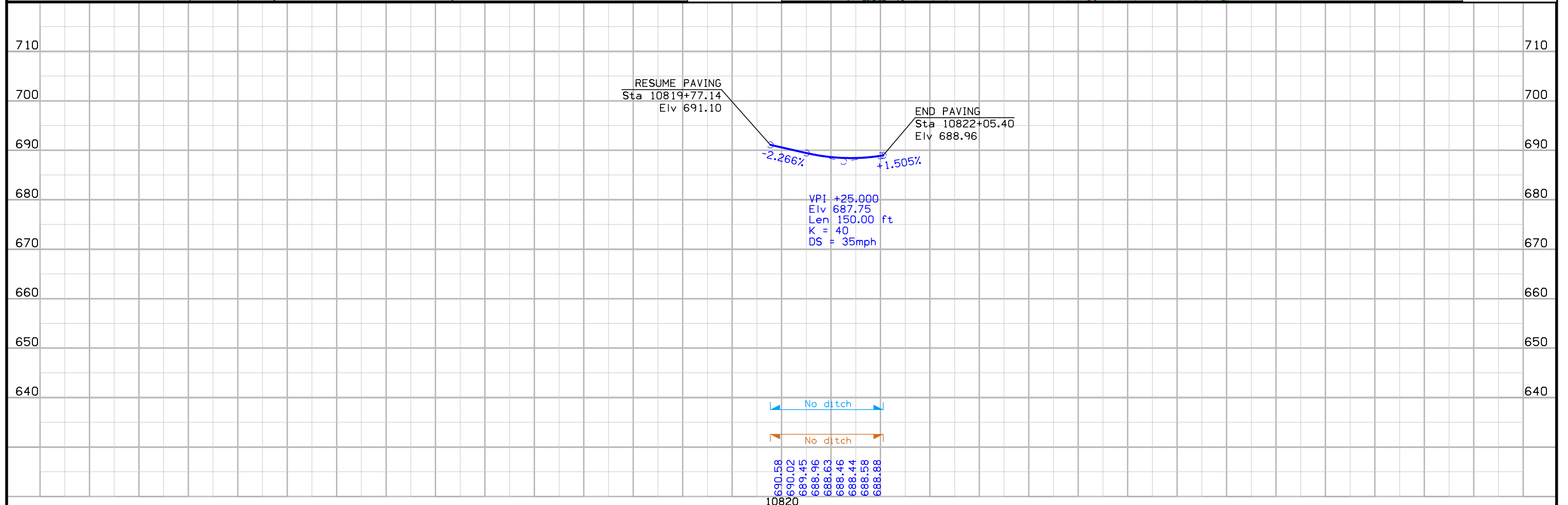
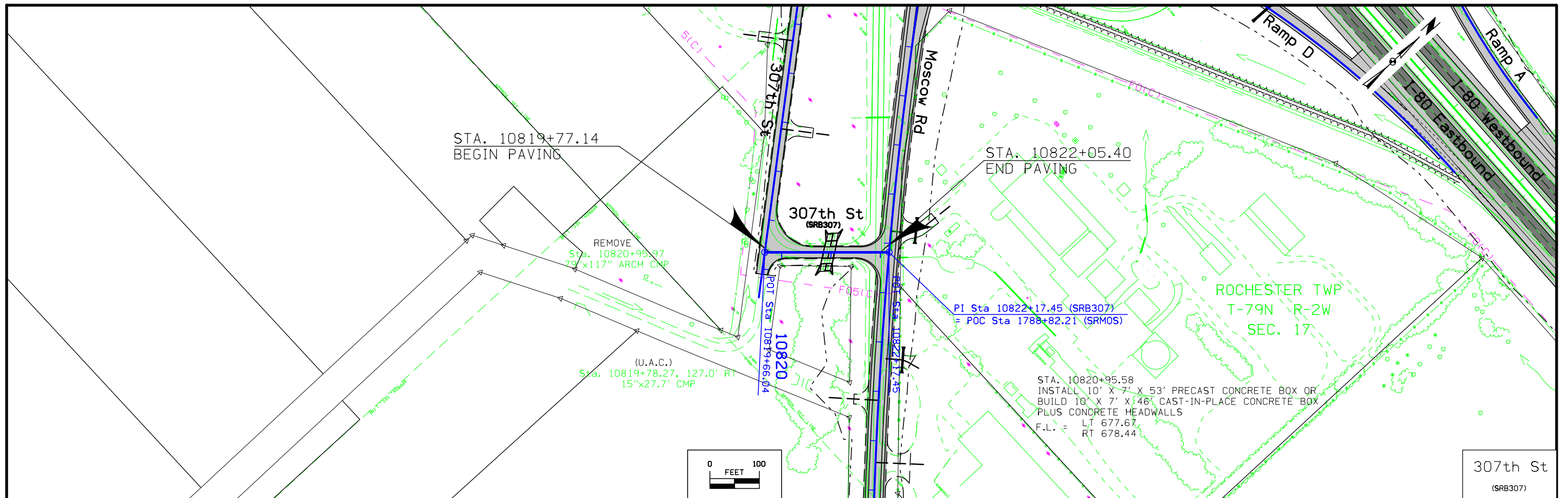

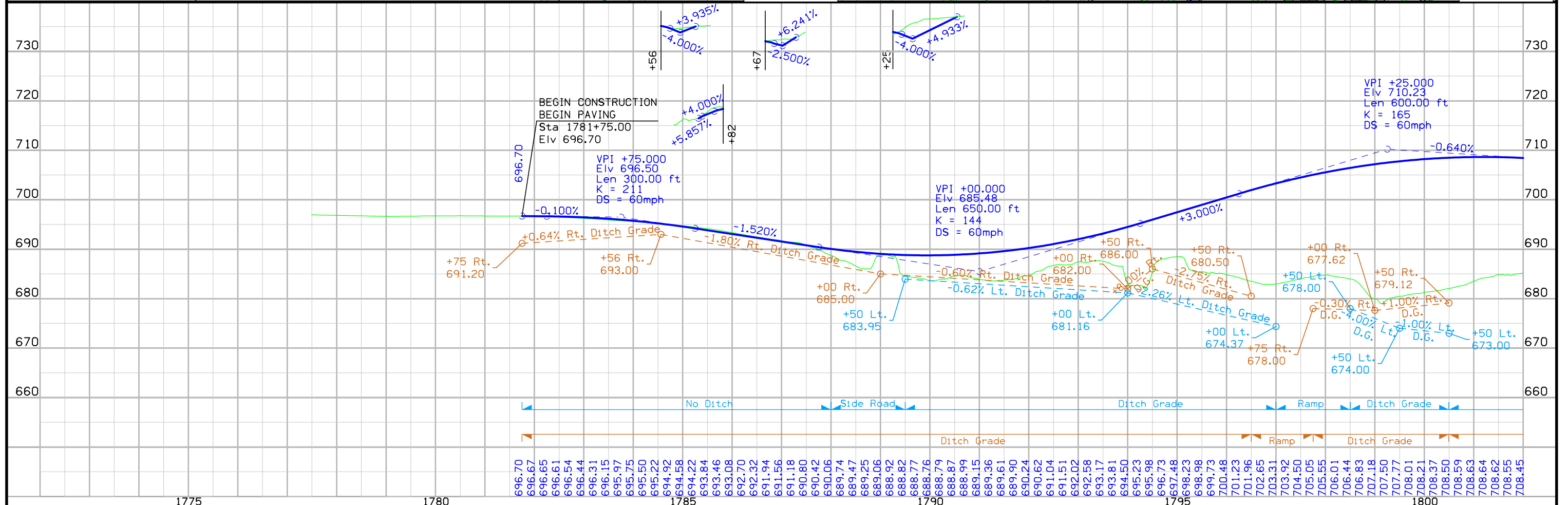
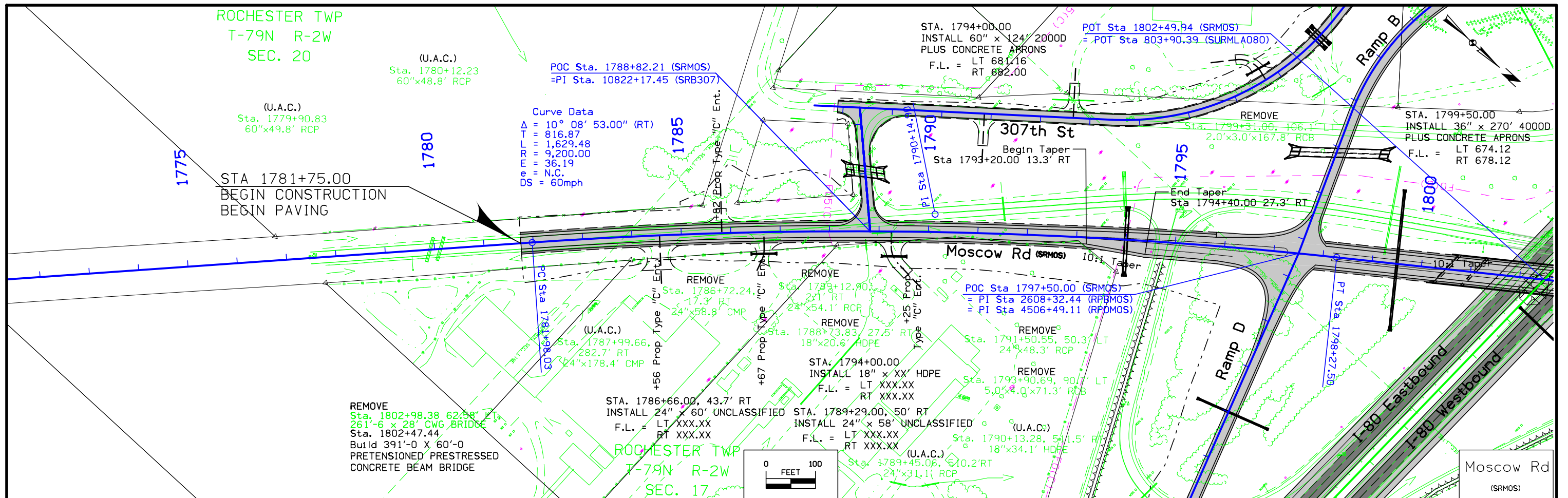

FILE NO.	ENGLISH	DESIGN TEAM	Iowa DOT \ HR Green	CEDAR COUNTY	PROJECT NUMBER	IM-NHS-080-7(134)266--03-16	SHEET NUMBER	E.6
----------	---------	-------------	---------------------	--------------	----------------	-----------------------------	--------------	-----

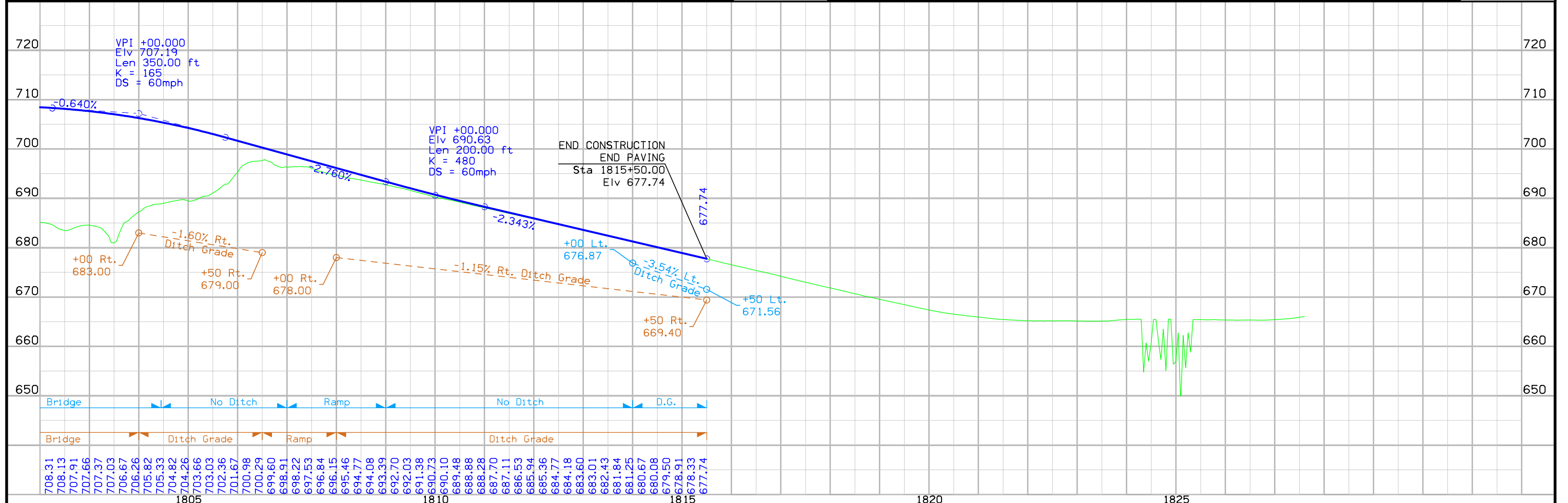
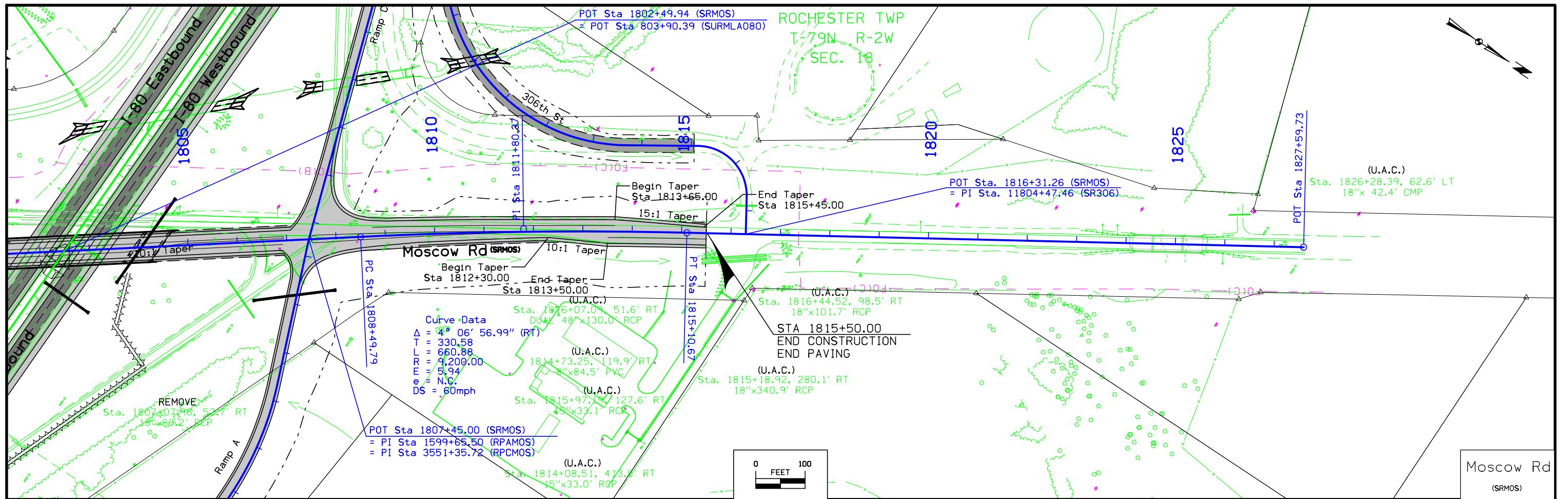



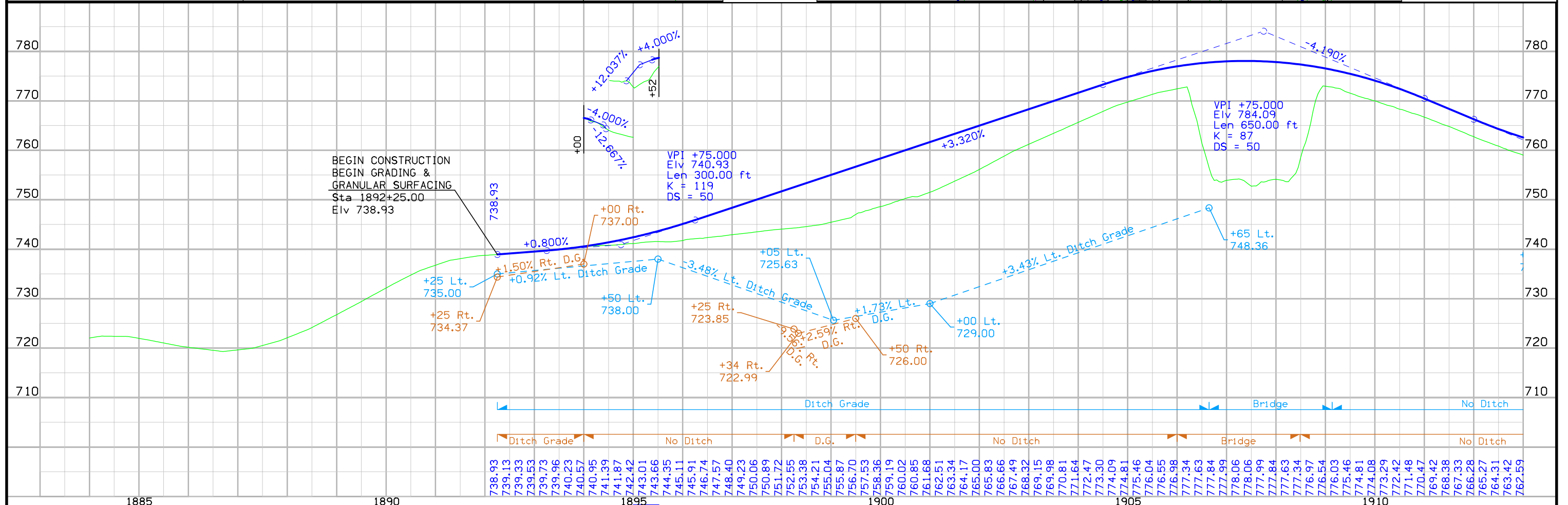
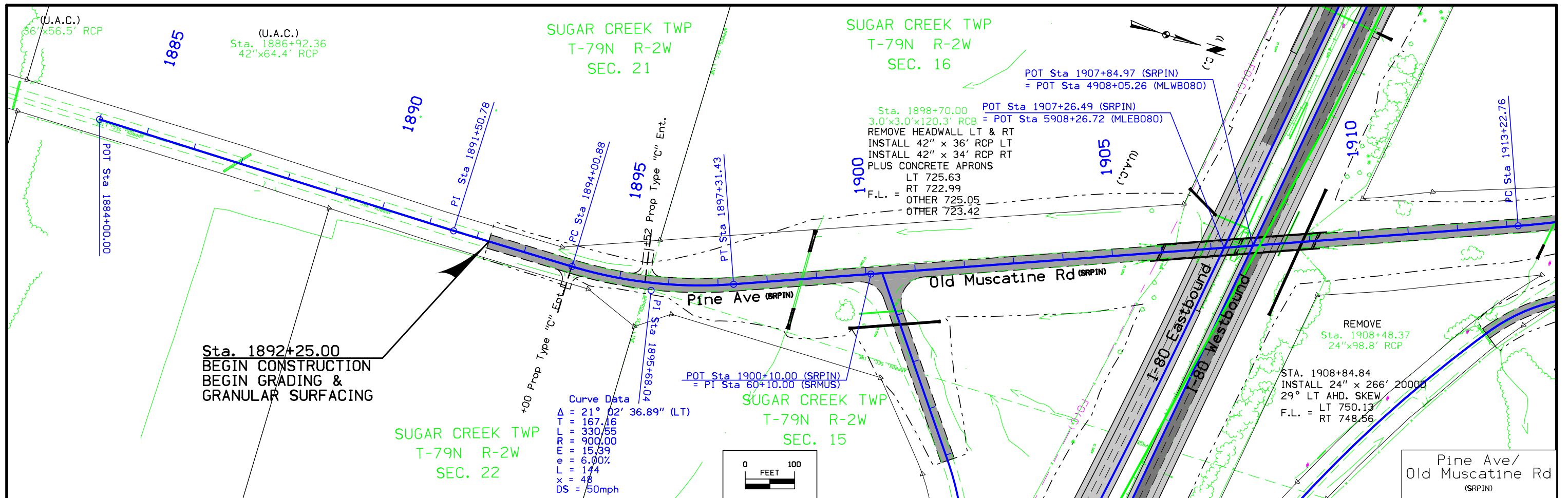

FILE NO.	ENGLISH	DESIGN TEAM	Iowa DOT \ HR Green	CEDAR COUNTY	PROJECT NUMBER	IM-NHS-080-7(134)266--03-16	SHEET NUMBER	E.8
----------	---------	-------------	---------------------	--------------	----------------	-----------------------------	--------------	-----

SUGAR CREEK TWP  
T-79N R-2W  
SEC. 16

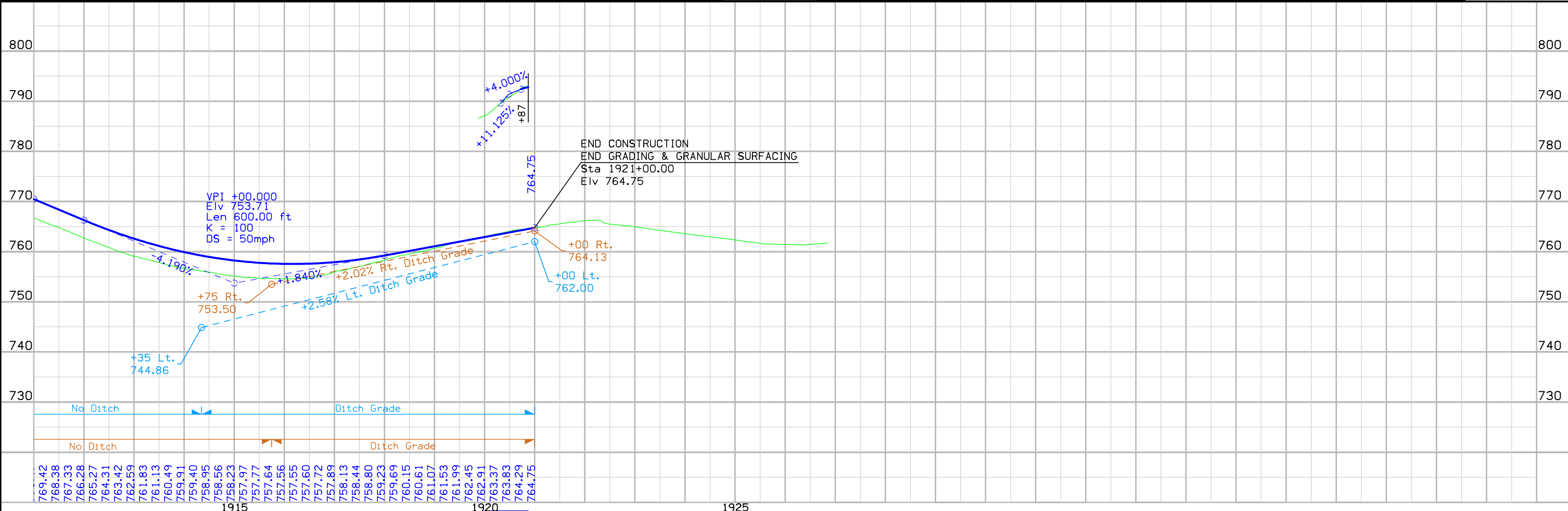
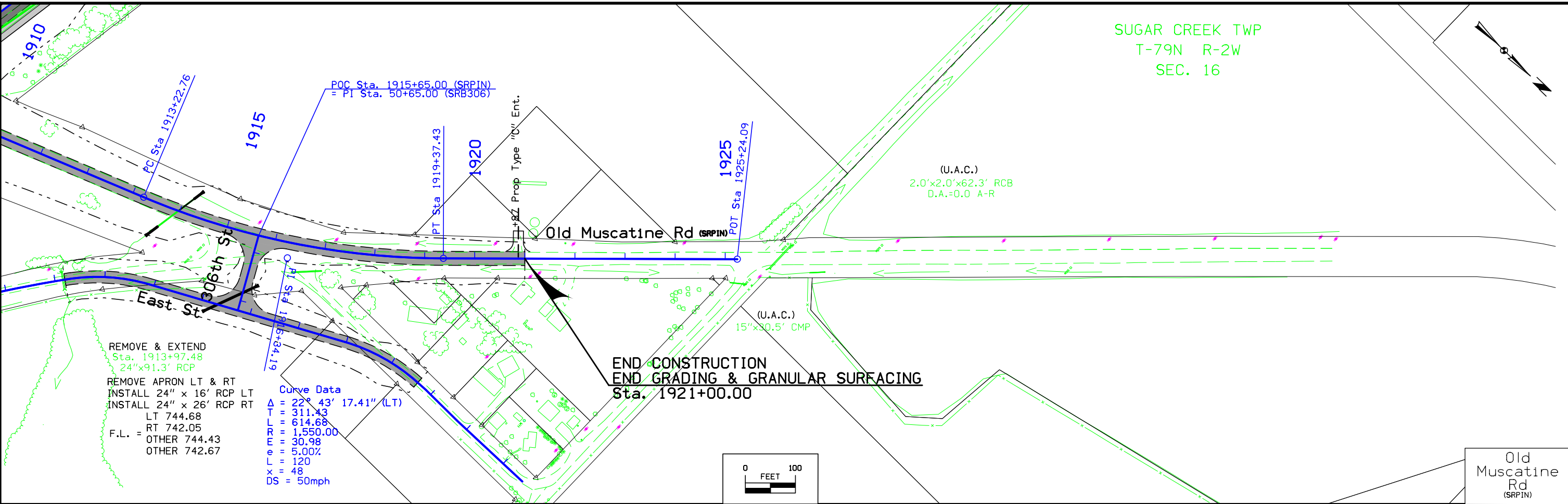

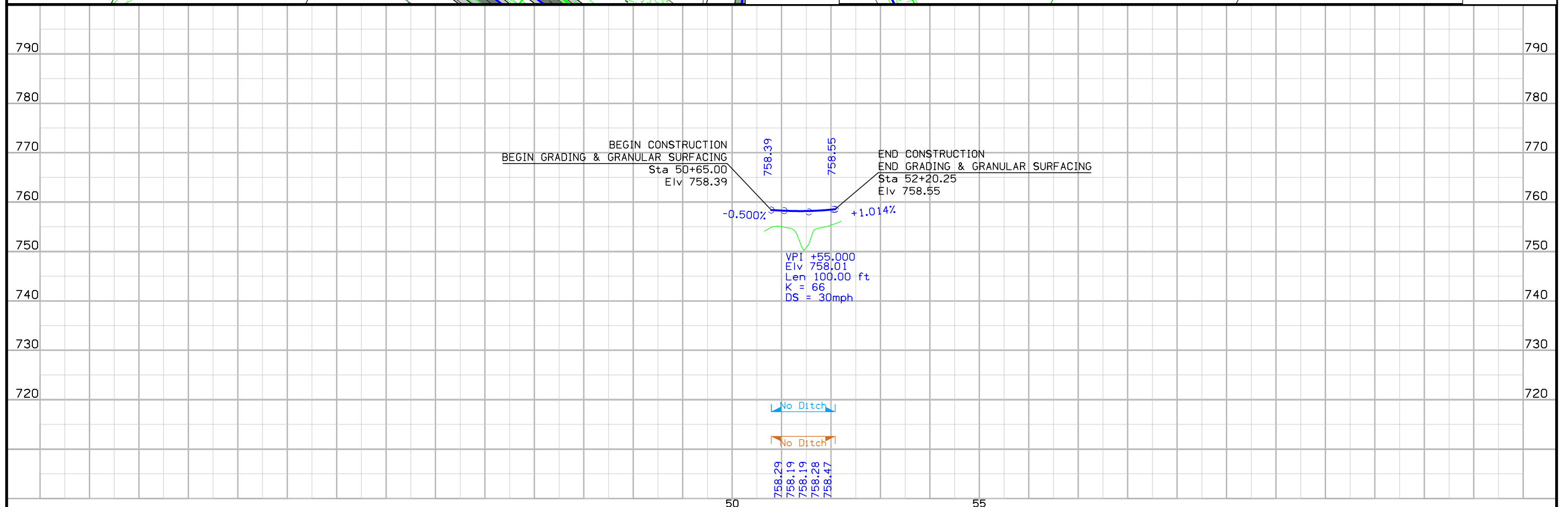
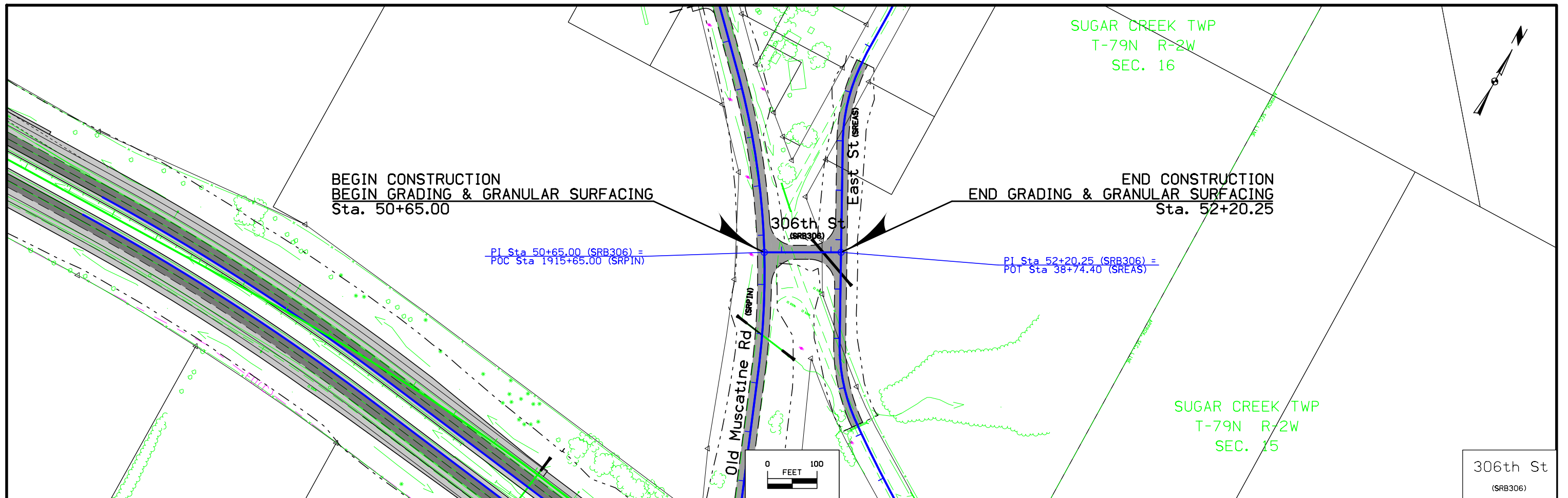



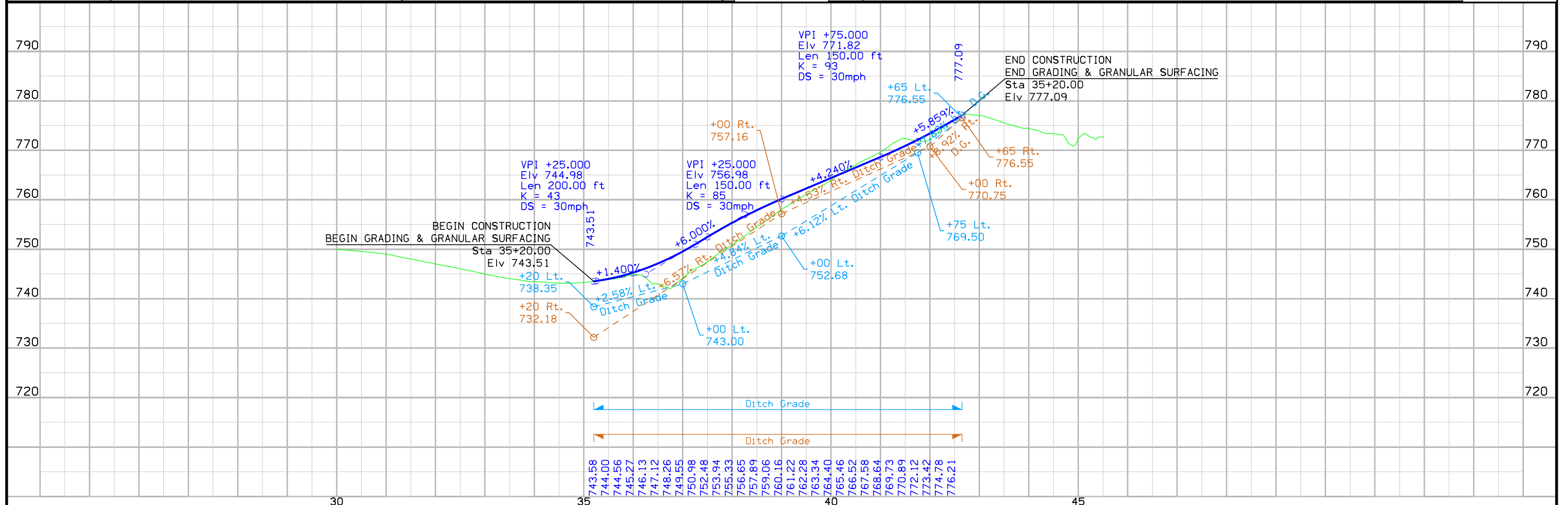
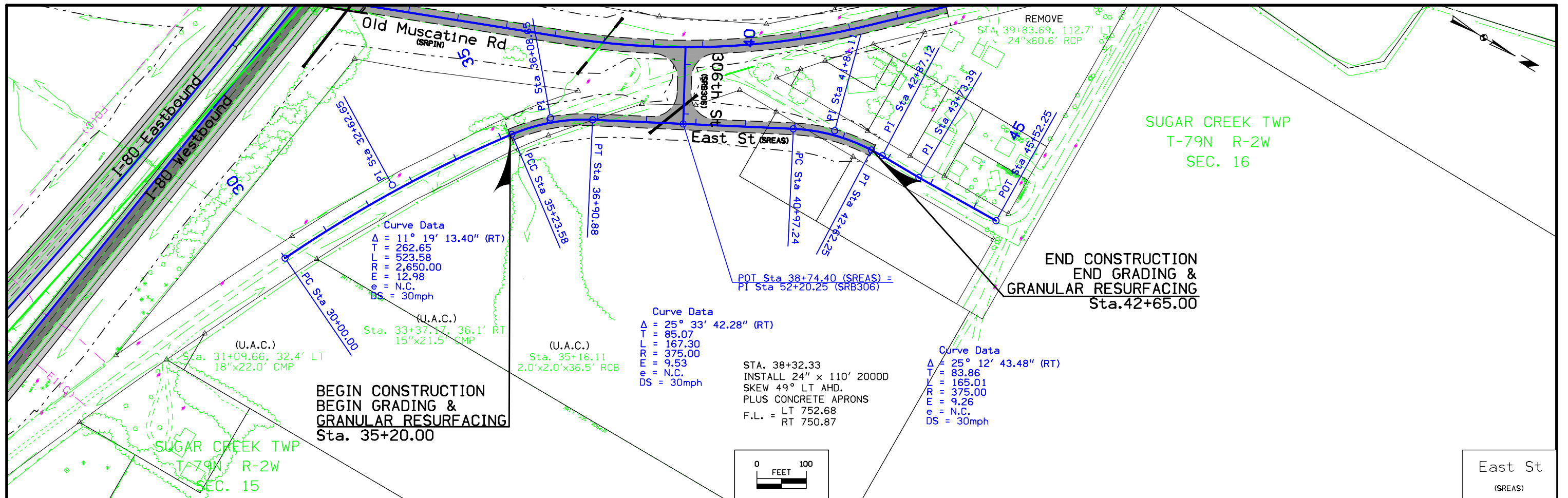

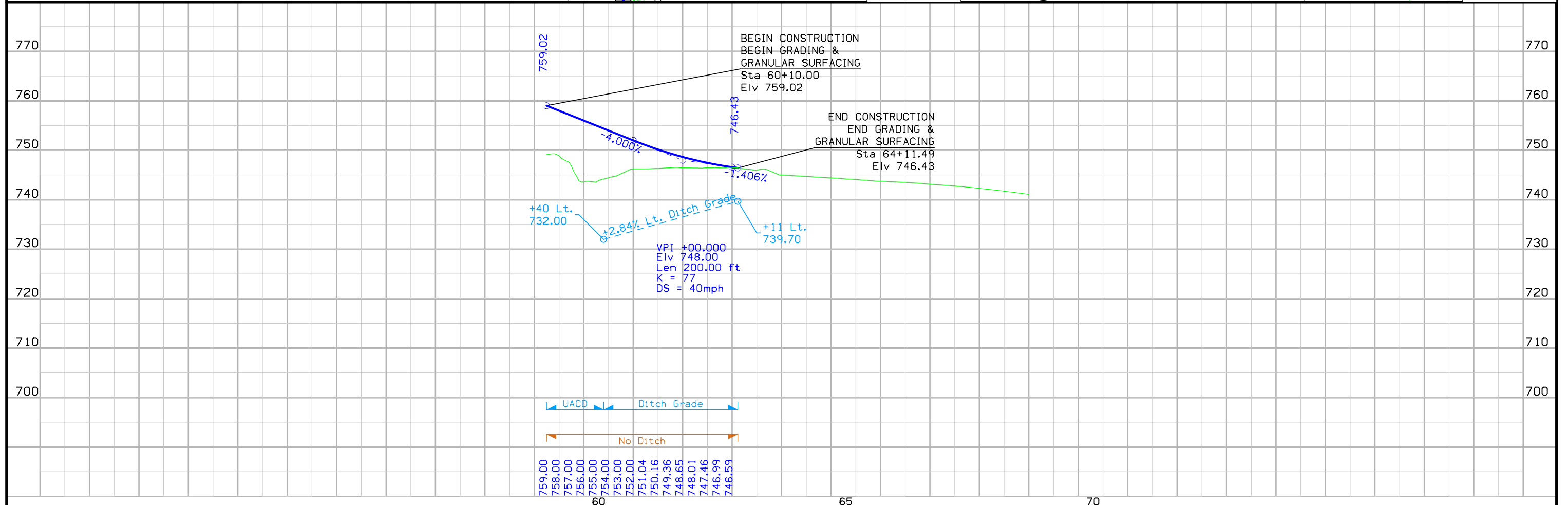
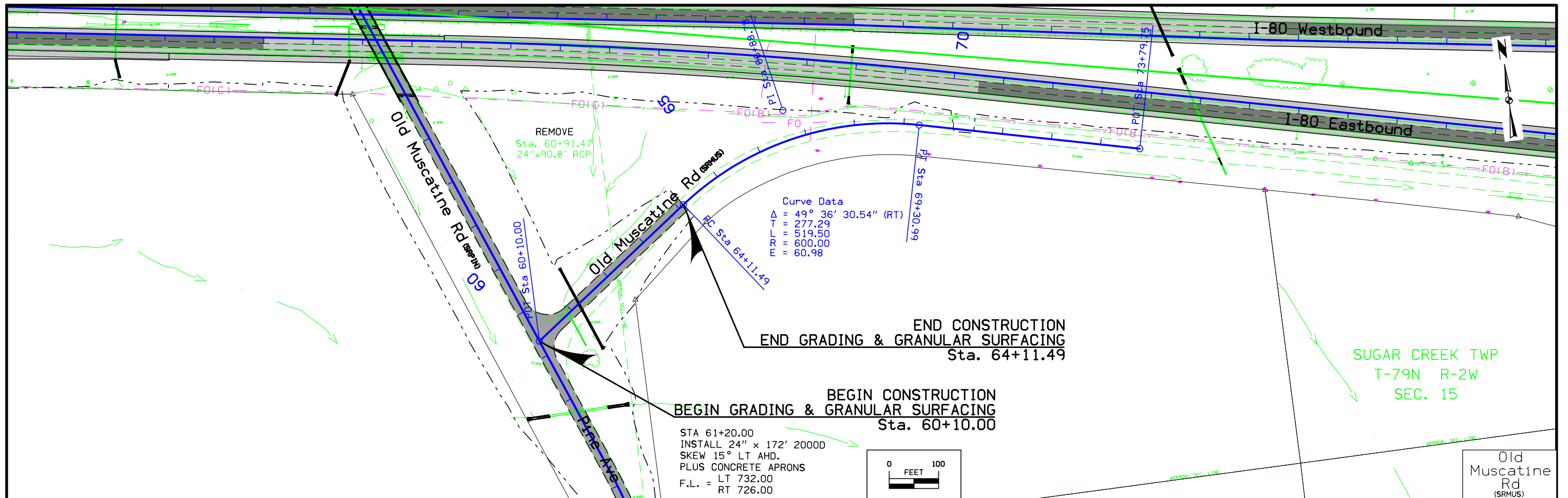

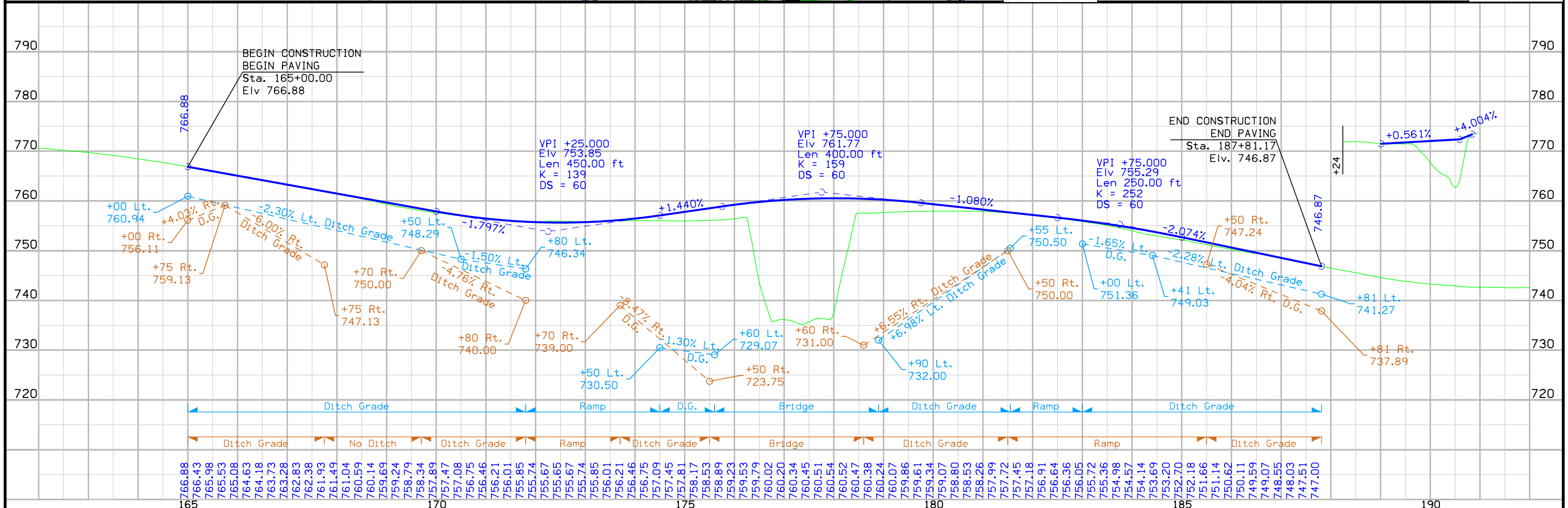
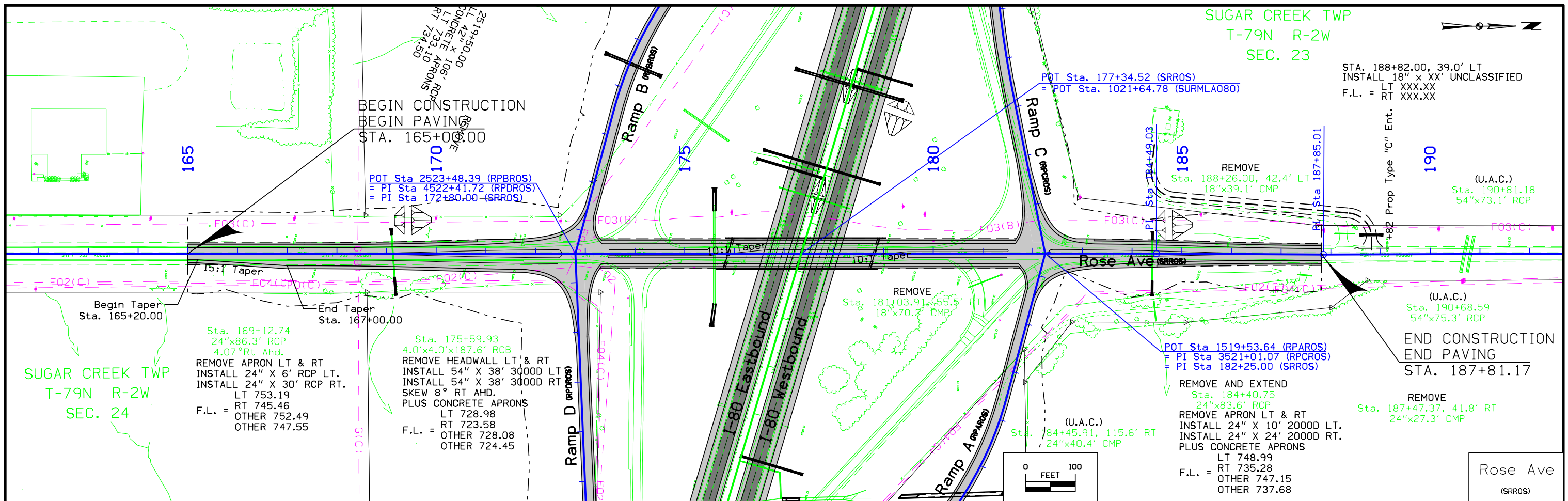



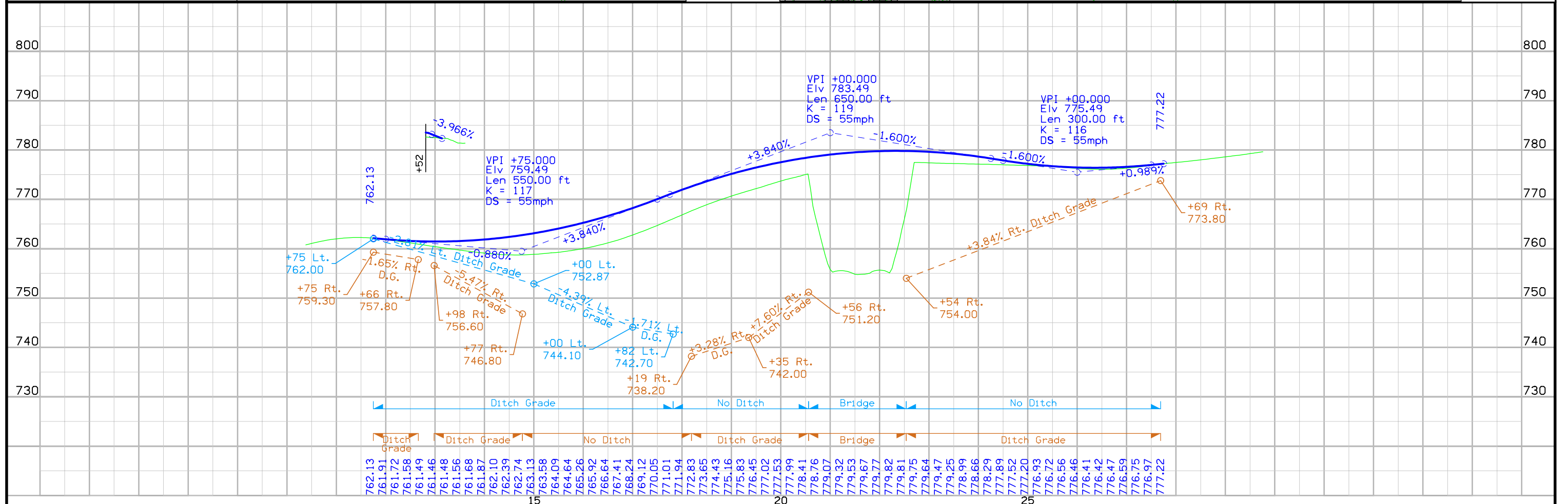
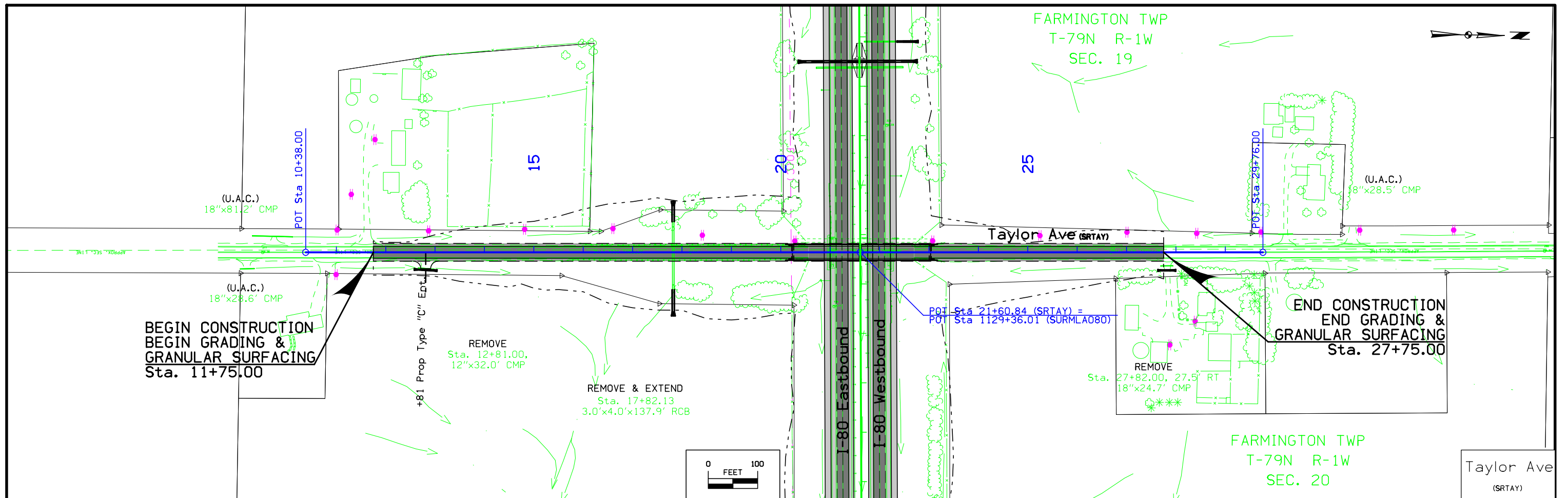

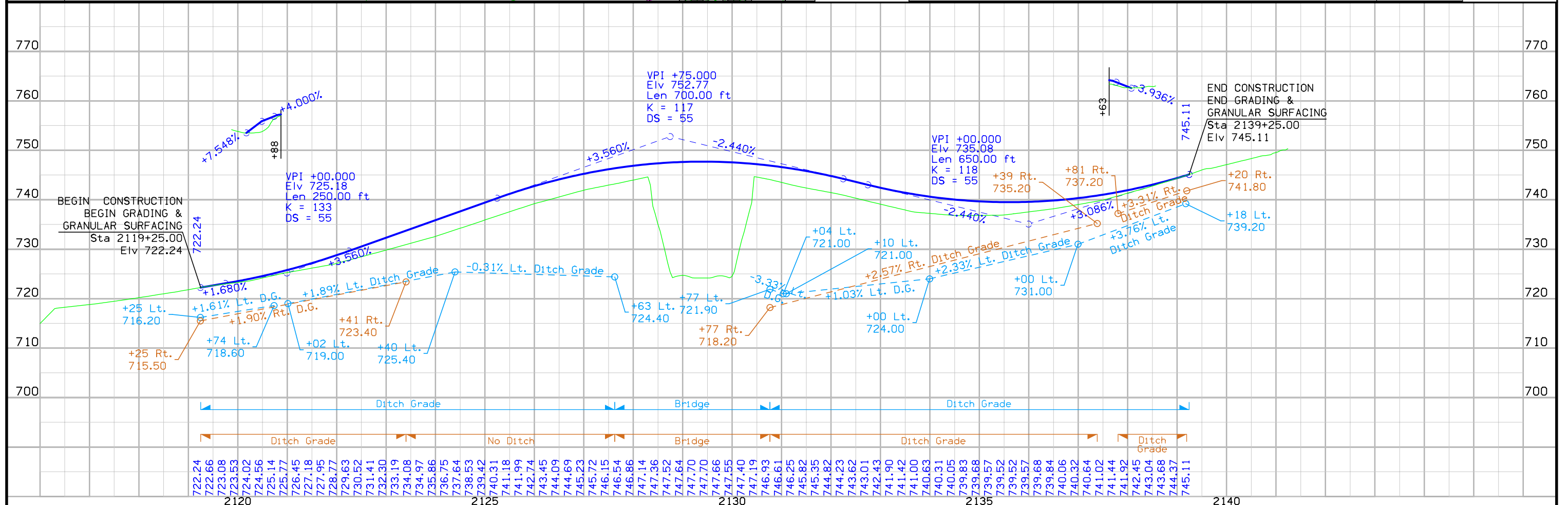
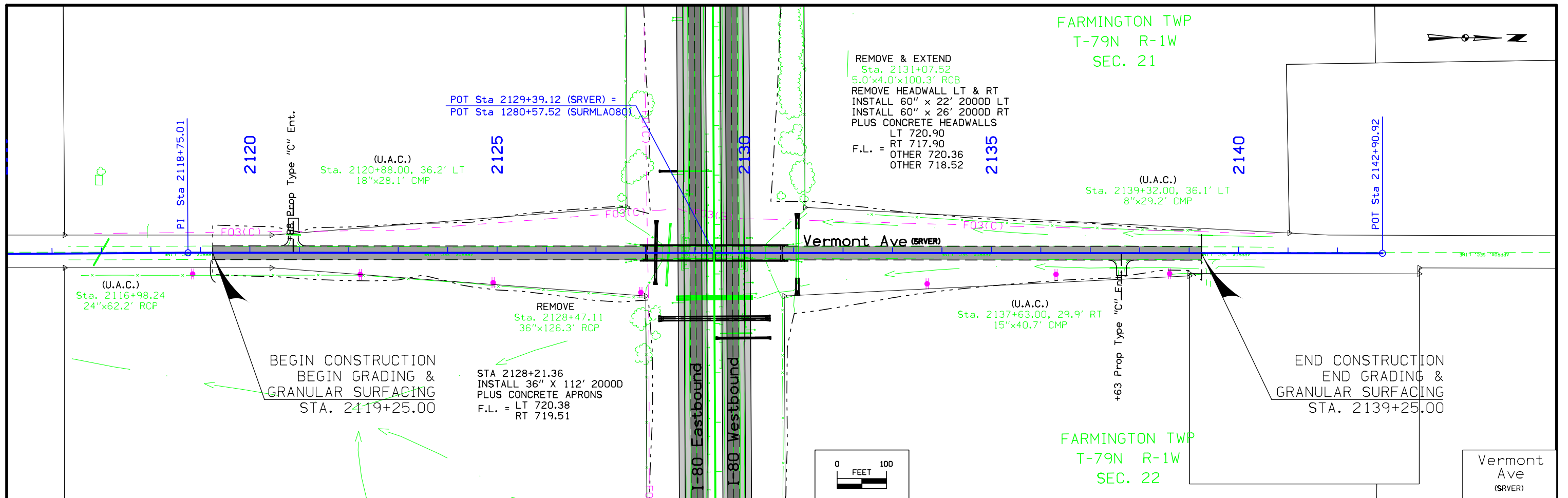

FILE NO.	ENGLISH	DESIGN TEAM	Iowa DOT \ HR Green	CEDAR COUNTY	PROJECT NUMBER	IM-NHS-080-7(134)266--03-16	SHEET NUMBER	E.15
----------	---------	-------------	---------------------	--------------	----------------	-----------------------------	--------------	------

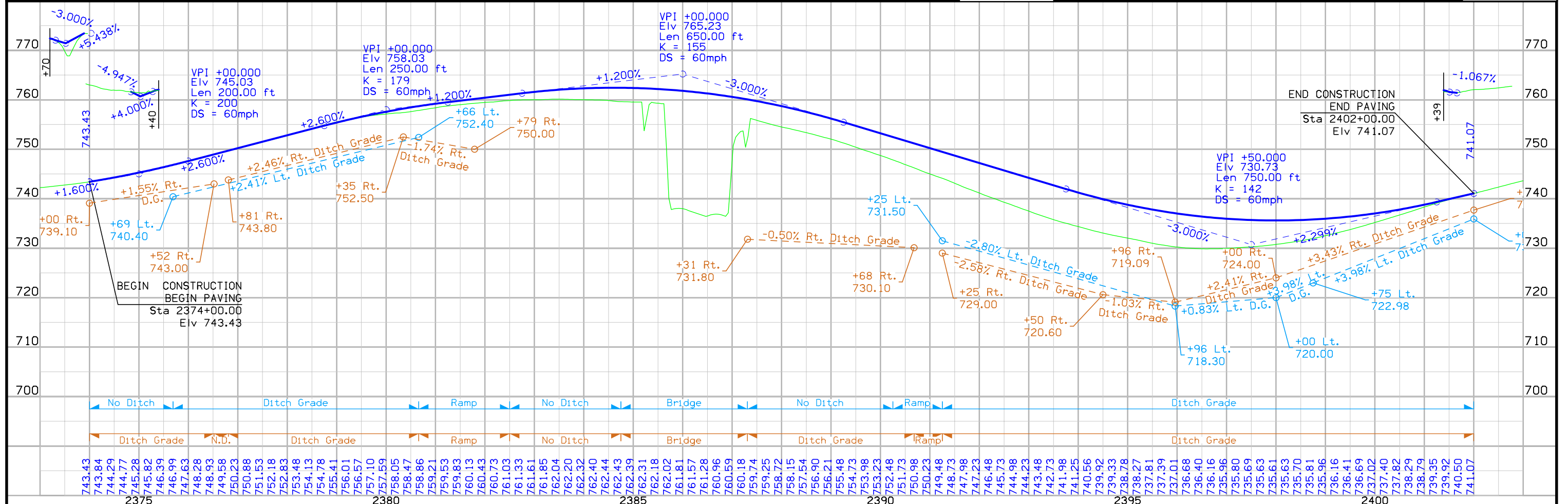
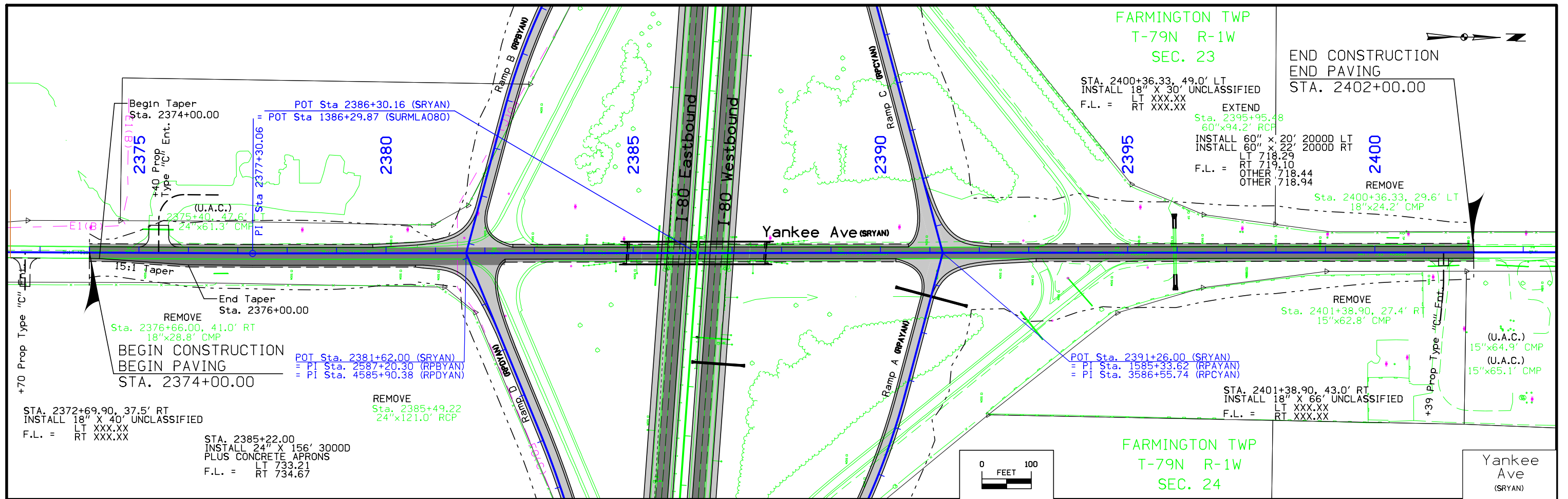



## Survey Information

Cedar County  
IM-080-7(132)266—13-16  
E of Cedar River to approx  
0.5 mi W of Co Rd Y26  
PIN 04-16-080-020

### General Information

Measurement units for this survey are US survey feet. This survey is for the preliminary design for the section of I-80 from Cedar River to the Cedar/Scott County line in Cedar County, Iowa. Project datum and control information is provided by Design Survey Office. This project is a Partial DTM with Photo control. This survey request was for the I-80 corridor only. Project horizontal datum is NAD83(2011), Iowa RCS Zone 10 (Cedar Rapids).

### Vertical Control

Vertical datum for this survey is relative to NAVD88 (computed using Geoid12B for the derived orthometric elevations listed). This survey consisted of observing 13 new FENO 1-meter rod monuments using minimum 2hr initial static observations along with data from 5 Iowa RTN CORS sites: Coralville (IACI), Muscatine (IAMU), Maquoketa (IAMQ), Davenport (IADA) and Tipton (IATI).

Additionally, 5 local existing county GPS monuments with published NAVD88 elevations were observed and used that are located in proximity to the I-80 corridor area: Scott County GPS 2005-624 along with Cedar County GPS points 2007-28, 2007-35, 2007-42 and 2007-48.

Scott County GPS Pt 2005-624 has a published Elv of: 726.41 usft  
Survey Elv = 726.4 usft

Cedar County GPS Pt 2007-28 has a published Elv of 718.04 usft  
Survey Elv = 718.03 usft

Cedar County GPS Pt 2007-35 has a published Elv of 737.79 usft  
Survey Elv = 737.80 usft

Cedar County GPS Pt 2007-42 has a published Elv of 731.74 usft  
Survey Elv = 731.74 usft

Cedar County GPS Pt 2007-48 has a published Elv of 748.57 usft  
Survey Elv = 748.57 usft

The final vertical adjustment results show standard deviations were less than 0.04 ft. at 95% confidence level (2 sigma) for the new FENO monuments.

### Horizontal Control

The project coordinate system for this survey is NAD83(2011) Iowa RCS Zone 10 (Cedar Rapids) us survey feet. This survey control is relative to IARTN reference stations. IARTN Reference Station coordinates are relative to the National Reference Station network datum: NAD83 (2011) for Epoch 2010.00. Coordinates were determined by averaging a minimum of two IARTN observations of 120 minutes minimum session length for the first observation, and 120 minutes minimum for the second observation with appropriate time spans between each session. The horizontal standard deviation of these adjusted observations was less than 0.02 ft. at 95% confidence level (2 sigma).

### Alignment Information

The horizontal alignment for this survey is a retrace of As-built Plans No. IR-80-7(57)256—12-16. Survey stationing was equated to the plan PI at STA 770+79.75 and run back and ahead with two station equations throughout the survey.

Survey stationing relates to as built plan stationing as follows:

PI STA 852+32.6 As-built Plans Project No. IR-80-7(57)256—12-16  
Survey PI STA 852+32.91

PI STA 901+28.40 As-built Plans Project No. IR-80-7(57)256—12-16  
Survey PI STA 901+25.46

PI STA 964+80.8 As-built Plans Project No. IR-80-7(57)256—12-16  
Survey PI STA 964+82.07

PI STA 1056+26.06 As-built Plans Project No. IR-80-7(57)256—12-16  
Survey PI STA 1056+23.36

PI STA 1097+36.09 As-built Plans Project No. IR-80-7(57)256—12-16  
Survey PI STA 1097+35.96

Equation  
PC STA 1155+72.21 (Back) =  
PC STA 1200+00.00 (Ahead)

PI STA 1204+62.50 As-built Plans Project No. IR-80-7(57)256—12-16  
Survey PI STA 1204+62.54

PI STA 1296+83.1 As-built Plans Project No. IR-80-7(57)256—12-16  
Survey PI STA 1296+83.17

PI STA 1359+99.7 As-built Plans Project No. IR-80-7(57)256—12-16  
Survey PI STA 1360+02.29

PI STA 1432+18.5 As-built Plans Project No. IR-80-7(57)256—12-16  
Survey PI STA 1432+16.38

Equation  
STA 1439+81.54 (Back) =  
STA 0+00.00 (Ahead)

## CONTROL POINT VICINITY MAP

This map is a guide to the vicinity of the primary project control points  
 Primary control is for use with RTK base stations and for RTN validation.  
 Future surveys will use primary project control to establish temporary control as needed for construction or other surveying applications.

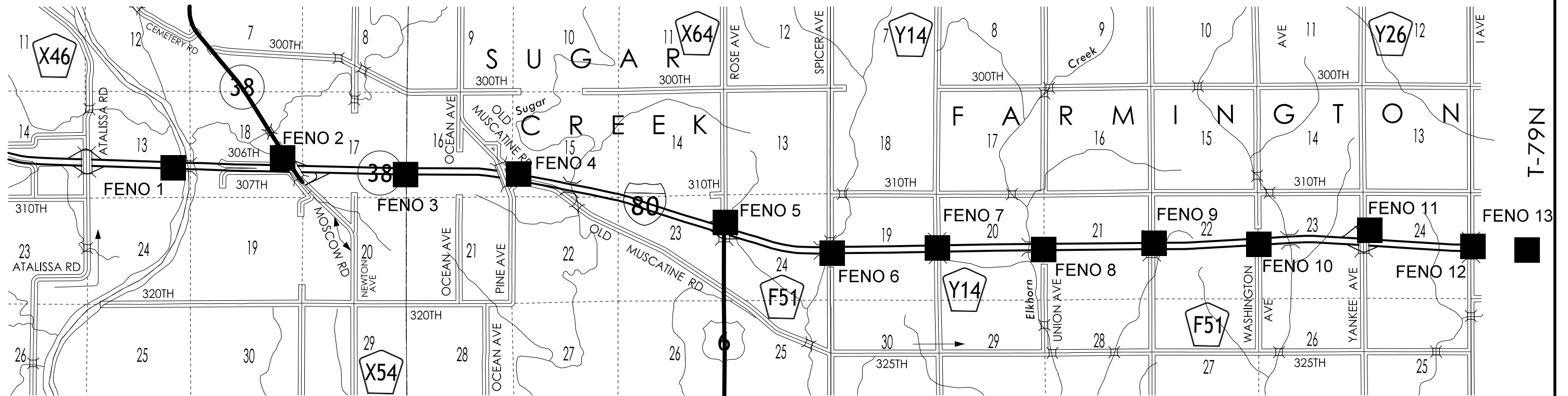

HORIZ. DATUM: NAD83(2011) EPOCH 2010.00

VERT. DATUM: NAVD88

1a. Regional Coordinate System Zone 10

Coordinate listing from next sheet will be used with 1aRTN for monument recovery. No other reference ties are given.

HORIZONTAL AND VERTICAL PROJECT CONTROL COORDINATE LISTING

HORIZ. DATUM: NAD83(2011) EPOCH 2010.00

VERT. DATUM: NAVD88

Ia. Regional Coordinate System Zone 10

Point Name	Northing	Easting	Elevation	Feature
FENO1	7931903.988	20645032.90	660.792	FENO
FENO2	7932401.155	20650487.31	675.723	FENO
FENO3	7931576.605	20656608.15	750.540	FENO
FENO4	7931615.375	20662241.43	745.228	FENO
FENO5	7929177.084	20672559.46	755.379	FENO
FENO6	7927658.057	20677873.71	707.123	FENO
FENO7	7928042.512	20683236.53	764.044	FENO
FENO8	7927833.998	20688433.39	696.149	FENO
FENO9	7928143.386	20693929.25	723.017	FENO
FENO10	7928103.960	20699161.29	736.667	FENO
FENO11	7928788.784	20704684.46	735.398	FENO
FENO12	7927995.048	20709822.03	721.353	FENO
FENO13	7927804.629	20712523.29	702.864	FENO

**TRAFFIC CONTROL PLAN**

Traffic control on this project shall be in accordance with the standard road plans shown in tabulation 105-4 and the specific layouts shown in the plans. For additional complementary information, refer to Part 6 of the Manual on Uniform Traffic Control Devices (MUTCD) and the current standard specifications and supplemental specifications.

Maintain two lanes of traffic in each direction on I-80 during daylight hours. Night time single-lane closures will be allowed.

**STAGING NOTES**

Construction:  
 - Paving of exterior shoulder within wide median area along I-80.  
 - Paving temporary pavement at widening transition reconstruction area.  
 - Paving temporary pavement at Cedar River transition reconstruction area.  
 - Paving and bridge construction of exterior lanes within Sugar Creek Bridge reconstruction area.  
 - Reconstruction of Old Muscatine Road.  
 - Paving ramps and auxiliary lanes at the Welcome Center and Rest area.  
 - Work associated with and necessary for said paving construction. This will include, but is not limited to, grading, paving, striping, signing, barrier, clearing and grubbing, and temporary erosion control.

Stage 3

Traffic:  
 - Apply "Pine Avenue Detour" and temporarily close Pine Avenue bridge and sideroad.  
 - Apply "Taylor Avenue Detour" and temporarily close Taylor Avenue bridge and sideroad.  
 - Apply "Yankee Avenue Detour" and temporarily close Yankee Avenue bridge and ramps.  
 - Maintain existing traffic in all other areas of project.

Construction:  
 - Construction and paving of Pine Avenue bridge and sideroad.  
 - Construction and paving of Taylor Avenue bridge and sideroad.  
 - Construction and paving of Yankee Avenue interchange.  
 - Work associated with and necessary for said paving construction. This will include, but is not limited to, grading, paving, striping, signing, barrier, clearing and grubbing, and temporary erosion control.

PHASE 2

Summary:  
 - This phase is primarily intended for the exterior grading within the 50 ft median area and interior grading within the wide median area, as well as construction of 306th Street, 307th Street, Moscow Road interchange, Rose Avenue interchange, and Vermont Avenue overpass.  
 - Stage 3B cannot be started until the completion of Stage 3A construction.

Stage 1

Traffic:  
 - Open I-80 traffic to previously constructed interior pavement within 50 ft median area. I-80 traffic will shift 8 ft towards the median operating on existing and previously constructed pavement. Temporary barrier shall be installed along outside lane.  
 - Maintain existing traffic in all other areas of project.

Construction:  
 - Grading along exterior shoulder within 50 ft median area along I-80.  
 - Reconstruction of 306th Street.  
 - Reconstruction and paving of 307th Street.  
 - Work associated with and necessary for said grading construction. This will include, but is not limited to, grading, paving, striping, signing, barrier, clearing and grubbing, and temporary erosion control.

Stage 2

Traffic:  
 - Open I-80 traffic to previously constructed exterior pavement within wide median area. I-80 traffic will shift 10 ft towards the outside shoulder operating on existing and previously constructed pavement. Temporary barrier shall be installed along inside lane.  
 - Maintain existing traffic in all other areas of project.

Construction:  
 - Grading along interior shoulder and median area within wide median area along I-80.  
 - Work associated with and necessary for said grading construction. This will include, but is not limited to, grading, signing, barrier, clearing and grubbing, and temporary erosion control.

Stage 3A

Traffic:  
 - Apply "Rose Avenue Detour" and temporarily close Rose Avenue bridge, sideroad, and ramps.  
 - Apply "Vermont Avenue Detour" and temporarily close Vermont Avenue bridge and sideroad.  
 - Maintain traffic access on Moscow Road.  
 - Maintain existing traffic in all other areas of project.

Construction:  
 - Construction of Moscow Road Bridge.  
 - Construction and paving of Rose Avenue bridge, sideroad.  
 - Construction and paving of Vermont Avenue bridge, sideroad, and ramps.  
 - Work associated with and necessary for said paving construction. This will include, but is not limited to, grading, paving, striping, signing, barrier, clearing and grubbing, and temporary erosion control.

Stage 3B

Traffic:  
 - Open Rose Avenue traffic to previously constructed pavement.  
 - Open Vermont Avenue traffic to previously constructed pavement.  
 - Apply "Moscow Road Detour" and temporarily close Moscow Road sideroad and ramps.  
 - Maintain existing traffic in all other areas of project.

Construction:  
 - Paving along Moscow Road ramps and sideroad.  
 - Work associated with and necessary for said paving construction. This will include, but is not limited to, grading, paving, striping, signing, barrier, clearing and grubbing, and temporary erosion control.

**STAGING NOTES**

**GENERAL NOTES:**

For the purpose of this submittal, construction sequencing shall be split into phases and stages. Phases are defined as larger construction packages of the overall project and may span over more than one construction season. Stages are defined as stages of construction within each phase and are derived from either specific traffic configuration requirements or specific locations of construction. Phase and Stage definitions and sequencing are subject to further refinement as design, construction packaging, and spending plans evolve.

It is not the intent of the sequence of construction to confine the Contractor's activity to the areas of suggested stages alone. It is understood that some of the various steps may occur simultaneously. Therefore, the Contractor may conduct several operations concurrently on the project, provided that traffic is maintained and that these operations do not conflict with the staging operations indicated herein.

Traffic access to the Rest Area and Welcome Center shall be maintained throughout the project.

PHASE 1

Summary:  
 - This phase is primarily intended for construction of the Sugar Creek Bridges, Old Muscatine Road and overpass, Taylor Avenue and overpass, Yankee Avenue interchange, interior shoulder and median work within the 50 ft median area, exterior shoulder within the wide median area, and temporary pavement at horizontal transition reconstruction areas.  
 - Stage 3 may occur concurrently with stages 1 and 2.

Stage 1

Traffic:  
 - Stage 1A: I-80 traffic will operate on existing mainline pavement within 50 ft median area. Existing two lanes will be shifted towards outside shoulder and temporary barrier shall be installed along inside lane.  
 - Stage 1B: I-80 traffic will operate on existing mainline pavement within 50 ft median area. Close inside lane for construction of pavement for proposed shoulder. Lane closure shall occur during night hours.  
 - I-80 traffic will operate on existing mainline pavement within Sugar Creek Bridge reconstruction area. Existing two lanes will be shifted towards outside shoulder and temporary barrier shall be installed along inside lane.  
 - Maintain existing traffic in all other areas of project.

Construction:  
 - Paving of interior shoulder and median grading within 50 ft median area along I-80.  
 - Paving and bridge construction of interior lanes within Sugar Creek Bridge reconstruction area.  
 - Work associated with and necessary for said paving construction. This will include, but is not limited to, grading, paving, striping, barrier, clearing and grubbing, and temporary erosion control.

Stage 2

Traffic:  
 - I-80 traffic will operate on existing mainline pavement within Cedar River transition area. Existing two lanes traveling EB will maintain existing route where possible and temporary barrier shall be installed along outside shoulder. Existing two lanes traveling WB and existing two lanes traveling EB, where it is not possible to maintain existing route, will be shifted towards inside shoulder and temporary barrier shall be installed along outside lane.  
 - I-80 traffic will operate on existing mainline pavement within widening transition areas. Existing two lanes will be shifted towards inside shoulder and temporary barrier shall be installed along outside lane.  
 - Stage 2A: I-80 traffic will operate on existing mainline pavement within wide median area. Existing two lanes will be shifted towards inside shoulder and temporary barrier shall be installed along outside lane.  
 - Stage 2B: I-80 traffic will operate on existing mainline pavement within wide median area. Close outside lane for construction of pavement for proposed shoulder. Lane closure shall occur during night hours.  
 - Open I-80 traffic to previously constructed pavement within Sugar Creek Bridge reconstruction area. Temporary barrier shall be installed along outside lane.  
 - Maintain existing traffic in all other areas of project.

**STAGING NOTES**

PHASE 3

Summary:

- This phase is primarily intended for the exterior paving within the 50 ft median area, interior paving within the wide median area, construction of the transition reconstruction areas, construction of the Truck Stop ramp and auxiliary lanes, and overlaying the entirety of the project.

Stage 1

Traffic:

- I-80 traffic will operate on existing and temporary mainline pavement within Cedar River transition area. Existing two lanes will be shifted and temporary barrier shall be installed along inside lane.
- I-80 traffic will operate on existing and temporary mainline pavement within widening transition areas. Existing two lanes will be shifted to 2 ft from outside edge of temporary pavement and temporary barrier shall be installed along outside lane.
- Maintain existing traffic in all other areas of project.

Construction:

- Paving interior widening within wide median area along I-80.
- Paving interior pavement along widening transition reconstruction areas.
- Paving interior pavement along Cedar River transition reconstruction area.
- Work associated with and necessary for said paving construction. This will include, but is not limited to, grading, paving, striping, signing, barrier, clearing and grubbing, and temporary erosion control.

Stage 2

Traffic:

- Open I-80 traffic to previously constructed pavement within Cedar River transition area. Existing traffic will be shifted towards inside shoulder and temporary barrier shall be installed along outside of previously constructed lane.
- Stage 2A: Open I-80 traffic to previously constructed pavement within widening transition reconstruction area. Existing traffic will be shifted to 1 ft from edge of inside lane and temporary barrier shall be installed along outside previously constructed lane.
- Stage 2B: Open I-80 traffic to previously constructed pavement within the widening transition reconstruction area. Existing traffic will be shifted to 2 ft from edge of outside shoulder and temporary barrier shall be installed along centerline of road.
- Maintain existing traffic in all other areas of project.

Construction:

- Paving exterior widening within 50 ft median area along I-80.
- Paving exterior pavement along widening transition reconstruction areas.
- Paving exterior pavement along Cedar River transition reconstruction area.
- Paving ramps and auxiliary lanes at the Truck Stop.
- Work associated with and necessary for said paving construction. This will include, but is not limited to, grading, paving, striping, signing, barrier, clearing and grubbing, and temporary erosion control.

Stage 3

Traffic:

- Single lane closures to occur during night hours.

Construction:

- Paving overlay throughout entirety of project; including existing pavement, previously constructed shoulders and widening, and reconstructed areas.

**COORDINATED OPERATIONS**

Other work in progress during the same period of time will include the construction of the projects listed. Coordinate operations with those of other contractors working within the same area.











Project	Type of Work
BRFIMX-080-7(108)270--14-16	Bridge Replacement - PPCB
IM-080-7(135)267--13-16	Bridge - Unspecified
IM-080-7(136)271--13-16	Bridge - Unspecified
IM-080-7(139)266--13-16	Traffic Signs
IM-080-7(141)266--13-16	Traffic Signs
IM-080-7(143)266--13-16	Grading
IMN-080-7(144)266--0E-16	Erosion Control
IM-NHS-080-7(134)266--03-16	Grading
IM-NHS-080-7(137)266--03-16	RCB Culvert - Unspecified
IM-NHS-080-7(138)266--03-16	Unknown Pavement - New
IM-NHS-080-7(140)266--03-16	Unknown Pavement - Grade + New
IM-NHS-080-7(142)266--03-16	RCB Culvert - Unspecified
ITS-080-7(146)266--25-16	(unspecified)
ITS-080-7(147)266--25-16	(unspecified)

**511 TRAVEL RESTRICTIONS**

















Route	Direction	County	Location Description	Feature Crossed	Object Type	Maint. Bridge No., Structure ID, or FHWA No.	Type of Restriction	Existing Measurement	Construction Measurement	Construction Measurement as Signed	Projected As Built Measurement	Remarks
I-80			No restrictions anticipated									















### CROSS SECTION VIEW COLOR LEGEND OF TRAFFIC CONTROL AND STAGING SHEETS

SHADING	Design Color No.		
Green, Light	(225)		Existing Pavement Shading
Gray, Light	(48)		Previously Constructed Pavement Shading
Gray, Med	(80)		Previously Constructed Granular Surface Shading
Blue, Light	(230)		Proposed Pavement Shading
Lavender	(9)		Temporary Pavement Shading
Red	(3)		Proposed Bridge Shading
Brown, Med	(237)		Proposed Grading
Green, Dashed	(10)		Existing Grading
Green, Solid	(237)		Previously Constructed Grading
Violet	(15)		Temporary Barrier Rail, Unpinned
Flush Orange	(228)		Temporary Barrier Rail, Pinned

### PLAN VIEW COLOR LEGEND OF TRAFFIC CONTROL AND STAGING SHEETS

LINEWORK	Design Color No.		
Green	(2)		Existing Topographic Features and Labels
Magenta	(5)		Pavement Marking Call Outs
Blue	(1)		Proposed Alignment, Stationing, Tic Marks, and Alignment Annotation
Yellow	(4)		Pavement Markings, Yellow
Off White	(254)		Pavement Markings, White
Violet	(15)		Temporary barrier rail, Unpinned
Flush Orange	(228)		Temporary barrier rail, Pinned
SHADING	Design Color No.		
Green, Light	(225)		Existing Pavement Shading
Gray, Light	(48)		Previously Constructed Pavement Shading
Gray, Med	(80)		Proposed Granular Surface Shading
Gray, Med	(80)		Previously Constructed Granular Surface Shading
Blue, Light	(230)		Proposed Pavement Shading
Lavender	(9)		Temporary Pavement Shading
Brown, Light	(236)		Proposed Grading Limits Shading
Pink, Dark	(13)		Proposed MSE or CIP Wall Shading
Red	(3)		Proposed Bridge Shading
Black w/Gray, Light Fill	(0,48)		Previously Constructed Structure

### PLAN VIEW PATTERN AND SYMBOL LEGEND OF TRAFFIC CONTROL AND STAGING SHEETS

●	Channelizing Device		Crash Cushion (Temp or Perm)
✕	Drum		Traffic Signal
■	Temporary Lane Separator		Flagger
◆	Tubular Marker		Temporary Floodlighting
◆	Channelizer Marker		Traffic Sign
△	Concrete Barrier Marker		Type III Barricade
◁	Delineator		Type A Warning Light
—	Temporary Barrier Rail		Direction of Traffic
	Pavement Removal		Safety Closure
	Sand Barrel Layout		Lane Identification

NOTE: Device spacing according to Standard Road Plans unless specifically dimensioned.

## TRAFFIC CONTROL AND STAGING LEGEND AND SYMBOL INFORMATION SHEET

(COVERS SHEET SERIES J)

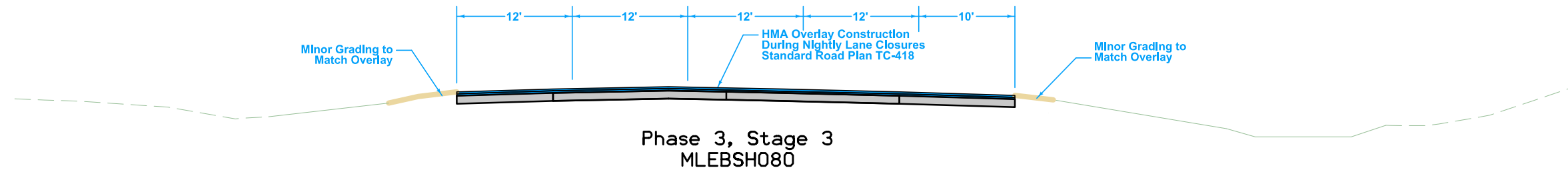
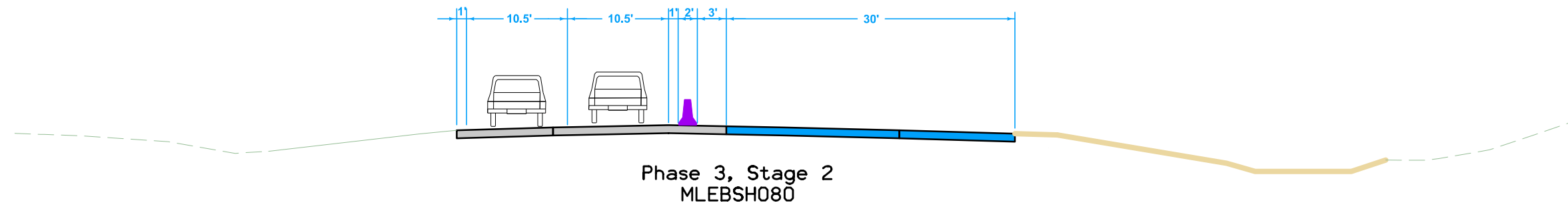
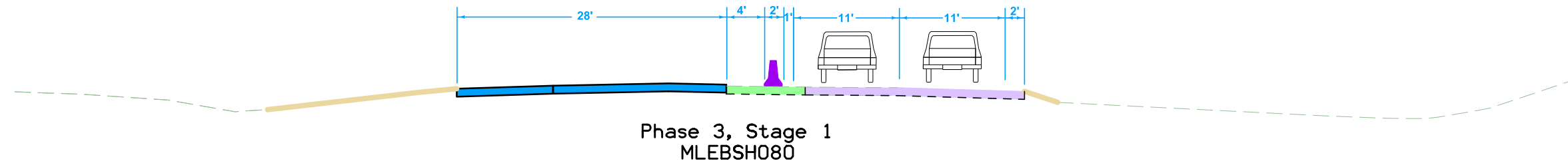
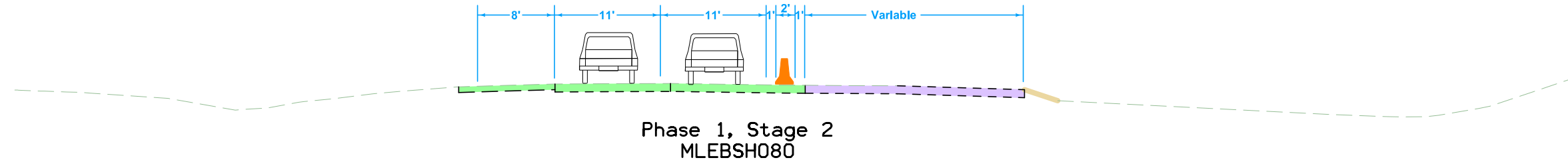

Reconstruction at Cedar River Transitions

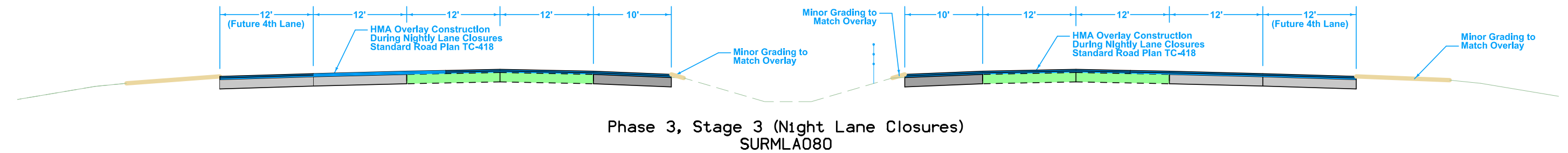
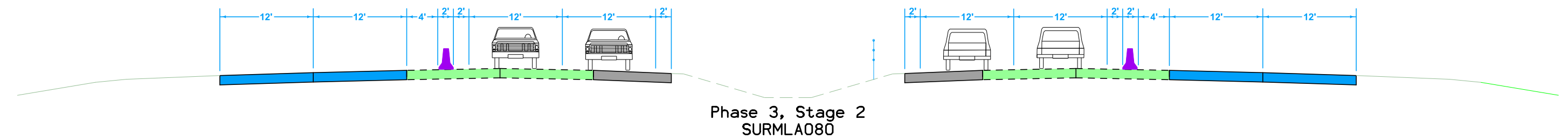
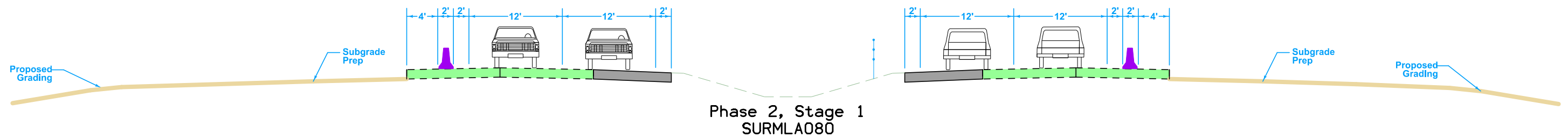
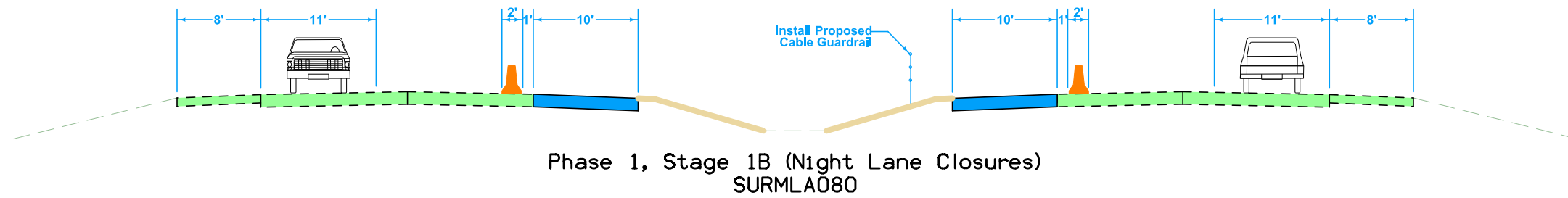
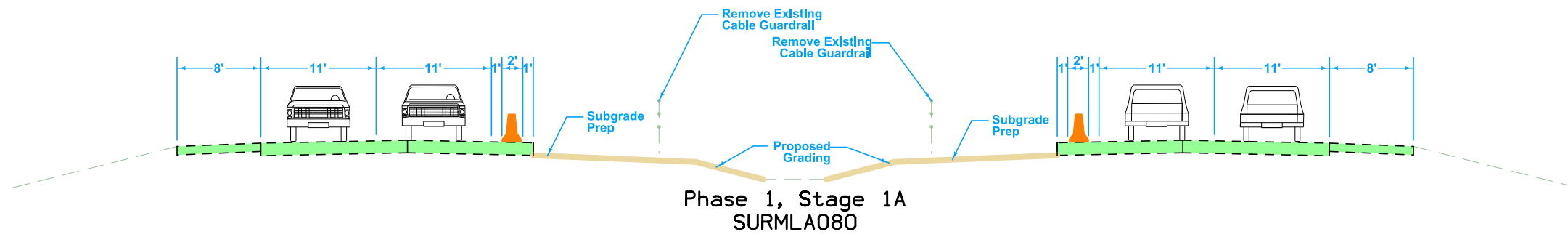

50 ft Median / Exterior Widening

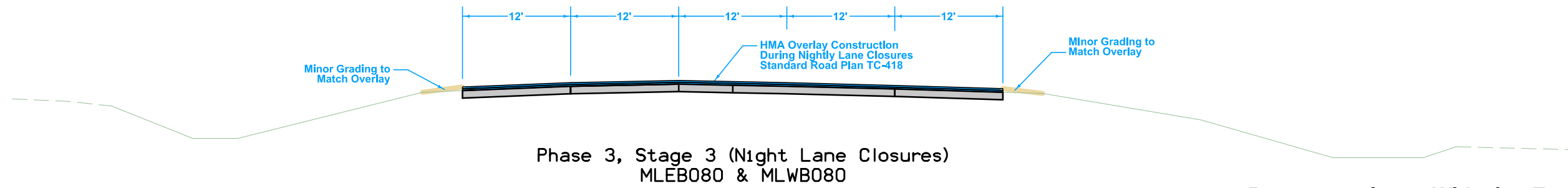
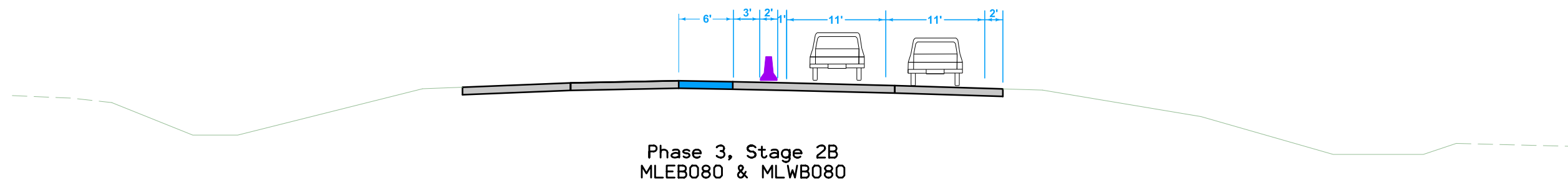
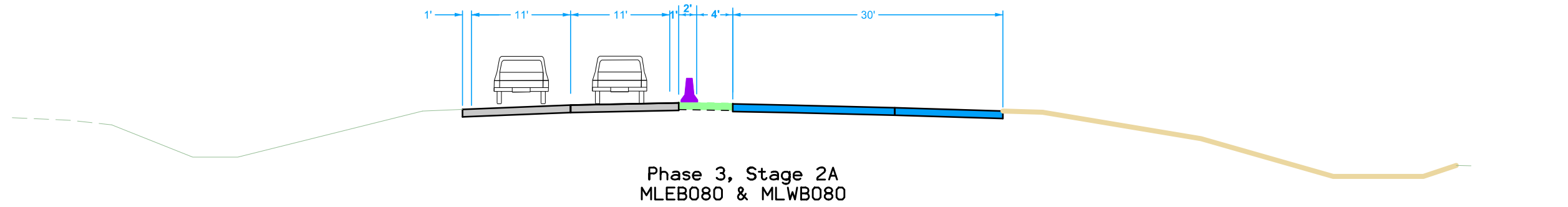
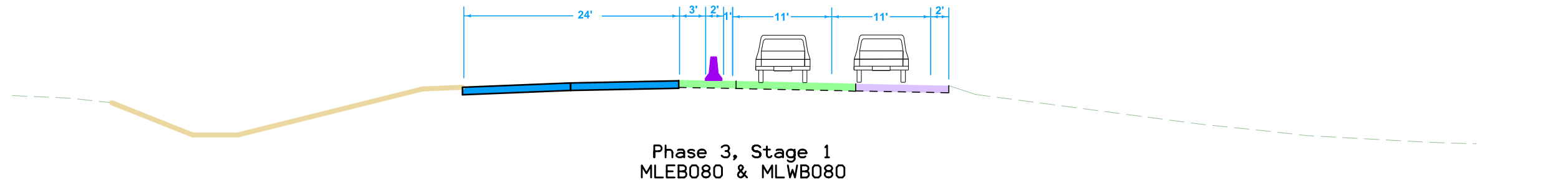
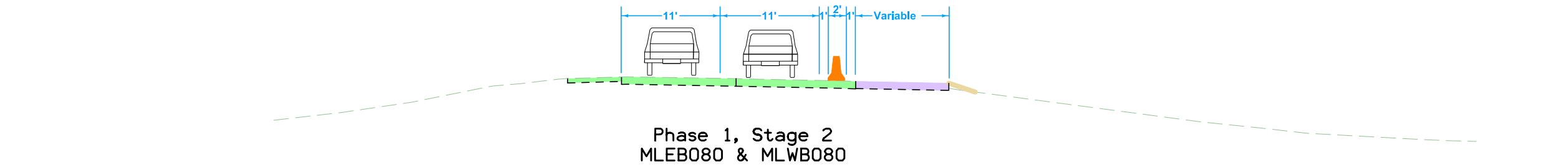

**Reconstruction at Widening Transitions**

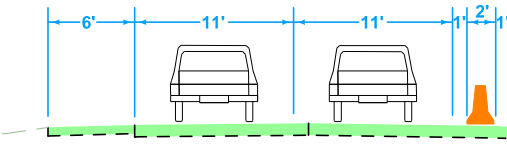

Phase 1, Stage 2A  
MLEB080 & MLWB080

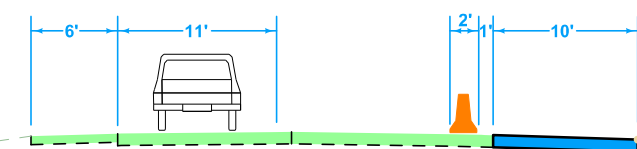

Phase 1, Stage 2B (Night Lane Closures)  
MLEB080 & MLWB080

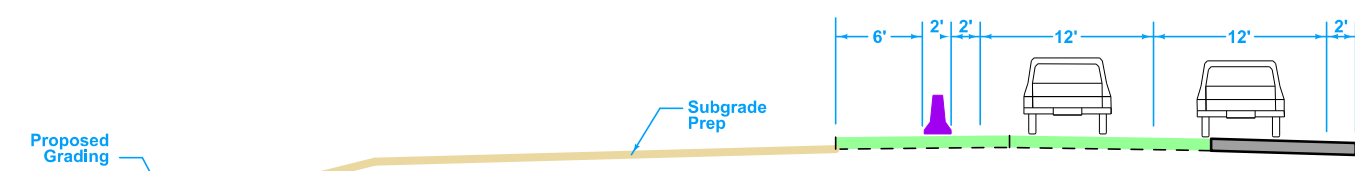

Phase 2, Stage 2  
MLEB080 & MLWB080

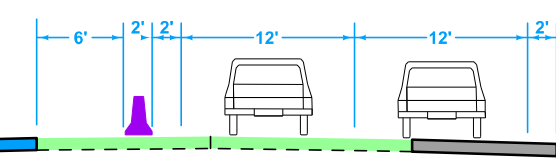

Phase 3, Stage 1  
MLEB080 & MLWB080

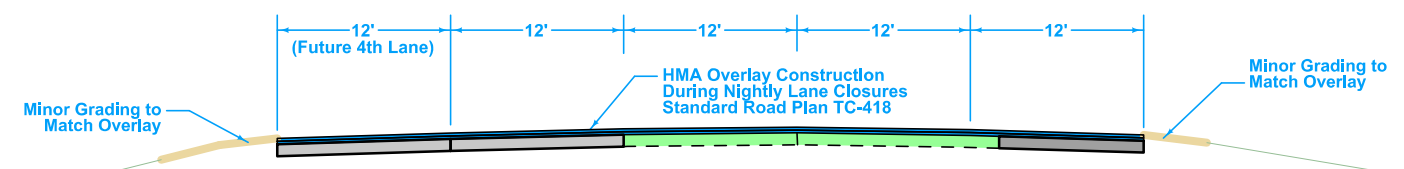

Phase 3, Stage 3 Night Lane Closures  
MLEB080 & MLWB080

Wide Median / Interior Widening



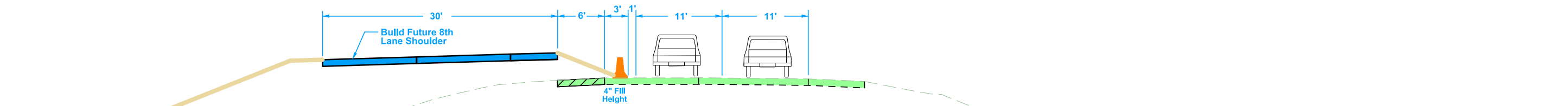

Phase 1, Stage 1  
MLEB080 & MLWB080

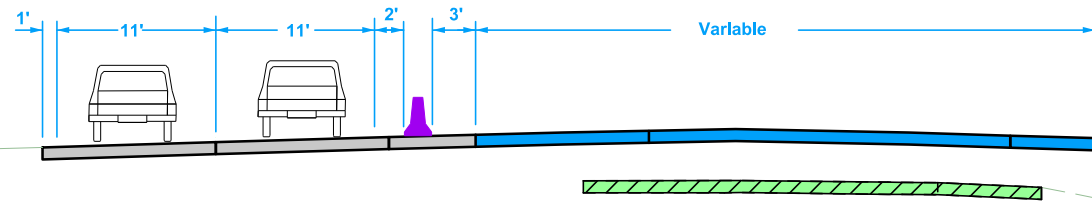

Phase 1, Stage 2  
MLEB080 & MLWB080

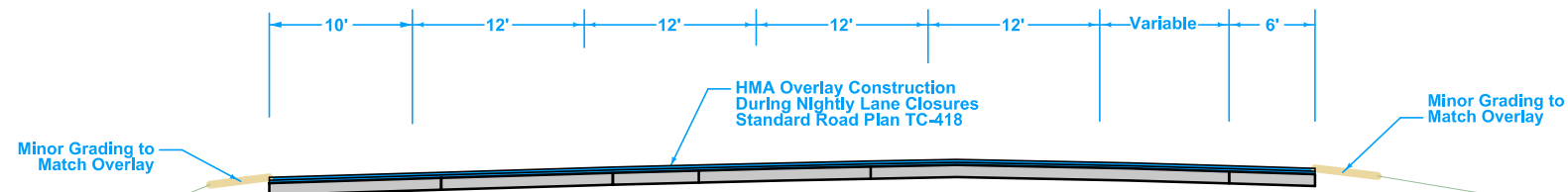

Phase 3, Stage 3  
MLEB080 & MLWB080

Sugar Creek Reconstruction

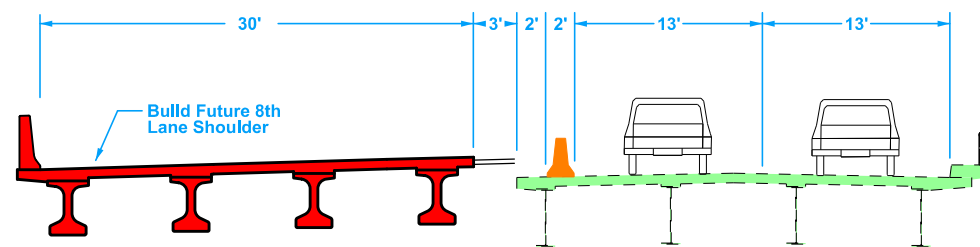

Phase 1, Stage 1  
MLEB080 & MLWB080  
(EB SHOWN)

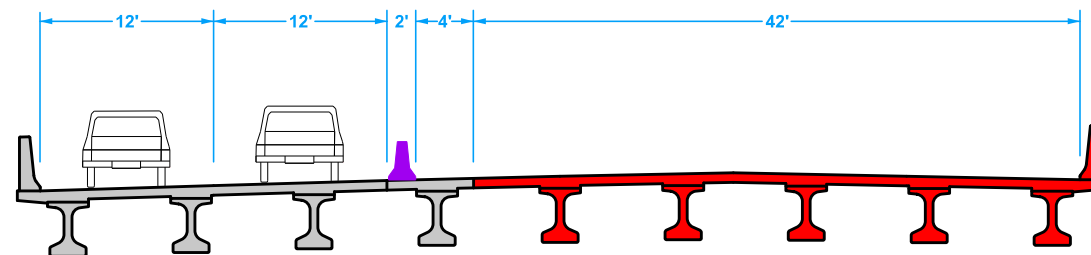

Phase 1, Stage 2  
MLEB080 & MLWB080  
(EB SHOWN)

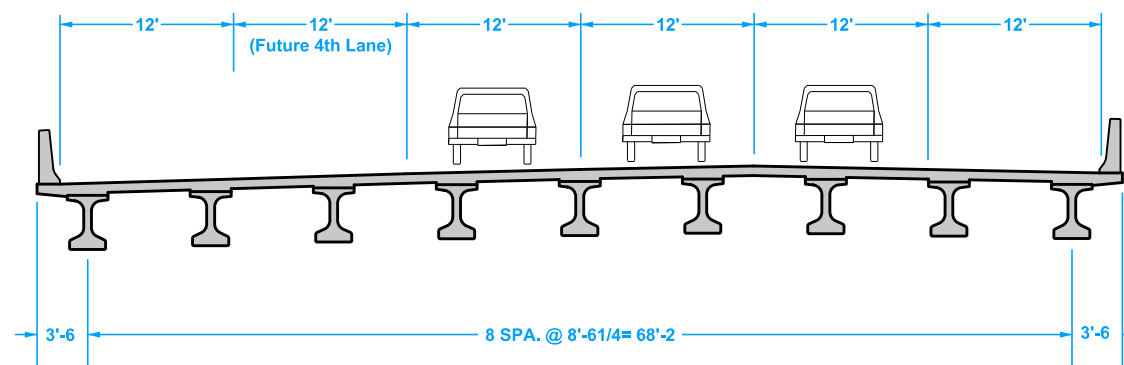

Phase 1 Final  
MLEB080 & MLWB080  
(EB SHOWN)

Sugar Creek Bridge Reconstruction

# LEGEND

INTERSTATE HIGHWAY	
PRIMARY HIGHWAY-DIVIDED	
PRIMARY HIGHWAY	
PORTLAND CEMENT CONCRETE ROAD	
ASPHALT ROAD	
BITUMINOUS ROAD	
GRAVEL ROAD	
EARTHEN ROAD	
CITY STREET MAJOR	
CITY STREET MINOR	
INTERSTATE HIGHWAY	
UNITED STATES HIGHWAY	
STATE HIGHWAY	
COUNTY HIGHWAY	
RAILROAD	
AIRPORT	
HYDROLOGY	
BRIDGE	
STATE BOUNDARY	
COUNTY BOUNDARY	
CORPORATE BOUNDARY	
TOWNSHIP LINE	
SECTION LINE	
ROAD NAMES	ABBHEY ROAD
UNINCORPORATED PLACE	ELWOOD

BRIDGE RECONSTRUCTION (MULTIPLE COLORS) INTERCHANGE (FULL CLOSURE)	
BRIDGE RECONSTRUCTION (MULTIPLE COLORS) INTERCHANGE (PARTIAL CLOSURE)	
BRIDGE RECONSTRUCTION (MULTIPLE COLORS) OVERPASS (FULL CLOSURE)	
PAVED DETOUR ROUTE (MULTIPLE COLORS)	
GRAVEL DETOUR ROUTE (MULTIPLE COLORS)	

## BRIDGE RECONSTRUCTION DETOUR ROUTES Legend

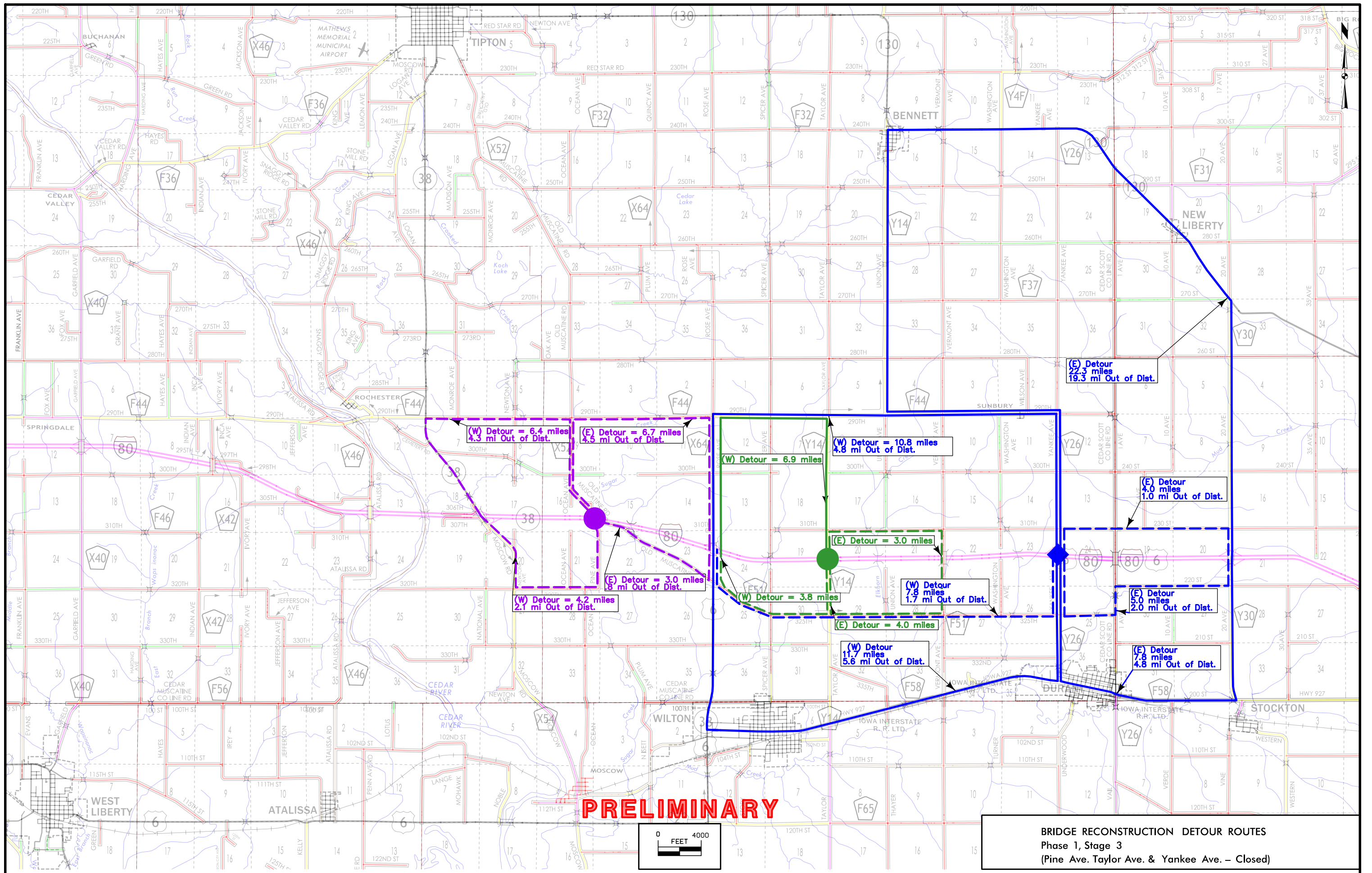



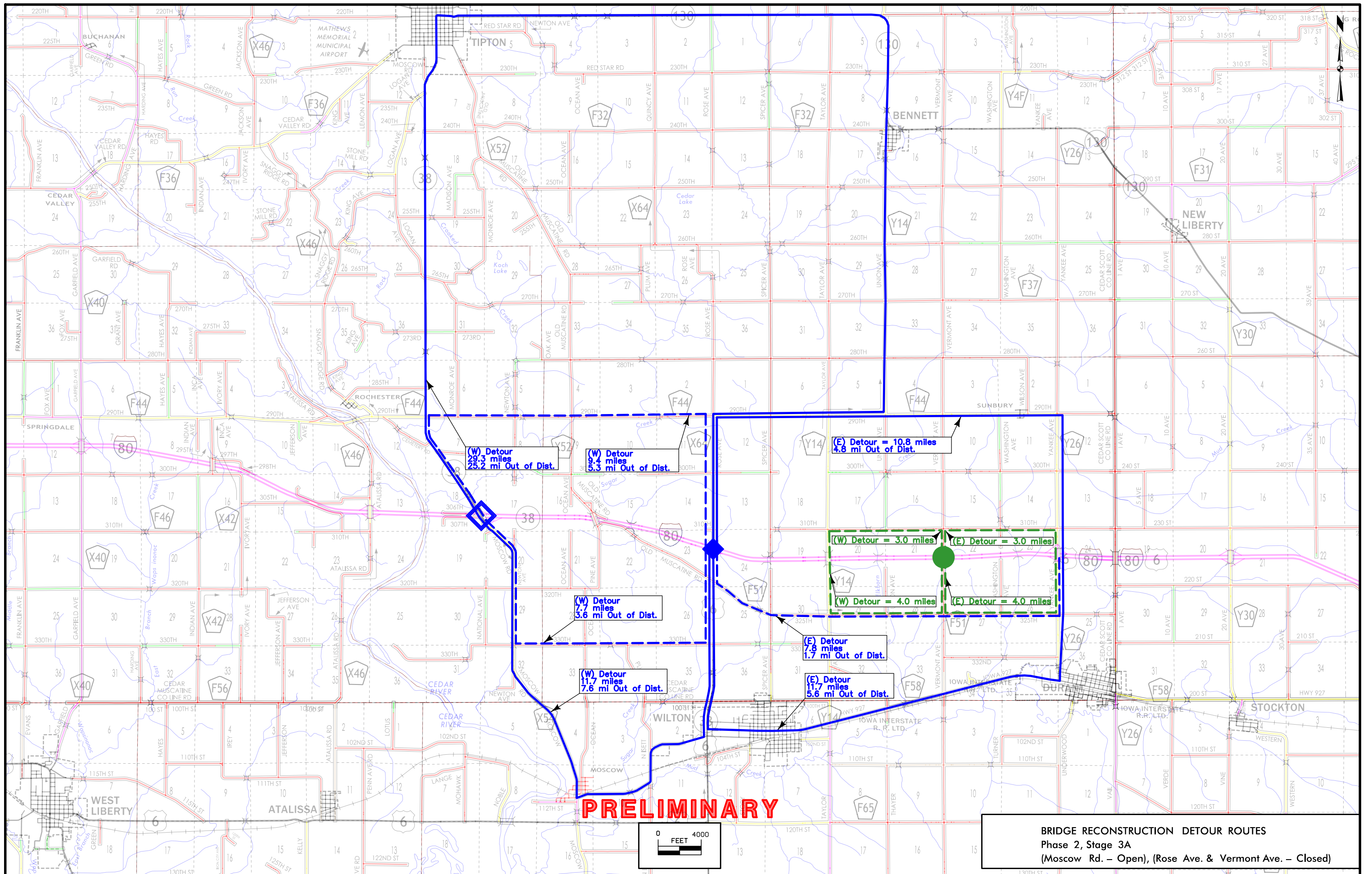



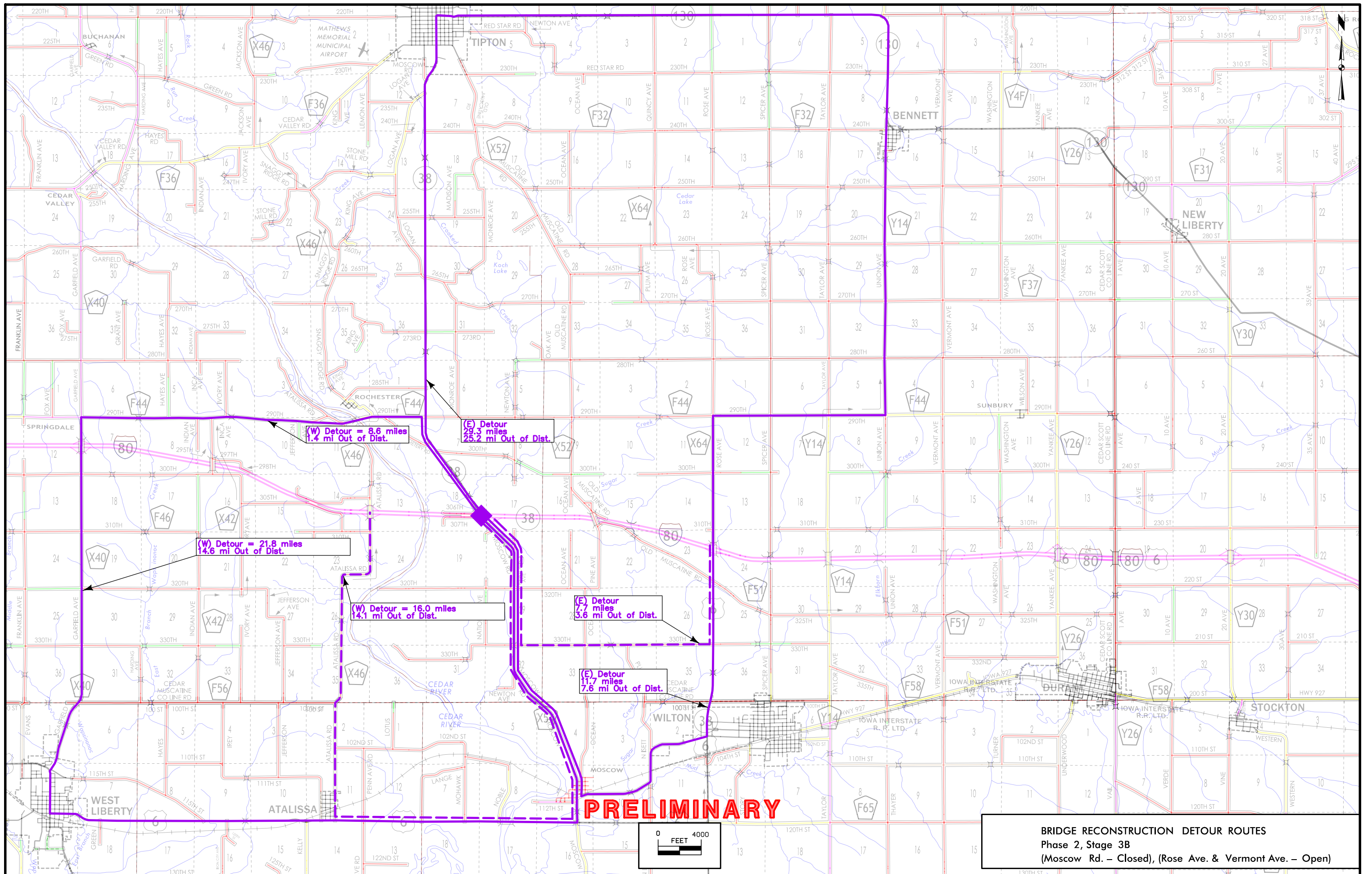

ROCHESTER TWP  
T-79N R-2W  
SEC. 18

Curve Data  
 $\Delta = 19^\circ 40' 16.06''$  (LT)  
 T = 346.74  
 L = 686.65  
 RR = 2,000.00  
 E = 29.83  
 e = 5.40%  
 L = 168  
 x = 62  
 DS = 60mph

Ramp A  $\Delta$  (RPAMOS)  
 Curve Data  
 $\Delta = 51^\circ 35' 44.68''$  (RT)  
 T = 314.19  
 L = 585.34  
 RR = 650.00  
 E = 71.95  
 e = 5.80%  
 L = 140  
 x = 48  
 DS = 40mph

Curve Data  
 $\Delta = 55^\circ 38' 06.41''$  (LT)  
 T = 263.82  
 L = 485.51  
 R = 500.00  
 E = 65.33  
 e = 6.00%  
 L = 144  
 x = 48  
 DS = 40mph

Curve Data  
 $\Delta = 28^\circ 35' 29.78''$  (RT)  
 T = 344.01  
 L = 673.67  
 R = 1,350.00  
 E = 43.14  
 e = 6.00%  
 L = 186  
 x = 62  
 DS = 60mph

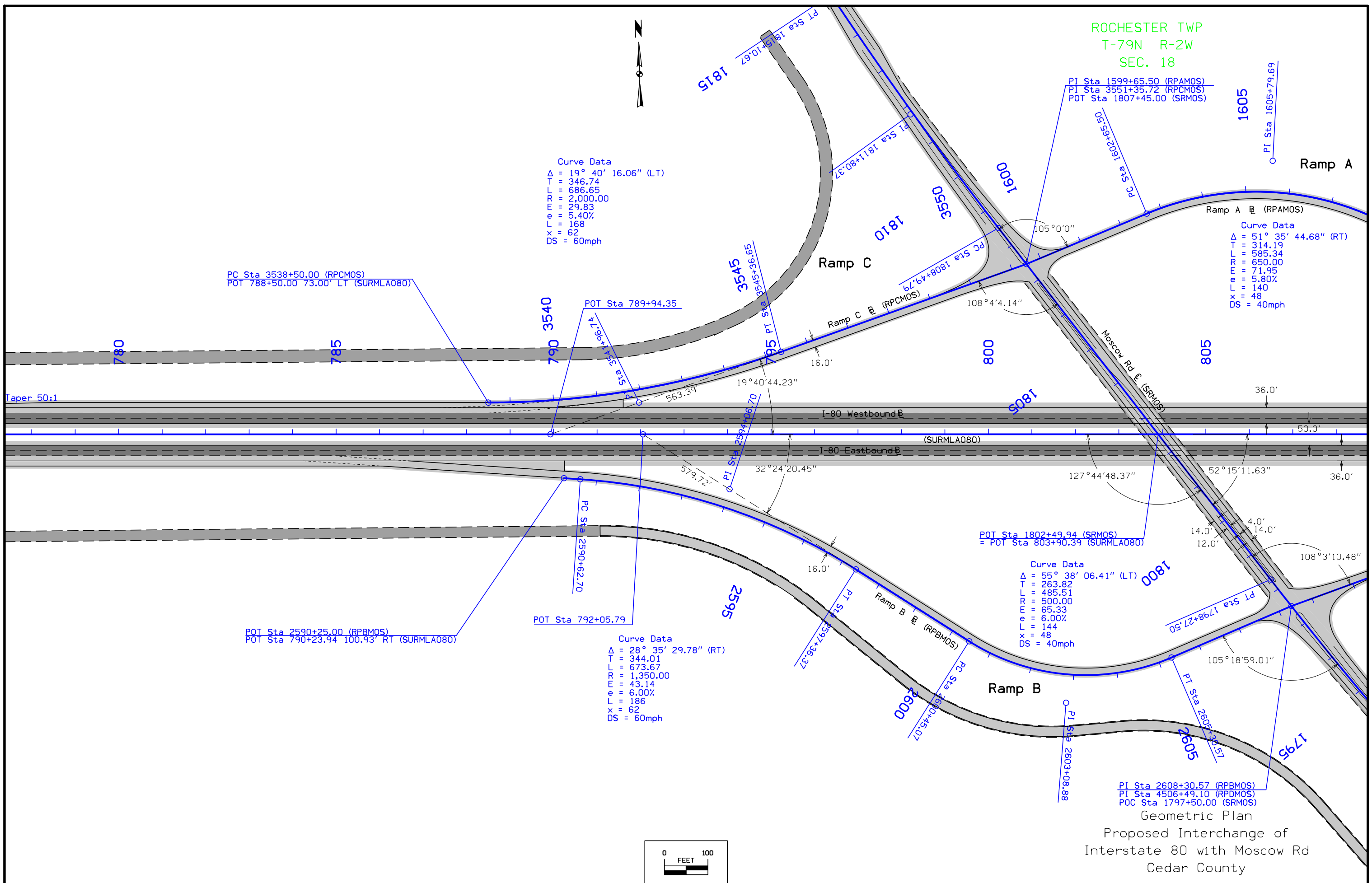

Geometric Plan  
 Proposed Interchange of  
 Interstate 80 with Moscow Rd  
 Cedar County

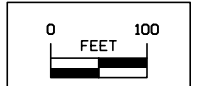

ROCHESTER TWP  
T-79N R-2W  
SEC. 18

ROCHESTER TWP  
T-79N R-2W  
SEC. 17

Curve Data  
 $\Delta = 25^\circ 02' 05.64''$  (LT)  
 T = 344.12  
 L = 677.26  
 R = 1,550.00  
 E = 37.74  
 e = 6.00%  
 L = 186  
 x = 62  
 DS = 60mph

Curve Data  
 $\Delta = 51^\circ 35' 44.68''$  (RT)  
 T = 314.19  
 L = 585.34  
 R = 650.00  
 E = 71.95  
 e = 5.80%  
 L = 140  
 x = 48  
 DS = 40mph

Curve Data  
 $\Delta = 55^\circ 38' 06.41''$  (LT)  
 T = 263.82  
 L = 485.51  
 R = 500.00  
 E = 65.33  
 e = 6.00%  
 L = 144  
 x = 48  
 DS = 40mph

Curve Data  
 $\Delta = 20^\circ 03' 31.80''$  (RT)  
 T = 353.71  
 L = 700.19  
 R = 2,000.00  
 E = 31.04  
 e = 5.40%  
 L = 168  
 x = 62  
 DS = 60mph

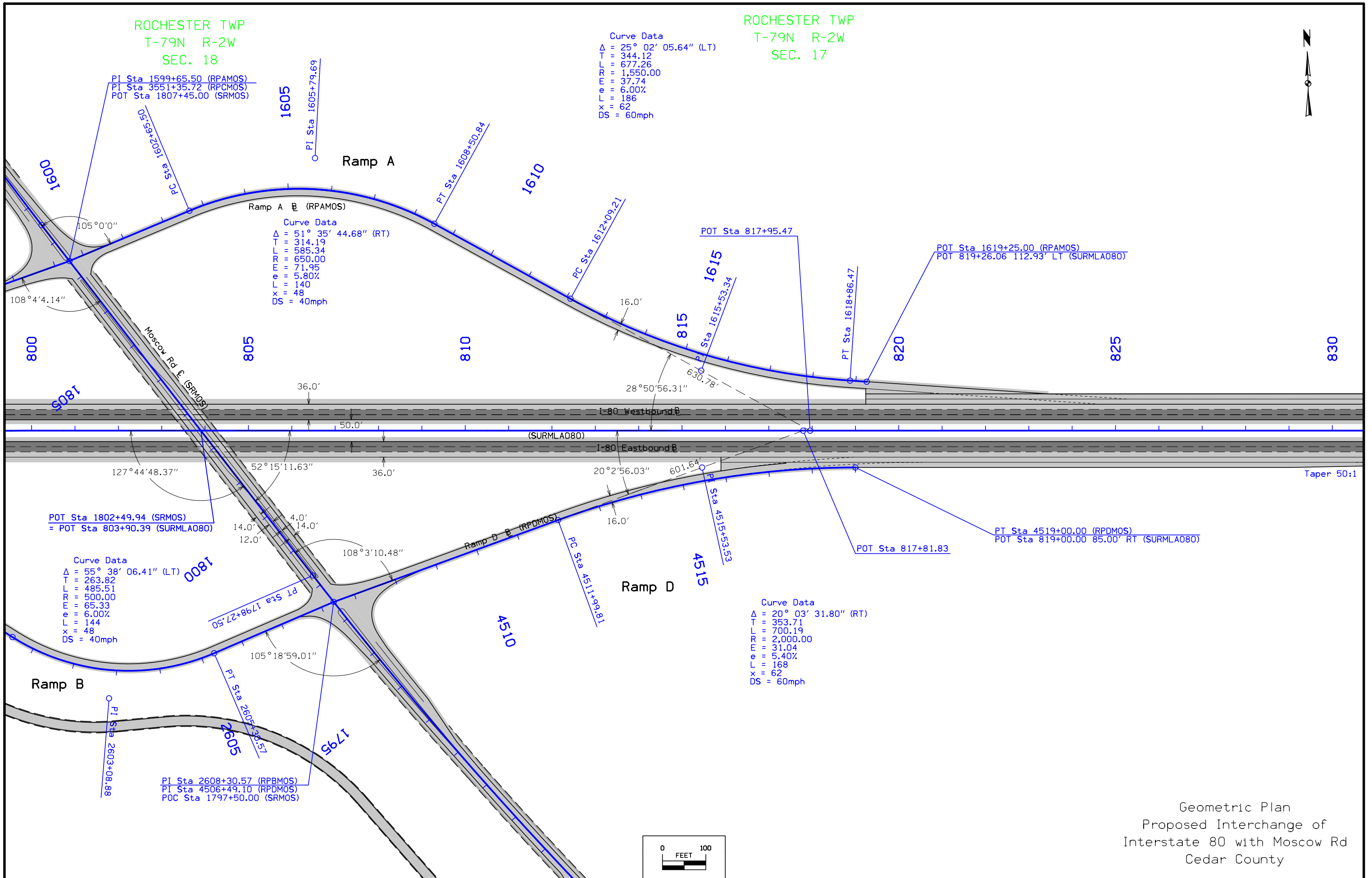

Geometric Plan  
 Proposed Interchange of  
 Interstate 80 with Moscow Rd  
 Cedar County



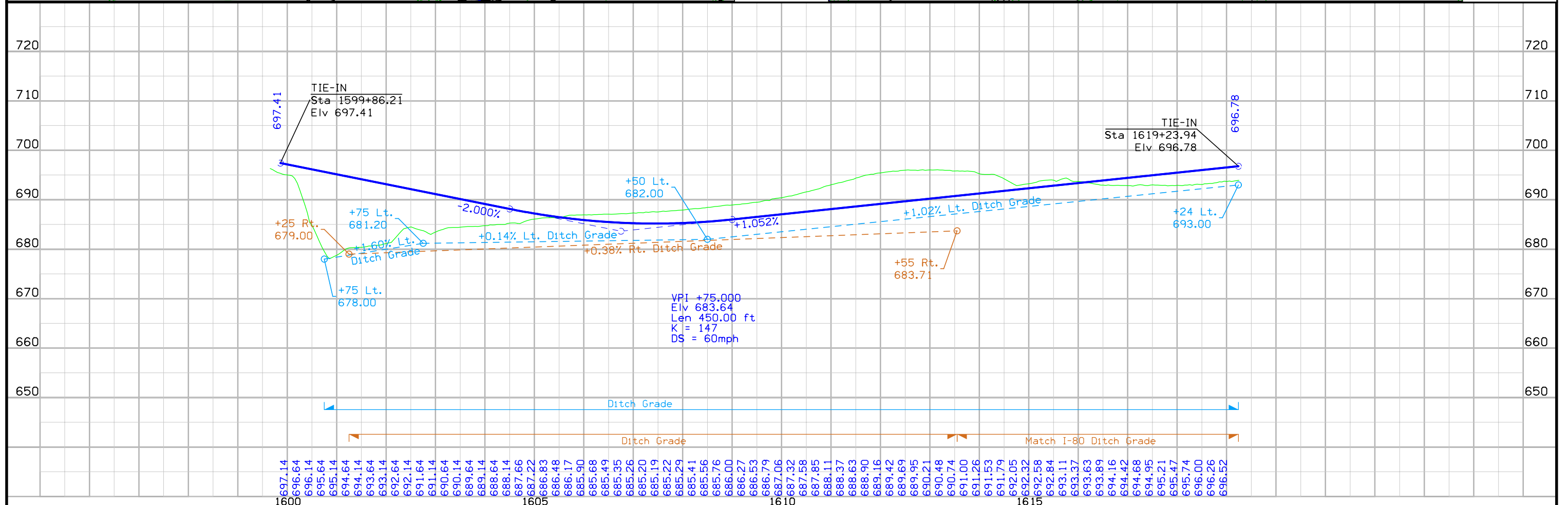
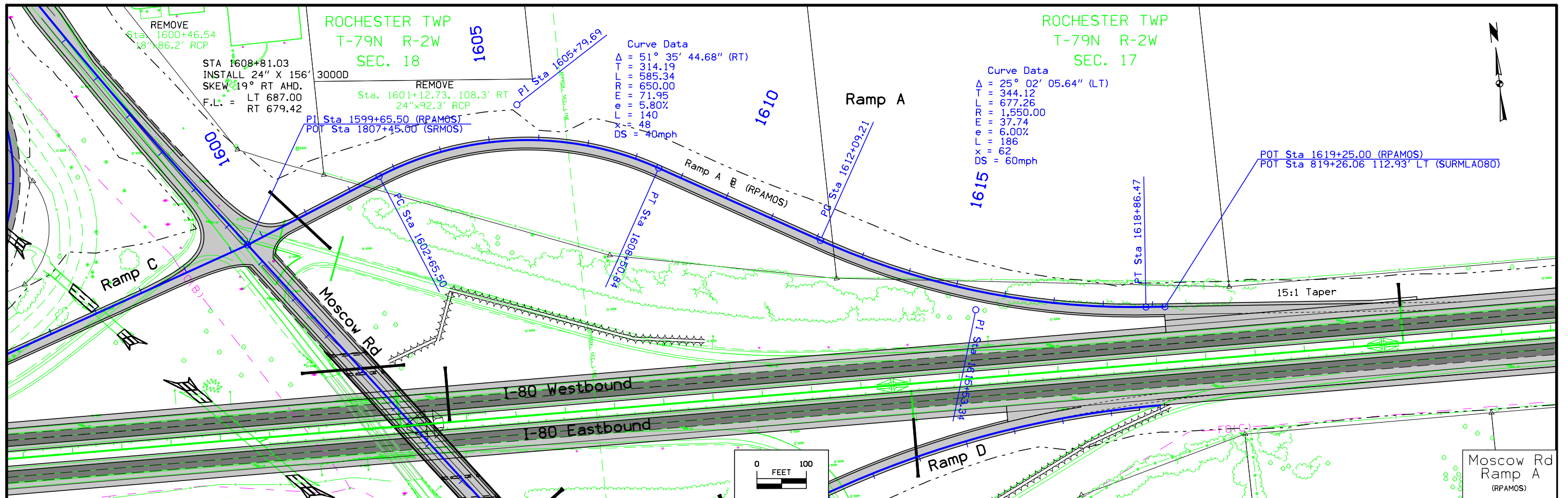

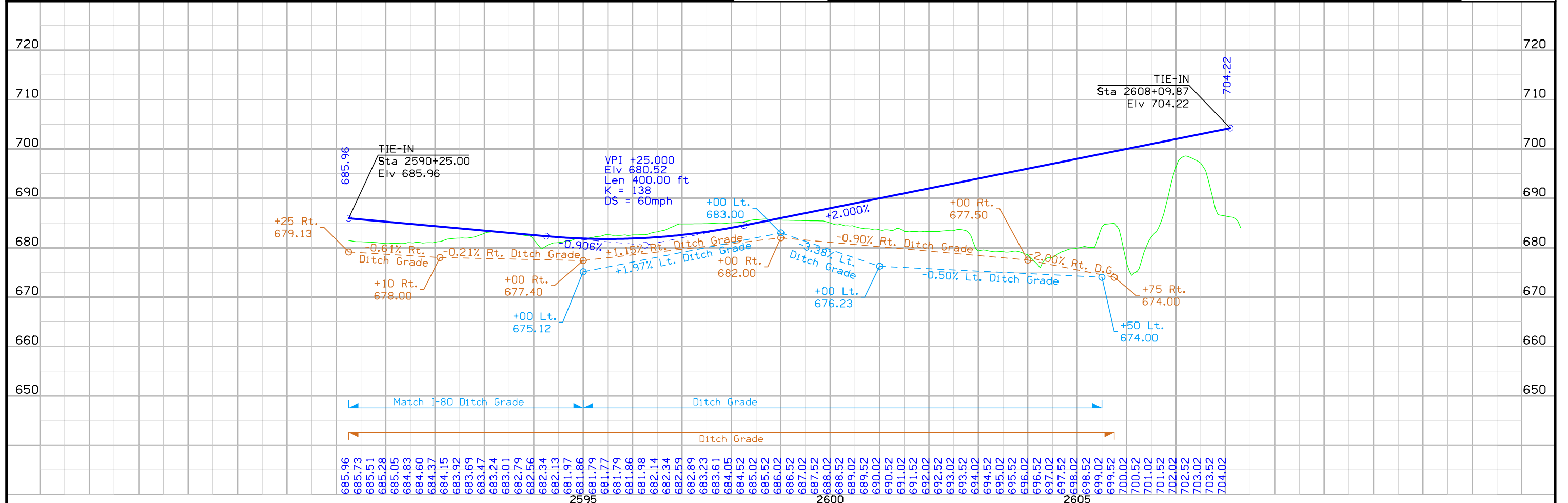
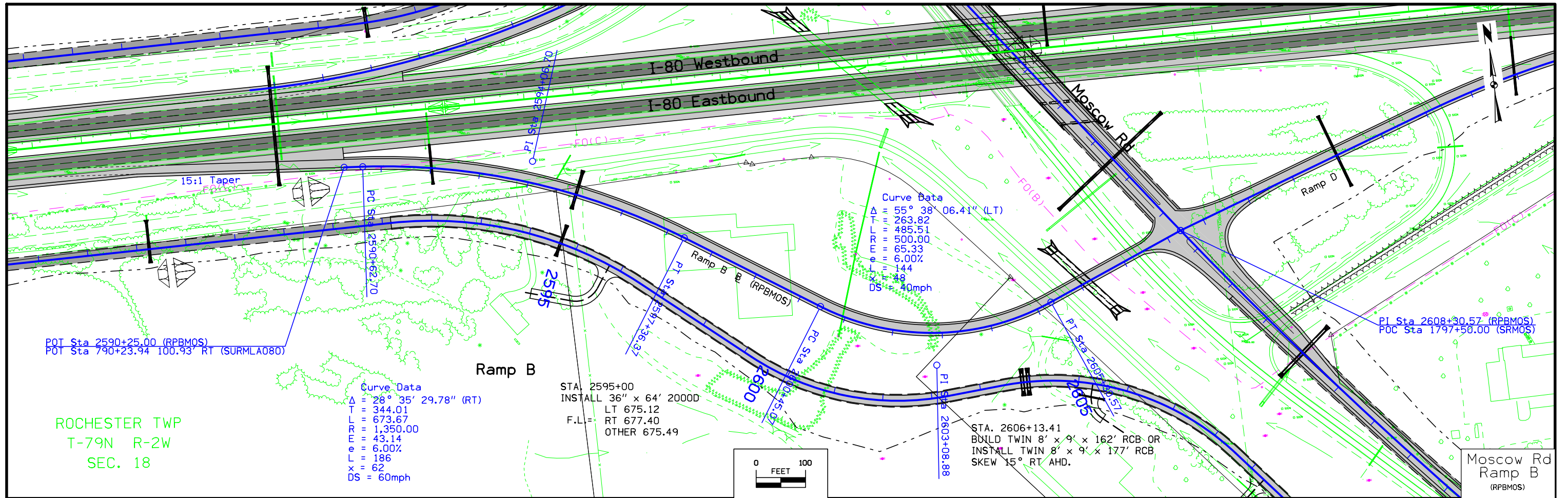

FILE NO.	ENGLISH	DESIGN TEAM	Iowa DOT \ HR Green	CEDAR COUNTY	PROJECT NUMBER	IM-NHS-080-7(134)266--03-16	SHEET NUMBER	K.4
5:40:14 PM	8/19/2019	mhahn	pw:\projectwise.dot.int.lan:PWMain\Documents\Projects\1608002014\Design\CADD_Files\Sheet_Files\SHT_16080132.K01.dgn					



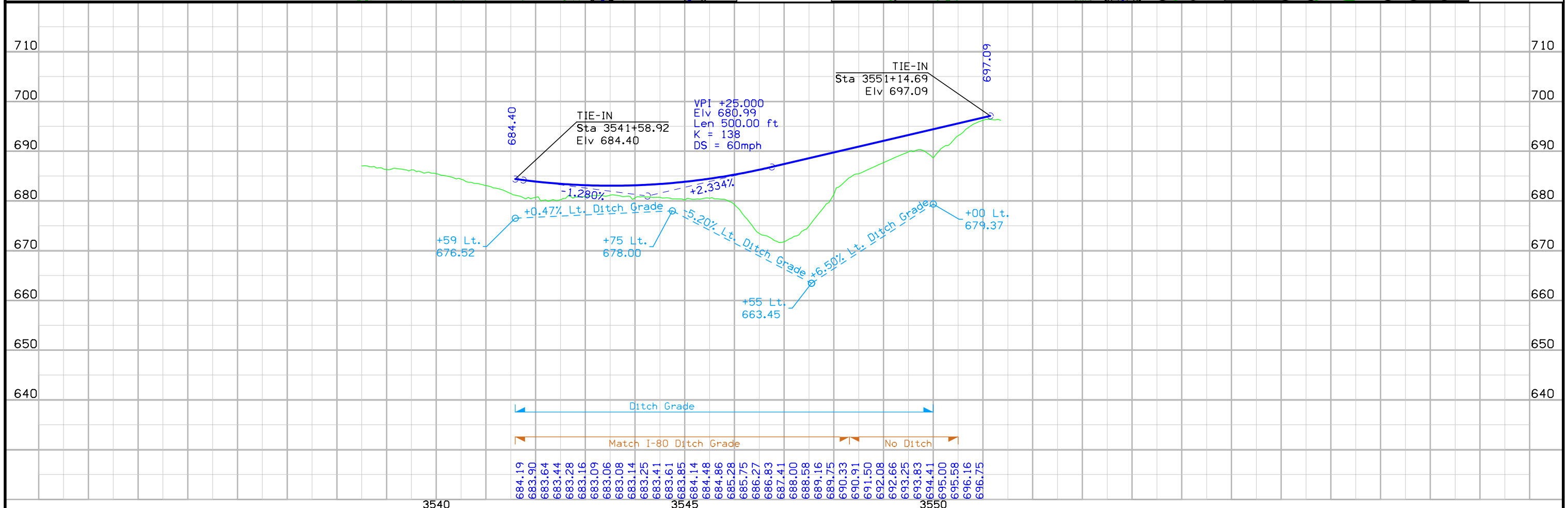
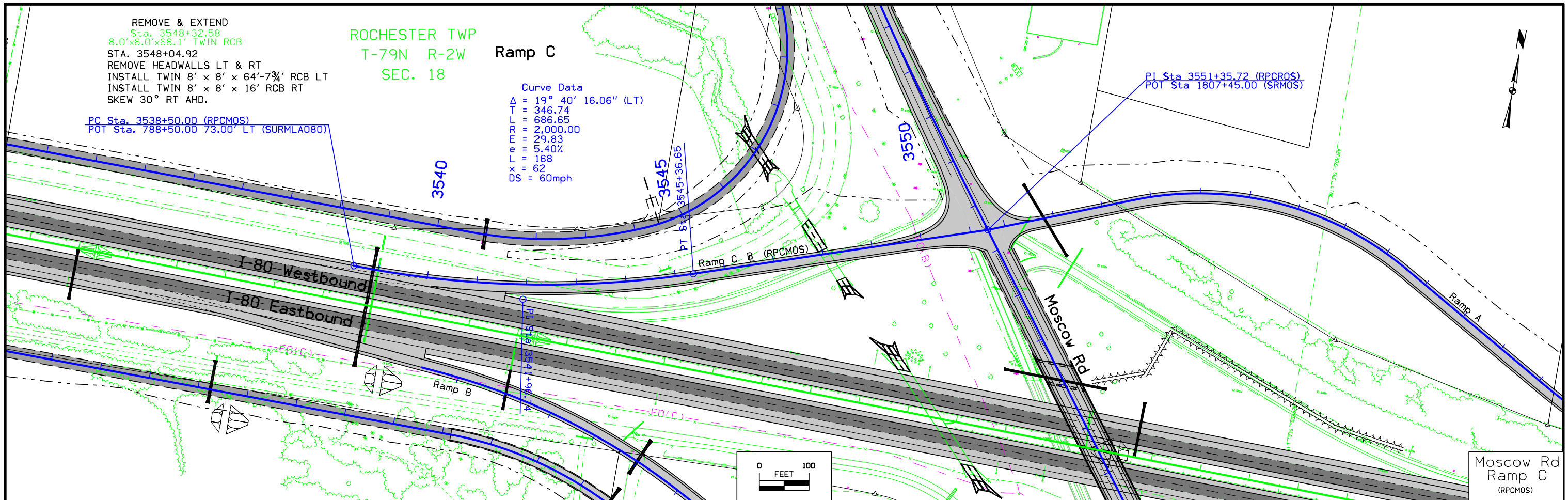

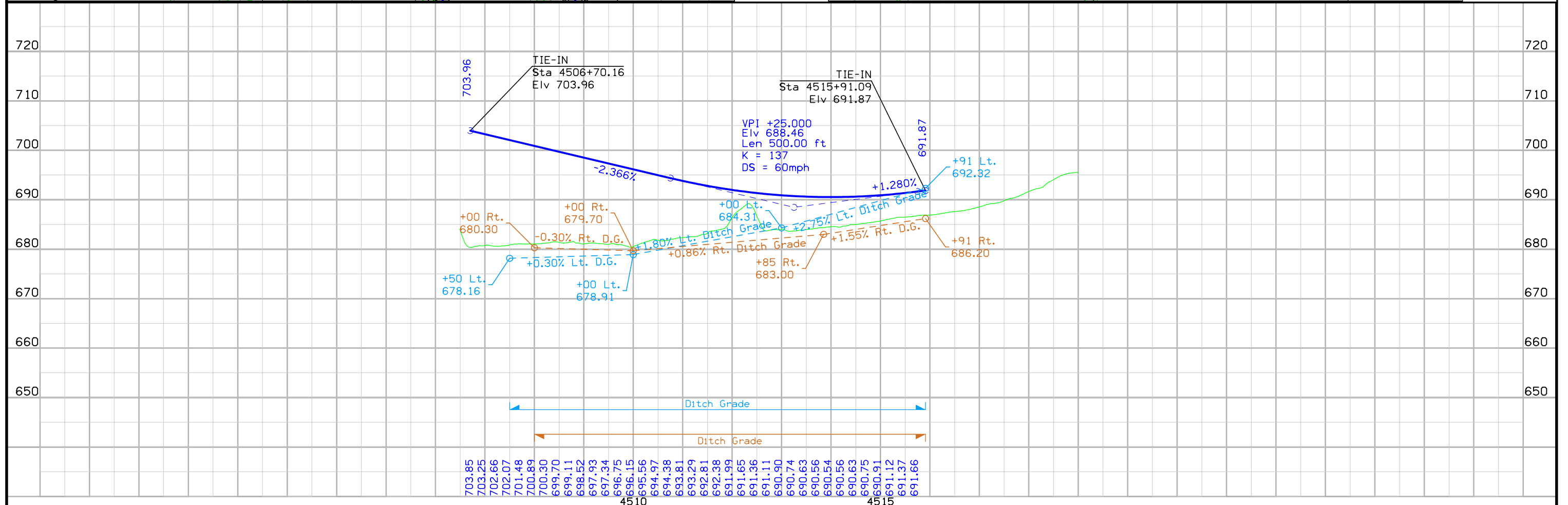
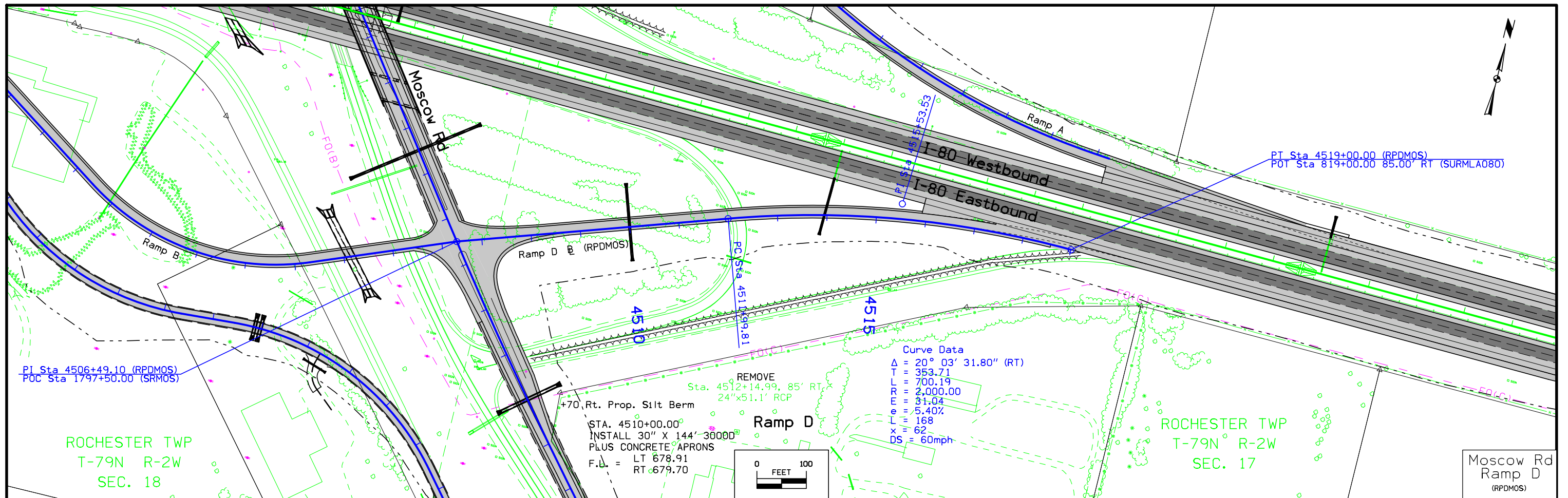

**SHEET INTENTIONALLY LEFT BLANK**

SUGAR CREEK TWP  
T-79N R-2W  
SEC. 16



Curve Data  
 $\Delta = 8^\circ 25' 14.18''$  (LT)  
 $T = 154.59$   
 $L = 308.63$   
 $R = 2,100.00$   
 $E = 5.68$   
 $e = 5.40\%$   
 $L = 168$   
 $x = 62$   
 $DS = 60\text{mph}$

Curve Data  
 $\Delta = 7^\circ 16' 01.78''$  (LT)  
 $T = 152.41$   
 $L = 304.41$   
 $R = 2,400.00$   
 $E = 4.83$   
 $e = 5.00\%$   
 $L = 72$   
 $x = 48$   
 $DS = 40\text{mph}$

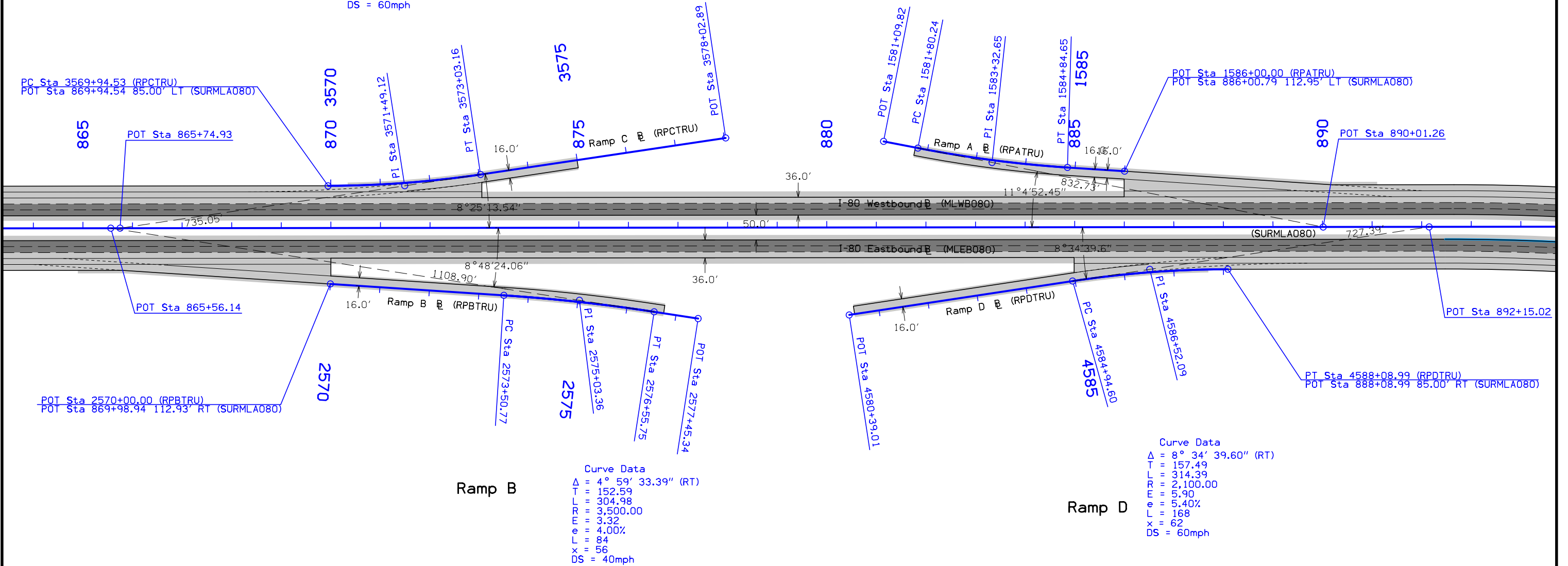

Ramp B

Curve Data  
 $\Delta = 4^\circ 59' 33.39''$  (RT)  
 $T = 152.59$   
 $L = 304.98$   
 $R = 3,500.00$   
 $E = 3.32$   
 $e = 4.00\%$   
 $L = 84$   
 $x = 56$   
 $DS = 40\text{mph}$

Ramp D

Curve Data  
 $\Delta = 8^\circ 34' 39.60''$  (RT)  
 $T = 157.49$   
 $L = 314.39$   
 $R = 2,100.00$   
 $E = 5.90$   
 $e = 5.40\%$   
 $L = 168$   
 $x = 62$   
 $DS = 60\text{mph}$

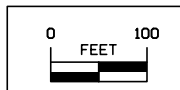

Geometric Plan  
 Proposed Ramps of  
 Interstate 80 at Truck Parking Area  
 Cedar County



Curve Data  
 $\Delta = 7^\circ 16' 01.78''$  (LT)  
 $T = 152.41$   
 $L = 304.41$   
 $R = 2,400.00$   
 $E = 4.83$   
 $e = 5.00\%$   
 $L = 72$   
 $x = 48$   
 $DS = 40\text{mph}$

SUGAR CREEK TWP  
 T-79N R-2W  
 SEC. 16

REMOVE  
 Sta. 1582+98.07  
 24'x38.5' RCP  
 D.A.=3.0 A-R (Plans)

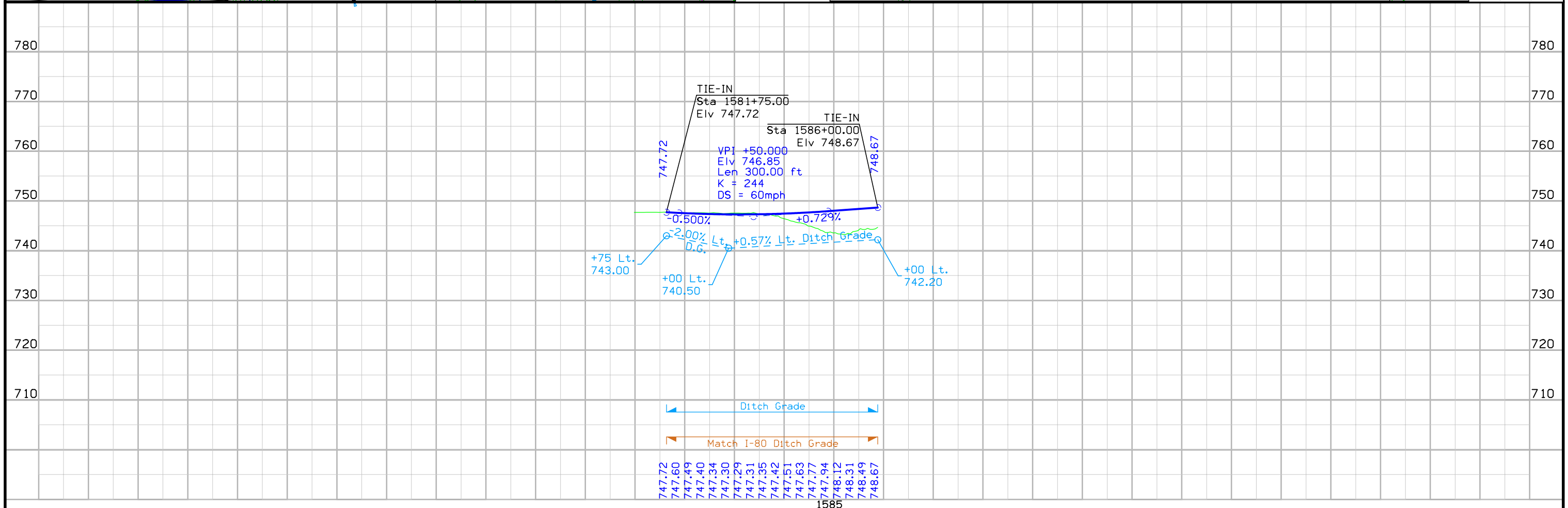
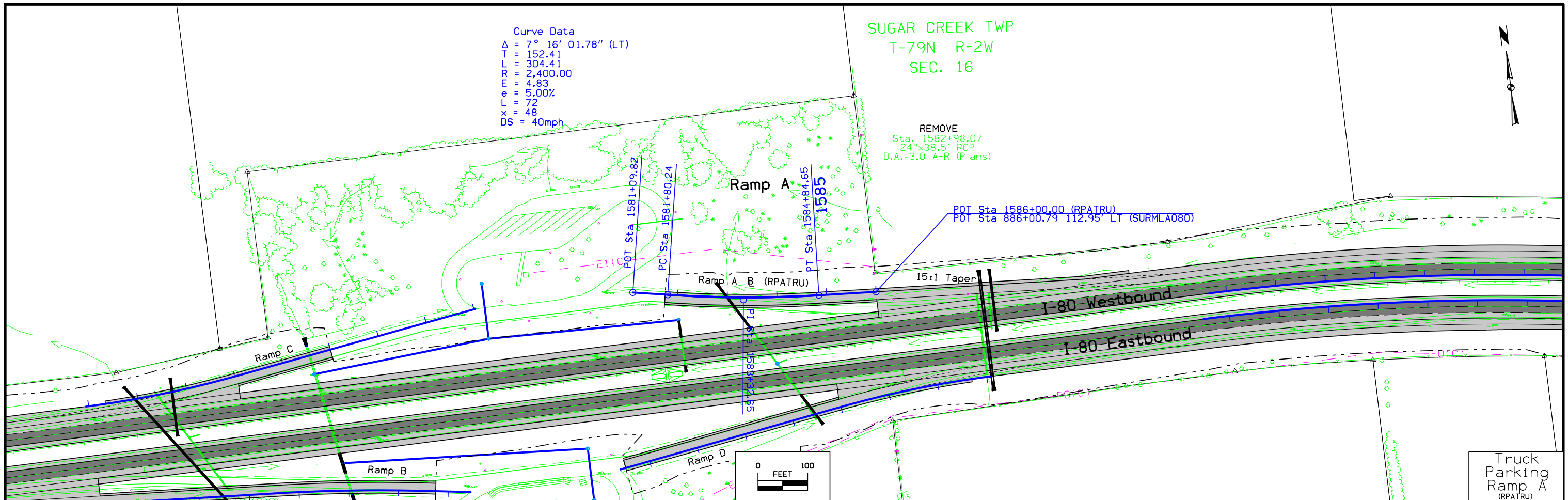



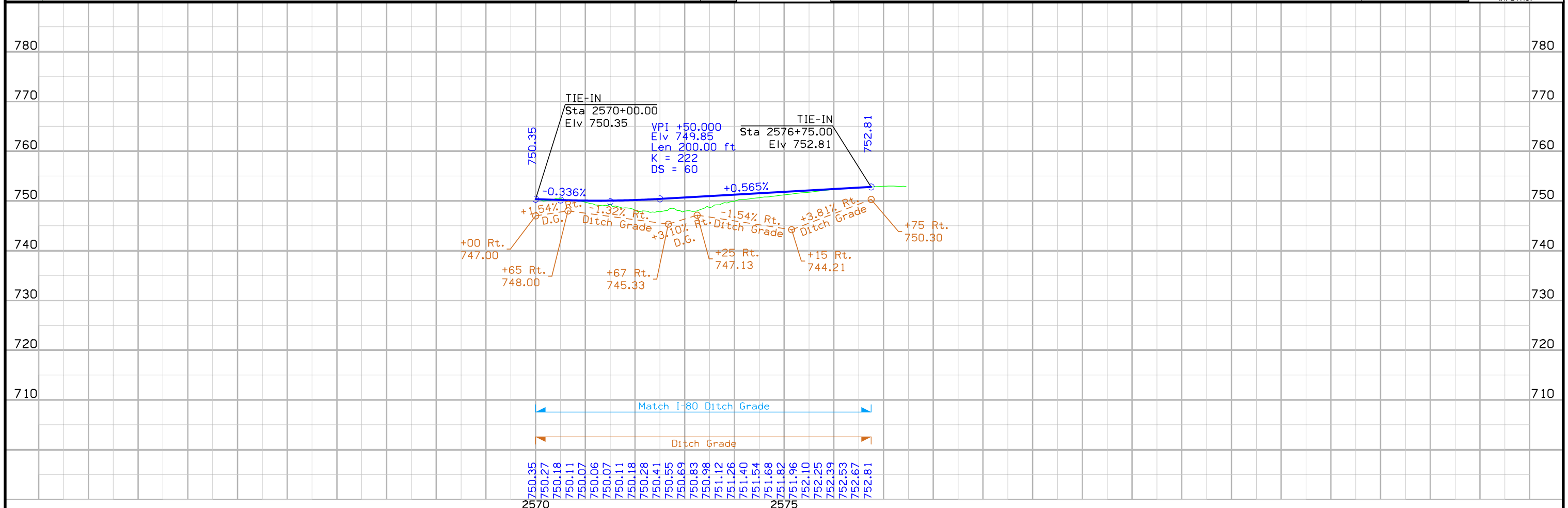
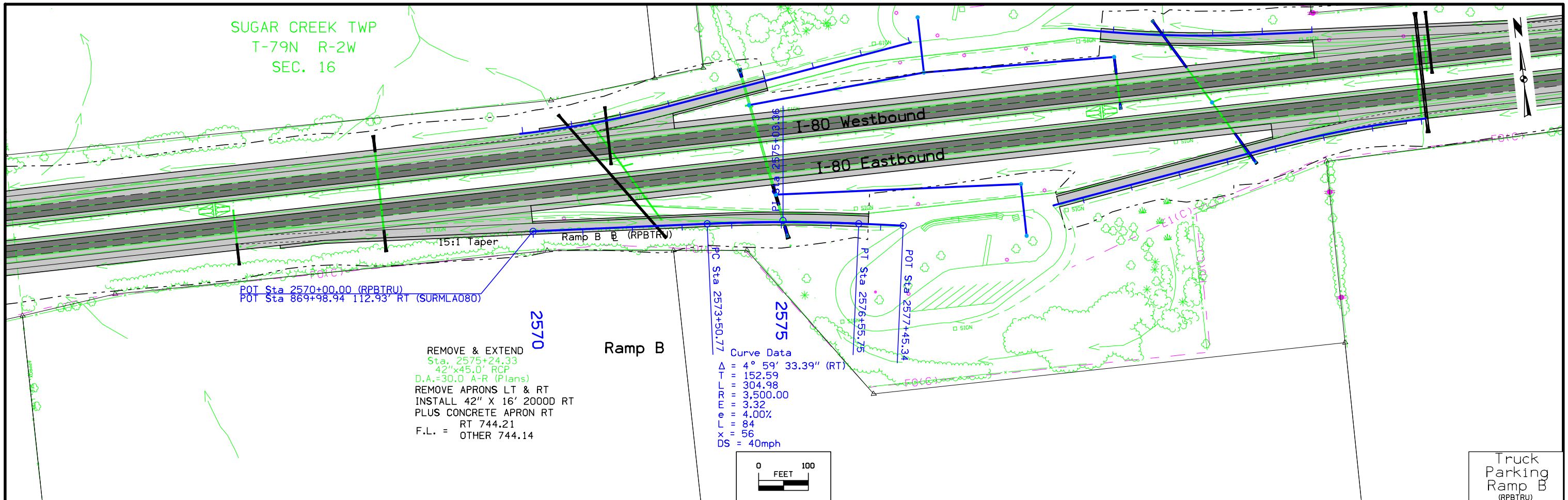

SUGAR CREEK TWP  
T-79N R-2W  
SEC. 16

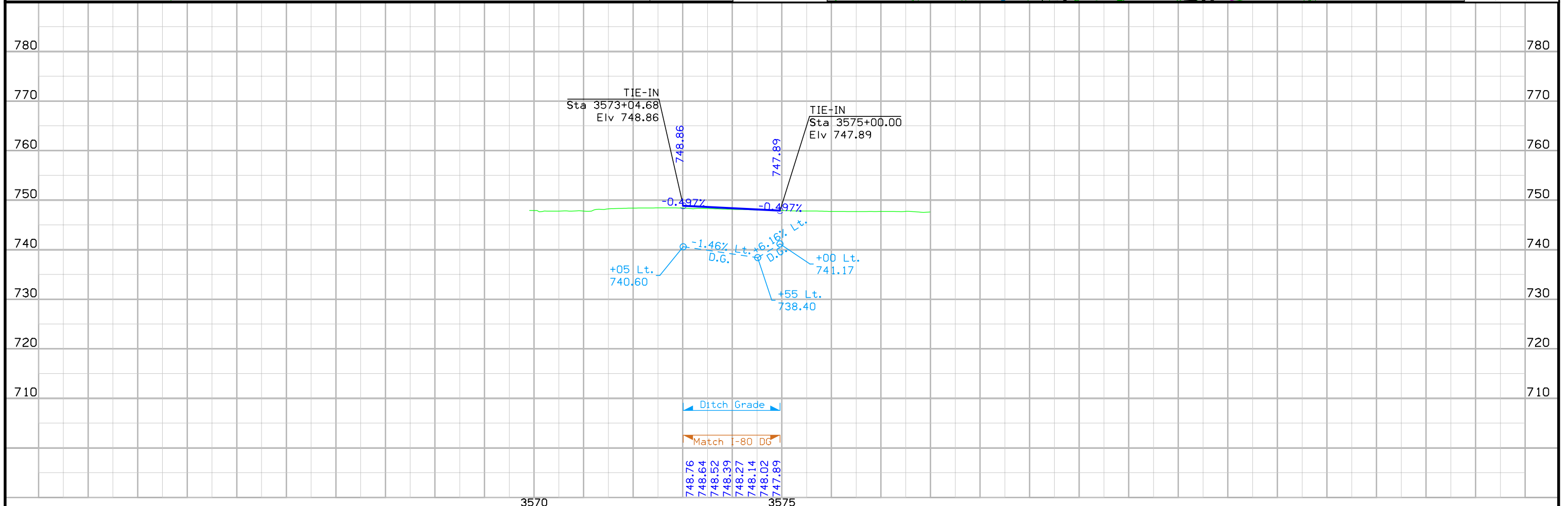
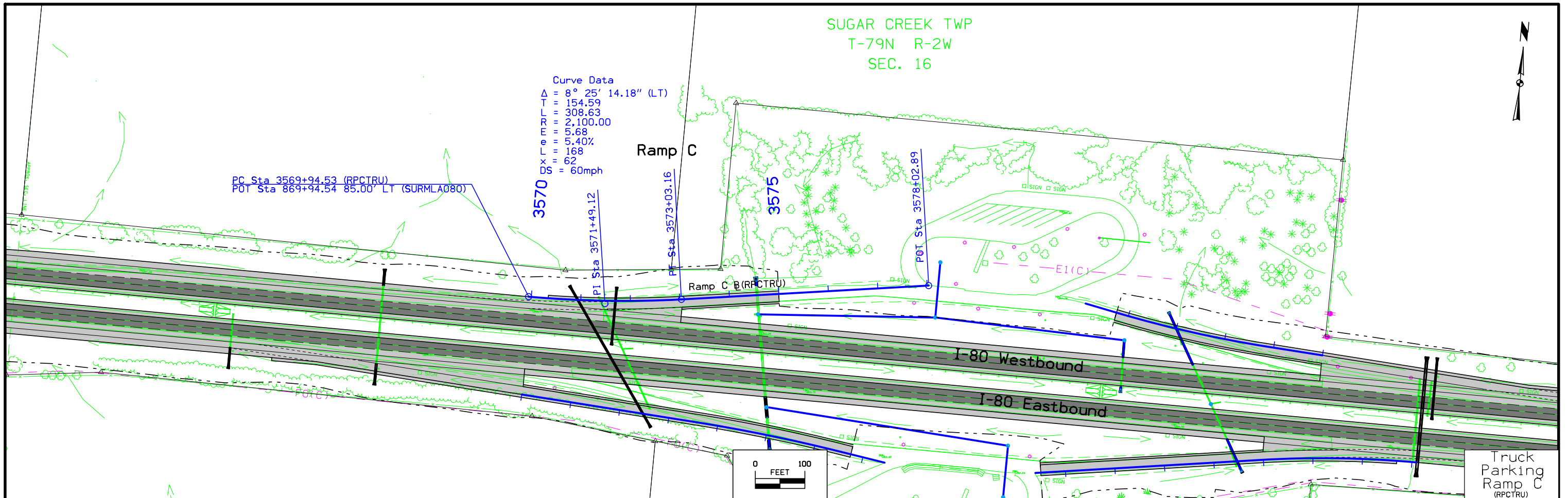

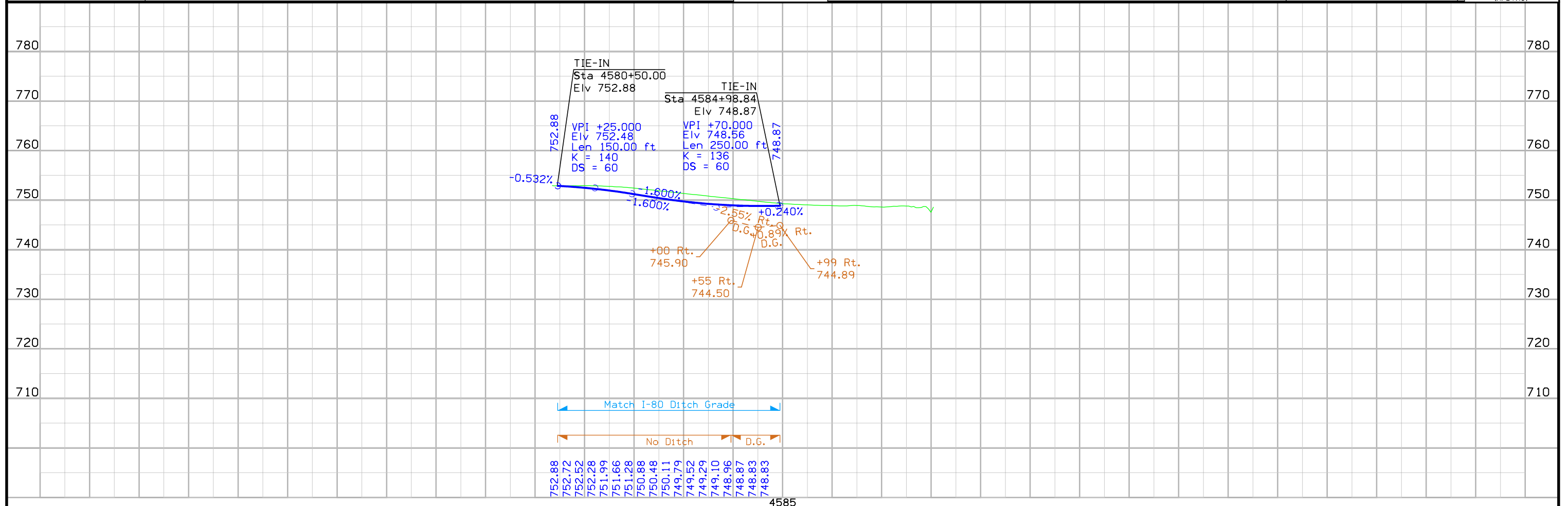
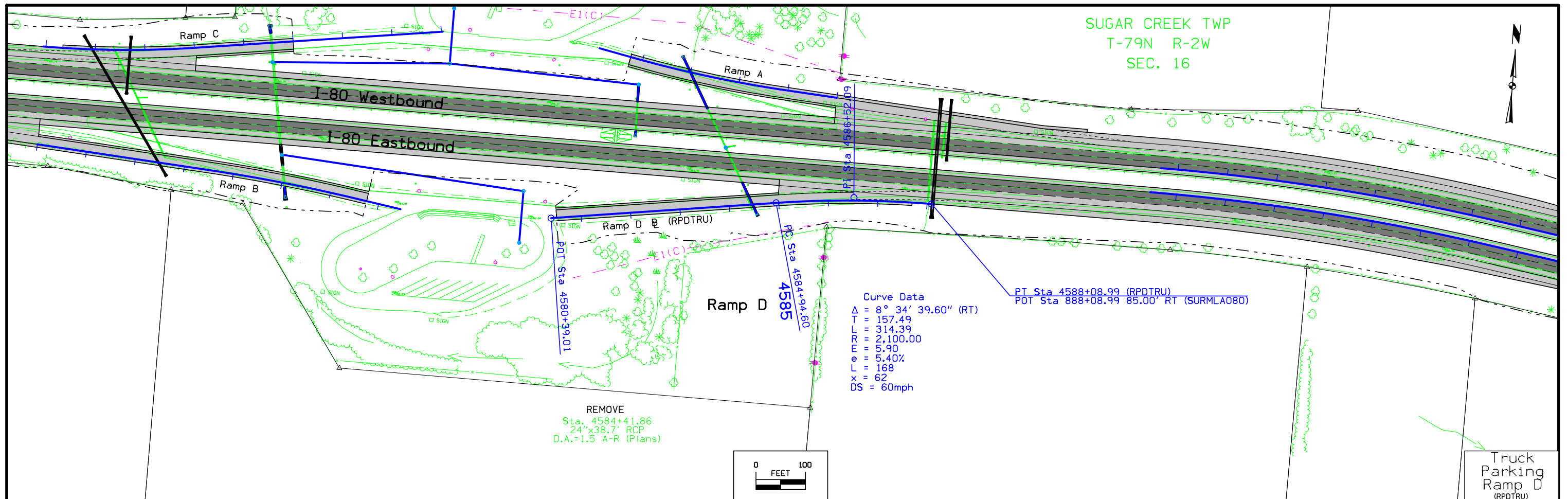

SUGAR CREEK TWP  
T-79N R-2W  
SEC. 15

Curve Data  
 $\Delta = 10^\circ 09' 23.89''$  (LT)  
 T = 177.73  
 L = 354.53  
 R = 2,000.00  
 E = 7.88  
 e = 5.40%  
 L = 168  
 x = 62  
 DS = 60mph

Curve Data  
 $\Delta = 4^\circ 48' 54.08''$  (RT)  
 T = 481.82  
 L = 963.08  
 R = 11,460.00  
 E = 10.12

PC Sta 3554+45.46 (RPCRES)  
 POT Sta 954+37.28 291.58' LT (SURMLA080)

Ramp C

PI Sta 3557+99.99 (RPCRES)

Ramp C

PI Sta 3556+23.11

I-80 Westbound E (MLWB080)

I-80 (SURMLA080)

I-80 Eastbound E (MLEB080)

Ramp B

POT Sta 2560+60.59 (EX\_RPBRES)  
 POT Sta 960+69.36 204.05' RT (SURMLA080)

Ramp B E (EX\_RPBRES)

PC Sta 2562+59.29

PI Sta 2565+03.01

PI Sta 2567+43.82

Curve Data  
 $\Delta = 15^\circ 20' 15.93''$  (RT)  
 T = 243.72  
 L = 484.53  
 R = 1,810.00  
 E = 16.34  
 DS = 60mph

SUGAR CREEK TWP  
T-79N R-2W  
SEC. 22

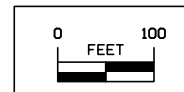

Geometric Plan  
Proposed Ramps of  
Interstate 80 at Rest Area  
Cedar County

SUGAR CREEK TWP  
T-79N R-2W  
SEC. 14

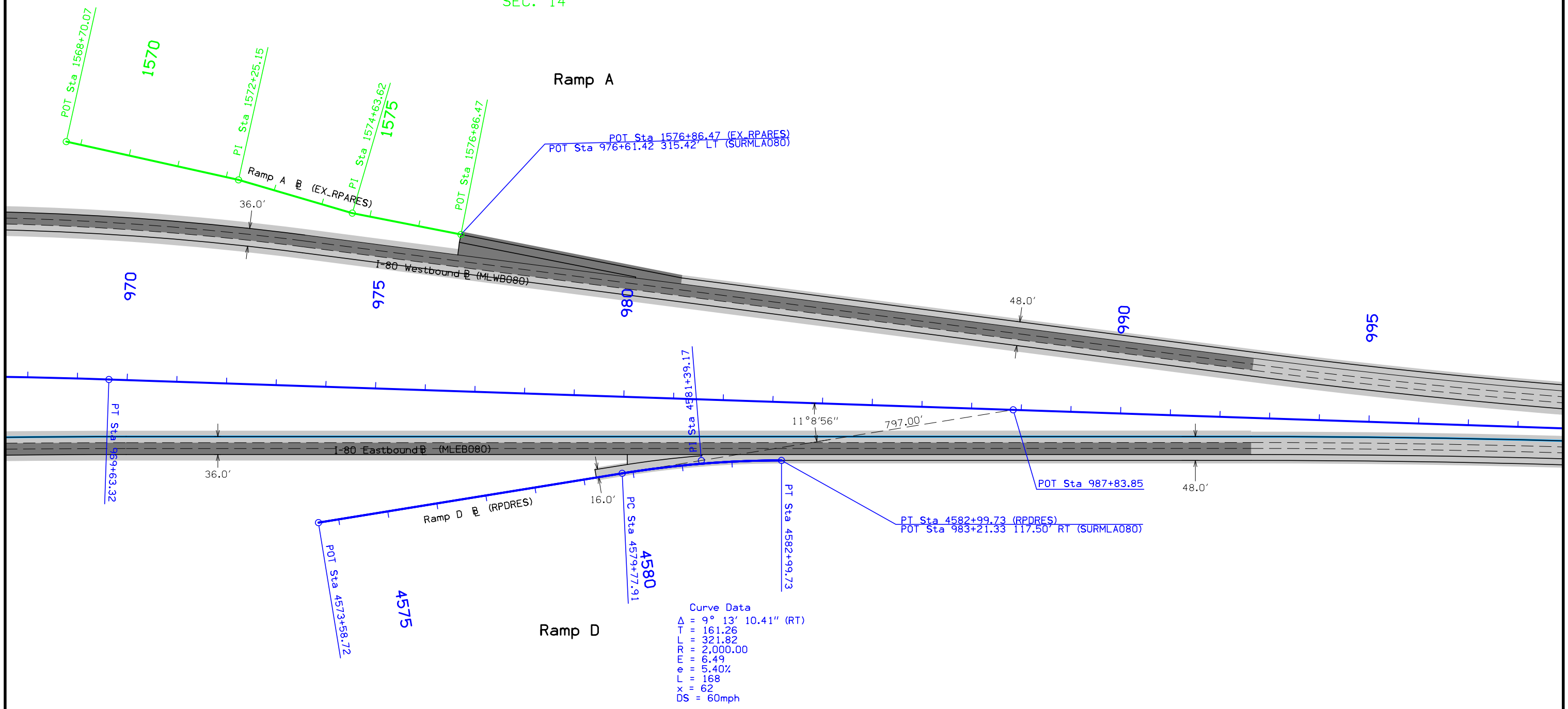

SUGAR CREEK TWP  
T-79N R-2W  
SEC. 23

Geometric Plan  
Proposed Ramps of  
Interstate 80 at Rest Area  
Cedar County

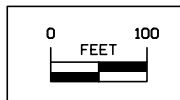



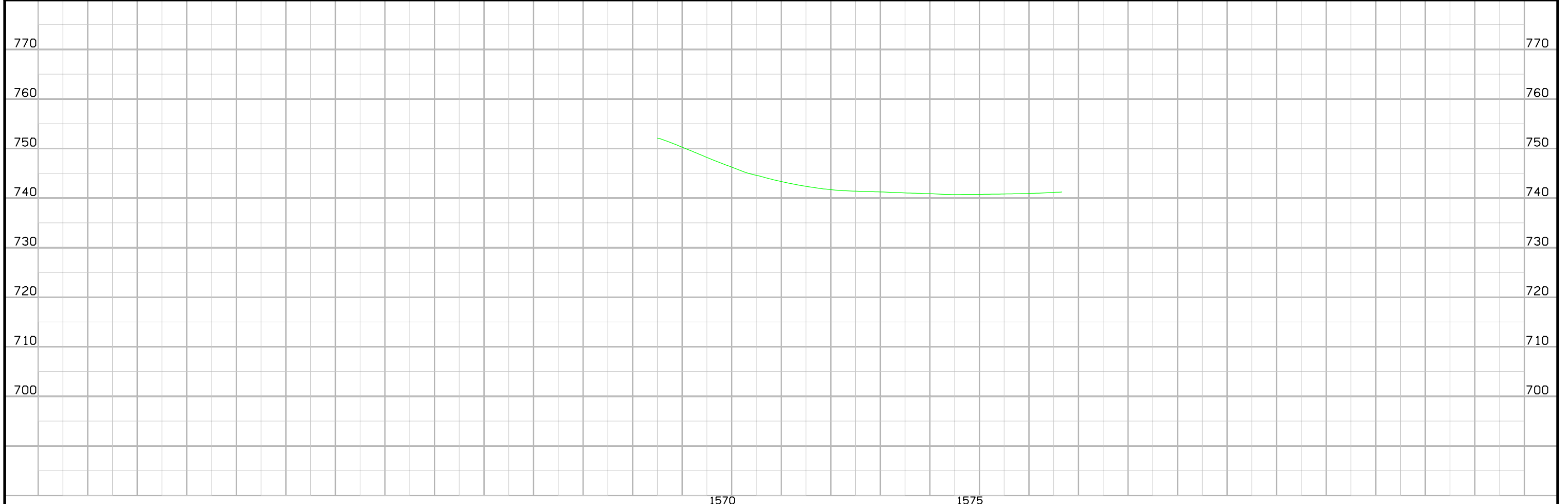
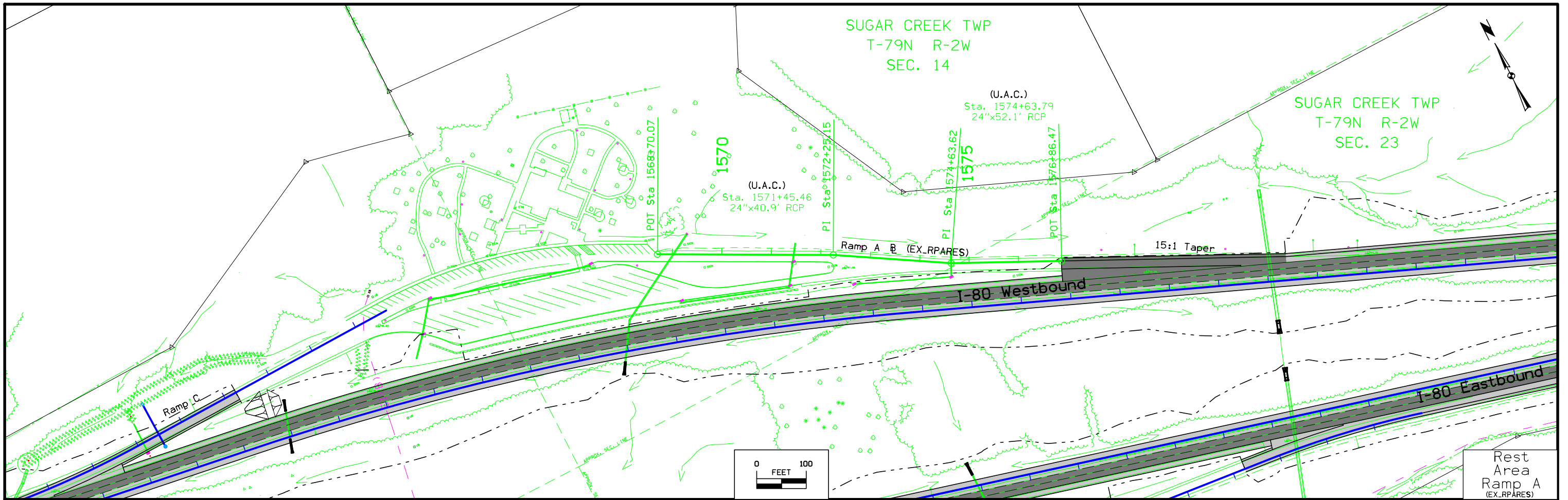

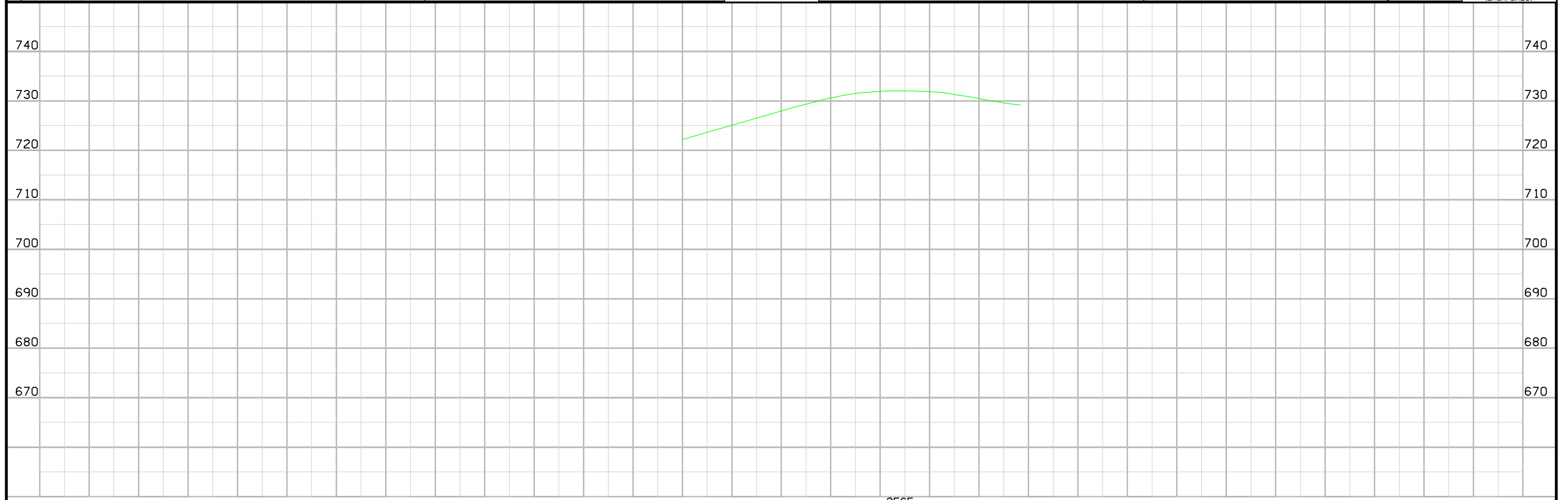
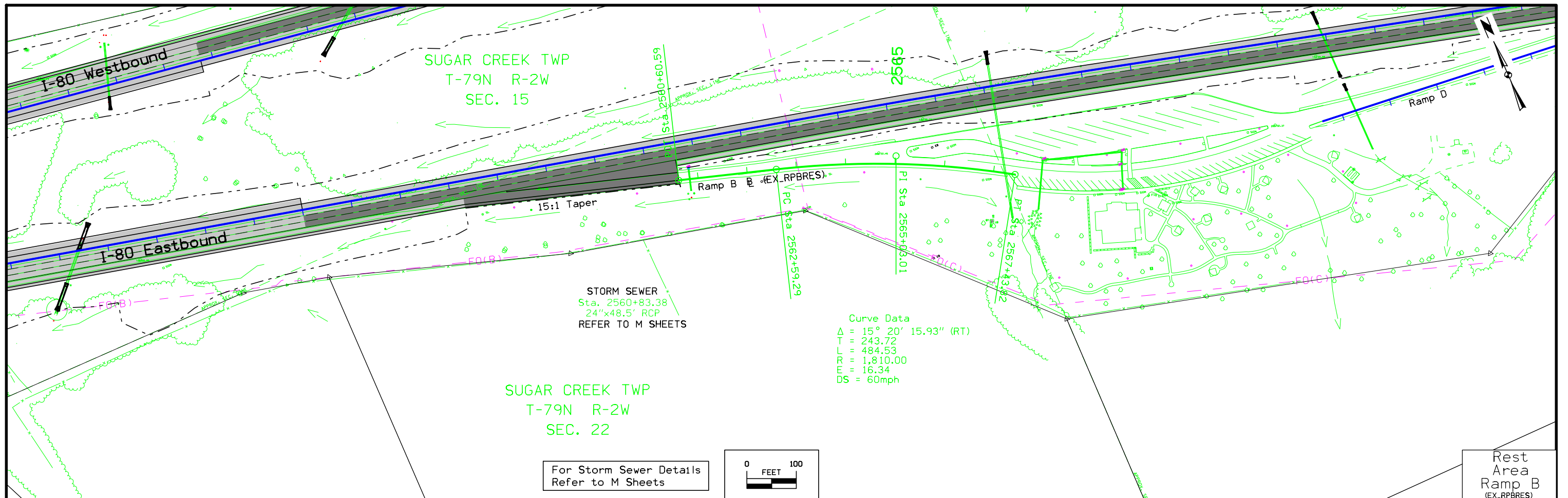

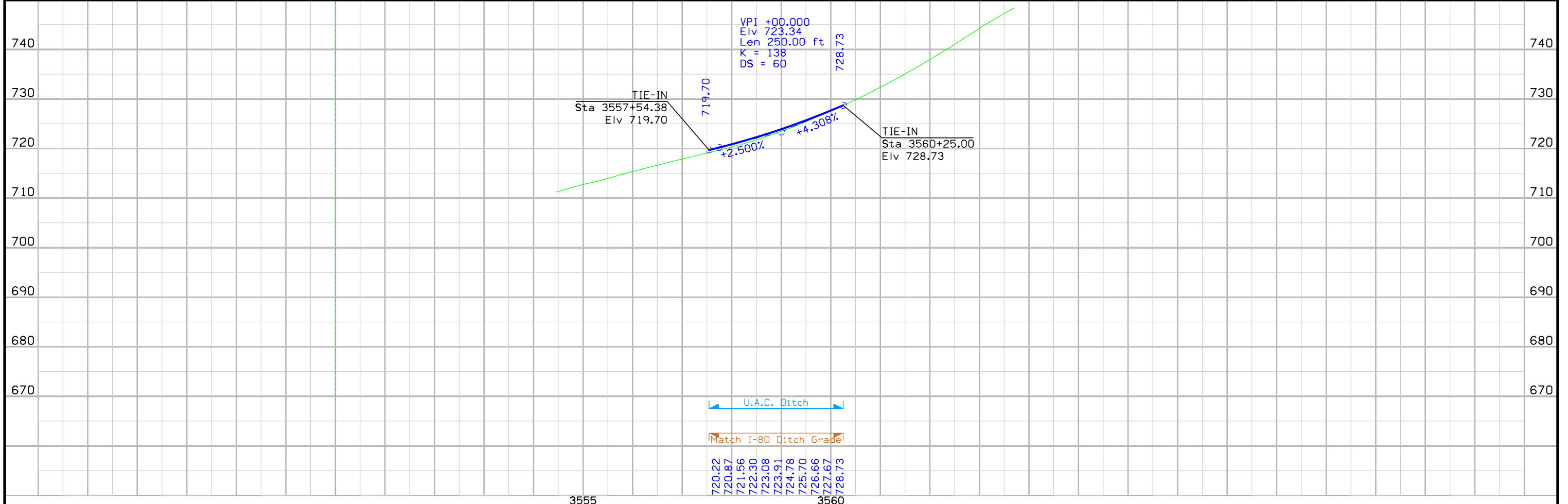
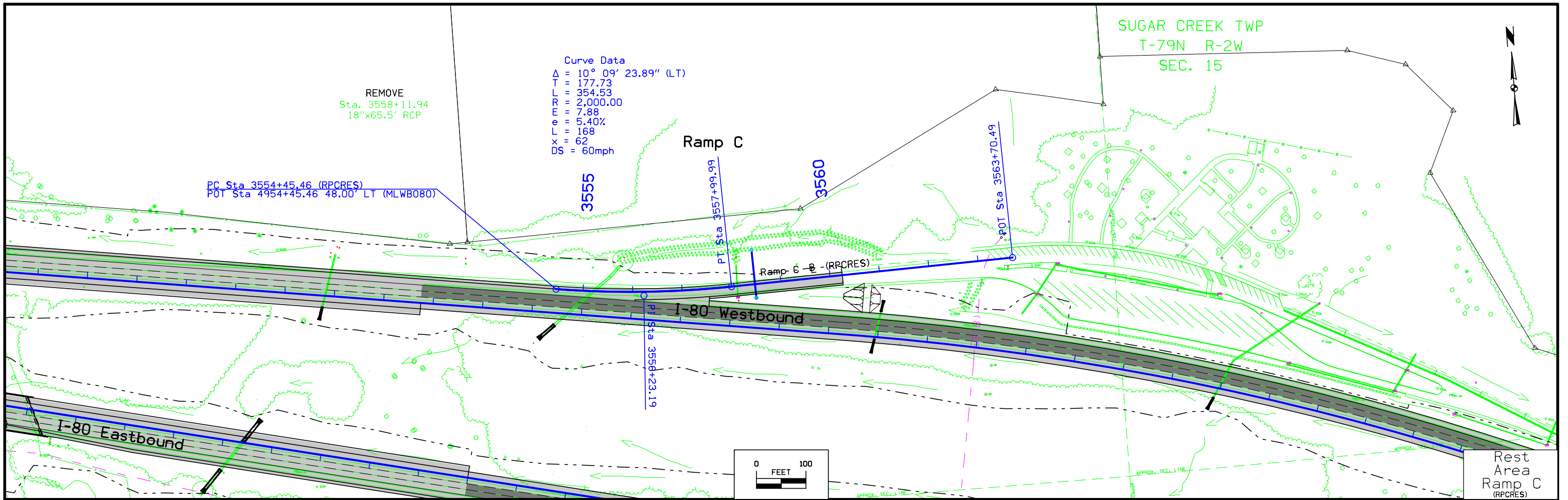

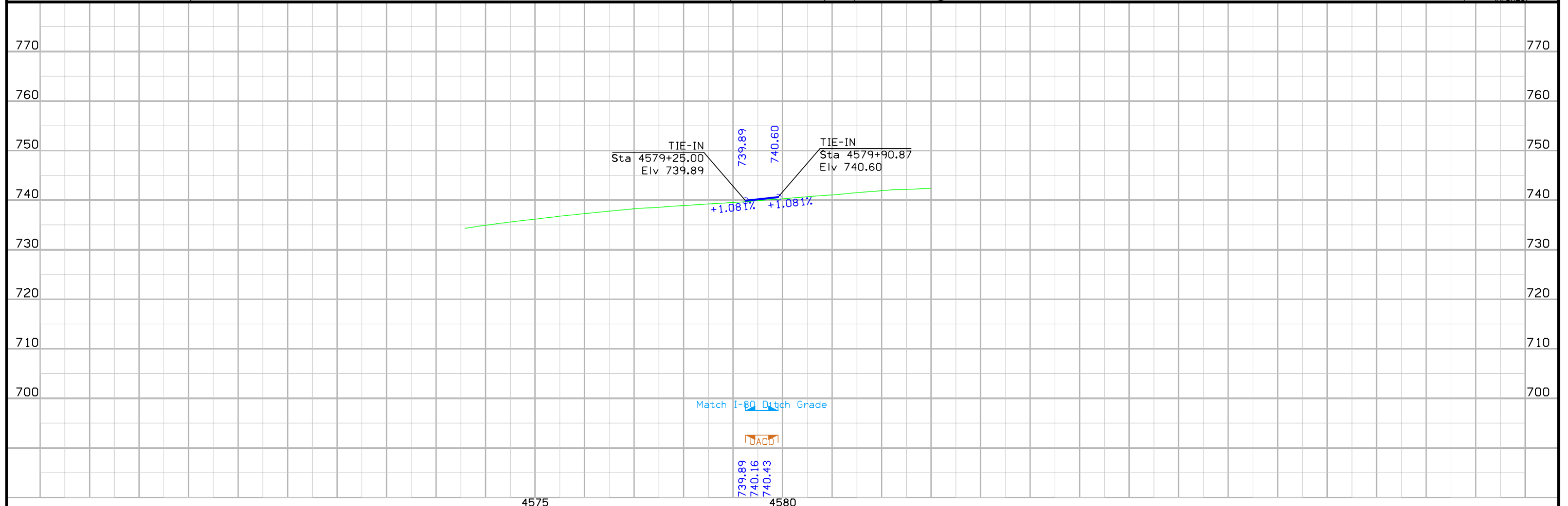
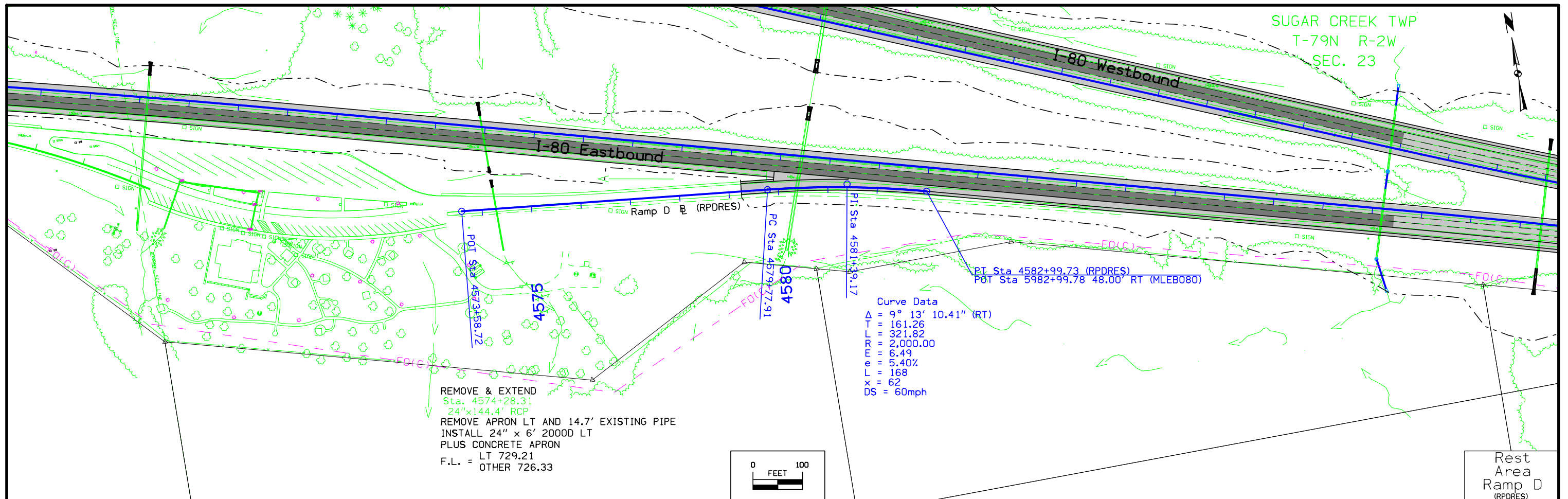



SUGAR CREEK TWP  
T-79N R-2W  
SEC. 23

SUGAR CREEK TWP  
T-79N R-2W  
SEC. 24

Curve Data  
Δ = 27° 49' 40.68" (LT)  
T = 495.47  
L = 971.38  
R = 2,000.00  
e = 60.46  
f = 5.40%  
L = 168  
x = 62  
DS = 60mph

Curve Data  
Δ = 20° 11' 45.60" (RT)  
T = 356.18  
L = 704.97  
R = 2,000.00  
e = 31.47  
f = 5.40%  
L = 168  
x = 62  
DS = 60mph

Curve Data  
Δ = 25° 32' 36.56" (LT)  
T = 170.01  
L = 334.36  
R = 750.00  
e = 19.03  
f = 5.60%  
L = 135  
x = 48  
DS = 40mph

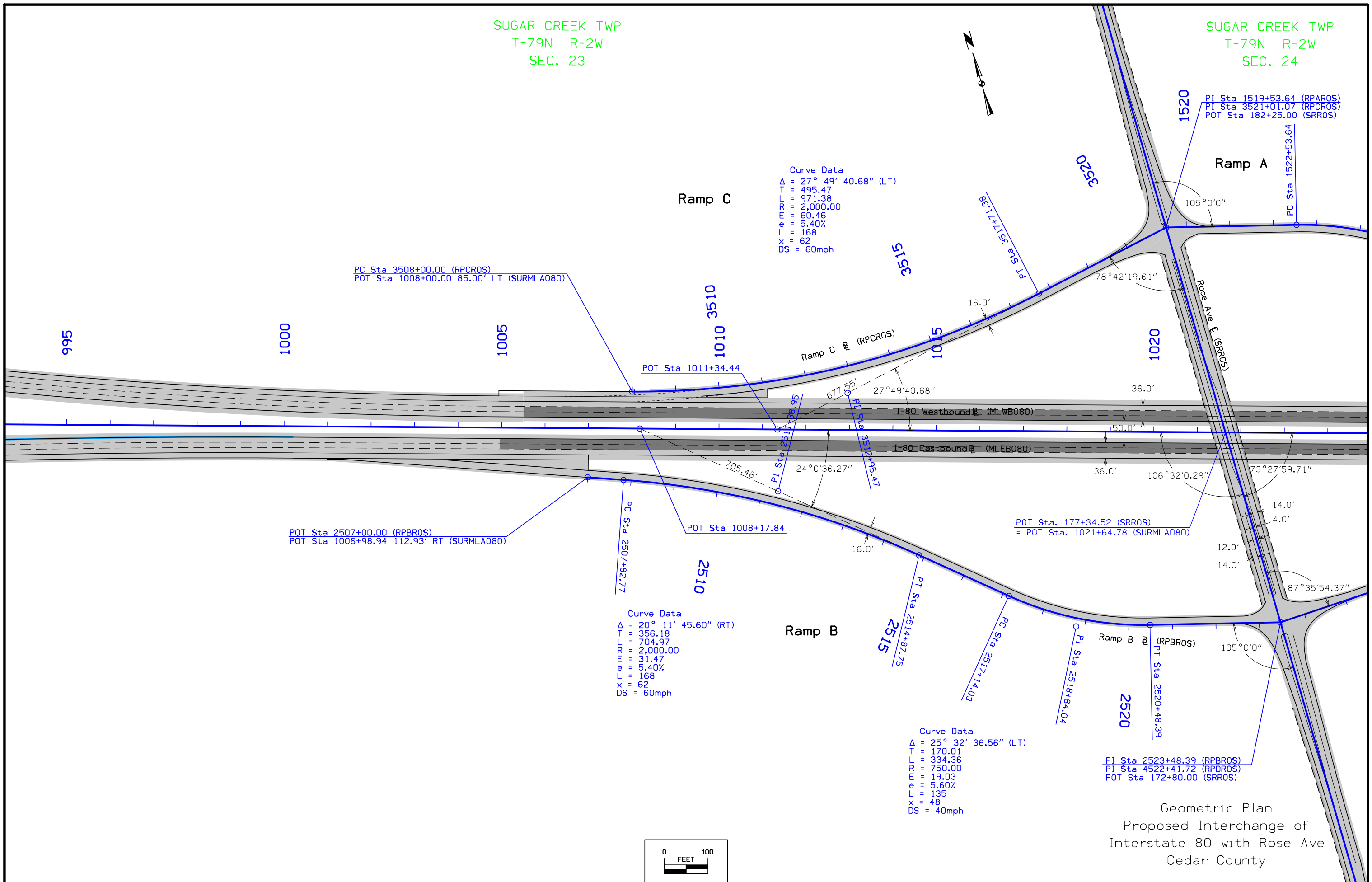

Geometric Plan  
Proposed Interchange of  
Interstate 80 with Rose Ave  
Cedar County

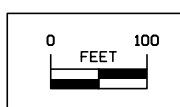



SUGAR CREEK TWP  
T-79N R-2W  
SEC. 24



Curve Data  
 $\Delta = 29^\circ 33' 05.76''$  (RT)  
 $T = 184.63$   
 $L = 361.04$   
 $RR = 700.00$   
 $E = 23.94$   
 $e = 5.60\%$   
 $L = 135$   
 $x = 48$   
 $DS = 40\text{mph}$

Curve Data  
 $\Delta = 24^\circ 12' 14.79''$  (LT)  
 $T = 300.19$   
 $L = 591.42$   
 $RR = 1,400.00$   
 $E = 31.82$   
 $e = 6.00\%$   
 $L = 186$   
 $x = 62$   
 $DS = 60\text{mph}$

Curve Data  
 $\Delta = 18^\circ 56' 05.38''$  (RT)  
 $T = 333.52$   
 $L = 660.95$   
 $RR = 2,000.00$   
 $E = 27.62$   
 $e = 5.40\%$   
 $L = 168$   
 $x = 62$   
 $DS = 60\text{mph}$

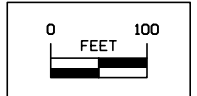
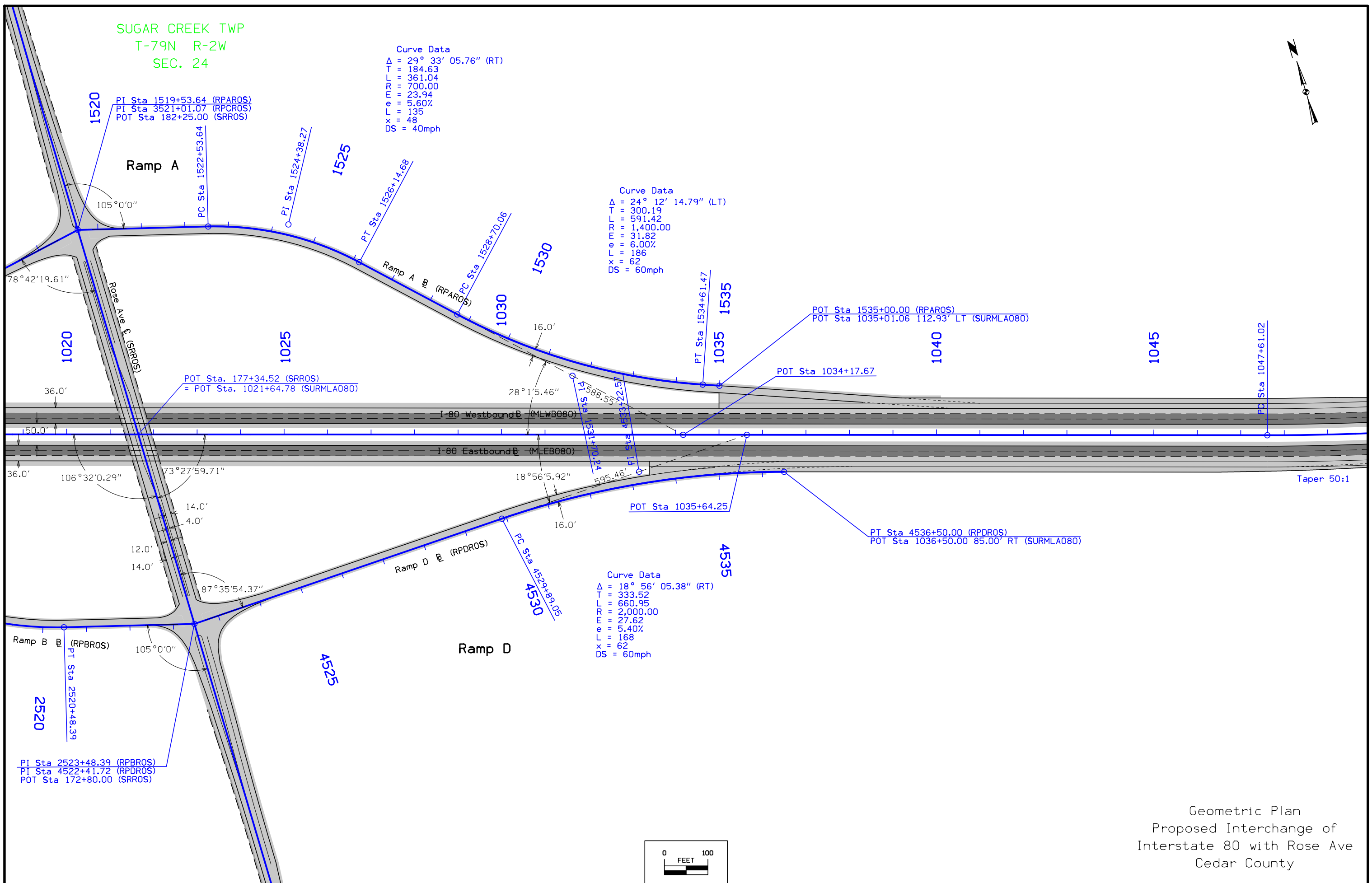

Geometric Plan  
Proposed Interchange of  
Interstate 80 with Rose Ave  
Cedar County

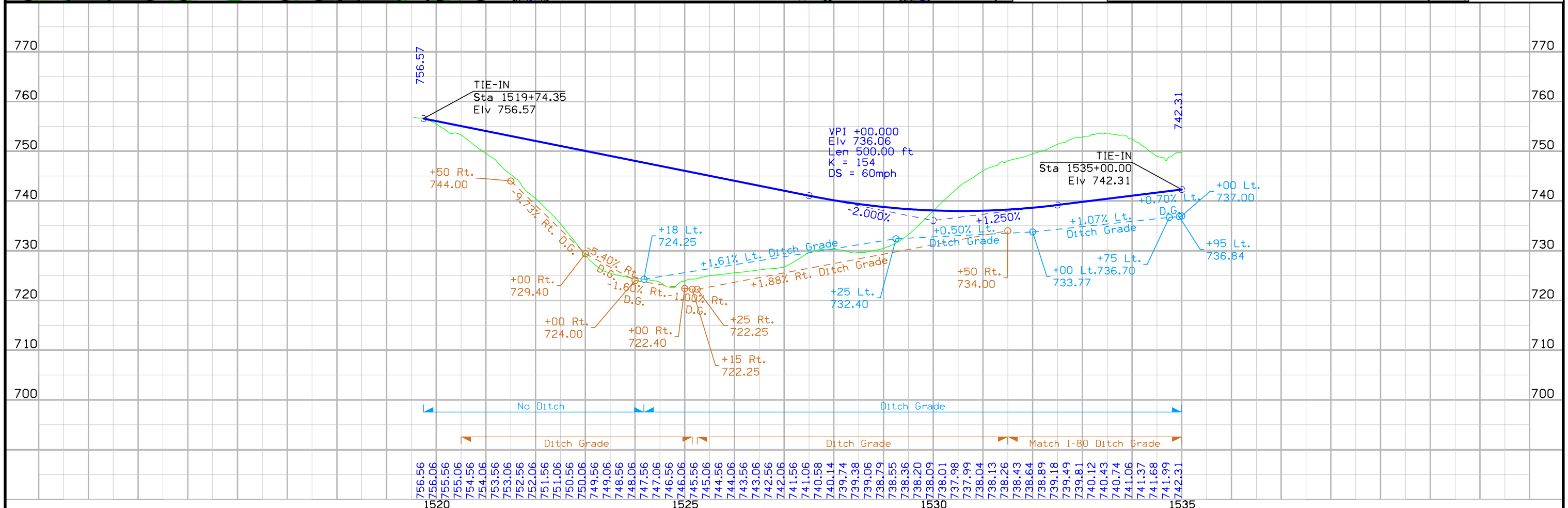
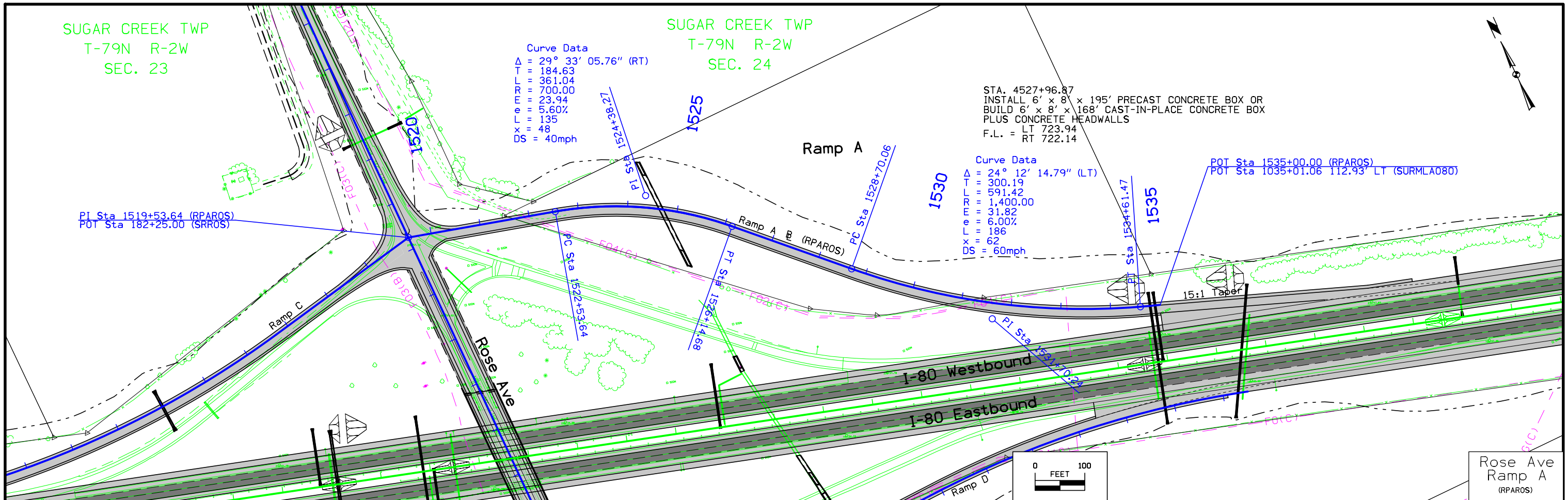

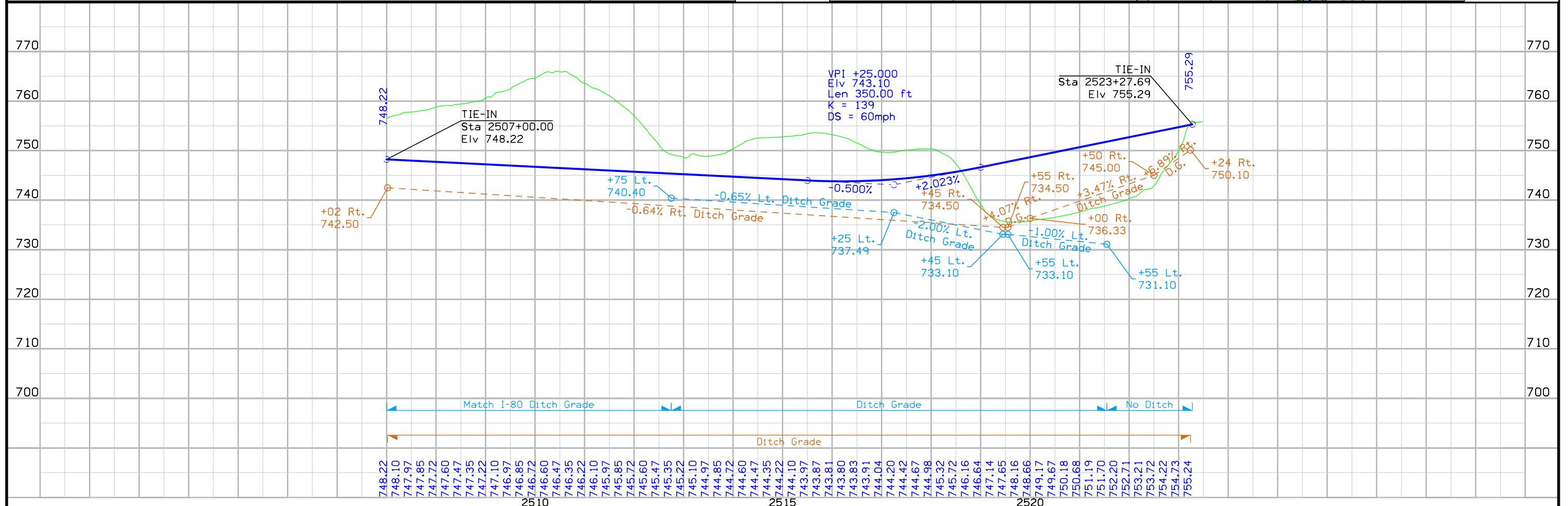
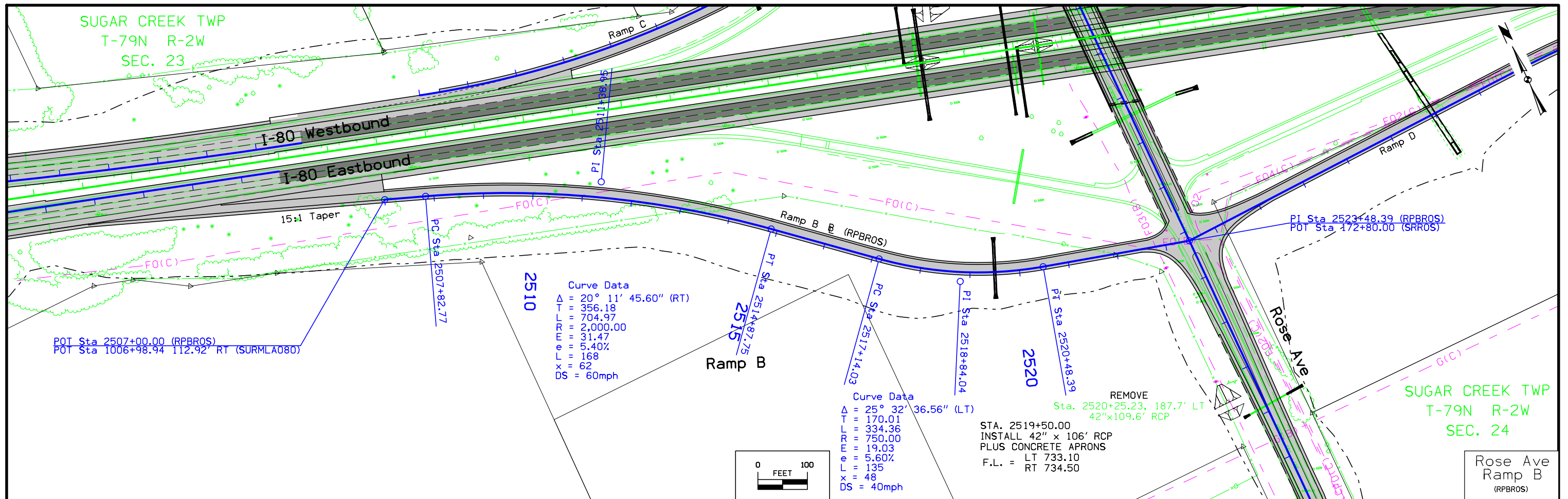



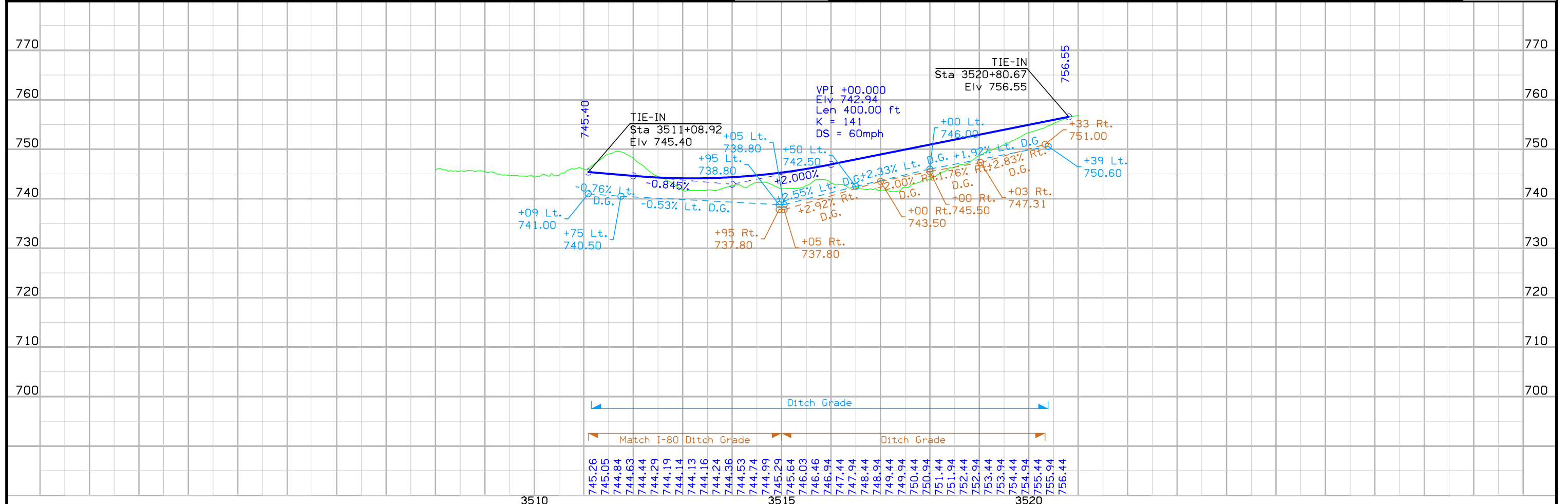
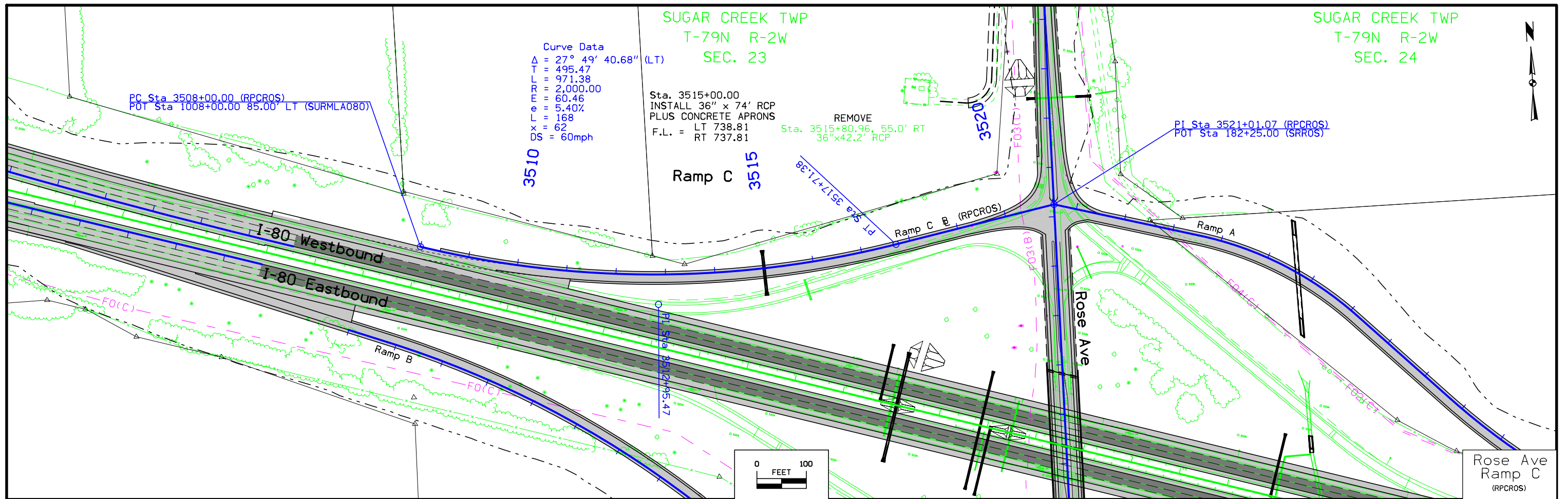

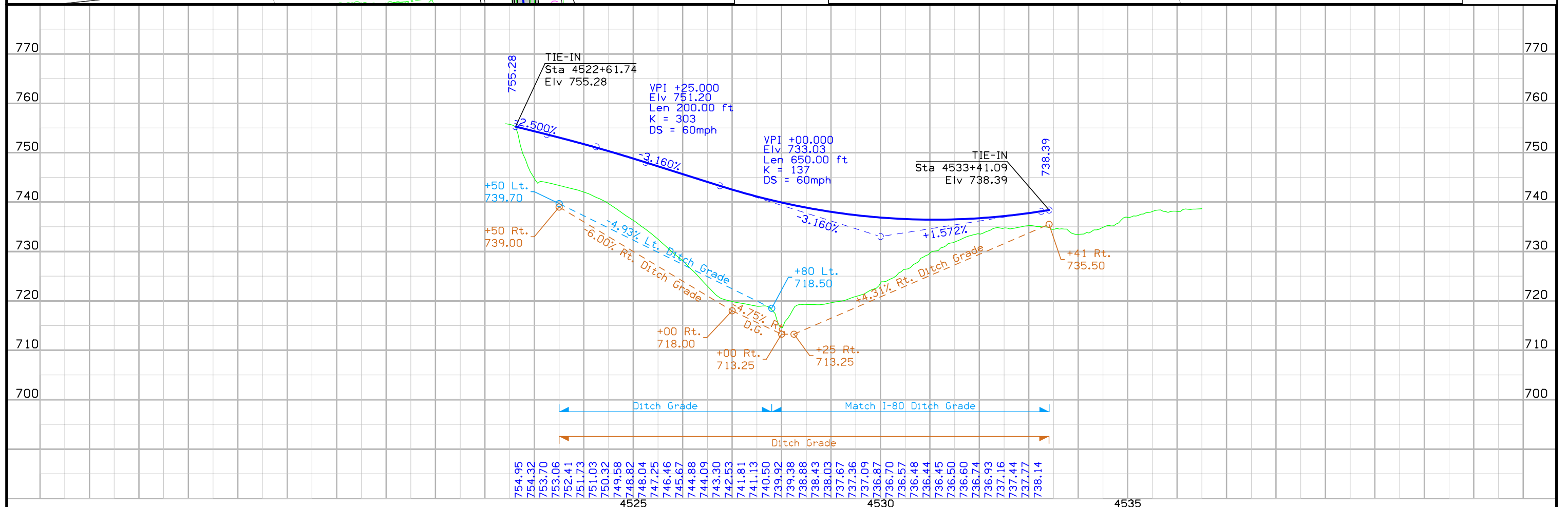
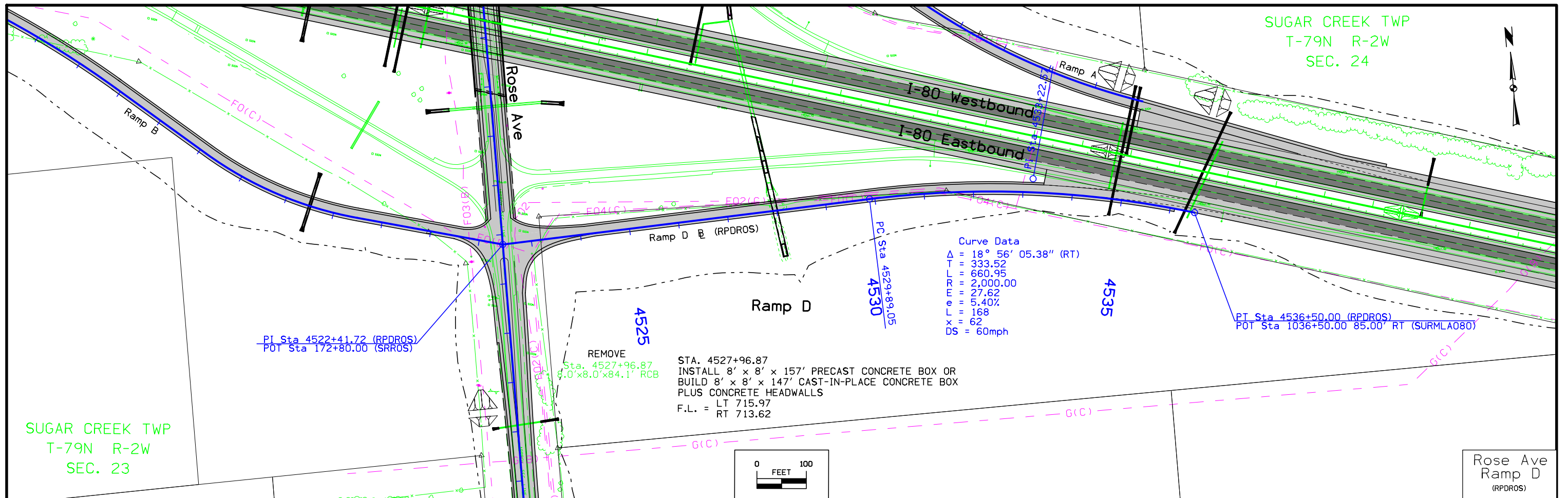



FARMINGTON TWP  
T-79N R-1W  
SEC. 23

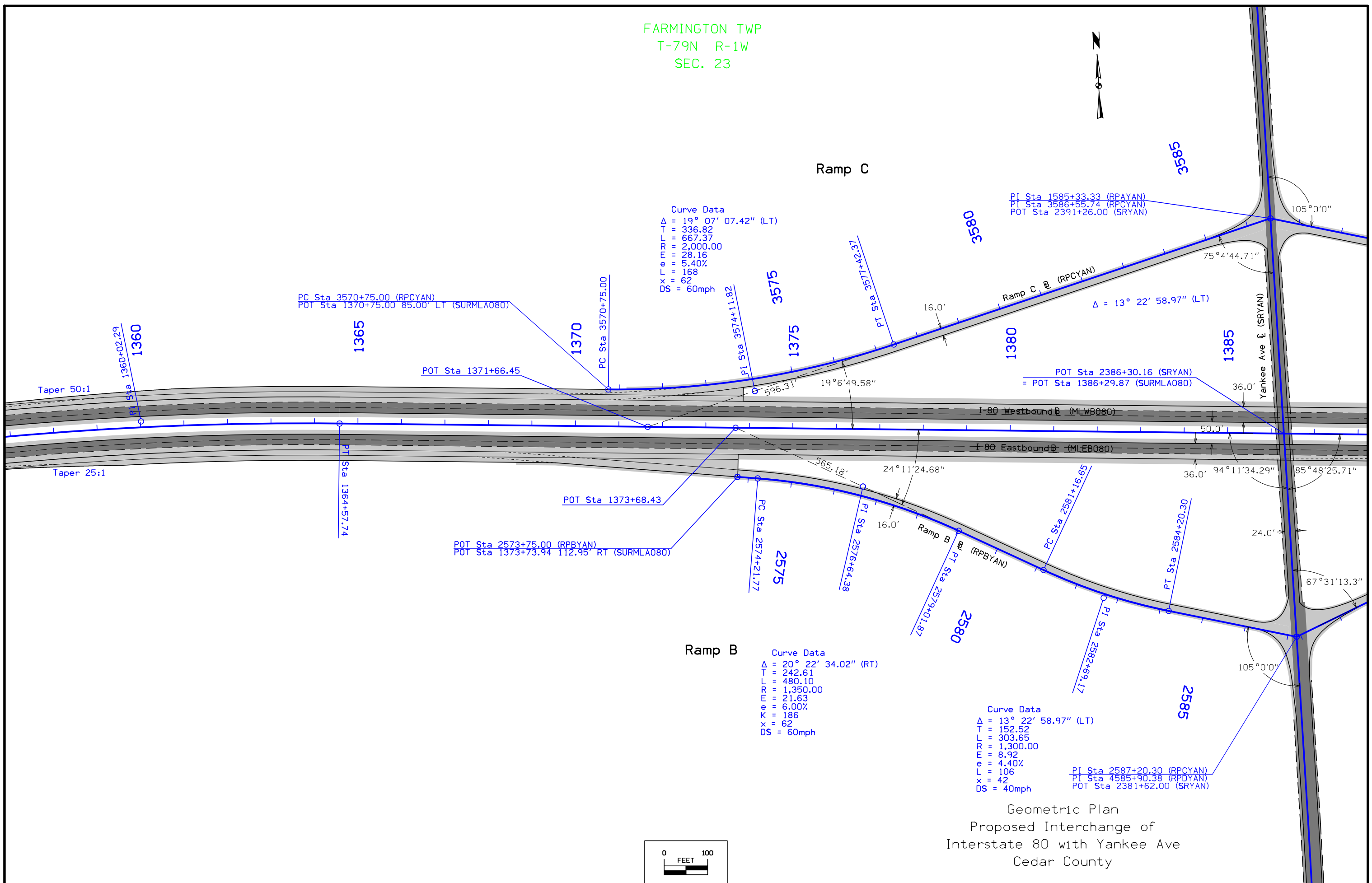

Geometric Plan  
Proposed Interchange of  
Interstate 80 with Yankee Ave  
Cedar County

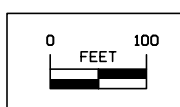

FARMINGTON TWP  
T-79N R-1W  
SEC. 24

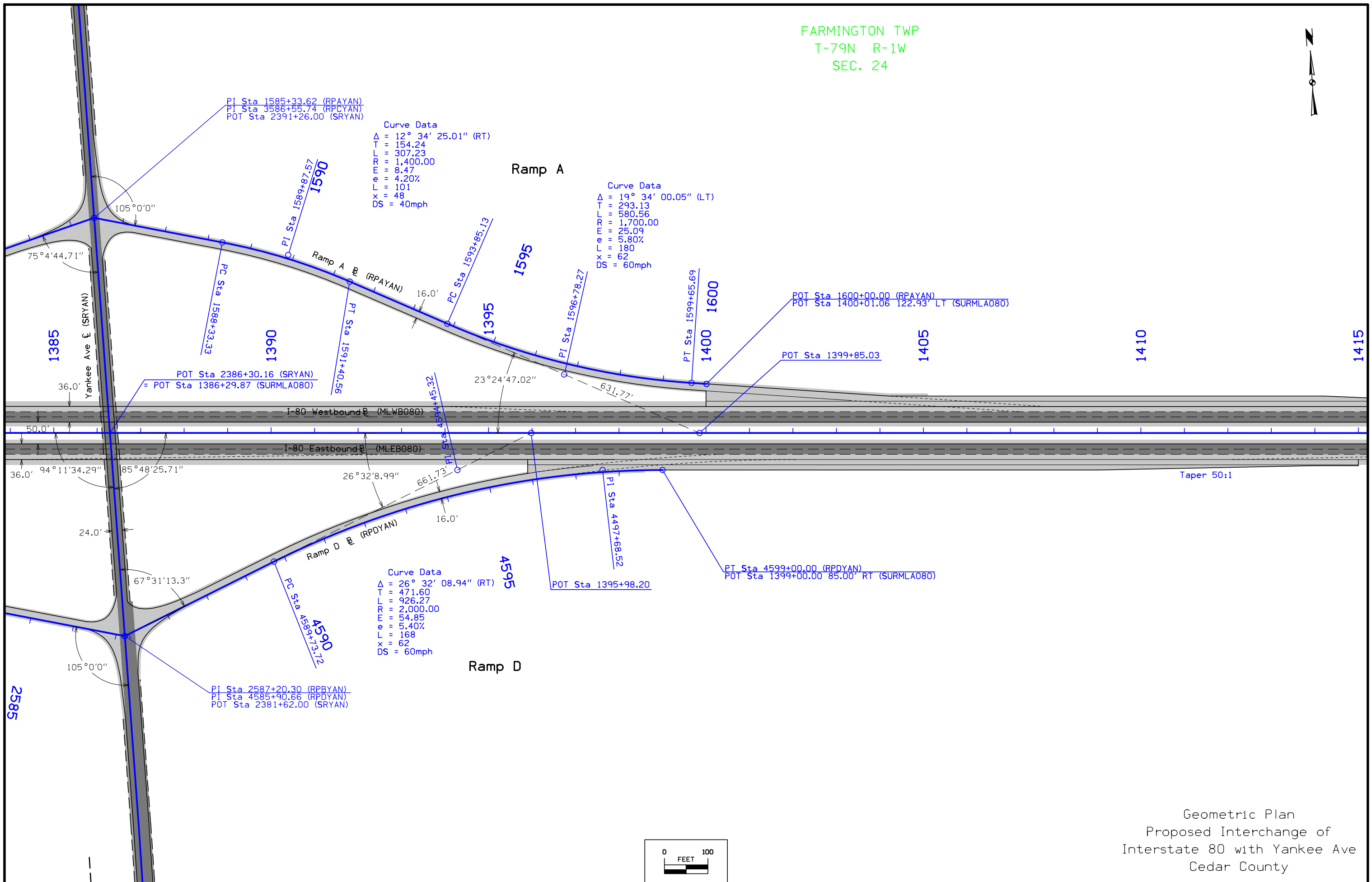

Geometric Plan  
Proposed Interchange of  
Interstate 80 with Yankee Ave  
Cedar County

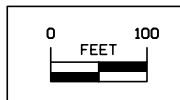

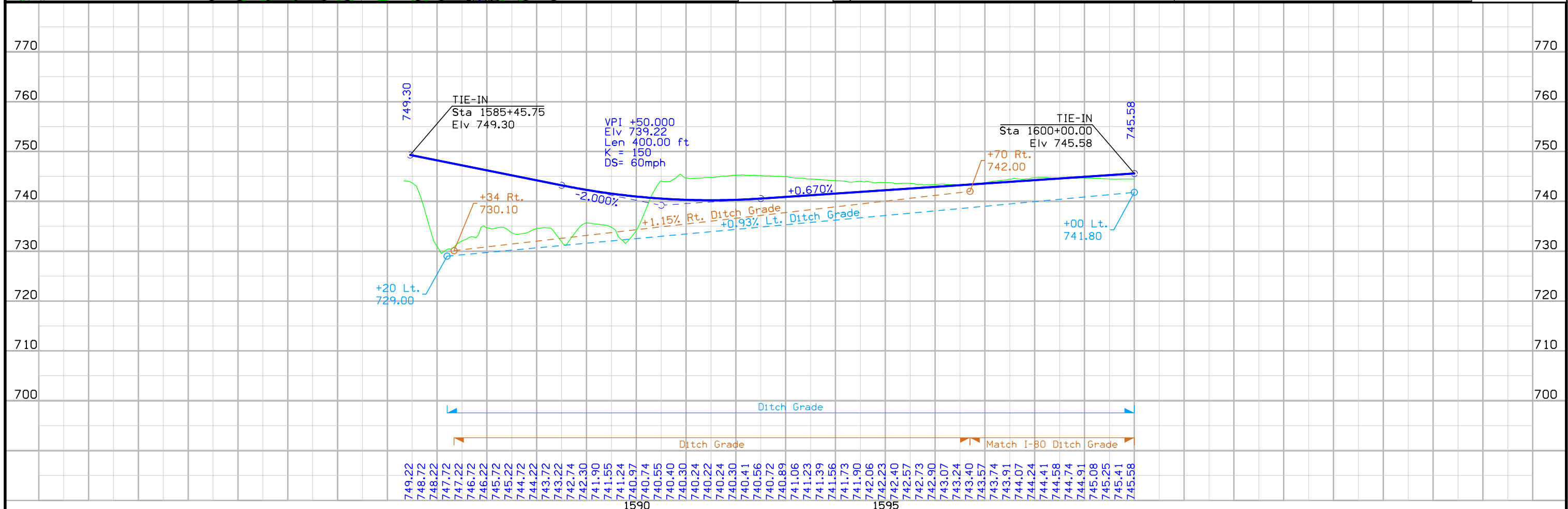
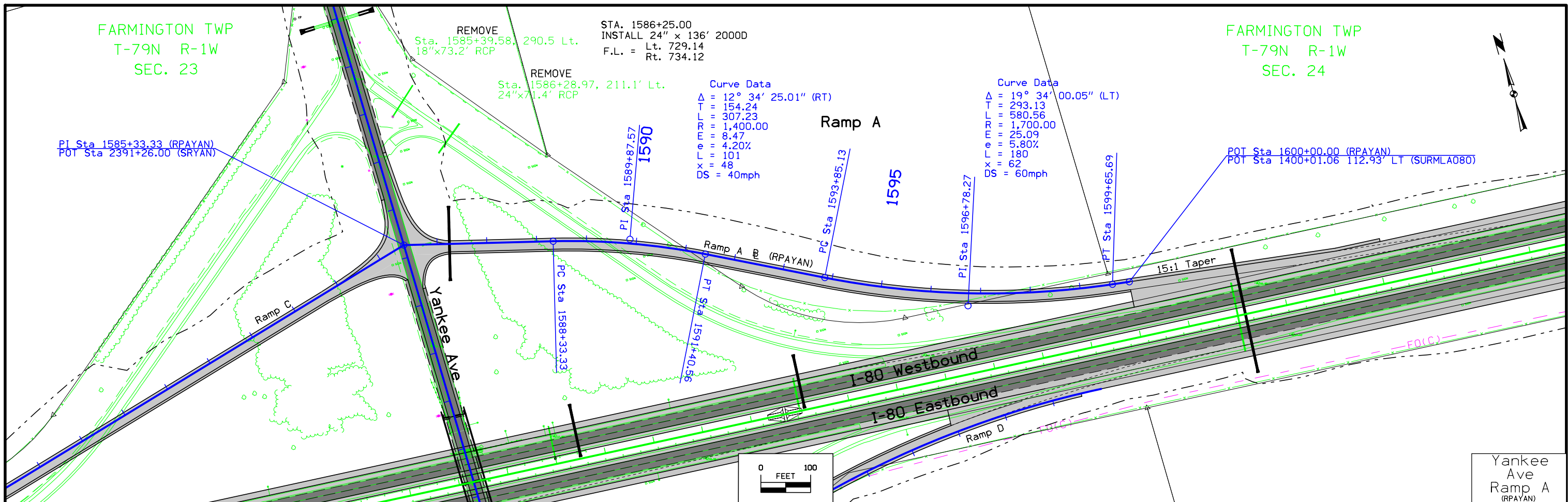

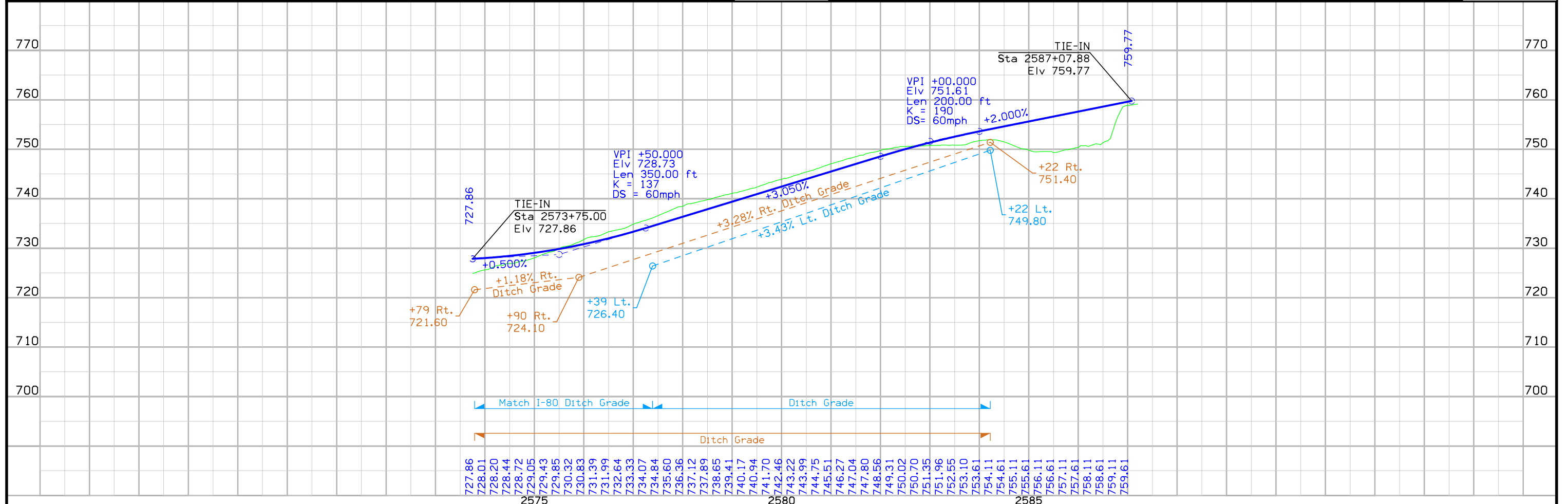
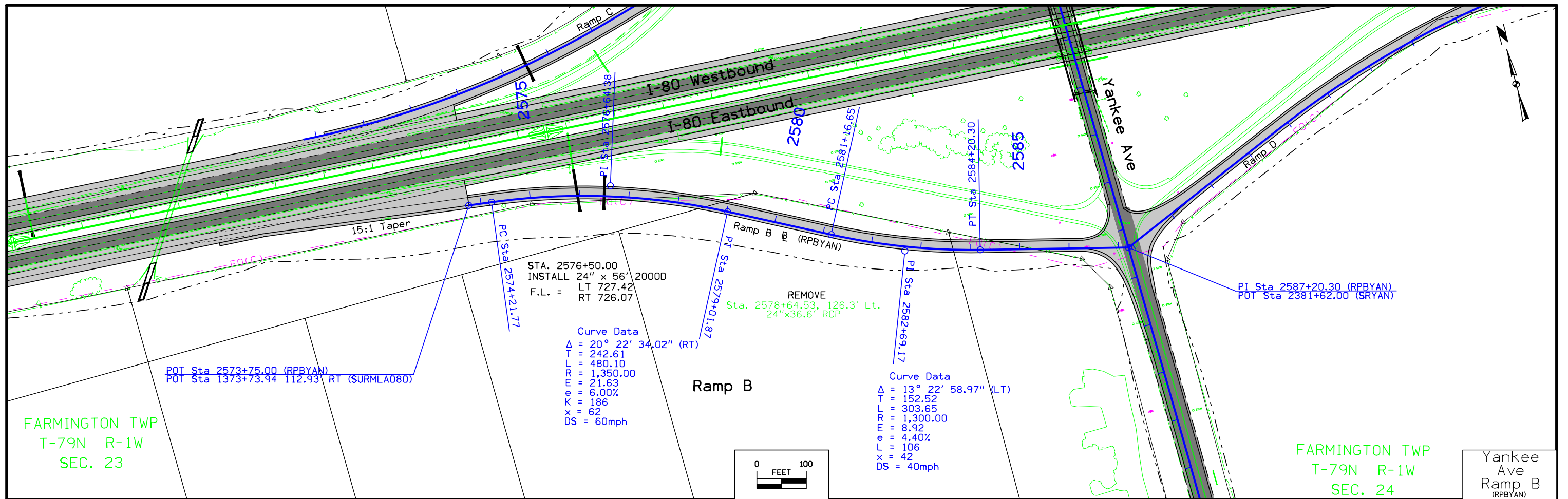



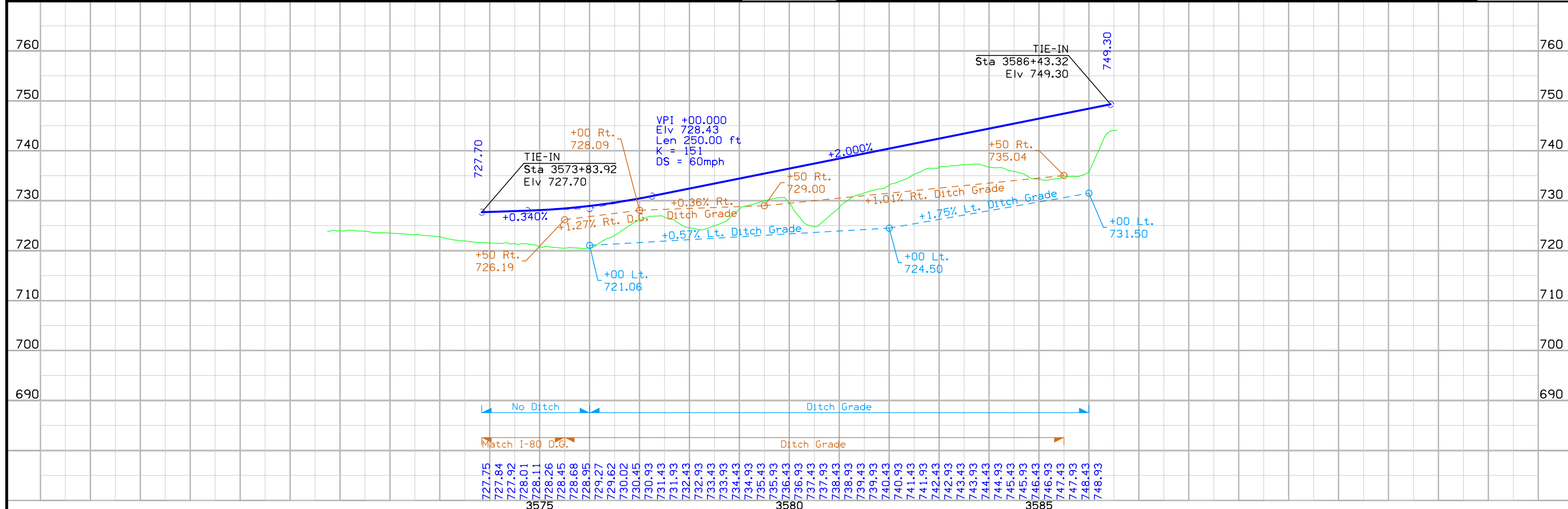
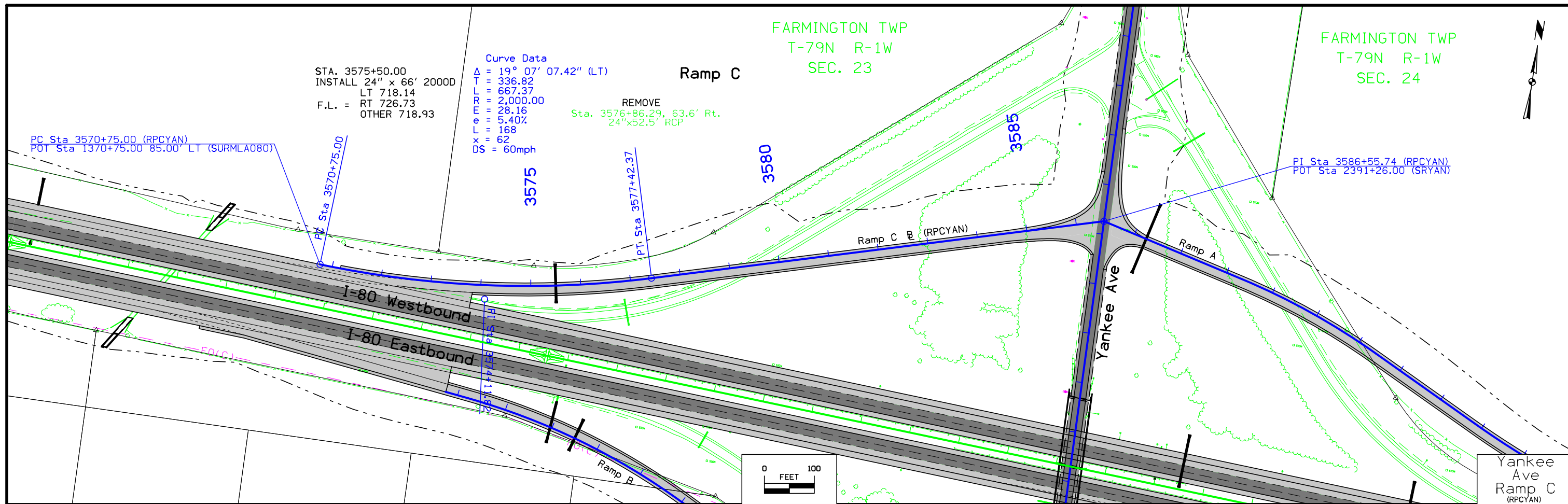



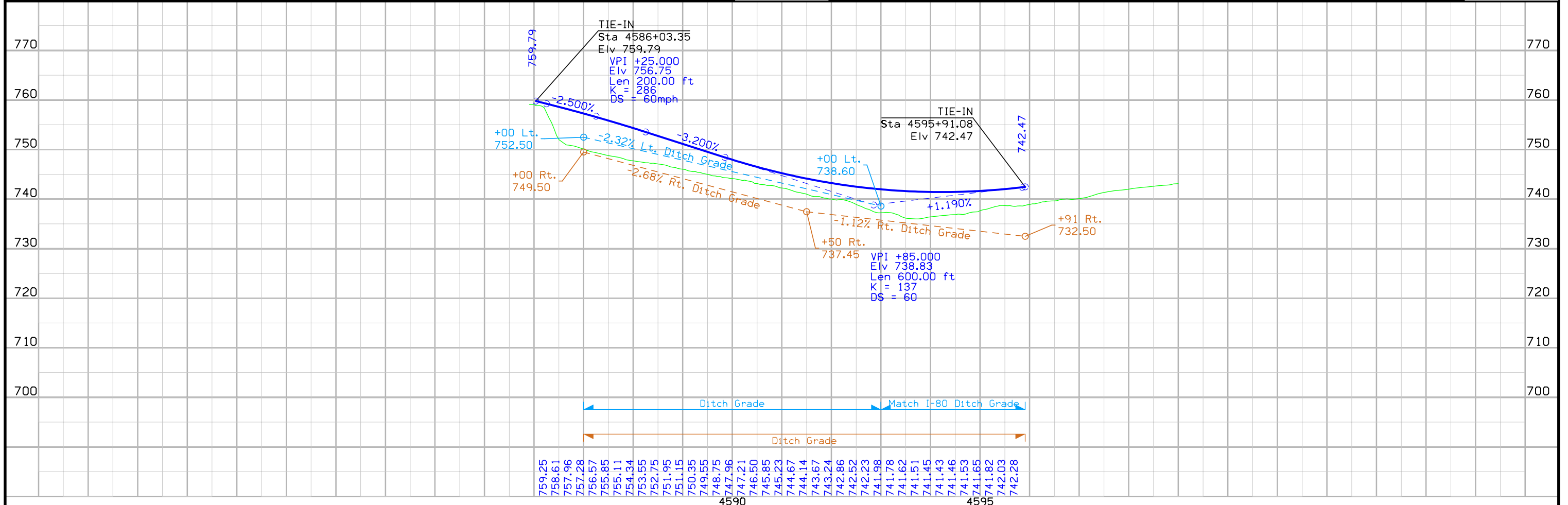
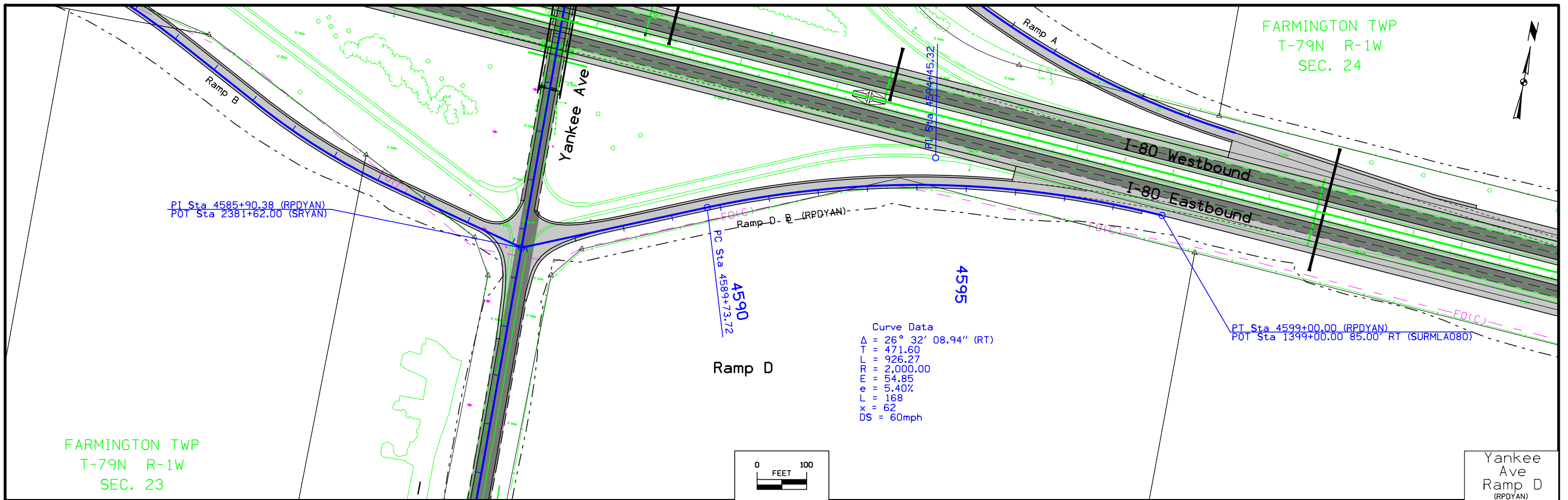

### SURVEY SYMBOLS

- FENO Control Monument
- + TOP Top of Bridge Piers
- + REF reference tie points
- SOP Size of pipe
- + SBR size of bridge
- ⊕ CP Control Point Generic
- UV Misc utility vault
- PIP pipes(cast iron, steel, tile, etc)
- STOP ST stop sign
- PRO profile-r.r. rail, swk, abut
- BM bench mark
- D cl of draw or stream
- TLNR tree line right
- × FW fence wire
- TDC tree deciduous
- GDL guard rails
- SI sign
- PPC power pole, Owner C
- PPB power pole, Owner B
- \* TEV evergreen tree
- ROW right of way rails
- PPA power pole, Owner A
- DU cl of draw upstream
- △ RIP rip-rap
- LUM luminaire
- + GR Ground Field Survey
- BNK stream bank
- TLNL tree line left
- WC Wildcard
- TW Top of Water
- SP Stream Profile
- EG edge of gravel road
- CON concrete or a/c slab
- + BD Bridge Deck
- ⊕ BLS Bridge Low Steel
- BCL bridge centerline
- BRG bridge
- C center of roadway
- EB electrical box
- \* PL Photo Location
- CUL culvert
- INB intake-beehive
- OUT tile outlet
- △ STP stump
- GDC Cable Guardrail
- BB billboard or sign
- SL speed limit sign
- MM mile marker post
- TPD telephone pedestal
- LC lot corner
- MH Misc manhole
- UE utility elevation
- IN intake-grate, curb, umbrella
- LIN miscellaneous line
- CMP corrugated metal pipes
- WHD water hydrant
- BLD foundation or building
- ⊕ SEP septic tank
- SHR shrub
- MIS miscellaneous
- ⊕ LP L.P. tank
- TR Telephone Riser Pole
- ENU edge of unpaved entrance&parking
- CU curb or center island
- GU gutter
- UB Misc utility box
- CS concrete slab
- RET retaining walls
- FWD wood fence
- ROC rock outcropping
- TV tv dish
- WW water valve
- EW edge of water
- FCL security & chain link
- GP guard post / Bollard
- S Soil sampling site

### UTILITY LEGEND

- PPA power pole, Owner A
- EL1B UG electric, Eastern Iowa Light & Power - Quality B
- EL1C UG electric, Eastern Iowa Light & Power - Quality C
- FO1B fiber optics, Iowa Communications Network - Quality B
- FO1C fiber optics, Iowa Communications Network - Quality C
- FO2B fiber optics, Aureon Network Services (INS) - Quality B
- FO2C fiber optics, Aureon Network Services (INS) - Quality C
- FO3B fiber optics, Windstream Communications - Quality B
- FO3B fiber optics, Windstream Communications - Quality C
- FO4C fiber optics, WTC Communications - Quality C
- FO5C fiber optics, HWH Corporation - Quality C
- GL1B gas line, OneOK North System - Quality B
- GL1C gas line, OneOK North System - Quality C

### PLAN VIEW COLOR LEGEND OF STORM SEWER SHEETS

LINEWORK	Design	Color No.	
Black	(17)	█	Proposed Storm Sewer Details
Blue	(1)	█	Alignment, Stationing, Tic Marks, and Alignment Annotation
SHADING		Design	Color No.
Gray, Light	(48)	█	Proposed PCC Pavement with HMA Surfacing Shading
Gray, Med	(80)	█	Proposed Granular Shading
Gray, Dark	(112)	█	Proposed HMA Resurfacing Shading

### PROFILE VIEW COLOR LEGEND OF STORM SEWER SHEETS

LINEWORK	Design	Color No.	
Green	(18)	█	Existing Ground Line Profile
Black	(17)	█	Proposed Ground Line Profile
Gray, Dark	(112)	█	Existing Storm Sewer Pipe
Blue	(1)	█	Proposed Storm Sewer Pipe
Blue, Light	(230)	█	Proposed Storm Sewer Structure

### PLAN VIEW LINE STYLE LEGEND OF STORM SEWER SHEETS

—	Proposed Storm Sewer Pipe
—	Proposed Storm Sewer Structure
—	Existing Culvert
—	Proposed Culvert

### PROFILE VIEW LINE STYLE LEGEND OF STORM SEWER SHEETS

—	Existing Ground
—	Proposed Ground
---	Existing Storm Sewer Pipe or Structure
—	Proposed Storm Sewer Pipe
—	Proposed Storm Sewer Structure

○	Reference Point
—	Station
△	Section Corner
---	Ground Line Intercept
////	Saw Cut
—	Guardrail

### RIGHT-OF-WAY LEGEND

△	Proposed Right-of-Way
△	Existing and Proposed Right-of-Way
△	Easement and Existing Right-of-Way
■	Borrow
○	Easement (Temporary)
⊕	Easement
×	Excess
A/C	Access Control

# STORM SEWER LEGEND AND SYMBOL INFORMATION SHEET

(COVERS SHEET SERIES M)

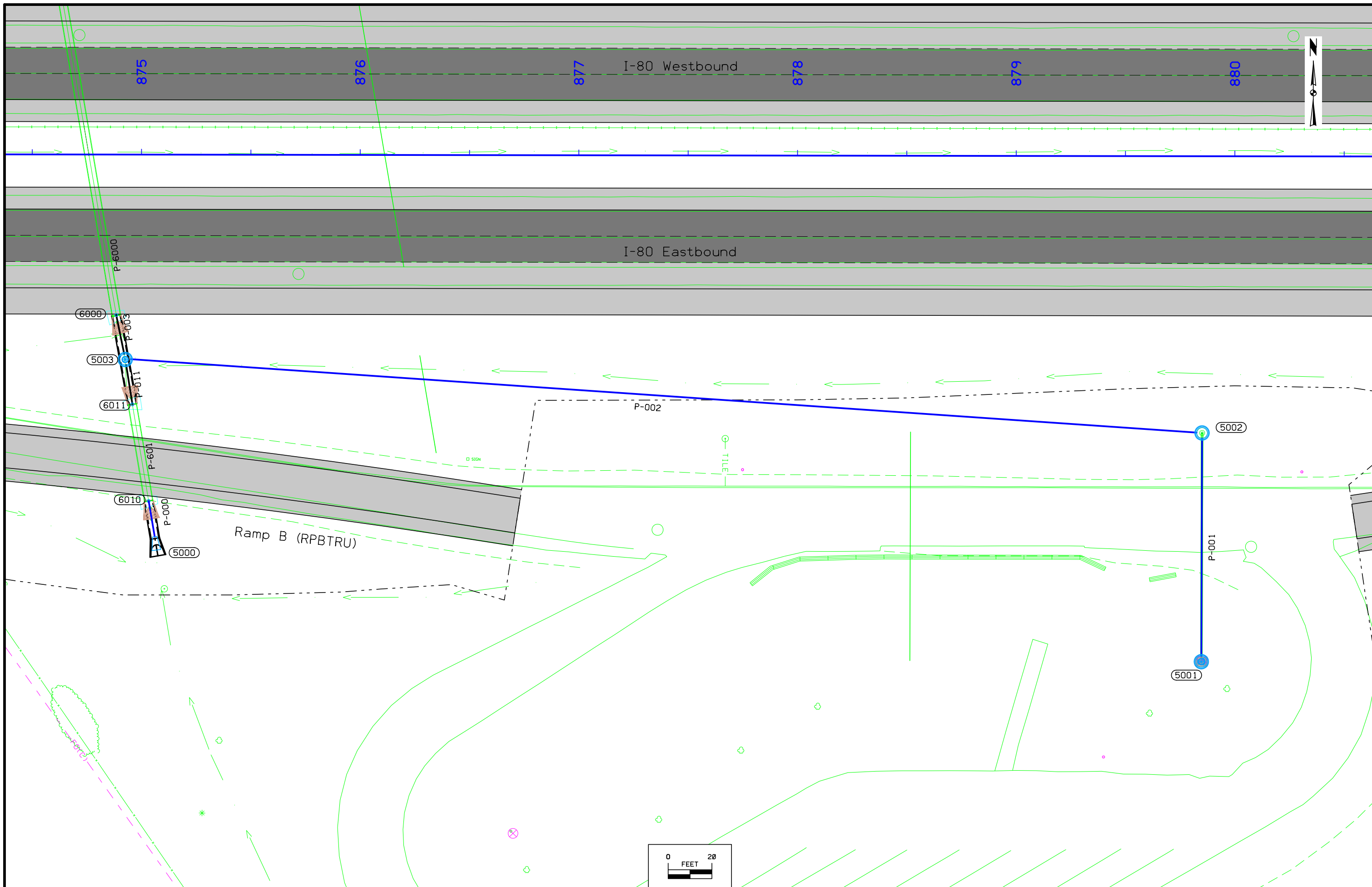

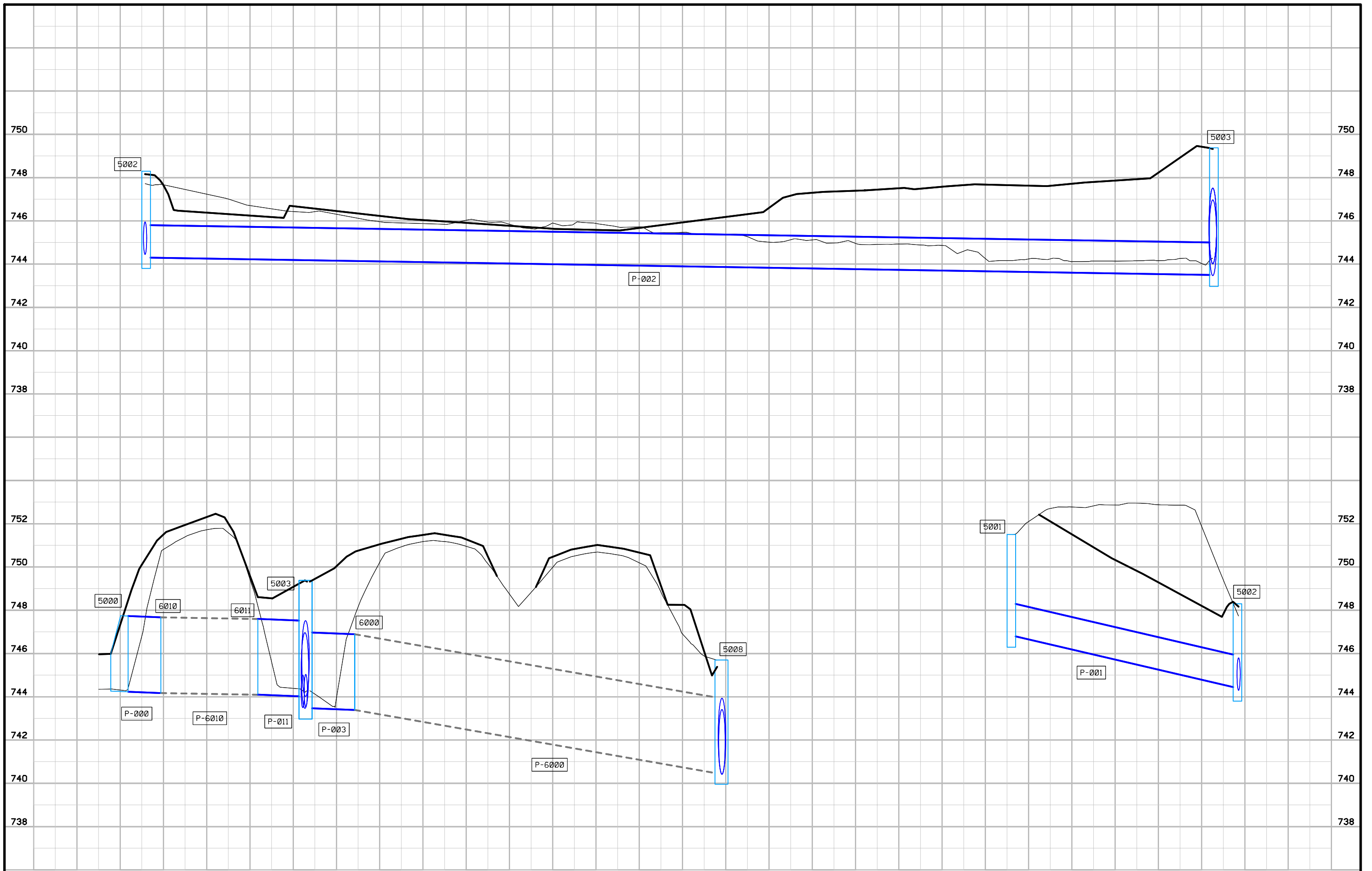

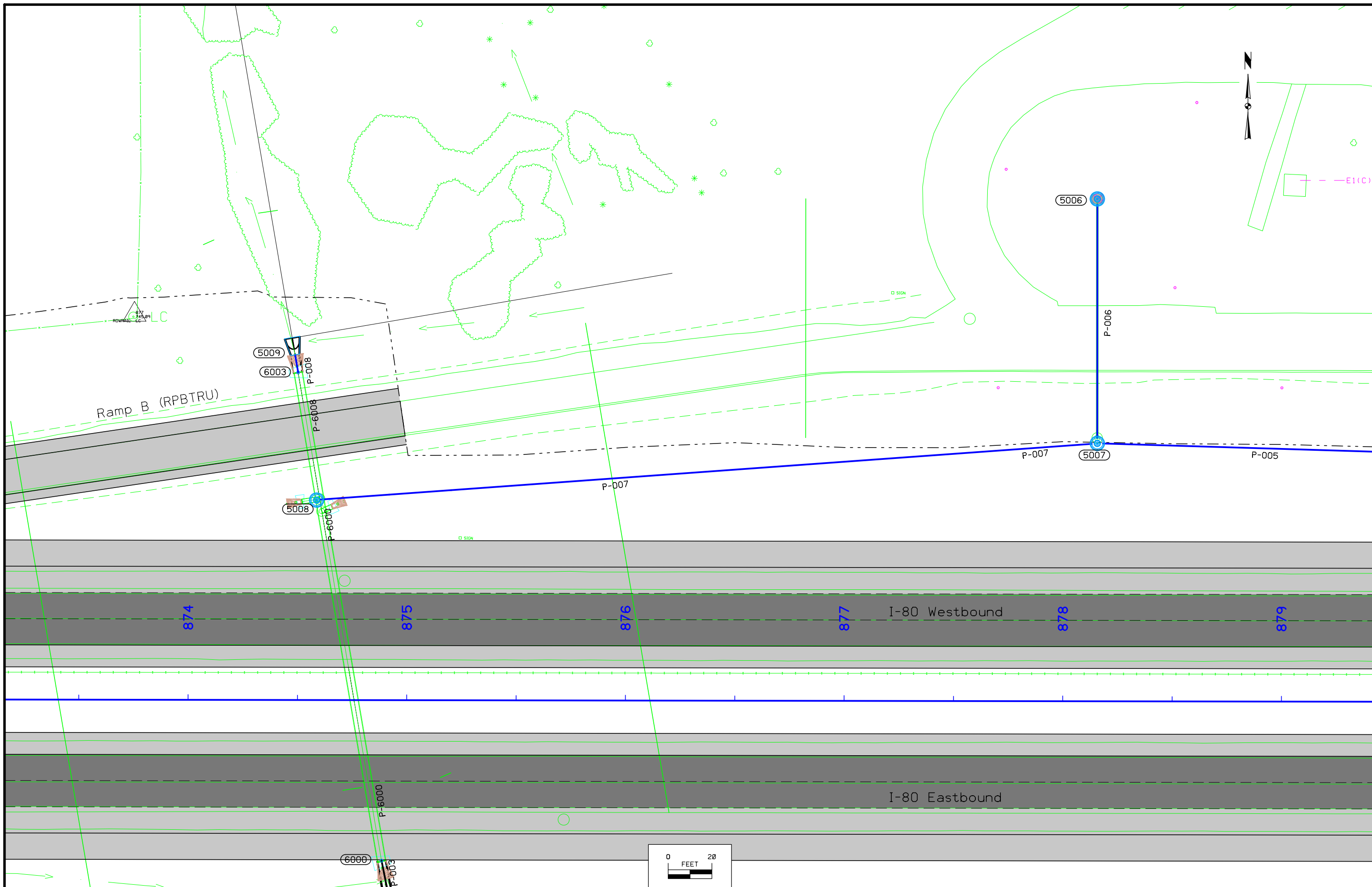



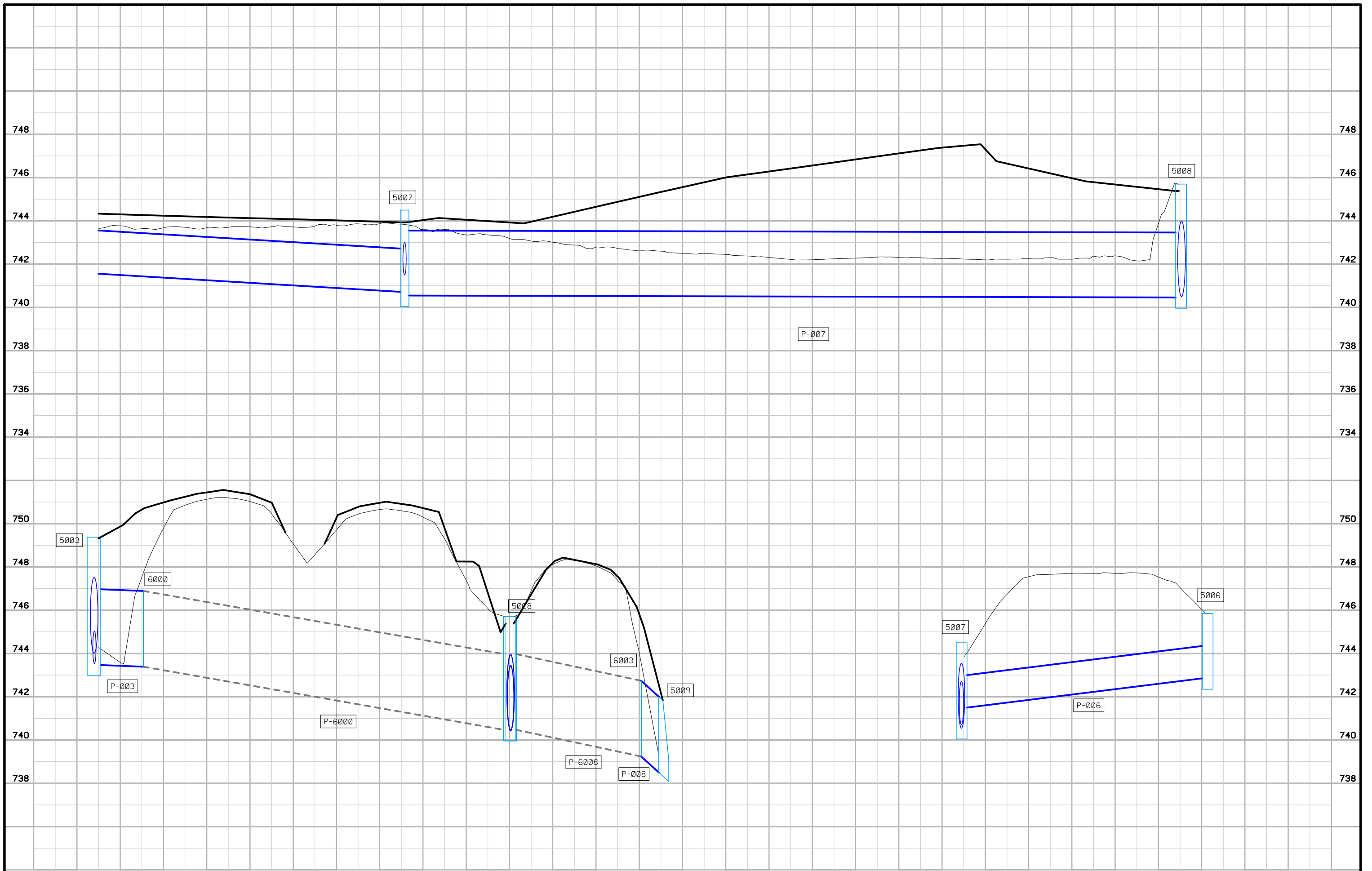

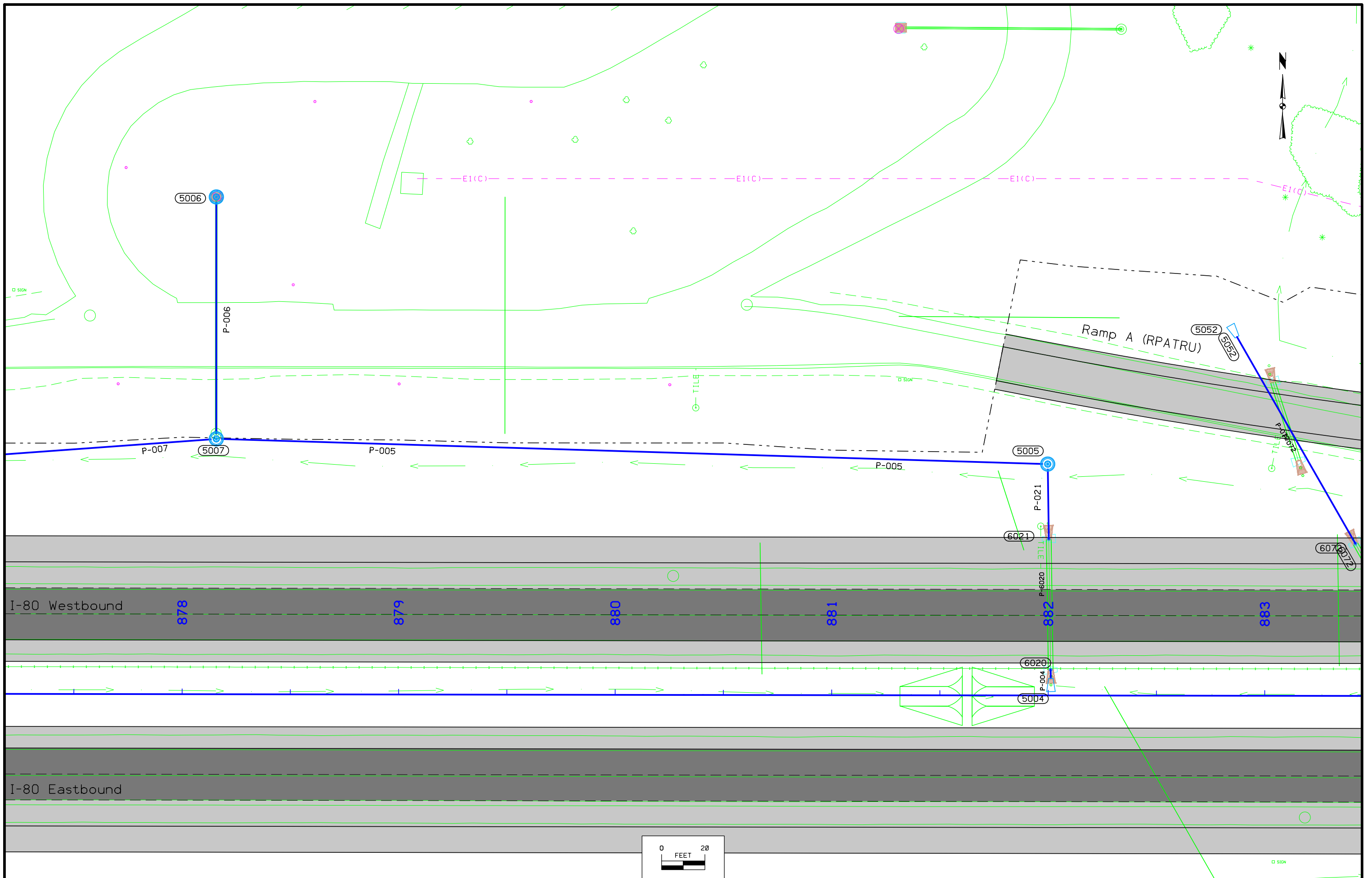

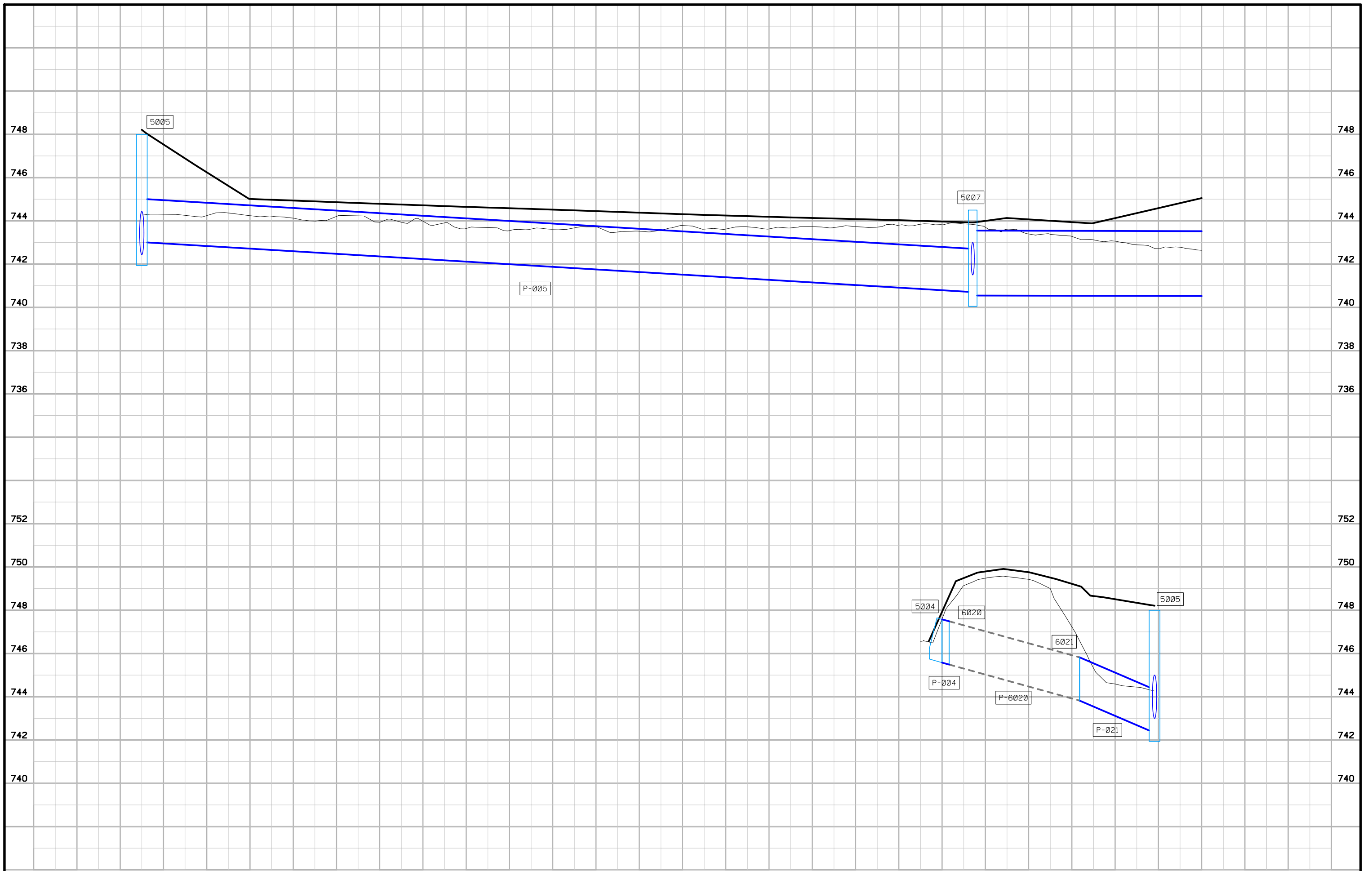

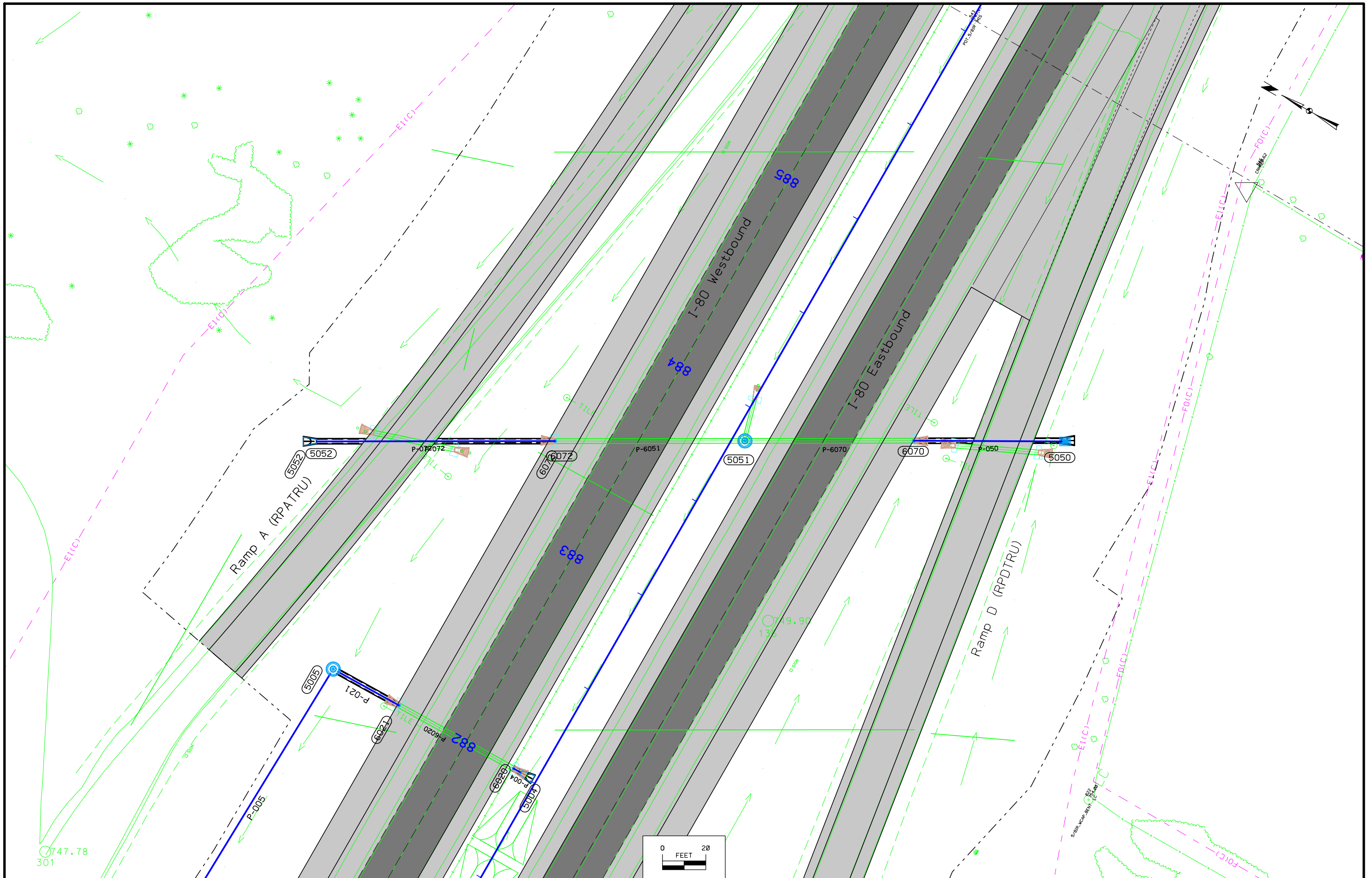

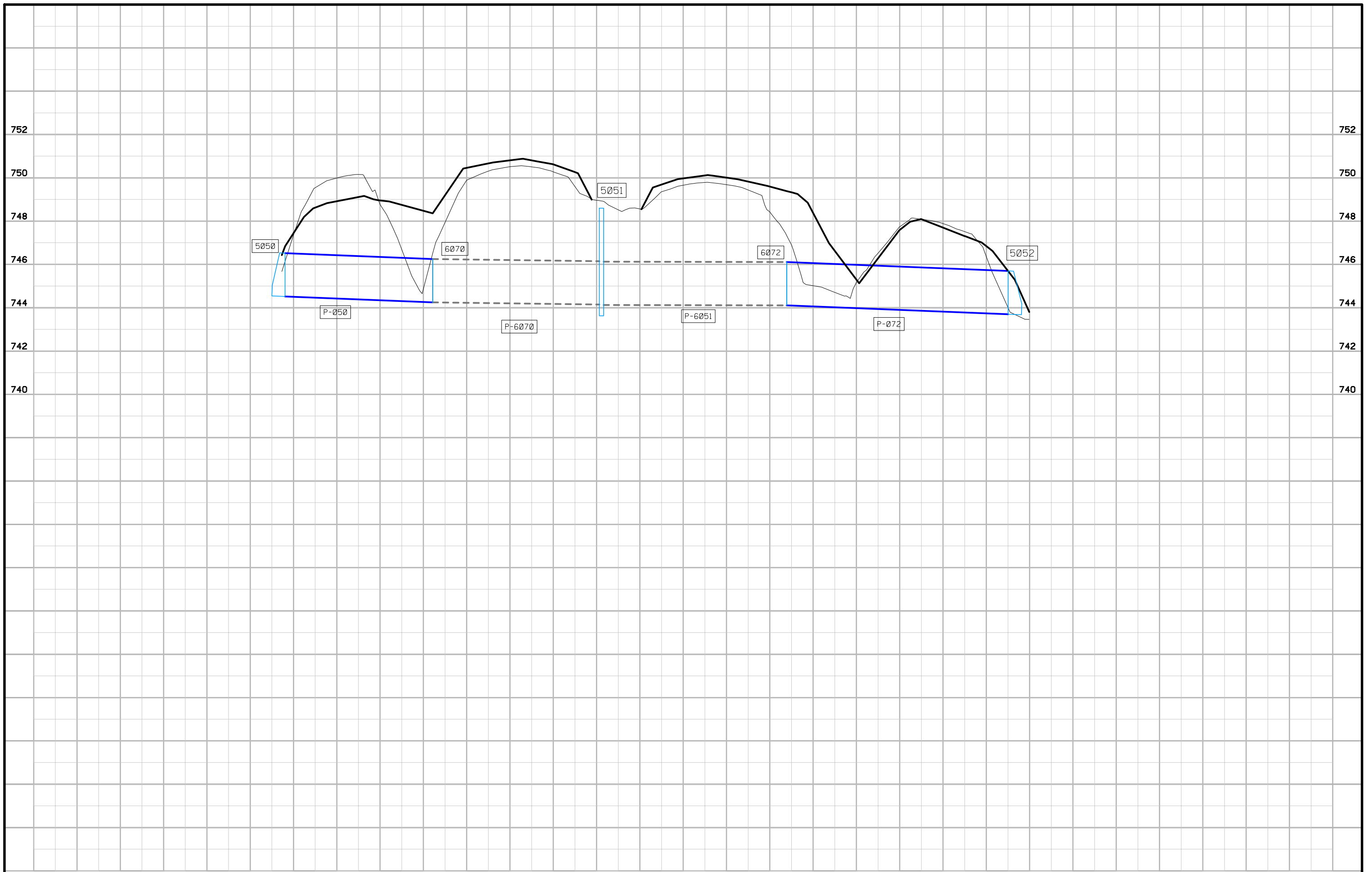



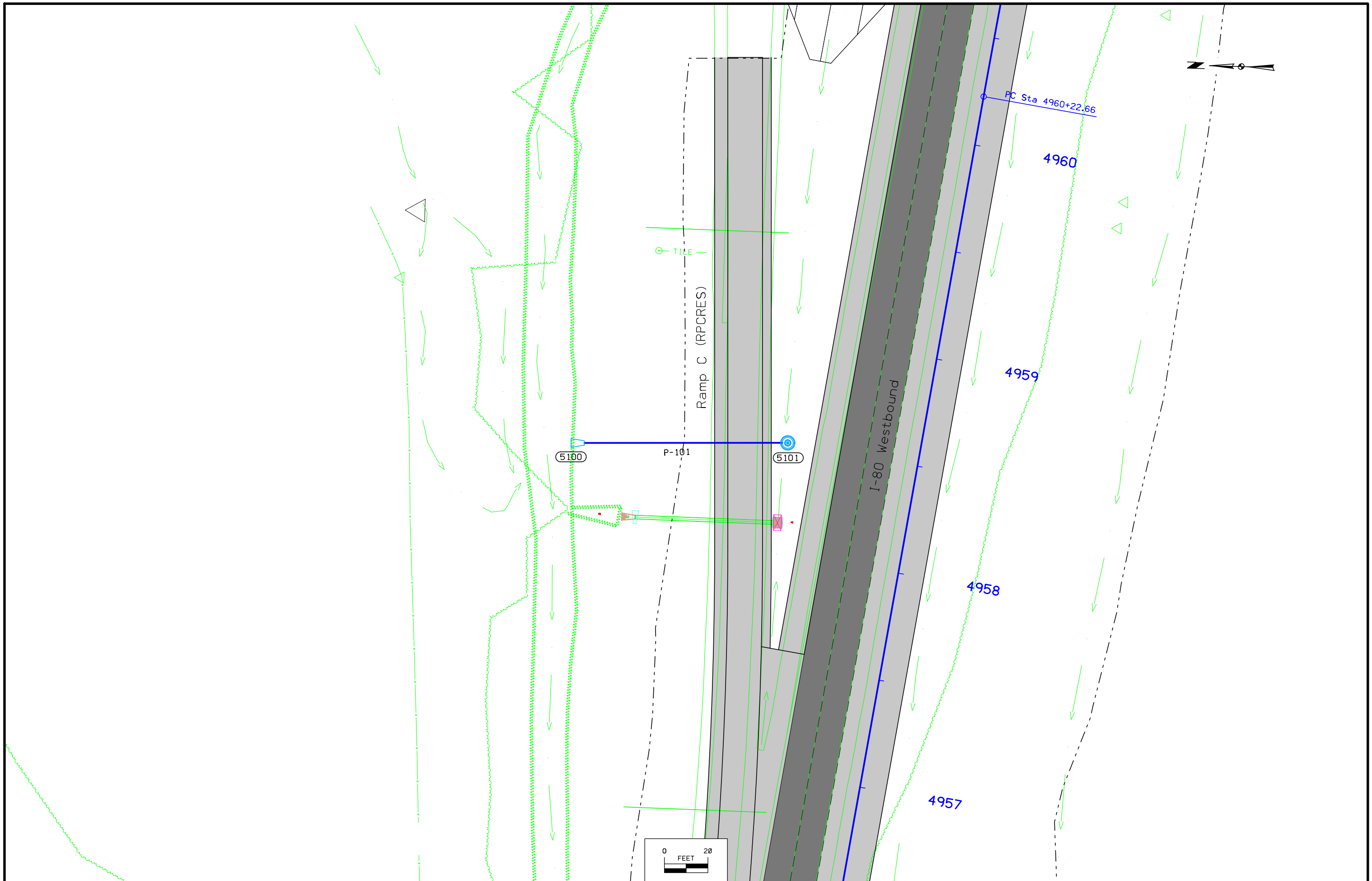

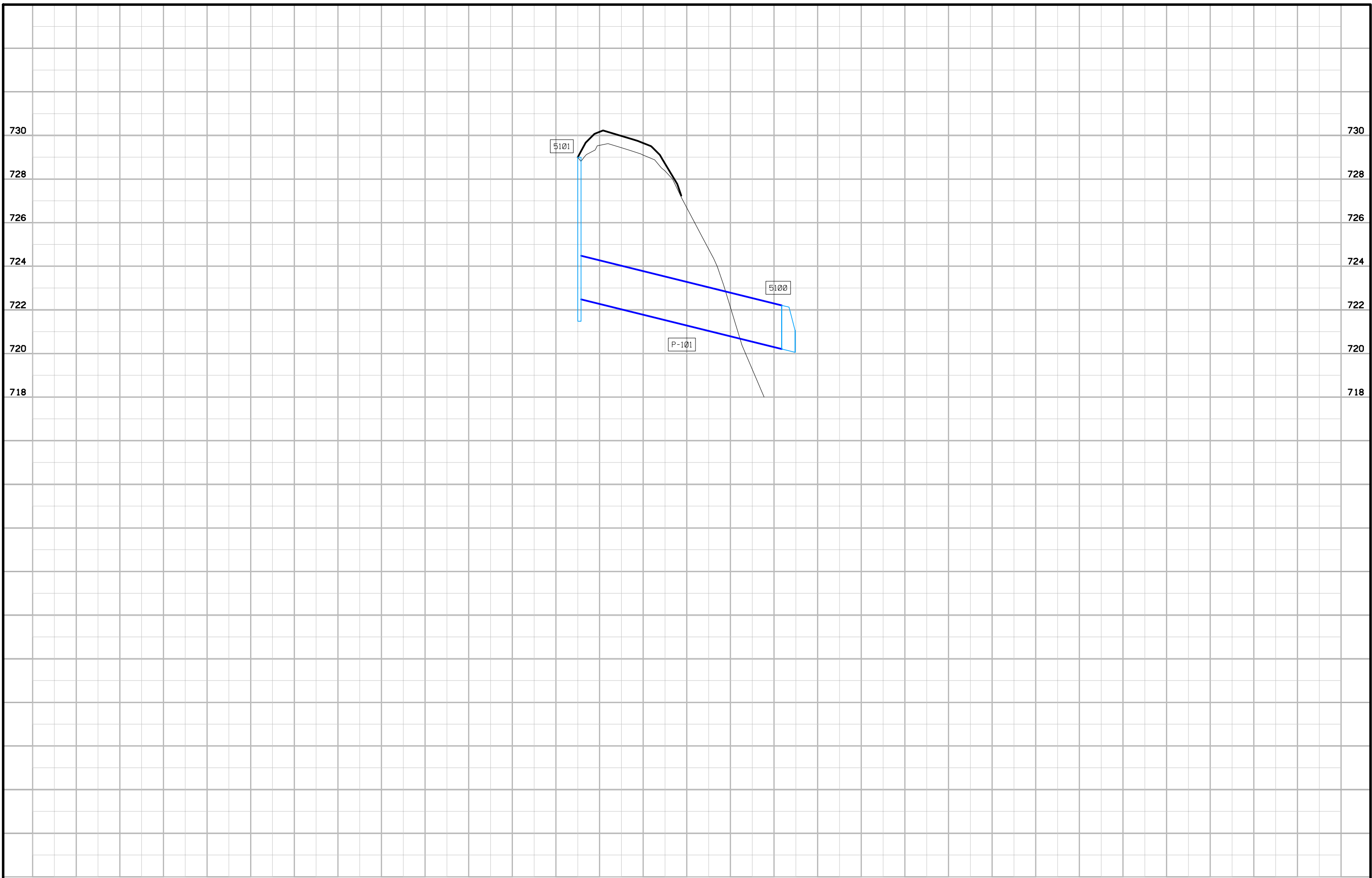

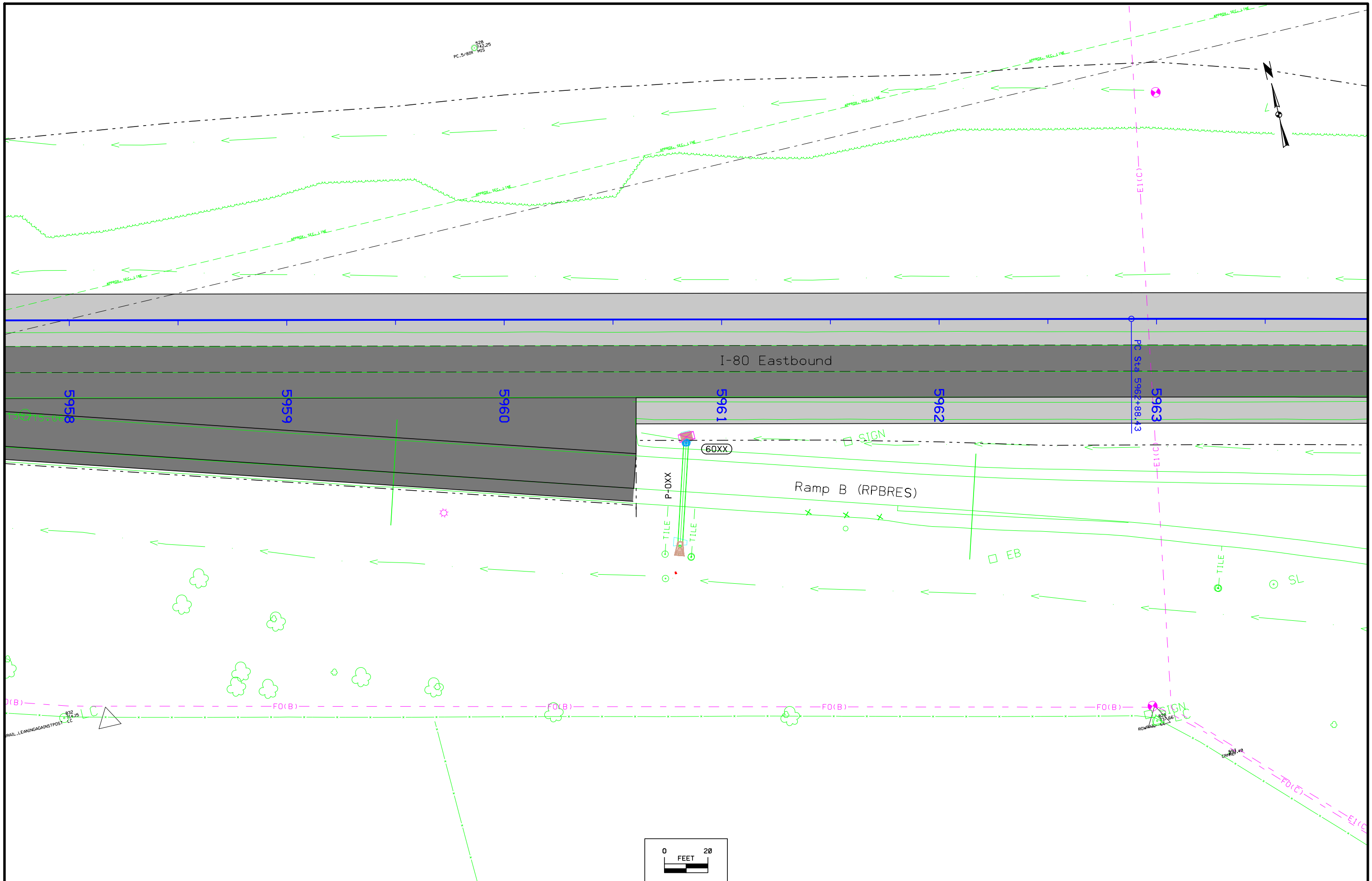

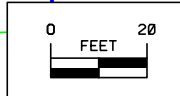
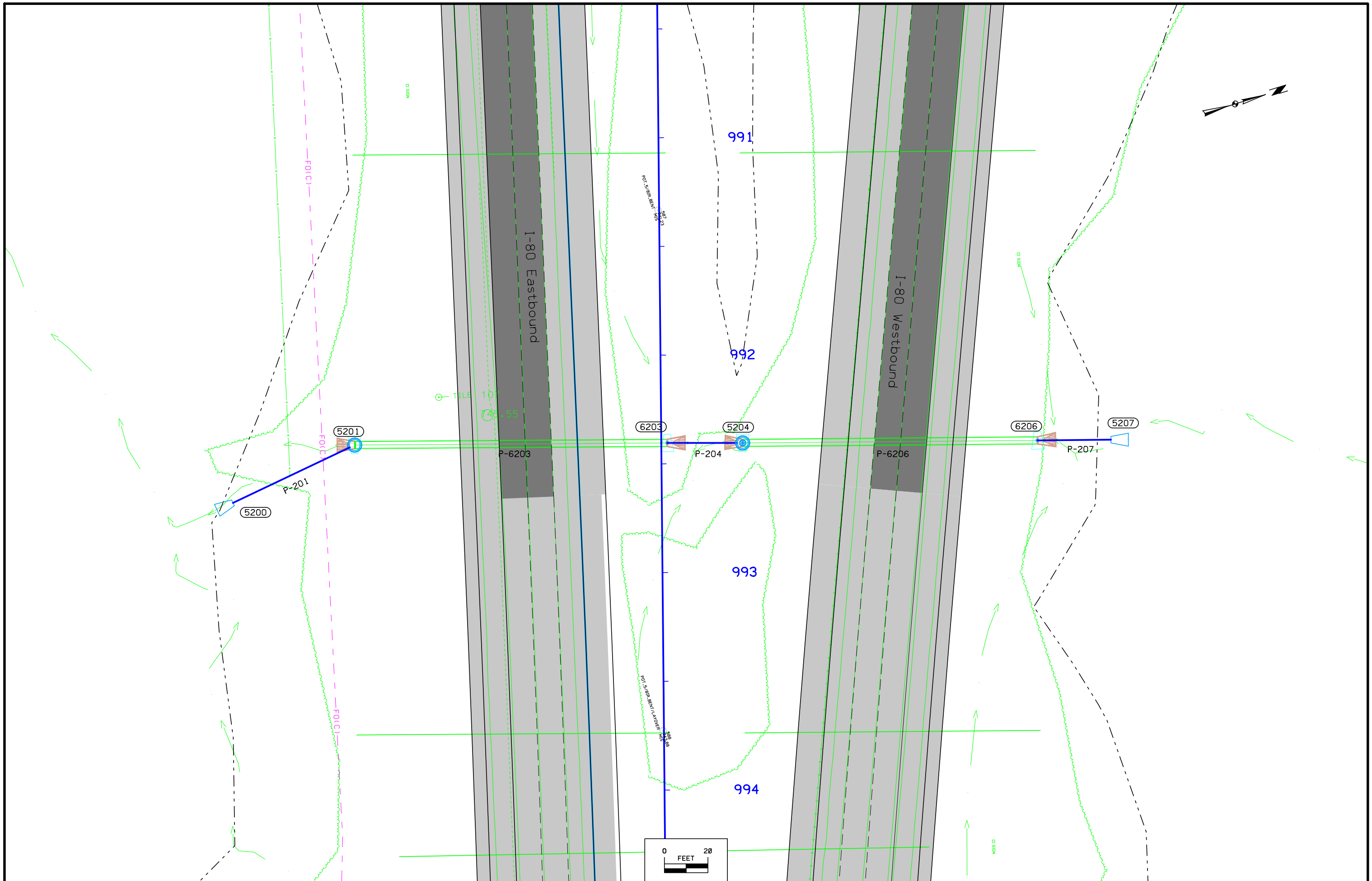

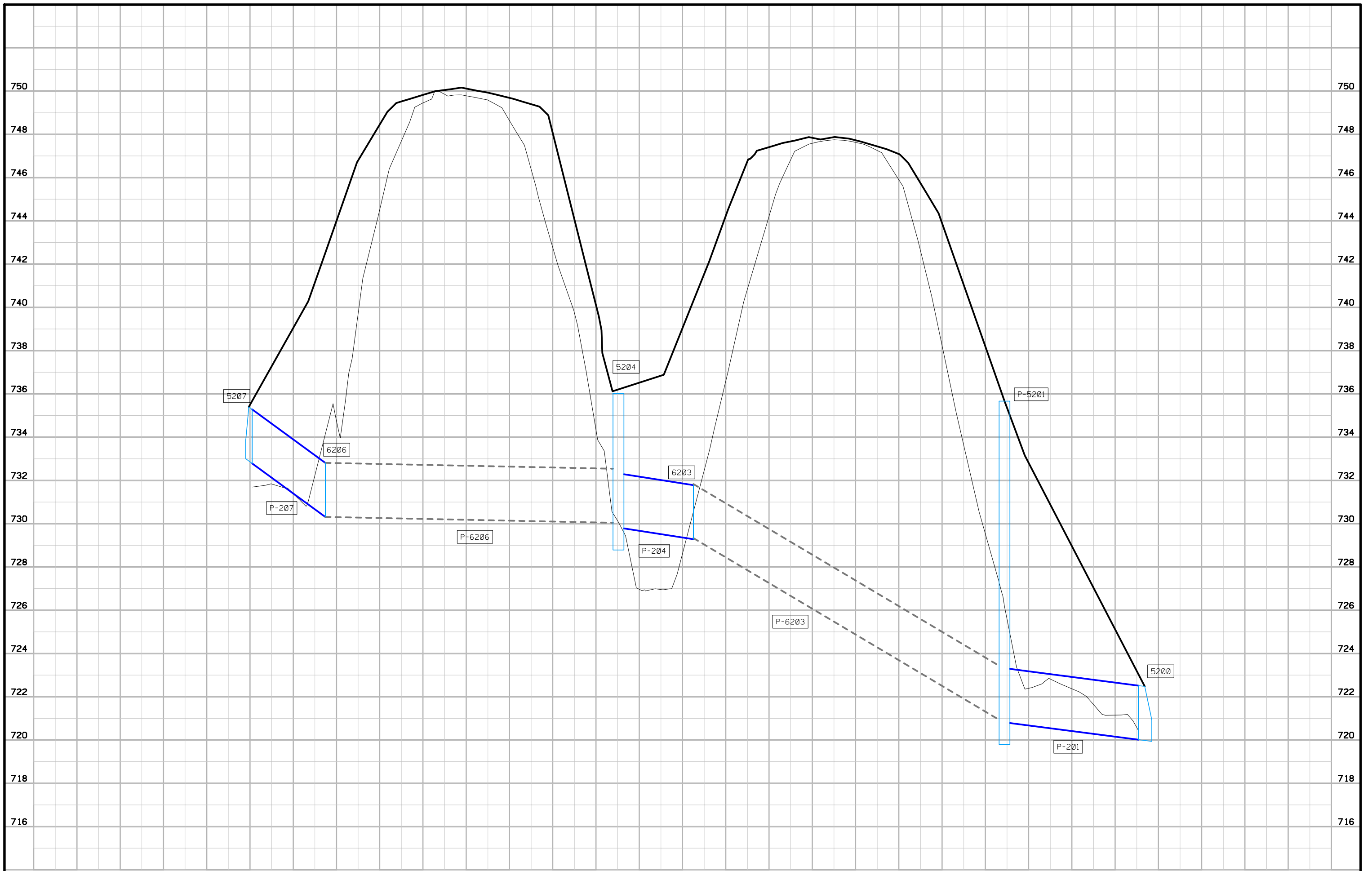



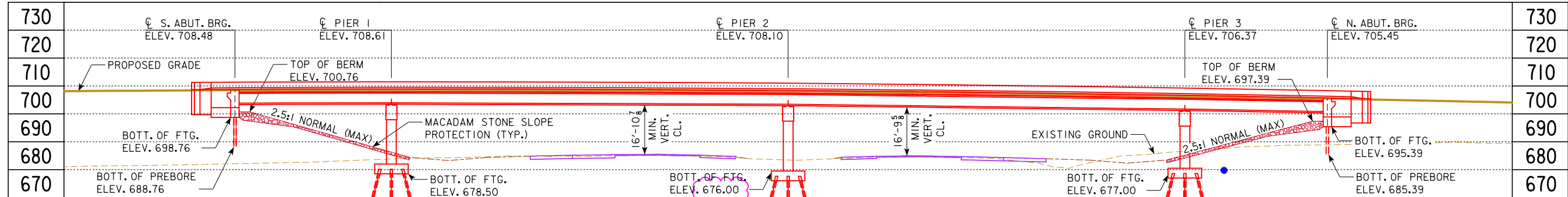

LONGITUDINAL SECTION ALONG CL MOSCOW RD.

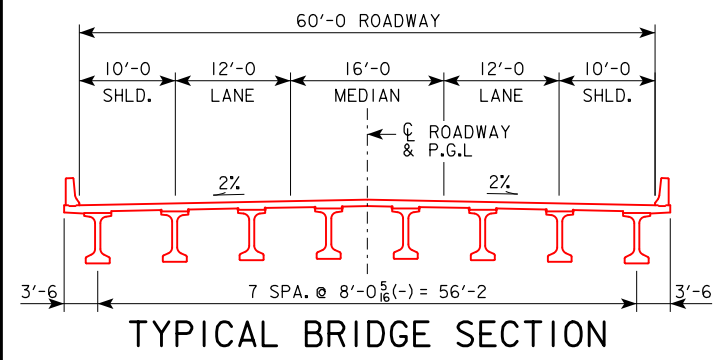

TYPICAL BRIDGE SECTION

MINIMUM VERTICAL CLEARANCE

**E.B. ROADWAY**  
 OVERHEAD STATION = 1801+81.41, OFFSET 28.08' RT  
 OVERHEAD ELEVATION = 707.97  
 DEPTH OF SUPERSTRUCTURE = 5.33'  
 UNDERPASS STATION = 804+54.55, OFFSET 37.00' RT  
 UNDERPASS ELEVATION = 685.74  
 MINIMUM VERTICAL CLEARANCE = 16.90'

**W.B. ROADWAY**  
 OVERHEAD STATION = 1802+74.99, OFFSET 28.08' RT  
 OVERHEAD ELEVATION = 707.35  
 DEPTH OF SUPERSTRUCTURE = 5.33'  
 UNDERPASS STATION = 803+97.26, OFFSET 37.00' LT  
 UNDERPASS ELEVATION = 685.22  
 MINIMUM VERTICAL CLEARANCE = 16.80'

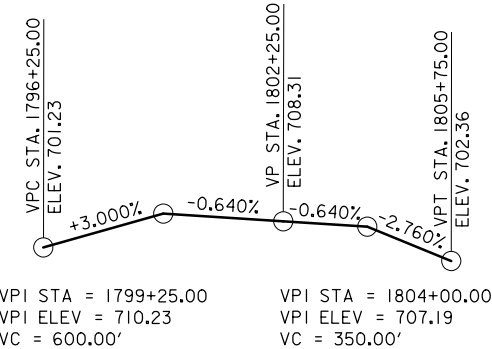

PROPOSED PROFILE GRADE MOSCOW RD.

TRAFFIC ESTIMATE

2020 AADT	3,221	V.P.D.
2040 AADT	3,950	V.P.D.
2040 DHV	-	V.P.H.
TRUCKS	17	%
TOTAL DESIGN ESALS	--	

- NOTES:
- TOP OF BRIDGE DECK CROWN IS 0.03' BELOW PROFILE GRADE.
  - NON-STANDARD 3'-6" INTEGRAL ABUTMENTS AND 4'-6" PIER CAPS.
  - NON-STANDARD 8'-6" WING EXTENSION REQUIRED, MEASURED FROM CL ABUT. BRG.
  - MASH TL-4 (38") BRIDGE RAILING PROPOSED.
  - PIER TYPE-FRAME.
  - PIER 2 COLUMNS DESIGNED FOR VEHICULAR COLLISION FORCE. PIERS 1 & 3 ARE EXEMPT.
  - BEAM TYPE-BTD.
  - MACADAM STONE.
  - PROP. VERTICAL DATUM IS APPROX. 8.34' HIGHER THAN USED ON EXISTING PLANS.
  - 1-80 ELEVATIONS BASED ON EXISTING RDWY. SURVEY PLUS 4" PROPOSED OVERLAY.
  - NON-STANDARD BTD140 BEAMS USED. DESIGN TO BE DONE BY FINAL DESIGNER.
- PRELIMINARY

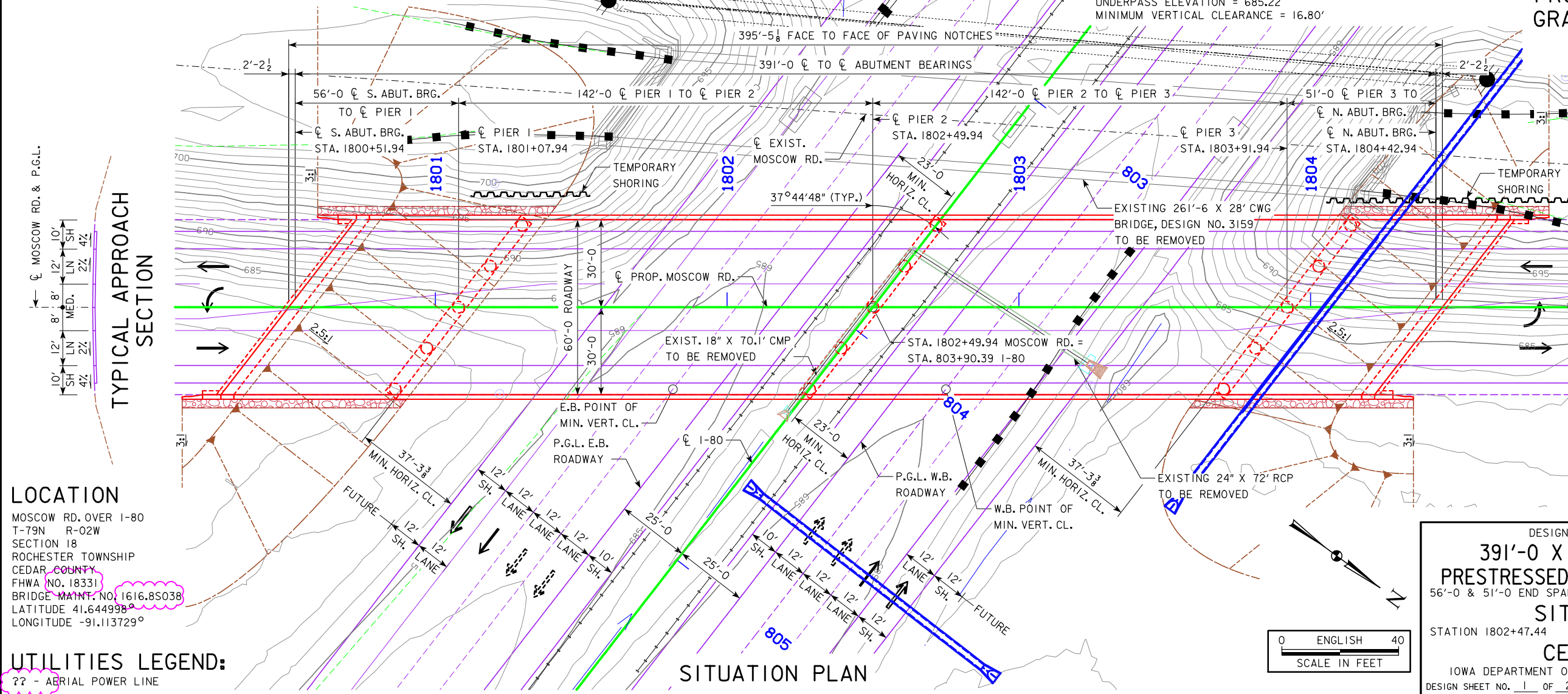

SITUATION PLAN

LOCATION

MOSCOW RD. OVER I-80  
 T-79N R-02W  
 SECTION 18  
 ROCHESTER TOWNSHIP  
 CEDAR COUNTY  
 FHWA NO. 18331  
 BRIDGE MAINT. NO. 1616.8S038  
 LATITUDE 41.644998°  
 LONGITUDE -91.113729°

UTILITIES LEGEND:

?? - AERIAL POWER LINE

DESIGN FOR 37°44'48" SKEW (L.A.)  
**391'-0" X 60'-0" PRETENSIONED PRESTRESSED CONCRETE BEAM BRIDGE**  
 56'-0" & 51'-0" END SPANS (BTD BEAMS) 142'-0" INTERIOR SPANS  
**SITUATION PLAN**  
 STATION 1802+47.44 (CL MOSCOW RD.) AUGUST 2019  
**CEDAR COUNTY**  
 IOWA DEPARTMENT OF TRANSPORTATION - HIGHWAY DIVISION  
 DESIGN SHEET NO. 1 OF 2 FILE NO. 31800 DESIGN NO. ?

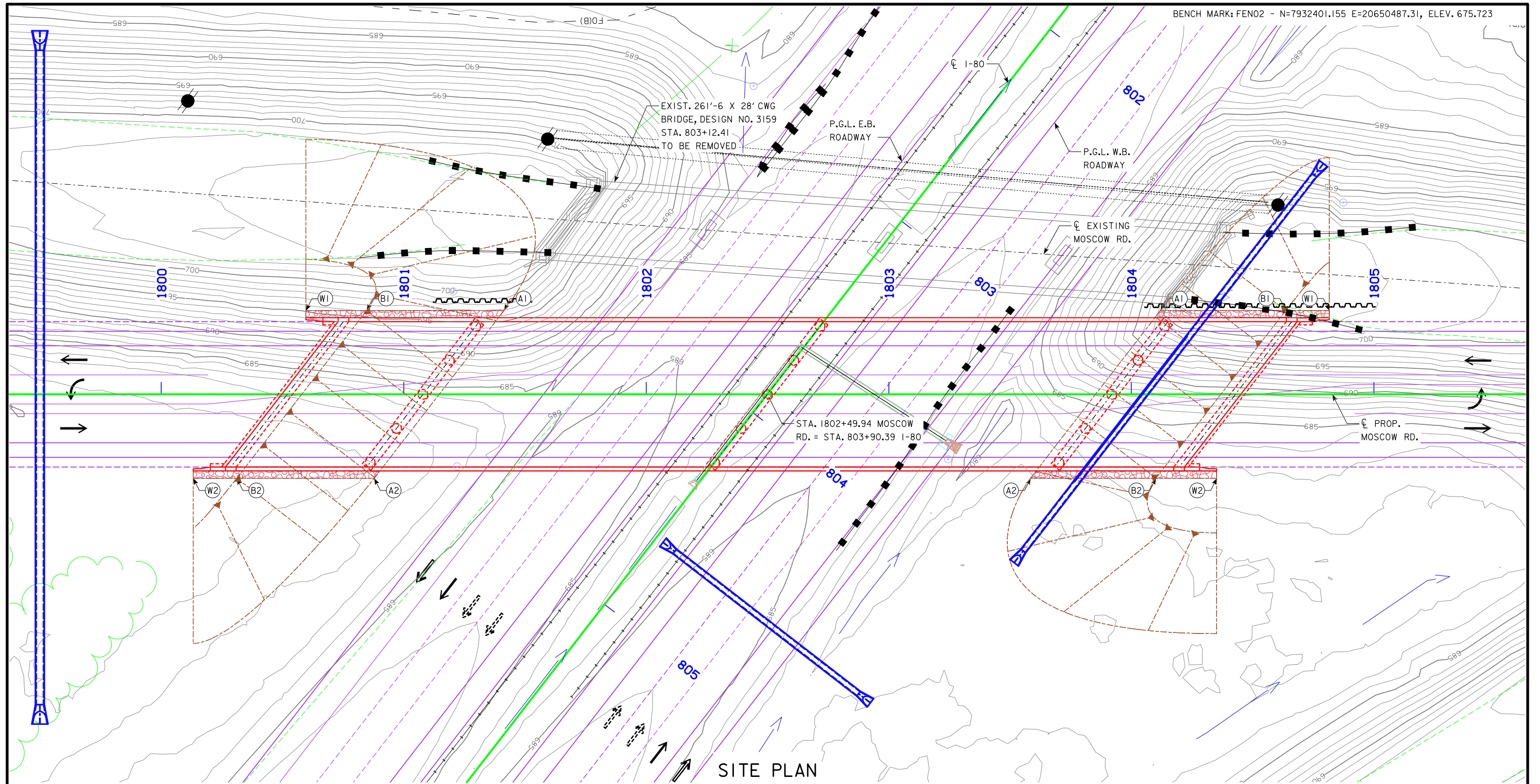

BENCH MARK: FEN02 - N=7932401.155 E=20650487.31, ELEV. 675.723

EXIST. 261'-6 X 28' CWG  
BRIDGE, DESIGN NO. 3159  
STA. 803+12.41  
TO BE REMOVED

P.G.L. E.B.  
ROADWAY

P.G.L. W.B.  
ROADWAY

EXISTING  
MOSCOW RD.

STA. 1802+49.94 MOSCOW  
RD. = STA. 803+90.39 I-80

PROP.  
MOSCOW RD.

SITE PLAN

**BERM SLOPE LOCATION TABLE**

POINTS	SOUTH ABUTMENT			NORTH ABUTMENT		
	STATION	OFFSET	ELEV.	STATION	OFFSET	ELEV.
A1	1801+41.40	34.58' LT	684.24	1804+12.03	34.58' LT	682.93
A2	1800+87.84	34.58' RT	684.85	1803+58.48	34.58' RT	683.53
B1	1800+84.72	34.58' LT	700.76	1804+63.71	34.58' LT	697.39
B2	1800+31.17	34.58' RT	700.76	1804+10.16	34.58' RT	697.39
W1	1800+59.67	34.58' LT	707.79	1804+81.67	34.58' LT	703.92
W2	1800+13.21	34.58' RT	707.55	1804+35.21	34.58' RT	704.88

BERM SLOPE ELEVATIONS REFLECT THE GRADING SURFACE

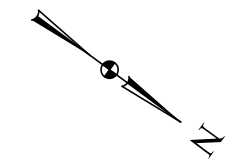

PRELIMINARY  
DESIGN FOR 37°44'48" SKEW (L.A.)  
**391'-0 X 60'-0 PRETENSIONED  
PRESTRESSED CONCRETE BEAM BRIDGE**  
142'-0 INTERIOR SPANS & 56'-0 & 51'-0 END SPANS (BTD BEAMS)  
**SITE PLAN**  
STATION 1802+47.44 (C MOSCOW RD.) AUGUST 2019  
**CEDAR COUNTY**  
IOWA DEPARTMENT OF TRANSPORTATION - HIGHWAY DIVISION  
DESIGN SHEET NO. 2 OF 2 FILE NO. 31800 DESIGN NO. ?



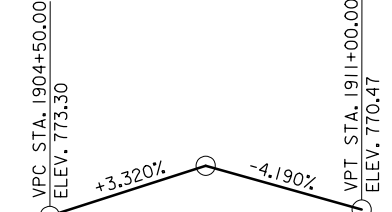
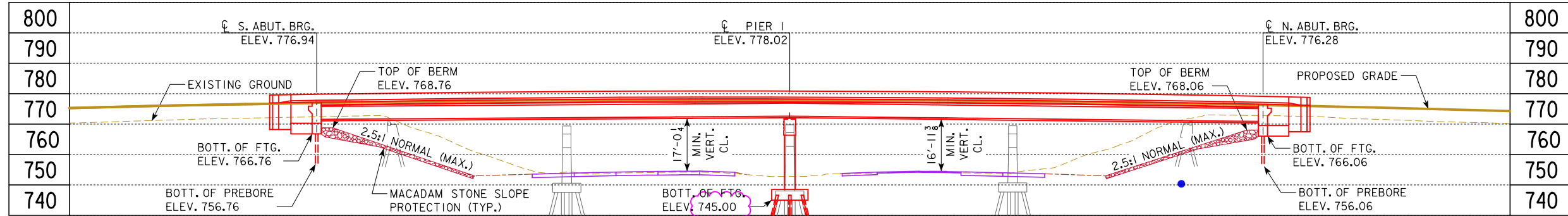

LONGITUDINAL SECTION ALONG CL OLD MUSCATINE RD.

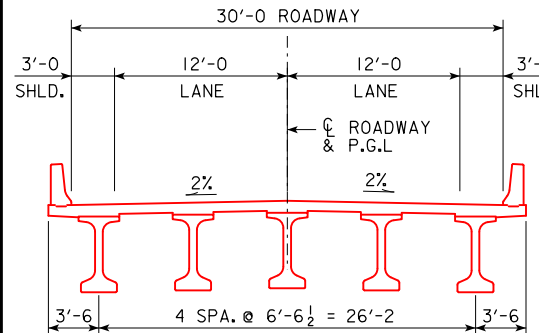

TYPICAL BRIDGE SECTION

MINIMUM VERTICAL CLEARANCE

E.B. ROADWAY  
 OVERHEAD STATION = 1907+20.14, OFFSET 13.08' LT  
 OVERHEAD ELEVATION = 777.79  
 DEPTH OF SUPERSTRUCTURE = 6.08'  
 UNDERPASS STATION = 5908+18.50, OFFSET 12.00' RT  
 UNDERPASS ELEVATION = 754.69  
 MINIMUM VERTICAL CLEARANCE = 17.02'

W.B. ROADWAY  
 OVERHEAD STATION = 1908+06.25, OFFSET 13.08' LT  
 OVERHEAD ELEVATION = 777.53  
 DEPTH OF SUPERSTRUCTURE = 6.08'  
 UNDERPASS STATION = 4907+83.35, OFFSET 12.00' LT  
 UNDERPASS ELEVATION = 754.50  
 MINIMUM VERTICAL CLEARANCE = 16.95

UTILITIES LEGEND:

FO(C) - IOWA COMMUNICATIONS NETWORK - QUALITY C

TRAFFIC ESTIMATE

2014 AADT	50	V.P.D.
2040 AADT	-	V.P.D.
2040 DHV	-	V.P.H.
TRUCKS	-	%
TOTAL DESIGN ESALS	-	-

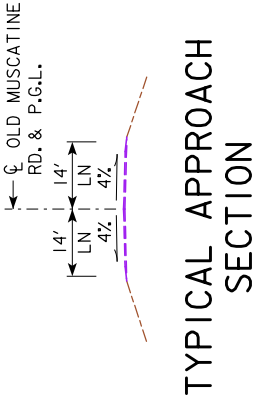

TYPICAL APPROACH SECTION

LOCATION

OLD MUSCATINE RD. OVER I-80  
 T-79N R-02W  
 SECTION 16  
 SUGAR CREEK TOWNSHIP  
 CEDAR COUNTY  
 FHWA NO. 18641  
 BRIDGE MAINT. NO. 1668.90080  
 LATITUDE 41.643982°  
 LONGITUDE -91.075793°

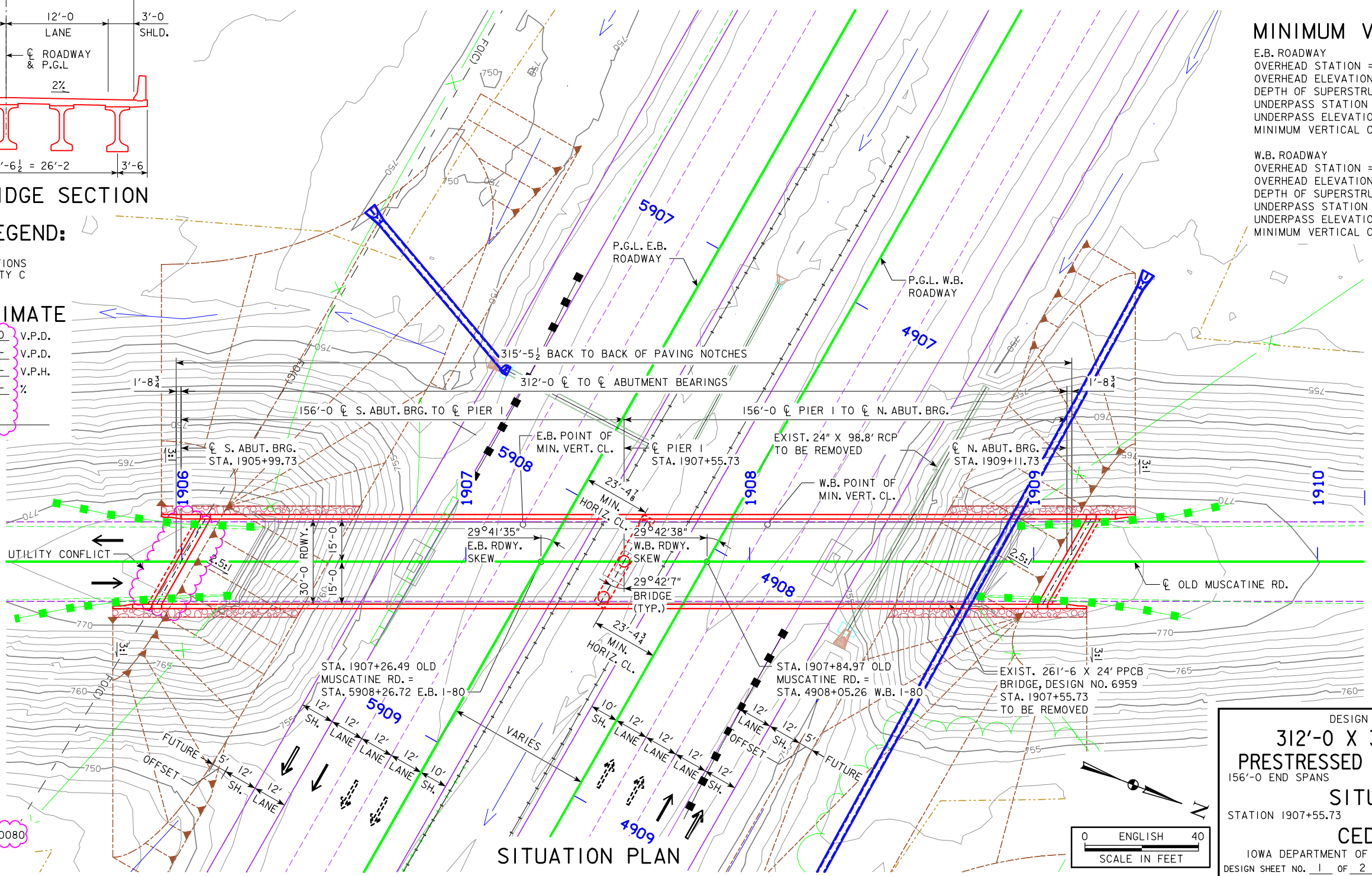

SITUATION PLAN

PROPOSED PROFILE GRADE E.B. I-80

- NOTES:
- TOP OF BRIDGE DECK CROWN IS 0.03' BELOW PROFILE GRADE.
  - STANDARD INTEGRAL ABUTMENT.
  - MASH TL-4 (38") BRIDGE RAILING PROPOSED.
  - PIER TYPE-FRAME.
  - PIER COLUMNS DESIGNED FOR VEHICULAR COLLISION FORCE.
  - BEAM TYPE-BTE.
  - MACADAM STONE.
  - PROP. VERTICAL DATUM IS APPROX. 8.43' HIGHER THAN USED ON EXISTING PLANS.
  - W.B. I-80 ELEVATIONS BASED ON EXISTING RDWY, SURVEY PLUS 4" PROPOSED OVERLAY.

DESIGN FOR 29°42'7" (L.A.) SKEW  
**312'-0" X 30'-0" PRETENSIONED  
 PRESTRESSED CONCRETE BEAM BRIDGE**  
 156'-0" END SPANS  
 (BTE BEAMS)  
**SITUATION PLAN**  
 STATION 1907+55.73 (CL OLD MUSCATINE RD.) AUGUST 2019  
**CEDAR COUNTY**  
 IOWA DEPARTMENT OF TRANSPORTATION - HIGHWAY DIVISION  
 DESIGN SHEET NO. 1 OF 2 FILE NO. 31800 DESIGN NO. ?



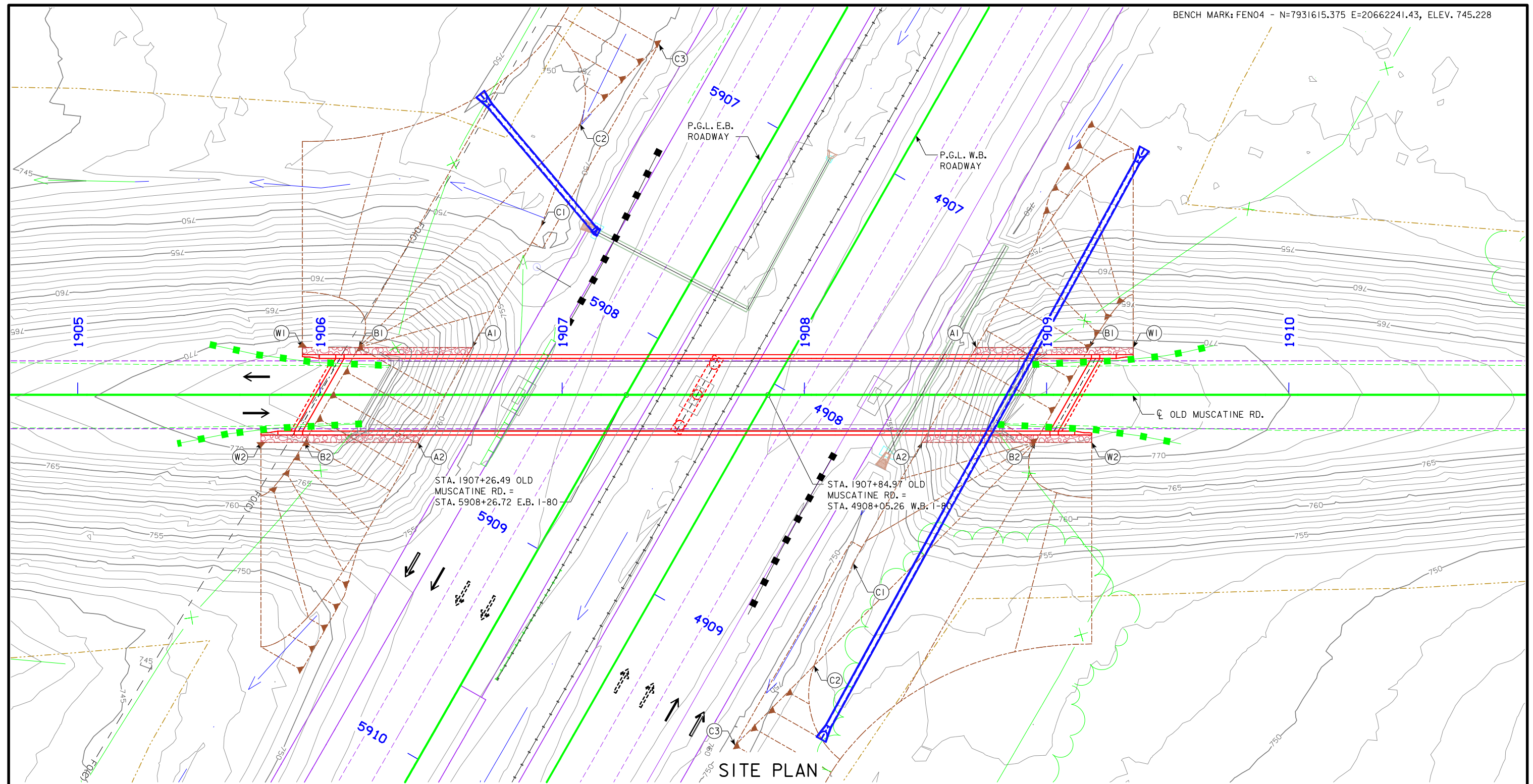

STA. 1907+26.49 OLD MUSCATINE RD. = STA. 5908+26.72 E.B. I-80  
 STA. 1907+84.97 OLD MUSCATINE RD. = STA. 4908+05.26 W.B. I-80

SITE PLAN

POINTS	SOUTH ABUTMENT			NORTH ABUTMENT		
	STATION	OFFSET	ELEV.	STATION	OFFSET	ELEV.
A1	1906+62.83	19.58' LT	753.06	1908+70.98	19.58' LT	753.02
A2	1906+40.50	19.58' RT	752.94	1908+48.63	19.58' RT	752.95
B1	1906+16.08	19.58' LT	768.76	1909+17.72	19.58' LT	768.06
B2	1905+93.74	19.58' RT	768.76	1908+95.38	19.58' RT	768.06
W1	1905+92.79	19.58' LT	776.41	1909+35.79	19.58' LT	775.34
W2	1905+75.67	19.58' RT	776.11	1909+18.67	19.58' RT	775.72

BERM SLOPE ELEVATIONS REFLECT THE GRADING SURFACE

PTS.	SOUTH ABUTMENT			NORTH ABUTMENT		
	STATION	OFFSET	ELEV.	STATION	OFFSET	ELEV.
C1	1906+91.32	69.54' LT	752.19	1908+20.16	69.48' RT	752.74
C2	1907+07.42	111.91' LT	753.01	1908+04.04	111.85' RT	752.28
C3	1907+40.03	144.87' LT	753.57	1907+71.42	144.80' RT	753.57
B	1906+16.08	19.58' LT	768.76	1908+95.38	19.58' RT	768.06

BERM SLOPE ELEVATIONS REFLECT THE GRADING SURFACE

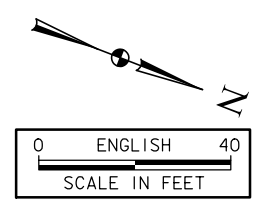

PRELIMINARY  
 DESIGN FOR 29°42'7" (L.A.) SKEW  
**312'-0 X 30'-0 PRETENSIONED  
 PRESTRESSED CONCRETE BEAM BRIDGE**  
 (BTE BEAMS)  
**SITE PLAN**  
 STATION 1907+55.73 (CL OLD MUSCATINE RD.) AUGUST 2019  
**CEDAR COUNTY**  
 IOWA DEPARTMENT OF TRANSPORTATION - HIGHWAY DIVISION  
 DESIGN SHEET NO. 2 OF 2 FILE NO. 31800 DESIGN NO. ?



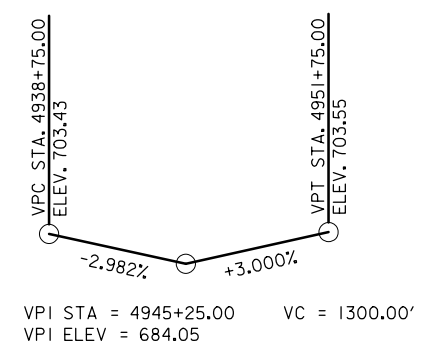
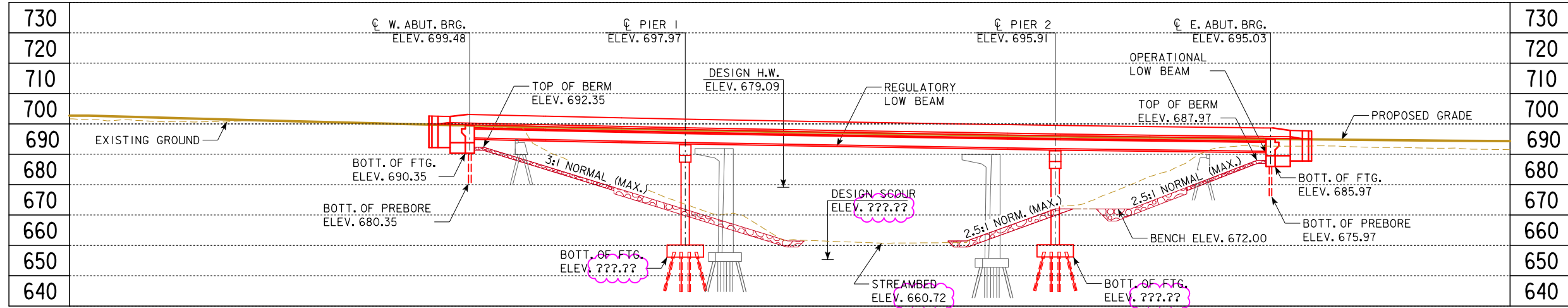

LONGITUDINAL SECTION ALONG PROP. W.B. I-80 & P.G.L.

PROPOSED PROFILE GRADE WB I-80

HYDRAULIC DATA

DRAINAGE AREA = 92.3 SQ. MI.  
 STREAM SLOPE = 2.0 FT./MI.  
 AVG. LOW WATER STAGE = EL. 662.14

Q<sub>25</sub> = 9,620 CFS  
 STAGE = 678.16  
 CHANNEL VELOCITY = 7.1 FPS

Q<sub>50</sub> = 11,600 CFS  
 STAGE = 679.09  
 BACKWATER = (-)0.06 FT.  
 AVG. BRIDGE VELOCITY = 7.72 FPS  
 REGULATORY LOW BEAM EL. 691.51

Q<sub>100</sub> = 13,500 CFS  
 STAGE = 680.51  
 BACKWATER = (-)0.09 FT.  
 AVG. BRIDGE VELOCITY = 7.8 FPS  
 OPERATIONAL LOW BEAM EL. 689.73

Q<sub>200</sub> = 17,300 CFS  
 STAGE = 681.85  
 CALCULATED DESIGN SCOUR = ????

Q<sub>500</sub> = 18,700 CFS  
 STAGE = 682.38  
 AVG. BRIDGE VELOCITY = 9.3 FPS  
 CALCULATED CHECK SCOUR = ????

- NOTES:
- STANDARD INTEGRAL ABUTMENT.
  - MASH TL-5 BRIDGE RAILING PROPOSED.
  - PIER TYPE-T PIER.
  - BEAM TYPE-BTC.
  - CLASS E REVETMENT STONE.
  - PROP. VERTICAL DATUM IS APPROX. 8.54' HIGHER THAN USED ON EXISTING PLANS.

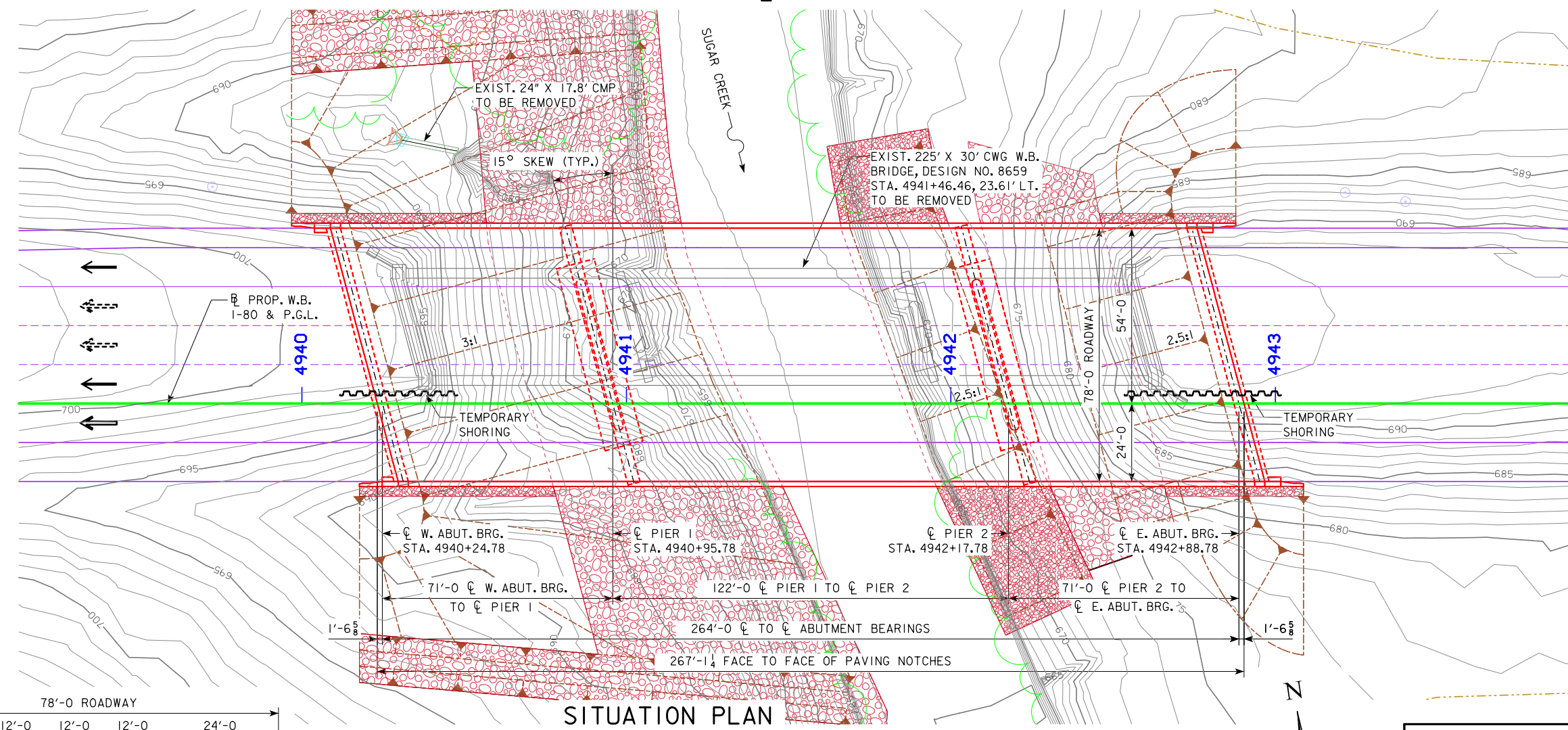

SITUATION PLAN

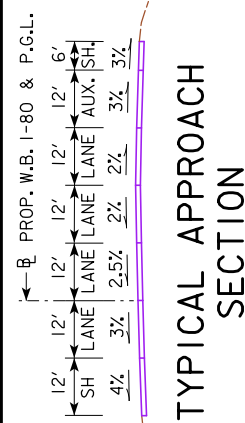

TYPICAL APPROACH SECTION

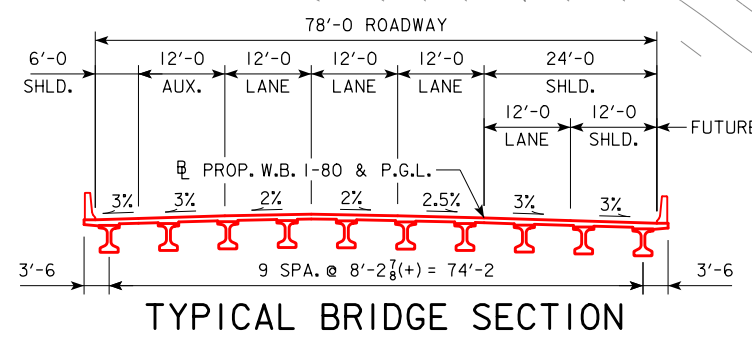

TYPICAL BRIDGE SECTION

UTILITIES LEGEND:  
 NO KNOWN UTILITIES

TRAFFIC ESTIMATE

2020 AADT	20,819	V.P.D.
2040 AADT	38,304	V.P.D.
2040 DHV		V.P.H.
TRUCKS	37%	%
TOTAL DESIGN ESALs		

LOCATION

WESTBOUND I-80 OVER SUGAR CREEK  
 T-79N R-02W  
 SECTION 15  
 SUGAR CREEK TOWNSHIP  
 CEDAR COUNTY  
 FHWA NO. 18661  
 BRIDGE MAINT. NO. 1669.5L080  
 LATITUDE 41.642579°  
 LONGITUDE -91.063756°



PRELIMINARY

DESIGN FOR 15° SKEW (R.A.)

**264'-0" X 78'-0" PRETENSIONED PRESTRESSED CONCRETE BEAM BRIDGE**

71'-0" END SPANS 122'-0" INTERIOR SPAN

**SITUATION PLAN**

STATION 4941+56.78 (WB I-80 OVER SUGAR CREEK) AUGUST 2019

**CEDAR COUNTY**

IOWA DEPARTMENT OF TRANSPORTATION - HIGHWAY DIVISION

DESIGN SHEET NO. 1 OF 4 FILE NO. 31800 DESIGN NO. ?



BENCH MARK: FEN04 - N=7931615.375 E=20662241.43, ELEV. 745.228

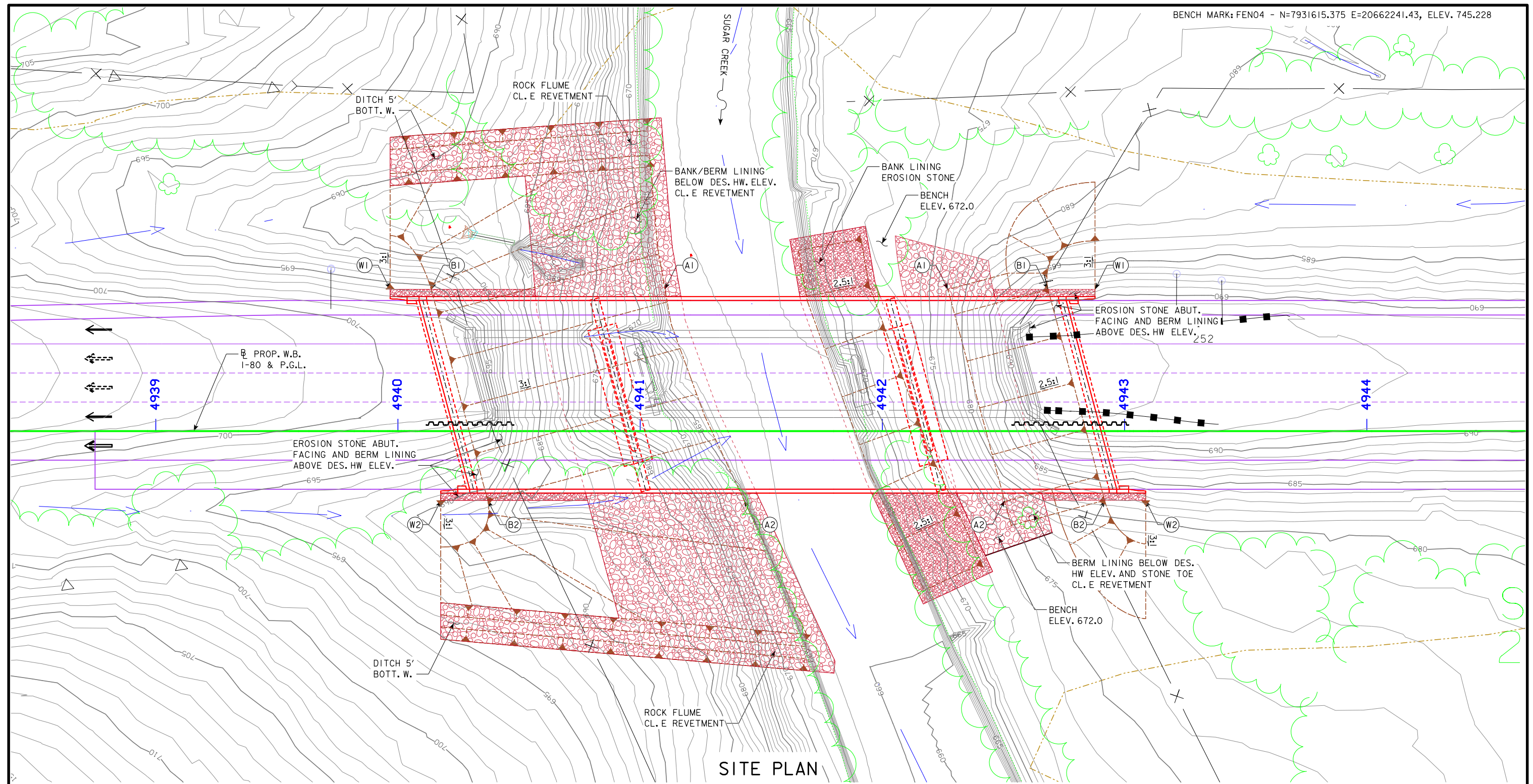

SITE PLAN

POINTS	WEST ABUTMENT			EAST ABUTMENT		
	STATION	OFFSET	ELEV.	STATION	OFFSET	ELEV.
A1	4941+10.29	58.58' LT	661.50	4942+27.09	58.58' LT	672.00
A2	4941+42.93	28.58' RT	661.50	4942+50.45	28.58' RT	672.00
B1	4940+13.74	58.58' LT	692.35	4942+68.43	58.58' LT	687.97
B2	4940+37.10	28.58' RT	692.35	4942+91.78	28.58' RT	687.97
W1	4939+96.81	58.58' LT	699.75	4942+87.81	58.58' LT	694.65
W2	4940+17.71	28.58' RT	698.77	4943+08.71	28.58' RT	693.96

BERM SLOPE ELEVATIONS REFLECT THE GRADING SURFACE  
 NOTE:  
 GCL - GRADING CONTROL LINE

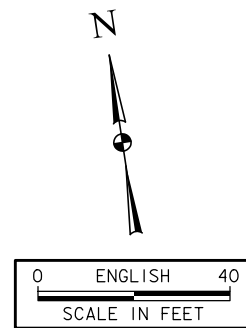

PRELIMINARY  
 DESIGN FOR 15° SKEW (R.A.)  
**264'-0 X 78'-0 PRETENSIONED  
 PRESTRESSED CONCRETE BEAM BRIDGE**  
 71'-0 END SPANS (BTC BEAMS) 122'-0 INTERIOR SPAN  
**SITE PLAN**  
 STATION 4941+56.78 (WB I-80 OVER SUGAR CREEK) AUGUST 2019  
**CEDAR COUNTY**  
 IOWA DEPARTMENT OF TRANSPORTATION - HIGHWAY DIVISION  
 DESIGN SHEET NO. 2 OF 4 FILE NO. 31800 DESIGN NO. ?

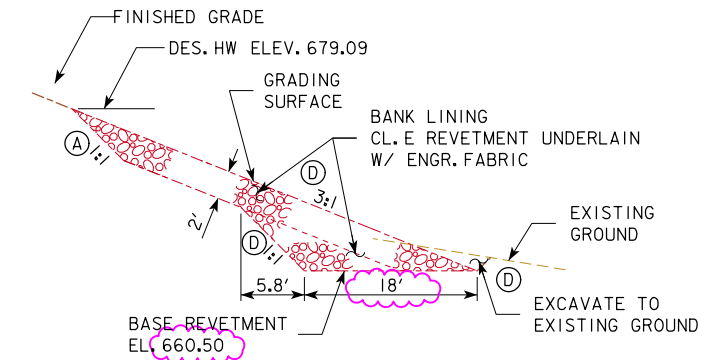

SECTION THROUGH BANK LINING WEST BANK

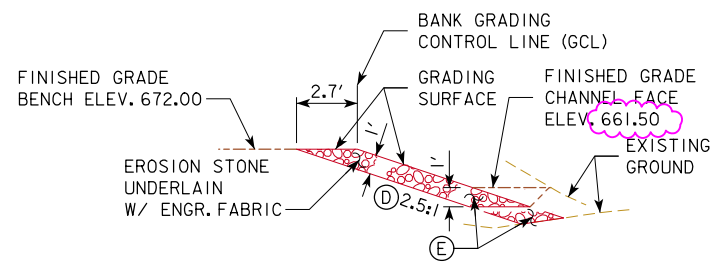
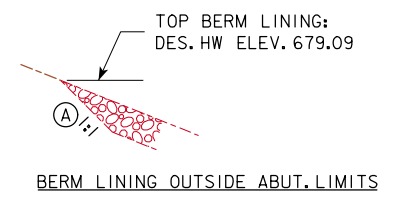

TYPICAL SECTION THROUGH EAST BANK LINING

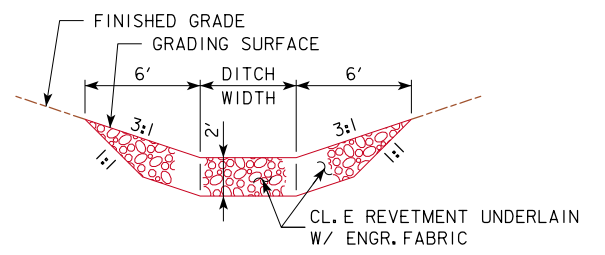

SECTION THROUGH ROCK FLUME

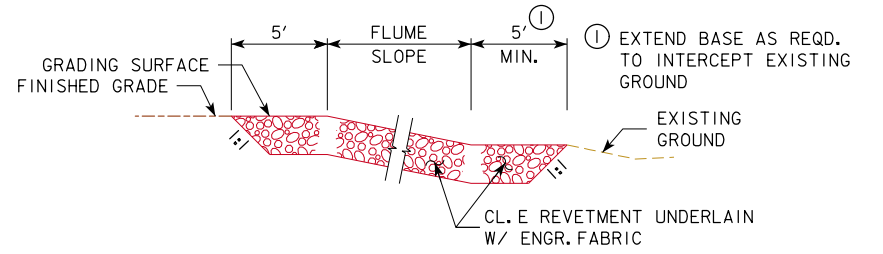

SECTION ALONG ROCK FLUME

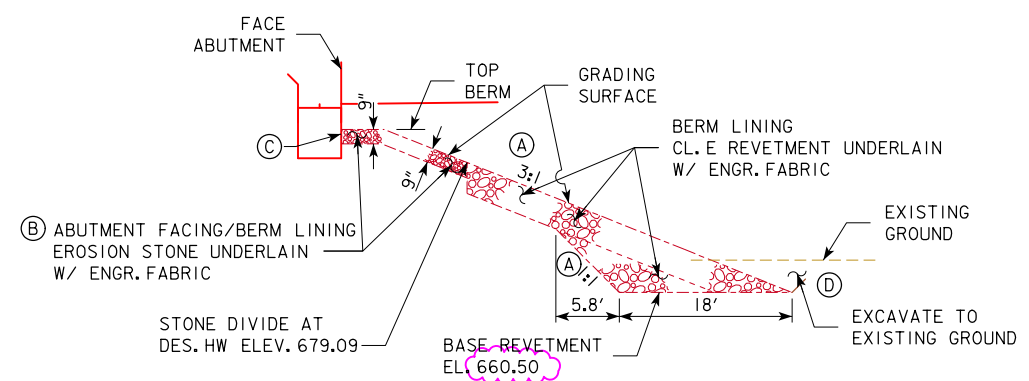

SECTION THROUGH BERM/BANK LINING WEST BANK

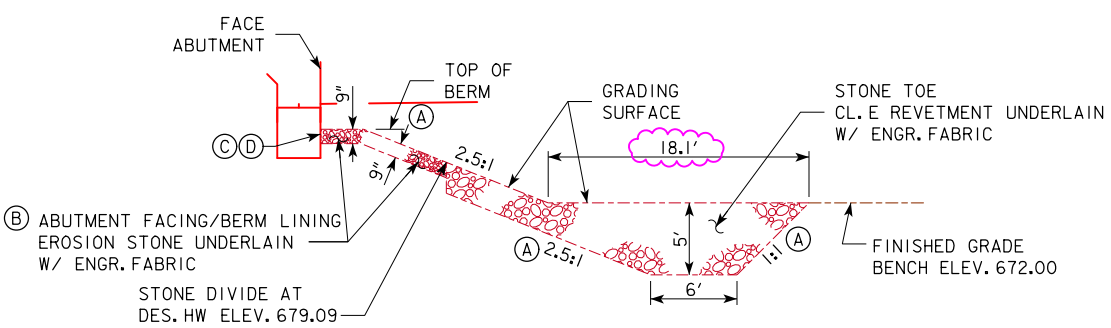

SECTION THROUGH BERM LINING AND STONE TOE EAST BANK

- (A) SLOPE NORMAL TO  $\perp$  ABUT. / GRADING CONTROL LINE.
- (B) EXTEND FACING OUT TO LATERAL LIMITS OF WING ARMORING.
- (C) CARRY ENGINEERING FABRIC UP TO FACE ABUTMENT.
- (D) SLOPE NORMAL TO BANK GRADING CONTROL LINE (GCL).
- (E) CARRY BANK LINING TO 1' BELOW FINISHED GRADE IN EXCAVATED SECTION. IN FILL SECTION EXTEND DOWN TO EXISTING GROUND.

ESTIMATED BERM ARMORING QTY. - I-80 W.B.

LOCATION	REVETMENT CL. E (TON)	EROSION STONE (TON)	ENGINEERING FABRIC (SY)	EXCAVATION (CY)
PROP. BRIDGE DESIGN NO. XXXX:				
BERM LINING/TOE - WEST	-	-	-	-
BANK LINING - WEST	-	-	-	-
ROCK FLUME - WEST	-	-	-	-
BERM LINING/TOE - EAST	-	-	-	-
BANK LINING - EAST	-	-	-	-
ROCK FLUME - EAST	-	-	-	-
TOTALS	--	--	--	--

EXCAVATION QUANTITY CALCULATED FROM GRADING SURFACE.  
 REVETMENT AND EROSION STONE ESTIMATED AT 1.6 TON/CY.

**HYDRAULIC DESIGN**

I hereby certify that this engineering document was prepared by me or under my direct personal supervision and that I am a duly licensed Professional Engineer under the laws of the State of Iowa.

Signature: Teresa H. Stadelmann Date: \_\_\_\_\_

Printed or Typed Name: Teresa H. Stadelmann

My license renewal date is December 31, 2019

Pages or sheets covered by this seal: V.5-V.8

PRELIMINARY  
 DESIGN FOR 15° SKEW (R.A.)  
**264'-0 X 78'-0 PRETENSIONED  
 PRESTRESSED CONCRETE BEAM BRIDGE**  
 71'-0 END SPANS (BTC BEAMS) 122'-0 INTERIOR SPAN  
**SITUATION PLAN - MISC.**  
 STATION 4941+56.78 (WB I-80 OVER SUGAR CREEK) AUGUST 2019  
**CEDAR COUNTY**  
 IOWA DEPARTMENT OF TRANSPORTATION - HIGHWAY DIVISION  
 DESIGN SHEET NO. 3 OF 4 FILE NO. 31800 DESIGN NO. ?

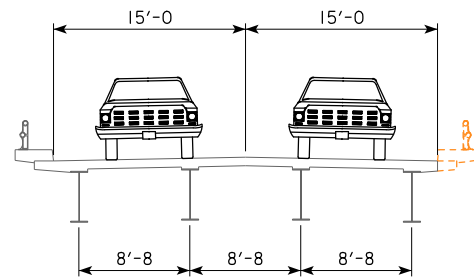

EXISTING CROSS SECTION

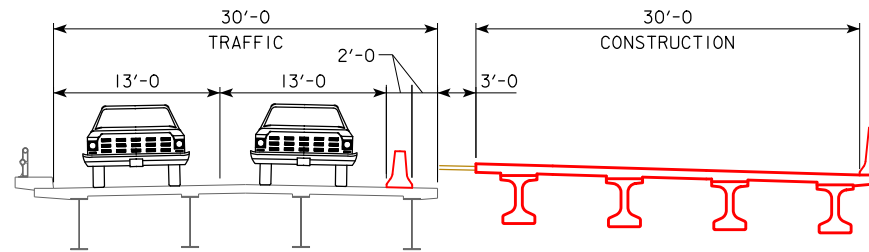

PHASE I, STAGE I

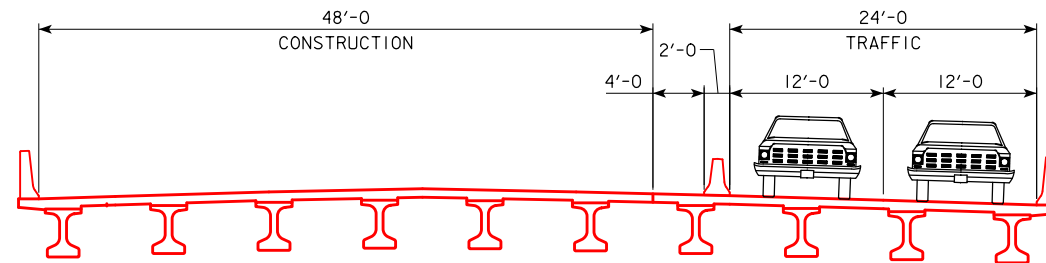

PHASE I, STAGE 2

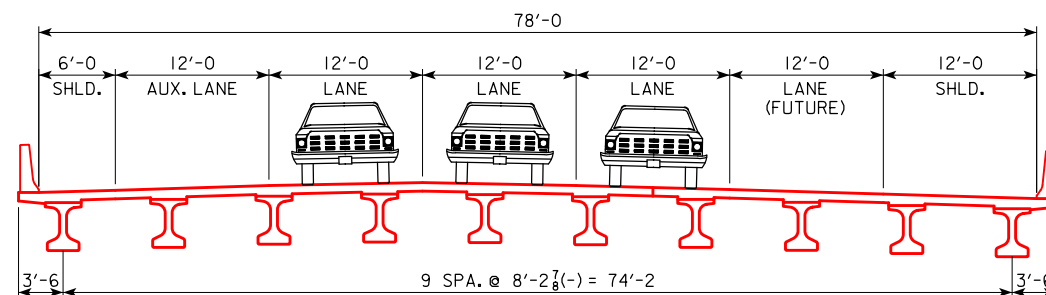

FINAL CROSS SECTION - W.B. I-80  
(LOOKING EAST)

PRELIMINARY  
 DESIGN FOR 15° SKEW (R.A.)  
**264'-0 X 78'-0 PRETENSIONED  
 PRESTRESSED CONCRETE BEAM BRIDGE**  
 71'-0 END SPANS (BTC BEAMS) 122'-0 INTERIOR SPAN  
**STAGE CONSTRUCTION**  
 STATION 4941+56.78 (WB I-80 OVER SUGAR CREEK) AUGUST 2019  
**CEDAR COUNTY**  
 IOWA DEPARTMENT OF TRANSPORTATION - HIGHWAY DIVISION  
 DESIGN SHEET NO. 4 OF 4 FILE NO. 31800 DESIGN NO. ?



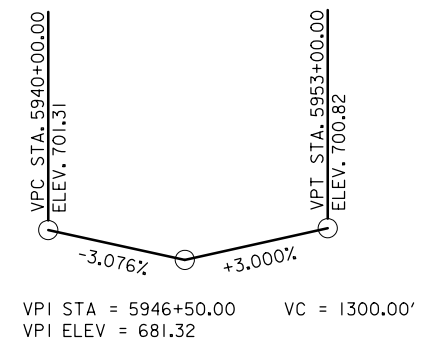
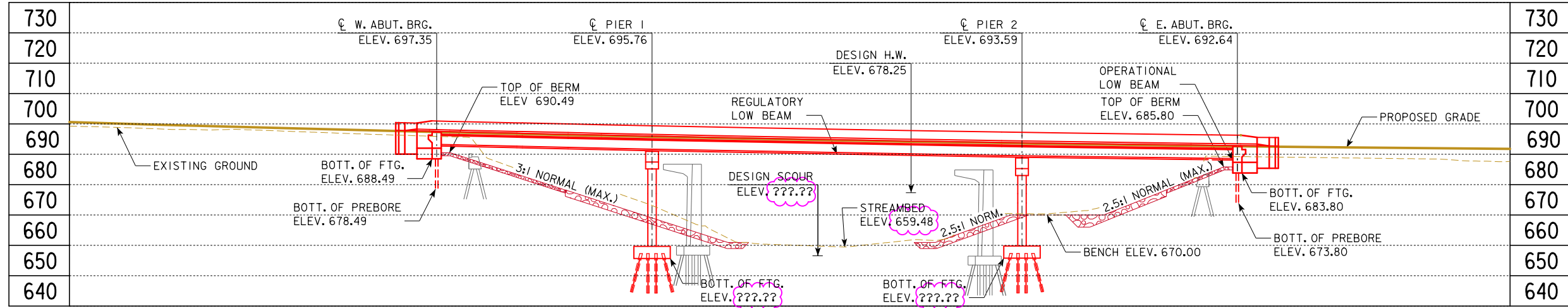

LONGITUDINAL SECTION ALONG CL PROP. E.B. I-80 & P.G.L.

PROPOSED PROFILE GRADE EB I-80

HYDRAULIC DATA

DRAINAGE AREA = 92.3 SQ. MI.  
 STREAM SLOPE = 2.0 FT./MI.  
 AVG. LOW WATER STAGE = EL. 661.00

Q<sub>25</sub> = 9,620 CFS  
 STAGE = 677.35  
 CHANNEL VELOCITY = 6.8 FPS

Q<sub>50</sub> = 11,600 CFS  
 STAGE = 678.25  
 BACKWATER = (-)0.02 FT.  
 AVG. BRIDGE VELOCITY = 7.5 FPS  
 REGULATORY LOW BEAM EL. 689.56

Q<sub>100</sub> = 13,500 CFS  
 STAGE = 679.77  
 BACKWATER = (-)0.01 FT.  
 AVG. BRIDGE VELOCITY = 7.6 FPS  
 OPERATIONAL LOW BEAM EL. 687.55

Q<sub>200</sub> = 17,300 CFS  
 STAGE = 680.86  
 CALCULATED DESIGN SCOUR = ????

Q<sub>500</sub> = 18,700 CFS  
 STAGE = 681.32  
 AVG. BRIDGE VELOCITY = 9.3 FPS  
 CALCULATED CHECK SCOUR = ????

- NOTES:
- STANDARD INTEGRAL ABUTMENT.
  - MASH TL-5 BRIDGE RAILING PROPOSED.
  - PIER TYPE-T PIER.
  - BEAM TYPE-BTC.
  - CLASS E REVETMENT STONE.
  - PROP. VERTICAL DATUM IS APPROX. 8.54' HIGHER THAN USED ON EXISTING PLANS.

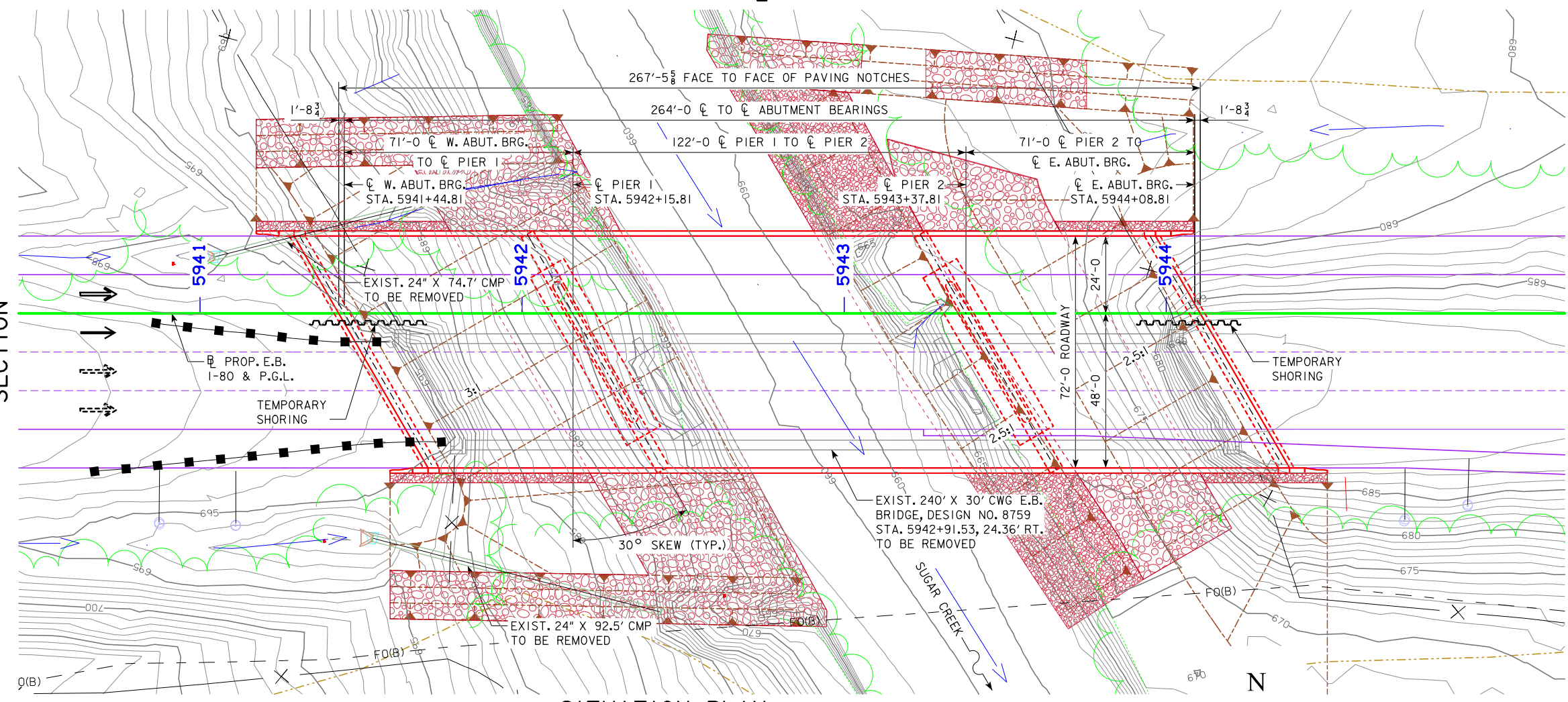

SITUATION PLAN

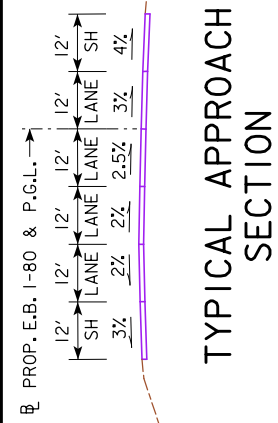

TYPICAL APPROACH SECTION

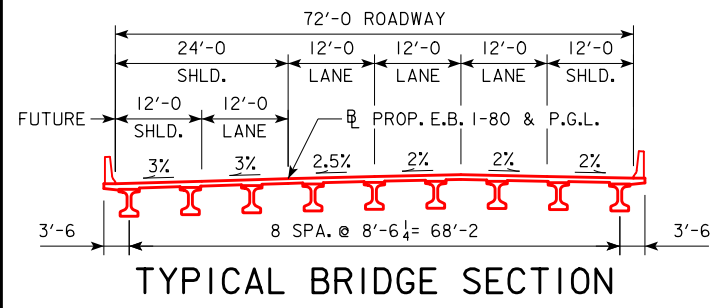

TYPICAL BRIDGE SECTION

UTILITIES LEGEND:  
 FO(B) - IOWA COMMUNICATIONS NETWORK

TRAFFIC ESTIMATE

2020 AADT	20,367	V.P.D.
2040 AADT	37,275	V.P.D.
20 DHV		V.P.H.
TRUCKS	37%	%
TOTAL DESIGN ESALs		

LOCATION

EASTBOUND I-80 OVER SUGAR CREEK  
 T-79N R-02W  
 SECTION 15  
 SUGAR CREEK TOWNSHIP  
 CEDAR COUNTY  
 FHWA NO. 18651  
 BRIDGE MAINT. NO. 1669.5R080  
 LATITUDE 41.641815°  
 LONGITUDE -91.063476°

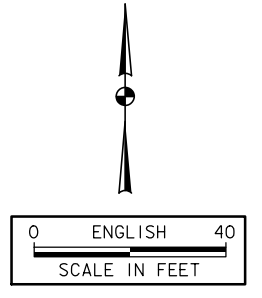

PRELIMINARY

DESIGN FOR 30° SKEW (R.A.)

**264'-0 X 72'-0 PRETENSIONED PRESTRESSED CONCRETE BEAM BRIDGE**

71'-0 END SPANS (BTC BEAMS) 122'-0 INTERIOR SPAN

**SITUATION PLAN**

STATION 5942+76.81 (EB I-80 OVER SUGAR CREEK) AUGUST 2019

**CEDAR COUNTY**

IOWA DEPARTMENT OF TRANSPORTATION - HIGHWAY DIVISION

DESIGN SHEET NO. 1 OF 4 FILE NO. 31800 DESIGN NO. ?



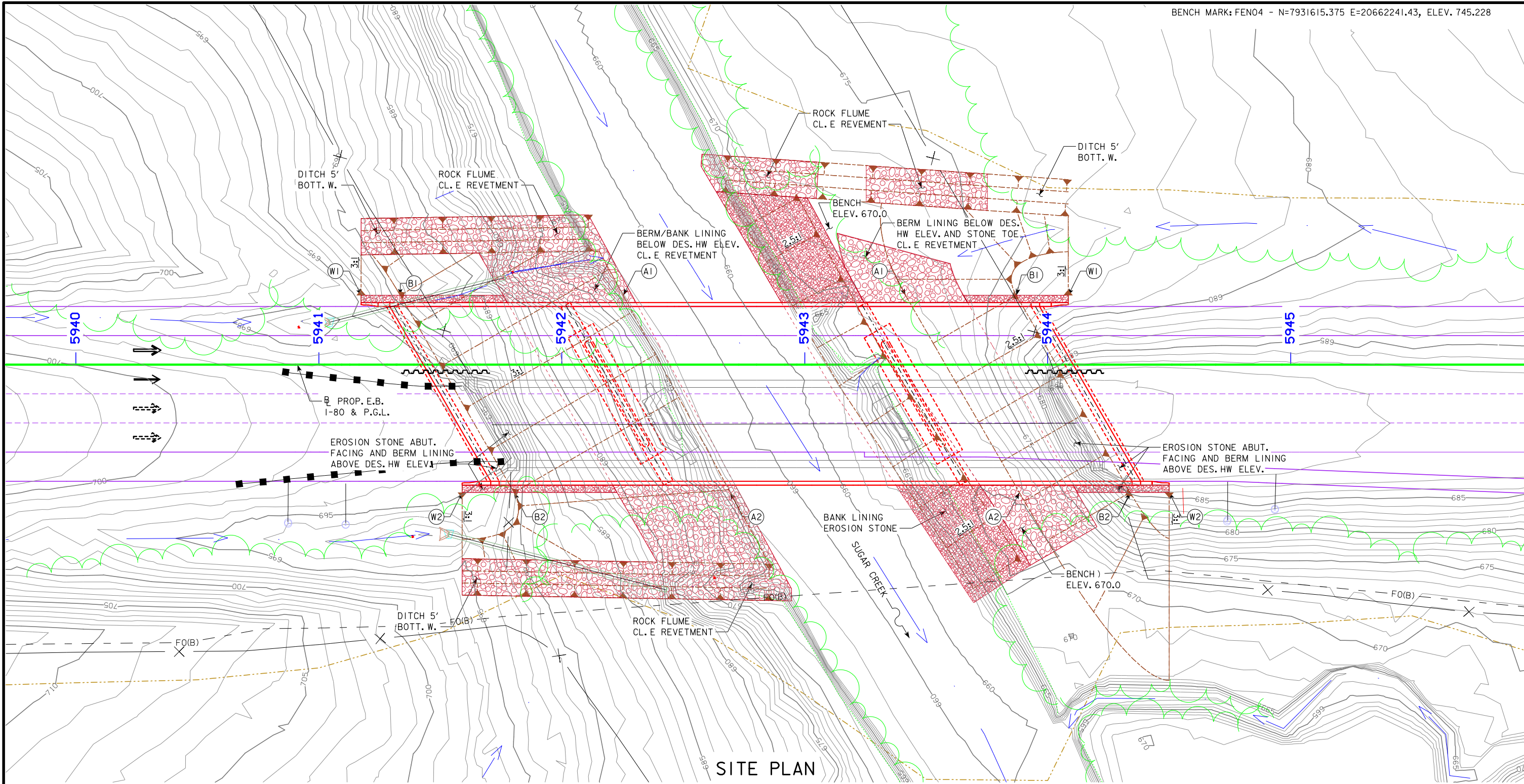

SITE PLAN

POINTS	WEST ABUTMENT			EAST ABUTMENT		
	STATION	OFFSET	ELEV.	STATION	OFFSET	ELEV.
A1	5942+25.31	28.58' LT	661.00	5943+41.50	28.58' LT	670.00
A2	5942+69.42	52.58' RT	661.00	5943+88.31	52.58' RT	670.00
B1	5941+33.50	28.58' LT	690.49	5943+87.11	28.58' LT	685.80
B2	5941+80.36	52.58' RT	690.49	5944+33.97	52.58' RT	685.80
W1	5941+17.45	28.58' LT	697.15	5944+08.45	28.58' LT	691.78
W2	5941+59.02	52.58' RT	696.92	5944+50.02	52.58' RT	692.11

BERM SLOPE ELEVATIONS REFLECT THE GRADING SURFACE

NOTES:  
GCL - GRADING CONTROL LINE



PRELIMINARY  
DESIGN FOR 30° SKEW (R.A.)  
**264'-0 X 72'-0 PRETENSIONED  
PRESTRESSED CONCRETE BEAM BRIDGE**  
71'-0 END SPANS (BTC BEAMS) 122'-0 INTERIOR SPAN  
**SITE PLAN**  
STATION 5942+76.80 (EB I-80 OVER SUGAR CREEK) AUGUST 2019  
**CEDAR COUNTY**  
IOWA DEPARTMENT OF TRANSPORTATION - HIGHWAY DIVISION  
DESIGN SHEET NO. 2 OF 4 FILE NO. 31800 DESIGN NO. ?



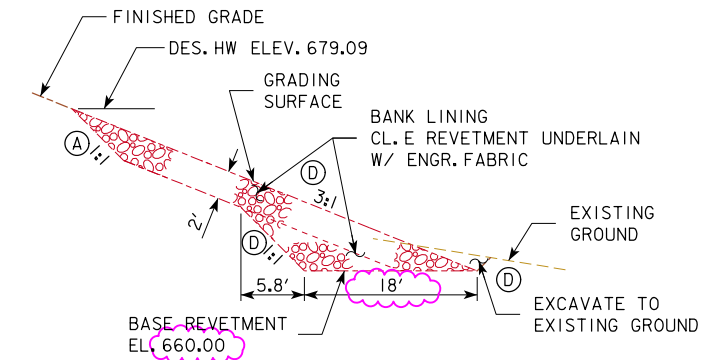

SECTION THROUGH BANK LINING WEST BANK

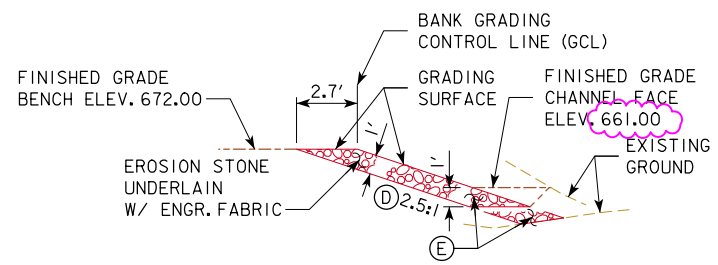
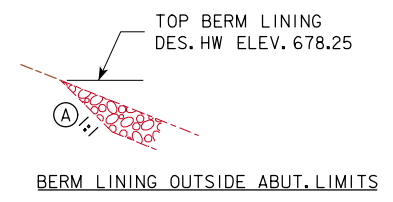

TYPICAL SECTION THROUGH EAST BANK LINING

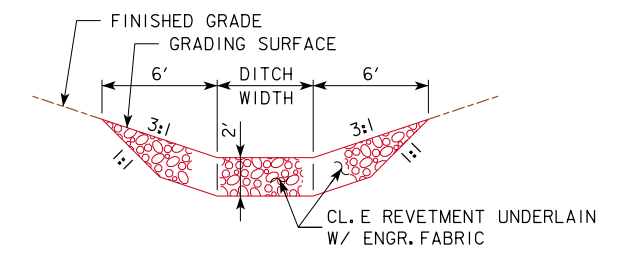

SECTION THROUGH ROCK FLUME

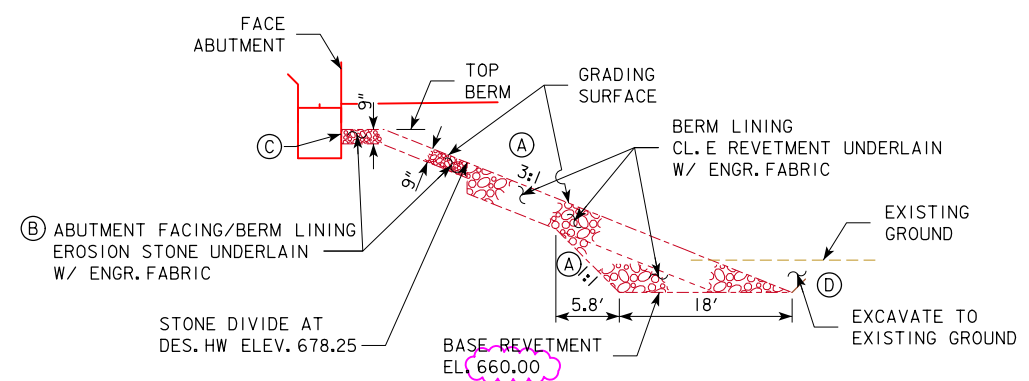

SECTION THROUGH BERM/BANK LINING WEST BANK

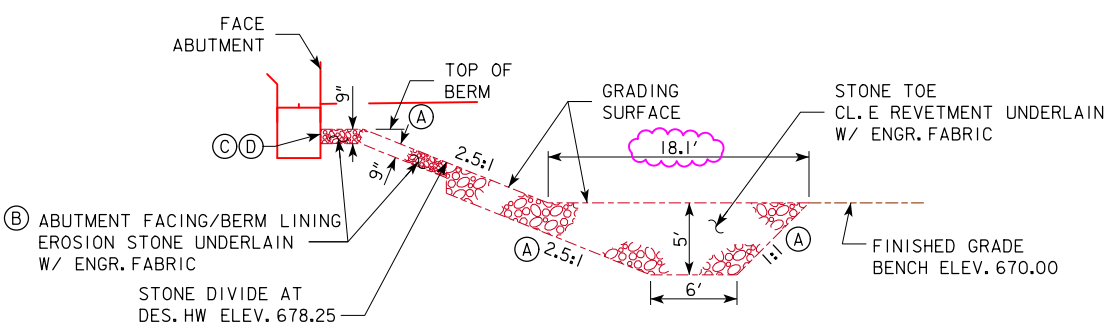

SECTION THROUGH BERM LINING AND STONE TOE EAST BANK

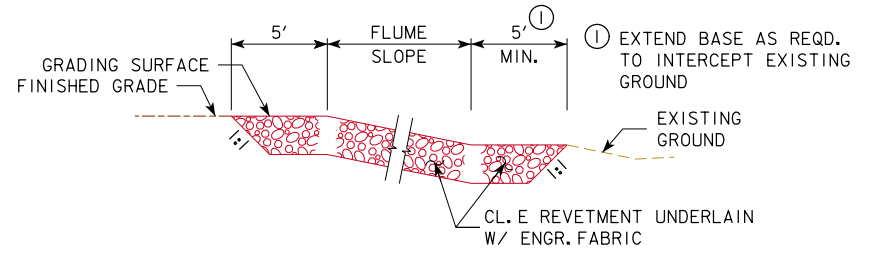

SECTION ALONG ROCK FLUME

- (A) SLOPE NORMAL TO  $\perp$  ABUT. / GRADING CONTROL LINE.
- (B) EXTEND FACING OUT TO LATERAL LIMITS OF WING ARMORING.
- (C) CARRY ENGINEERING FABRIC UP TO FACE ABUTMENT.
- (D) SLOPE NORMAL TO BANK GRADING CONTROL LINE (GCL).
- (E) CARRY BANK LINING TO 1' BELOW FINISHED GRADE IN EXCAVATED SECTION. IN FILL SECTION EXTEND DOWN TO EXISTING GROUND.

ESTIMATED BERM ARMORING QTY. - I-80 E.B.

LOCATION	REVETMENT CL. E (TON)	EROSION STONE (TON)	ENGINEERING FABRIC (SY)	EXCAVATION (CY)
PROP. BRIDGE DESIGN NO. XXXX:				
BERM LINING/TOE - WEST	-	-	-	-
BANK LINING - WEST	-	-	-	-
ROCK FLUME - WEST	-	-	-	-
BERM LINING/TOE - EAST	-	-	-	-
BANK LINING - EAST	-	-	-	-
ROCK FLUME - EAST	-	-	-	-
TOTALS	--	--	--	--

EXCAVATION QUANTITY CALCULATED FROM GRADING SURFACE.  
 REVETMENT AND EROSION STONE ESTIMATED AT 1.6 TON/CY.

**HYDRAULIC DESIGN**

I hereby certify that this engineering document was prepared by me or under my direct personal supervision and that I am a duly licensed Professional Engineer under the laws of the State of Iowa.

Signature: Teresa H. Stadelmann Date: \_\_\_\_\_

Printed or Typed Name: Teresa H. Stadelmann

My license renewal date is December 31, 2019

Pages or sheets covered by this seal: V.9-V.12

PRELIMINARY  
 DESIGN FOR 30° SKEW (R.A.)  
**264'-0 X 72'-0 PRETENSIONED  
 PRESTRESSED CONCRETE BEAM BRIDGE**  
 71'-0 END SPANS (BTC BEAMS) 122'-0 INTERIOR SPAN  
**STAGE CONSTRUCTION**  
 STATION 5942+76.80 (EB I-80 OVER SUGAR CREEK) AUGUST 2019  
**CEDAR COUNTY**  
 IOWA DEPARTMENT OF TRANSPORTATION - HIGHWAY DIVISION  
 DESIGN SHEET NO. 3 OF 4 FILE NO. 31800 DESIGN NO. ?

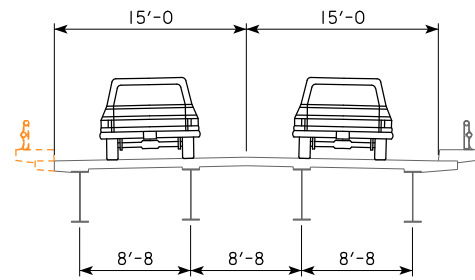

EXISTING CROSS SECTION

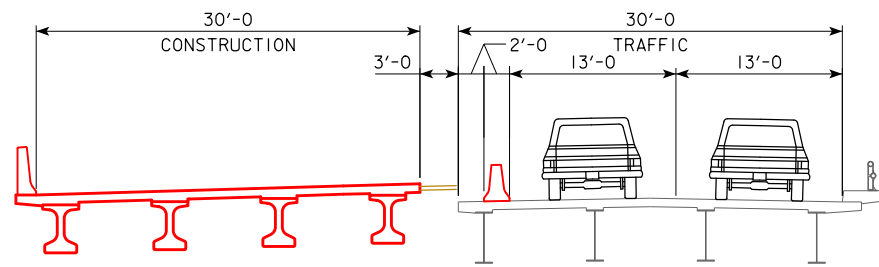

PHASE I, STAGE I

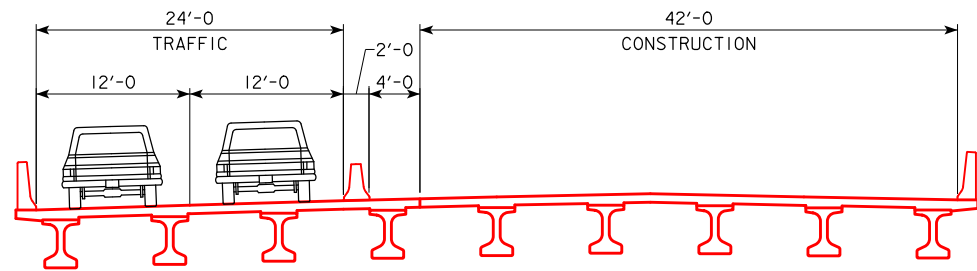

PHASE I, STAGE 2

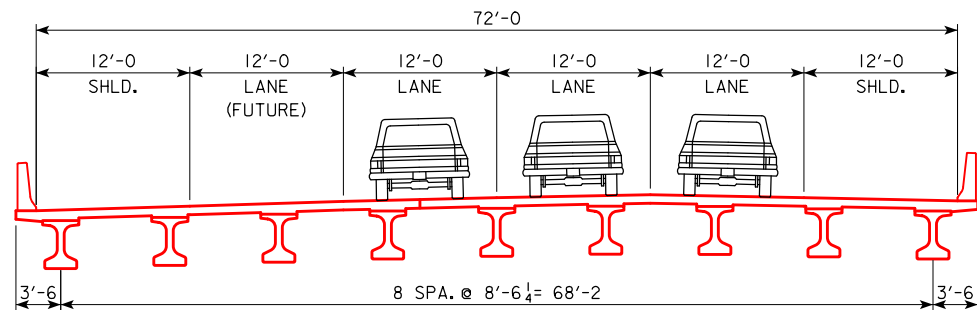

FINAL CROSS SECTION - E.B. I-80  
(LOOKING EAST)

PRELIMINARY  
 DESIGN FOR 30° SKEW (R.A.)  
**264'-0 X 72'-0 PRETENSIONED  
 PRESTRESSED CONCRETE BEAM BRIDGE**  
 71'-0 END SPANS (BTC BEAMS) 122'-0 INTERIOR SPAN  
**STAGE CONSTRUCTION**  
 STATION 5942+76.81 (EB I-80 OVER SUGAR CREEK) AUGUST 2019  
**CEDAR COUNTY**  
 IOWA DEPARTMENT OF TRANSPORTATION - HIGHWAY DIVISION  
 DESIGN SHEET NO. 4 OF 4 FILE NO. 31800 DESIGN NO. ?

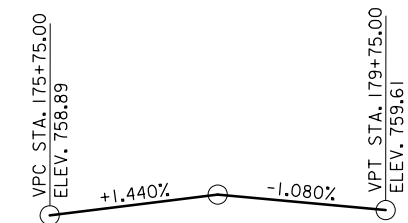
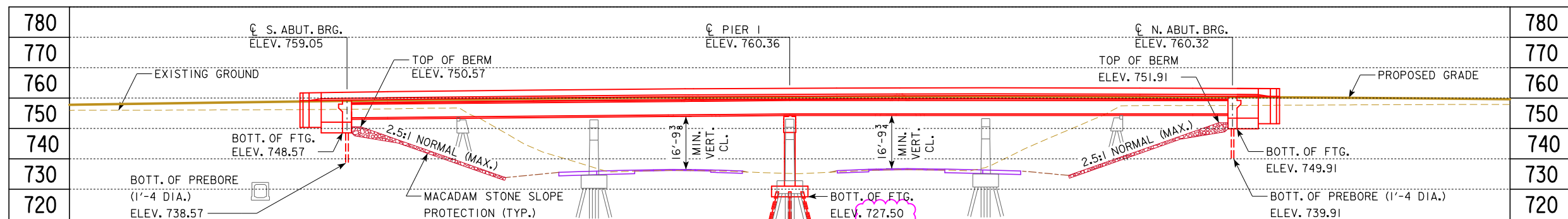

**PROPOSED PROFILE GRADE ROSE AVE.**

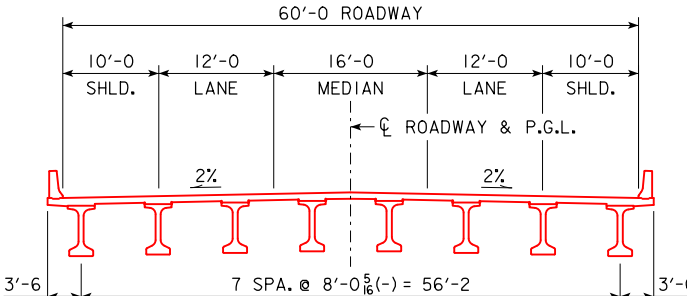

**TYPICAL BRIDGE SECTION**

**MINIMUM VERTICAL CLEARANCE**

**E.B. ROADWAY**  
 OVERHEAD STATION = 177+04.26, OFFSET 28.08' LT  
 OVERHEAD ELEVATION = 759.66  
 DEPTH OF SUPERSTRUCTURE = 6.08'  
 UNDERPASS STATION = 1021+46.46, OFFSET 37.00' RT  
 UNDERPASS ELEVATION = 736.80  
 MINIMUM VERTICAL CLEARANCE = 16.78'

**W.B. ROADWAY**  
 OVERHEAD STATION = 177+81.45, OFFSET 28.08' LT  
 OVERHEAD ELEVATION = 759.96  
 DEPTH OF SUPERSTRUCTURE = 6.08'  
 UNDERPASS STATION = 1021+24.50, OFFSET 37.00' LT  
 UNDERPASS ELEVATION = 737.07  
 MINIMUM VERTICAL CLEARANCE = 16.81'

**UTILITIES LEGEND:**

- F03(B) WINDSTREAM COMMUNICATIONS
- ?? - AERIAL POWERLINE

**TRAFFIC ESTIMATE**

2020 AADT	2,322	V.P.D.
2040 AADT	2,636	V.P.D.
2040 DHV	-	V.P.H.
TRUCKS	19	%
TOTAL DESIGN ESALS	--	

- NOTES:**
- TOP OF BRIDGE DECK CROWN IS 0.03' BELOW PROFILE GRADE.
  - STANDARD INTEGRAL ABUTMENT.
  - MASH TL-4 (38") BRIDGE RAILING PROPOSED.
  - PIER TYPE-FRAME.
  - PIERS COLUMNS DESIGNED FOR VEHICULAR COLLISION FORCE.
  - BEAM TYPE-BTE.
  - MACADAM STONE.
  - PROP. VERTICAL DATUM IS APPROX. 8.59' HIGHER THAN USED ON EXISTING PLANS.
  - 1-80 ELEVATIONS BASED ON EXISTING RDWY. SURVEY PLUS 4" PROPOSED OVERLAY.

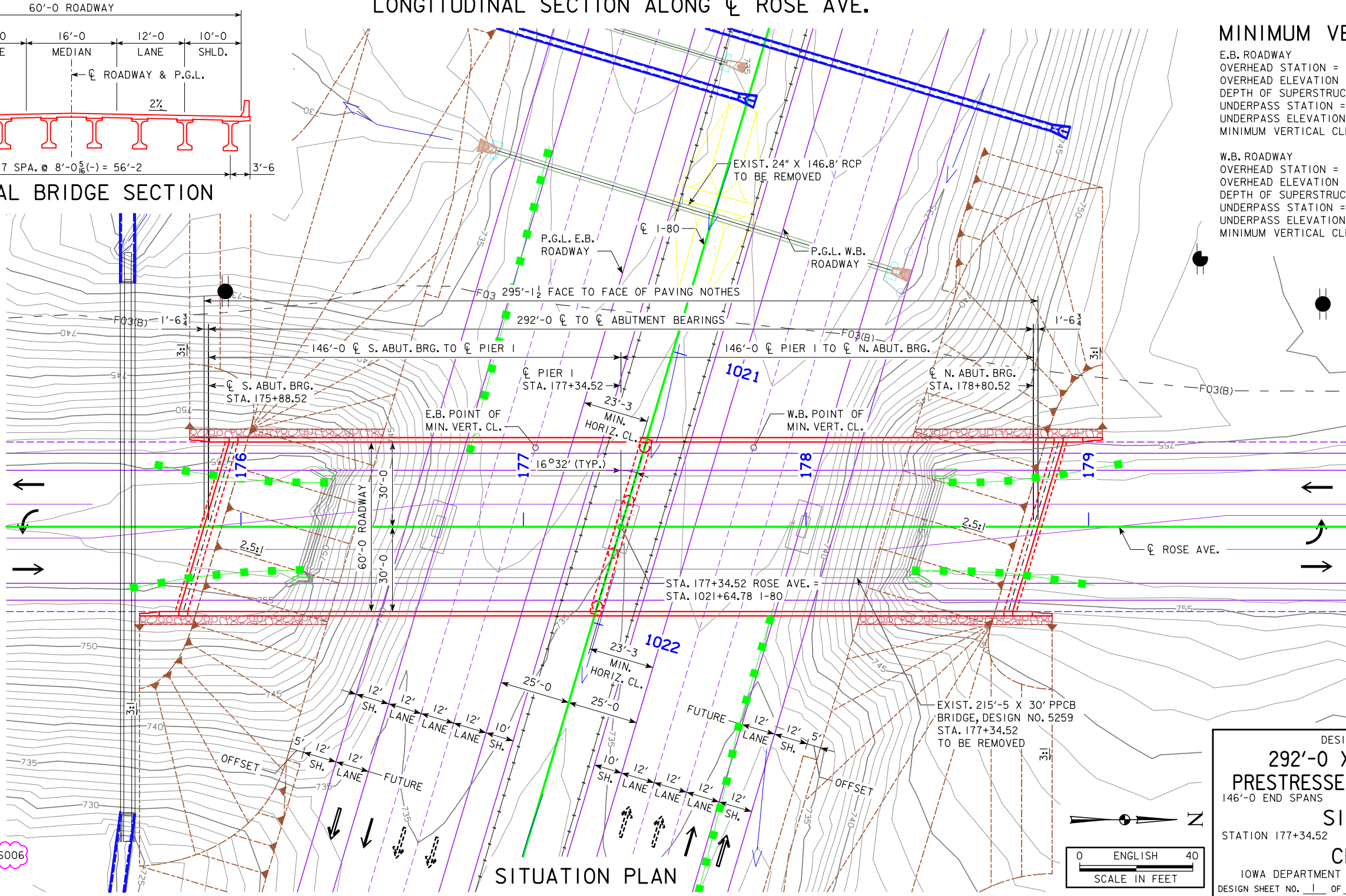

**SITUATION PLAN**

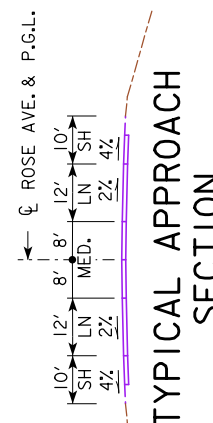

**TYPICAL APPROACH SECTION**

**LOCATION**

ROSE AVE. OVER I-80  
 T-79N R-02W  
 SECTION 23 & 24  
 SUGAR CREEK TOWNSHIP  
 CEDAR COUNTY  
 FHWA NO. 18321  
 BRIDGE MAINT. NO. 1685.3S006  
 LATITUDE 41.636183°  
 LONGITUDE -91.035692°

PRELIMINARY

DESIGN FOR 16°32'0" SKEW (L.A.)

**292'-0" X 60'-0" PRETENSIONED PRESTRESSED CONCRETE BEAM BRIDGE**  
 (BTE BEAMS)

146'-0" END SPANS

**SITUATION PLAN**  
 STATION 177+34.52 (CL ROSE AVE.)

AUGUST 2019

**CEDAR COUNTY**

IOWA DEPARTMENT OF TRANSPORTATION - HIGHWAY DIVISION  
 DESIGN SHEET NO. 1 OF 2 FILE NO. 31800 DESIGN NO. ?



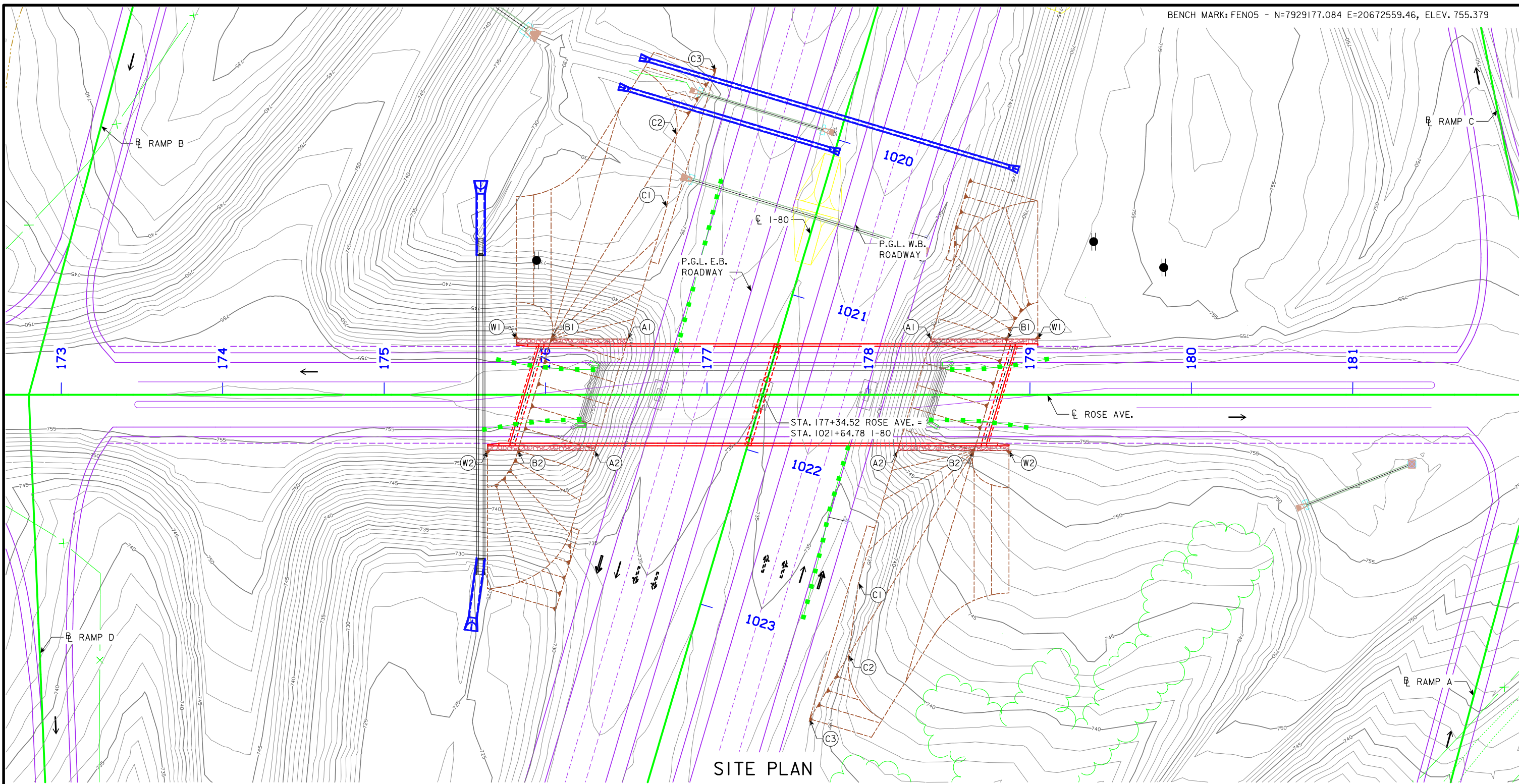

SITE PLAN

BERM SLOPE LOCATION TABLE						
POINTS	SOUTH ABUTMENT			NORTH ABUTMENT		
	STATION	OFFSET	ELEV.	STATION	OFFSET	ELEV.
A1	176+50.91	34.58' LT	735.19	178+38.67	34.58' LT	735.77
A2	176+30.37	34.58' RT	734.43	178+18.19	34.58' RT	734.97
B1	176+03.48	34.58' LT	750.57	178+86.09	34.58' LT	751.91
B2	175+82.95	34.58' RT	750.57	178+65.56	34.58' RT	751.91
W1	175+81.93	34.58' LT	758.24	179+04.93	34.58' LT	759.46
W2	175+64.11	34.58' RT	757.98	178+87.11	34.58' RT	759.57

BERM SLOPE ELEVATIONS REFLECT THE GRADING SURFACE

RECOVERABLE BERM LOCATION TABLE						
	SOUTH ABUTMENT			NORTH ABUTMENT		
	STATION	OFFSET	ELEV.	STATION	OFFSET	ELEV.
C1	176+75.17	116.33' LT	736.20	177+93.87	116.33' RT	734.07
C2	176+81.21	161.25' LT	736.48	177+87.84	161.25' RT	733.39
C3	177+05.45	200.77' LT	737.57	177+63.59	200.77' RT	733.56
B	176+03.48	34.58' LT	750.57	178+65.56	34.58' RT	751.91

BERM SLOPE ELEVATIONS REFLECT THE GRADING SURFACE

PRELIMINARY  
 DESIGN FOR 16°32'0" SKEW (L.A.)  
**292'-0" X 60'-0" PRETENSIONED  
 PRESTRESSED CONCRETE BEAM BRIDGE**  
 146'-0" END SPANS (BTE BEAMS)  
**SITE PLAN**  
 STATION 177+34.52 (CL ROSE AVE.) AUGUST 2019  
**CEDAR COUNTY**  
 IOWA DEPARTMENT OF TRANSPORTATION - HIGHWAY DIVISION  
 DESIGN SHEET NO. 2 OF 2 FILE NO. 31800 DESIGN NO. ?

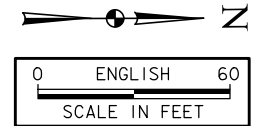



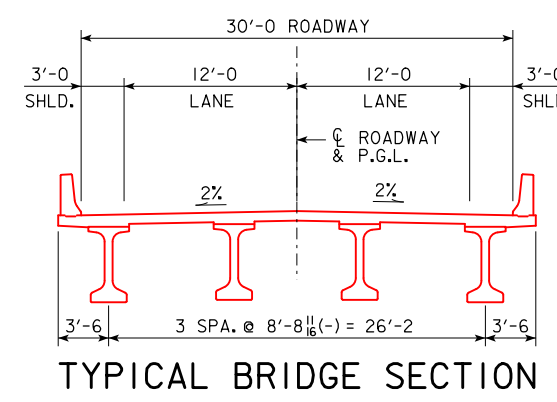
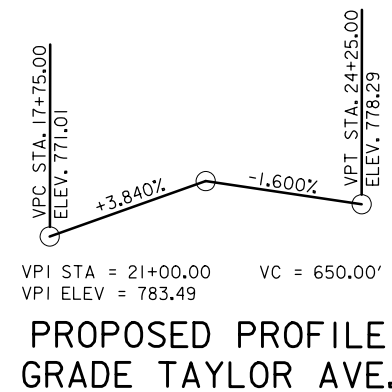
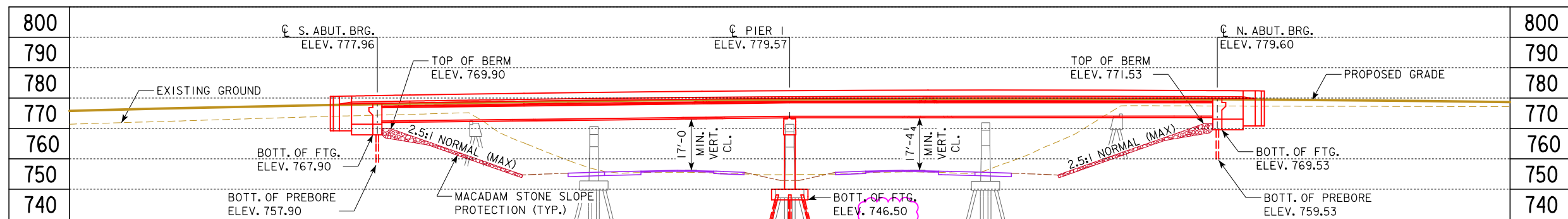

**MINIMUM VERTICAL CLEARANCE**

**E.B. ROADWAY**  
 OVERHEAD STATION = 21+23.79, OFFSET 13.08' LT  
 OVERHEAD ELEVATION = 779.05  
 DEPTH OF SUPERSTRUCTURE = 6.08'  
 UNDERPASS STATION = 1129+22.77, OFFSET 37.00' RT  
 UNDERPASS ELEVATION = 755.97  
 MINIMUM VERTICAL CLEARANCE = 17.00'

**W.B. ROADWAY**  
 OVERHEAD STATION = 21+97.79, OFFSET 13.08' LT  
 OVERHEAD ELEVATION = 779.50  
 DEPTH OF SUPERSTRUCTURE = 6.08'  
 UNDERPASS STATION = 1129+23.08, OFFSET 37.00' LT  
 UNDERPASS ELEVATION = 756.07  
 MINIMUM VERTICAL CLEARANCE = 17.35'

**UTILITIES LEGEND:**

FO(C) IOWA COMMUNICATION NETWORK  
 ?? - AERIAL POWER LINES

**TRAFFIC ESTIMATE**

2020 AADT	570	V.P.D.
2040 AADT	-	V.P.D.
2040 DHV	-	V.P.H.
TRUCKS	-	%
TOTAL DESIGN ESALs	--	

- NOTES:**
- TOP OF BRIDGE DECK CROWN IS 0.03' BELOW PROFILE GRADE.
  - STANDARD INTEGRAL ABUTMENT.
  - MASH TL-4 (38") BRIDGE RAILING PROPOSED.
  - PIER TYPE-FRAME.
  - PIER COLUMNS DESIGNED FOR VEHICULAR COLLISION FORCE.
  - BEAM TYPE-BTE.
  - MACADAM STONE.
  - PROP. VERTICAL DATUM IS APPROX. 8.62' HIGHER THAN USED ON EXISTING PLANS.
  - I-80 ELEVATIONS BASED ON EXISTING RDWY. SURVEY PLUS 4" PROPOSED OVERLAY.

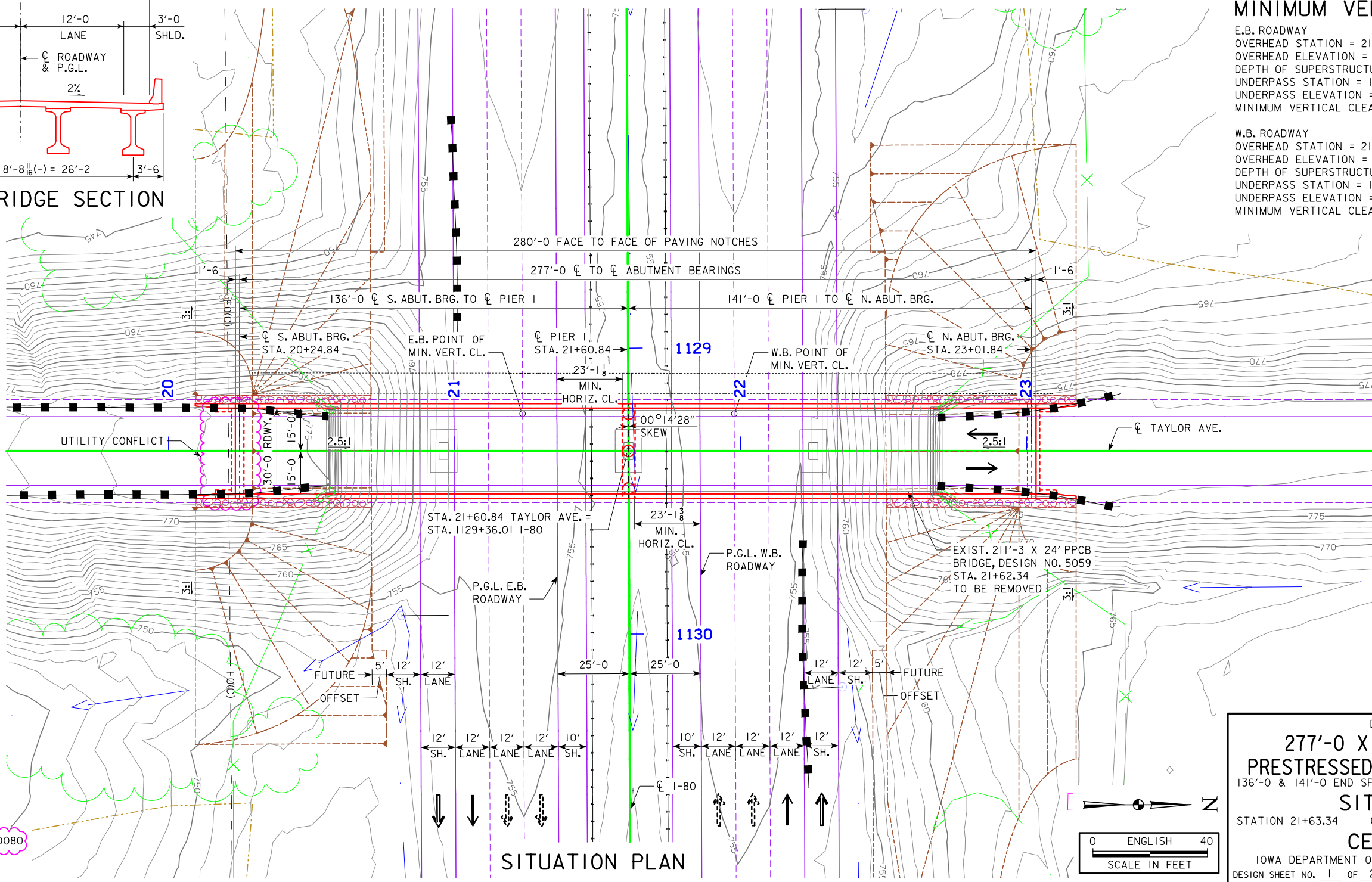
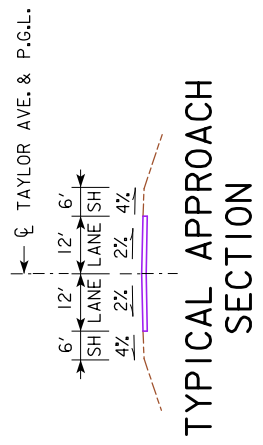

**LOCATION**  
 TAYLOR AVE. OVER I-80  
 T-79N R-01W  
 SECTION 19 & 20  
 FARMINGTOWN TOWNSHIP  
 CEDAR COUNTY  
 FHWA NO. 18691  
 BRIDGE MAINT. NO. 1673.10080  
 LATITUDE 41.633486°  
 LONGITUDE -90.996862°

PRELIMINARY  
 DESIGN FOR 0° SKEW  
**277'-0" X 30'-0" PRETENSIONED  
 PRESTRESSED CONCRETE BEAM BRIDGE**  
 136'-0" & 141'-0" END SPANS (BTE BEAMS)  
**SITUATION PLAN**  
 STATION 21+63.34 (CL TAYLOR AVE.) AUGUST 2019  
**CEDAR COUNTY**  
 IOWA DEPARTMENT OF TRANSPORTATION - HIGHWAY DIVISION  
 DESIGN SHEET NO. 1 OF 2 FILE NO. 31800 DESIGN NO. ?

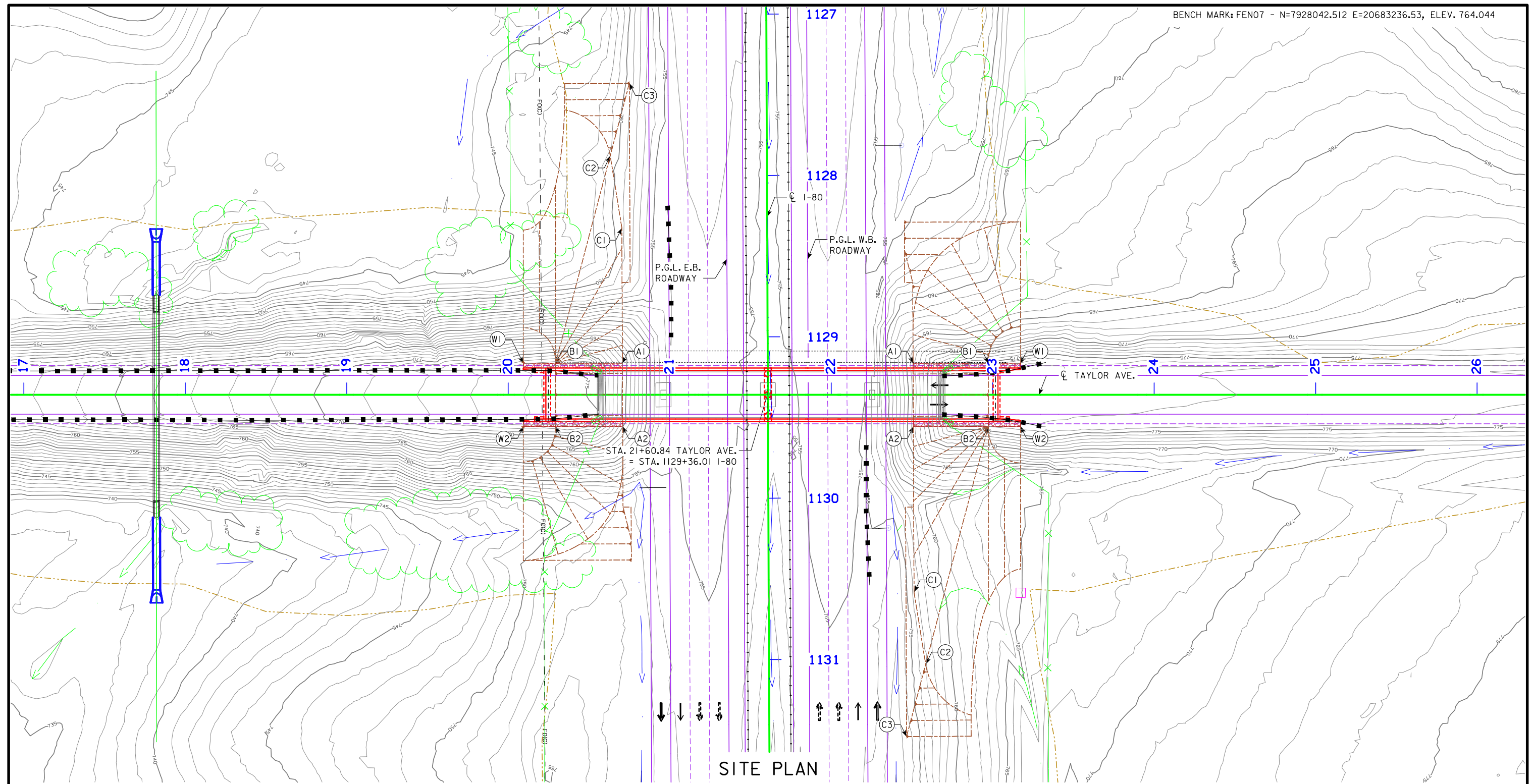

SITE PLAN

BERM SLOPE LOCATION TABLE						
POINTS	SOUTH ABUTMENT			NORTH ABUTMENT		
	STATION	OFFSET	ELEV.	STATION	OFFSET	ELEV.
A1	20+70.76	19.58' LT	754.53	22+50.76	19.58' LT	754.66
A2	20+70.92	19.58' RT	754.39	22+50.92	19.58' RT	754.45
B1	20+29.34	19.58' LT	769.90	22+97.34	19.58' LT	771.53
B2	20+29.34	19.58' RT	769.90	22+97.34	19.58' RT	771.53
W1	20+09.34	19.58' LT	777.26	23+17.34	19.58' LT	779.08
W2	20+09.34	19.58' RT	777.26	23+17.34	19.58' RT	779.08

BERM SLOPE ELEVATIONS REFLECT THE GRADING SURFACE

RECOVERABLE BERM LOCATION TABLE						
	SOUTH ABUTMENT			NORTH ABUTMENT		
	STATION	OFFSET	ELEV.	STATION	OFFSET	ELEV.
C1	20+70.41	103.42' LT	754.87	21+51.36	122.10' RT	753.99
C2	20+63.22	148.17' LT	754.79	22+58.54	166.85' RT	753.47
C3	20+75.03	193.01' LT	755.45	22+46.73	211.69' RT	753.72
B	20+29.34	19.58' LT	769.90	22+97.34	19.58' RT	771.53

BERM SLOPE ELEVATIONS REFLECT THE GRADING SURFACE

PRELIMINARY  
DESIGN FOR 0° SKEW

**277'-0 X 30'-0 PRETENSIONED  
PRESTRESSED CONCRETE BEAM BRIDGE**  
136'-0 & 141'-0 END SPANS (BTE BEAMS)

**SITE PLAN**  
STATION 21+63.36 (☉ TAYLOR AVE.) AUGUST 2019  
**CEDAR COUNTY**  
IOWA DEPARTMENT OF TRANSPORTATION - HIGHWAY DIVISION  
DESIGN SHEET NO. 2 OF 2 FILE NO. 31800 DESIGN NO. ?

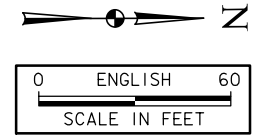



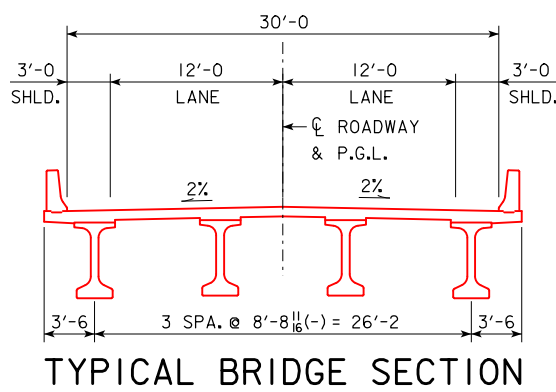
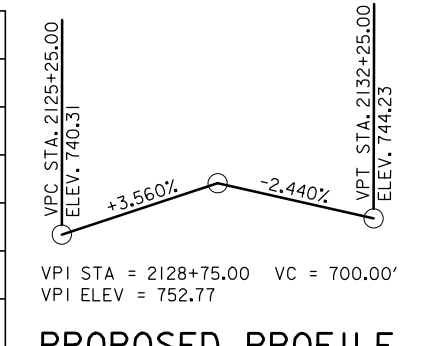
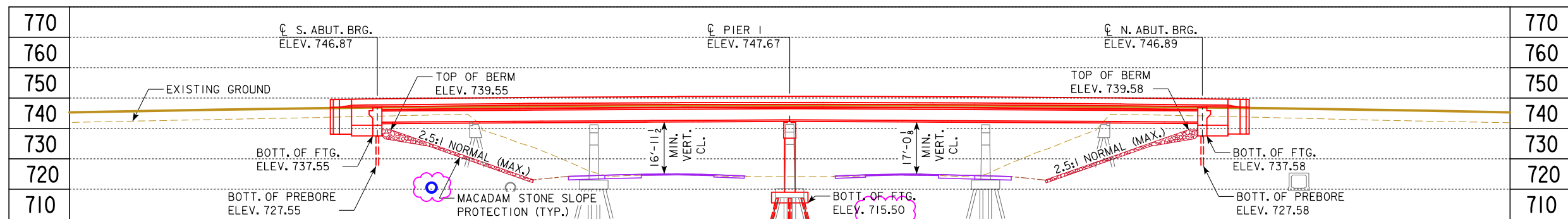

**MINIMUM VERTICAL CLEARANCE**

E.B. ROADWAY  
 OVERHEAD STATION = 2129+02.04, OFFSET 13.08' LT  
 OVERHEAD ELEVATION = 747.38  
 DEPTH OF SUPERSTRUCTURE = 5.33'  
 UNDERPASS STATION = 1280+44.22, OFFSET 37.00' RT  
 UNDERPASS ELEVATION = 725.09  
 MINIMUM VERTICAL CLEARANCE = 16.96'

W.B. ROADWAY  
 OVERHEAD STATION = 2129+76.04, OFFSET 13.08' LT  
 OVERHEAD ELEVATION = 747.39  
 DEPTH OF SUPERSTRUCTURE = 5.33'  
 UNDERPASS STATION = 1280+44.65, OFFSET 37.00' LT  
 UNDERPASS ELEVATION = 725.04  
 MINIMUM VERTICAL CLEARANCE = 17.01'

**UTILITIES LEGEND:**

F03(C) - IOWA COMMUNICATIONS NETWORK  
 F03(B) - WINDSTREAM COMMUNICATIONS  
 F03(C) - WINDSTREAM COMMUNICATIONS  
 ?? - AERIAL POWER LINE

**TRAFFIC ESTIMATE**

2014 AADT	50	V.P.D.
2040 AADT	-	V.P.D.
2040 DHV	-	V.P.H.
TRUCKS	-	%
TOTAL DESIGN ESALs	--	

- NOTES:**
- TOP OF BRIDGE DECK CROWN IS 0.03' BELOW PROFILE GRADE.
  - STANDARD INTEGRAL ABUTMENT.
  - MASH TL-4 (38") BRIDGE RAILING PROPOSED.
  - PIER TYPE-FRAME.
  - PIER COLUMNS DESIGNED FOR VEHICULAR COLLISION FORCE.
  - BEAM TYPE-BTD.
  - MACADAM STONE.
  - PROP. VERTICAL DATUM IS APPROX. 8.96' HIGHER THAN USED ON EXISTING PLANS.
  - 1-80 ELEVATIONS BASED ON EXISTING RDWY, SURVEY PLUS 4" PROPOSED OVERLAY.

PRELIMINARY

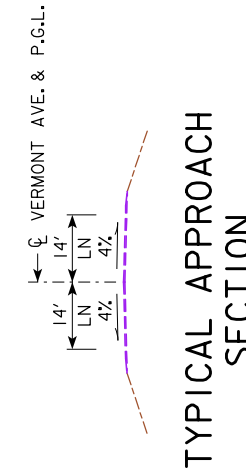
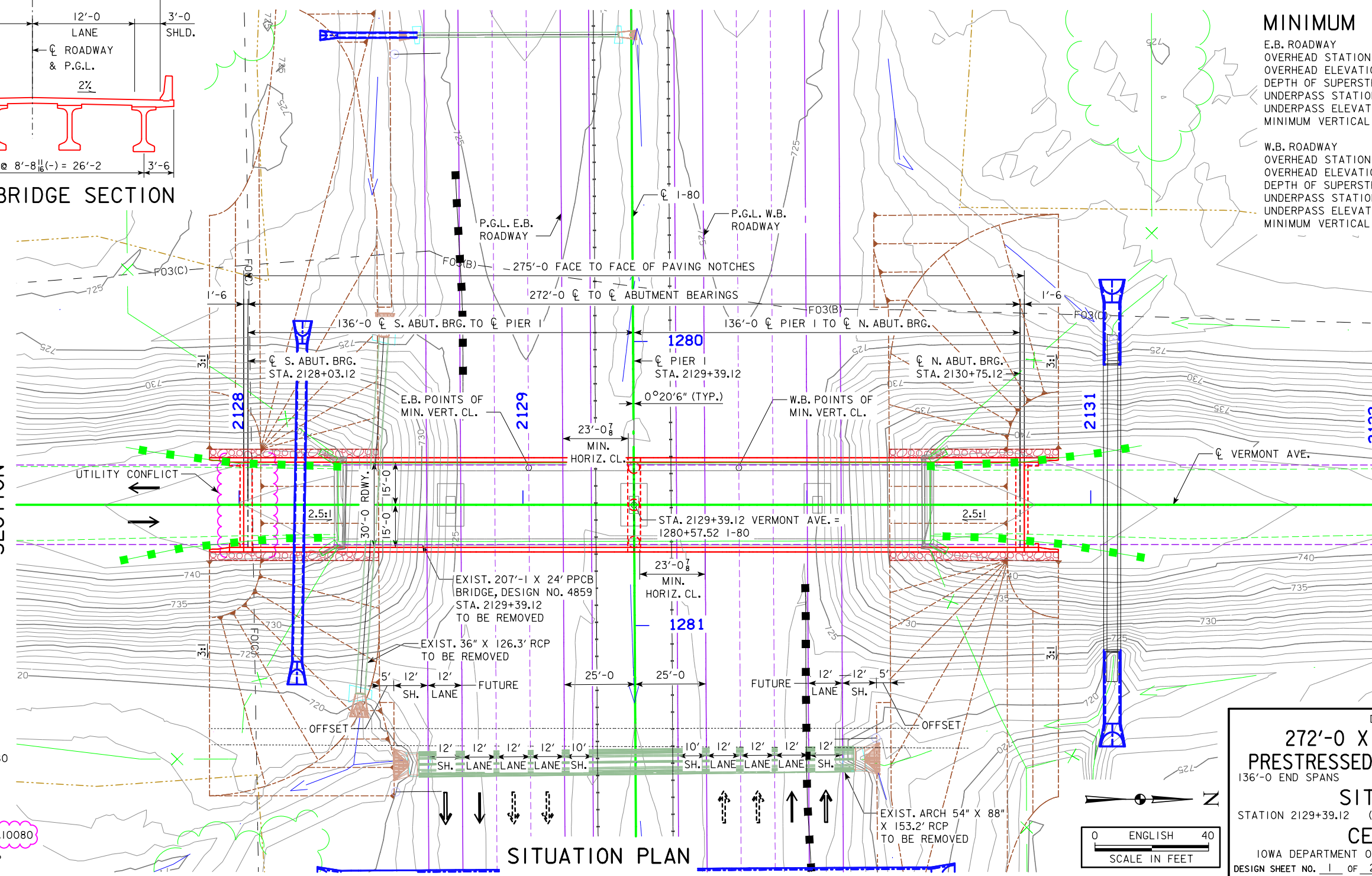

**LOCATION**

VERMONT AVE. OVER I-80  
 T-79N R-01W  
 SECTION 21 & 22  
 FARMINGTON TOWNSHIP  
 CEDAR COUNTY  
 FHWA NO. 18711  
 BRIDGE MAINT. NO. 1675.10080  
 LATITUDE 41.633592°  
 LONGITUDE -90.957703°

DESIGN FOR 0° SKEW

**272'-0" X 30'-0" PRETENSIONED  
 PRESTRESSED CONCRETE BEAM BRIDGE**  
 136'-0" END SPANS (BTD BEAMS)

**SITUATION PLAN**  
 STATION 2129+39.12 (CL VERMONT AVE.)  
 CEDAR COUNTY  
 IOWA DEPARTMENT OF TRANSPORTATION - HIGHWAY DIVISION  
 DESIGN SHEET NO. 1 OF 2 FILE NO. 31800 DESIGN NO. ?

AUGUST 2019

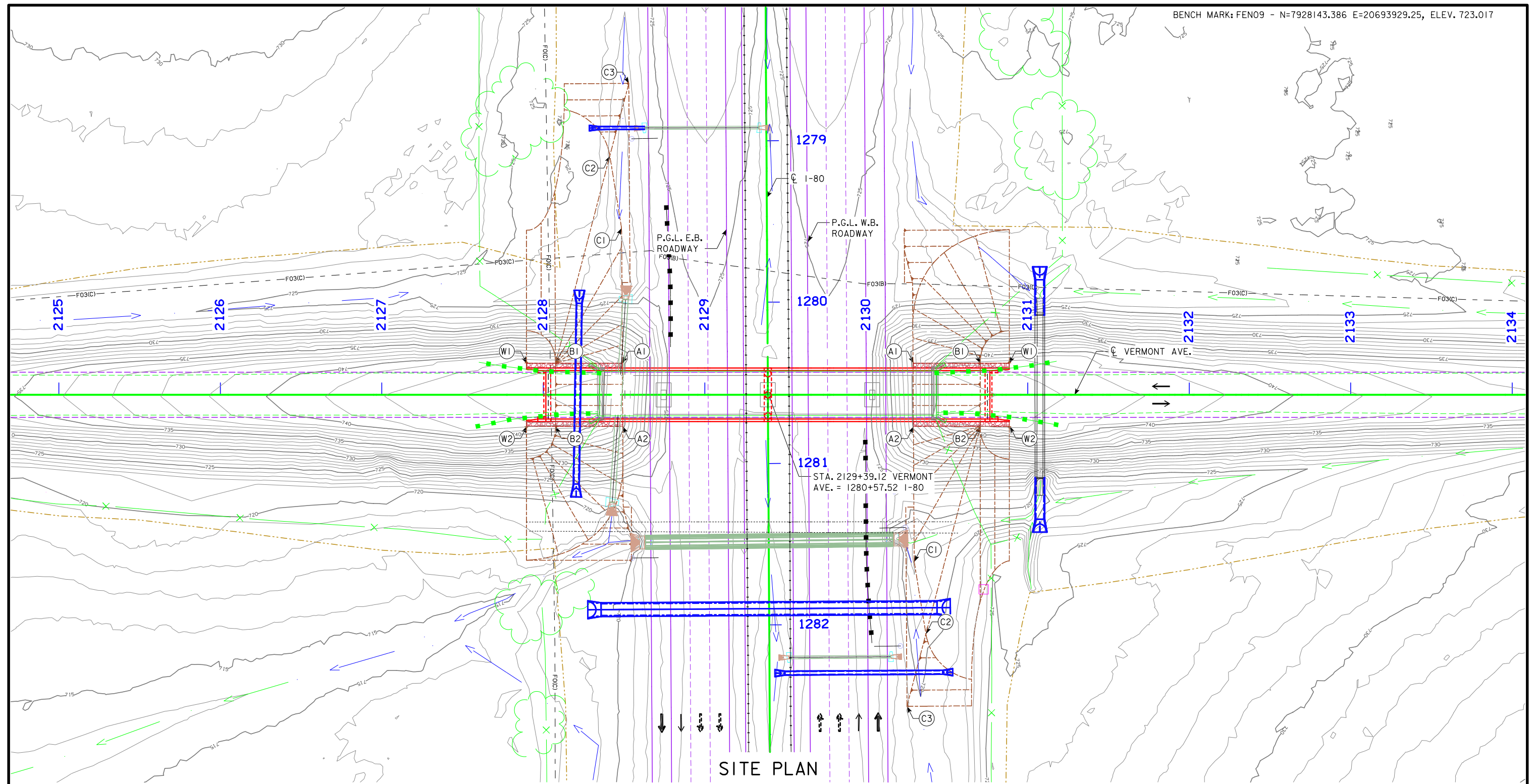

SITE PLAN

**BERM SLOPE LOCATION TABLE**

POINTS	SOUTH ABUTMENT			NORTH ABUTMENT		
	STATION	OFFSET	ELEV.	STATION	OFFSET	ELEV.
A1	2128+49.00	19.58' LT	723.63	2130+29.00	19.58' LT	723.54
A2	2128+49.23	19.58' RT	723.45	2130+29.23	19.58' RT	723.35
B1	2128+07.62	19.58' LT	739.55	2130+70.62	19.58' LT	739.58
B2	2128+07.62	19.58' RT	739.55	2130+70.62	19.58' RT	739.58
W1	2127+89.62	19.58' LT	746.28	2130+88.62	19.58' LT	746.31
W2	2127+89.62	19.58' RT	746.28	2130+88.62	19.58' RT	746.31

BERM SLOPE ELEVATIONS REFLECT THE GRADING SURFACE

**RECOVERABLE BERM LOCATION TABLE**

	SOUTH ABUTMENT			NORTH ABUTMENT		
	STATION	OFFSET	ELEV	STATION	OFFSET	ELEV
C1	2128+48.51	103.36' LT	724.24	2130+29.72	103.36' RT	723.13
C2	2128+41.25	148.10' LT	724.42	2130+36.98	148.10' RT	722.90
C3	2128+52.99	192.96' LT	725.43	2130+25.25	192.96' RT	723.45
B	2128+07.62	19.58' LT	739.55	2130+70.62	19.58' RT	739.58

BERM SLOPE ELEVATIONS REFLECT THE GRADING SURFACE

PRELIMINARY  
 DESIGN FOR 0° SKEW  
**272'-0 X 30'-0 PRETENSIONED  
 PRESTRESSED CONCRETE BEAM BRIDGE**  
 136'-0 END SPANS (BTD BEAMS)  
**SITE PLAN**  
 STATION 2129+39.12 (☉ VERMONT AVE.) AUGUST 2019  
**CEDAR COUNTY**  
 IOWA DEPARTMENT OF TRANSPORTATION - HIGHWAY DIVISION  
 DESIGN SHEET NO. 2 OF 2 FILE NO. 31800 DESIGN NO. ?

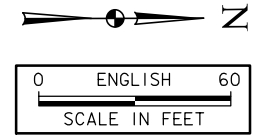



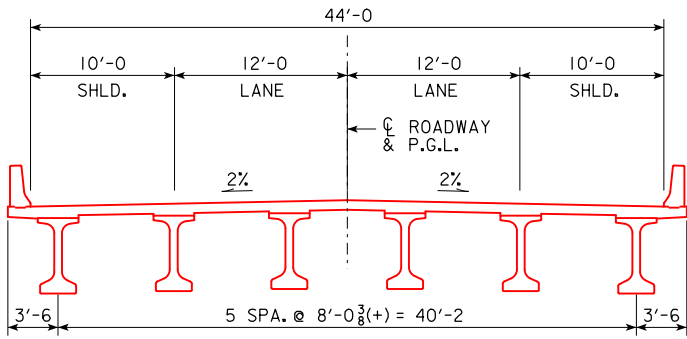
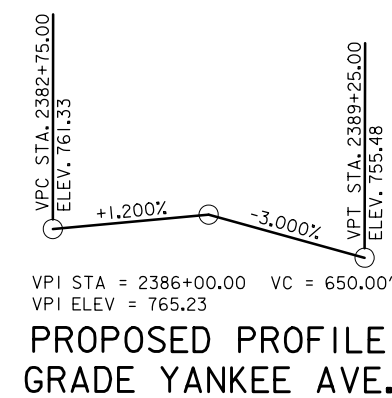
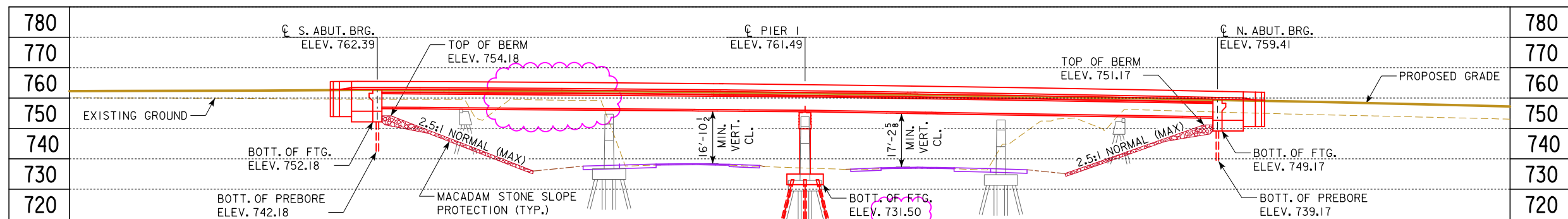

**MINIMUM VERTICAL CLEARANCE**

**E.B. ROADWAY**  
 OVERHEAD STATION = 2385+91.63, OFFSET 20.08' RT  
 OVERHEAD ELEVATION = 761.49  
 DEPTH OF SUPERSTRUCTURE = 6.08'  
 UNDERPASS STATION = 1386+52.14, OFFSET 37.00' RT  
 UNDERPASS ELEVATION = 738.54  
 MINIMUM VERTICAL CLEARANCE = 16.87'

**W.B. ROADWAY**  
 OVERHEAD STATION = 2386+65.83, OFFSET 20.08' RT  
 OVERHEAD ELEVATION = 760.68  
 DEPTH OF SUPERSTRUCTURE = 6.08'  
 UNDERPASS STATION = 1386+46.72, OFFSET 37.00' LT  
 UNDERPASS ELEVATION = 737.38  
 MINIMUM VERTICAL CLEARANCE = 17.22'

**UTILITIES LEGEND:**

?? - AERIAL POWER LINES

**TRAFFIC ESTIMATE**

2020 AADT	1,846	V.P.D.
2040 AADT	2,098	V.P.D.
2040 DHV	-	V.P.H.
TRUCKS	17	%
TOTAL DESIGN ESALs	--	

- NOTES:**
- TOP OF BRIDGE DECK CROWN IS 0.03' BELOW PROFILE GRADE.
  - STANDARD INTEGRAL ABUTMENT.
  - MASH TL-4 (38") BRIDGE RAILING PROPOSED.
  - PIER TYPE-FRAME.
  - PIER COLUMNS DESIGNED FOR VEHICULAR COLLISION FORCE.
  - BEAM TYPE-BTE.
  - MACADAM STONE.
  - PROP. VERTICAL DATUM IS APPROX. 8.54' HIGHER THAN USED ON EXISTING PLANS.
  - I-80 ELEVATIONS BASED ON EXISTING RDWY, SURVEY PLUS 4' PROPOSED OVERLAY.

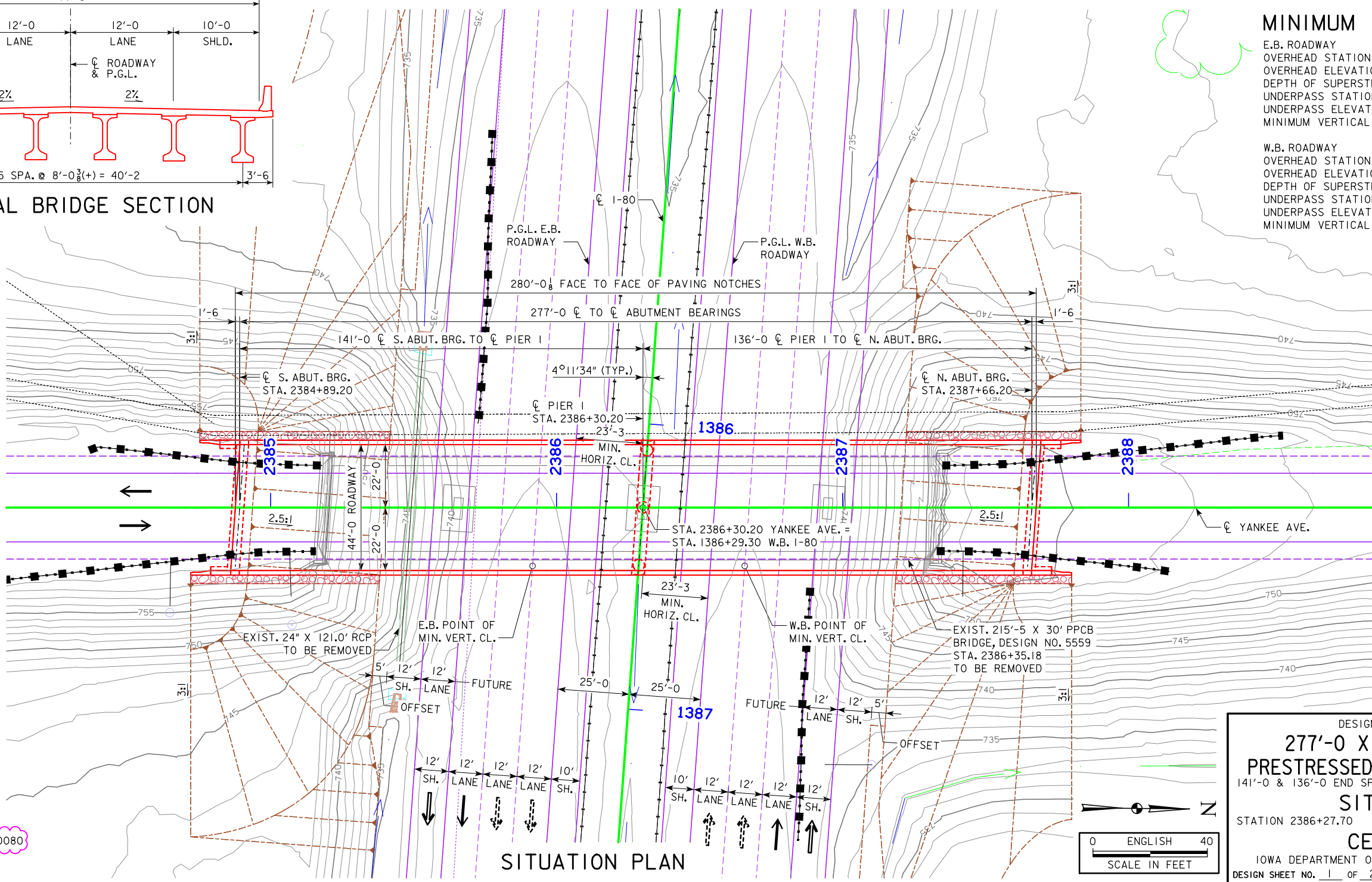
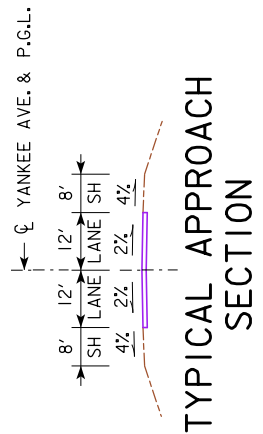

**LOCATION**  
 YANKEE AVE. OVER I-80  
 T-79N R-01W  
 SECTION 23 & 24  
 FARMINGTON TOWNSHIP  
 CEDAR COUNTY  
 FHWA NO. 18731  
 BRIDGE MAINT. NO. 1677.10080  
 LATITUDE 41.633874°  
 LONGITUDE -90.919101°

PRELIMINARY  
 DESIGN FOR 4°11'34" SKEW (L.A.)  
**277'-0" X 44'-0" PRETENSIONED  
 PRESTRESSED CONCRETE BEAM BRIDGE**  
 141'-0" & 136'-0" END SPANS (BTE BEAMS)  
**SITUATION PLAN**  
 STATION 2386+27.70 (CL YANKEE AVE.)  
 CEDAR COUNTY  
 IOWA DEPARTMENT OF TRANSPORTATION - HIGHWAY DIVISION  
 DESIGN SHEET NO. 1 OF 2 FILE NO. 31800 DESIGN NO. ?

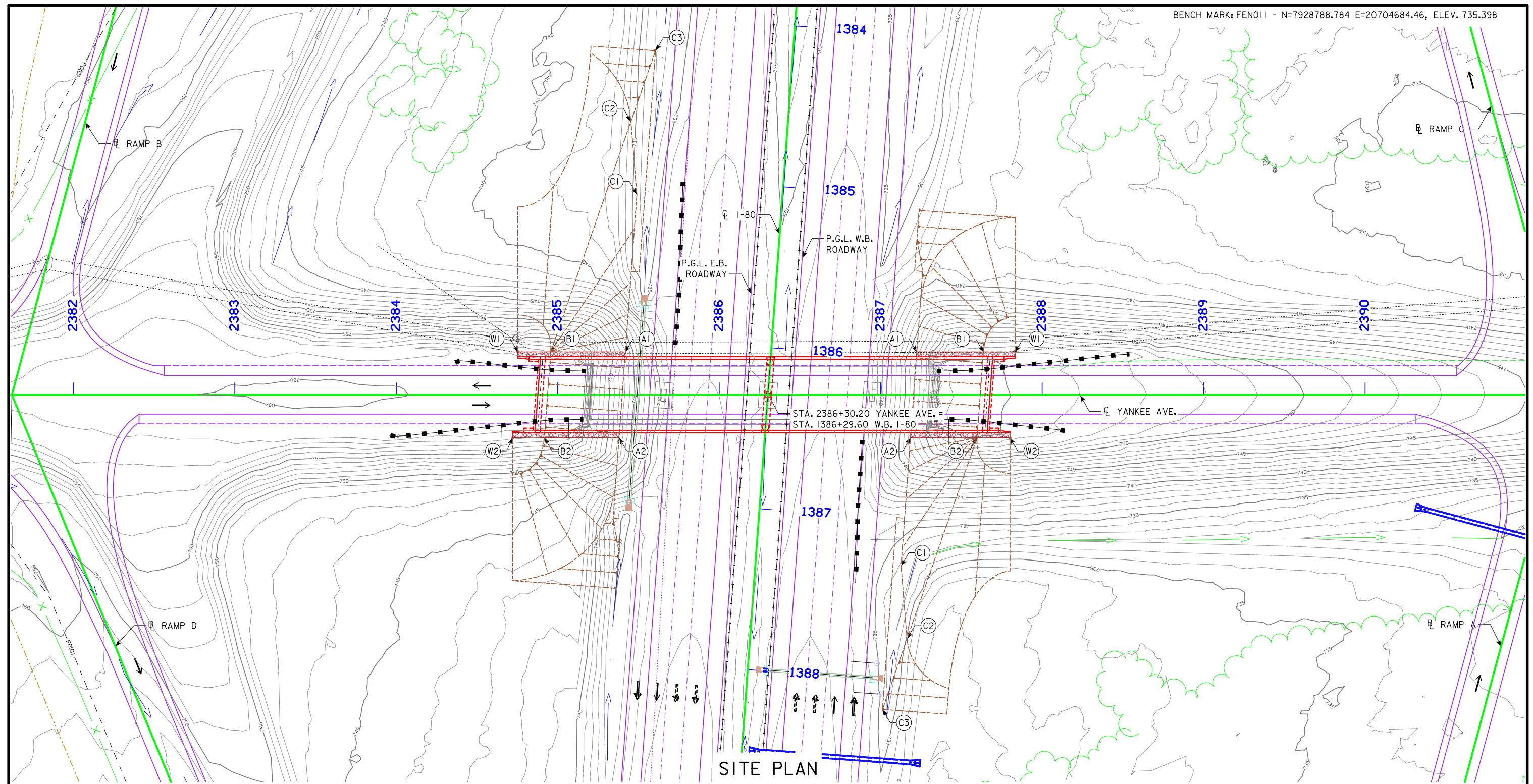

SITE PLAN

POINTS	SOUTH ABUTMENT			NORTH ABUTMENT		
	STATION	OFFSET	ELEV.	STATION	OFFSET	ELEV.
A1	2385+41.91	26.58' LT	736.72	2387+22.39	26.58' LT	735.52
A2	2385+38.01	26.58' RT	737.13	2387+18.50	26.58' RT	735.87
B1	2384+95.66	26.58' LT	754.18	2387+63.64	26.58' LT	751.17
B2	2384+91.77	26.58' RT	754.18	2387+59.74	26.58' RT	751.17
W1	2384+75.31	26.58' LT	761.85	2387+83.32	26.58' LT	758.49
W2	2384+72.09	26.58' RT	761.85	2387+80.09	26.58' RT	758.56

BERM SLOPE ELEVATIONS REFLECT THE GRADING SURFACE

	SOUTH ABUTMENT			NORTH ABUTMENT		
	STATION	OFFSET	ELEV	STATION	OFFSET	ELEV
C1	2385+49.07	124.22' LT	735.98	2387+12.68	105.97' RT	736.39
C2	2385+45.36	169.39' LT	735.42	2387+16.38	151.14' RT	736.49
C3	2385+60.60	213.18' LT	735.61	2387+01.14	194.93' RT	737.39
B	2384+95.66	26.58' LT	754.18	2387+59.74	26.58' RT	751.17

BERM SLOPE ELEVATIONS REFLECT THE GRADING SURFACE

PRELIMINARY  
 DESIGN FOR 4°11'34" SKEW (L.A.)  
**282'-0" X 44'-0" PRETENSIONED  
 PRESTRESSED CONCRETE BEAM BRIDGE**  
 146'-0" & 136'-0" END SPANS (BTE BEAMS)  
**SITE PLAN**  
 STATION 2386+25.18 (CL YANKEE AVE.) AUGUST 2019  
**CEDAR COUNTY**  
 IOWA DEPARTMENT OF TRANSPORTATION - HIGHWAY DIVISION  
 DESIGN SHEET NO. 2 OF 2 FILE NO. 31800 DESIGN NO. ?

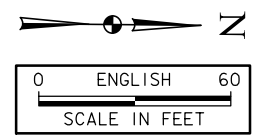



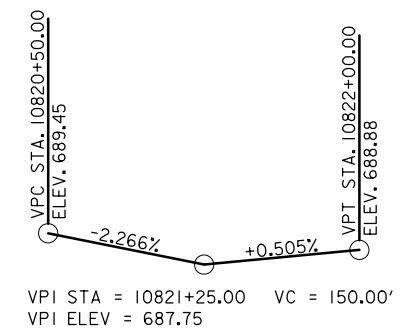
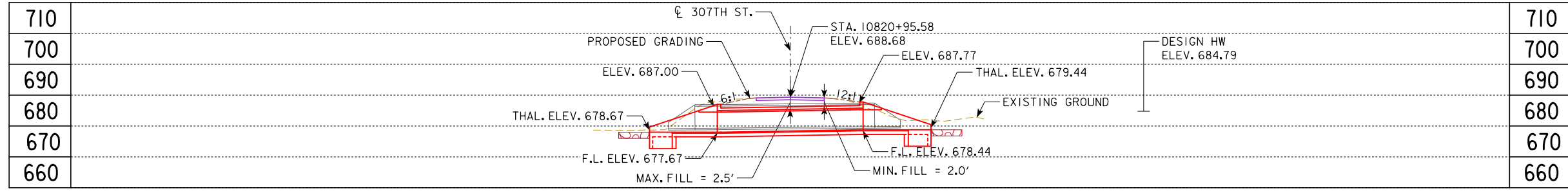

LONGITUDINAL SECTION ALONG CL CULVERT

PROPOSED PROFILE GRADE 307TH ST.

HYDRAULIC DATA

DRAINAGE AREA = 0.78 SQ. MI.  
 Q<sub>50</sub> = 647 CFS  
 HW ELEV. = 684.12  
 EXIT VELOCITY = 6.97 FPS  
 STREAM SLOPE = 53.2 FT./MI.  
 Q<sub>100</sub> = 777 CFS  
 HW ELEV. = 684.79  
 EXIT VELOCITY = 7.60 FPS

UTILITIES LEGEND:

F05(C) - HWH CORPORATION  
 ?? - AERIAL POWER LINE

TRAFFIC ESTIMATE

2014 AADT 150 V.P.D.  
 2040 AADT - V.P.D.  
 2040 DHV - V.P.H.  
 TRUCKS %  
 TOTAL DESIGN ESALs -

LOCATION

307TH ST. OVER CREEK  
 T-79N R-02W  
 SECTION 18  
 ROCHESTER TOWNSHIP  
 CEDAR COUNTY  
 FHWA NO. ?  
 BRIDGE MAINT. NO. ?  
 LATITUDE 41.641832°  
 LONGITUDE -91.111106°

NOTES:  
 1. CULVERT F.L. ELEVATION SUMPED 1' BELOW THALWEG ELEVATION.

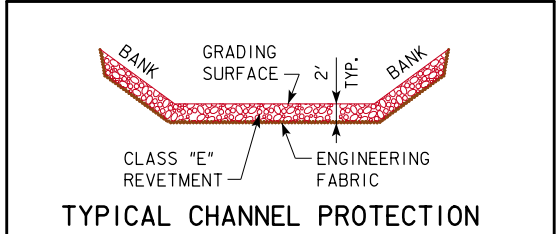

TYPICAL CHANNEL PROTECTION

ESTIMATED REVETMENT QUANTITIES INCLUDED WITH ROAD PLANS

LOCATION	REVETMENT CL. "E" (TON)	ENGINEERING FABRIC (SY)	EXCAVATION (CY)
INLET	XX	XX	XX
OUTLET	XX	XX	XX
TOTALS	XX	XX	XX

EXCAVATION QUANTITY CALCULATED FROM GRADING SURFACE. QUANTITIES SHOWN FOR INFORMATION ONLY. SEE ROAD SHEETS.

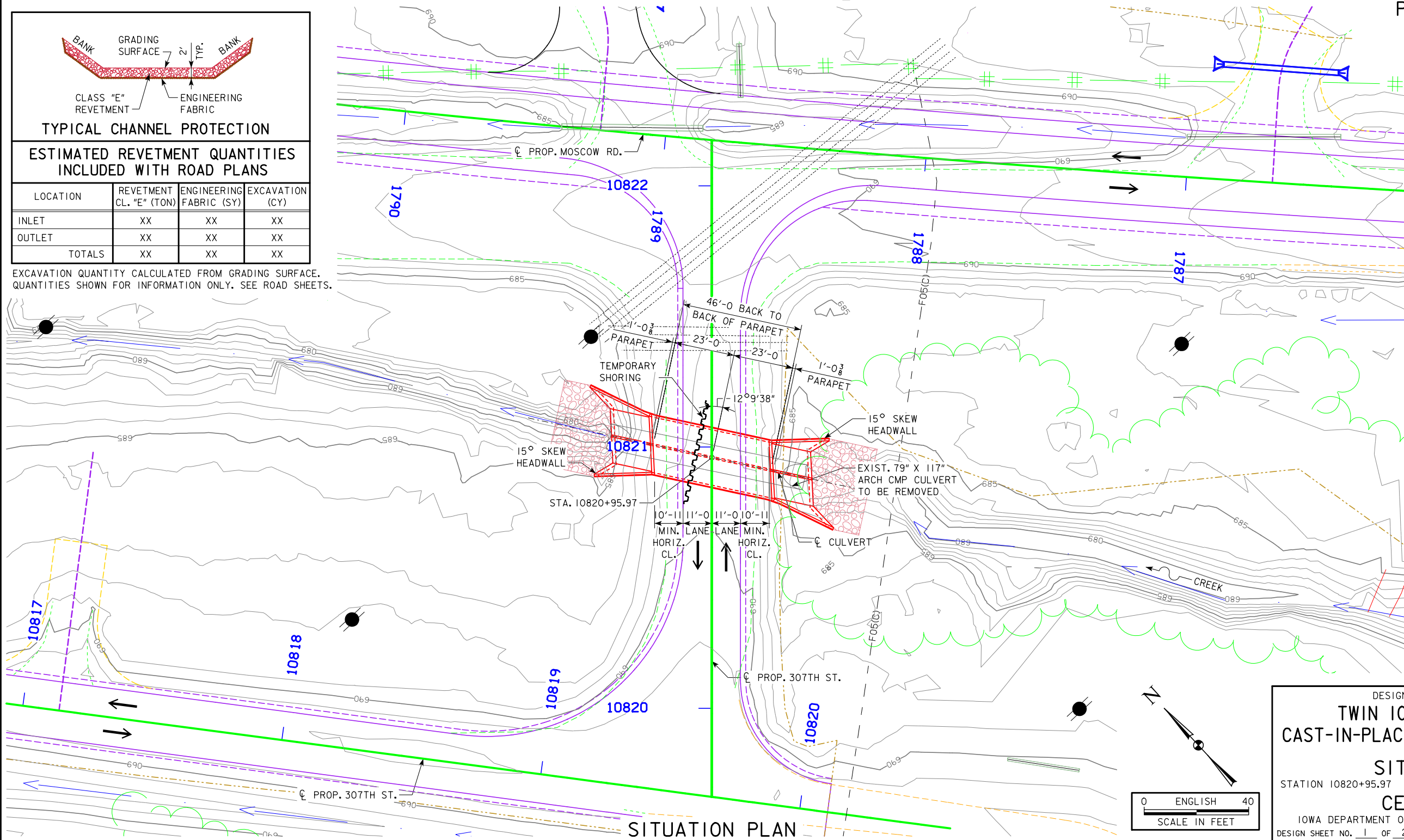

SITUATION PLAN

PRELIMINARY  
 DESIGN FOR 12°9'38" SKEW (L.A.)  
**TWIN 10'-0" X 7'-0" X 46'-0"**  
**CAST-IN-PLACE CONCRETE BOX CULVERT**  
 SITUATION PLAN  
 STATION 10820+95.97  
 AUGUST 2019  
**CEDAR COUNTY**  
 IOWA DEPARTMENT OF TRANSPORTATION - HIGHWAY DIVISION  
 DESIGN SHEET NO. 1 OF 2 FILE NO. 31800 DESIGN NO. ?



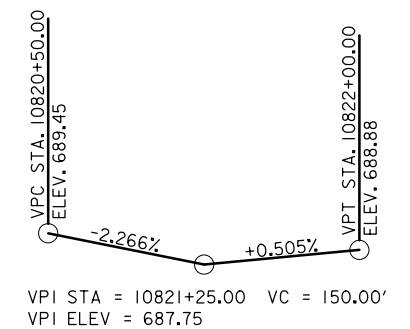
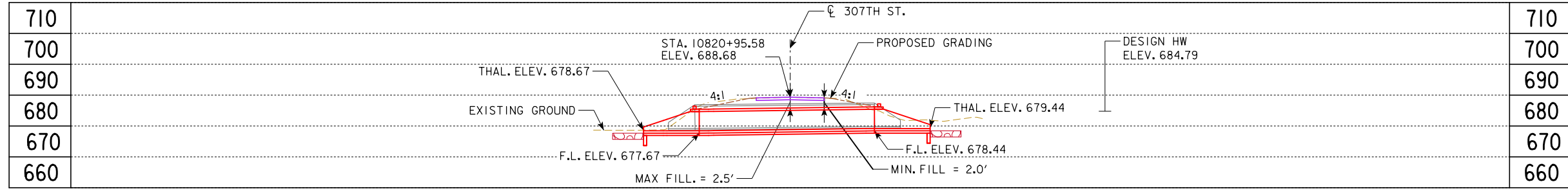

**TYPICAL CHANNEL PROTECTION**

**ESTIMATED REVETMENT QUANTITIES INCLUDED WITH ROAD PLANS**

LOCATION	REVETMENT CL. "E" (TON)	ENGINEERING FABRIC (SY)	EXCAVATION (CY)
INLET	XX	XX	XX
OUTLET	XX	XX	XX
TOTALS	XX	XX	XX

EXCAVATION QUANTITY CALCULATED FROM GRADING SURFACE. QUANTITIES SHOWN FOR INFORMATION ONLY. SEE ROAD SHEETS.

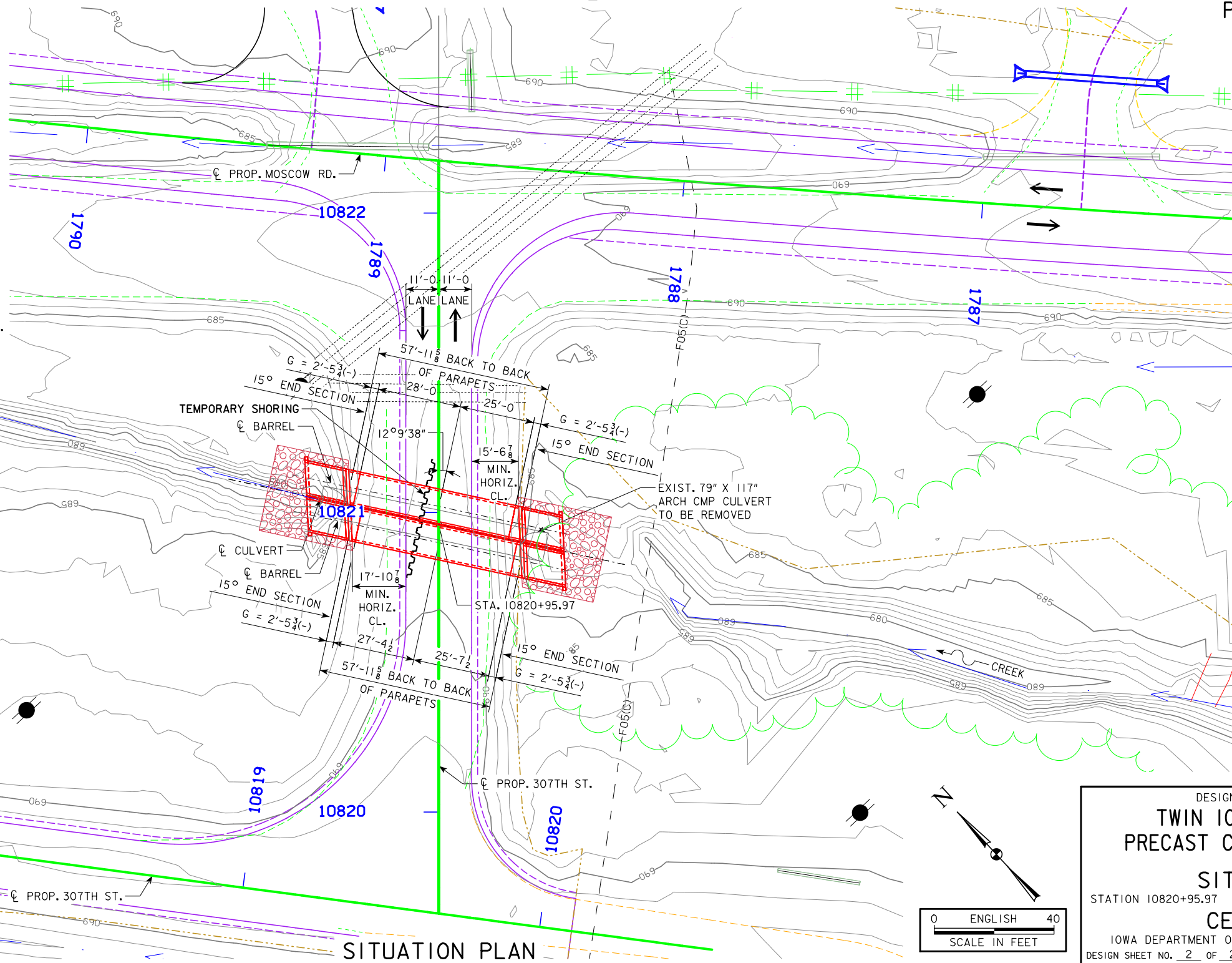

**UTILITIES LEGEND:**

F05(C) - HWH CORPORATION  
?? - AERIAL POWER LINE

**TRAFFIC ESTIMATE**

2014 AADT	150	V.P.D.
2040 AADT	-	V.P.D.
2040 DHV	-	V.P.H.
TRUCKS	-	%
TOTAL DESIGN ESALS	-	

**LOCATION**

307TH ST. OVER CREEK  
T-79N R-02W  
SECTION 18  
ROCHESTER TOWNSHIP  
CEDAR COUNTY  
FHWA NO. ?  
BRIDGE MAINT. NO. ?  
LATITUDE 41.641832°  
LONGITUDE -91.111106°

**NOTES:**

1. CULVERT F.L. ELEVATION SUMPED 1' BELOW THALWEG ELEVATION.

PRELIMINARY

DESIGN FOR 12°9'38" SKEW (L.A.)

**TWIN 10'-0" X 7'-0" X 53'-0" PRECAST CONCRETE BOX CULVERT**

SITUATION PLAN

STATION 10820+95.97

AUGUST 2019

**CEDAR COUNTY**

IOWA DEPARTMENT OF TRANSPORTATION - HIGHWAY DIVISION

DESIGN SHEET NO. 2 OF 2 FILE NO. 31800 DESIGN NO. ?





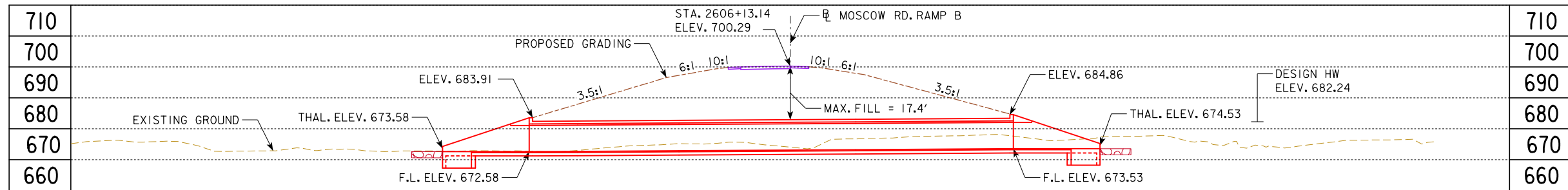

LONGITUDINAL SECTION ALONG CL CULVERT

PROPOSED PROFILE GRADE MOSCOW RD. RAMP B

HYDRAULIC DATA

DRAINAGE AREA = 1.03 SQ. MI.  
 Q<sub>50</sub> = 707 CFS  
 HW ELEV. = 681.24  
 EXIT VELOCITY = 7.5 FPS  
 STREAM SLOPE = 49.0 FT./MI.  
 Q<sub>100</sub> = 848 CFS  
 HW ELEV. = 682.24  
 EXIT VELOCITY = 7.7 FPS

UTILITIES LEGEND:

FO(B) - IOWA COMMUNICATIONS NETWORK  
 ?? - AERIAL POWER LINE

TRAFFIC ESTIMATE

2020 AADT	815	V.P.D.
2040 AADT	1,144	V.P.D.
2040 DHV		V.P.H.
TRUCKS	13	%
TOTAL DESIGN ESALS		

LOCATION

MOSCOW RD. RAMP B OVER CREEK  
 T-79N R-02W  
 SECTION 18  
 ROCHESTER TOWNSHIP  
 CEDAR COUNTY  
 LATITUDE 41.644085°  
 LONGITUDE -91.113731°

NOTES:  
 1. CULVERT F.L. ELEVATION SUMPED 1' BELOW THALWEG ELEVATION.

**TYPICAL CHANNEL PROTECTION**

LOCATION	REVETMENT CL. "E" (TON)	ENGINEERING FABRIC (SY)	EXCAVATION (CY)
INLET	XX	XX	XX
OUTLET	XX	XX	XX
TOTALS	XX	XX	XX

EXCAVATION QUANTITY CALCULATED FROM GRADING SURFACE. QUANTITIES SHOWN FOR INFORMATION ONLY. SEE ROAD SHEETS.

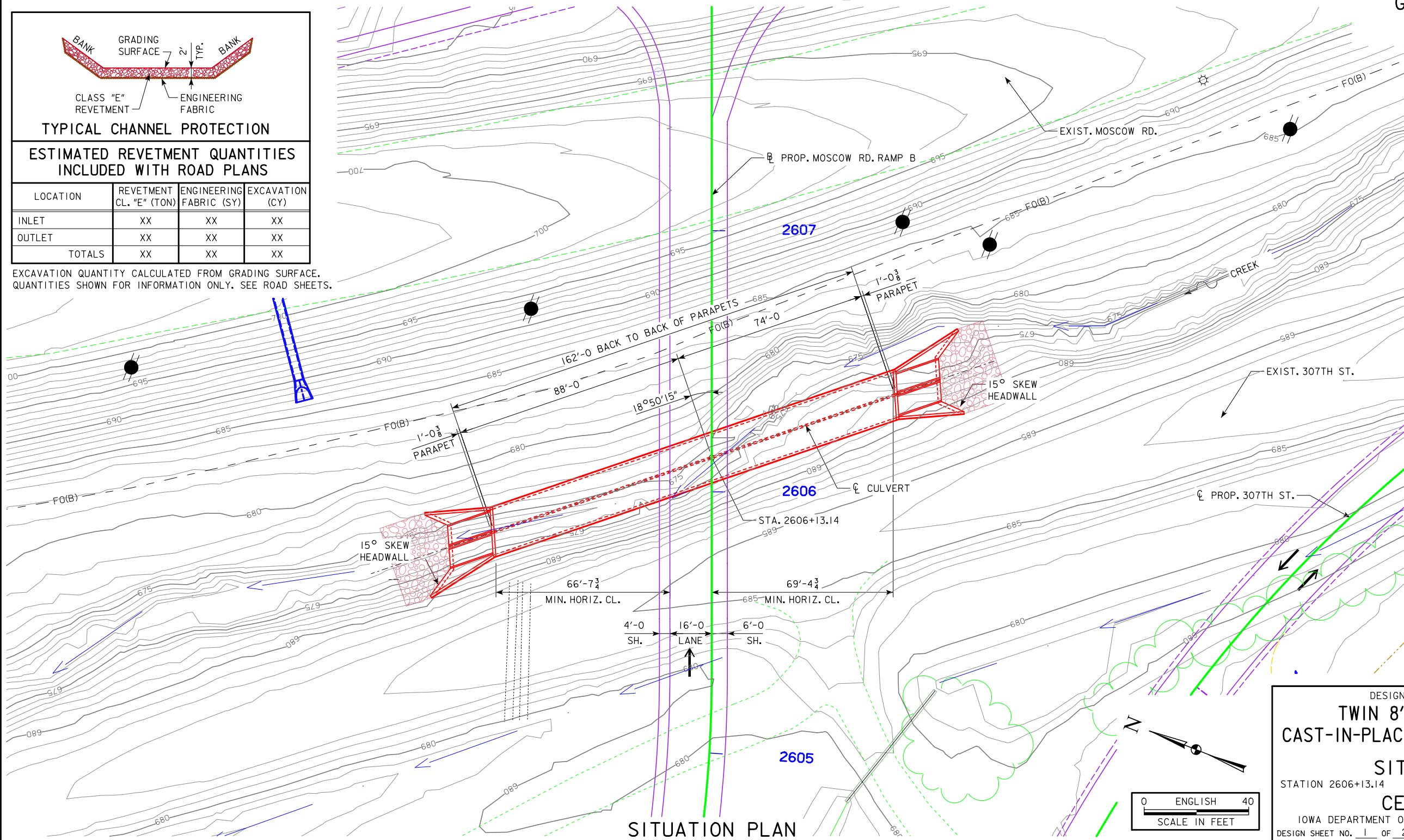

SITUATION PLAN

PRELIMINARY  
 DESIGN FOR 18°50'15" SKEW (R.A.)  
**TWIN 8'-0" X 9'-0" X 162'-0"**  
**CAST-IN-PLACE CONCRETE BOX CULVERT**  
 SITUATION PLAN  
 STATION 2606+13.14  
 AUGUST 2019  
**CEDAR COUNTY**  
 IOWA DEPARTMENT OF TRANSPORTATION - HIGHWAY DIVISION  
 DESIGN SHEET NO. 1 OF 2 FILE NO. 31800 DESIGN NO. ?

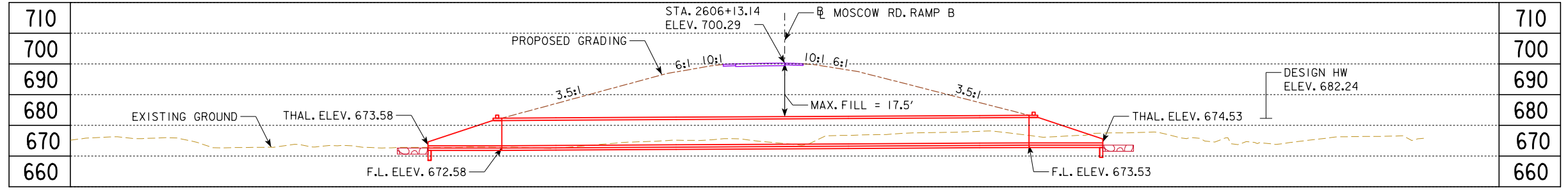

PROPOSED PROFILE GRADE MOSCOW RD. RAMP B

**TYPICAL CHANNEL PROTECTION**

**ESTIMATED REVETMENT QUANTITIES INCLUDED WITH ROAD PLANS**

LOCATION	REVETMENT CL. "E" (TON)	ENGINEERING FABRIC (SY)	EXCAVATION (CY)
INLET	XX	XX	XX
OUTLET	XX	XX	XX
TOTALS	XX	XX	XX

EXCAVATION QUANTITY CALCULATED FROM GRADING SURFACE. QUANTITIES SHOWN FOR INFORMATION ONLY. SEE ROAD SHEETS.

**HYDRAULIC DATA**  
 DRAINAGE AREA = 1.03 SQ. MI.  
 Q<sub>50</sub> = 707 CFS  
 HW ELEV. = 681.24  
 EXIT VELOCITY = 7.5 FPS  
 STREAM SLOPE = 49.0 FT./MI.  
 Q<sub>100</sub> = 848 CFS  
 HW ELEV. = 682.24  
 EXIT VELOCITY = 7.7 FPS

**UTILITIES LEGEND:**  
 FO(B) - IOWA COMMUNICATIONS NETWORK  
 ?? - AERIAL POWER LINE

**TRAFFIC ESTIMATE**

2020 AADT	815	V.P.D.
2040 AADT	1,144	V.P.D.
2040 DHV	-	V.P.H.
TRUCKS	13	%
TOTAL DESIGN ESALS	-	-

**LOCATION**  
 MOSCOW RD. RAMP B OVER CREEK  
 T-79N R-02W  
 SECTION 18  
 ROCHESTER TOWNSHIP  
 CEDAR COUNTY  
 LATITUDE 41.644085°  
 LONGITUDE -91.113731°

**NOTES:**  
 1. CULVERT F.L. ELEVATION SUMPED 1' BELOW THALWEG ELEVATION.

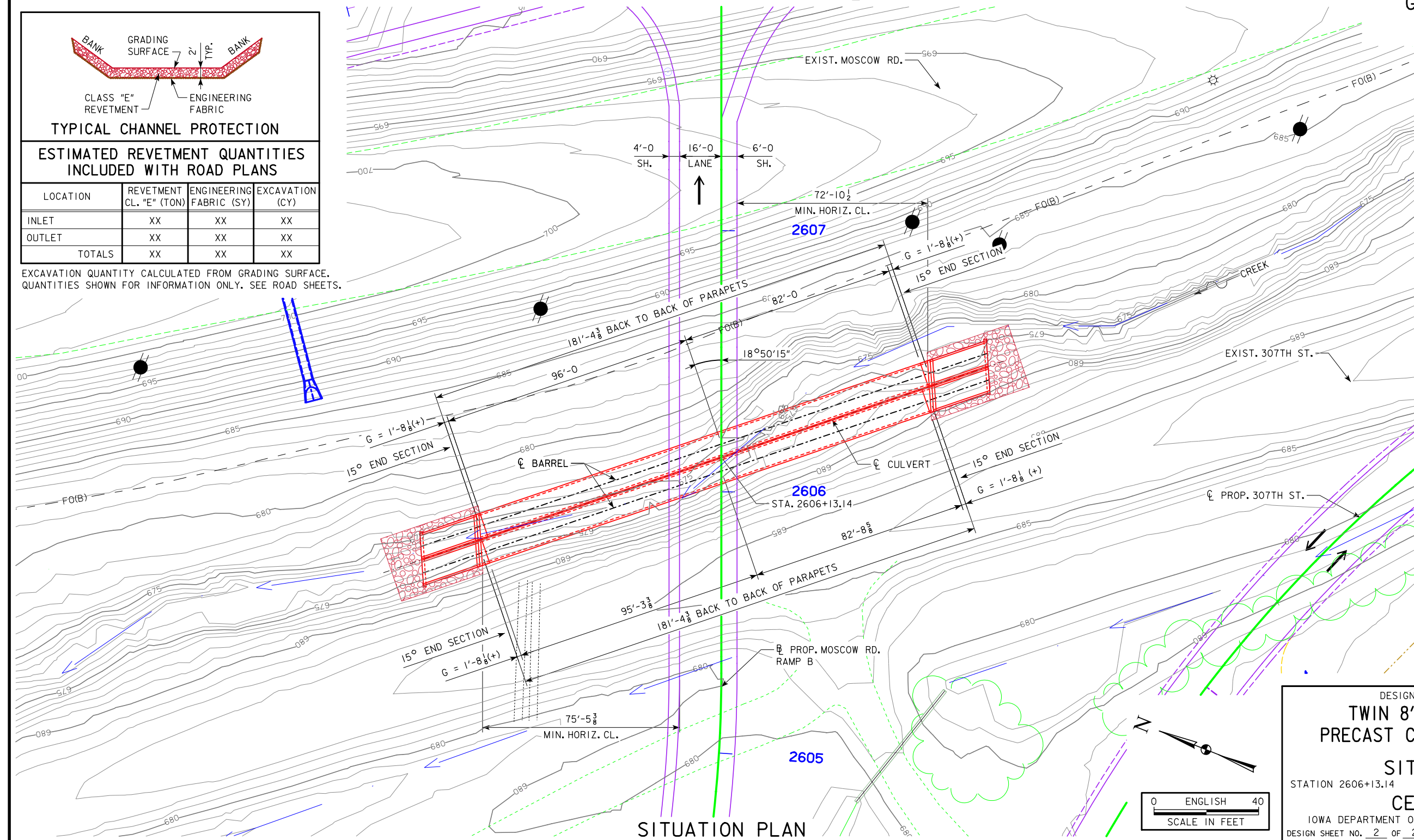

PRELIMINARY  
 DESIGN FOR 18°50'15" SKEW (R.A.)  
**TWIN 8'-0 X 9'-0 X 177'-0**  
**PRECAST CONCRETE BOX CULVERT**  
 SITUATION PLAN  
 STATION 2606+13.14  
 CEDAR COUNTY  
 IOWA DEPARTMENT OF TRANSPORTATION - HIGHWAY DIVISION  
 DESIGN SHEET NO. 2 OF 2 FILE NO. 31800 DESIGN NO. ?  
 AUGUST 2019



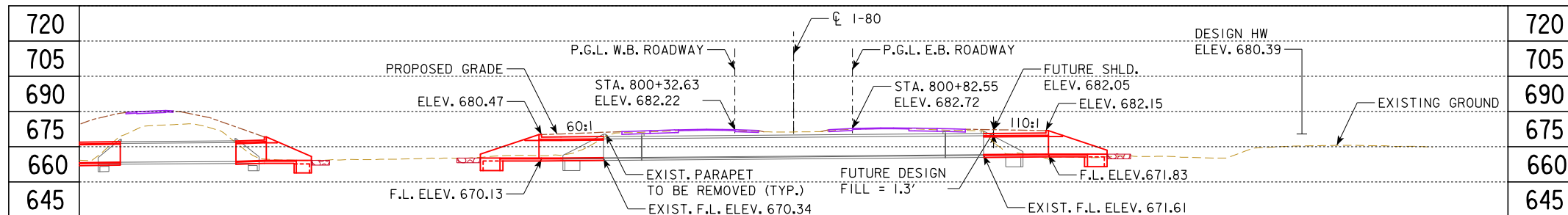

LONGITUDINAL SECTION ALONG CL CULVERT

**HYDRAULIC DATA**

DRAINAGE AREA = 1.03 SQ. MI.

Q<sub>50</sub> = 821 CFS  
HW ELEV. = 679.36  
EXIT VELOCITY = 8.0 FPS  
STREAM SLOPE = 23.7 FT./MI.

Q<sub>100</sub> = 985 CFS  
HW ELEV. = 680.39  
EXIT VELOCITY = 8.3 FPS

**UTILITIES LEGEND:**

FO(B) - IOWA COMMUNICATIONS NETWORK  
FO(C) - IOWA COMMUNICATIONS NETWORK  
?? AERIAL POWER LINE

**TRAFFIC ESTIMATE**

2020 AADT	40,383	V.P.D.
2040 AADT	74,533	V.P.D.
2040 DHV		V.P.H.
TRUCKS	38	%
TOTAL DESIGN ESALS		

**LOCATION**

I-80 OVER CREEK  
T-79N R-02W  
SECTION 18  
ROCHESTER TOWNSHIP  
CEDAR COUNTY  
FHWA NO. ?  
BRIDGE MAINT. NO. ?  
LATITUDE 41.645061°  
LONGITUDE -91.115126°

**NOTES:**

1. PROP. VERTICAL DATUM IS APPROX. 8.40' HIGHER THAN USED ON EXISTING PLANS.
2. I-80 ELEVATIONS BASED ON EXISTING ROADWAY SURVEY PLUS 4" PROPOSED OVERLAY.
3. DESIGN FILL BASED ON FUTURE 4% SHOULDER.
4. EXISTING EXTENSION DES. NO. 191 WAS DESIGNED FOR 2' OF FILL. PROP. FILL WOULD BE 1.7'.
5. EXISTING PARAPETS FROM ORIGINAL CONSTRUCTION AND PREVIOUS EXTENSIONS TO BE REMOVED TO AVOID CONFLICT WITH PROPOSED PAVEMENT AND GRADING.

PRELIMINARY

DESIGN FOR 44°56'17" SKEW (R.A.)

**TWIN 8' X 8' REINFORCED CONCRETE BOX CULVERT EXTENSION**

**SITUATION PLAN**

STATION 800+57.59 AUGUST 2019

**CEDAR COUNTY**

IOWA DEPARTMENT OF TRANSPORTATION - HIGHWAY DIVISION  
DESIGN SHEET NO. 1 OF 1 FILE NO. 31800 DESIGN NO. ?

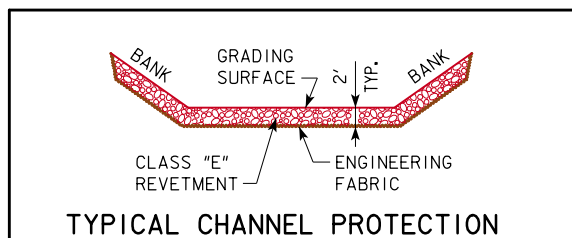

**ESTIMATED REVELTMENT QUANTITIES INCLUDED WITH ROAD PLANS**

LOCATION	REVELTMENT CL. "E" (TON)	ENGINEERING FABRIC (SY)	EXCAVATION (CY)
INLET	XX	XX	XX
OUTLET	XX	XX	XX
TOTALS	XX	XX	XX

EXCAVATION QUANTITY CALCULATED FROM GRADING SURFACE. QUANTITIES SHOWN FOR INFORMATION ONLY. SEE ROAD SHEETS.

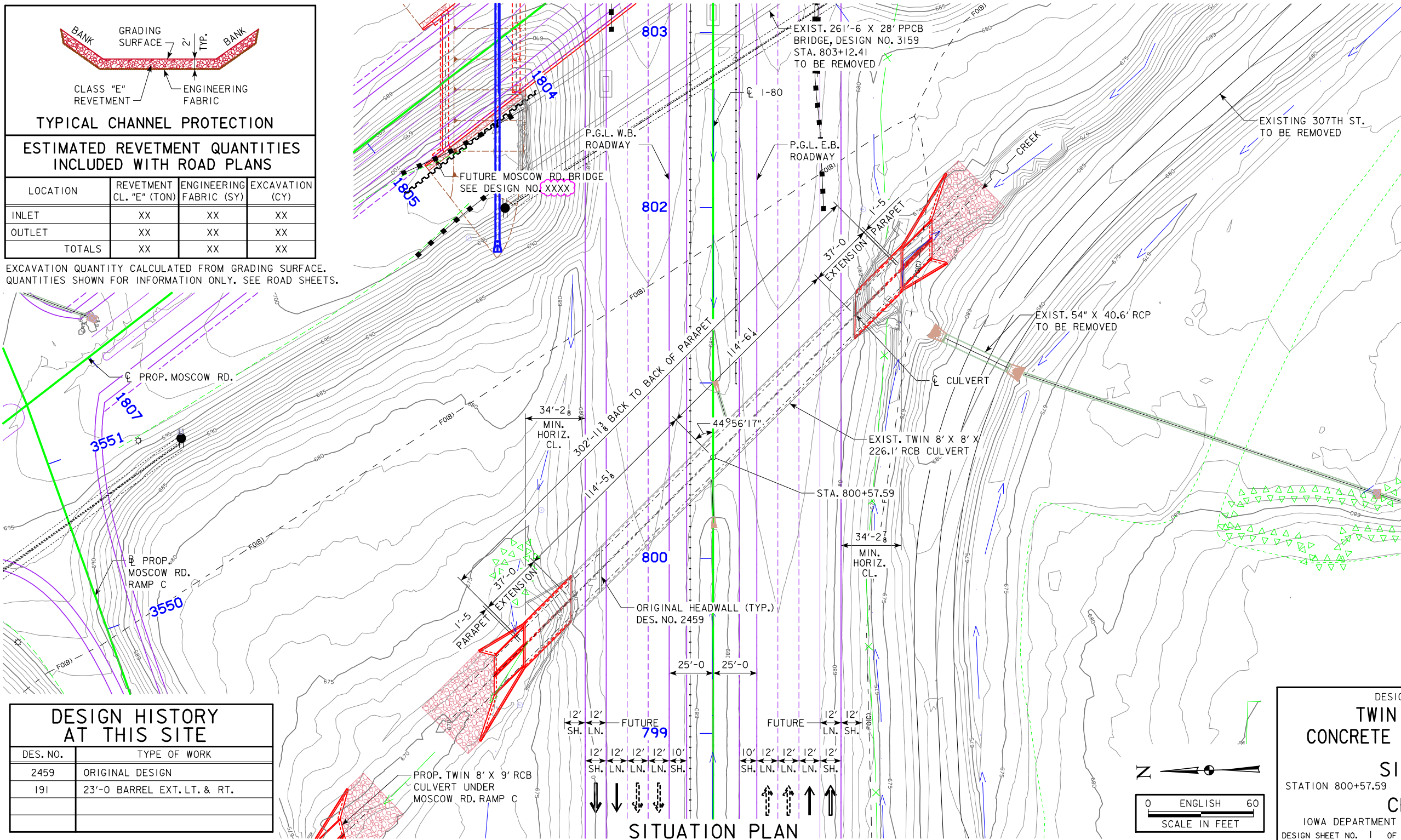

**DESIGN HISTORY AT THIS SITE**

DES. NO.	TYPE OF WORK
2459	ORIGINAL DESIGN
191	23'-0 BARREL EXT. LT. & RT.

**SITUATION PLAN**

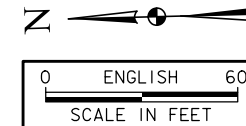



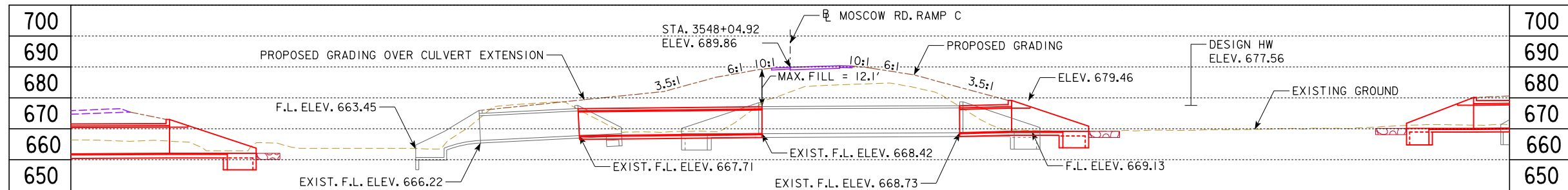

PROPOSED PROFILE GRADE MOSCOW RD. RAMP C

HYDRAULIC DATA

DRAINAGE AREA = 1.04 SQ. MI.  
 Q<sub>50</sub> = 824 CFS  
 HW ELEV. = 676.60  
 EXIT VELOCITY = 11.8 FPS  
 STREAM SLOPE = 90.5 FT./MI.  
 Q<sub>100</sub> = 989 CFS  
 HW ELEV. = 677.56  
 EXIT VELOCITY = 12.6 FPS

UTILITIES LEGEND:

FO(C) - IOWA COMMUNICATIONS NETWORK

TRAFFIC ESTIMATE

2020 AADT	1,007	V.P.D.
2040 AADT	1,428	V.P.D.
2040 DHV	-	V.P.H.
TRUCKS	17	%
TOTAL DESIGN ESALS	-	-

LOCATION

MOSCOW RD. RAMP C OVER CREEK  
 T-79N R-02W  
 SECTION 18  
 ROCHESTER TOWNSHIP  
 CEDAR COUNTY  
 FHWA NO. ?  
 BRIDGE MAINT. NO. ?  
 LATITUDE 41.645916°  
 LONGITUDE -91.116125°

- NOTES:
1. PROP. VERTICAL DATUM IS APPROX. 8.83' HIGHER THAN USED ON EXISTING PLANS.
  2. EXISTING RCB DES. NO. 2559 WAS DESIGNED FOR 8' OF FILL. PROP. FILL WOULD BE 13.1'.

**TYPICAL CHANNEL PROTECTION**

**ESTIMATED REVETMENT QUANTITIES INCLUDED WITH ROAD PLANS**

LOCATION	REVETMENT CL. "E" (TON)	ENGINEERING FABRIC (SY)	EXCAVATION (CY)
INLET	XX	XX	XX
OUTLET	XX	XX	XX
TOTALS	XX	XX	XX

EXCAVATION QUANTITY CALCULATED FROM GRADING SURFACE. QUANTITIES SHOWN FOR INFORMATION ONLY. SEE ROAD SHEETS.

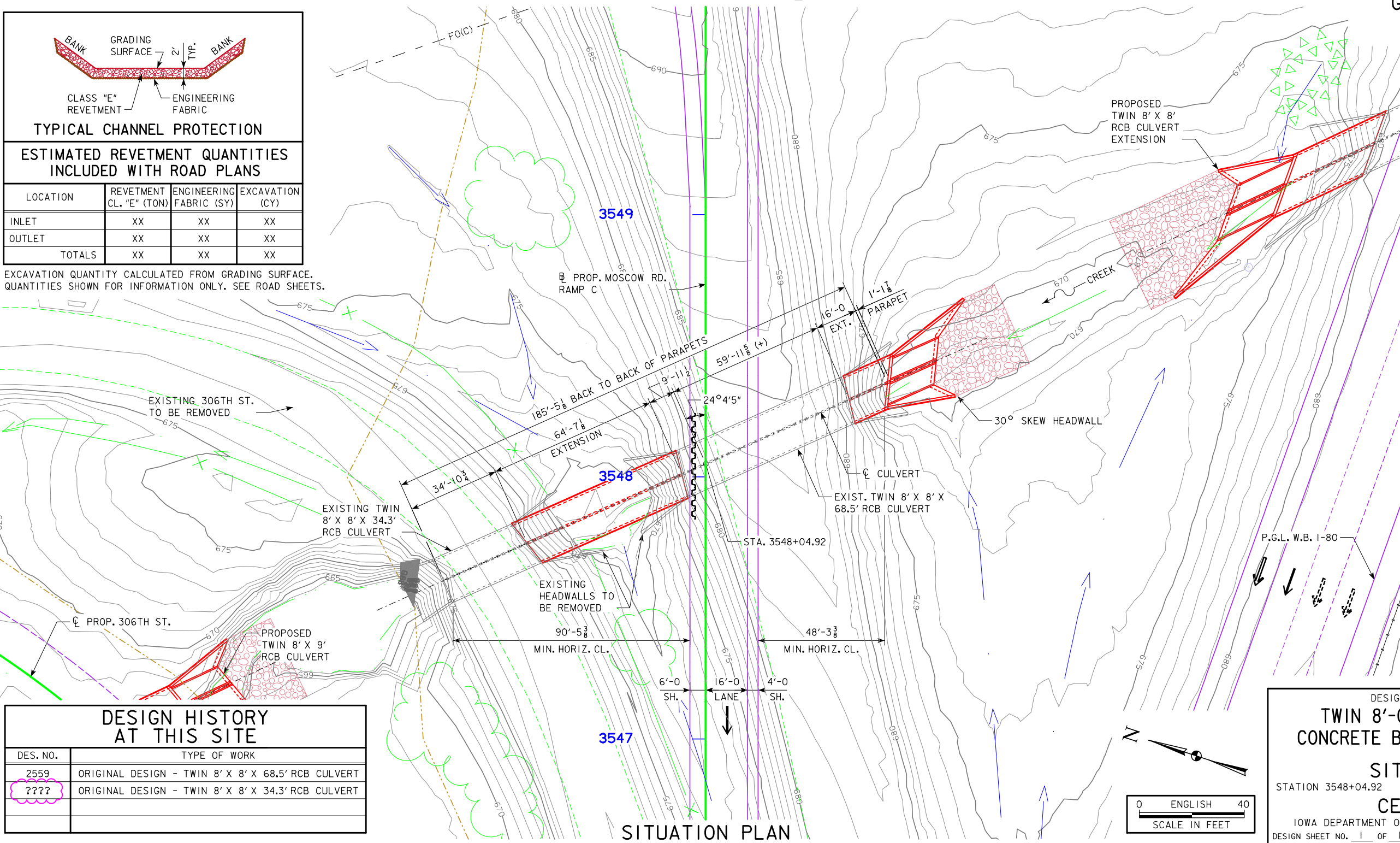

**DESIGN HISTORY AT THIS SITE**

DES. NO.	TYPE OF WORK
2559	ORIGINAL DESIGN - TWIN 8' X 8' X 68.5' RCB CULVERT
????	ORIGINAL DESIGN - TWIN 8' X 8' X 34.3' RCB CULVERT

PRELIMINARY  
 DESIGN FOR 24°4'5" SKEW (R.A.)  
**TWIN 8'-0 X 8'-0 REINFORCED CONCRETE BOX CULVERT EXTENSION**  
 SITUATION PLAN  
 STATION 3548+04.92  
 AUGUST 2019  
 CEDAR COUNTY  
 IOWA DEPARTMENT OF TRANSPORTATION - HIGHWAY DIVISION  
 DESIGN SHEET NO. 1 OF 1 FILE NO. 31800 DESIGN NO. ?



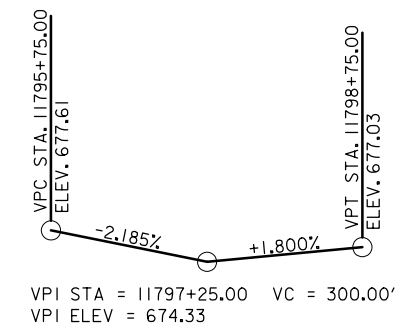
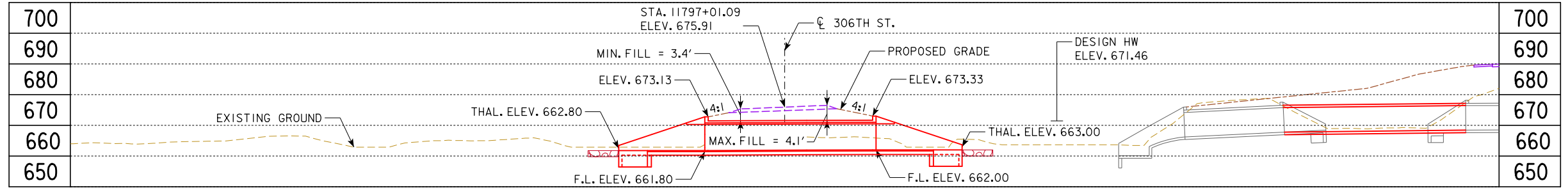

**TYPICAL CHANNEL PROTECTION**

**ESTIMATED REVETMENT QUANTITIES INCLUDED WITH ROAD PLANS**

LOCATION	REVETMENT CL. "E" (TON)	ENGINEERING FABRIC (SY)	EXCAVATION (CY)
INLET	XX	XX	XX
OUTLET	XX	XX	XX
TOTALS	XX	XX	XX

EXCAVATION QUANTITY CALCULATED FROM GRADING SURFACE. QUANTITIES SHOWN FOR INFORMATION ONLY. SEE ROAD SHEETS.

**PROPOSED PROFILE GRADE 306TH ST.**

**HYDRAULIC DATA**  
 DRAINAGE AREA = 1.1 SQ. MI.  
 Q<sub>50</sub> = 824 CFS  
 HW ELEV. = 670.50  
 EXIT VELOCITY = 11.8 FPS  
 STREAM SLOPE = 43.4 FT./MI.  
 Q<sub>100</sub> = 989 CFS  
 HW ELEV. = 671.46  
 EXIT VELOCITY = 12.6 FPS

**UTILITIES LEGEND:**  
 FO(C) - IOWA COMMUNICATIONS NETWORK

**TRAFFIC ESTIMATE**

2014 AADT	119	V.P.D.
2040 AADT	-	V.P.D.
2040 DHV	-	V.P.H.
TRUCKS	-	%
TOTAL DESIGN ESALS	-	

**LOCATION**  
 306TH ST. OVER CREEK  
 T-79N R-02W  
 SECTION 18  
 ROCHESTER TOWNSHIP  
 CEDAR COUNTY  
 LATITUDE 41.646334°  
 LONGITUDE -91.116631°

- NOTES:**
- CULVERT F.L. ELEVATION SUMPED 1' BELOW THALWEG ELEVATION.
  - EACH HEADWALL HAS DIFFERENT SKEW.

**CURVE DATA**

PI STA. 11798+63.62  
 Δ = 91°51'1"  
 D = 15°26'37"  
 T = 440.97'  
 L = 646.55'  
 E = 205.28'  
 R = 371.00'  
 e = 4.00%  
 I = 567.78'  
 x = 132.15'  
 PC STA. 11794+22.65  
 PT STA. 11800+69.20

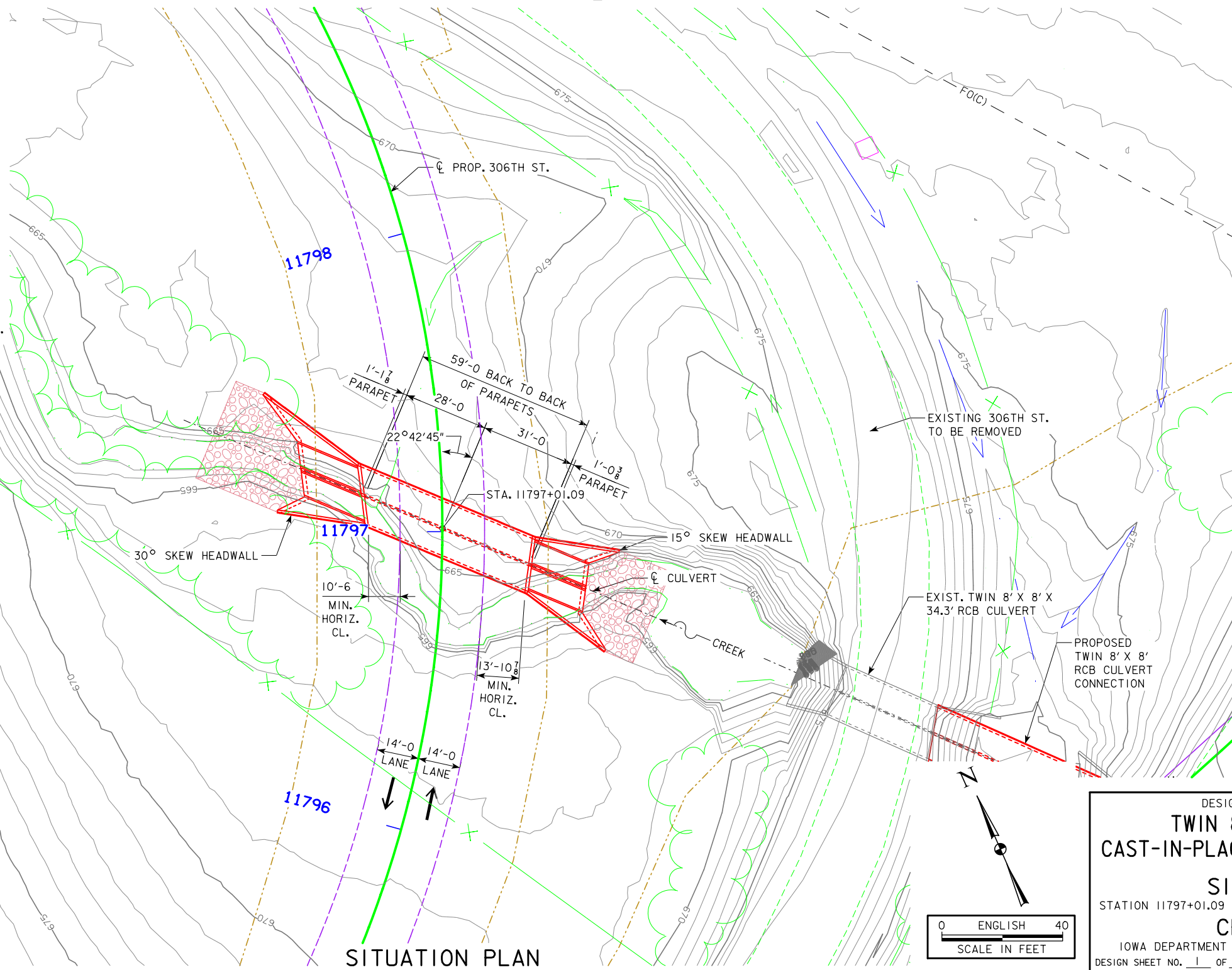

PRELIMINARY

DESIGN FOR 22°42'45" SKEW (L.A.)

**TWIN 8'-0" X 9'-0" X 59'-0"**

**CAST-IN-PLACE CONCRETE BOX CULVERT**

**SITUATION PLAN**

STATION 11797+01.09

AUGUST 2019

**CEDAR COUNTY**

IOWA DEPARTMENT OF TRANSPORTATION - HIGHWAY DIVISION

DESIGN SHEET NO. 1 OF 3 FILE NO. 31800 DESIGN NO. ?

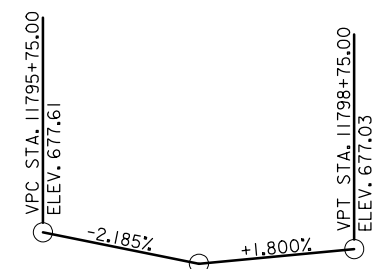
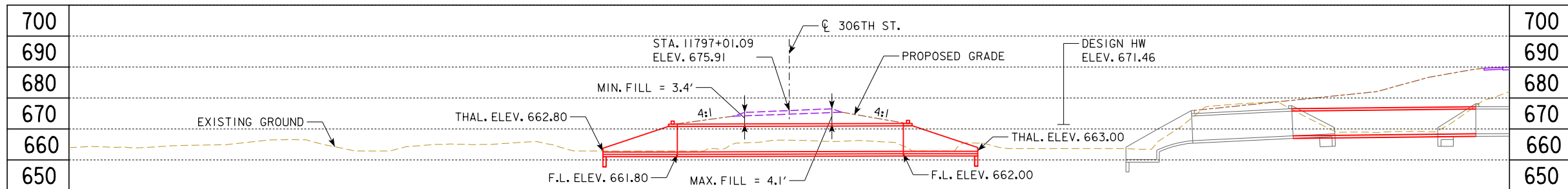

VPI STA = 11797+25.00 VC = 300.00'  
VPI ELEV = 674.33

**PROPOSED PROFILE GRADE 306TH ST.**

**HYDRAULIC DATA**

DRAINAGE AREA = 1.1 SQ. MI.  
Q<sub>50</sub> = 824 CFS  
HW ELEV. = 670.50  
EXIT VELOCITY = 11.8 FPS  
STREAM SLOPE = 43.4 FT./MI.  
Q<sub>100</sub> = 989 CFS  
HW ELEV. = 671.46  
EXIT VELOCITY = 12.6 FPS

**UTILITIES LEGEND:**

FO(C) - IOWA COMMUNICATIONS NETWORK

**TRAFFIC ESTIMATE**

2014 AADT	119	V.P.D.
2040 AADT	-	V.P.D.
2040 DHV	-	V.P.H.
TRUCKS	-	%
TOTAL DESIGN ESALS	-	

**LOCATION**

306TH ST. OVER CREEK  
T-79N R-02W  
SECTION 18  
ROCHESTER TOWNSHIP  
CEDAR COUNTY  
LATITUDE 41.646334°  
LONGITUDE -91.116631°

- NOTES:  
1. CULVERT F.L. ELEVATION SUMPED 1' BELOW THALWEG ELEVATIONS.  
2. EACH HEADWALL HAS DIFFERENT SKEW.

**TYPICAL CHANNEL PROTECTION**

CLASS "E" REVETMENT, ENGINEERING FABRIC

LOCATION	REVETMENT CL. "E" (TON)	ENGINEERING FABRIC (SY)	EXCAVATION (CY)
INLET	XX	XX	XX
OUTLET	XX	XX	XX
TOTALS	XX	XX	XX

EXCAVATION QUANTITY CALCULATED FROM GRADING SURFACE. QUANTITIES SHOWN FOR INFORMATION ONLY. SEE ROAD SHEETS.

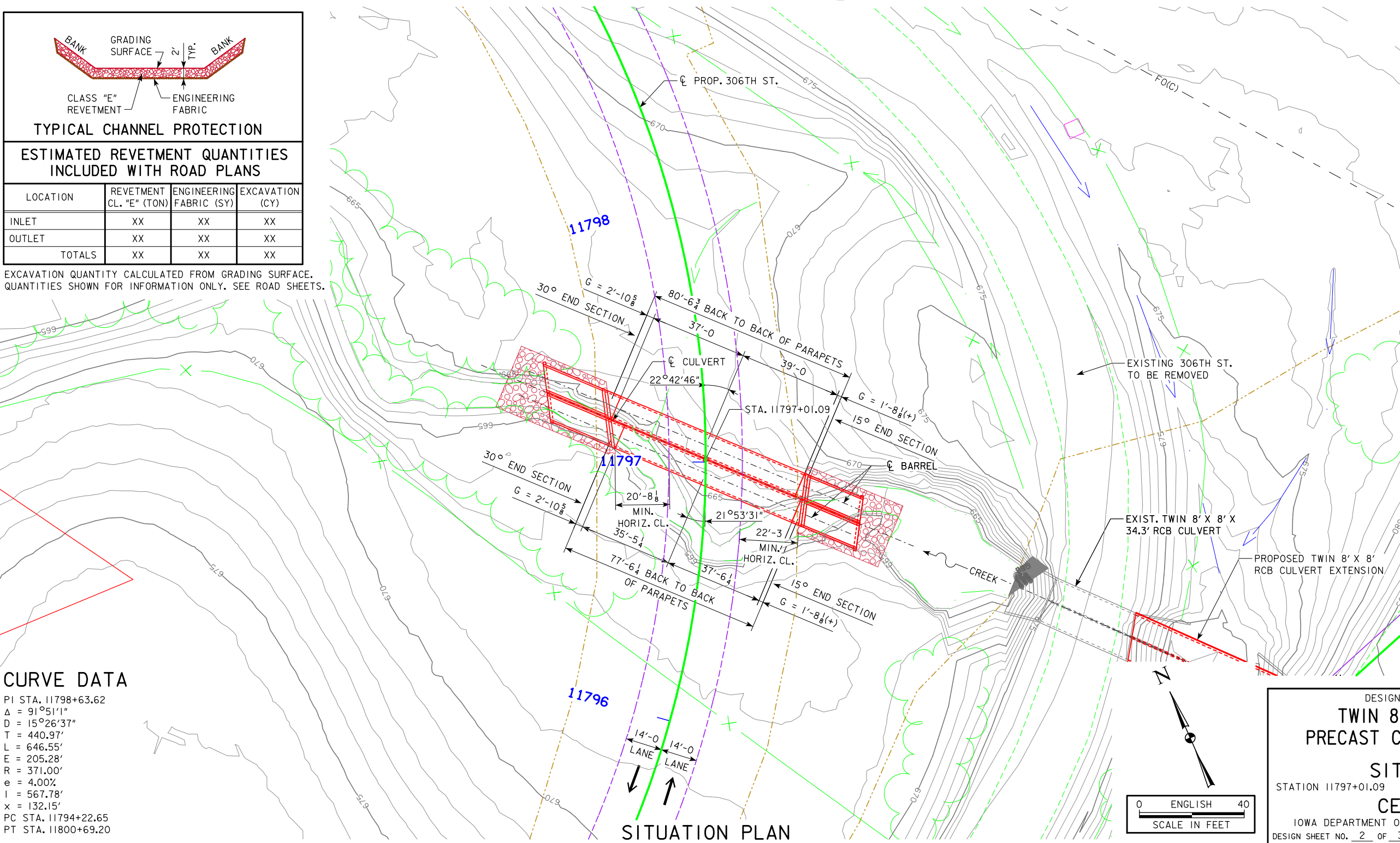

**CURVE DATA**

PI STA. 11798+63.62  
Δ = 91°51'1"  
D = 15°26'37"  
T = 440.97'  
L = 646.55'  
E = 205.28'  
R = 371.00'  
e = 4.00%  
l = 567.78'  
x = 132.15'  
PC STA. 11794+22.65  
PT STA. 11800+69.20



PRELIMINARY

DESIGN FOR 22°42'45" SKEW (L.A.)

**TWIN 8'-0 X 9'-0 X 76'-0  
PRECAST CONCRETE BOX CULVERT**

SITUATION PLAN

STATION 11797+01.09 AUGUST 2019

**CEDAR COUNTY**

IOWA DEPARTMENT OF TRANSPORTATION - HIGHWAY DIVISION  
DESIGN SHEET NO. 2 OF 3 FILE NO. 31800 DESIGN NO. ?



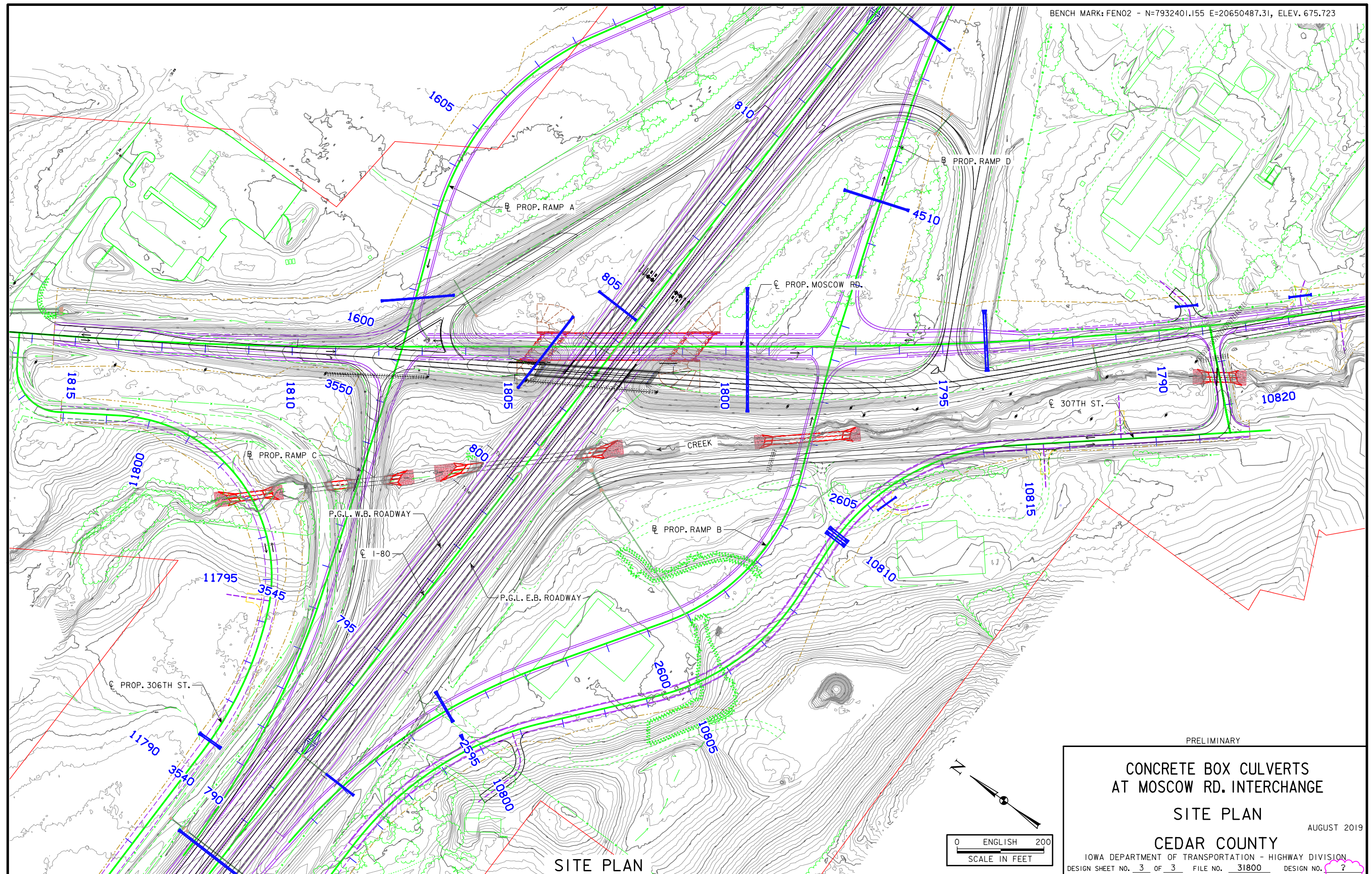

SITE PLAN

PRELIMINARY

**CONCRETE BOX CULVERTS  
AT MOSCOW RD. INTERCHANGE**

**SITE PLAN**

AUGUST 2019

**CEDAR COUNTY**

IOWA DEPARTMENT OF TRANSPORTATION - HIGHWAY DIVISION

DESIGN SHEET NO. 3 OF 3 FILE NO. 31800 DESIGN NO. ?



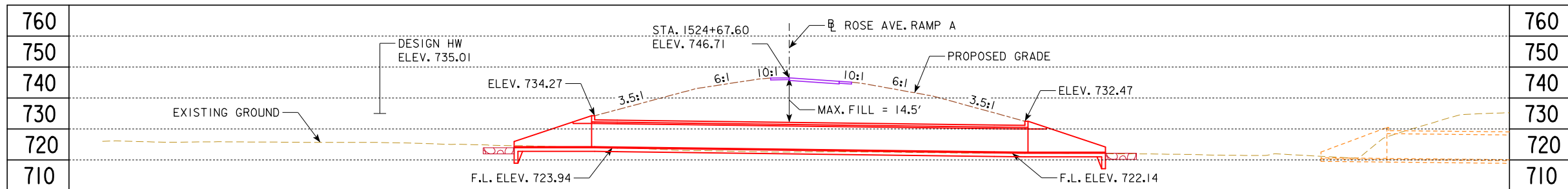

PROPOSED PROFILE GRADE ROSE AVE. RAMP A

HYDRAULIC DATA

DRAINAGE AREA = 0.50 SQ. MI.

Q<sub>50</sub> = 441 CFS  
 HW ELEV. = 733.43  
 EXIT VELOCITY = 17.0 FPS  
 STREAM SLOPE = 57.6 FT./MI.

Q<sub>100</sub> = 529 CFS  
 HW ELEV. = 735.01  
 EXIT VELOCITY = 17.7 FPS

UTILITIES LEGEND:

NO KNOWN UTILITIES

TRAFFIC ESTIMATE

2020 AADT	327	V.P.D.
2040 AADT	371	V.P.D.
2040 DHV		V.P.H.
TRUCKS	39	%
TOTAL DESIGN ESALs		

LOCATION

ROSE AVE. RAMP A OVER CREEK  
 T-79N R-02W  
 SECTION 24  
 SUGAR CREEK TOWNSHIP  
 CEDAR COUNTY  
 LATITUDE 41.637081°  
 LONGITUDE -91.033983°

NOTES:  
 1. EACH HEADWALL HAS DIFFERENT SKEW

**TYPICAL CHANNEL PROTECTION**

**ESTIMATED REVETMENT QUANTITIES INCLUDED WITH ROAD PLANS**

LOCATION	REVETMENT CL. "E" (TON)	ENGINEERING FABRIC (SY)	EXCAVATION (CY)
INLET	XX	XX	XX
OUTLET	XX	XX	XX
TOTALS	XX	XX	XX

EXCAVATION QUANTITY CALCULATED FROM GRADING SURFACE. QUANTITIES SHOWN FOR INFORMATION ONLY. SEE ROAD SHEETS.

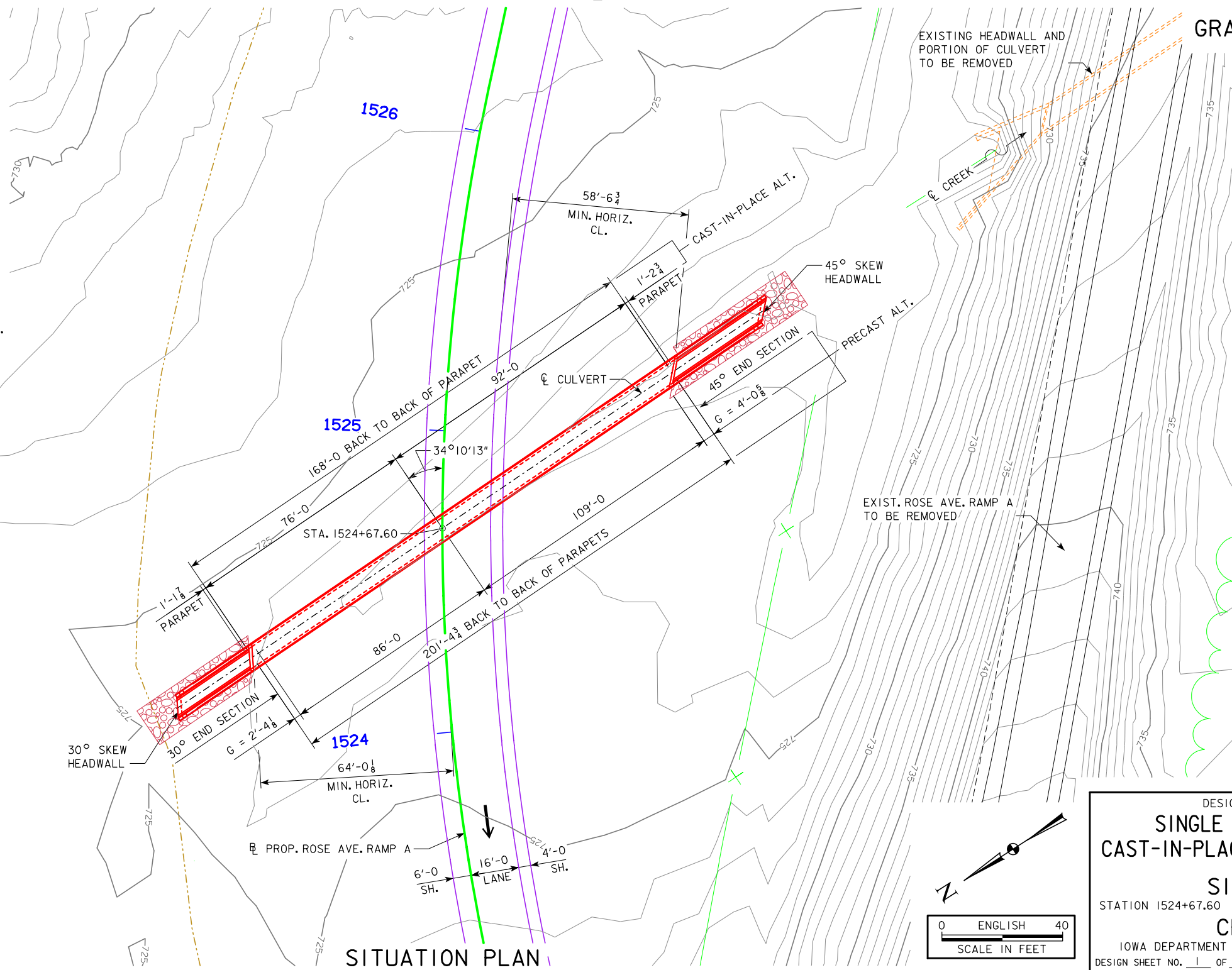

CURVE DATA

PI STA. 1522+53.64  
 Δ = 29°33'06"  
 D = 8°11'06"  
 T = 184.63'  
 L = 361.04'  
 E = 23.94'  
 R = 700.00'  
 e = 2.0%  
 I = 357.05'  
 x = 23.14'  
 PC STA. 1522+53.64  
 PT STA. 1526+14.68

PRELIMINARY

DESIGN FOR 34°10'13" SKEW (R.A.)

**SINGLE 6'-0" X 8'-0" X 168'-0" CAST-IN-PLACE CONCRETE BOX CULVERT**

SITUATION PLAN

STATION 1524+67.60

AUGUST 2019

CEDAR COUNTY

IOWA DEPARTMENT OF TRANSPORTATION - HIGHWAY DIVISION

DESIGN SHEET NO. 1 OF 1 FILE NO. 31800 DESIGN NO. ?



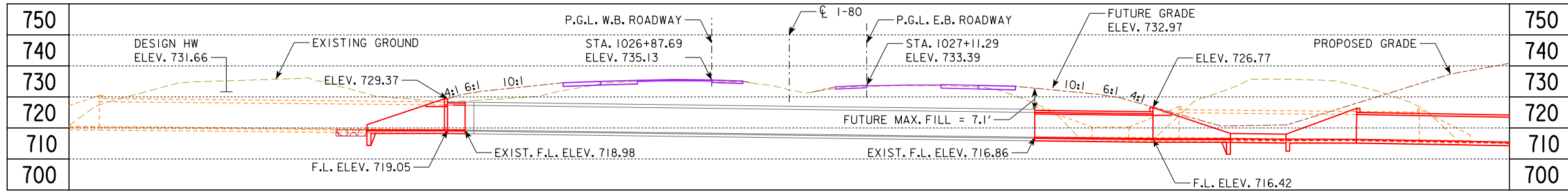

LONGITUDINAL SECTION ALONG  $\varnothing$  CULVERT

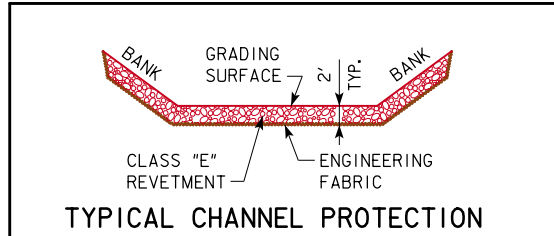

**ESTIMATED REVETMENT QUANTITIES INCLUDED WITH ROAD PLANS**

LOCATION	REVETMENT CL. "E" (TON)	ENGINEERING FABRIC (SY)	EXCAVATION (CY)
INLET	XX	XX	XX
OUTLET	XX	XX	XX
TOTALS	XX	XX	XX

EXCAVATION QUANTITY CALCULATED FROM GRADING SURFACE. QUANTITIES SHOWN FOR INFORMATION ONLY. SEE ROAD SHEETS.

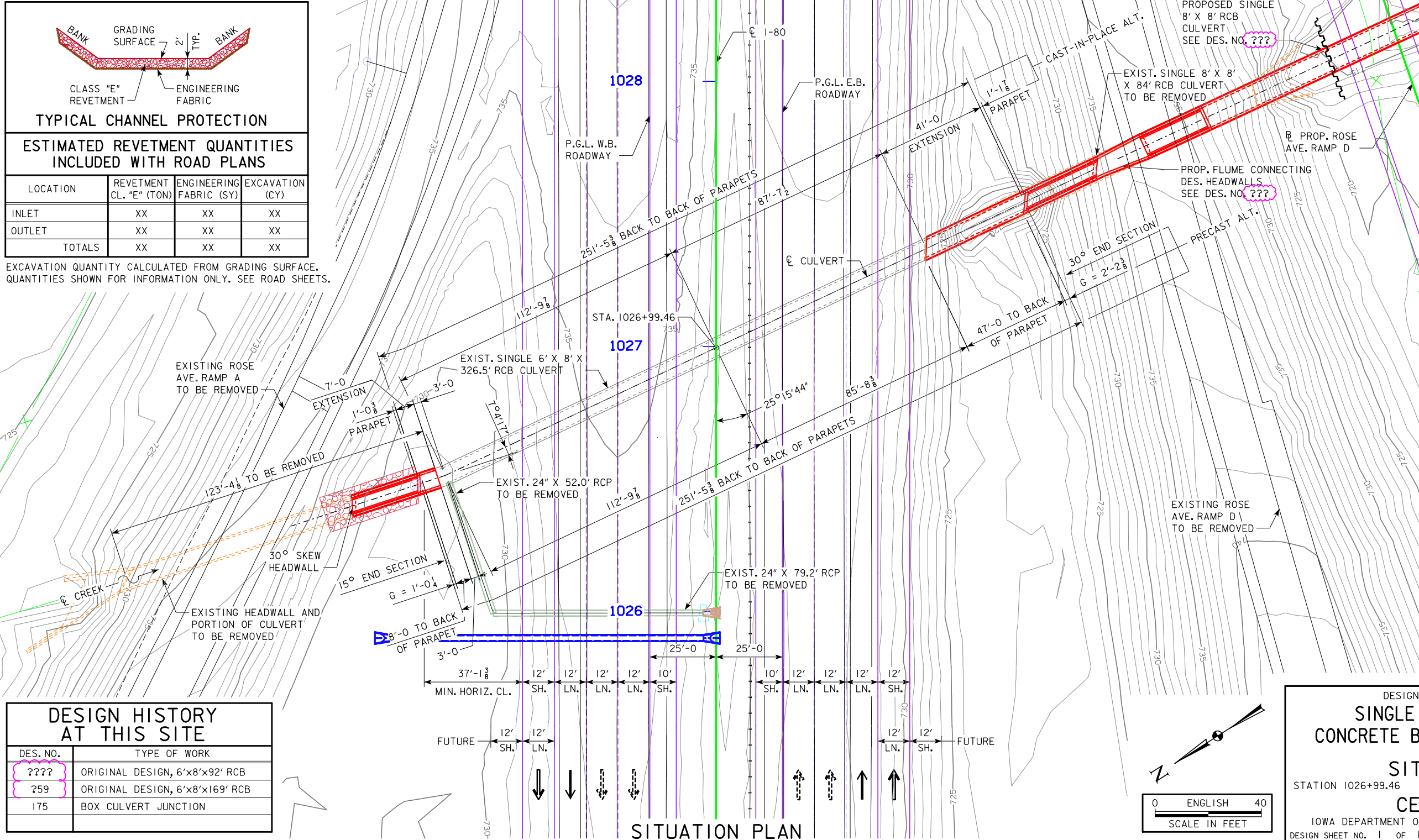

**HYDRAULIC DATA**

DRAINAGE AREA = 0.52 SQ. MI.  
 $Q_{50}$  = 506 CFS  
 HW ELEV. = 729.69  
 EXIT VELOCITY = 15.6 FPS  
 STREAM SLOPE = 57.6 FT./MI.  
 $Q_{100}$  = 606 CFS  
 HW ELEV. = 731.66  
 EXIT VELOCITY = 16.2 FPS

**UTILITIES LEGEND:**

NO KNOWN UTILITIES

**TRAFFIC ESTIMATE**

2020 AADT	38,414	V.P.D.
2040 AADT	72,430	V.P.D.
2040 DHV	-	V.P.H.
TRUCKS	39	%
TOTAL DESIGN ESALS	-	-

**LOCATION**

I-80 OVER CREEK  
 T-79N R-02W  
 SECTION 24  
 SUGAR CREEK TOWNSHIP  
 CEDAR COUNTY  
 LATITUDE 41.635735°  
 LONGITUDE -91.033820°

- NOTES:**
1. PROP. VERTICAL DATUM IS APPROX. 8.13' HIGHER THAN USED ON EXISTING PLANS.
  2. I-80 ELEVATIONS BASED ON EXISTING ROADWAY SURVEY PLUS PROPOSED 4" OVERLAY.
  3. MAX FILL BASED ON FUTURE 4% SHLD.
  4. INCLUDES REMOVING 123'-4" OF EXISTING RCB.
  5. EACH HEADWALL HAS DIFFERENT SKEW

**DESIGN HISTORY AT THIS SITE**

DES. NO.	TYPE OF WORK
????	ORIGINAL DESIGN, 6'x8'x92' RCB
?59	ORIGINAL DESIGN, 6'x8'x169' RCB
175	BOX CULVERT JUNCTION

PRELIMINARY  
 DESIGN FOR VARIABLE SKEW (R.A.)  
**SINGLE 6' X 8' REINFORCED CONCRETE BOX CULVERT EXTENSION**  
 SITUATION PLAN  
 STATION 1026+99.46  
 CEDAR COUNTY  
 IOWA DEPARTMENT OF TRANSPORTATION - HIGHWAY DIVISION  
 DESIGN SHEET NO. 1 OF 1 FILE NO. 31800 DESIGN NO. ?

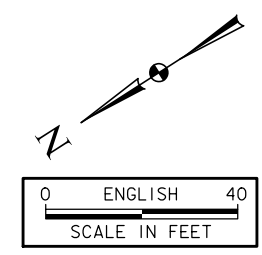

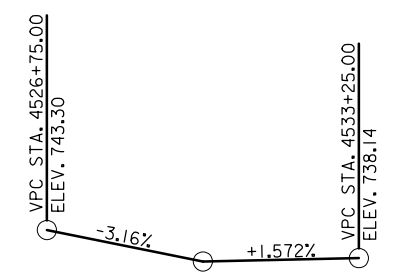
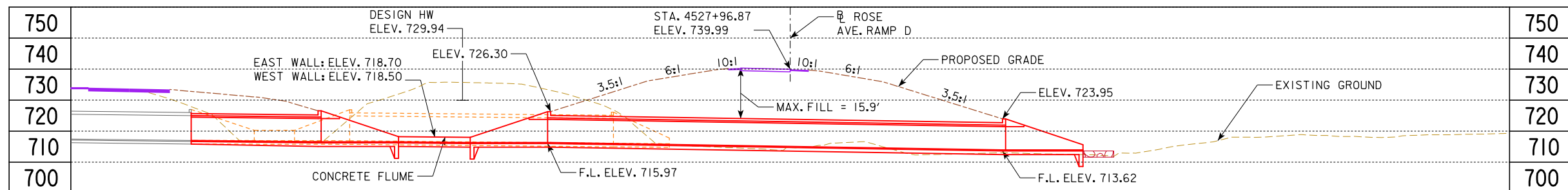

LONGITUDINAL SECTION ALONG CL CULVERT

PROPOSED PROFILE GRADE ROSE AVE. RAMP D

HYDRAULIC DATA

DRAINAGE AREA = 0.64 SQ. MI.  
 Q<sub>50</sub> = 743 CFS  
 HW ELEV. = 727.58  
 EXIT VELOCITY = 19.3 FPS  
 STREAM SLOPE = 57.6 FT./MI.  
 Q<sub>100</sub> = 890 CFS  
 HW ELEV. = 729.94  
 EXIT VELOCITY = 20.1 FPS

UTILITIES LEGEND:

F0(C) - IOWA COMMUNICATIONS NETWORK  
 F02(C) - AUREON NETWORK SERVICES (INS)  
 F04(C) - WTC COMMUNICATIONS

TRAFFIC ESTIMATE

2020 AADT	328	V.P.D.
2040 AADT	372	V.P.D.
2040 DHV	-	V.P.H.
TRUCKS	17	%
TOTAL DESIGN ESALs	-	

LOCATION

ROSE AVE. RAMP D OVER CREEK  
 T-79N R-02W  
 SECTION 24  
 SUGAR CREEK TOWNSHIP  
 CEDAR COUNTY  
 LATITUDE 41.635050°  
 LONGITUDE -91.033689°

NOTES:  
 1. INCLUDES CONSTRUCTION OF CONCRETE FLUME TO CONNECT TO CULVERT EXTENSION DESIGN NO. XXXX.

**TYPICAL CHANNEL PROTECTION**

**ESTIMATED REVETMENT QUANTITIES INCLUDED WITH ROAD PLANS**

LOCATION	REVETMENT CL. "E" (TON)	ENGINEERING FABRIC (SY)	EXCAVATION (CY)
INLET	XX	XX	XX
OUTLET	XX	XX	XX
TOTALS	XX	XX	XX

EXCAVATION QUANTITY CALCULATED FROM GRADING SURFACE. QUANTITIES SHOWN FOR INFORMATION ONLY. SEE ROAD SHEETS.

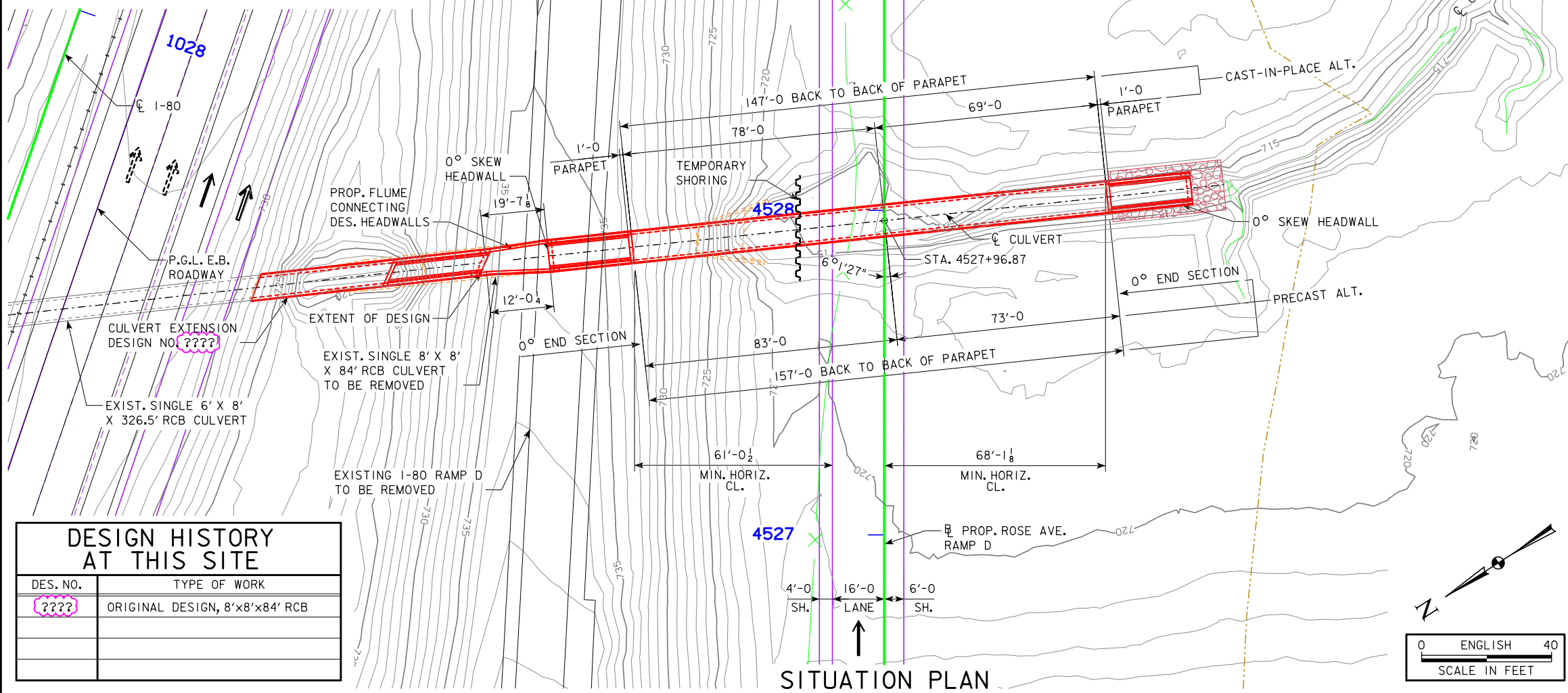

**DESIGN HISTORY AT THIS SITE**

DES. NO.	TYPE OF WORK
????	ORIGINAL DESIGN, 8'x8'x84' RCB

PRELIMINARY  
 DESIGN FOR 6°1'27" SKEW (R.A.)  
**SINGLE 8'-0 X 8'-0 X 147'-0**  
**CAST-IN-PLACE CONCRETE BOX CULVERT**  
 SITUATION PLAN  
 STATION 4527+96.87  
 AUGUST 2019  
**CEDAR COUNTY**  
 IOWA DEPARTMENT OF TRANSPORTATION - HIGHWAY DIVISION  
 DESIGN SHEET NO. 1 OF 2 FILE NO. 31800 DESIGN NO. ?

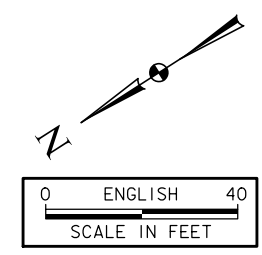



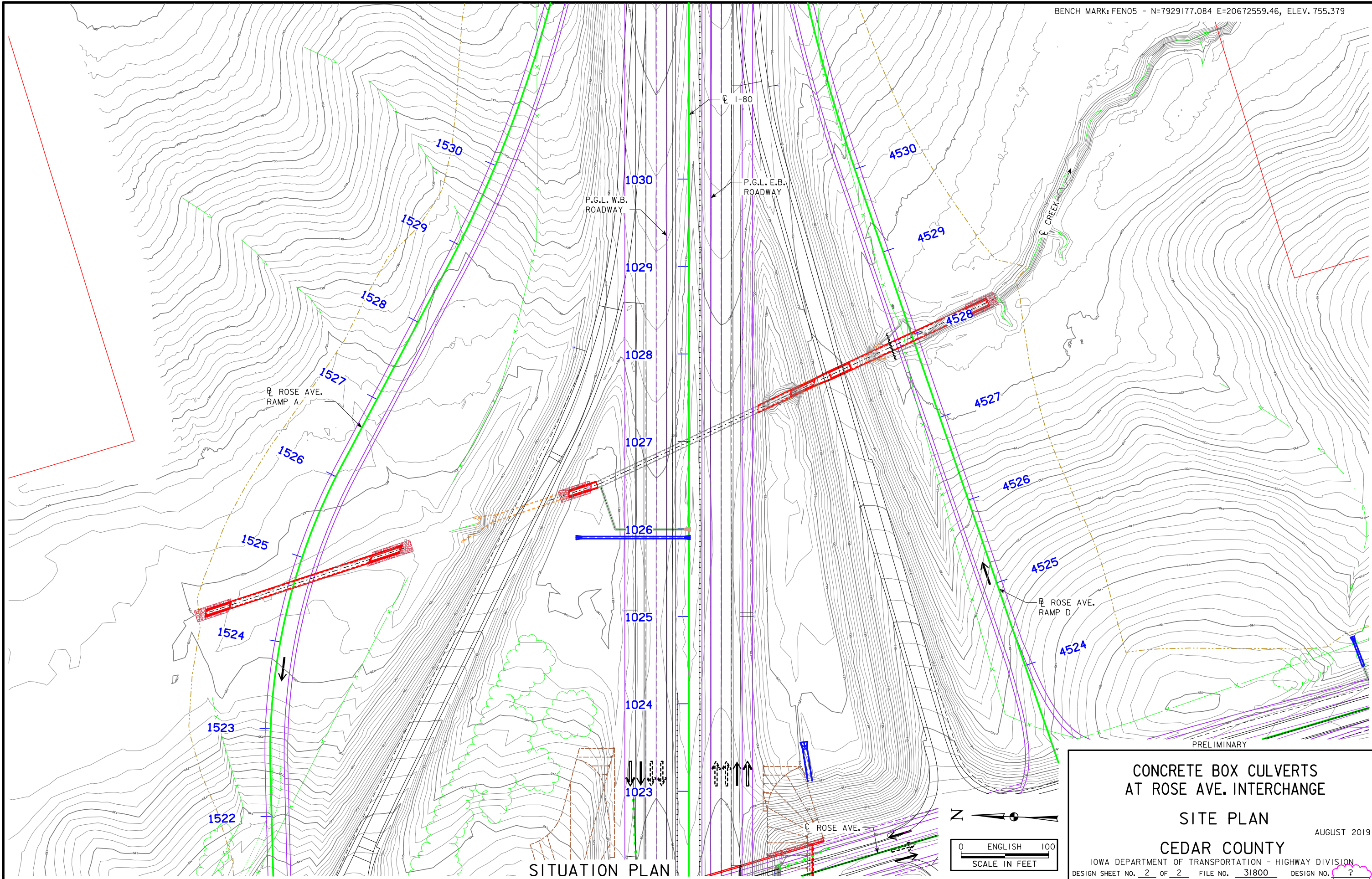

SITUATION PLAN

PRELIMINARY

**CONCRETE BOX CULVERTS  
AT ROSE AVE. INTERCHANGE**

**SITE PLAN**

AUGUST 2019

**CEDAR COUNTY**

IOWA DEPARTMENT OF TRANSPORTATION - HIGHWAY DIVISION  
 DESIGN SHEET NO. 2 OF 2 FILE NO. 31800 DESIGN NO. ?



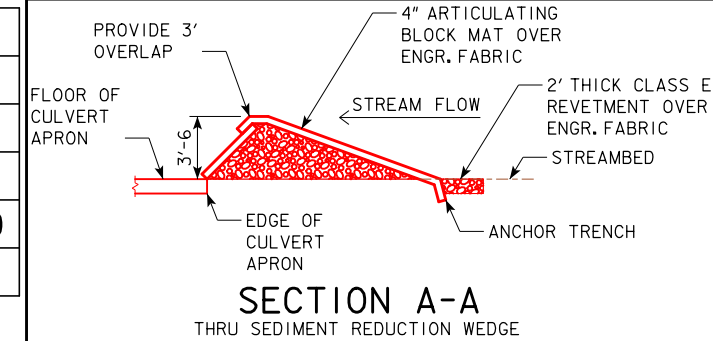
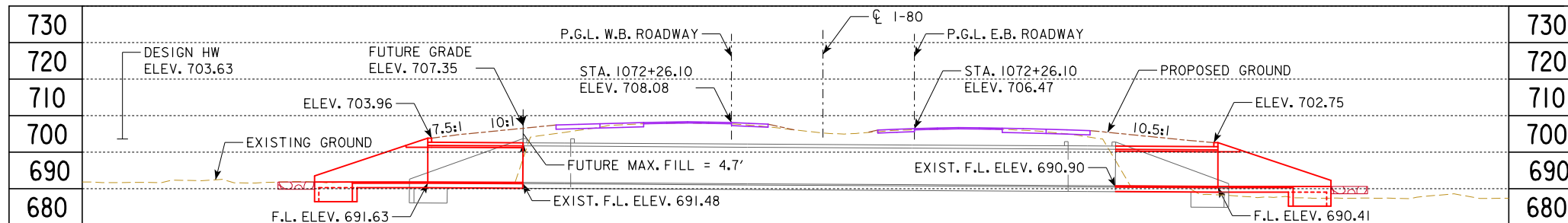

**TYPICAL CHANNEL PROTECTION**

BANK GRADING SURFACE 2' TYPE BANK  
CLASS "E" REVELMENT ENGINEERING FABRIC

**ESTIMATED REVELMENT QUANTITIES INCLUDED WITH ROAD PLANS**

LOCATION	REVELMENT CL. "E" (TON)	ENGINEERING FABRIC (SY)	EXCAVATION (CY)
INLET	XX	XX	XX
OUTLET	XX	XX	XX
TOTALS	XX	XX	XX

EXCAVATION QUANTITY CALCULATED FROM GRADING SURFACE. QUANTITIES SHOWN FOR INFORMATION ONLY. SEE ROAD SHEETS.

**HYDRAULIC DATA**

DRAINAGE AREA = 6.18 SQ. MI.

Q<sub>50</sub> = 3,072 CFS  
HW ELEV. = 702.25  
EXIT VELOCITY = 9.08 FPS  
STREAM SLOPE = 23.23 FT./MI.

Q<sub>100</sub> = 3,708 CFS  
HW ELEV. = 703.63  
EXIT VELOCITY = 10.30 FPS

**UTILITIES LEGEND:**

FO(C) - IOWA COMMUNICATION NETWORK

**TRAFFIC ESTIMATE**

2020 AADT	39,069	V.P.D.
2040 AADT	73,173	V.P.D.
2040 DHV	-	V.P.H.
TRUCKS	39	%
TOTAL DESIGN ESALS	-	

**LOCATION**

I-80 OVER OTTER CREEK  
T-79N R-02W  
SECTION 24  
SUGAR CREEK TOWNSHIP  
CEDAR COUNTY  
FHWA NO. 18680  
BRIDGE MAINT. NO. 1672.0S080  
LATITUDE 41.633377°  
LONGITUDE -91.017740°

- NOTES:**
1. PROP. VERTICAL DATUM IS APPROX. 8.08' HIGHER THAN USED ON EXISTING PLANS.
  2. I-80 ELEVATIONS BASED ON EXISTING ROADWAY SURVEY PLUS PROPOSED 4" OVERLAY.
  3. MAX FILL BASED ON FUTURE 4% SHLD.
  4. EXISTING EXTENSION DES. NO. 291 DESIGNED FOR 3' OF FILL. PROPOSED FILL WOULD BE 5.4' OVER EXISTING CULVERT.
  5. EXTENSION INCLUDES SEDIMENT REDUCTION WEDGE AT UPSTREAM HEADWALL.

PRELIMINARY

DESIGN FOR 0° SKEW

**TRIPLE 12' X 10' REINFORCED CONCRETE BOX CULVERT EXTENSION**

**SITUATION PLAN**

STATION 1072+26.10 AUGUST 2019

**CEDAR COUNTY**

IOWA DEPARTMENT OF TRANSPORTATION - HIGHWAY DIVISION  
DESIGN SHEET NO. 1 OF 1 FILE NO. 31800 DESIGN NO. ?

**DESIGN HISTORY AT THIS SITE**

DES. NO.	TYPE OF WORK
1459	ORIGINAL DESIGN
291	12'-0 BARREL EXT. LT. & RT.

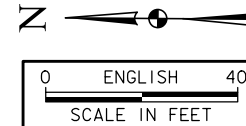
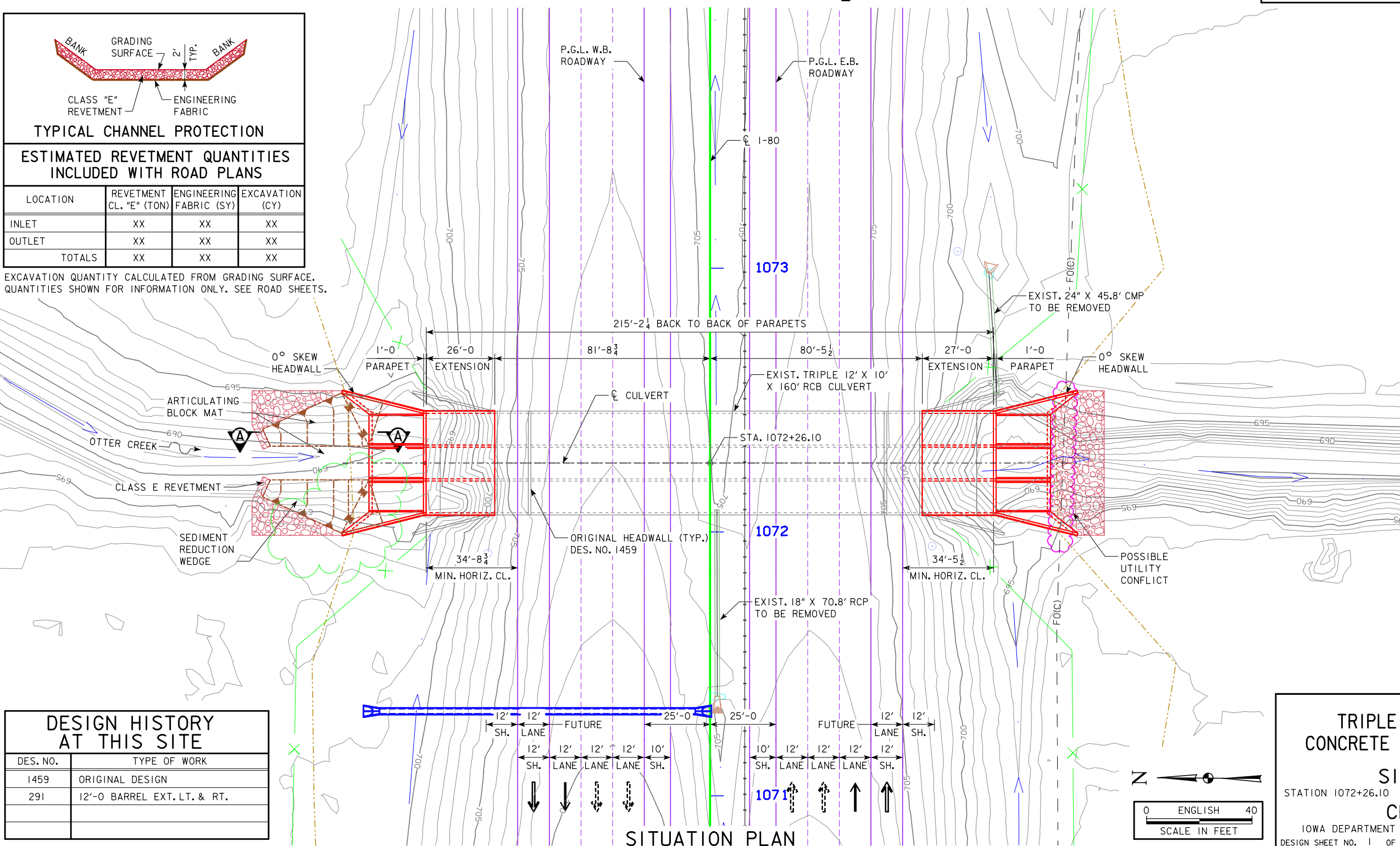



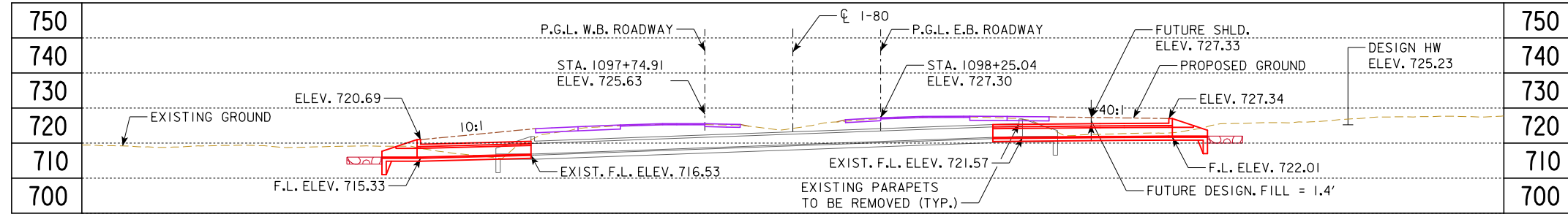

**HYDRAULIC DATA**

DRAINAGE AREA = 0.09 SQ. MI.  
 Q = 95 CFS  
 HW ELEV. = 724.69  
 EXIT VELOCITY = 14.1 FPS  
 STREAM SLOPE = 79.4 FT./MI.  
 Q<sub>100</sub> = 113 CFS  
 HW ELEV. = 725.23  
 EXIT VELOCITY = 14.9 FPS

**UTILITIES LEGEND:**

FO(C) - IOWA COMMUNICATION NETWORK

**TRAFFIC ESTIMATE**

2020 AADT	39,069	V.P.D.
2040 AADT	73,173	V.P.D.
2040 DHV	-	V.P.H.
TRUCKS	39	%
TOTAL DESIGN ESALS	-	

**LOCATION**

I-80 OVER CREEK  
 T-79N R-02W  
 SECTION 24  
 SUGAR CREEK TOWNSHIP  
 CEDAR COUNTY  
 LATITUDE 41.633379°  
 LONGITUDE -91.008287°

**NOTES:**

- PROP. VERTICAL DATUM IS APPROX. 8.12' HIGHER THAN USED ON EXISTING PLANS.
- I-80 ELEVATIONS BASED ON EXISTING ROADWAY SURVEY PLUS PROPOSED 4" OVERLAY.
- DESIGN MAX FILL BASED ON FUTURE 4% SHLD.
- EXISTING EXTENSION DES. NO. ??? DESIGNED FOR 4' OF FILL. PROPOSED FILL WOULD BE 2.5' OVER EXISTING CULVERT.
- EXISTING PARAPETS FROM ORIGINAL CONSTRUCTION TO BE REMOVED TO AVOID CONFLICT WITH 6. PROPOSED PAVEMENT AND GRADING. INCLUDES REMOVING 10'-6 OF EXISTING RCB.

**TYPICAL CHANNEL PROTECTION**

**ESTIMATED REVETMENT QUANTITIES INCLUDED WITH ROAD PLANS**

LOCATION	REVETMENT CL. "E" (TON)	ENGINEERING FABRIC (SY)	EXCAVATION (CY)
INLET	XX	XX	XX
OUTLET	XX	XX	XX
TOTALS	XX	XX	XX

EXCAVATION QUANTITY CALCULATED FROM GRADING SURFACE. QUANTITIES SHOWN FOR INFORMATION ONLY. SEE ROAD SHEETS.

**DESIGN HISTORY AT THIS SITE**

DES. NO.	TYPE OF WORK
????	ORIGINAL DESIGN

**CURVE DATA**

PI STA.  
 Δ = 0°42'0"  
 D = 0°14'16"  
 T = 140.01'  
 L = 280.02'  
 E = 0.4276'  
 R = 22,920'  
 e = 0.0%  
 I = 280.0182'  
 x = 0.4276'  
 PC STA. 1095+95.95  
 PT STA. 1098+75.97

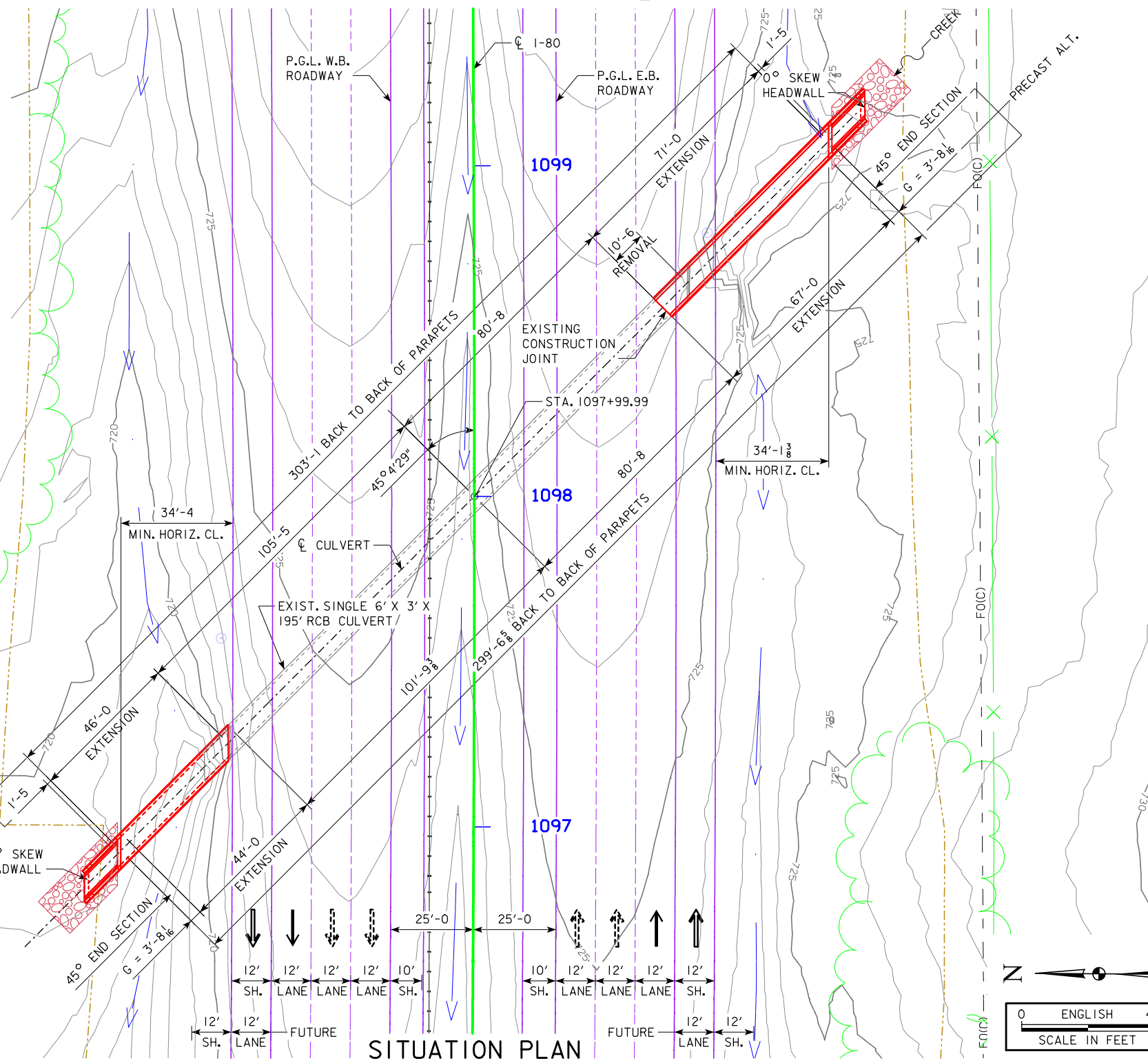

PRELIMINARY

DESIGN FOR 45°4'29" SKEW (R.A.)

**SINGLE 6' X 3' REINFORCED CONCRETE BOX CULVERT EXTENSION**

**SITUATION PLAN**

STATION 1097+99.99      AUGUST 2019

**CEDAR COUNTY**

IOWA DEPARTMENT OF TRANSPORTATION - HIGHWAY DIVISION

DESIGN SHEET NO. 1 OF 1      FILE NO. 31800      DESIGN NO. ?

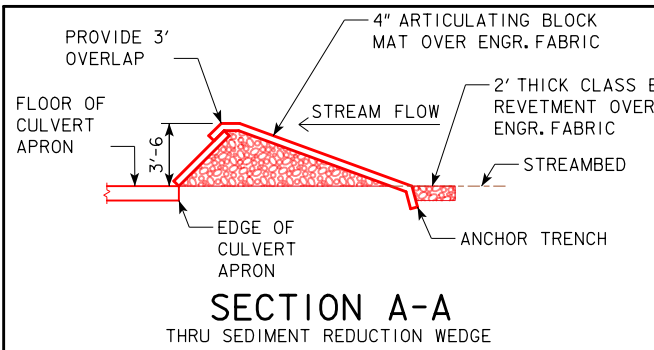
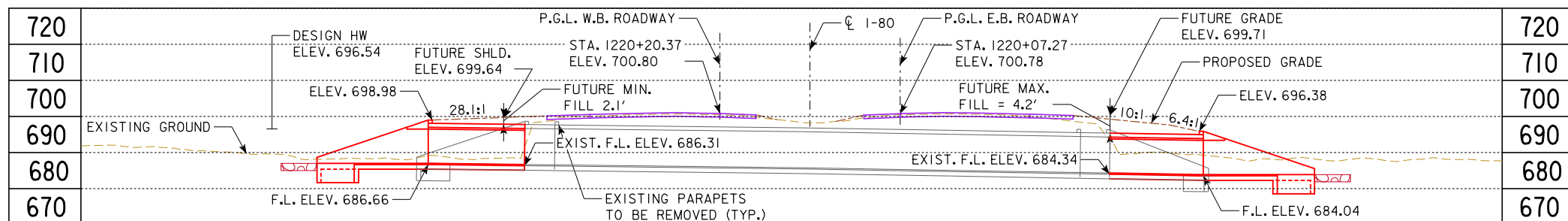

LONGITUDINAL SECTION ALONG CL CULVERT

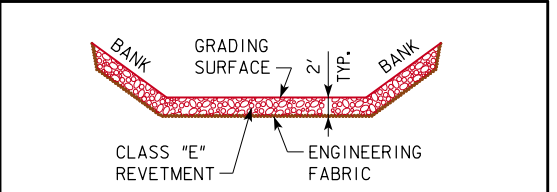

**ESTIMATED REVETMENT QUANTITIES INCLUDED WITH ROAD PLANS**

LOCATION	REVETMENT CL. "E" (TON)	ENGINEERING FABRIC (SY)	EXCAVATION (CY)
INLET	XX	XX	XX
OUTLET	XX	XX	XX
TOTALS	XX	XX	XX

**HYDRAULIC DATA**

DRAINAGE AREA = 7.62 SQ. MI.  
 Q<sub>50</sub> = 3,250 CFS  
 HW ELEV. = 695.44  
 EXIT VELOCITY = 19.09 FPS  
 STREAM SLOPE = 19.01 FT./MI.  
 Q<sub>100</sub> = 3,860 CFS  
 HW ELEV. = 696.54  
 EXIT VELOCITY = 19.89 FPS

**UTILITIES LEGEND:**

FO(C) - IOWA COMMUNICATION NETWORK

**LOCATION**

I-80 OVER LITTLE ELKHORN CREEK  
 T-79N R-01W  
 SECTION 20  
 FARMINGTON TOWNSHIP  
 CEDAR COUNTY  
 FHWA NO. 18700  
 BRIDGE MAINT. NO. 1673.95080  
 LATITUDE 41.633575°  
 LONGITUDE -90.979843°

**TRAFFIC ESTIMATE**

2020 AADT	39,069	V.P.D.
2040 AADT	73,173	V.P.D.
2040 DHV		V.P.H.
TRUCKS	39	%
TOTAL DESIGN ESALS		

- NOTES:
- PROP. VERTICAL DATUM IS APPROX. 8.23' HIGHER THAN USED ON EXISTING PLANS
  - I-80 ELEVATIONS BASED ON EXISTING ROADWAY SURVEY PLUS PROPOSED 4" OVERLAY.
  - MAX. FILL BASED ON FUTURE 4% SHLD.
  - EXISTING EXTENSION DES. NO. 391 WAS DESIGNED FOR 2' OF FILL. PROP. FILL WOULD BE 4.6'.
  - NON STANDARD CULVERT DESIGN.
  - EXTENSION INCLUDES SEDIMENT REDUCTION WEDGE AT UPSTREAM HEADWALL.
  - EXISTING PARAPETS FROM ORIGINAL CONSTRUCTION AND PREVIOUS EXTENSIONS TO BE REMOVED TO AVOID CONFLICT WITH PROPOSED PAVEMENT AND GRADING.

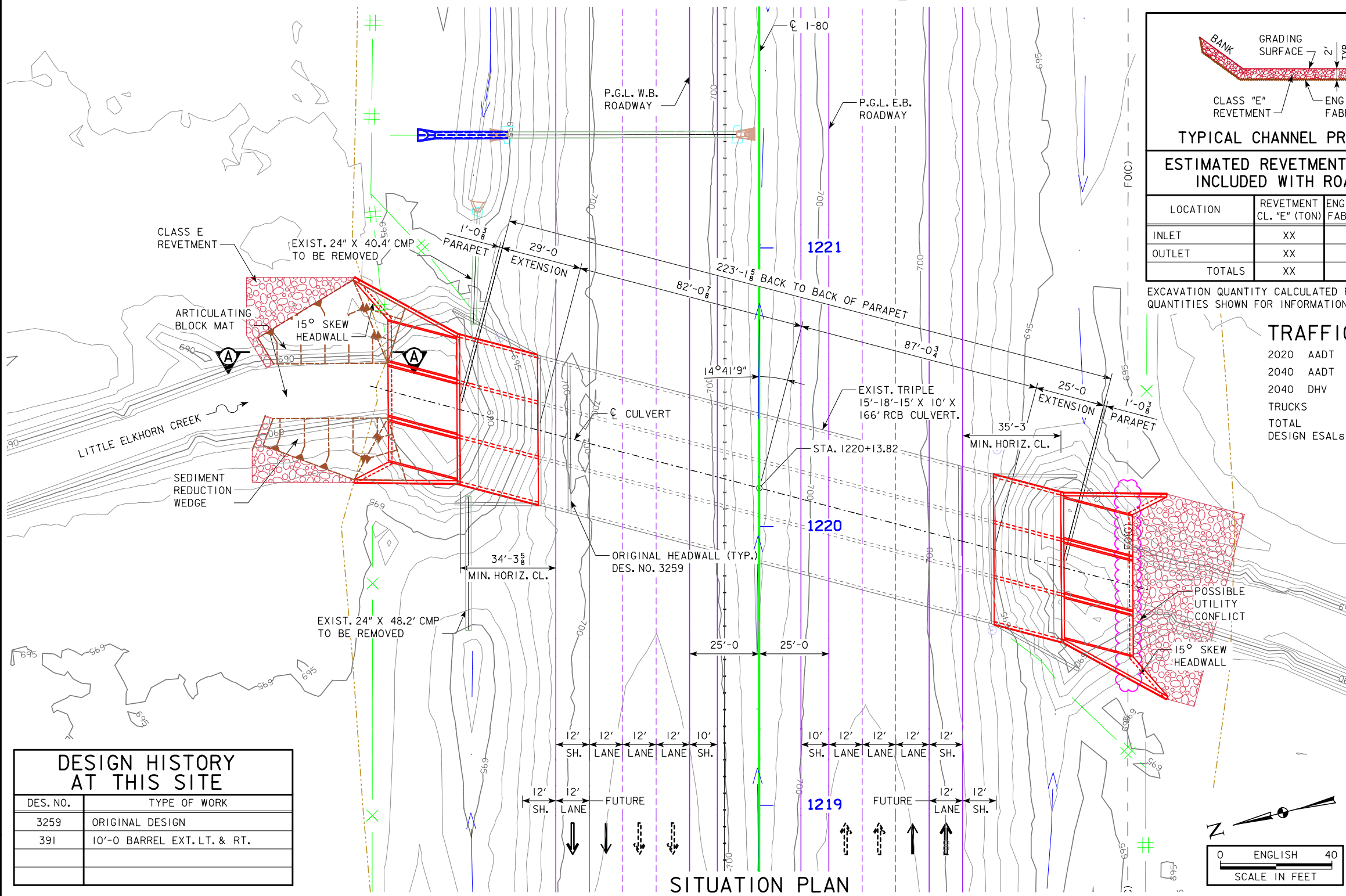

**DESIGN HISTORY AT THIS SITE**

DES. NO.	TYPE OF WORK
3259	ORIGINAL DESIGN
391	10'-0" BARREL EXT. LT. & RT.

PRELIMINARY  
 DESIGN FOR 14°41'9" SKEW (L.A.)  
**TRIPLE 15'-18'-15' X 10' REINFORCED CONCRETE BOX CULVERT EXTENSION**  
 SITUATION PLAN  
 STATION 1220+13.82  
 CEDAR COUNTY  
 IOWA DEPARTMENT OF TRANSPORTATION - HIGHWAY DIVISION  
 DESIGN SHEET NO. 1 OF 1 FILE NO. 31800 DESIGN NO. ?



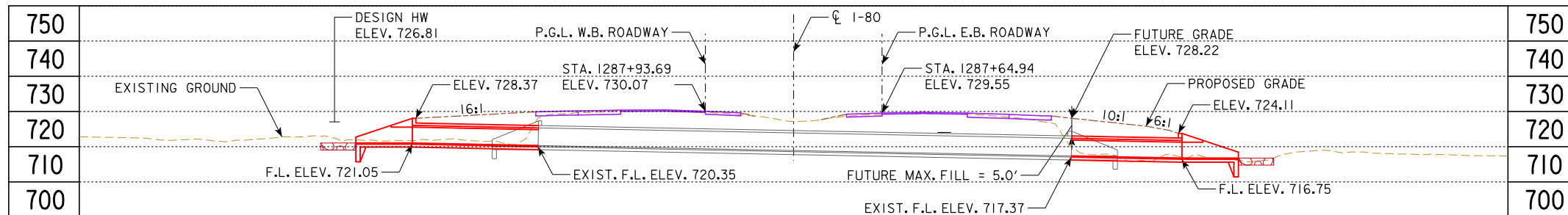

LONGITUDINAL SECTION ALONG CL CULVERT

HYDRAULIC DATA

DRAINAGE AREA = 0.26 SQ. MI.

Q<sub>50</sub> = 235 CFS  
 HW ELEV. = 726.11  
 EXIT VELOCITY = 15.5 FPS  
 STREAM SLOPE = 67.6 FT./MI.

Q<sub>100</sub> = 281 CFS  
 HW ELEV. = 726.81  
 EXIT VELOCITY = 16.2 FPS

UTILITIES LEGEND:

FO(C) - IOWA COMMUNICATIONS NETWORK

TRAFFIC ESTIMATE

2020 AADT	39,067	V.P.D.
2040 AADT	73,173	V.P.D.
2040 DHV		V.P.H.
TRUCKS	39	%
TOTAL DESIGN ESALS		

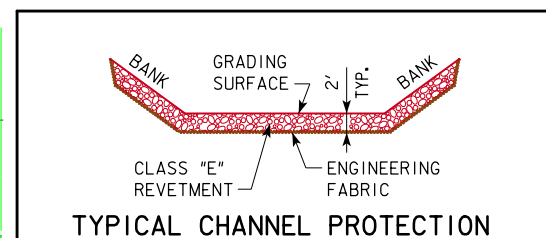

ESTIMATED REVETMENT QUANTITIES INCLUDED WITH ROAD PLANS

LOCATION	REVETMENT CL. "E" (TON)	ENGINEERING FABRIC (SY)	EXCAVATION (CY)
INLET	XX	XX	XX
OUTLET	XX	XX	XX
TOTALS	XX	XX	XX

EXCAVATION QUANTITY CALCULATED FROM GRADING SURFACE. QUANTITIES SHOWN FOR INFORMATION ONLY. SEE ROAD SHEETS.

LOCATION

I-80 OVER CREEK  
 T-79N R-1W  
 SECTION 22  
 FARMINGTON TOWNSHIP  
 CEDAR COUNTY  
 LATITUDE 41.633584°  
 LONGITUDE -90.955105°

NOTES:

1. PROP. VERTICAL DATUM IS APPROX. 8.36' HIGHER THAN USED ON EXISTING PLANS.
2. I-80 ELEVATIONS BASED ON EXISTING ROADWAY SURVEY PLUS 4" OVERLAY.
3. MAX. FILL BASED ON FUTURE 4% SHLD.
4. EXISTING EXTENSION DES. NO. ??? DESIGNED FOR 5.0' OF FILL. PROPOSED FILL WOULD BE 5.9' OVER EXISTING CULVERT.

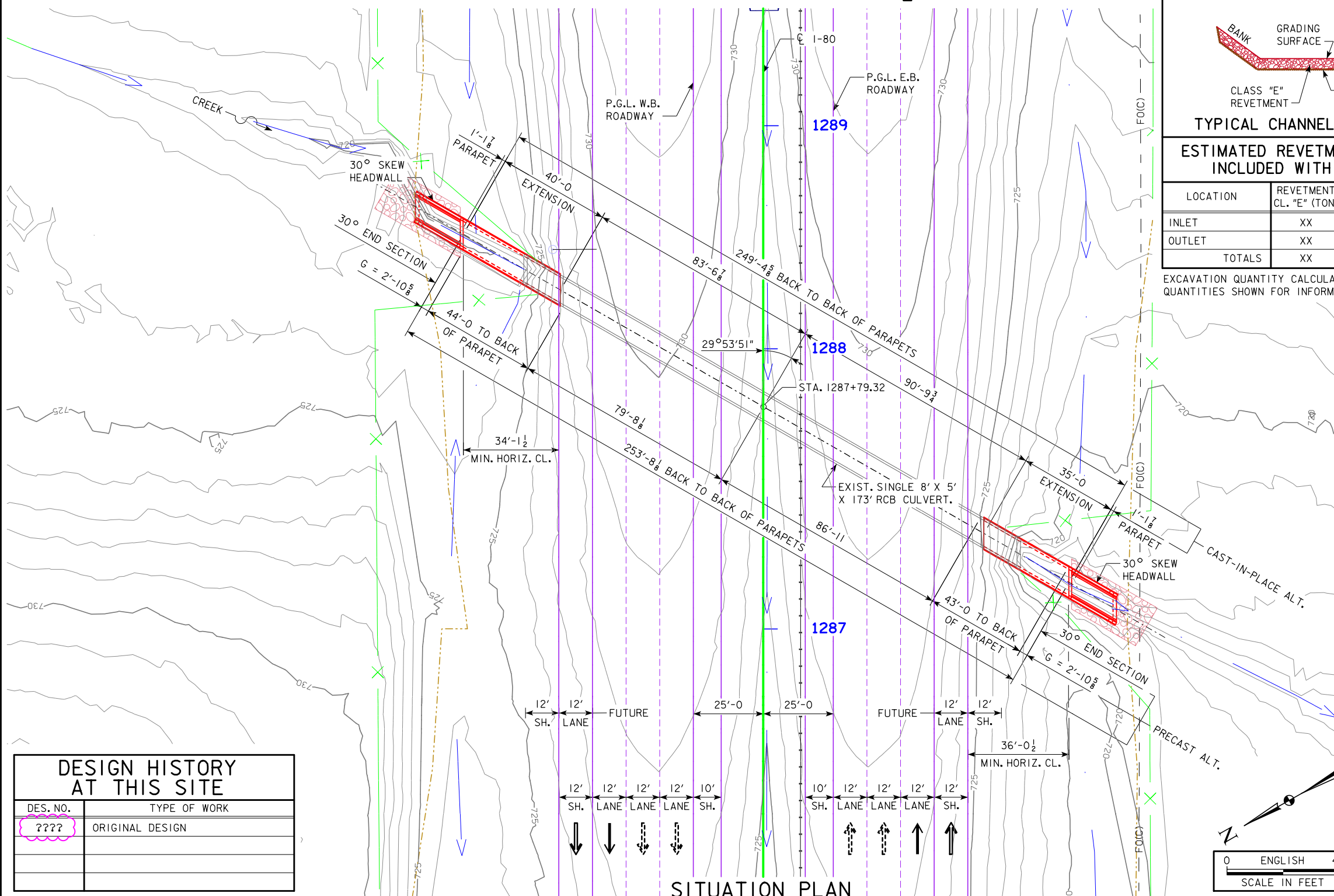

SITUATION PLAN

DESIGN HISTORY AT THIS SITE

DES. NO.	TYPE OF WORK
????	ORIGINAL DESIGN

PRELIMINARY  
 DESIGN FOR 29°53'51" SKEW (L.A.)  
**SINGLE 8'-0 X 5'-0 REINFORCED CONCRETE BOX CULVERT EXTENSION**  
 SITUATION PLAN  
 STATION 1287+79.32  
 CEDAR COUNTY  
 IOWA DEPARTMENT OF TRANSPORTATION - HIGHWAY DIVISION  
 DESIGN SHEET NO. 1 OF 1 FILE NO. 31800 DESIGN NO. ?

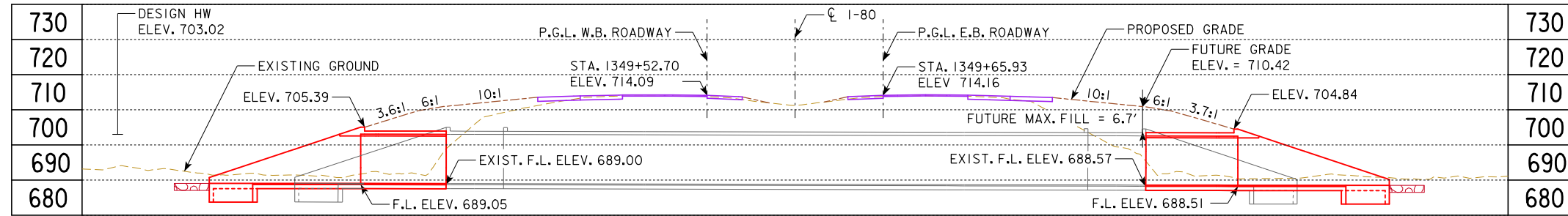

LONGITUDINAL SECTION ALONG CULVERT

TYPICAL CHANNEL PROTECTION			
ESTIMATED REVETMENT QUANTITIES INCLUDED WITH ROAD PLANS			
LOCATION	REVETMENT CL. "E" (TON)	ENGINEERING FABRIC (SY)	EXCAVATION (CY)
INLET	XX	XX	XX
OUTLET	XX	XX	XX
TOTALS	XX	XX	XX

EXCAVATION QUANTITY CALCULATED FROM GRADING SURFACE. QUANTITIES SHOWN FOR INFORMATION ONLY. SEE ROAD SHEETS.

**HYDRAULIC DATA**

DRAINAGE AREA = 4.74 SQ. MI.

Q<sub>50</sub> = 2,510 CFS  
 HW ELEV. = 701.59  
 EXIT VELOCITY = 11.53 FPS  
 STREAM SLOPE = 22.70 FT./MI.

Q<sub>100</sub> = 2,990 CFS  
 HW ELEV. = 703.02  
 EXIT VELOCITY = 12.64 FPS

**UTILITIES LEGEND:**

FO(C) - IOWA COMMUNICATION NETWORK

**TRAFFIC ESTIMATE**

2020 AADT	39,069	V.P.D.
2040 AADT	73,173	V.P.D.
2040 DHV		V.P.H.
TRUCKS	39	%
TOTAL DESIGN ESALs		

**LOCATION**

I-80 OVER CREEK  
 T-79N R-01W  
 SECTION 23  
 FARMINGTON TOWNSHIP  
 CEDAR COUNTY  
 FHWA NO. 18720  
 BRIDGE MAINT. NO. 1676.4S080  
 LATITUDE 41.634278°  
 LONGITUDE -90.932484°

- NOTES:
- PROP. VERTICAL DATUM IS APPROX. 8.06' HIGHER THAN USED ON EXISTING PLANS.
  - I-80 ELEVATIONS BASED ON EXISTING ROADWAY SURVEY PLUS PROPOSED 4" OVERLAY.
  - MAX. FILL BASED ON FUTURE 4% SHLD.
  - EXISTING EXTENSION DES. NO. 491 WAS DESIGNED FOR 5' OF FILL. PROPOSED FILL WOULD BE 9.4'.
  - NONSTANDARD CULVERT DESIGN

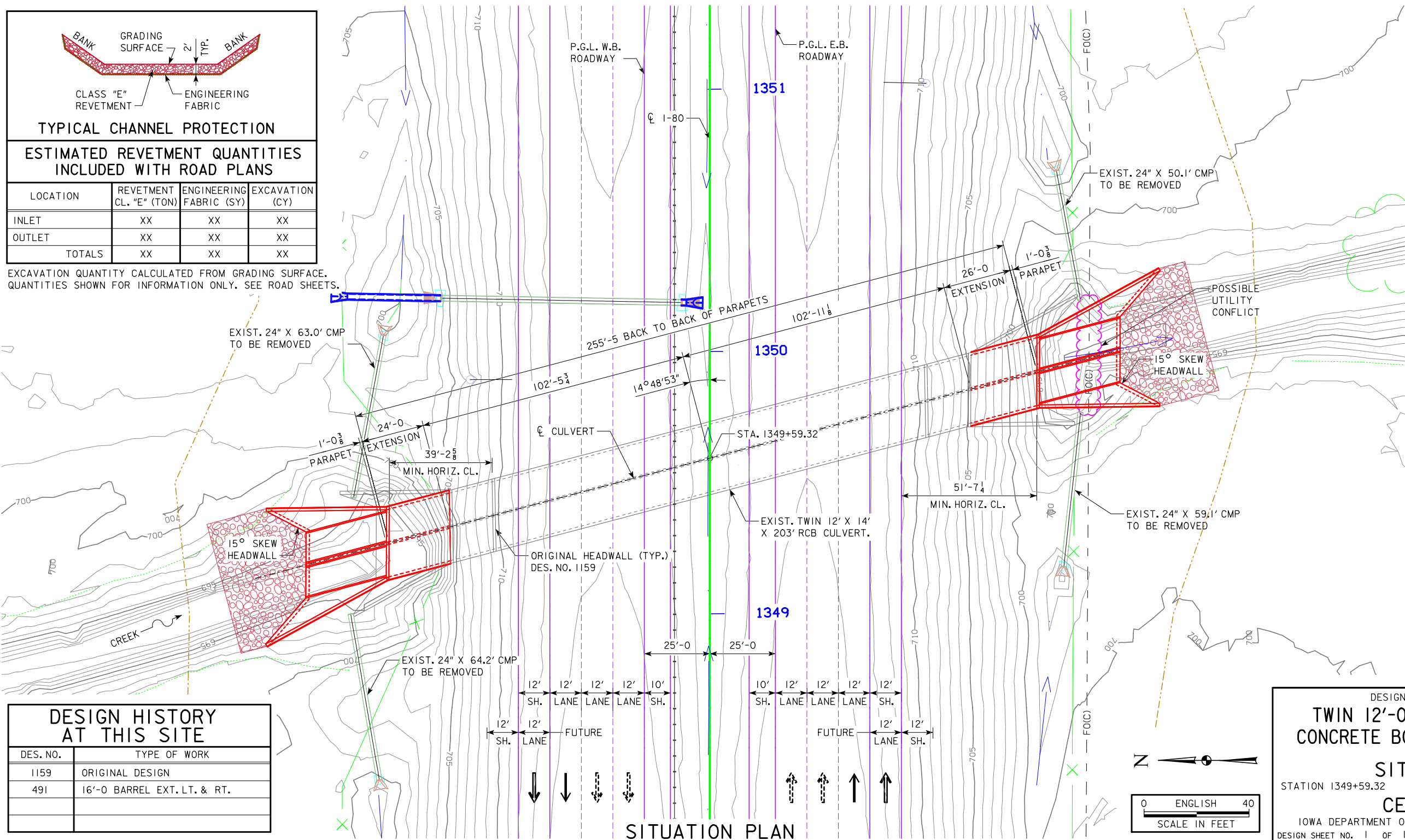

DESIGN HISTORY AT THIS SITE	
DES. NO.	TYPE OF WORK
1159	ORIGINAL DESIGN
491	16'-0 BARREL EXT. LT. & RT.

PRELIMINARY  
 DESIGN FOR 14°48'53" SKEW (R.A.)  
**TWIN 12'-0 X 14'-0 REINFORCED CONCRETE BOX CULVERT EXTENSION**  
 SITUATION PLAN  
 STATION 1349+59.32  
 CEDAR COUNTY  
 IOWA DEPARTMENT OF TRANSPORTATION - HIGHWAY DIVISION  
 DESIGN SHEET NO. 1 OF 1 FILE NO. 31800 DESIGN NO. ?



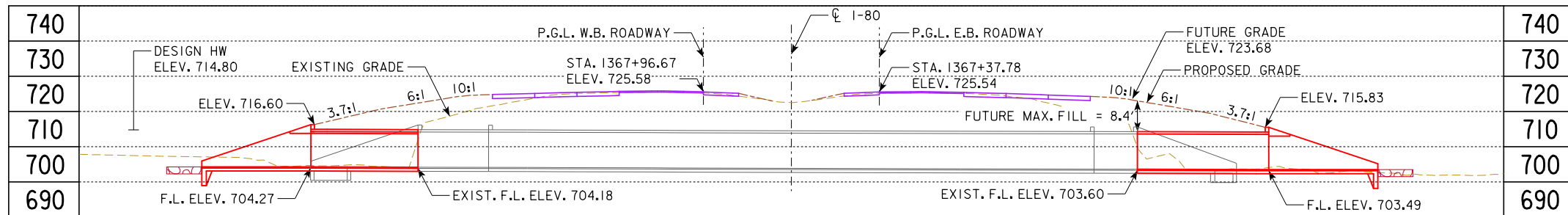

LONGITUDINAL SECTION ALONG CL CULVERT

HYDRAULIC DATA

DRAINAGE AREA = 0.91 SQ. MI.

Q<sub>50</sub> = 576 CFS  
 HW ELEV. = 713.62  
 EXIT VELOCITY = 13.2 FPS  
 STREAM SLOPE = 42.2 FT./MI.

Q<sub>100</sub> = 690 CFS  
 HW ELEV. = 714.80  
 EXIT VELOCITY = 14.1 FPS

UTILITIES LEGEND:

FO(C) IOWA COMMUNICATIONS NETWORK

TRAFFIC ESTIMATE

2020 AADT	39,067	V.P.D.
2040 AADT	73,173	V.P.D.
2040 DHV	-	V.P.H.
TRUCKS	39	%
TOTAL DESIGN ESALS	-	-

LOCATION

I-80 OVER CREEK  
 T-79N R-1W  
 SECTION 23  
 FARMINGTON TOWNSHIP  
 CEDAR COUNTY  
 LATITUDE 41.634252°  
 LONGITUDE -90.925866°

NOTES:

1. PROP. VERTICAL DATUM IS APPROX. 8.26' HIGHER THAN USED ON EXISTING PLANS.
2. I-80 ELEVATIONS BASED ON EXISTING ROADWAY SURVEY PLUS PROPOSED 4" OVERLAY.
3. MAX FILL BASED ON FUTURE 4% SHLD.
4. EXISTING EXTENSION DES. 591 DESIGNED FOR 11' OF FILL. PROPOSED FILL WOULD BE 10.0' OVER EXISTING CULVERT.

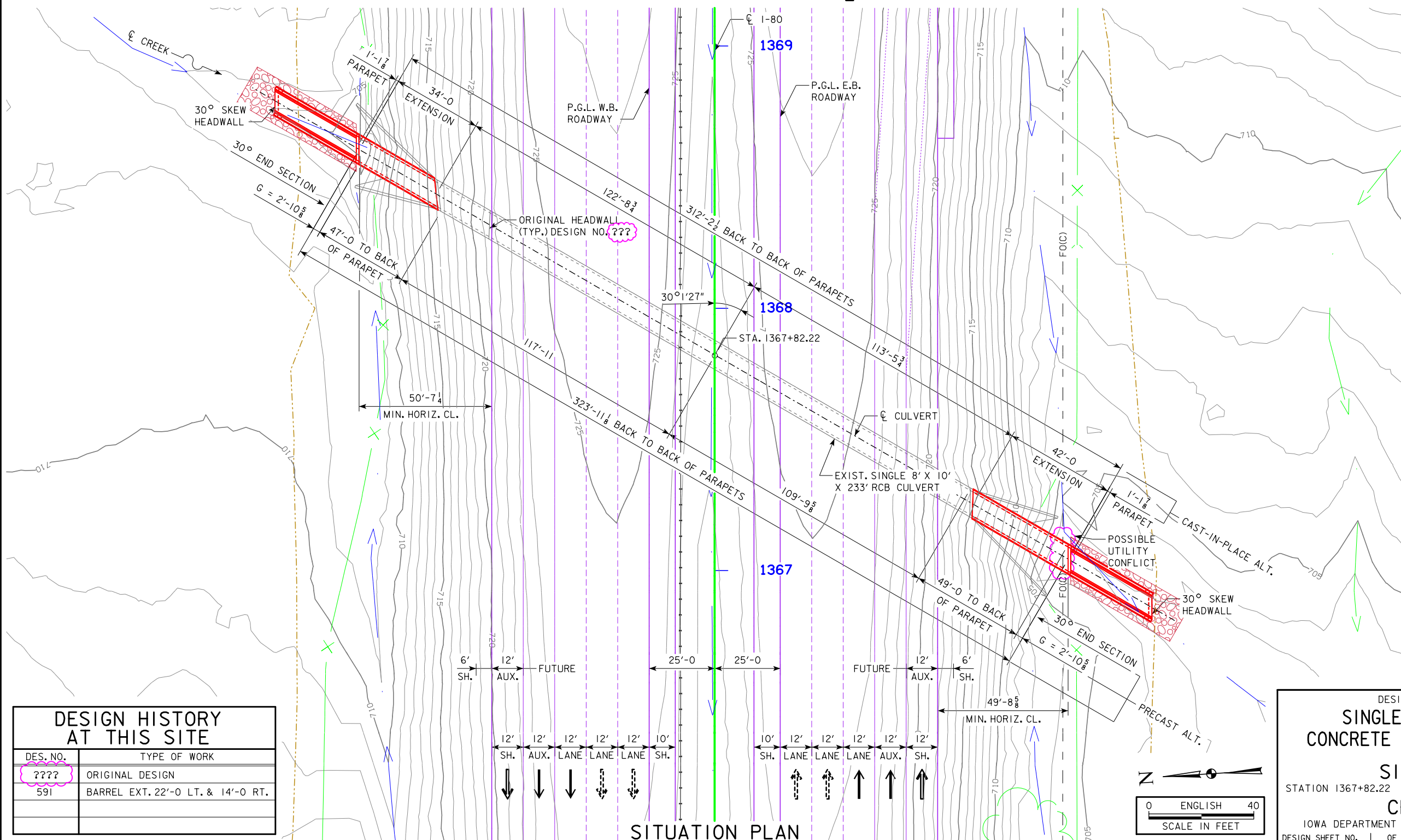

SITUATION PLAN

DESIGN HISTORY AT THIS SITE	
DES. NO.	TYPE OF WORK
???	ORIGINAL DESIGN
591	BARREL EXT. 22'-0" LT. & 14'-0" RT.

PRELIMINARY  
 DESIGN FOR 30° 1' 27" SKEW (L.A.)  
**SINGLE 8' X 10' REINFORCED CONCRETE BOX CULVERT EXTENSION**  
 SITUATION PLAN  
 STATION 1367+82.22  
 CEDAR COUNTY  
 IOWA DEPARTMENT OF TRANSPORTATION - HIGHWAY DIVISION  
 DESIGN SHEET NO. 1 OF 1 FILE NO. 31800 DESIGN NO. ?

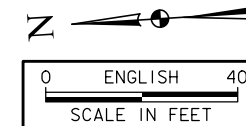

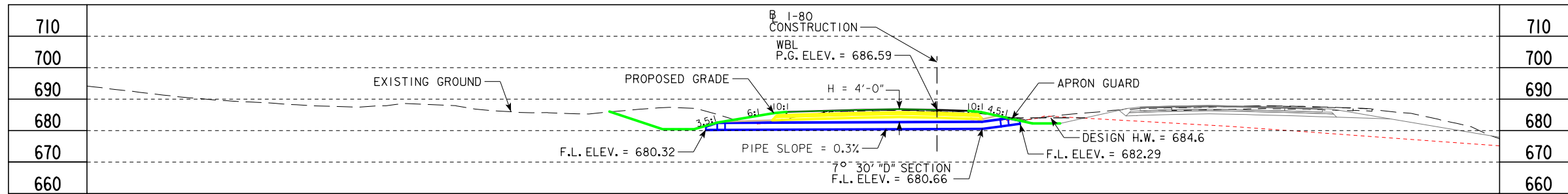

LONGITUDINAL SECTION ALONG  $\phi$  CULVERT

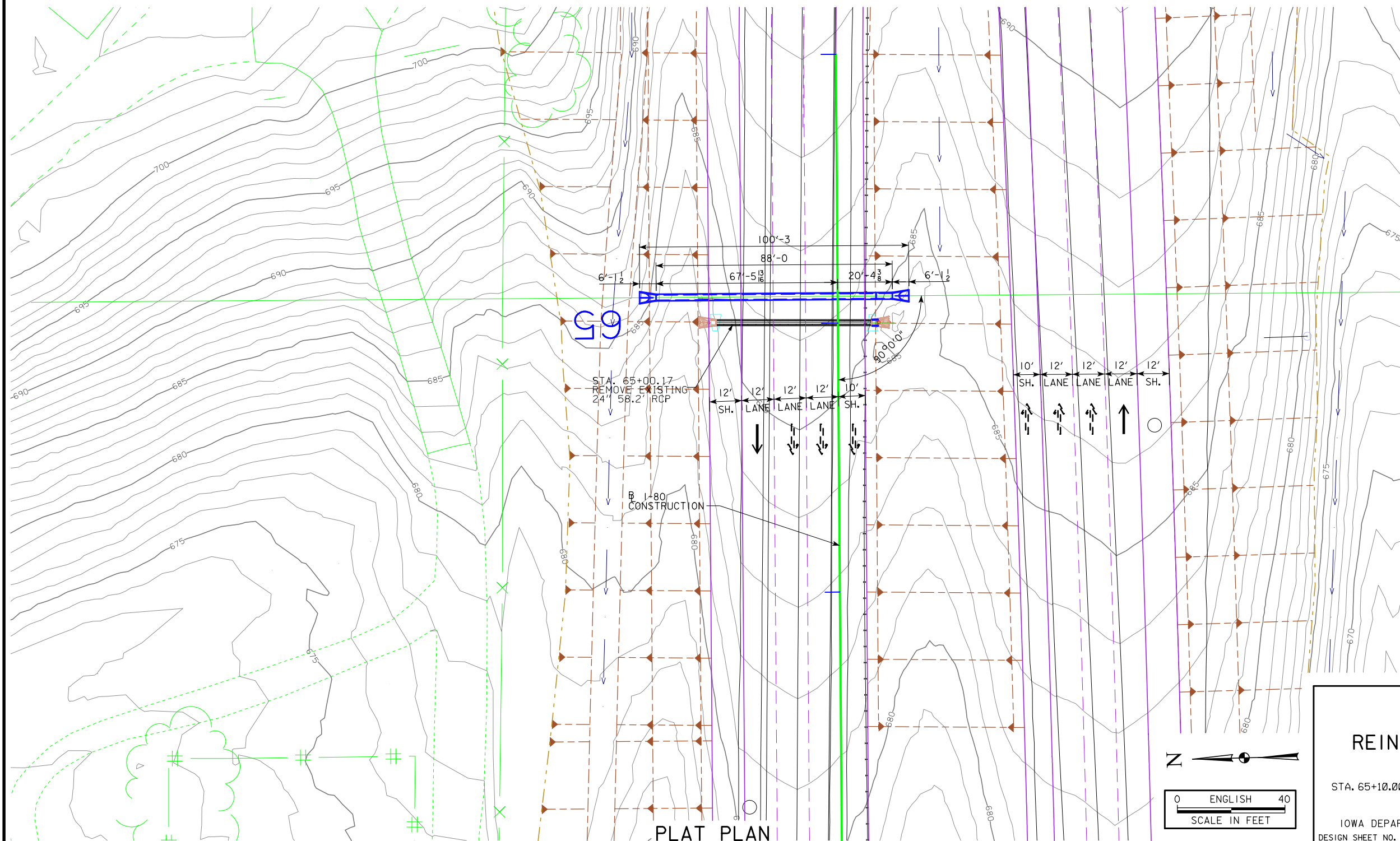

**LOCATION**

I-80  
T-79N R-2W  
SECTION 18  
SUGAR CREEK TOWNSHIP  
CEDAR COUNTY

**HYDRAULIC DATA**

DRAINAGE AREA = 1.4 ACRES  
DESIGN DISCHARGE = 33.78 CFS



DESIGN FOR 0° SKEW  
**24" x 88'**  
**REINFORCED CONCRETE PIPE**  
**PLAT PLAN**

STA. 65+10.00  
AUGUST 2019  
**CEDAR COUNTY**  
IOWA DEPARTMENT OF TRANSPORTATION - HIGHWAY DIVISION  
DESIGN SHEET NO. ? OF ? FILE NO. ? DESIGN NO. ?

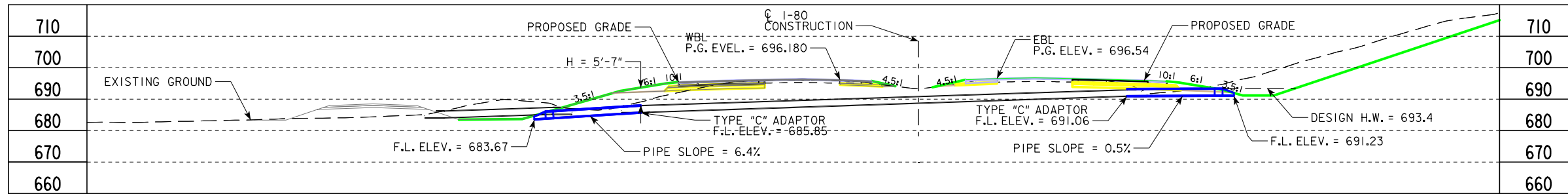

LONGITUDINAL SECTION ALONG CULVERT

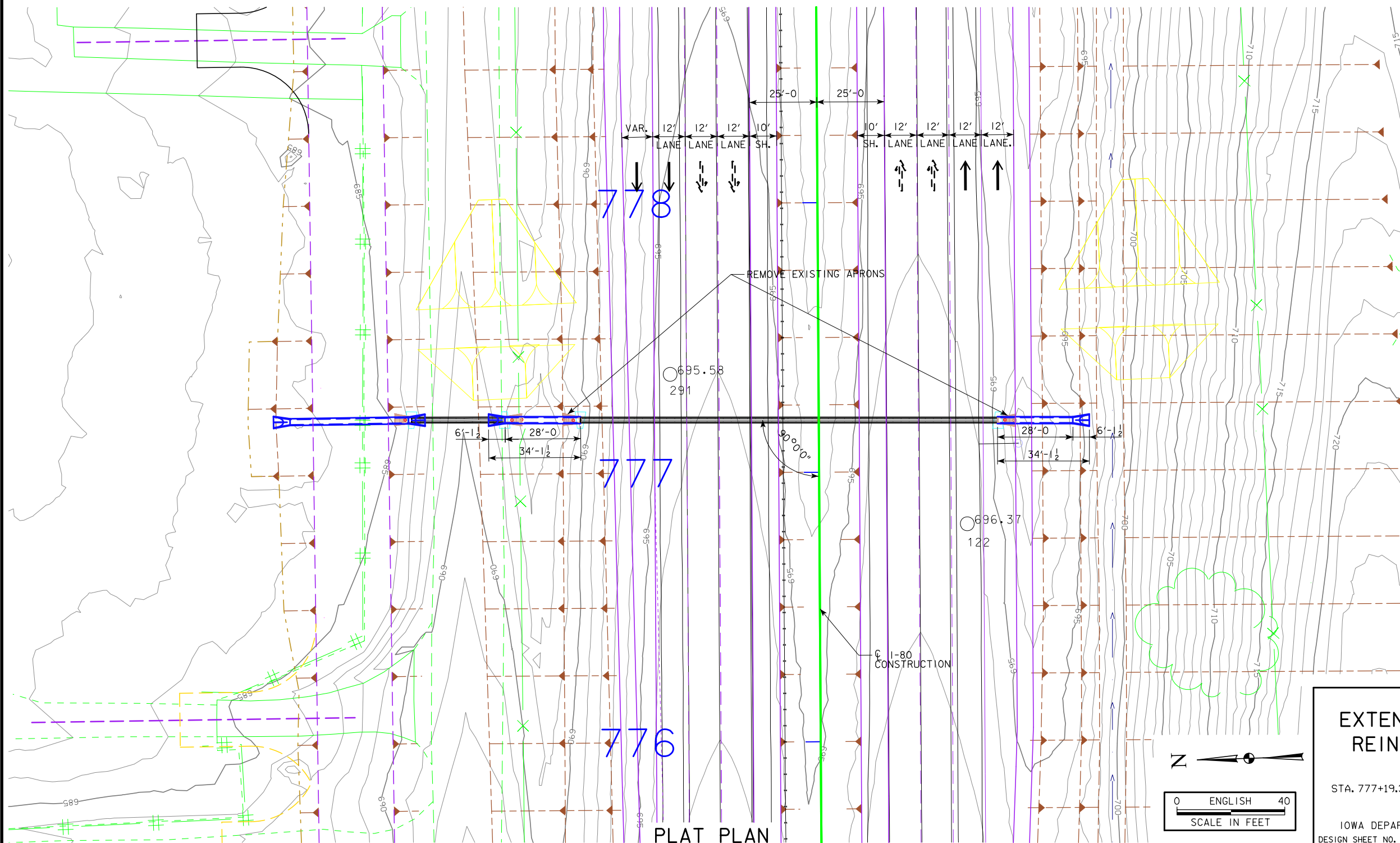

LOCATION

I-80  
T-79N R-2W  
SECTION 18  
SUGAR CREEK TOWNSHIP  
CEDAR COUNTY

HYDRAULIC DATA

DRAINAGE AREA = 1.7 ACRES  
DESIGN DISCHARGE = 42.8 CFS

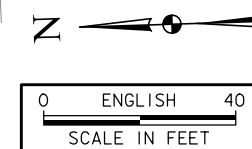

DESIGN FOR 0° SKEW  
**EXTEND 24" x 28' LT & 28' RT  
REINFORCED CONCRETE PIPE  
PLAT PLAN**  
STA. 777+19.34 EB  
AUGUST 2019  
**CEDAR COUNTY**  
IOWA DEPARTMENT OF TRANSPORTATION - HIGHWAY DIVISION  
DESIGN SHEET NO. ? OF ? FILE NO. ? DESIGN NO. ?



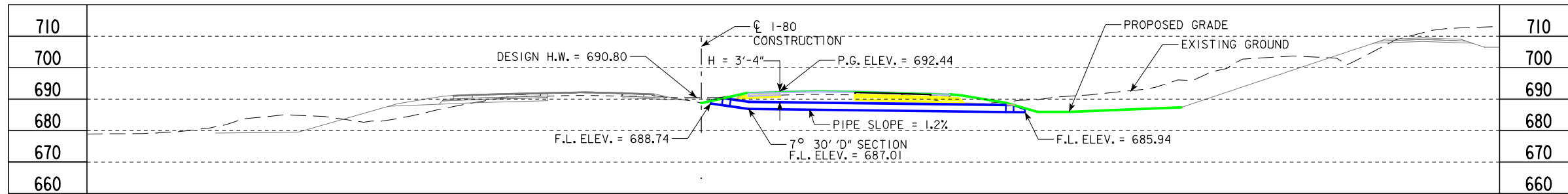

LONGITUDINAL SECTION ALONG  $\text{CL}$  CULVERT

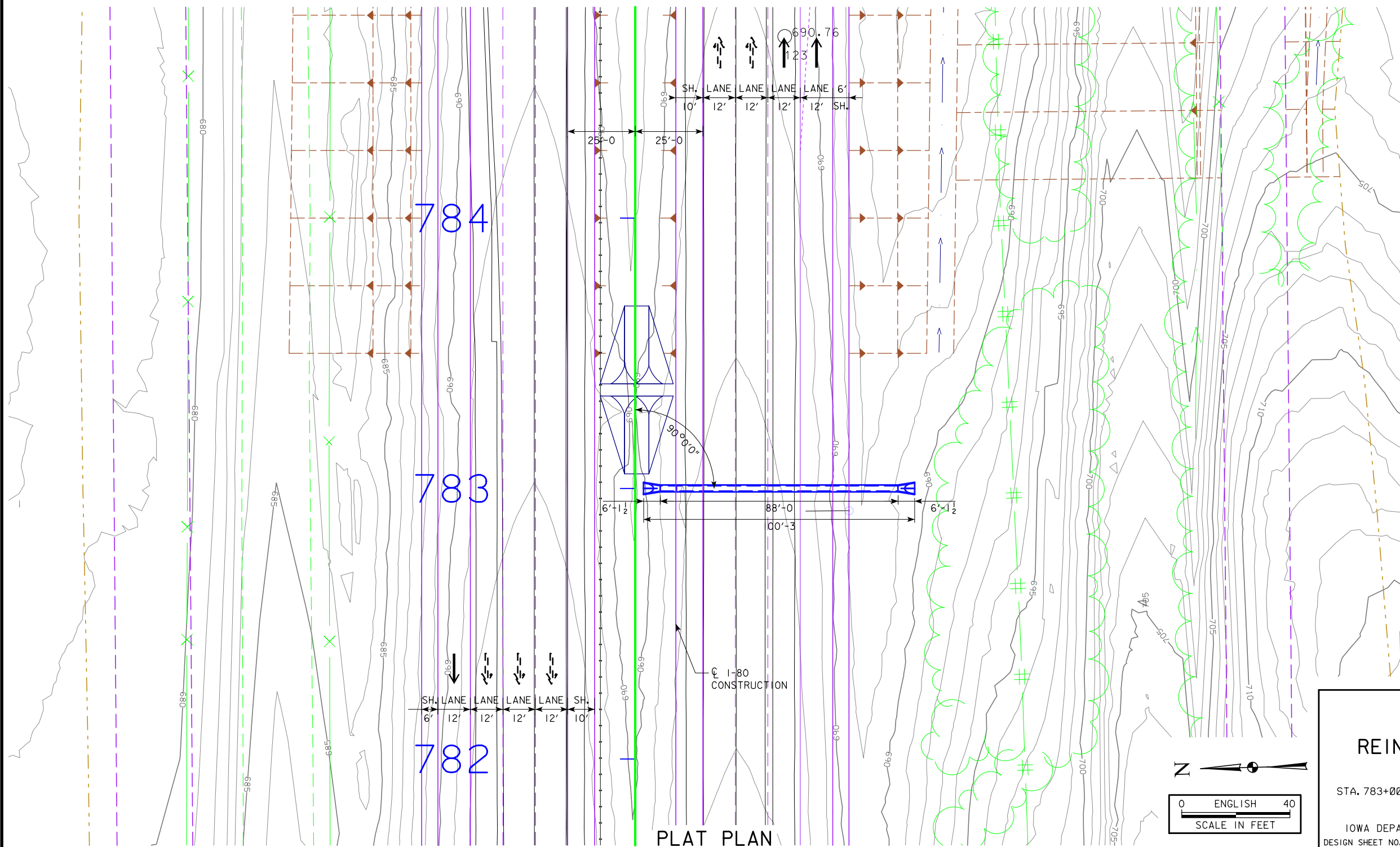

LOCATION

I-80  
 T-79N R-2W  
 SECTION 18  
 SUGAR CREEK TOWNSHIP  
 CEDAR COUNTY

HYDRAULIC DATA

DRAINAGE AREA = 2.2 ACRES  
 DESIGN DISCHARGE = 39.12 CFS

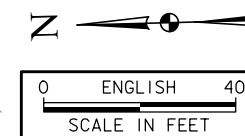

DESIGN FOR 0° SKEW  
**24" x 88'**  
**REINFORCED CONCRETE PIPE**  
**PLAT PLAN**  
 STA. 783+00.00  
 AUGUST 2019  
**CEDAR COUNTY**  
 IOWA DEPARTMENT OF TRANSPORTATION - HIGHWAY DIVISION  
 DESIGN SHEET NO. ? OF ? FILE NO. ? DESIGN NO. ?



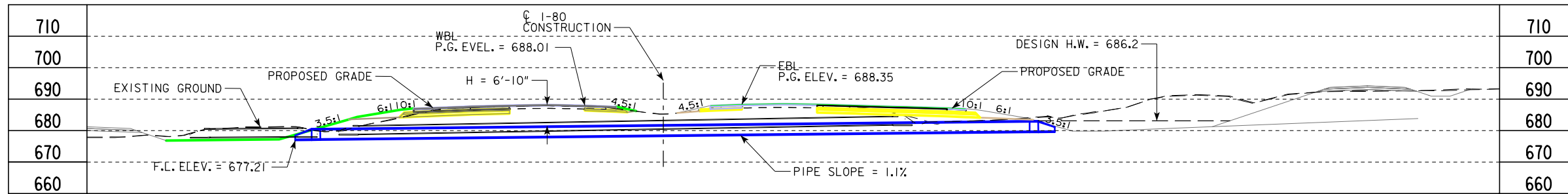

LONGITUDINAL SECTION ALONG CULVERT

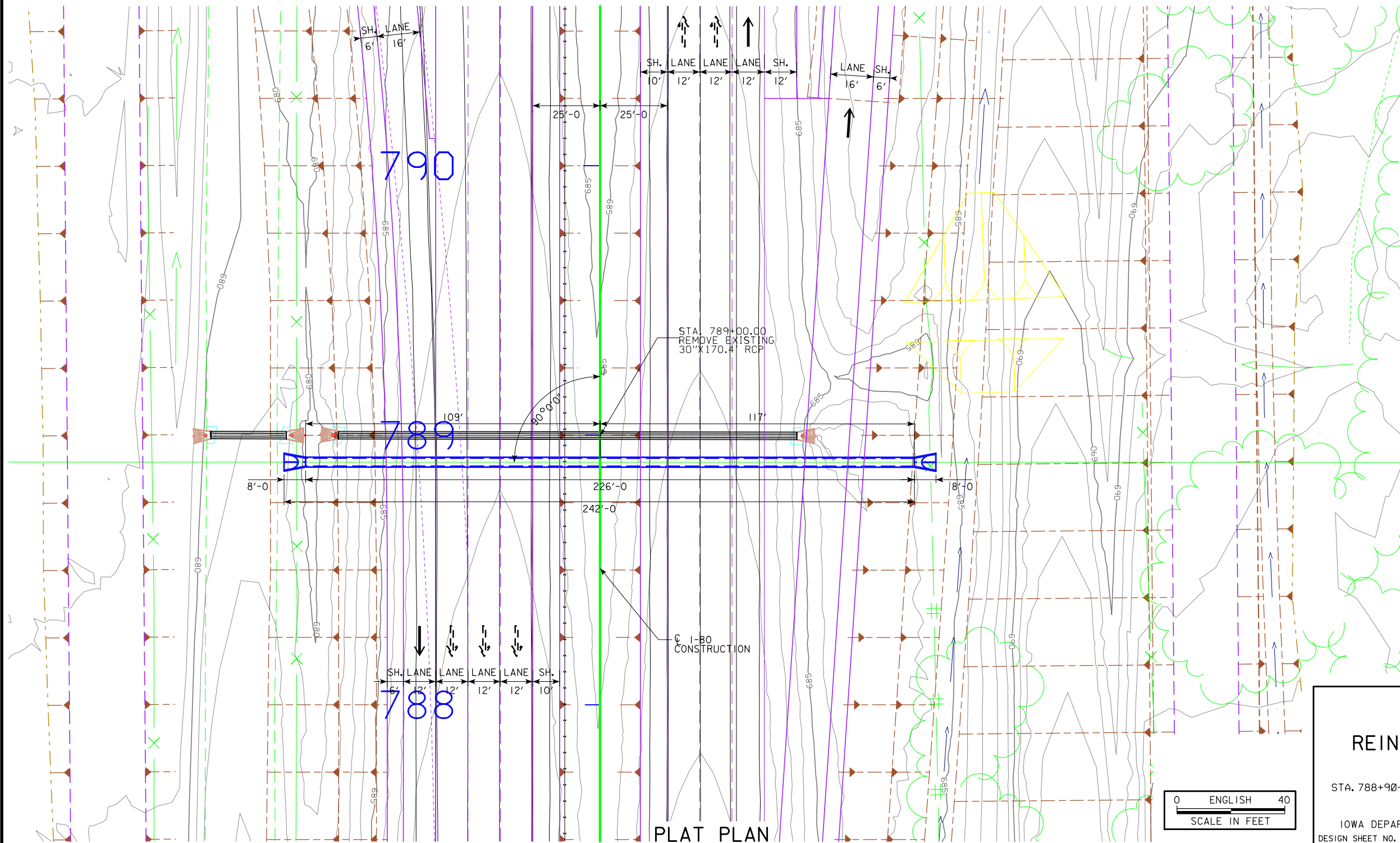

LOCATION

I-80  
T-79N R-2W  
SECTION 18  
SUGAR CREEK TOWNSHIP  
CEDAR COUNTY

HYDRAULIC DATA

DRAINAGE AREA = 14.6 ACRES  
DESIGN DISCHARGE = ?? CFS



DESIGN FOR 0° SKEW  
**36" x 226'**  
**REINFORCED CONCRETE PIPE**  
**PLAT PLAN**  
STA. 788+90+00 EB AUGUST 2019  
**CEDAR COUNTY**  
IOWA DEPARTMENT OF TRANSPORTATION - HIGHWAY DIVISION  
DESIGN SHEET NO. ? OF ? FILE NO. ? DESIGN NO. ?

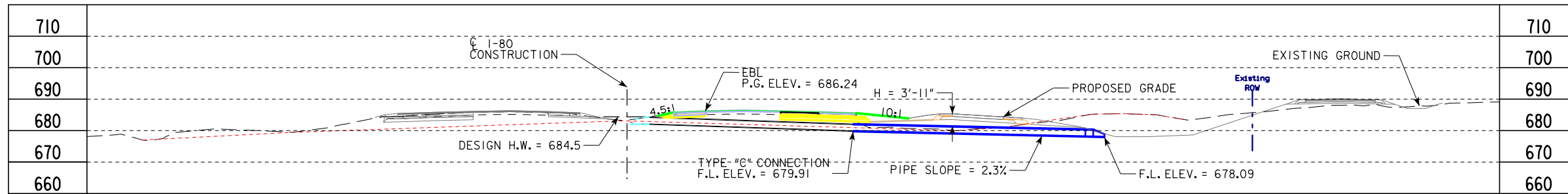

LONGITUDINAL SECTION ALONG  $\bar{C}$  CULVERT

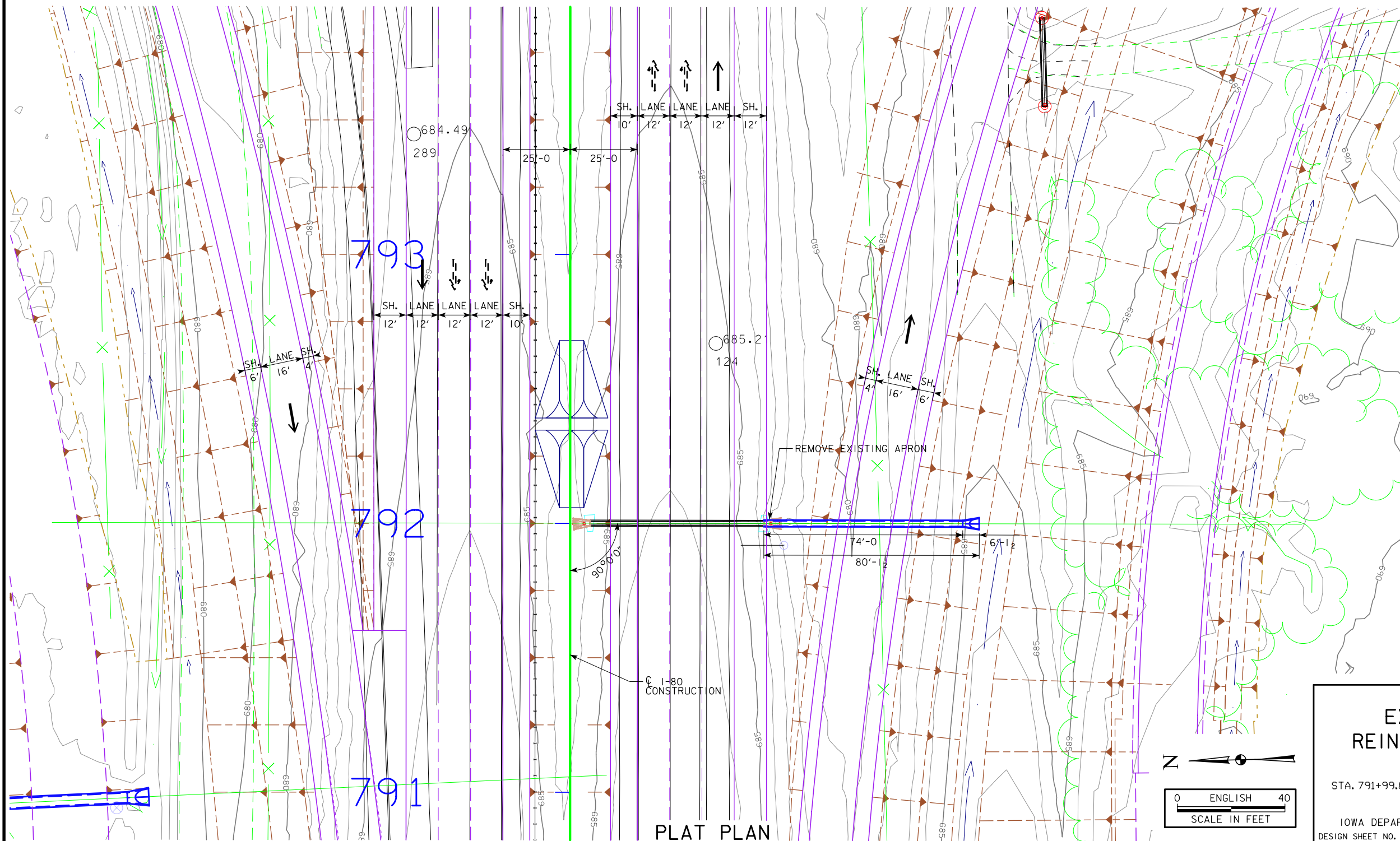

LOCATION

I-80  
T-79N R-2W  
SECTION 18  
SUGAR CREEK TOWNSHIP  
CEDAR COUNTY

HYDRAULIC DATA

DRAINAGE AREA = 1.4 ACRES  
DESIGN DISCHARGE = 41.03 CFS

DESIGN FOR 0° SKEW  
**EXTEND 24" x 74' RT  
REINFORCED CONCRETE PIPE  
PLAT PLAN**  
STA. 791+99.80 EB AUGUST 2019  
**CEDAR COUNTY**  
IOWA DEPARTMENT OF TRANSPORTATION - HIGHWAY DIVISION  
DESIGN SHEET NO. ? OF ? FILE NO. ? DESIGN NO. ?



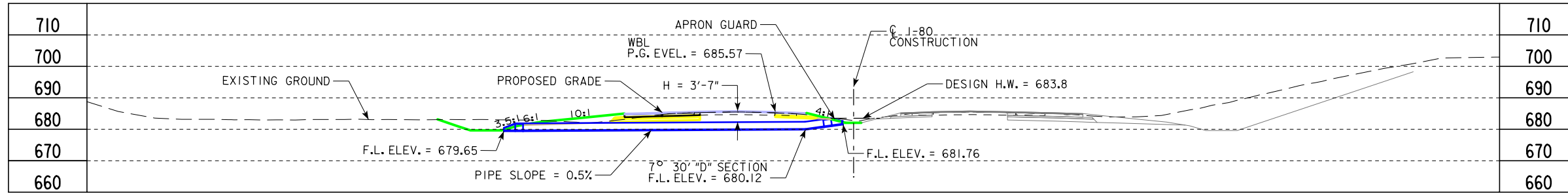

LONGITUDINAL SECTION ALONG CULVERT

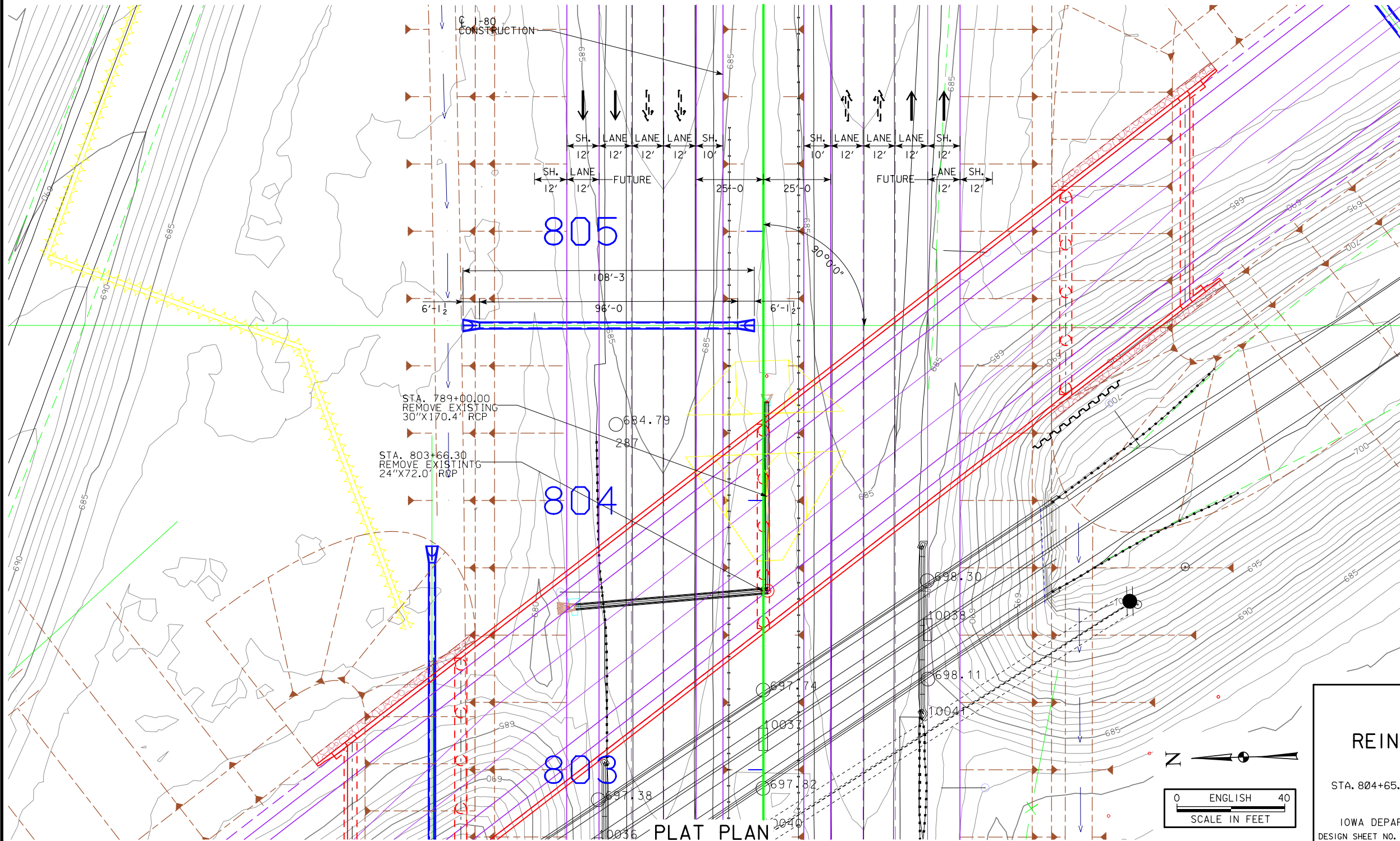

LOCATION

I-80  
T-79N R-2W  
SECTION 18  
SUGAR CREEK TOWNSHIP  
CEDAR COUNTY

HYDRAULIC DATA

DRAINAGE AREA = 1.6 ACRES  
DESIGN DISCHARGE = 33.55 CFS

DESIGN FOR 0° SKEW  
**24" x 96'**  
**REINFORCED CONCRETE PIPE**  
**PLAT PLAN**  
 STA. 804+65.00 WB  
**CEDAR COUNTY**  
 IOWA DEPARTMENT OF TRANSPORTATION - HIGHWAY DIVISION  
 DESIGN SHEET NO. ? OF ? FILE NO. ? DESIGN NO. ?  
 AUGUST 2019

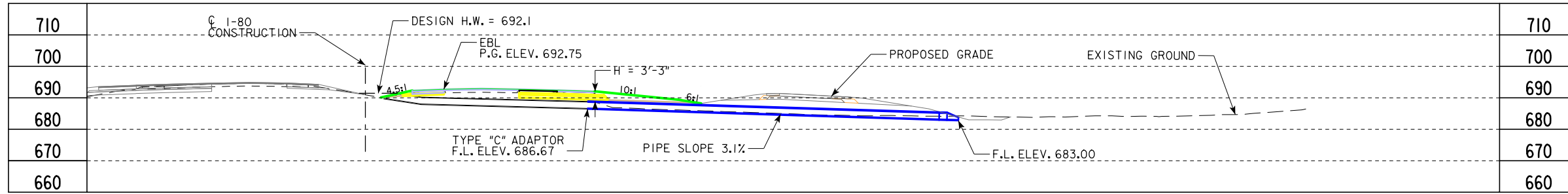

LONGITUDINAL SECTION ALONG CULVERT

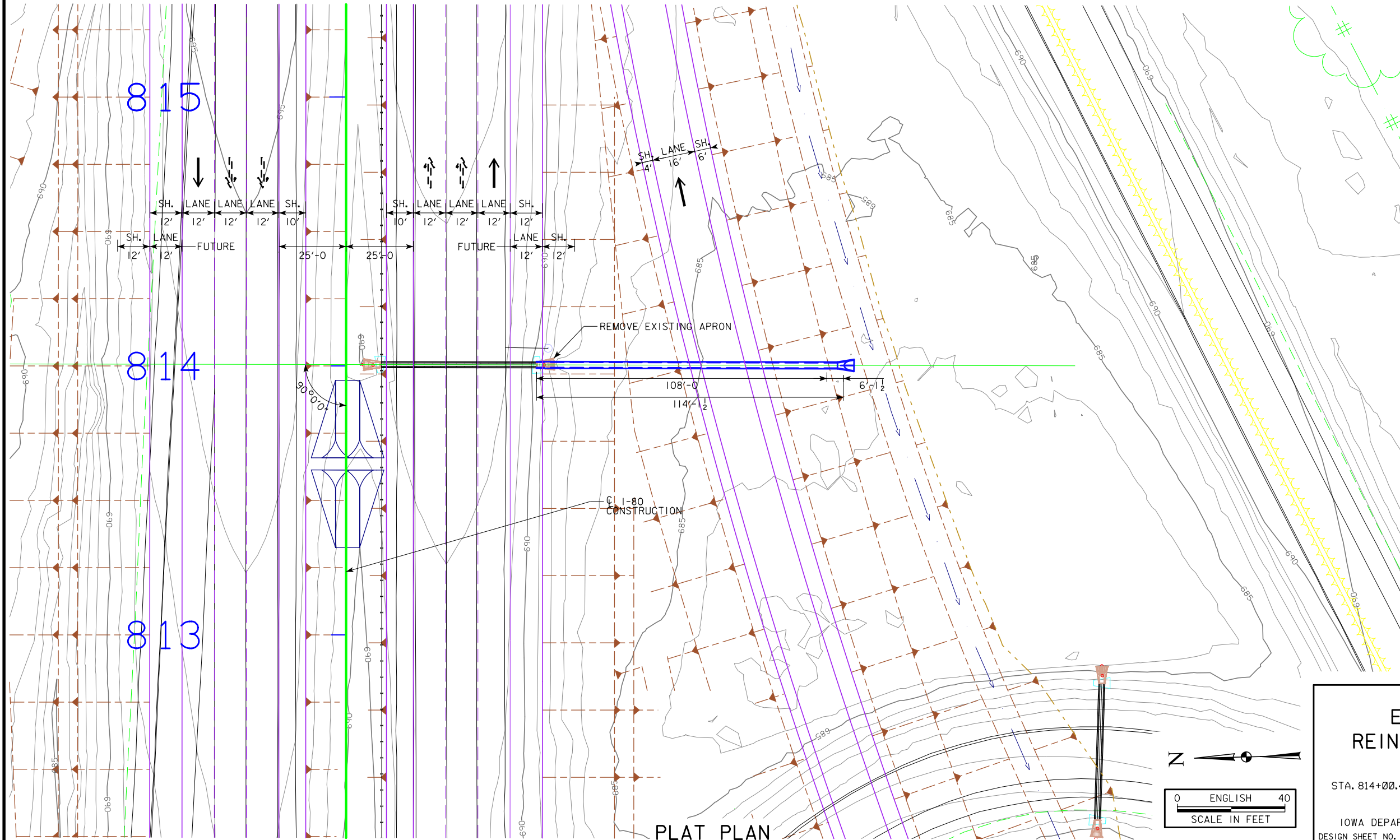

LOCATION

I-80  
T-79N R-2W  
SECTION 17  
SUGAR CREEK TOWNSHIP  
CEDAR COUNTY

HYDRAULIC DATA

DRAINAGE AREA = 1.4 ACRES  
DESIGN DISCHARGE = 45.97 CFS

DESIGN FOR 0° SKEW  
**EXTEND 24" x 108' RT REINFORCED CONCRETE PIPE PLAT PLAN**  
STA. 814+00.44 EB AUGUST 2019  
**CEDAR COUNTY**  
IOWA DEPARTMENT OF TRANSPORTATION - HIGHWAY DIVISION  
DESIGN SHEET NO. ? OF ? FILE NO. ? DESIGN NO. ?



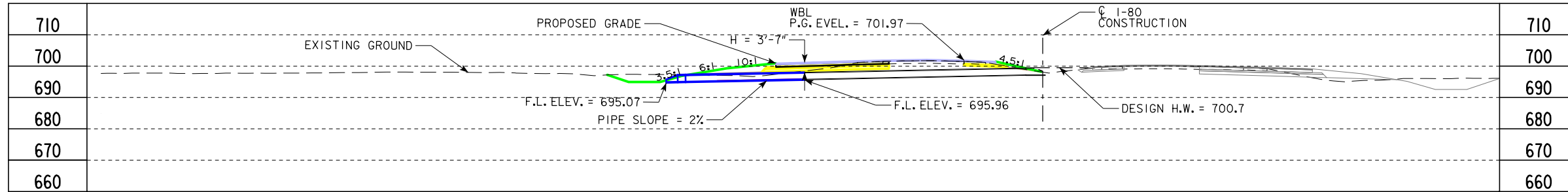

LONGITUDINAL SECTION ALONG CULVERT

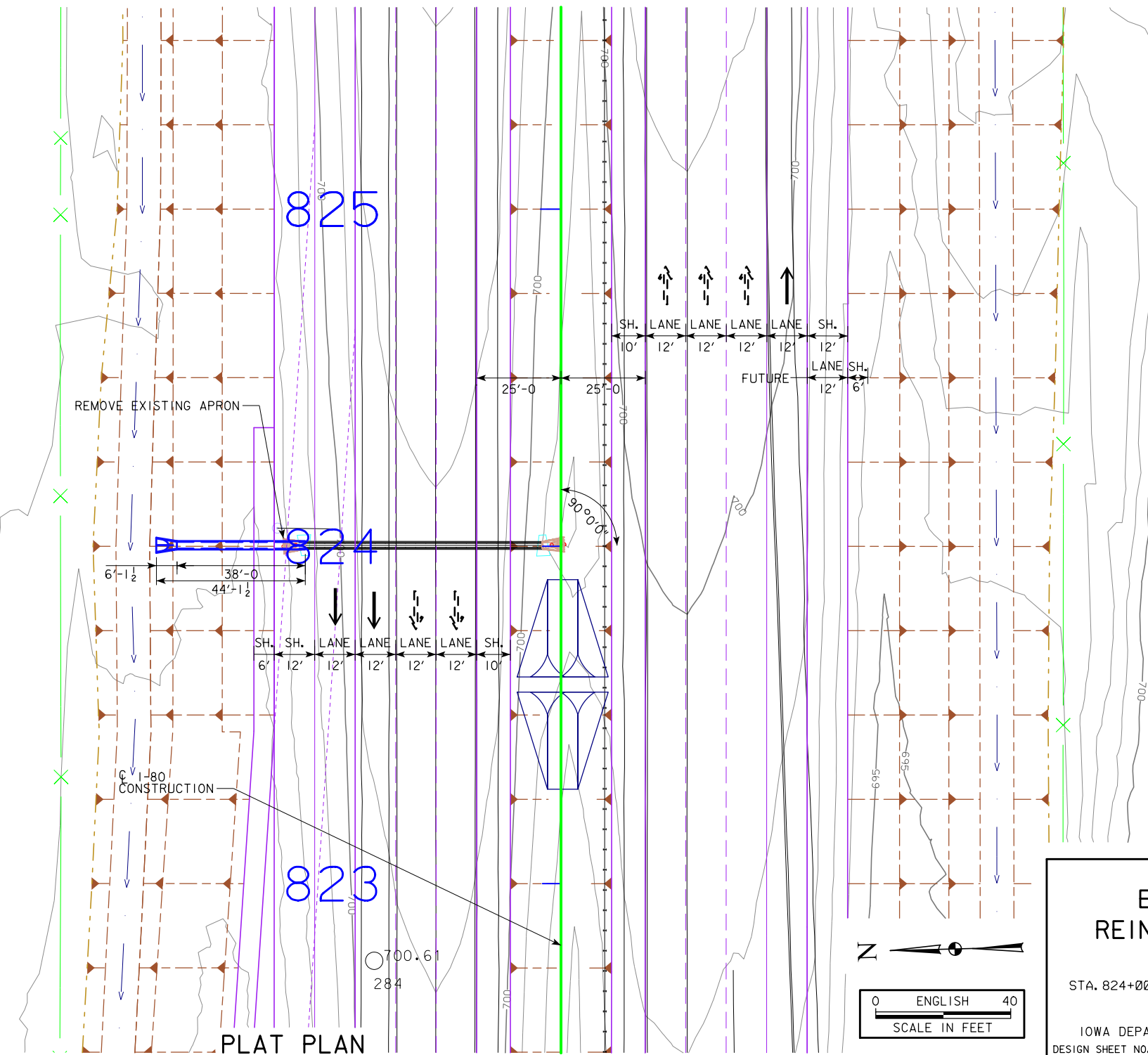

LOCATION

I-80  
T-79N R-2W  
SECTION 17  
SUGAR CREEK TOWNSHIP  
CEDAR COUNTY

HYDRAULIC DATA

DRAINAGE AREA = 1.8 ACRES  
DESIGN DISCHARGE = 35.26 CFS

DESIGN FOR 0° SKEW  
**EXTEND 24" x 38' LT REINFORCED CONCRETE PIPE PLAT PLAN**  
STA. 824+00.26 WB AUGUST 2019  
**CEDAR COUNTY**  
IOWA DEPARTMENT OF TRANSPORTATION - HIGHWAY DIVISION  
DESIGN SHEET NO. ? OF ? FILE NO. ? DESIGN NO. ?

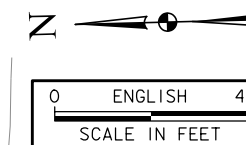

PLAT PLAN

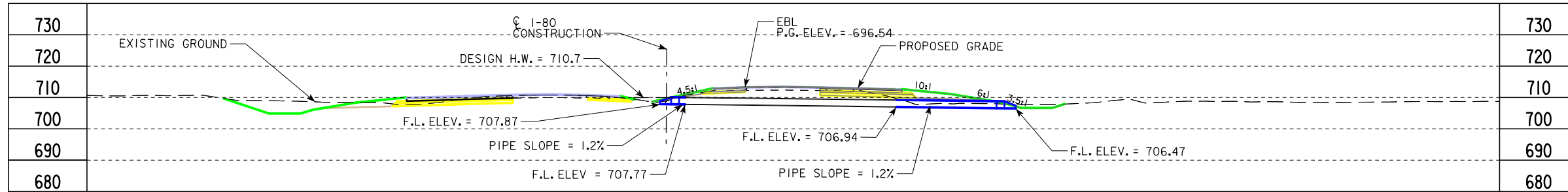

LONGITUDINAL SECTION ALONG  $\text{C}$  CULVERT

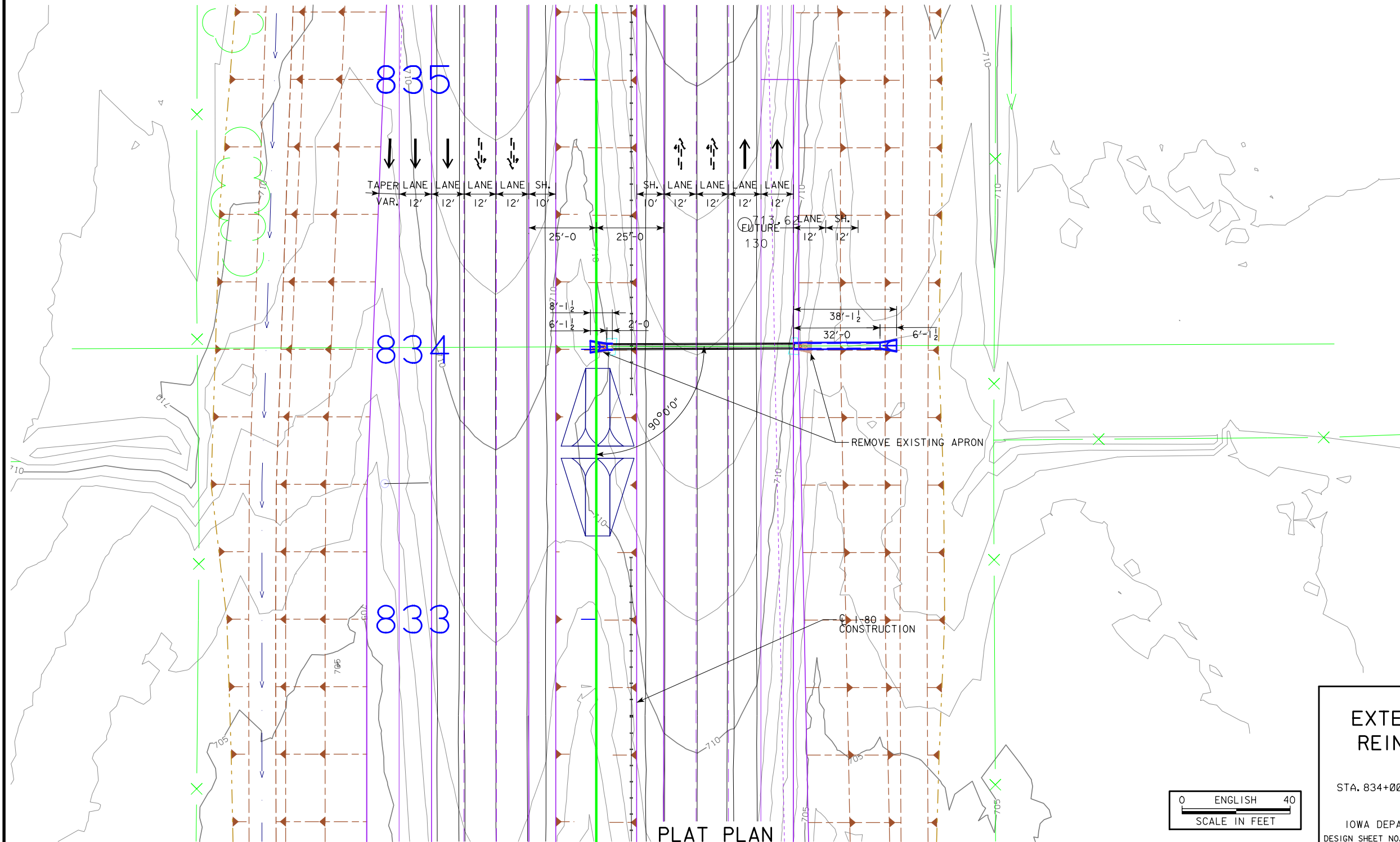

LOCATION

I-80  
T-79N R-2W  
SECTION 17  
SUGAR CREEK TOWNSHIP  
CEDAR COUNTY

HYDRAULIC DATA

DRAINAGE AREA = 1.7 ACRES  
DESIGN DISCHARGE = 26.48 CFS



DESIGN FOR 0° SKEW  
**EXTEND 24" x 2' LT & 32' RT  
 REINFORCED CONCRETE PIPE  
 PLAT PLAN**  
 STA. 834+00.97 EB AUGUST 2019  
**CEDAR COUNTY**  
 IOWA DEPARTMENT OF TRANSPORTATION - HIGHWAY DIVISION  
 DESIGN SHEET NO. ? OF ? FILE NO. ? DESIGN NO. ?

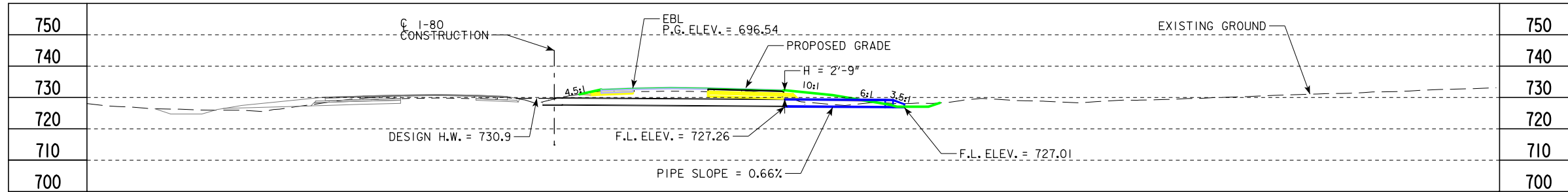

LONGITUDINAL SECTION ALONG CULVERT

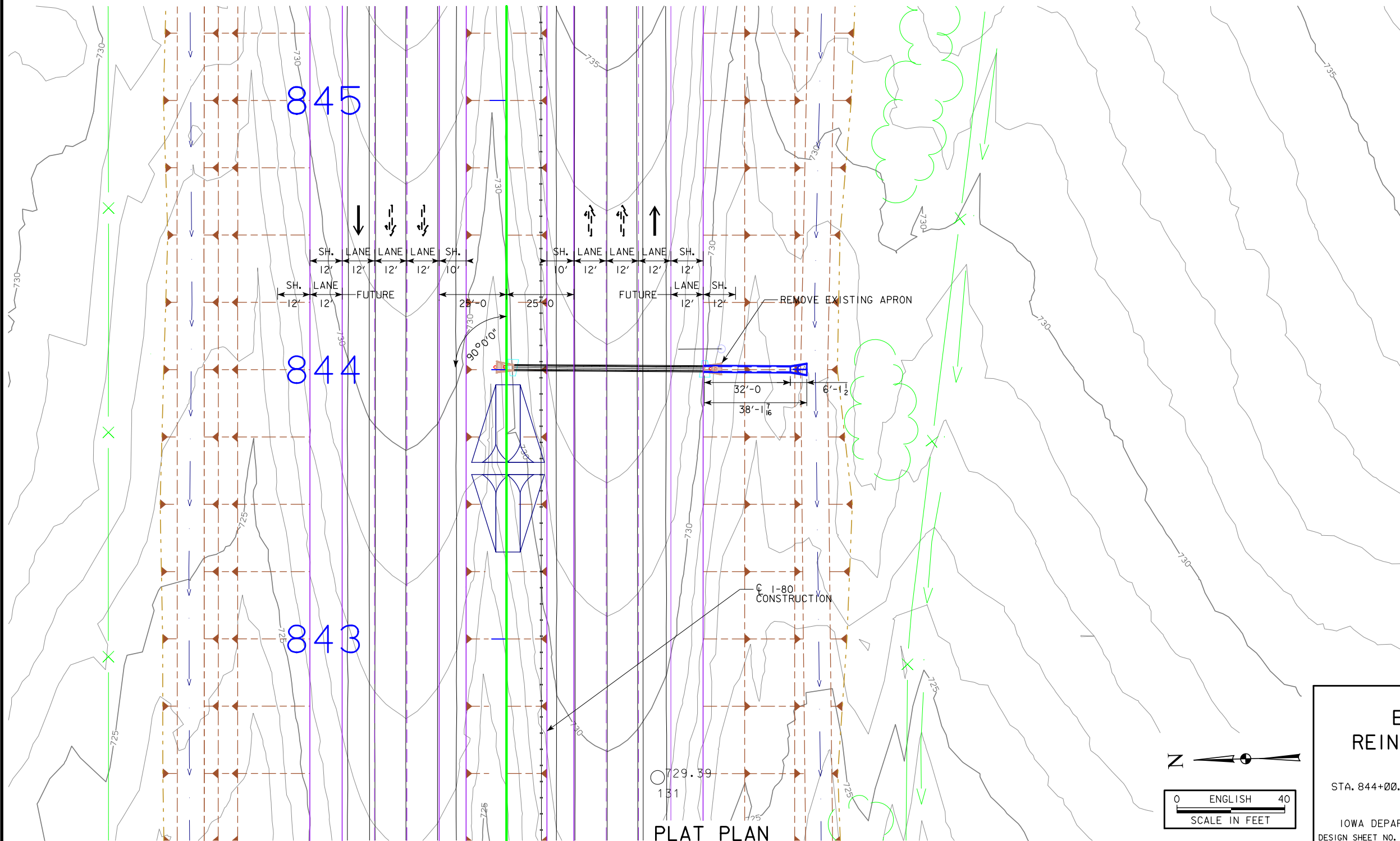

LOCATION

I-80  
T-79N R-2W  
SECTION 17  
SUGAR CREEK TOWNSHIP  
CEDAR COUNTY

HYDRAULIC DATA

DRAINAGE AREA = 1.7 ACRES  
DESIGN DISCHARGE = 22.28 CFS

DESIGN FOR 0° SKEW  
**EXTEND 24" x 32' RT  
REINFORCED CONCRETE PIPE  
PLAT PLAN**  
STA. 844+00.78 EB AUGUST 2019  
**CEDAR COUNTY**  
IOWA DEPARTMENT OF TRANSPORTATION - HIGHWAY DIVISION  
DESIGN SHEET NO. ? OF ? FILE NO. ? DESIGN NO. ?

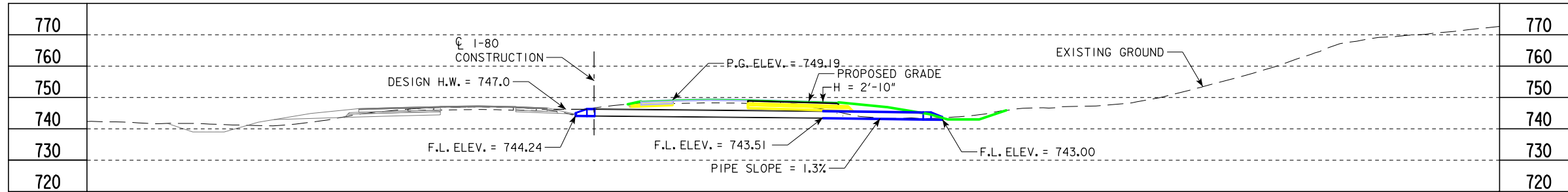

LONGITUDINAL SECTION ALONG  $\text{CL}$  CULVERT

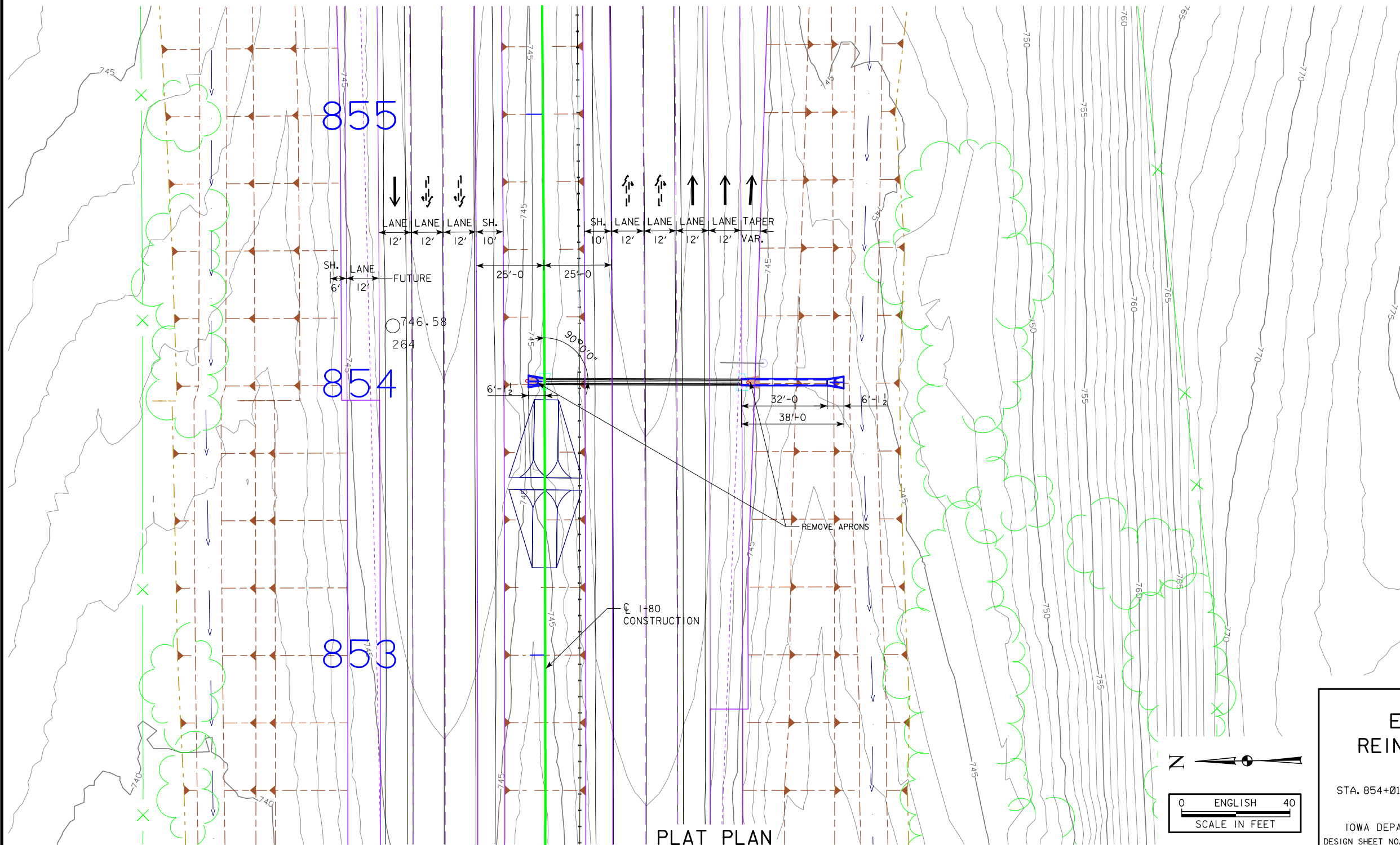

LOCATION

I-80  
T-79N R-2W  
SECTION 17  
SUGAR CREEK TOWNSHIP  
CEDAR COUNTY

HYDRAULIC DATA

DRAINAGE AREA = 1.7 ACRES  
DESIGN DISCHARGE = 21.70 CFS

DESIGN FOR 0° SKEW  
**EXTEND 24" x 32' RT  
REINFORCED CONCRETE PIPE  
PLAT PLAN**  
STA. 854+01.17 EB AUGUST 2019  
**CEDAR COUNTY**  
IOWA DEPARTMENT OF TRANSPORTATION - HIGHWAY DIVISION  
DESIGN SHEET NO. ? OF ? FILE NO. ? DESIGN NO. ?

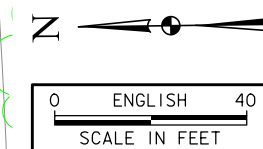



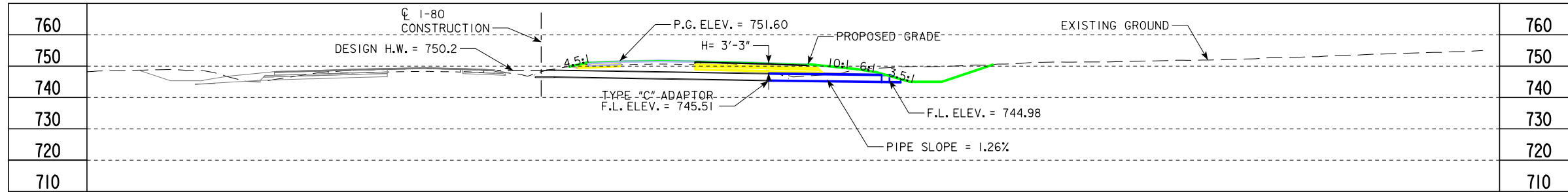

LONGITUDINAL SECTION ALONG CL CULVERT

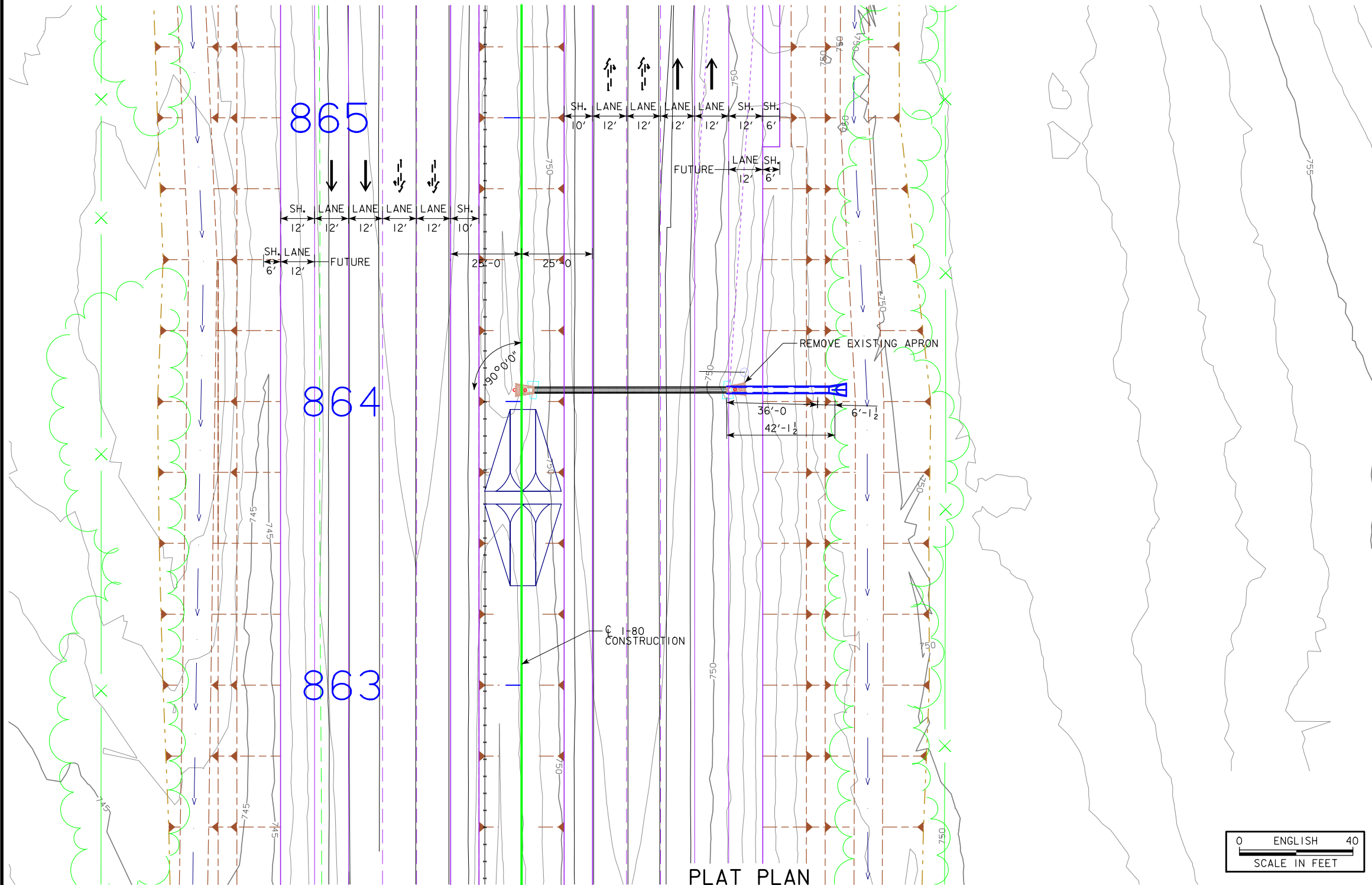

PLAT PLAN

LOCATION

I-80  
 T-79N R-2W  
 SECTION 16  
 SUGAR CREEK TOWNSHIP  
 CEDAR COUNTY

HYDRAULIC DATA

DRAINAGE AREA = 1.6 ACRES  
 DESIGN DISCHARGE = 19.41 CFS



DESIGN FOR 0° SKEW  
**EXTEND 24" x 36' RT  
 REINFORCED CONCRETE PIPE  
 PLAT PLAN**  
 STA. 864+04.03 EB AUGUST 2019  
**CEDAR COUNTY**  
 IOWA DEPARTMENT OF TRANSPORTATION - HIGHWAY DIVISION  
 DESIGN SHEET NO. ? OF ? FILE NO. ? DESIGN NO. ?

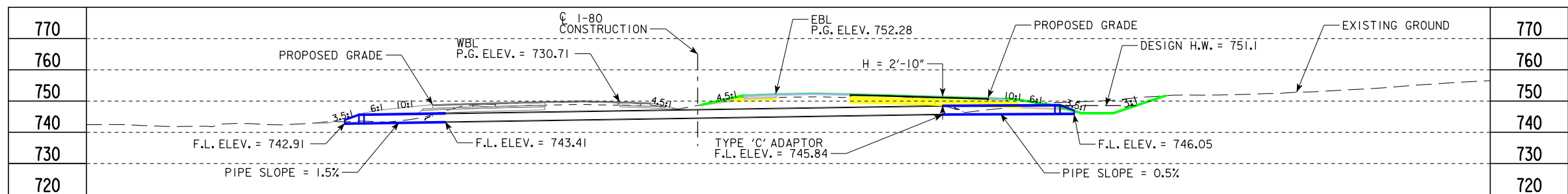

### LONGITUDINAL SECTION ALONG $\phi$ CULVERT

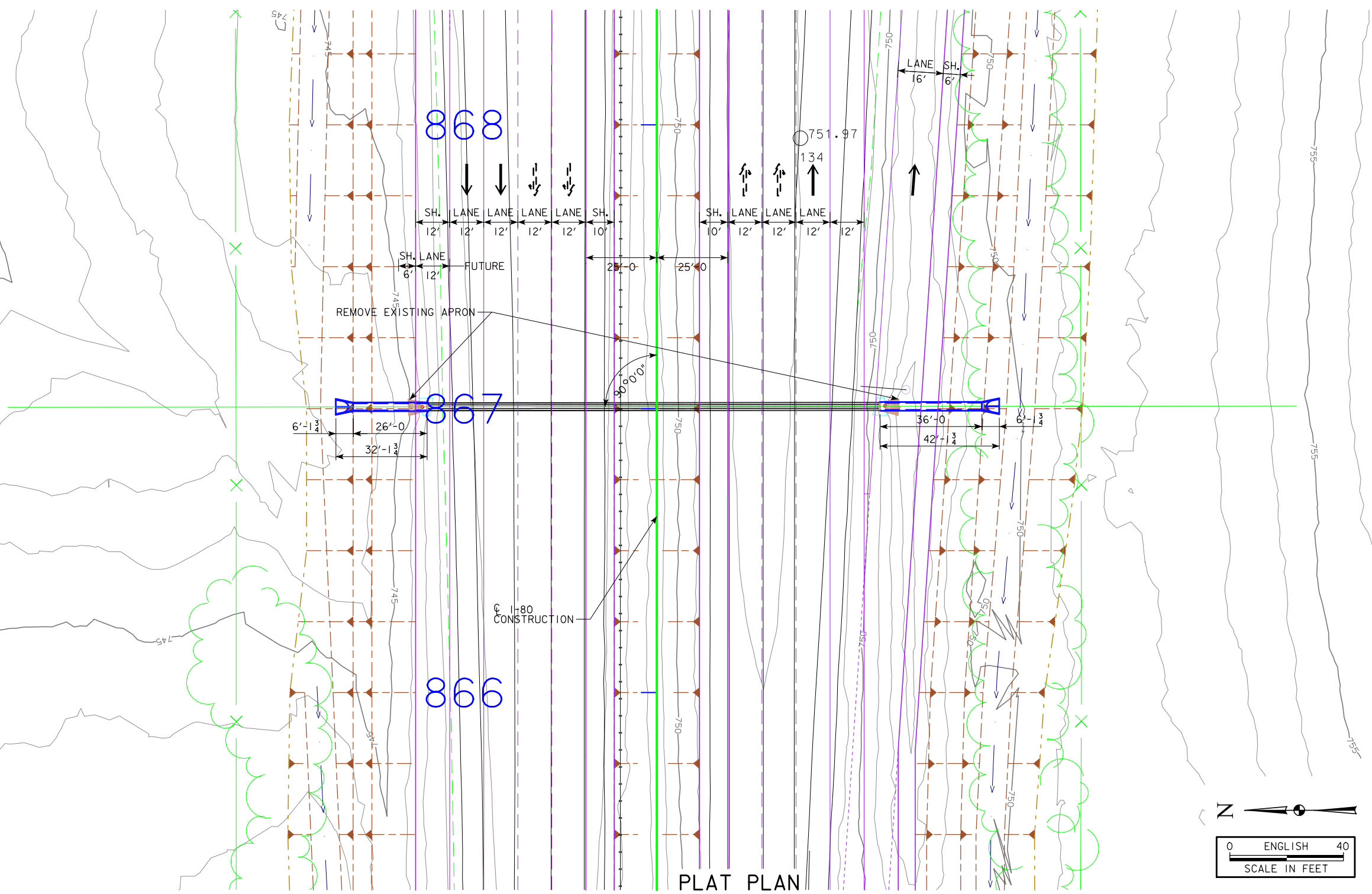

### LOCATION

I-80  
T-79N R-2W  
SECTION 16  
SUGAR CREEK TOWNSHIP  
CEDAR COUNTY

### HYDRAULIC DATA

DRAINAGE AREA = 8.4 ACRES  
DESIGN DISCHARGE = 48.70 CFS

DESIGN FOR 0° SKEW  
**EXTEND 30" x 26' LT & 36' RT  
REINFORCED CONCRETE PIPE  
PLAT PLAN**  
STA. 867+00.74 AUGUST 2019  
**CEDAR COUNTY**  
IOWA DEPARTMENT OF TRANSPORTATION - HIGHWAY DIVISION  
DESIGN SHEET NO. ? OF ? FILE NO. ? DESIGN NO. ?

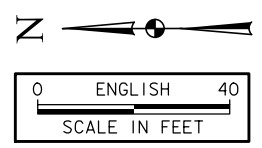

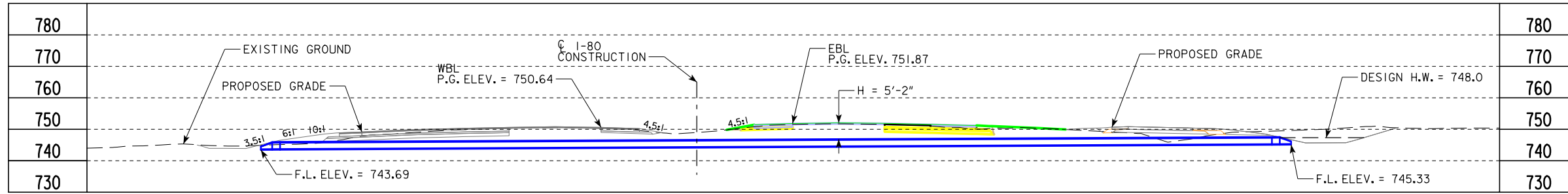

LONGITUDINAL SECTION ALONG  $\bar{C}$  CULVERT

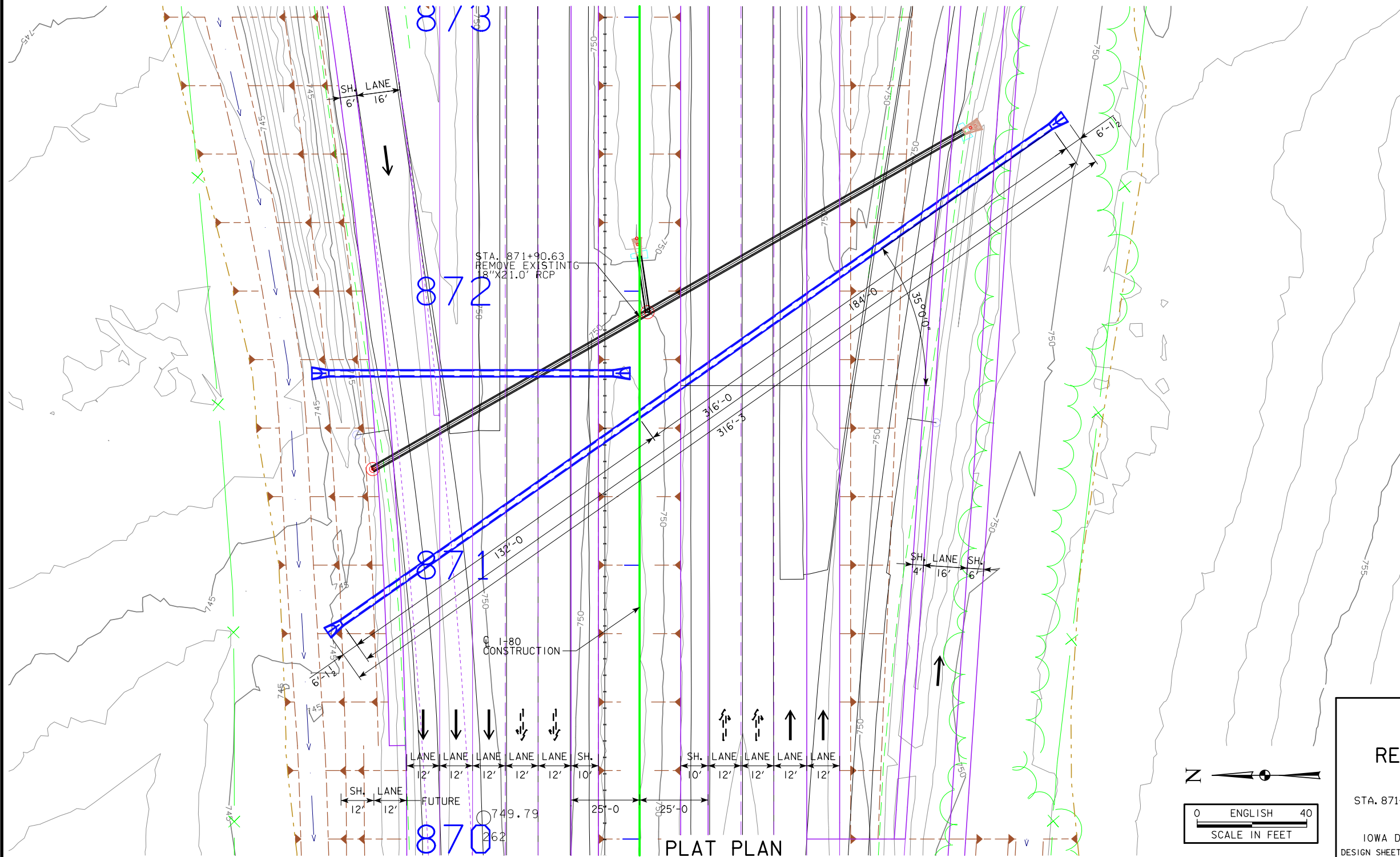

**LOCATION**

I-80  
T-79N R-2W  
SECTION 16  
SUGAR CREEK TOWNSHIP  
CEDAR COUNTY

**HYDRAULIC DATA**

DRAINAGE AREA = 2.6 ACRES  
DESIGN DISCHARGE = 15.17 CFS

DESIGN FOR 35° SKEW RT AHD.  
**24" x 316'**  
**REINFORCED CONCRETE PIPE**  
**PLAT PLAN**  
STA. 871+55.00 AUGUST 2019  
**CEDAR COUNTY**  
IOWA DEPARTMENT OF TRANSPORTATION - HIGHWAY DIVISION  
DESIGN SHEET NO. ? OF ? FILE NO. ? DESIGN NO. ?

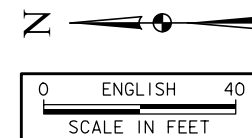

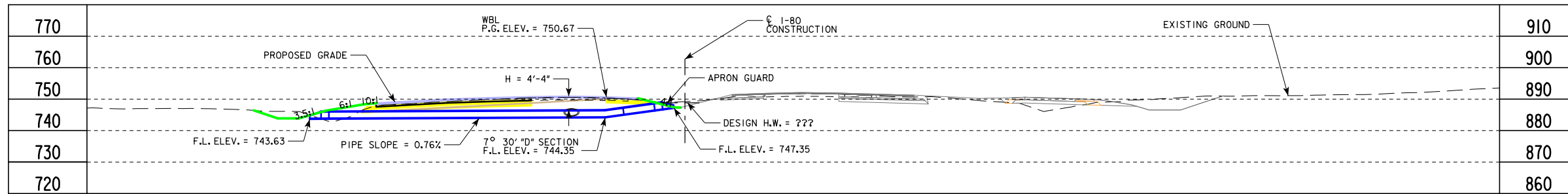

LONGITUDINAL SECTION ALONG CULVERT

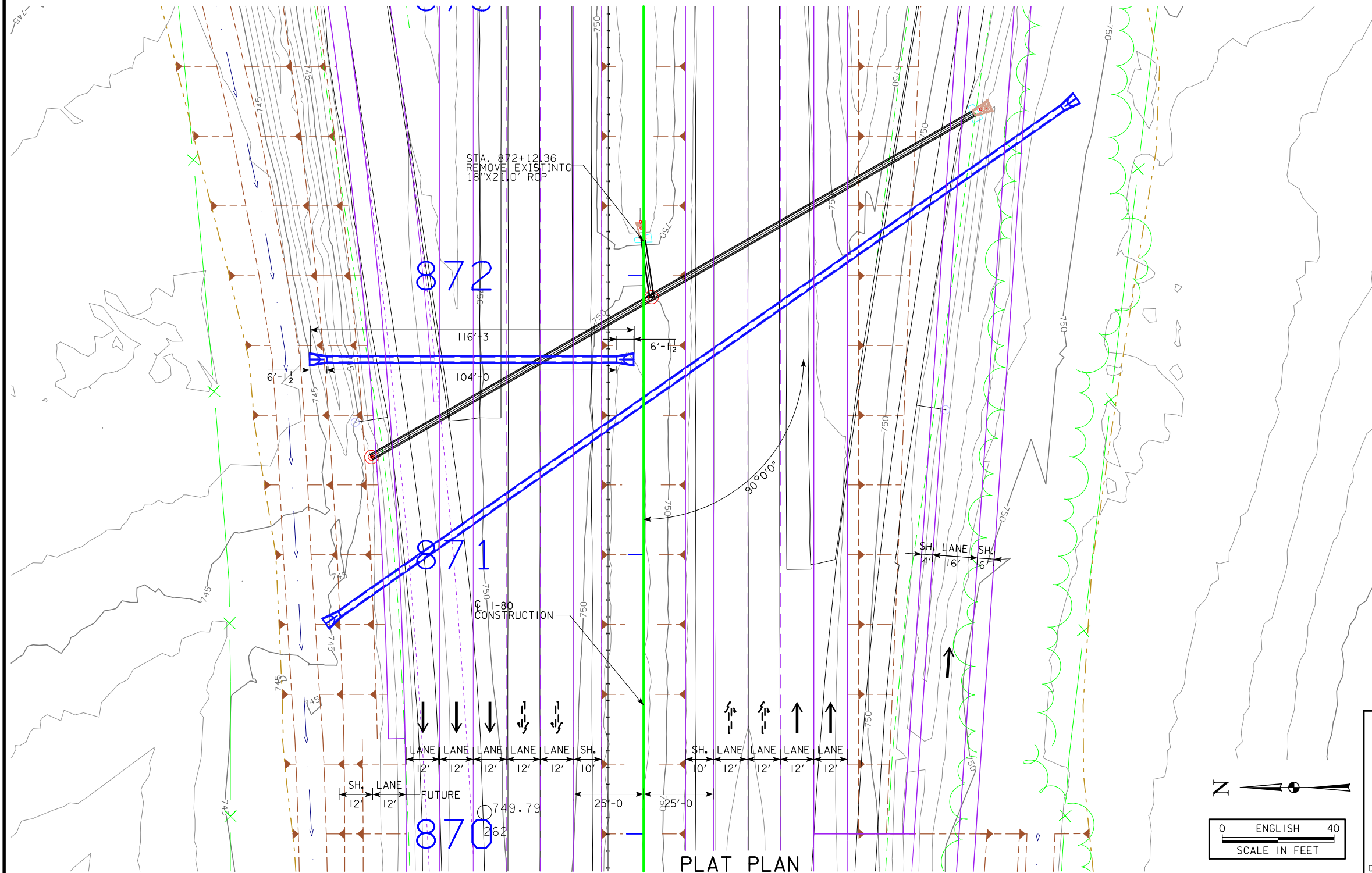

LOCATION

I-80  
T-79N R-2W  
SECTION 16  
SUGAR CREEK TOWNSHIP  
CEDAR COUNTY

HYDRAULIC DATA

DRAINAGE AREA = ??? ACRES  
DESIGN DISCHARGE = ??? CFS

DESIGN FOR 0° SKEW  
**24" x 104'**  
**REINFORCED CONCRETE PIPE**  
**PLAT PLAN**  
STA. 871+70.00 WB  
AUGUST 2019  
**CEDAR COUNTY**  
IOWA DEPARTMENT OF TRANSPORTATION - HIGHWAY DIVISION  
DESIGN SHEET NO. ? OF ? FILE NO. ? DESIGN NO. ?

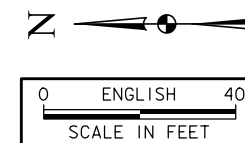



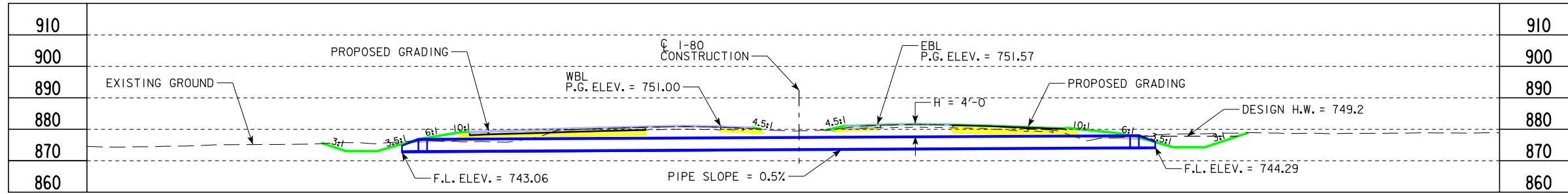

LONGITUDINAL SECTION ALONG C<sub>L</sub> CULVERT

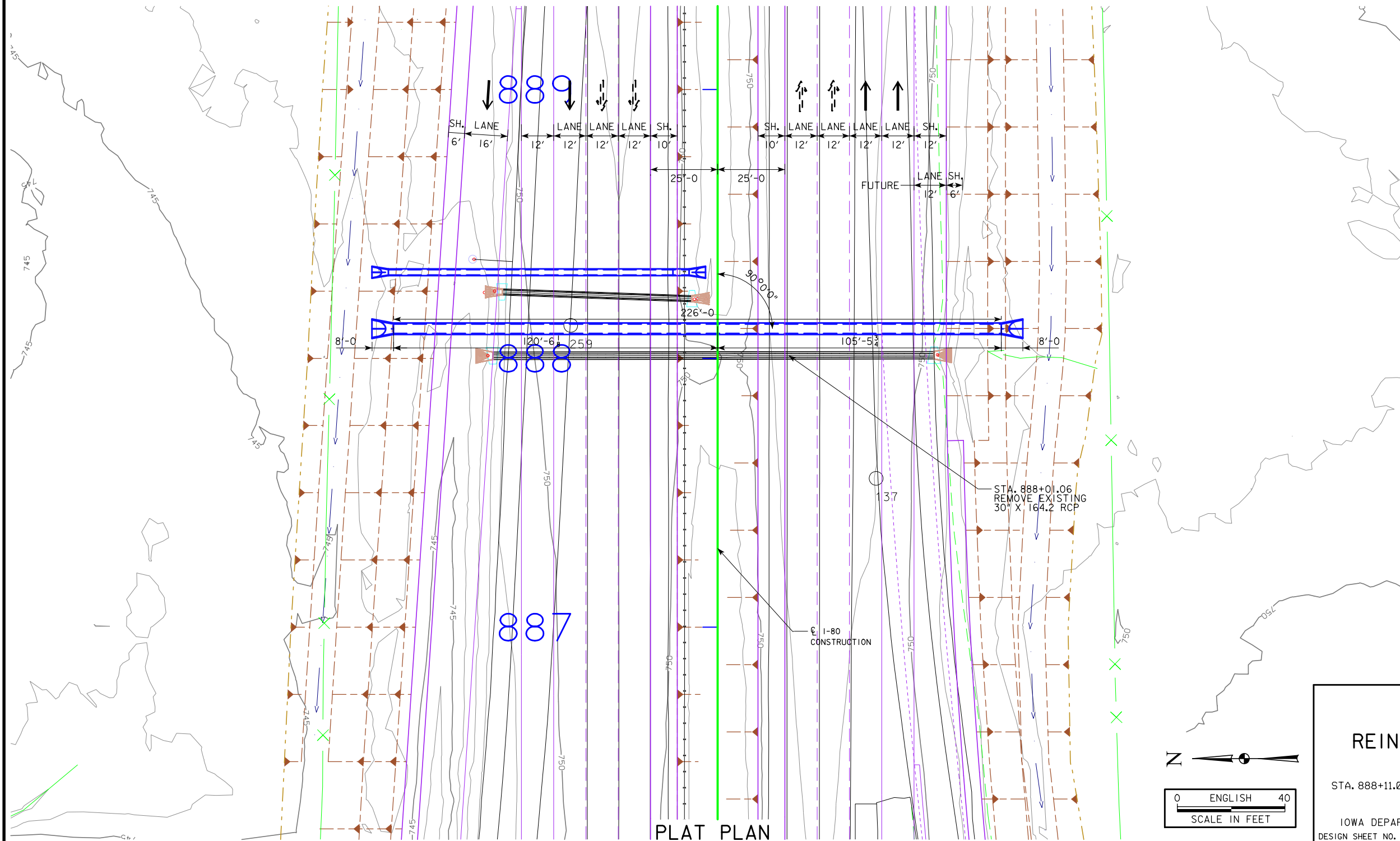

LOCATION

I-80  
T-79N R-2W  
SECTION 16  
SUGAR CREEK TOWNSHIP  
CEDAR COUNTY

HYDRAULIC DATA

DRAINAGE AREA = 9.6 ACRES  
DESIGN DISCHARGE = 84.17 CFS

DESIGN FOR 0° SKEW  
**42" x 226'**  
**REINFORCED CONCRETE PIPE**  
**PLAT PLAN**  
STA. 888+11.00 AUGUST 2019  
**CEDAR COUNTY**  
IOWA DEPARTMENT OF TRANSPORTATION - HIGHWAY DIVISION  
DESIGN SHEET NO. ? OF ? FILE NO. ? DESIGN NO. ?

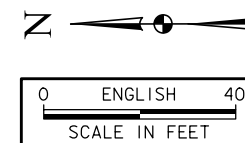

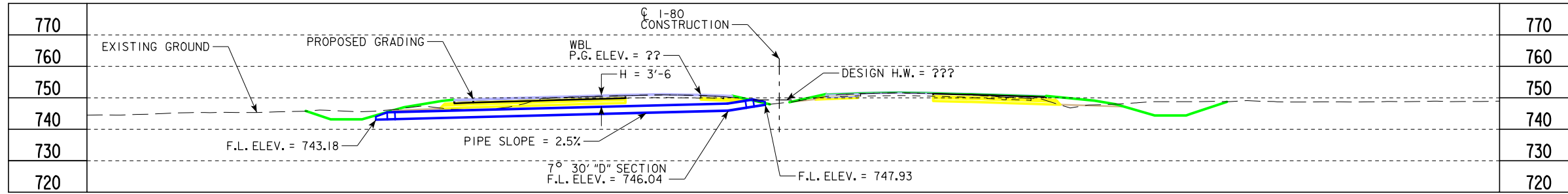

LONGITUDINAL SECTION ALONG  $\bar{C}$  CULVERT

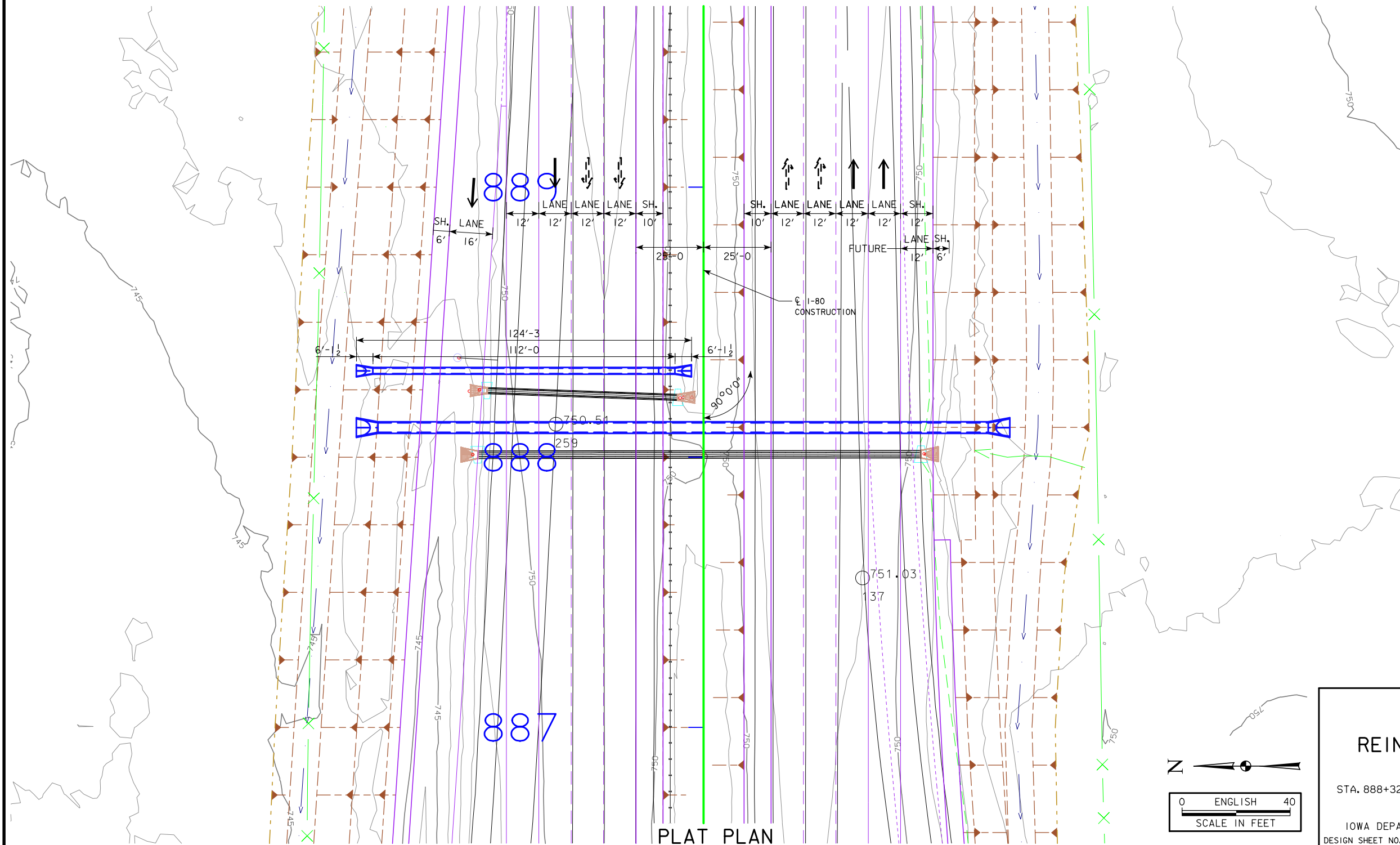

LOCATION

I-80  
T-79N R-2W  
SECTION 16  
SUGAR CREEK TOWNSHIP  
CEDAR COUNTY

HYDRAULIC DATA

DRAINAGE AREA = ??? ACRES  
DESIGN DISCHARGE = ??? CFS



DESIGN FOR 0° SKEW  
**24" x 112'**  
**REINFORCED CONCRETE PIPE**  
**PLAT PLAN**  
STA. 888+32.00 AUGUST 2019  
**CEDAR COUNTY**  
IOWA DEPARTMENT OF TRANSPORTATION - HIGHWAY DIVISION  
DESIGN SHEET NO. ? OF ? FILE NO. ? DESIGN NO. ?

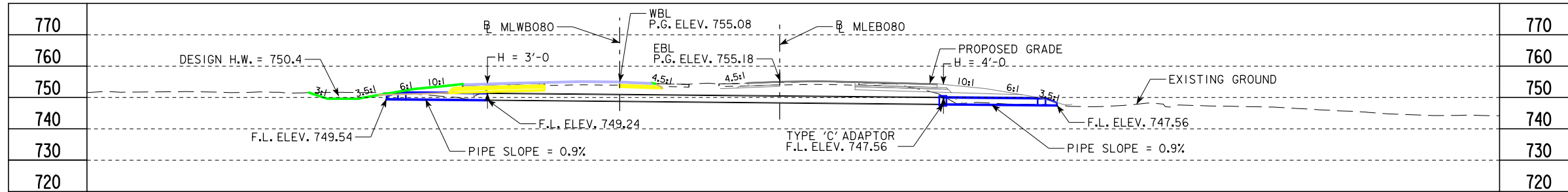

LONGITUDINAL SECTION ALONG  $\text{CL}$  CULVERT

LOCATION

MLWB080  
T-79N R-2W  
SECTION 16  
SUGAR CREEK TOWNSHIP  
CEDAR COUNTY

HYDRAULIC DATA

DRAINAGE AREA = 2.1 ACRES  
DESIGN DISCHARGE = 21.93 CFS

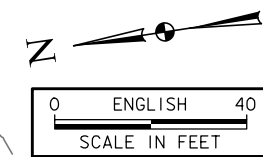
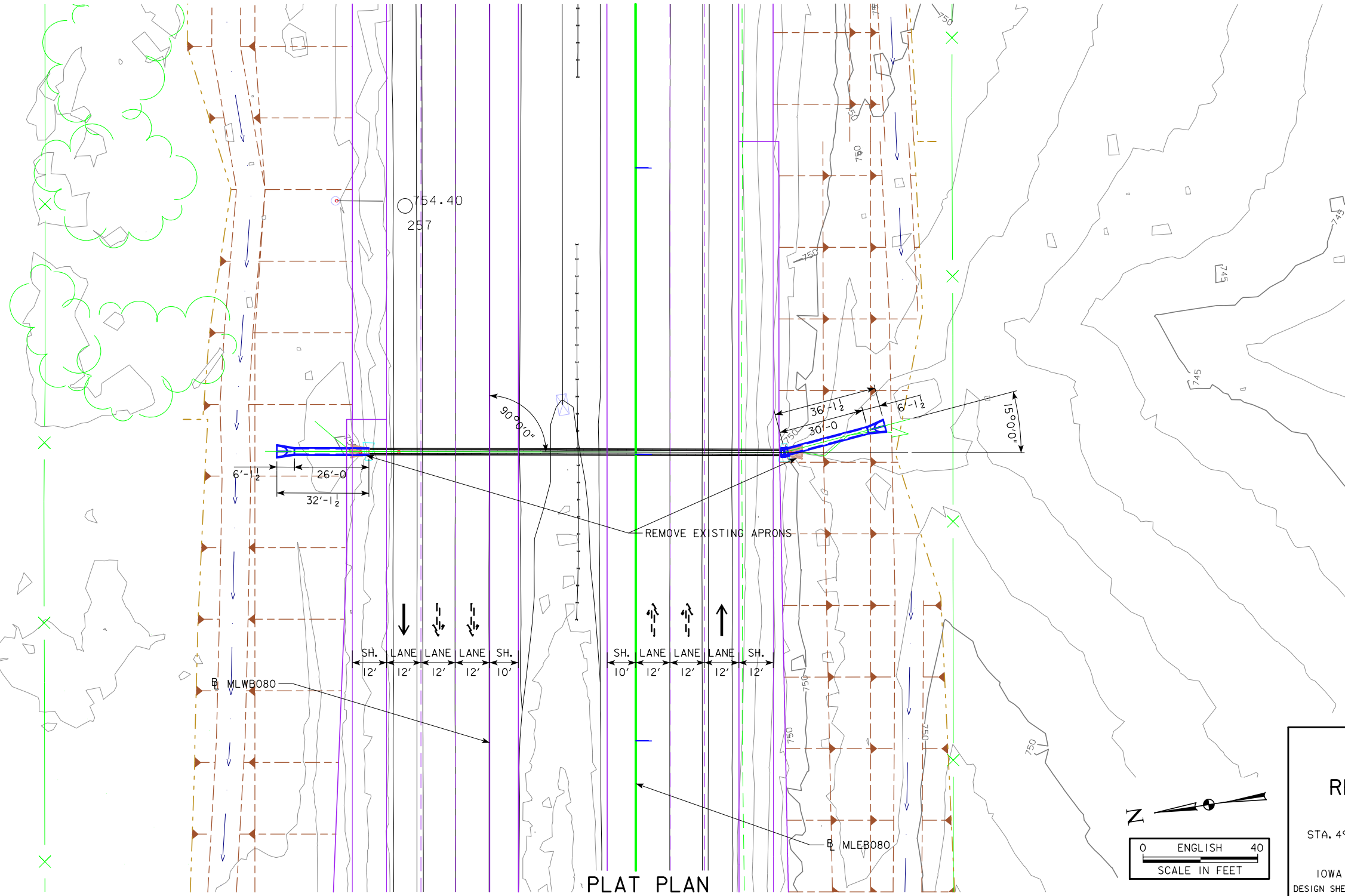

RT DESIGN FOR 15° SKEW RT AHD.  
**24" x 26' LT & 30' RT  
REINFORCED CONCRETE PIPE  
PLAT PLAN**  
STA. 4903+08.46 WB AUGUST 2019  
**CEDAR COUNTY**  
IOWA DEPARTMENT OF TRANSPORTATION - HIGHWAY DIVISION  
DESIGN SHEET NO. ? OF ? FILE NO. ? DESIGN NO. ?

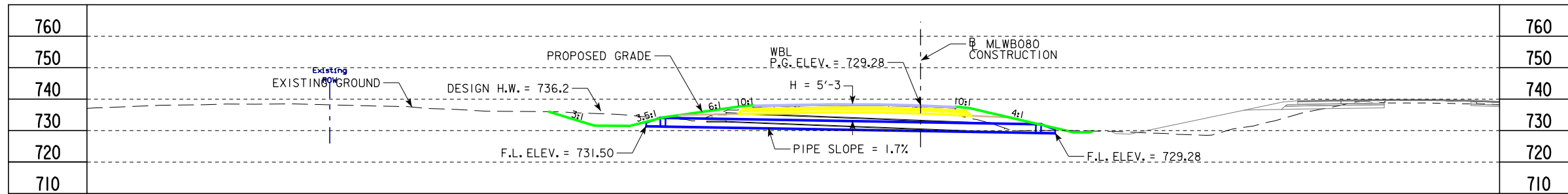

LONGITUDINAL SECTION ALONG CULVERT

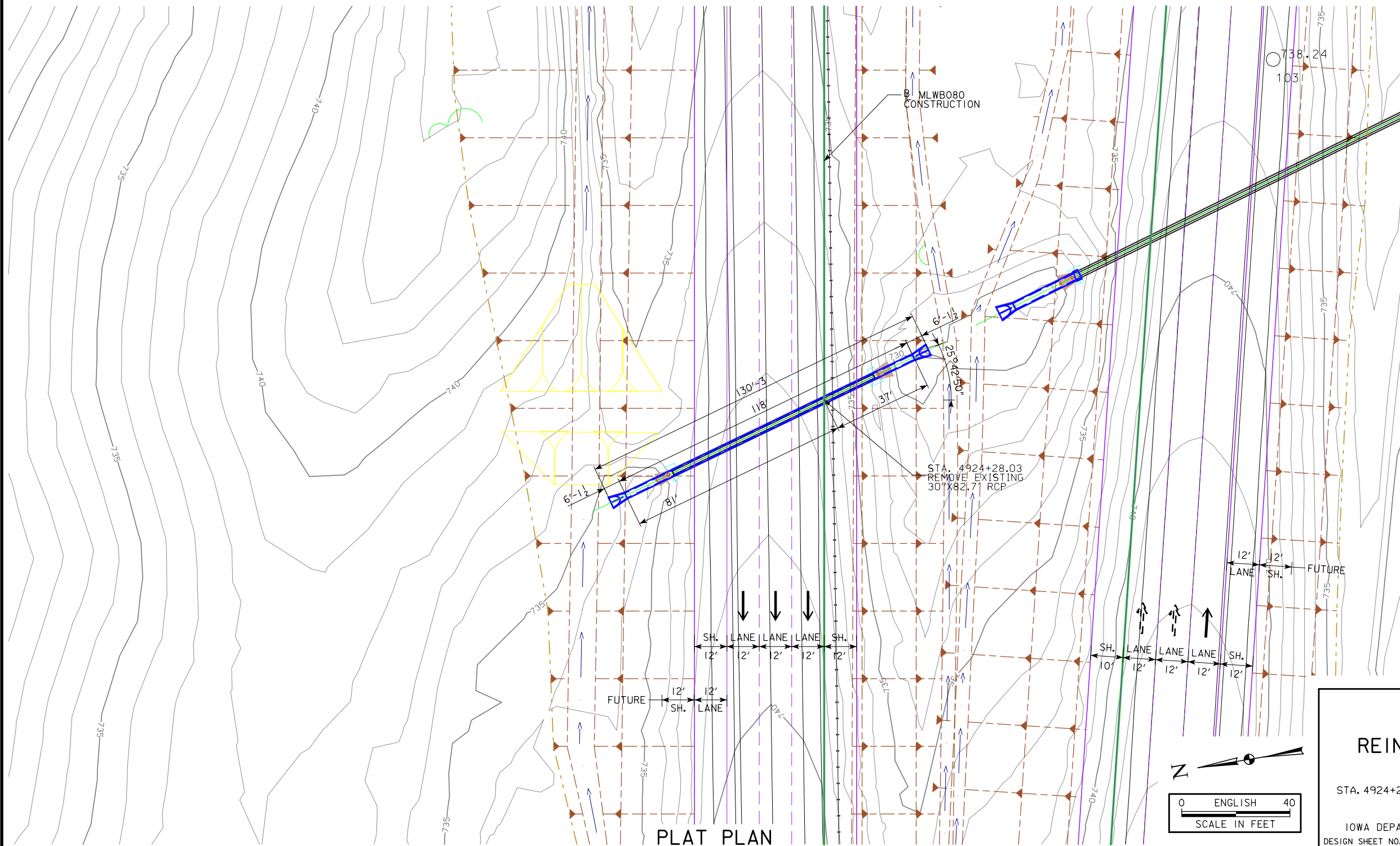

PLAT PLAN

LOCATION

I-80  
 T-79N R-2W  
 SECTION 15  
 SUGAR CREEK TOWNSHIP  
 CEDAR COUNTY

HYDRAULIC DATA

DRAINAGE AREA = 9.9 ACRES  
 DESIGN DISCHARGE = 43.02 CFS

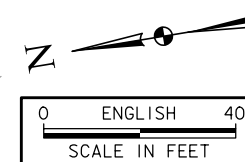

DESIGN FOR 26° SKEW RT AHD.  
**30" x 118'**  
**REINFORCED CONCRETE PIPE**  
**PLAT PLAN**  
 STA. 4924+28.03 AUGUST 2019  
**CEDAR COUNTY**  
 IOWA DEPARTMENT OF TRANSPORTATION - HIGHWAY DIVISION  
 DESIGN SHEET NO. ? OF ? FILE NO. ? DESIGN NO. ?



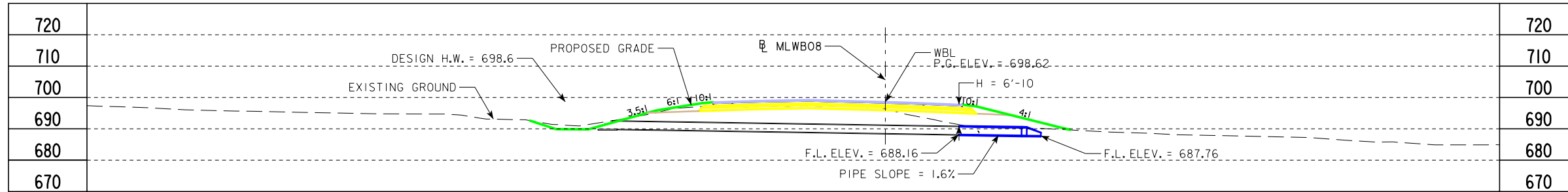

LONGITUDINAL SECTION ALONG  $\phi$  CULVERT

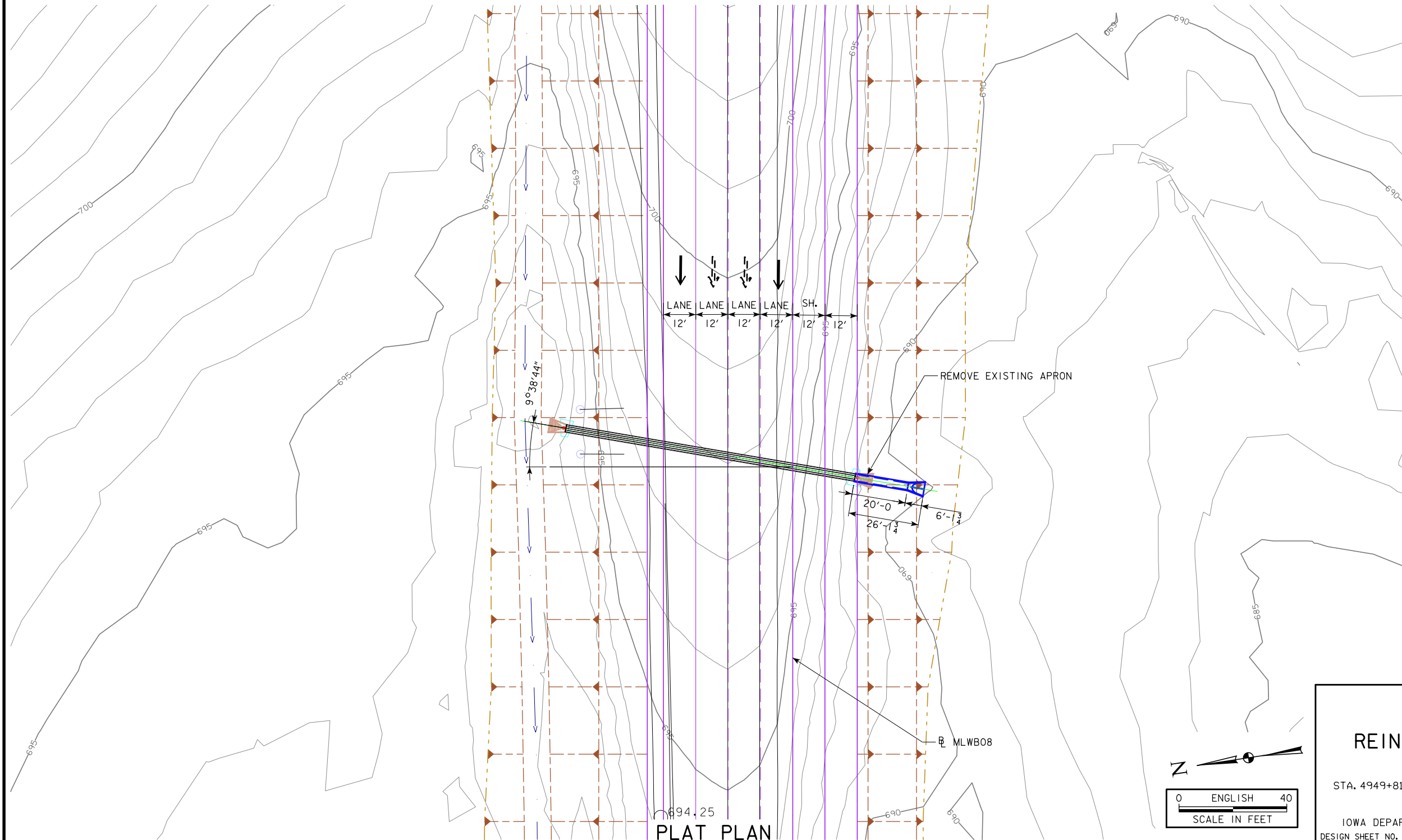

PLAT PLAN

**LOCATION**

MLWB08  
T-79N R-2W  
SECTION 15  
SUGAR CREEK TOWNSHIP  
CEDAR COUNTY

**HYDRAULIC DATA**

DRAINAGE AREA = 5.0 ACRES  
DESIGN DISCHARGE = 52.52 CFS

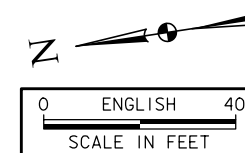

DESIGN FOR 10° SKEW LT AHD.  
**30" x 20'**  
**REINFORCED CONCRETE PIPE**  
**PLAT PLAN**  
STA. 494+81.71 WB AUGUST 2019  
**CEDAR COUNTY**  
IOWA DEPARTMENT OF TRANSPORTATION - HIGHWAY DIVISION  
DESIGN SHEET NO. ? OF ? FILE NO. ? DESIGN NO. ?

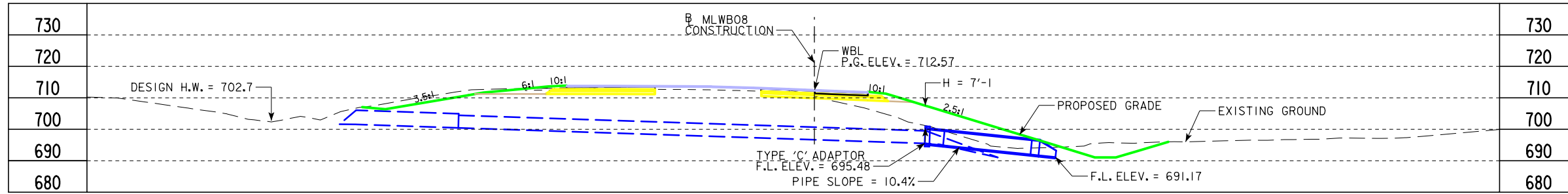

LONGITUDINAL SECTION ALONG  $\phi$  CULVERT

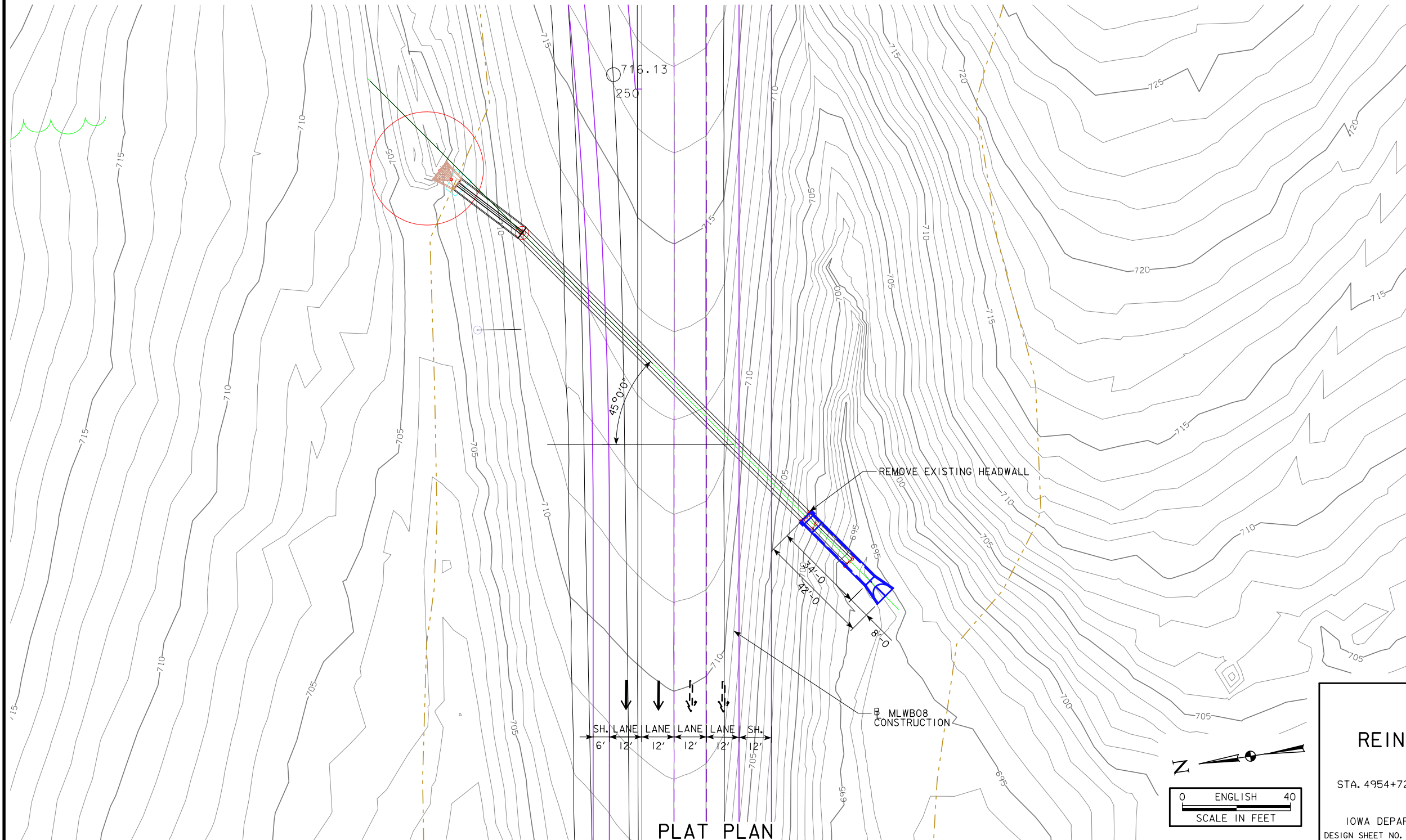

PLAT PLAN

**LOCATION**

MLWB08  
 T-79N R-2W  
 SECTION 15  
 SUGAR CREEK TOWNSHIP  
 CEDAR COUNTY

**HYDRAULIC DATA**

DRAINAGE AREA = 55.6 ACRES  
 DESIGN DISCHARGE = 310.91 CFS

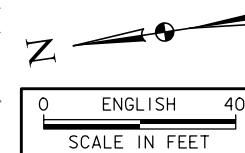

DESIGN FOR 45° SKEW LT. AHD.  
**54" x 34'**  
**REINFORCED CONCRETE PIPE**  
**PLAT PLAN**  
 STA. 4954+72.00 WB AUGUST 2019  
**CEDAR COUNTY**  
 IOWA DEPARTMENT OF TRANSPORTATION - HIGHWAY DIVISION  
 DESIGN SHEET NO. ? OF ? FILE NO. ? DESIGN NO. ?

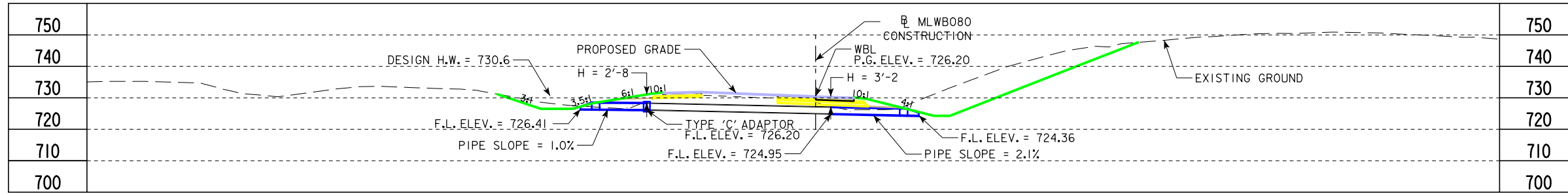

LONGITUDINAL SECTION ALONG CULVERT

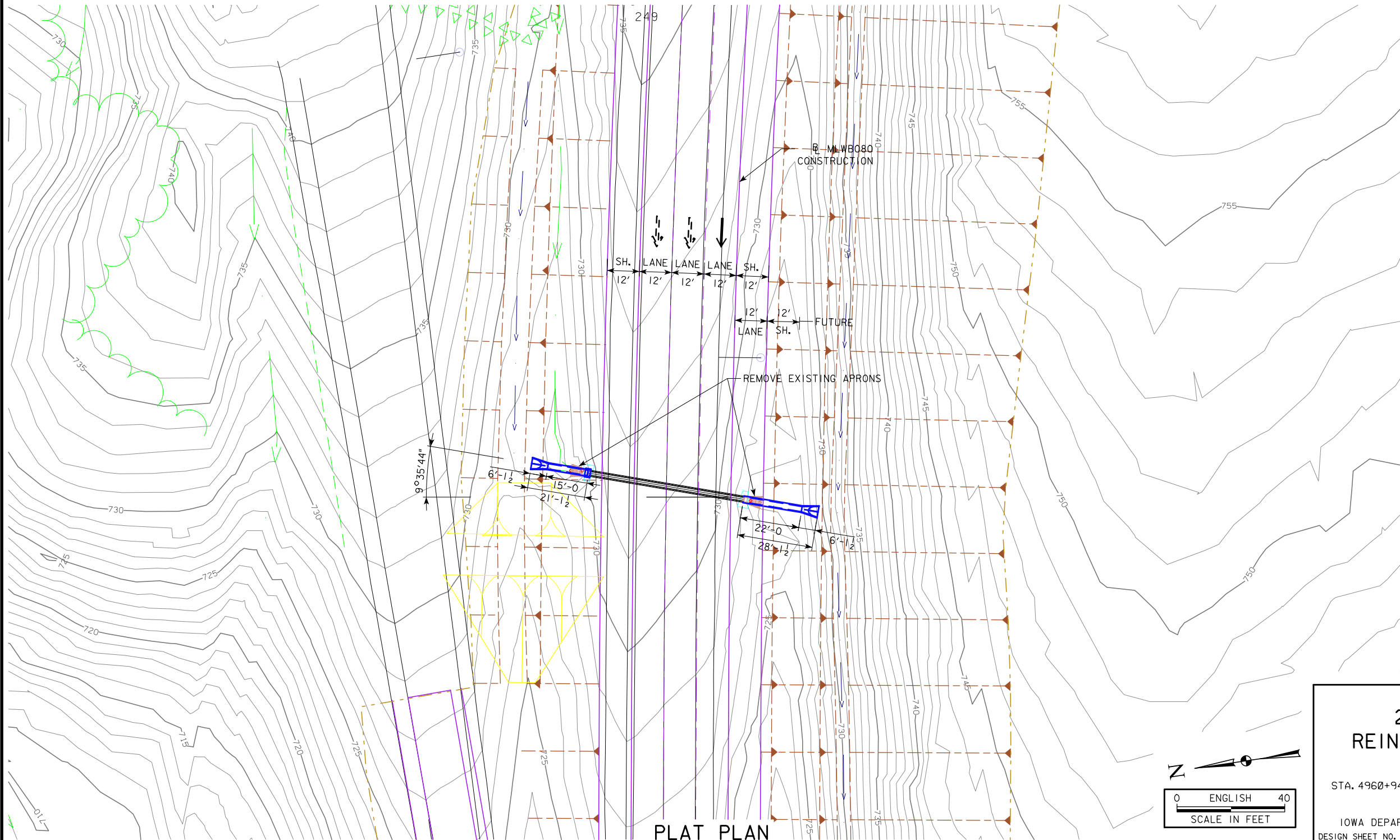

LOCATION

MLWB080  
 T-79N R-2W  
 SECTION 22  
 SUGAR CREEK TOWNSHIP  
 CEDAR COUNTY

HYDRAULIC DATA

DRAINAGE AREA = 2.3 ACRES  
 DESIGN DISCHARGE = 33.09 CFS

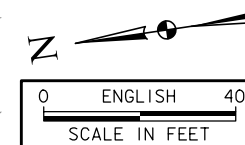

DESIGN FOR 10° SKEW LT AHD.  
**24" x 16' LT & 22 RT  
 REINFORCED CONCRETE PIPE  
 PLAT PLAN**  
 STA. 4960+94.64 WB AUGUST 2019  
**CEDAR COUNTY**  
 IOWA DEPARTMENT OF TRANSPORTATION - HIGHWAY DIVISION  
 DESIGN SHEET NO. ? OF ? FILE NO. ? DESIGN NO. ?



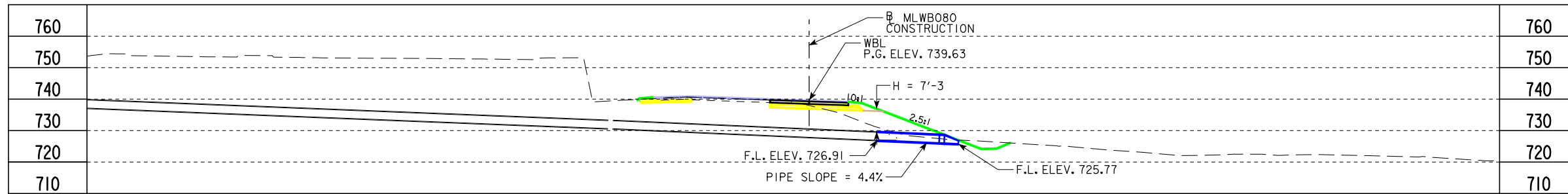

LONGITUDINAL SECTION ALONG  $\phi$  CULVERT

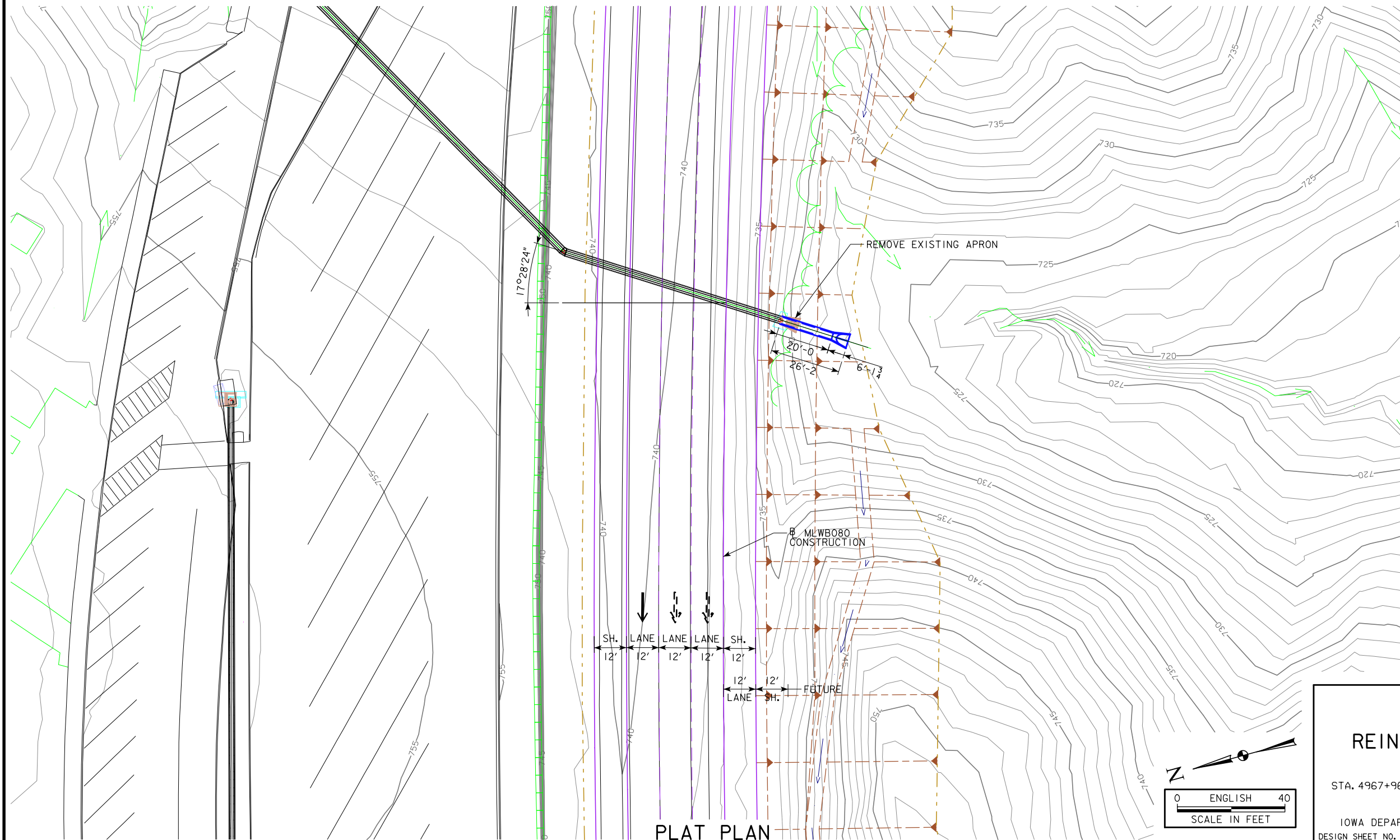

PLAT PLAN

**LOCATION**

MLWB080  
T-79N R-2W  
SECTION 23  
SUGAR CREEK TOWNSHIP  
CEDAR COUNTY

**HYDRAULIC DATA**

DRAINAGE AREA = 2.9 ACRES  
DESIGN DISCHARGE = 81.62 CFS

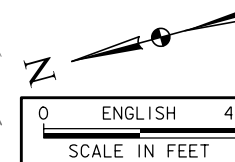

DESIGN FOR 17° SKEW LT AHD.  
**30" x 20'**  
**REINFORCED CONCRETE PIPE**  
**PLAT PLAN**  
 STA. 4967+96.16 WB AUGUST 2019  
**CEDAR COUNTY**  
 IOWA DEPARTMENT OF TRANSPORTATION - HIGHWAY DIVISION  
 DESIGN SHEET NO. ? OF ? FILE NO. ? DESIGN NO. ?



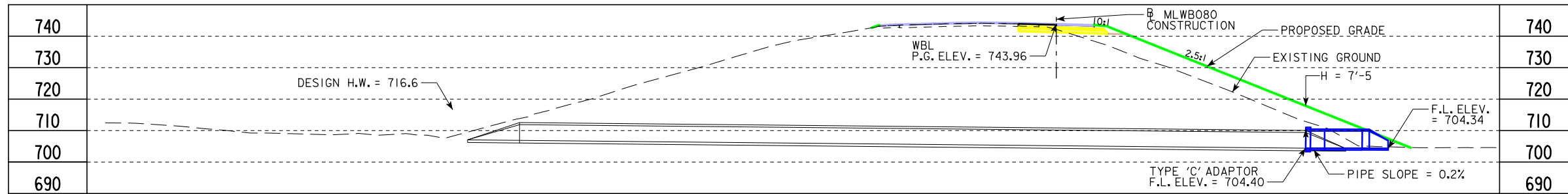

LONGITUDINAL SECTION ALONG  $\phi$  CULVERT

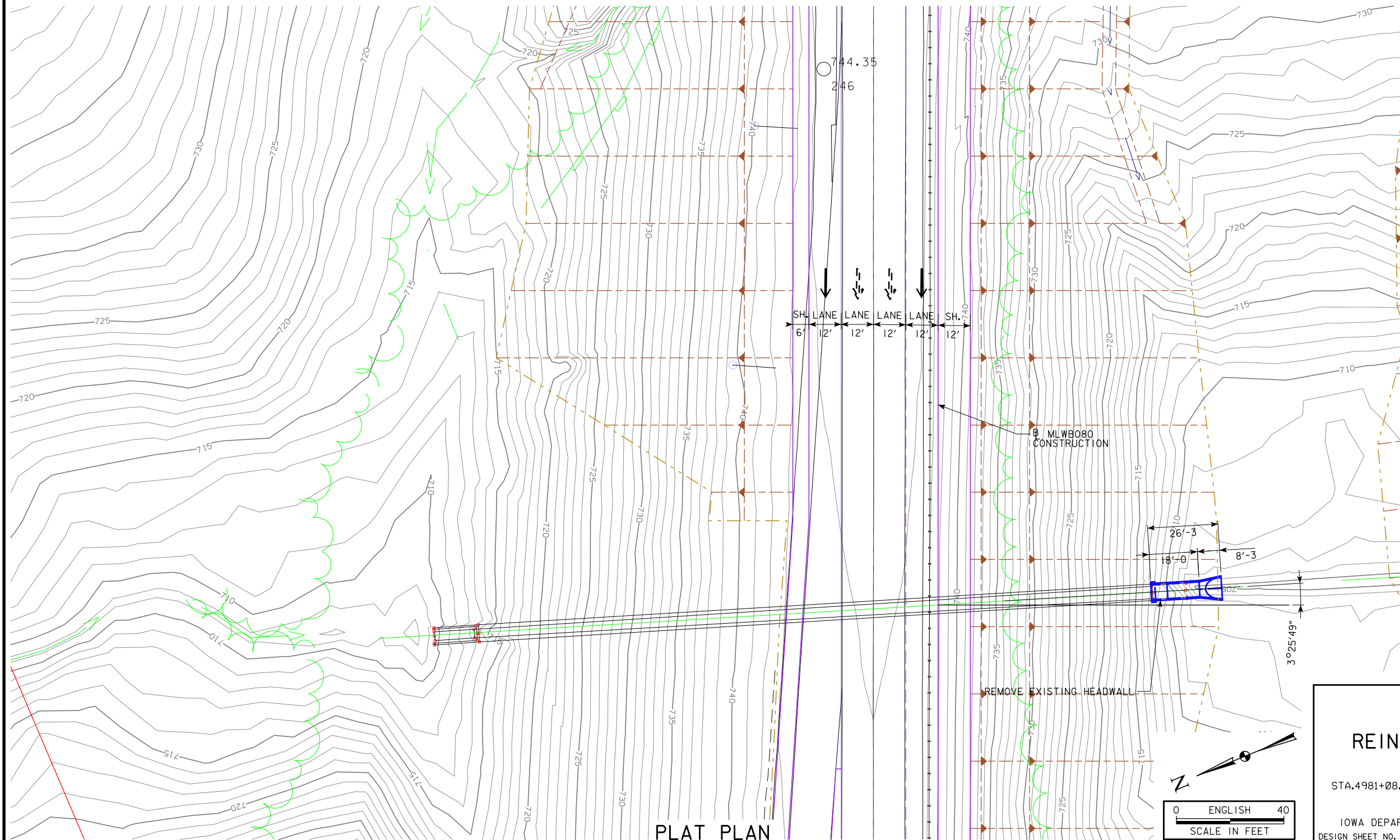

LOCATION

MLWB080  
T-79N R-2W  
SECTION 23  
SUGAR CREEK TOWNSHIP  
CEDAR COUNTY

HYDRAULIC DATA

DRAINAGE AREA = 99.2 ACRES  
DESIGN DISCHARGE = 448.00 CFS

DESIGN FOR 3° SKEW RT AHD.

**18" x 66'**  
**REINFORCED CONCRETE PIPE**  
**PLAT PLAN**

STA.4981+08.09 WB AUGUST 2019

**CEDAR COUNTY**

IOWA DEPARTMENT OF TRANSPORTATION - HIGHWAY DIVISION  
DESIGN SHEET NO. ? OF ? FILE NO. ? DESIGN NO. ?



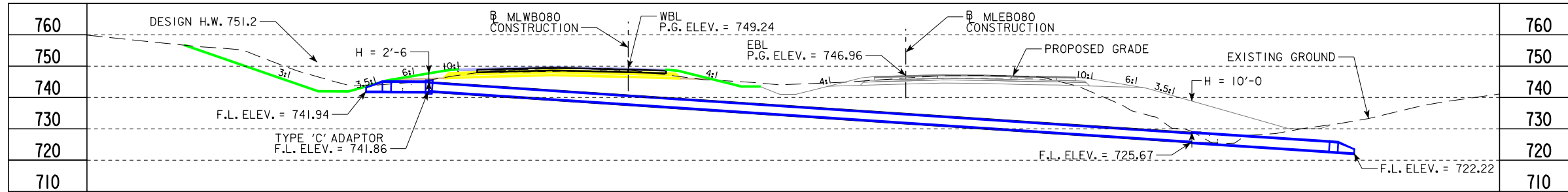

LONGITUDINAL SECTION ALONG C<sub>L</sub> CULVERT

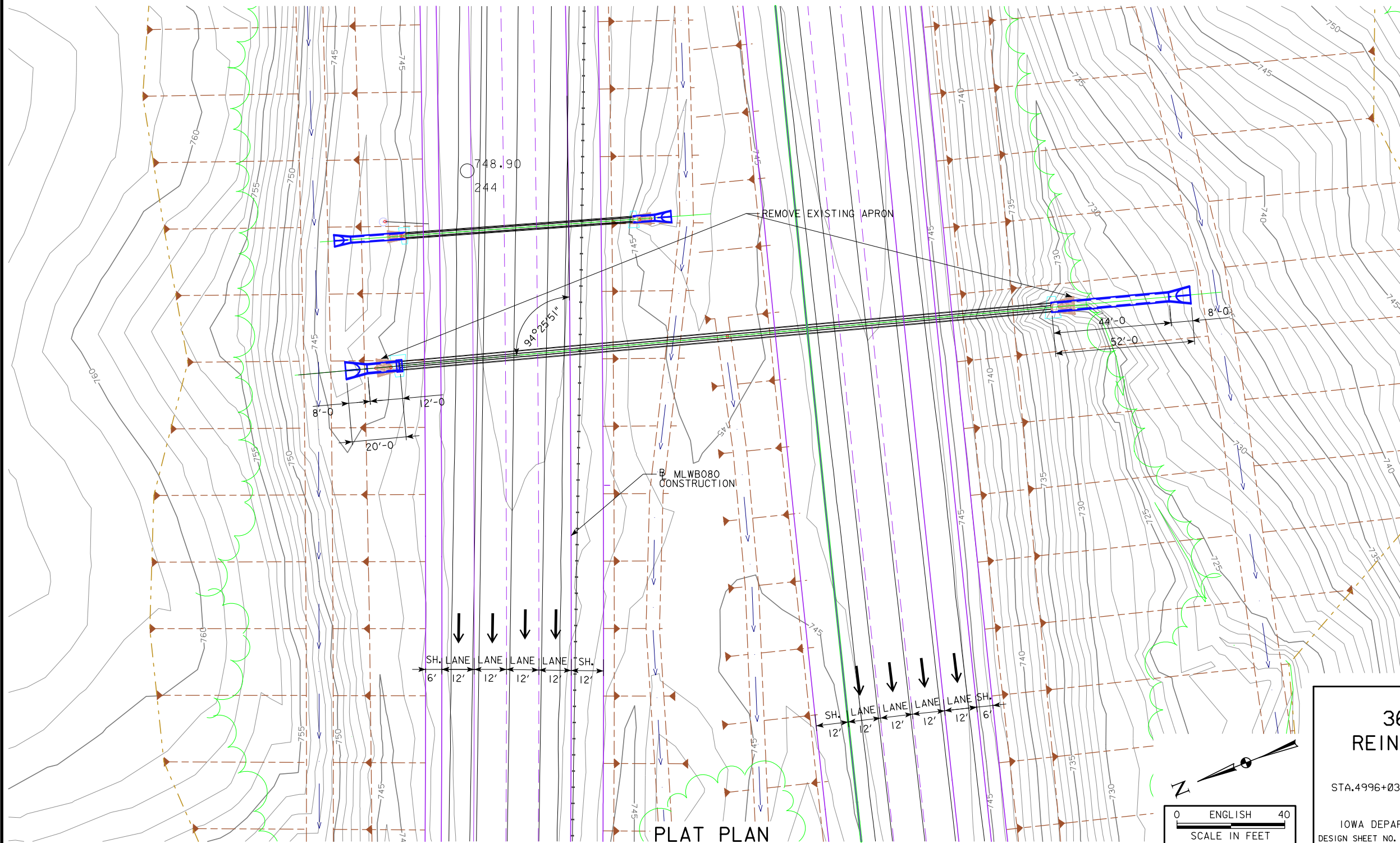

LOCATION

I-80  
T-??N R-??W  
SECTION ??  
?????? TOWNSHIP  
CEDAR COUNTY

HYDRAULIC DATA

DRAINAGE AREA = 18.1 ACRES  
DESIGN DISCHARGE = ?? CFS

DESIGN FOR ?° SKEW

**36" x 12' LT & 44' RT**  
**REINFORCED CONCRETE PIPE**  
**PLAT PLAN**

STA.4996+03.17 WB AUGUST 2019

**CEDAR COUNTY**

IOWA DEPARTMENT OF TRANSPORTATION - HIGHWAY DIVISION  
DESIGN SHEET NO. ? OF ? FILE NO. ? DESIGN NO. ?

0 ENGLISH 40  
SCALE IN FEET



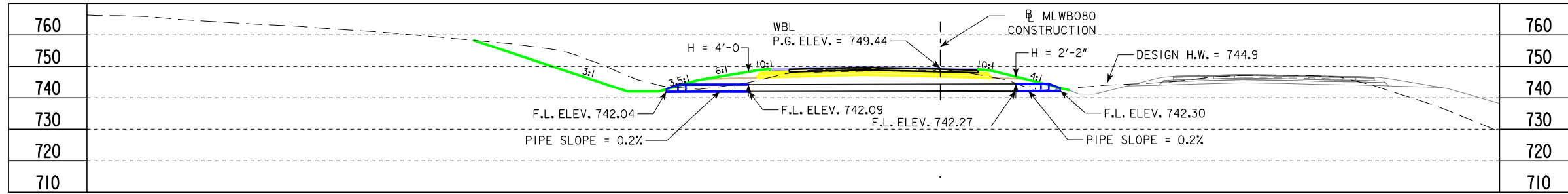

LONGITUDINAL SECTION ALONG CULVERT

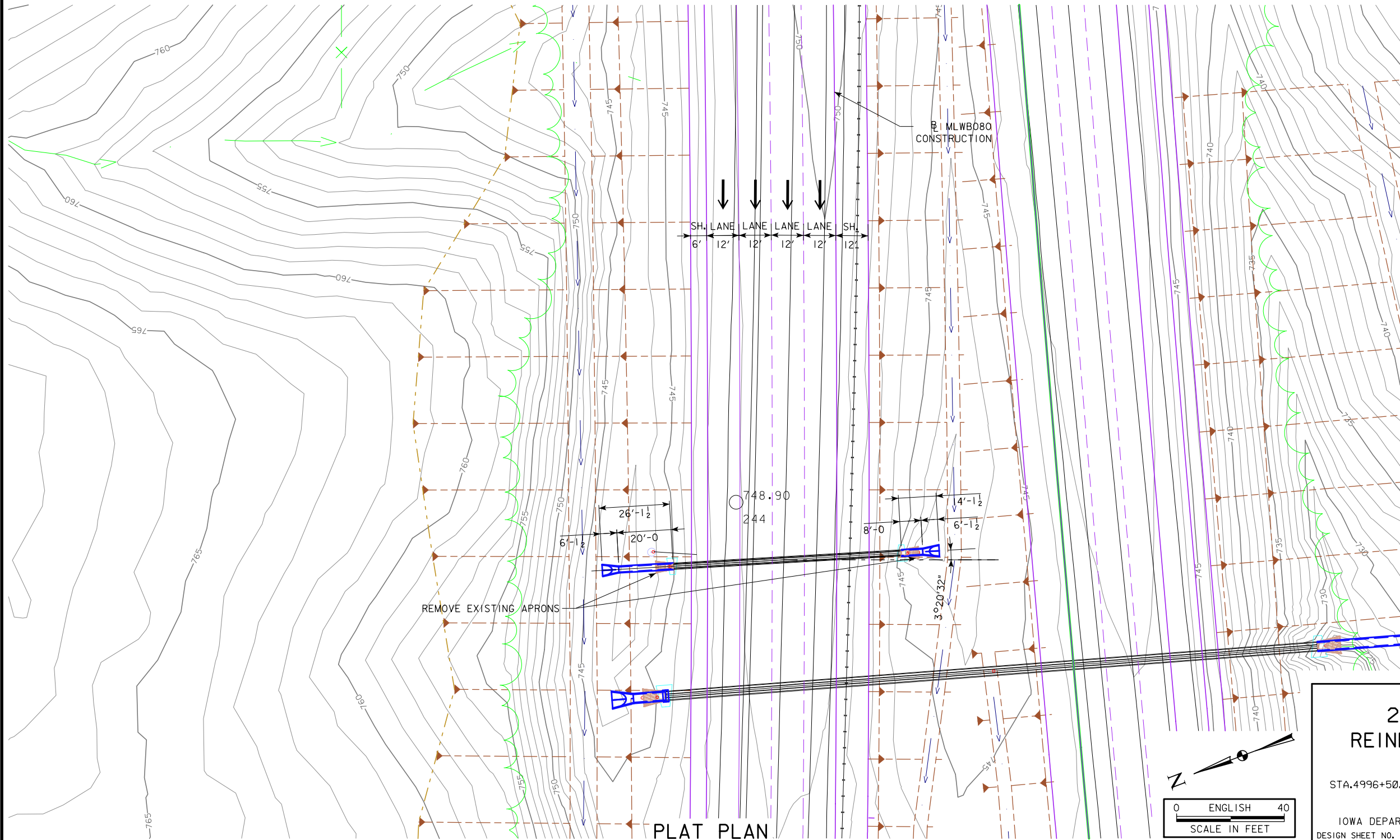

LOCATION

I-80  
T-??N R-??W  
SECTION ??  
????? TOWNSHIP  
CEDAR COUNTY

HYDRAULIC DATA

DRAINAGE AREA = 2.0 ACRES  
DESIGN DISCHARGE = 10.61 CFS

DESIGN FOR 3° SKEW  
**24" x 20' LT & 8' RT  
REINFORCED CONCRETE PIPE  
PLAT PLAN**  
STA.4996+50.12 WB AUGUST 2019  
**CEDAR COUNTY**  
IOWA DEPARTMENT OF TRANSPORTATION - HIGHWAY DIVISION  
DESIGN SHEET NO. ? OF ? FILE NO. ? DESIGN NO. ?

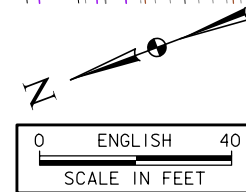

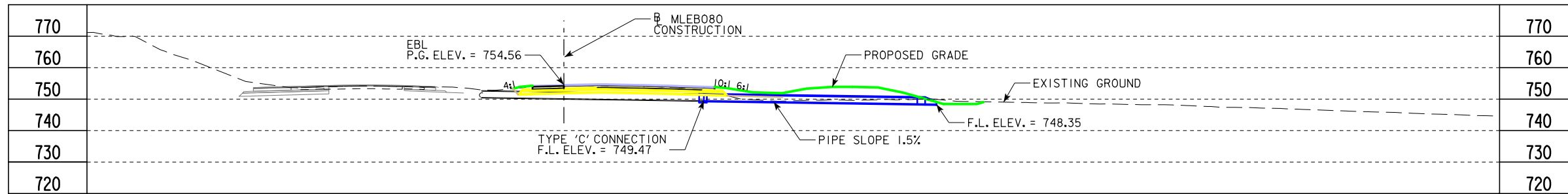

LONGITUDINAL SECTION ALONG  $\hat{C}$  CULVERT

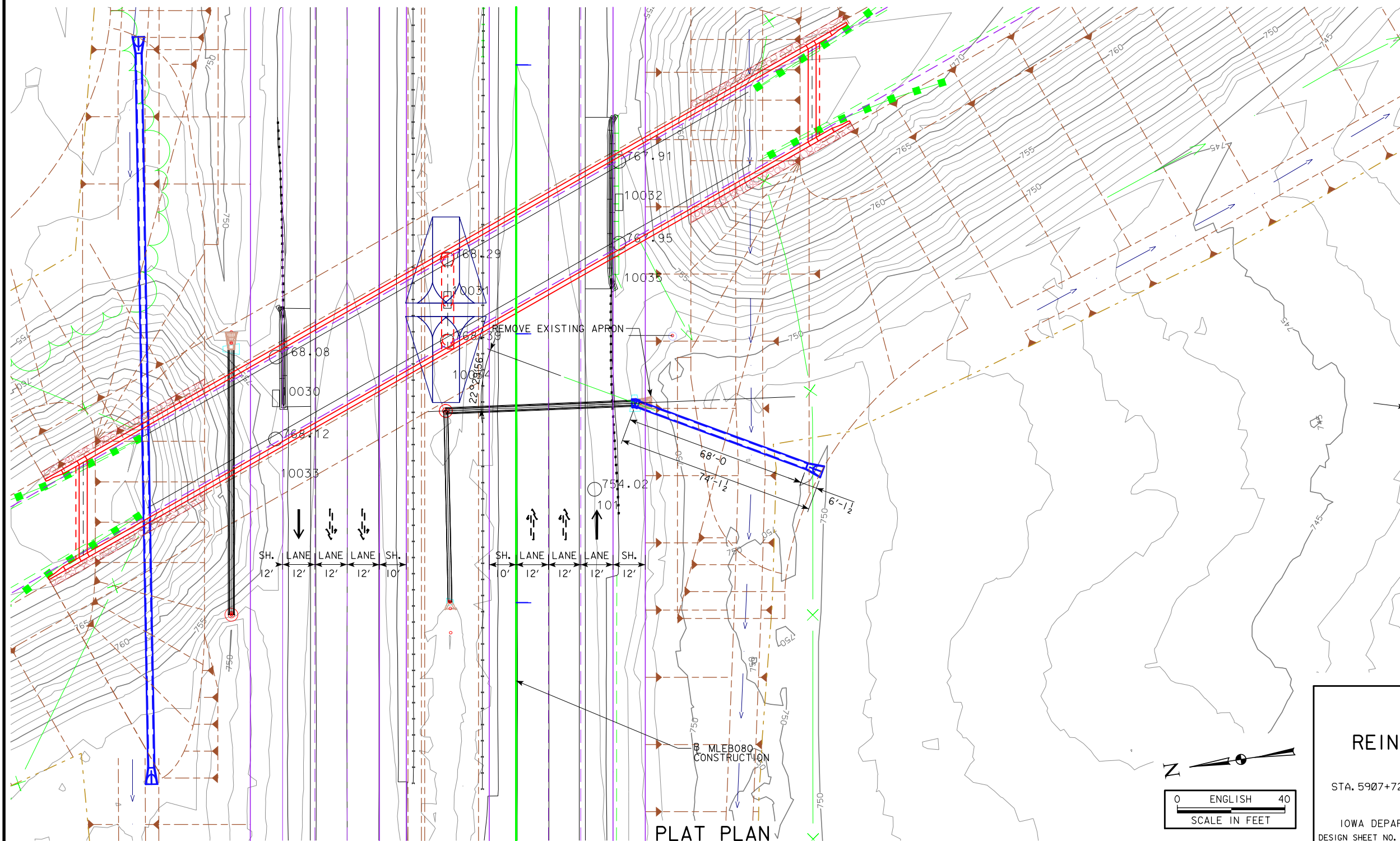

**LOCATION**

MLEB080  
T-79N R-2W  
SECTION 16  
SUGAR CREEK TOWNSHIP  
CEDAR COUNTY

**HYDRAULIC DATA**

DRAINAGE AREA = 0.7 ACRES  
DESIGN DISCHARGE = 19.46 CFS

DESIGN FOR 22°30' SKEW LT AHD.  
**EXTEND 24" x 68'**  
**REINFORCED CONCRETE PIPE**  
**PLAT PLAN**  
STA. 5907+72.33 EB AUGUST 2019  
**CEDAR COUNTY**  
IOWA DEPARTMENT OF TRANSPORTATION - HIGHWAY DIVISION  
DESIGN SHEET NO. ? OF ? FILE NO. ? DESIGN NO. ?



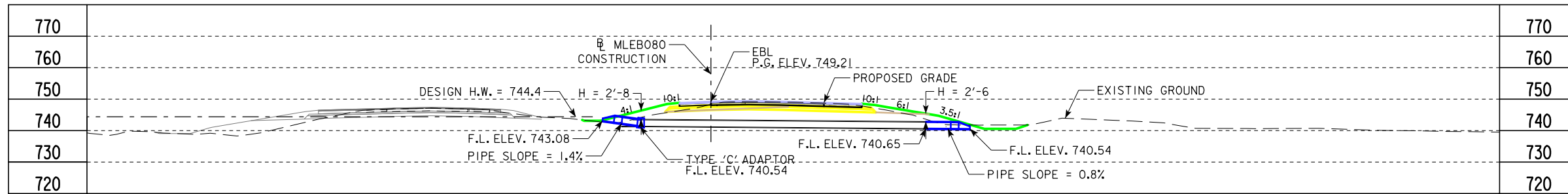

LONGITUDINAL SECTION ALONG  $\odot$  CULVERT

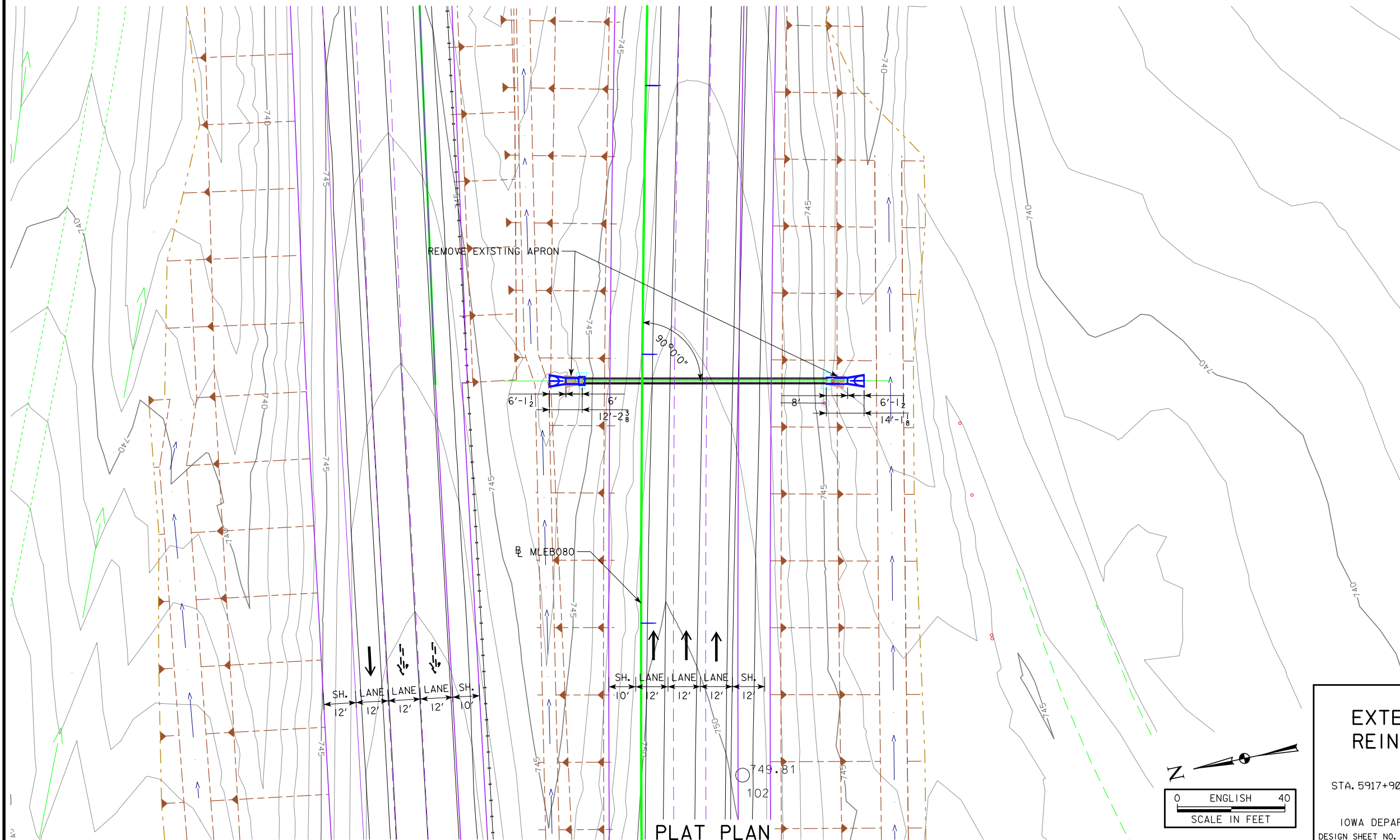

PLAT PLAN

LOCATION

MLEB080  
T-79N R-2W  
SECTION 15  
SUGAR CREEK TOWNSHIP  
CEDAR COUNTY

HYDRAULIC DATA

DRAINAGE AREA = 2.0 ACRES  
DESIGN DISCHARGE = 28.52 CFS

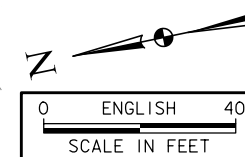

DESIGN FOR 0° SKEW  
**EXTEND 24" x 6' LT & 8' RT REINFORCED CONCRETE PIPE PLAT PLAN**  
STA. 5917+90.05 EB AUGUST 2019  
**CEDAR COUNTY**  
IOWA DEPARTMENT OF TRANSPORTATION - HIGHWAY DIVISION  
DESIGN SHEET NO. ? OF ? FILE NO. ? DESIGN NO. ?

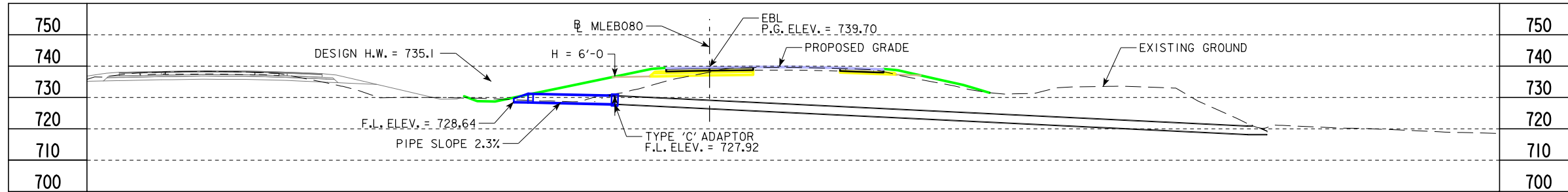

LONGITUDINAL SECTION ALONG CULVERT

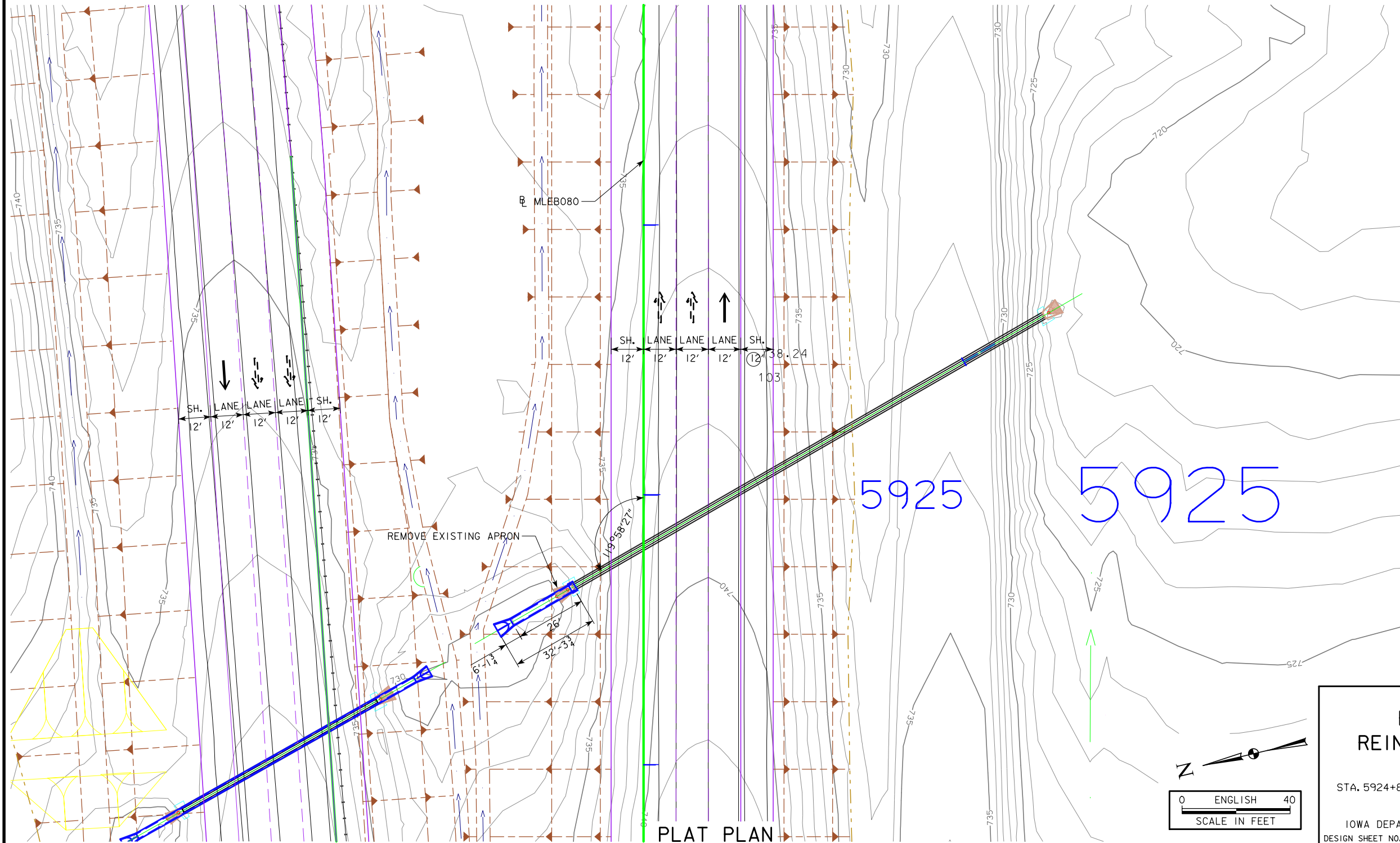

LOCATION

MLEB080  
 T-79N R-2W  
 SECTION 15  
 SUGAR CREEK TOWNSHIP  
 CEDAR COUNTY

HYDRAULIC DATA

DRAINAGE AREA = 2.1 ACRES  
 DESIGN DISCHARGE = 16.1 CFS

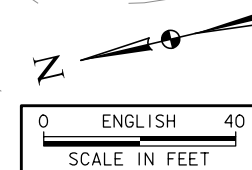

DESIGN FOR 0° SKEW  
**EXTEND 30" x 26' LT  
 REINFORCED CONCRETE PIPE  
 PLAT PLAN**  
 STA. 5924+80.83 AUGUST 2019  
**CEDAR COUNTY**  
 IOWA DEPARTMENT OF TRANSPORTATION - HIGHWAY DIVISION  
 DESIGN SHEET NO. ? OF ? FILE NO. ? DESIGN NO. ?

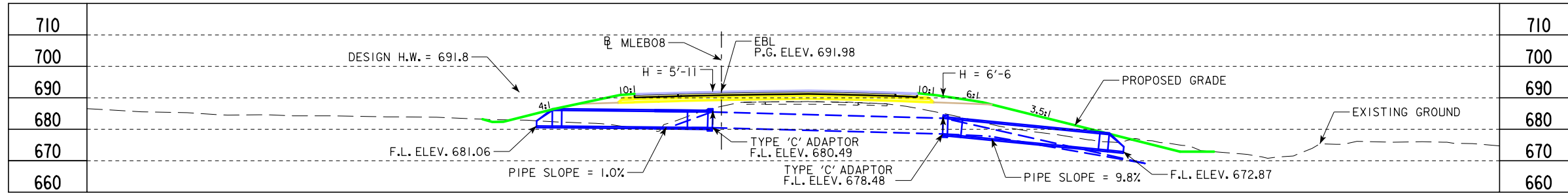

LONGITUDINAL SECTION ALONG  $\phi$  CULVERT

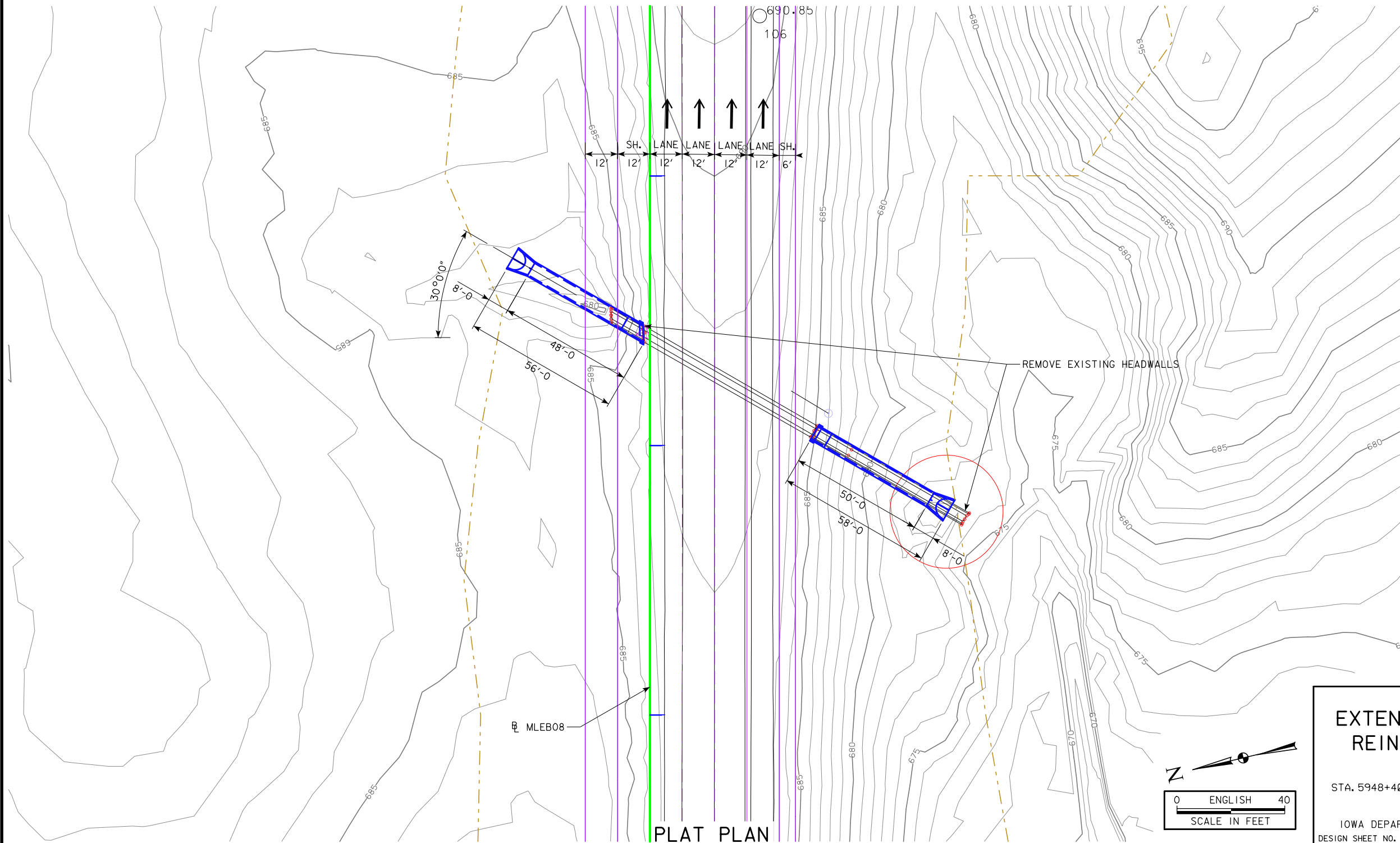

LOCATION

MLWB080  
T-79N R-2W  
SECTION 15  
SUGAR CREEK TOWNSHIP  
CEDAR COUNTY

HYDRAULIC DATA

DRAINAGE AREA = 76.6 ACRES  
DESIGN DISCHARGE = 543.17 CFS

DESIGN FOR 0° SKEW

**EXTEND 60" X 48' LT & 50' RT  
REINFORCED CONCRETE PIPE  
PLAT PLAN**

STA. 5948+40.00 EB

AUGUST 2019

**CEDAR COUNTY**

IOWA DEPARTMENT OF TRANSPORTATION - HIGHWAY DIVISION

DESIGN SHEET NO. ? OF ? FILE NO. ? DESIGN NO. ?

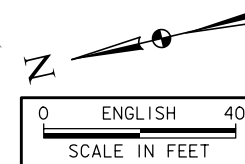



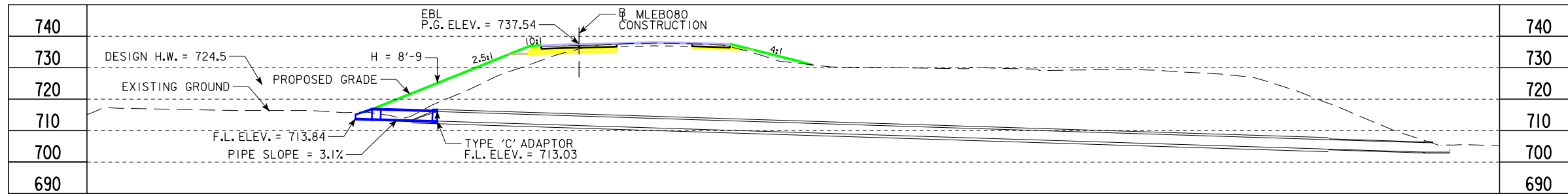

LONGITUDINAL SECTION ALONG  $\odot$  CULVERT

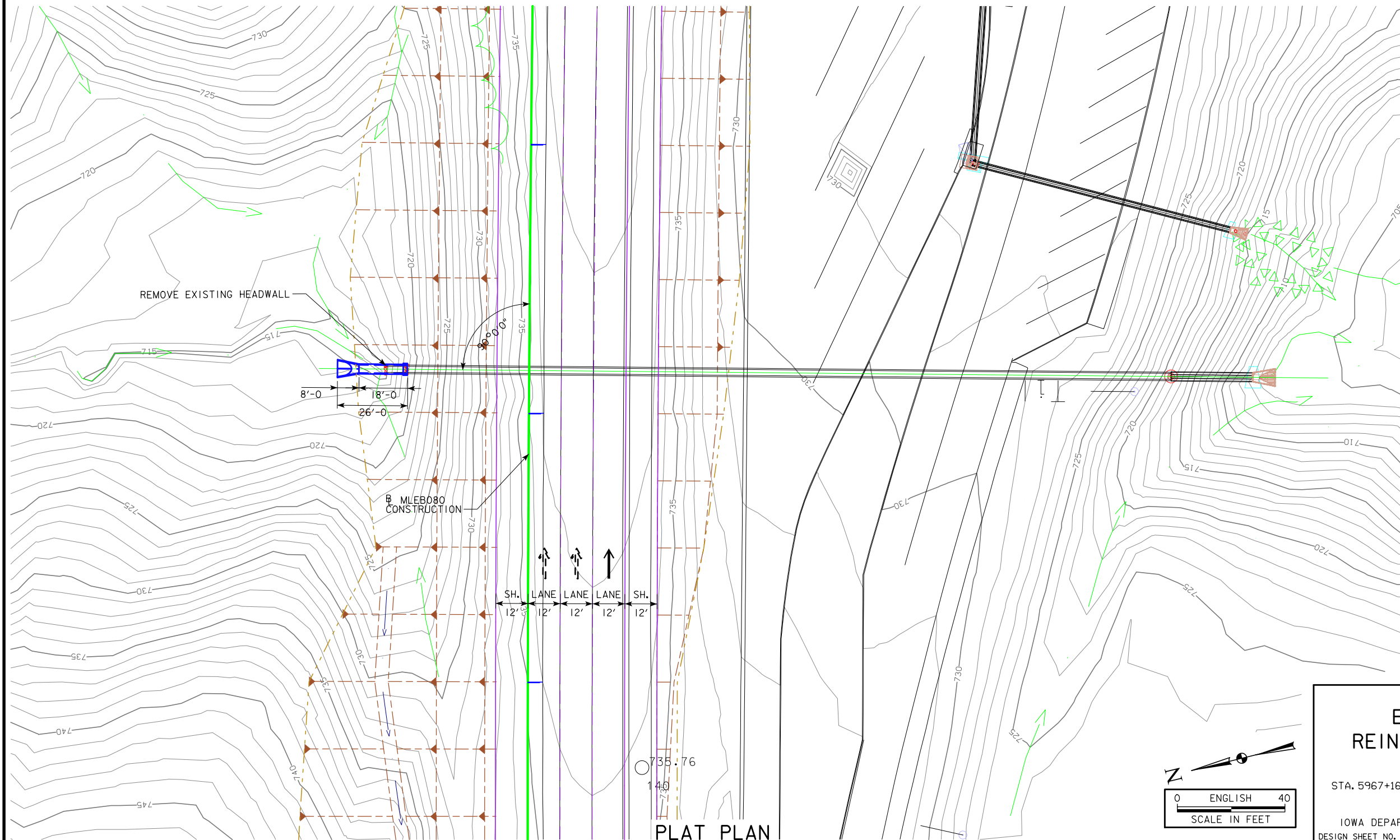

**LOCATION**

MLEB080  
 T-79N R-2W  
 SECTION 23  
 SUGAR CREEK TOWNSHIP  
 CEDAR COUNTY

**HYDRAULIC DATA**

DRAINAGE AREA = 12.0 ACRES  
 DESIGN DISCHARGE = 126.02 CFS

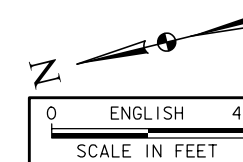

DESIGN FOR 0° SKEW  
**EXTEND 36" x 18' LT  
 REINFORCED CONCRETE PIPE  
 PLAT PLAN**  
 STA. 5967+16.04 EB AUGUST 2019  
**CEDAR COUNTY**  
 IOWA DEPARTMENT OF TRANSPORTATION - HIGHWAY DIVISION  
 DESIGN SHEET NO. ? OF ? FILE NO. ? DESIGN NO. ?



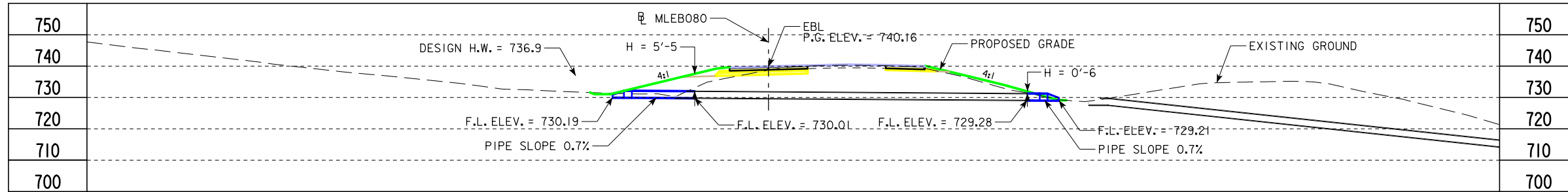

LONGITUDINAL SECTION ALONG  $\text{CL}$  CULVERT

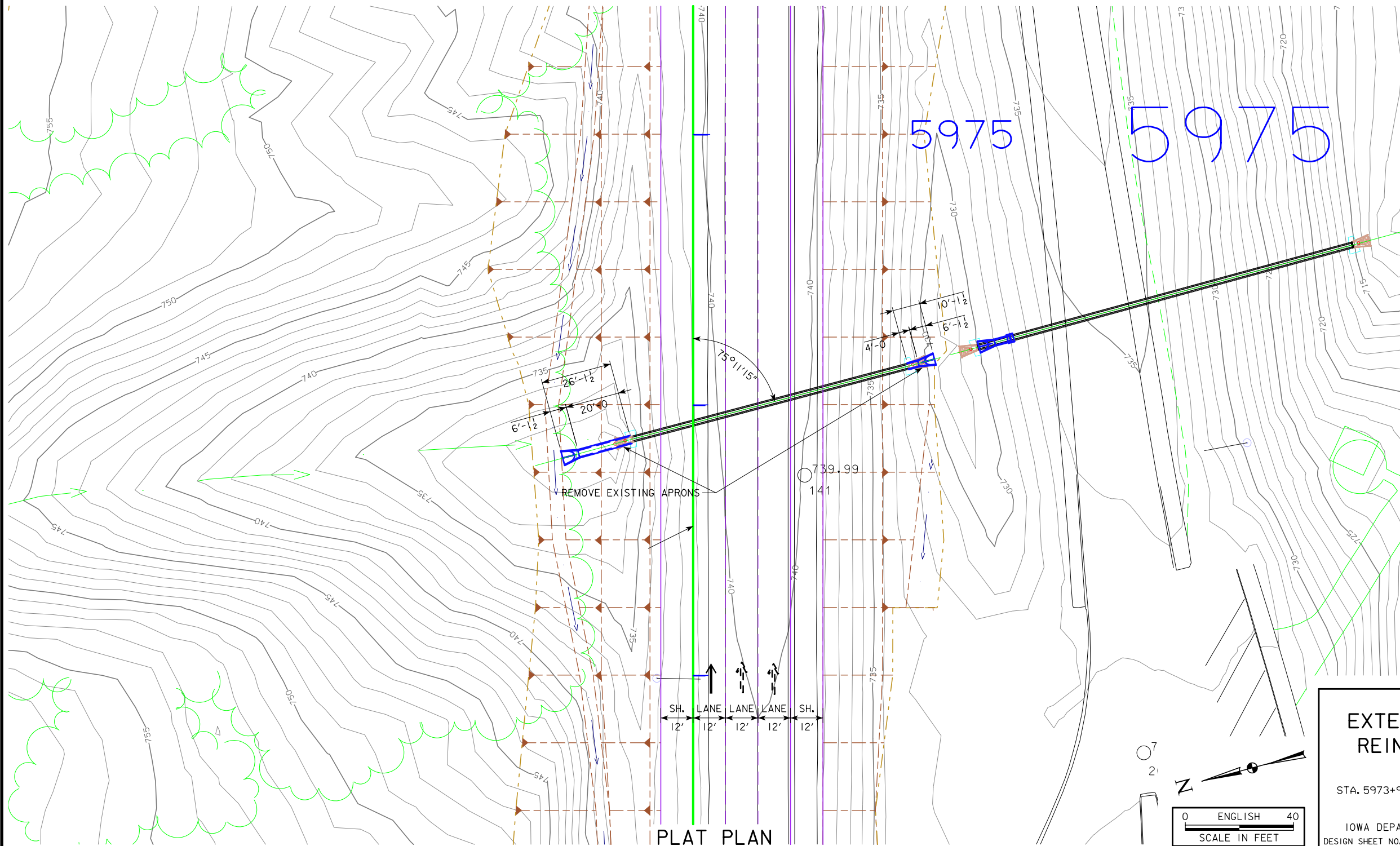

**LOCATION**

MLEB080  
T-79N R-2W  
SECTION 23  
SUGAR CREEK TOWNSHIP  
CEDAR COUNTY

**HYDRAULIC DATA**

DRAINAGE AREA = 3.2 ACRES  
DESIGN DISCHARGE = 19.59 CFS

DESIGN FOR 0° SKEW  
**EXTEND 24" X 20' LT & 4' RT  
REINFORCED CONCRETE PIPE  
PLAT PLAN**  
STA. 5973+92.54 EB AUGUST 2019  
**CEDAR COUNTY**  
IOWA DEPARTMENT OF TRANSPORTATION - HIGHWAY DIVISION  
DESIGN SHEET NO. ? OF ? FILE NO. ? DESIGN NO. ?

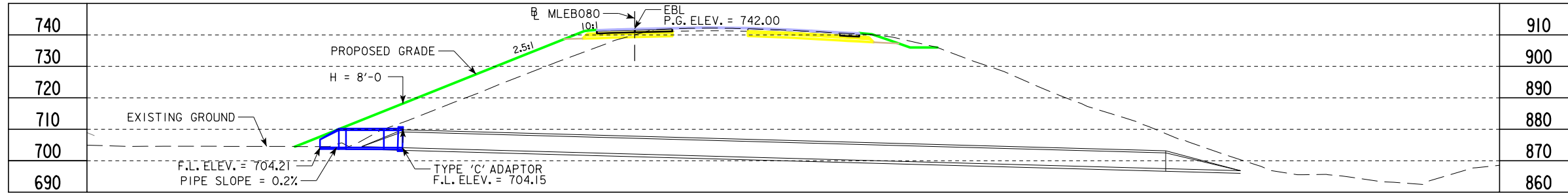

LONGITUDINAL SECTION ALONG  $\bar{C}$  CULVERT

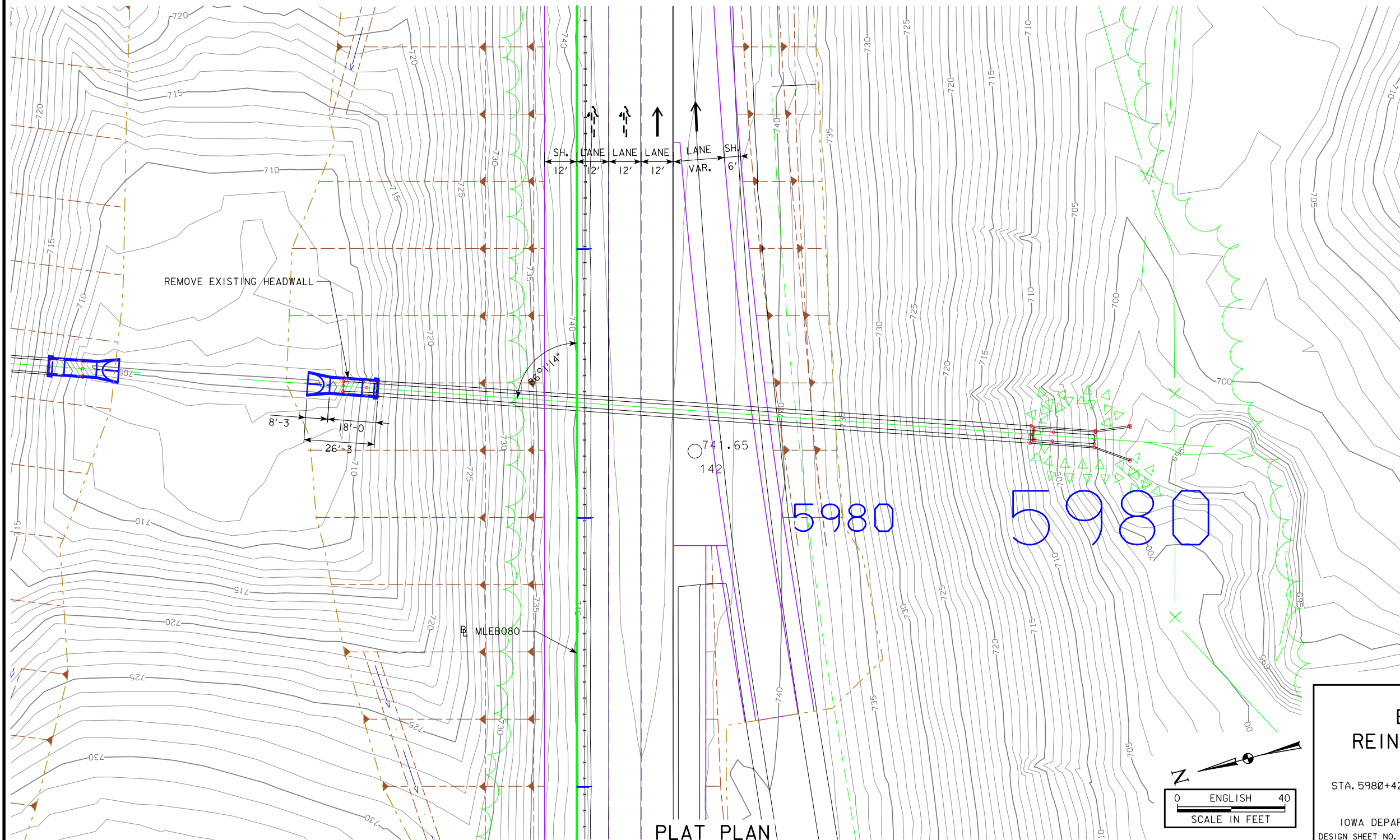

PLAT PLAN

LOCATION

MLEB080  
T-79N R-2W  
SECTION 23  
SUGAR CREEK TOWNSHIP  
CEDAR COUNTY

HYDRAULIC DATA

DRAINAGE AREA = 9.0 ACRES  
DESIGN DISCHARGE = 545.60 CFS

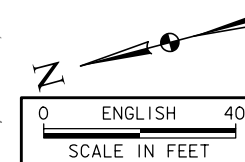

DESIGN FOR 0° SKEW  
**EXTEND 66' X 18' RT  
REINFORCED CONCRETE PIPE  
PLAT PLAN**  
STA. 5980+42.66 EB  
AUGUST 2019  
**CEDAR COUNTY**  
IOWA DEPARTMENT OF TRANSPORTATION - HIGHWAY DIVISION  
DESIGN SHEET NO. ? OF ? FILE NO. ? DESIGN NO. ?



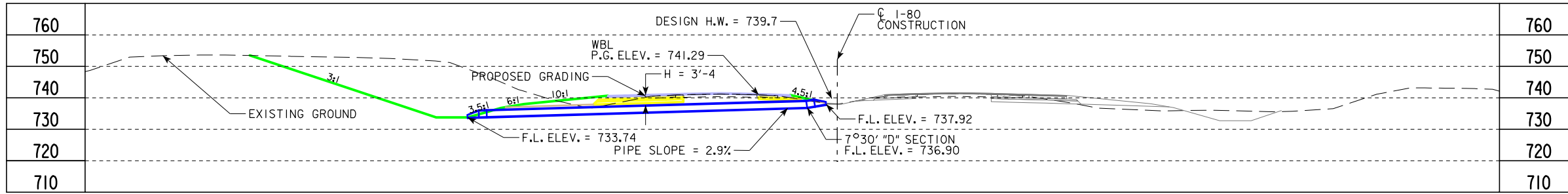

LONGITUDINAL SECTION ALONG  $\text{C}$  CULVERT

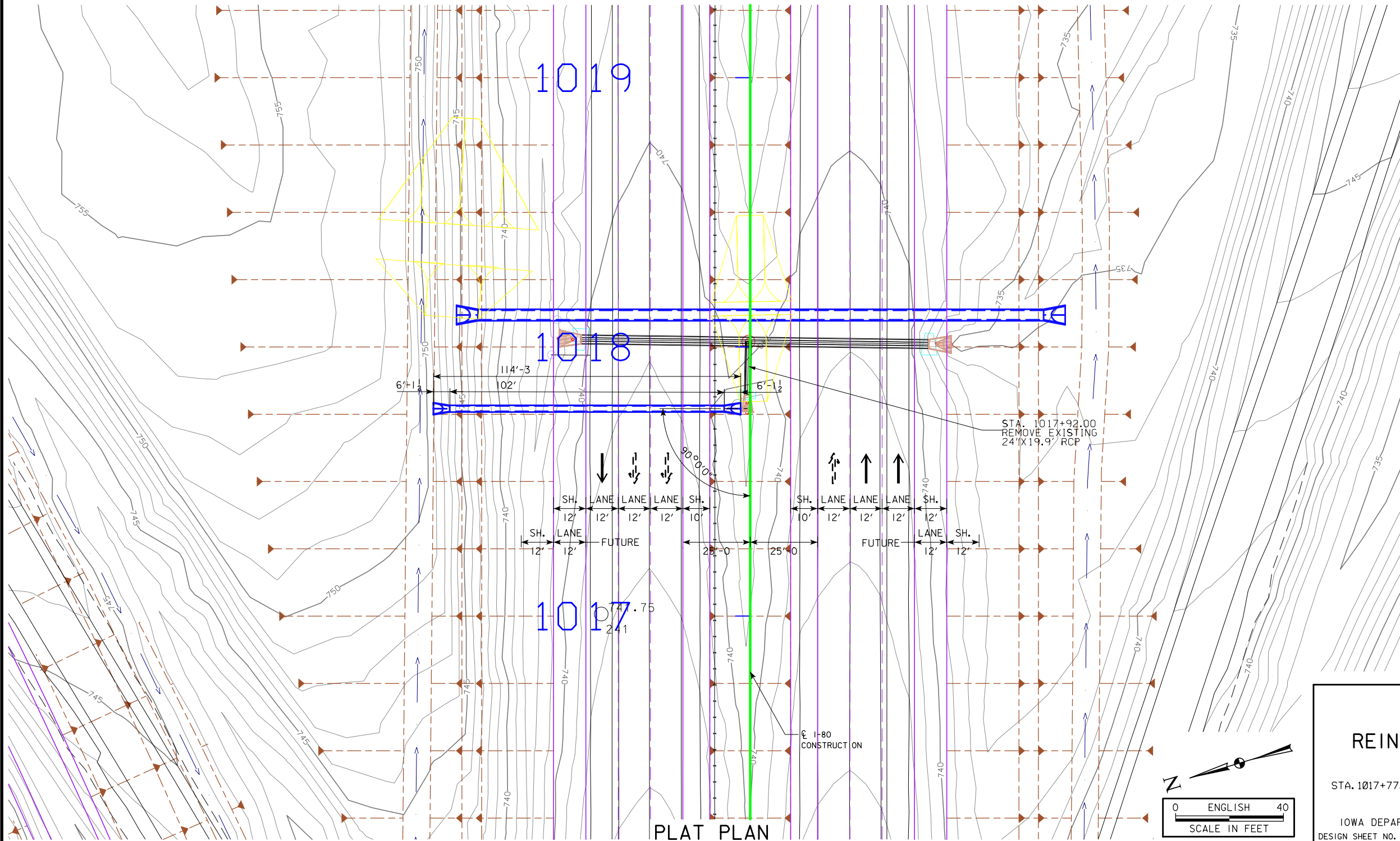

**LOCATION**

I-80  
T-79N R-2W  
SECTION 23  
SUGAR CREEK TOWNSHIP  
CEDAR COUNTY

**HYDRAULIC DATA**

DRAINAGE AREA = 2.2 ACRES  
DESIGN DISCHARGE = 42.20 CFS

DESIGN FOR 0° SKEW  
**24" x 102'**  
**REINFORCED CONCRETE PIPE**  
**PLAT PLAN**  
 STA. 1017+77.00  
 AUGUST 2019  
**CEDAR COUNTY**  
 IOWA DEPARTMENT OF TRANSPORTATION - HIGHWAY DIVISION  
 DESIGN SHEET NO. ? OF ? FILE NO. ? DESIGN NO. ?

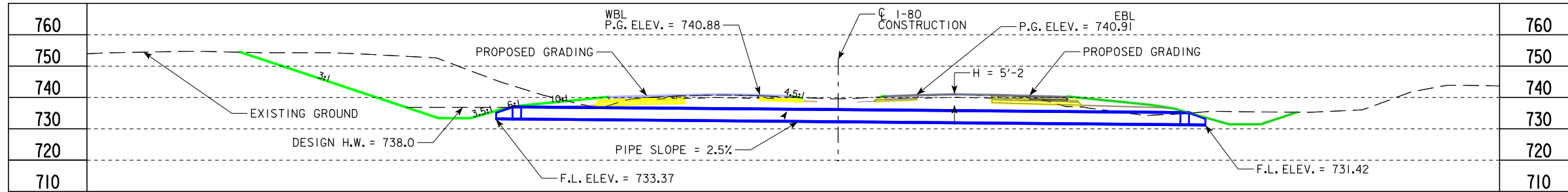

LONGITUDINAL SECTION ALONG C<sub>L</sub> CULVERT

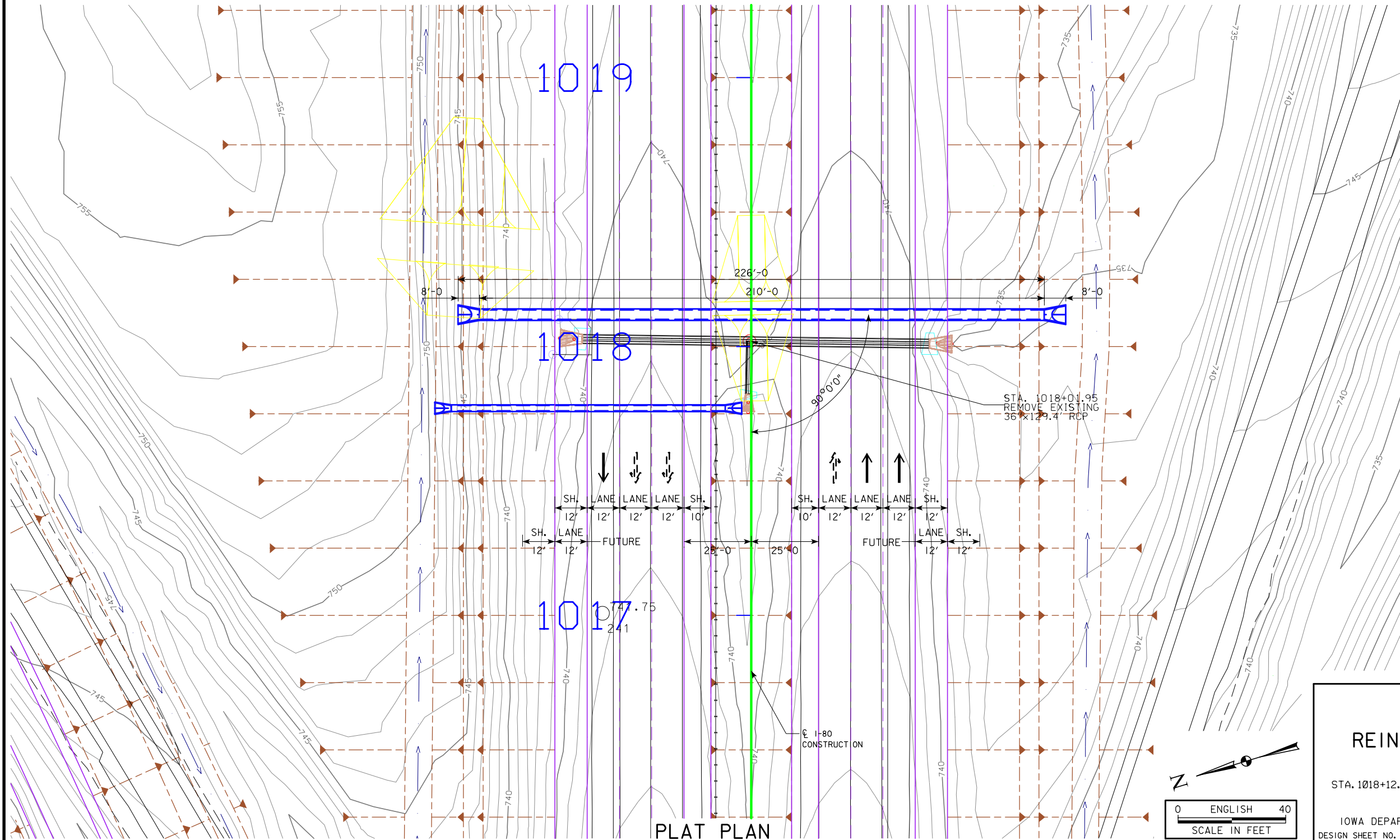

LOCATION

I-80  
T-79N R-2W  
SECTION 23  
SUGAR CREEK TOWNSHIP  
CEDAR COUNTY

HYDRAULIC DATA

DRAINAGE AREA = 20.6 ACRES  
DESIGN DISCHARGE = 76.62 CFS

DESIGN FOR 0° SKEW  
**42" x 210'**  
**REINFORCED CONCRETE PIPE**  
**PLAT PLAN**  
STA. 1018+12.00  
AUGUST 2019  
**CEDAR COUNTY**  
IOWA DEPARTMENT OF TRANSPORTATION - HIGHWAY DIVISION  
DESIGN SHEET NO. ? OF ? FILE NO. ? DESIGN NO. ?

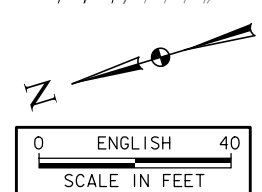



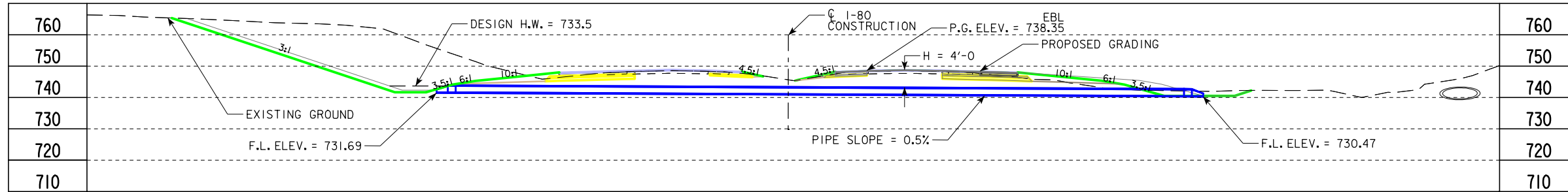

LONGITUDINAL SECTION ALONG  $\text{CL}$  CULVERT

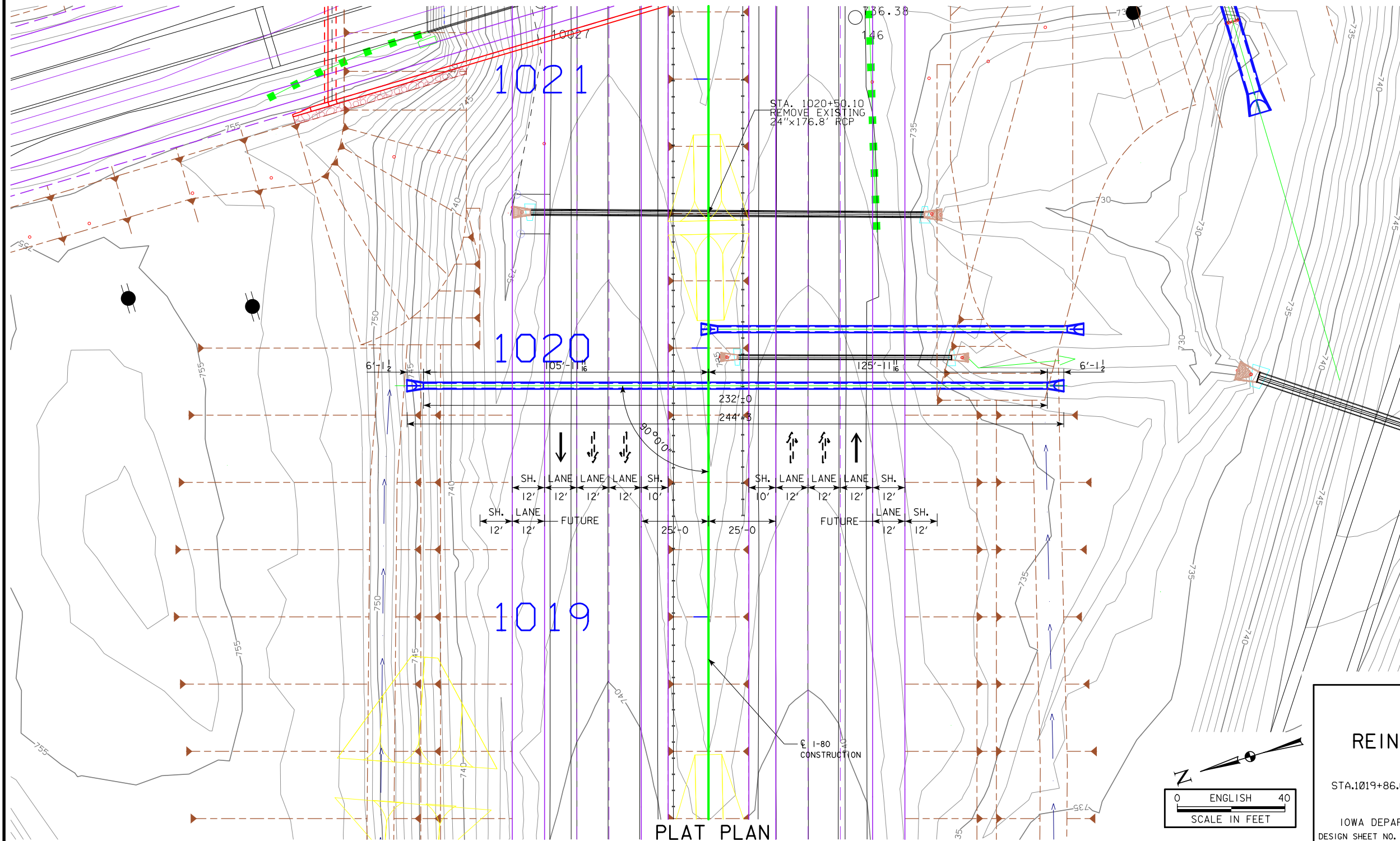

PLAT PLAN

LOCATION

I-80  
 T-79N R-2W  
 SECTION 23  
 SUGAR CREEK TOWNSHIP  
 CEDAR COUNTY

HYDRAULIC DATA

DRAINAGE AREA = 1.6 ACRES  
 DESIGN DISCHARGE = 16.31 CFS

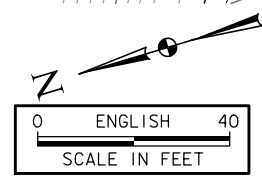

DESIGN FOR 0° SKEW  
**24" x 232'**  
**REINFORCED CONCRETE PIPE**  
**PLAT PLAN**  
 STA. 1019+86.00 AUGUST 2019  
**CEDAR COUNTY**  
 IOWA DEPARTMENT OF TRANSPORTATION - HIGHWAY DIVISION  
 DESIGN SHEET NO. ? OF ? FILE NO. ? DESIGN NO. ?

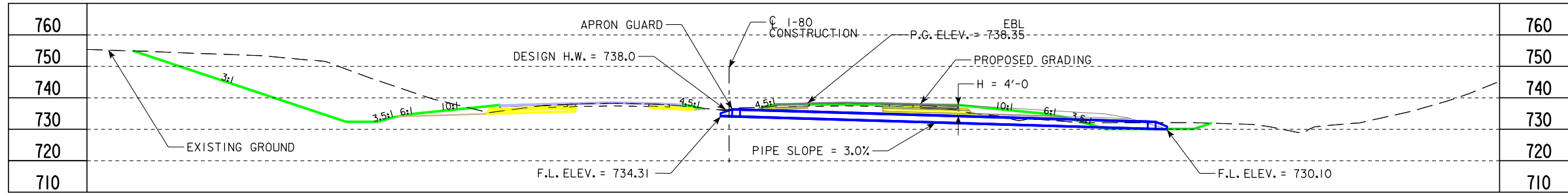

LONGITUDINAL SECTION ALONG CULVERT

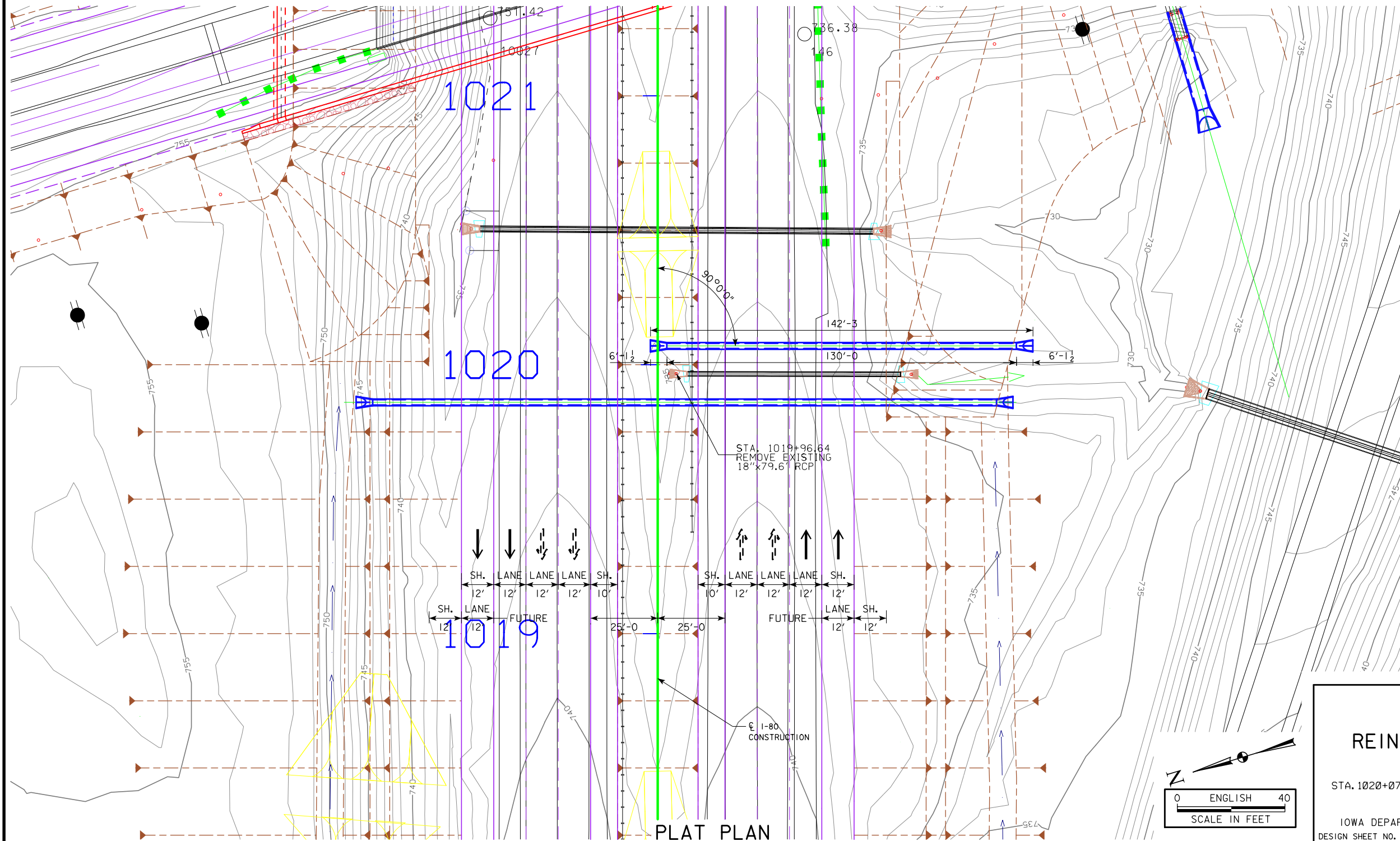

**LOCATION**

I-80  
T-79N R-2W  
SECTION 23  
SUGAR CREEK TOWNSHIP  
CEDAR COUNTY

**HYDRAULIC DATA**

DRAINAGE AREA = 20.6 ACRES  
DESIGN DISCHARGE = 76.62 CFS

DESIGN FOR 0° SKEW  
**24" x 130'**  
**REINFORCED CONCRETE PIPE**  
**PLAT PLAN**  
STA. 1020+07.00 EB  
AUGUST 2019  
**CEDAR COUNTY**  
IOWA DEPARTMENT OF TRANSPORTATION - HIGHWAY DIVISION  
DESIGN SHEET NO. ? OF ? FILE NO. ? DESIGN NO. ?

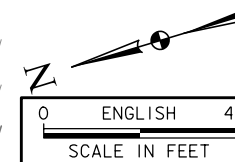

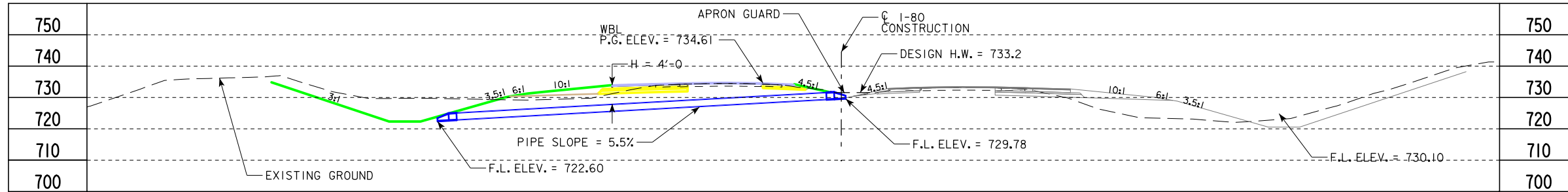

LONGITUDINAL SECTION ALONG CULVERT

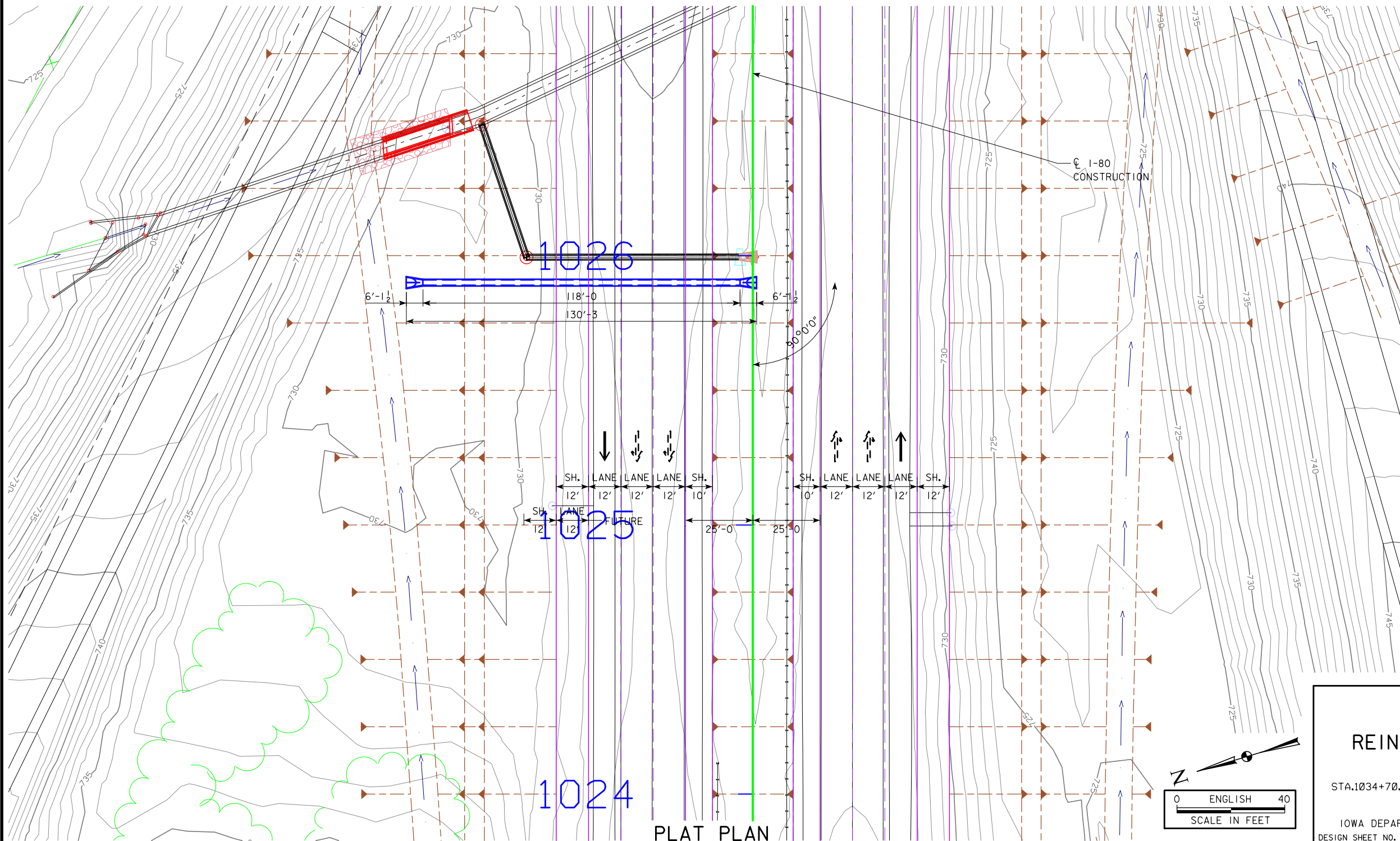

LOCATION

I-80  
T-79N R-2W  
SECTION 24  
SUGAR CREEK TOWNSHIP  
CEDAR COUNTY

HYDRAULIC DATA

DRAINAGE AREA = 2.8 ACRES  
DESIGN DISCHARGE = 42.74 CFS

DESIGN FOR 0° SKEW  
**24" x 118'**  
**REINFORCED CONCRETE PIPE**  
**PLAT PLAN**  
STA. 1034+70.71 AUGUST 2019  
**CEDAR COUNTY**  
IOWA DEPARTMENT OF TRANSPORTATION - HIGHWAY DIVISION  
DESIGN SHEET NO. ? OF ? FILE NO. ? DESIGN NO. ?

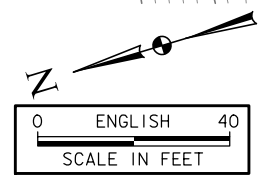



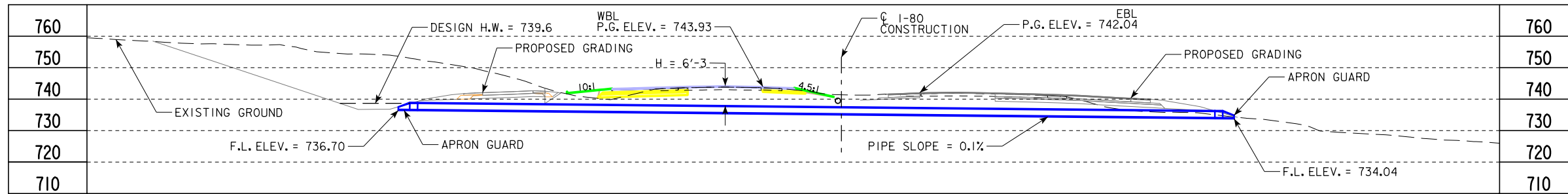

LONGITUDINAL SECTION ALONG  $\bar{C}$  CULVERT

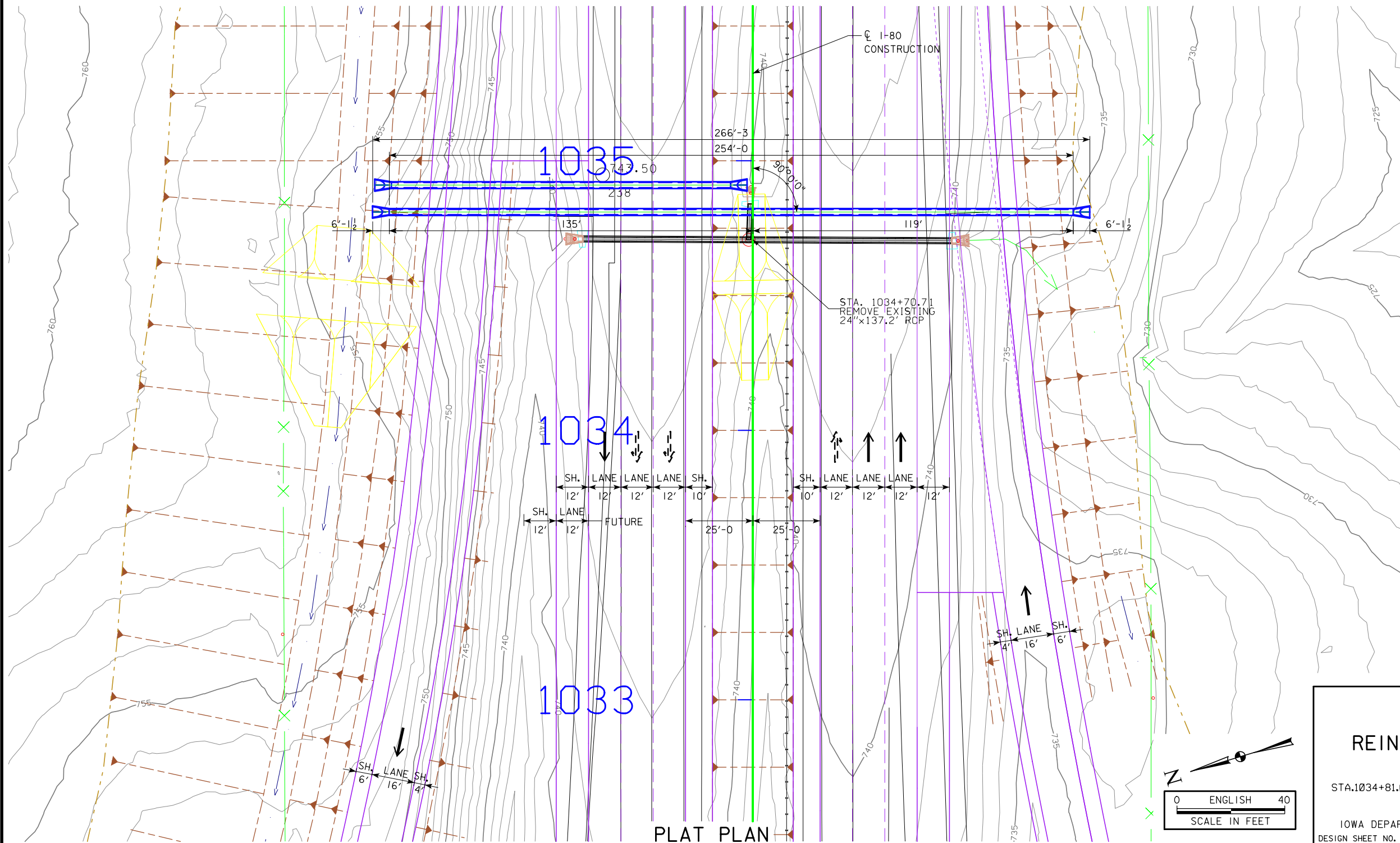

LOCATION

I-80  
 T-79N R-2W  
 SECTION 24  
 SUGAR CREEK TOWNSHIP  
 CEDAR COUNTY

HYDRAULIC DATA

DRAINAGE AREA = 1.3 ACRES  
 DESIGN DISCHARGE = 22.85 CFS

DESIGN FOR 0° SKEW  
**24" x 254'**  
**REINFORCED CONCRETE PIPE**  
**PLAT PLAN**  
 STA. 1034+81.00  
 CEDAR COUNTY  
 IOWA DEPARTMENT OF TRANSPORTATION - HIGHWAY DIVISION  
 DESIGN SHEET NO. ? OF ? FILE NO. ? DESIGN NO. ?  
 AUGUST 2019

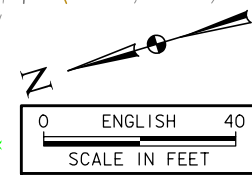

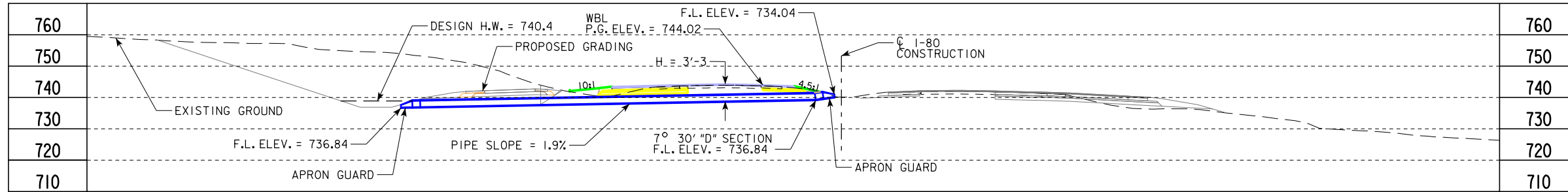

LONGITUDINAL SECTION ALONG CULVERT

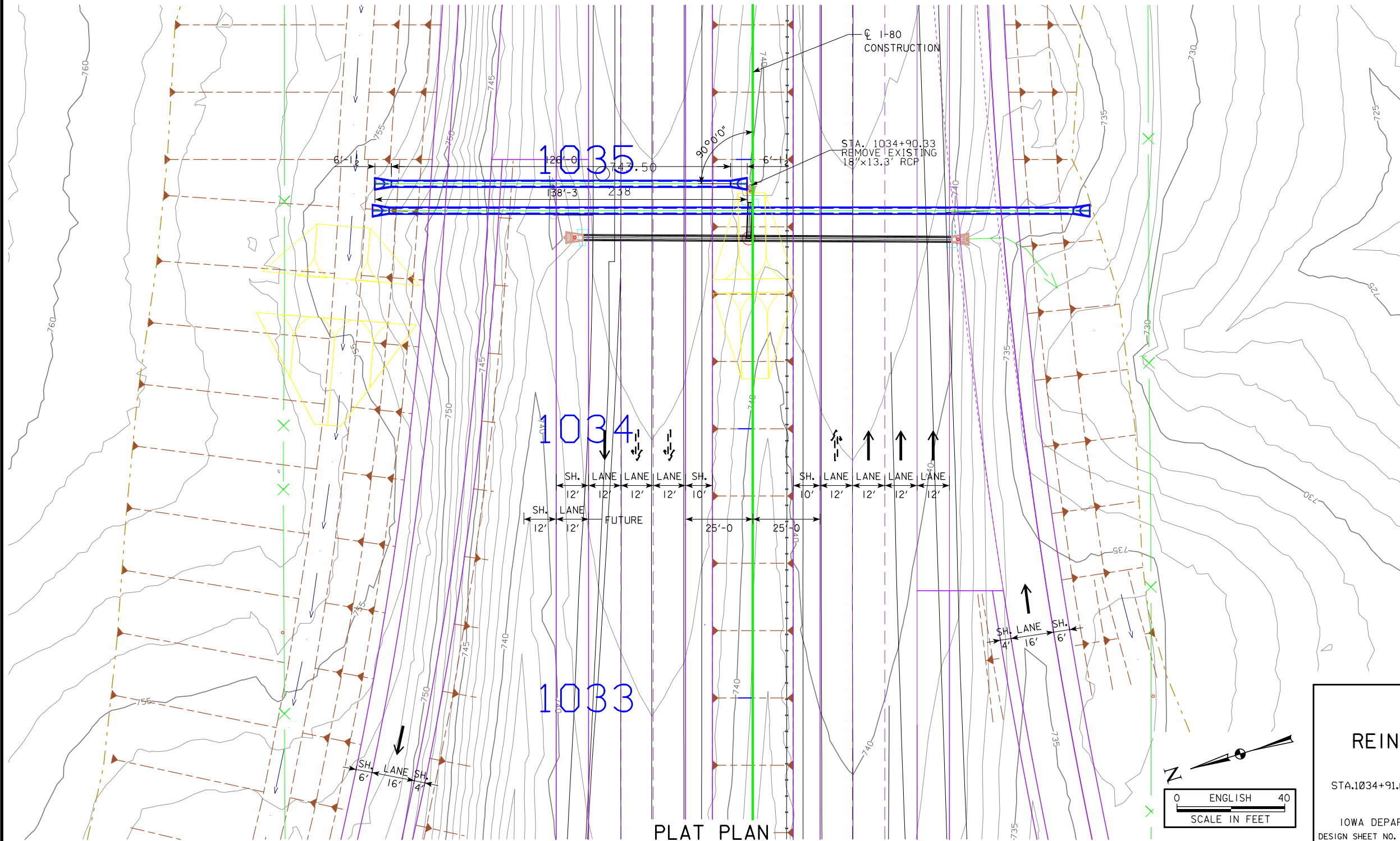

LOCATION

I-80  
 T-79N R-2W  
 SECTION 24  
 SUGAR CREEK TOWNSHIP  
 CEDAR COUNTY

HYDRAULIC DATA

DRAINAGE AREA = 1.1 ACRES  
 DESIGN DISCHARGE = 39.51 CFS

DESIGN FOR 0° SKEW  
**24" x 126'**  
**REINFORCED CONCRETE PIPE**  
**PLAT PLAN**  
 STA. 1034+91.00  
 AUGUST 2019  
**CEDAR COUNTY**  
 IOWA DEPARTMENT OF TRANSPORTATION - HIGHWAY DIVISION  
 DESIGN SHEET NO. ? OF ? FILE NO. ? DESIGN NO. ?

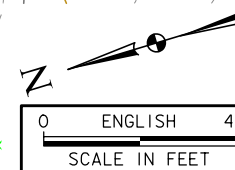

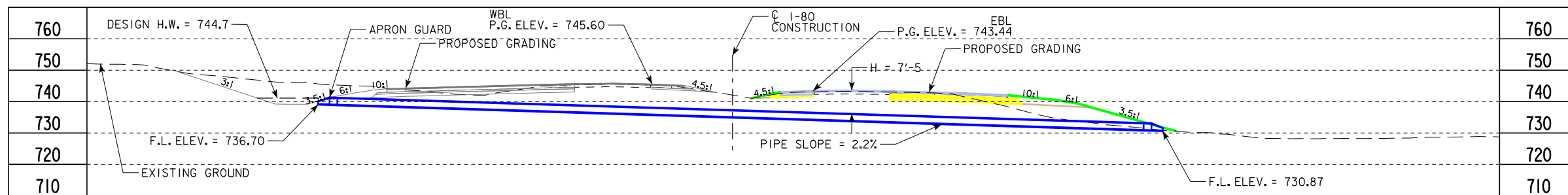

LONGITUDINAL SECTION ALONG  $\text{C}$  CULVERT

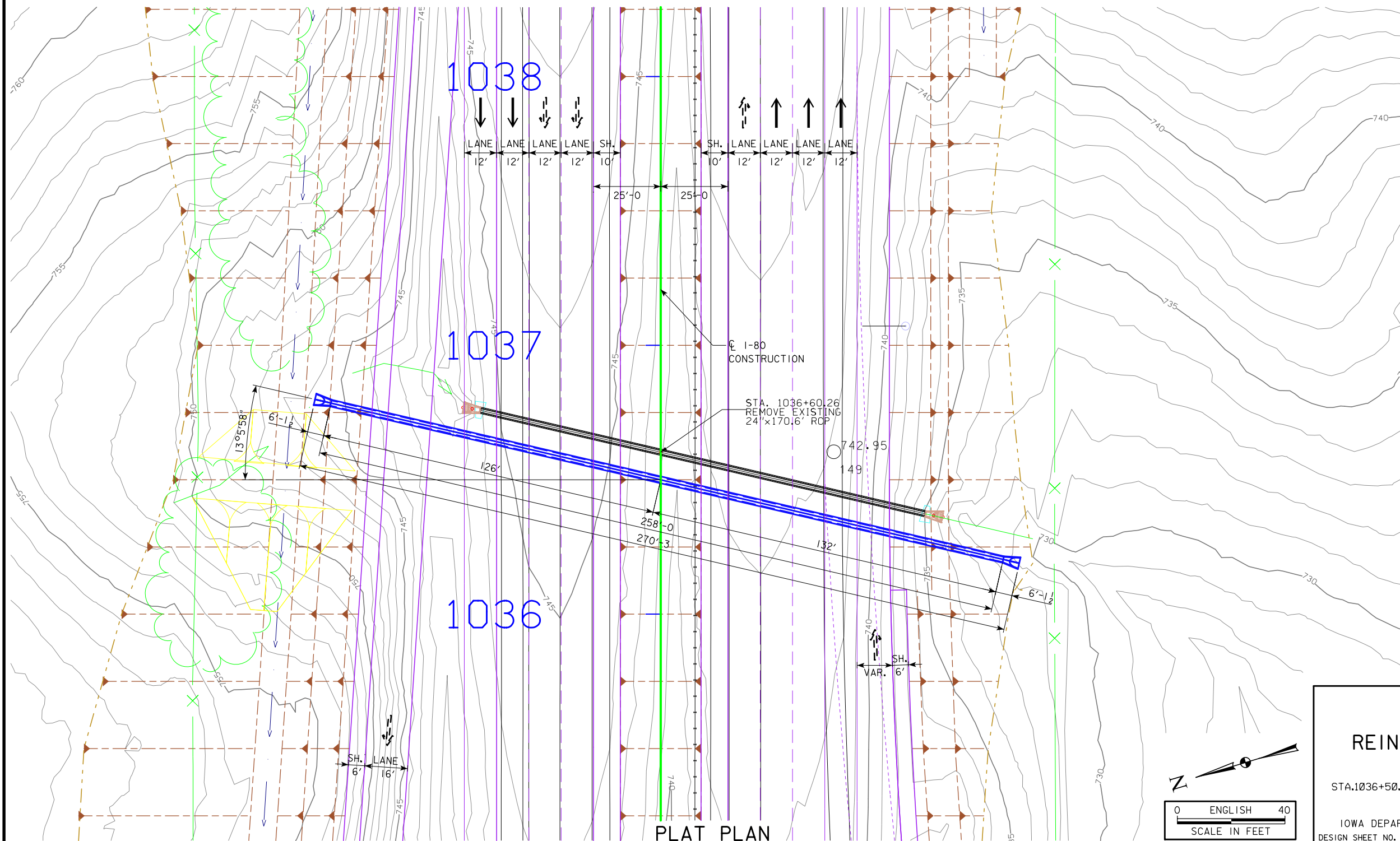

LOCATION

I-80  
T-79N R-2W  
SECTION 24  
SUGAR CREEK TOWNSHIP  
CEDAR COUNTY

HYDRAULIC DATA

DRAINAGE AREA = 6.1 ACRES  
DESIGN DISCHARGE = 40.97 CFS

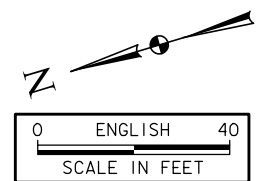

DESIGN FOR 13° SKEW LT AHD.  
**24" x 258'**  
**REINFORCED CONCRETE PIPE**  
**PLAT PLAN**  
STA.1036+50.00 AUGUST 2019  
**CEDAR COUNTY**  
IOWA DEPARTMENT OF TRANSPORTATION - HIGHWAY DIVISION  
DESIGN SHEET NO. ? OF ? FILE NO. ? DESIGN NO. ?



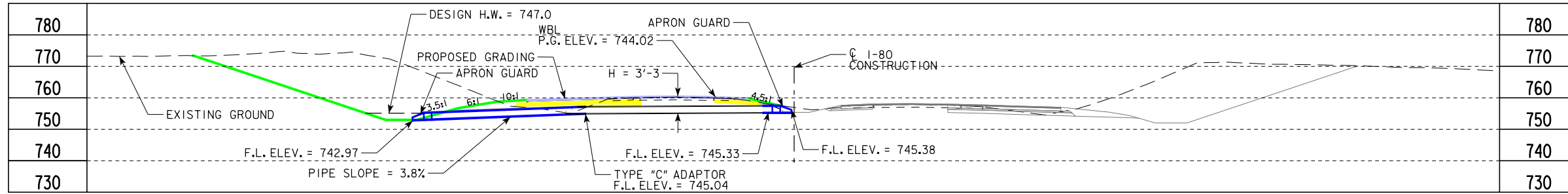

LONGITUDINAL SECTION ALONG CULVERT

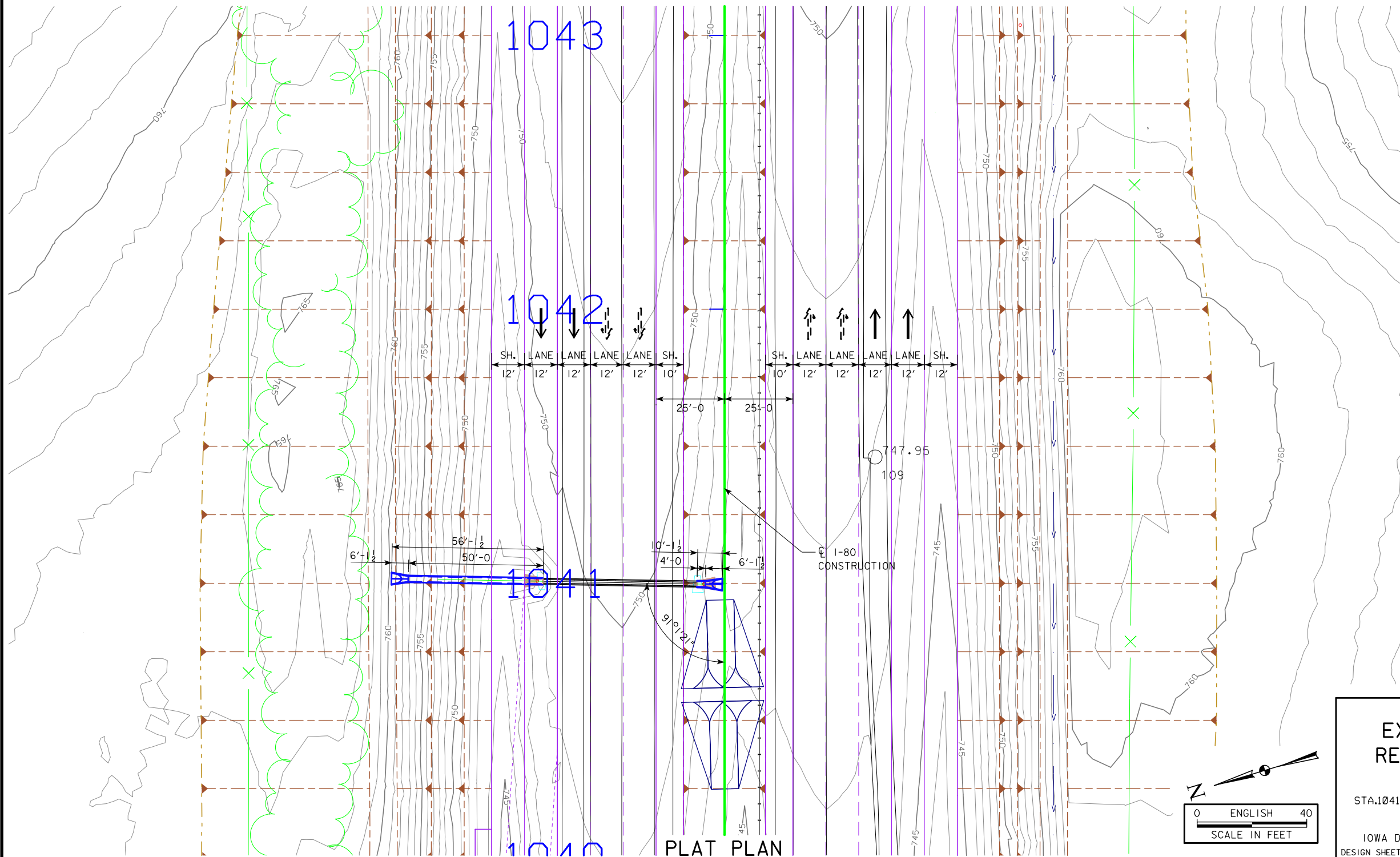

LOCATION

I-80  
 T-79N R-2W  
 SECTION 24  
 SUGAR CREEK TOWNSHIP  
 CEDAR COUNTY

HYDRAULIC DATA

DRAINAGE AREA = 1.1 ACRES  
 DESIGN DISCHARGE = 30.70 CFS

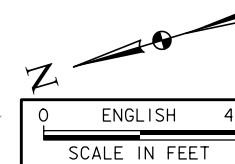

DESIGN FOR 0° SKEW  
**EXTEND 24" x 4' & RT 50' LT REINFORCED CONCRETE PIPE PLAT PLAN**  
 STA.1041+00.00 AUGUST 2019  
**CEDAR COUNTY**  
 IOWA DEPARTMENT OF TRANSPORTATION - HIGHWAY DIVISION  
 DESIGN SHEET NO. ? OF ? FILE NO. ? DESIGN NO. ?

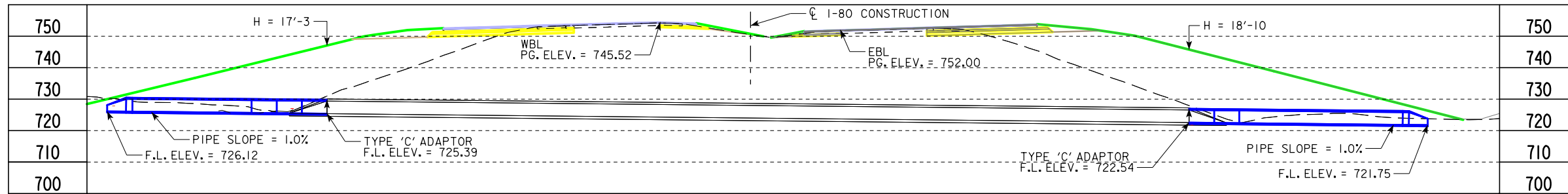

LONGITUDINAL SECTION ALONG  $\phi$  CULVERT

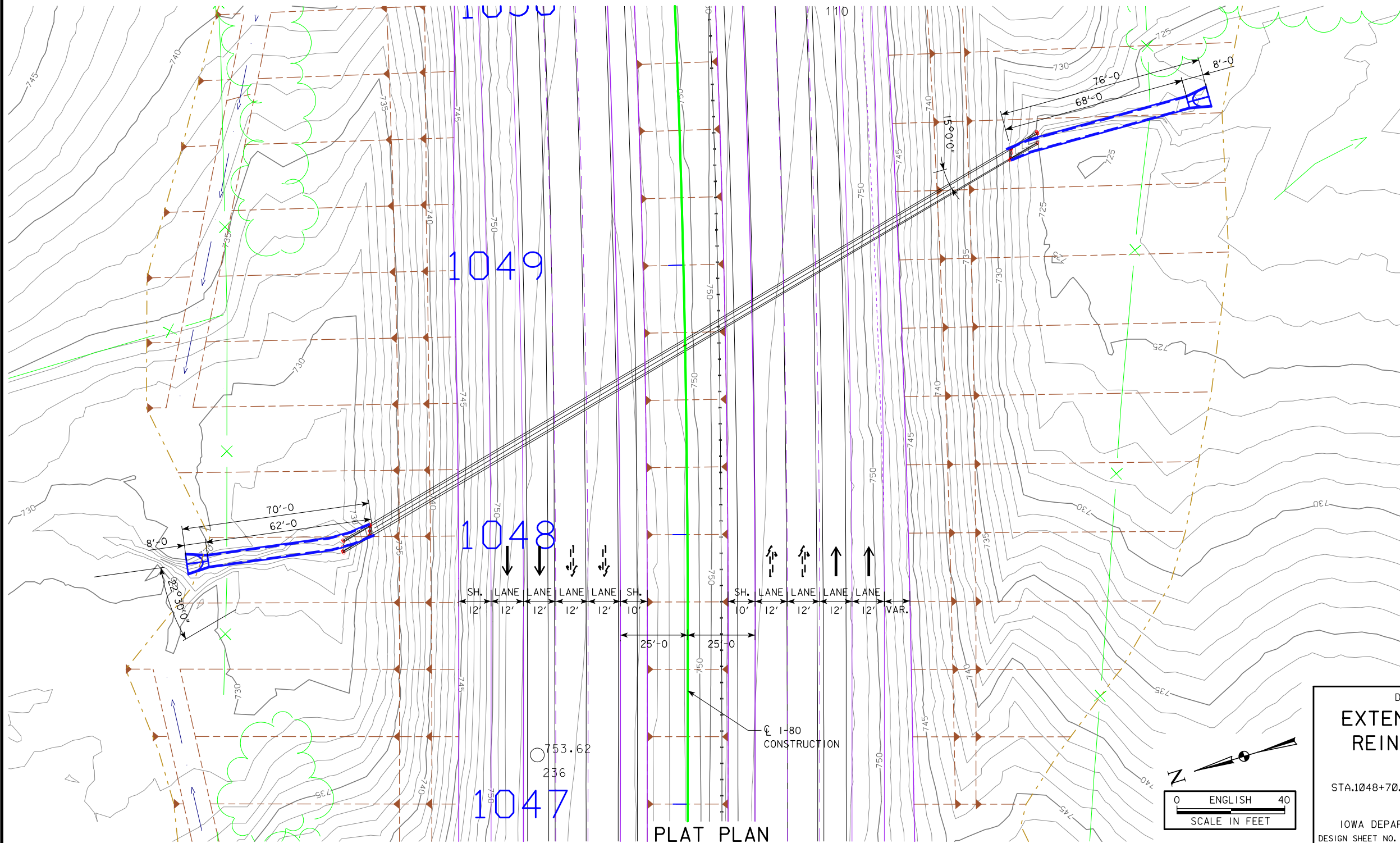

**LOCATION**

I-80  
T-79N R-2W  
SECTION 24  
SUGAR CREEK TOWNSHIP  
CEDAR COUNTY

**HYDRAULIC DATA**

DRAINAGE AREA = 41.2 ACRES  
DESIGN DISCHARGE = 149.27 CFS

DESIGN FOR 22° & 15° SKEW LT AHD.  
**EXTEND 48" x 62' LT & 68' RT  
 REINFORCED CONCRETE PIPE  
 PLAT PLAN**  
 STA. 1048+70.30 AUGUST 2019  
**CEDAR COUNTY**  
 IOWA DEPARTMENT OF TRANSPORTATION - HIGHWAY DIVISION  
 DESIGN SHEET NO. ? OF ? FILE NO. ? DESIGN NO. ?

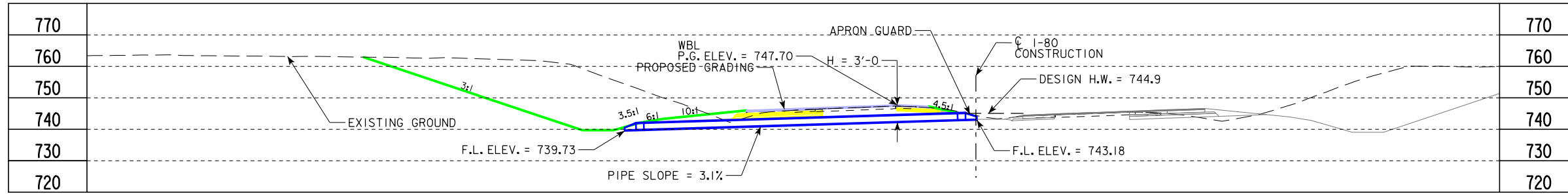

LONGITUDINAL SECTION ALONG  $\phi$  CULVERT

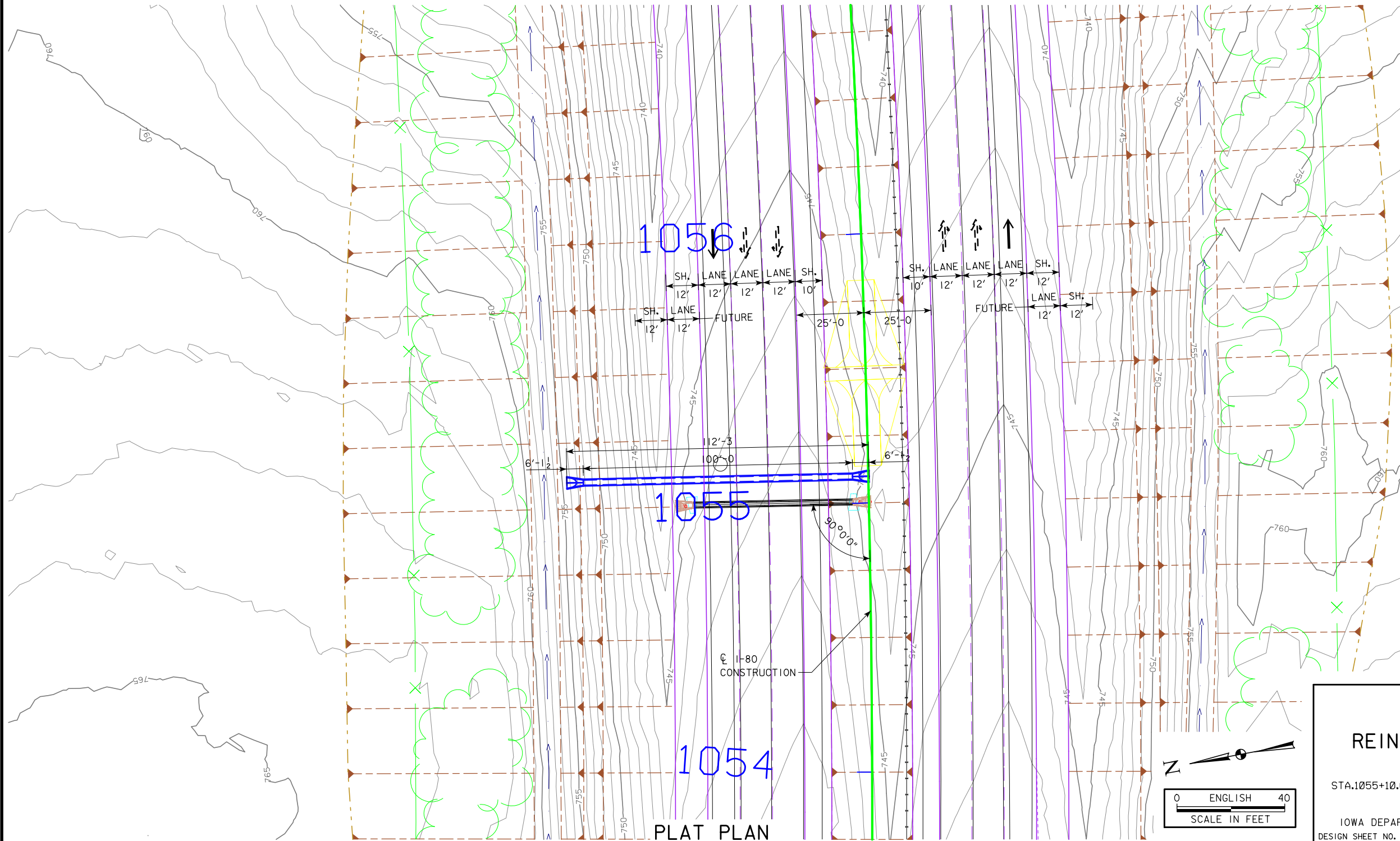

LOCATION

I-80  
T-79N R-2W  
SECTION 24  
SUGAR CREEK TOWNSHIP  
CEDAR COUNTY

HYDRAULIC DATA

DRAINAGE AREA = 1.3 ACRES  
DESIGN DISCHARGE = 41.96 CFS

DESIGN FOR 0° SKEW  
**24" x 100'**  
**REINFORCED CONCRETE PIPE**  
**PLAT PLAN**  
STA.1055+10.00 WB AUGUST 2019  
**CEDAR COUNTY**  
IOWA DEPARTMENT OF TRANSPORTATION - HIGHWAY DIVISION  
DESIGN SHEET NO. ? OF ? FILE NO. ? DESIGN NO. ?



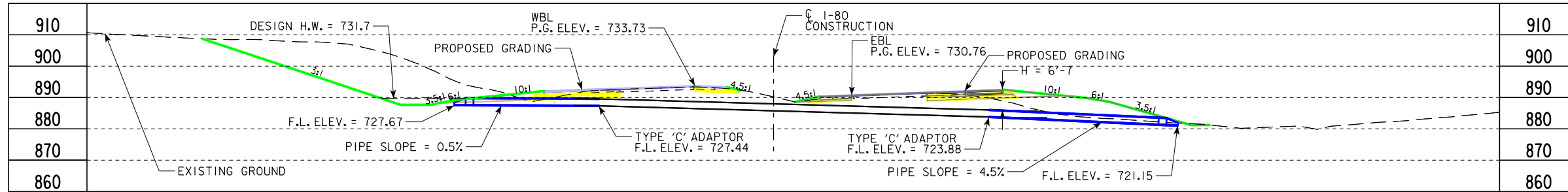

LONGITUDINAL SECTION ALONG  $\text{CL}$  CULVERT

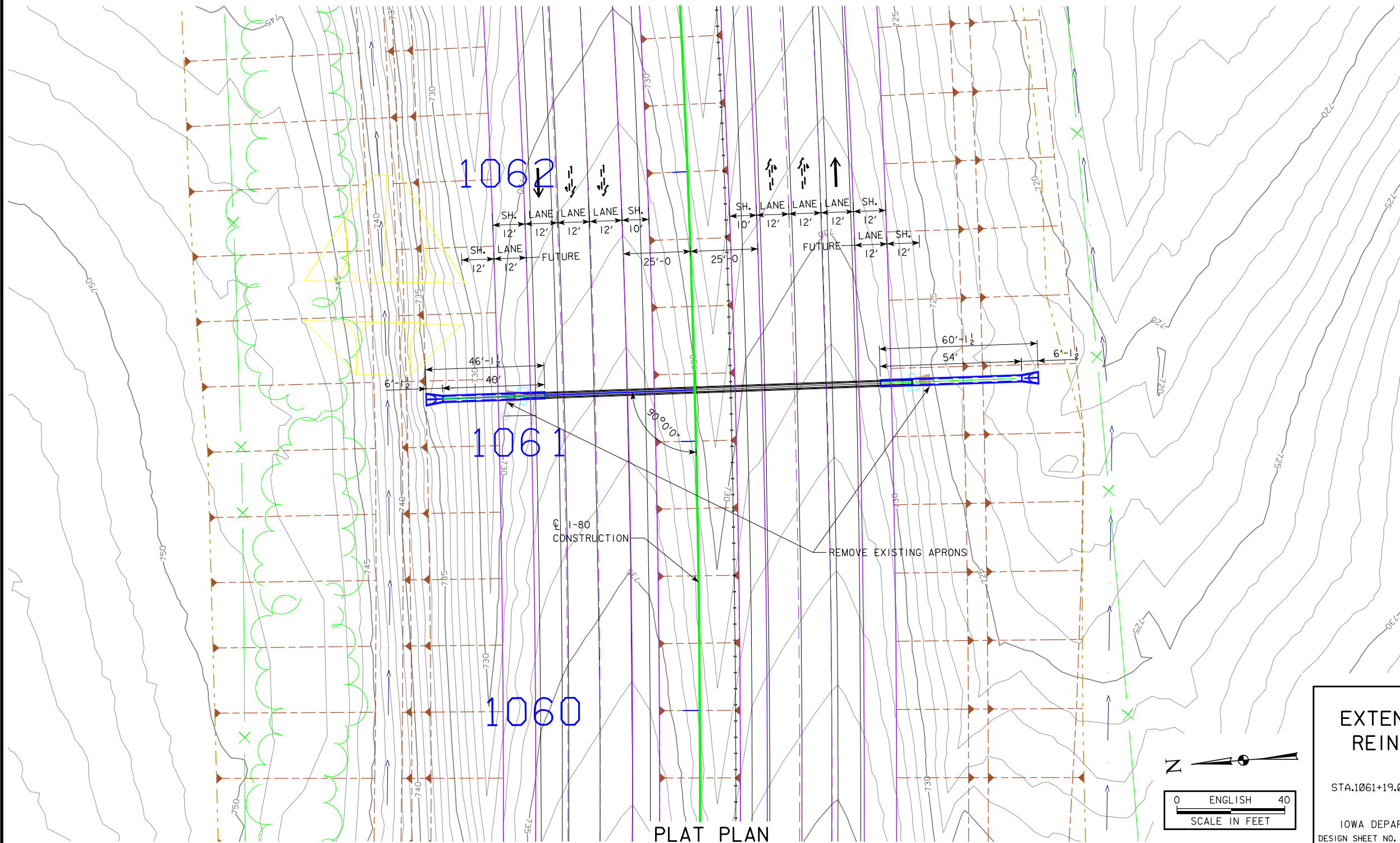

LOCATION

I-80  
 T-79N R-2W  
 SECTION 24  
 SUGAR CREEK TOWNSHIP  
 CEDAR COUNTY

HYDRAULIC DATA

DRAINAGE AREA = 5.30 ACRES  
 DESIGN DISCHARGE = 38.08 CFS

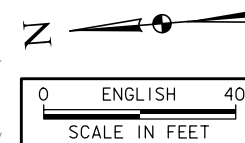

DESIGN FOR 0° SKEW  
**EXTEND 24" x 54' RT & 40' LT  
 REINFORCED CONCRETE PIPE  
 PLAT PLAN**  
 STA. 1061+19.00 AUGUST 2019  
**CEDAR COUNTY**  
 IOWA DEPARTMENT OF TRANSPORTATION - HIGHWAY DIVISION  
 DESIGN SHEET NO. ? OF ? FILE NO. ? DESIGN NO. ?

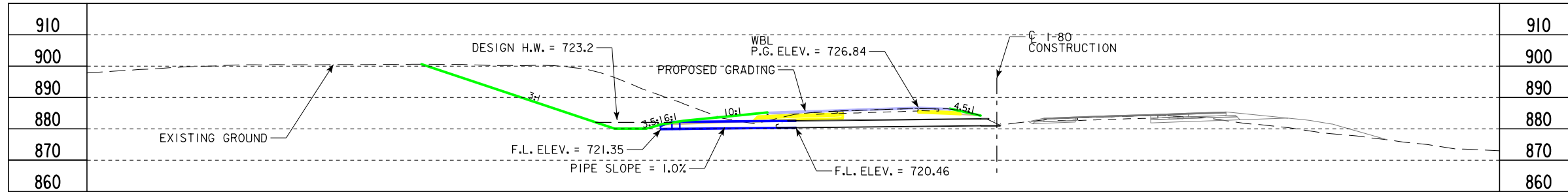

LONGITUDINAL SECTION ALONG C<sub>L</sub> CULVERT

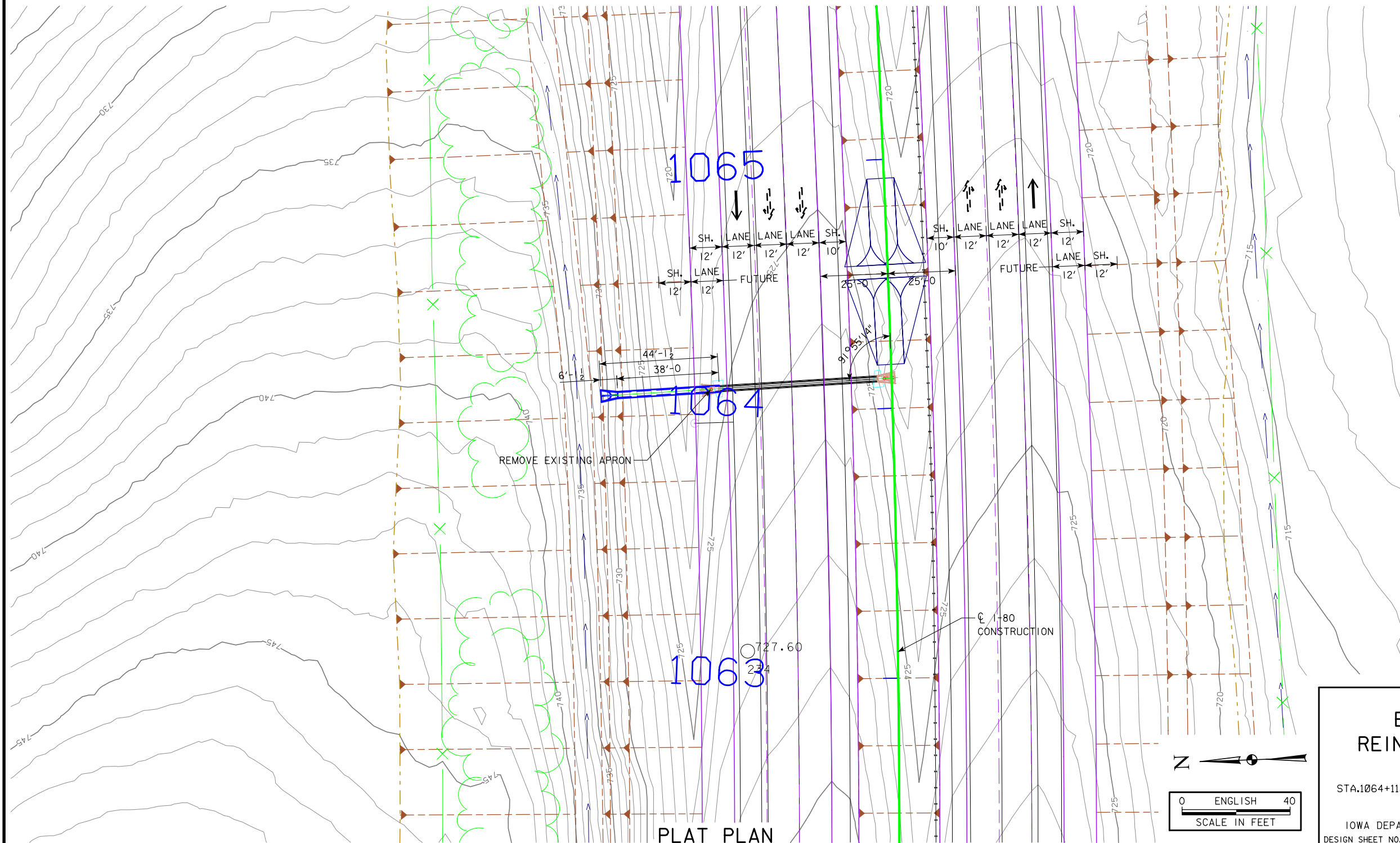

LOCATION

I-80  
 T-79N R-2W  
 SECTION 24  
 SUGAR CREEK TOWNSHIP  
 CEDAR COUNTY

HYDRAULIC DATA

DRAINAGE AREA = 1.6 ACRES  
 DESIGN DISCHARGE = 23.83 CFS

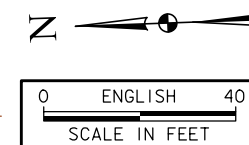

DESIGN FOR 0° SKEW  
**EXTEND 24" x 38' LT  
 REINFORCED CONCRETE PIPE  
 PLAT PLAN**  
 STA. 1064+11.38 AUGUST 2019  
**CEDAR COUNTY**  
 IOWA DEPARTMENT OF TRANSPORTATION - HIGHWAY DIVISION  
 DESIGN SHEET NO. ? OF ? FILE NO. ? DESIGN NO. ?

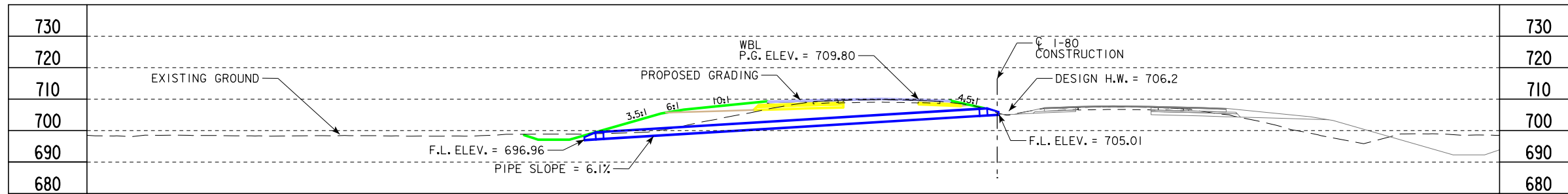

LONGITUDINAL SECTION ALONG  $\text{CL}$  CULVERT

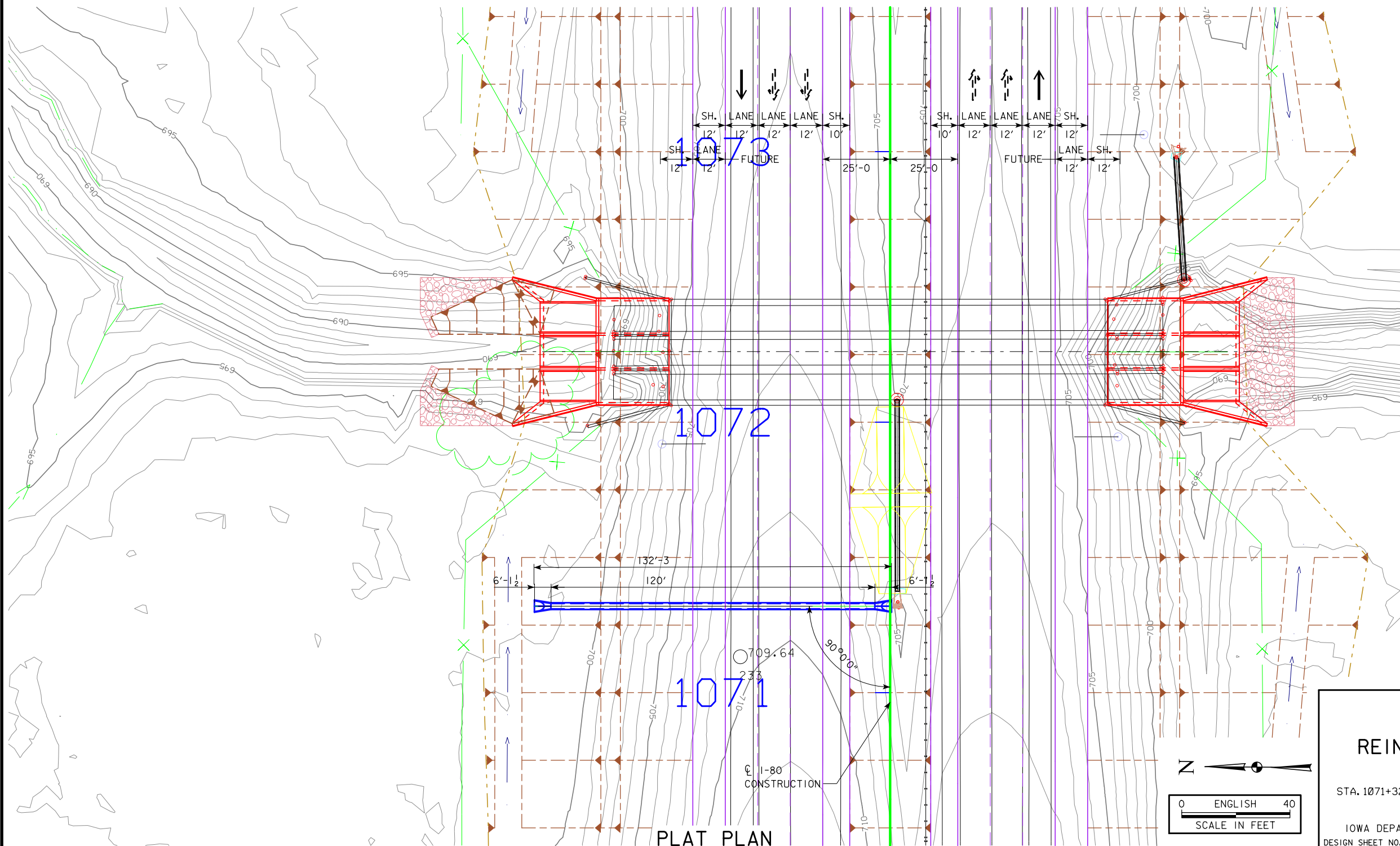

LOCATION

I-80  
 T-79N R-2W  
 SECTION 24  
 SUGAR CREEK TOWNSHIP  
 CEDAR COUNTY

HYDRAULIC DATA

DRAINAGE AREA = 1.3 ACRES  
 DESIGN DISCHARGE = 55.64 CFS

DESIGN FOR 0° SKEW  
**24" x 120'**  
**REINFORCED CONCRETE PIPE**  
**PLAT PLAN**  
 STA. 1071+32.00 WB  
 CEDAR COUNTY  
 IOWA DEPARTMENT OF TRANSPORTATION - HIGHWAY DIVISION  
 DESIGN SHEET NO. ? OF ? FILE NO. ? DESIGN NO. ?

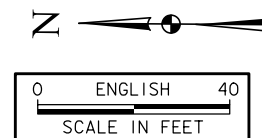



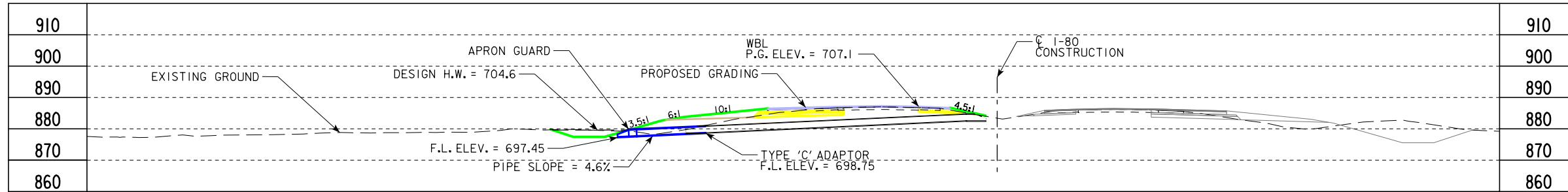

LONGITUDINAL SECTION ALONG CULVERT

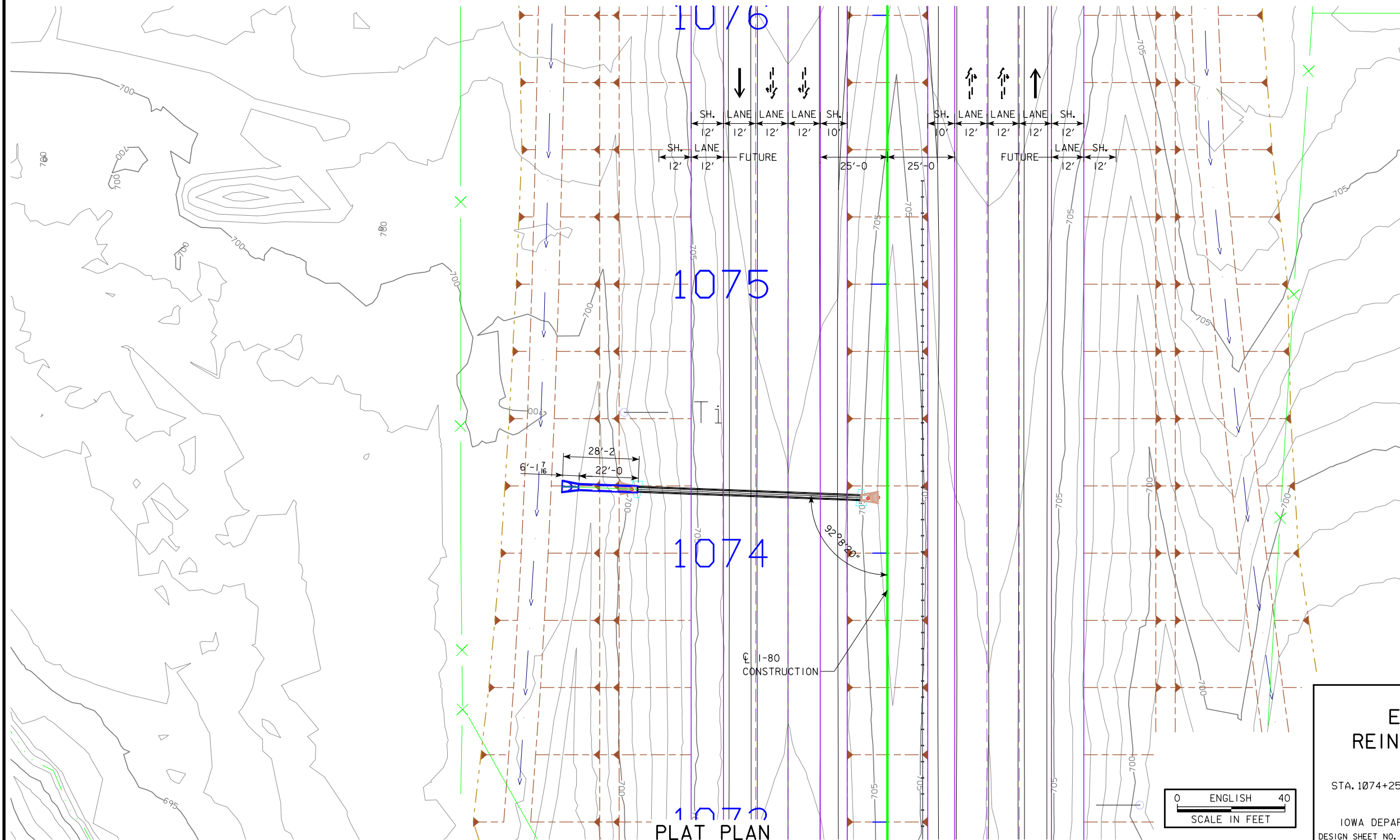

LOCATION

I-80  
 T-79N R-2W  
 SECTION 24  
 SUGAR CREEK TOWNSHIP  
 CEDAR COUNTY

HYDRAULIC DATA

DRAINAGE AREA = 1.4 ACRES  
 DESIGN DISCHARGE = 54.41 CFS



DESIGN FOR 0° SKEW  
**EXTEND 24" x 22' LT  
 REINFORCED CONCRETE PIPE  
 PLAT PLAN**  
 STA. 1074+25.00 AUGUST 2019  
**CEDAR COUNTY**  
 IOWA DEPARTMENT OF TRANSPORTATION - HIGHWAY DIVISION  
 DESIGN SHEET NO. ? OF ? FILE NO. ? DESIGN NO. ?



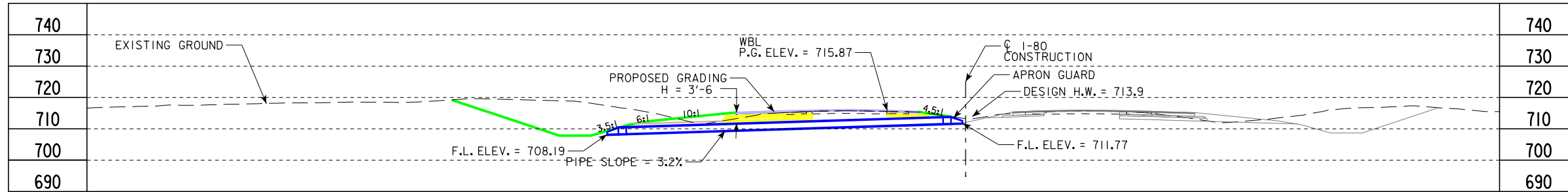

LONGITUDINAL SECTION ALONG CULVERT

LOCATION

I-80  
T-79N R-1W  
SECTION 19  
FARMINGTON TOWNSHIP  
CEDAR COUNTY

HYDRAULIC DATA

DRAINAGE AREA = 1.6 ACRES  
DESIGN DISCHARGE = 40.28 CFS

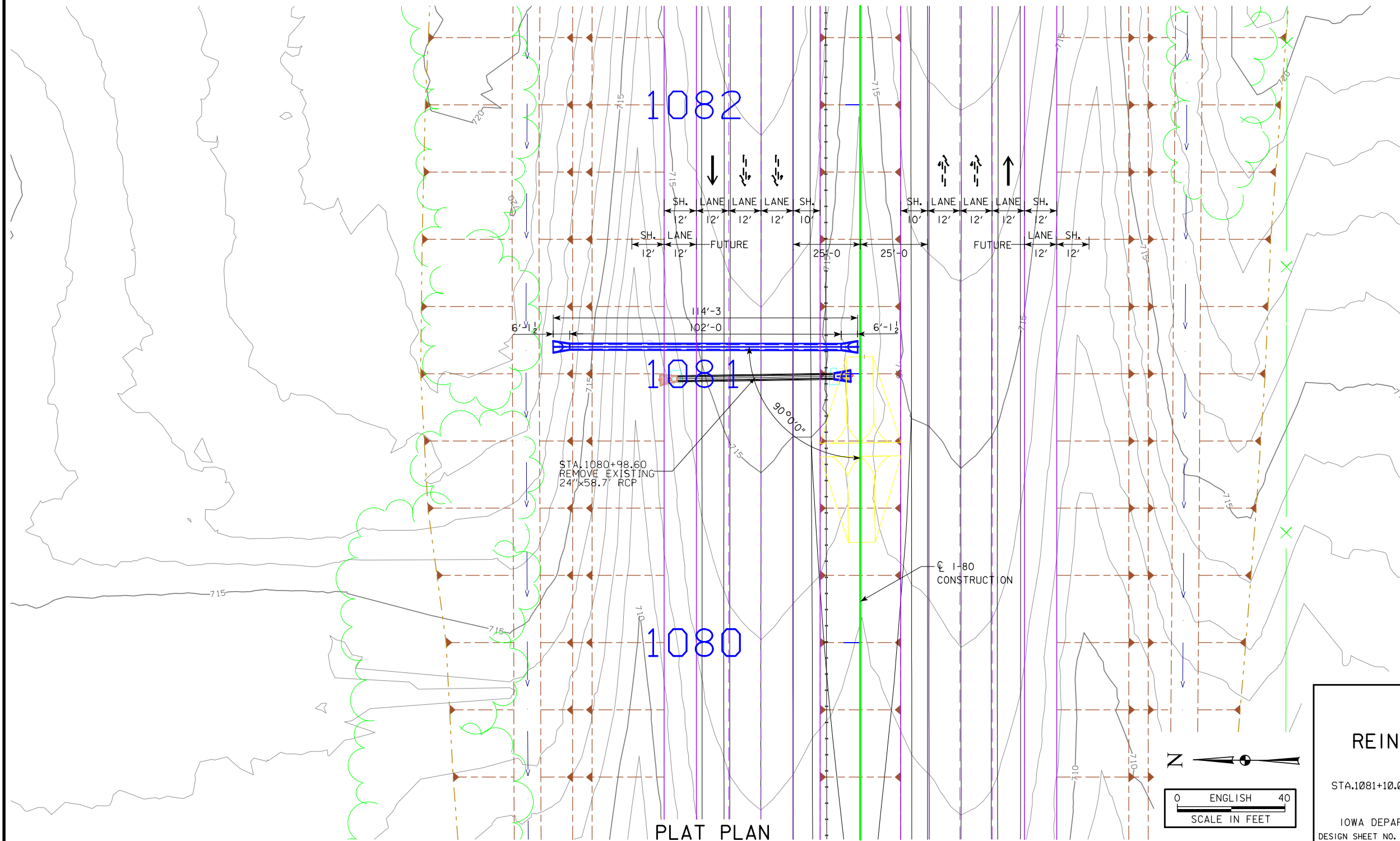

PLAT PLAN

DESIGN FOR 0° SKEW  
**24" x 102'**  
**REINFORCED CONCRETE PIPE**  
**PLAT PLAN**  
 STA. 1081+10.00 WB  
 AUGUST 2019  
**CEDAR COUNTY**  
 IOWA DEPARTMENT OF TRANSPORTATION - HIGHWAY DIVISION  
 DESIGN SHEET NO. ? OF ? FILE NO. ? DESIGN NO. ?

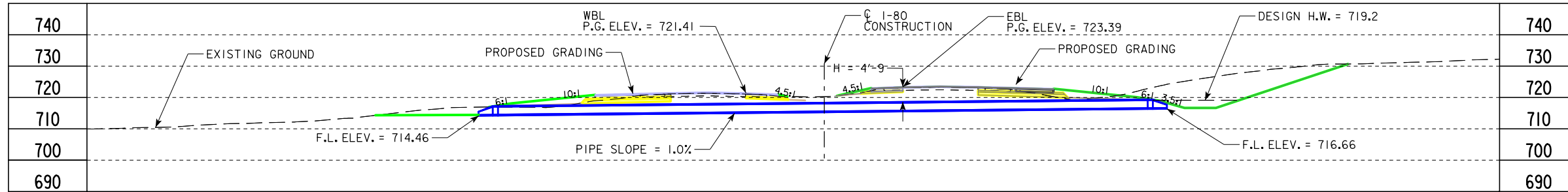

LONGITUDINAL SECTION ALONG CULVERT

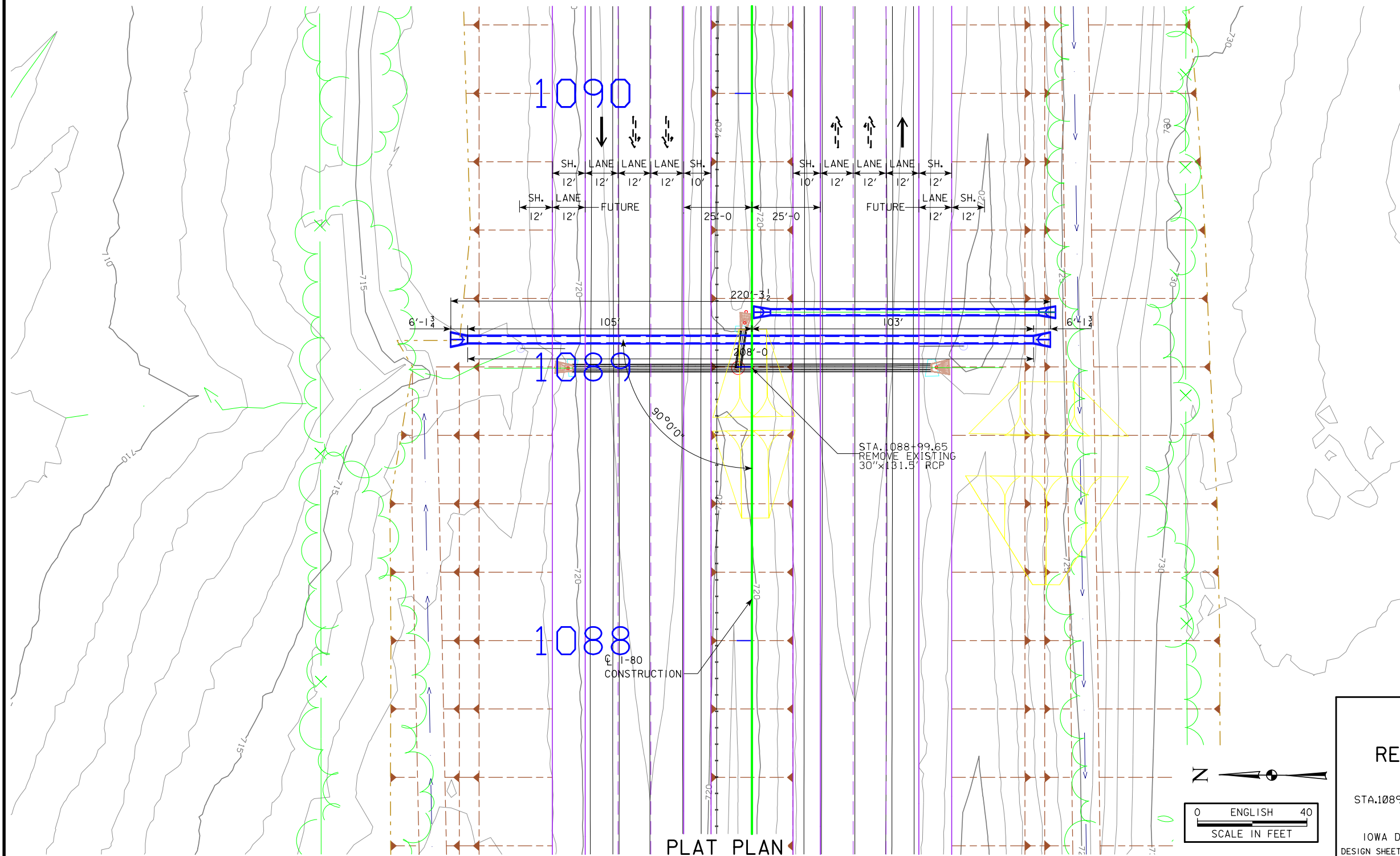

LOCATION

I-80  
 T-79N R-1W  
 SECTION 19  
 FARMINGTON TOWNSHIP  
 CEDAR COUNTY

HYDRAULIC DATA

DRAINAGE AREA = 4.3 ACRES  
 DESIGN DISCHARGE = 33.07 CFS

DESIGN FOR 0° SKEW  
**30" x 208'**  
**REINFORCED CONCRETE PIPE**  
**PLAT PLAN**  
 STA. 1089+10.00  
 AUGUST 2019  
**CEDAR COUNTY**  
 IOWA DEPARTMENT OF TRANSPORTATION - HIGHWAY DIVISION  
 DESIGN SHEET NO. ? OF ? FILE NO. ? DESIGN NO. ?

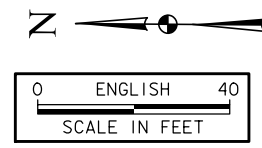



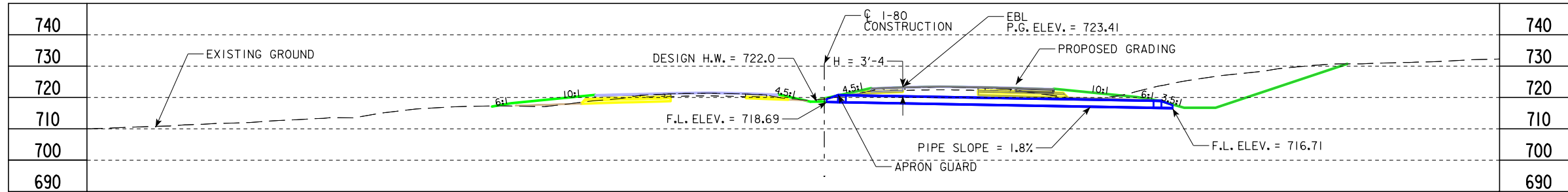

LONGITUDINAL SECTION ALONG CL CULVERT

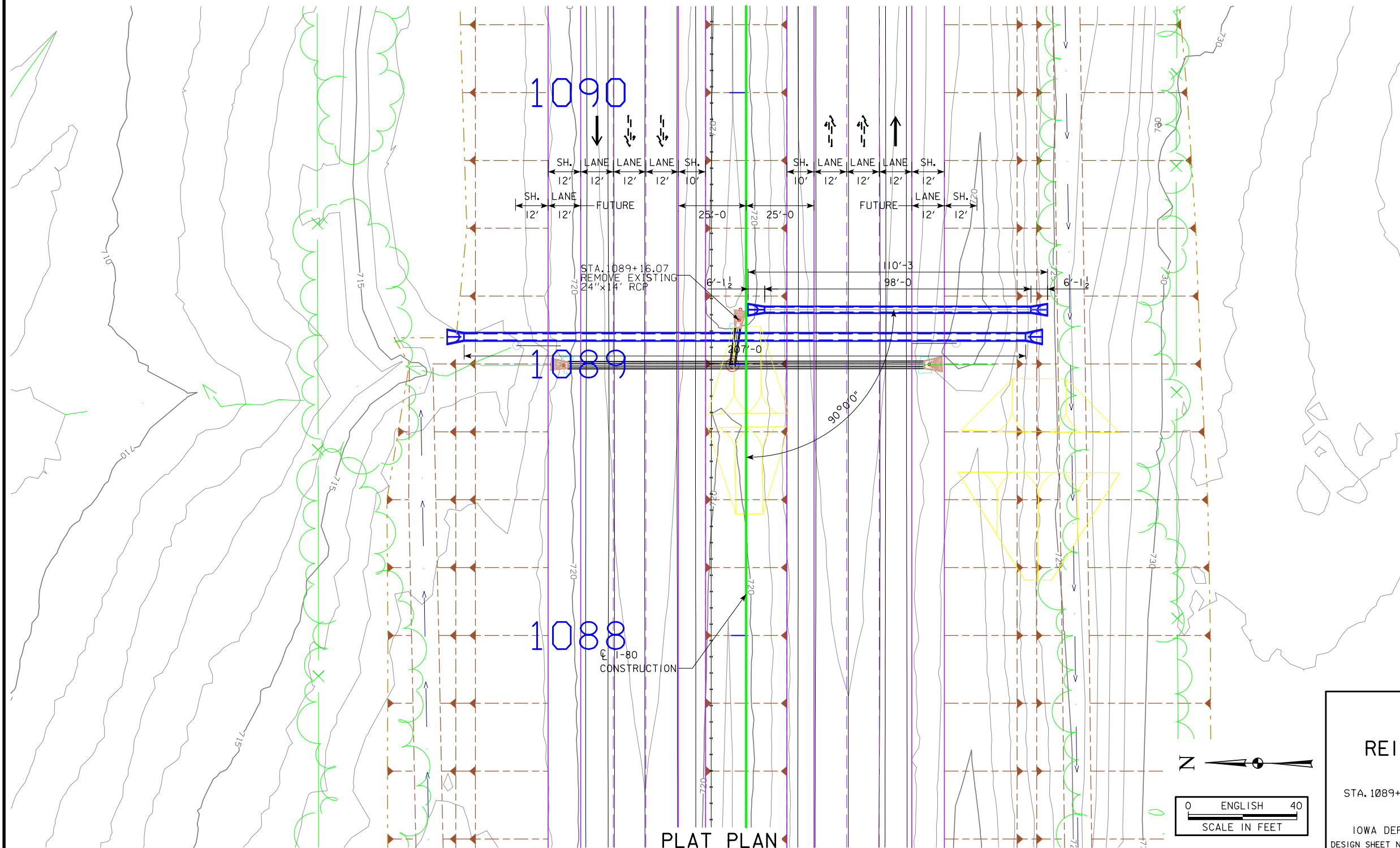

LOCATION

I-80  
T-79N R-1W  
SECTION 19  
FARMINGTON TOWNSHIP  
CEDAR COUNTY

HYDRAULIC DATA

DRAINAGE AREA = 4.3 ACRES  
DESIGN DISCHARGE = 33.07 CFS

DESIGN FOR 0° SKEW  
**24" x 98'**  
**REINFORCED CONCRETE PIPE**  
**PLAT PLAN**  
STA. 1089+20.00 EB AUGUST 2019  
**CEDAR COUNTY**  
IOWA DEPARTMENT OF TRANSPORTATION - HIGHWAY DIVISION  
DESIGN SHEET NO. ? OF ? FILE NO. ? DESIGN NO. ?

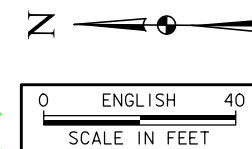

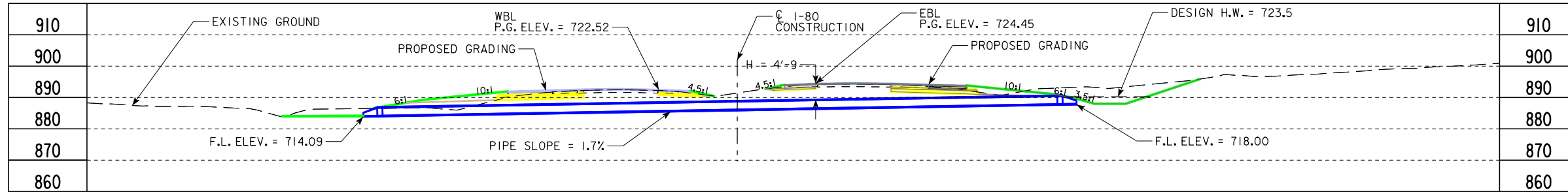

LONGITUDINAL SECTION ALONG CULVERT

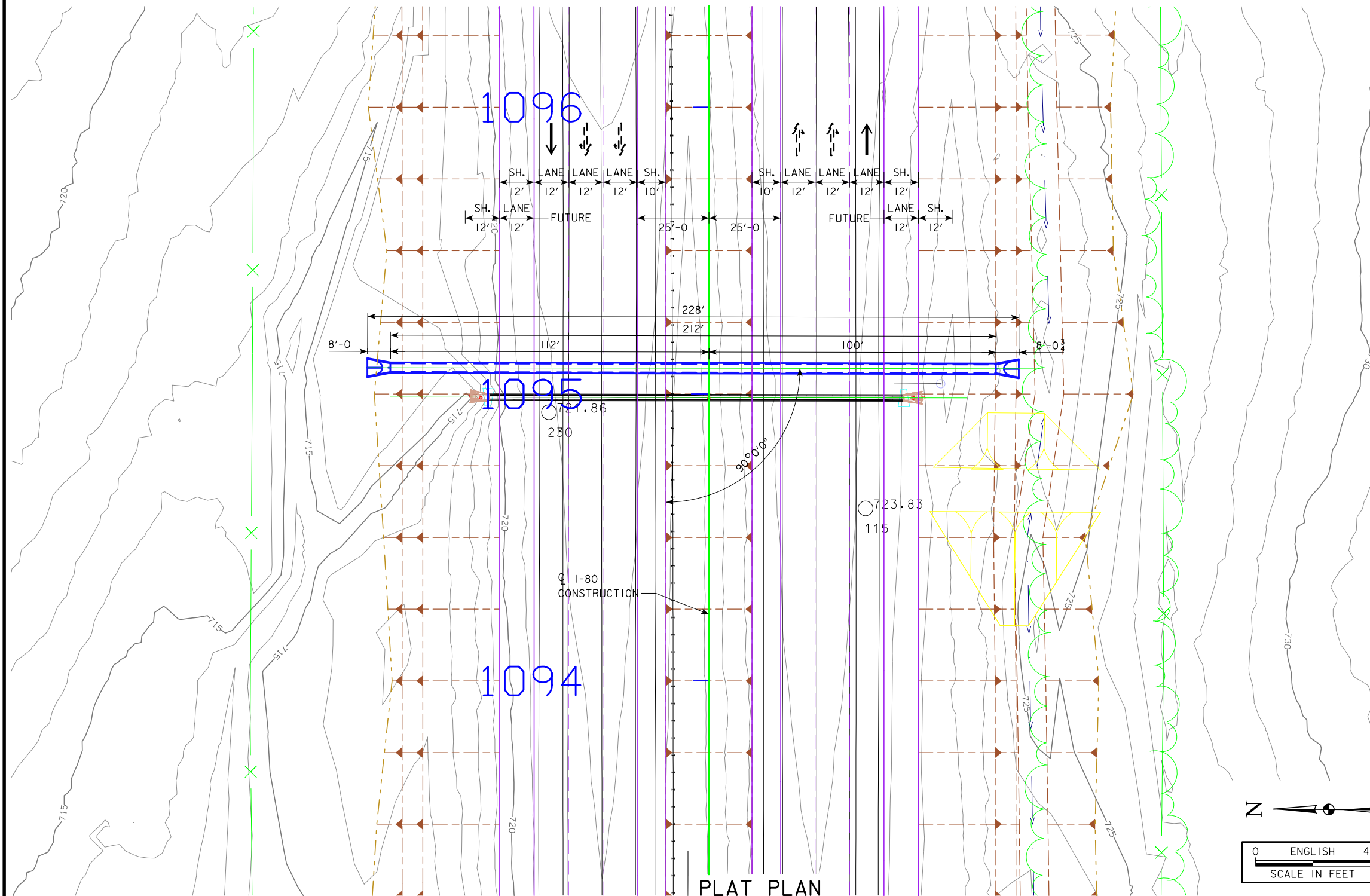

PLAT PLAN

LOCATION

I-80  
 T-79N R-1W  
 SECTION 19  
 FARMINGTON TOWNSHIP  
 CEDAR COUNTY

HYDRAULIC DATA

DRAINAGE AREA = 9.0 ACRES  
 DESIGN DISCHARGE = 54.41 CFS

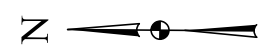

DESIGN FOR 0° SKEW  
**30" x 212'**  
**REINFORCED CONCRETE PIPE**  
**PLAT PLAN**  
 STA.1095+09.00 AUGUST 2019  
**CEDAR COUNTY**  
 IOWA DEPARTMENT OF TRANSPORTATION - HIGHWAY DIVISION  
 DESIGN SHEET NO. ? OF ? FILE NO. ? DESIGN NO. ?

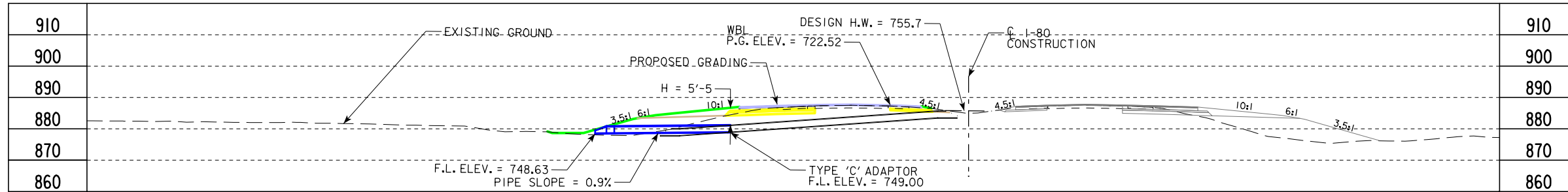

LONGITUDINAL SECTION ALONG CULVERT

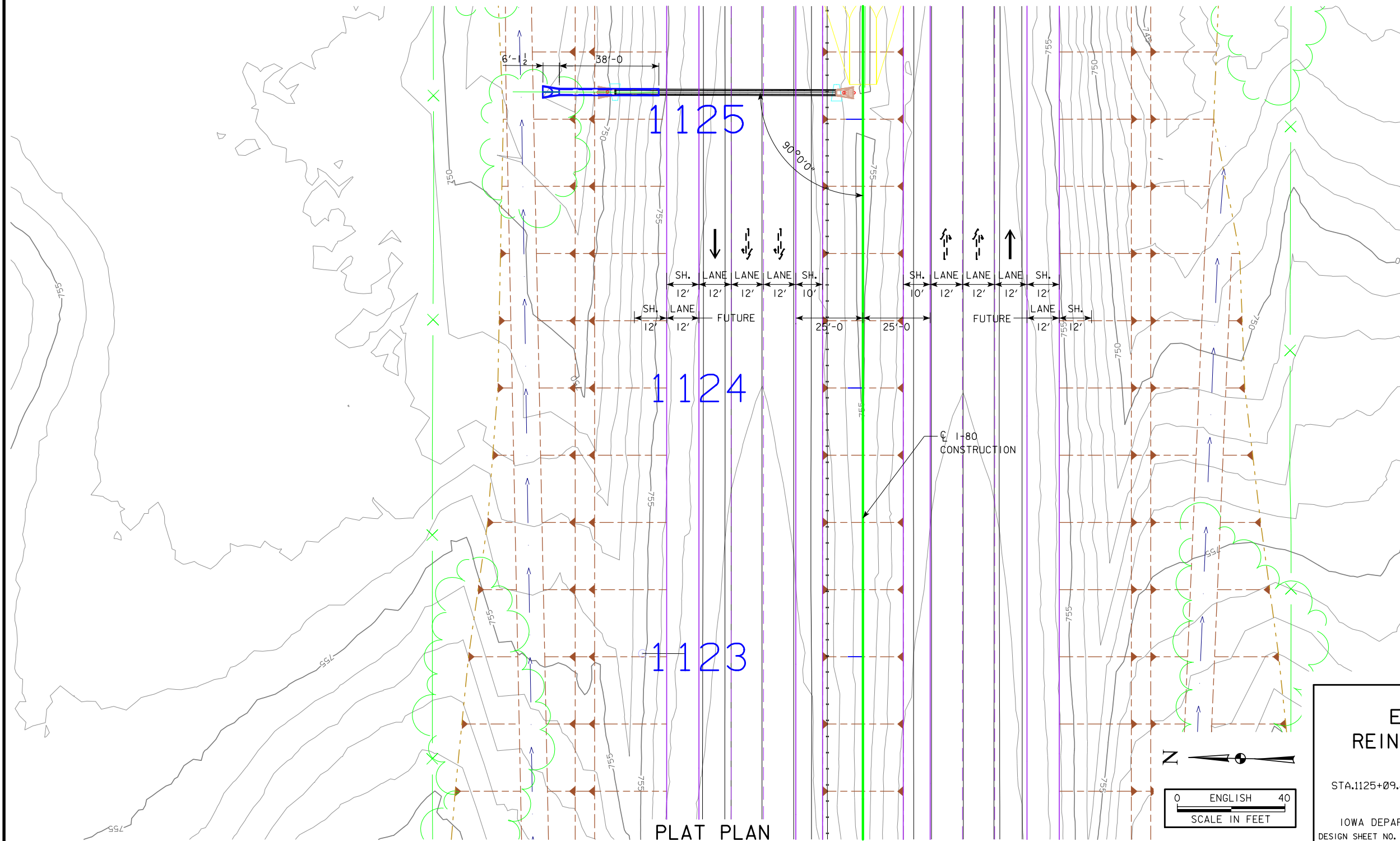

PLAT PLAN

LOCATION

I-80  
 T-79N R-1W  
 SECTION 19  
 FARMINGTON TOWNSHIP  
 CEDAR COUNTY

HYDRAULIC DATA

DRAINAGE AREA = 1.8 ACRES  
 DESIGN DISCHARGE = 49.51 CFS

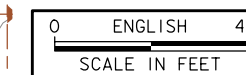

DESIGN FOR 0° SKEW  
**EXTEND 24" x 37' LT  
 REINFORCED CONCRETE PIPE  
 PLAT PLAN**  
 STA.1125+09.80 WB AUGUST 2019  
**CEDAR COUNTY**  
 IOWA DEPARTMENT OF TRANSPORTATION - HIGHWAY DIVISION  
 DESIGN SHEET NO. ? OF ? FILE NO. ? DESIGN NO. ?



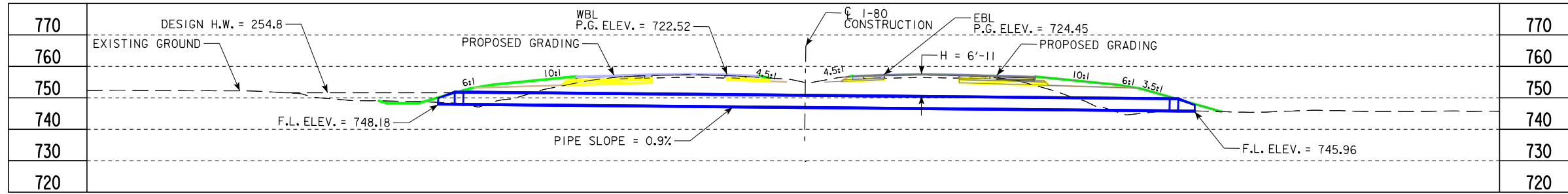

LONGITUDINAL SECTION ALONG CULVERT

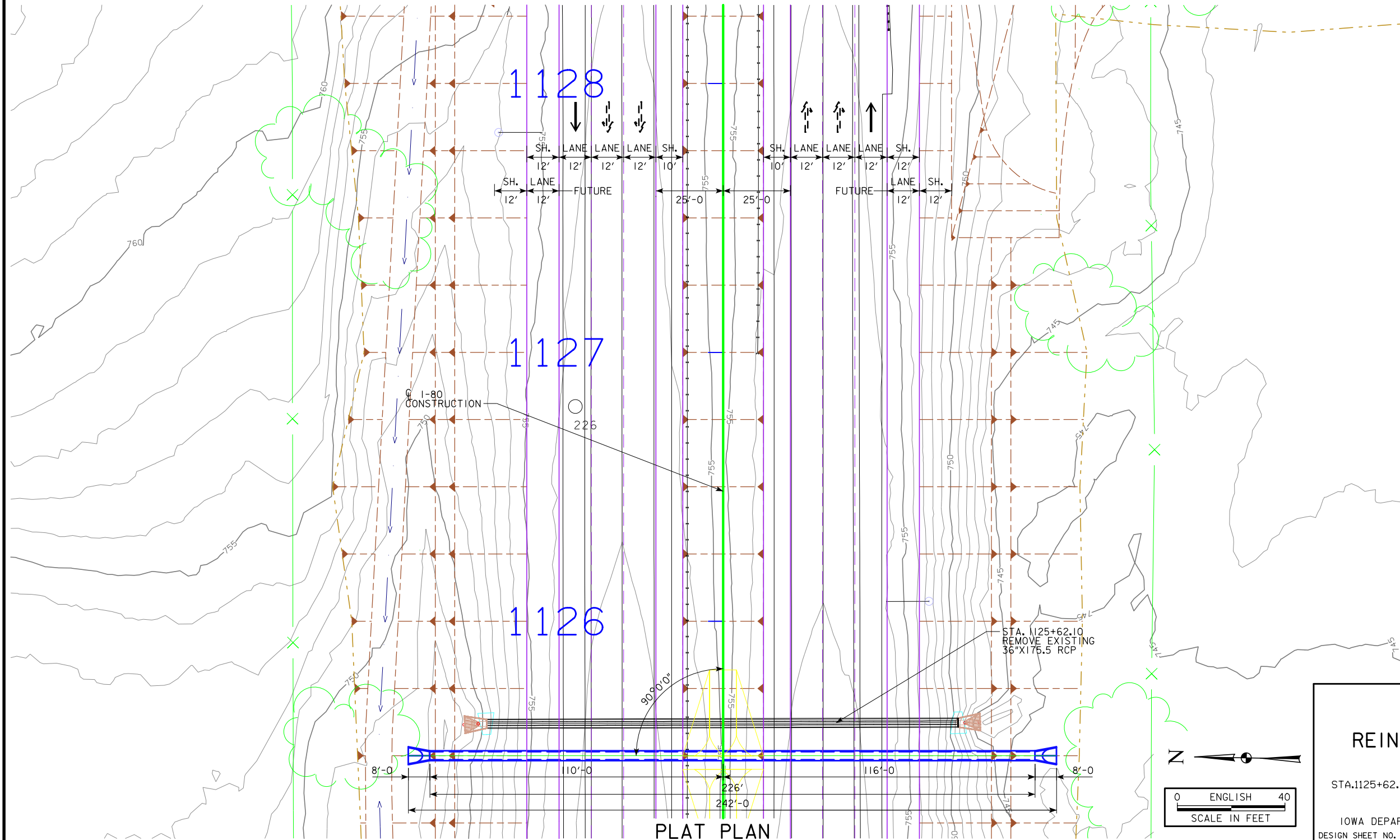

LOCATION

I-80  
 T-79N R-1W  
 SECTION 19  
 FARMINGTON TOWNSHIP  
 CEDAR COUNTY

HYDRAULIC DATA

DRAINAGE AREA = 27.7 ACRES  
 DESIGN DISCHARGE = 96.5 CFS

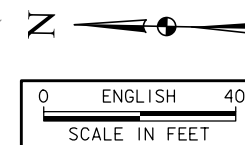

DESIGN FOR 0° SKEW  
**42" x 226'**  
**REINFORCED CONCRETE PIPE**  
**PLAT PLAN**  
 STA. 1125+62.10  
 AUGUST 2019  
**CEDAR COUNTY**  
 IOWA DEPARTMENT OF TRANSPORTATION - HIGHWAY DIVISION  
 DESIGN SHEET NO. ? OF ? FILE NO. ? DESIGN NO. ?

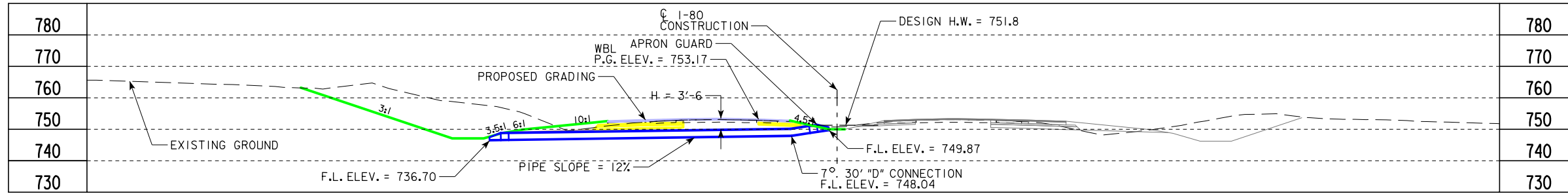

LONGITUDINAL SECTION ALONG  $\text{C}$  CULVERT

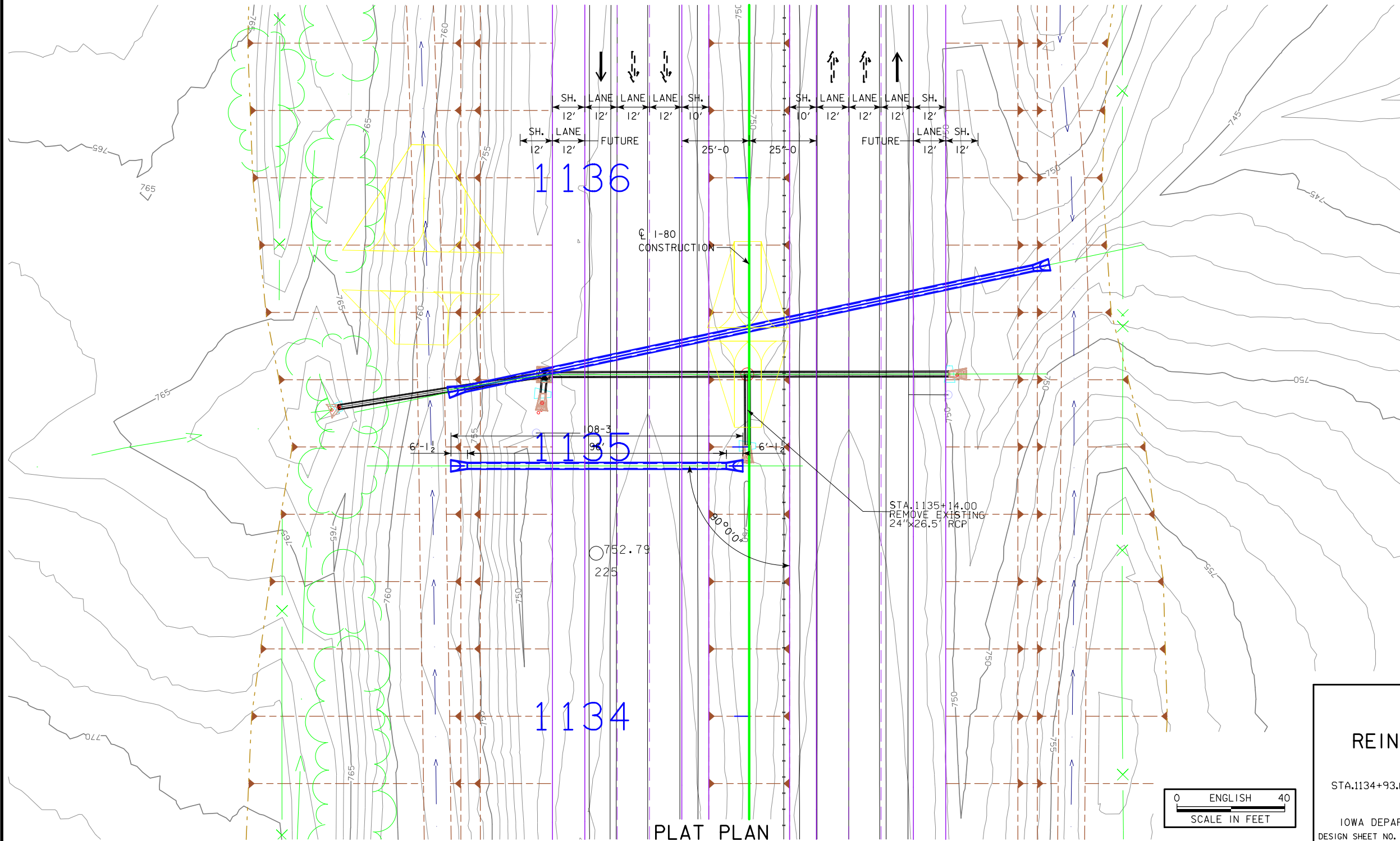

**LOCATION**

I-80  
T-79N R-1W  
SECTION 20  
FARMINGTON TOWNSHIP  
CEDAR COUNTY

**HYDRAULIC DATA**

DRAINAGE AREA = 1.8 ACRES  
DESIGN DISCHARGE = 39.38 CFS

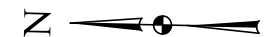

DESIGN FOR 0° SKEW  
**24" x 96'**  
**REINFORCED CONCRETE PIPE**  
**PLAT PLAN**  
STA.1134+93.00 AUGUST 2019  
**CEDAR COUNTY**  
IOWA DEPARTMENT OF TRANSPORTATION - HIGHWAY DIVISION  
DESIGN SHEET NO. ? OF ? FILE NO. ? DESIGN NO. ?



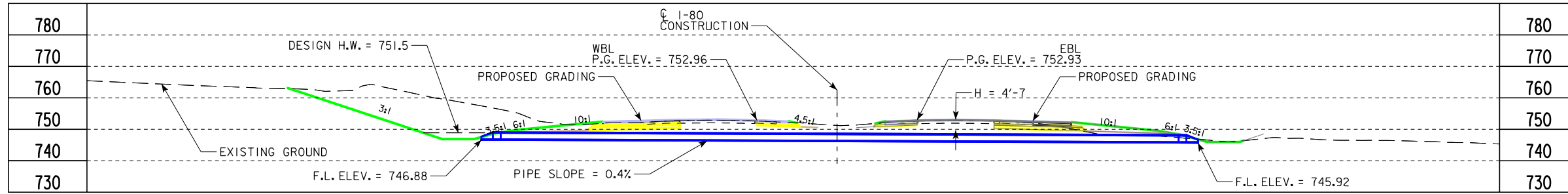

LONGITUDINAL SECTION ALONG  $\text{CL}$  CULVERT

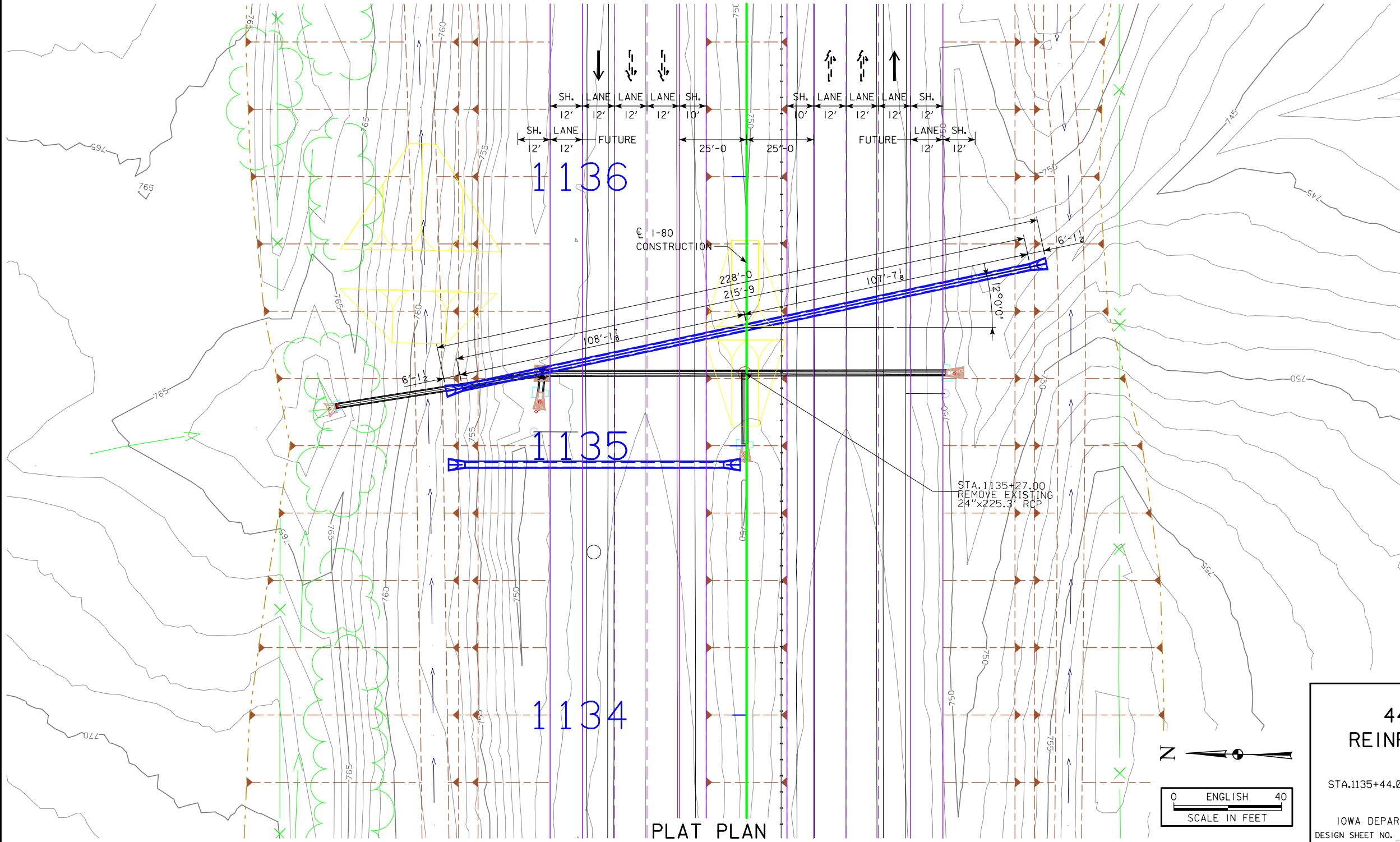

**LOCATION**  
 I-80  
 T-79N R-1W  
 SECTION 20  
 FARMINGTON TOWNSHIP  
 CEDAR COUNTY

**HYDRAULIC DATA**  
 DRAINAGE AREA = 10.7 ACRES  
 DESIGN DISCHARGE = 36.54 CFS

DESIGN FOR 12° SKEW  
**44" x 27" ARCH x 214'**  
**REINFORCED CONCRETE PIPE**  
**PLAT PLAN**  
 STA.1135+44.00  
 AUGUST 2019  
**CEDAR COUNTY**  
 IOWA DEPARTMENT OF TRANSPORTATION - HIGHWAY DIVISION  
 DESIGN SHEET NO. ? OF ? FILE NO. ? DESIGN NO. ?

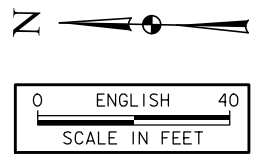



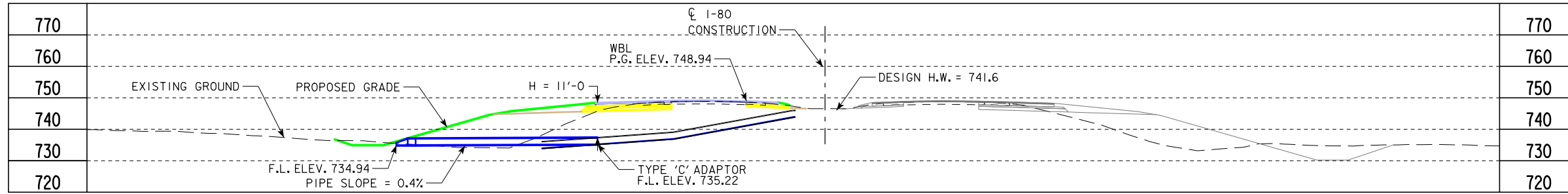

LONGITUDINAL SECTION ALONG  $\phi$  CULVERT

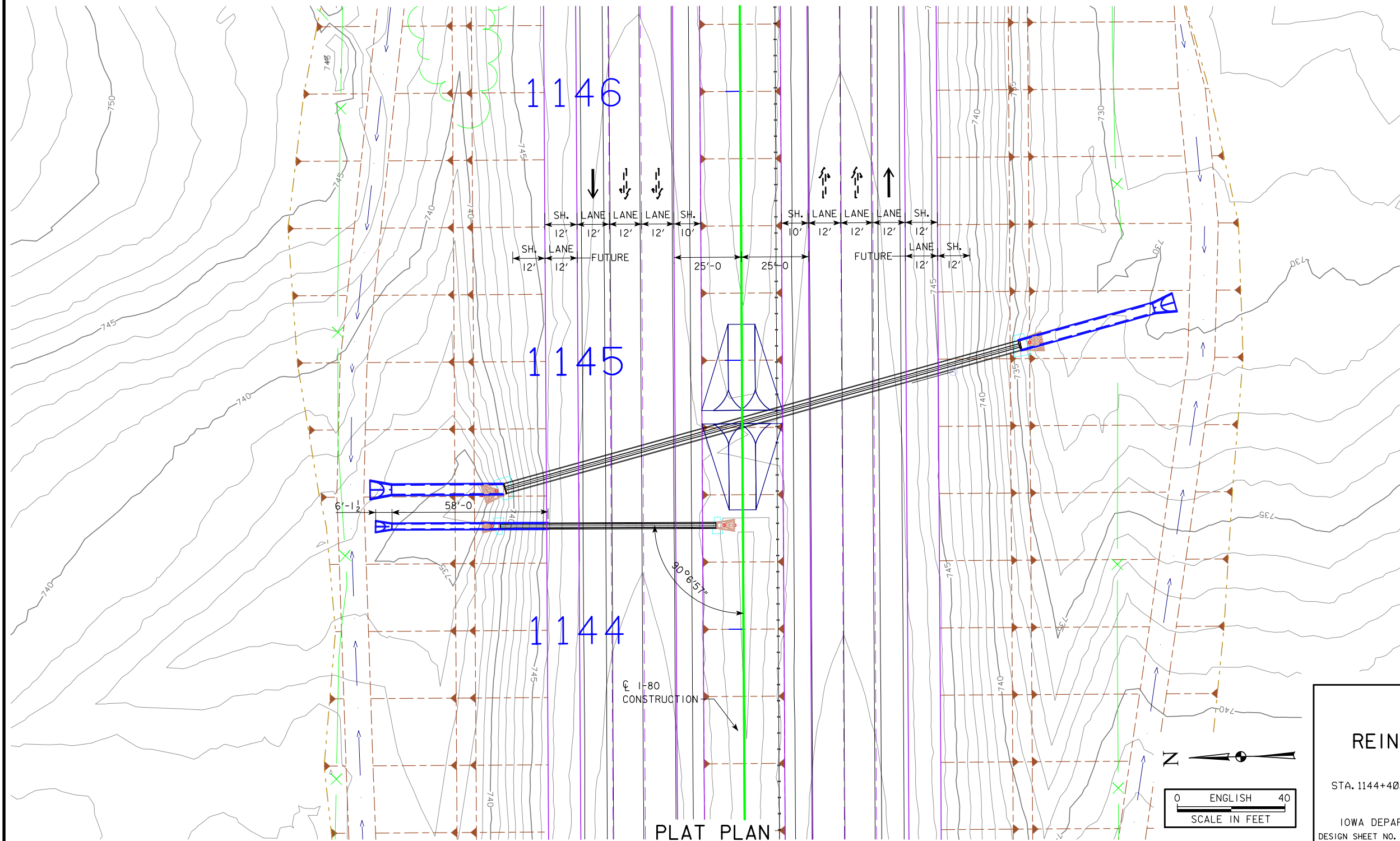

LOCATION

I-80  
T-79N R-1W  
SECTION 20  
FARMINGTON TOWNSHIP  
CEDAR COUNTY

HYDRAULIC DATA

DRAINAGE AREA = 1.7 ACRES  
DESIGN DISCHARGE = ??? CFS

DESIGN FOR 0° SKEW  
**EXTEND 24" x 58'**  
**REINFORCED CONCRETE PIPE**  
**PLAT PLAN**

STA. 1144+40.00 WB AUGUST 2019  
**CEDAR COUNTY**  
IOWA DEPARTMENT OF TRANSPORTATION - HIGHWAY DIVISION  
DESIGN SHEET NO. ? OF ? FILE NO. ? DESIGN NO. ?

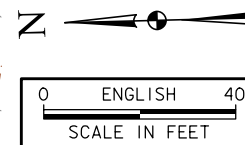

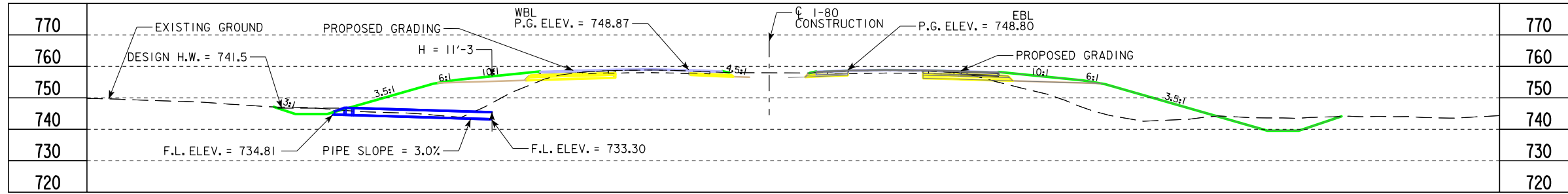

LONGITUDINAL SECTION ALONG C<sub>L</sub> CULVERT

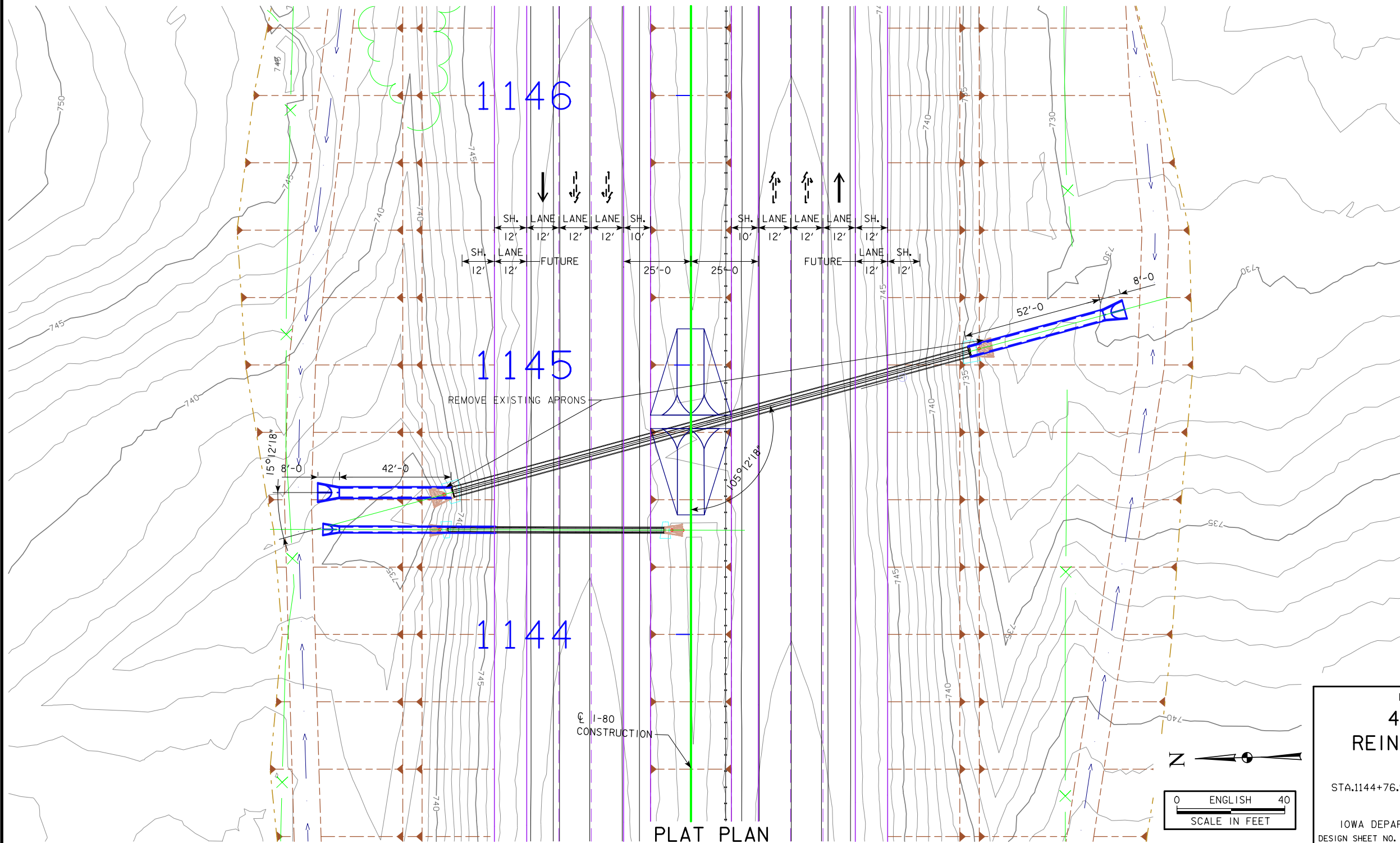

**LOCATION**

I-80  
T-79N R-1W  
SECTION 20  
FARMINGTON TOWNSHIP  
CEDAR COUNTY

**HYDRAULIC DATA**

DRAINAGE AREA = 30.3 ACRES  
DESIGN DISCHARGE = 166.53 CFS

DESIGN FOR 15° SKEW & 15° SKEW LT  
**44" x 52' RT & 44' LT**  
**REINFORCED CONCRETE PIPE**  
**PLAT PLAN**  
 STA.1144+76.90 AUGUST 2019  
**CEDAR COUNTY**  
 IOWA DEPARTMENT OF TRANSPORTATION - HIGHWAY DIVISION  
 DESIGN SHEET NO. ? OF ? FILE NO. ? DESIGN NO. ?

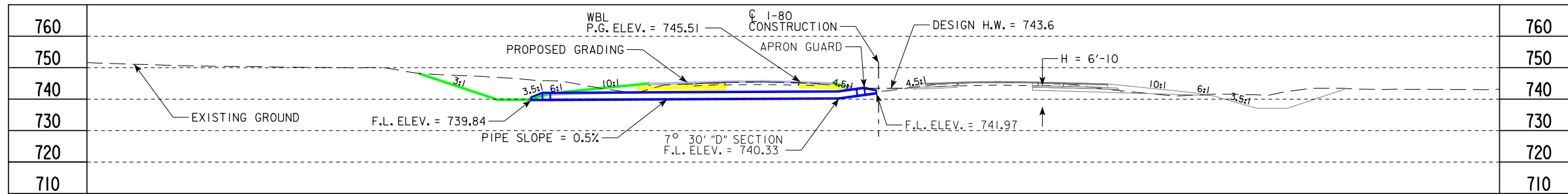

LONGITUDINAL SECTION ALONG CULVERT

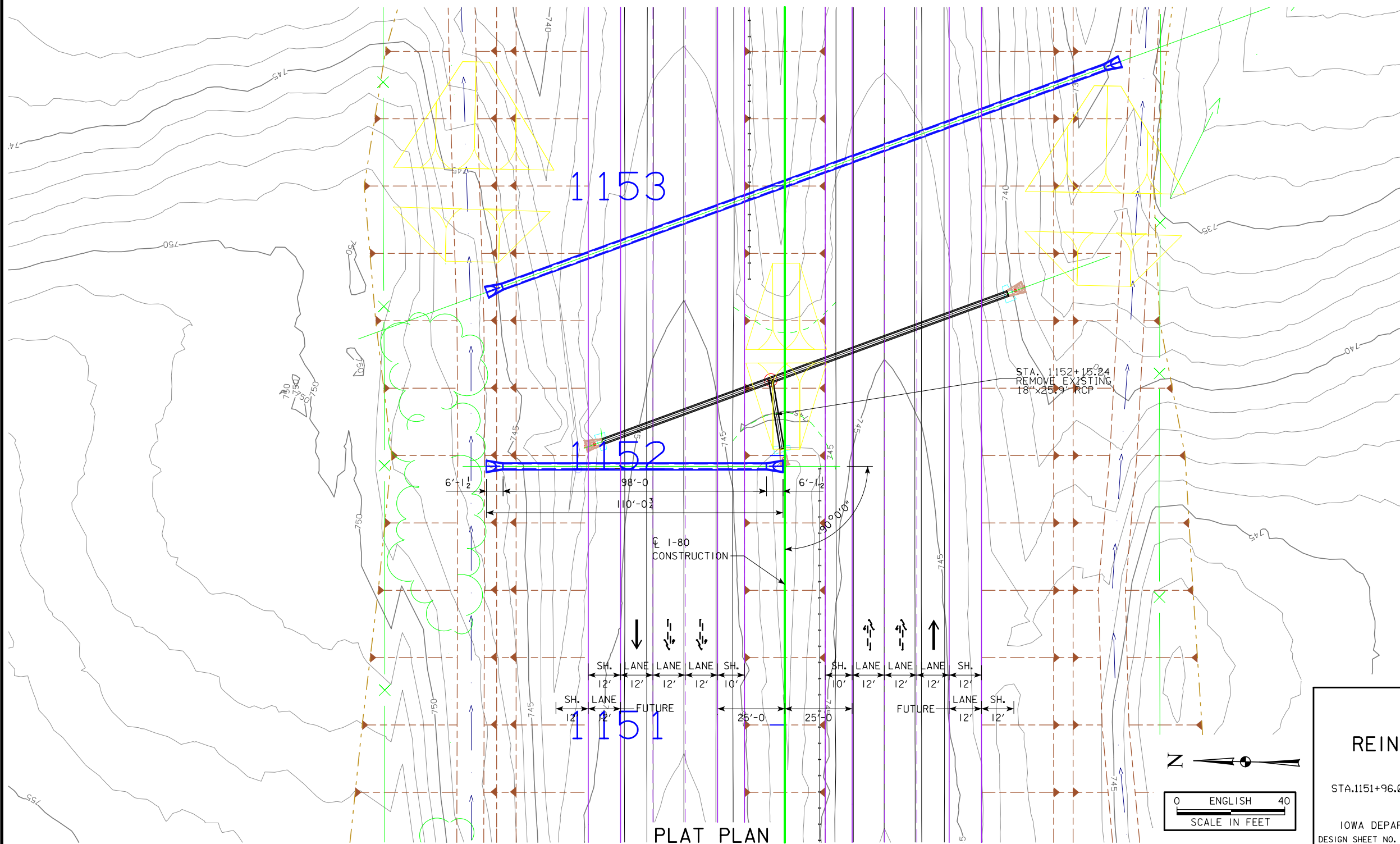

**LOCATION**

I-80  
 T-79N R-1W  
 SECTION 20  
 FARMINGTON TOWNSHIP  
 CEDAR COUNTY

**HYDRAULIC DATA**

DRAINAGE AREA = 1.4 ACRES  
 DESIGN DISCHARGE = 20.23 CFS

DESIGN FOR 0° SKEW  
**24" x 98'**  
**REINFORCED CONCRETE PIPE**  
**PLAT PLAN**  
 STA.1151+96.00  
 AUGUST 2019  
**CEDAR COUNTY**  
 IOWA DEPARTMENT OF TRANSPORTATION - HIGHWAY DIVISION  
 DESIGN SHEET NO. ? OF ? FILE NO. ? DESIGN NO. ?





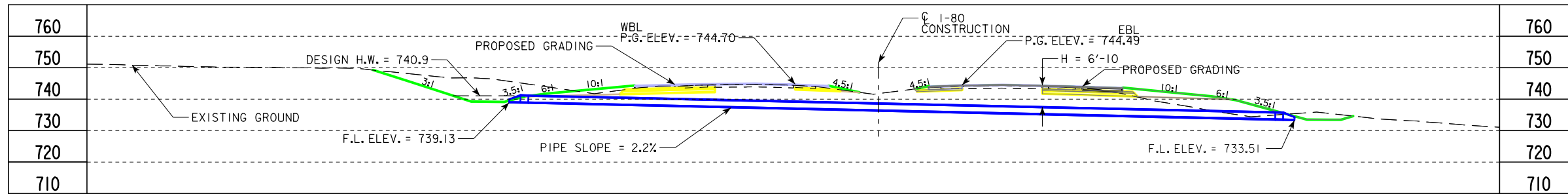

LONGITUDINAL SECTION ALONG C<sub>L</sub> CULVERT

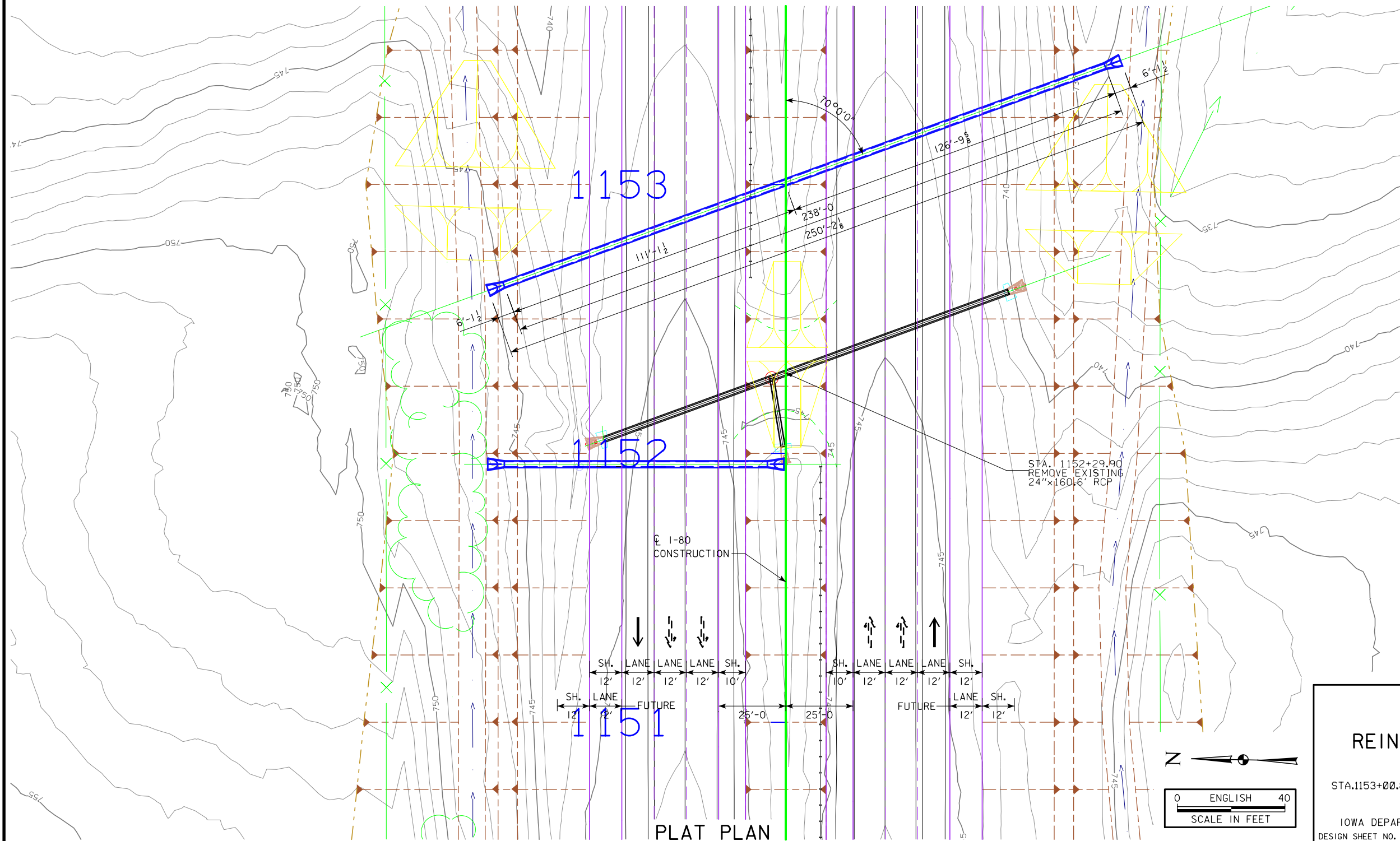

LOCATION

I-80  
 T-79N R-1W  
 SECTION 20  
 FARMINGTON TOWNSHIP  
 CEDAR COUNTY

HYDRAULIC DATA

DRAINAGE AREA = 1.9 ACRES  
 DESIGN DISCHARGE = 27.24 CFS

DESIGN FOR 20° SKEW  
**24" x 238'**  
**REINFORCED CONCRETE PIPE**  
**PLAT PLAN**  
 STA.1153+00.85  
 AUGUST 2019  
**CEDAR COUNTY**  
 IOWA DEPARTMENT OF TRANSPORTATION - HIGHWAY DIVISION  
 DESIGN SHEET NO. ? OF ? FILE NO. ? DESIGN NO. ?

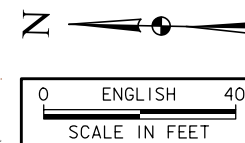

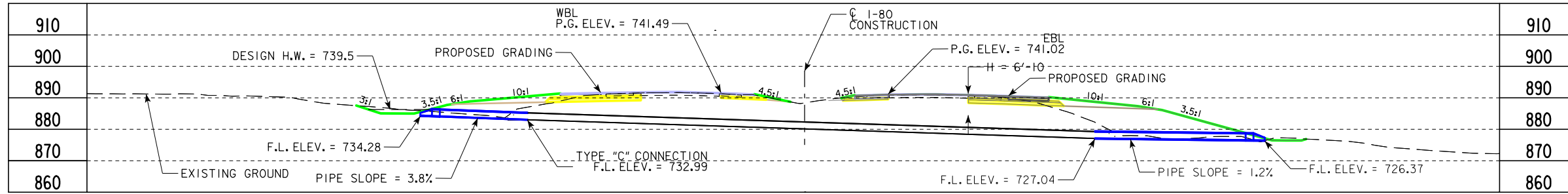

LONGITUDINAL SECTION ALONG  $\bar{C}$  CULVERT

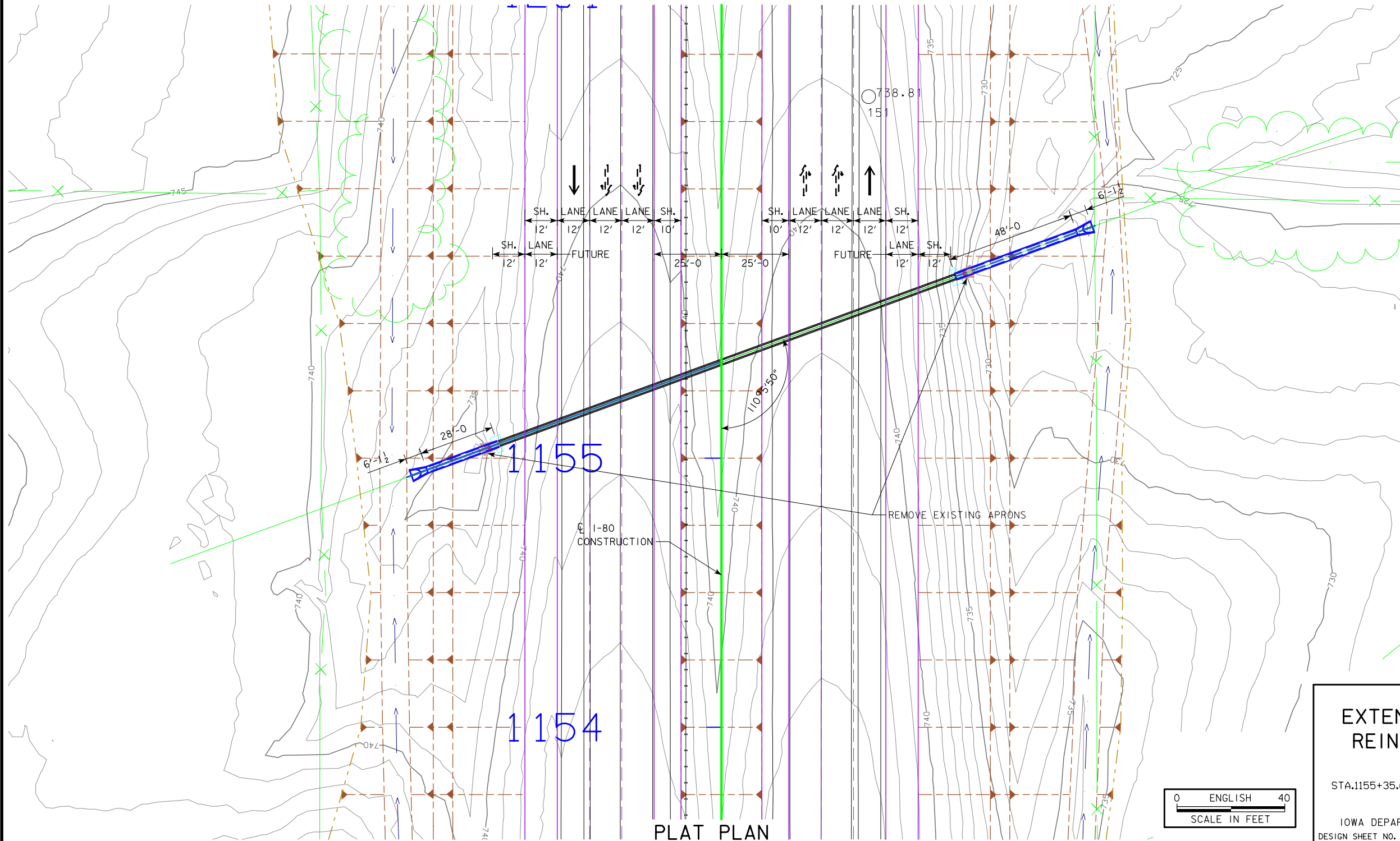

LOCATION

I-80  
 T-79N R-1W  
 SECTION 20  
 FARMINGTON TOWNSHIP  
 CEDAR COUNTY

HYDRAULIC DATA

DRAINAGE AREA = 6.8 ACRES  
 DESIGN DISCHARGE = 41.03 CFS

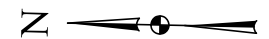

DESIGN FOR 20° SKEW  
**EXTEND 24" x 48' RT & 28' LT  
 REINFORCED CONCRETE PIPE  
 PLAT PLAN**  
 STA.1155+35.60 AUGUST 2019  
**CEDAR COUNTY**  
 IOWA DEPARTMENT OF TRANSPORTATION - HIGHWAY DIVISION  
 DESIGN SHEET NO. ? OF ? FILE NO. ? DESIGN NO. ?

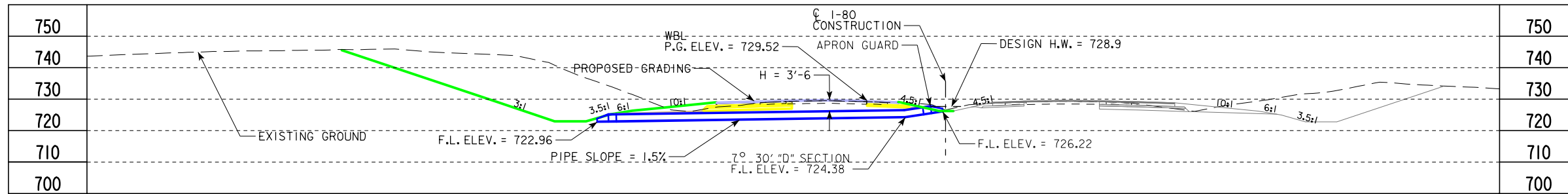

LONGITUDINAL SECTION ALONG  $\text{C}$  CULVERT

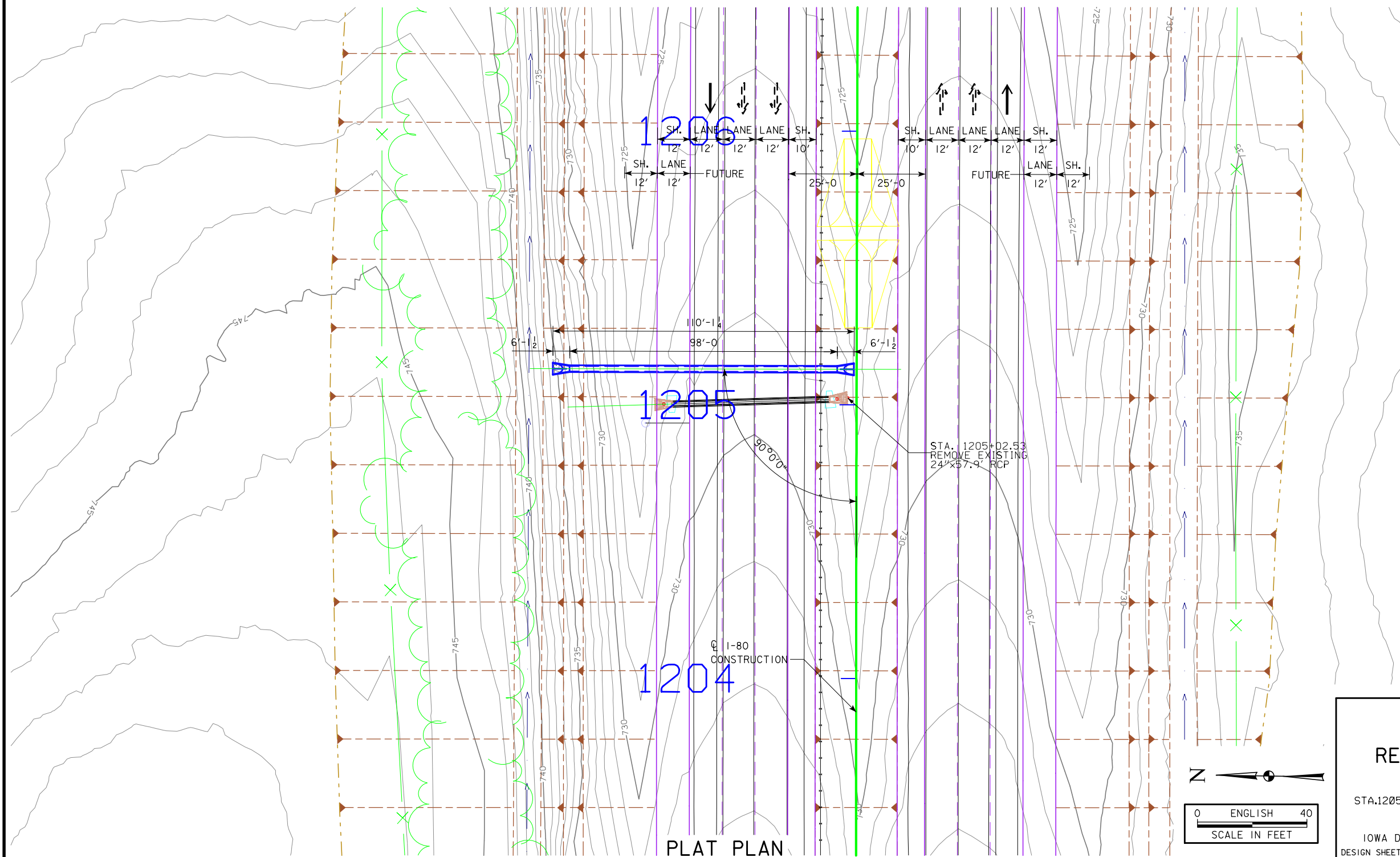

PLAT PLAN

LOCATION

I-80  
T-79N R-1W  
SECTION 20  
FARMINGTON TOWNSHIP  
CEDAR COUNTY

HYDRAULIC DATA

DRAINAGE AREA = 1.6 ACRES  
DESIGN DISCHARGE = 38.92 CFS

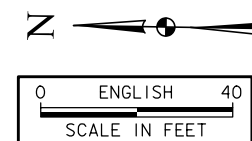

DESIGN FOR 0° SKEW  
**24" x 98'**  
**REINFORCED CONCRETE PIPE**  
**PLAT PLAN**  
STA. 1205+13.00 WB AUGUST 2019  
**CEDAR COUNTY**  
IOWA DEPARTMENT OF TRANSPORTATION - HIGHWAY DIVISION  
DESIGN SHEET NO. ? OF ? FILE NO. ? DESIGN NO. ?



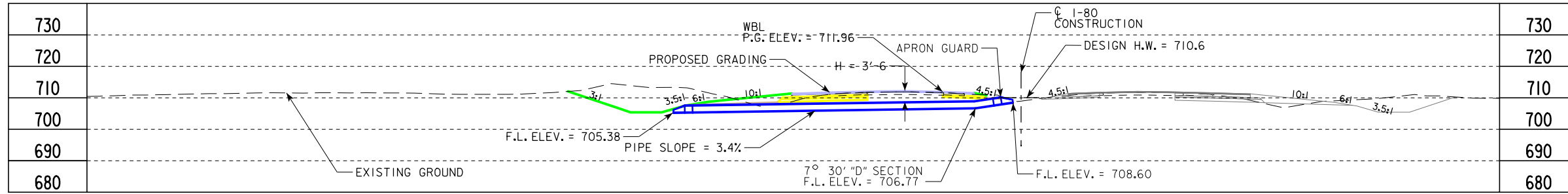

LONGITUDINAL SECTION ALONG CULVERT

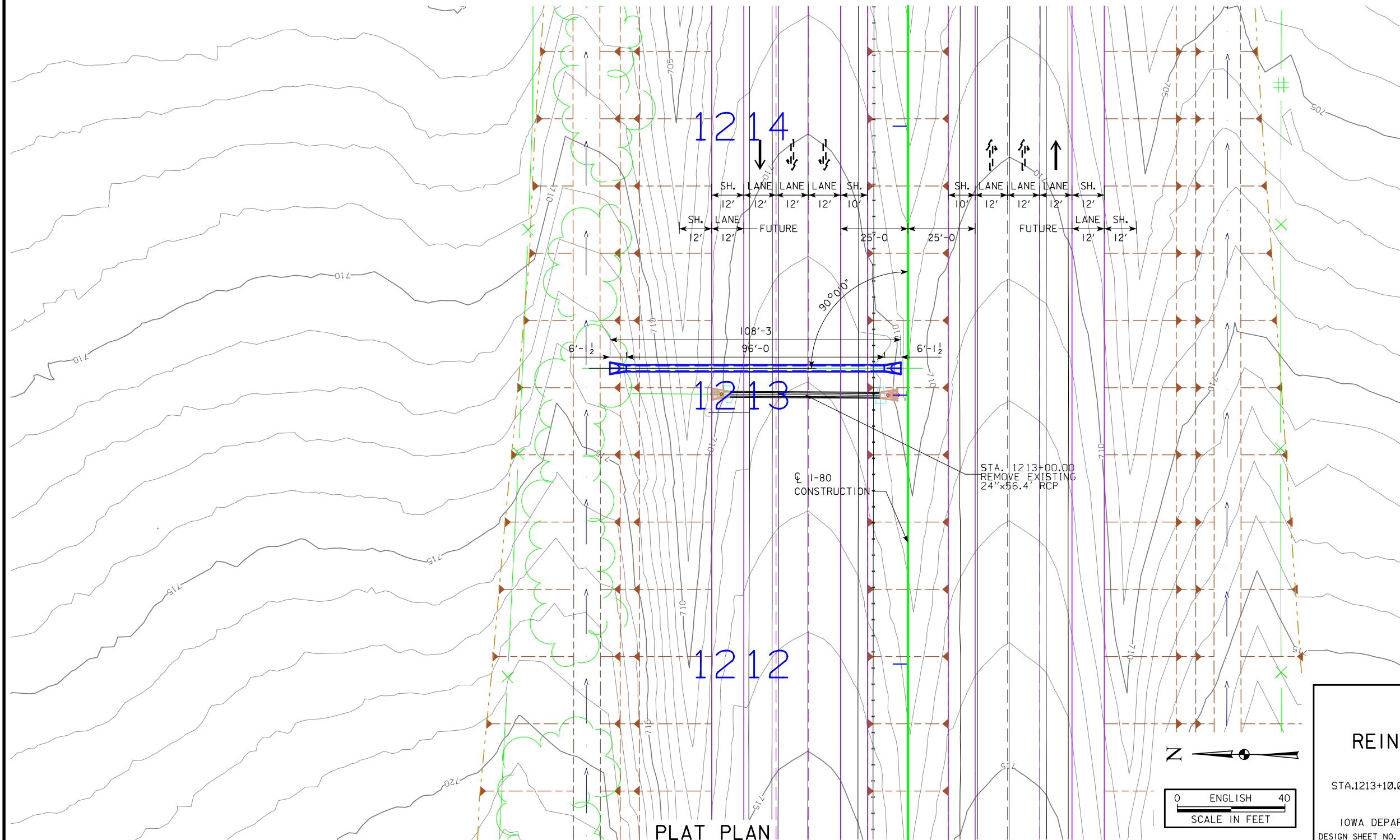

LOCATION

I-80  
 T-79N R-1W  
 SECTION 20  
 FARMINGTON TOWNSHIP  
 CEDAR COUNTY

HYDRAULIC DATA

DRAINAGE AREA = 1.5 ACRES  
 DESIGN DISCHARGE = 39.05 CFS

DESIGN FOR 0° SKEW  
**24" x 96'**  
**REINFORCED CONCRETE PIPE**  
**PLAT PLAN**  
 STA. 1213+10.00 WB AUGUST 2019  
**CEDAR COUNTY**  
 IOWA DEPARTMENT OF TRANSPORTATION - HIGHWAY DIVISION  
 DESIGN SHEET NO. ? OF ? FILE NO. ? DESIGN NO. ?

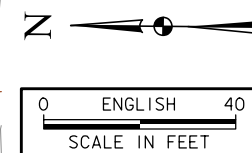

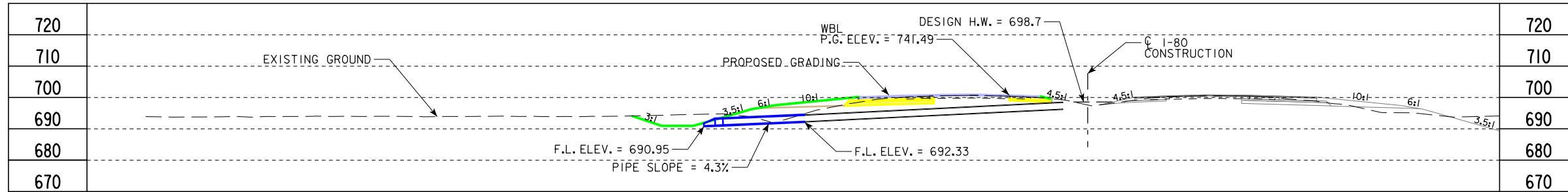

LONGITUDINAL SECTION ALONG CULVERT

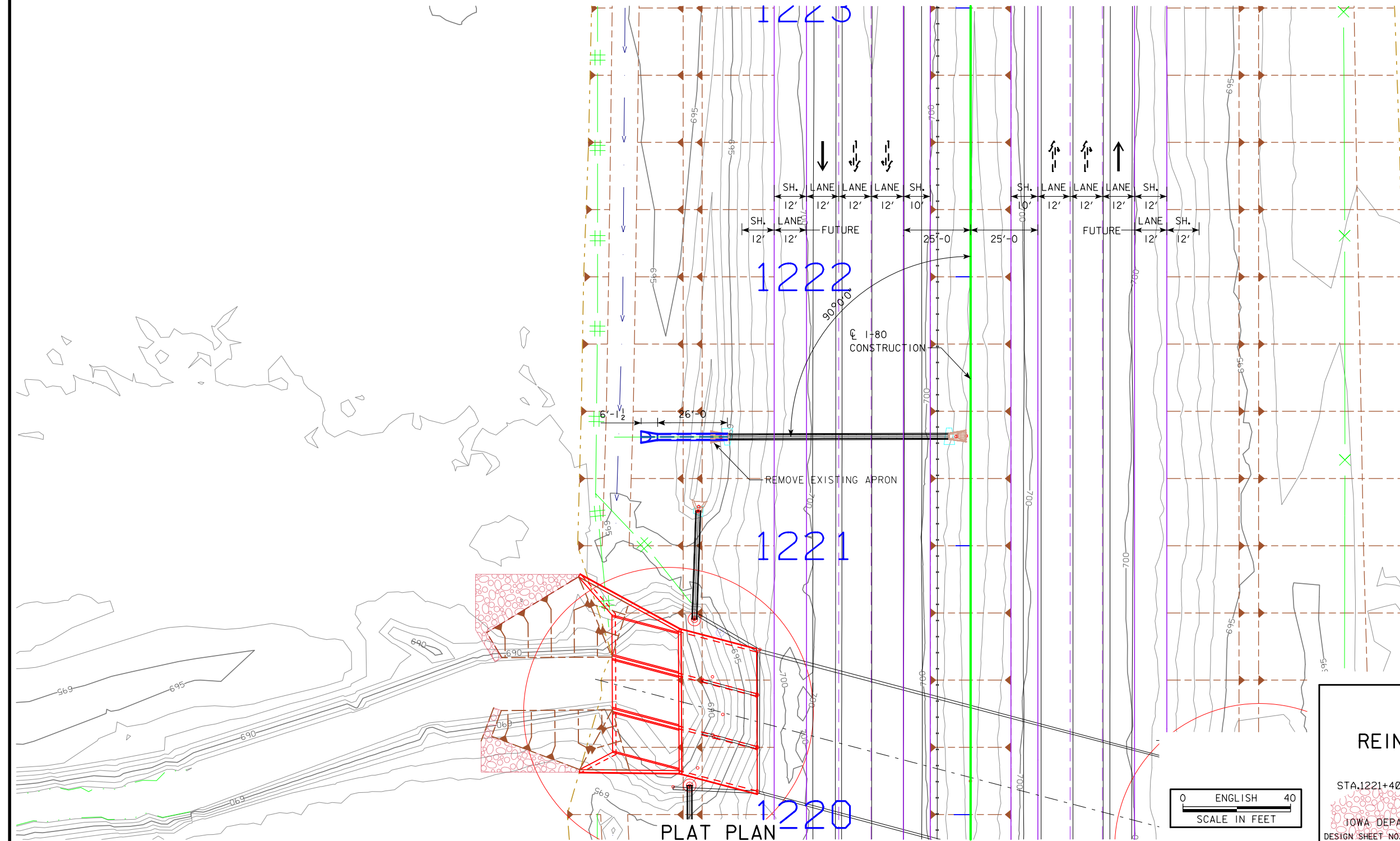

LOCATION

I-80  
 T-79N R-1W  
 SECTION 20  
 FARMINGTON TOWNSHIP  
 CEDAR COUNTY

HYDRAULIC DATA

DRAINAGE AREA = 2.9 ACRES  
 DESIGN DISCHARGE = 49.41 CFS

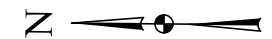

DESIGN FOR 0° SKEW  
**EXTEND 24" x 26' LT  
 REINFORCED CONCRETE PIPE  
 PLAT PLAN**  
 STA. 1221+40.80 WB  
 AUGUST 2019  
**CEDAR COUNTY**  
 IOWA DEPARTMENT OF TRANSPORTATION - HIGHWAY DIVISION  
 DESIGN SHEET NO. ? OF ? FILE NO. ? DESIGN NO. ?



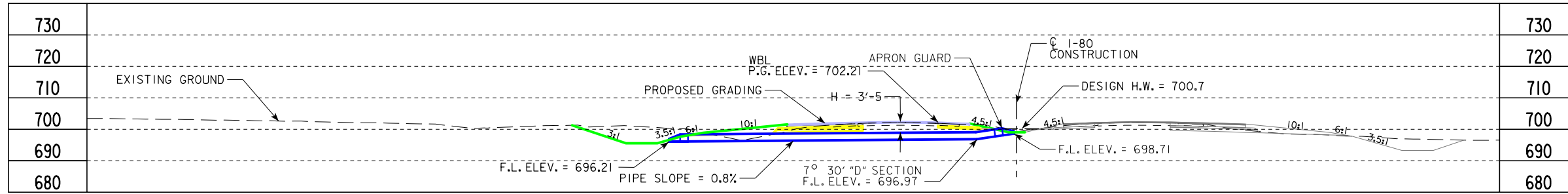

LONGITUDINAL SECTION ALONG CULVERT

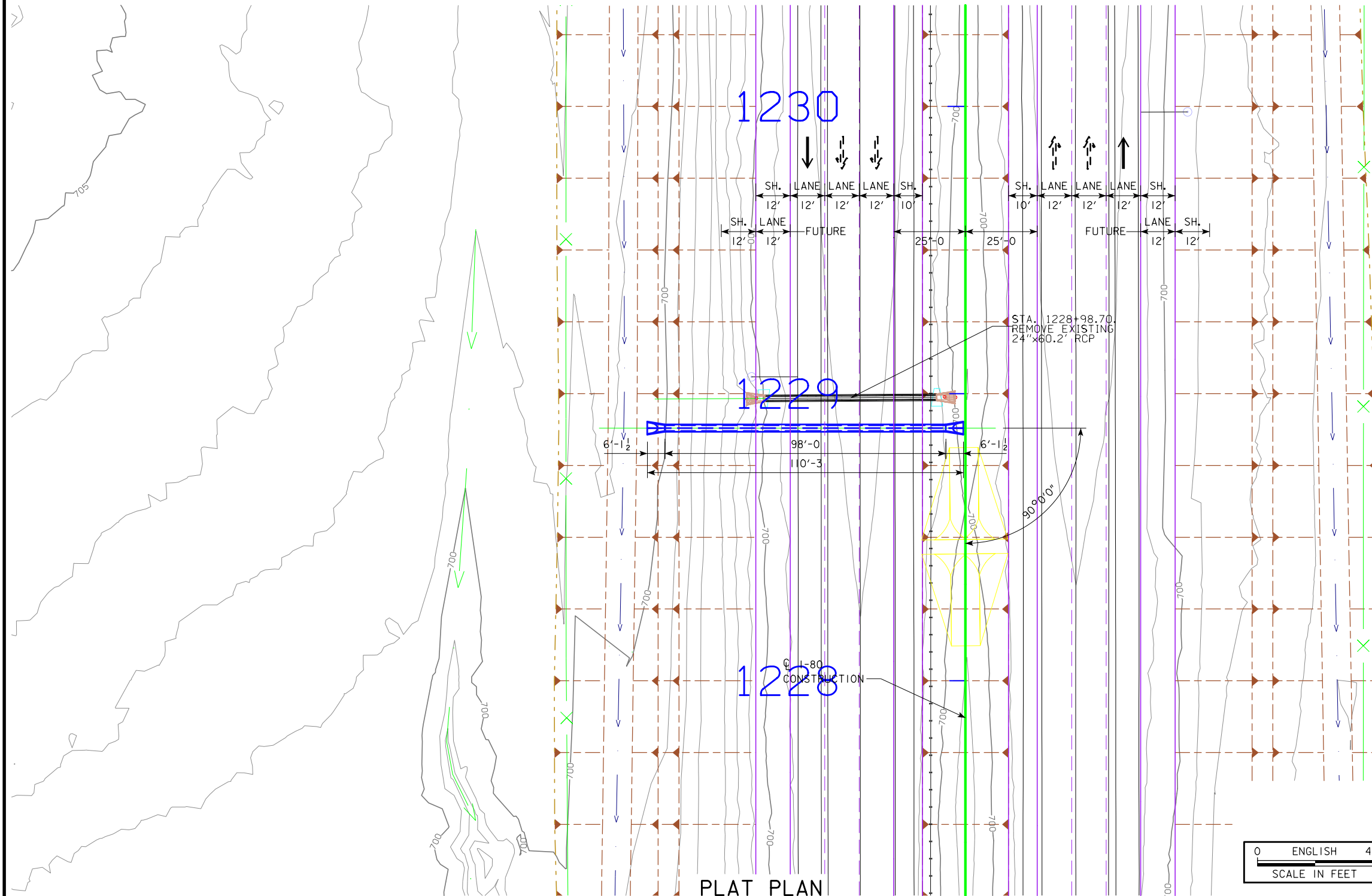

PLAT PLAN

LOCATION

I-80  
 T-79N R-1W  
 SECTION 21  
 FARMINGTON TOWNSHIP  
 CEDAR COUNTY

HYDRAULIC DATA

DRAINAGE AREA = 1.7 ACRES  
 DESIGN DISCHARGE = 38.26 CFS



DESIGN FOR 0° SKEW  
**24" x 98'**  
**REINFORCED CONCRETE PIPE**  
**PLAT PLAN**  
 STA. 1228+88.00 WB AUGUST 2019  
**CEDAR COUNTY**  
 IOWA DEPARTMENT OF TRANSPORTATION - HIGHWAY DIVISION  
 DESIGN SHEET NO. ? OF ? FILE NO. ? DESIGN NO. ?



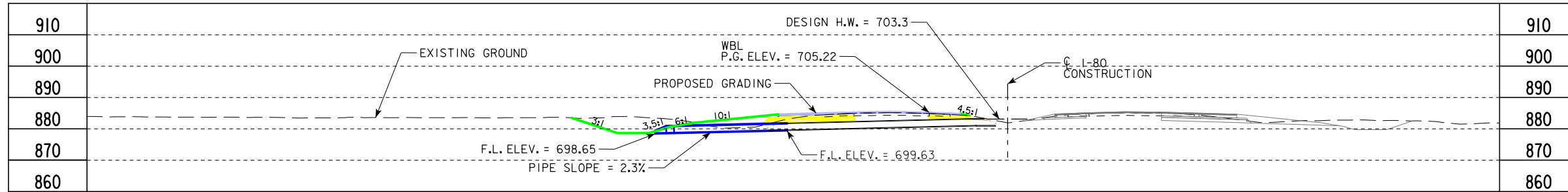

LONGITUDINAL SECTION ALONG  $\phi$  CULVERT

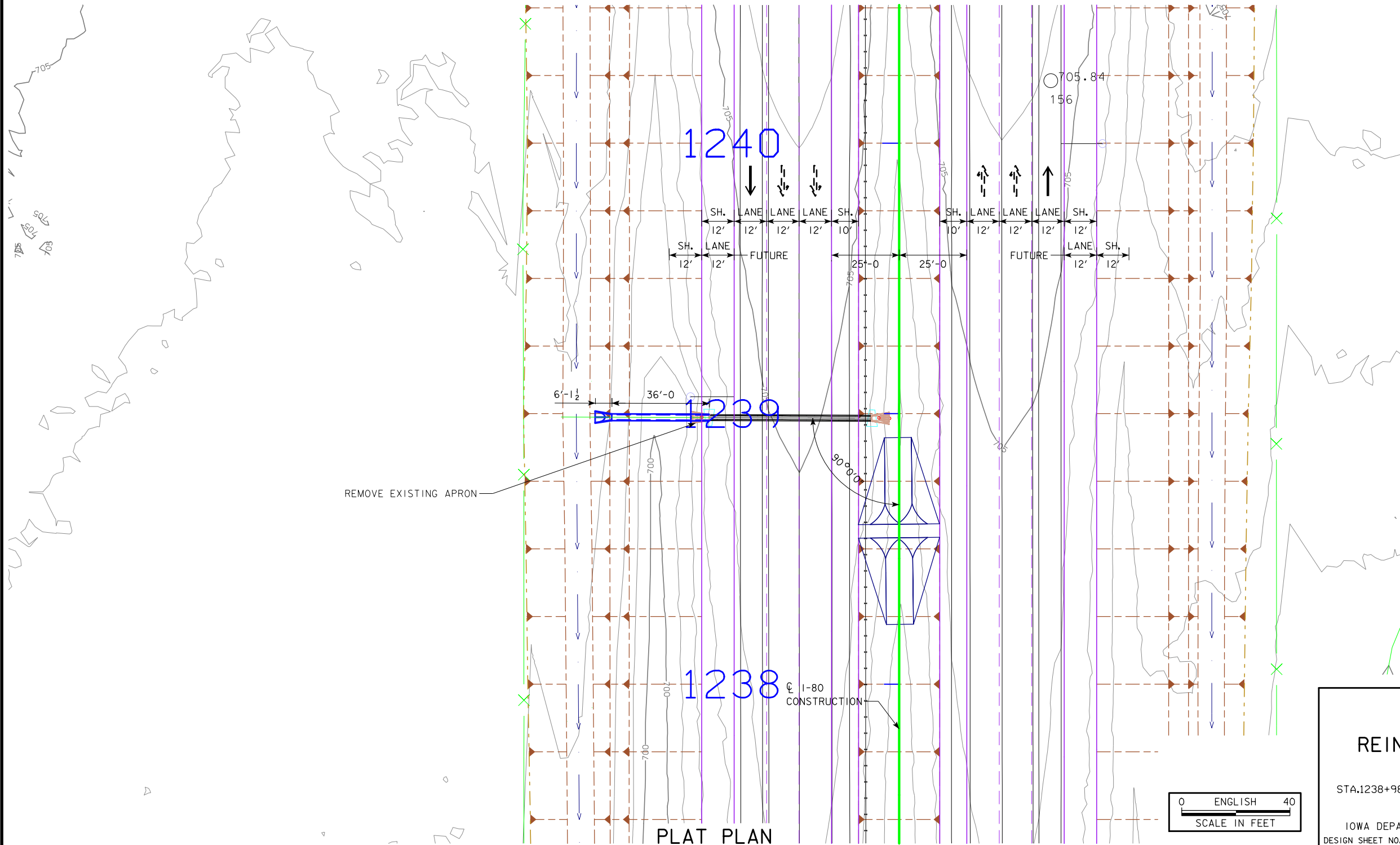

LOCATION

I-80  
 T-79N R-1W  
 SECTION 21  
 FARMINGTON TOWNSHIP  
 CEDAR COUNTY

HYDRAULIC DATA

DRAINAGE AREA = 1.7 ACRES  
 DESIGN DISCHARGE = 34.75 CFS



DESIGN FOR 0° SKEW  
**EXTEND 24" x 36' LT REINFORCED CONCRETE PIPE PLAT PLAN**  
 STA.1238+98.30 WB AUGUST 2019  
**CEDAR COUNTY**  
 IOWA DEPARTMENT OF TRANSPORTATION - HIGHWAY DIVISION  
 DESIGN SHEET NO. ? OF ? FILE NO. ? DESIGN NO. ?



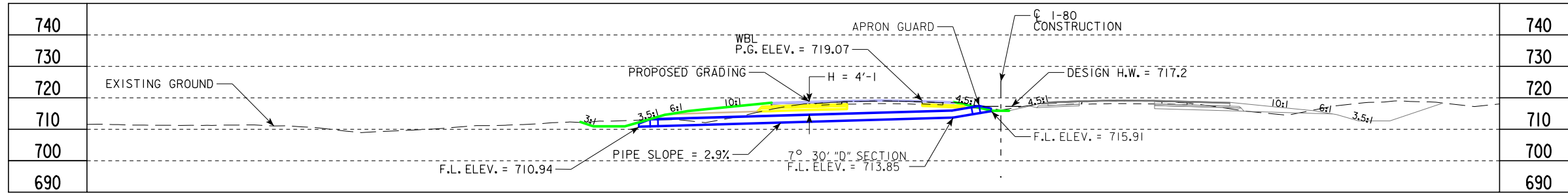

LONGITUDINAL SECTION ALONG CL CULVERT

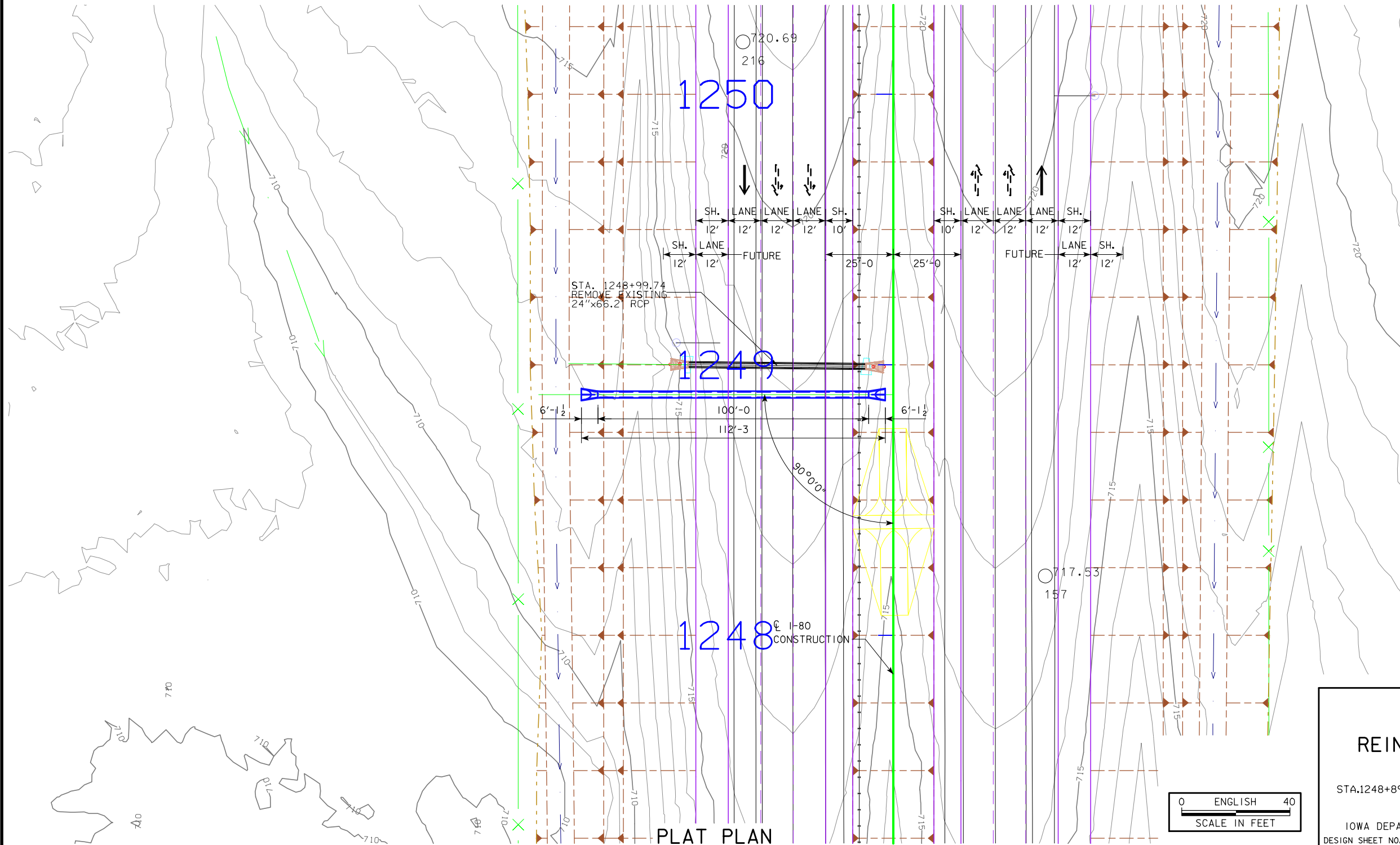

PLAT PLAN

LOCATION

I-80  
T-79N R-1W  
SECTION 21  
FARMINGTON TOWNSHIP  
CEDAR COUNTY

HYDRAULIC DATA

DRAINAGE AREA = 1.3 ACRES  
DESIGN DISCHARGE = 46.52 CFS



DESIGN FOR 0° SKEW

**24" x 100'**

**REINFORCED CONCRETE PIPE**

**PLAT PLAN**

STA. 1248+89.00 WB AUGUST 2019

**CEDAR COUNTY**

IOWA DEPARTMENT OF TRANSPORTATION - HIGHWAY DIVISION

DESIGN SHEET NO. ? OF ? FILE NO. ? DESIGN NO. ?

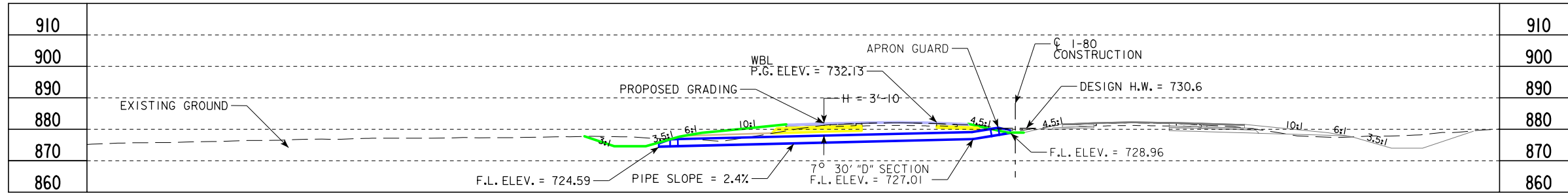

LONGITUDINAL SECTION ALONG CL CULVERT

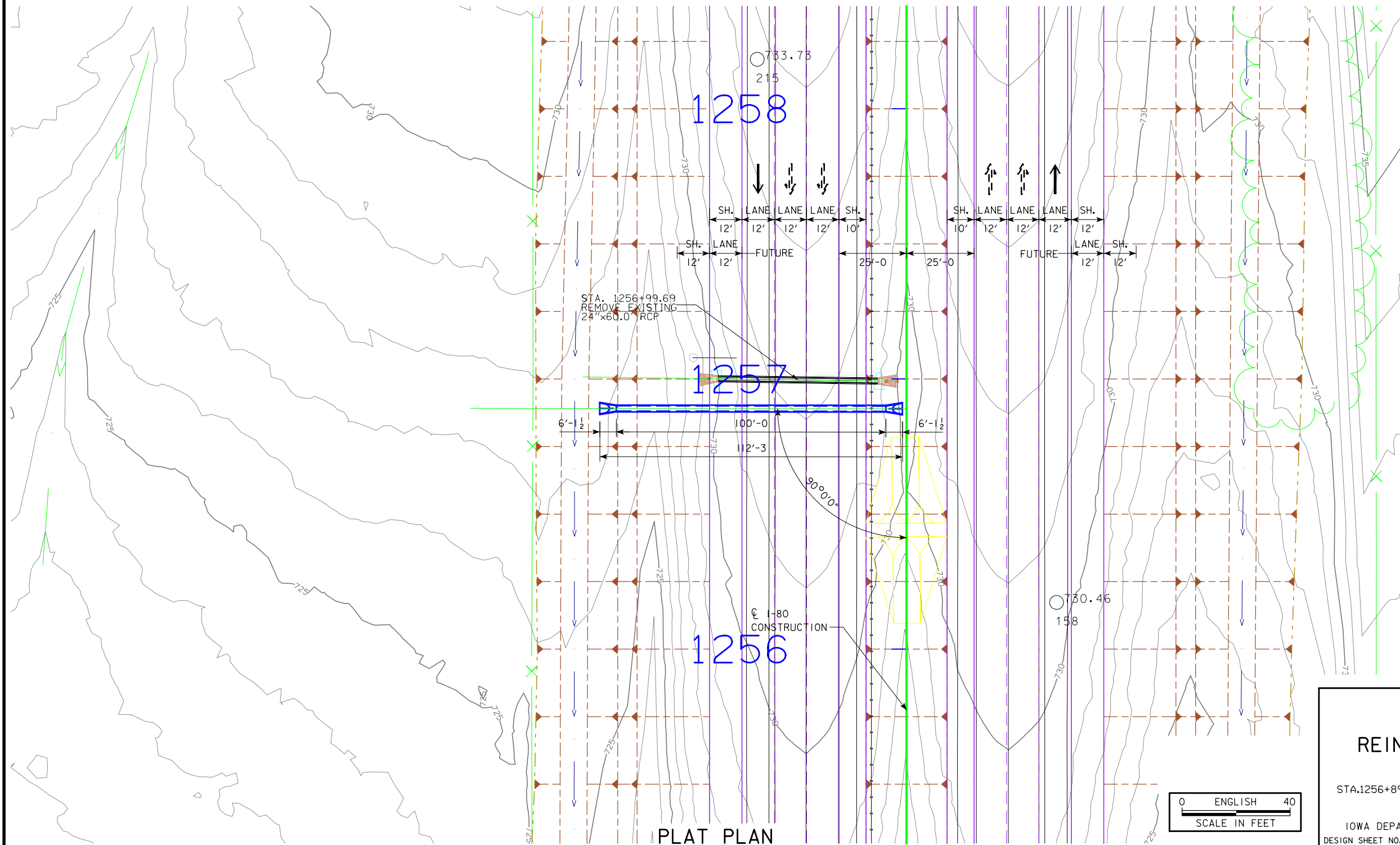

PLAT PLAN

LOCATION

I-80  
T-79N R-1W  
SECTION 21  
FARMINGTON TOWNSHIP  
CEDAR COUNTY

HYDRAULIC DATA

DRAINAGE AREA = 1.2 ACRES  
DESIGN DISCHARGE = 43.81 CFS

DESIGN FOR 0° SKEW

**24" x 100'**

**REINFORCED CONCRETE PIPE**

**PLAT PLAN**

STA. 1256+89.00 WB AUGUST 2019

**CEDAR COUNTY**

IOWA DEPARTMENT OF TRANSPORTATION - HIGHWAY DIVISION

DESIGN SHEET NO. ? OF ? FILE NO. ? DESIGN NO. ?



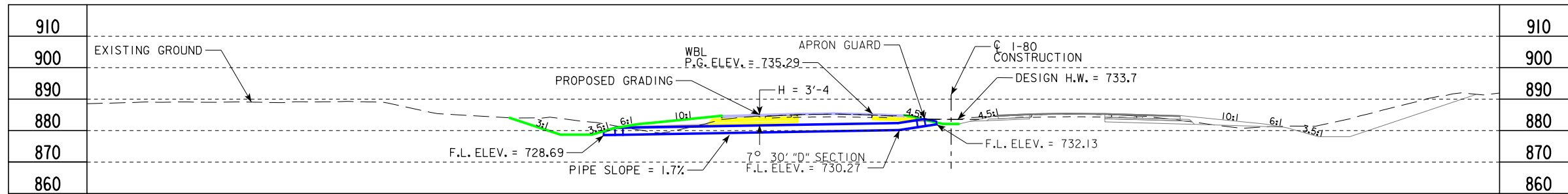

LONGITUDINAL SECTION ALONG CL CULVERT

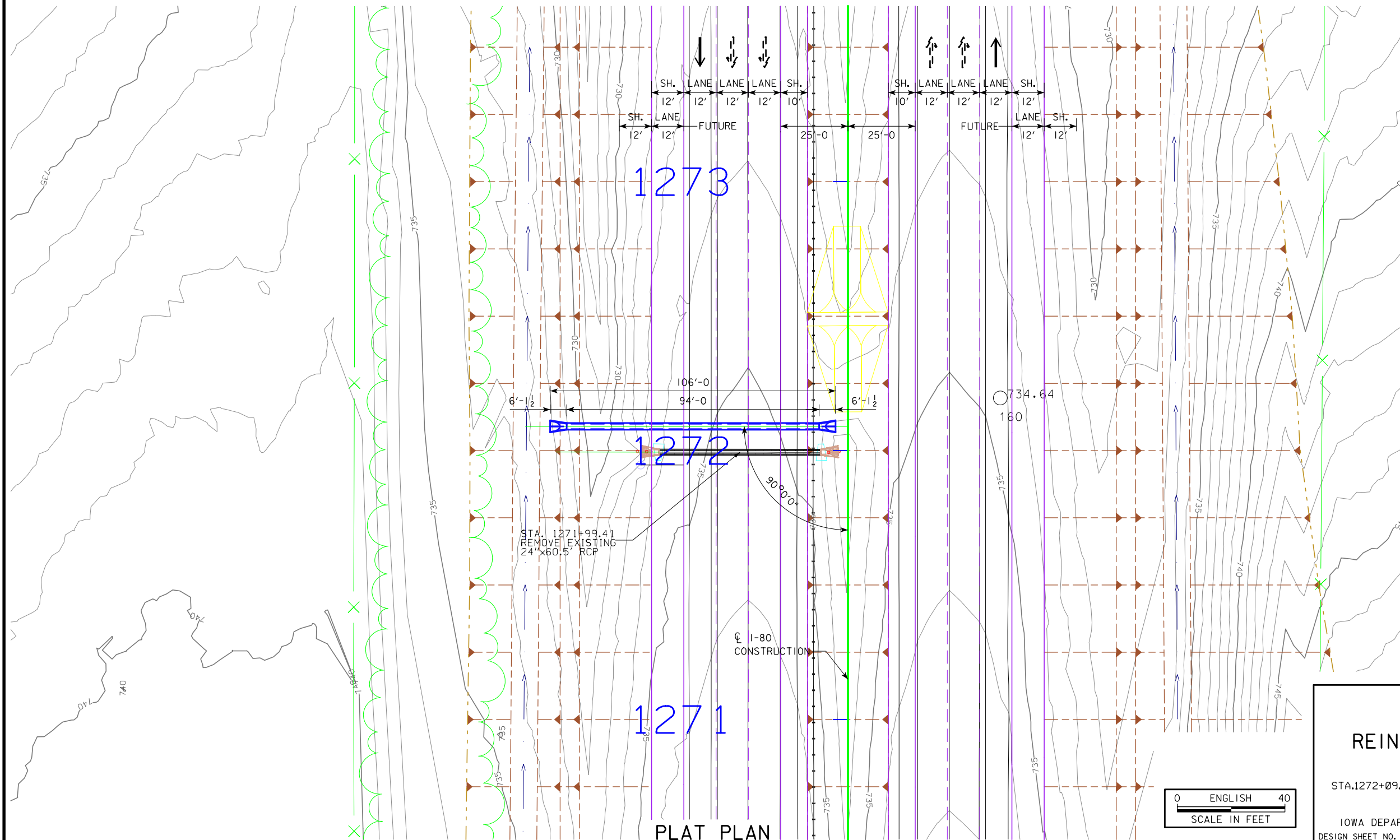

LOCATION

I-80  
T-79N R-1W  
SECTION 21  
FARMINGTON TOWNSHIP  
CEDAR COUNTY

HYDRAULIC DATA

DRAINAGE AREA = 1.3 ACRES  
DESIGN DISCHARGE = 39.25 CFS



DESIGN FOR 0° SKEW

**24" x 94'**

**REINFORCED CONCRETE PIPE**

**PLAT PLAN**

STA. 1272+09.00 WB AUGUST 2019

**CEDAR COUNTY**

IOWA DEPARTMENT OF TRANSPORTATION - HIGHWAY DIVISION

DESIGN SHEET NO. ? OF ? FILE NO. ? DESIGN NO. ?

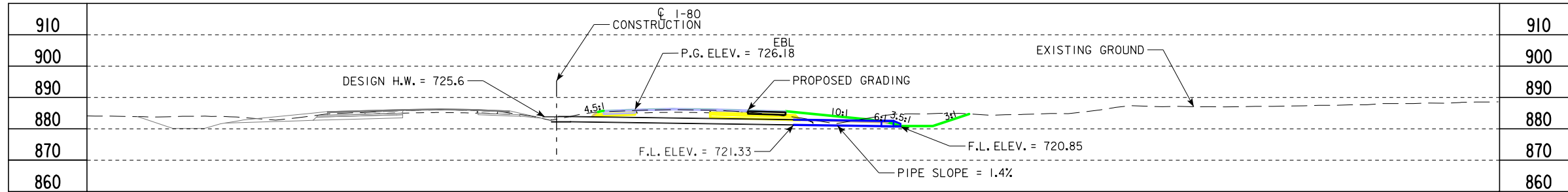

LONGITUDINAL SECTION ALONG CULVERT

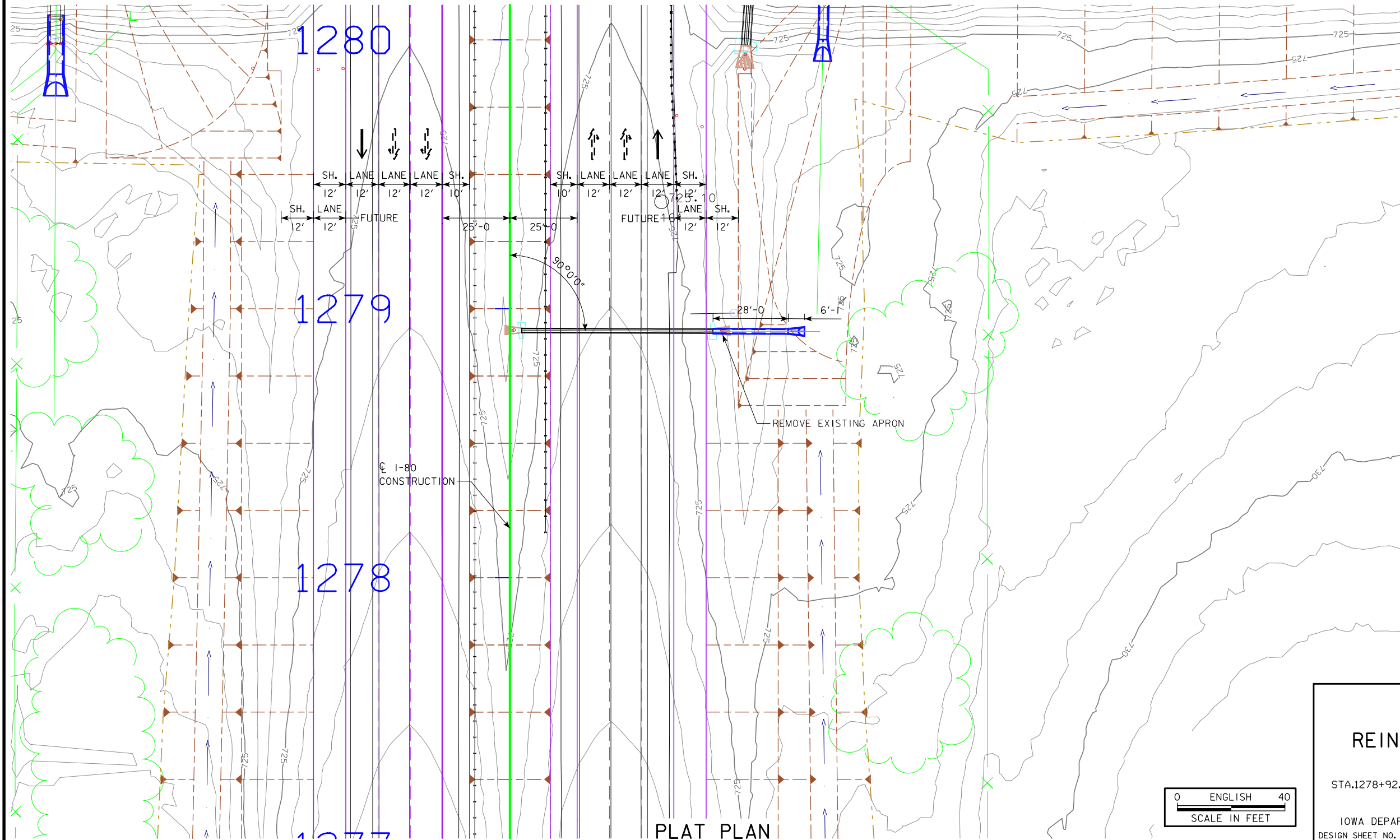

LOCATION

I-80  
 T-79N R-1W  
 SECTION 21  
 FARMINGTON TOWNSHIP  
 CEDAR COUNTY

HYDRAULIC DATA

DRAINAGE AREA = 1.6 ACRES  
 DESIGN DISCHARGE = 26.38 CFS



DESIGN FOR 0° SKEW  
**18" x 28'**  
**REINFORCED CONCRETE PIPE**  
**PLAT PLAN**  
 STA.1278+92.00 EB AUGUST 2019  
**CEDAR COUNTY**  
 IOWA DEPARTMENT OF TRANSPORTATION - HIGHWAY DIVISION  
 DESIGN SHEET NO. ? OF ? FILE NO. ? DESIGN NO. ?

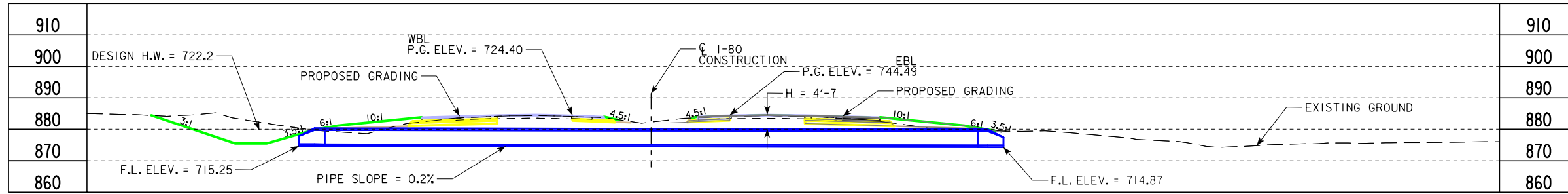

LONGITUDINAL SECTION ALONG  $\text{CL}$  CULVERT

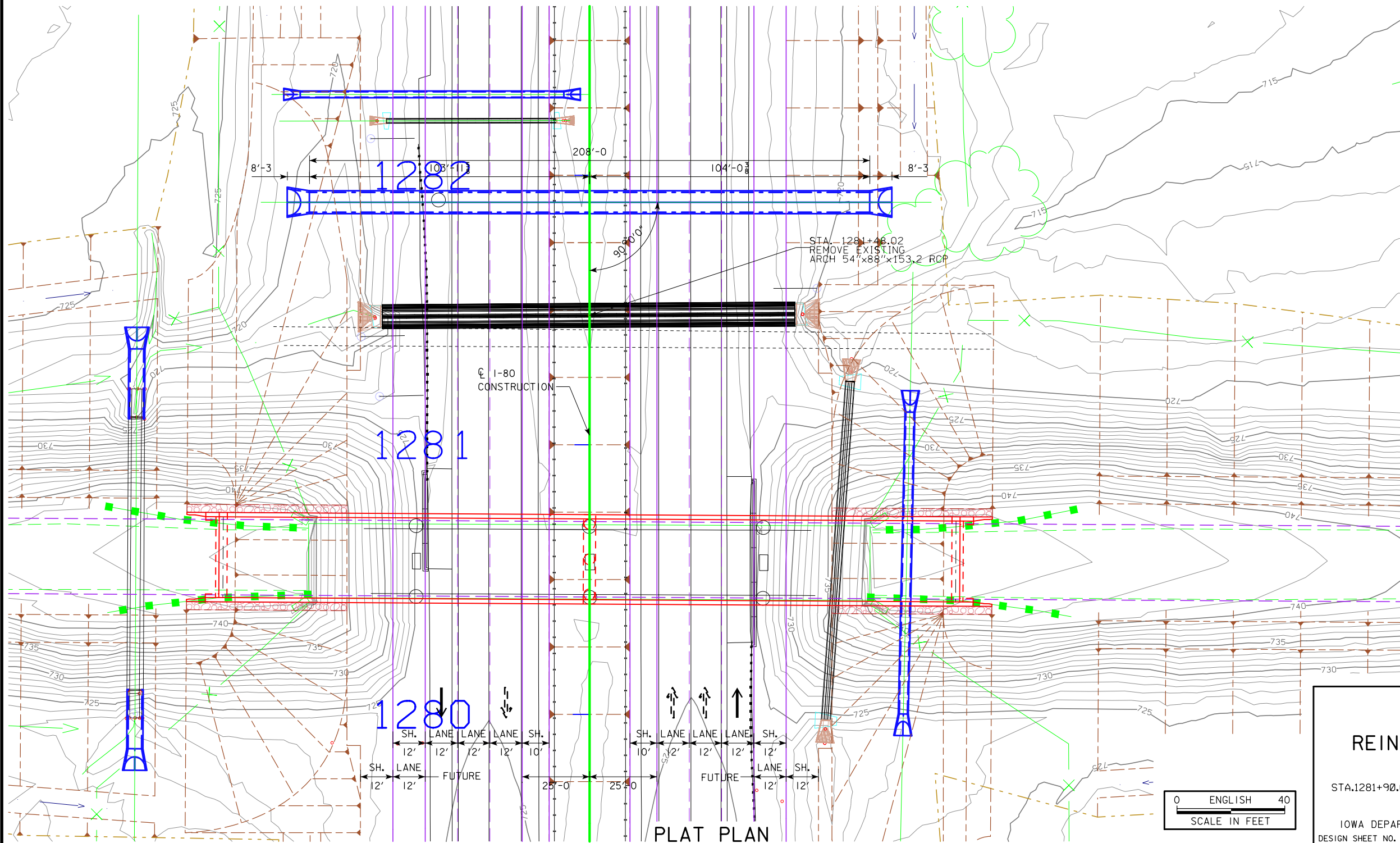

PLAT PLAN

LOCATION

I-80  
T-79N R-1W  
SECTION 22  
FARMINGTON TOWNSHIP  
CEDAR COUNTY

HYDRAULIC DATA

DRAINAGE AREA = 86.9 ACRES  
DESIGN DISCHARGE = 151.11 CFS



DESIGN FOR 0° SKEW  
**H 54"x88" x 208'**  
**REINFORCED CONCRETE PIPE**  
**PLAT PLAN**  
 STA.1281+90.00 AUGUST 2019  
**CEDAR COUNTY**  
 IOWA DEPARTMENT OF TRANSPORTATION - HIGHWAY DIVISION  
 DESIGN SHEET NO. ? OF ? FILE NO. ? DESIGN NO. ?



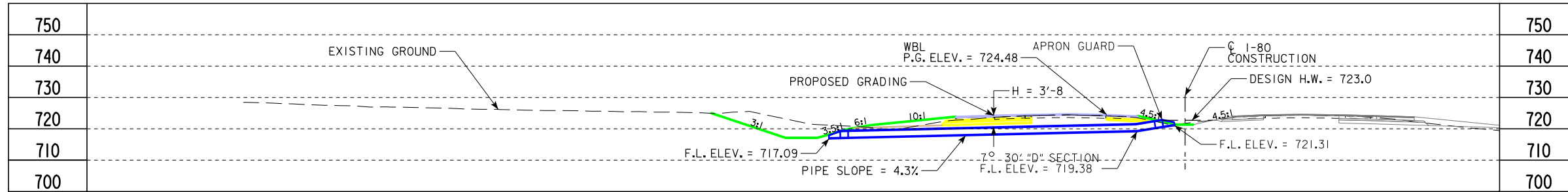

LONGITUDINAL SECTION ALONG CULVERT

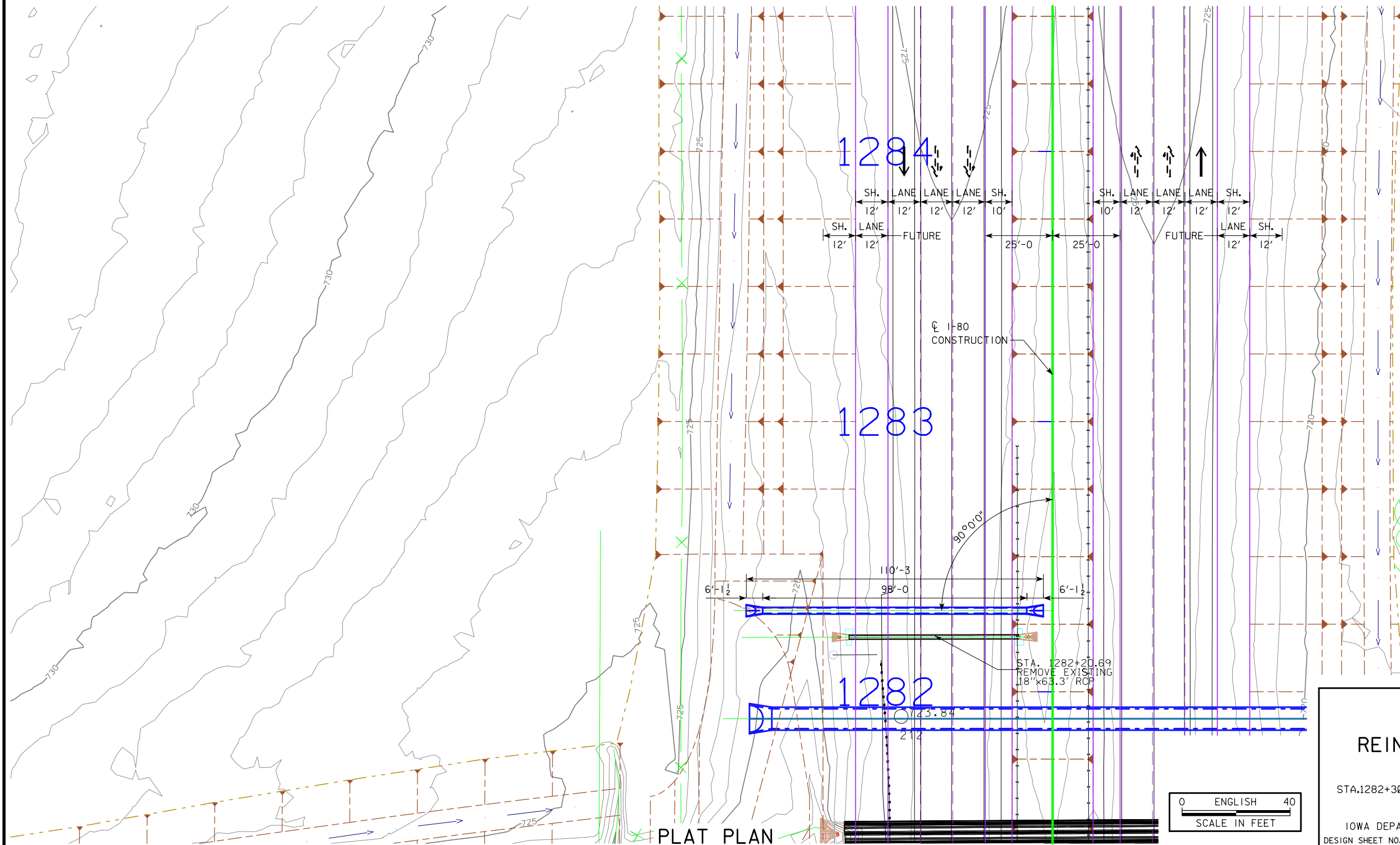

LOCATION

I-80  
 T-79N R-1W  
 SECTION 22  
 FARMINGTON TOWNSHIP  
 CEDAR COUNTY

HYDRAULIC DATA

DRAINAGE AREA = 2.0 ACRES  
 DESIGN DISCHARGE = 36.64 CFS

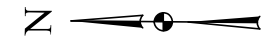

DESIGN FOR 0° SKEW  
**24" x 98'**  
**REINFORCED CONCRETE PIPE**  
**PLAT PLAN**  
 STA.1282+30.00 WB AUGUST 2019  
**CEDAR COUNTY**  
 IOWA DEPARTMENT OF TRANSPORTATION - HIGHWAY DIVISION  
 DESIGN SHEET NO. ? OF ? FILE NO. ? DESIGN NO. ?



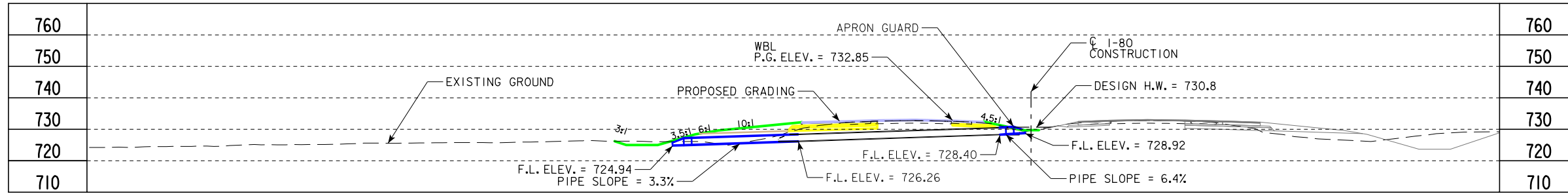

LONGITUDINAL SECTION ALONG CULVERT

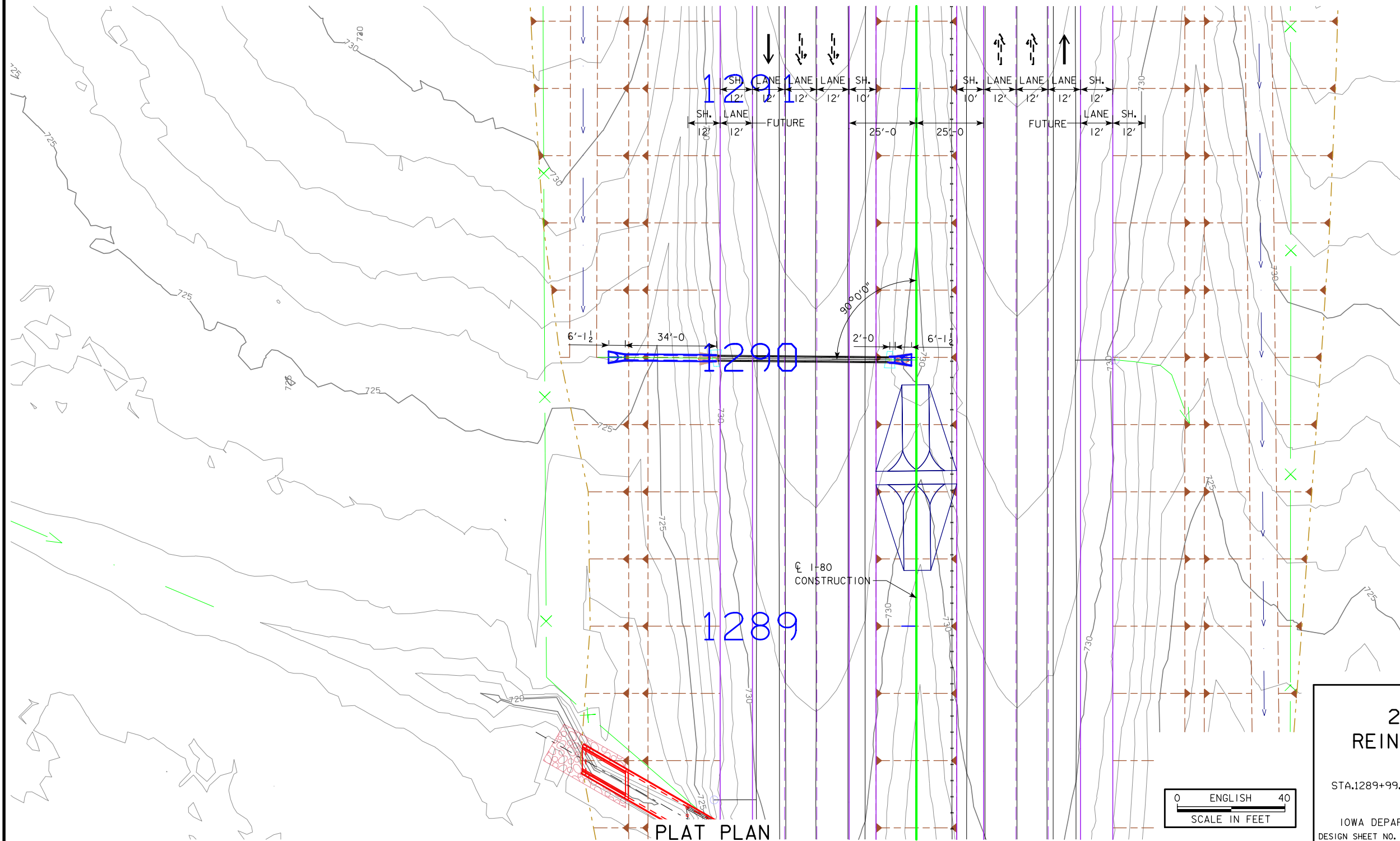

**LOCATION**  
 I-80  
 T-79N R-1W  
 SECTION 22  
 FARMINGTON TOWNSHIP  
 CEDAR COUNTY

**HYDRAULIC DATA**  
 DRAINAGE AREA = 1.4 ACRES  
 DESIGN DISCHARGE = 41.22 CFS



DESIGN FOR 0° SKEW  
**24" x 2' RT & 34' LT  
 REINFORCED CONCRETE PIPE  
 PLAT PLAN**  
 STA.1289+99.00 WB AUGUST 2019  
**CEDAR COUNTY**  
 IOWA DEPARTMENT OF TRANSPORTATION - HIGHWAY DIVISION  
 DESIGN SHEET NO. ? OF ? FILE NO. ? DESIGN NO. ?



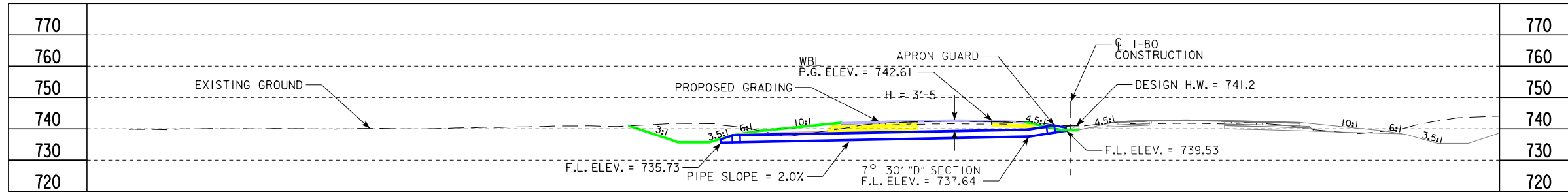

LONGITUDINAL SECTION ALONG  $\bar{C}$  CULVERT

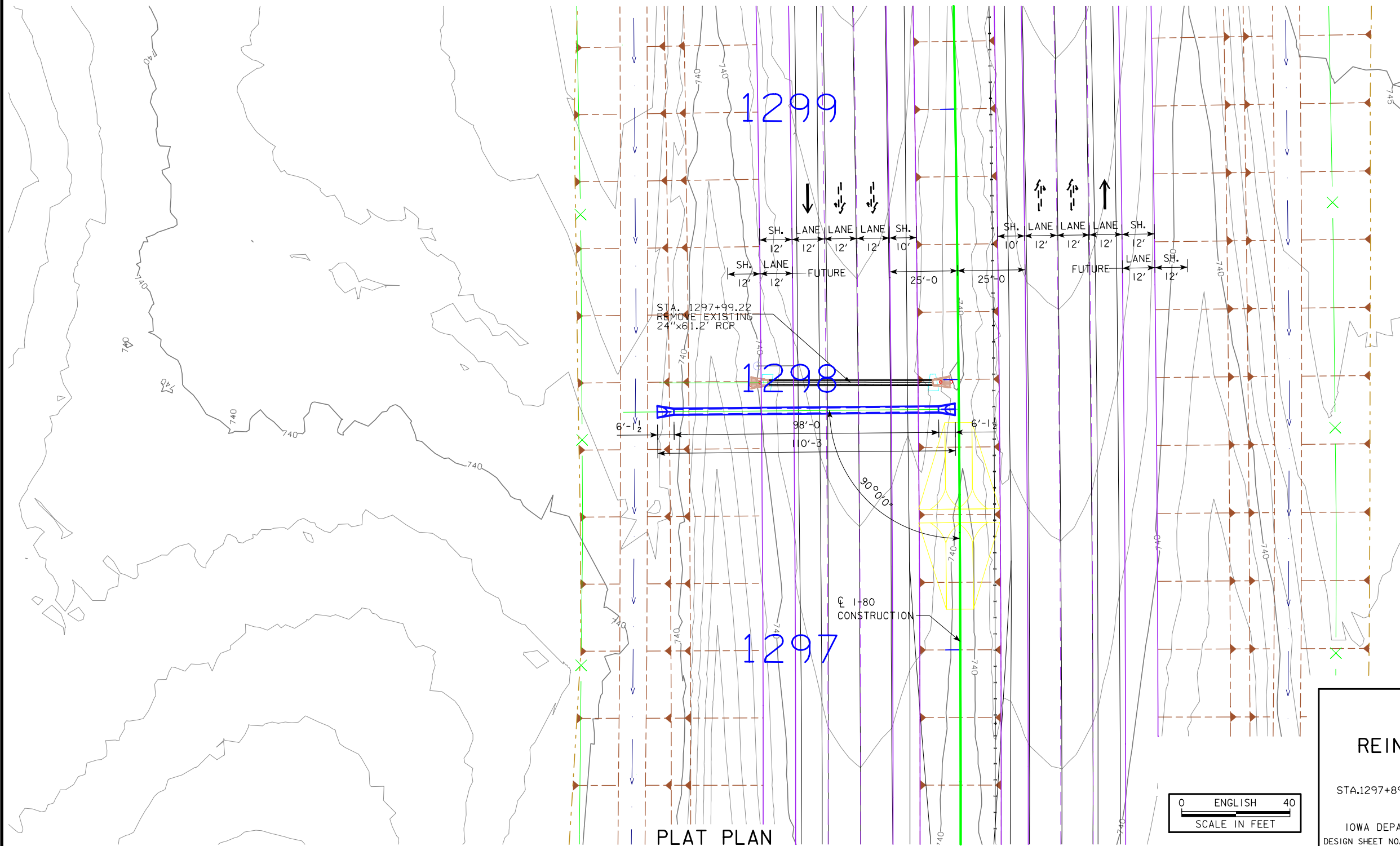

LOCATION

I-80  
 T-79N R-1W  
 SECTION 22  
 FARMINGTON TOWNSHIP  
 CEDAR COUNTY

HYDRAULIC DATA

DRAINAGE AREA = 1.5 ACRES  
 DESIGN DISCHARGE = 39.44 CFS

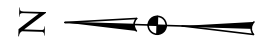

DESIGN FOR 0° SKEW  
**24" x 98'**  
**REINFORCED CONCRETE PIPE**  
**PLAT PLAN**  
 STA.1297+89.00 WB AUGUST 2019  
**CEDAR COUNTY**  
 IOWA DEPARTMENT OF TRANSPORTATION - HIGHWAY DIVISION  
 DESIGN SHEET NO. ? OF ? FILE NO. ? DESIGN NO. ?



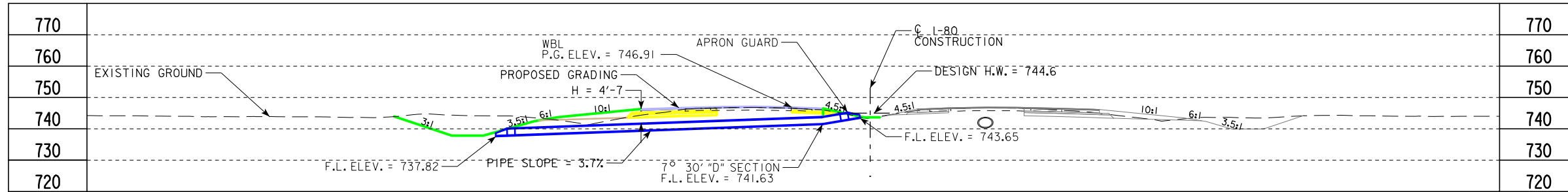

LONGITUDINAL SECTION ALONG CULVERT

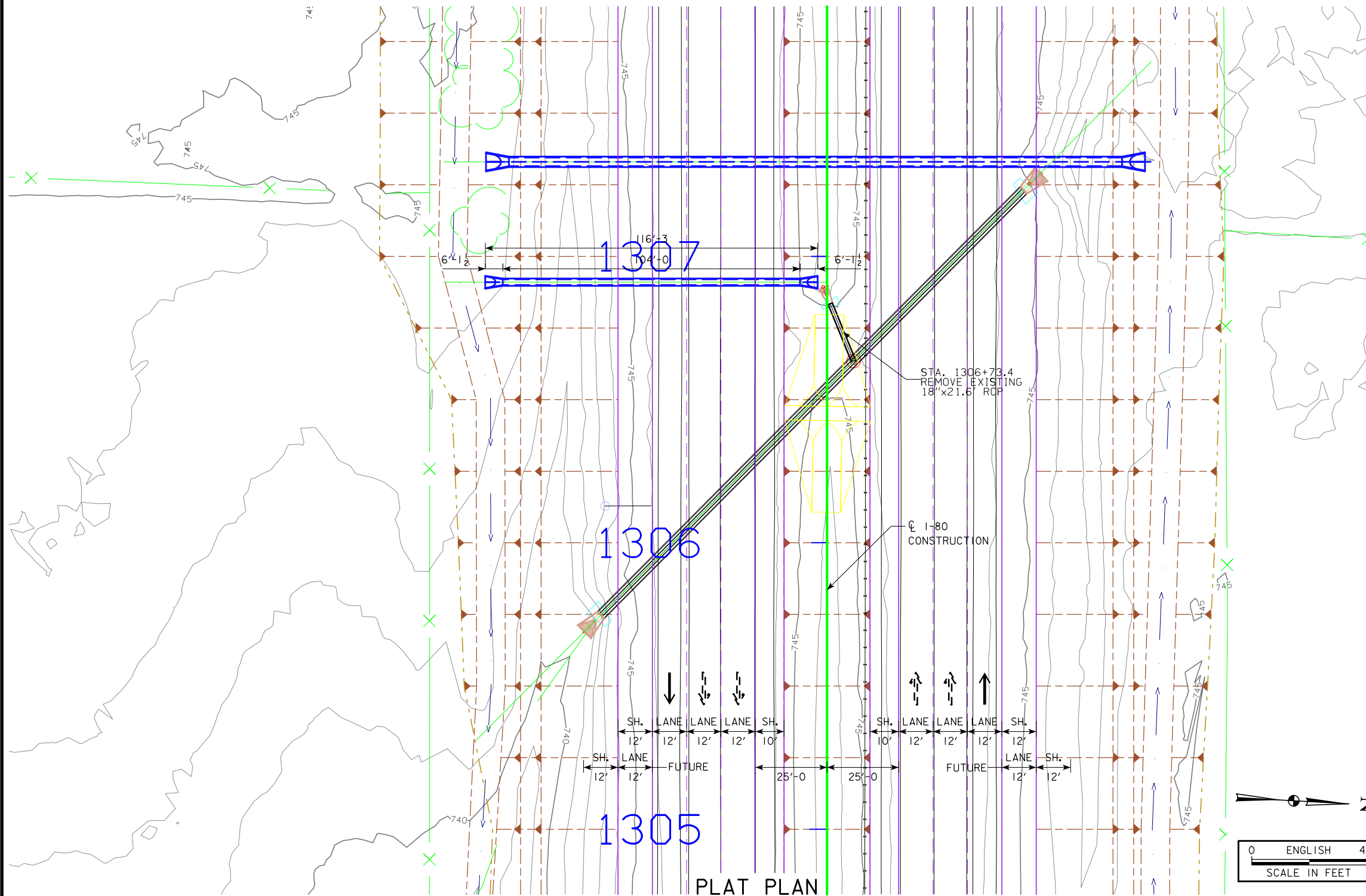

LOCATION

I-80  
 T-79N R-1W  
 SECTION 22  
 FARMINGTON TOWNSHIP  
 CEDAR COUNTY

HYDRAULIC DATA

DRAINAGE AREA = 1.5 ACRES  
 DESIGN DISCHARGE = 44.33 CFS

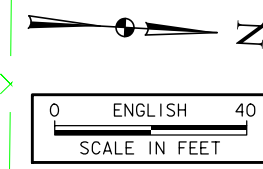

DESIGN FOR 0° SKEW  
**24" x 104'**  
**REINFORCED CONCRETE PIPE**  
**PLAT PLAN**  
 STA.1306+91.00 AUGUST 2019  
**CEDAR COUNTY**  
 IOWA DEPARTMENT OF TRANSPORTATION - HIGHWAY DIVISION  
 DESIGN SHEET NO. ? OF ? FILE NO. ? DESIGN NO. ?

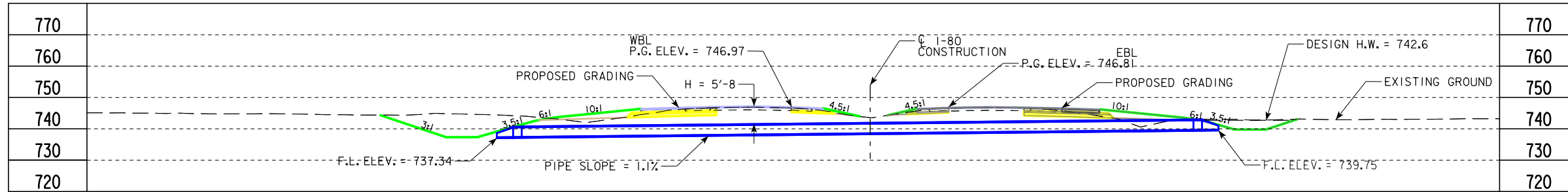

LONGITUDINAL SECTION ALONG  $\bar{C}$  CULVERT

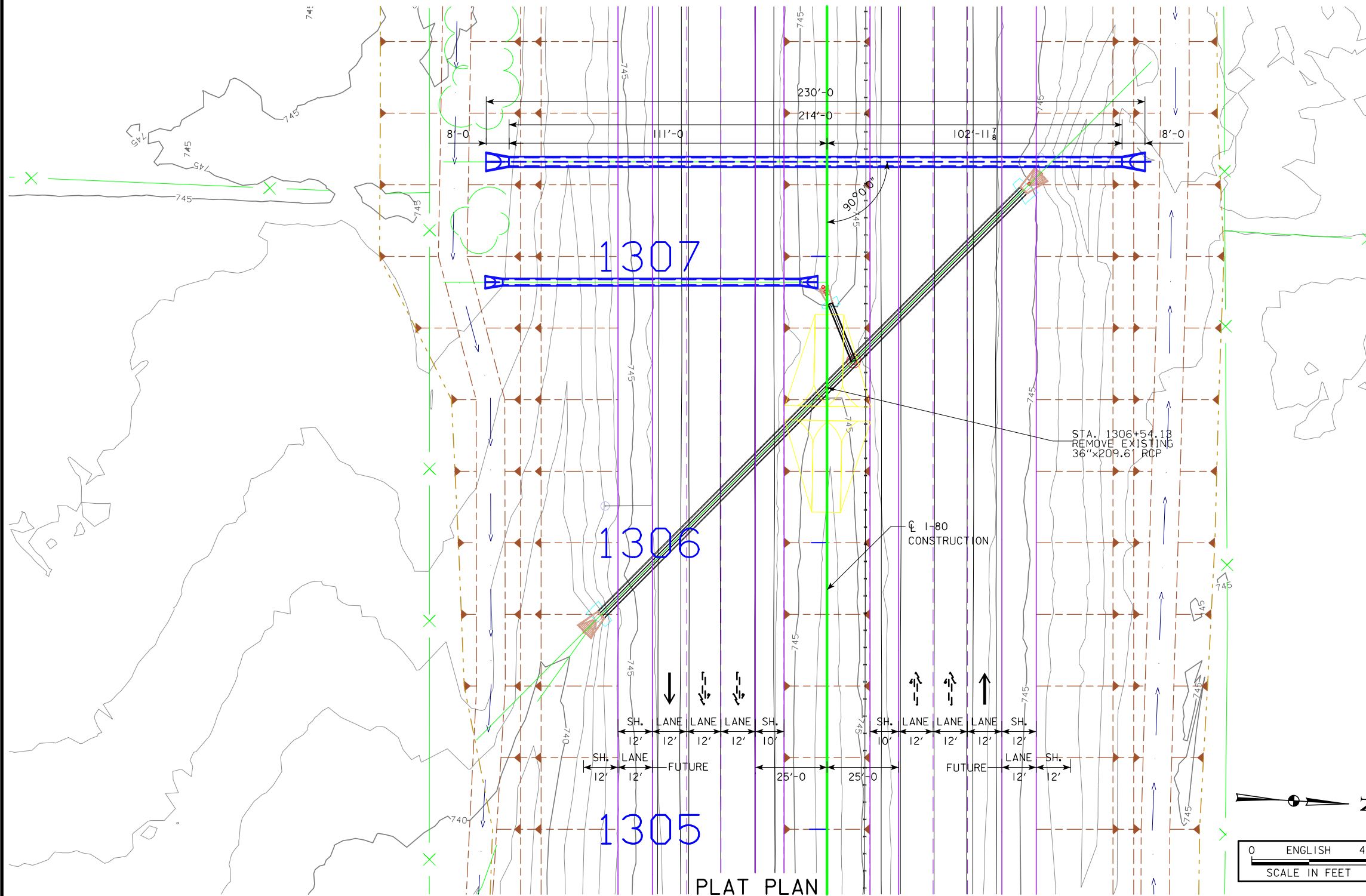

LOCATION

I-80  
 T-79N R-1W  
 SECTION 22  
 FARMINGTON TOWNSHIP  
 CEDAR COUNTY

HYDRAULIC DATA

DRAINAGE AREA = 13.6 ACRES  
 DESIGN DISCHARGE = 81.41 CFS

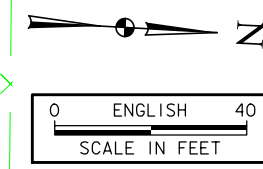

DESIGN FOR 0° SKEW  
**36" x 214'**  
**REINFORCED CONCRETE PIPE**  
**PLAT PLAN**  
 STA.1307+33.00 AUGUST 2019  
**CEDAR COUNTY**  
 IOWA DEPARTMENT OF TRANSPORTATION - HIGHWAY DIVISION  
 DESIGN SHEET NO. ? OF ? FILE NO. ? DESIGN NO. ?

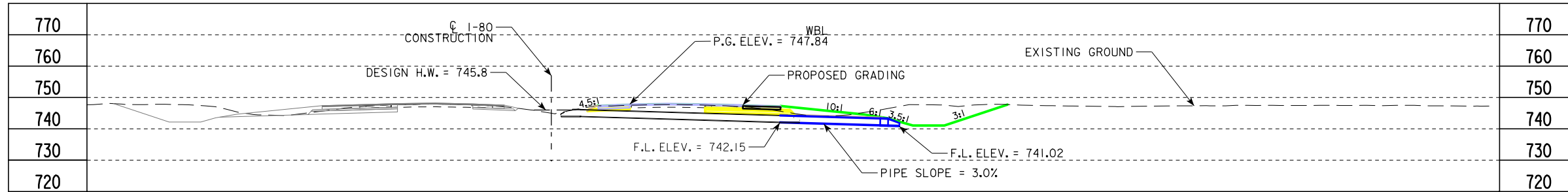

LONGITUDINAL SECTION ALONG CULVERT

LOCATION

I-80  
 T-79N R-1W  
 SECTION 22  
 FARMINGTON TOWNSHIP  
 CEDAR COUNTY

HYDRAULIC DATA

DRAINAGE AREA = 1.2 ACRES  
 DESIGN DISCHARGE = 38.26 CFS

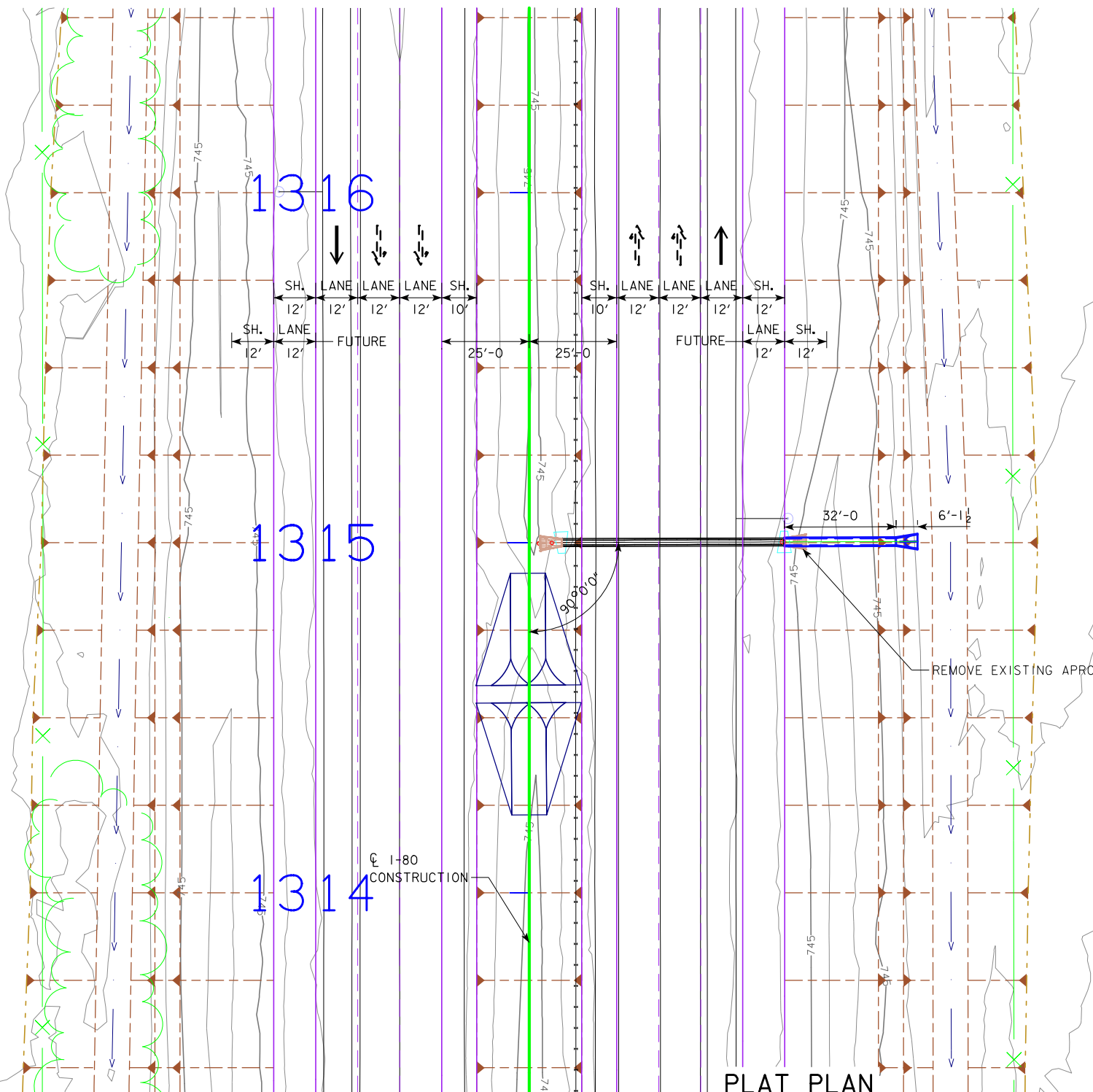
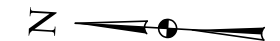

PLAT PLAN

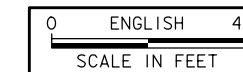

DESIGN FOR 0° SKEW  
**EXTEND 24" x 32' RT  
 REINFORCED CONCRETE PIPE  
 PLAT PLAN**  
 STA.1315+90.00 EB AUGUST 2019  
**CEDAR COUNTY**  
 IOWA DEPARTMENT OF TRANSPORTATION - HIGHWAY DIVISION  
 DESIGN SHEET NO. ? OF ? FILE NO. ? DESIGN NO. ?



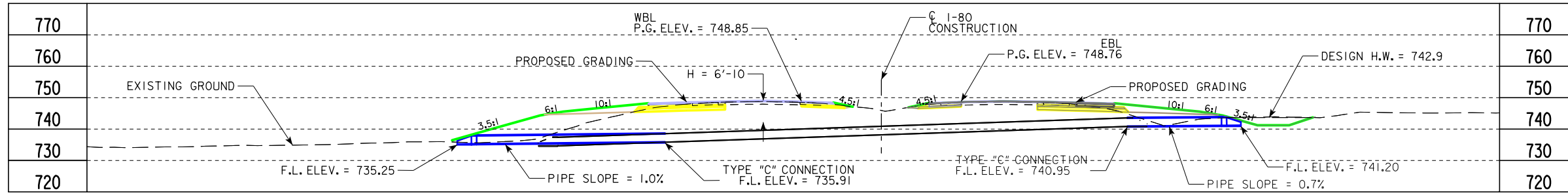

LONGITUDINAL SECTION ALONG CULVERT

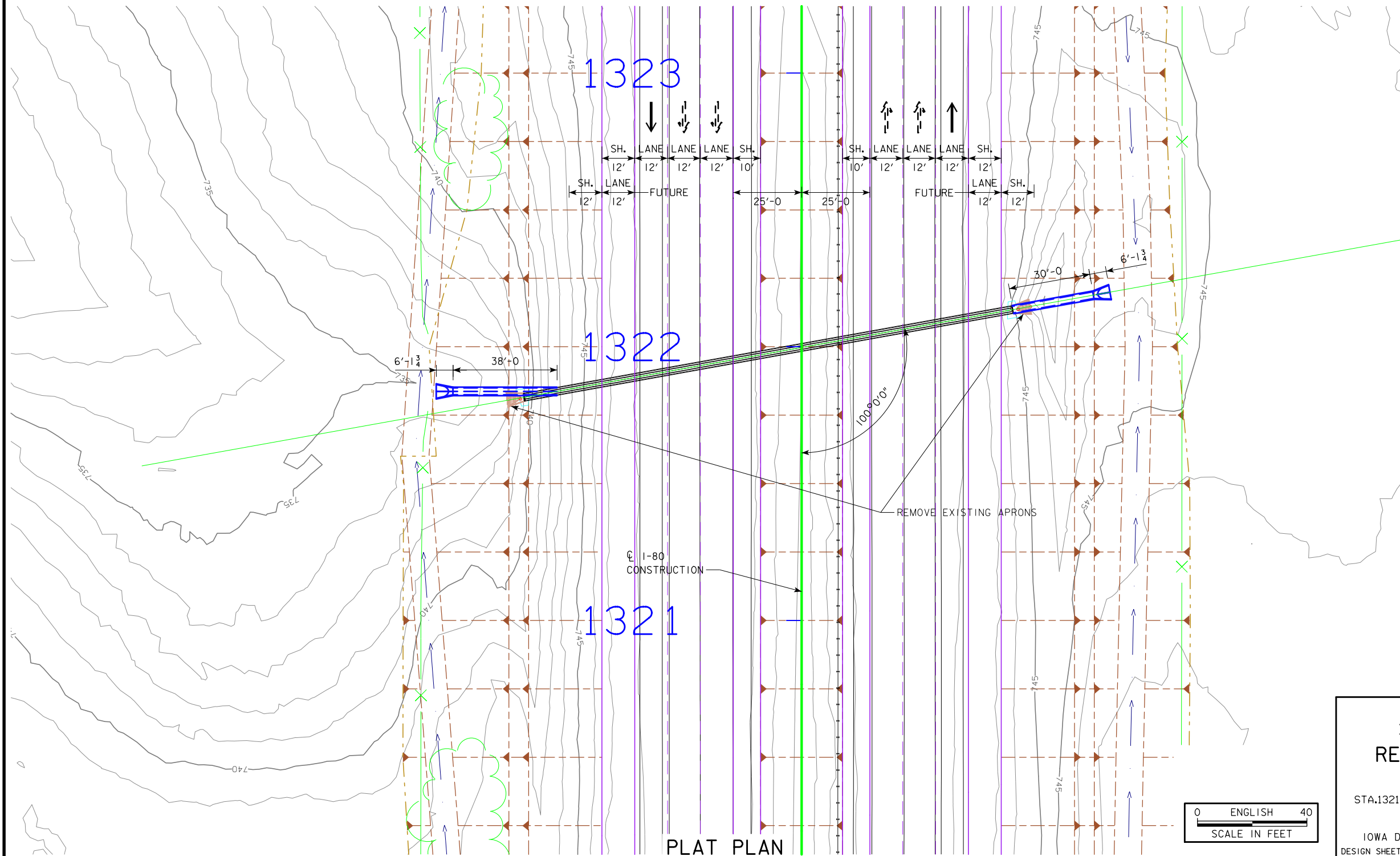

**LOCATION**  
 I-80  
 T-79N R-1W  
 SECTION 22  
 FARMINGTON TOWNSHIP  
 CEDAR COUNTY

**HYDRAULIC DATA**  
 DRAINAGE AREA = 4.8 ACRES  
 DESIGN DISCHARGE = 62.20 CFS



DESIGN FOR 10° SKEW  
**30" x 30' RT & 38' LT**  
**REINFORCED CONCRETE PIPE**  
**PLAT PLAN**  
 STA.1321+99.73 AUGUST 2019  
**CEDAR COUNTY**  
 IOWA DEPARTMENT OF TRANSPORTATION - HIGHWAY DIVISION  
 DESIGN SHEET NO. ? OF ? FILE NO. ? DESIGN NO. ?



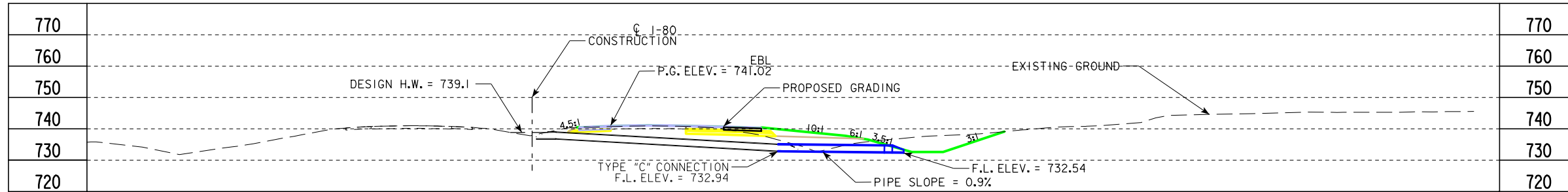

LONGITUDINAL SECTION ALONG  $\hat{C}$  CULVERT

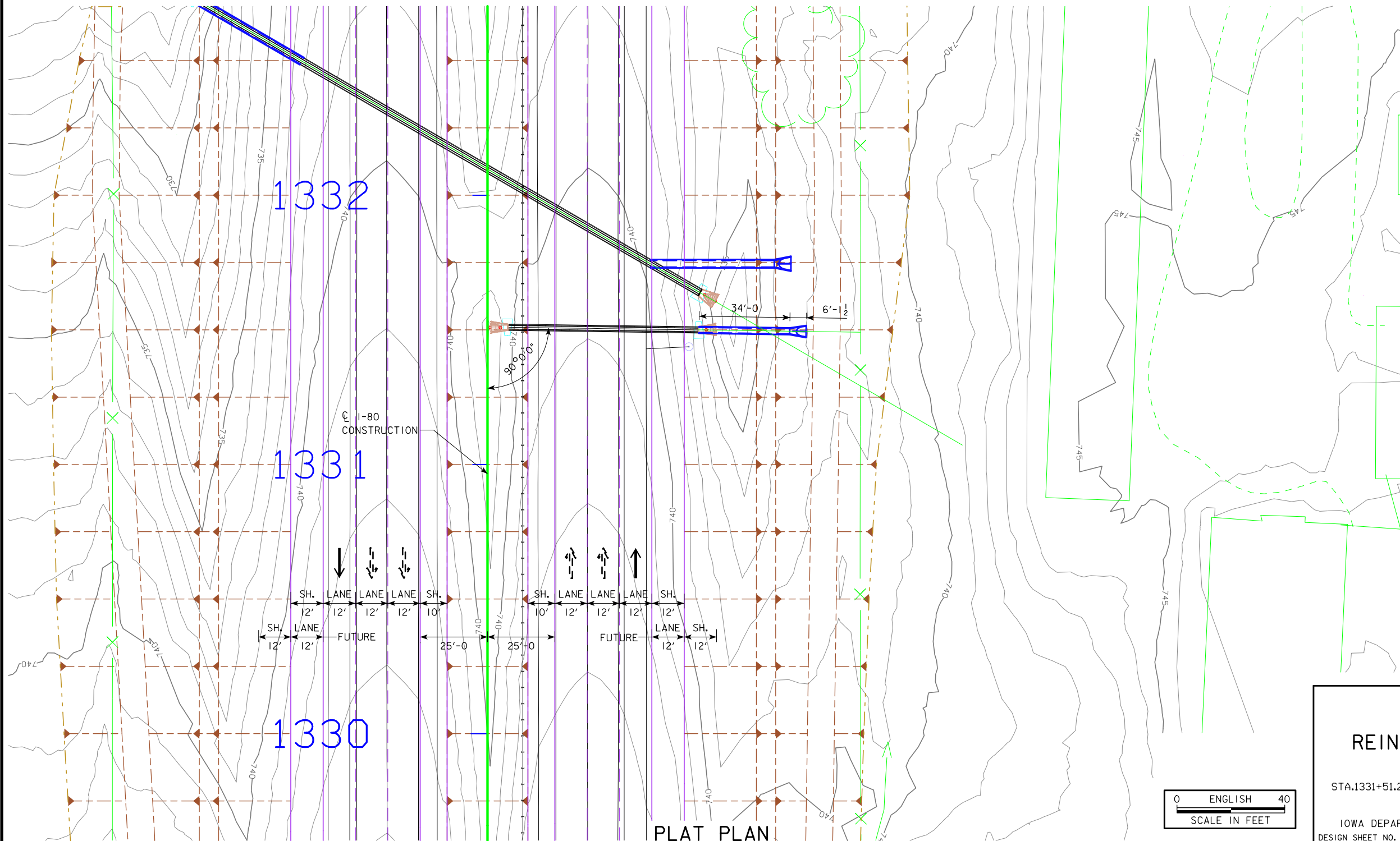

PLAT PLAN

LOCATION

I-80  
T-79N R-1W  
SECTION 22  
FARMINGTON TOWNSHIP  
CEDAR COUNTY

HYDRAULIC DATA

DRAINAGE AREA = 1.7 ACRES  
DESIGN DISCHARGE = 44.56 CFS



DESIGN FOR 0° SKEW  
24" x 34' RT  
REINFORCED CONCRETE PIPE  
PLAT PLAN  
STA.1331+51.20 EB AUGUST 2019  
CEDAR COUNTY  
IOWA DEPARTMENT OF TRANSPORTATION - HIGHWAY DIVISION  
DESIGN SHEET NO. ? OF ? FILE NO. ? DESIGN NO. ?

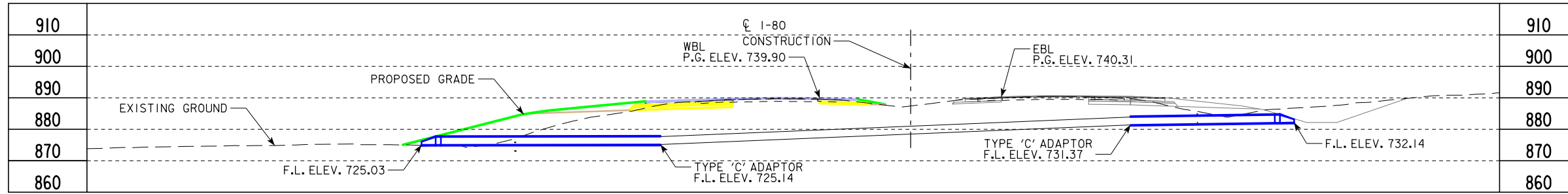

LONGITUDINAL SECTION ALONG  $\phi$  CULVERT

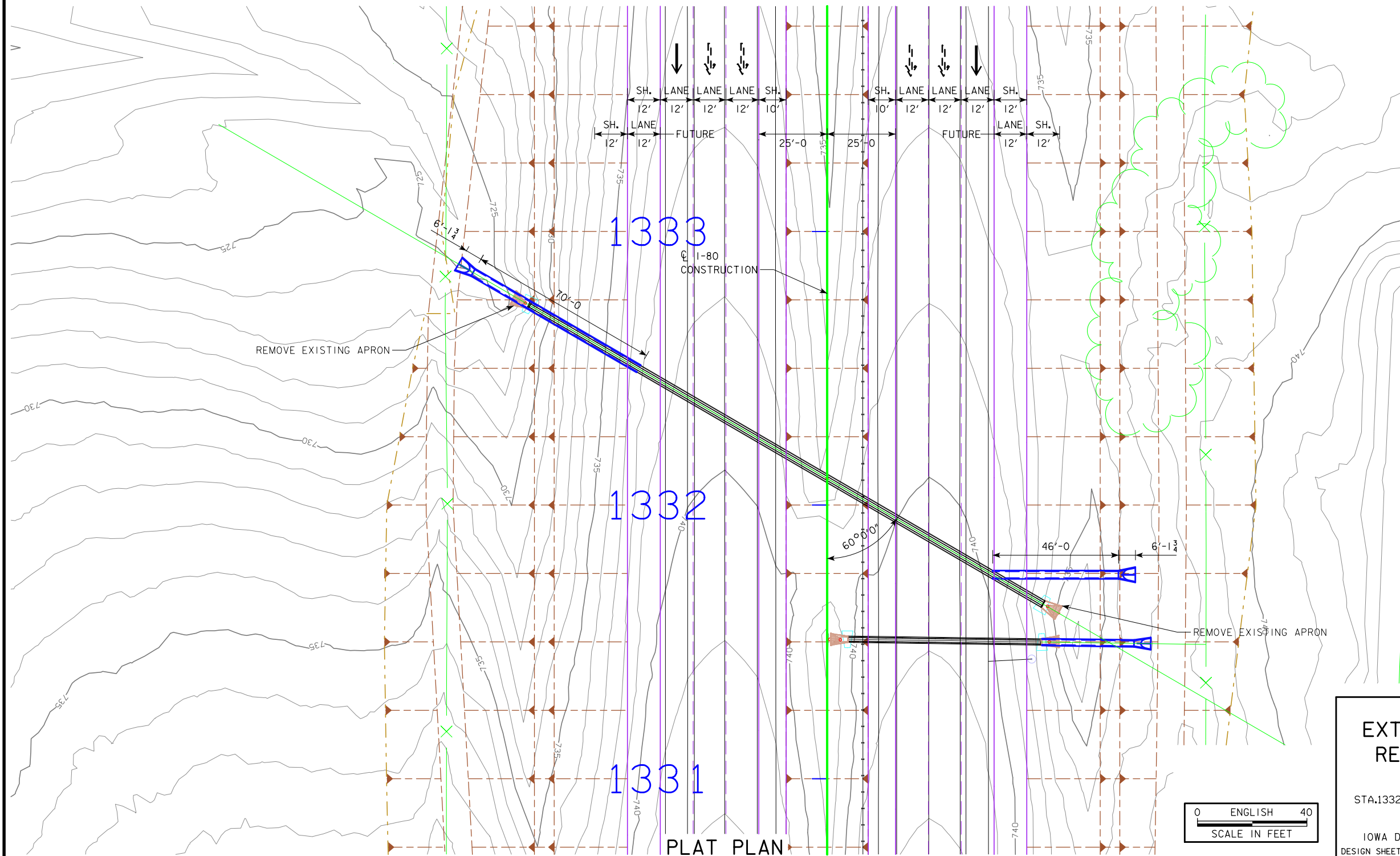

LOCATION

I-80  
T-79N R-1W  
SECTION 22  
FARMINGTON TOWNSHIP  
CEDAR COUNTY

HYDRAULIC DATA

DRAINAGE AREA = 5.9 ACRES  
DESIGN DISCHARGE = 65.62 CFS



DESIGN FOR 30° SKEW  
**EXTEND 30" x 46' LT & 70' LT REINFORCED CONCRETE PIPE PLAT PLAN**  
STA.1332+09.76  
AUGUST 2019  
**CEDAR COUNTY**  
IOWA DEPARTMENT OF TRANSPORTATION - HIGHWAY DIVISION  
DESIGN SHEET NO. ? OF ? FILE NO. ? DESIGN NO. ?





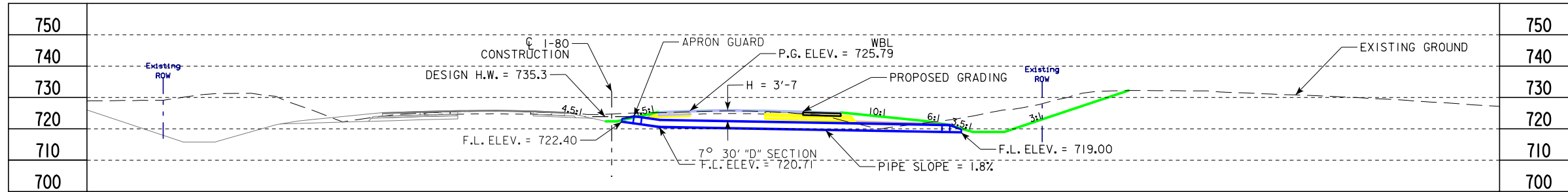

LONGITUDINAL SECTION ALONG  $\bar{C}$  CULVERT

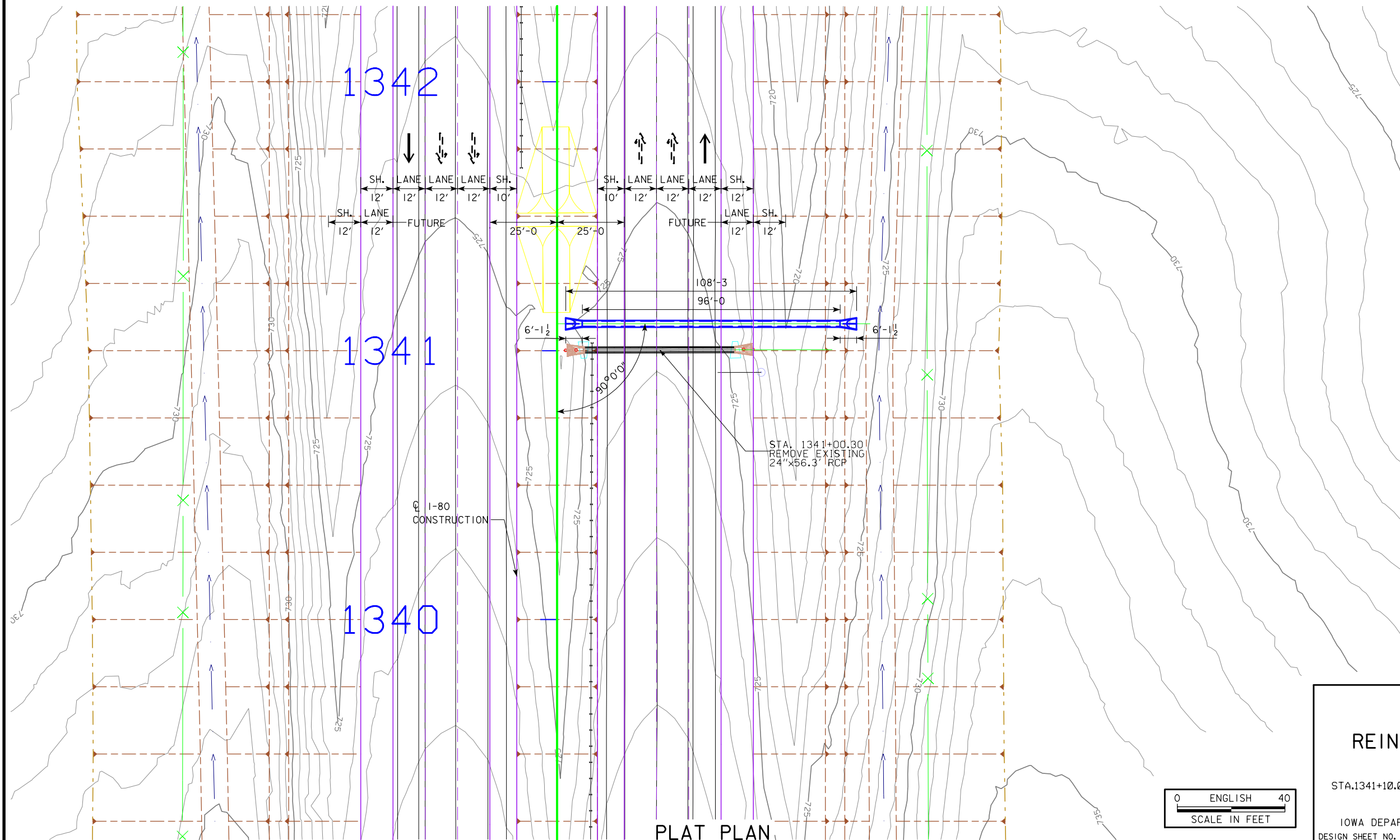

LOCATION

I-80  
T-79N R-1W  
SECTION 23  
FARMINGTON TOWNSHIP  
CEDAR COUNTY

HYDRAULIC DATA

DRAINAGE AREA = 5.9 ACRES  
DESIGN DISCHARGE = 65.62 CFS



DESIGN FOR 0° SKEW  
**24" x 96'**  
**REINFORCED CONCRETE PIPE**  
**PLAT PLAN**  
STA.1341+10.00 WB AUGUST 2019  
**CEDAR COUNTY**  
IOWA DEPARTMENT OF TRANSPORTATION - HIGHWAY DIVISION  
DESIGN SHEET NO. ? OF ? FILE NO. ? DESIGN NO. ?

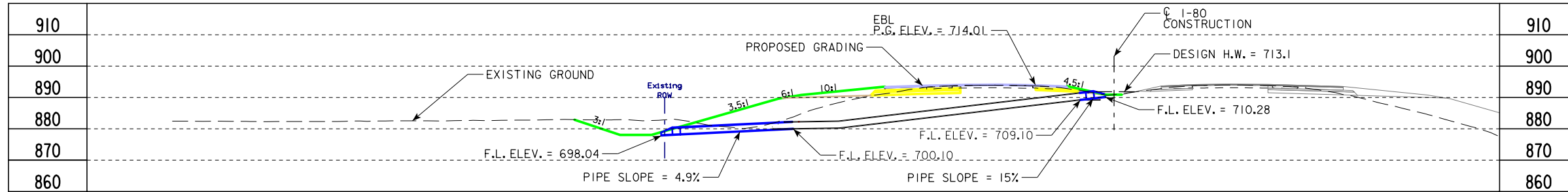

LONGITUDINAL SECTION ALONG C CULVERT

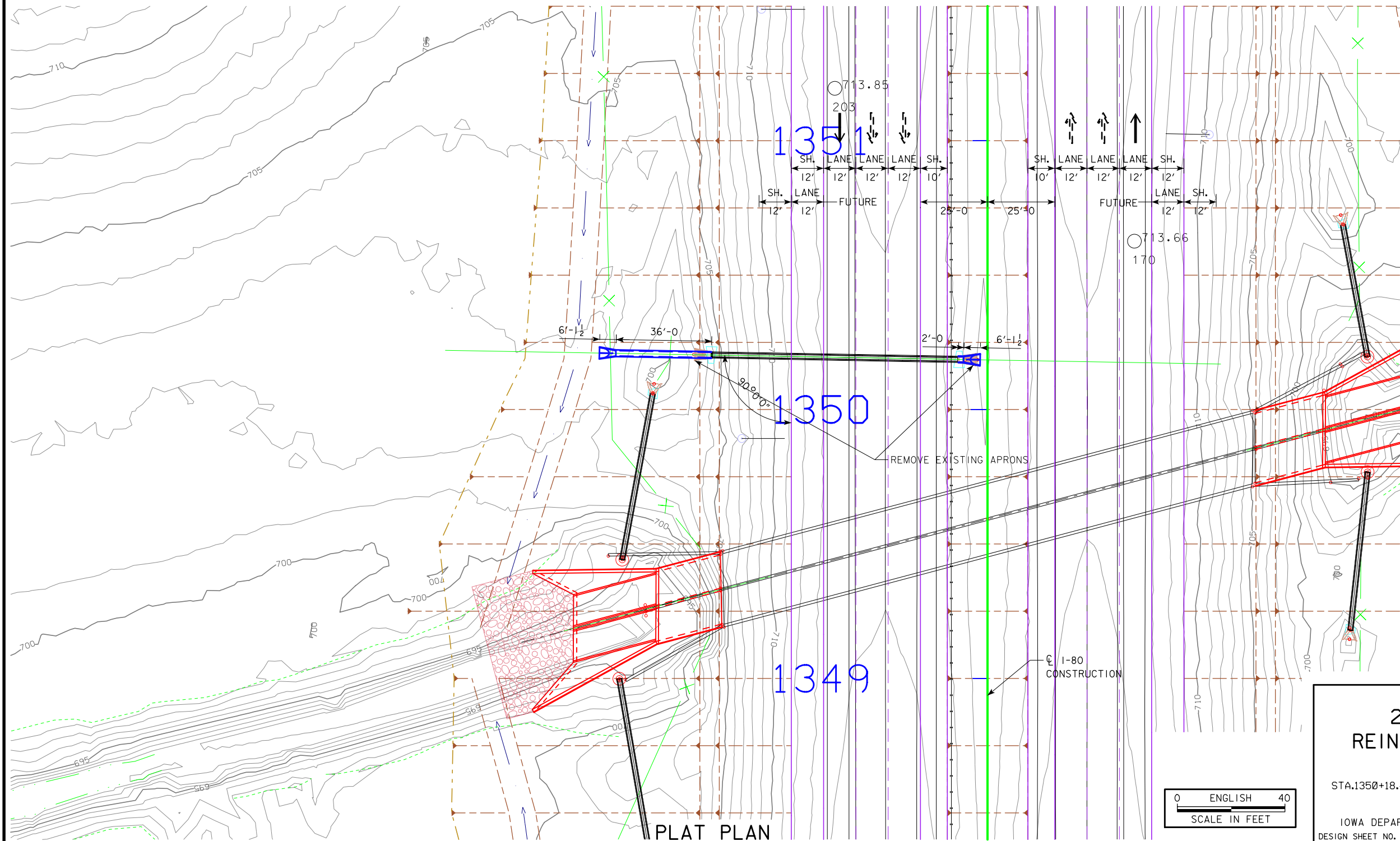

LOCATION

I-80  
 T-79N R-1W  
 SECTION 23  
 FARMINGTON TOWNSHIP  
 CEDAR COUNTY

HYDRAULIC DATA

DRAINAGE AREA = 2.7 ACRES  
 DESIGN DISCHARGE = ?? CFS

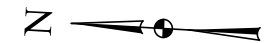

DESIGN FOR 0° SKEW  
**24" x 2' RT & 36' LT**  
**REINFORCED CONCRETE PIPE**  
**PLAT PLAN**  
 STA.1350+18.49 WB  
 AUGUST 2019  
**CEDAR COUNTY**  
 IOWA DEPARTMENT OF TRANSPORTATION - HIGHWAY DIVISION  
 DESIGN SHEET NO. ? OF ? FILE NO. ? DESIGN NO. ?



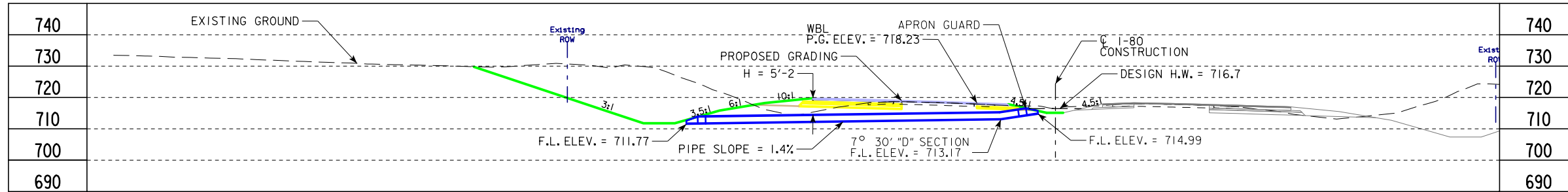

LONGITUDINAL SECTION ALONG CULVERT

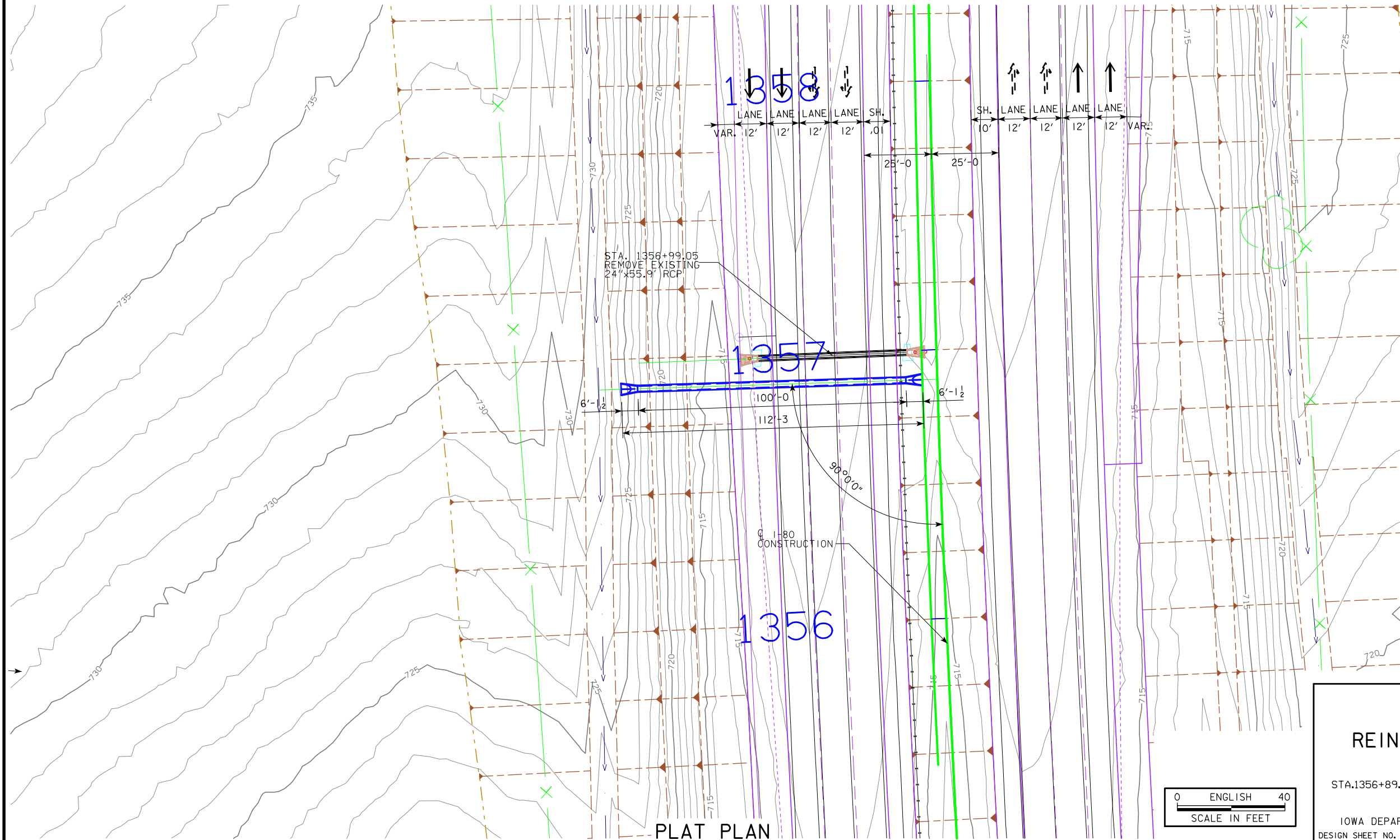

LOCATION

I-80  
T-79N R-1W  
SECTION 23  
FARMINGTON TOWNSHIP  
CEDAR COUNTY

HYDRAULIC DATA

DRAINAGE AREA = 1.4 ACRES  
DESIGN DISCHARGE = 38.85 CFS



DESIGN FOR 0° SKEW  
**24" x 100'**  
**REINFORCED CONCRETE PIPE**  
**PLAT PLAN**  
STA. 1356+89.00 WB AUGUST 2019  
**CEDAR COUNTY**  
IOWA DEPARTMENT OF TRANSPORTATION - HIGHWAY DIVISION  
DESIGN SHEET NO. ? OF ? FILE NO. ? DESIGN NO. ?



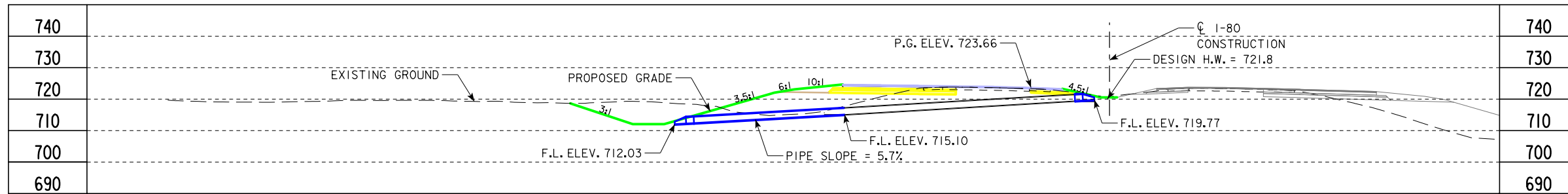

LONGITUDINAL SECTION ALONG  $\text{C}$  CULVERT

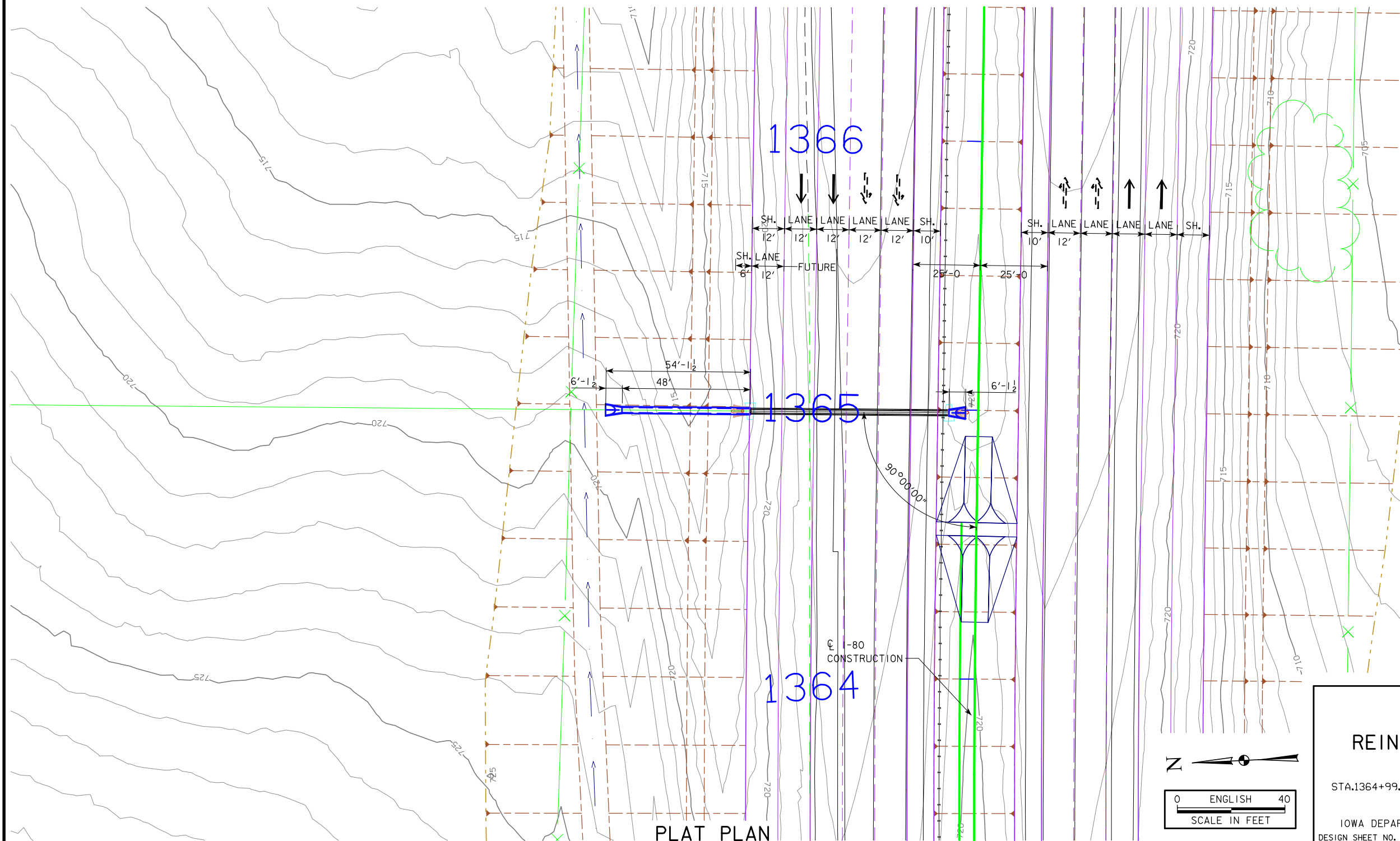

LOCATION

I-80  
T-79N R-1W  
SECTION 23  
FARMINGTON TOWNSHIP  
CEDAR COUNTY

HYDRAULIC DATA

DRAINAGE AREA = 2.3 ACRES  
DESIGN DISCHARGE = 54.15 CFS

PLAT PLAN

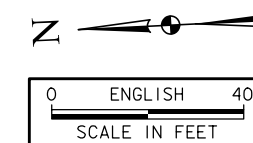

DESIGN FOR 0° SKEW  
**24" x 48'**  
**REINFORCED CONCRETE PIPE**  
**PLAT PLAN**  
STA.1364+99.13 WB AUGUST 2019  
**CEDAR COUNTY**  
IOWA DEPARTMENT OF TRANSPORTATION - HIGHWAY DIVISION  
DESIGN SHEET NO. ? OF ? FILE NO. ? DESIGN NO. ?

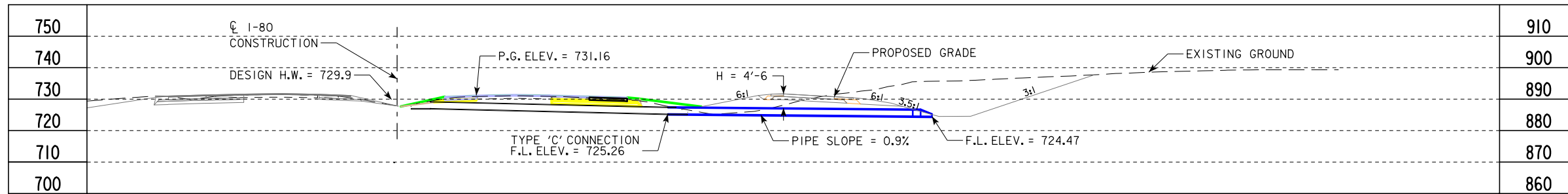

LONGITUDINAL SECTION ALONG CL CULVERT

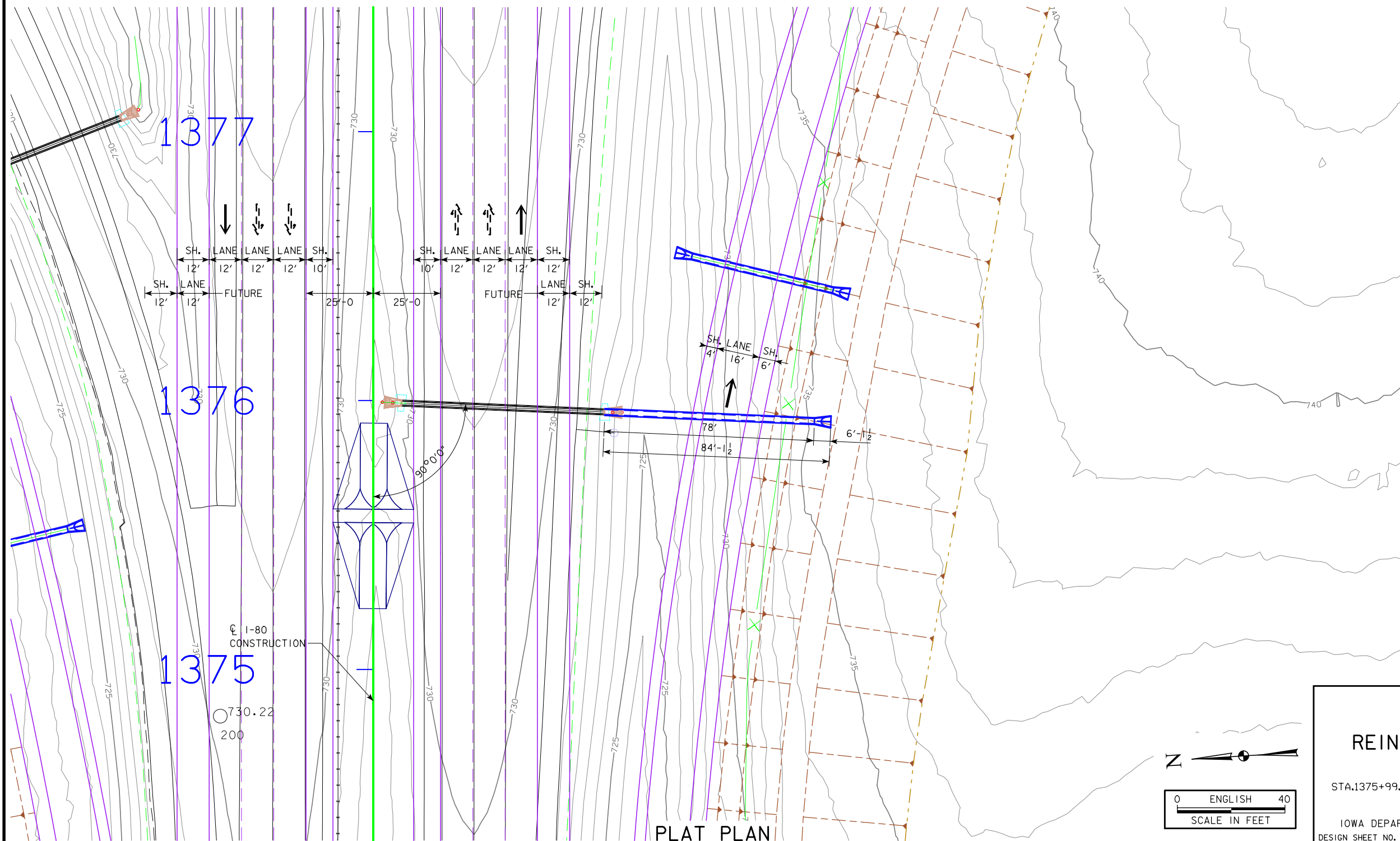

LOCATION

I-80  
 T-79N R-1W  
 SECTION 23  
 FARMINGTON TOWNSHIP  
 CEDAR COUNTY

HYDRAULIC DATA

DRAINAGE AREA = 2.3 ACRES  
 DESIGN DISCHARGE = 34.31 CFS

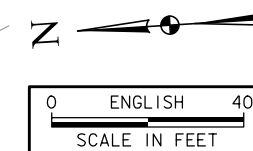

DESIGN FOR 0° SKEW  
**24" x 78'**  
**REINFORCED CONCRETE PIPE**  
**PLAT PLAN**  
 STA.1375+99.41 EB AUGUST 2019  
**CEDAR COUNTY**  
 IOWA DEPARTMENT OF TRANSPORTATION - HIGHWAY DIVISION  
 DESIGN SHEET NO. ? OF ? FILE NO. ? DESIGN NO. ?

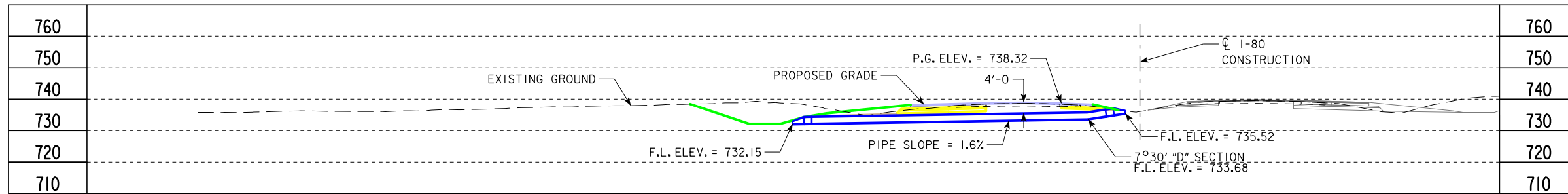

LONGITUDINAL SECTION ALONG CL CULVERT

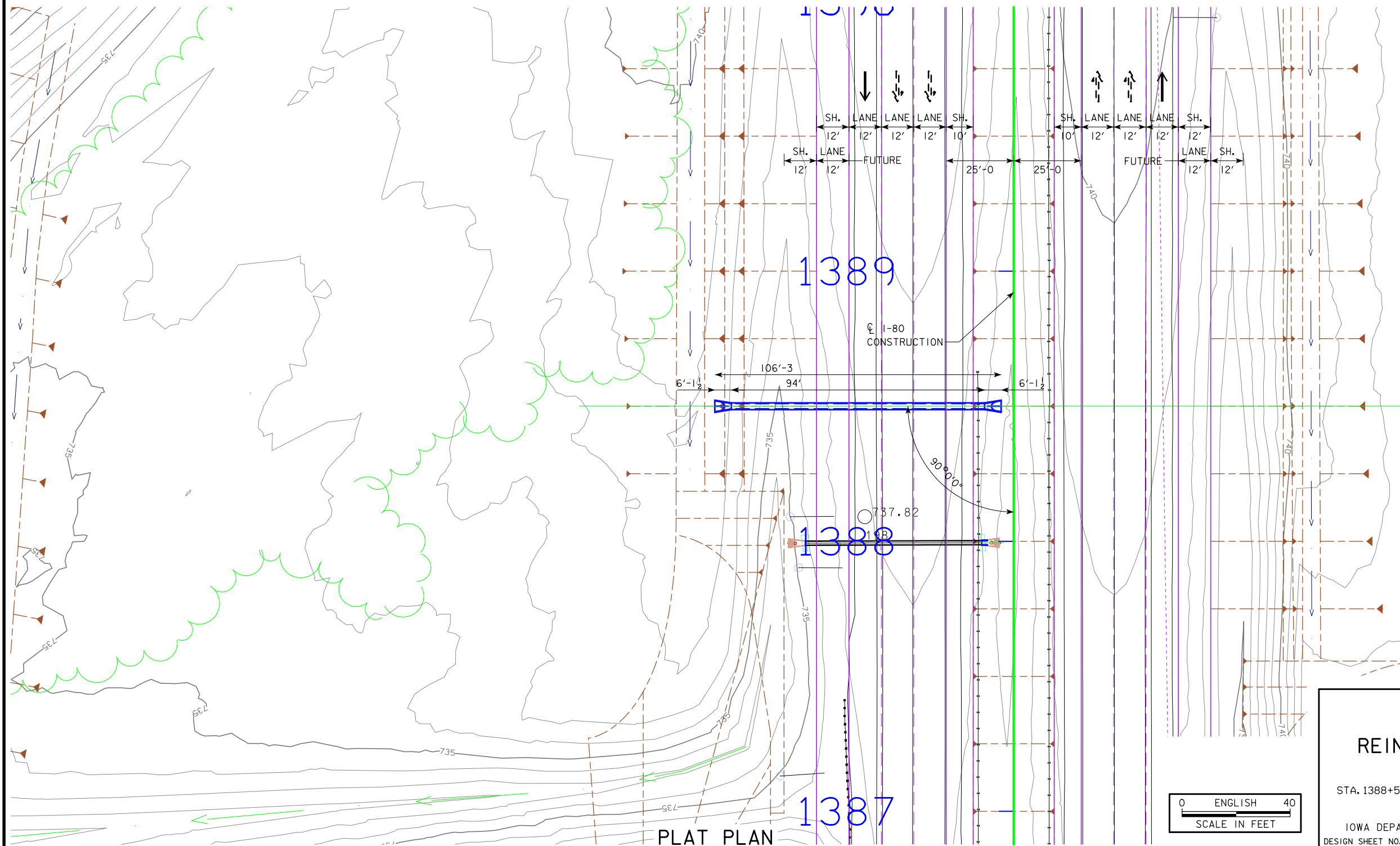

LOCATION

I-80  
T-79N R-1W  
SECTION 24  
FARMINGTON TOWNSHIP  
CEDAR COUNTY

HYDRAULIC DATA

DRAINAGE AREA = 0.9 ACRES  
DESIGN DISCHARGE = 39.25 CFS

DESIGN FOR 0° SKEW  
**24" x 94'**  
**REINFORCED CONCRETE PIPE**  
**PLAT PLAN**  
 STA. 1388+50.00 WB AUGUST 2019  
**CEDAR COUNTY**  
 IOWA DEPARTMENT OF TRANSPORTATION - HIGHWAY DIVISION  
 DESIGN SHEET NO. ? OF ? FILE NO. ? DESIGN NO. ?





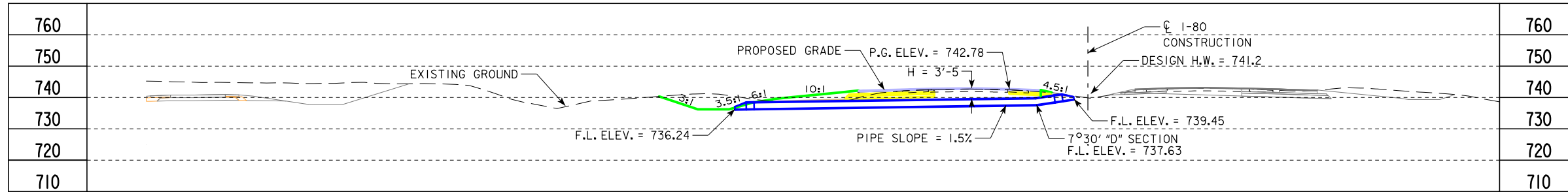

LONGITUDINAL SECTION ALONG  $\text{C}$  CULVERT

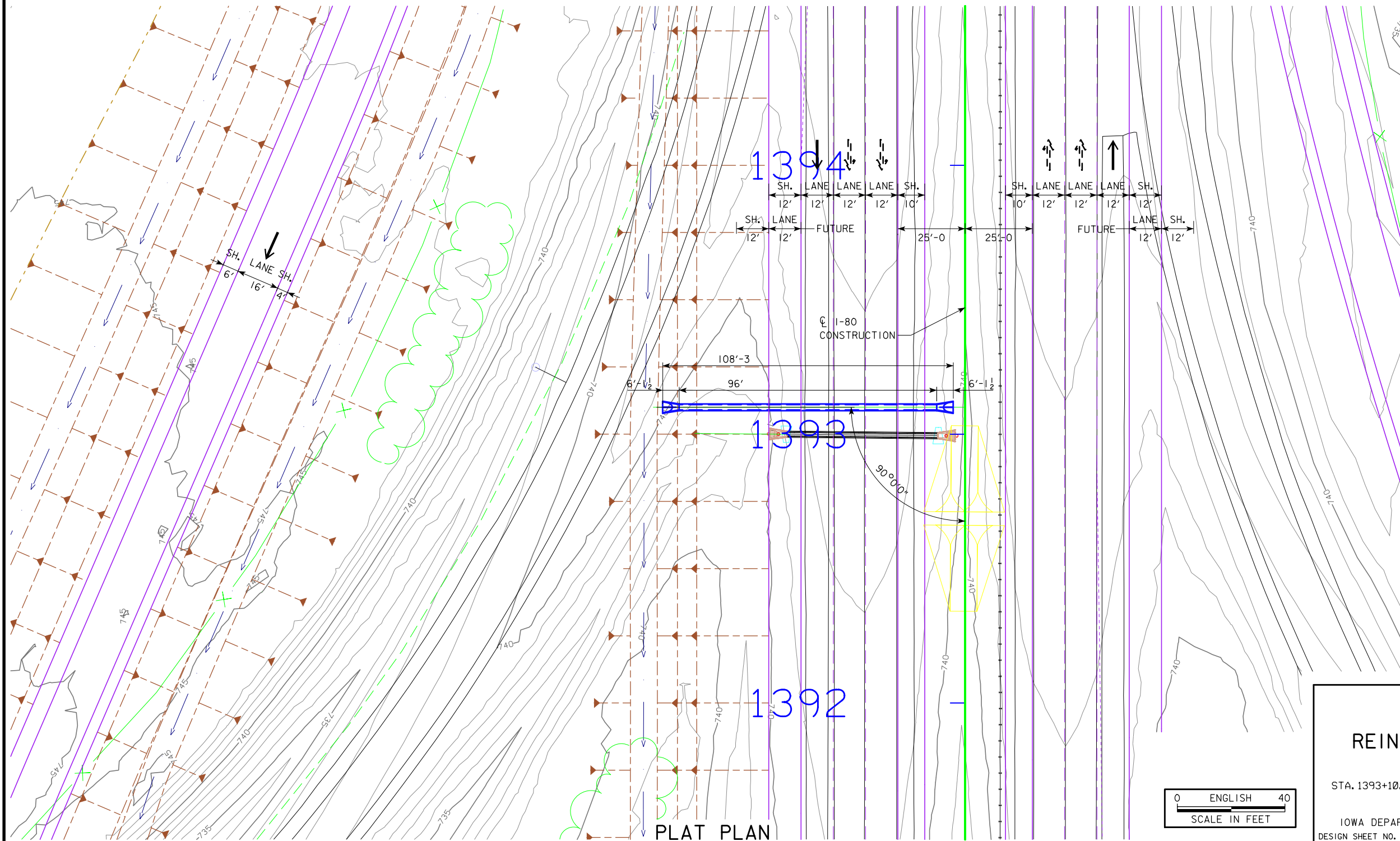

LOCATION

I-80  
 T-79N R-1W  
 SECTION 24  
 FARMINGTON TOWNSHIP  
 CEDAR COUNTY

HYDRAULIC DATA

DRAINAGE AREA = 1.4 ACRES  
 DESIGN DISCHARGE = 38.98 CFS



DESIGN FOR 0° SKEW  
**24" x 96'**  
**REINFORCED CONCRETE PIPE**  
**PLAT PLAN**  
 STA. 1393+10.00 WB AUGUST 2019  
**CEDAR COUNTY**  
 IOWA DEPARTMENT OF TRANSPORTATION - HIGHWAY DIVISION  
 DESIGN SHEET NO. ? OF ? FILE NO. ? DESIGN NO. ?

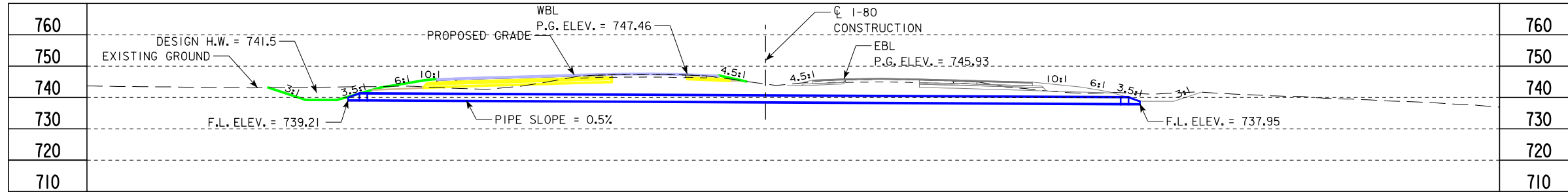

LONGITUDINAL SECTION ALONG CULVERT

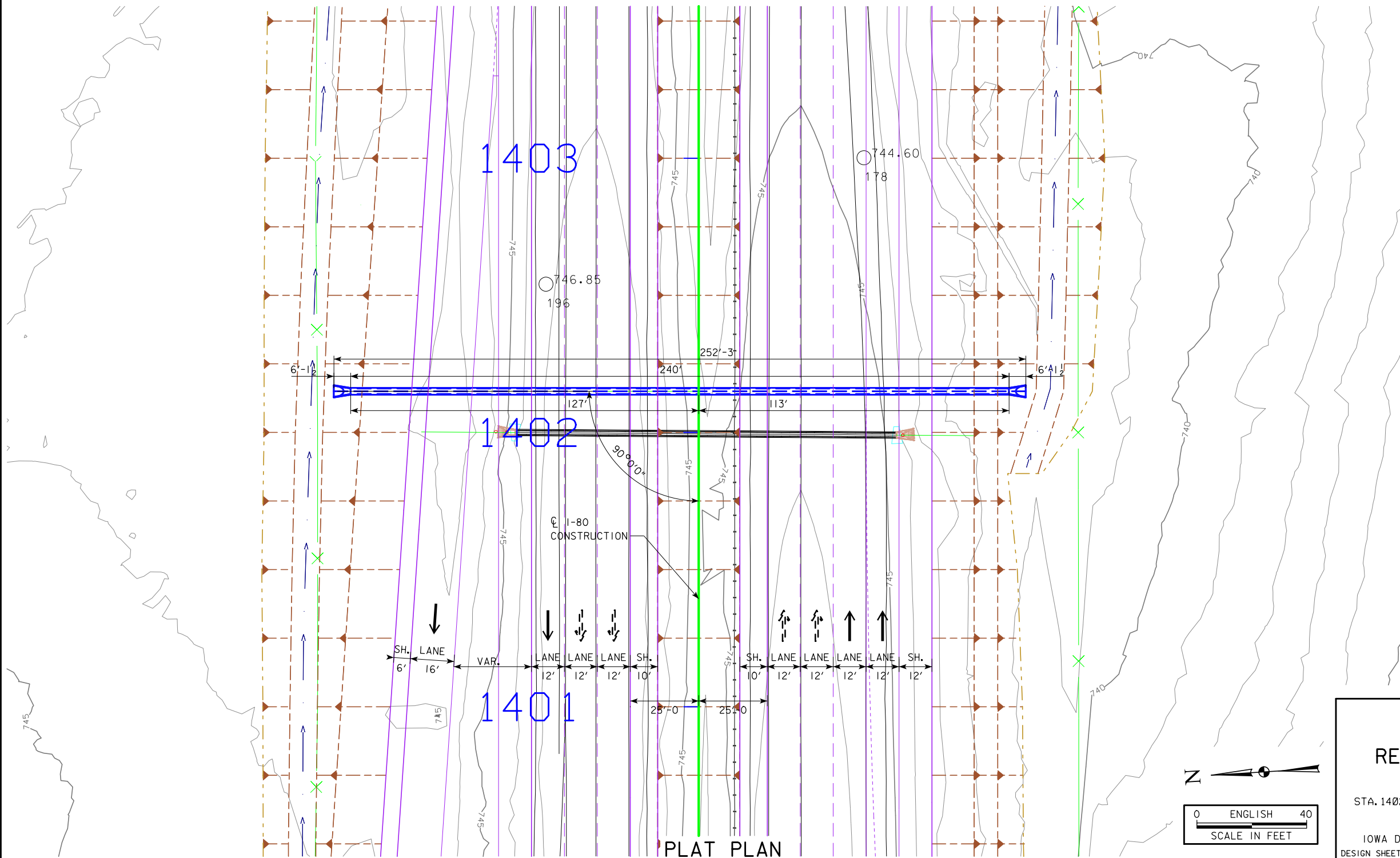

**LOCATION**  
 I-80  
 T-79N R-1W  
 SECTION 24  
 FARMINGTON TOWNSHIP  
 CEDAR COUNTY

**HYDRAULIC DATA**  
 DRAINAGE AREA = 2.6 ACRES  
 DESIGN DISCHARGE = 16.00 CFS

DESIGN FOR 0° SKEW  
**24" x 240'**  
**REINFORCED CONCRETE PIPE**  
**PLAT PLAN**  
 STA. 1402+15.00  
 AUGUST 2019  
**CEDAR COUNTY**  
 IOWA DEPARTMENT OF TRANSPORTATION - HIGHWAY DIVISION  
 DESIGN SHEET NO. ? OF ? FILE NO. ? DESIGN NO. ?

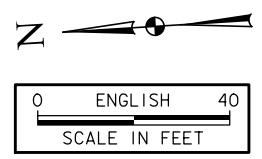

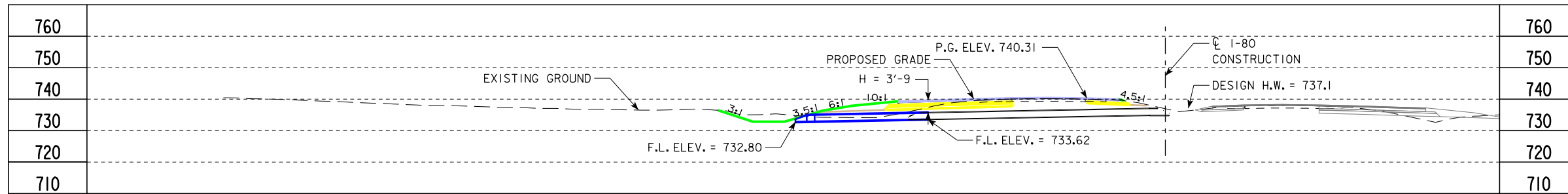

LONGITUDINAL SECTION ALONG CL CULVERT

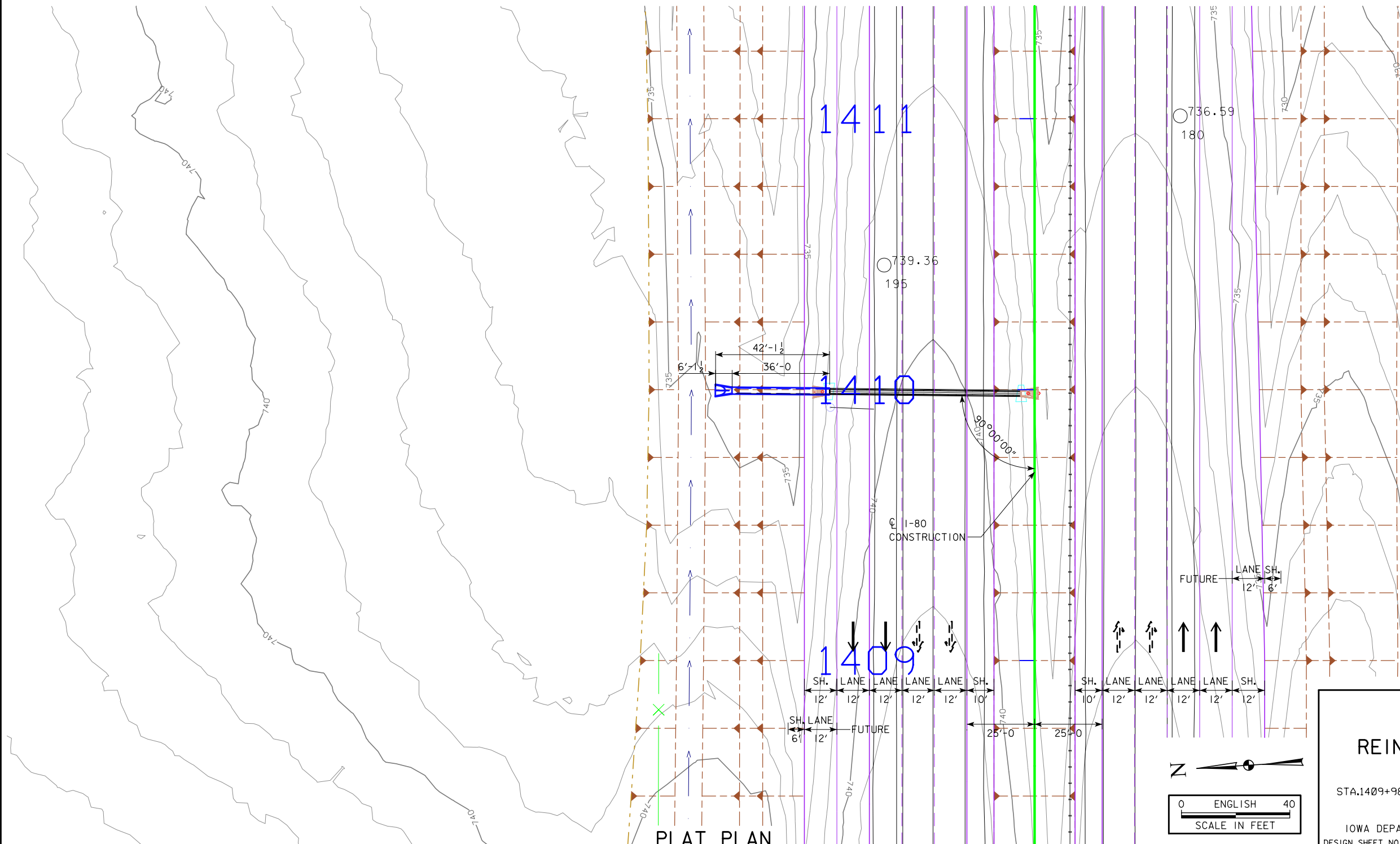

PLAT PLAN

LOCATION

I-80  
 T-79N R-1W  
 SECTION 24  
 FARMINGTON TOWNSHIP  
 CEDAR COUNTY

HYDRAULIC DATA

DRAINAGE AREA = 1.7 ACRES  
 DESIGN DISCHARGE = 30.27 CFS

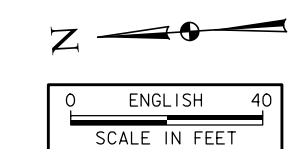

DESIGN FOR 0° SKEW  
**24" x 36'**  
**REINFORCED CONCRETE PIPE**  
**PLAT PLAN**  
 STA.1409+98.60 WB AUGUST 2019  
**CEDAR COUNTY**  
 IOWA DEPARTMENT OF TRANSPORTATION - HIGHWAY DIVISION  
 DESIGN SHEET NO. ? OF ? FILE NO. ? DESIGN NO. ?



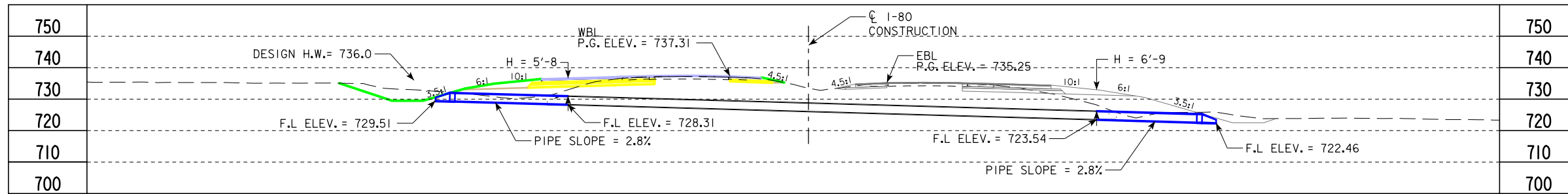

LONGITUDINAL SECTION ALONG C<sub>L</sub> CULVERT

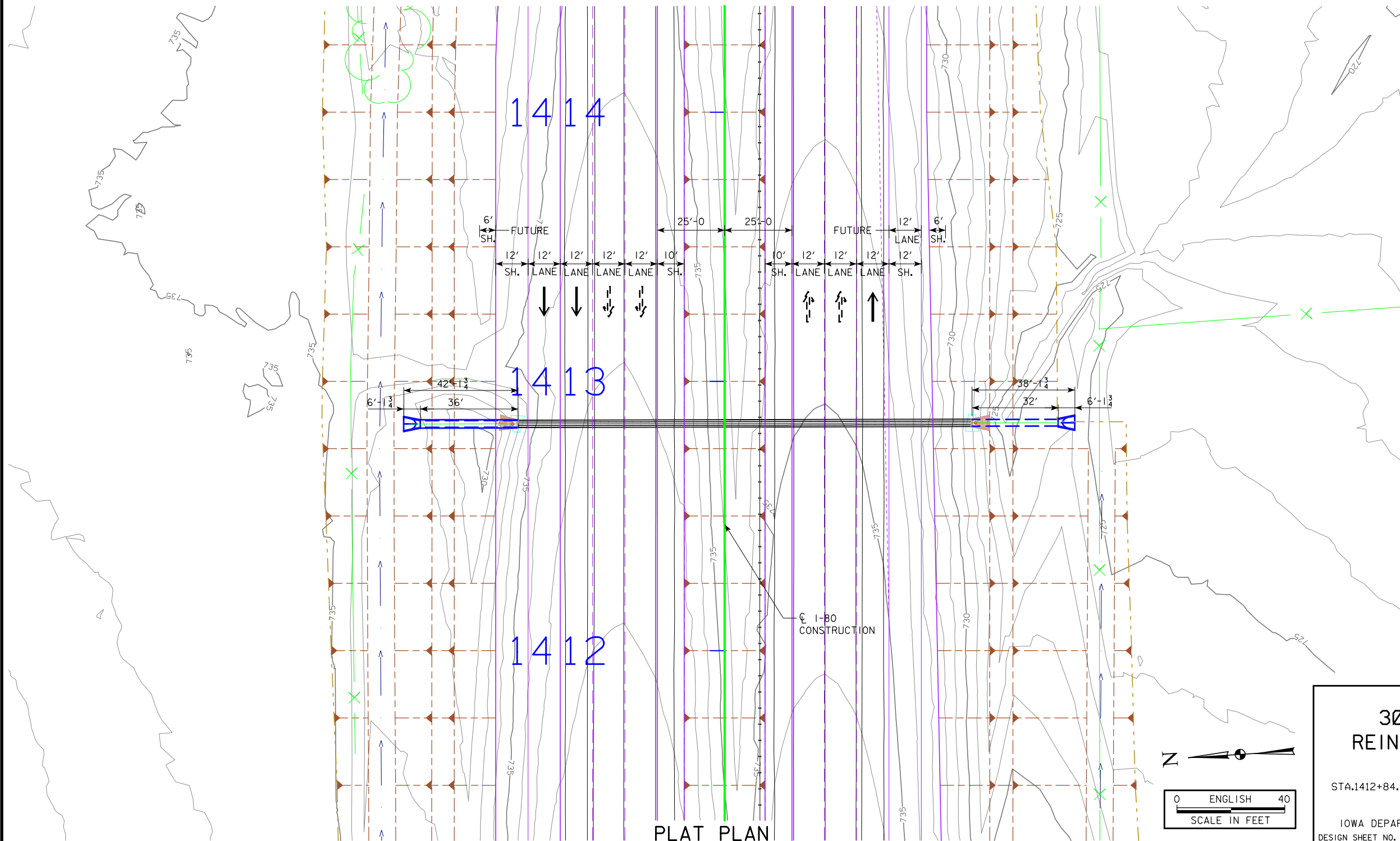

LOCATION

I-80  
 T-79N R-1W  
 SECTION 24  
 FARMINGTON TOWNSHIP  
 CEDAR COUNTY

HYDRAULIC DATA

DRAINAGE AREA = 17.0 ACRES  
 DESIGN DISCHARGE = 69.00 CFS

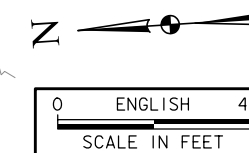

DESIGN FOR 0° SKEW  
**30" x 36' LT & 32' RT**  
**REINFORCED CONCRETE PIPE**  
**PLAT PLAN**  
 STA.1412+84.40 AUGUST 2019  
**CEDAR COUNTY**  
 IOWA DEPARTMENT OF TRANSPORTATION - HIGHWAY DIVISION  
 DESIGN SHEET NO. ? OF ? FILE NO. ? DESIGN NO. ?

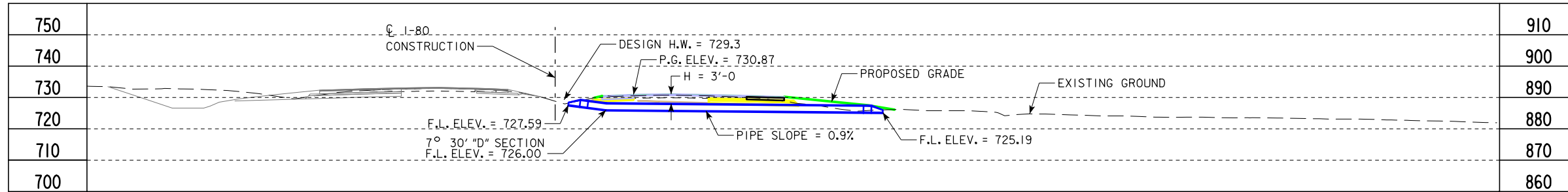

LONGITUDINAL SECTION ALONG C<sub>L</sub> CULVERT

**LOCATION**

I-80  
T-79N R-1W  
SECTION 24  
FARMINGTON TOWNSHIP  
CEDAR COUNTY

**HYDRAULIC DATA**

DRAINAGE AREA = 1.2 ACRES  
DESIGN DISCHARGE = 37.78 CFS

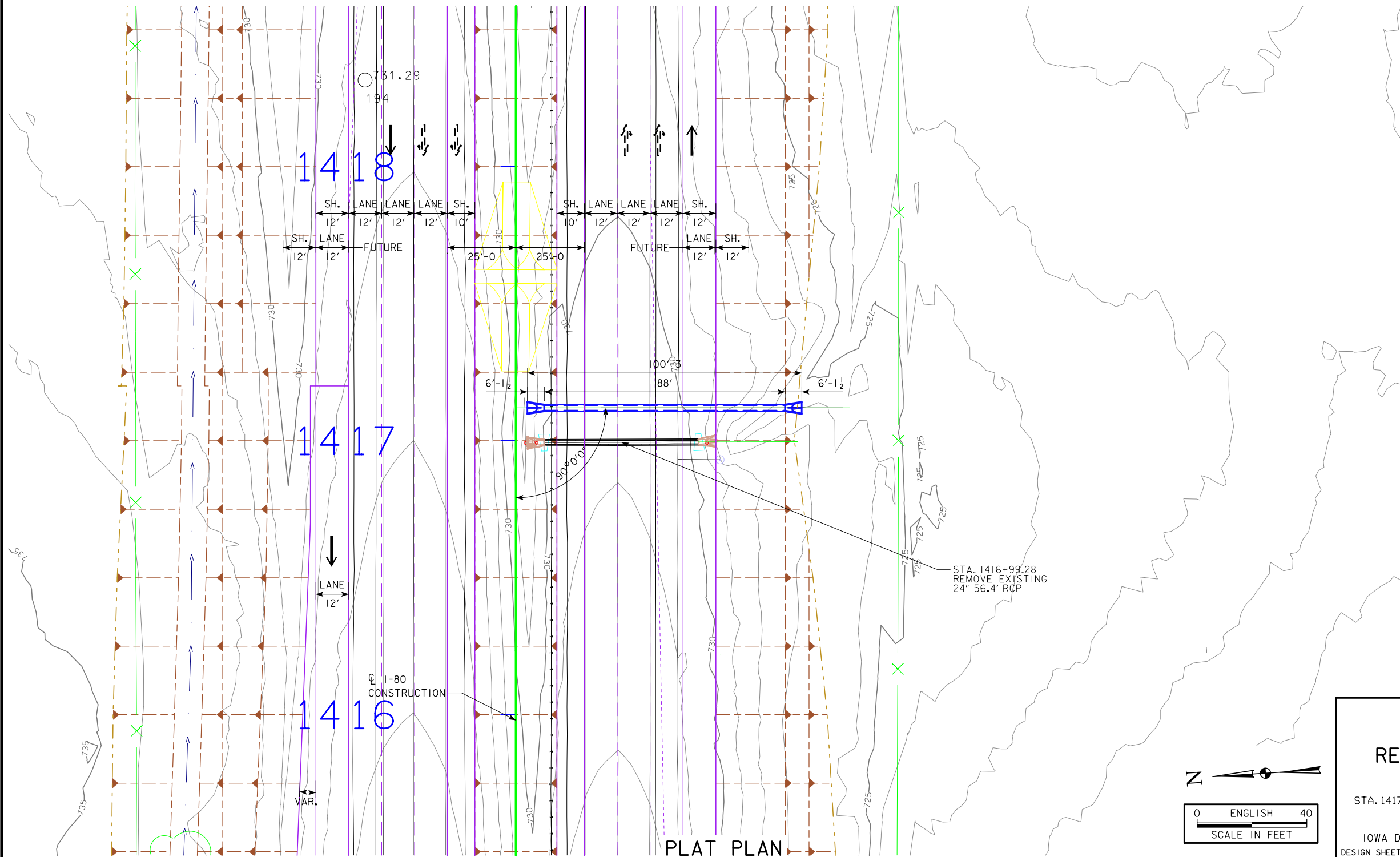

PLAT PLAN

DESIGN FOR 0° SKEW  
**24" x 88'**  
**REINFORCED CONCRETE PIPE**  
**PLAT PLAN**  
 STA. 1417+12.00 EB AUGUST 2019  
**CEDAR COUNTY**  
 IOWA DEPARTMENT OF TRANSPORTATION - HIGHWAY DIVISION  
 DESIGN SHEET NO. ? OF ? FILE NO. ? DESIGN NO. ?

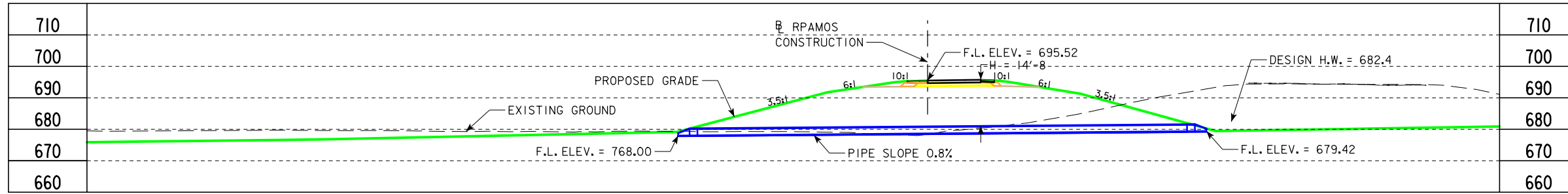

LONGITUDINAL SECTION ALONG  $\text{CL}$  CULVERT

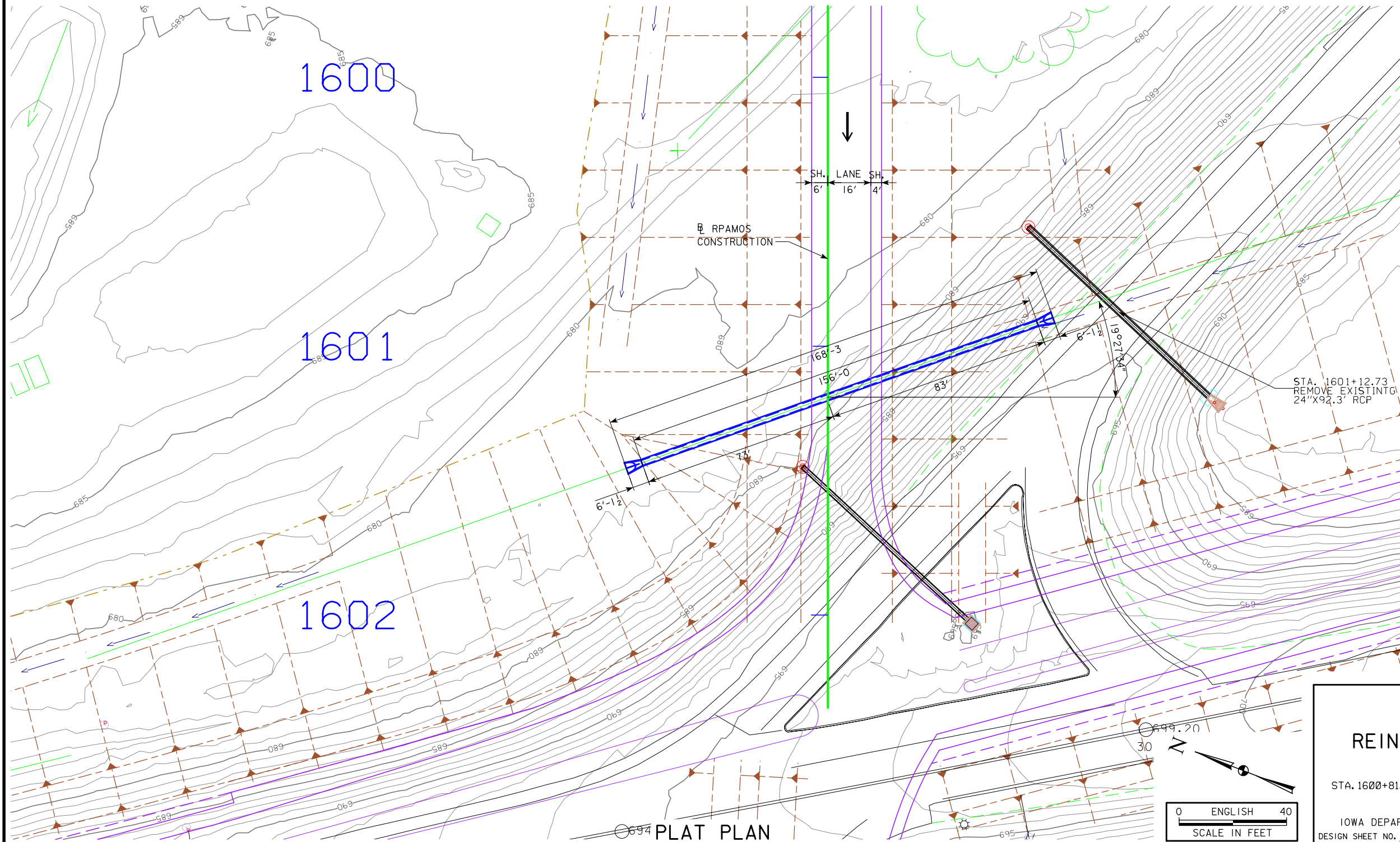

**LOCATION**

RPAMOS  
T-79N R-2W  
SECTION 18  
SUGAR CREEK TOWNSHIP  
CEDAR COUNTY

**HYDRAULIC DATA**

DRAINAGE AREA = 9.3 ACRES  
DESIGN DISCHARGE = 21.58 CFS

DESIGN FOR 19° SKEW  
**24" x 156'**  
**REINFORCED CONCRETE PIPE**  
**PLAT PLAN**  
STA. 1600+81.03  
AUGUST 2019  
**CEDAR COUNTY**  
IOWA DEPARTMENT OF TRANSPORTATION - HIGHWAY DIVISION  
DESIGN SHEET NO. ? OF ? FILE NO. ? DESIGN NO. ?





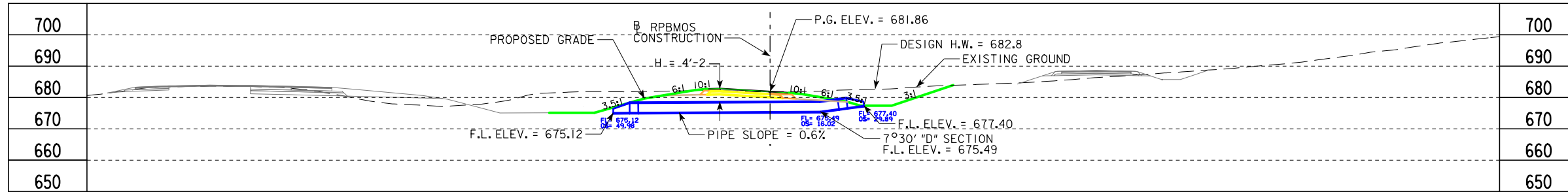

LONGITUDINAL SECTION ALONG C<sub>L</sub> CULVERT

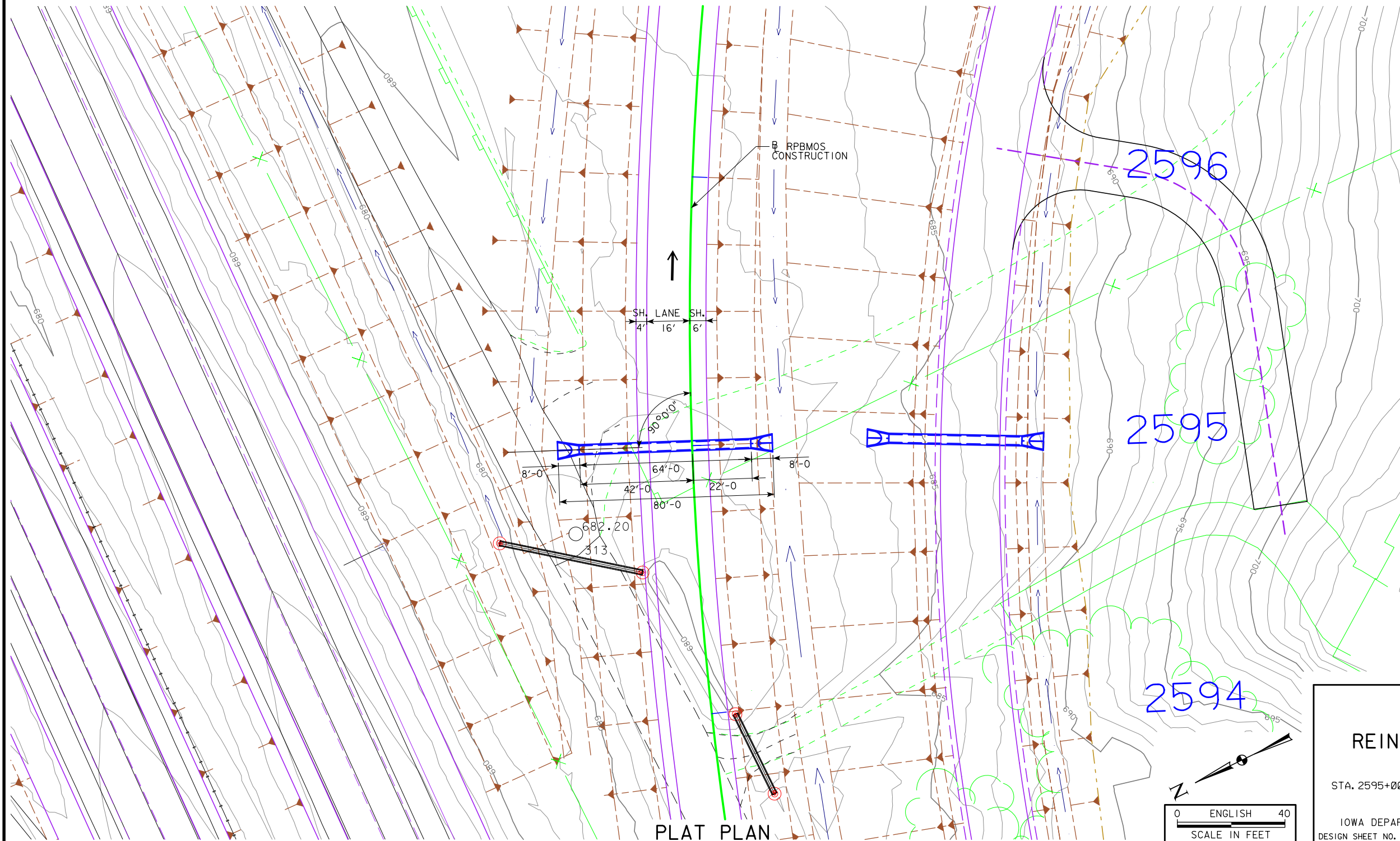

PLAT PLAN

LOCATION

RPB MOS  
 T-79N R-2W  
 SECTION 18  
 SUGAR CREEK TOWNSHIP  
 CEDAR COUNTY

HYDRAULIC DATA

DRAINAGE AREA = 16.7 ACRES  
 DESIGN DISCHARGE = ?? CFS

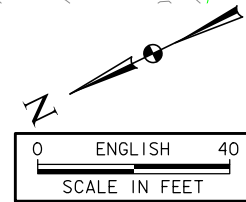

DESIGN FOR 0° SKEW  
**36" x 64'**  
**REINFORCED CONCRETE PIPE**  
**PLAT PLAN**  
 STA. 2595+00.00 AUGUST 2019  
**CEDAR COUNTY**  
 IOWA DEPARTMENT OF TRANSPORTATION - HIGHWAY DIVISION  
 DESIGN SHEET NO. ? OF ? FILE NO. ? DESIGN NO. ?

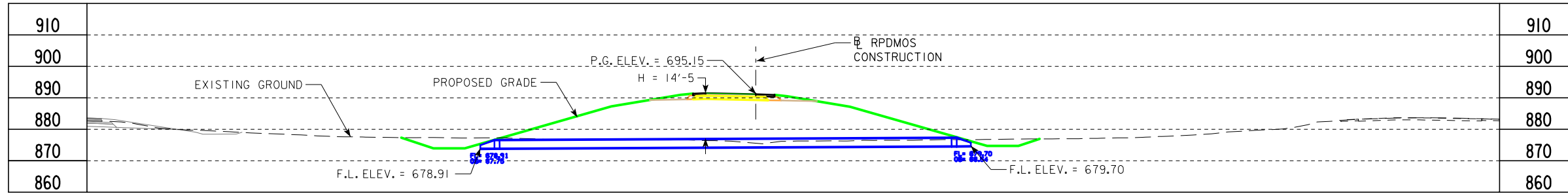

LONGITUDINAL SECTION ALONG  $\phi$  CULVERT

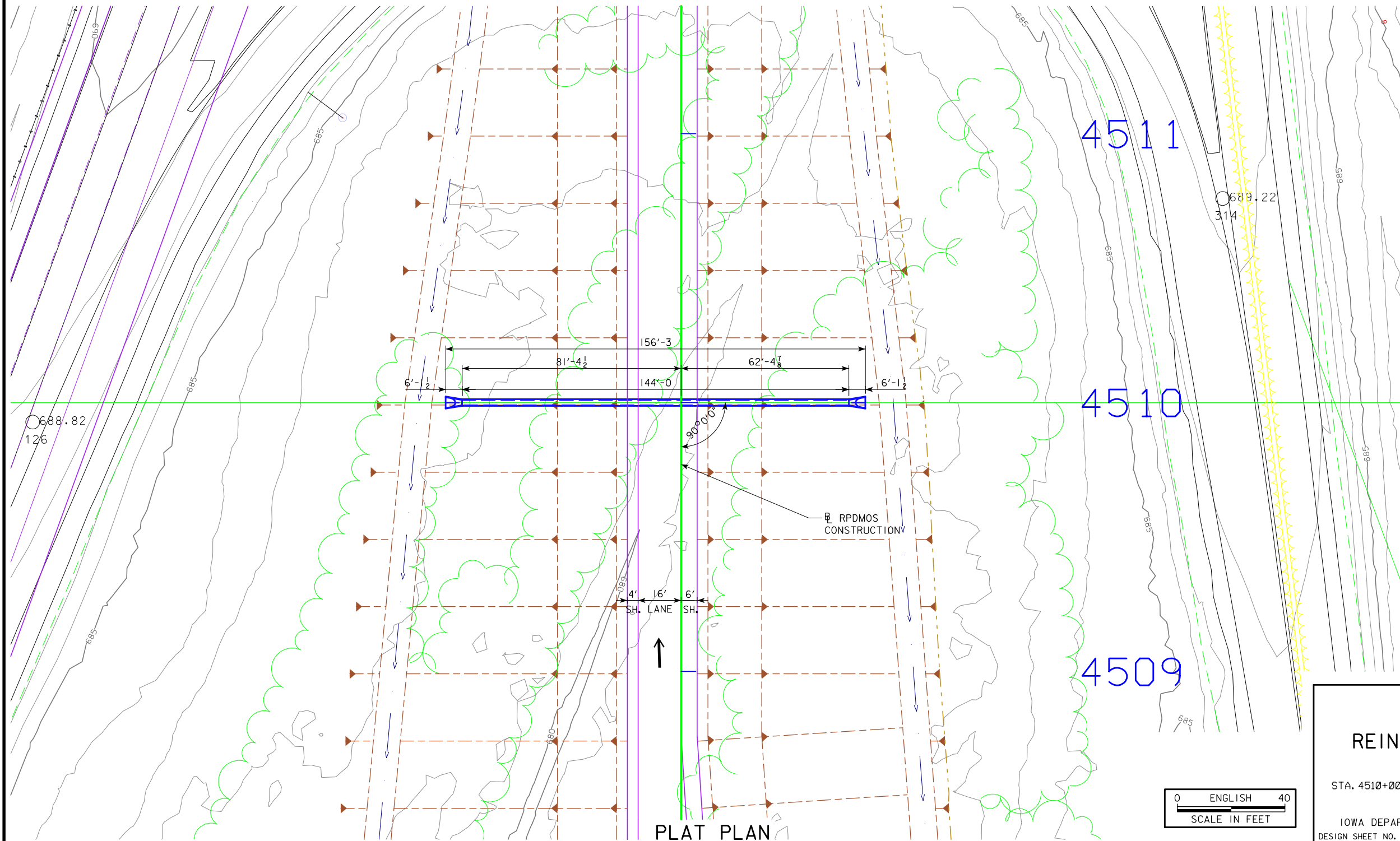

LOCATION

RPBMOS  
T-79N R-2W  
SECTION 17  
SUGAR CREEK TOWNSHIP  
CEDAR COUNTY

HYDRAULIC DATA

DRAINAGE AREA = ??? ACRES  
DESIGN DISCHARGE = ??? CFS

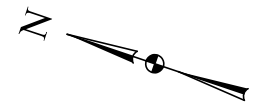

DESIGN FOR  $??^\circ$  SKEW  
**??" x ???'**  
**REINFORCED CONCRETE PIPE  
PLAT PLAN**  
STA. 4510+00.00 AUGUST 2019  
**CEDAR COUNTY**  
IOWA DEPARTMENT OF TRANSPORTATION - HIGHWAY DIVISION  
DESIGN SHEET NO. ? OF ? FILE NO. ? DESIGN NO. ?

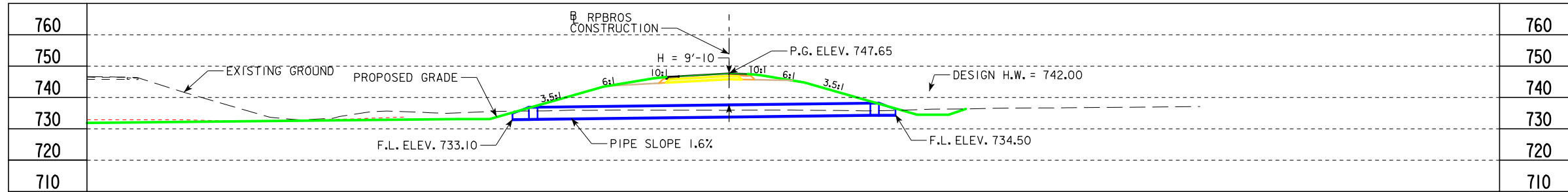

LONGITUDINAL SECTION ALONG  $\phi$  CULVERT

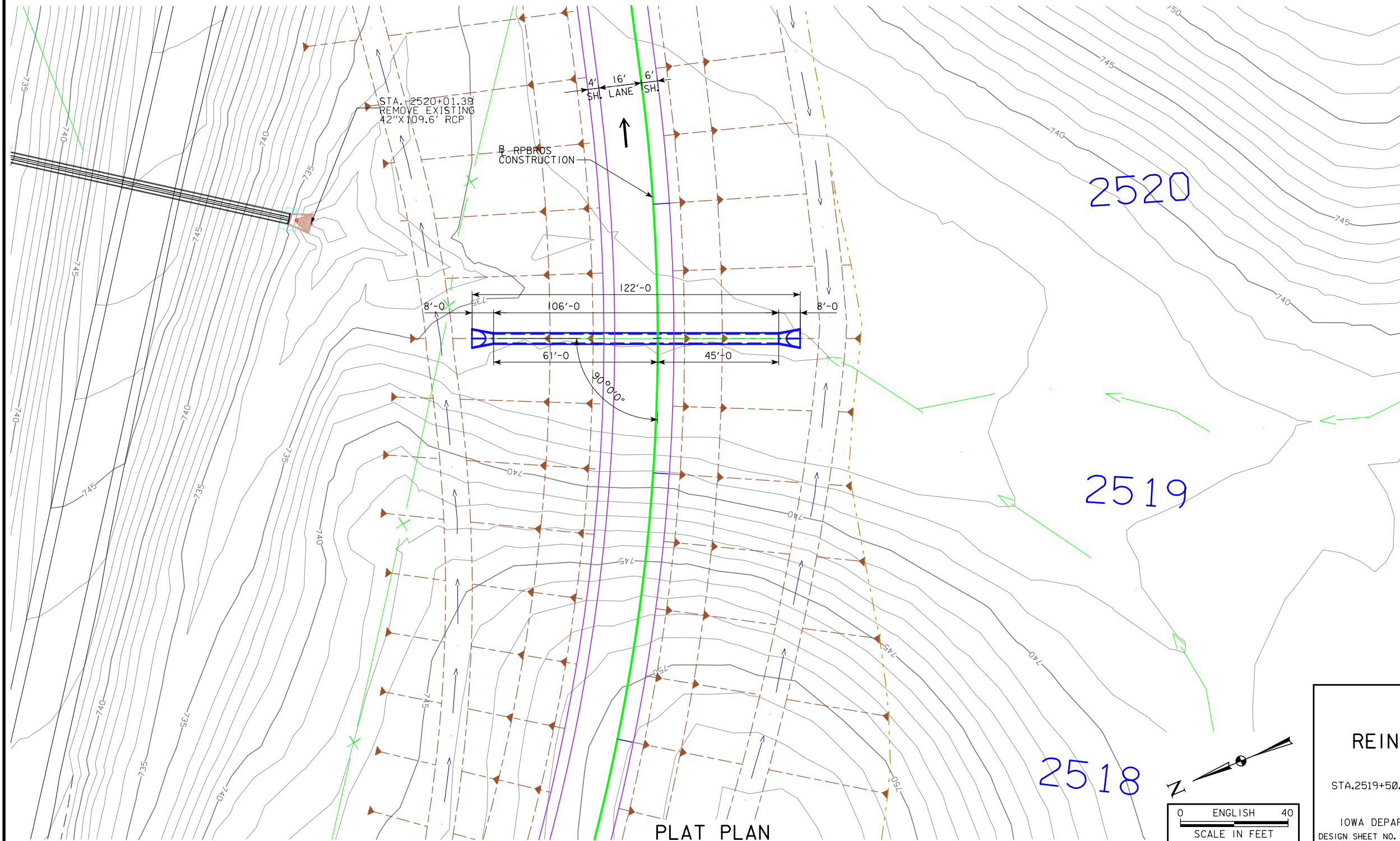

PLAT PLAN

LOCATION

RPBROS  
T-79N R-2W  
SECTION 23  
SUGAR CREEK TOWNSHIP  
CEDAR COUNTY

HYDRAULIC DATA

DRAINAGE AREA = 35.9 ACRES  
DESIGN DISCHARGE = 77.28 CFS

DESIGN FOR 0° SKEW  
**42" x 106'**  
**REINFORCED CONCRETE PIPE**  
**PLAT PLAN**  
STA. 2519+50.00 AUGUST 2019  
**CEDAR COUNTY**  
IOWA DEPARTMENT OF TRANSPORTATION - HIGHWAY DIVISION  
DESIGN SHEET NO. ? OF ? FILE NO. ? DESIGN NO. ?

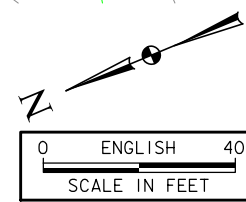



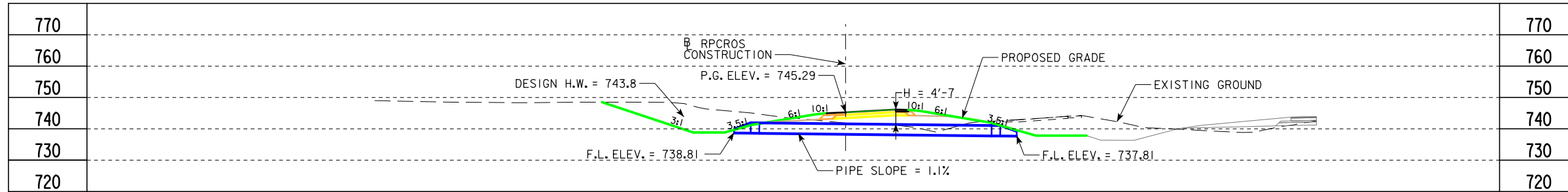

LONGITUDINAL SECTION ALONG CULVERT

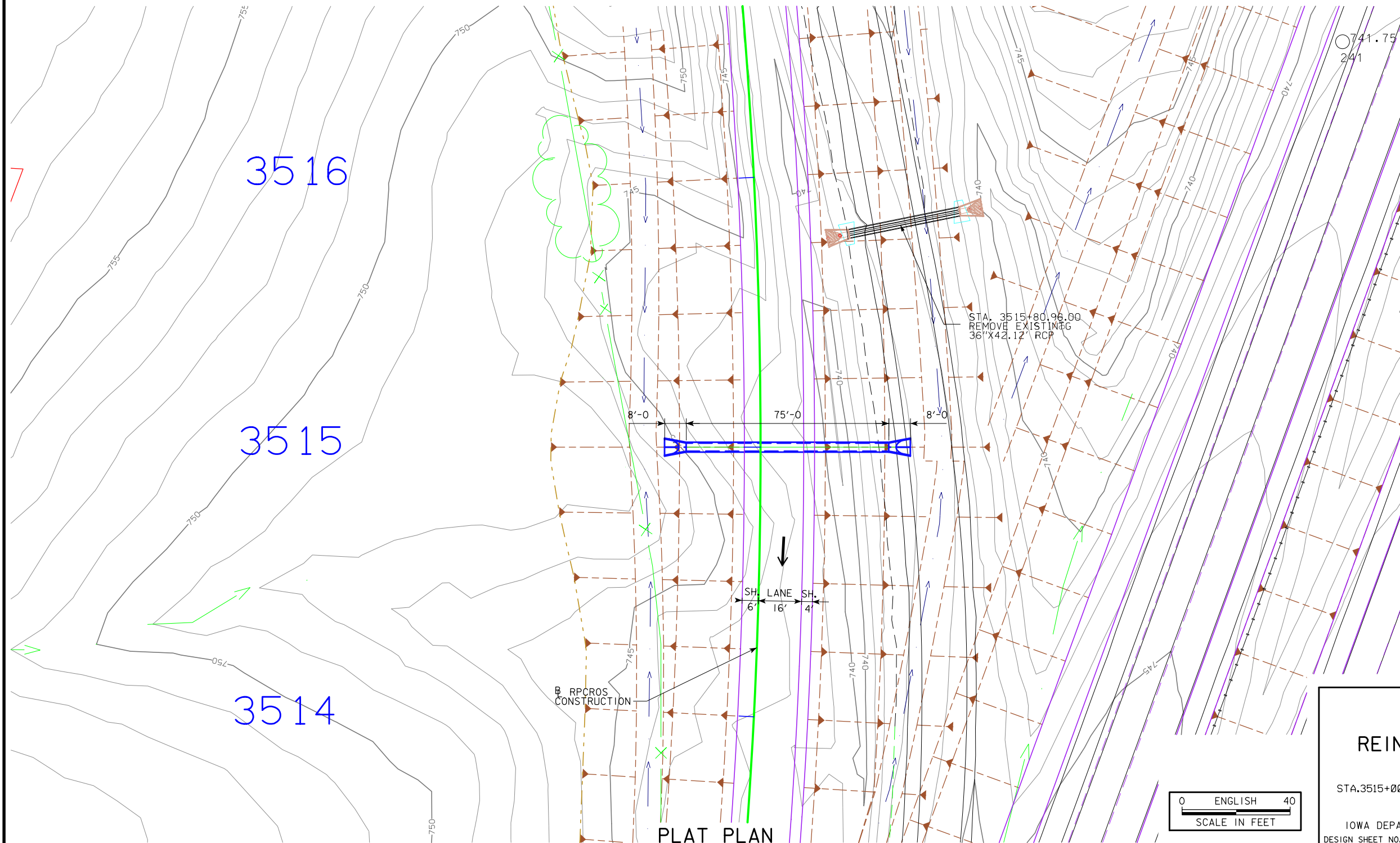

LOCATION

RPCROS  
 T-79N R-2W  
 SECTION 23  
 SUGAR CREEK TOWNSHIP  
 CEDAR COUNTY

HYDRAULIC DATA

DRAINAGE AREA = 16.4 ACRES  
 DESIGN DISCHARGE = 66.69 CFS



DESIGN FOR 0° SKEW  
**36" x 74'**  
**REINFORCED CONCRETE PIPE**  
**PLAT PLAN**  
 STA. 3515+00.00 WB AUGUST 2019  
**CEDAR COUNTY**  
 IOWA DEPARTMENT OF TRANSPORTATION - HIGHWAY DIVISION  
 DESIGN SHEET NO. ? OF ? FILE NO. ? DESIGN NO. ?

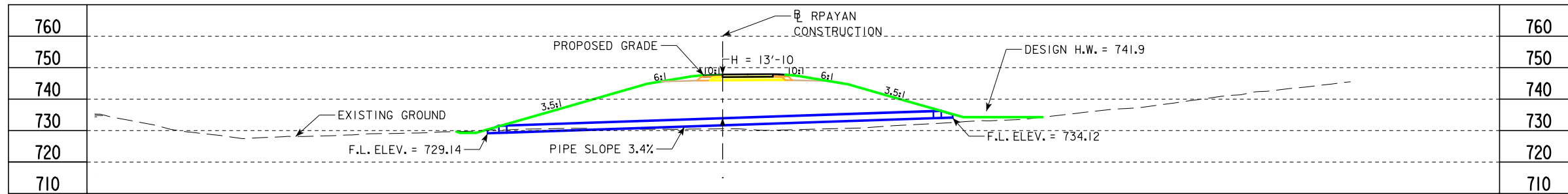

LONGITUDINAL SECTION ALONG  $\phi$  CULVERT

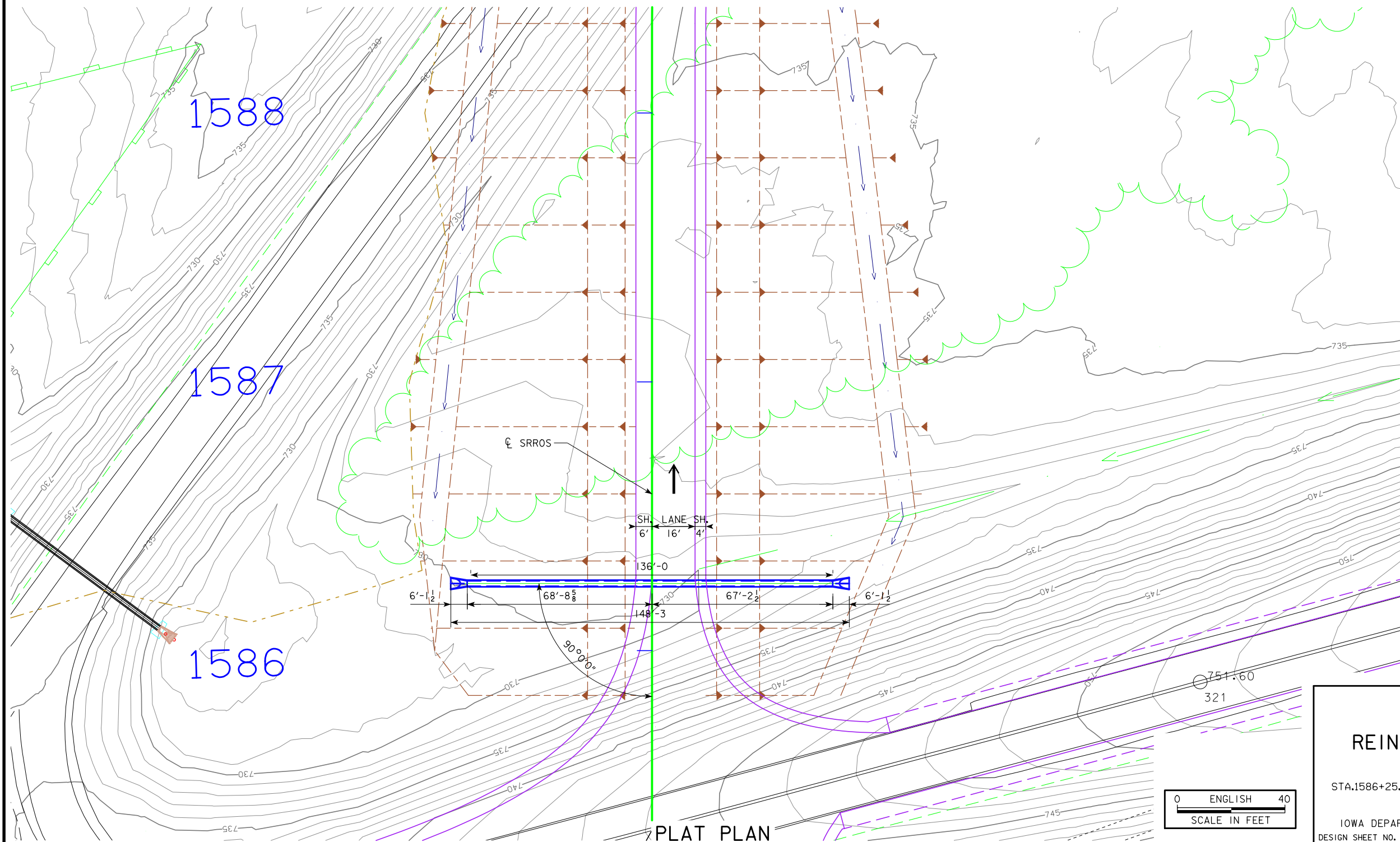

**LOCATION**

RPAYAN  
T-79N R-1W  
SECTION 24  
FARMINGTON TOWNSHIP  
CEDAR COUNTY

**HYDRAULIC DATA**

DRAINAGE AREA = 10.4 ACRES  
DESIGN DISCHARGE = 41.47 CFS

DESIGN FOR 0° SKEW  
**24" x 136'**  
**REINFORCED CONCRETE PIPE**  
**PLAT PLAN**  
STA.1586+25.00 AUGUST 2019  
**CEDAR COUNTY**  
IOWA DEPARTMENT OF TRANSPORTATION - HIGHWAY DIVISION  
DESIGN SHEET NO. ? OF ? FILE NO. ? DESIGN NO. ?



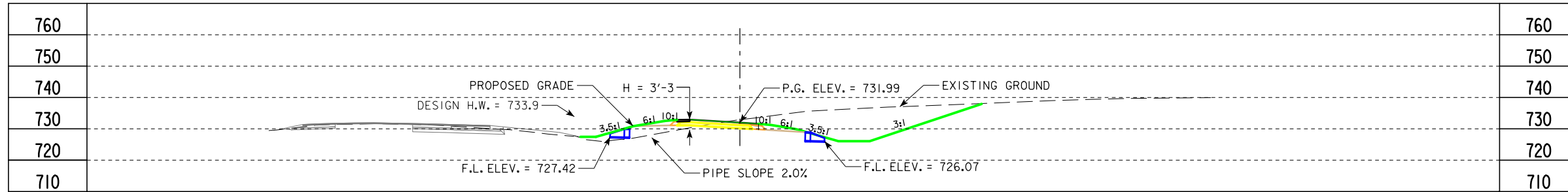

LONGITUDINAL SECTION ALONG CULVERT

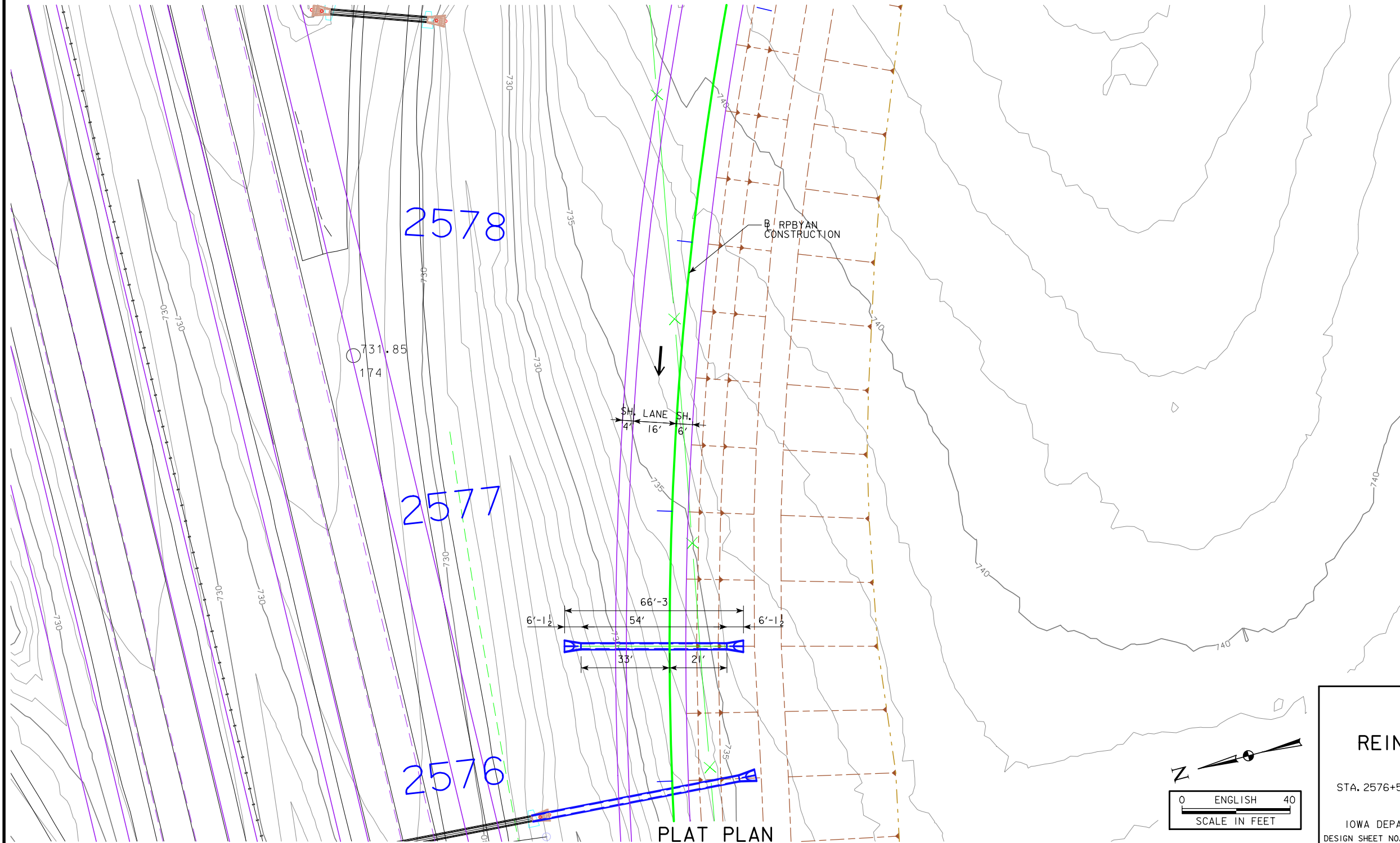

LOCATION

SRVER  
T-79N R-1W  
SECTION 23  
FARMINGTON TOWNSHIP  
CEDAR COUNTY

HYDRAULIC DATA

DRAINAGE AREA = 14.3 ACRES  
DESIGN DISCHARGE = ?? CFS

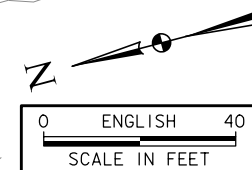

DESIGN FOR 0° SKEW  
**30" x 56'**  
**REINFORCED CONCRETE PIPE**  
**PLAT PLAN**  
STA. 2576+50.00 AUGUST 2019  
**CEDAR COUNTY**  
IOWA DEPARTMENT OF TRANSPORTATION - HIGHWAY DIVISION  
DESIGN SHEET NO. ? OF ? FILE NO. ? DESIGN NO. ?



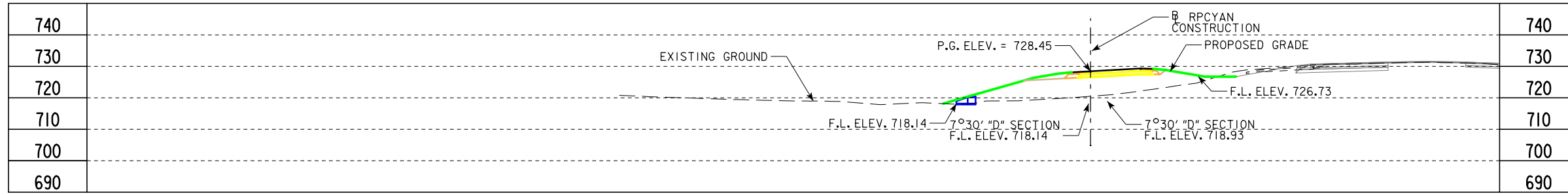

LONGITUDINAL SECTION ALONG C<sub>L</sub> CULVERT

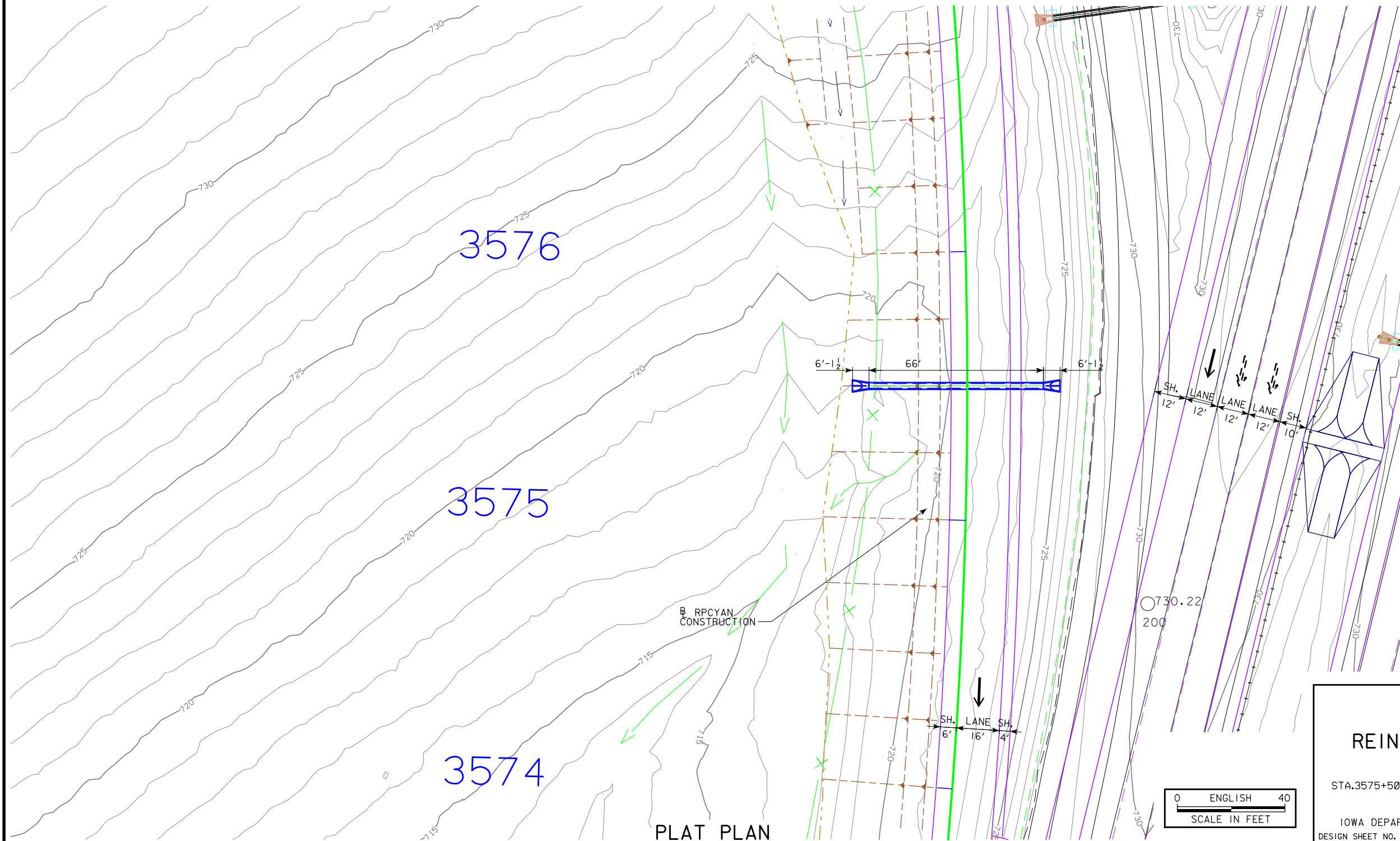

**LOCATION**

RPCYAN  
T-79N R-1W  
SECTION 23  
FARMINGTON TOWNSHIP  
CEDAR COUNTY

**HYDRAULIC DATA**

DRAINAGE AREA = ??? ACRES  
DESIGN DISCHARGE = ??? CFS

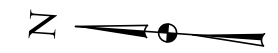

DESIGN FOR 0° SKEW  
**24" x 66'**  
**REINFORCED CONCRETE PIPE**  
**PLAT PLAN**  
STA. 3575+50.00 WB AUGUST 2019  
**CEDAR COUNTY**  
IOWA DEPARTMENT OF TRANSPORTATION - HIGHWAY DIVISION  
DESIGN SHEET NO. ? OF ? FILE NO. ? DESIGN NO. ?

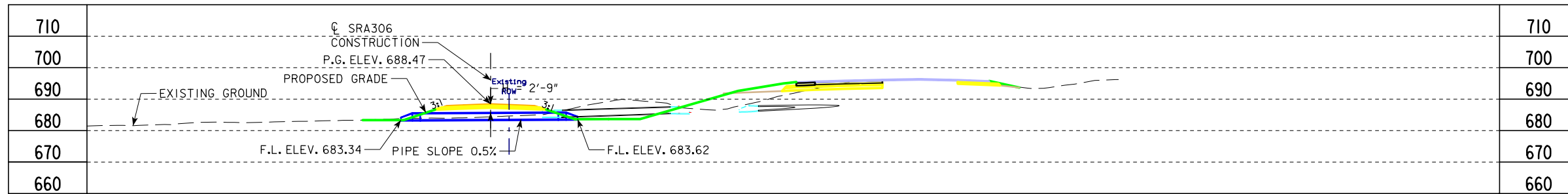

LONGITUDINAL SECTION ALONG CL CULVERT

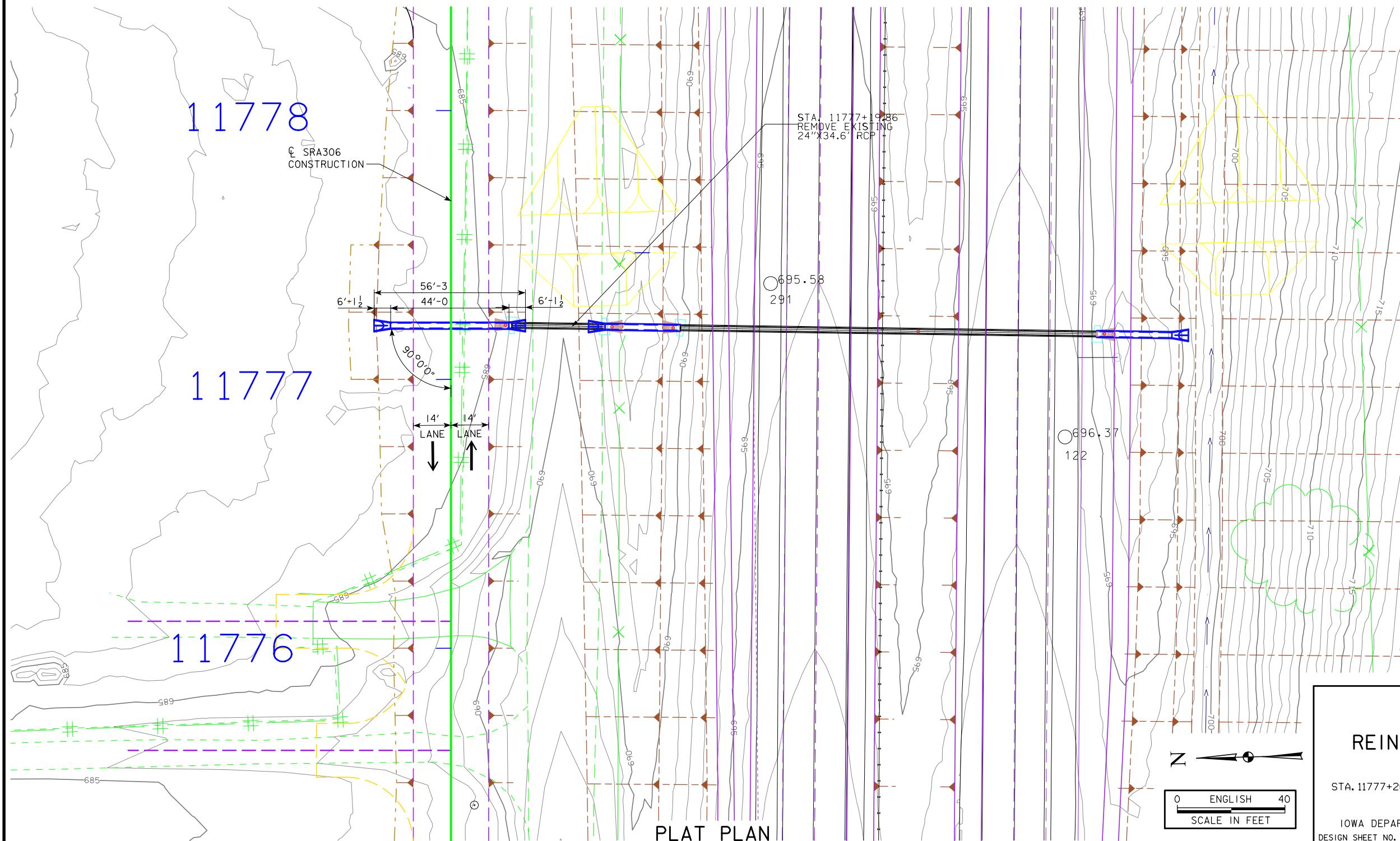

PLAT PLAN

**LOCATION**

SRA306  
T-79N R-2W  
SECTION 18  
SUGAR CREEK TOWNSHIP  
CEDAR COUNTY

**HYDRAULIC DATA**

DRAINAGE AREA = 1.2 ACRES  
DESIGN DISCHARGE = ---- CFS

DESIGN FOR 0° SKEW  
**24" x 44'**  
**REINFORCED CONCRETE PIPE**  
**PLAT PLAN**  
STA. 11777+20.00 AUGUST 2019  
**CEDAR COUNTY**  
IOWA DEPARTMENT OF TRANSPORTATION - HIGHWAY DIVISION  
DESIGN SHEET NO. ? OF ? FILE NO. ? DESIGN NO. ?

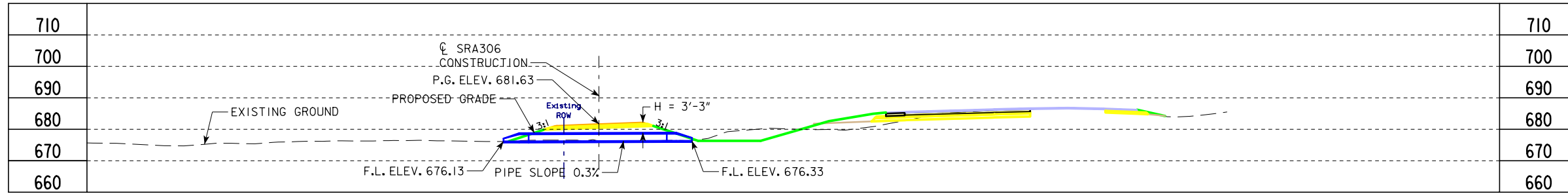

LONGITUDINAL SECTION ALONG  $\phi$  CULVERT

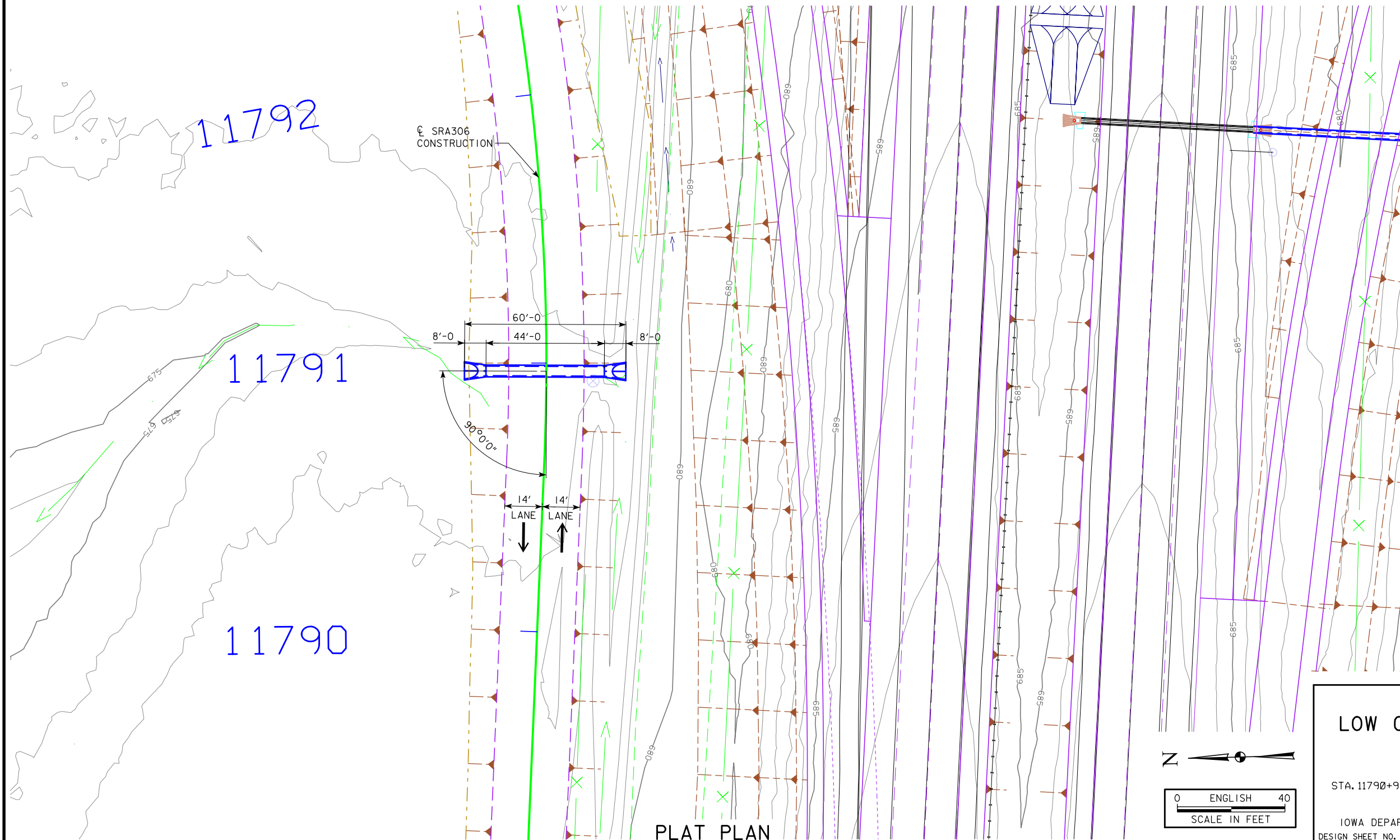

PLAT PLAN

LOCATION

SRA306  
 T-79N R-2W  
 SECTION 18  
 SUGAR CREEK TOWNSHIP  
 CEDAR COUNTY

HYDRAULIC DATA

DRAINAGE AREA = 26.3 ACRES  
 DESIGN DISCHARGE = ---- CFS

DESIGN FOR 0° SKEW

44" x 27" x 44'  
 LOW CLEARANCE REINFORCED  
 CONCRETE PIPE  
 PLAT PLAN

STA. 11790+97.00

AUGUST 2019

CEDAR COUNTY

IOWA DEPARTMENT OF TRANSPORTATION - HIGHWAY DIVISION  
 DESIGN SHEET NO. ? OF ? FILE NO. ? DESIGN NO. ?





710		710
700		700
690		690
680		680
670		670
660		660

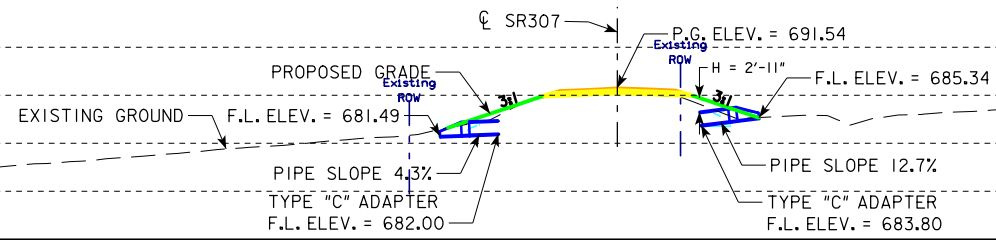

LONGITUDINAL SECTION ALONG  $\phi$  CULVERT

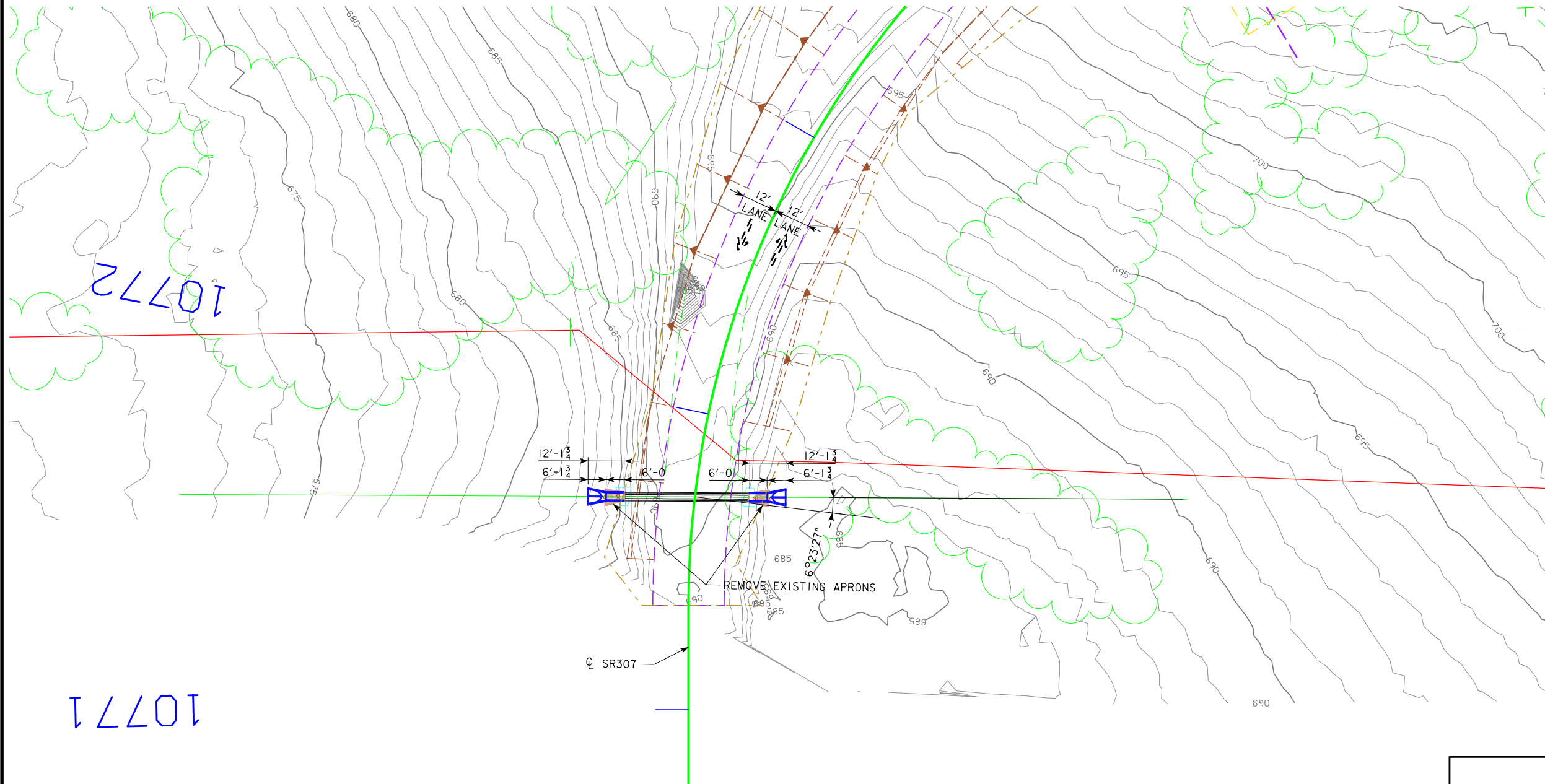

**LOCATION**

SR307  
T-79N R-2W  
SECTION 18  
SUGAR CREEK TOWNSHIP  
CEDAR COUNTY

**HYDRAULIC DATA**

DRAINAGE AREA = 10.8 ACRES  
DESIGN DISCHARGE = 41.0 CFS



DESIGN FOR 6° SKEW  
**EXTEND 30" x 6' LT & 30" x 6' RT  
REINFORCED CONCRETE PIPE  
PLAT PLAN**

STA. 10771+71.74

AUGUST 2019

**CEDAR COUNTY**

IOWA DEPARTMENT OF TRANSPORTATION - HIGHWAY DIVISION  
DESIGN SHEET NO. ? OF ? FILE NO. ? DESIGN NO. ?



PLAT PLAN

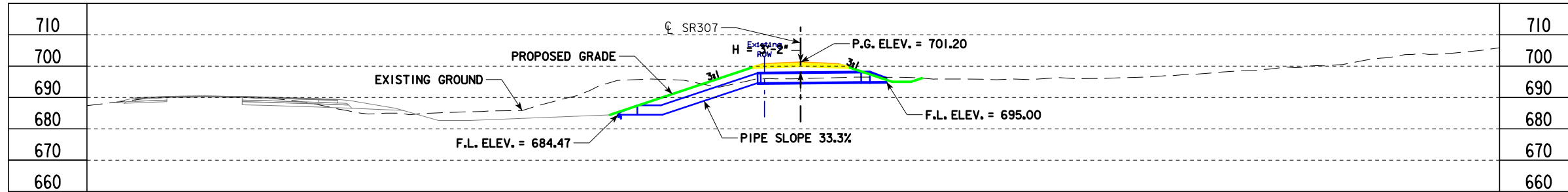

LONGITUDINAL SECTION ALONG  $\text{CL}$  CULVERT

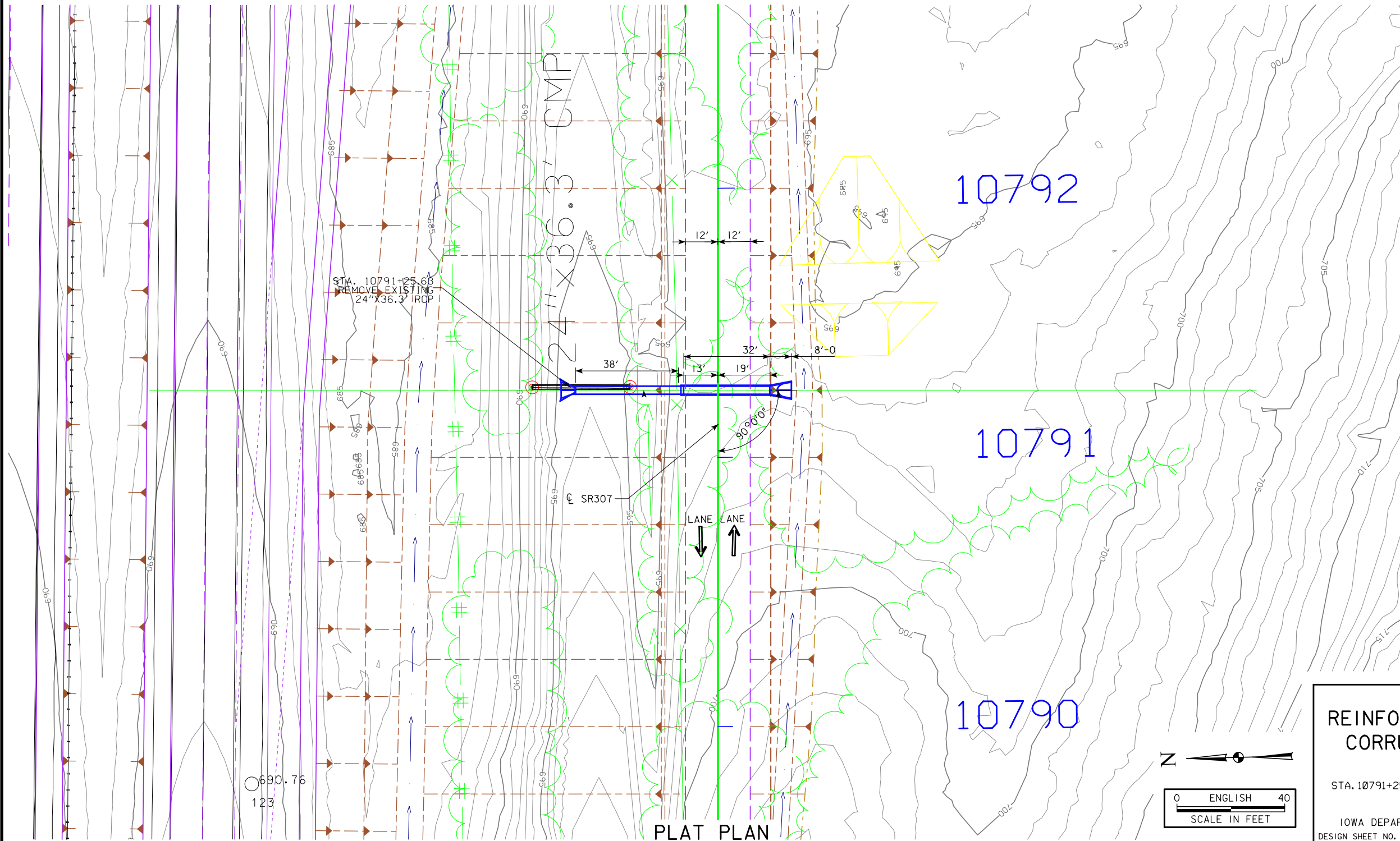

LOCATION

SR307  
T-79N R-2W  
SECTION 18  
SUGAR CREEK TOWNSHIP  
CEDAR COUNTY

HYDRAULIC DATA

DRAINAGE AREA = 7.3 ACRES  
DESIGN DISCHARGE = 75.3 CFS

DESIGN FOR 0° SKEW

36" x 70'  
REINFORCED CONCRETE PIPE &  
CORRUGATED PLASTIC PIPE  
PLAT PLAN

STA. 10791+25.00

AUGUST 2019

CEDAR COUNTY

IOWA DEPARTMENT OF TRANSPORTATION - HIGHWAY DIVISION  
DESIGN SHEET NO. ? OF ? FILE NO. ? DESIGN NO. ?



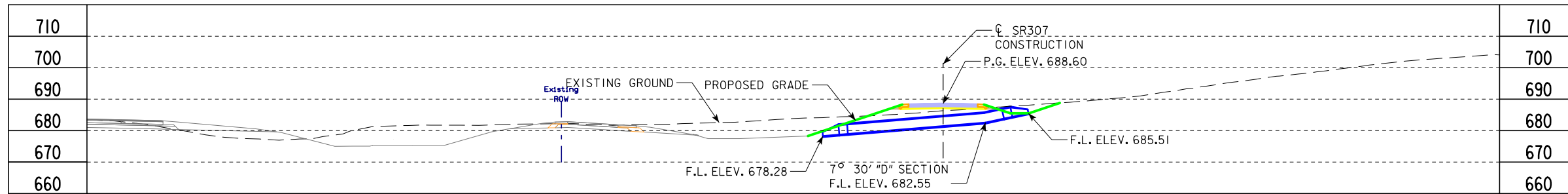

LONGITUDINAL SECTION ALONG  $\phi$  CULVERT

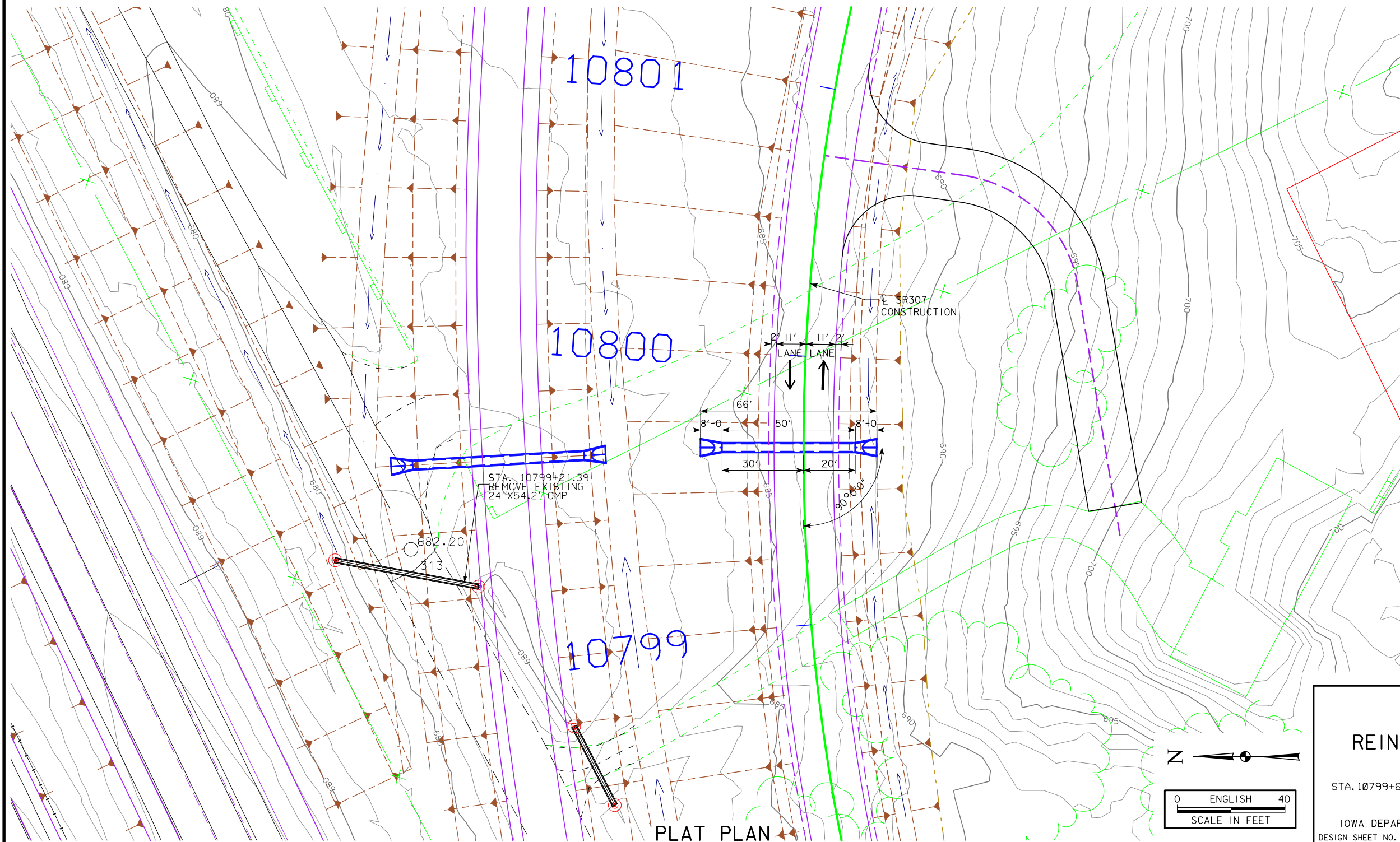

**LOCATION**

SR307  
T-79N R-2W  
SECTION 18  
SUGAR CREEK TOWNSHIP  
CEDAR COUNTY

**HYDRAULIC DATA**

DRAINAGE AREA = 15.0 ACRES  
DESIGN DISCHARGE = ---- CFS

DESIGN FOR 0° SKEW  
**36" x 50'**  
**REINFORCED CONCRETE PIPE**  
**PLAT PLAN**  
STA. 10799+66.00 AUGUST 2019  
**CEDAR COUNTY**  
IOWA DEPARTMENT OF TRANSPORTATION - HIGHWAY DIVISION  
DESIGN SHEET NO. ? OF ? FILE NO. ? DESIGN NO. ?



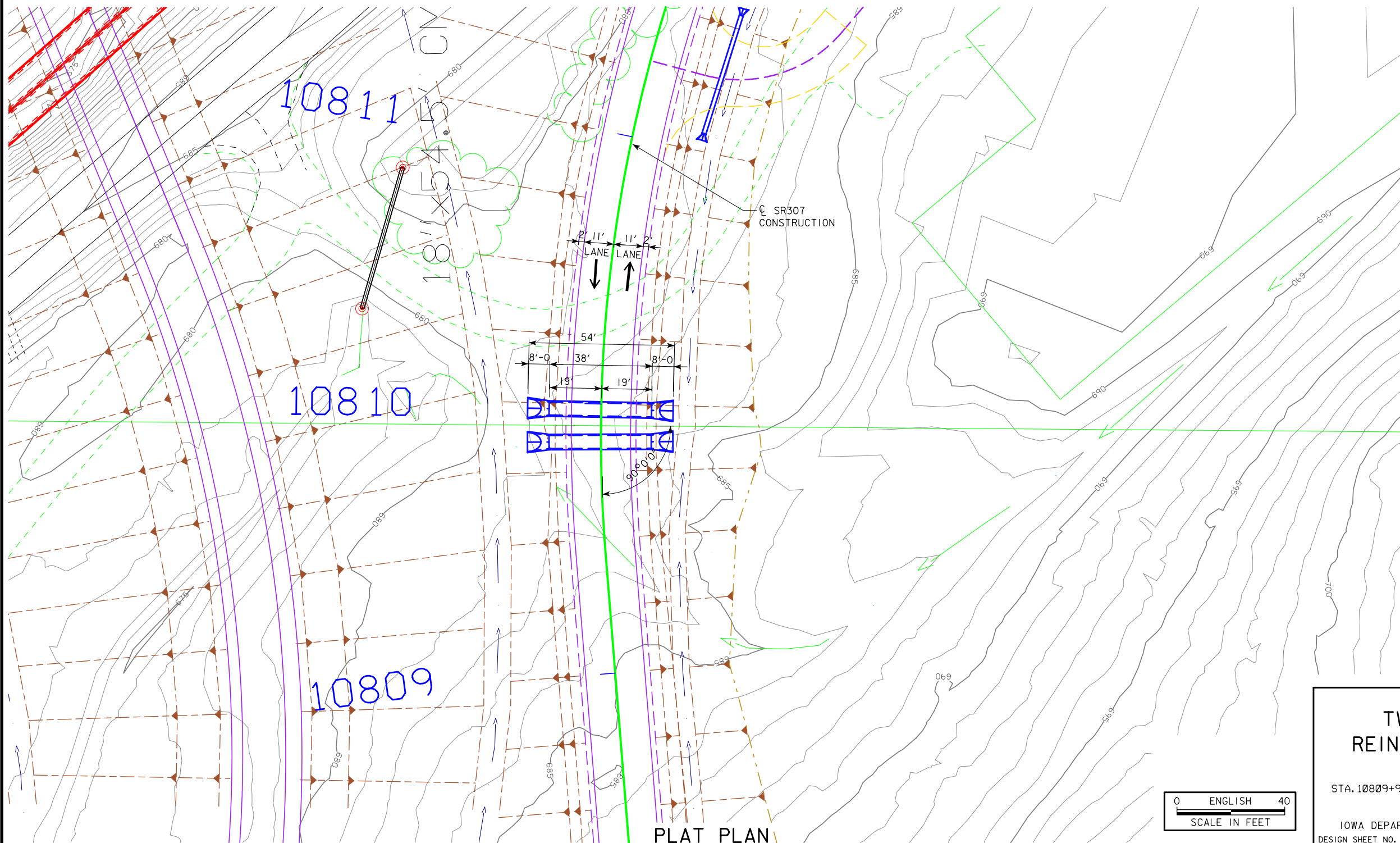
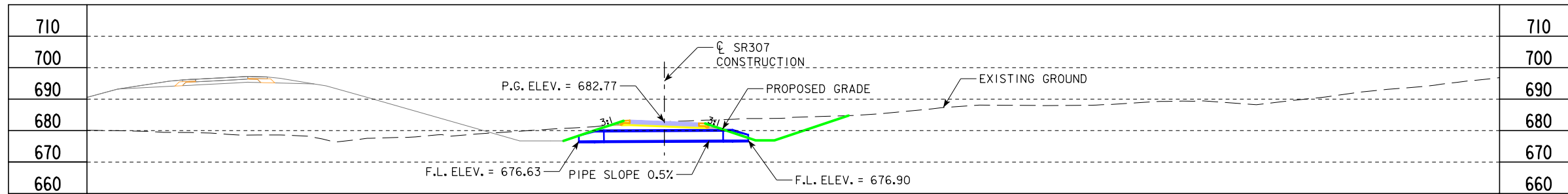

**LOCATION**

SR307  
T-79N R-2W  
SECTION 18  
SUGAR CREEK TOWNSHIP  
CEDAR COUNTY

**HYDRAULIC DATA**

DRAINAGE AREA = 59.8 ACRES  
DESIGN DISCHARGE = ---- CFS



DESIGN FOR 0° SKEW  
**TWIN 59" x 36" x 38'**  
**REINFORCED CONCRETE PIPE**  
**PLAT PLAN**  
STA. 10809+92.00 AUGUST 2019  
**CEDAR COUNTY**  
IOWA DEPARTMENT OF TRANSPORTATION - HIGHWAY DIVISION  
DESIGN SHEET NO. ? OF ? FILE NO. ? DESIGN NO. ?

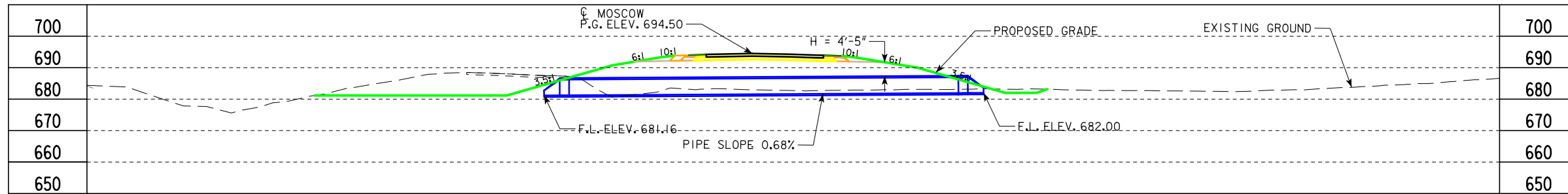

LONGITUDINAL SECTION ALONG CL CULVERT

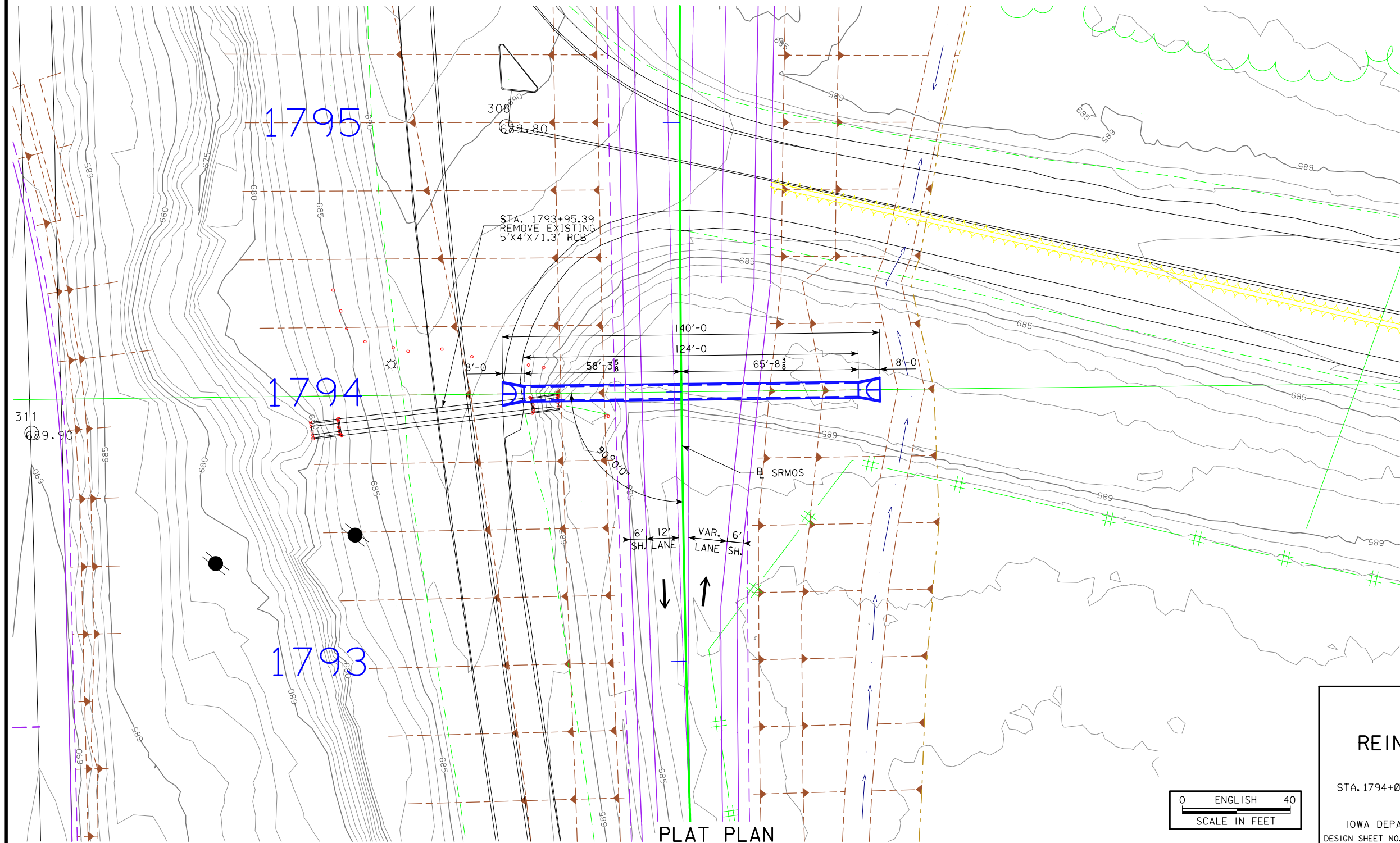

LOCATION

SRMOS  
T-79N R-2W  
SECTION 17  
SUGAR CREEK TOWNSHIP  
CEDAR COUNTY

HYDRAULIC DATA

DRAINAGE AREA = 106.6 ACRES  
DESIGN DISCHARGE = 214.8 CFS

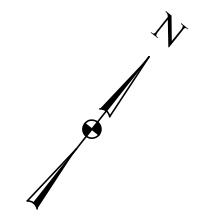

DESIGN FOR 0° SKEW  
**60" x 124'**  
**REINFORCED CONCRETE PIPE**  
**PLAT PLAN**  
 STA. 1794+00.00 AUGUST 2019  
**CEDAR COUNTY**  
 IOWA DEPARTMENT OF TRANSPORTATION - HIGHWAY DIVISION  
 DESIGN SHEET NO. ? OF ? FILE NO. ? DESIGN NO. ?

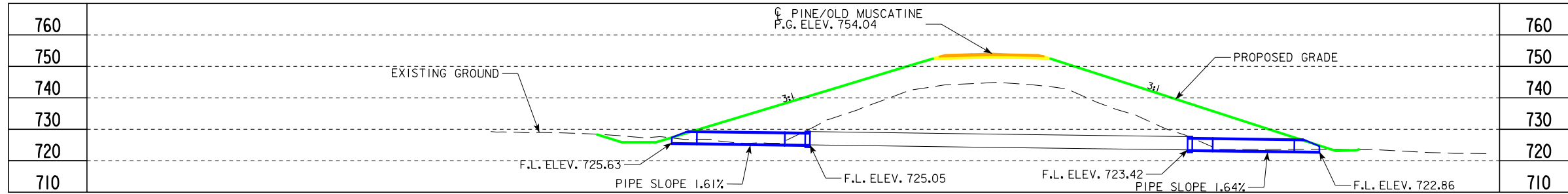

LONGITUDINAL SECTION ALONG  $\text{CL}$  CULVERT

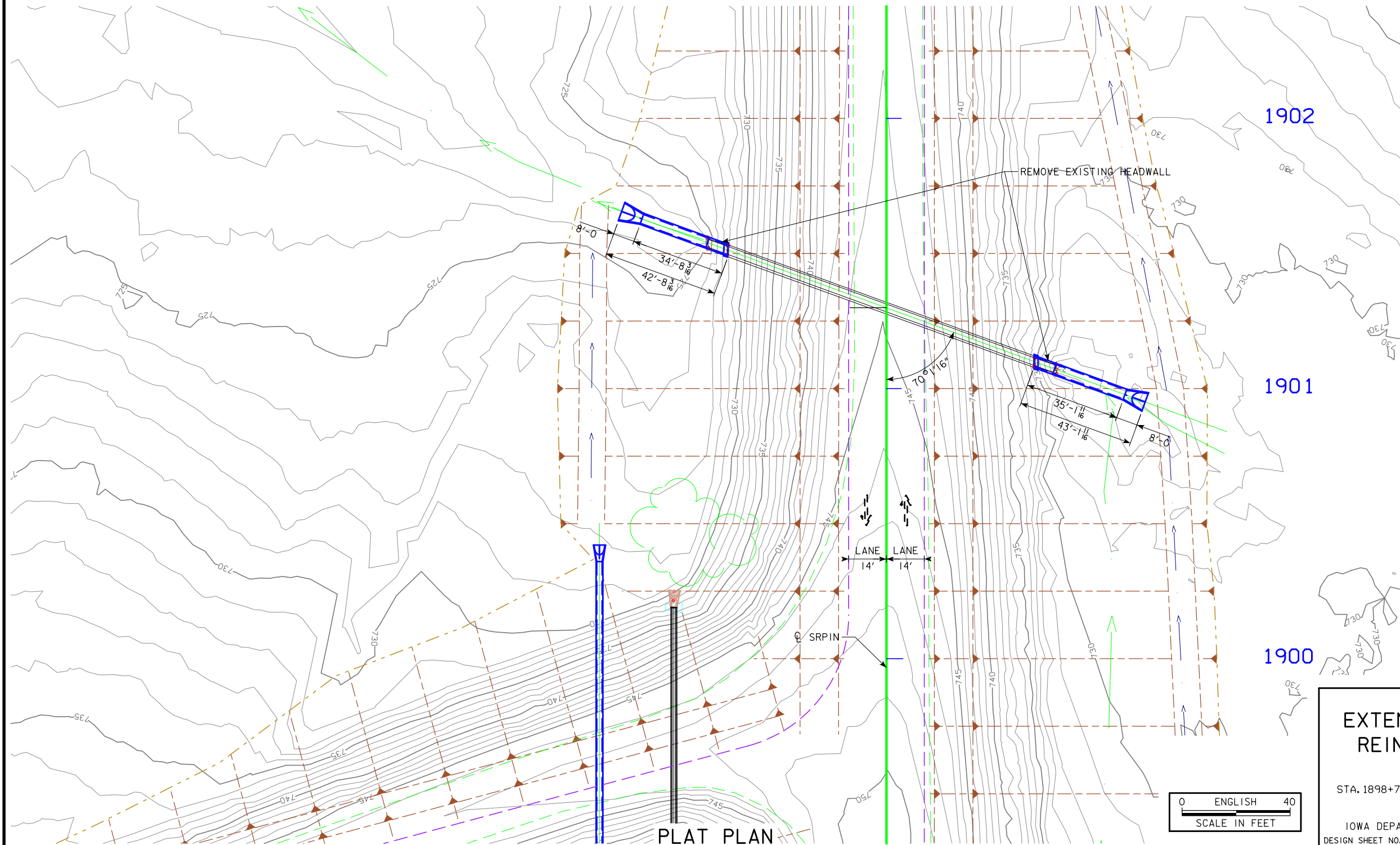

**LOCATION**

SRPIN  
T-79N R-2W  
SECTION 16  
SUGAR CREEK TOWNSHIP  
CEDAR COUNTY

**HYDRAULIC DATA**

DRAINAGE AREA = 2.4 ACRES  
DESIGN DISCHARGE = 113.8 CFS



DESIGN FOR 20° SKEW LT. AHD.  
**EXTEND 48" x 36' LT & 34' RT  
REINFORCED CONCRETE PIPE  
PLAT PLAN**  
STA. 1898+70.17  
AUGUST 2019  
**CEDAR COUNTY**  
IOWA DEPARTMENT OF TRANSPORTATION - HIGHWAY DIVISION  
DESIGN SHEET NO. ? OF ? FILE NO. ? DESIGN NO. ?





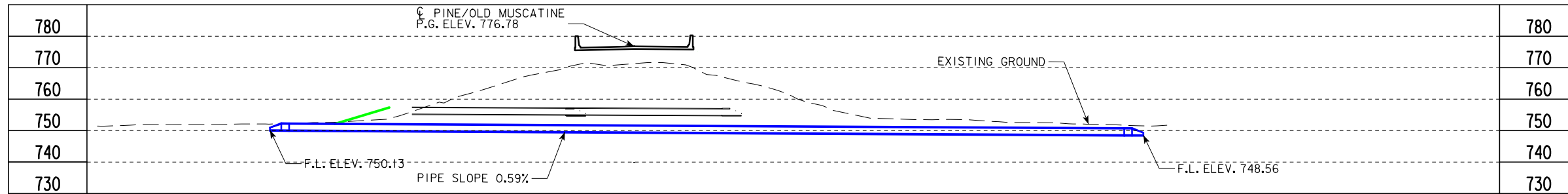

LONGITUDINAL SECTION ALONG  $\text{CL}$  CULVERT

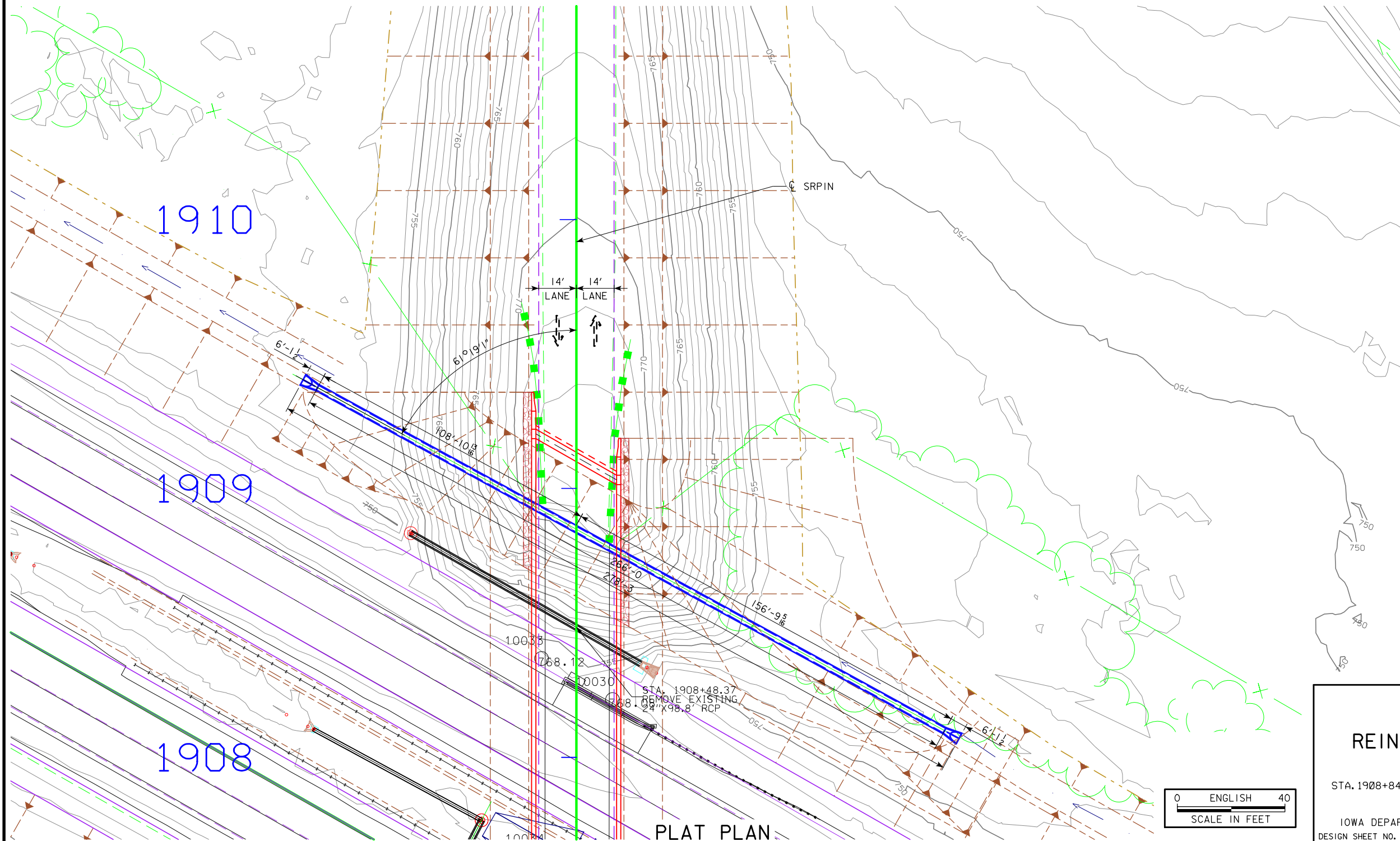

**LOCATION**

RPAYAN  
T-79N R-2W  
SECTION 16  
SUGAR CREEK TOWNSHIP  
CEDAR COUNTY

**HYDRAULIC DATA**

DRAINAGE AREA = 2.4 ACRES  
DESIGN DISCHARGE = 16.9 CFS

DESIGN FOR 29° SKEW LT. AHD.  
**24" x 266'**  
**REINFORCED CONCRETE PIPE**  
**PLAT PLAN**  
STA. 1908+84.84 AUGUST 2019  
**CEDAR COUNTY**  
IOWA DEPARTMENT OF TRANSPORTATION - HIGHWAY DIVISION  
DESIGN SHEET NO. ? OF ? FILE NO. ? DESIGN NO. ?



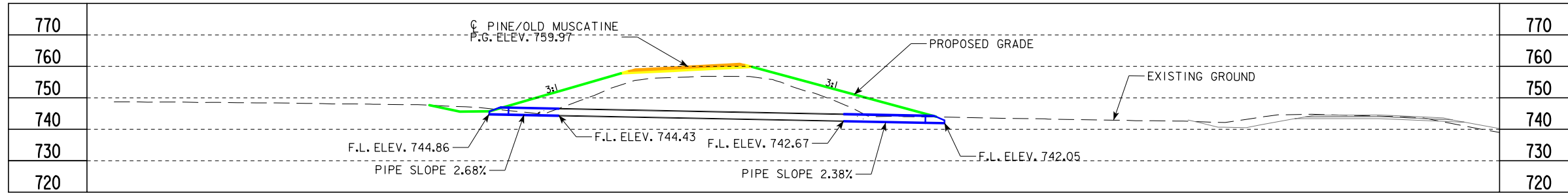

LONGITUDINAL SECTION ALONG  $\text{CL}$  CULVERT

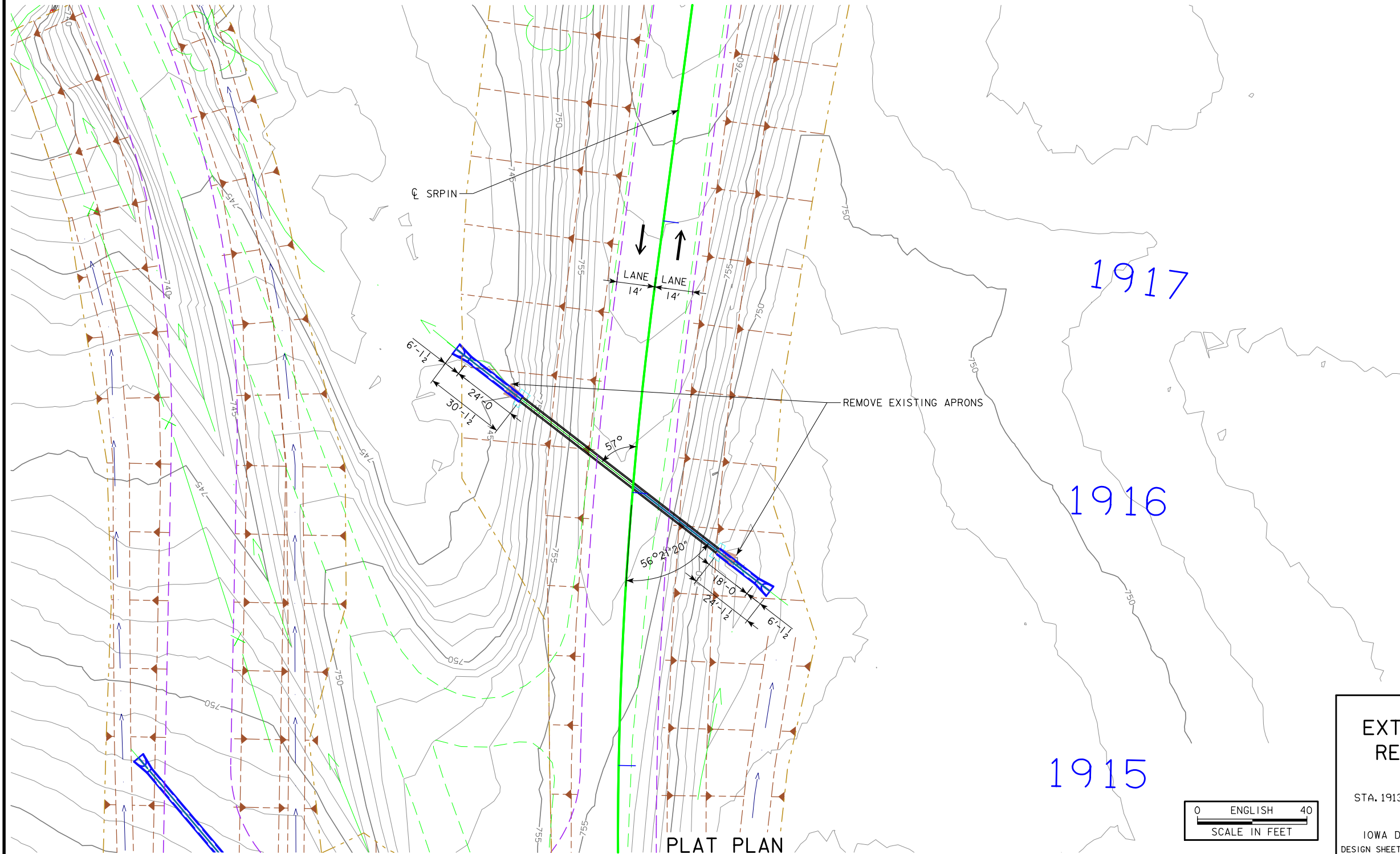

**LOCATION**

SRPIN  
T-79N R-2W  
SECTION 16  
SUGAR CREEK TOWNSHIP  
CEDAR COUNTY

**HYDRAULIC DATA**

DRAINAGE AREA = 1.7 ACRES  
DESIGN DISCHARGE = 30.4 CFS

DESIGN FOR 33° SKEW LT. AHD.  
**EXTEND 24" x 16' LT & 26' RT  
REINFORCED CONCRETE PIPE  
PLAT PLAN**  
STA. 1913+97.48 AUGUST 2019  
**CEDAR COUNTY**  
IOWA DEPARTMENT OF TRANSPORTATION - HIGHWAY DIVISION  
DESIGN SHEET NO. ? OF ? FILE NO. ? DESIGN NO. ?





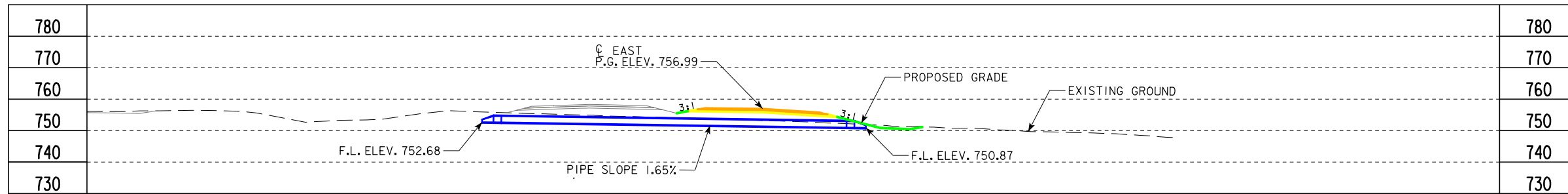

LONGITUDINAL SECTION ALONG CL CULVERT

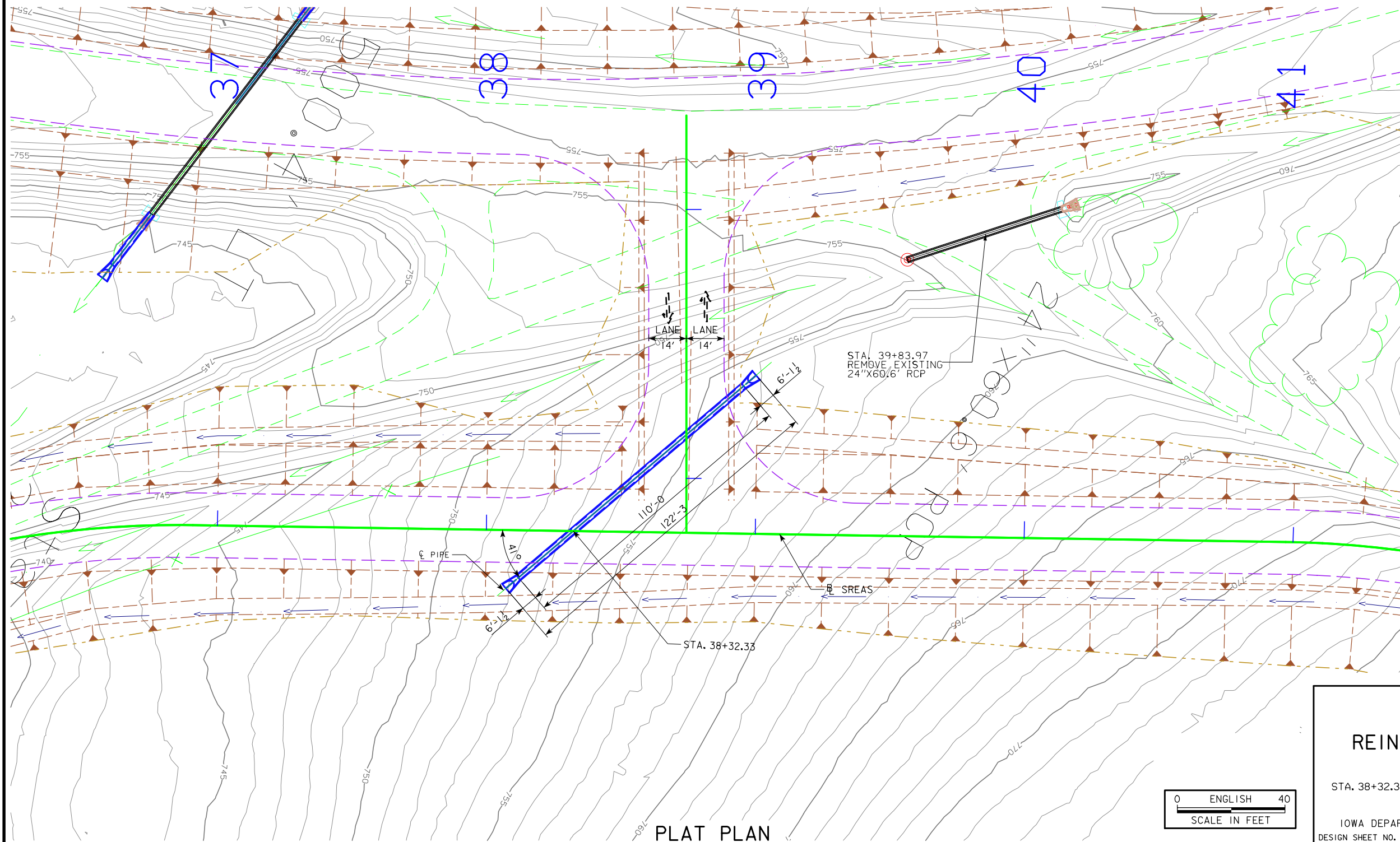

**LOCATION**

SREAS  
T-79N R-2W  
SECTION 16  
SUGAR CREEK TOWNSHIP  
CEDAR COUNTY

**HYDRAULIC DATA**

DRAINAGE AREA = 2.2 ACRES  
DESIGN DISCHARGE = 40.8 CFS

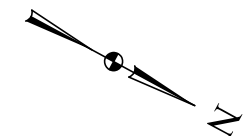

DESIGN FOR 49° SKEW LT. AHD.  
**24" x 110'**  
**REINFORCED CONCRETE PIPE**  
**PLAT PLAN**  
STA. 38+32.33  
AUGUST 2019  
**CEDAR COUNTY**  
IOWA DEPARTMENT OF TRANSPORTATION - HIGHWAY DIVISION  
DESIGN SHEET NO. ? OF ? FILE NO. ? DESIGN NO. ?



PLAT PLAN



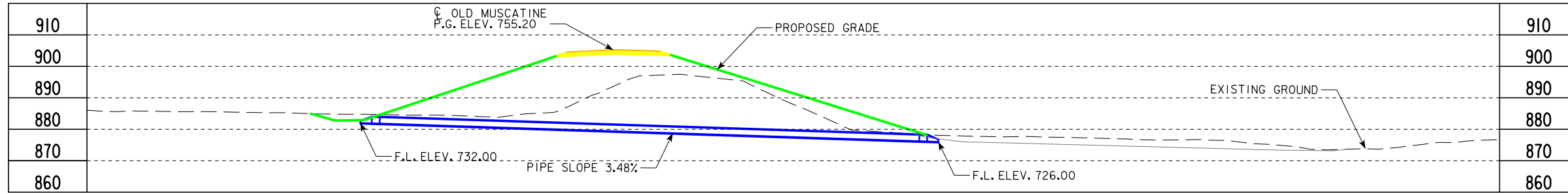

LONGITUDINAL SECTION ALONG  $\phi$  CULVERT

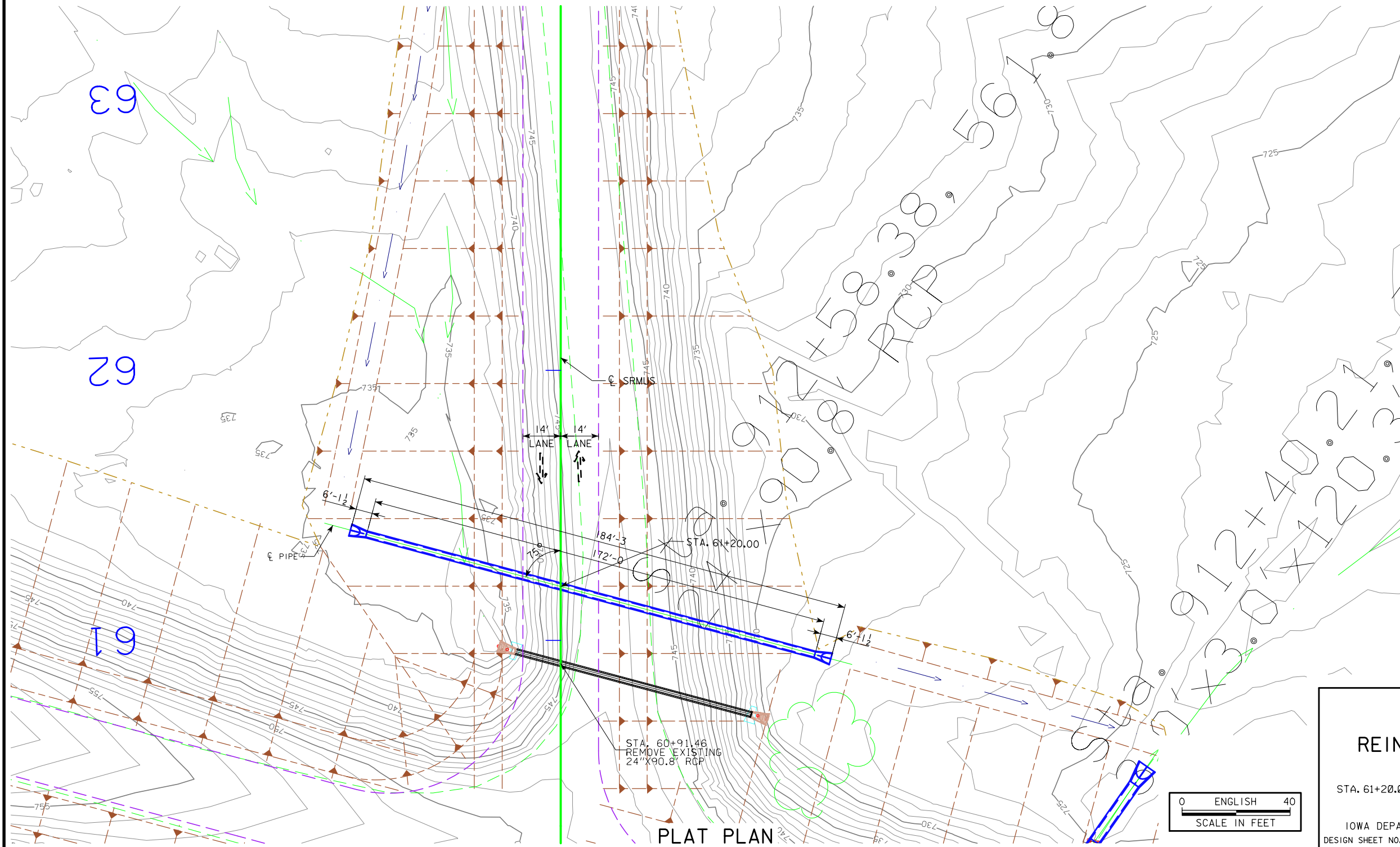

**LOCATION**

SRMUS  
T-79N R-2W  
SECTION 16  
SUGAR CREEK TOWNSHIP  
CEDAR COUNTY

**HYDRAULIC DATA**

DRAINAGE AREA = 6.1 ACRES  
DESIGN DISCHARGE = 27.5 CFS

DESIGN FOR 15° SKEW  
**24" x 172'**  
**REINFORCED CONCRETE PIPE**  
**PLAT PLAN**  
STA. 61+20.00  
AUGUST 2019  
**CEDAR COUNTY**  
IOWA DEPARTMENT OF TRANSPORTATION - HIGHWAY DIVISION  
DESIGN SHEET NO. ? OF ? FILE NO. ? DESIGN NO. ?



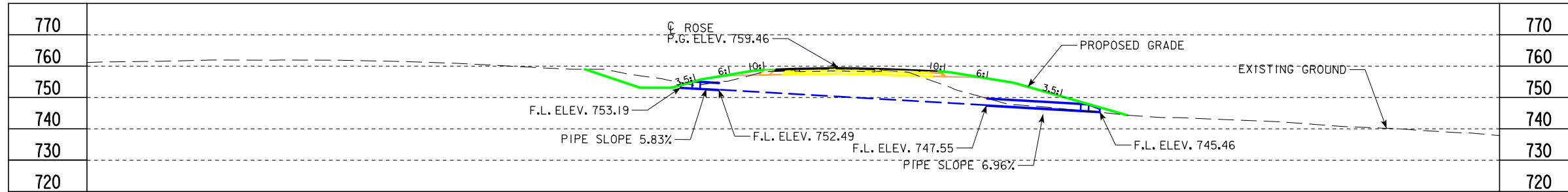

LONGITUDINAL SECTION ALONG C<sub>L</sub> CULVERT

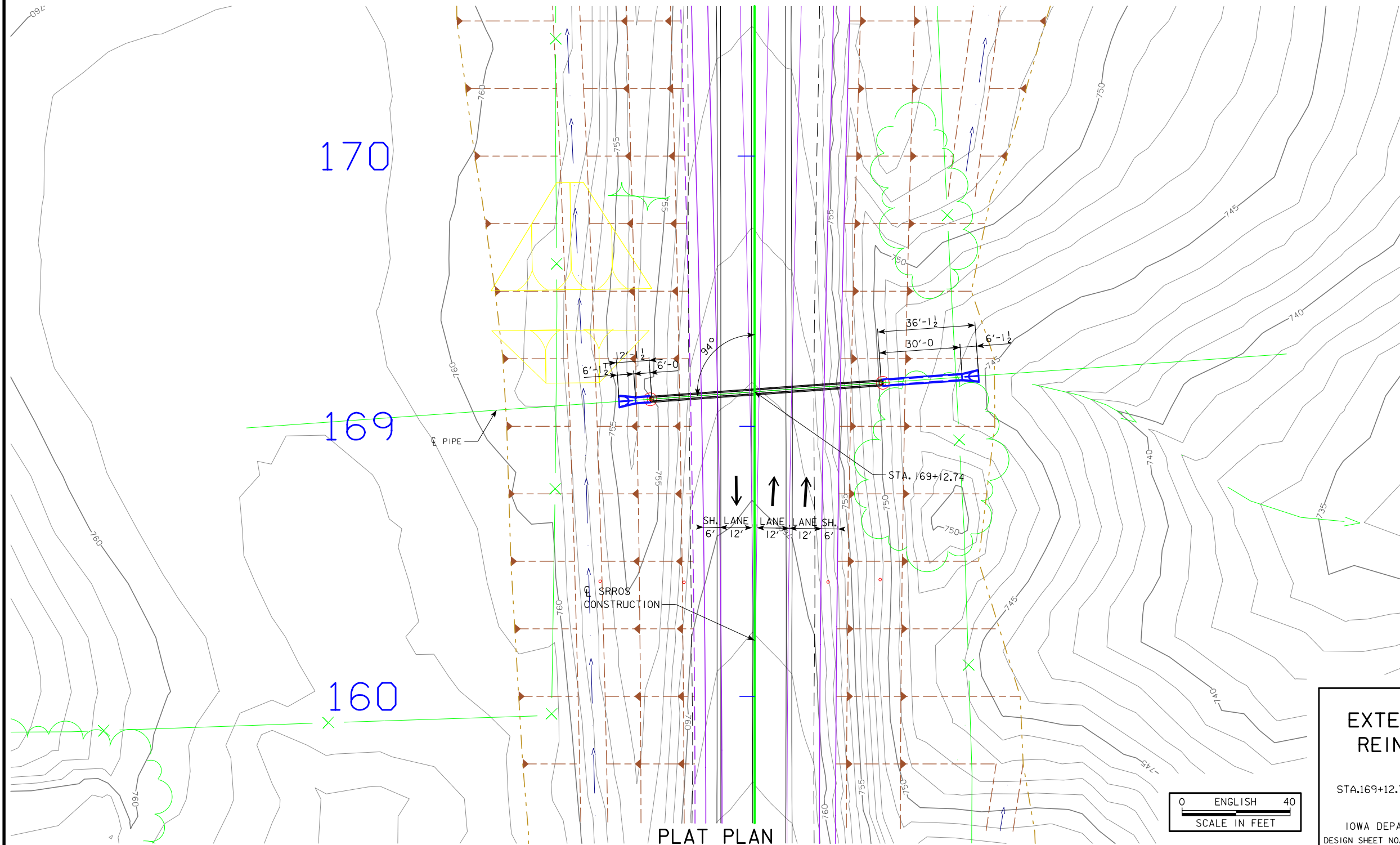

**LOCATION**

SRROS  
T-79N R-2W  
SECTION 23  
SUGAR CREEK TOWNSHIP  
CEDAR COUNTY

**HYDRAULIC DATA**

DRAINAGE AREA = 4.9 ACRES  
DESIGN DISCHARGE = 56.9 CFS

DESIGN FOR 4° SKEW  
**EXTEND 24" x 6' LT & 30' RT  
REINFORCED CONCRETE PIPE  
PLAT PLAN**  
STA. 169+12.74  
AUGUST 2019  
**CEDAR COUNTY**  
IOWA DEPARTMENT OF TRANSPORTATION - HIGHWAY DIVISION  
DESIGN SHEET NO. ? OF ? FILE NO. ? DESIGN NO. ?





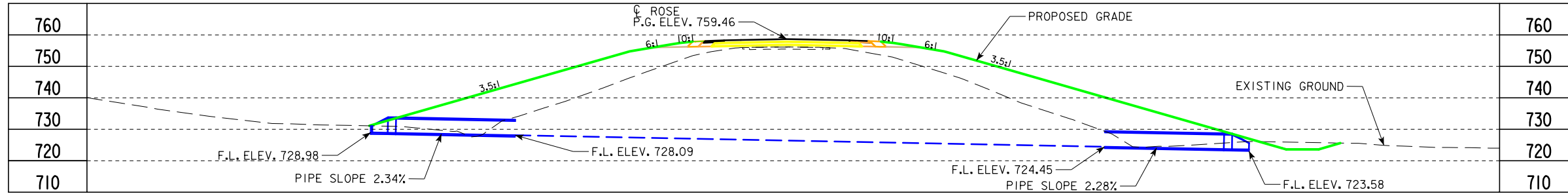

LONGITUDINAL SECTION ALONG  $\bar{C}$  CULVERT

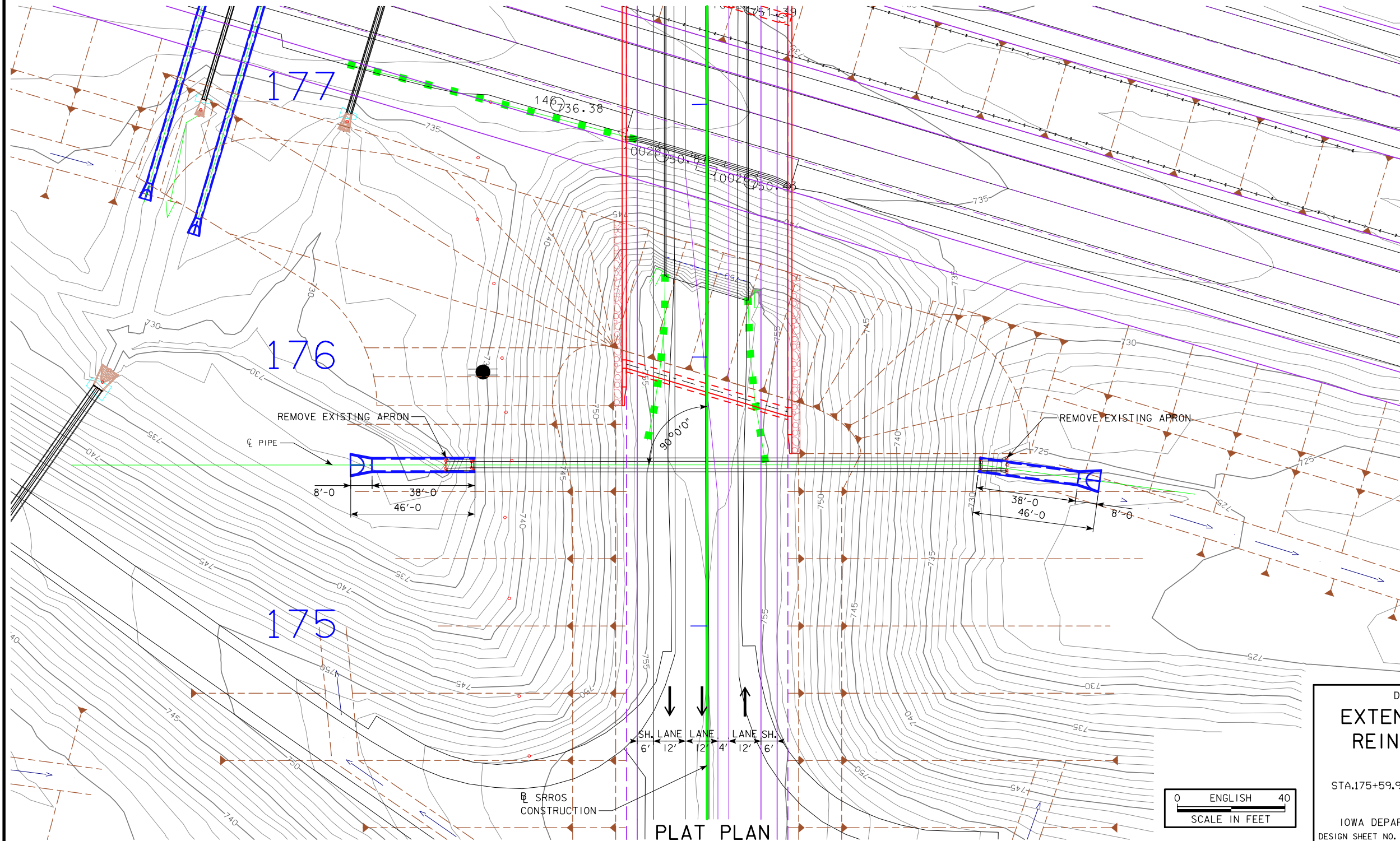

**LOCATION**

SRROS  
T-79N R-2W  
SECTION 23  
SUGAR CREEK TOWNSHIP  
CEDAR COUNTY

**HYDRAULIC DATA**

DRAINAGE AREA = 69.2 ACRES  
DESIGN DISCHARGE = 287.0 CFS

DESIGN FOR RT. EXT. 8° SKEW RT. AHD.  
**EXTEND 54" x 20' LT & 22' RT  
 REINFORCED CONCRETE PIPE  
 PLAT PLAN**  
 STA. 175+59.93  
 AUGUST 2019  
**CEDAR COUNTY**  
 IOWA DEPARTMENT OF TRANSPORTATION - HIGHWAY DIVISION  
 DESIGN SHEET NO. ? OF ? FILE NO. ? DESIGN NO. ?





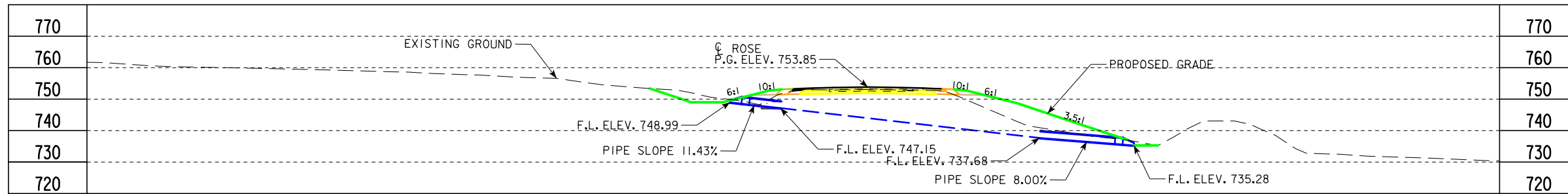

LONGITUDINAL SECTION ALONG  $\phi$  CULVERT

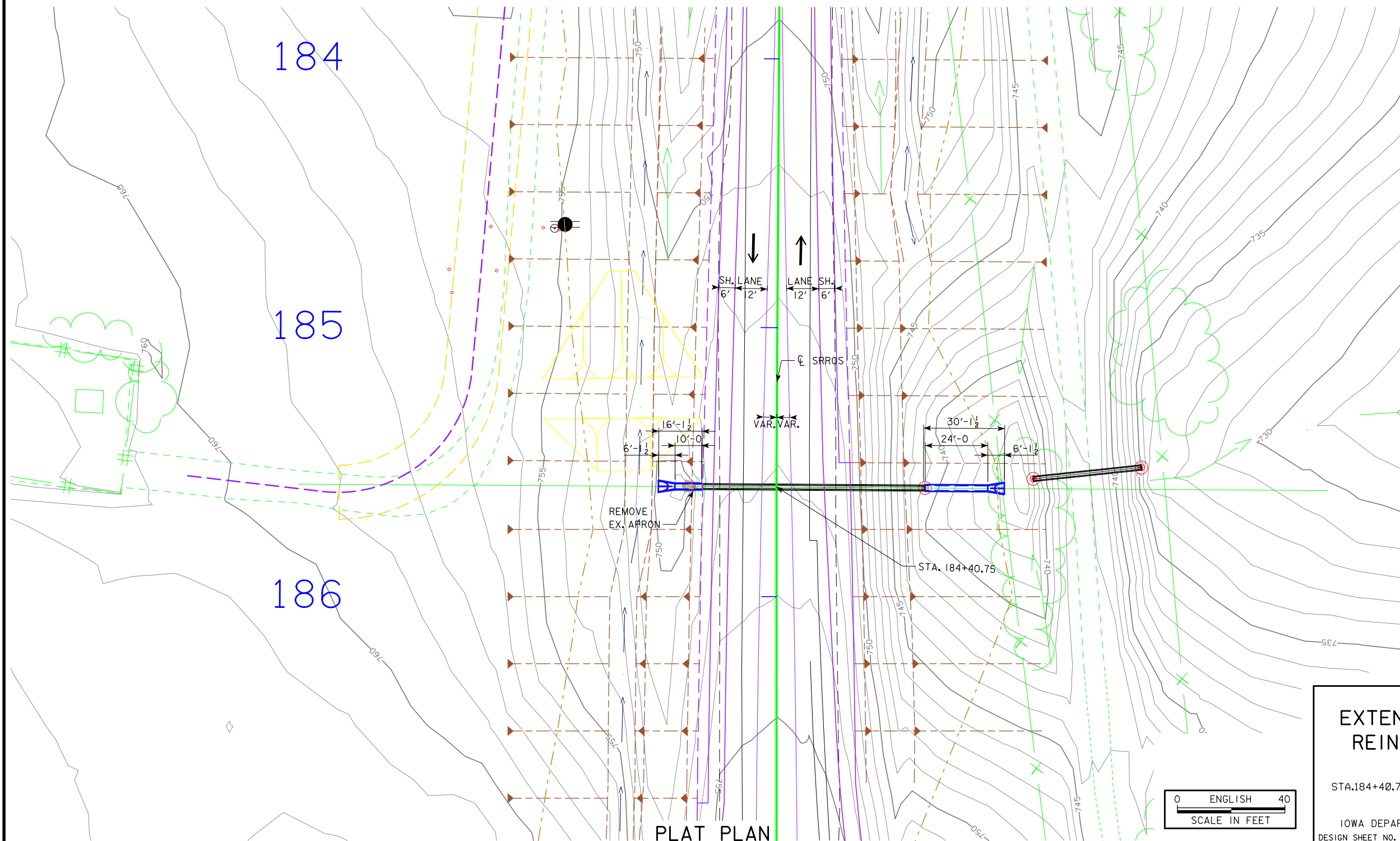

PLAT PLAN

**LOCATION**

SRROS  
T-79N R-2W  
SECTION 23  
SUGAR CREEK TOWNSHIP  
CEDAR COUNTY

**HYDRAULIC DATA**

DRAINAGE AREA = 1.7 ACRES  
DESIGN DISCHARGE = ---- CFS



DESIGN FOR 0° SKEW  
**EXTEND 24" x 10' LT & 24' RT  
 REINFORCED CONCRETE PIPE  
 PLAT PLAN**  
 STA.184+40.75 AUGUST 2019  
**CEDAR COUNTY**  
 IOWA DEPARTMENT OF TRANSPORTATION - HIGHWAY DIVISION  
 DESIGN SHEET NO. ? OF ? FILE NO. ? DESIGN NO. ?

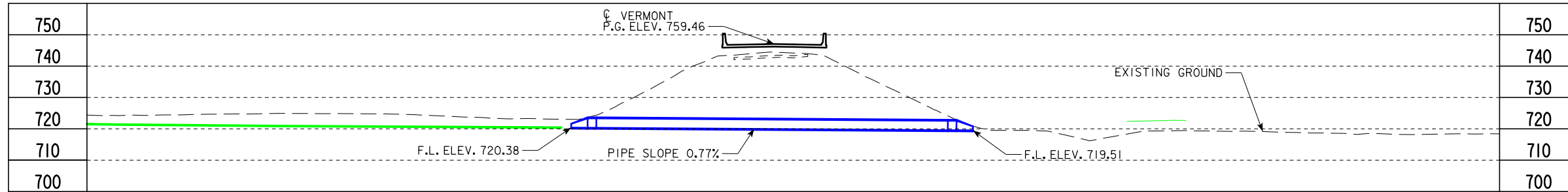

LONGITUDINAL SECTION ALONG  $\phi$  CULVERT

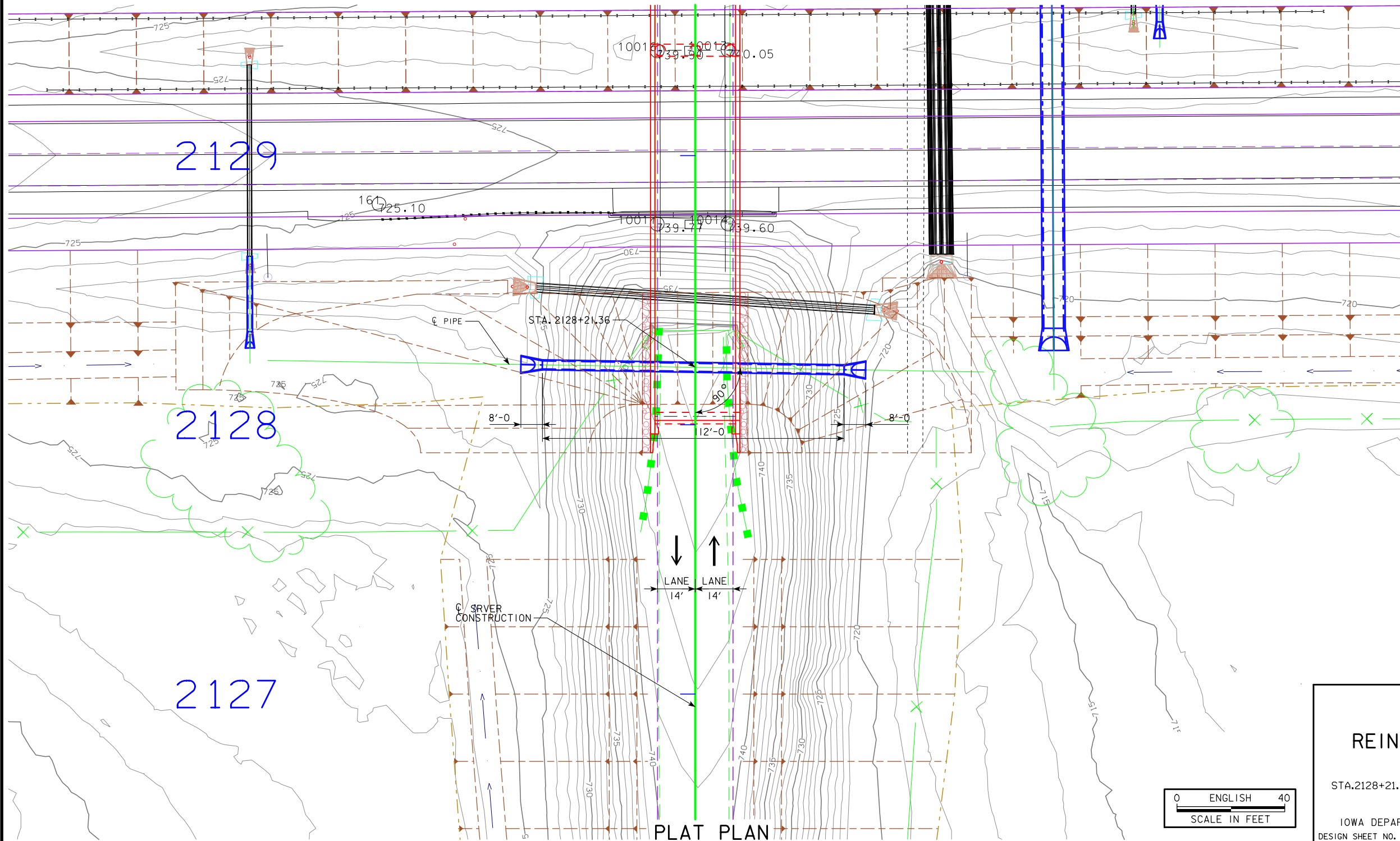

**LOCATION**

SRVER  
T-79N R-1W  
SECTION 21  
FARMINGTON TOWNSHIP  
CEDAR COUNTY

**HYDRAULIC DATA**

DRAINAGE AREA = 11.6 ACRES  
DESIGN DISCHARGE = 55.0 CFS



DESIGN FOR 0° SKEW  
**36" x 112'**  
**REINFORCED CONCRETE PIPE**  
**PLAT PLAN**  
STA.2128+21.36 AUGUST 2019  
**CEDAR COUNTY**  
IOWA DEPARTMENT OF TRANSPORTATION - HIGHWAY DIVISION  
DESIGN SHEET NO. ? OF ? FILE NO. ? DESIGN NO. ?

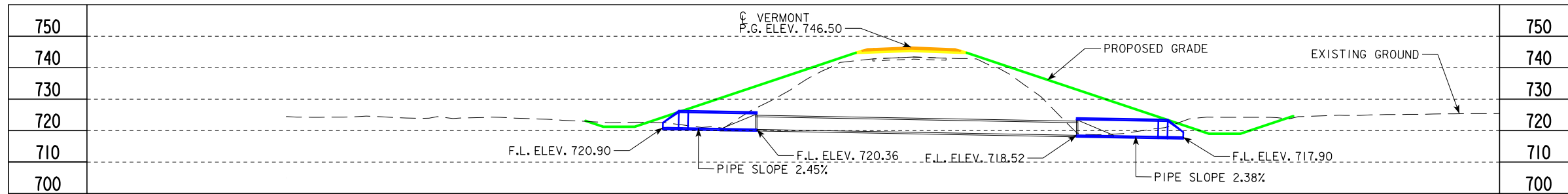

LONGITUDINAL SECTION ALONG  $\bar{C}$  CULVERT

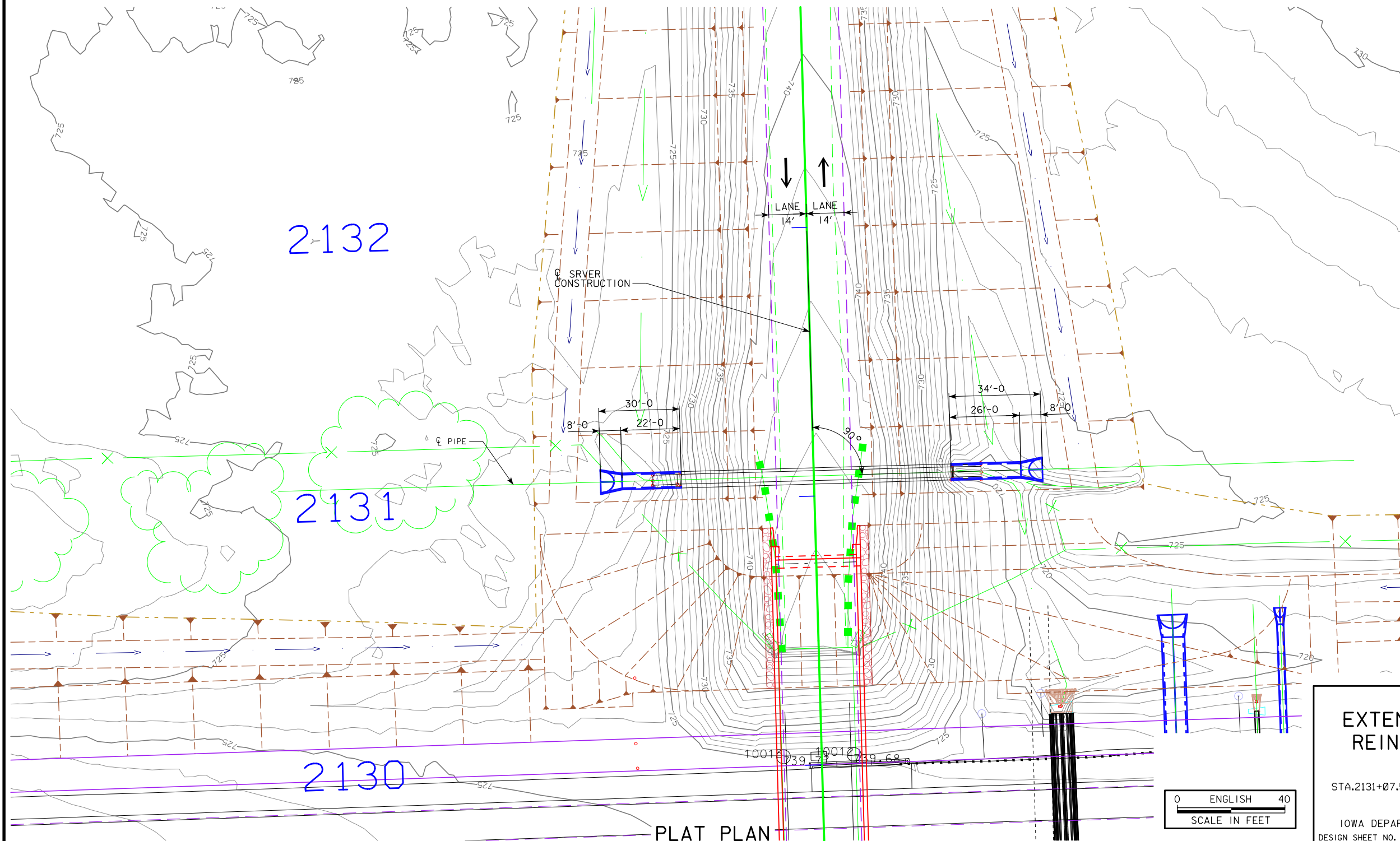

**LOCATION**

SRVER  
T-79N R-1W  
SECTION 21  
FARMINGTON TOWNSHIP  
CEDAR COUNTY

**HYDRAULIC DATA**

DRAINAGE AREA = 77.3 ACRES  
DESIGN DISCHARGE = 350.4 CFS



DESIGN FOR 0° SKEW  
**EXTEND 60" x 22' LT & 26' RT  
 REINFORCED CONCRETE PIPE  
 PLAT PLAN**  
 STA.2131+07.52  
 AUGUST 2019  
**CEDAR COUNTY**  
 IOWA DEPARTMENT OF TRANSPORTATION - HIGHWAY DIVISION  
 DESIGN SHEET NO. ? OF ? FILE NO. ? DESIGN NO. ?





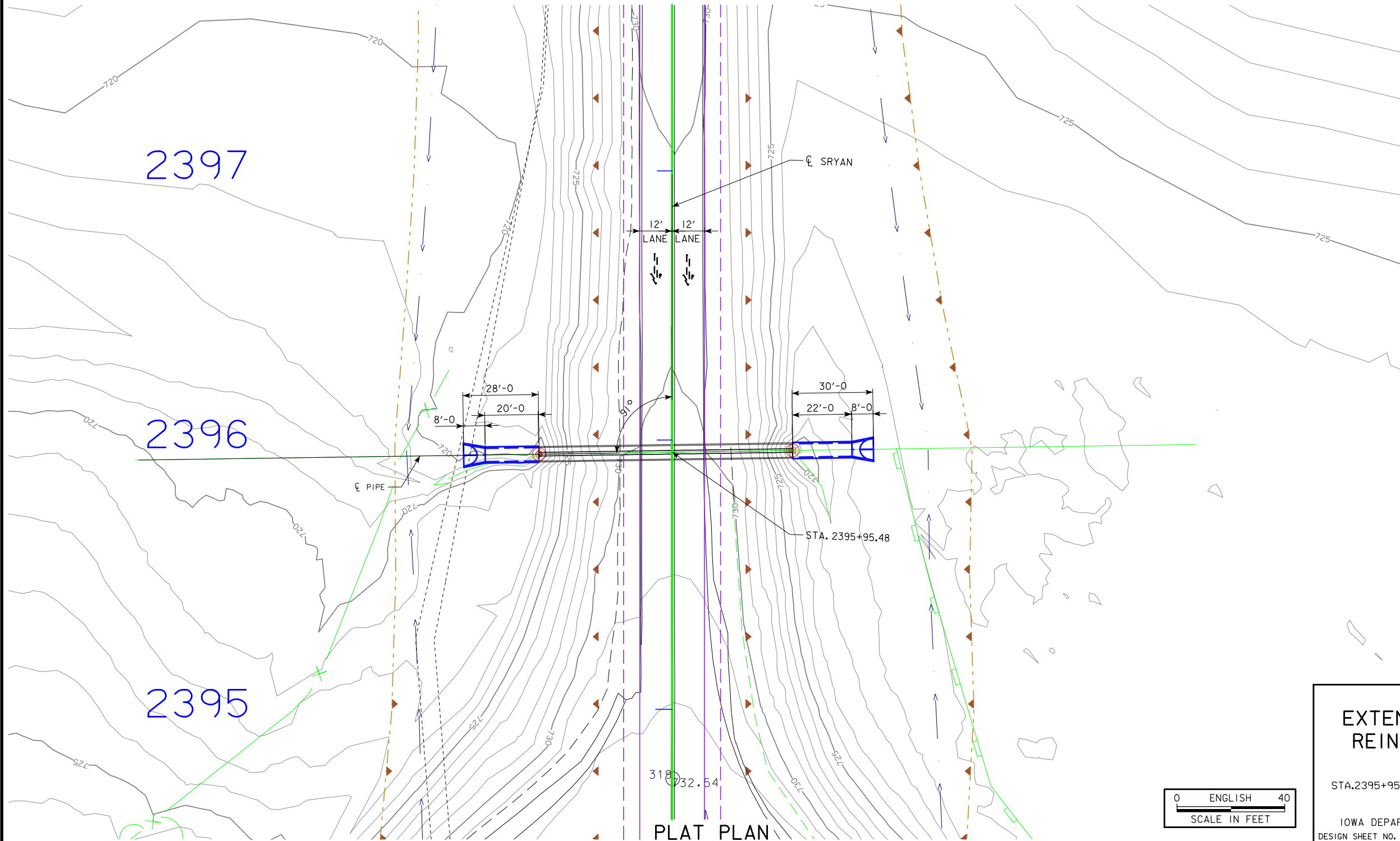
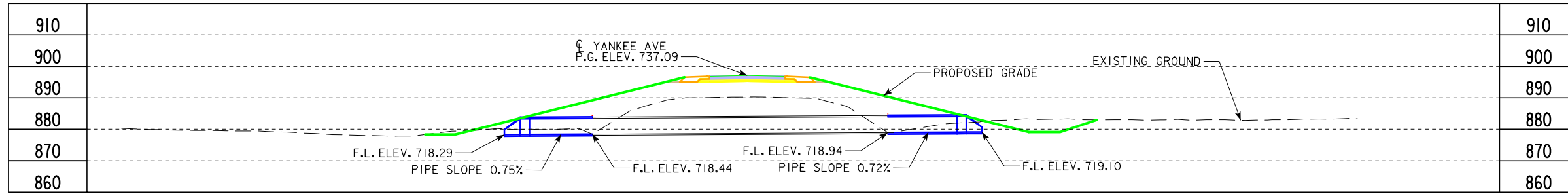

**LOCATION**

SRVER  
T-79N R-1W  
SECTION 23  
FARMINGTON TOWNSHIP  
CEDAR COUNTY

**HYDRAULIC DATA**

DRAINAGE AREA = 136.9 ACRES  
DESIGN DISCHARGE = 189.6 CFS



DESIGN FOR 1° SKEW RT. AHD.

**EXTEND 60" x 20' LT & 22' RT  
REINFORCED CONCRETE PIPE  
PLAT PLAN**

STA. 2395+95.48

AUGUST 2019

**CEDAR COUNTY**

IOWA DEPARTMENT OF TRANSPORTATION - HIGHWAY DIVISION

DESIGN SHEET NO. ? OF ? FILE NO. ? DESIGN NO. ?

**LINE STYLE LEGEND OF CROSS SECTION SHEETS (ROAD)**

- · · · · Existing Ground Line
- Proposed Template
- Proposed Topsoil Placement
- · · · · Additional Topsoil Removal
- Subgrade Treatment
- · · · · Granular Shoulder
- Pavement
- · · · · Existing Pipe\RCB
- Proposed Pipe\RCB
- Proposed Dike
- All Elements Associated with Proposed Entrances

**LINE STYLE LEGEND OF CROSS SECTION SHEETS (SOILS)**

- TOPSOIL ——— Topsoil (Class 10)
- Slope Dressing Only
- CL 10 ——— Class 10 Materials
- SEL LO ——— Select Loams And Clay-Loams
- SEL SA ——— Select Sand
- UNS A ——— Unsuitable Type A Disposal
- UNS B ——— Unsuitable Type B Disposal
- UNS C ——— Unsuitable Type C Disposal
- SHALE ——— Shale
- WASTE ——— Waste
- B&W LS ——— Broken and Weathered Rock
- ROCK ——— Solid Rock
- BLDRS ——— Boulders

Note: All layer lines and descriptions identify layers above the line.

Note: Vertical or near vertical lines connecting soil layers at edges of cross sections are only for the purpose of calculating template quantities and do not depict soil stratification.

**SYMBOL LEGEND OF CROSS SECTION SHEETS**

- Existing ROW  
|  
Existing Right-of-Way Limit
- Proposed ROW  
|  
Proposed Right-of-Way Limit
- Temporary ROW  
|  
Temporary Right-of-Way Limit

**CROSS SECTION  
LEGEND AND SYMBOL  
INFORMATION SHEET**

(COVERS SHEET SERIES W, X, Y, & Z)

# I-80 WB (MLWBSH080) Preliminary

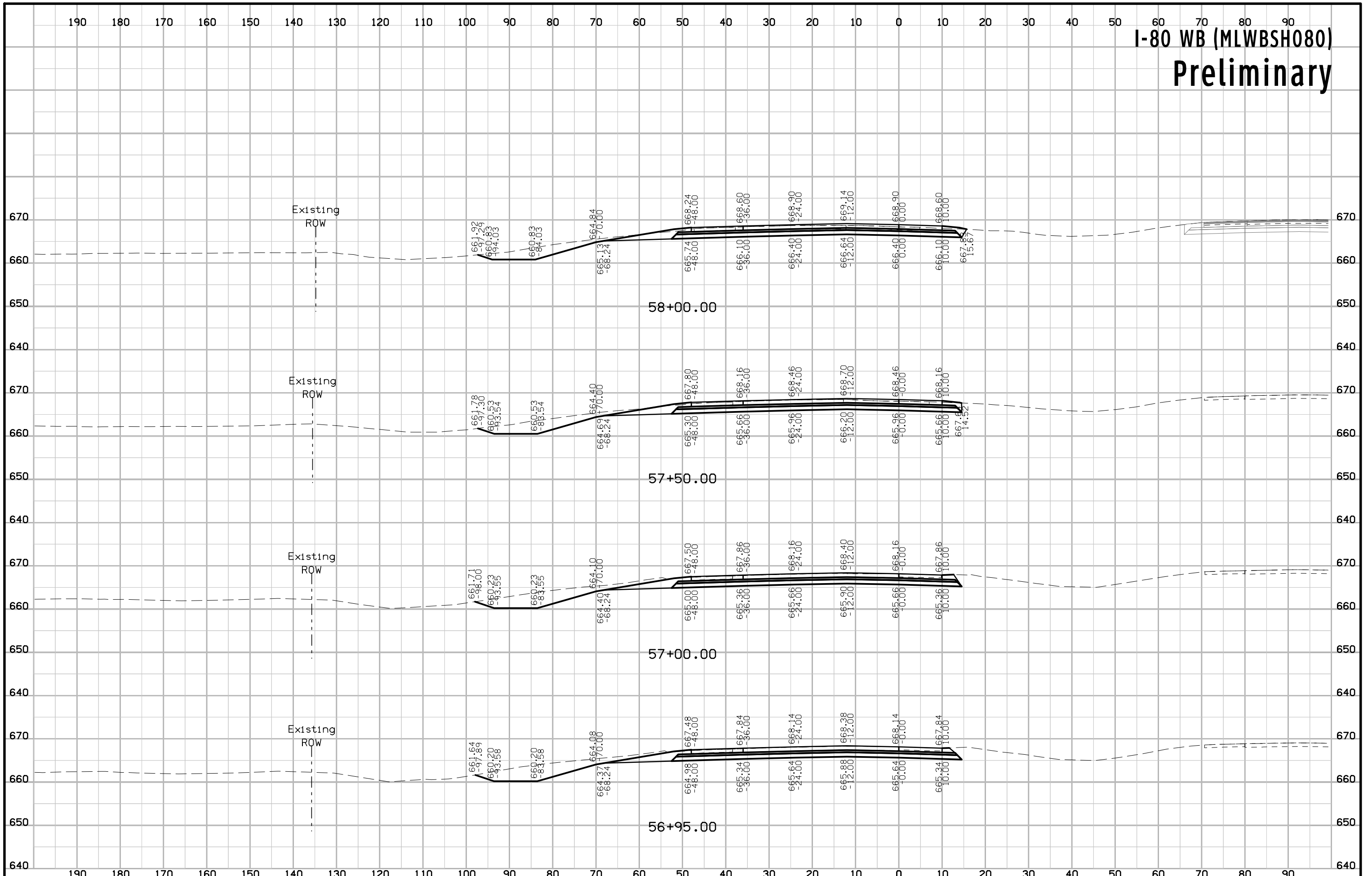



# I-80 WB (MLWBSH080) Preliminary

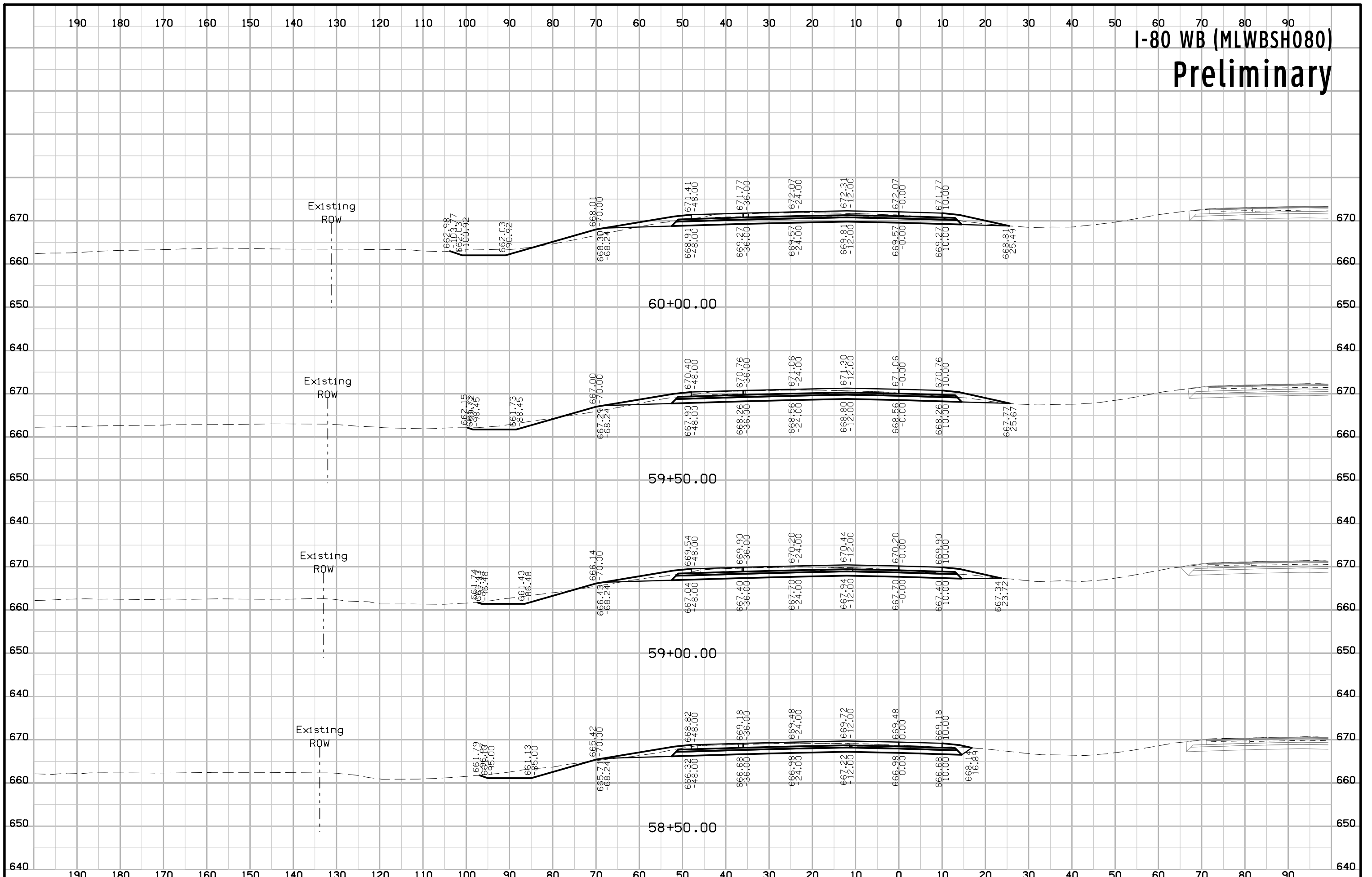

# I-80 WB (MLWBSH080) Preliminary

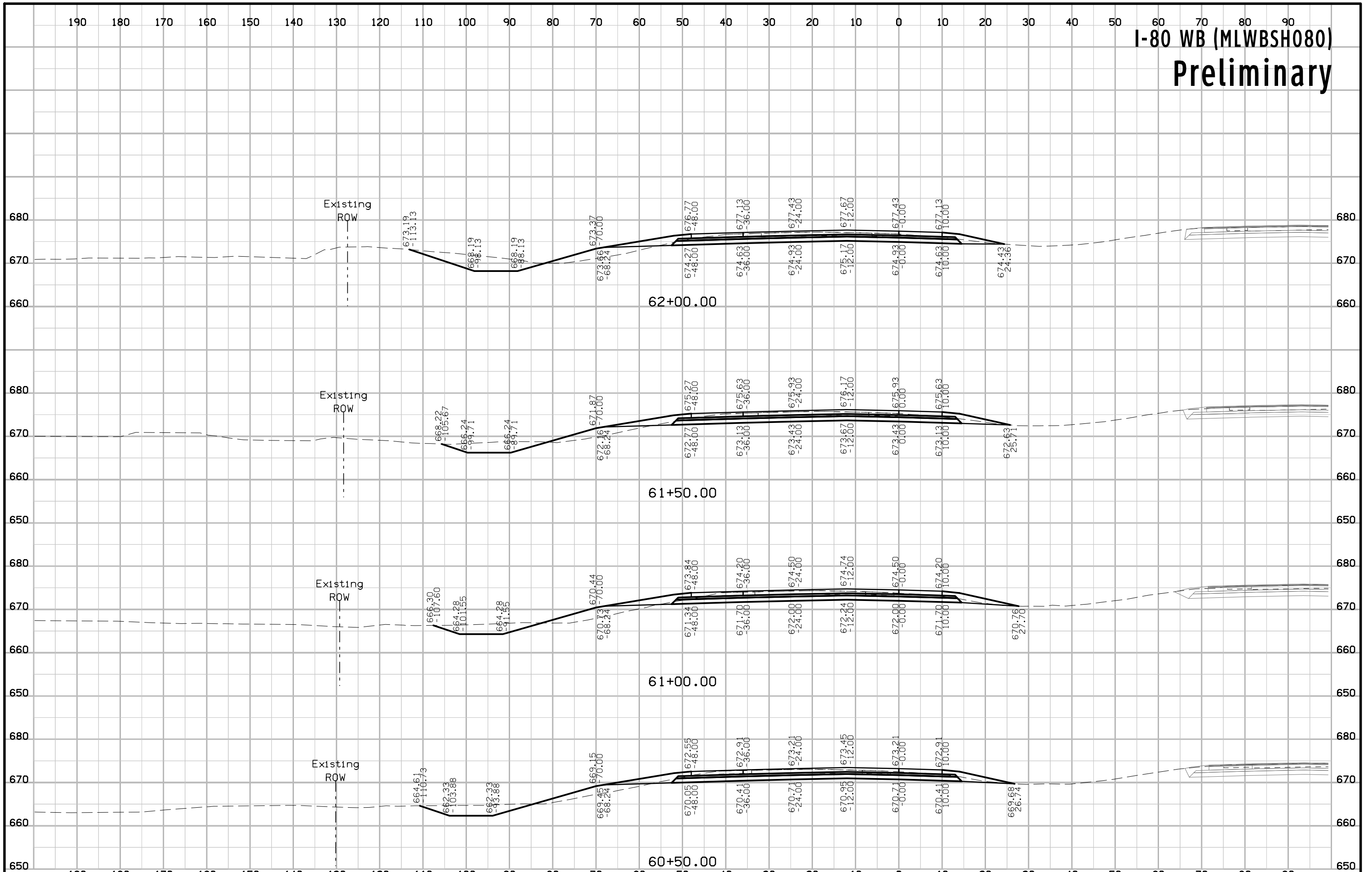

Preliminary

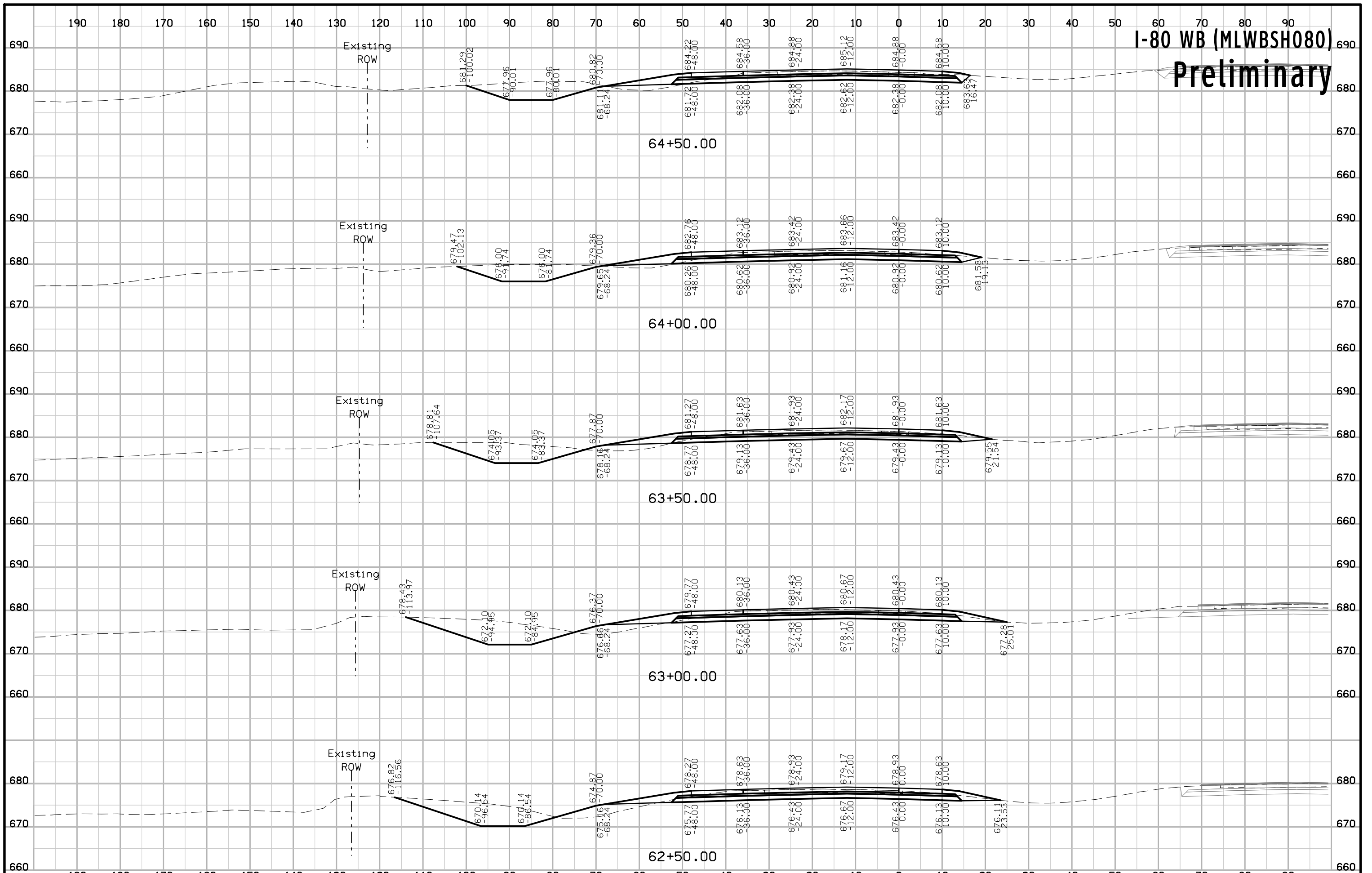



# I-80 WB (MLWBSH080) Preliminary

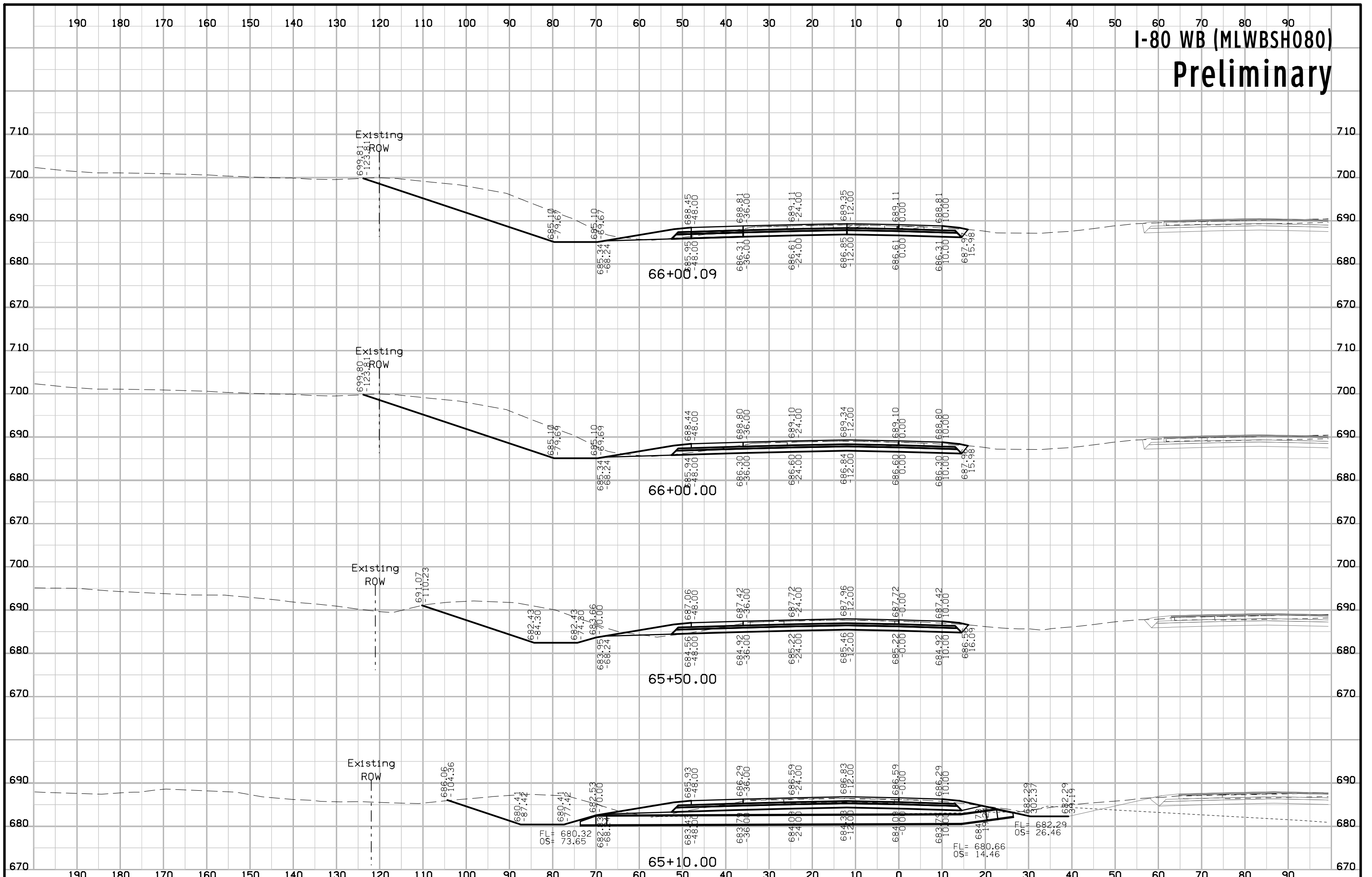

# I-80 WB (SURMLA080) Preliminary

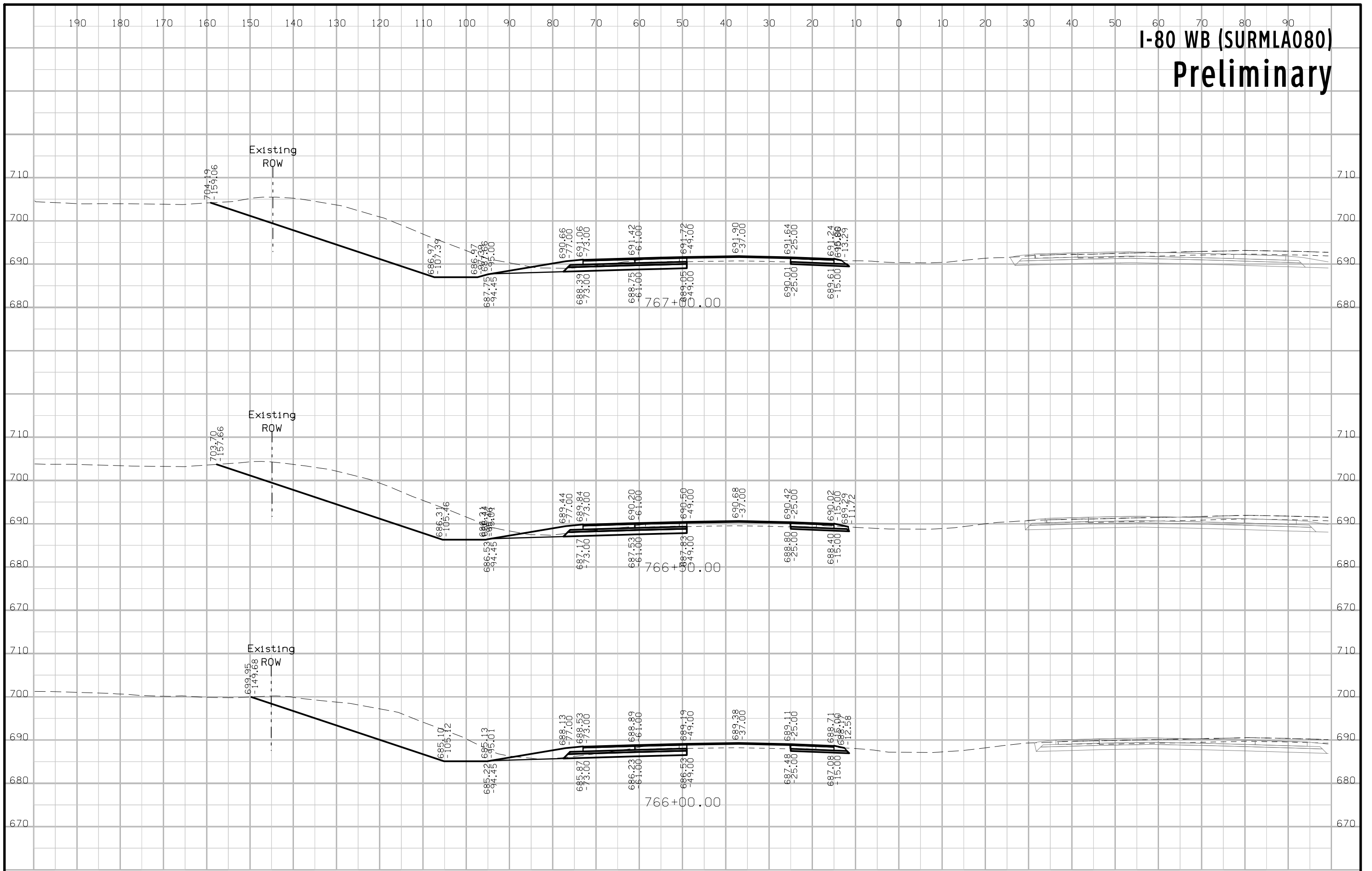

# I-80 WB (SURMLA080) Preliminary

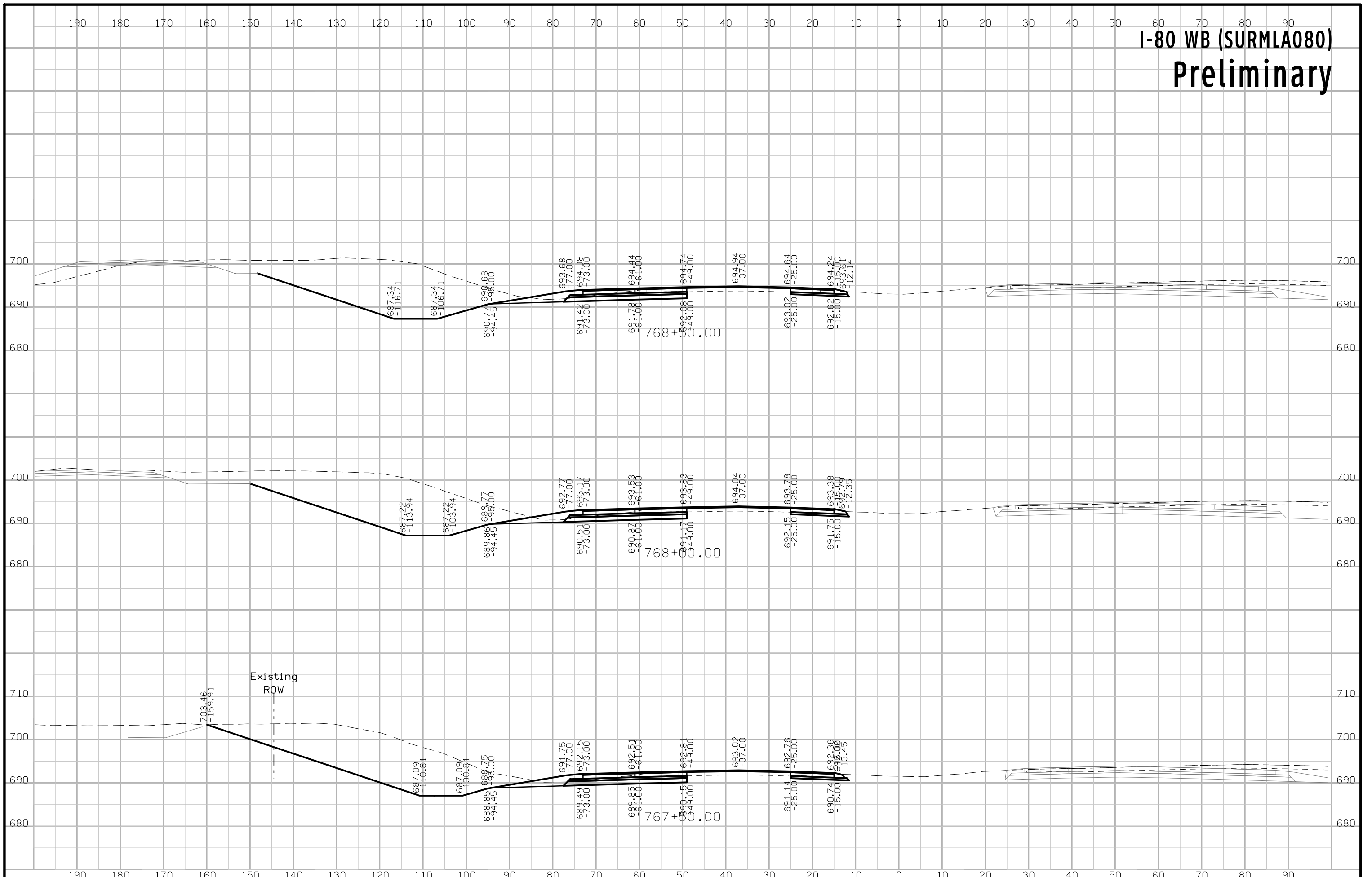



# I-80 WB (SURMLA080) Preliminary

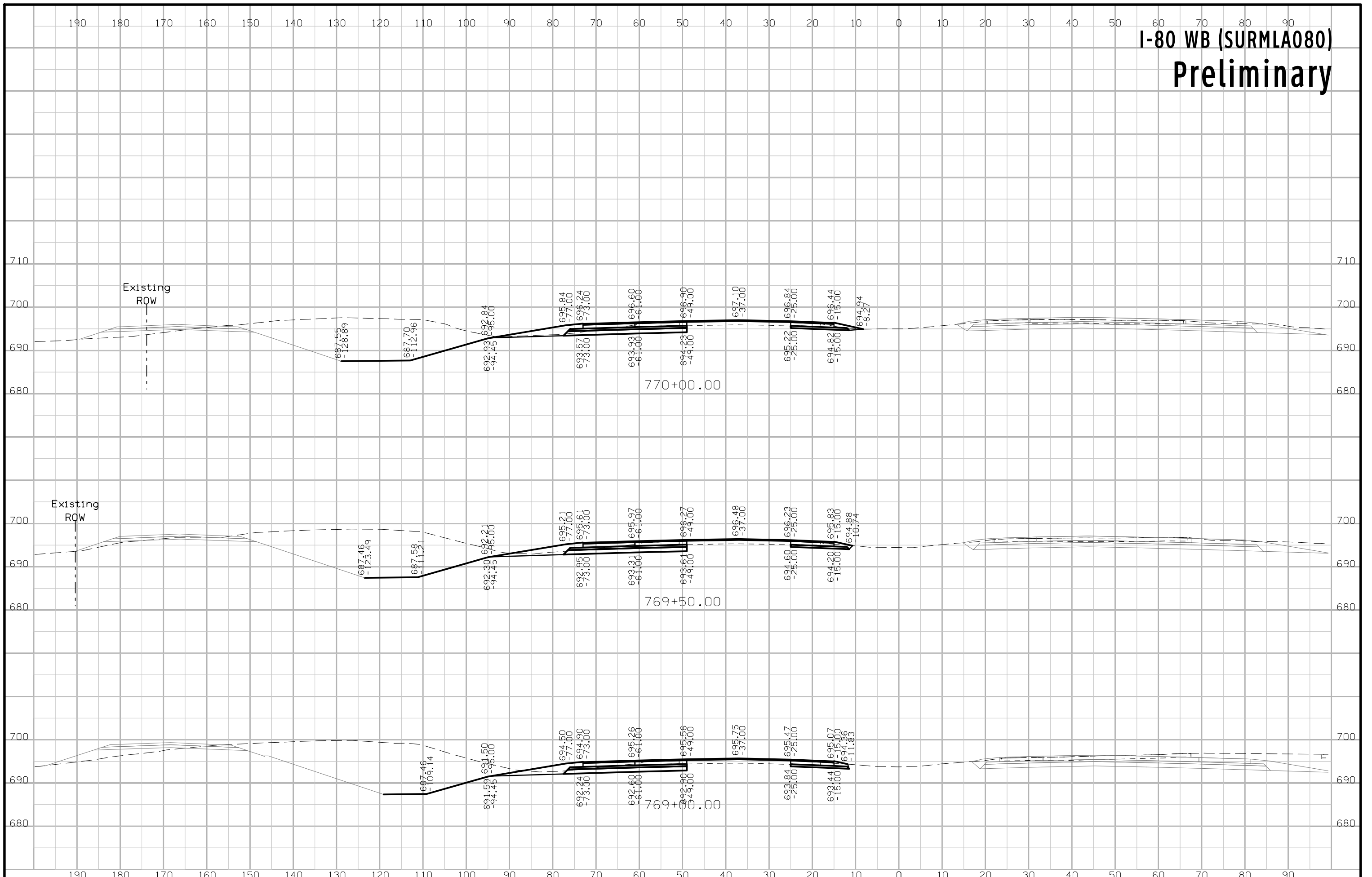

# I-80 WB (SURMLA080) Preliminary

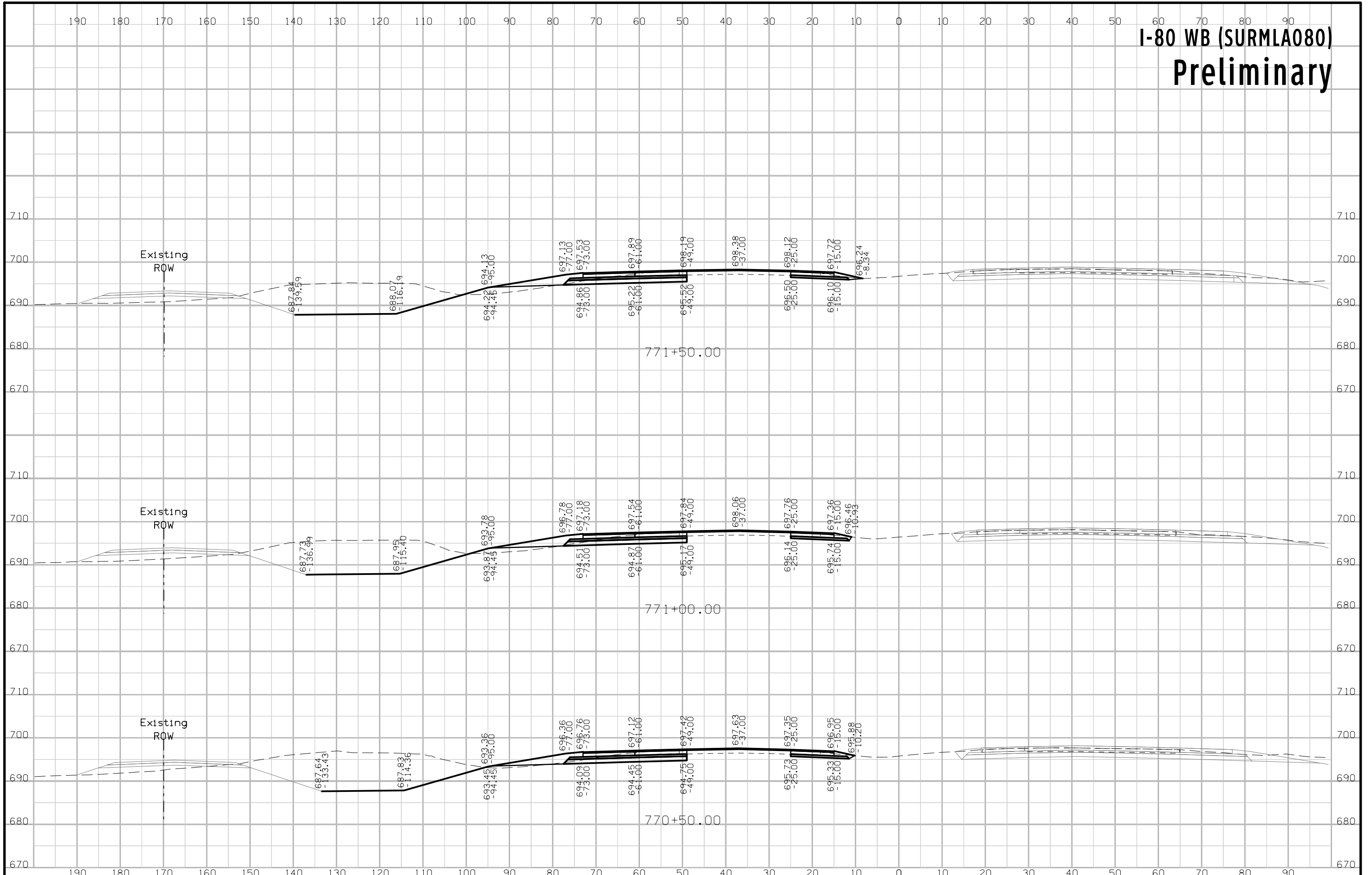

# I-80 WB (SURMLA080) Preliminary

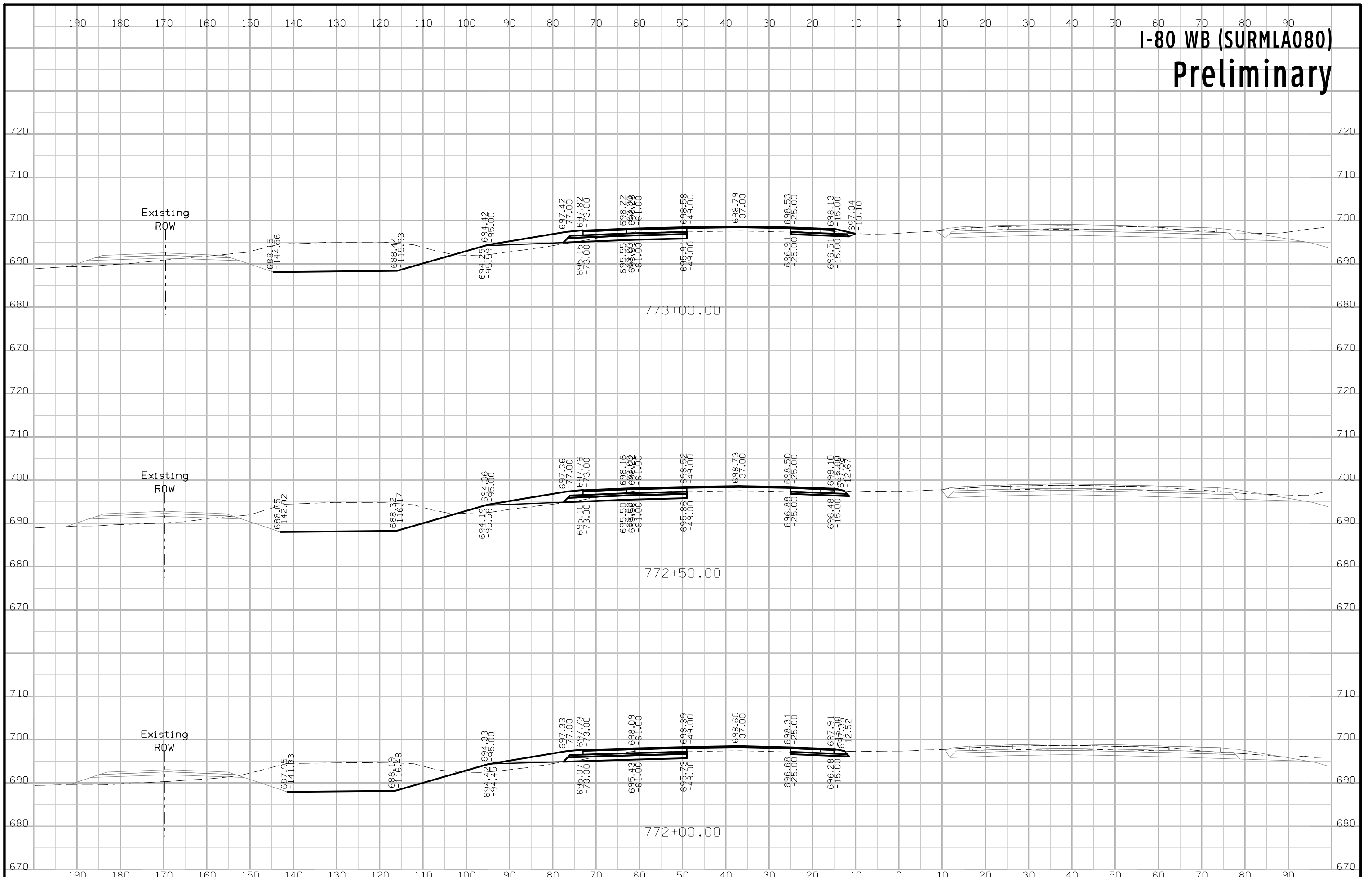



# I-80 WB (SURMLA080) Preliminary

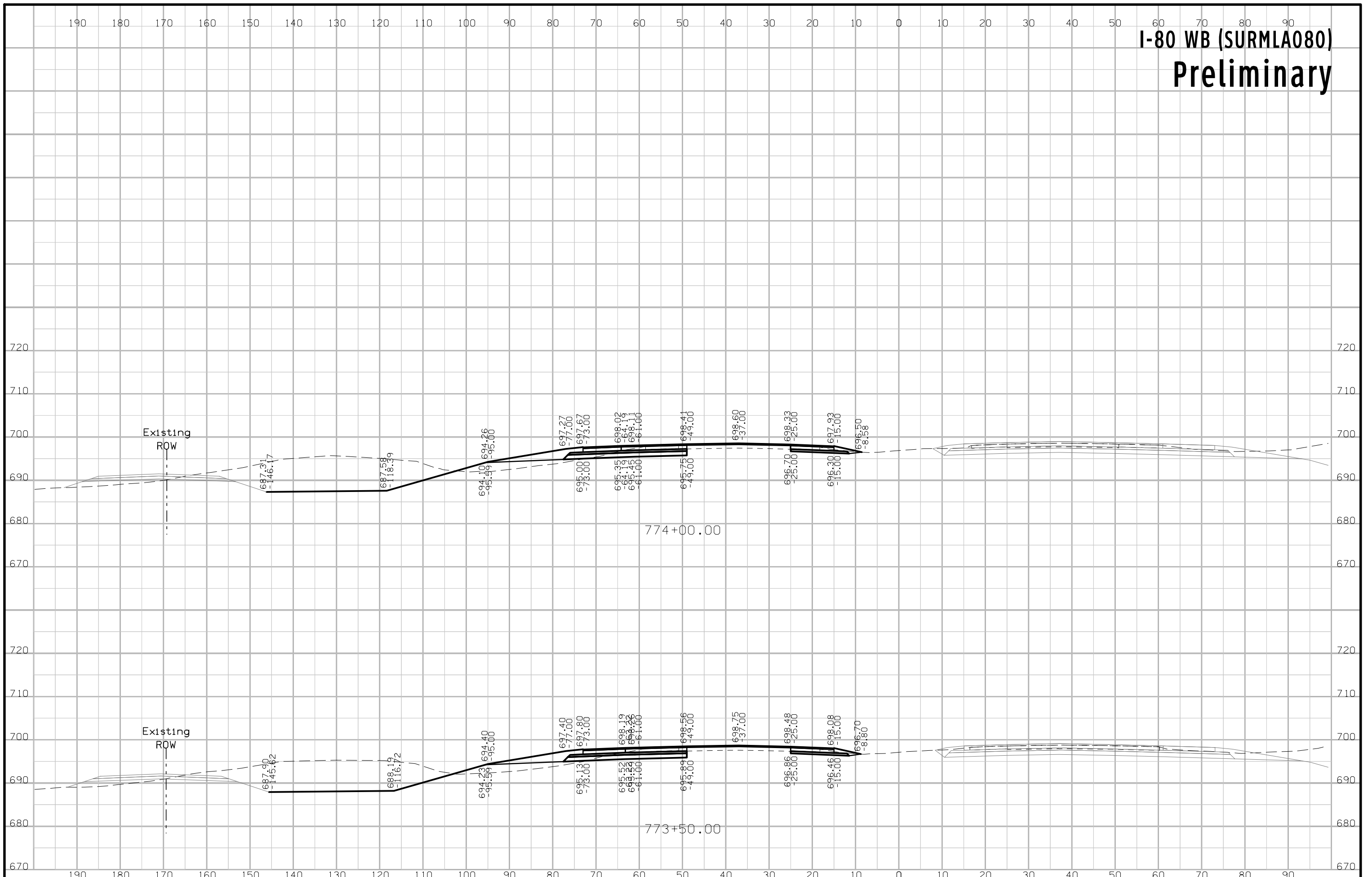

# I-80 WB (SURMLA080) Preliminary

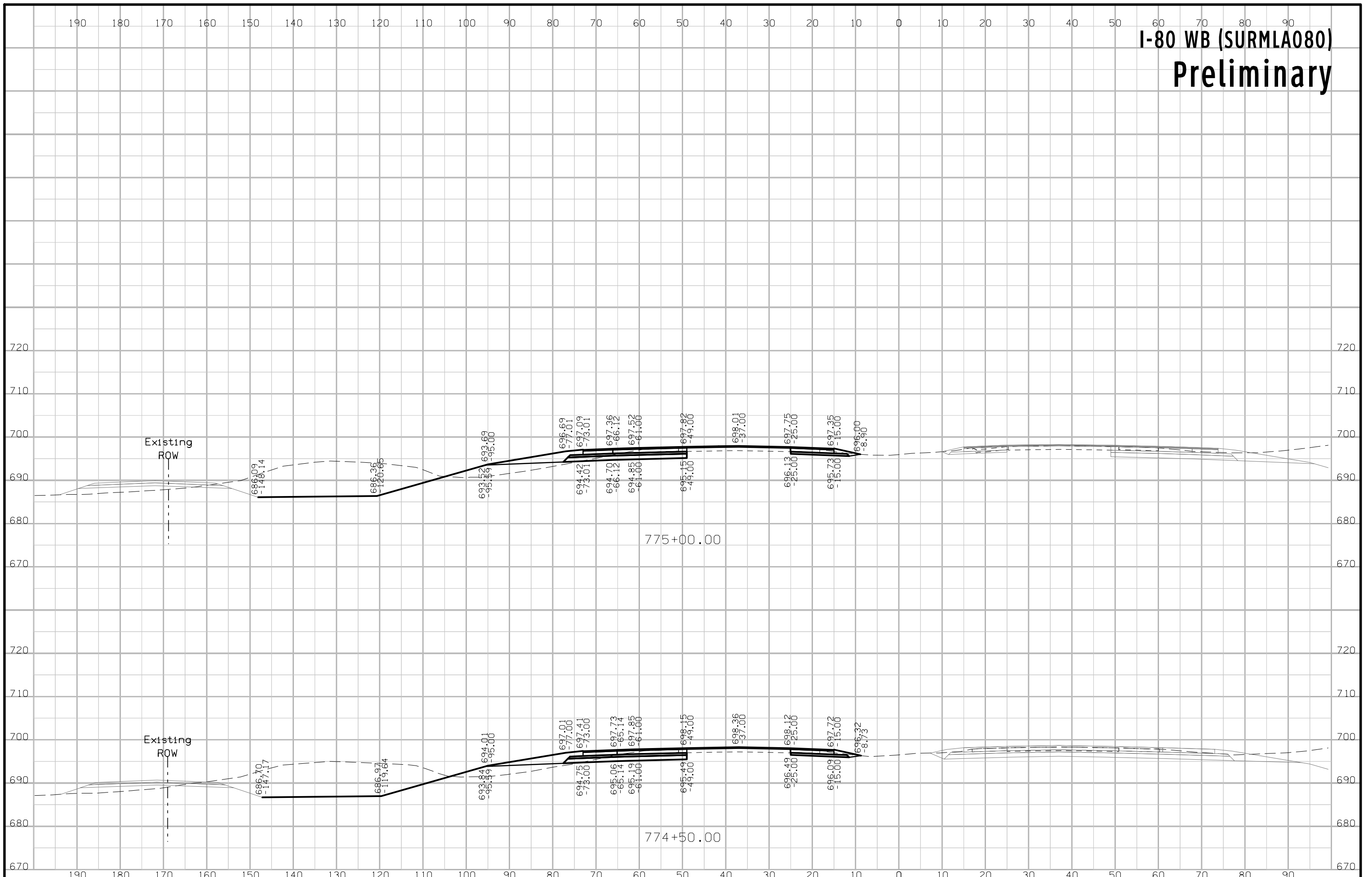

# I-80 WB (SURMLA080) Preliminary

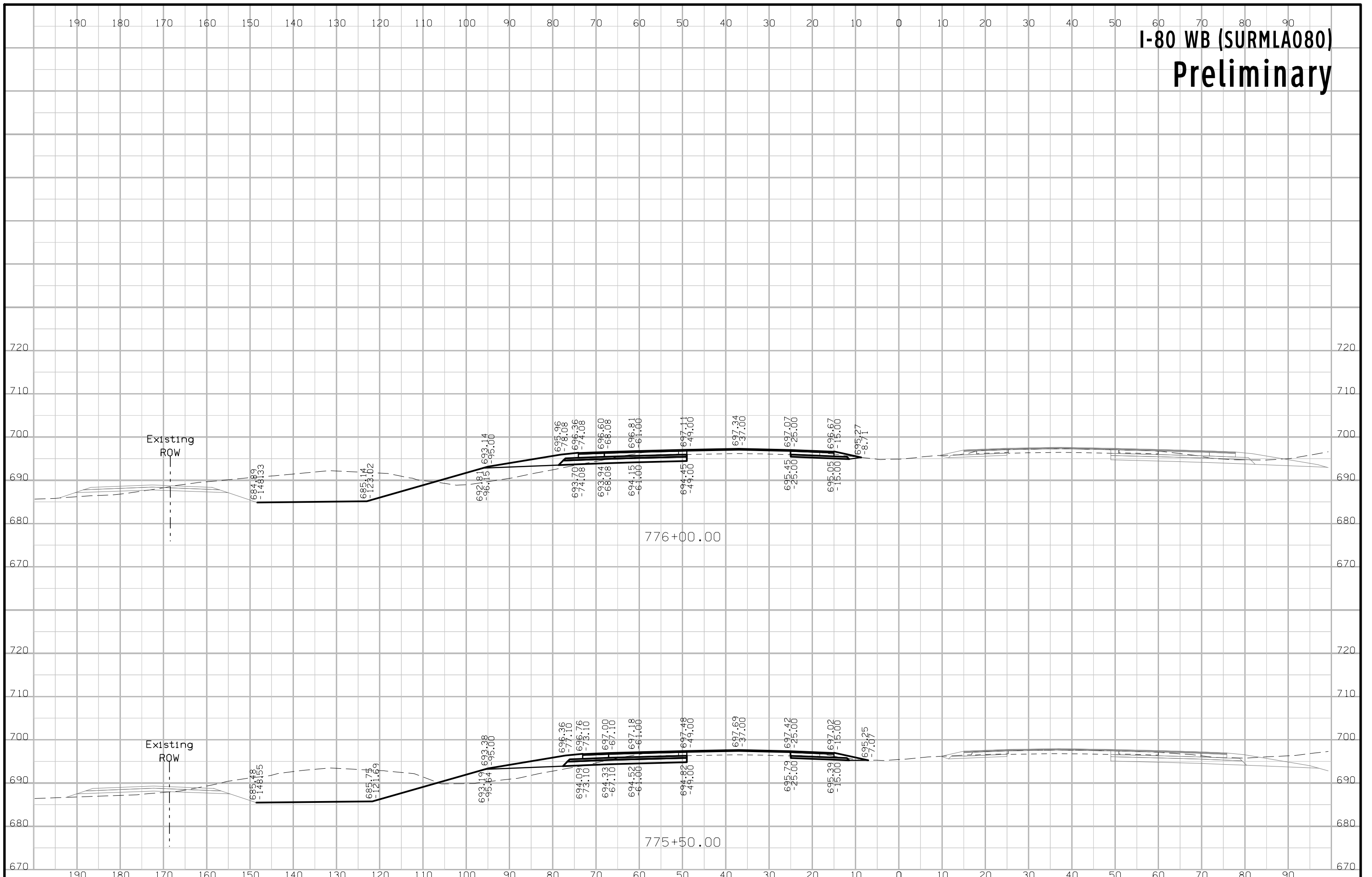



# I-80 WB (SURMLA080) Preliminary

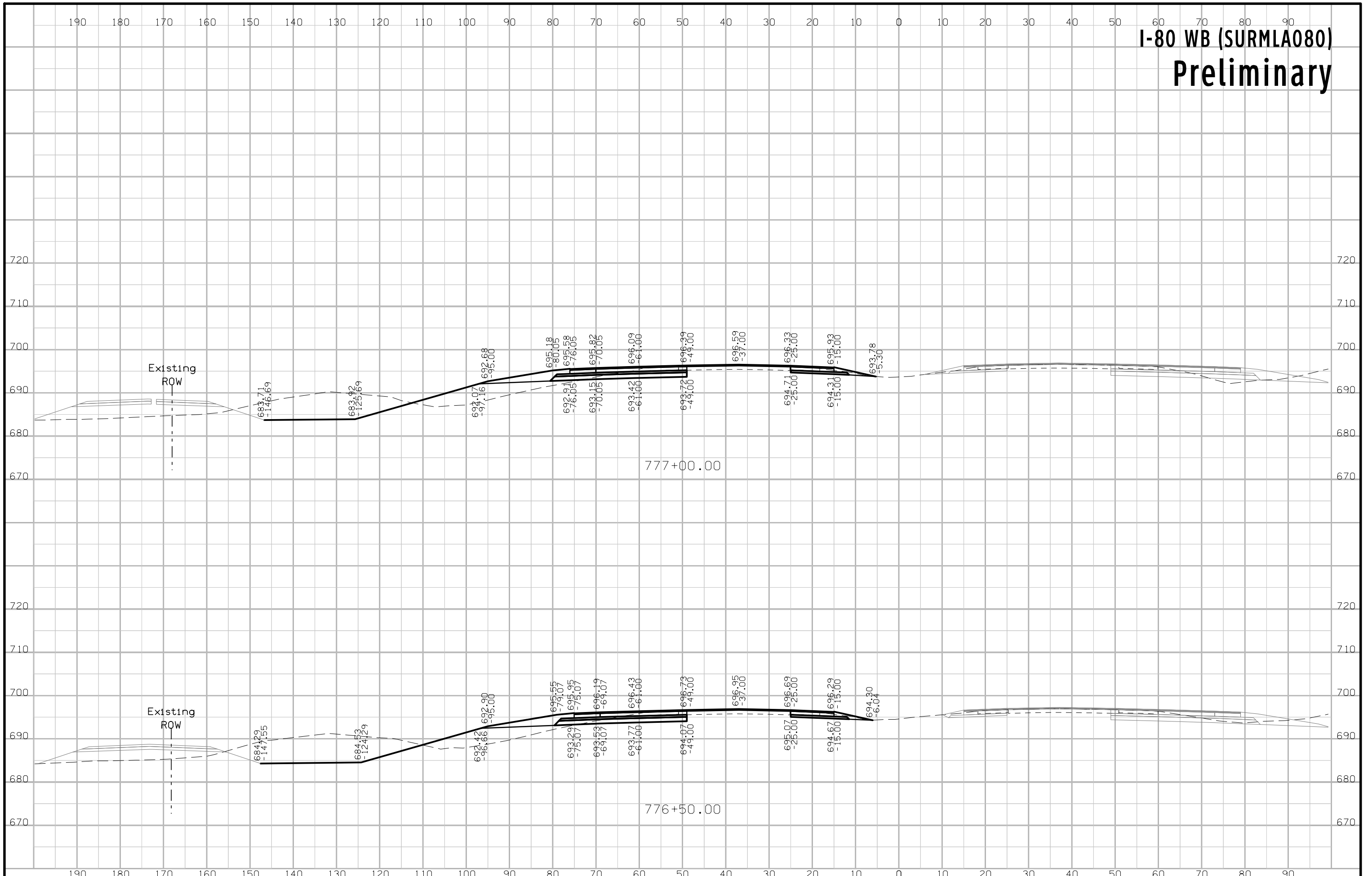

# I-80 WB (SURMLA080) Preliminary

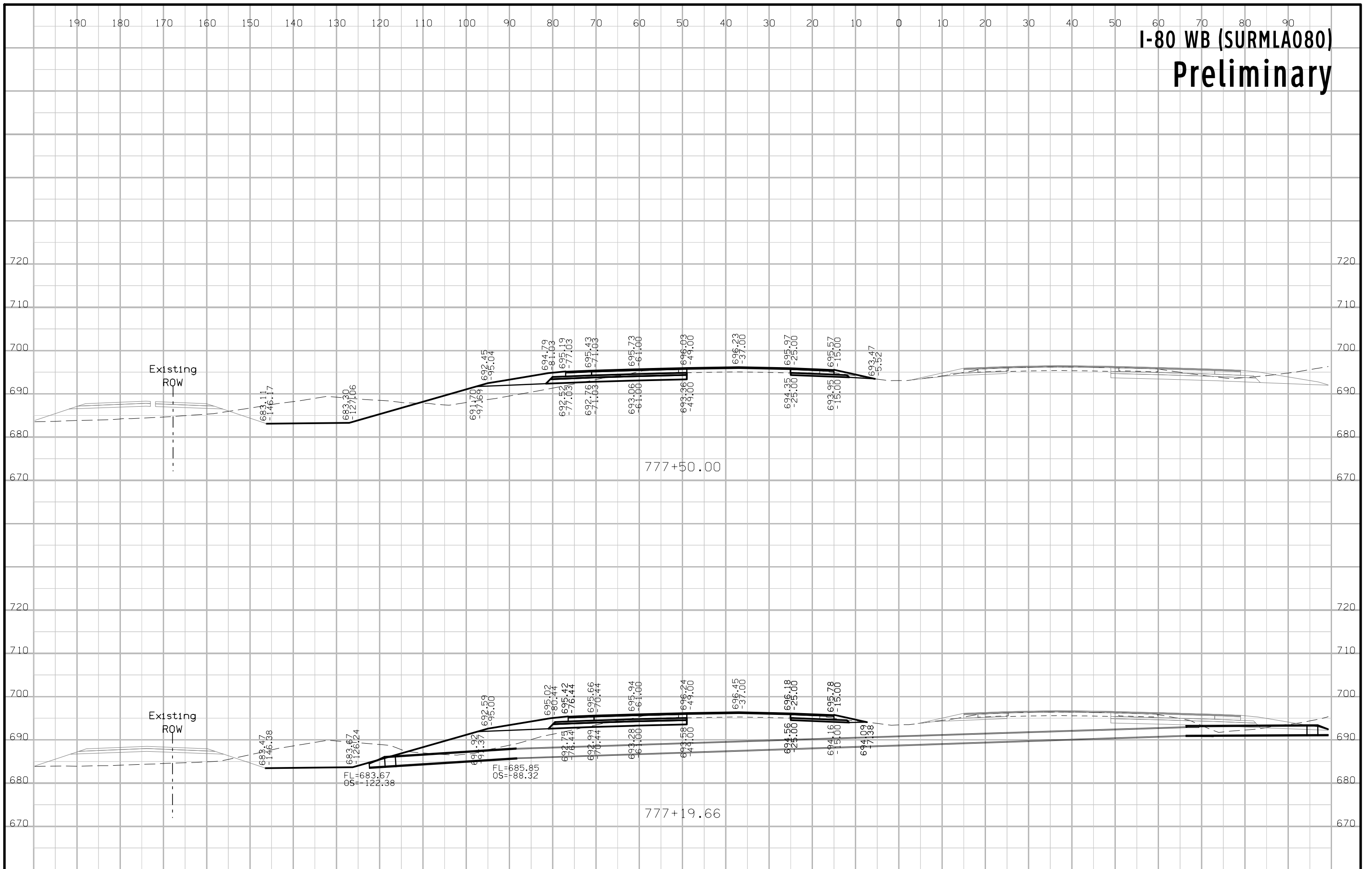

# I-80 WB (SURMLA080) Preliminary

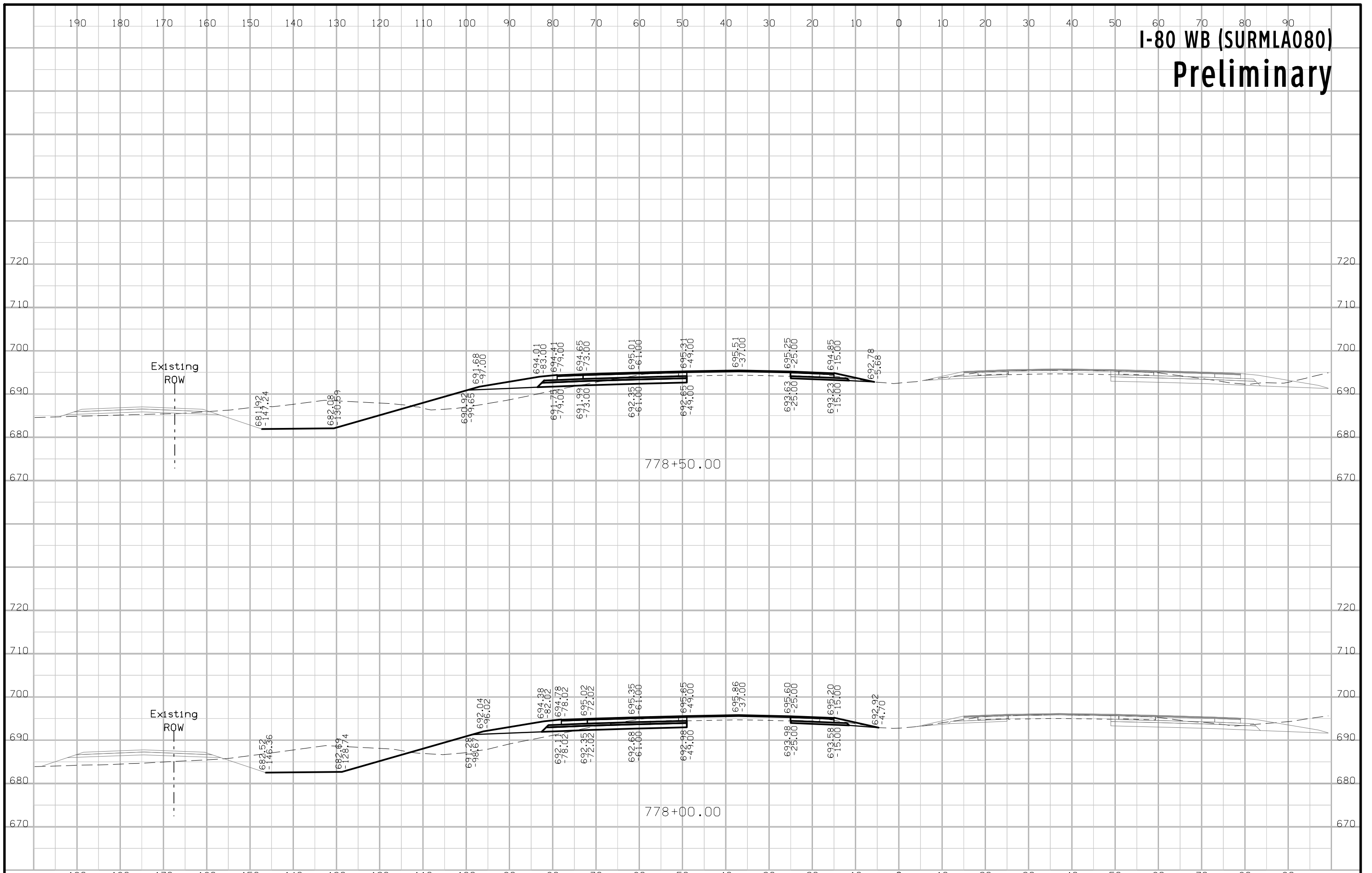



# I-80 WB (SURMLA080) Preliminary

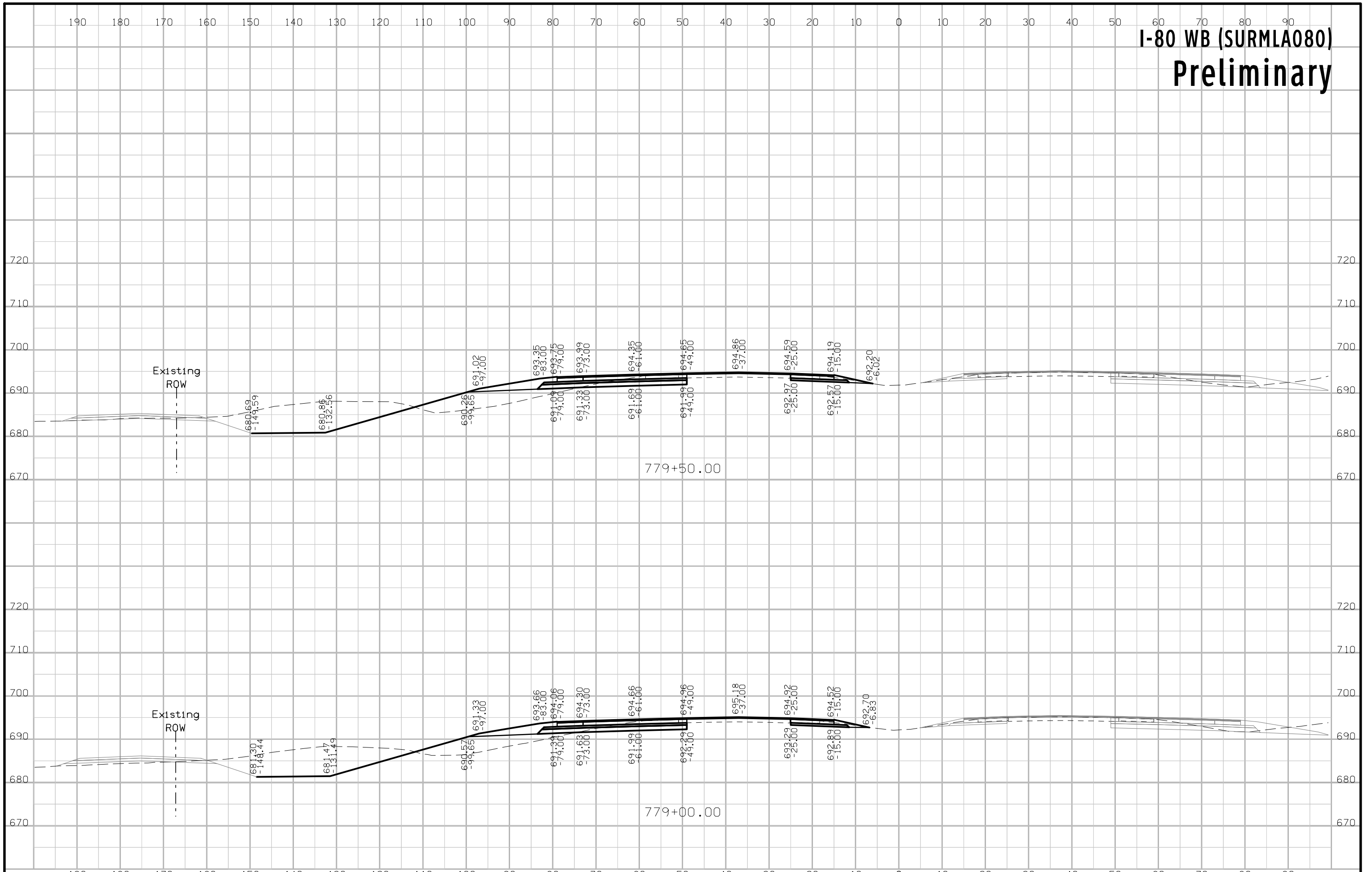

# I-80 WB (SURMLA080) Preliminary

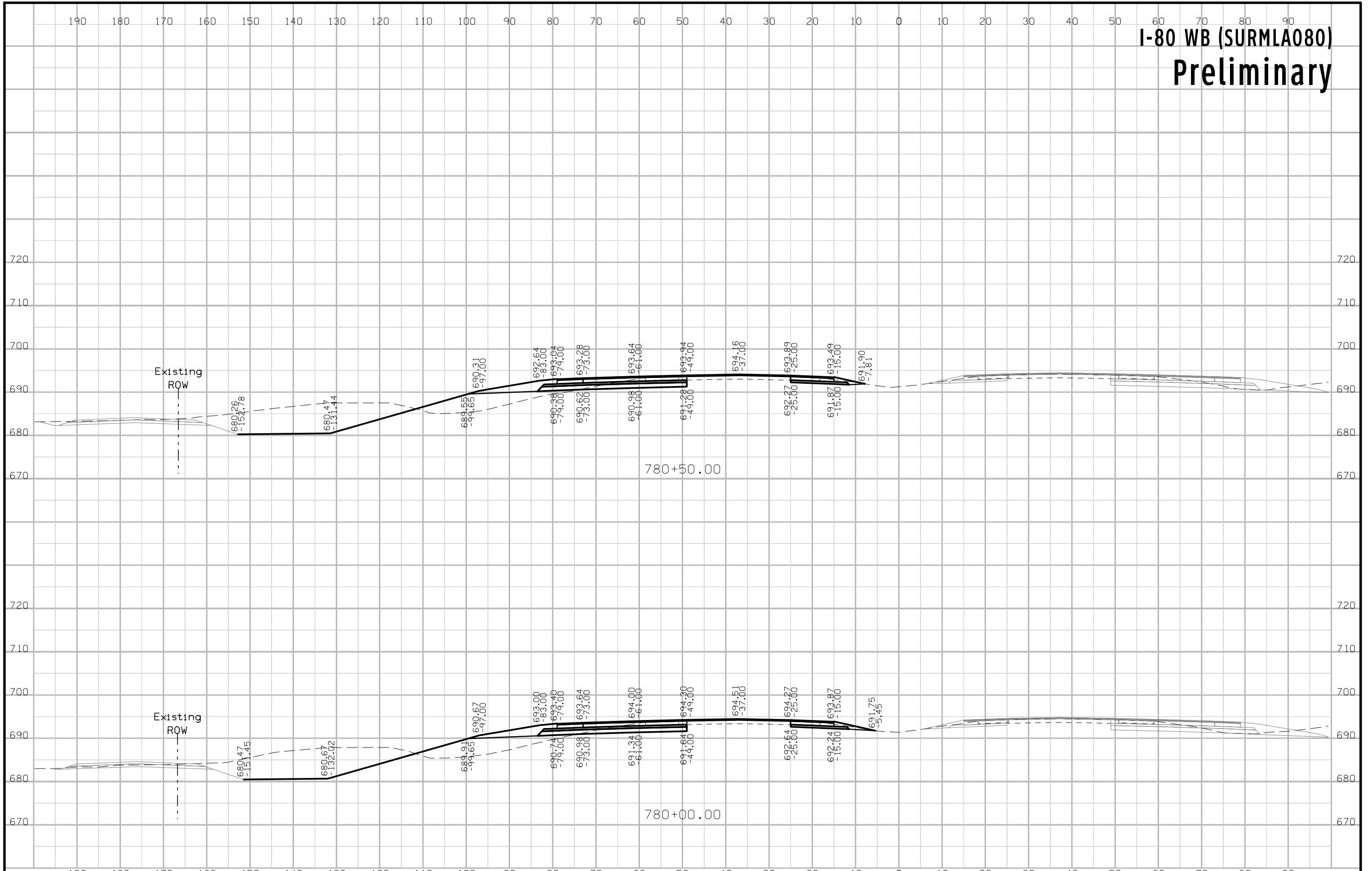

# I-80 WB (SURMLA080) Preliminary

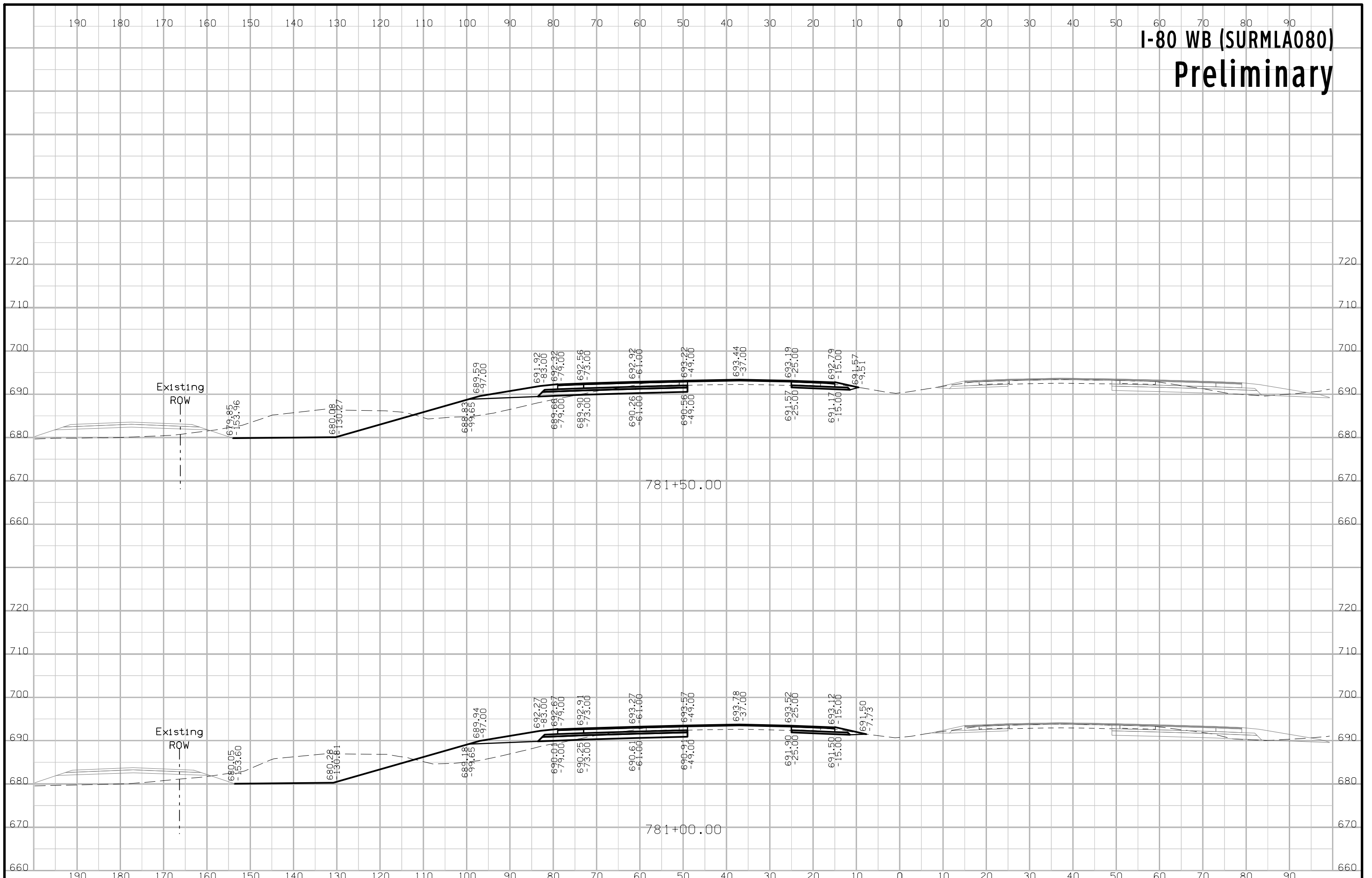



# I-80 WB (SURMLA080) Preliminary

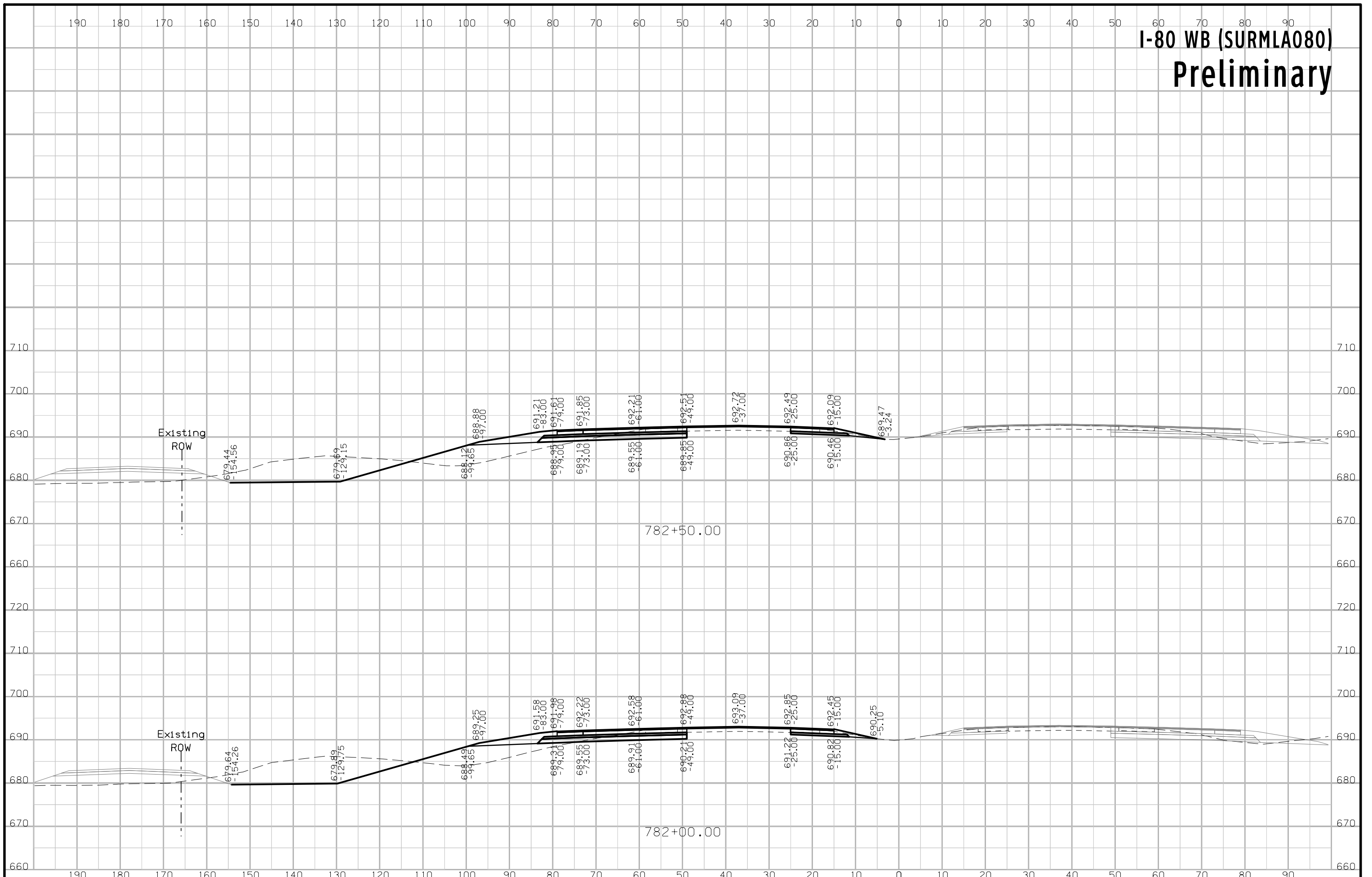

# I-80 WB (SURMLA080) Preliminary

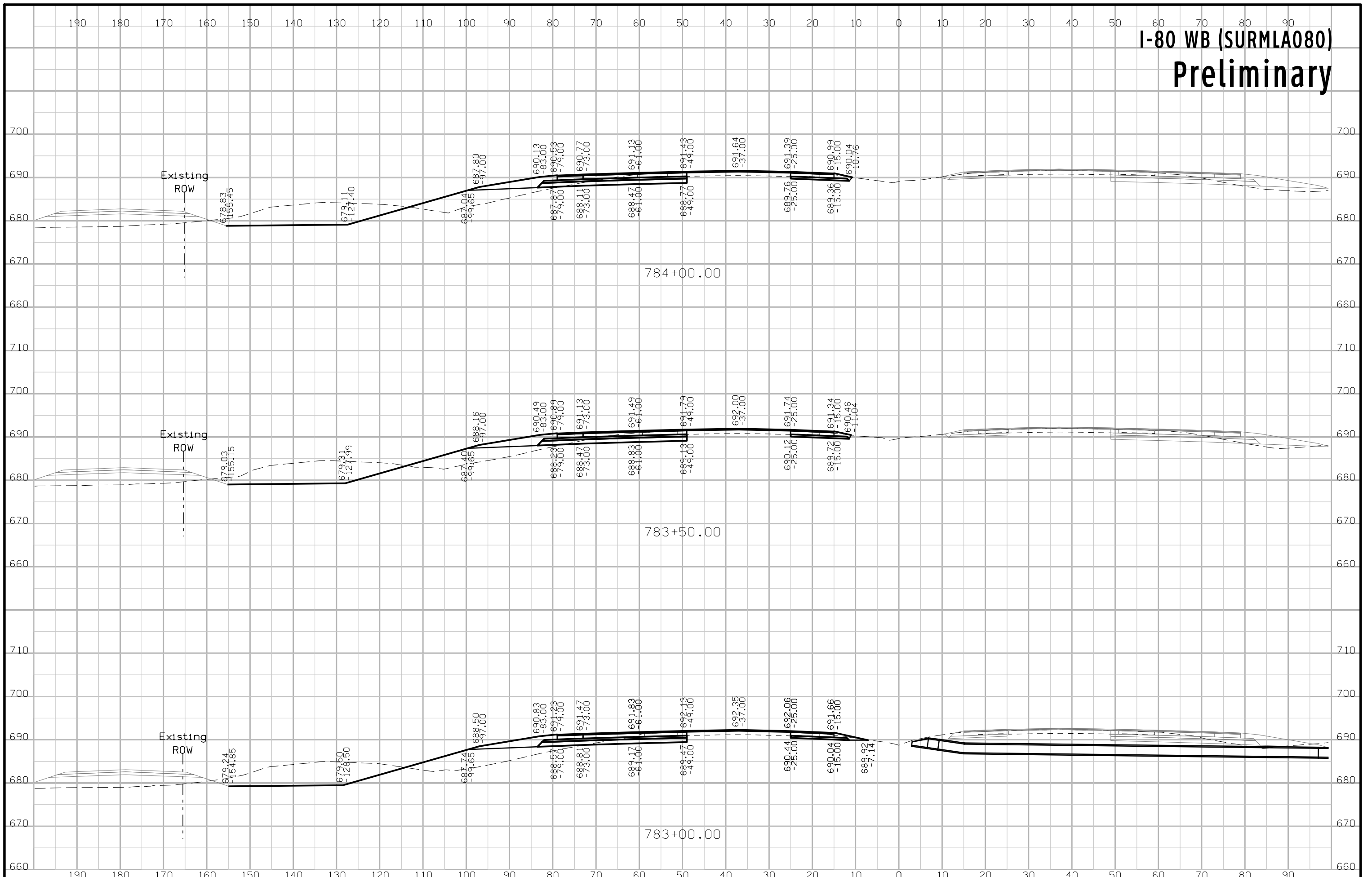

# I-80 WB (SURMLA080) Preliminary

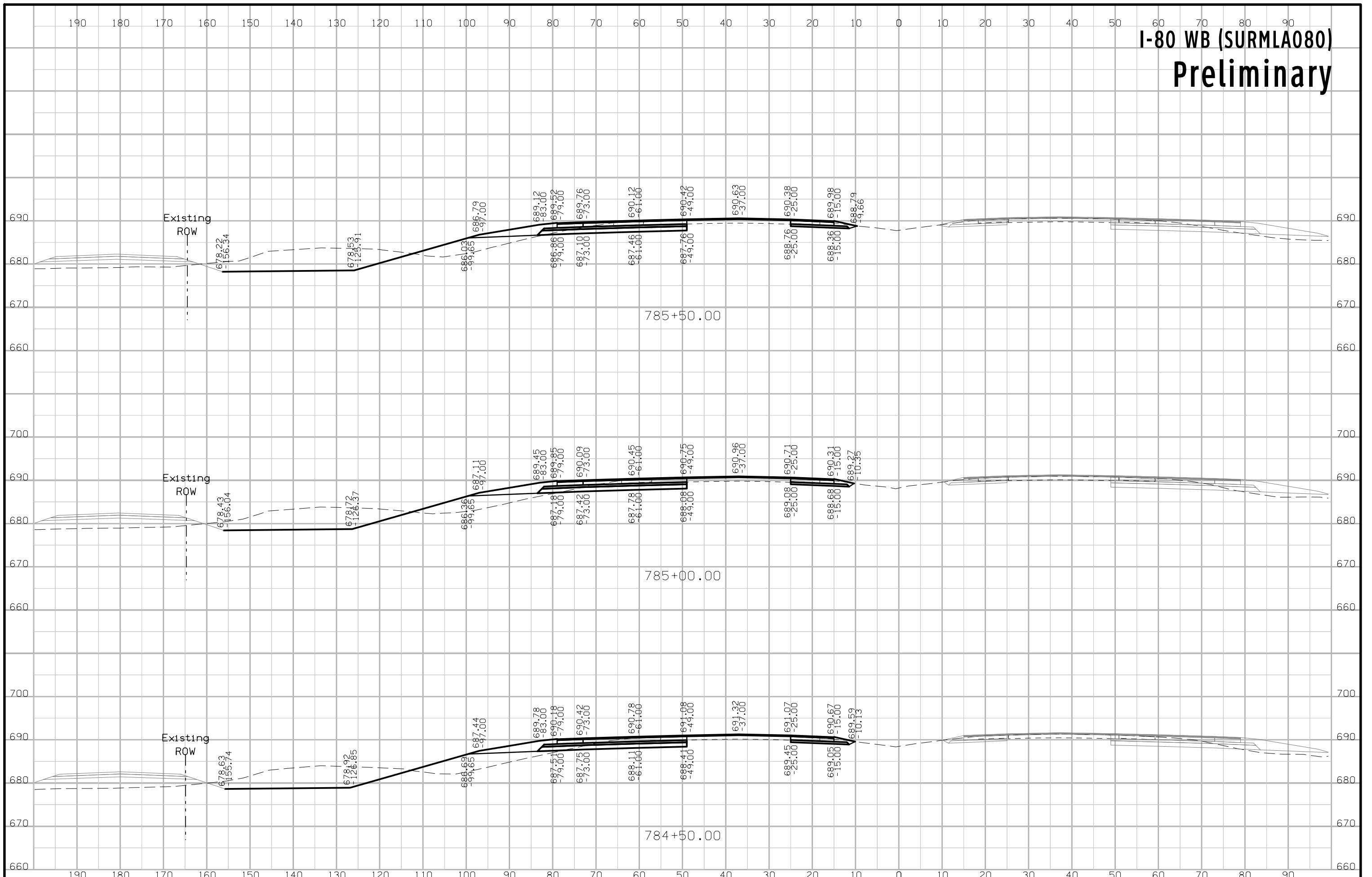

**I-80 WB (SURMLA080)**  
**Preliminary**

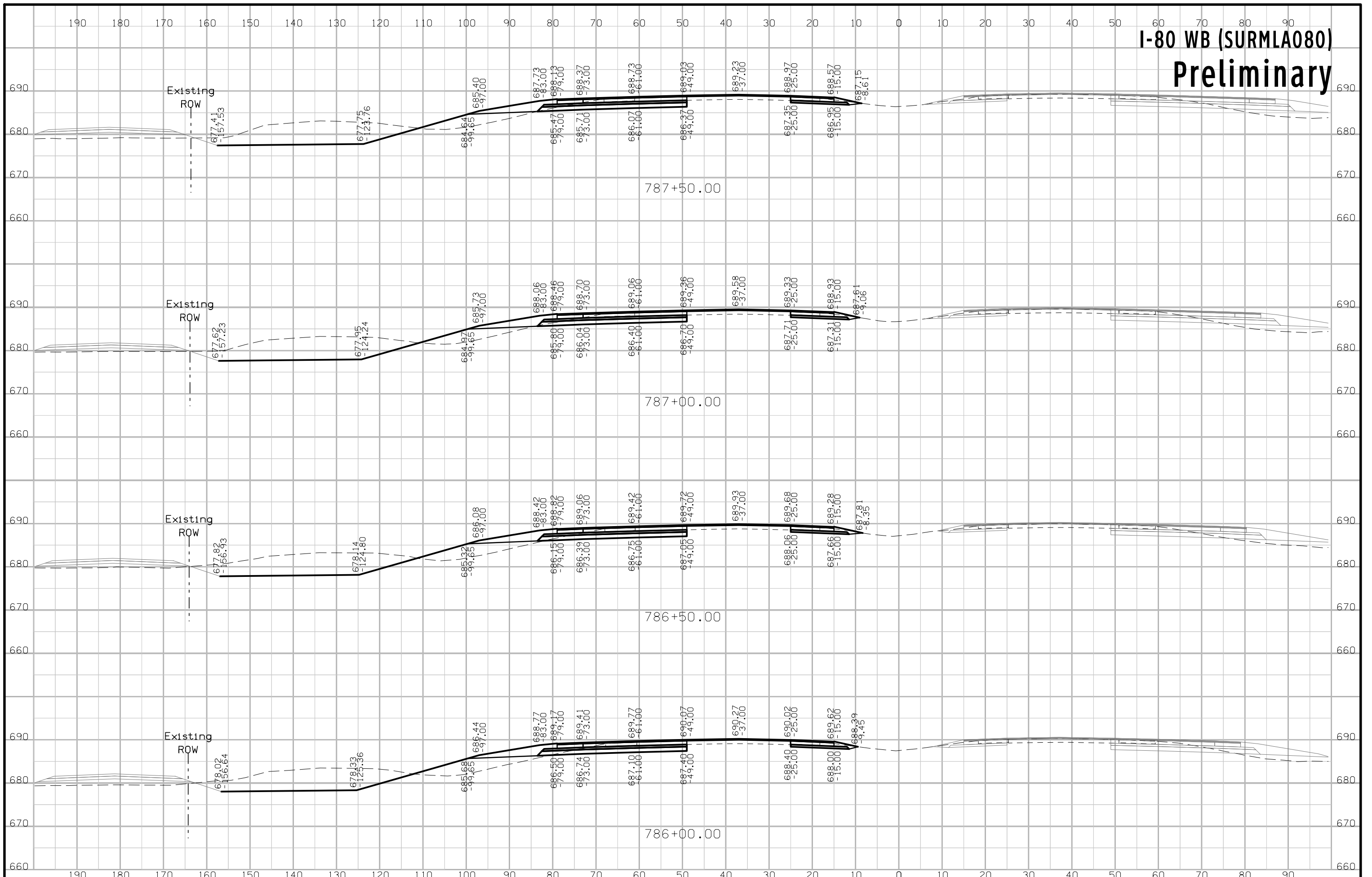



# I-80 WB (SURMLA080) Preliminary

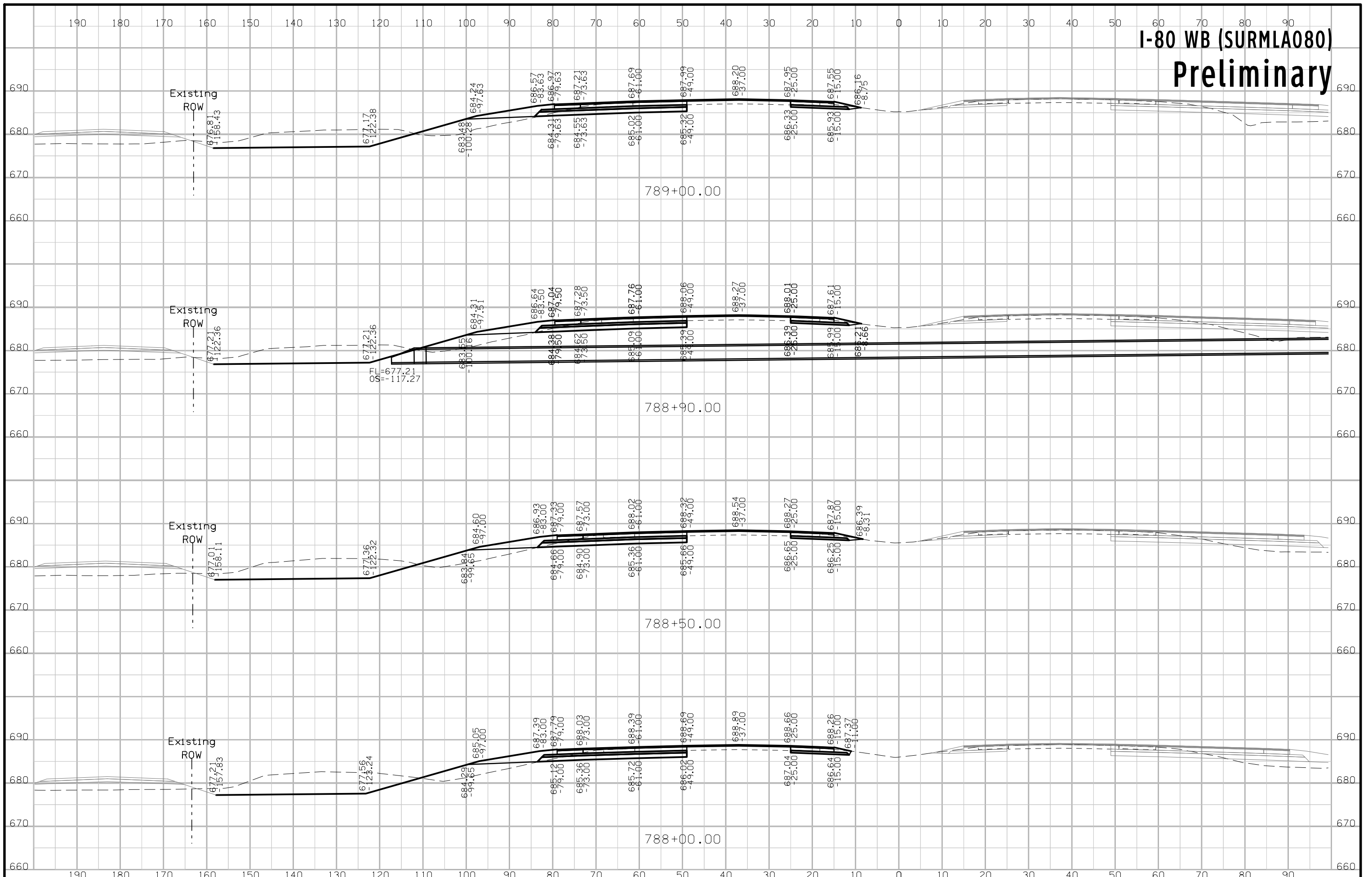

# I-80 WB (SURMLA080) Preliminary

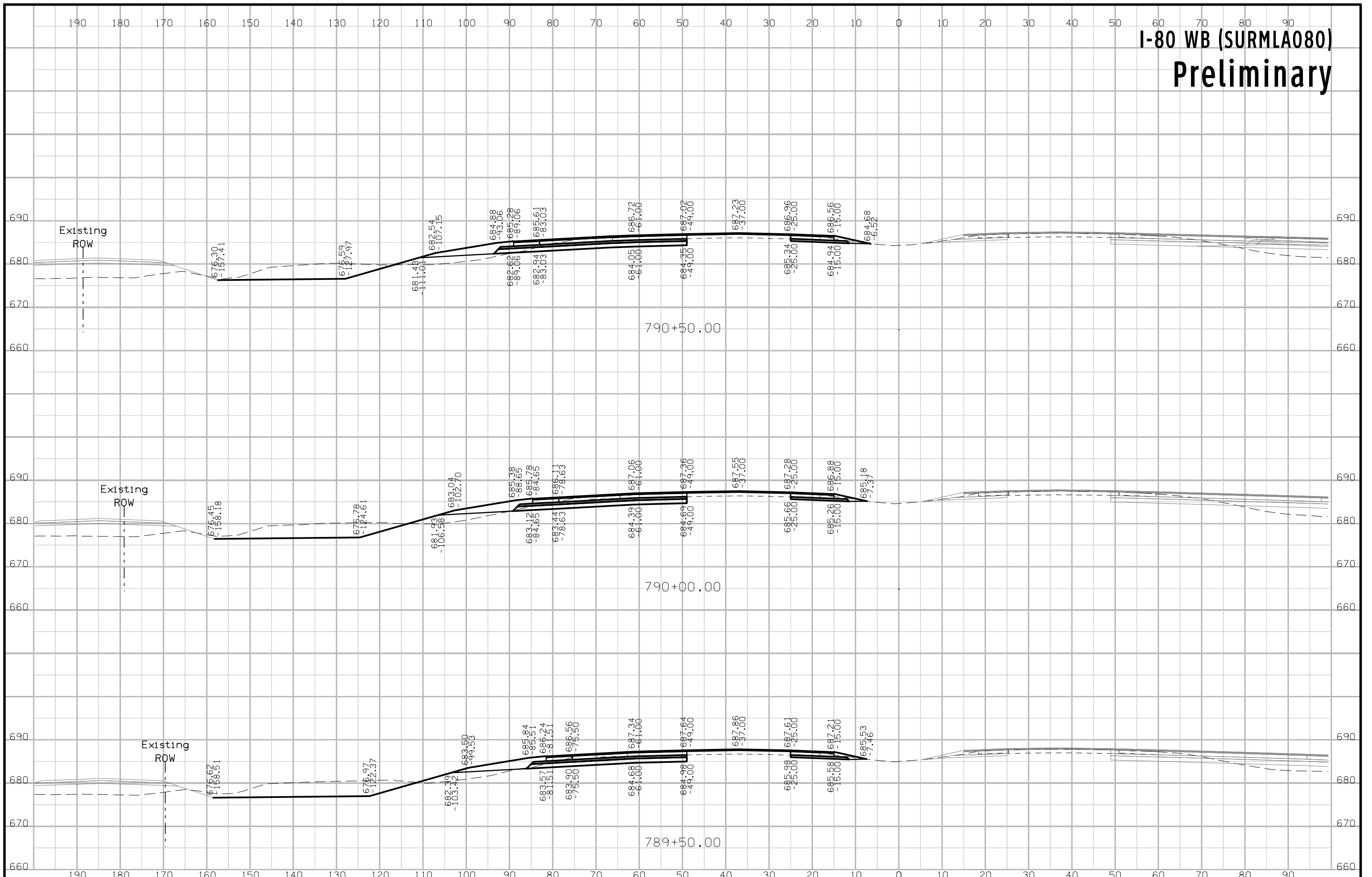

# I-80 WB (SURMLA080) Preliminary

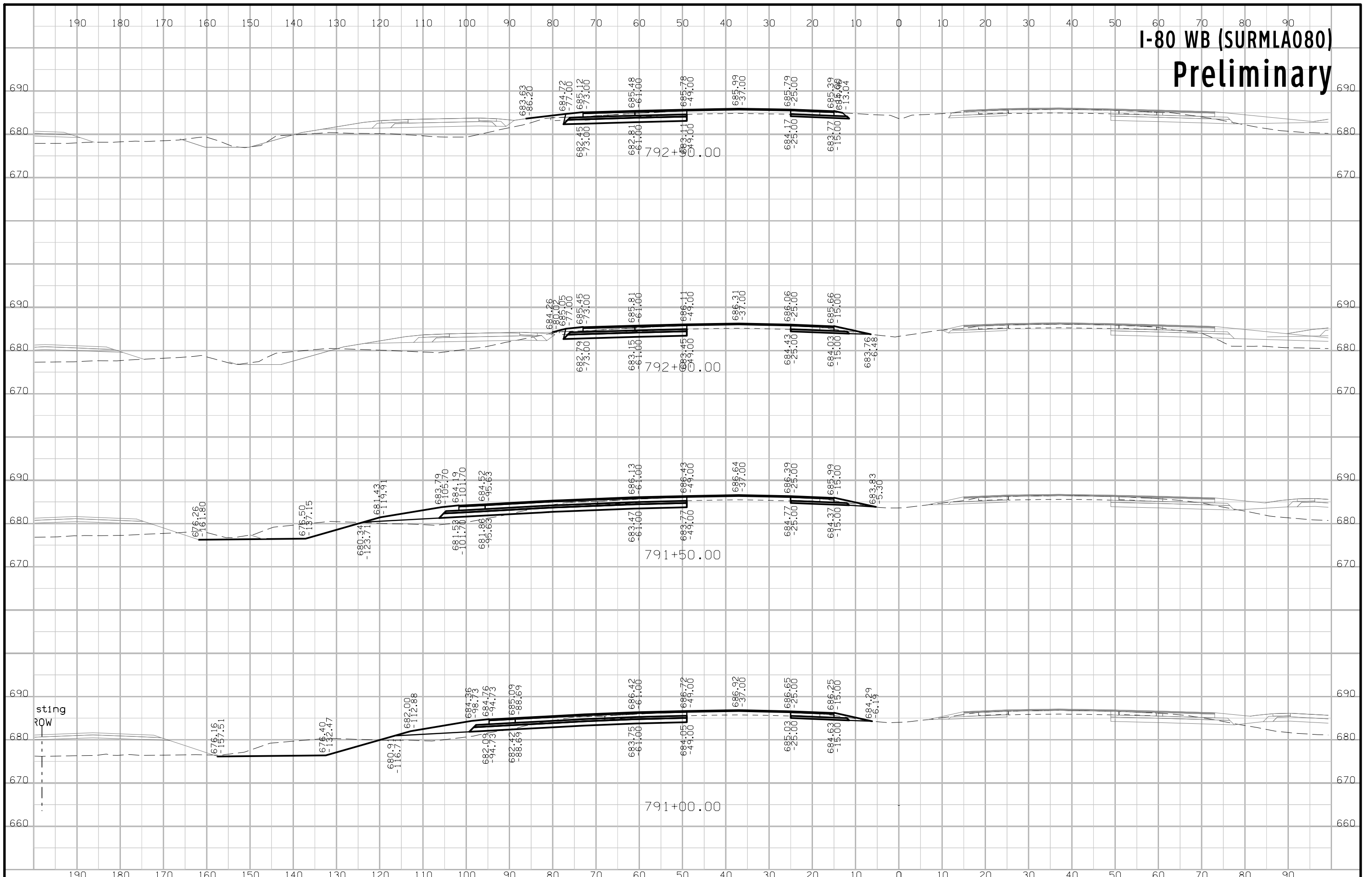

# I-80 WB (SURMLA080) Preliminary

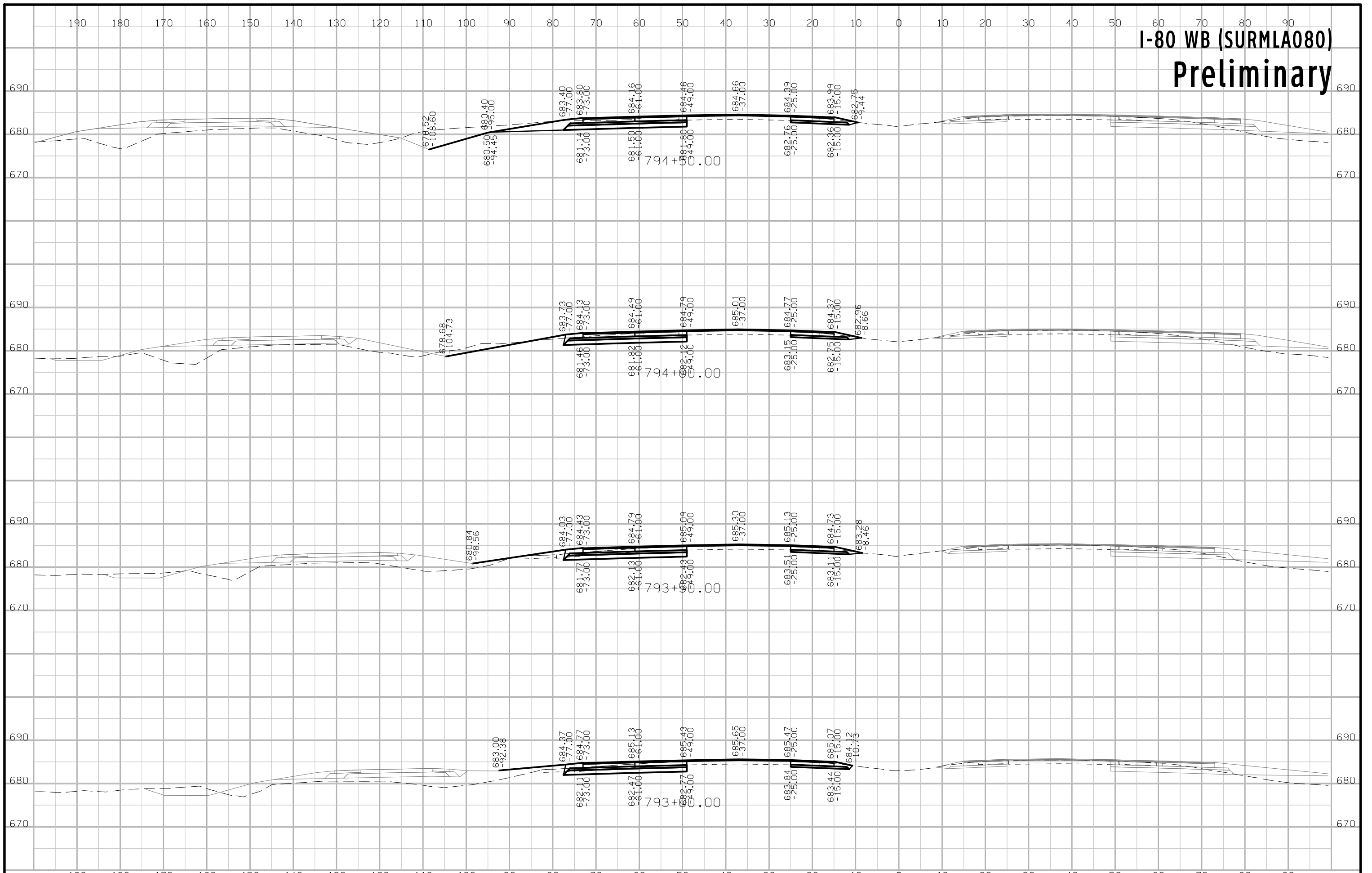



# I-80 WB (SURMLA080) Preliminary

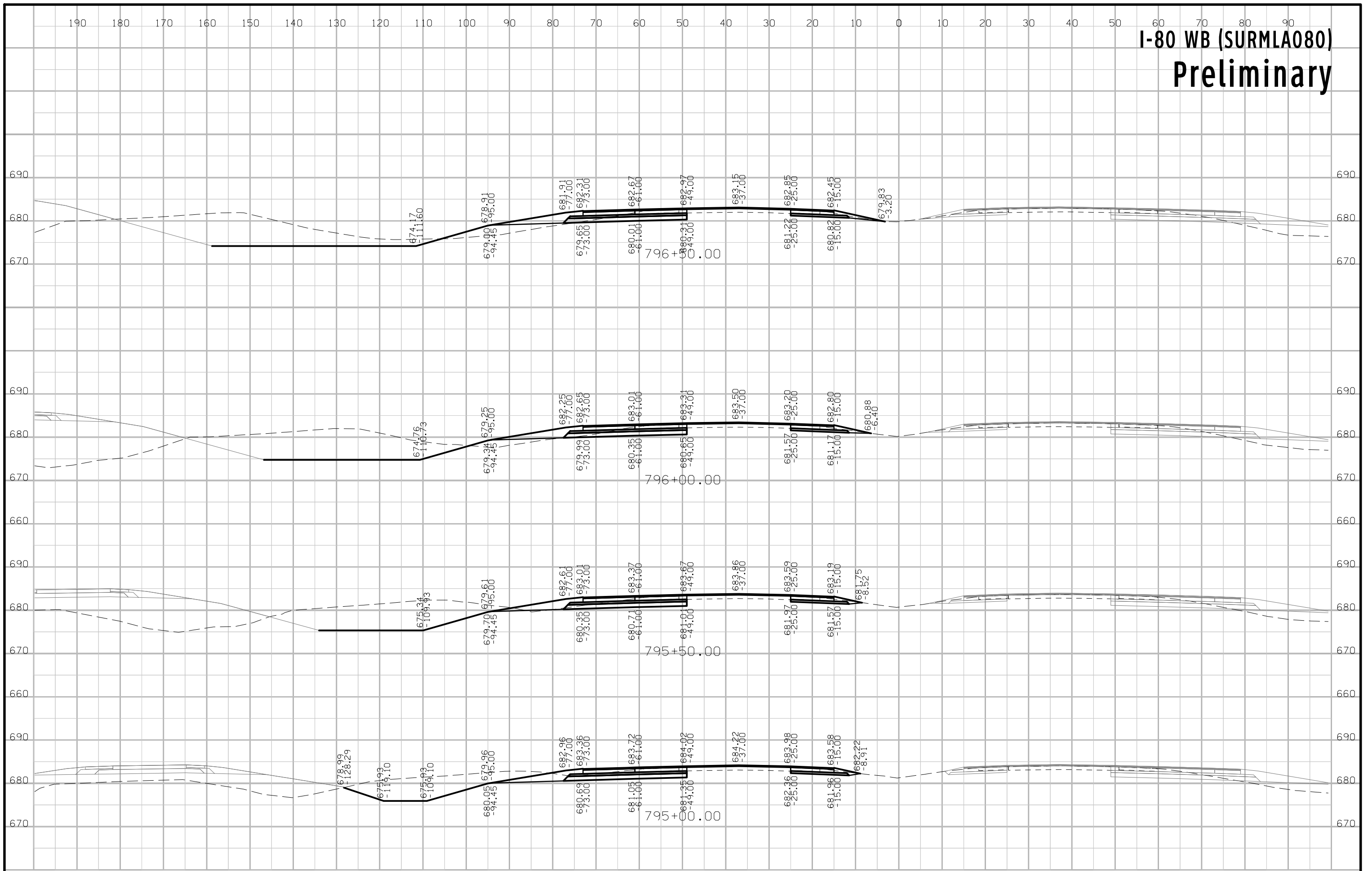

# I-80 WB (SURMLA080) Preliminary

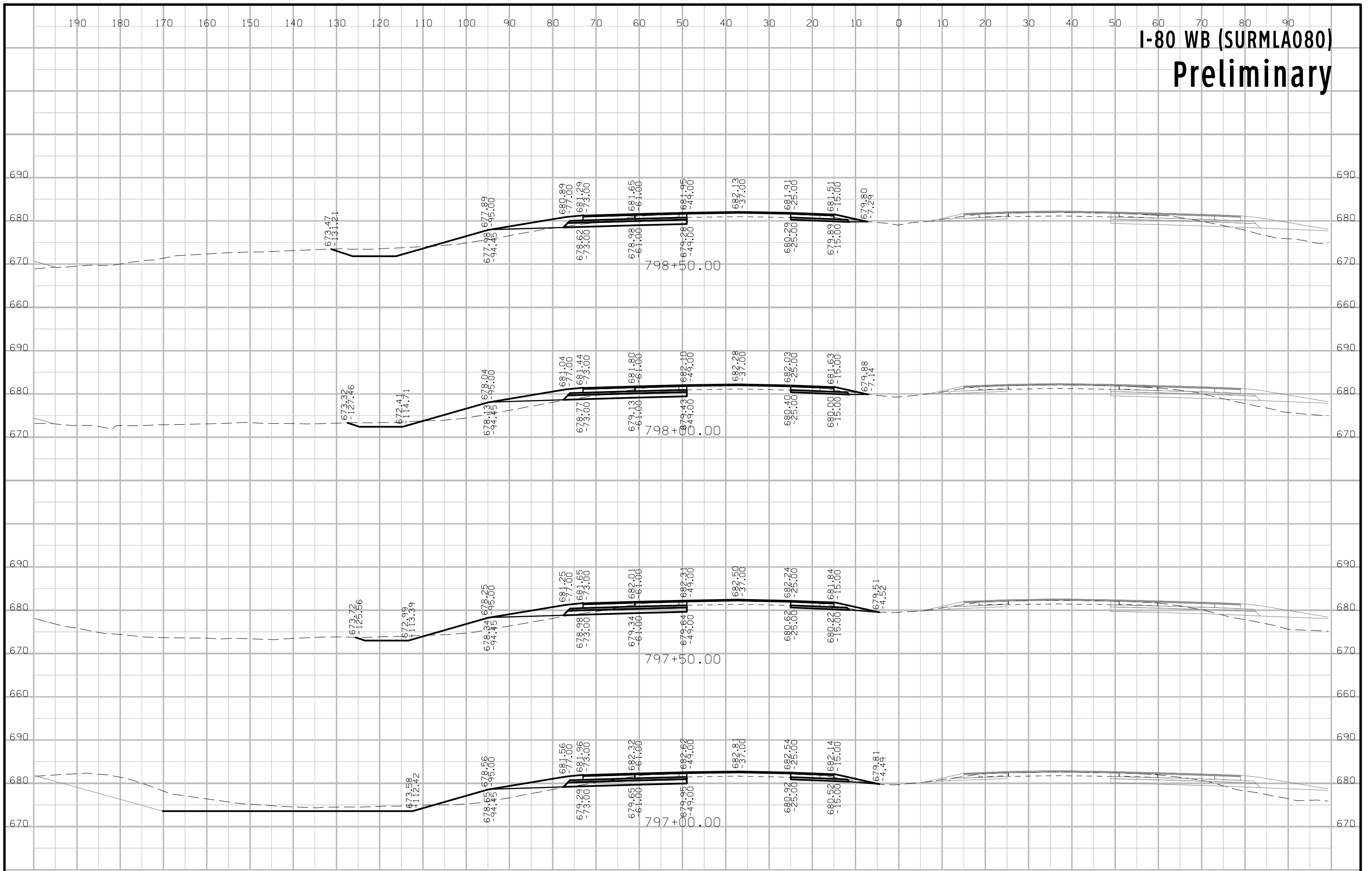

# I-80 WB (SURMLA080) Preliminary

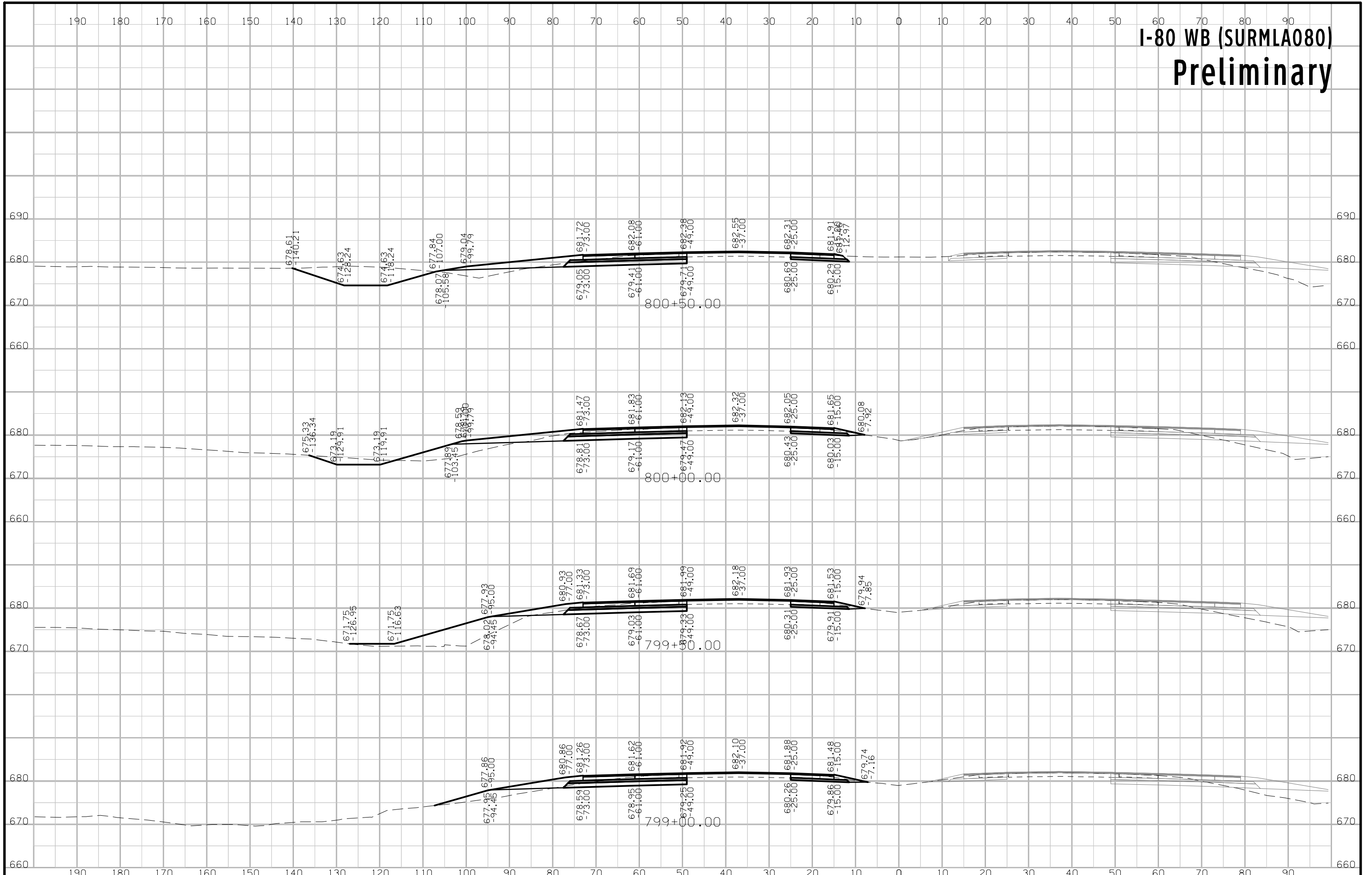

# I-80 WB (SURMLA080) Preliminary

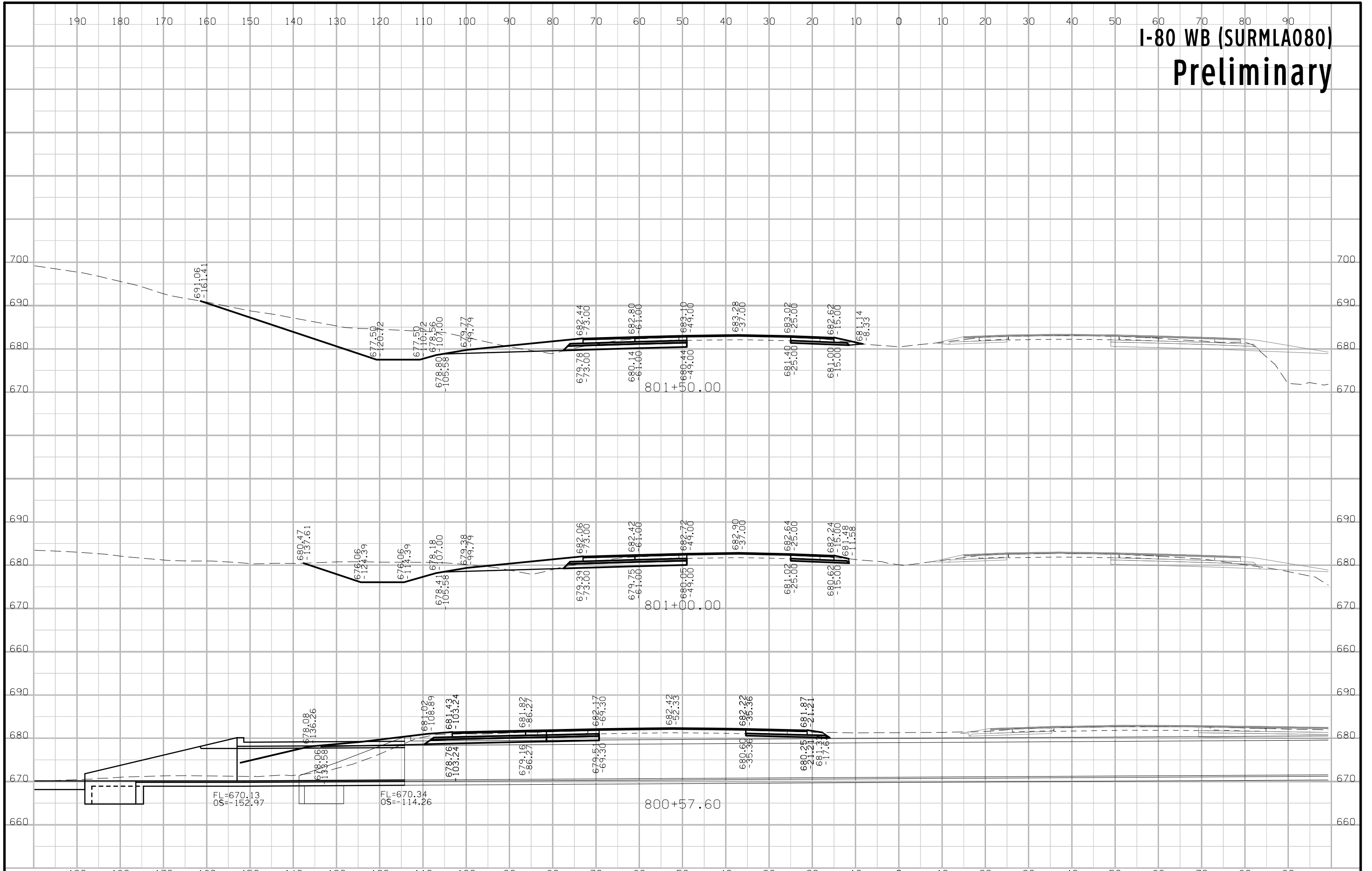



# I-80 WB (SURMLA080) Preliminary

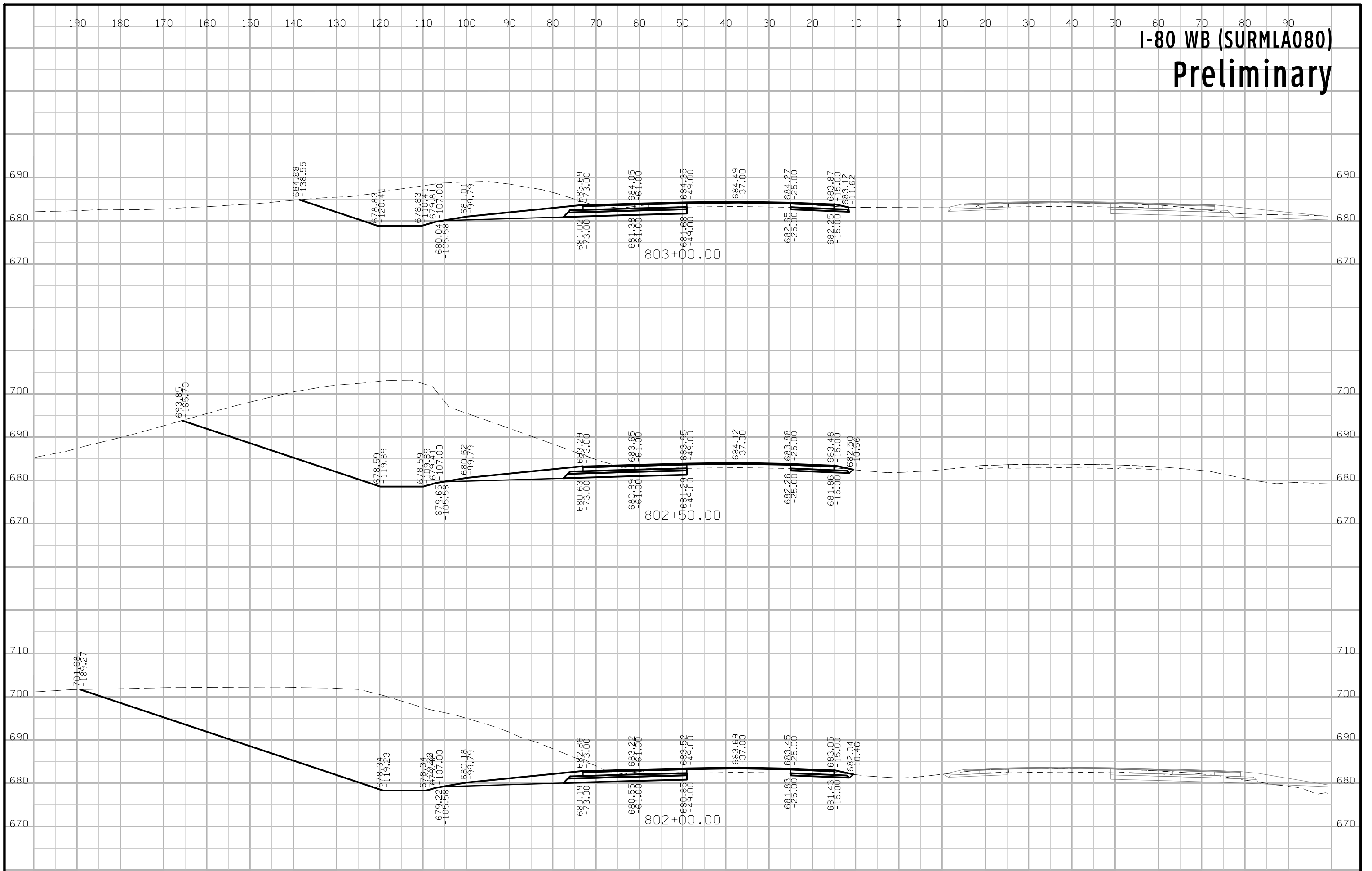

# I-80 WB (SURMLA080) Preliminary

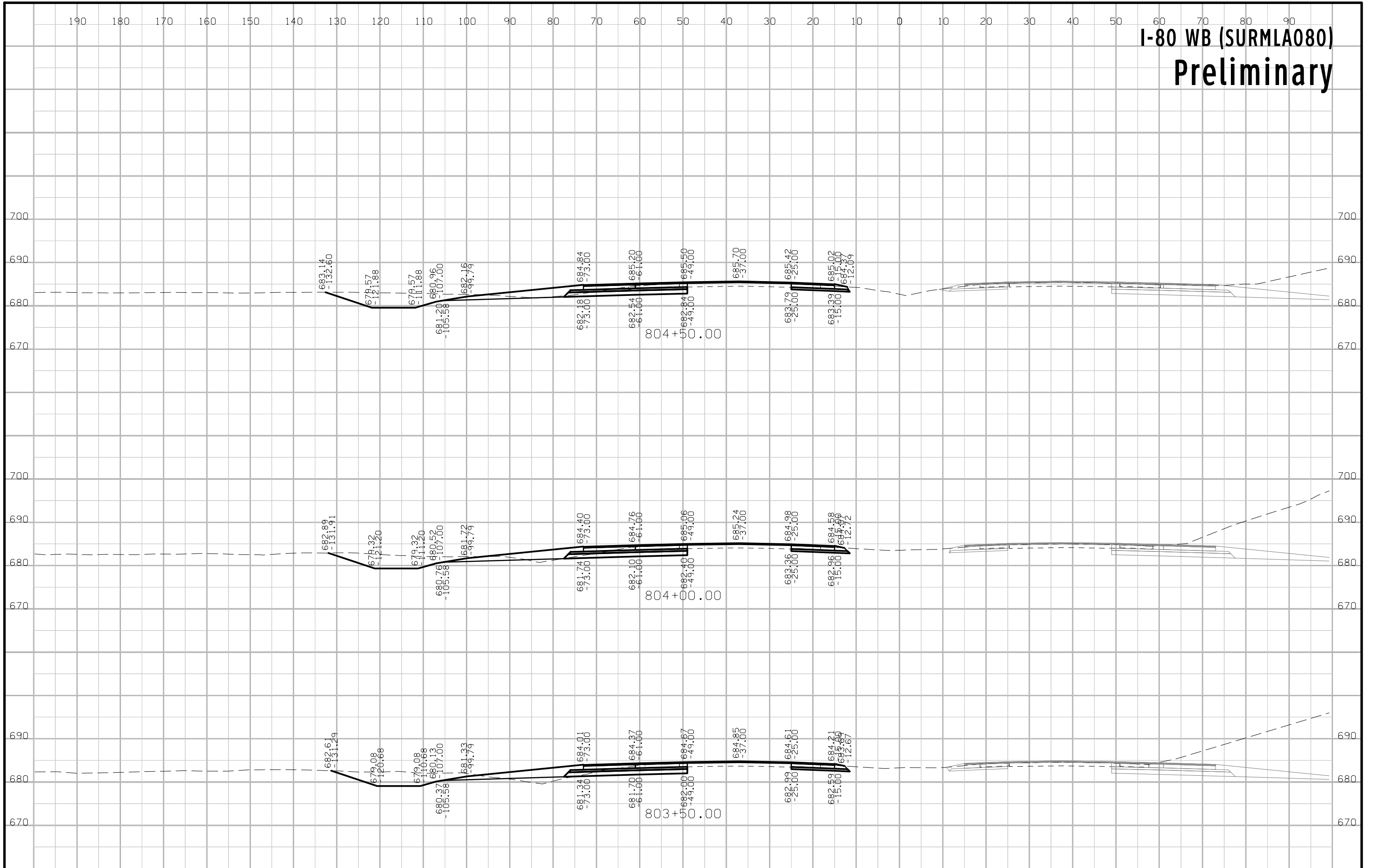

# I-80 WB (SURMLA080) Preliminary

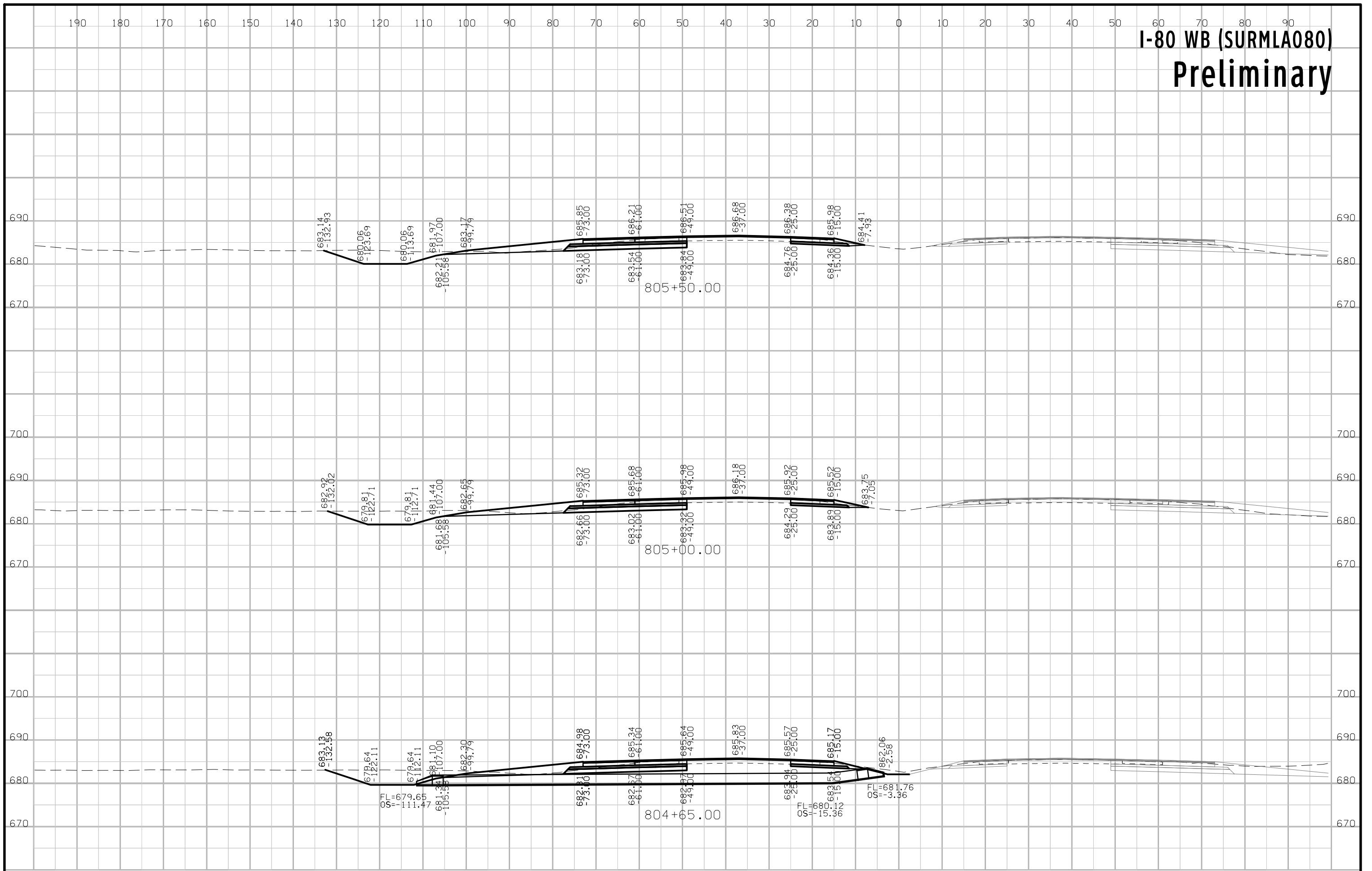

# I-80 WB (SURMLA080) Preliminary

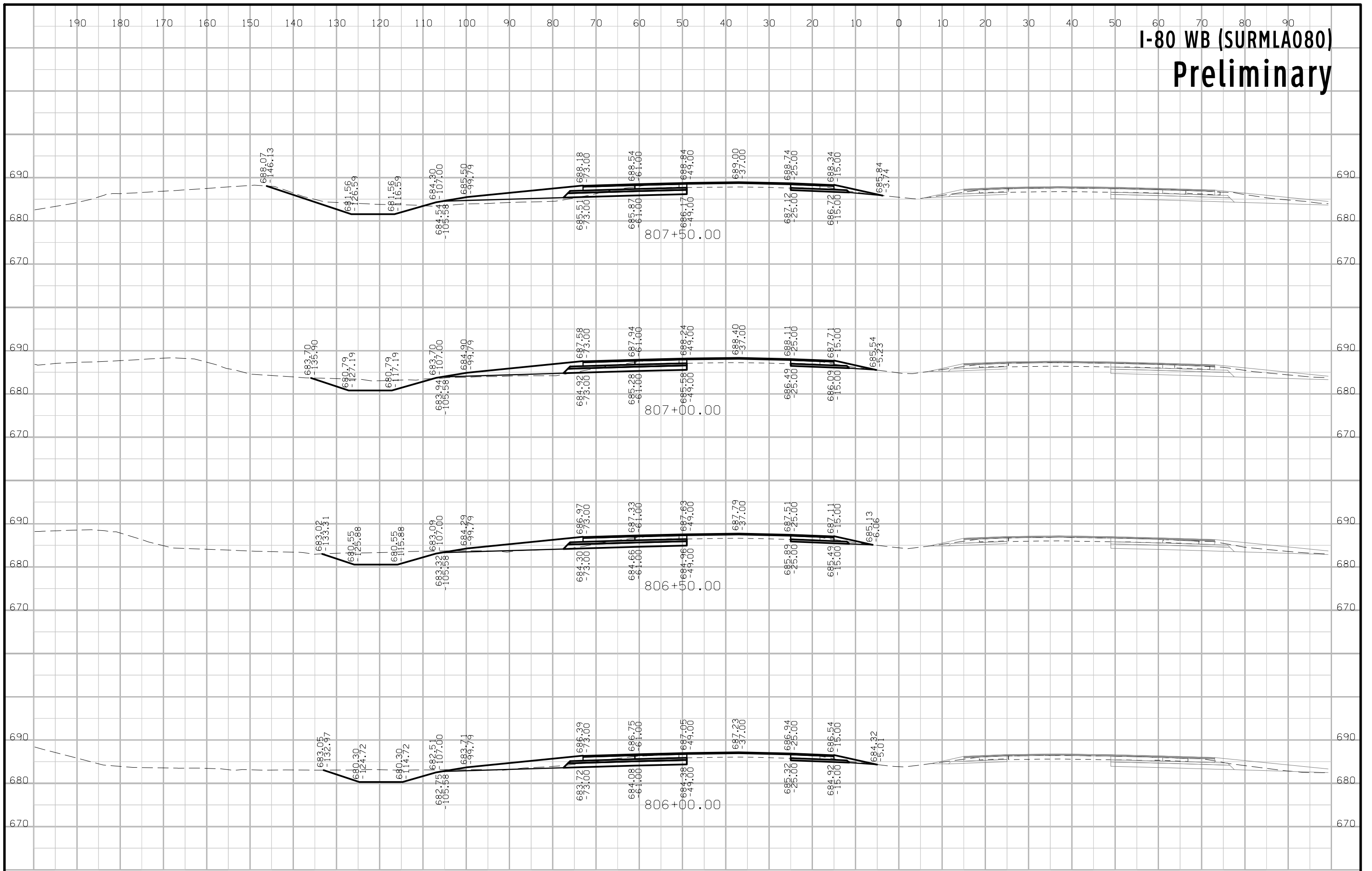



# I-80 WB (SURMLA080) Preliminary

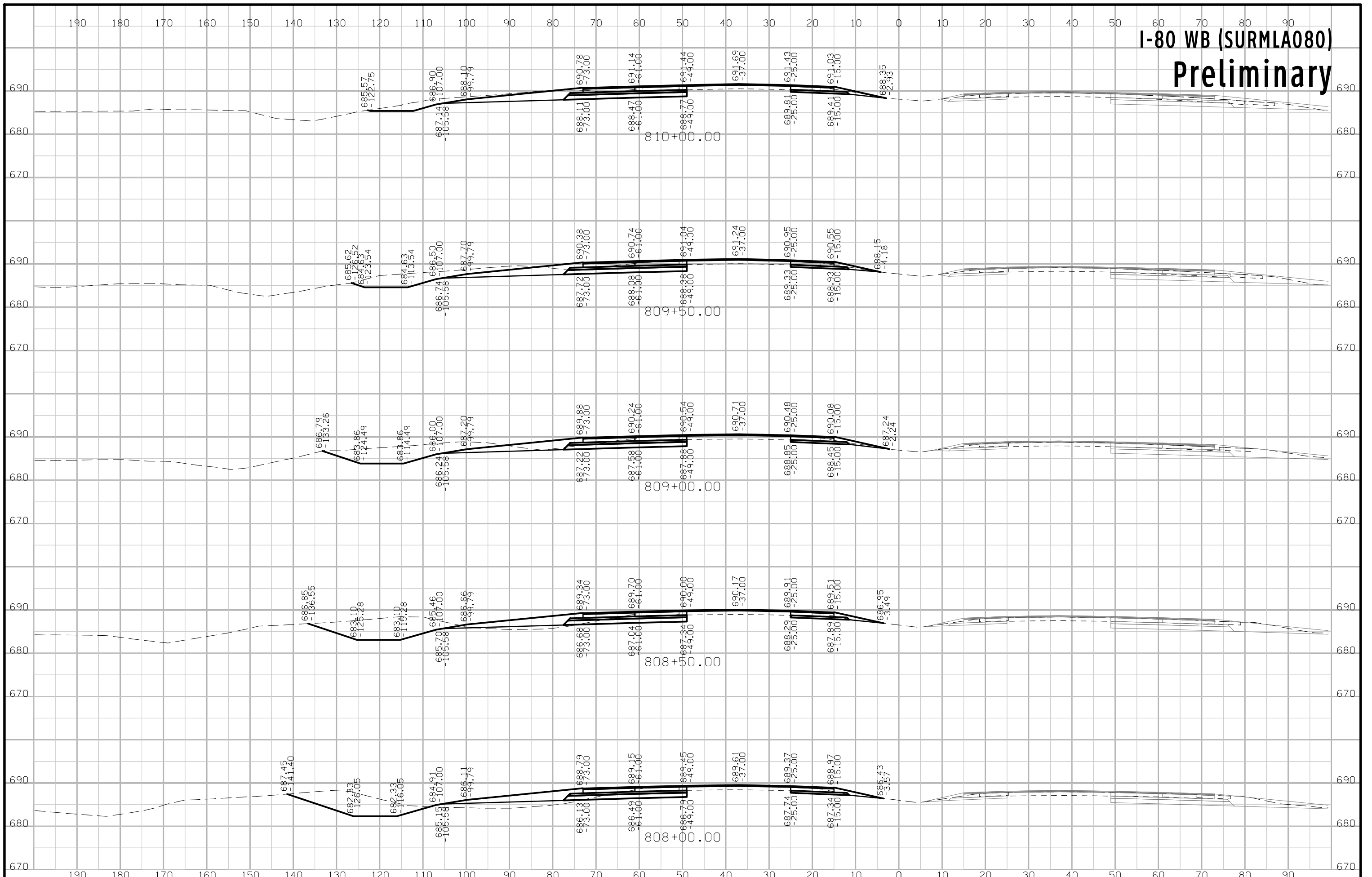

# I-80 WB (SURMLA080) Preliminary

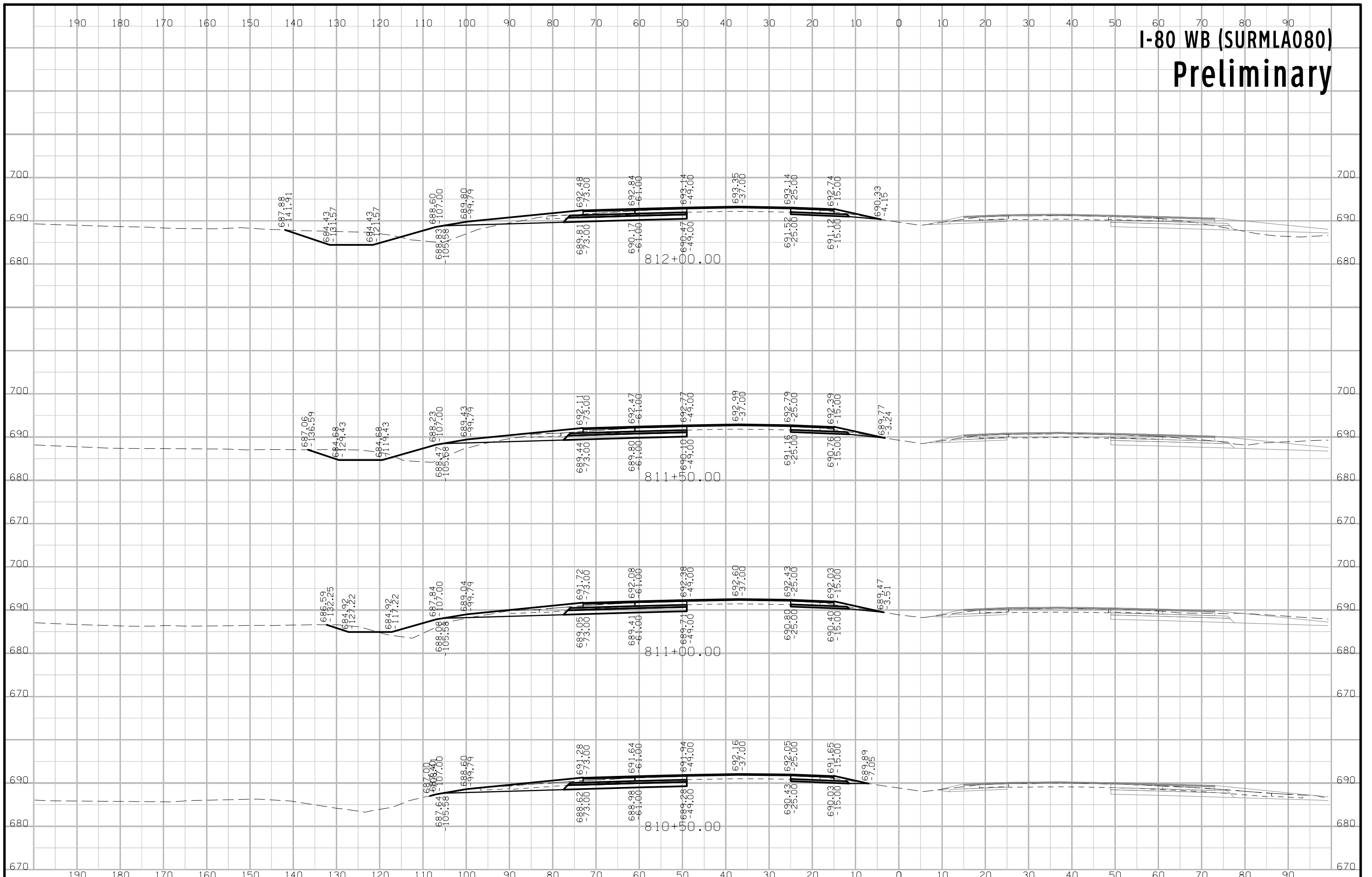

# I-80 WB (SURMLA080) Preliminary

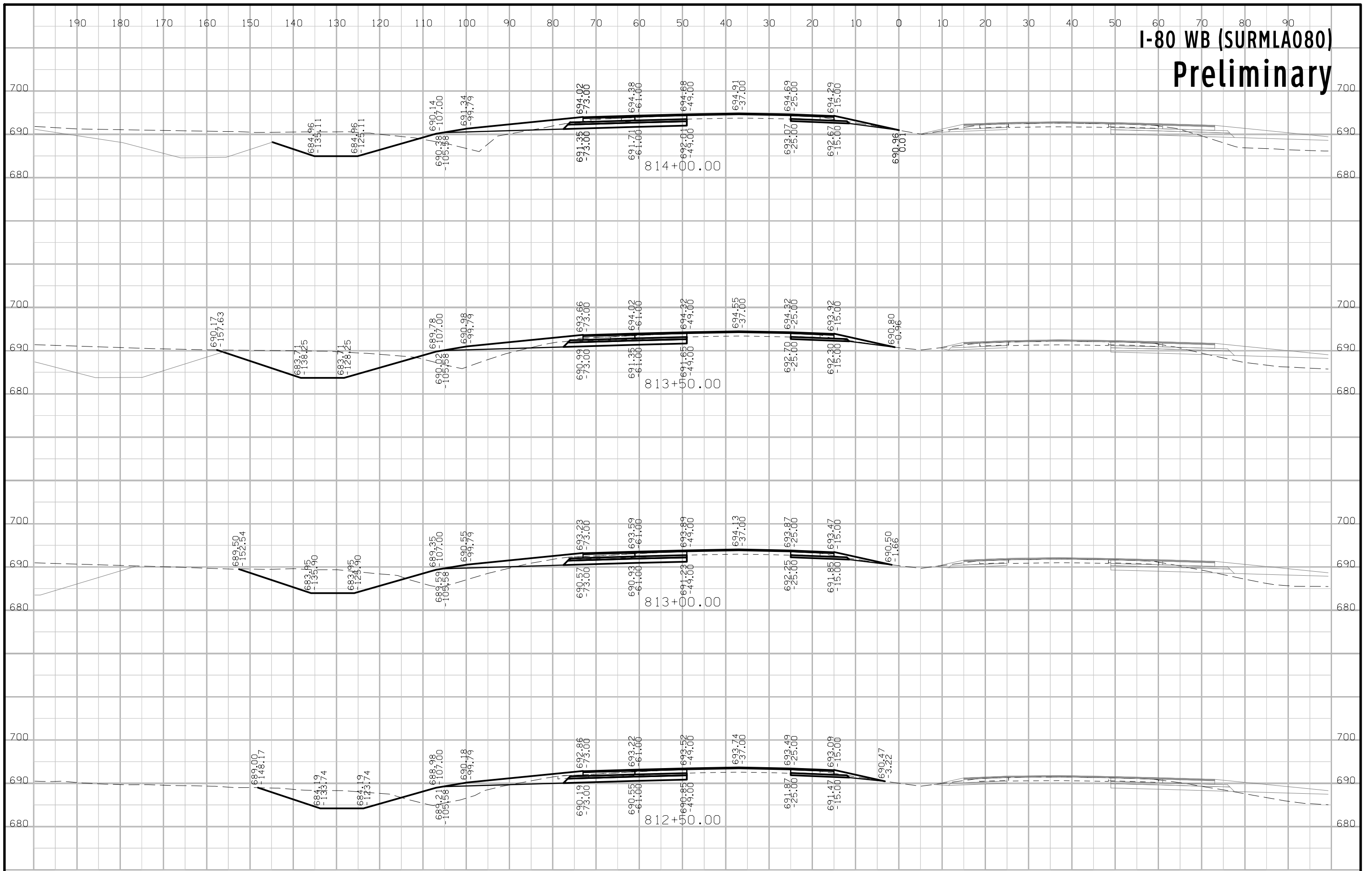

# I-80 WB (SURMLA080) Preliminary

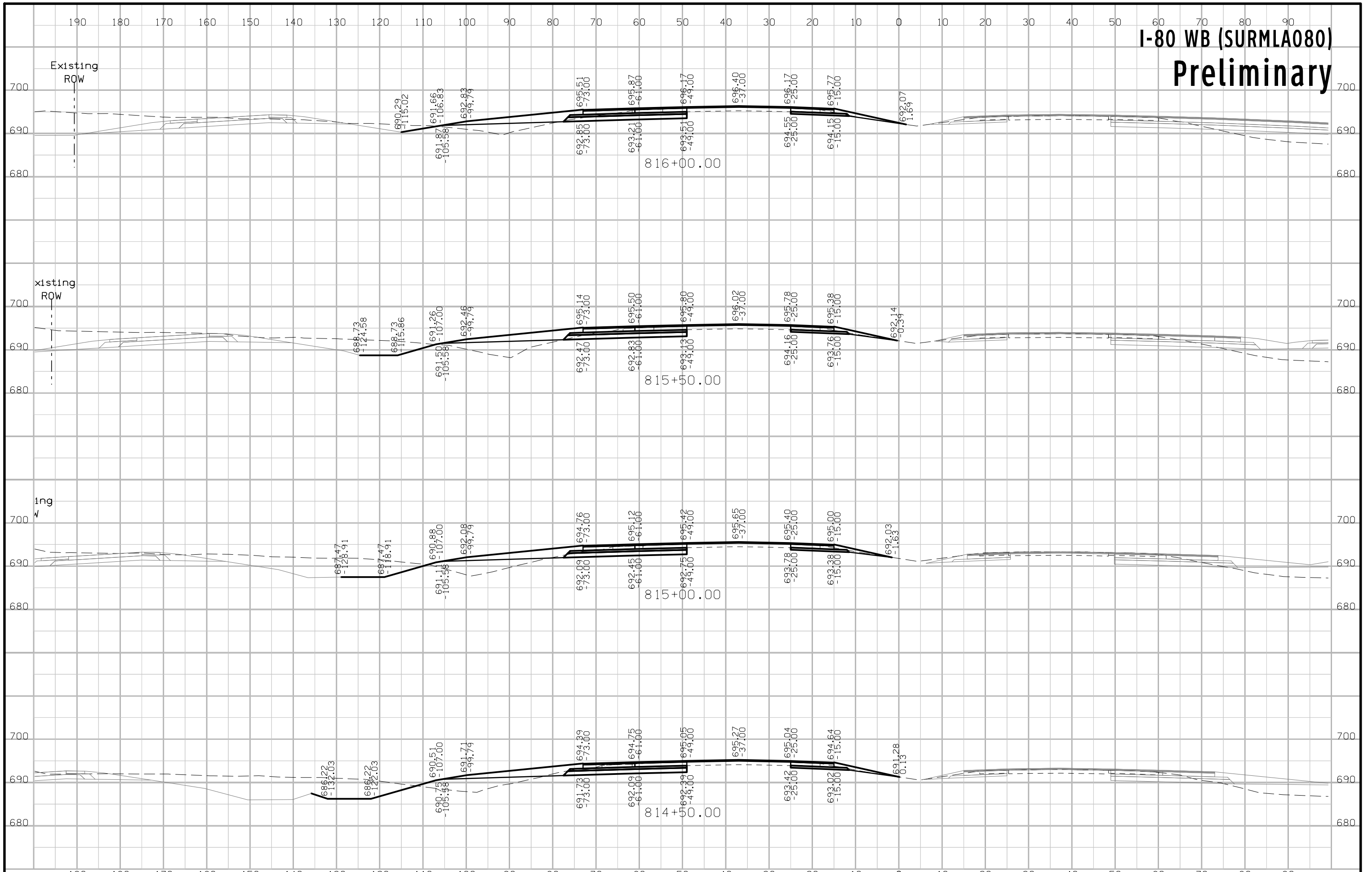



# I-80 WB (SURMLA080) Preliminary

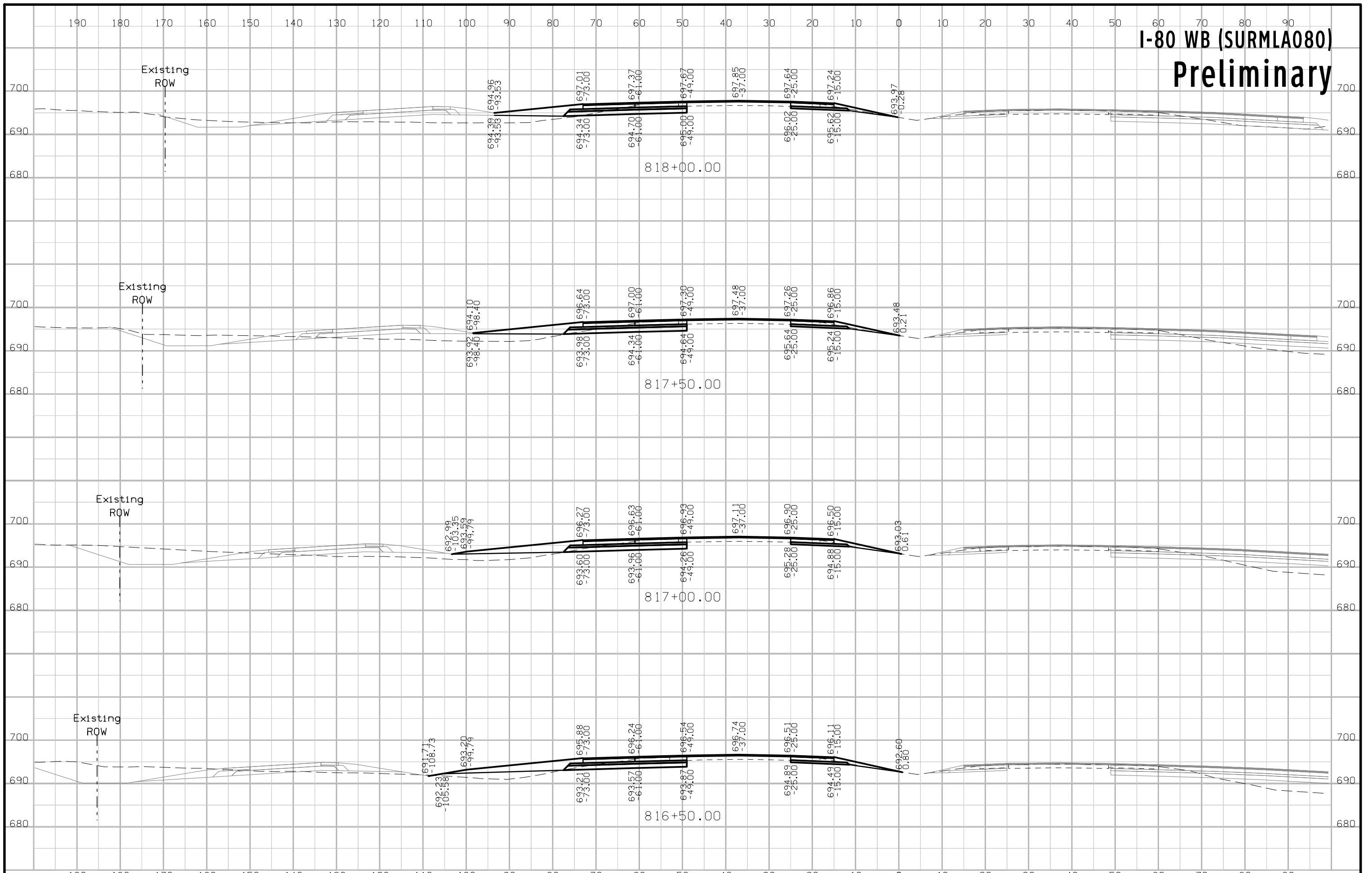

# I-80 WB (SURMLA080) Preliminary

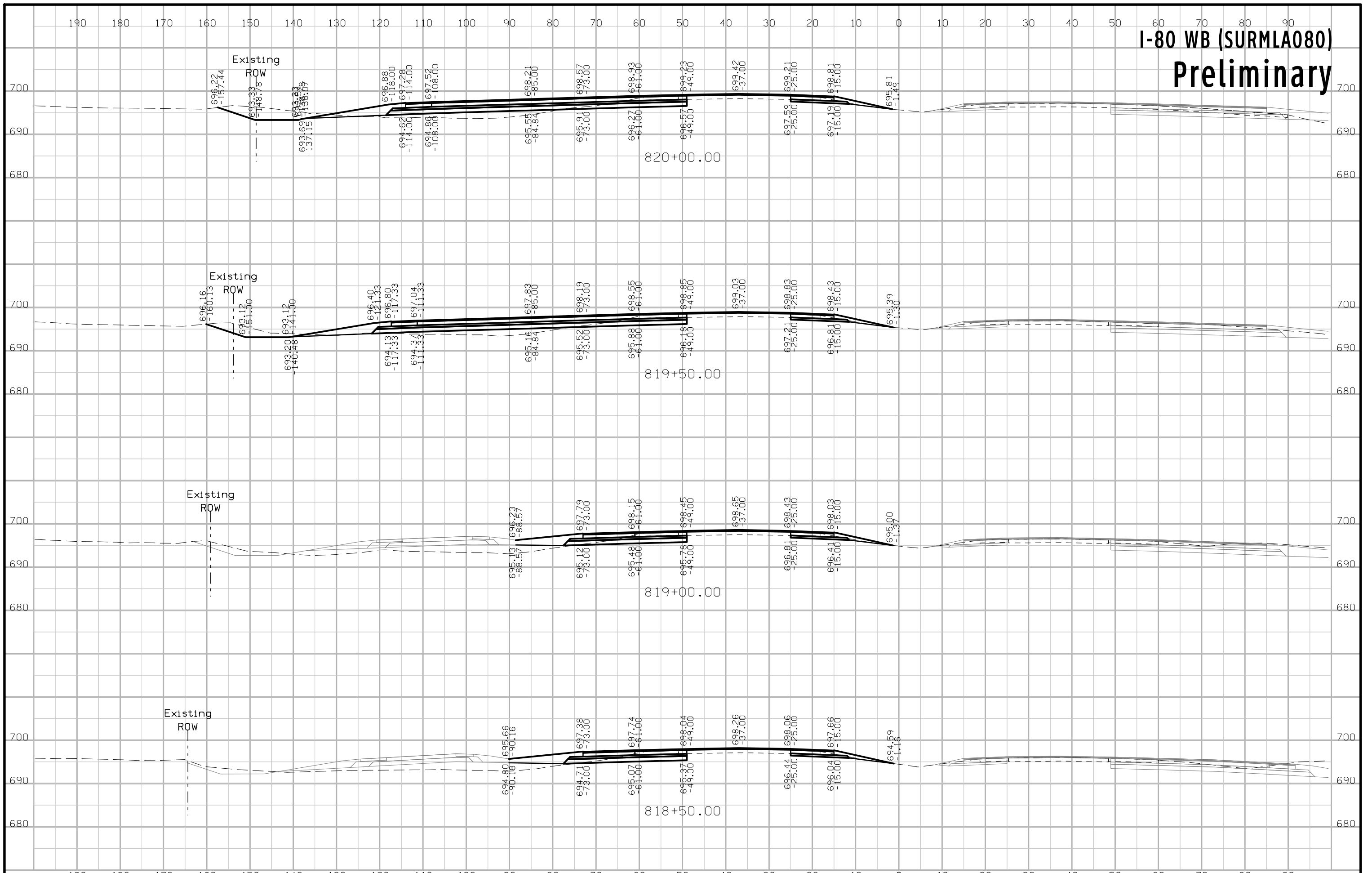

# I-80 WB (SURMLA080) Preliminary

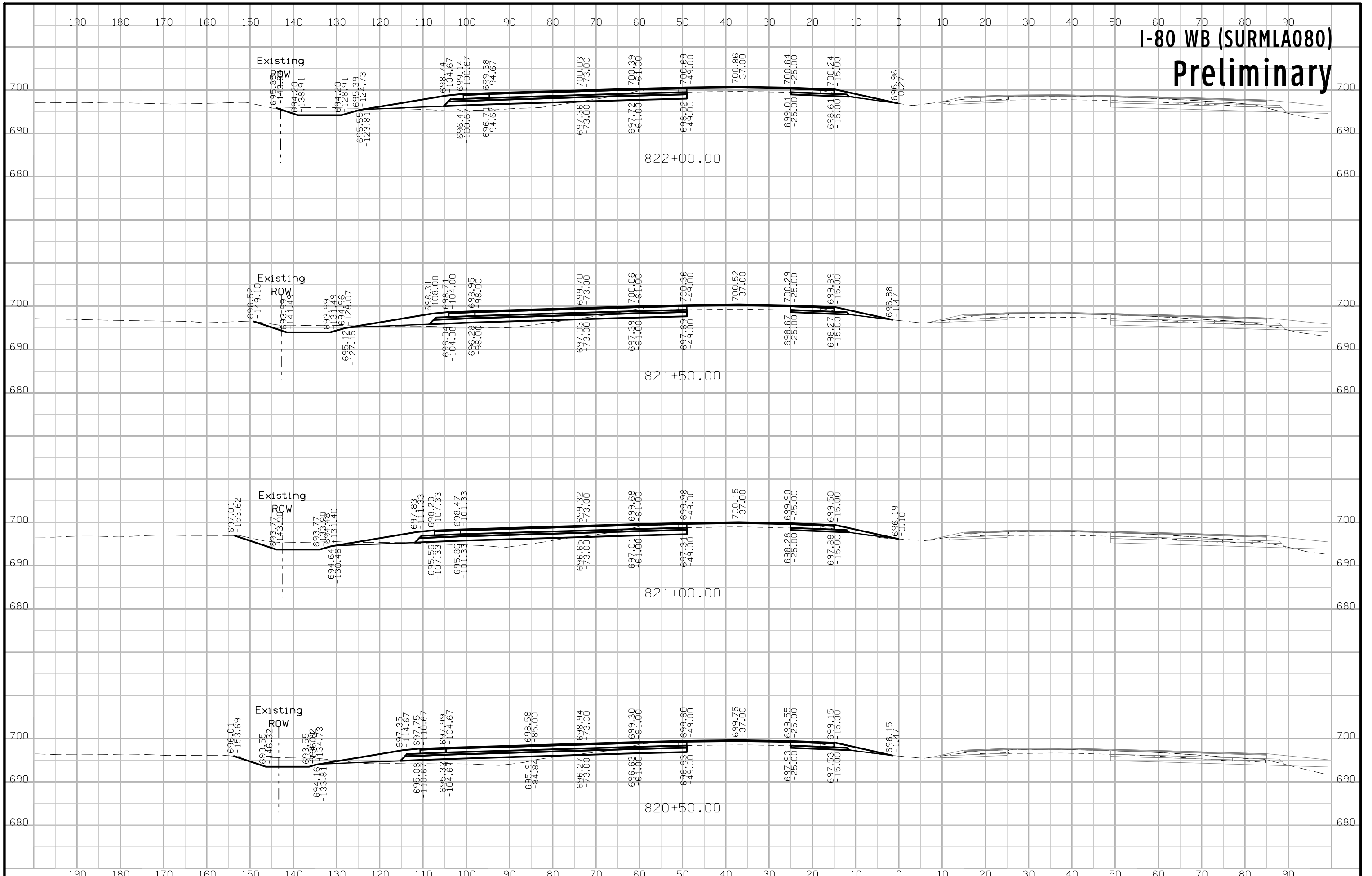

# I-80 WB (SURMLA080) Preliminary

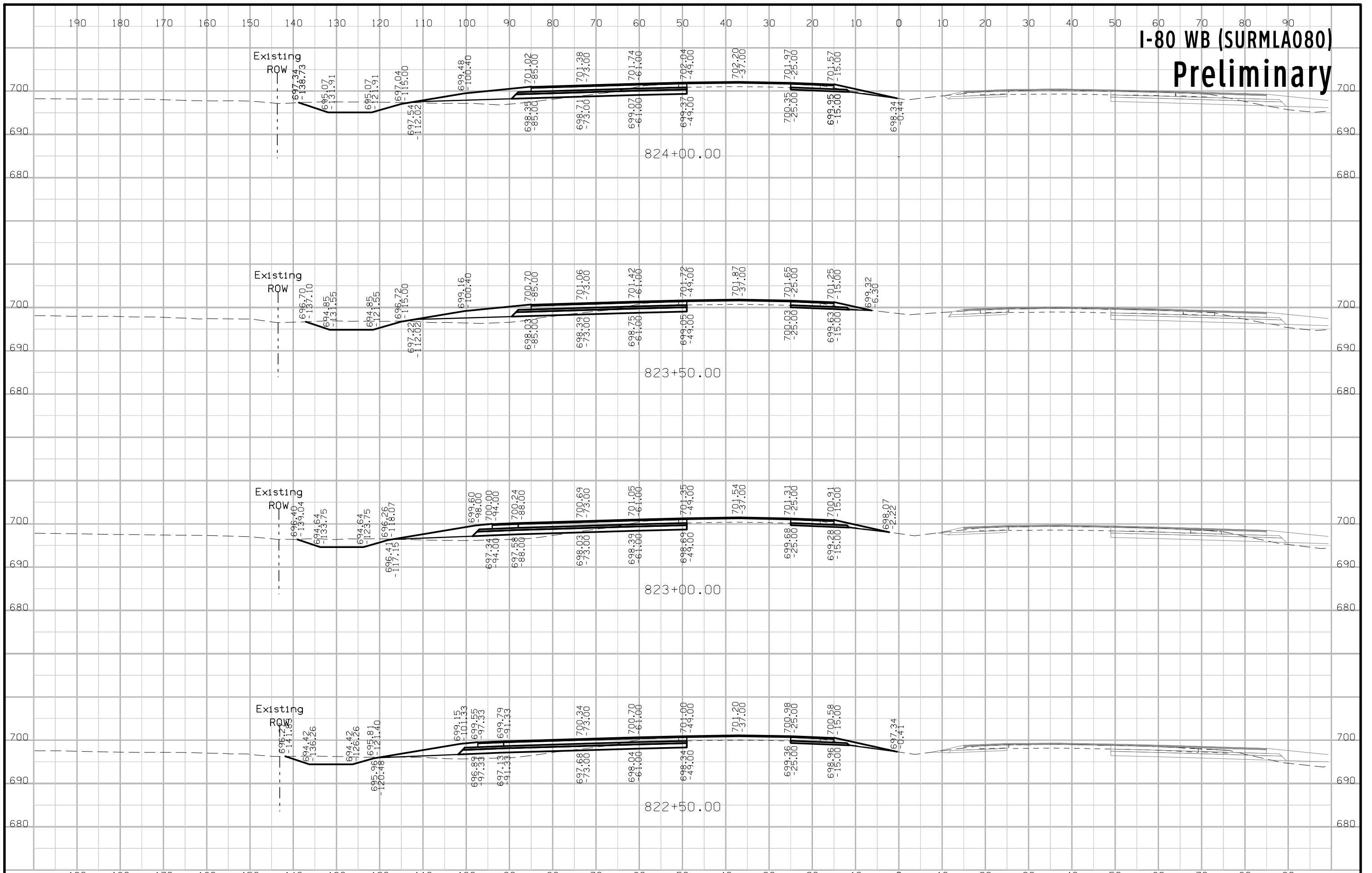



# I-80 WB (SURMLA080) Preliminary

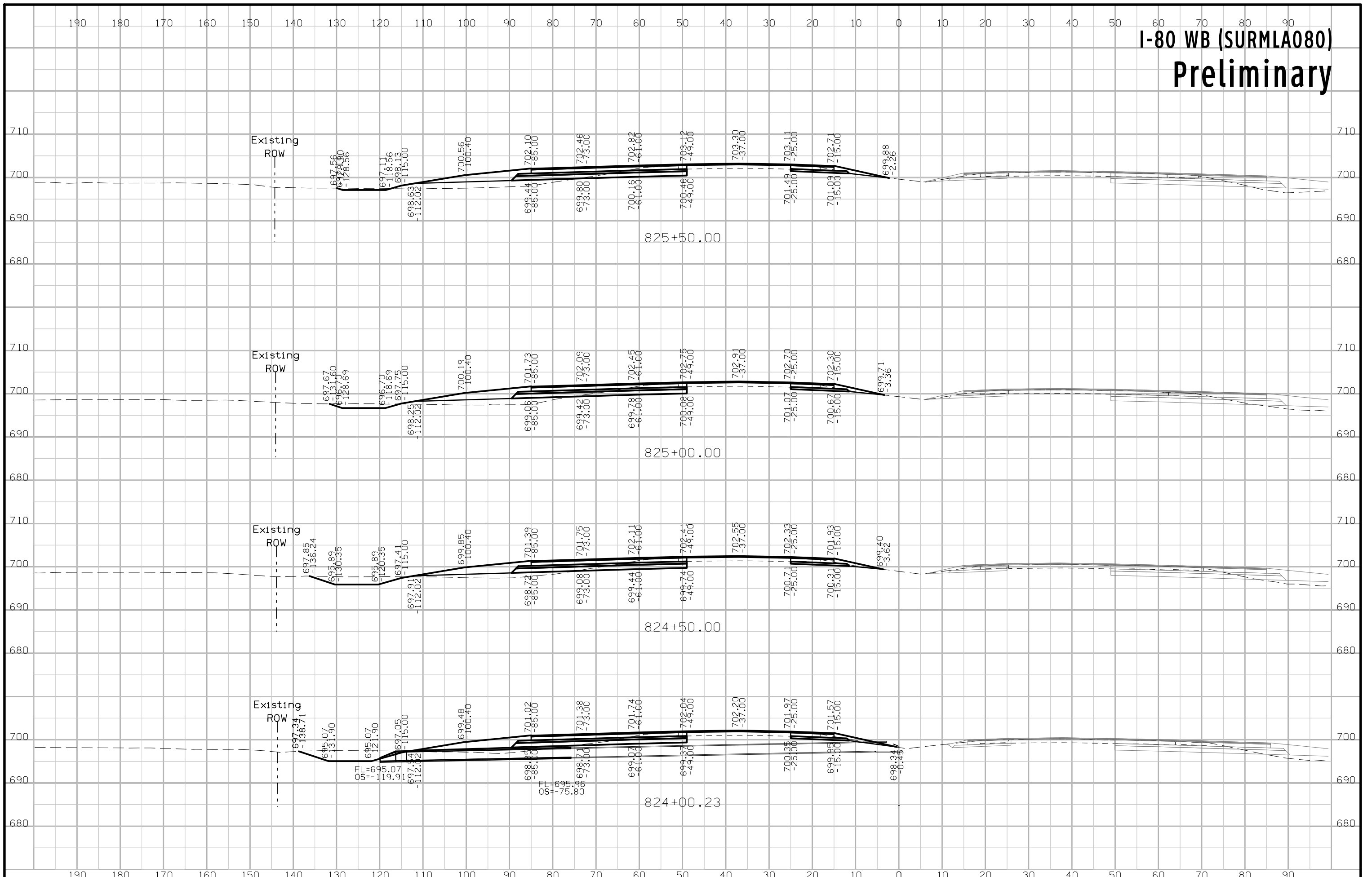

# I-80 WB (SURMLA080) Preliminary

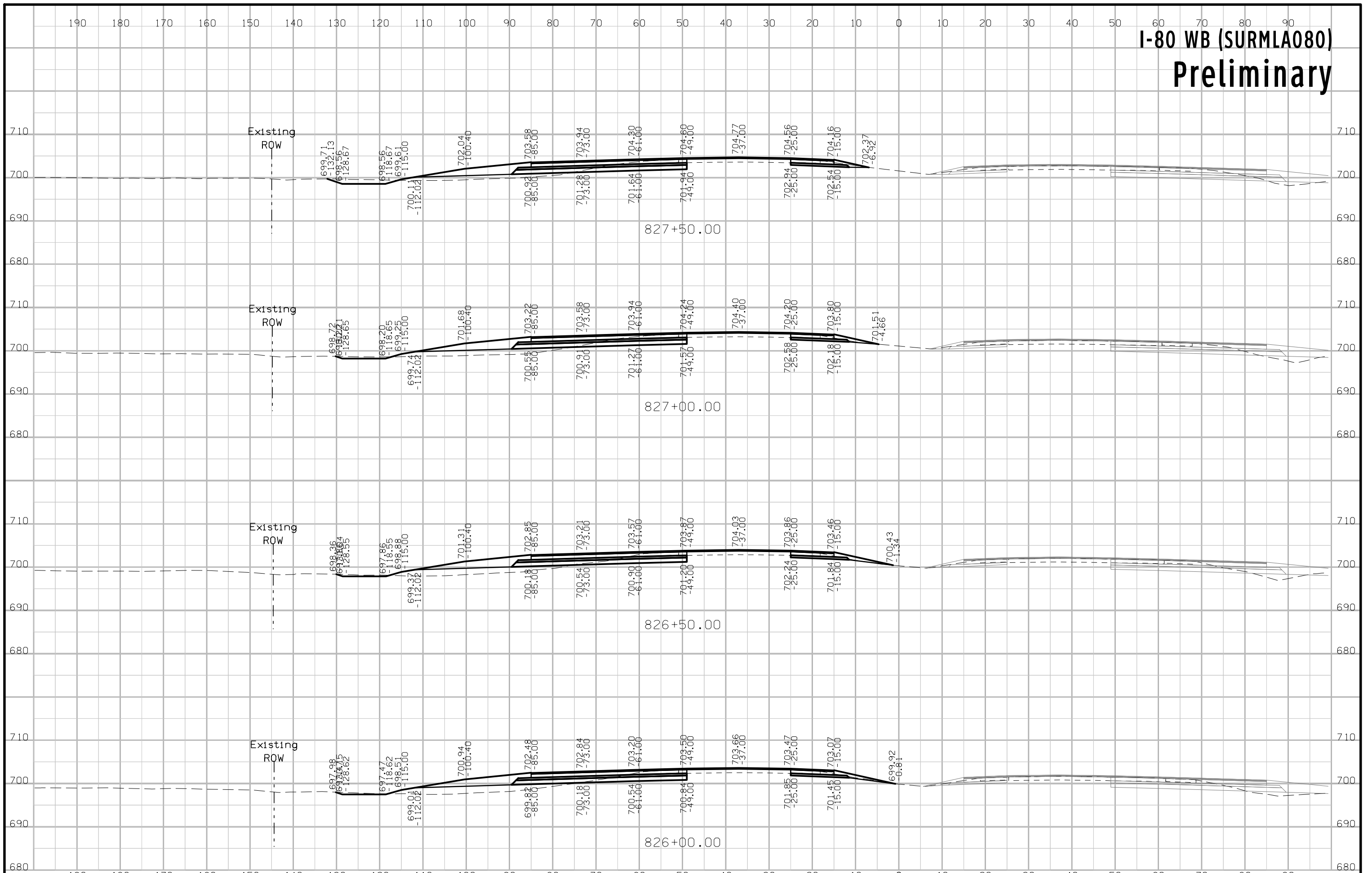

# I-80 WB (SURMLA080) Preliminary

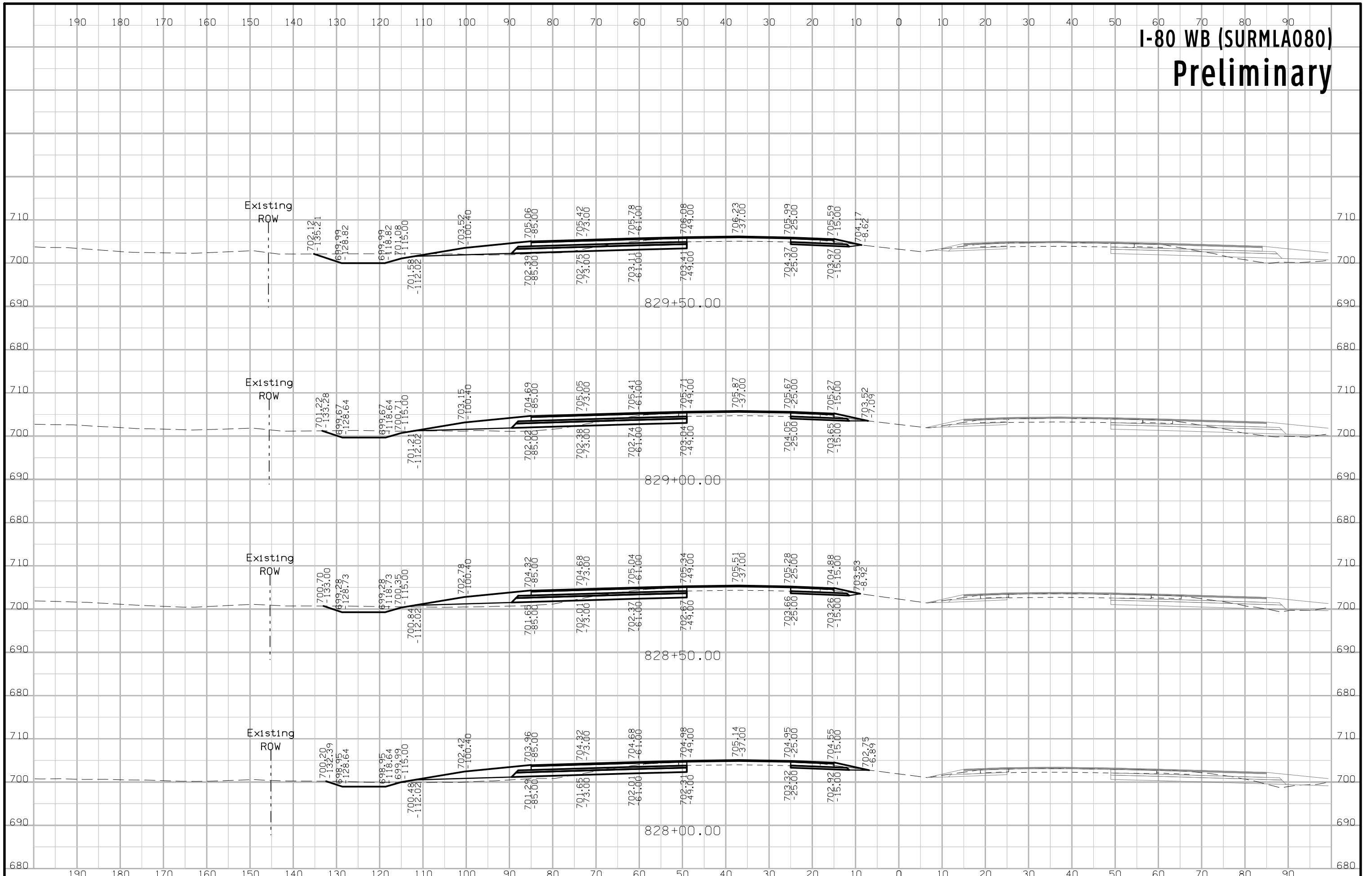

# I-80 WB (SURMLA080) Preliminary

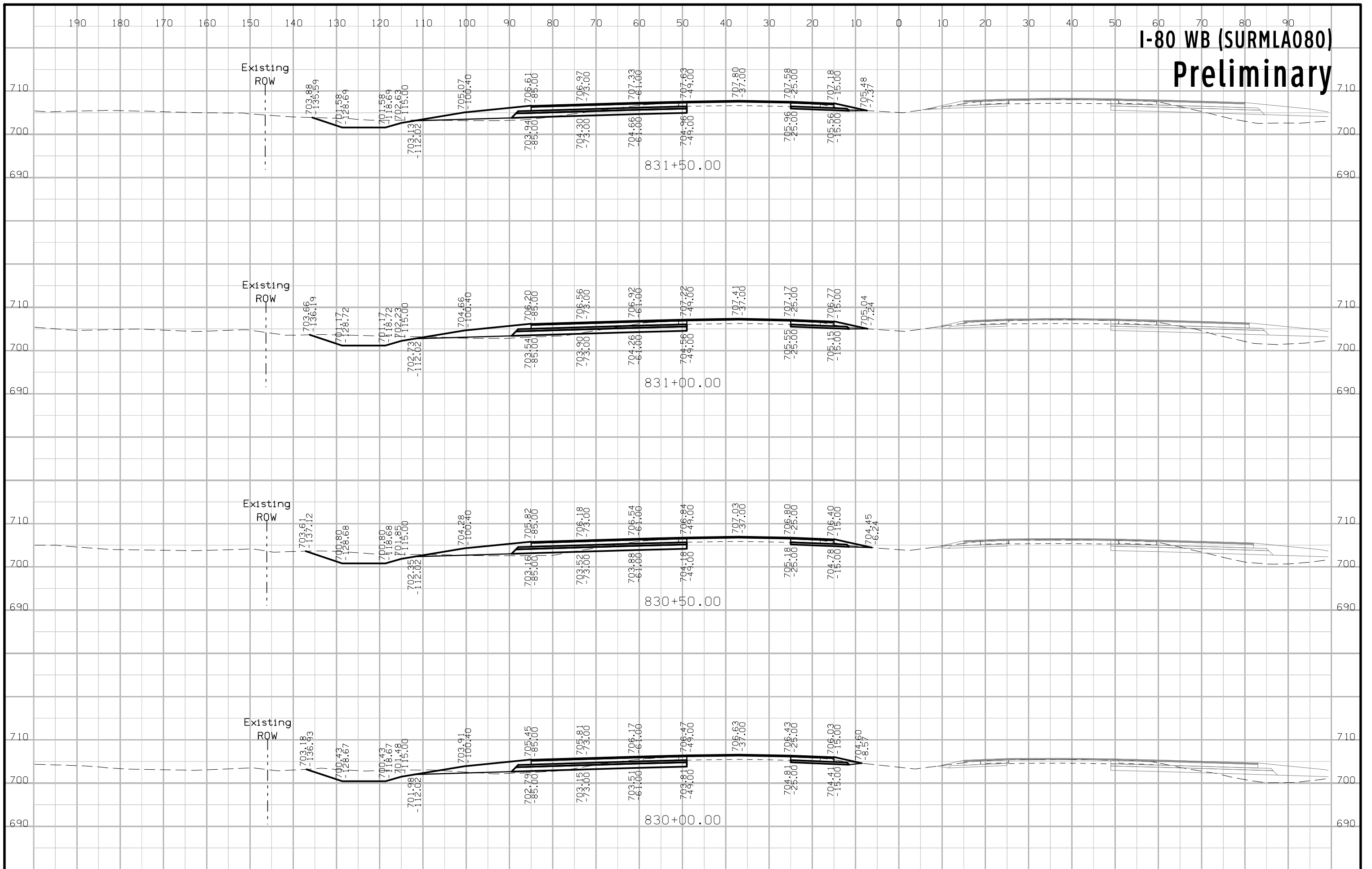



# I-80 WB (SURMLA080) Preliminary

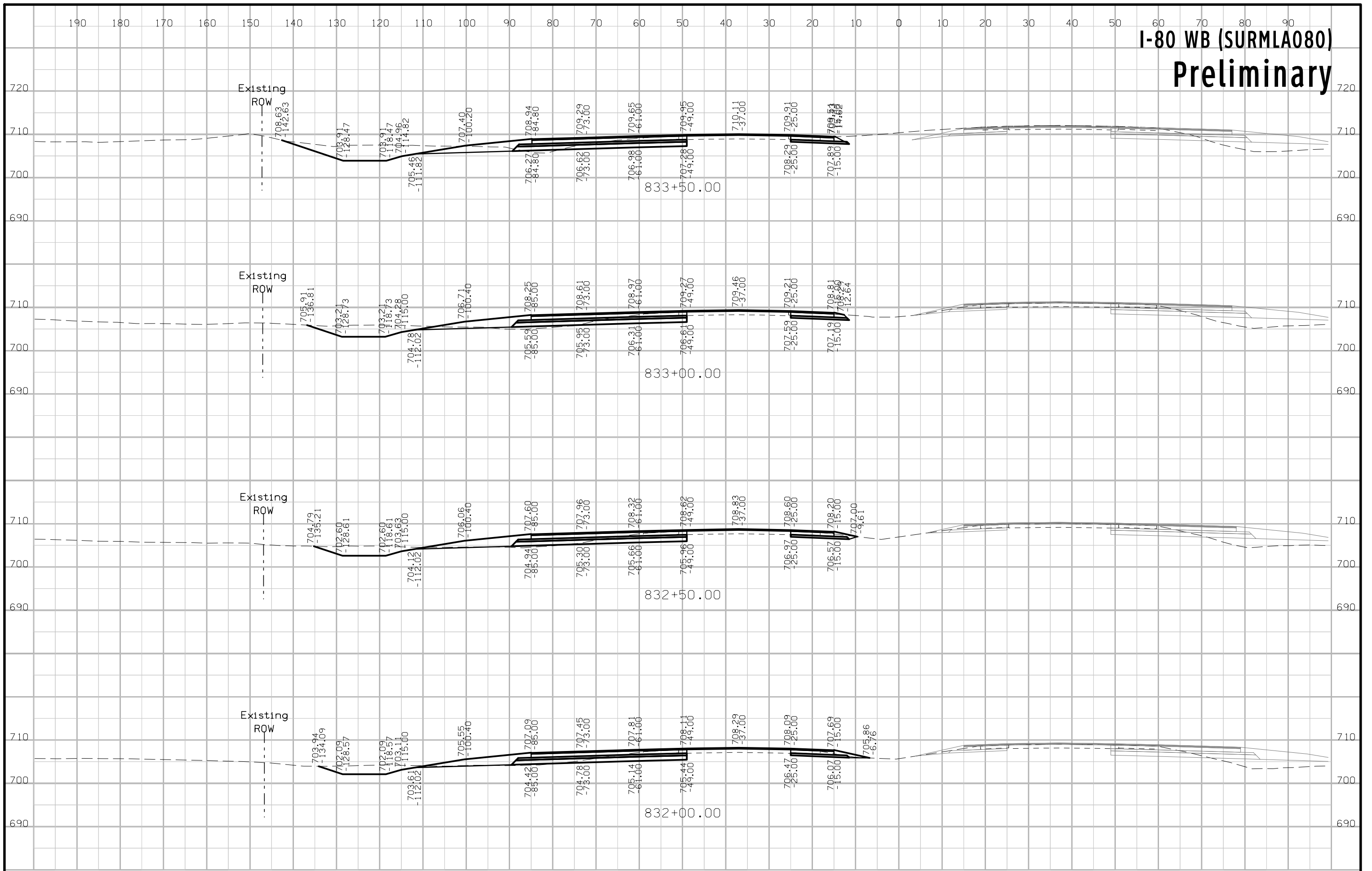

# I-80 WB (SURMLA080) Preliminary

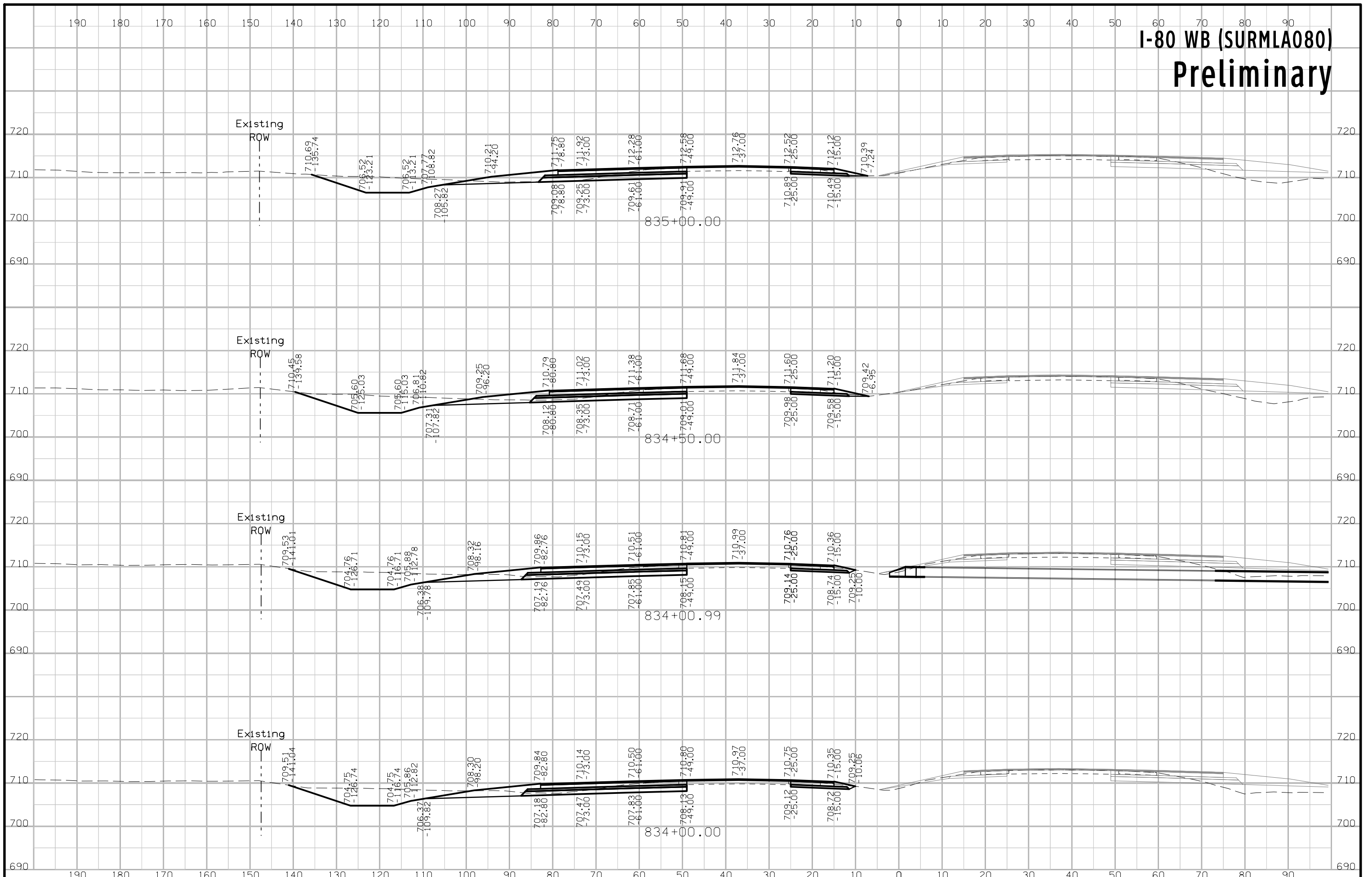

# I-80 WB (SURMLA080) Preliminary

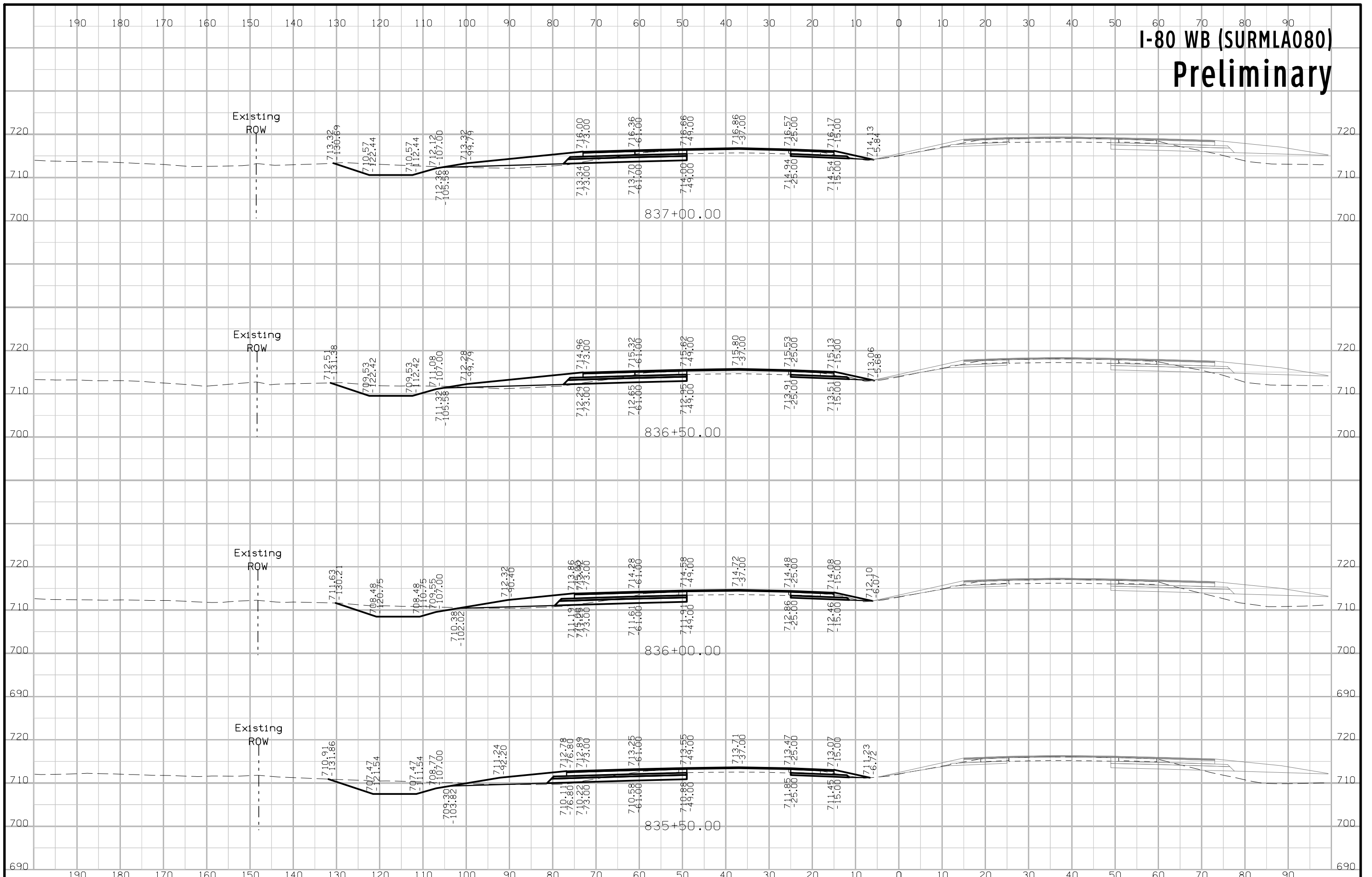

# I-80 WB (SURMLA080) Preliminary

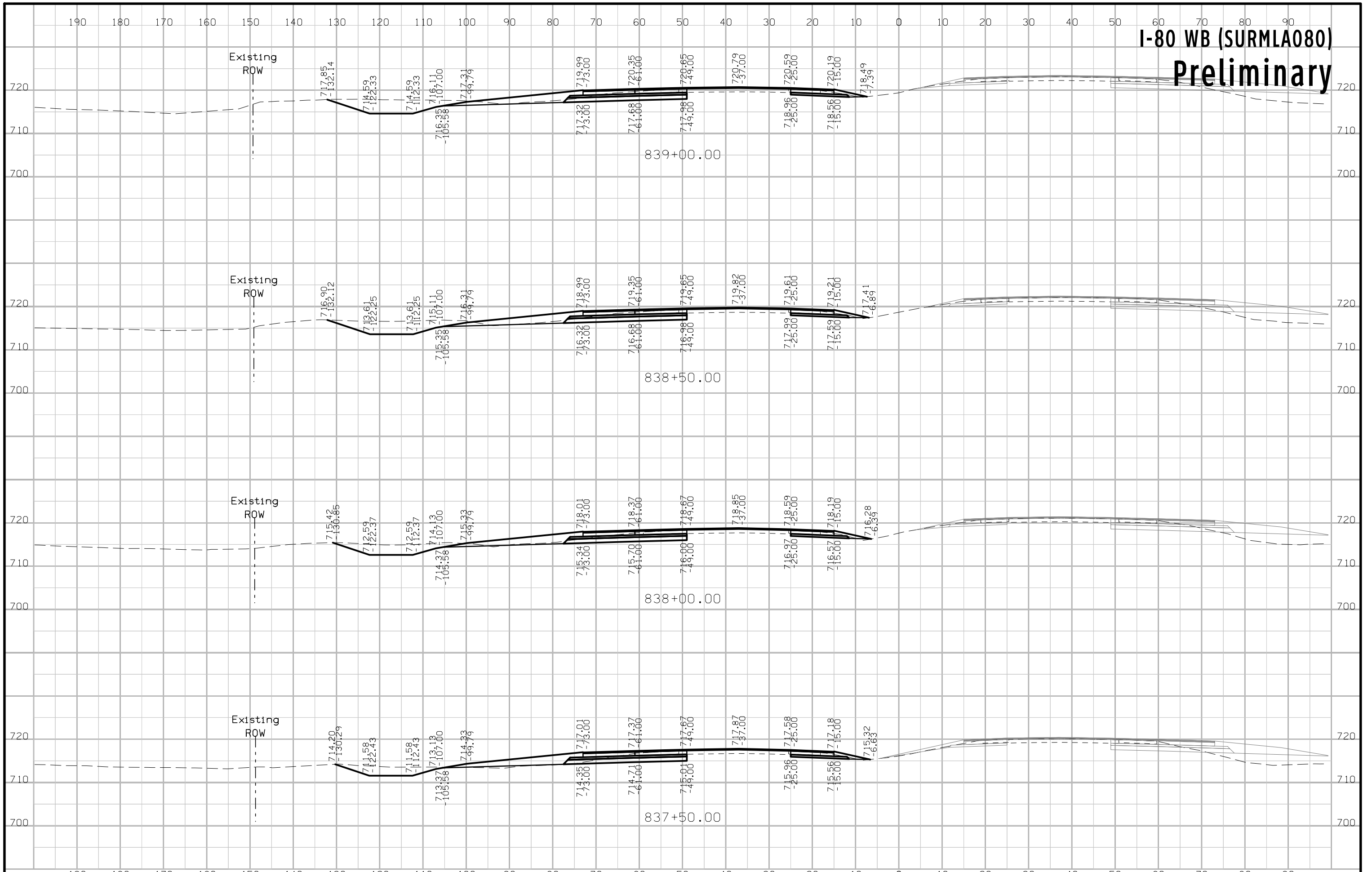



# I-80 WB (SURMLA080) Preliminary

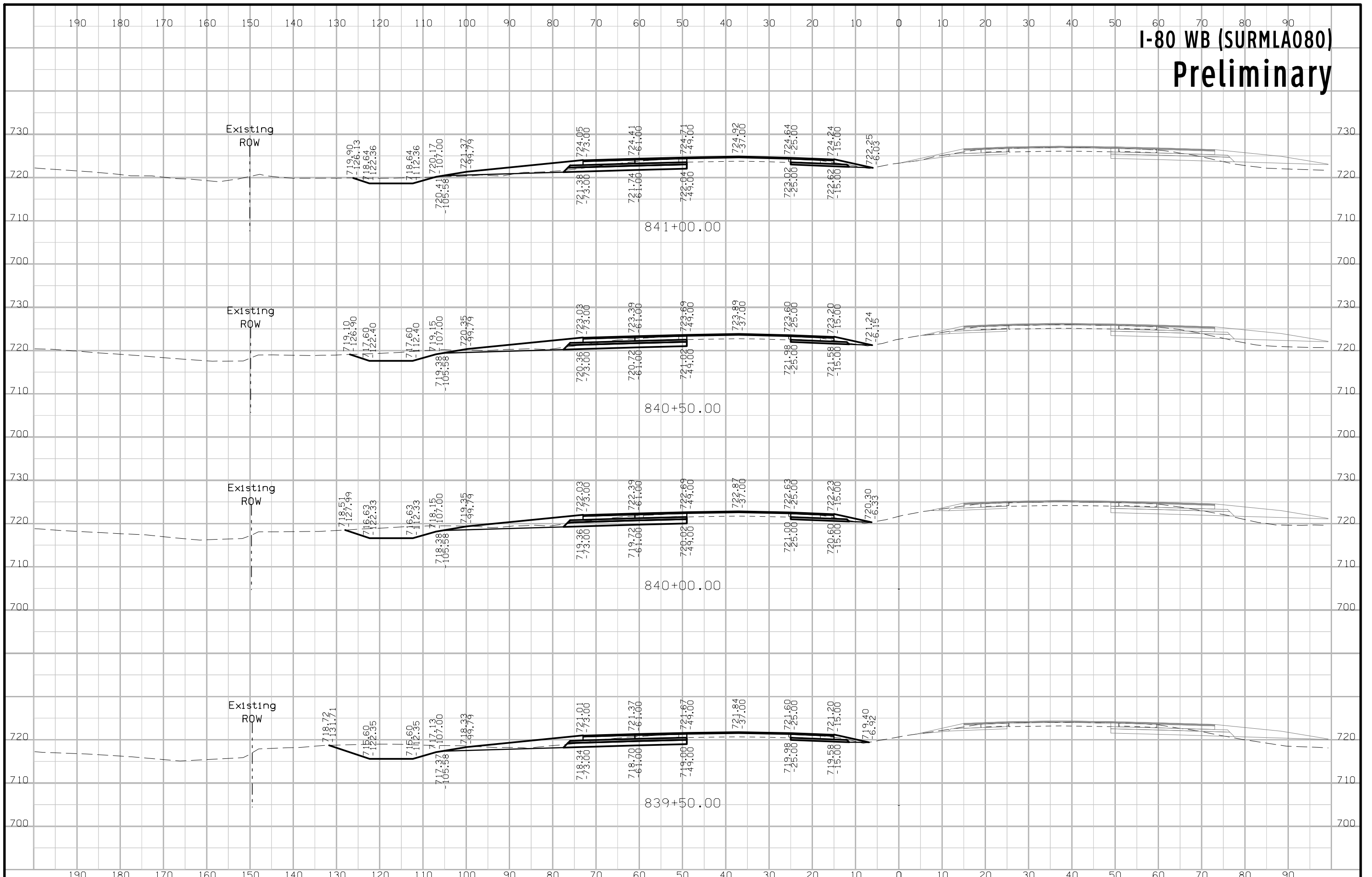

# I-80 WB (SURMLA080) Preliminary

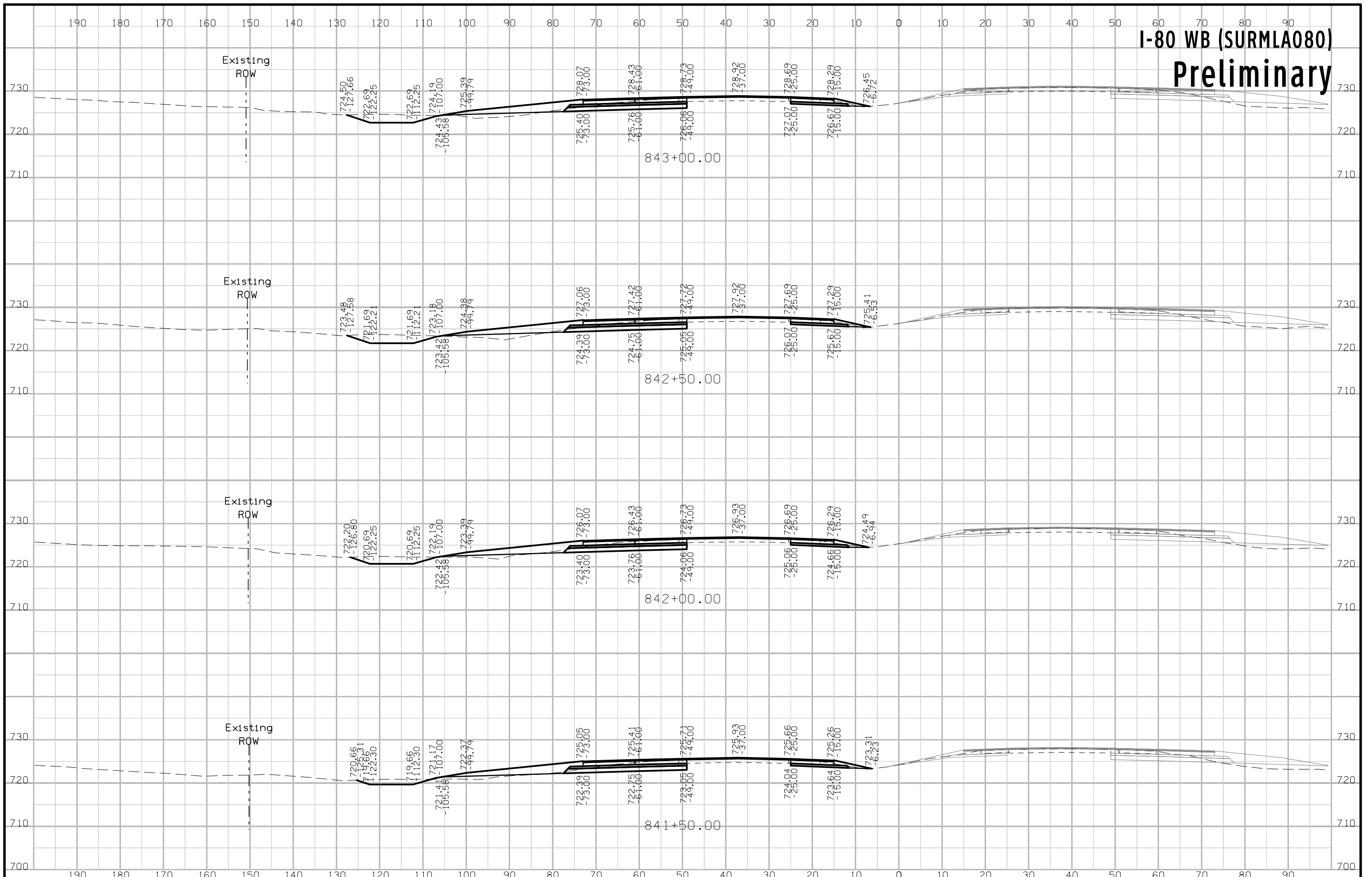

# I-80 WB (SURMLA080) Preliminary

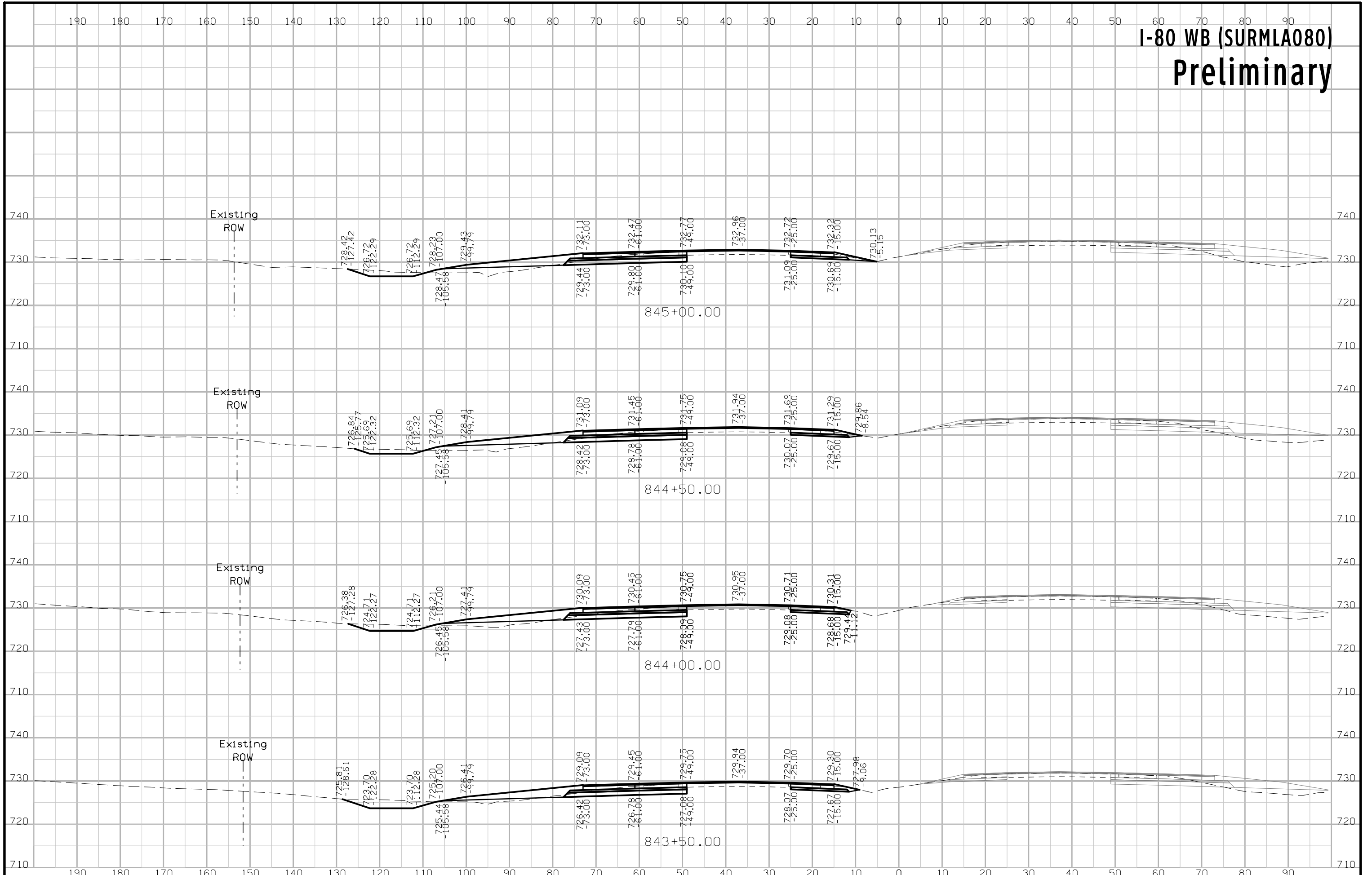

# I-80 WB (SURMLA080) Preliminary

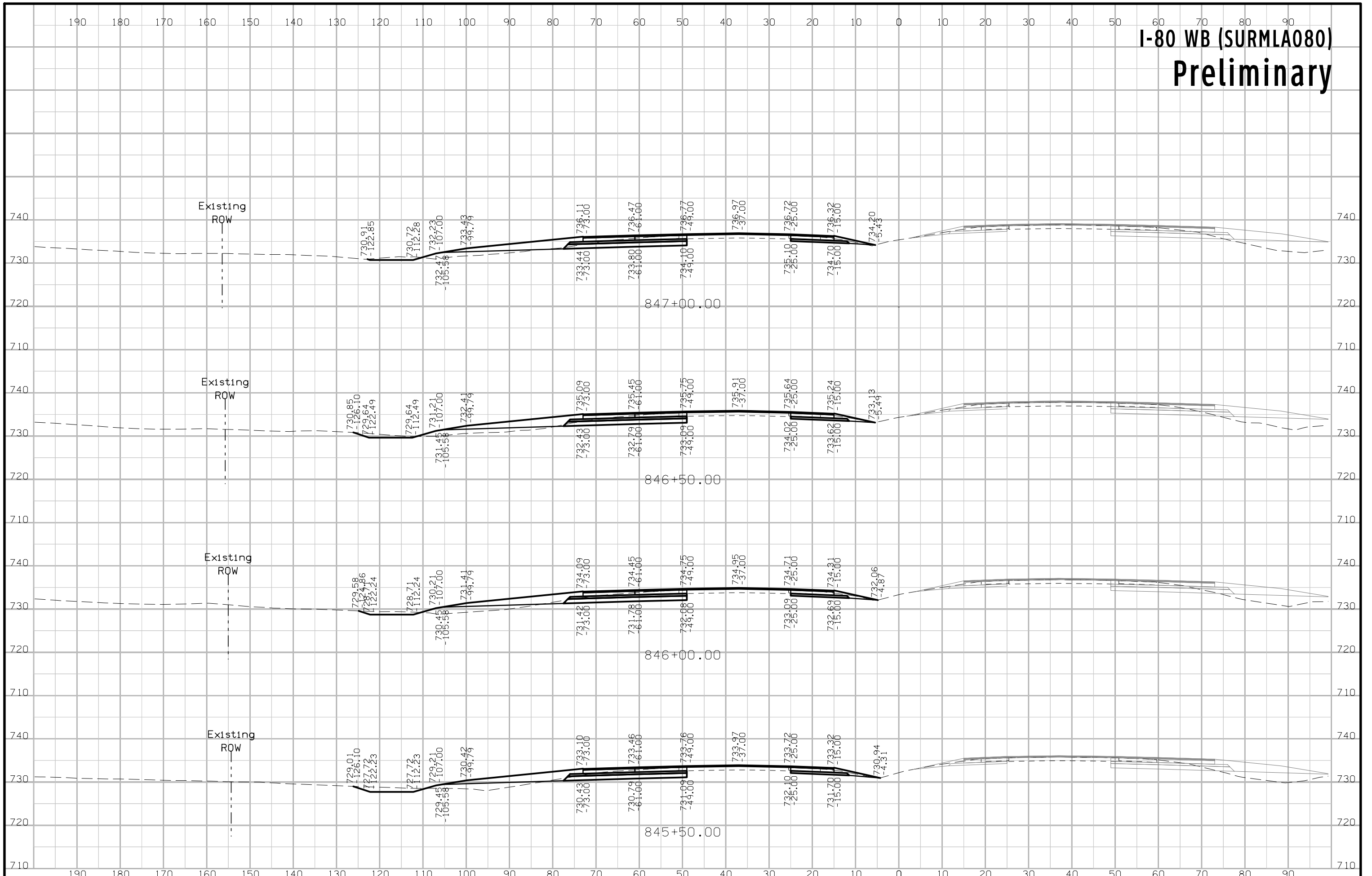



# I-80 WB (SURMLA080) Preliminary

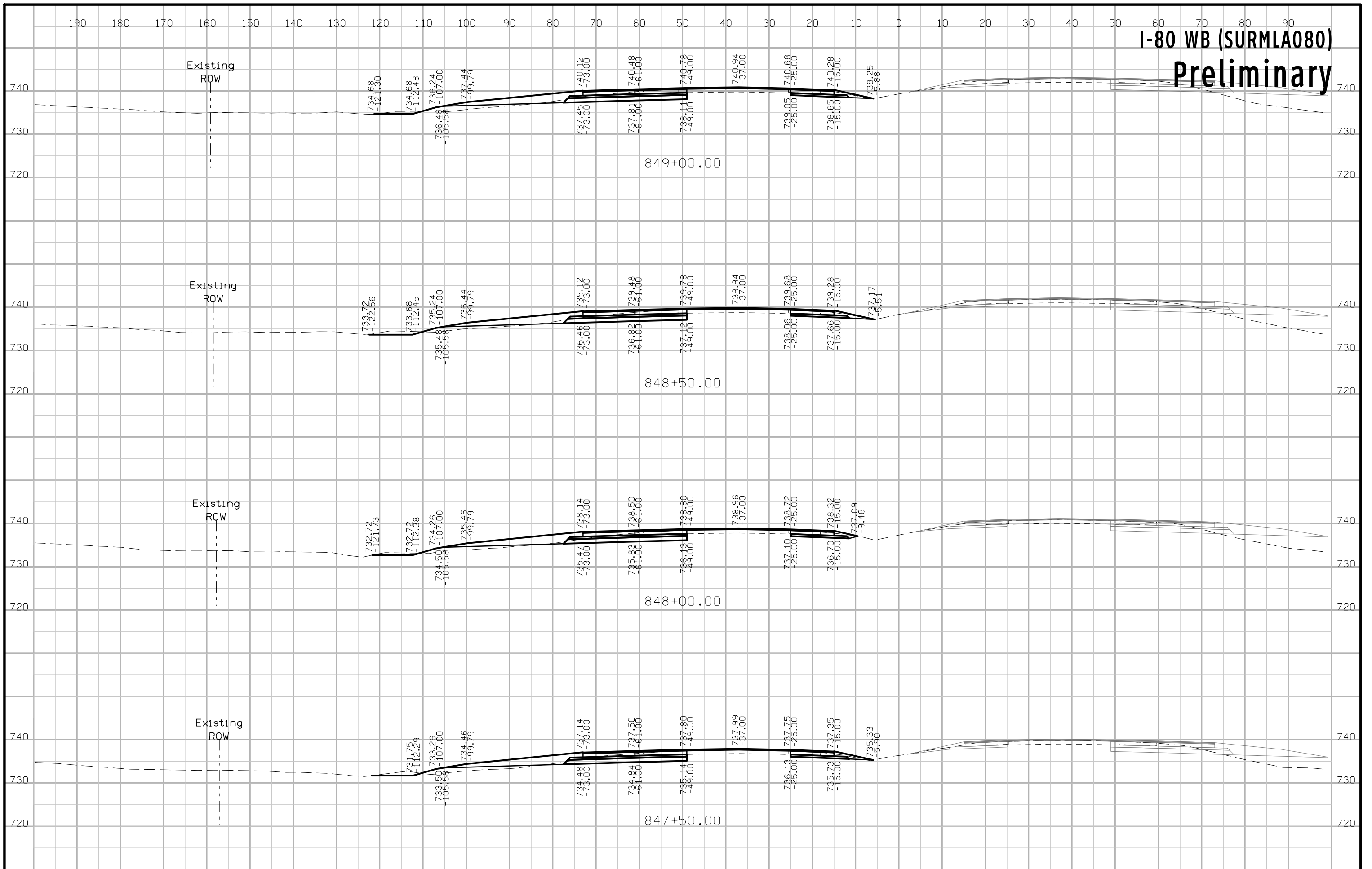

# I-80 WB (SURMLA080) Preliminary

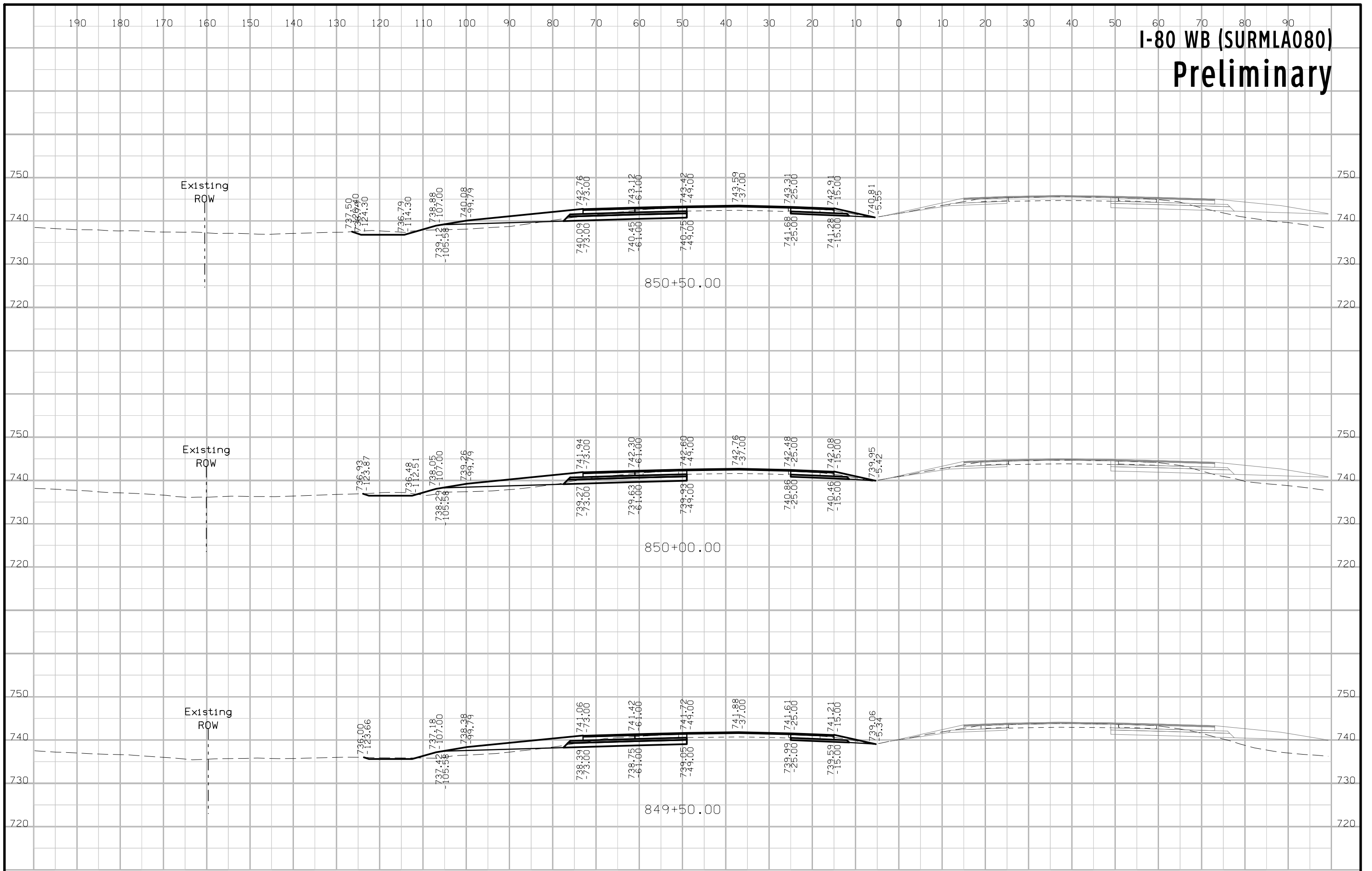

# I-80 WB (SURMLA080) Preliminary

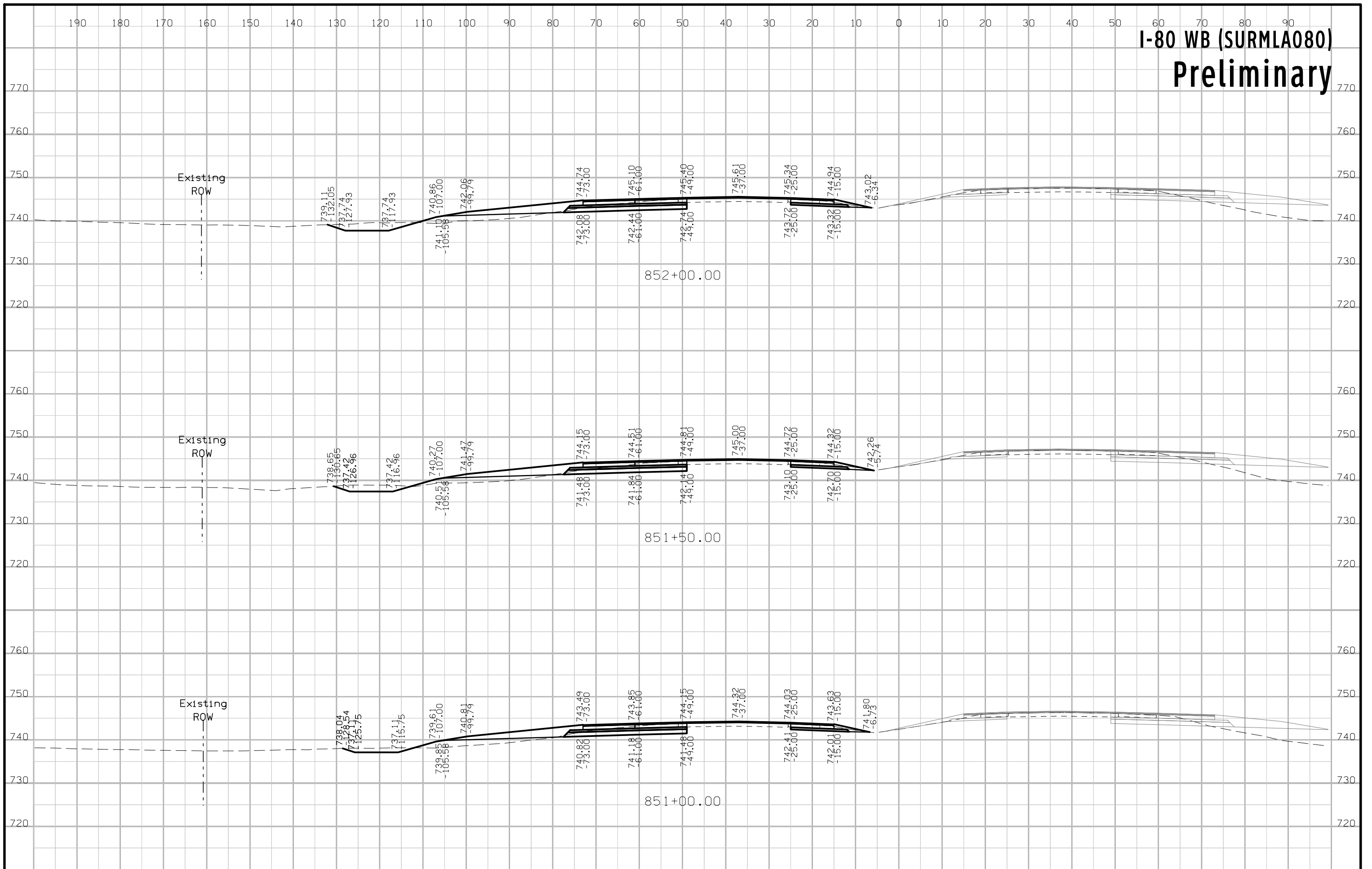

# I-80 WB (SURMLA080) Preliminary

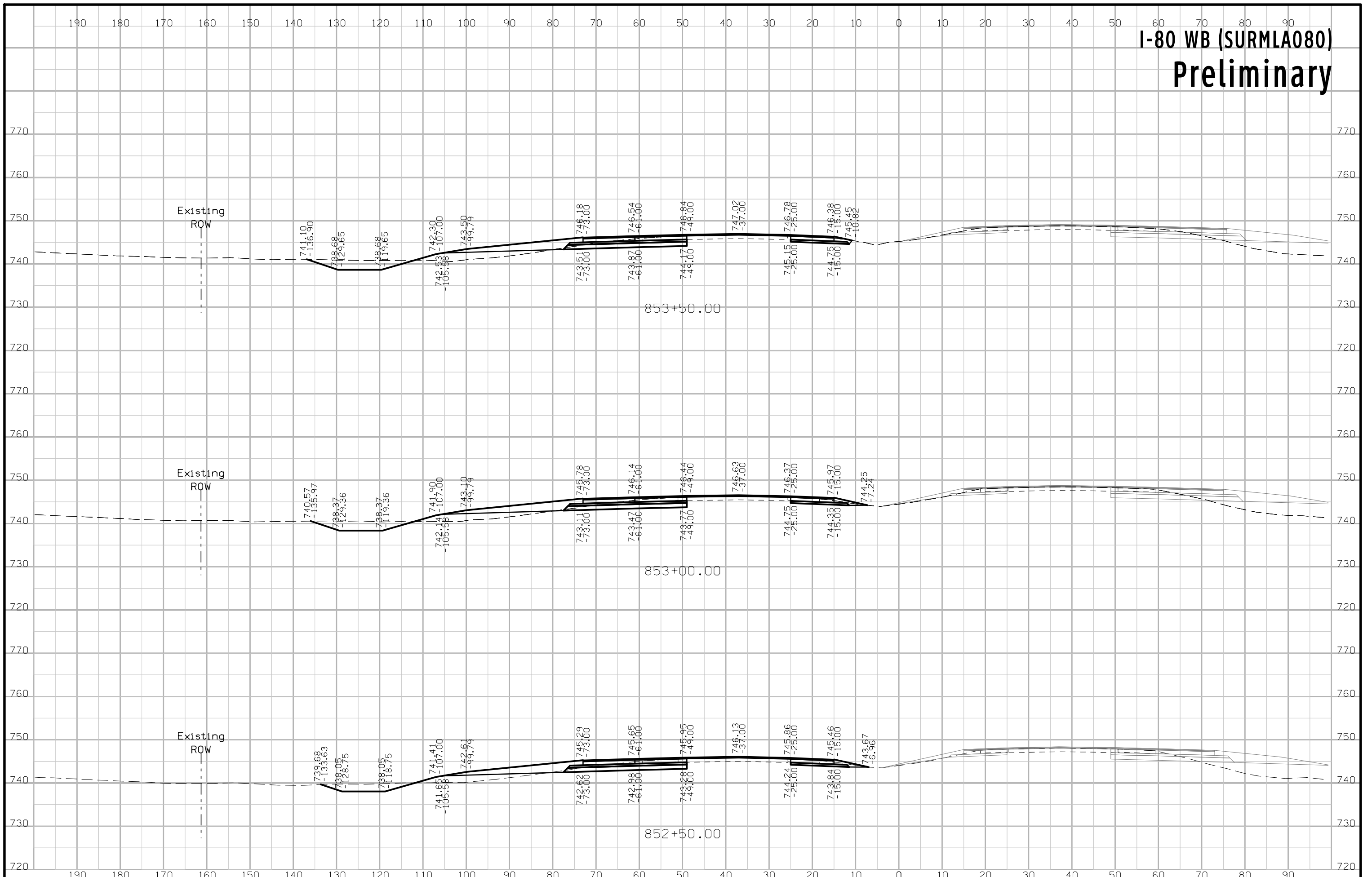



# I-80 WB (SURMLA080) Preliminary

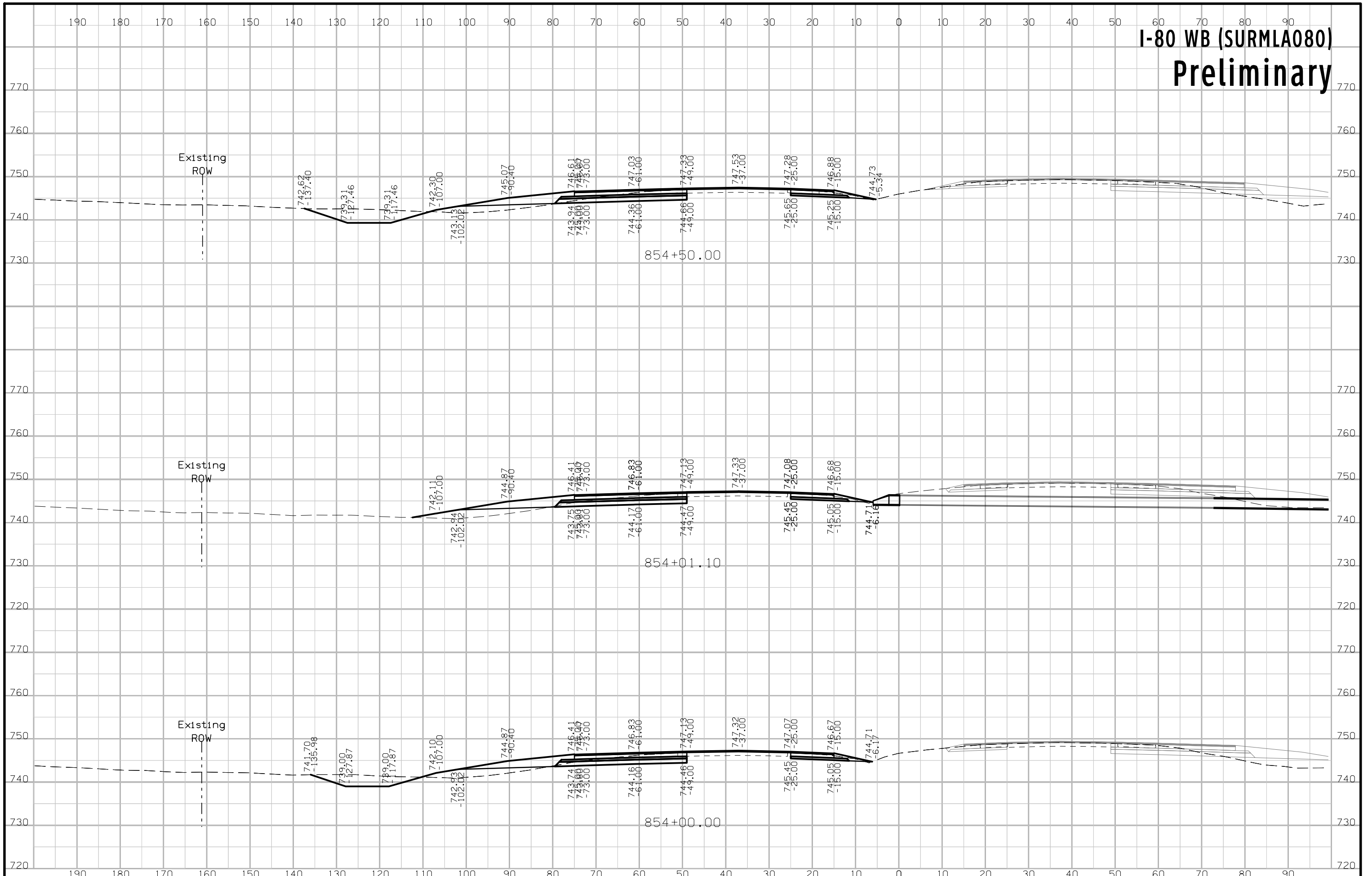

# I-80 WB (SURMLA080) Preliminary

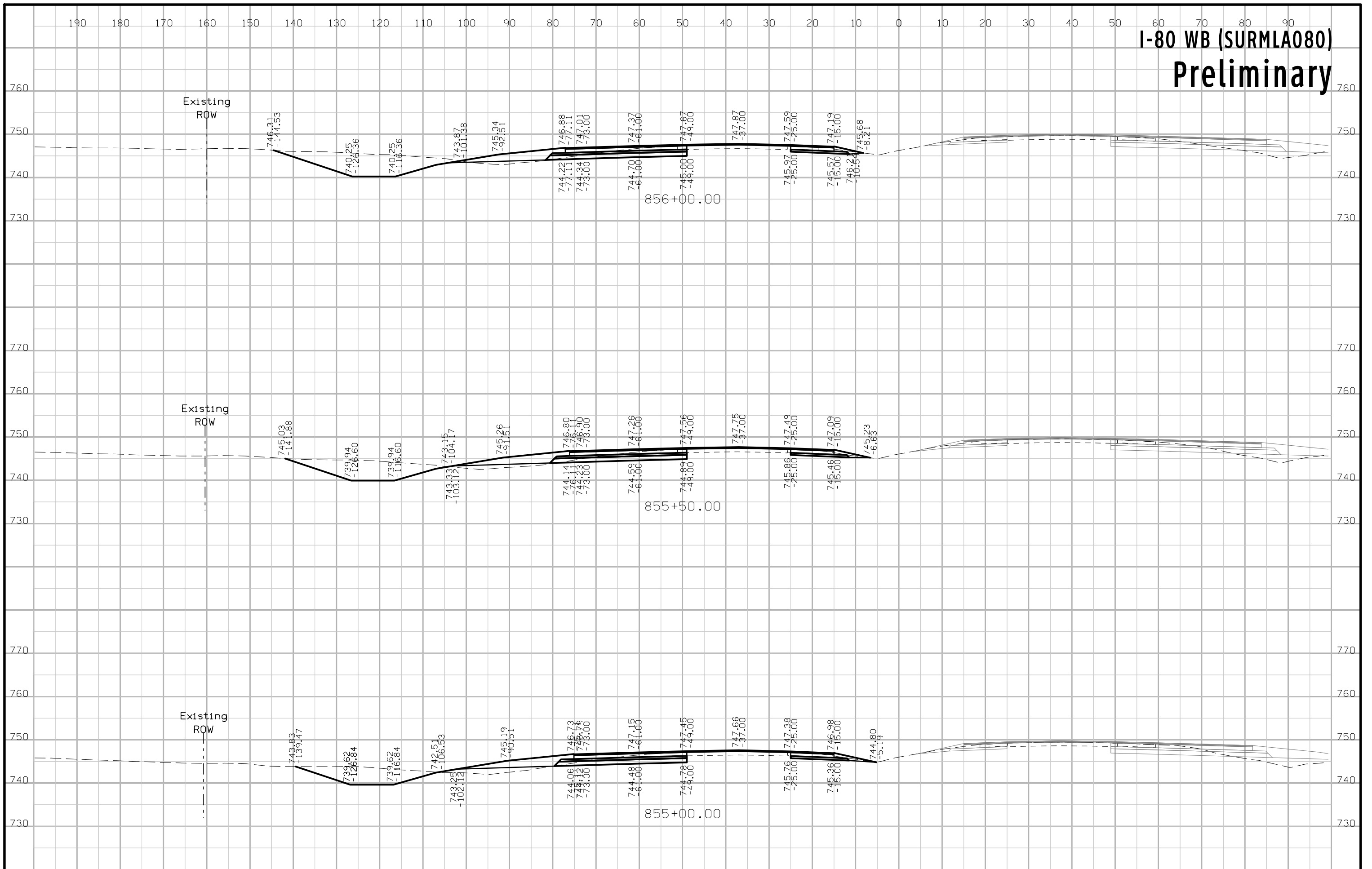

# I-80 WB (SURMLA080) Preliminary

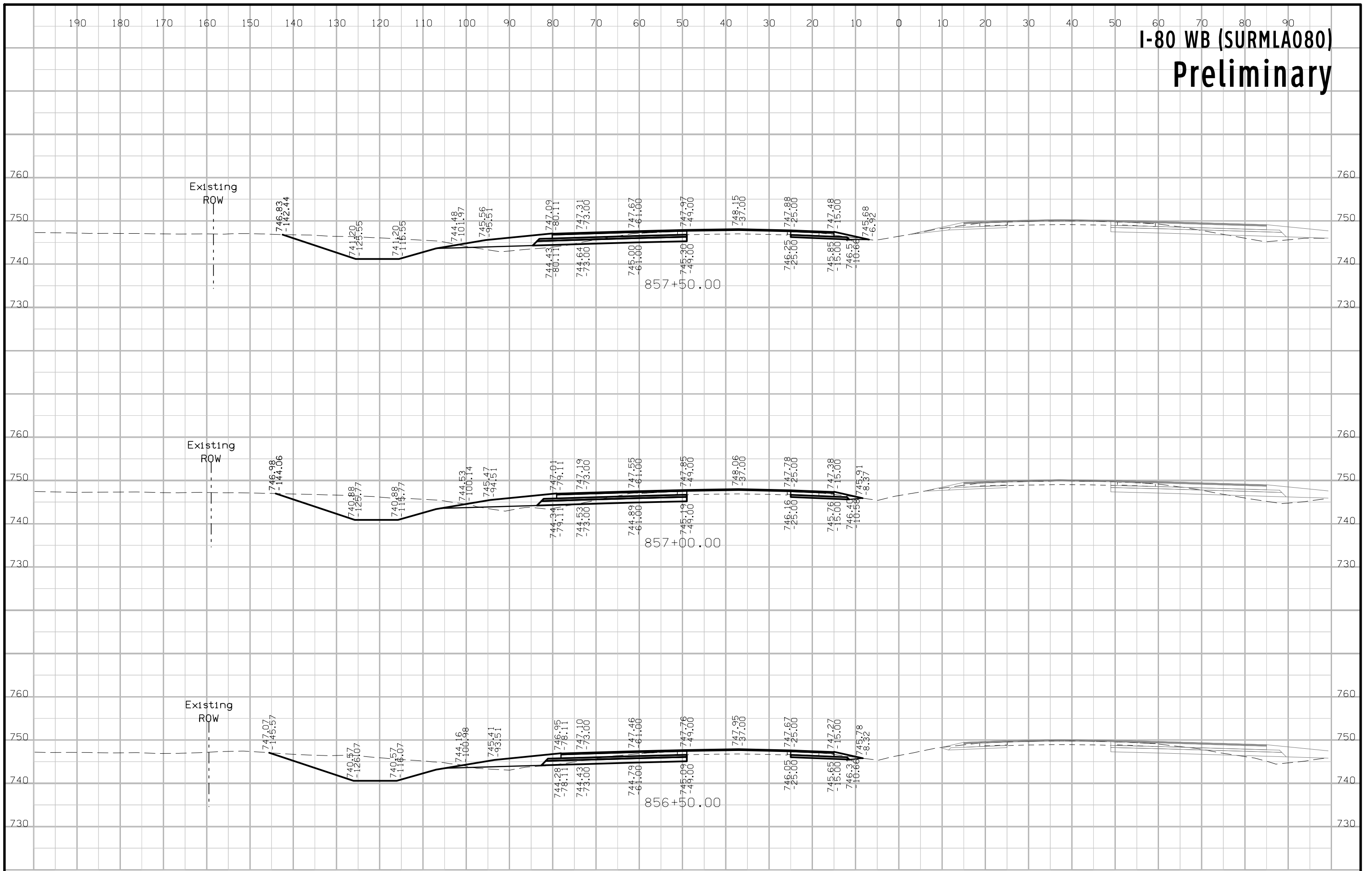

# I-80 WB (SURMLA080) Preliminary

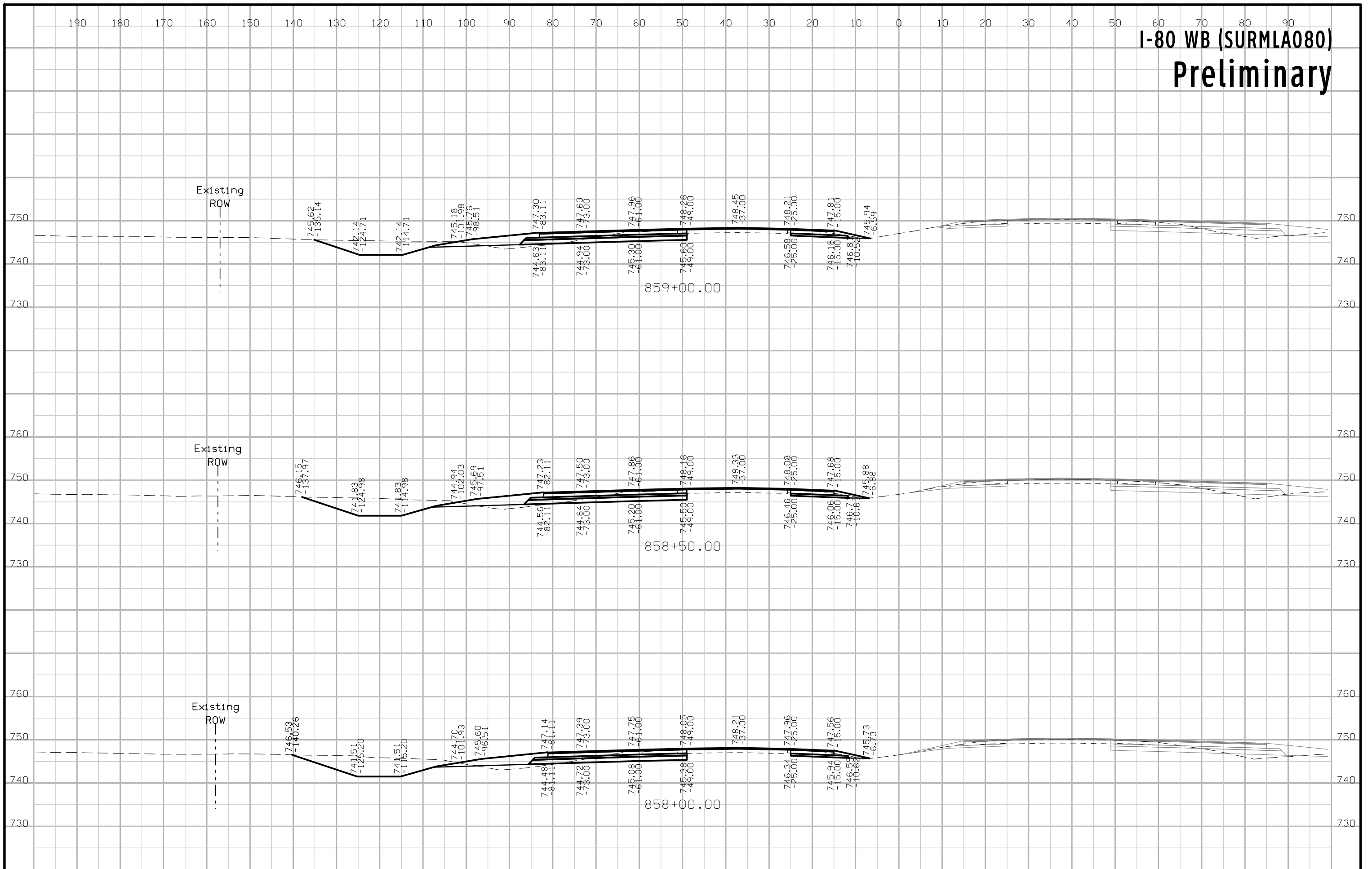



# I-80 WB (SURMLA080) Preliminary

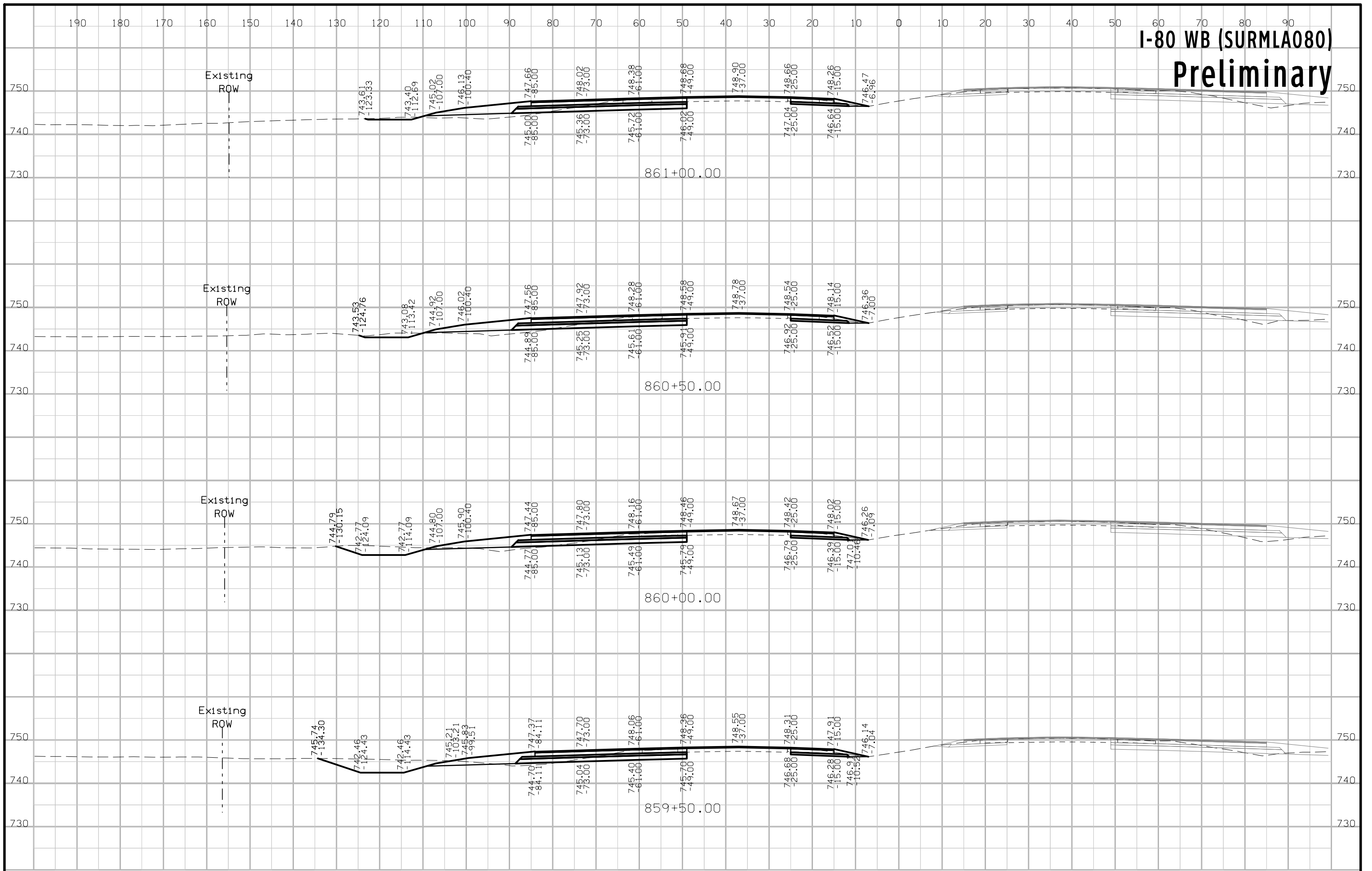

# I-80 WB (SURMLA080) Preliminary

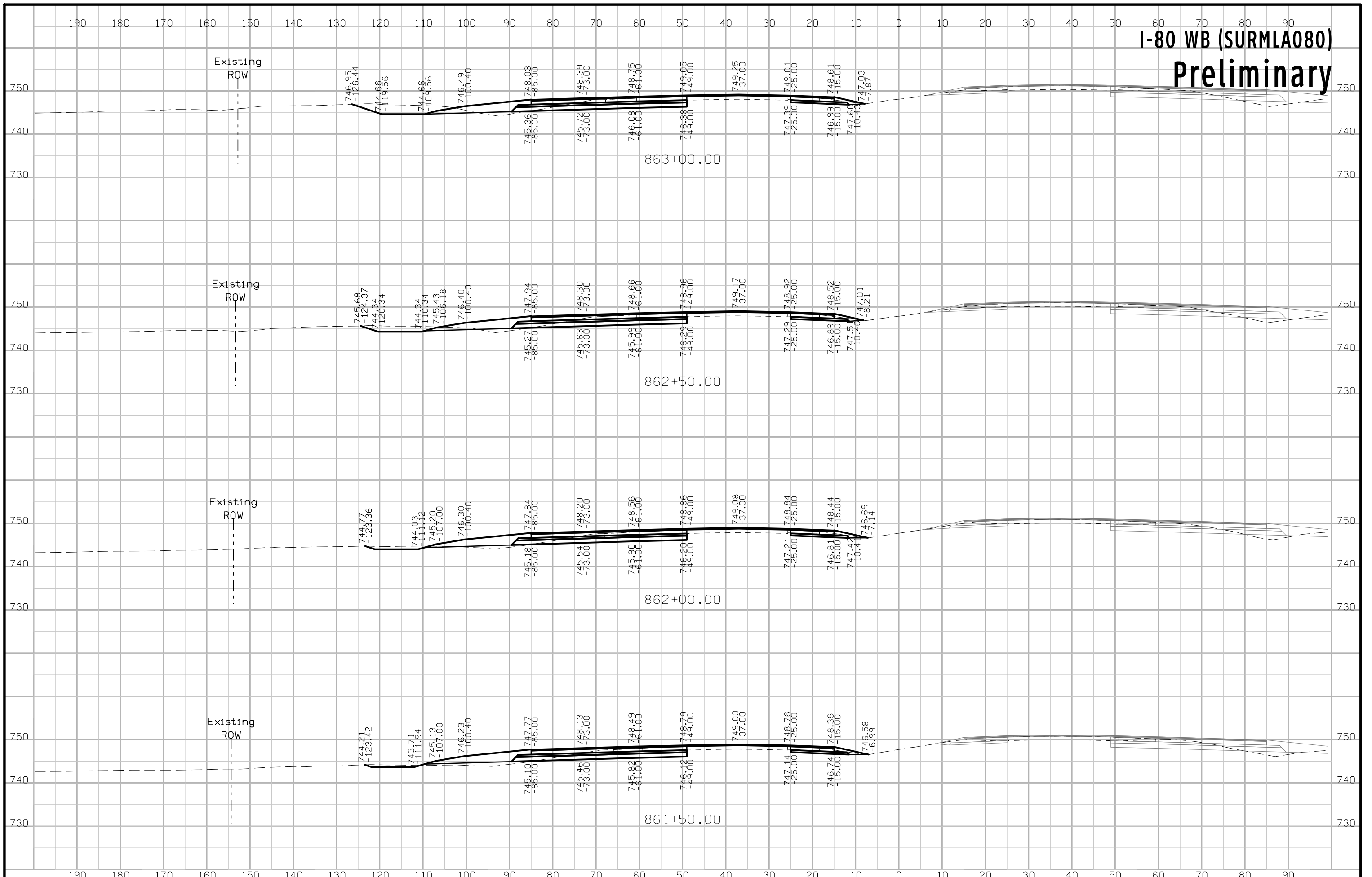

# I-80 WB (SURMLA080) Preliminary

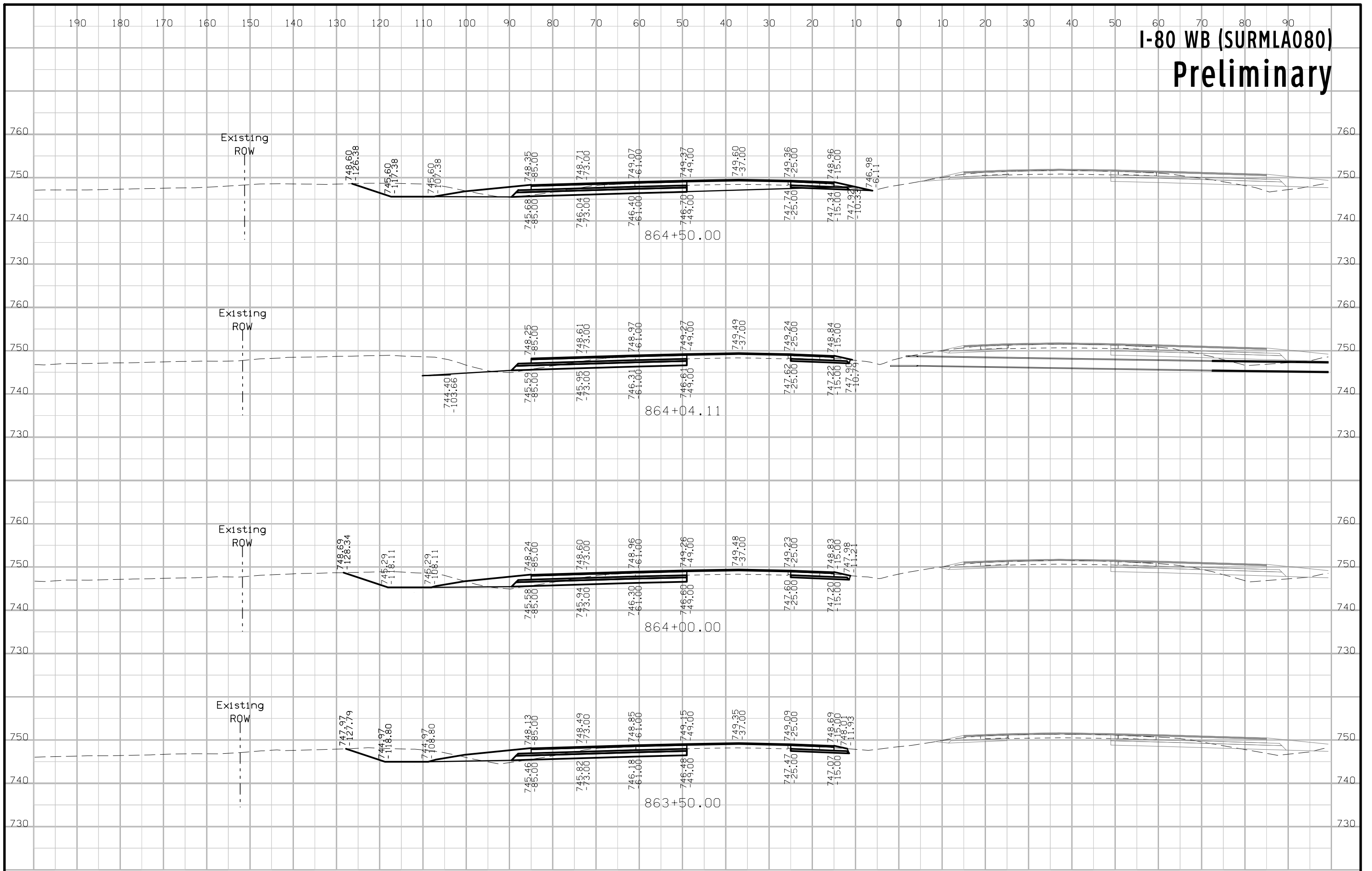

# I-80 WB (SURMLA080) Preliminary

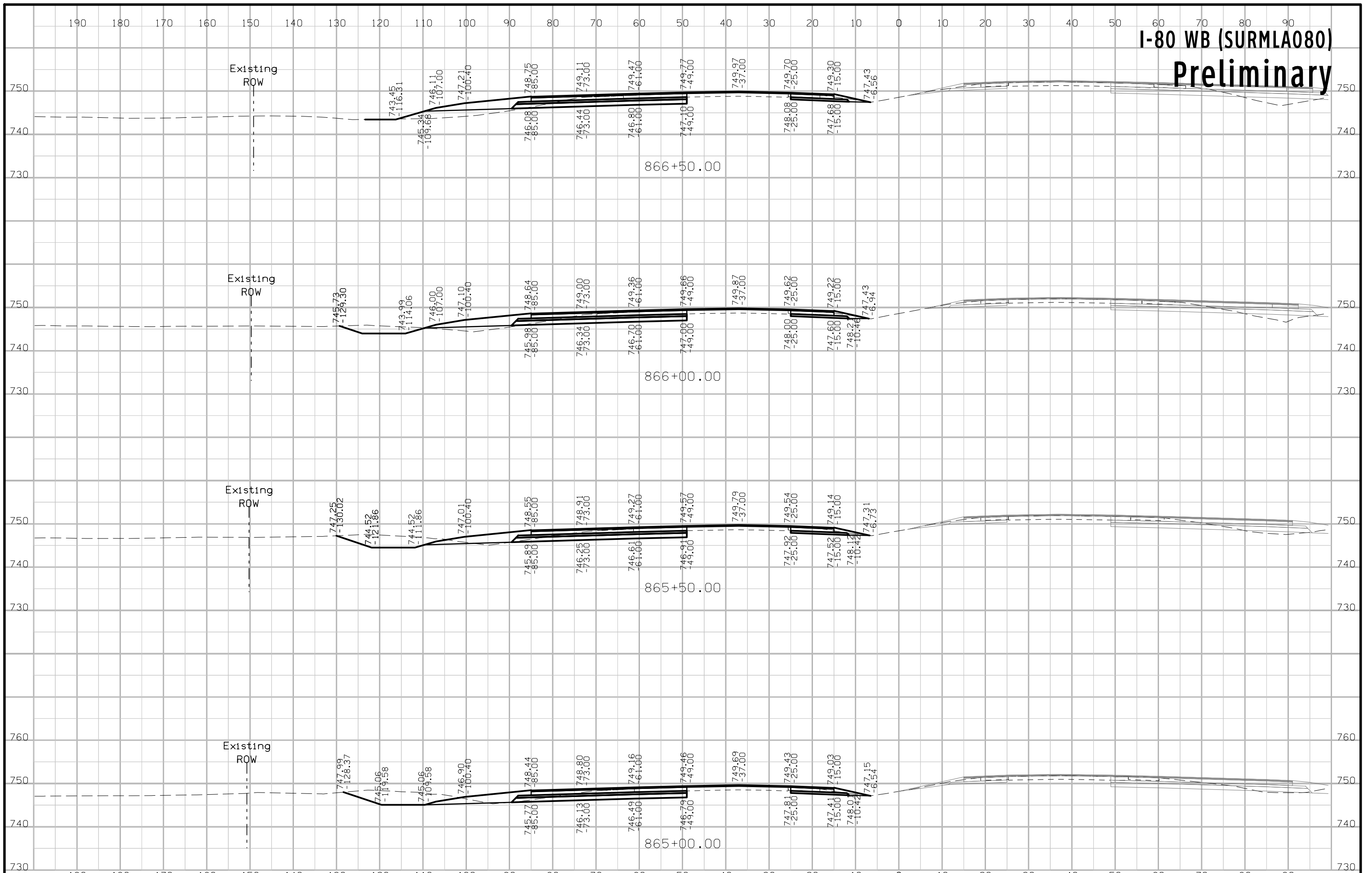



# I-80 WB (SURMLA080) Preliminary

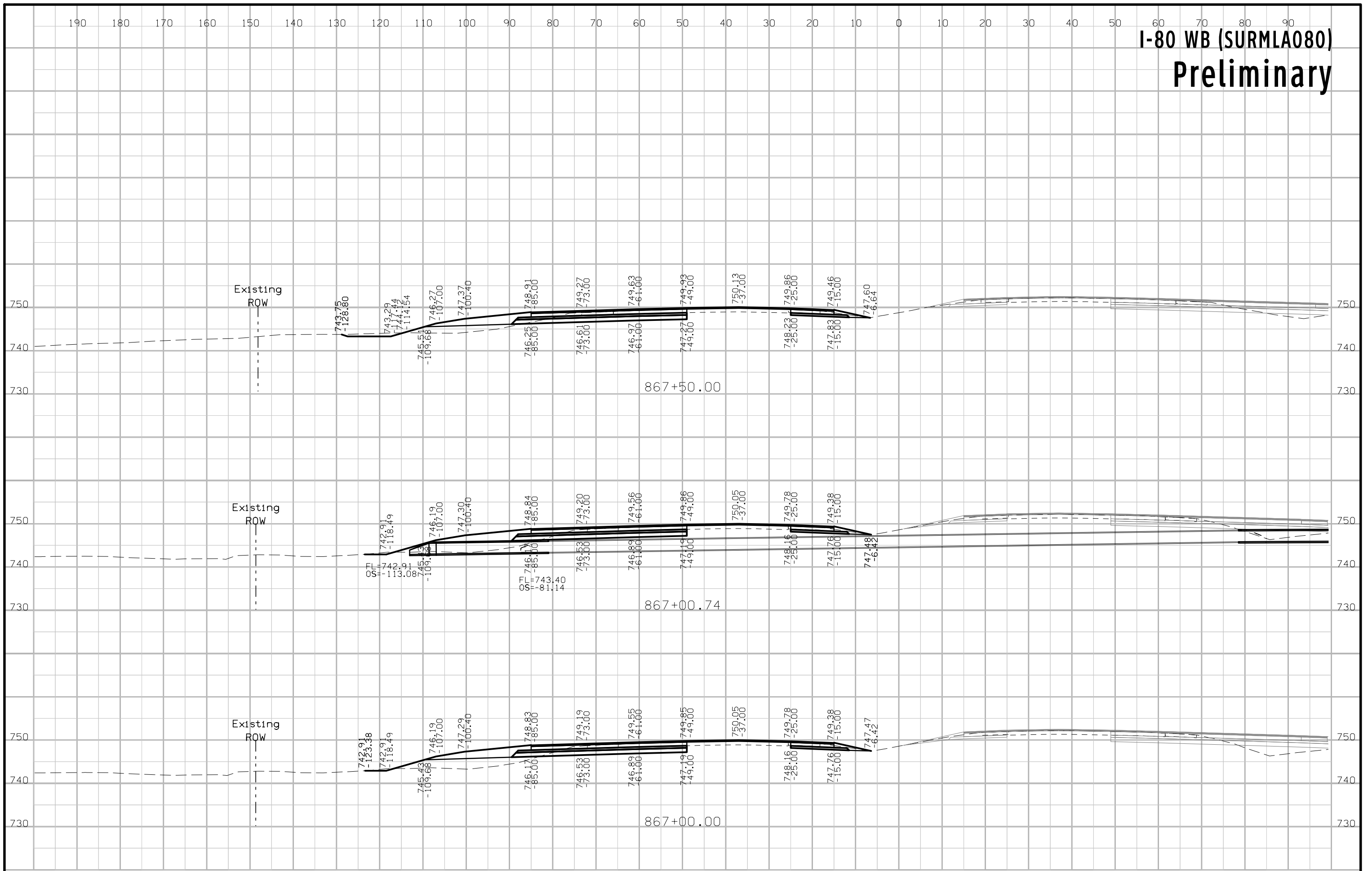

# I-80 WB (SURMLA080) Preliminary

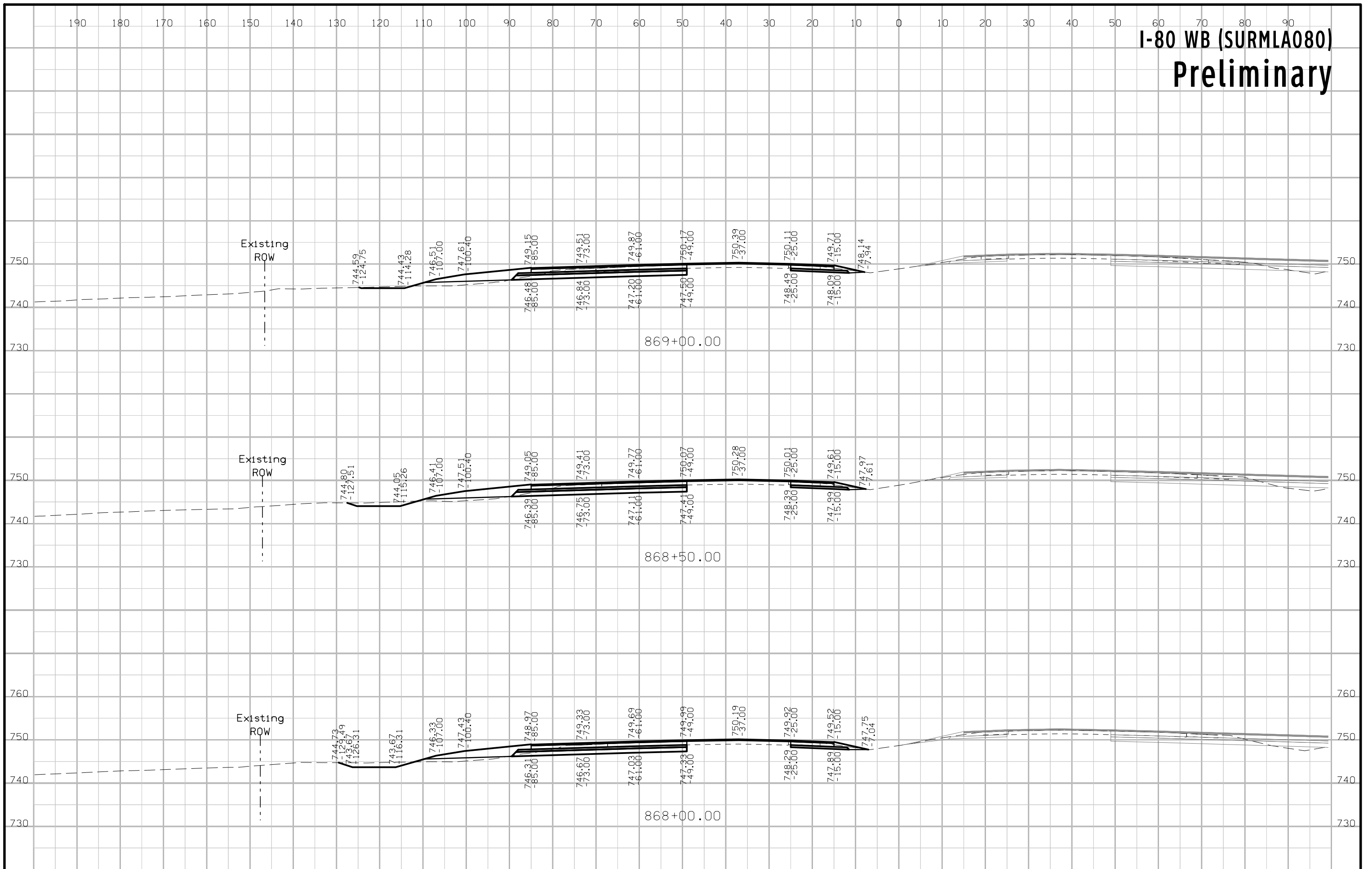

# I-80 WB (SURMLA080) Preliminary

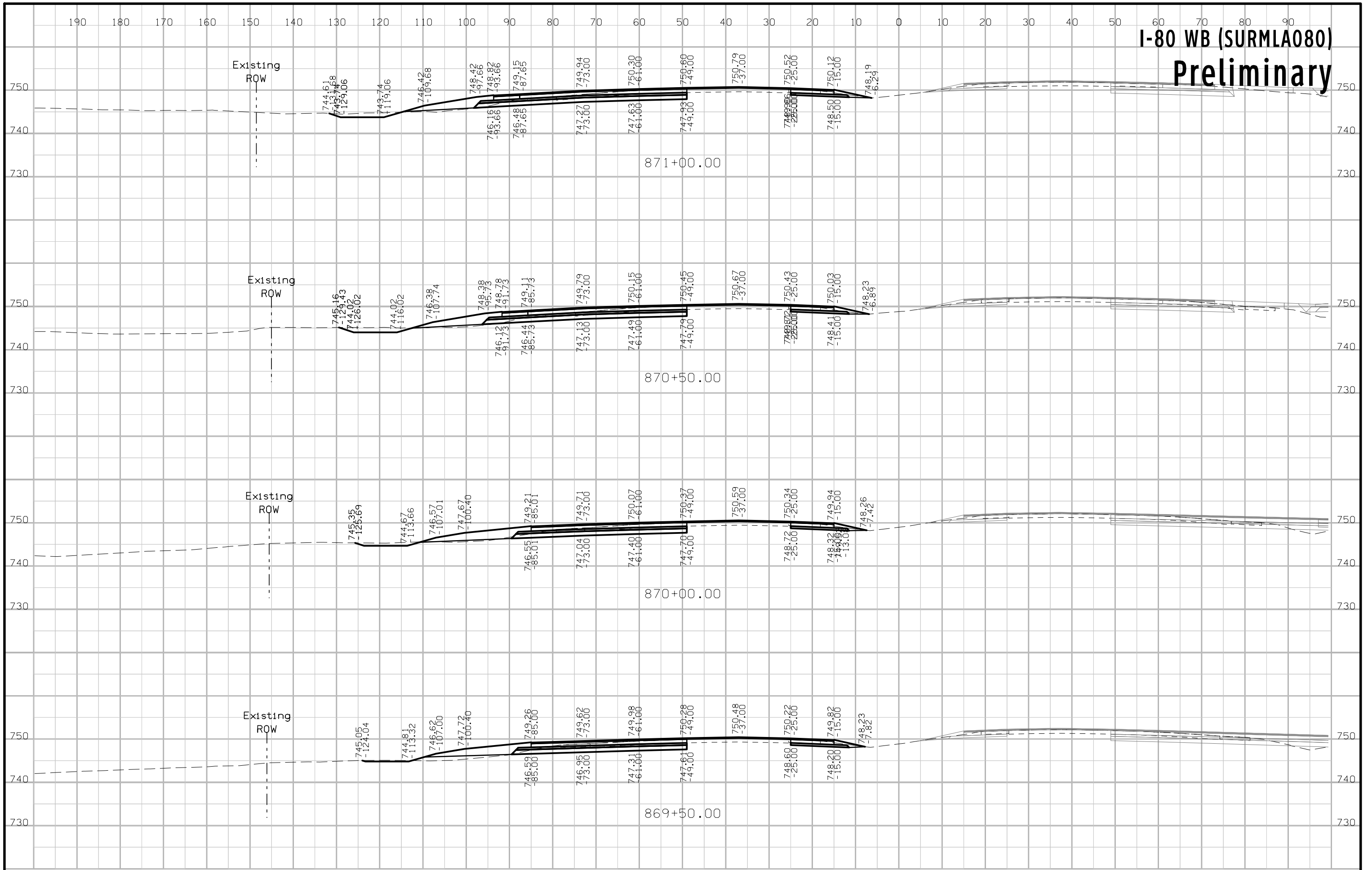

# I-80 WB (SURMLA080) Preliminary

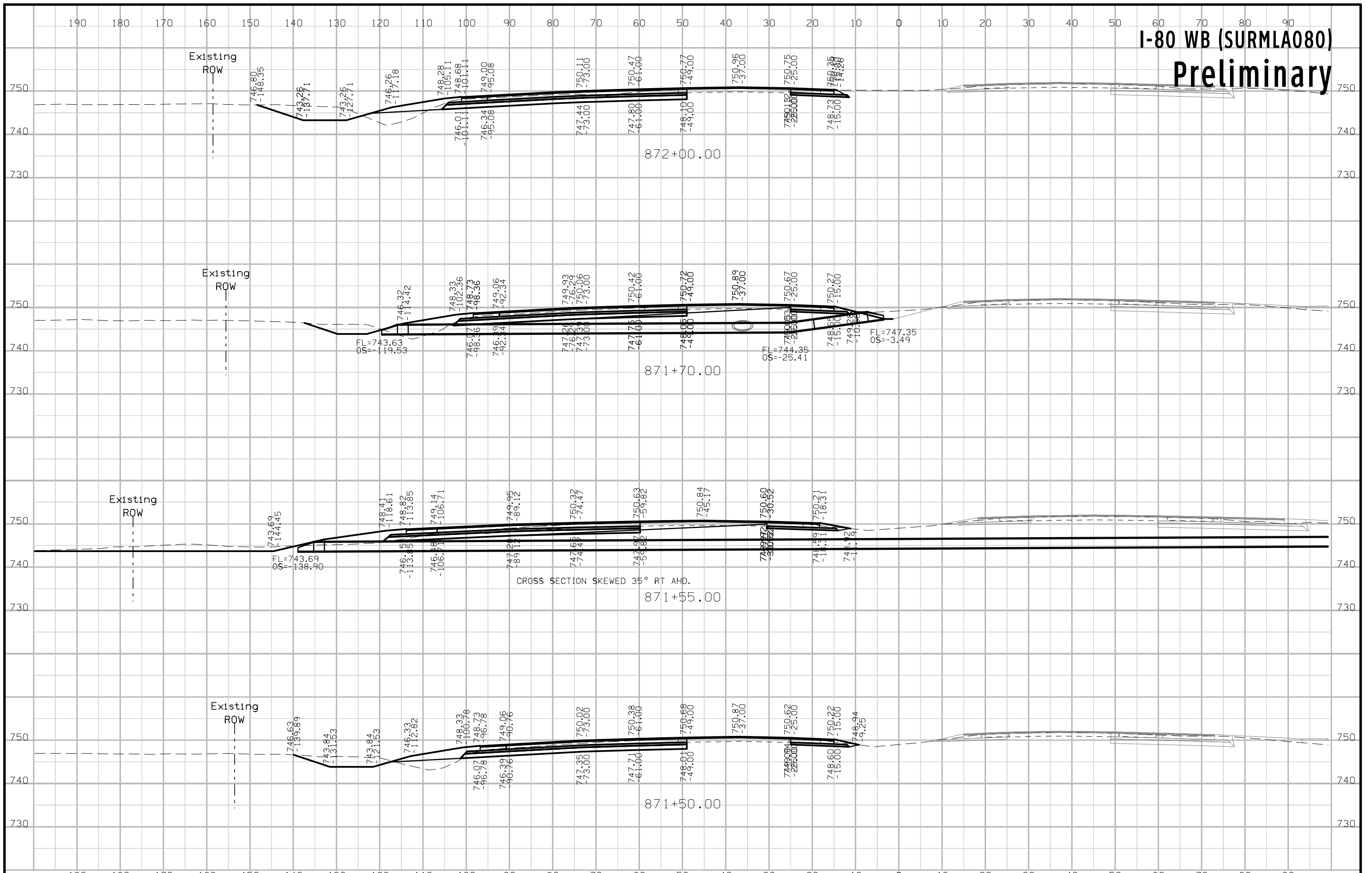



# I-80 WB (SURMLA080) Preliminary

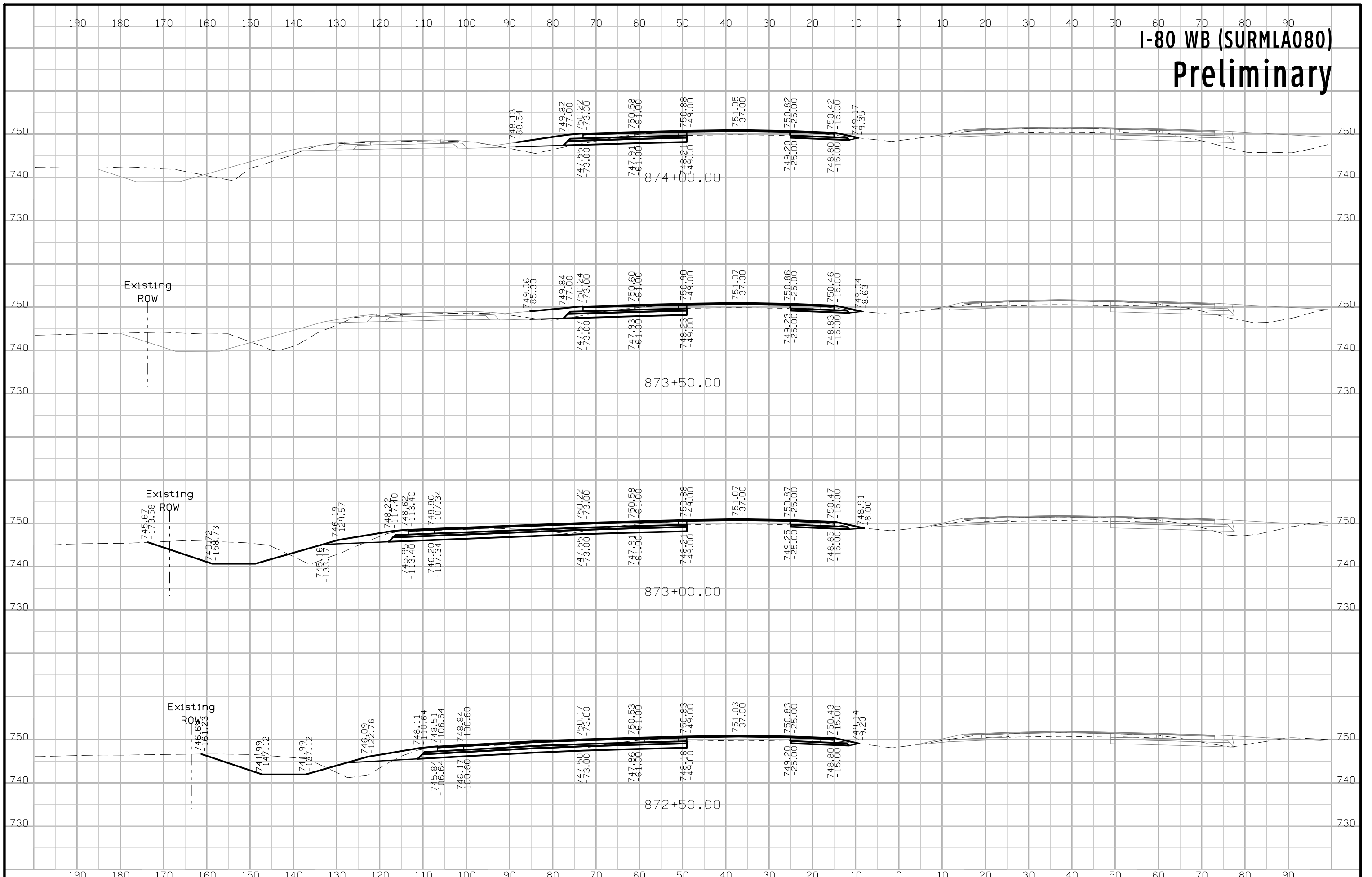

# I-80 WB (SURMLA080) Preliminary

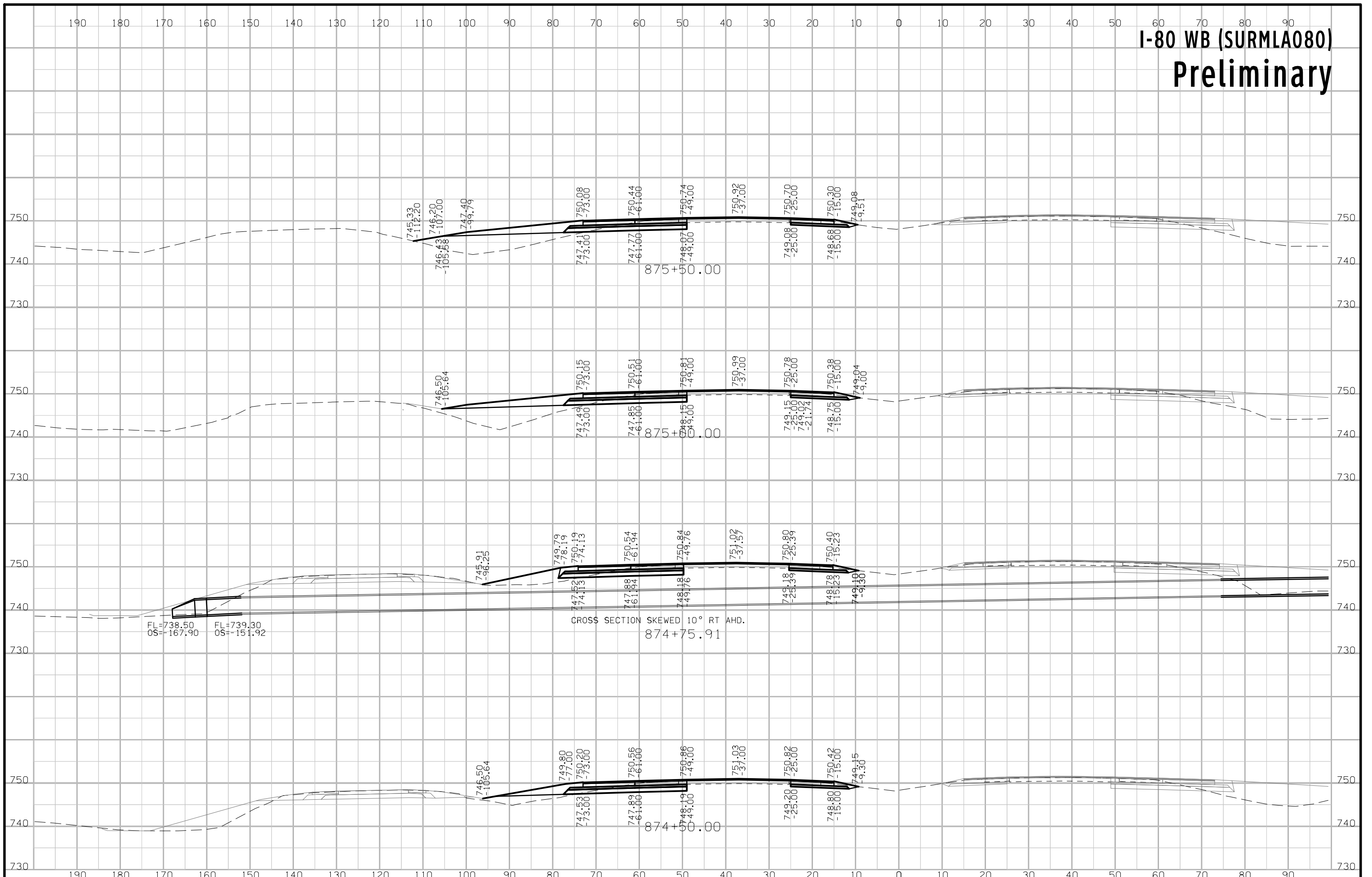

FL=738.50 OS=-167.90  
FL=739.30 OS=-151.92

CROSS SECTION SKEWED 10° RT AHD.  
874+75.91

# I-80 WB (SURMLA080) Preliminary

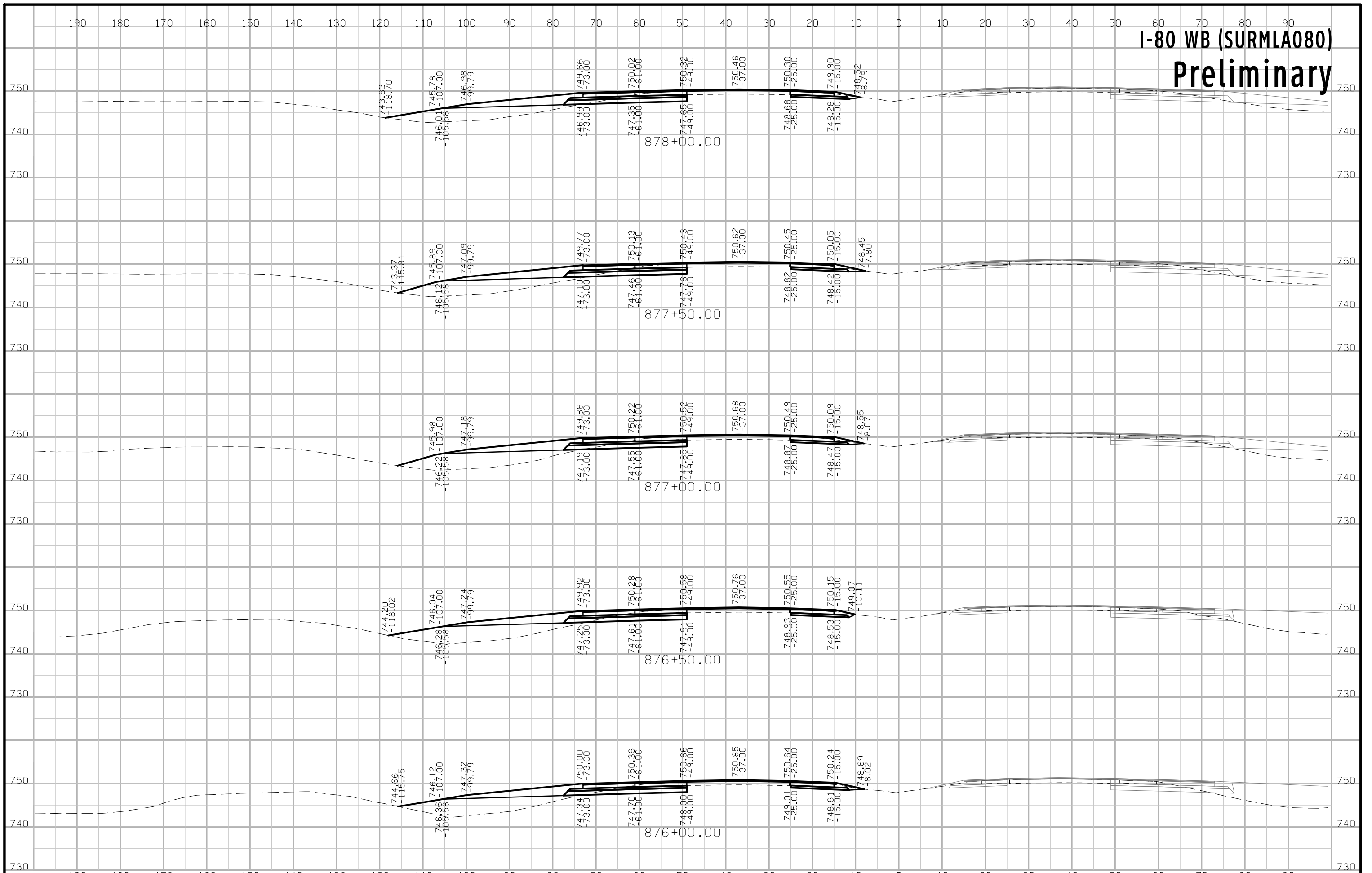

# I-80 WB (SURMLA080) Preliminary

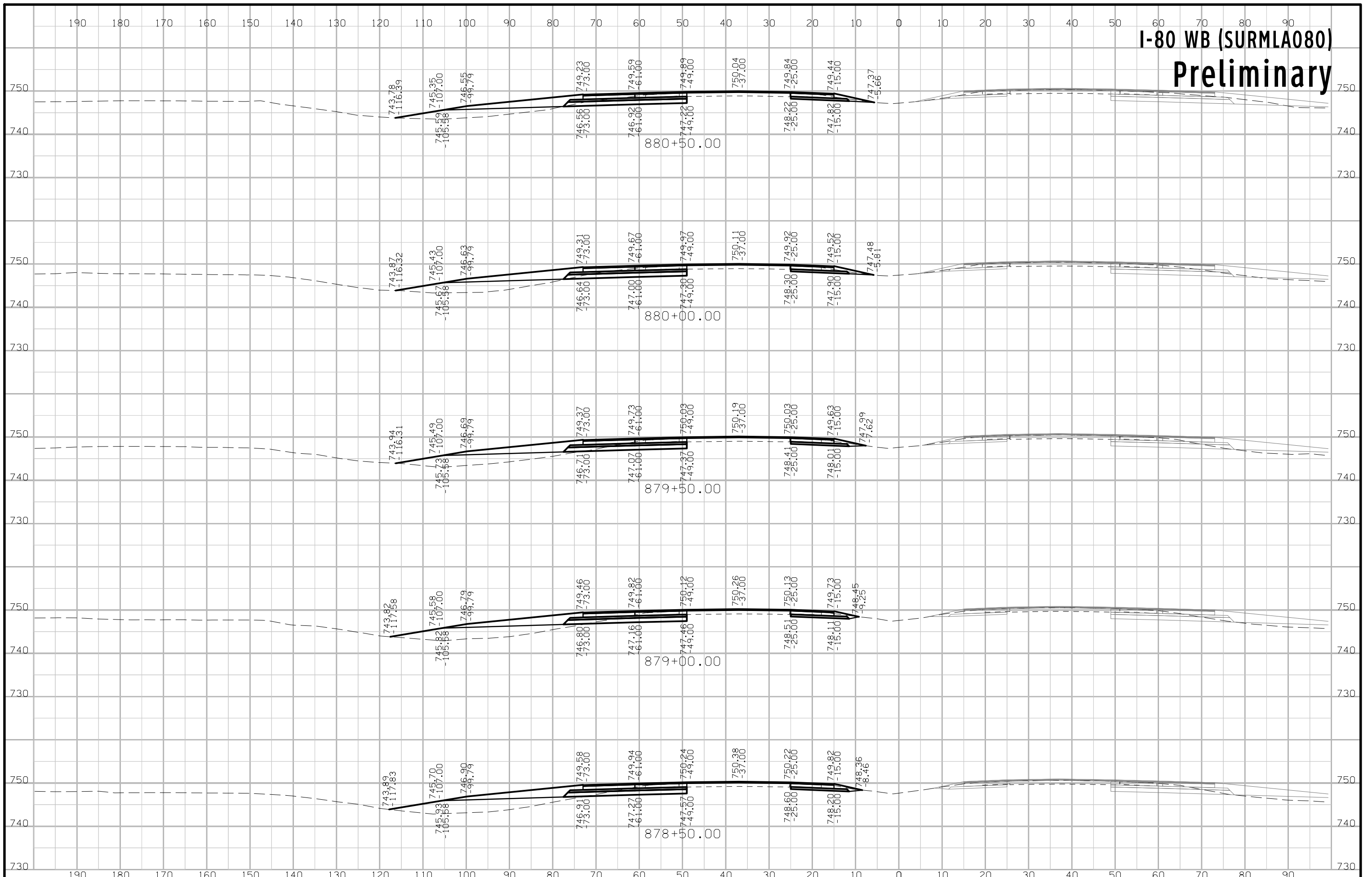



# I-80 WB (SURMLA080) Preliminary

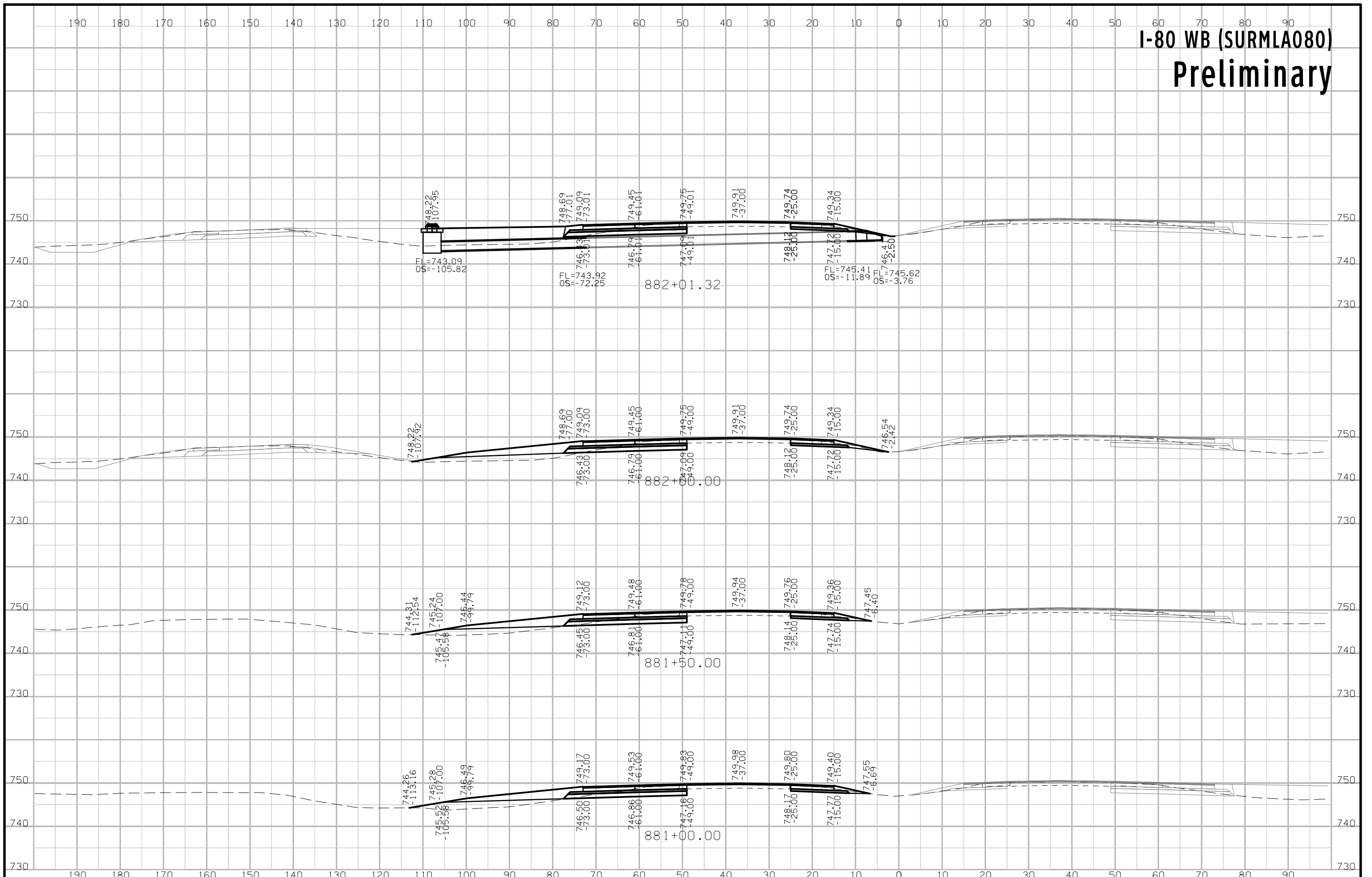

# I-80 WB (SURMLA080) Preliminary

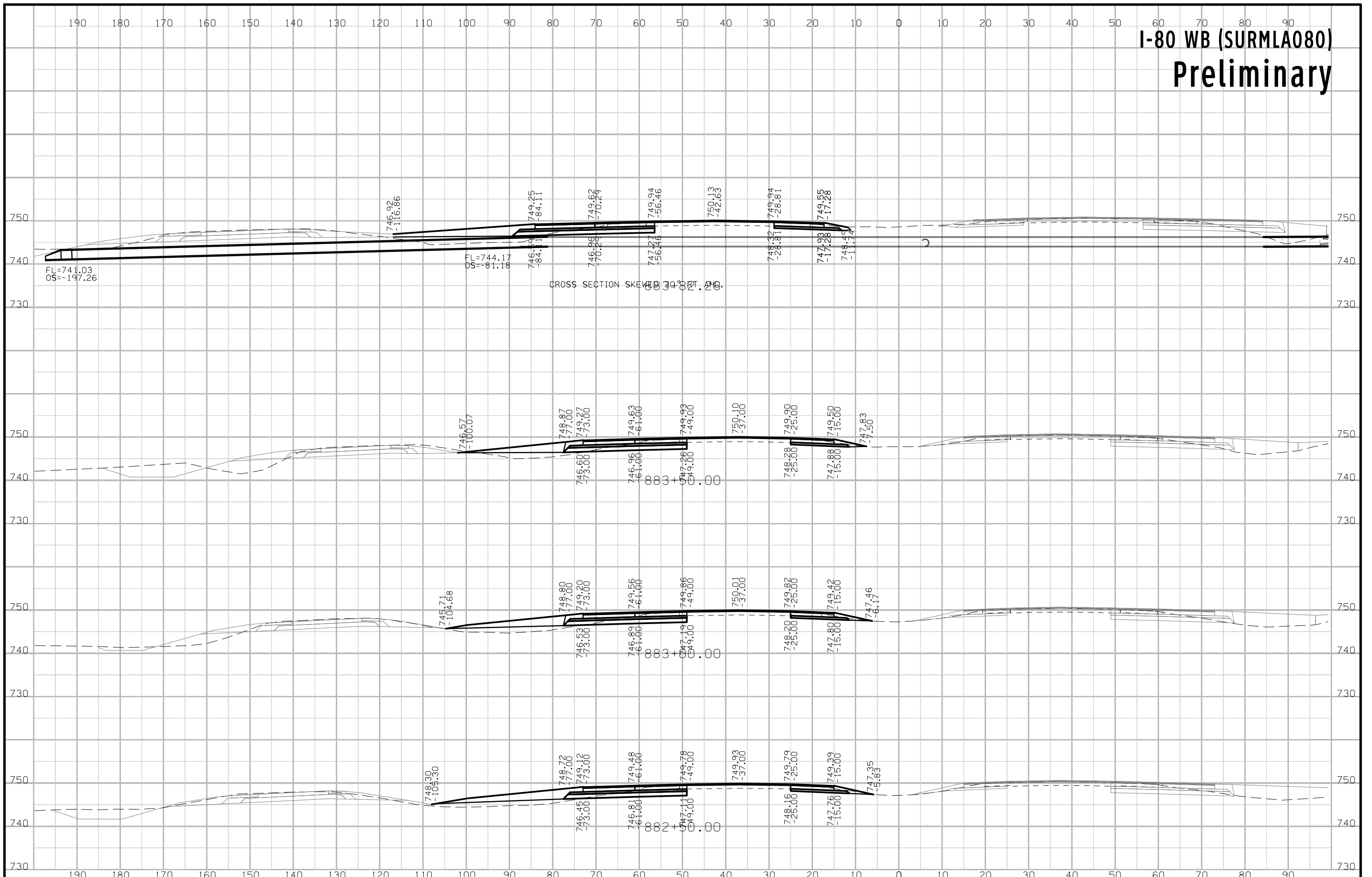

# I-80 WB (SURMLA080) Preliminary

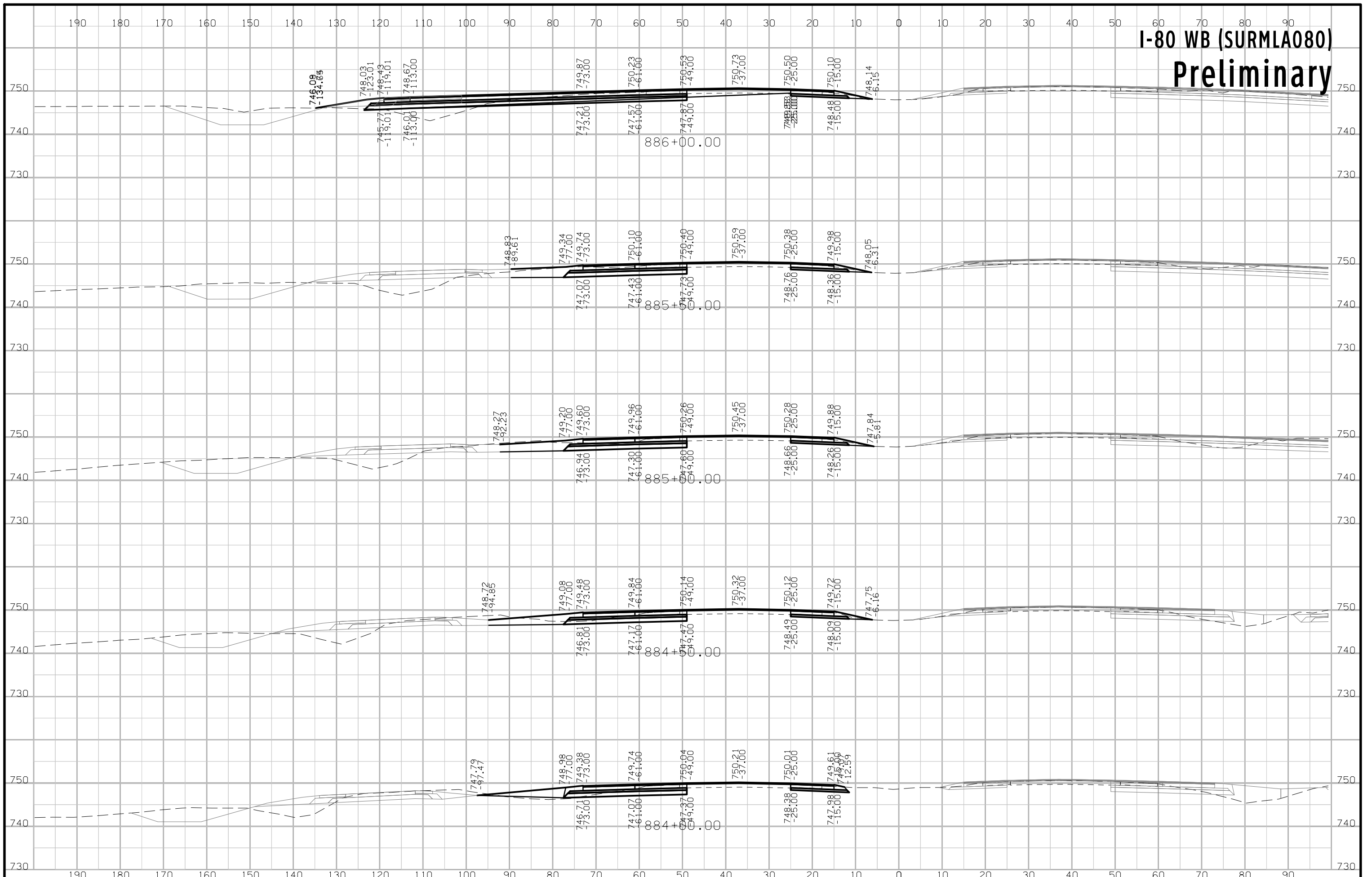

# I-80 WB (SURMLA080) Preliminary

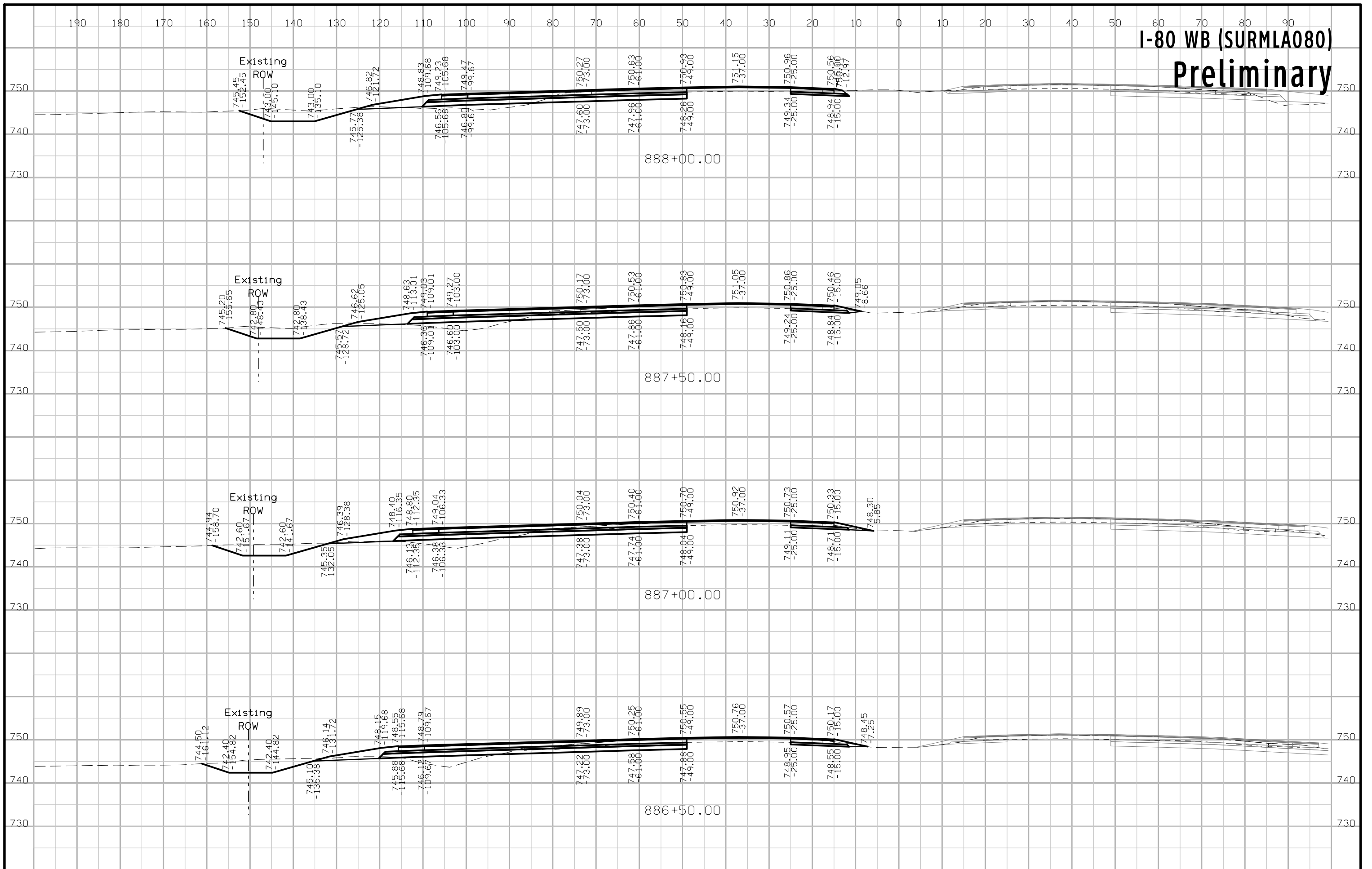



# I-80 WB (SURMLA080) Preliminary

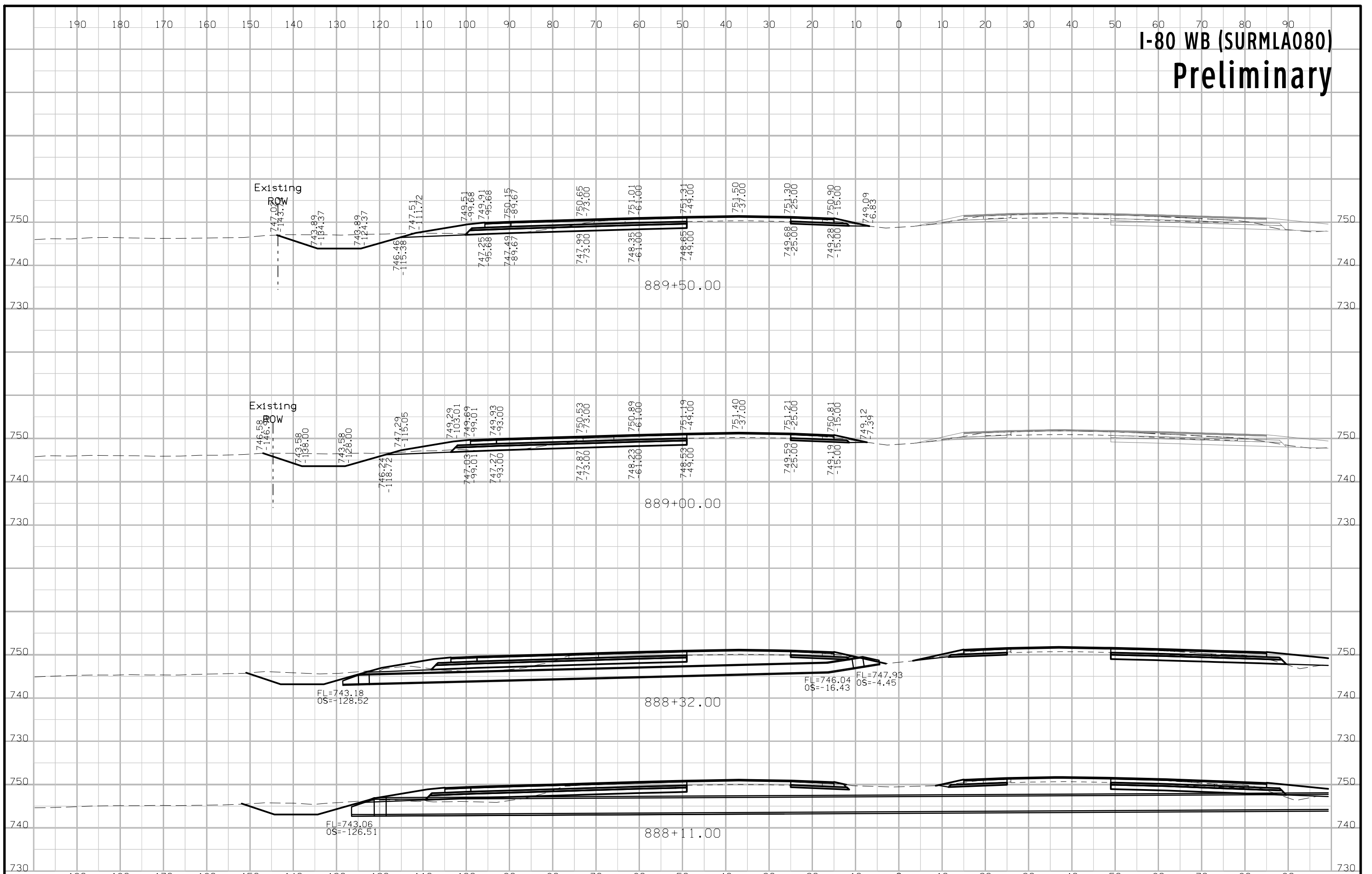

# I-80 WB (SURMLA080) Preliminary

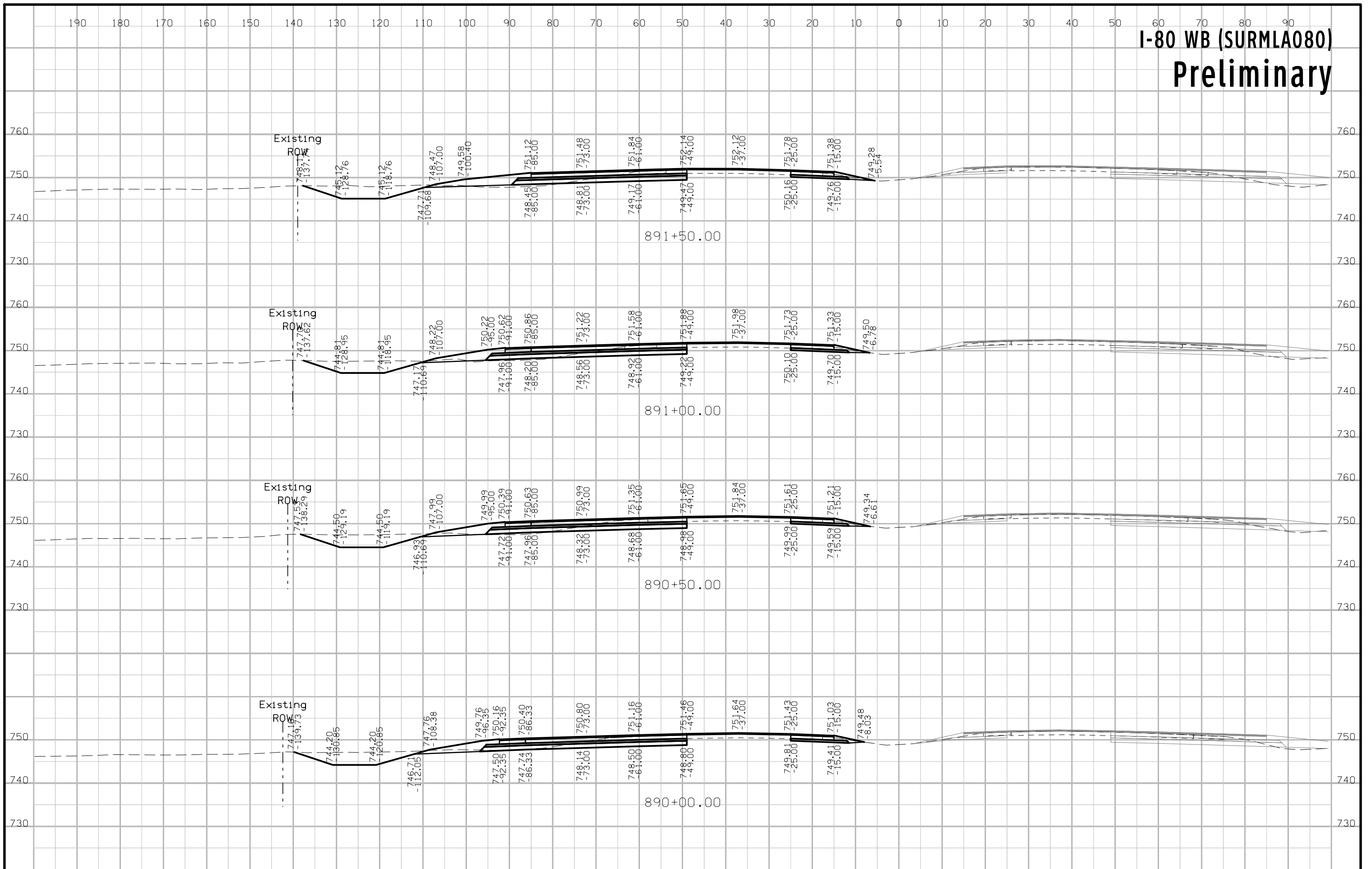

# I-80 WB (SURMLA080) Preliminary

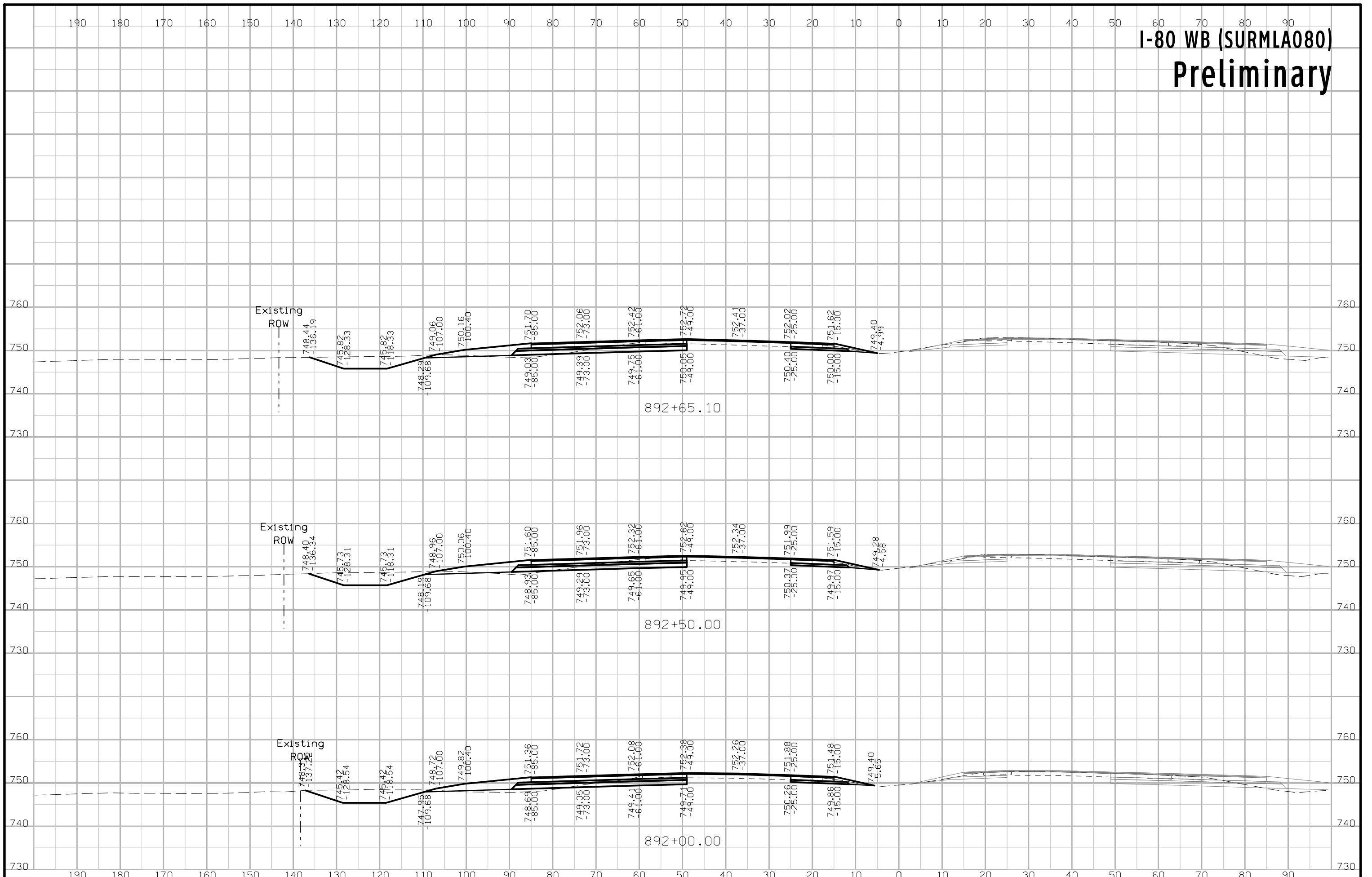

# I-80 WB (MLWB080) Preliminary

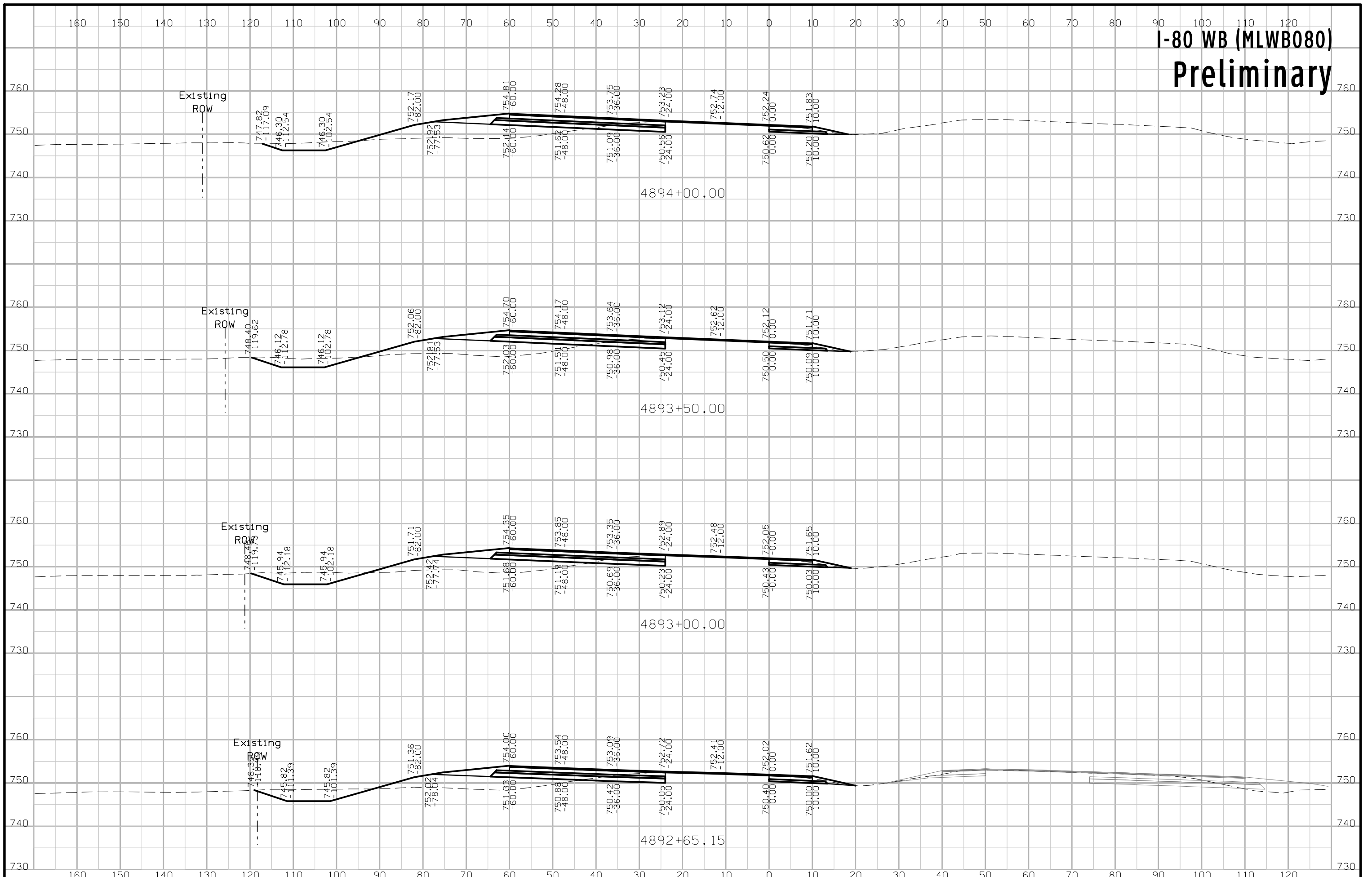



# I-80 WB (MLWB080) Preliminary

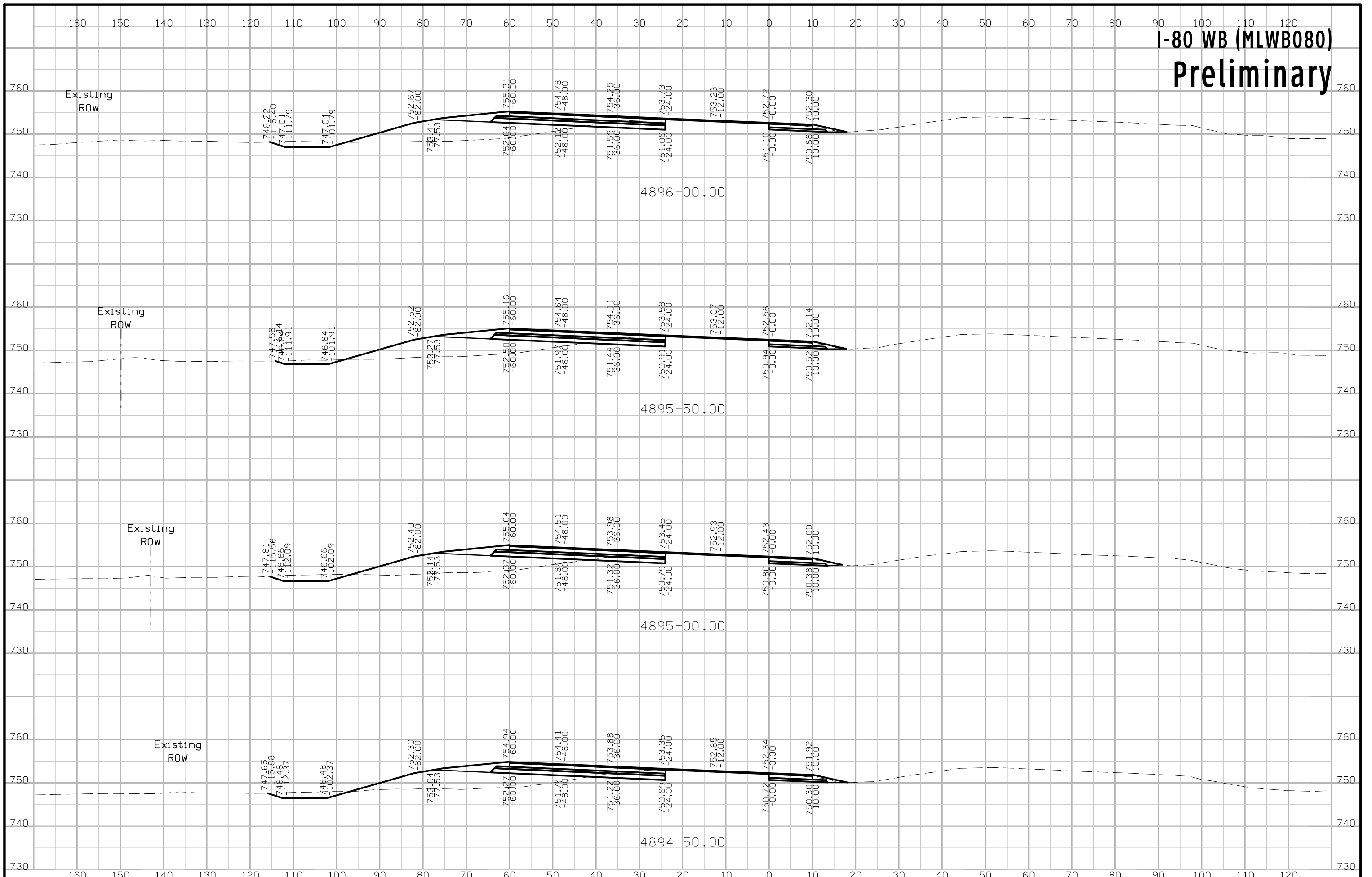

# I-80 WB (MLWB080) Preliminary

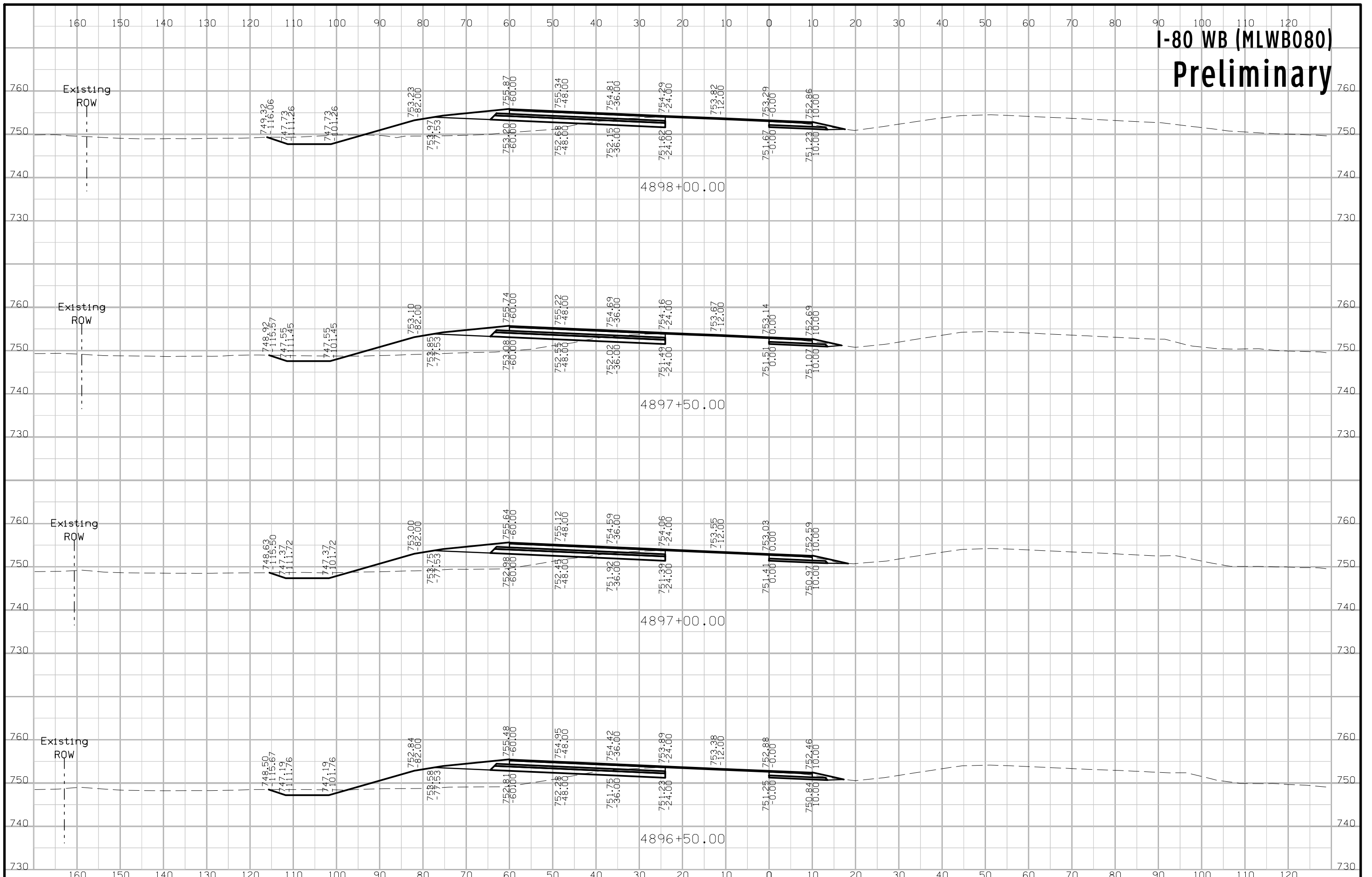

# I-80 WB (MLWB080) Preliminary

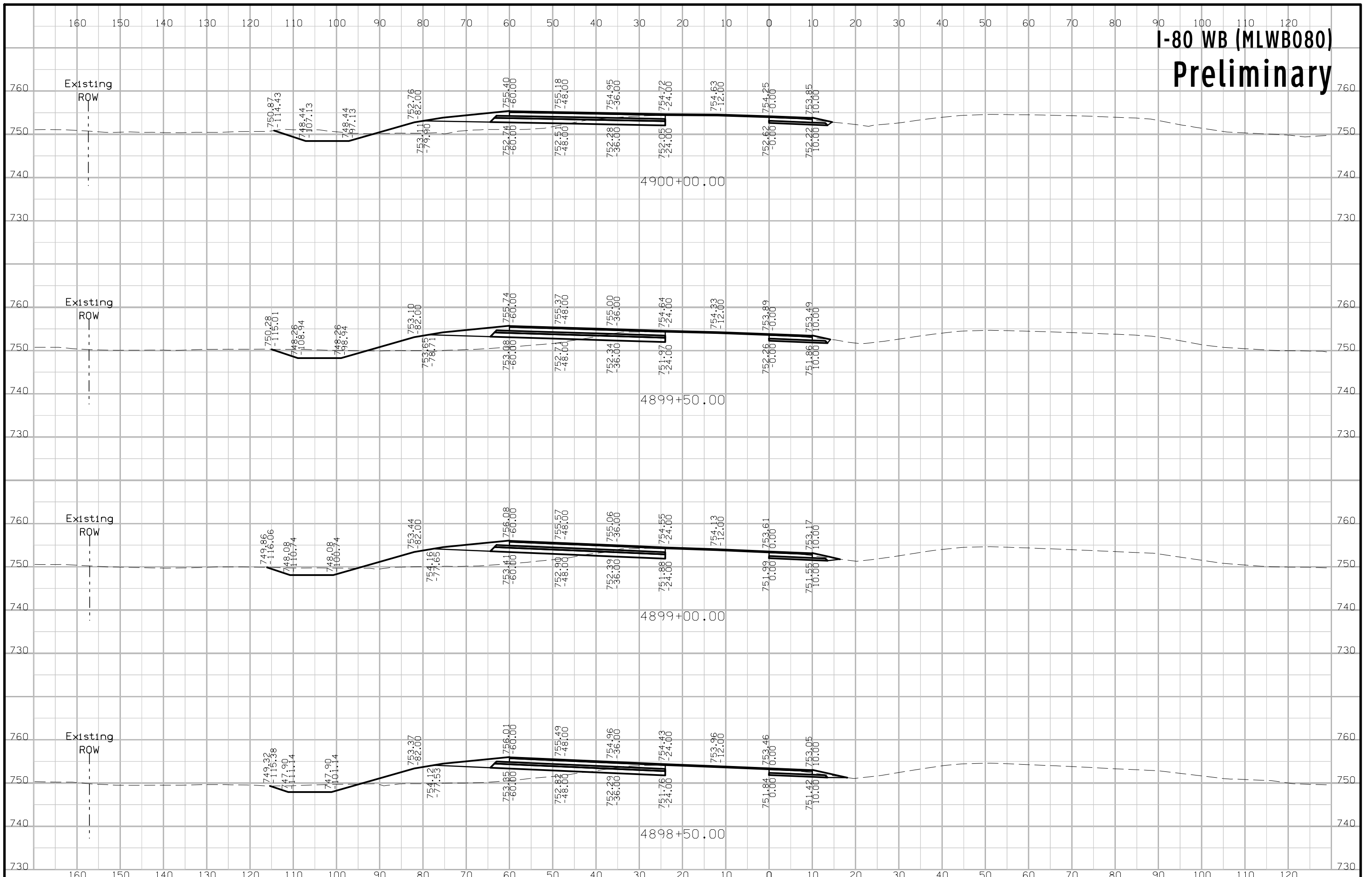

# I-80 WB (MLWB080) Preliminary

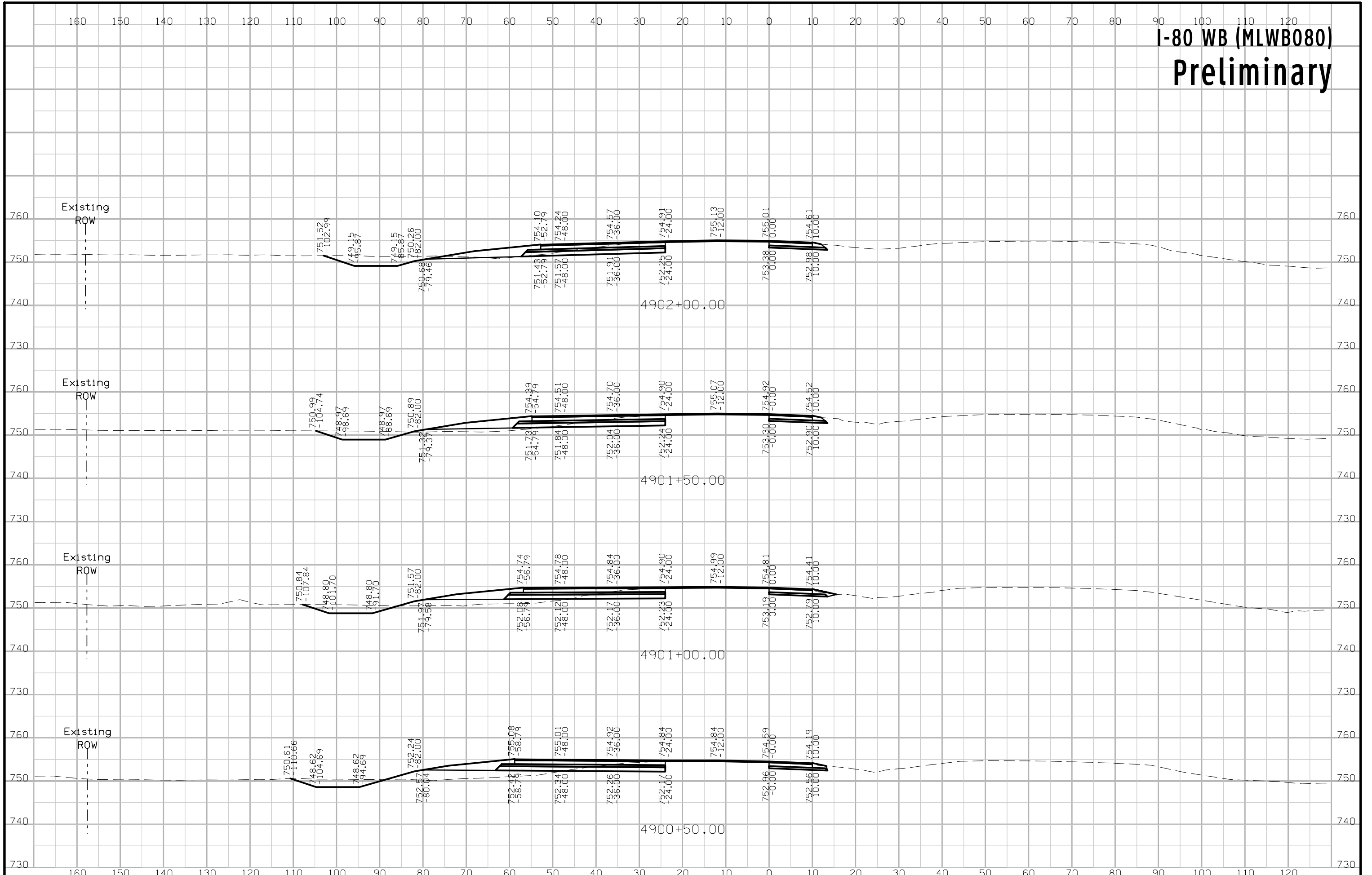



# I-80 WB (MLWB080) Preliminary

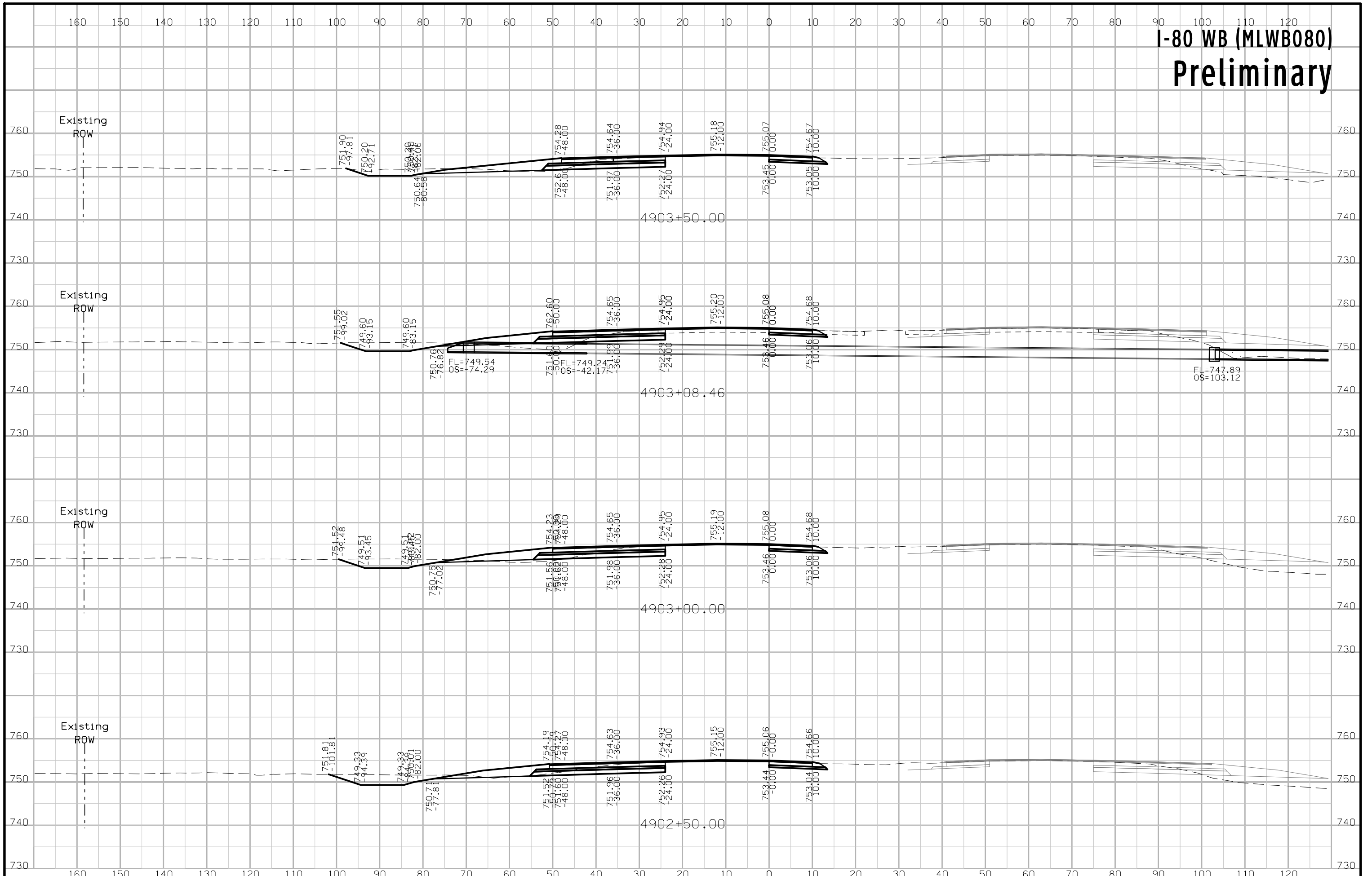

# I-80 WB (MLWB080) Preliminary

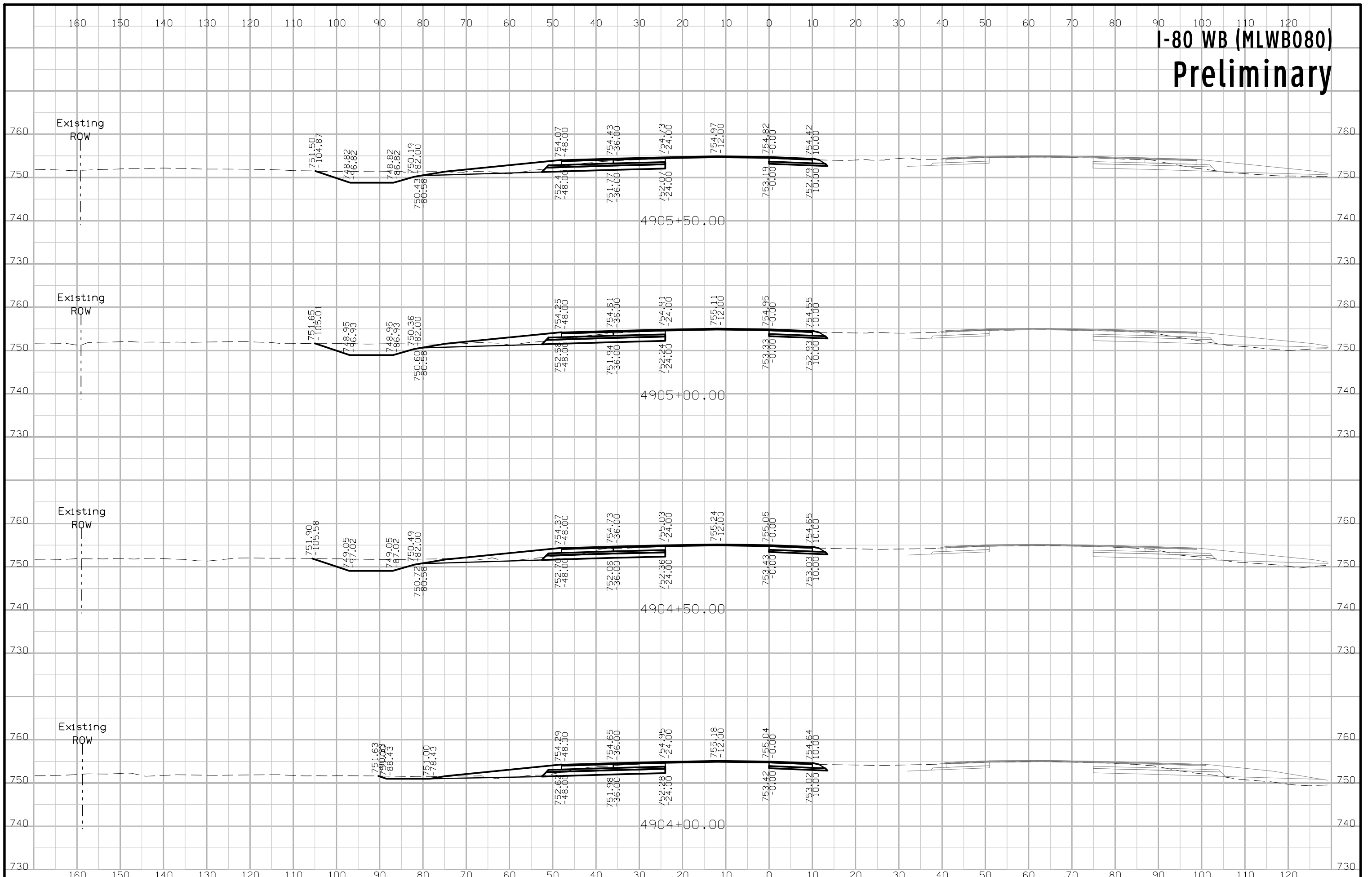

# I-80 WB (MLWB080) Preliminary

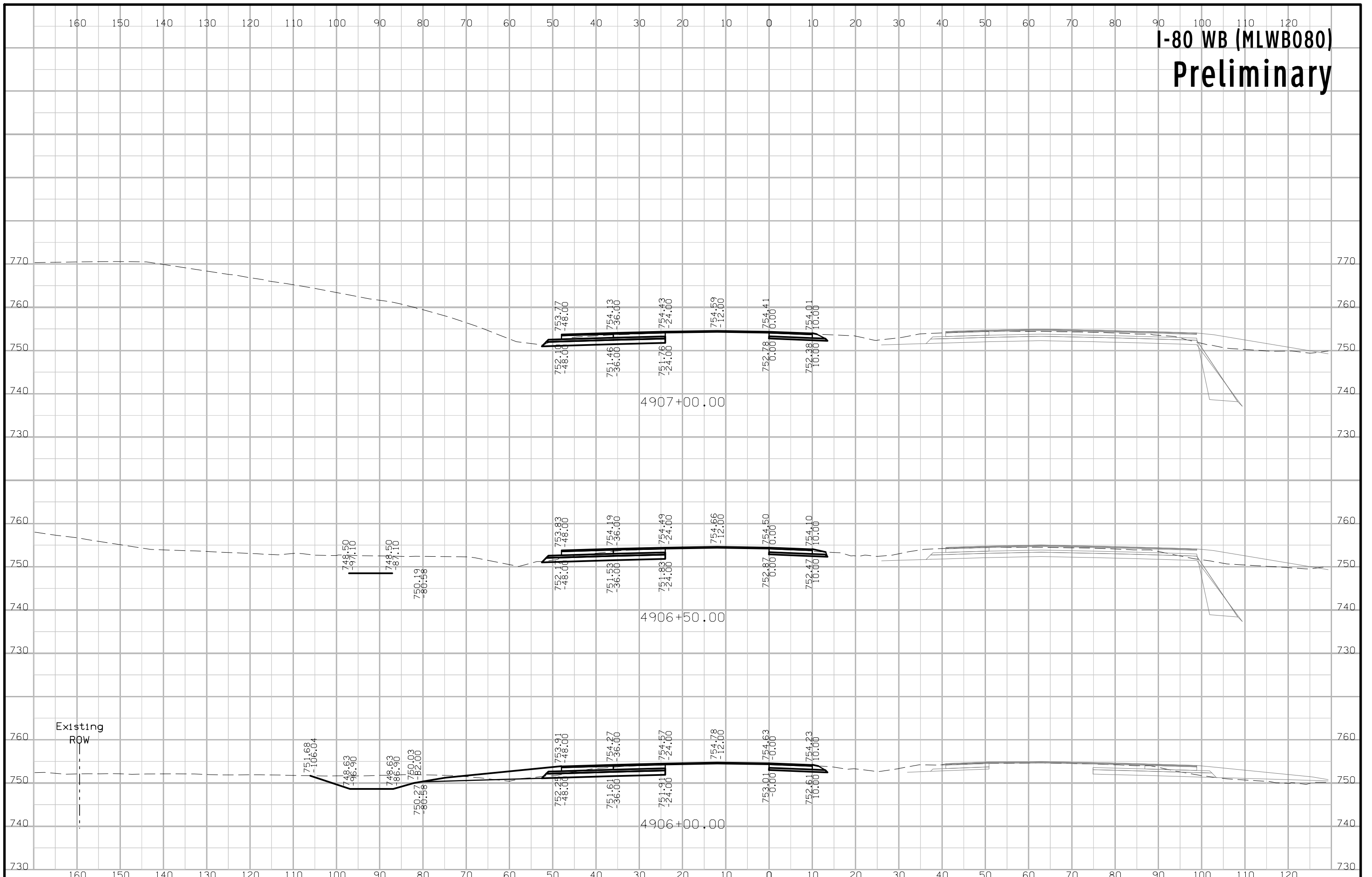

# I-80 WB (MLWB080) Preliminary

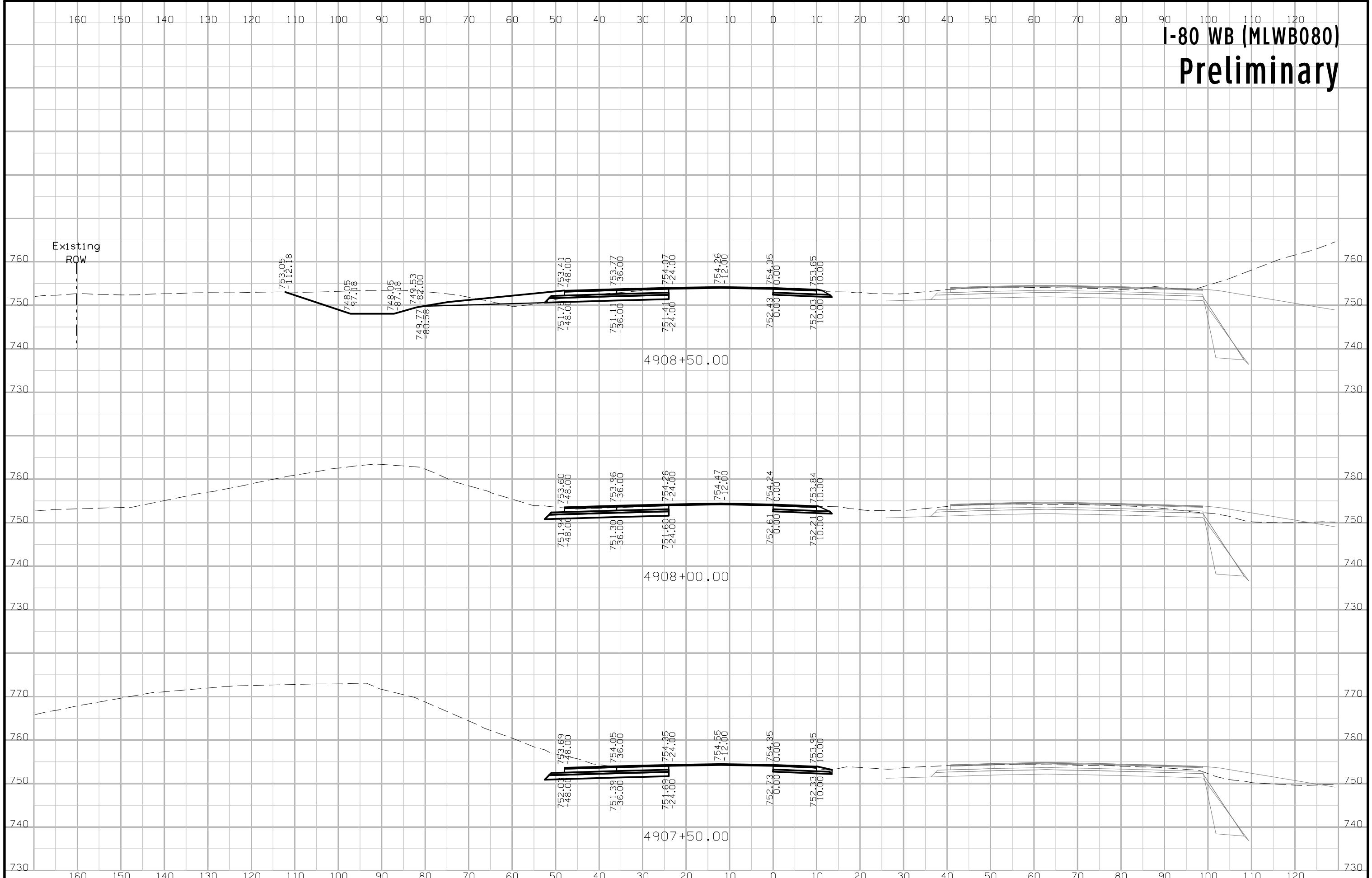



# I-80 WB (MLWB080) Preliminary

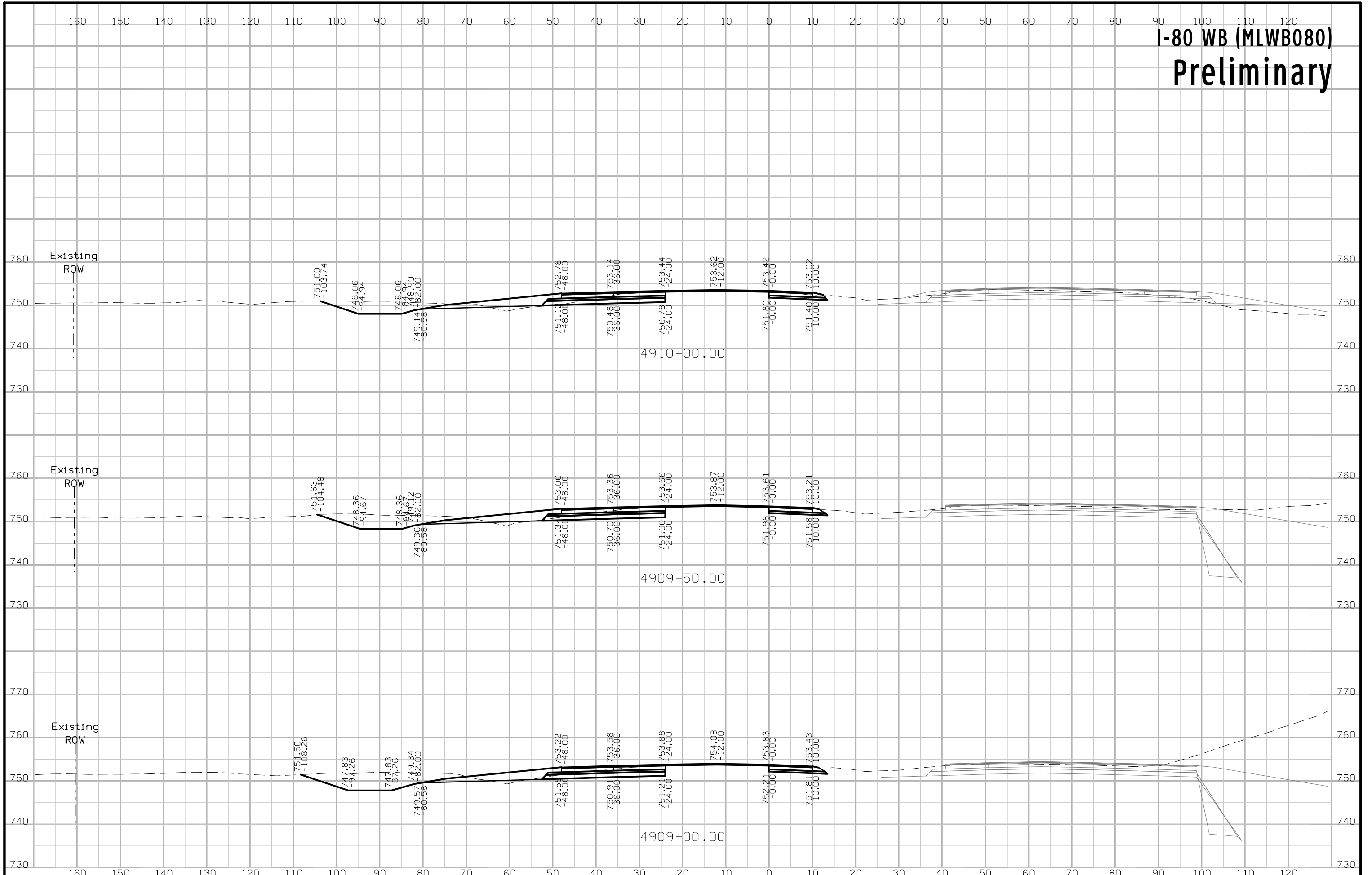

# I-80 WB (MLWB080) Preliminary

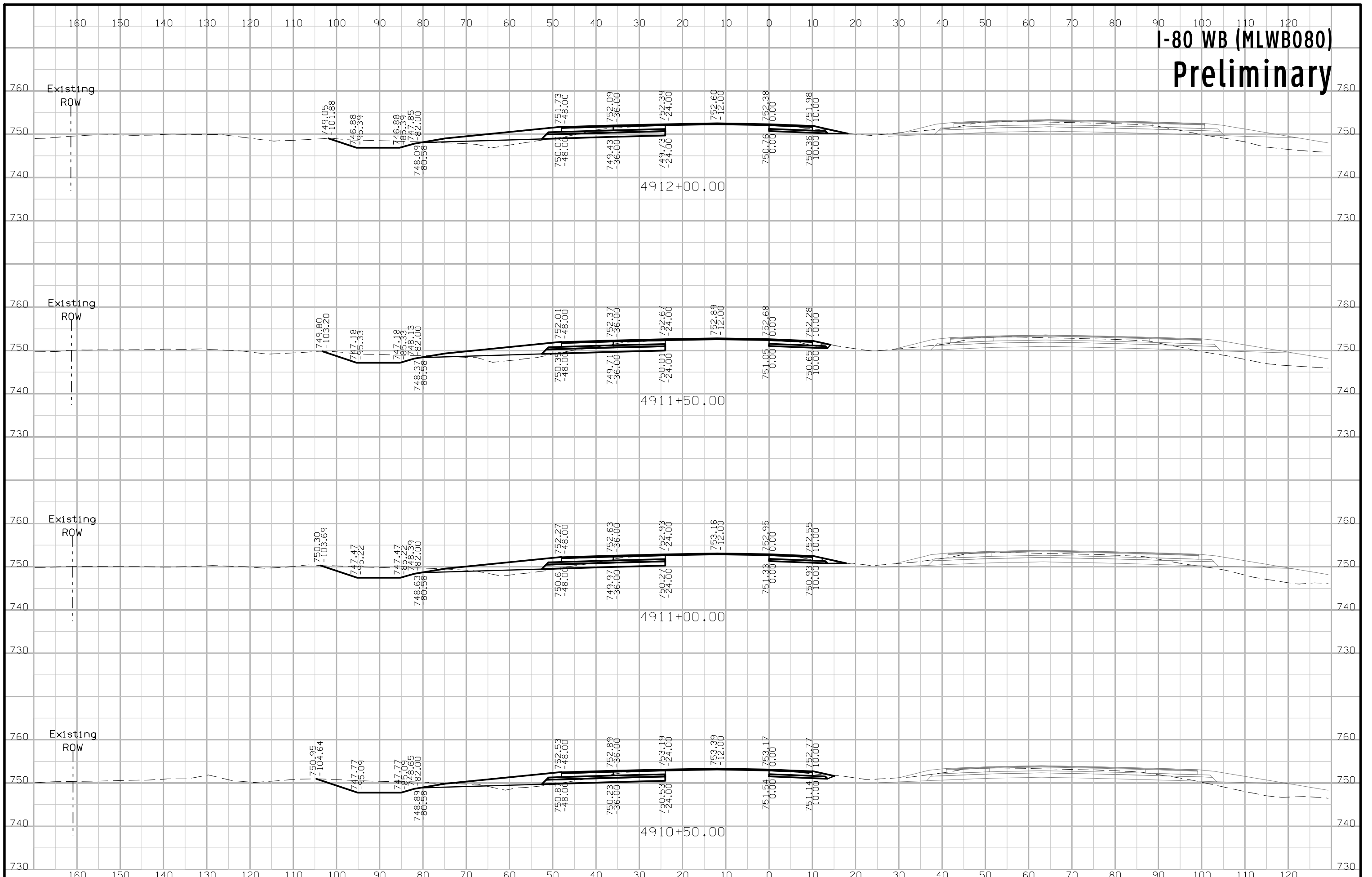

# I-80 WB (MLWB080) Preliminary

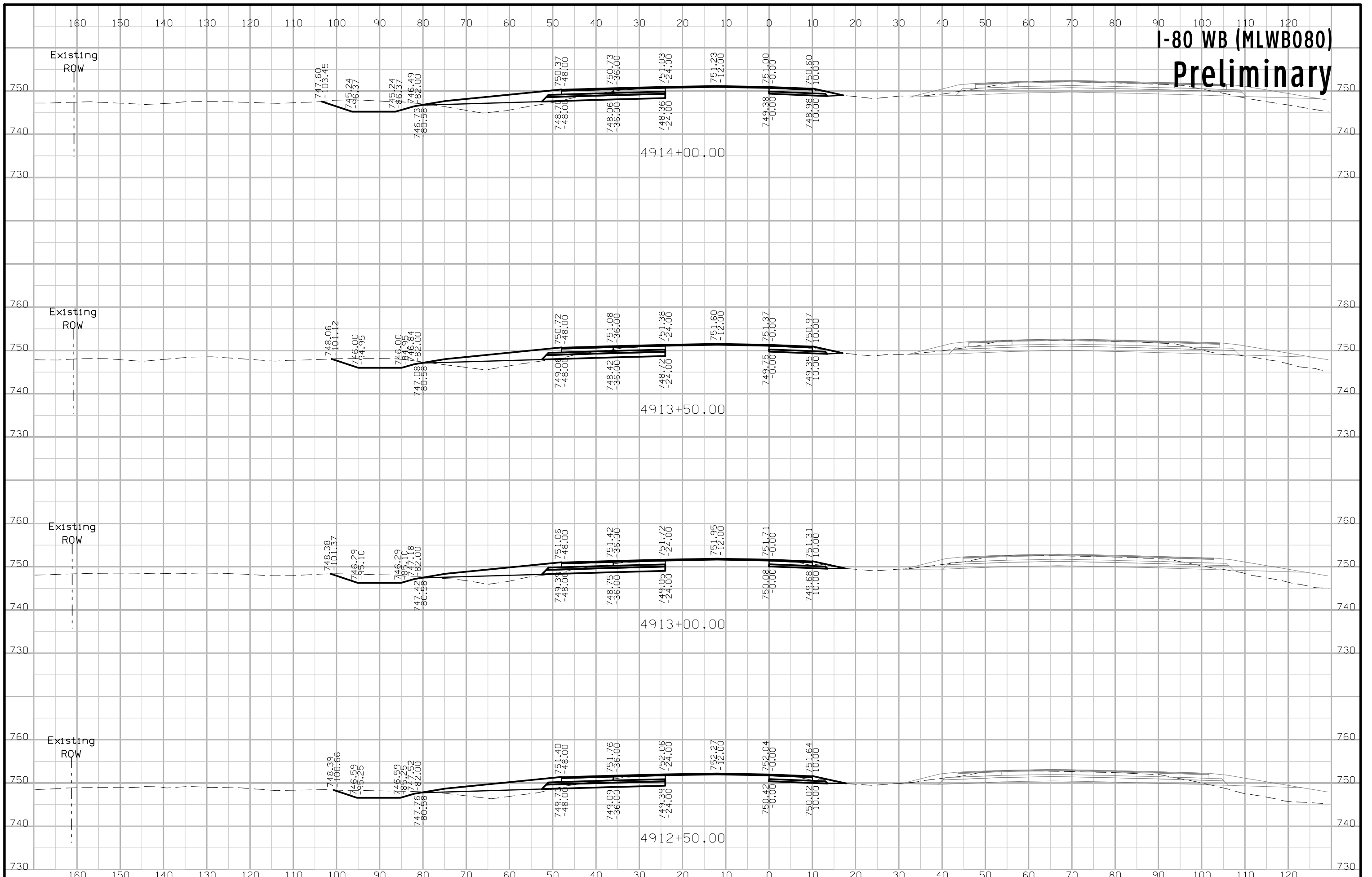

# I-80 WB (MLWB080) Preliminary

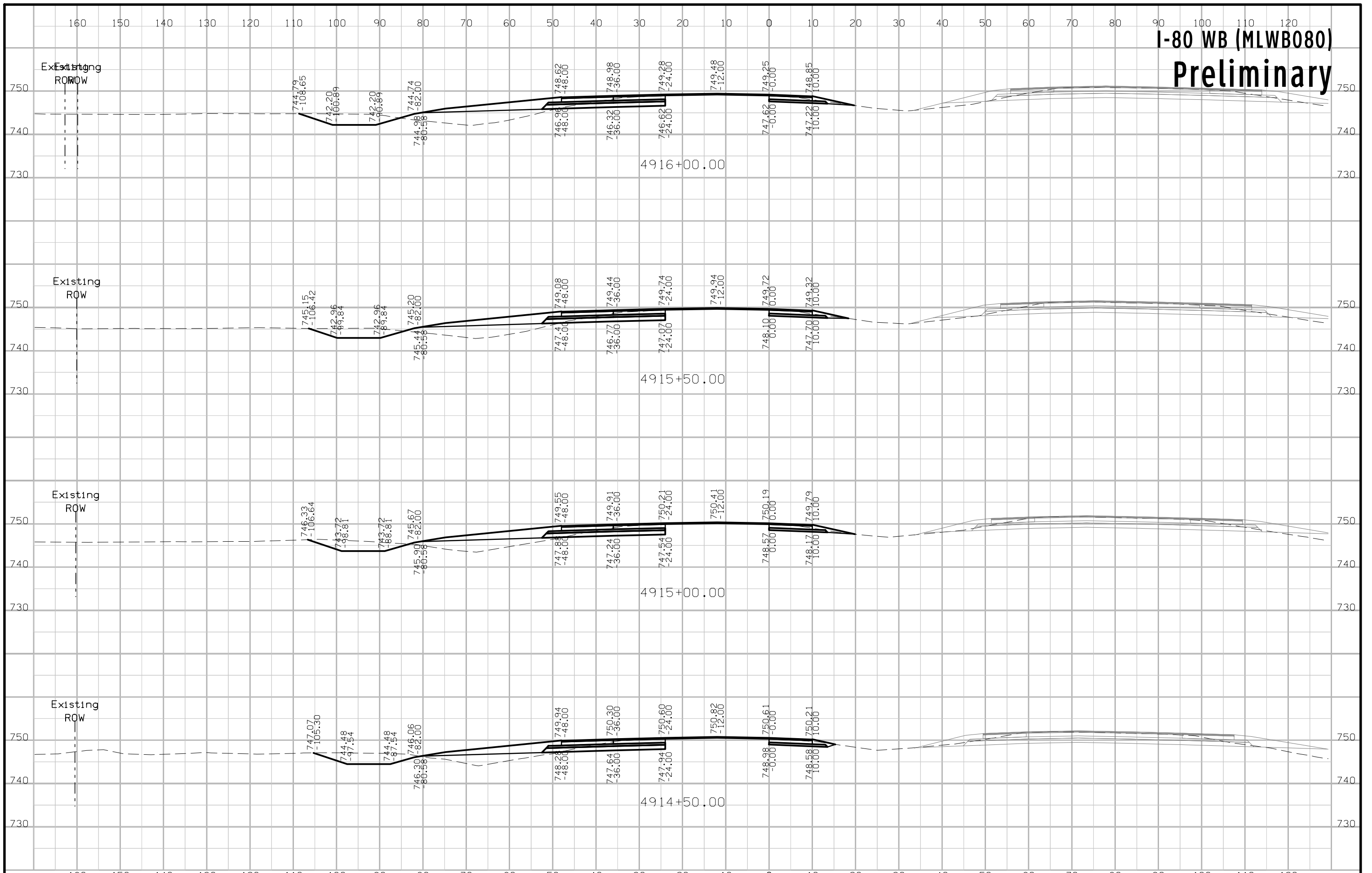



# I-80 WB (MLWB080) Preliminary

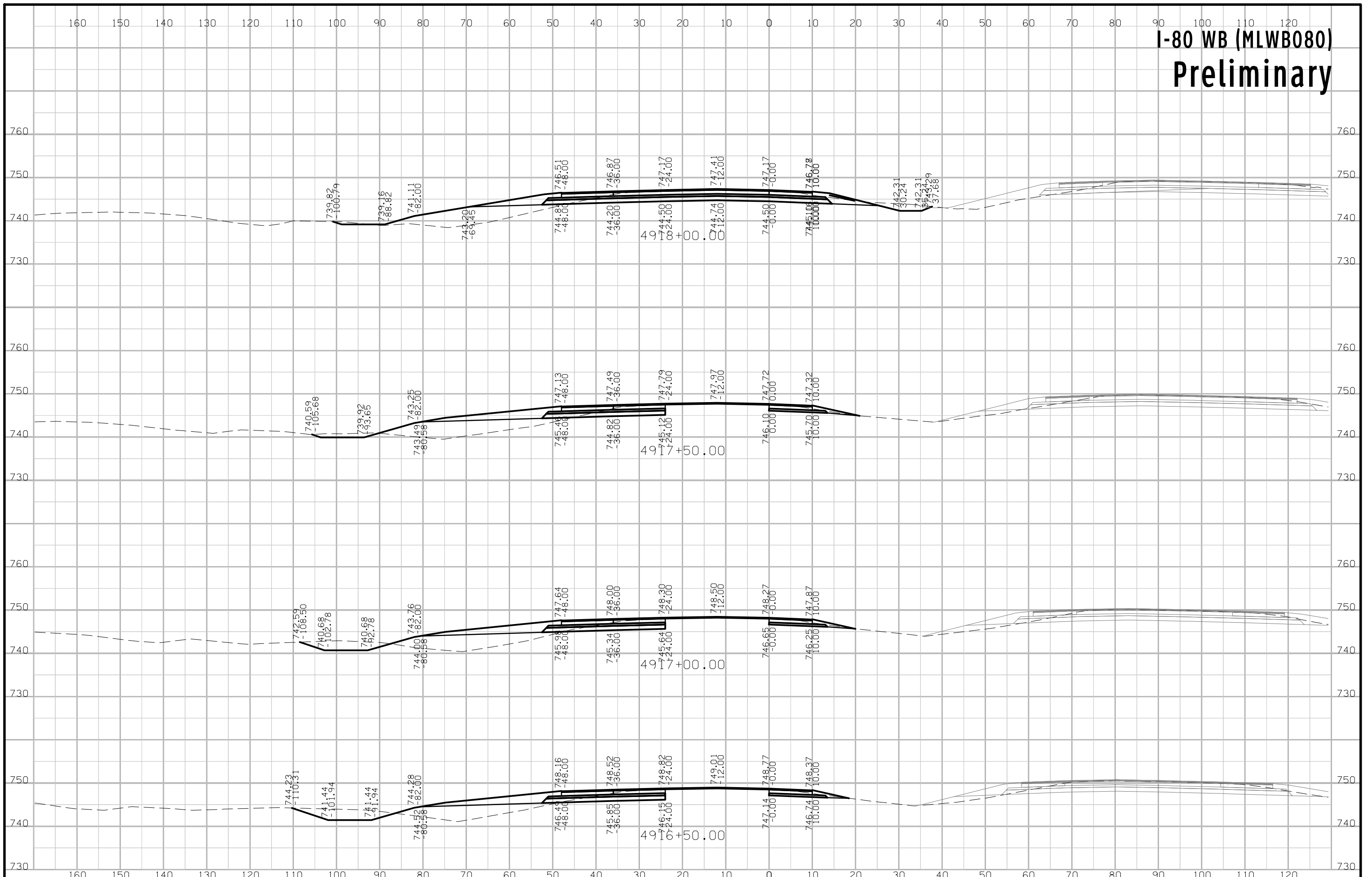

# I-80 WB (MLWB080) Preliminary

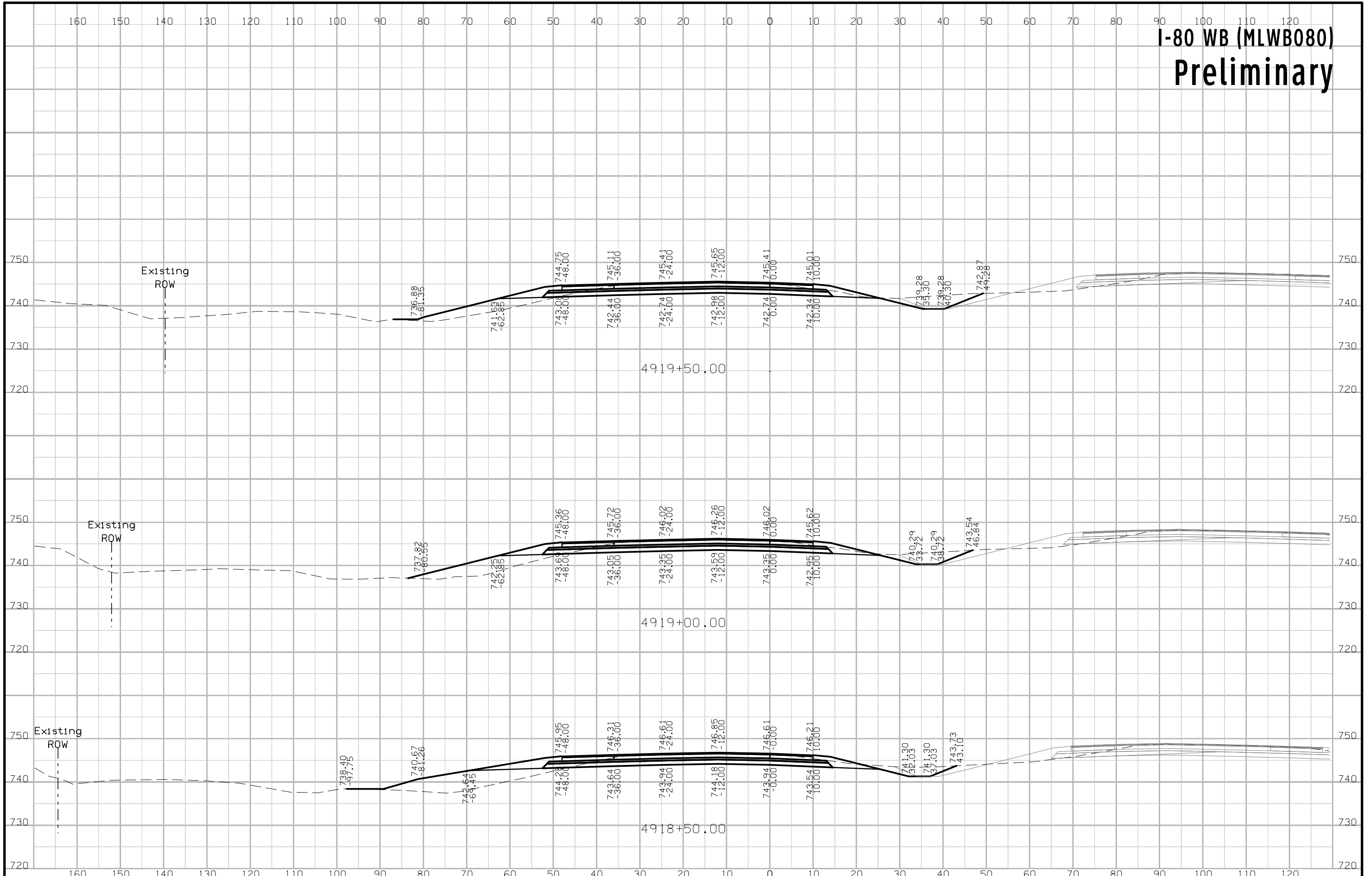

# I-80 WB (MLWB080) Preliminary

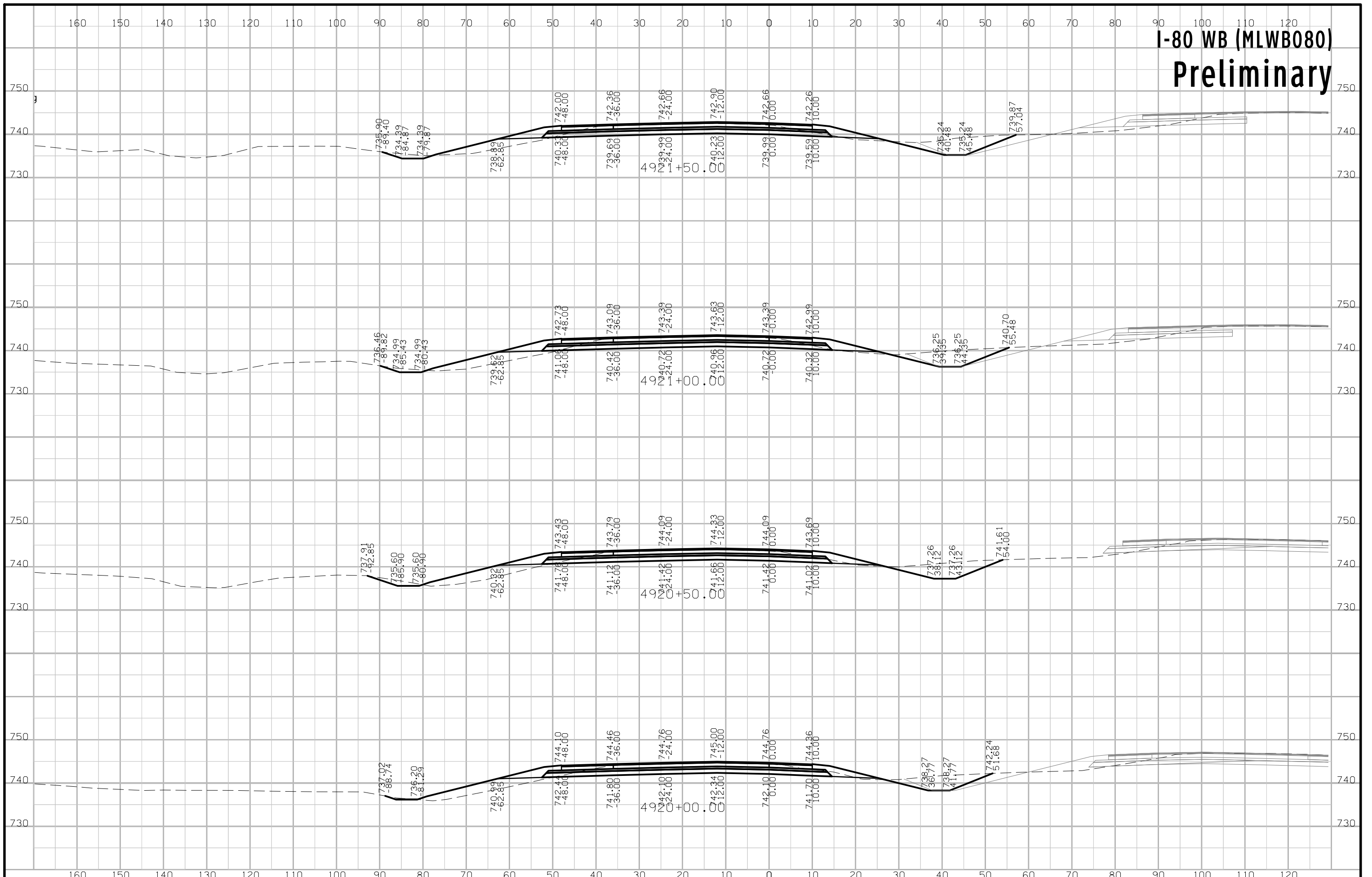

# I-80 WB (MLWB080) Preliminary

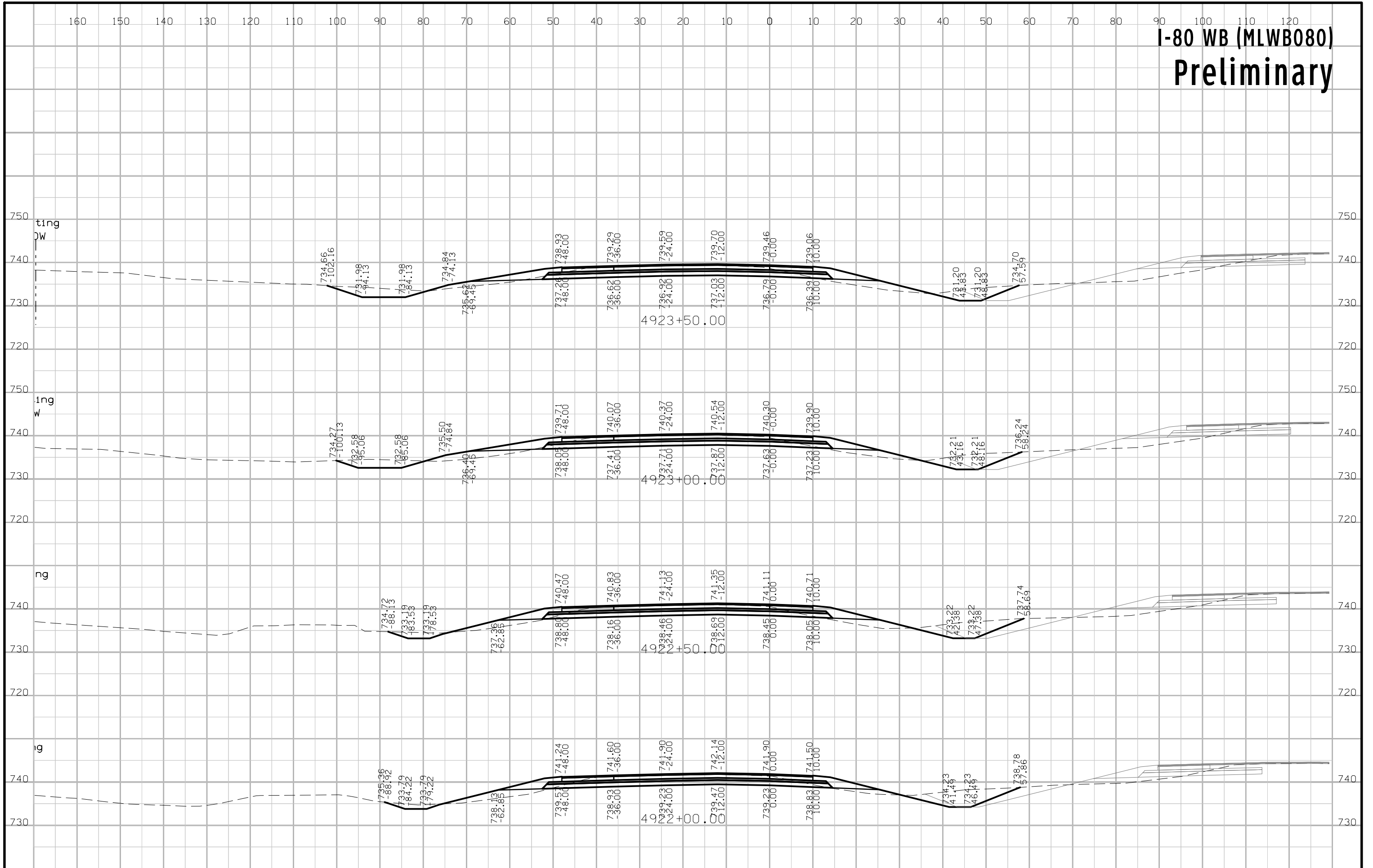



# I-80 WB (MLWB080) Preliminary

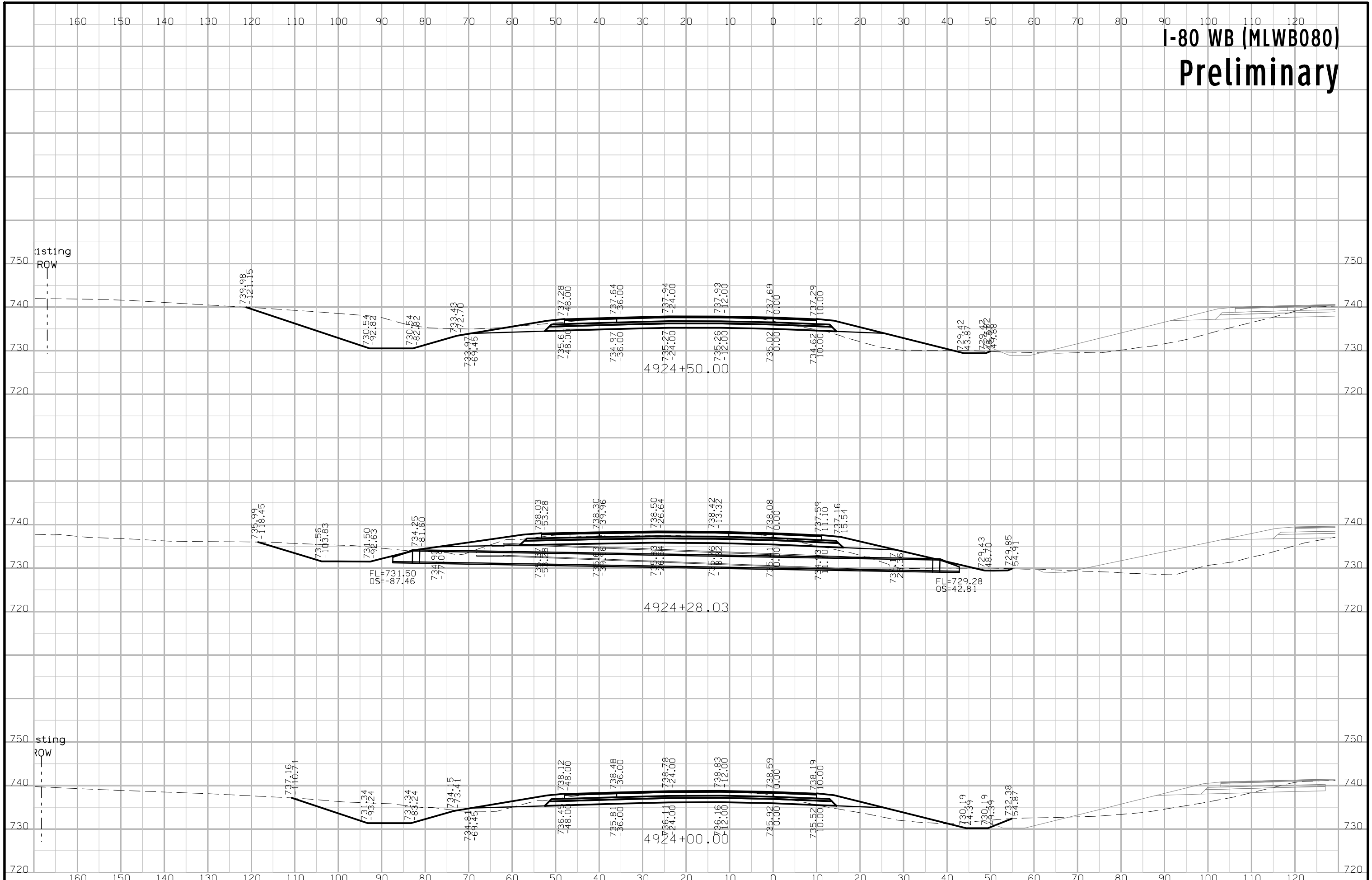

# I-80 WB (MLWB080) Preliminary

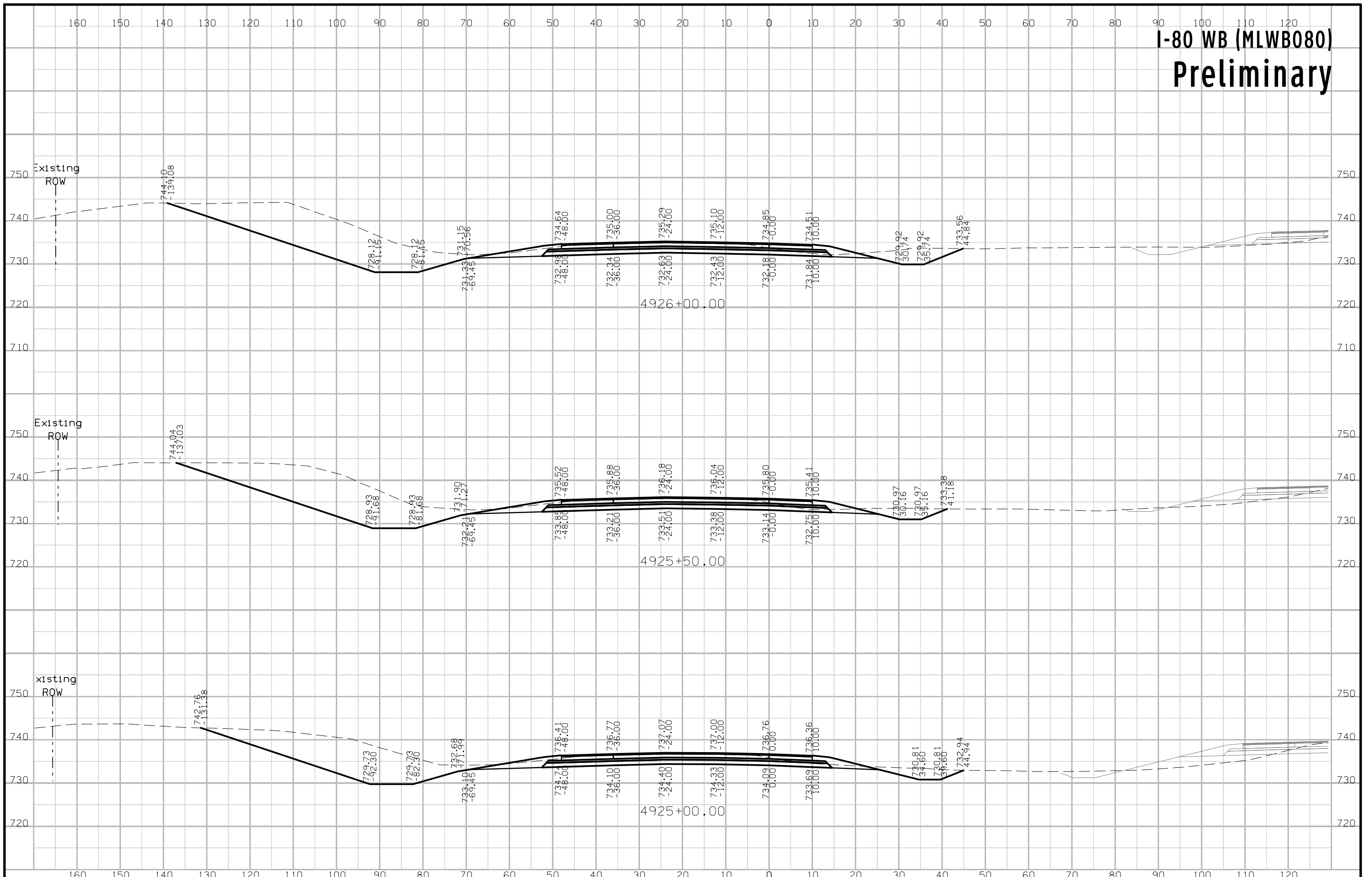

# I-80 WB (MLWB080) Preliminary

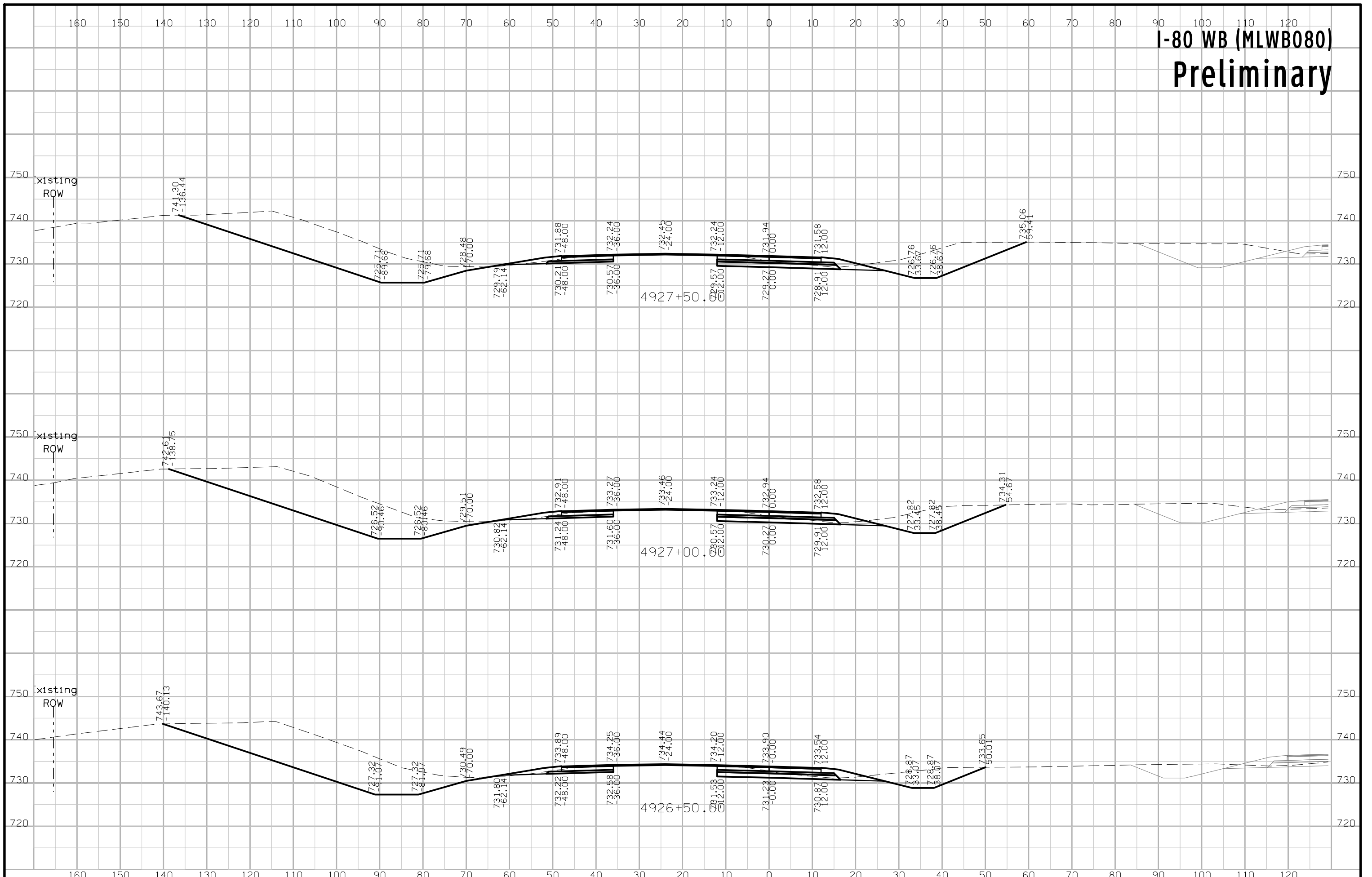

# I-80 WB (MLWB080) Preliminary

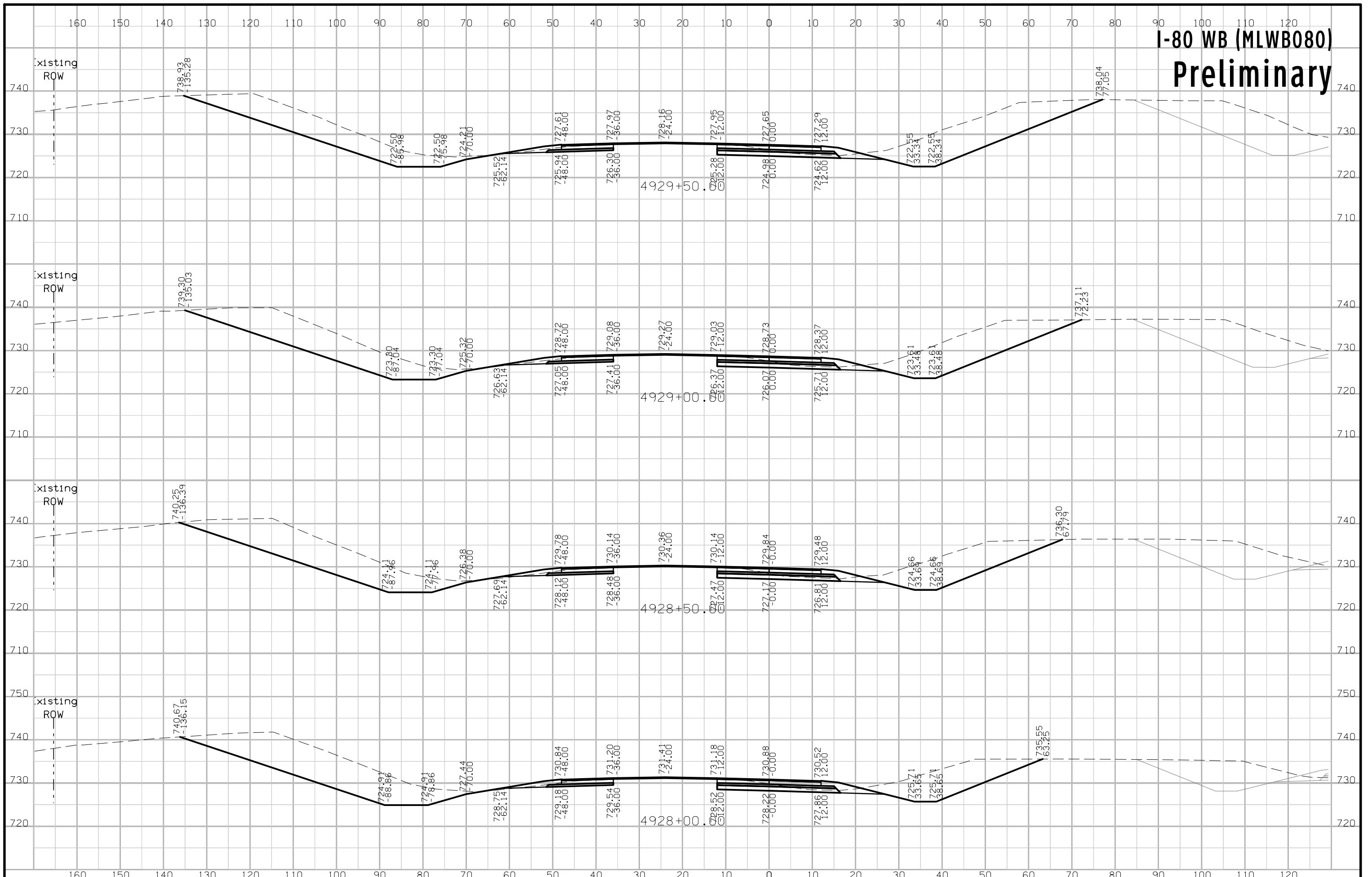



# I-80 WB (MLWB080) Preliminary

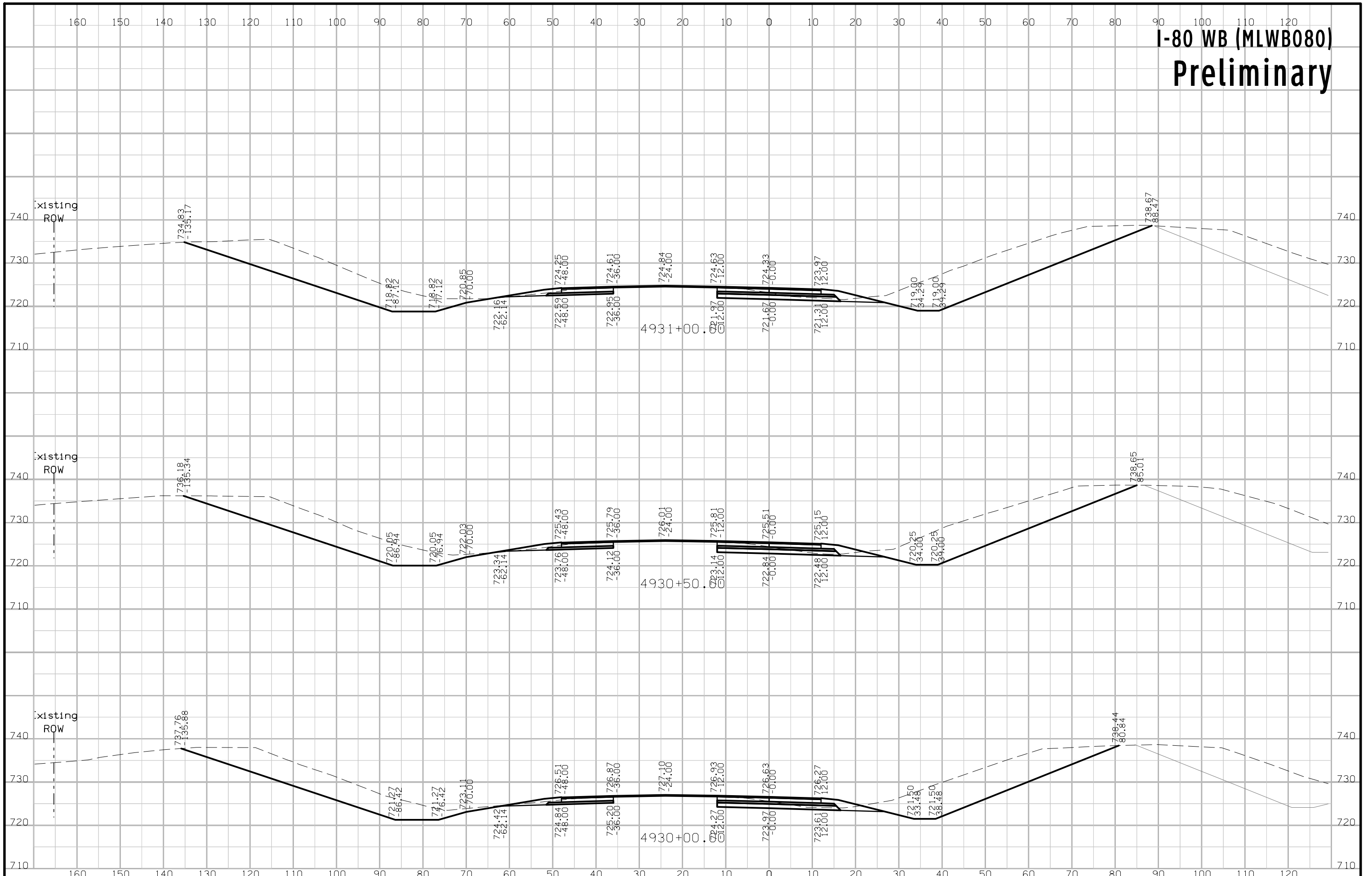

# I-80 WB (MLWB080) Preliminary

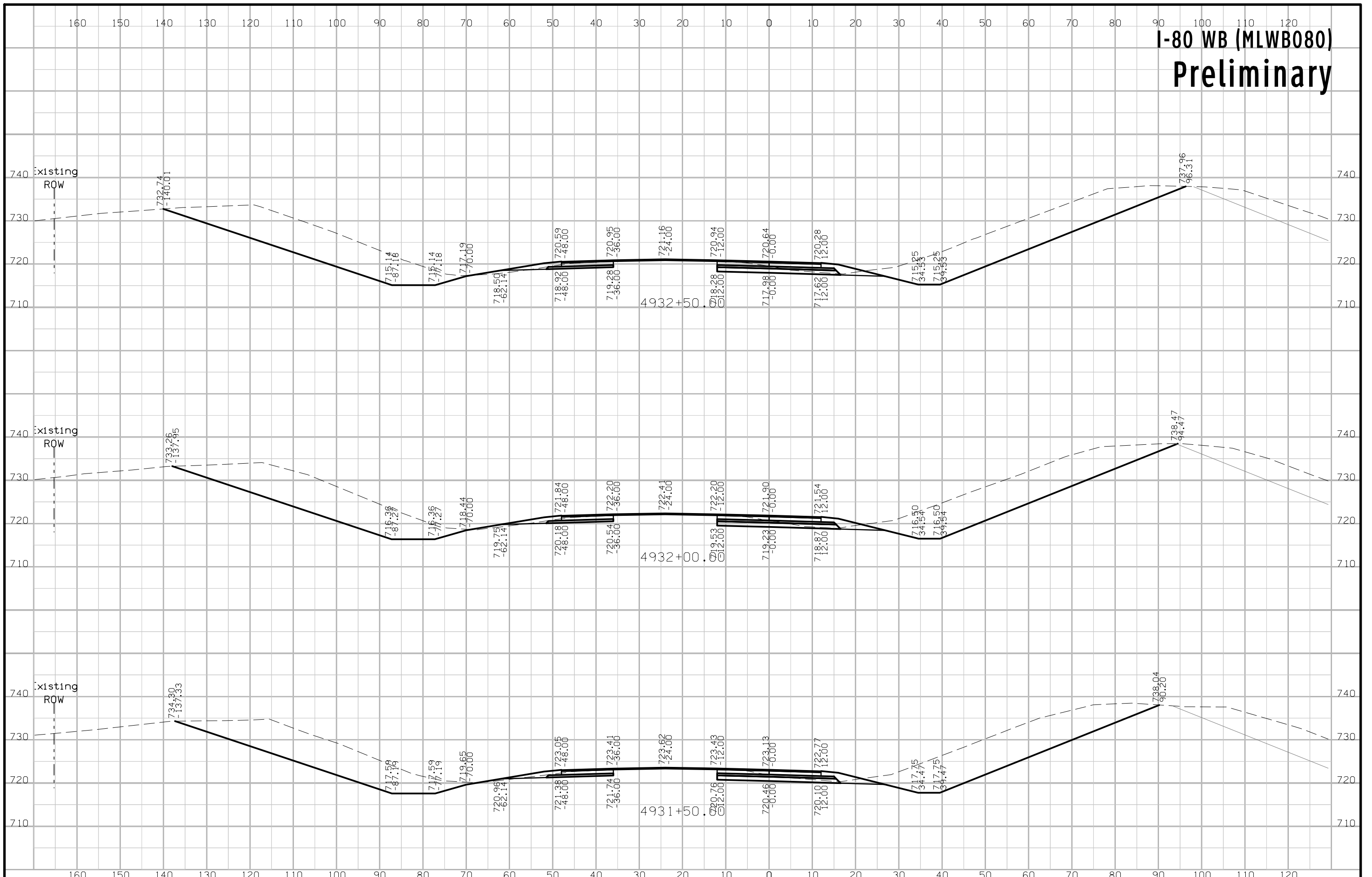

# I-80 WB (MLWB080) Preliminary

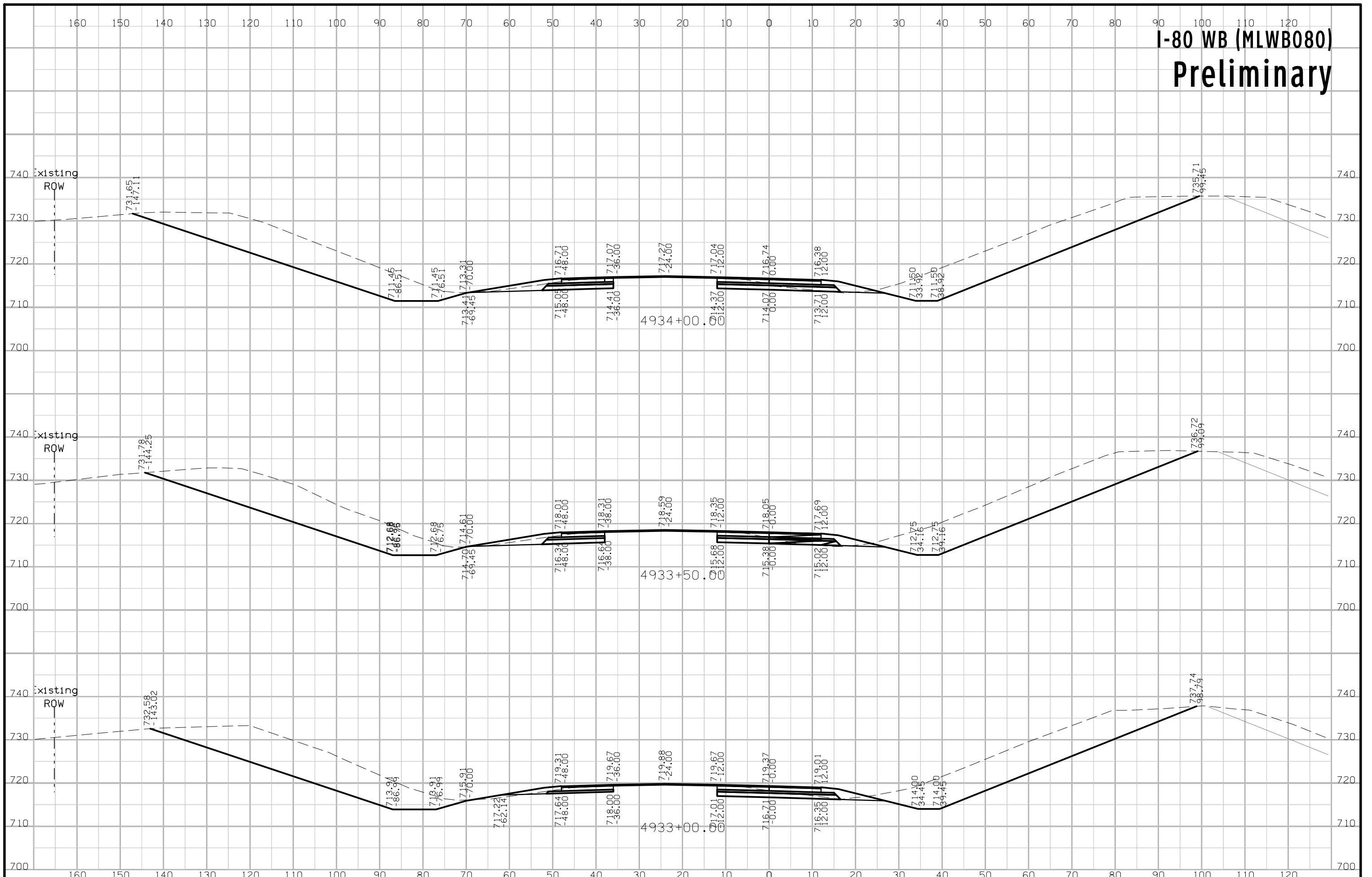

# I-80 WB (MLWB080) Preliminary

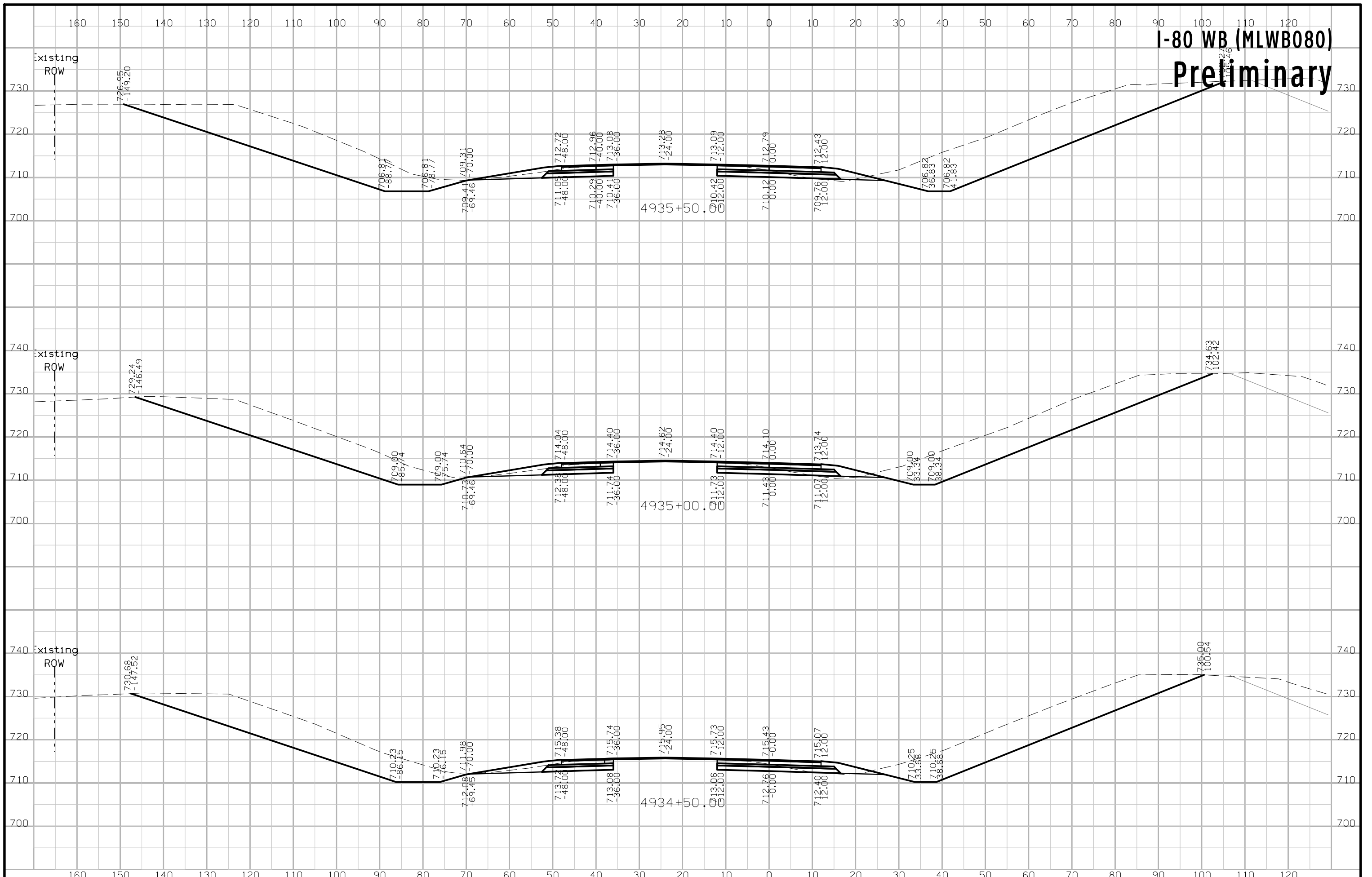



# I-80 WB (MLWB080) Preliminary

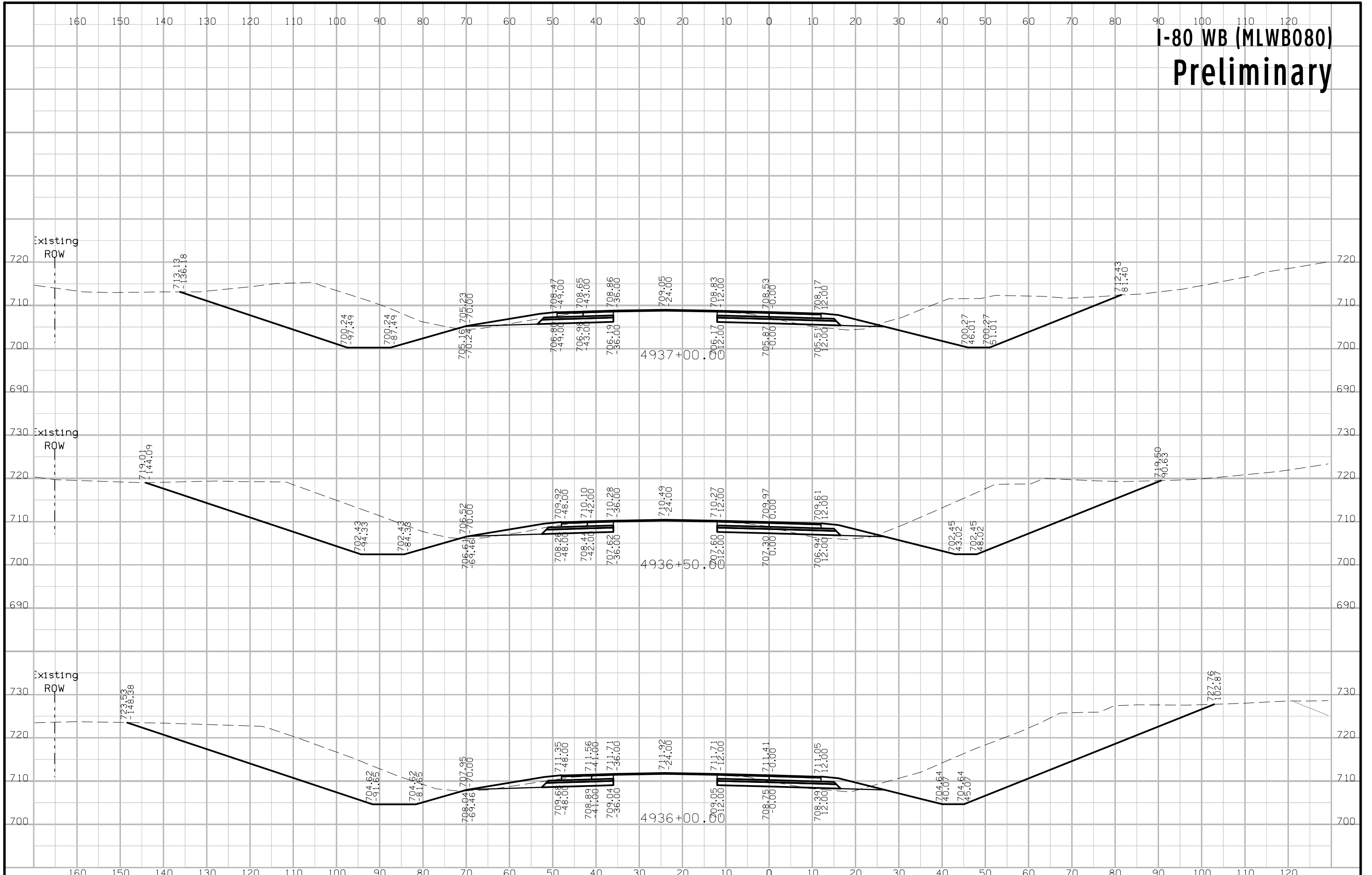

# I-80 WB (MLWB080) Preliminary

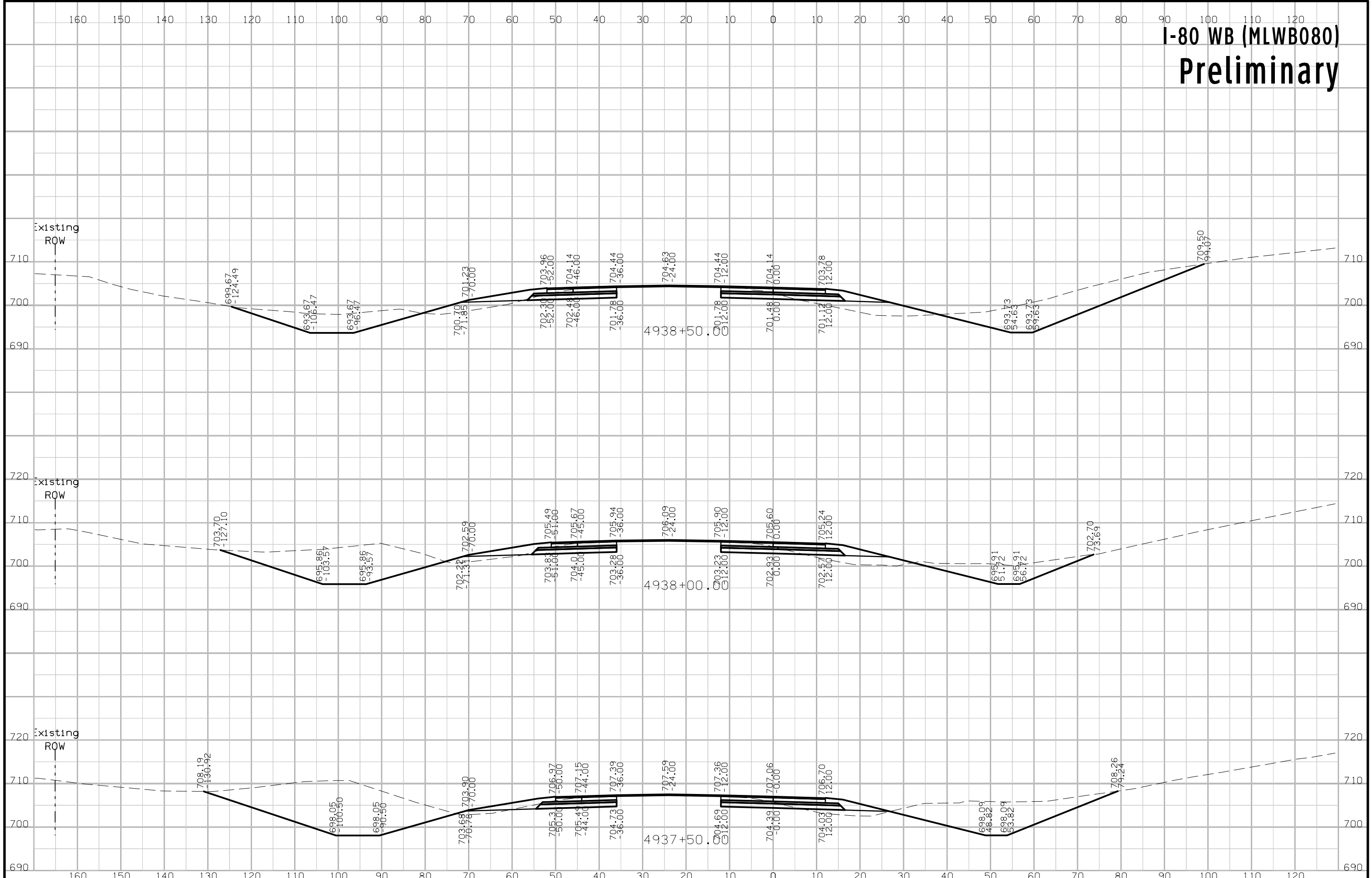

# I-80 WB (MLWB080) Preliminary

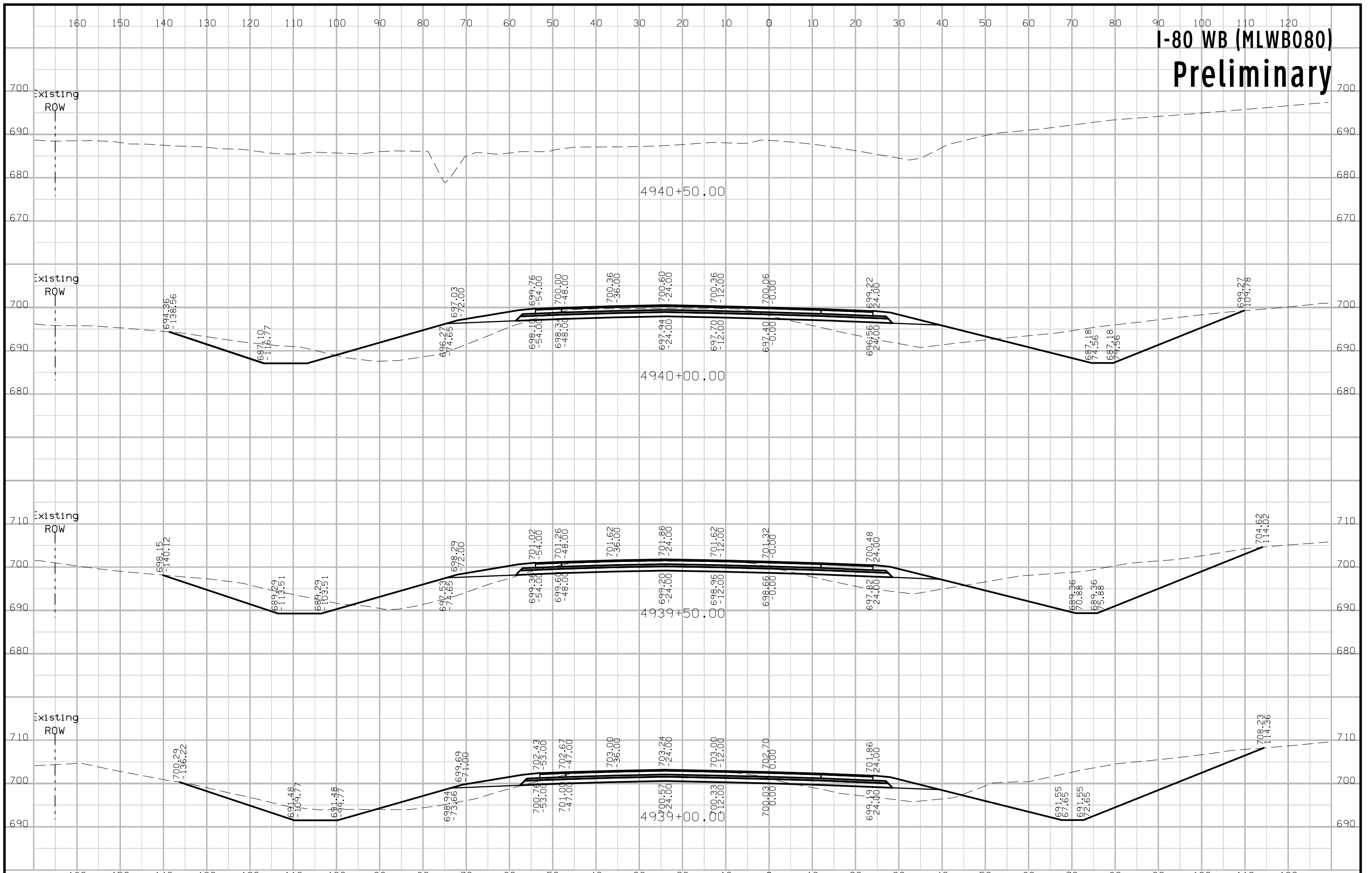

# I-80 WB (MLWB080) Preliminary

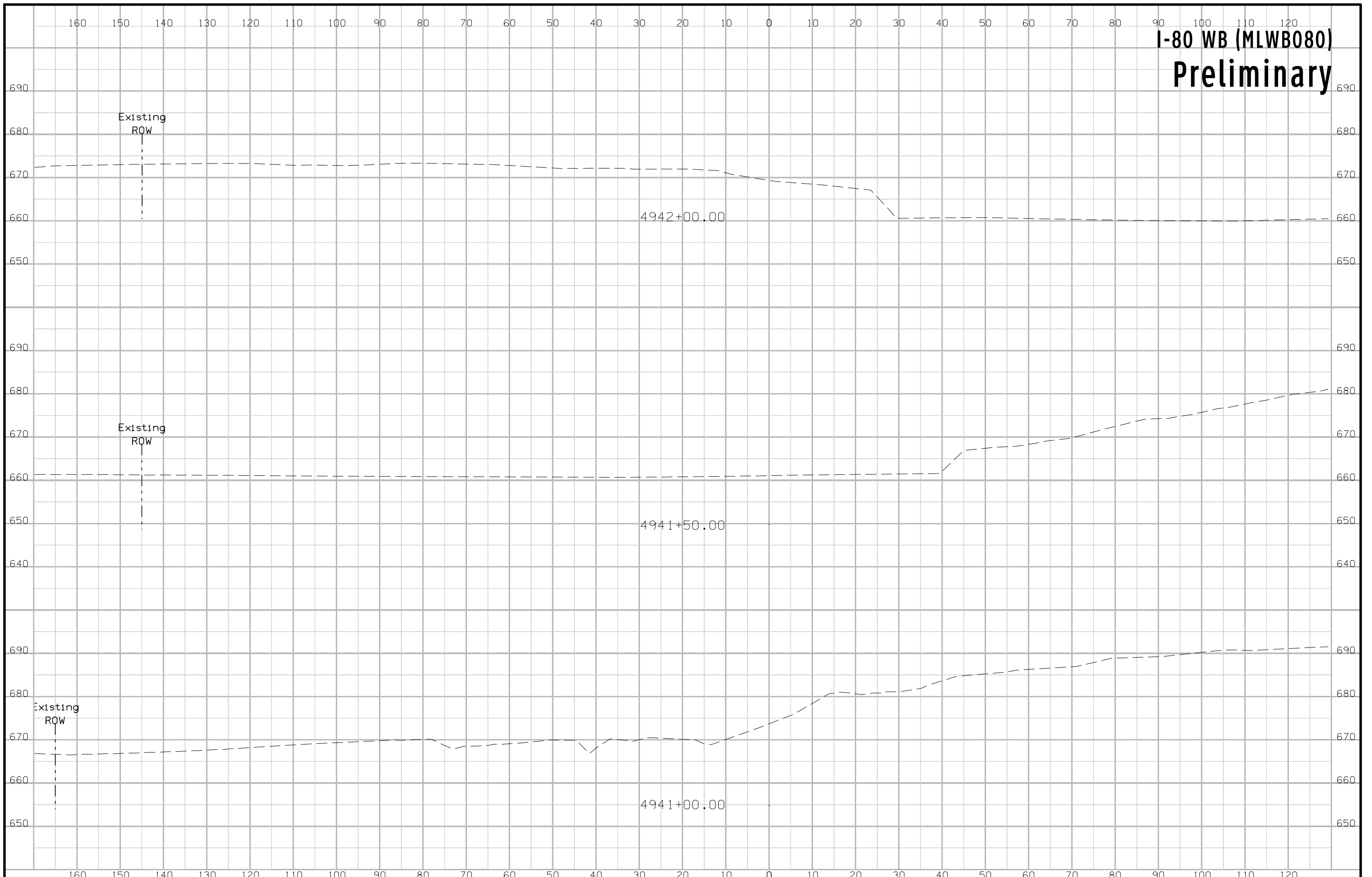



# I-80 WB (MLWB080) Preliminary

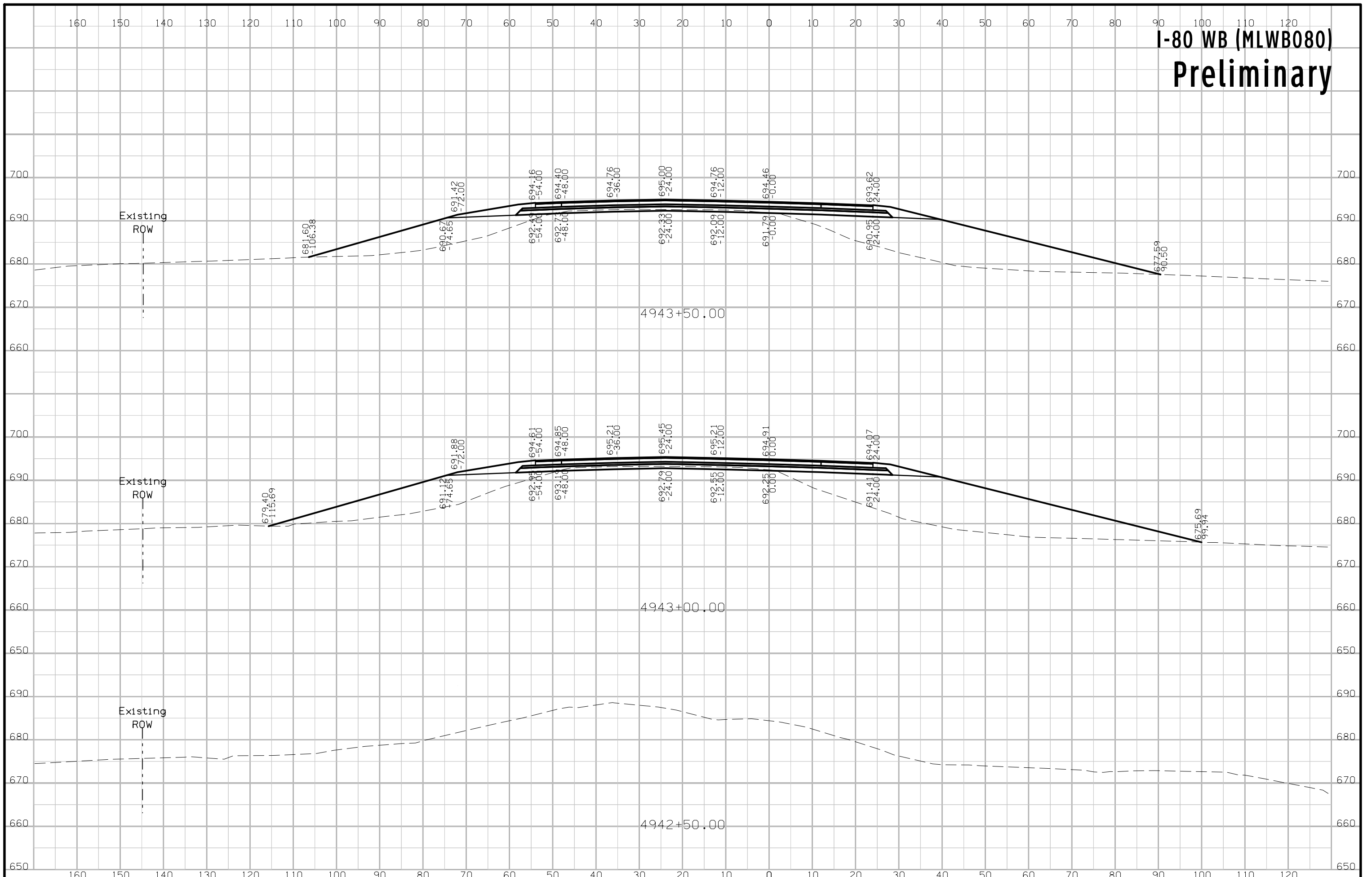

# I-80 WB (MLWB080) Preliminary

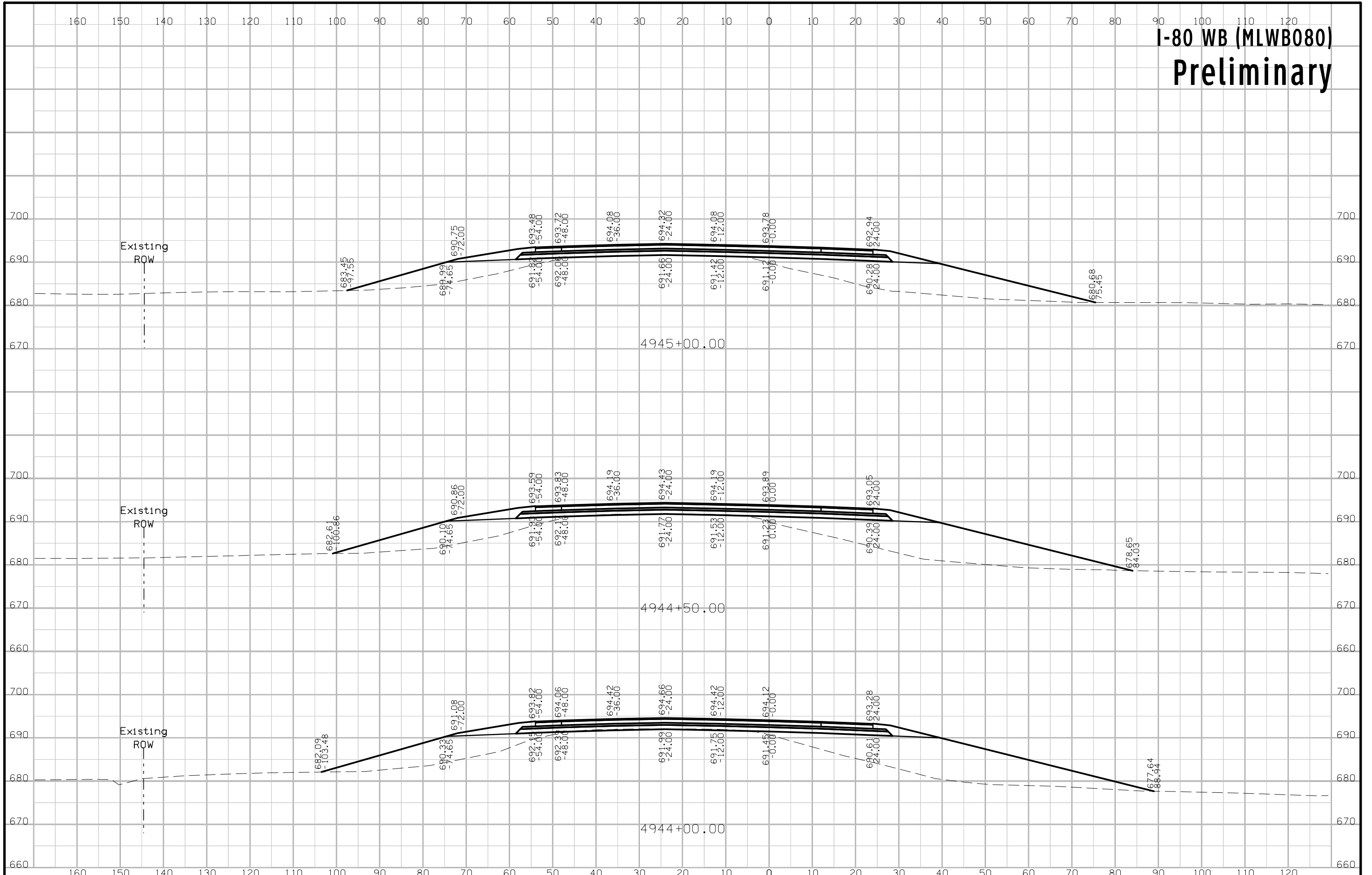

# I-80 WB (MLWB080) Preliminary

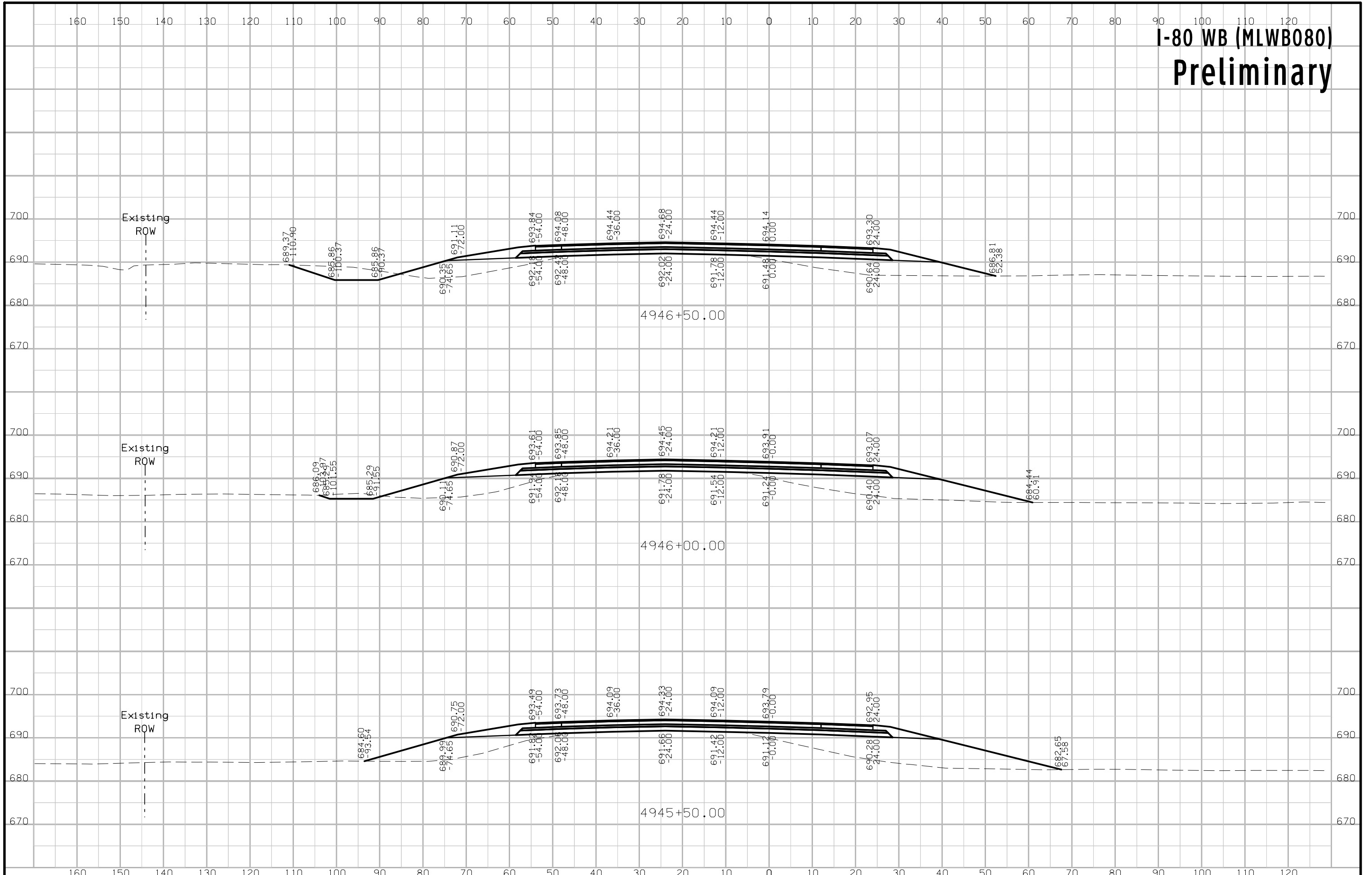

# I-80 WB (MLWB080) Preliminary

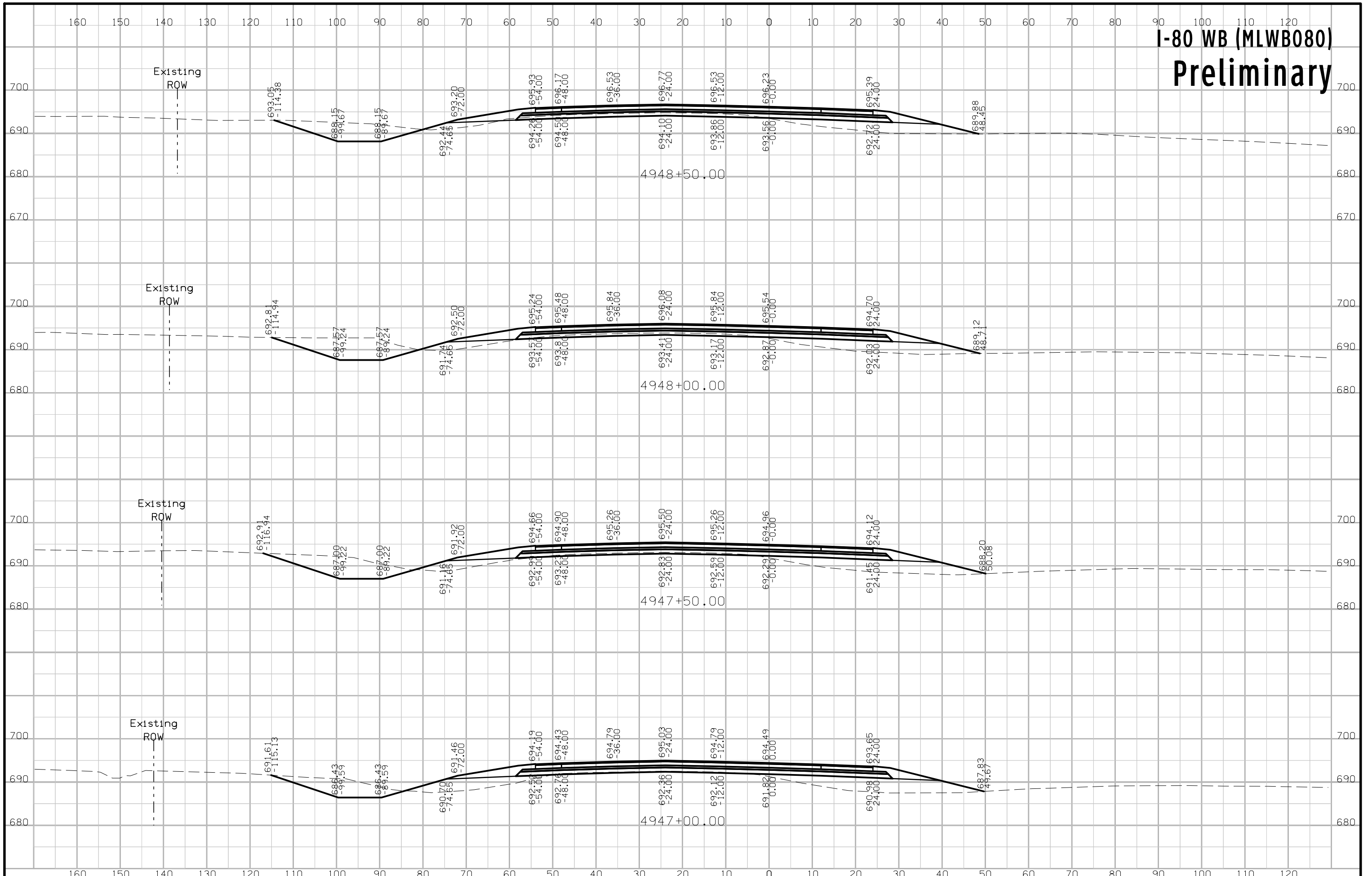



# I-80 WB (MLWB080) Preliminary

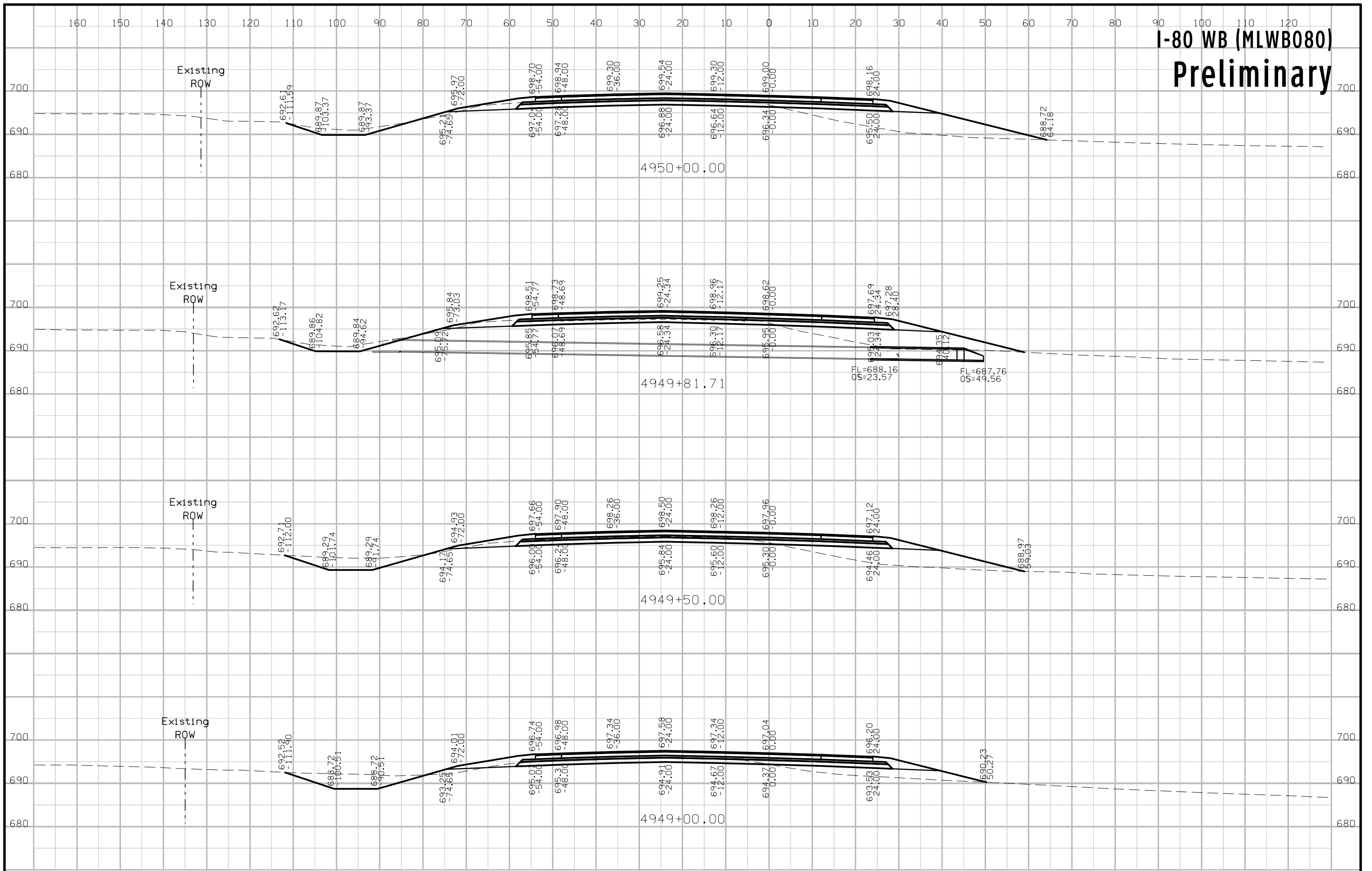

# I-80 WB (MLWB080) Preliminary

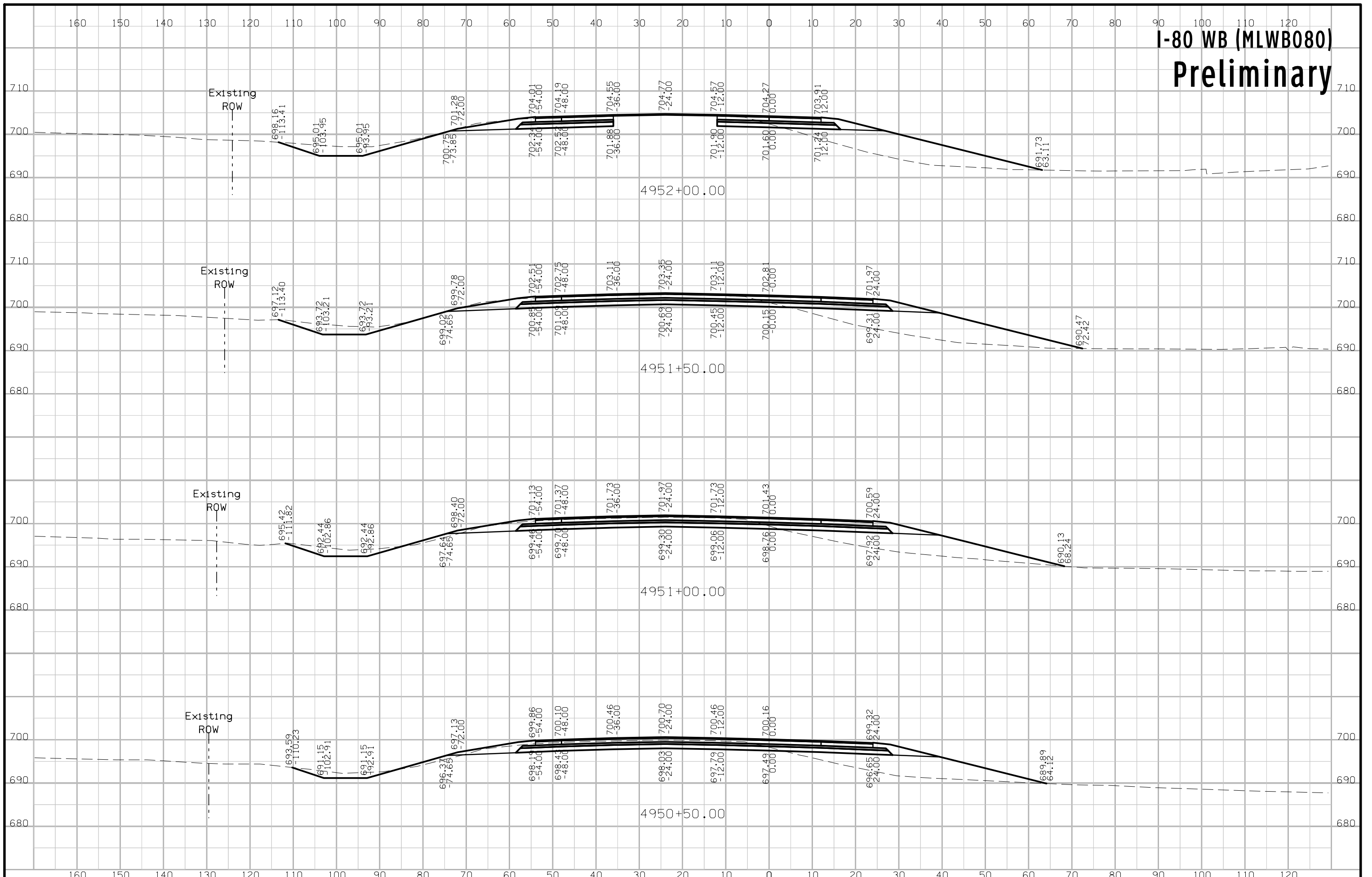

# I-80 WB (MLWB080) Preliminary

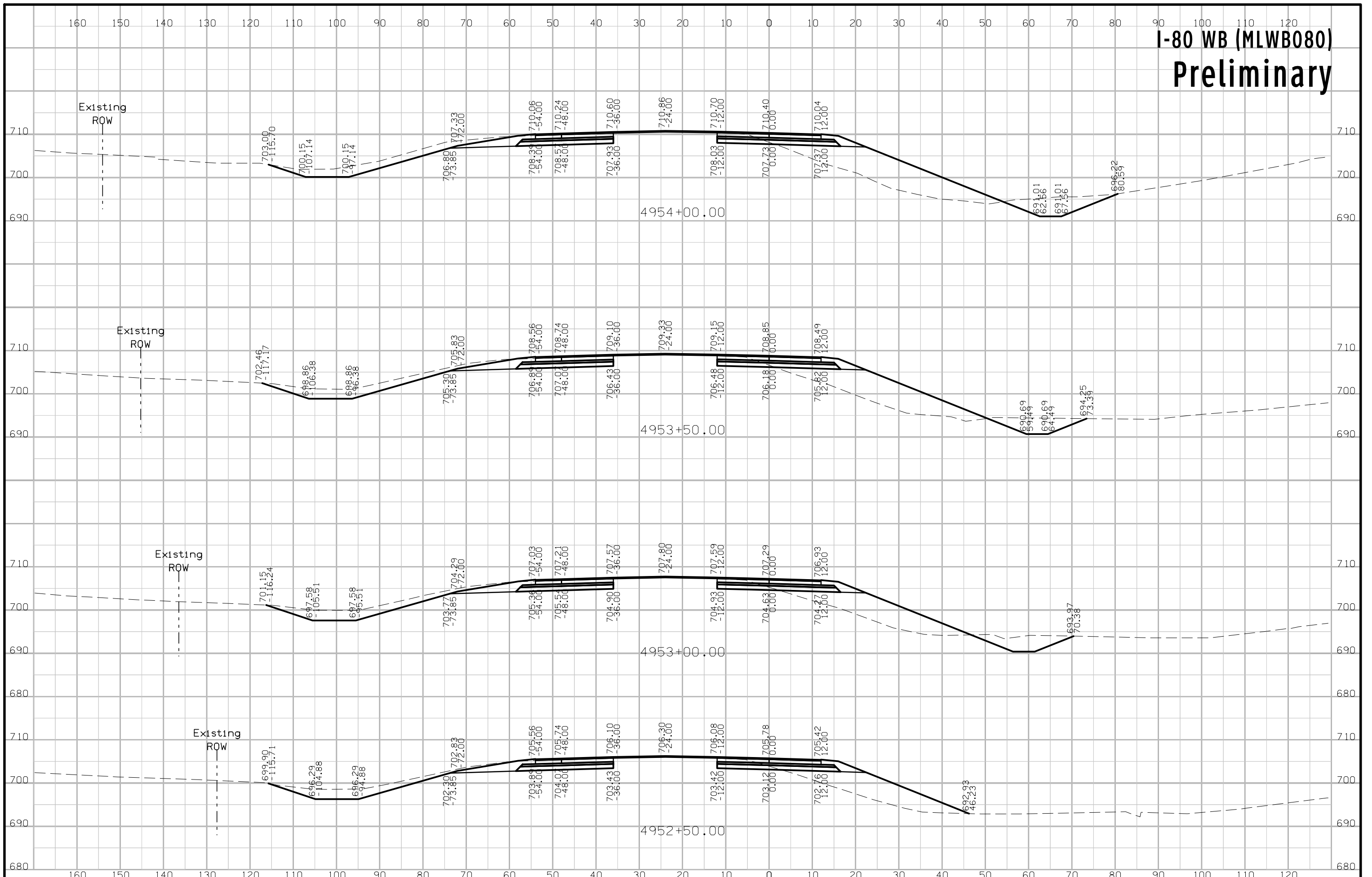

# I-80 WB (MLWB080) Preliminary

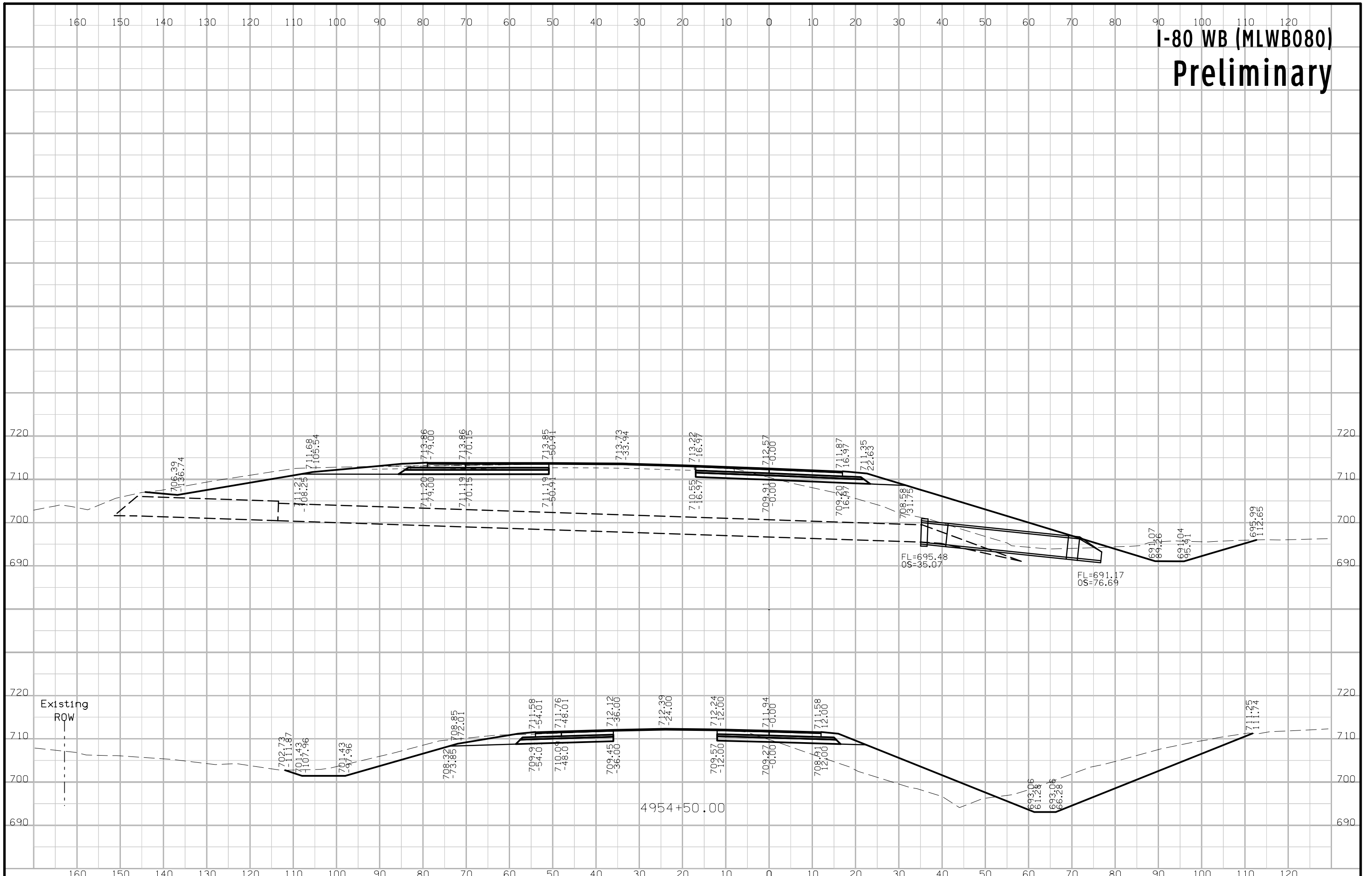



# I-80 WB (MLWB080) Preliminary

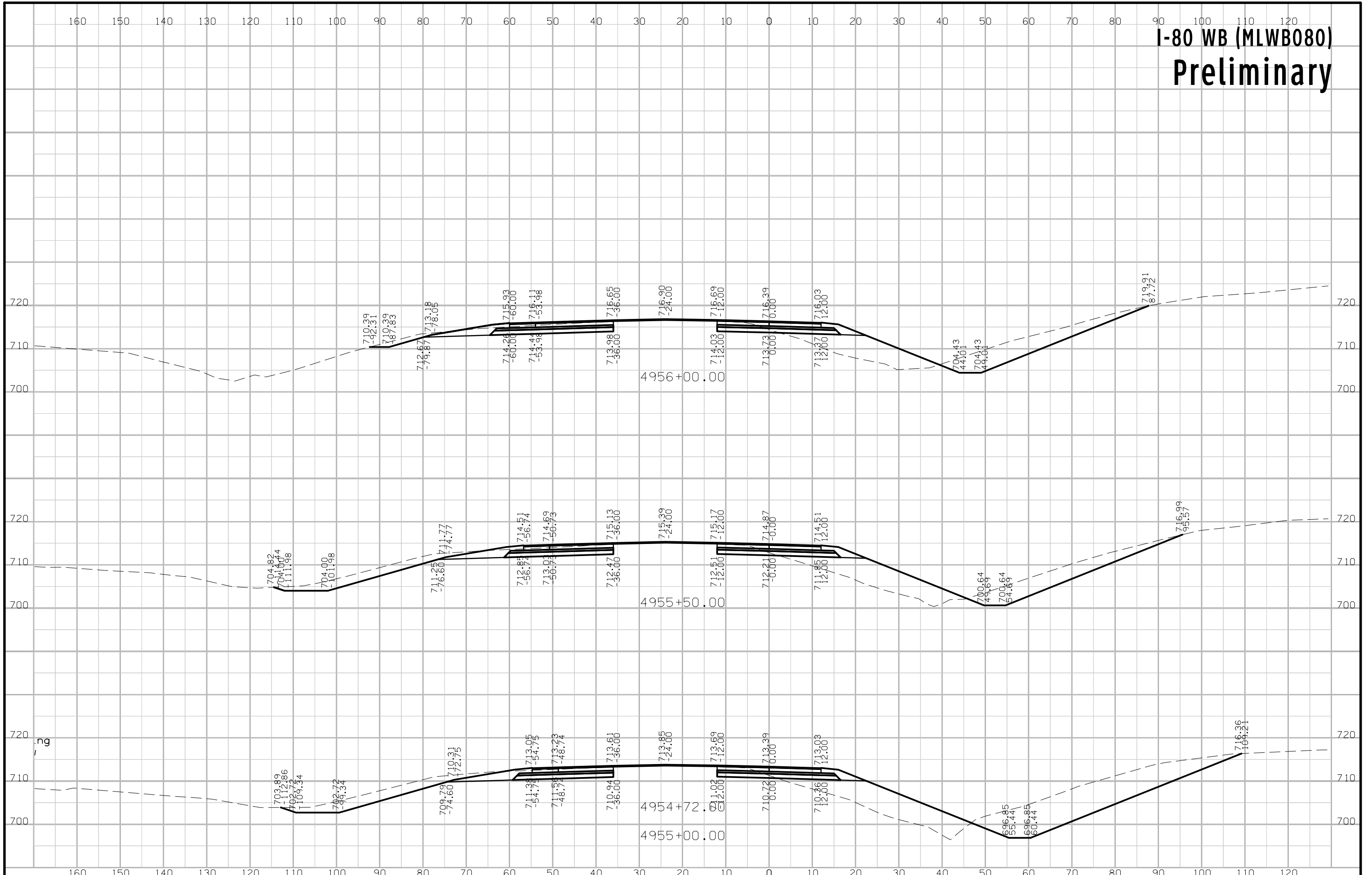

# I-80 WB (MLWB080) Preliminary

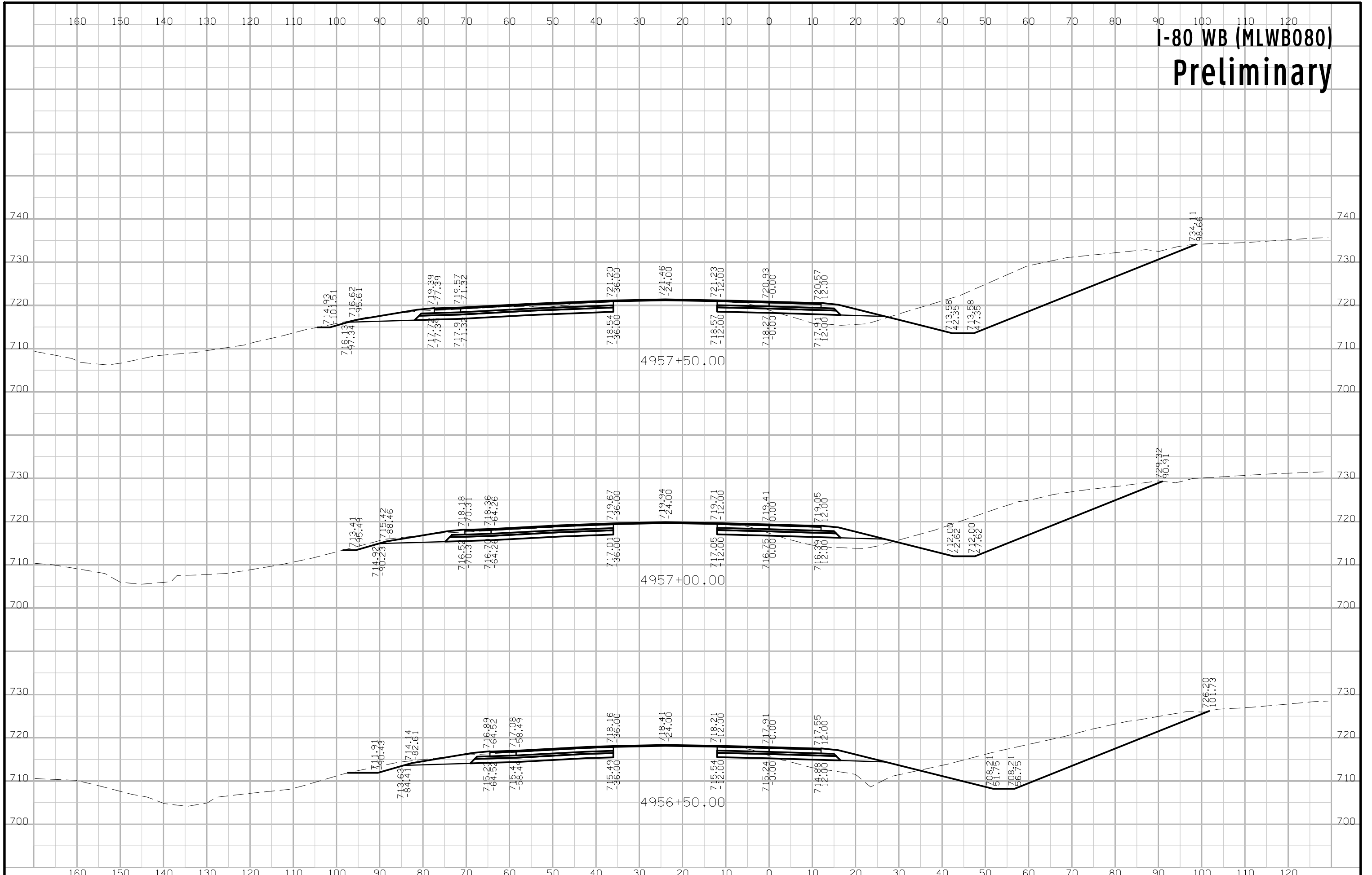

# I-80 WB (MLWB080) Preliminary

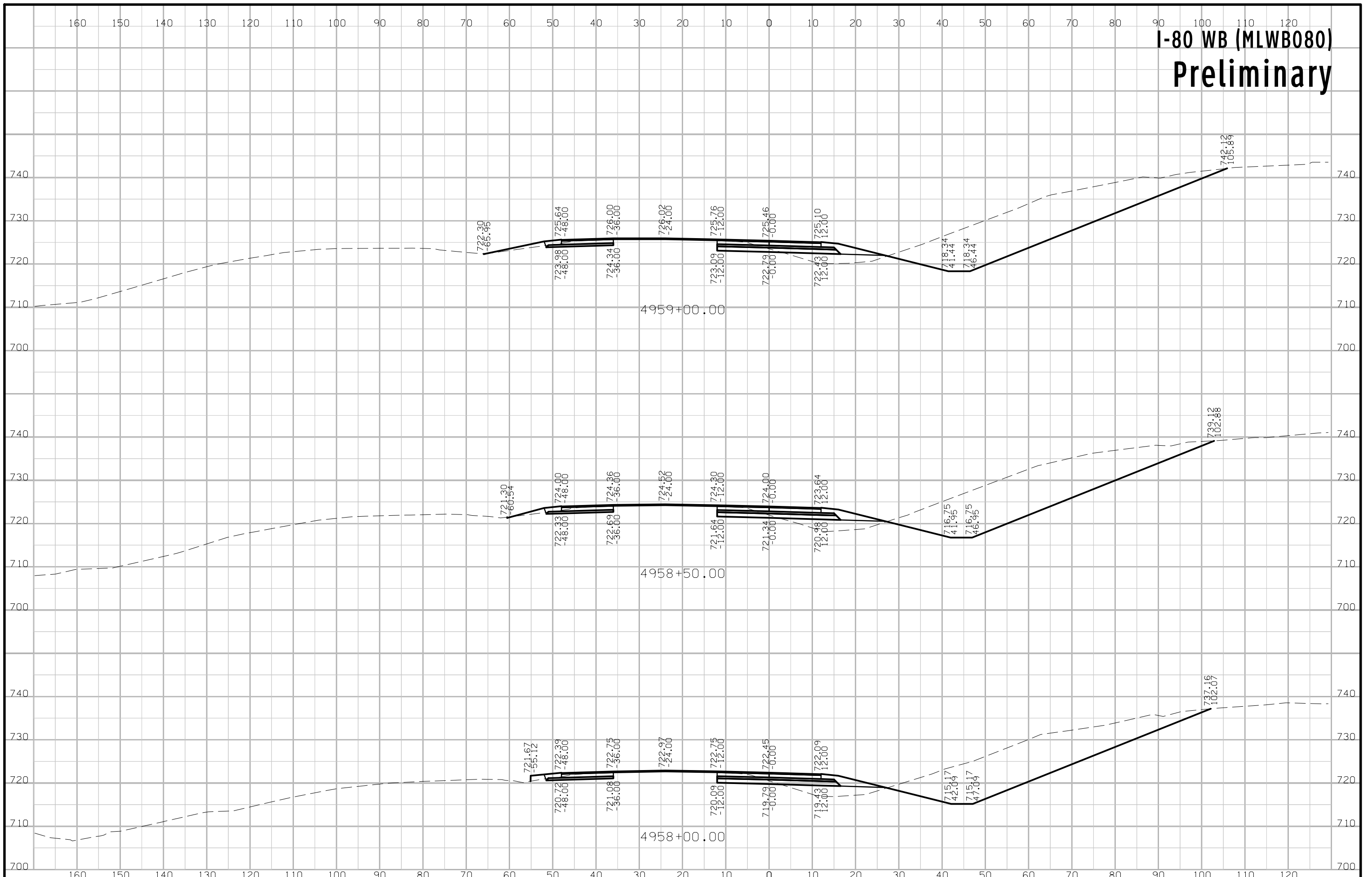

# I-80 WB (MLWB080) Preliminary

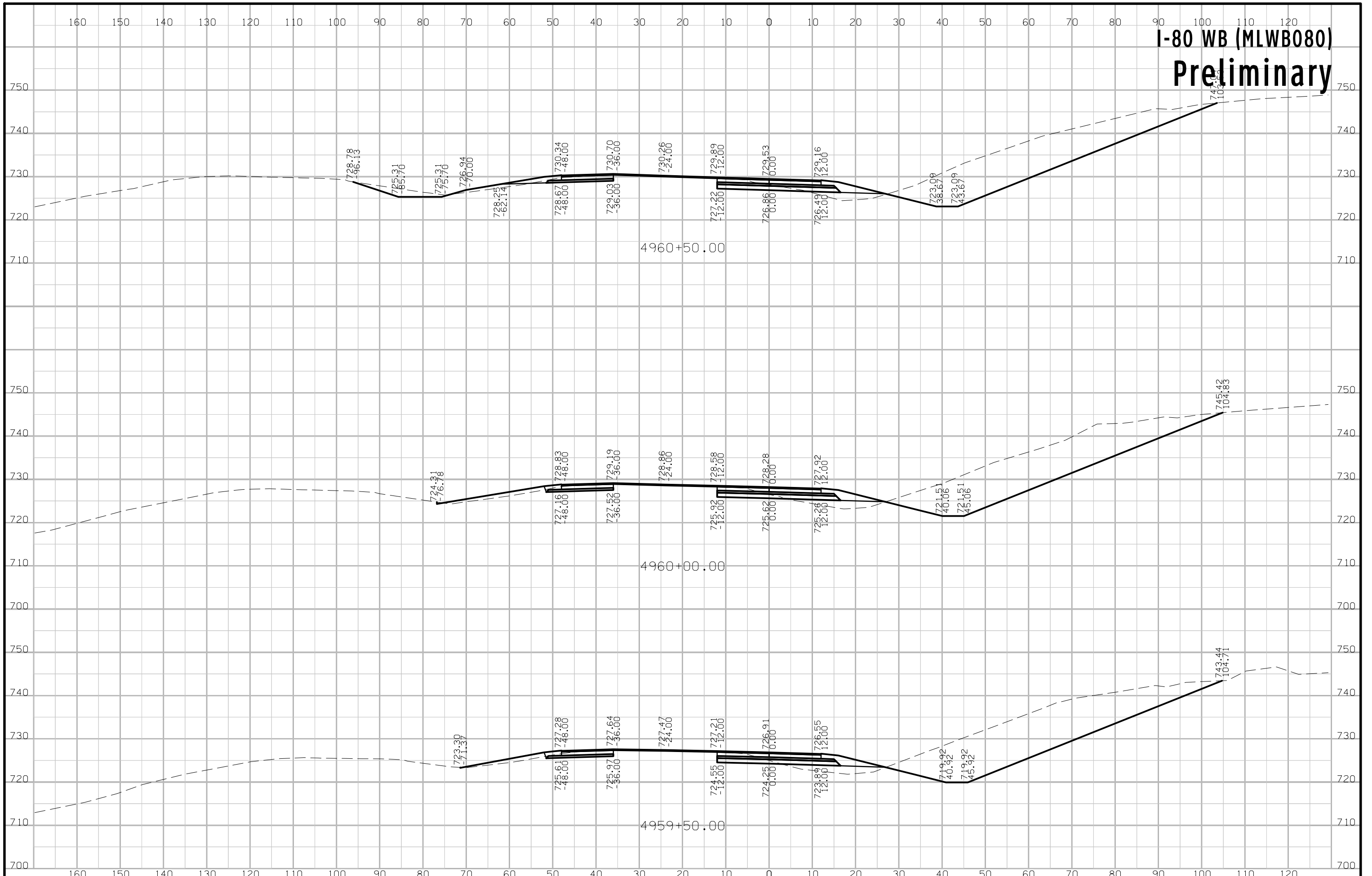



# I-80 WB (MLWB080) Preliminary

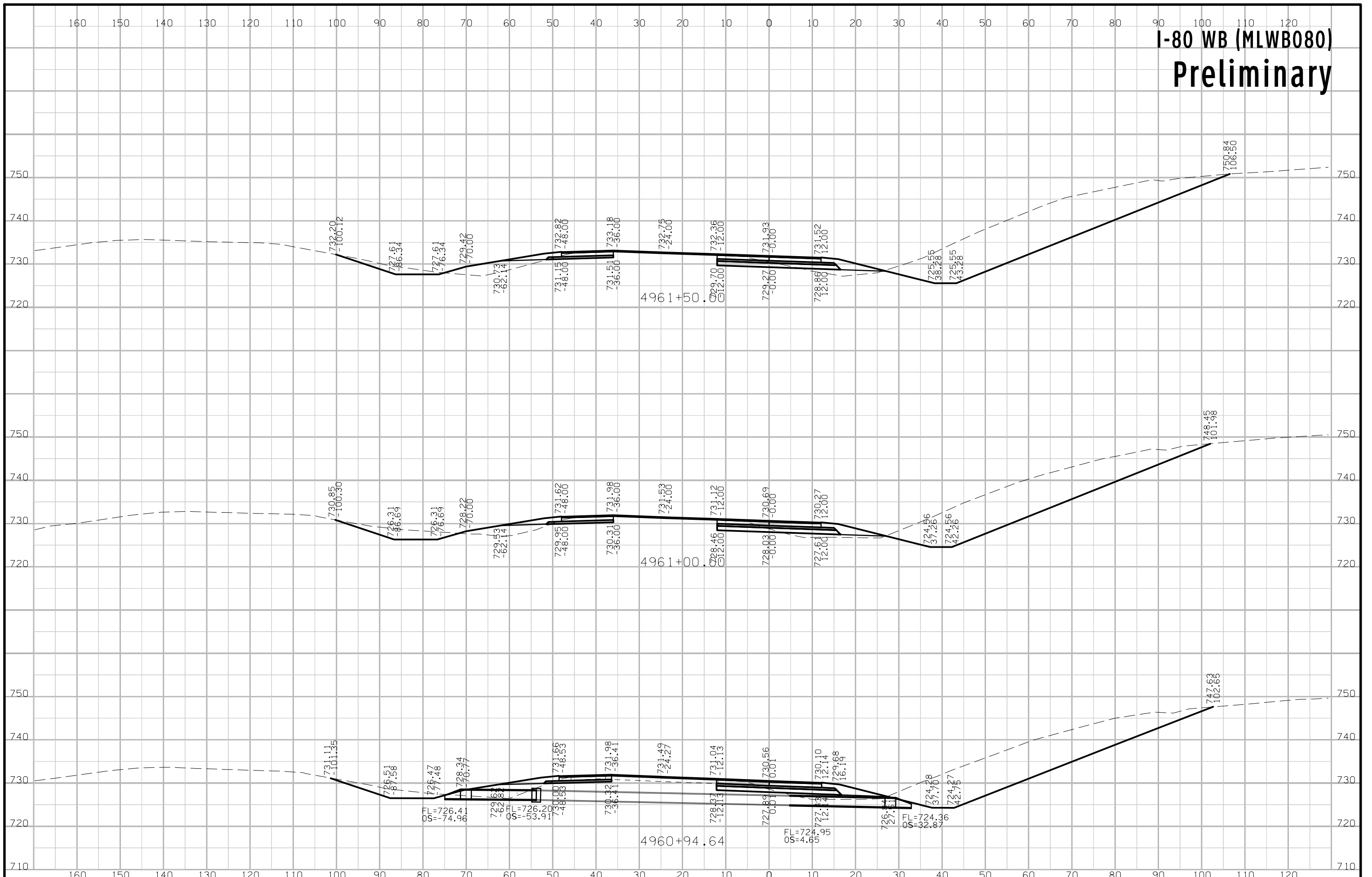

# I-80 WB (MLWB080) Preliminary

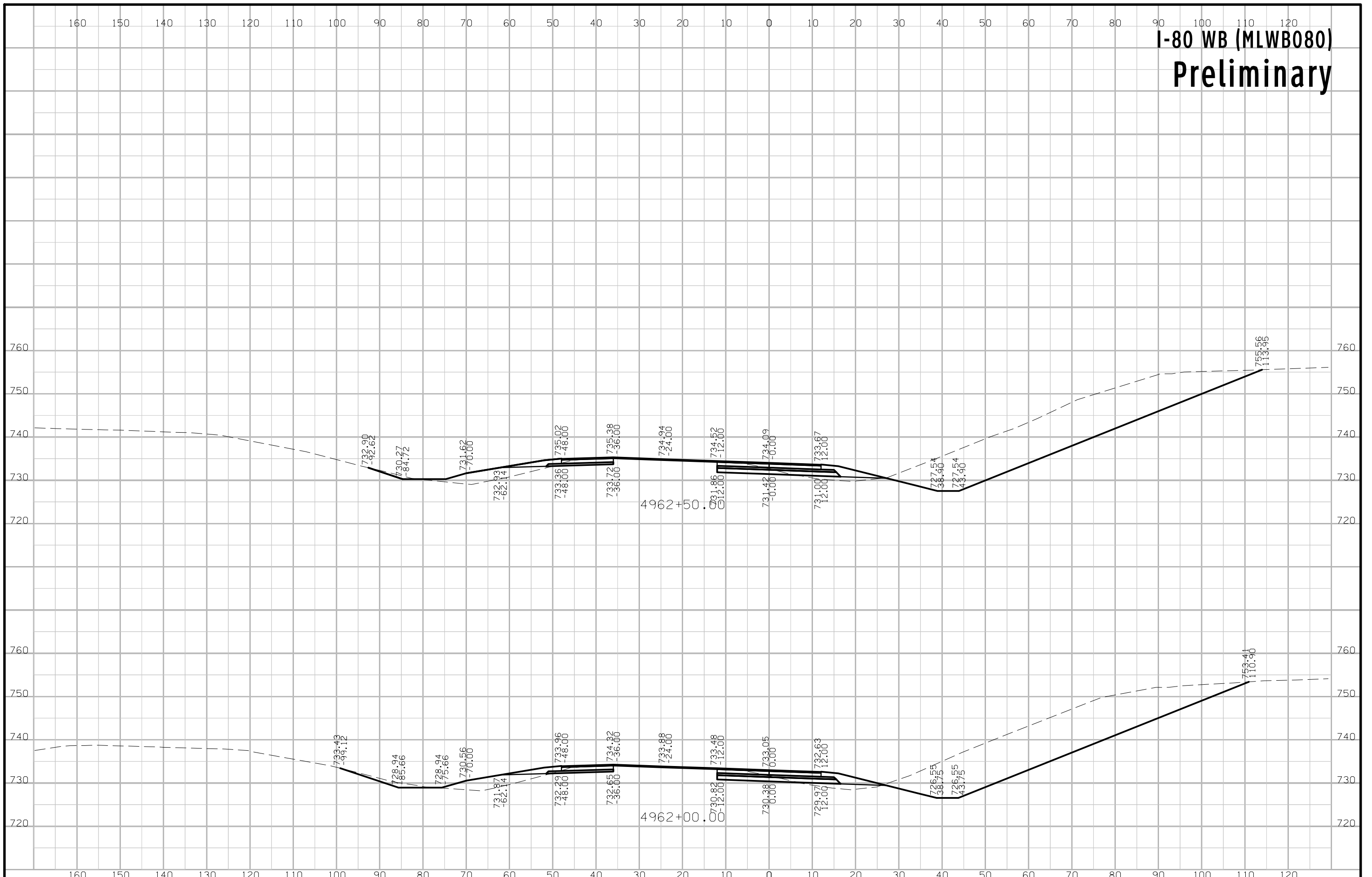

# I-80 WB (MLWB080) Preliminary

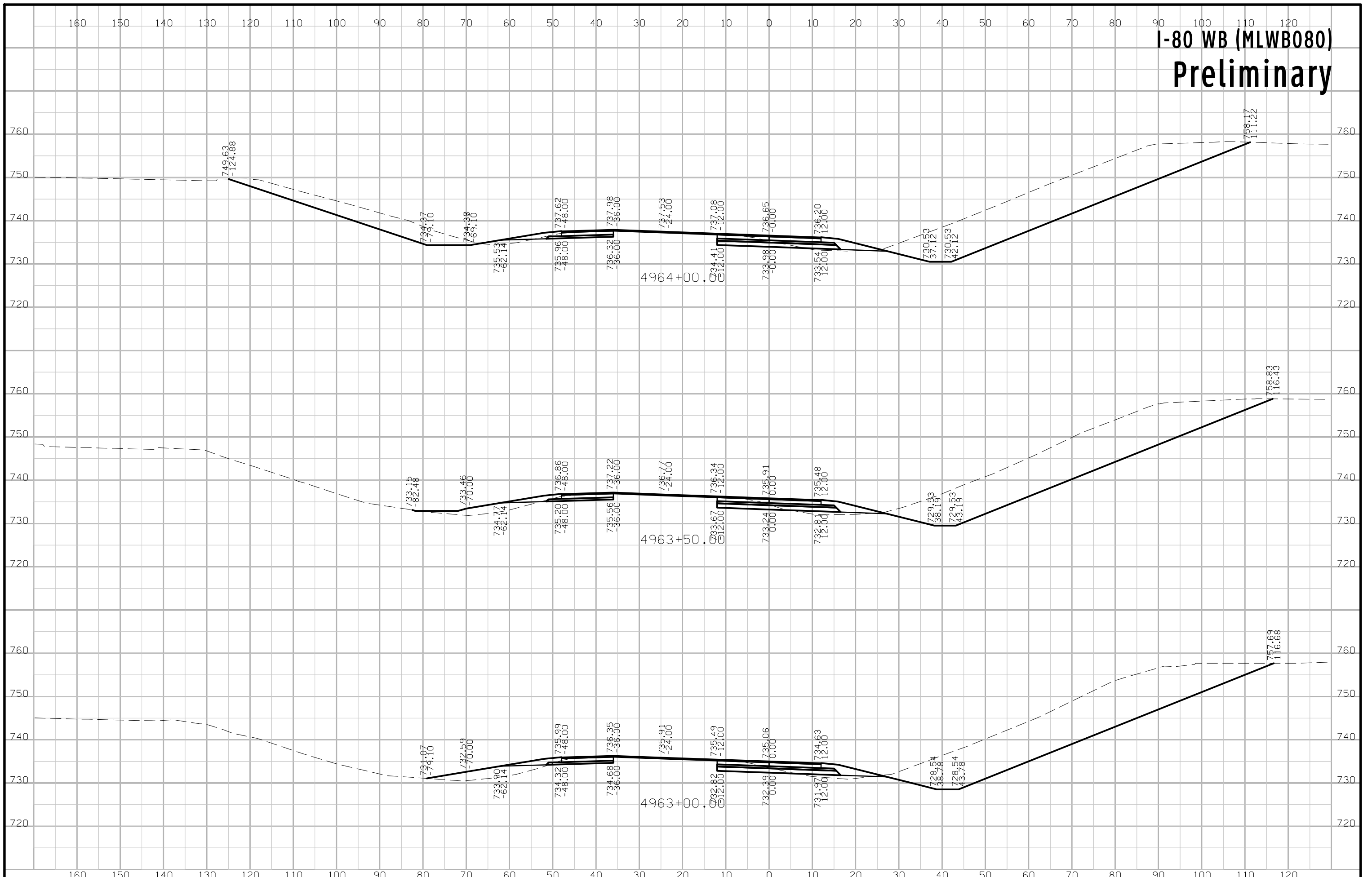

# I-80 WB (MLWB080) Preliminary

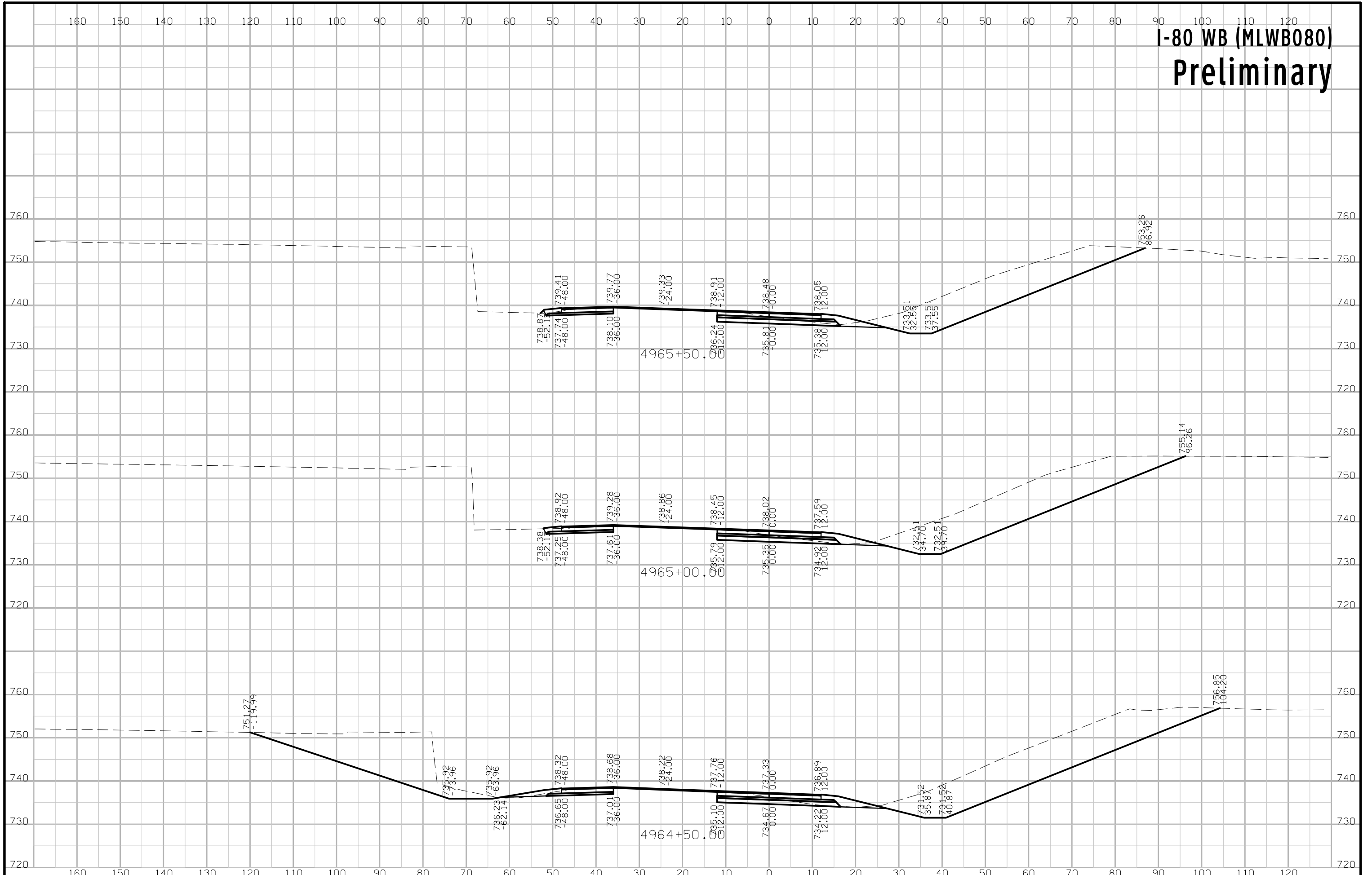

# I-80 WB (MLWB080) Preliminary

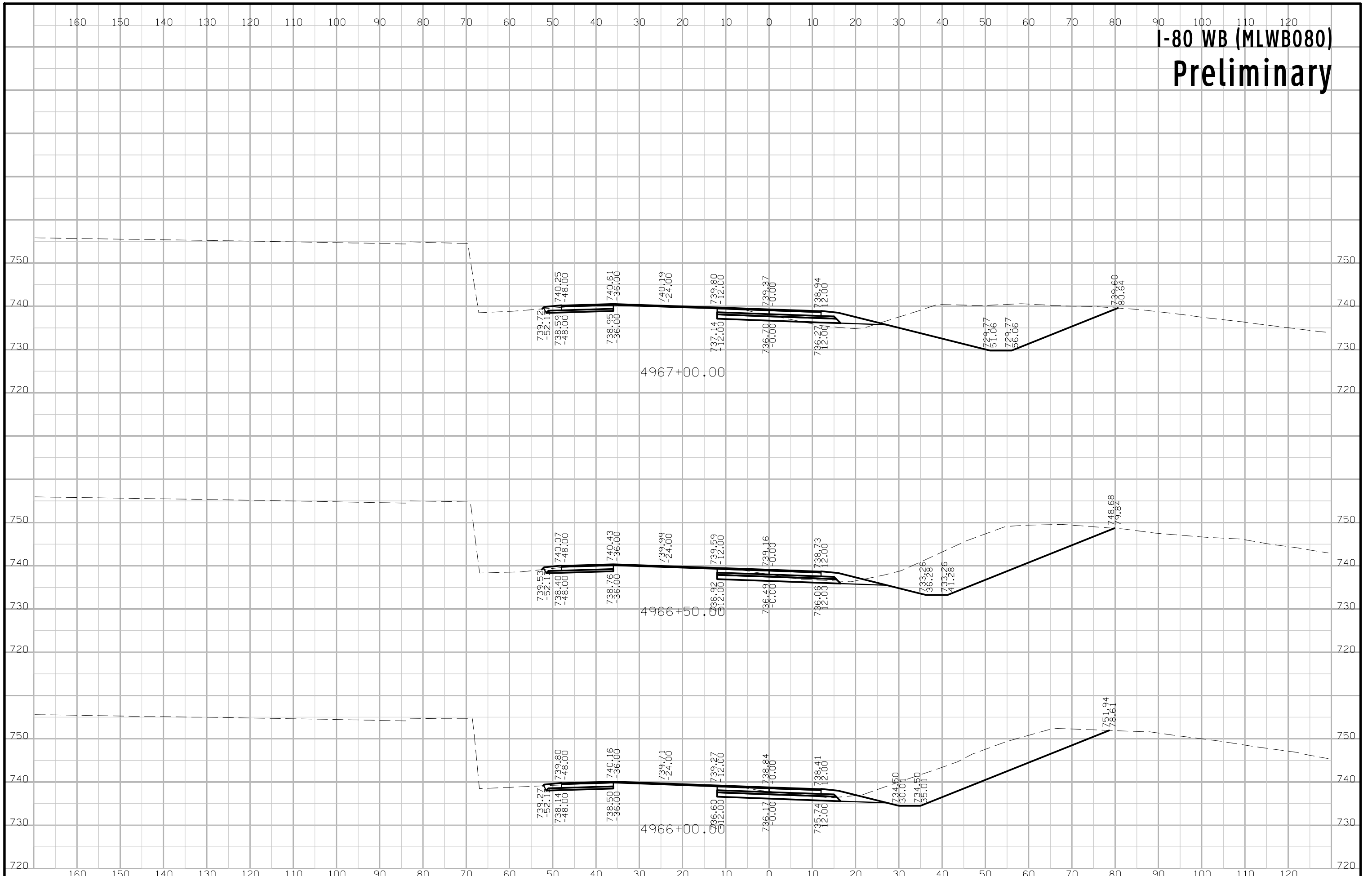



# I-80 WB (MLWB080) Preliminary

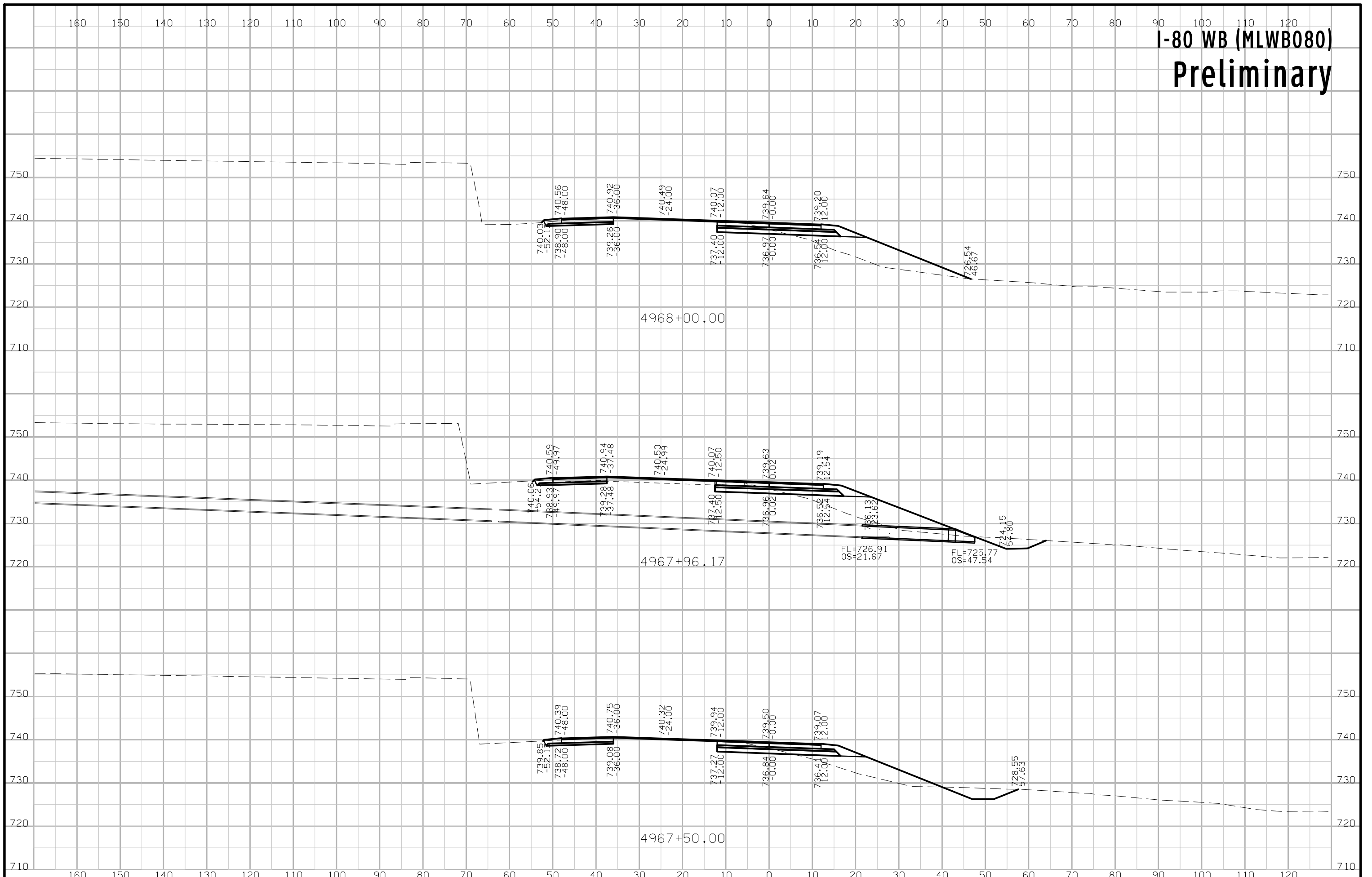

# I-80 WB (MLWB080) Preliminary

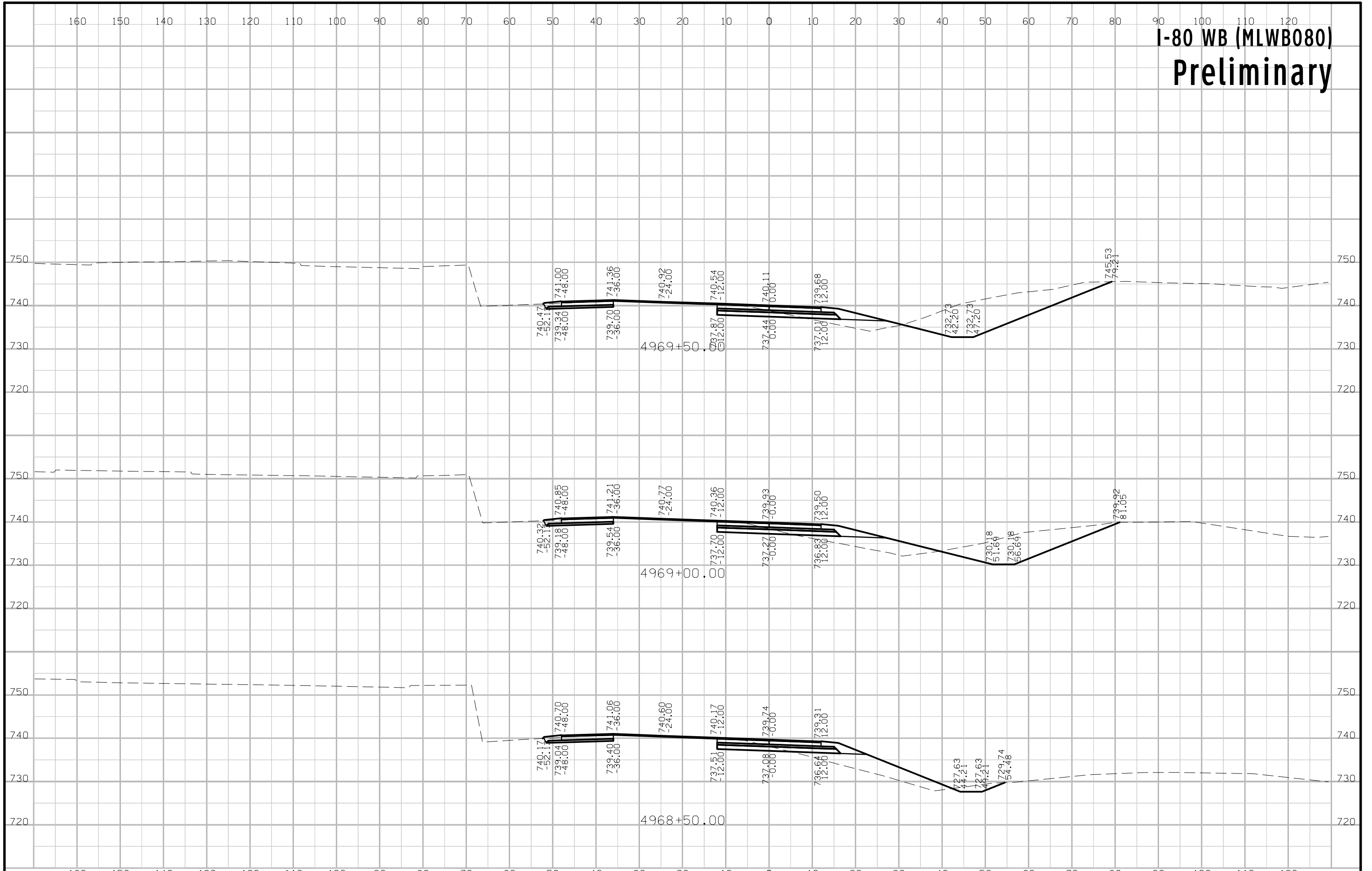

# I-80 WB (MLWB080) Preliminary

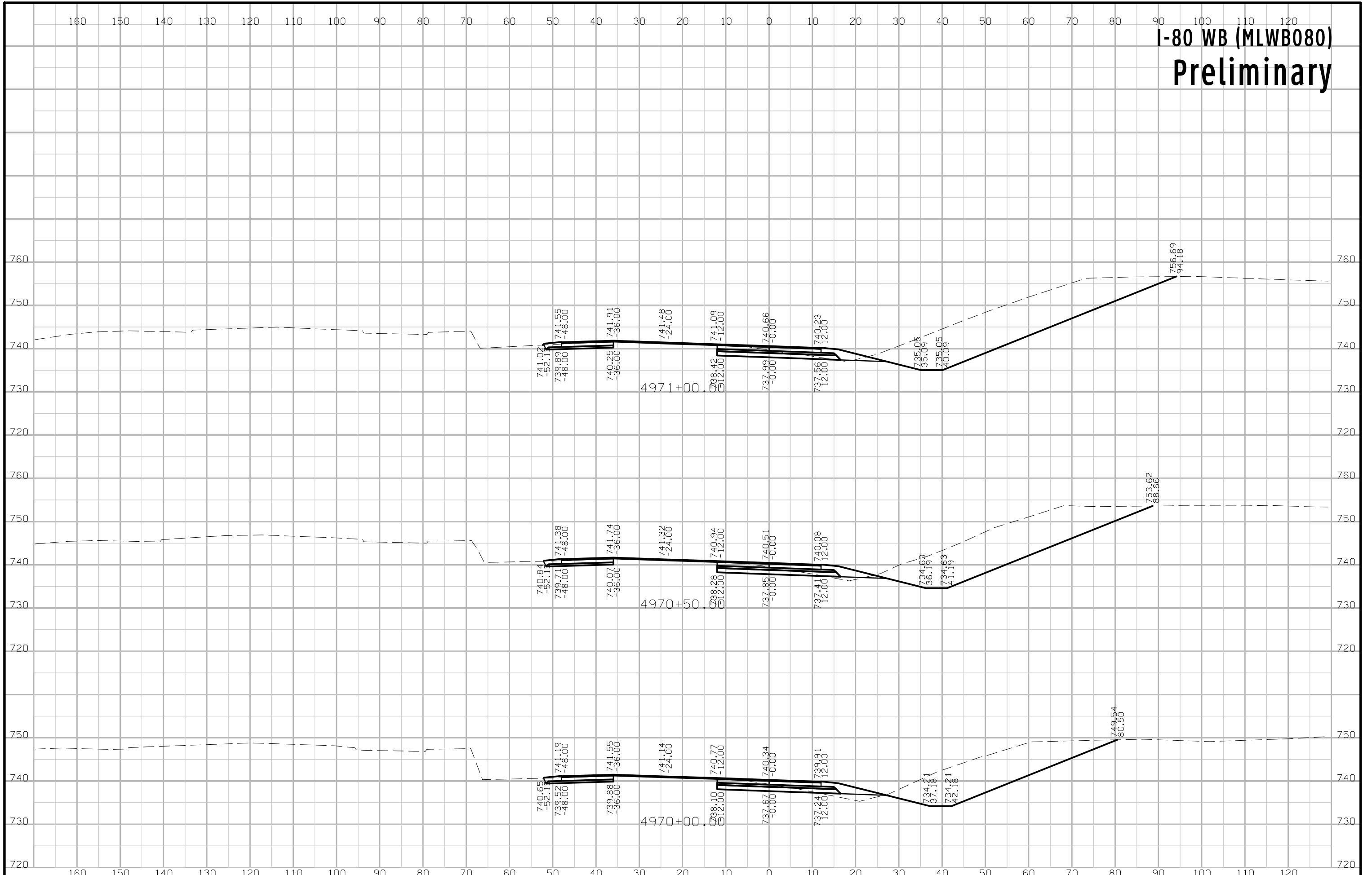

# I-80 WB (MLWB080) Preliminary

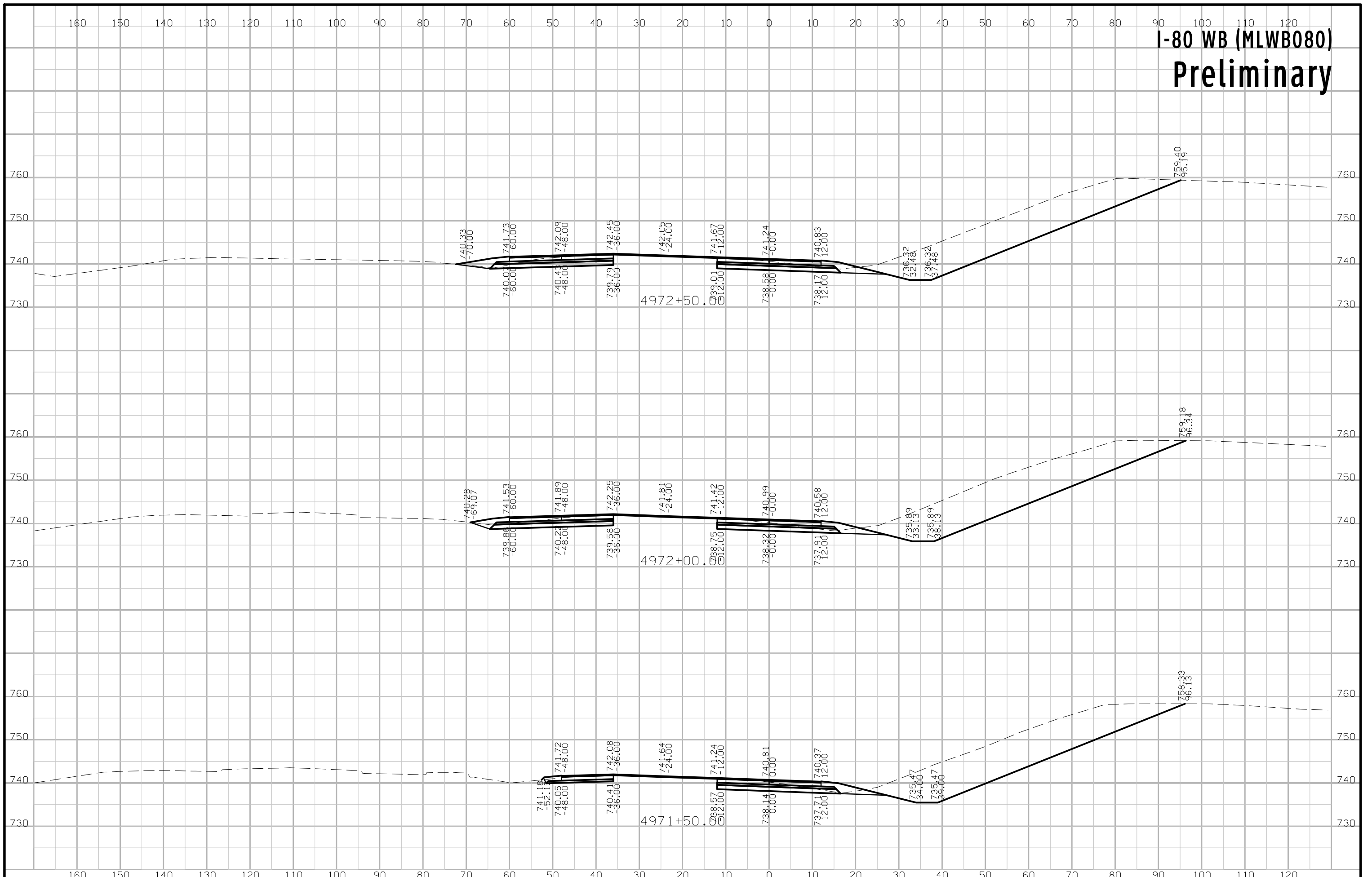

# I-80 WB (MLWB080) Preliminary

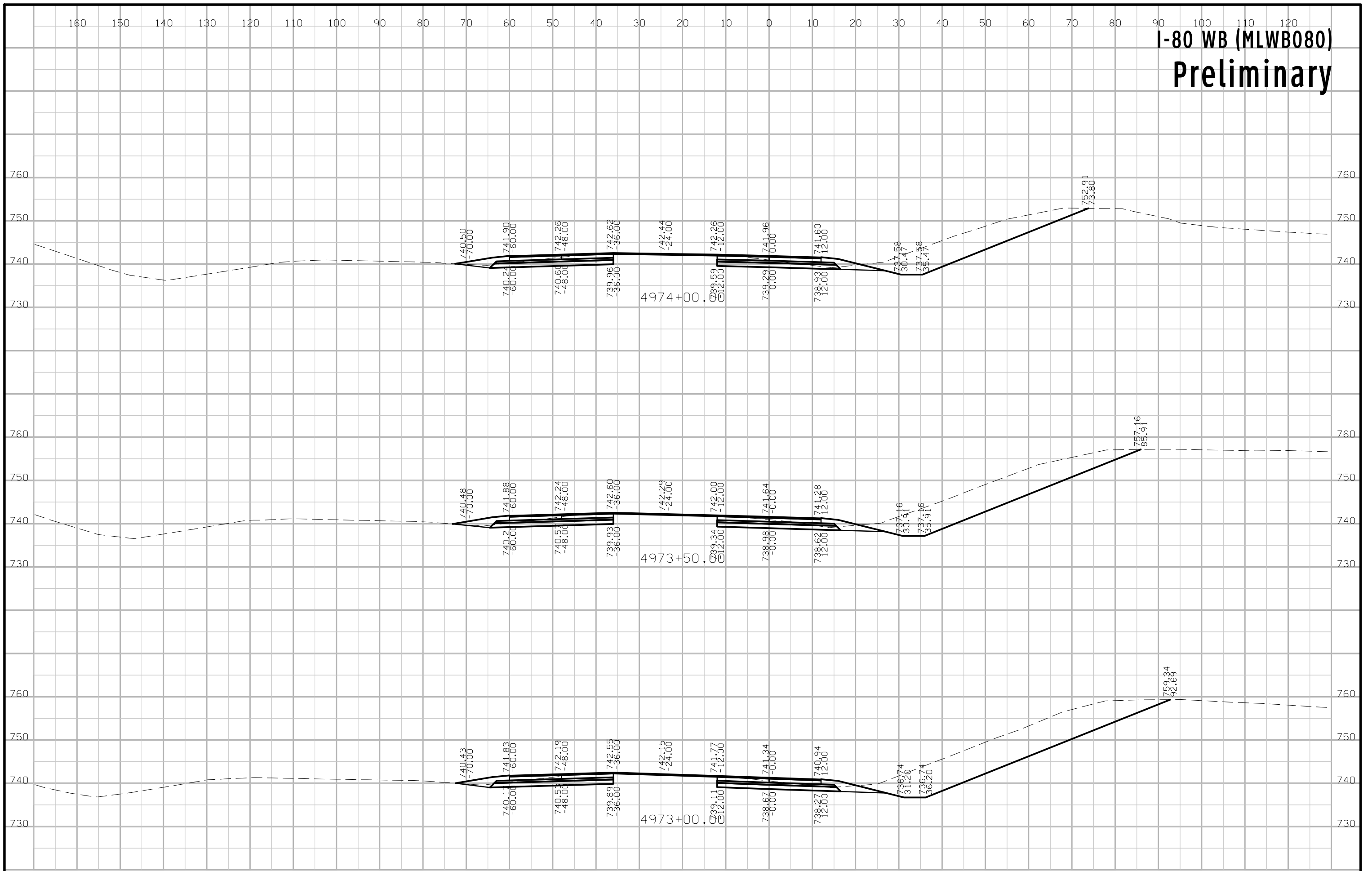



# I-80 WB (MLWB080) Preliminary

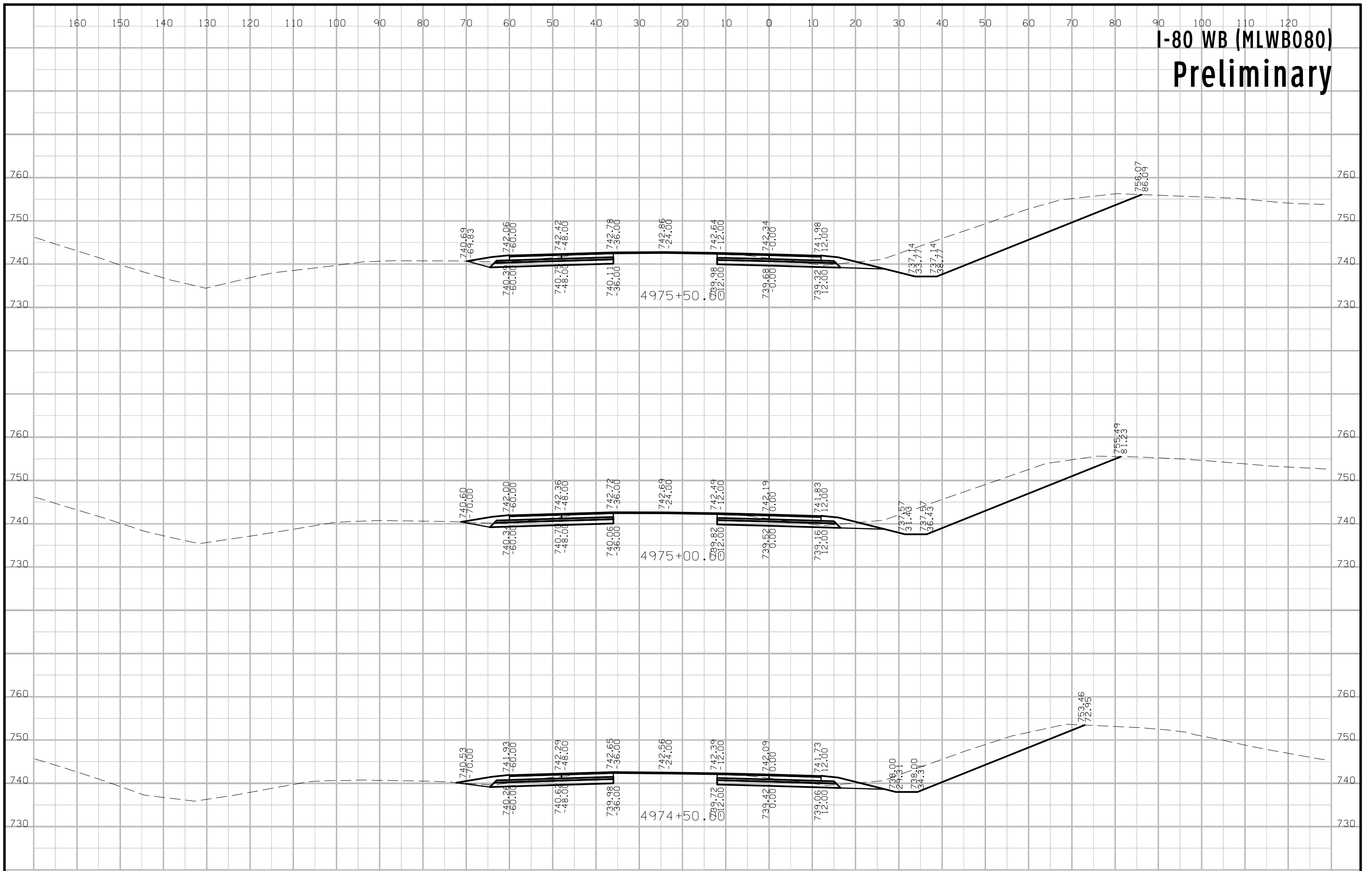

# I-80 WB (MLWB080) Preliminary

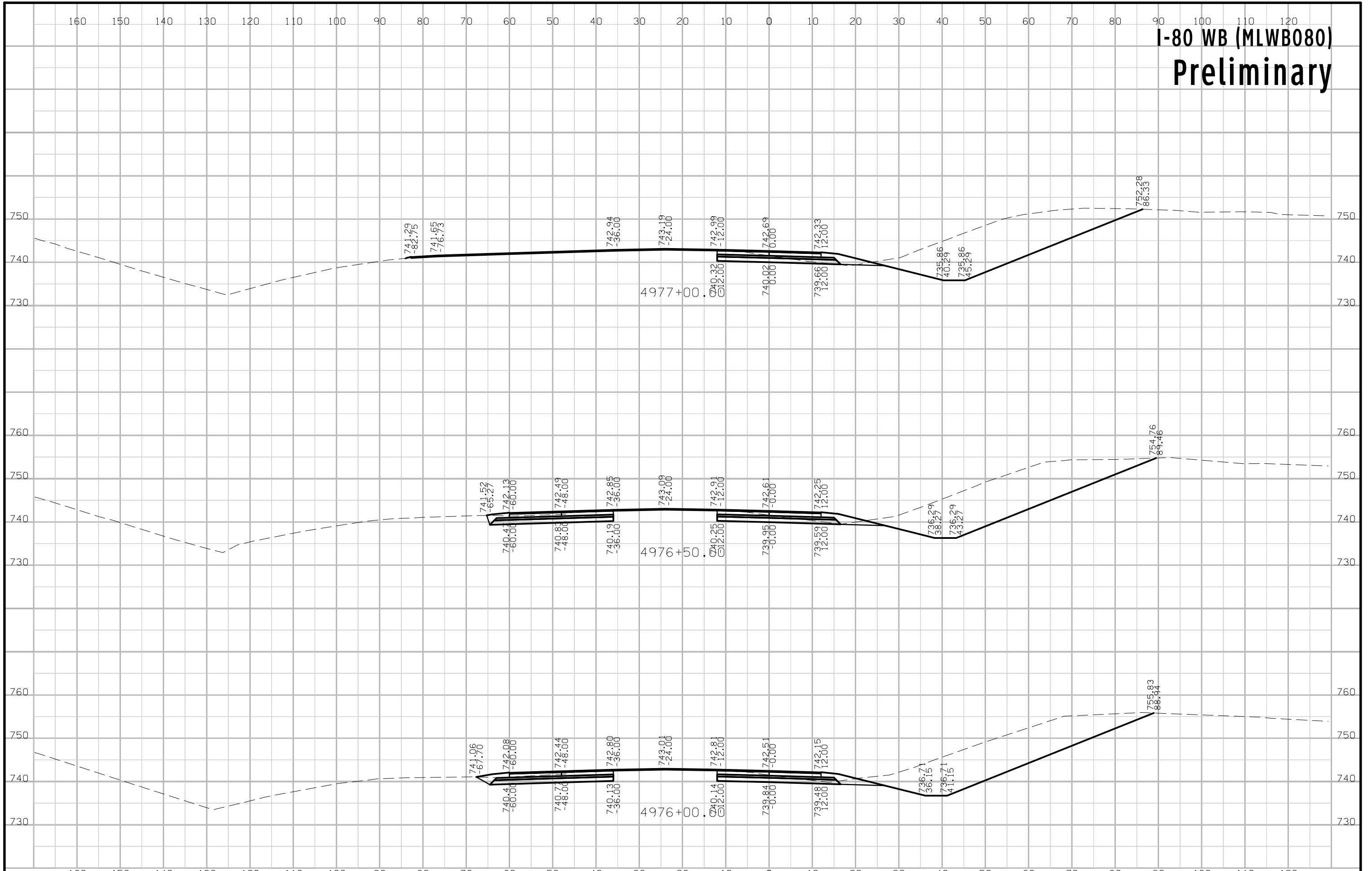

# I-80 WB (MLWB080) Preliminary

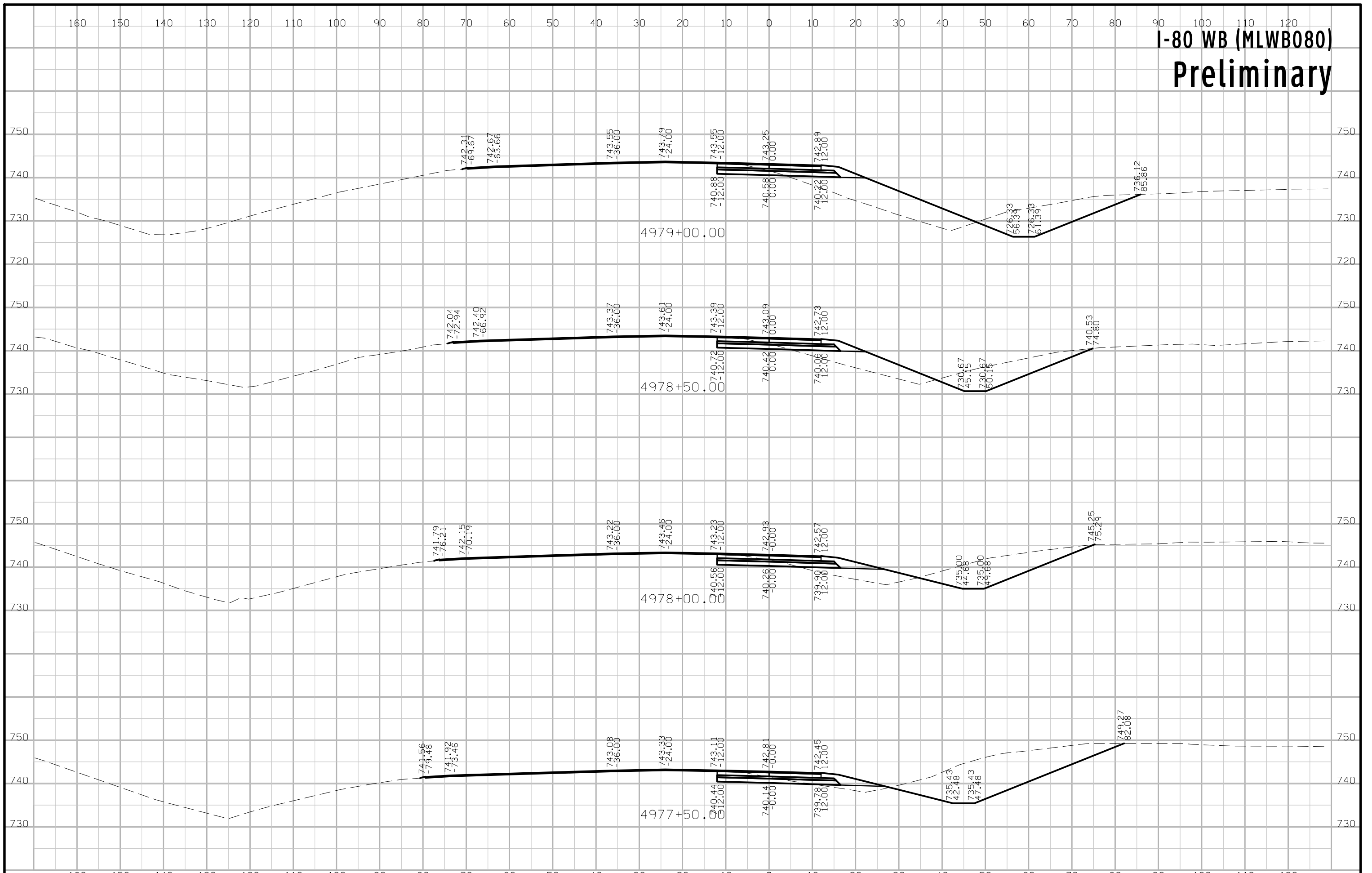

# I-80 WB (MLWB080) Preliminary

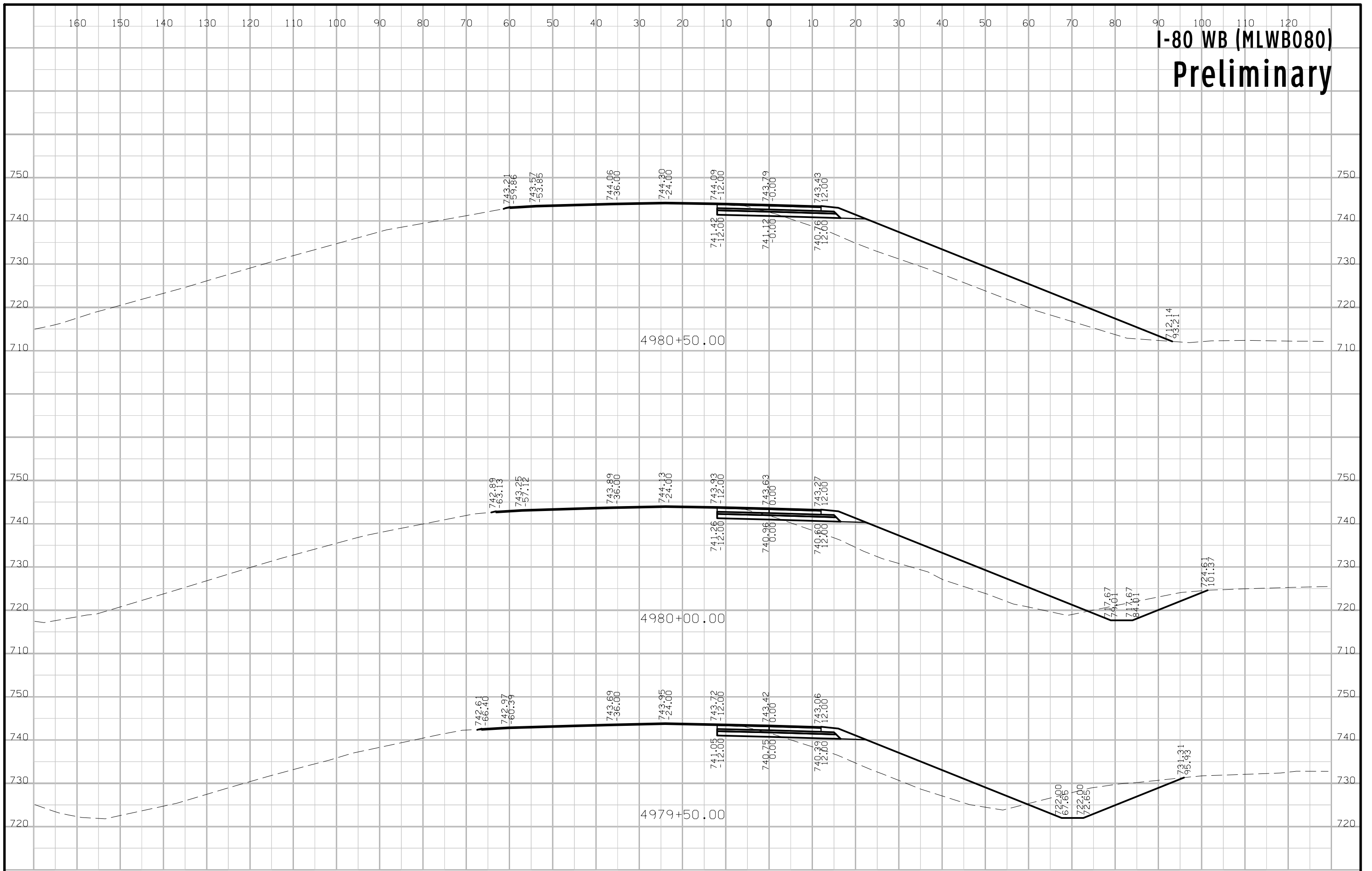

# I-80 WB (MLWB080) Preliminary

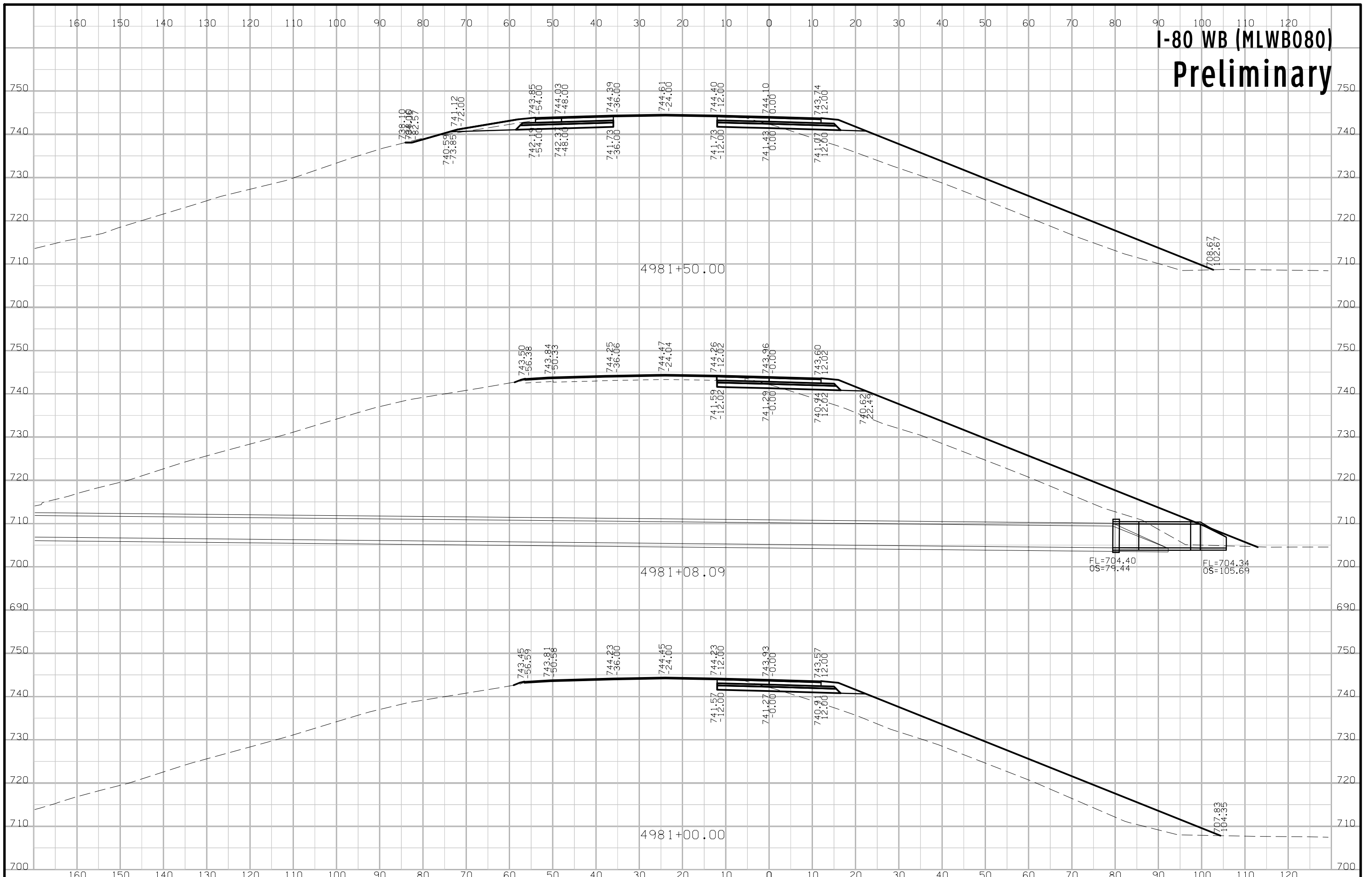



# I-80 WB (MLWB080) Preliminary

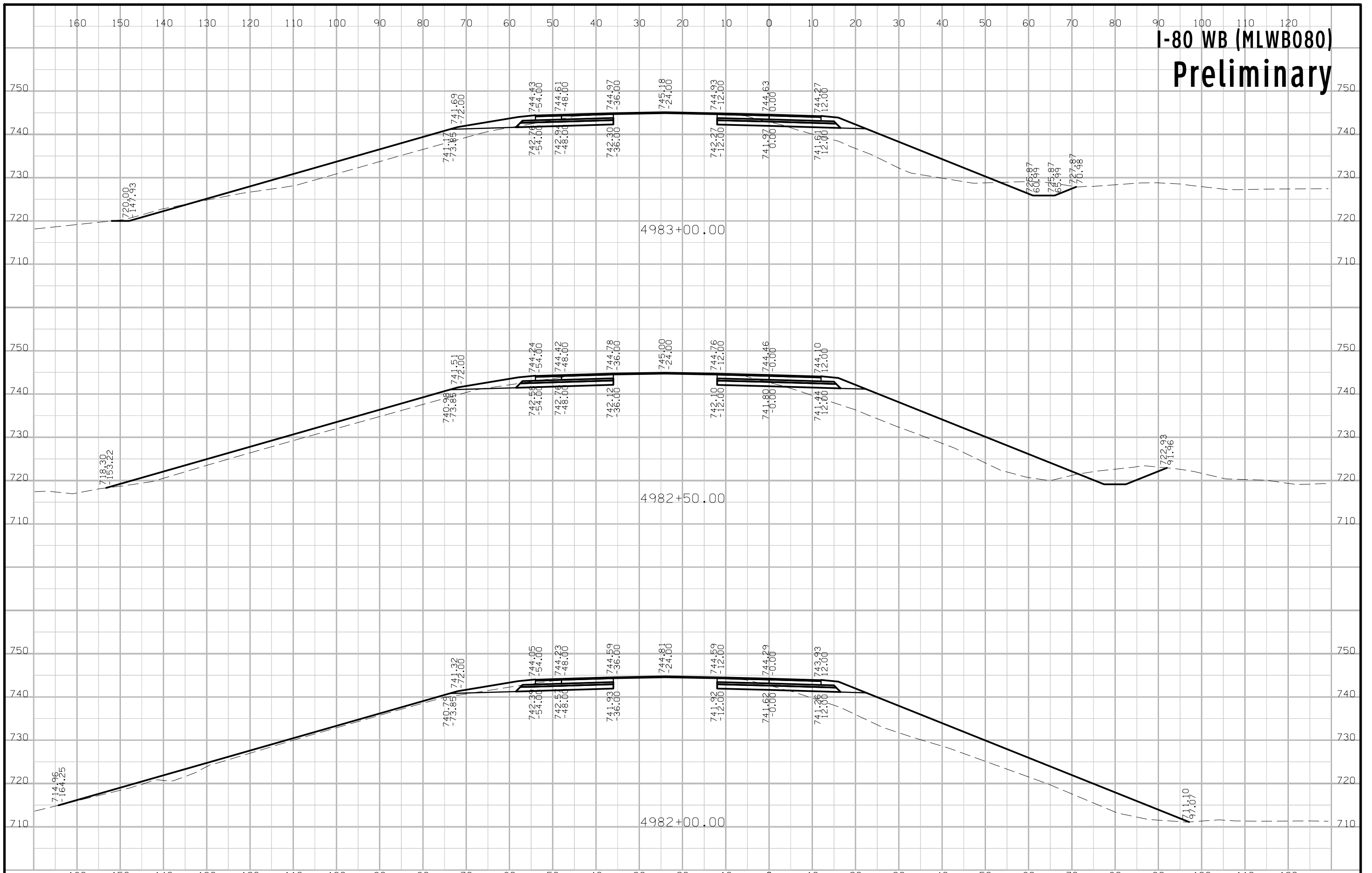

# I-80 WB (MLWB080) Preliminary

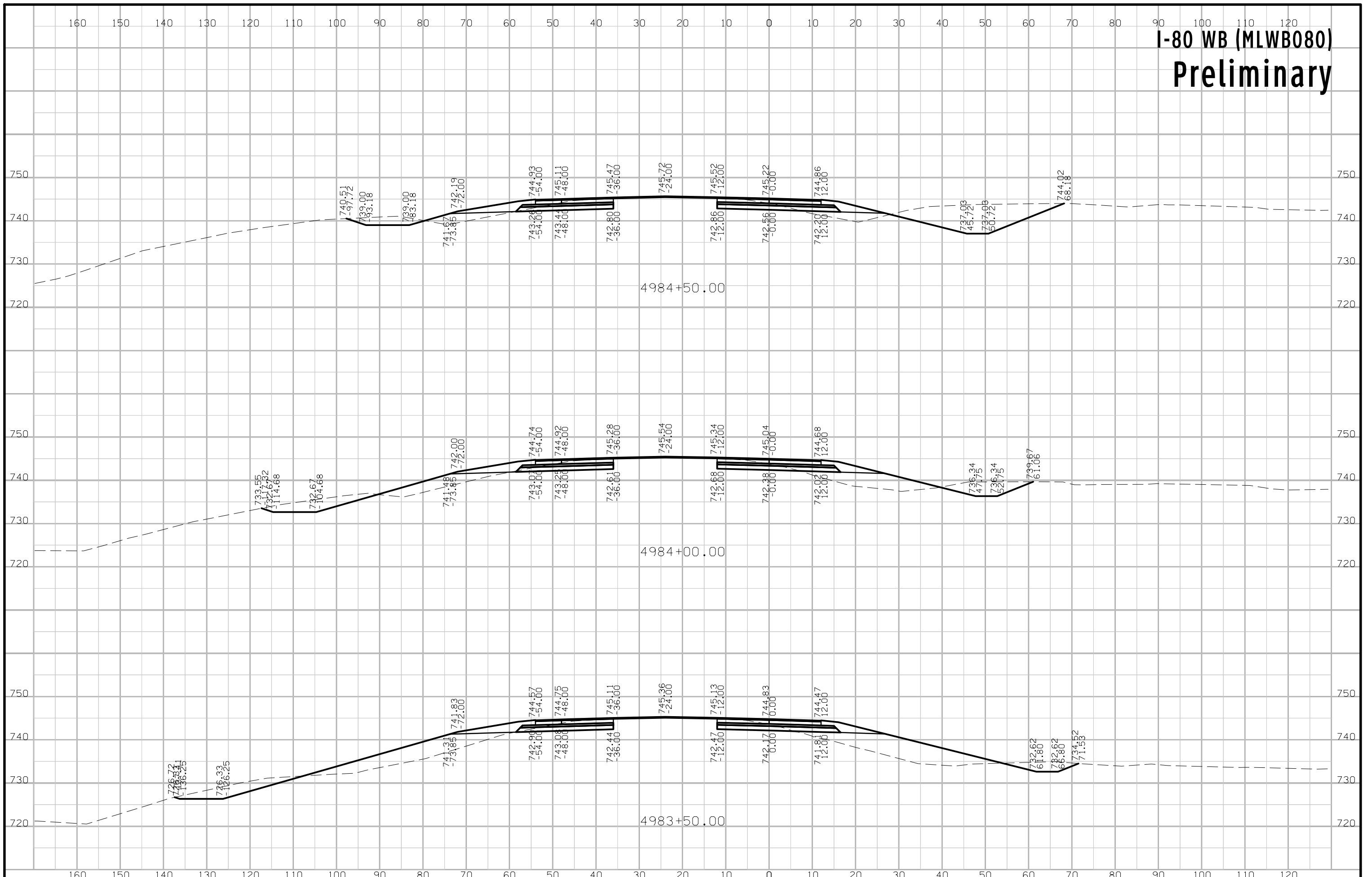

# I-80 WB (MLWB080) Preliminary

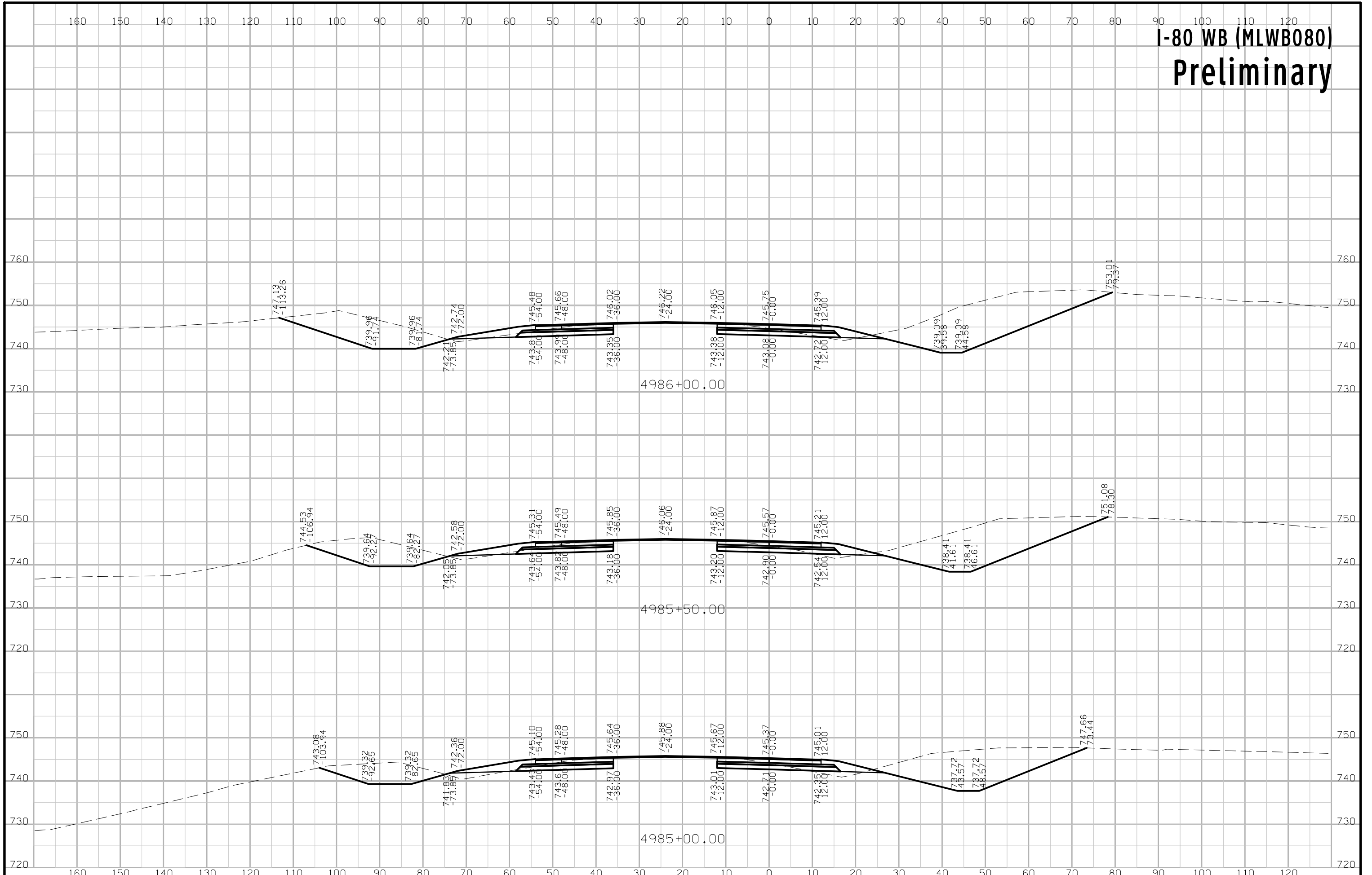

# I-80 WB (MLWB080) Preliminary

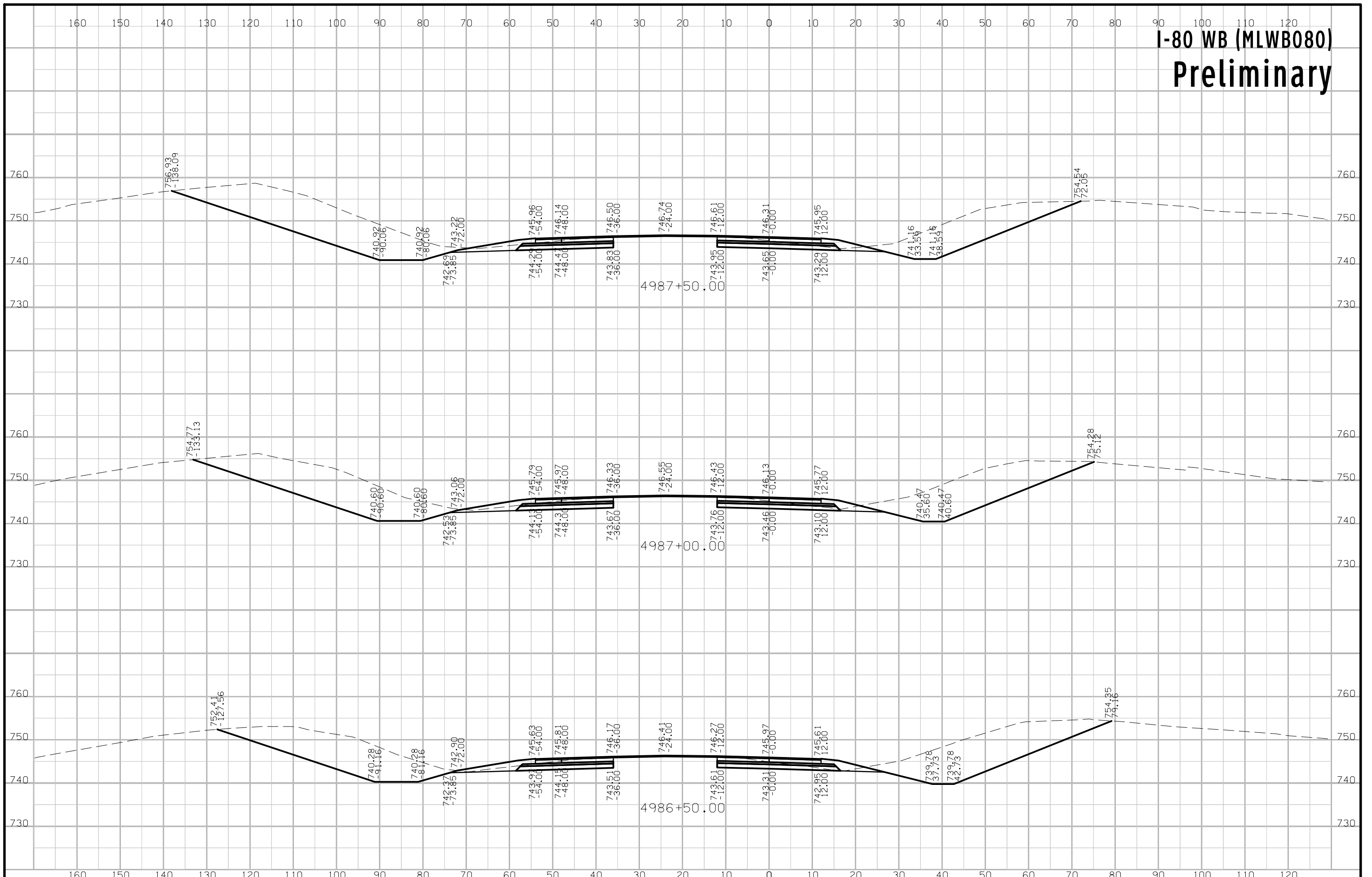

# I-80 WB (MLWB080) Preliminary

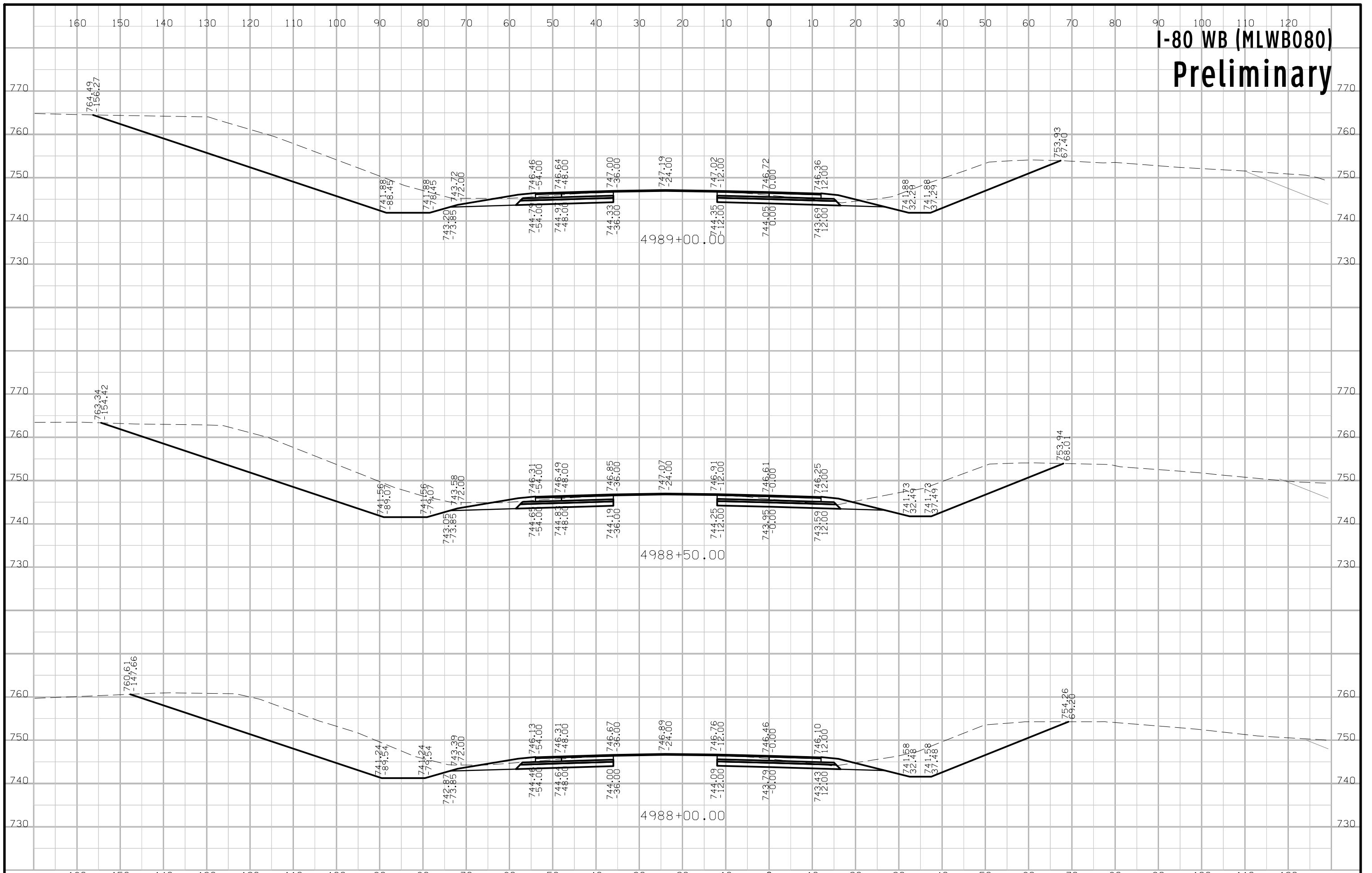



# I-80 WB (MLWB080) Preliminary

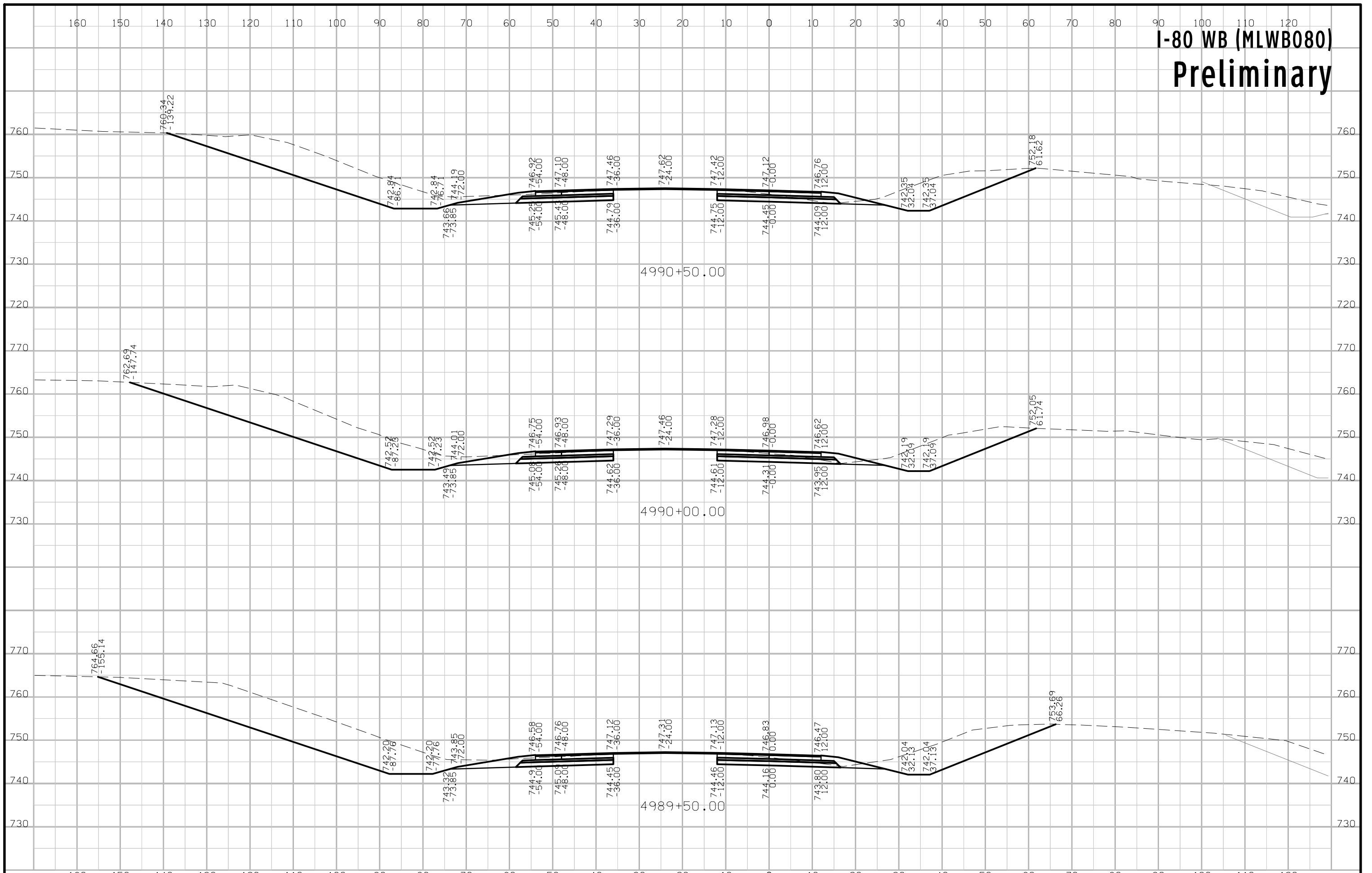

# I-80 WB (MLWB080) Preliminary

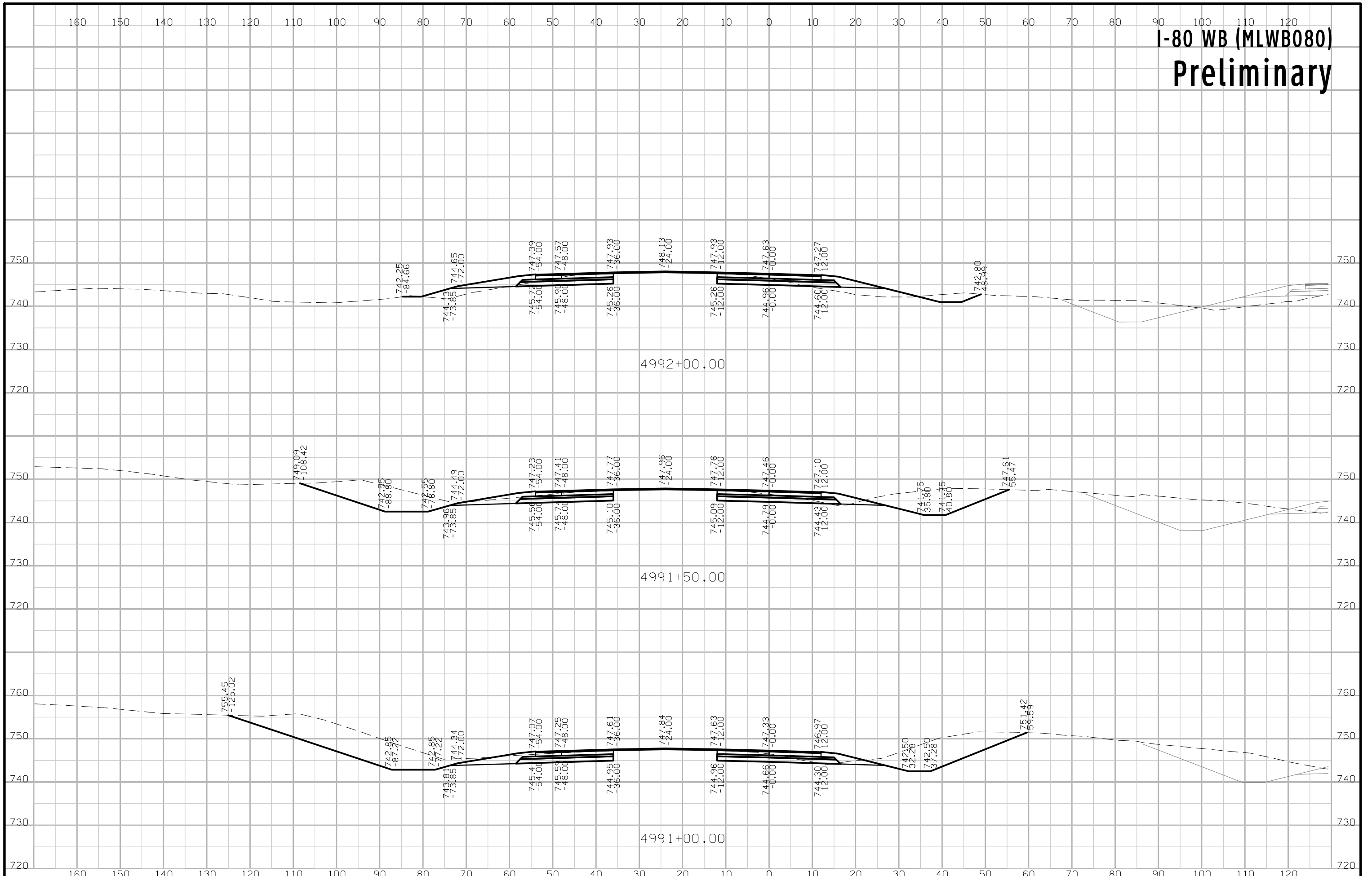

# I-80 WB (MLWB080) Preliminary

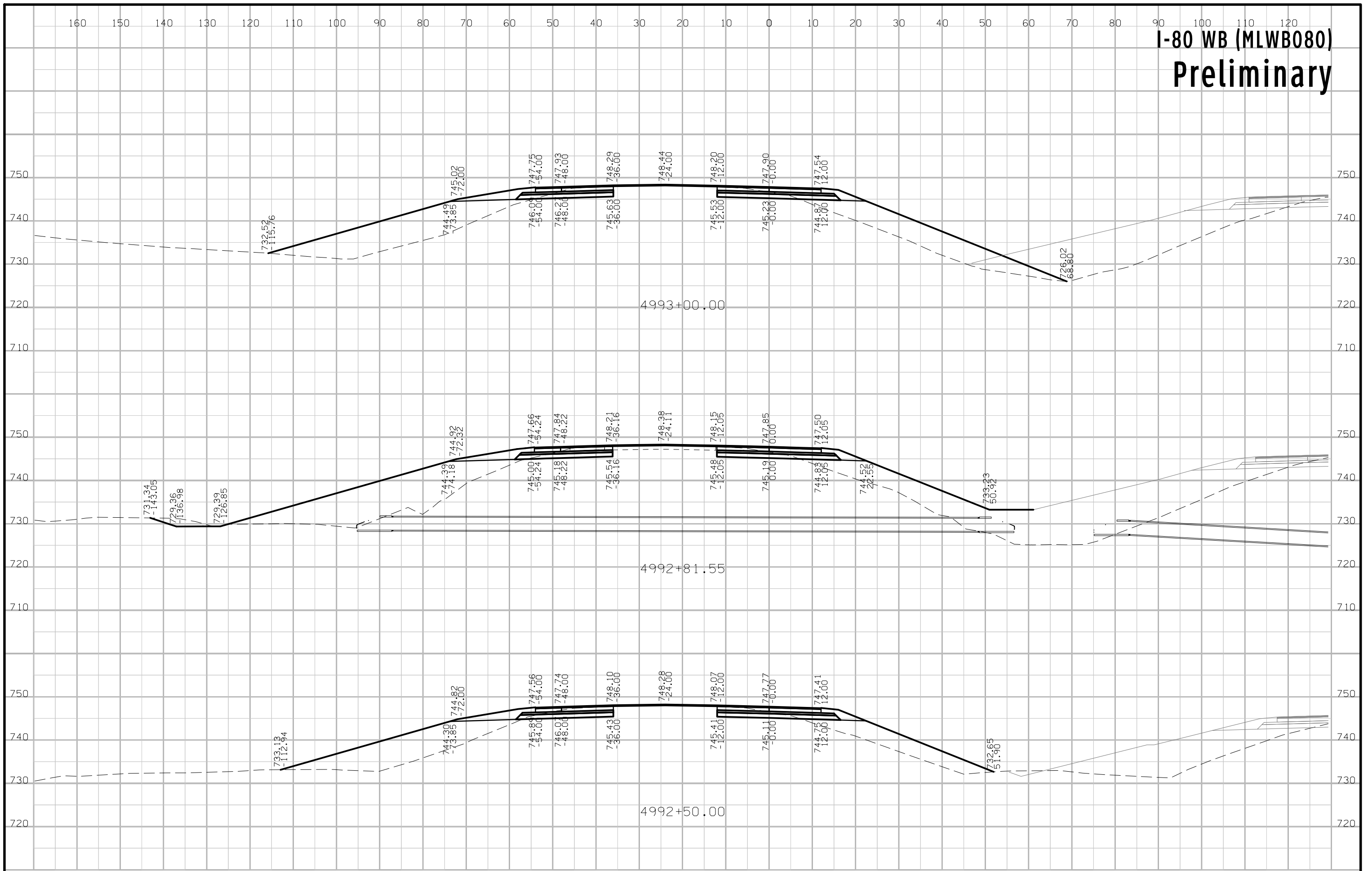

# I-80 WB (MLWB080) Preliminary

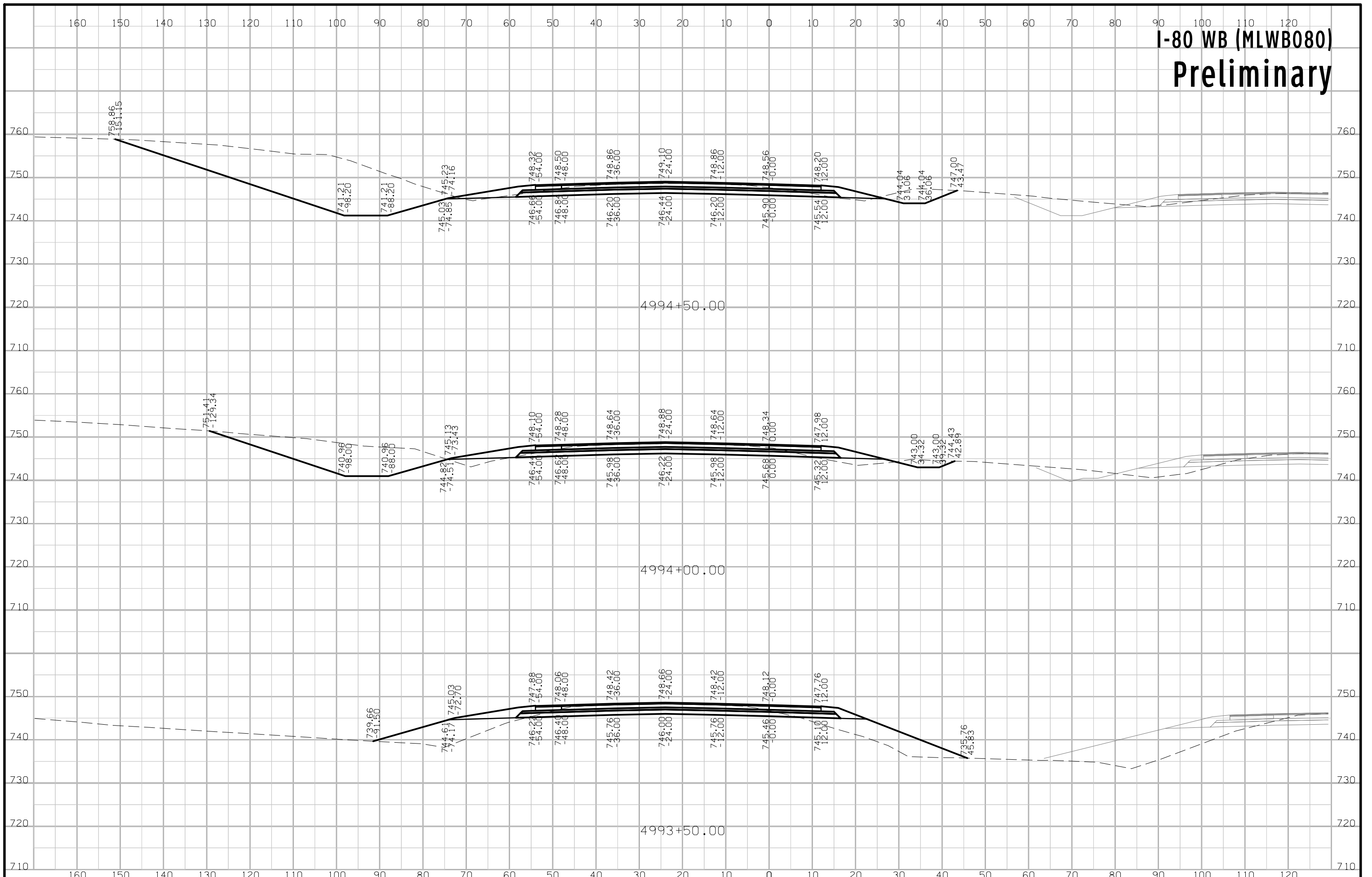

# I-80 WB (MLWB080) Preliminary

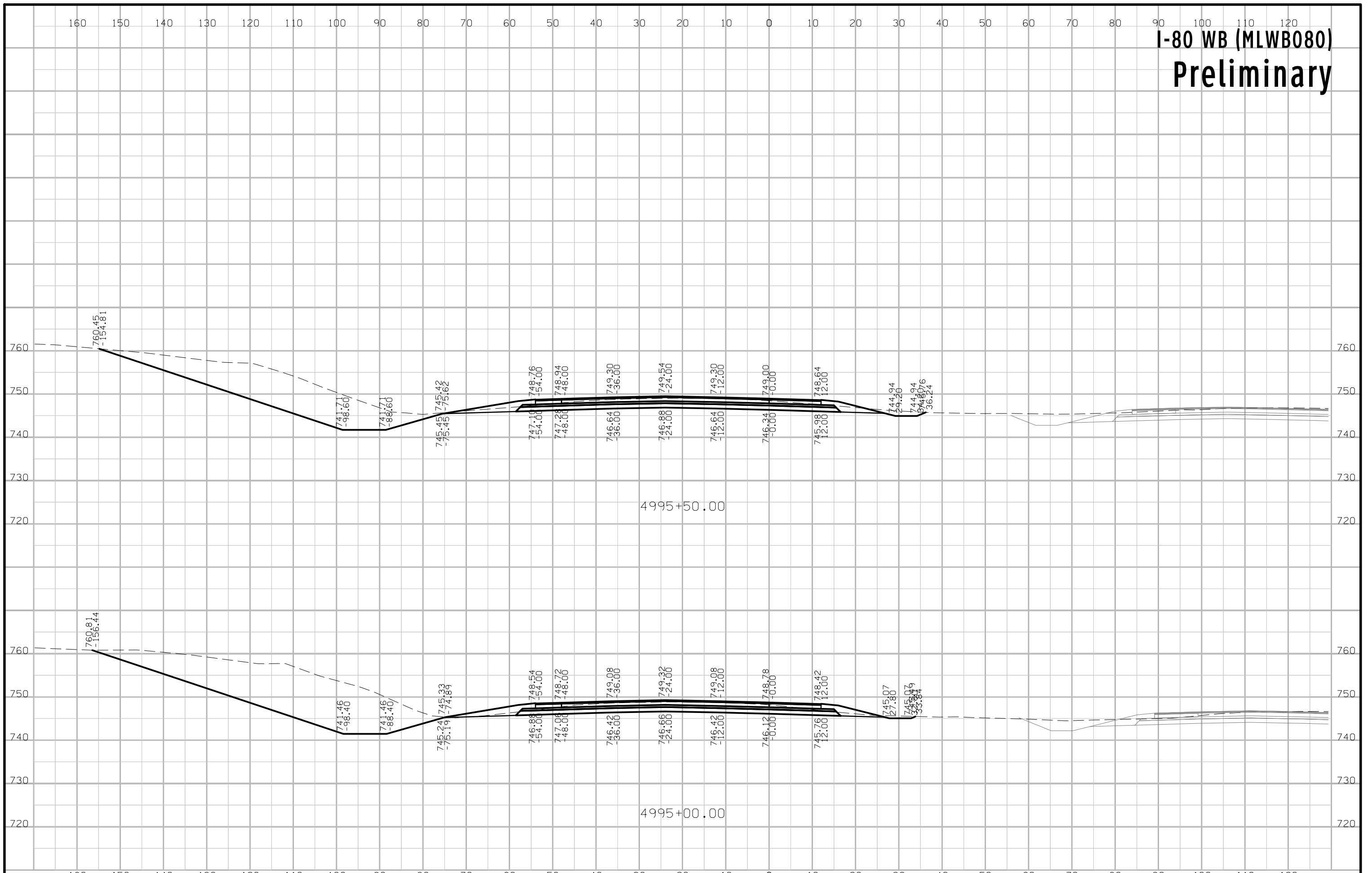



# I-80 WB (MLWB080) Preliminary

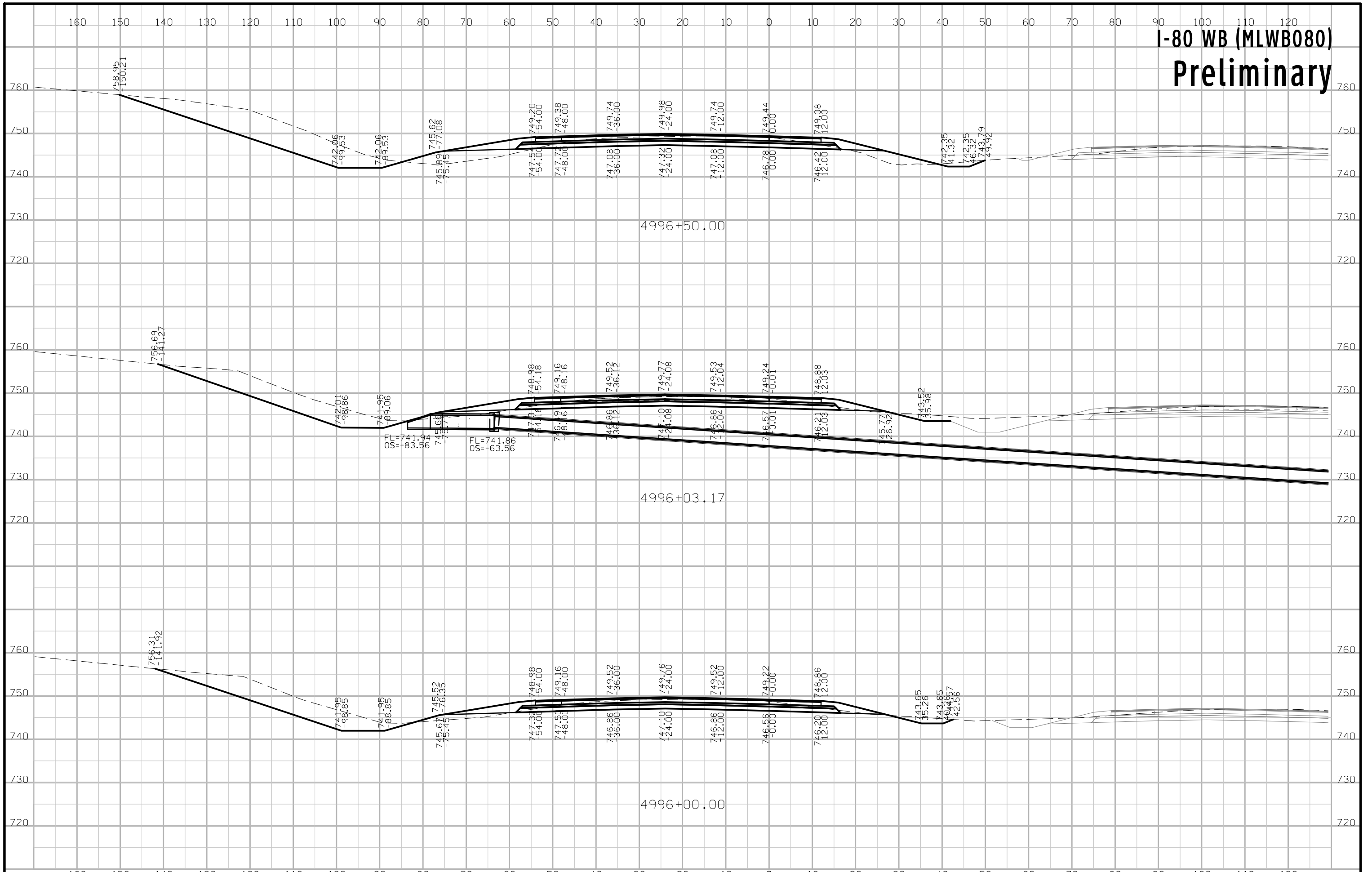

# I-80 WB (MLWB080) Preliminary

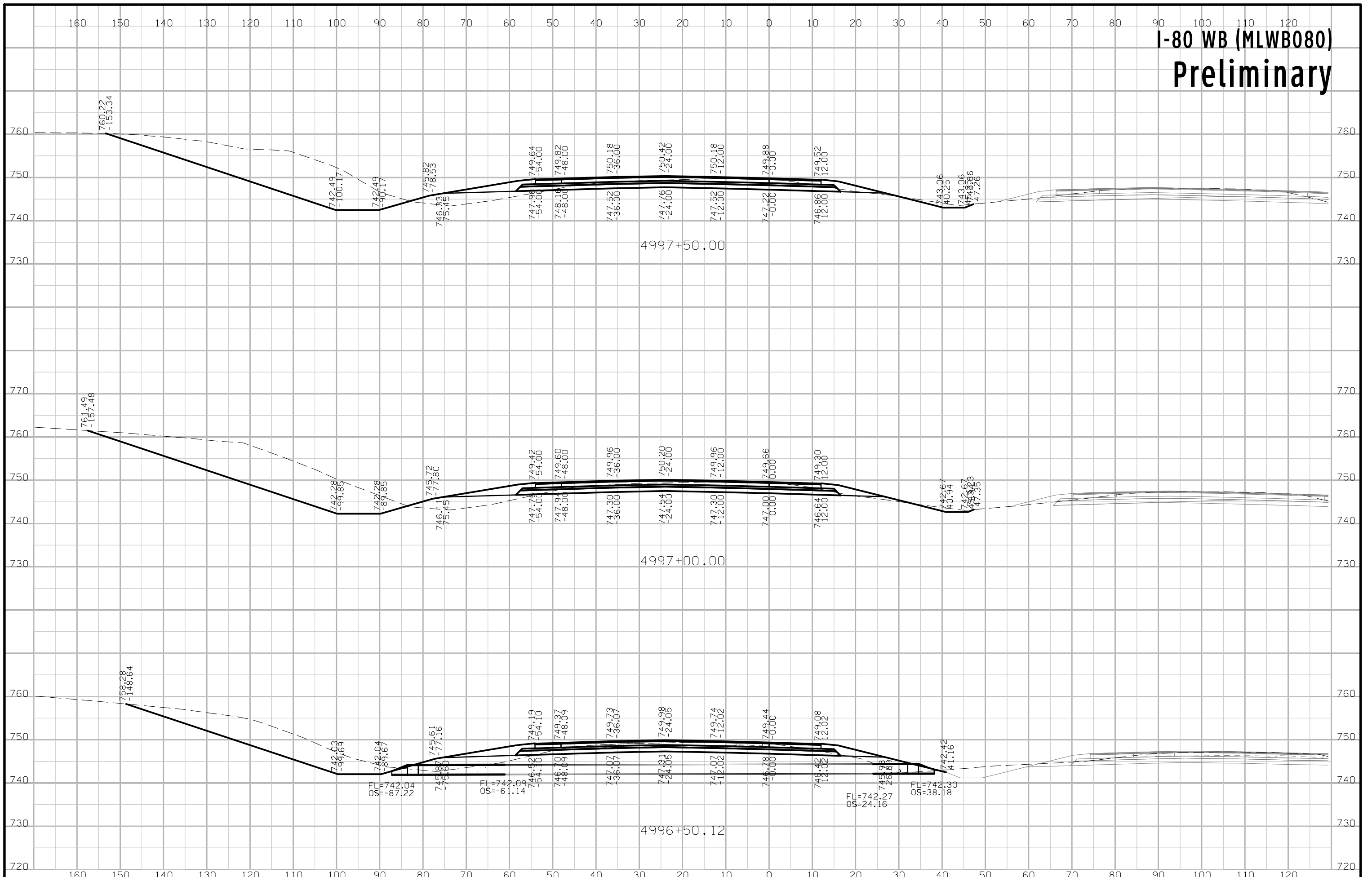

# I-80 WB (MLWB080) Preliminary

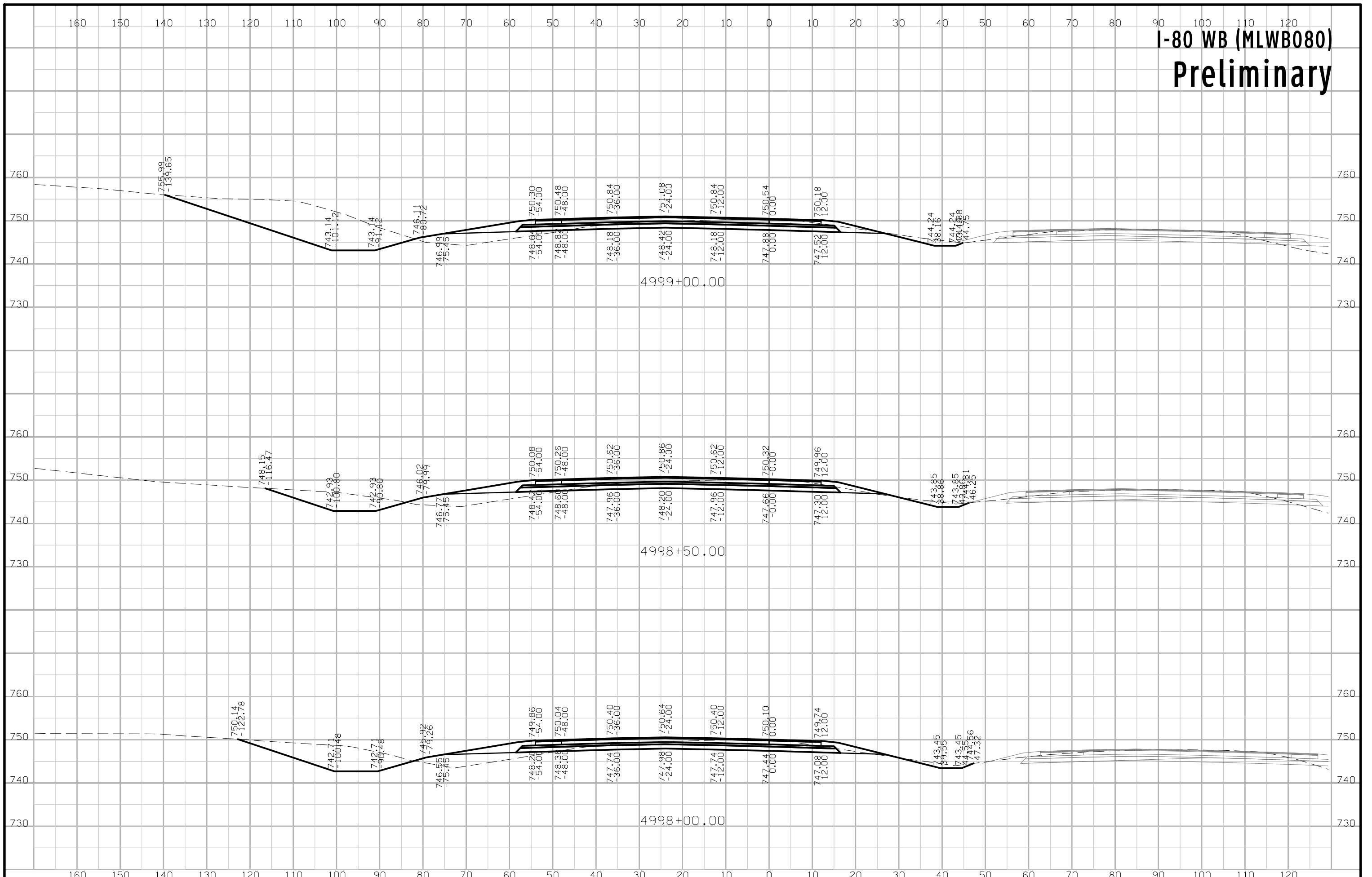

# I-80 WB (MLWB080) Preliminary

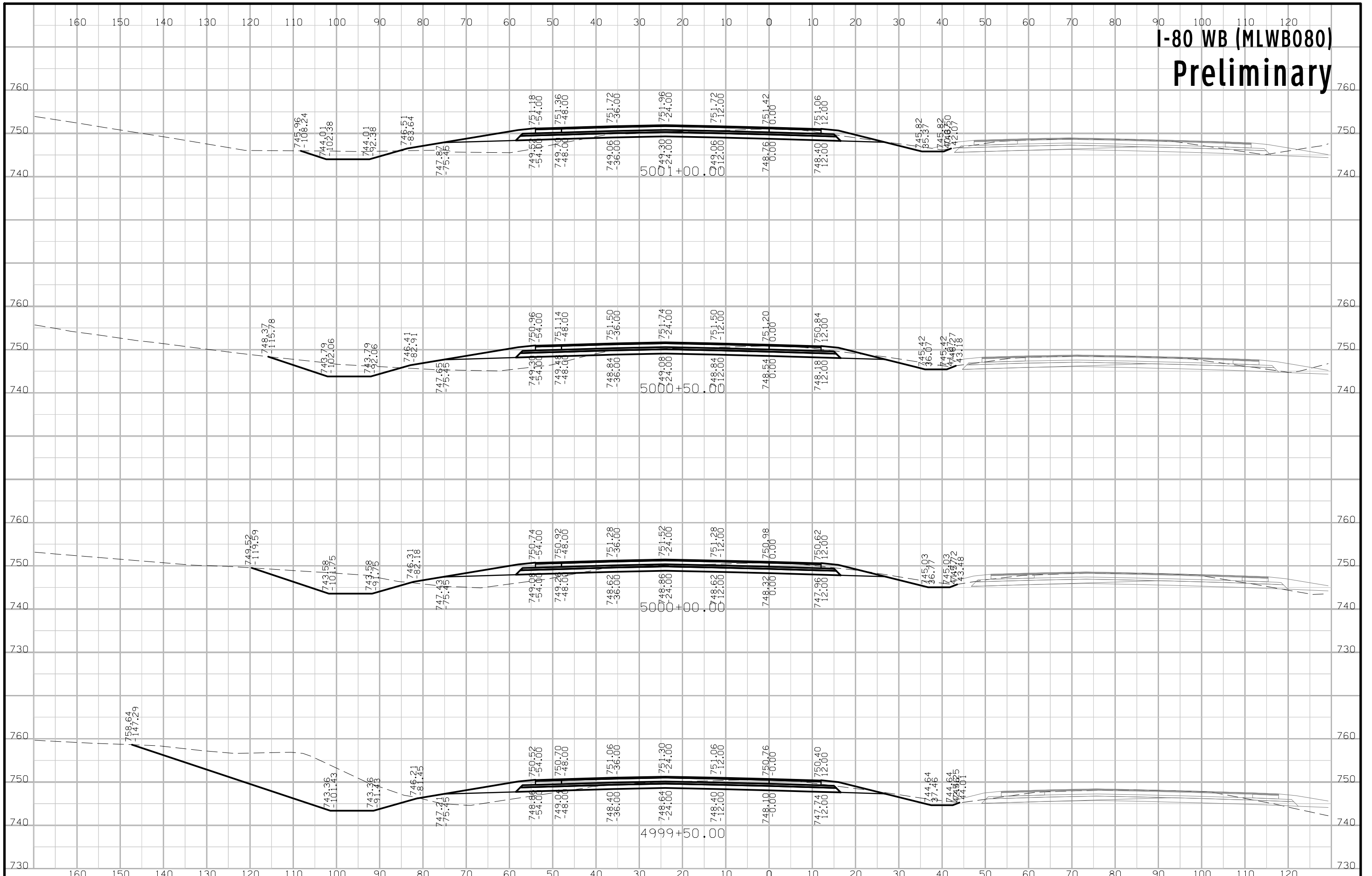

# I-80 WB (MLWB080) Preliminary

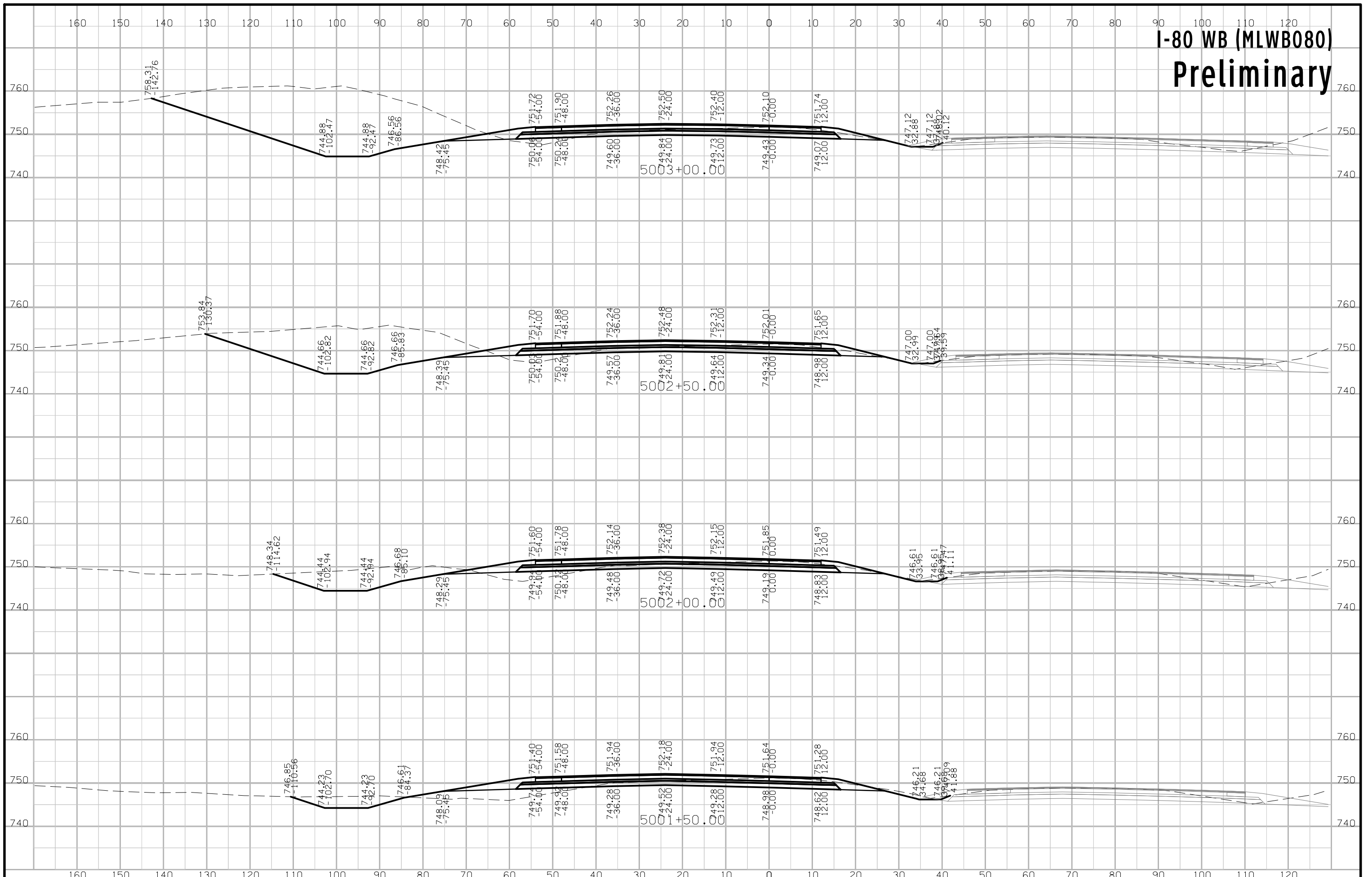



# I-80 WB (MLWB080) Preliminary

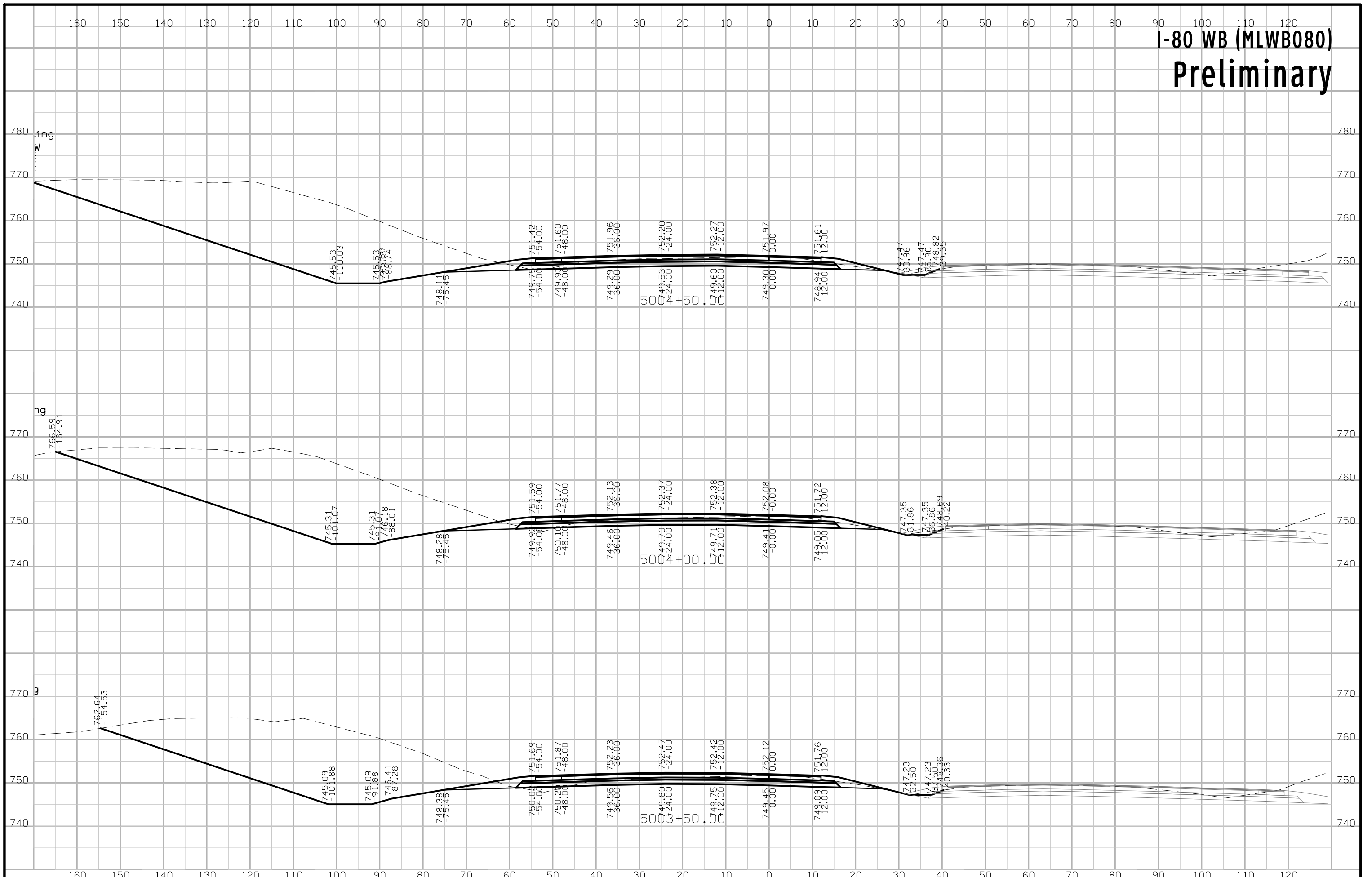

# I-80 WB (MLWB080) Preliminary

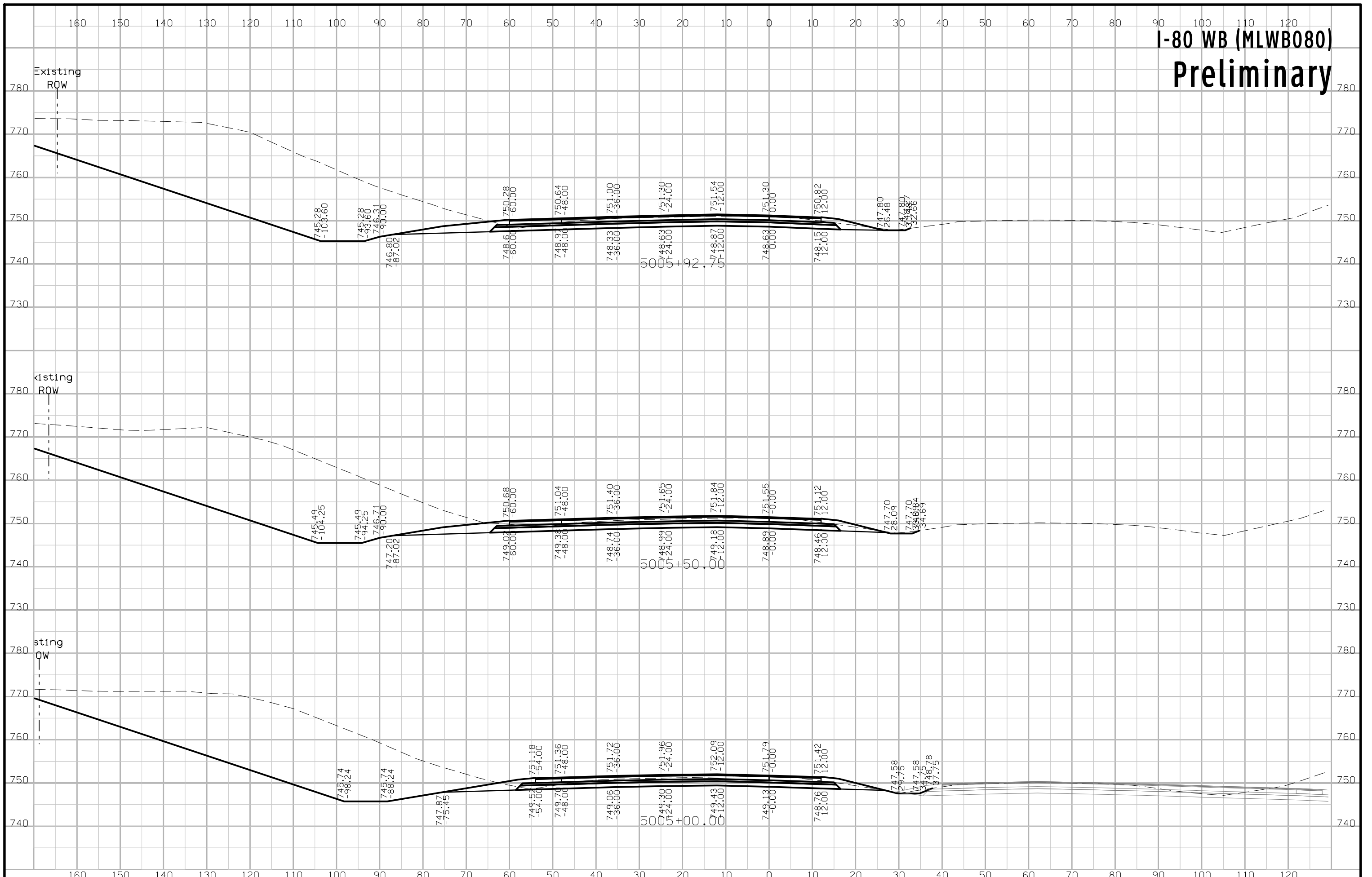

# I-80 WB (SURMLA080) Preliminary

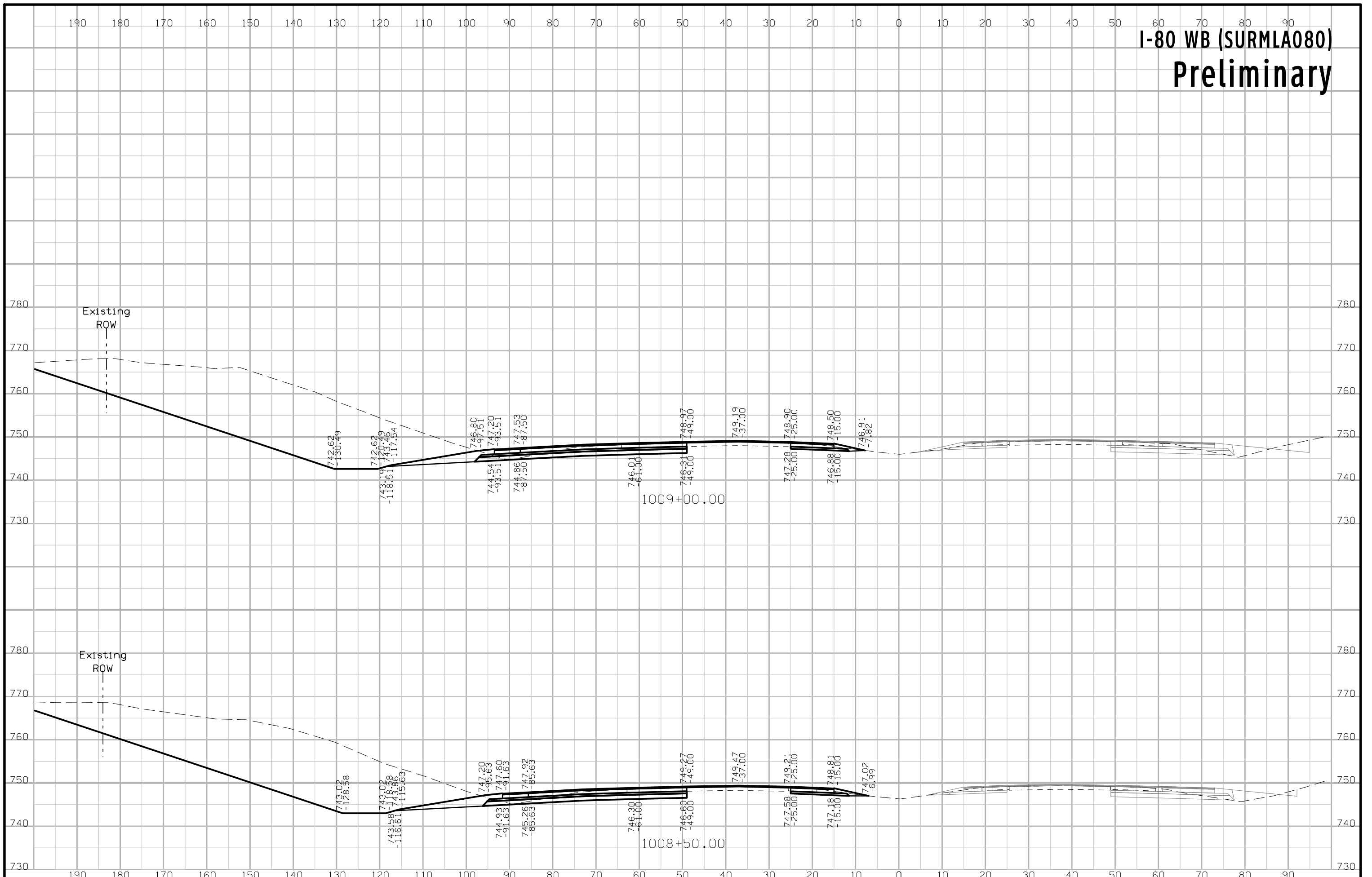

# I-80 WB (SURMLA080) Preliminary

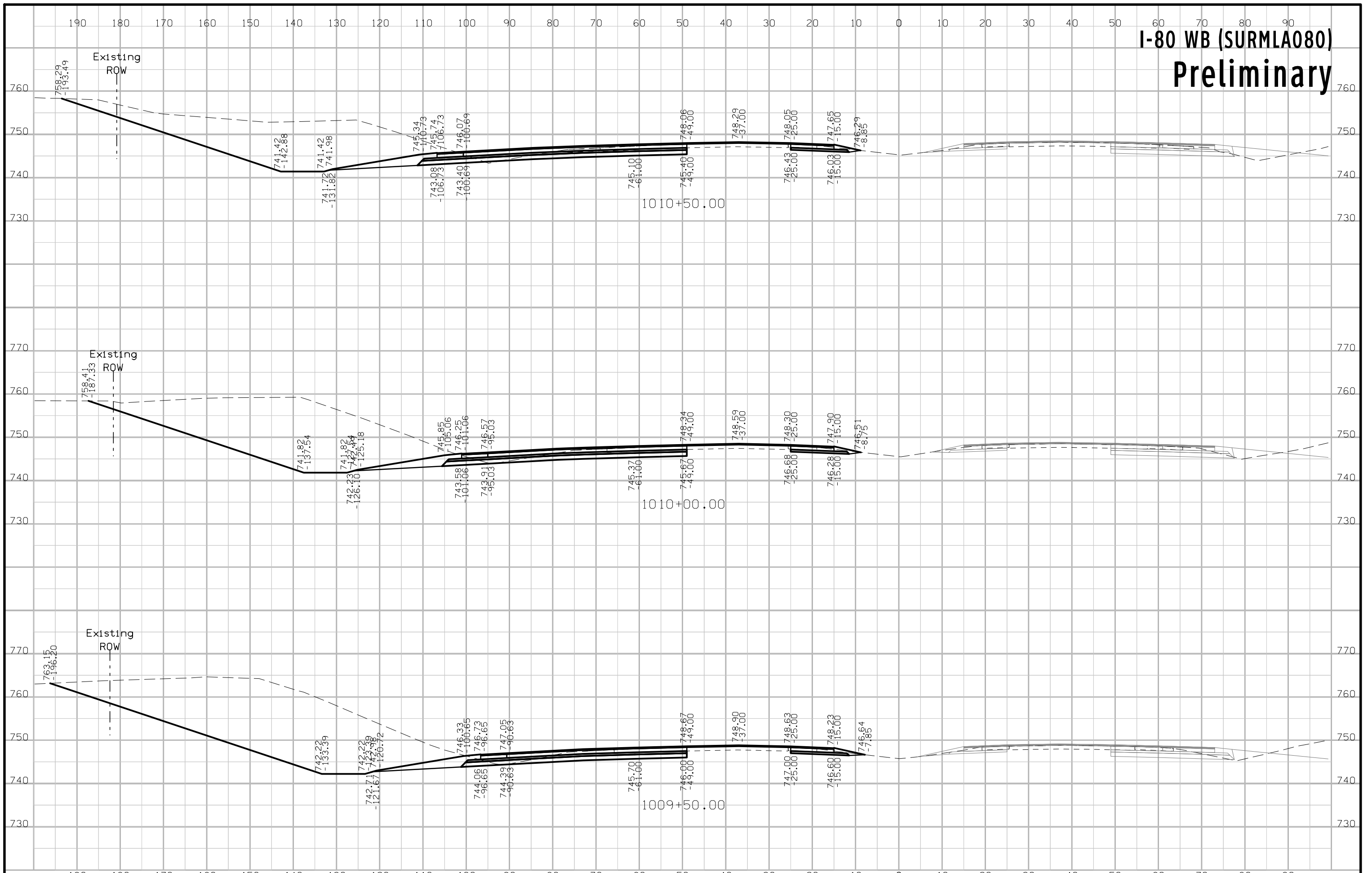

# I-80 WB (SURMLA080) Preliminary

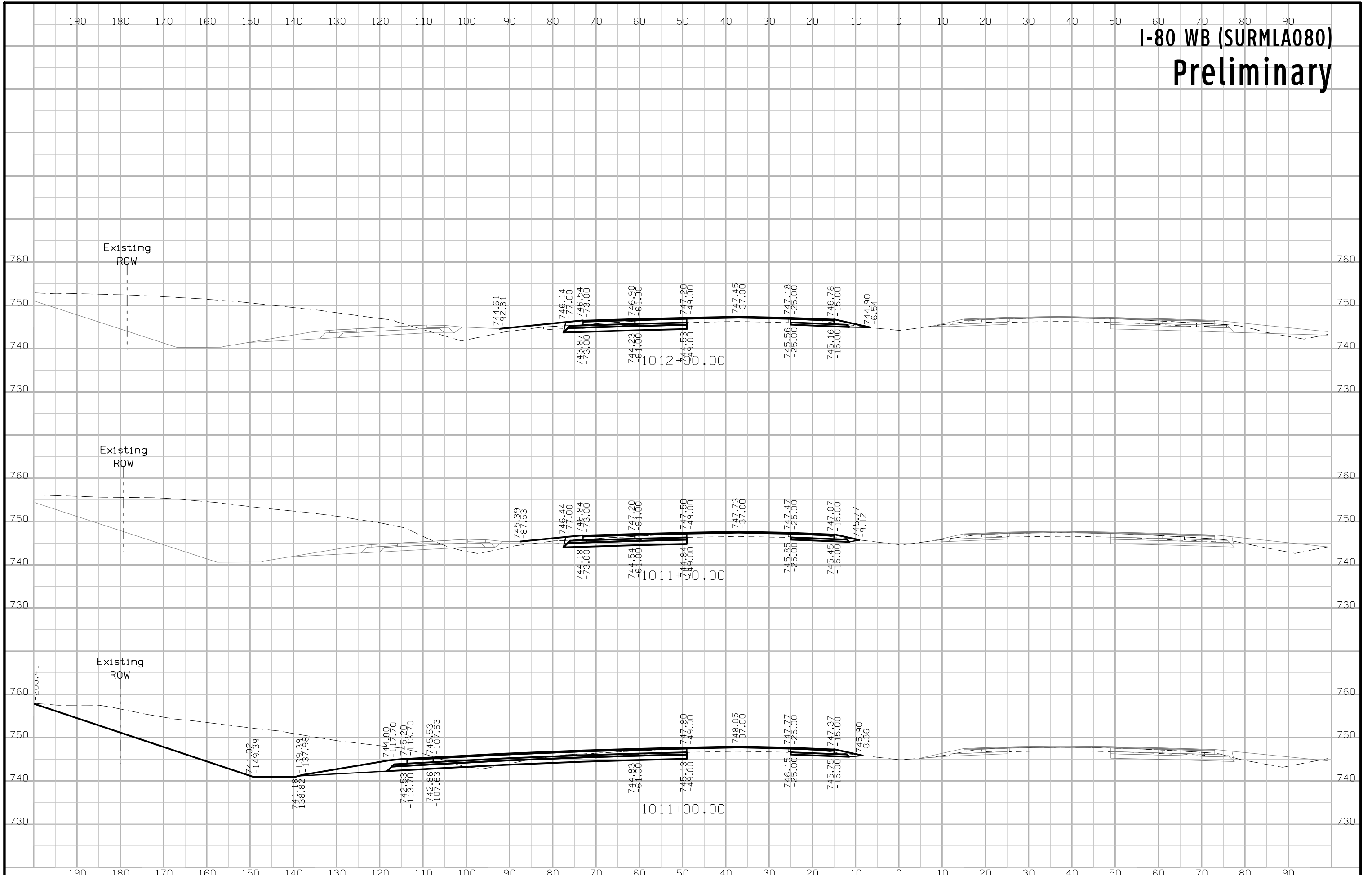



# I-80 WB (SURMLA080) Preliminary

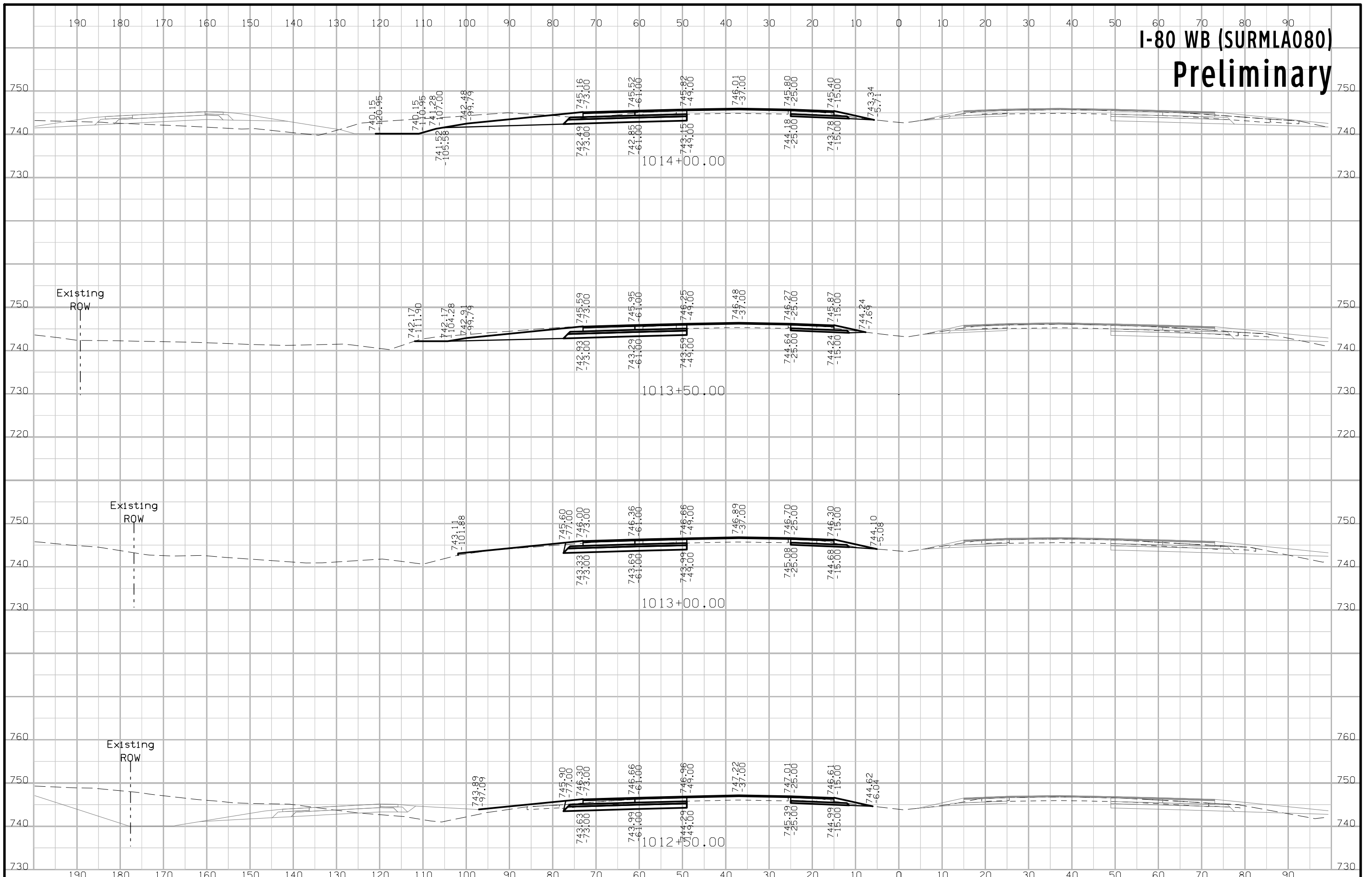

# I-80 WB (SURMLA080) Preliminary

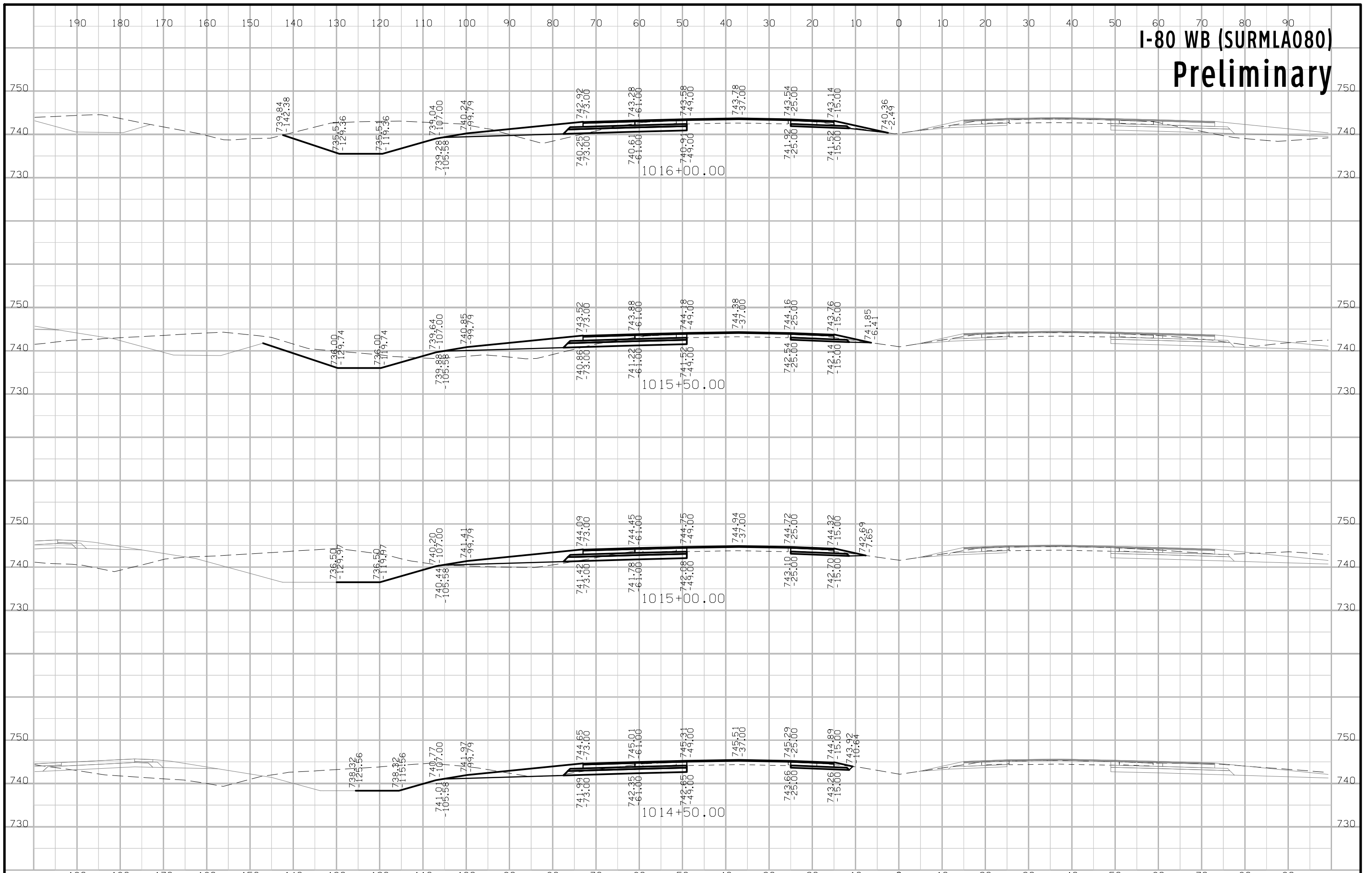

# I-80 WB (SURMLA080) Preliminary

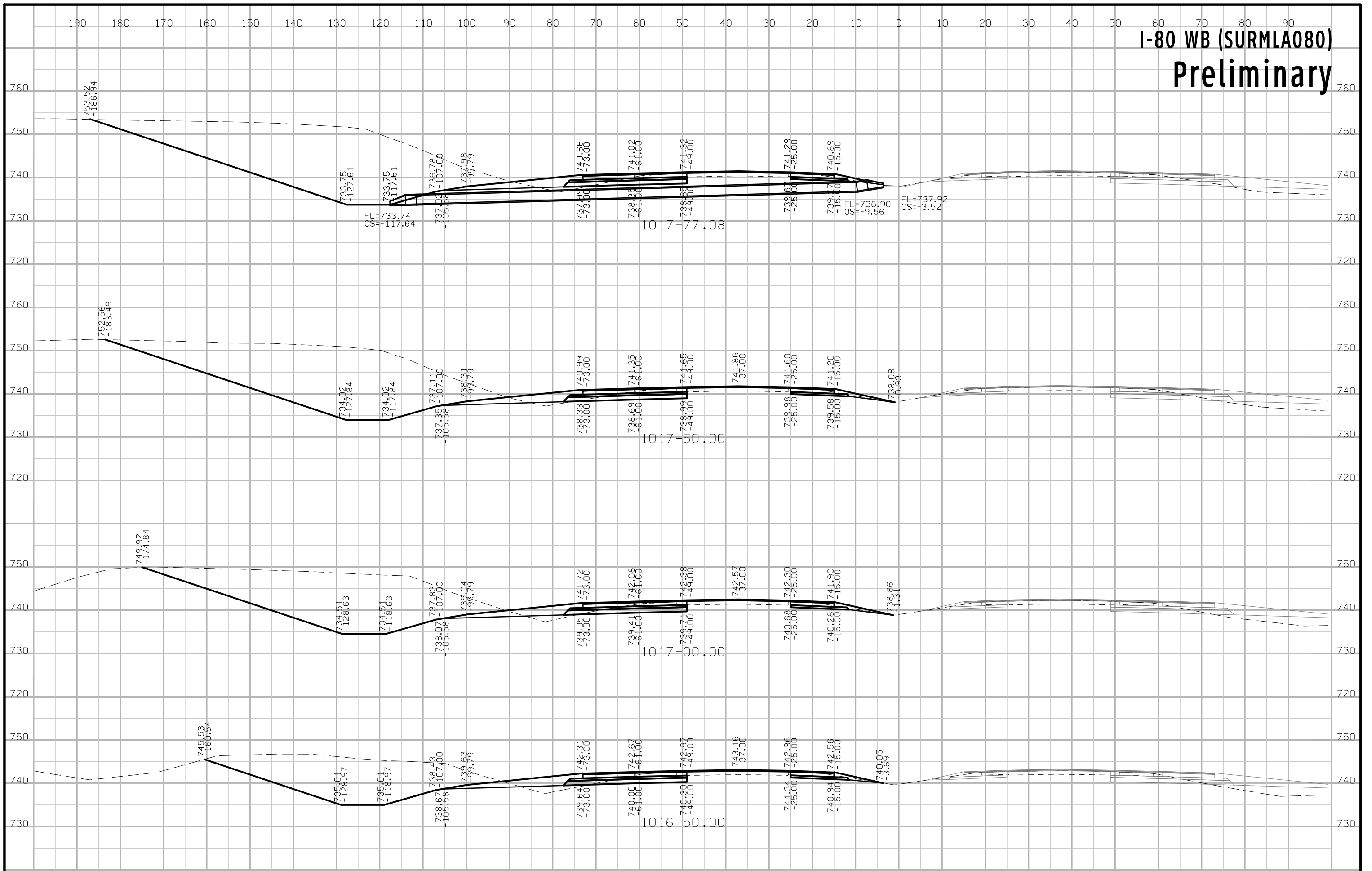

# I-80 WB (SURMLA080) Preliminary

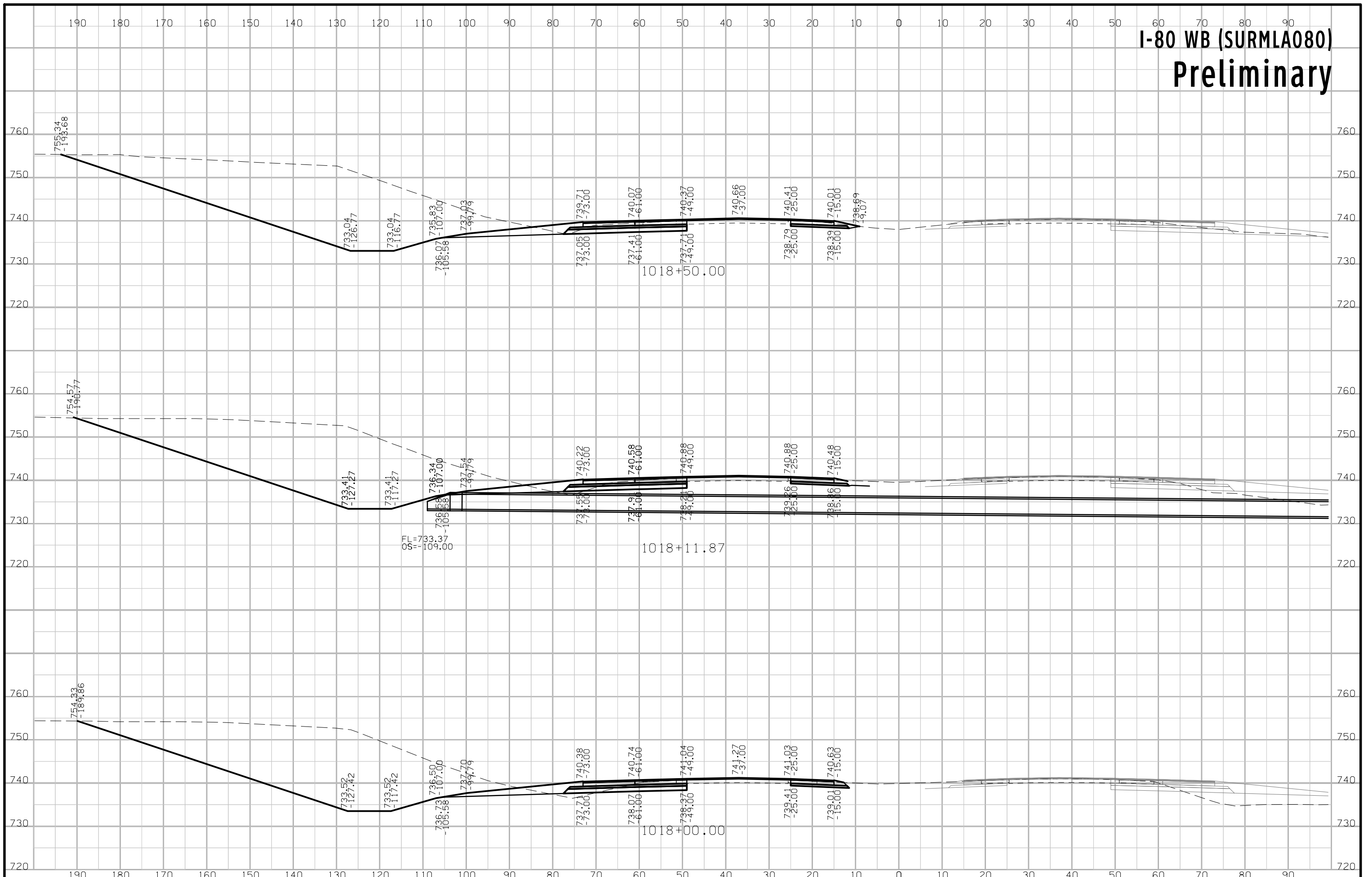

# I-80 WB (SURMLA080) Preliminary

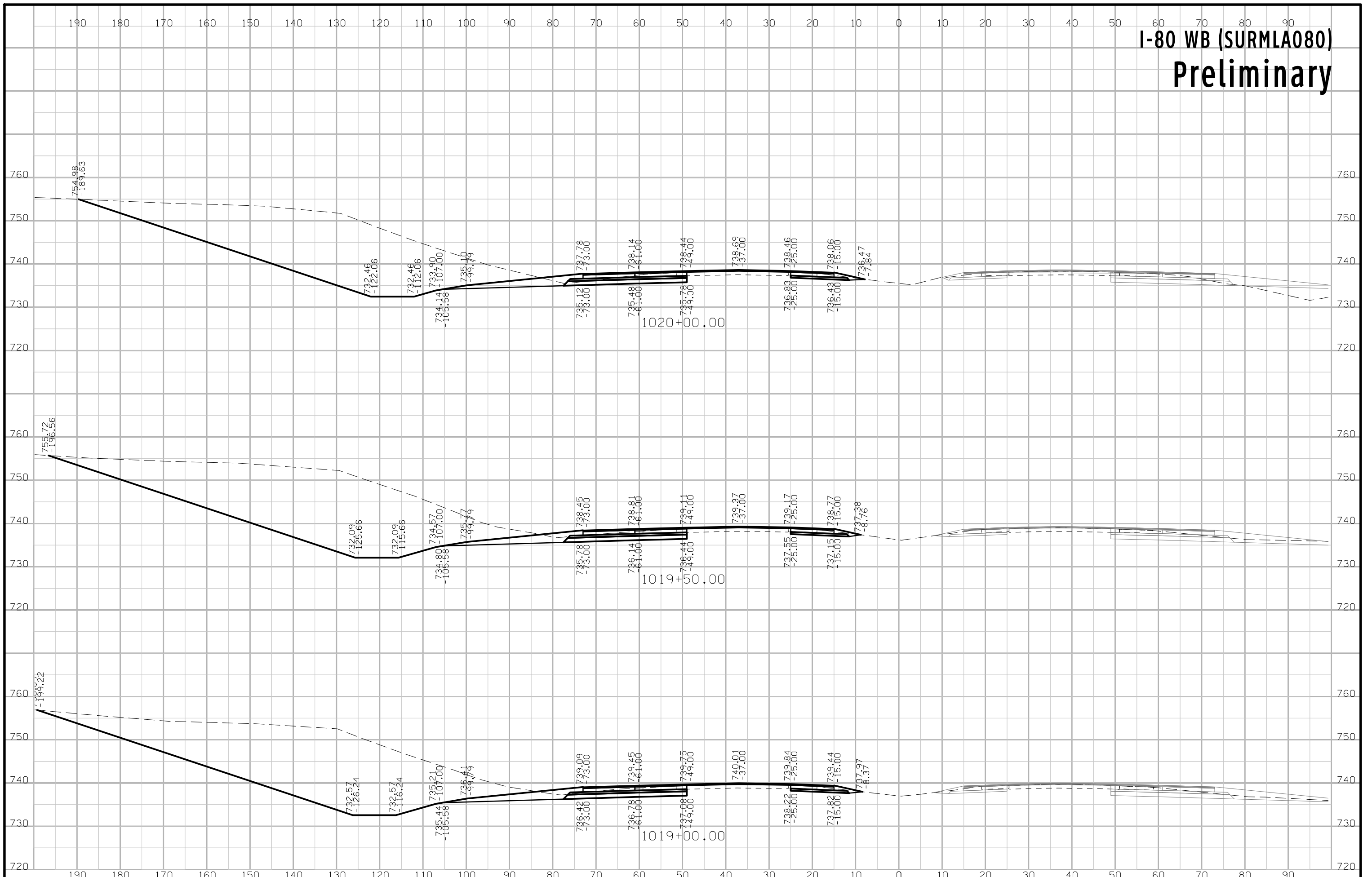



# I-80 WB (SURMLA080) Preliminary

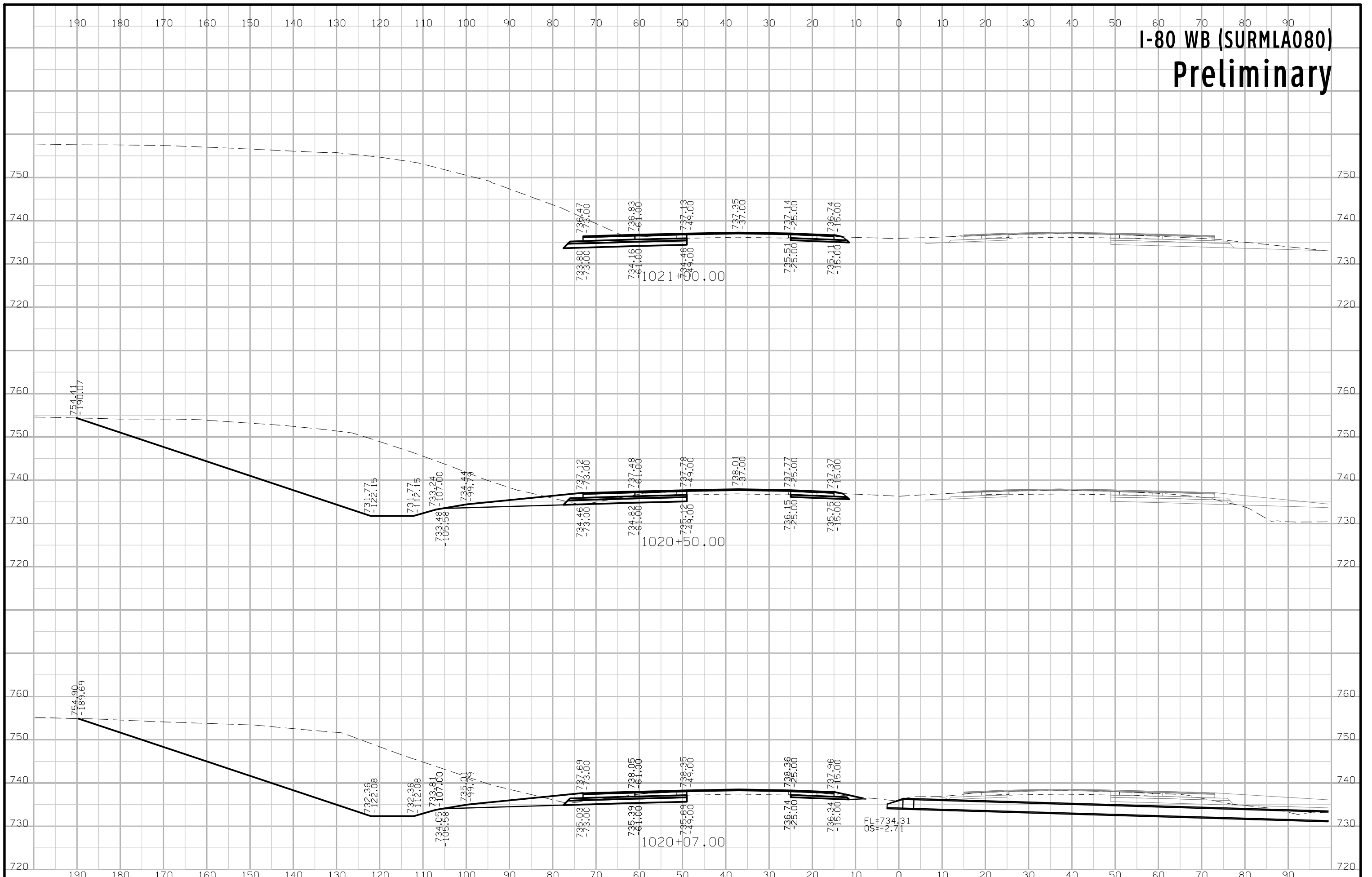

# I-80 WB (SURMLA080) Preliminary

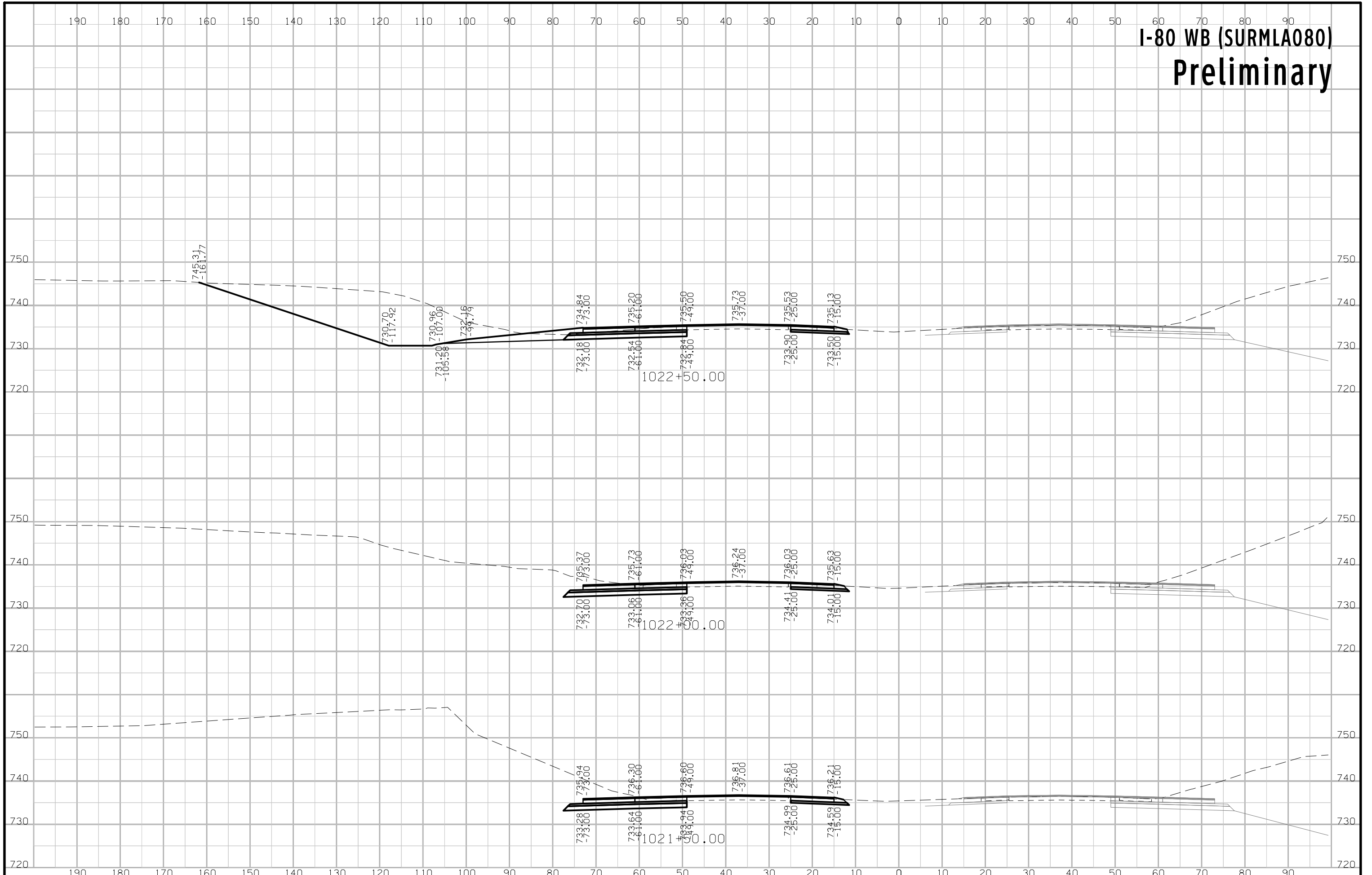

# I-80 WB (SURMLA080) Preliminary

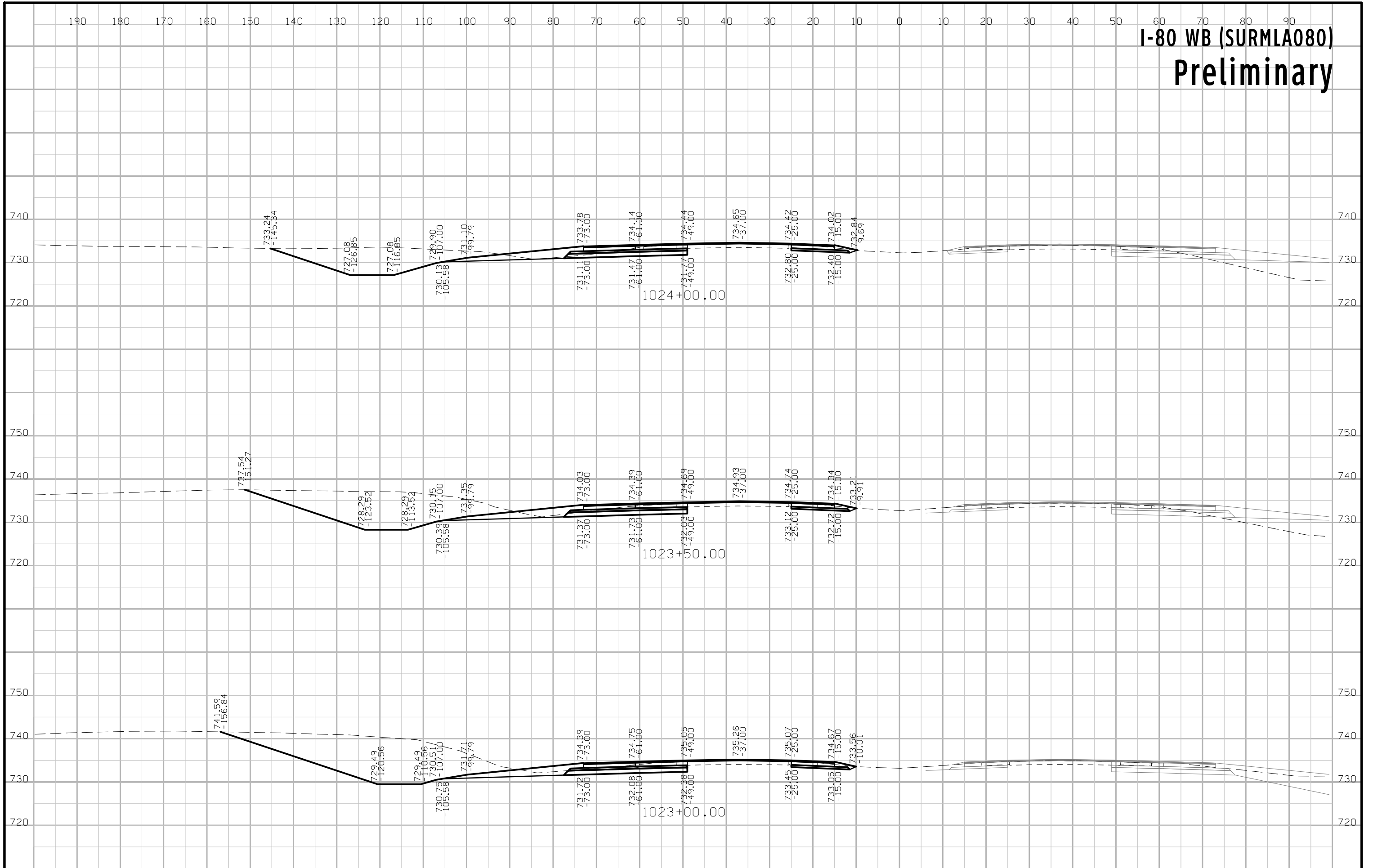

# I-80 WB (SURMLA080) Preliminary

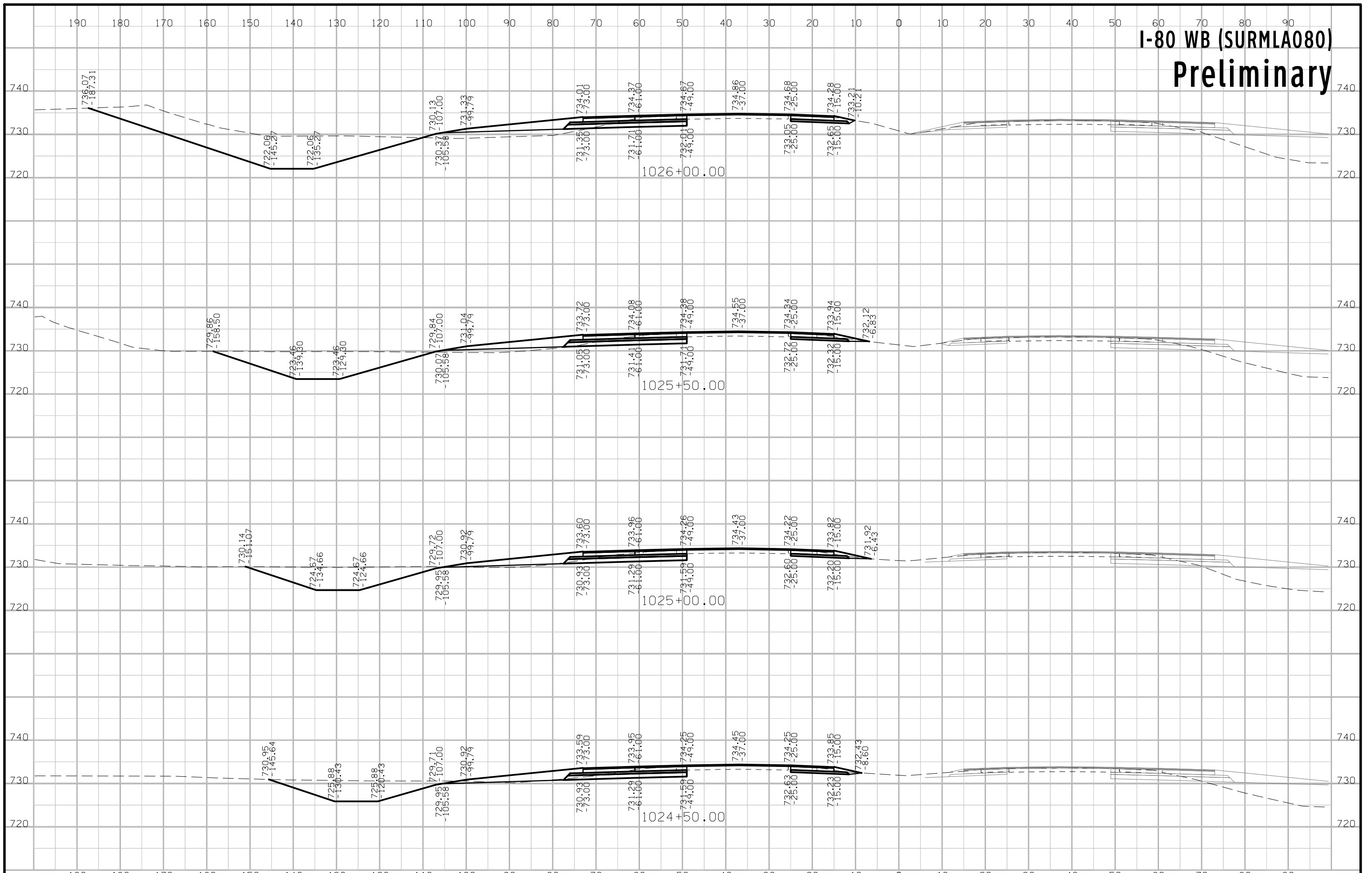

# I-80 WB (SURMLA080) Preliminary

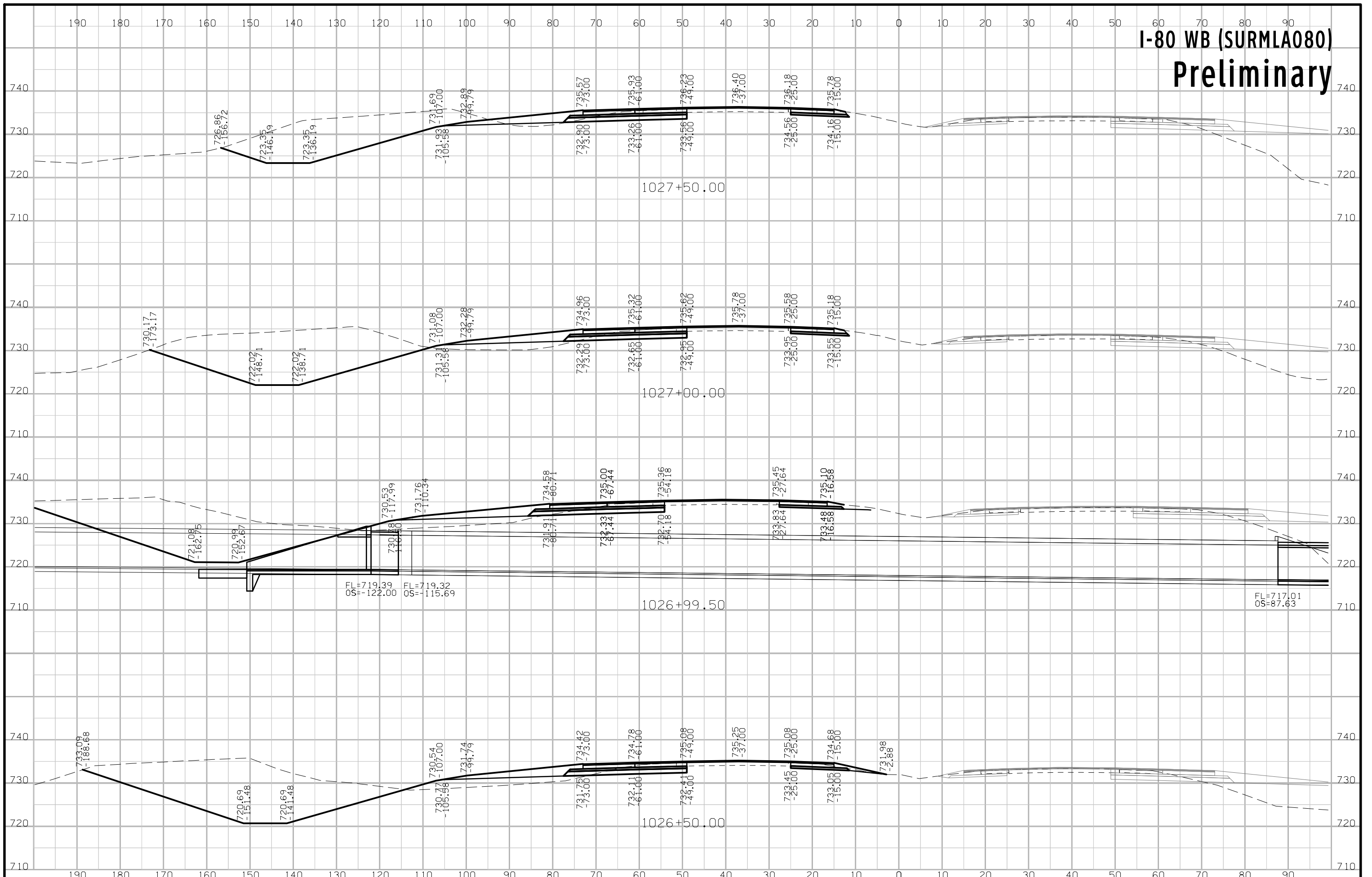



# I-80 WB (SURMLA080) Preliminary

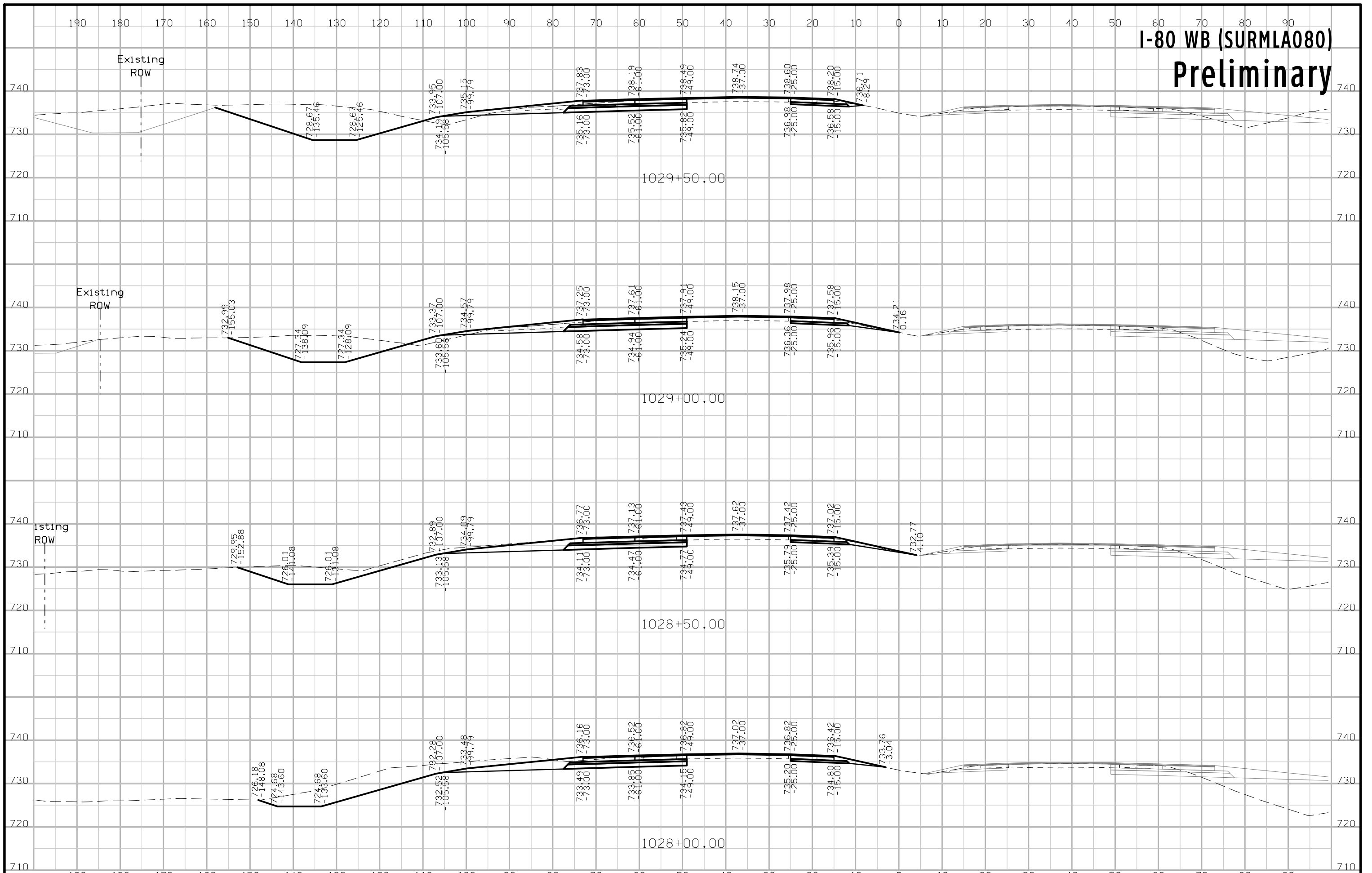

# I-80 WB (SURMLA080) Preliminary

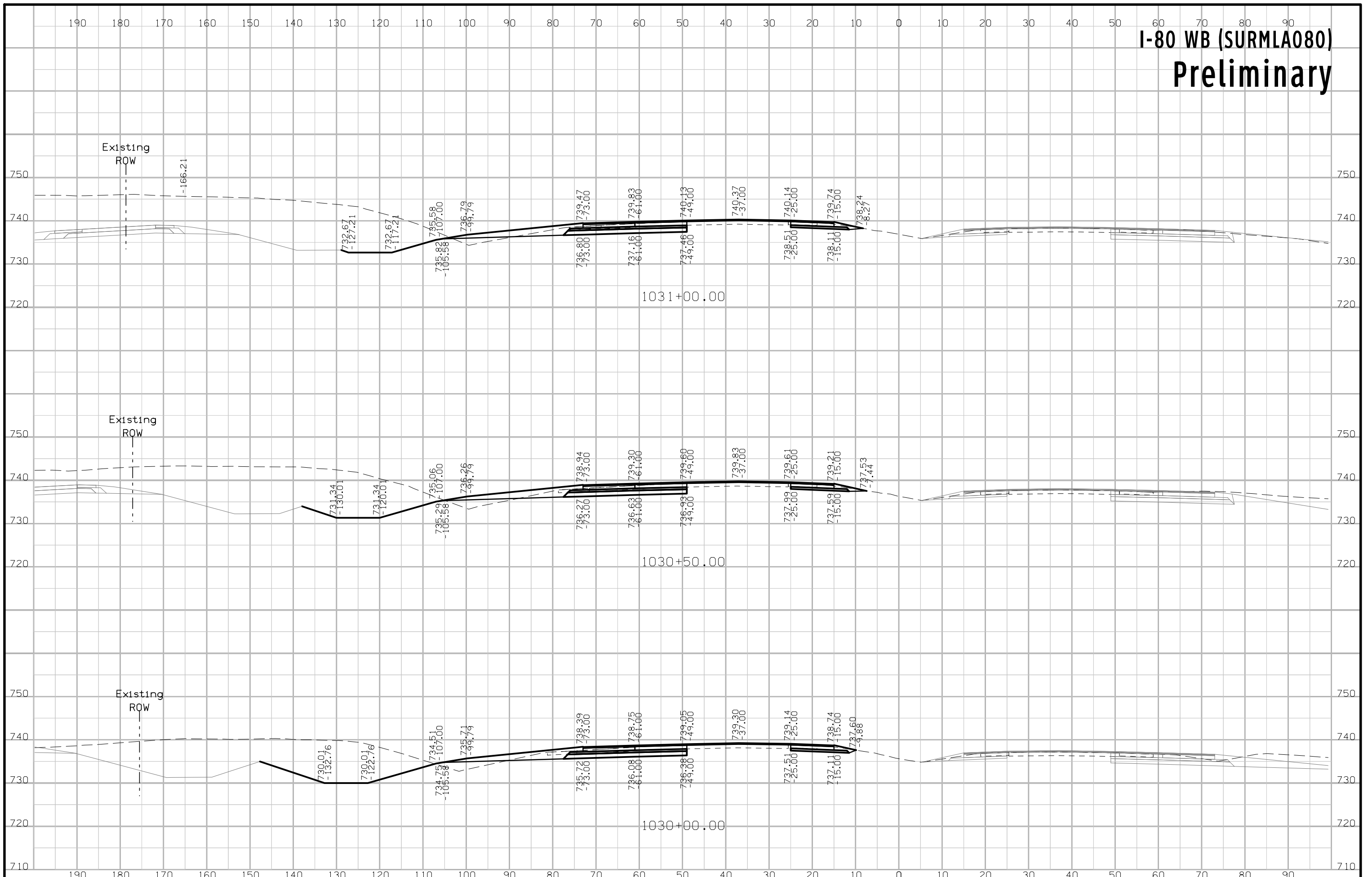

# I-80 WB (SURMLA080) Preliminary

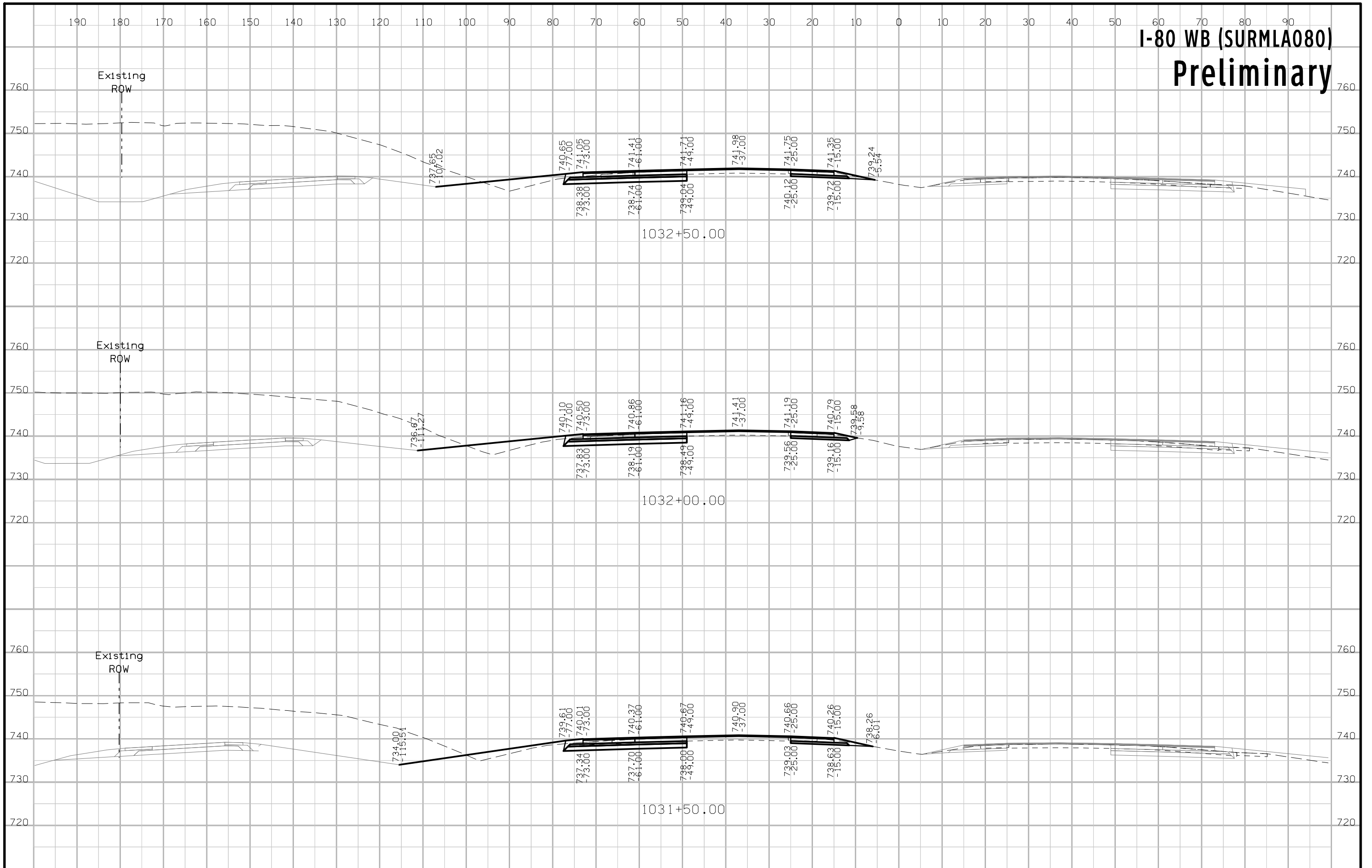

# I-80 WB (SURMLA080) Preliminary

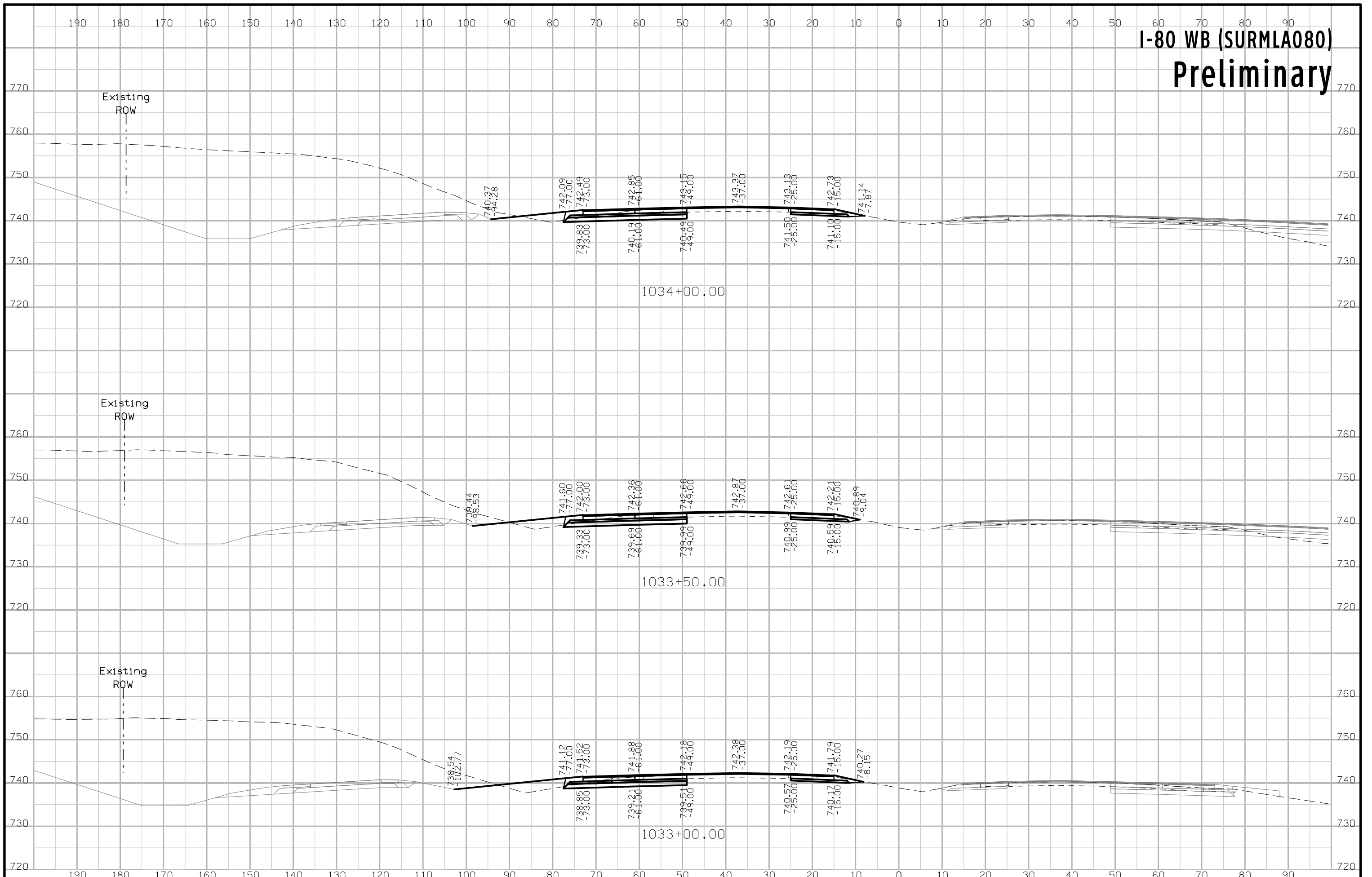

# I-80 WB (SURMLA080) Preliminary

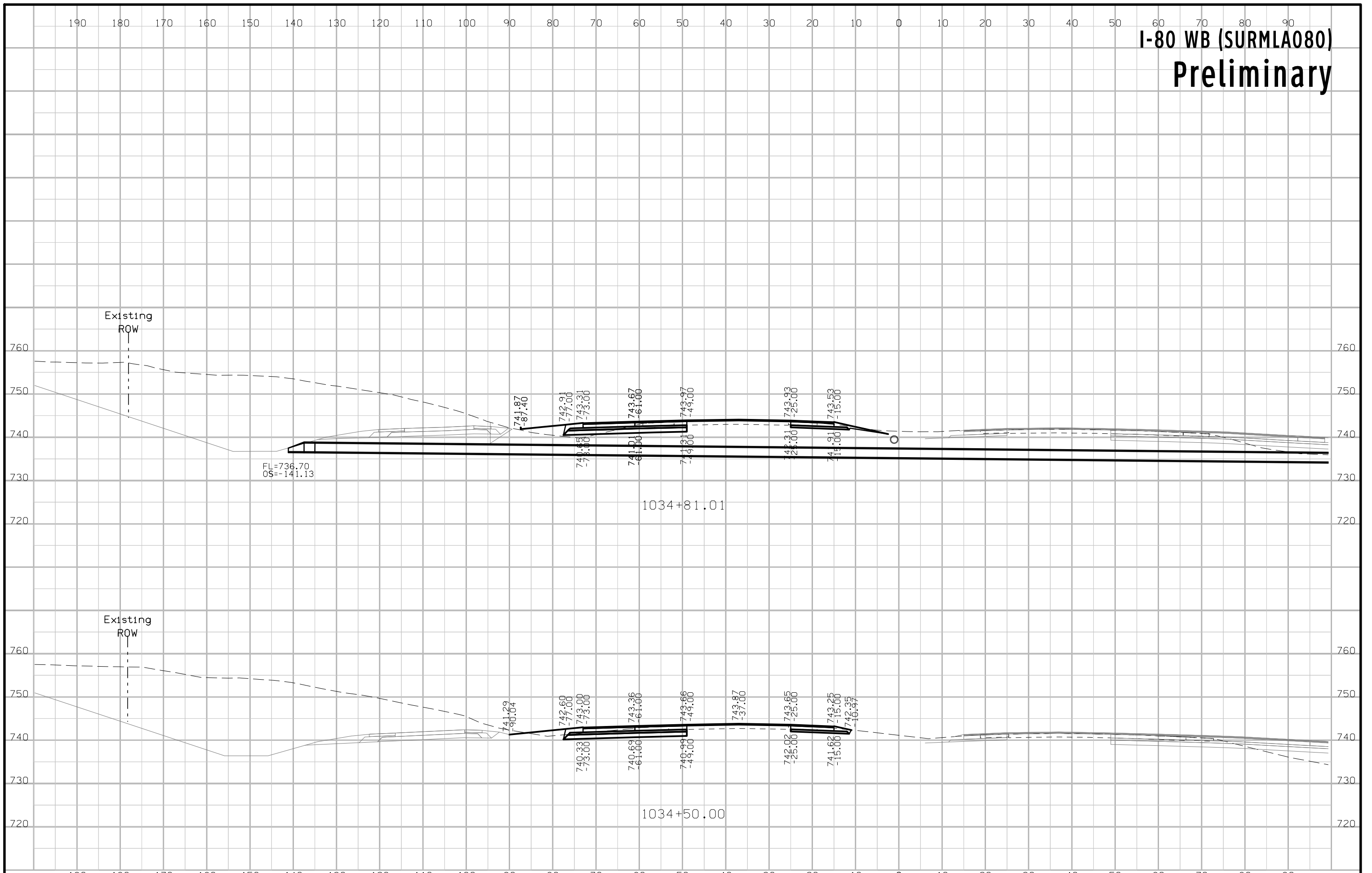



# I-80 WB (SURMLA080) Preliminary

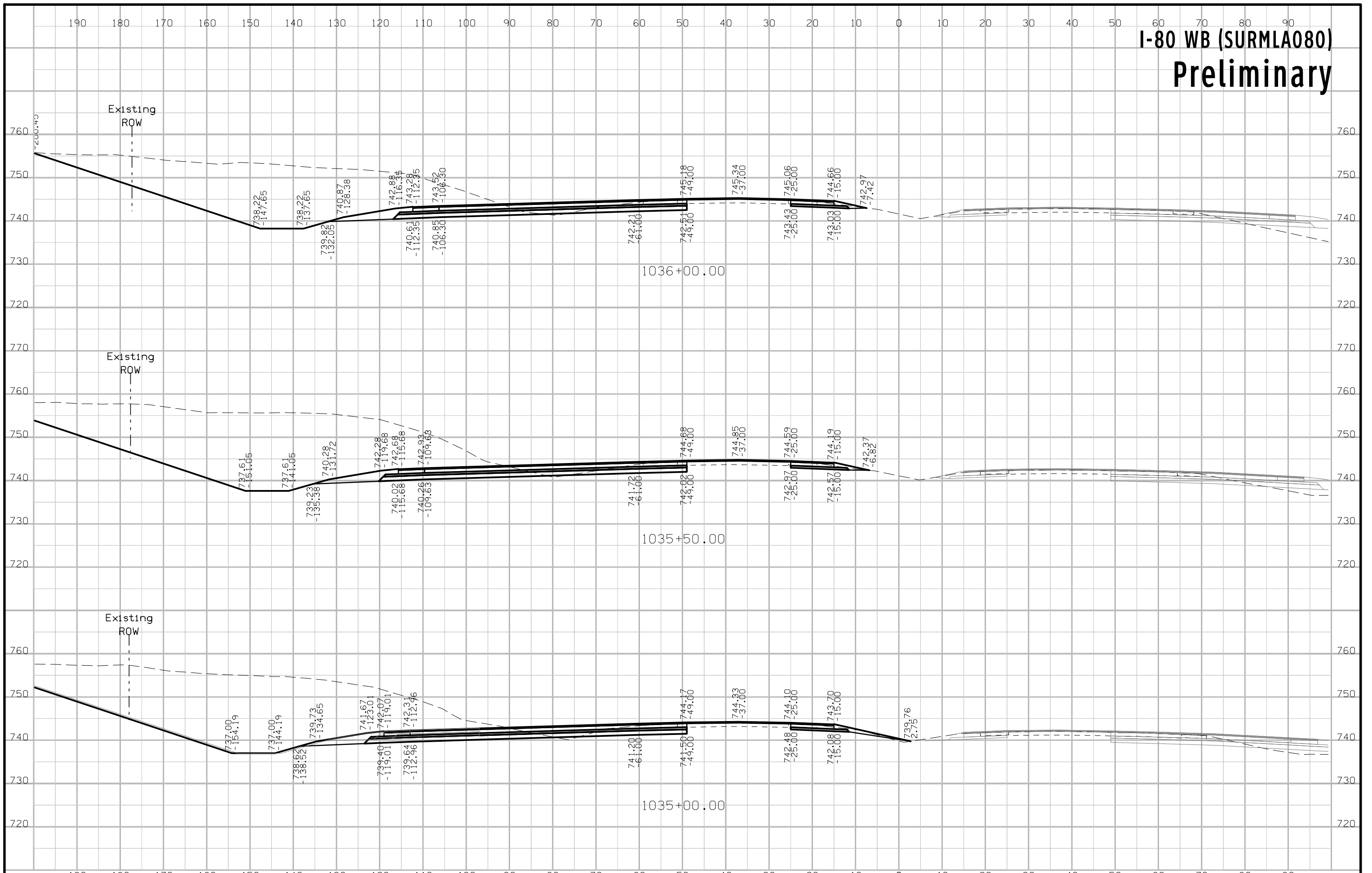

# I-80 WB (SURMLA080) Preliminary

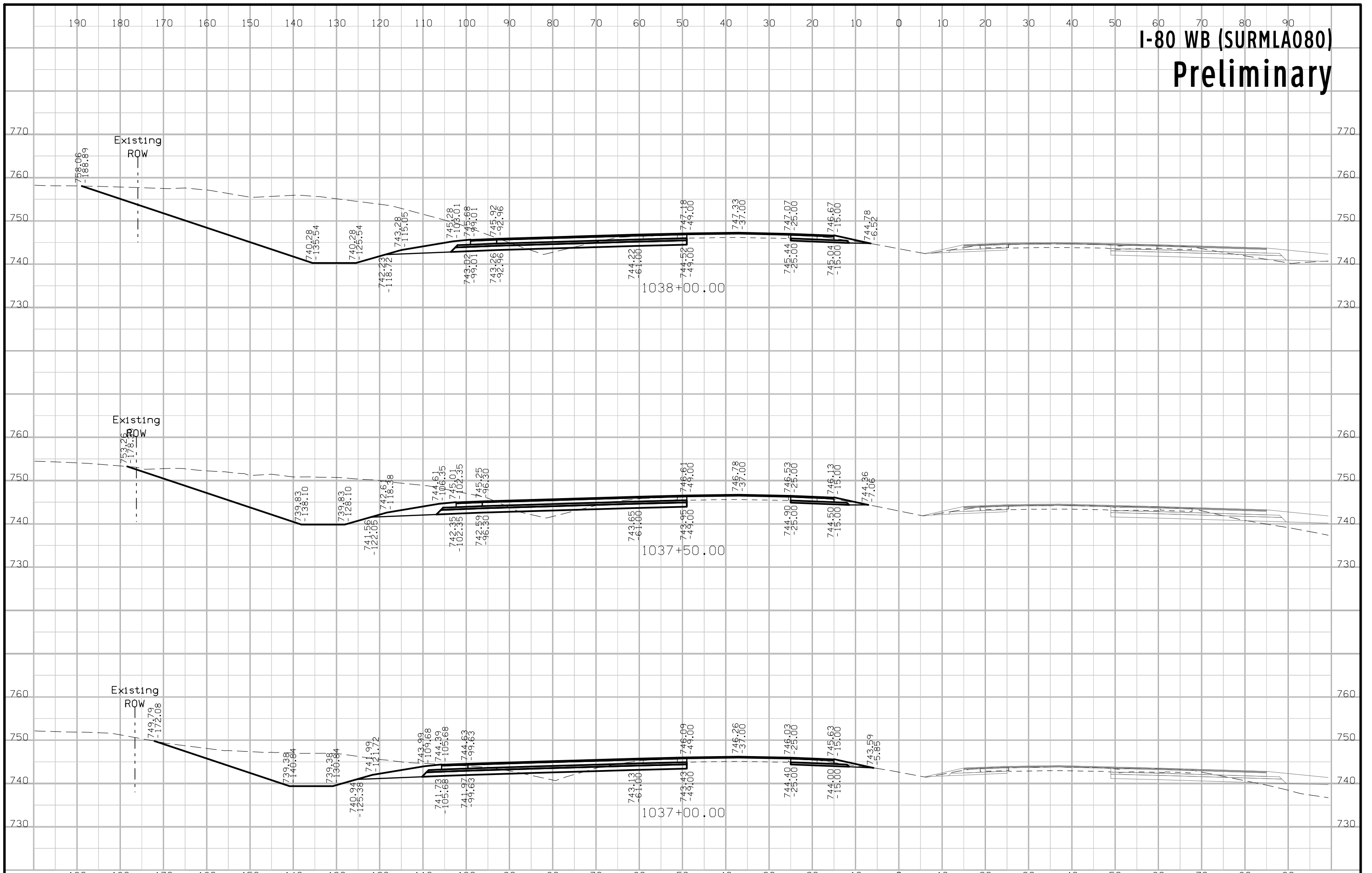

# I-80 WB (SURMLA080) Preliminary

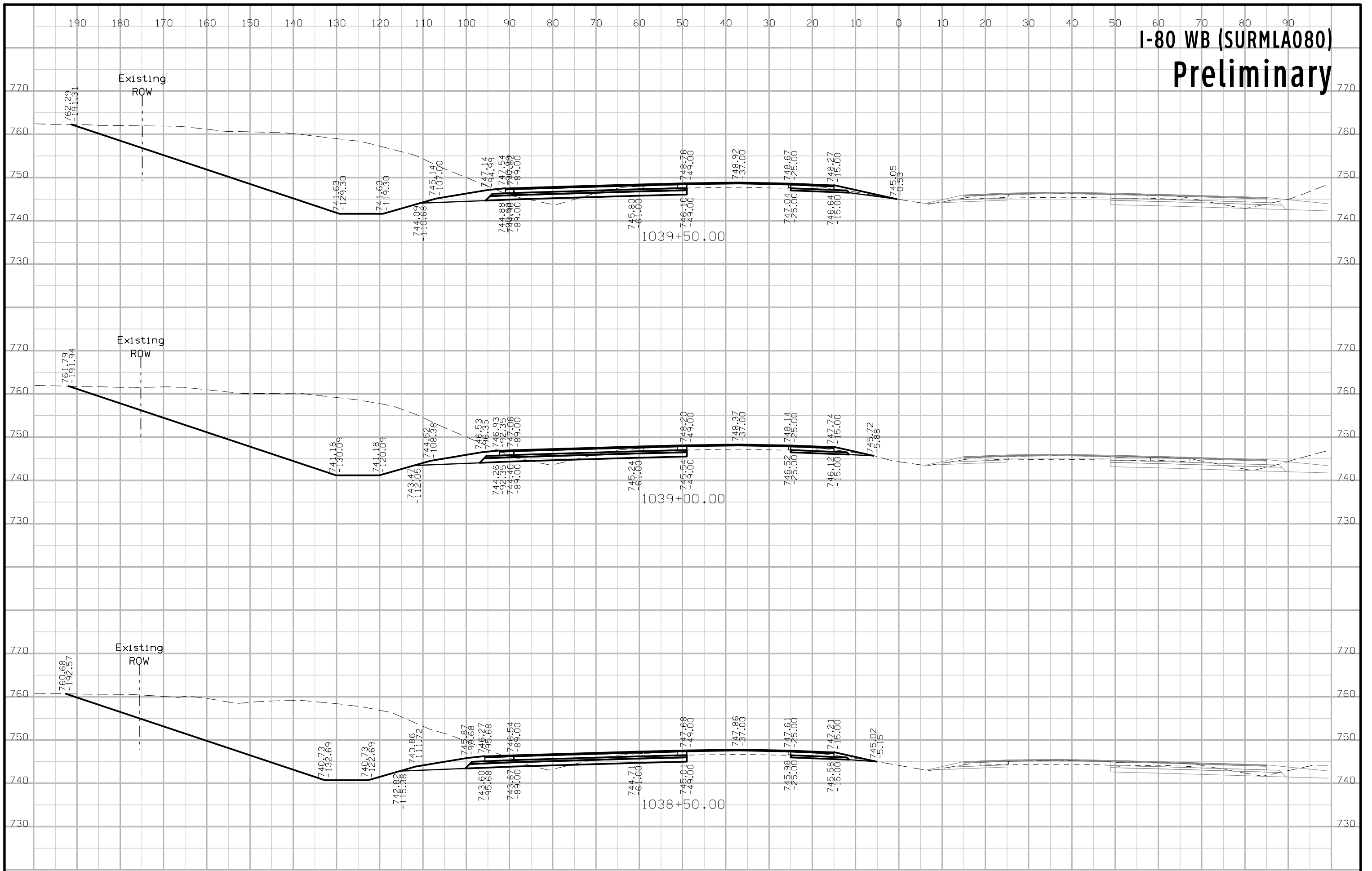

# I-80 WB (SURMLA080) Preliminary

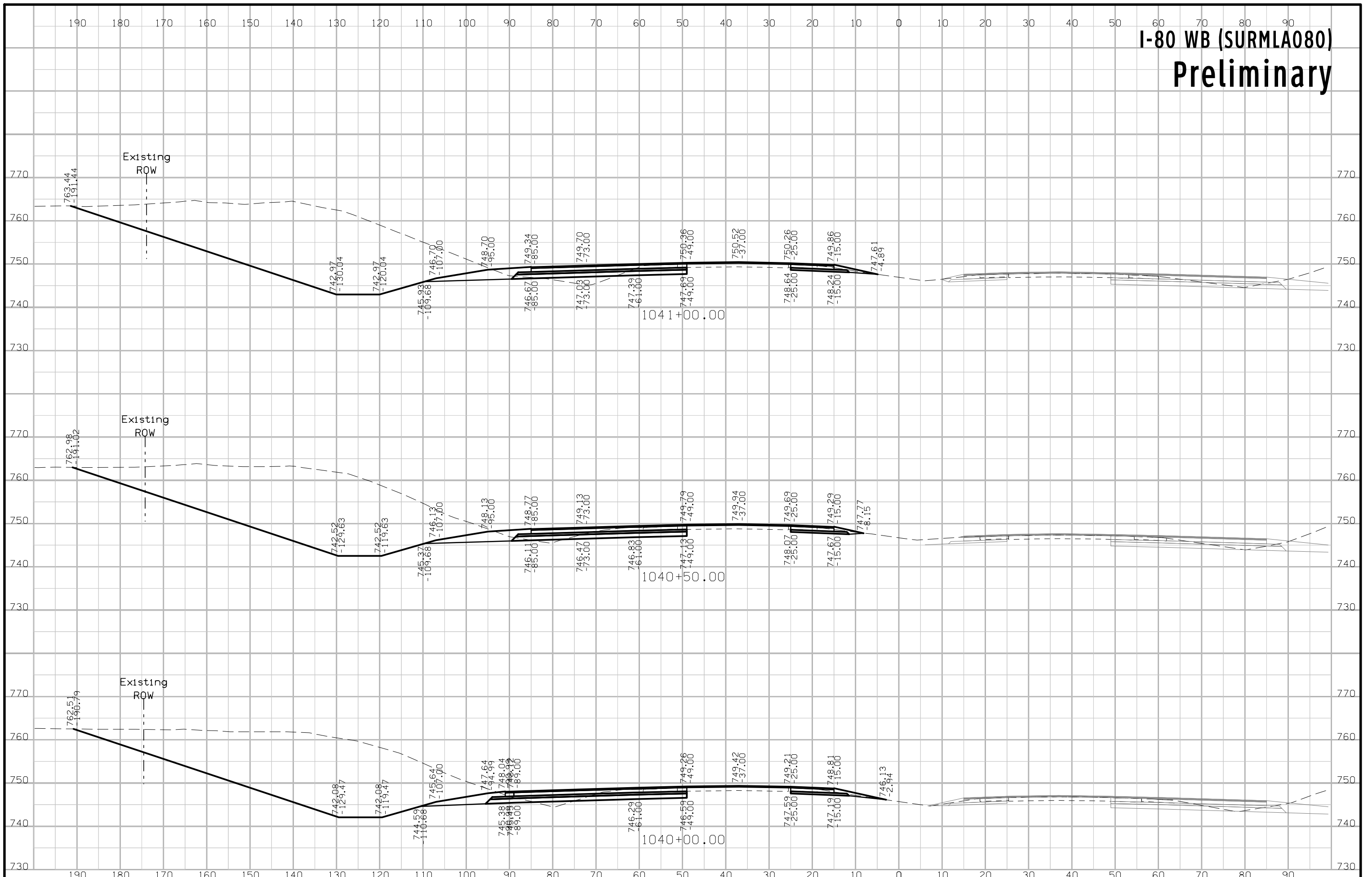

# I-80 WB (SURMLA080) Preliminary

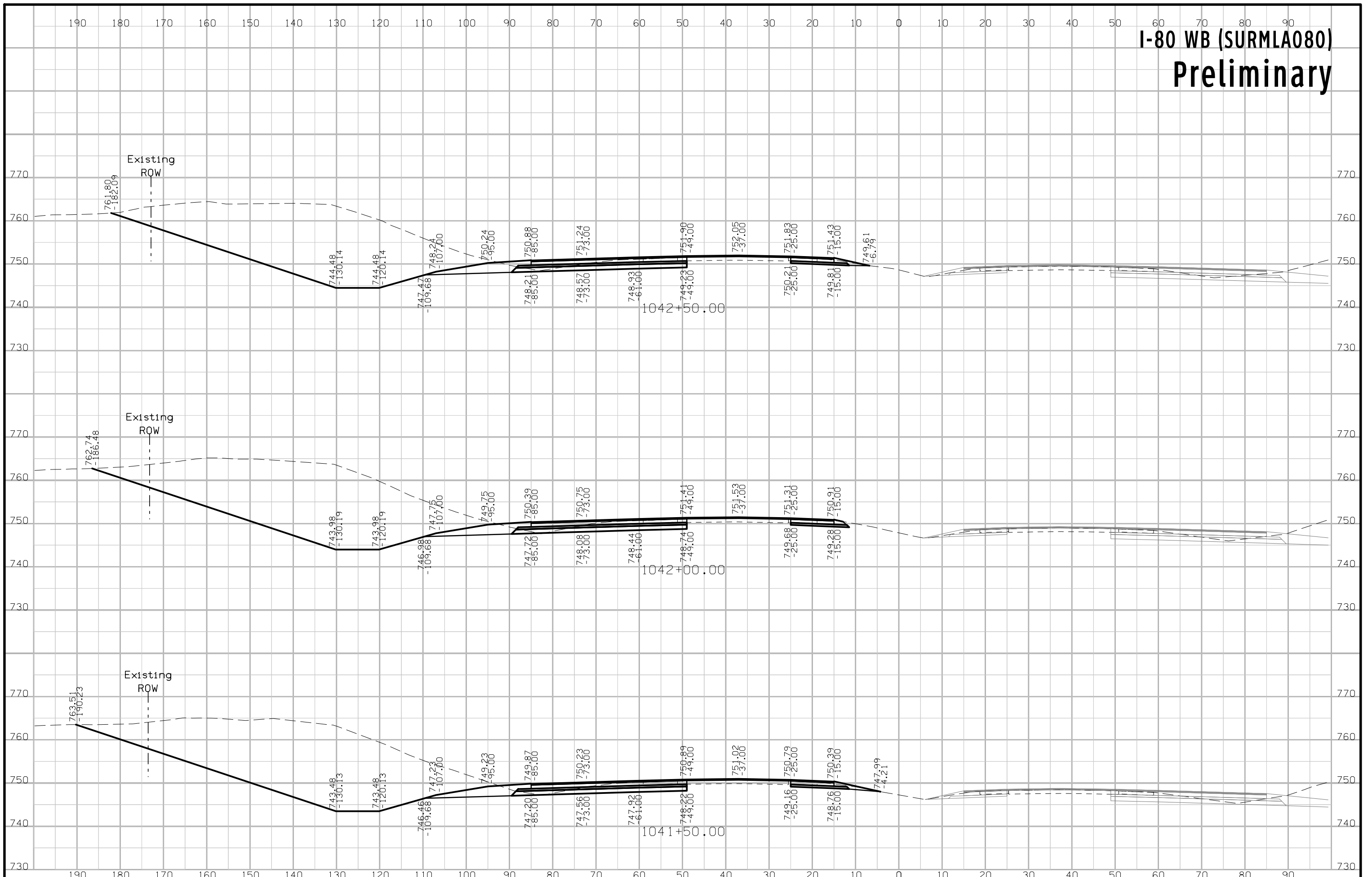



# I-80 WB (SURMLA080) Preliminary

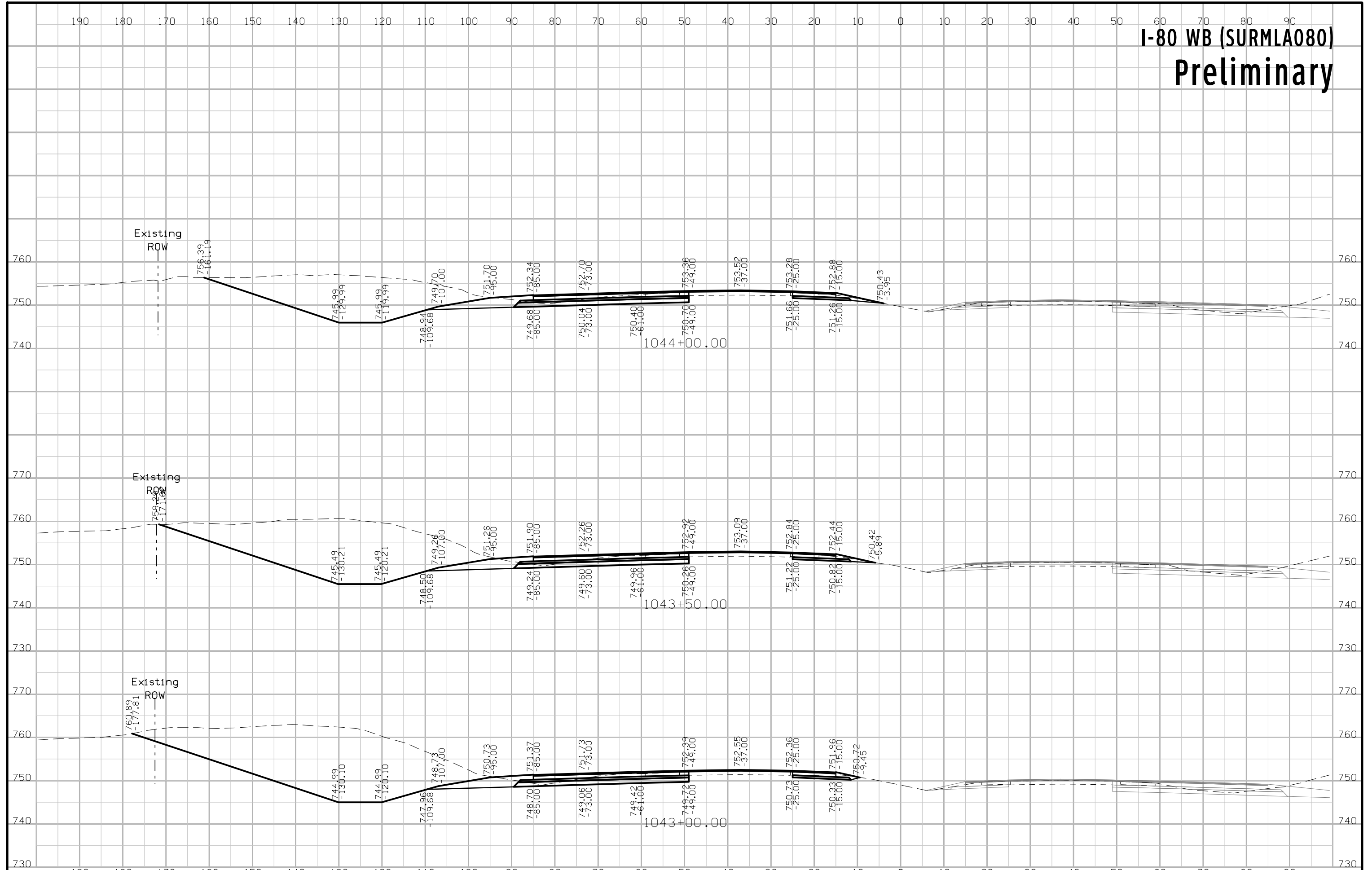

# I-80 WB (SURMLA080) Preliminary

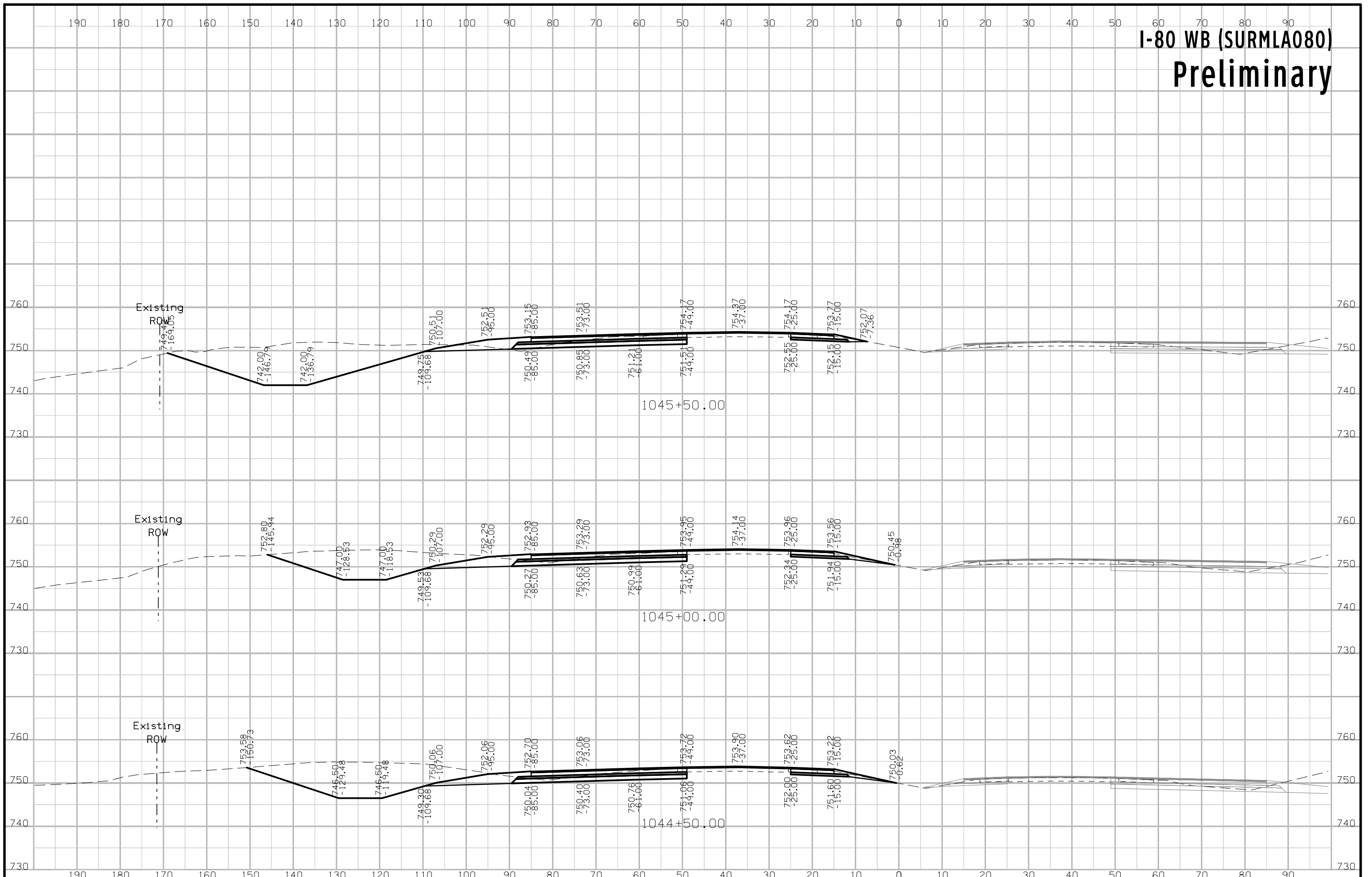

# I-80 WB (SURMLA080) Preliminary

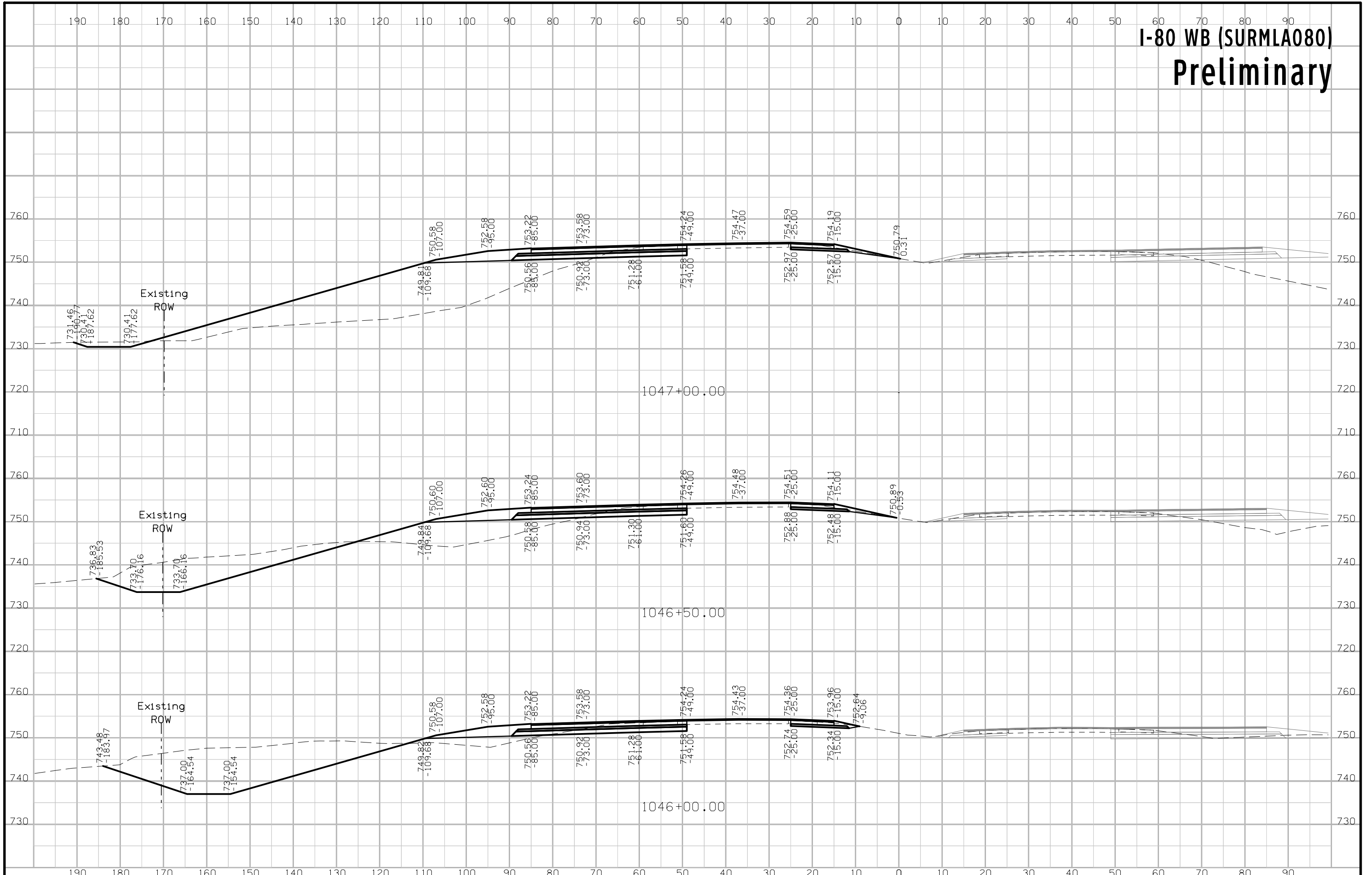

# I-80 WB (SURMLA080) Preliminary

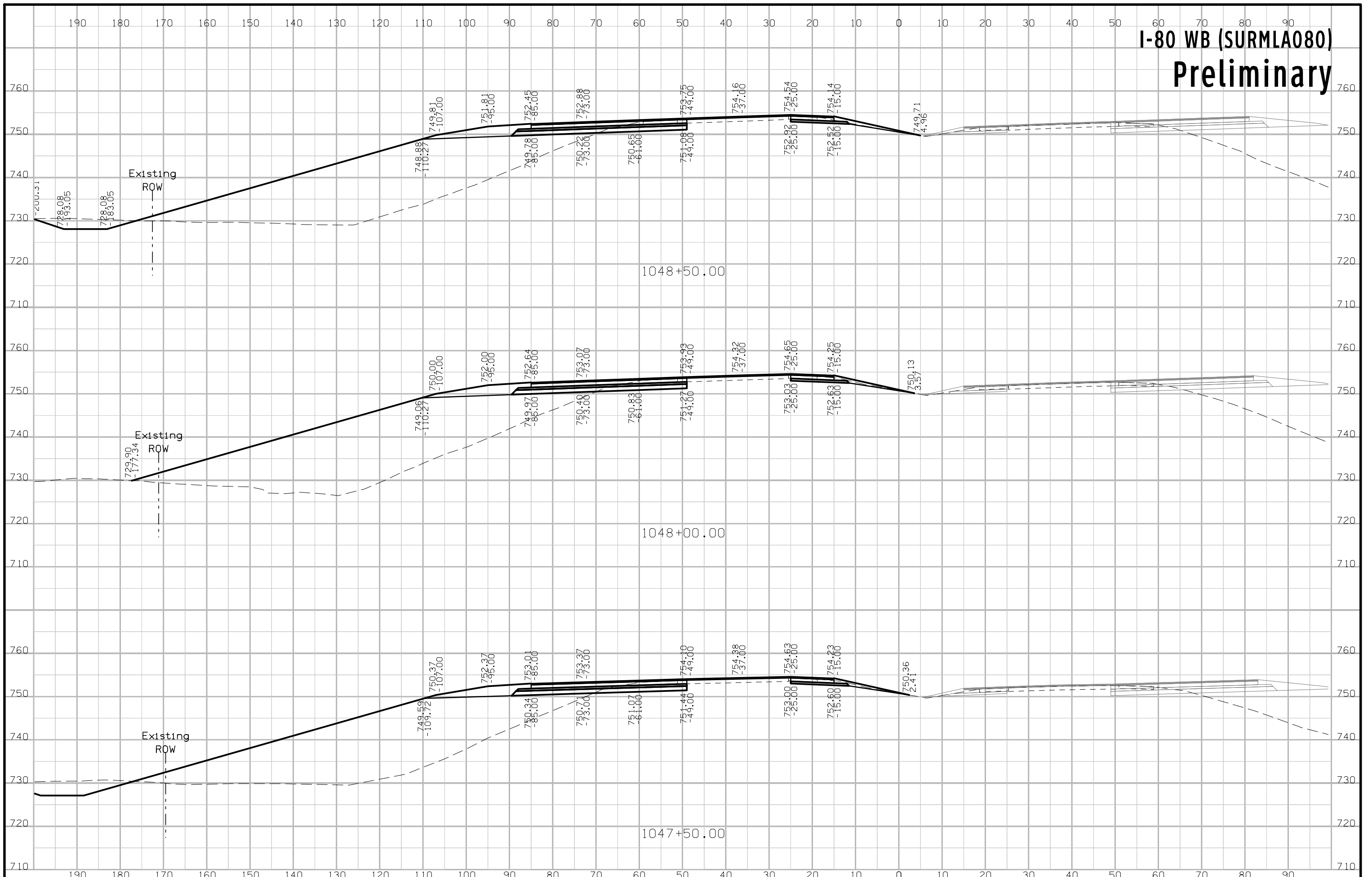

# I-80 WB (SURMLA080) Preliminary

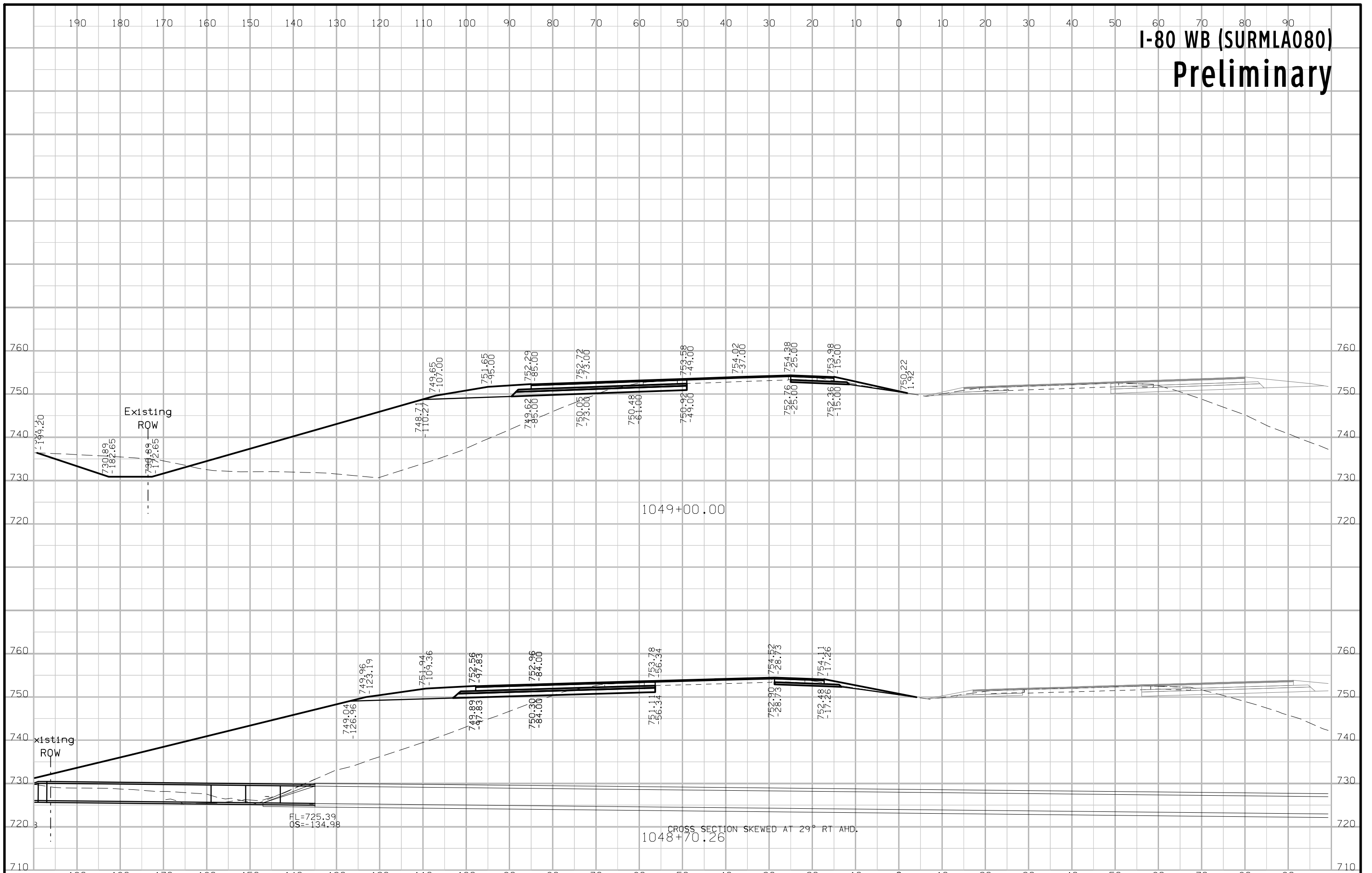



# I-80 WB (SURMLA080) Preliminary

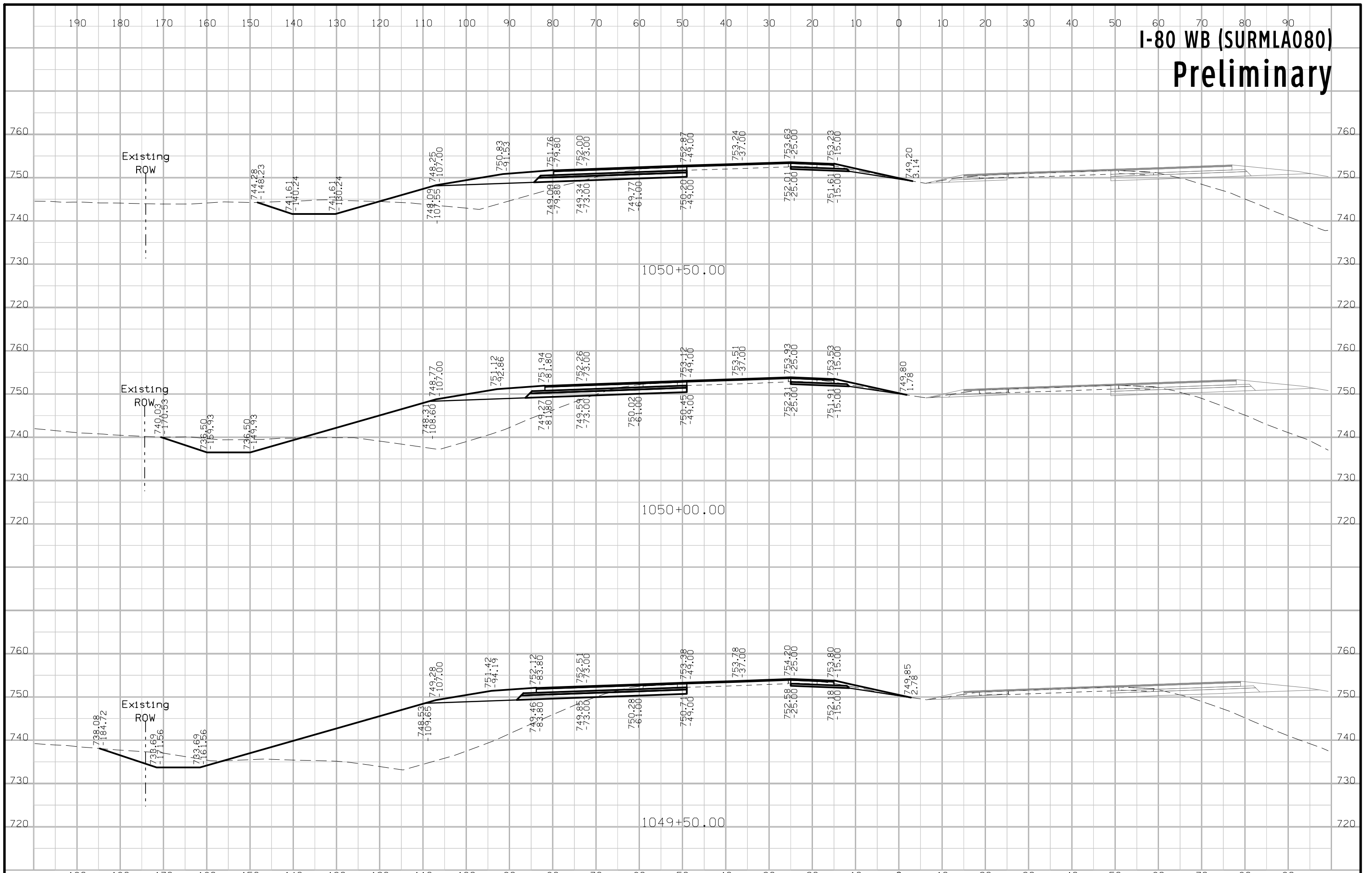

# I-80 WB (SURMLA080) Preliminary

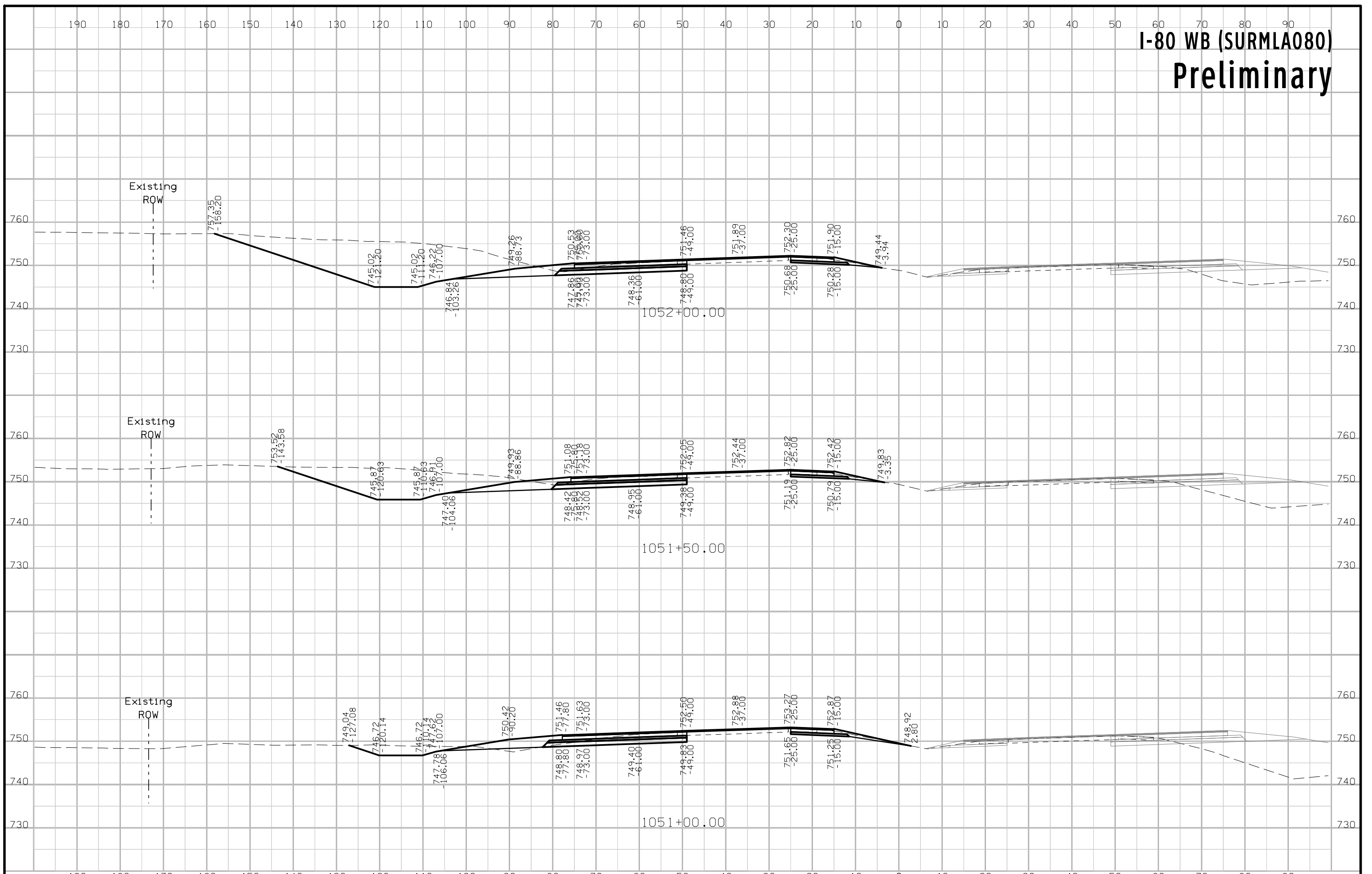

# I-80 WB (SURMLA080) Preliminary

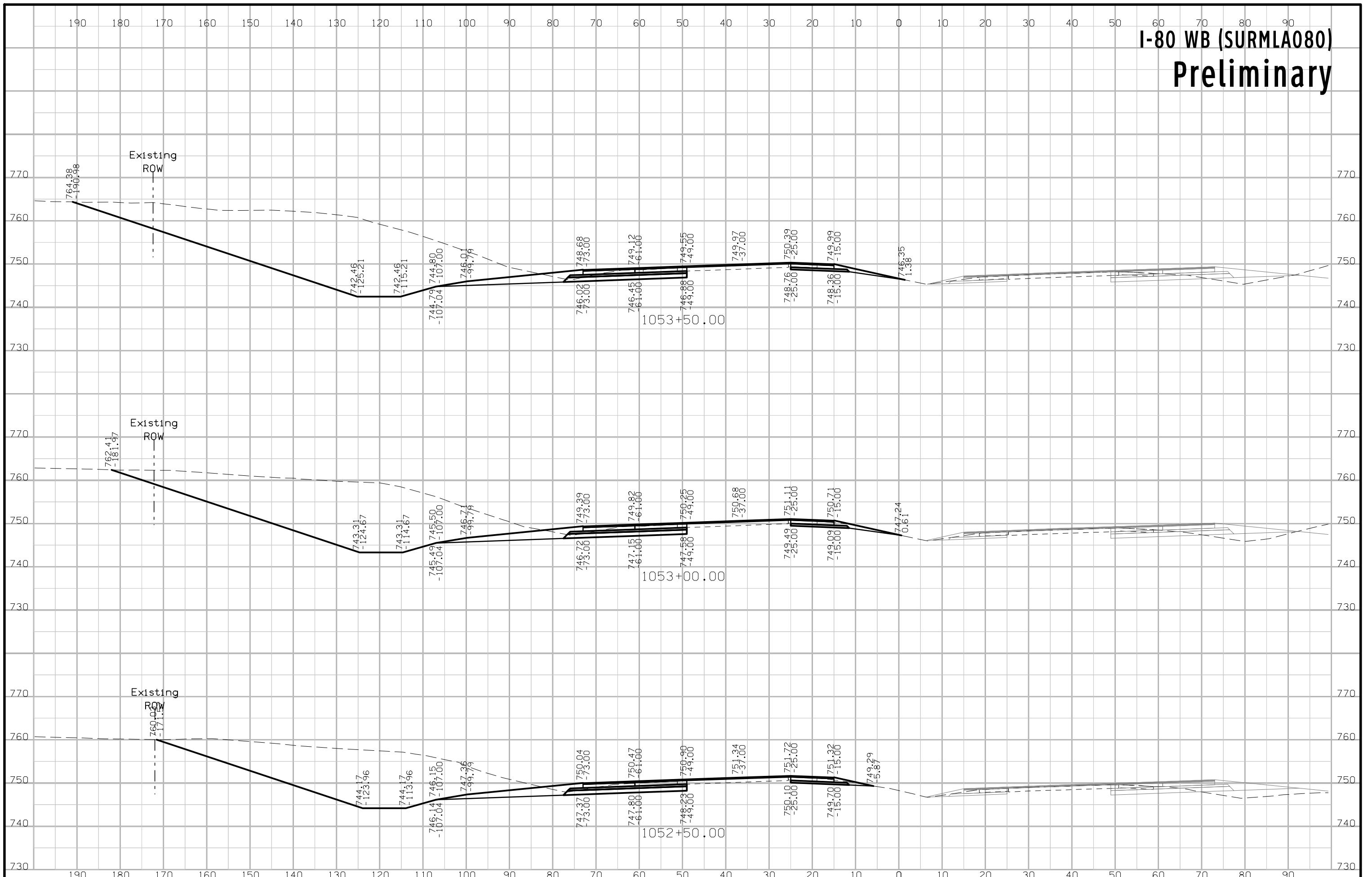

# I-80 WB (SURMLA080) Preliminary

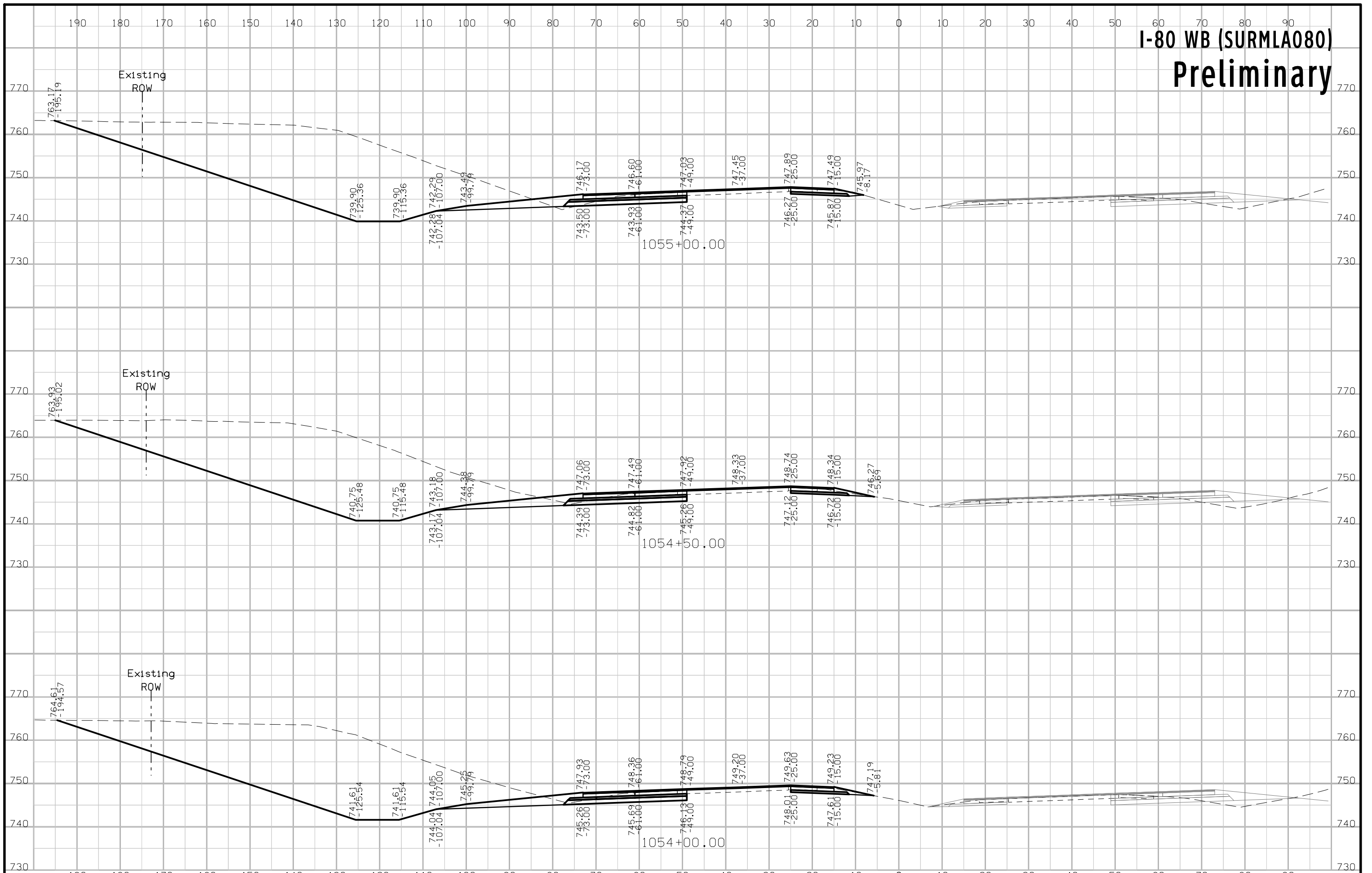

# I-80 WB (SURMLA080) Preliminary

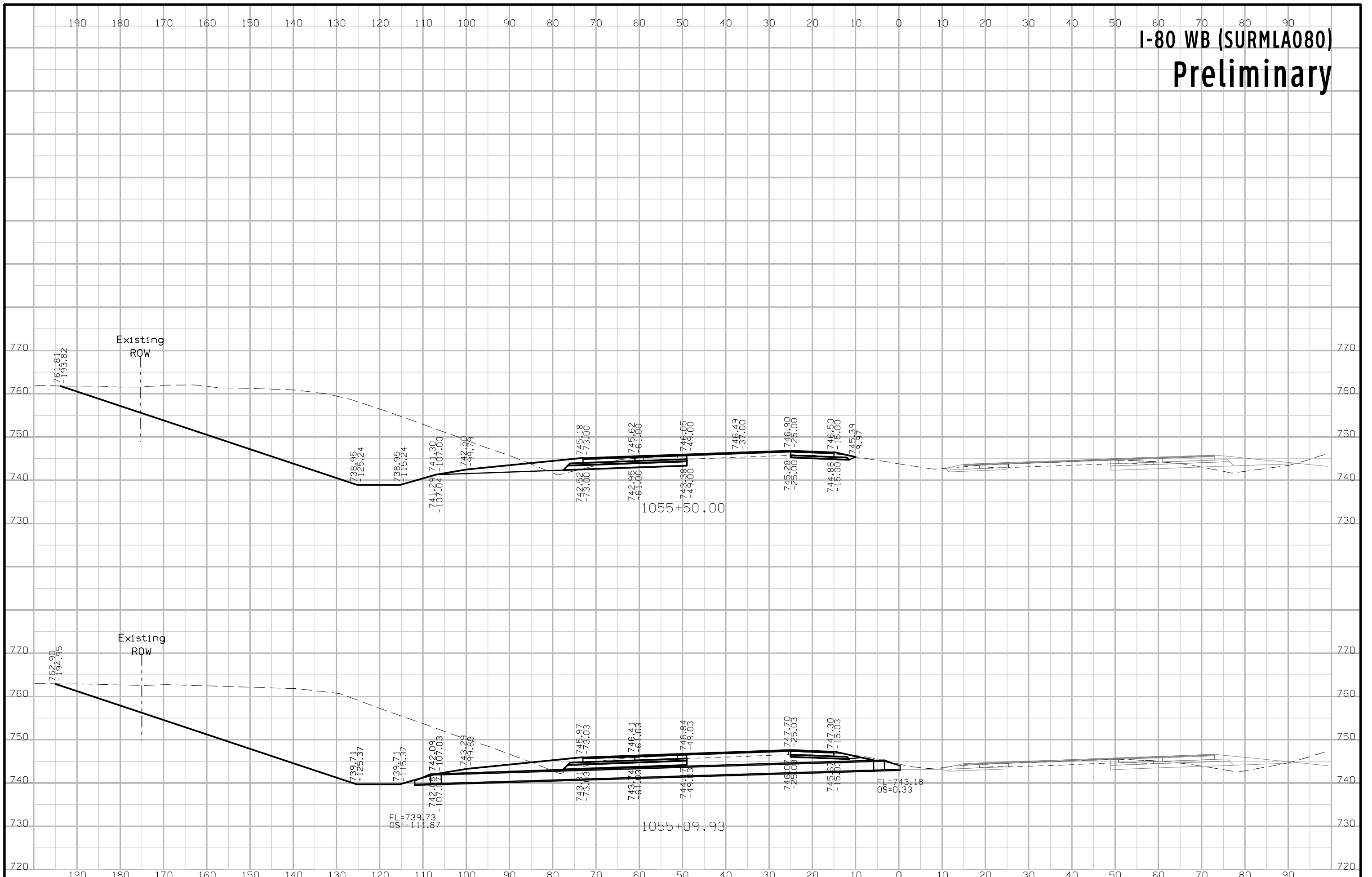



# I-80 WB (SURMLA080) Preliminary

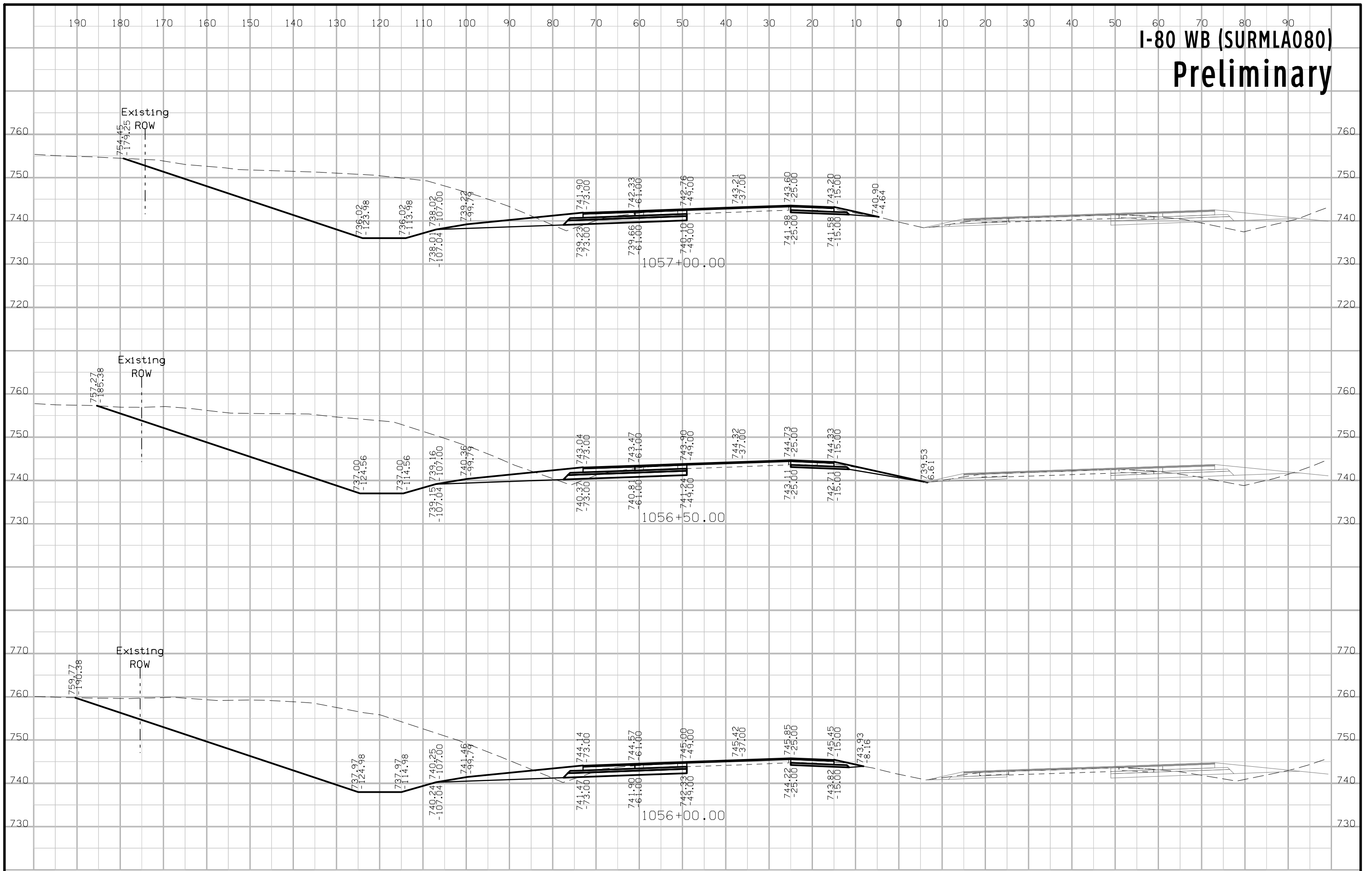

# I-80 WB (SURMLA080) Preliminary

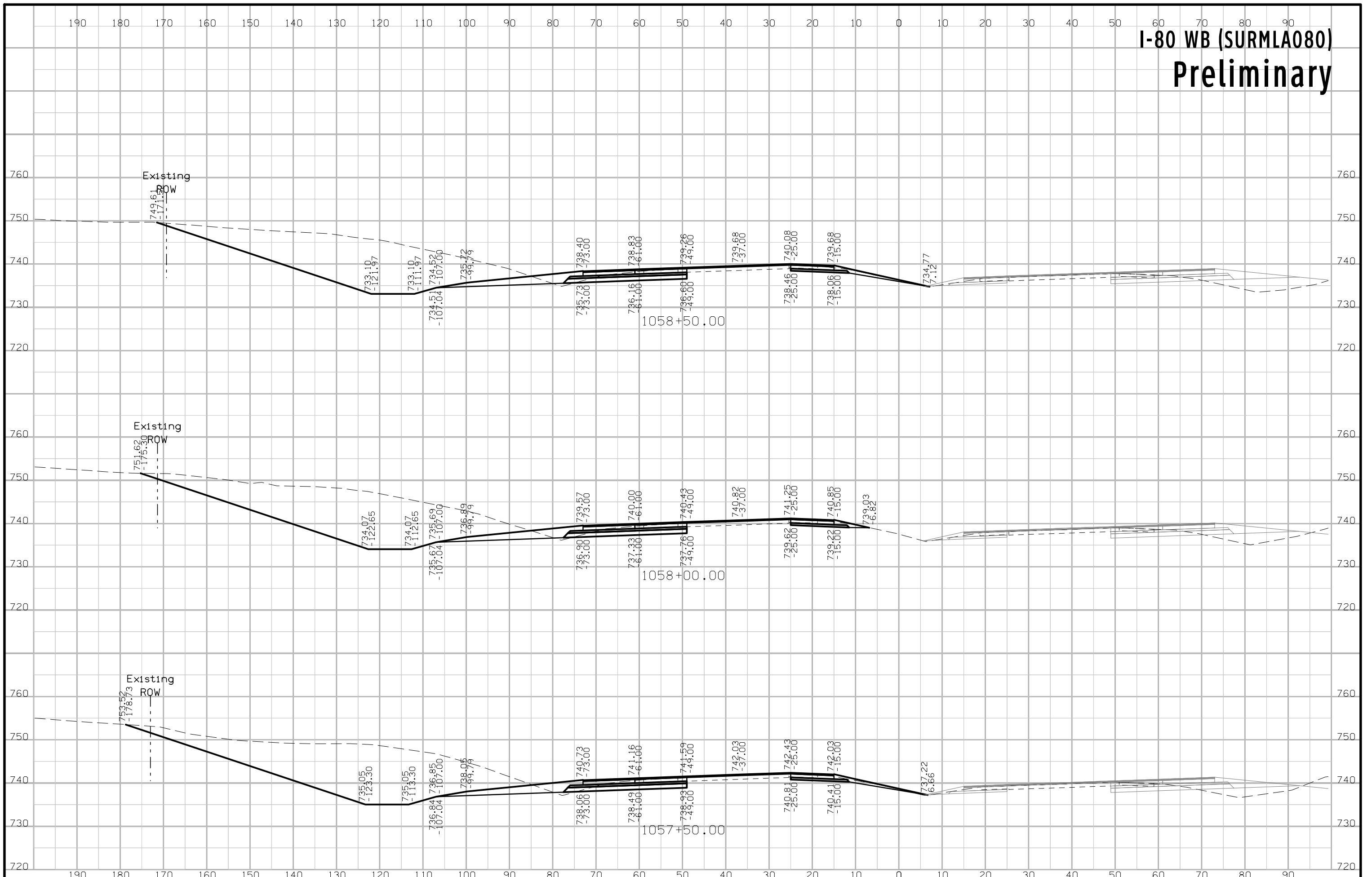

# I-80 WB (SURMLA080) Preliminary

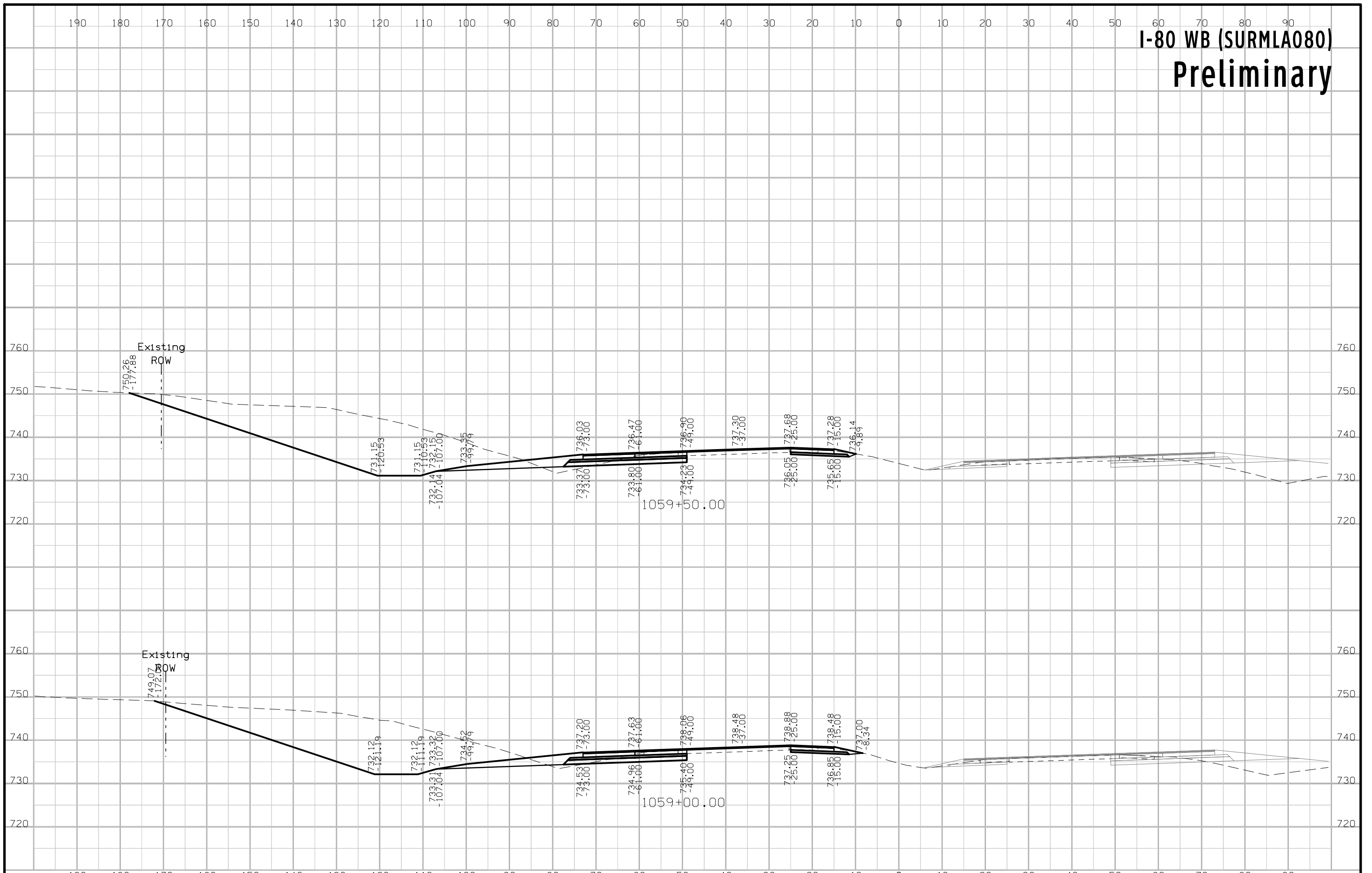

# I-80 WB (SURMLA080) Preliminary

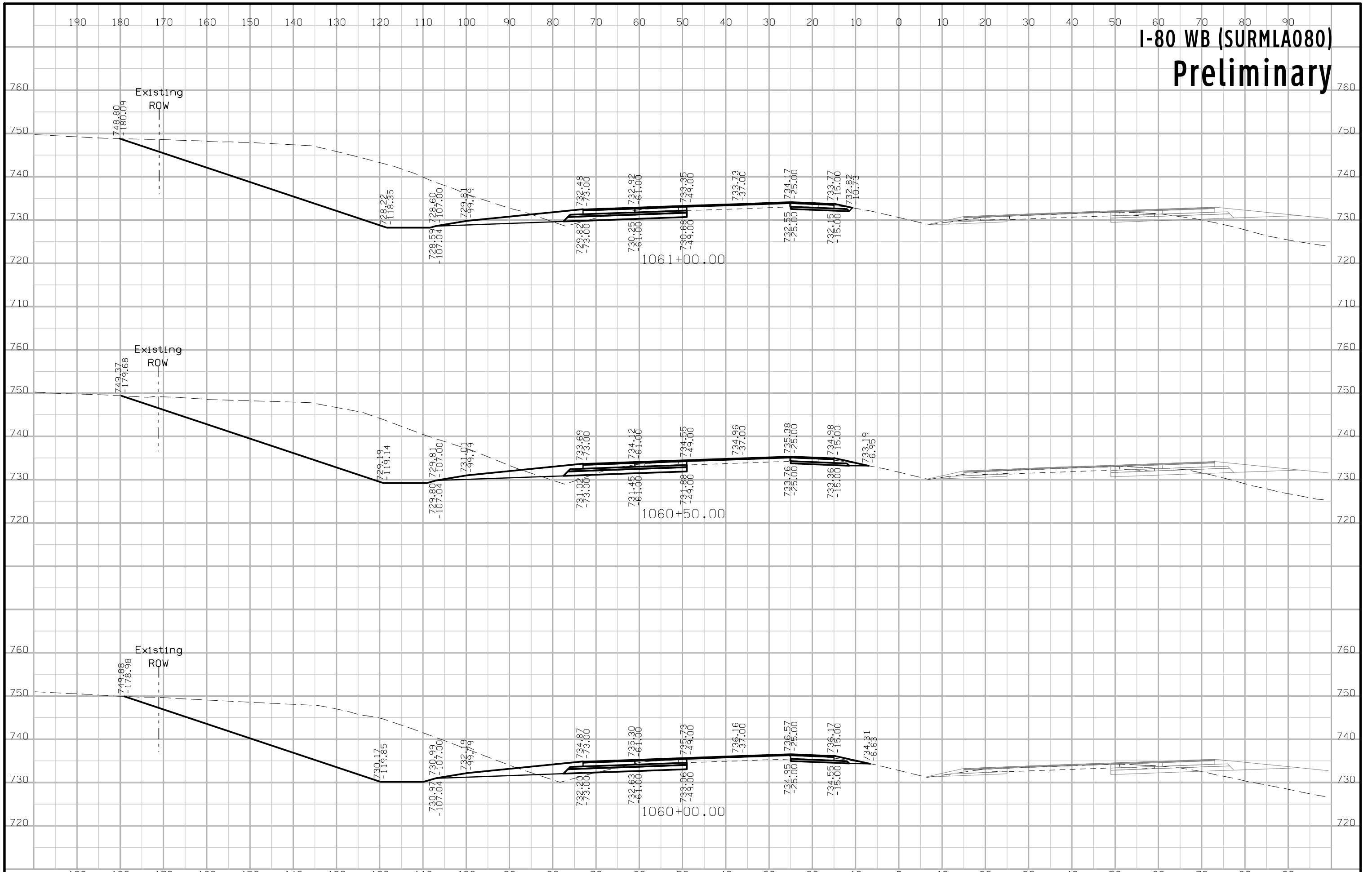

# I-80 WB (SURMLA080) Preliminary

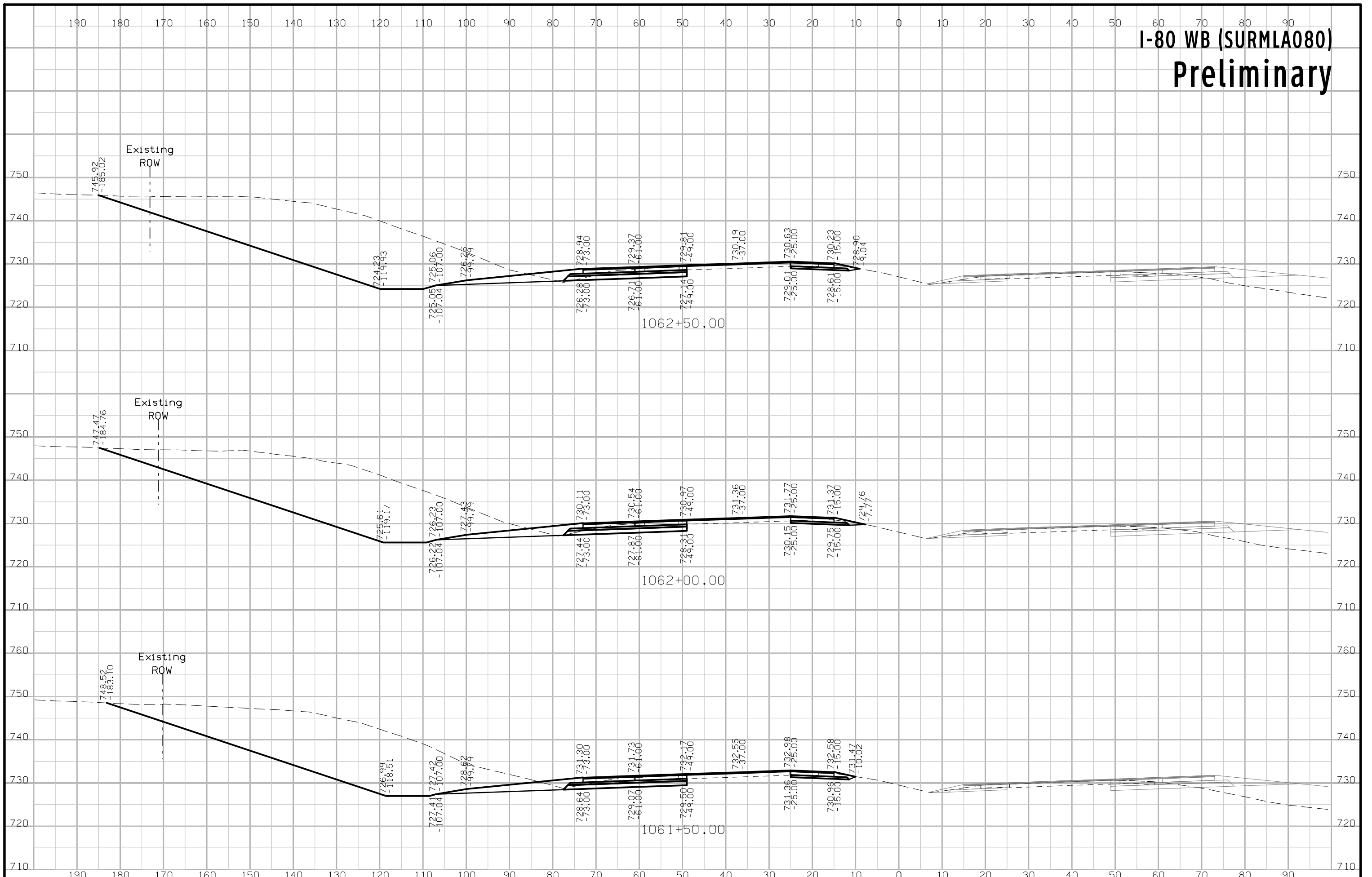



# I-80 WB (SURMLA080) Preliminary

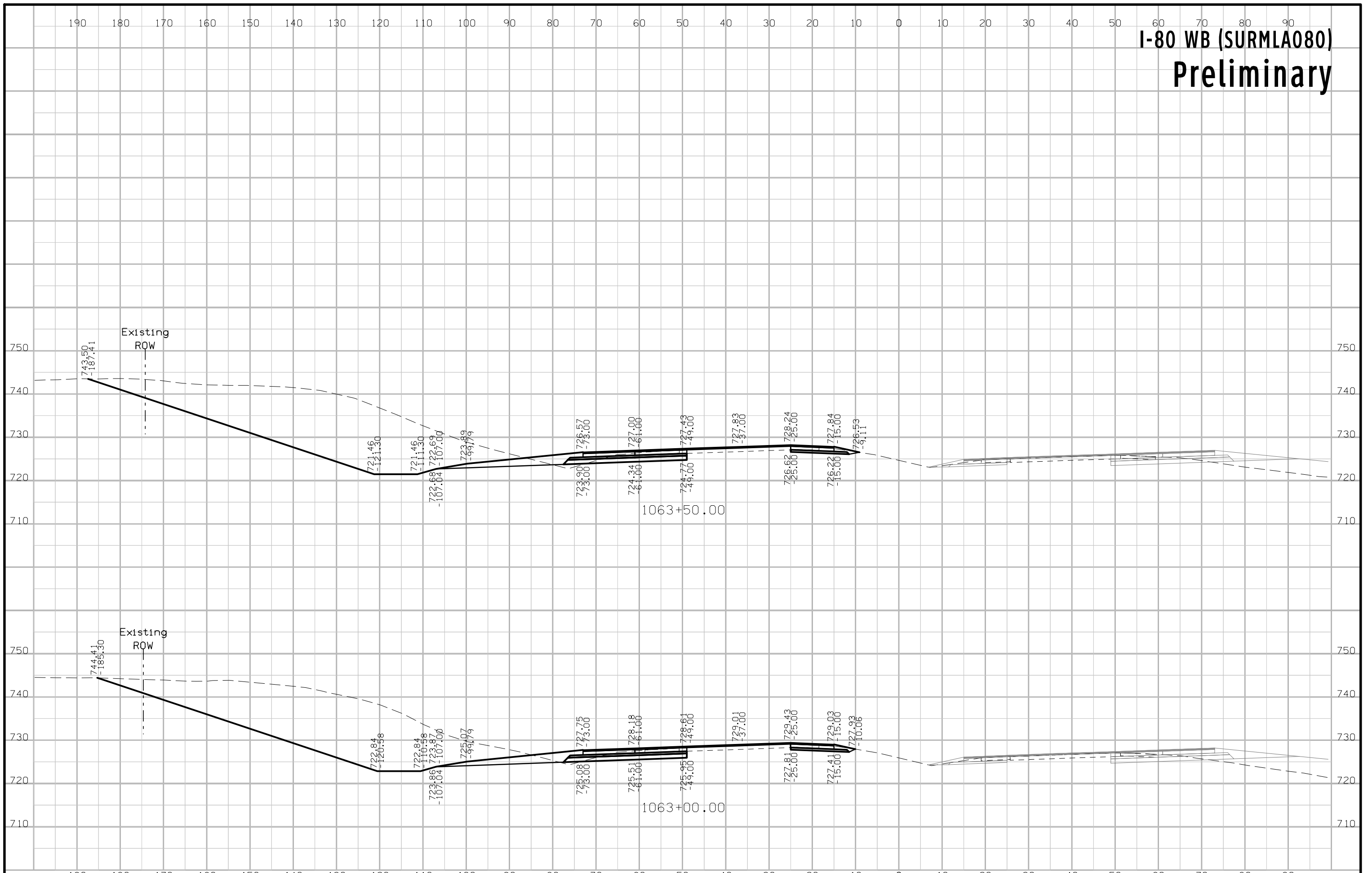

# I-80 WB (SURMLA080) Preliminary

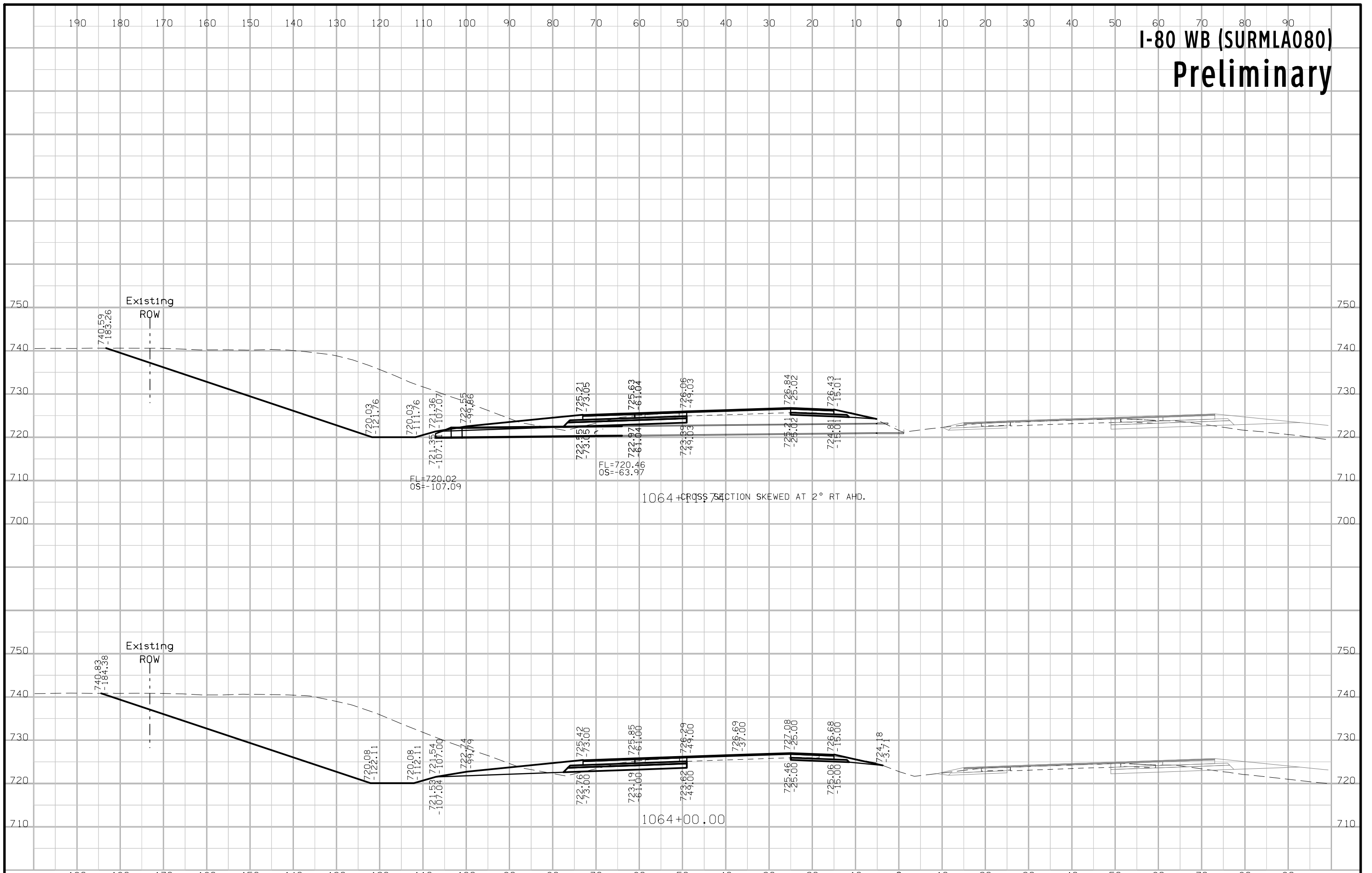

# I-80 WB (SURMLA080) Preliminary

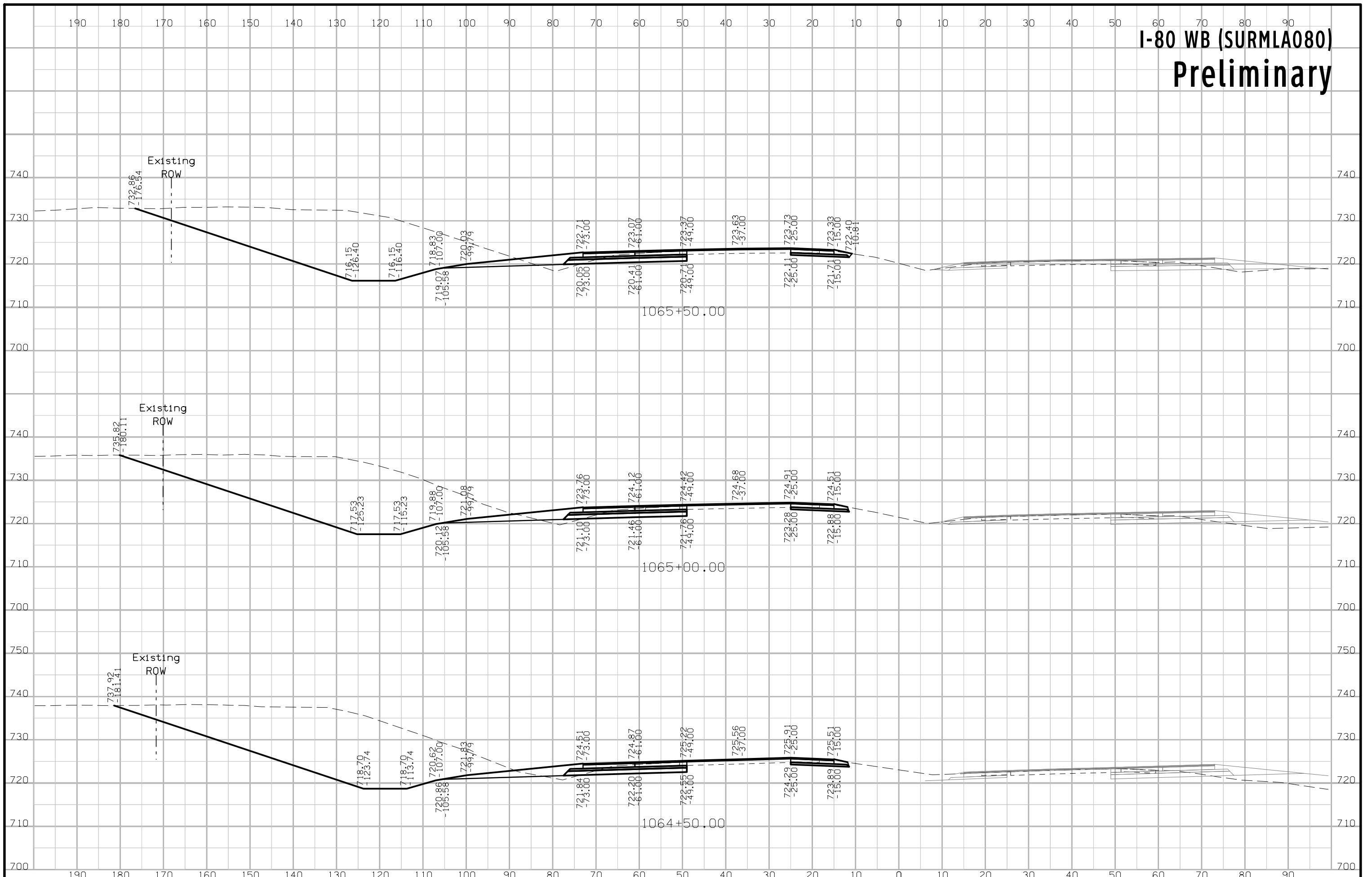

# I-80 WB (SURMLA080) Preliminary

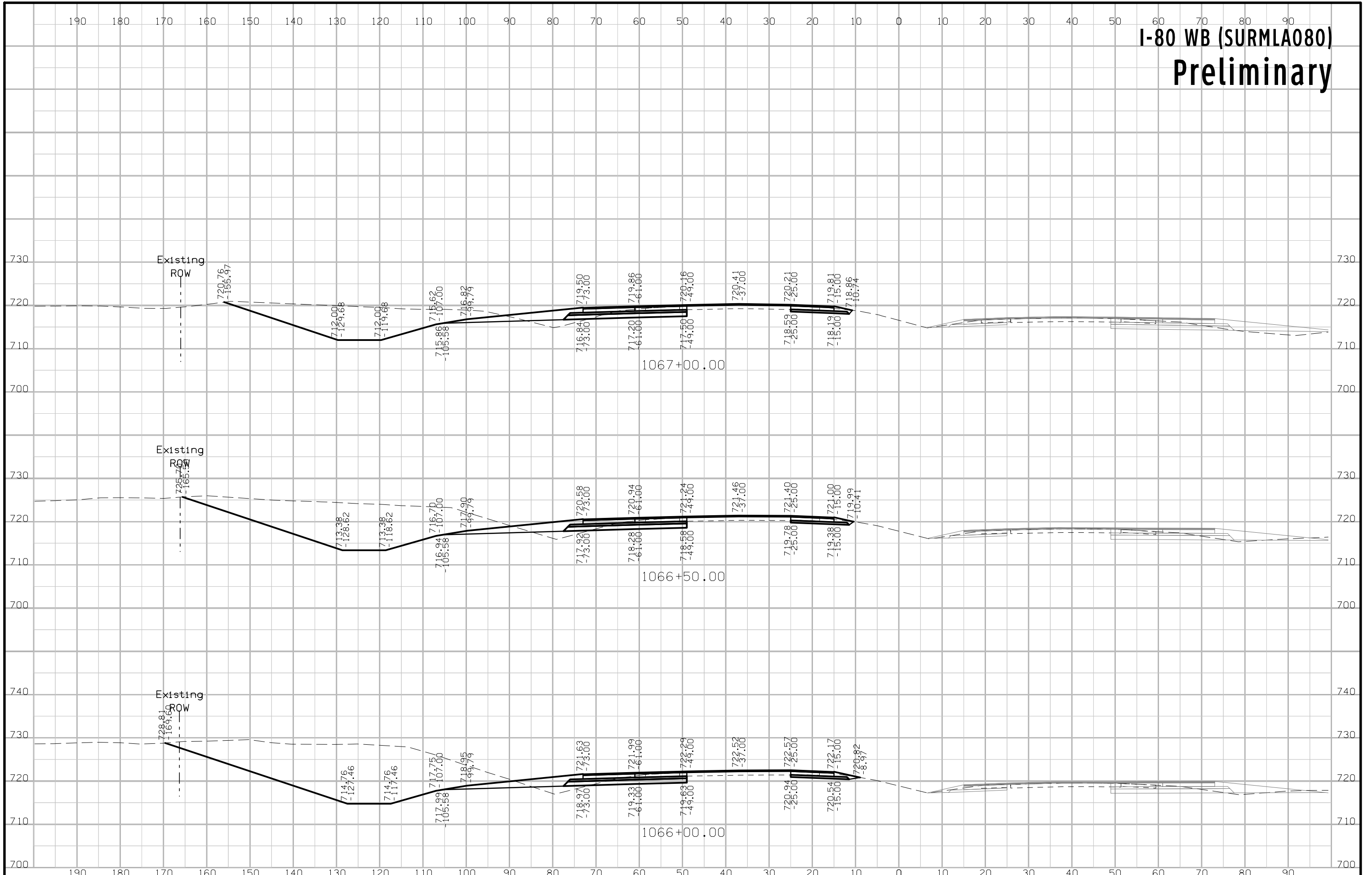

# I-80 WB (SURMLA080) Preliminary

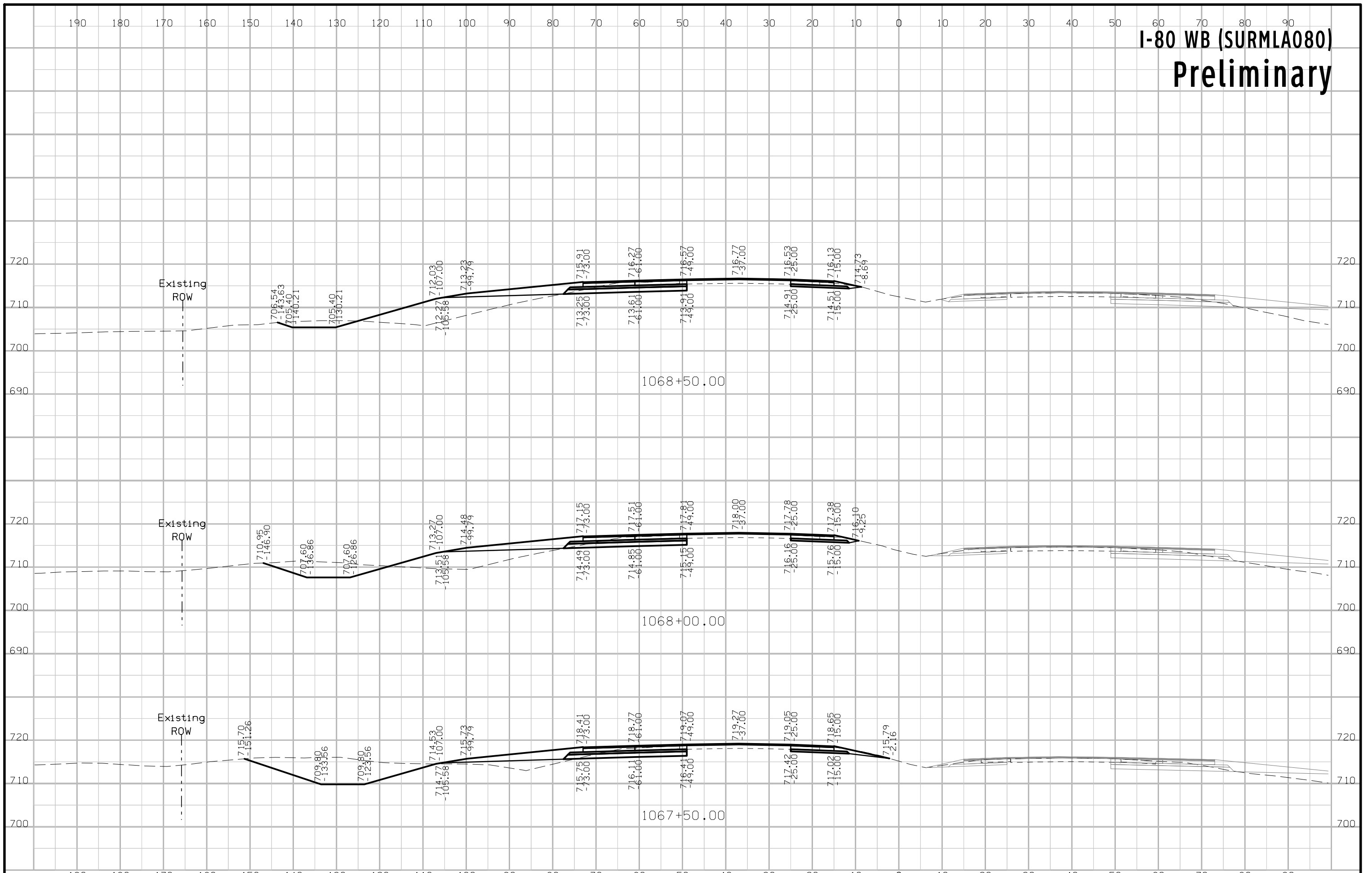



# I-80 WB (SURMLA080) Preliminary

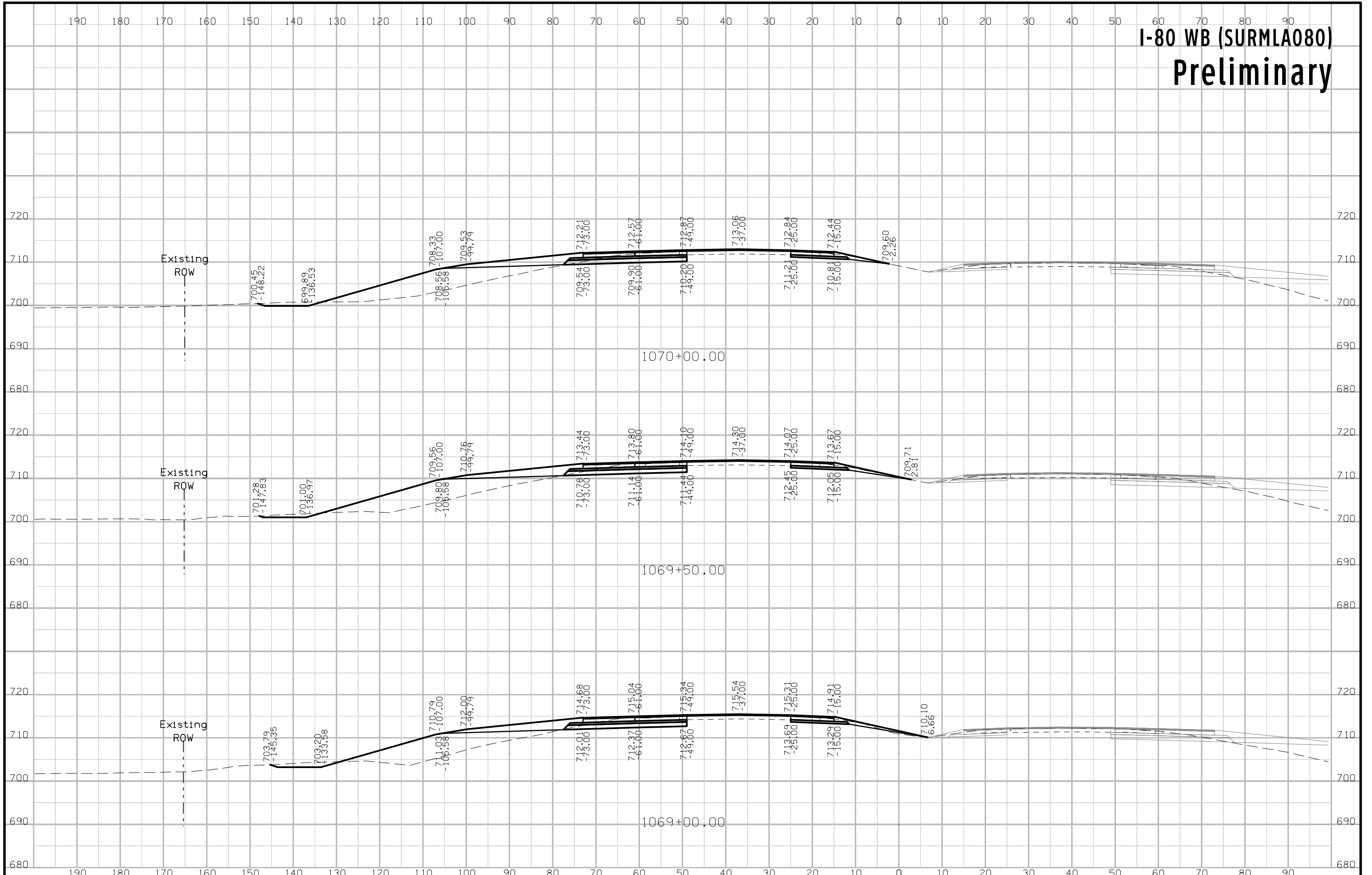

# I-80 WB (SURMLA080) Preliminary

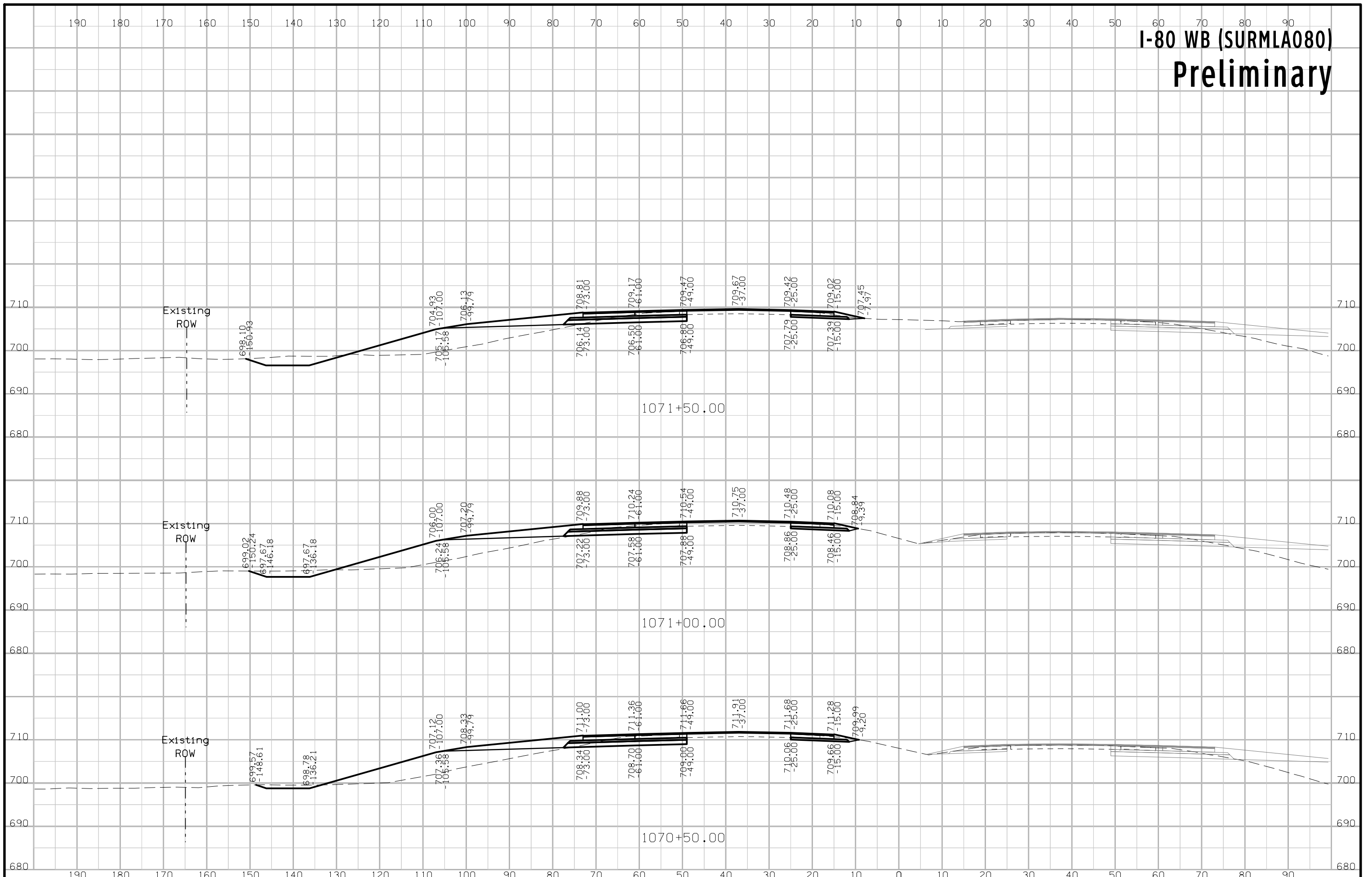

# I-80 WB (SURMLA080) Preliminary

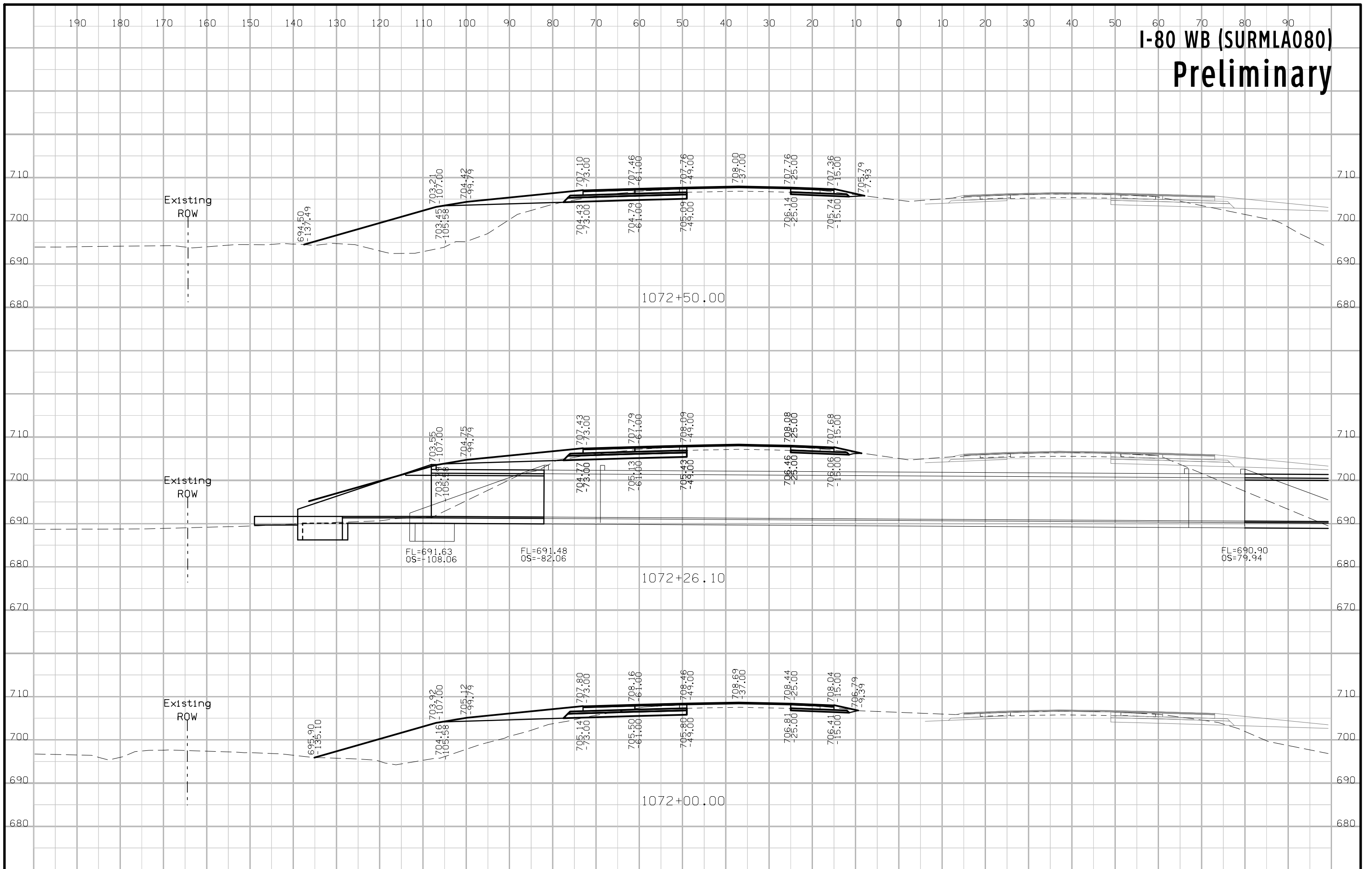

# I-80 WB (SURMLA080) Preliminary

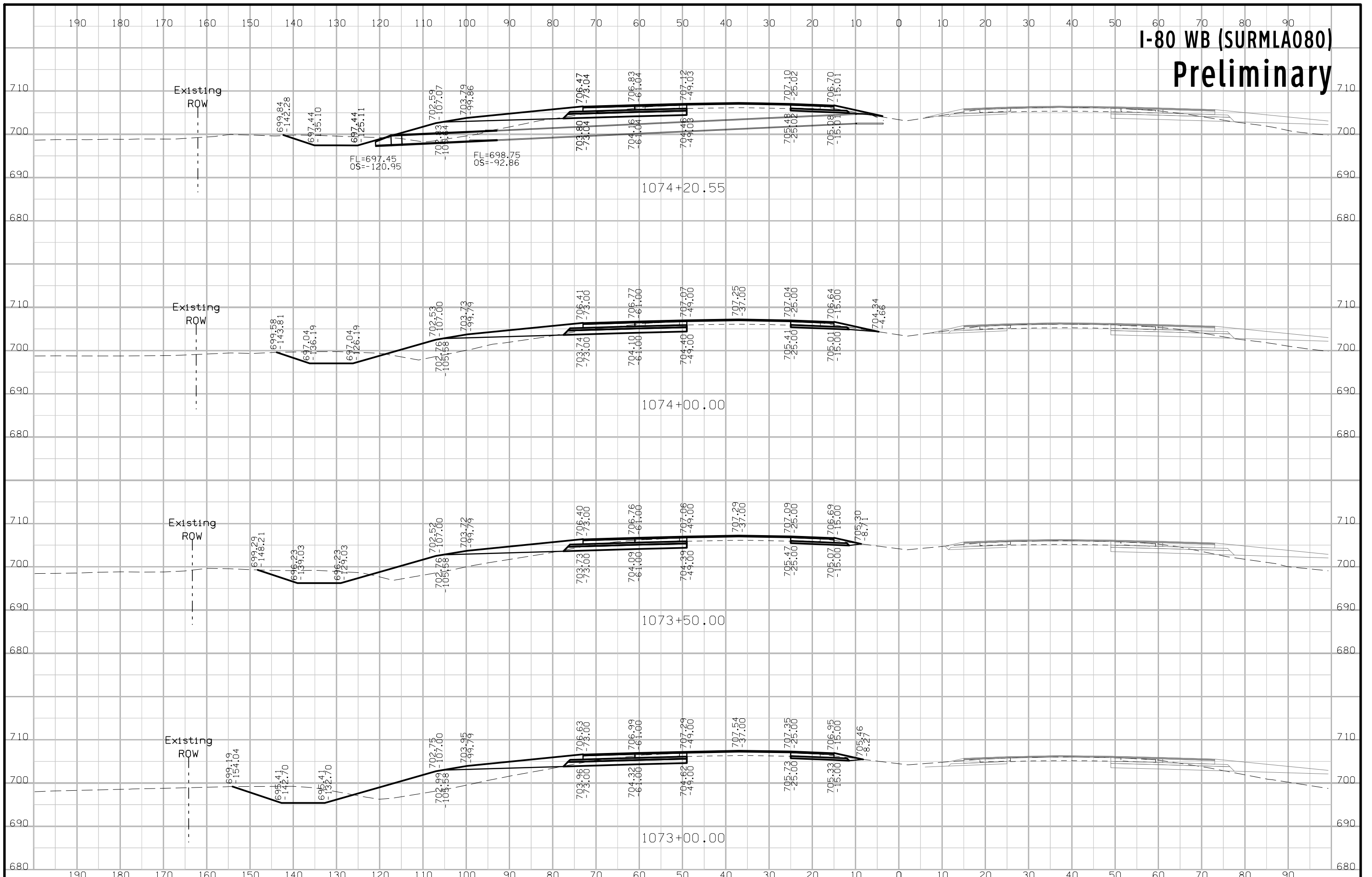

# I-80 WB (SURMLA080) Preliminary

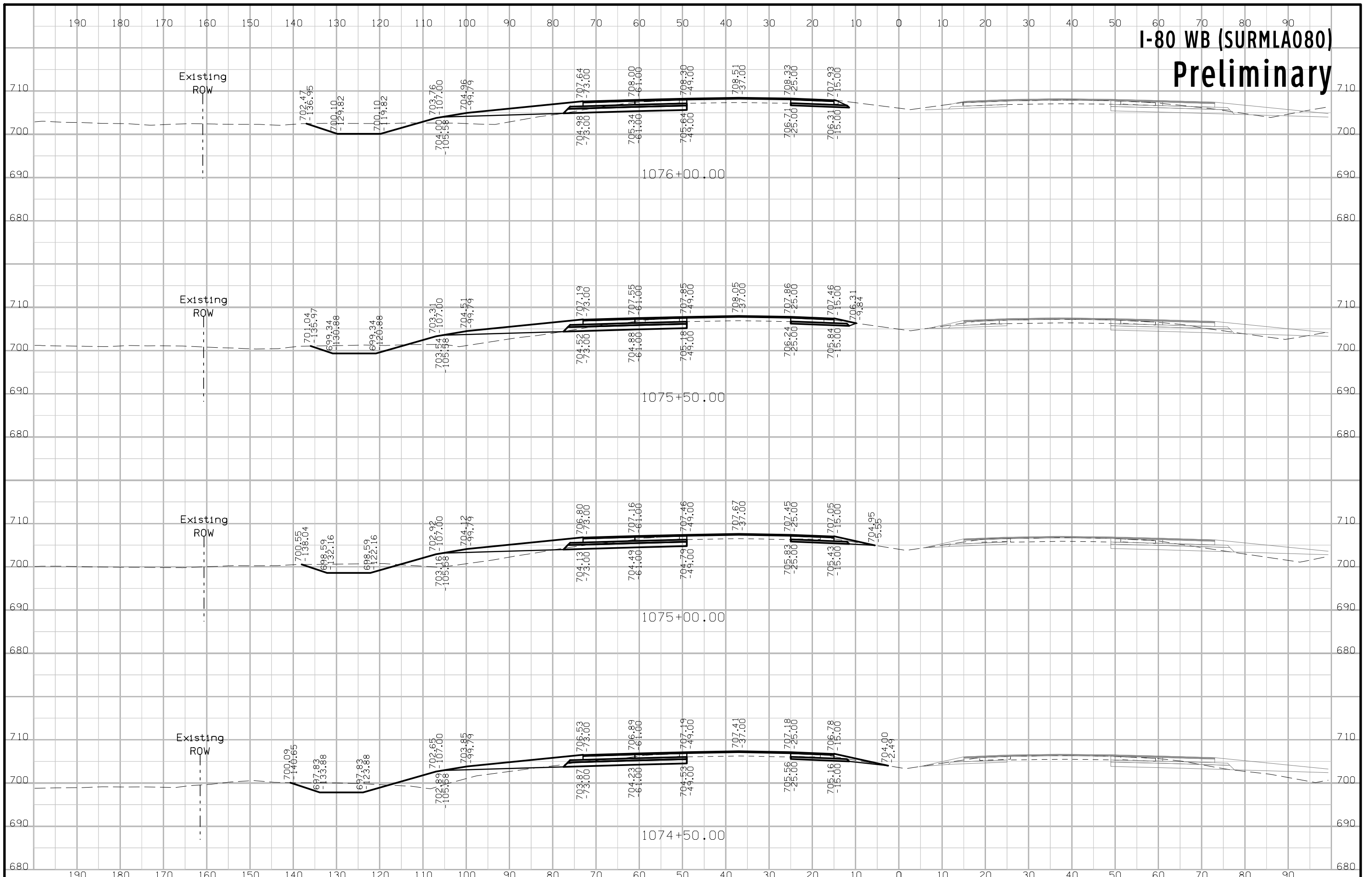



# I-80 WB (SURMLA080) Preliminary

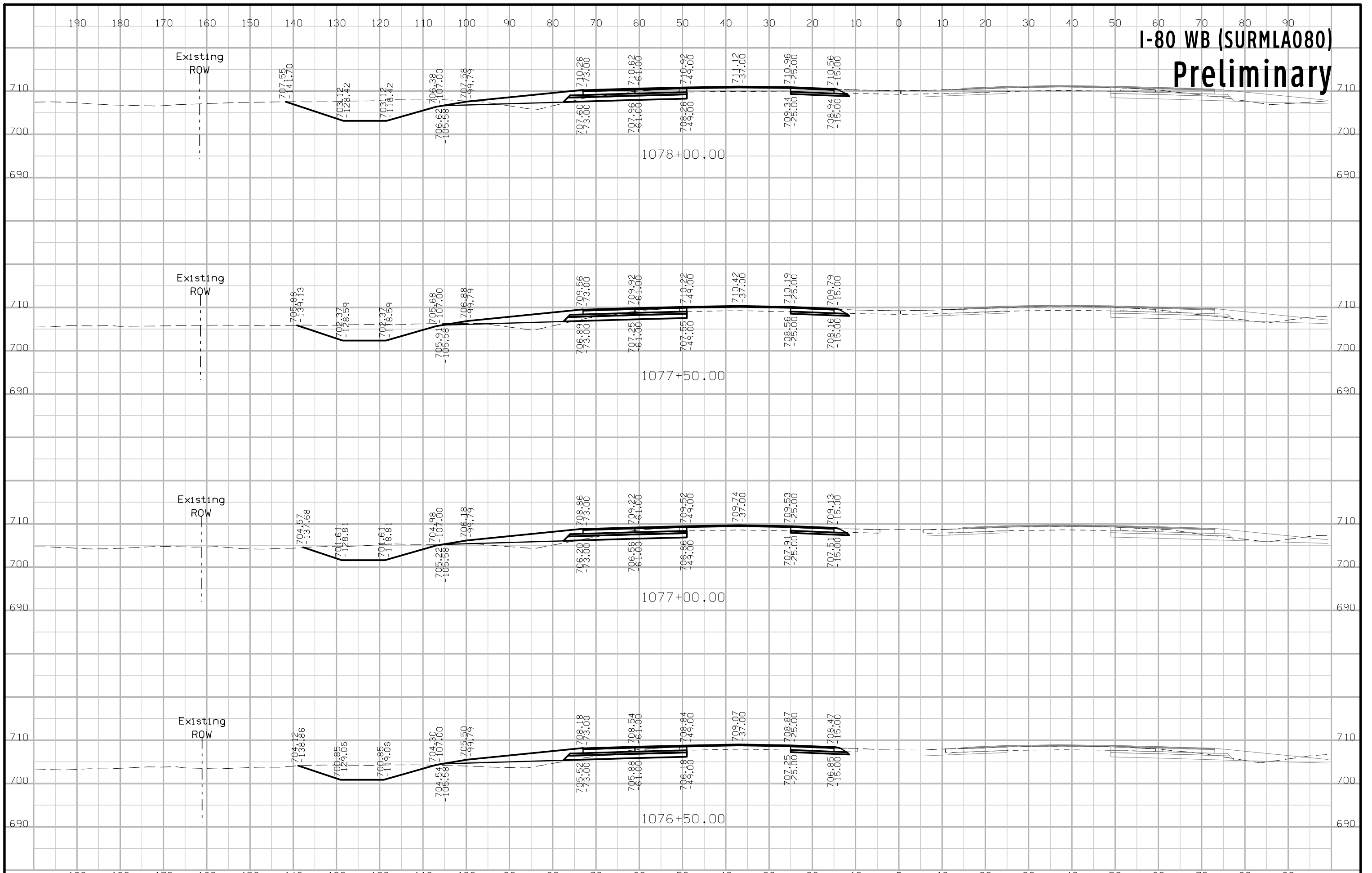

# I-80 WB (SURMLA080) Preliminary

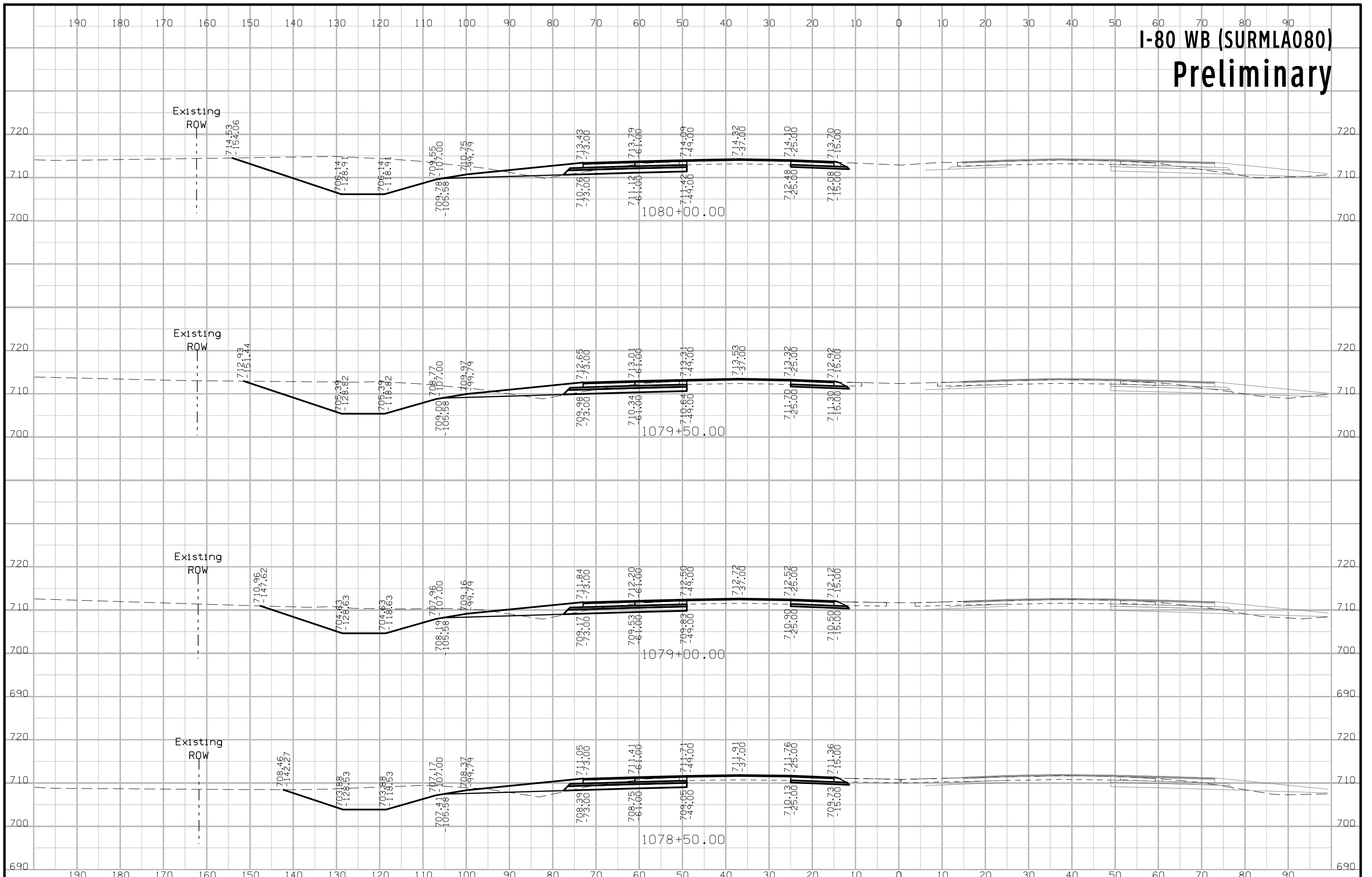

# I-80 WB (SURMLA080) Preliminary

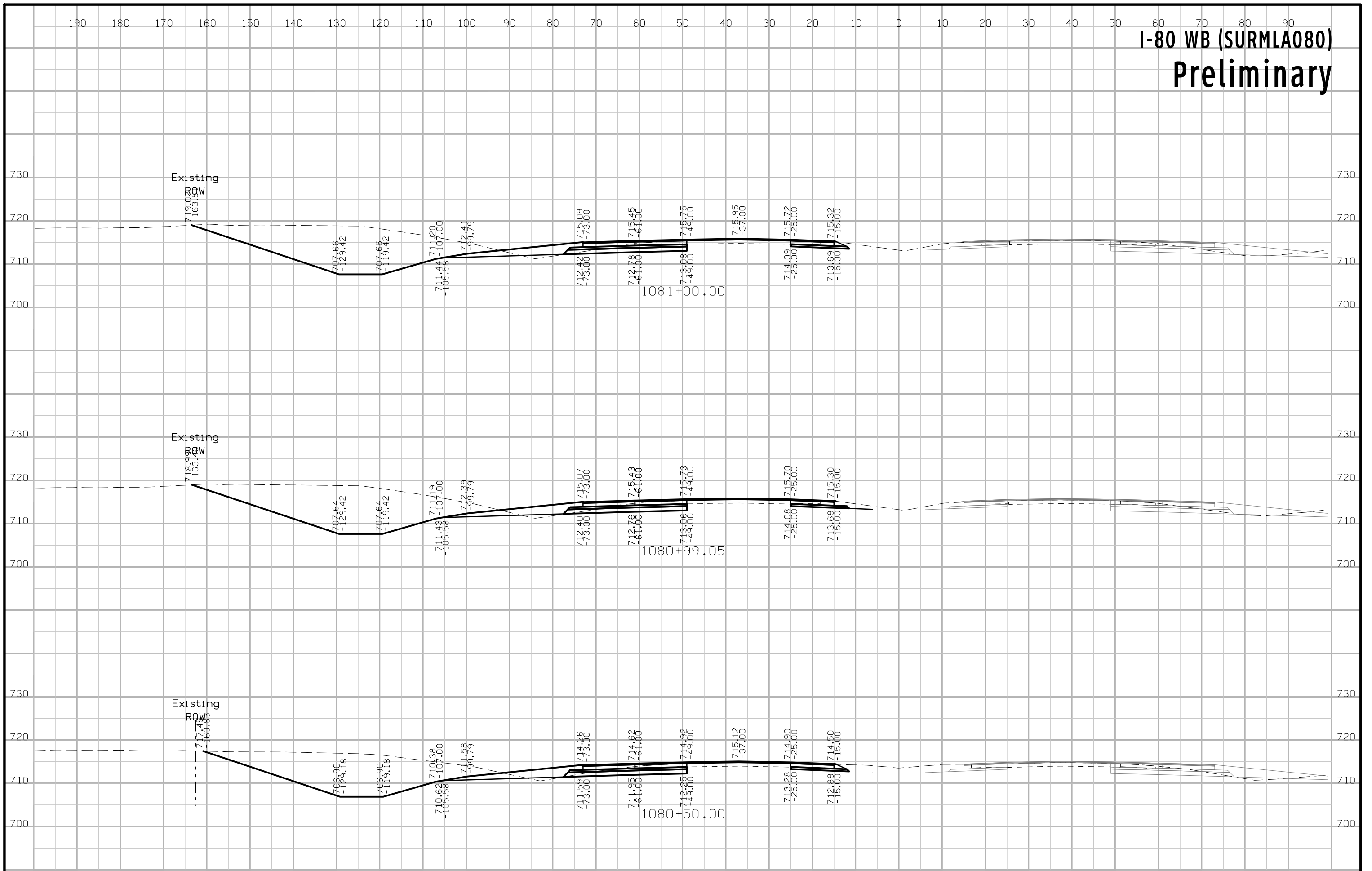

# I-80 WB (SURMLA080) Preliminary

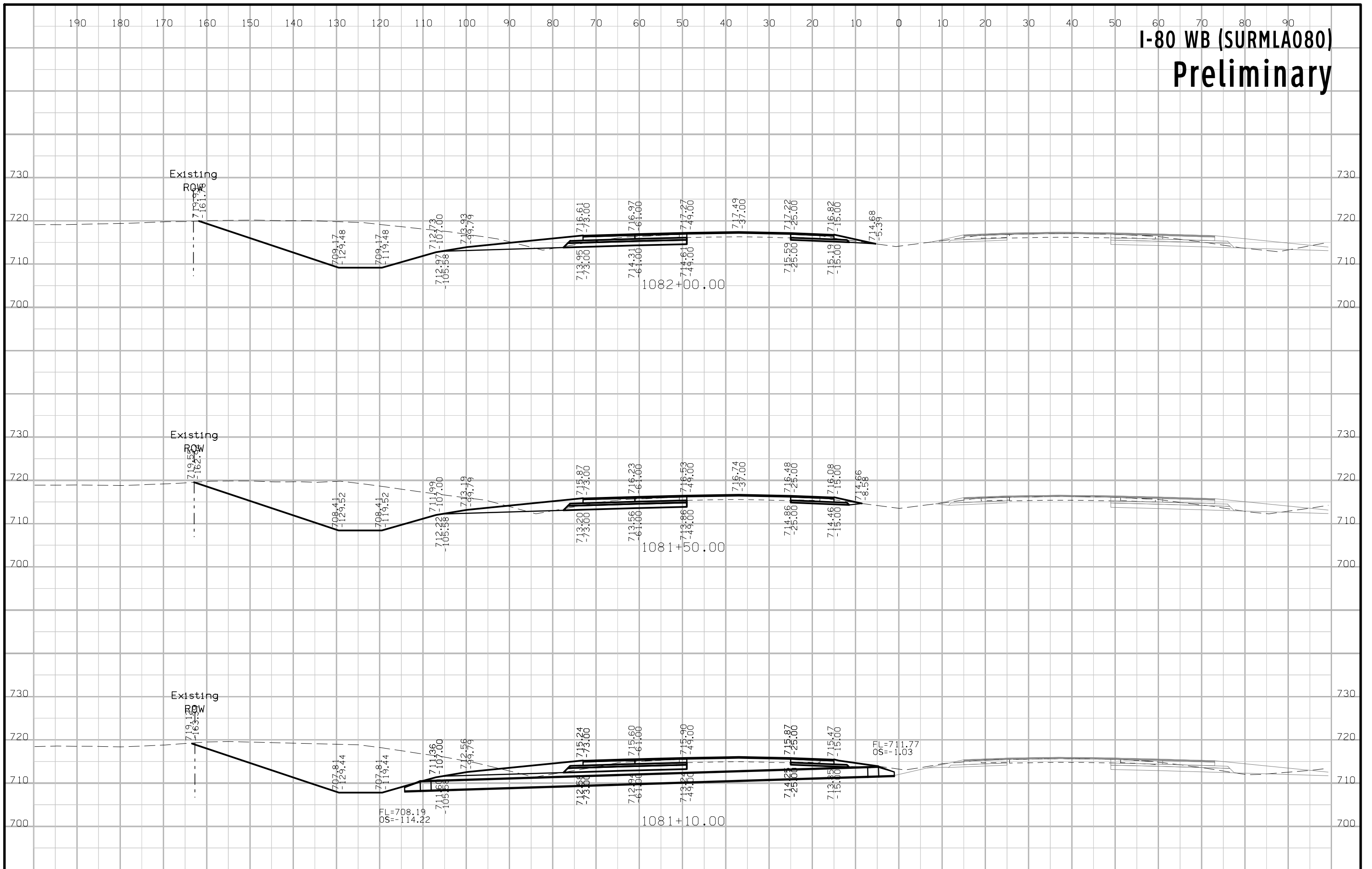

# I-80 WB (SURMLA080) Preliminary

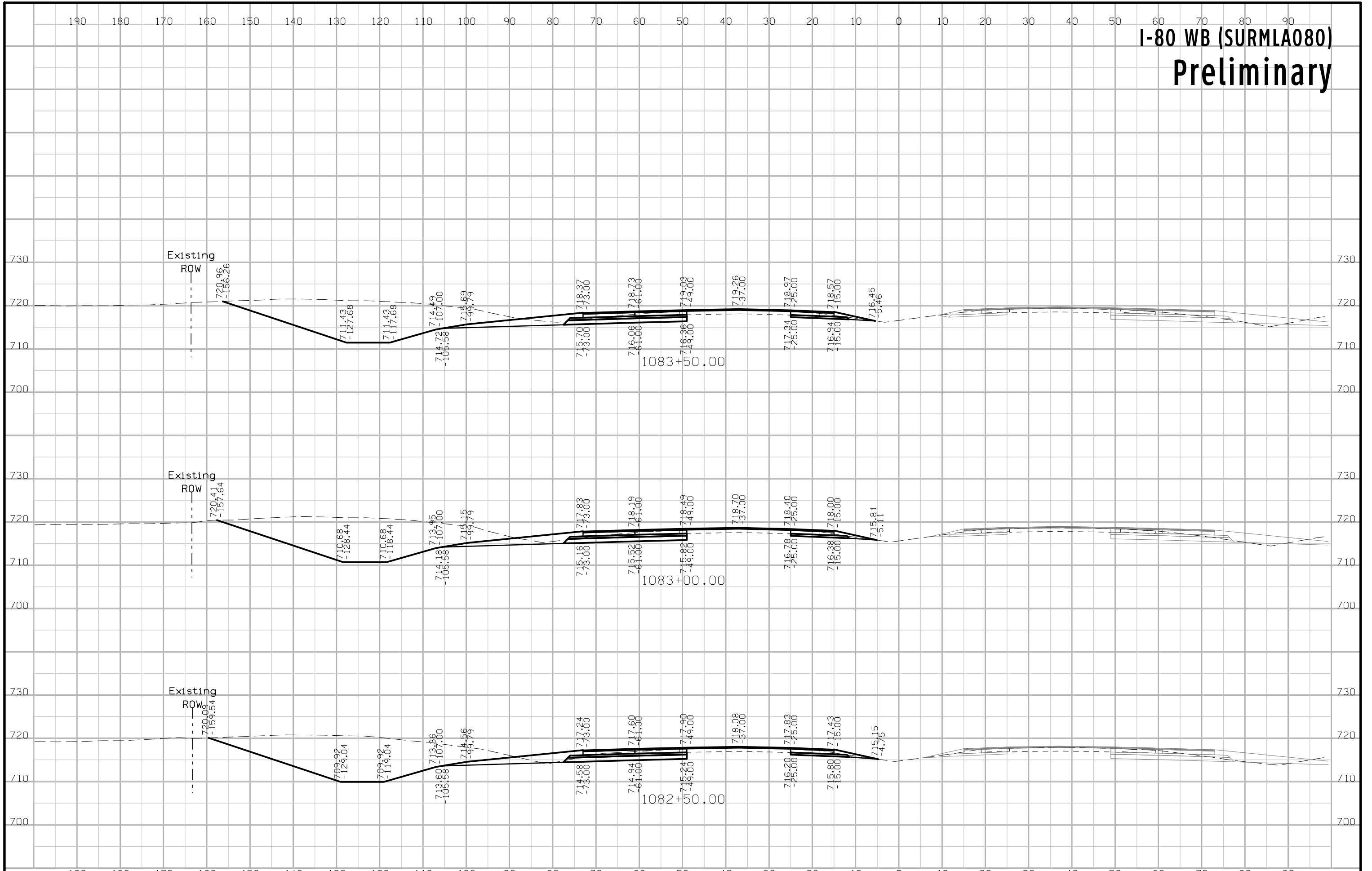



# I-80 WB (SURMLA080) Preliminary

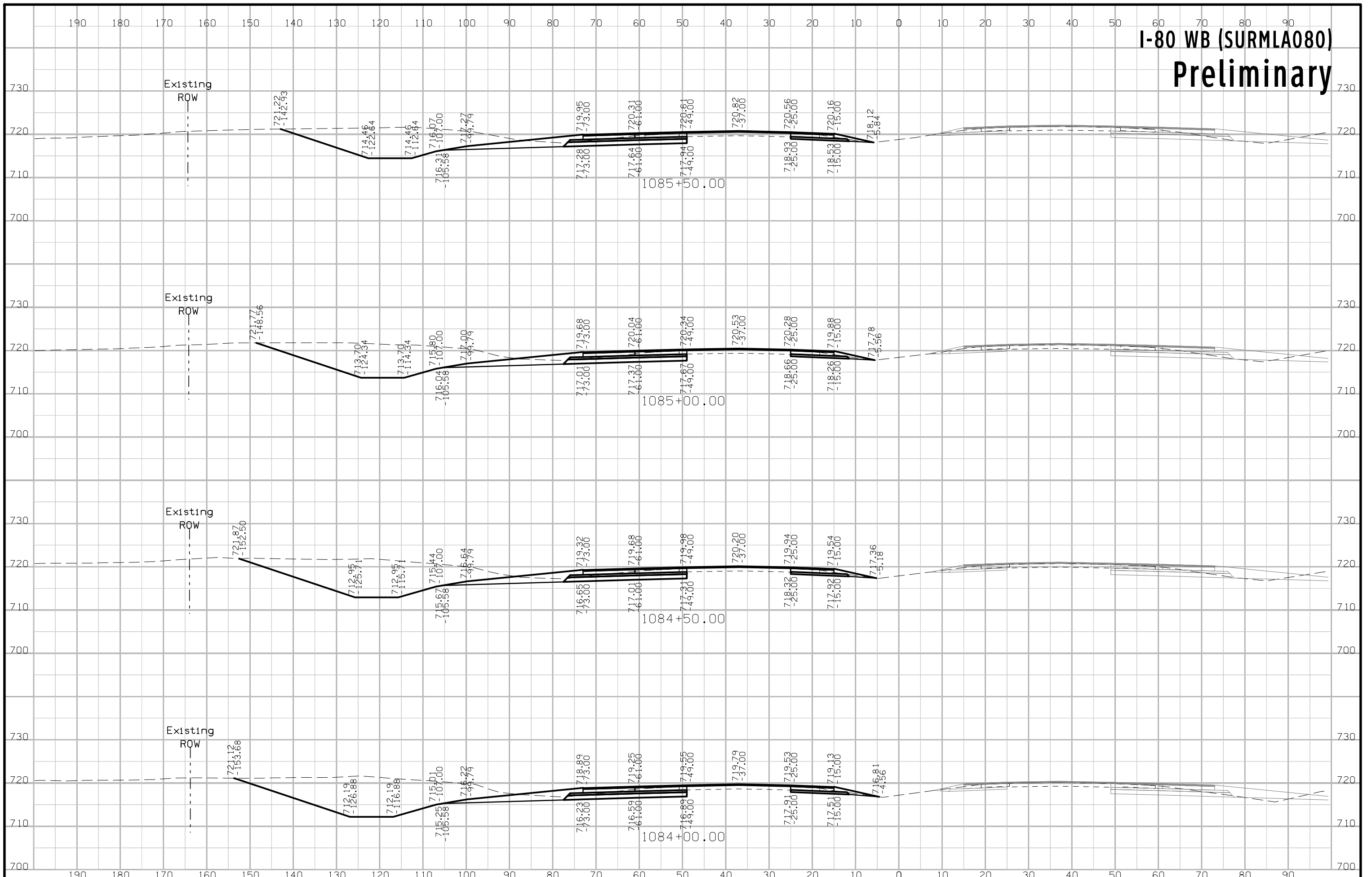

# I-80 WB (SURMLA080) Preliminary

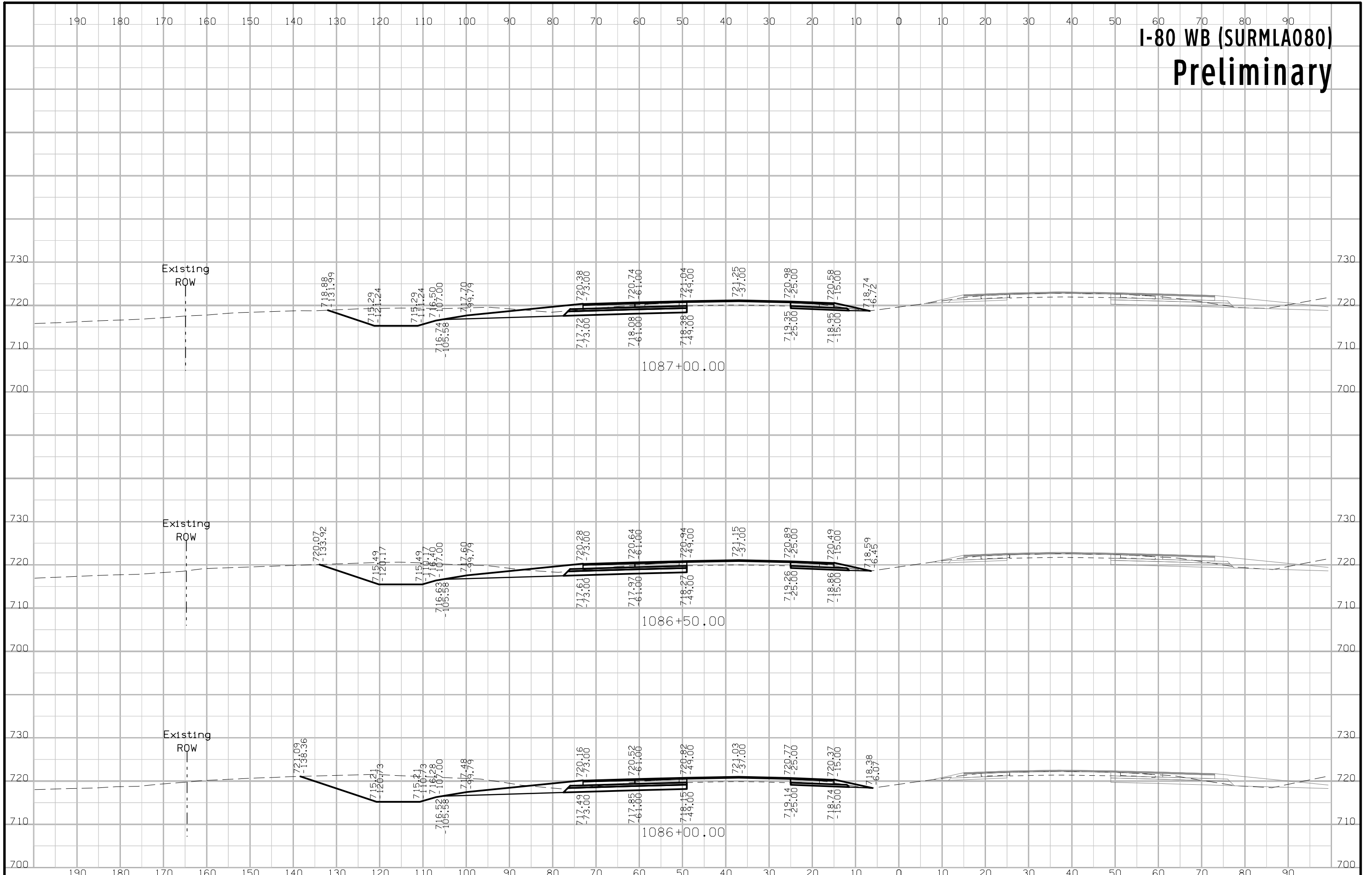

# I-80 WB (SURMLA080) Preliminary

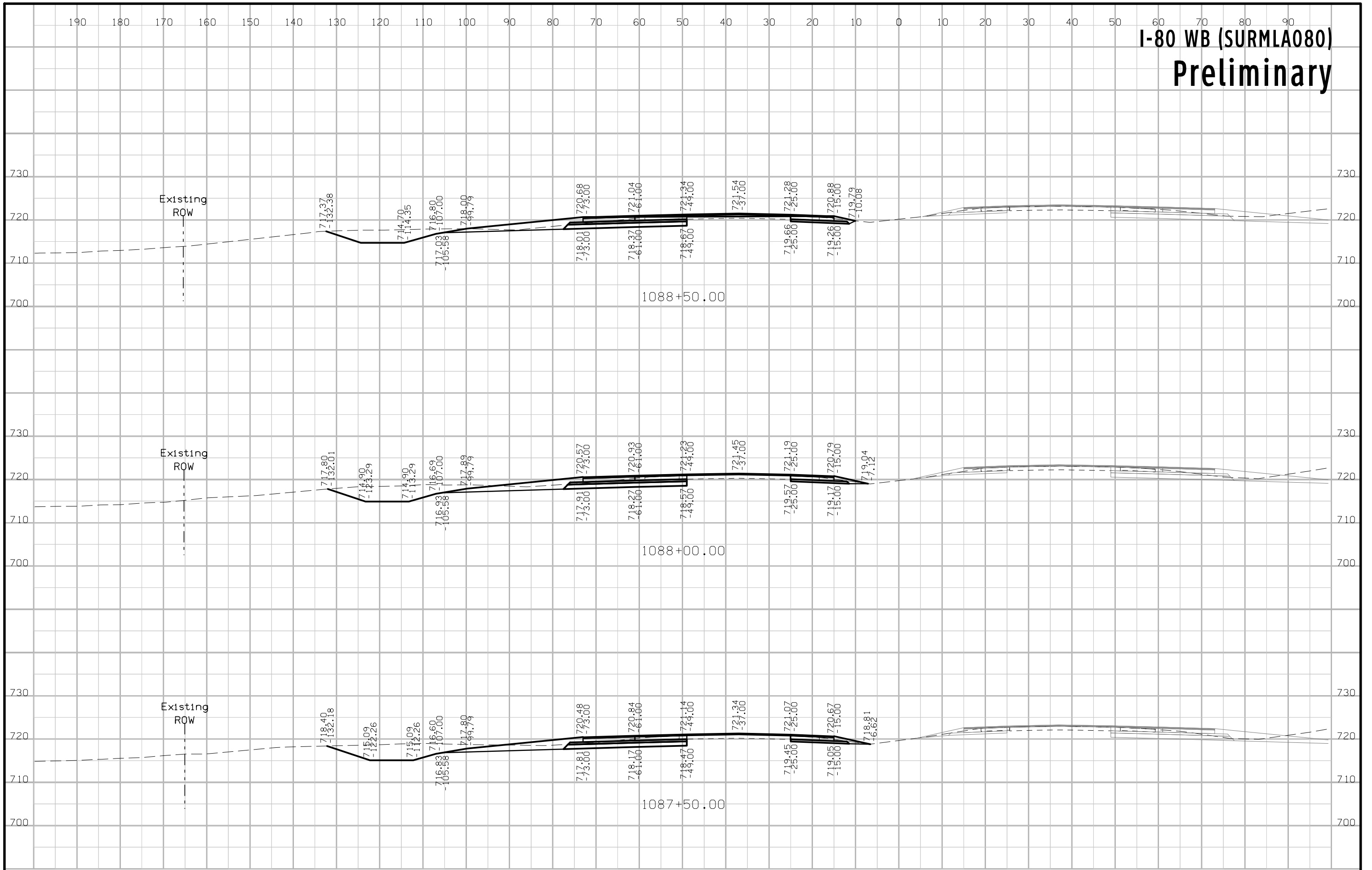

# I-80 WB (SURMLA080) Preliminary

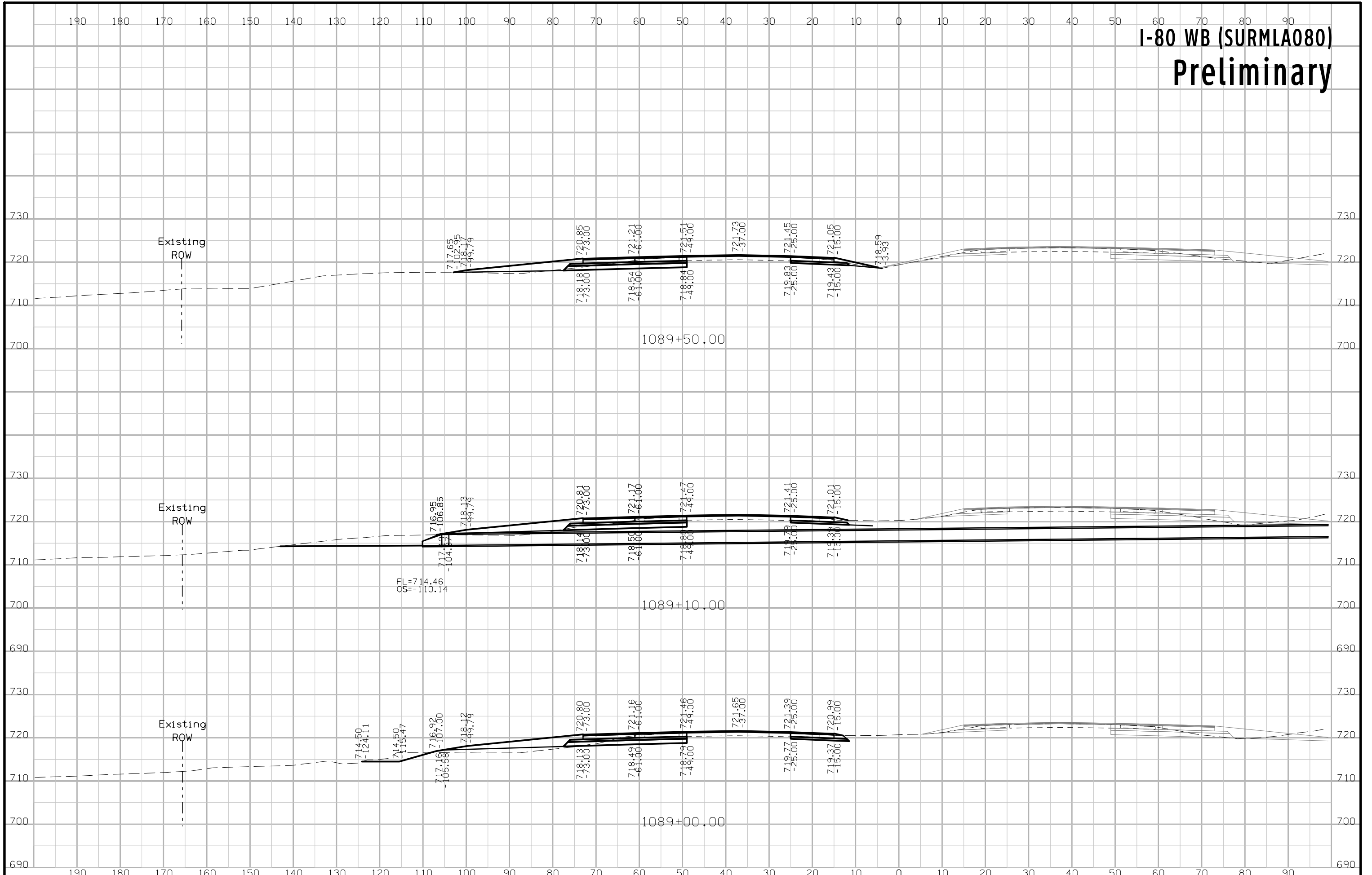

# I-80 WB (SURMLA080) Preliminary

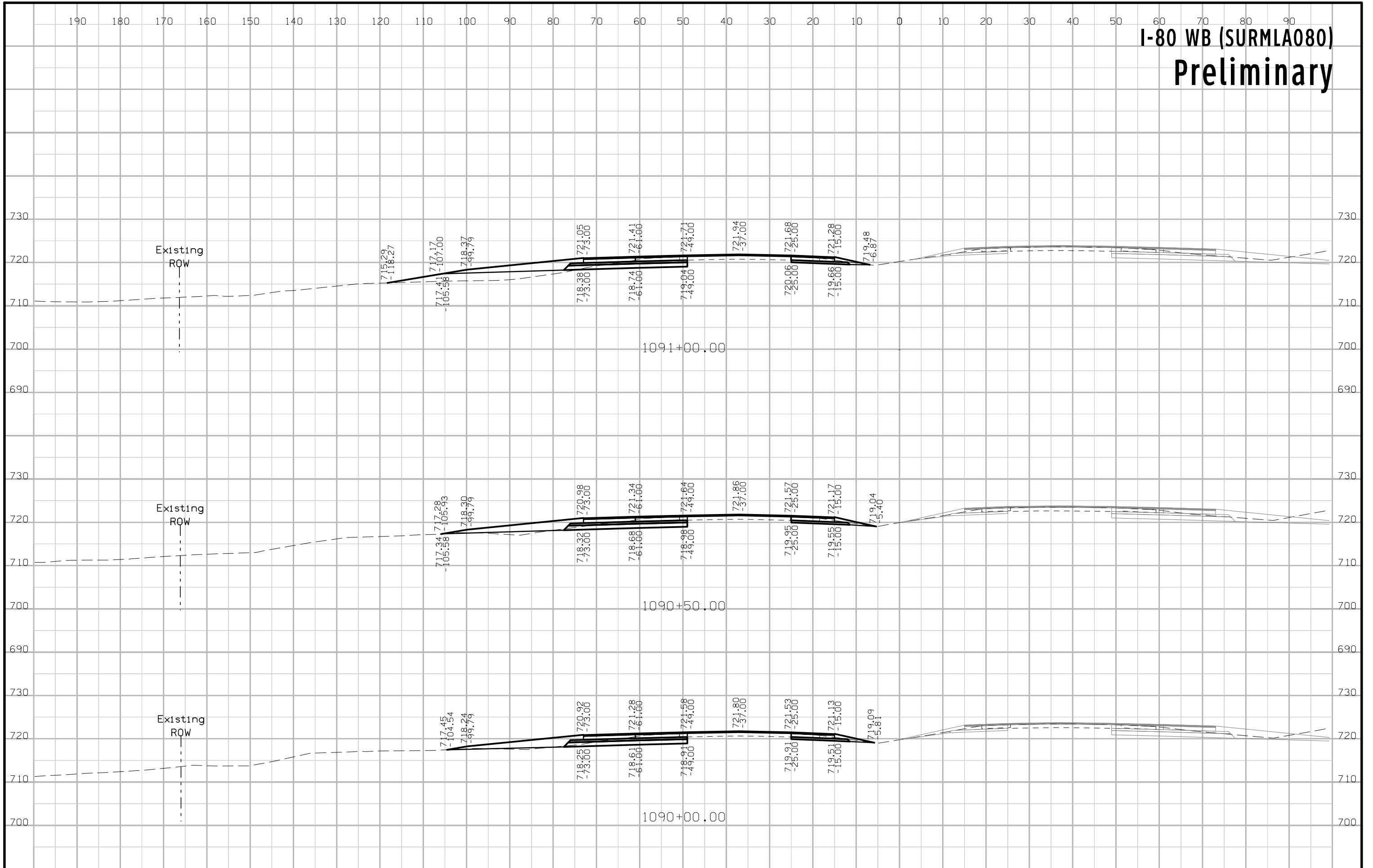



# I-80 WB (SURMLA080) Preliminary

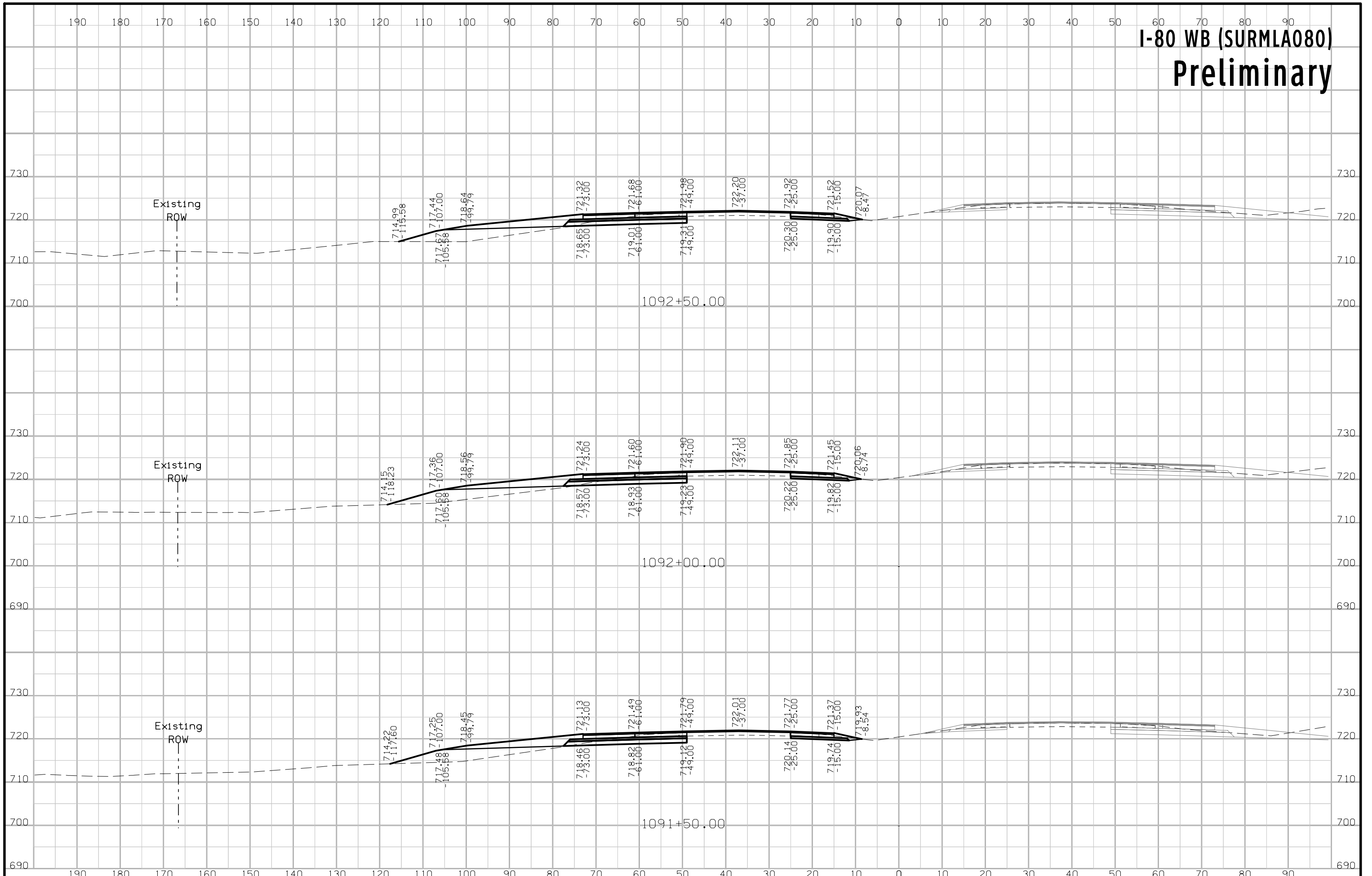

# I-80 WB (SURMLA080) Preliminary

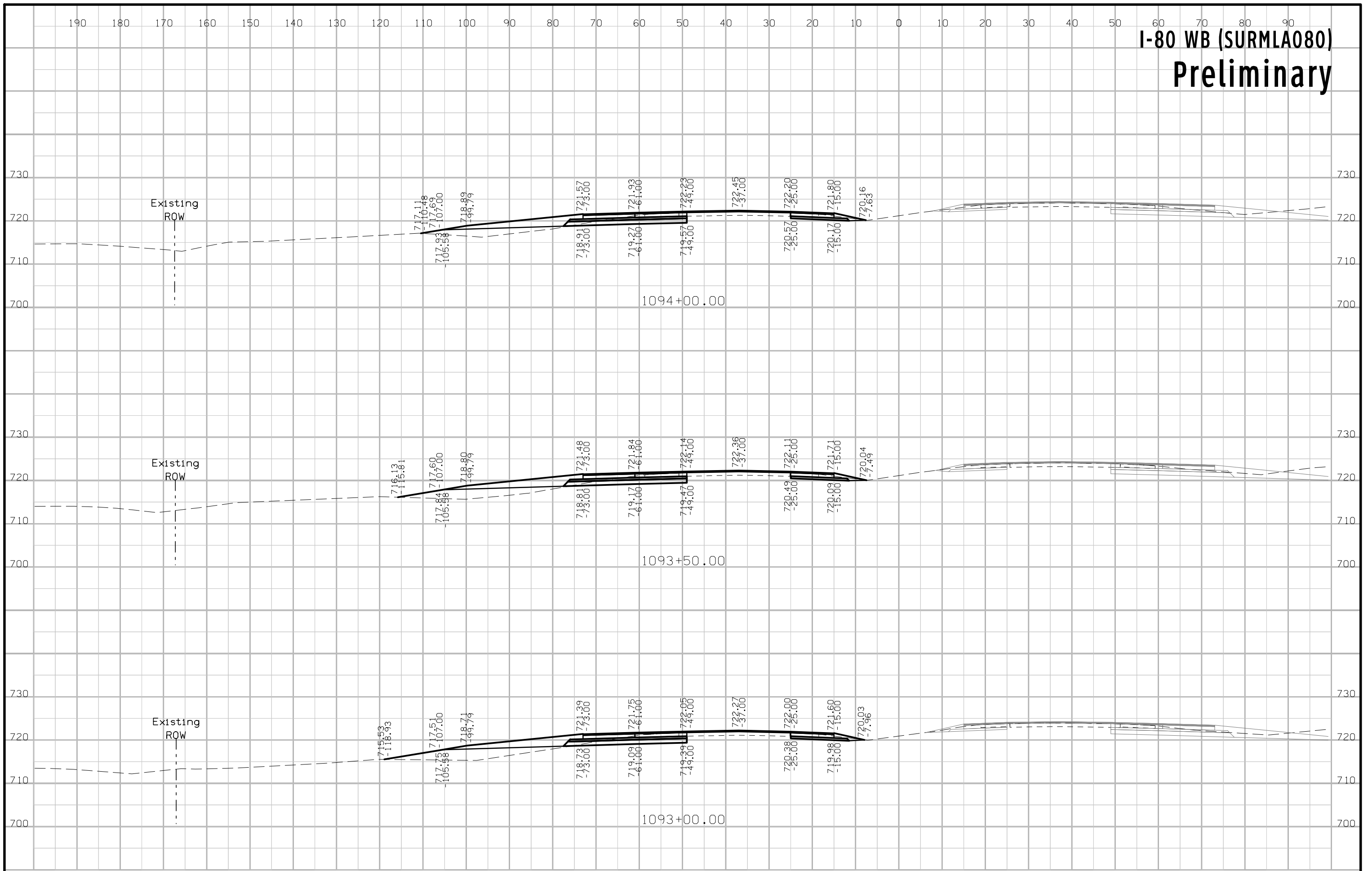

# I-80 WB (SURMLA080) Preliminary

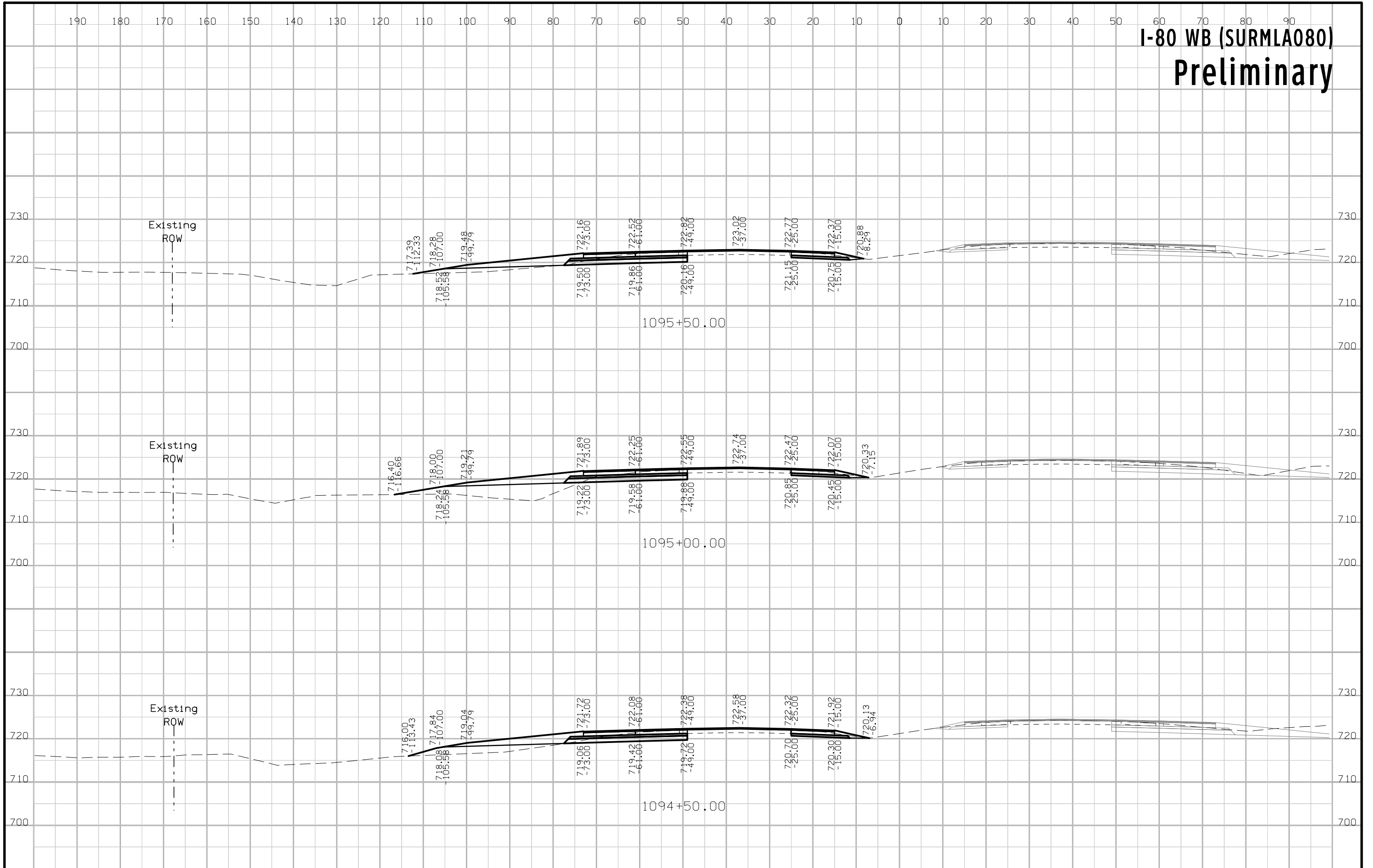

# I-80 WB (SURMLA080) Preliminary

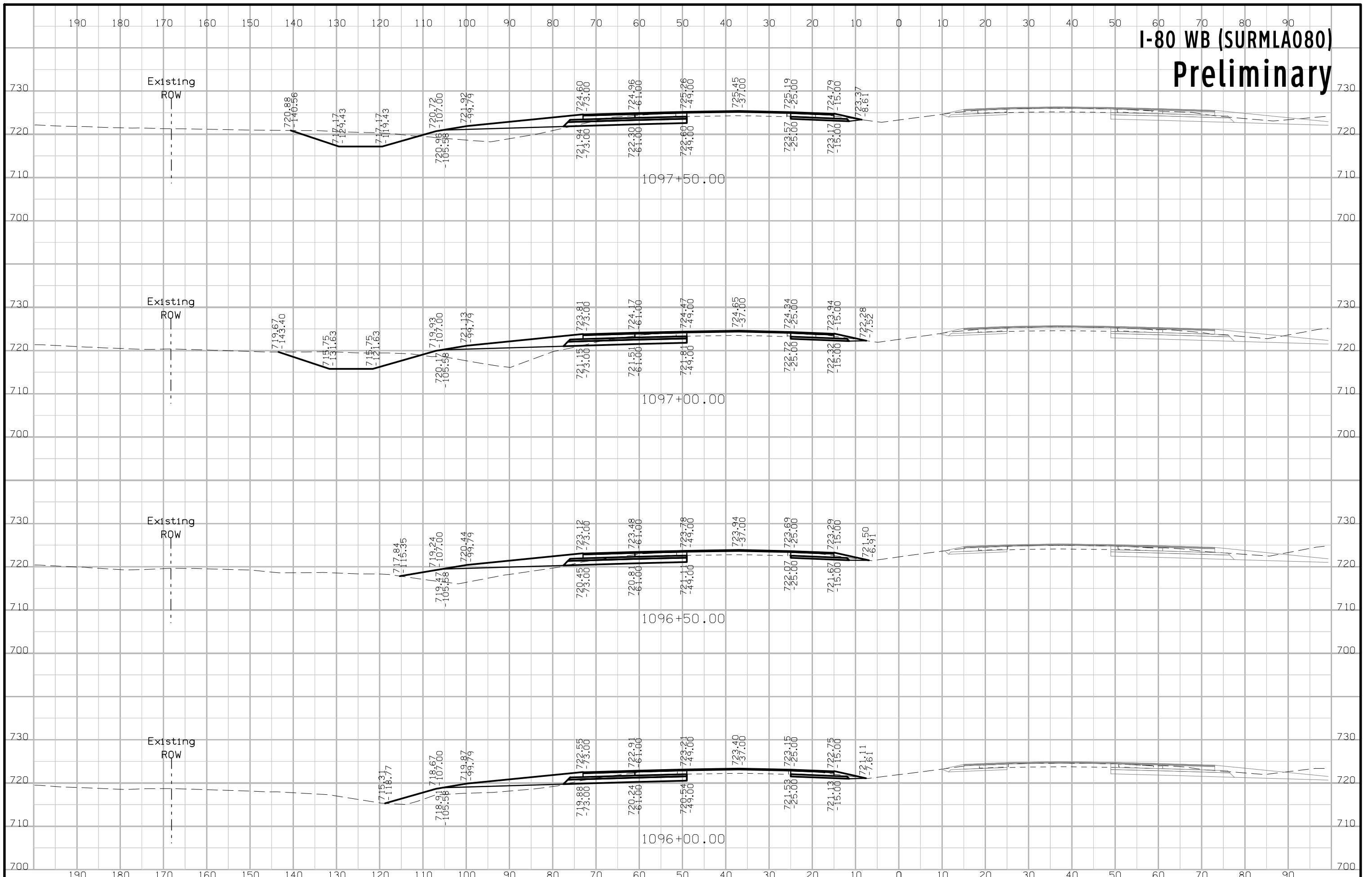

# I-80 WB (SURMLA080) Preliminary

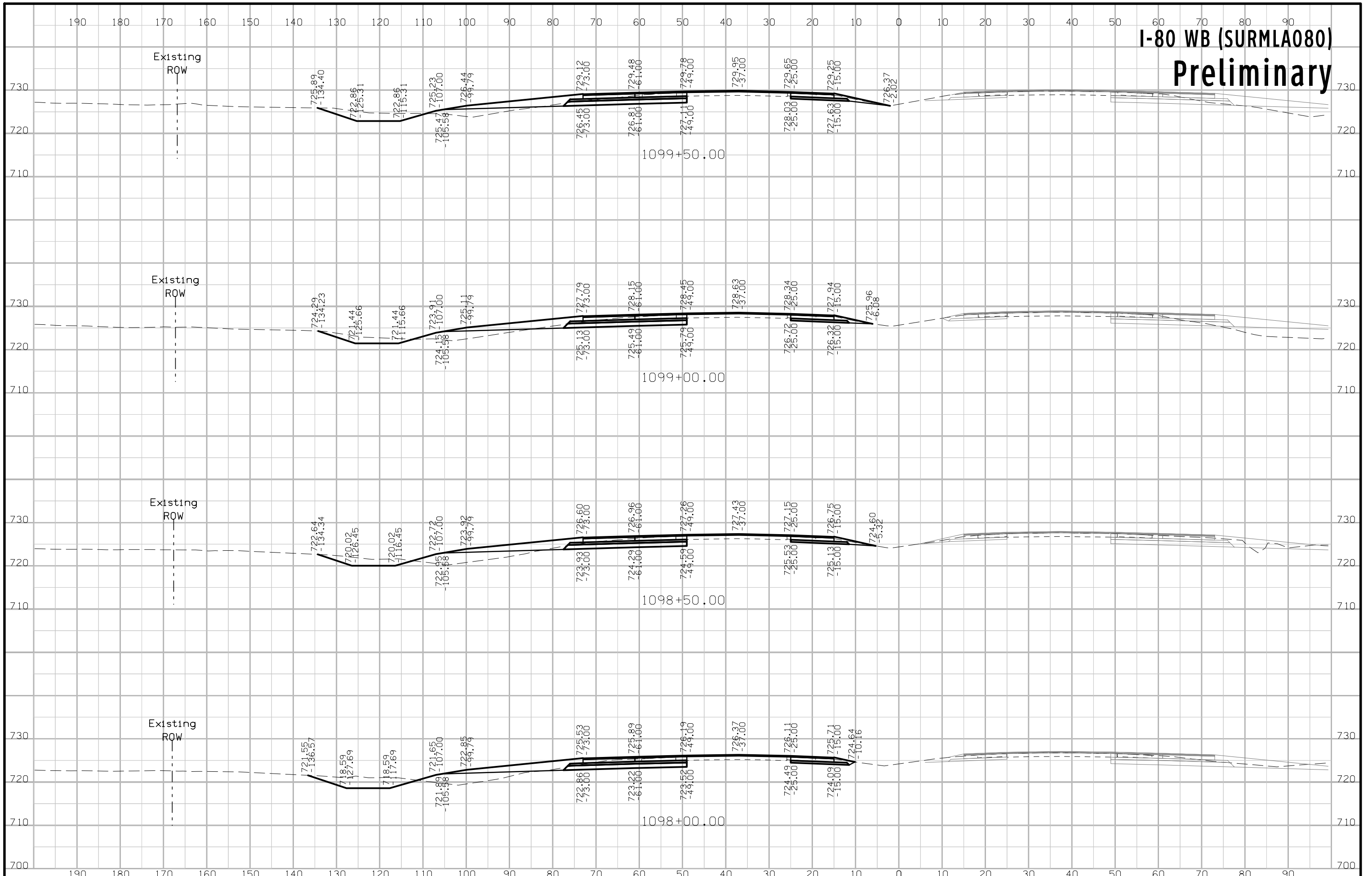



# I-80 WB (SURMLA080) Preliminary

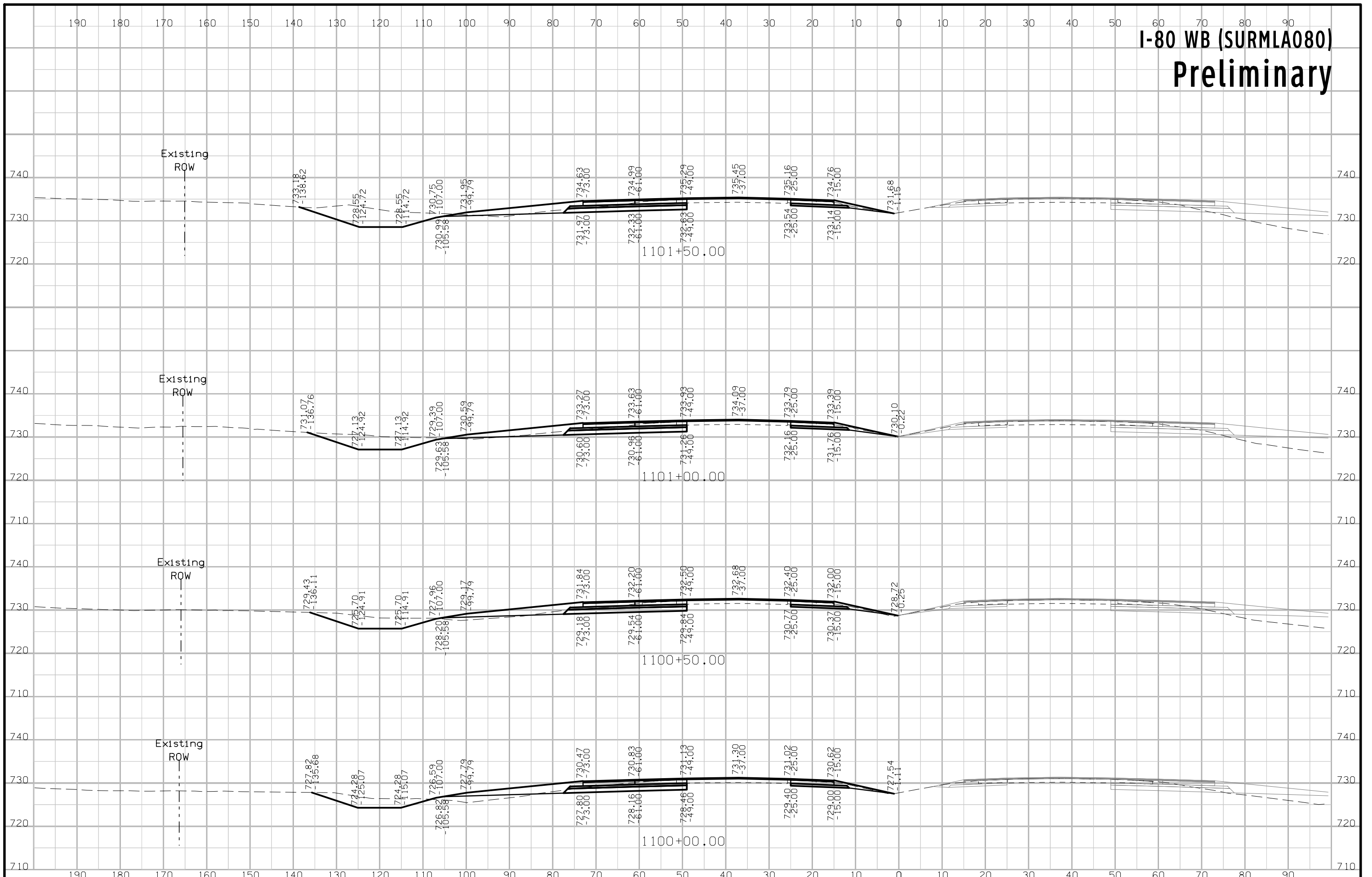

# I-80 WB (SURMLA080) Preliminary

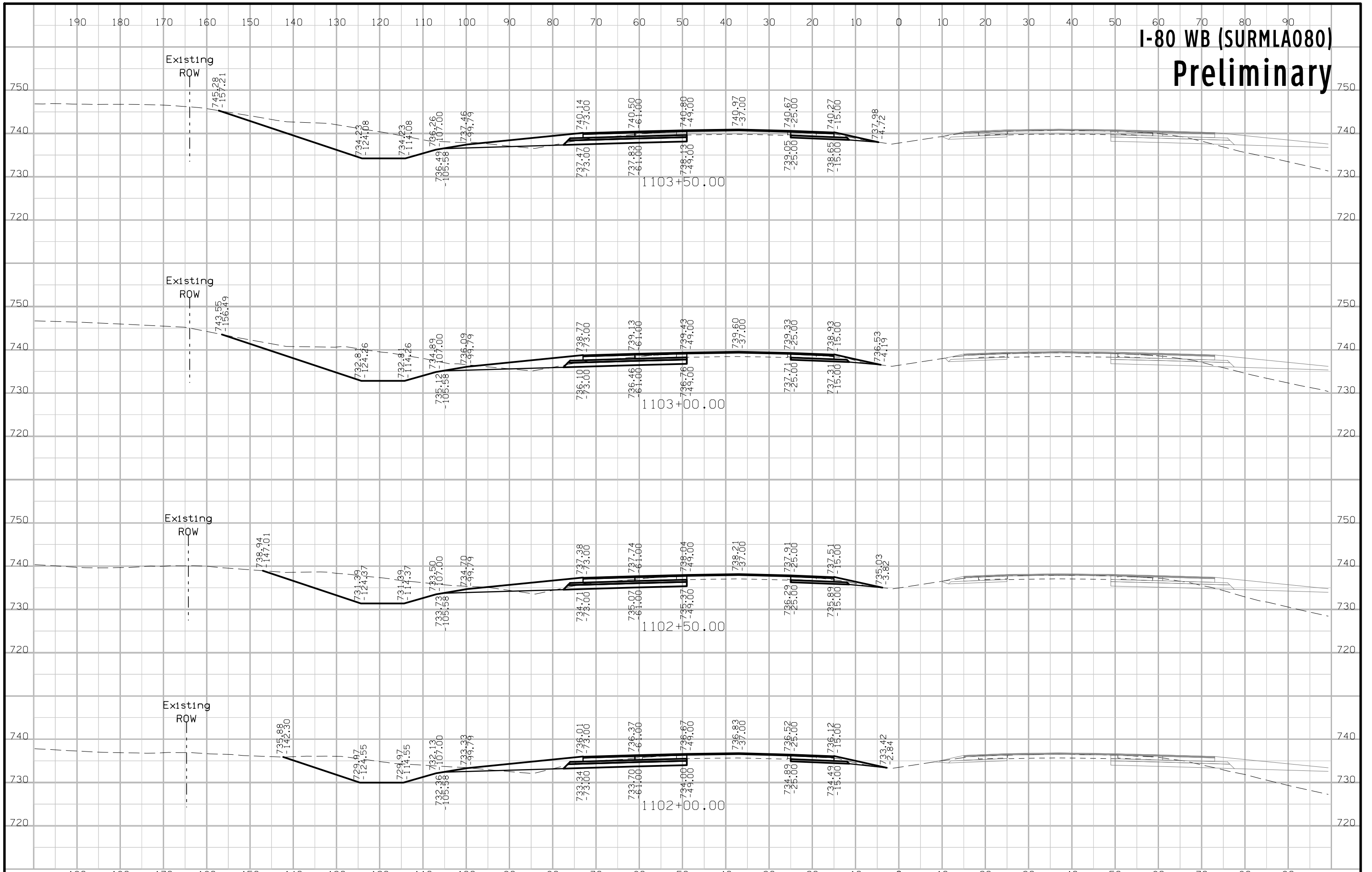

# I-80 WB (SURMLA080) Preliminary

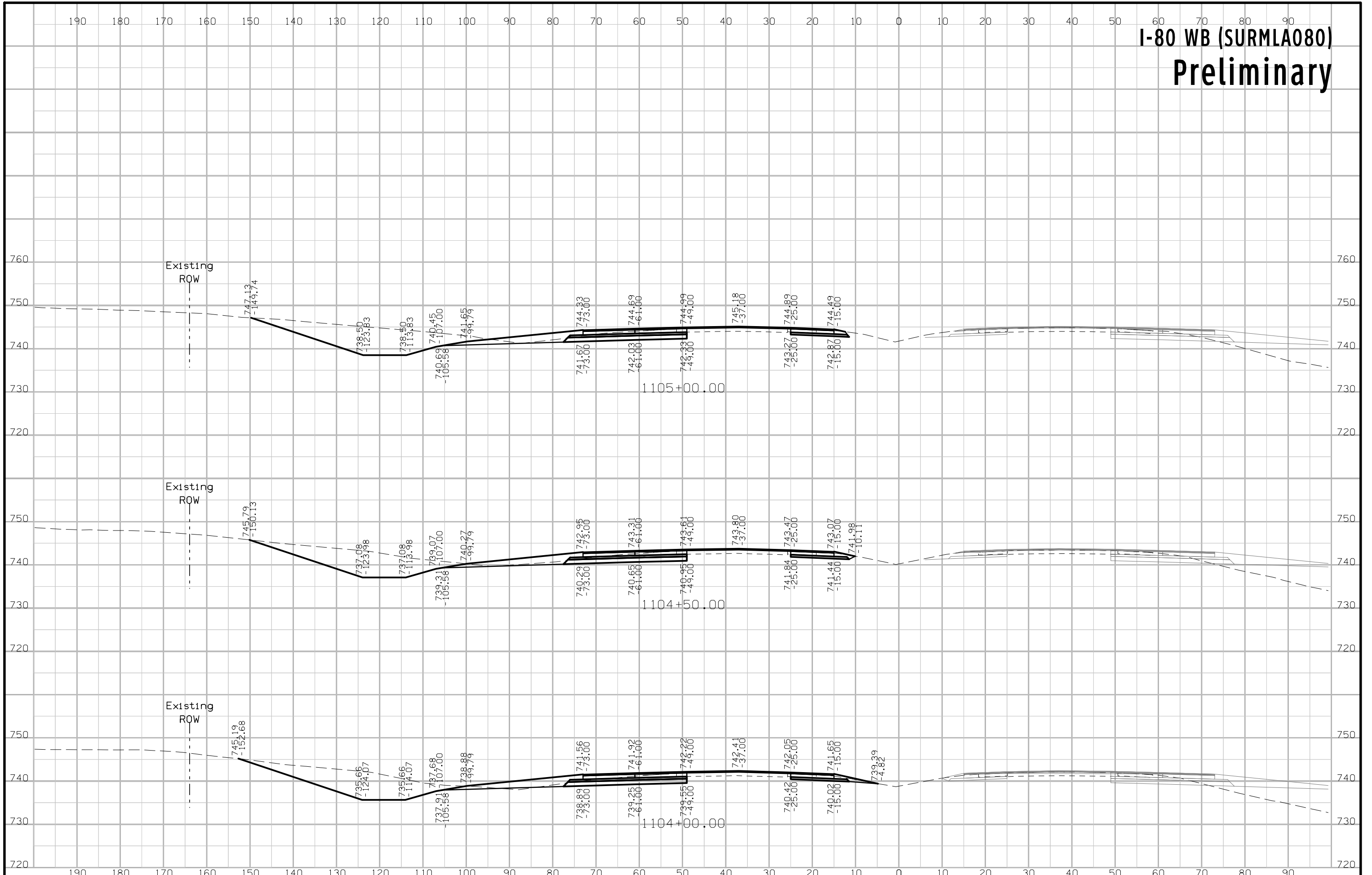

# I-80 WB (SURMLA080) Preliminary

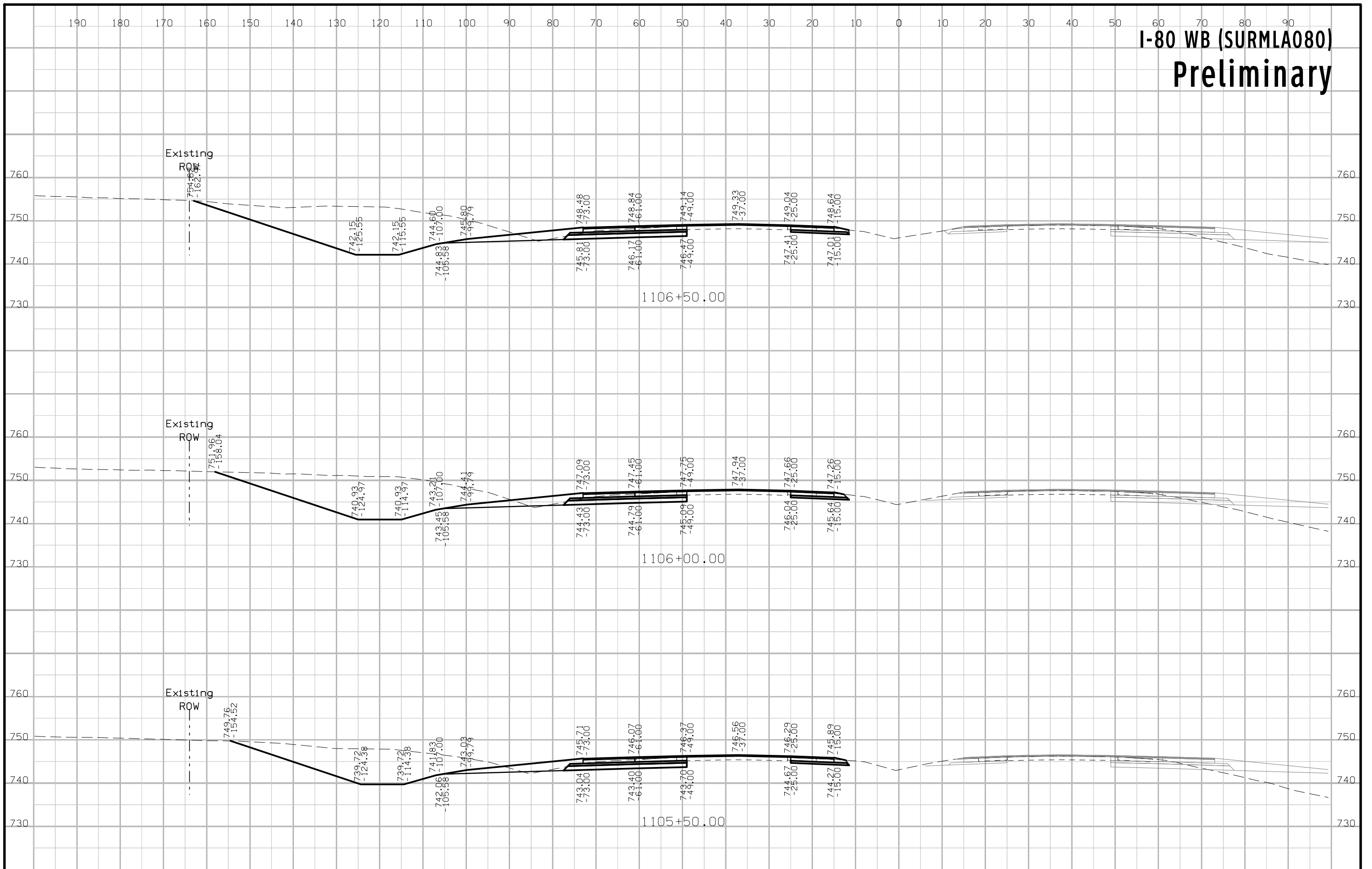

# I-80 WB (SURMLA080) Preliminary

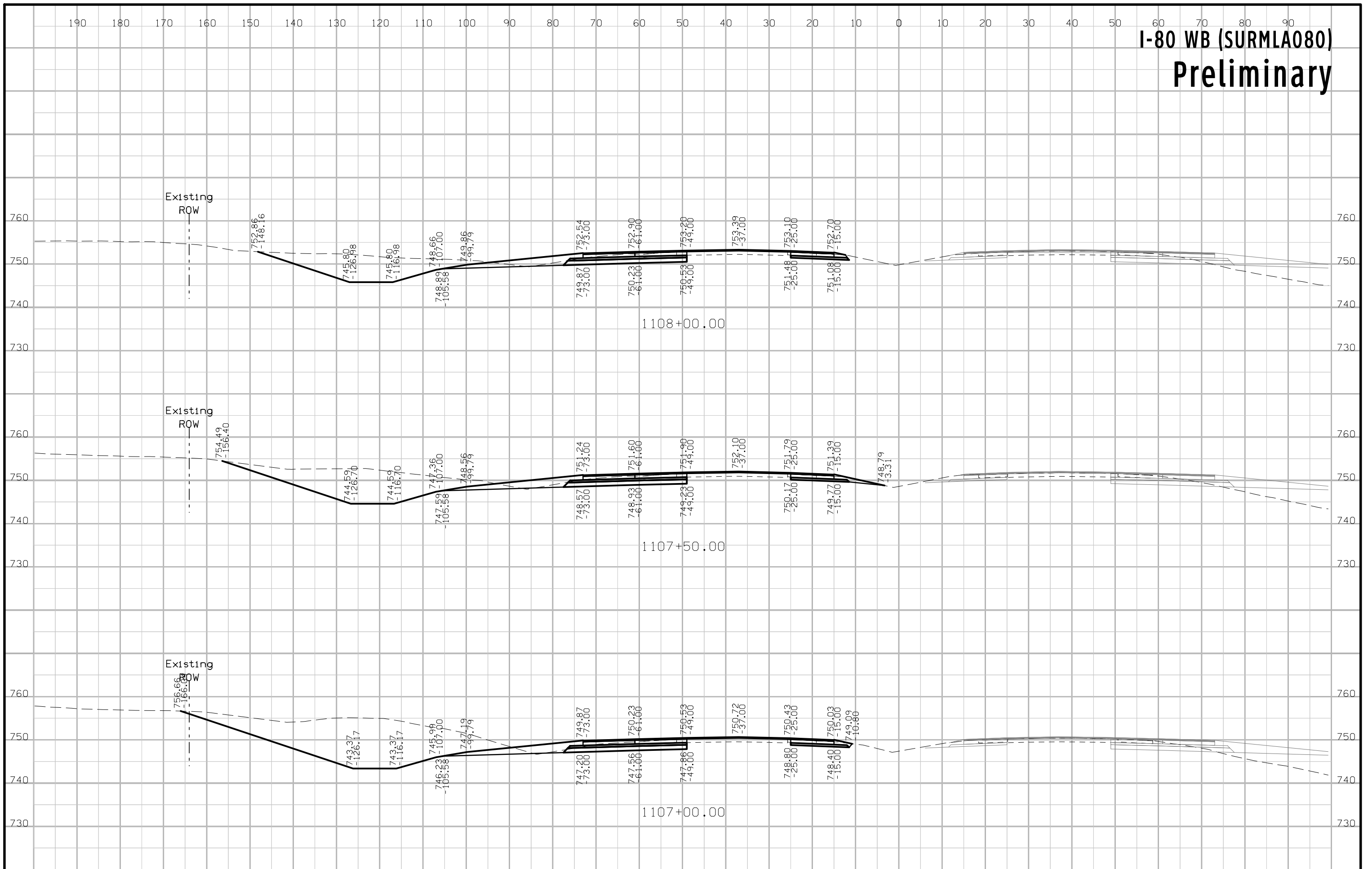



# I-80 WB (SURMLA080) Preliminary

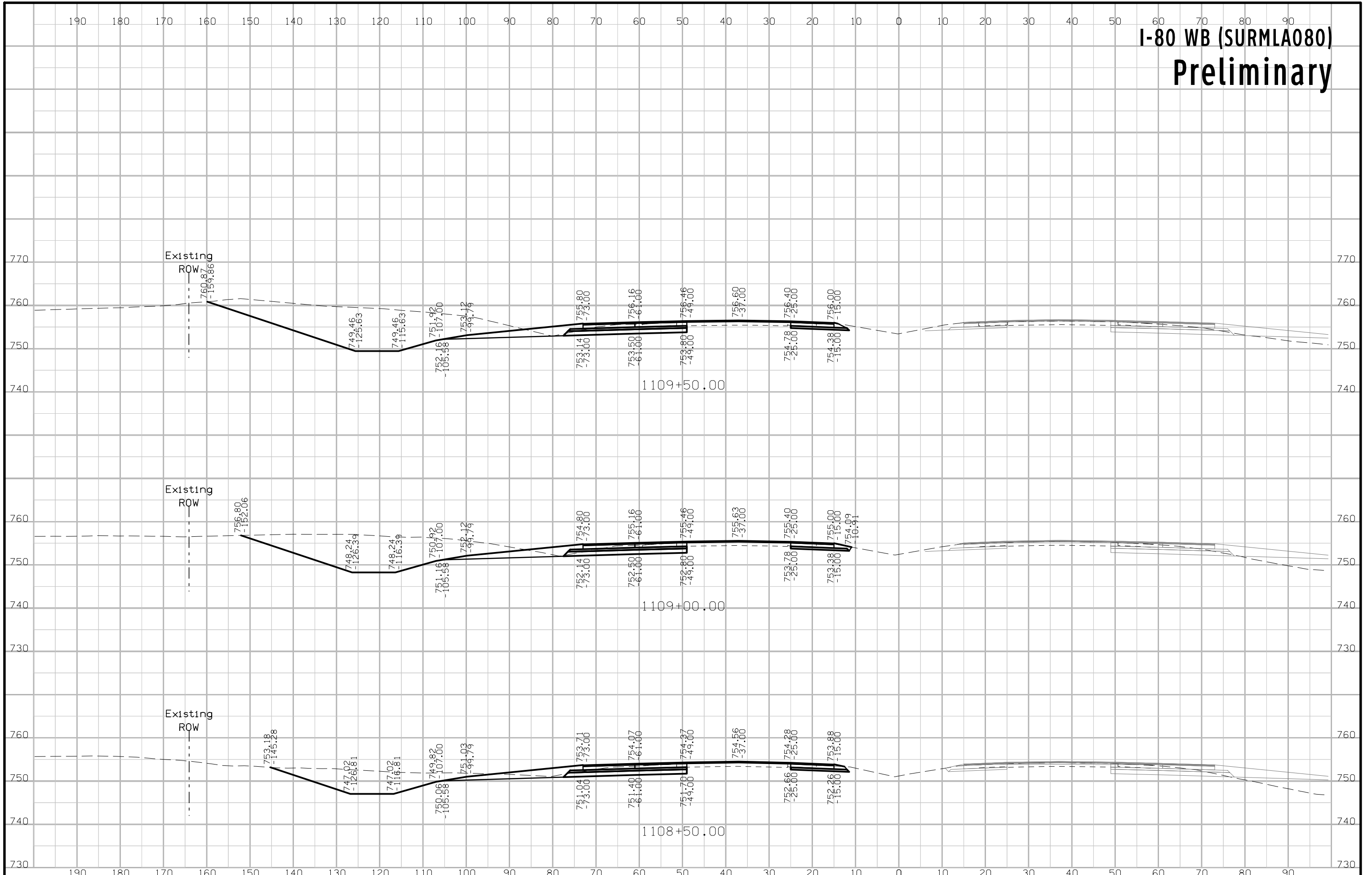

# I-80 WB (SURMLA080) Preliminary

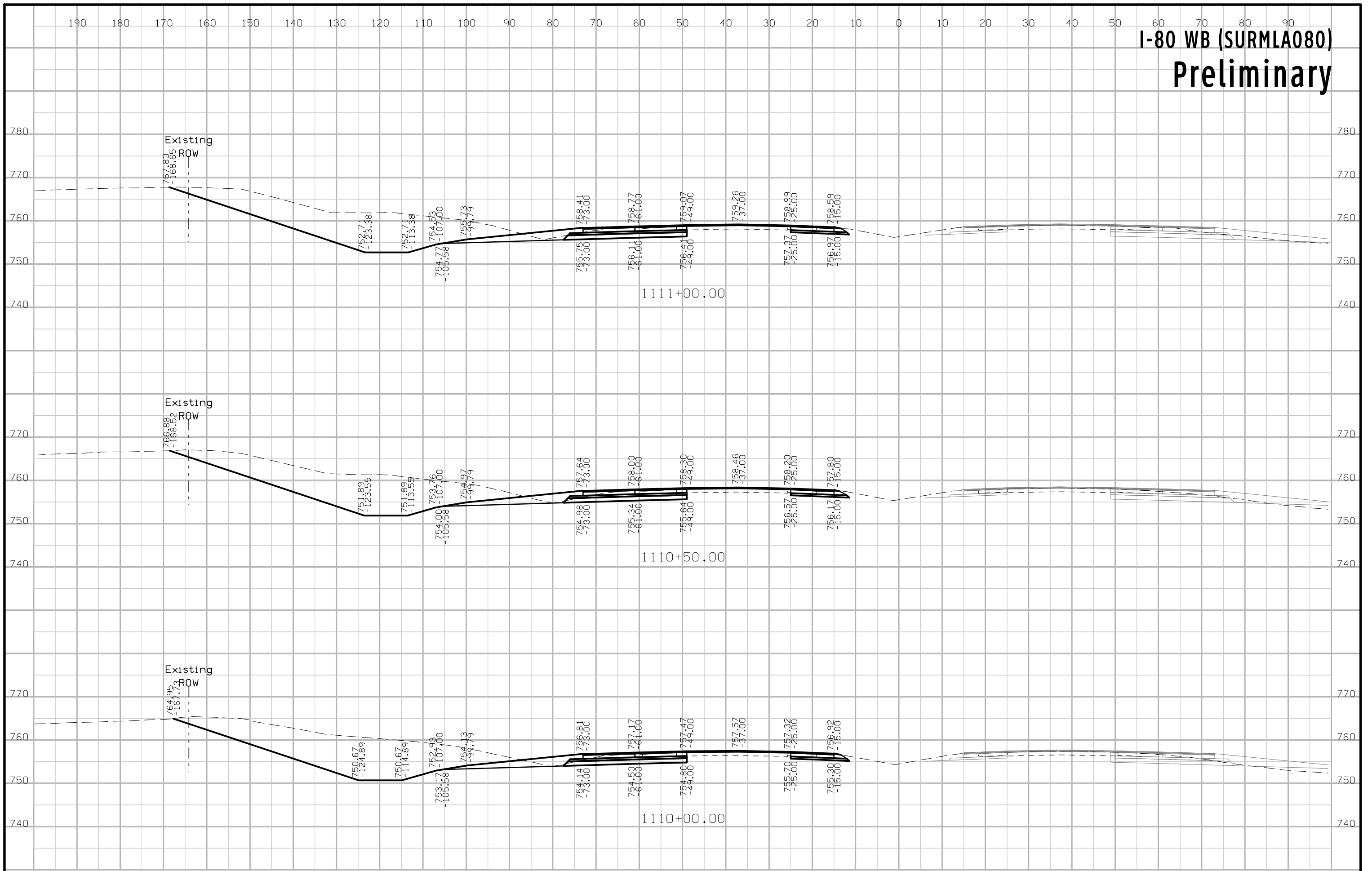

# I-80 WB (SURMLA080) Preliminary

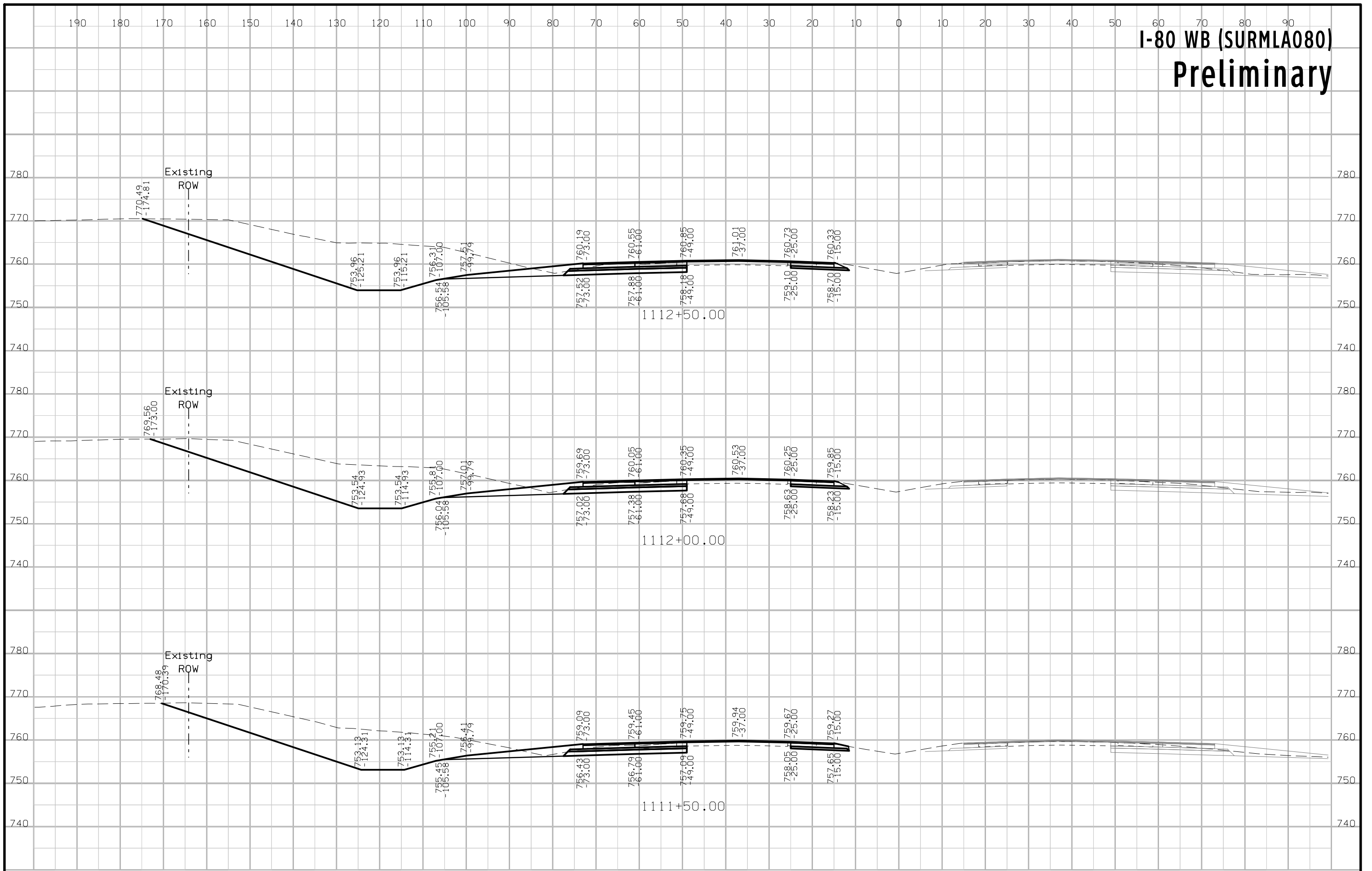

# I-80 WB (SURMLA080) Preliminary

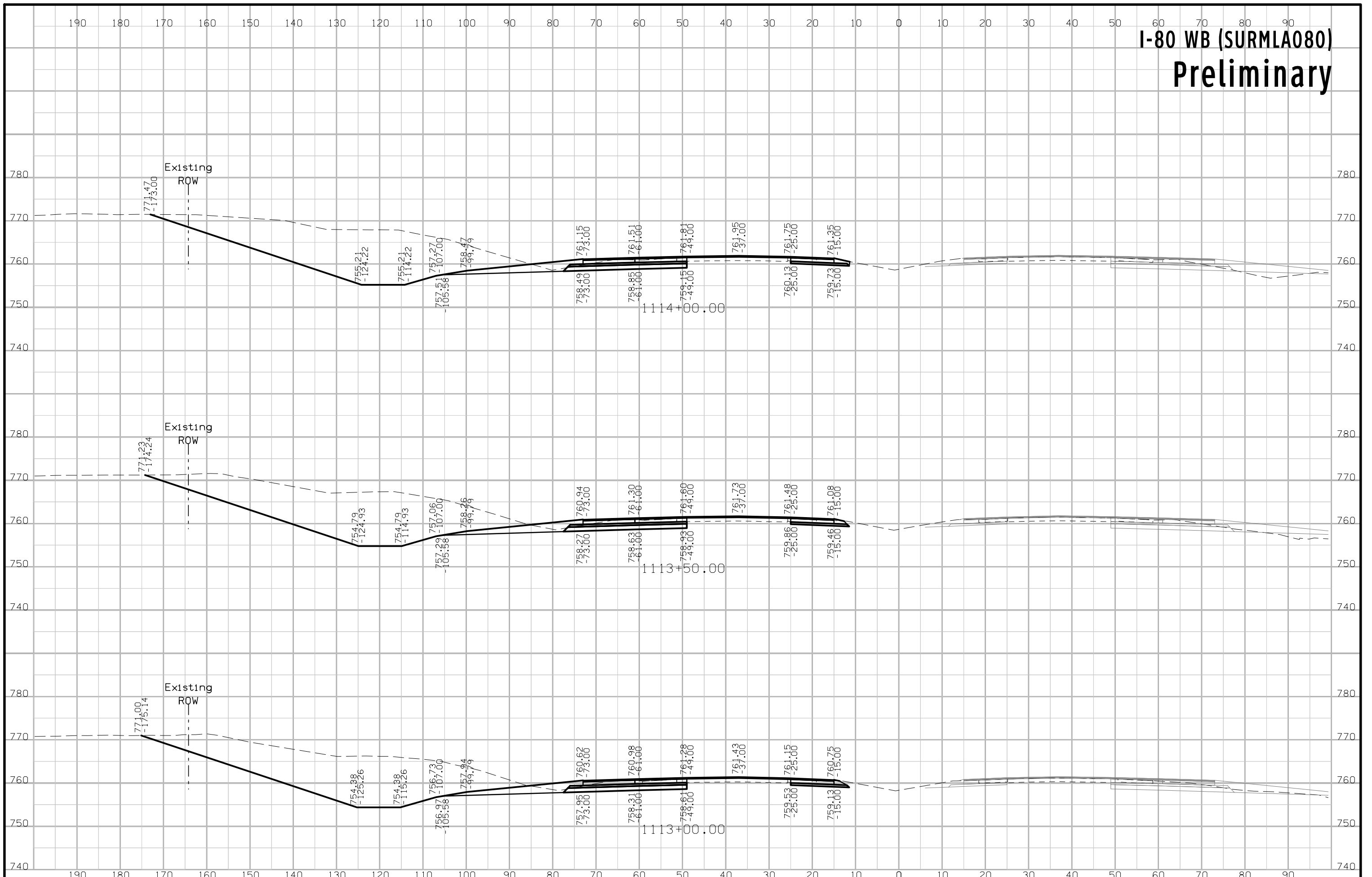

# I-80 WB (SURMLA080) Preliminary

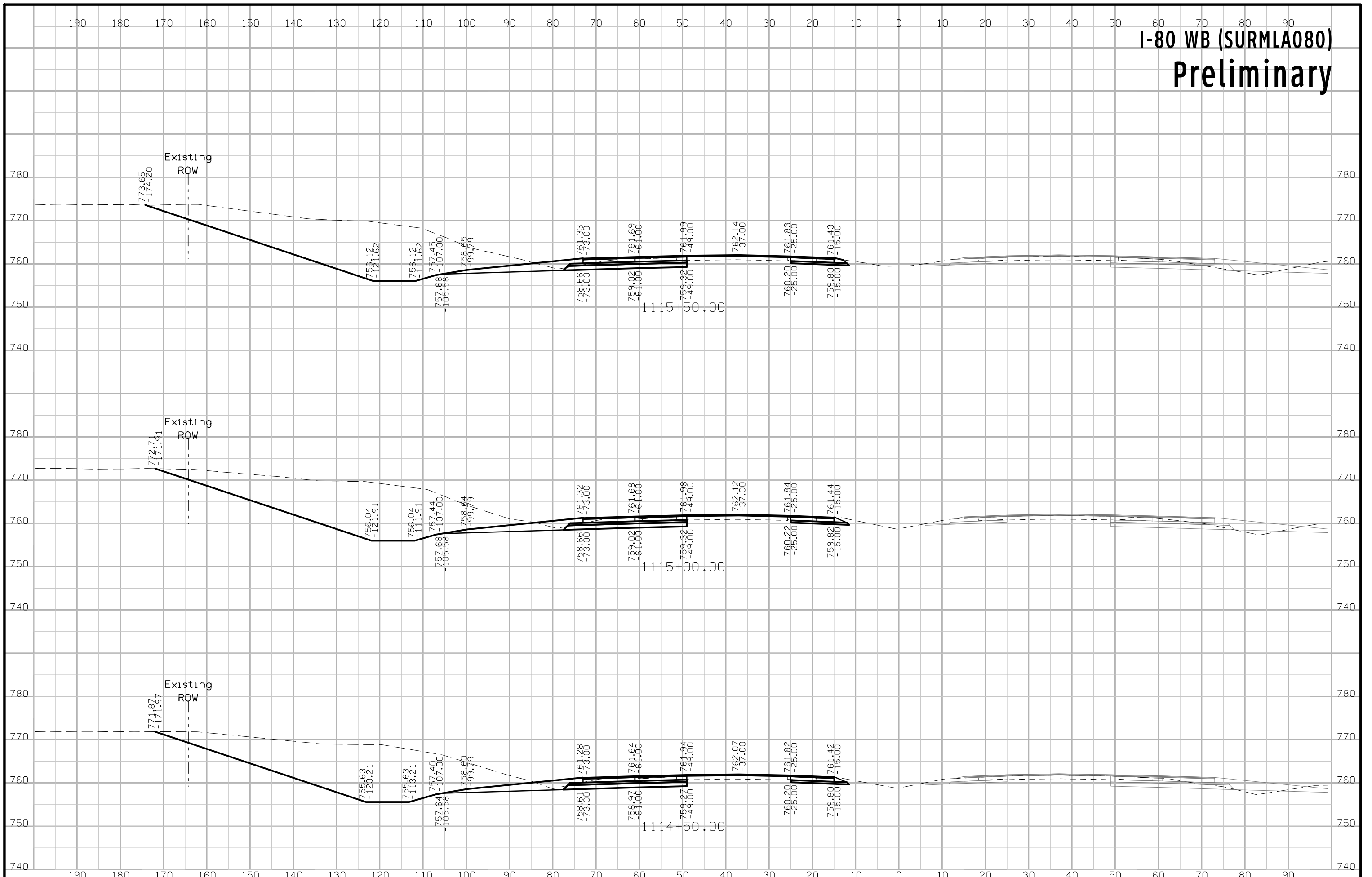



# I-80 WB (SURMLA080) Preliminary

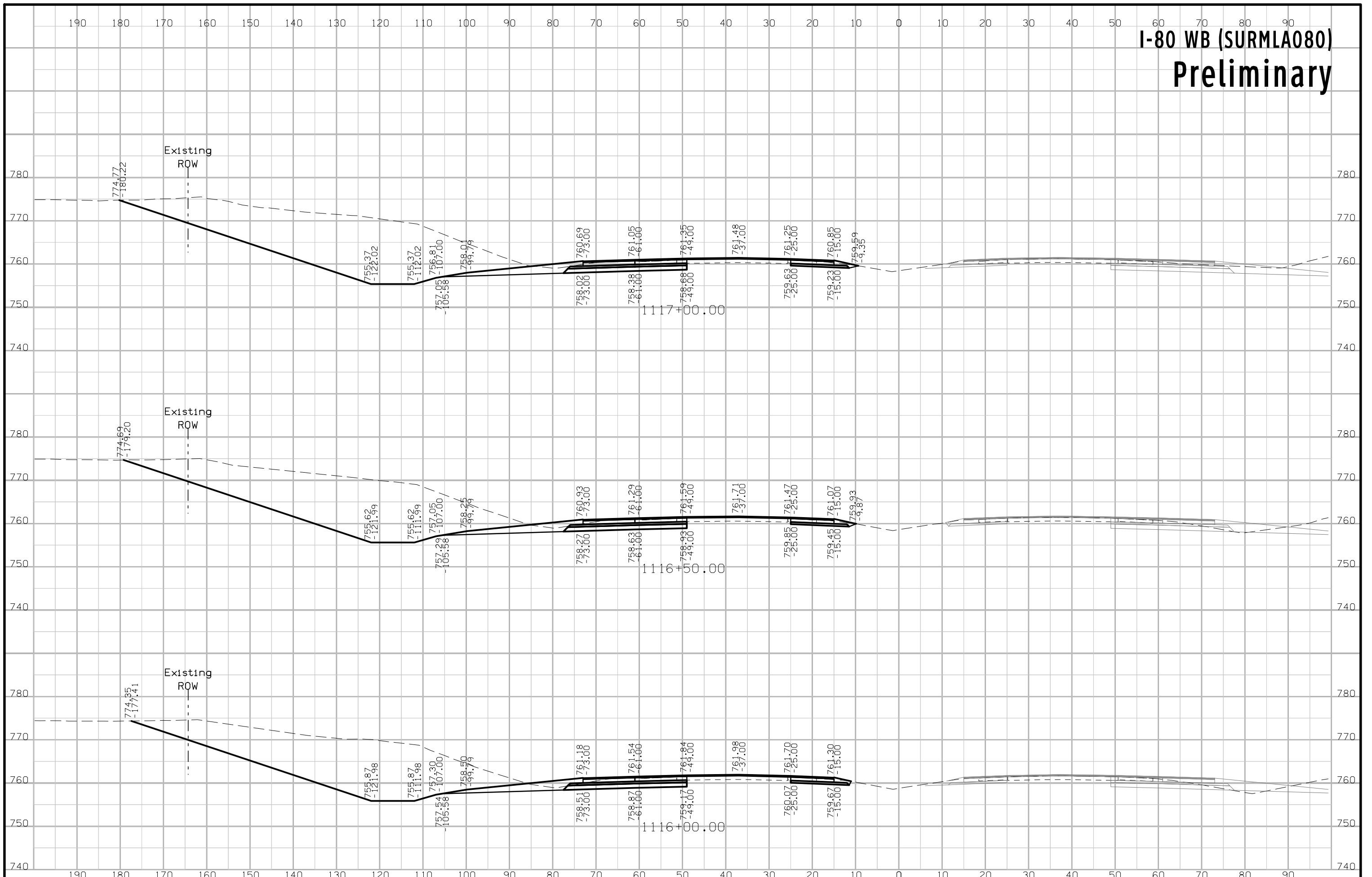

# I-80 WB (SURMLA080) Preliminary

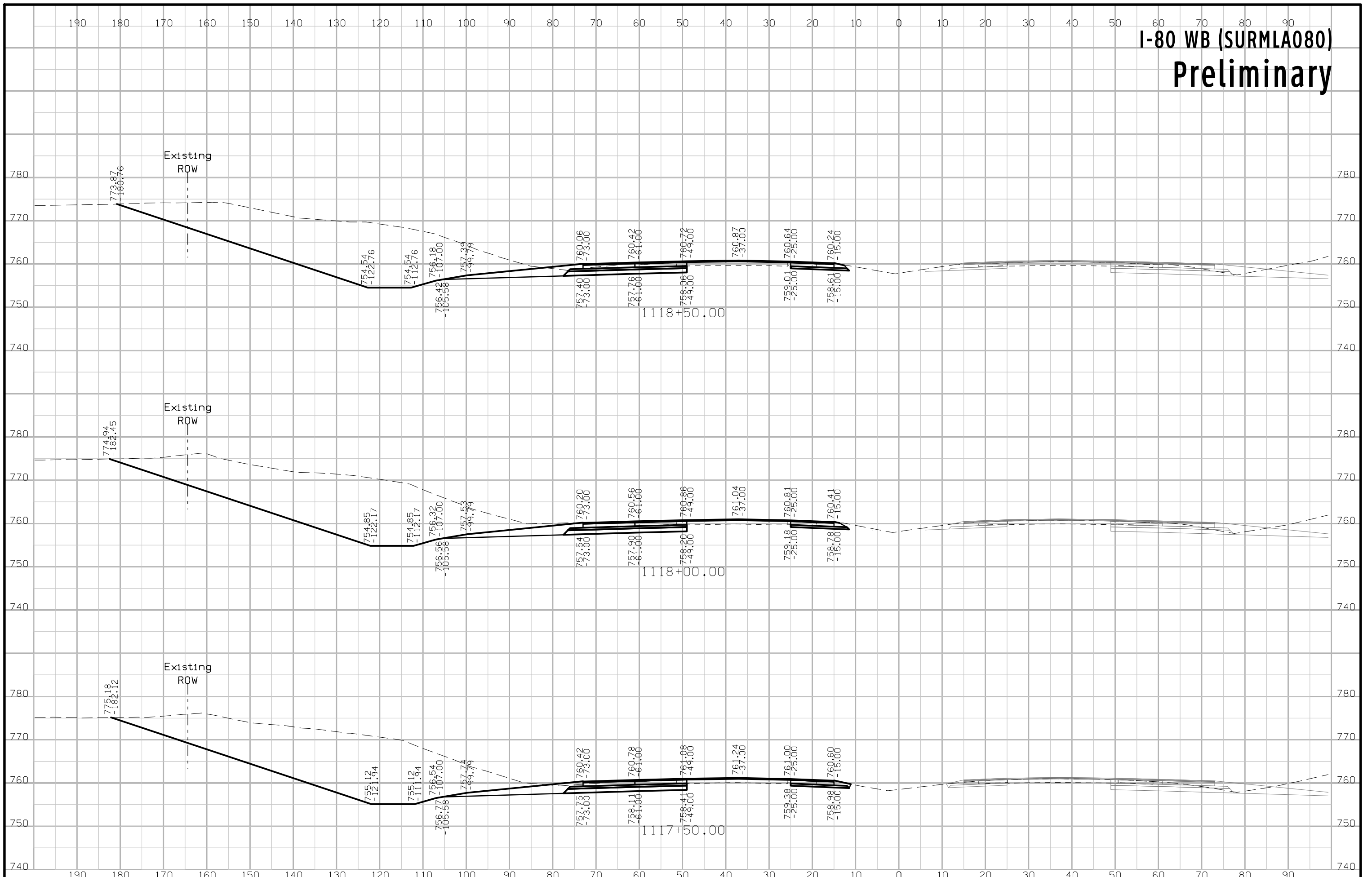

# I-80 WB (SURMLA080) Preliminary

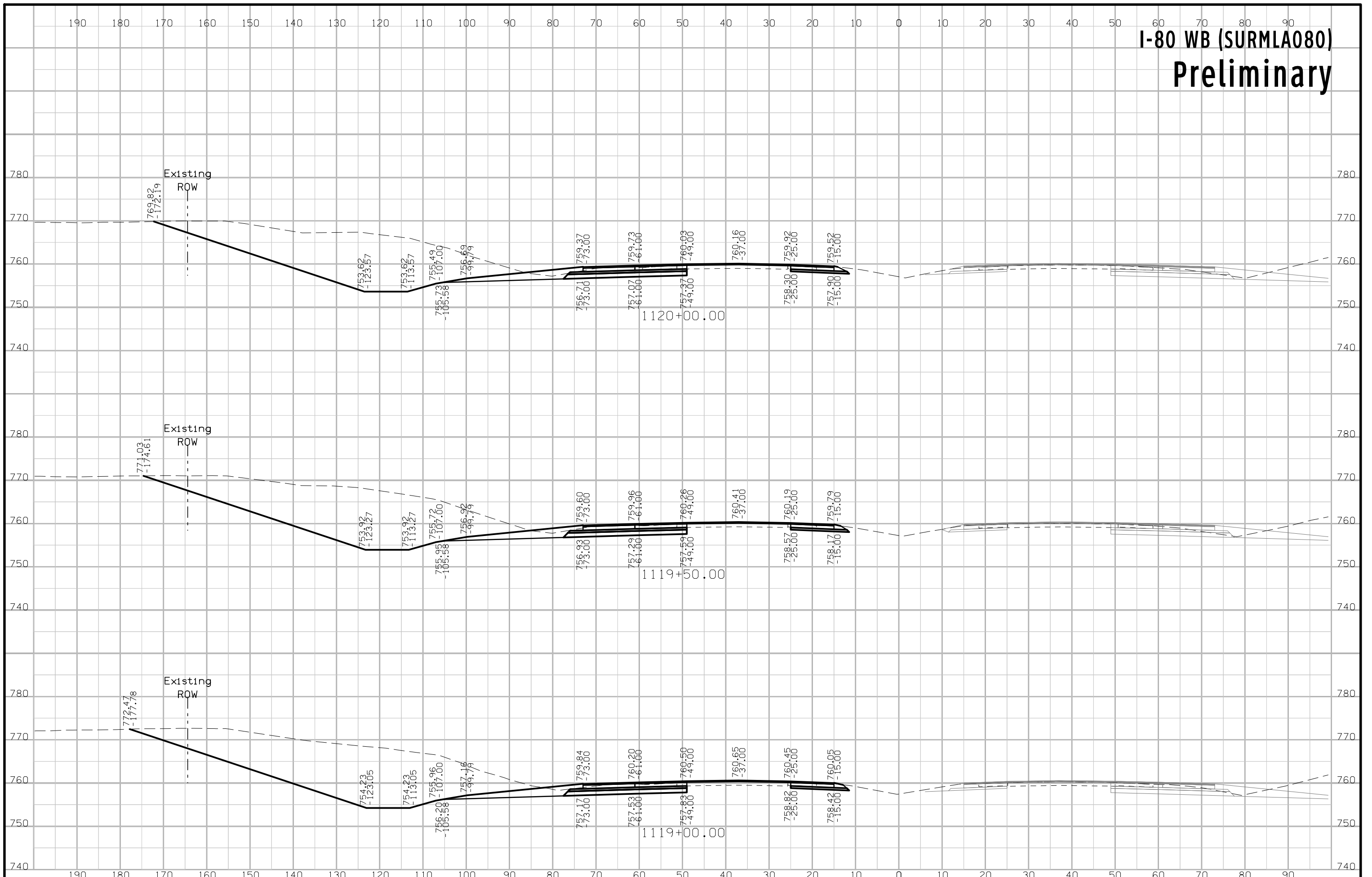

# I-80 WB (SURMLA080) Preliminary

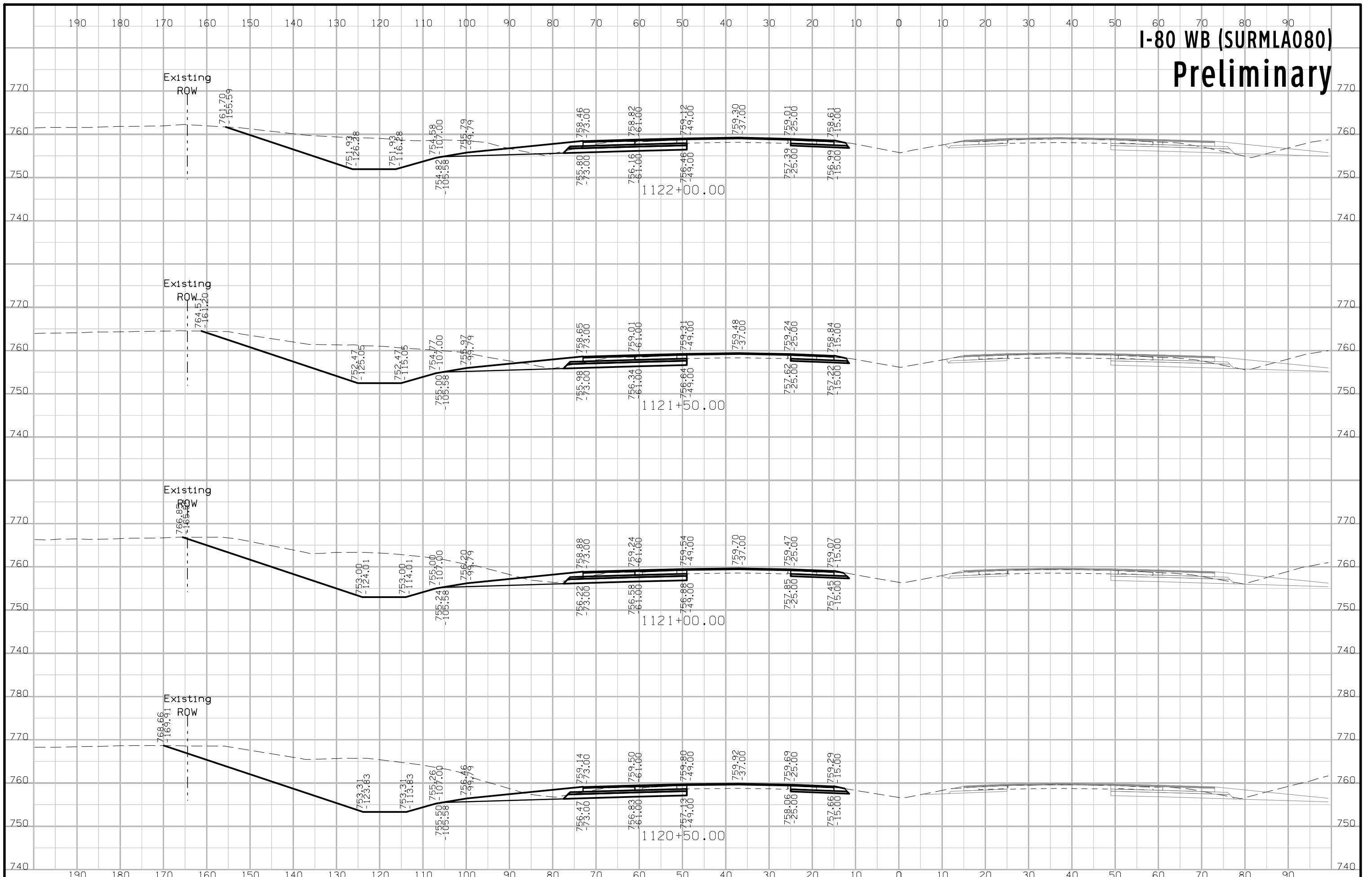

# I-80 WB (SURMLA080) Preliminary

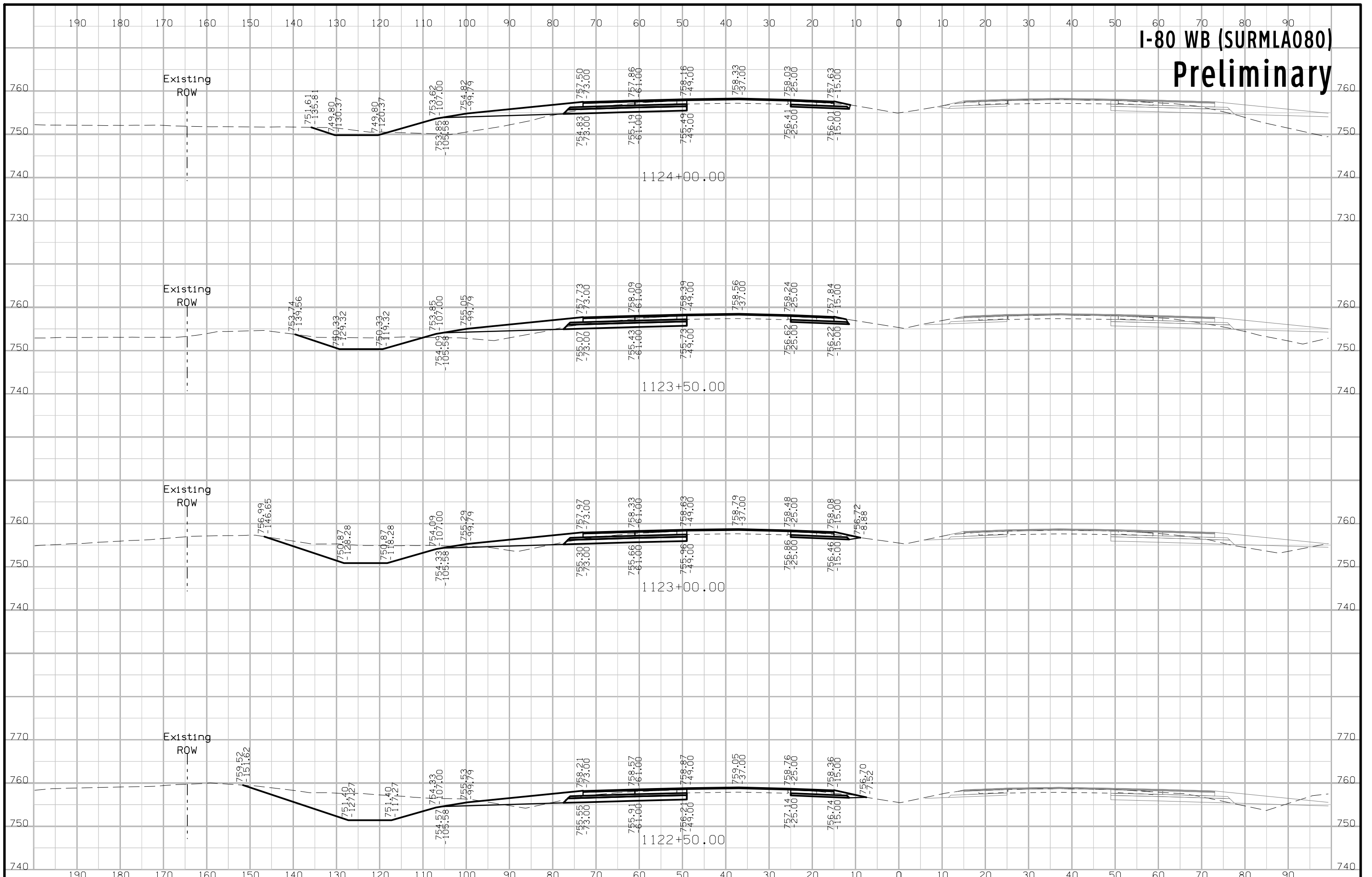



# I-80 WB (SURMLA080) Preliminary

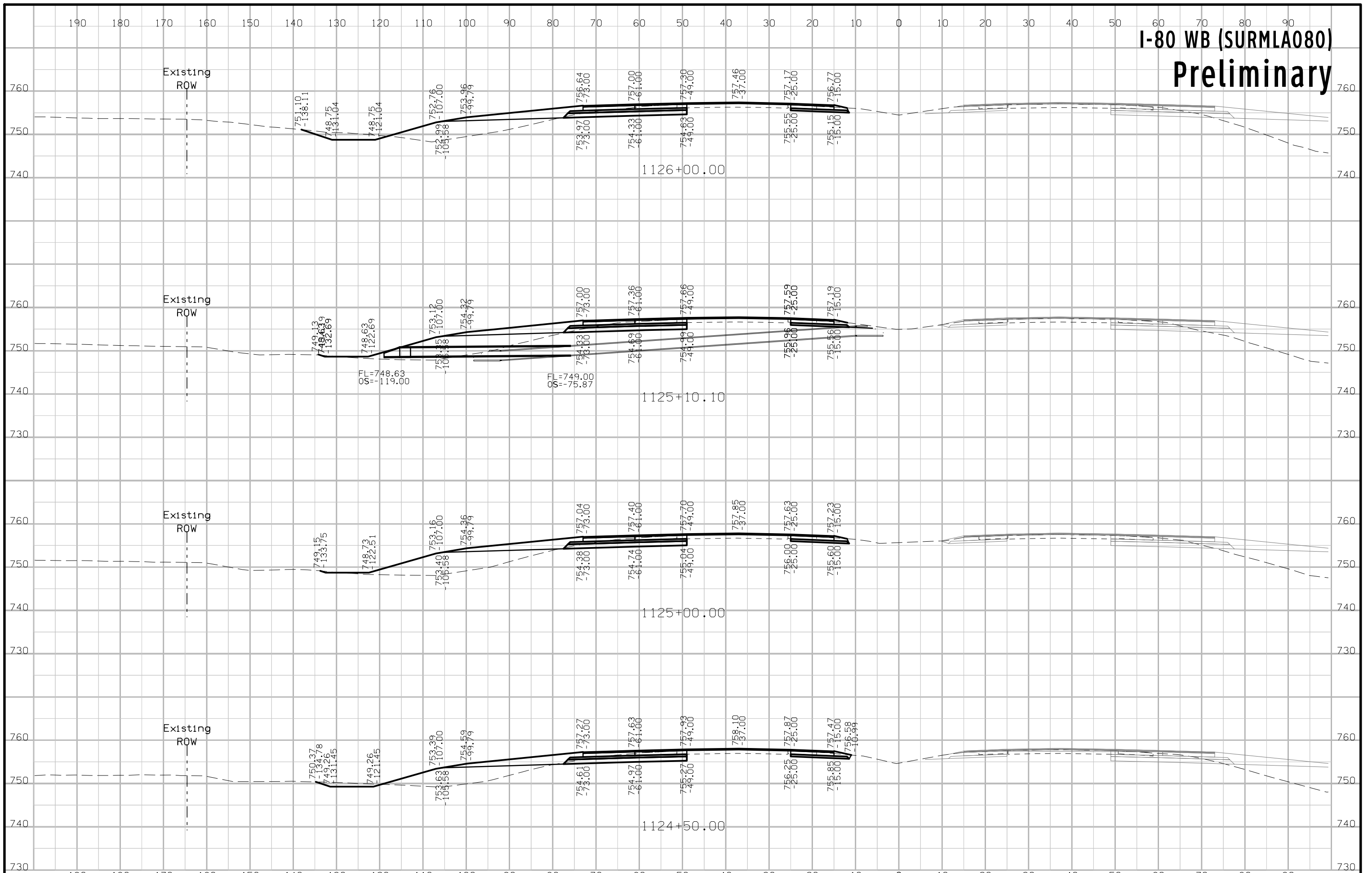

# I-80 WB (SURMLA080) Preliminary



# I-80 WB (SURMLA080) Preliminary

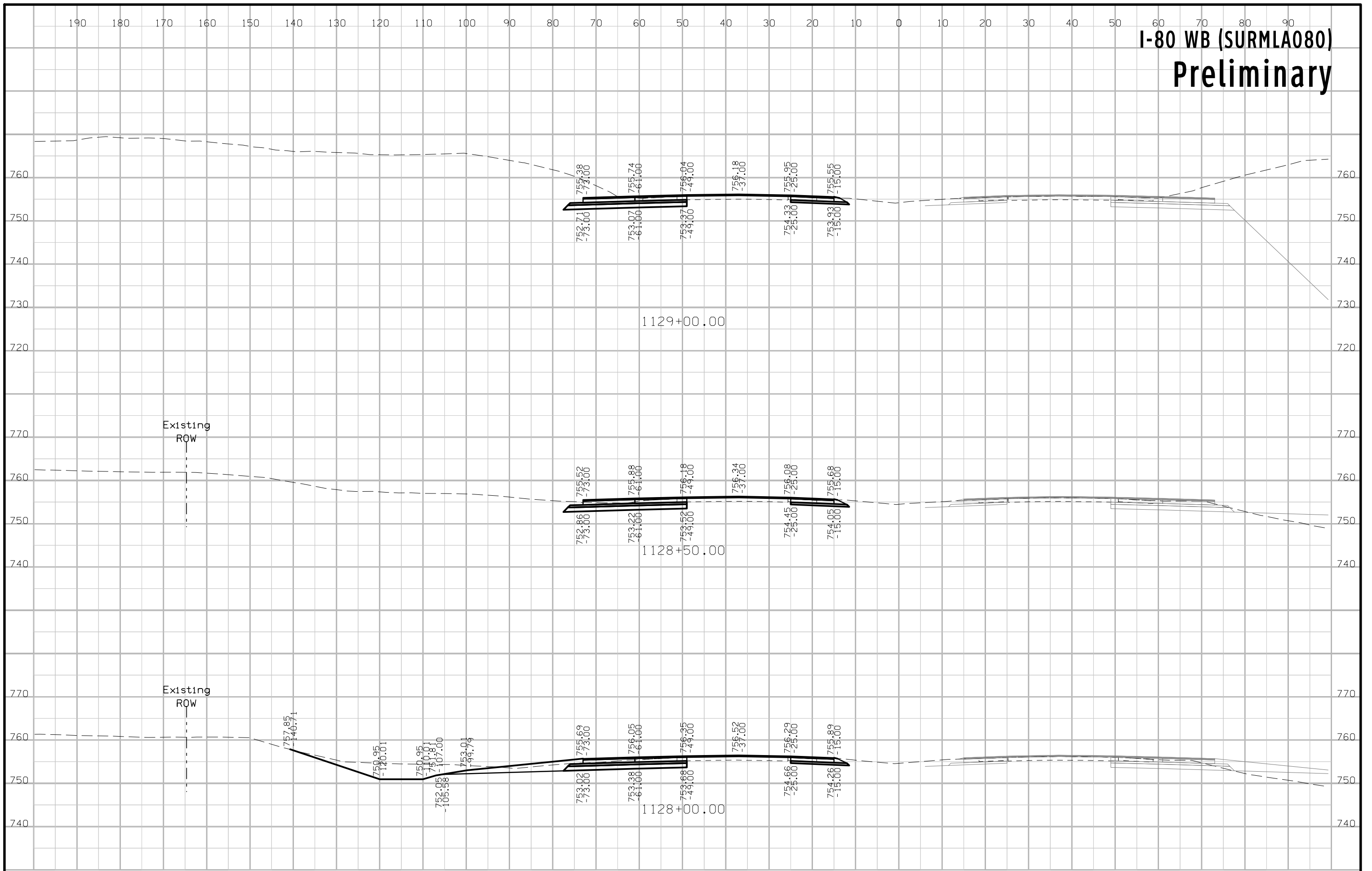

# I-80 WB (SURMLA080) Preliminary

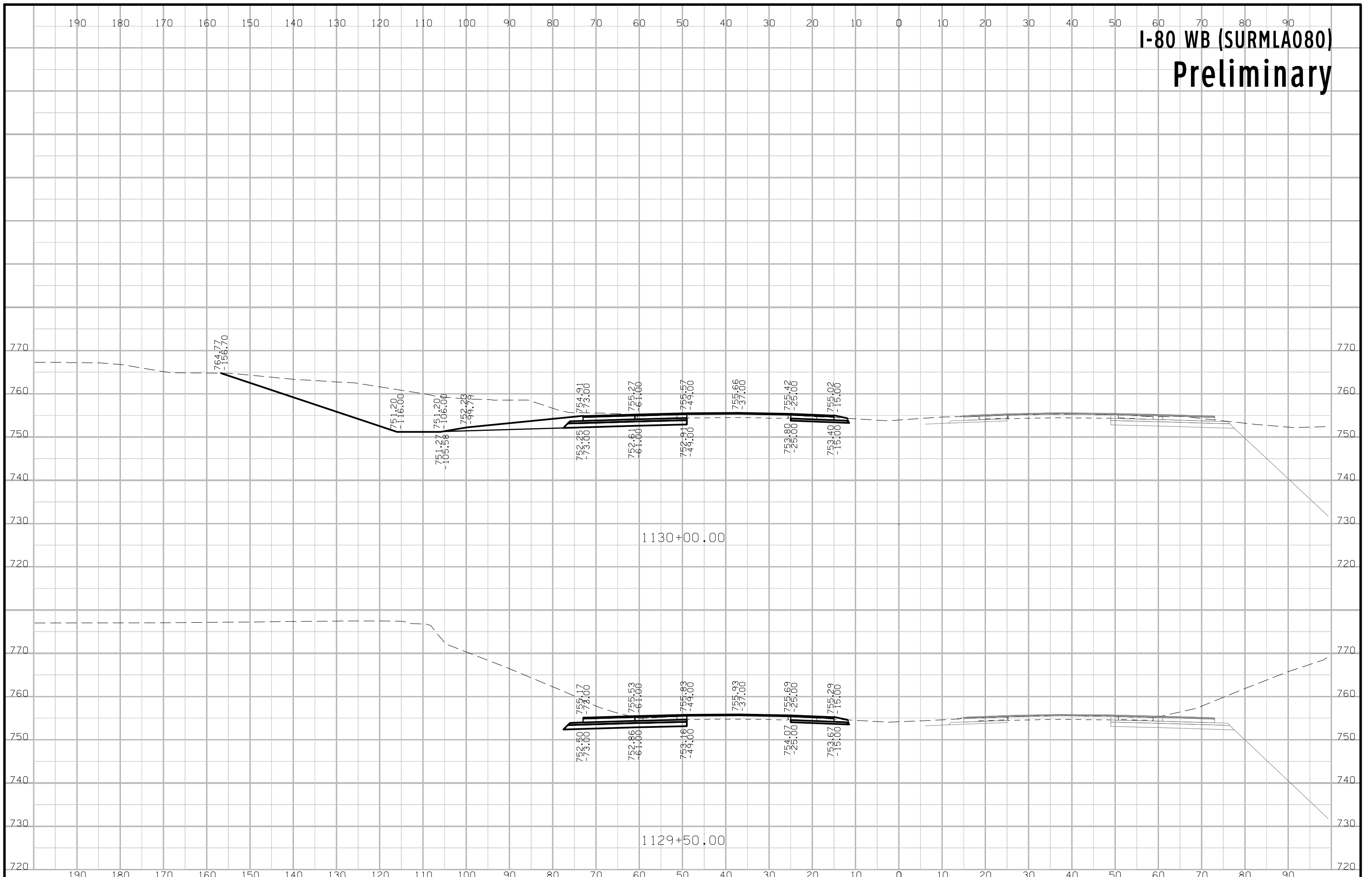

# I-80 WB (SURMLA080) Preliminary

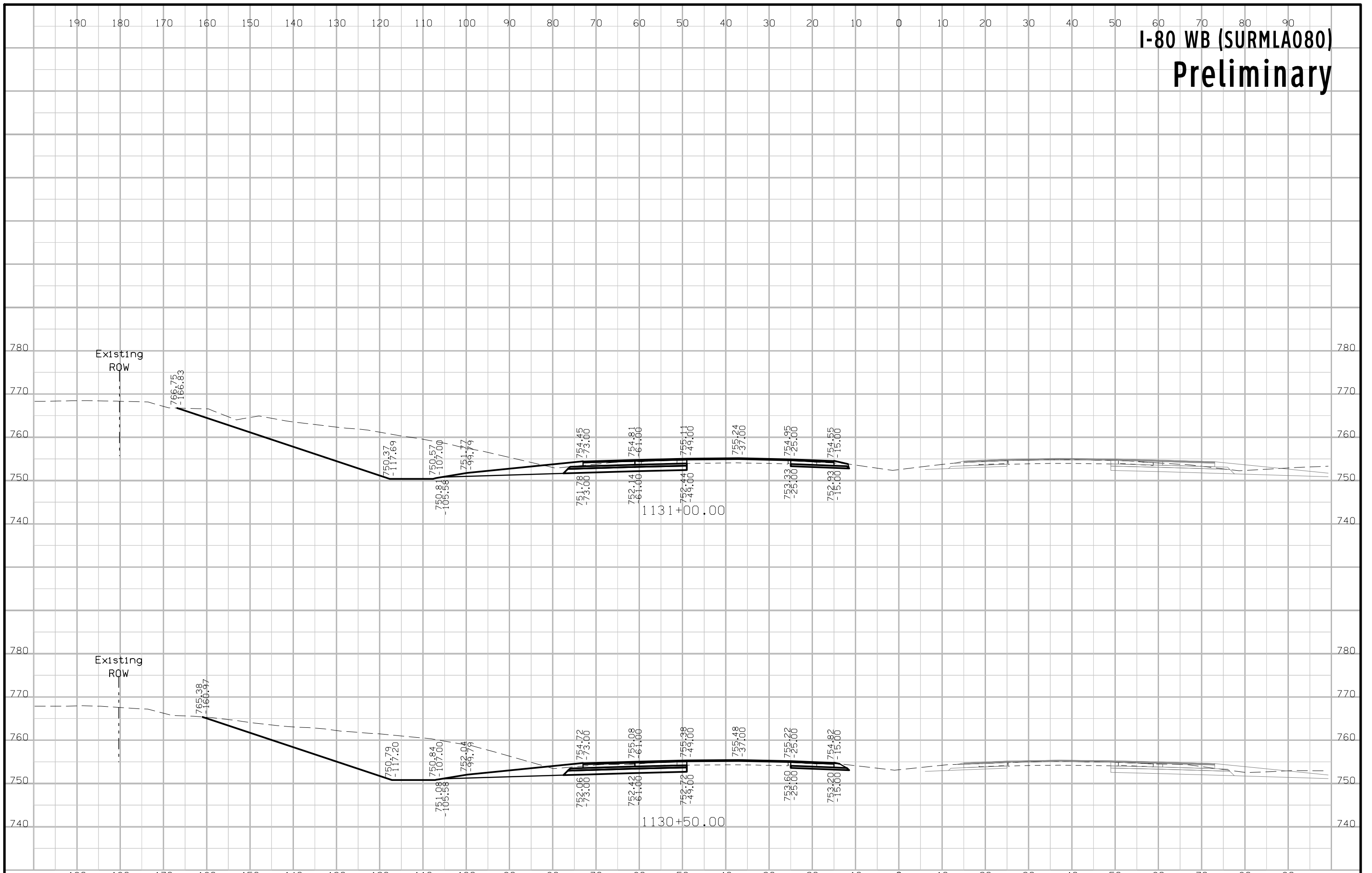



# I-80 WB (SURMLA080) Preliminary

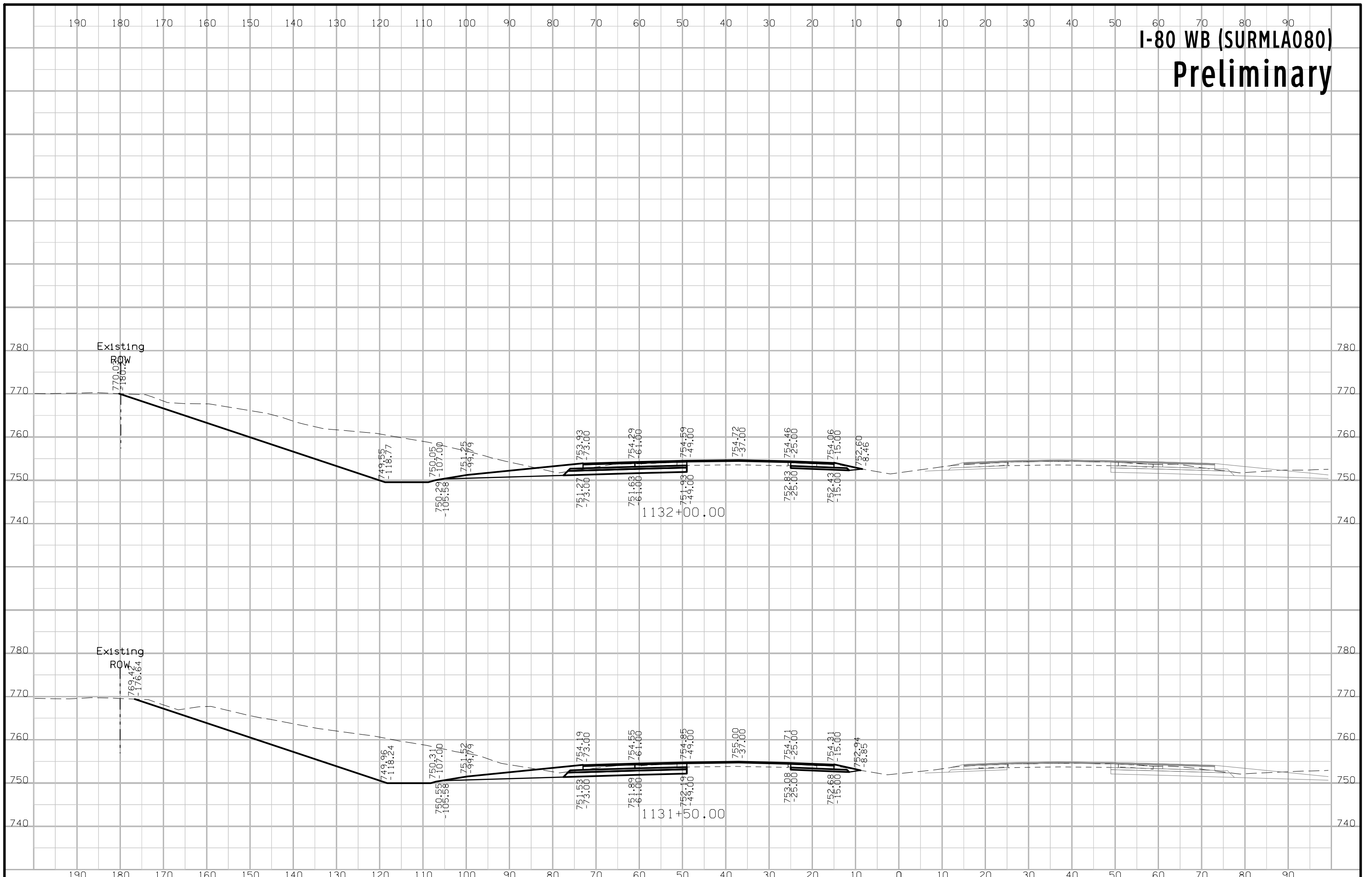

# I-80 WB (SURMLA080) Preliminary

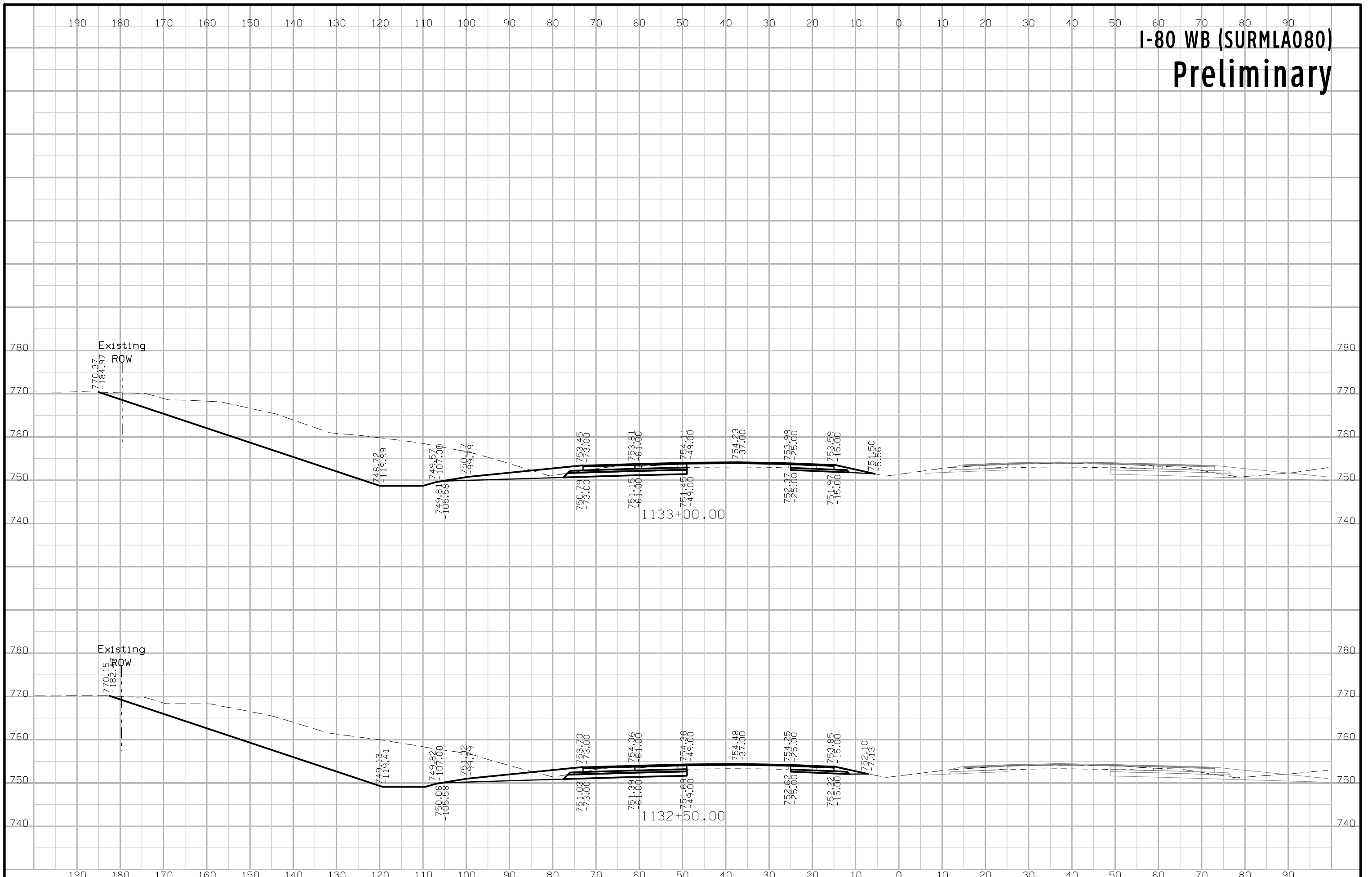

# I-80 WB (SURMLA080) Preliminary

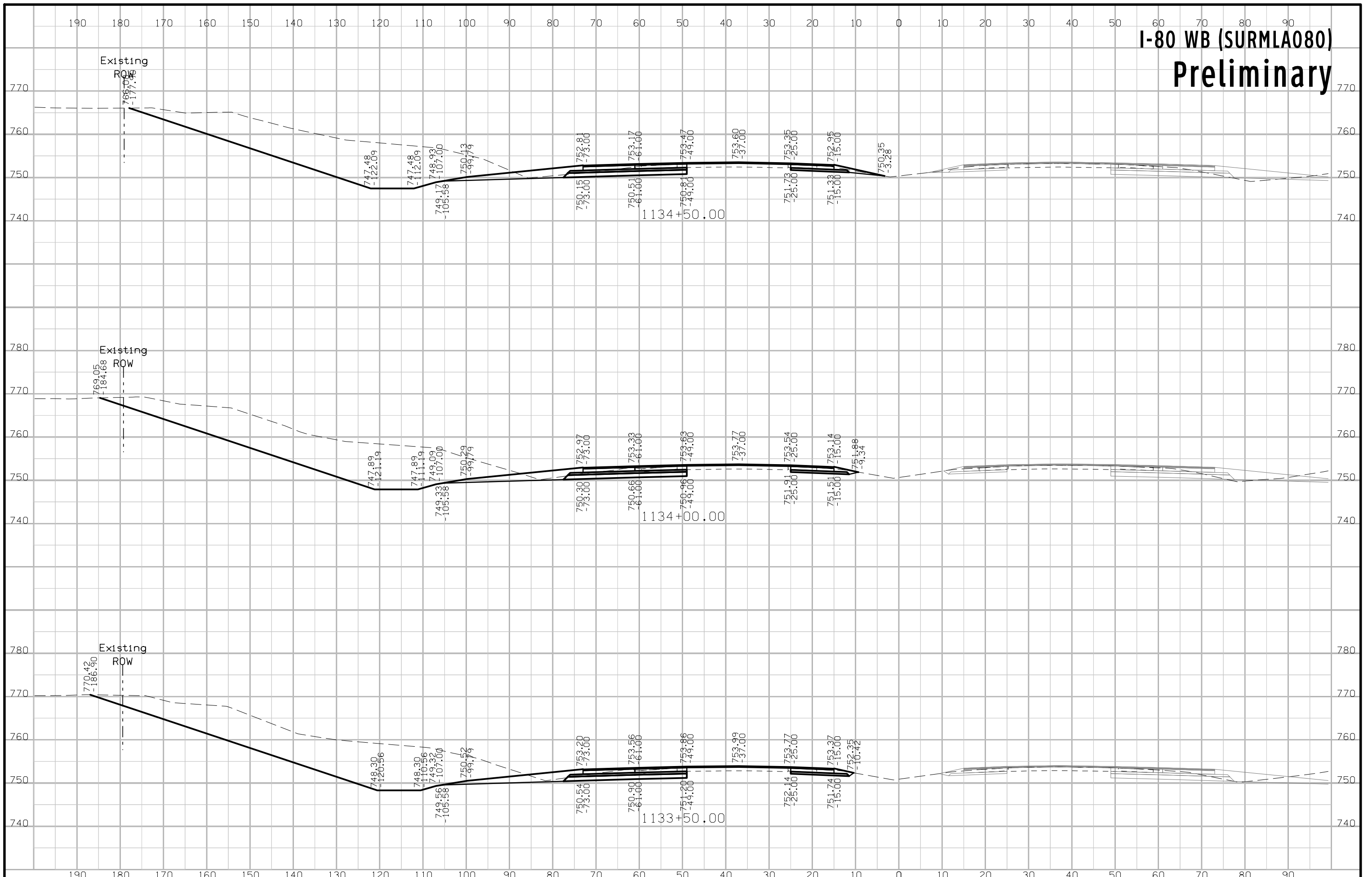

# I-80 WB (SURMLA080) Preliminary

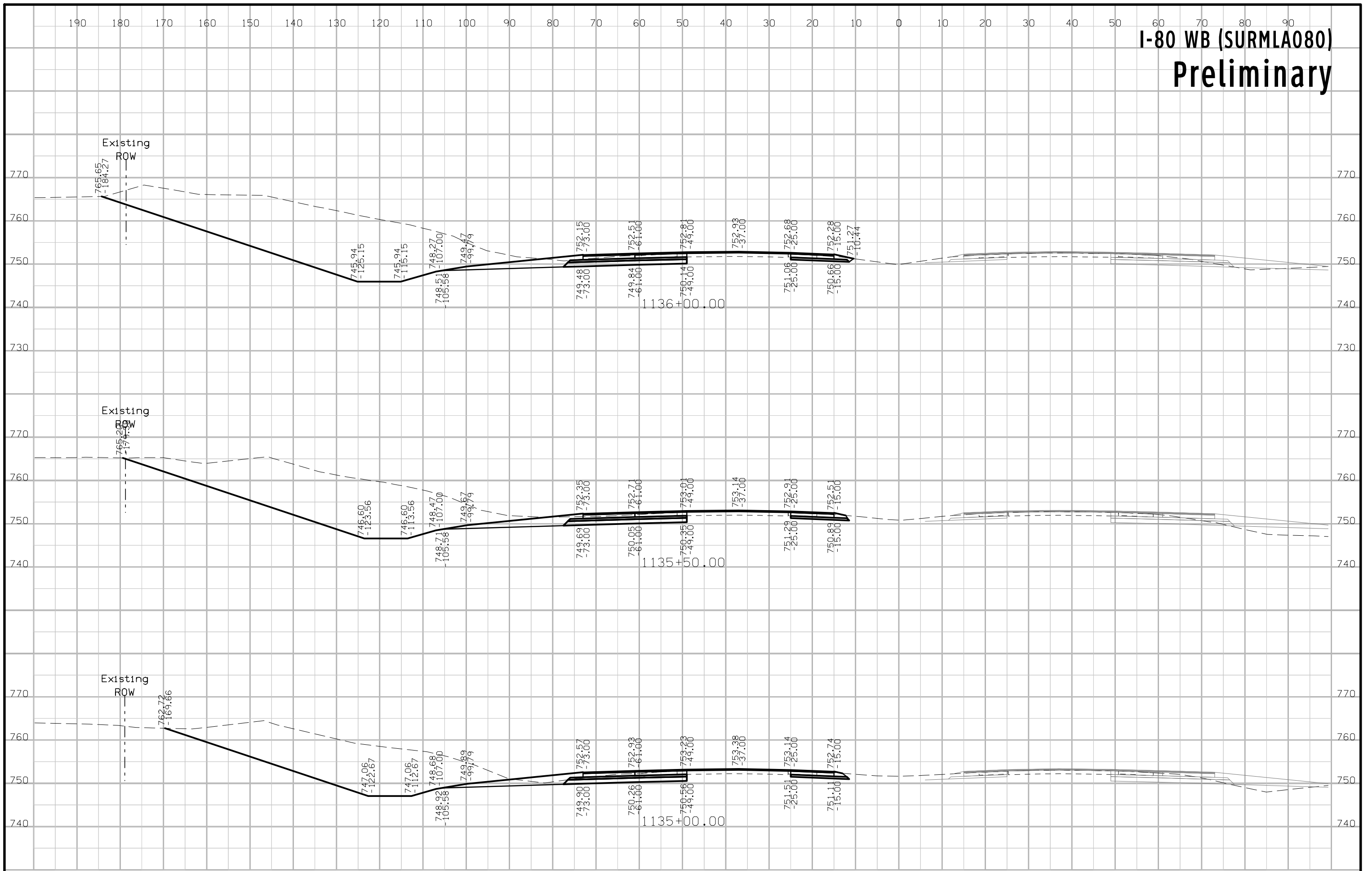

# I-80 WB (SURMLA080) Preliminary

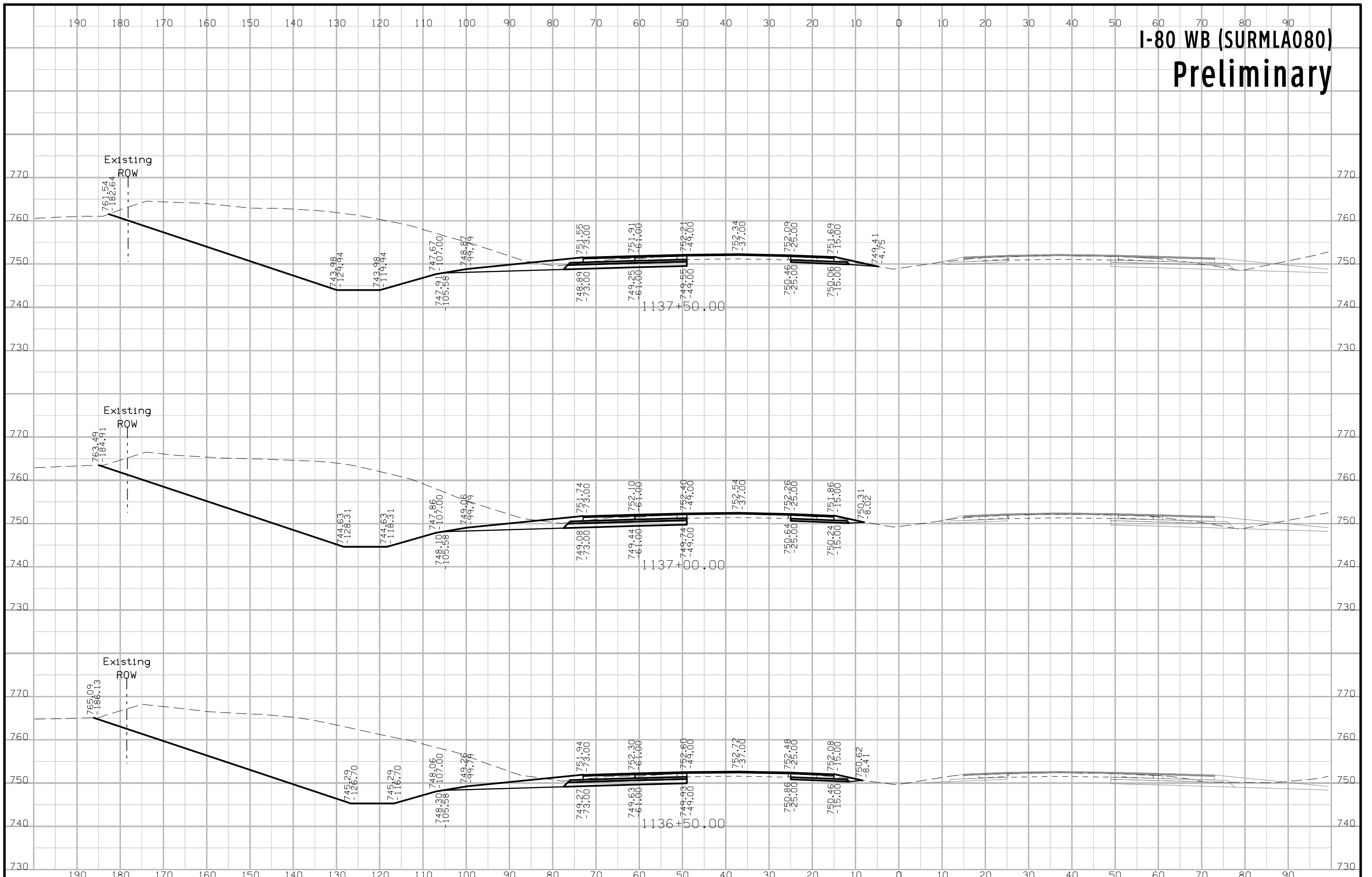



# I-80 WB (SURMLA080) Preliminary

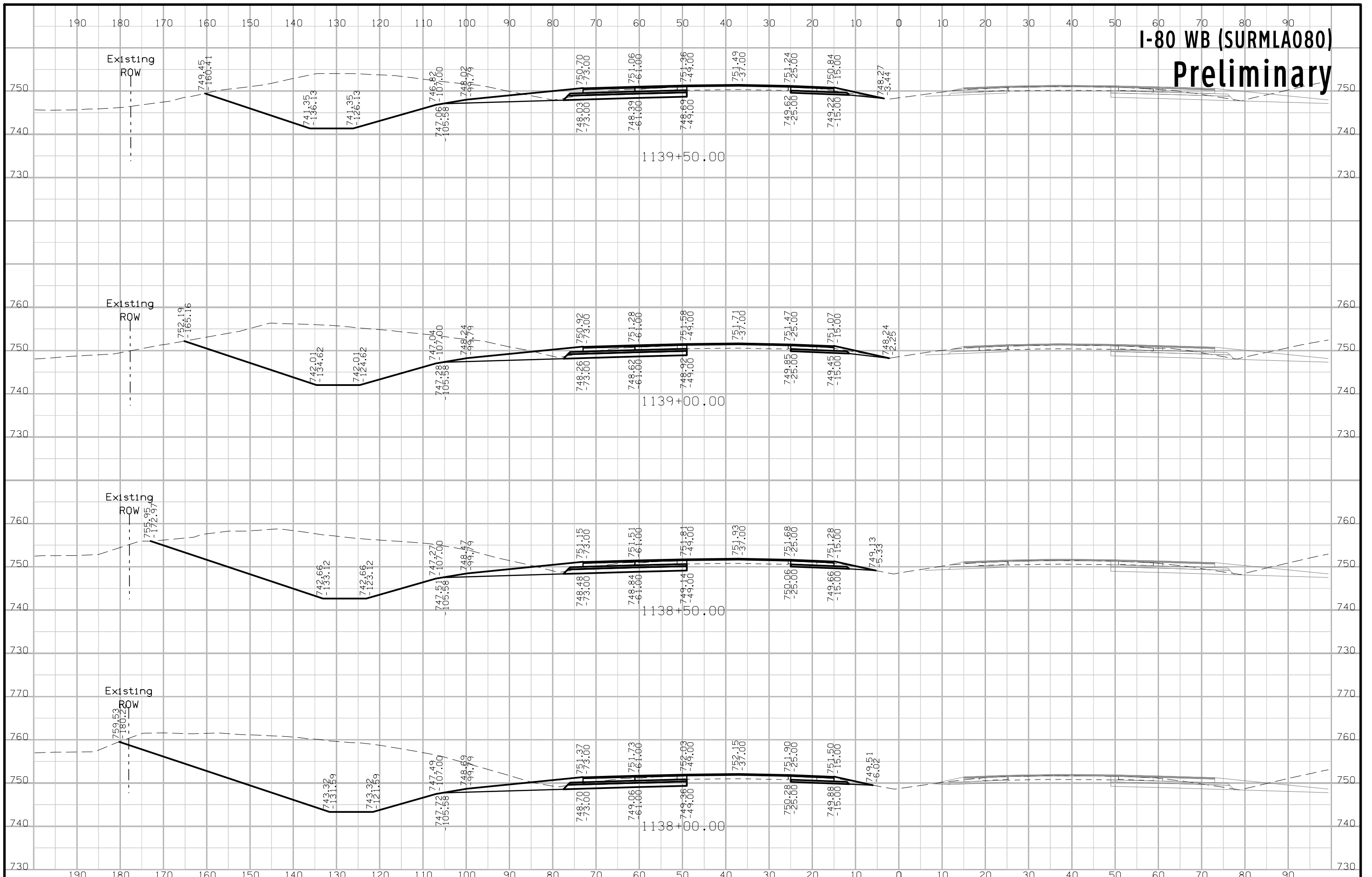

# I-80 WB (SURMLA080) Preliminary

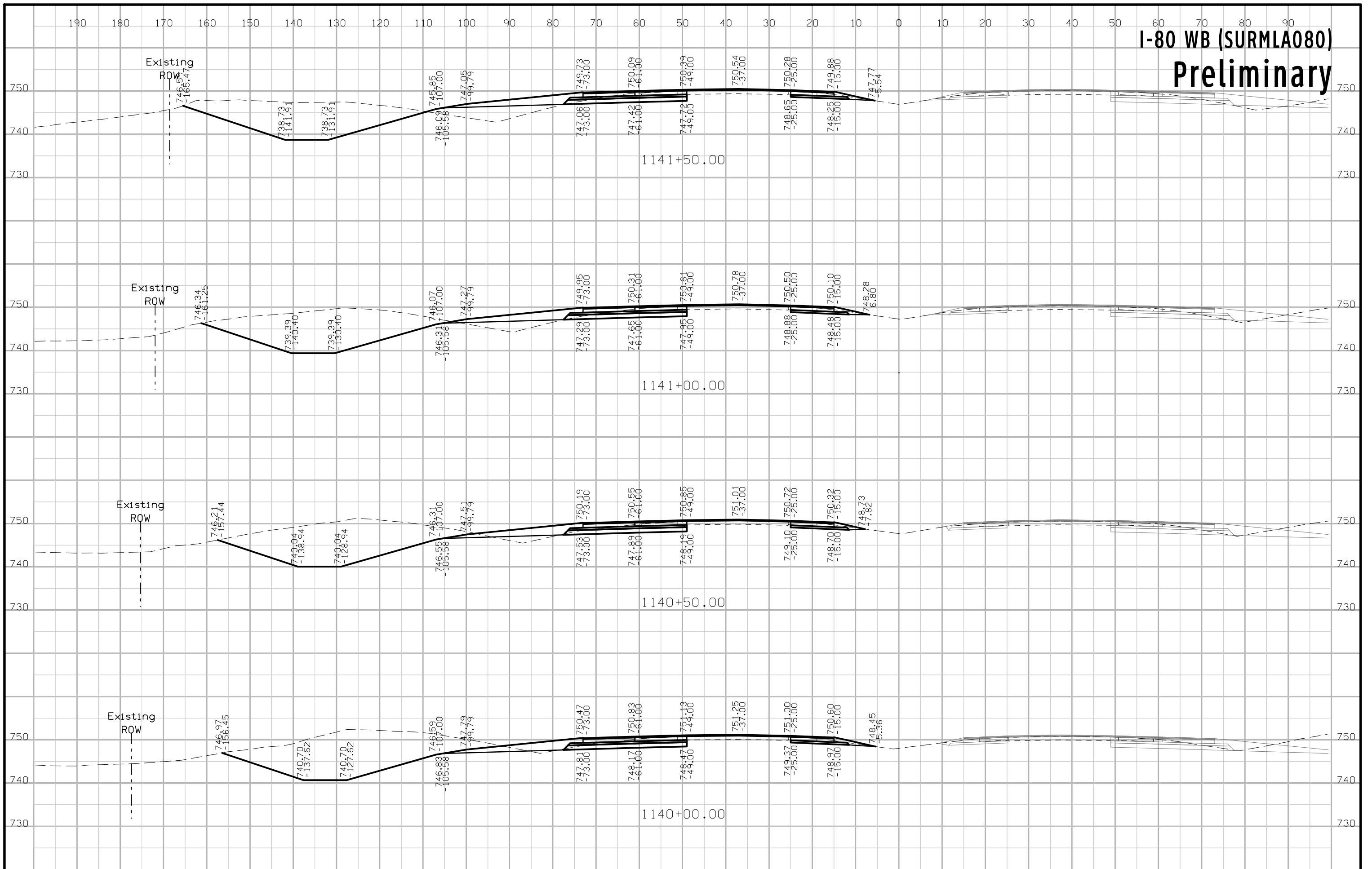

# I-80 WB (SURMLA080) Preliminary

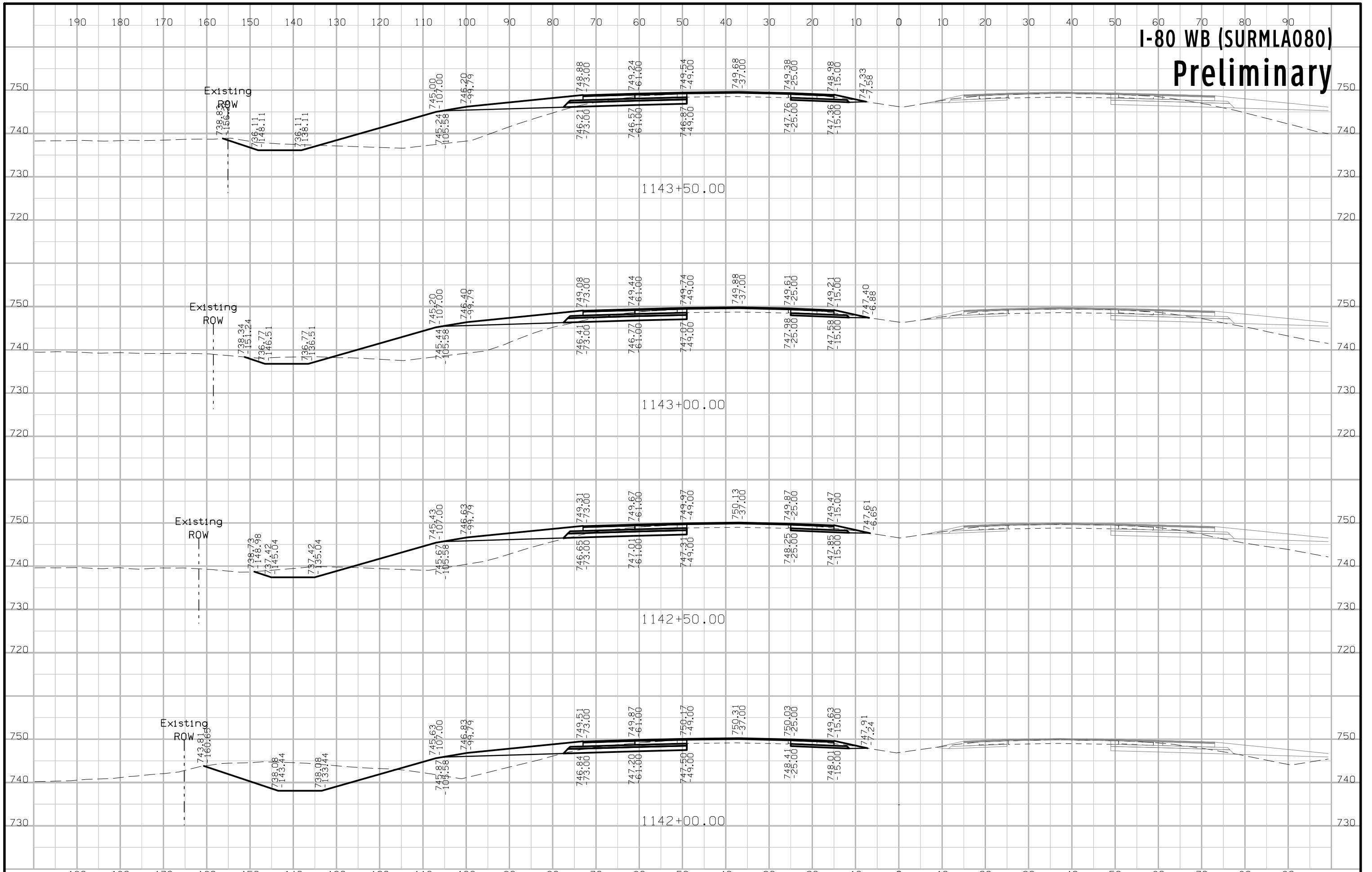

# I-80 WB (SURMLA080) Preliminary

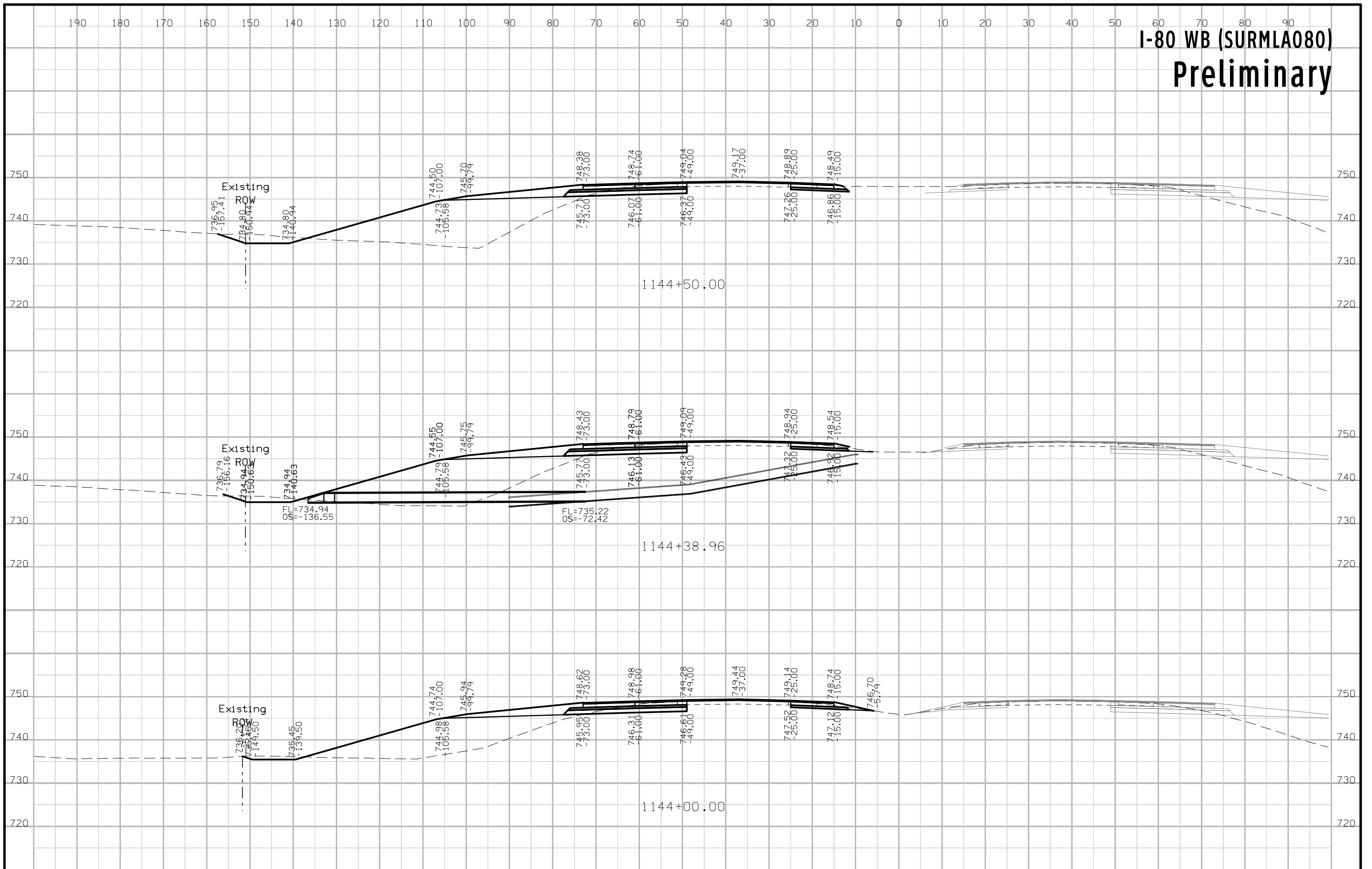

# I-80 WB (SURMLA080) Preliminary

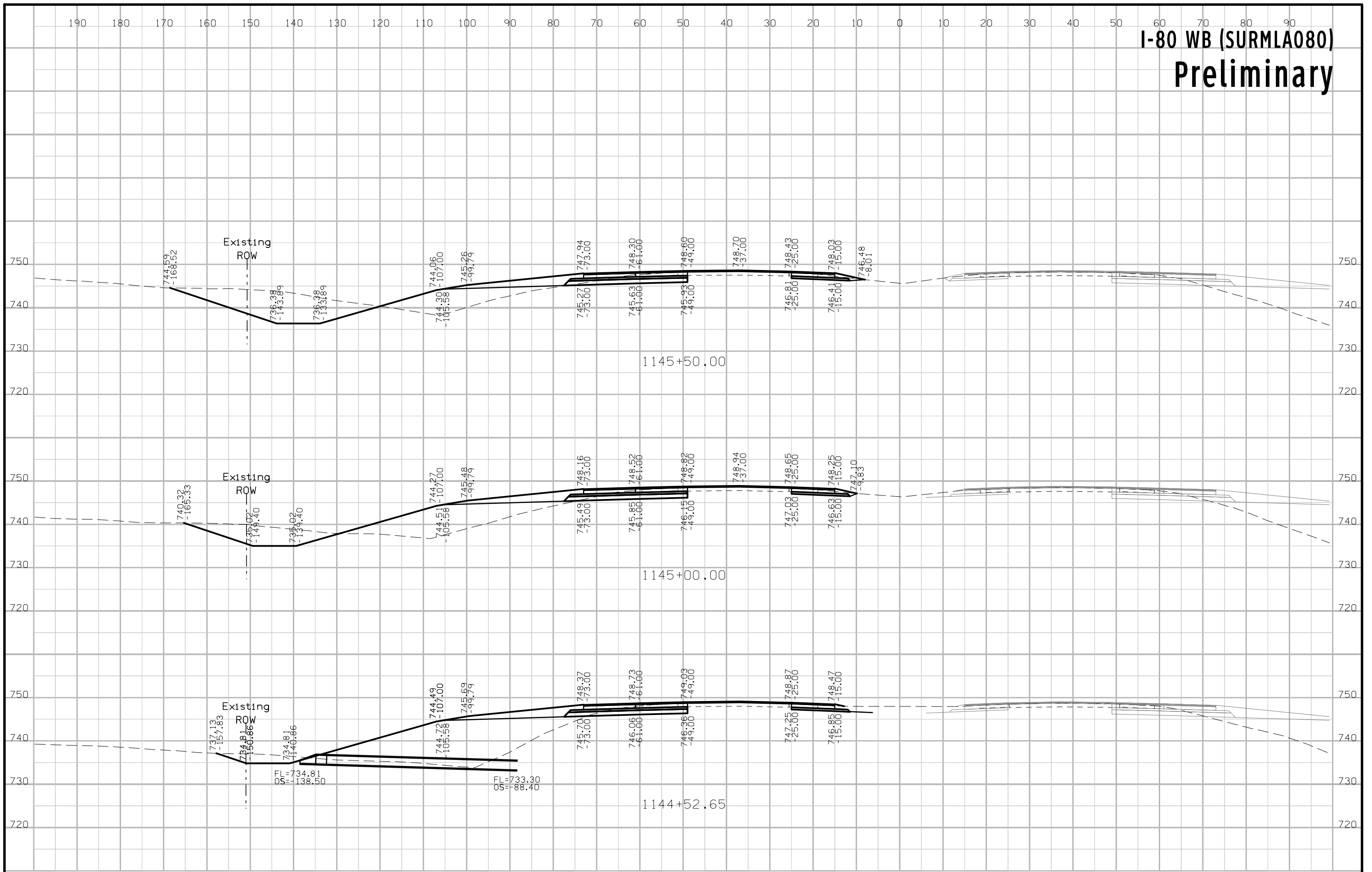

# I-80 WB (SURMLA080) Preliminary

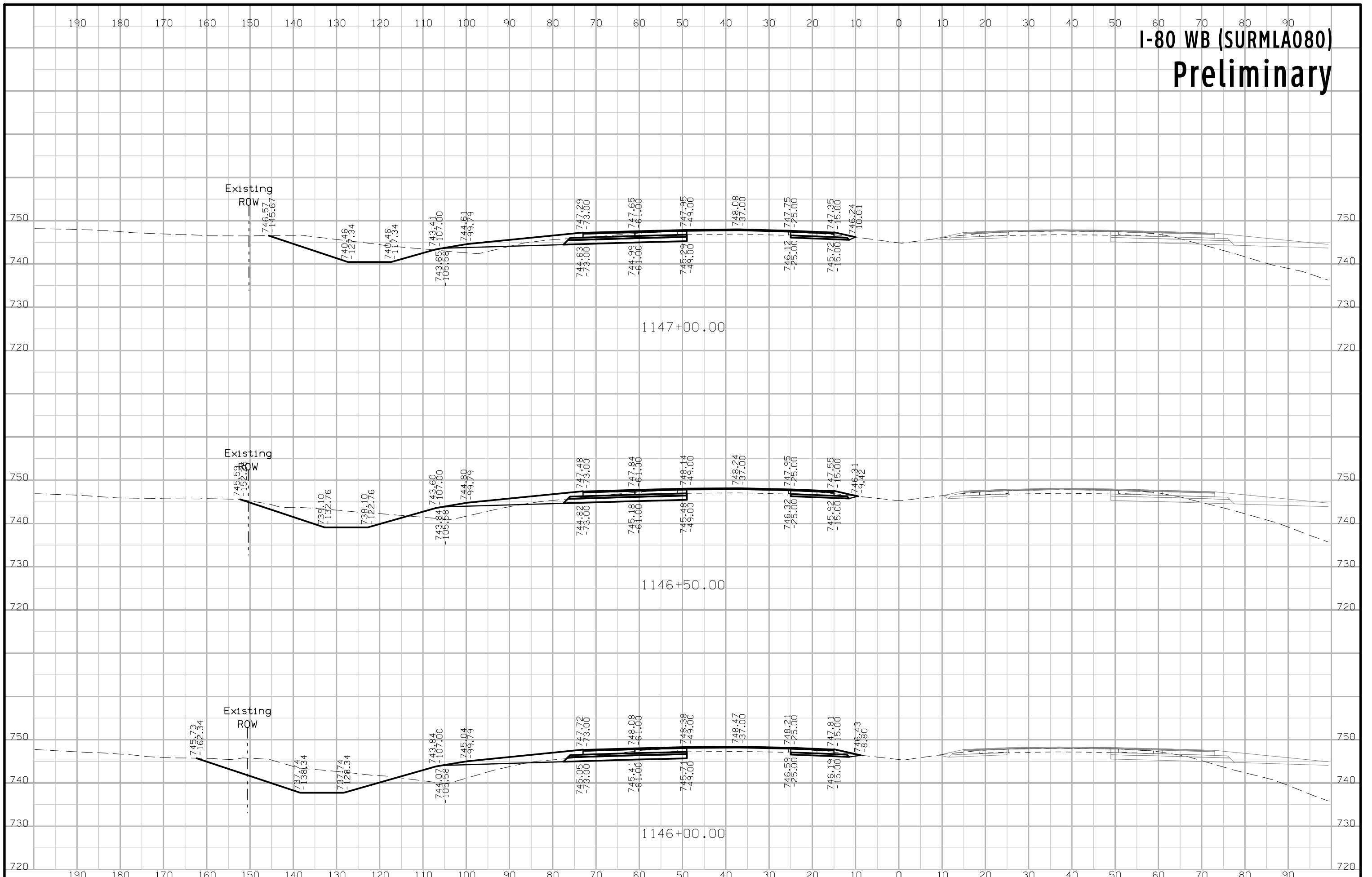



# I-80 WB (SURMLA080) Preliminary

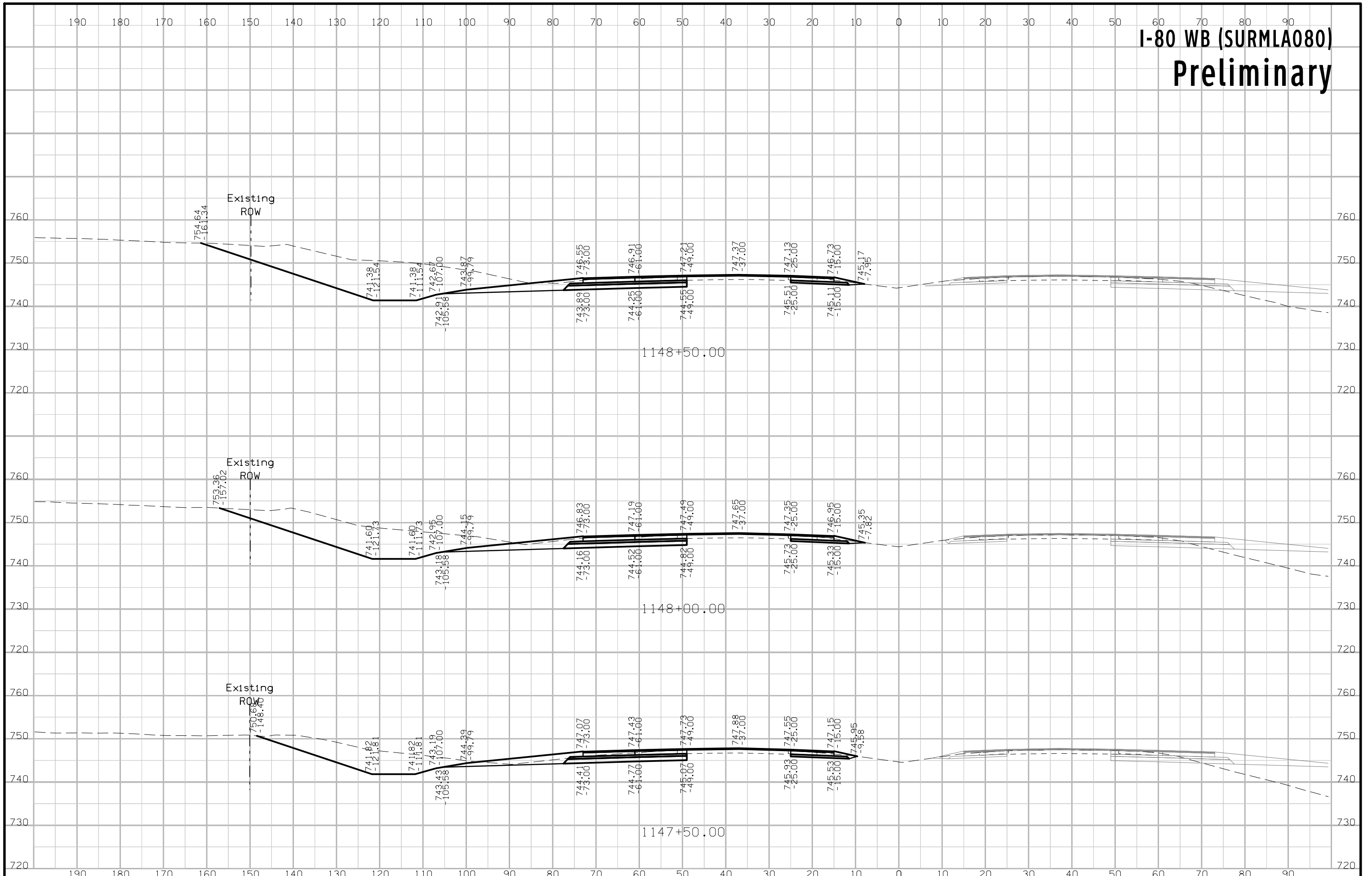

# I-80 WB (SURMLA080) Preliminary

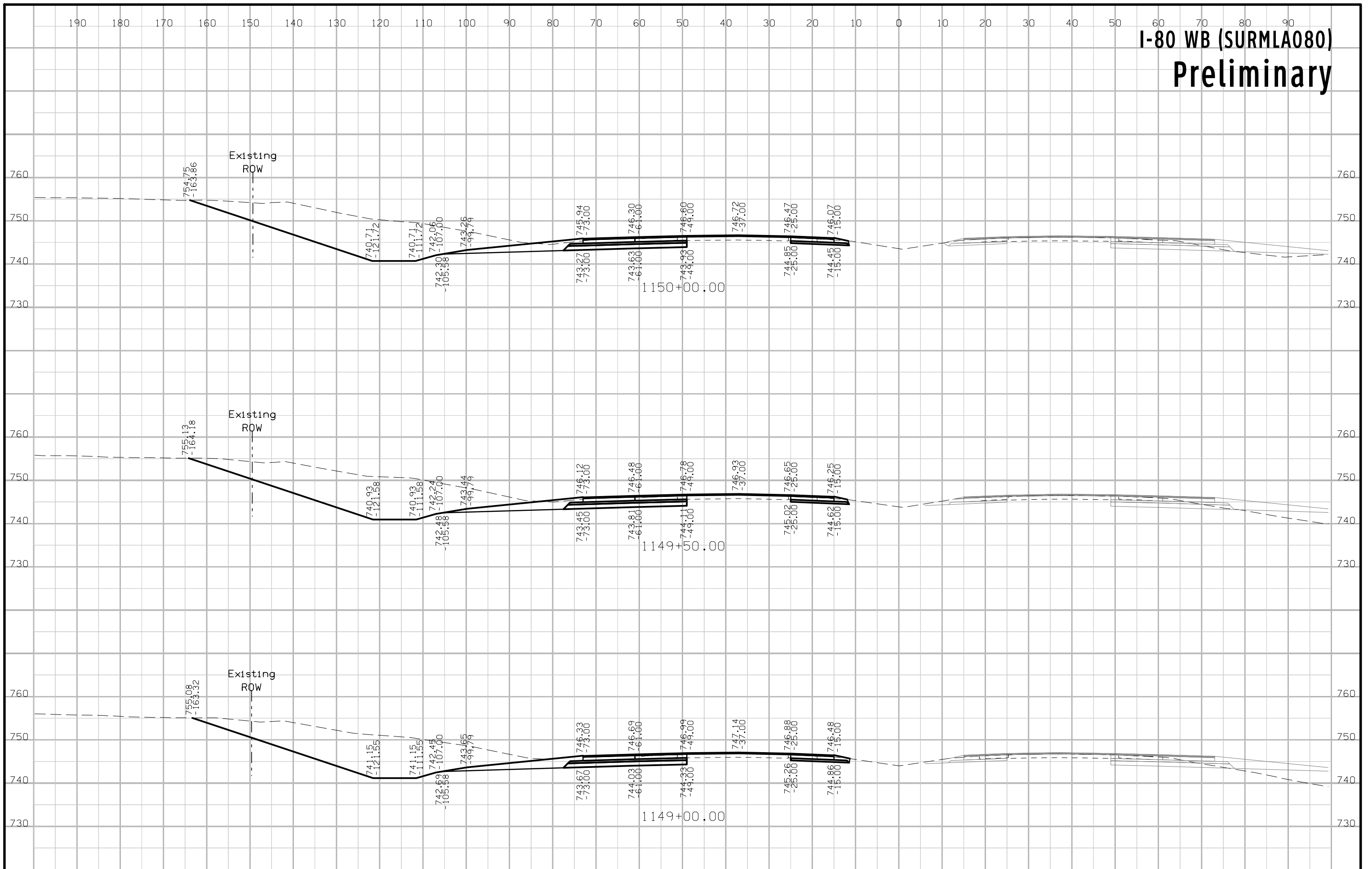

# I-80 WB (SURMLA080) Preliminary

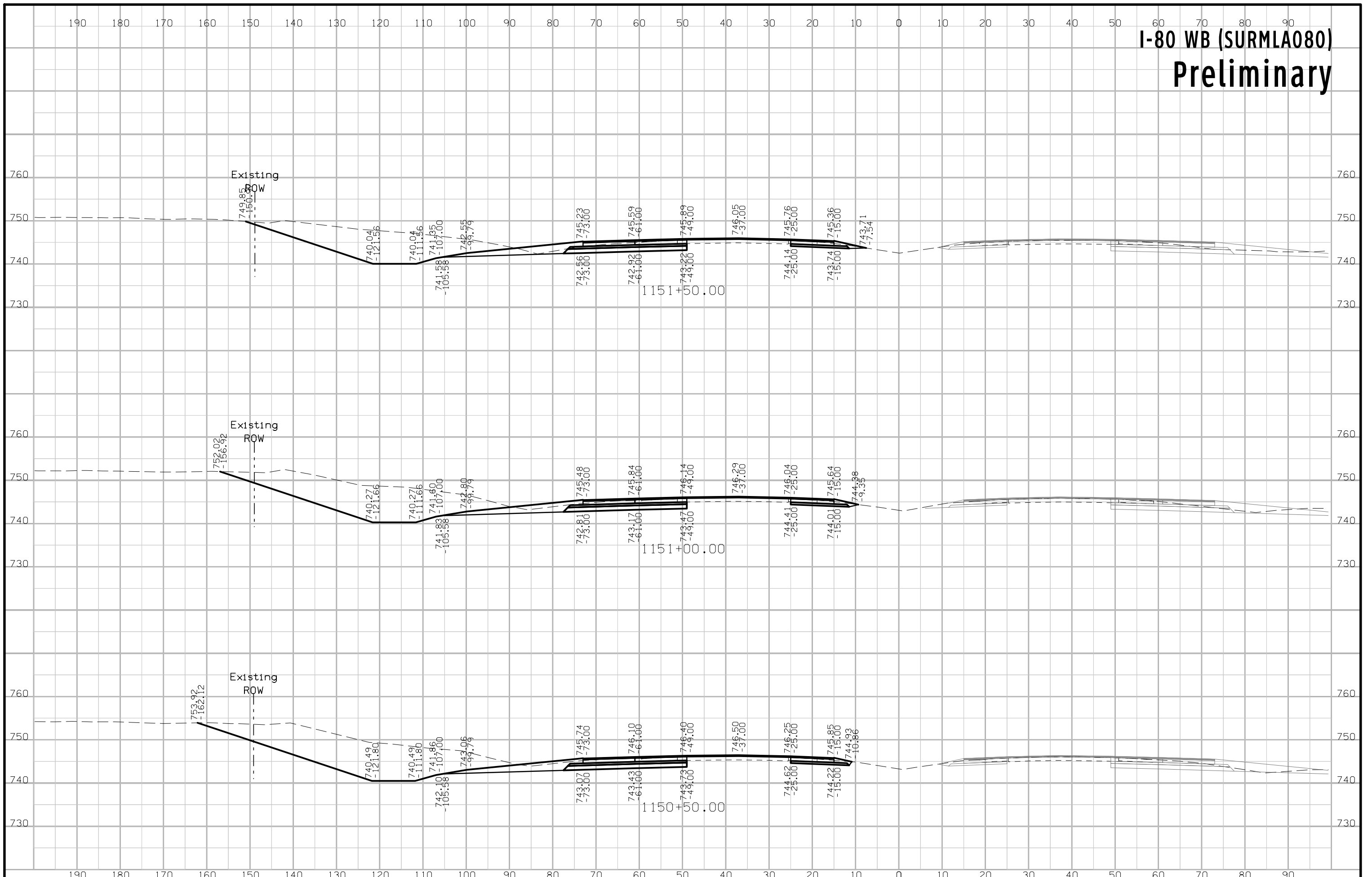

# I-80 WB (SURMLA080) Preliminary

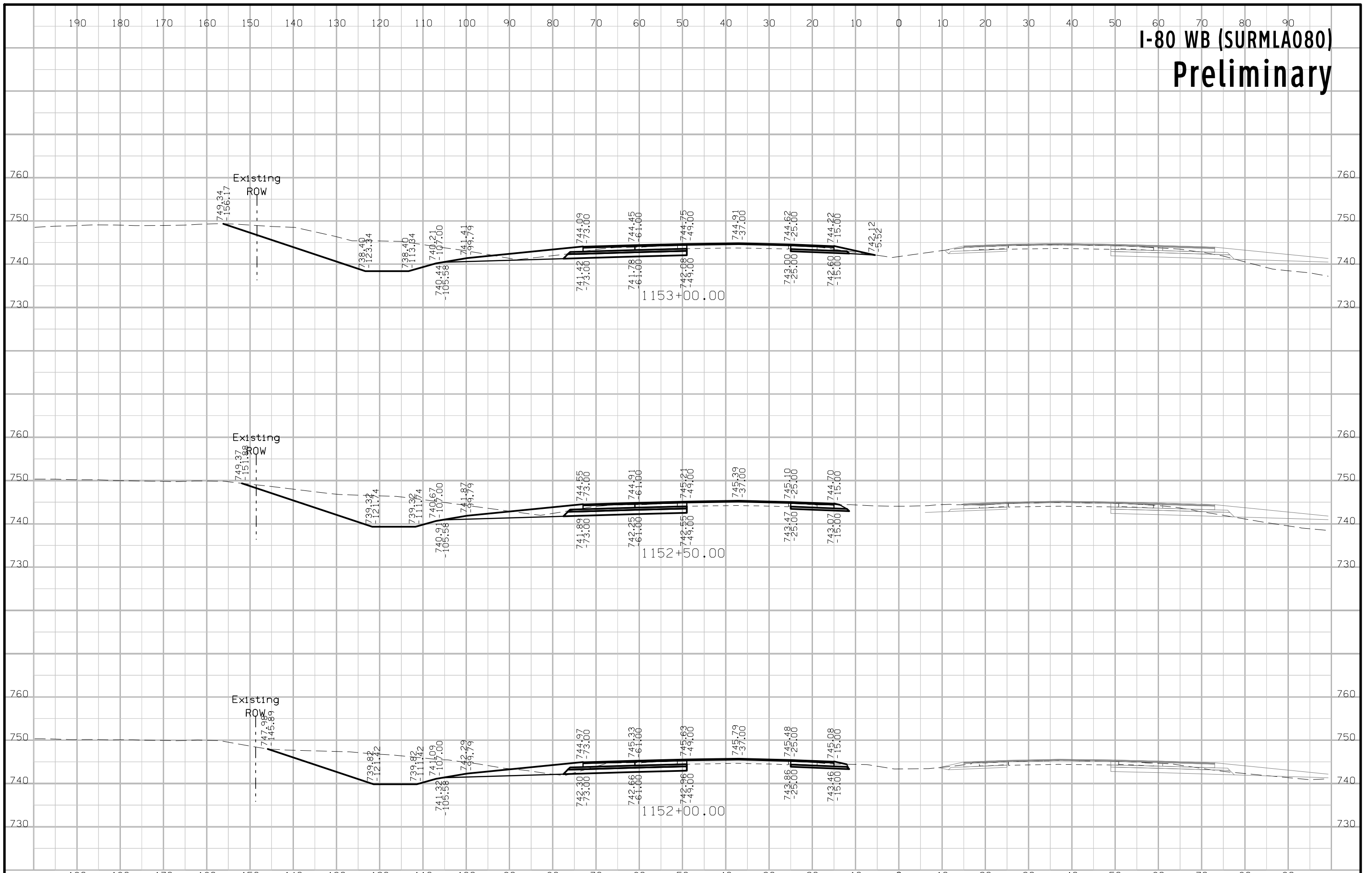

# I-80 WB (SURMLA080) Preliminary

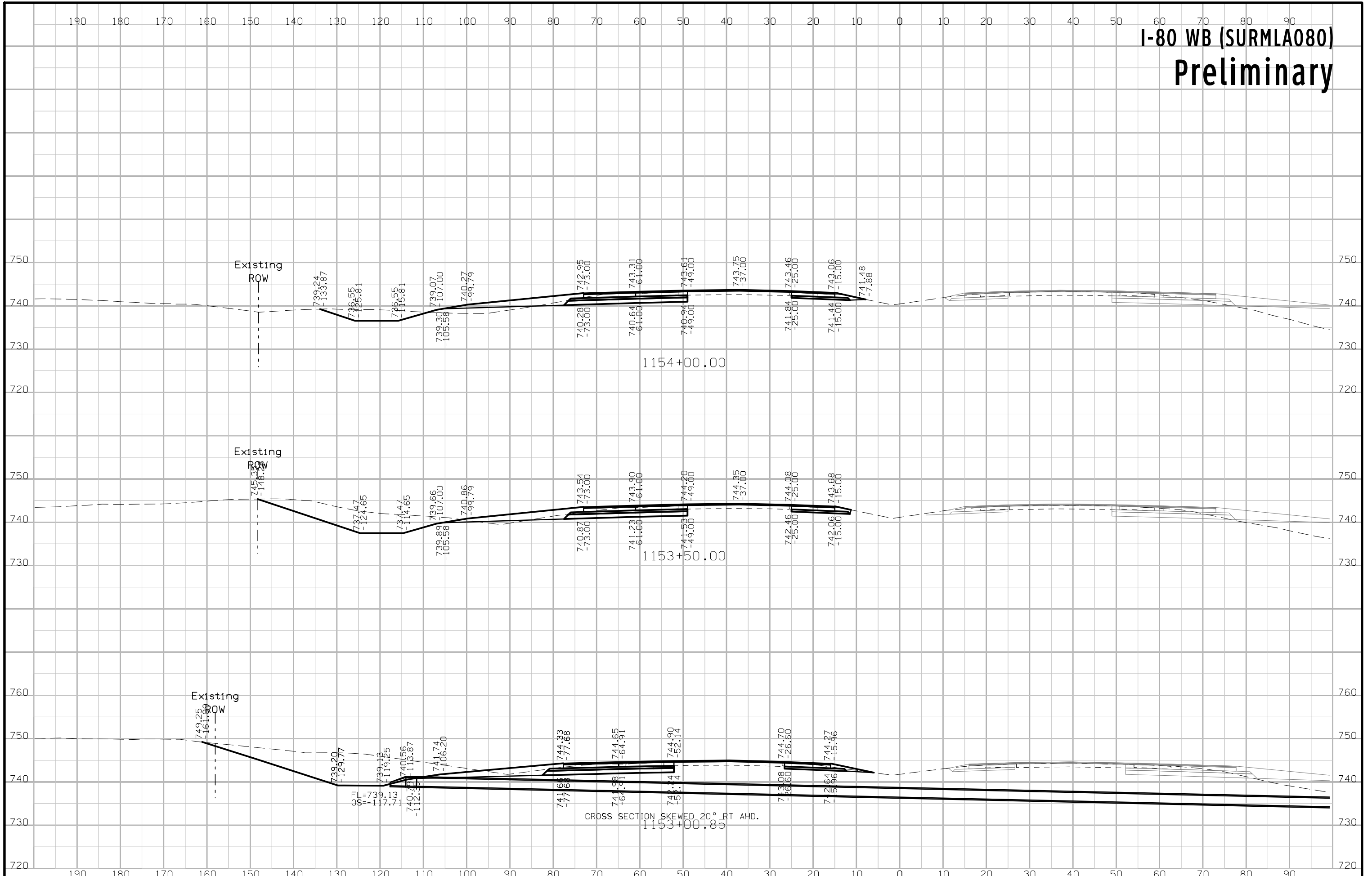

# I-80 WB (SURMLA080) Preliminary

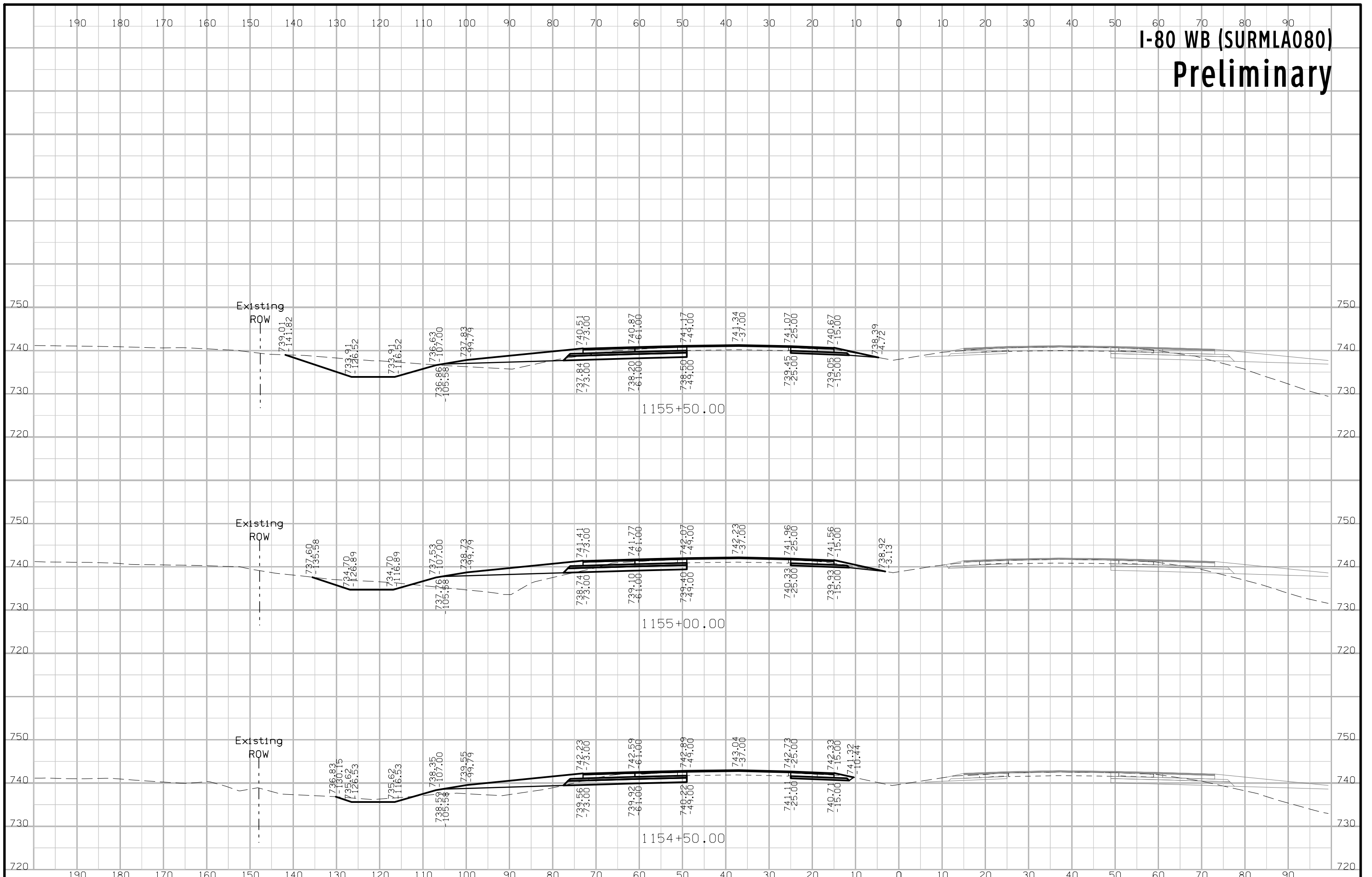



# I-80 WB (SURMLA080) Preliminary

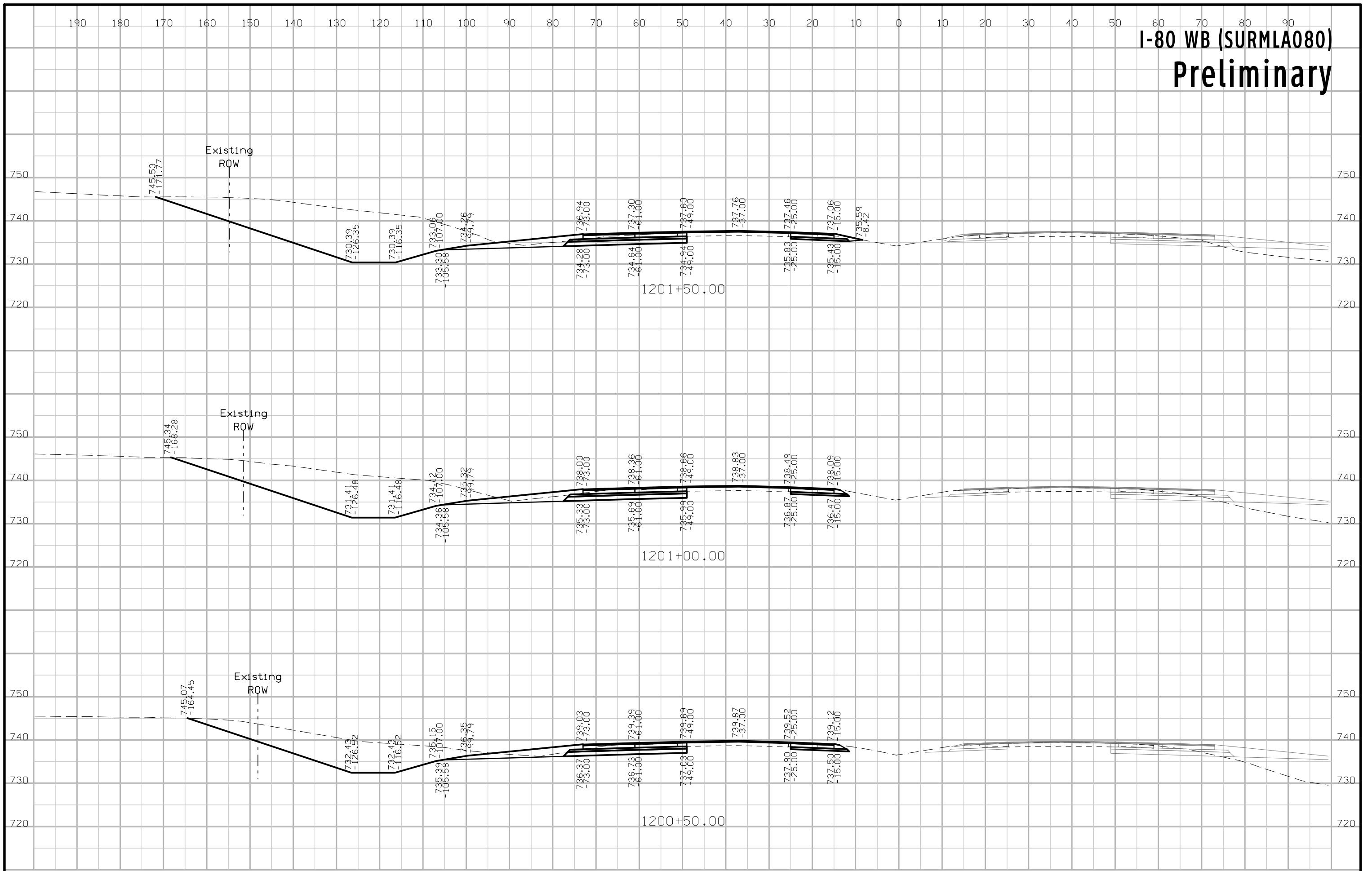

# I-80 WB (SURMLA080) Preliminary

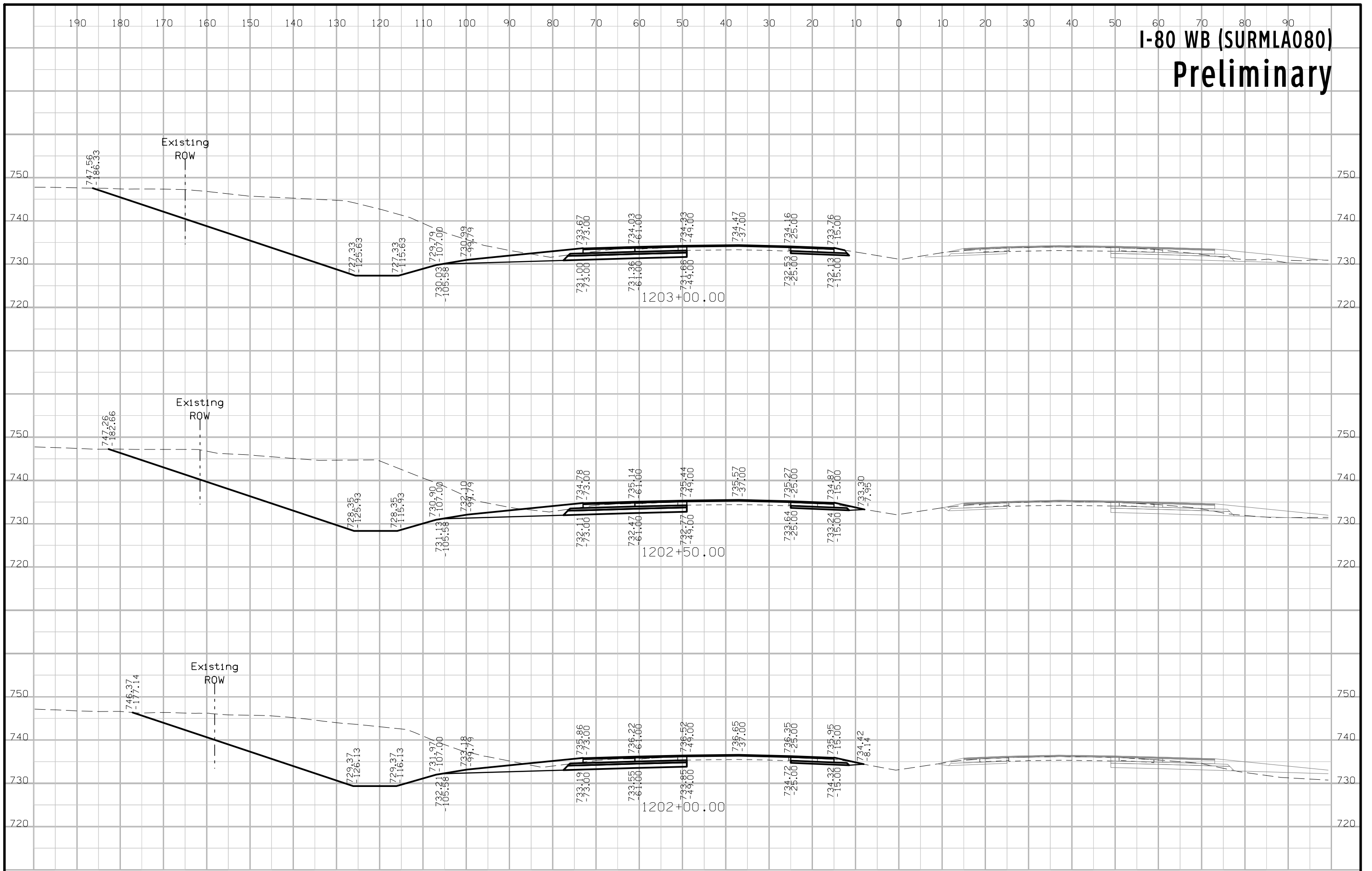

# I-80 WB (SURMLA080) Preliminary

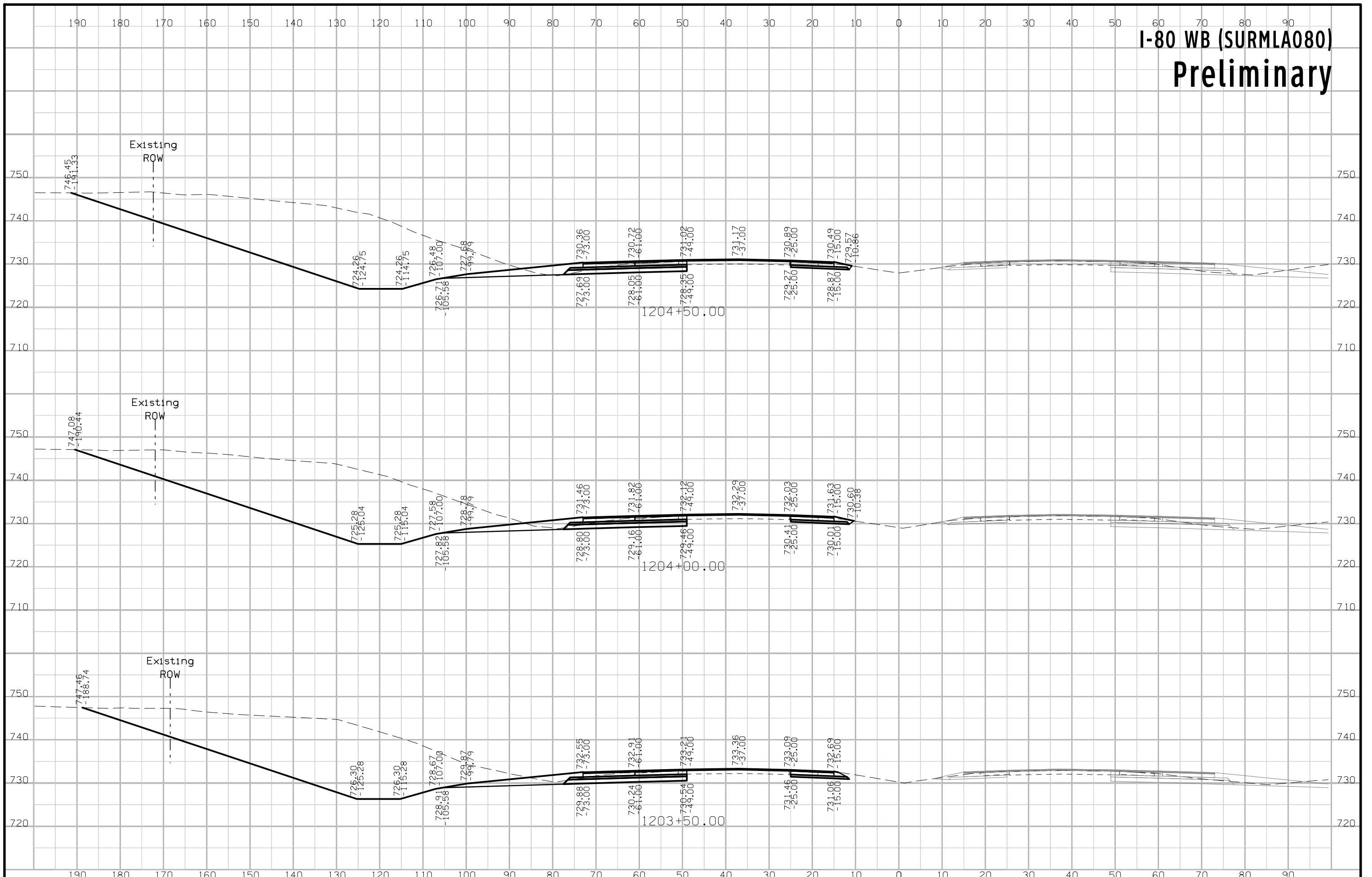

# I-80 WB (SURMLA080) Preliminary

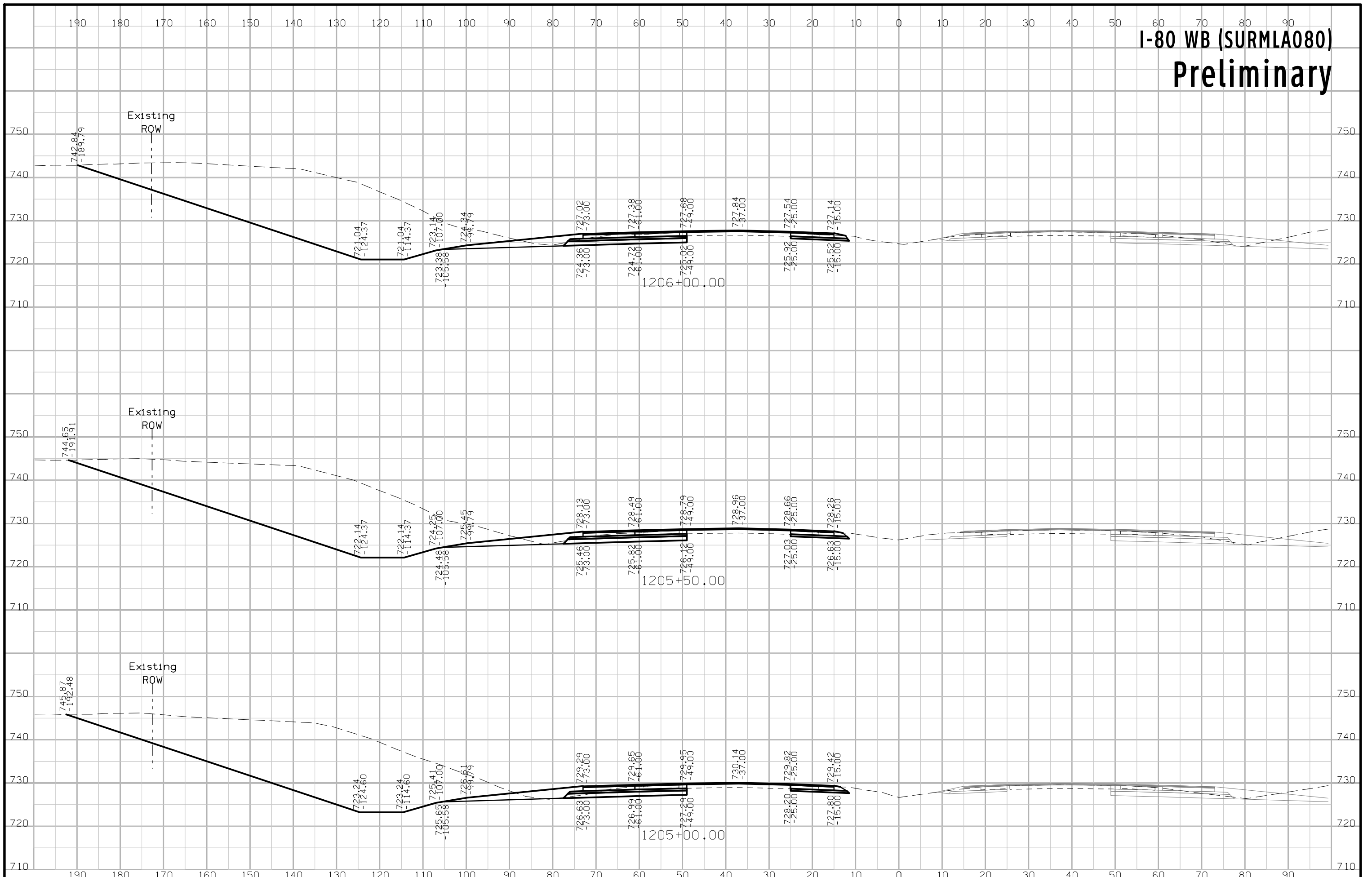

# I-80 WB (SURMLA080) Preliminary

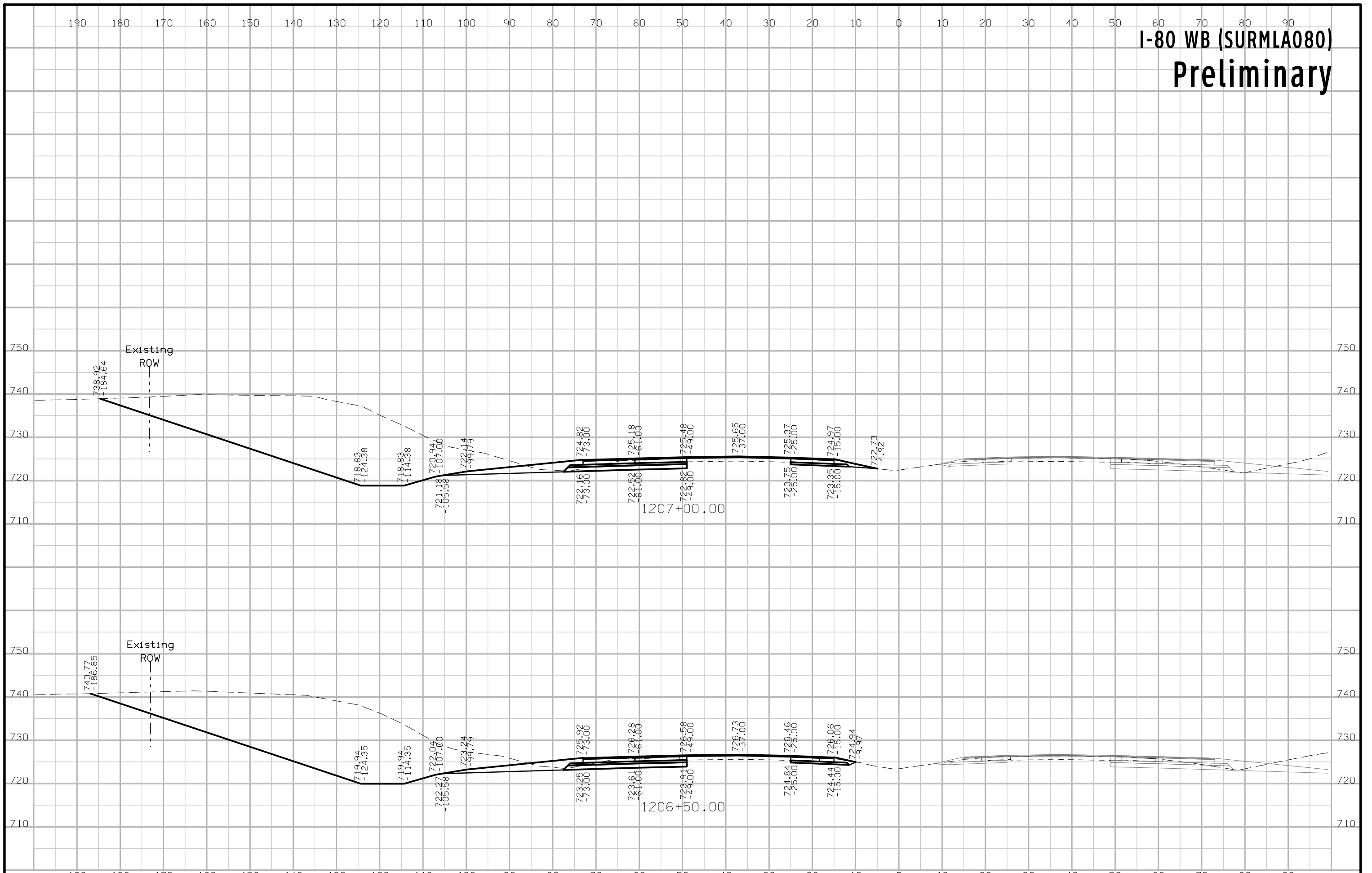

# I-80 WB (SURMLA080) Preliminary

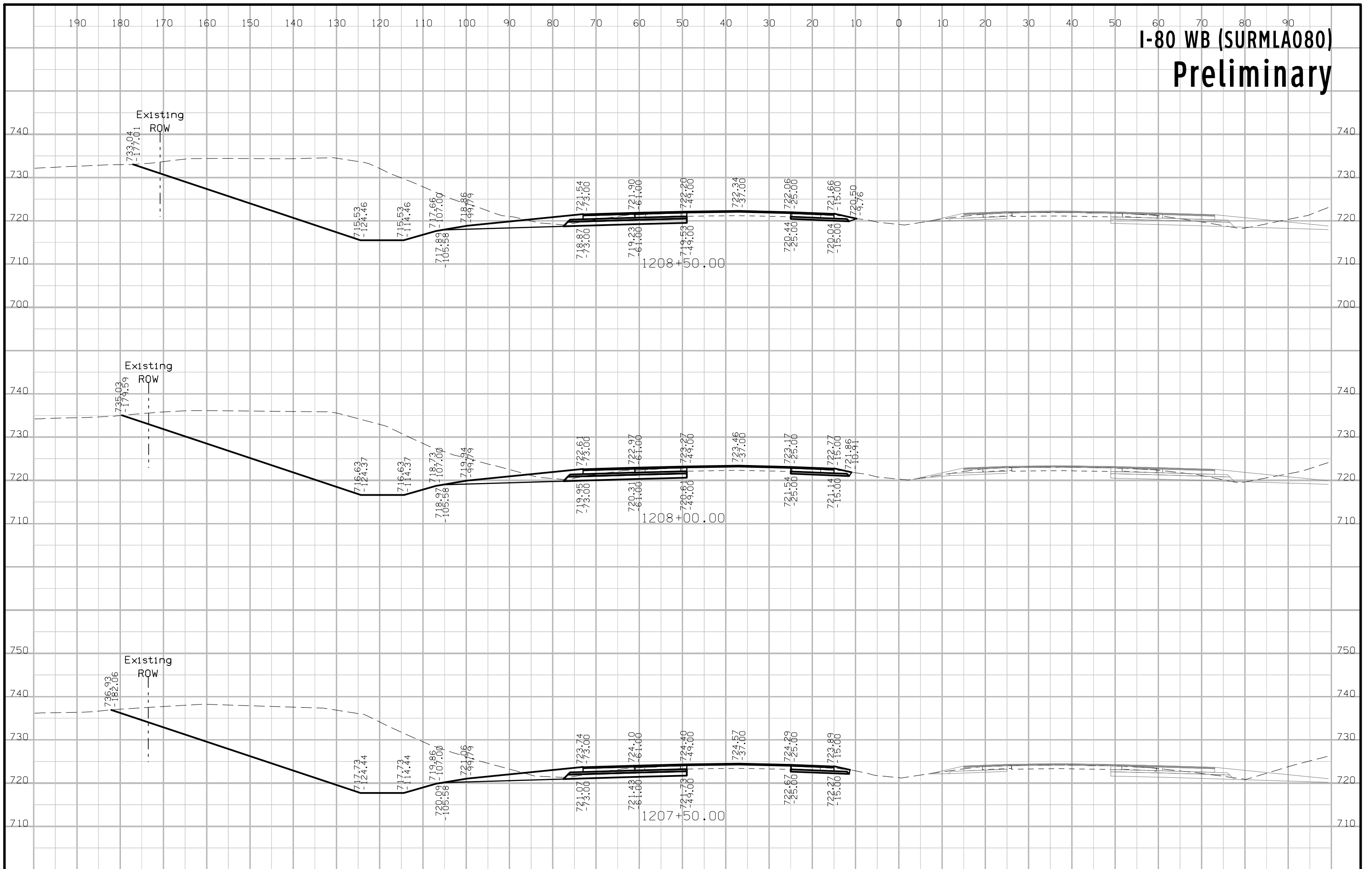



# I-80 WB (SURMLA080) Preliminary

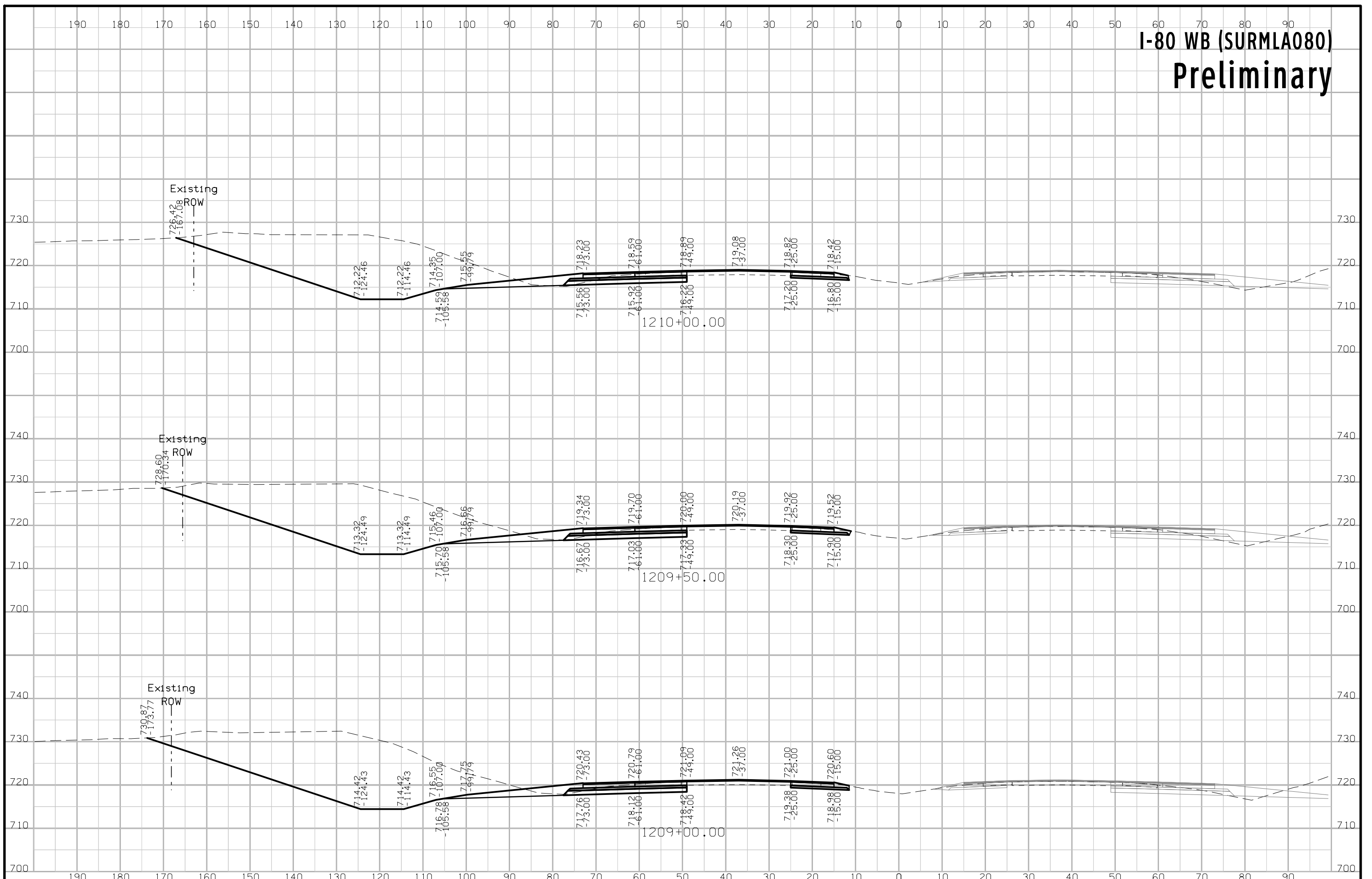

# I-80 WB (SURMLA080) Preliminary

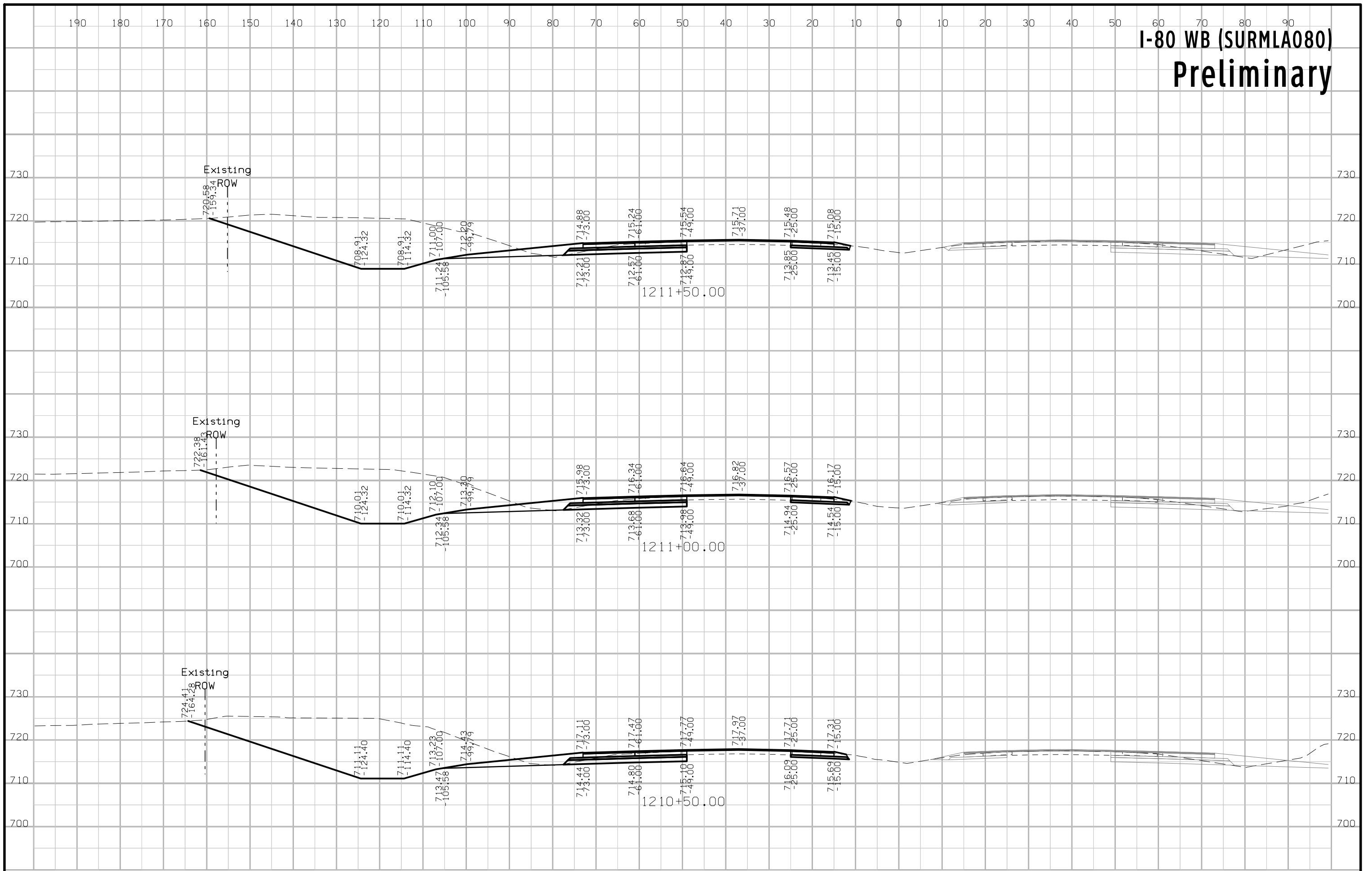

# I-80 WB (SURMLA080) Preliminary

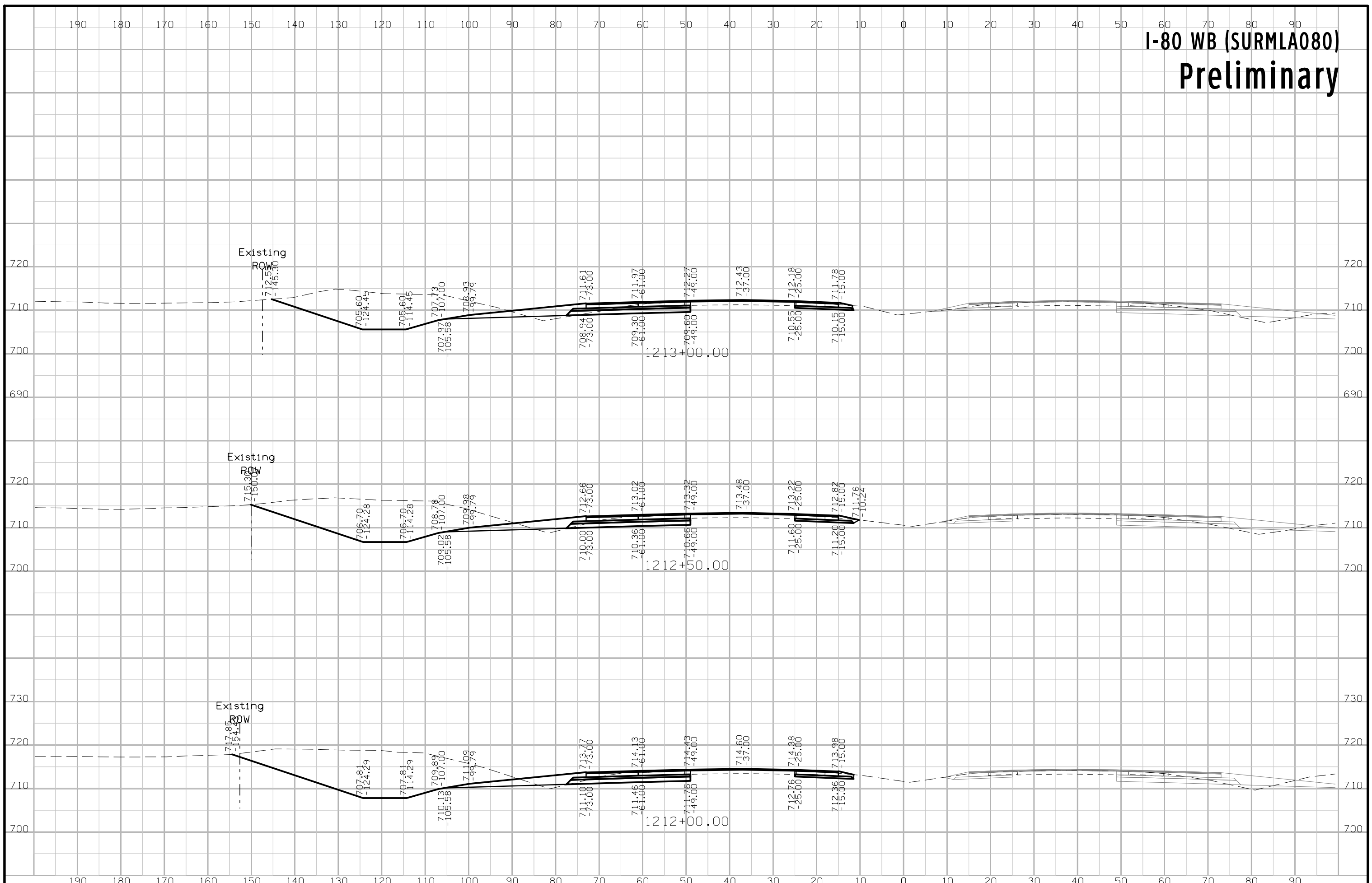

# I-80 WB (SURMLA080) Preliminary

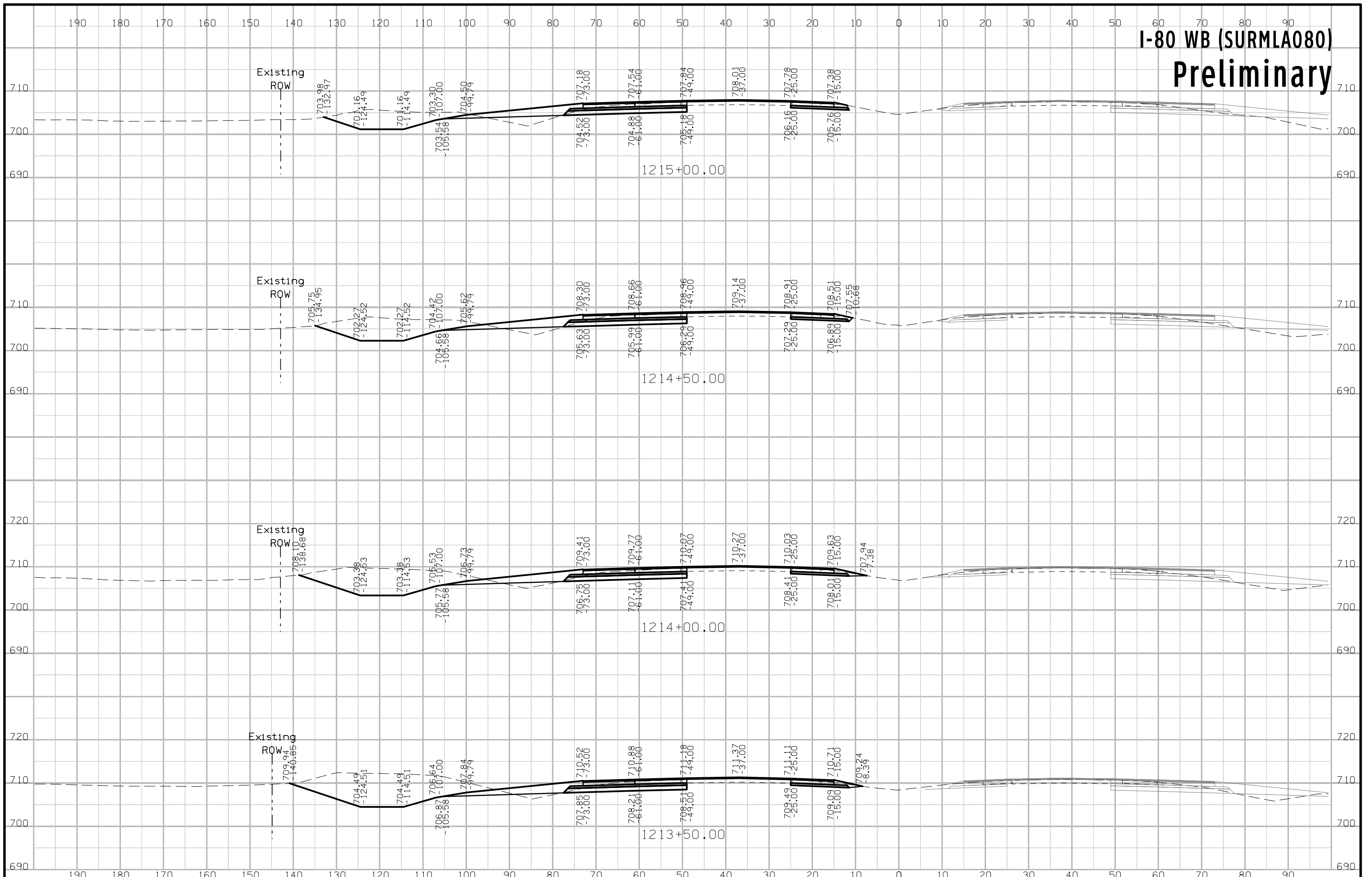

# I-80 WB (SURMLA080) Preliminary

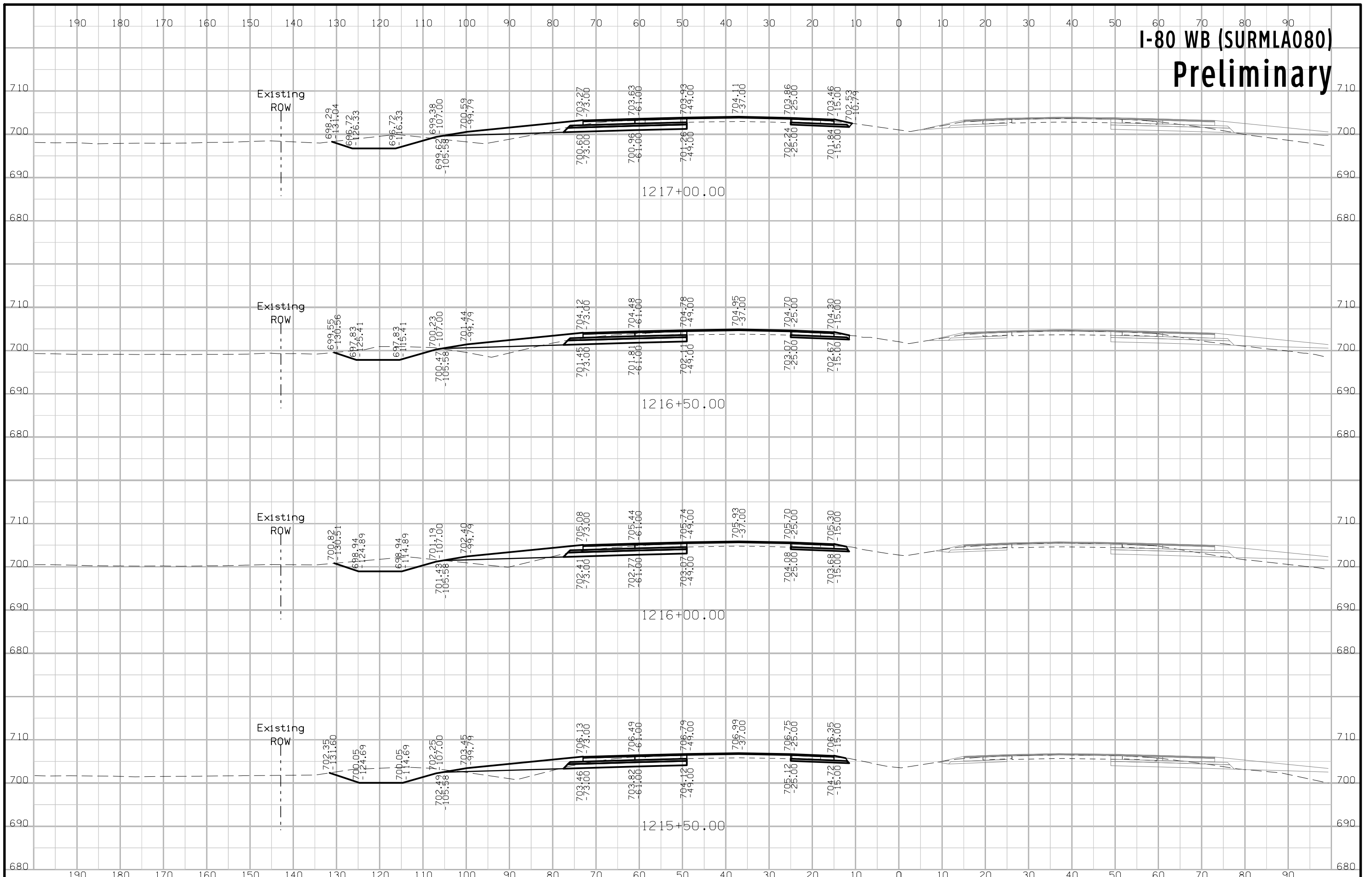

# I-80 WB (SURMLA080) Preliminary

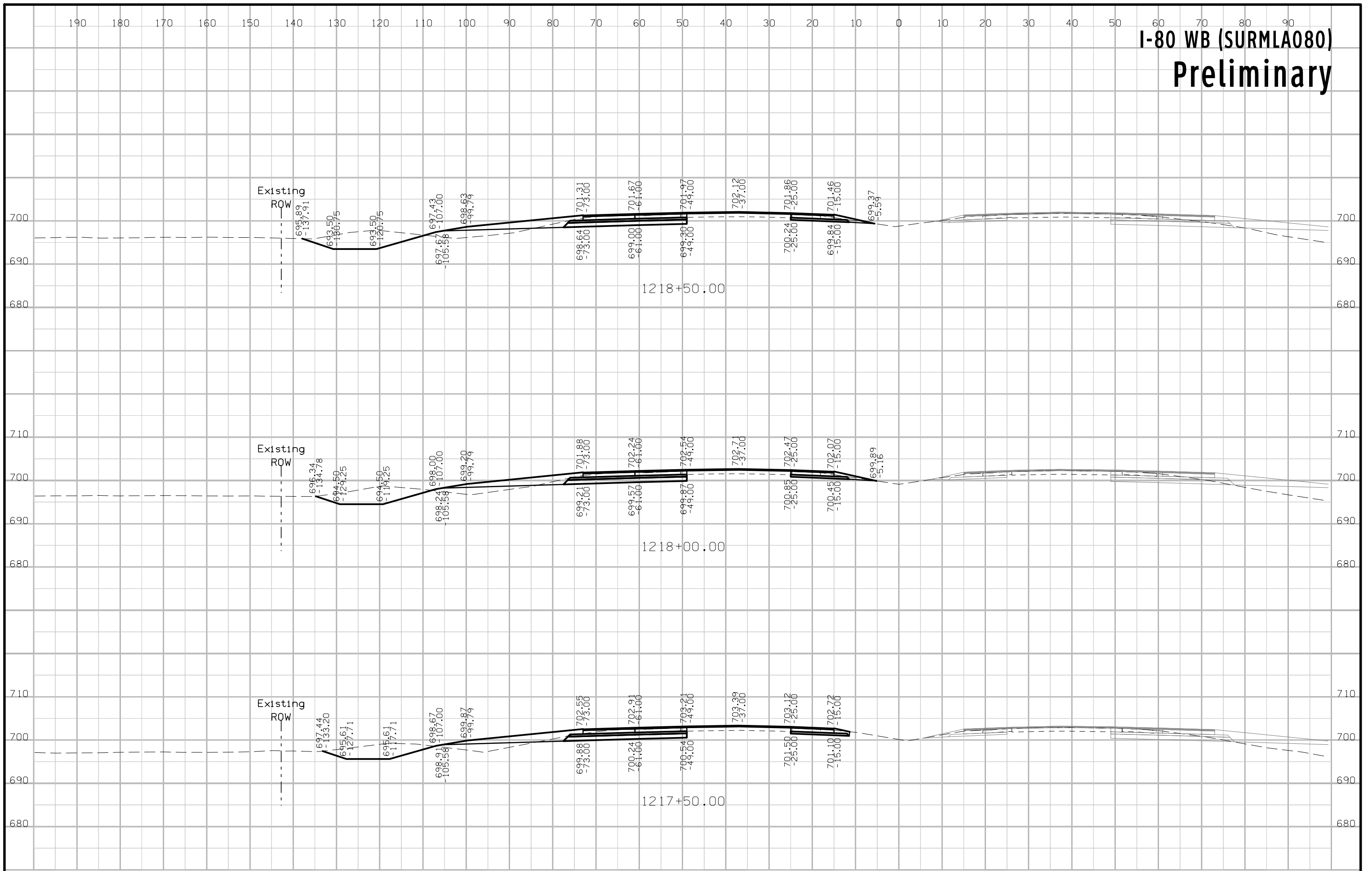



# I-80 WB (SURMLA080) Preliminary

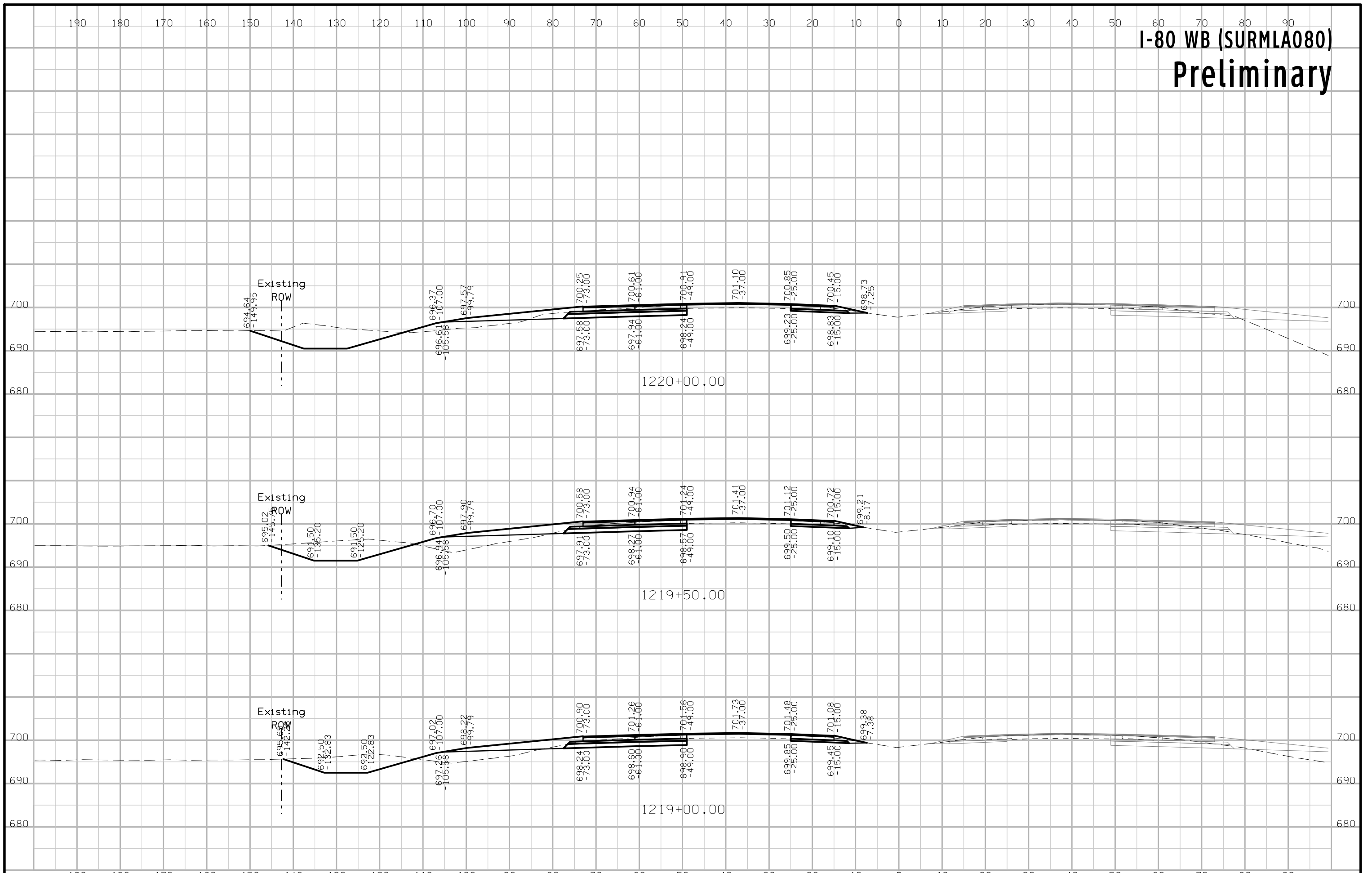

# I-80 WB (SURMLA080) Preliminary

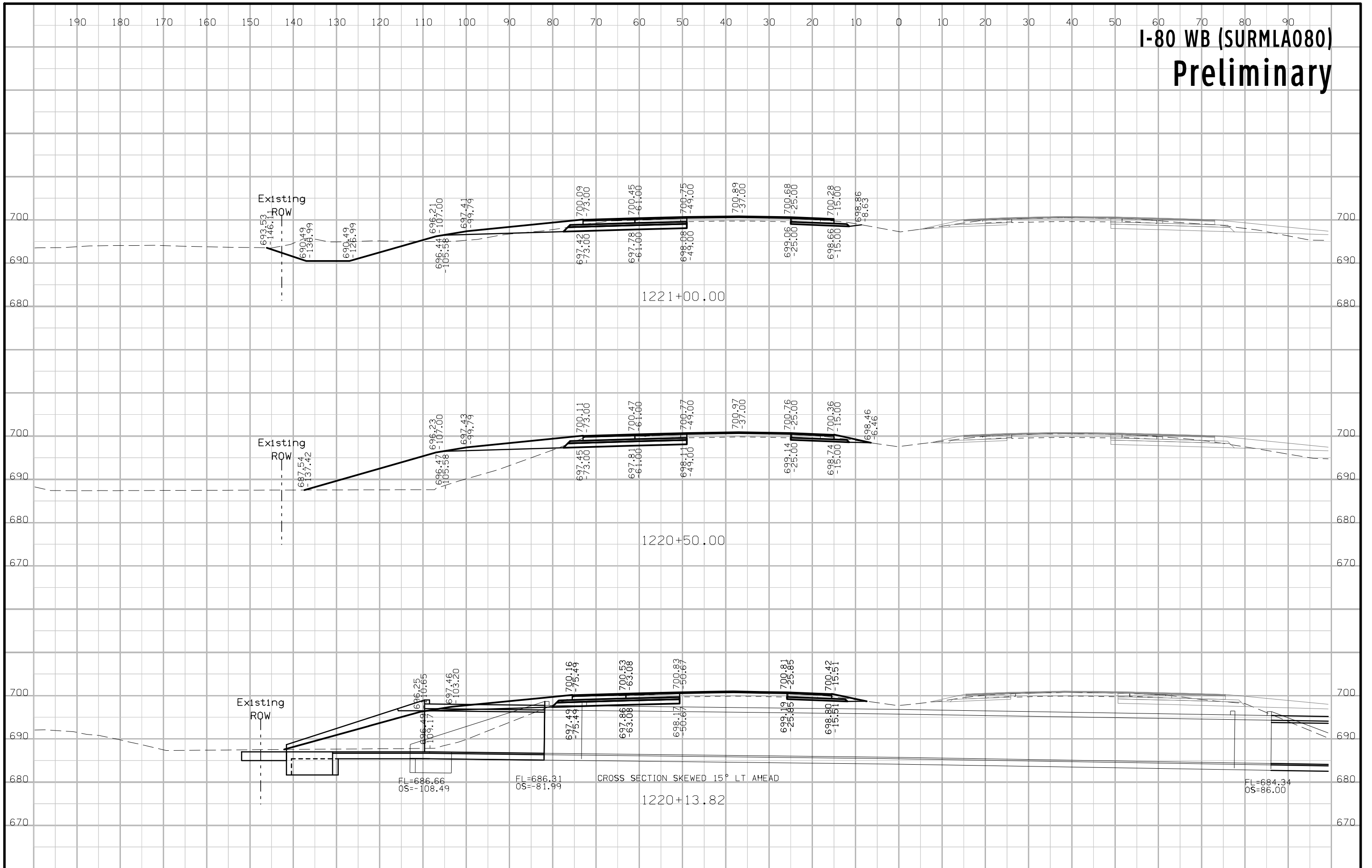

# I-80 WB (SURMLA080) Preliminary

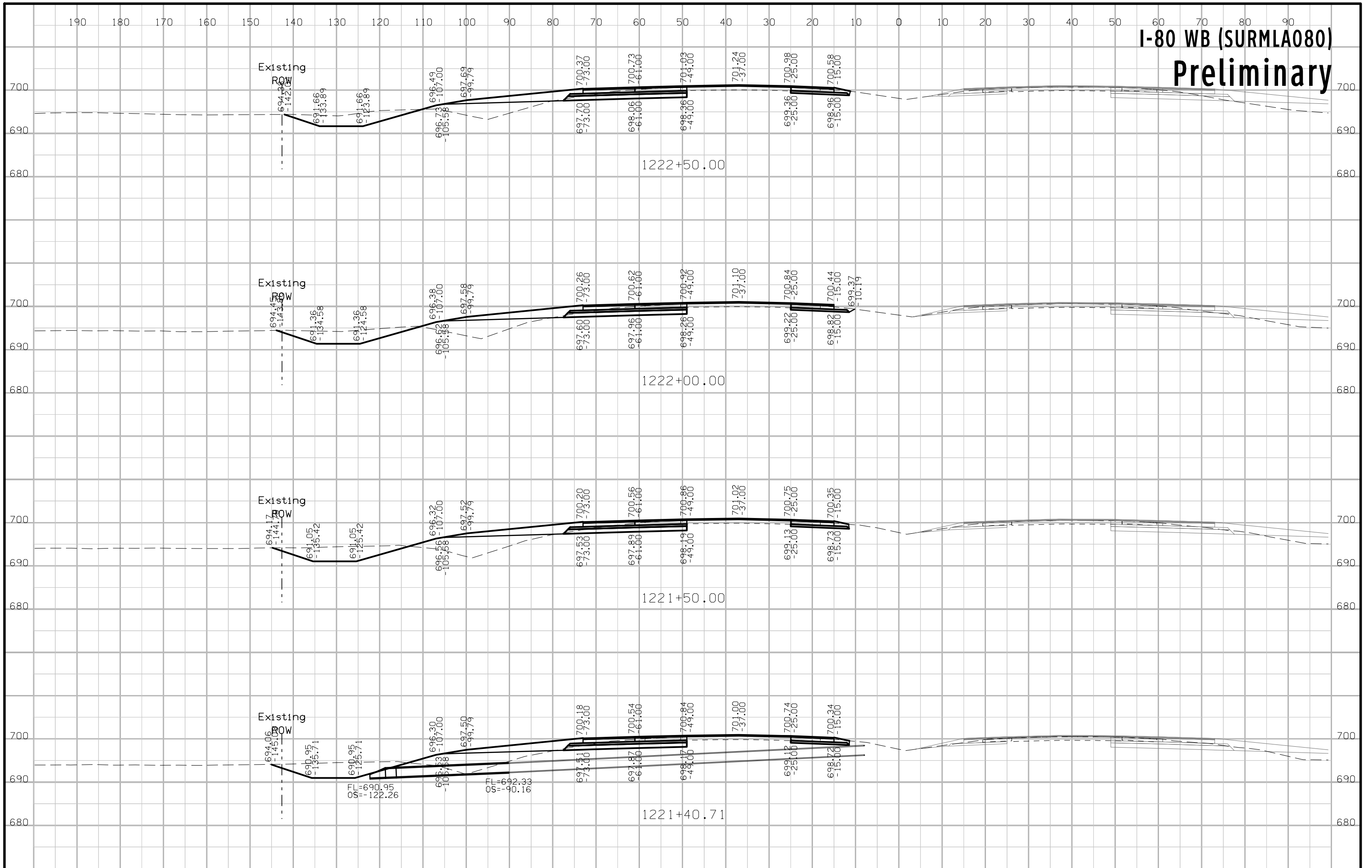

# I-80 WB (SURMLA080) Preliminary

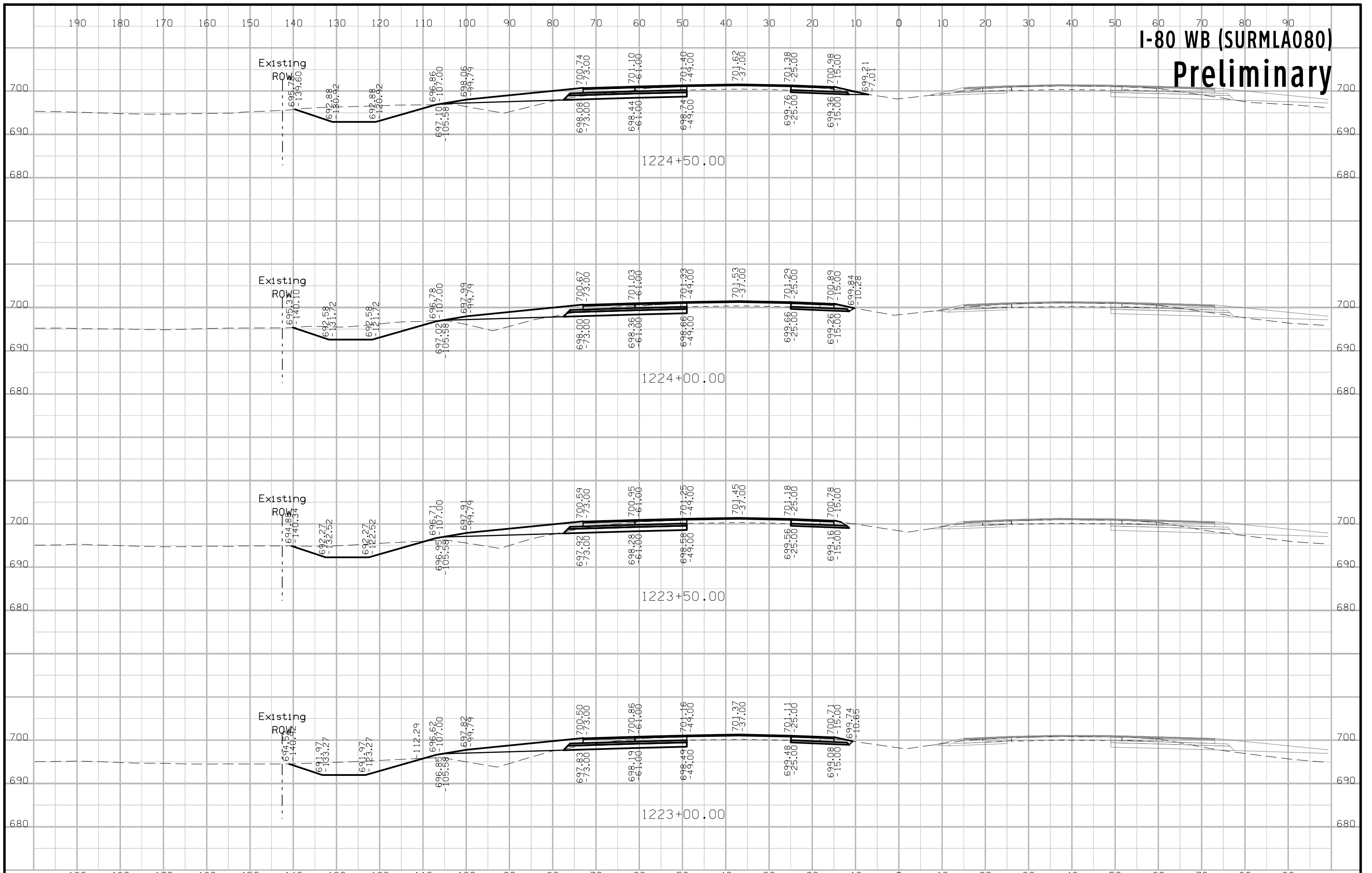

# I-80 WB (SURMLA080) Preliminary

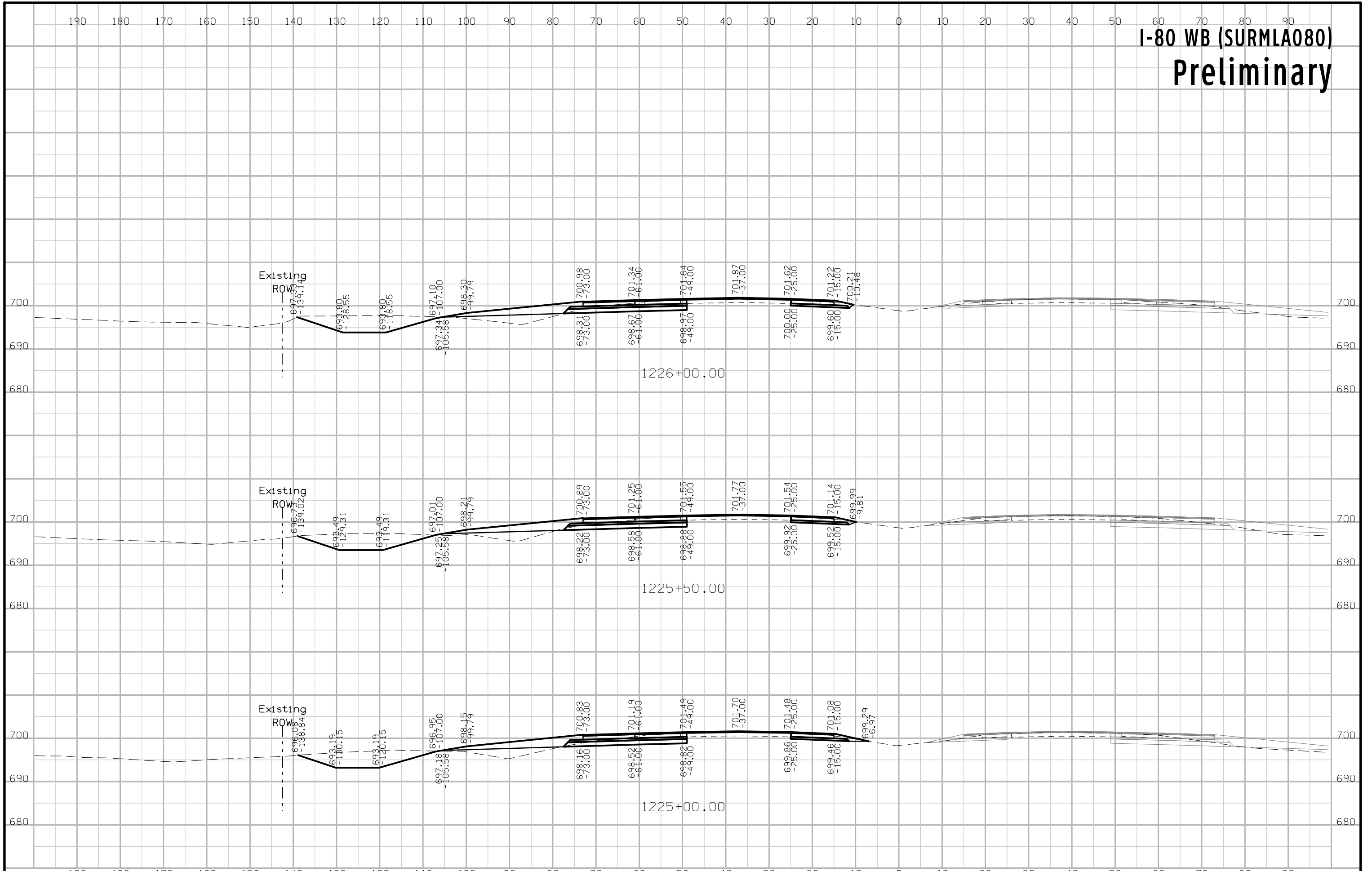

# I-80 WB (SURMLA080) Preliminary

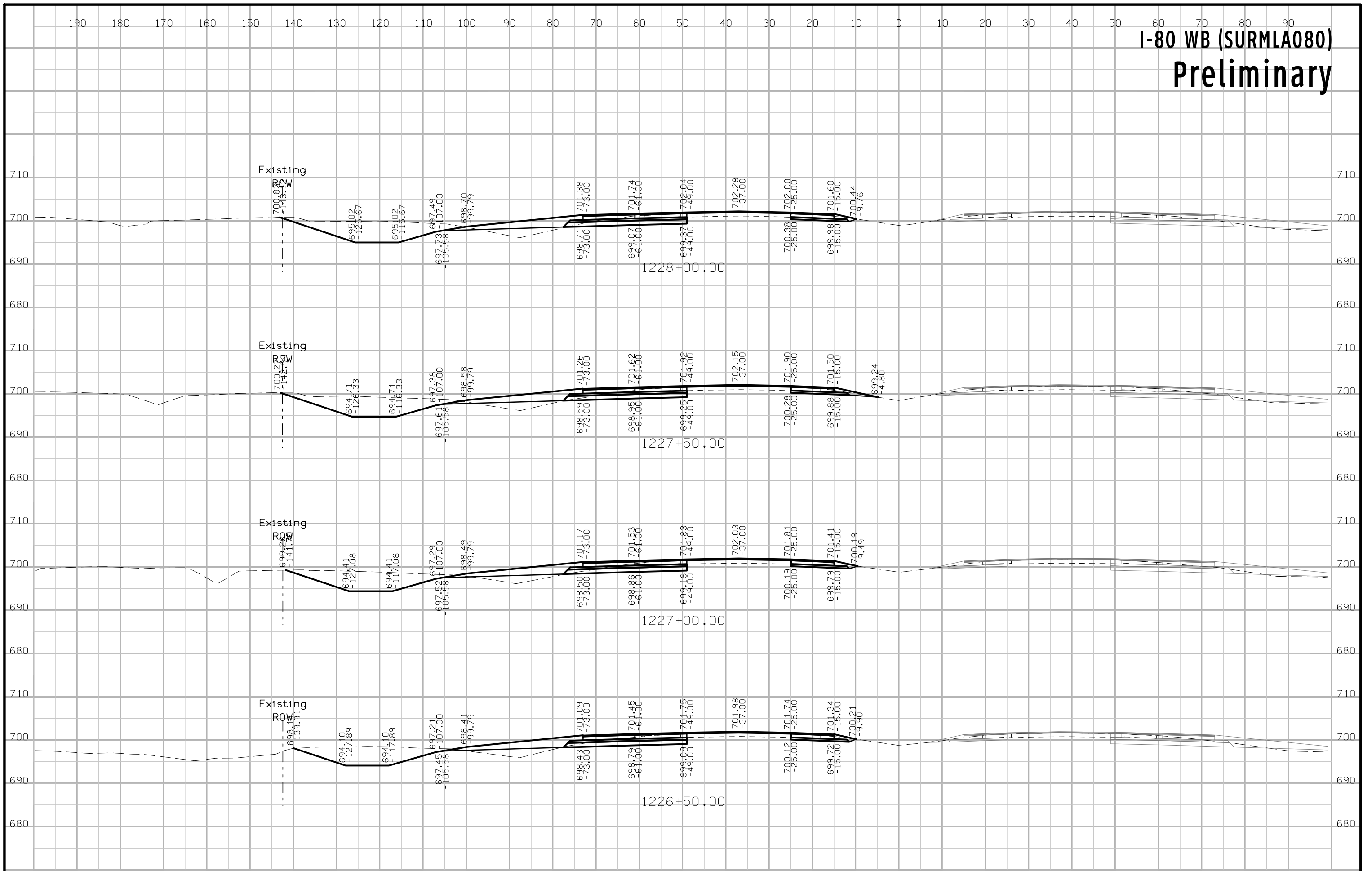



# I-80 WB (SURMLA080) Preliminary

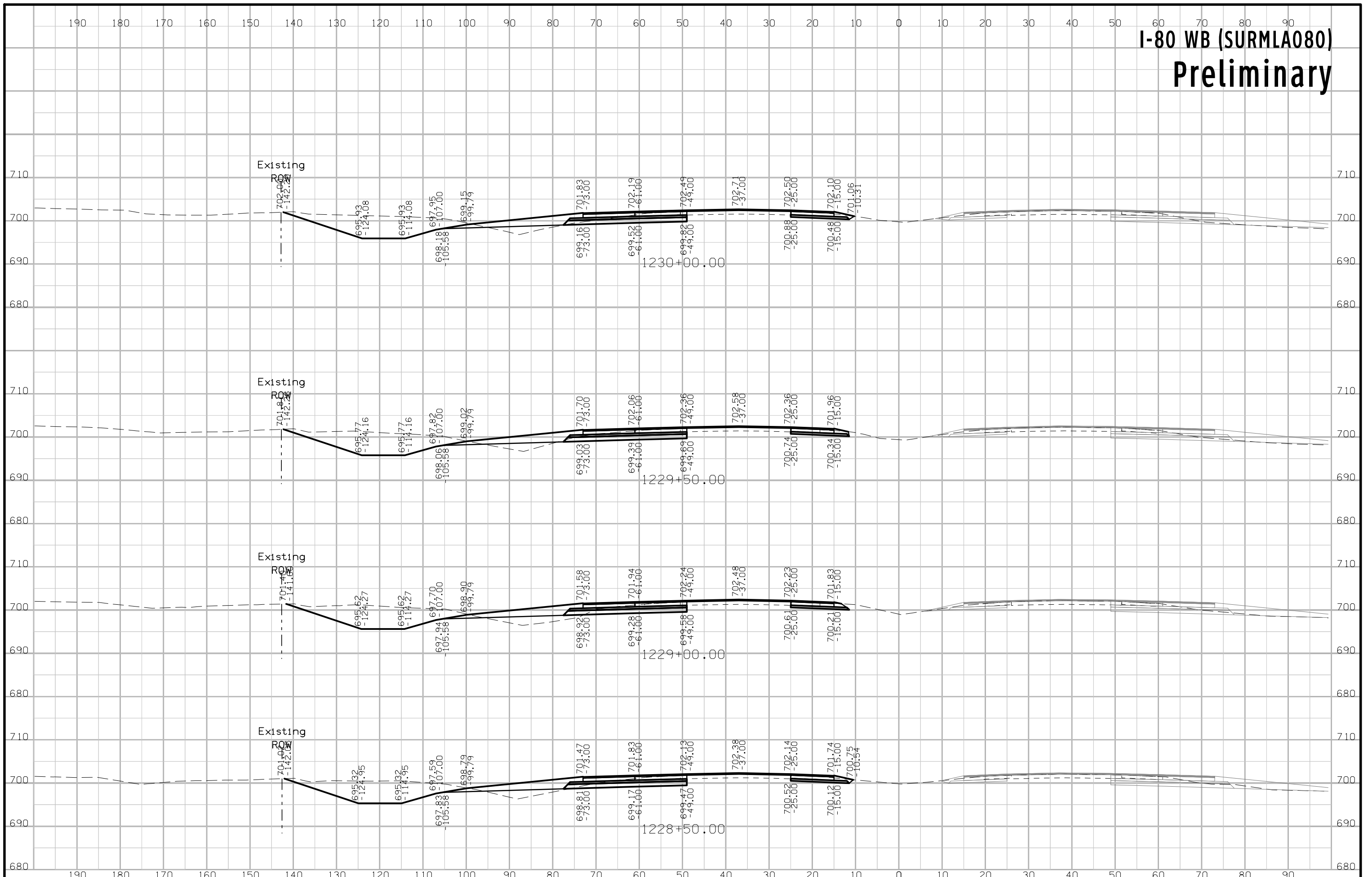

# I-80 WB (SURMLA080) Preliminary

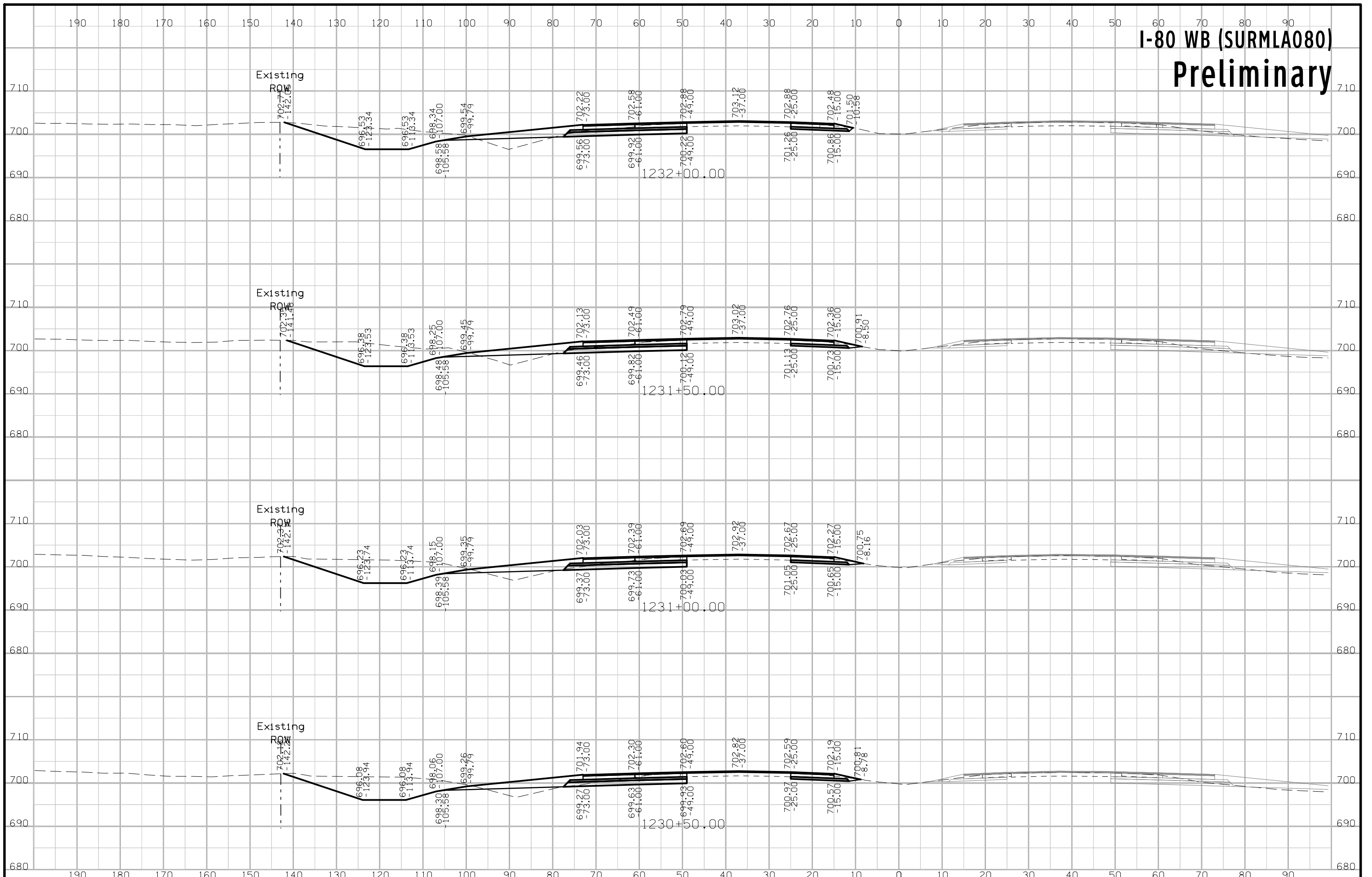

# I-80 WB (SURMLA080) Preliminary

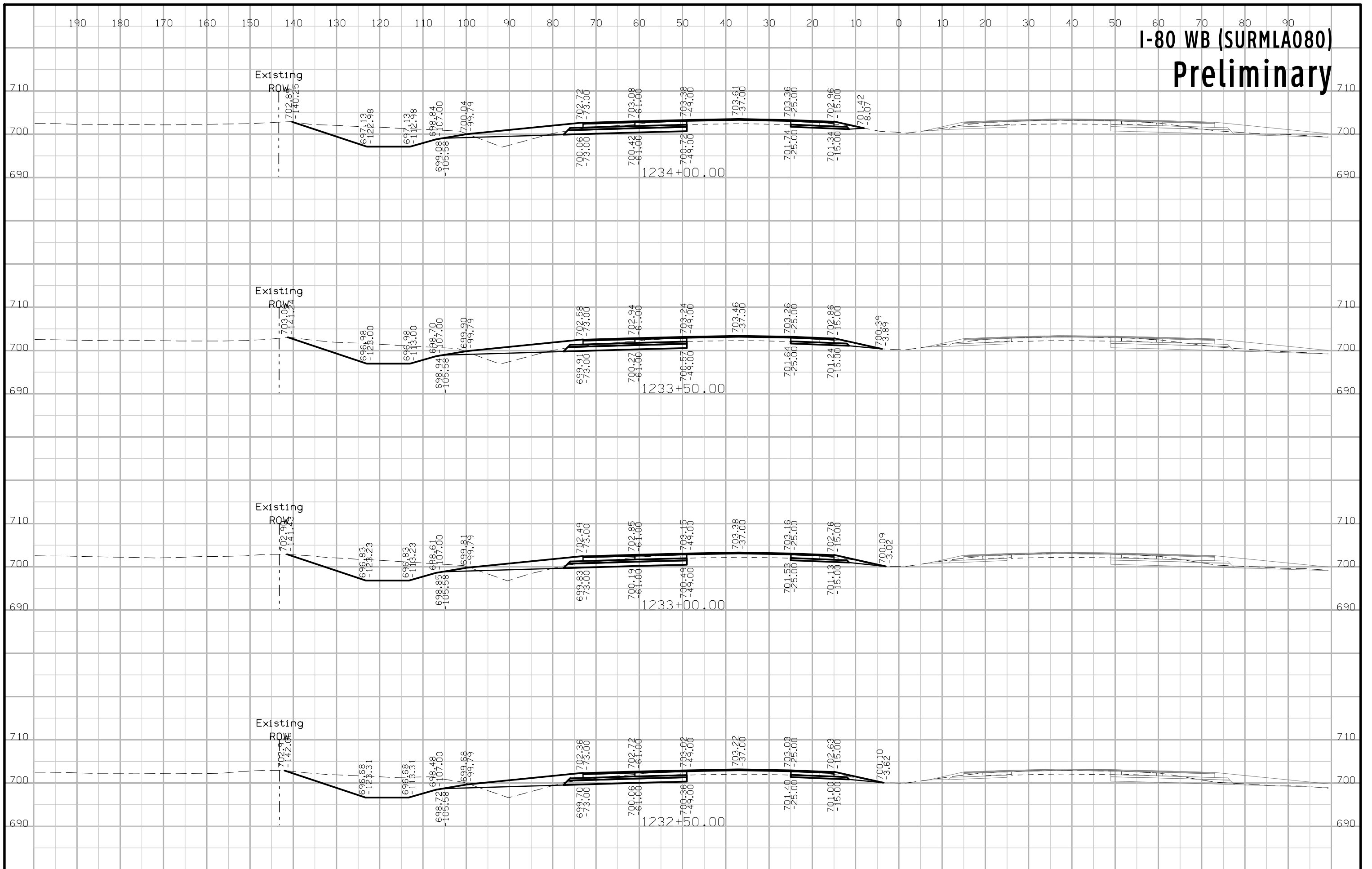

# I-80 WB (SURMLA080) Preliminary

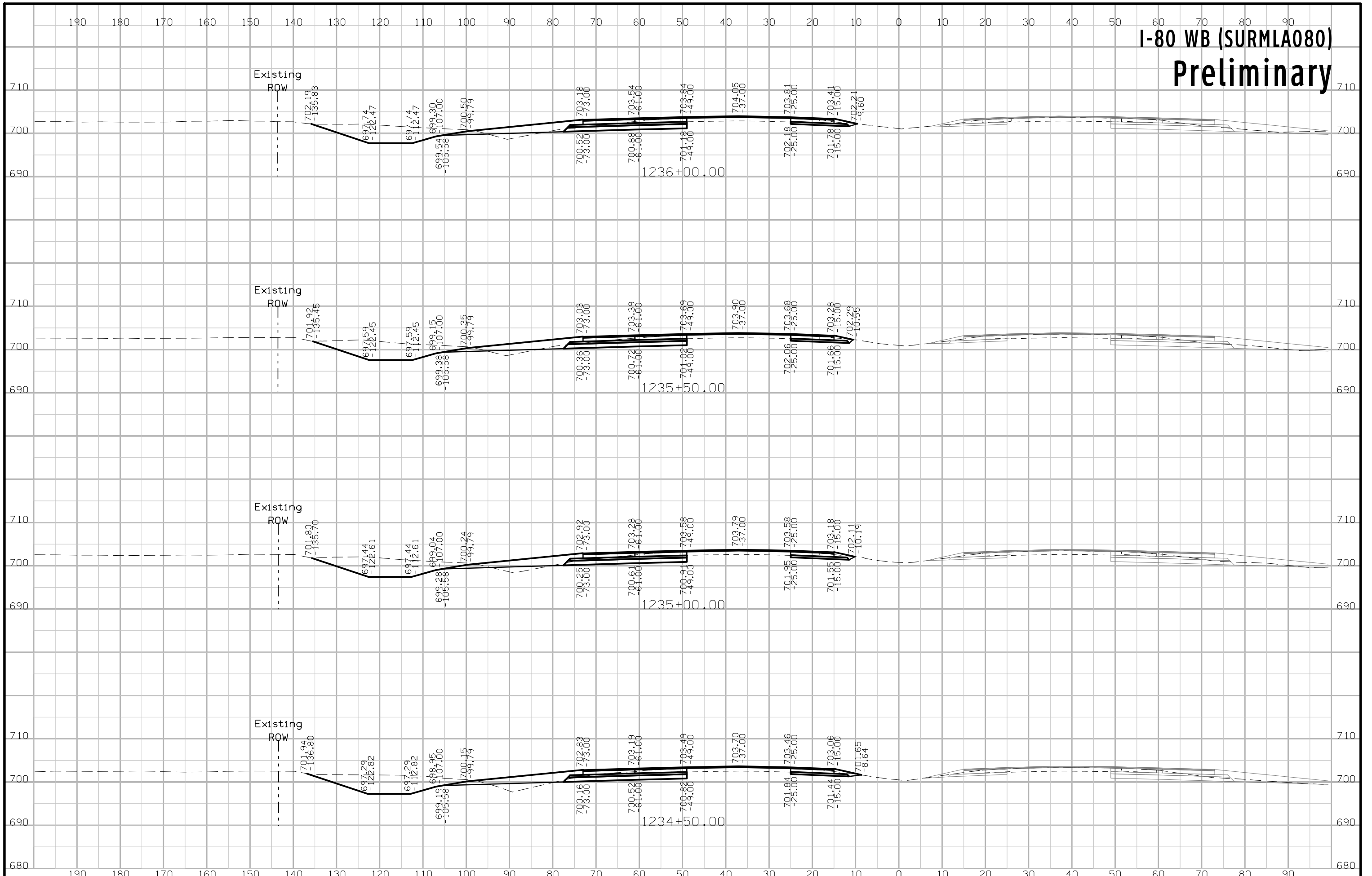

# I-80 WB (SURMLA080) Preliminary

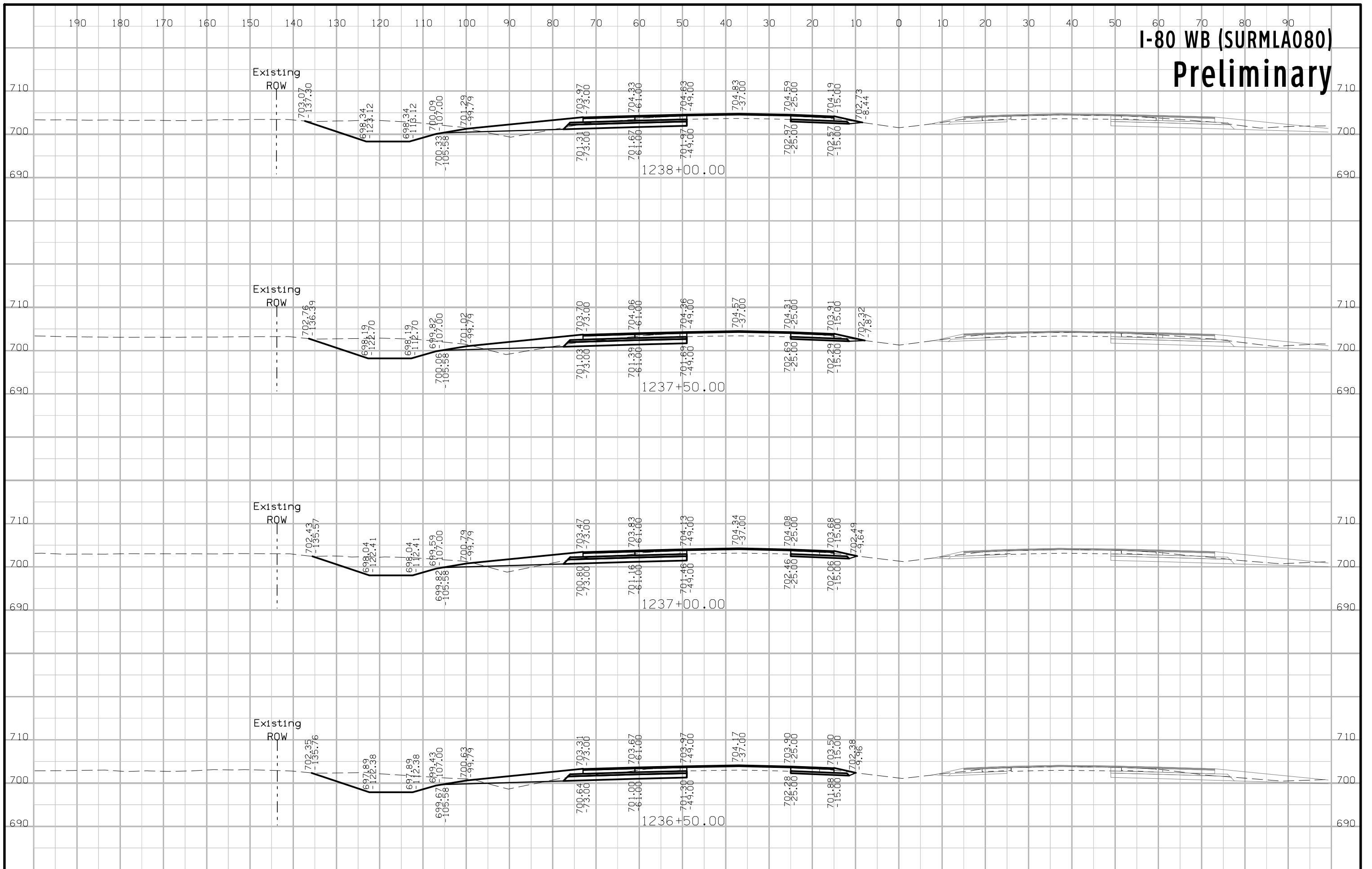

# I-80 WB (SURMLA080) Preliminary

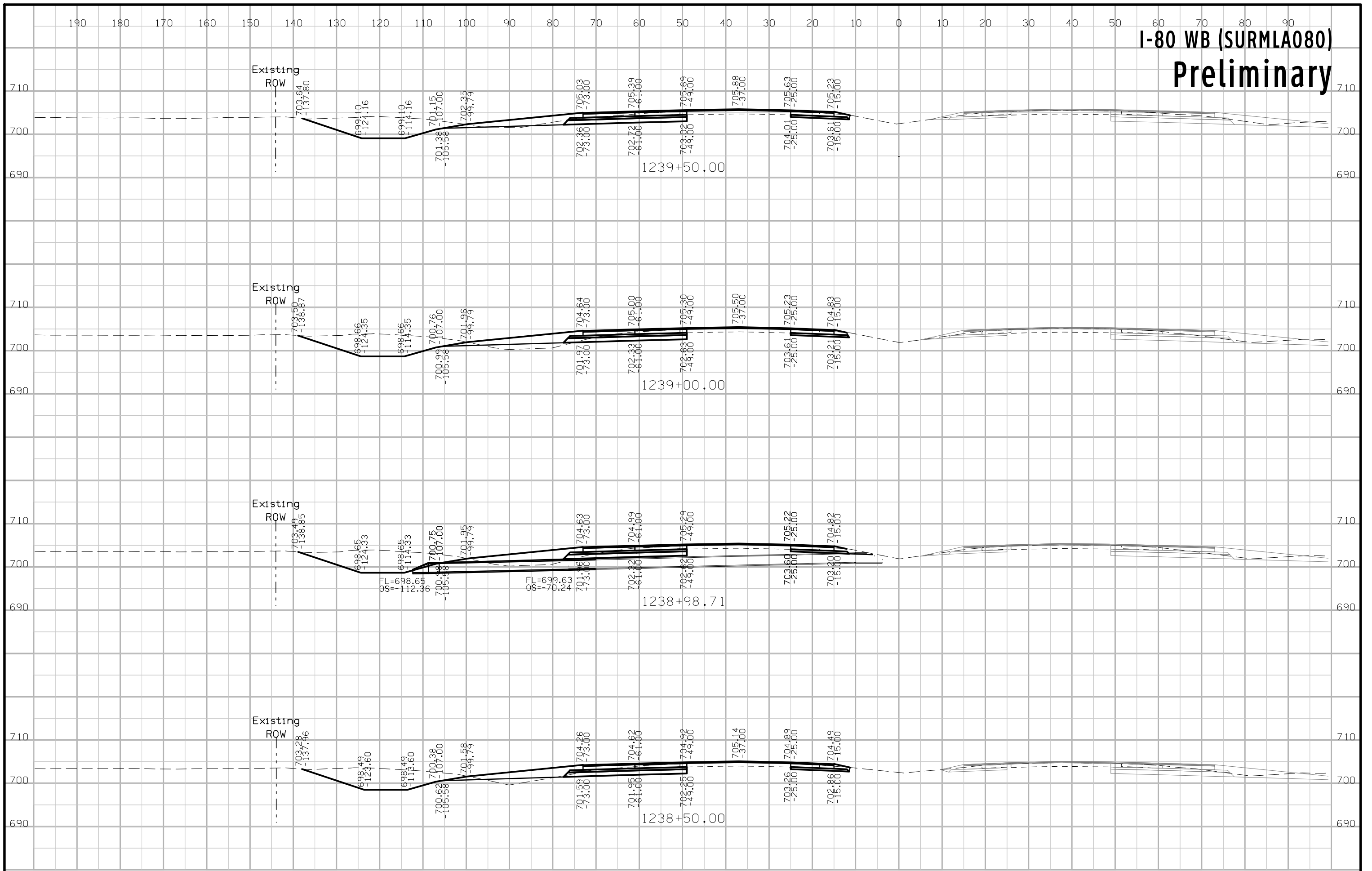



# I-80 WB (SURMLA080) Preliminary

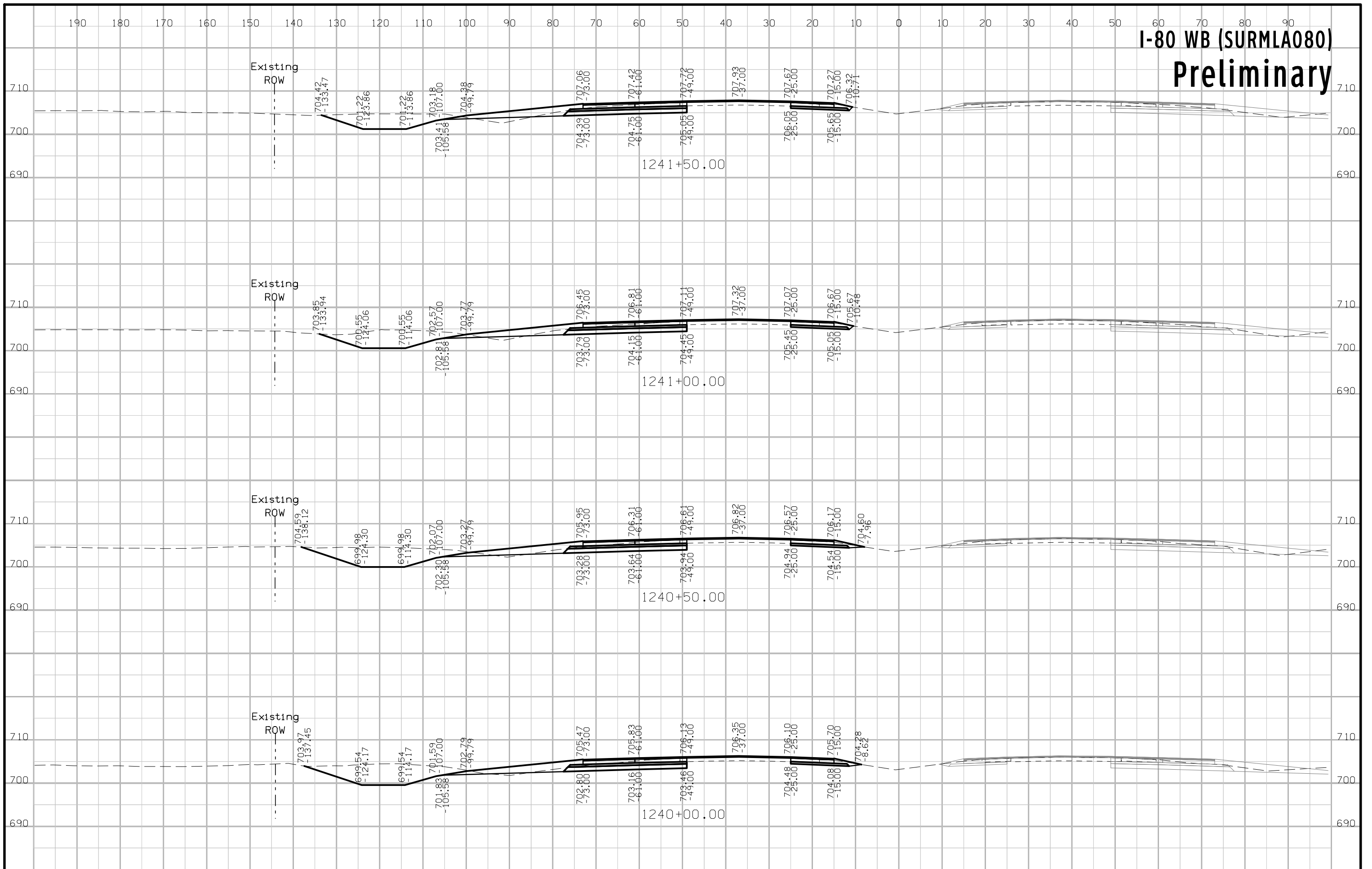

# I-80 WB (SURMLA080) Preliminary

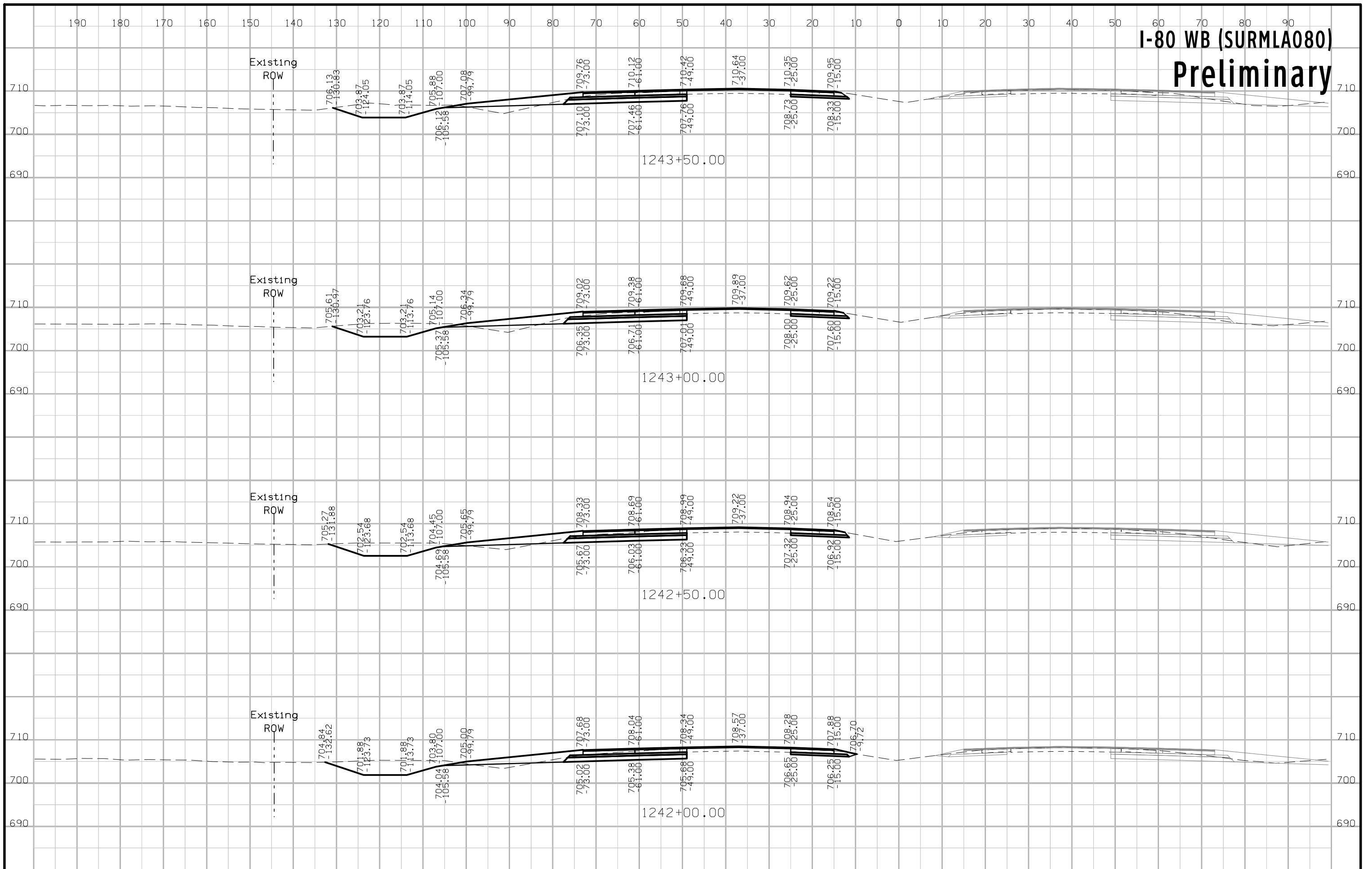

# I-80 WB (SURMLA080) Preliminary

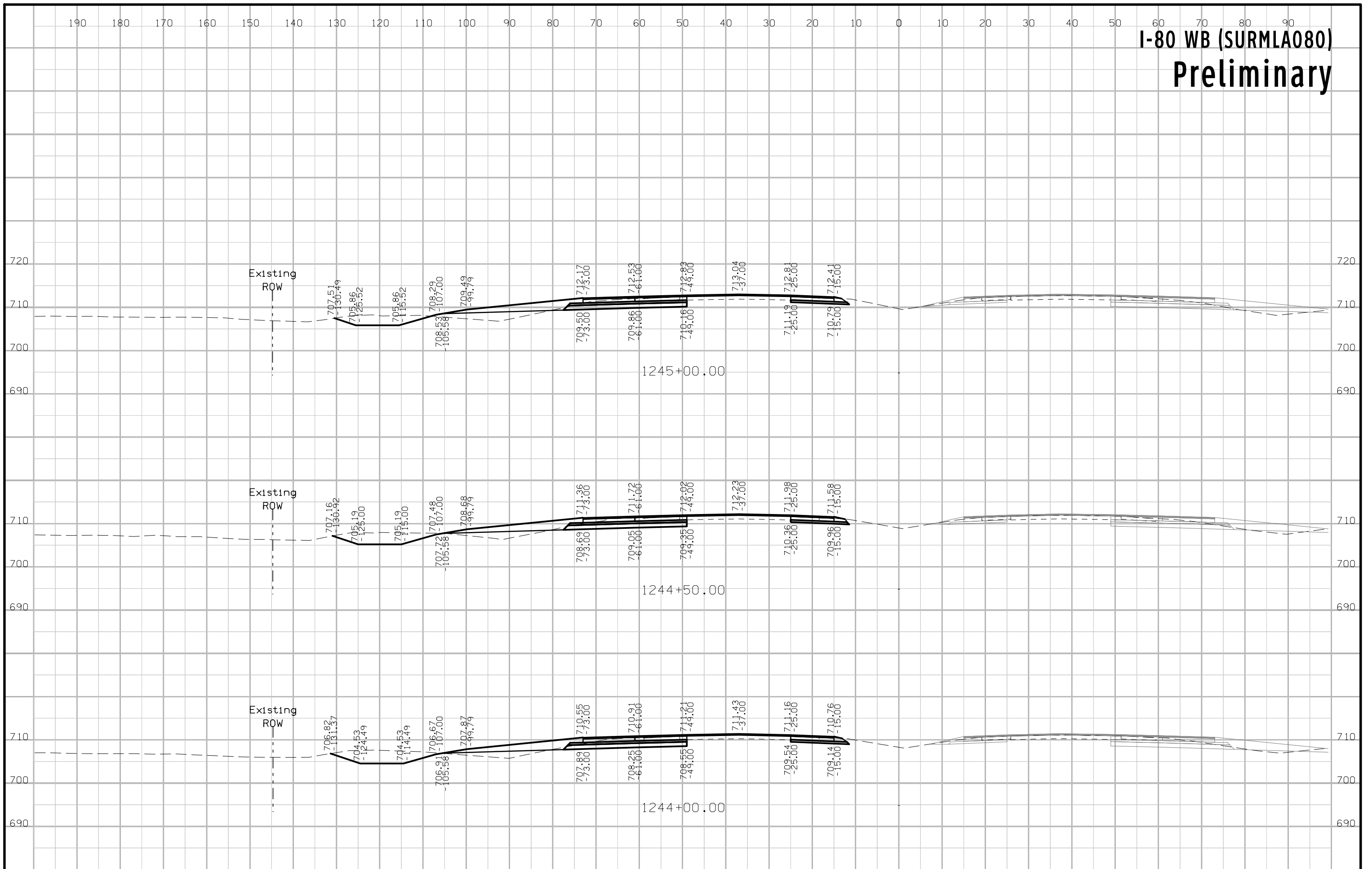

# I-80 WB (SURMLA080) Preliminary

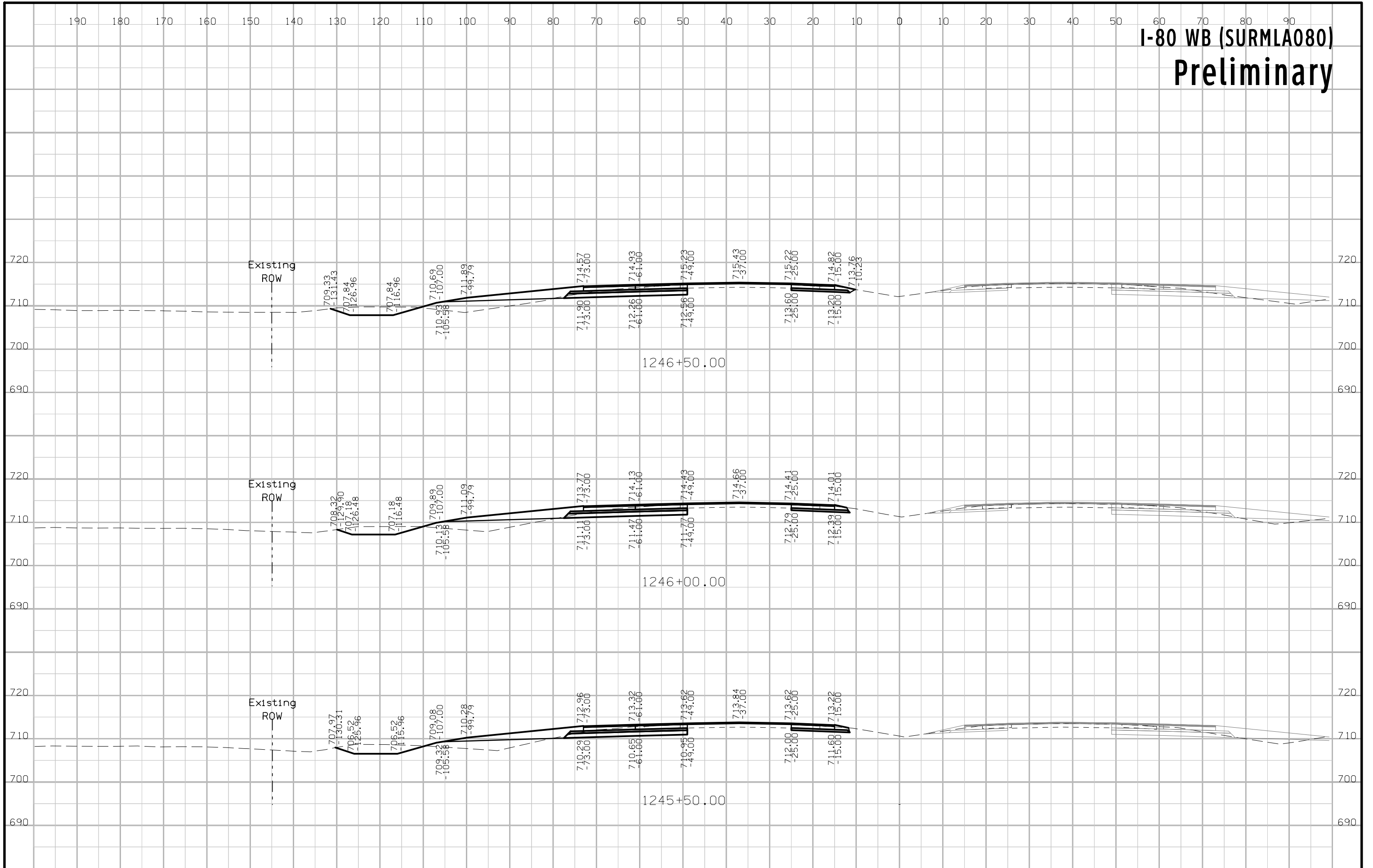

# I-80 WB (SURMLA080) Preliminary

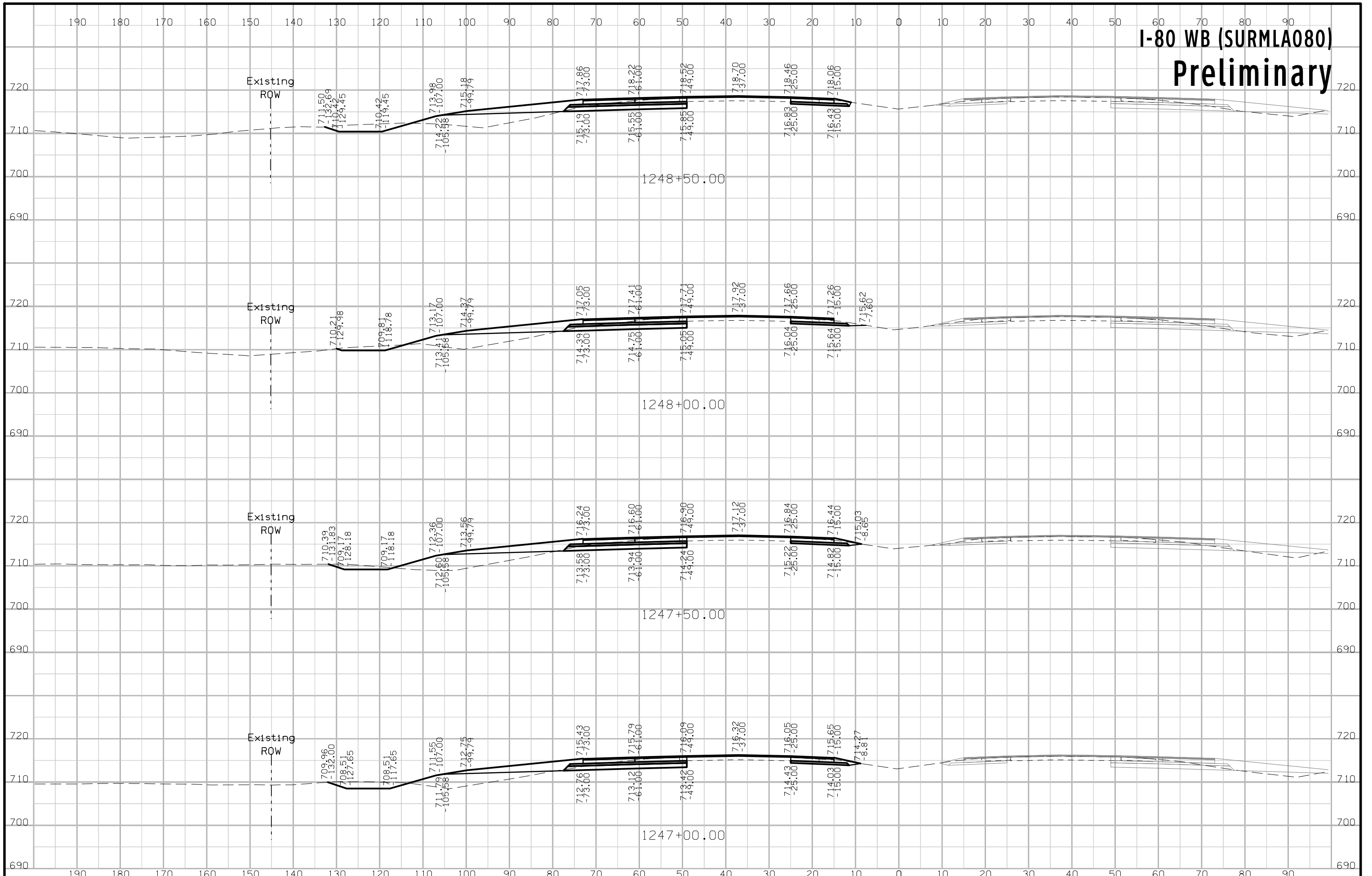

# I-80 WB (SURMLA080) Preliminary

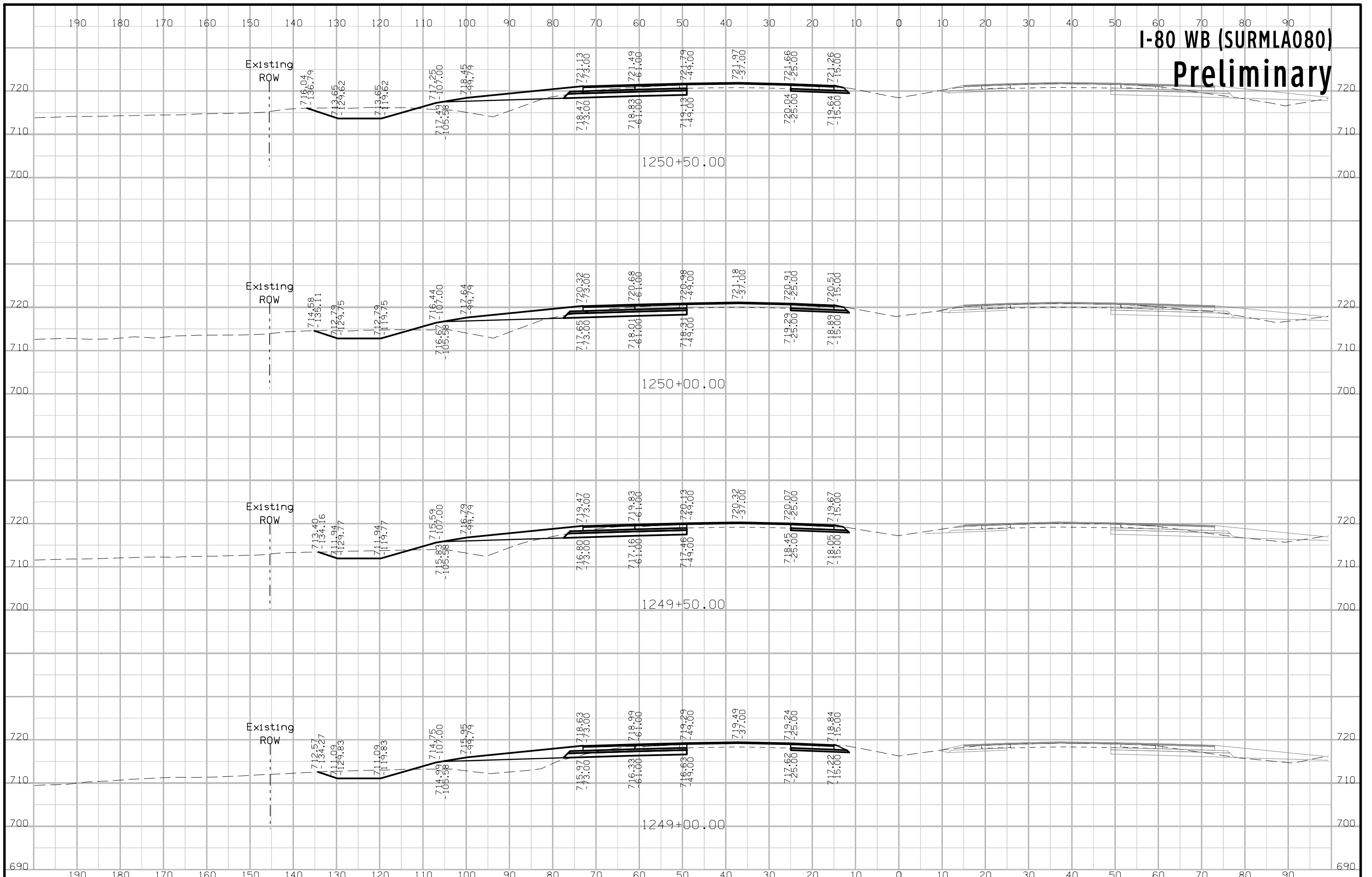



# I-80 WB (SURMLA080) Preliminary

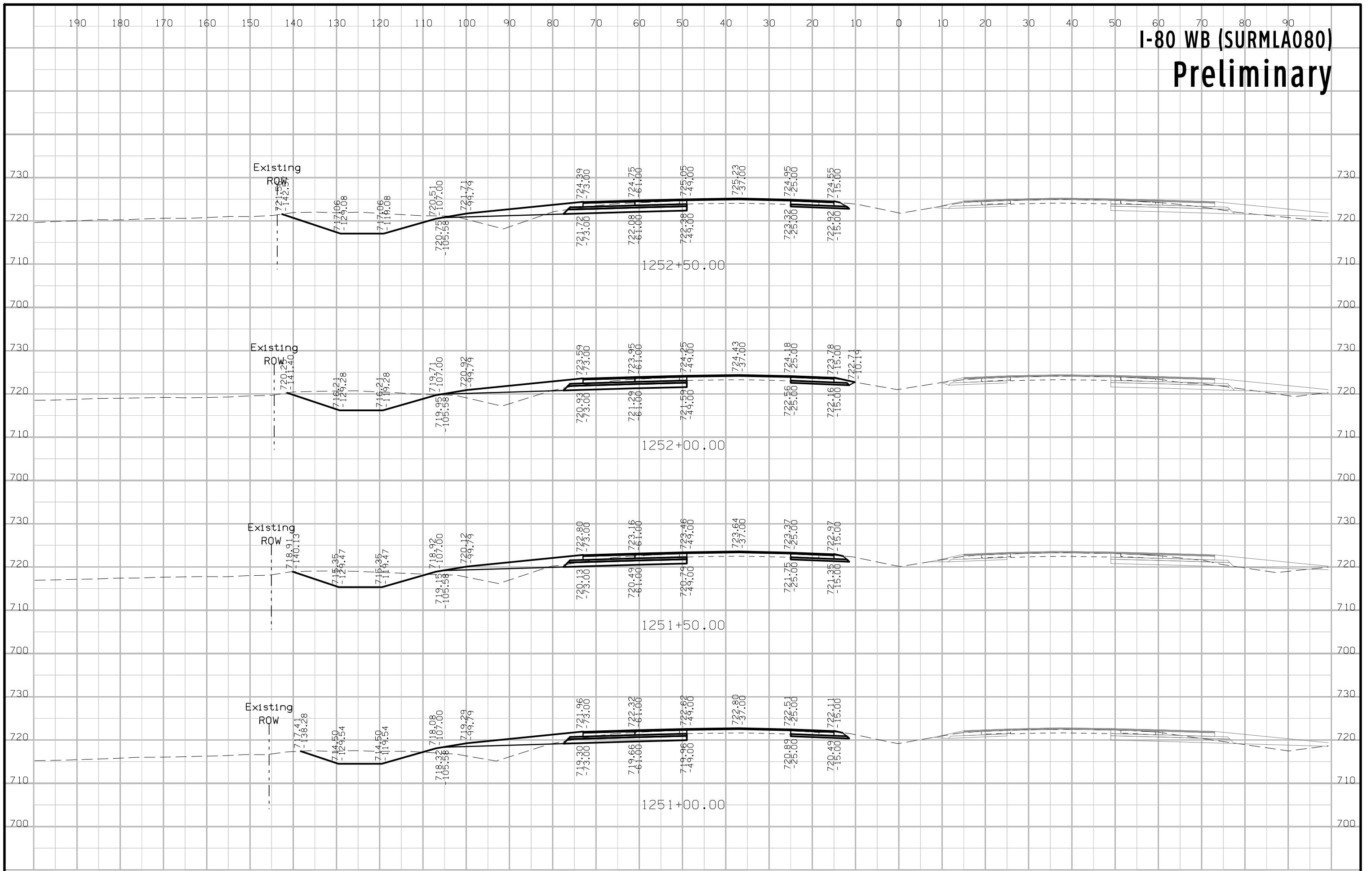

# I-80 WB (SURMLA080) Preliminary

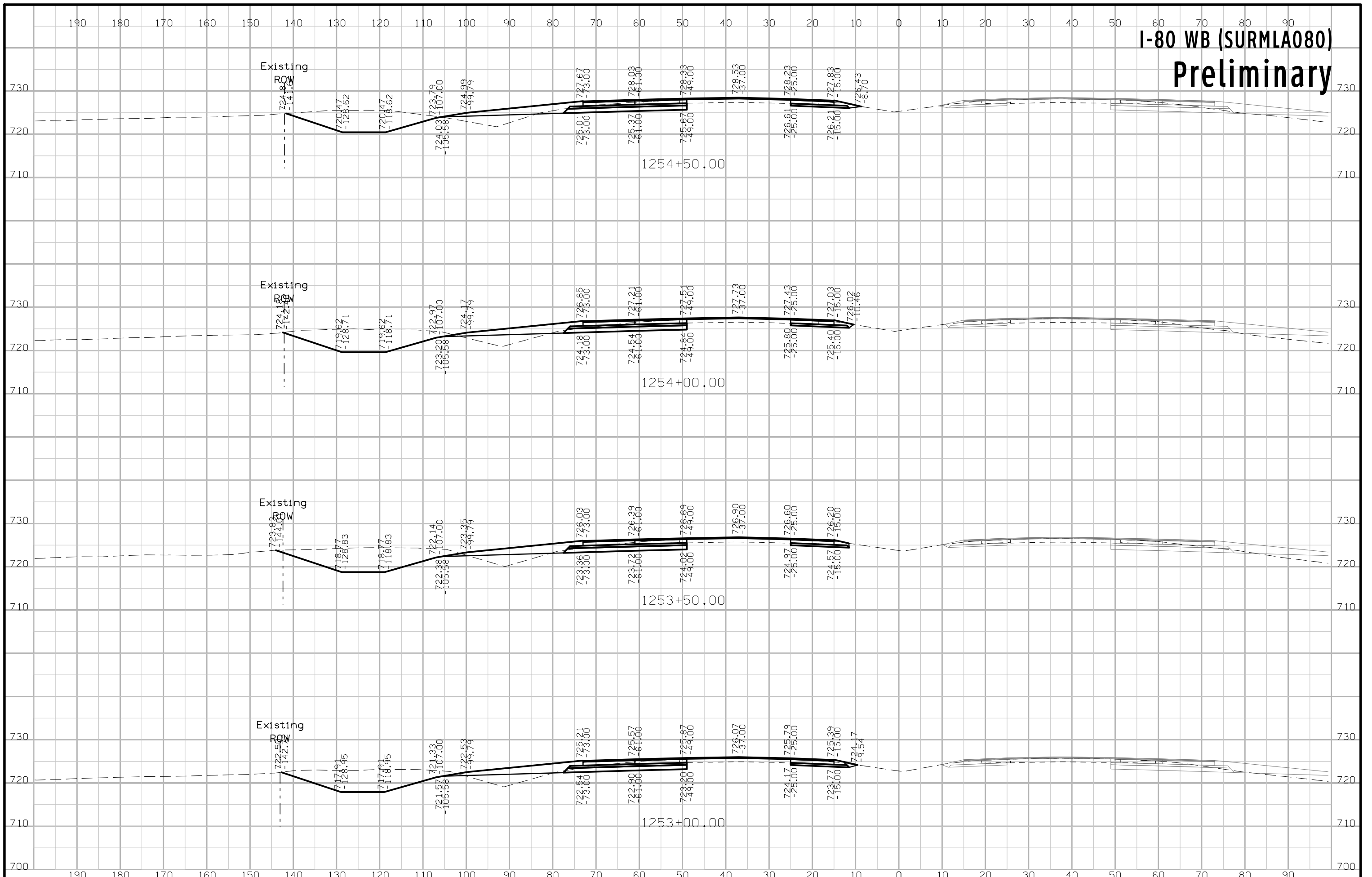

# I-80 WB (SURMLA080) Preliminary

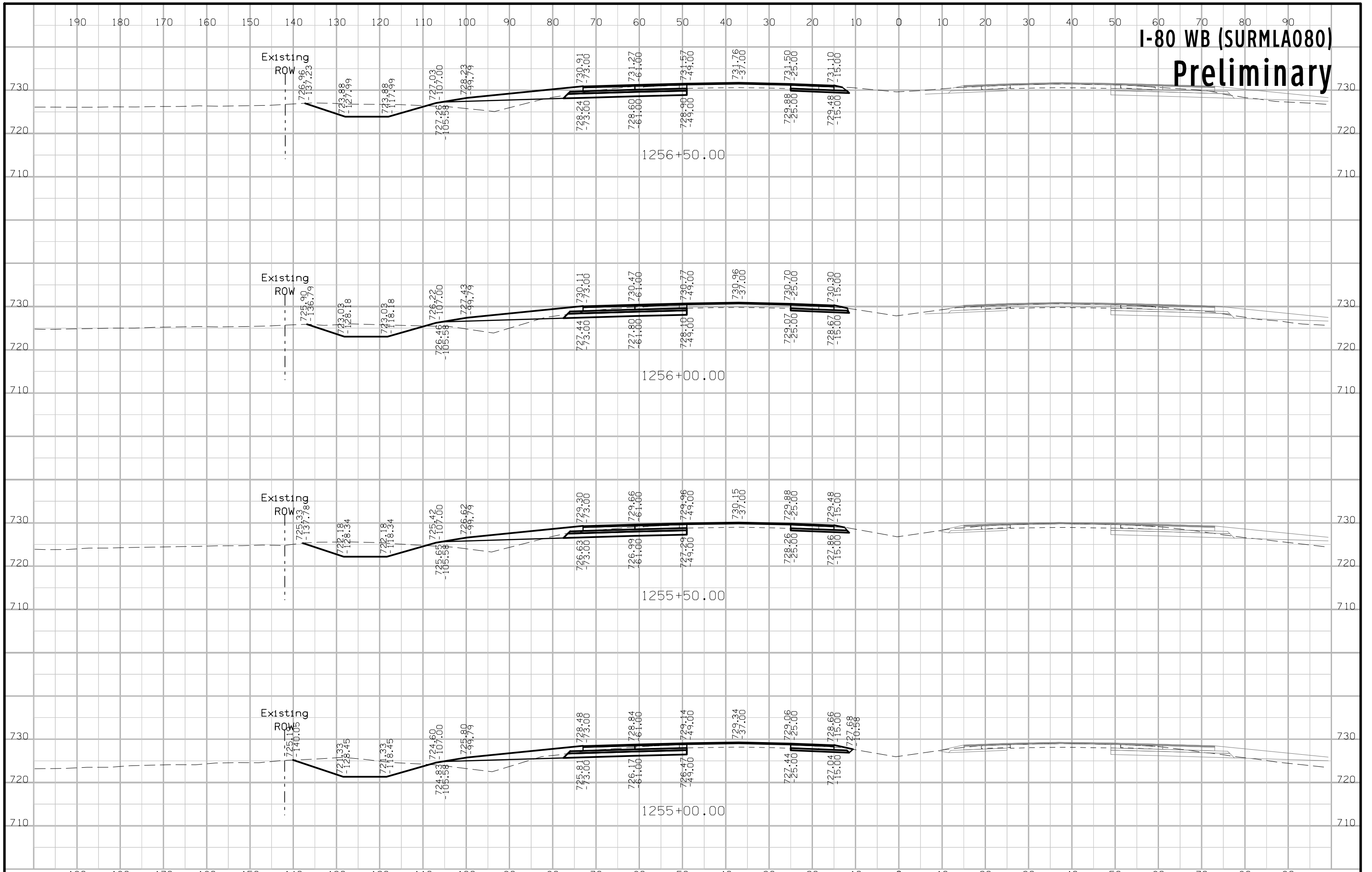

# I-80 WB (SURMLA080) Preliminary

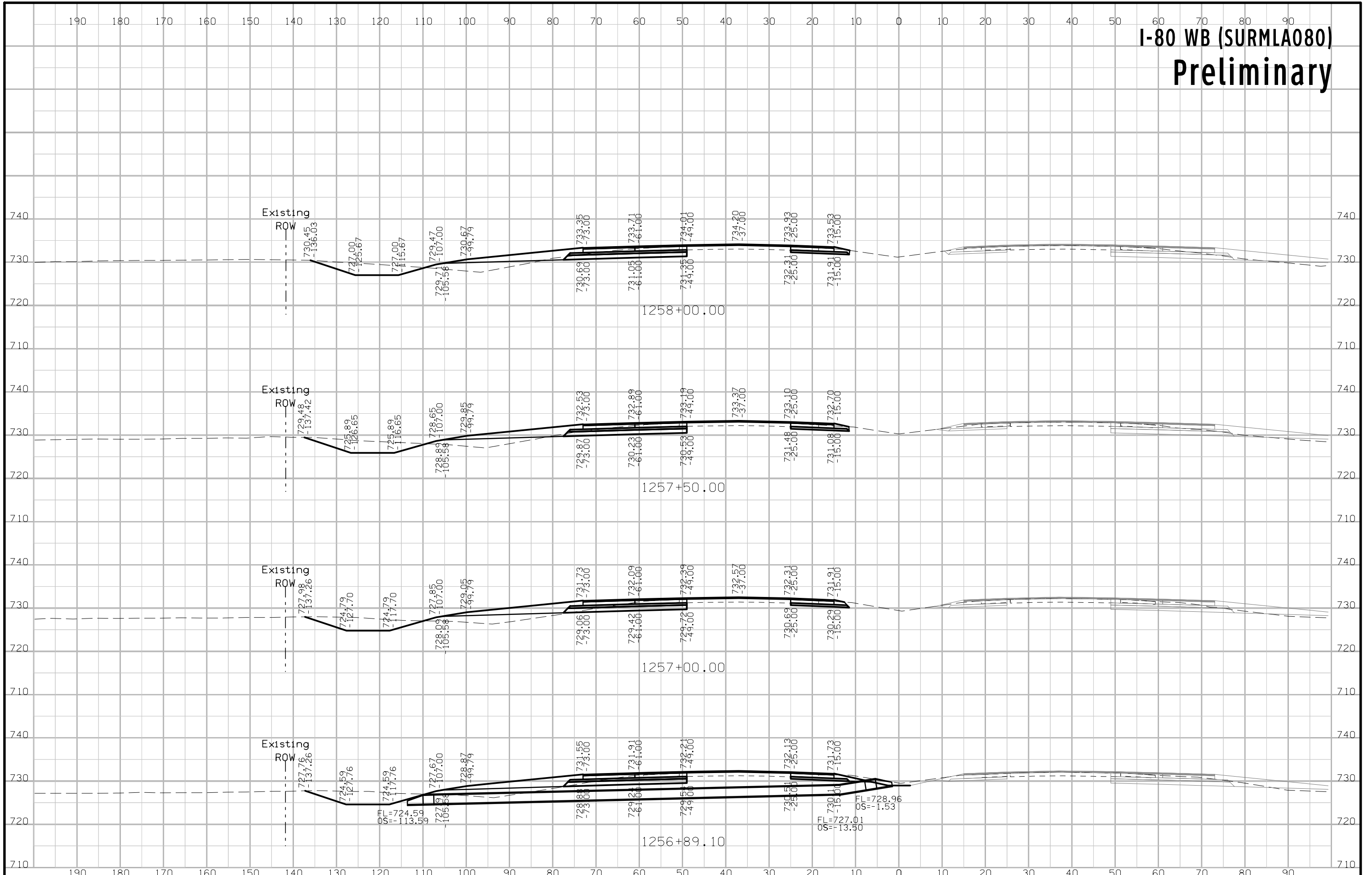

# I-80 WB (SURMLA080) Preliminary

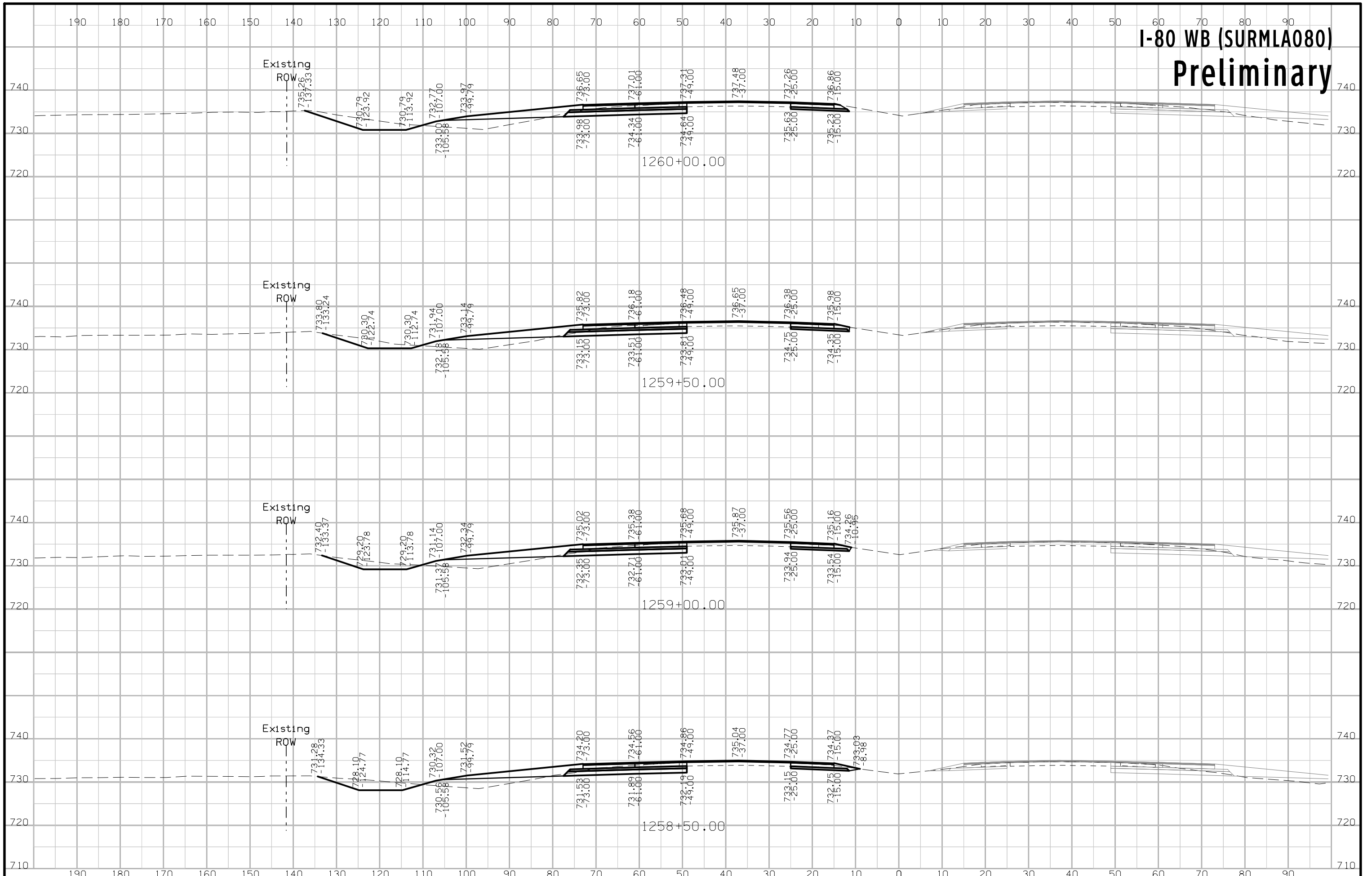

# I-80 WB (SURMLA080) Preliminary

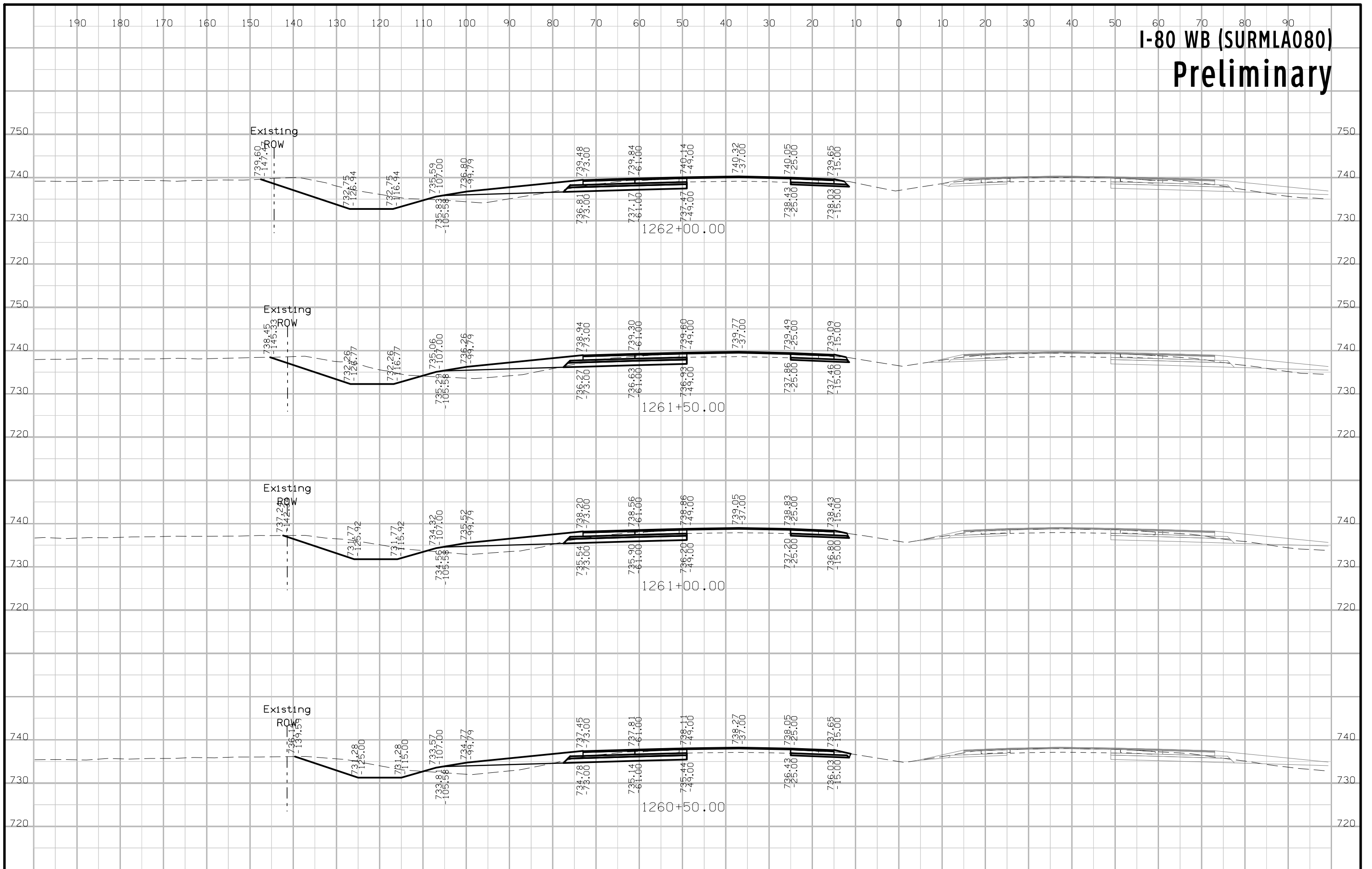



# I-80 WB (SURMLA080) Preliminary

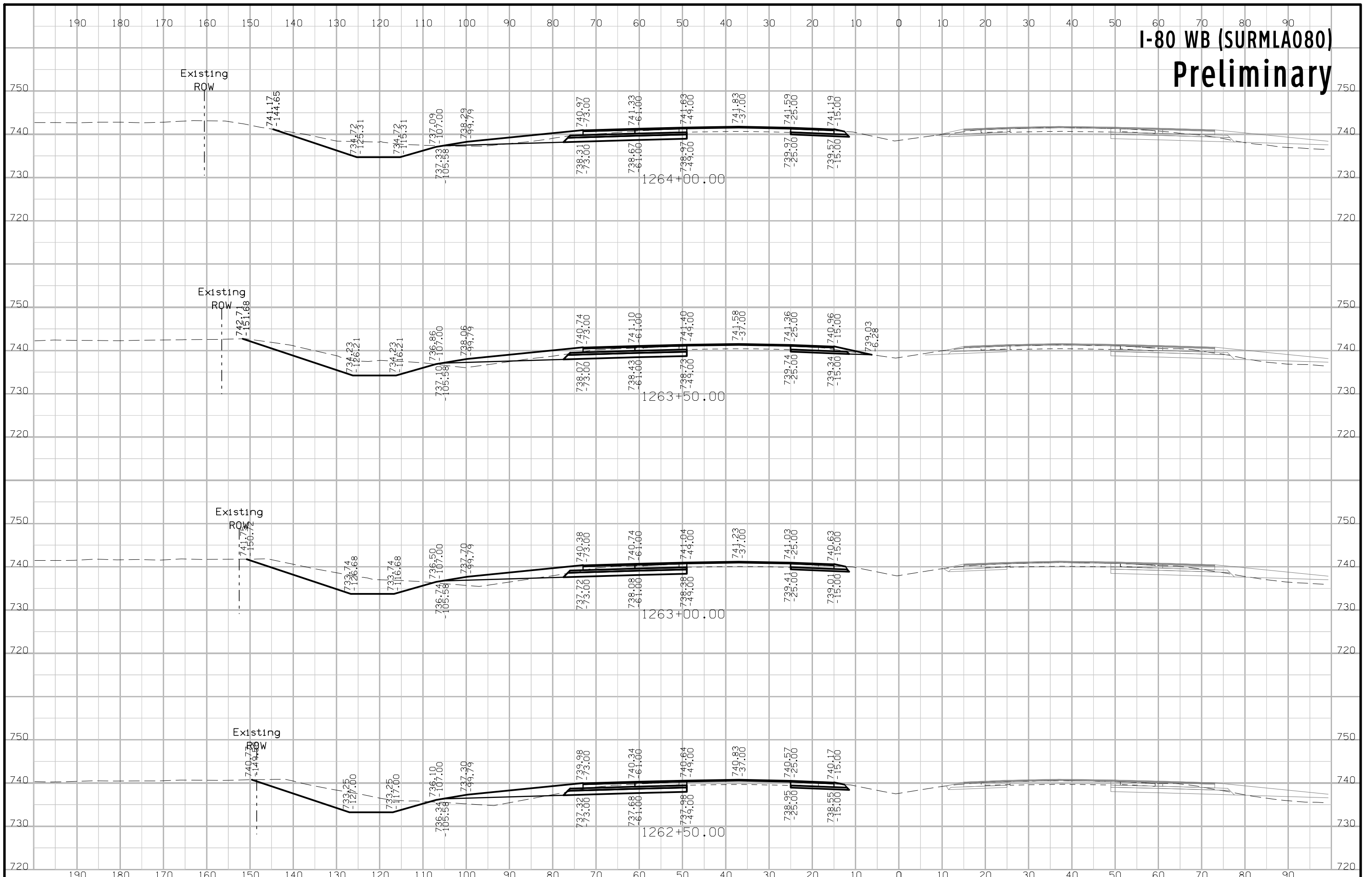

# I-80 WB (SURMLA080) Preliminary

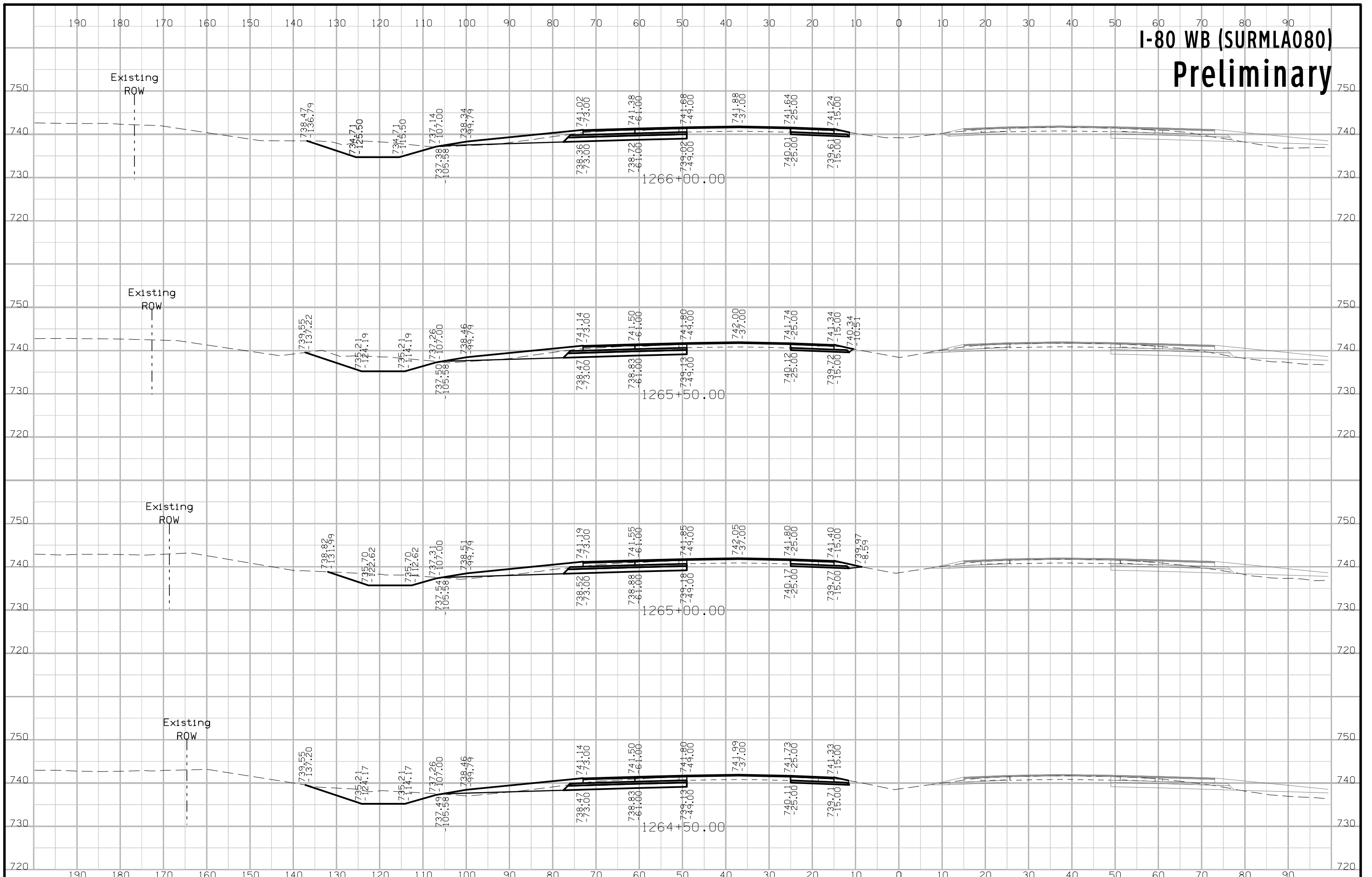

# I-80 WB (SURMLA080) Preliminary

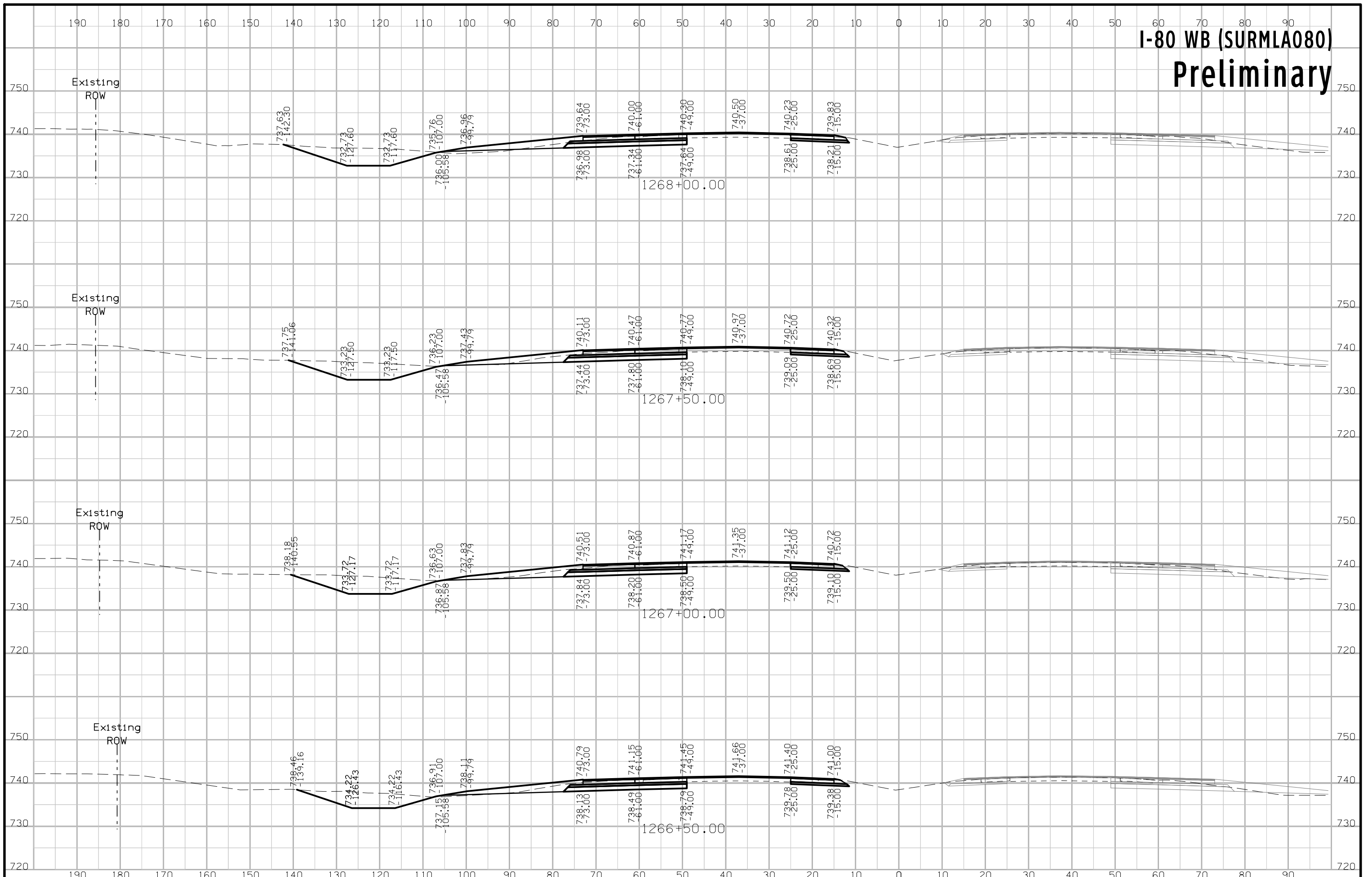

# I-80 WB (SURMLA080) Preliminary

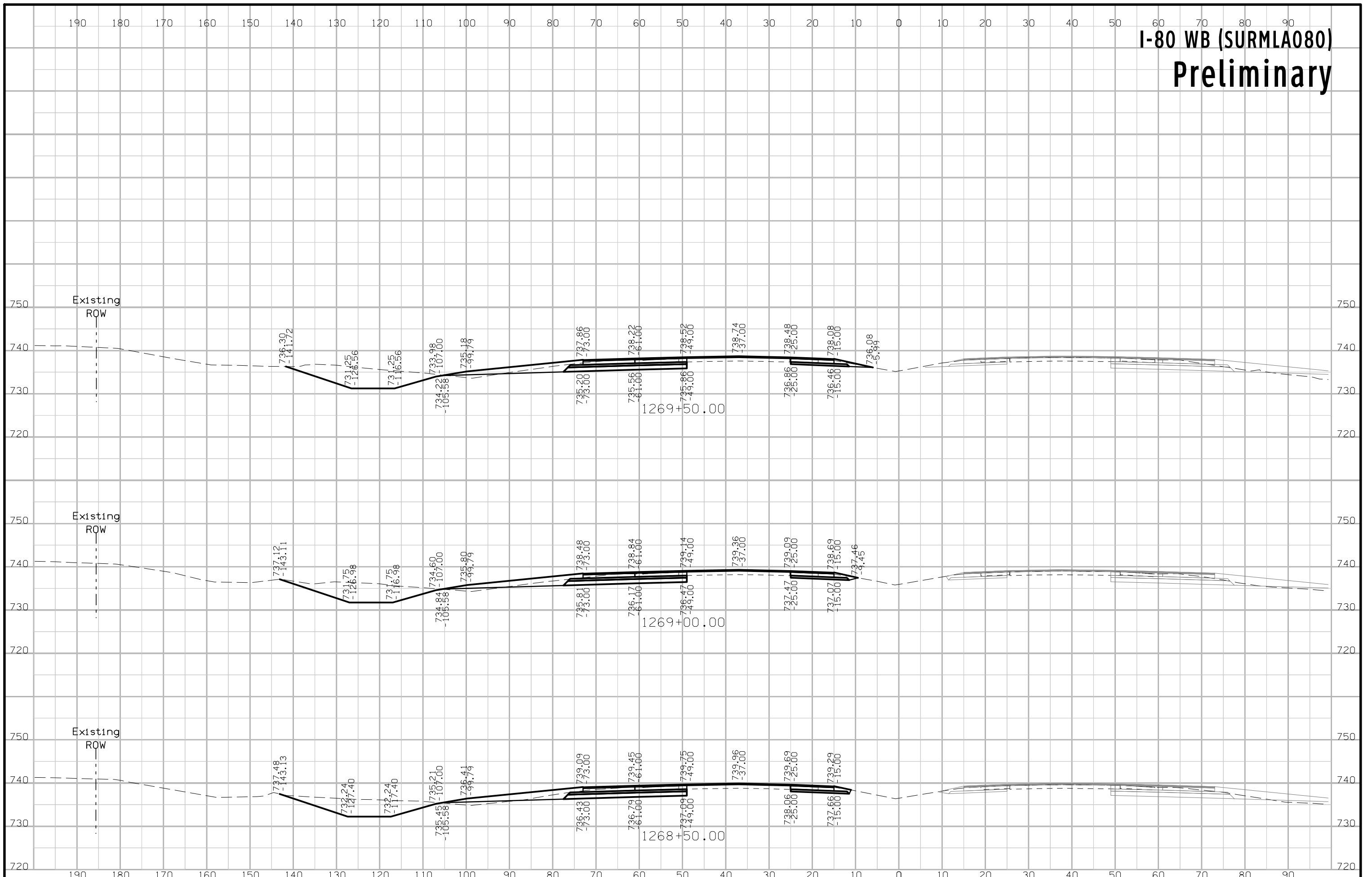

# I-80 WB (SURMLA080) Preliminary

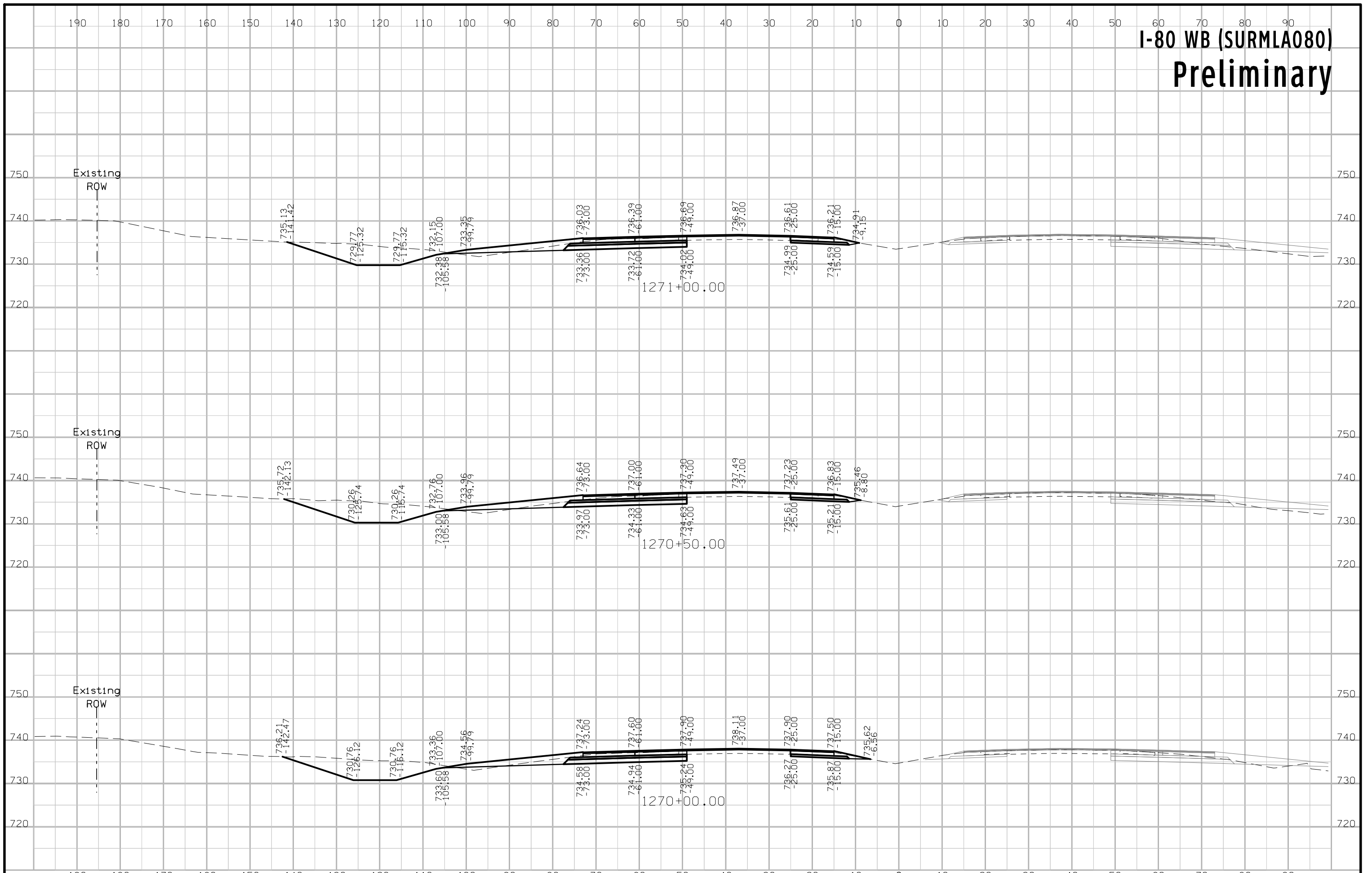

# I-80 WB (SURMLA080) Preliminary

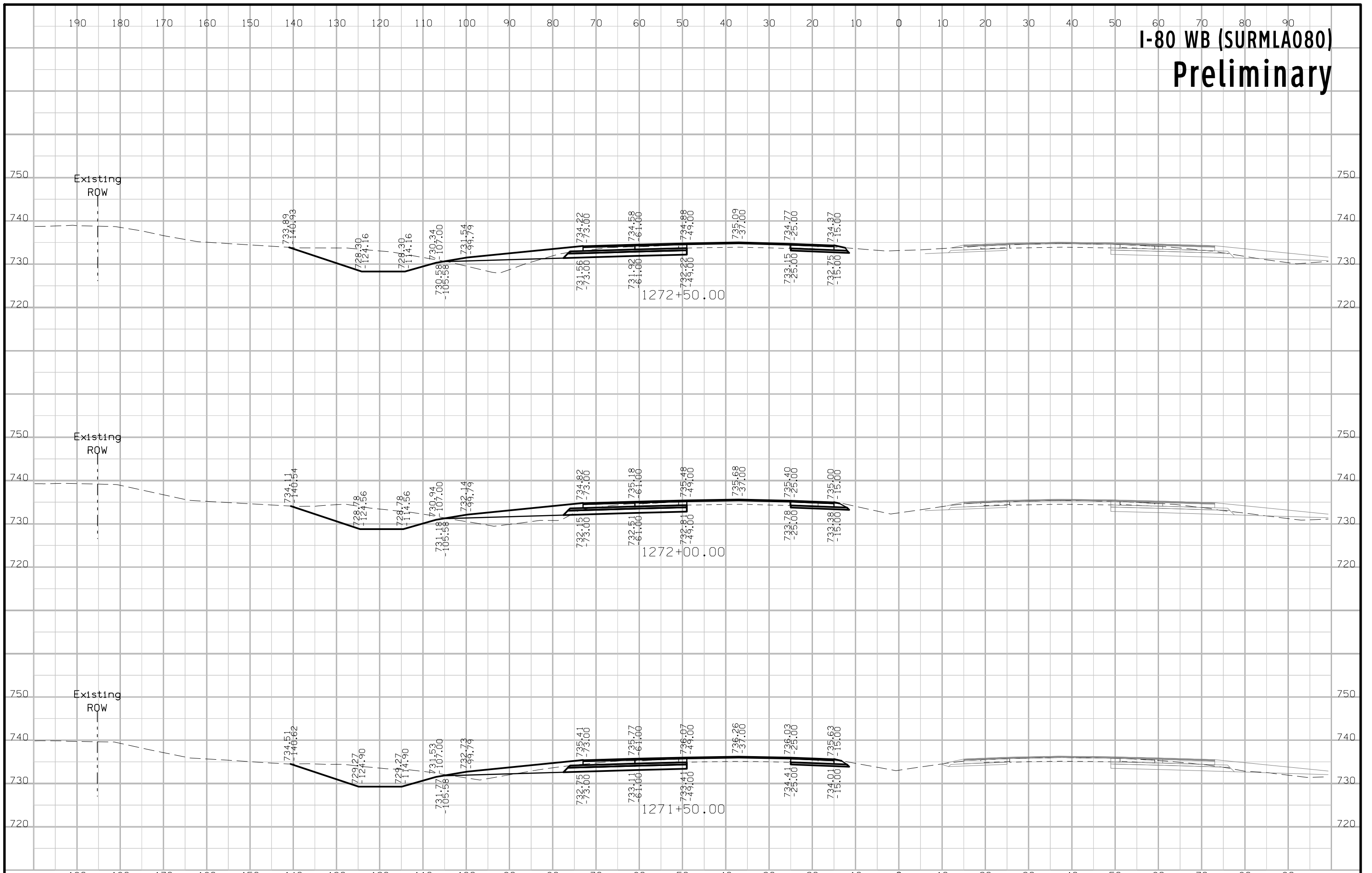



# I-80 WB (SURMLA080) Preliminary

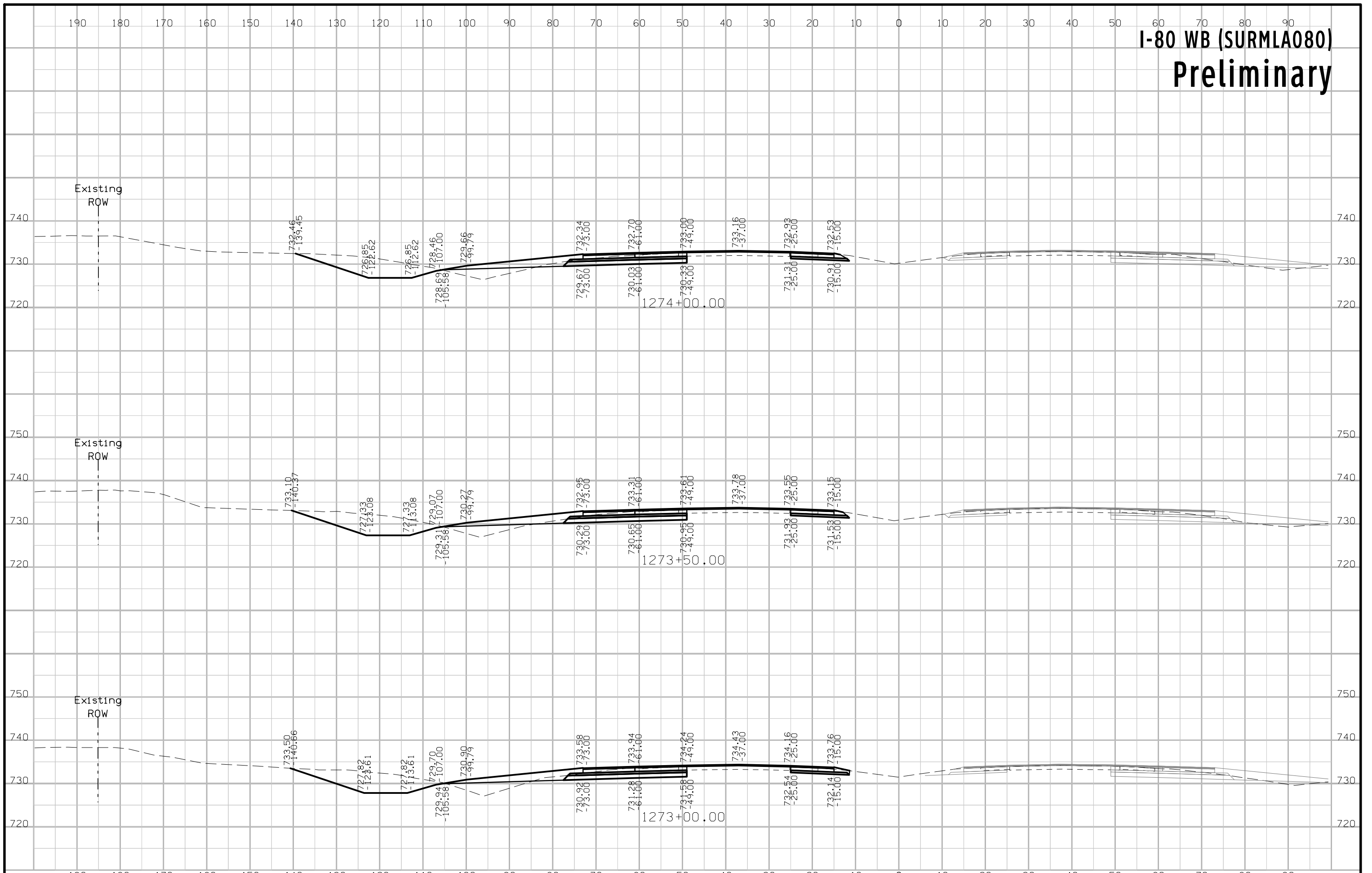

# I-80 WB (SURMLA080) Preliminary

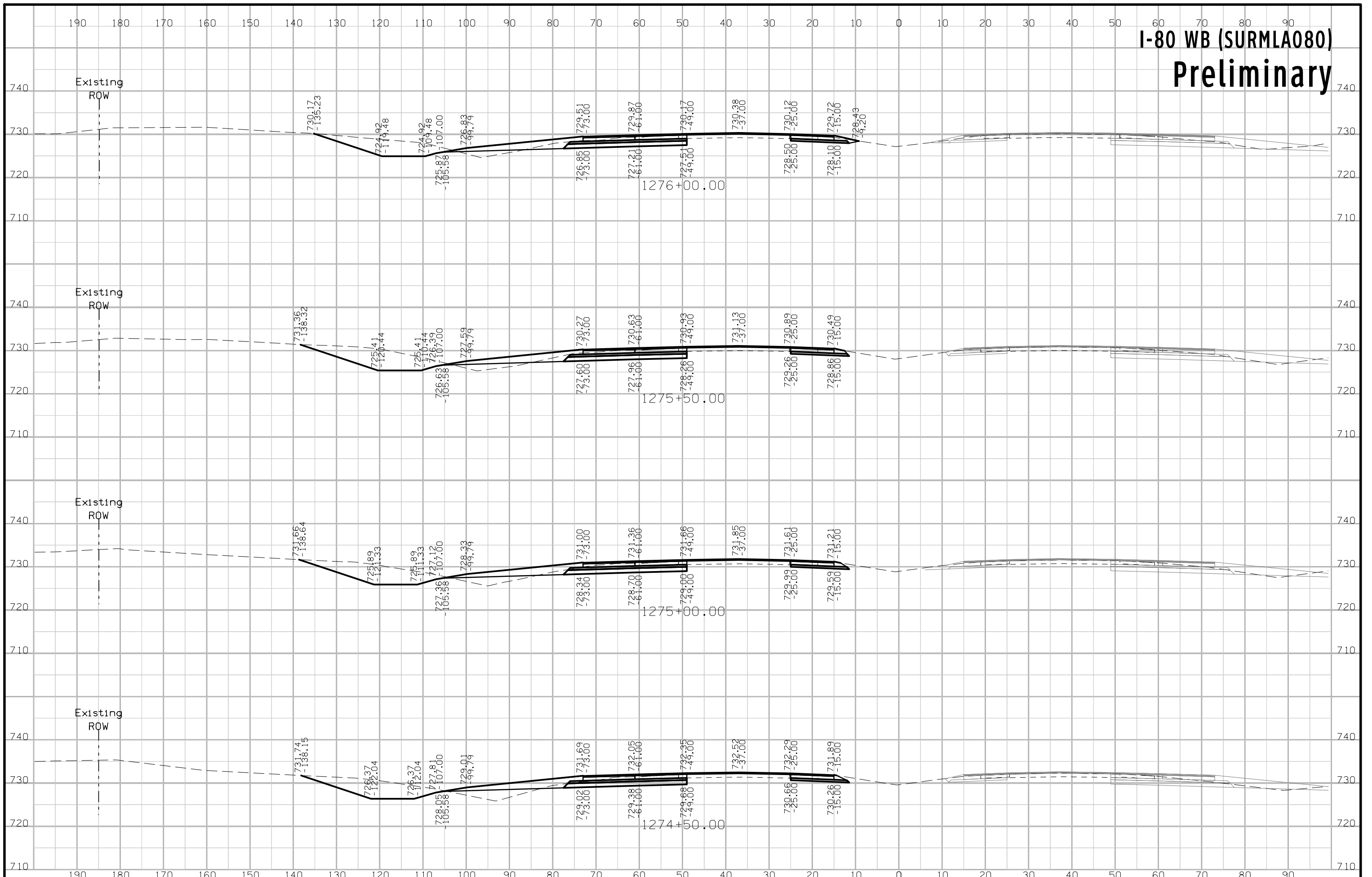

# I-80 WB (SURMLA080) Preliminary

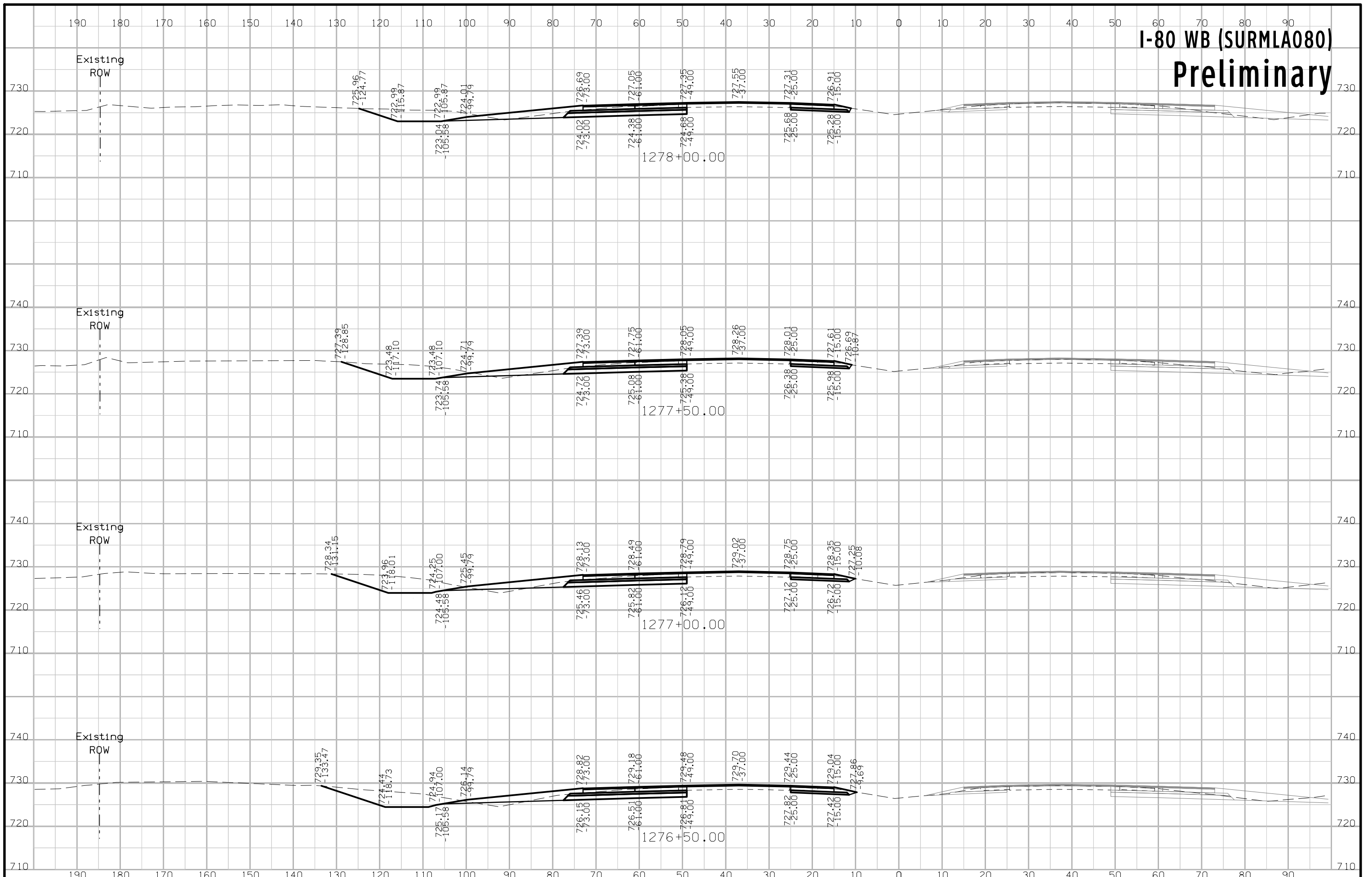

# I-80 WB (SURMLA080) Preliminary

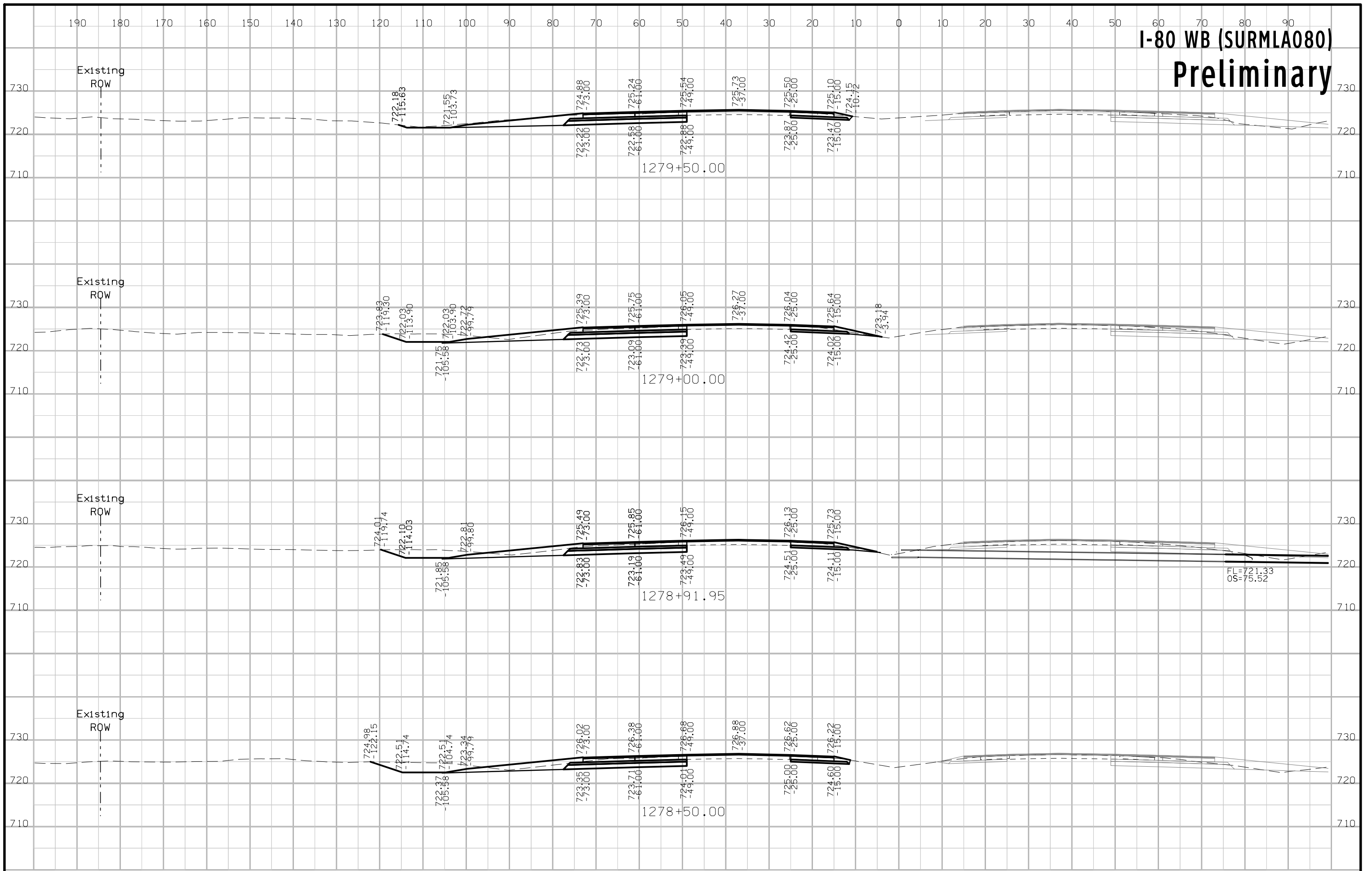

# I-80 WB (SURMLA080) Preliminary

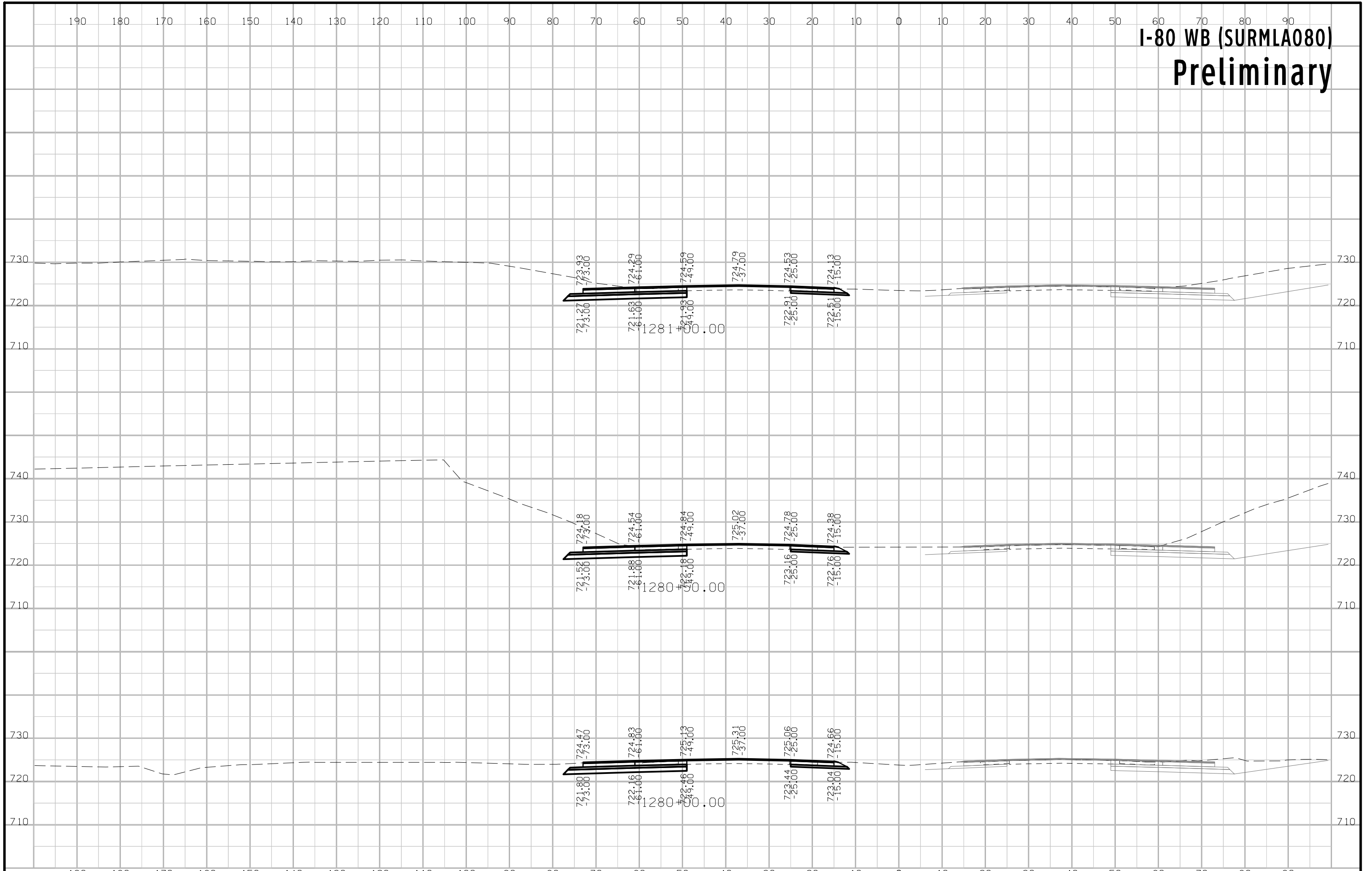

# I-80 WB (SURMLA080) Preliminary

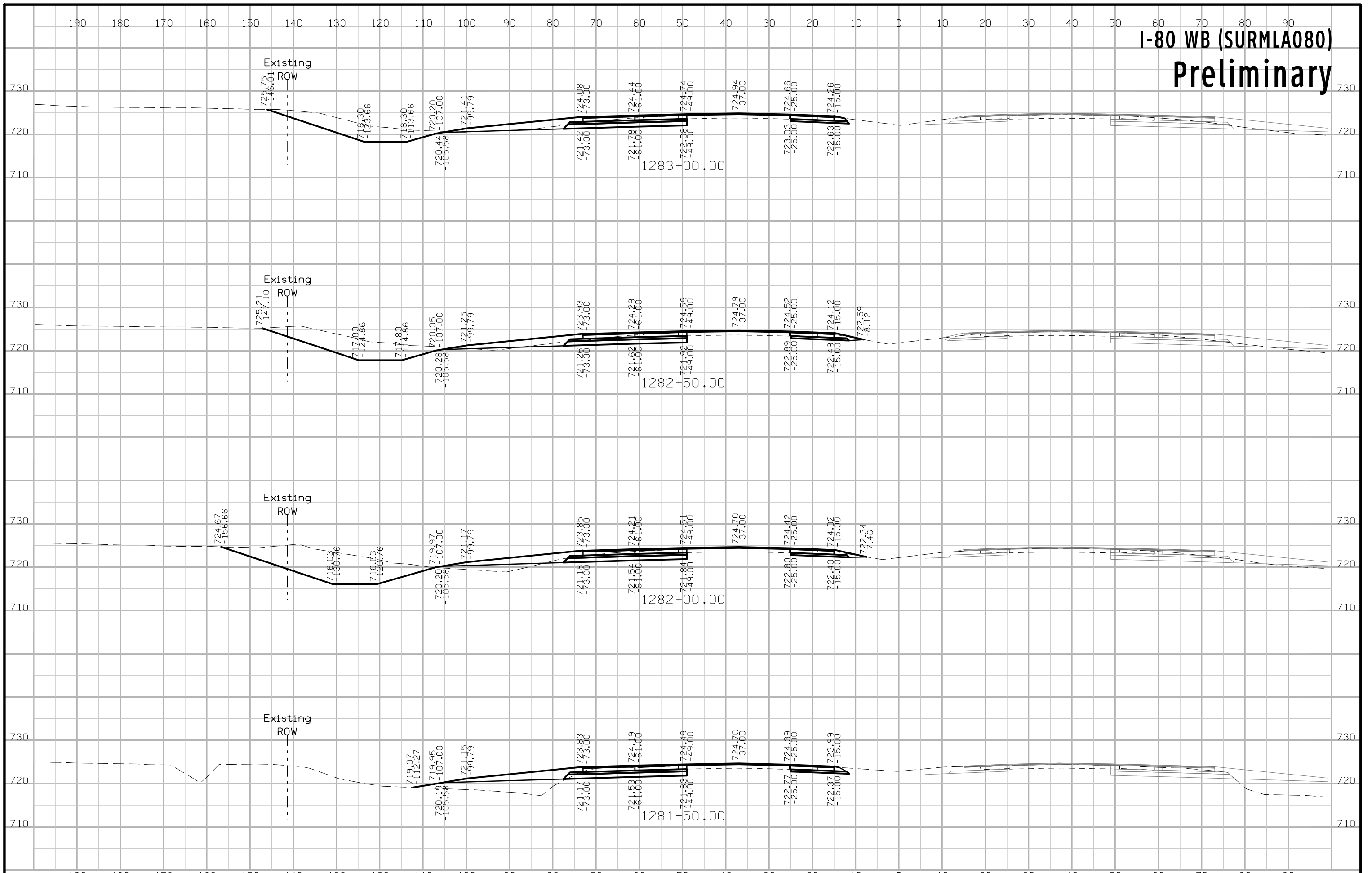



# I-80 WB (SURMLA080) Preliminary

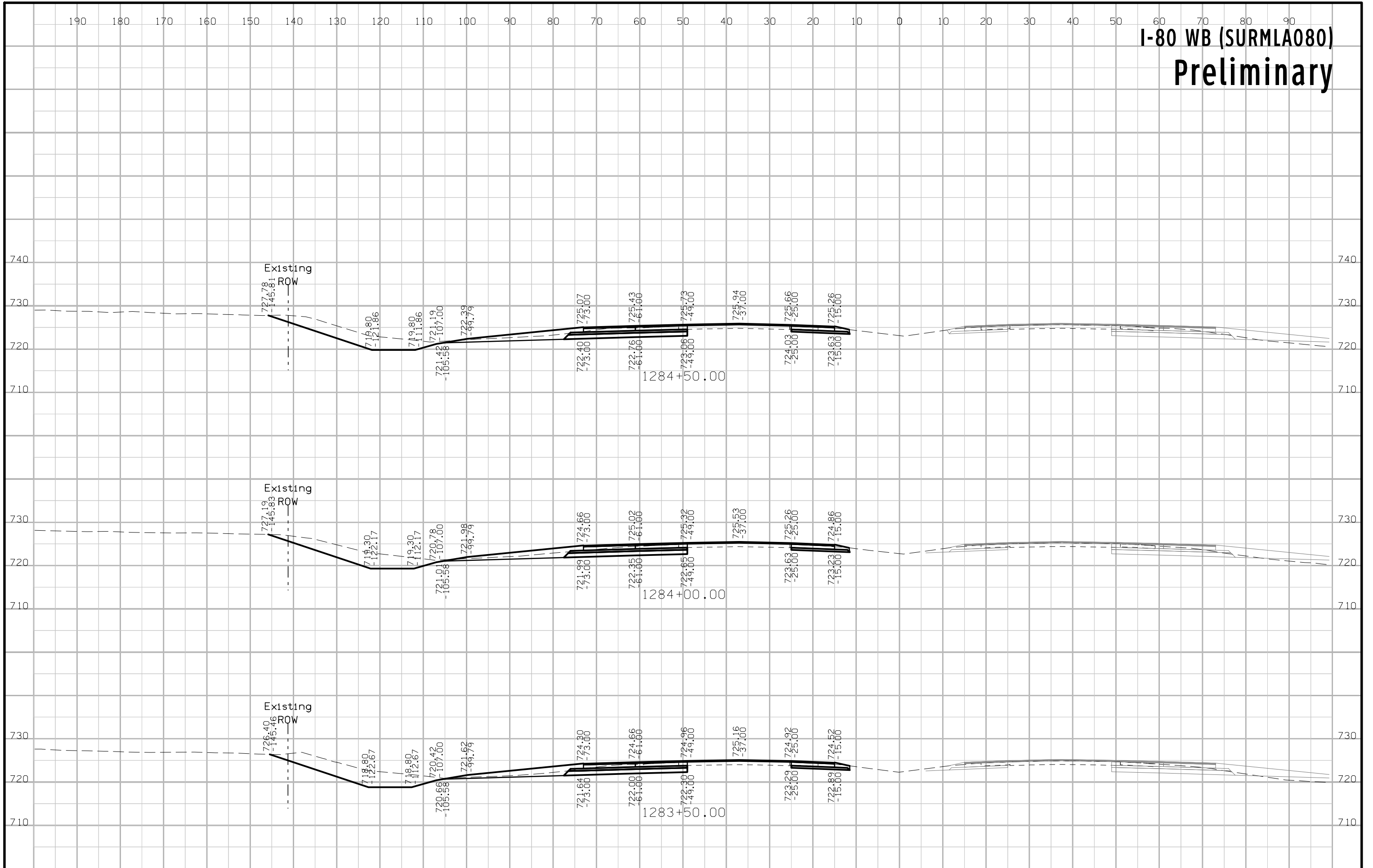

# I-80 WB (SURMLA080) Preliminary

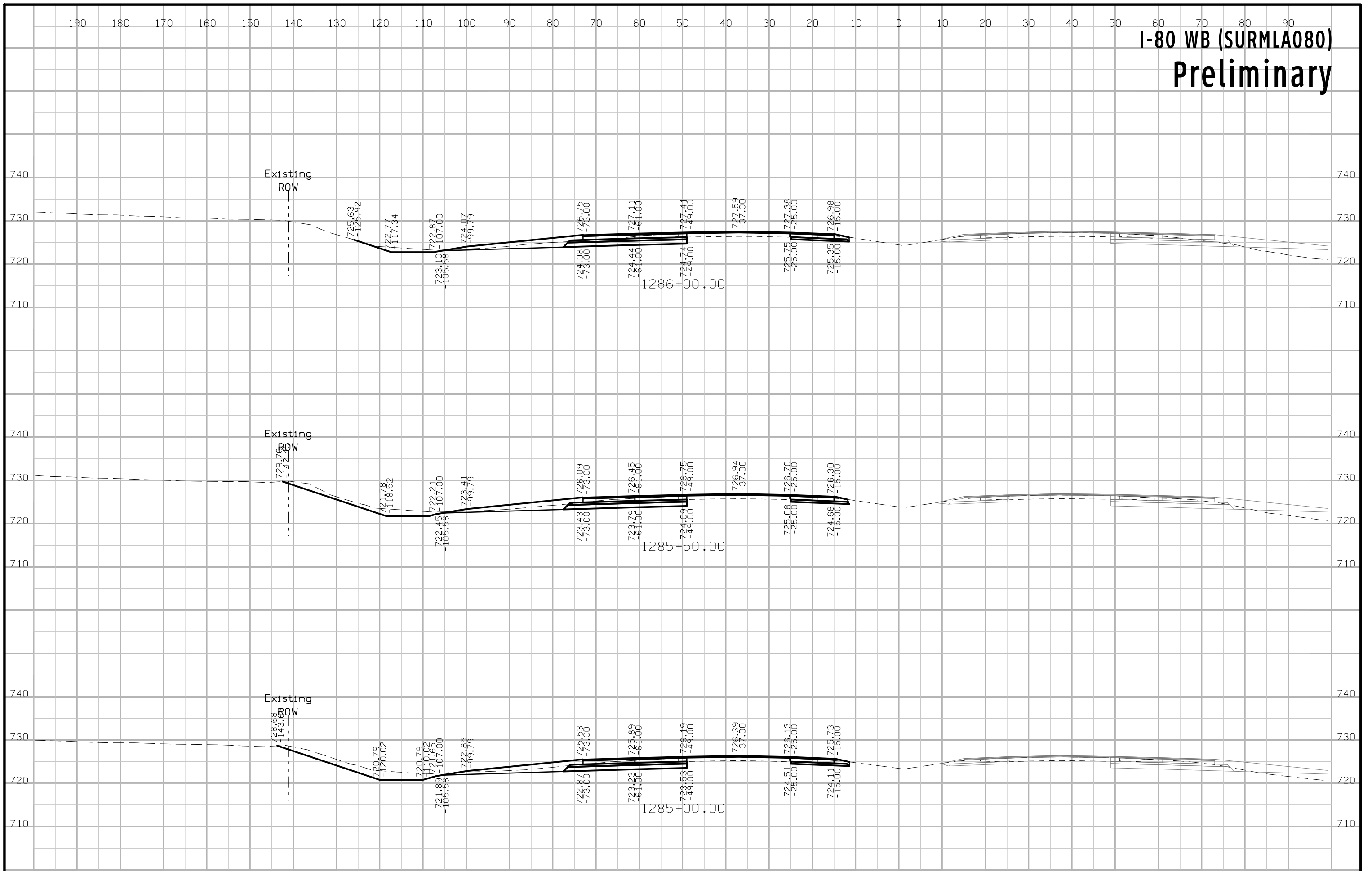

# I-80 WB (SURMLA080) Preliminary

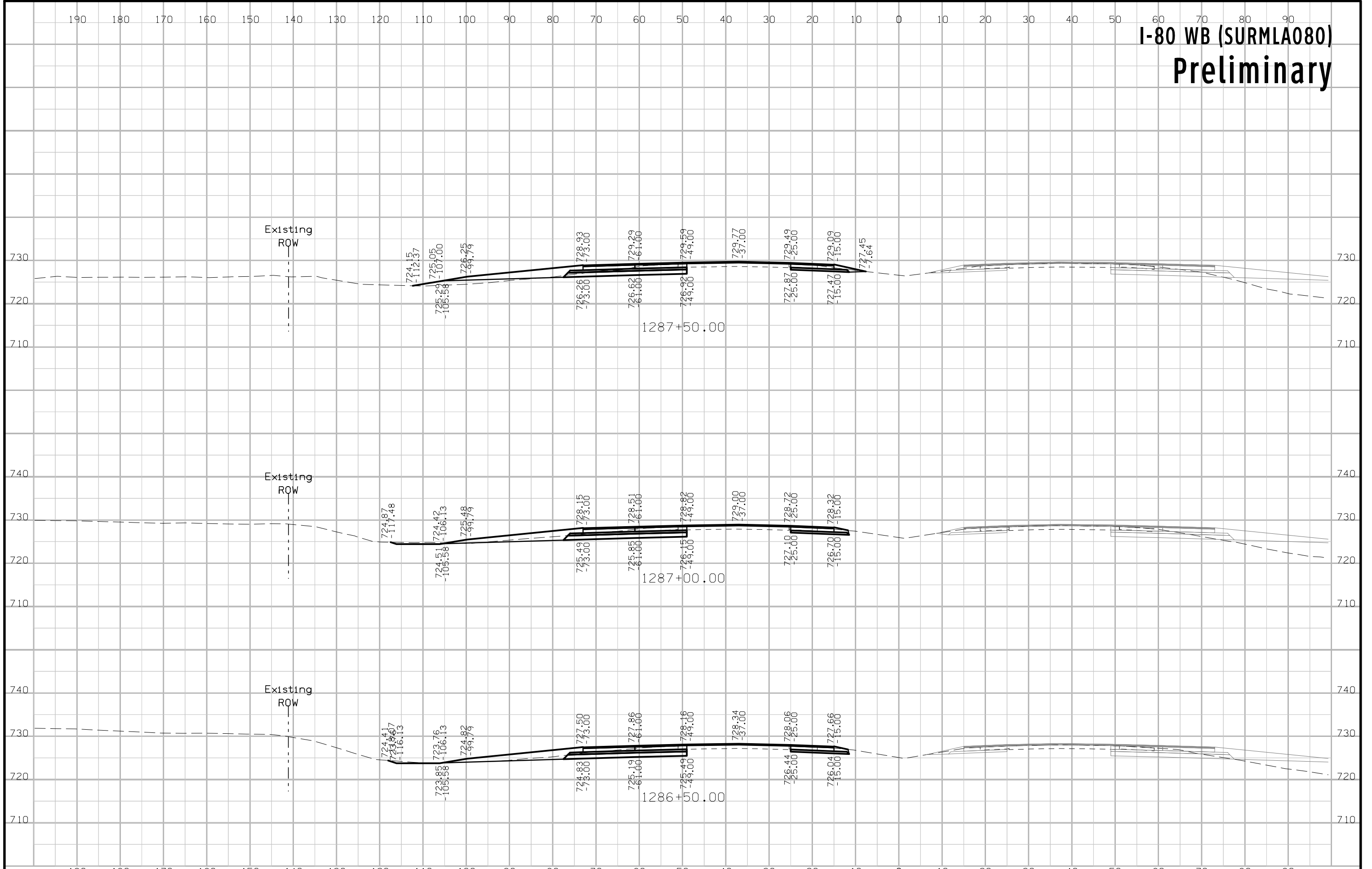

# I-80 WB (SURMLA080) Preliminary

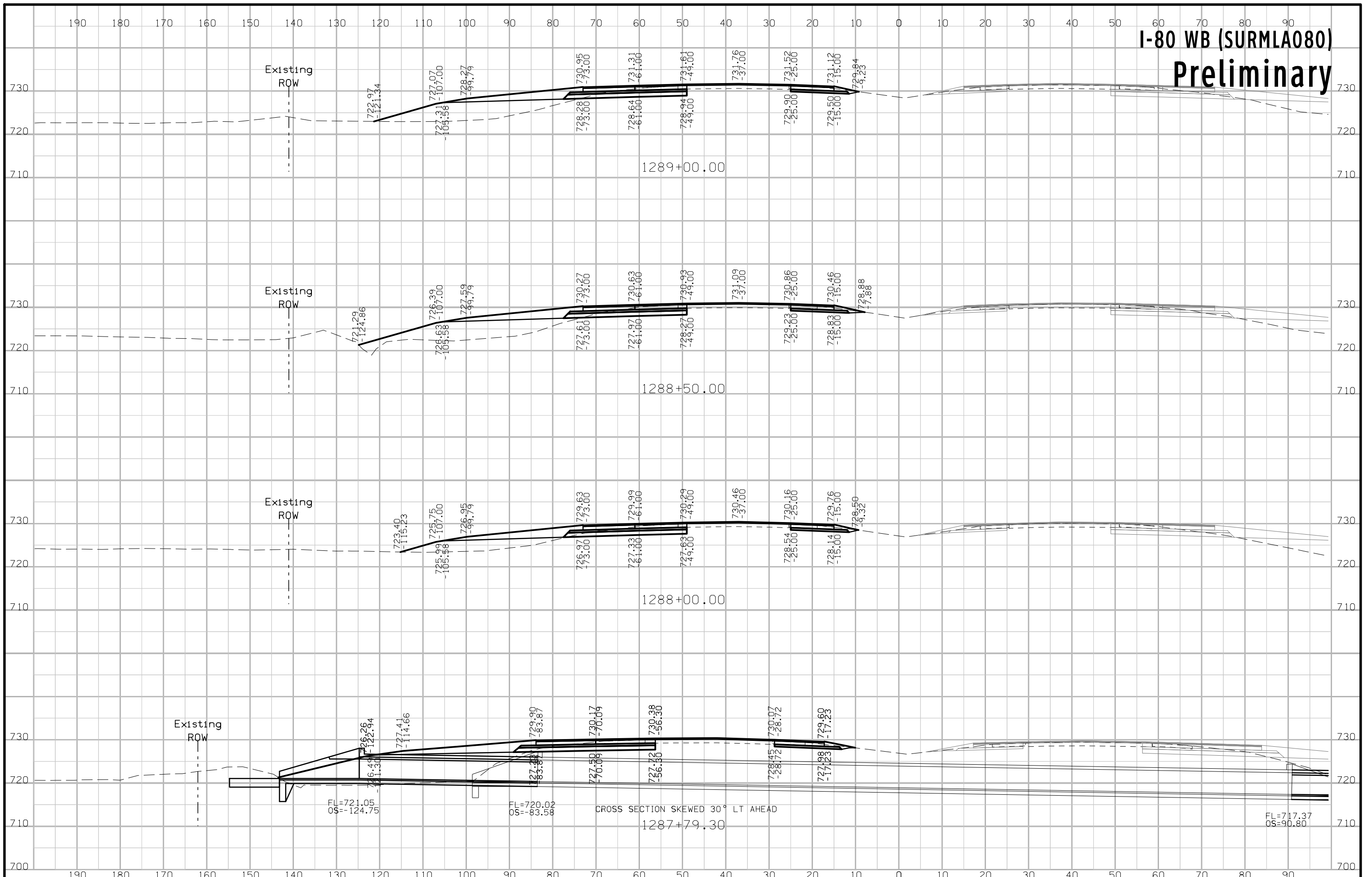

# I-80 WB (SURMLA080) Preliminary

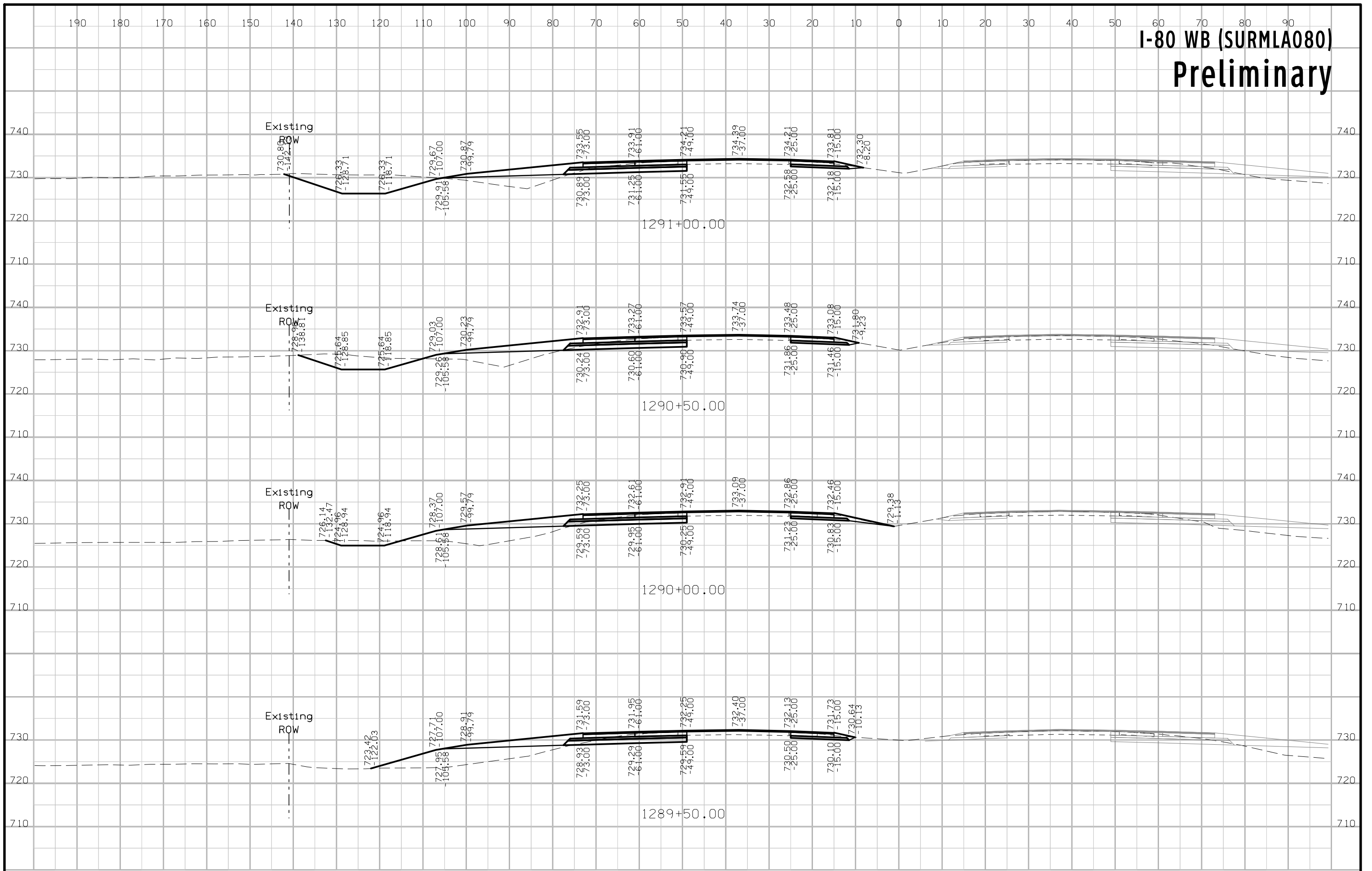

# I-80 WB (SURMLA080) Preliminary

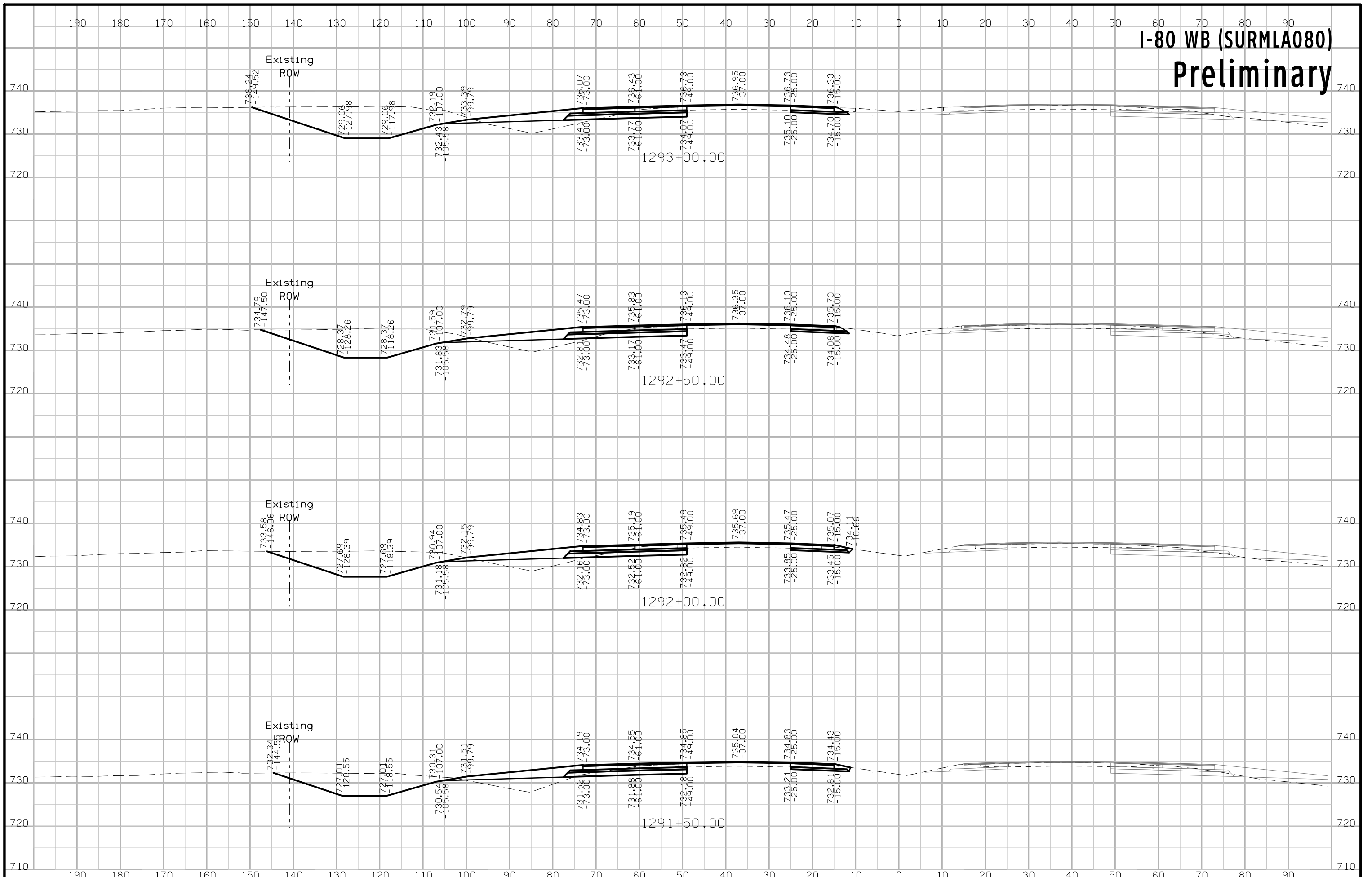



# I-80 WB (SURMLA080) Preliminary

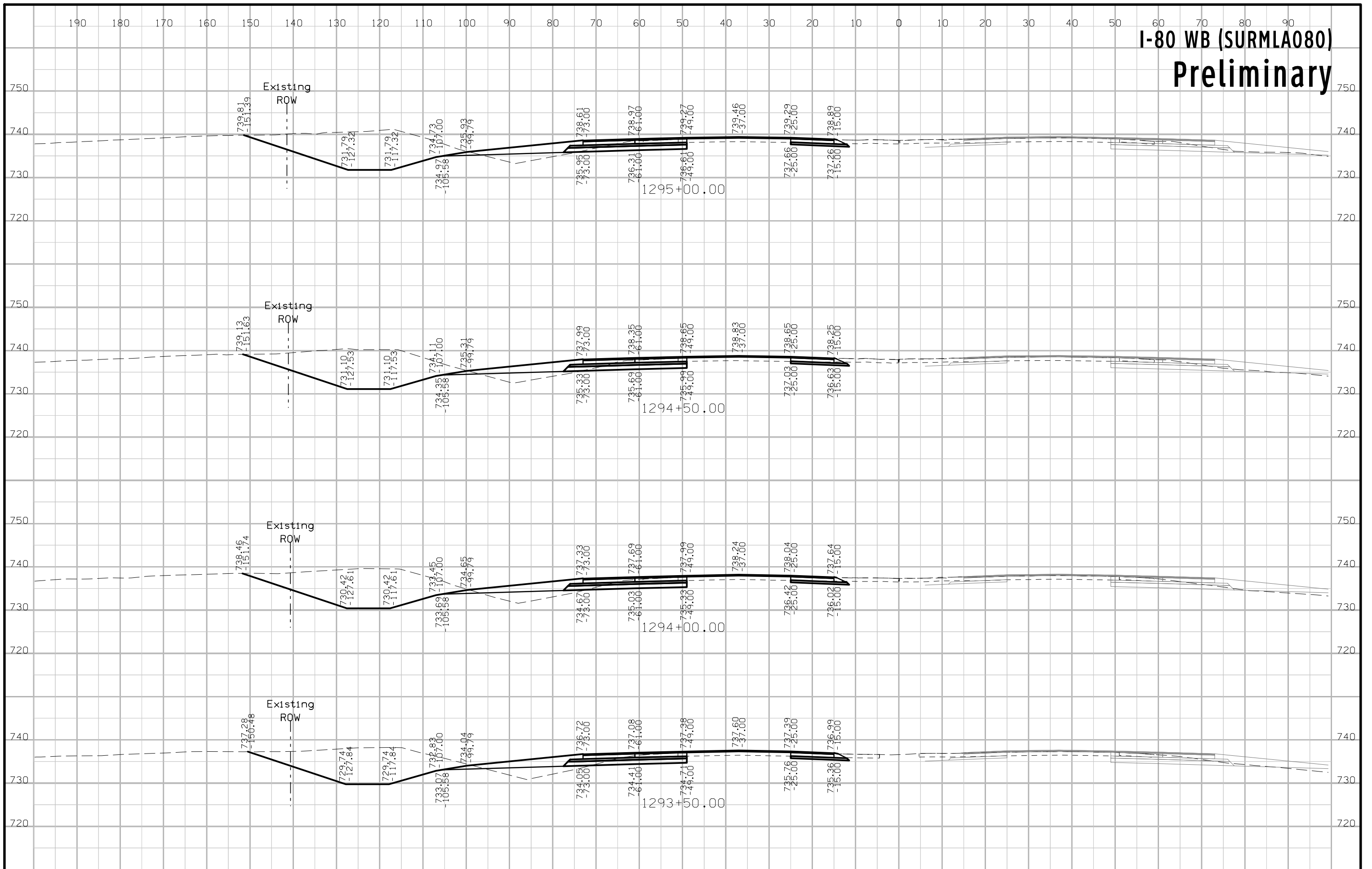

# I-80 WB (SURMLA080) Preliminary

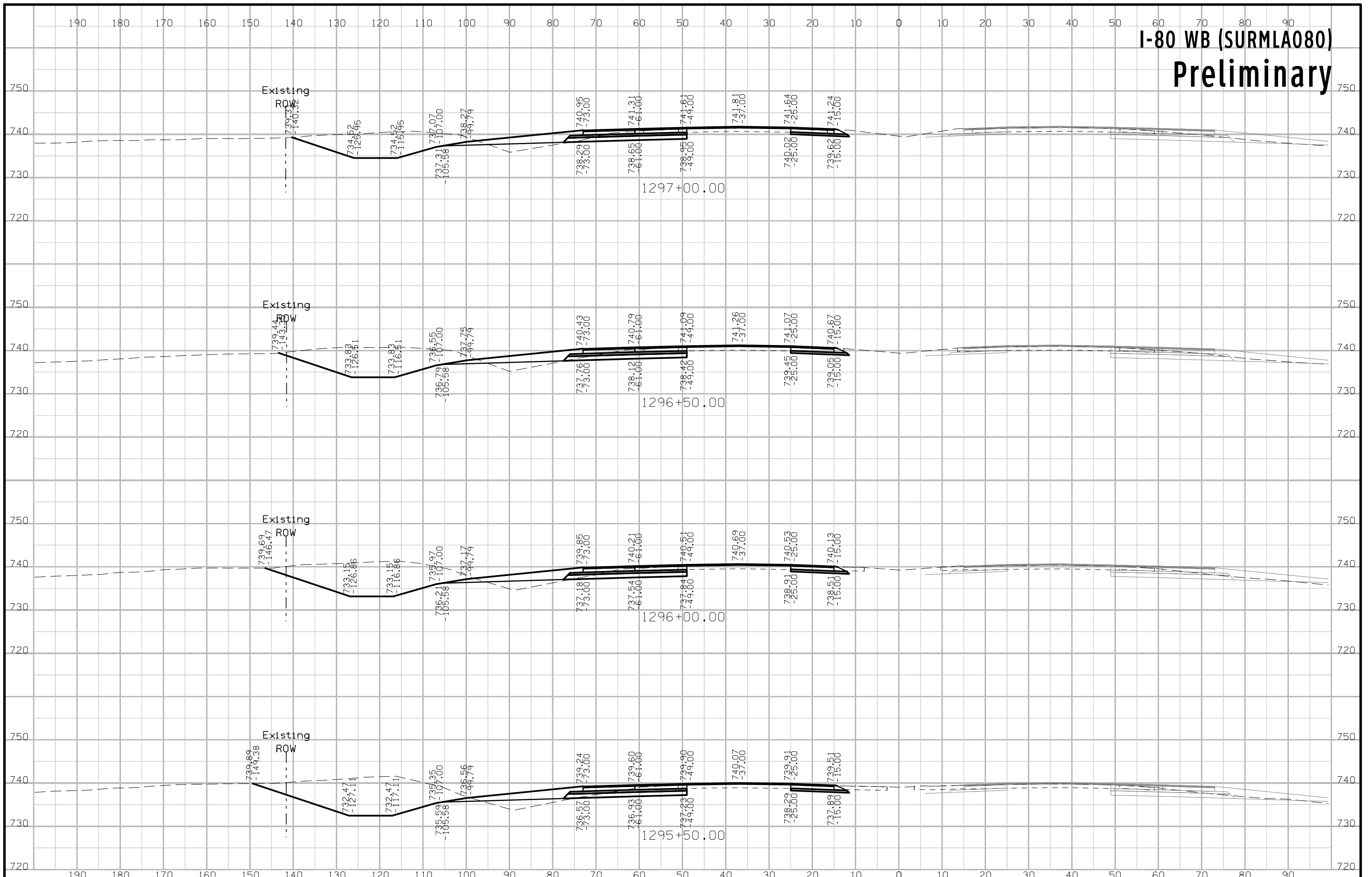

# I-80 WB (SURMLA080) Preliminary

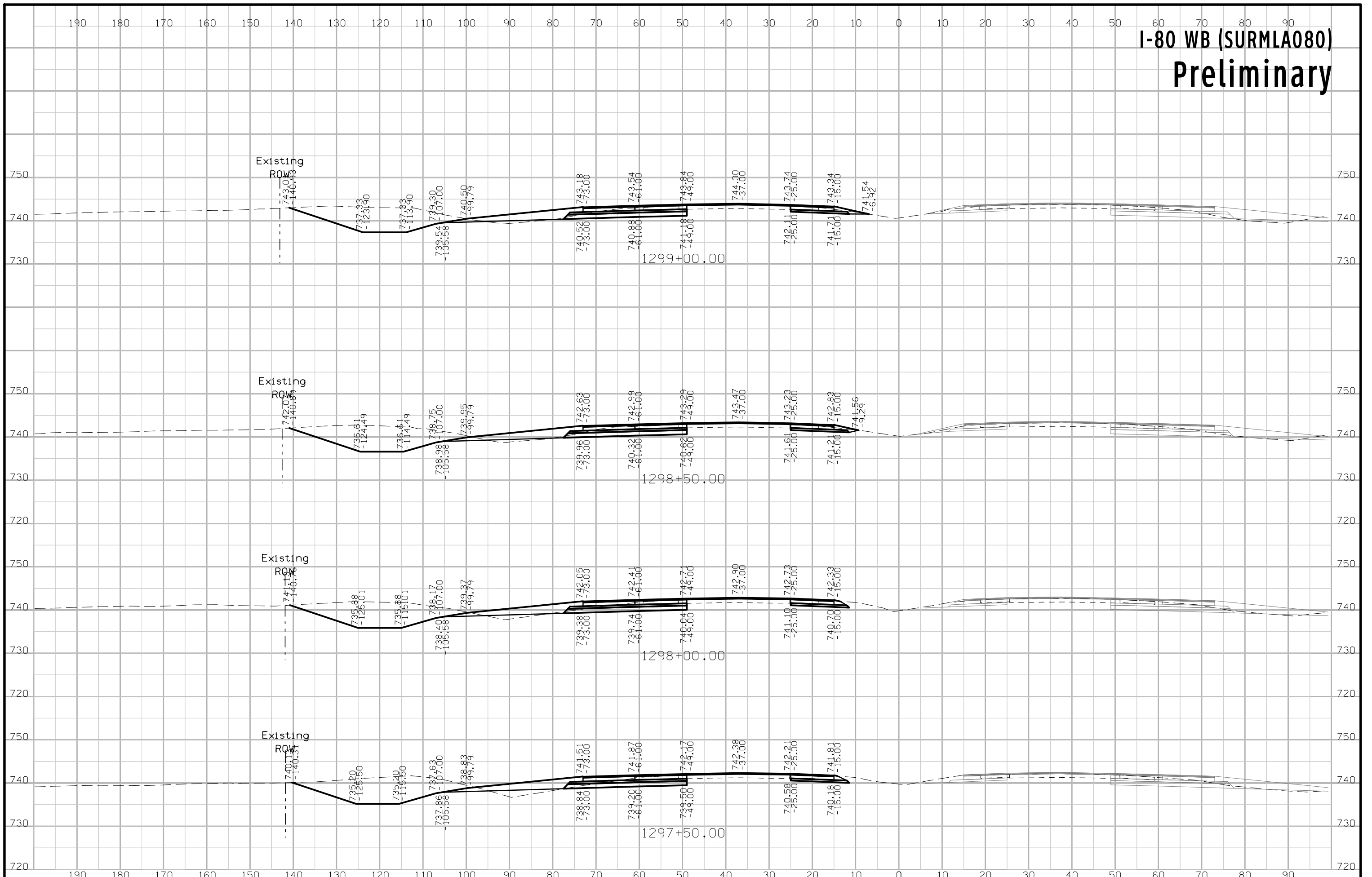

# I-80 WB (SURMLA080) Preliminary

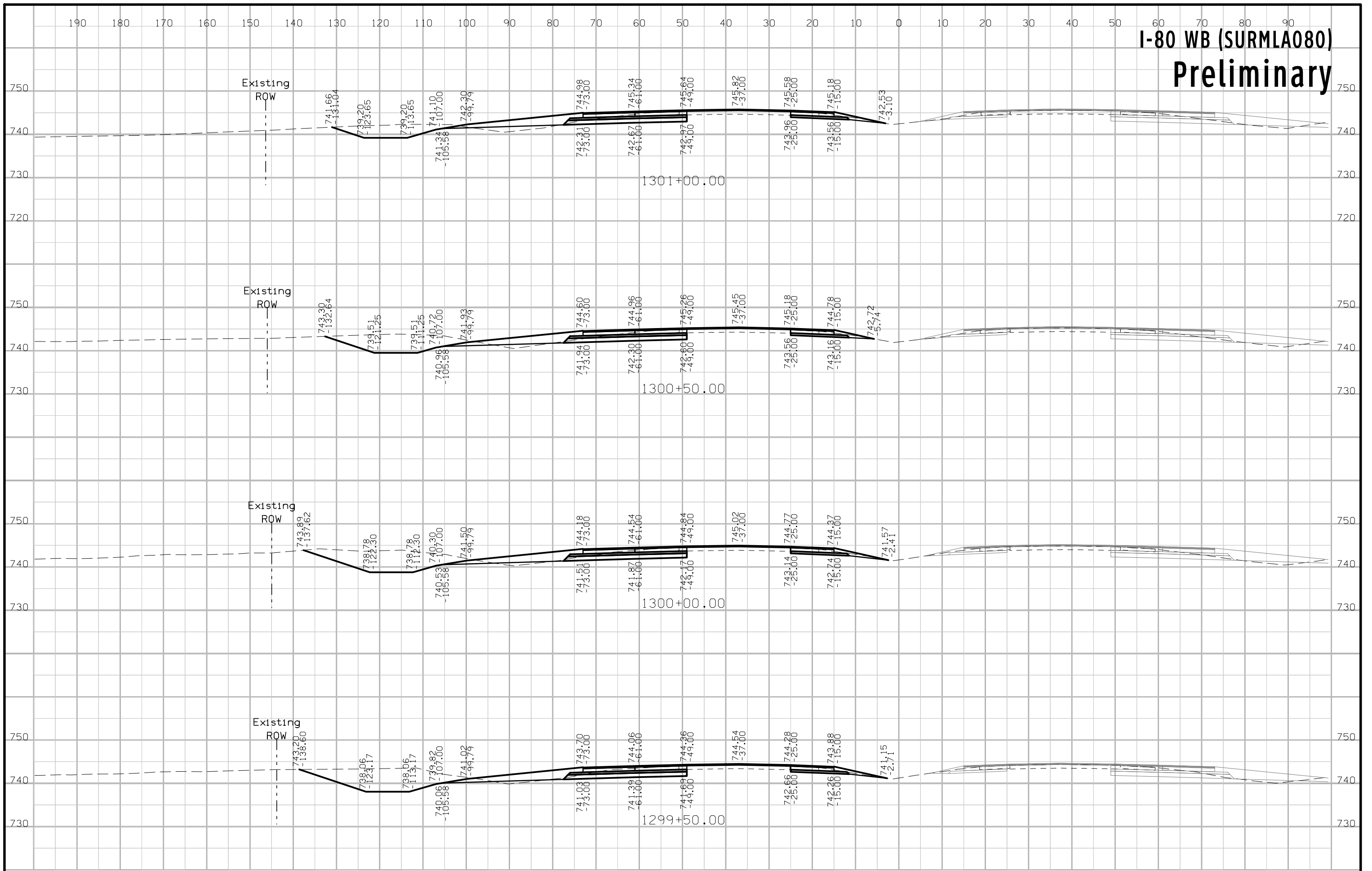

# I-80 WB (SURMLA080) Preliminary

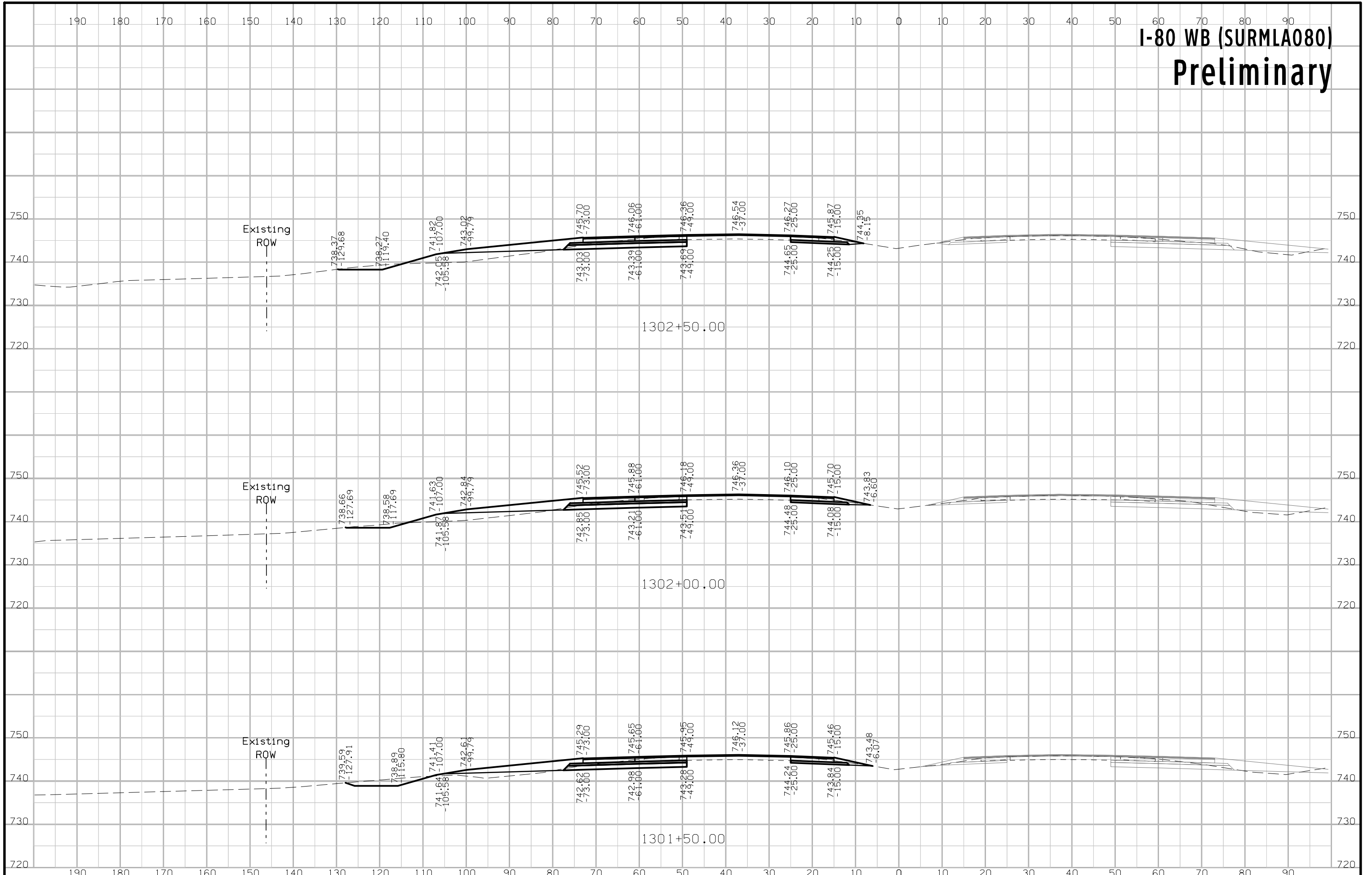

# I-80 WB (SURMLA080) Preliminary

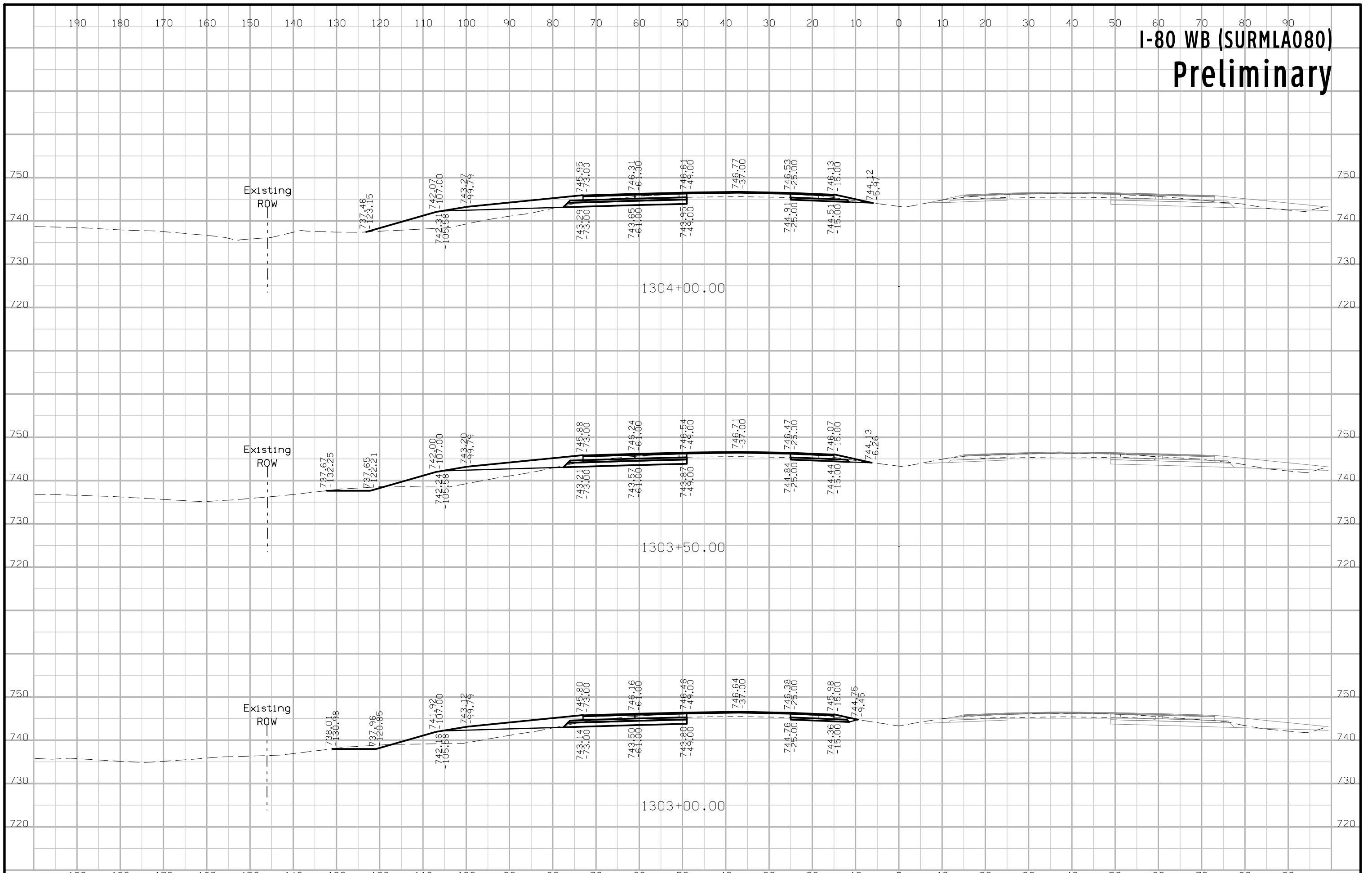



# I-80 WB (SURMLA080) Preliminary

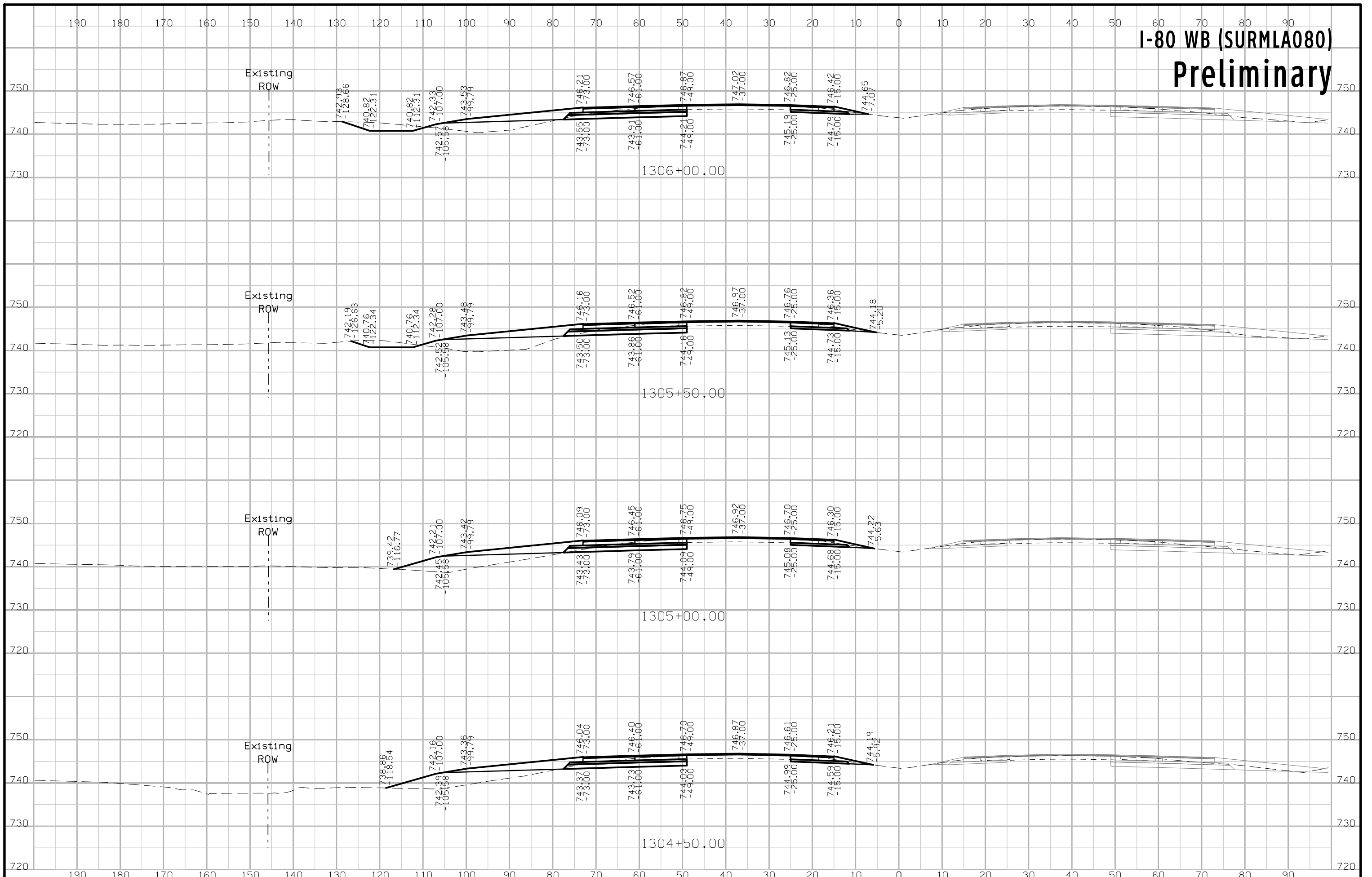

# I-80 WB (SURMLA080) Preliminary

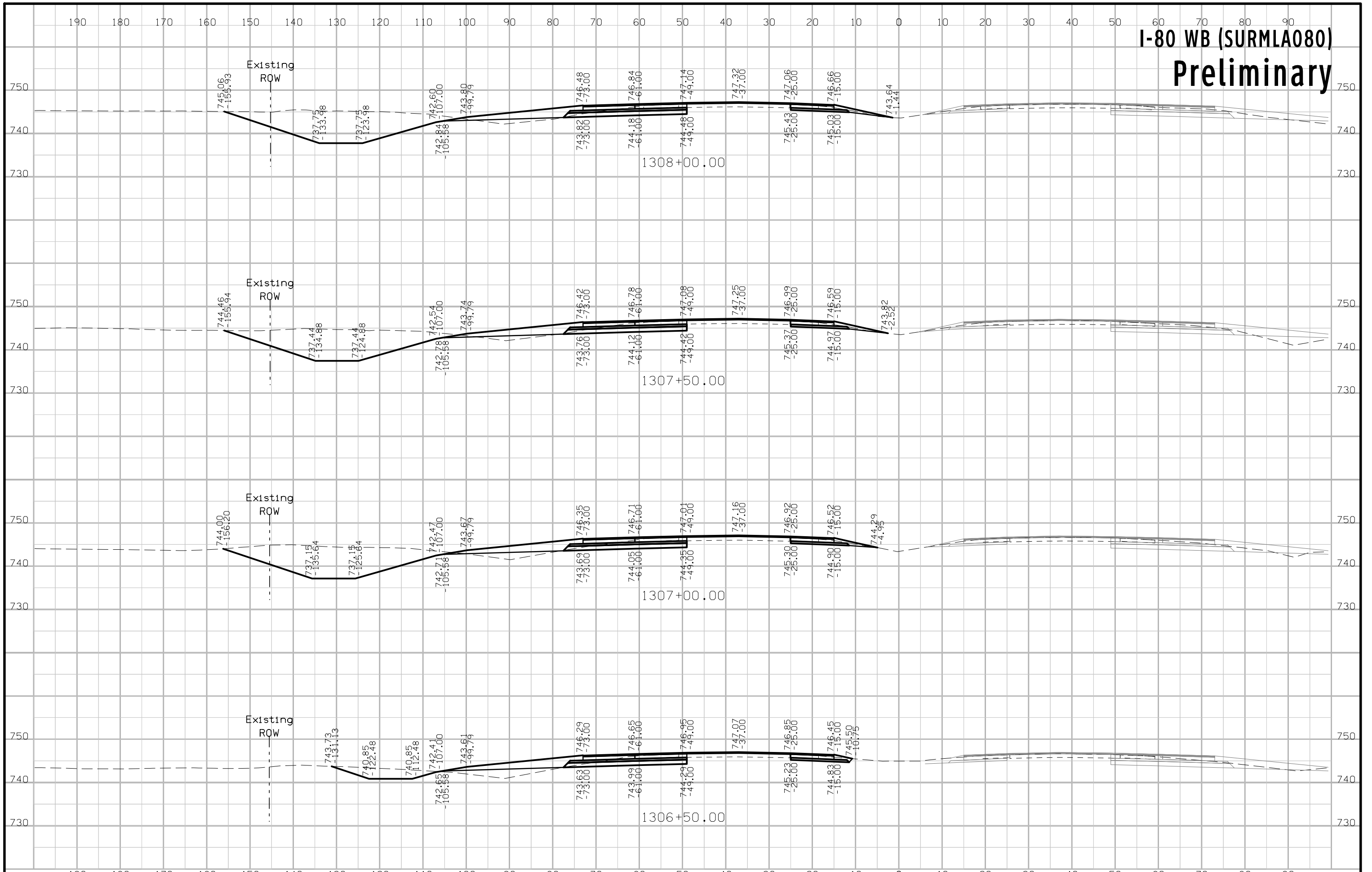

# I-80 WB (SURMLA080) Preliminary

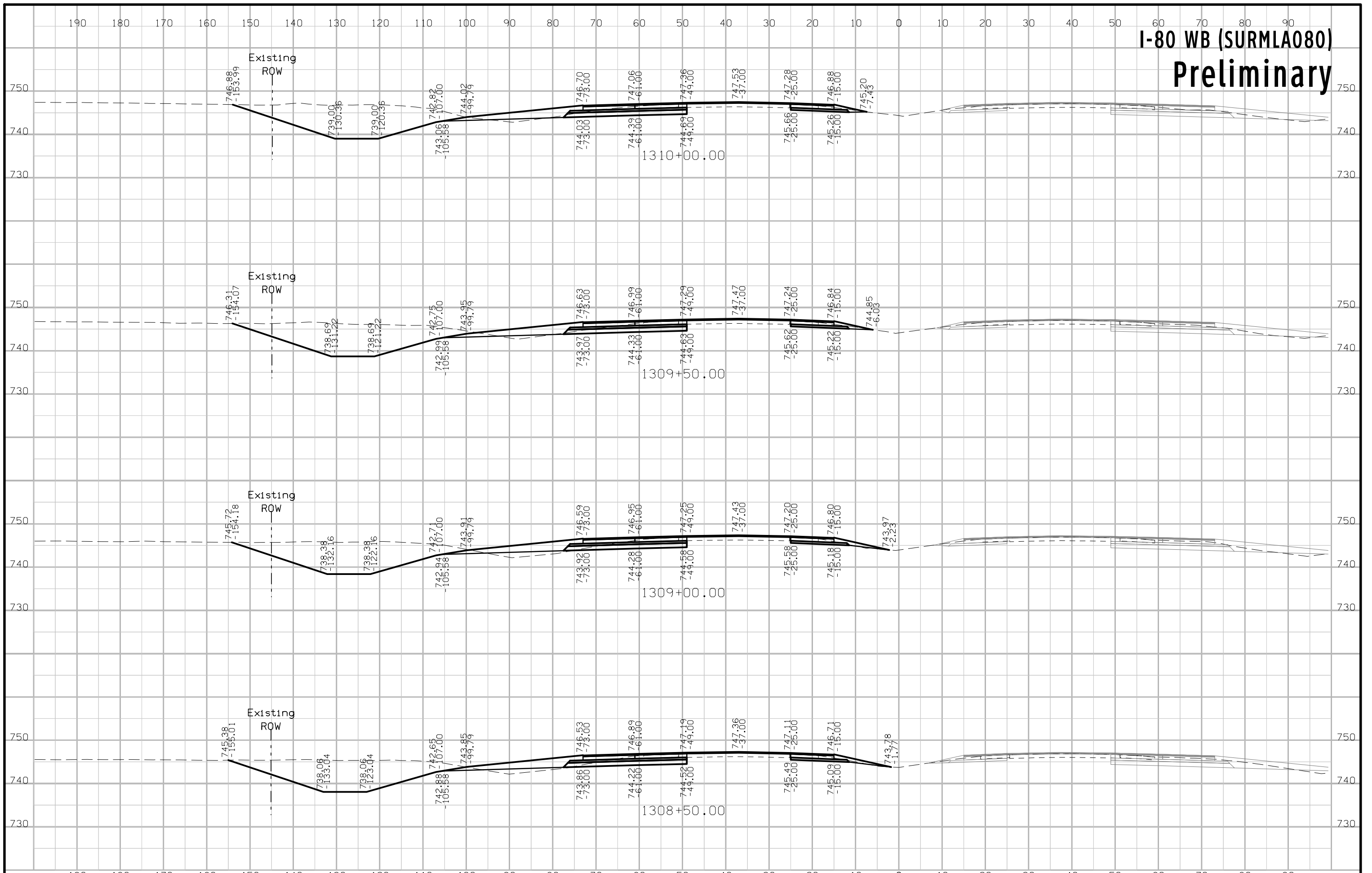

# I-80 WB (SURMLA080) Preliminary

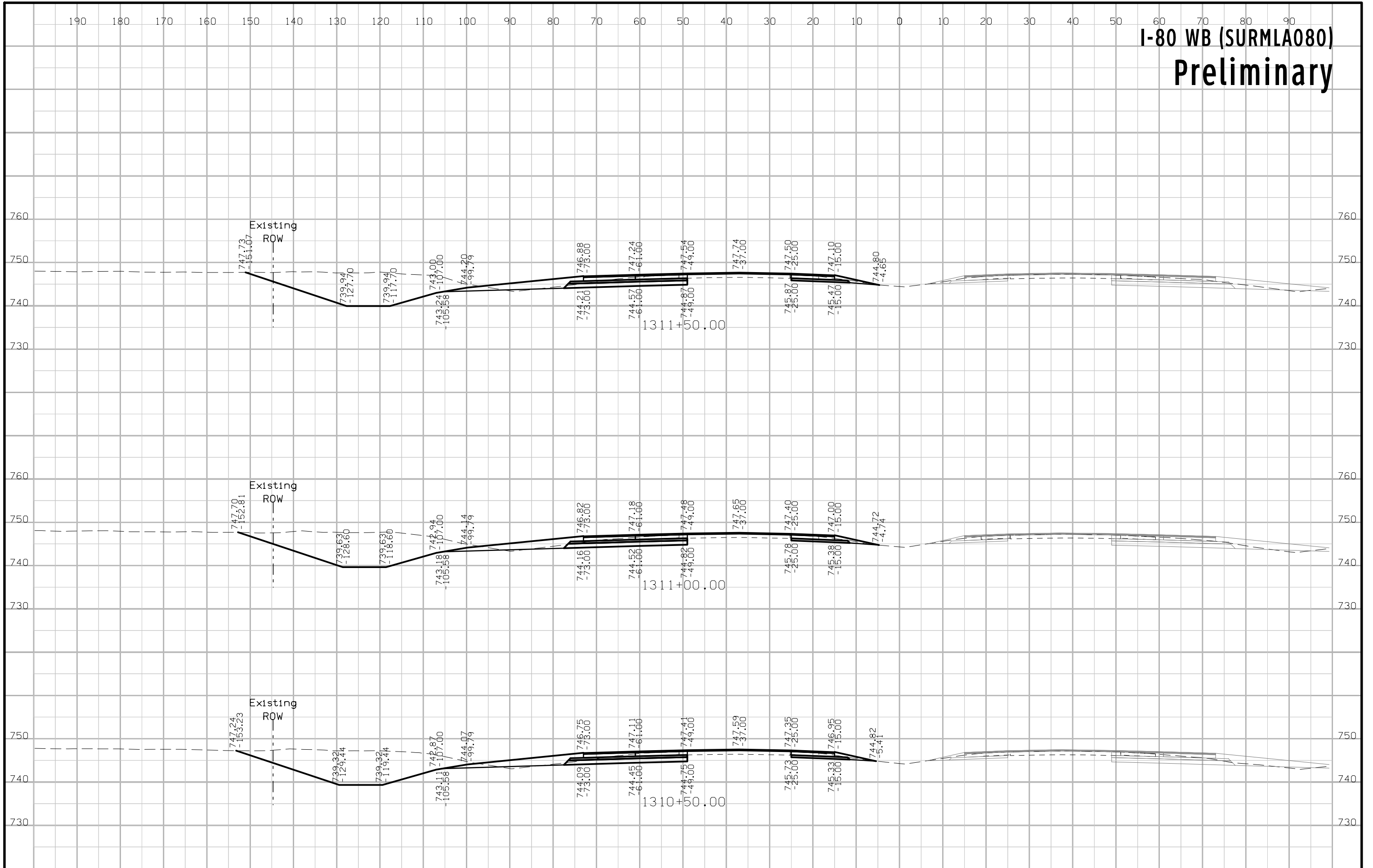

# I-80 WB (SURMLA080) Preliminary

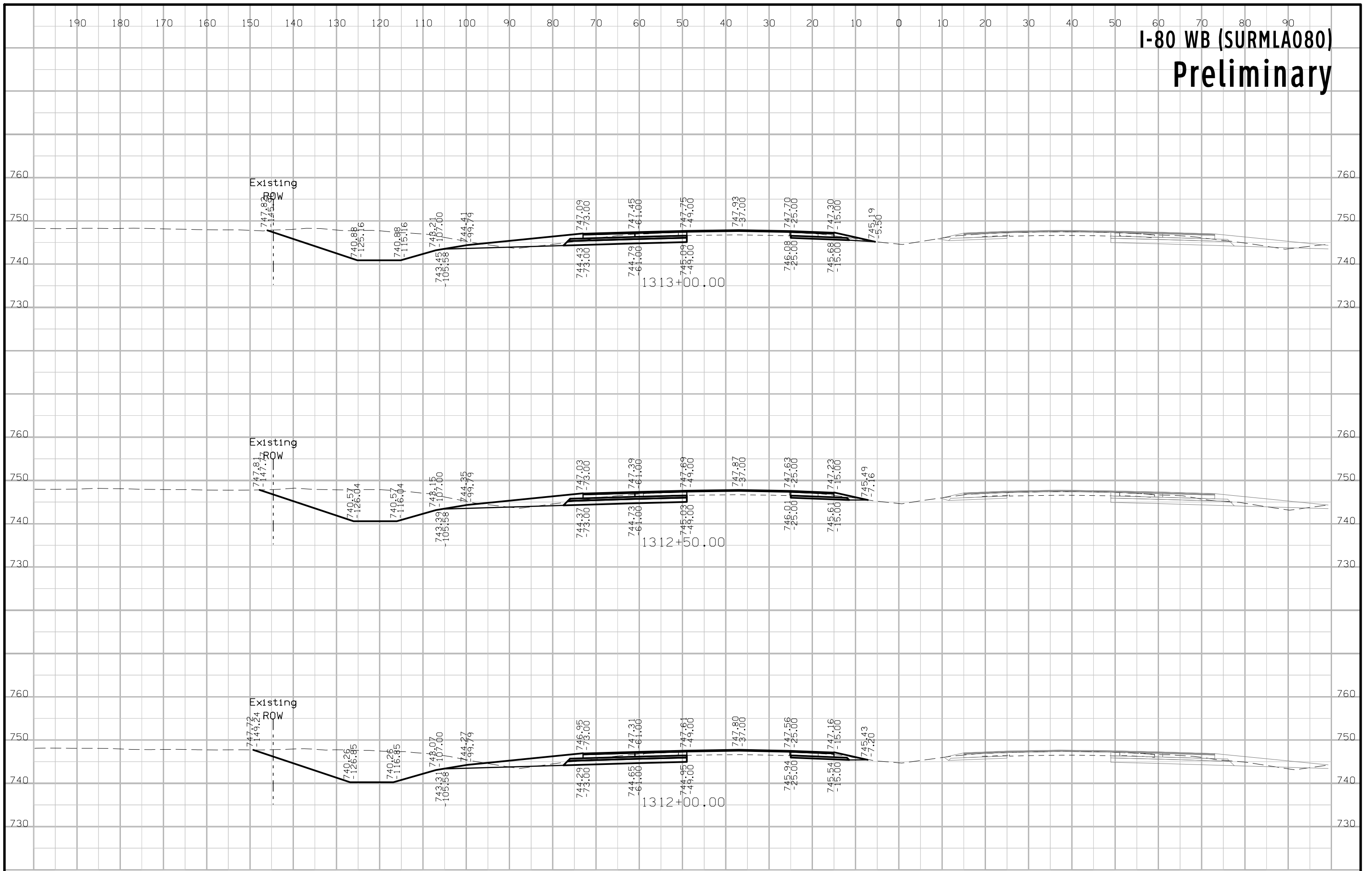

# I-80 WB (SURMLA080) Preliminary

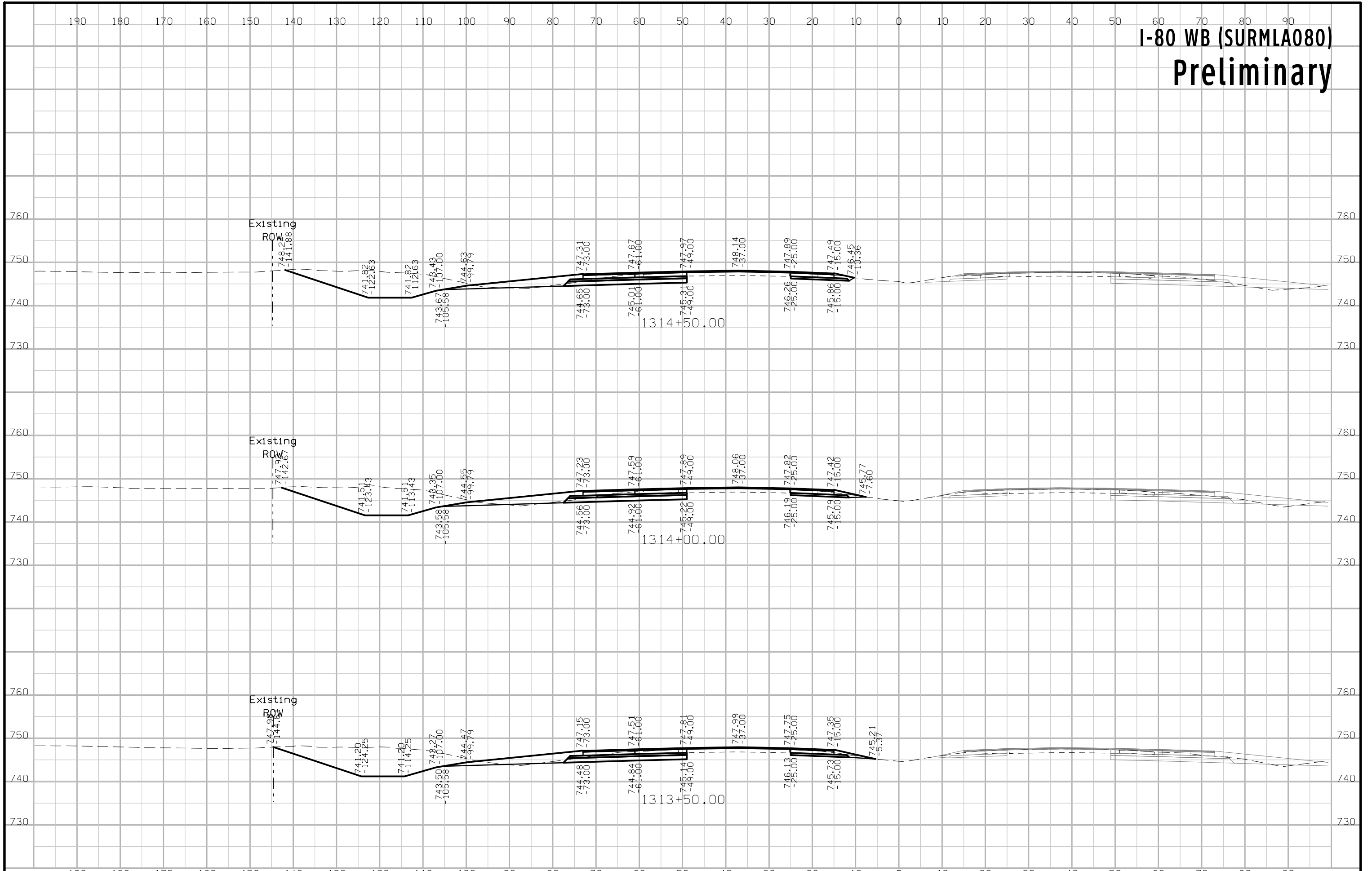



# I-80 WB (SURMLA080) Preliminary

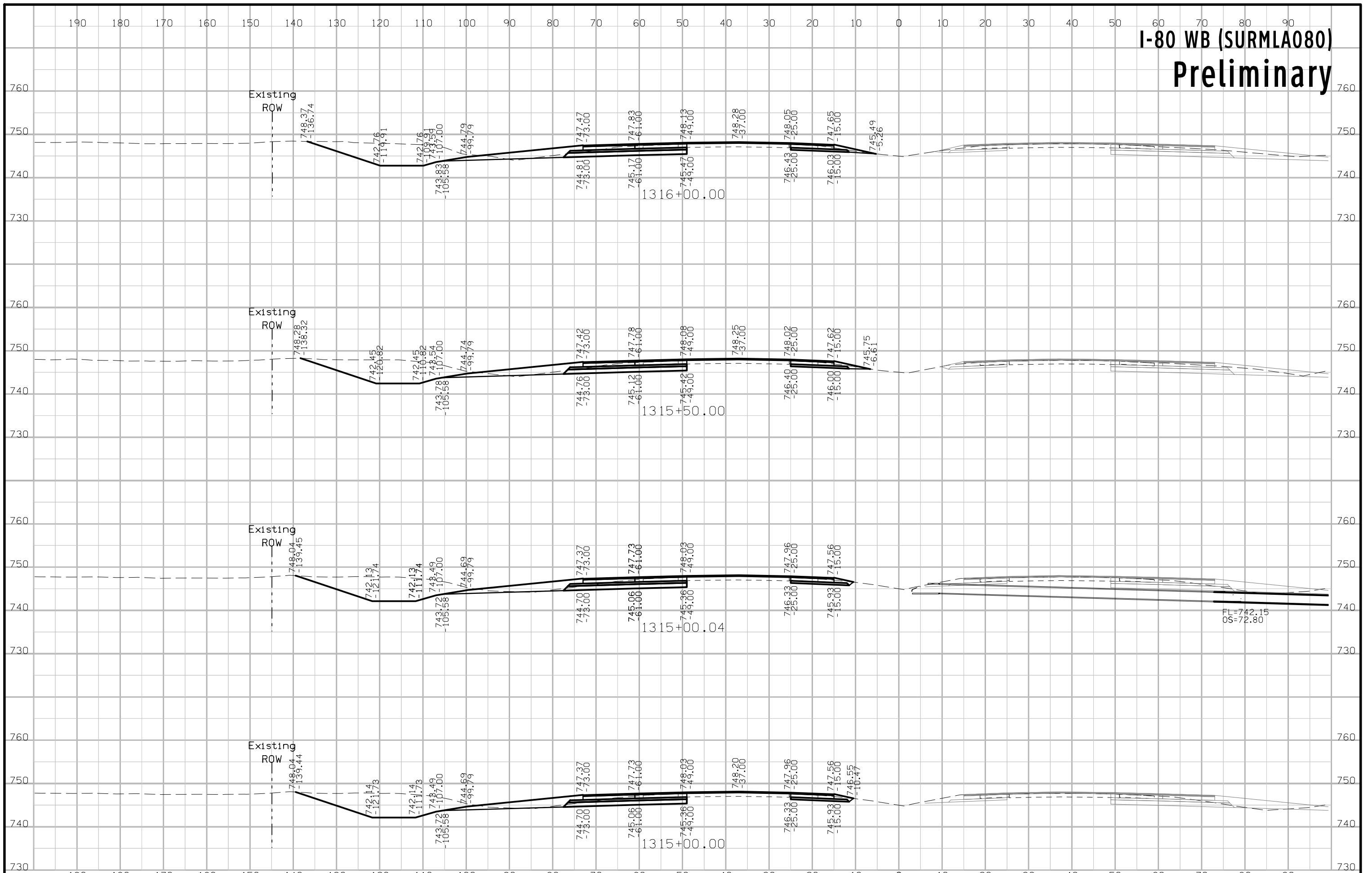

# I-80 WB (SURMLA080) Preliminary

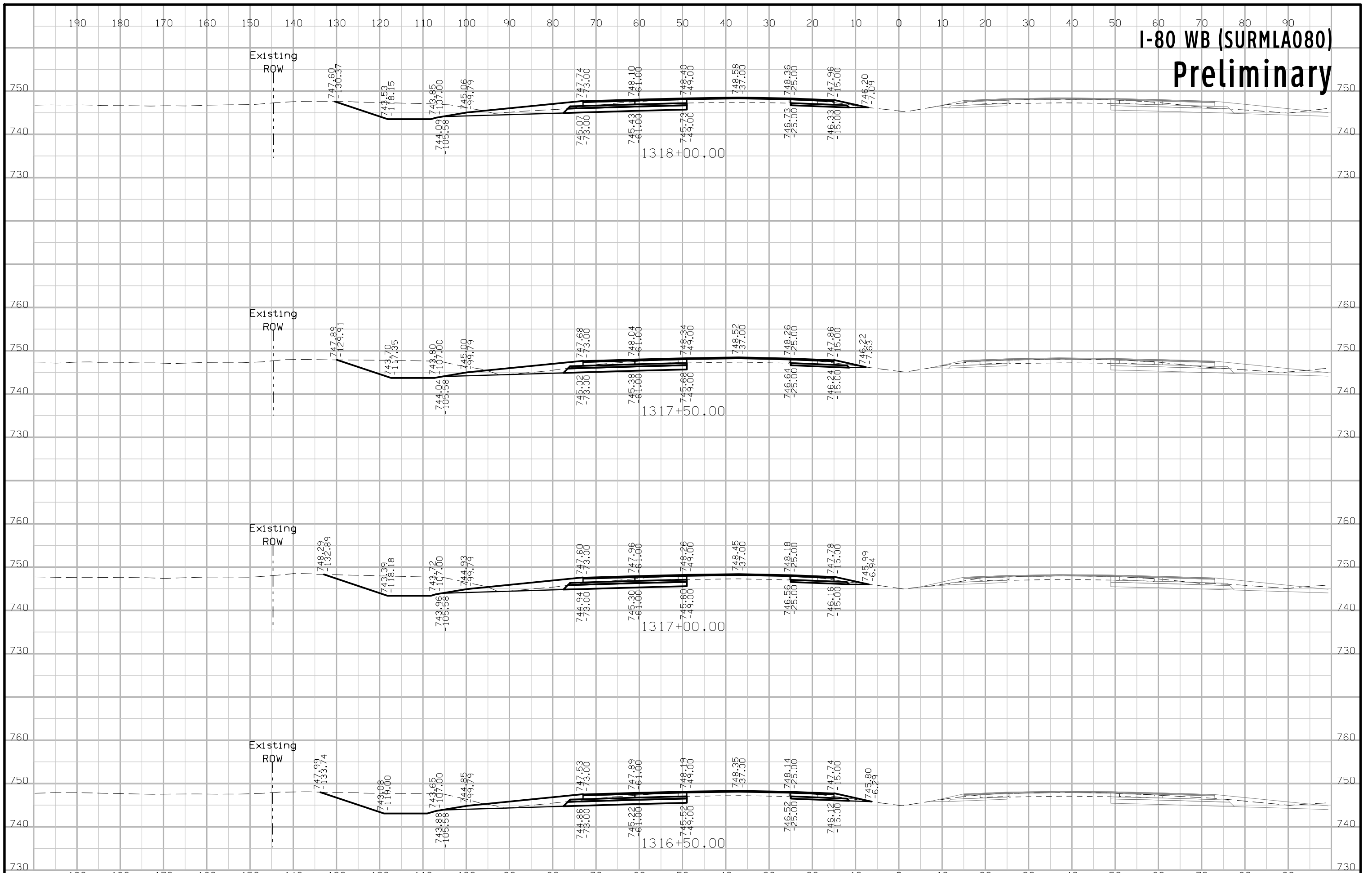

# I-80 WB (SURMLA080) Preliminary

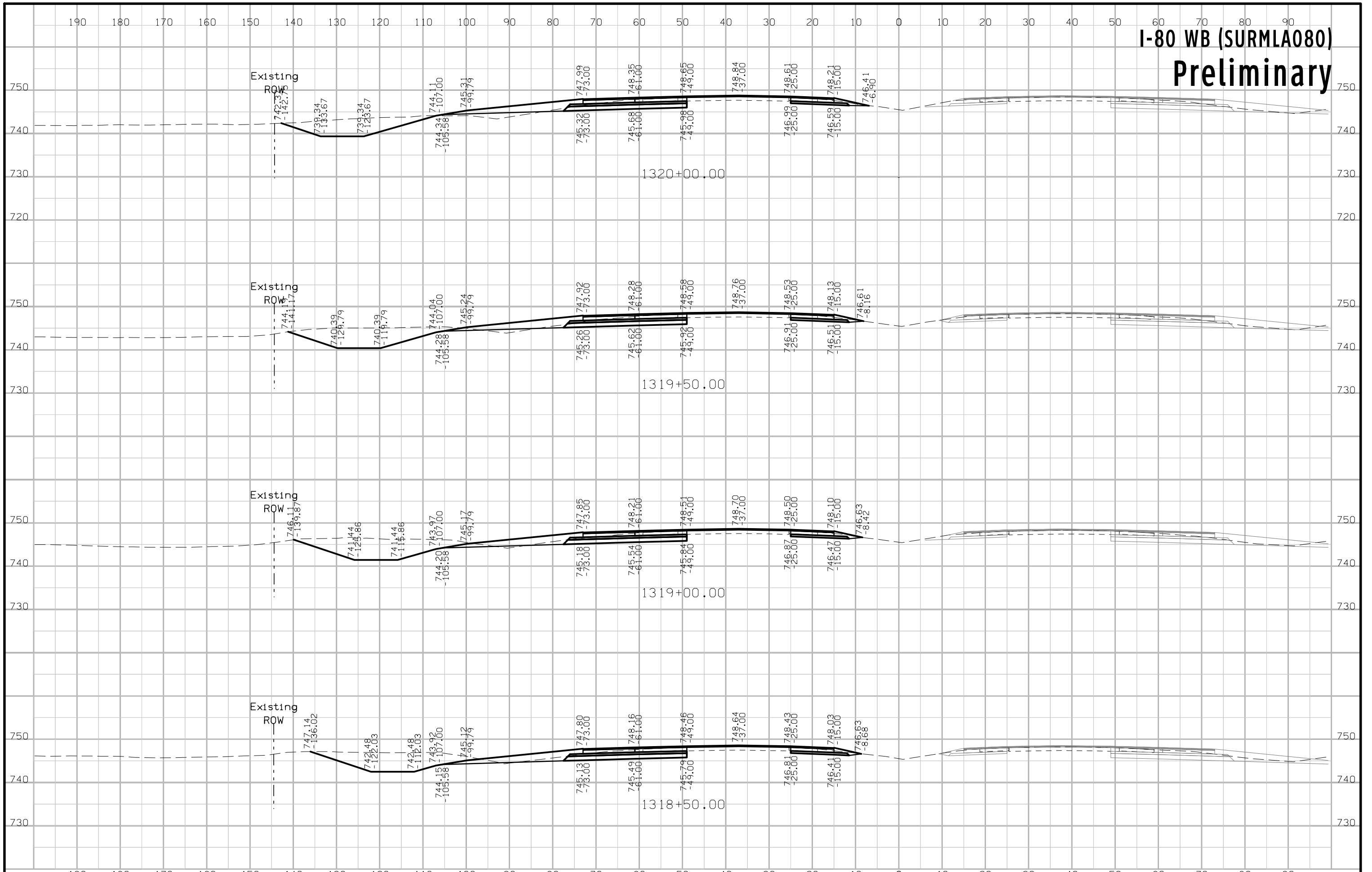

# I-80 WB (SURMLA080) Preliminary

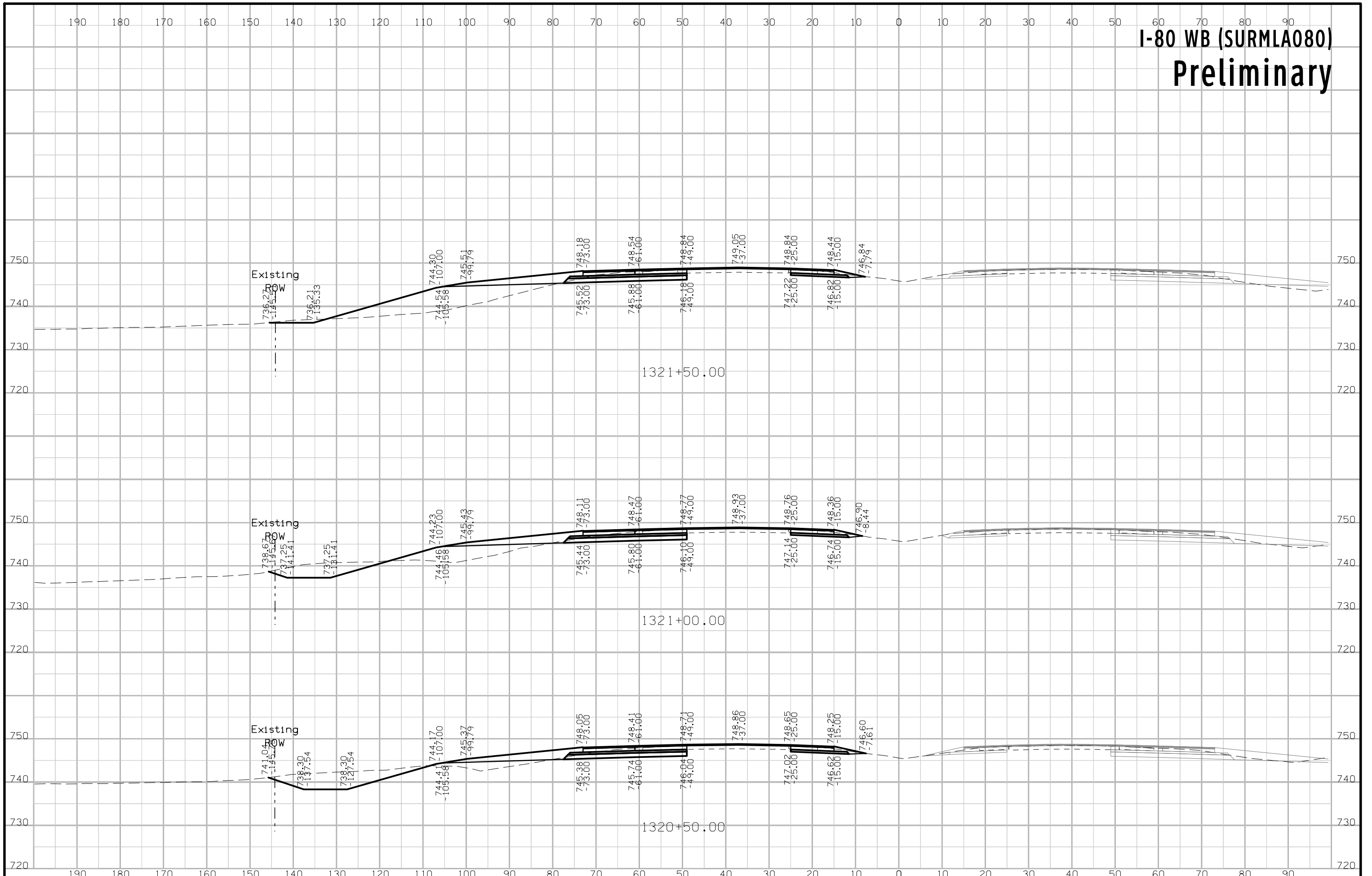

# I-80 WB (SURMLA080) Preliminary

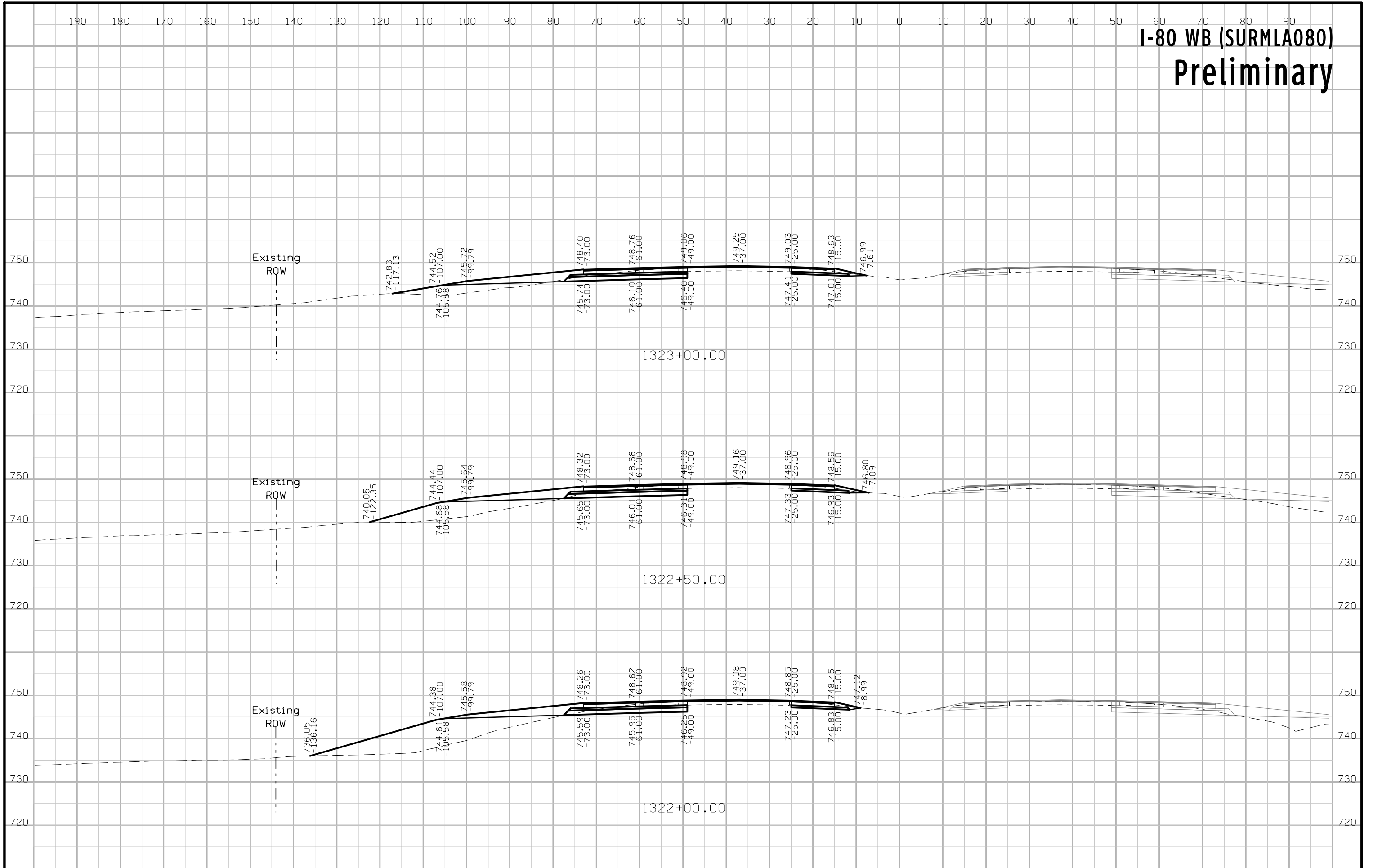

# I-80 WB (SURMLA080) Preliminary

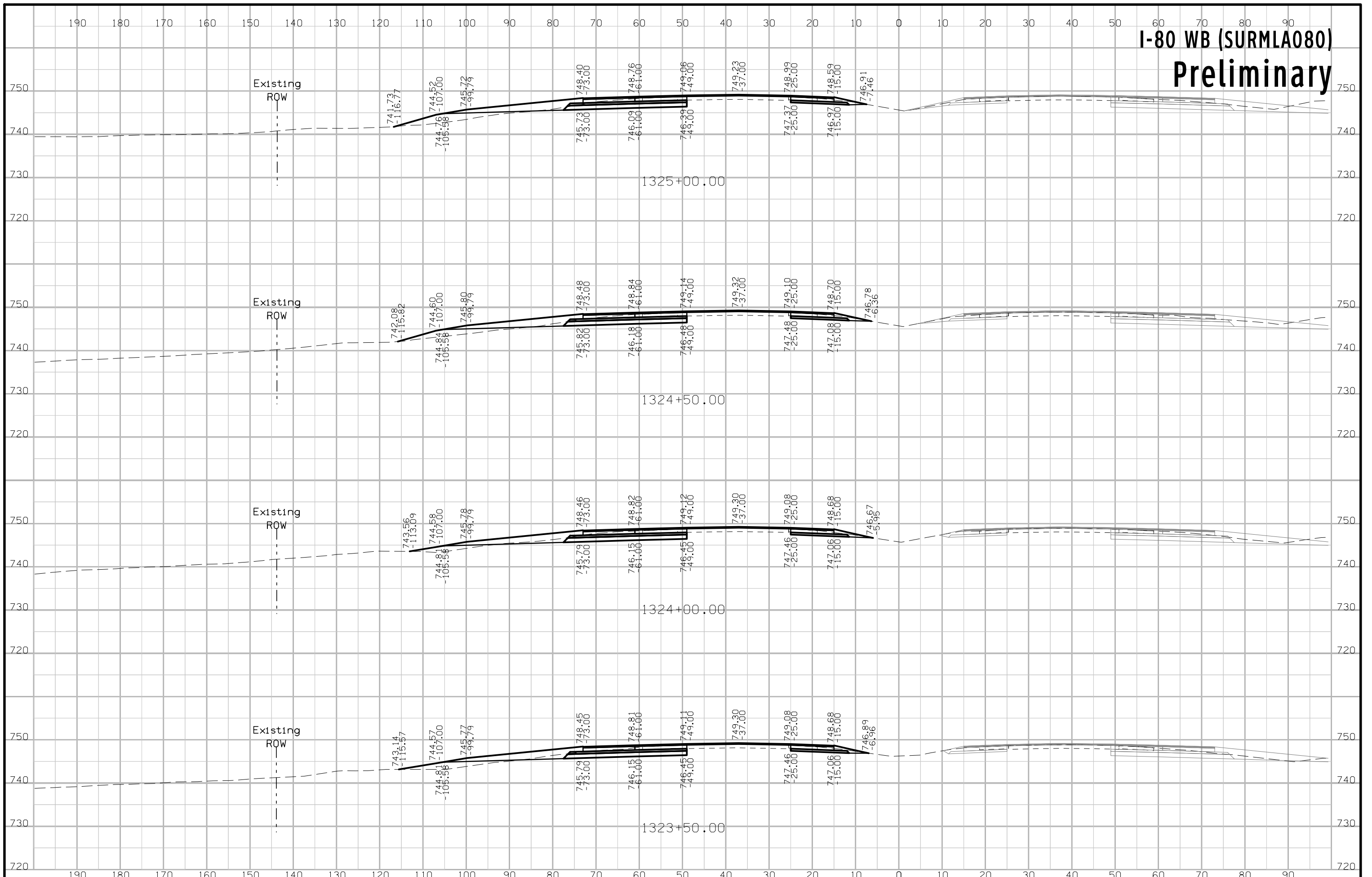



# I-80 WB (SURMLA080) Preliminary

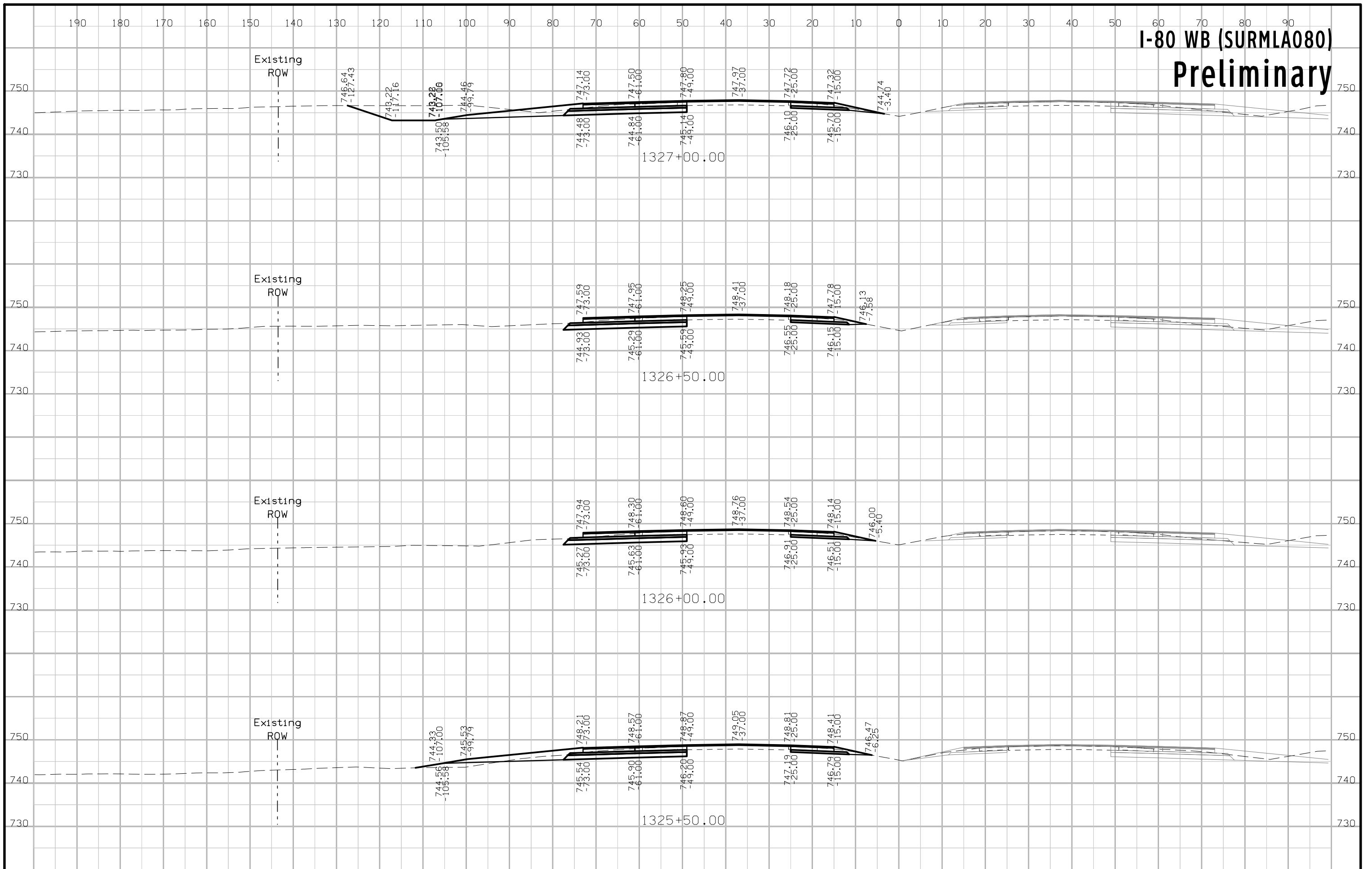

# I-80 WB (SURMLA080) Preliminary

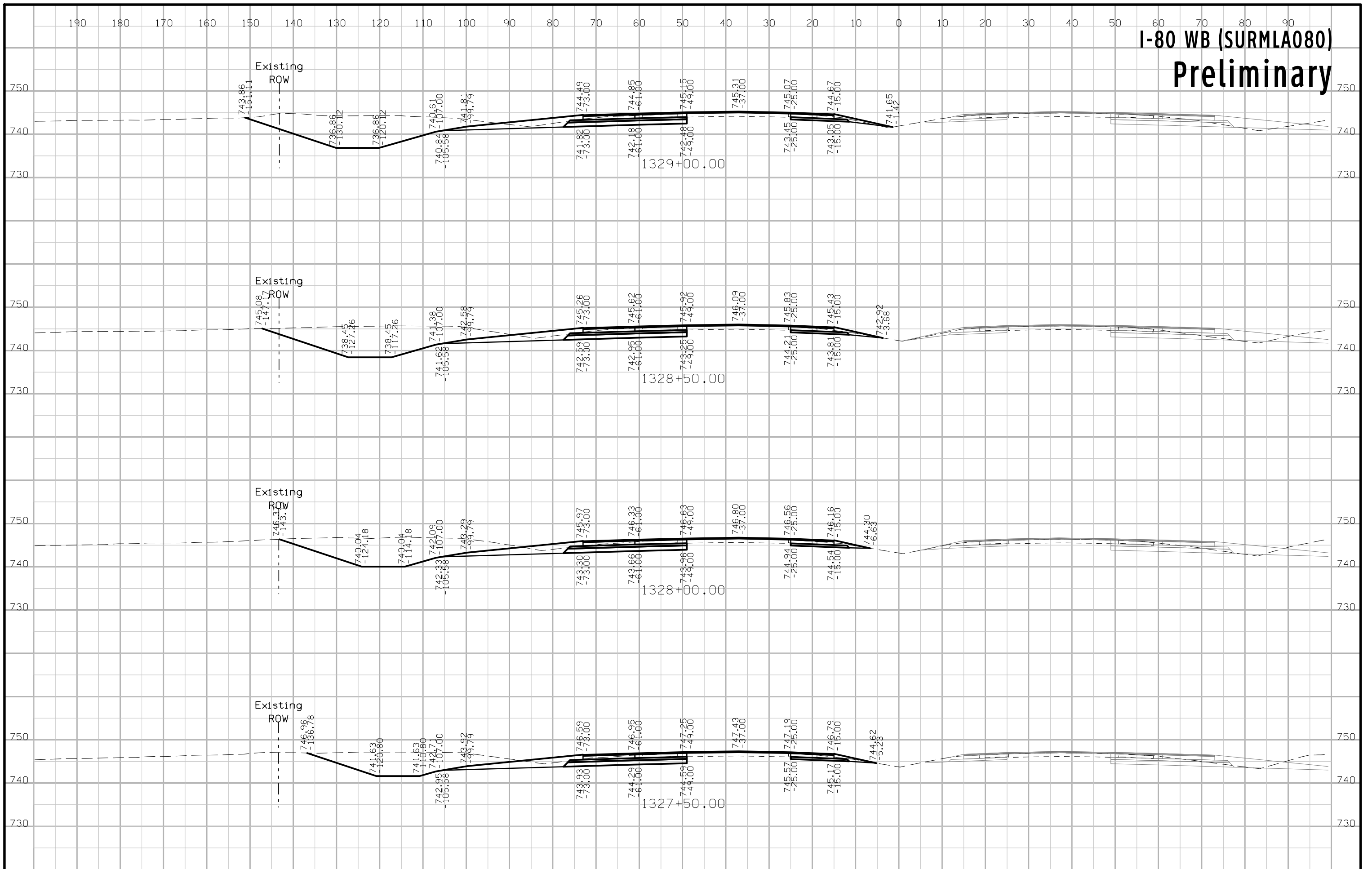

# I-80 WB (SURMLA080) Preliminary

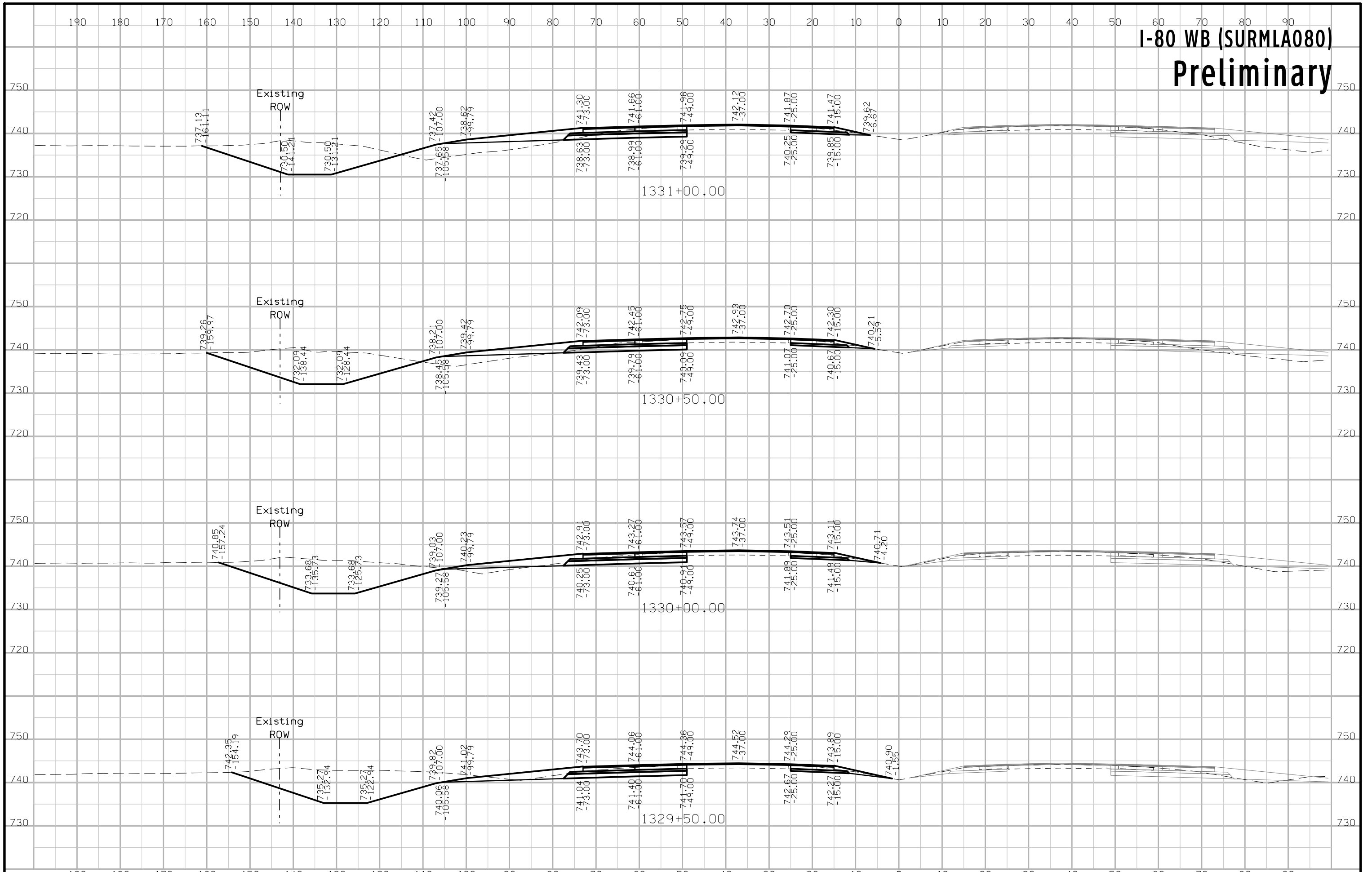

# I-80 WB (SURMLA080) Preliminary

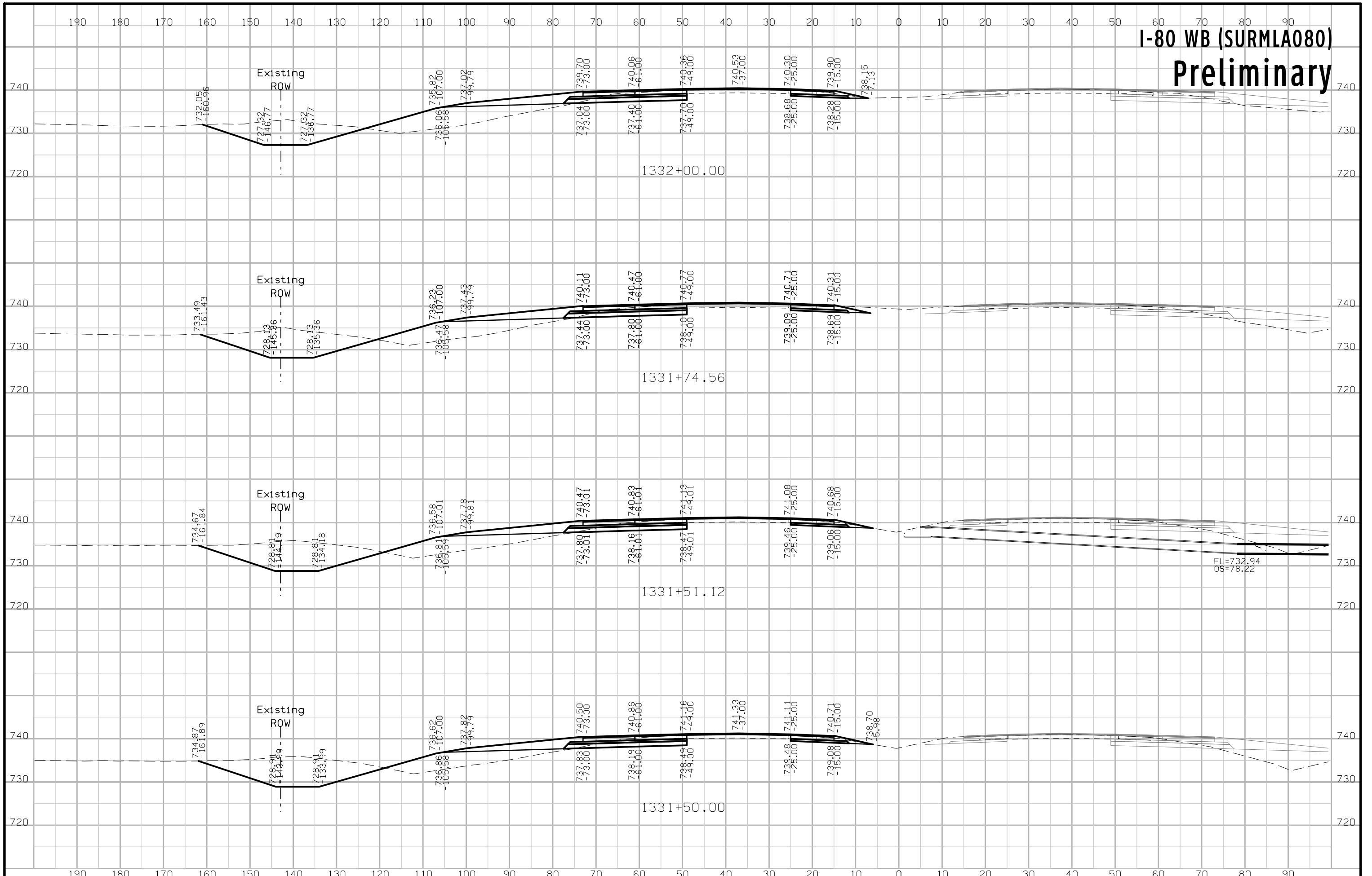

FL=732.94  
OS=78.22

# I-80 WB (SURMLA080) Preliminary

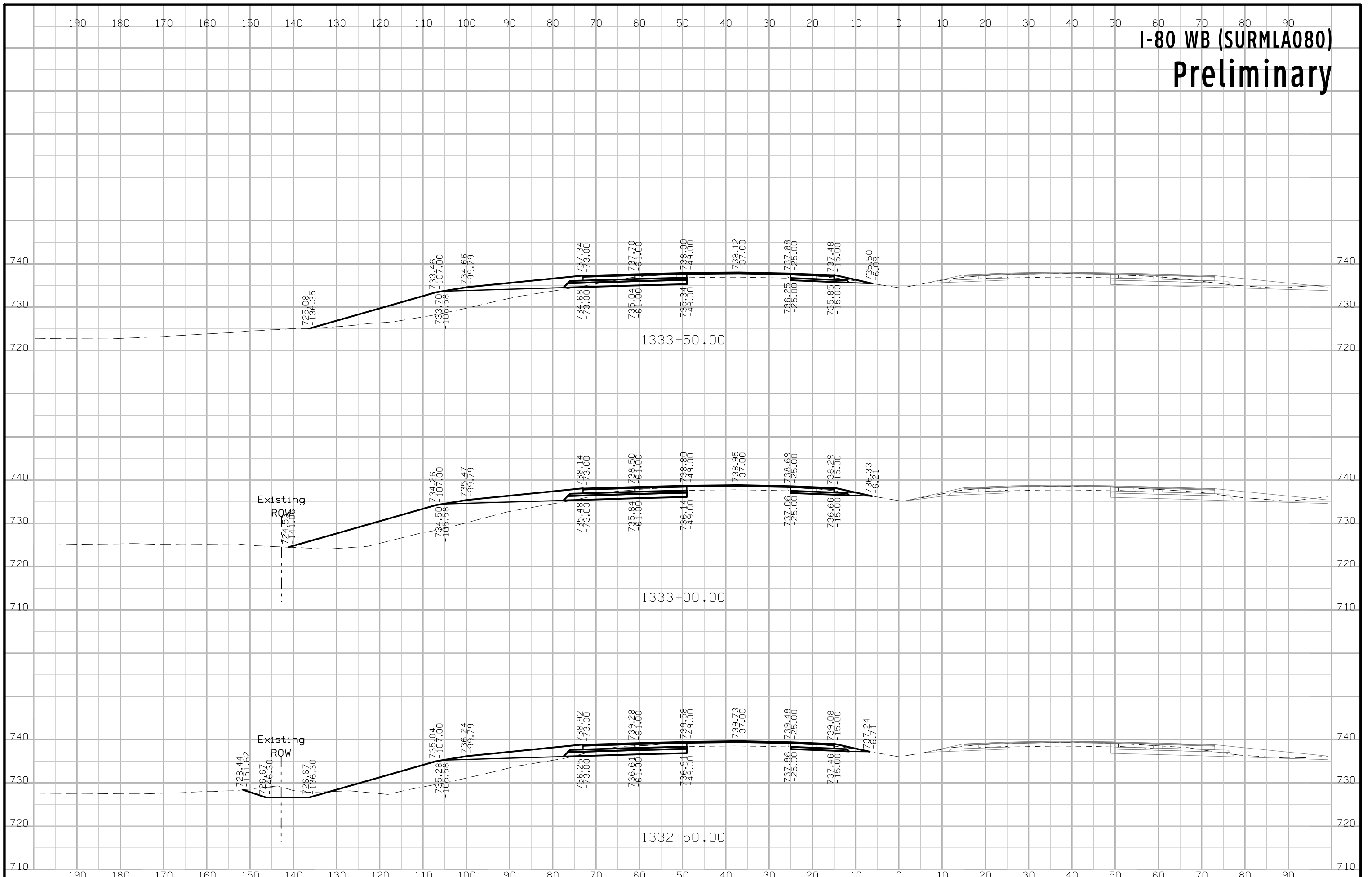

# I-80 WB (SURMLA080) Preliminary

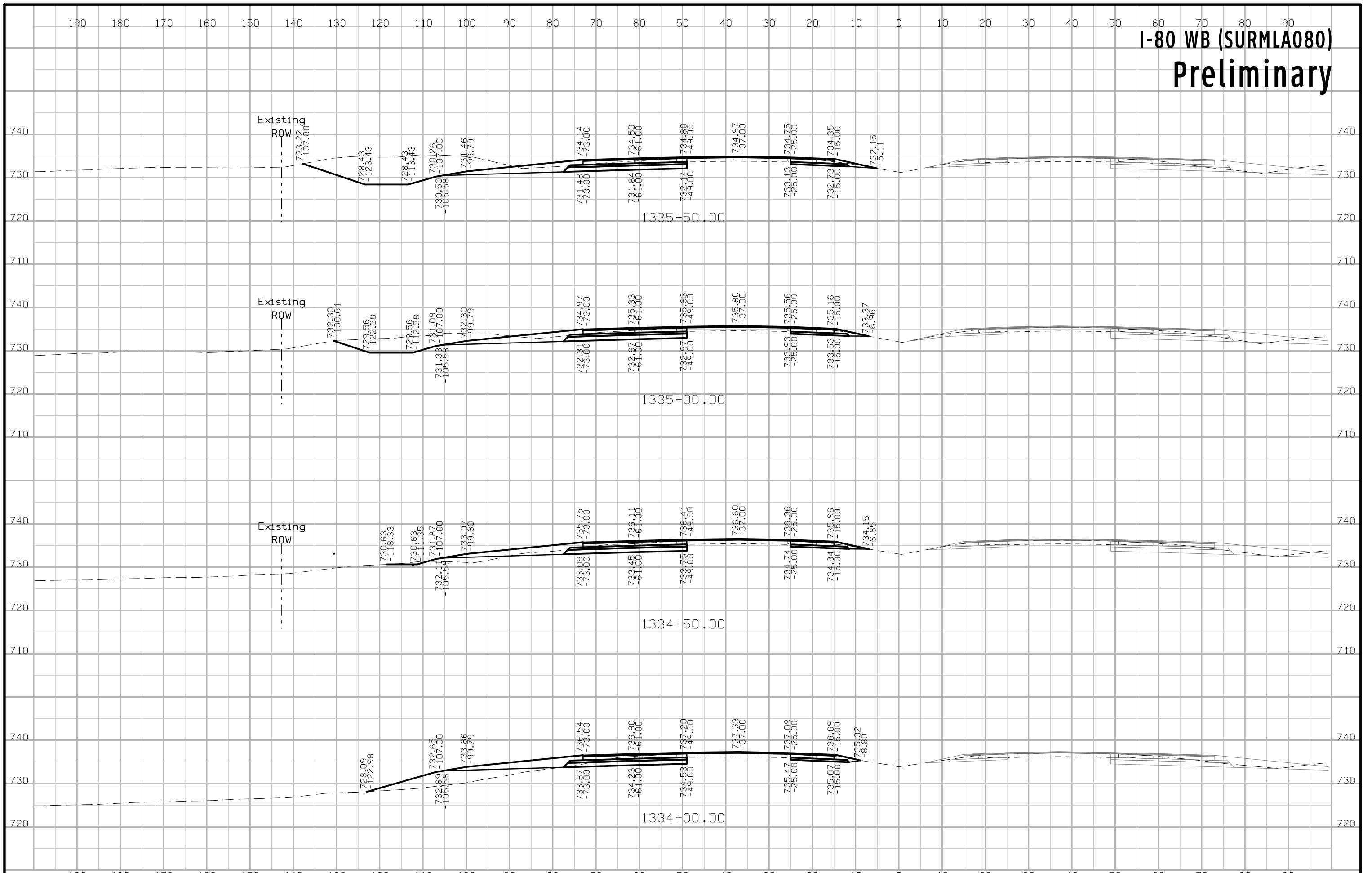



# I-80 WB (SURMLA080) Preliminary

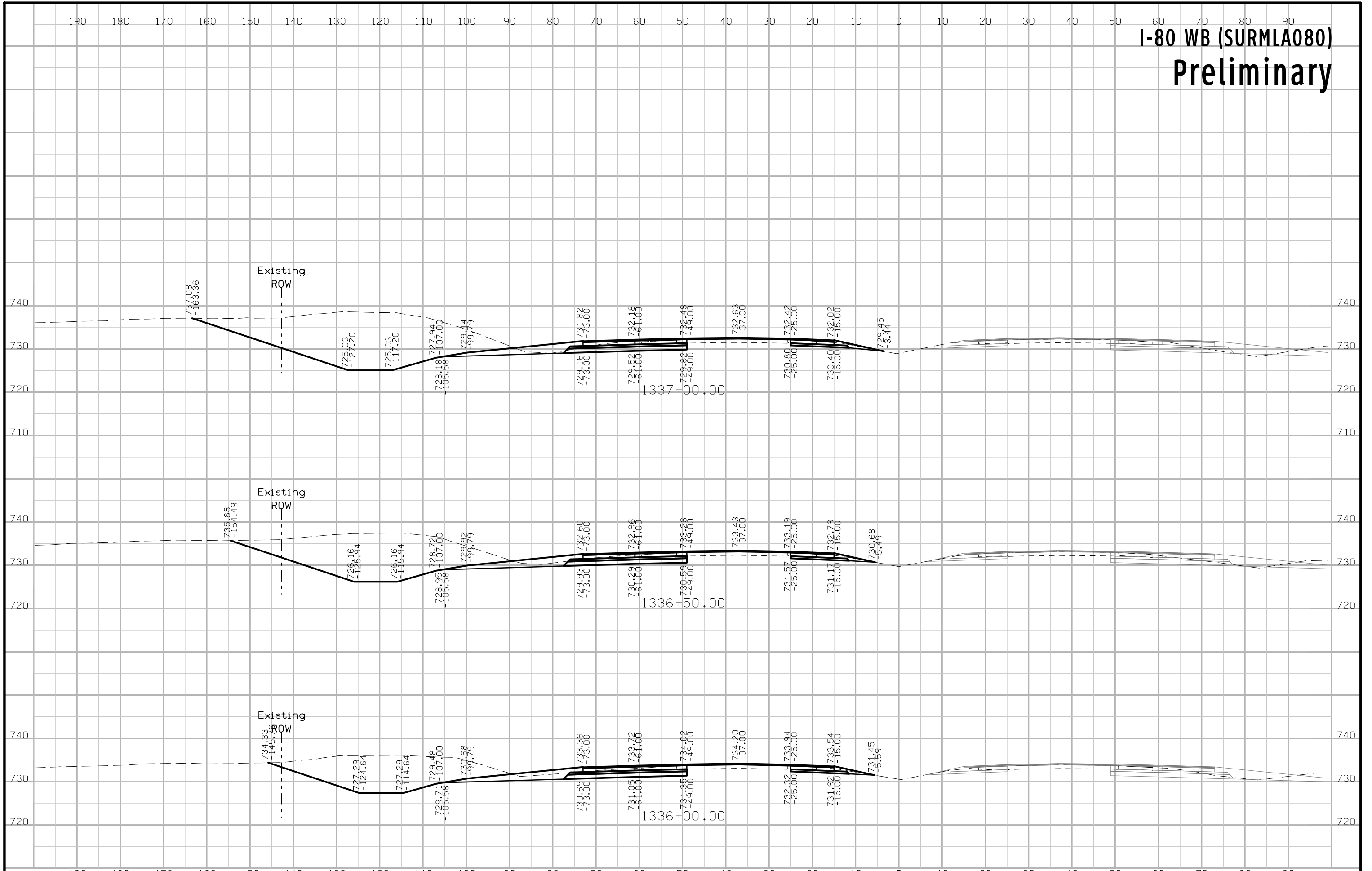

# I-80 WB (SURMLA080) Preliminary

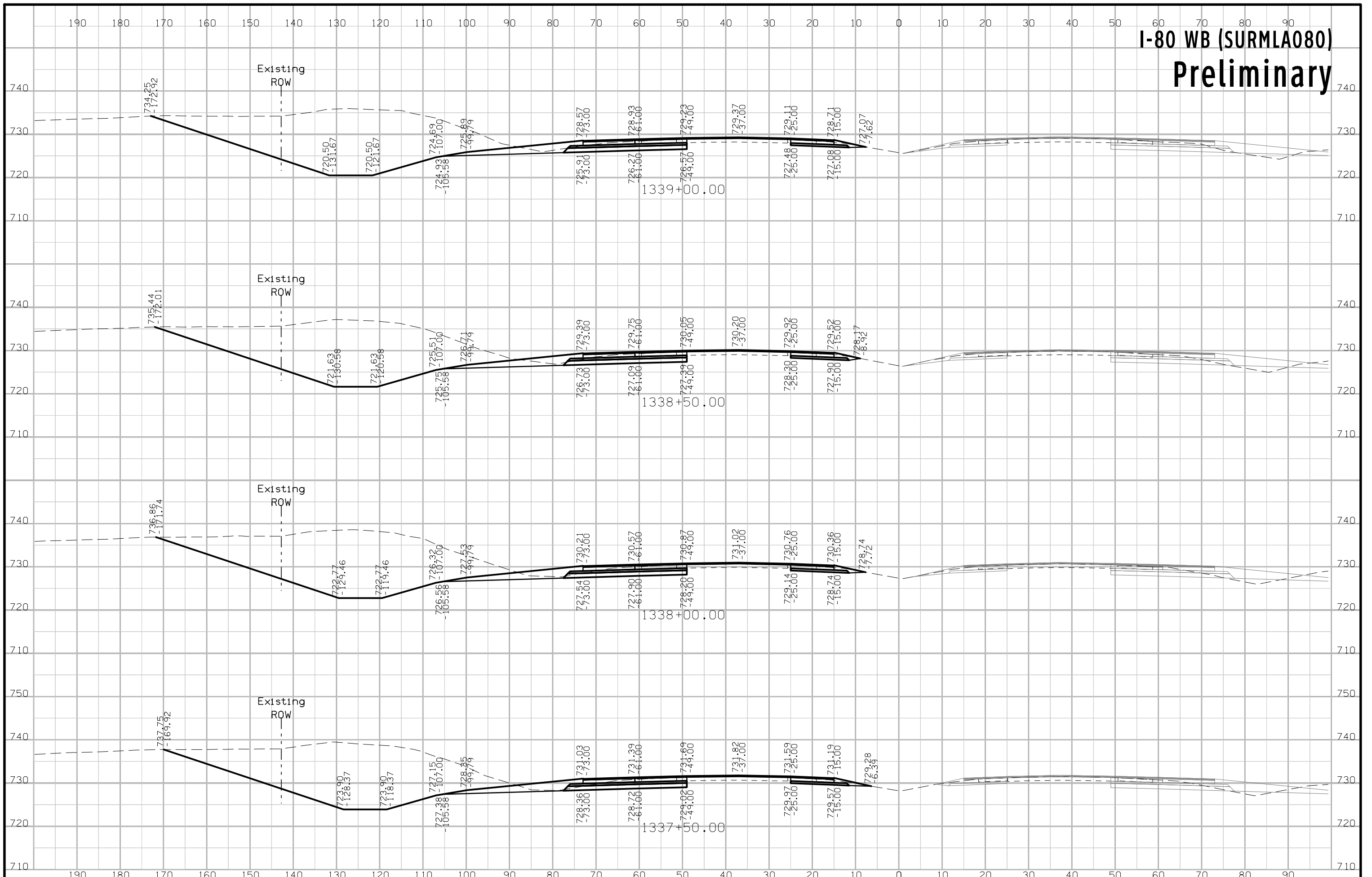

# I-80 WB (SURMLA080) Preliminary

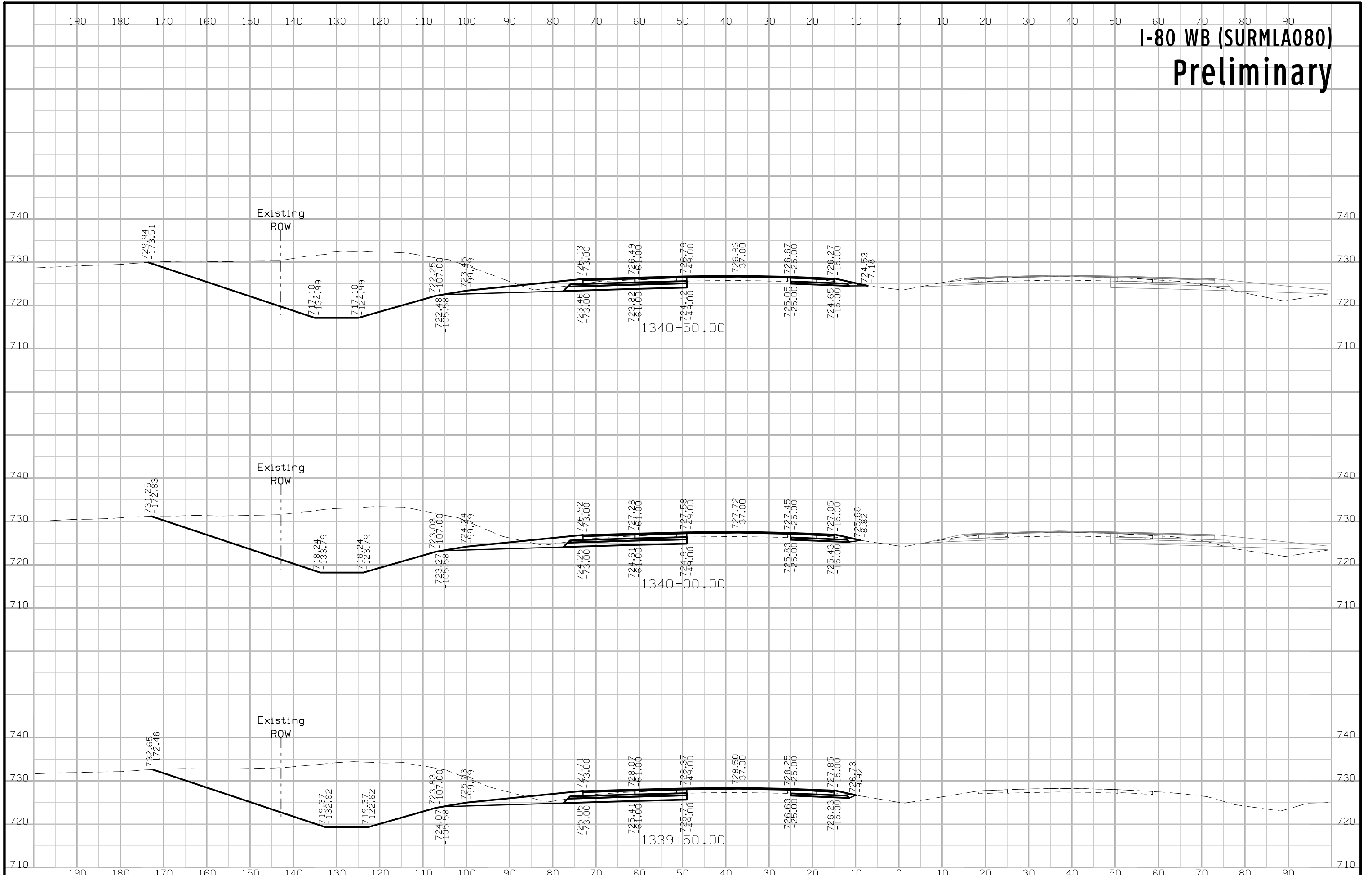

# I-80 WB (SURMLA080) Preliminary

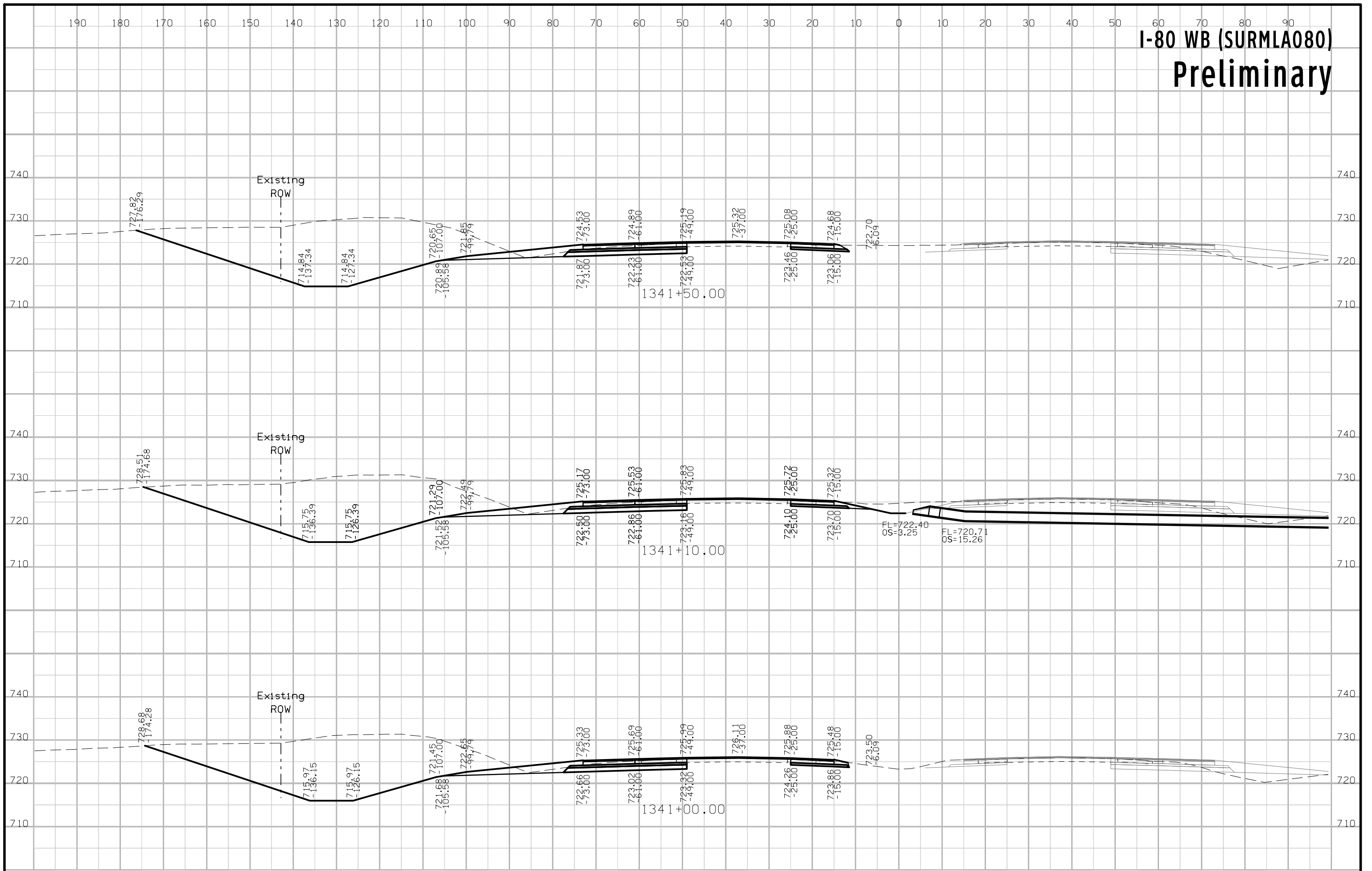

# I-80 WB (SURMLA080) Preliminary

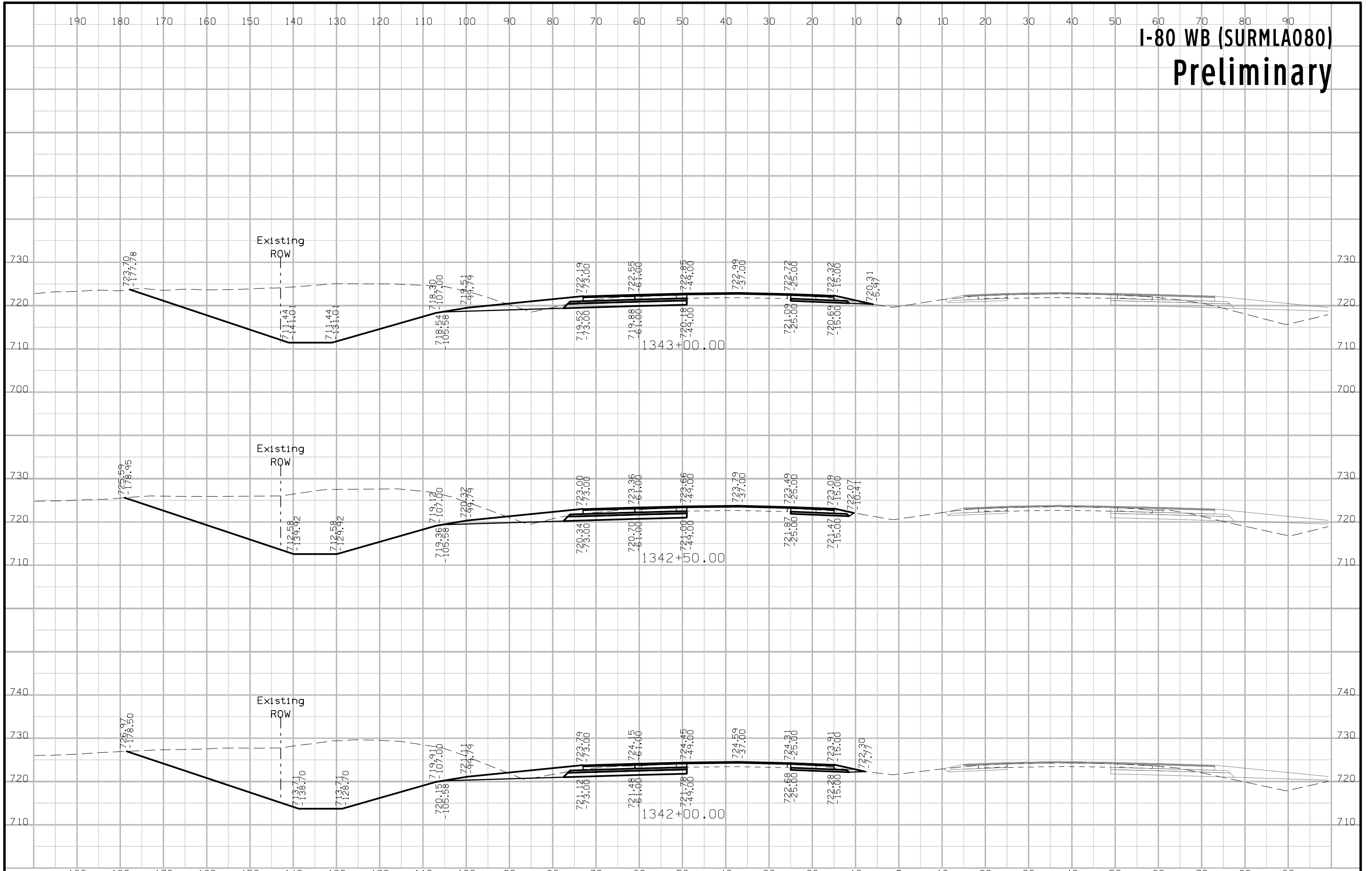

# I-80 WB (SURMLA080) Preliminary

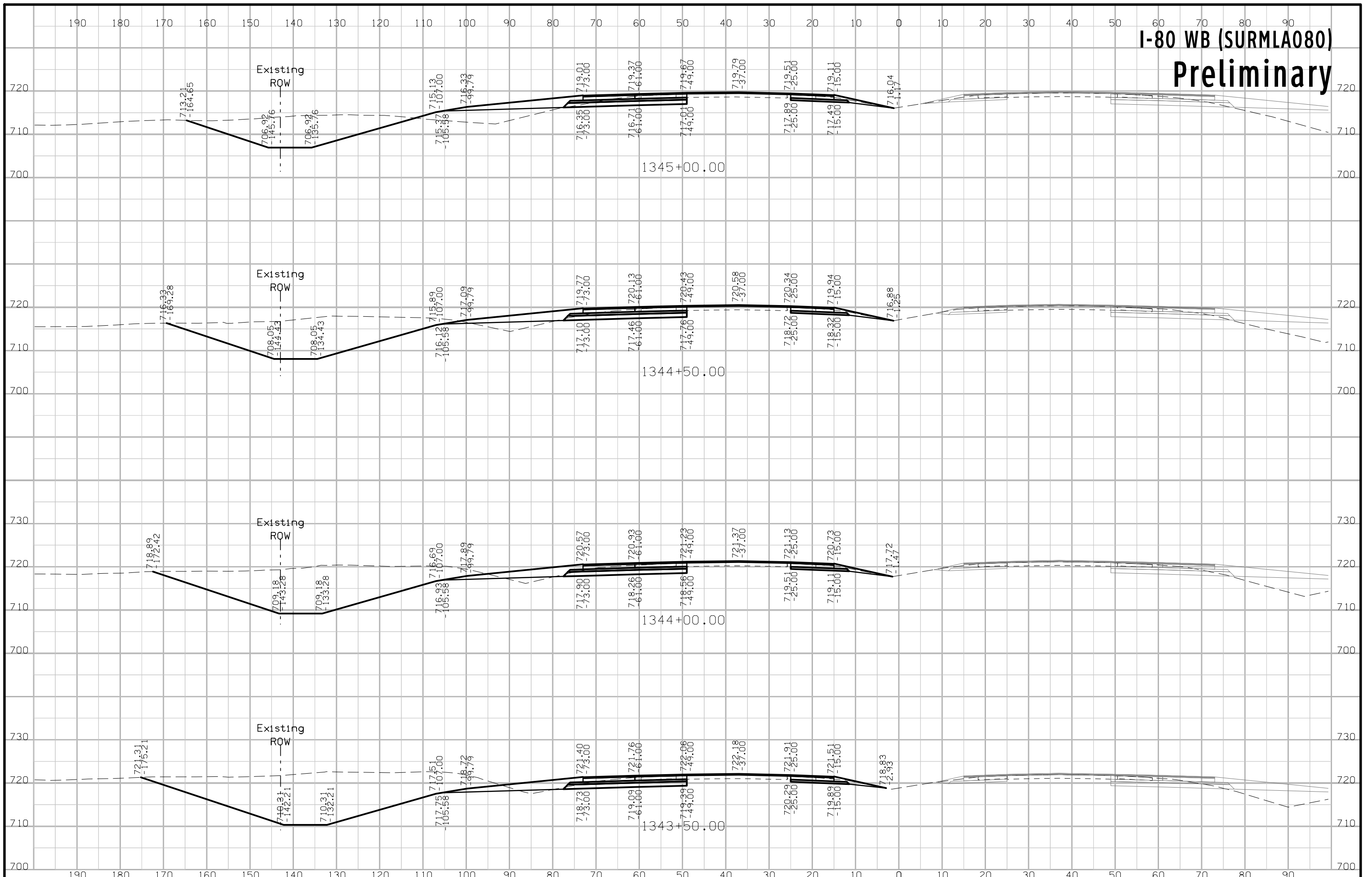



# I-80 WB (SURMLA080) Preliminary

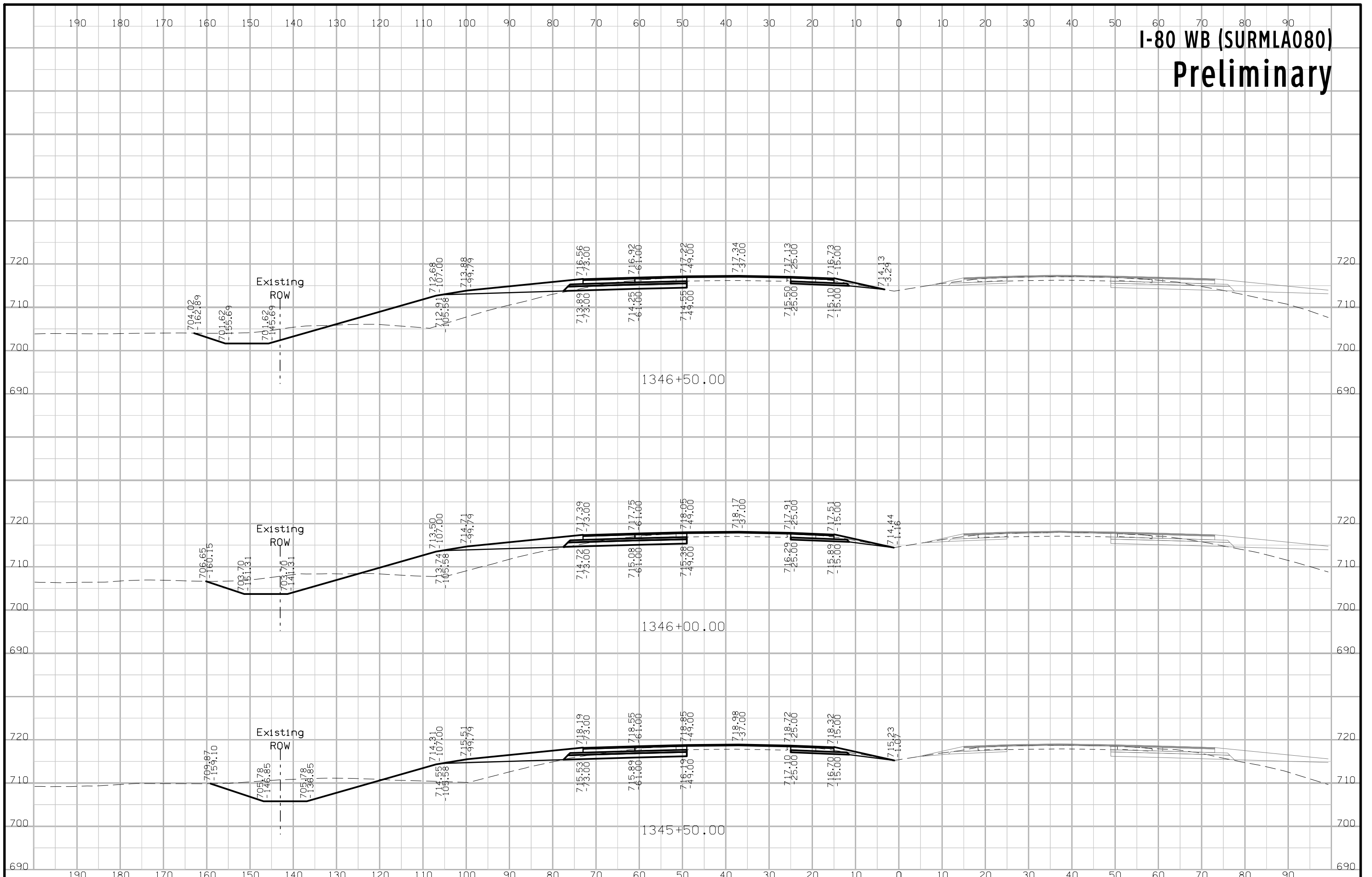

# I-80 WB (SURMLA080) Preliminary

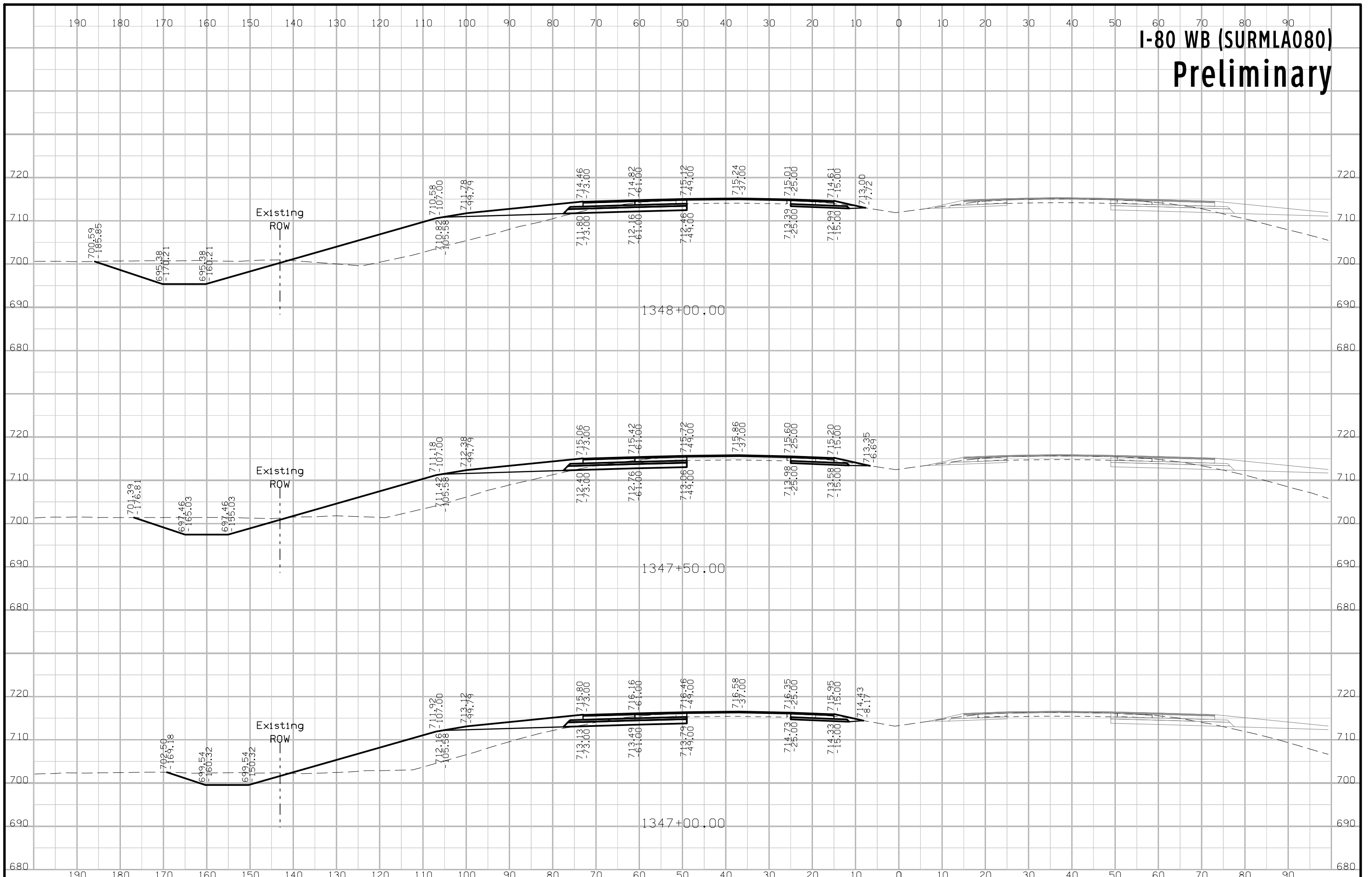

# I-80 WB (SURMLA080) Preliminary

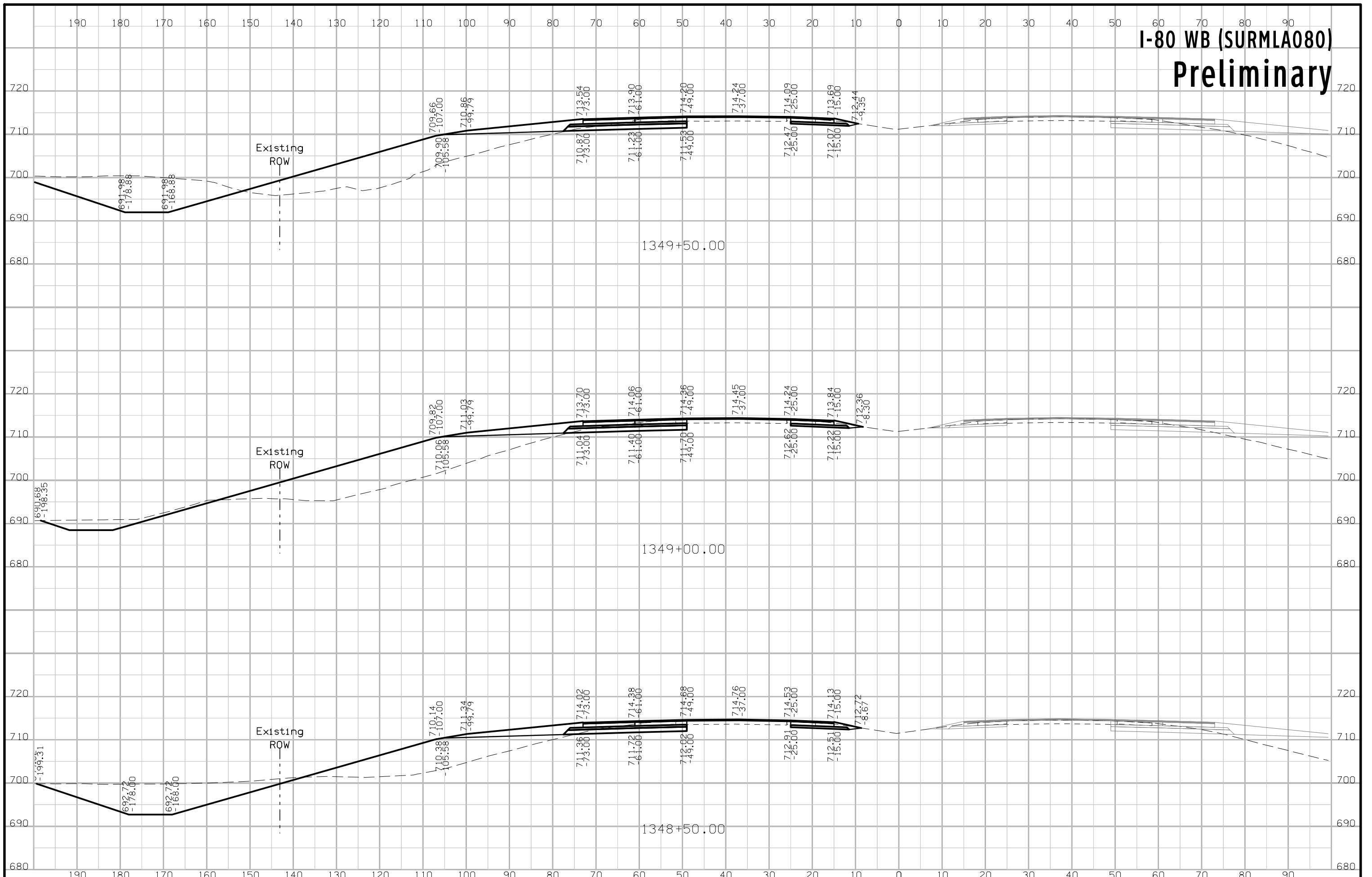

# I-80 WB (SURMLA080) Preliminary

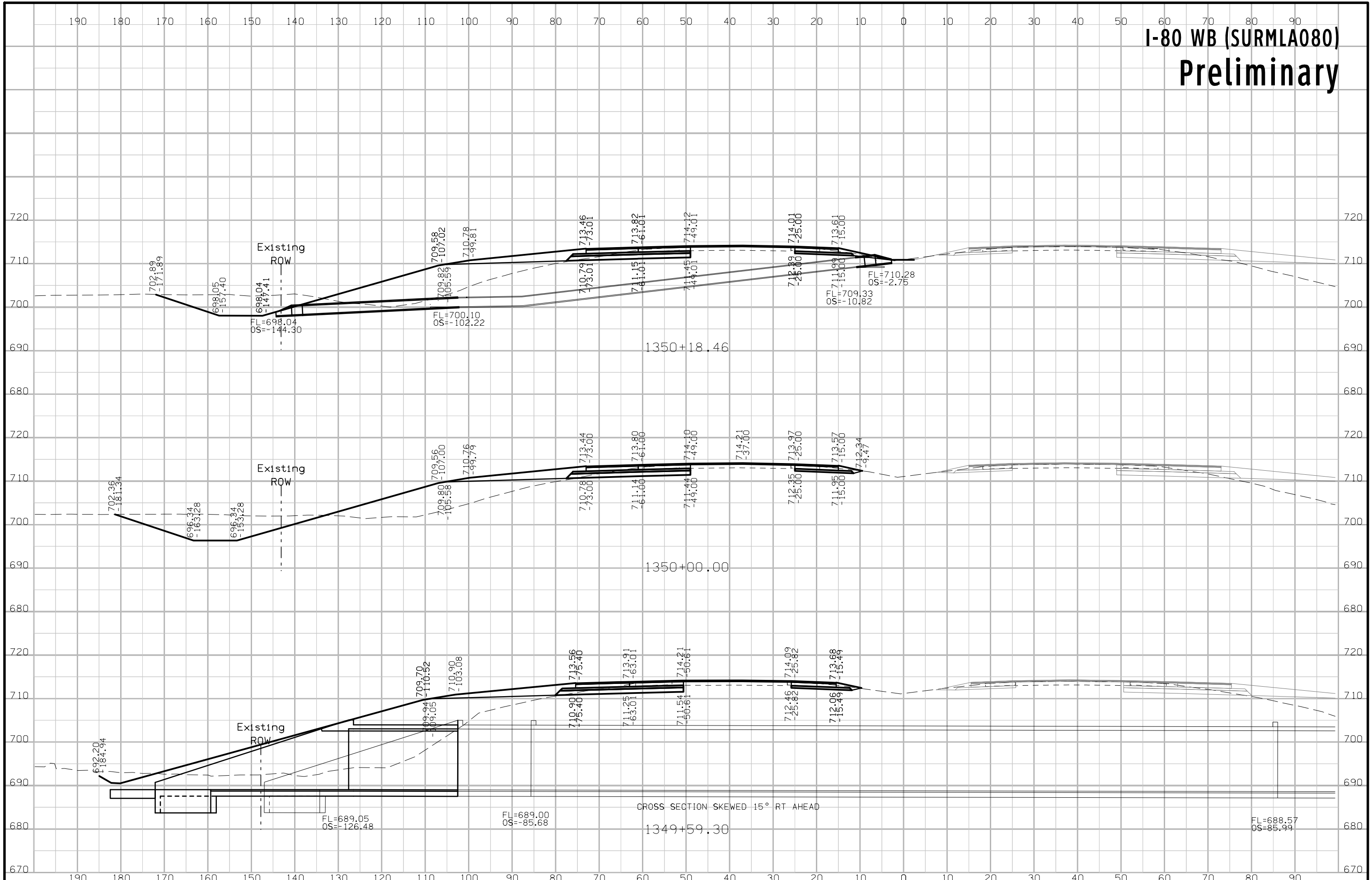

# I-80 WB (SURMLA080) Preliminary

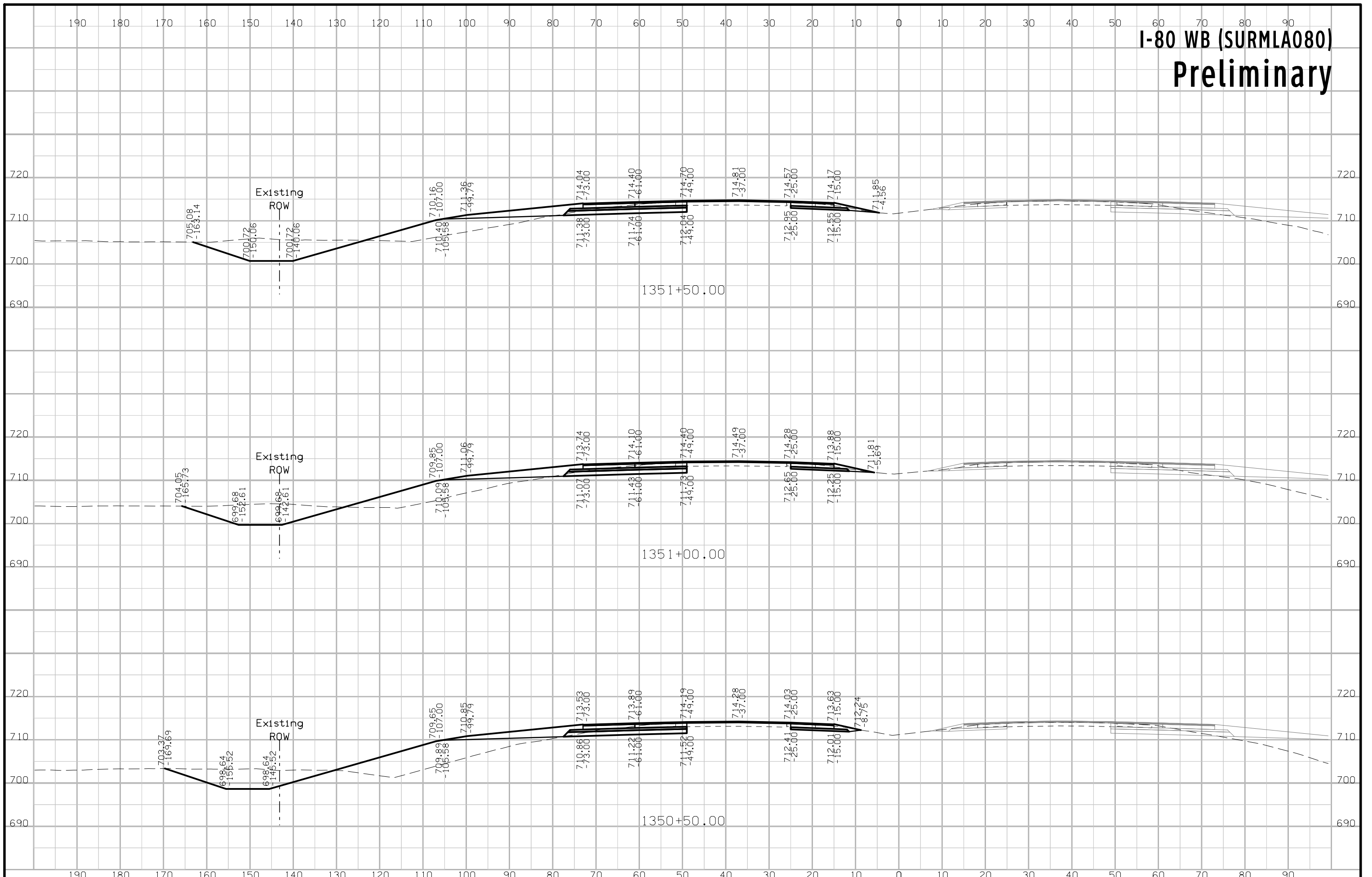

# I-80 WB (SURMLA080) Preliminary

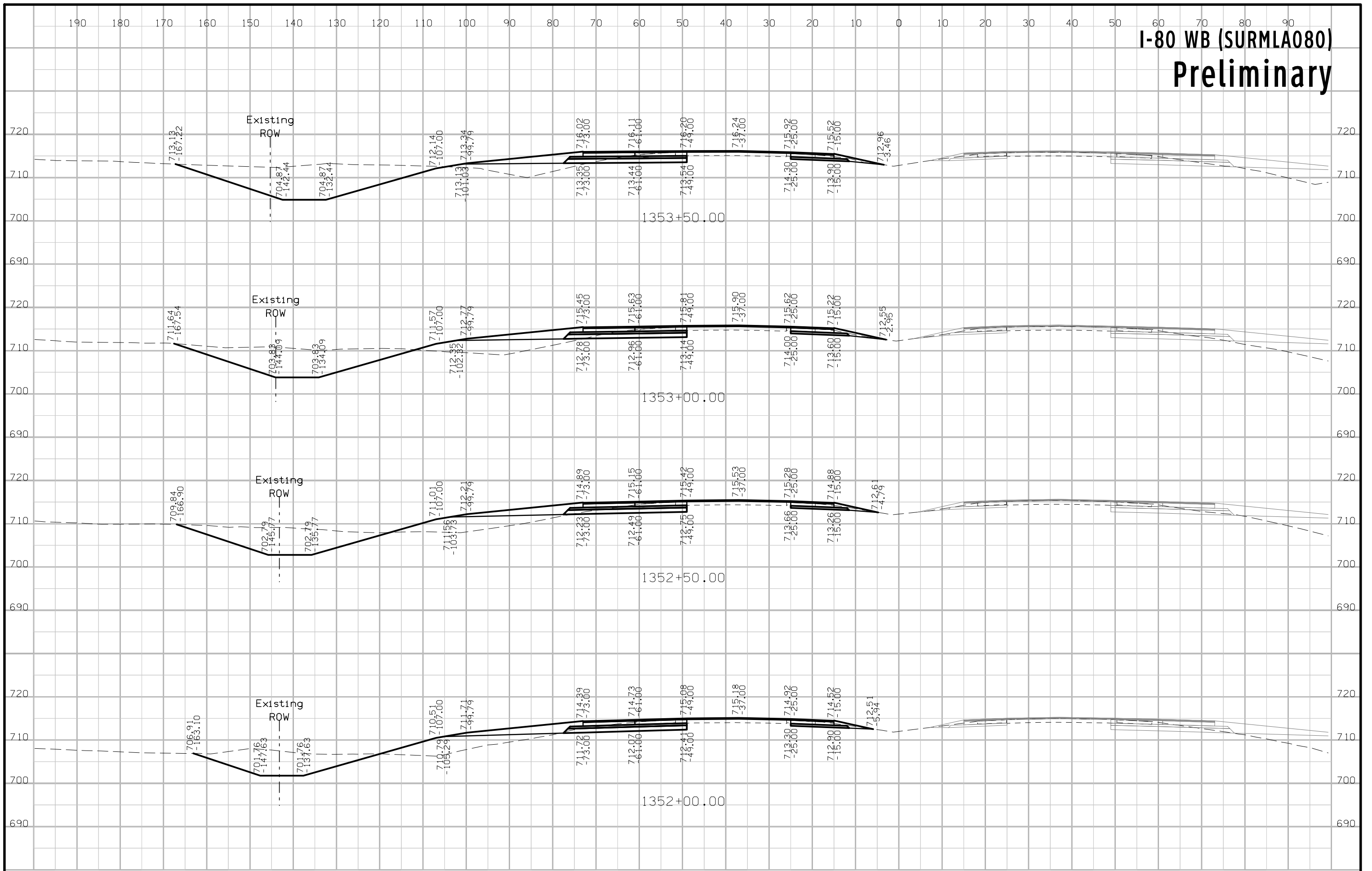



# I-80 WB (SURMLA080) Preliminary

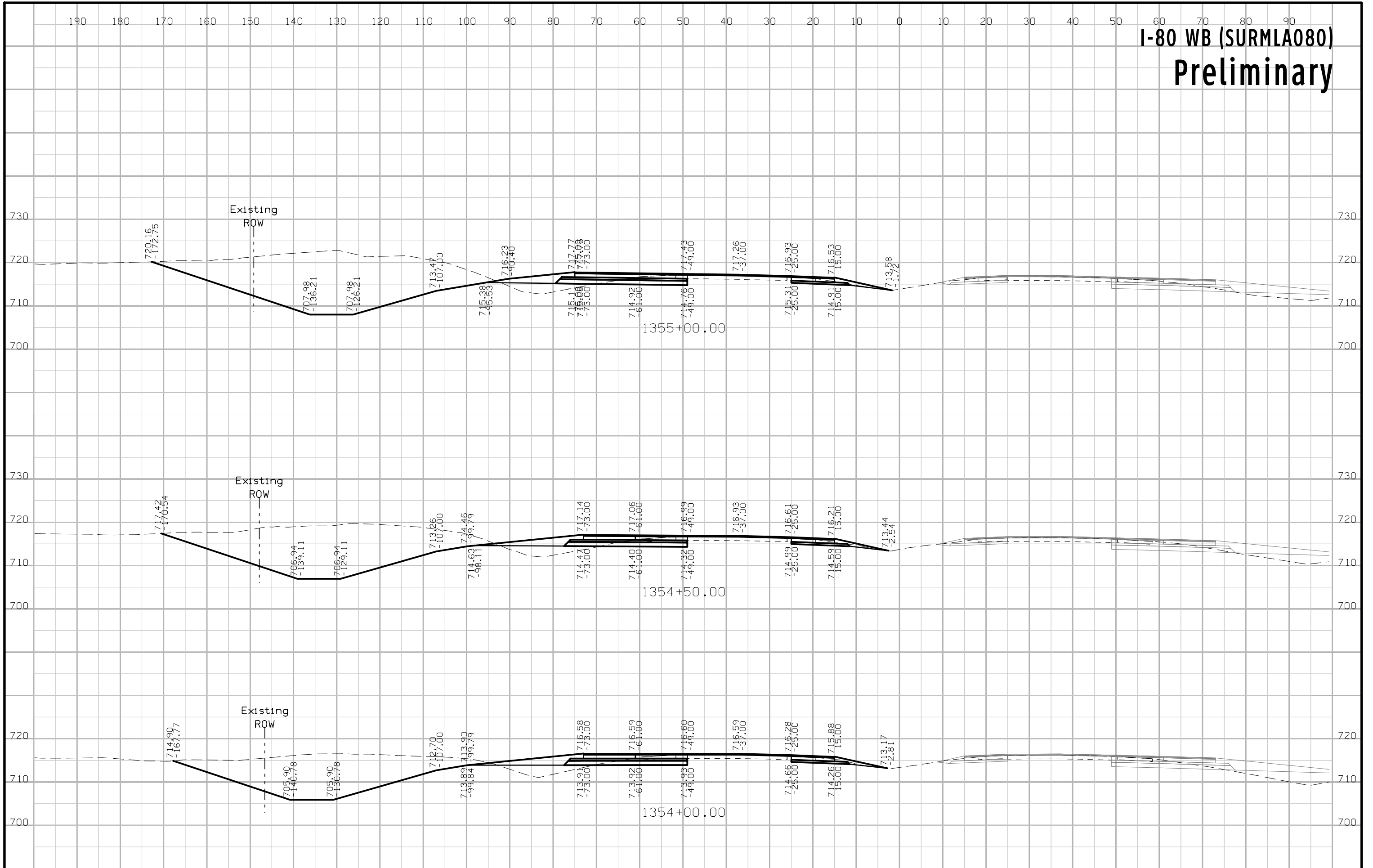

# I-80 WB (SURMLA080) Preliminary

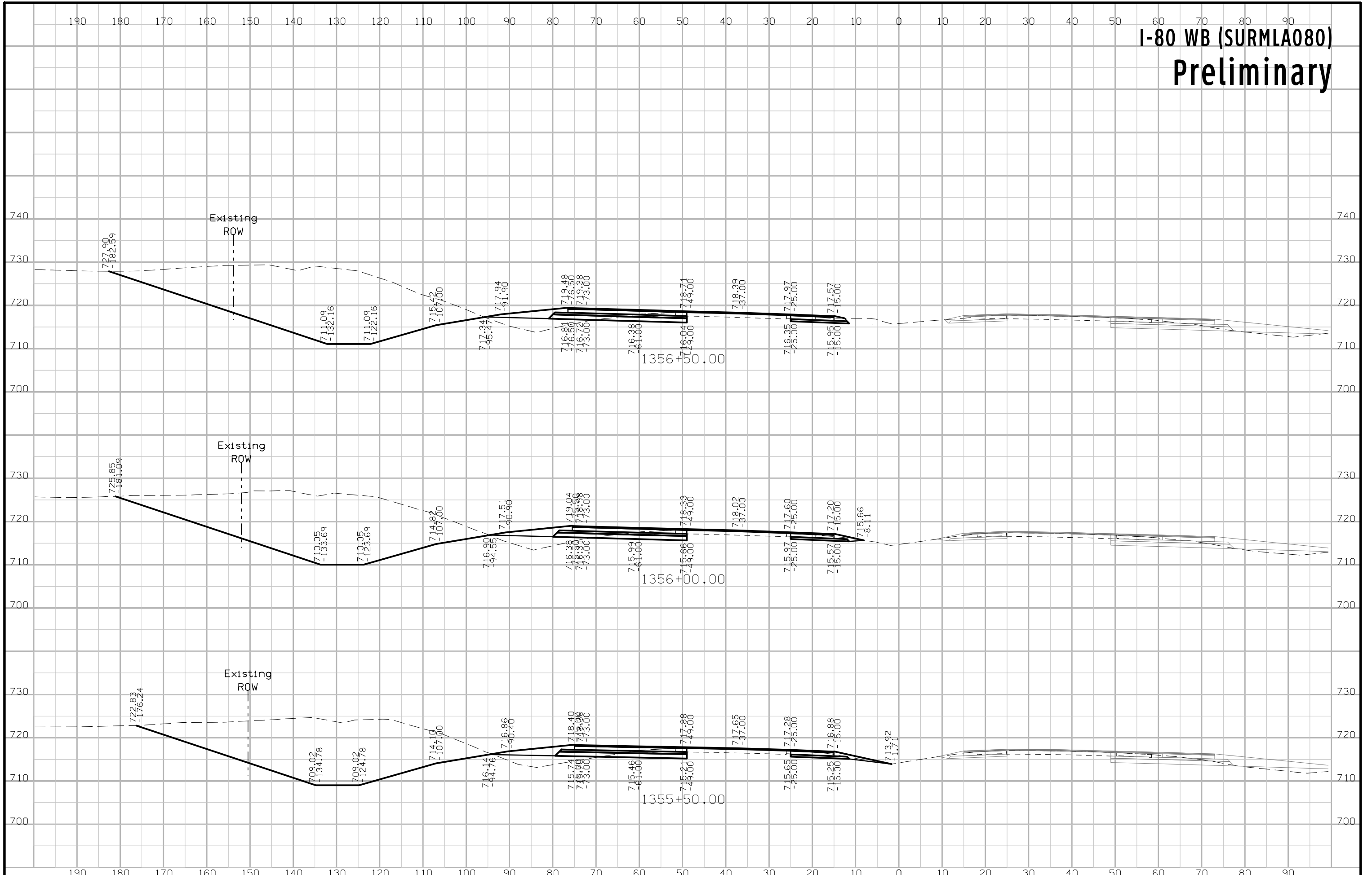

# I-80 WB (SURMLA080) Preliminary

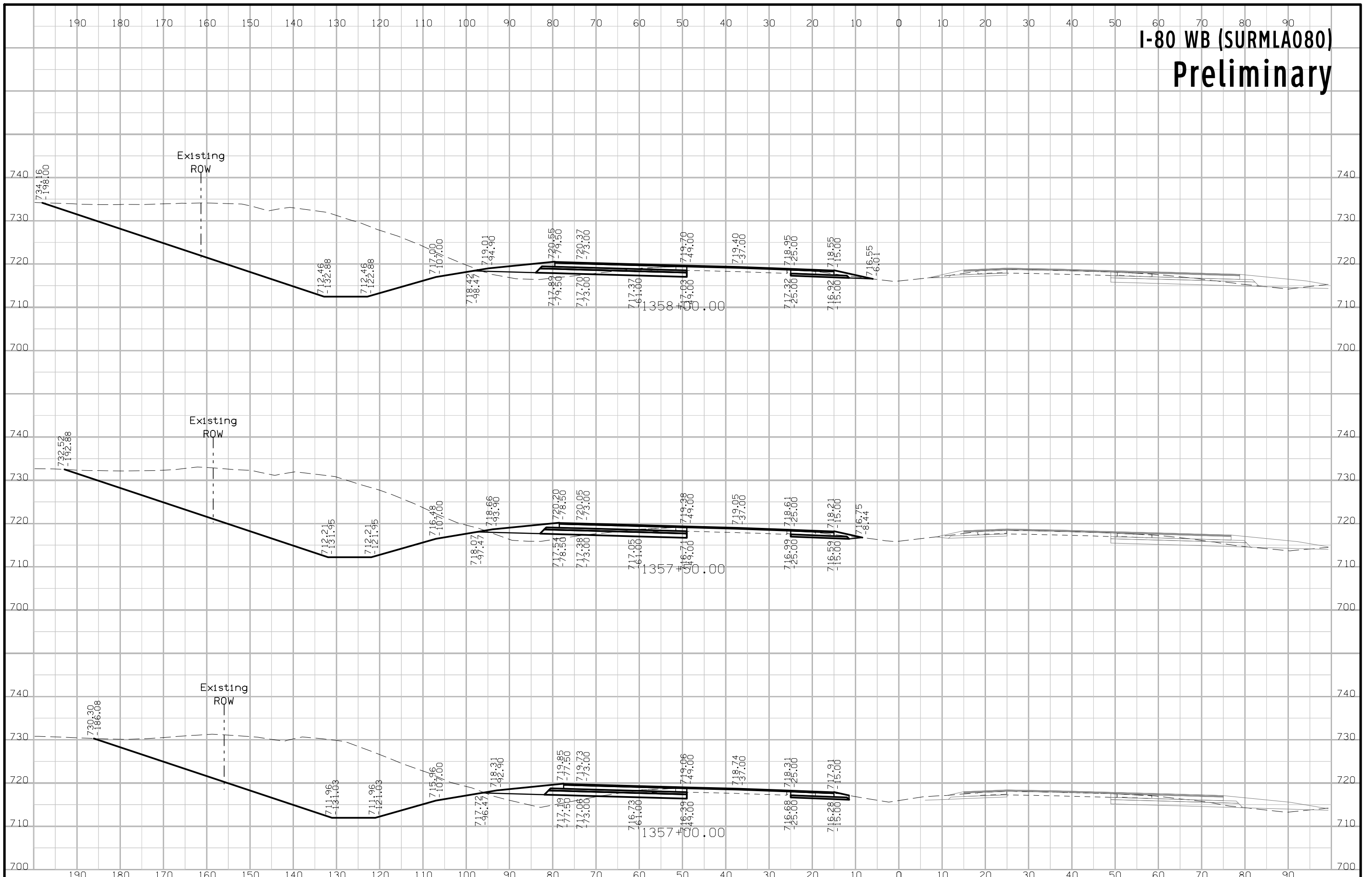

# I-80 WB (SURMLA080) Preliminary

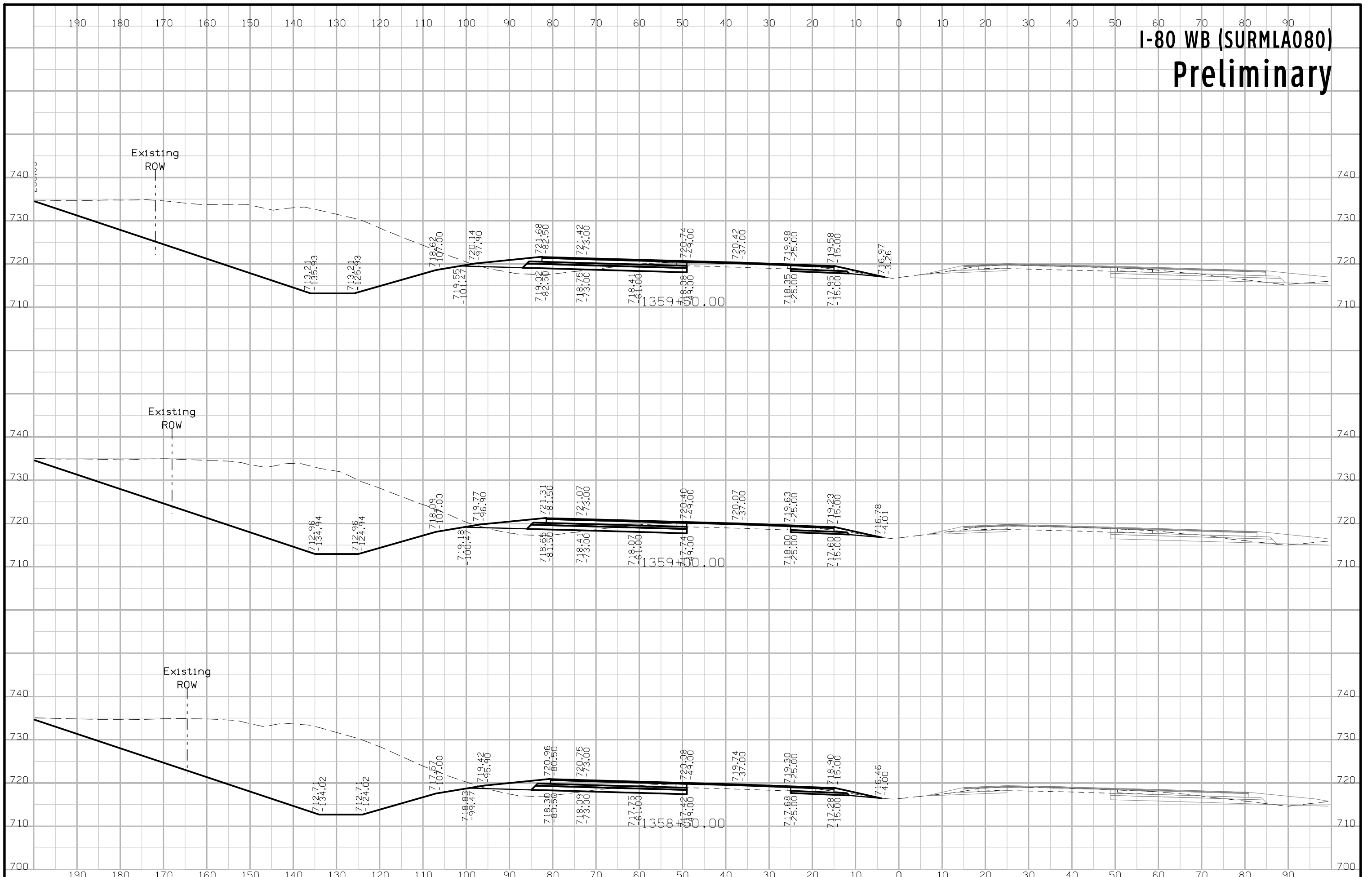

# I-80 WB (SURMLA080) Preliminary

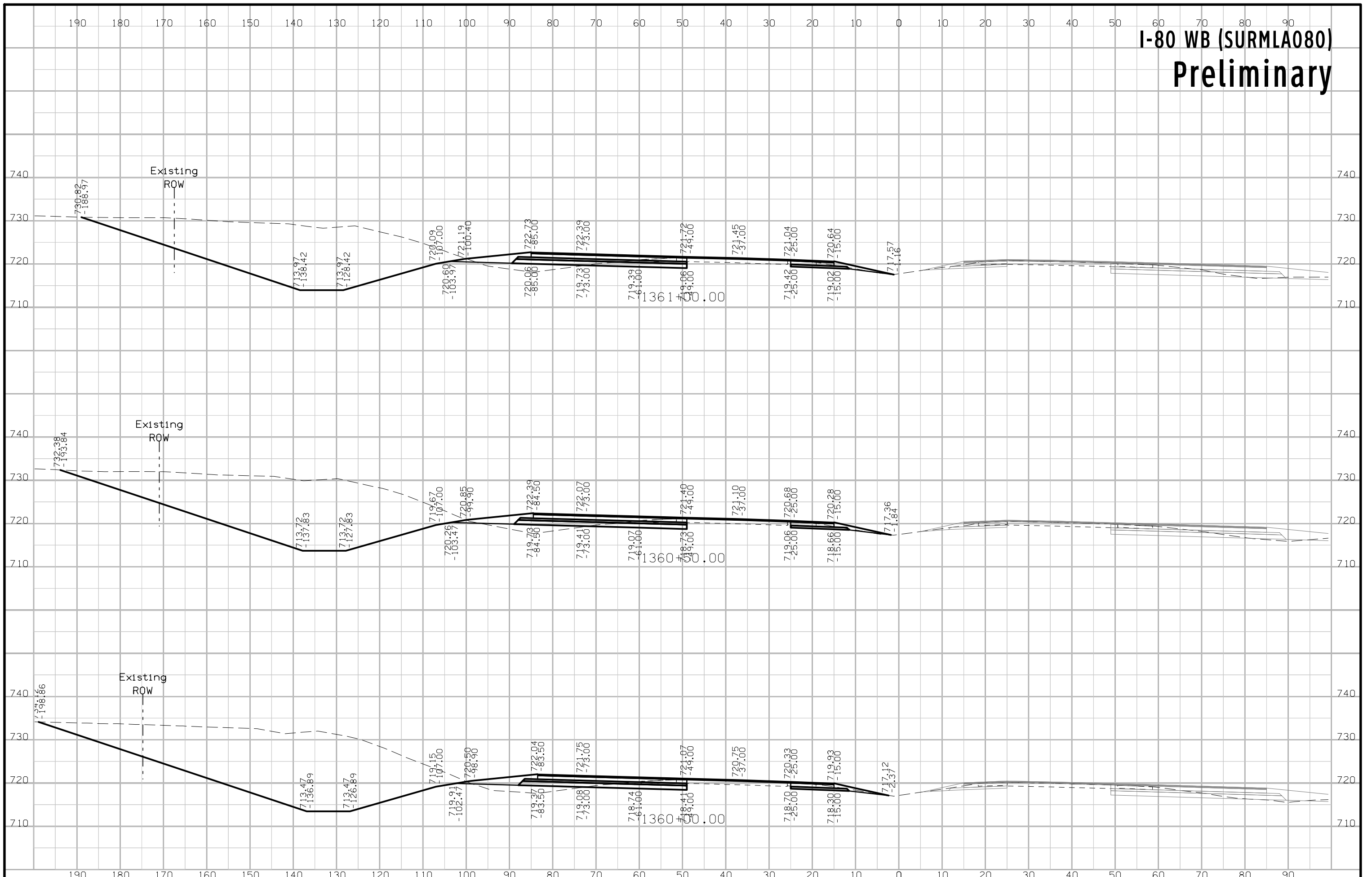

# I-80 WB (SURMLA080) Preliminary

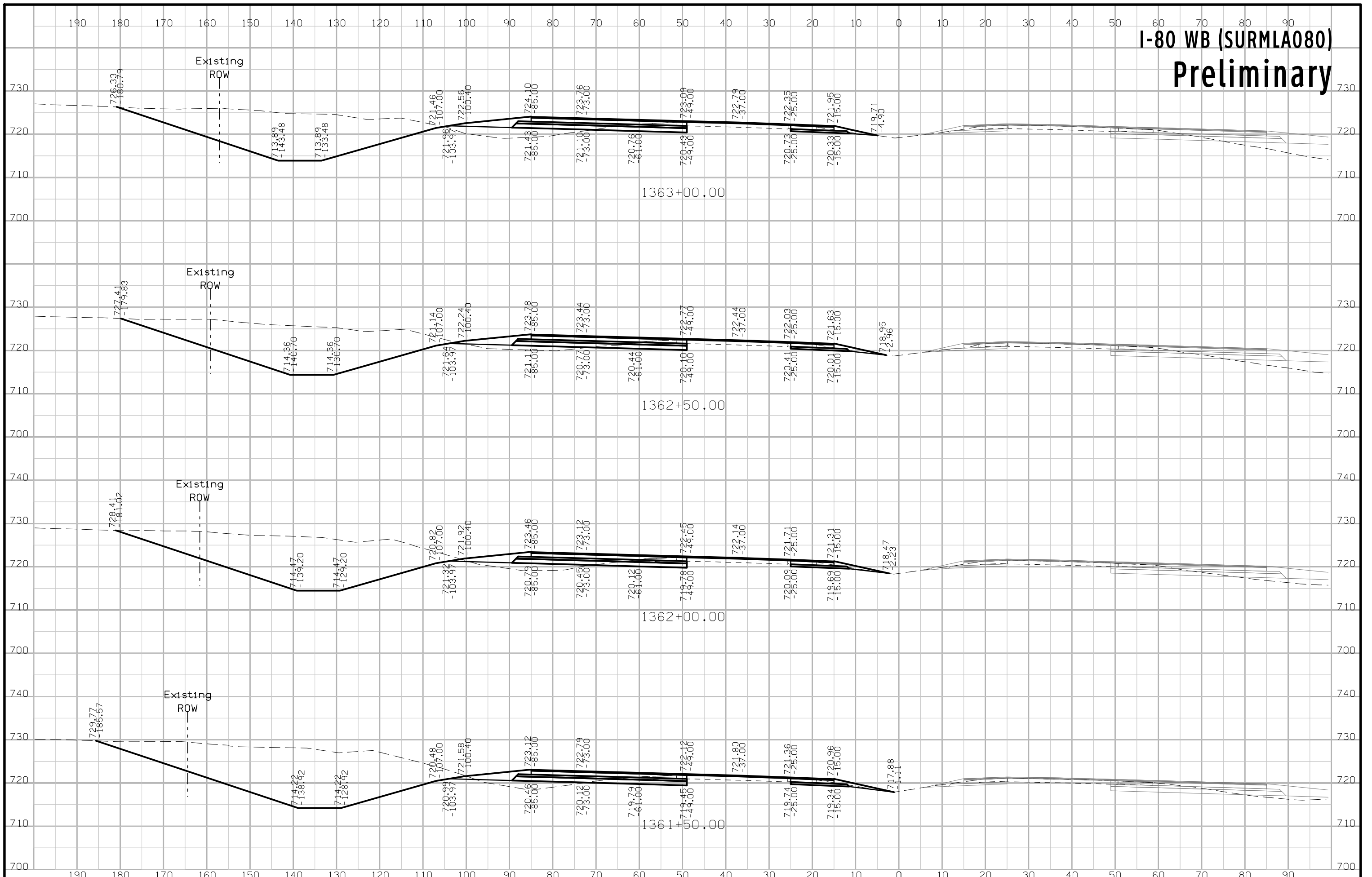



# I-80 WB (SURMLA080) Preliminary

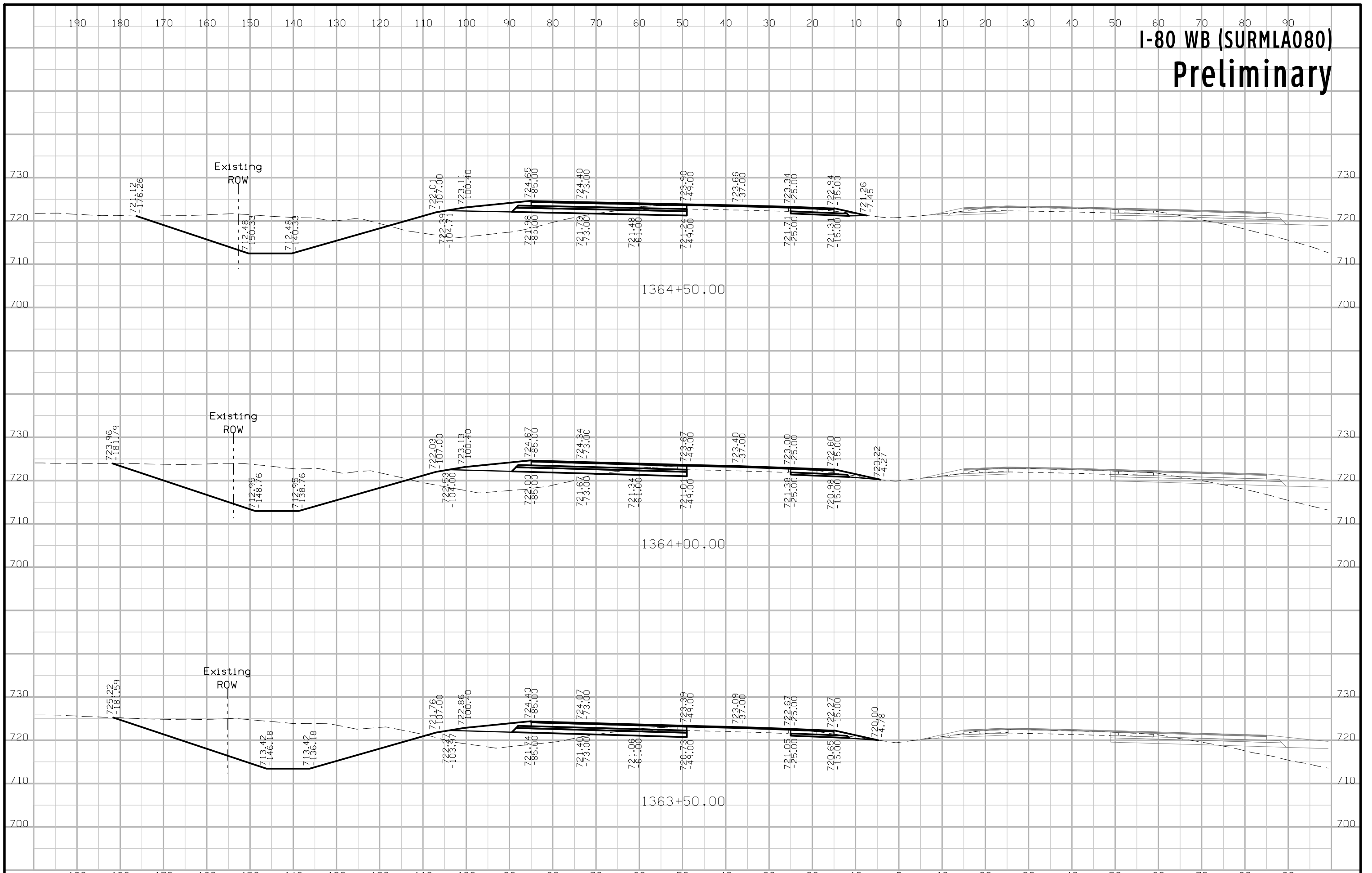

# I-80 WB (SURMLA080) Preliminary

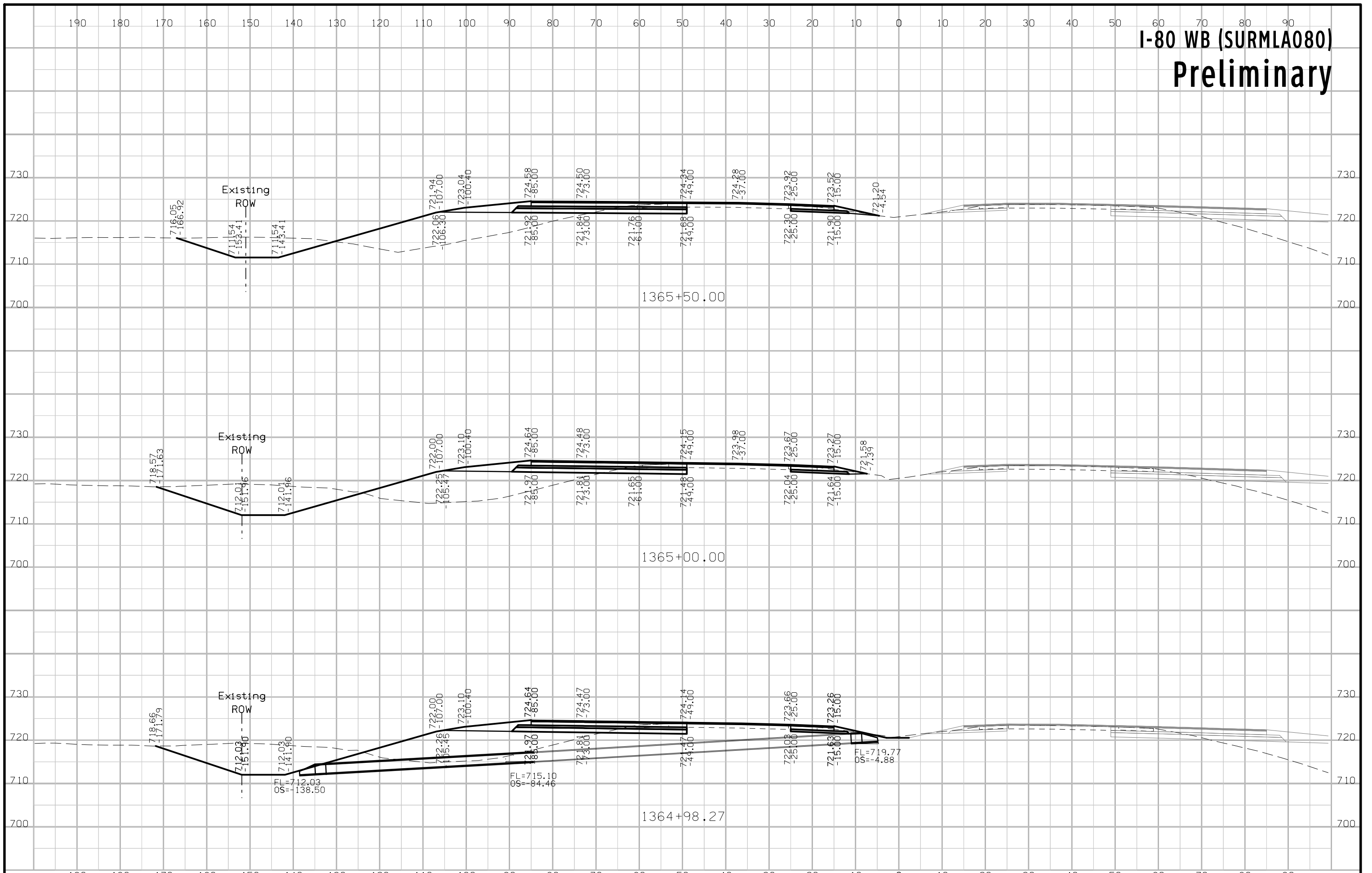

# I-80 WB (SURMLA080) Preliminary

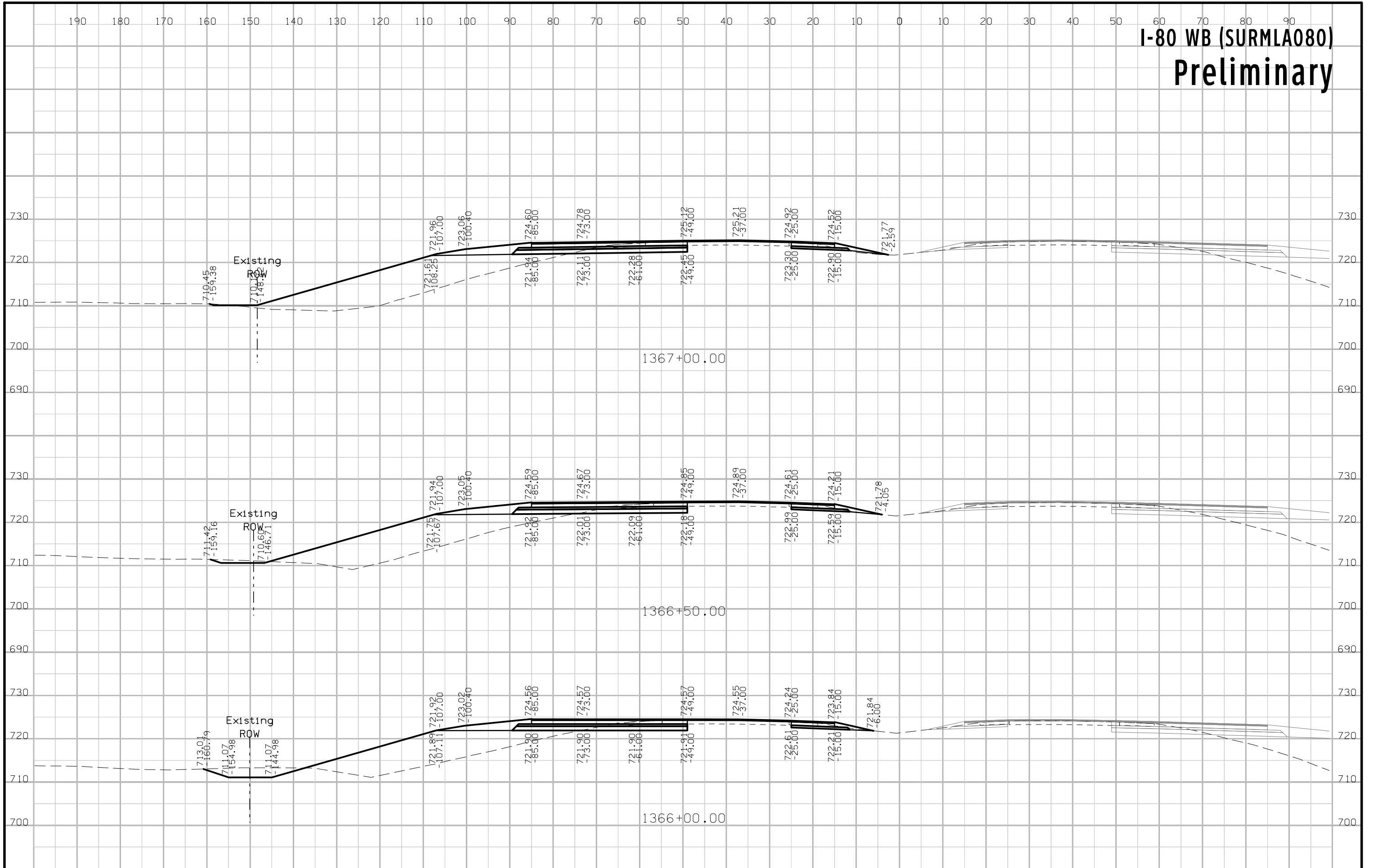

# I-80 WB (SURMLA080) Preliminary

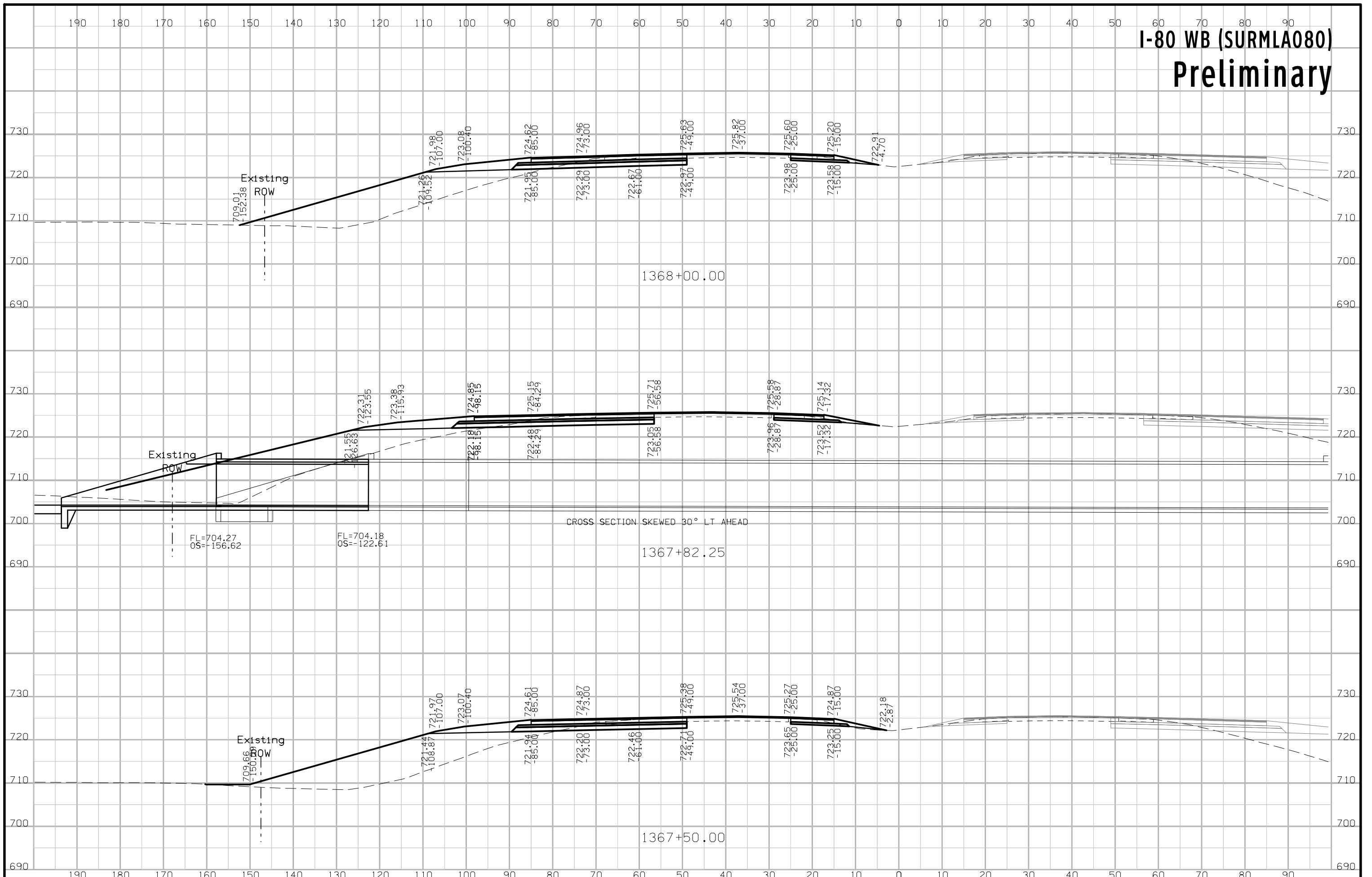

# I-80 WB (SURMLA080) Preliminary

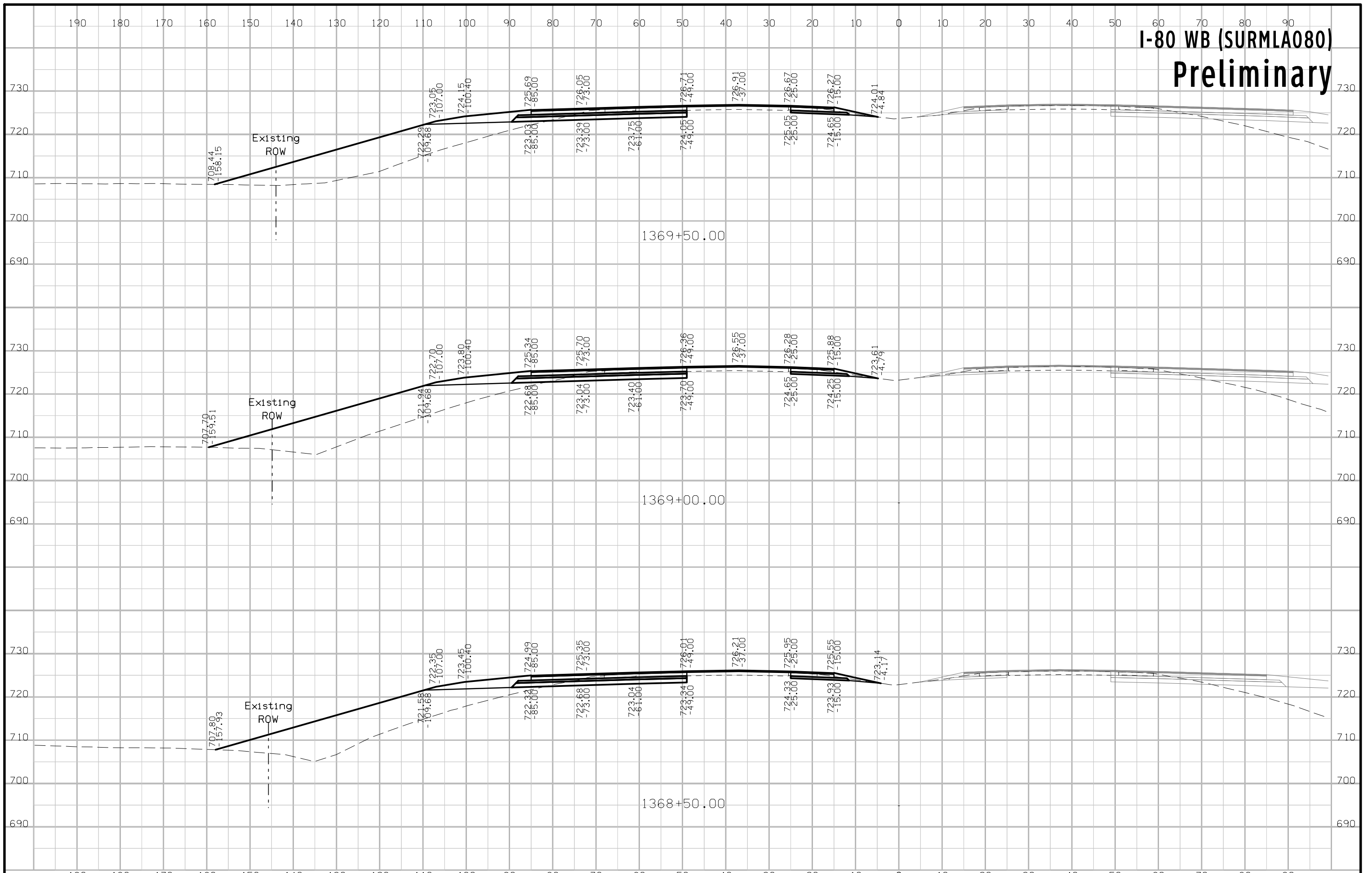

# I-80 WB (SURMLA080) Preliminary

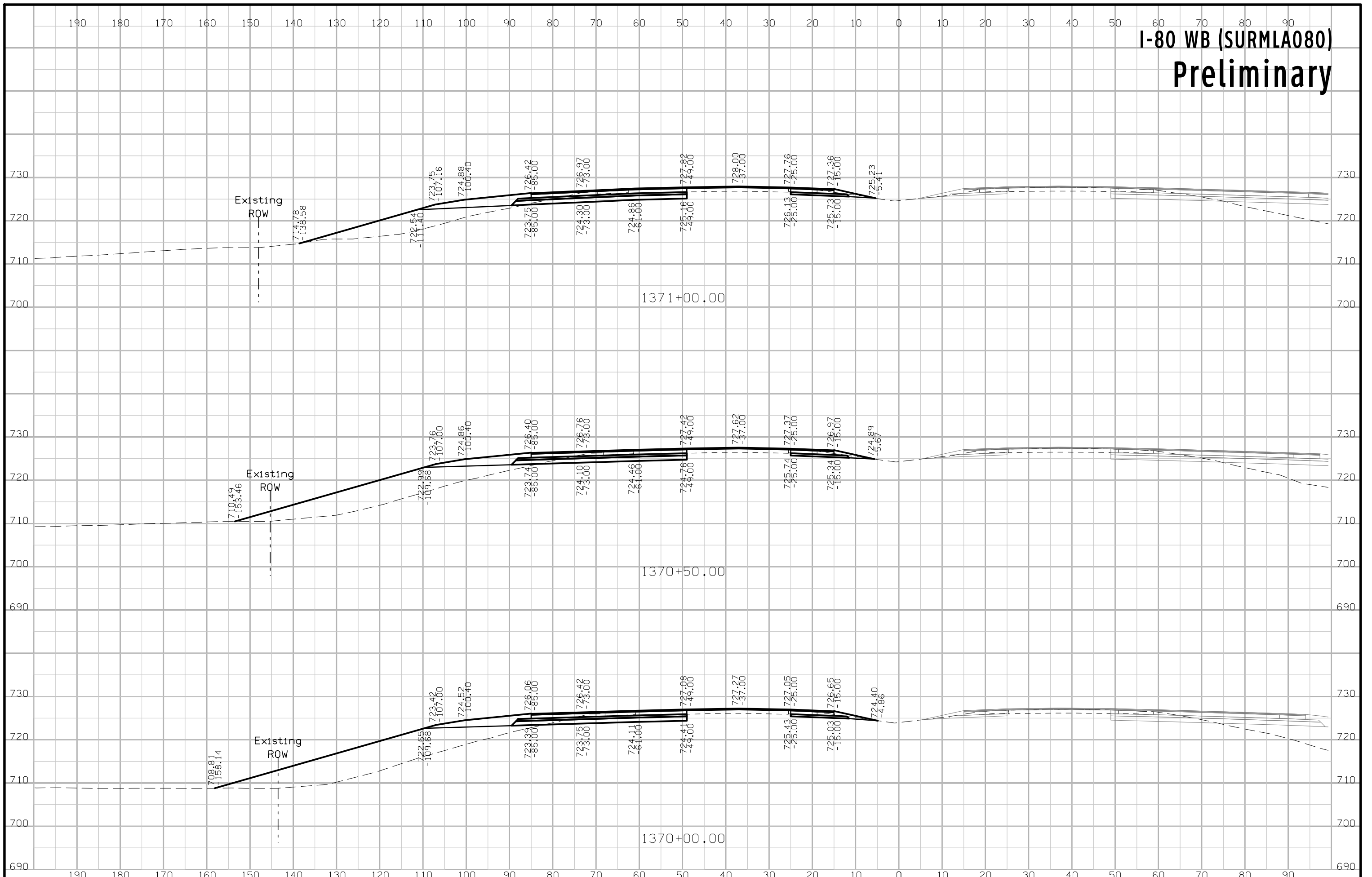



# I-80 WB (SURMLA080) Preliminary

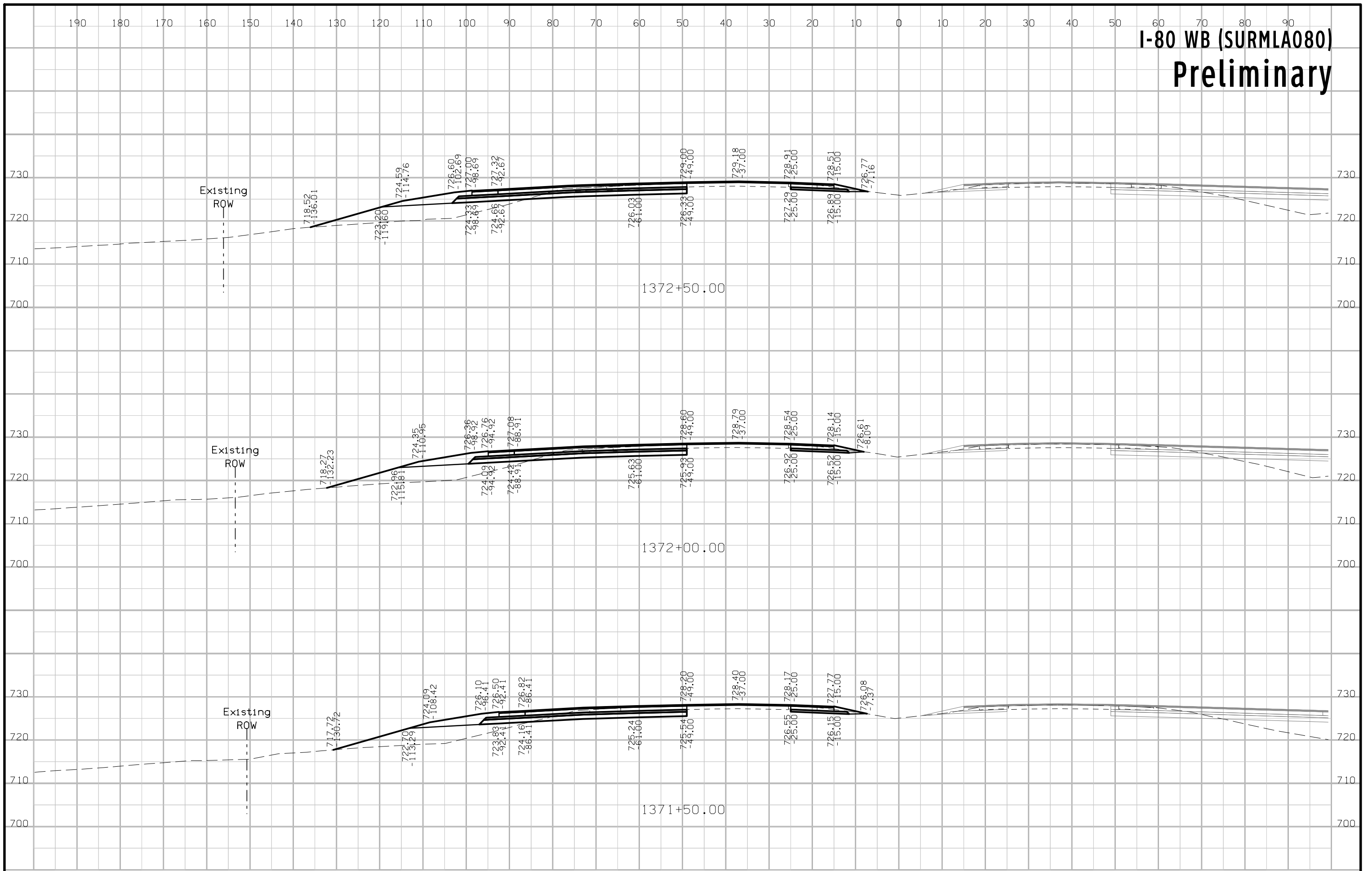

# I-80 WB (SURMLA080) Preliminary

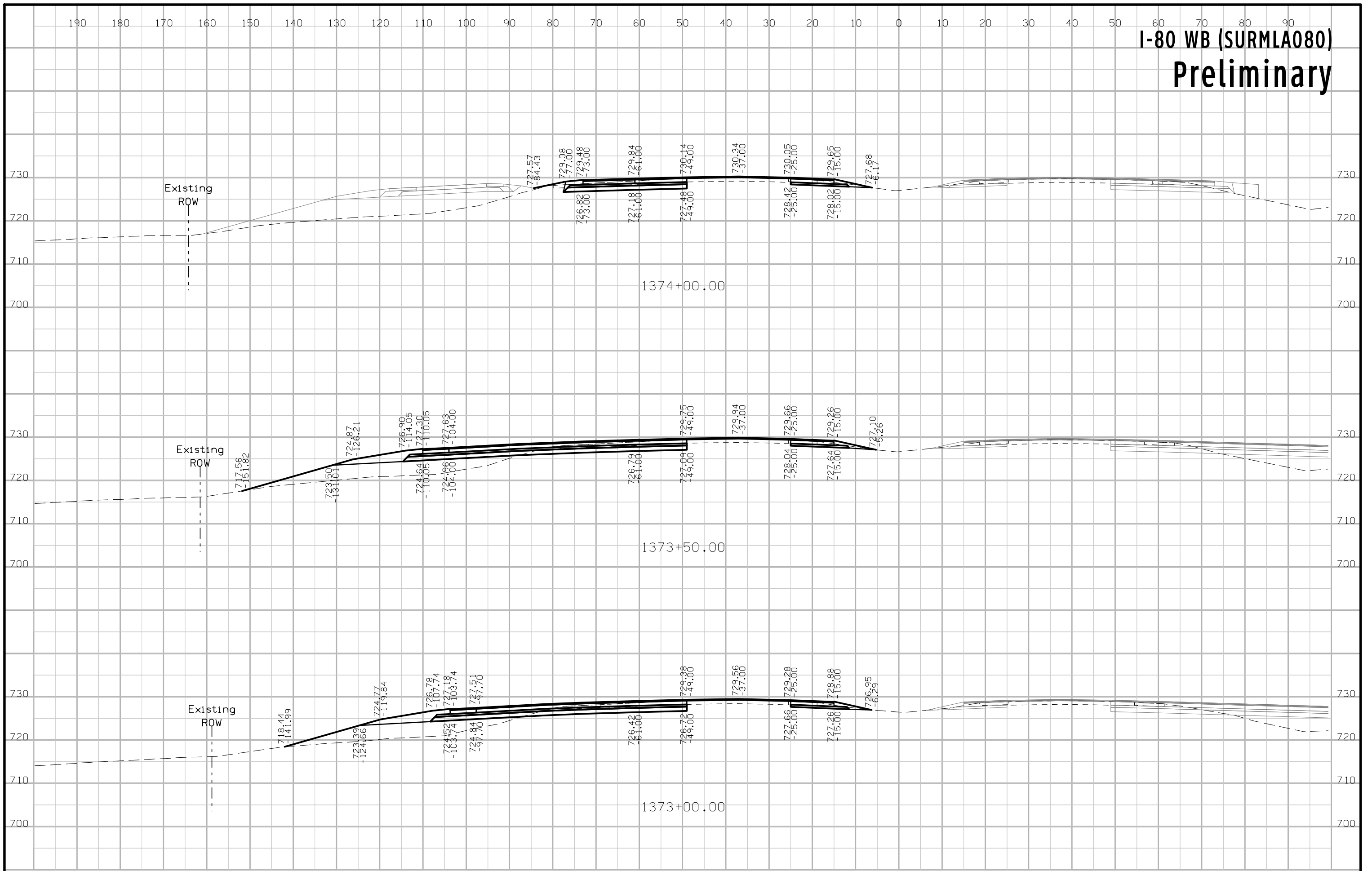

# I-80 WB (SURMLA080) Preliminary

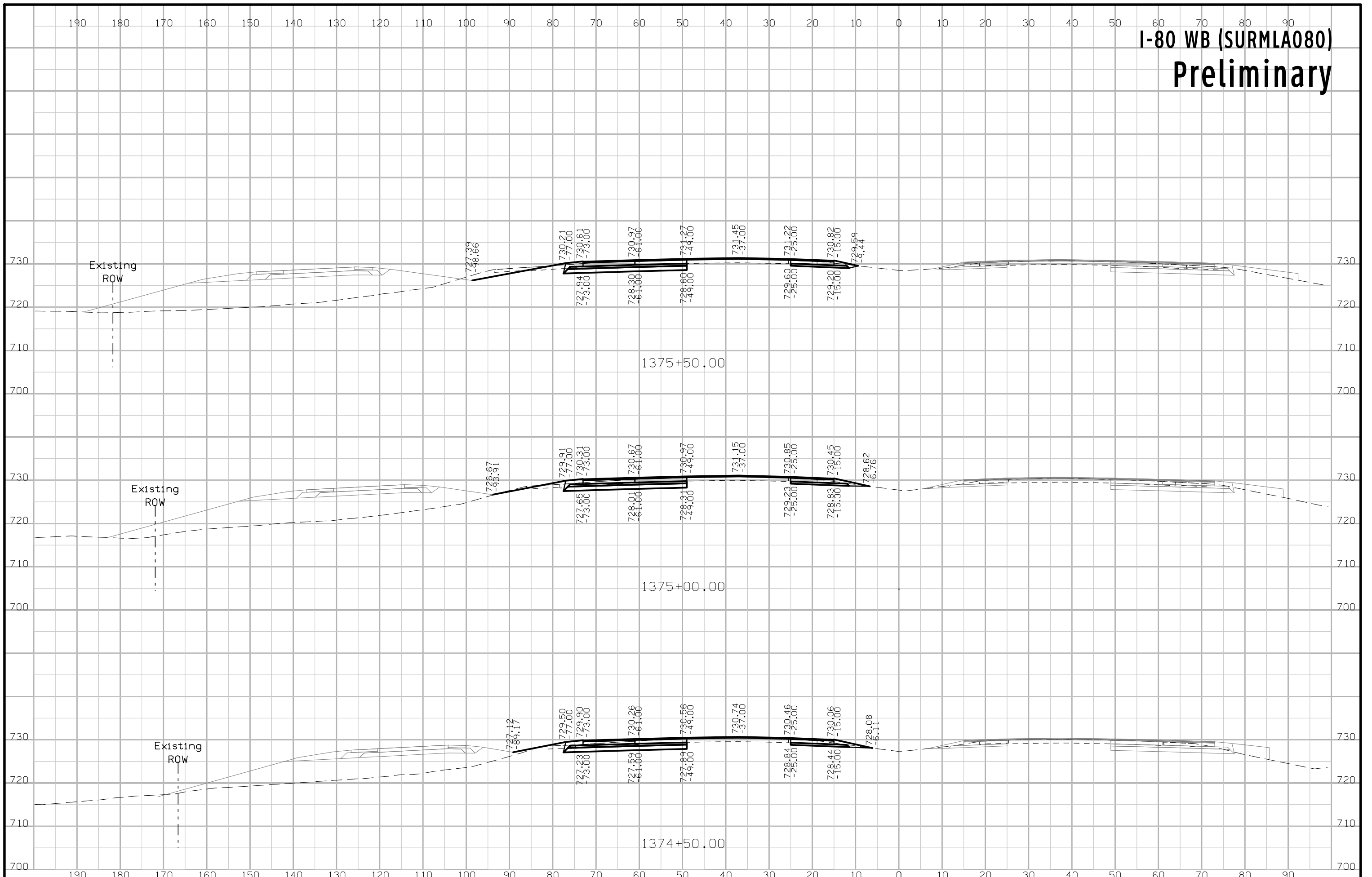

# I-80 WB (SURMLA080) Preliminary

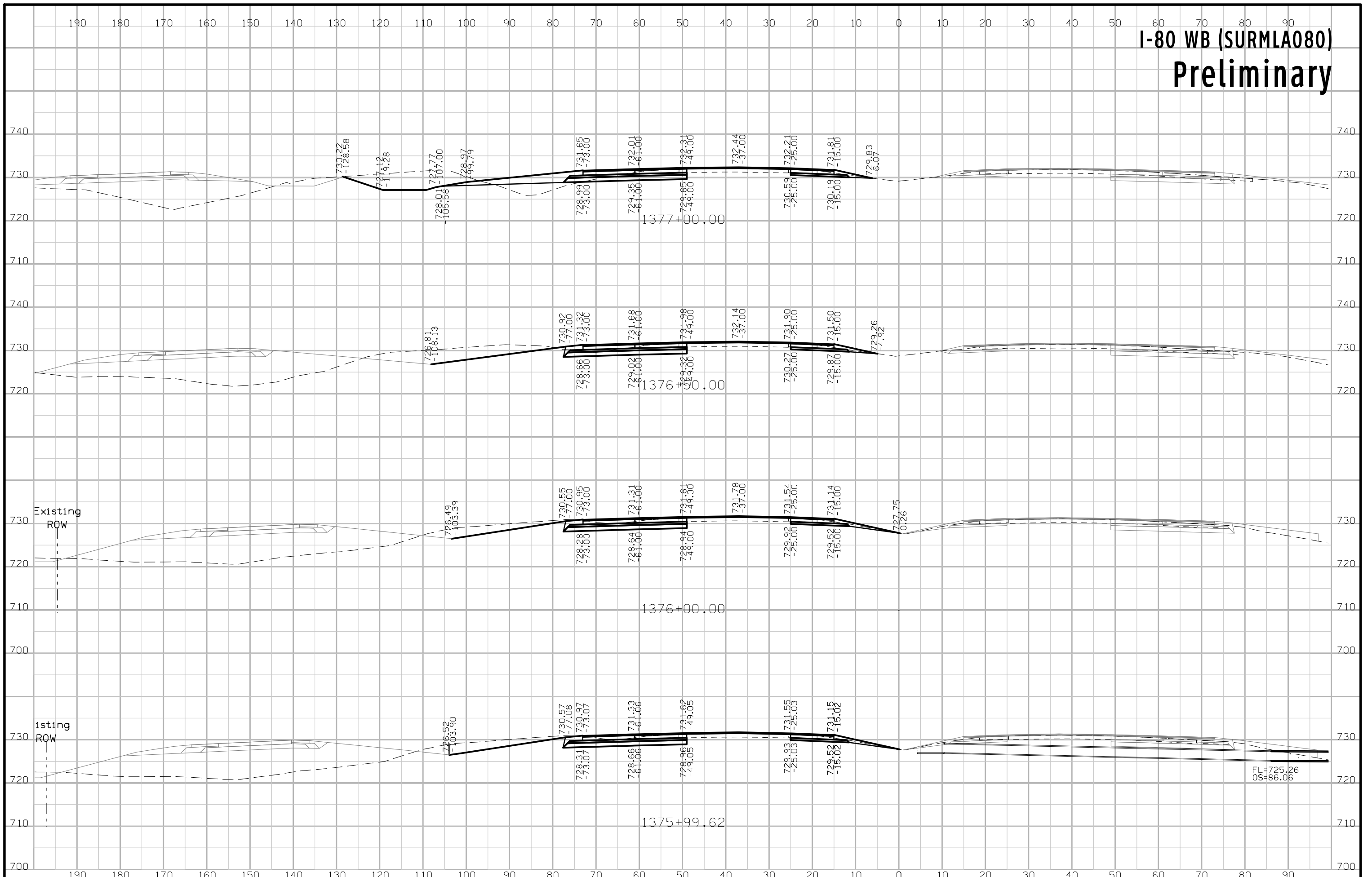

# I-80 WB (SURMLA080) Preliminary

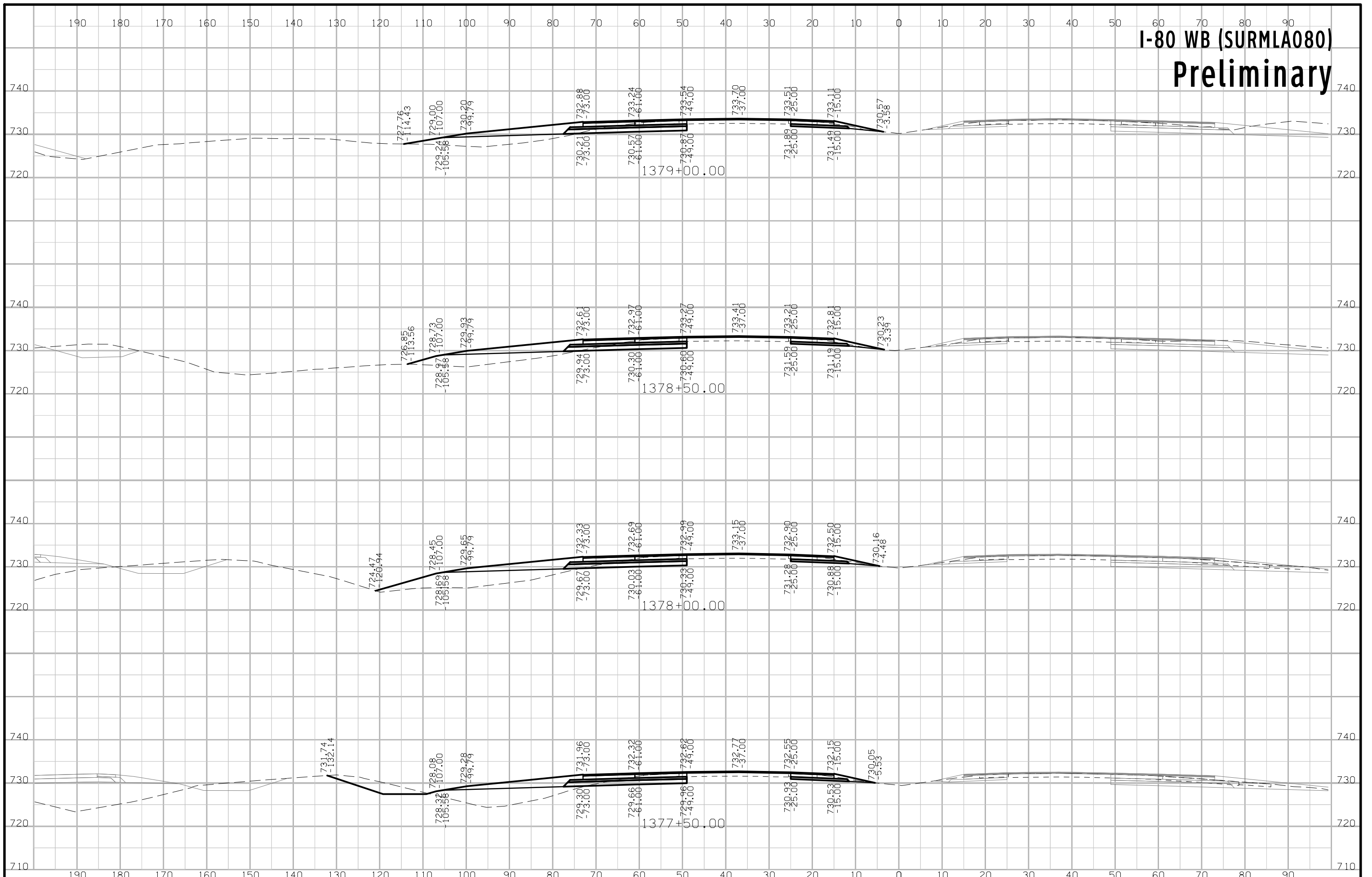

# I-80 WB (SURMLA080) Preliminary

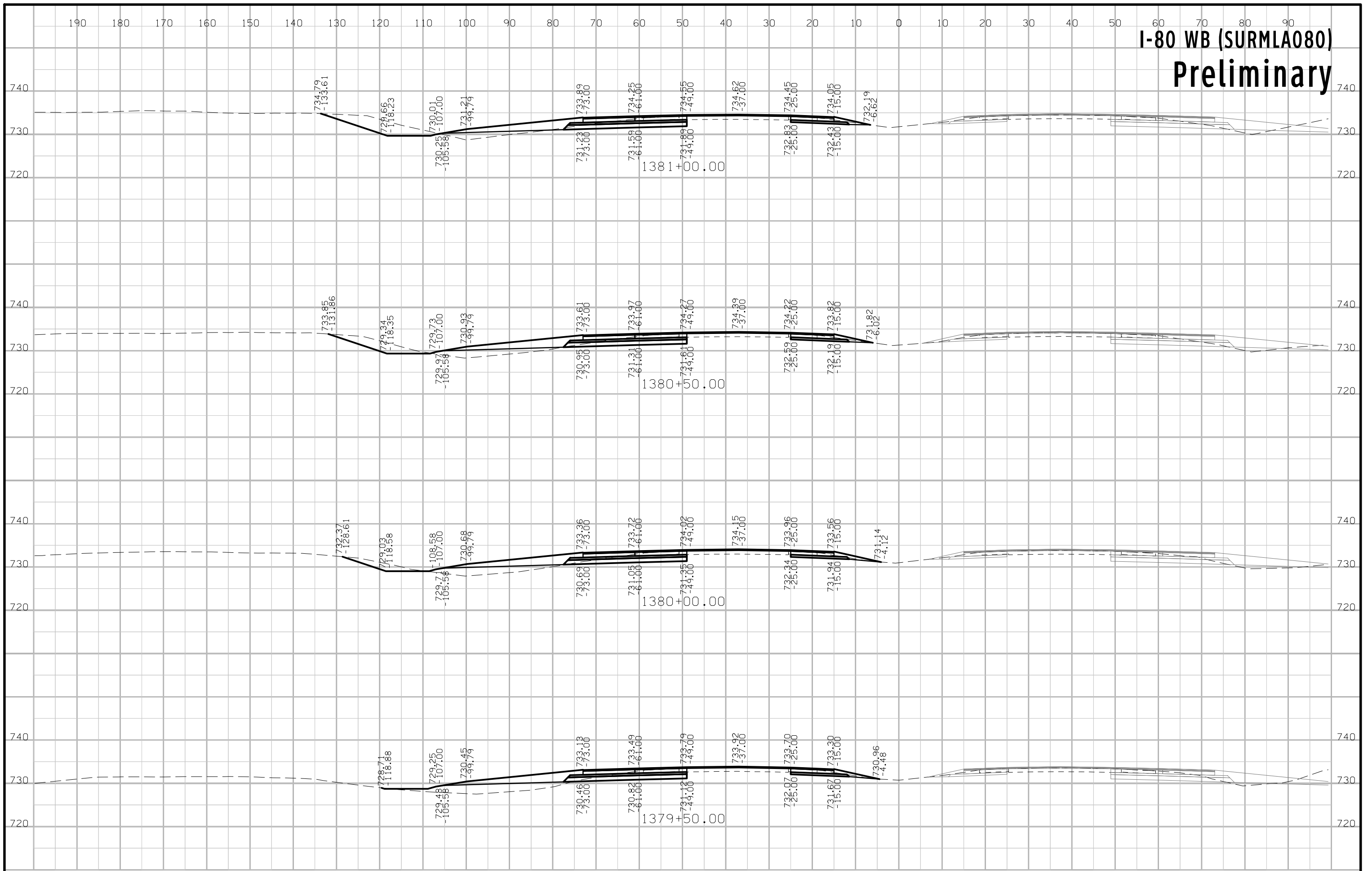



# I-80 WB (SURMLA080) Preliminary

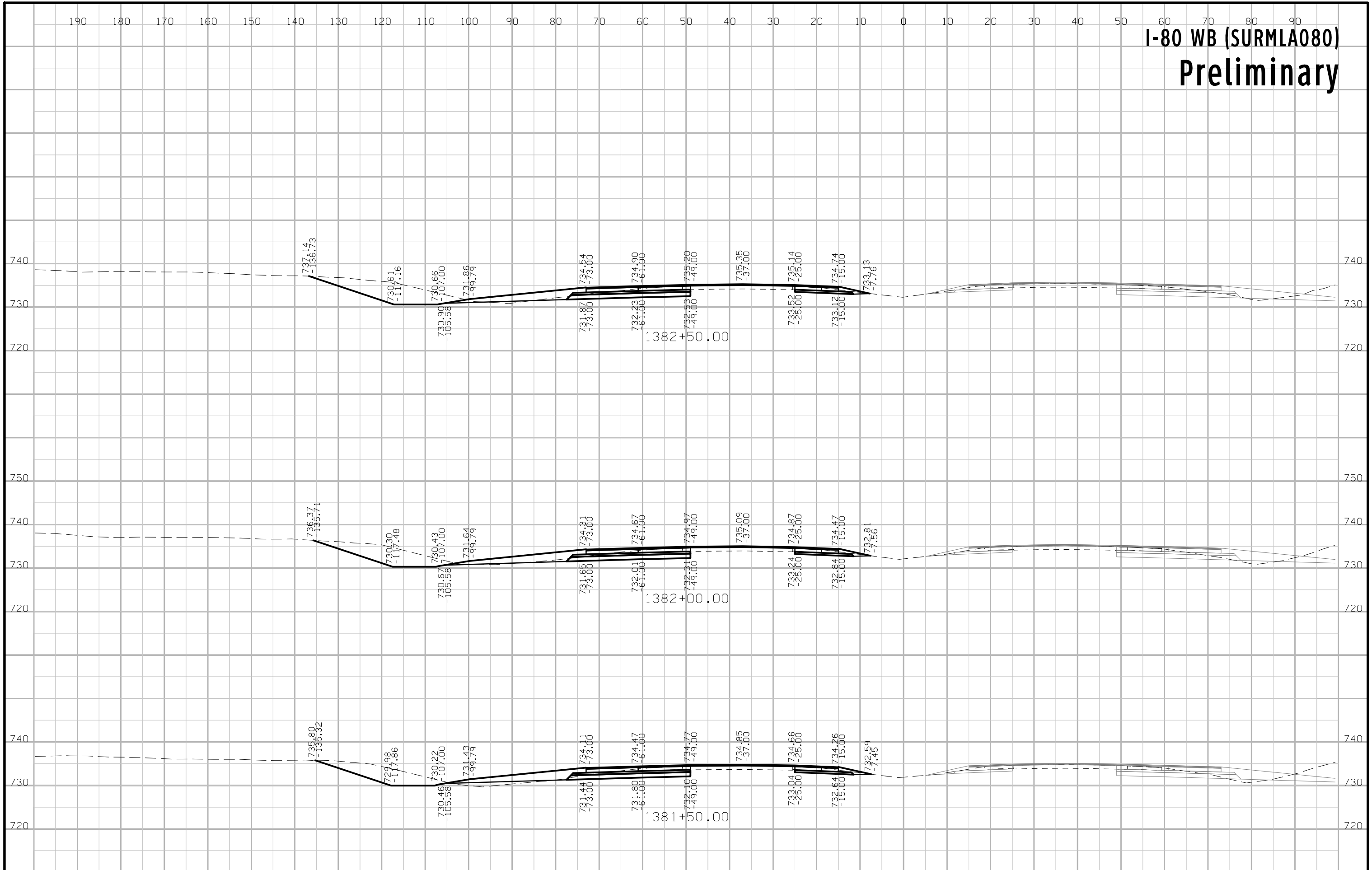

# I-80 WB (SURMLA080) Preliminary

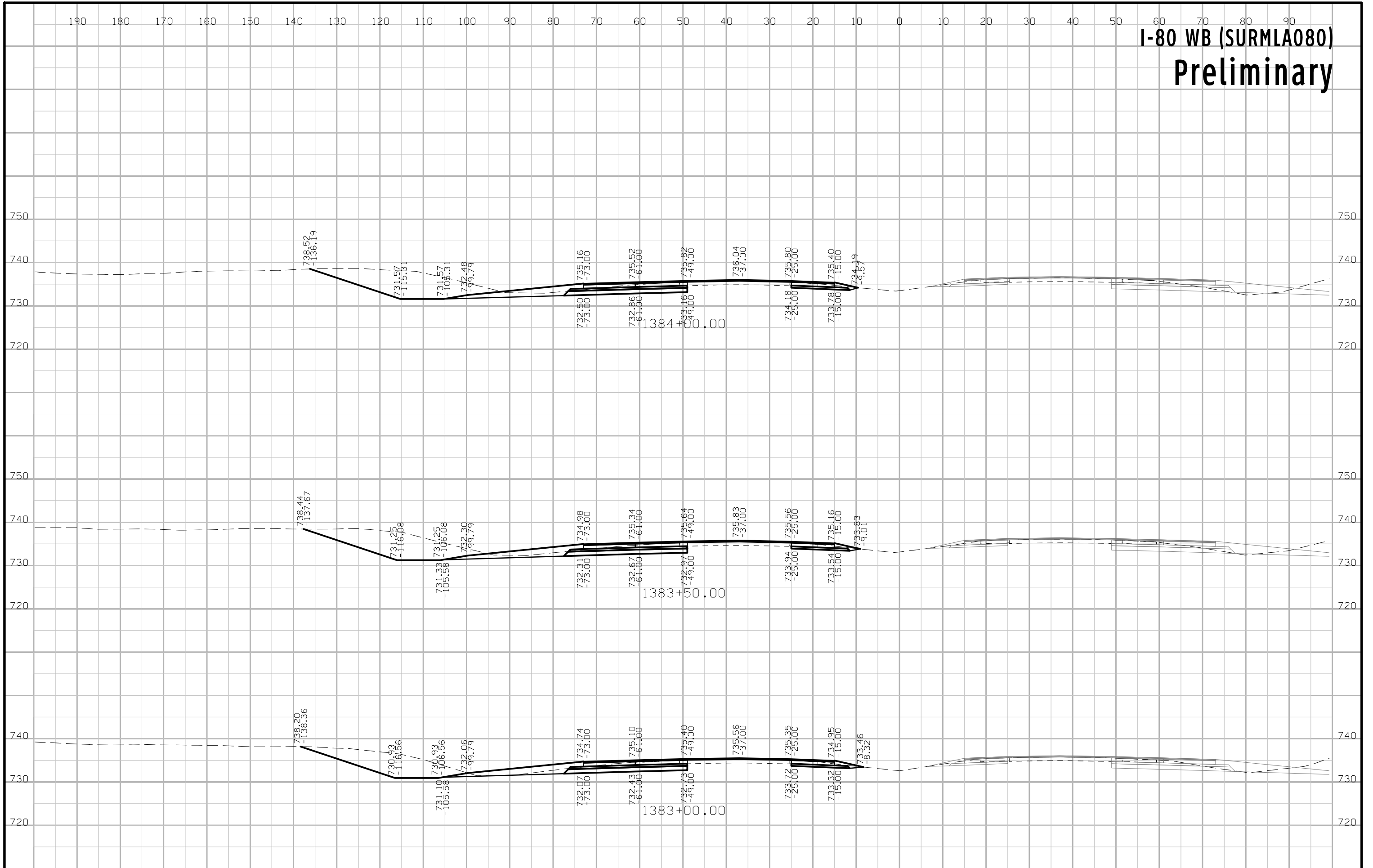

# I-80 WB (SURMLA080) Preliminary

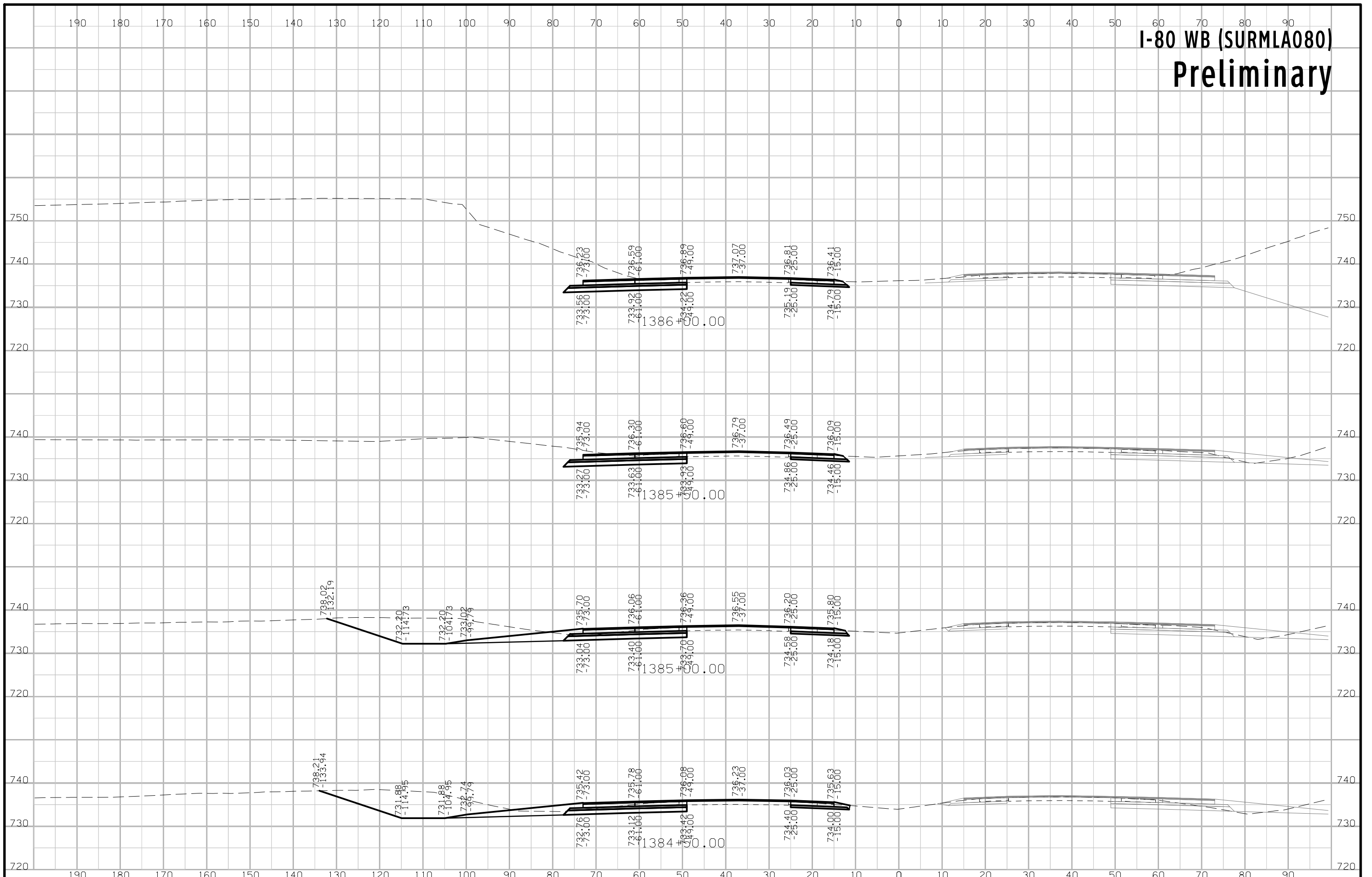

# I-80 WB (SURMLA080) Preliminary

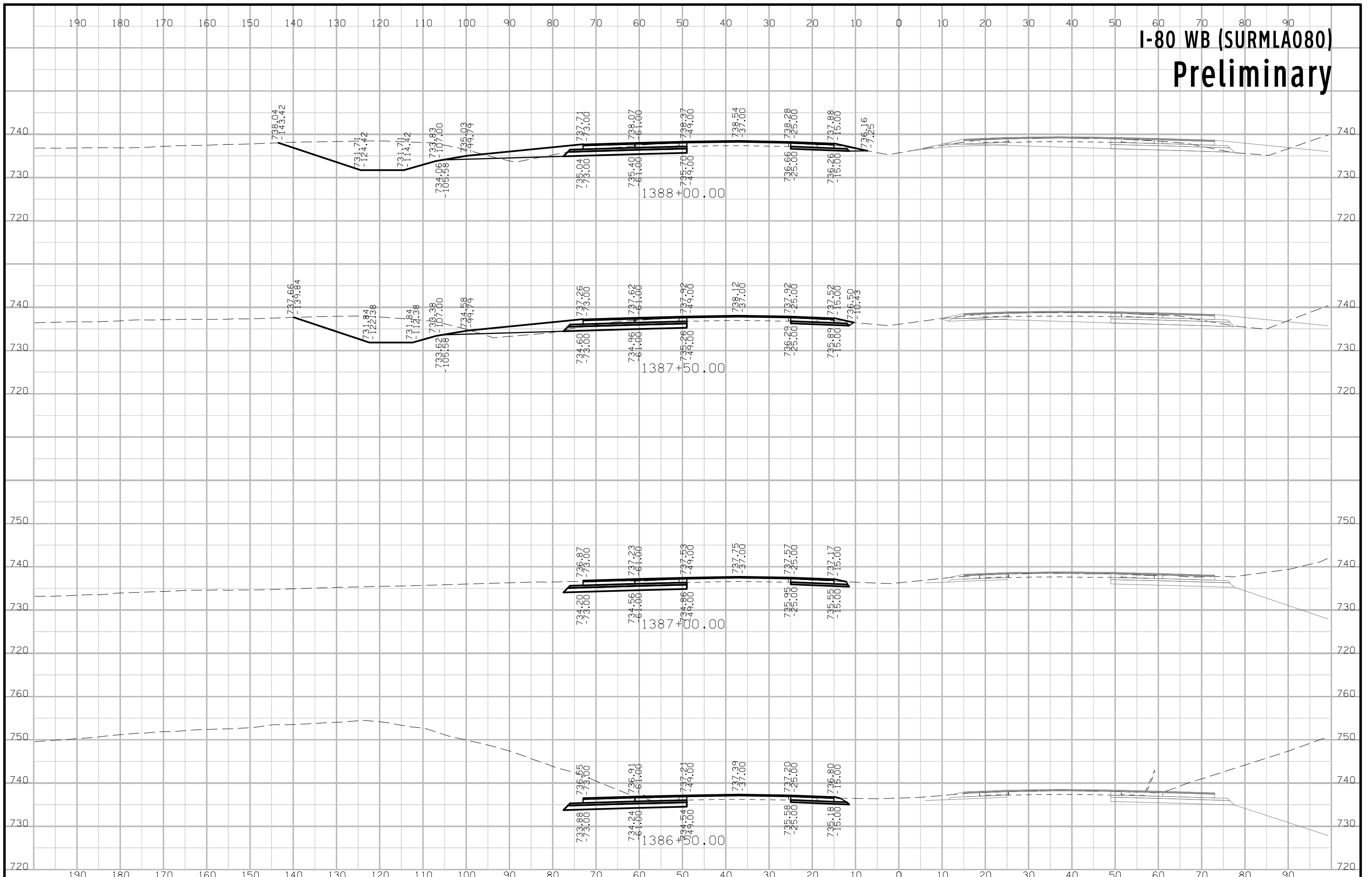

# I-80 WB (SURMLA080) Preliminary

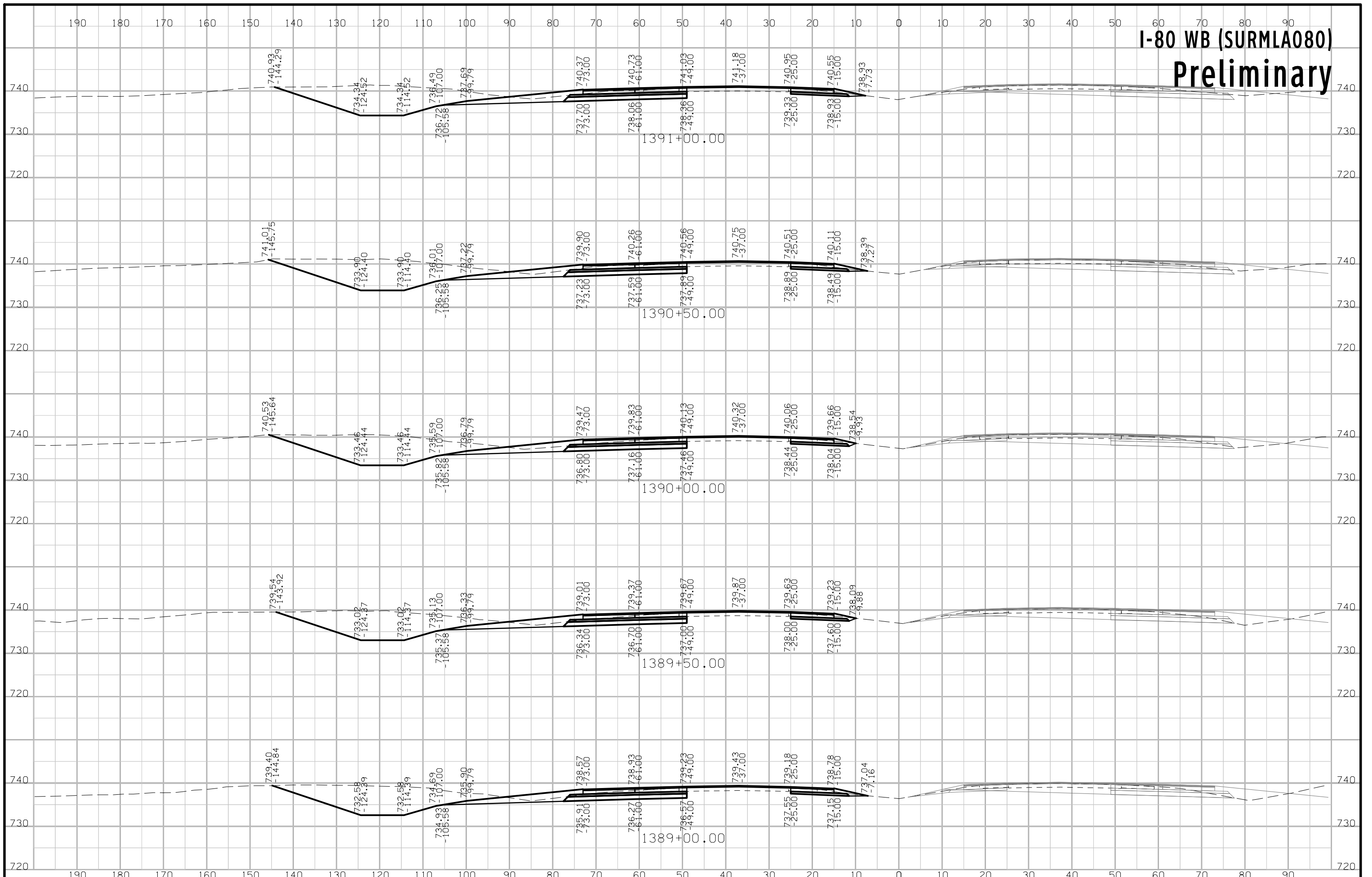

# I-80 WB (SURMLA080) Preliminary

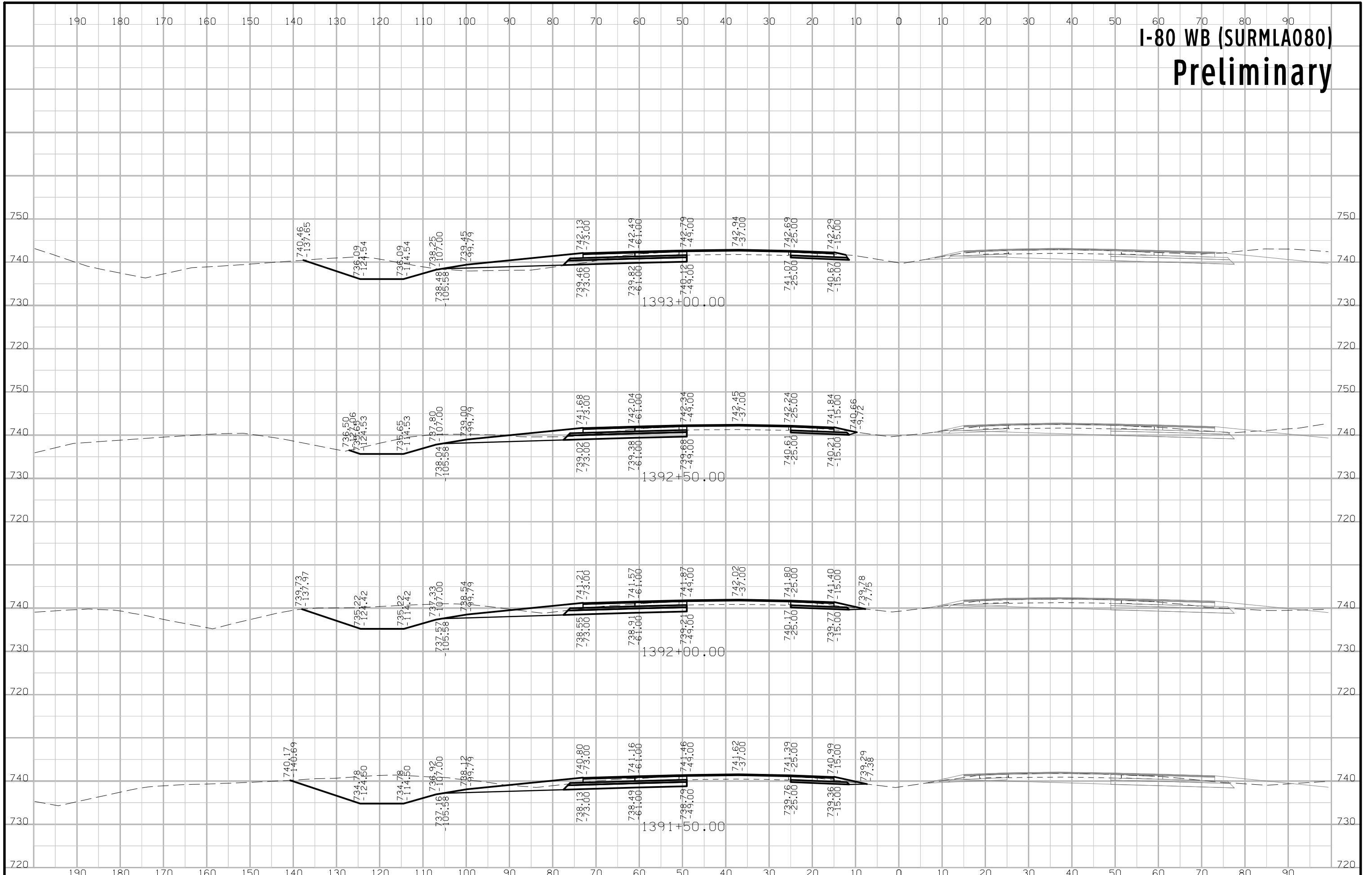



# I-80 WB (SURMLA080) Preliminary

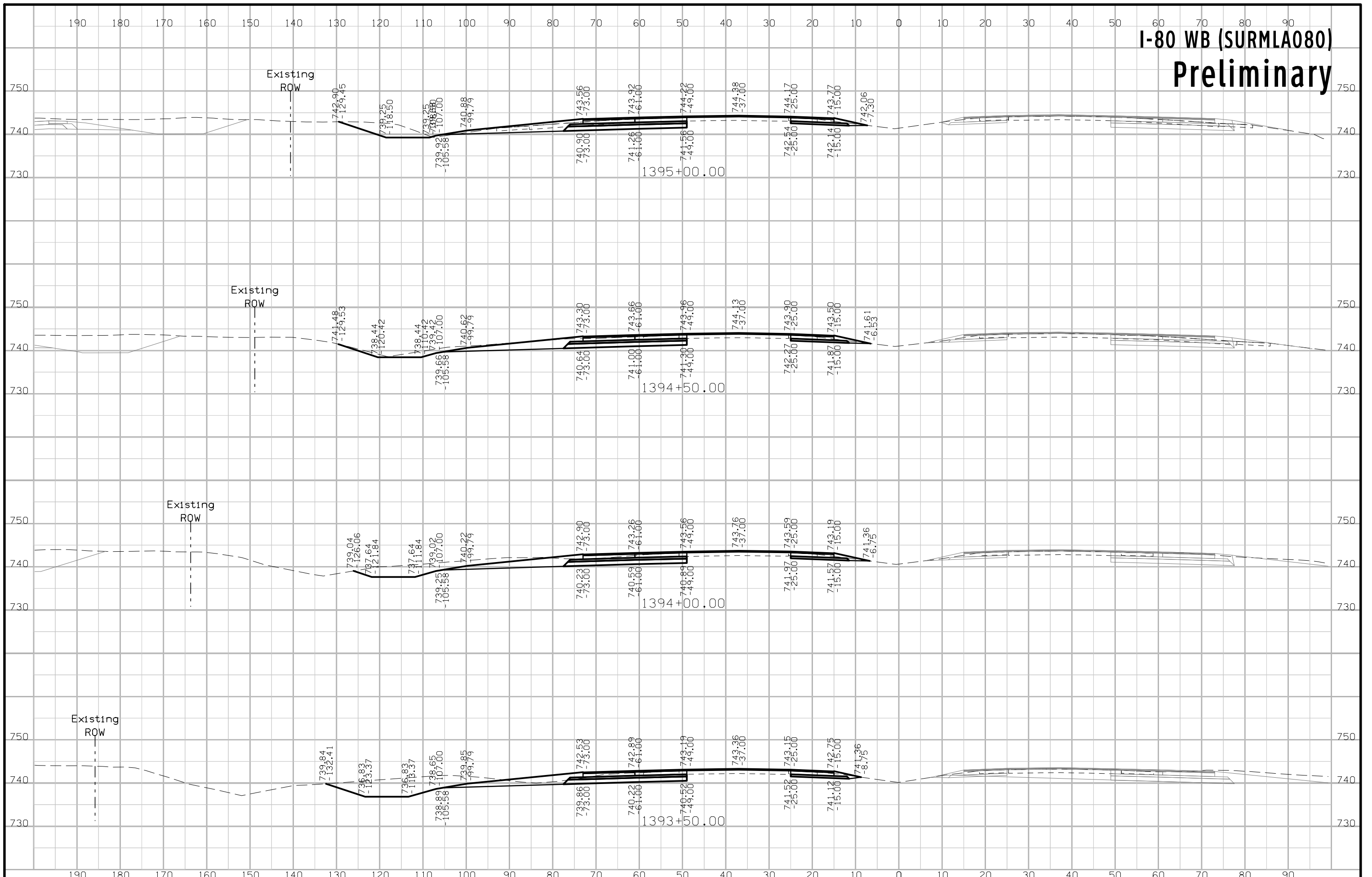

# I-80 WB (SURMLA080) Preliminary

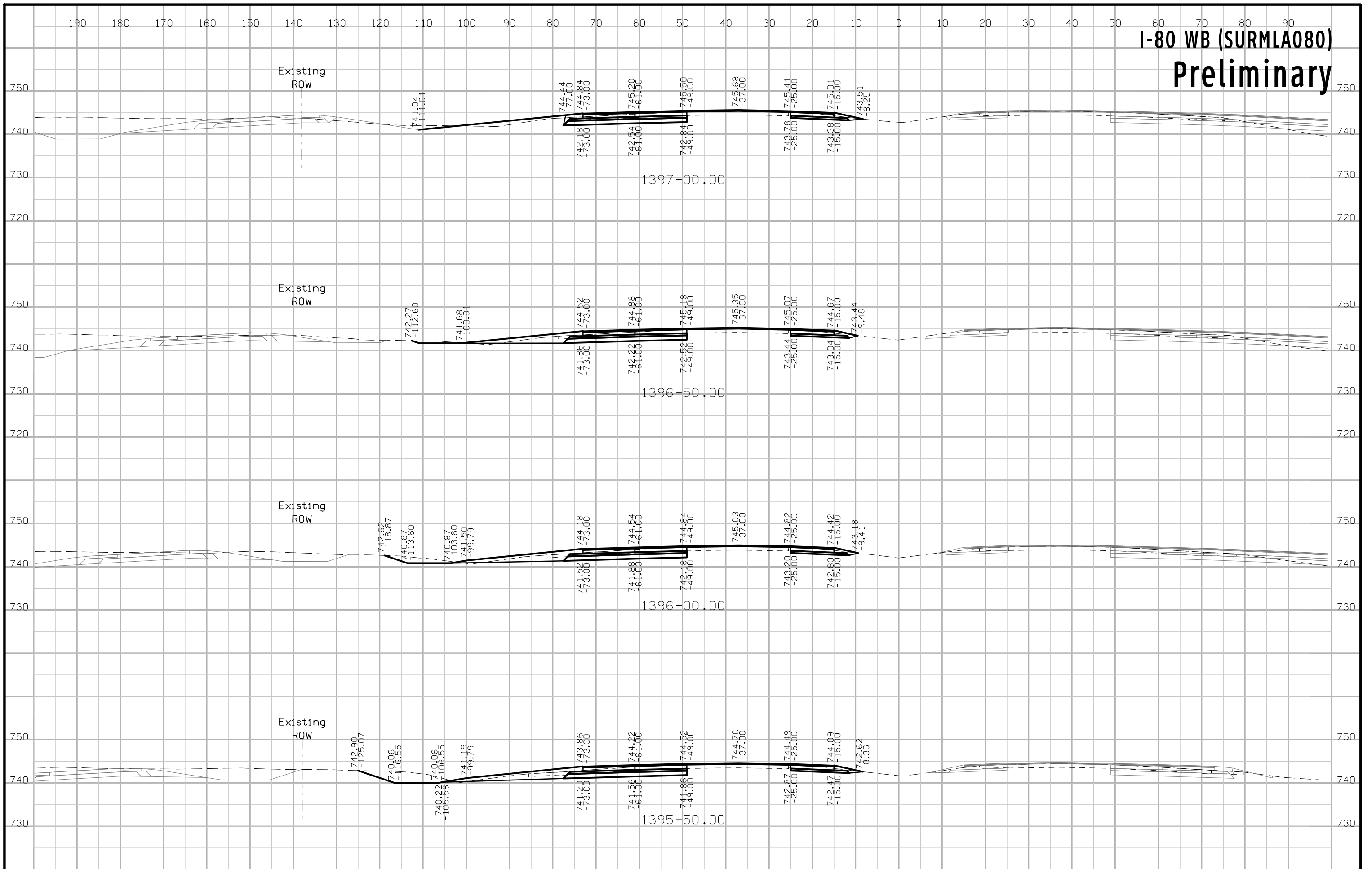

# I-80 WB (SURMLA080) Preliminary

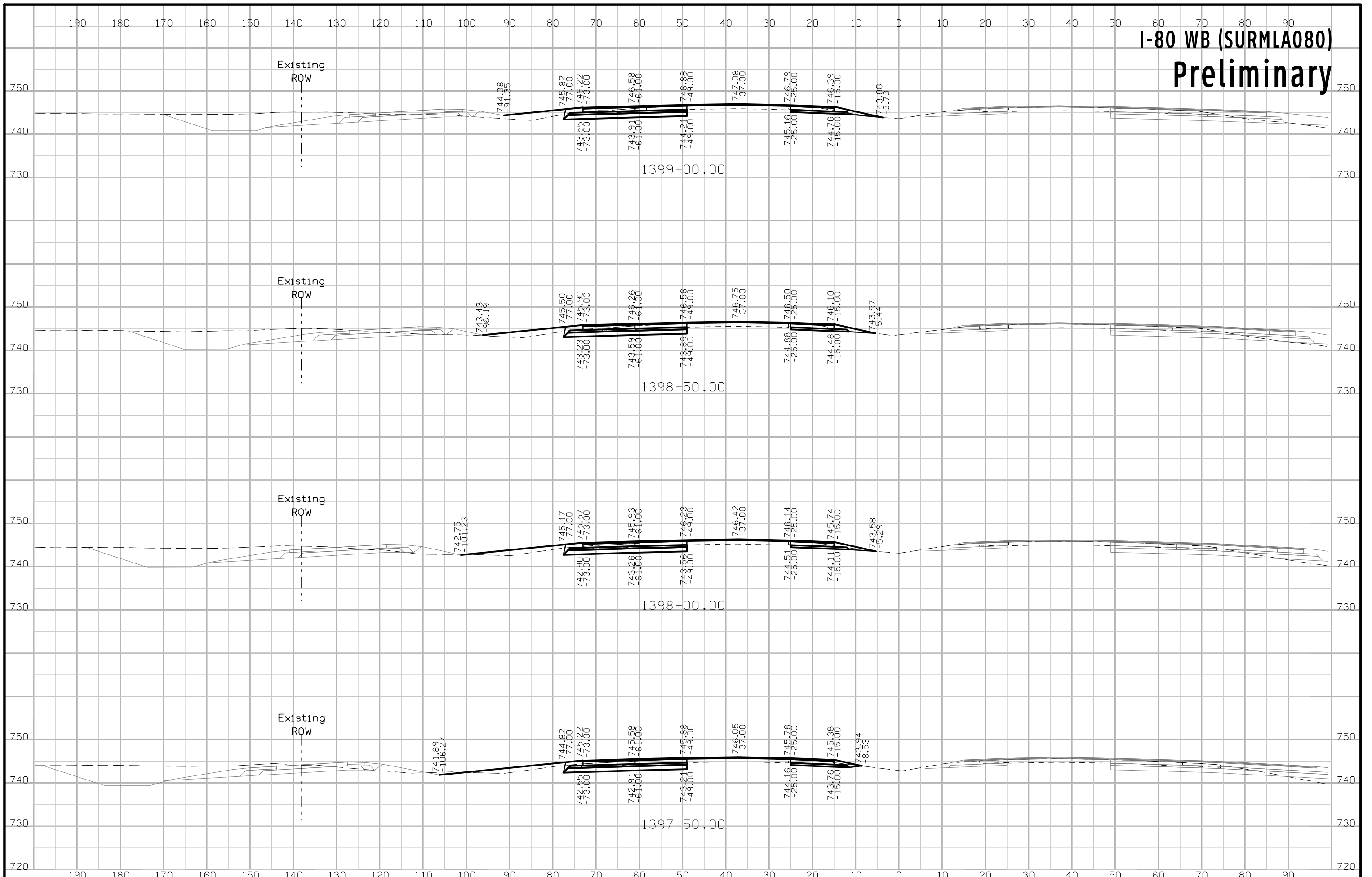

# I-80 WB (SURMLA080) Preliminary

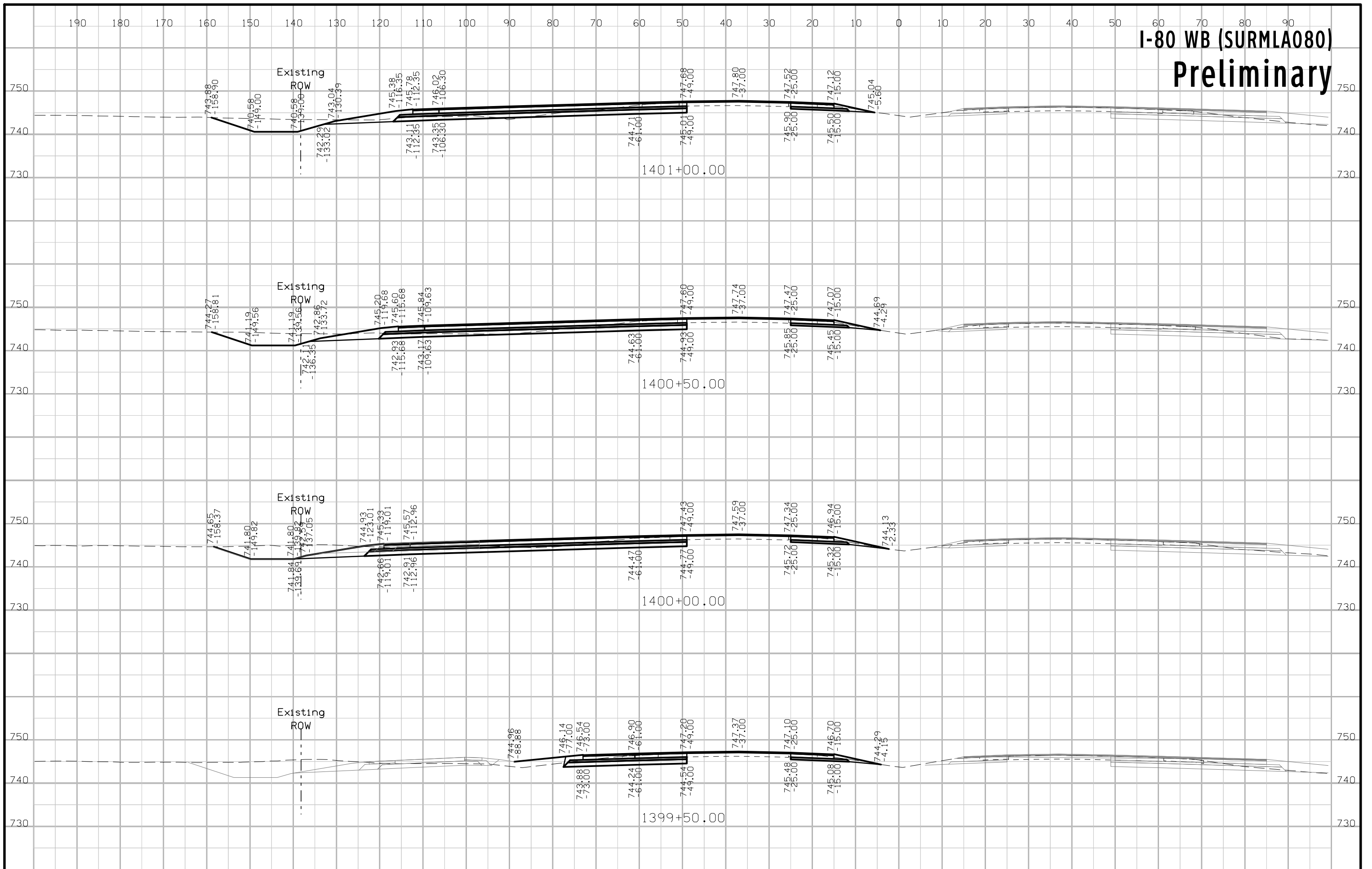

# I-80 WB (SURMLA080) Preliminary

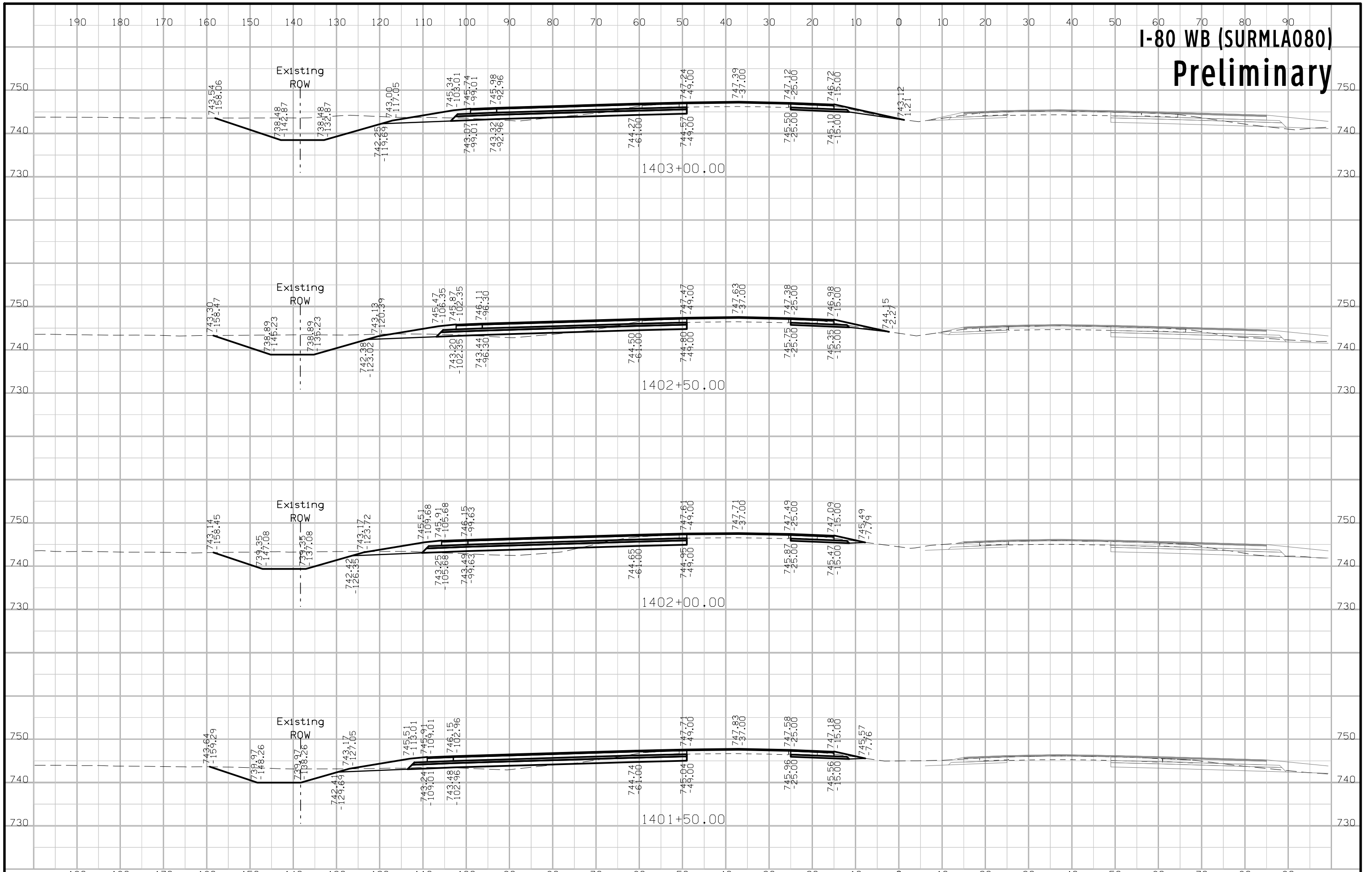

# I-80 WB (SURMLA080) Preliminary

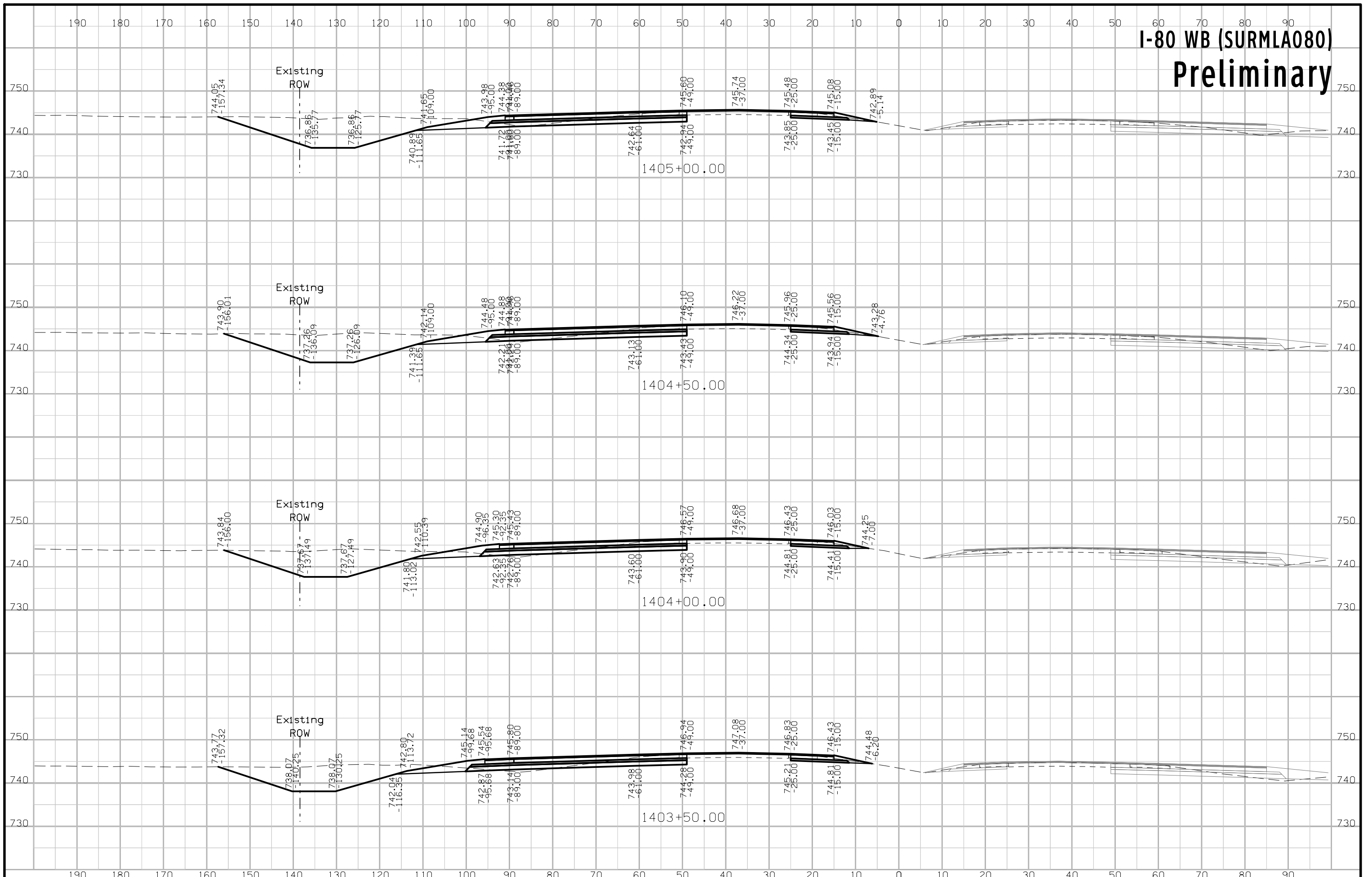



# I-80 WB (SURMLA080) Preliminary

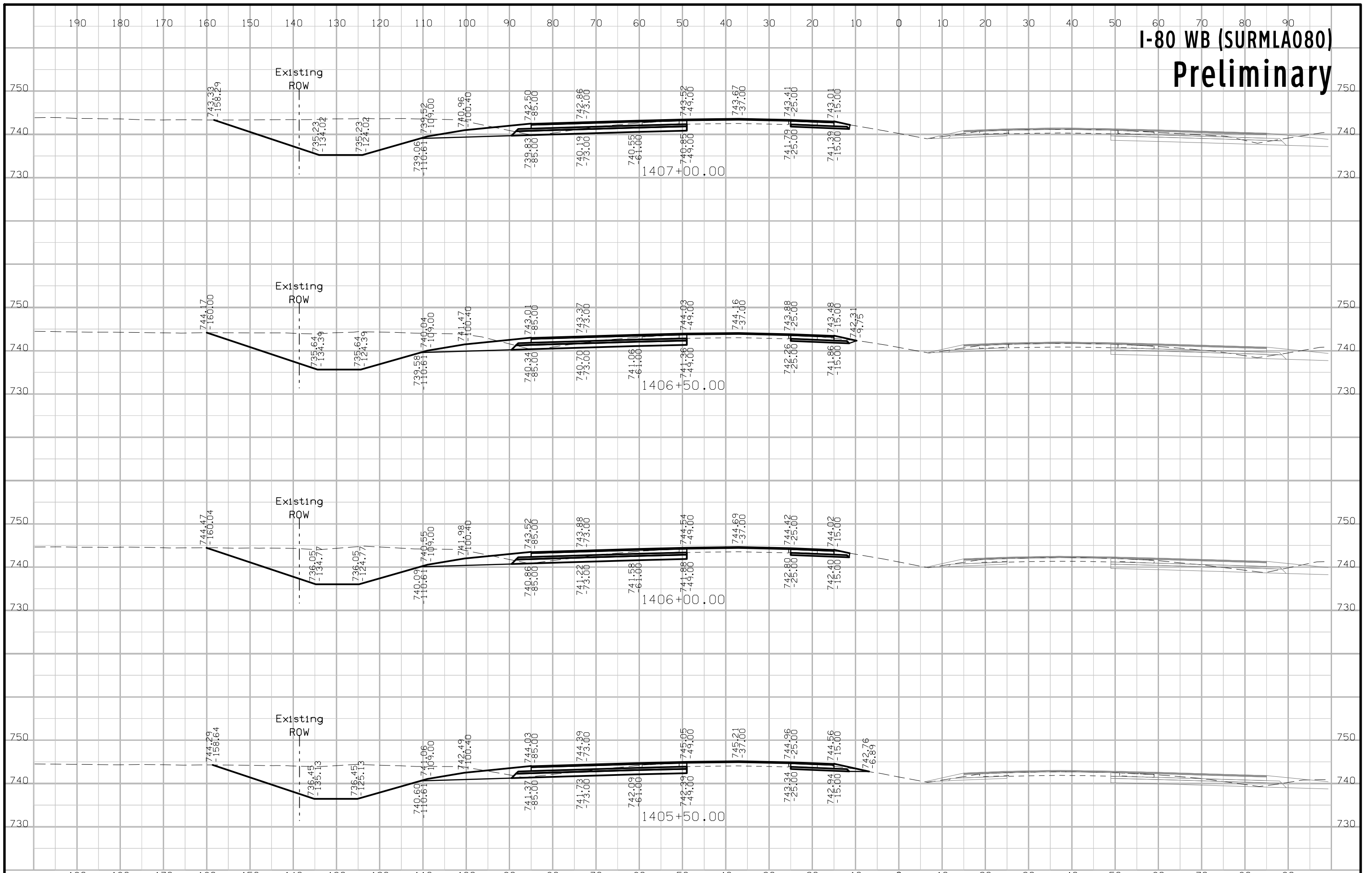

# I-80 WB (SURMLA080) Preliminary

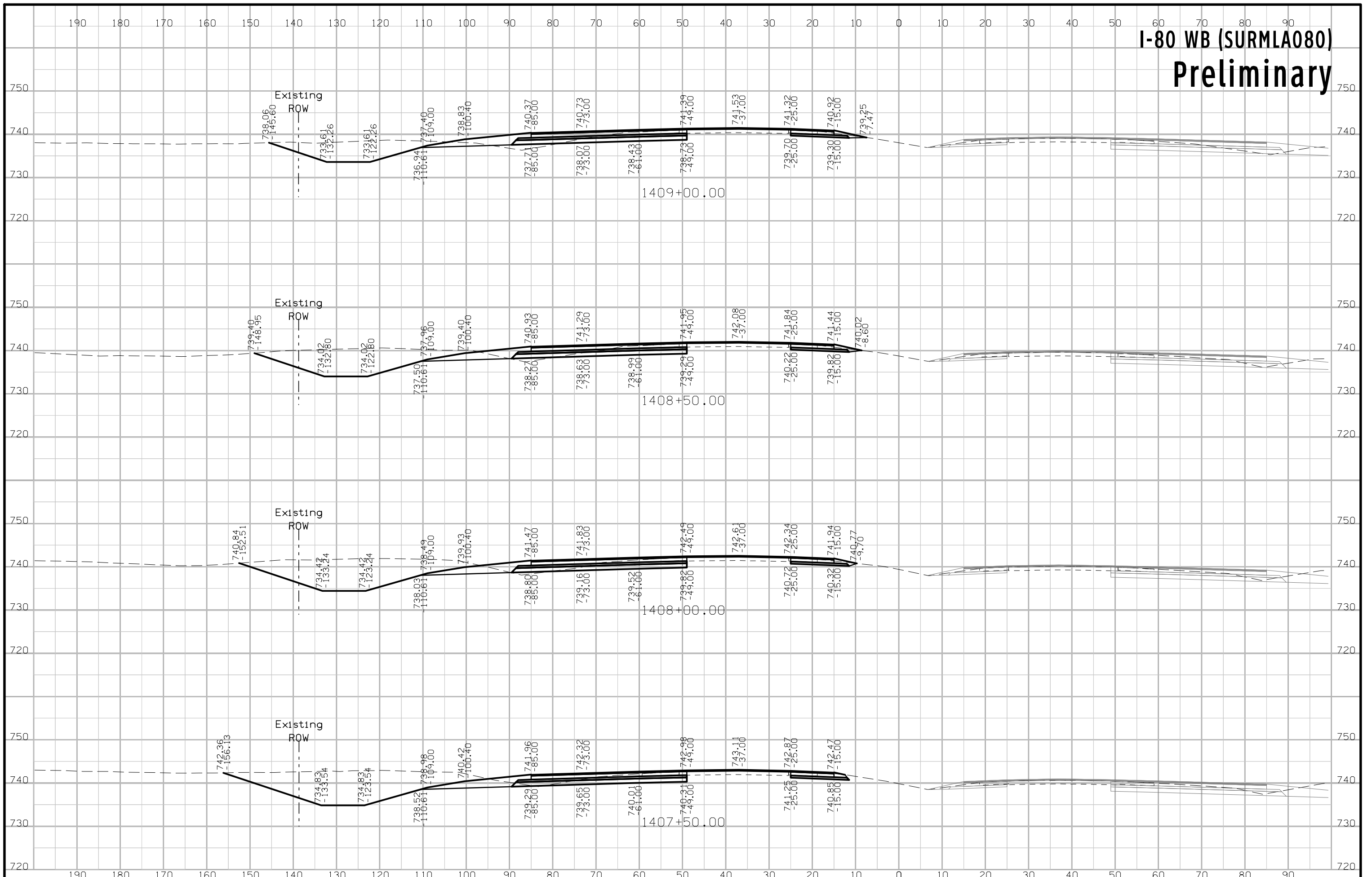

# I-80 WB (SURMLA080) Preliminary

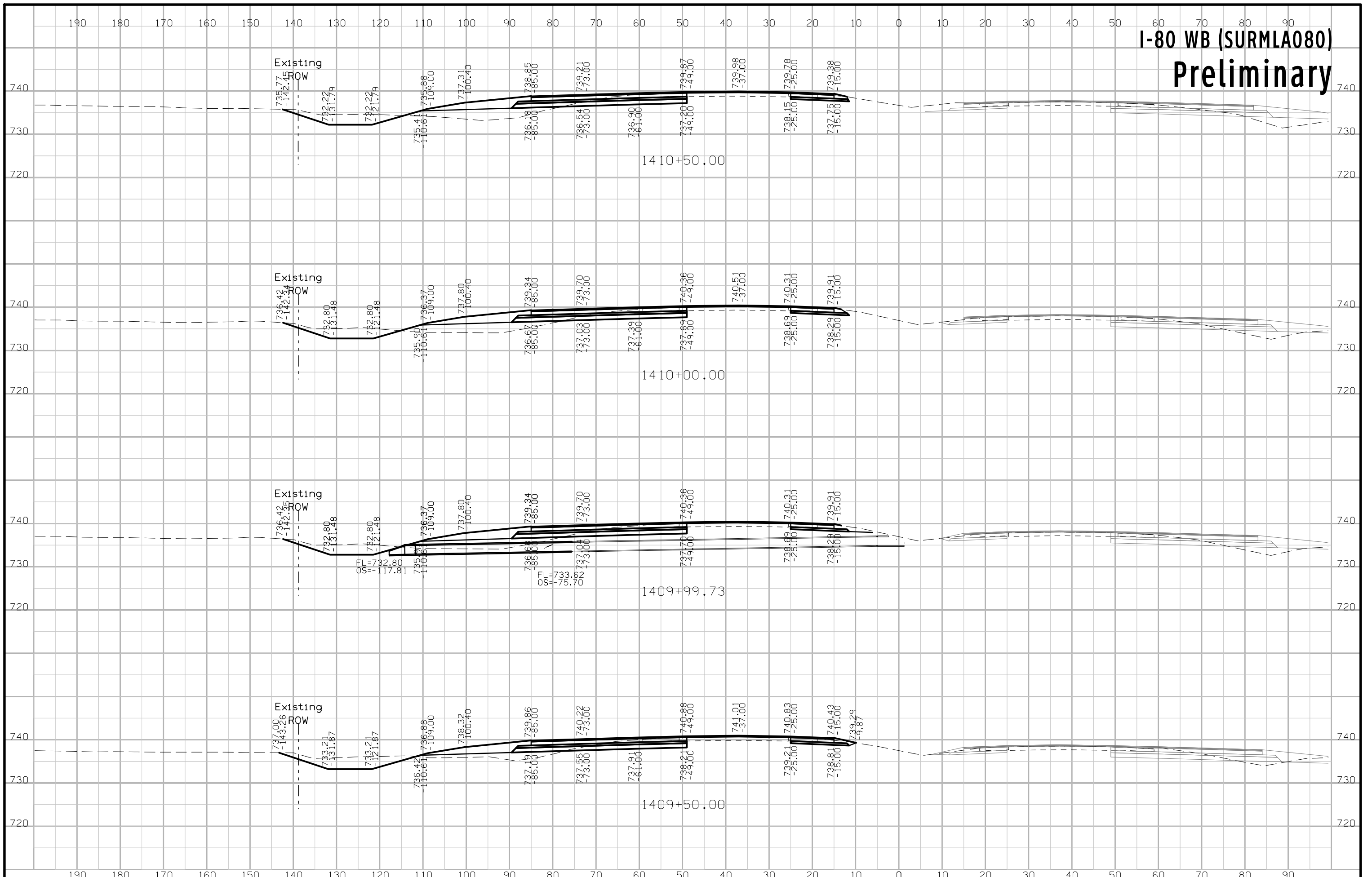

# I-80 WB (SURMLA080) Preliminary

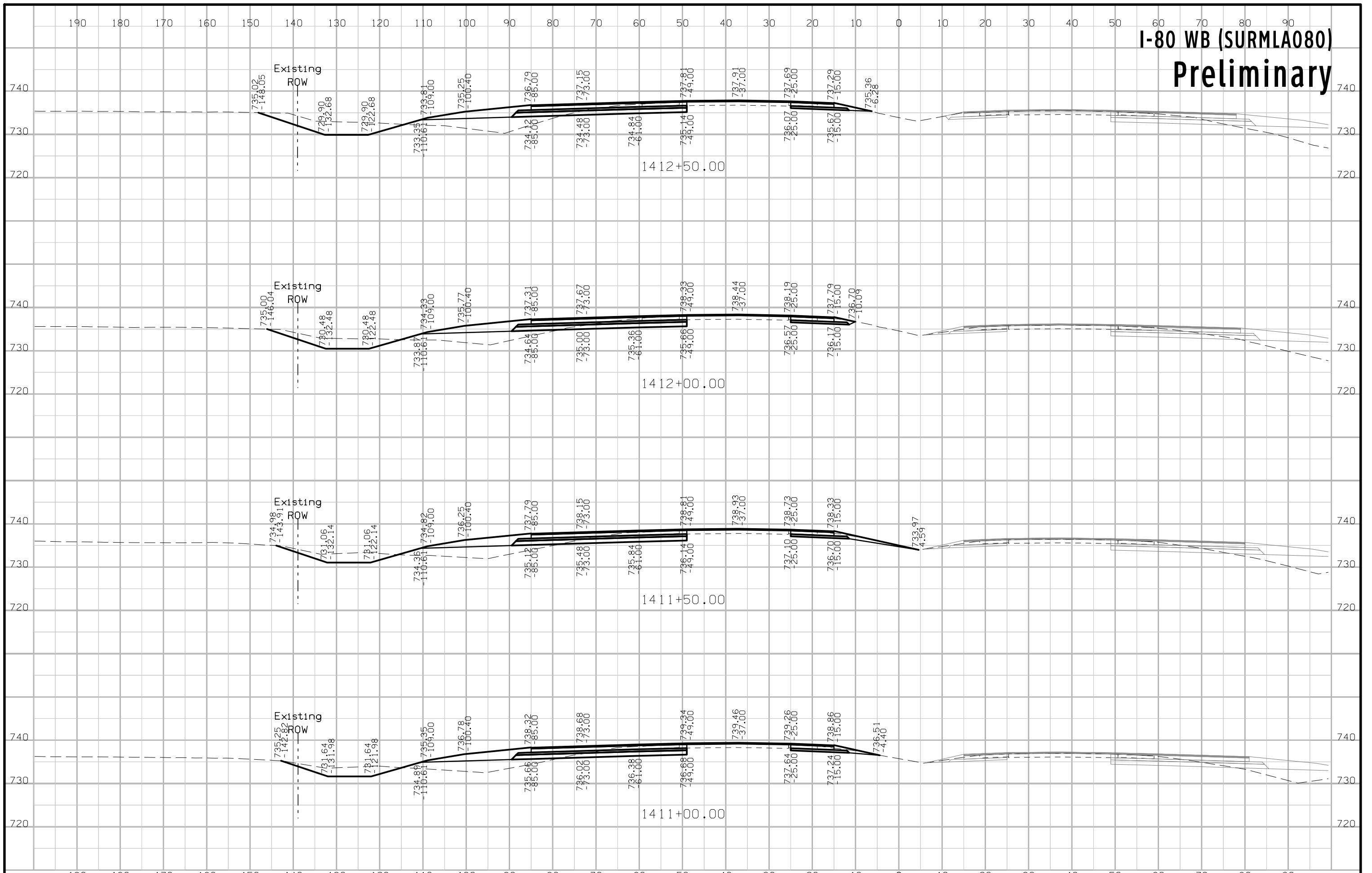

# I-80 WB (SURMLA080) Preliminary

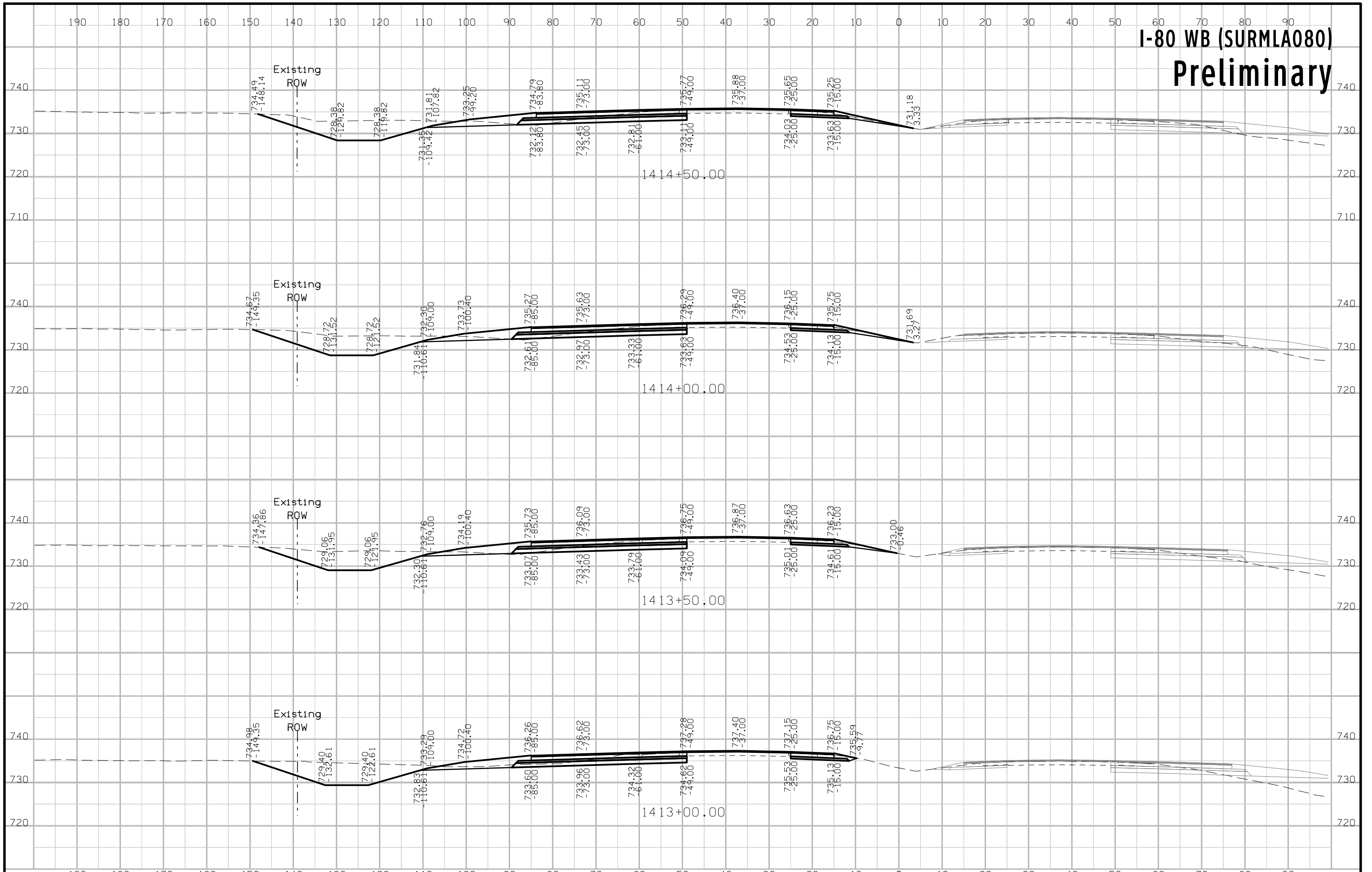

# I-80 WB (SURMLA080) Preliminary

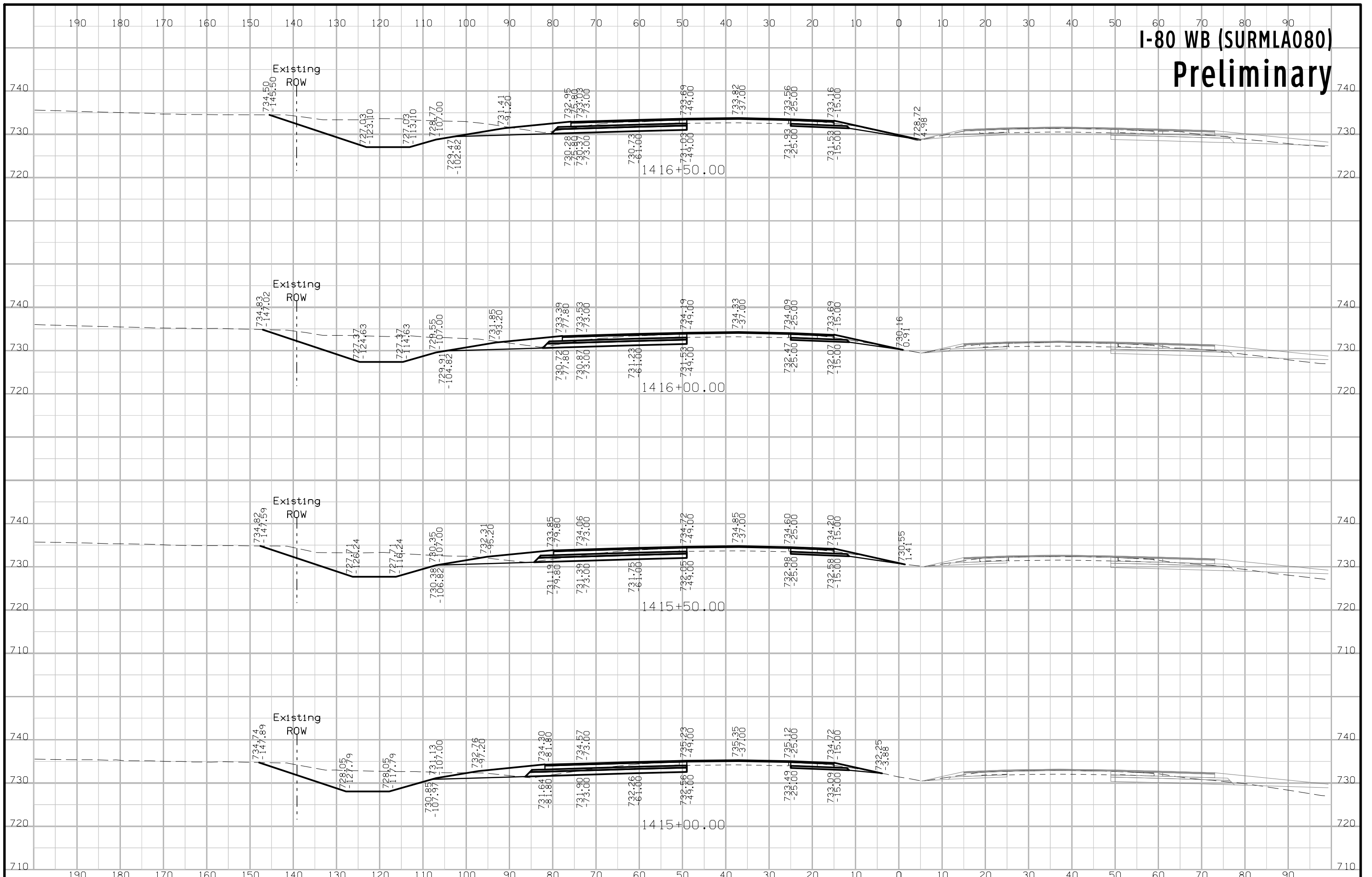



# I-80 WB (SURMLA080) Preliminary

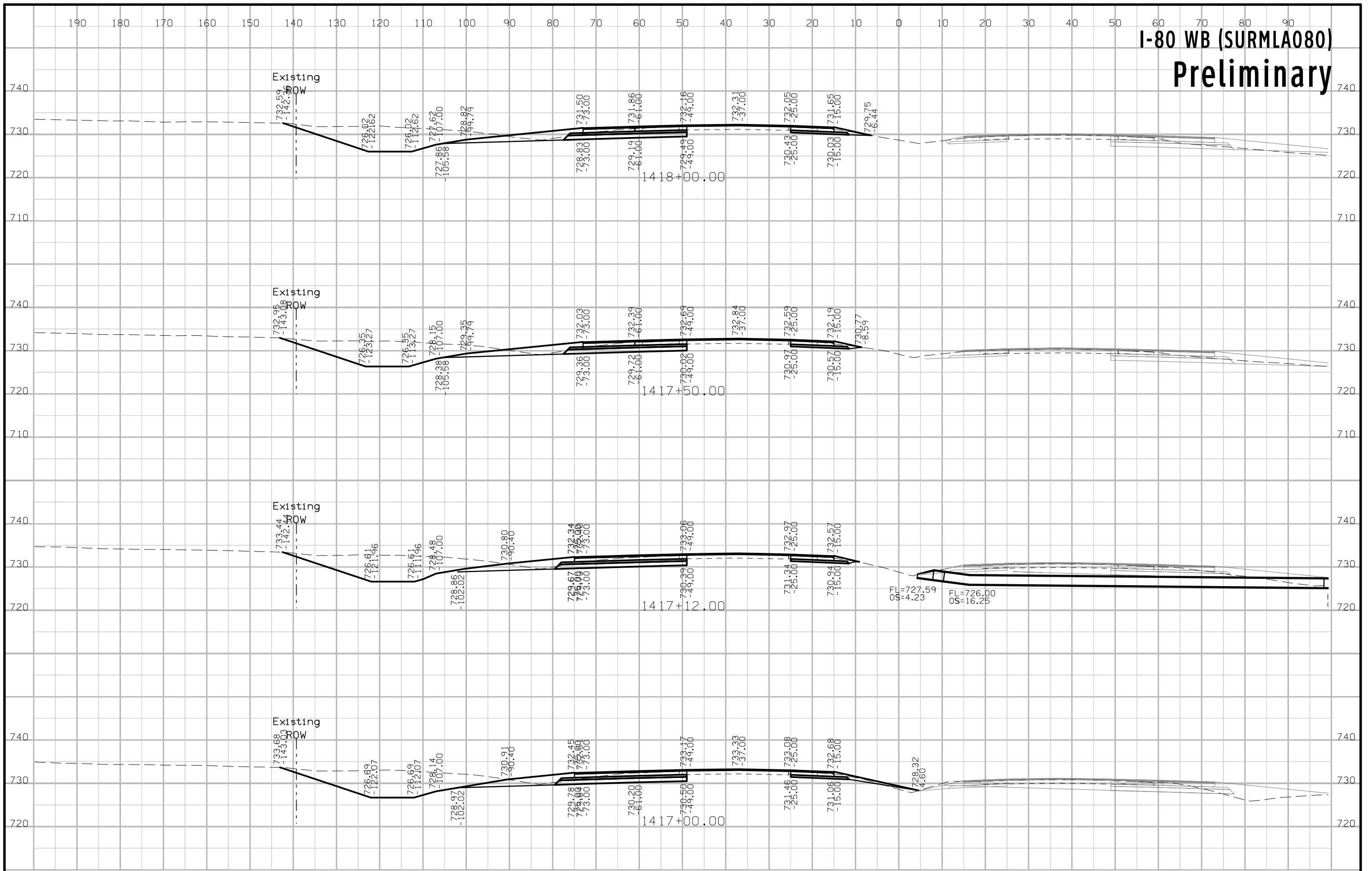

# I-80 WB (SURMLA080) Preliminary

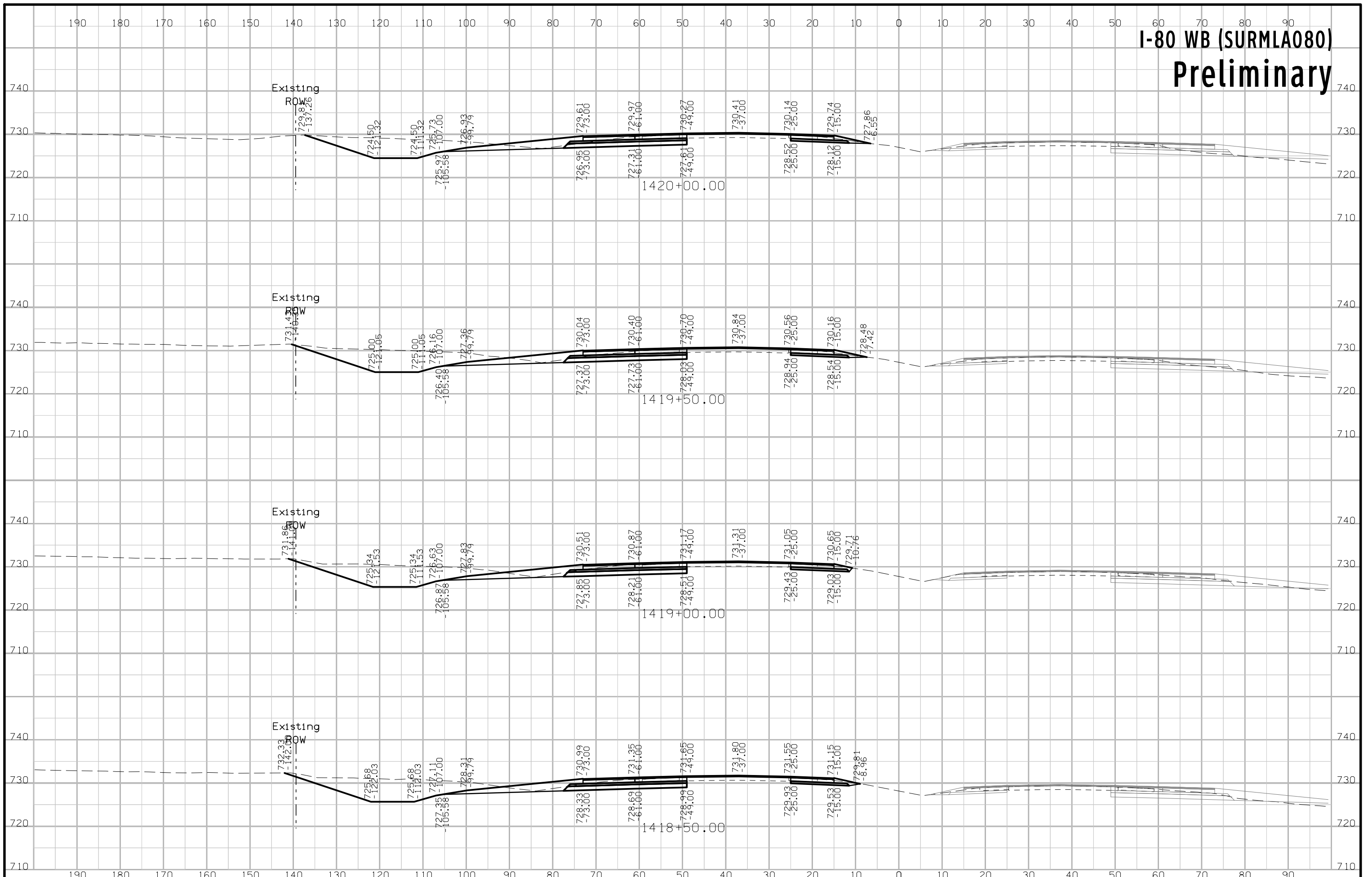

# I-80 WB (SURMLA080) Preliminary

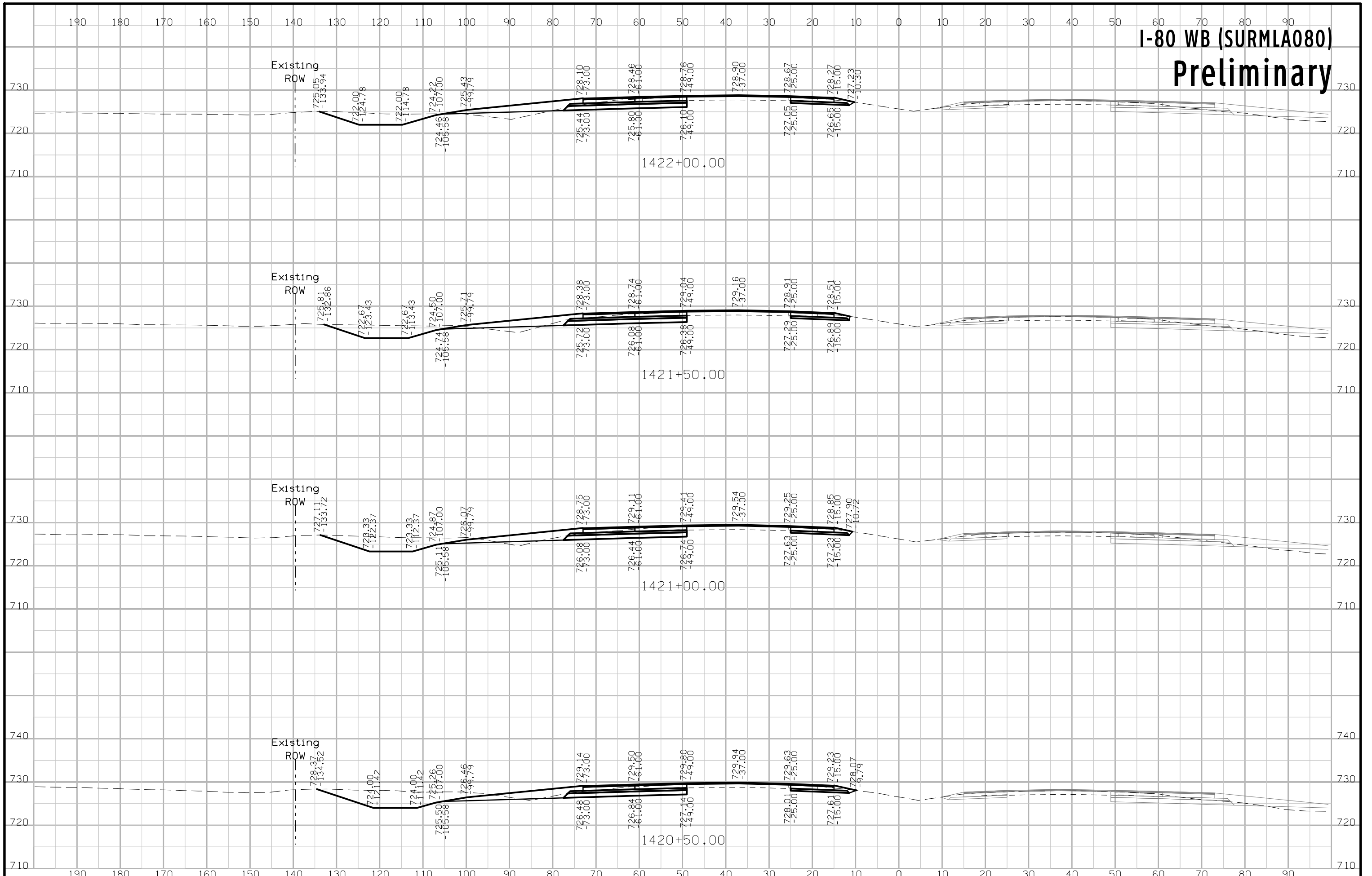

# I-80 WB (SURMLA080) Preliminary

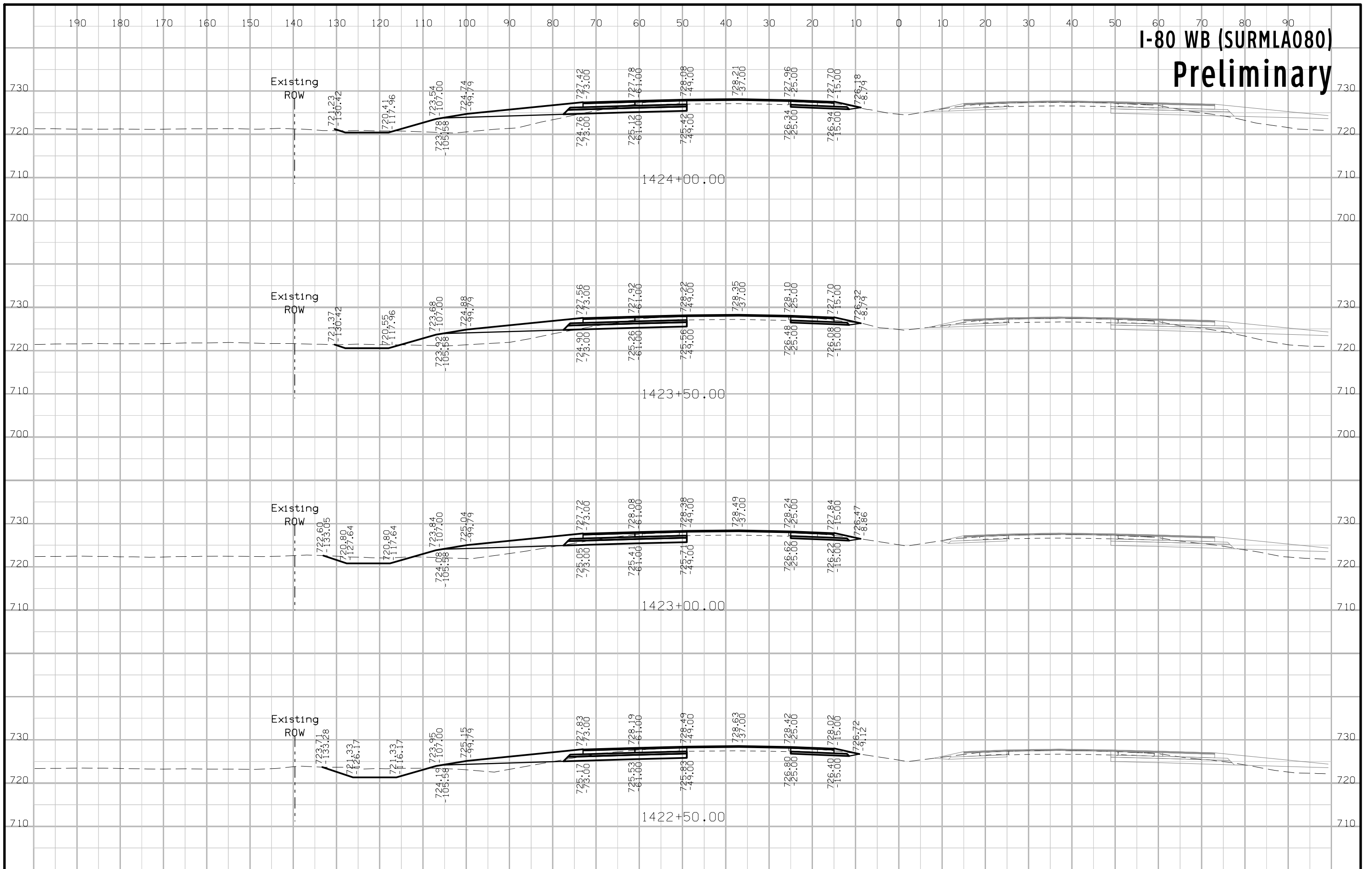

**SHEET INTENTIONALLY LEFT BLANK**

# I-80 EB (MLEBSH080) Preliminary

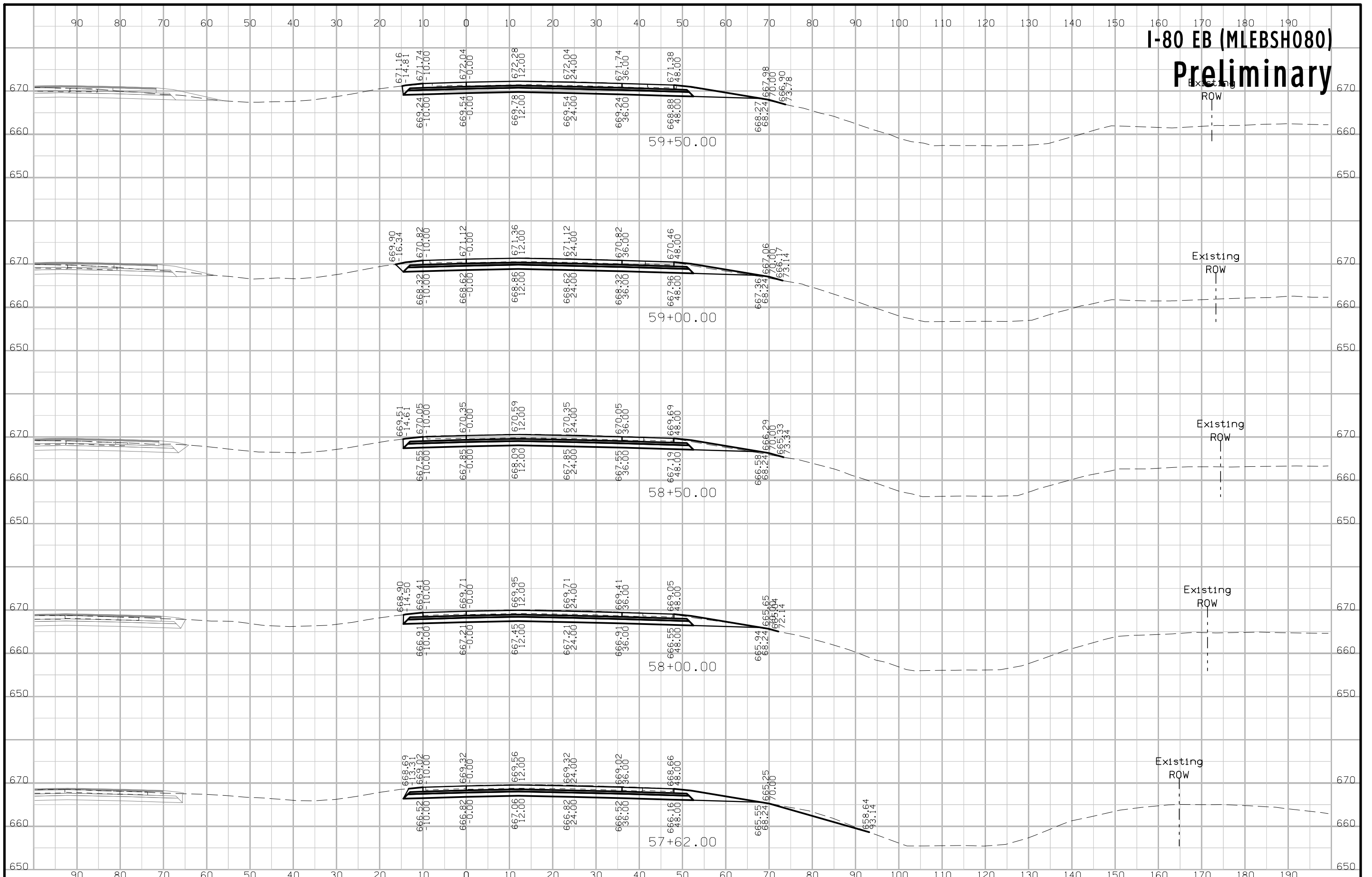



# I-80 EB (MLEBSH080) Preliminary

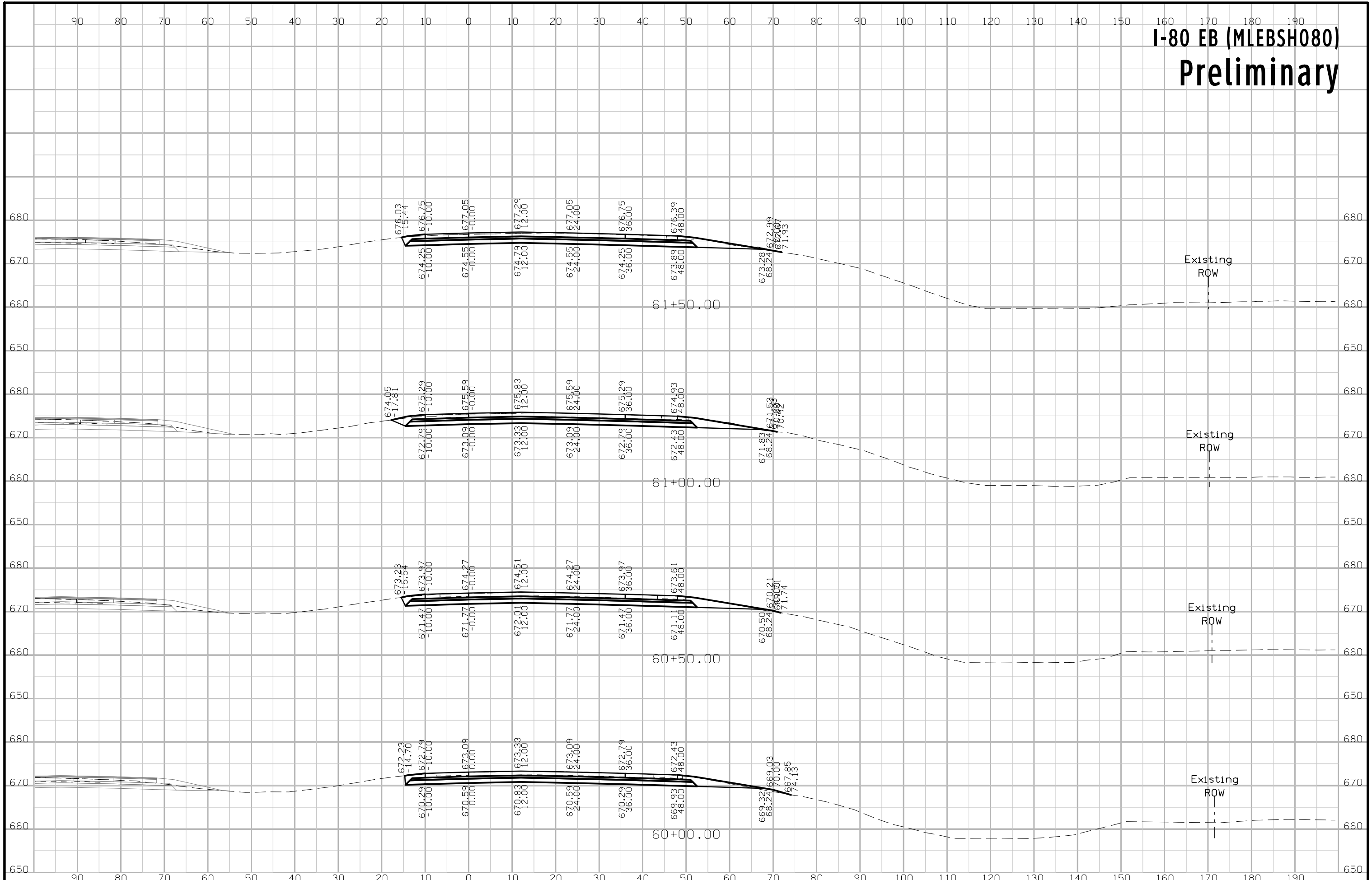

# I-80 EB (MLEBSH080) Preliminary

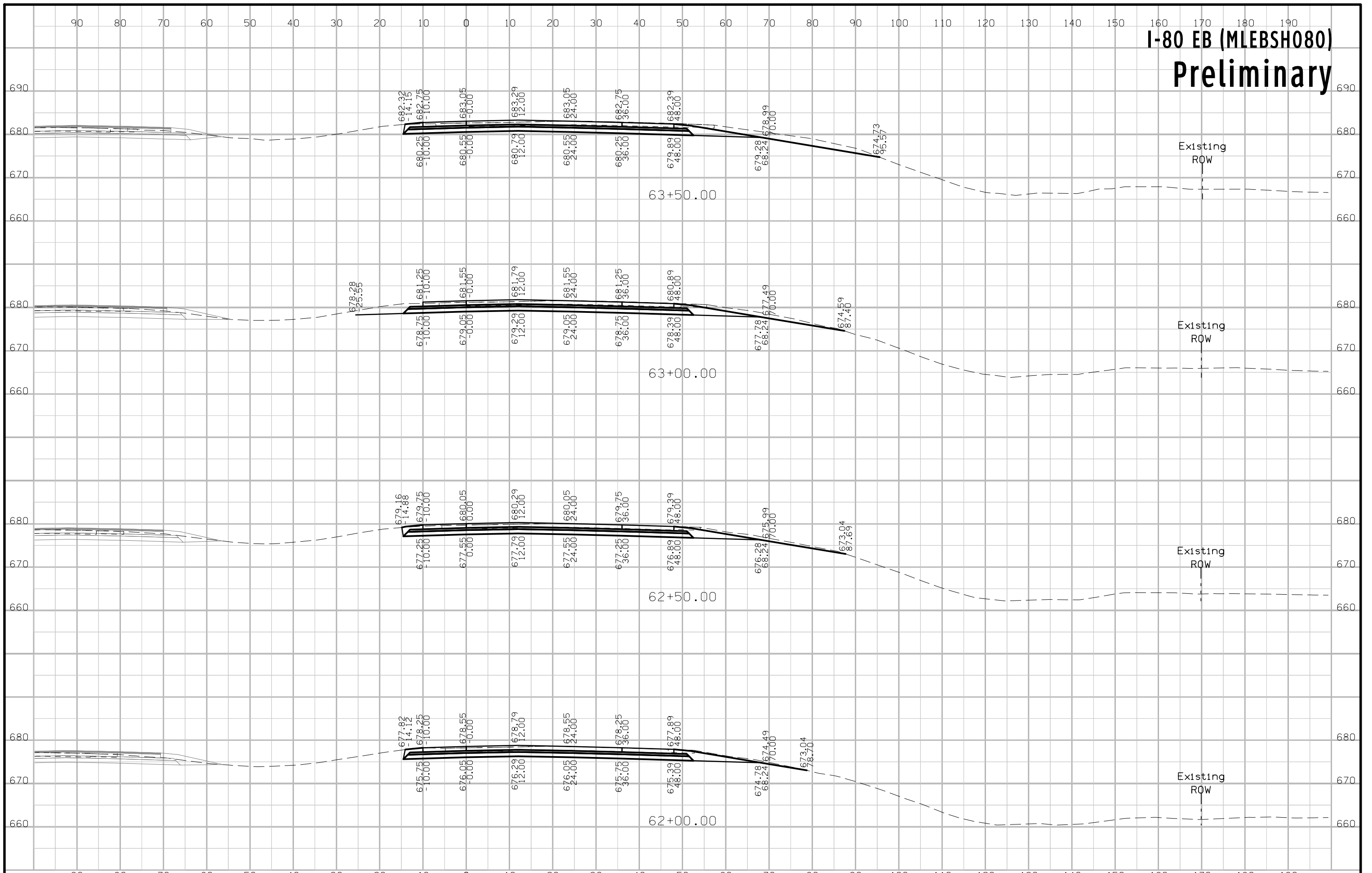

# I-80 EB (MLEBSH080) Preliminary

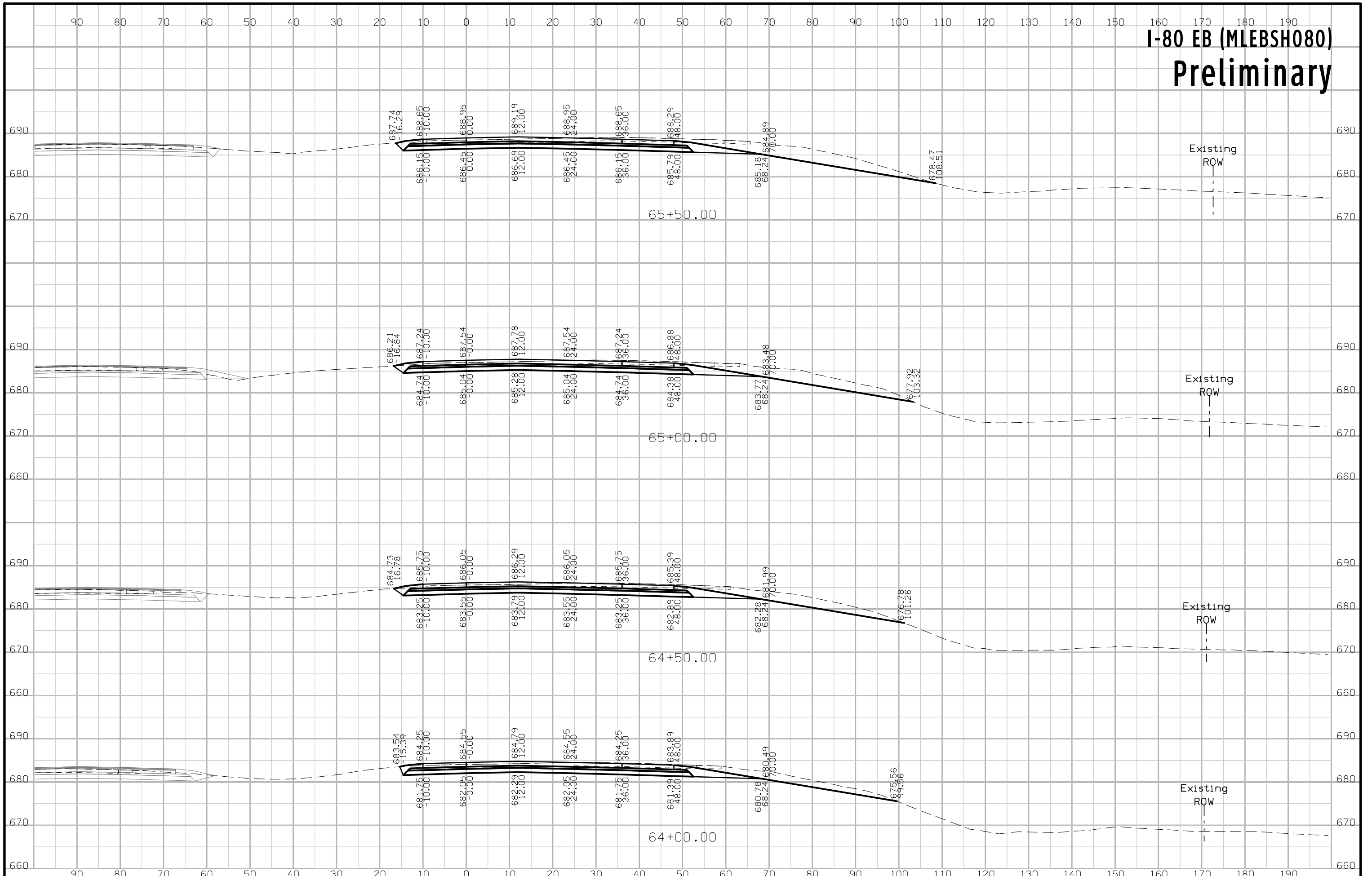

# I-80 EB (MLEBSH080) Preliminary

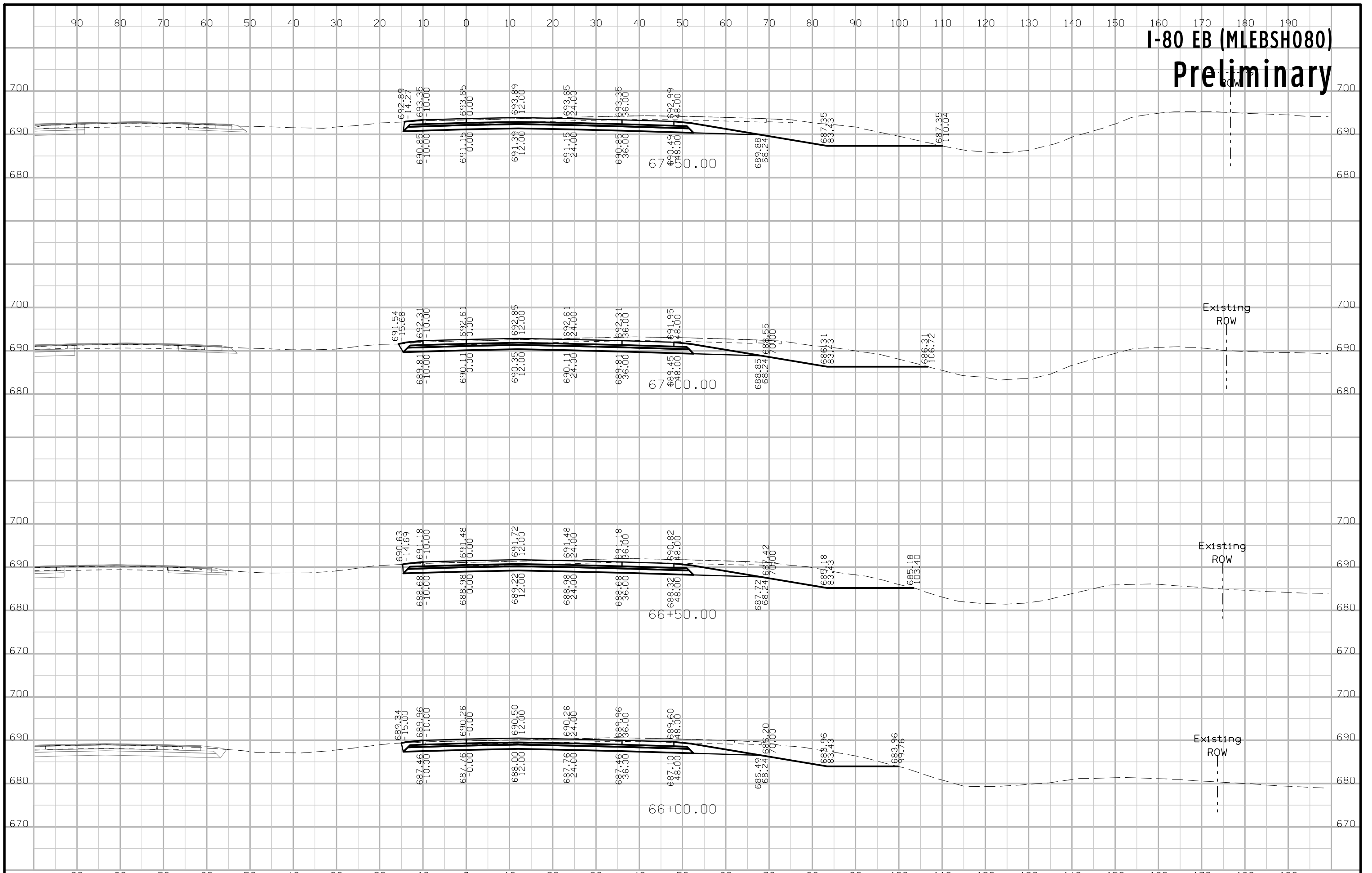

# I-80 EB (MLEBSH080) Preliminary

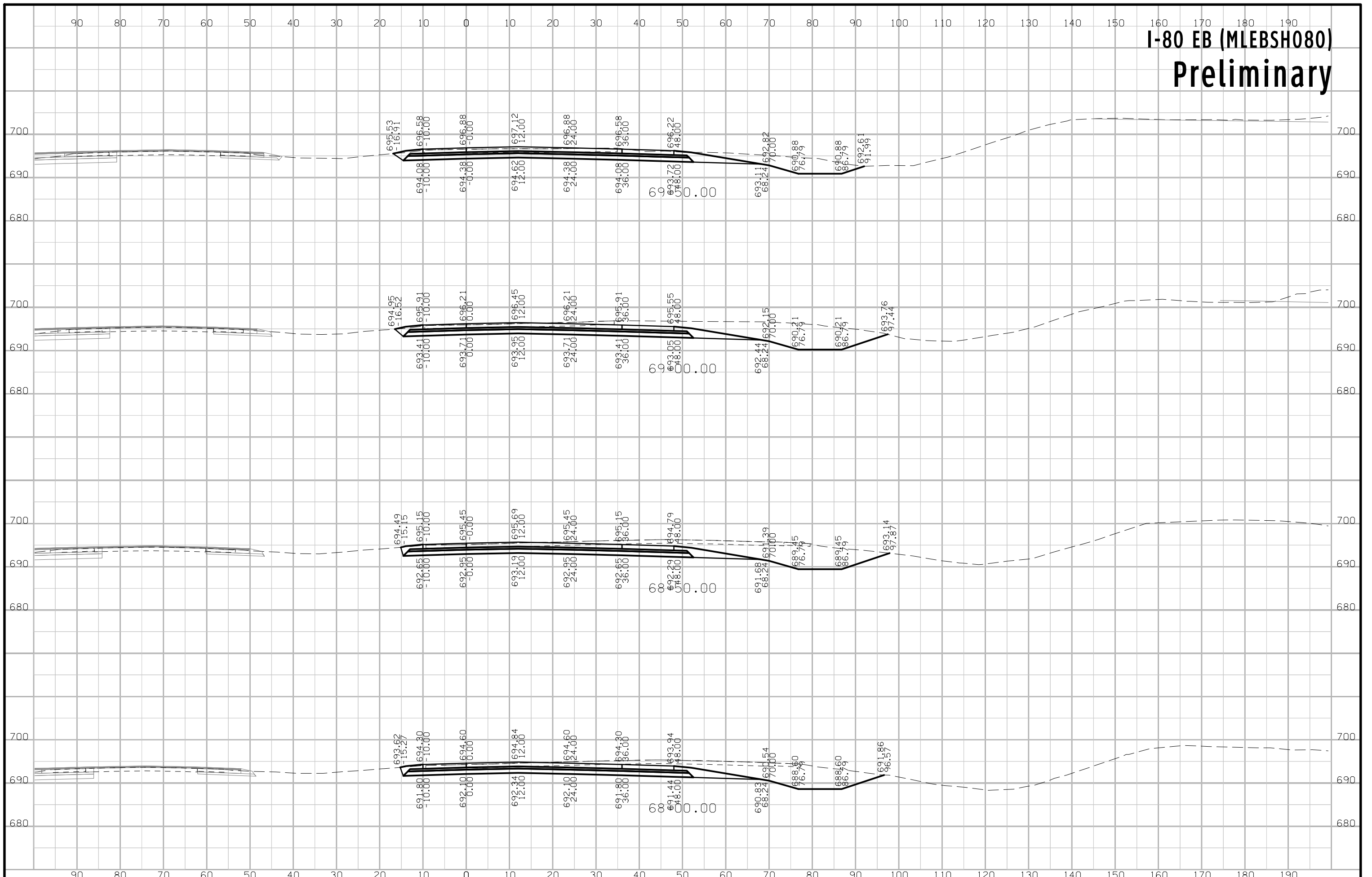

# I-80 EB (MLEBSH080) Preliminary

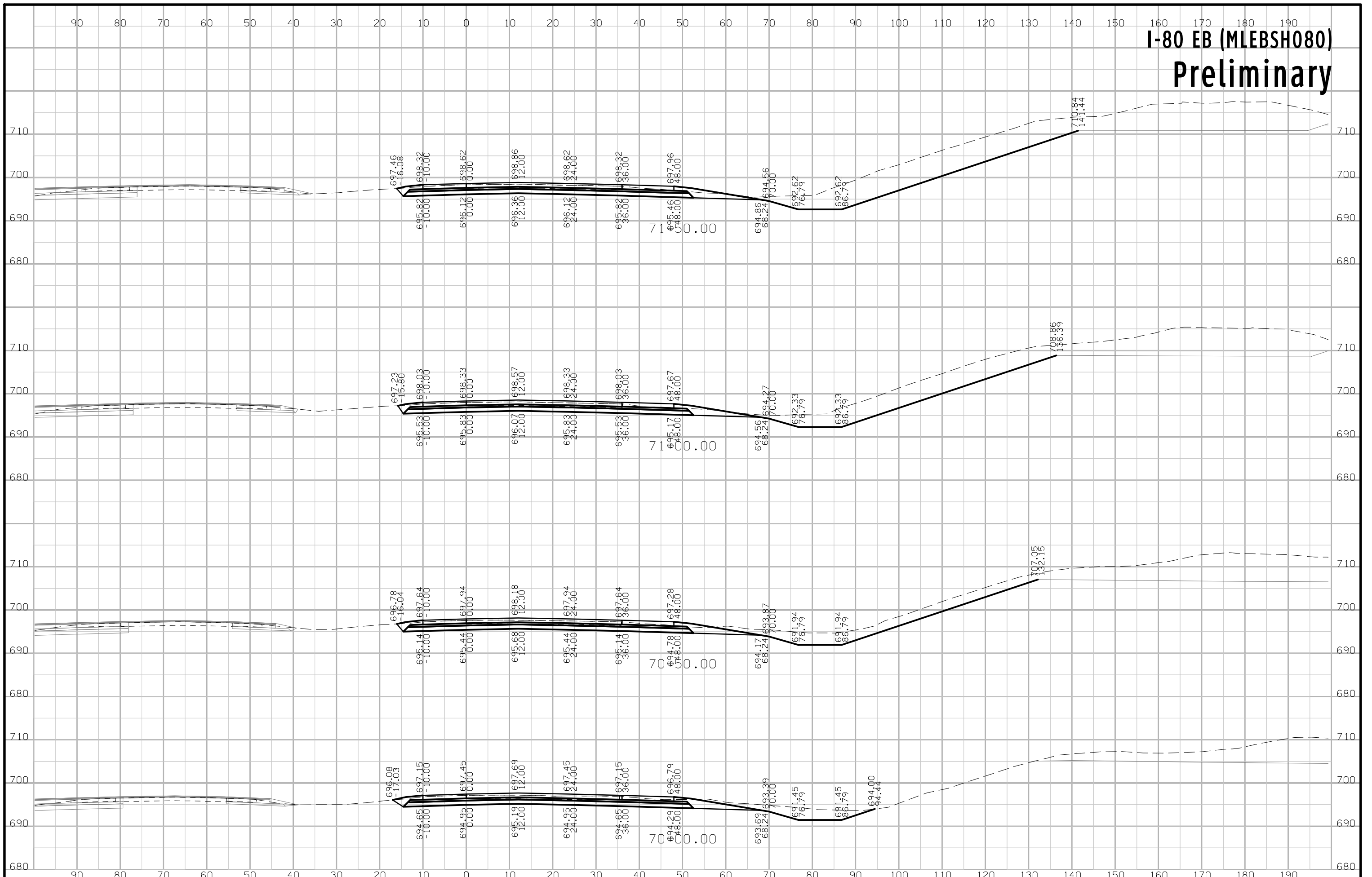



# I-80 EB (MLEBSH080) Preliminary

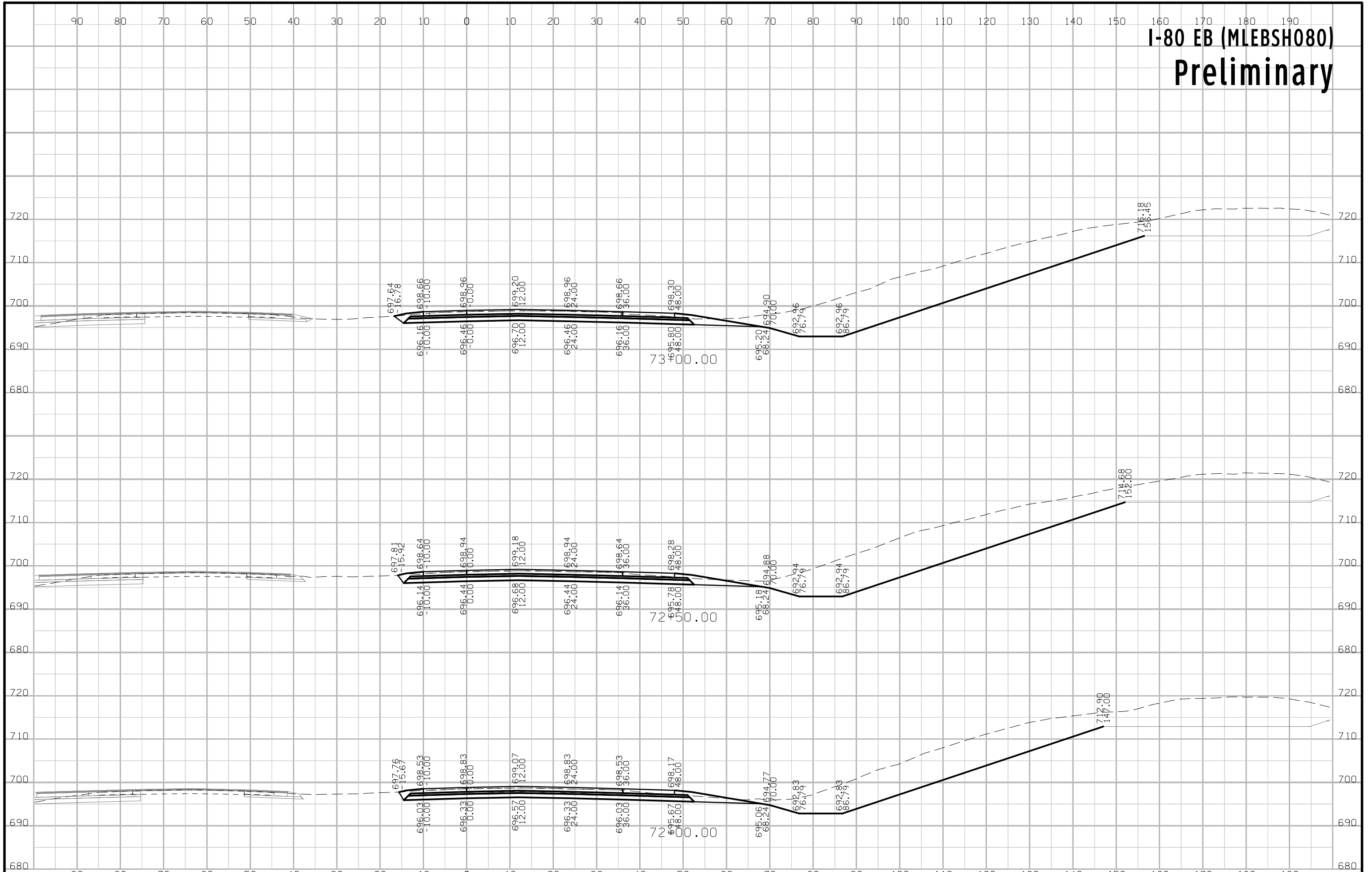

# I-80 EB (MLEBSH080) Preliminary

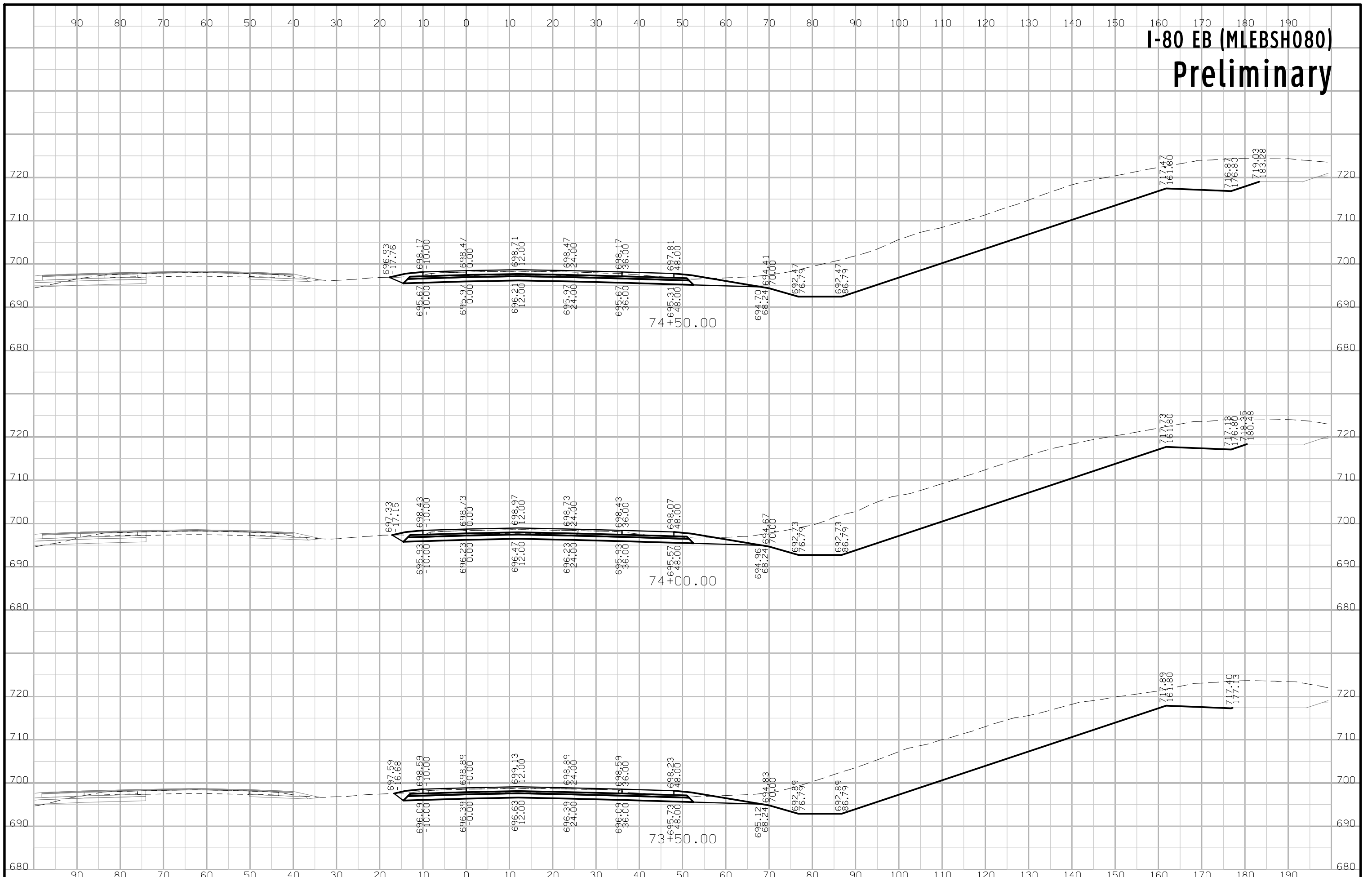

# I-80 EB (MLEBSH080) Preliminary

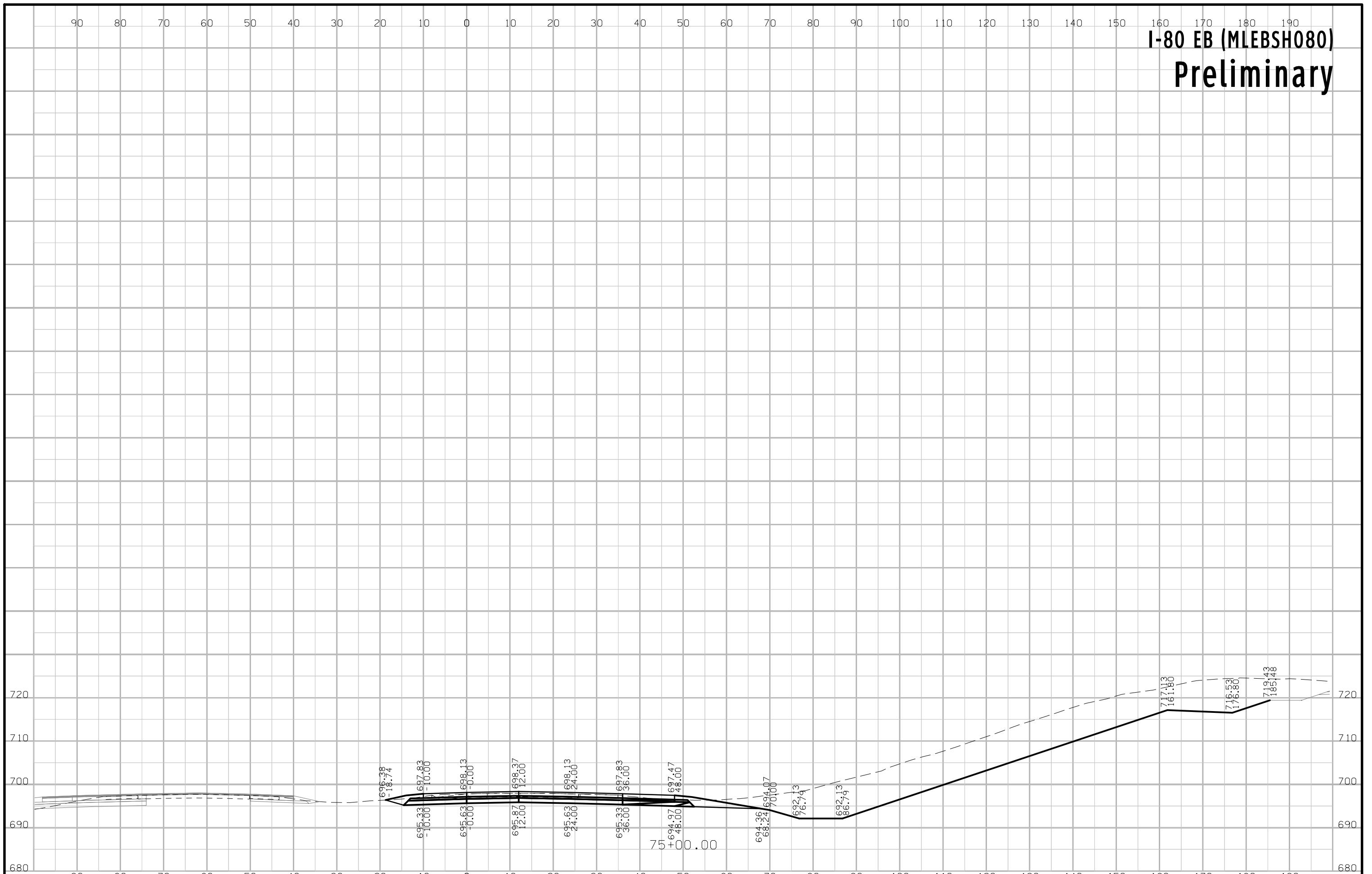

# I-80 EB (SURMLA080) Preliminary

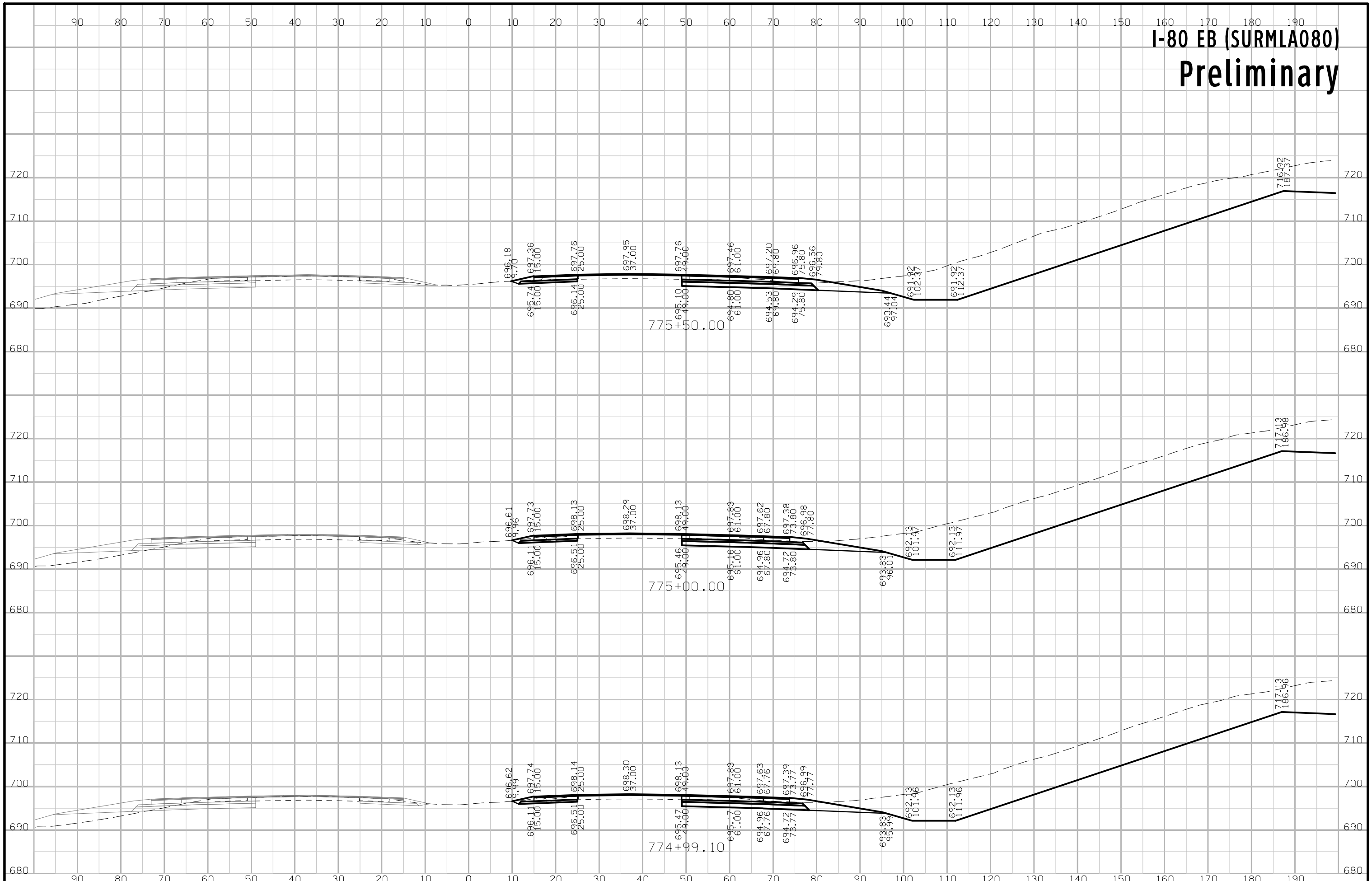

# I-80 EB (SURMLA080) Preliminary

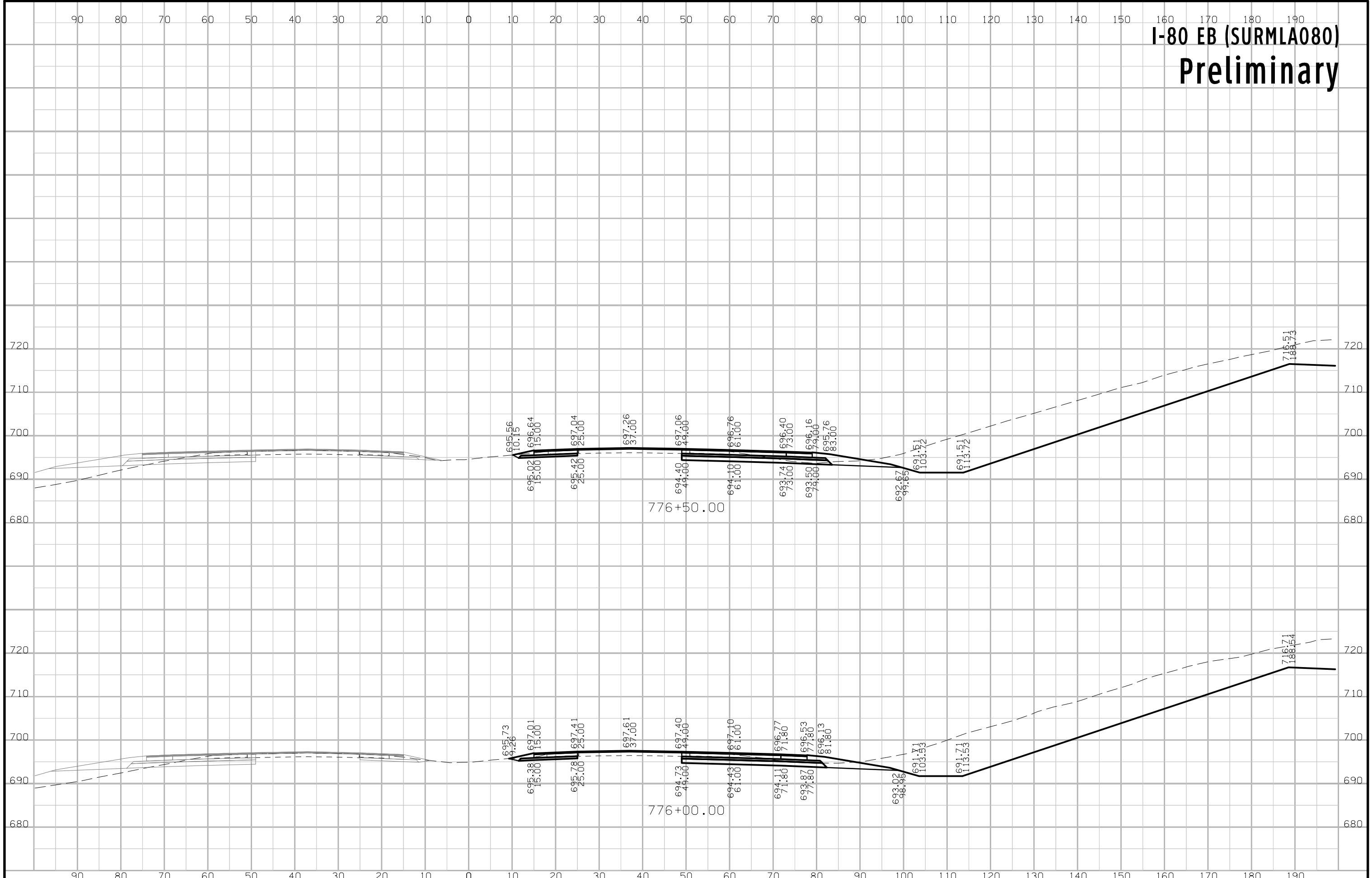

# I-80 EB (SURMLA080) Preliminary

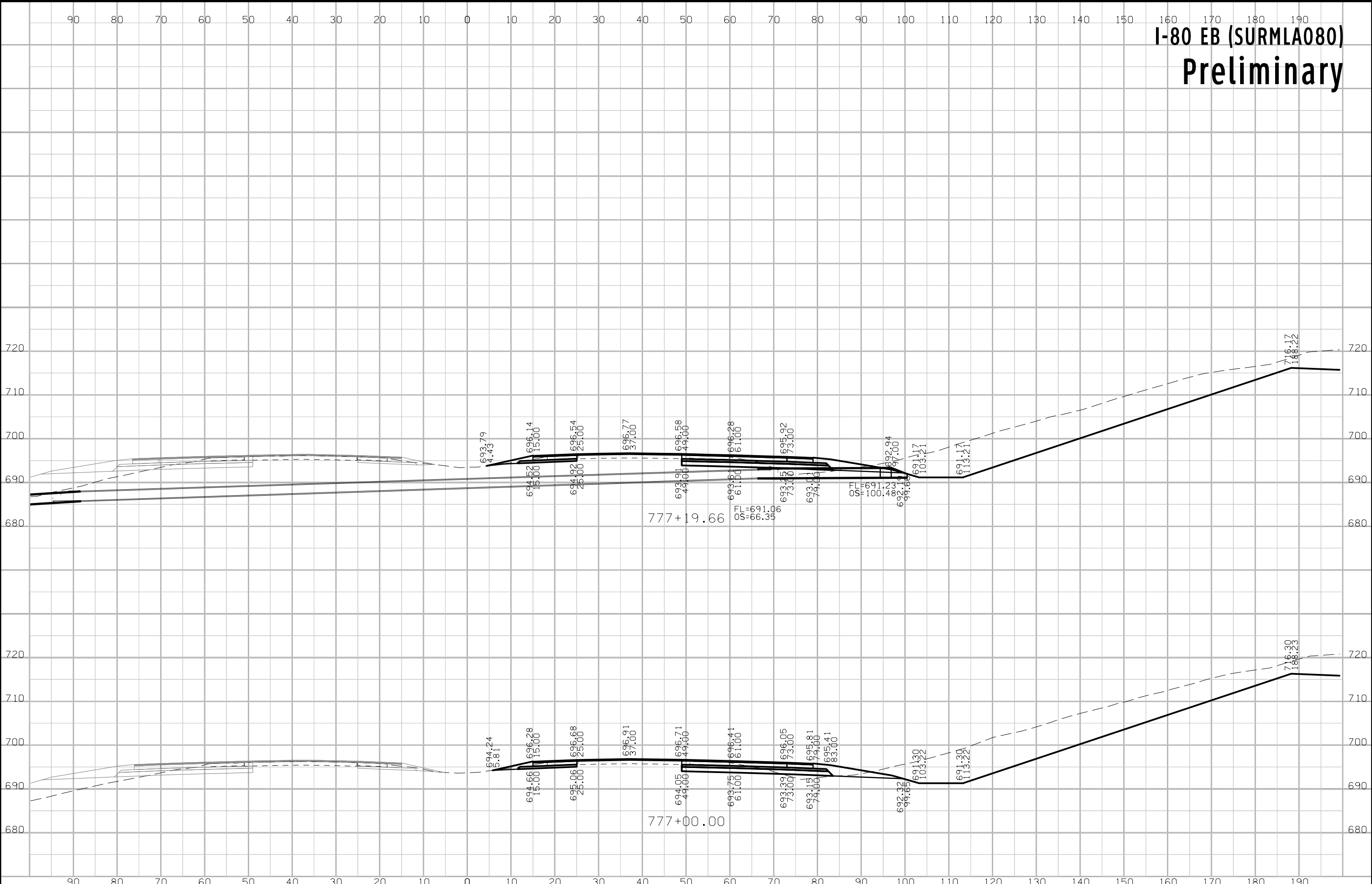

# I-80 EB (SURMLA080) Preliminary

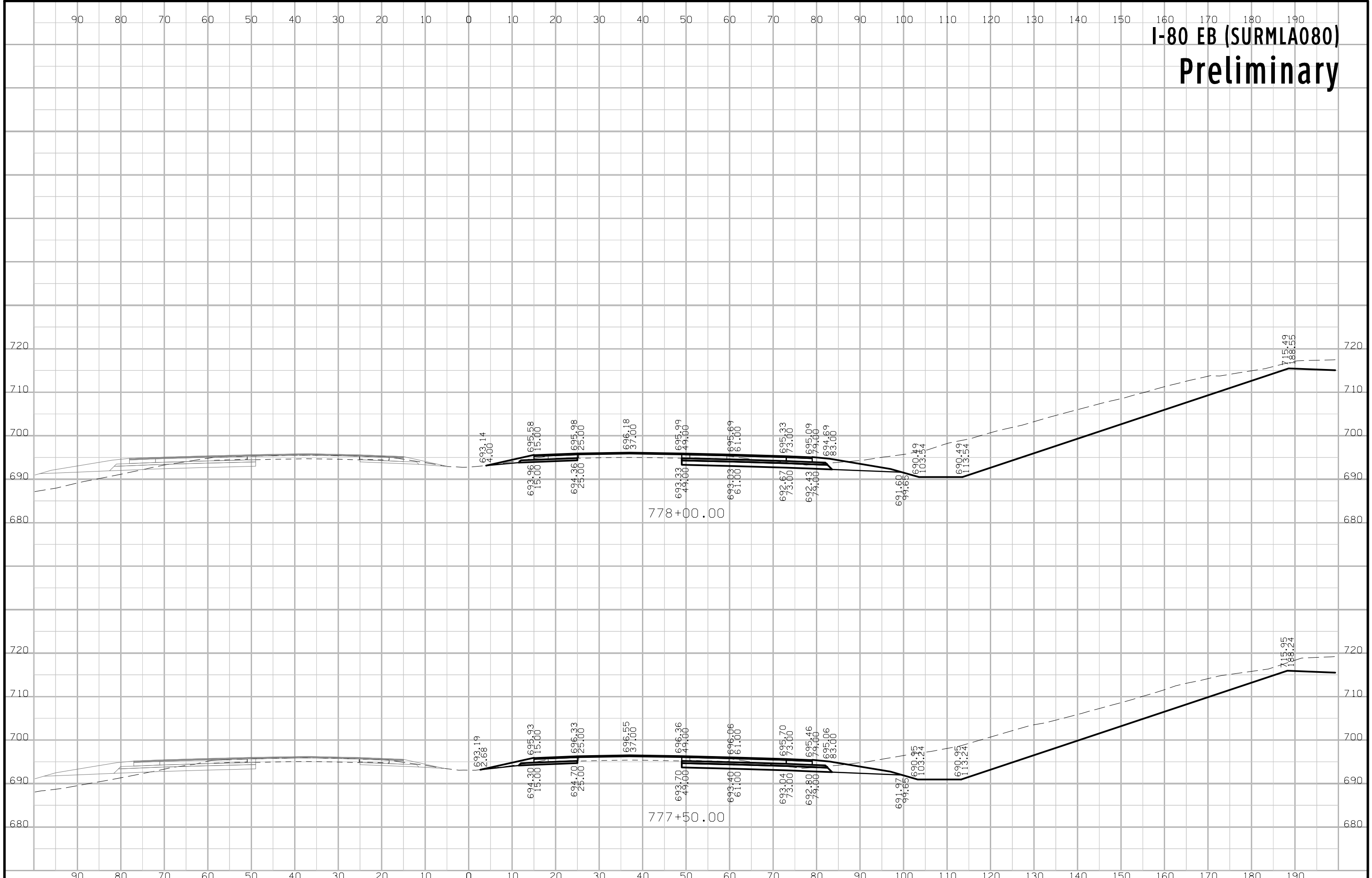



# I-80 EB (SURMLA080) Preliminary

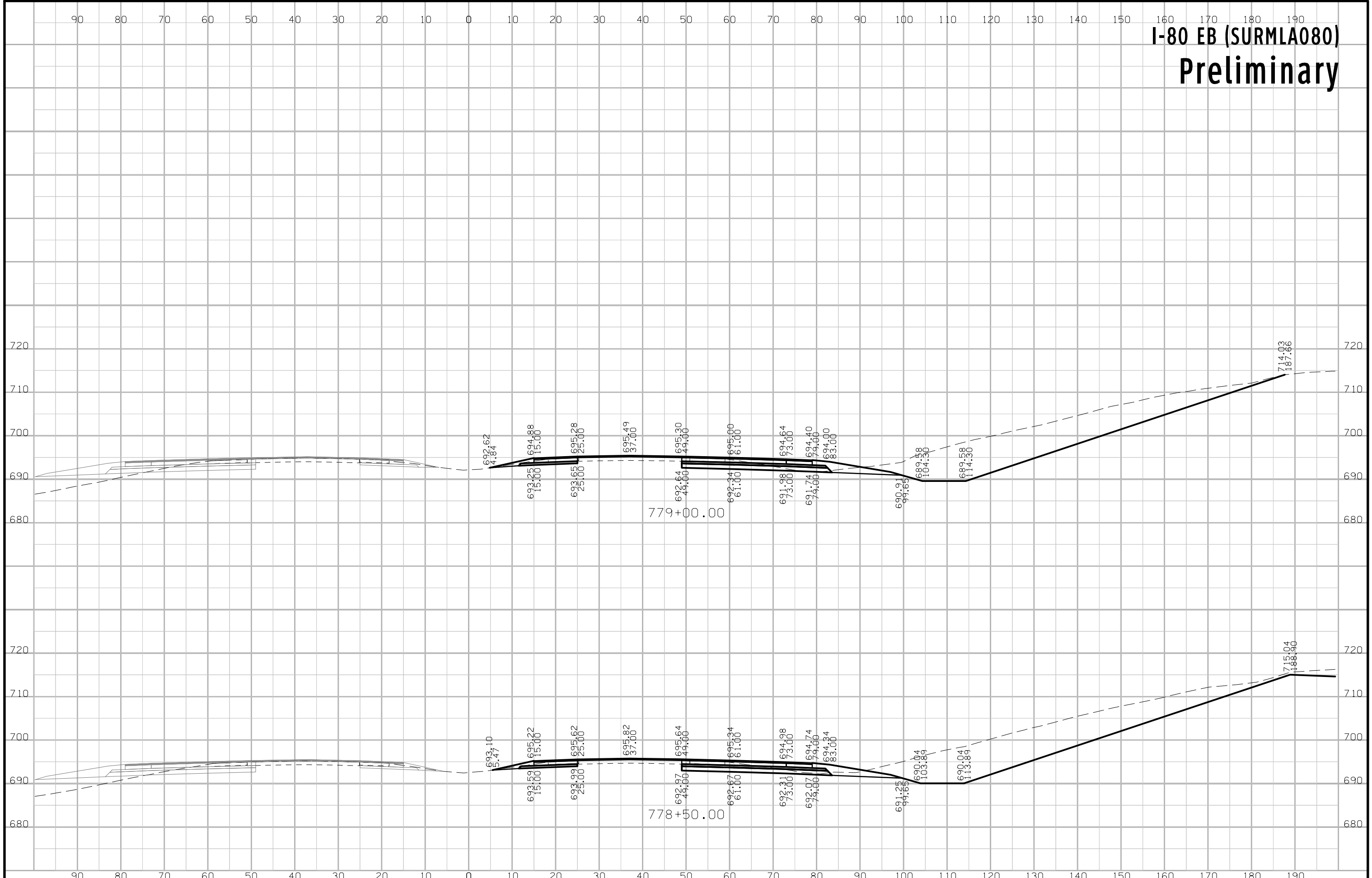

# I-80 EB (SURMLA080) Preliminary

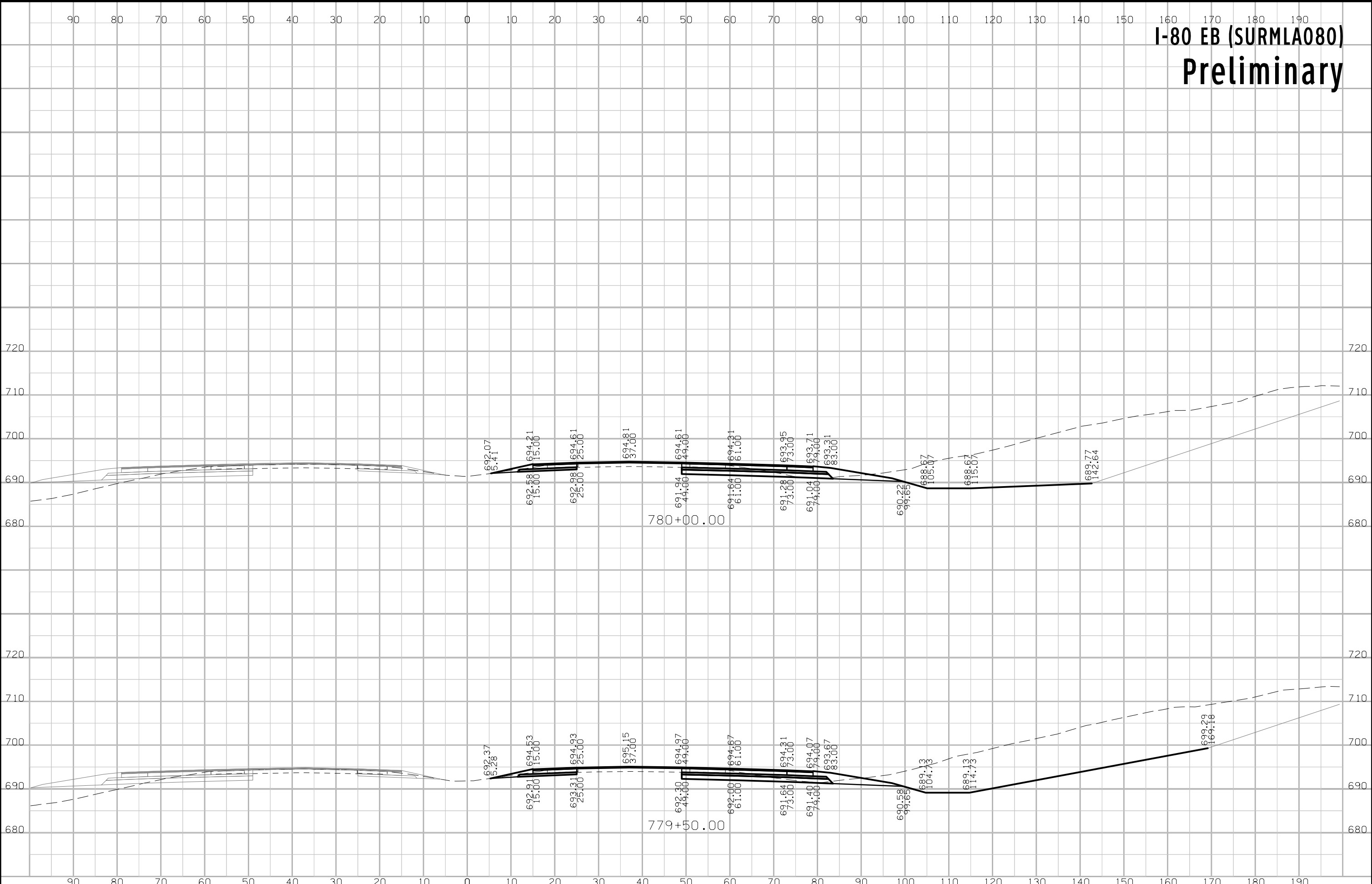

# I-80 EB (SURMLA080) Preliminary

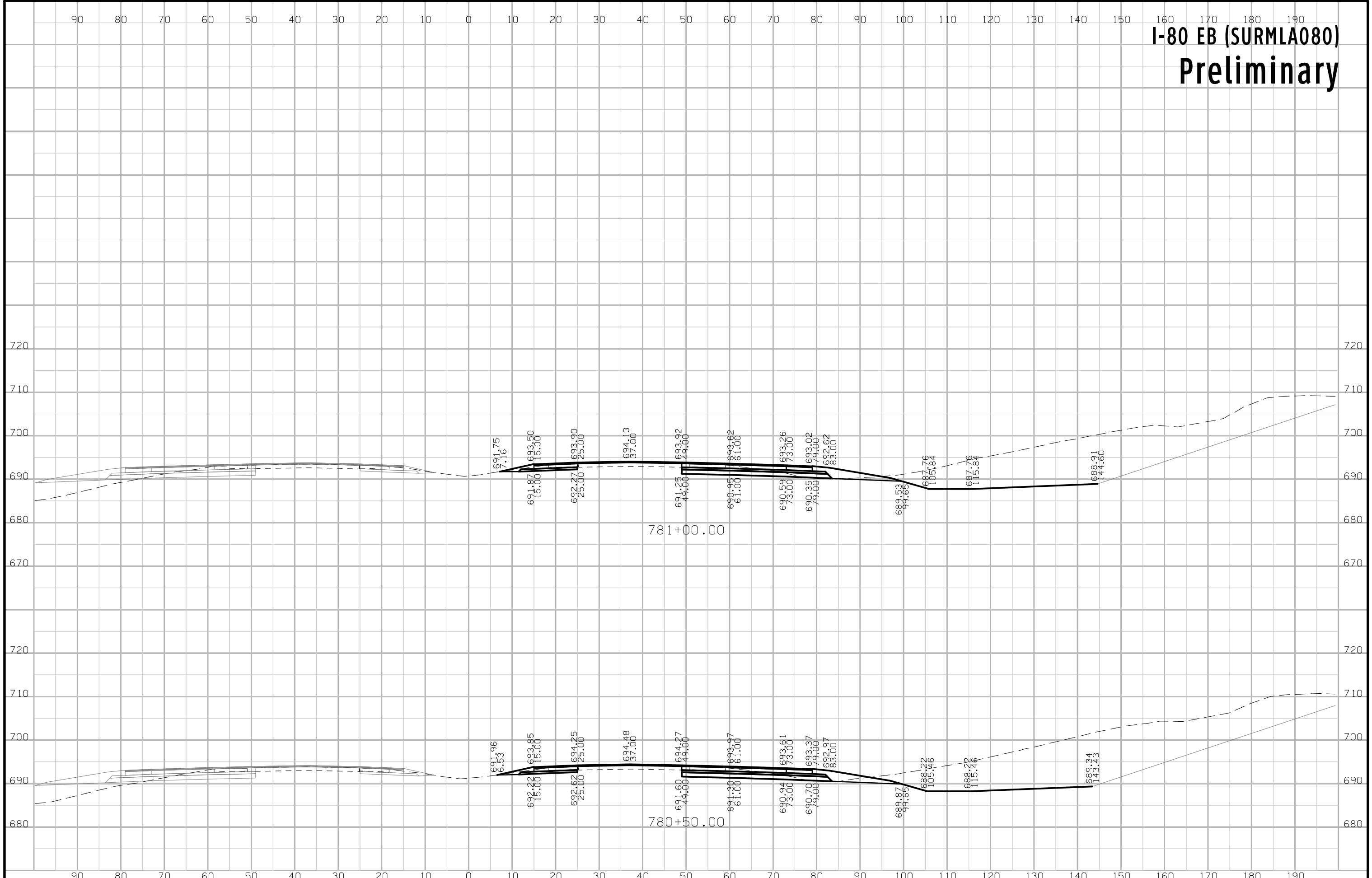

# I-80 EB (SURMLA080) Preliminary

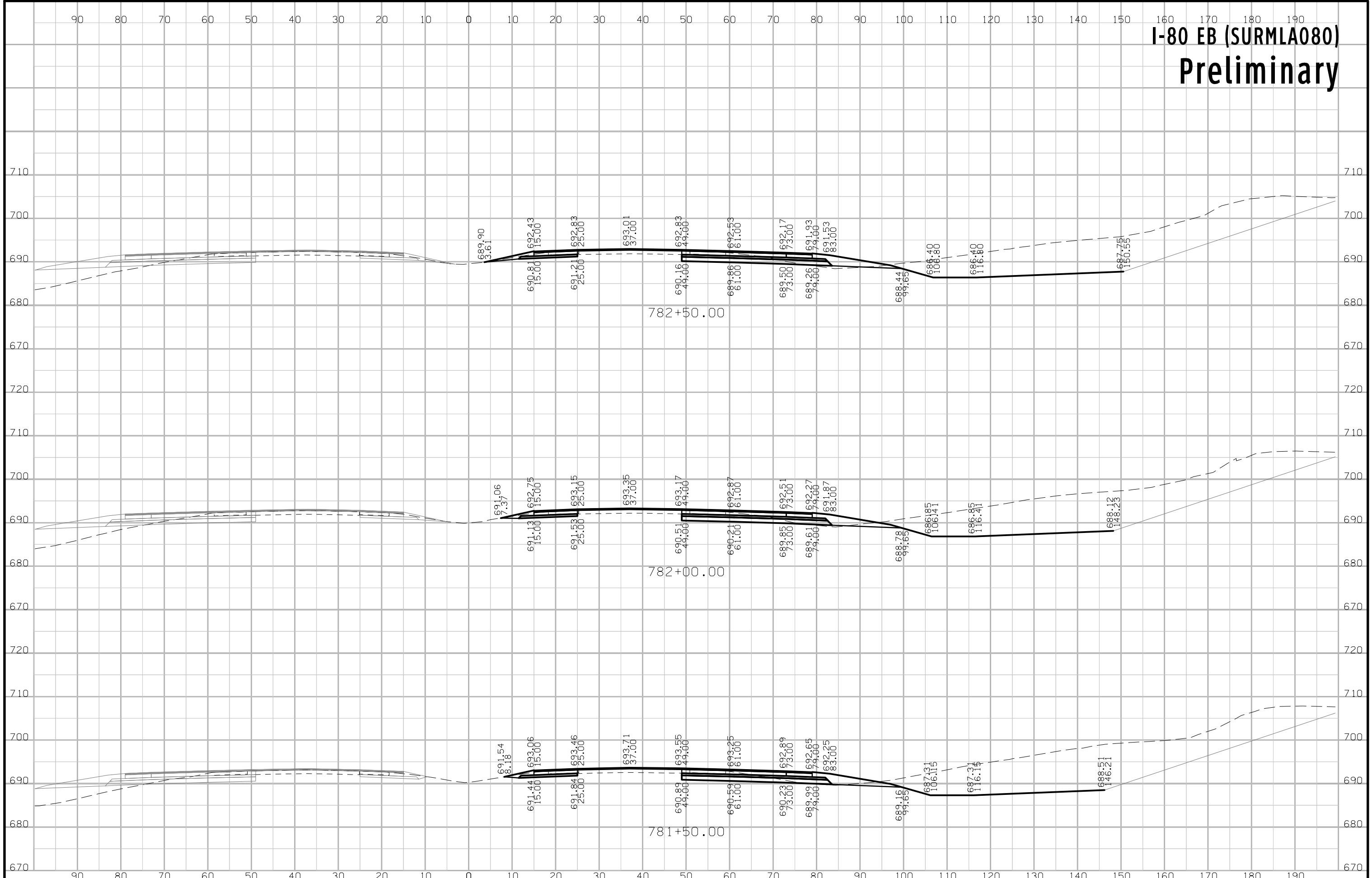

# I-80 EB (SURMLA080) Preliminary

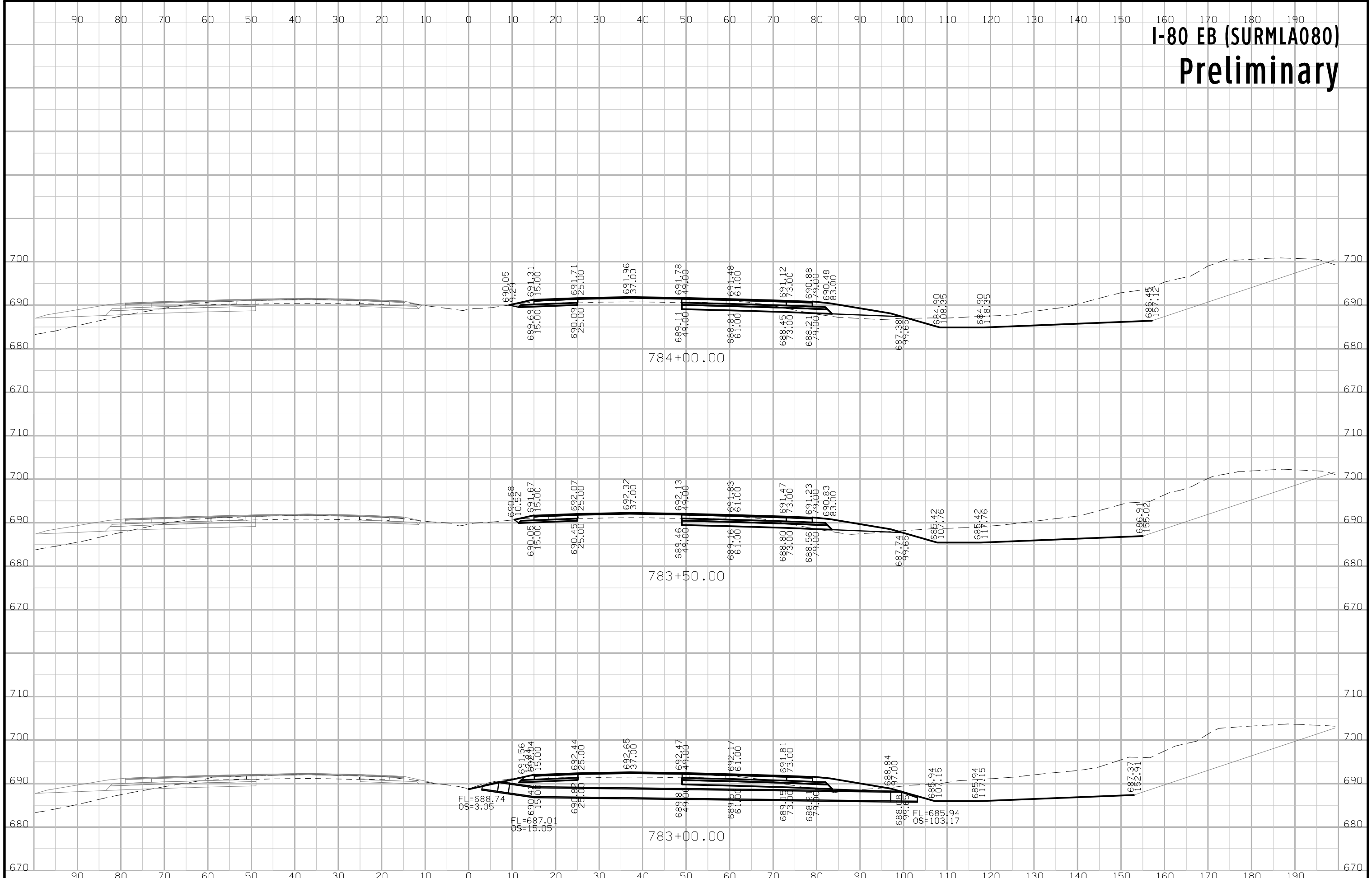

# I-80 EB (SURMLA080) Preliminary

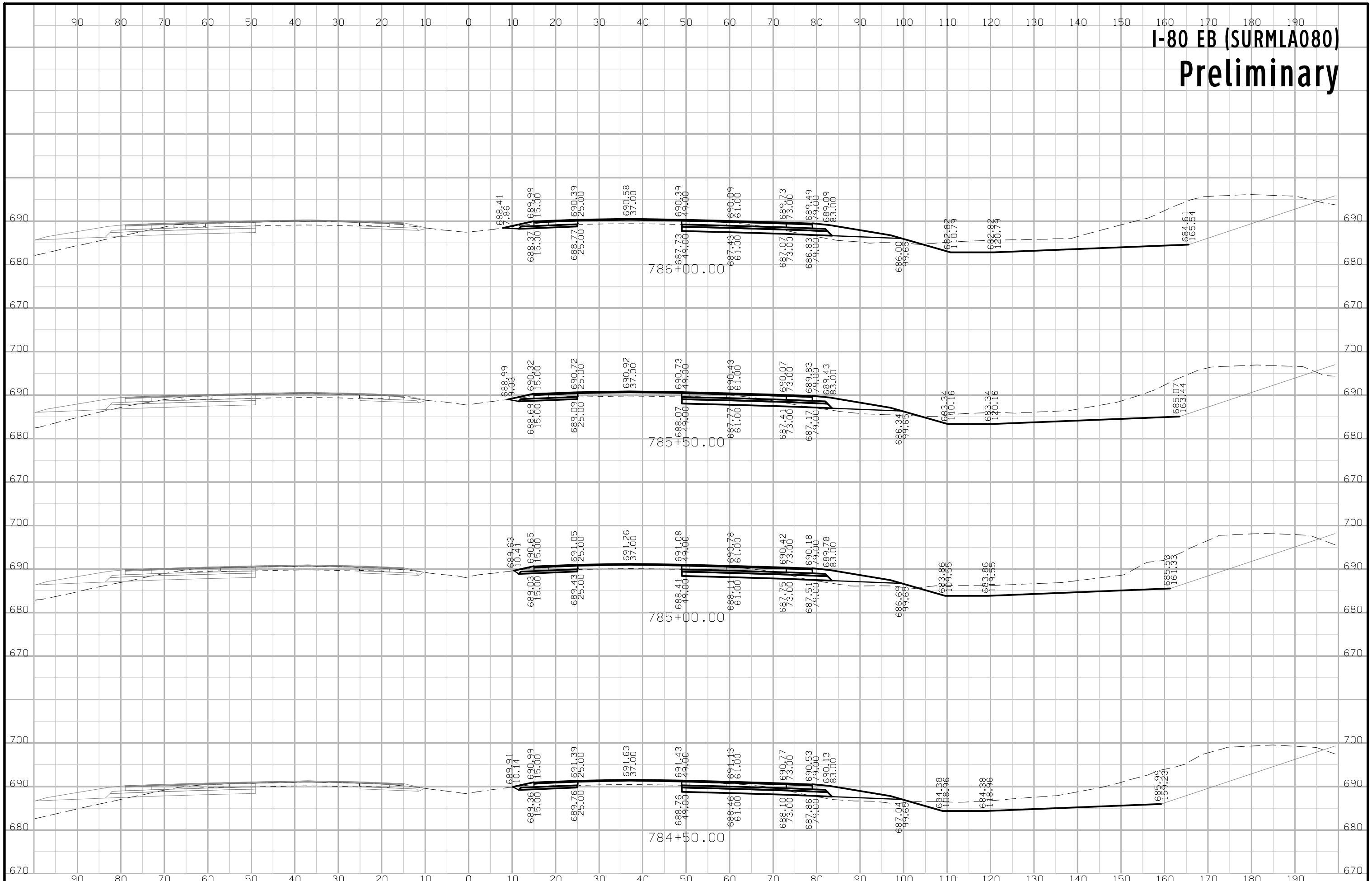

# I-80 EB (SURMLA080) Preliminary

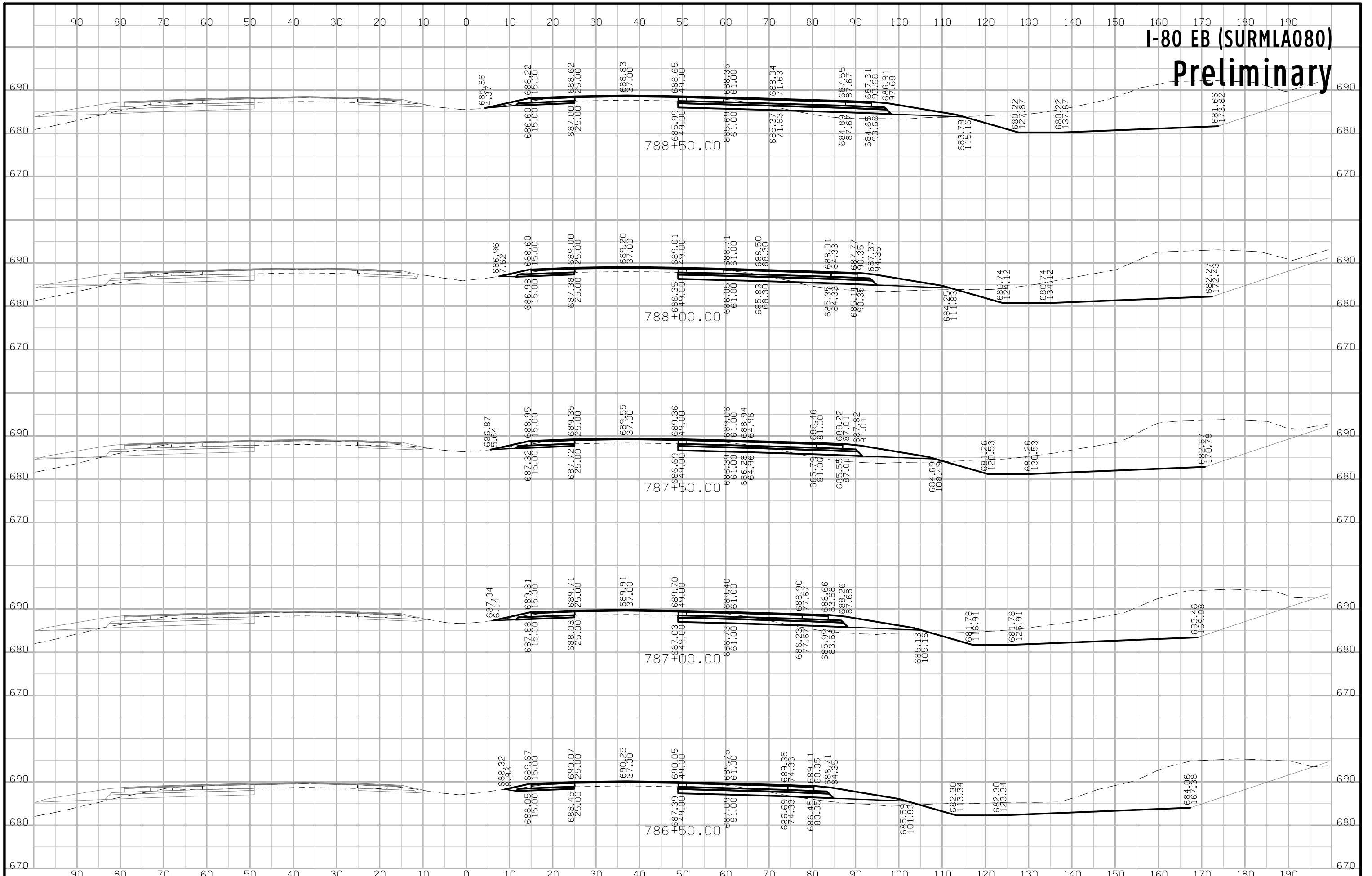



# I-80 EB (SURMLA080) Preliminary

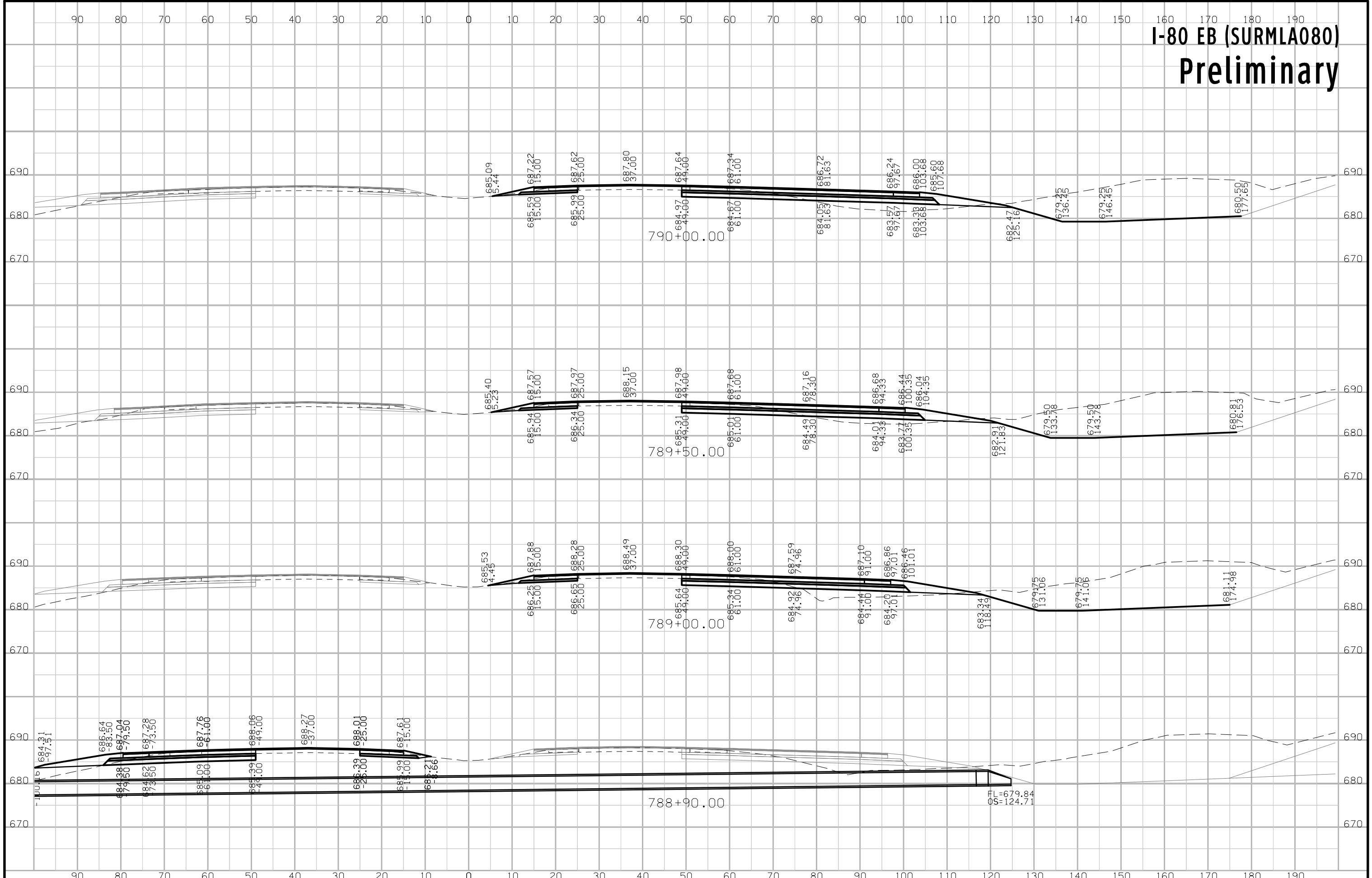

# I-80 EB (SURMLA080) Preliminary

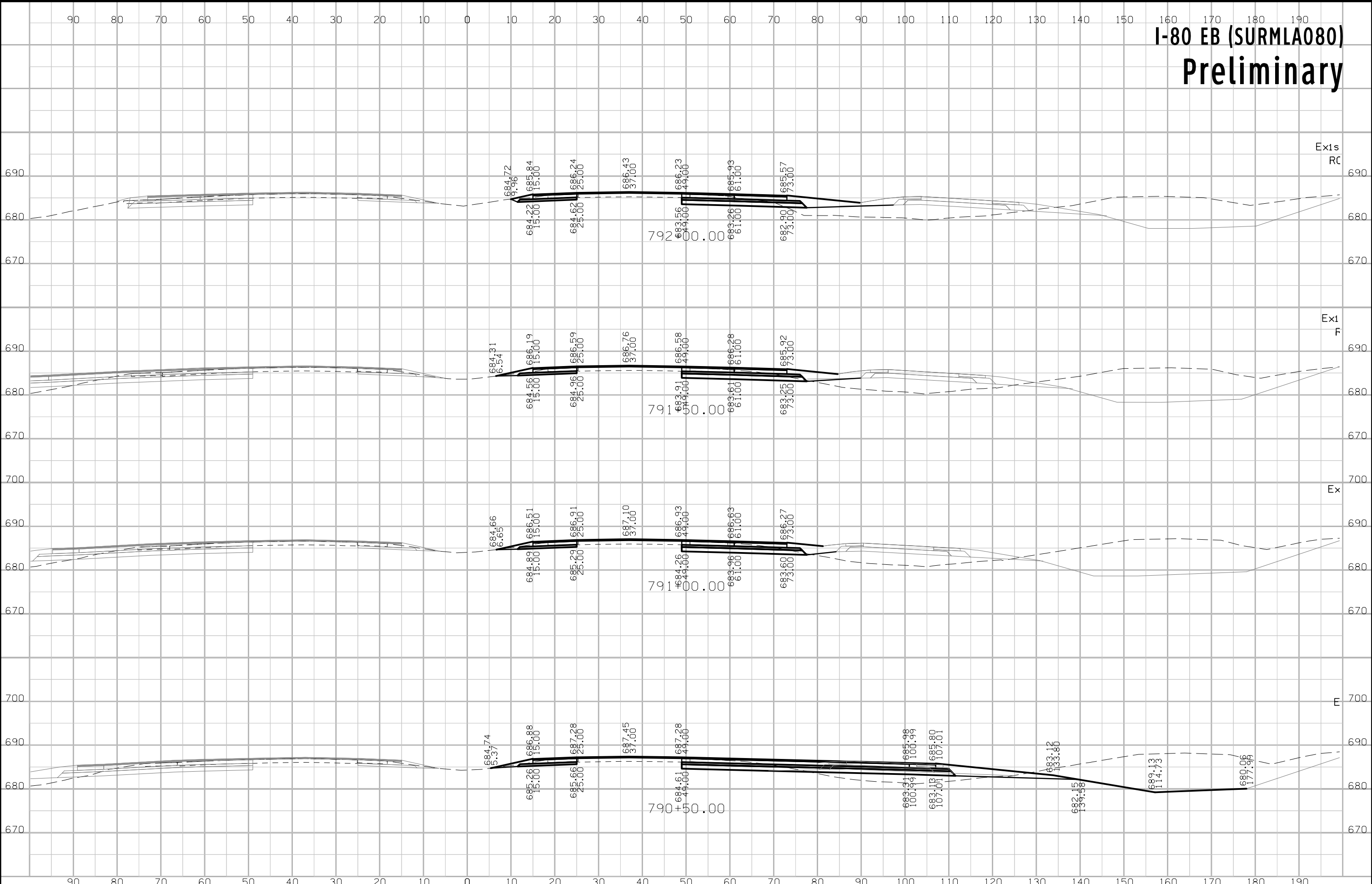

# I-80 EB (SURMLA080) Preliminary

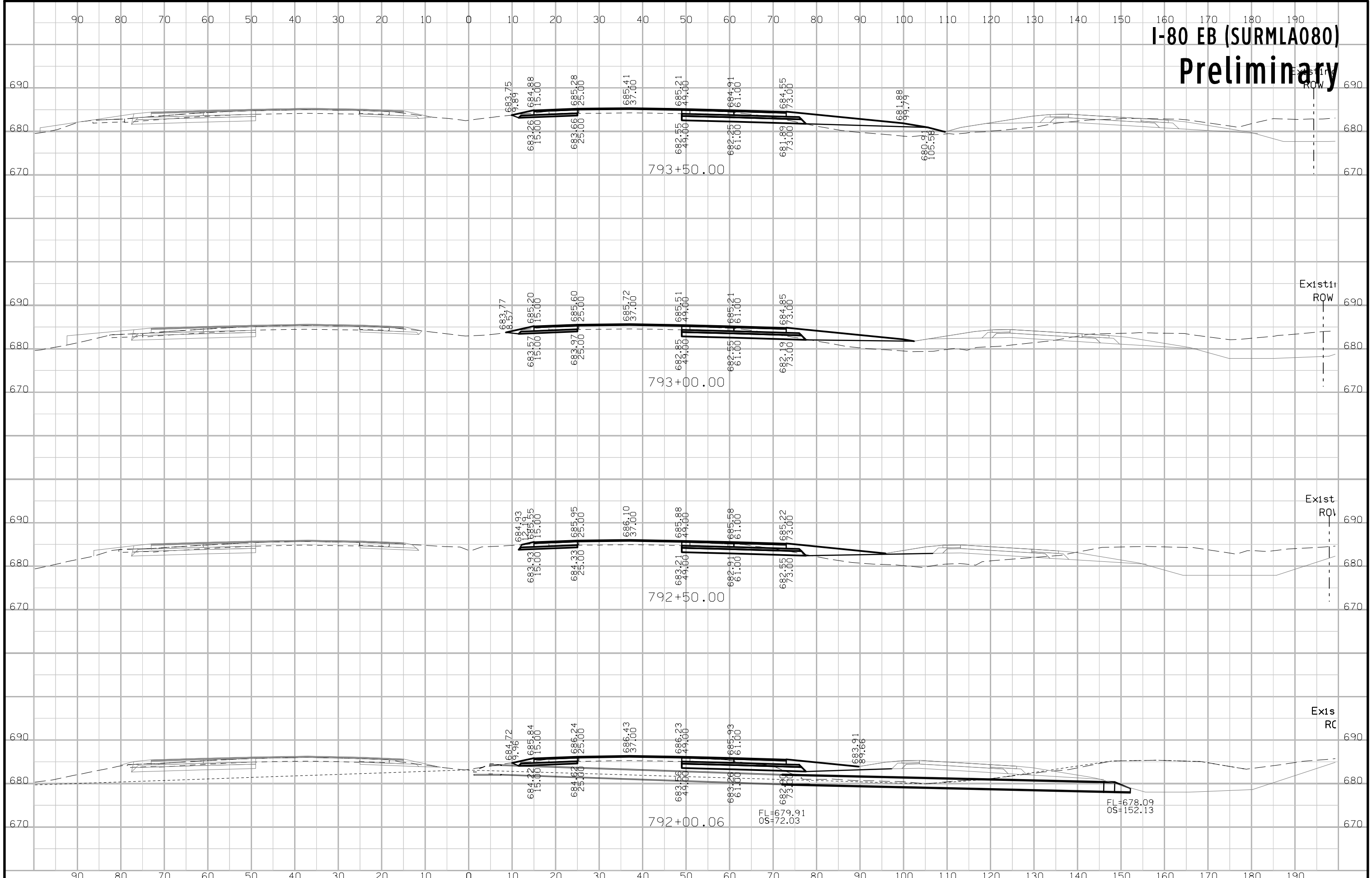

# I-80 EB (SURMLA080) Preliminary

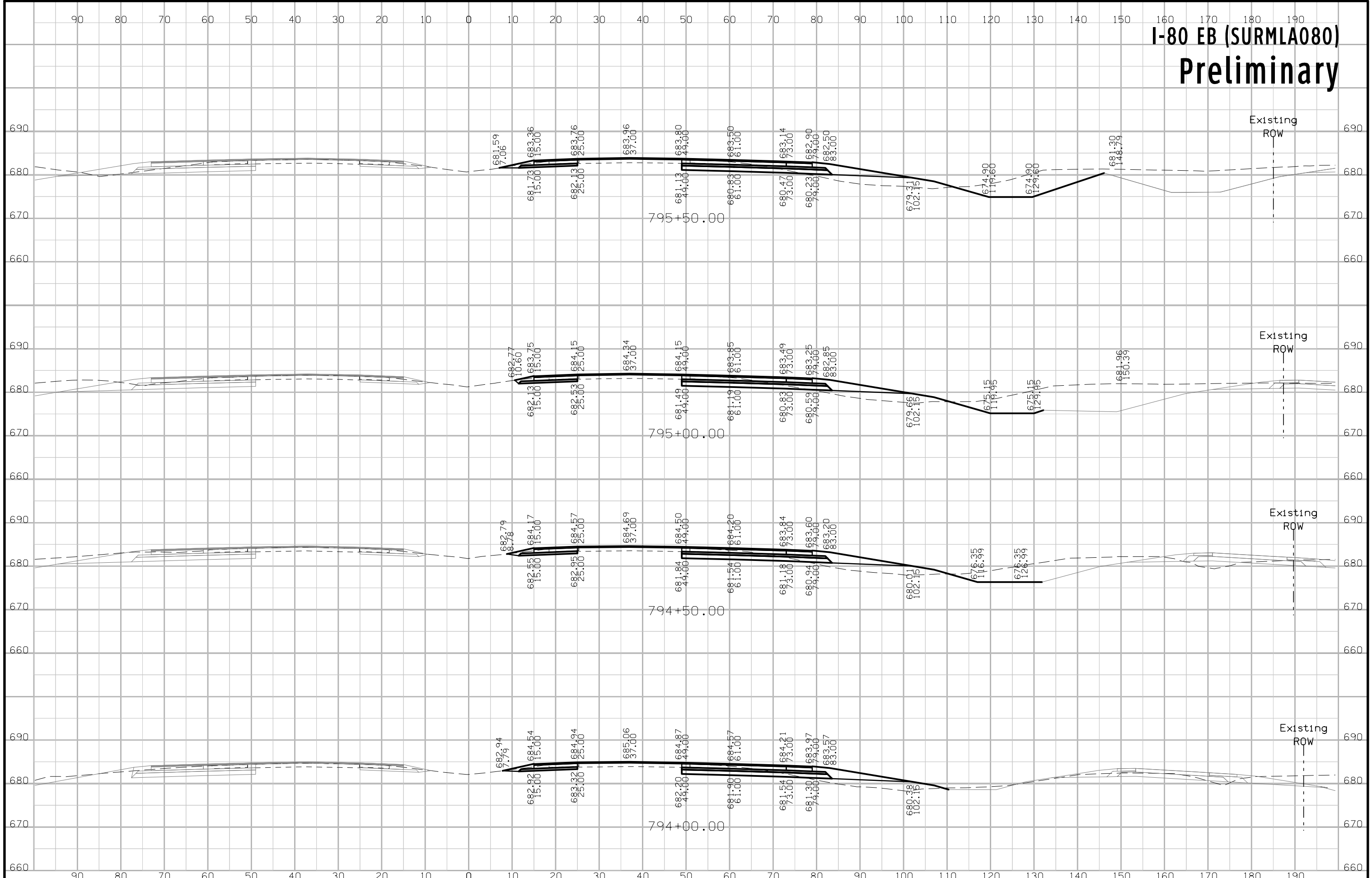

# I-80 EB (SURMLA080) Preliminary

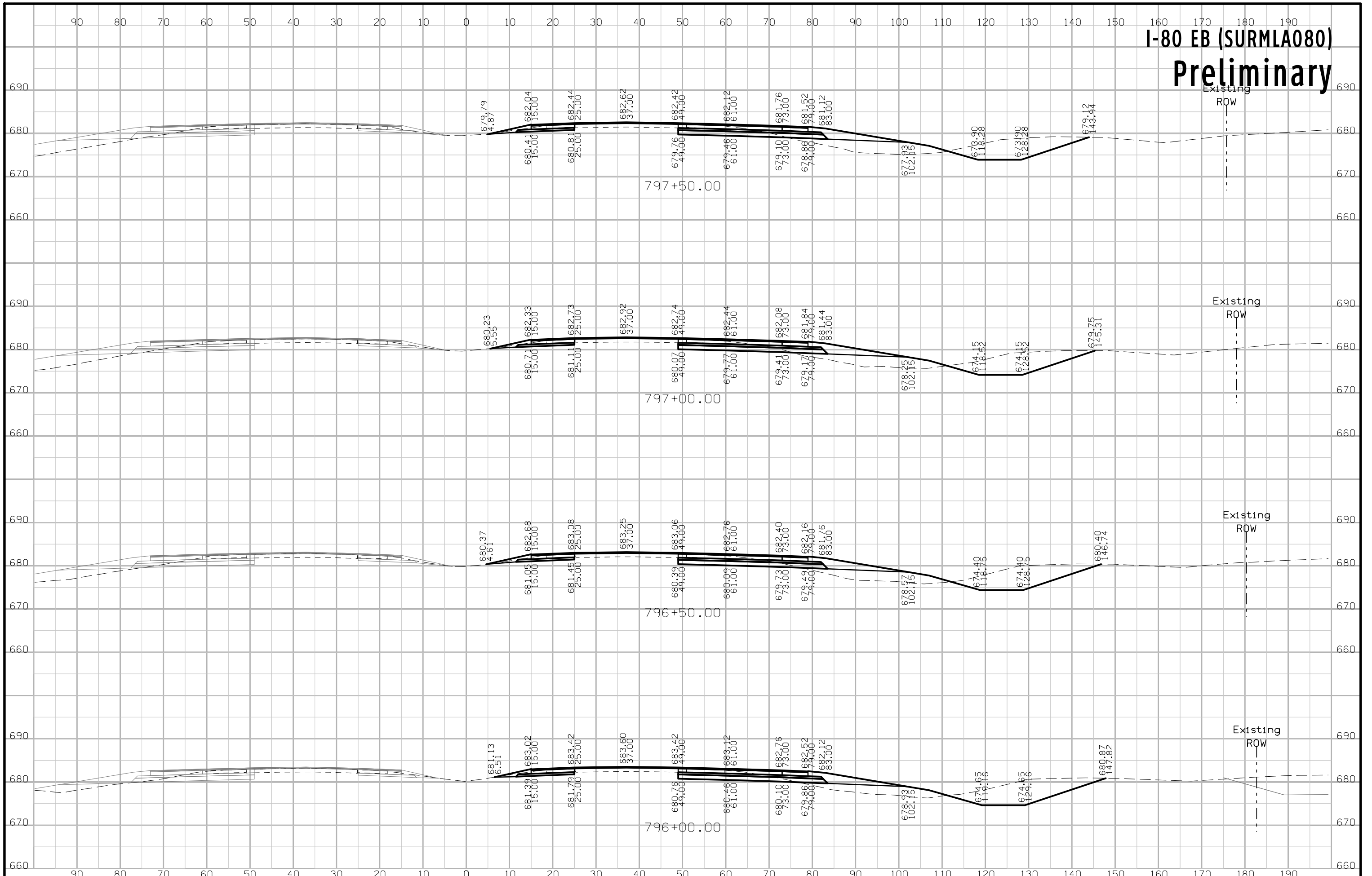

# I-80 EB (SURMLA080) Preliminary

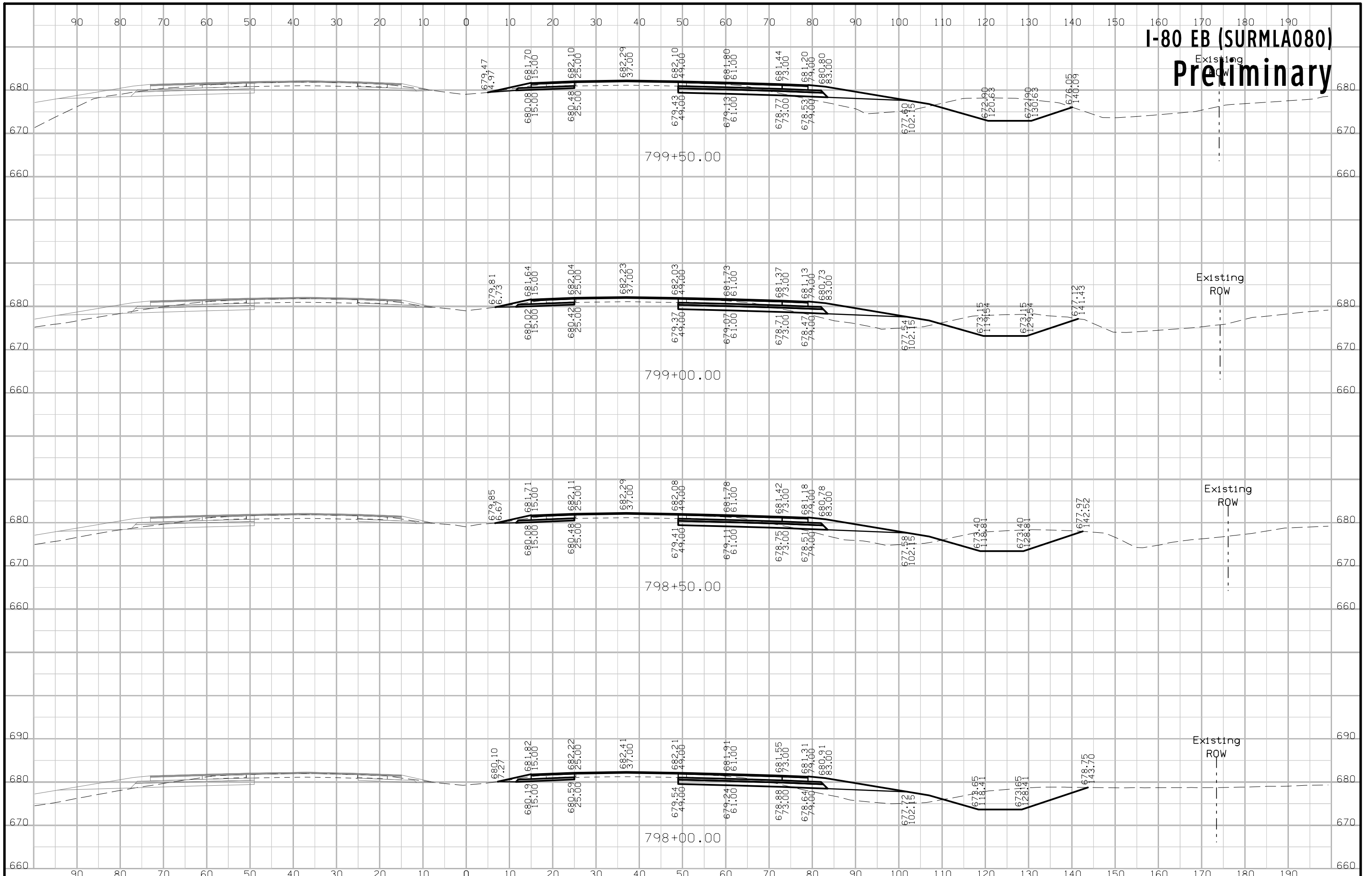

# I-80 EB (SURMLA080) Preliminary

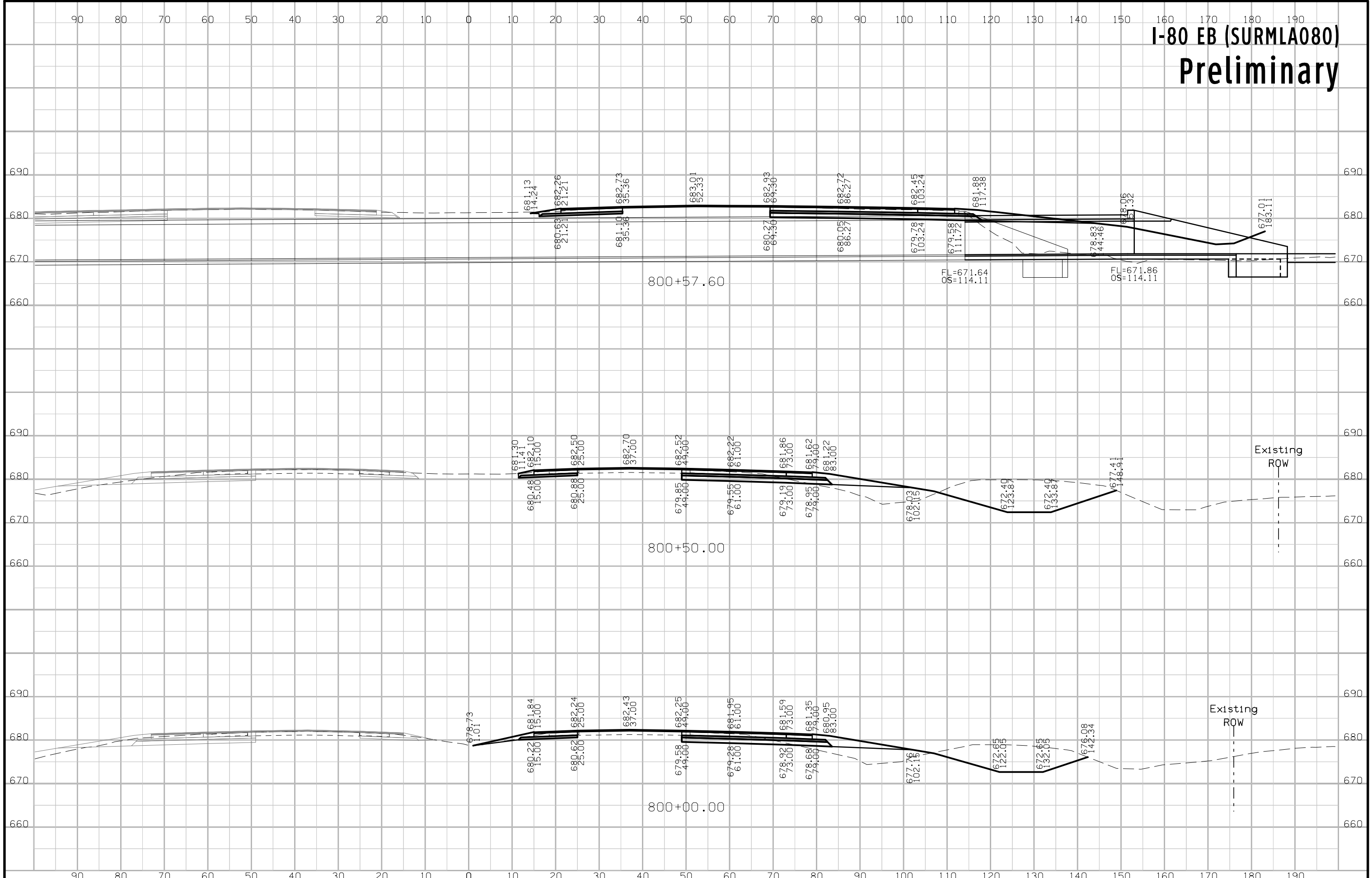



# I-80 EB (SURMLA080) Preliminary

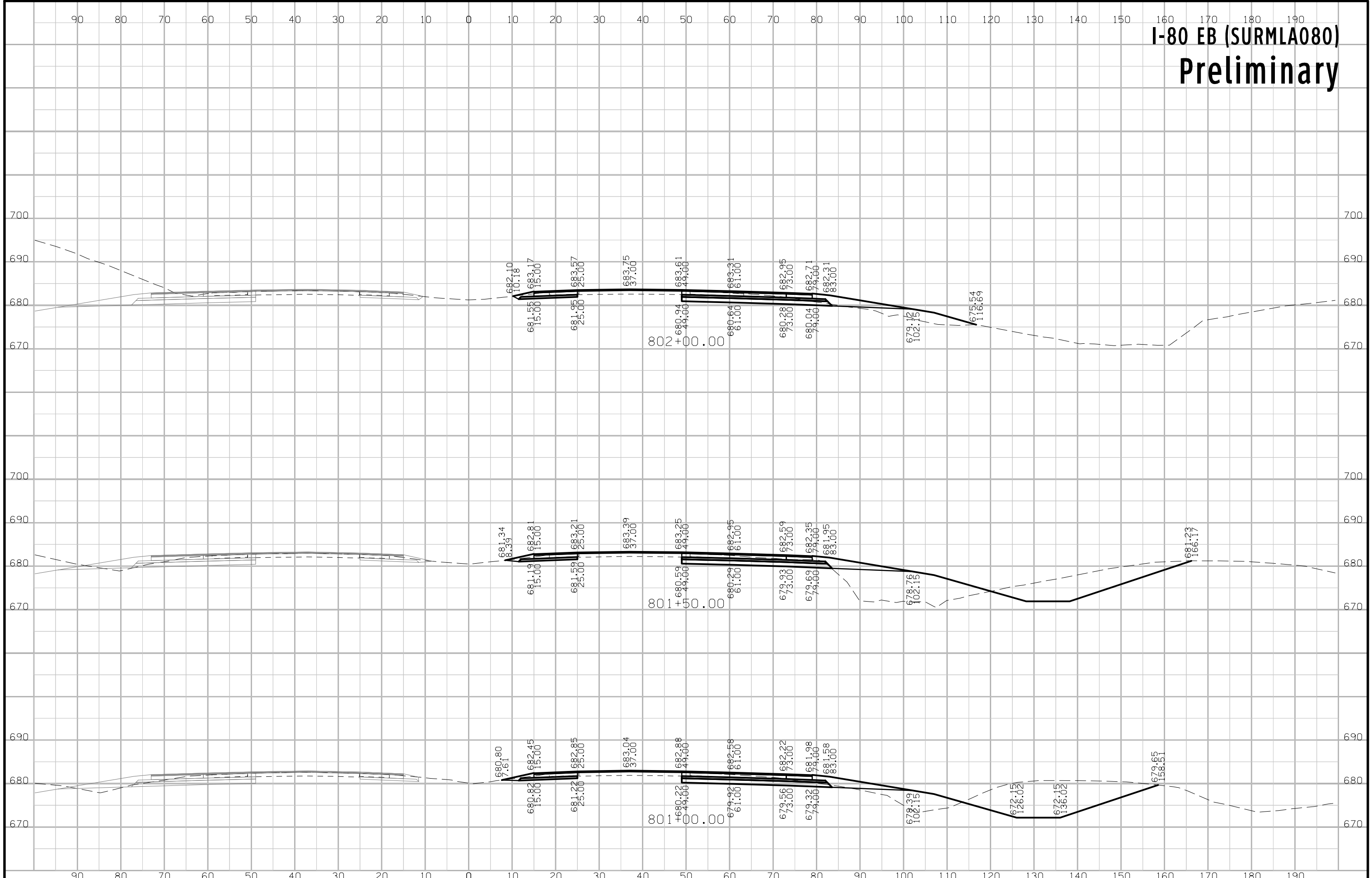

# I-80 EB (SURMLA080) Preliminary

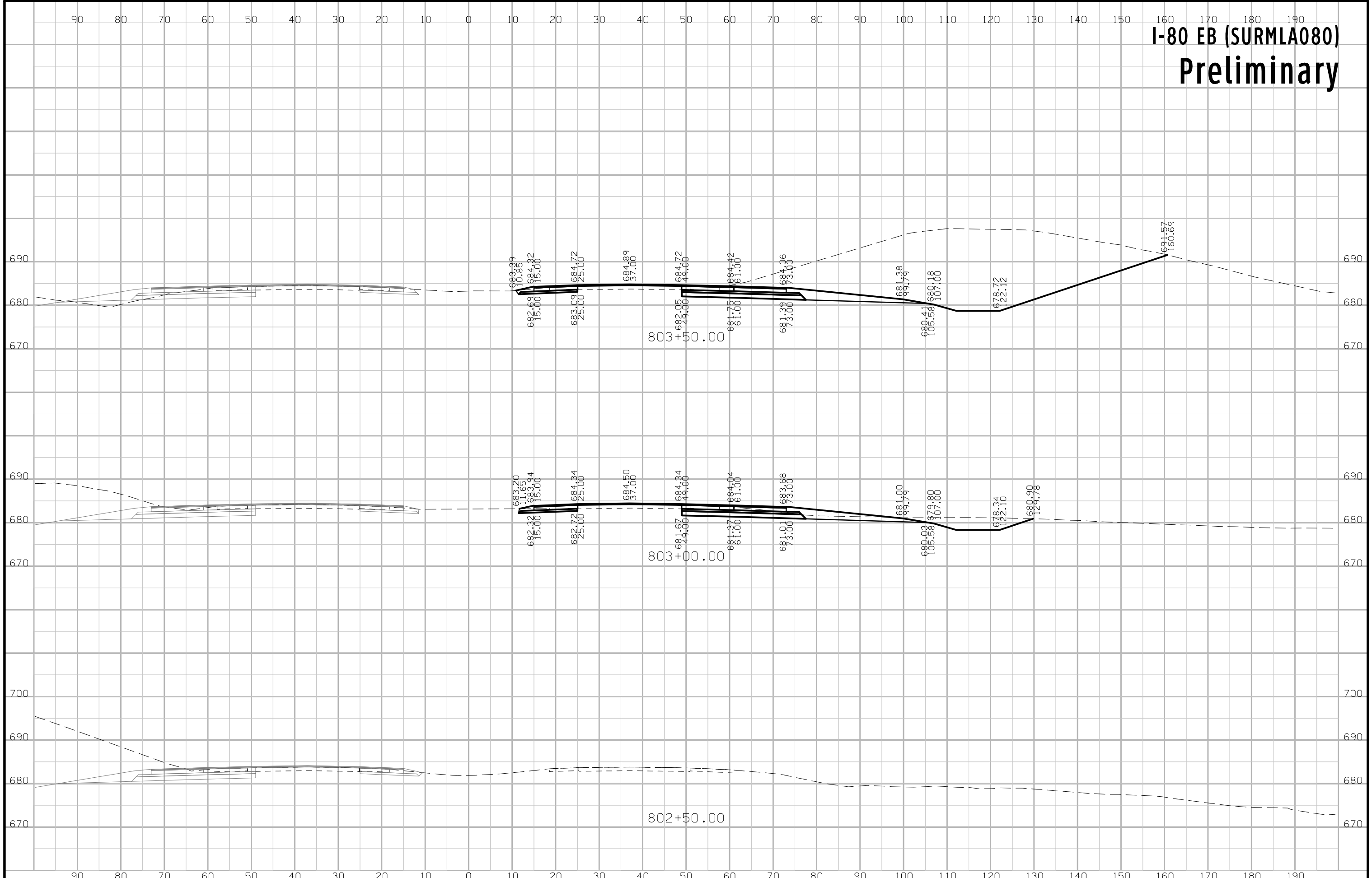

# I-80 EB (SURMLA080) Preliminary

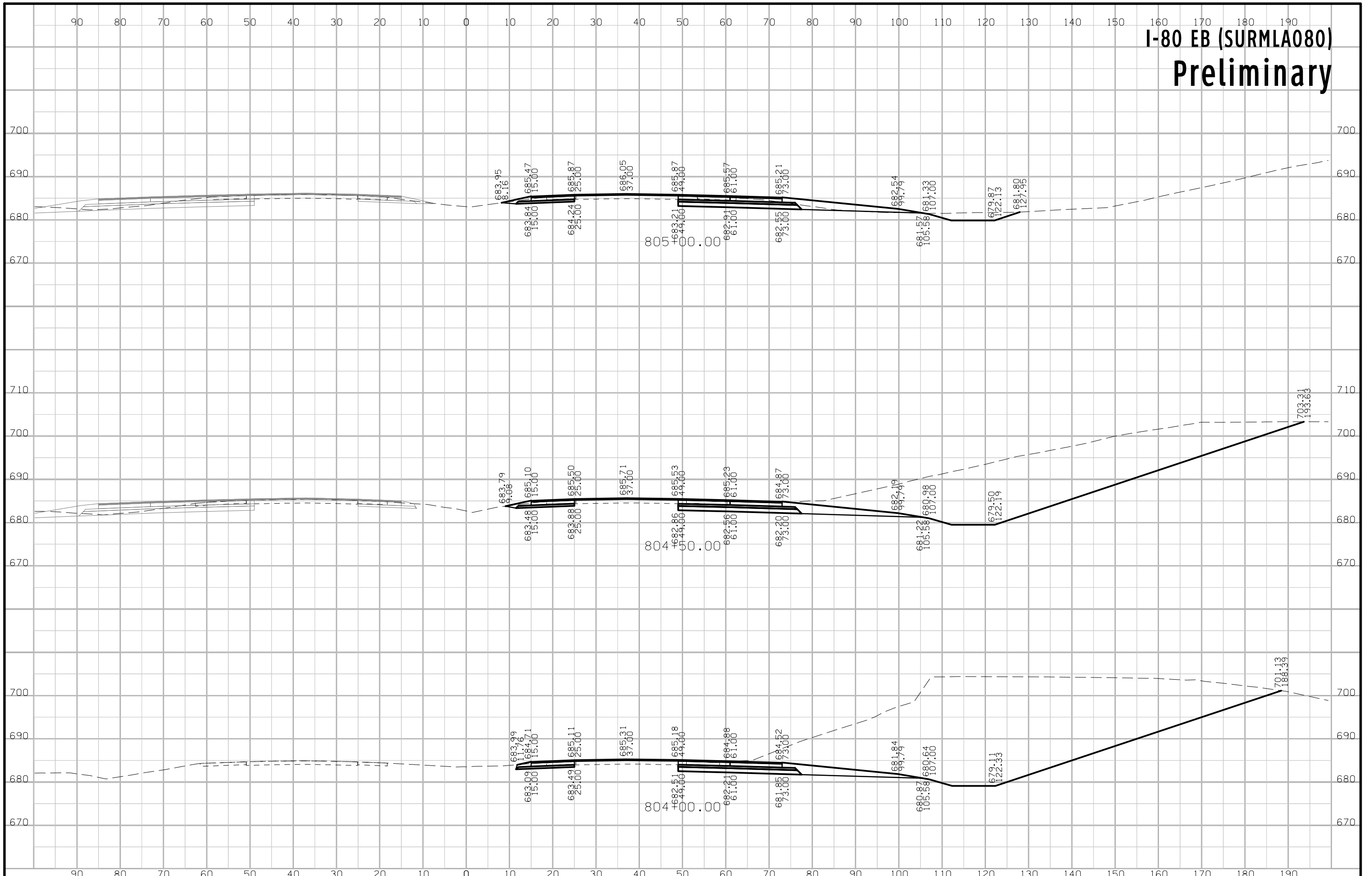

# I-80 EB (SURMLA080) Preliminary

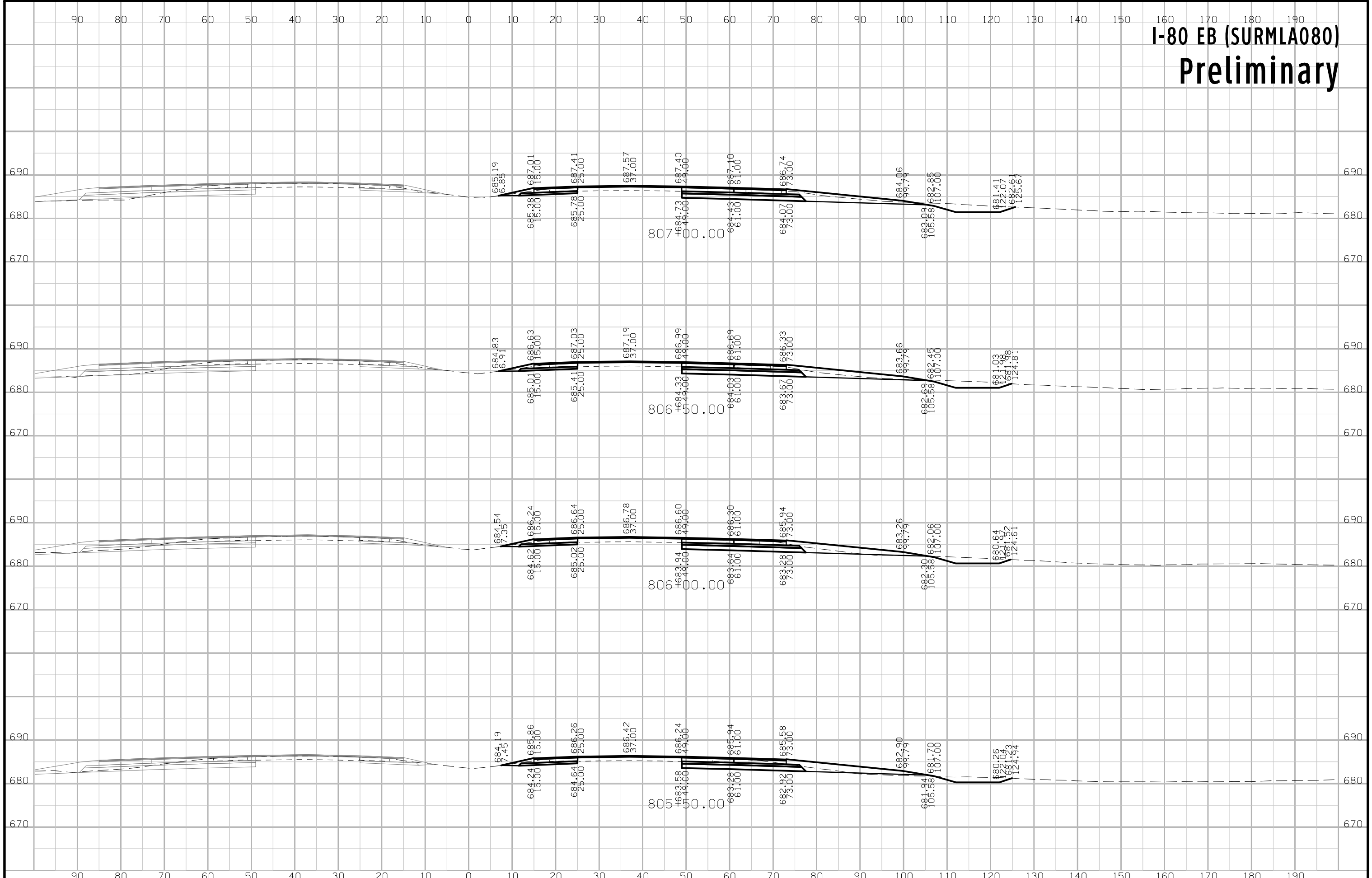

# I-80 EB (SURMLA080) Preliminary

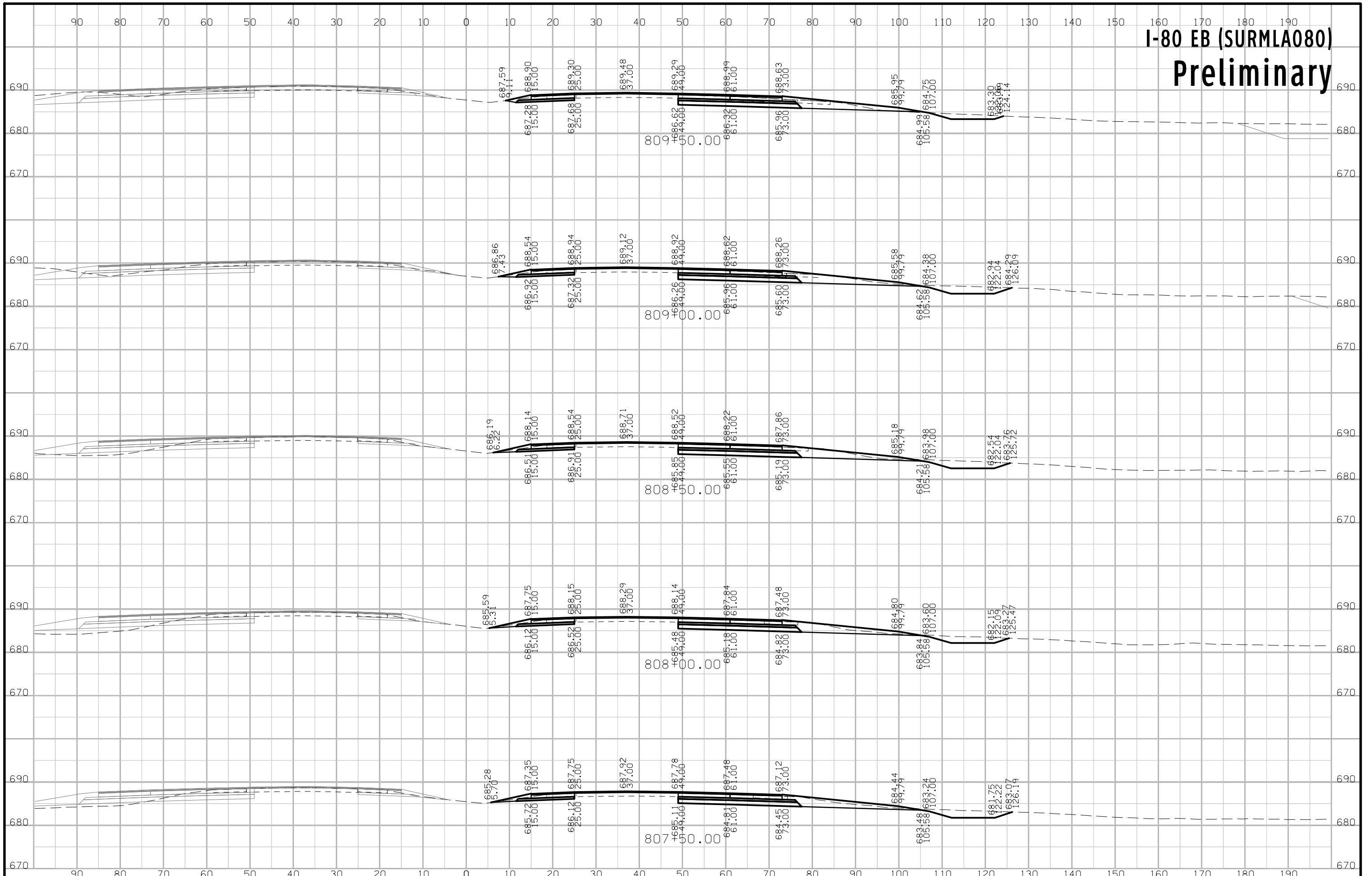

# I-80 EB (SURMLA080) Preliminary

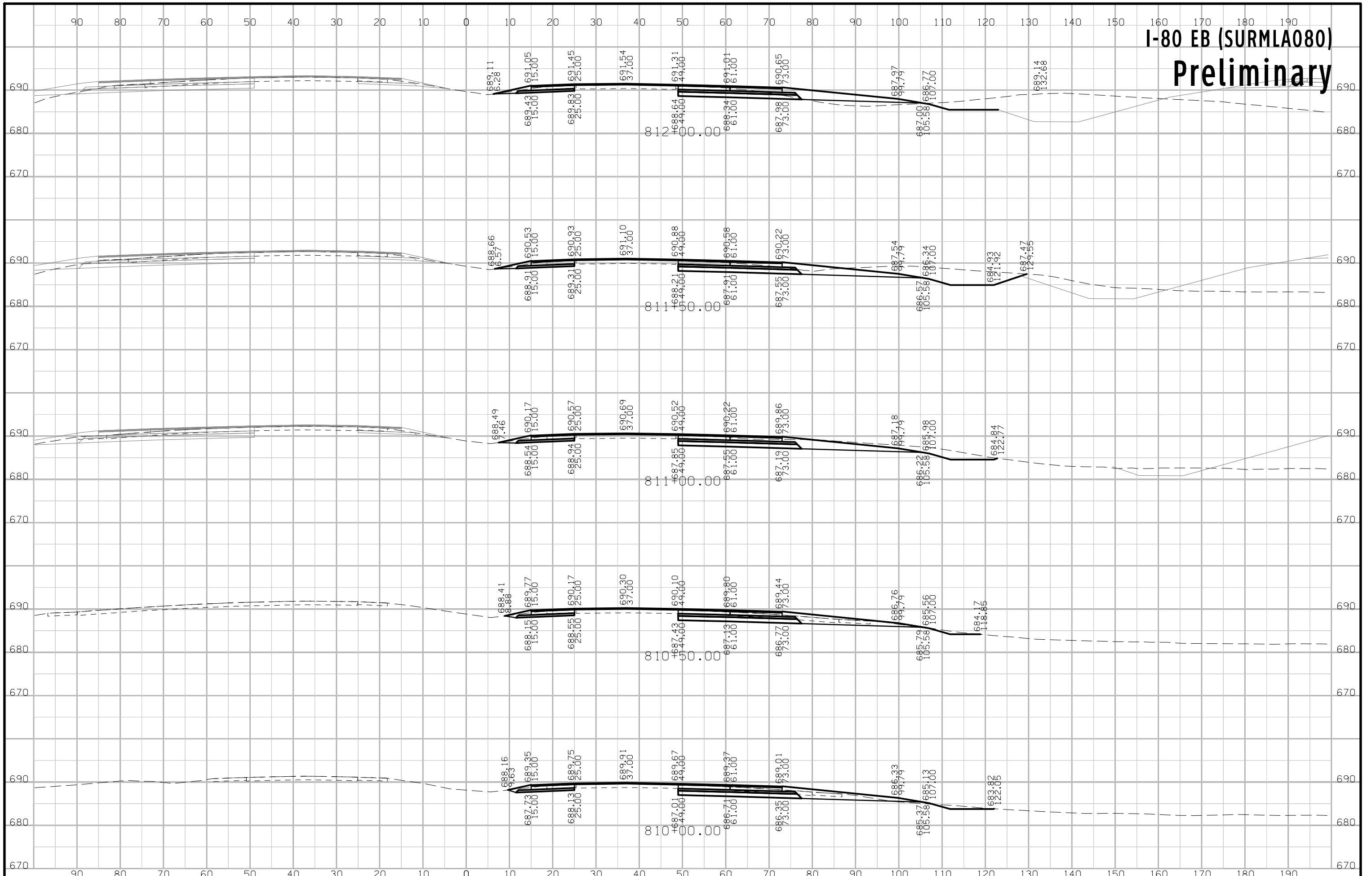

# I-80 EB (SURMLA080) Preliminary

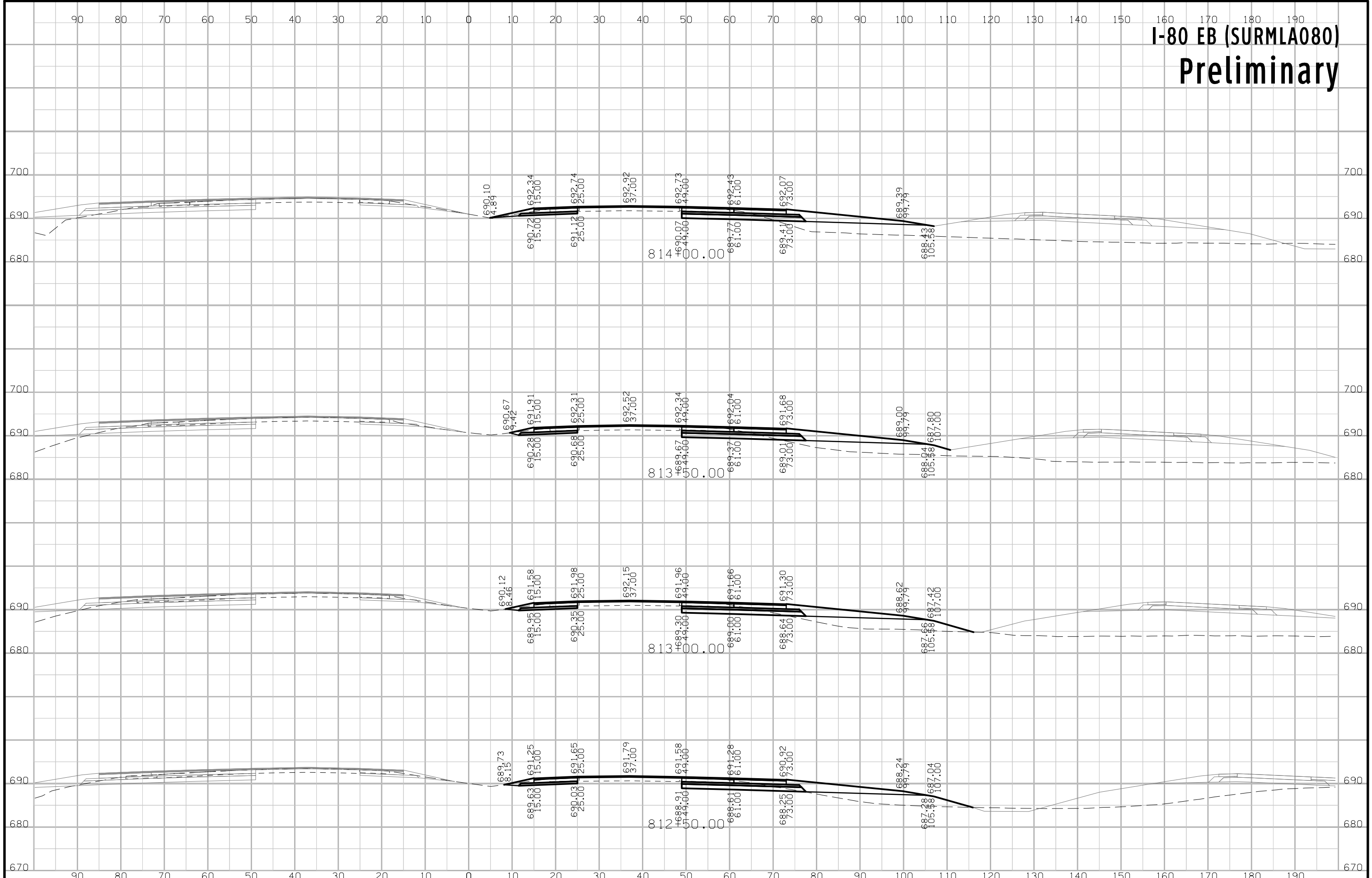



I-80 EB (SURMLA080)  
**Preliminary**

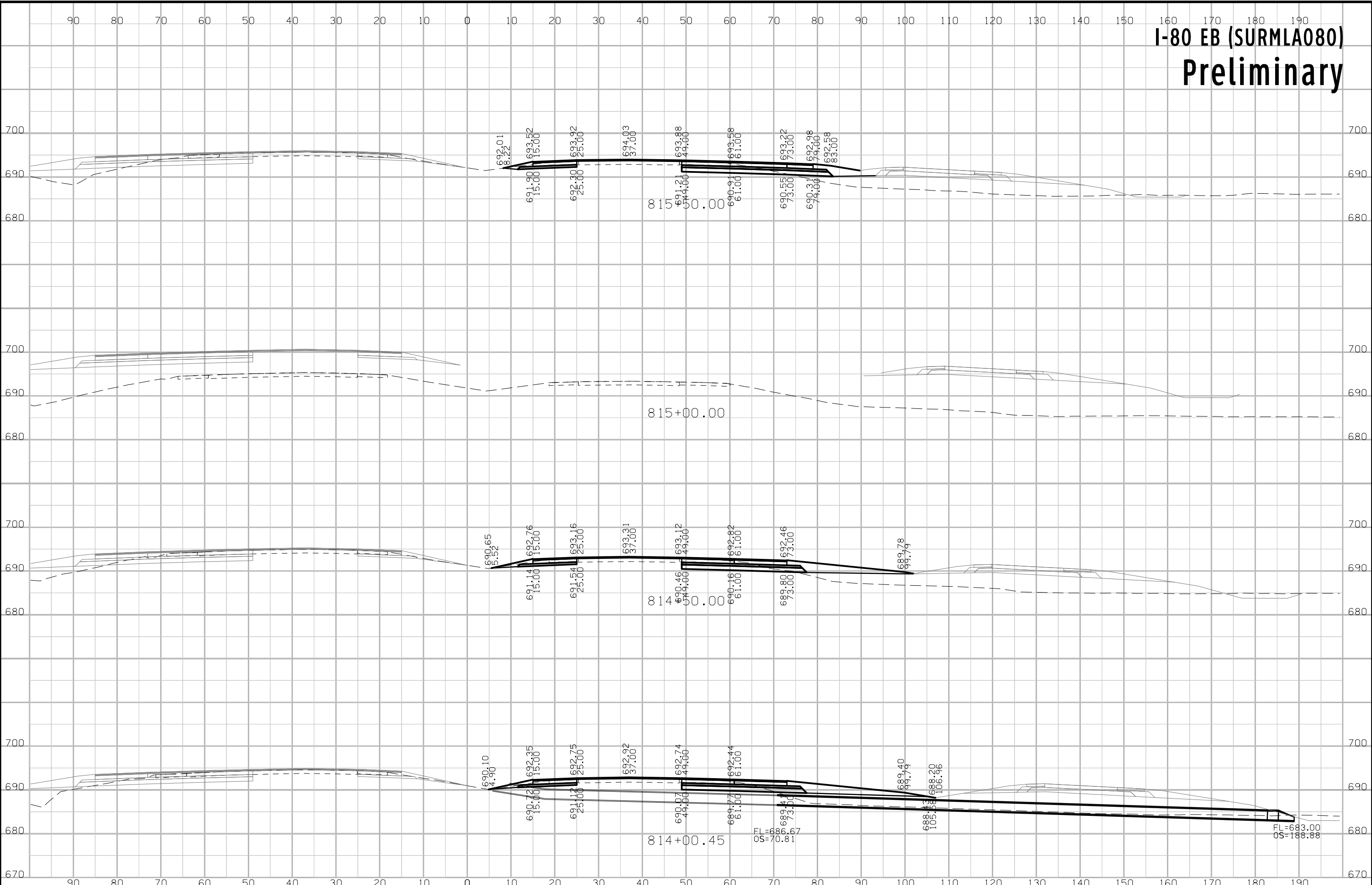

# I-80 EB (SURMLA080) Preliminary

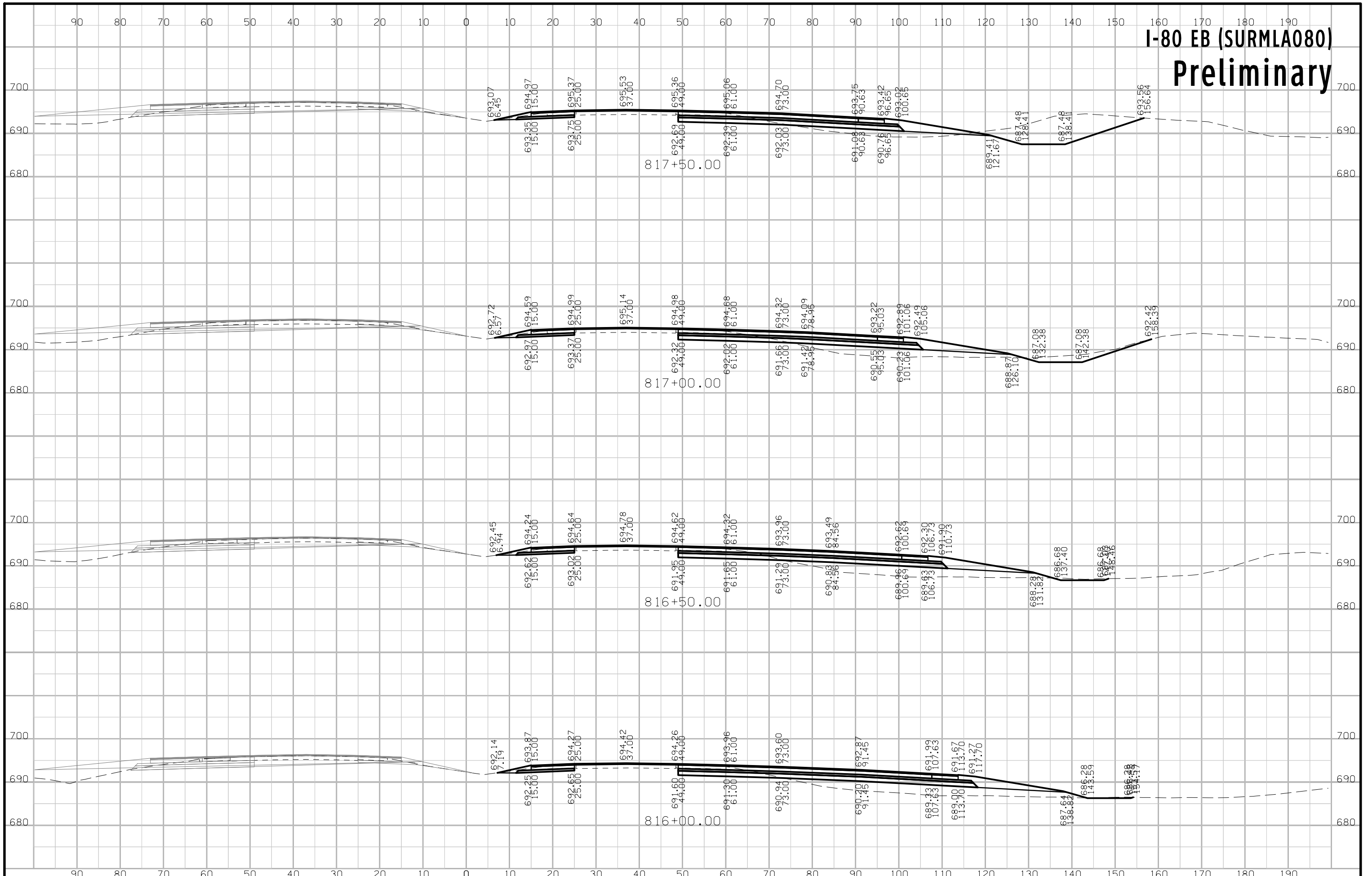

# I-80 EB (SURMLA080) Preliminary

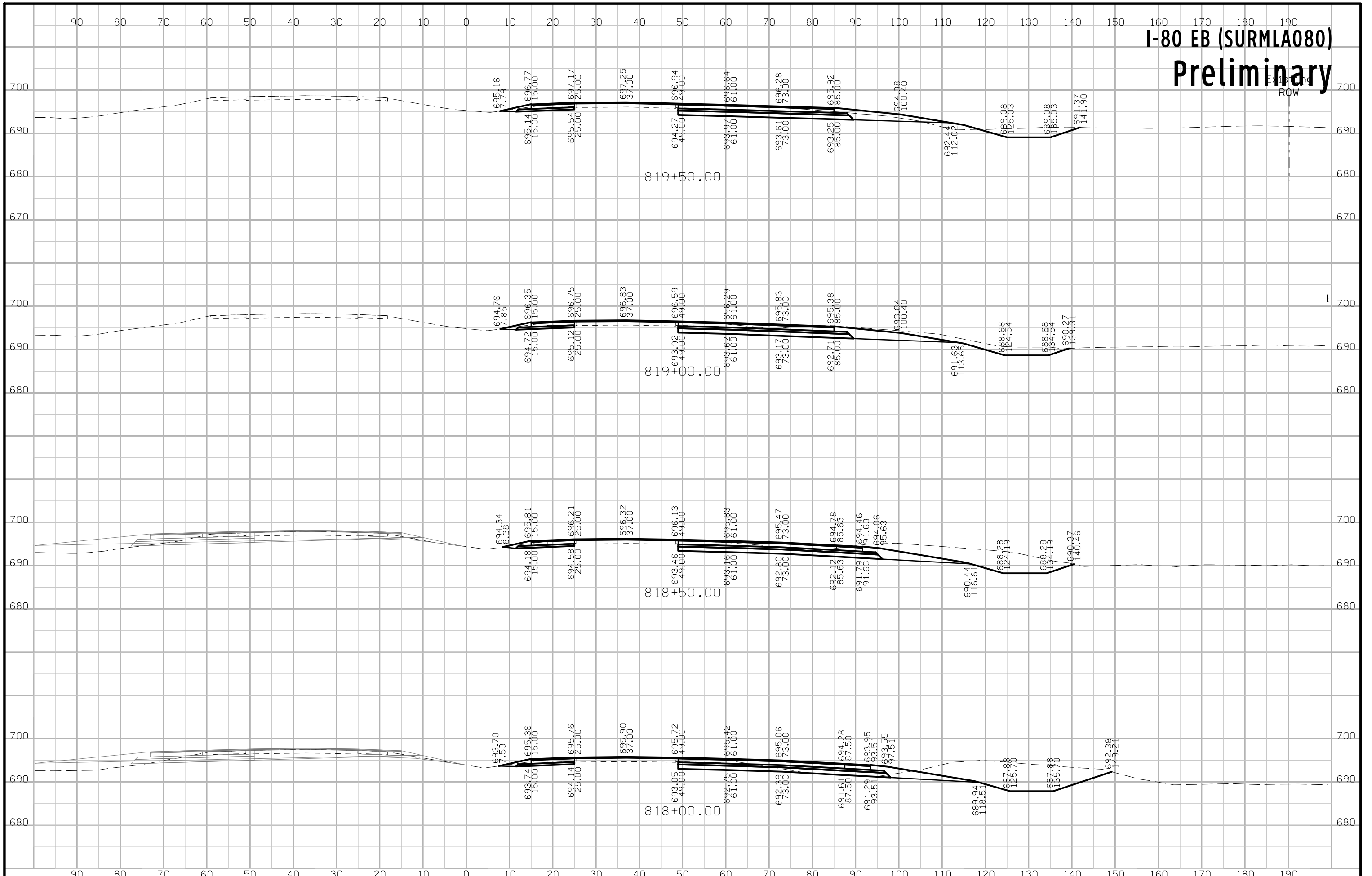

# I-80 EB (SURMLA080) Preliminary

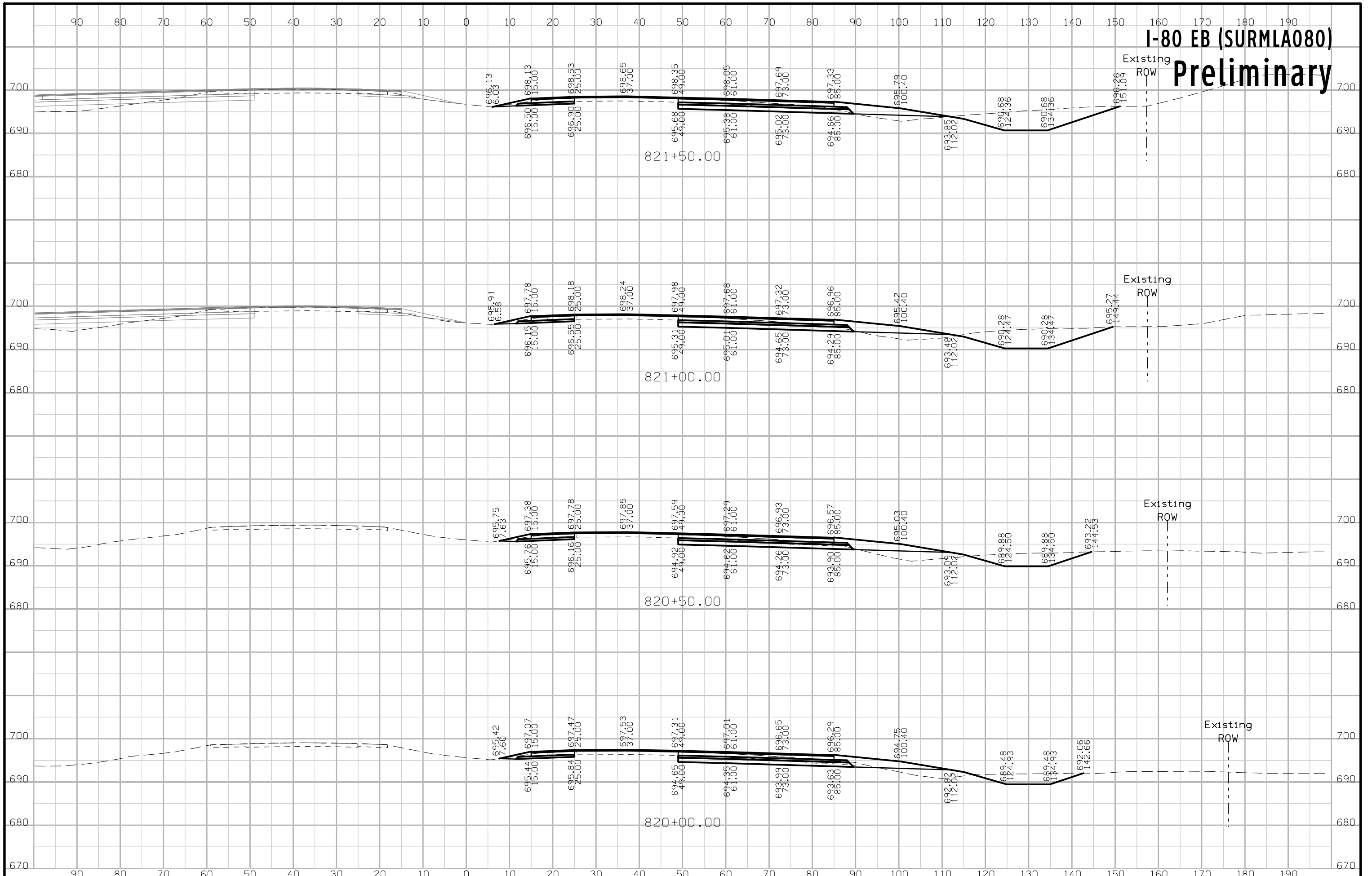

# I-80 EB (SURMLA080) Preliminary

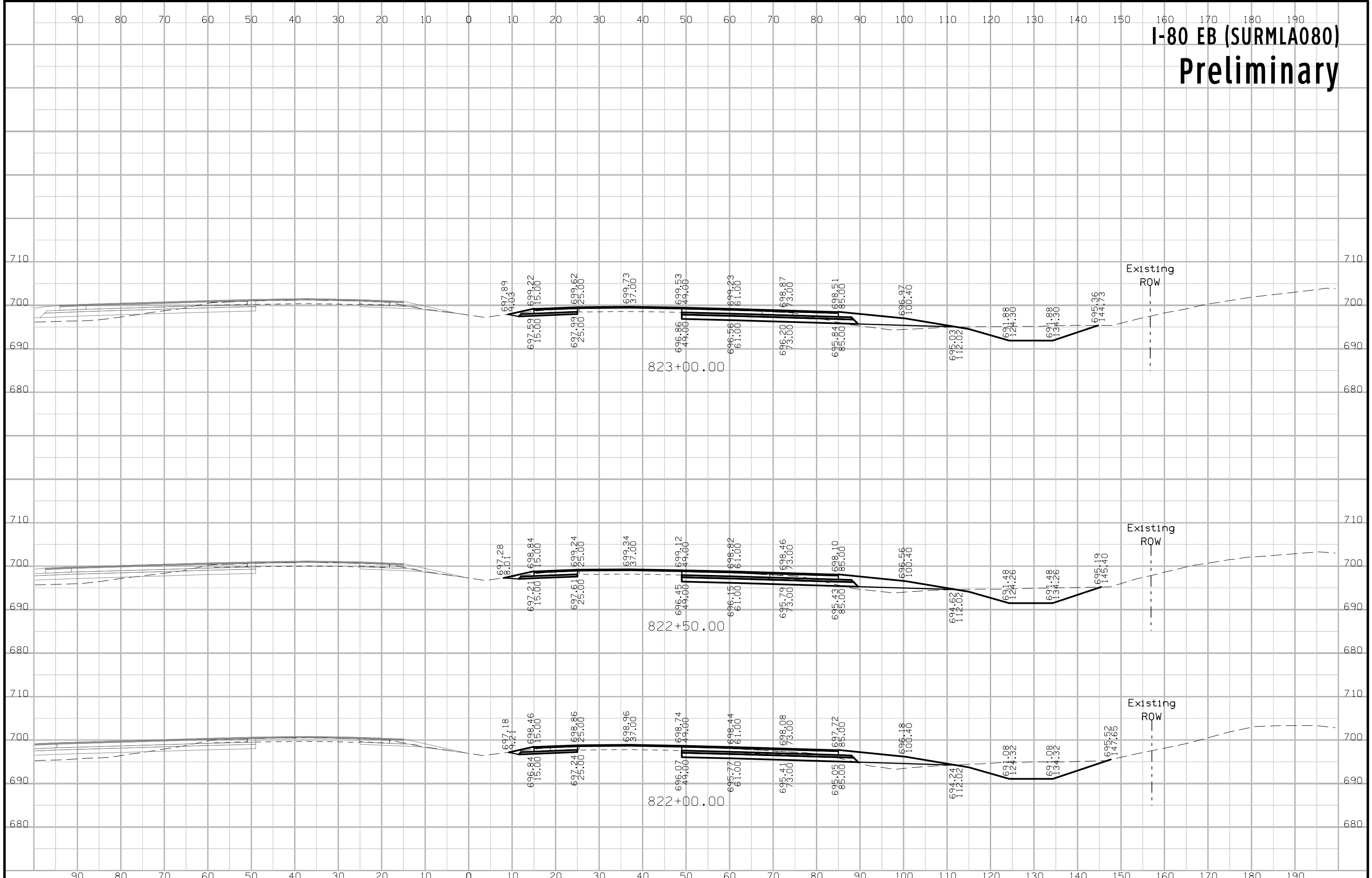

# I-80 EB (SURMLA080) Preliminary

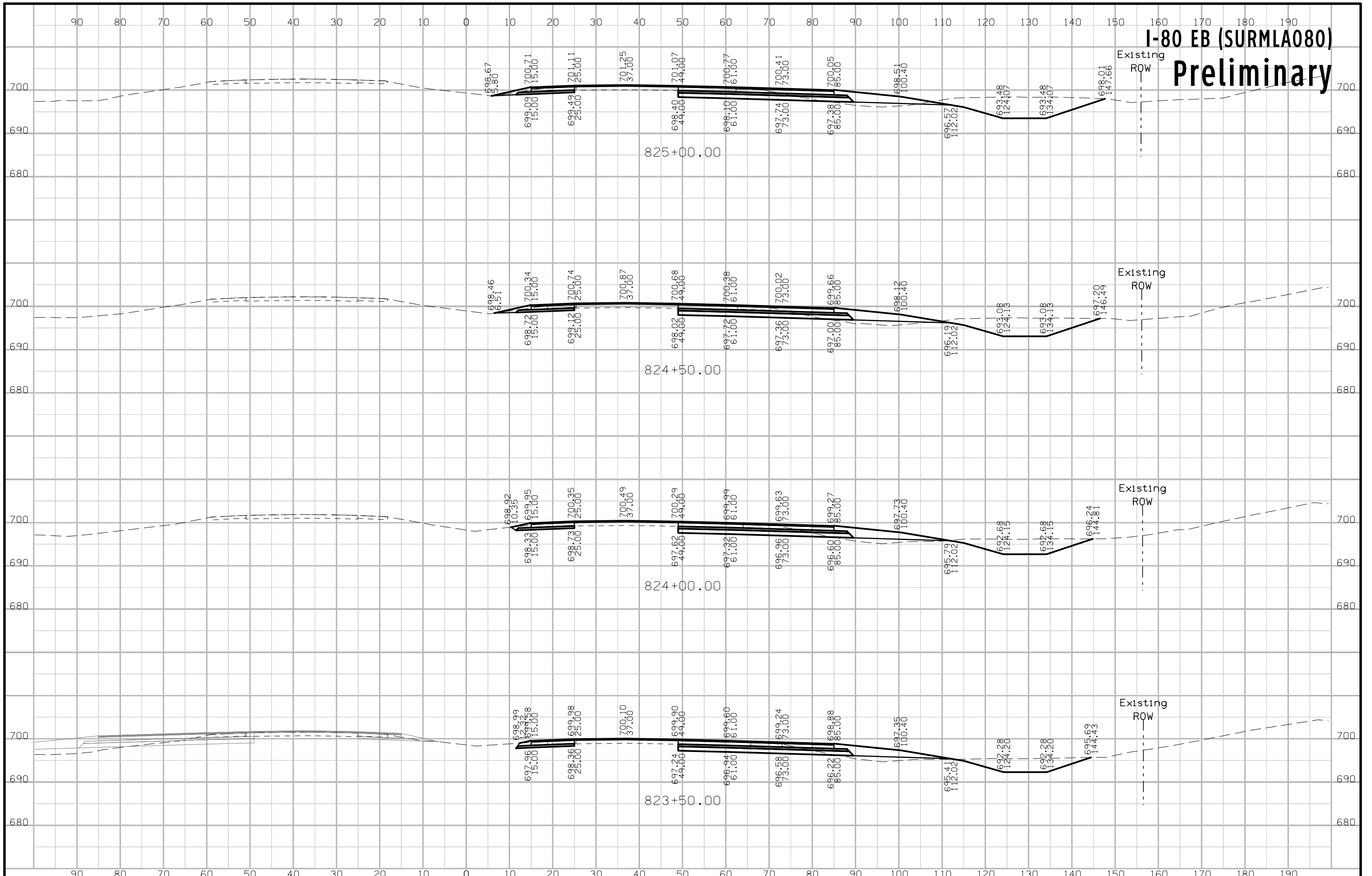

# I-80 EB (SURMLA080) Preliminary

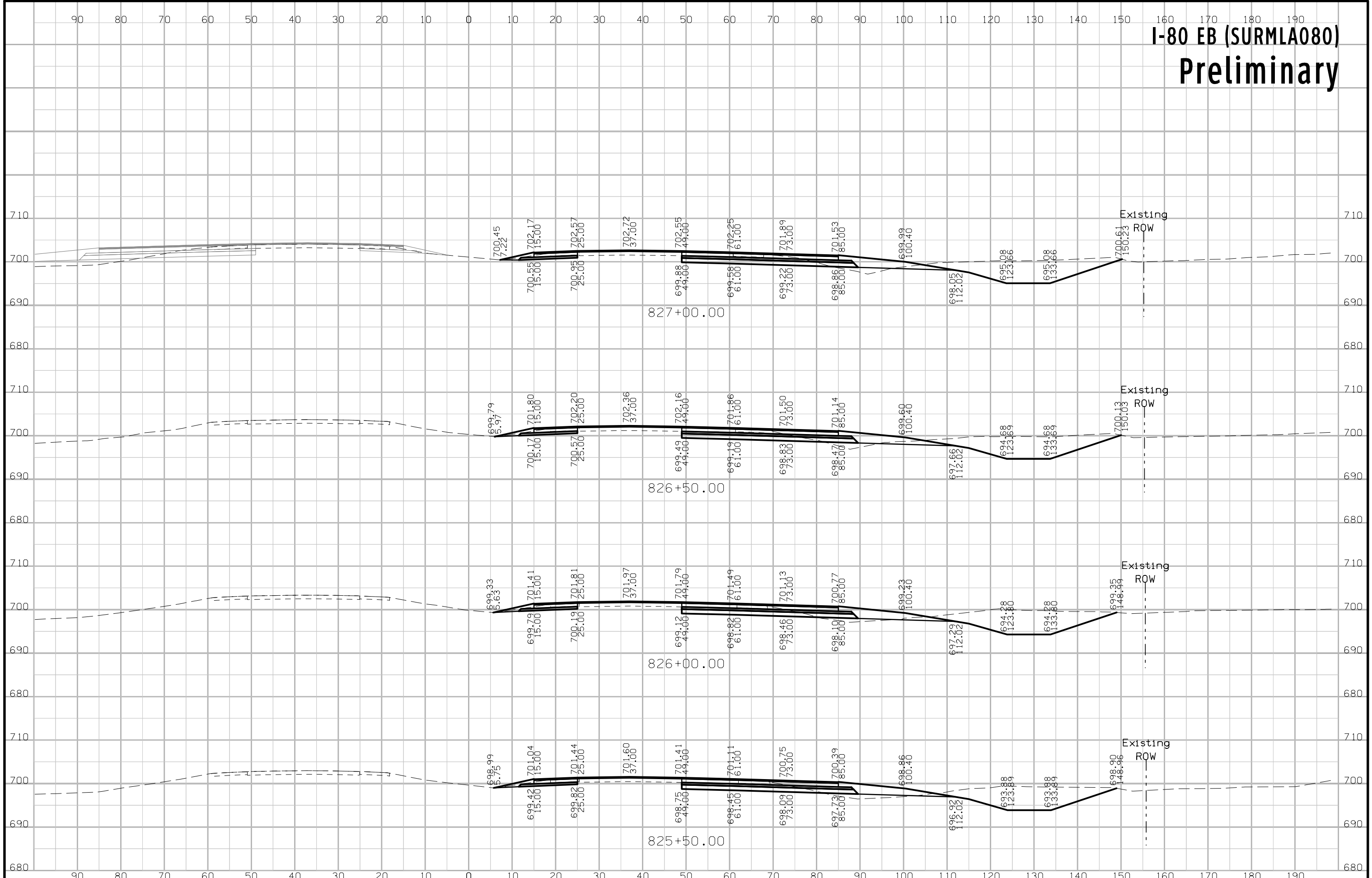



# I-80 EB (SURMLA080) Preliminary

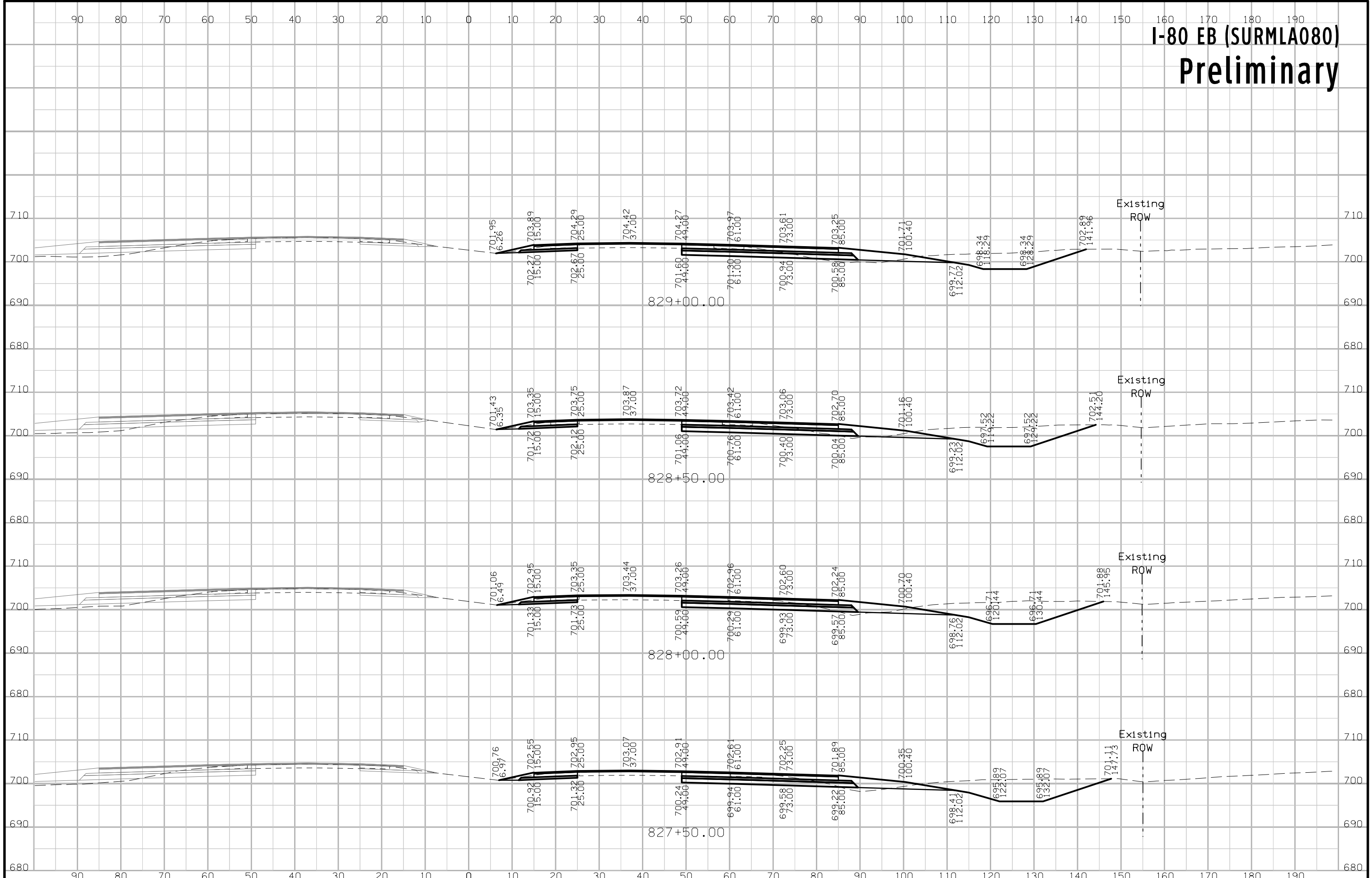

# I-80 EB (SURMLA080) Preliminary

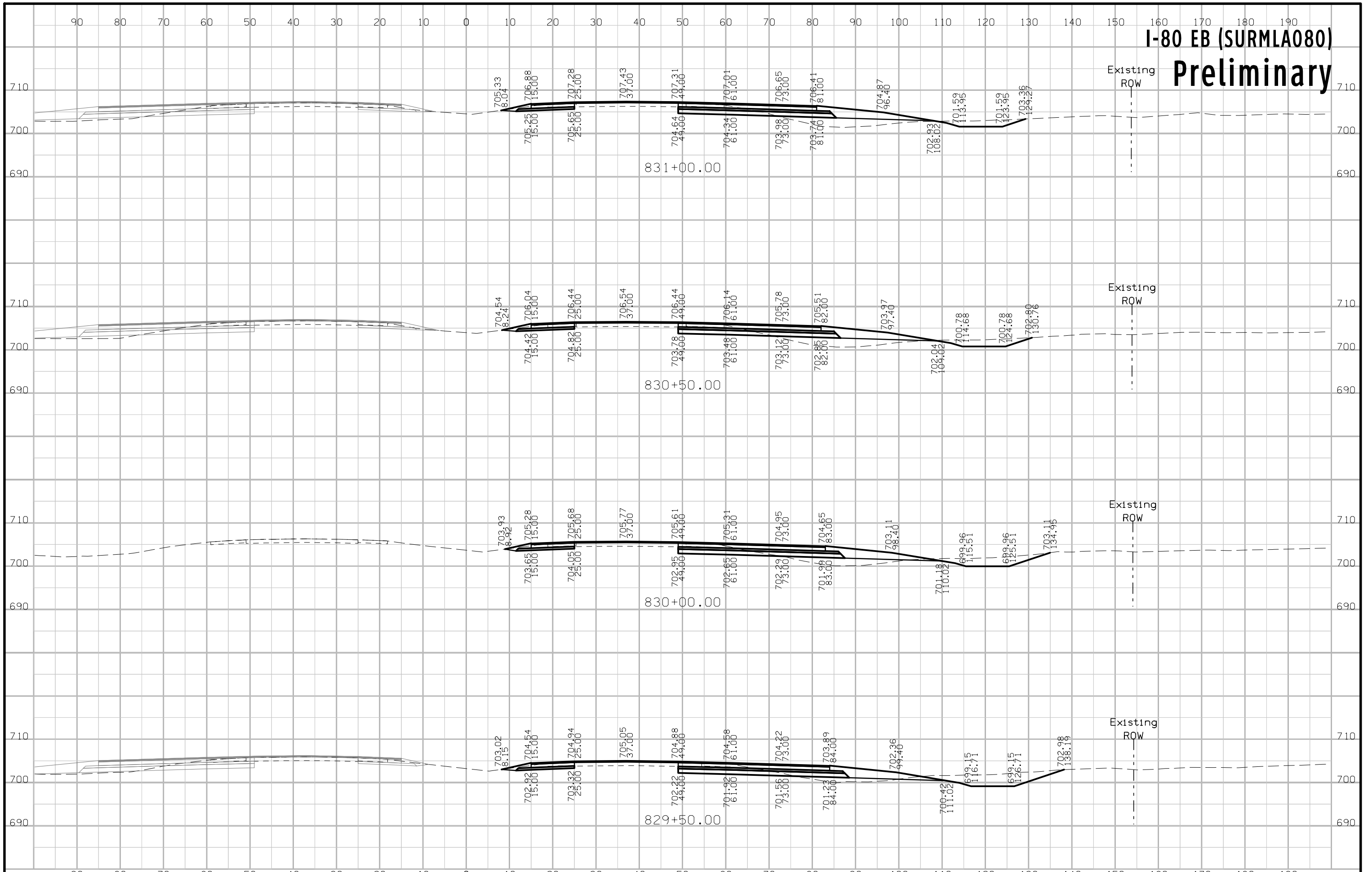

# I-80 EB (SURMLA080) Preliminary

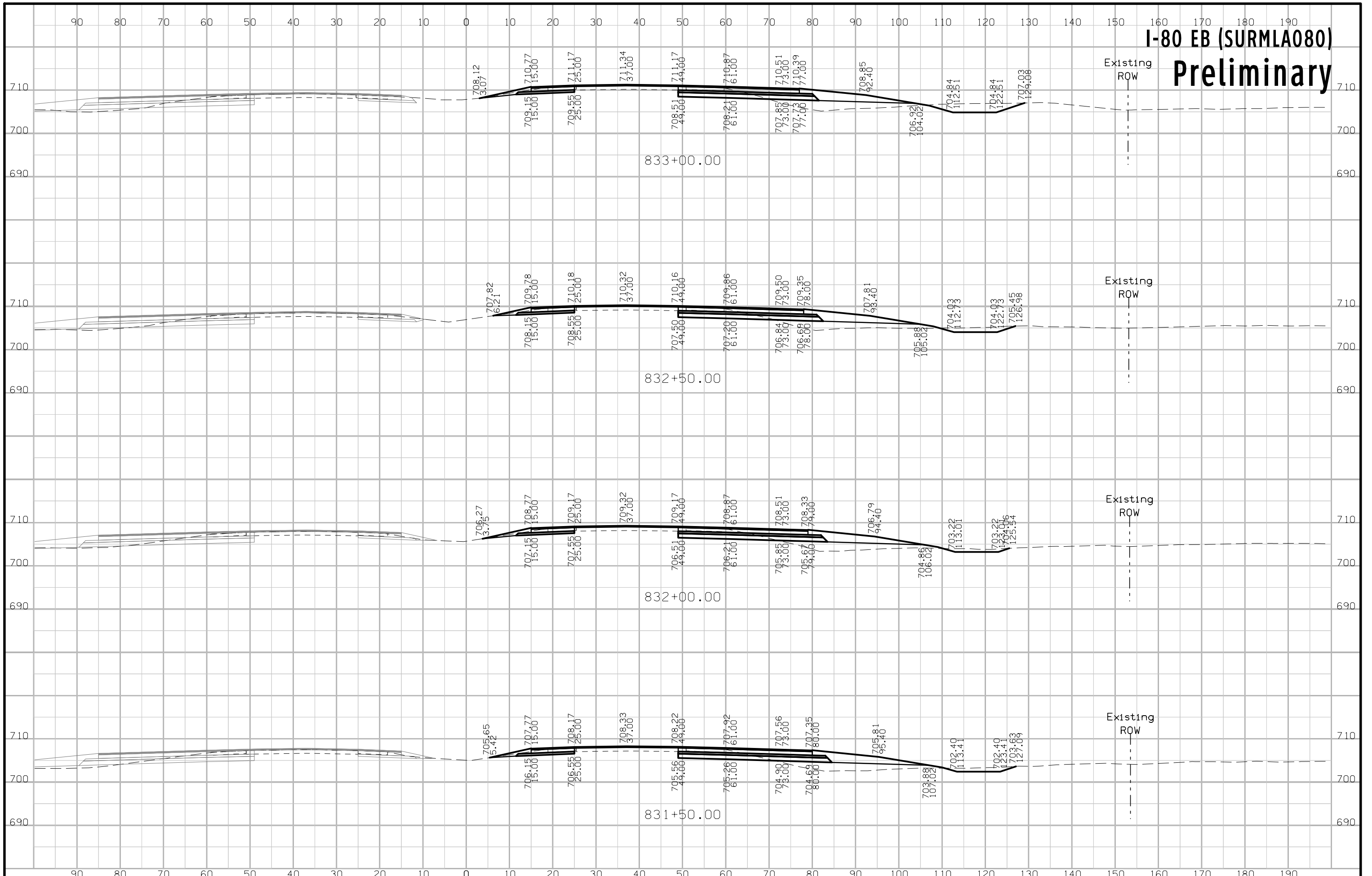

# I-80 EB (SURMLA080) Preliminary

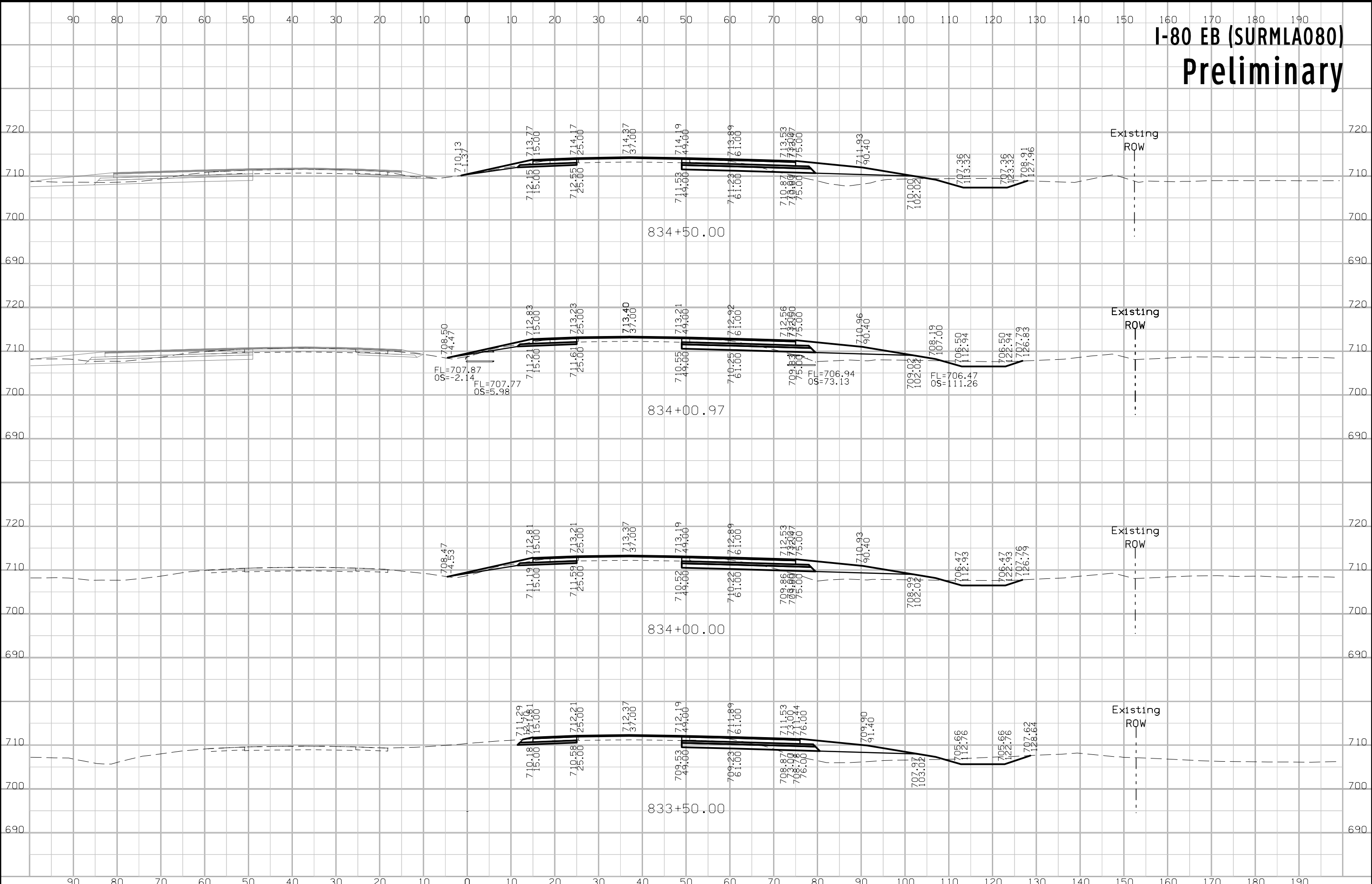

# I-80 EB (SURMLA080) Preliminary

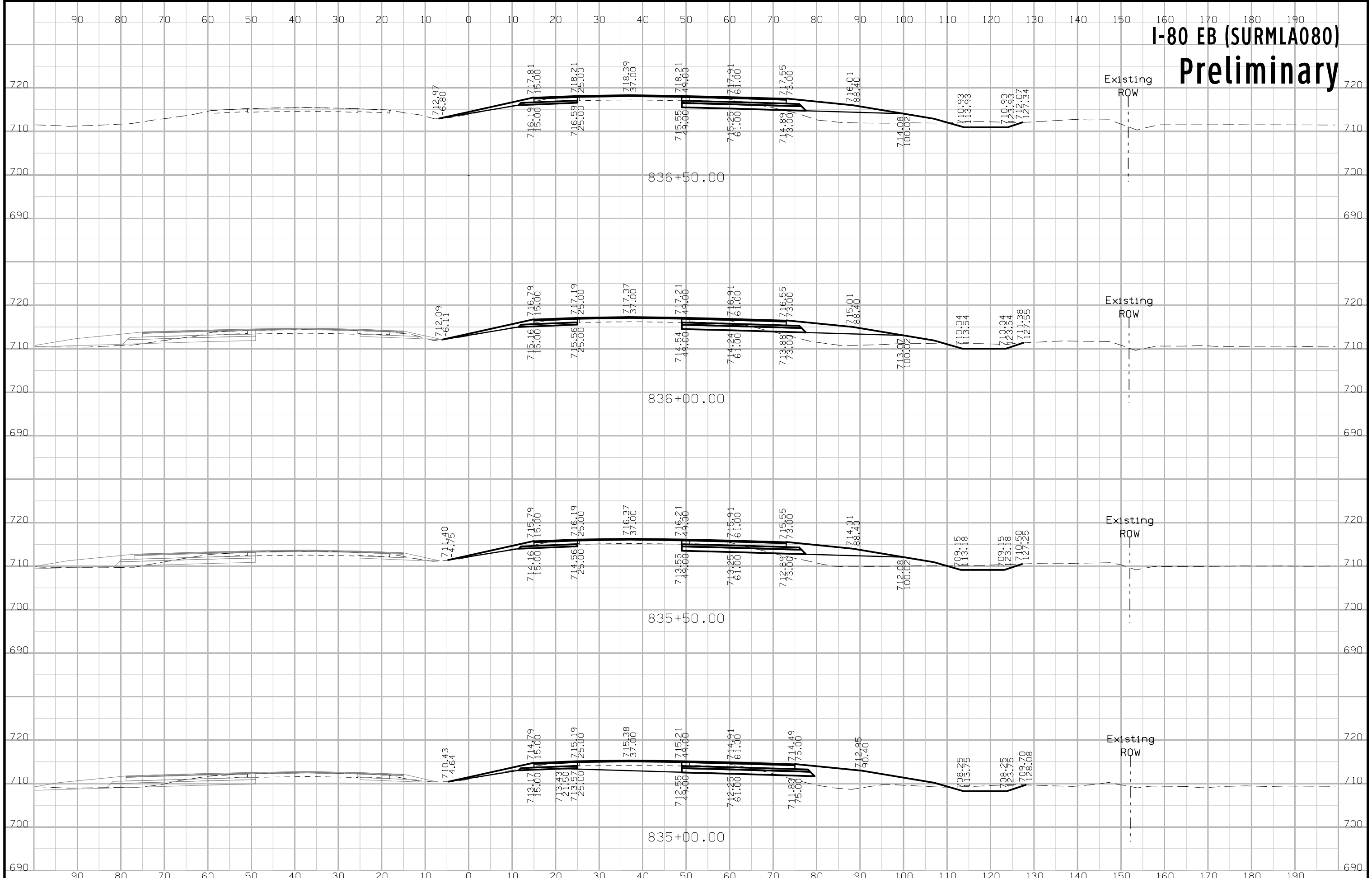

# I-80 EB (SURMLA080) Preliminary

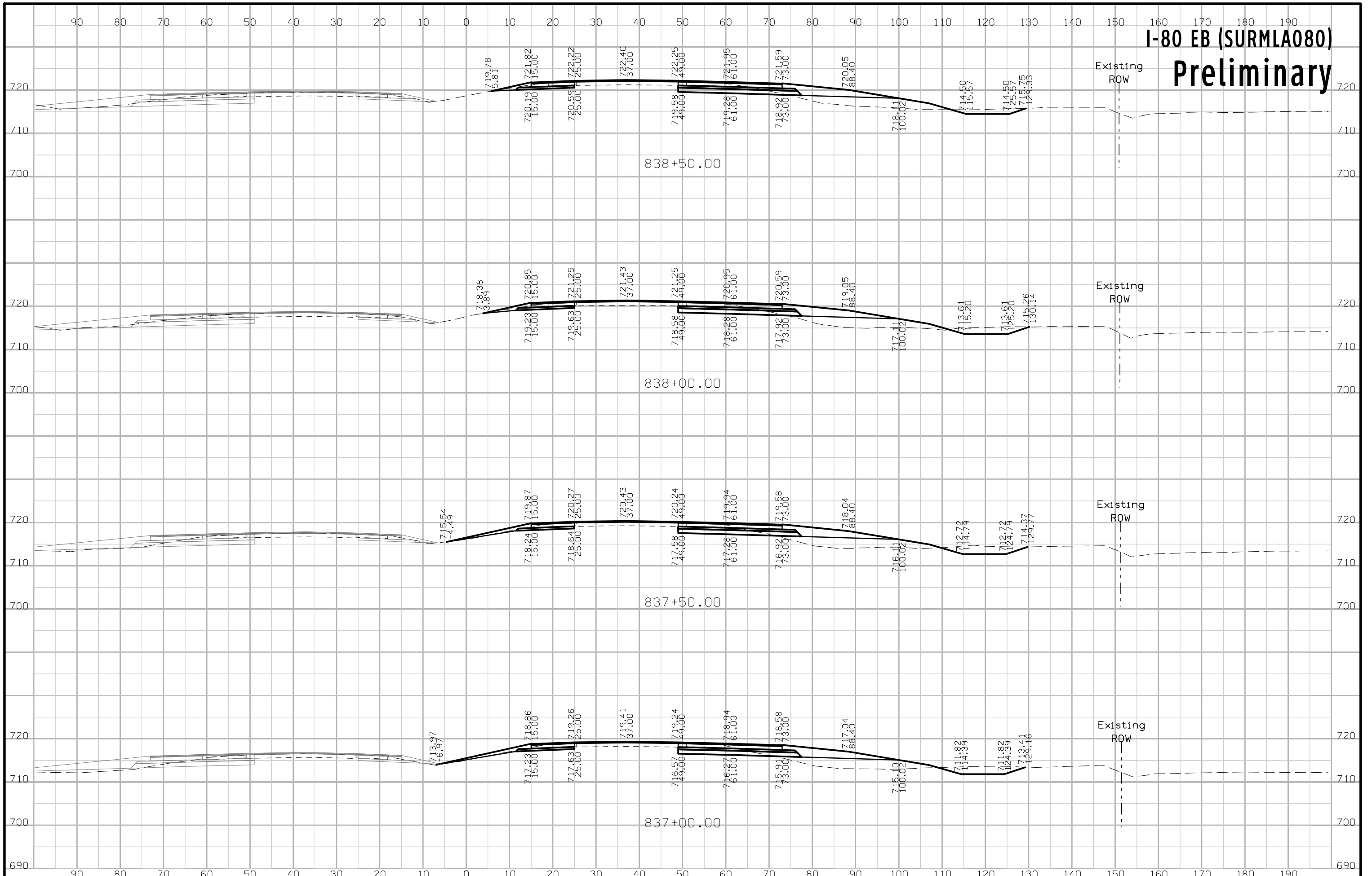

# I-80 EB (SURMLA080) Preliminary

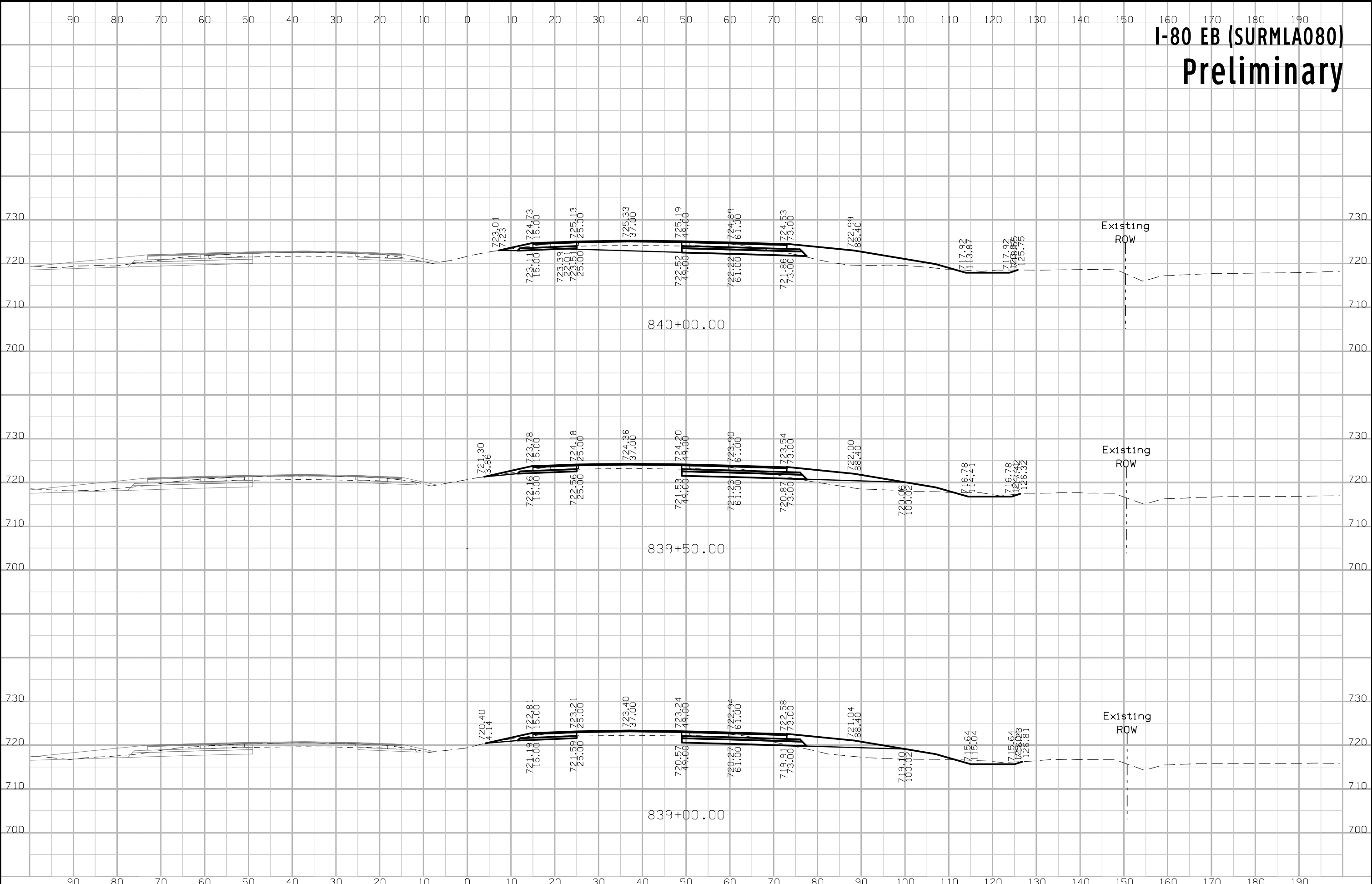



# I-80 EB (SURMLA080) Preliminary

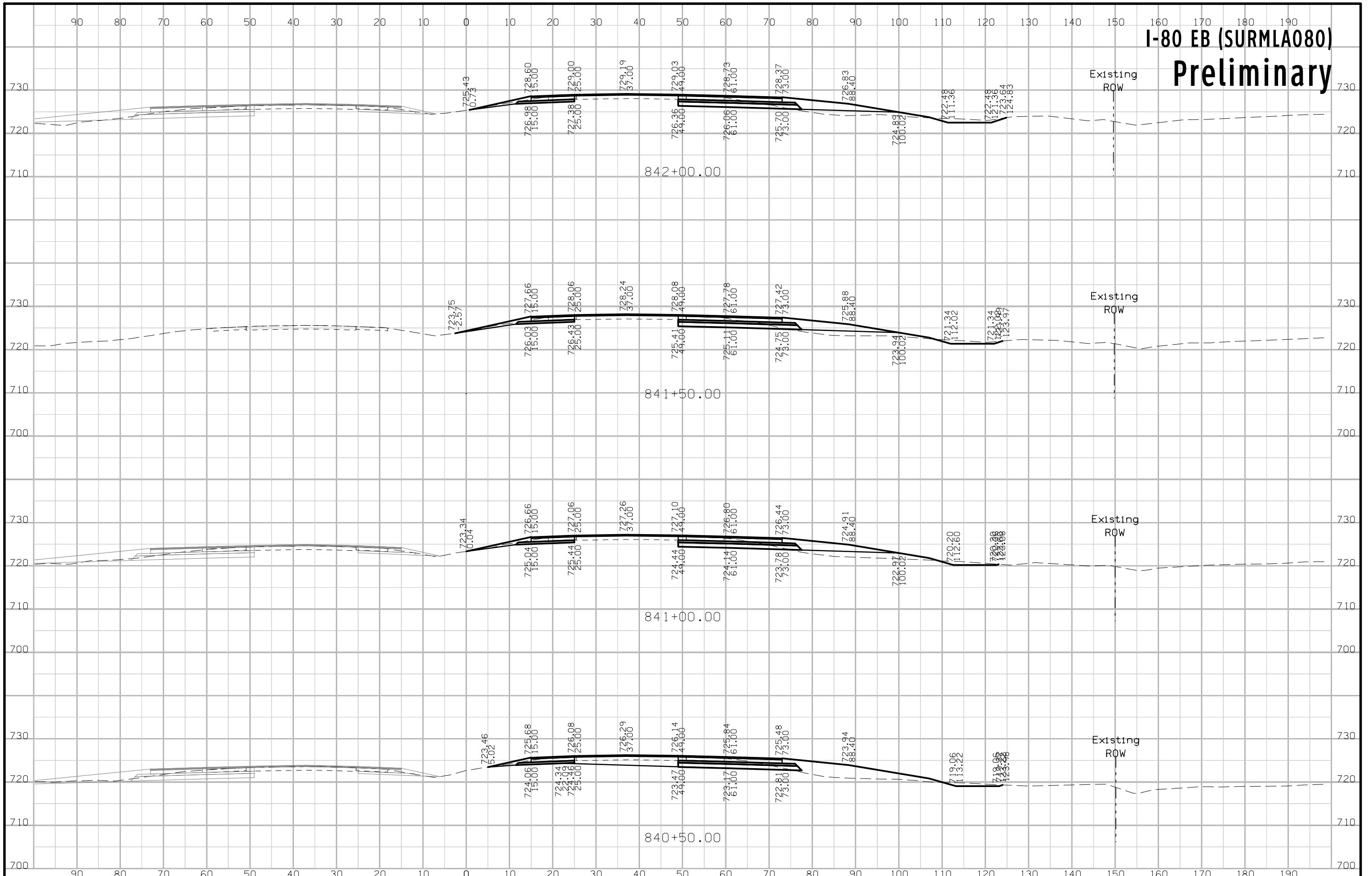

# I-80 EB (SURMLA080) Preliminary

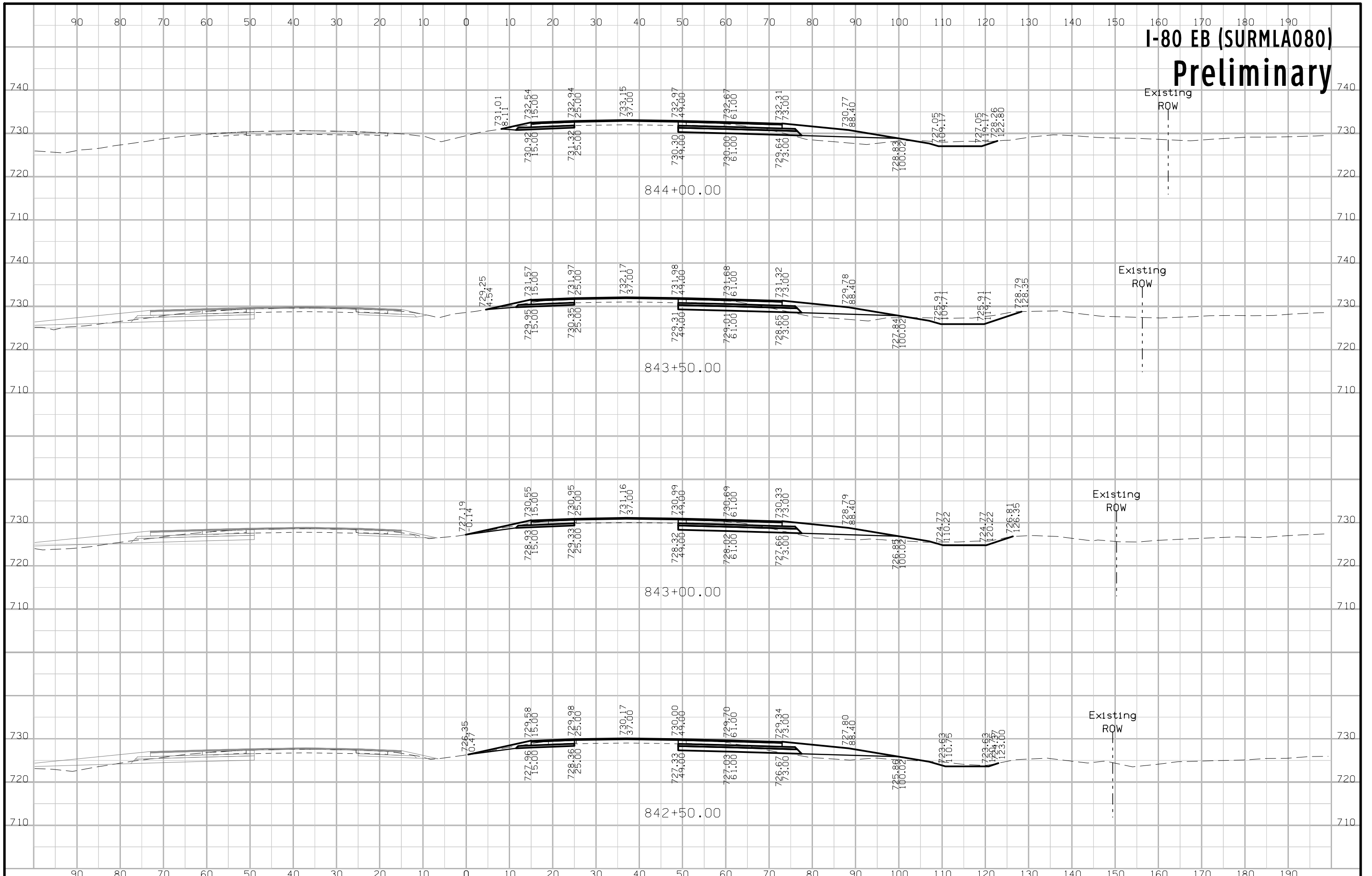

# I-80 EB (SURMLA080) Preliminary

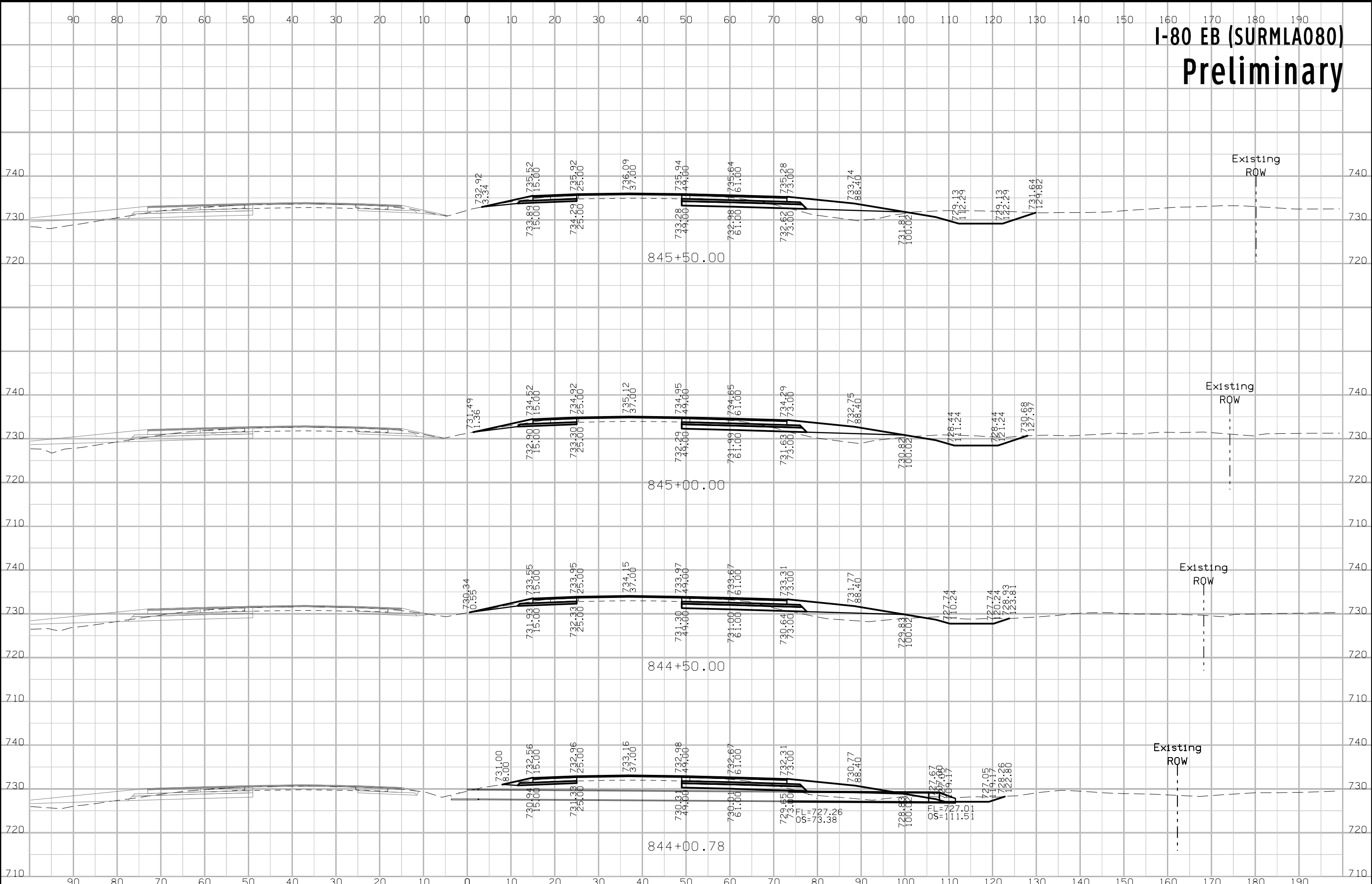

# I-80 EB (SURMLA080) Preliminary

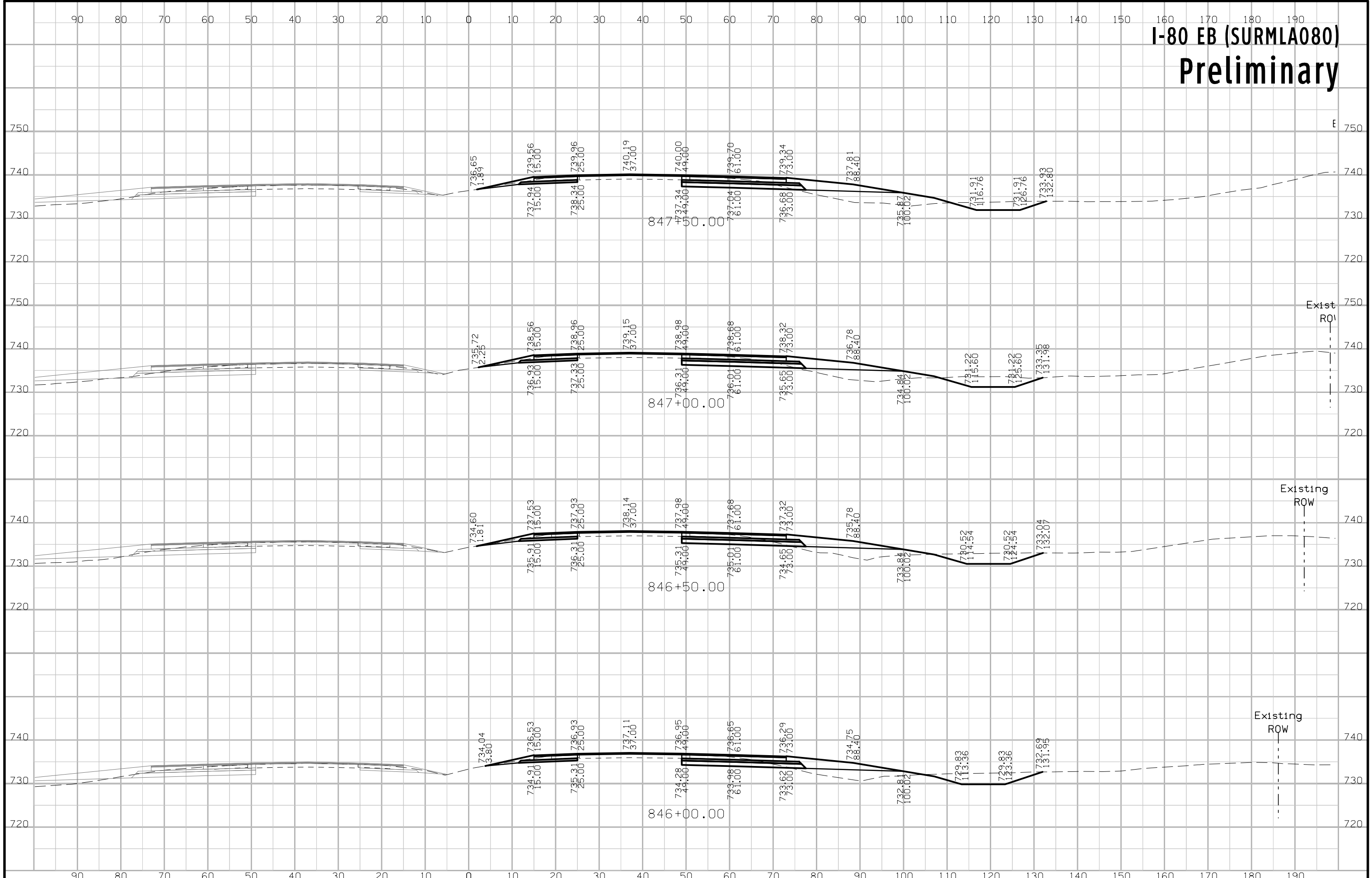

# I-80 EB (SURMLA080) Preliminary

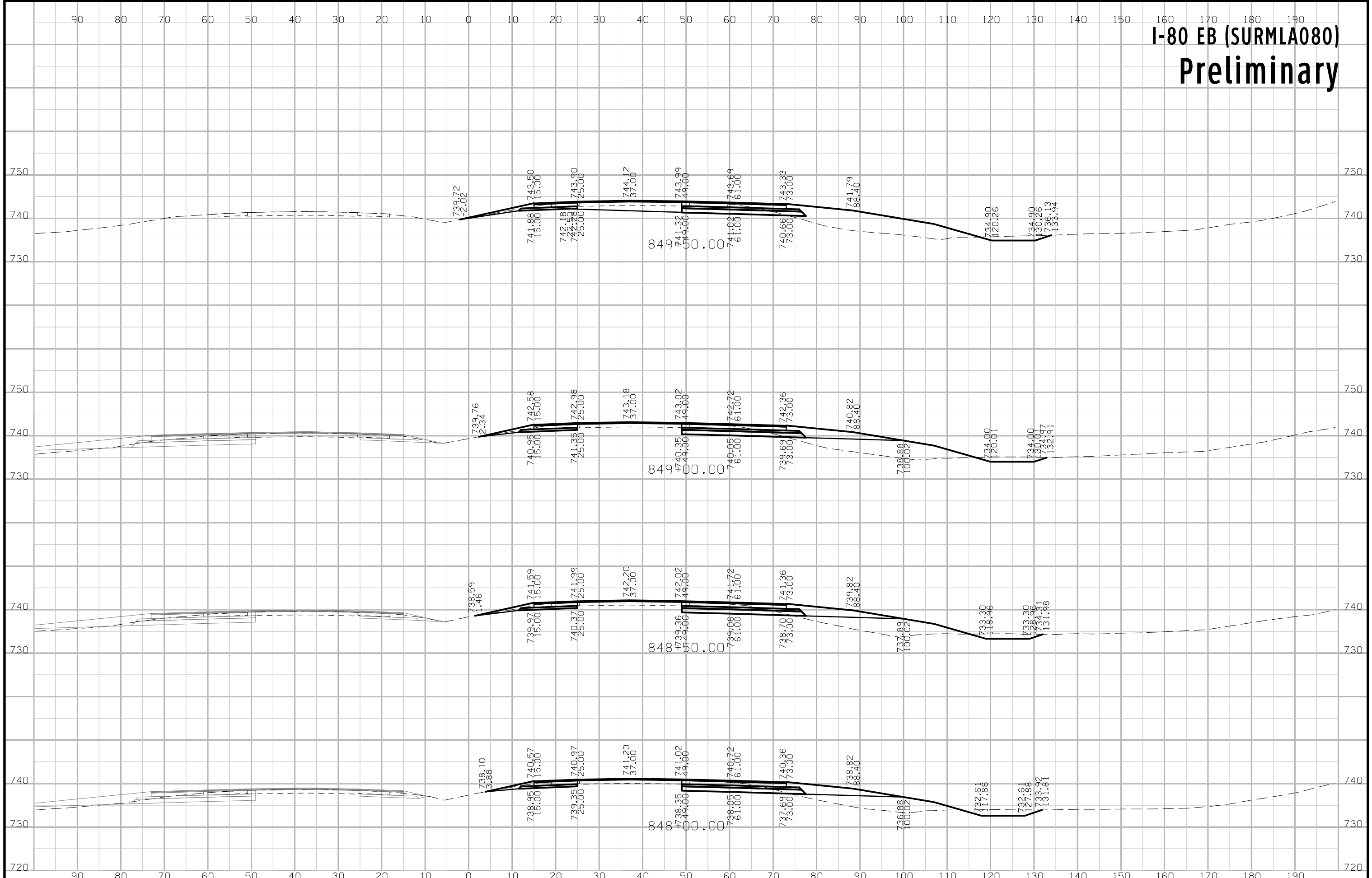

# I-80 EB (SURMLA080) Preliminary

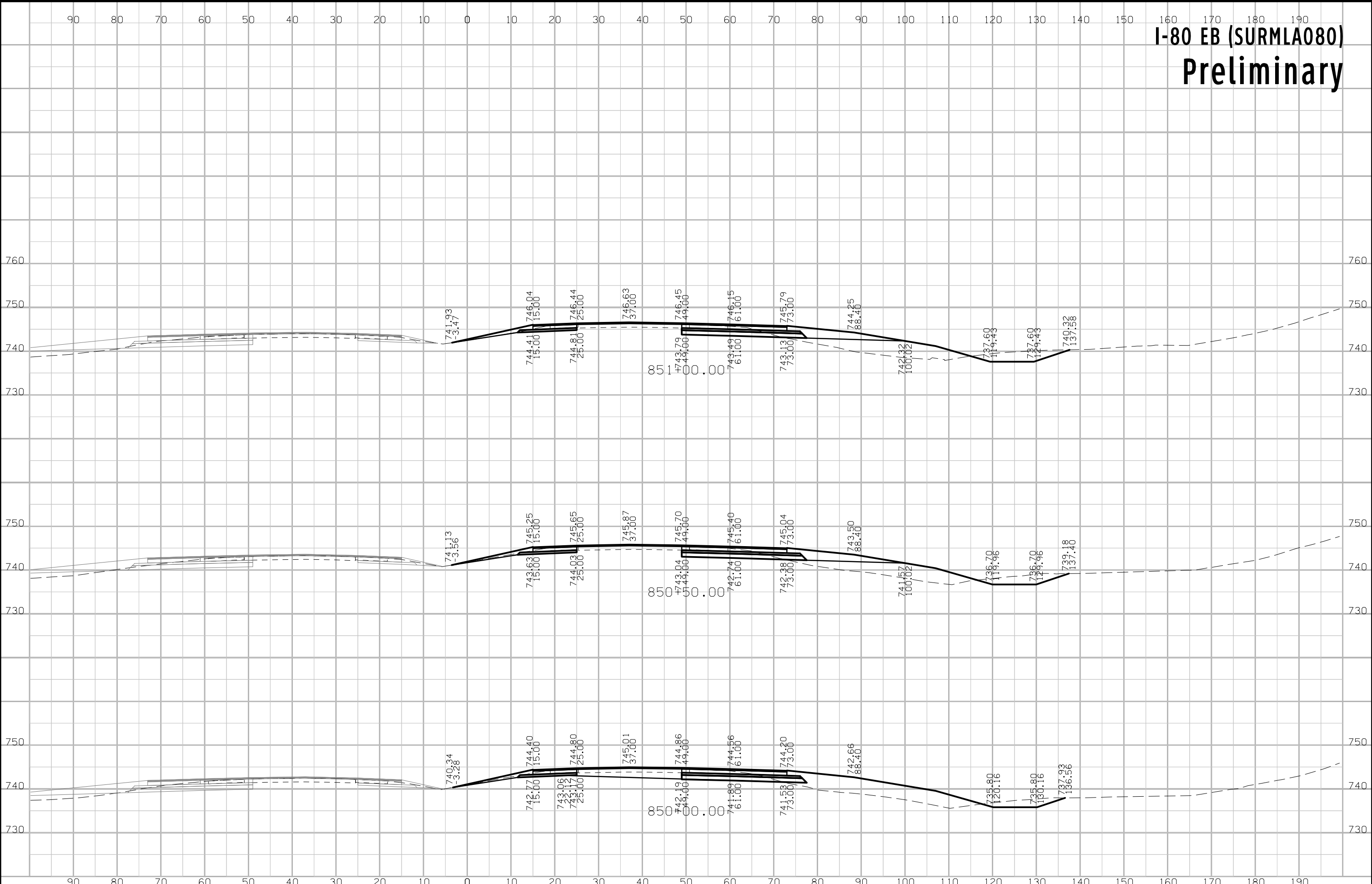

# I-80 EB (SURMLA080) Preliminary

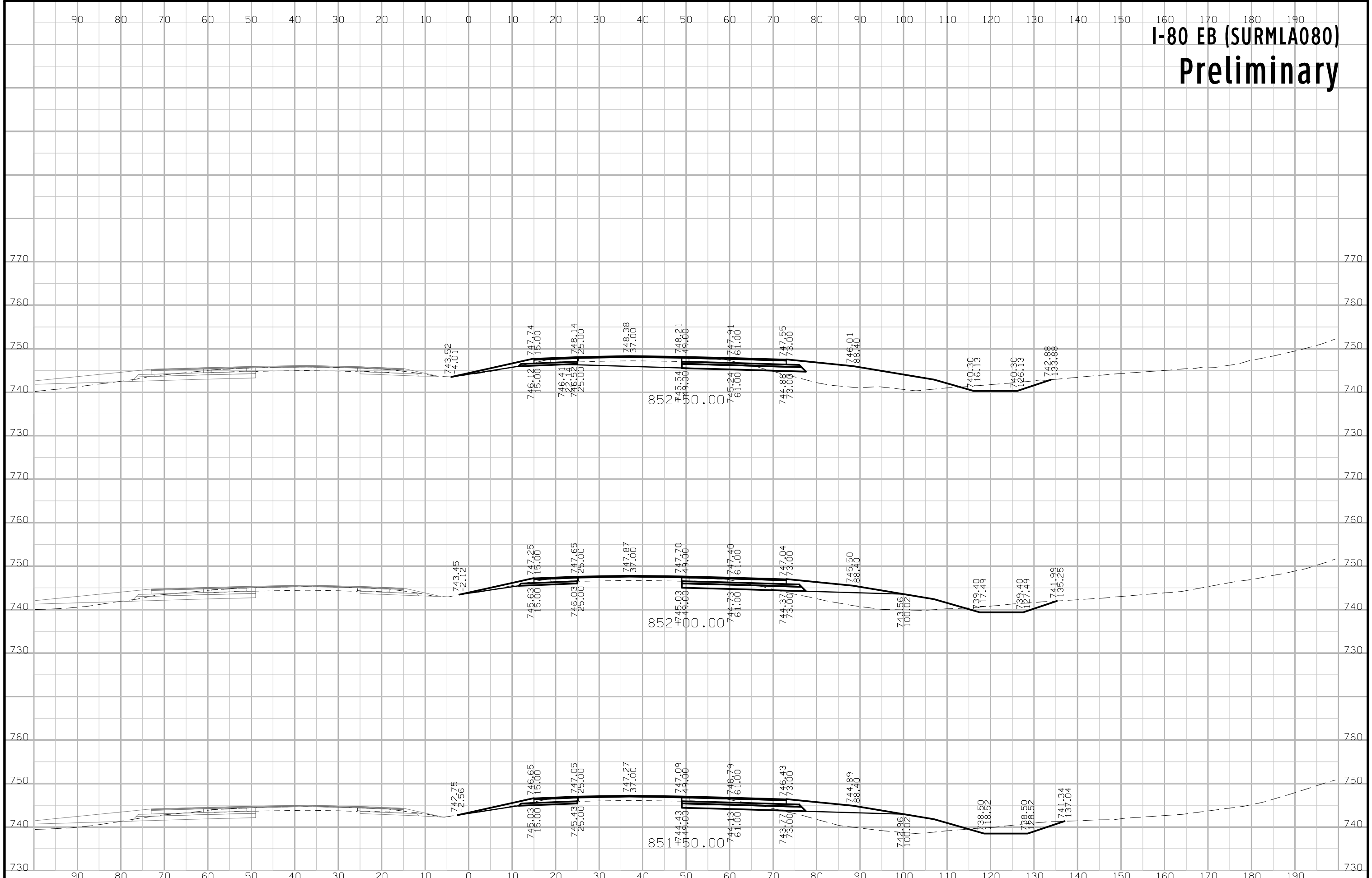



# I-80 EB (SURMLA080) Preliminary

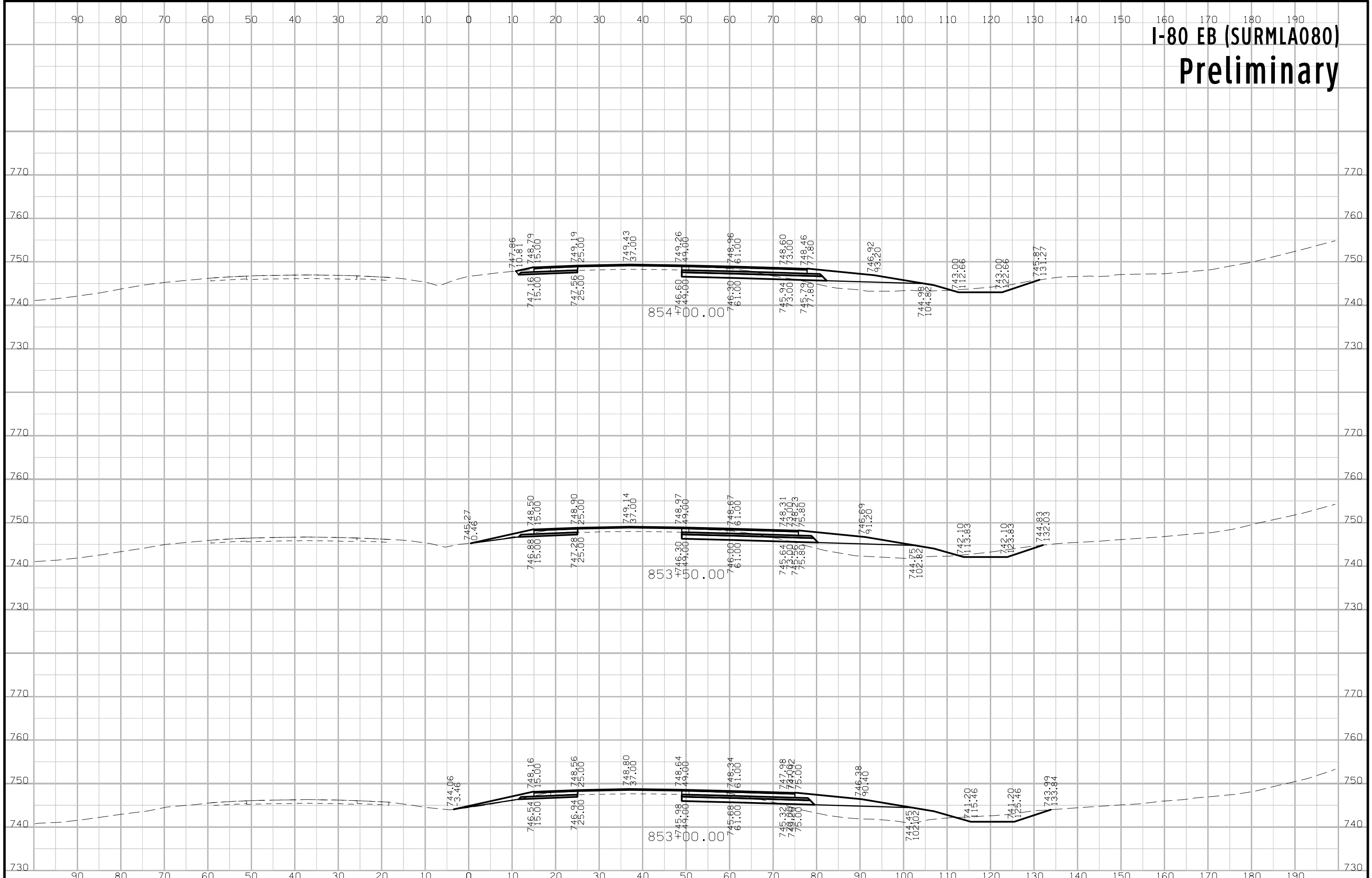

# I-80 EB (SURMLA080) Preliminary

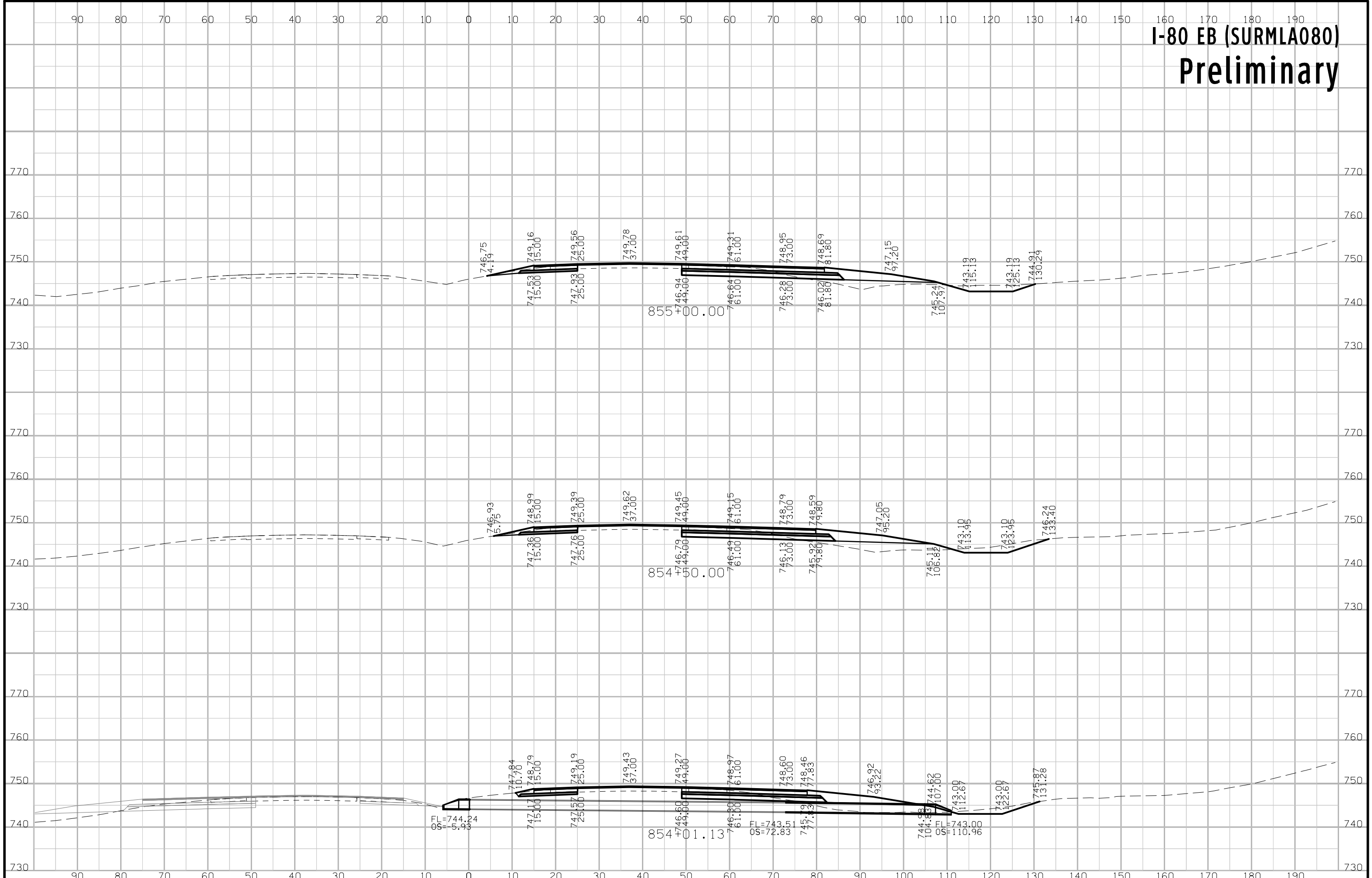

# I-80 EB (SURMLA080) Preliminary

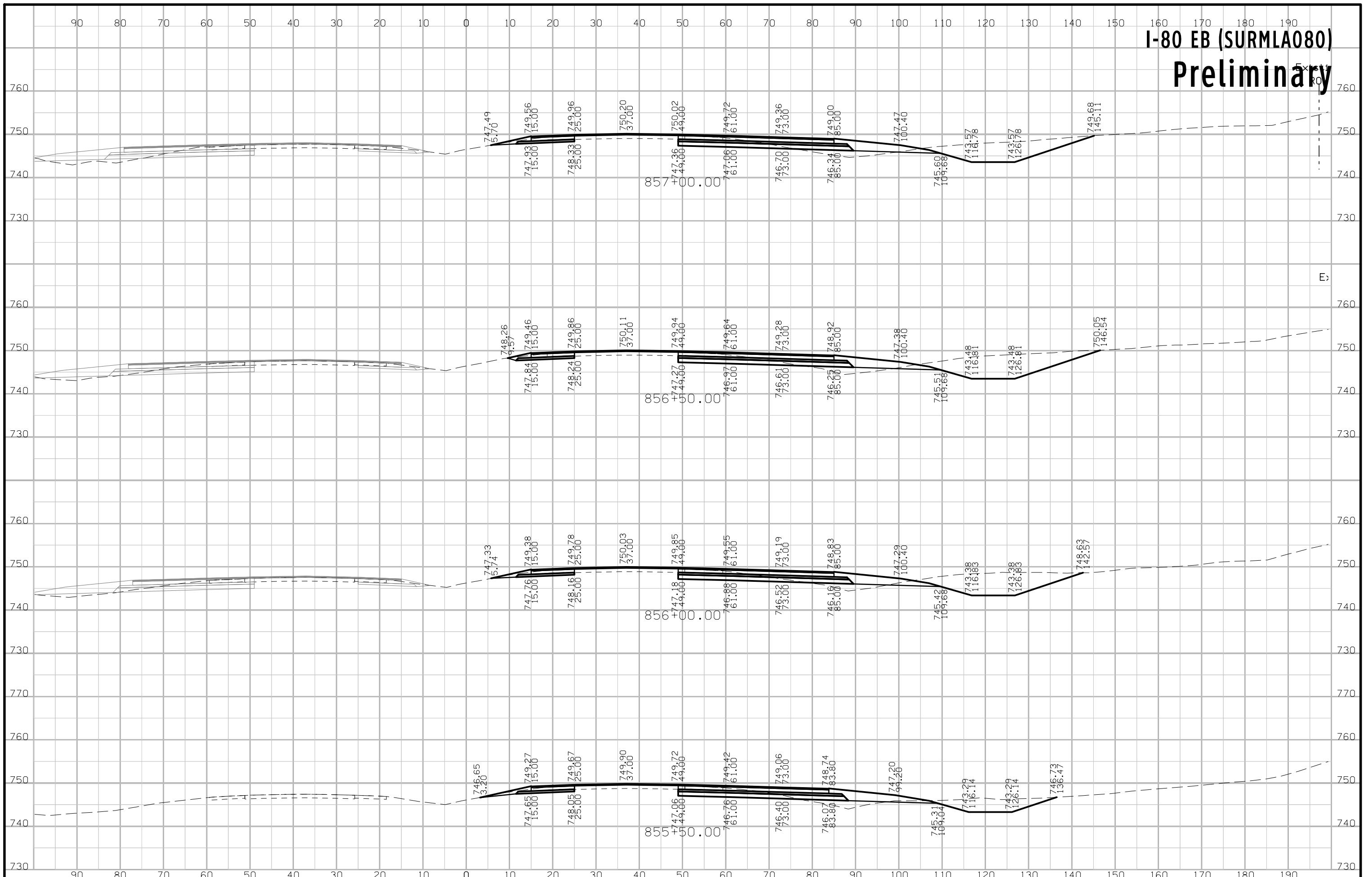

# I-80 EB (SURMLA080) Preliminary



# I-80 EB (SURMLA080) Preliminary

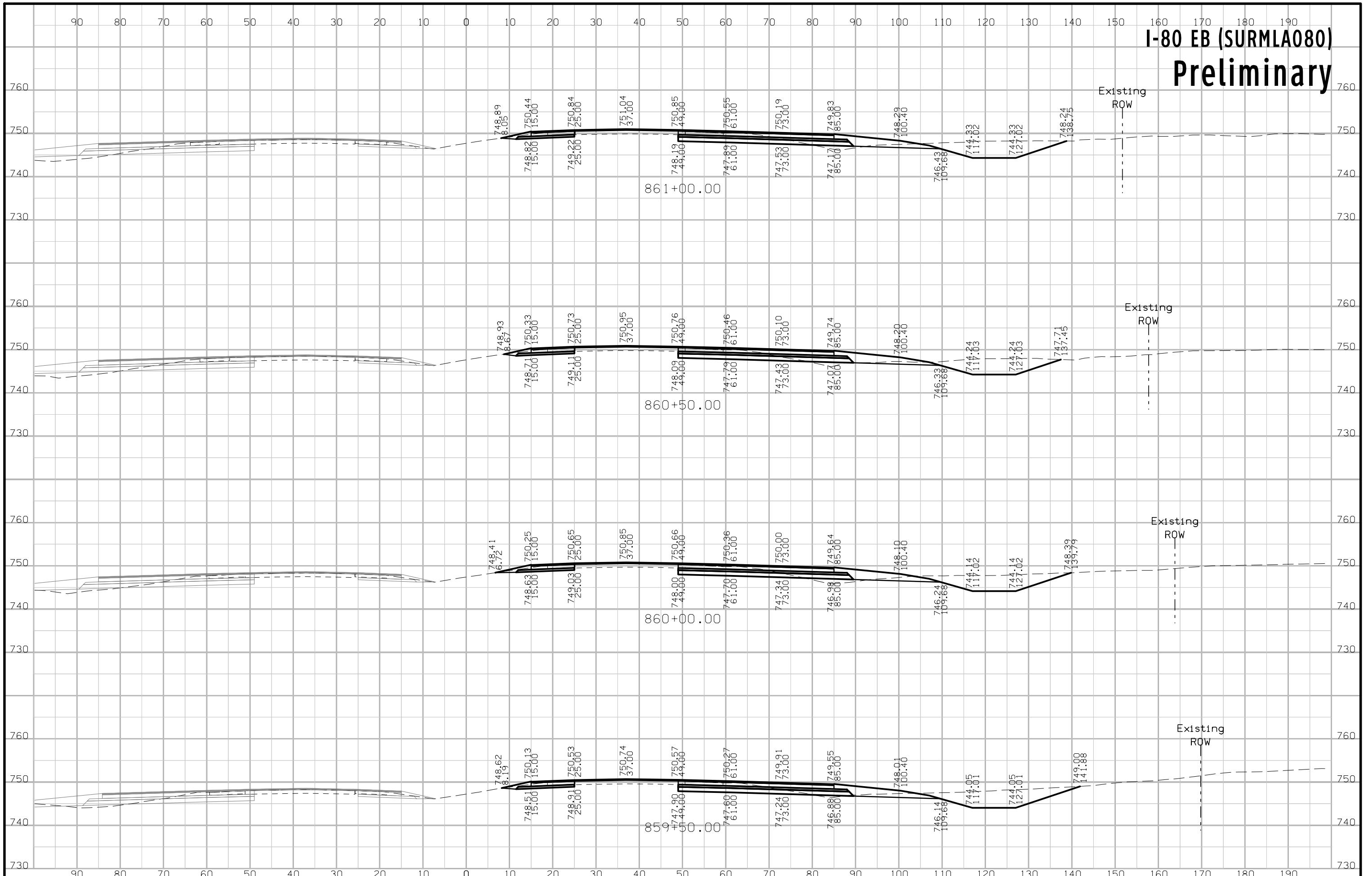

# I-80 EB (SURMLA080) Preliminary

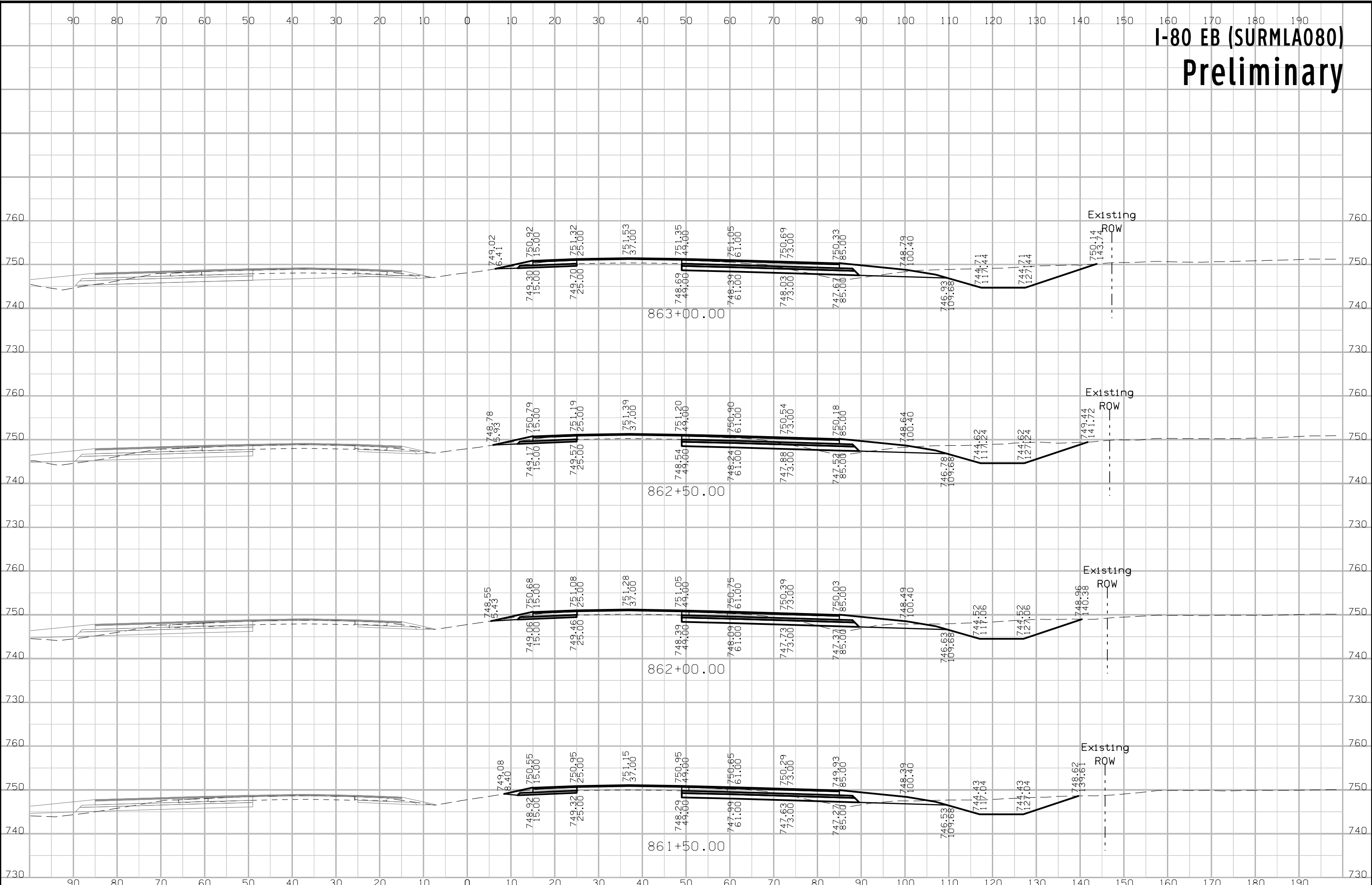

# I-80 EB (SURMLA080) Preliminary

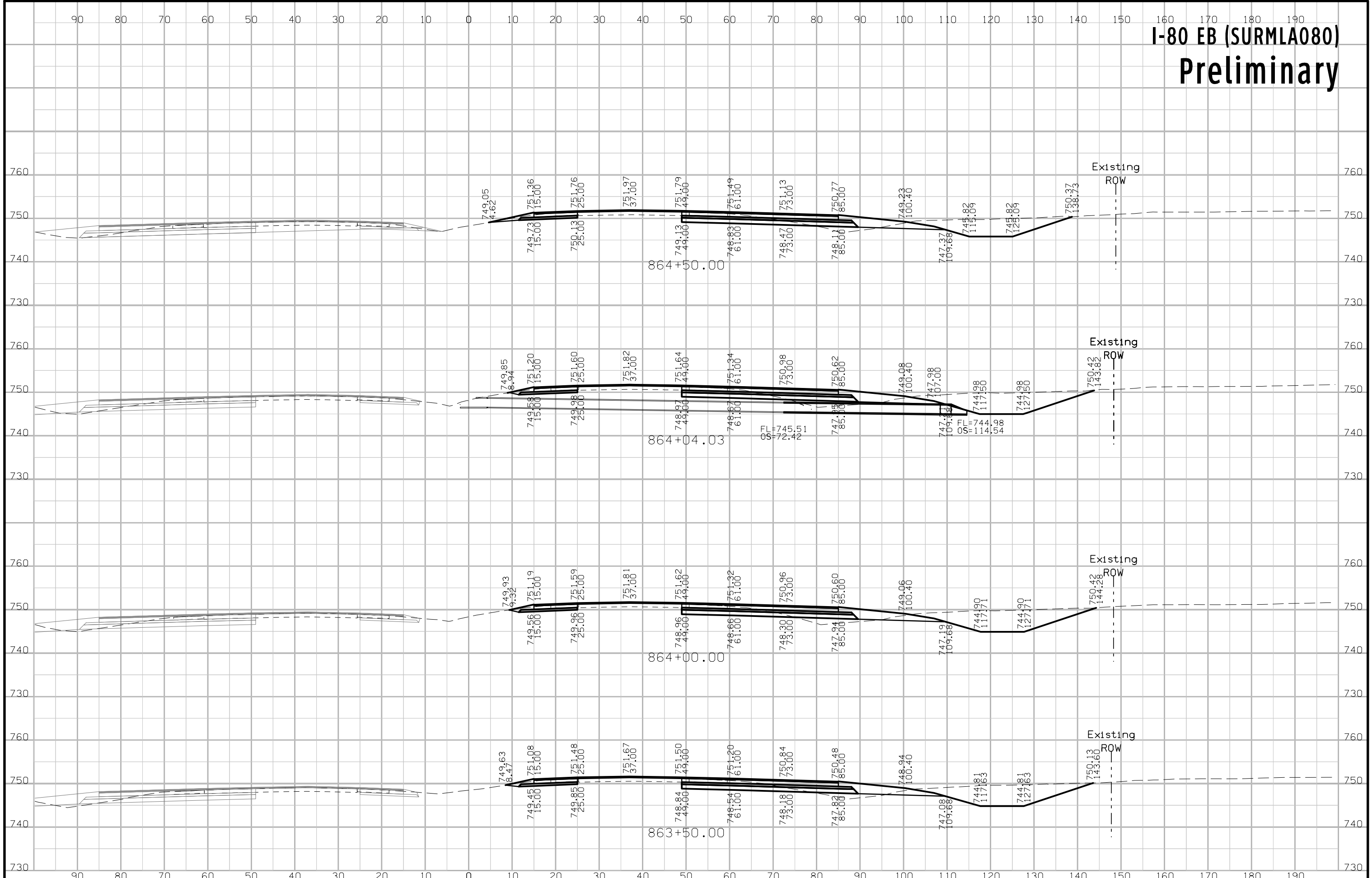



# I-80 EB (SURMLA080) Preliminary

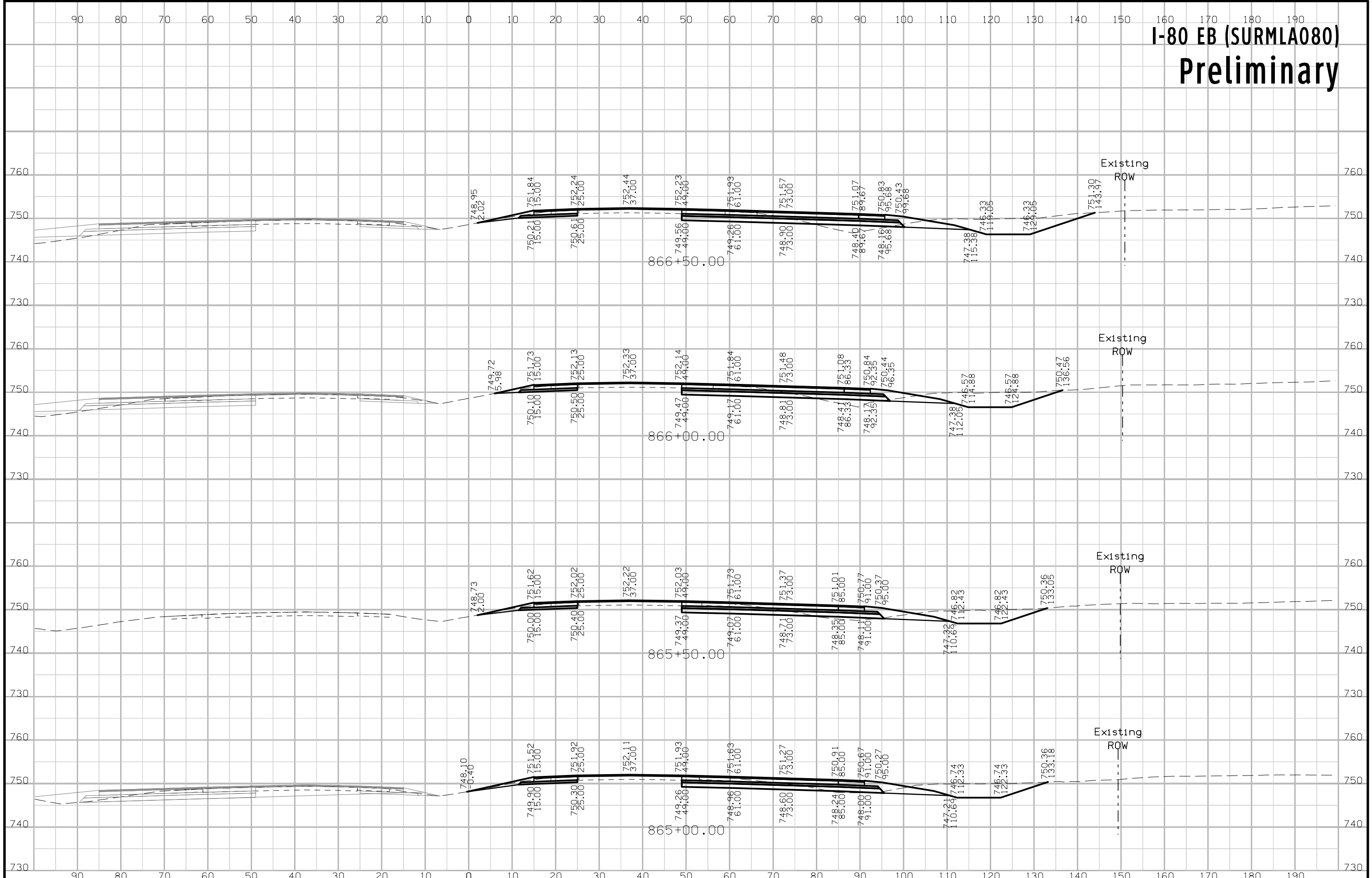

# I-80 EB (SURMLA080) Preliminary

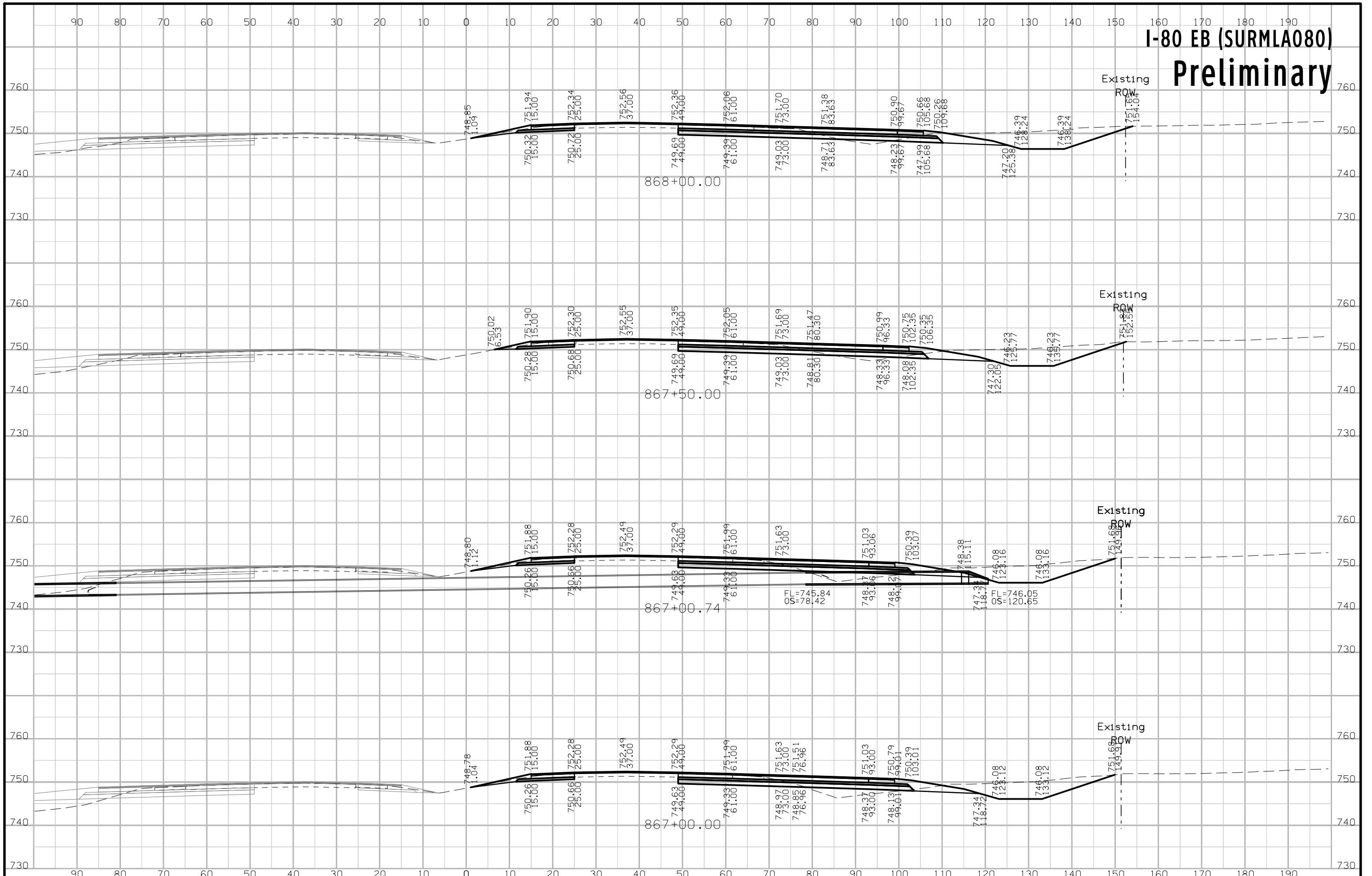

# I-80 EB (SURMLA080) Preliminary

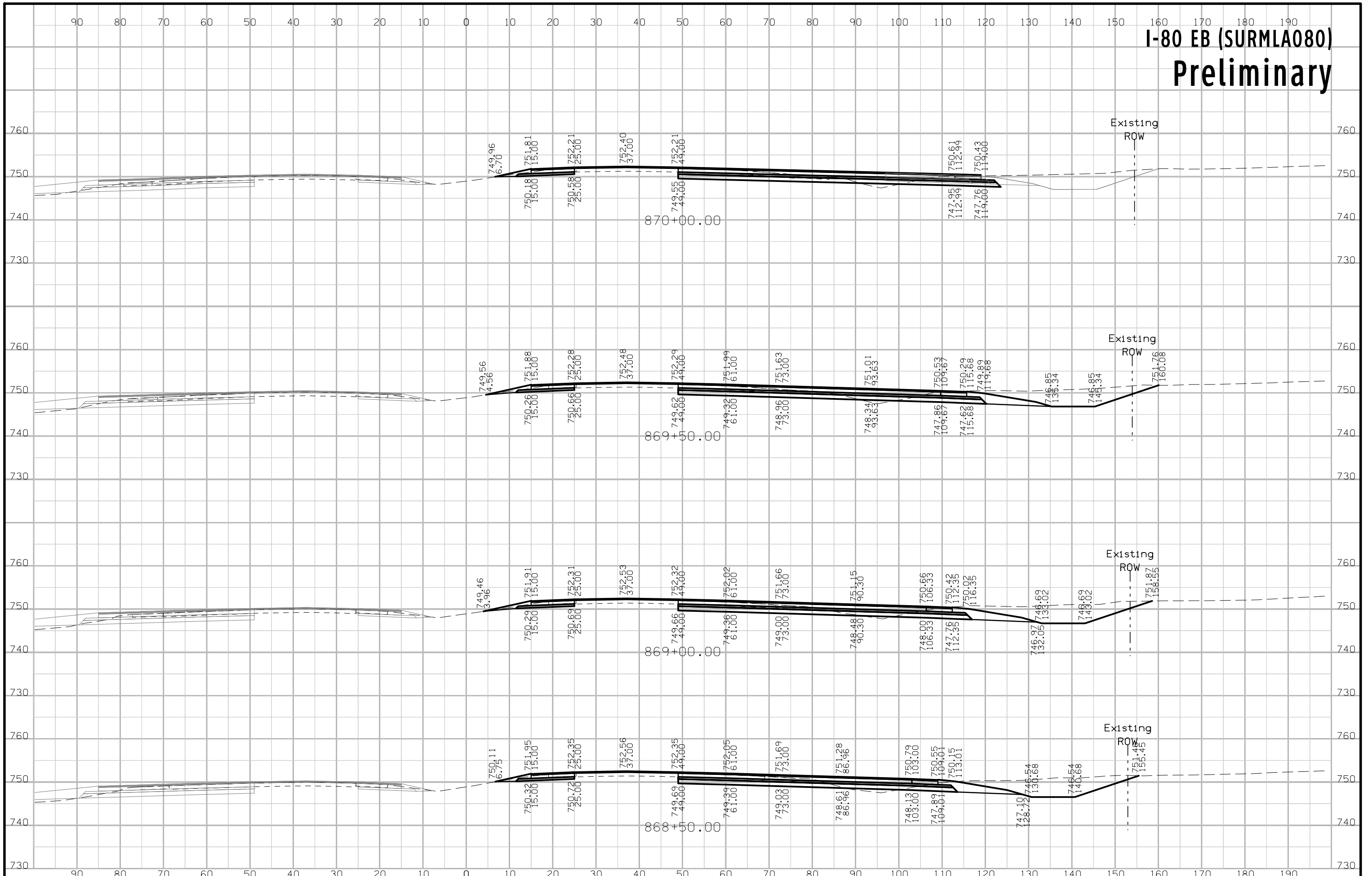

# I-80 EB (SURMLA080) Preliminary

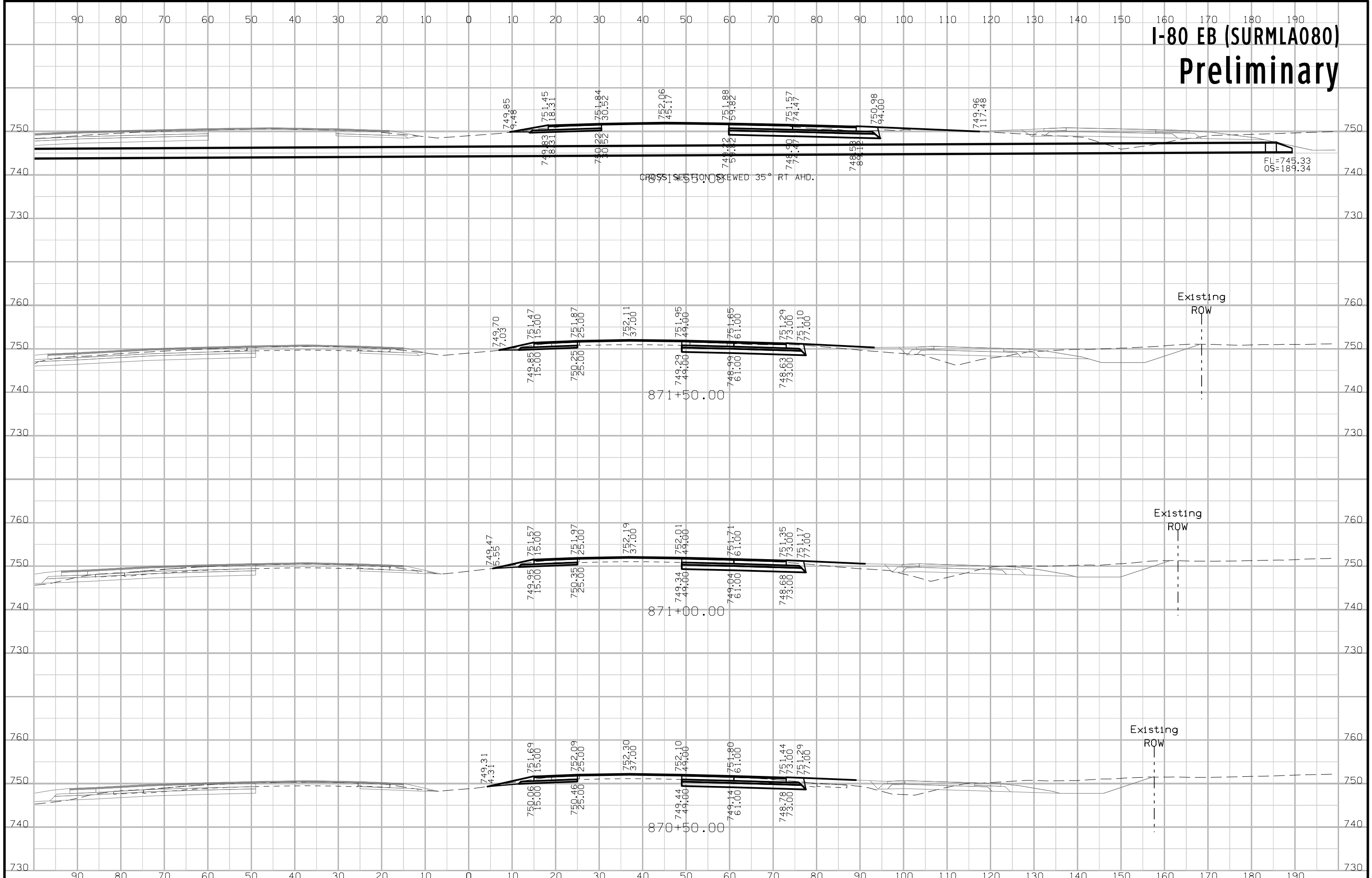

# I-80 EB (SURMLA080) Preliminary

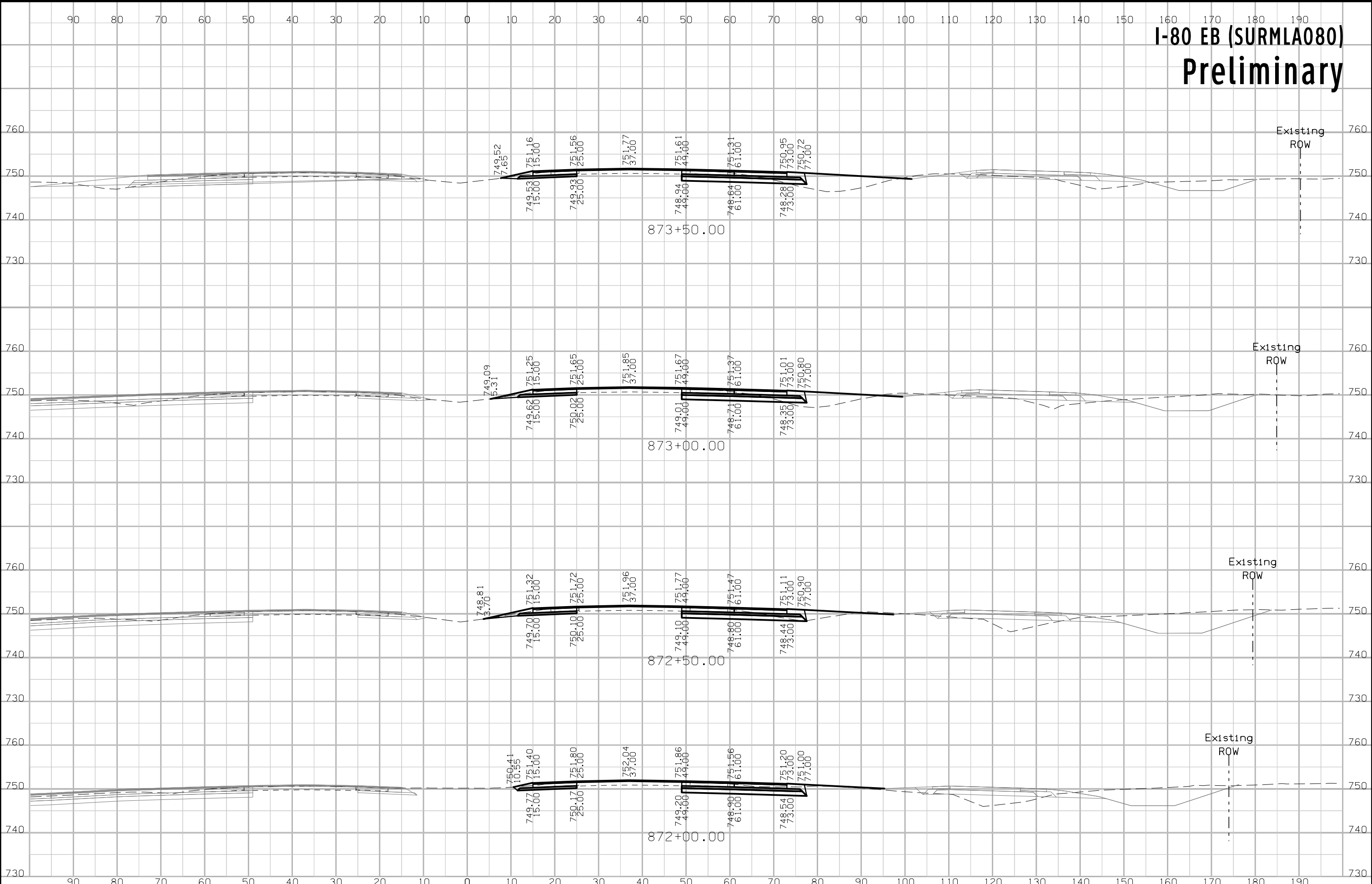

# I-80 EB (SURMLA080) Preliminary

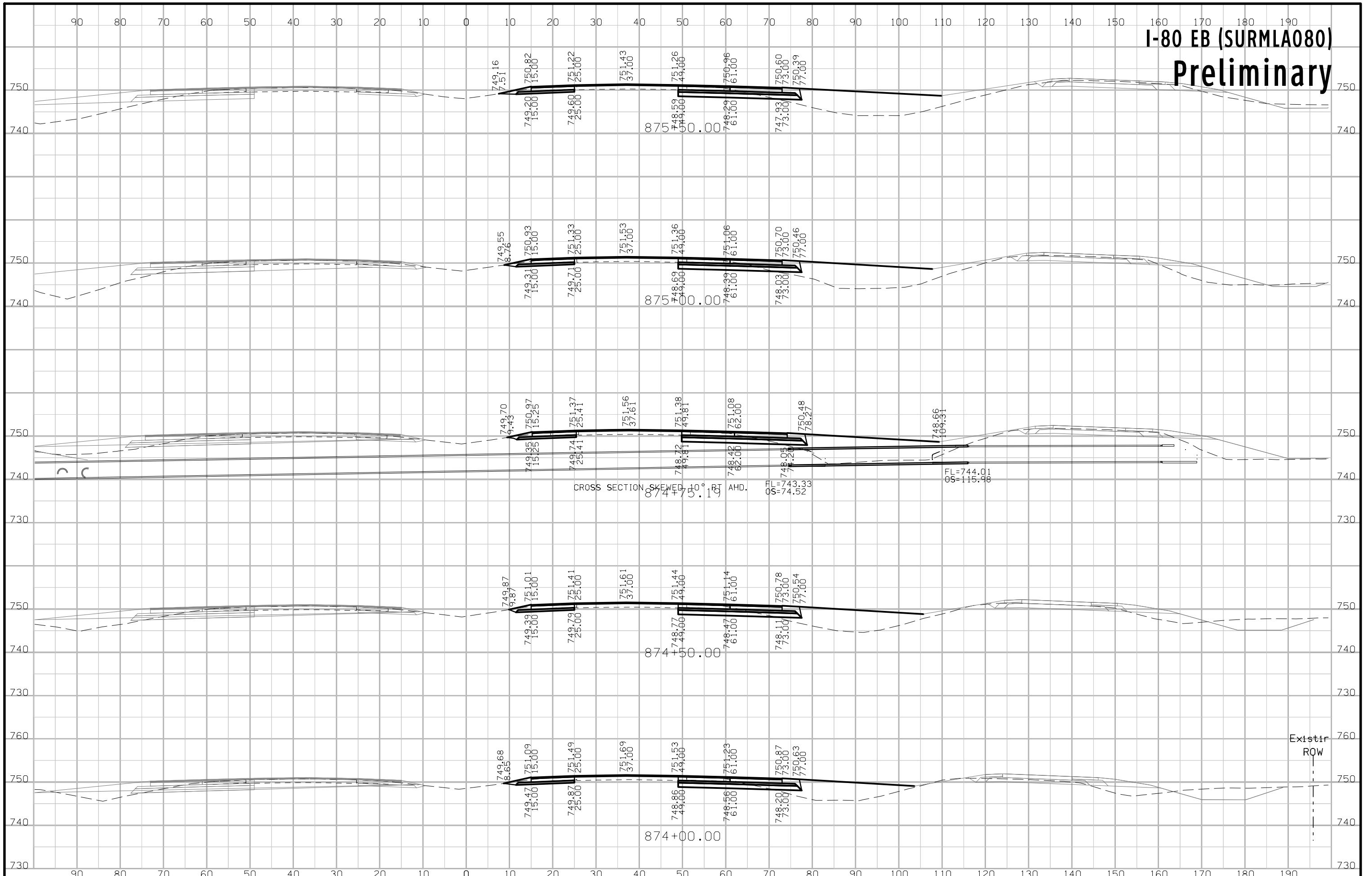

CROSS SECTION SKEWED 40° RHD.  
 874+75.19  
 FL=743.33  
 OS=74.52  
 FL=744.01  
 OS=115.98

# I-80 EB (SURMLA080) Preliminary

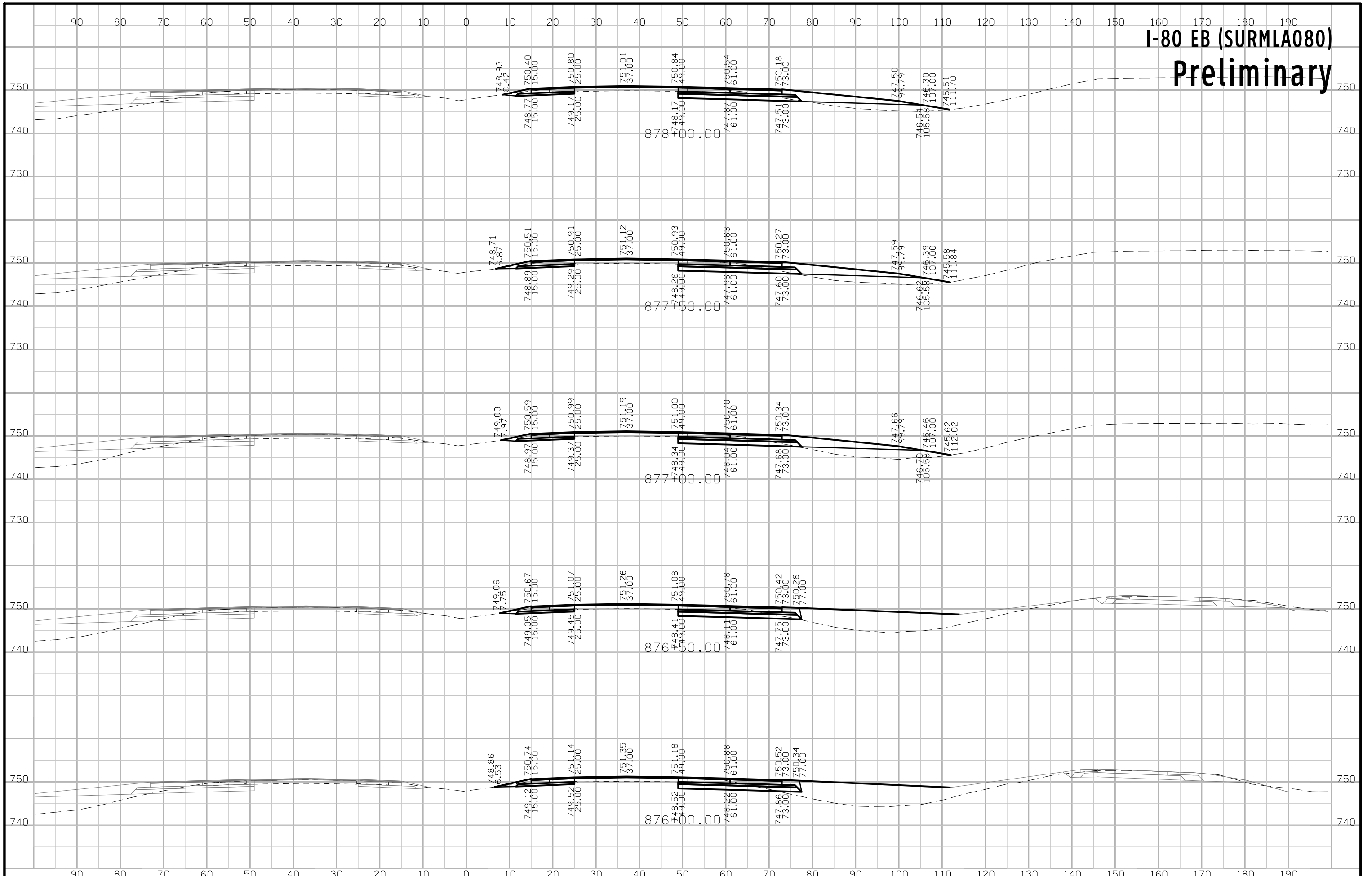



# I-80 EB (SURMLA080) Preliminary

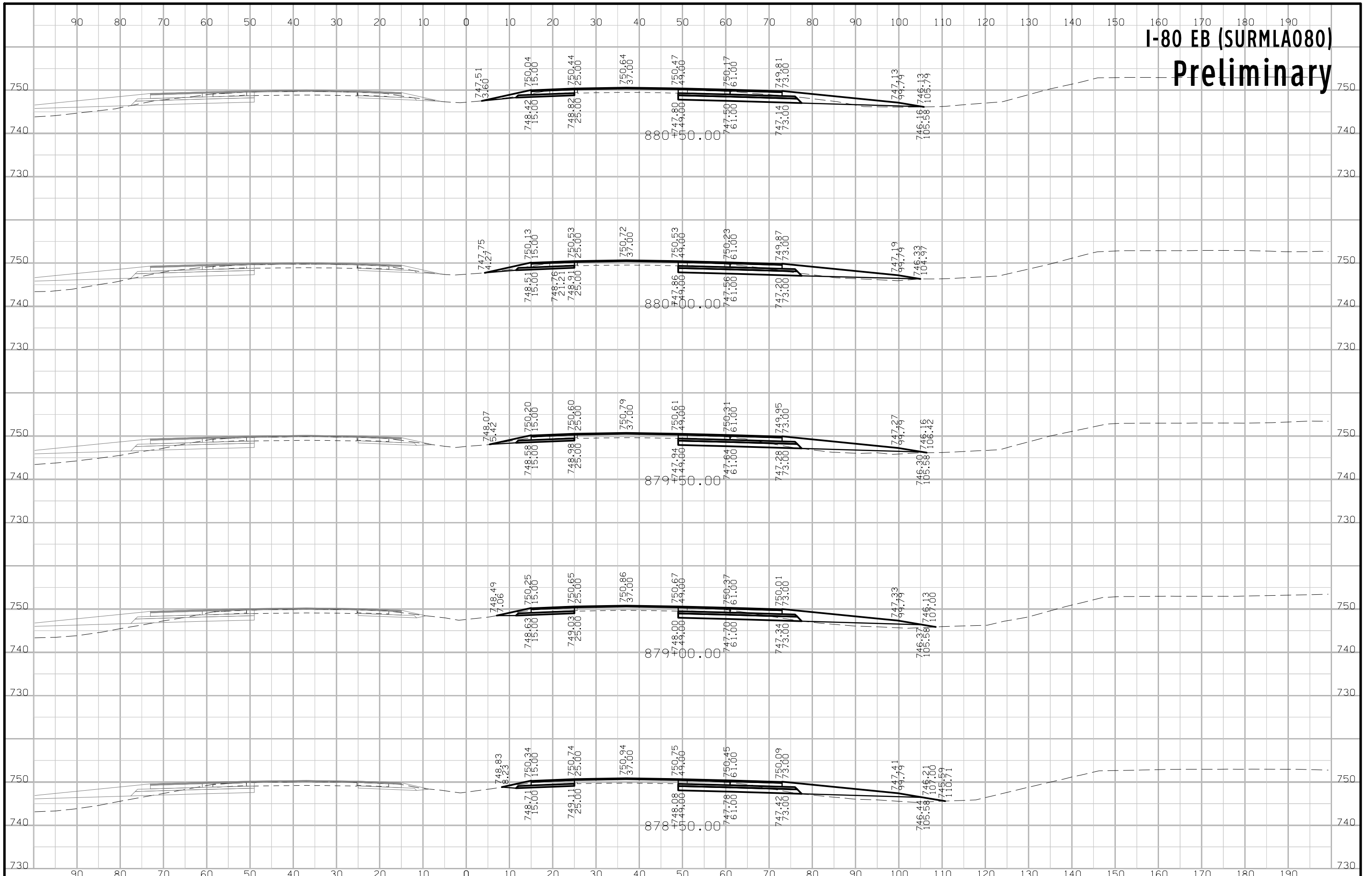

**I-80 EB (SURMLA080)  
Preliminary**

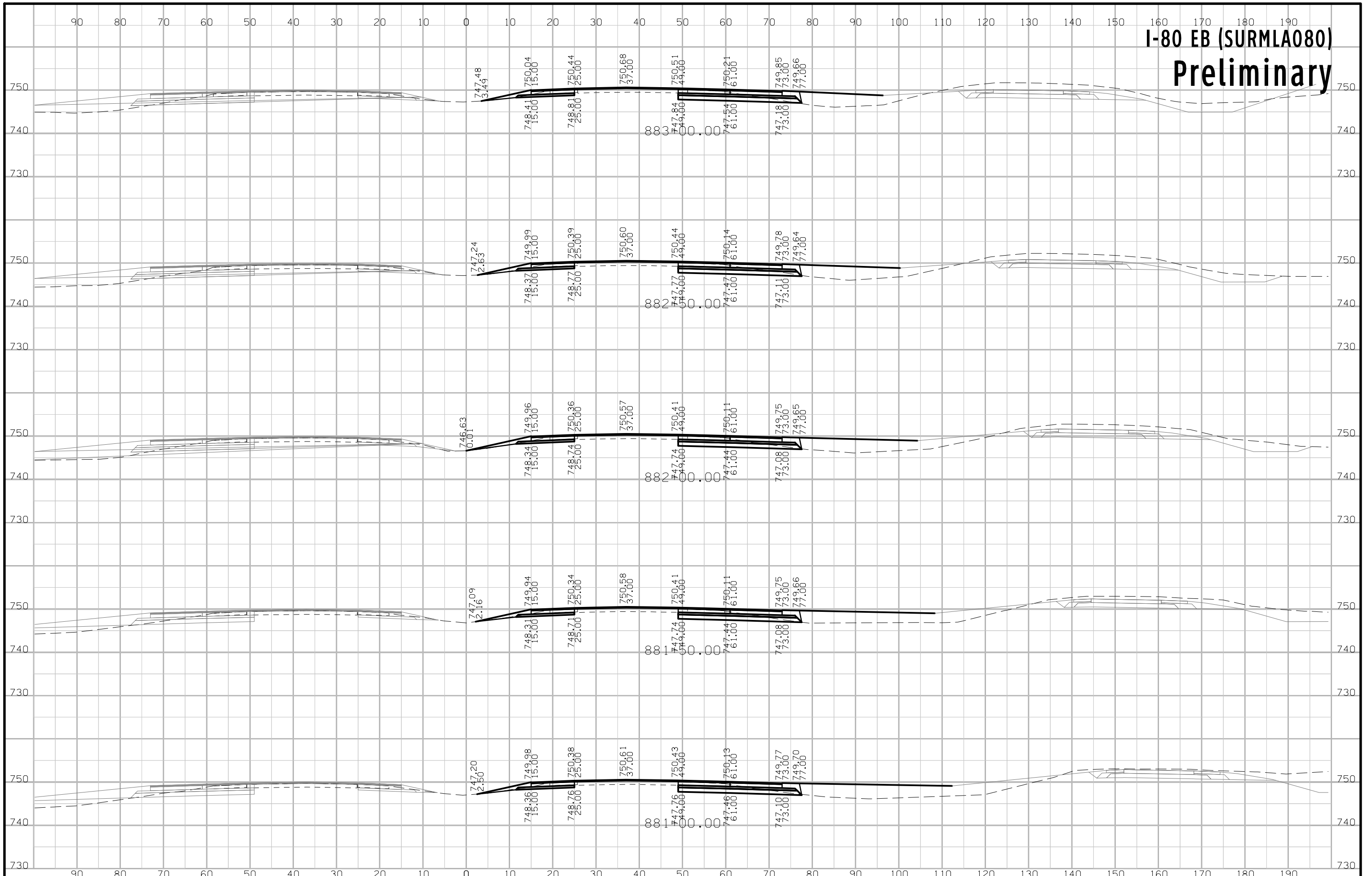

# I-80 EB (SURMLA080) Preliminary

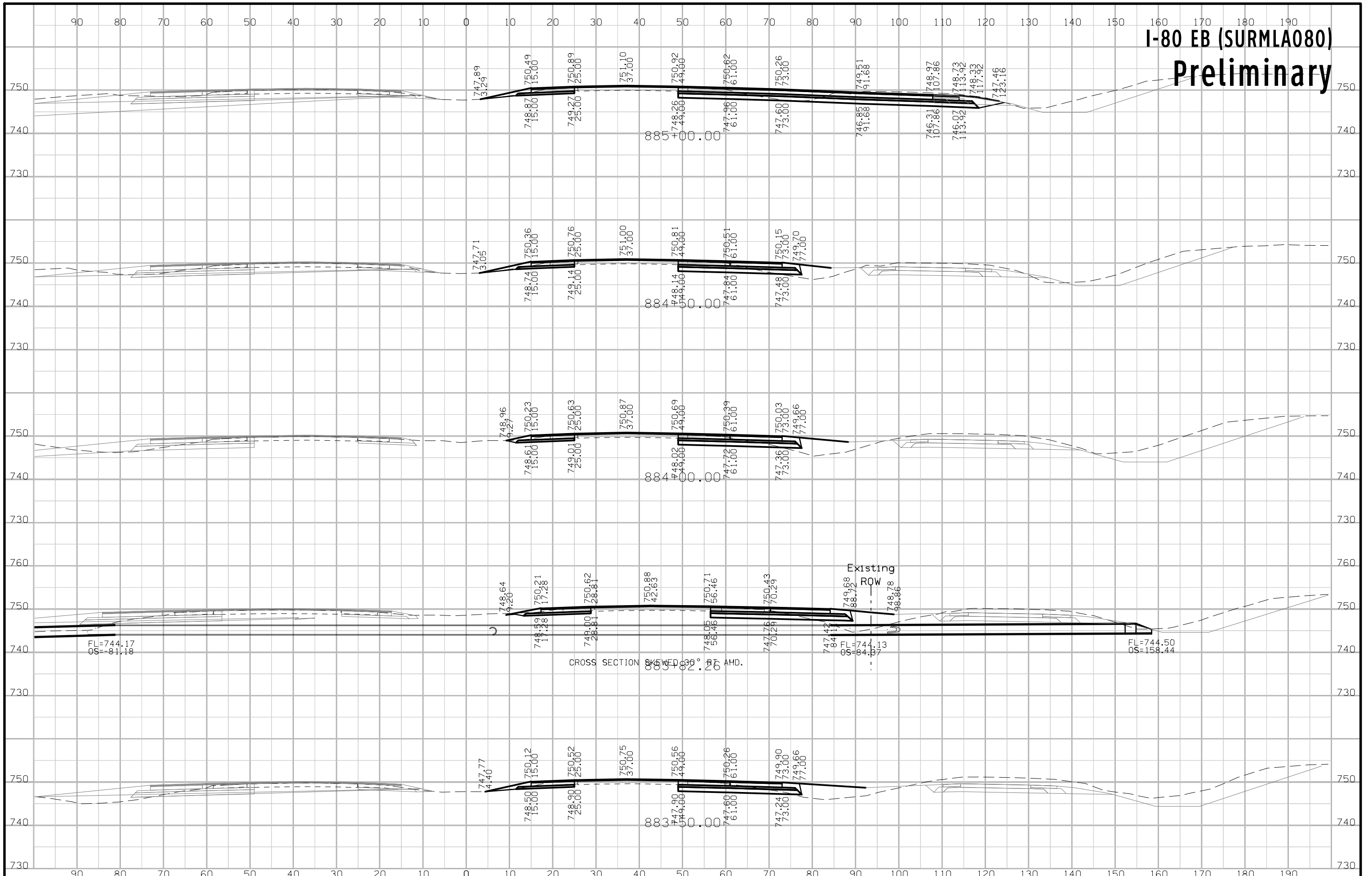

CROSS SECTION SKewed 30° BT AHD.

Existing ROW

# I-80 EB (SURMLA080) Preliminary

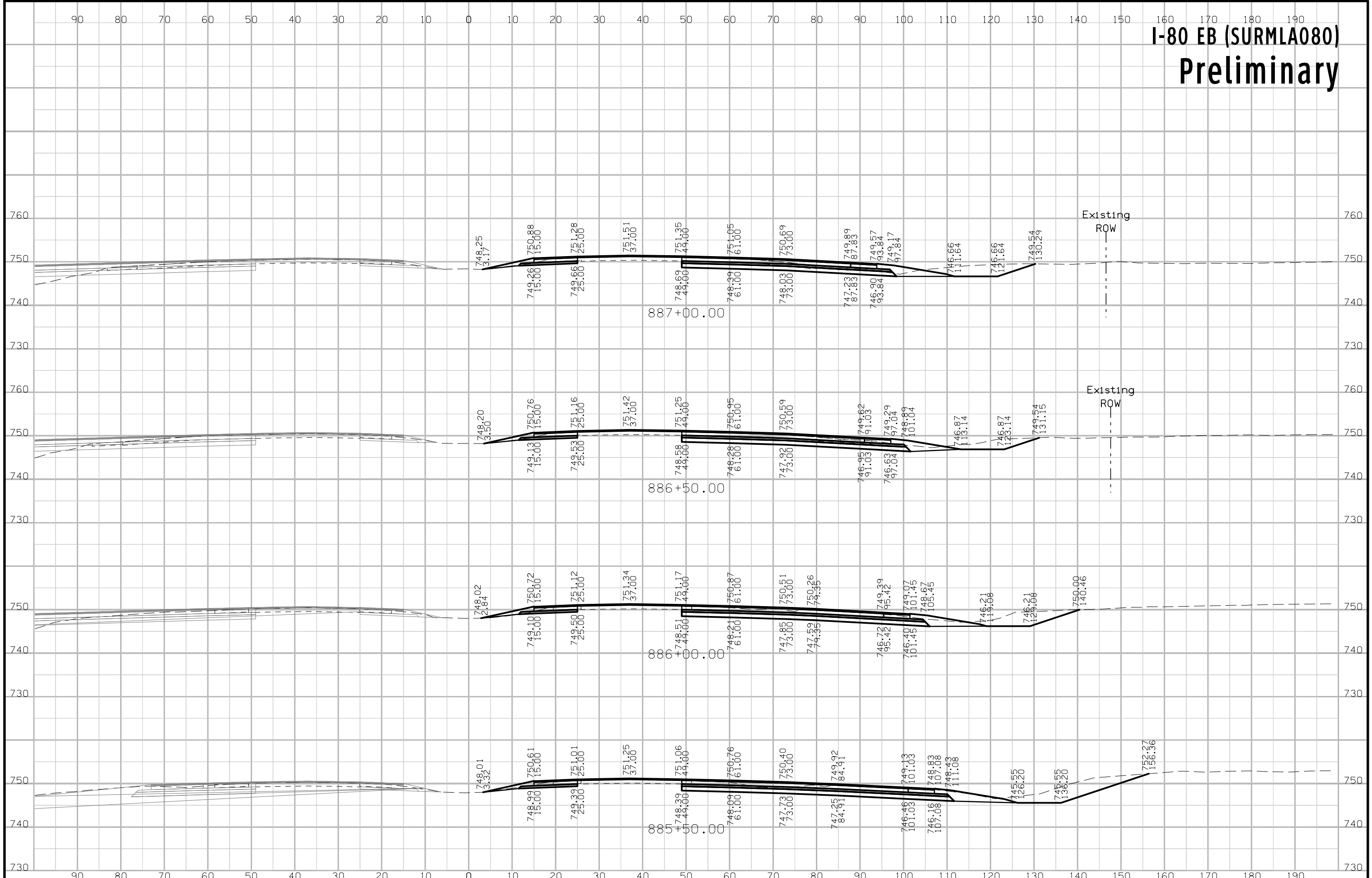

# I-80 EB (SURMLA080) Preliminary

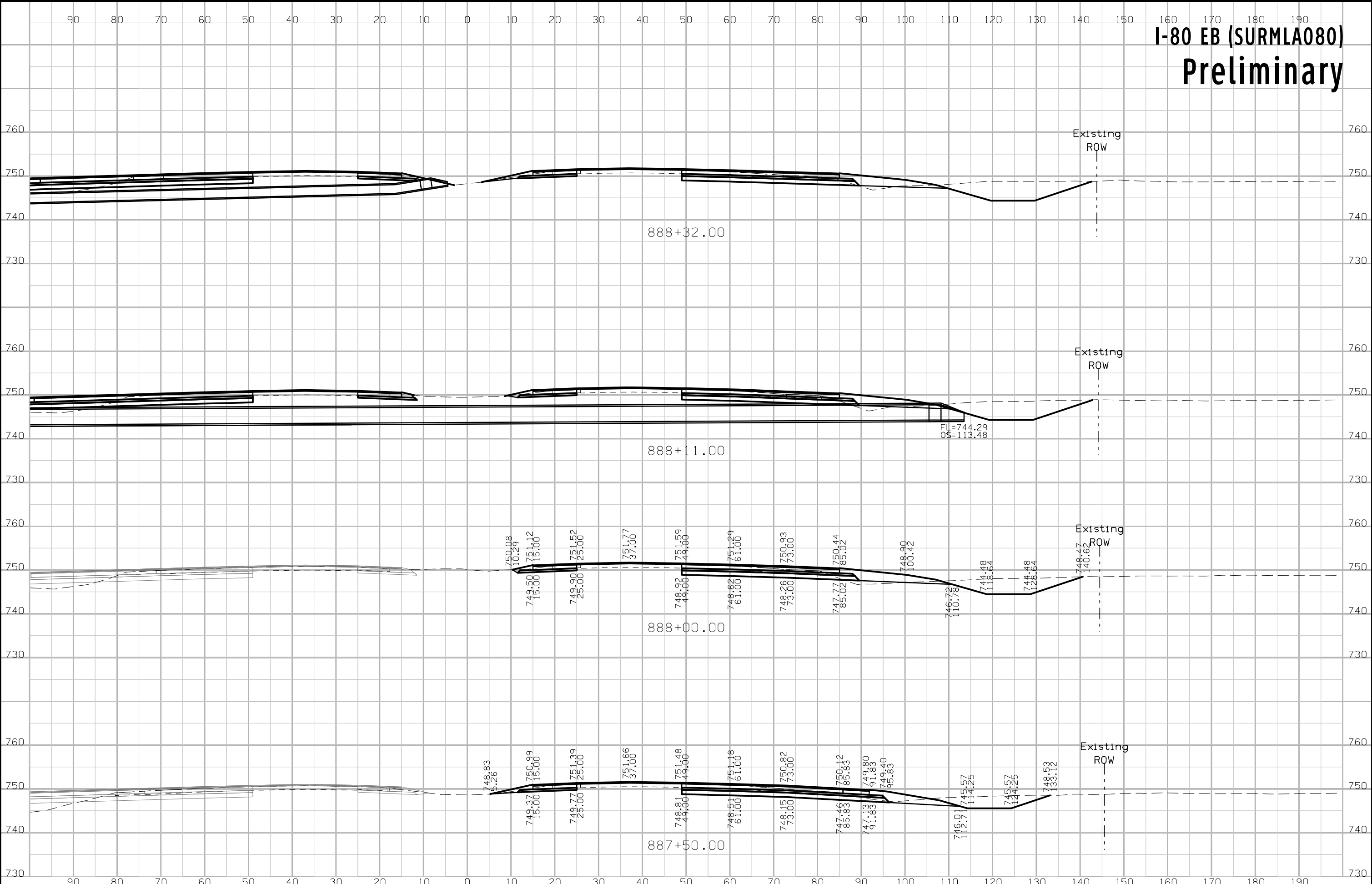

# I-80 EB (SURMLA080) Preliminary

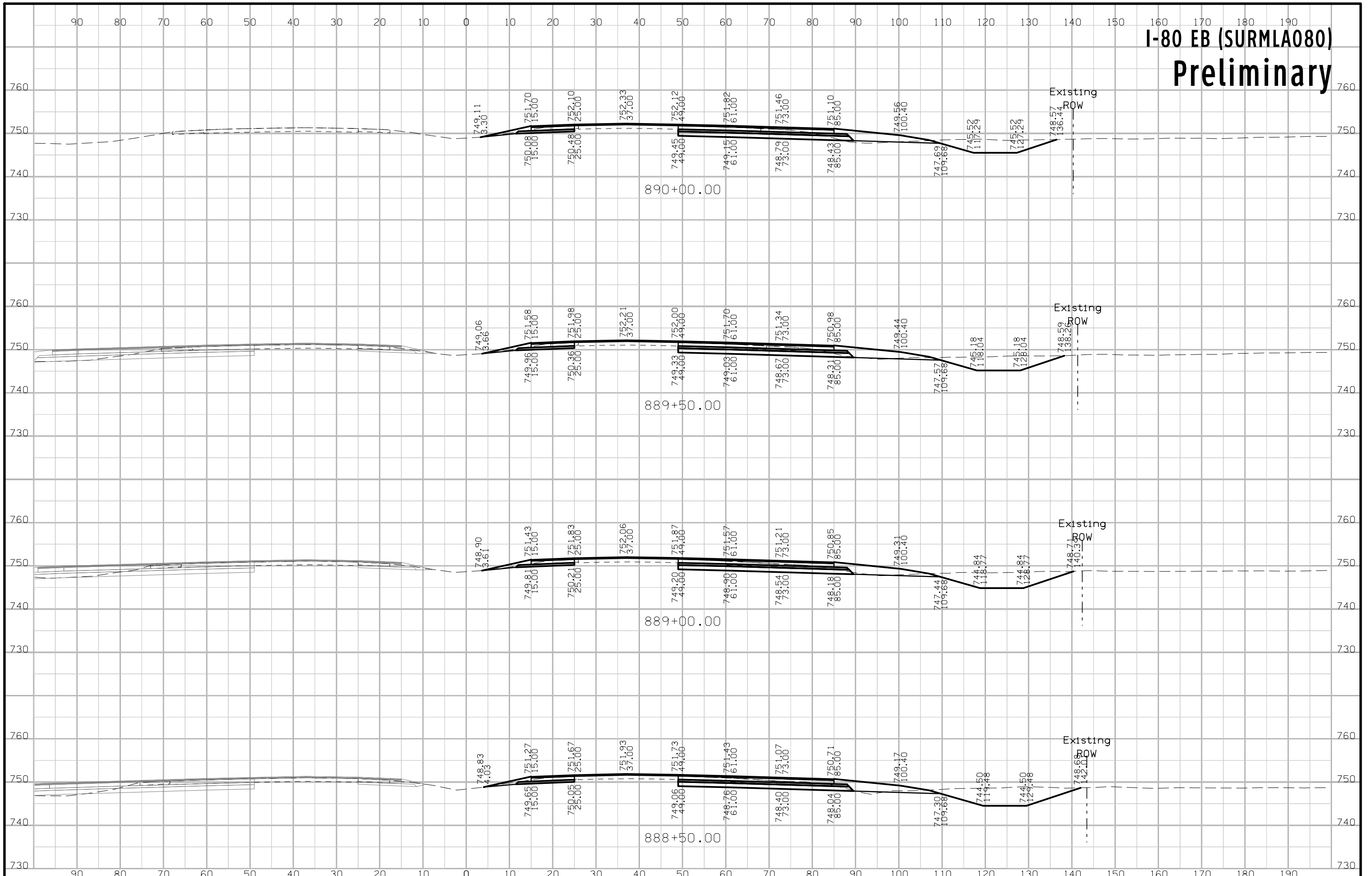

# I-80 EB (SURMLA080) Preliminary

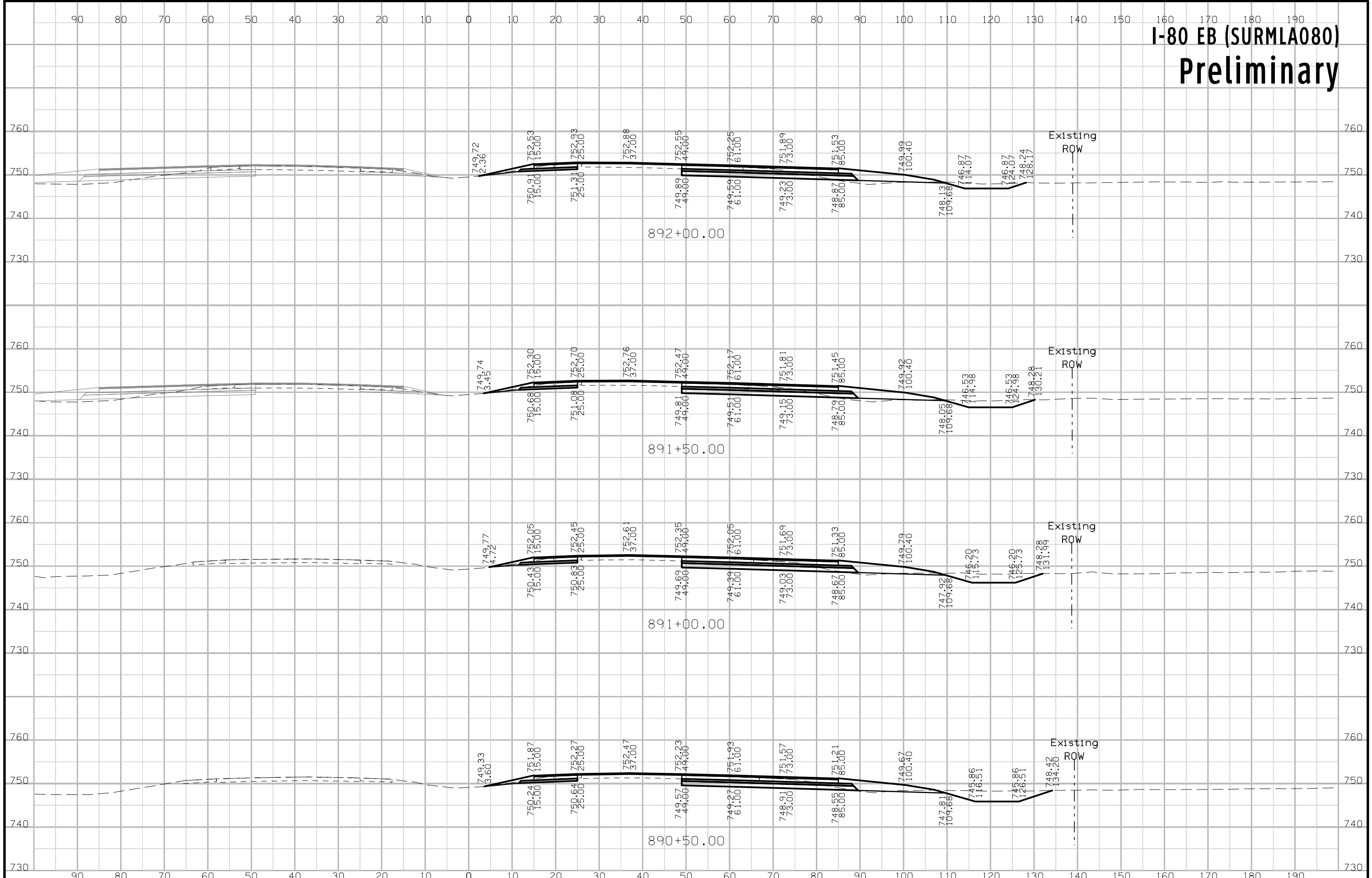



# I-80 EB (SURMLA080) Preliminary

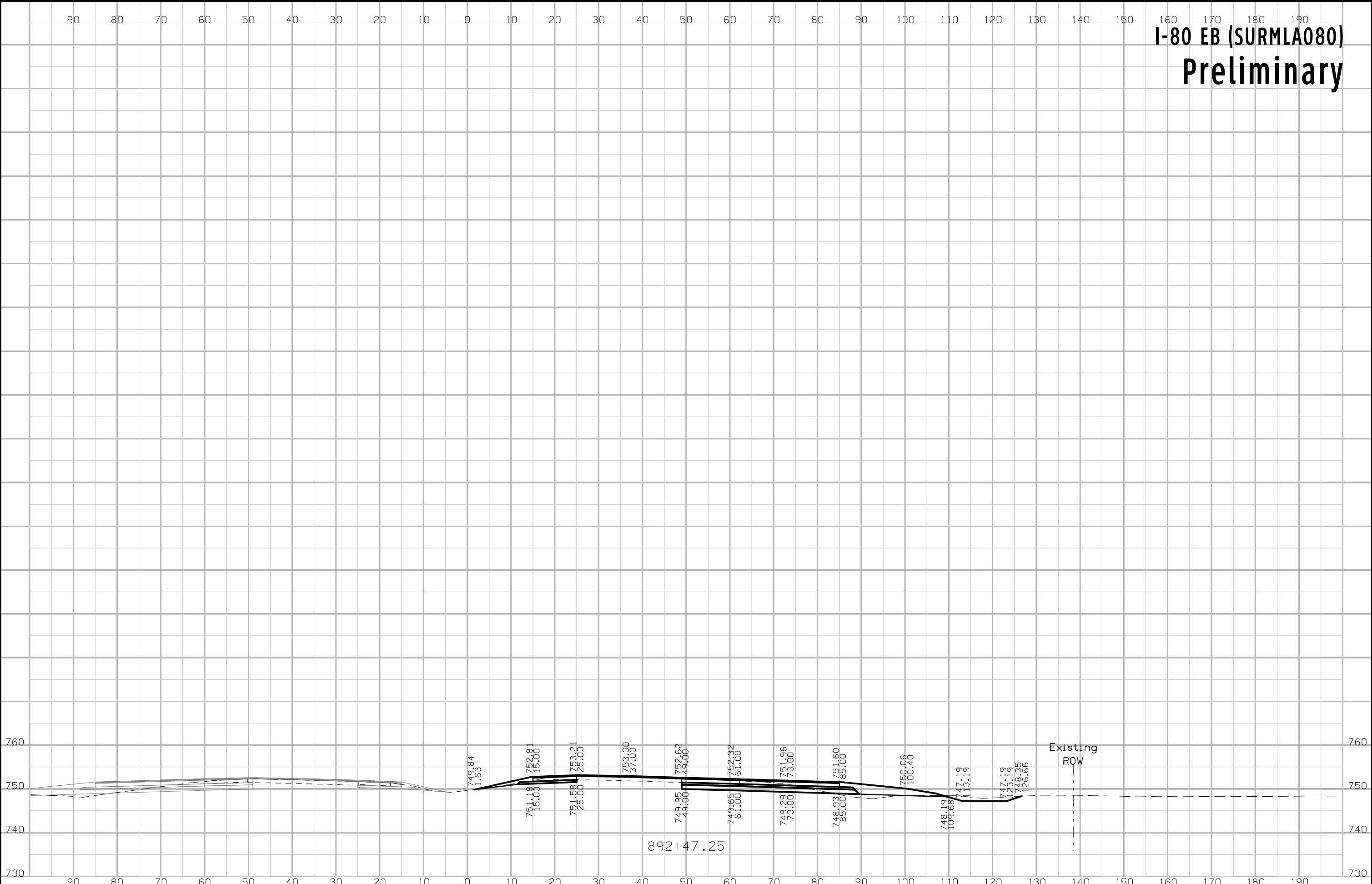

# I-80 EB (MLEB080) Preliminary

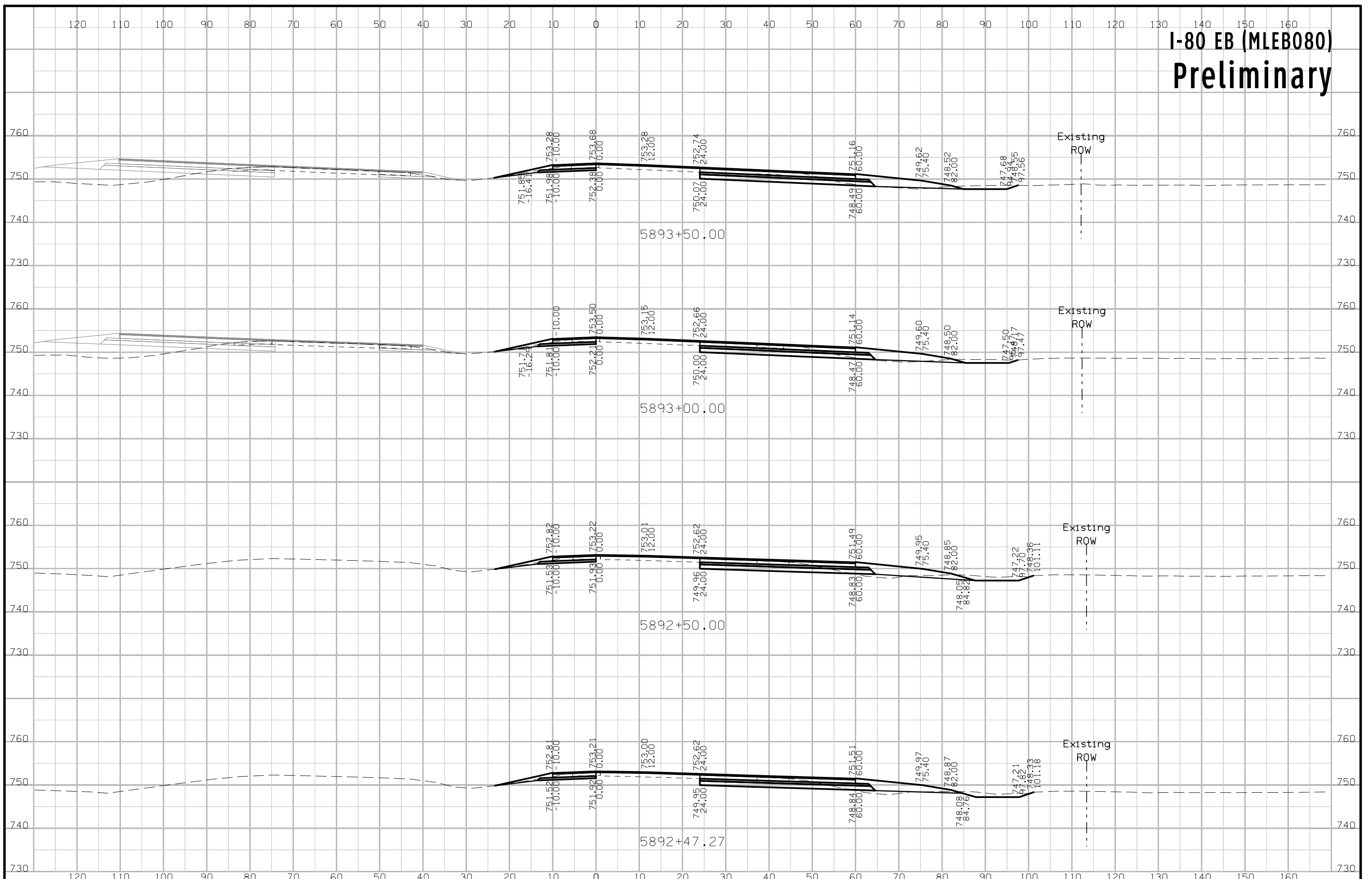

# I-80 EB (MLEB080) Preliminary

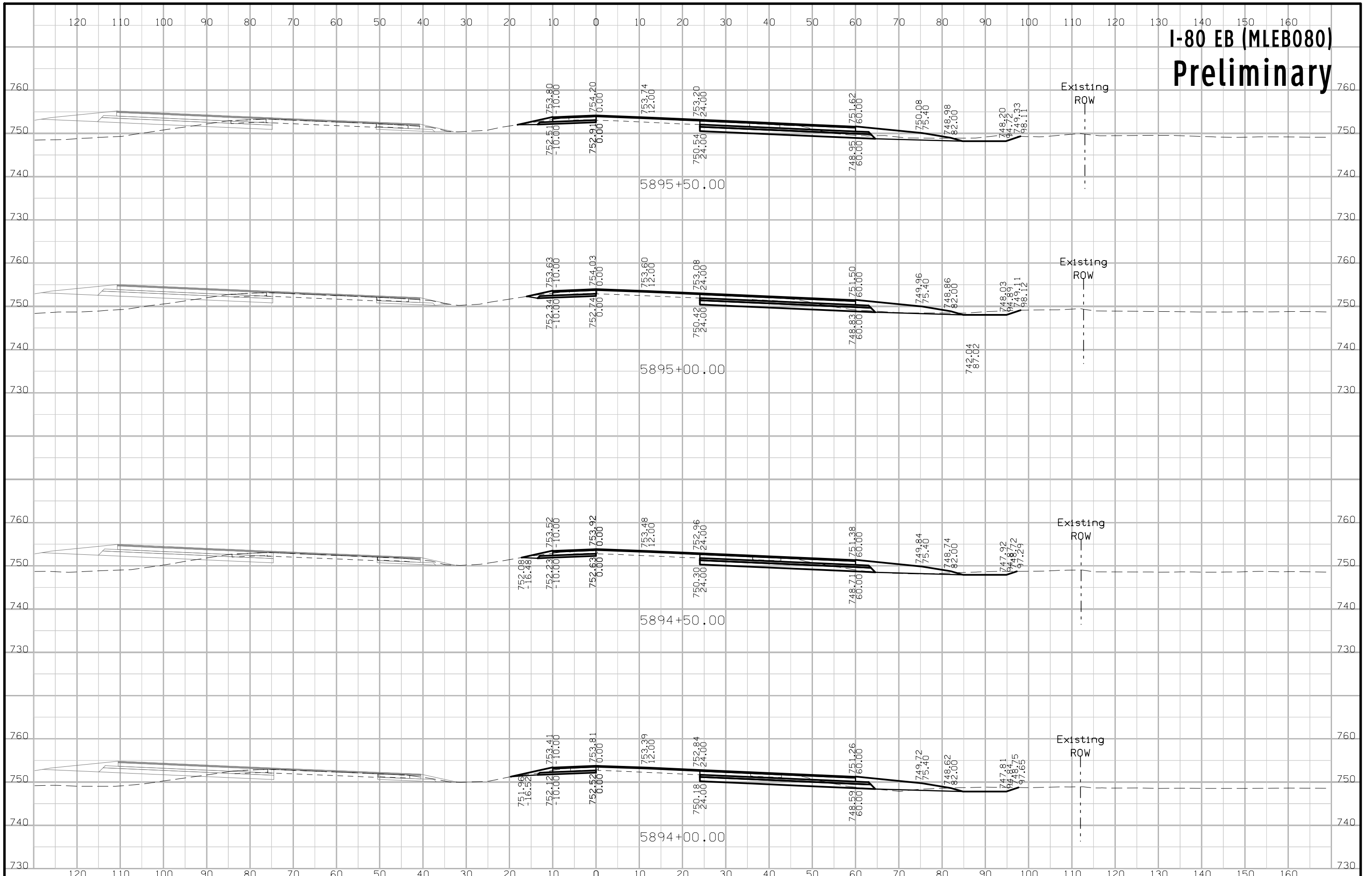

# I-80 EB (MLEB080) Preliminary

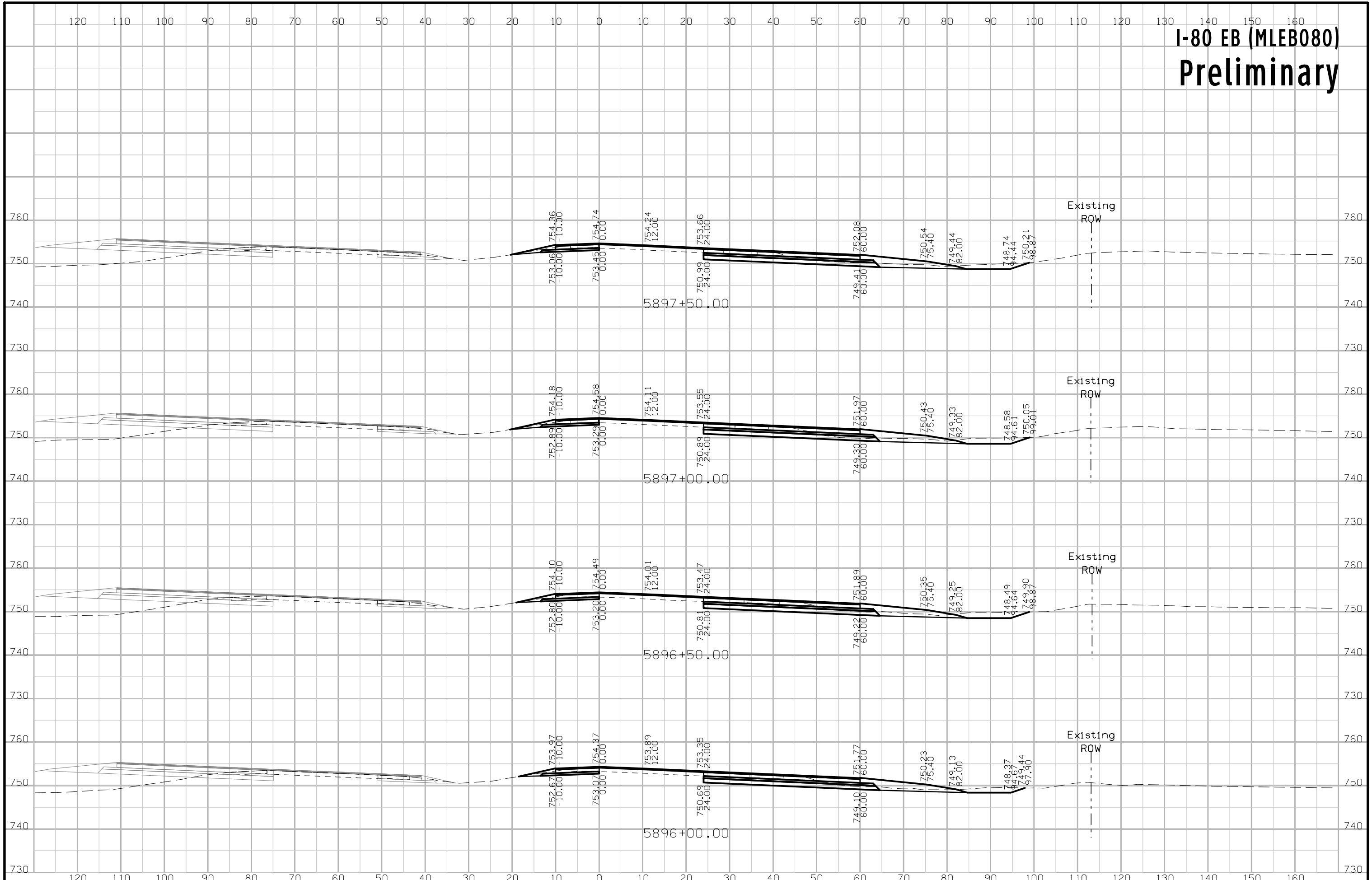

# I-80 EB (MLEB080) Preliminary

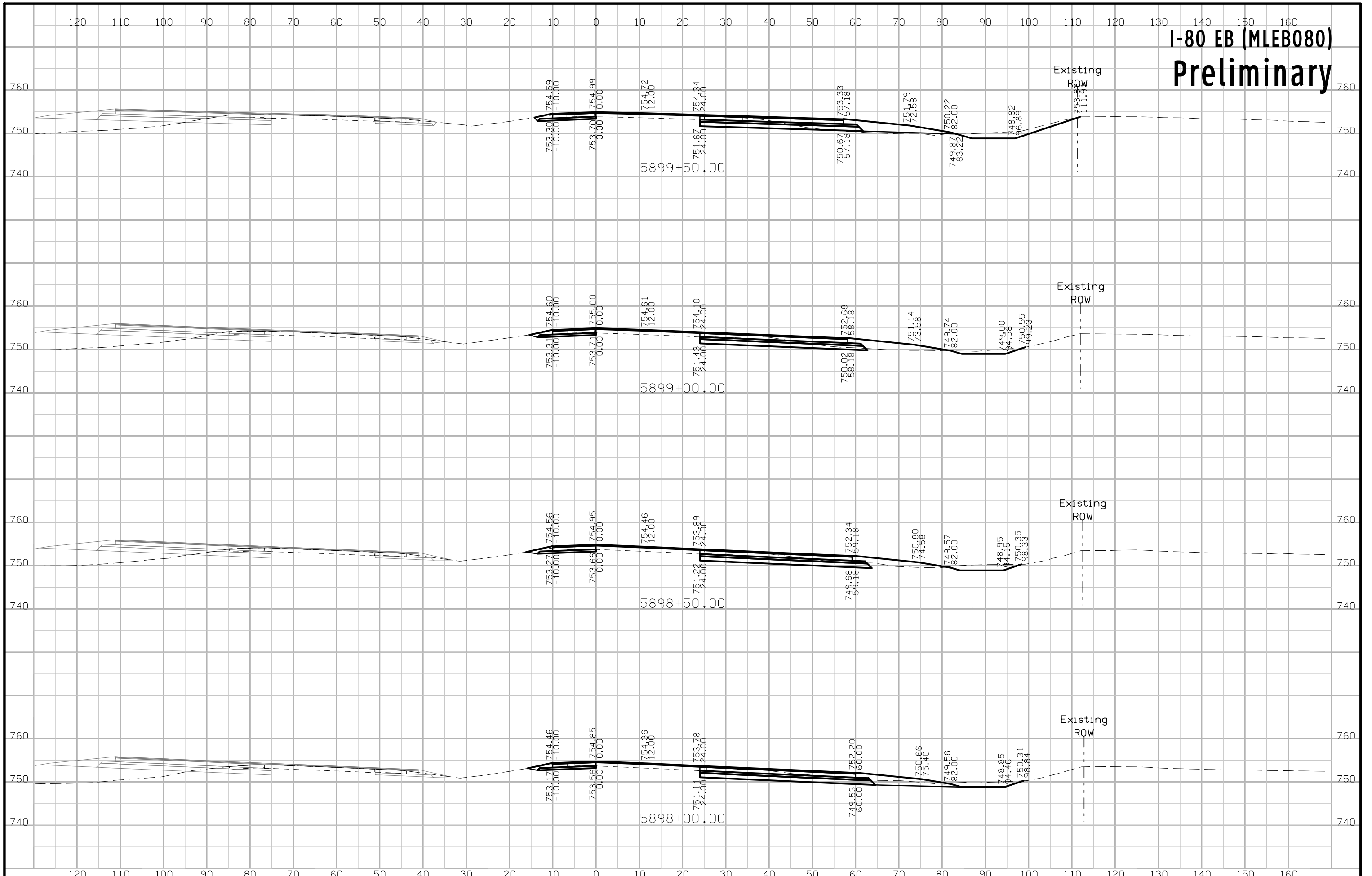

# I-80 EB (MLEB080) Preliminary

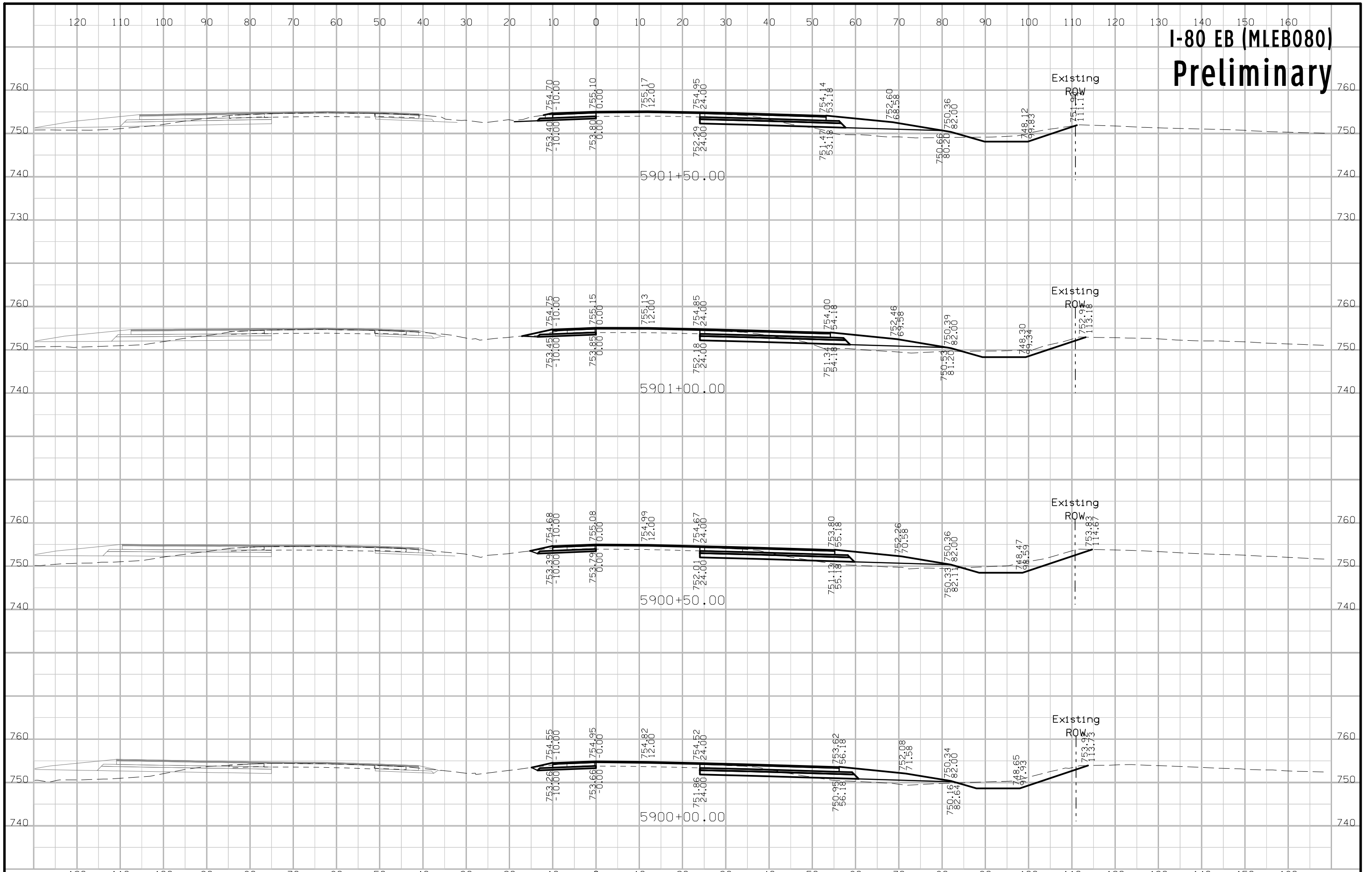

# I-80 EB (MLEB080) Preliminary

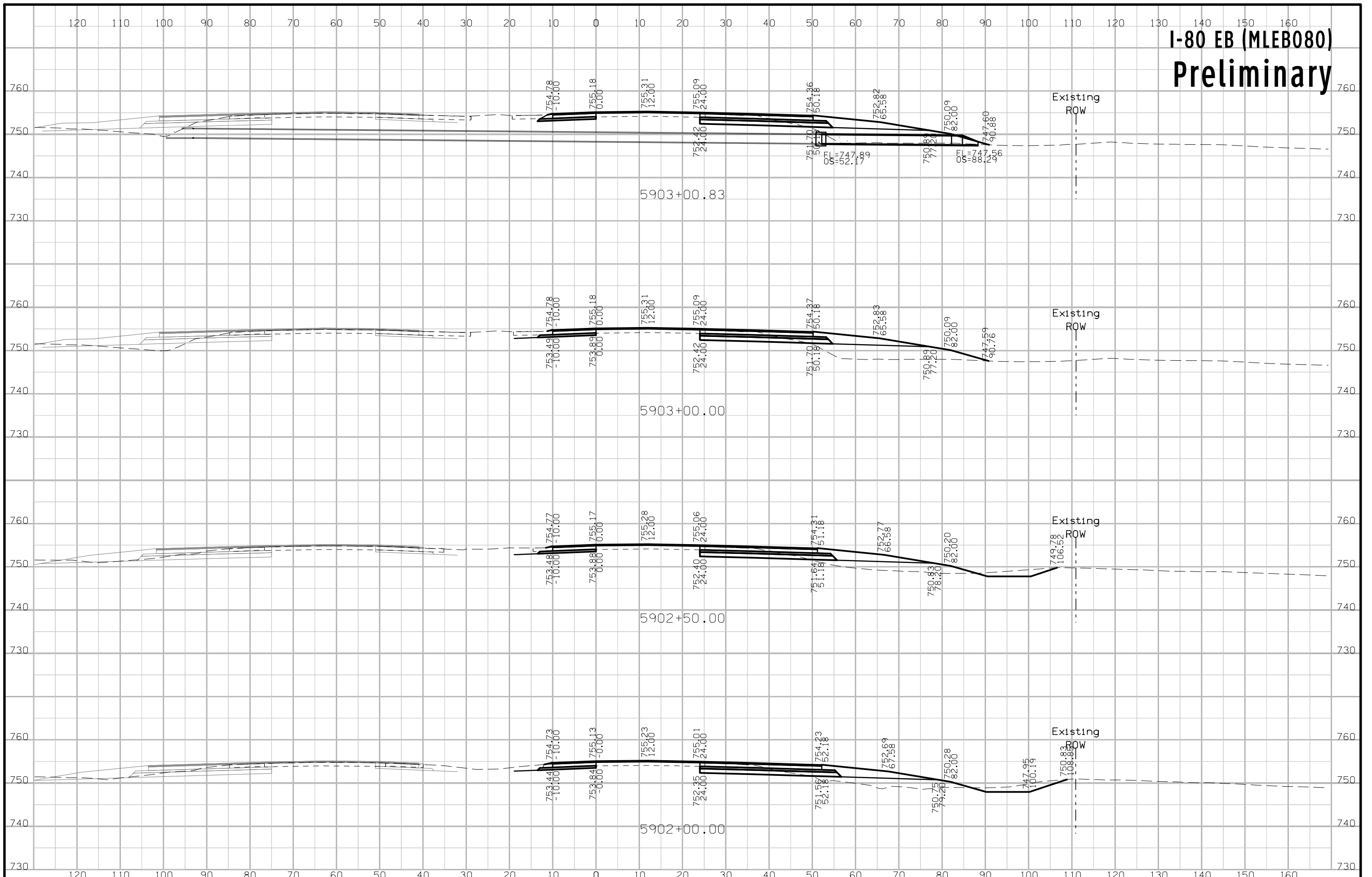



# I-80 EB (MLEB080) Preliminary

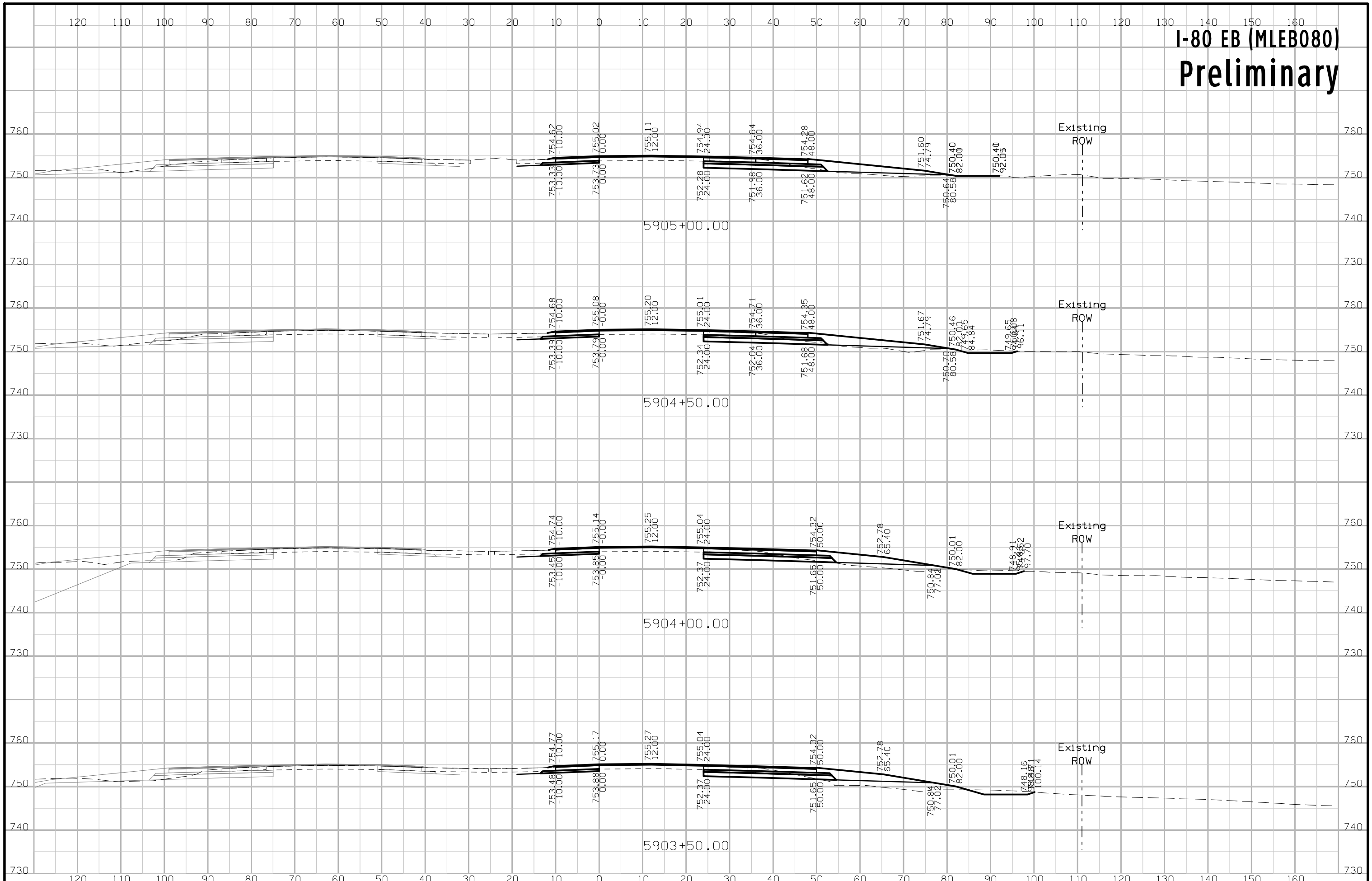

# I-80 EB (MLEB080) Preliminary

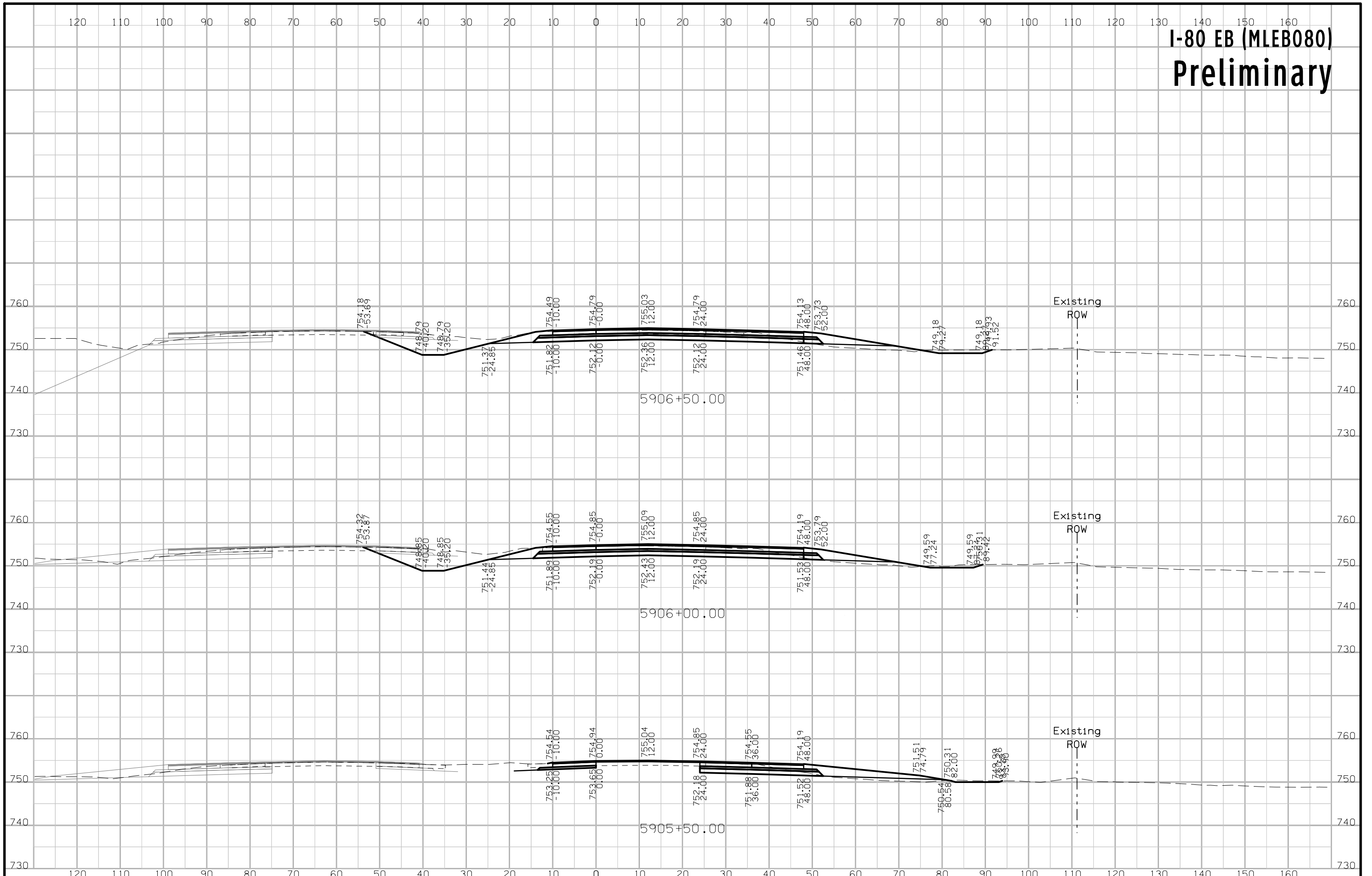

# I-80 EB (MLEB080) Preliminary

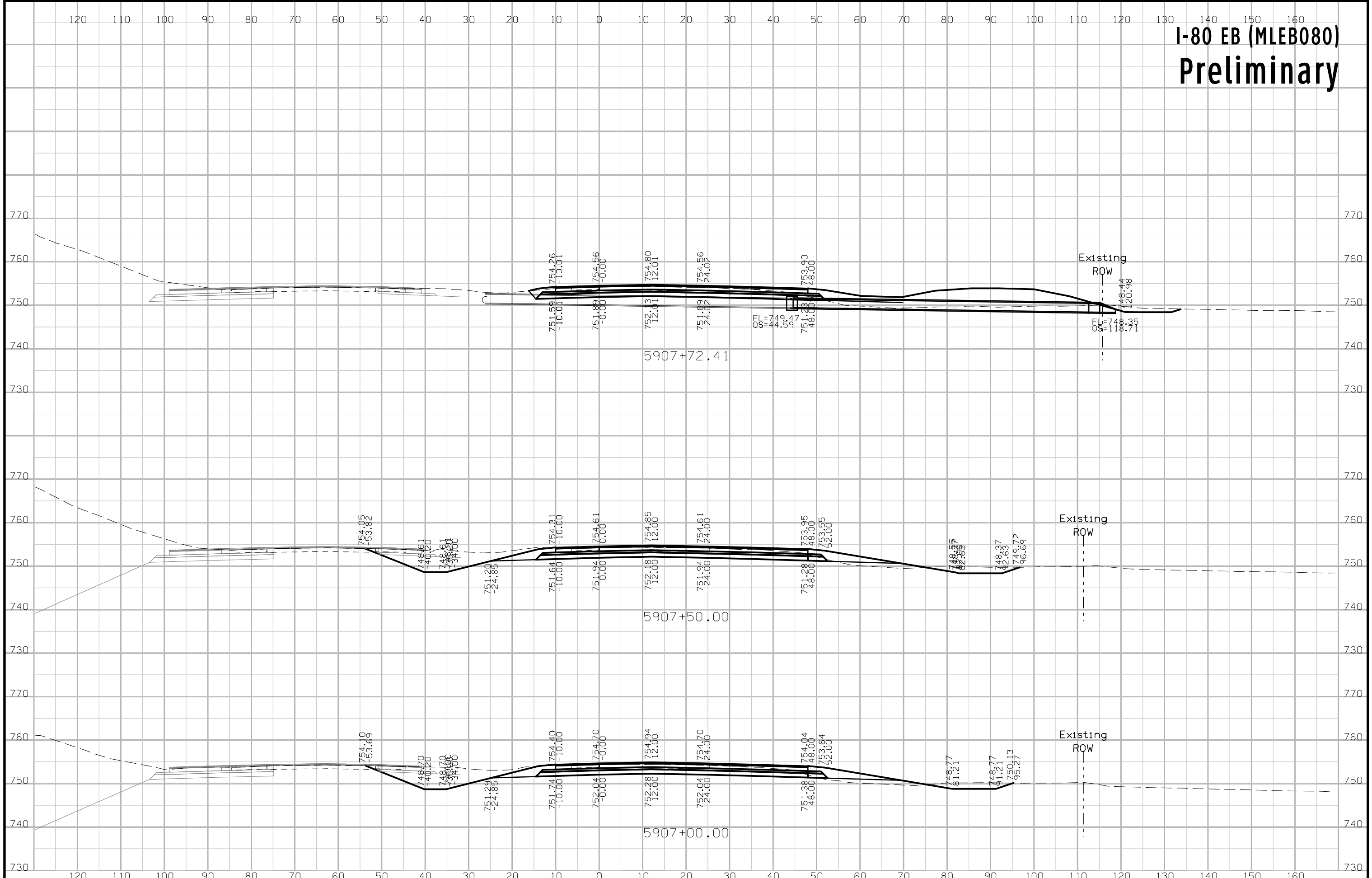

# I-80 EB (MLEB080) Preliminary

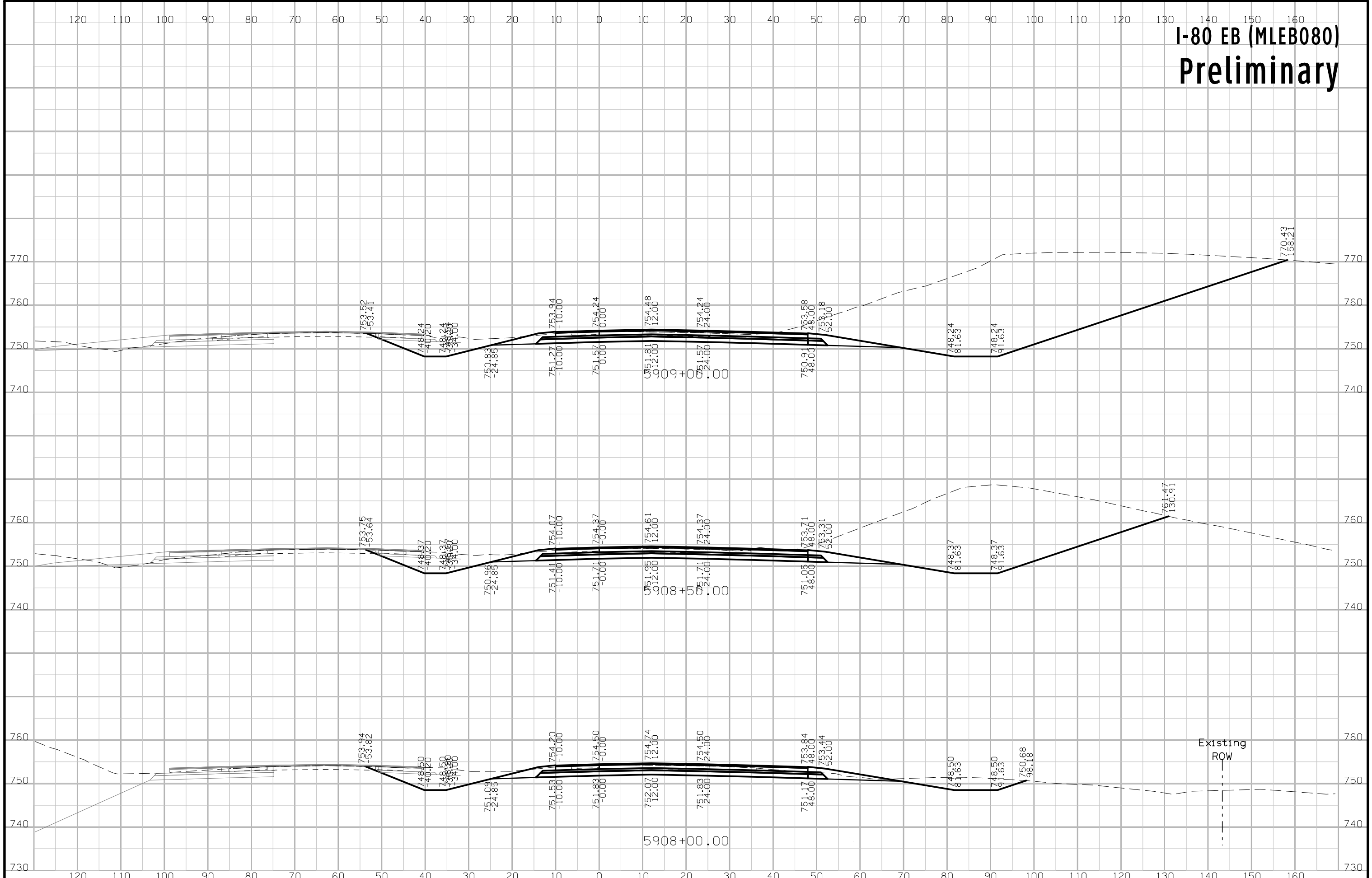

# I-80 EB (MLEB080) Preliminary

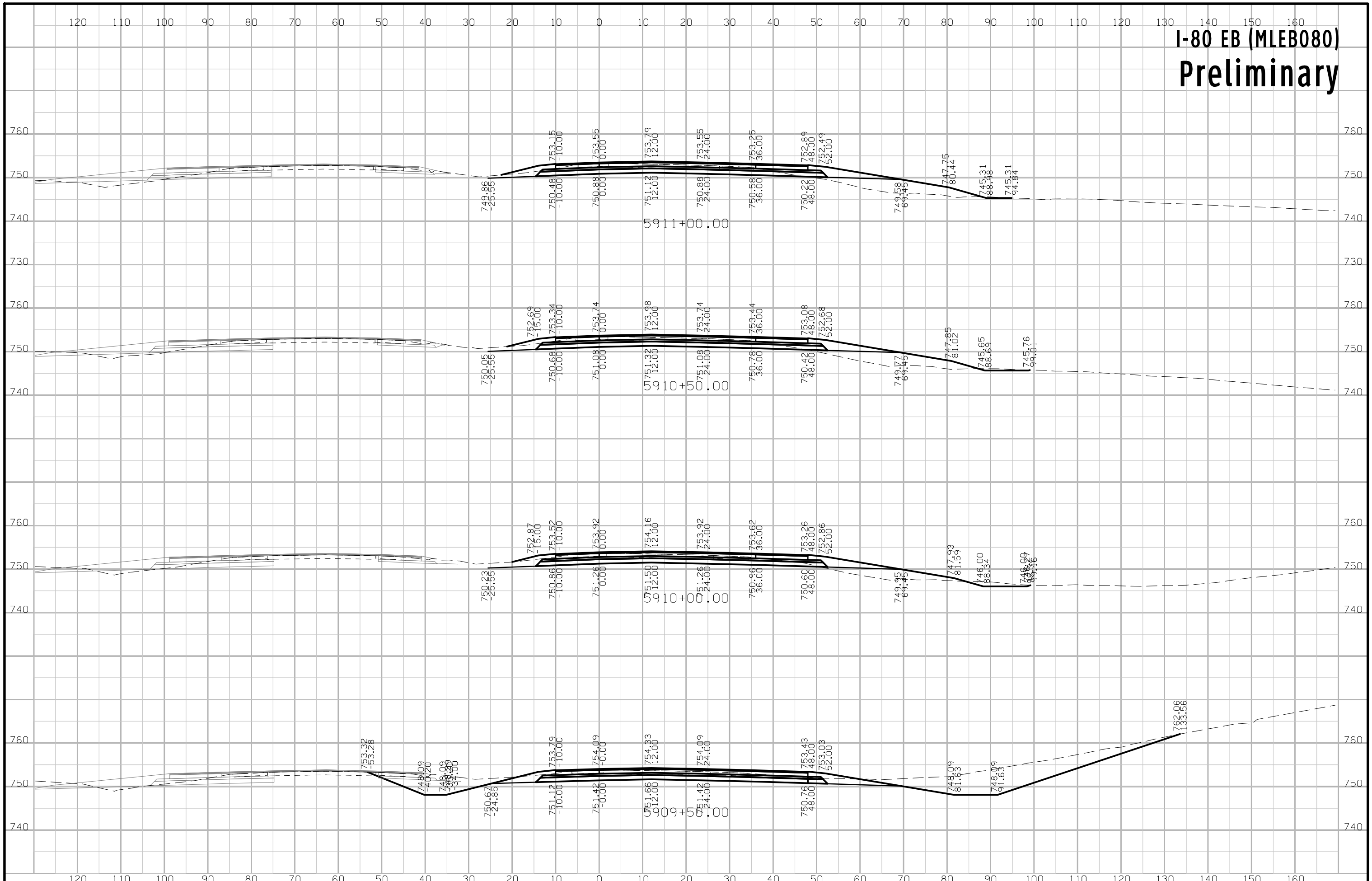

# I-80 EB (MLEB080) Preliminary

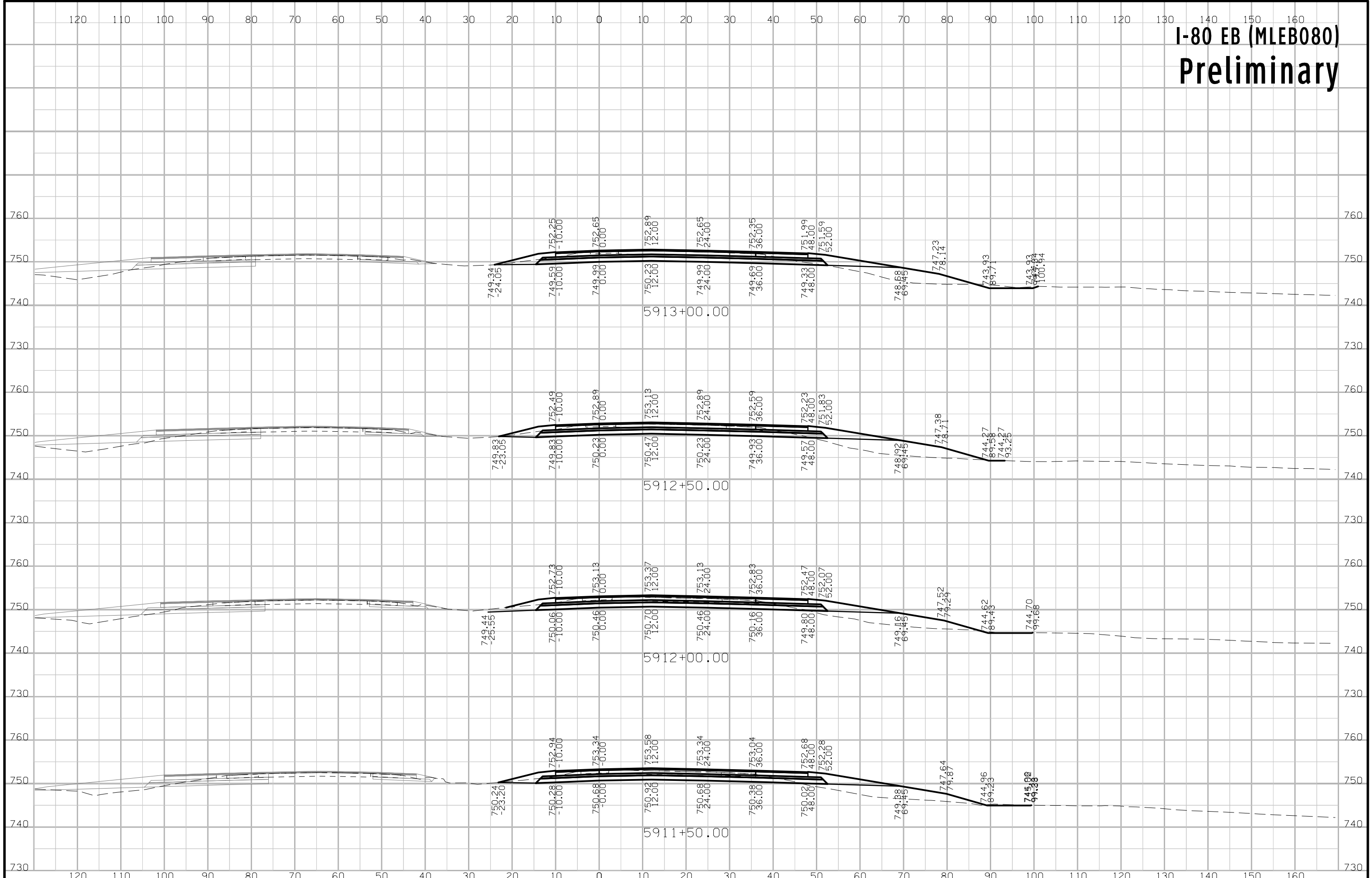

# I-80 EB (MLEB080) Preliminary

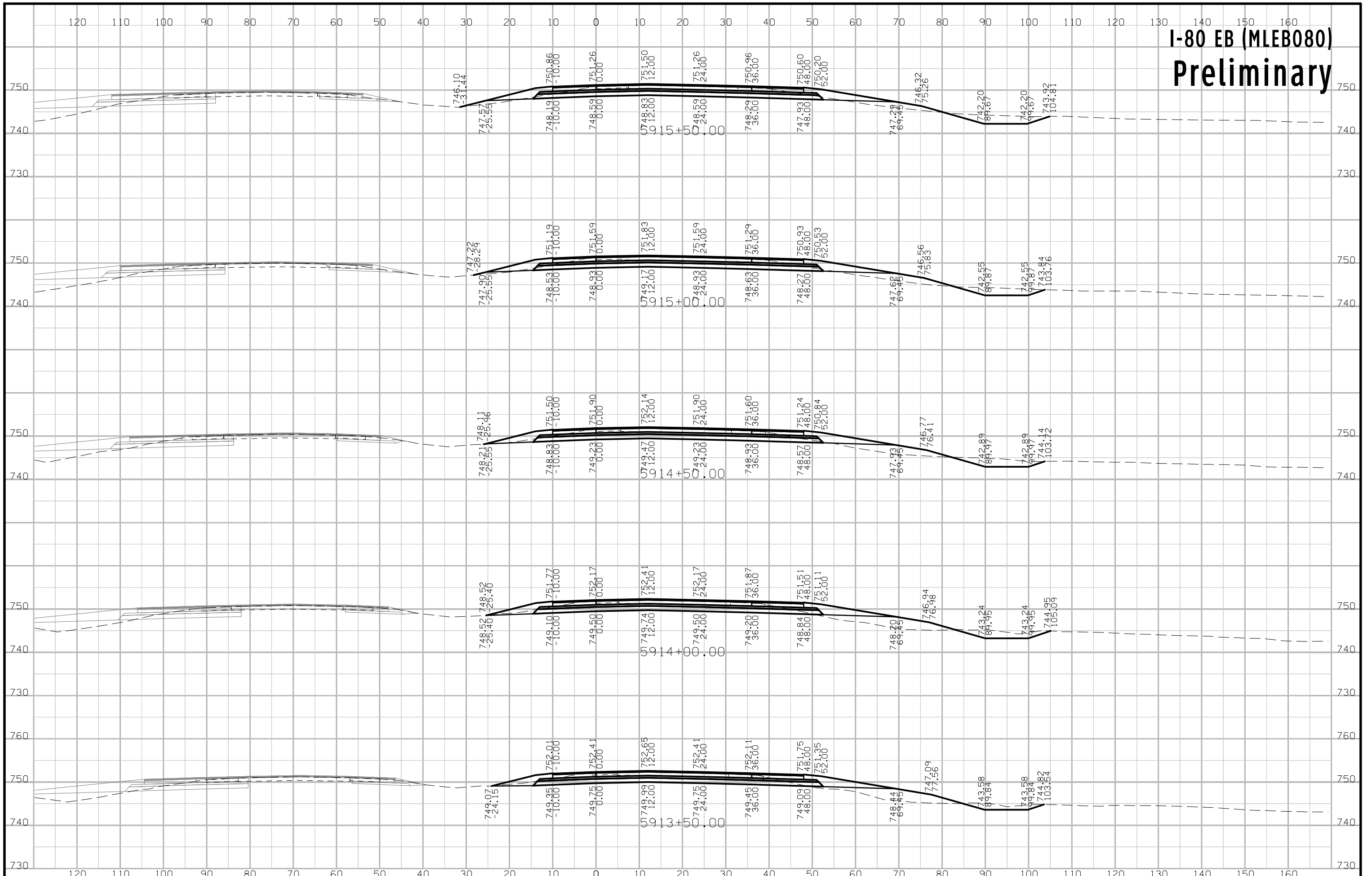



# I-80 EB (MLEB080) Preliminary

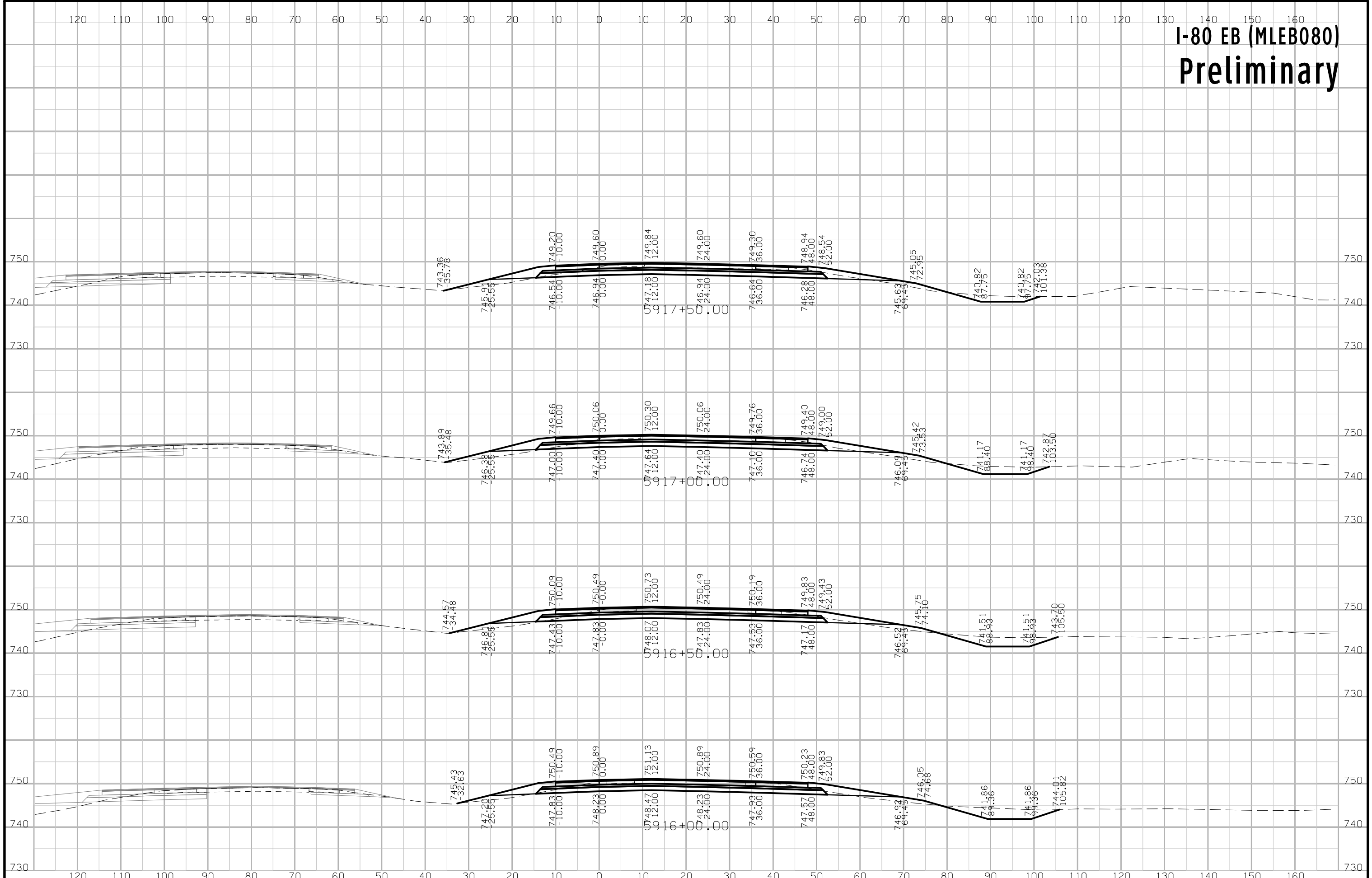

# I-80 EB (MLEB080) Preliminary

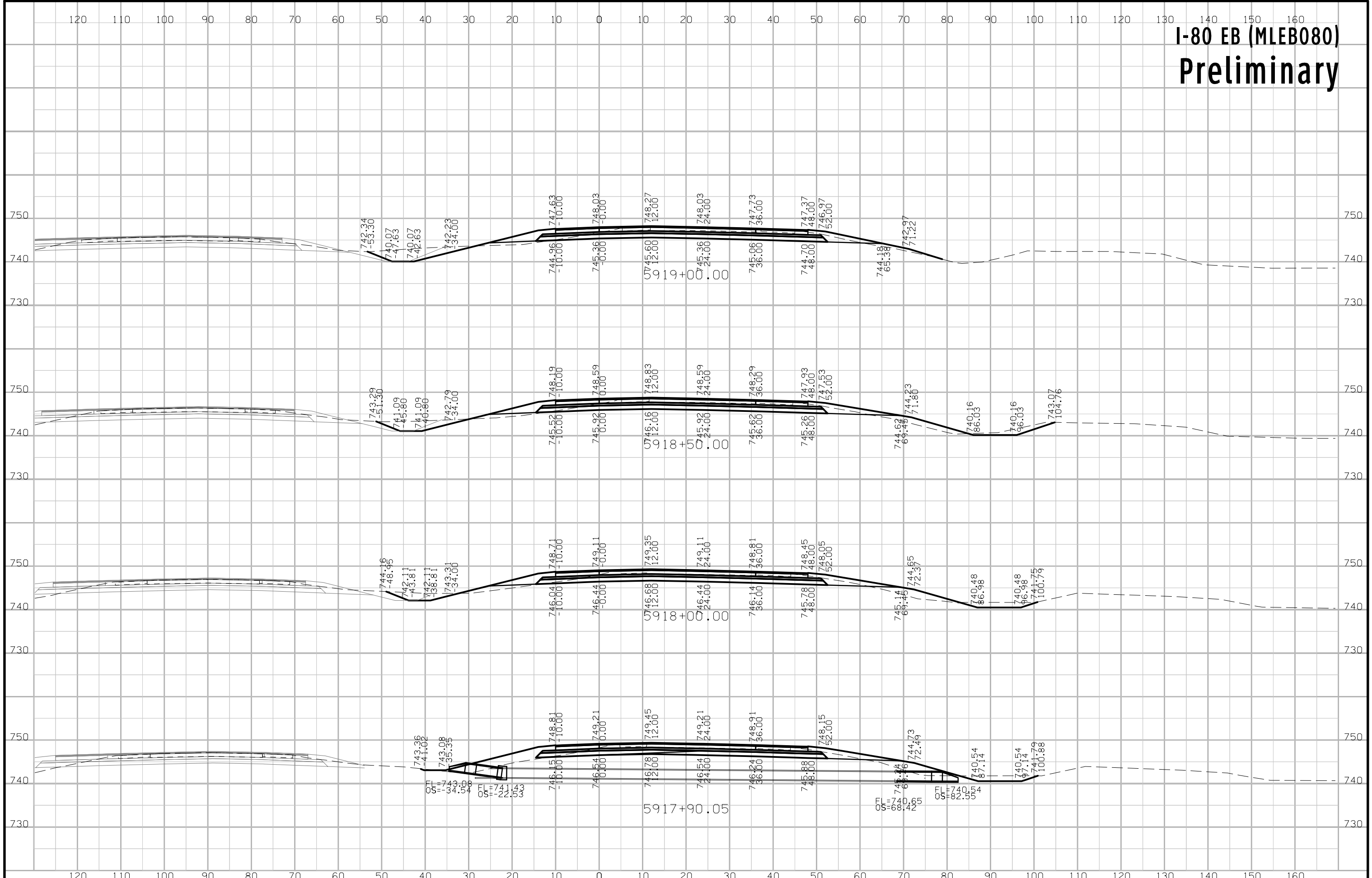

# I-80 EB (MLEB080) Preliminary

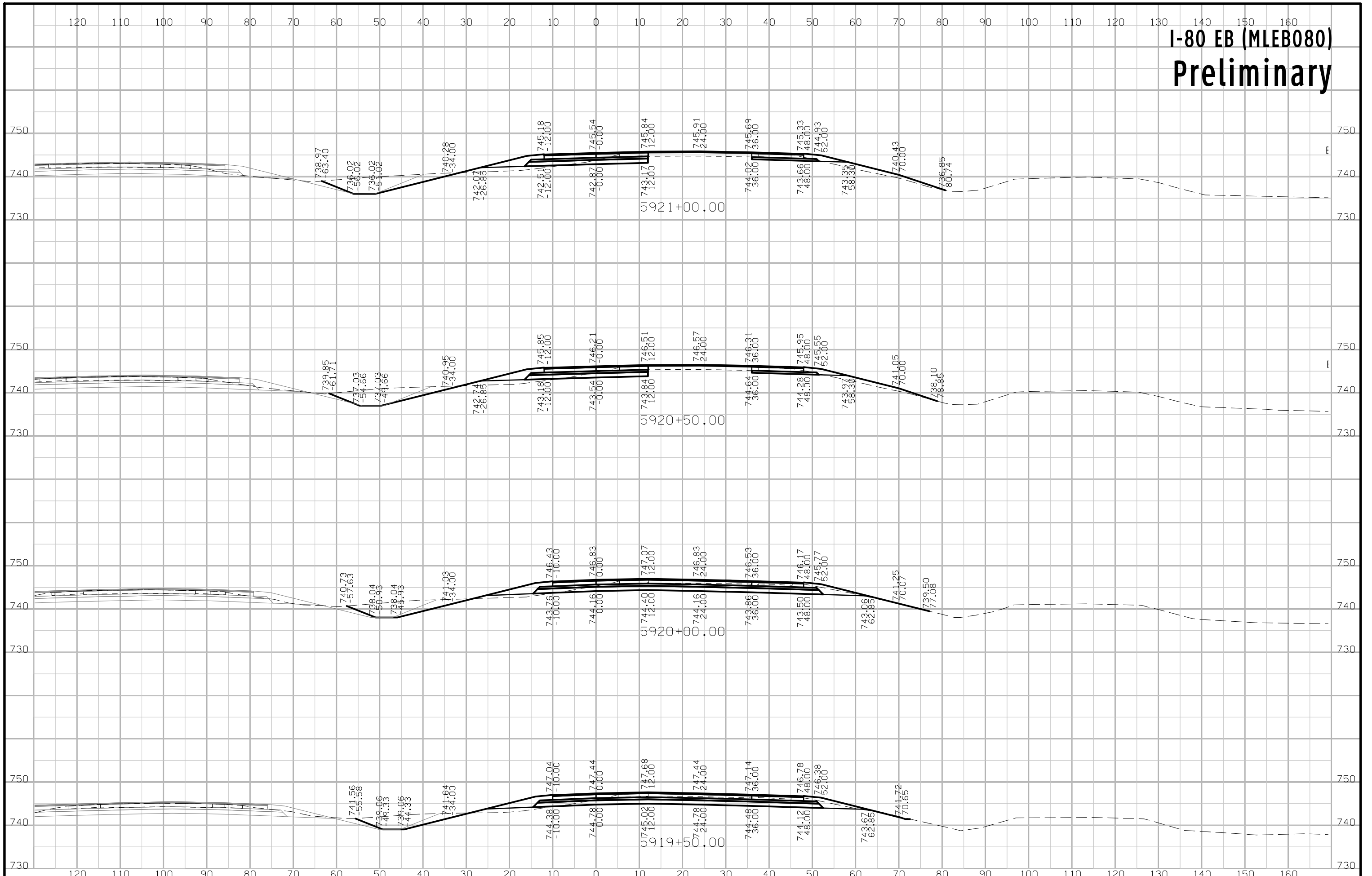

# I-80 EB (MLEB080) Preliminary

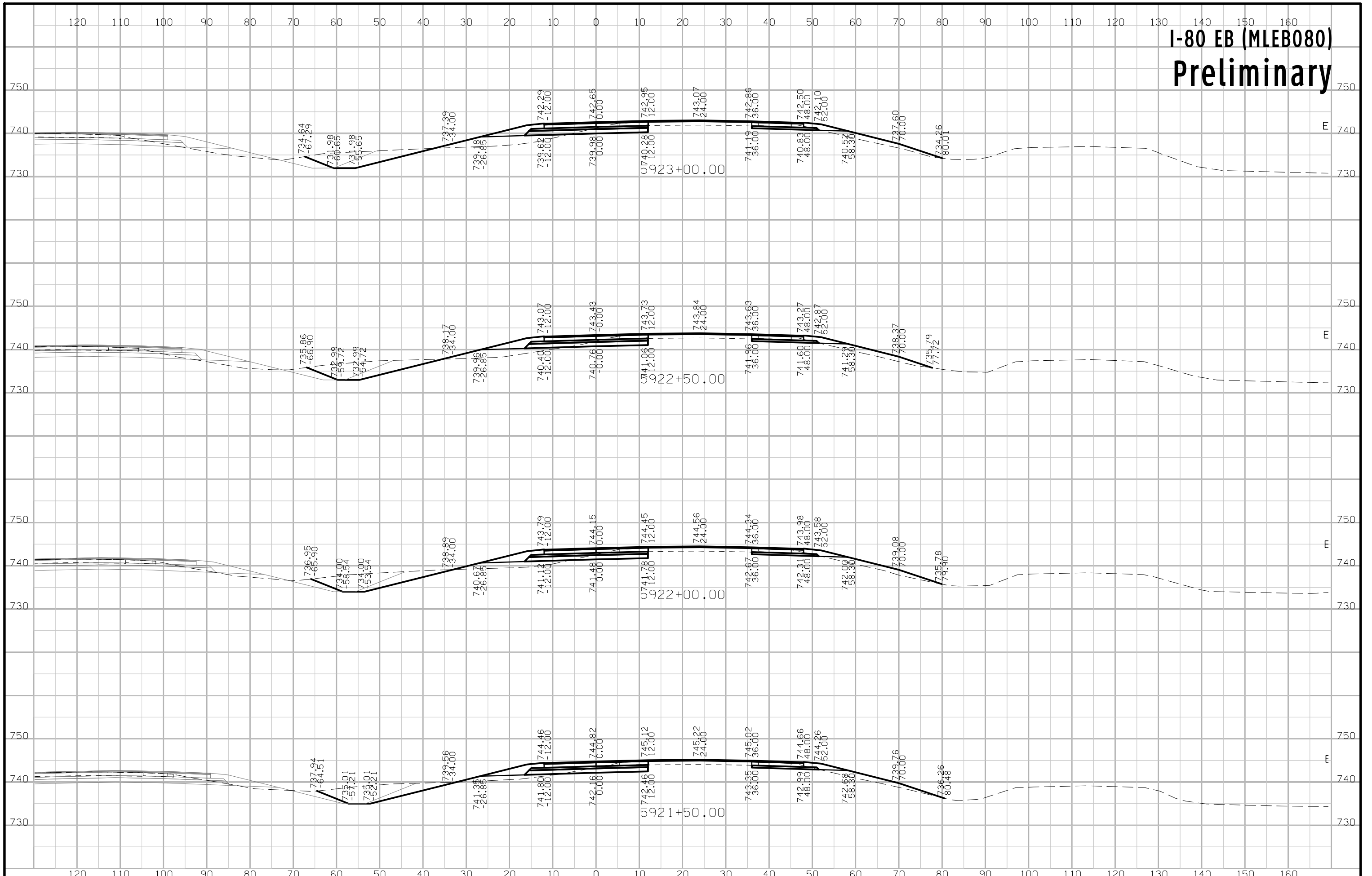

# I-80 EB (MLEB080) Preliminary

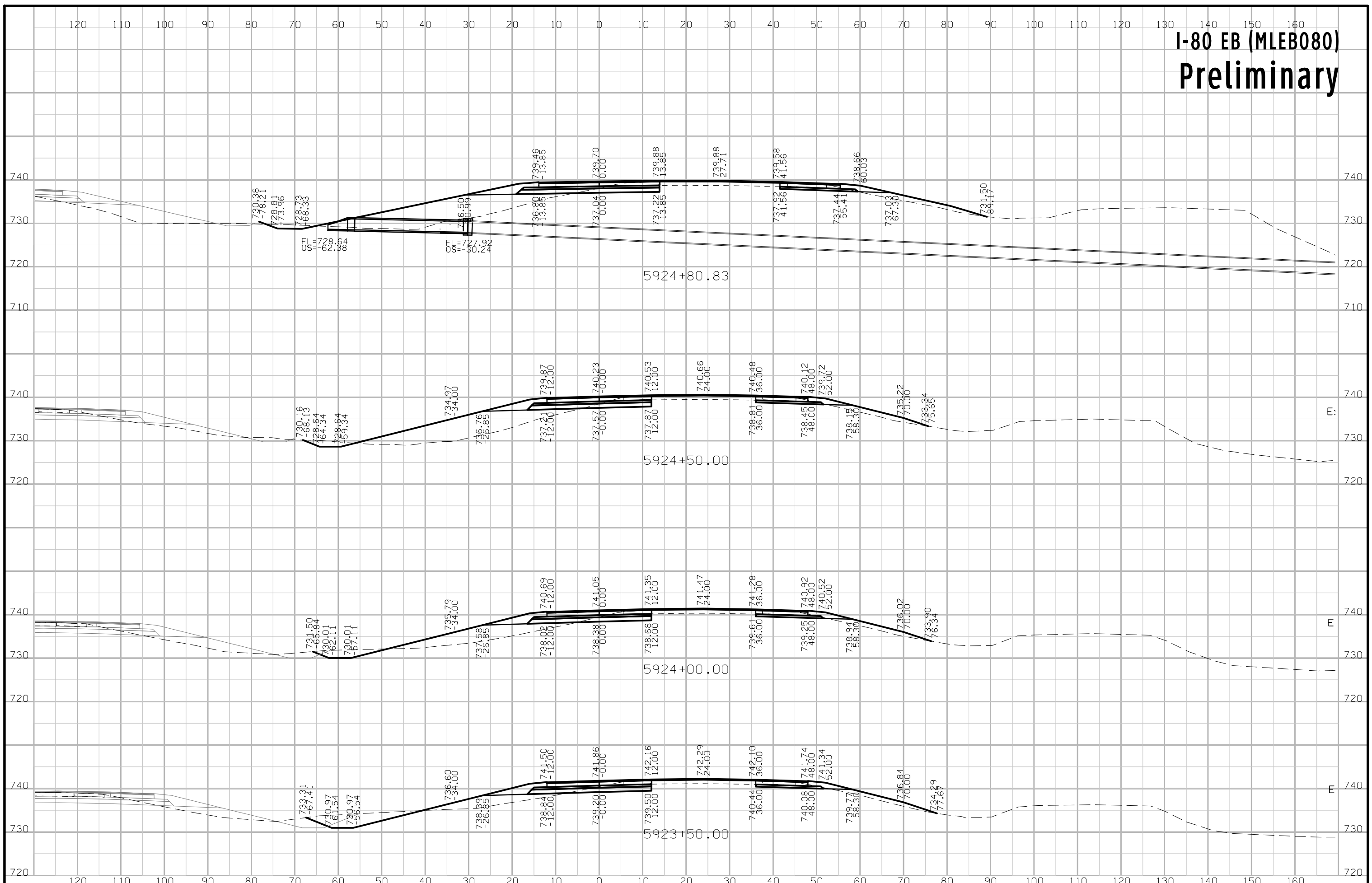

# I-80 EB (MLEB080) Preliminary

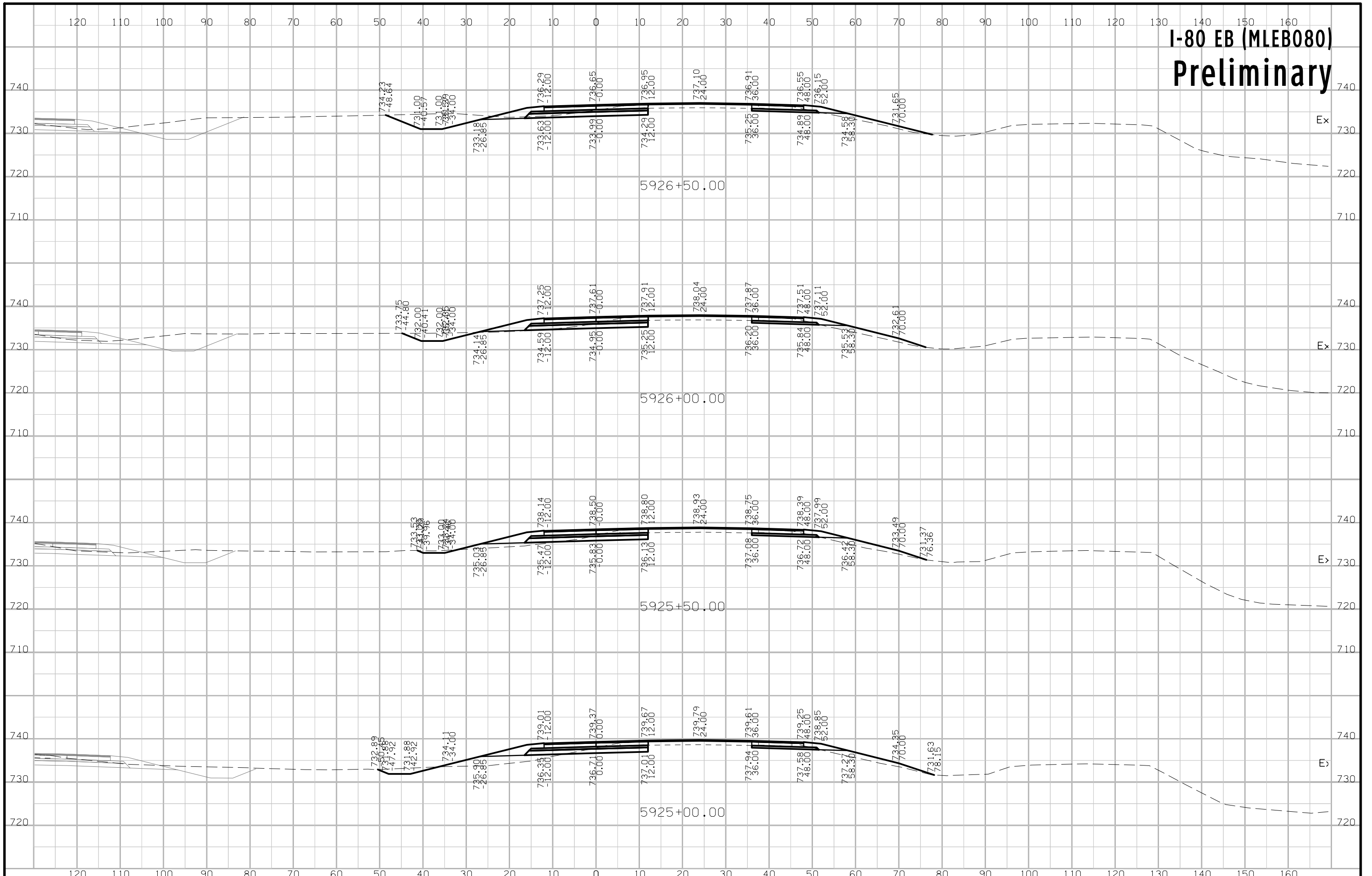

# I-80 EB (MLEB080) Preliminary

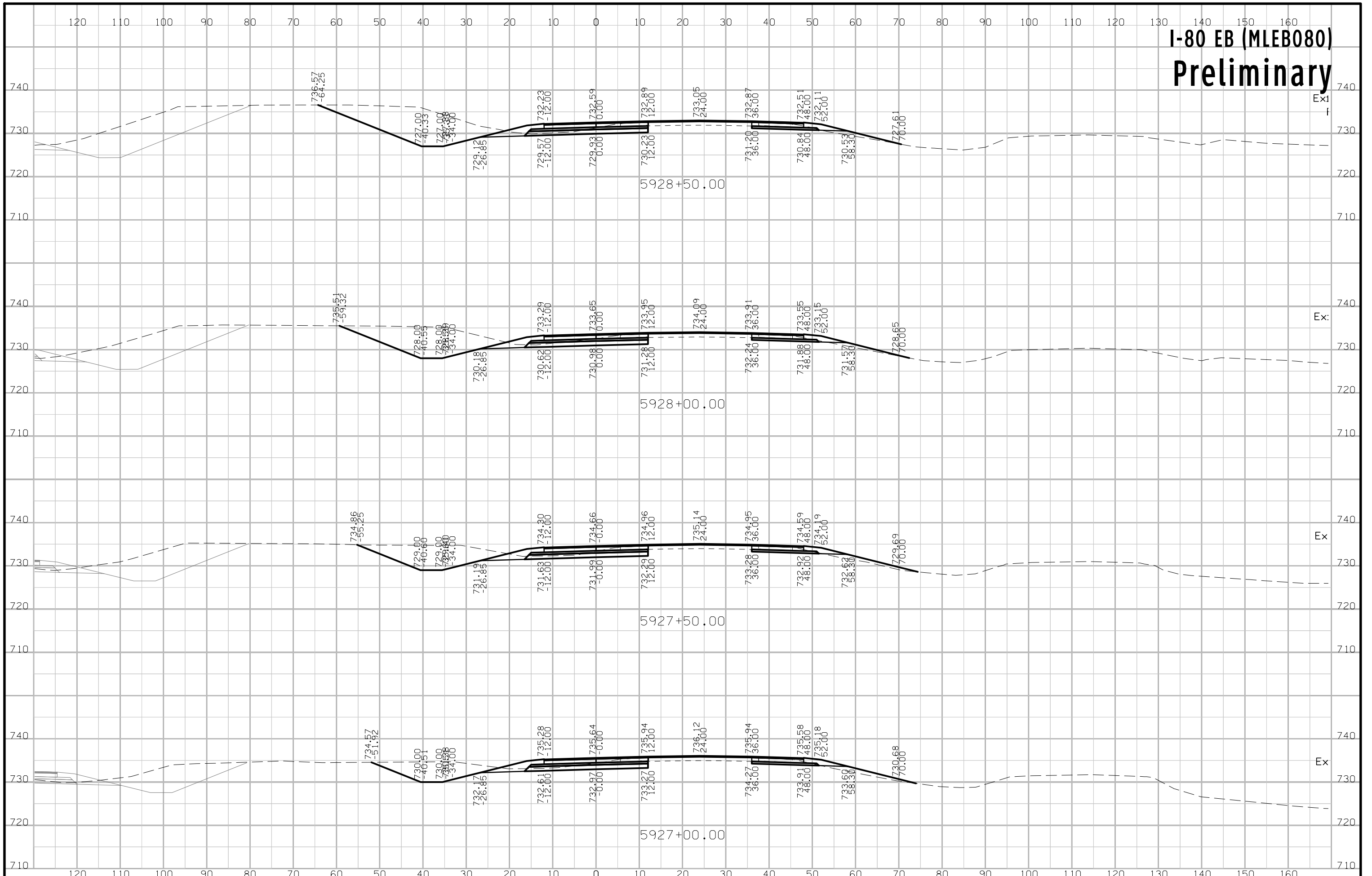



# I-80 EB (MLEB080) Preliminary

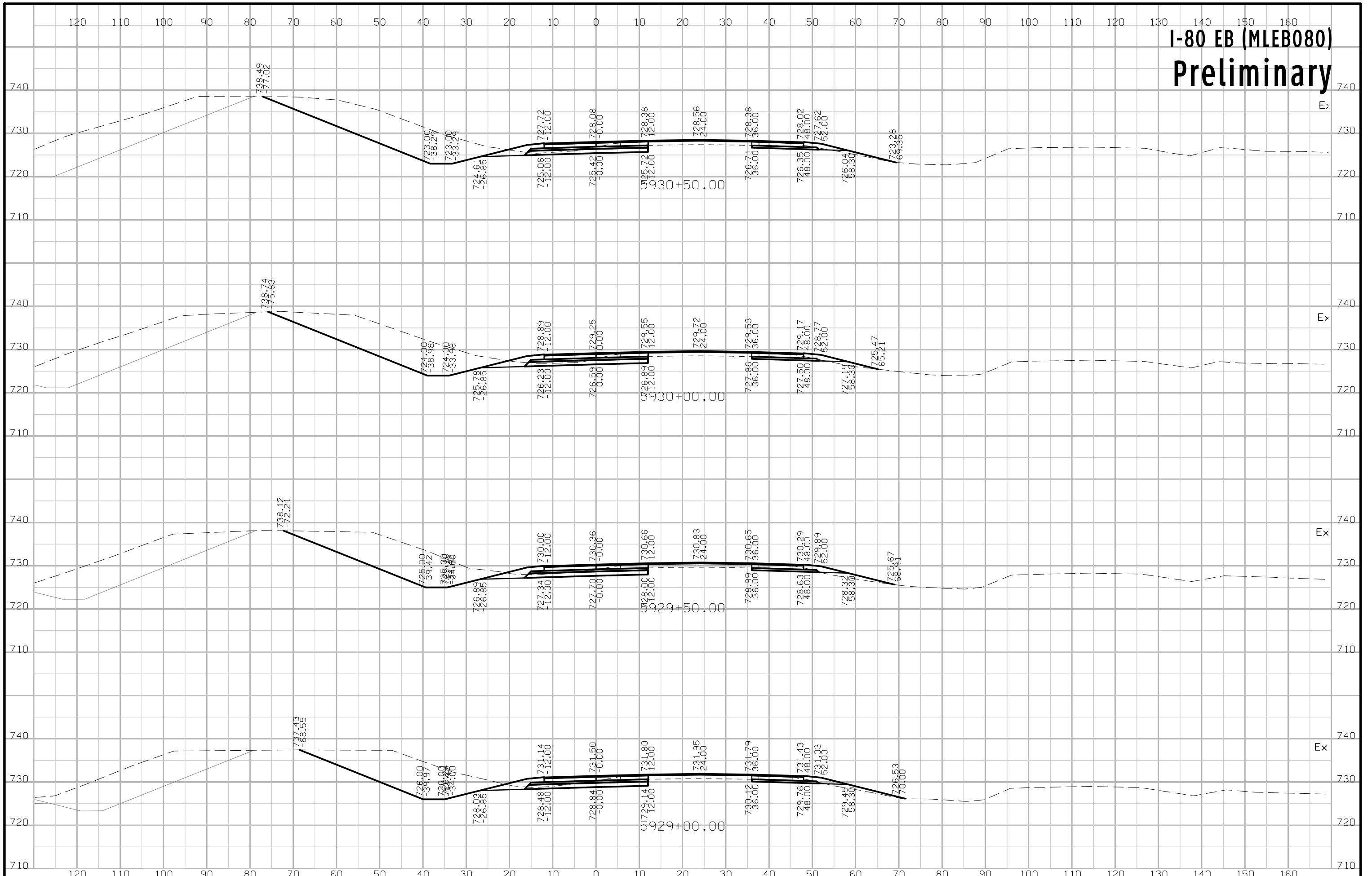

# I-80 EB (MLEB080) Preliminary

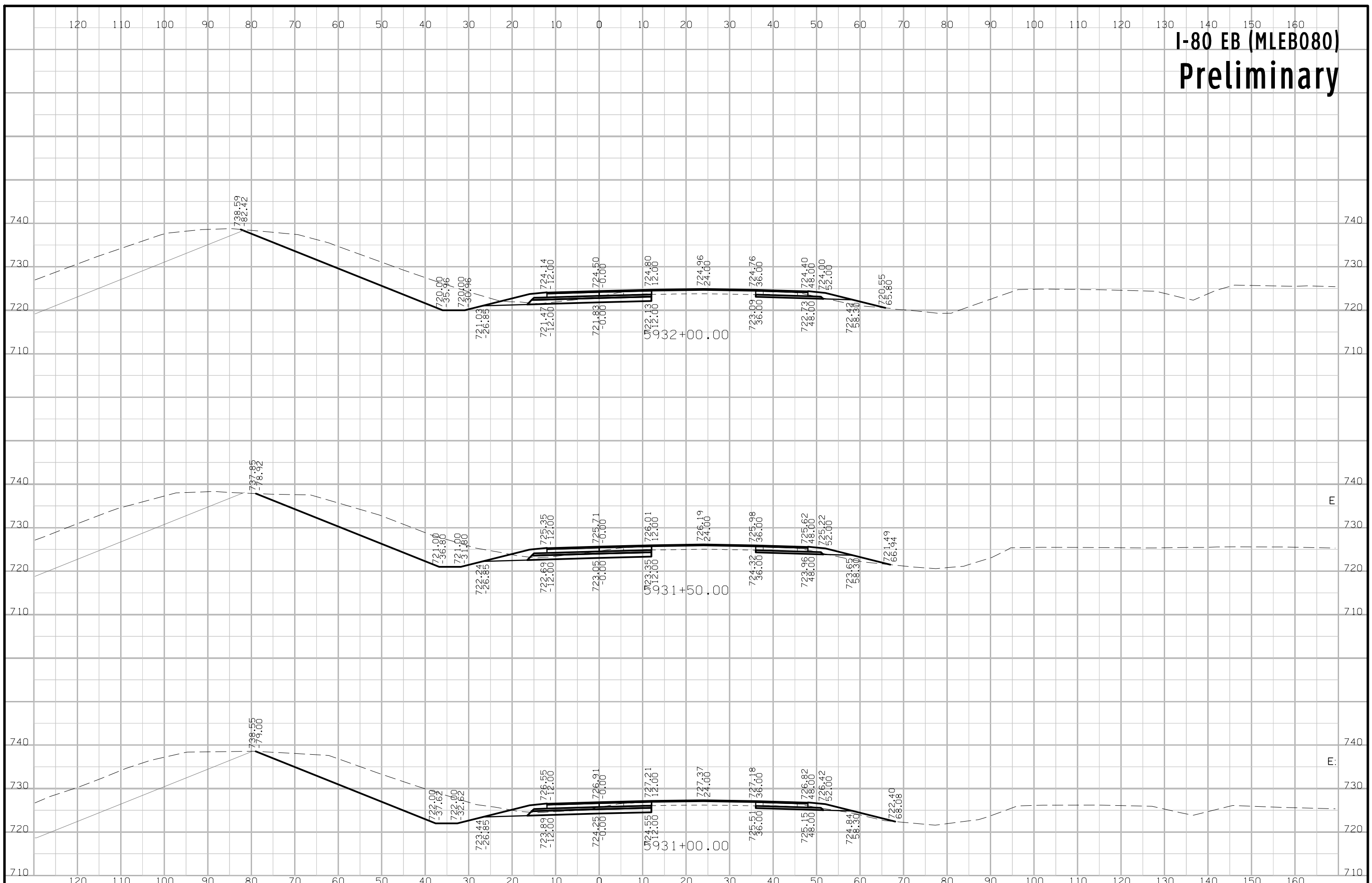

# I-80 EB (MLEB080) Preliminary

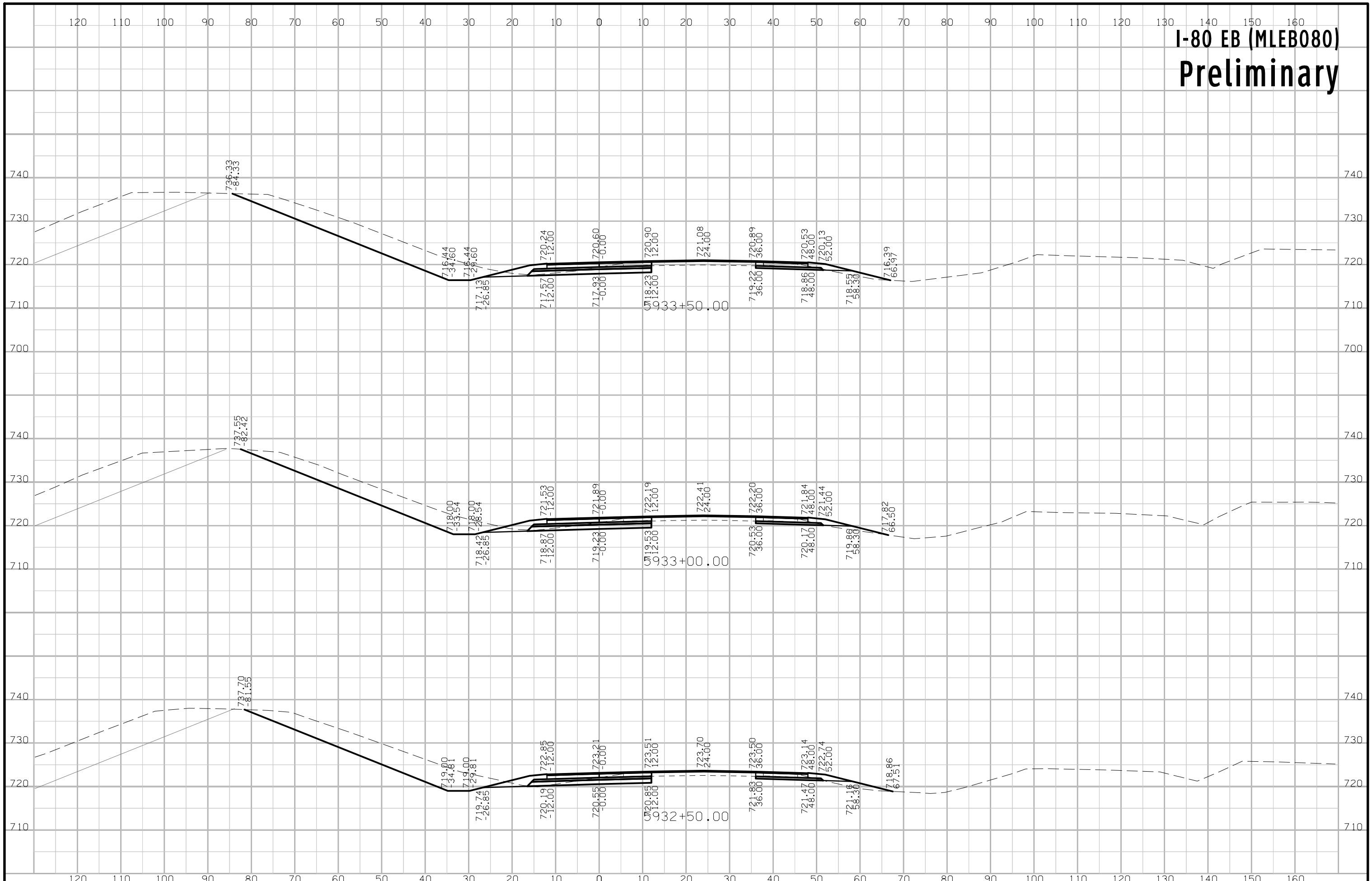

FILE NO.	ENGLISH	DESIGN TEAM	Iowa DOT \ HR Green	CEDAR COUNTY	PROJECT NUMBER	IM-NHS-080-7(134)266--03-16	SHEET NUMBER	W.487
----------	---------	-------------	---------------------	--------------	----------------	-----------------------------	--------------	-------

# I-80 EB (MLEB080) Preliminary

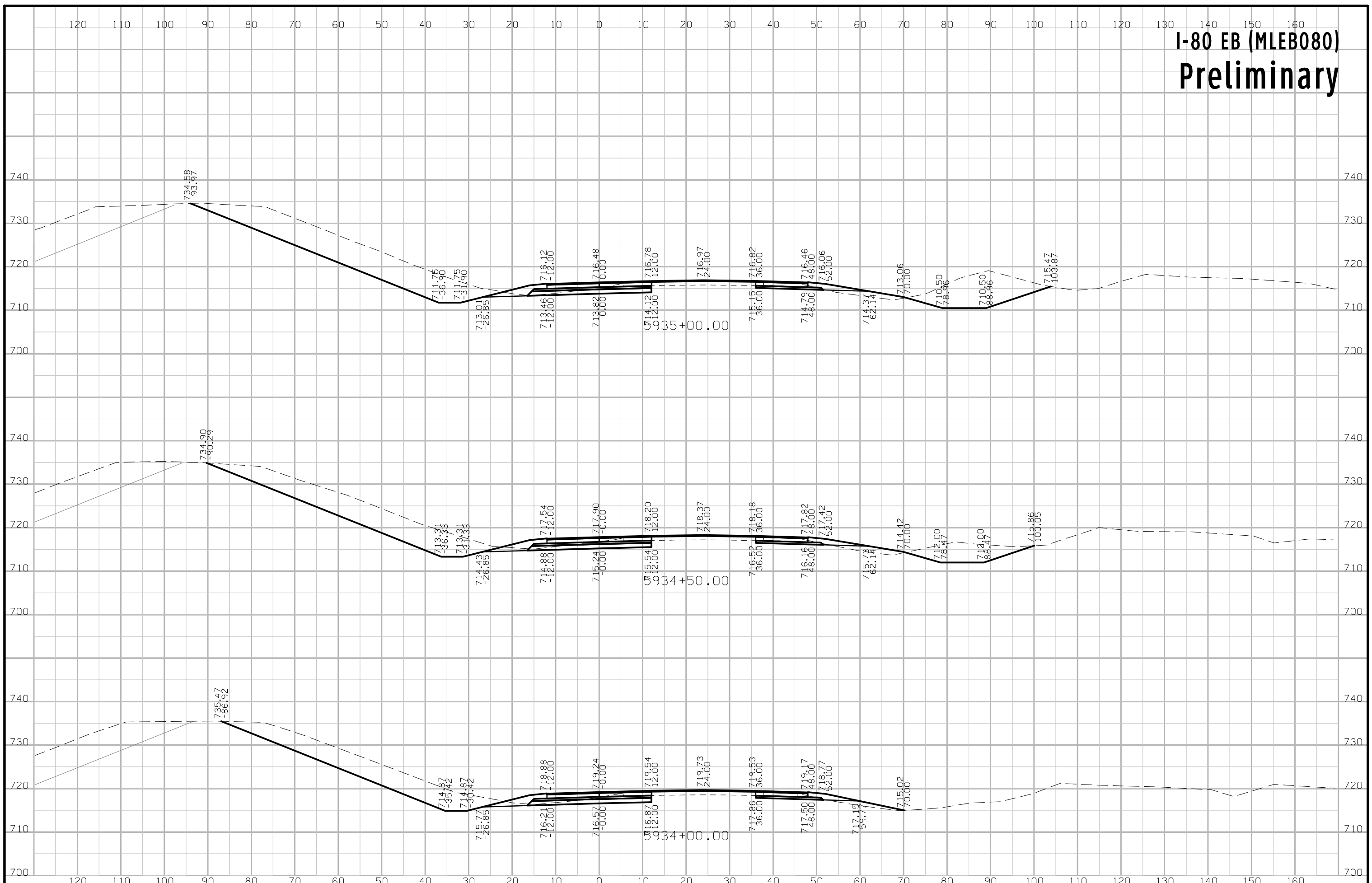

# I-80 EB (MLEB080) Preliminary

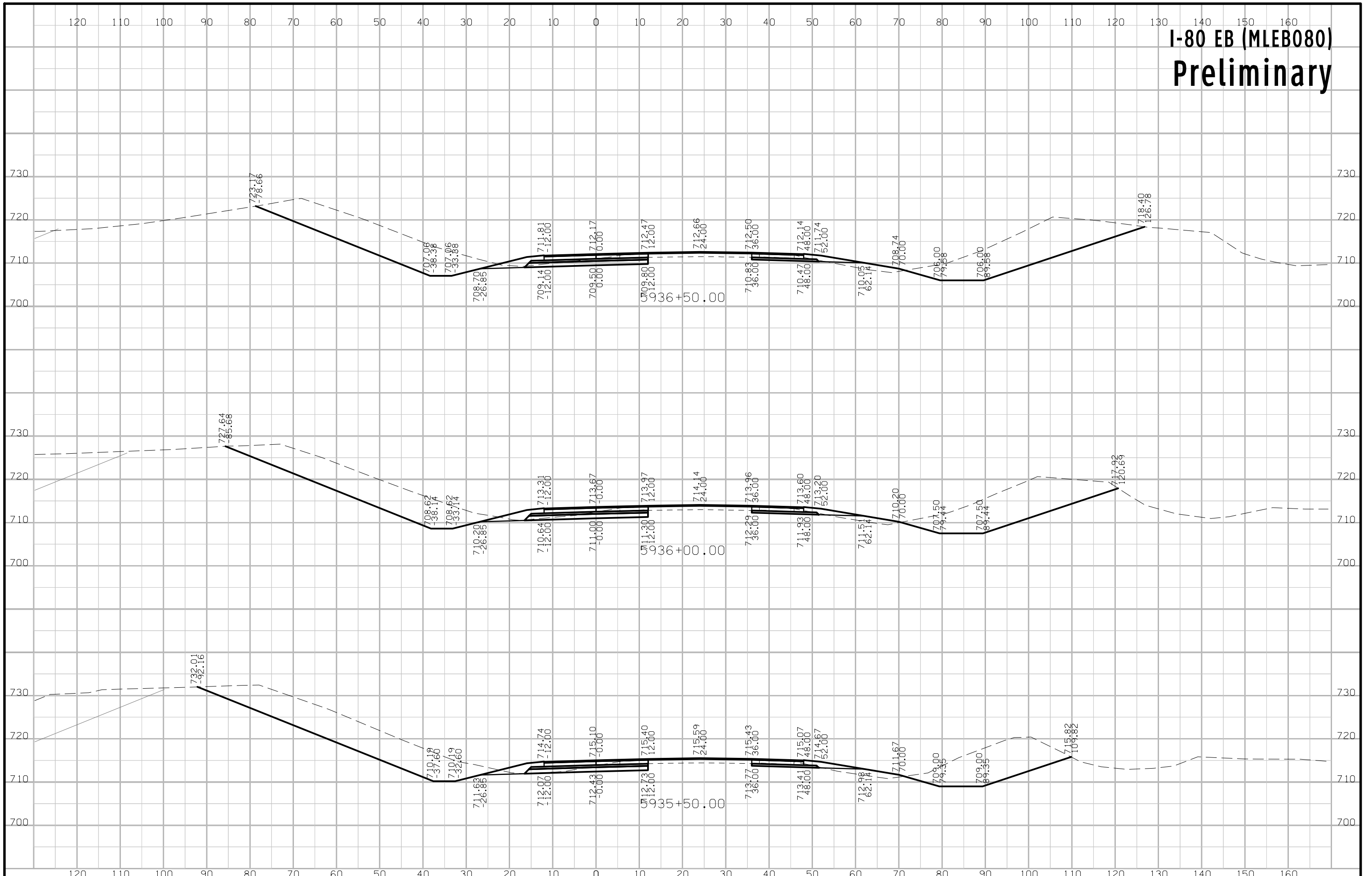

# I-80 EB (MLEB080) Preliminary

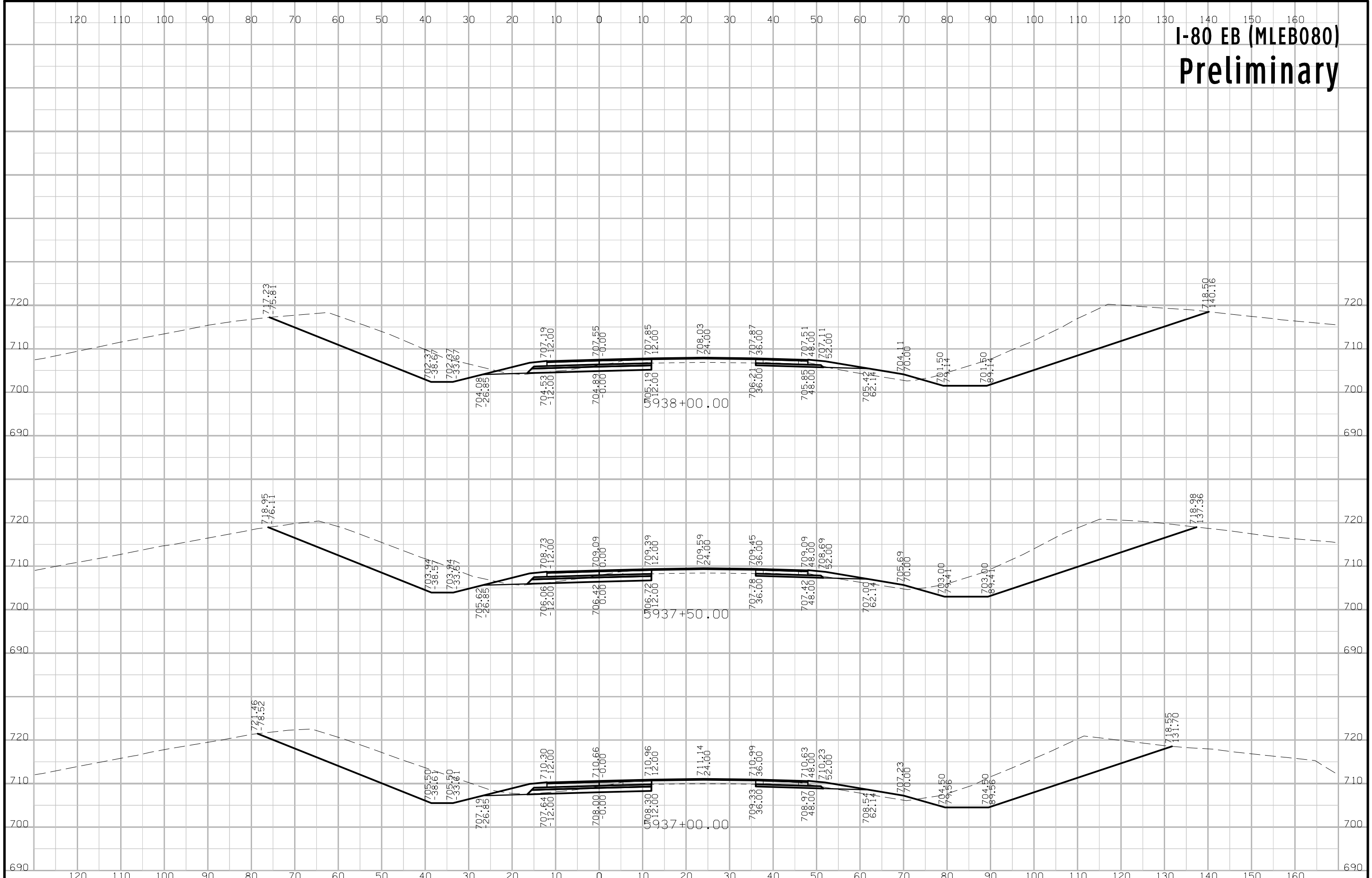

# I-80 EB (MLEB080) Preliminary

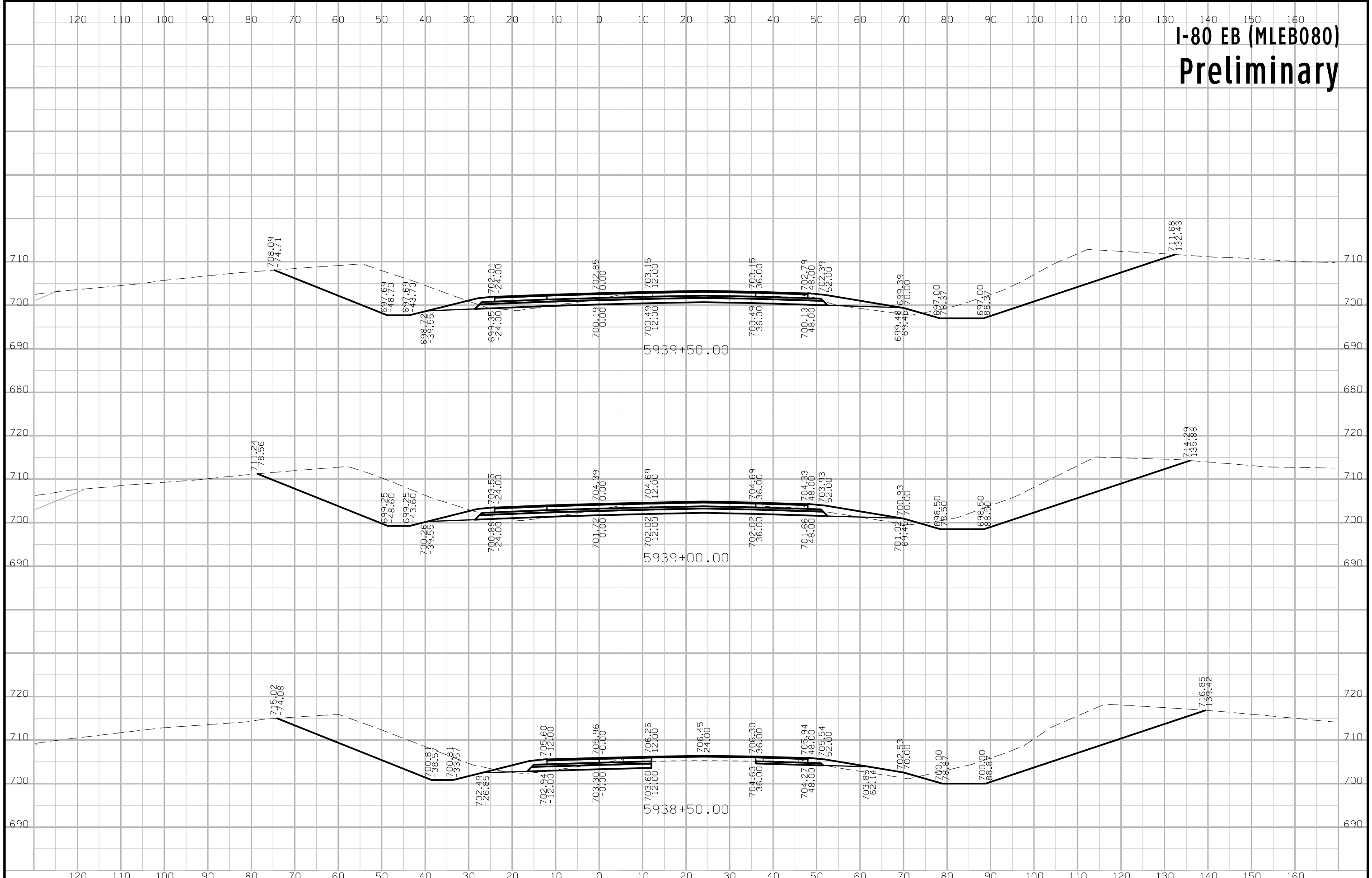



# I-80 EB (MLEB080) Preliminary

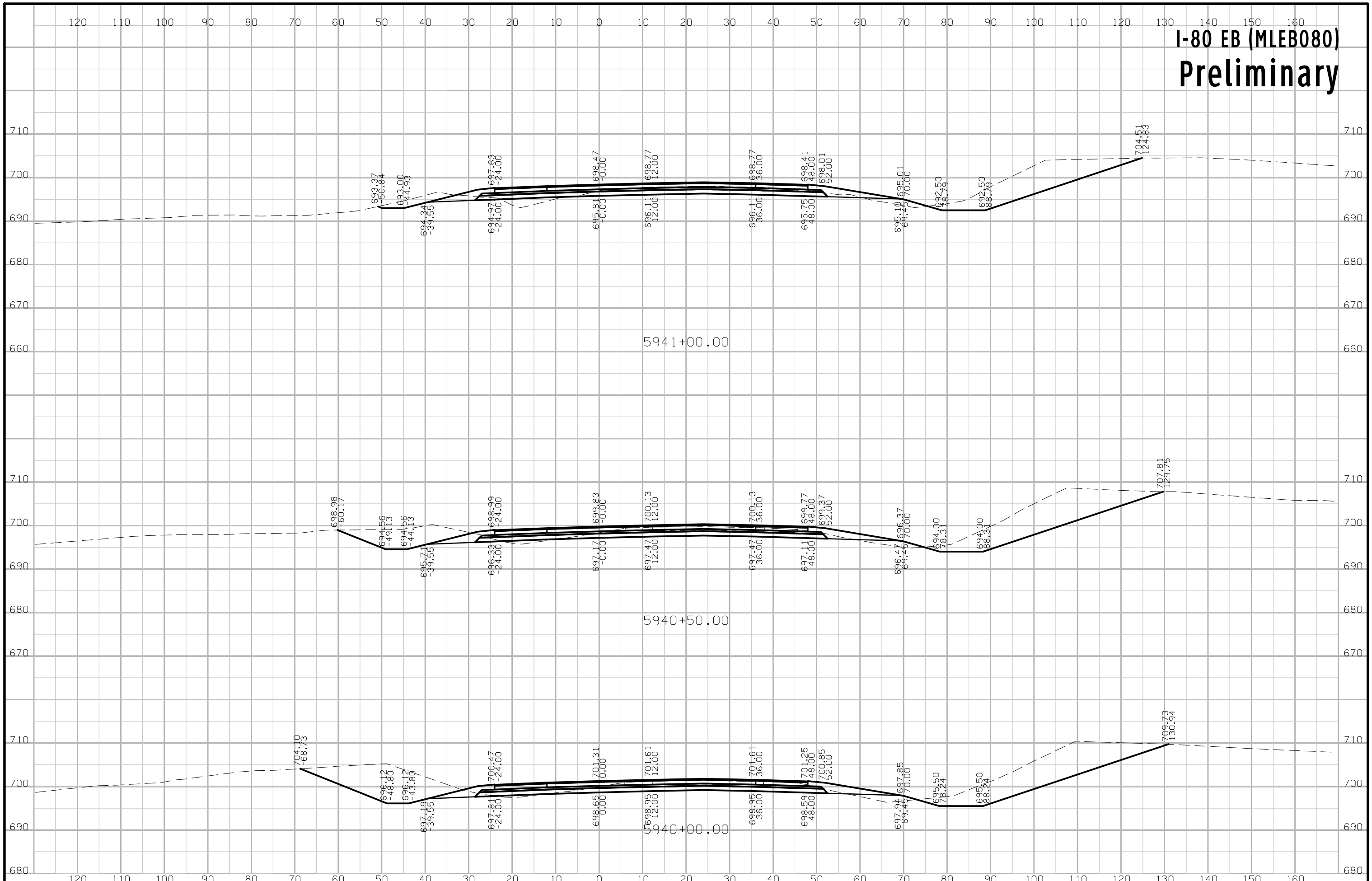

# I-80 EB (MLEB080) Preliminary

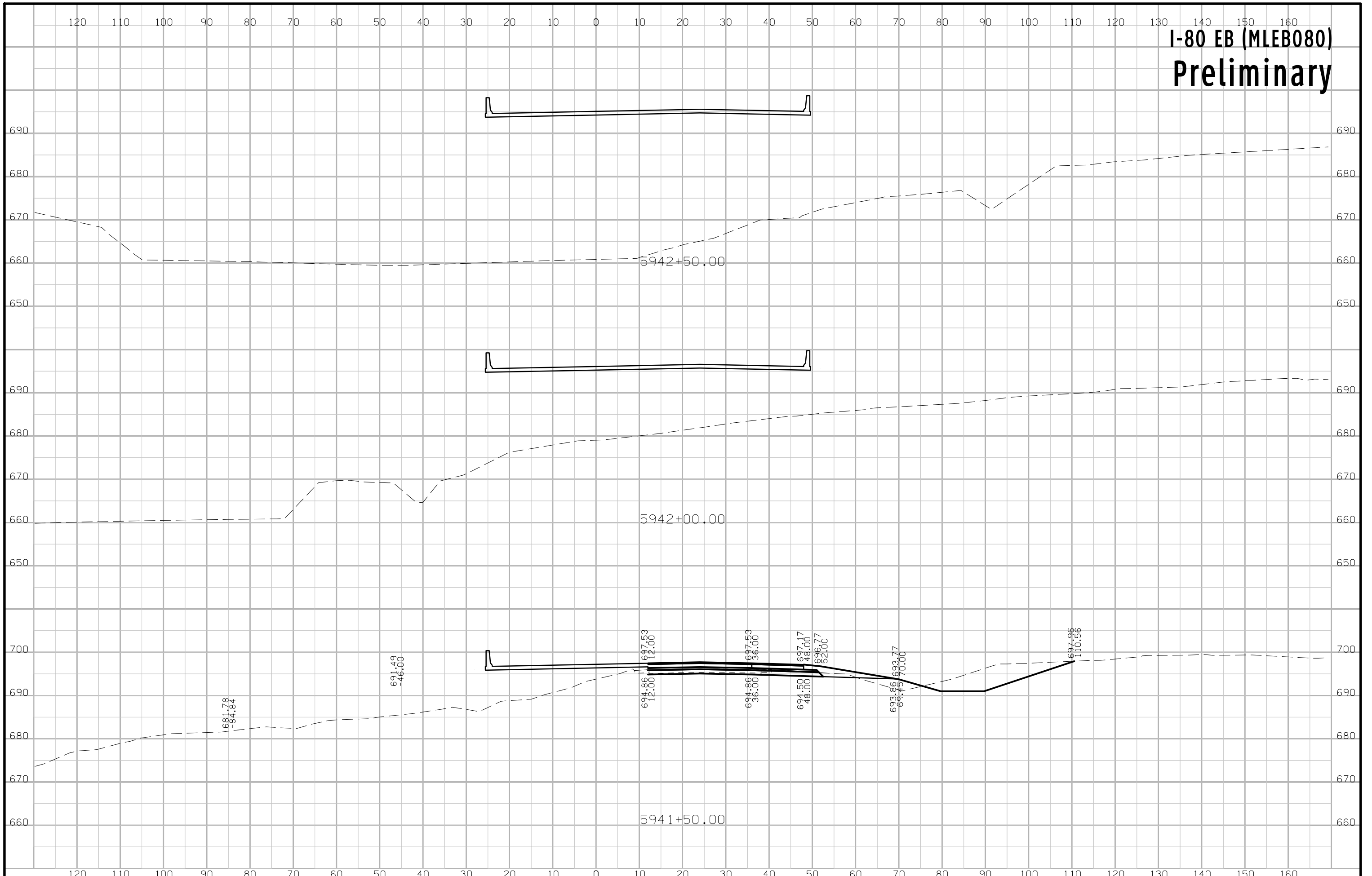

# I-80 EB (MLEB080) Preliminary

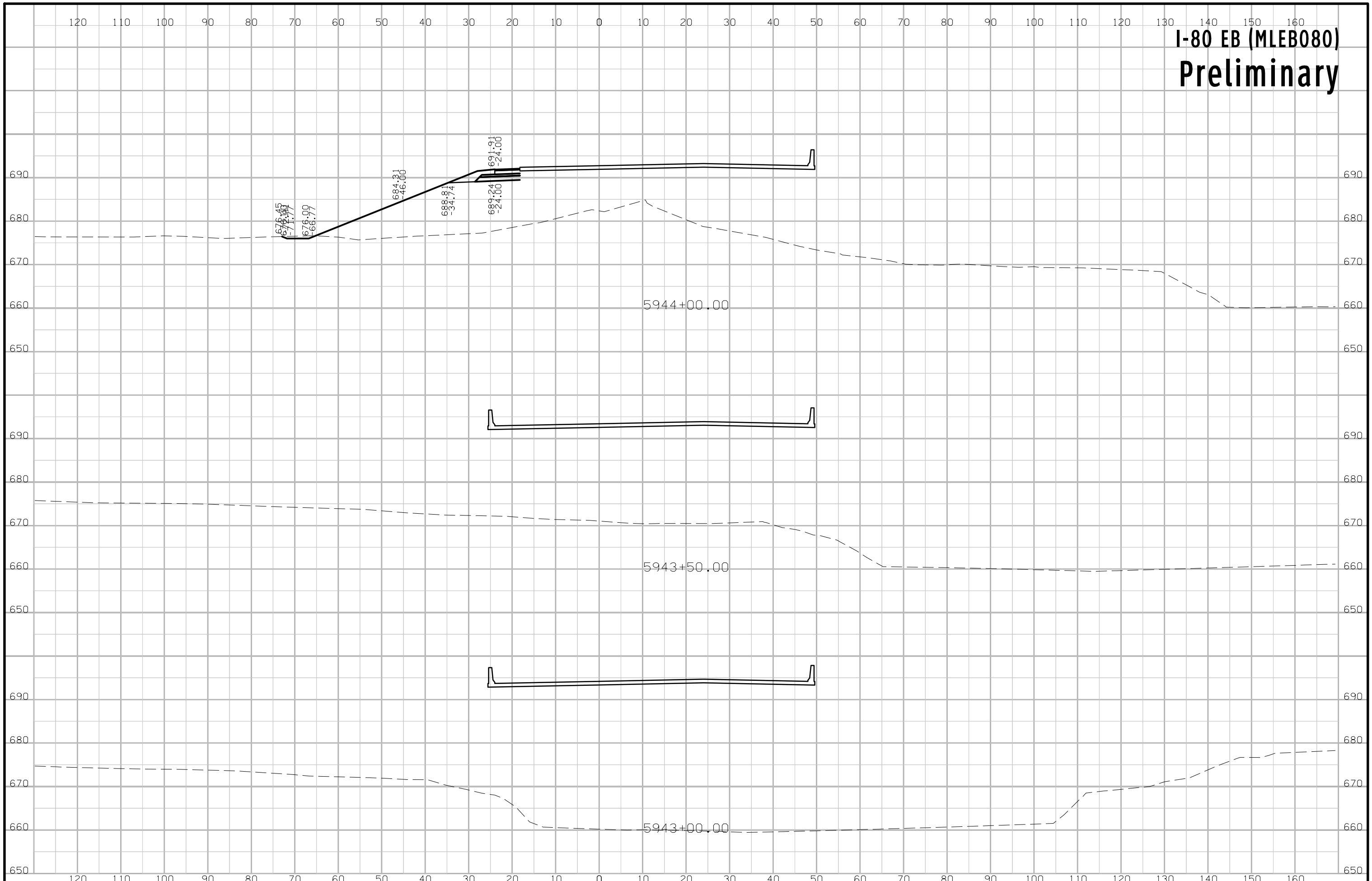

# I-80 EB (MLEB080) Preliminary

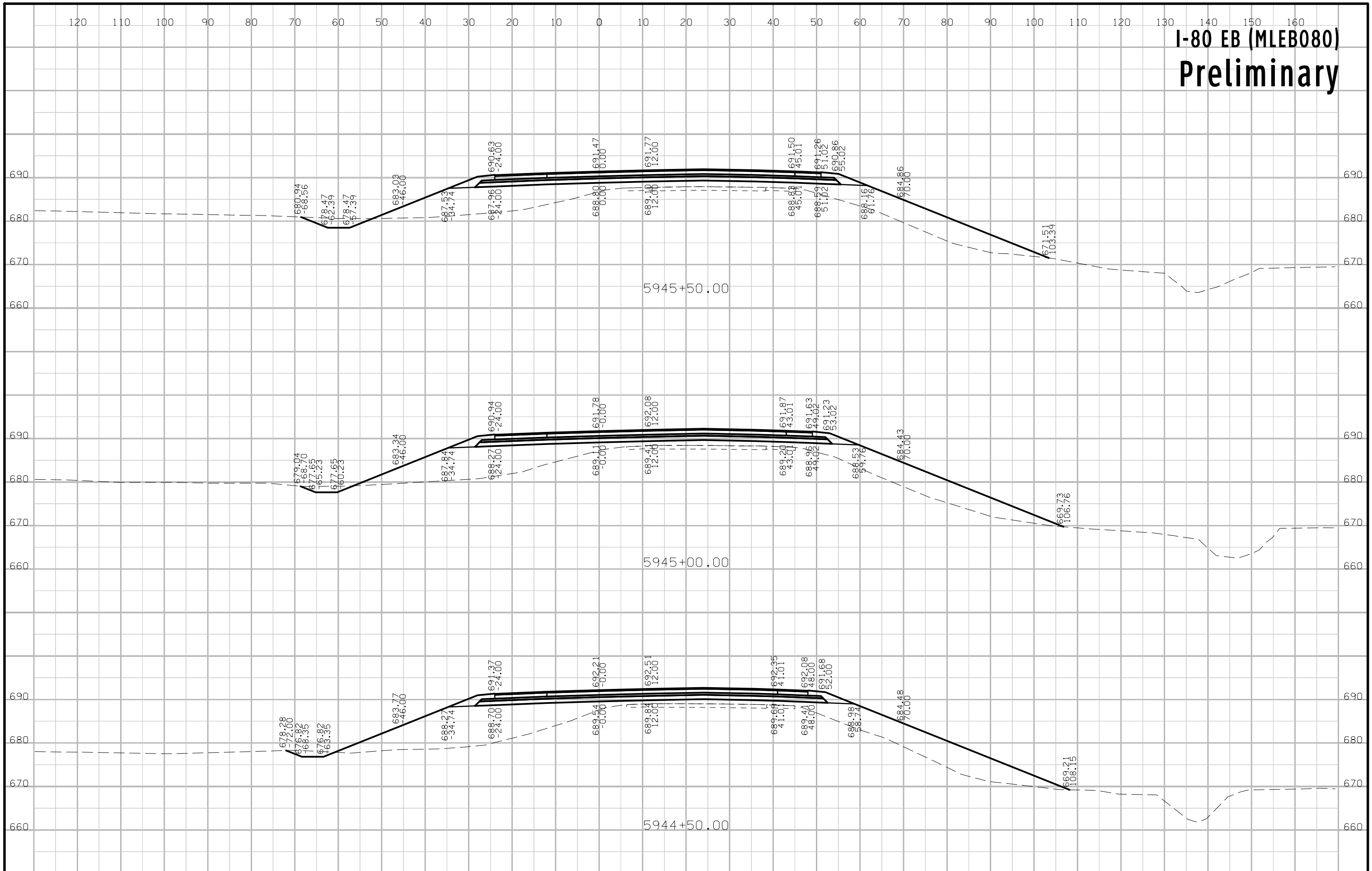

# I-80 EB (MLEB080) Preliminary

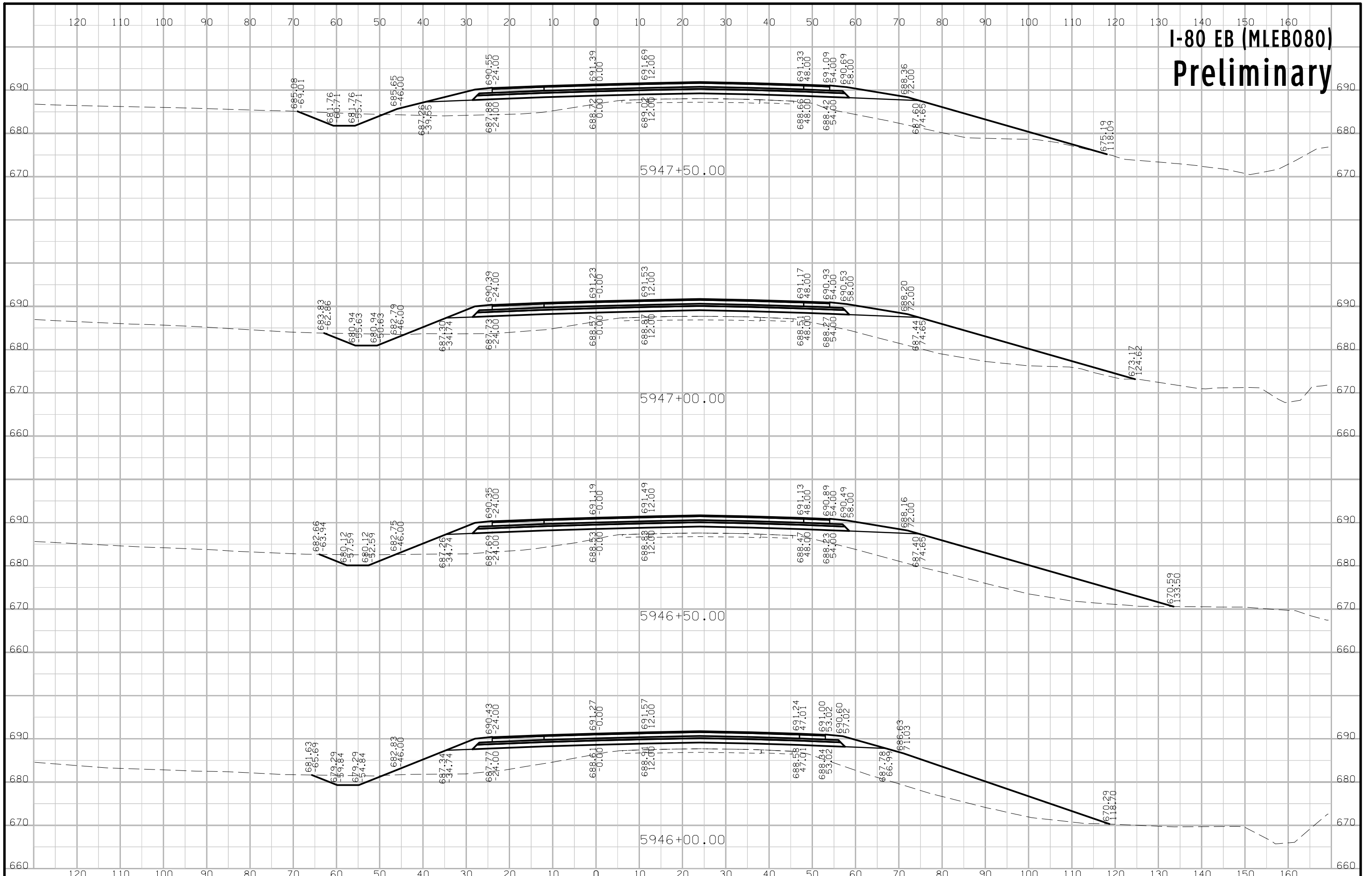

# I-80 EB (MLEB080) Preliminary

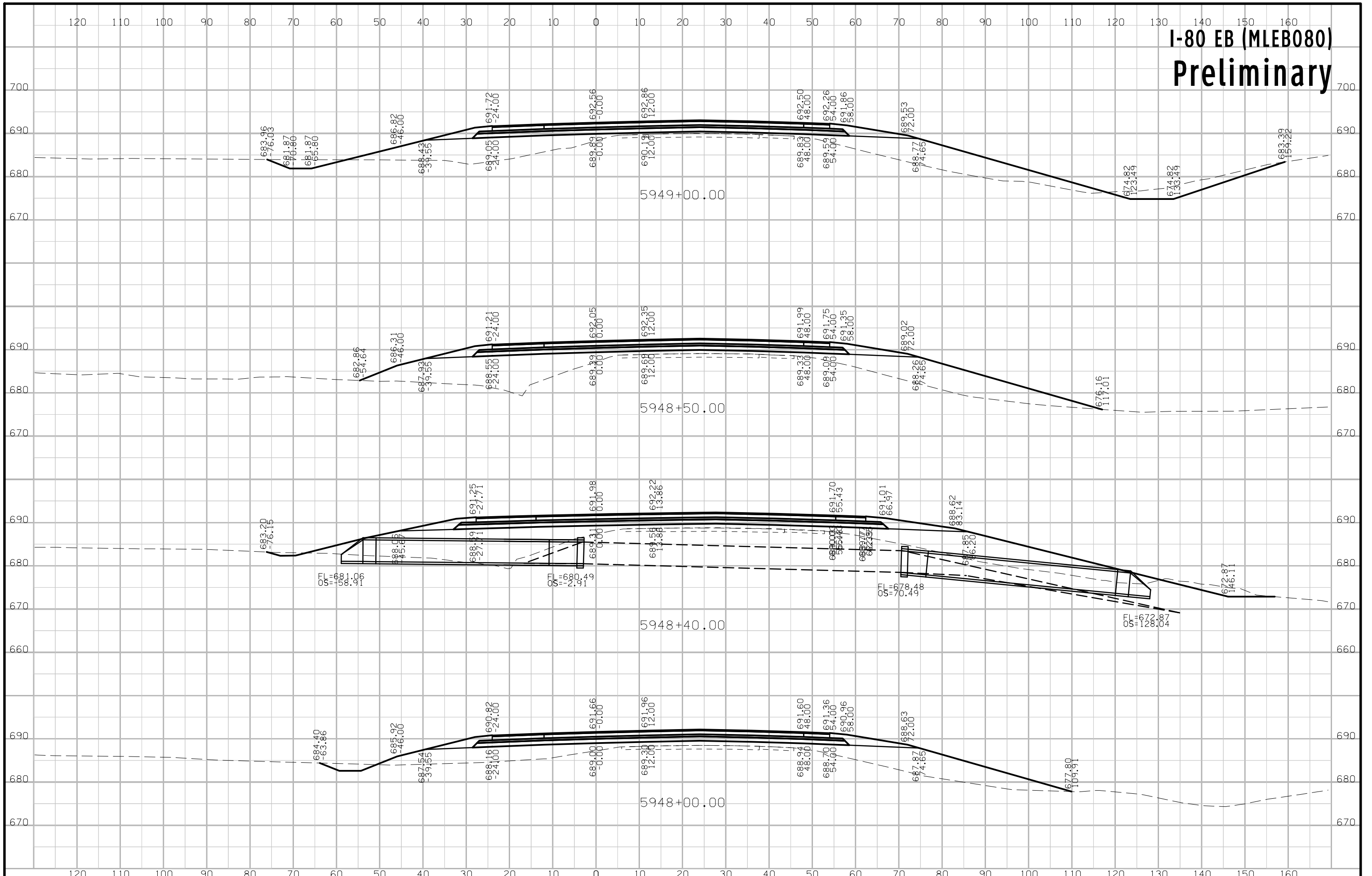

# I-80 EB (MLEB080) Preliminary

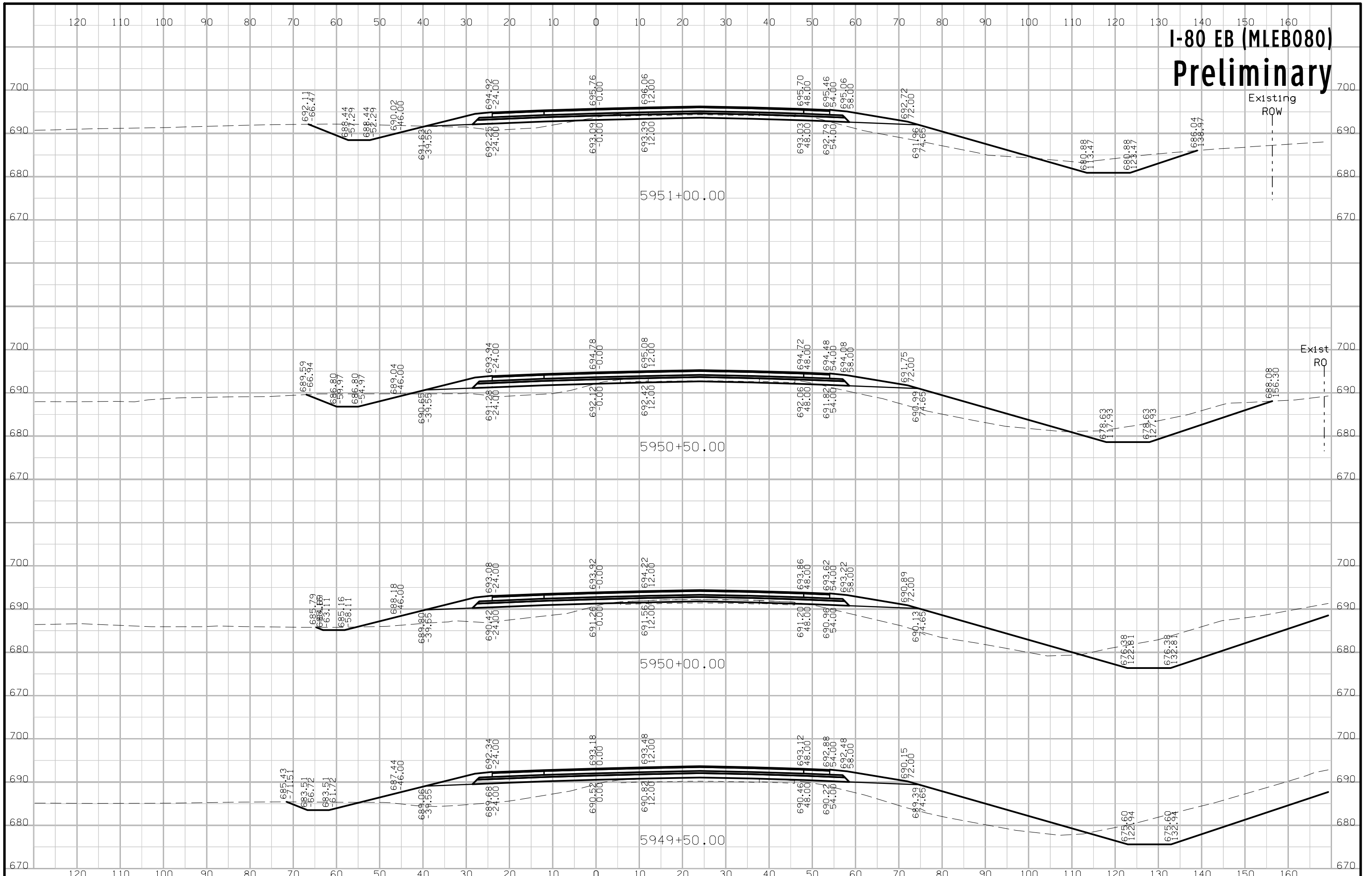



# I-80 EB (MLEB080) Preliminary

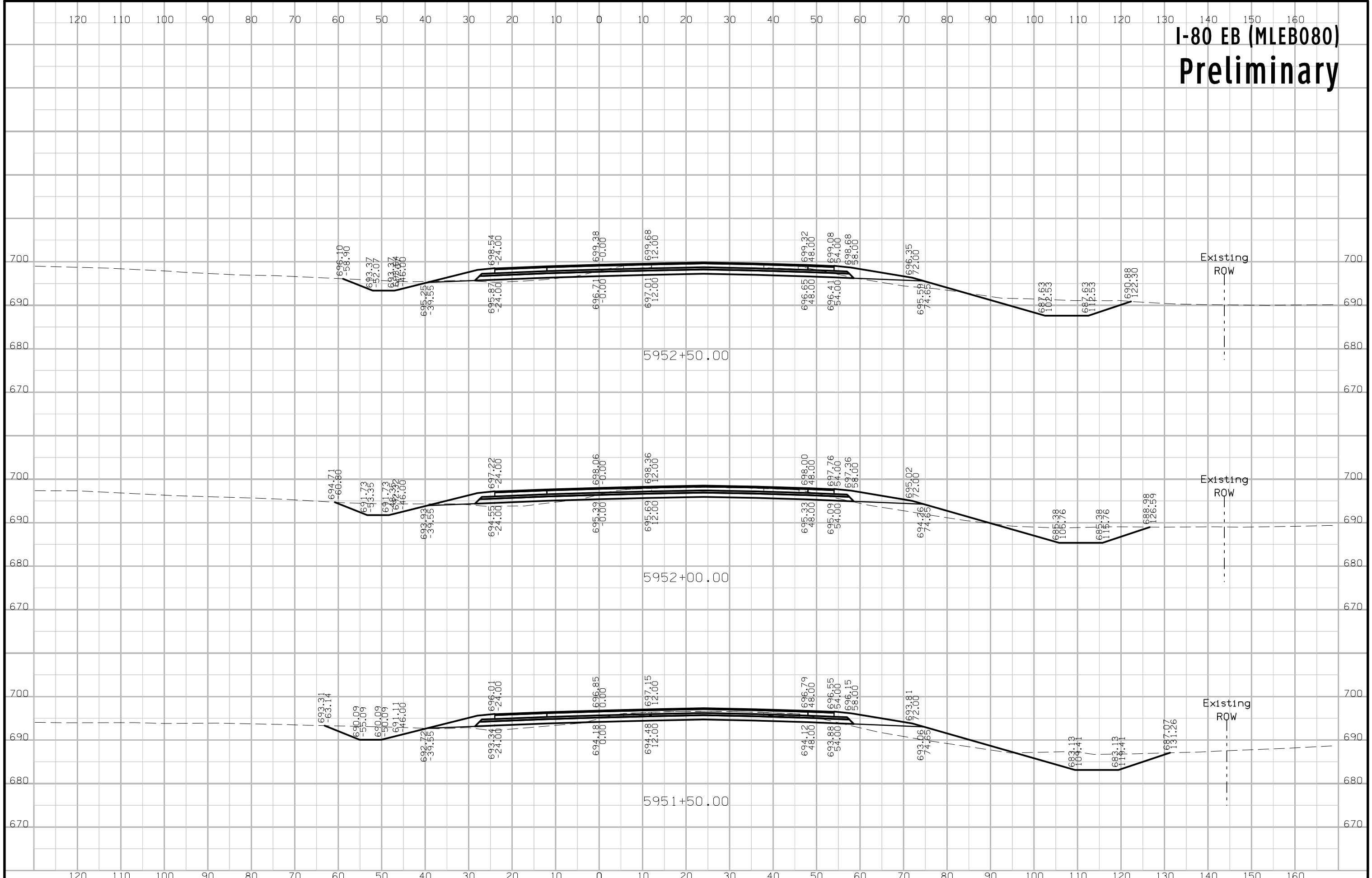

# I-80 EB (MLEB080) Preliminary

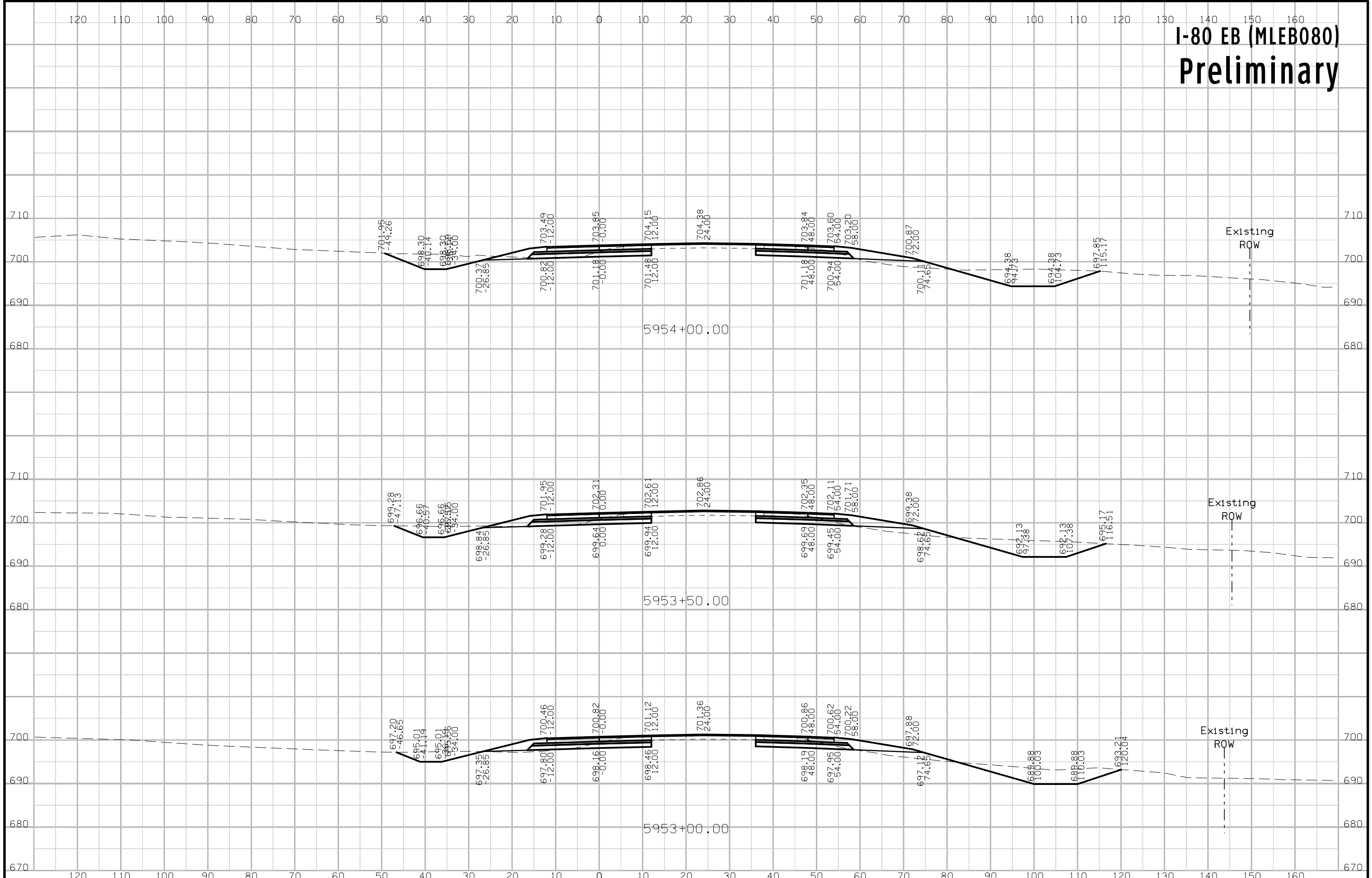

# I-80 EB (MLEB080) Preliminary

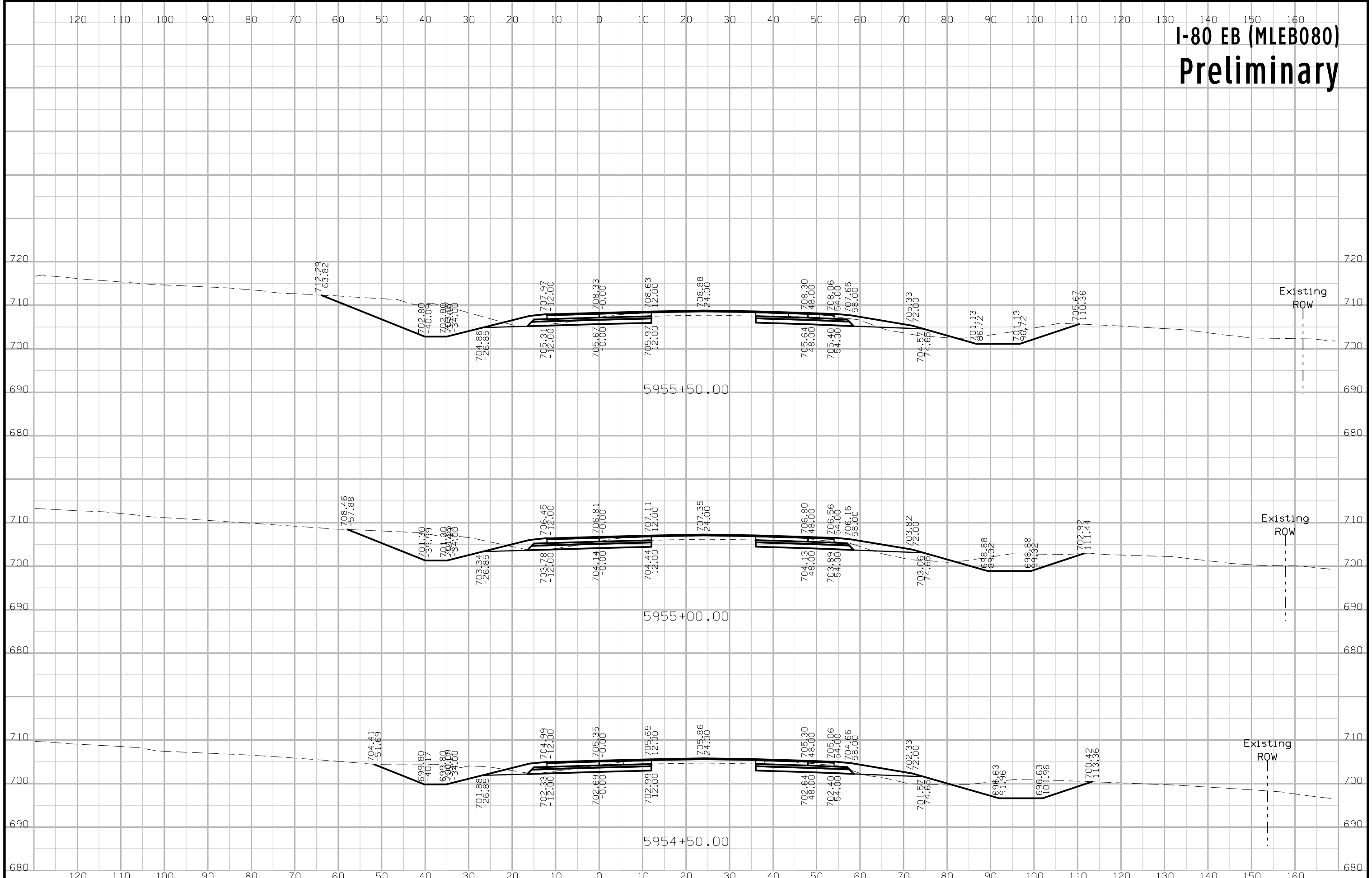

# I-80 EB (MLEB080) Preliminary

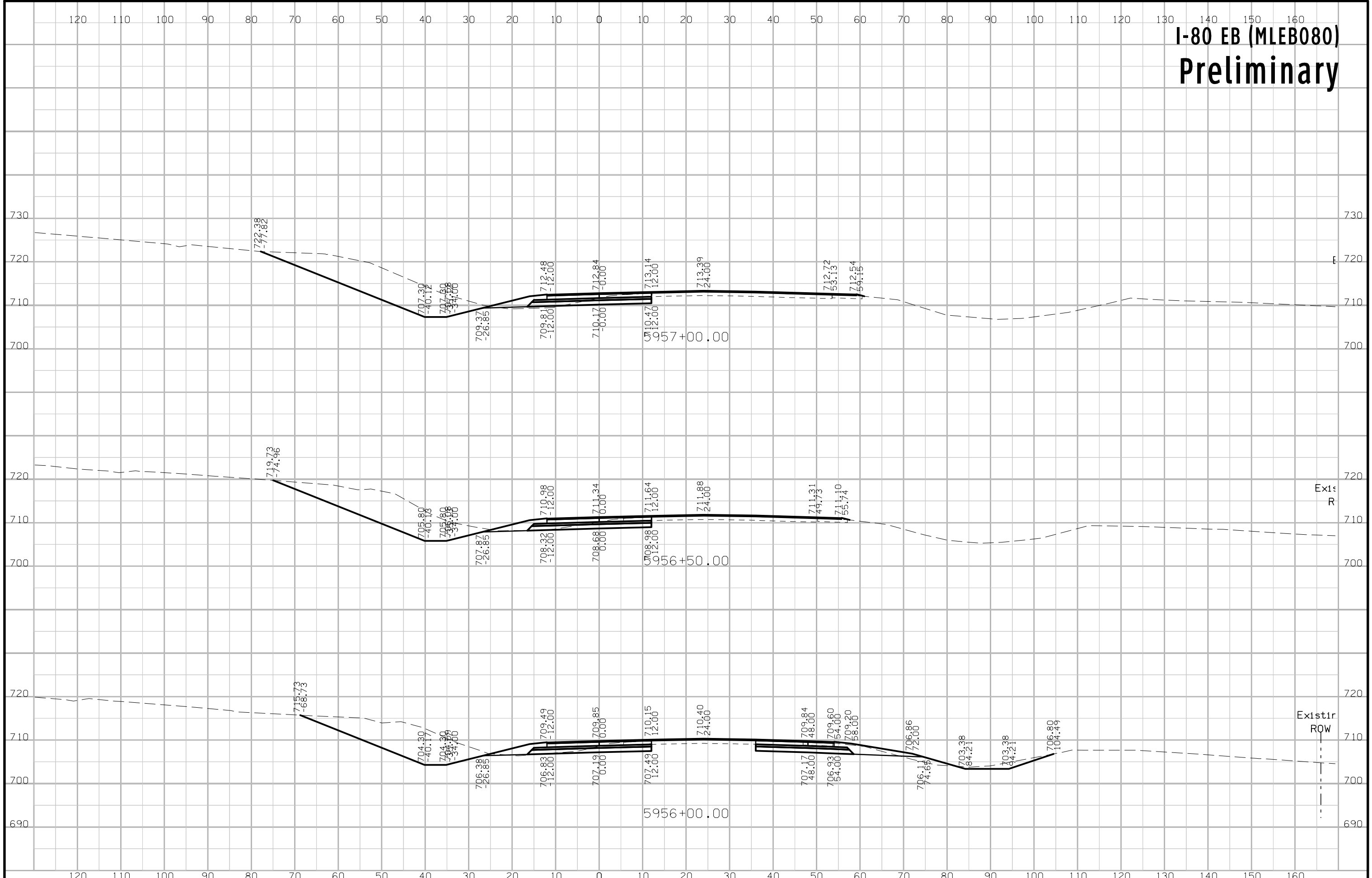

# I-80 EB (MLEB080) Preliminary

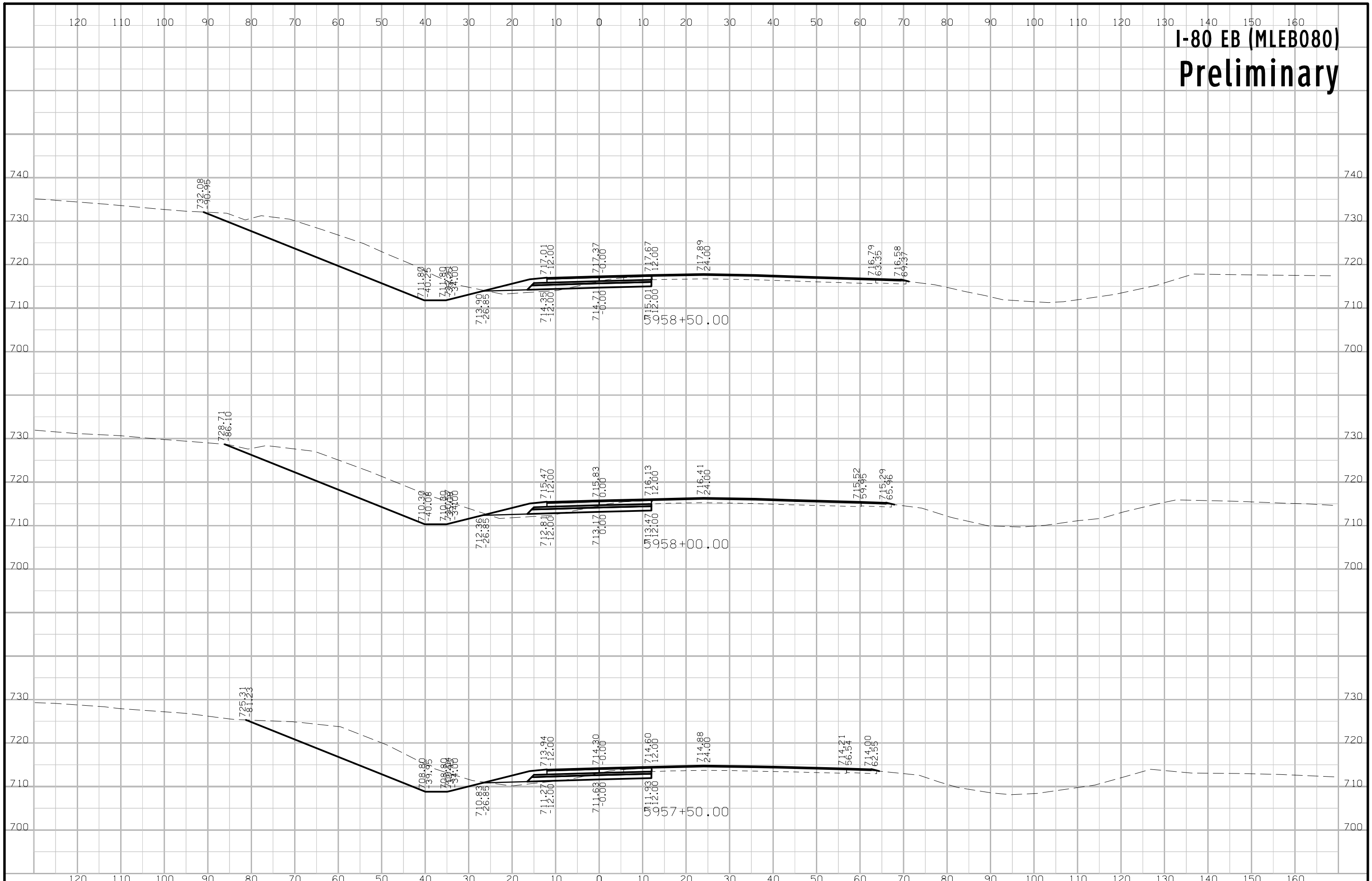

# I-80 EB (MLEB080) Preliminary

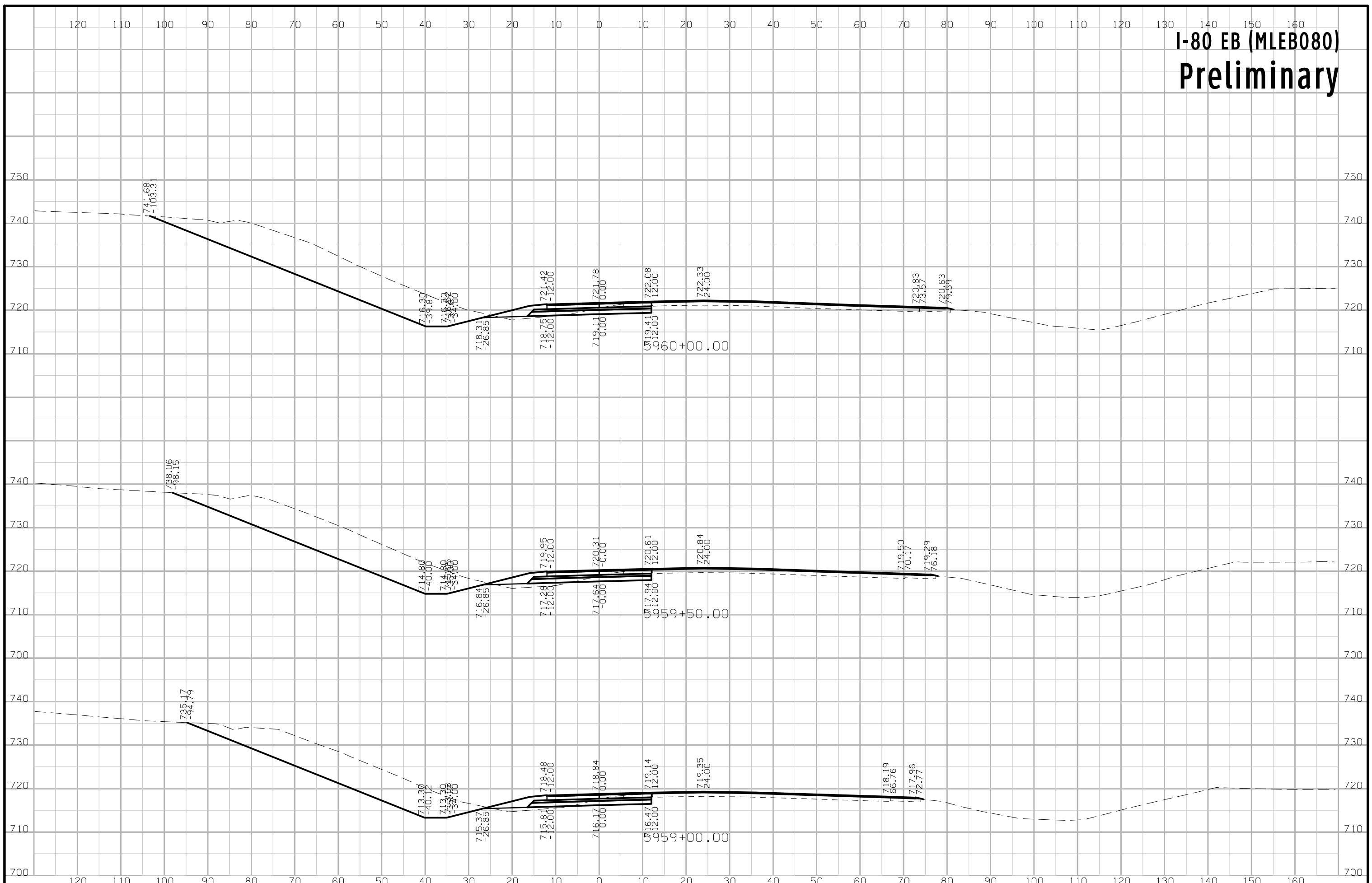

# I-80 EB (MLEB080) Preliminary

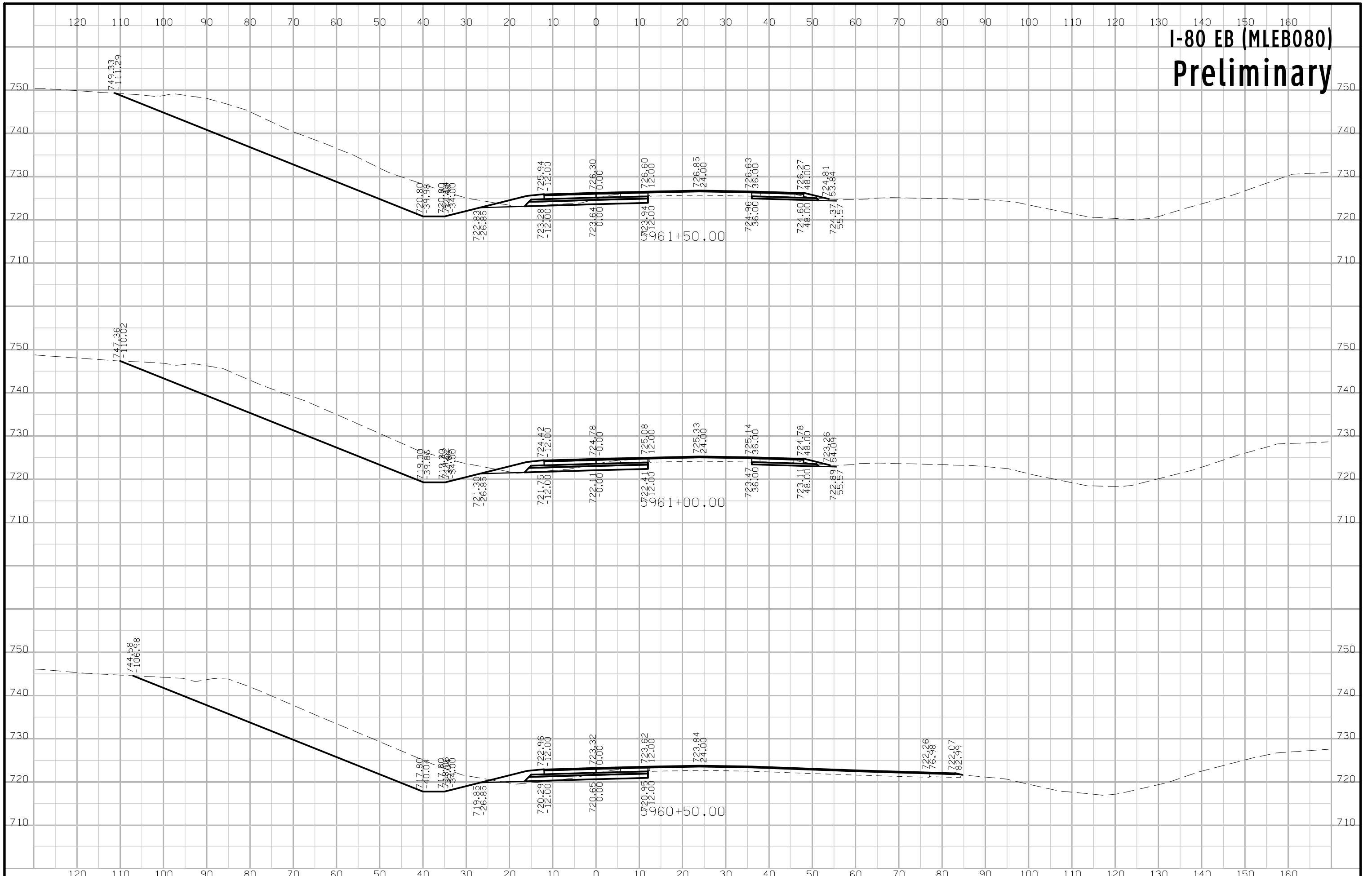



# I-80 EB (MLEB080) Preliminary

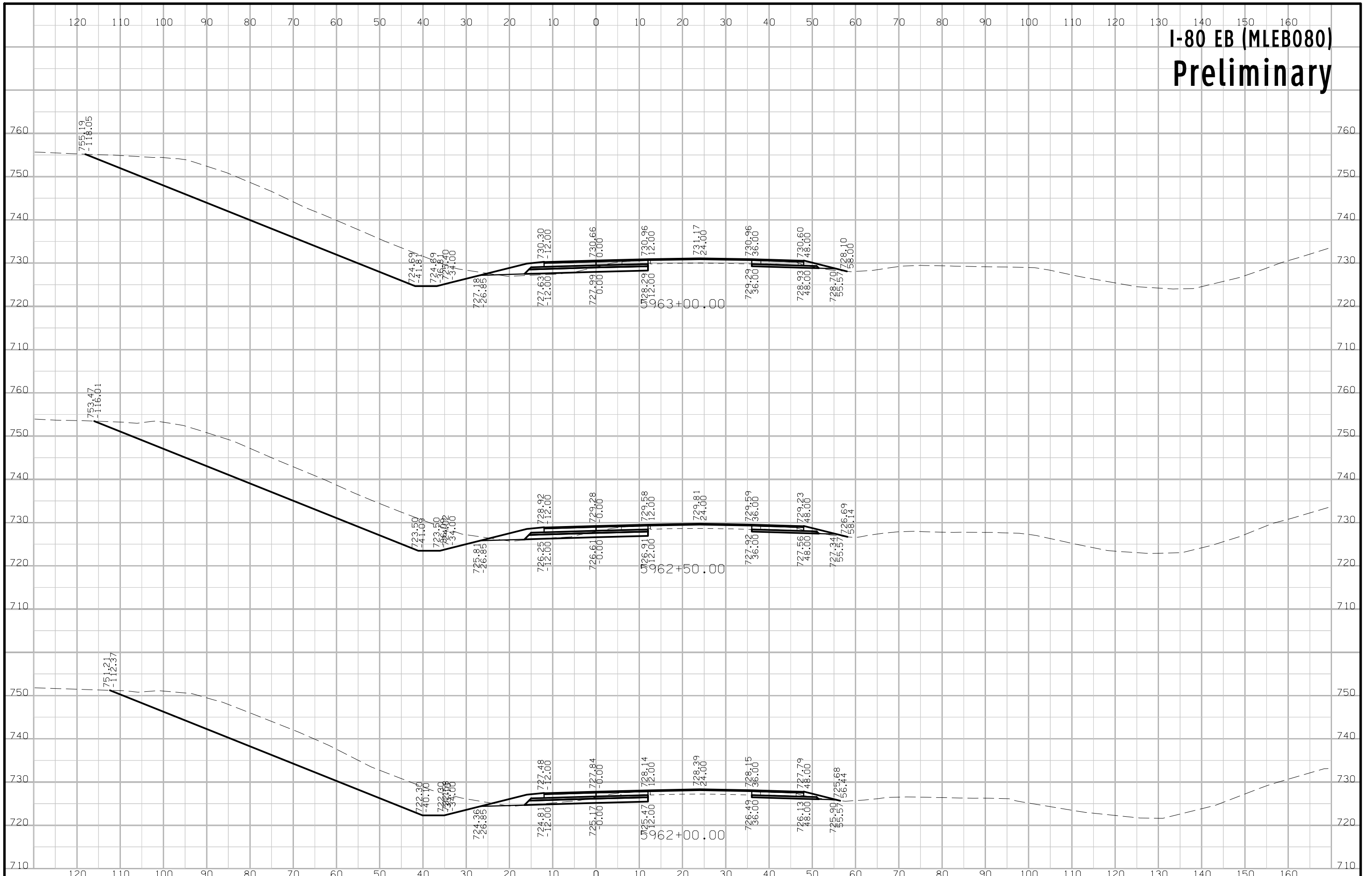

# I-80 EB (MLEB080) Preliminary

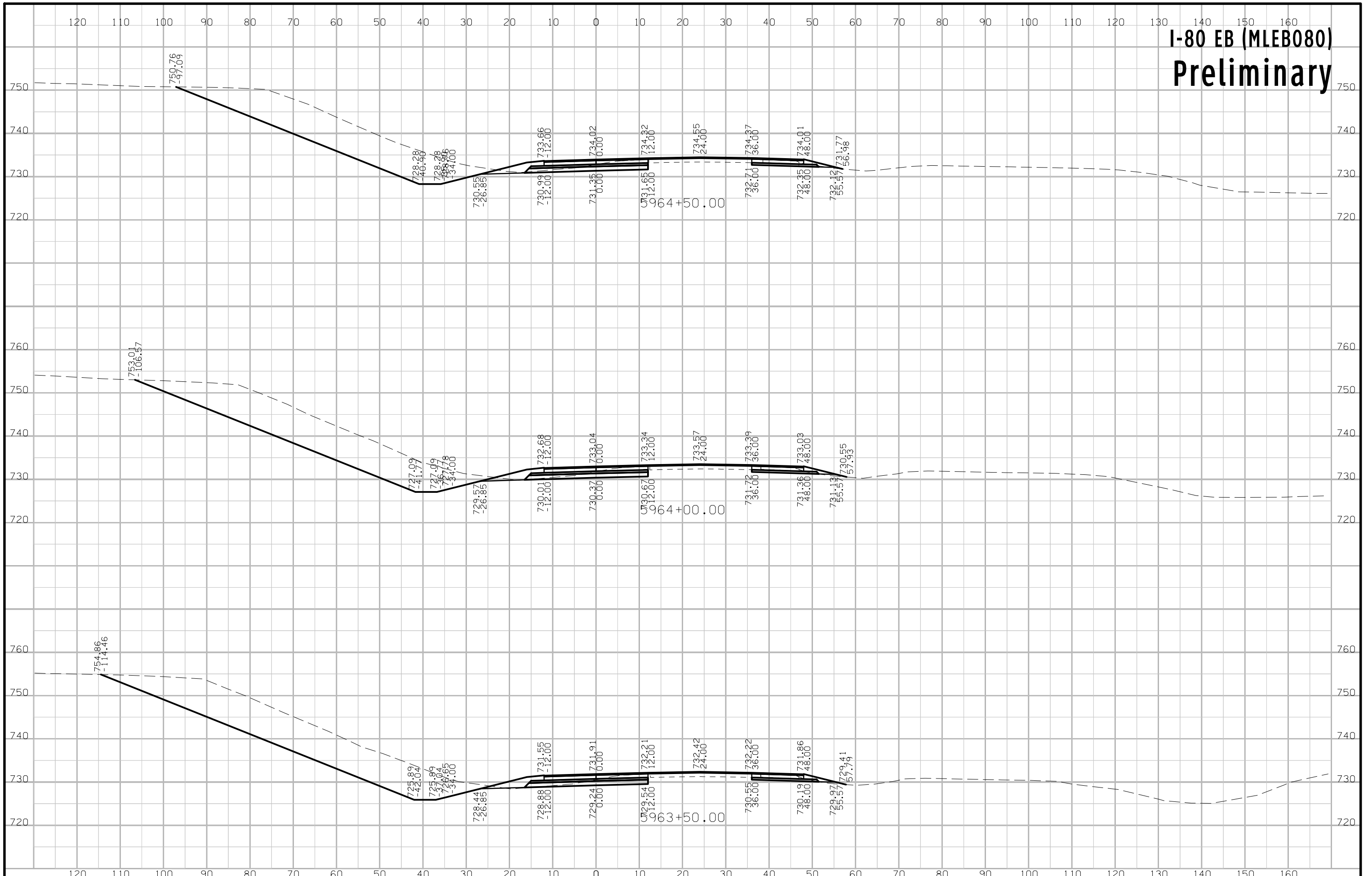

# I-80 EB (MLEB080) Preliminary

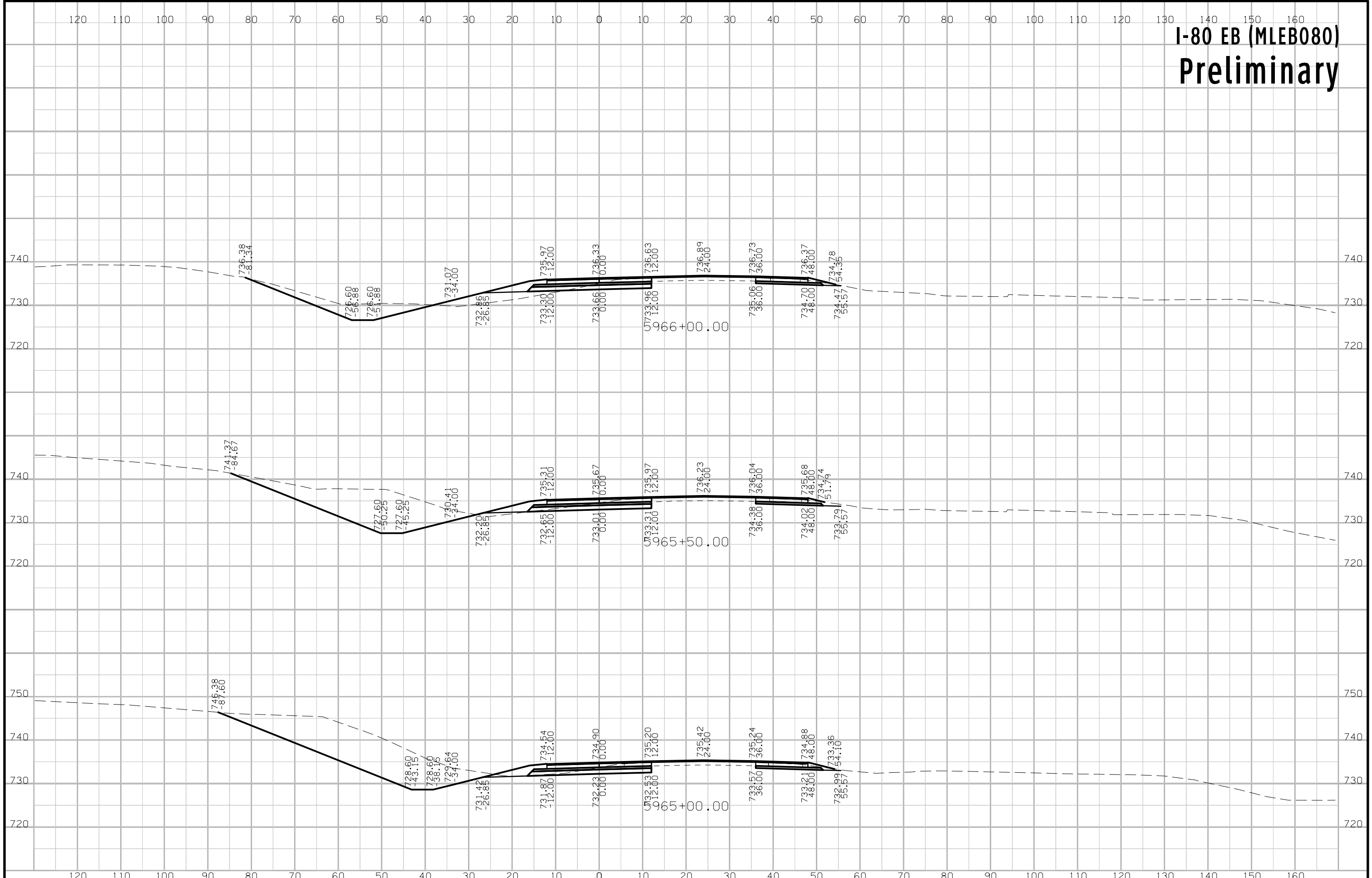

# I-80 EB (MLEB080) Preliminary

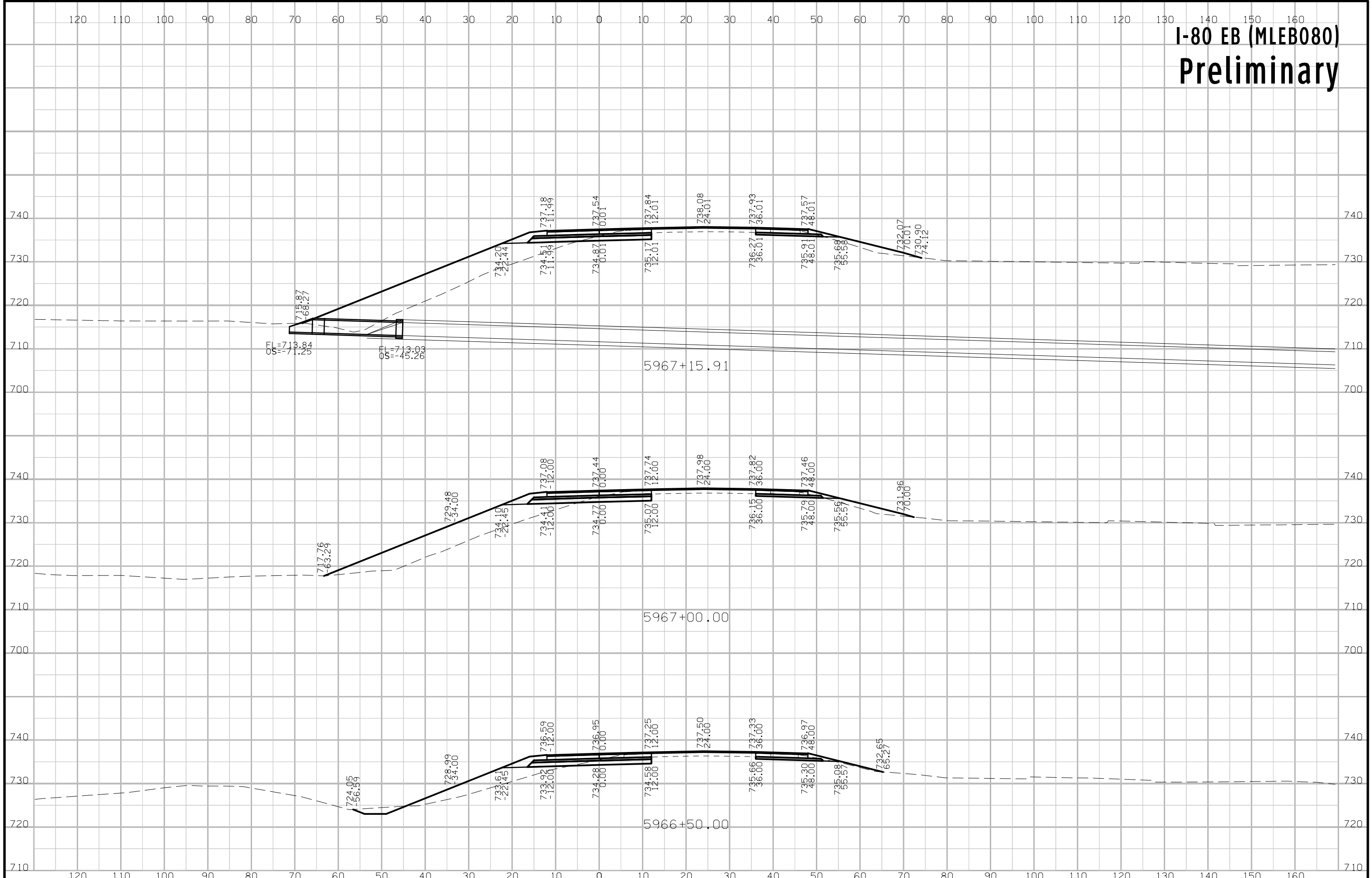

# I-80 EB (MLEB080) Preliminary

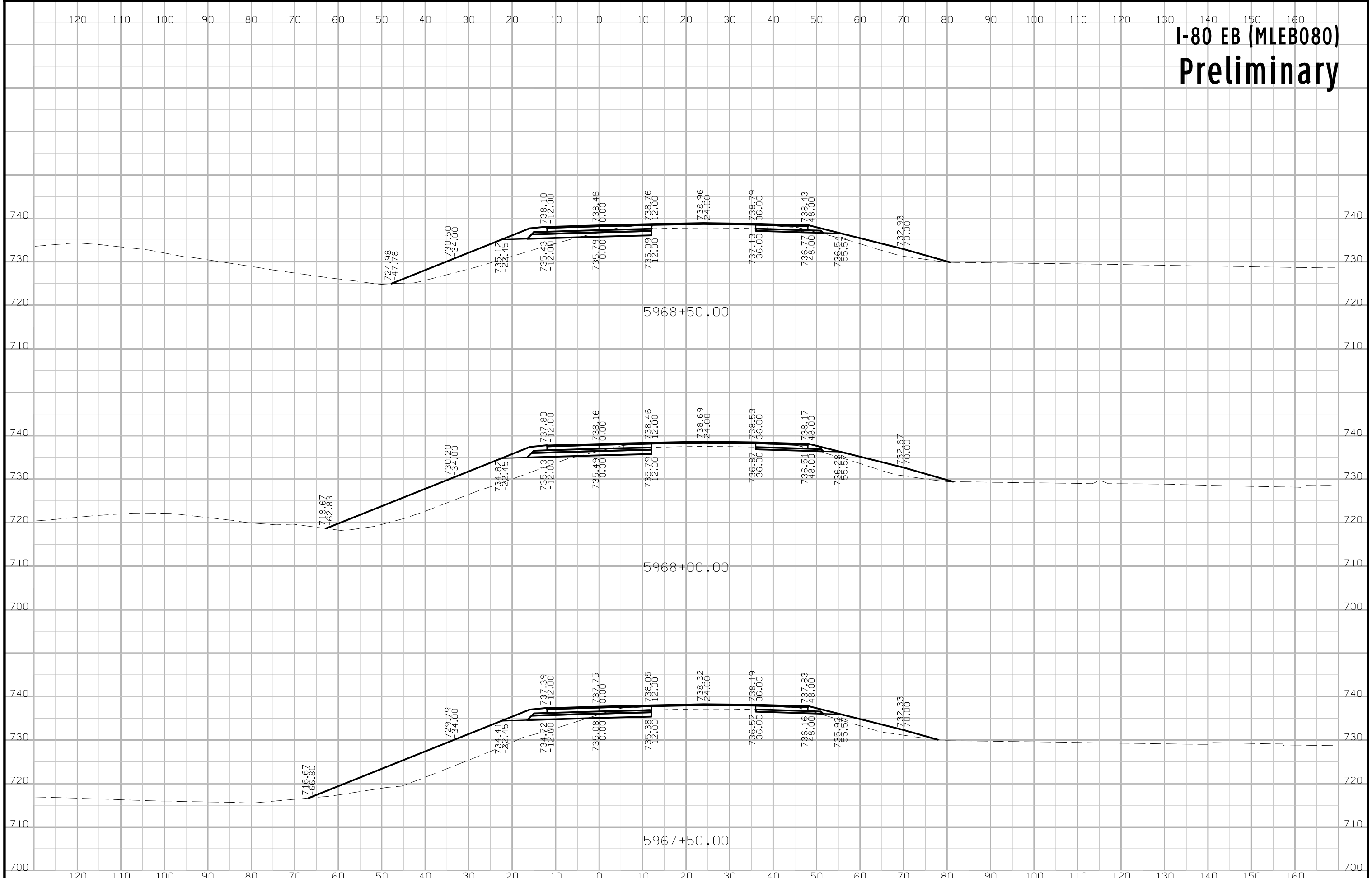

# I-80 EB (MLEB080) Preliminary

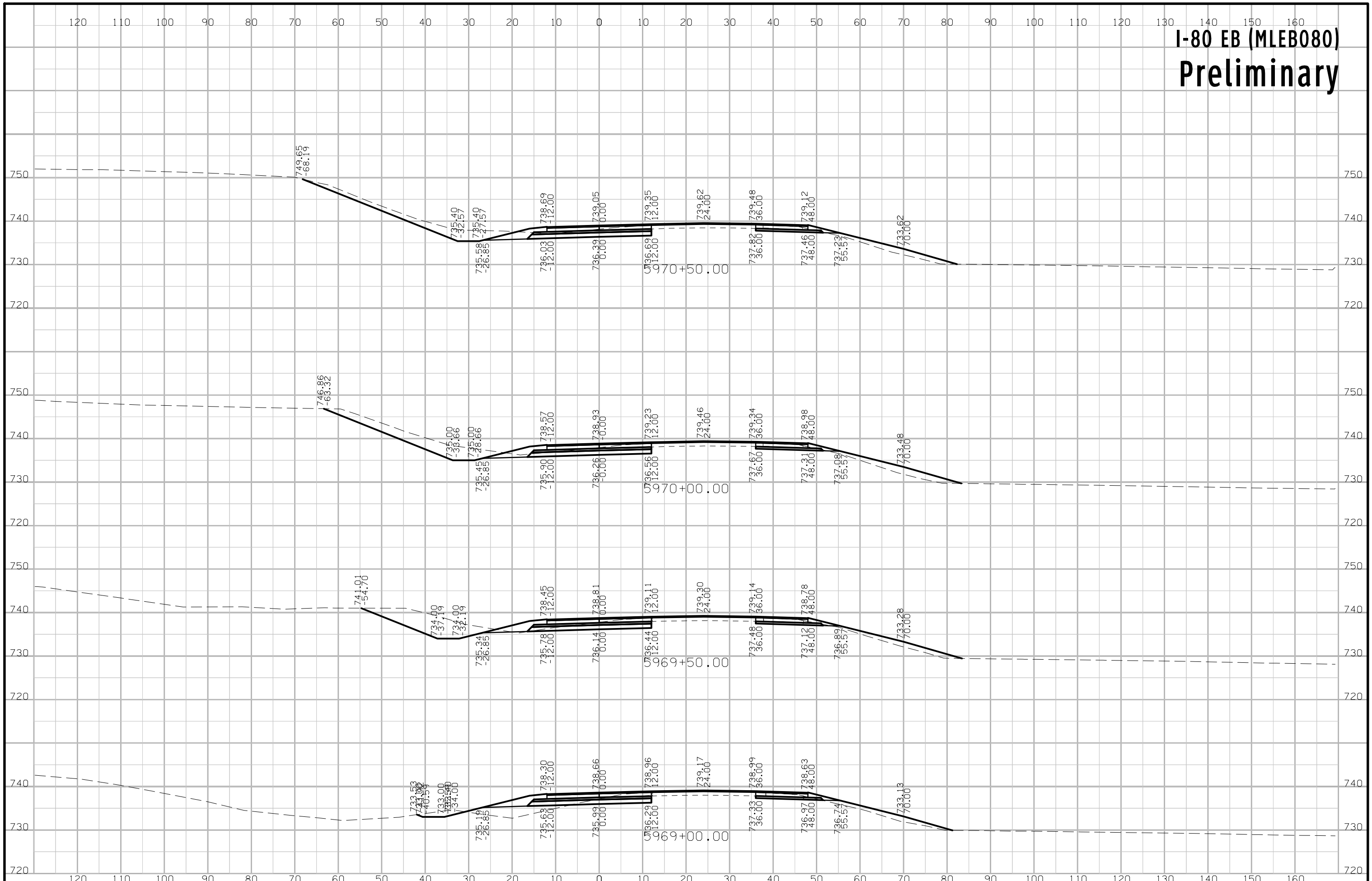

# I-80 EB (MLEB080) Preliminary

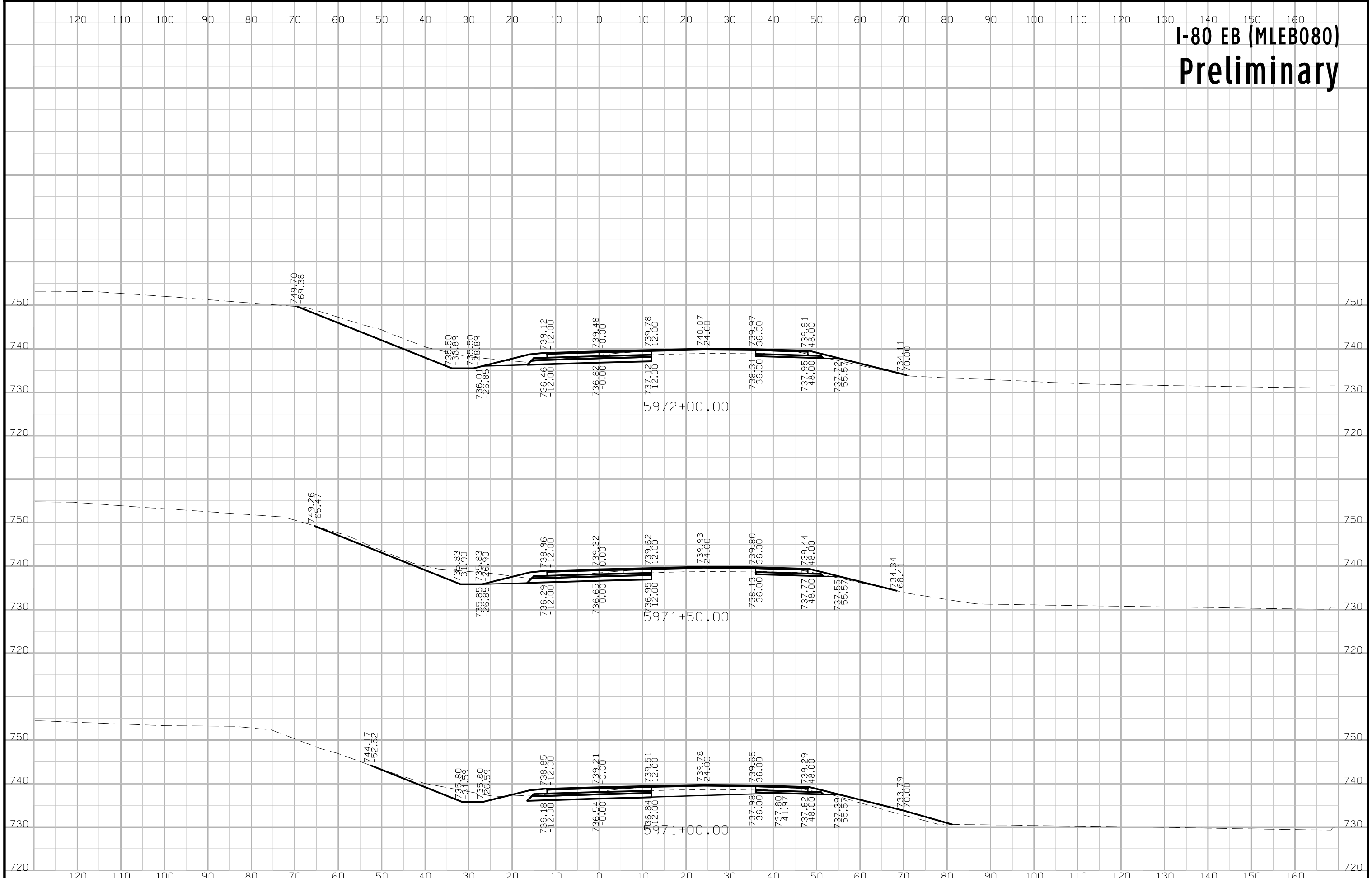



# I-80 EB (MLEB080) Preliminary

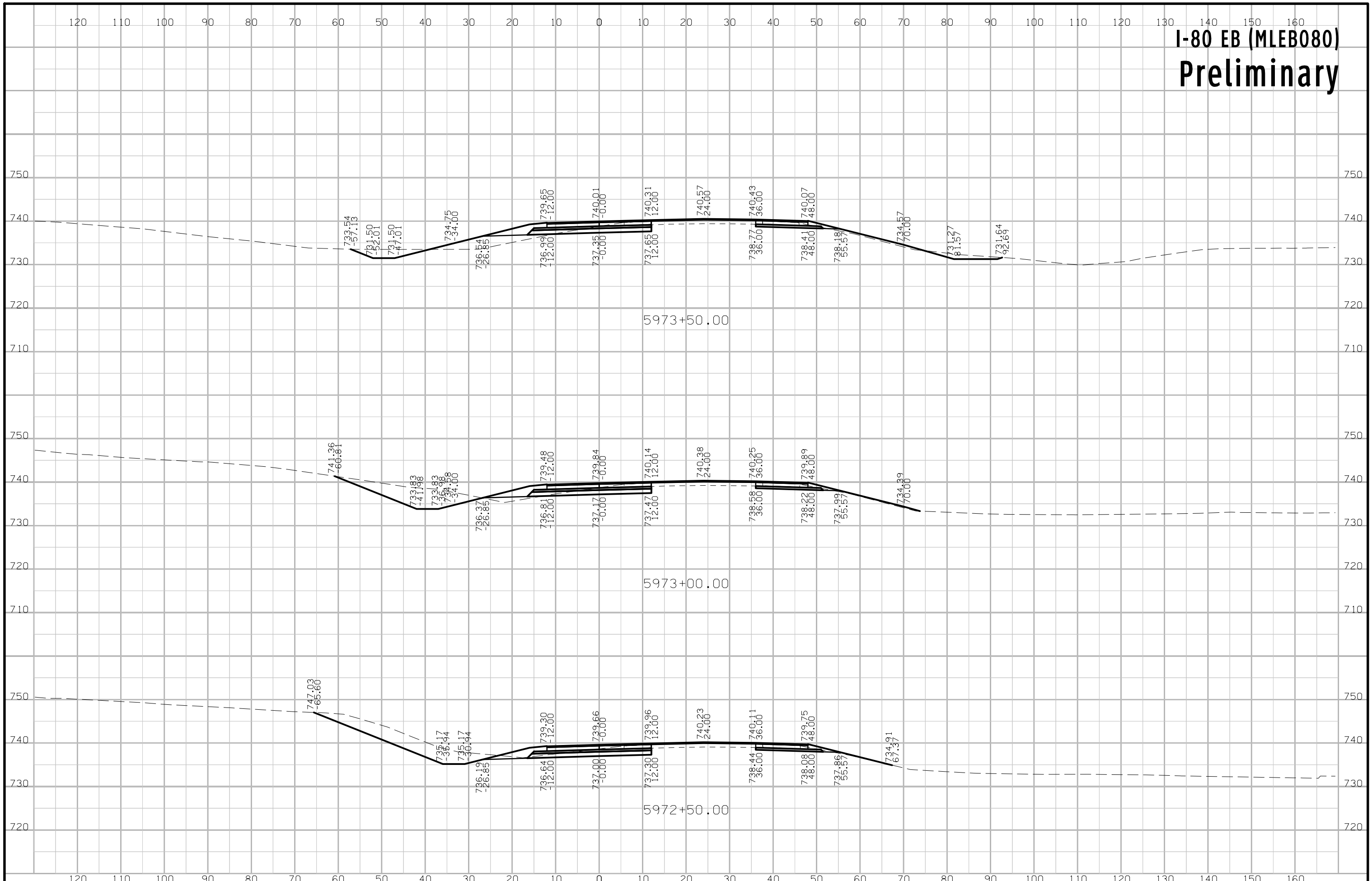

# I-80 EB (MLEB080) Preliminary

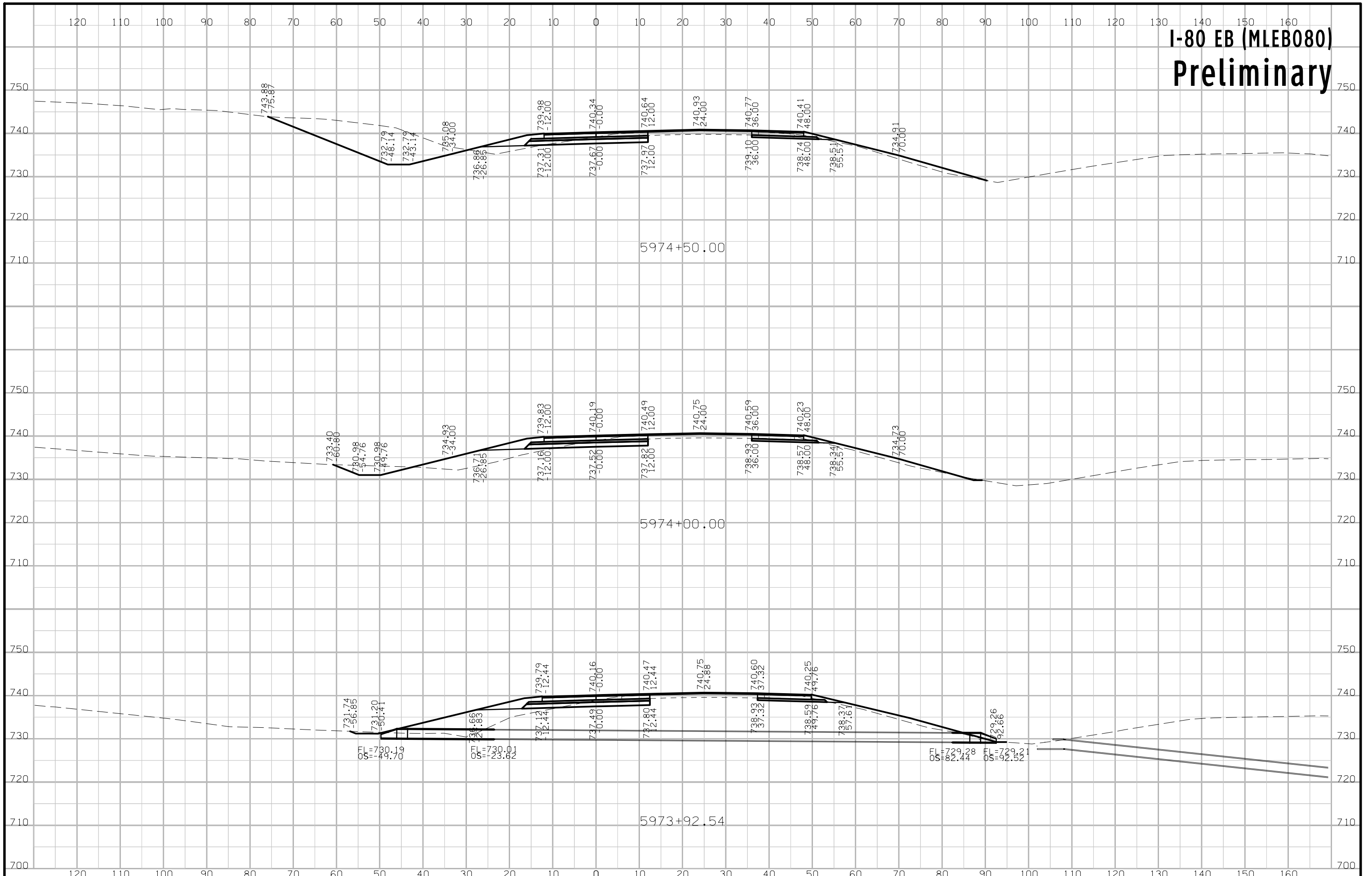

# I-80 EB (MLEB080) Preliminary

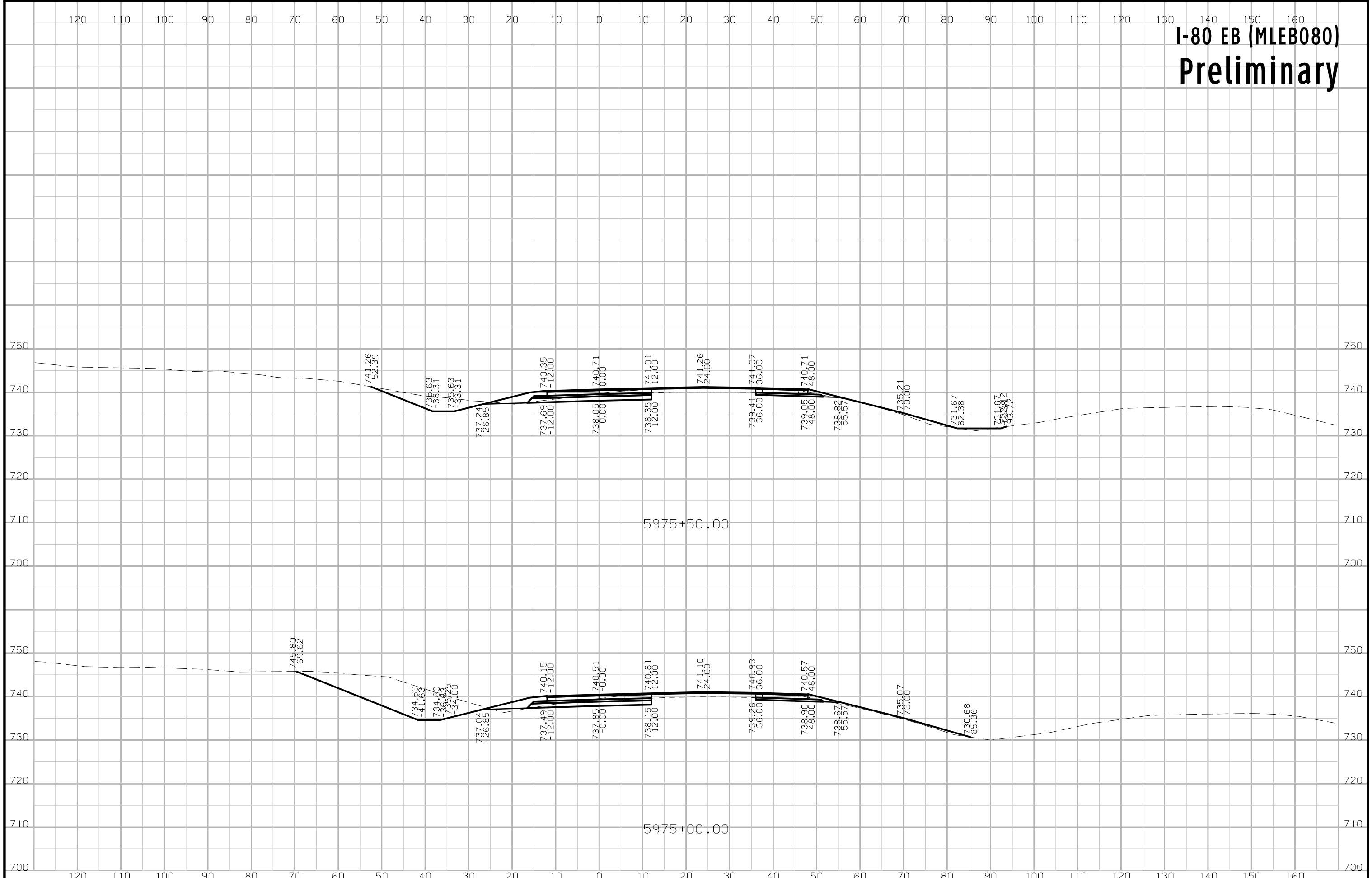

# I-80 EB (MLEB080) Preliminary

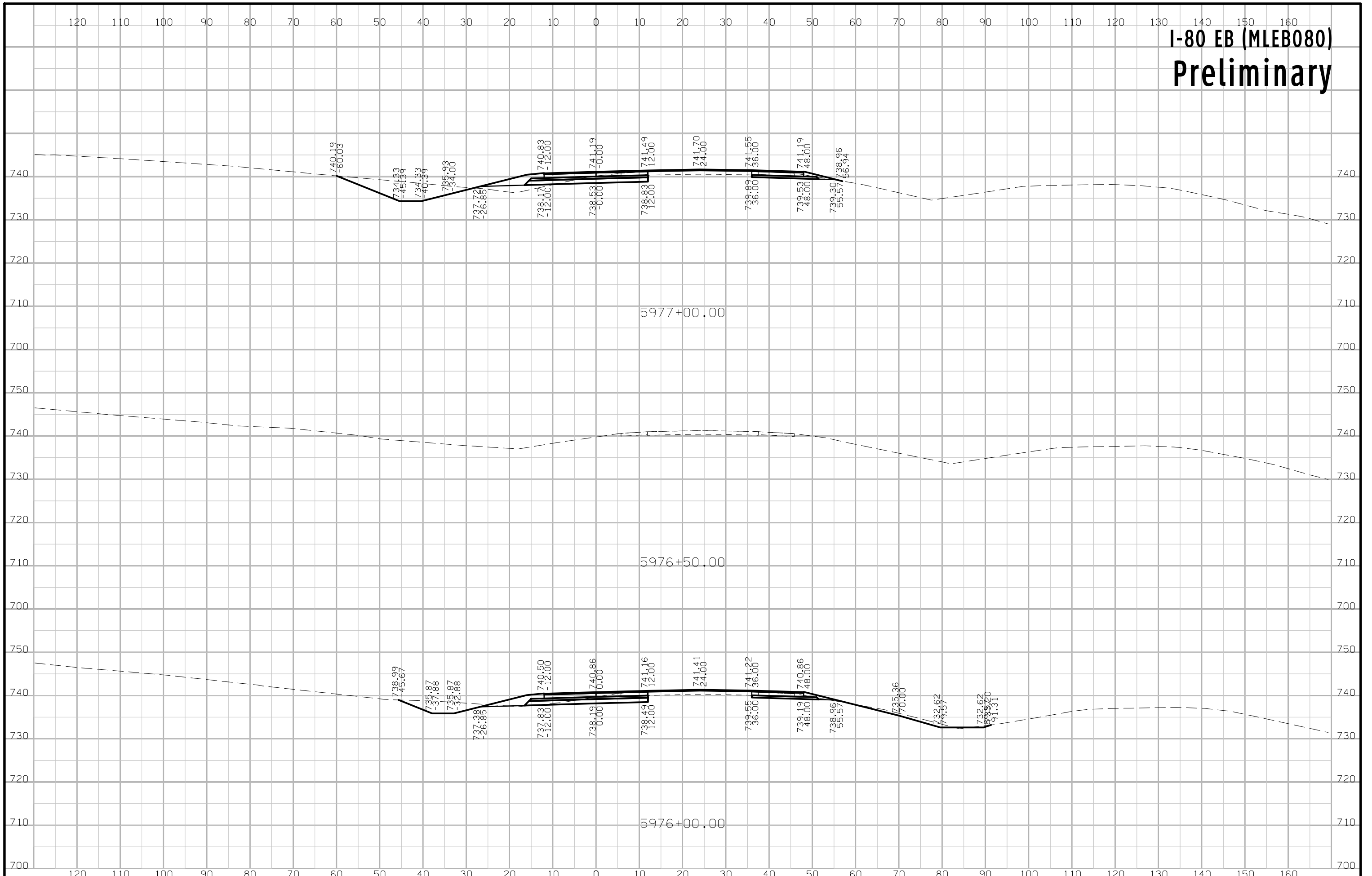

# I-80 EB (MLEB080) Preliminary

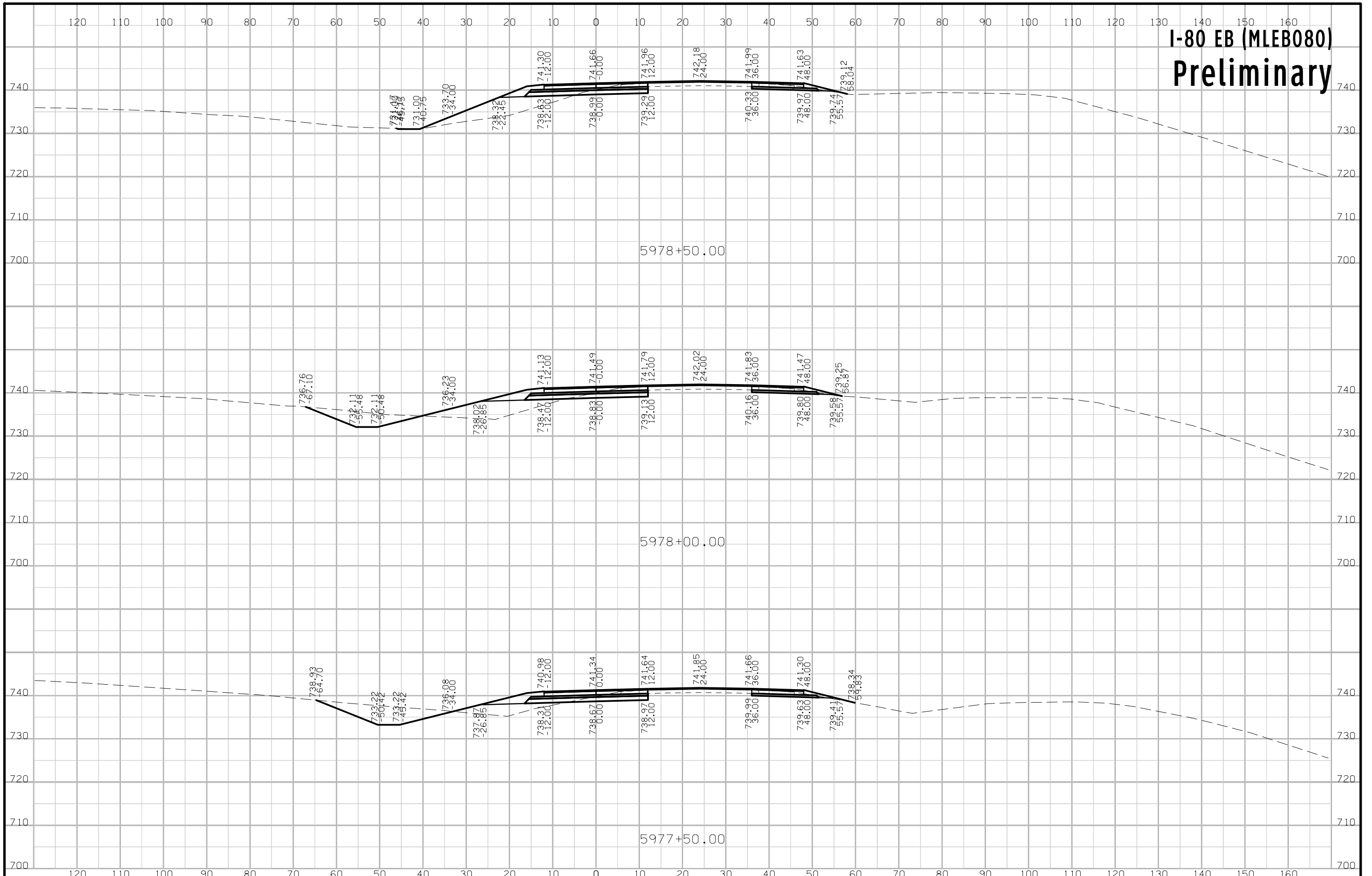

# I-80 EB (MLEB080) Preliminary

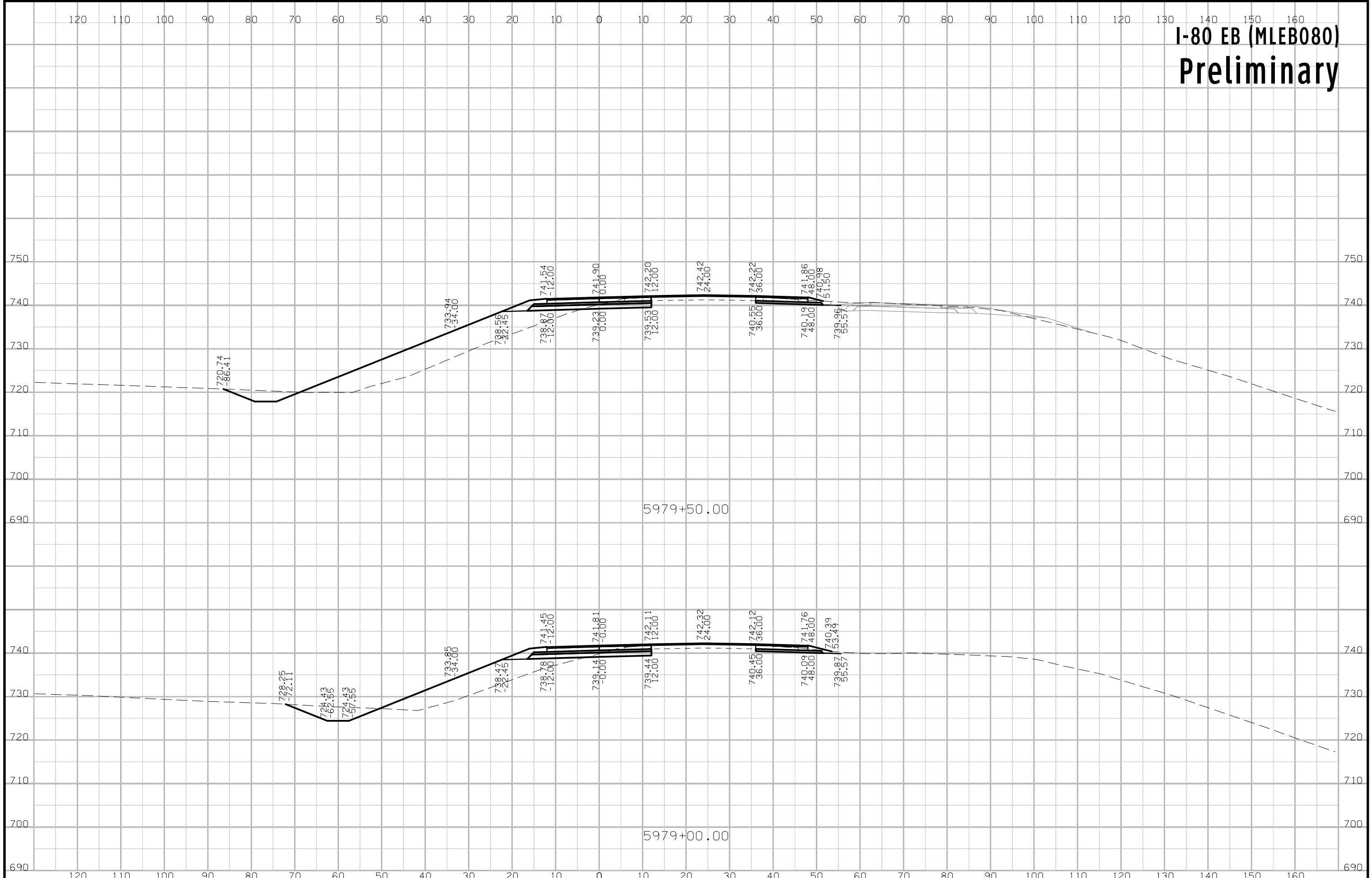

# I-80 EB (MLEB080) Preliminary

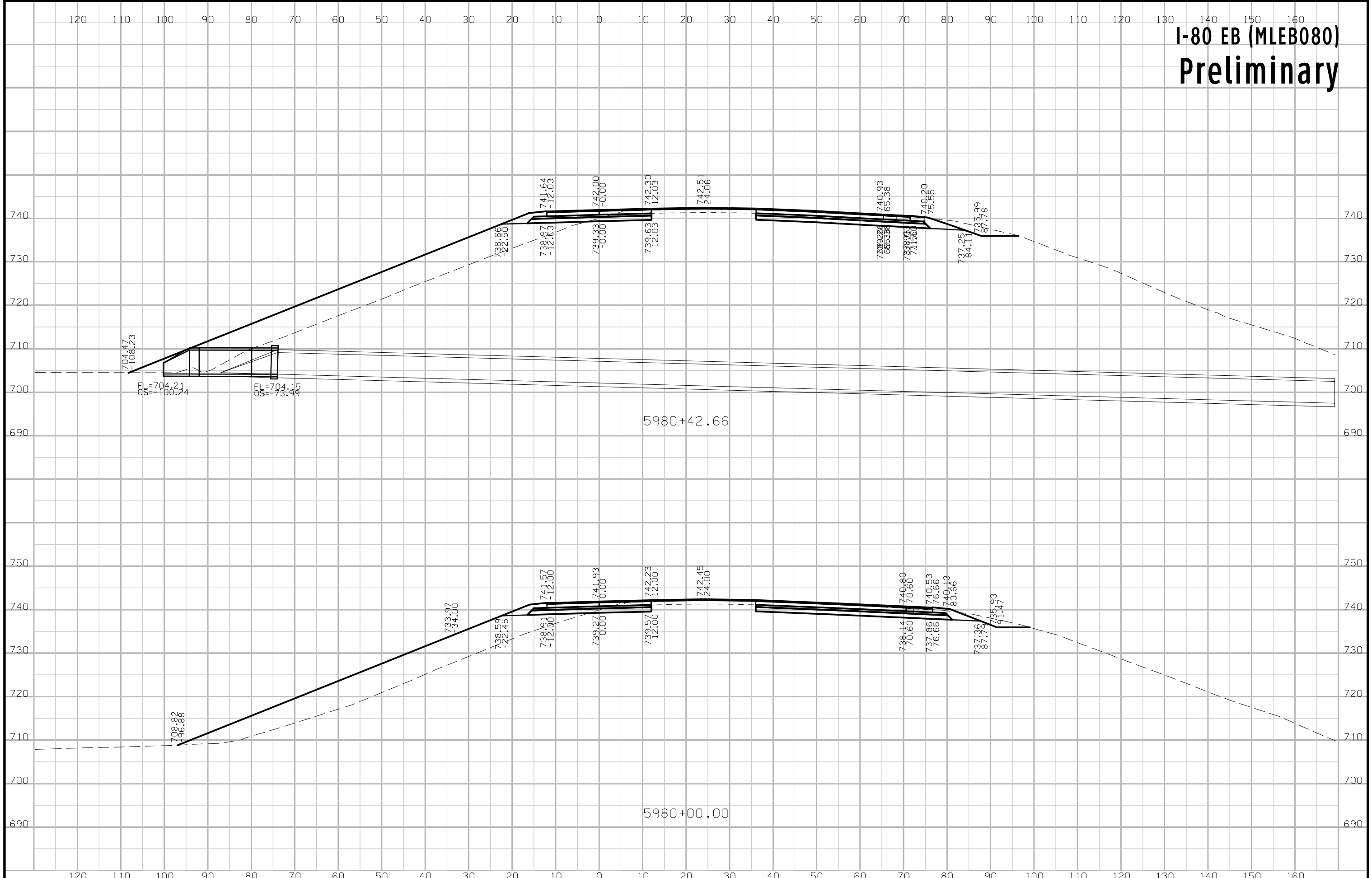



# I-80 EB (MLEB080) Preliminary

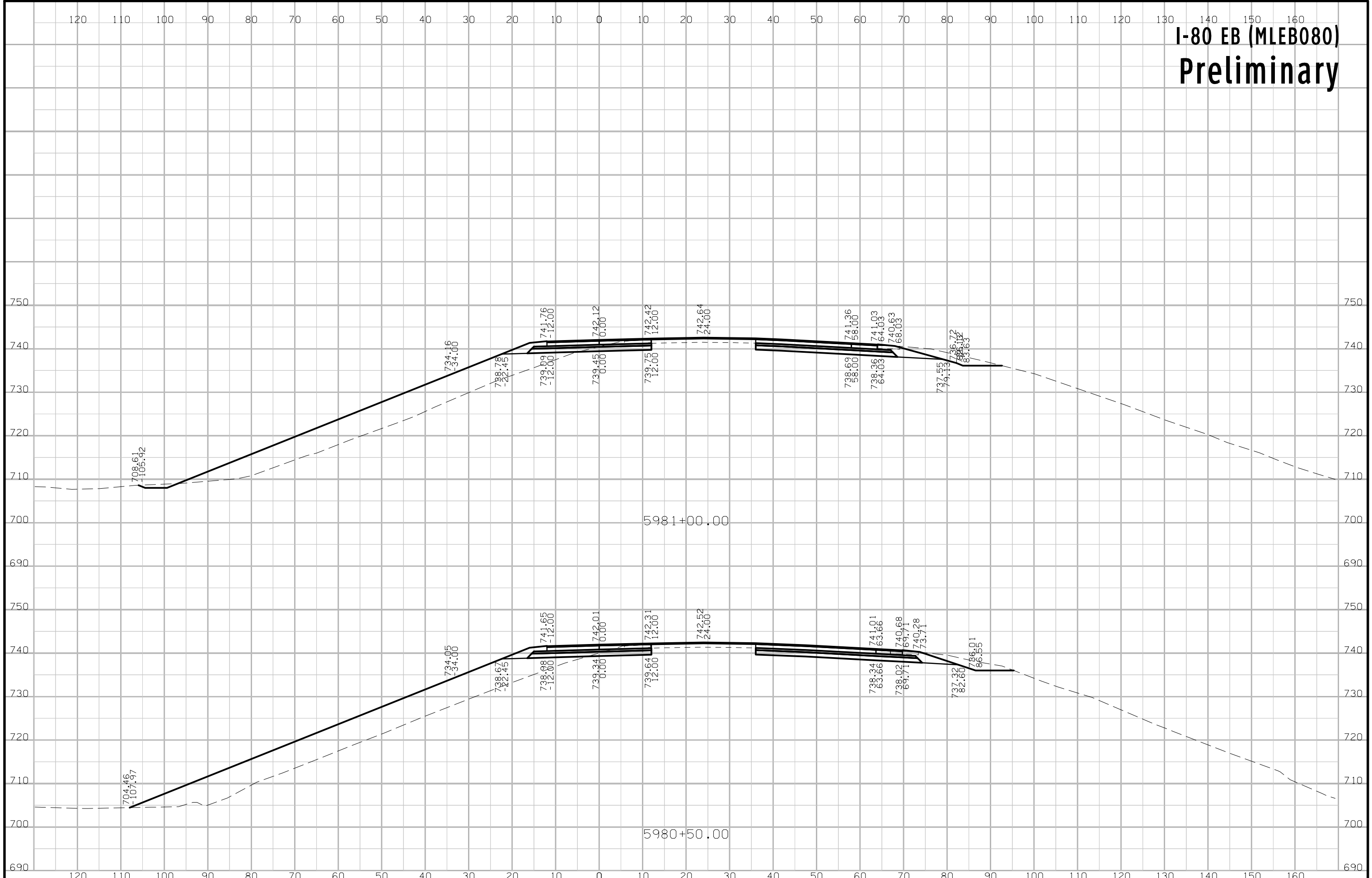

# I-80 EB (MLEB080) Preliminary

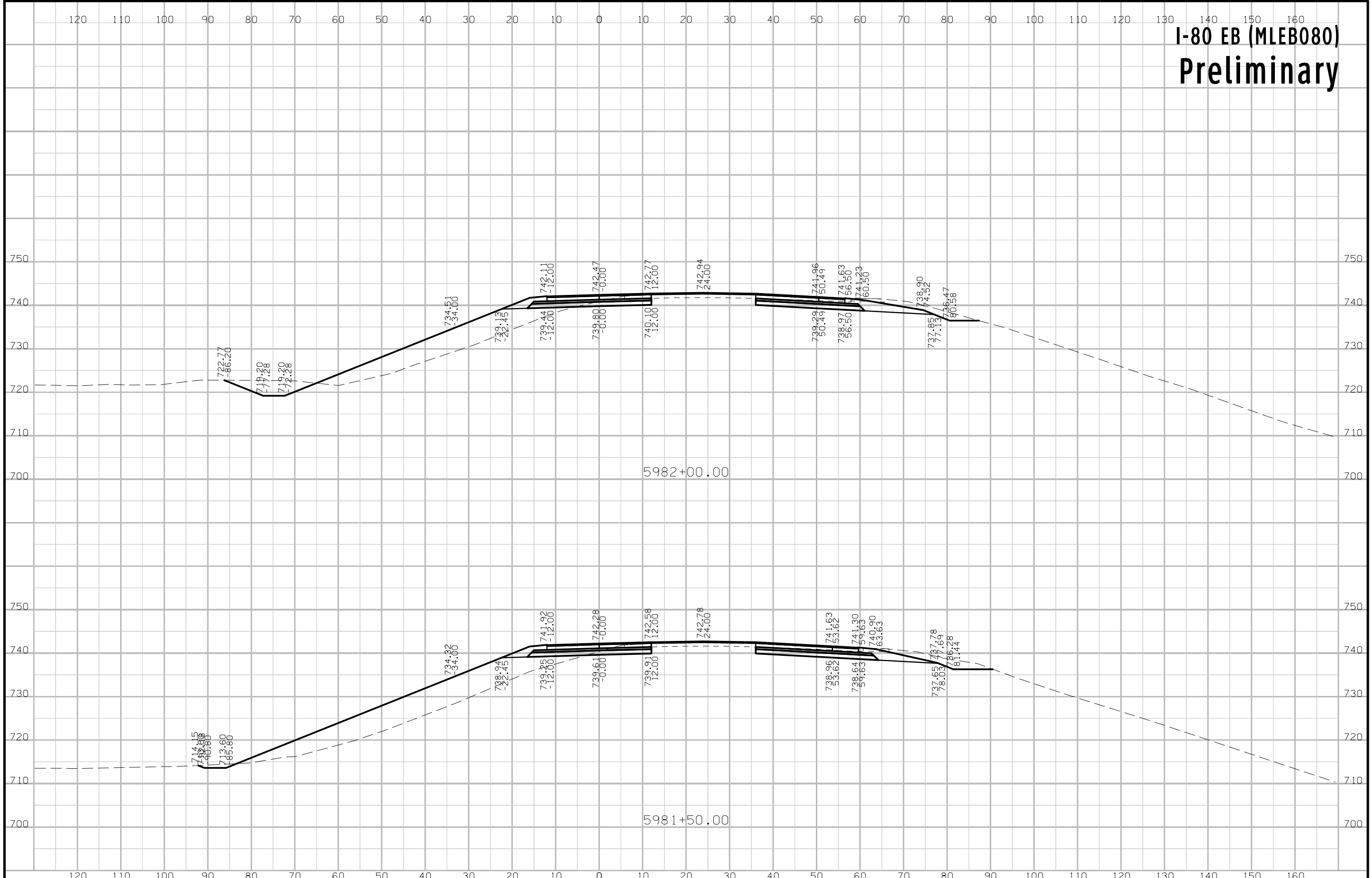

# I-80 EB (MLEB080) Preliminary

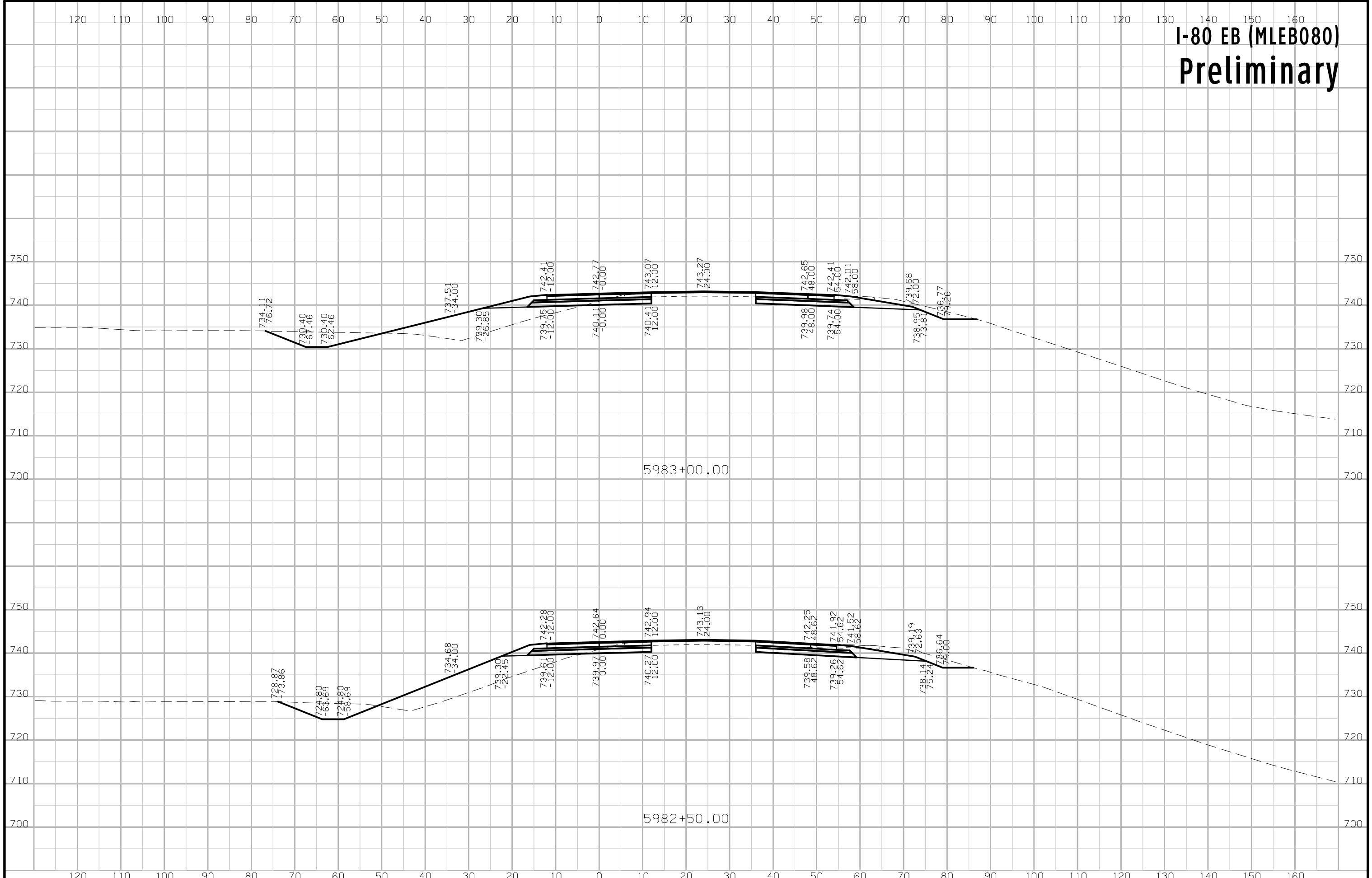

# I-80 EB (MLEB080) Preliminary

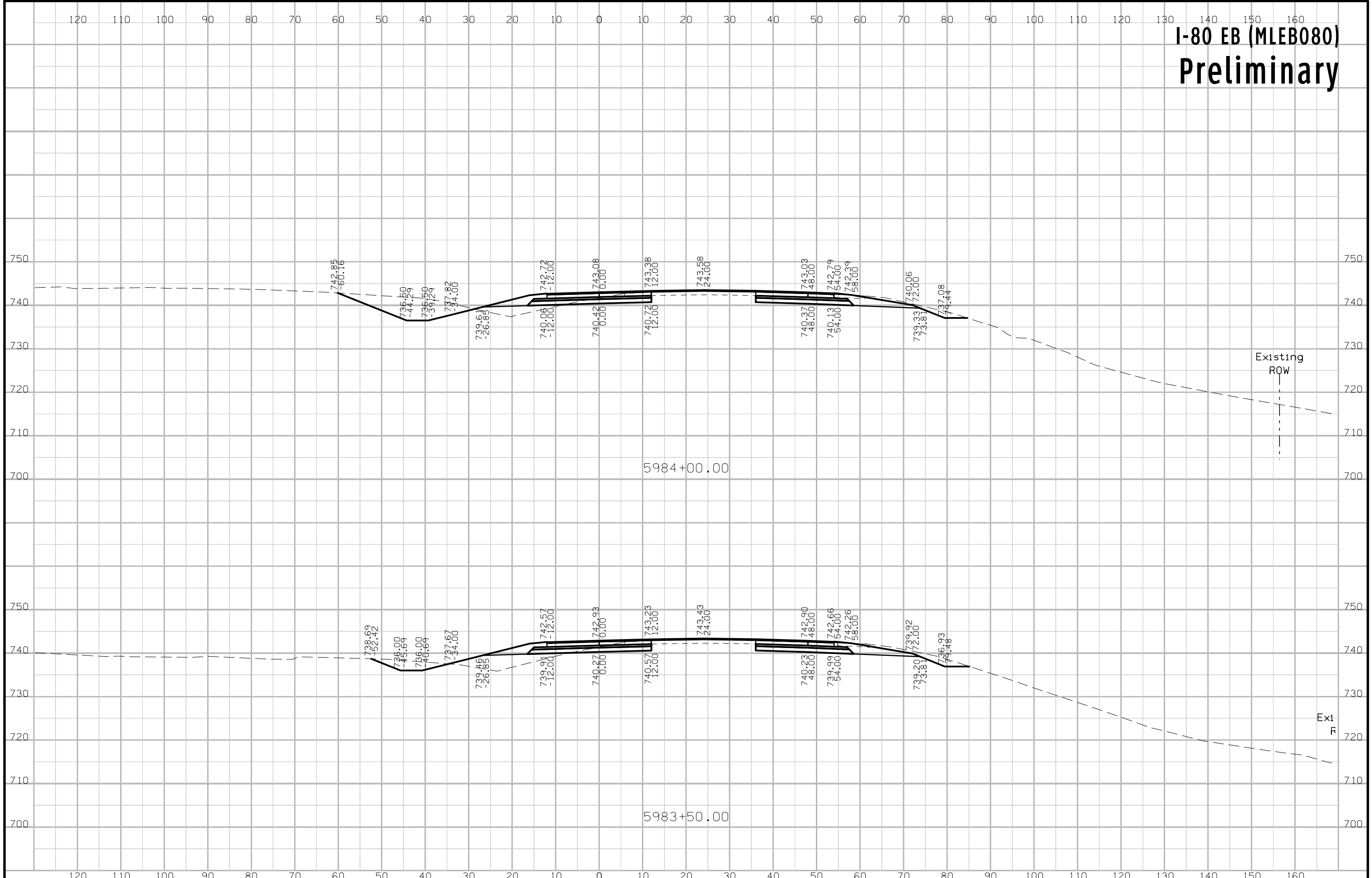

# I-80 EB (MLEB080) Preliminary

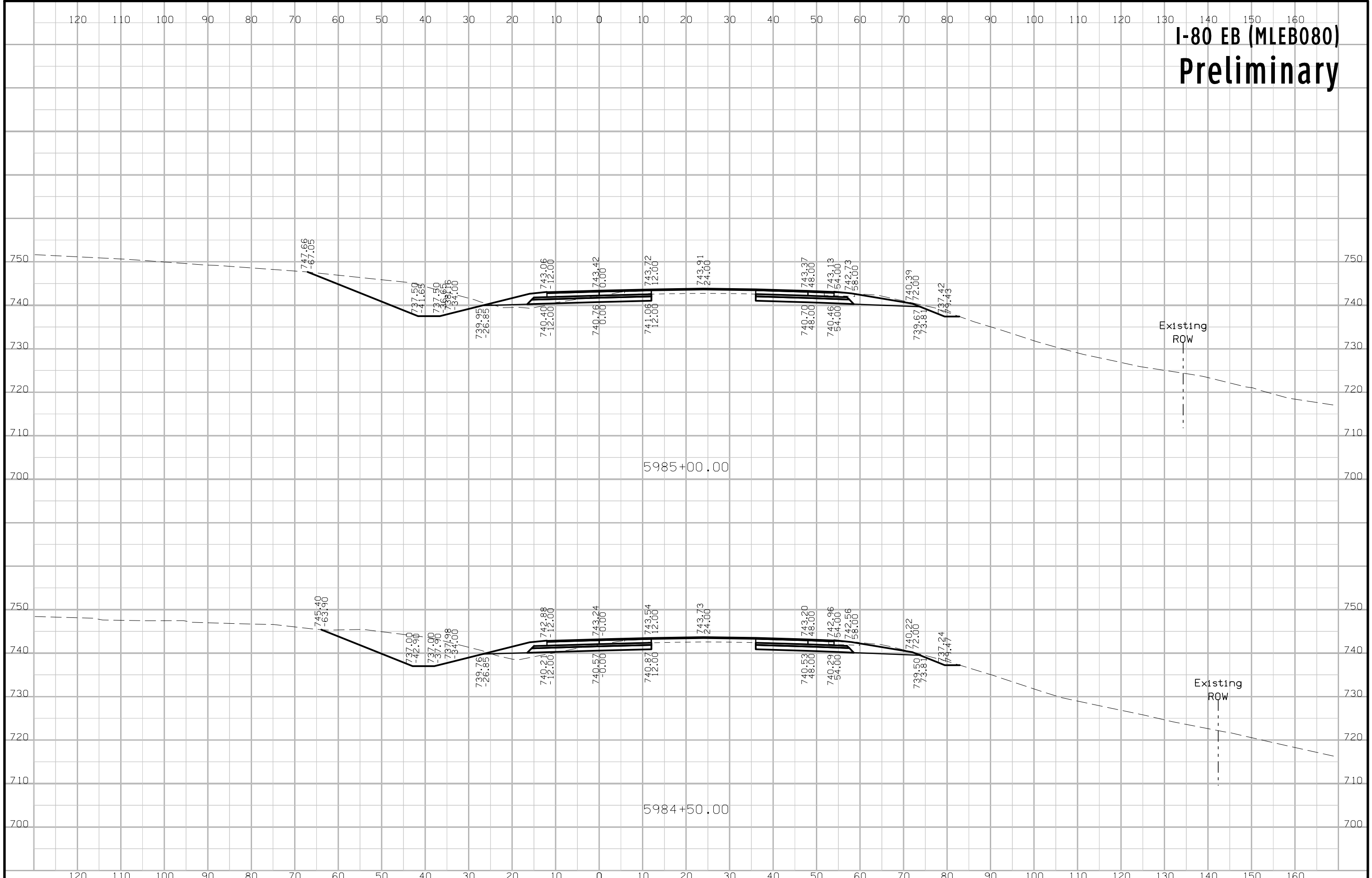

# I-80 EB (MLEB080) Preliminary

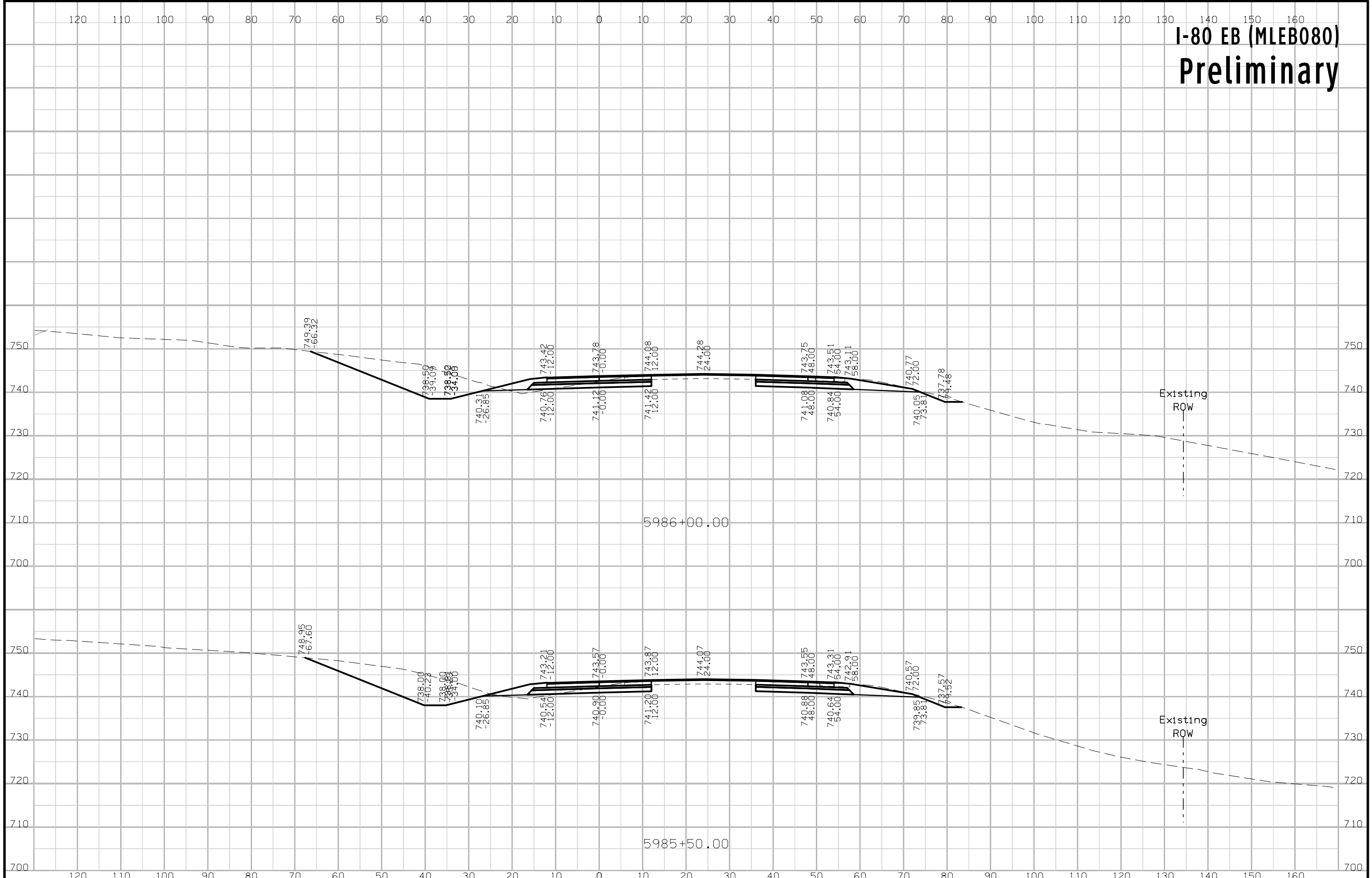

# I-80 EB (MLEB080) Preliminary

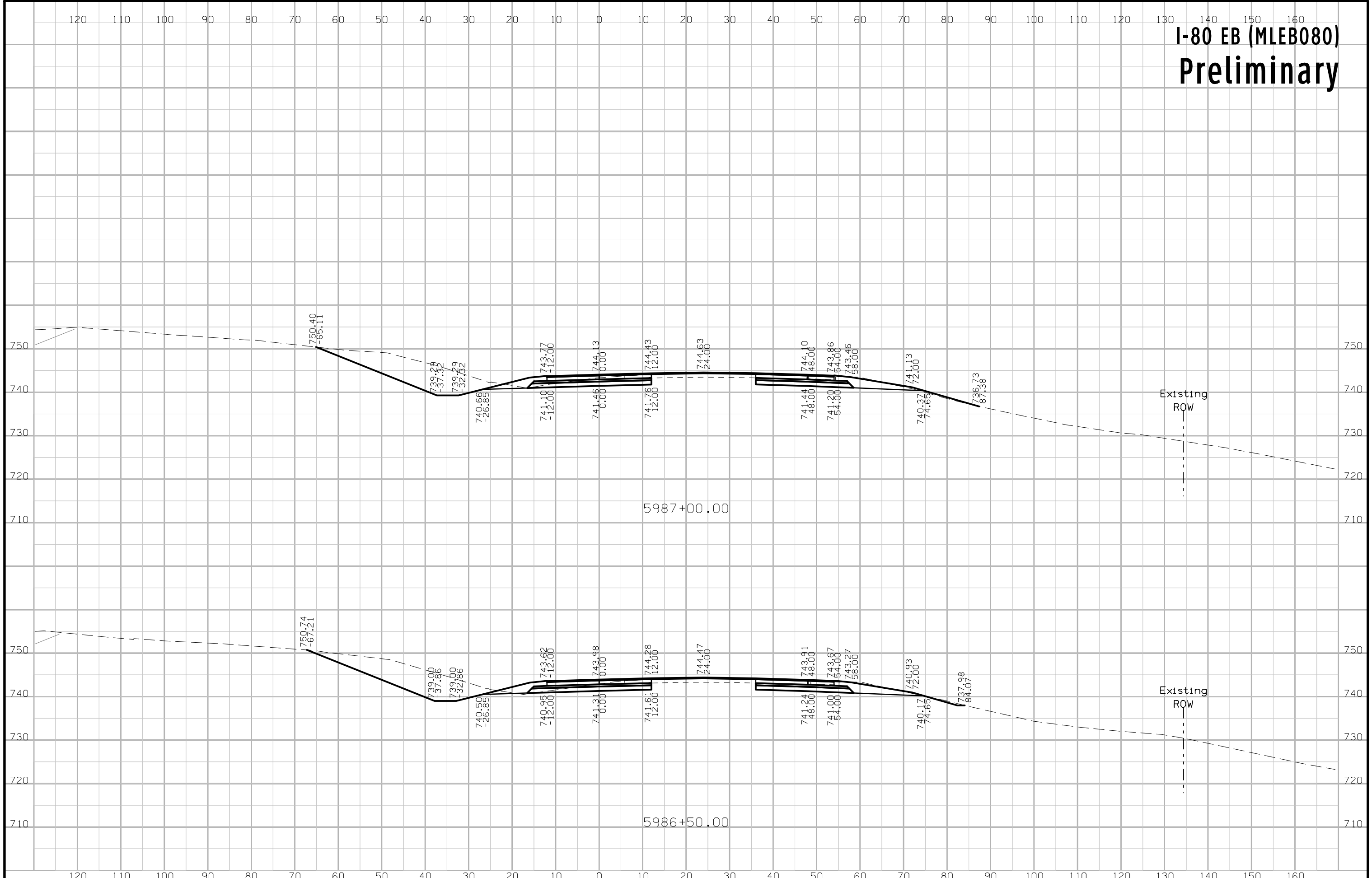



# I-80 EB (MLEB080) Preliminary

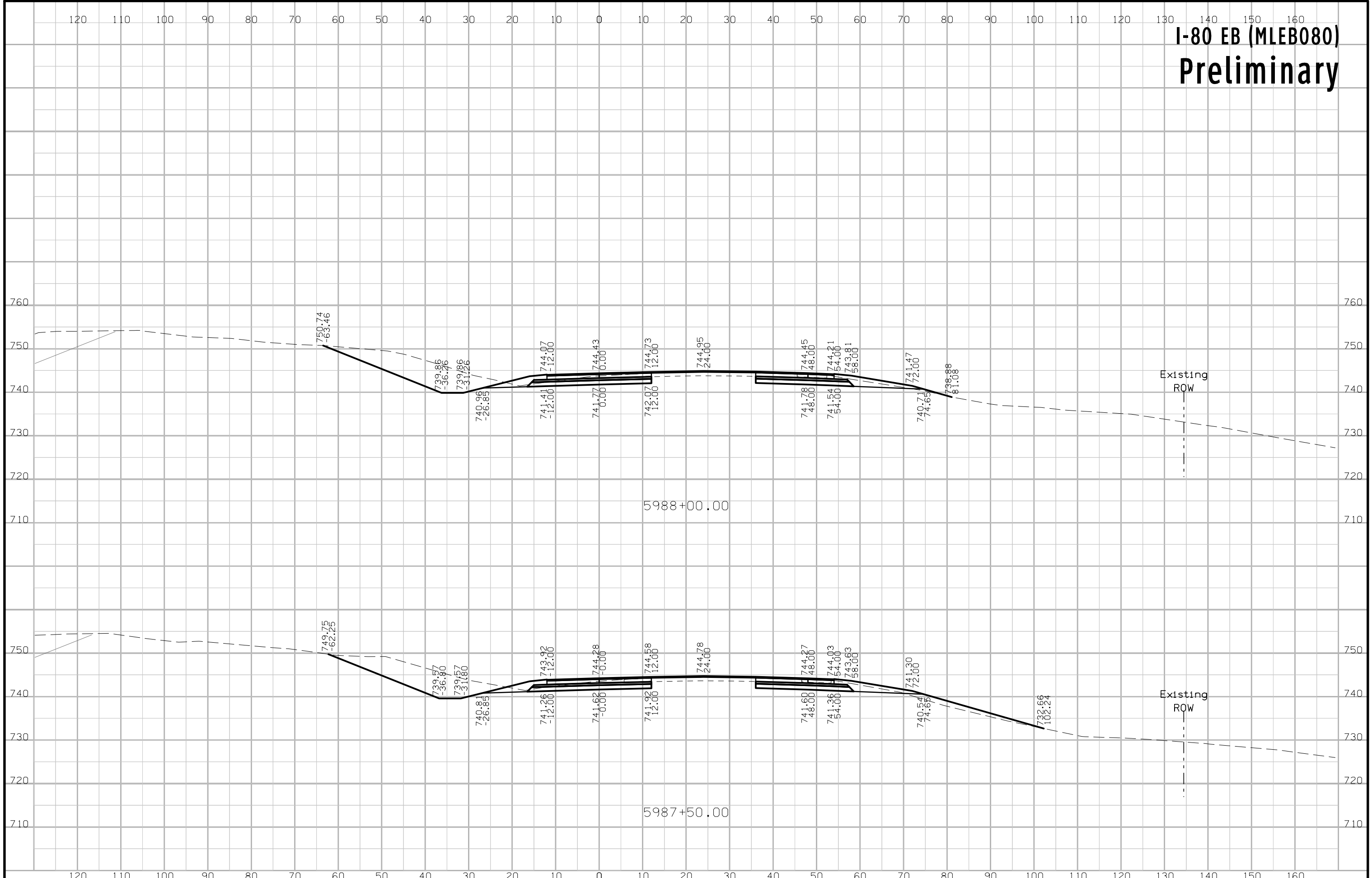

# I-80 EB (MLEB080) Preliminary

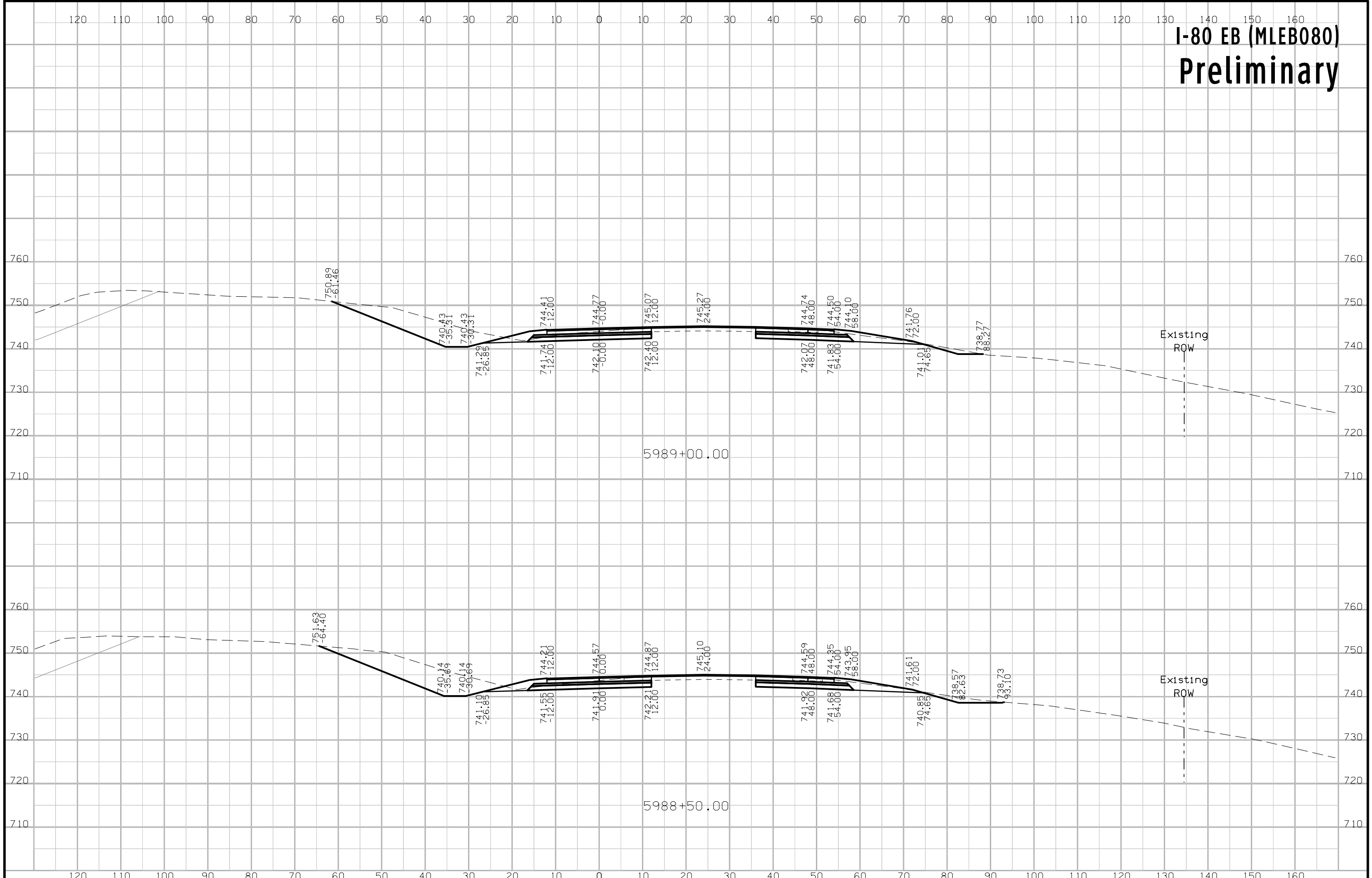

# I-80 EB (MLEB080) Preliminary

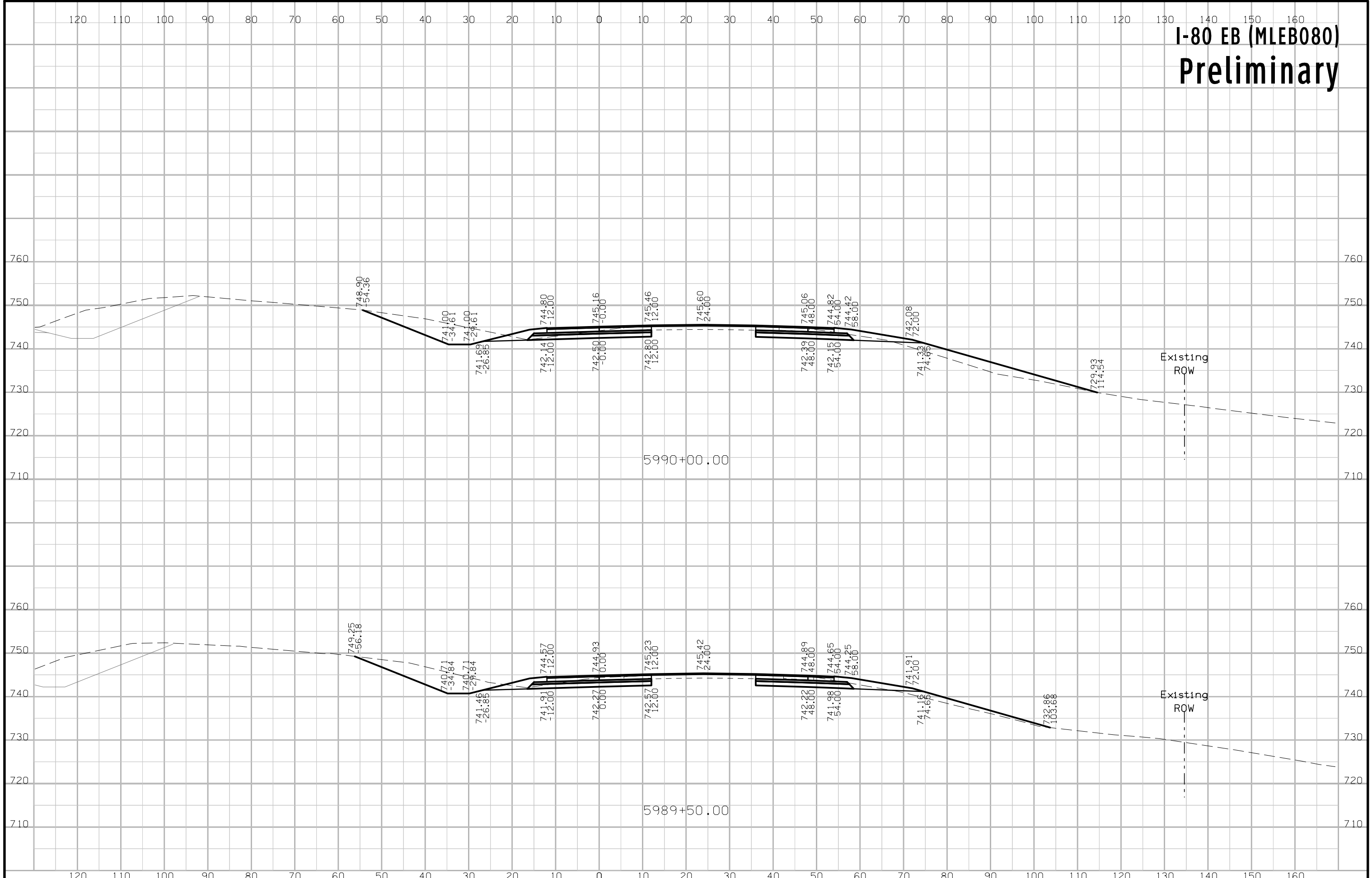

# I-80 EB (MLEB080) Preliminary

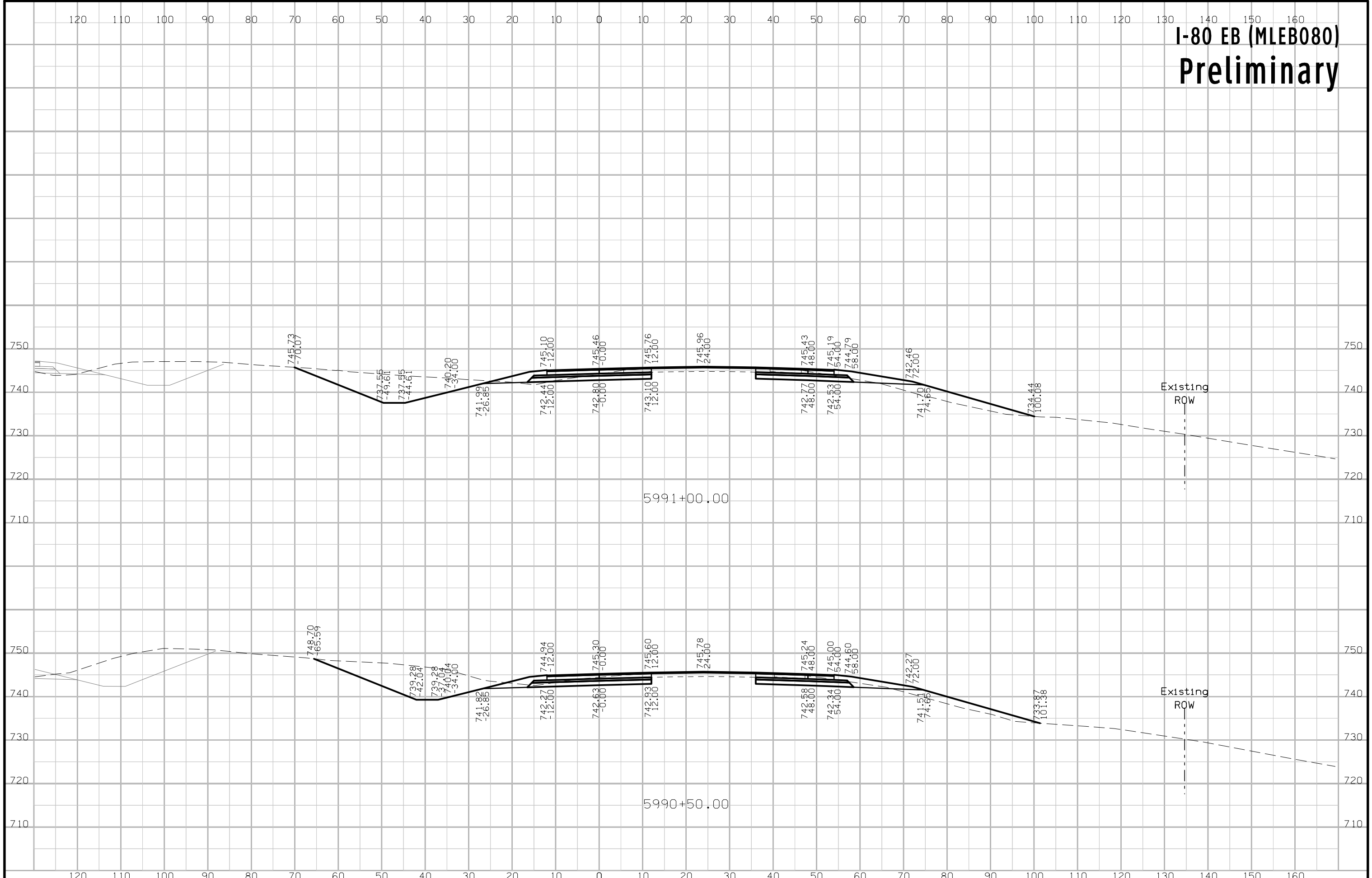

# I-80 EB (MLEB080) Preliminary

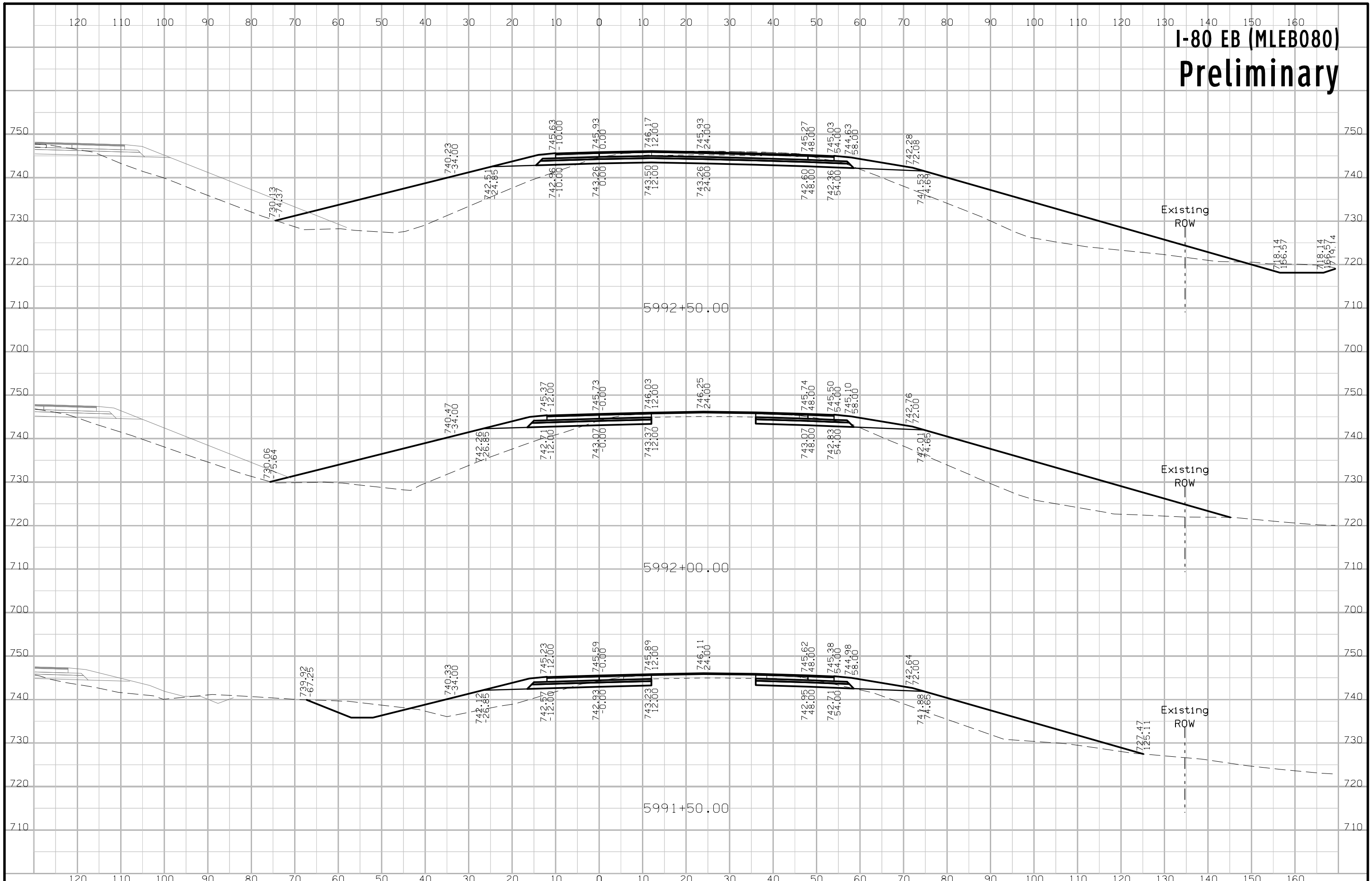

# I-80 EB (MLEB080) Preliminary

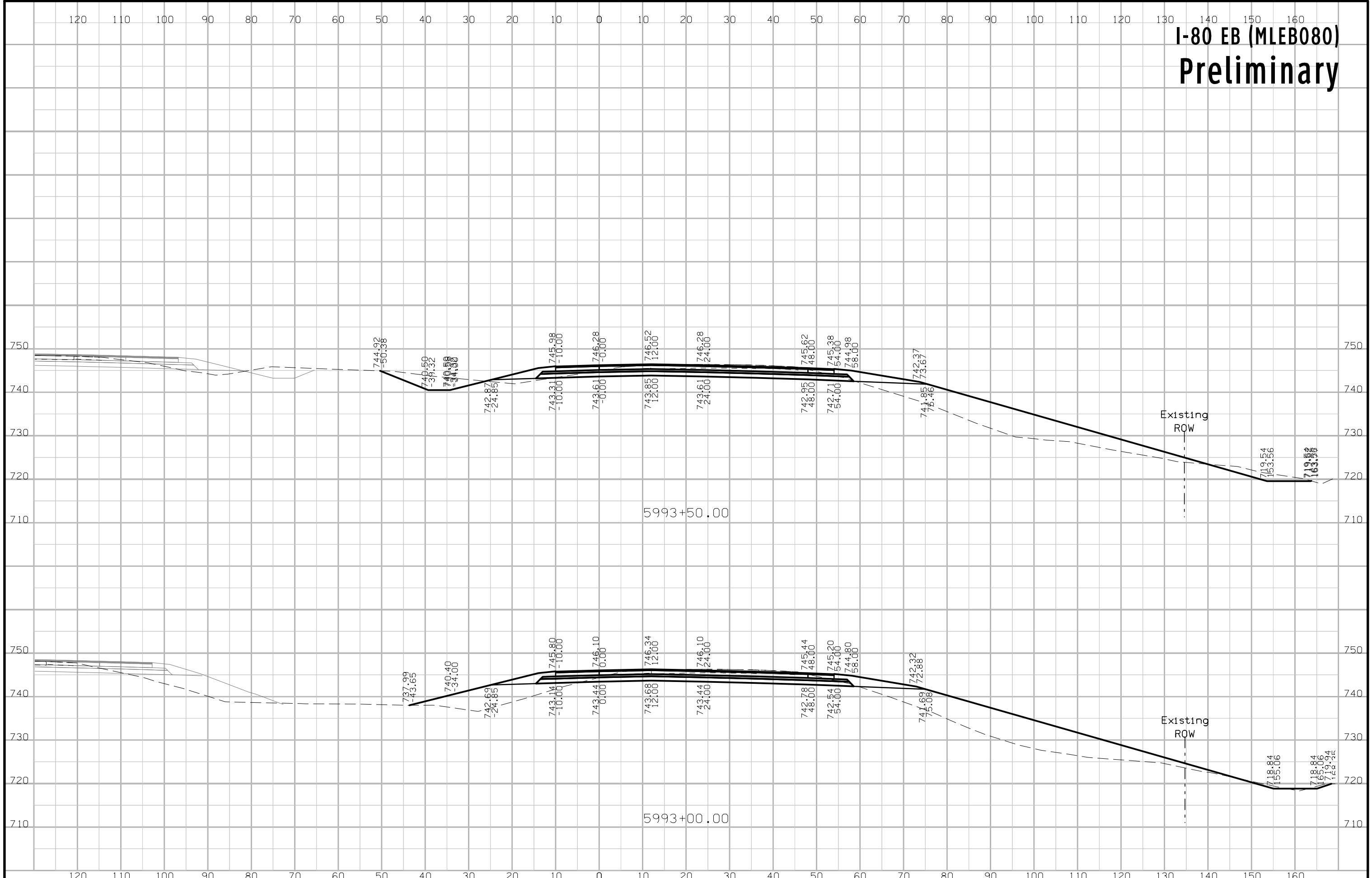

# I-80 EB (MLEB080) Preliminary

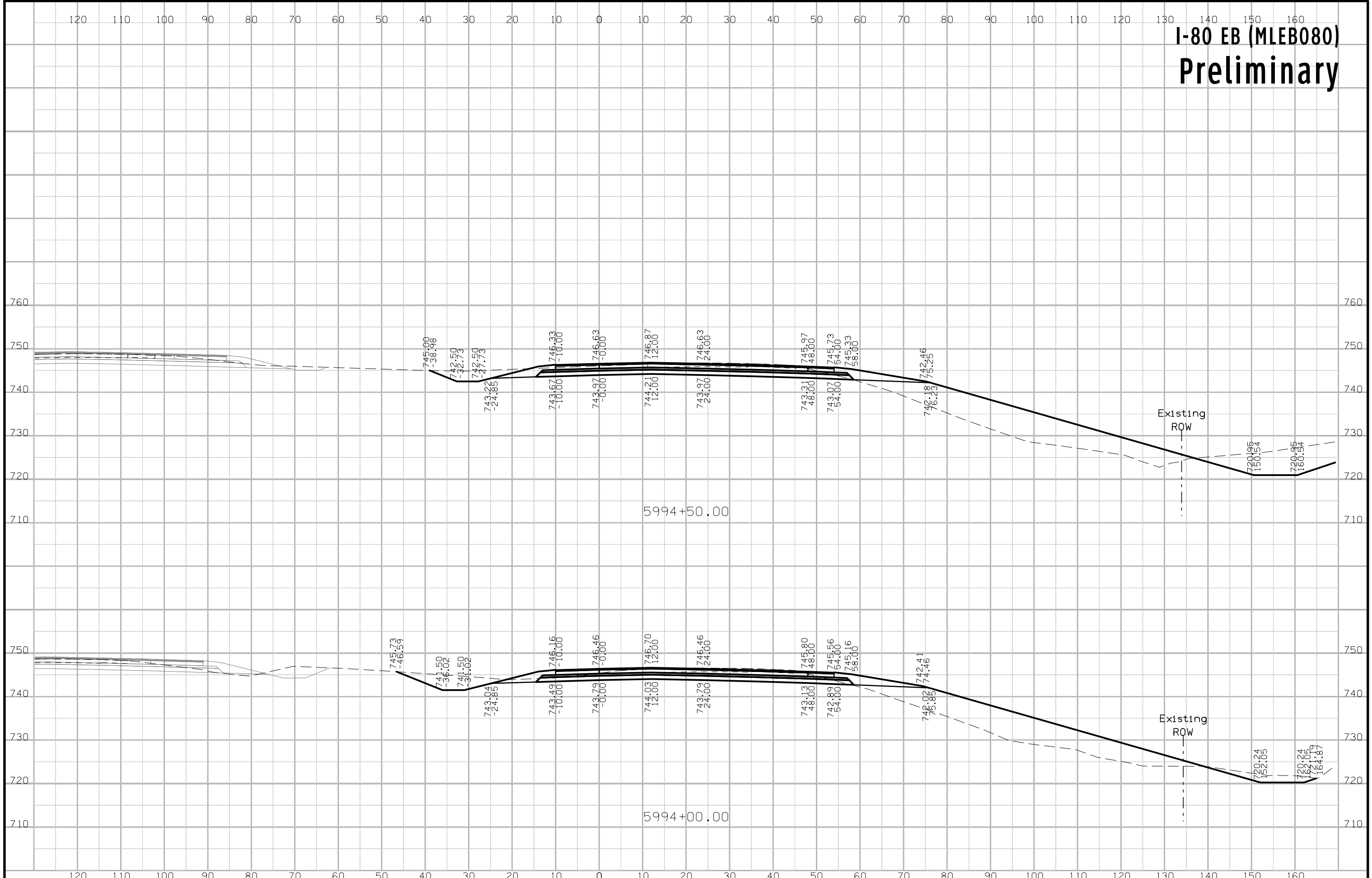



# I-80 EB (MLEB080) Preliminary

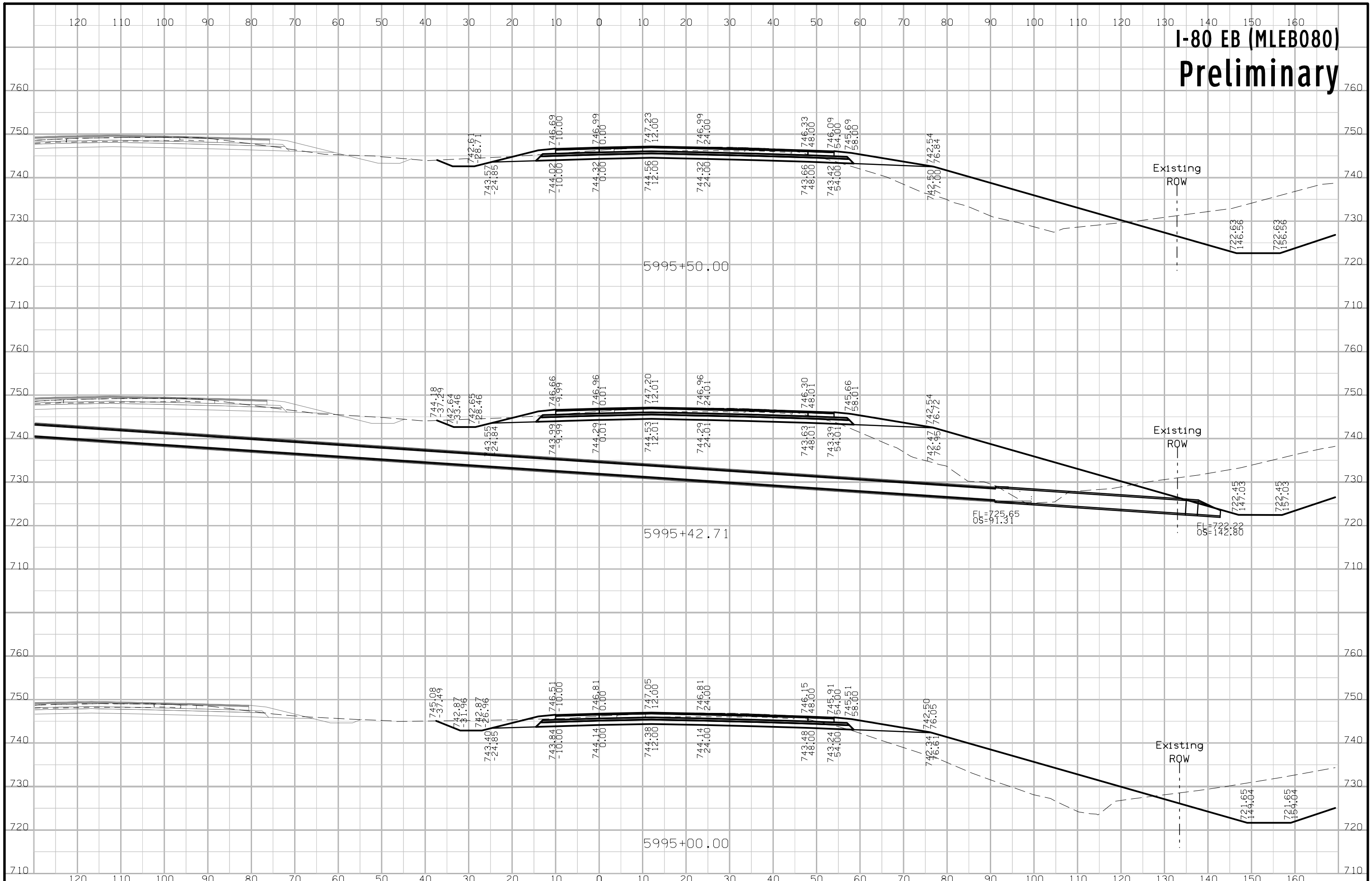

# I-80 EB (MLEB080) Preliminary

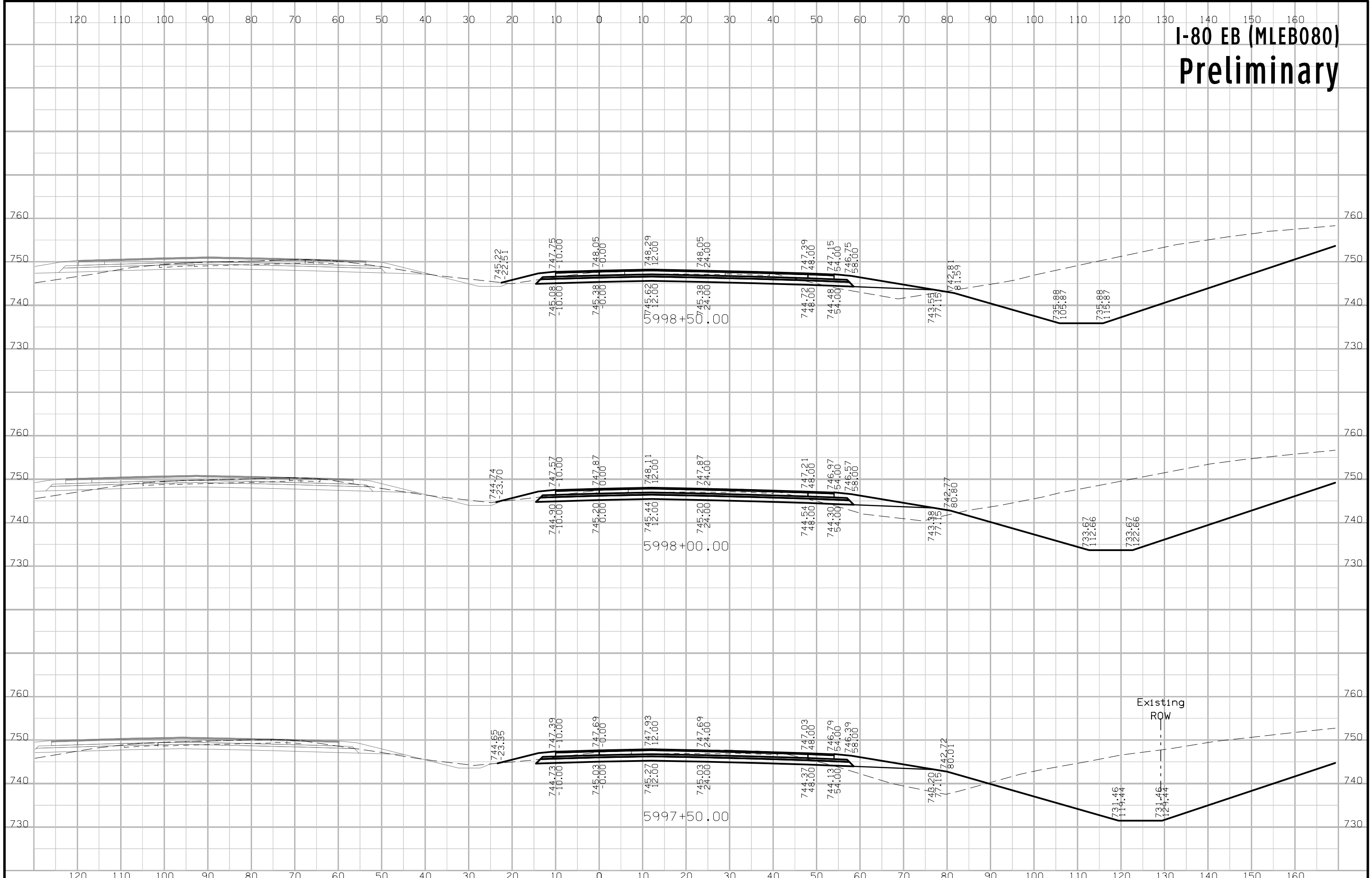

# I-80 EB (MLEB080) Preliminary

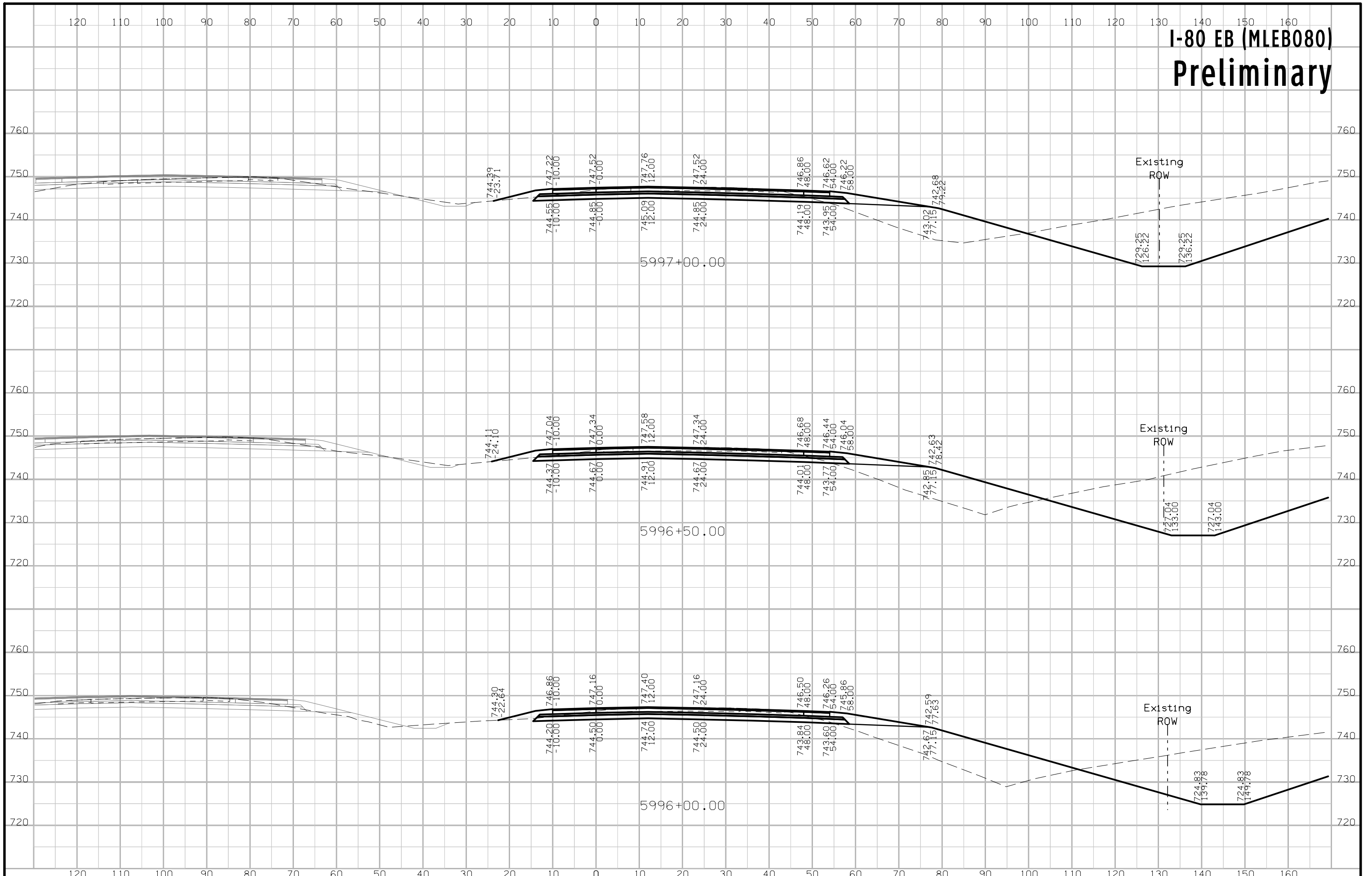

# I-80 EB (MLEB080) Preliminary

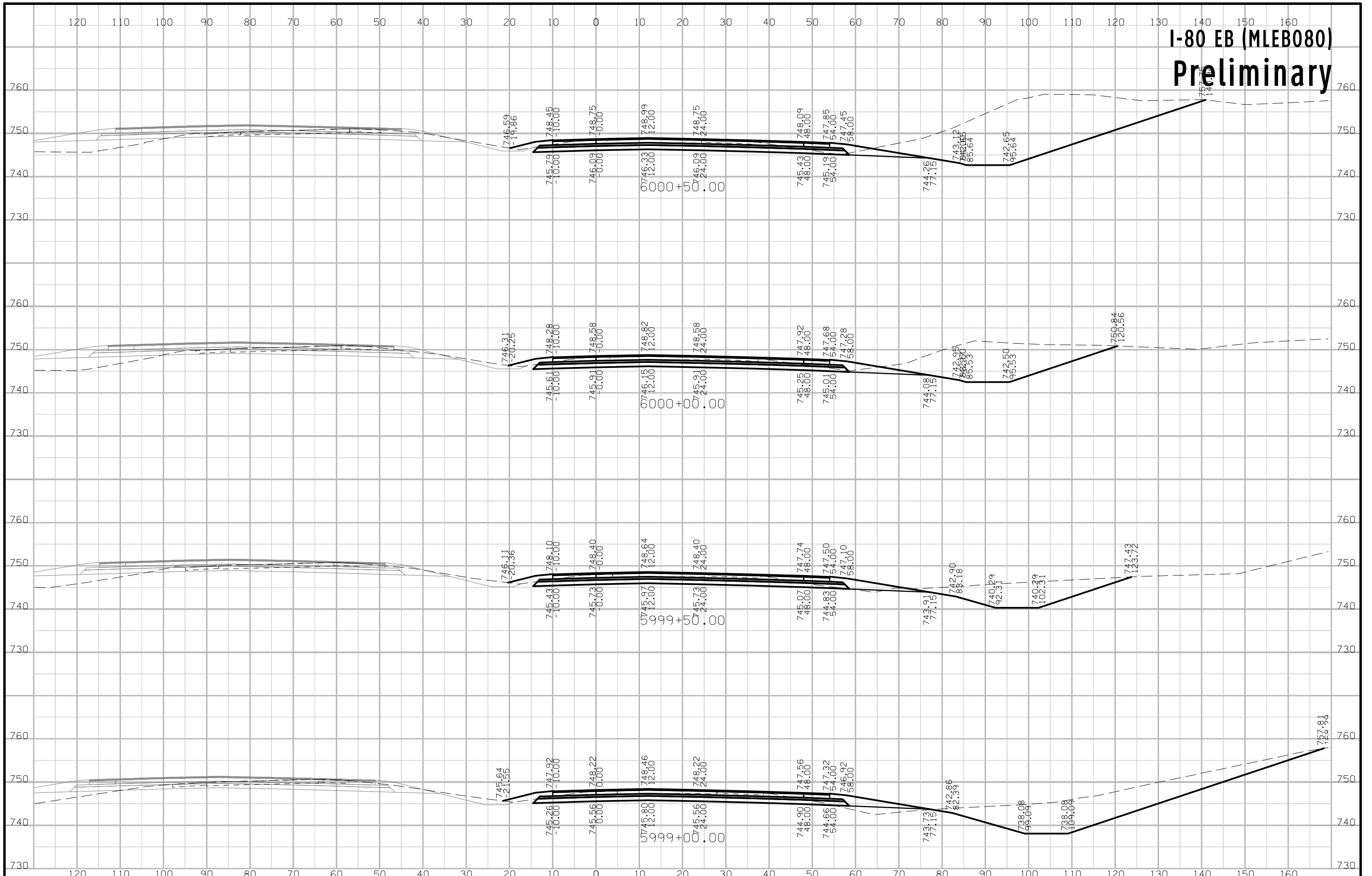

# I-80 EB (MLEB080) Preliminary

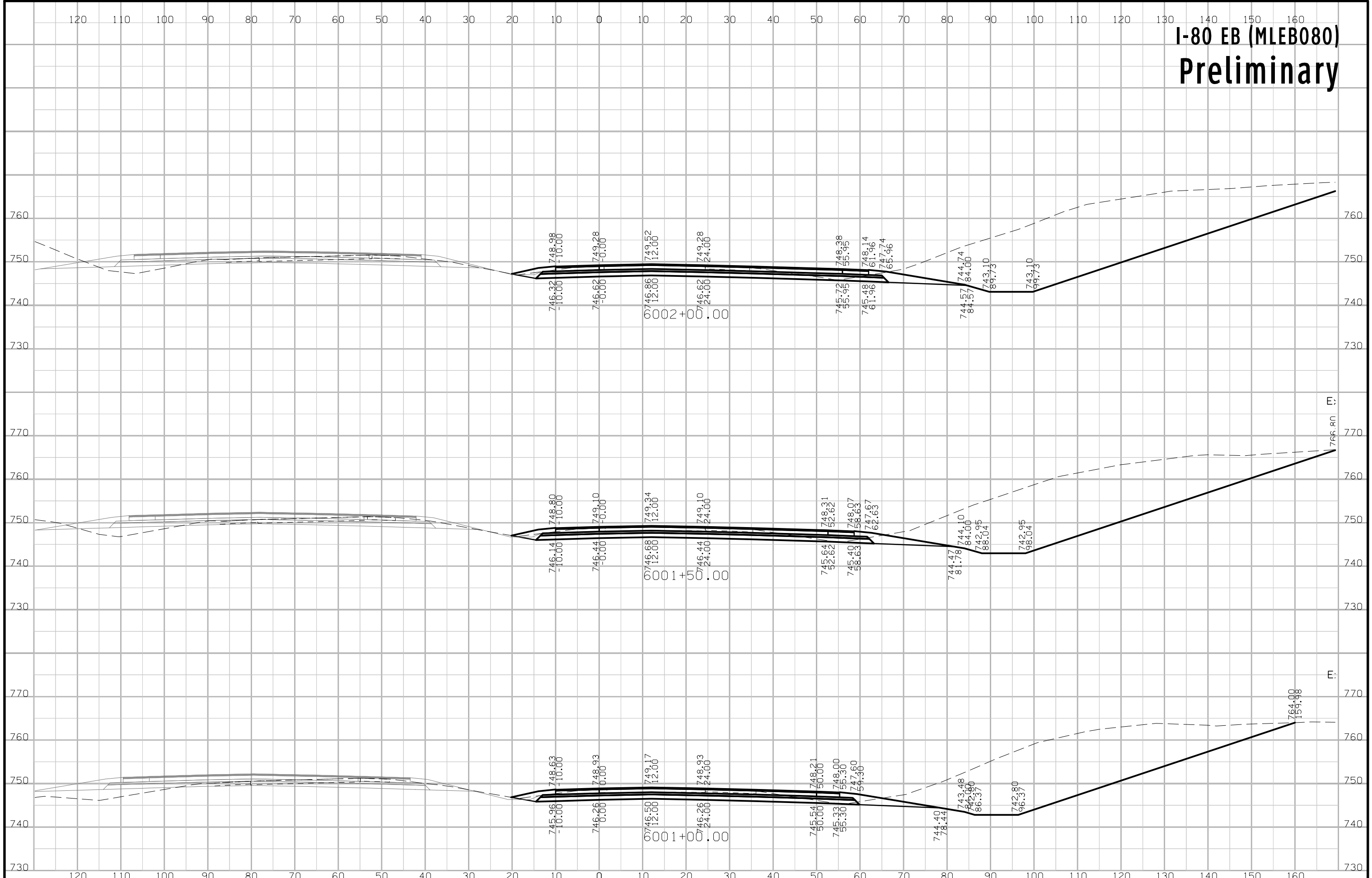

# I-80 EB (MLEB080) Preliminary

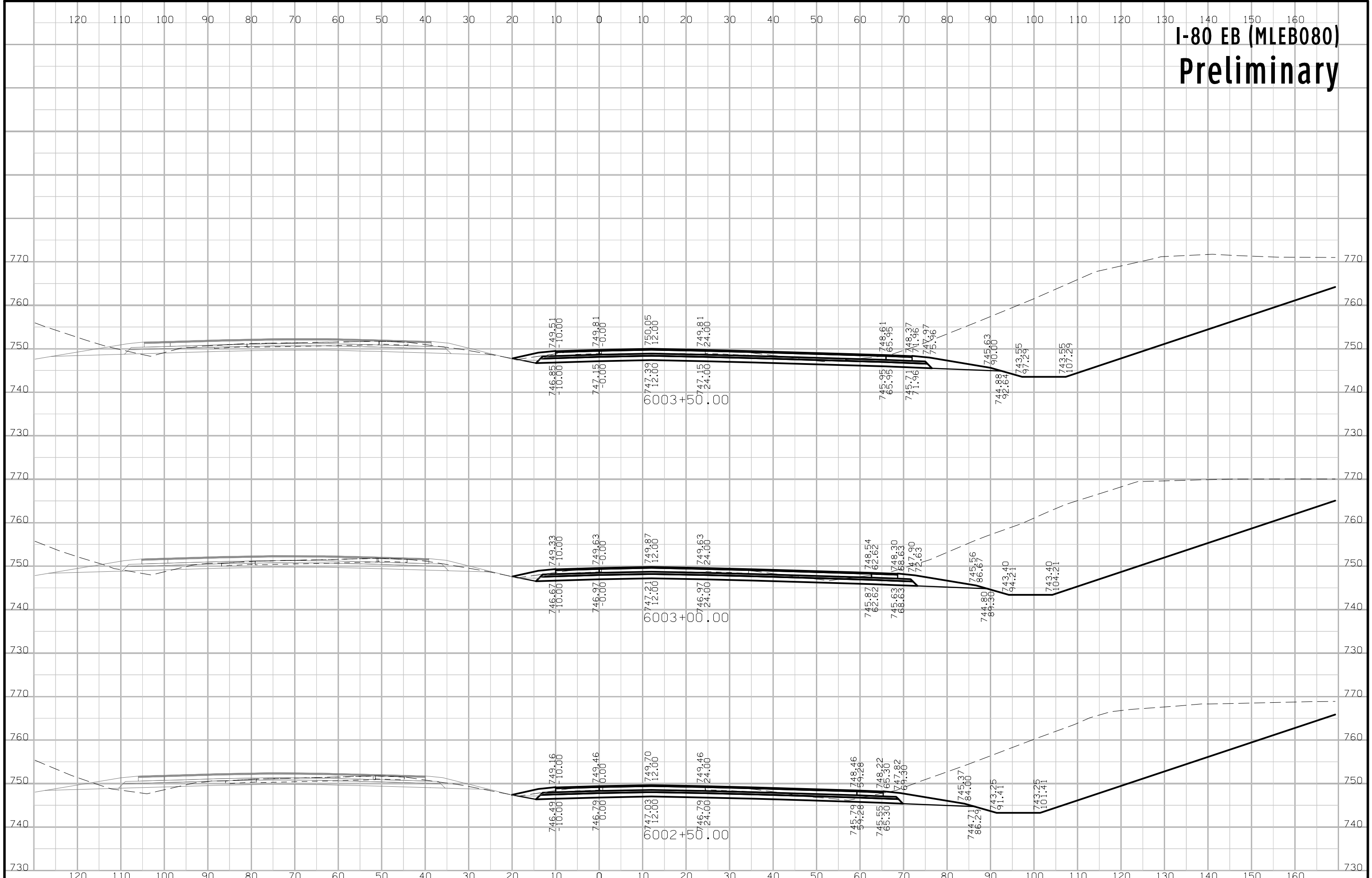

# I-80 EB (MLEB080) Preliminary

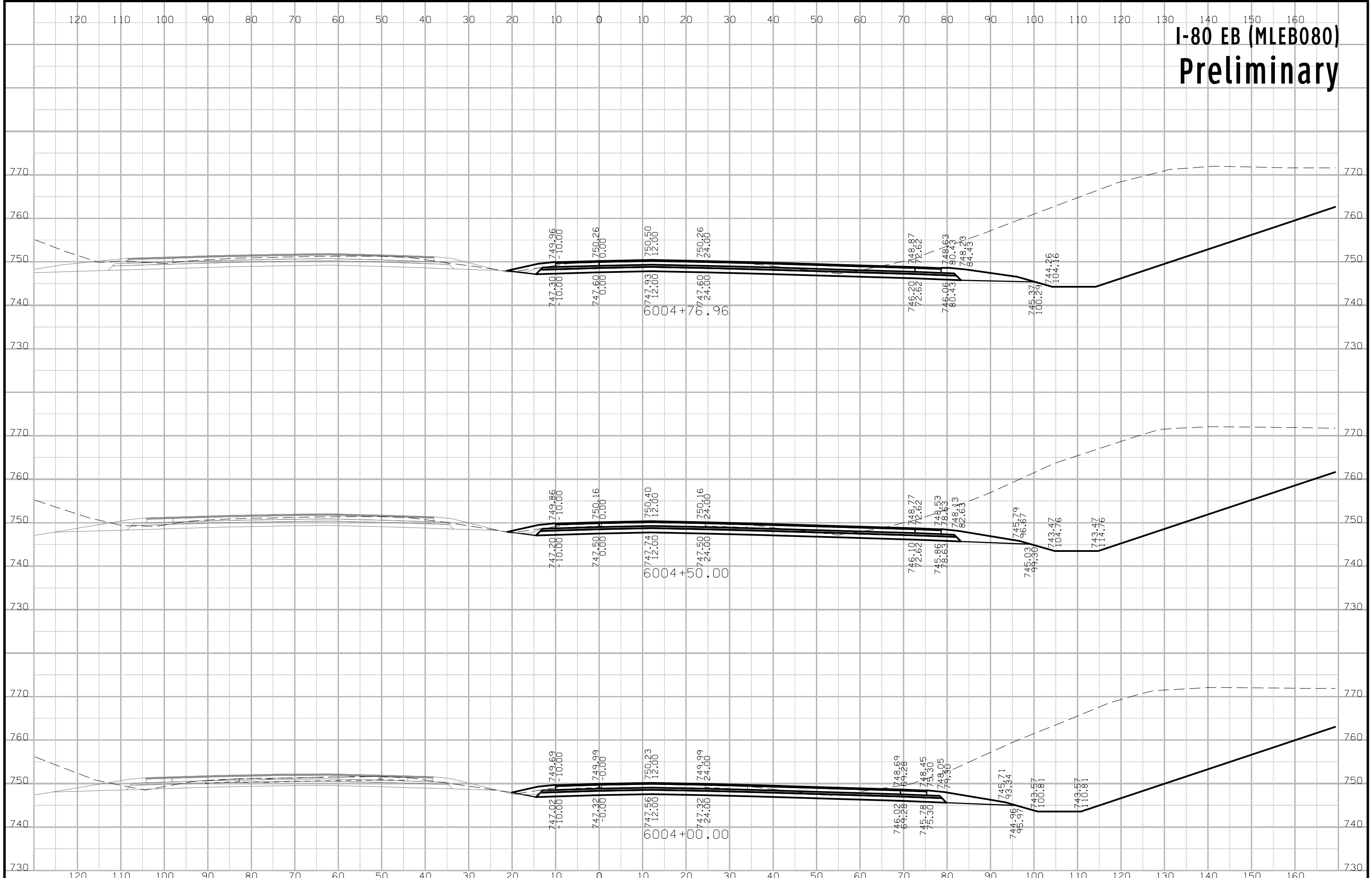



# I-80 EB (SURMLA080) Preliminary

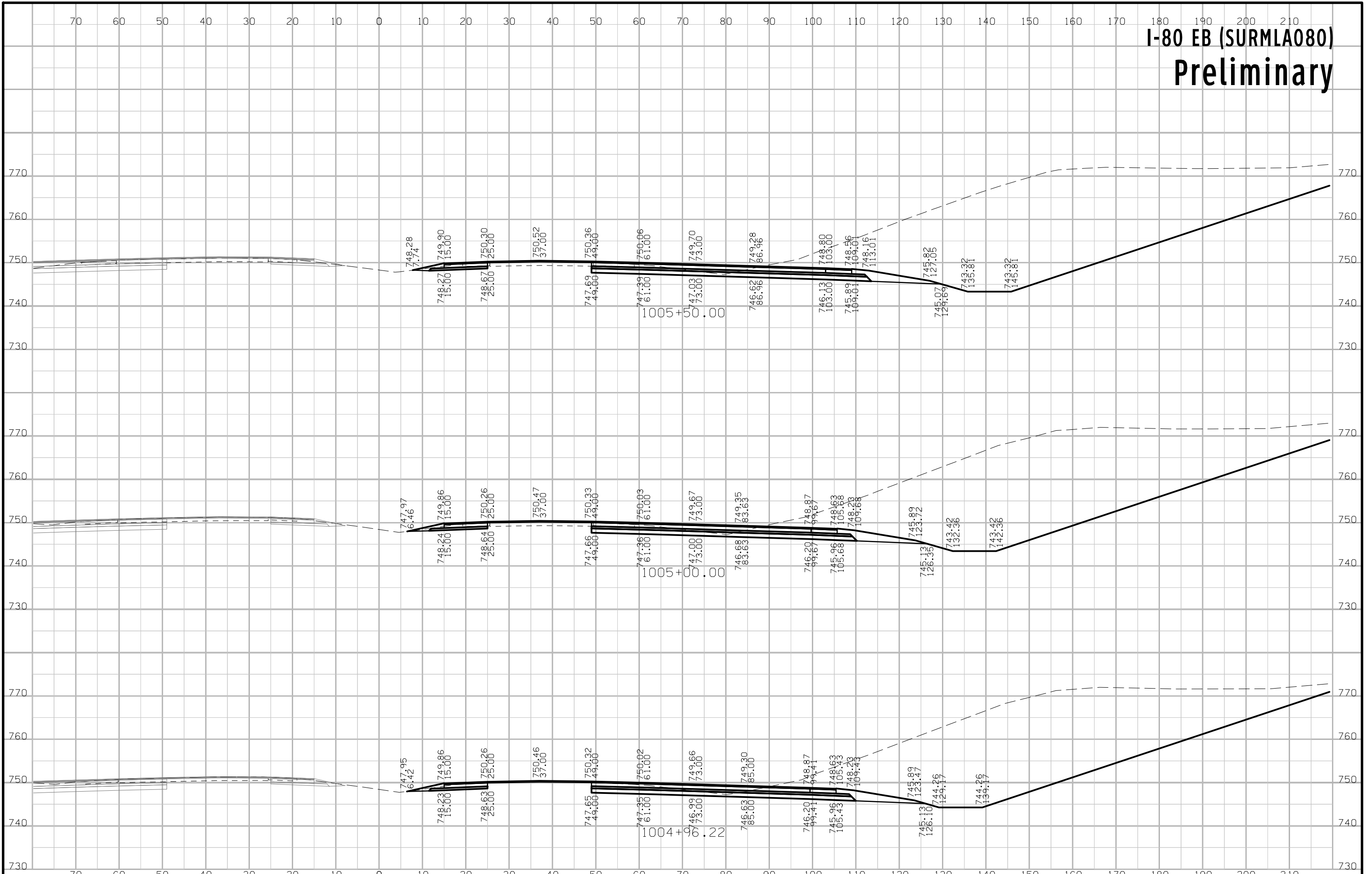

# I-80 EB (SURMLA080) Preliminary

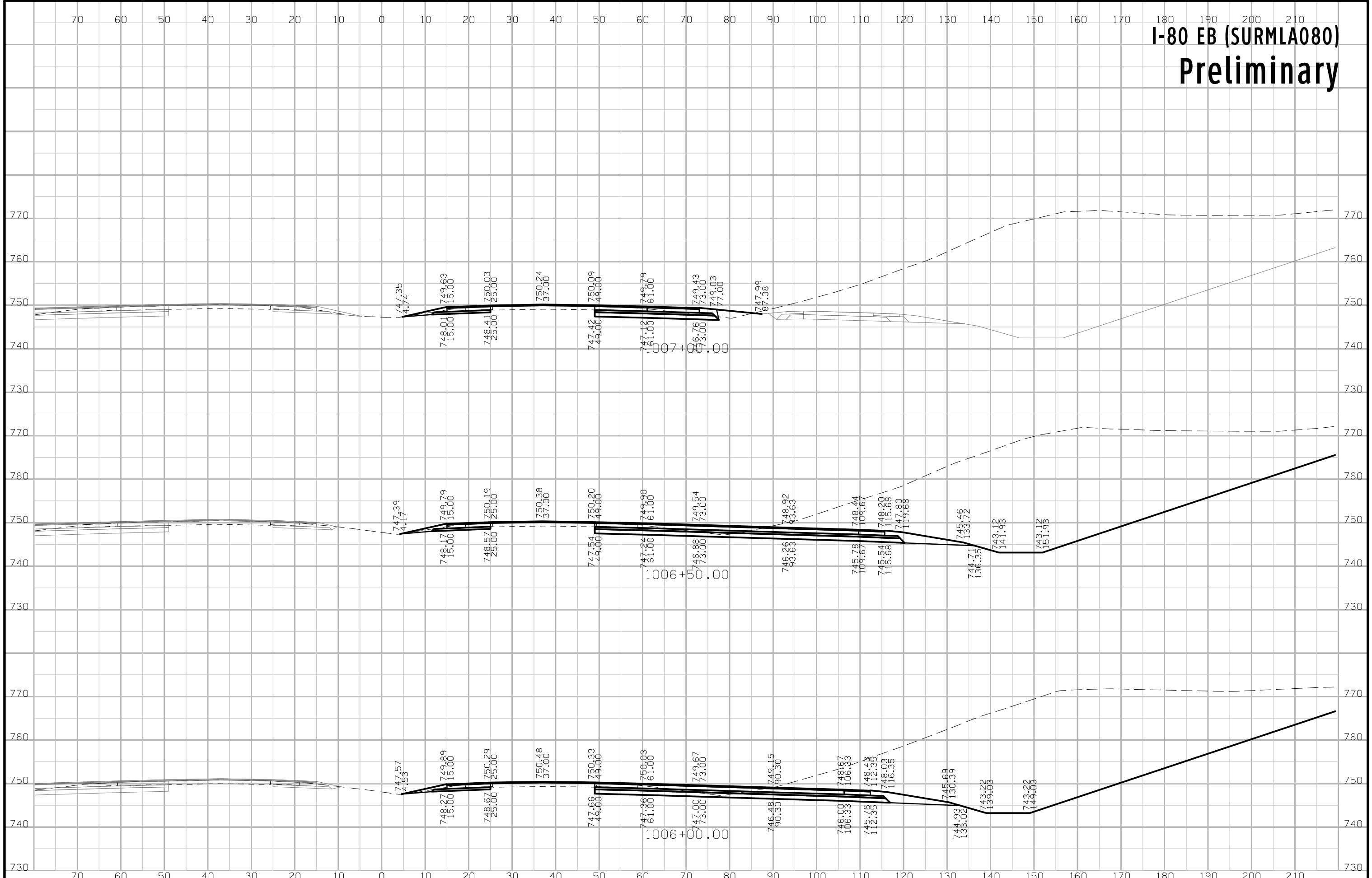

# I-80 EB (SURMLA080) Preliminary

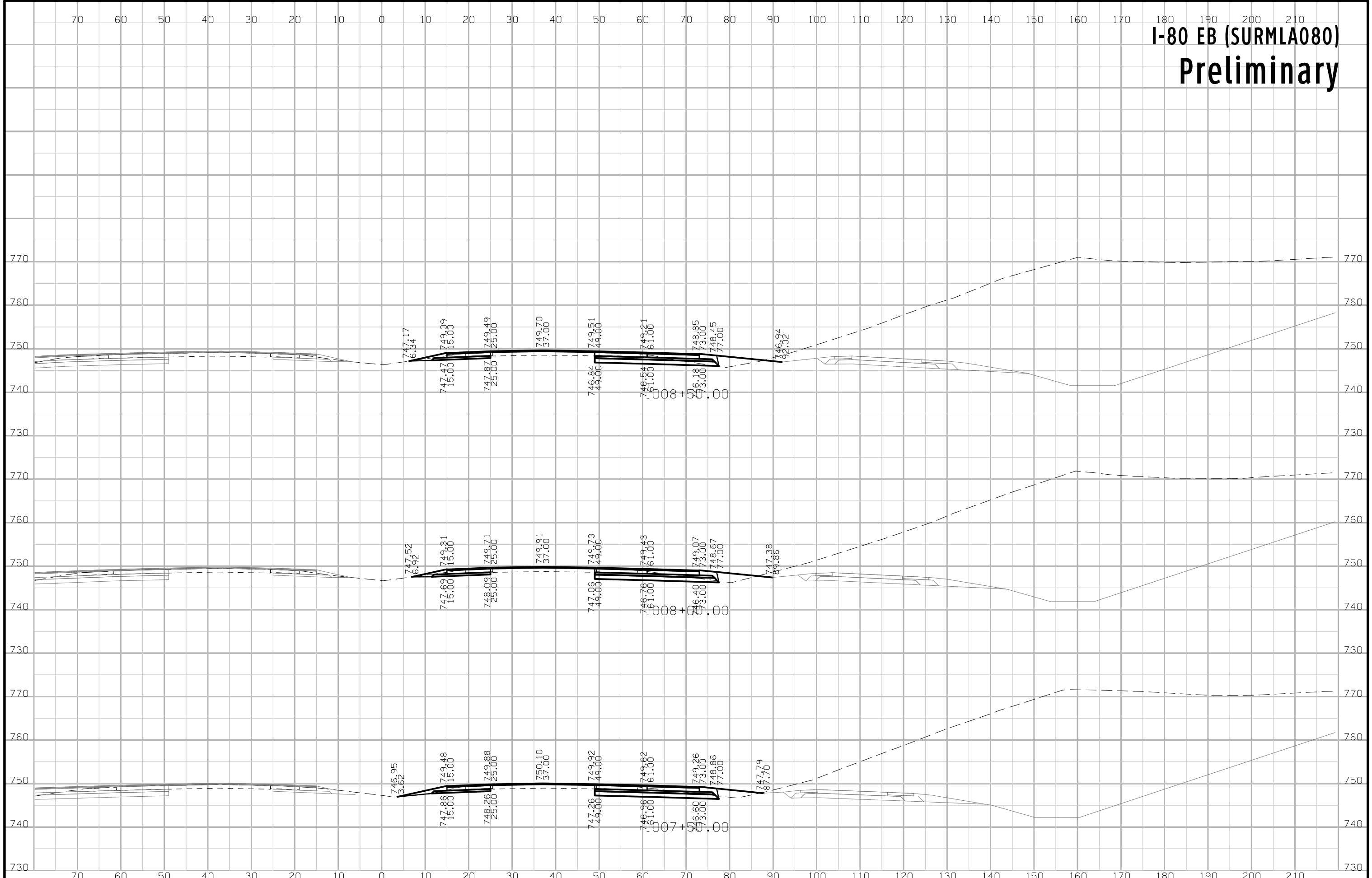

# I-80 EB (SURMLA080) Preliminary

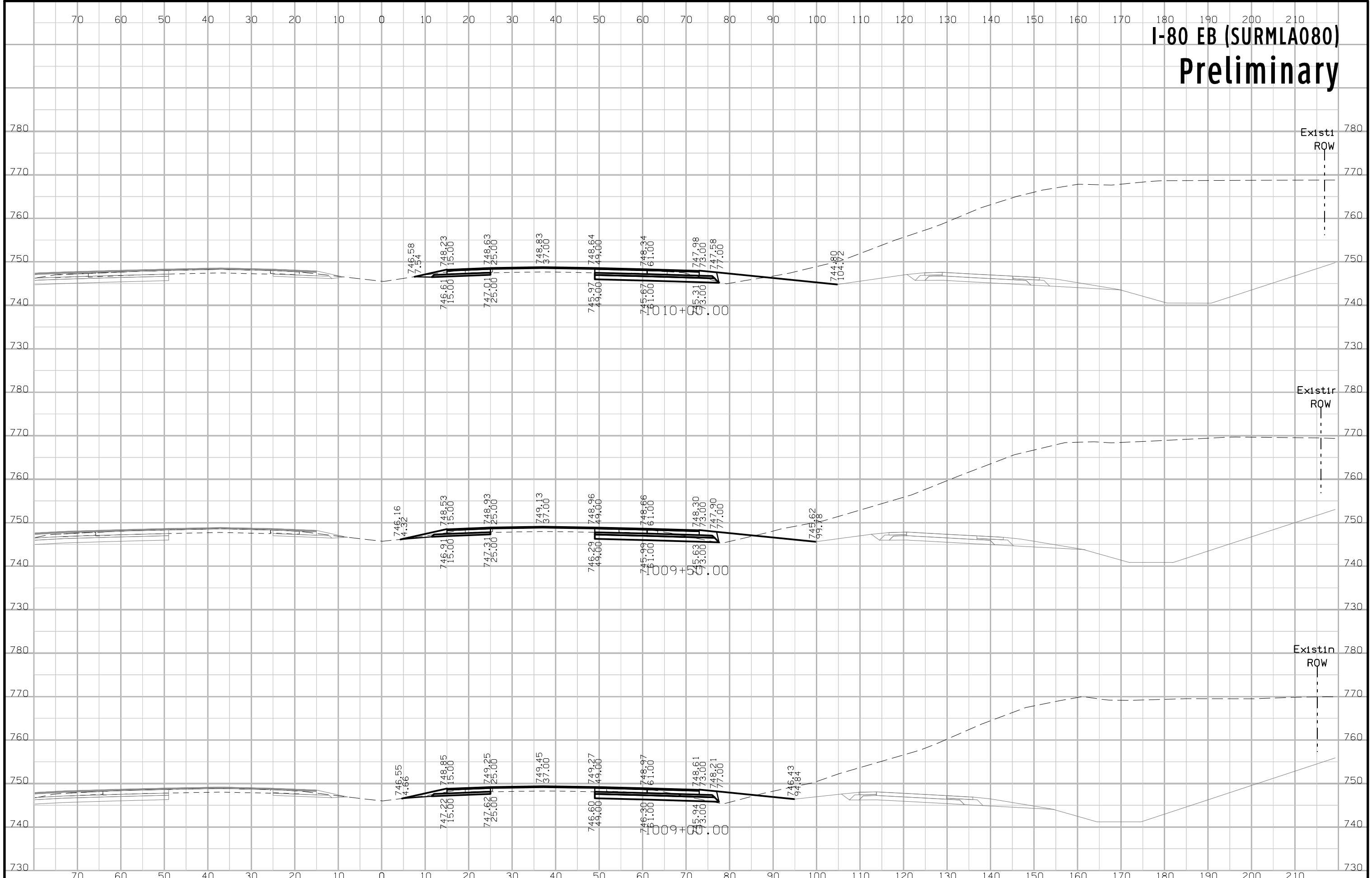

# I-80 EB (SURMLA080) Preliminary

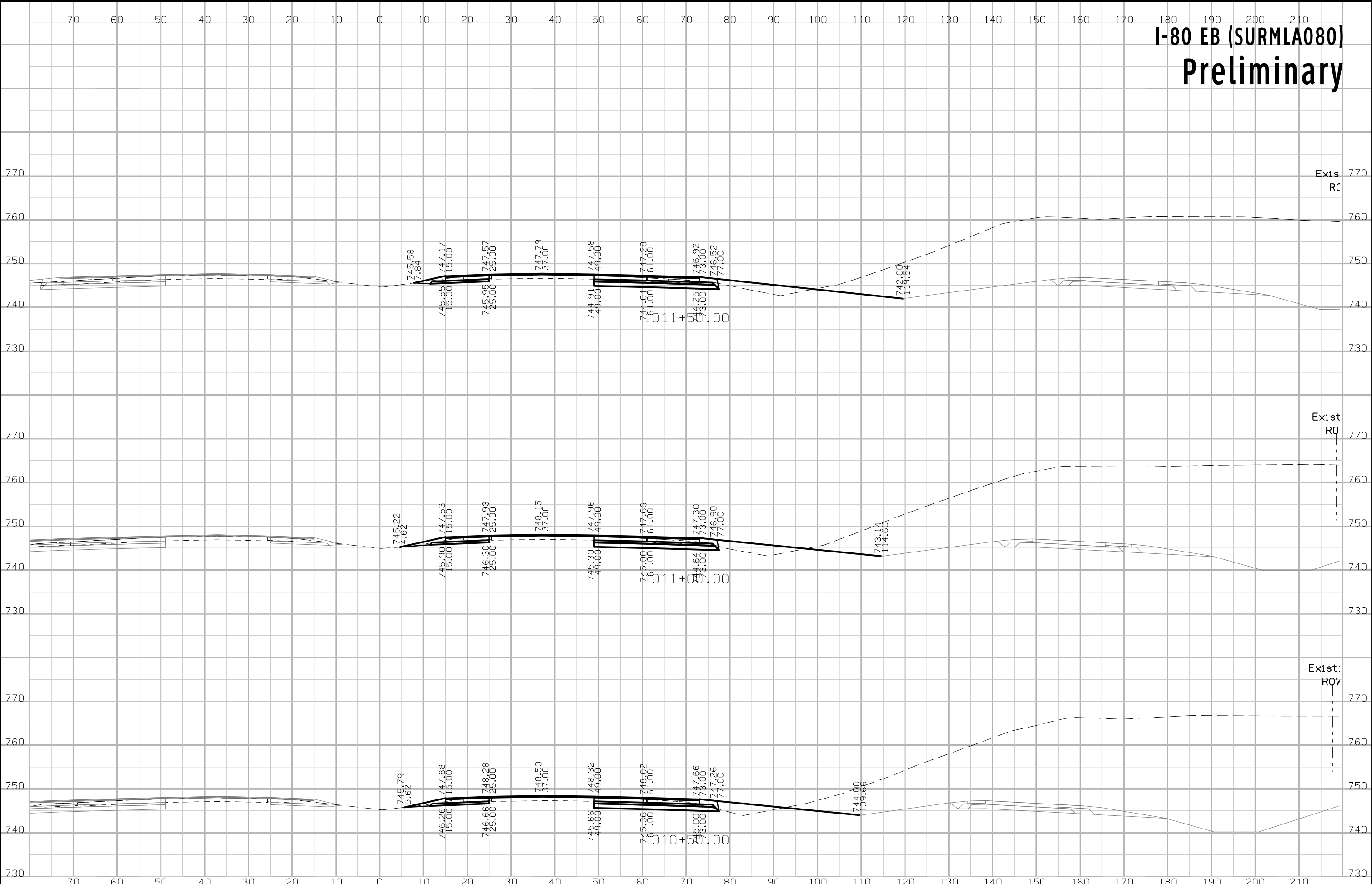

# I-80 EB (SURMLA080) Preliminary

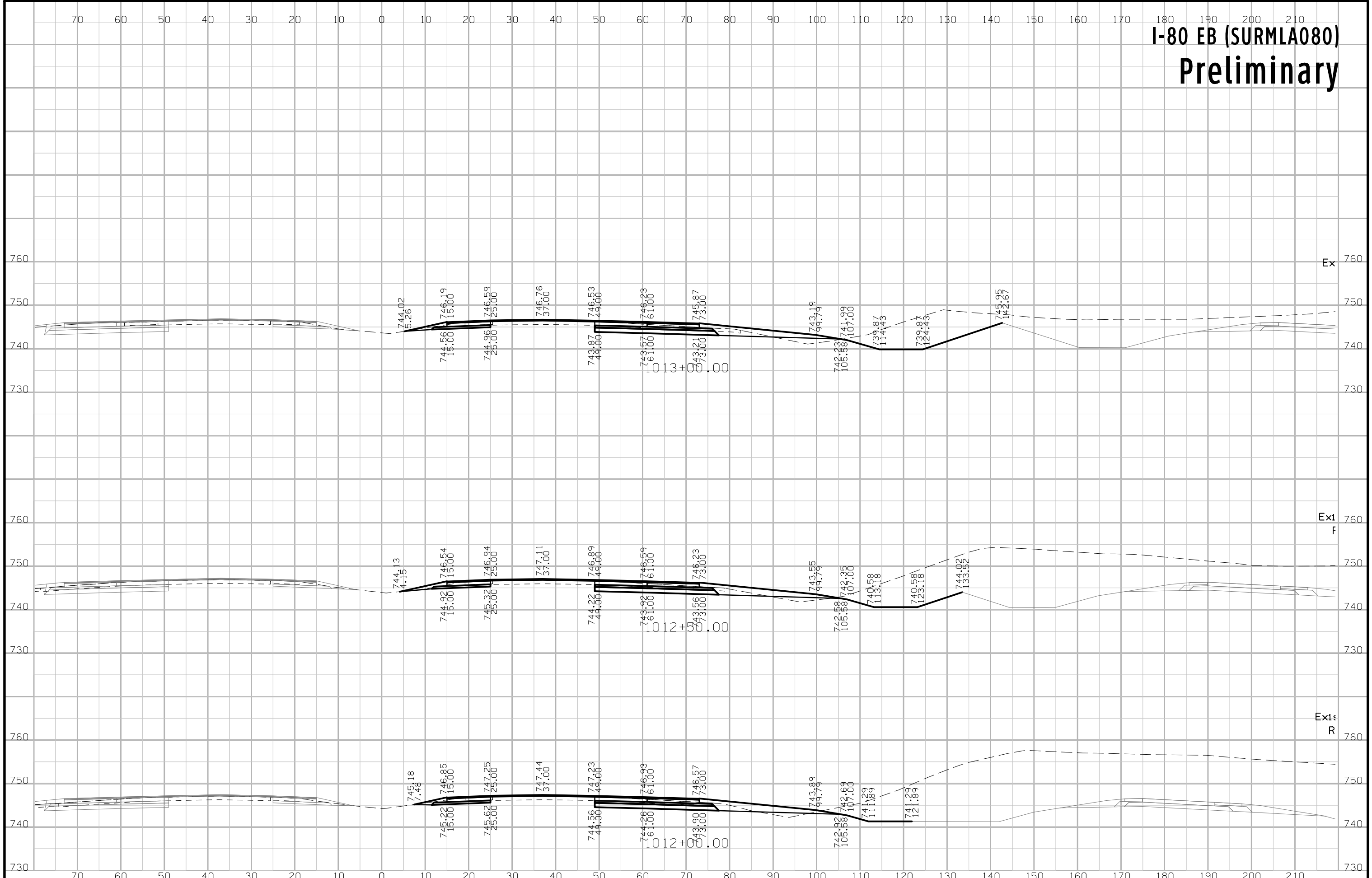

# I-80 EB (SURMLA080) Preliminary

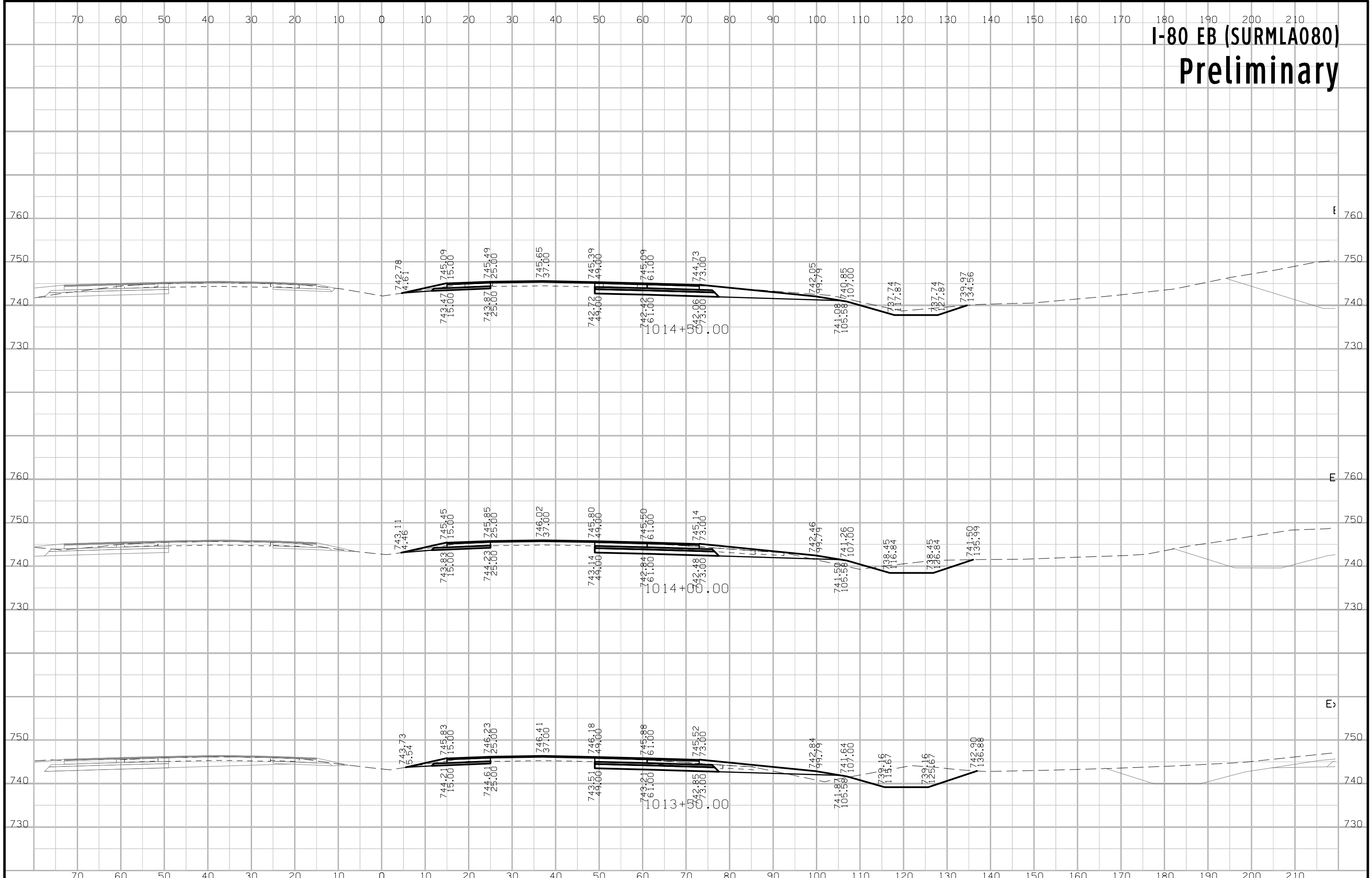



# I-80 EB (SURMLA080) Preliminary

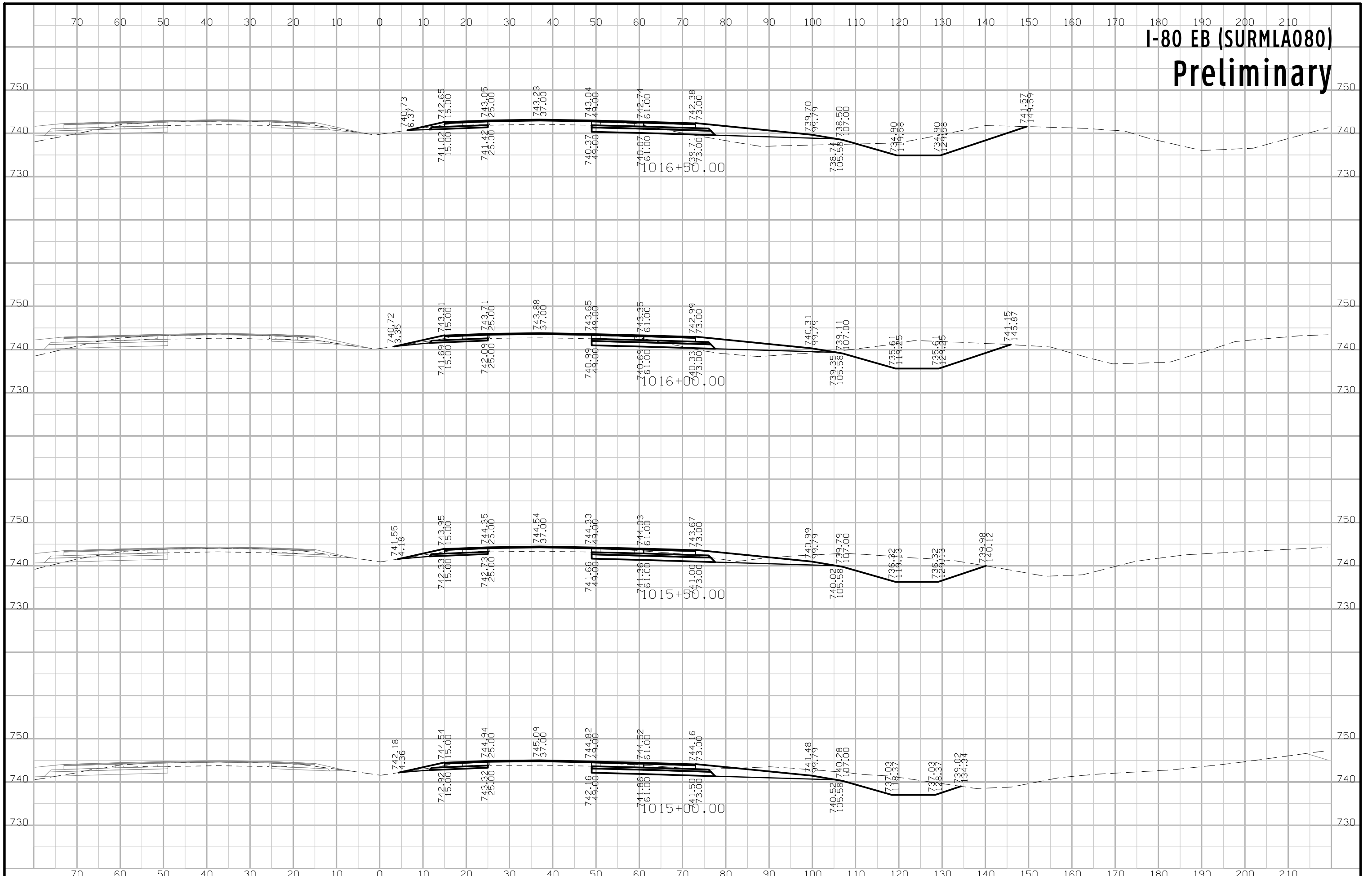

# I-80 EB (SURMLA080) Preliminary

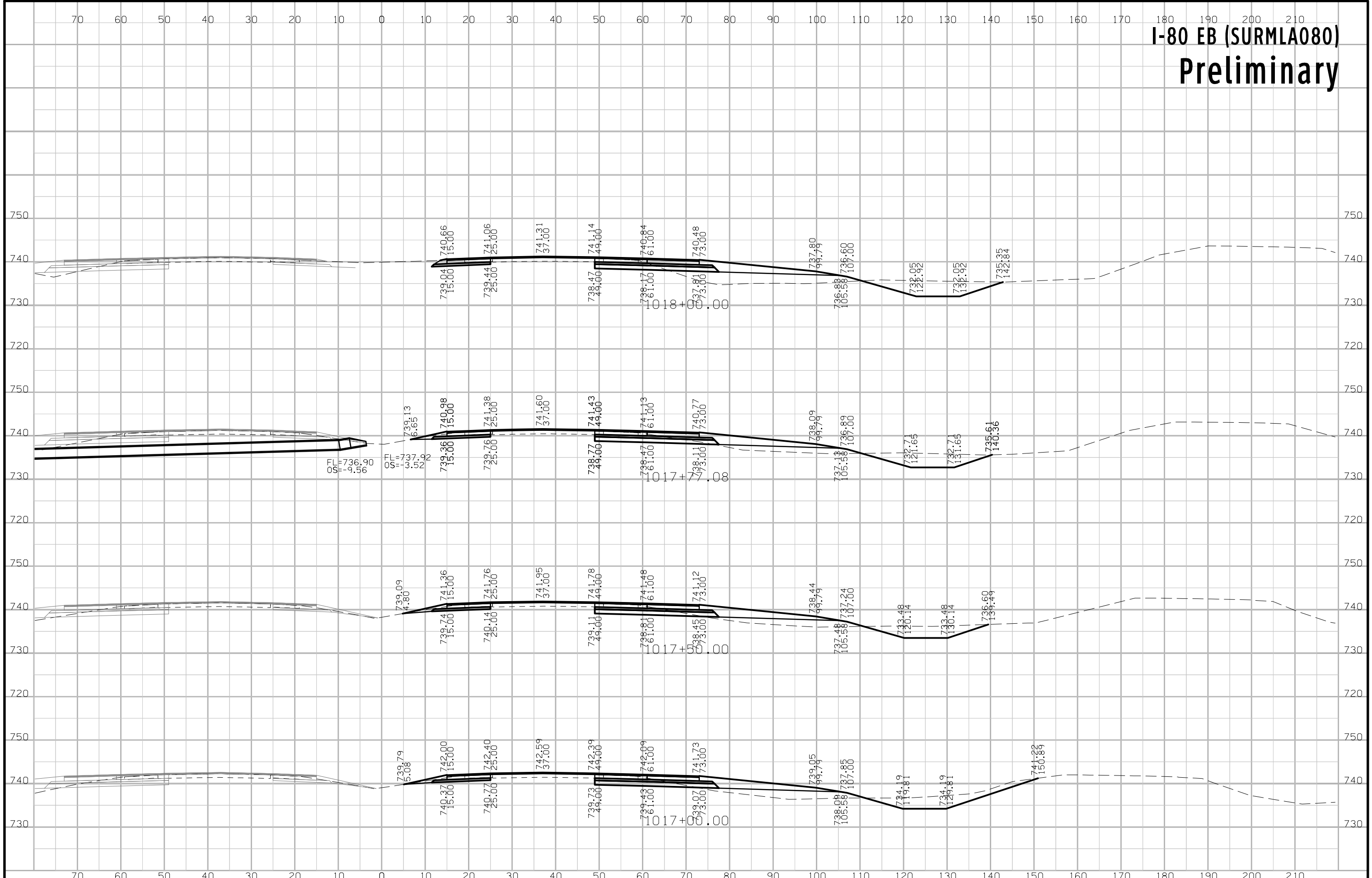

# I-80 EB (SURMLA080) Preliminary

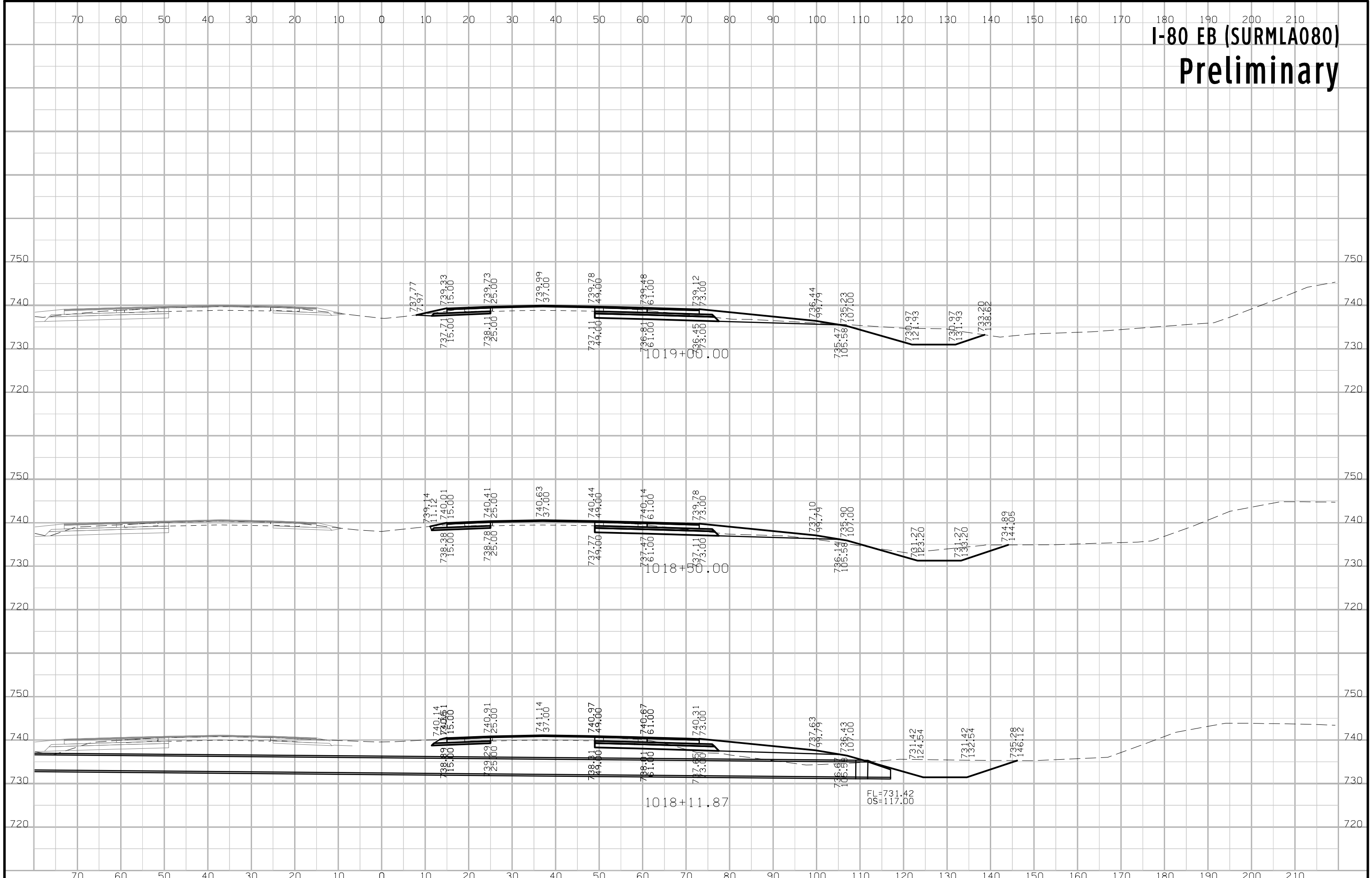

# I-80 EB (SURMLA080) Preliminary

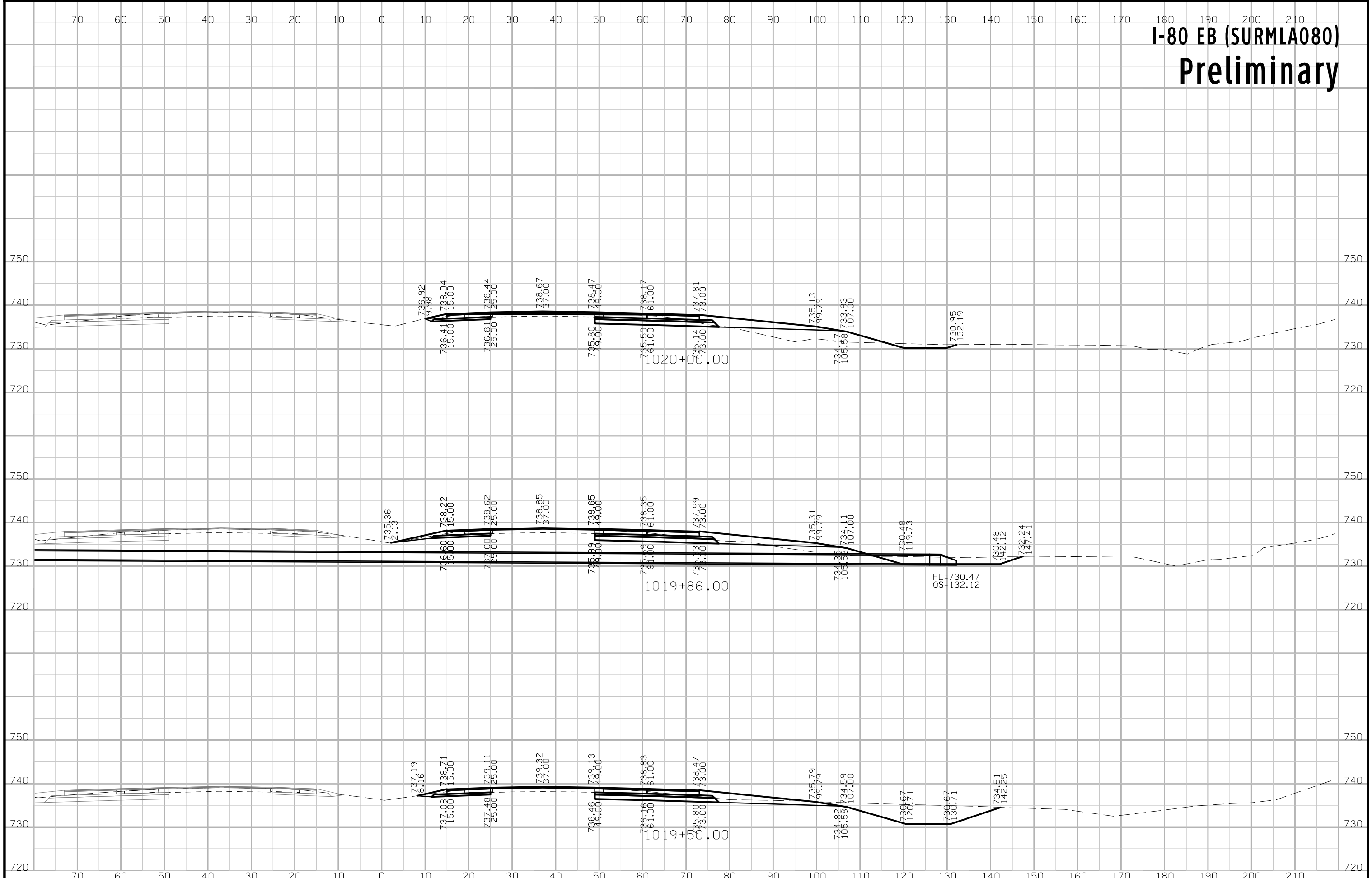

# I-80 EB (SURMLA080) Preliminary

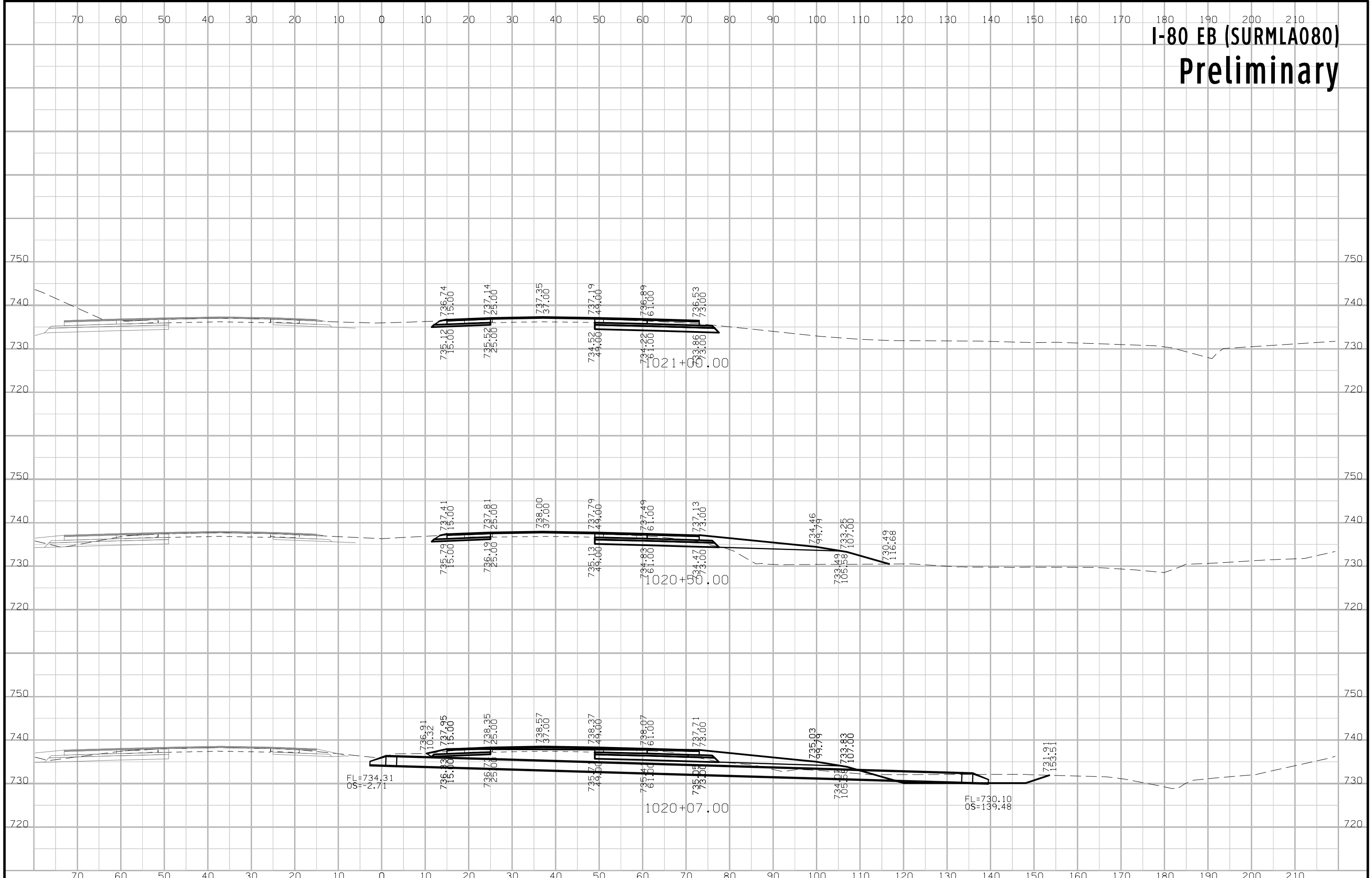

# I-80 EB (SURMLA080) Preliminary

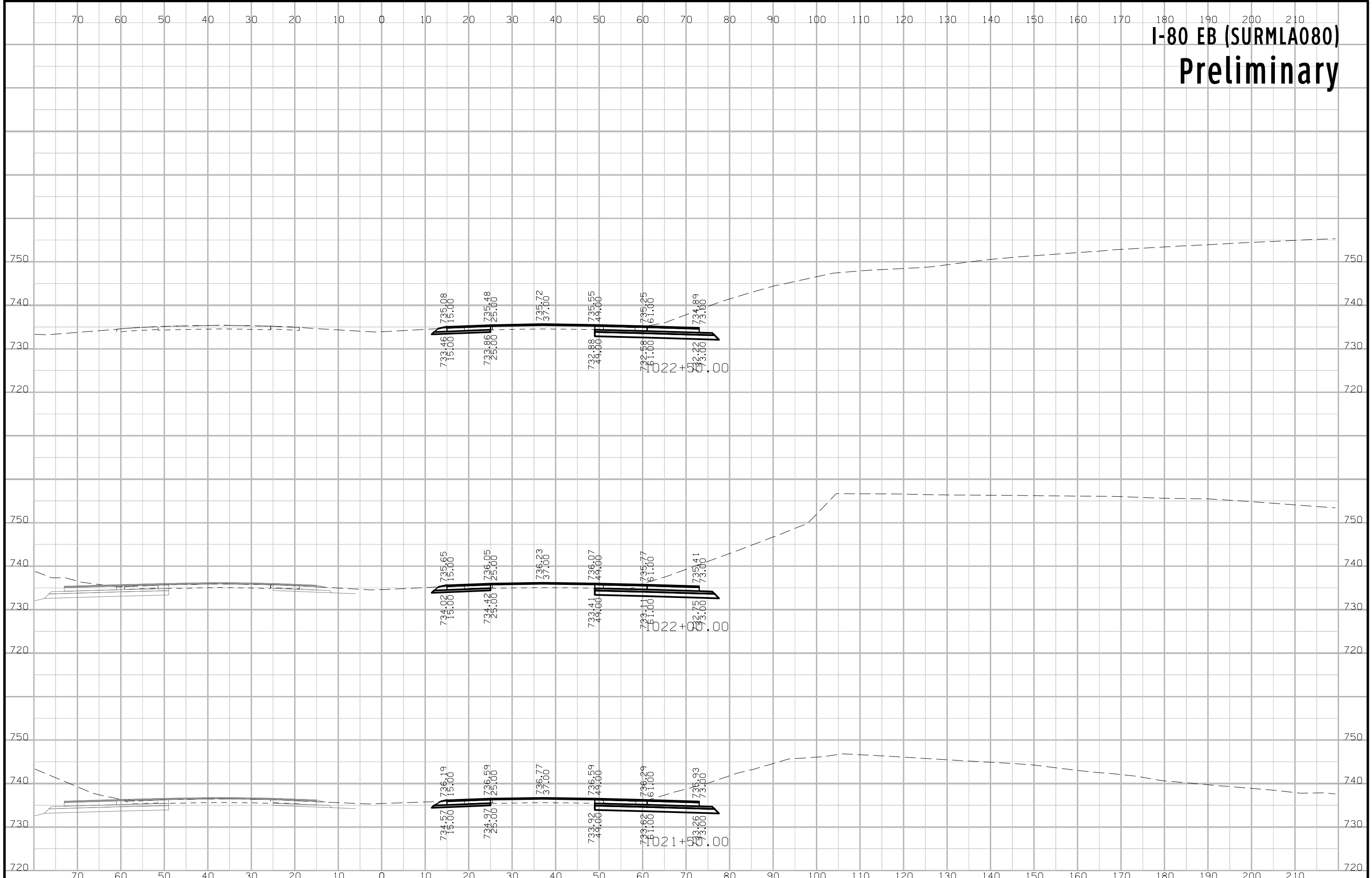

# I-80 EB (SURMLA080) Preliminary

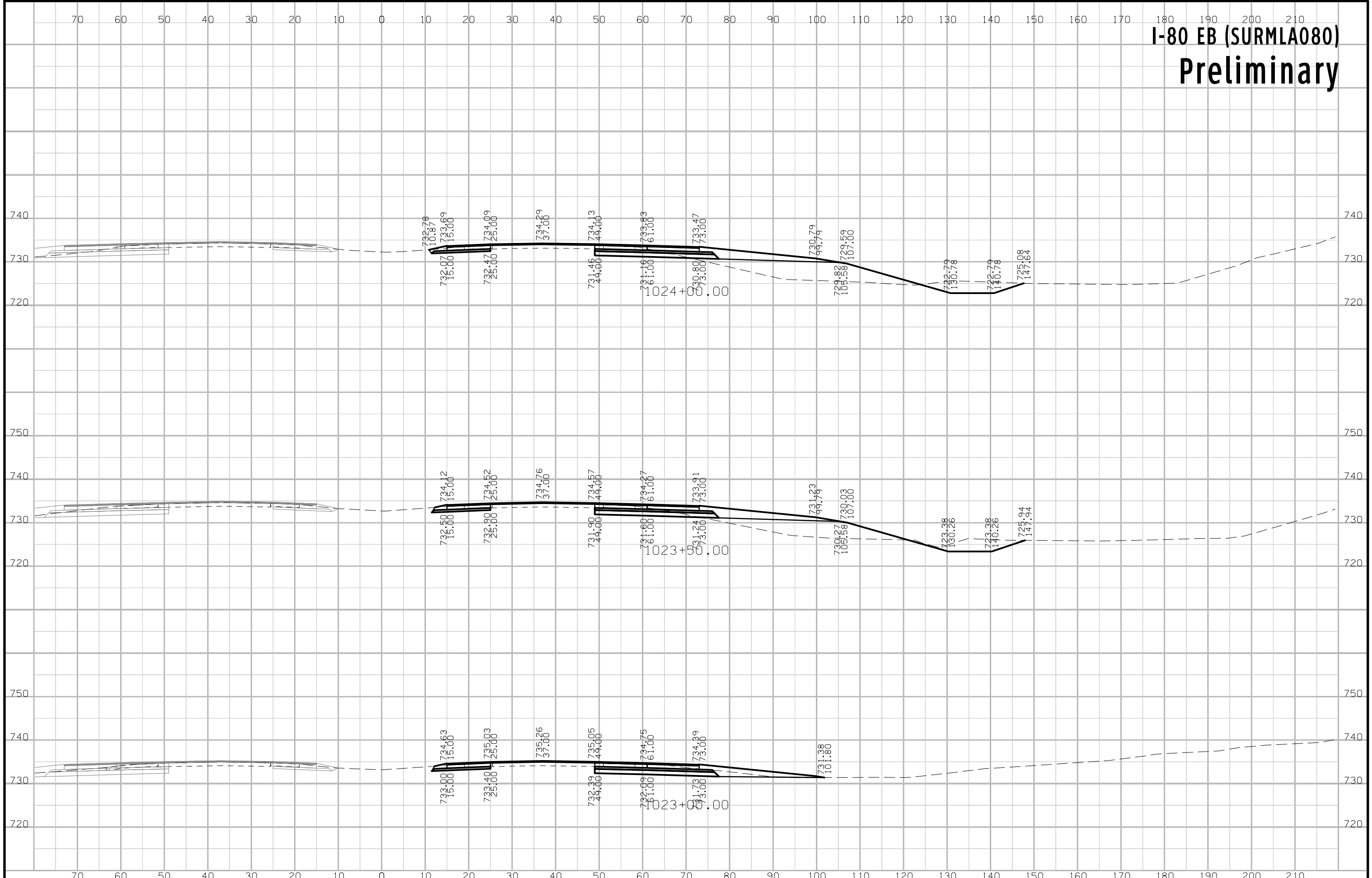



# I-80 EB (SURMLA080) Preliminary

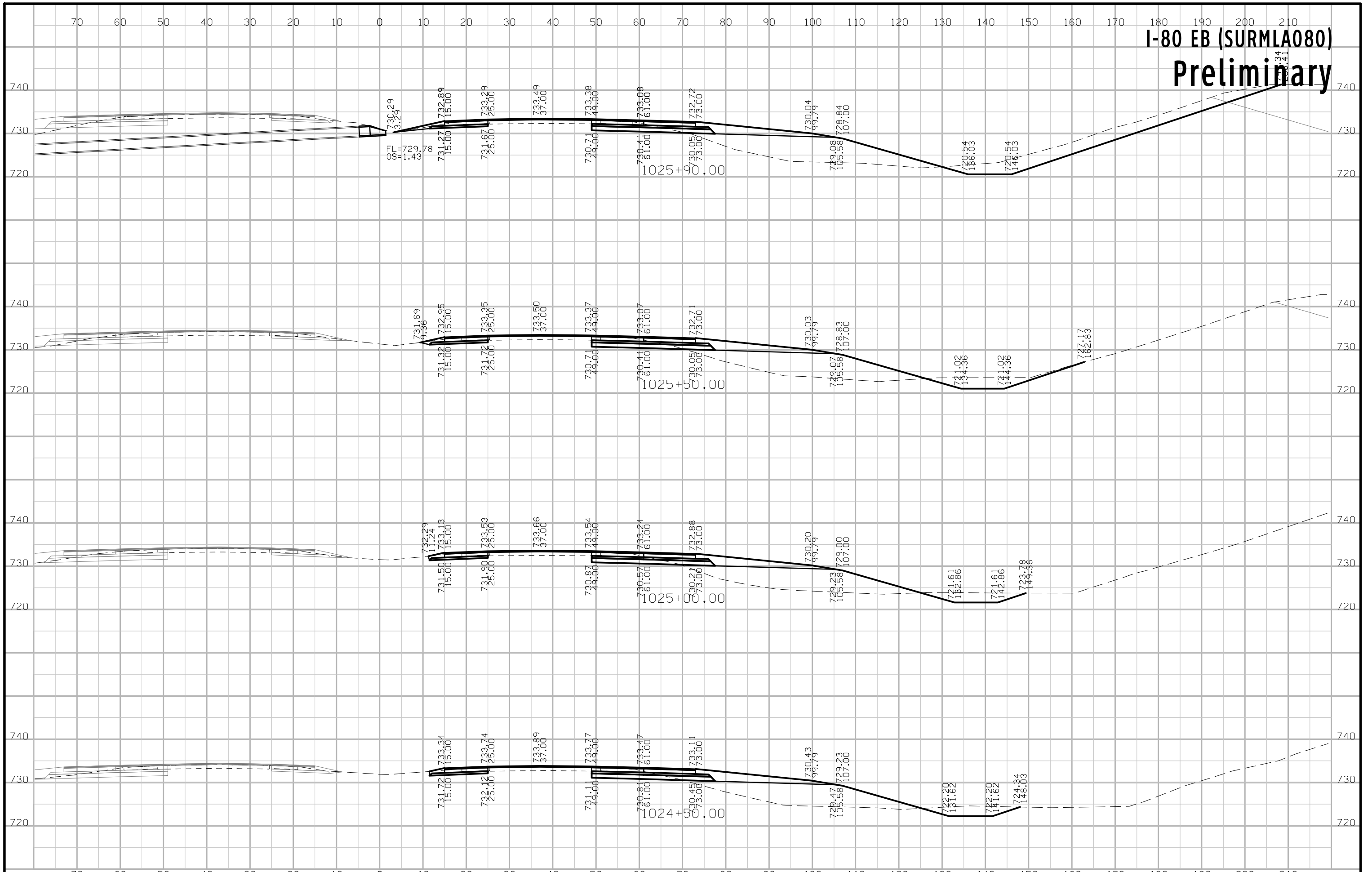

# I-80 EB (SURMLA080) Preliminary

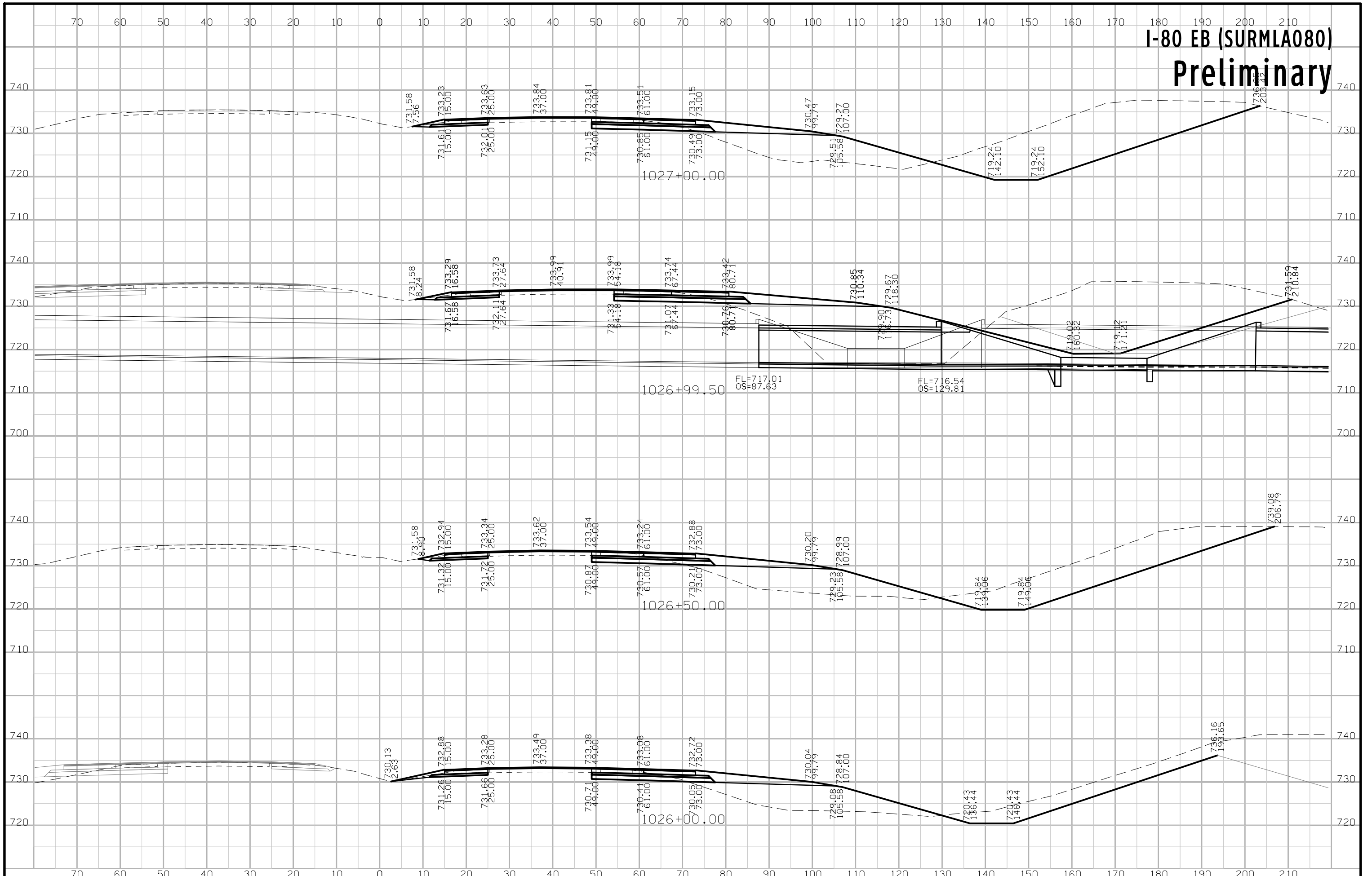

# I-80 EB (SURMLA080) Preliminary

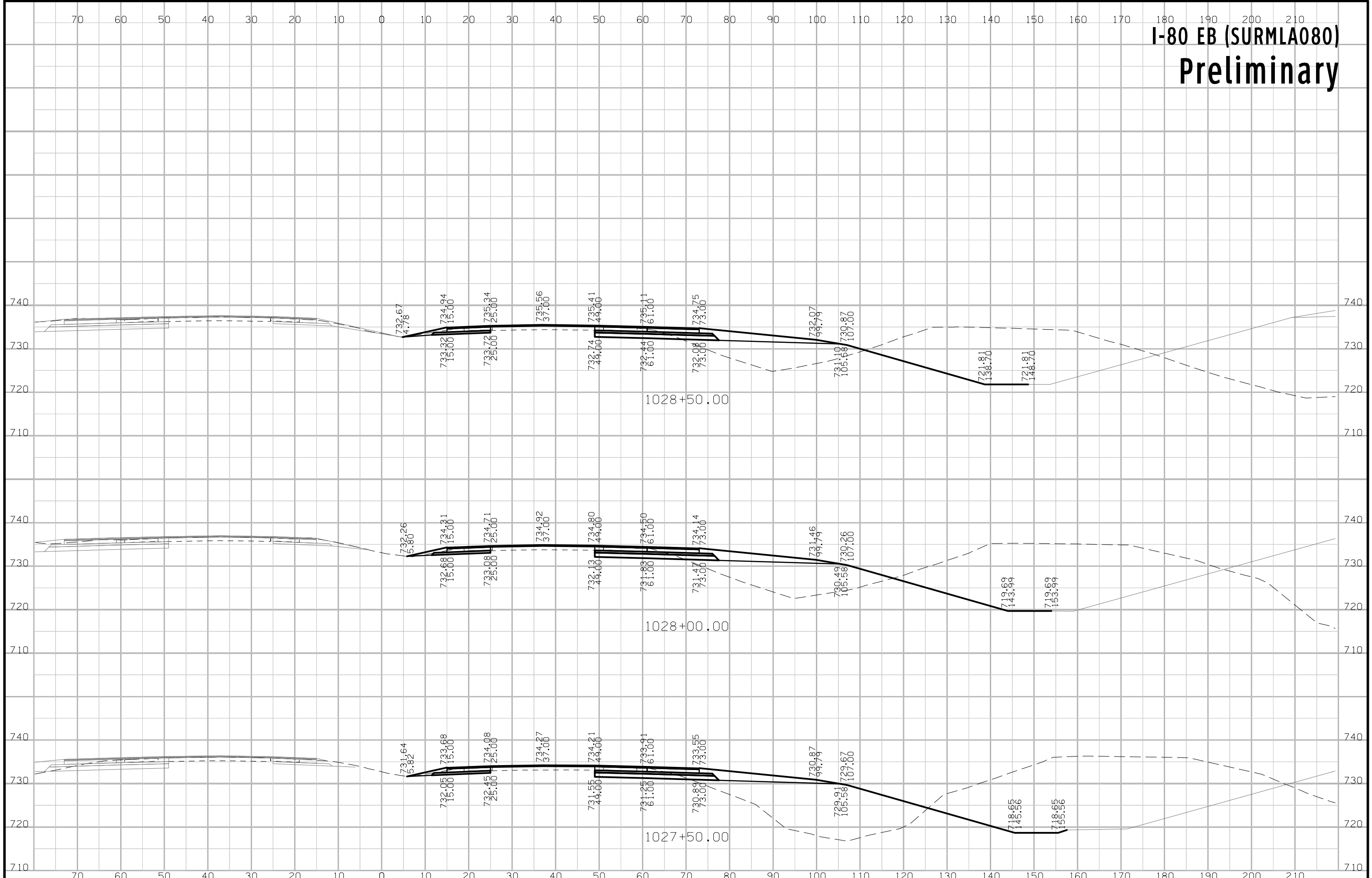

# I-80 EB (SURMLA080) Preliminary

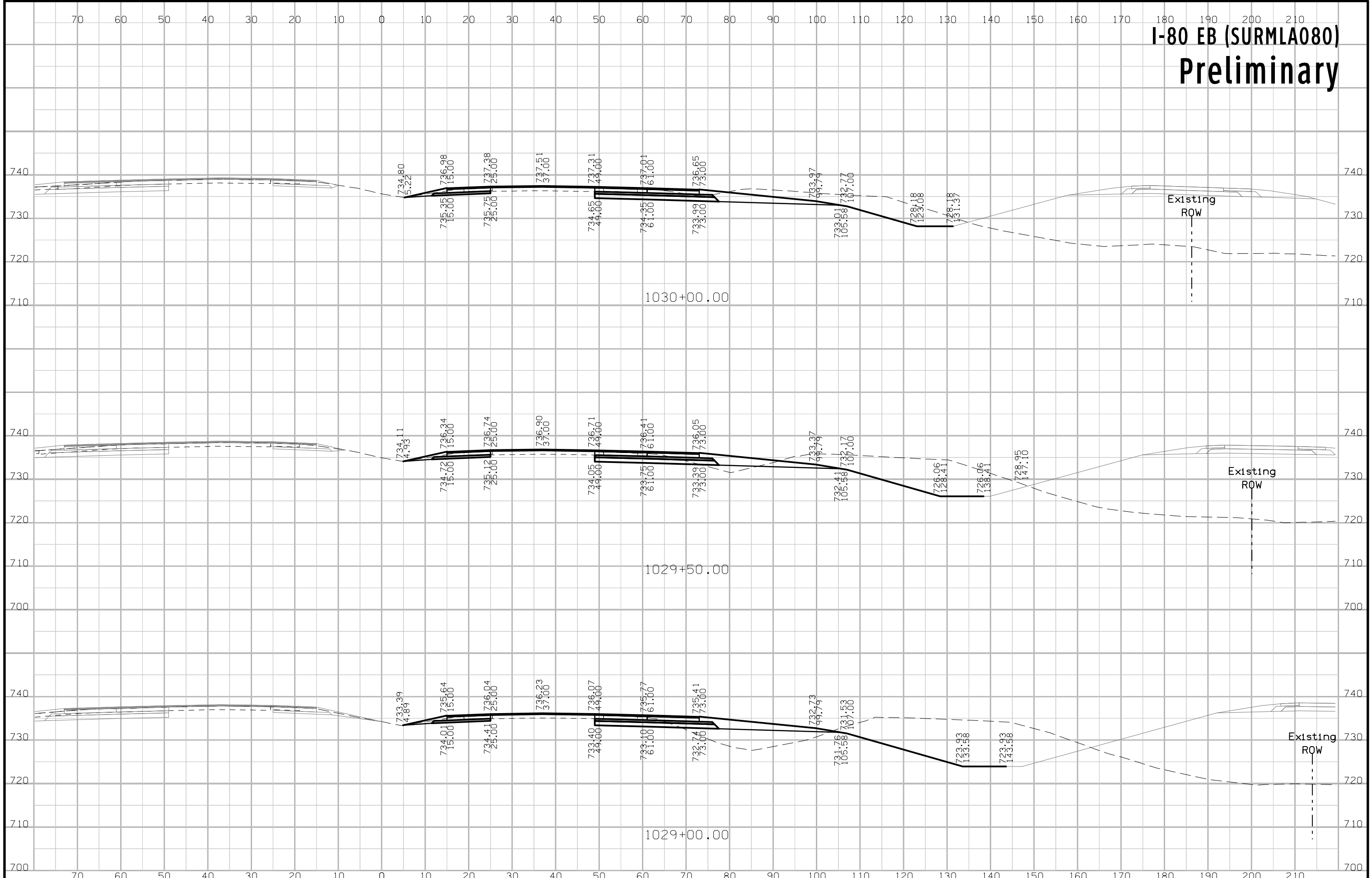

# I-80 EB (SURMLA080) Preliminary

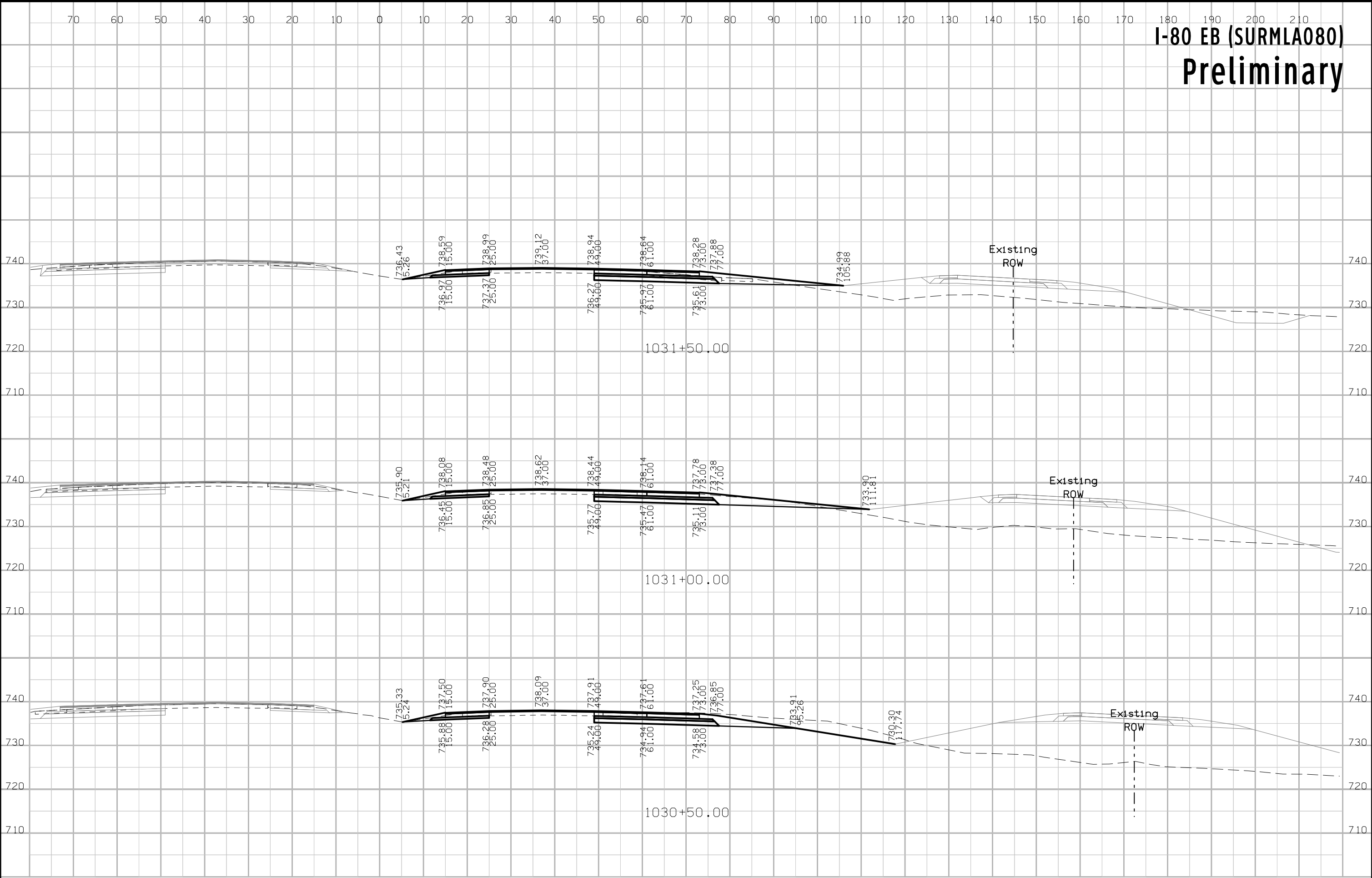

# I-80 EB (SURMLA080) Preliminary

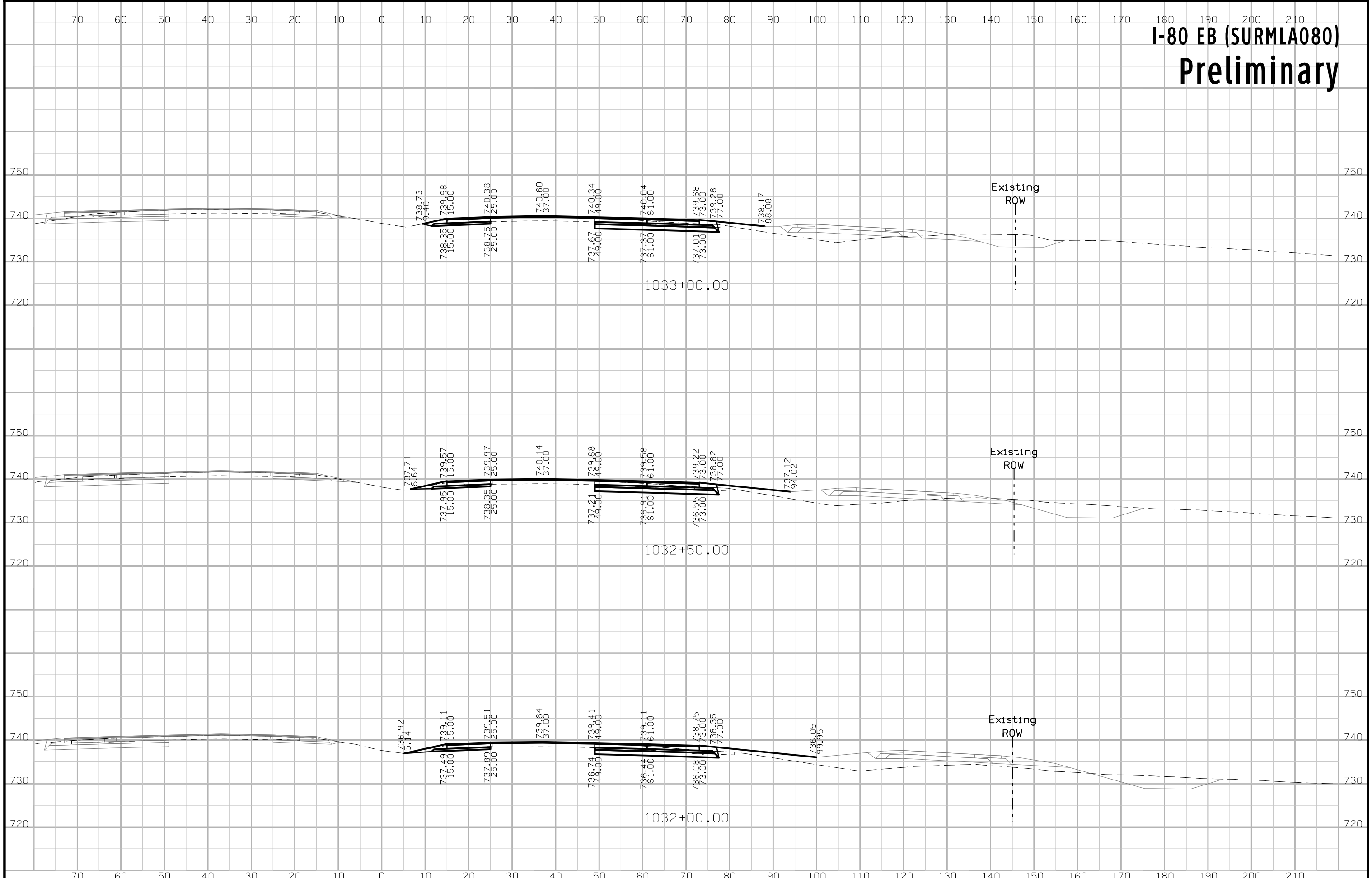

# I-80 EB (SURMLA080) Preliminary

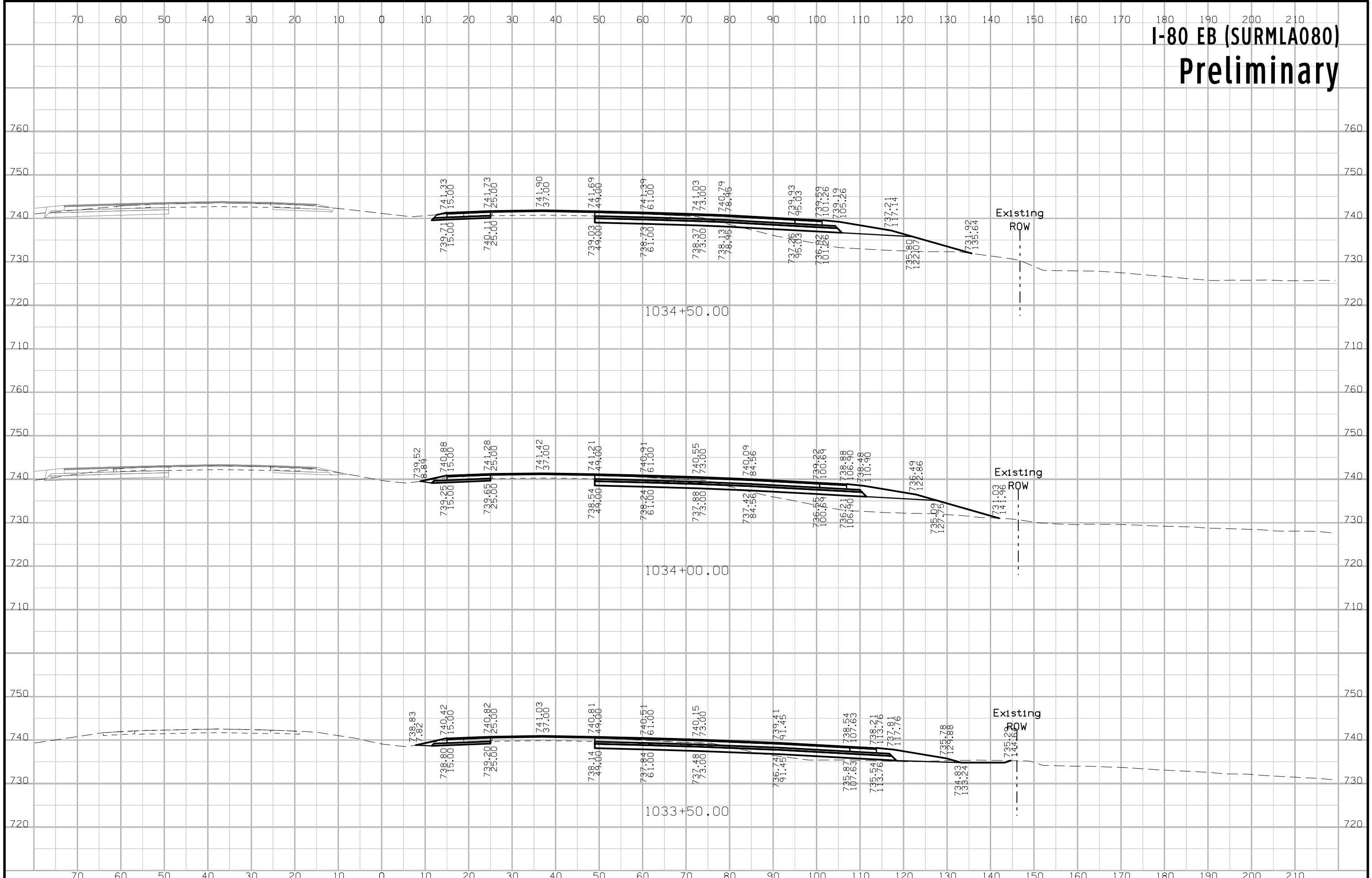

# I-80 EB (SURMLA080) Preliminary

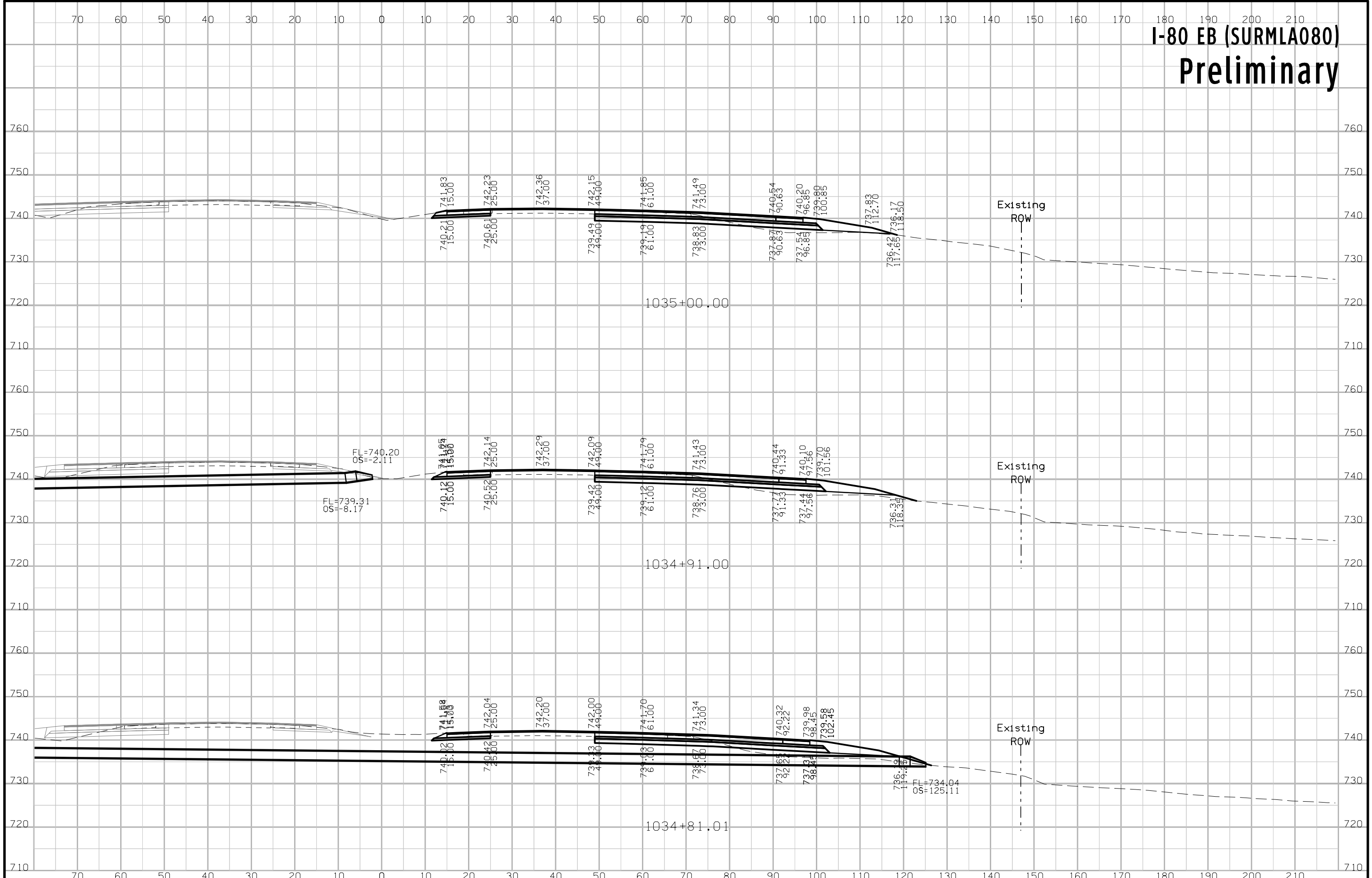



# I-80 EB (SURMLA080) Preliminary

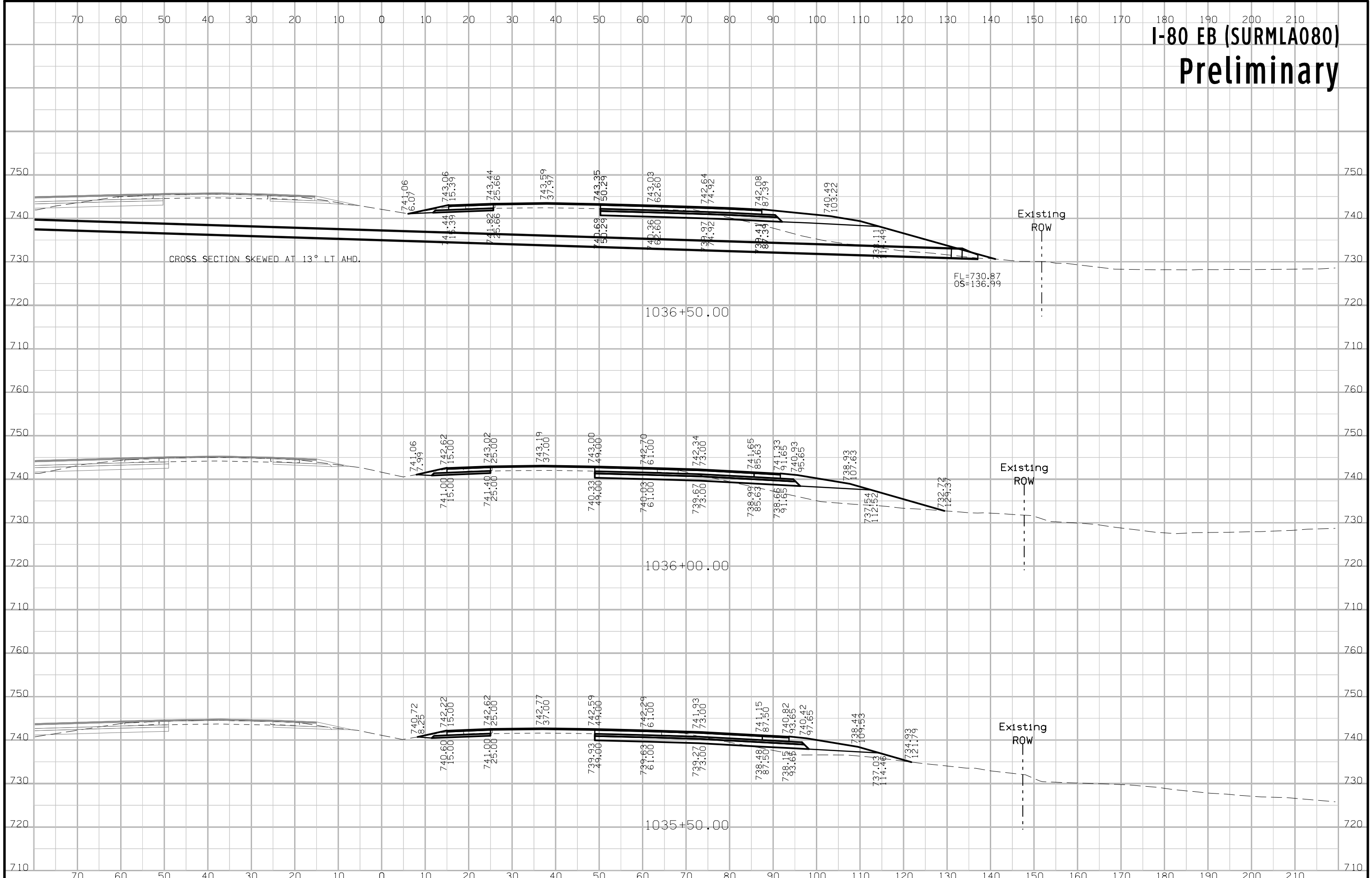

# I-80 EB (SURMLA080) Preliminary

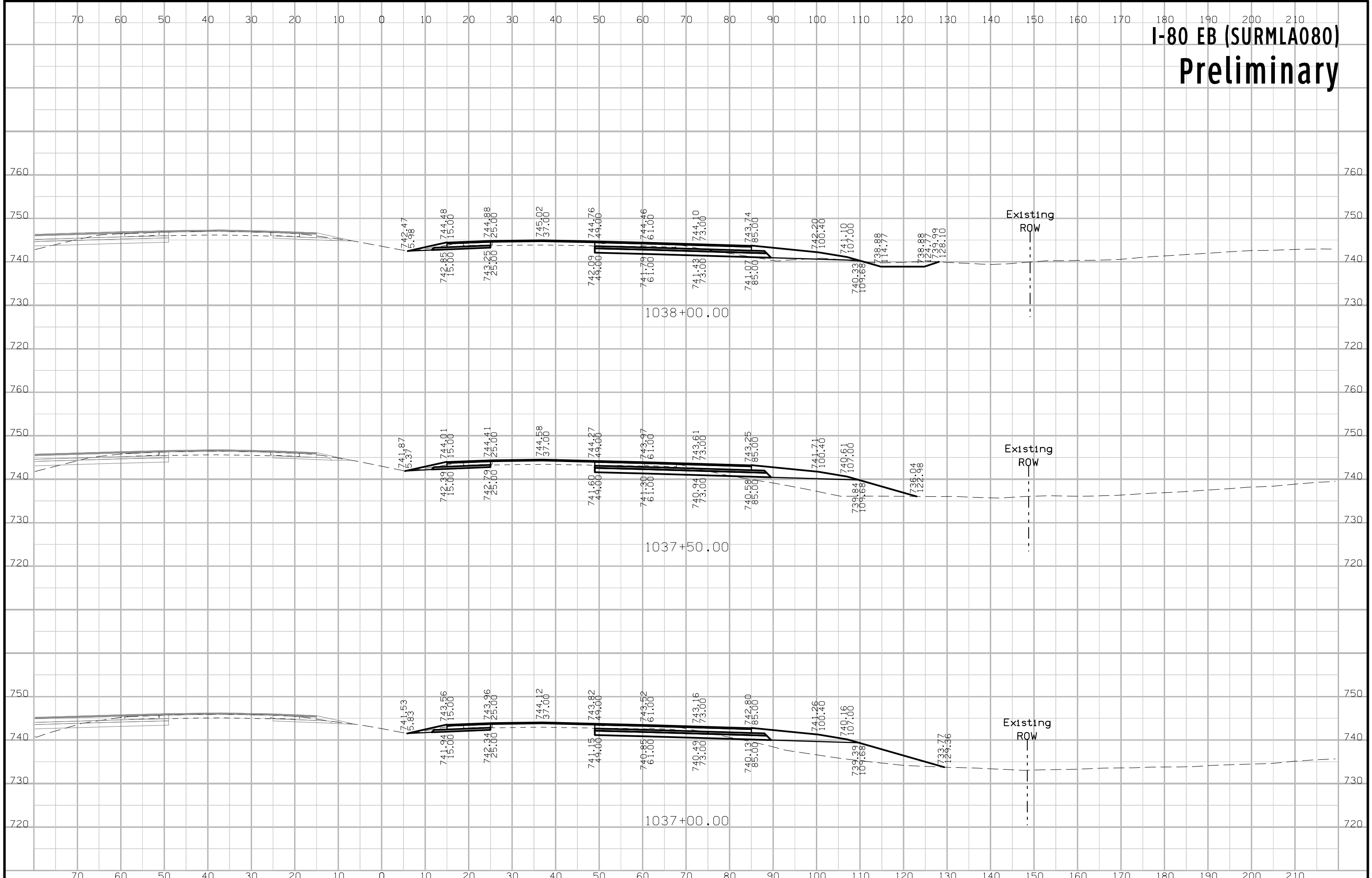

# I-80 EB (SURMLA080) Preliminary

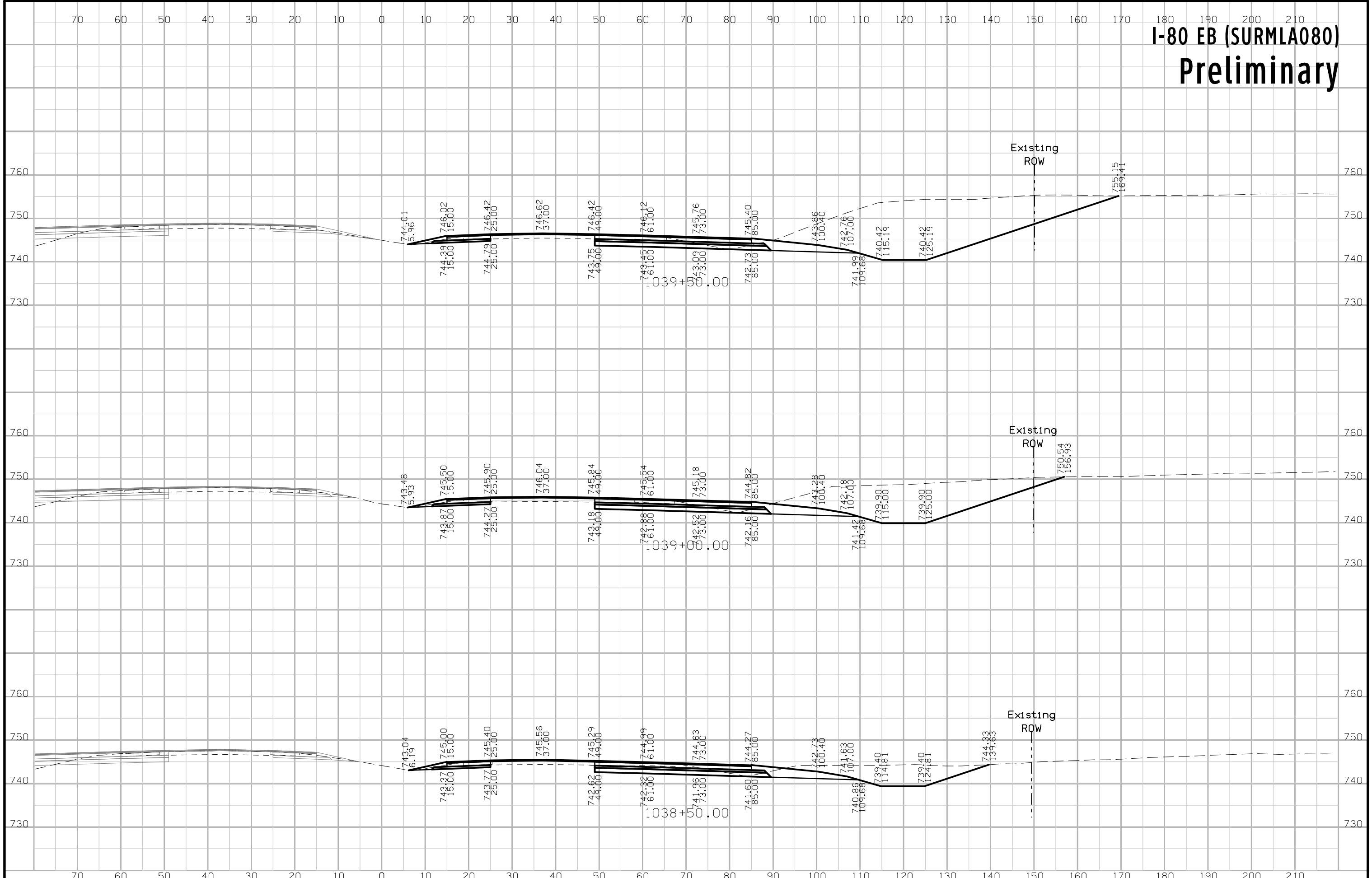

# I-80 EB (SURMLA080) Preliminary

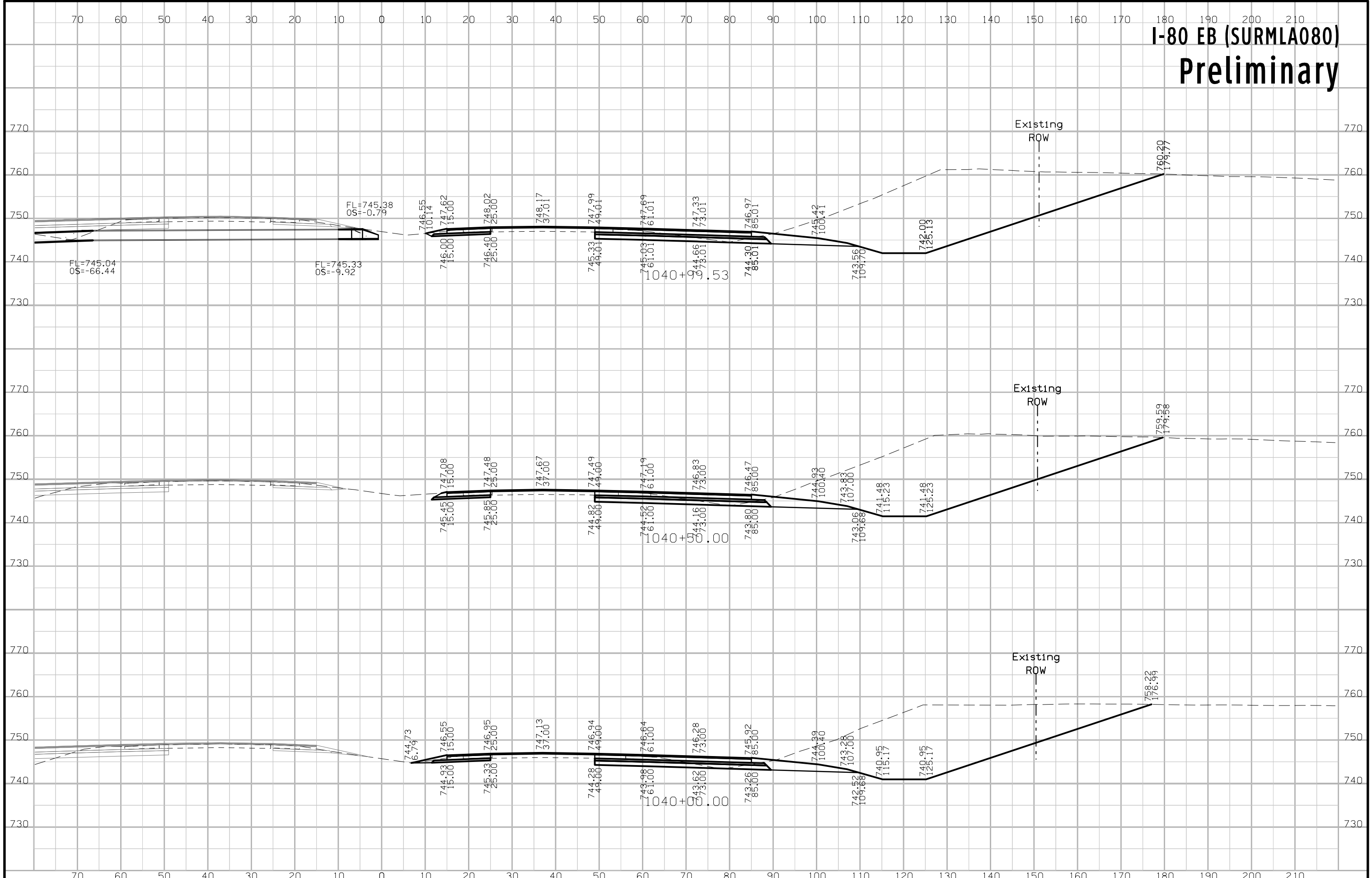

# I-80 EB (SURMLA080) Preliminary

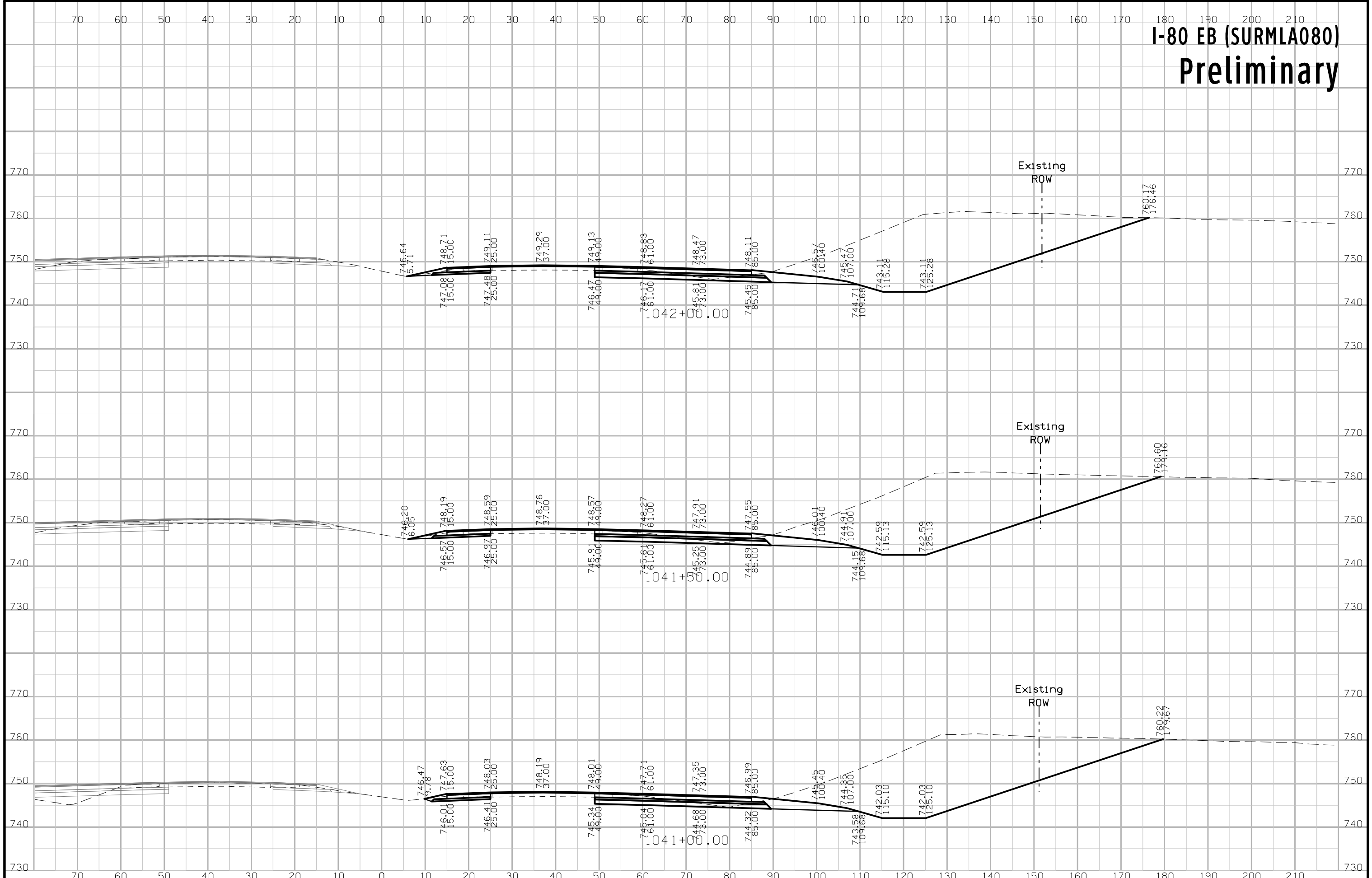

# I-80 EB (SURMLA080) Preliminary

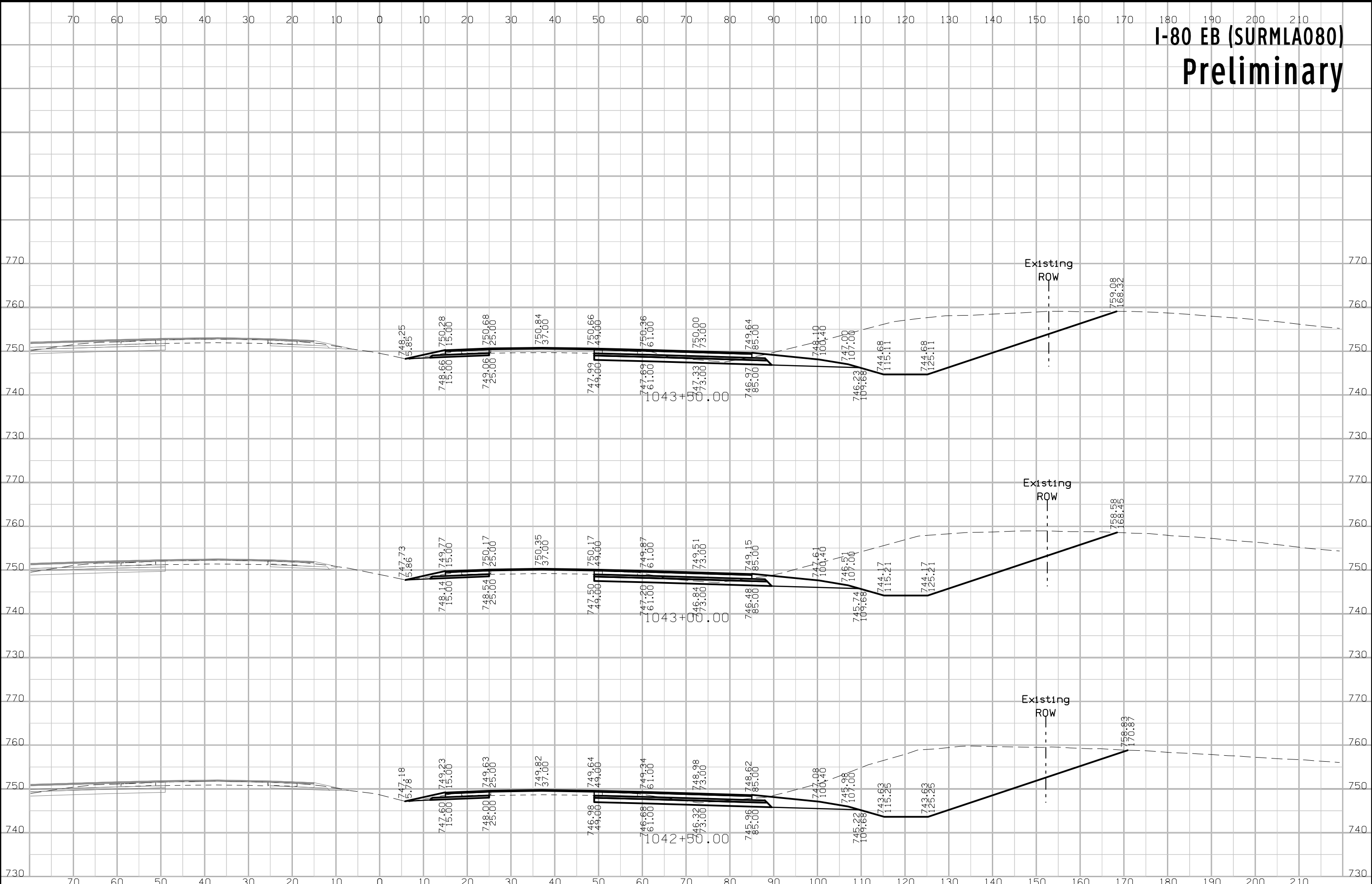

# I-80 EB (SURMLA080) Preliminary

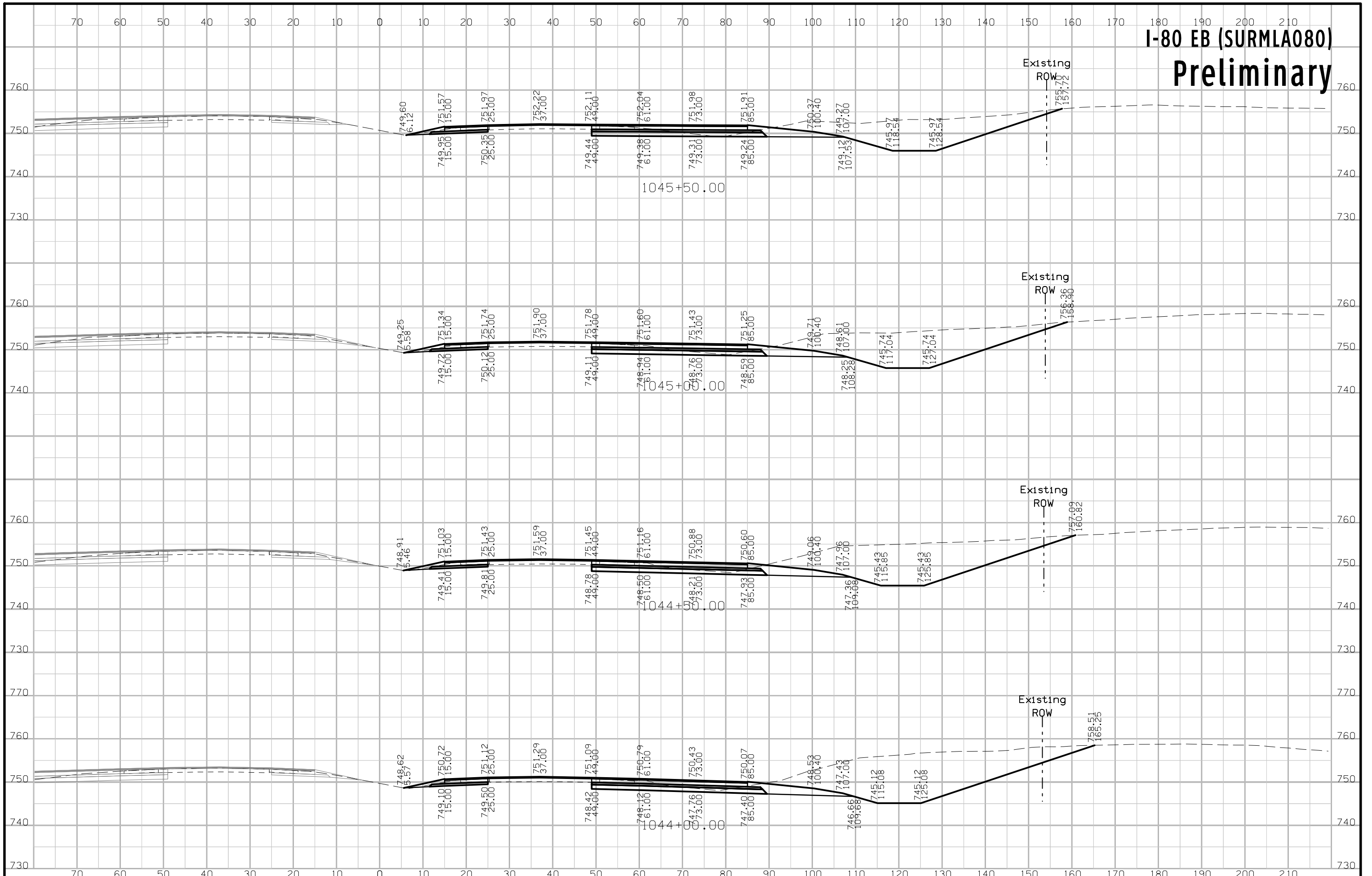

# I-80 EB (SURMLA080) Preliminary

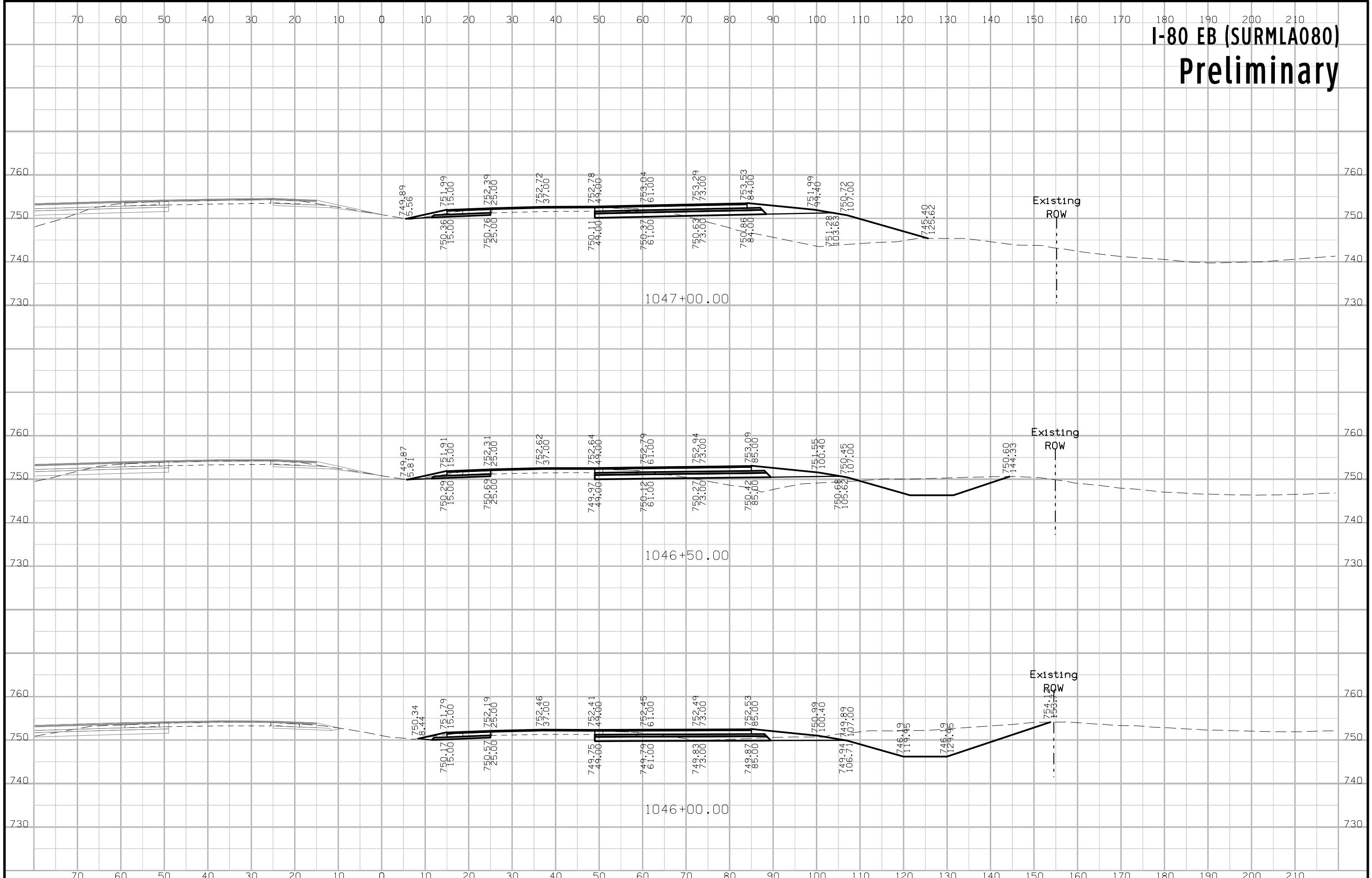



# I-80 EB (SURMLA080) Preliminary

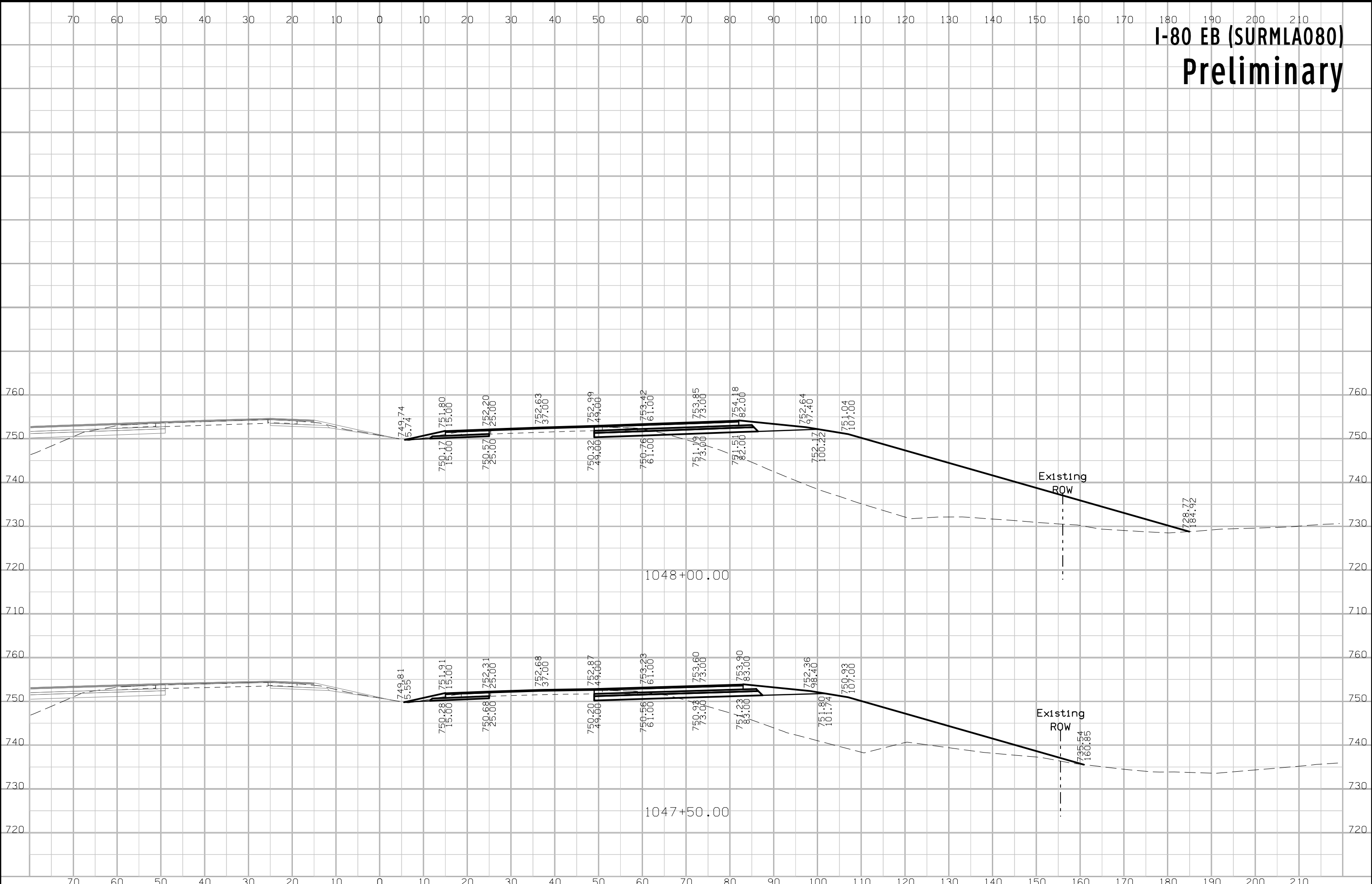

# I-80 EB (SURMLA080) Preliminary

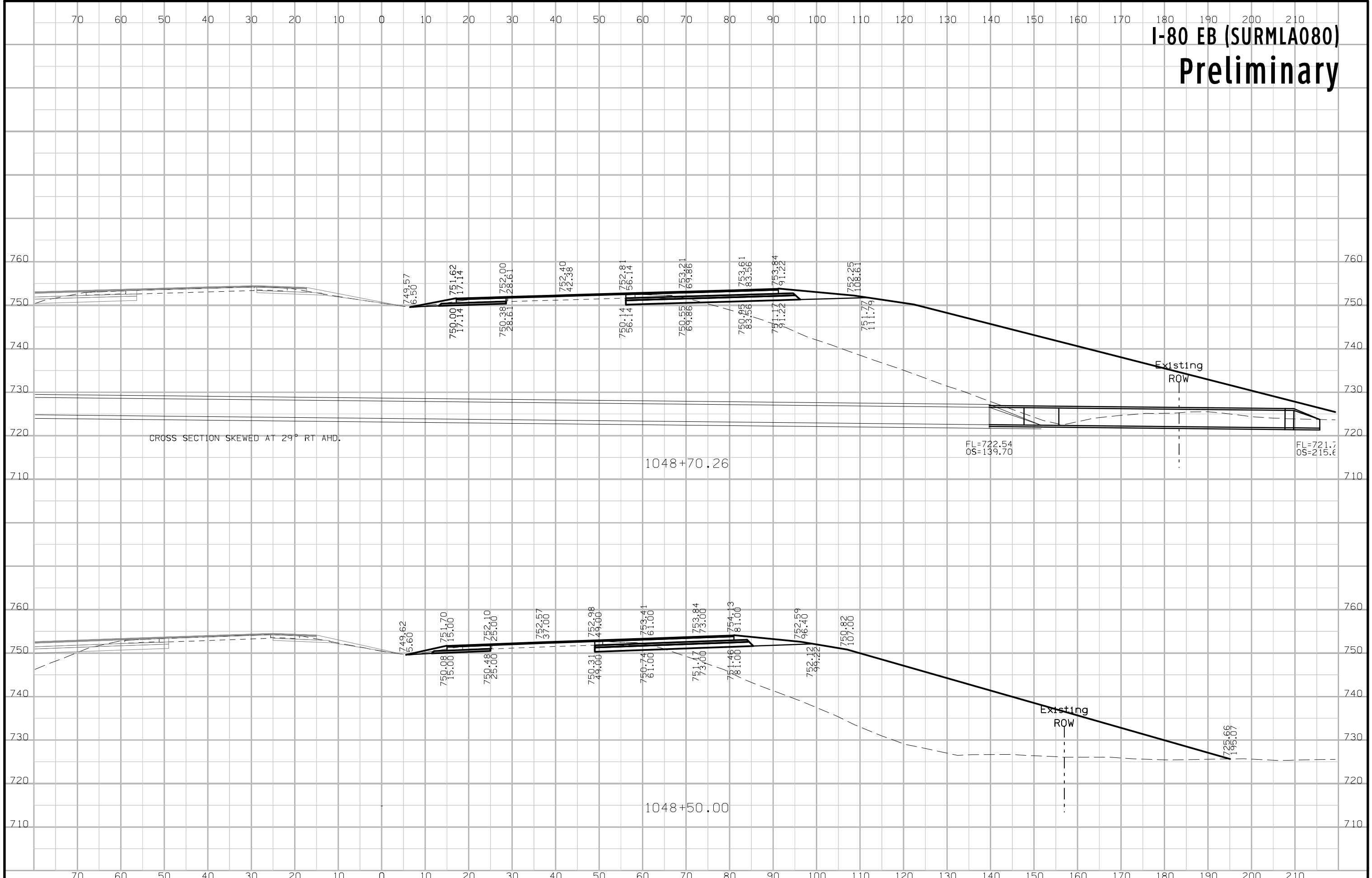

CROSS SECTION SKEWED AT 29° RT AHD.

Existing ROW

Existing ROW

# I-80 EB (SURMLA080) Preliminary

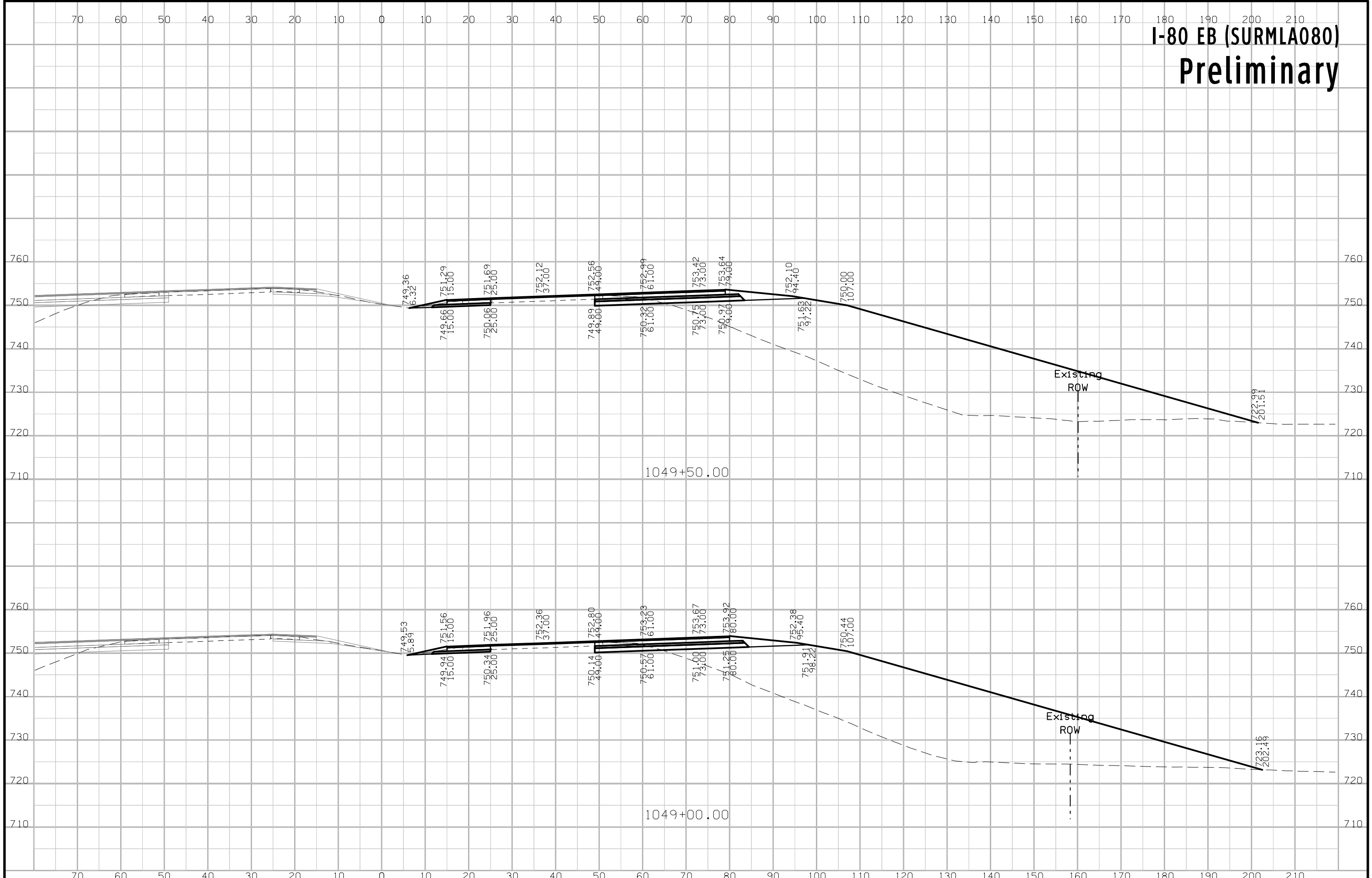

# I-80 EB (SURMLA080) Preliminary

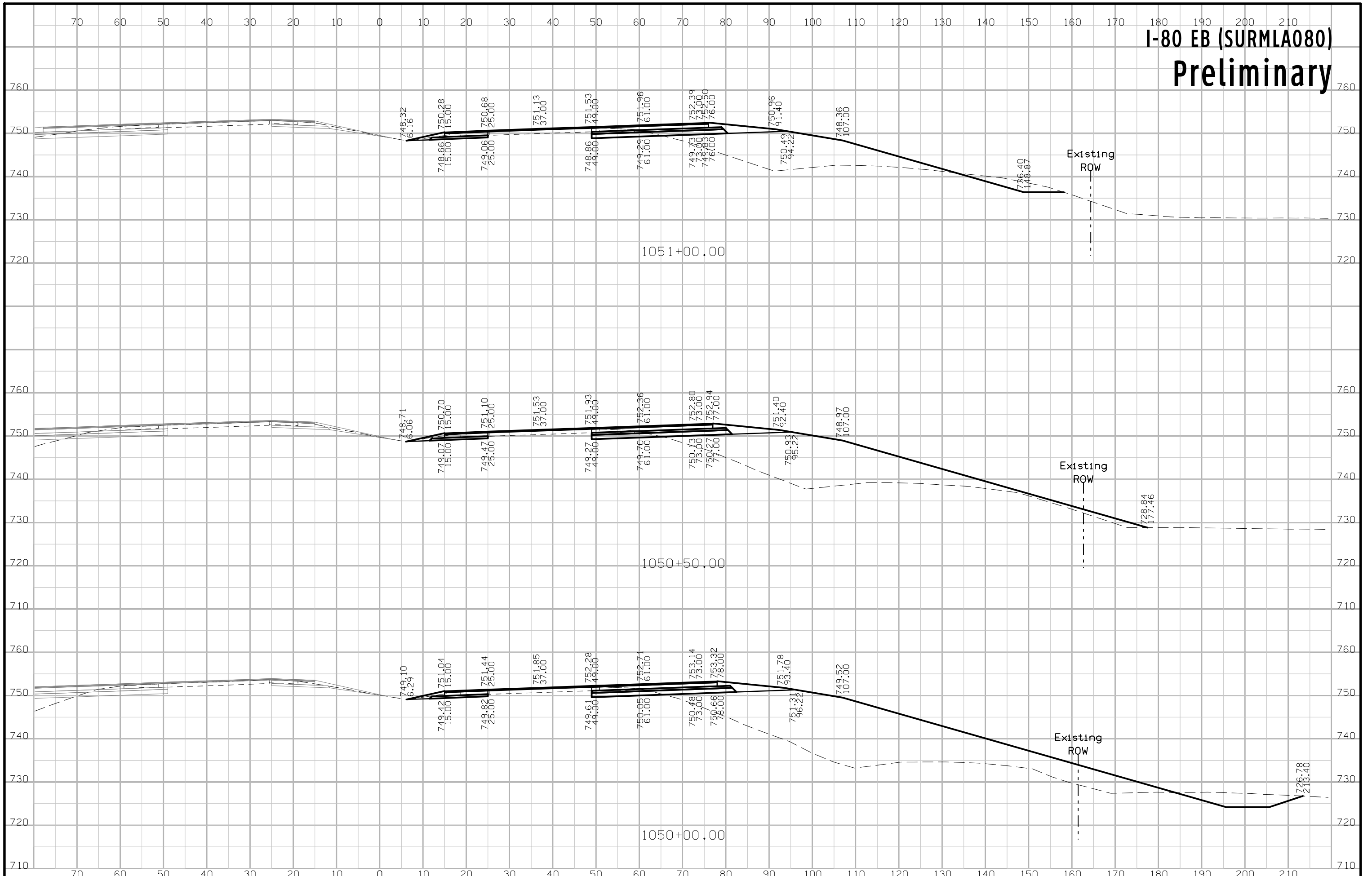

# I-80 EB (SURMLA080) Preliminary

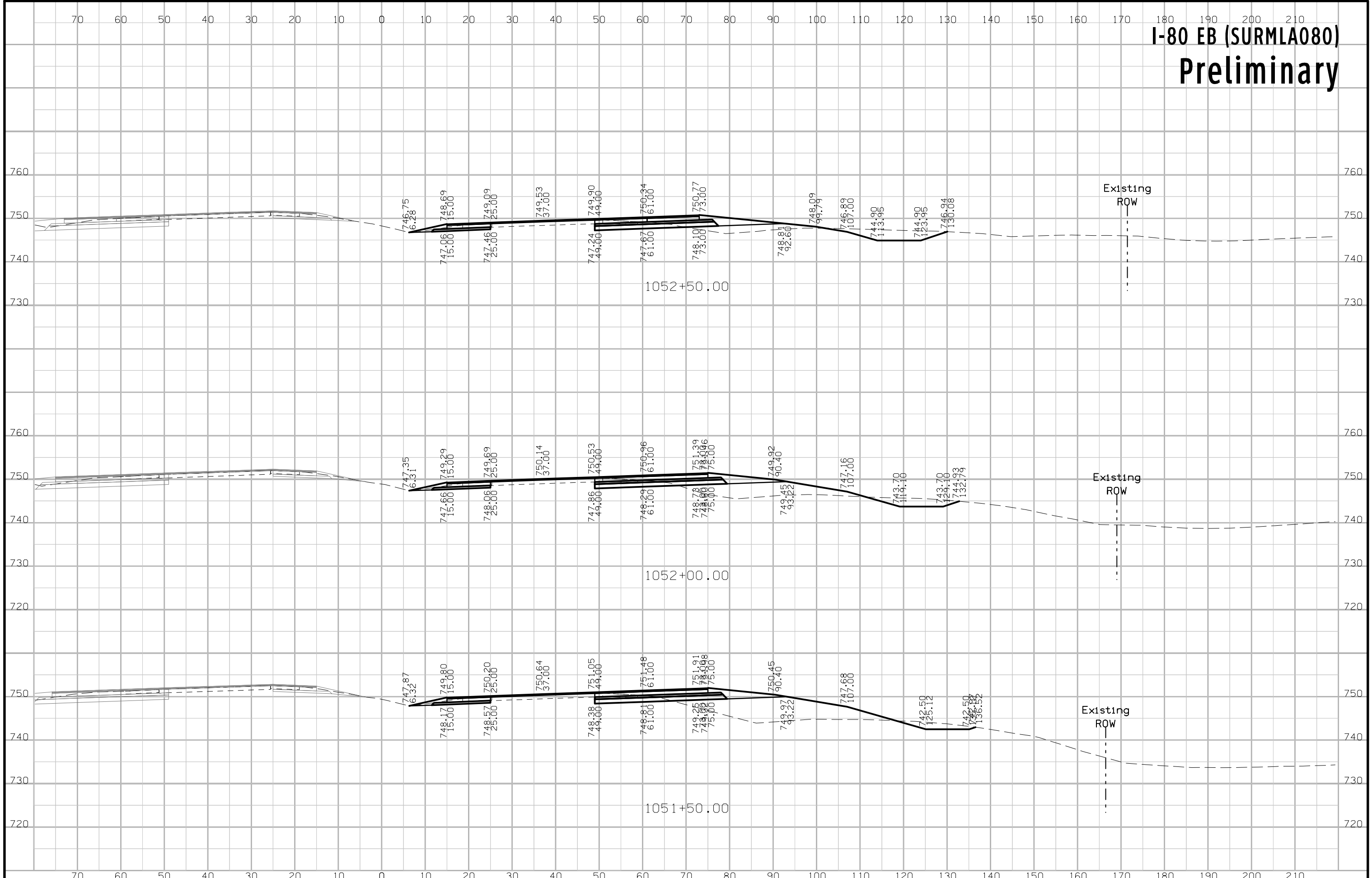

# I-80 EB (SURMLA080) Preliminary

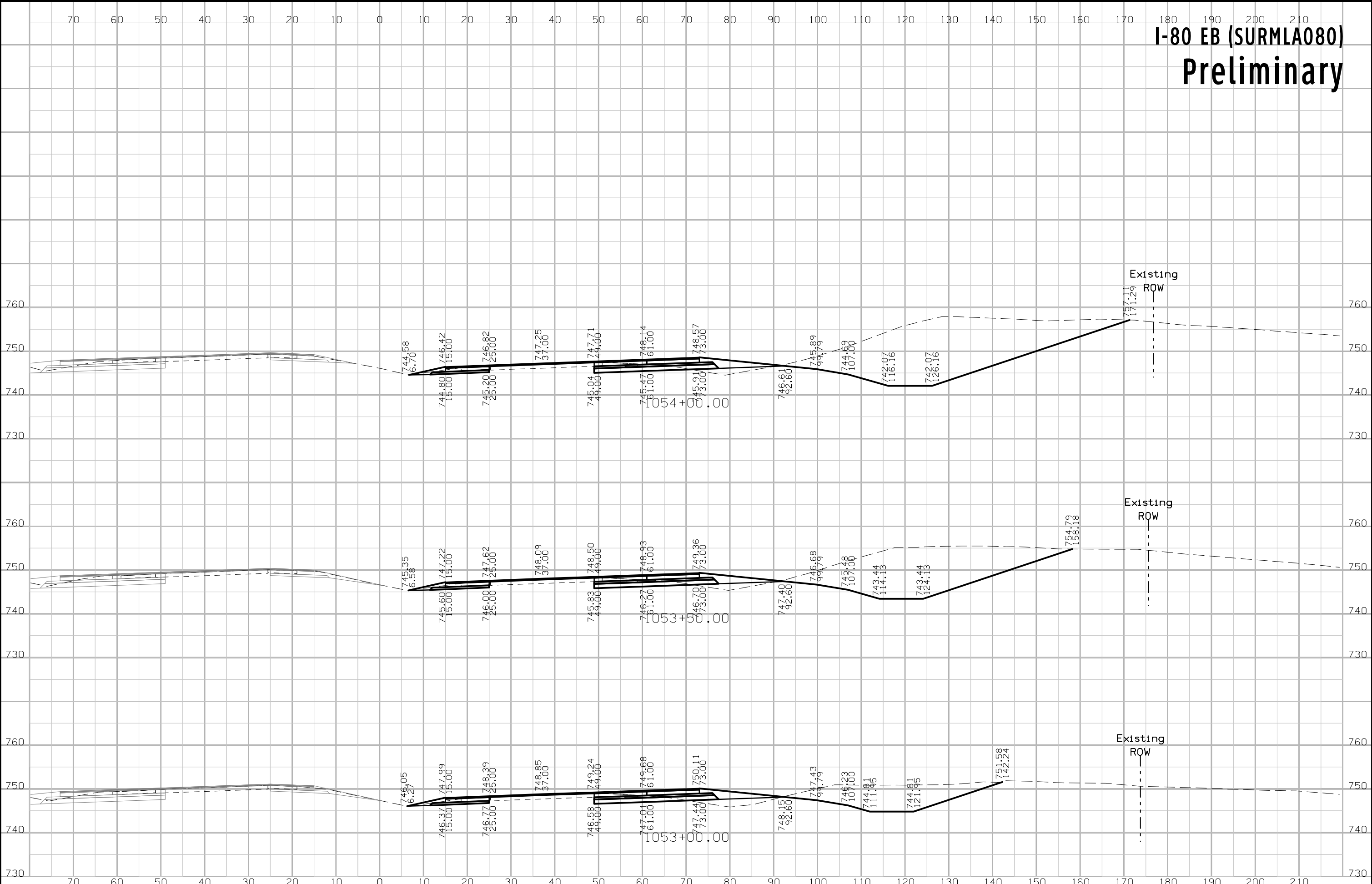

# I-80 EB (SURMLA080) Preliminary

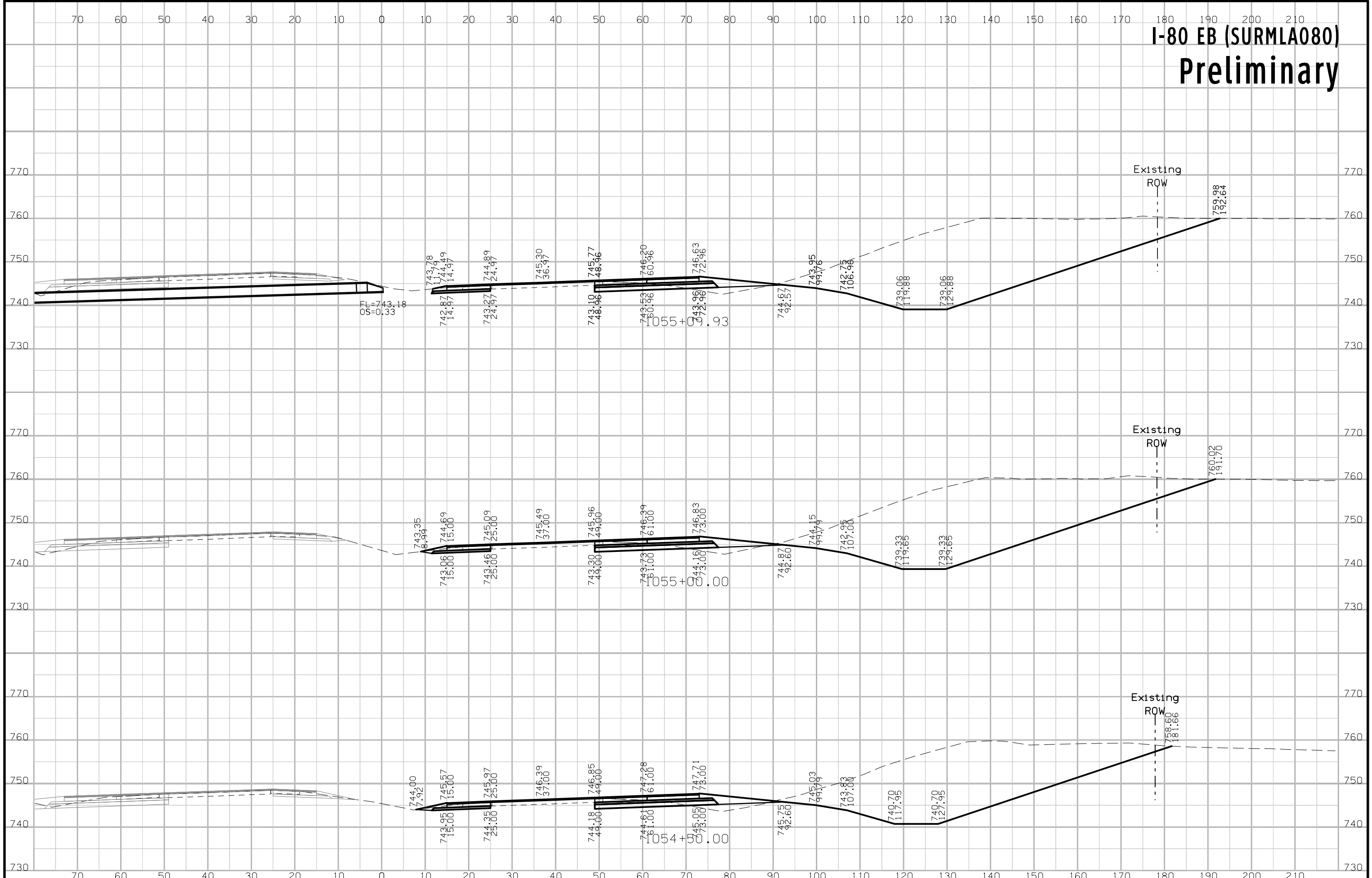

# I-80 EB (SURMLA080) Preliminary

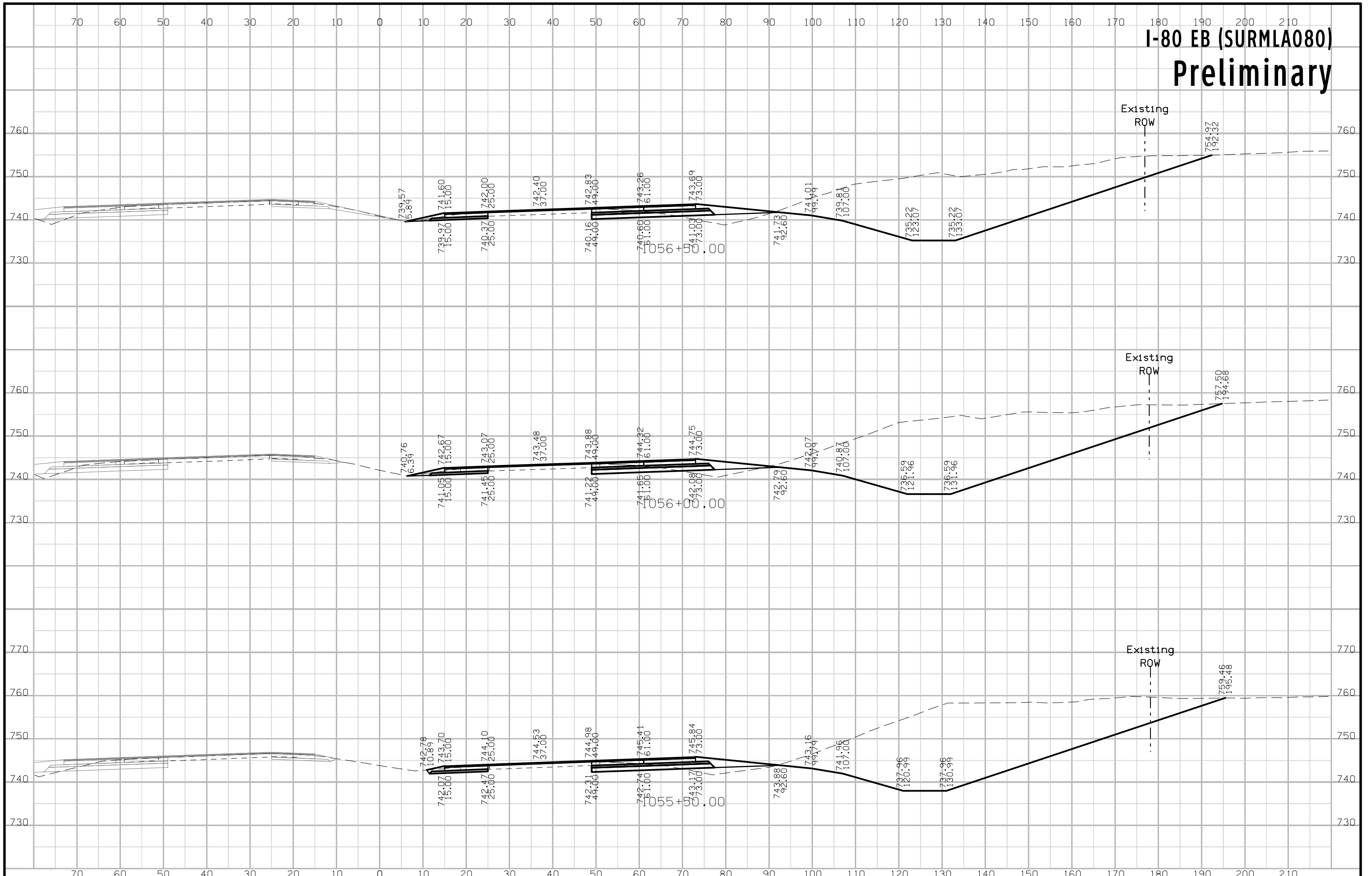



# I-80 EB (SURMLA080) Preliminary

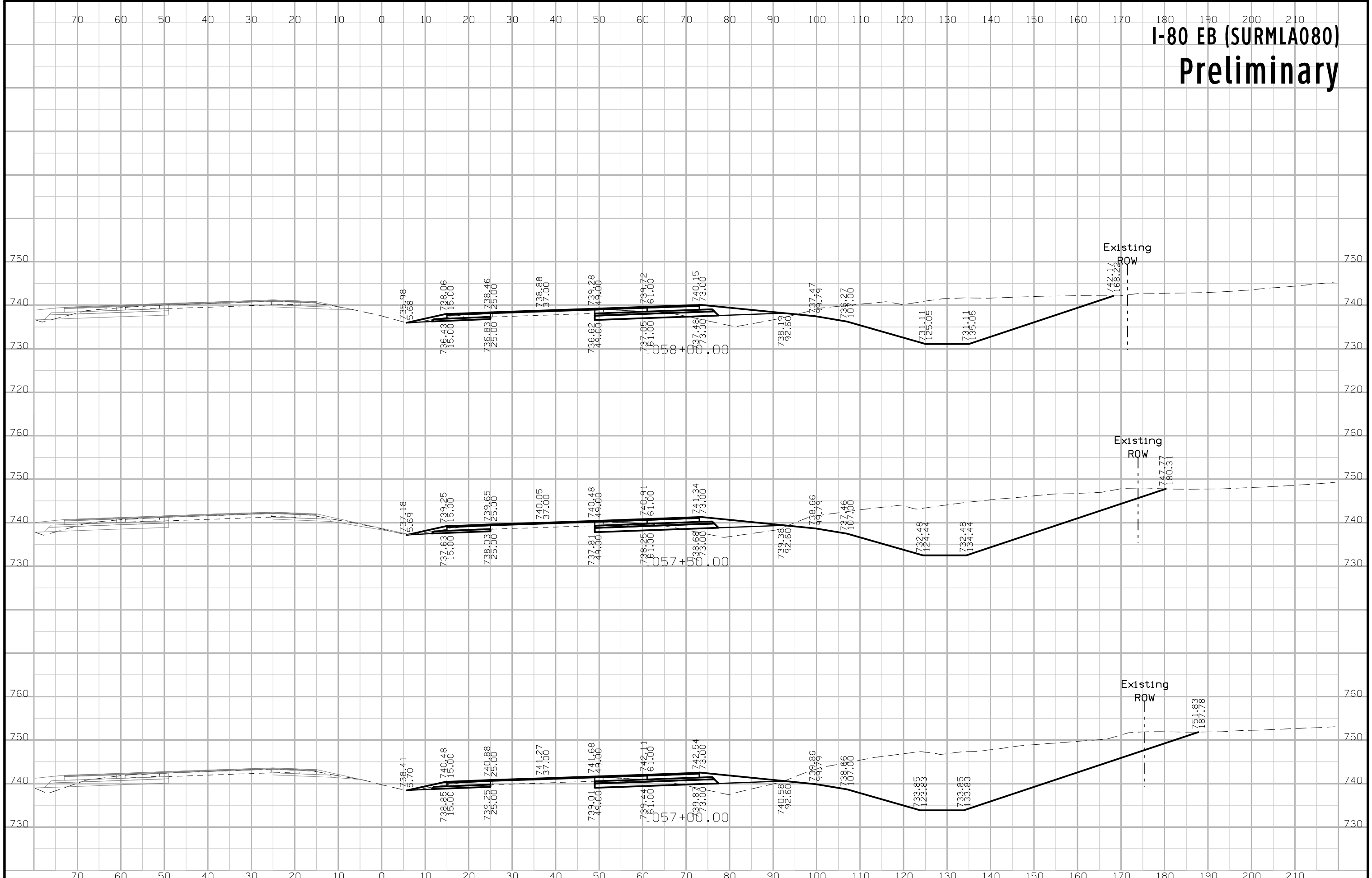

# I-80 EB (SURMLA080) Preliminary

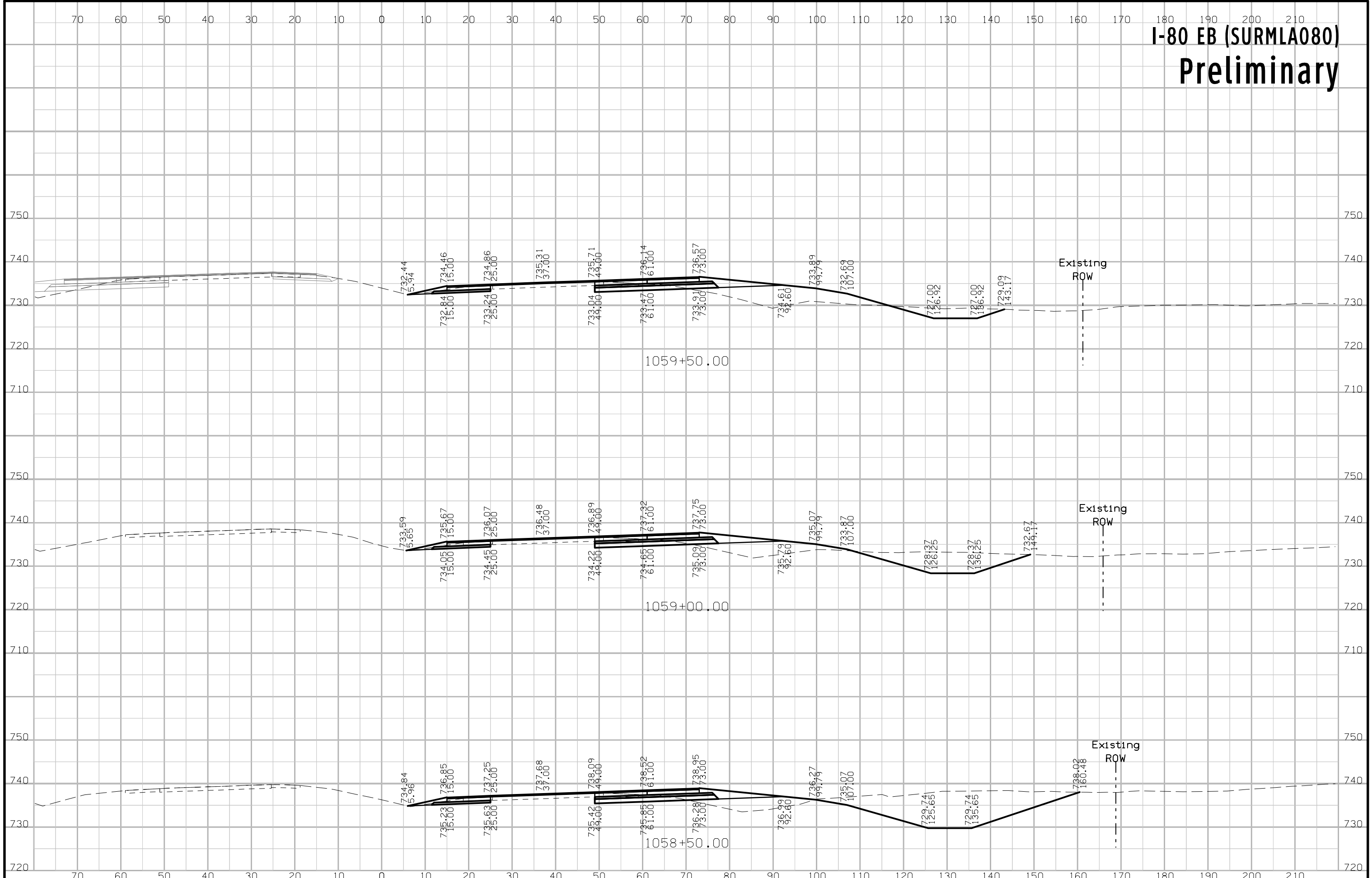

# I-80 EB (SURMLA080) Preliminary

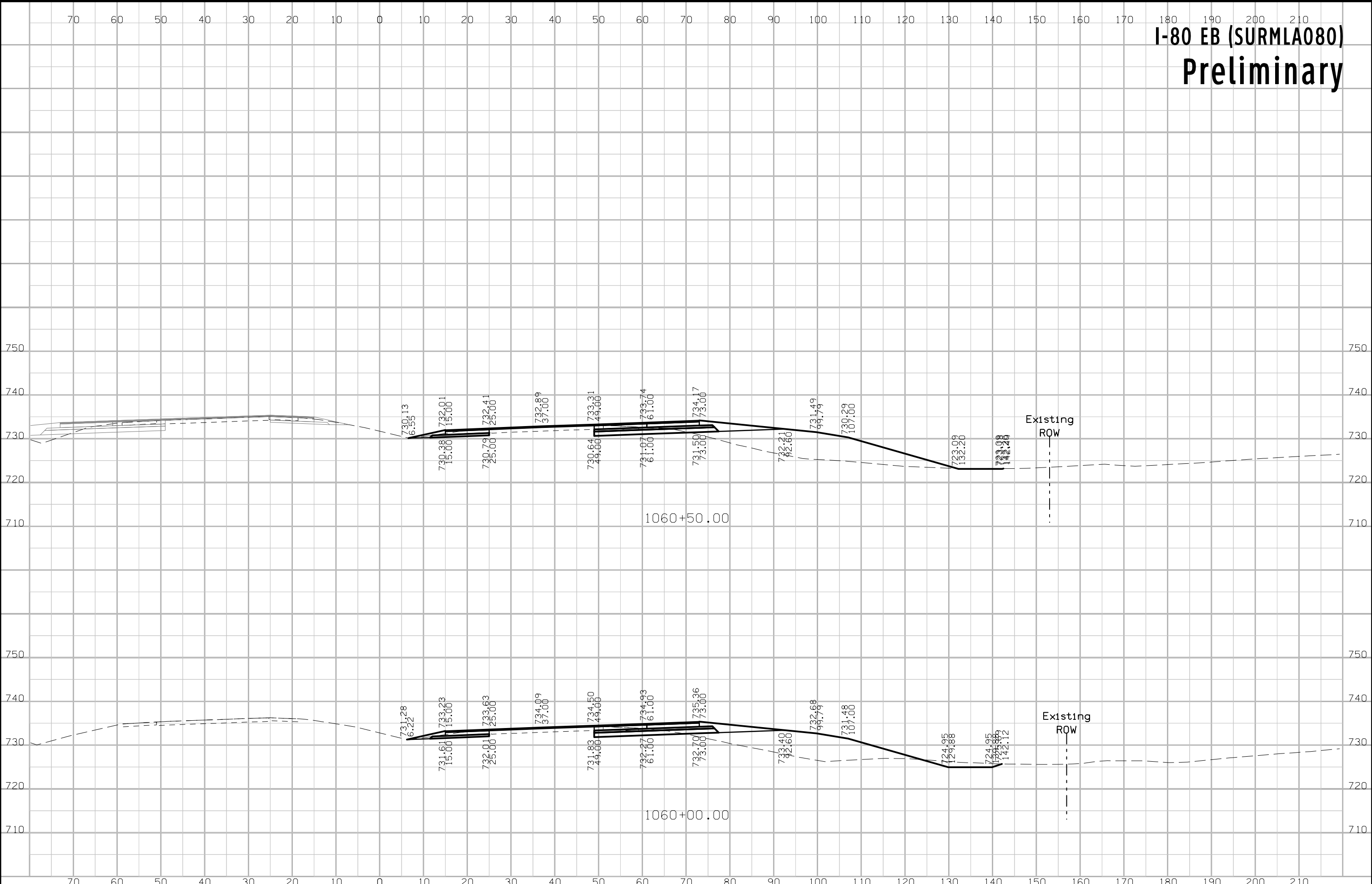

# I-80 EB (SURMLA080) Preliminary

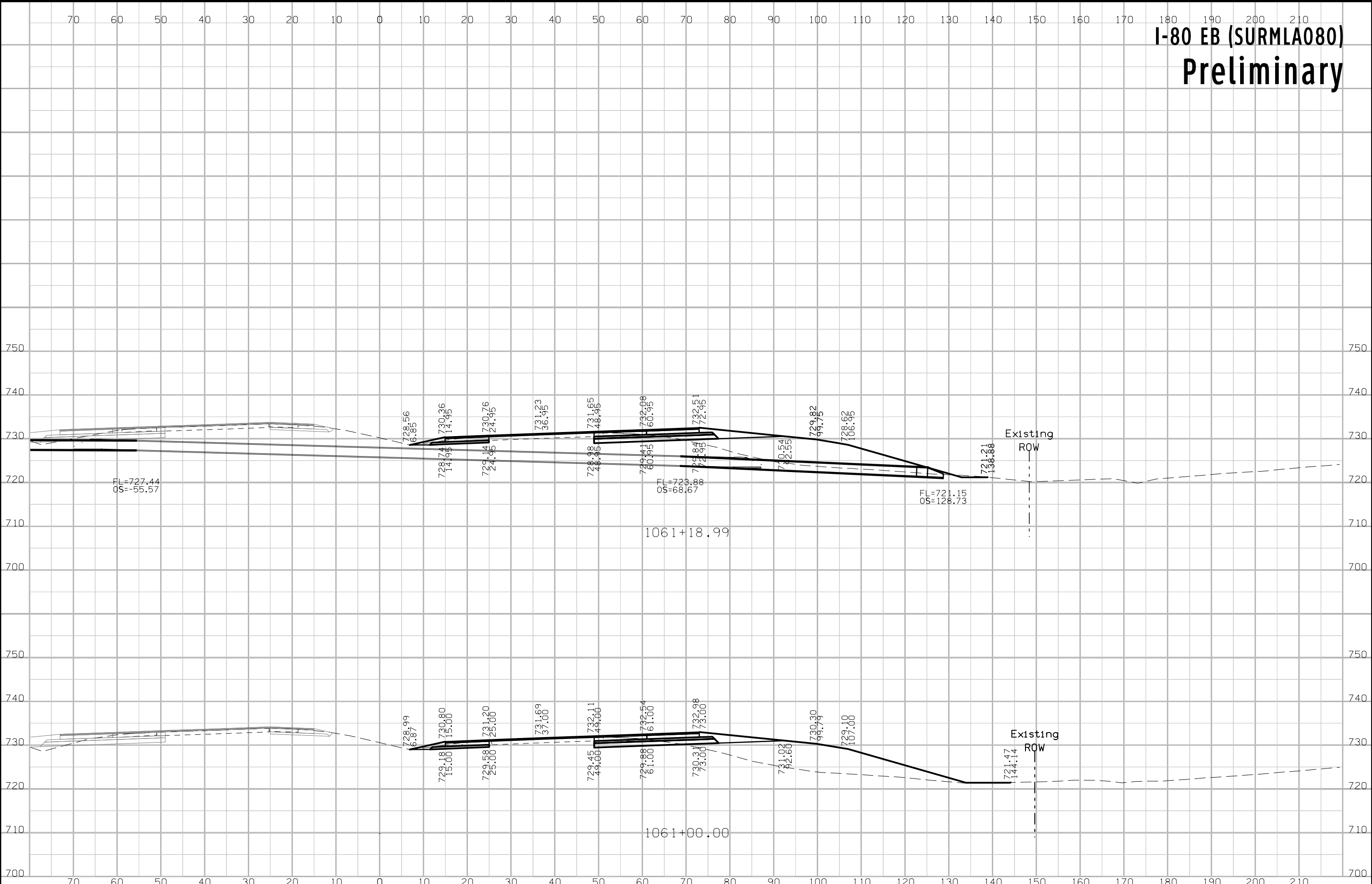

# I-80 EB (SURMLA080) Preliminary

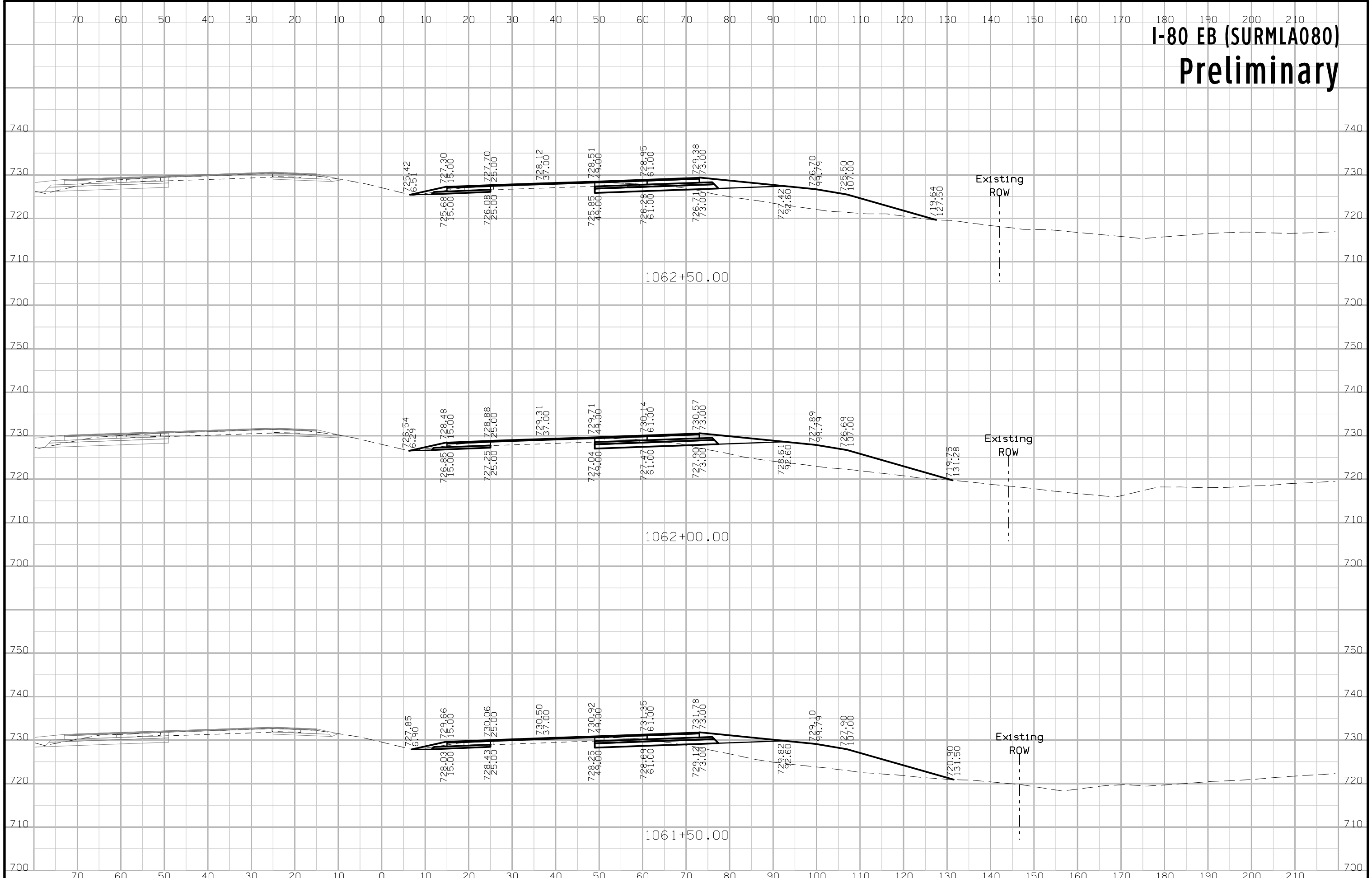

# I-80 EB (SURMLA080) Preliminary

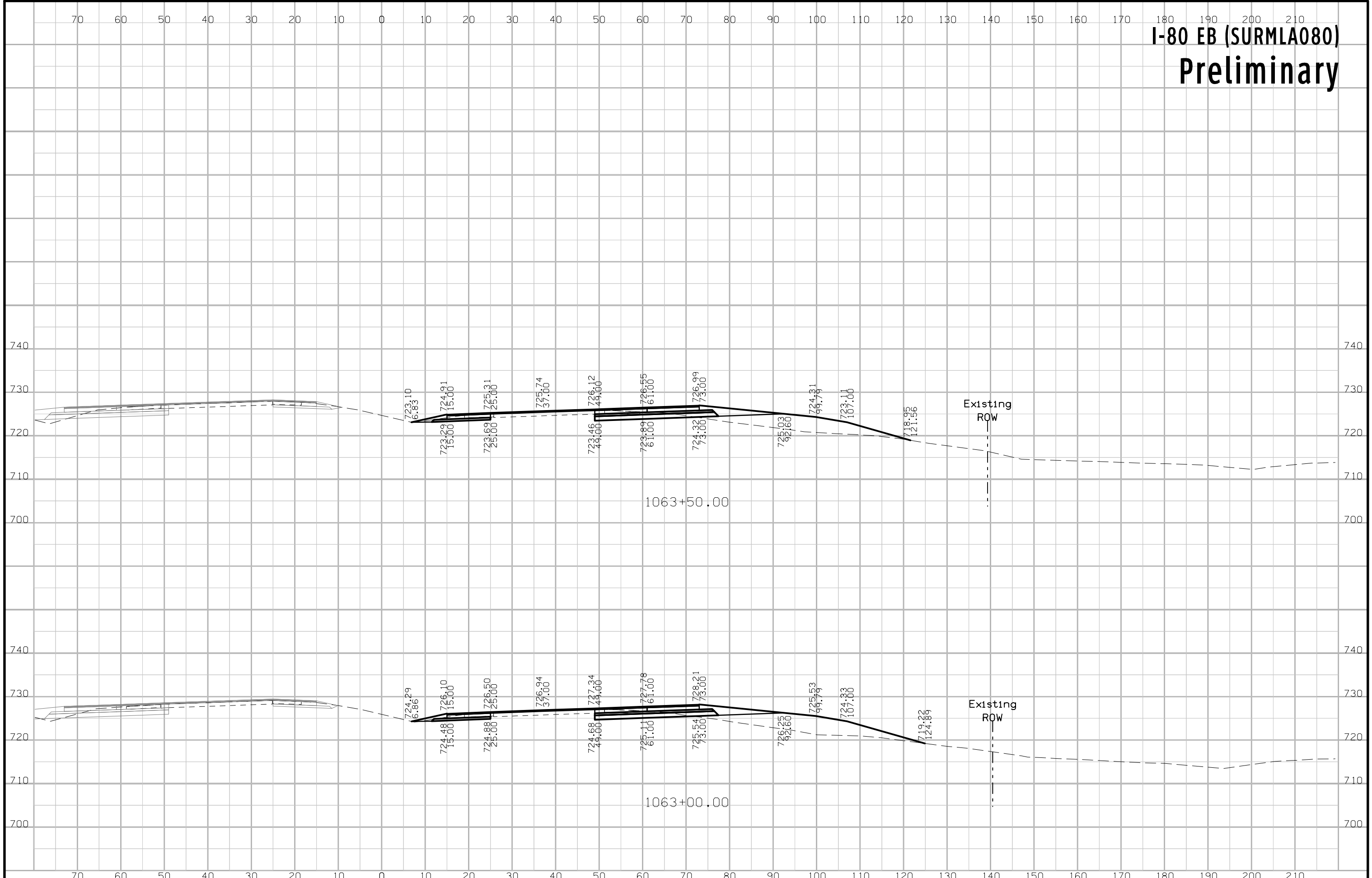

# I-80 EB (SURMLA080) Preliminary

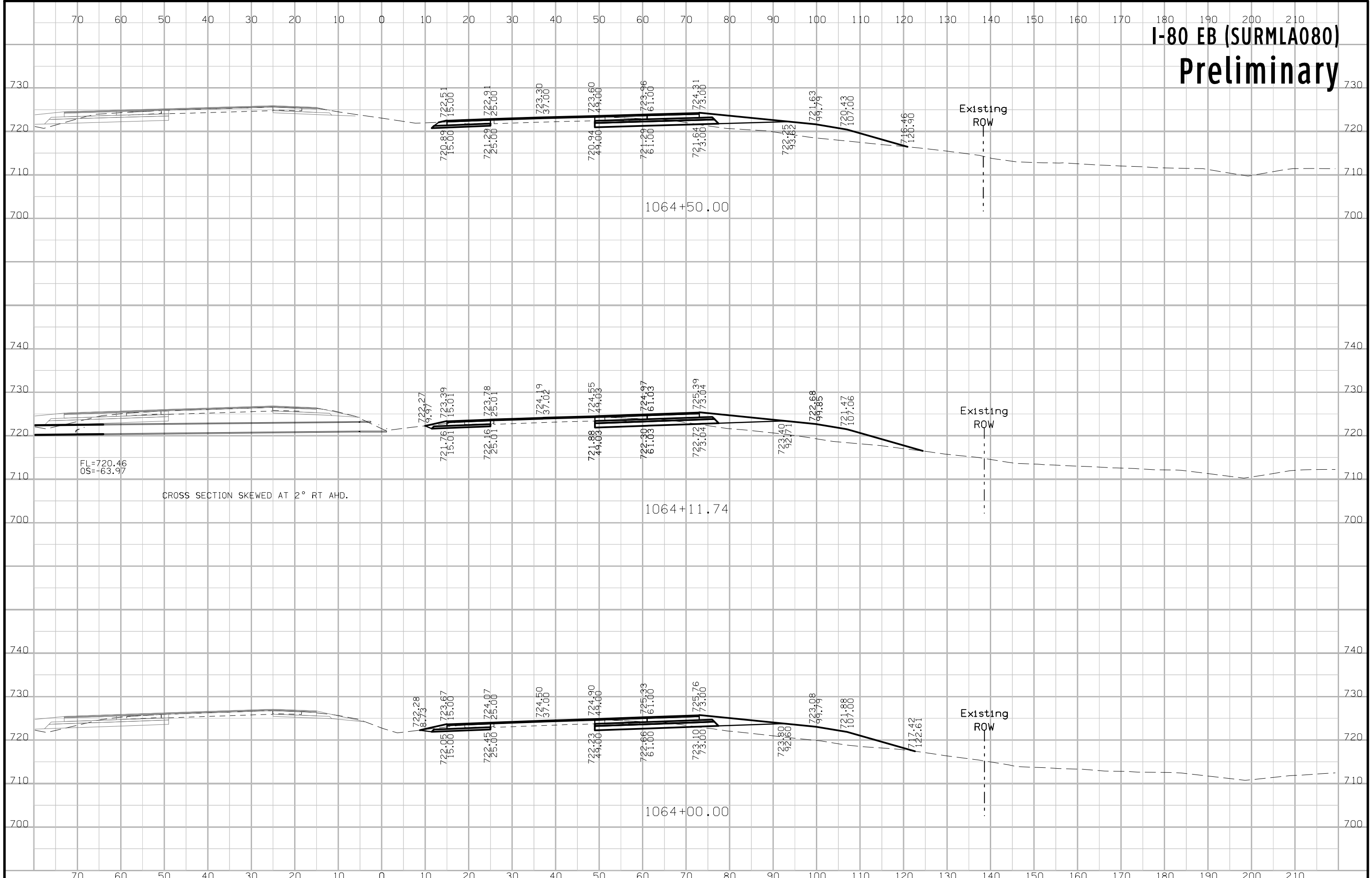

FL=720.46  
OS=-63.97

CROSS SECTION SKEWED AT 2° RT AHD.

# I-80 EB (SURMLA080) Preliminary

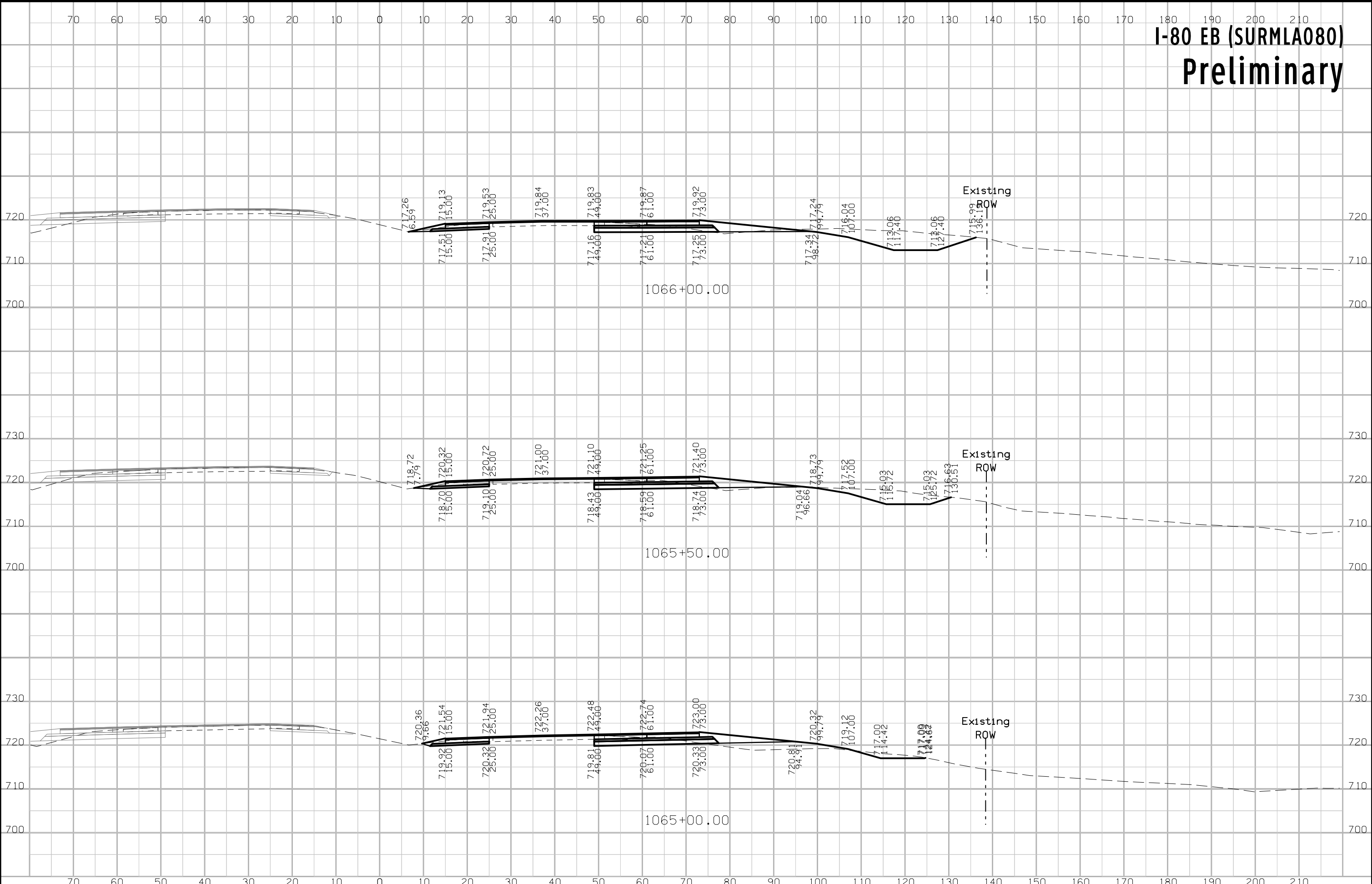



# I-80 EB (SURMLA080) Preliminary

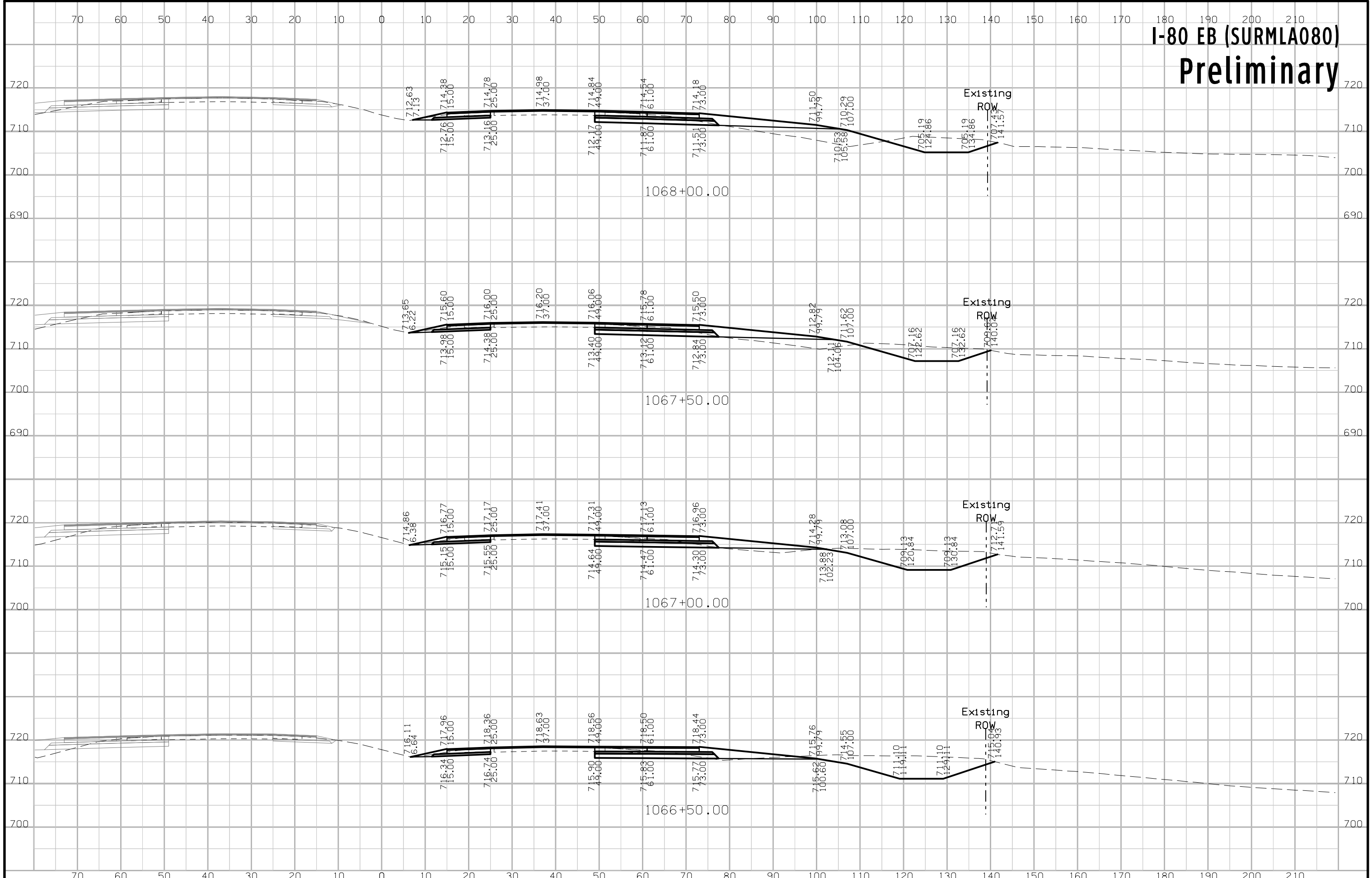

# I-80 EB (SURMLA080) Preliminary

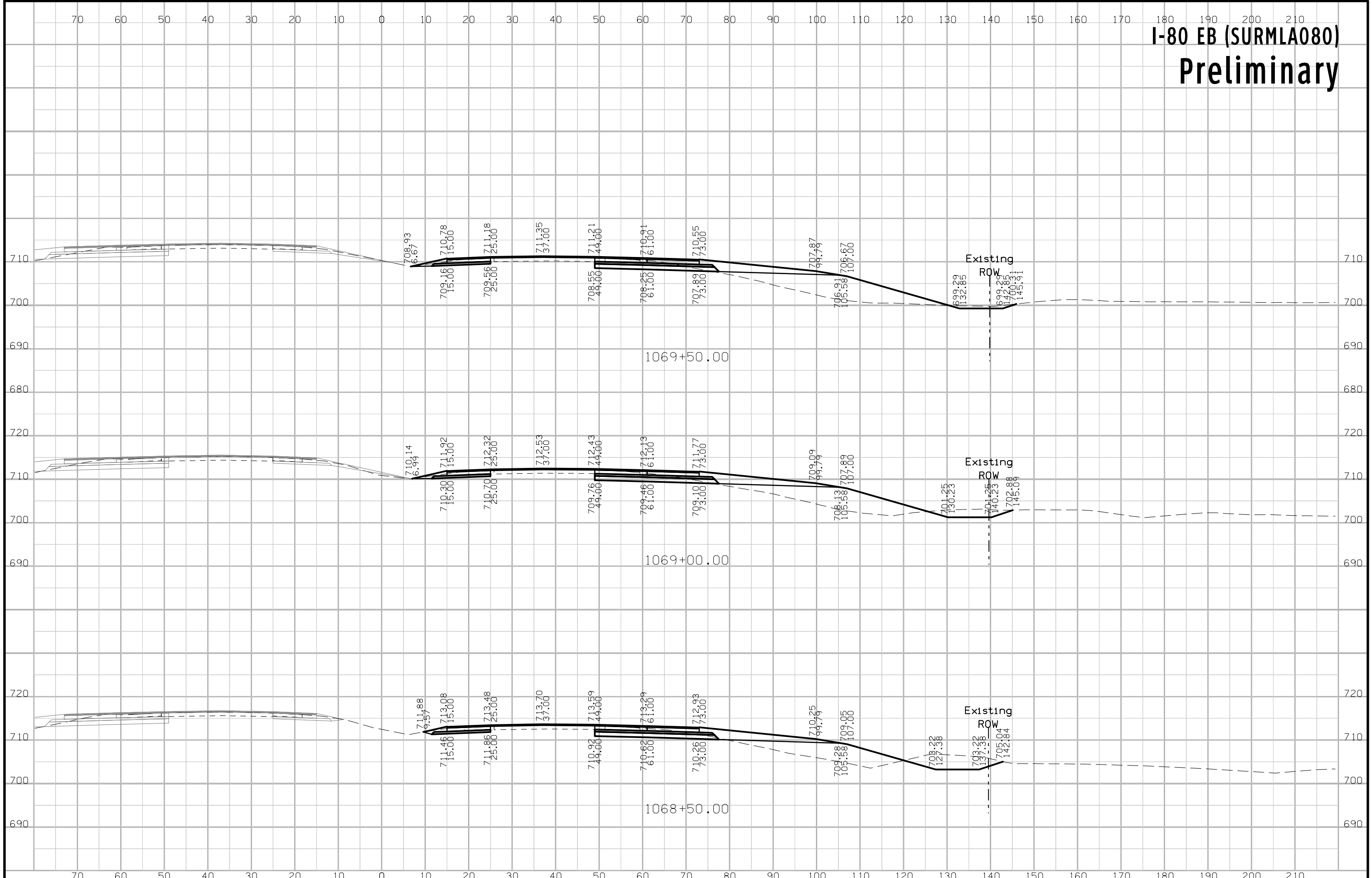

# I-80 EB (SURMLA080) Preliminary

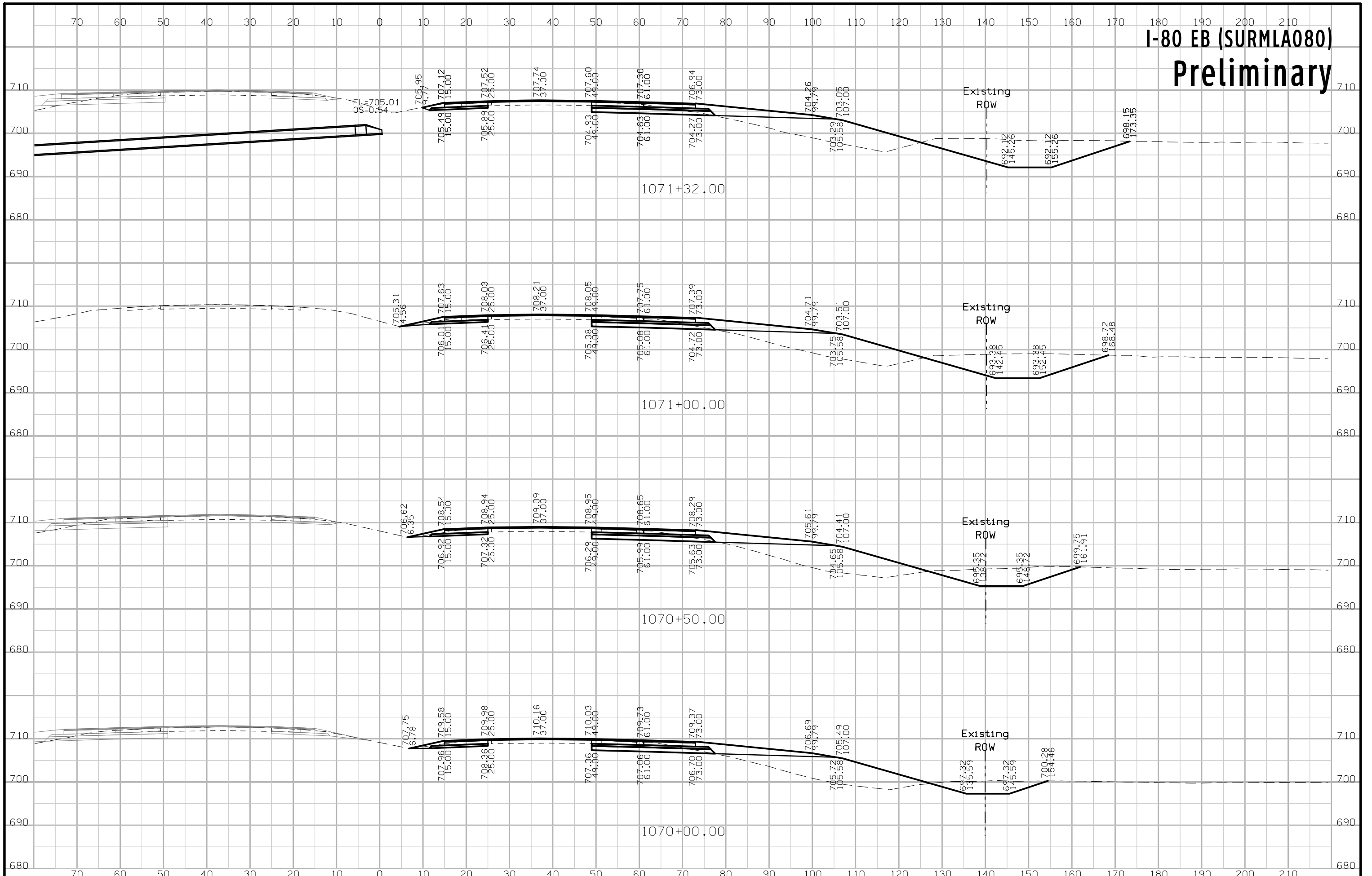

# I-80 EB (SURMLA080) Preliminary

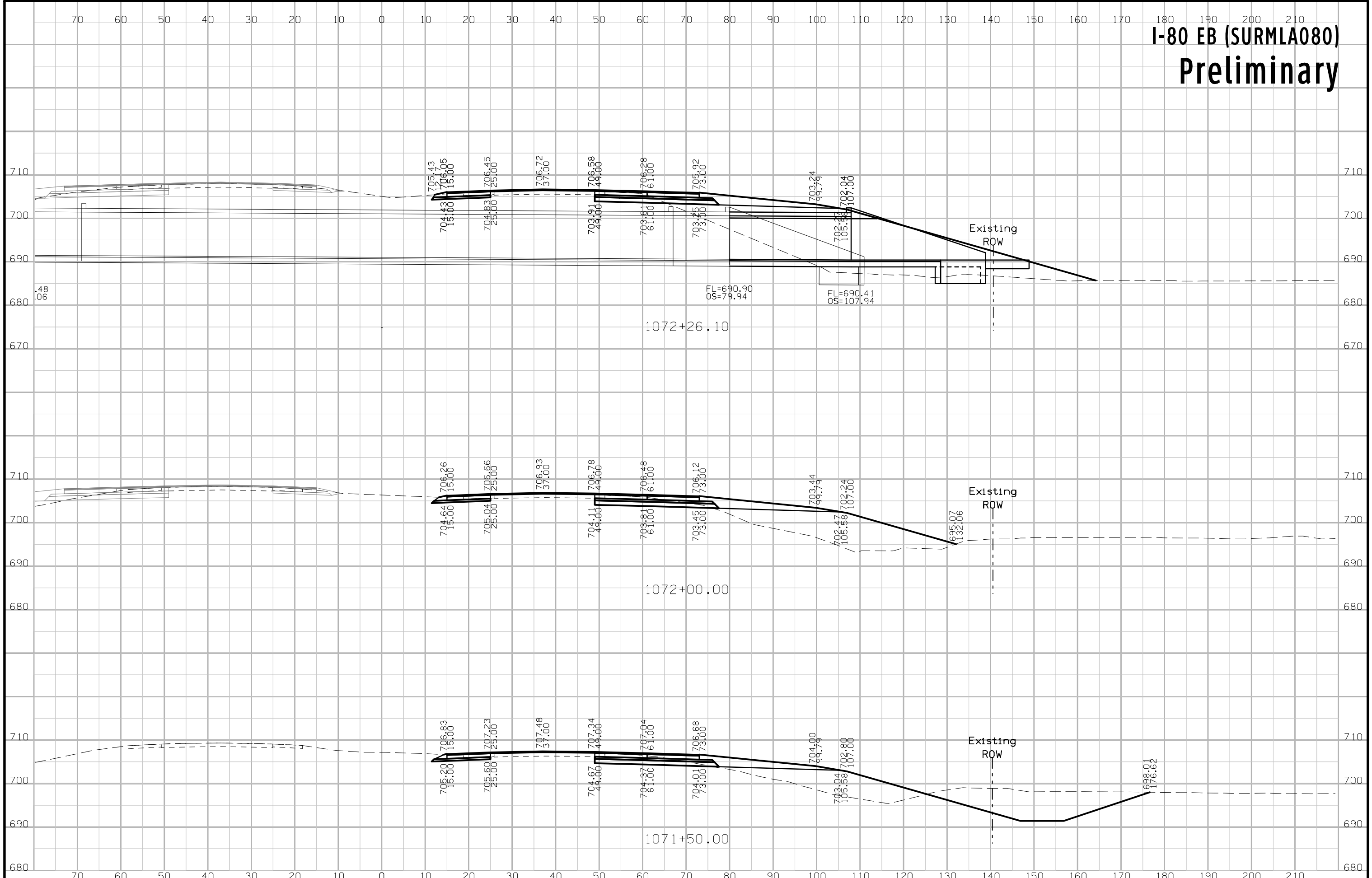

# I-80 EB (SURMLA080) Preliminary

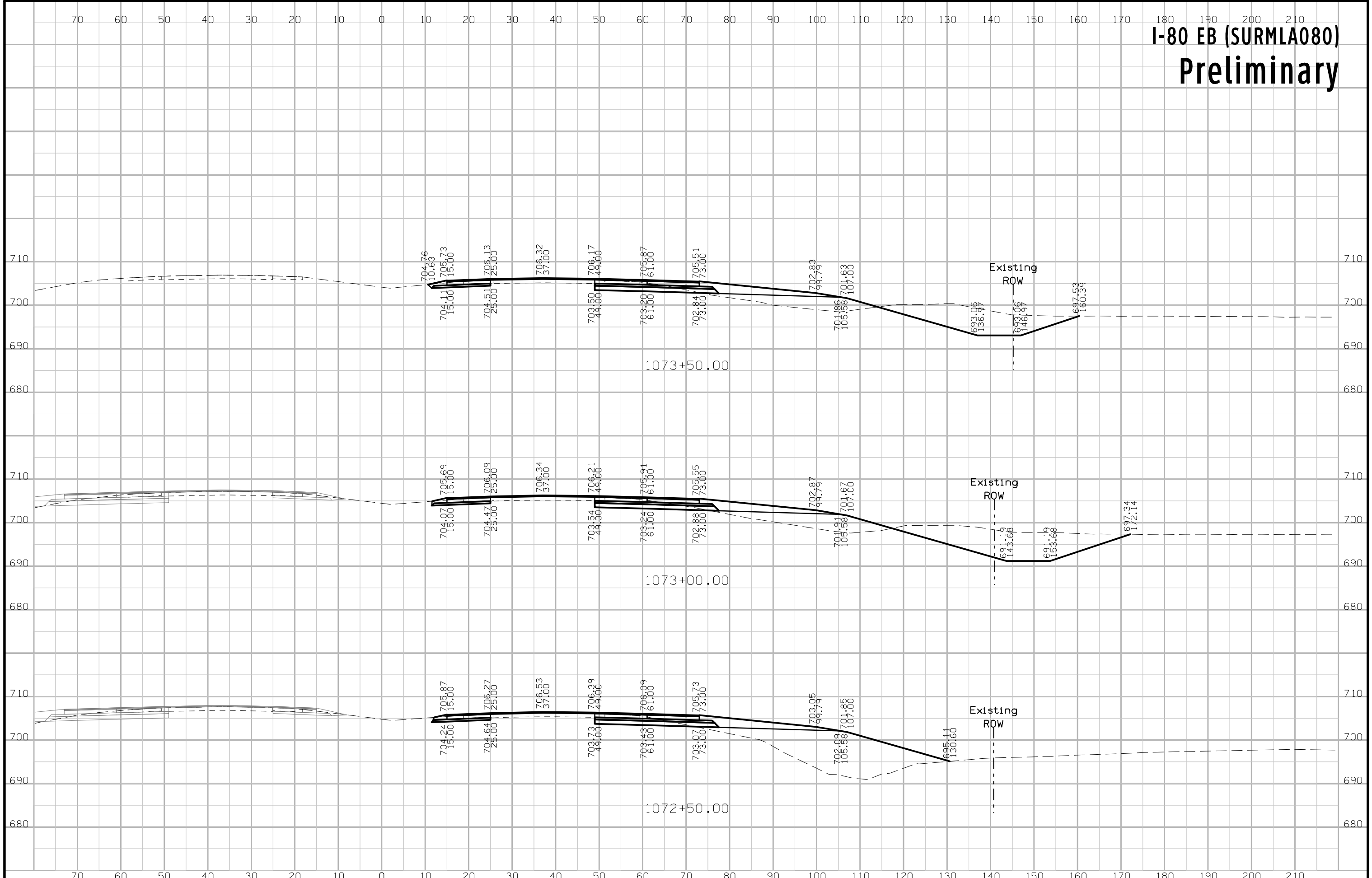

# I-80 EB (SURMLA080) Preliminary

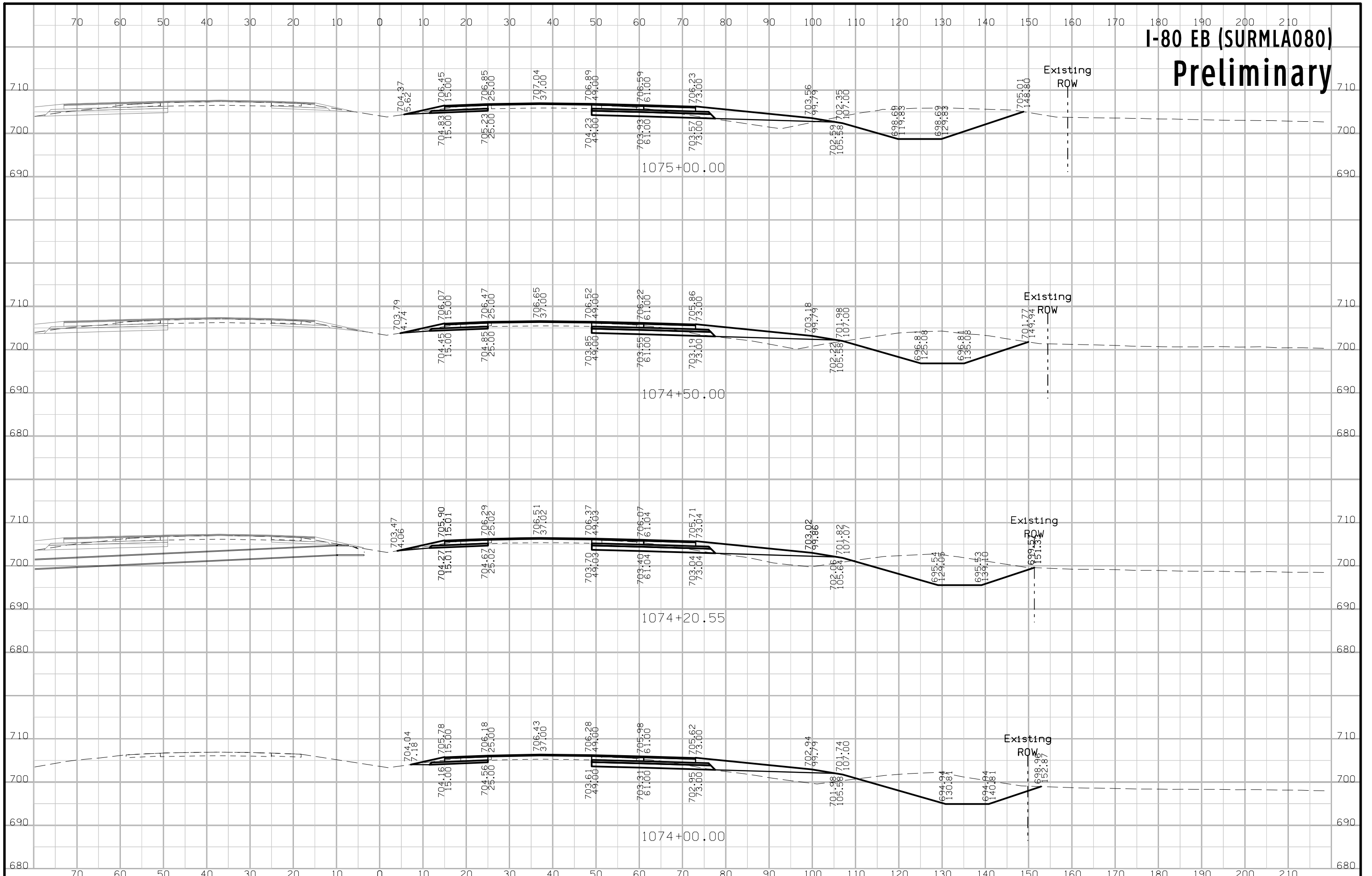

# I-80 EB (SURMLA080) Preliminary

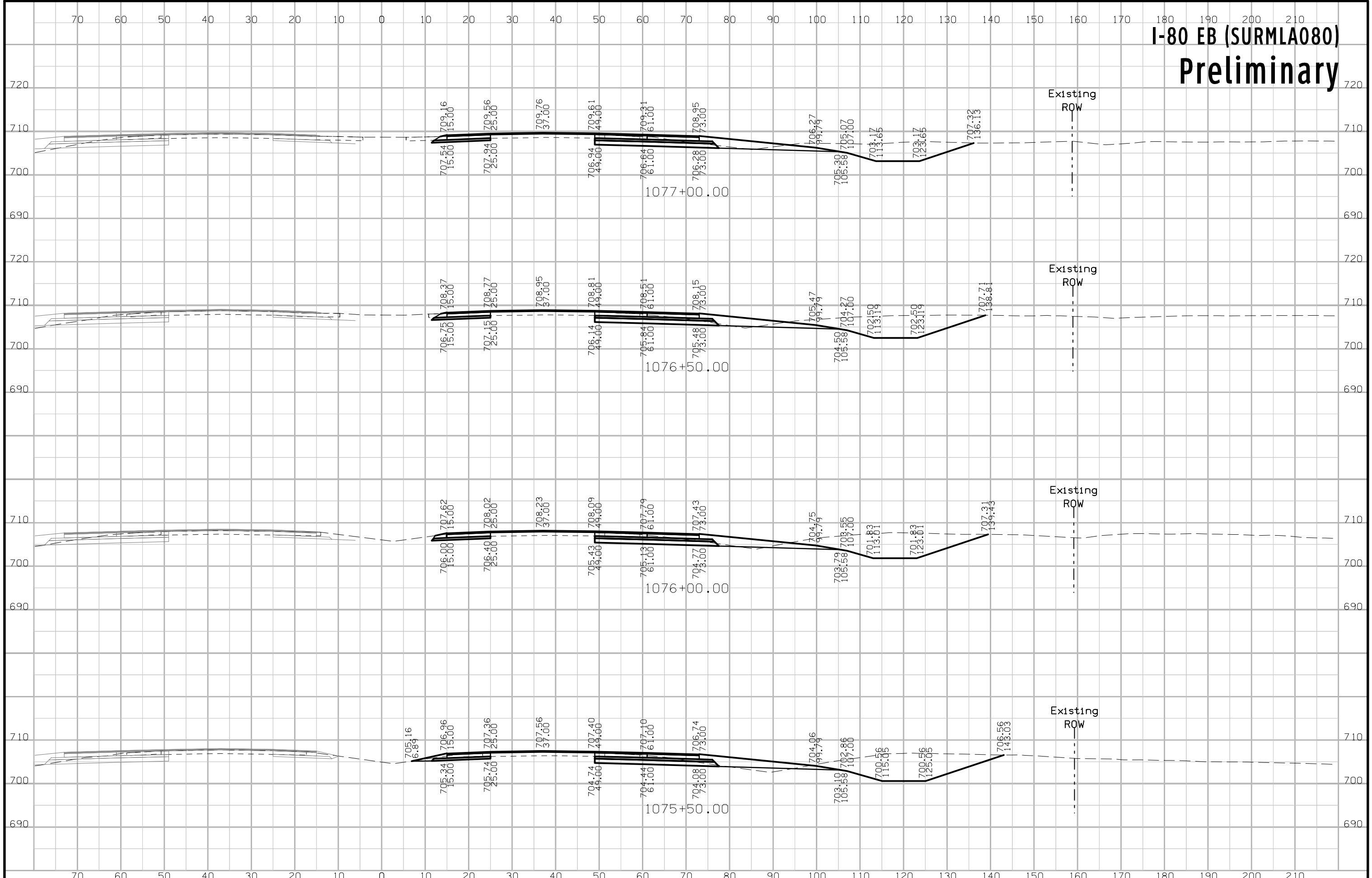

# I-80 EB (SURMLA080) Preliminary

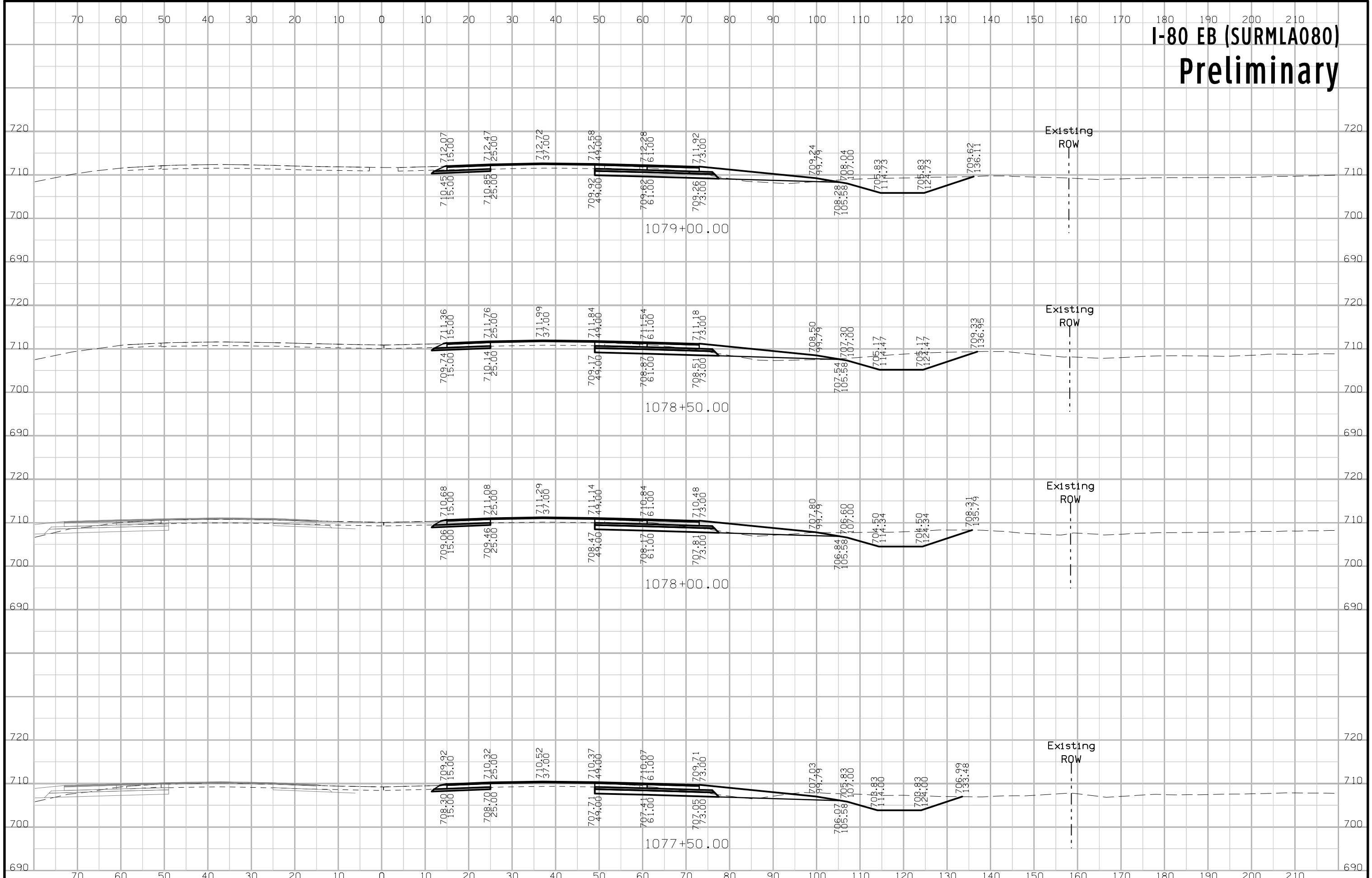



# I-80 EB (SURMLA080) Preliminary

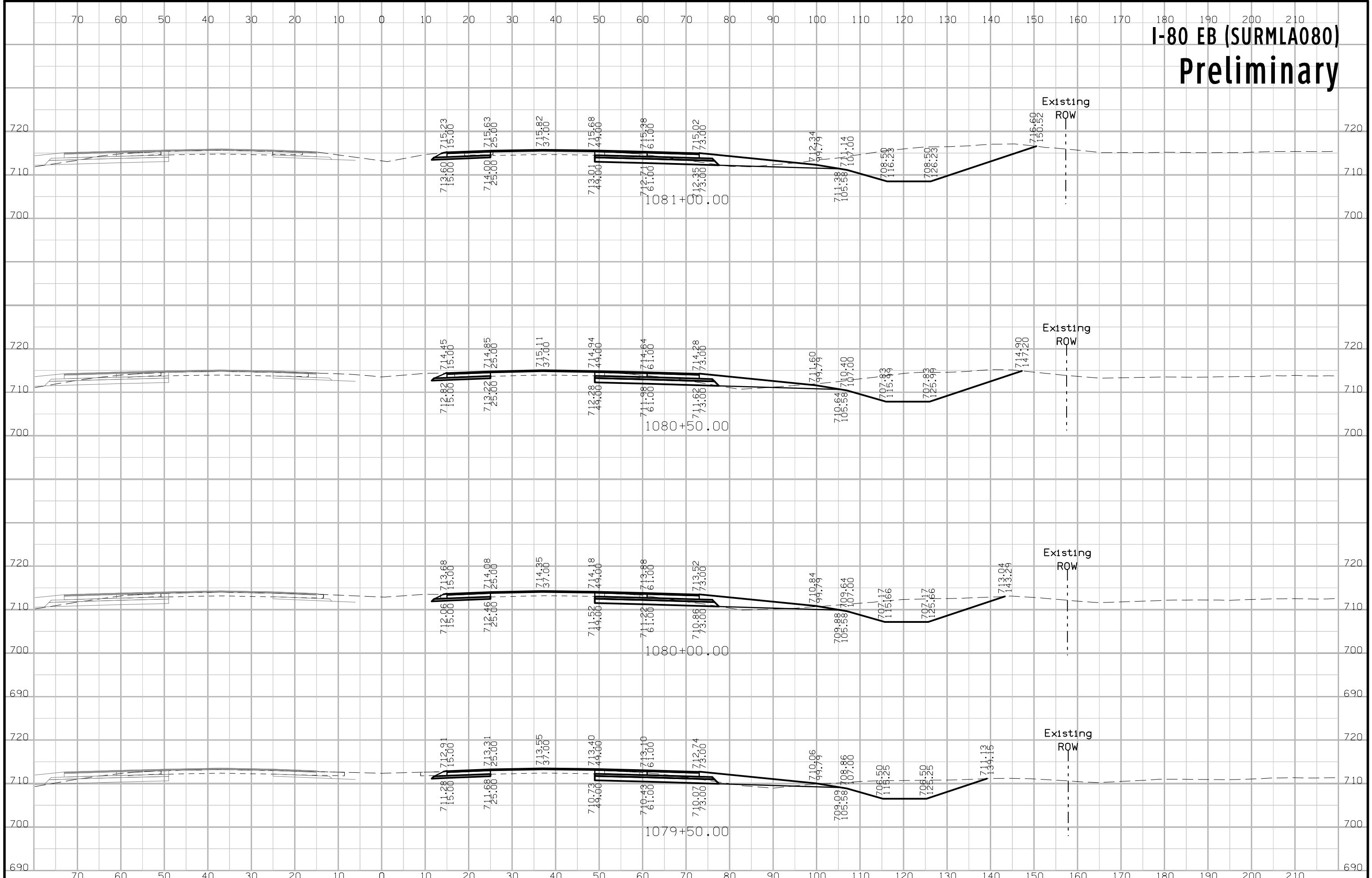

# I-80 EB (SURMLA080) Preliminary

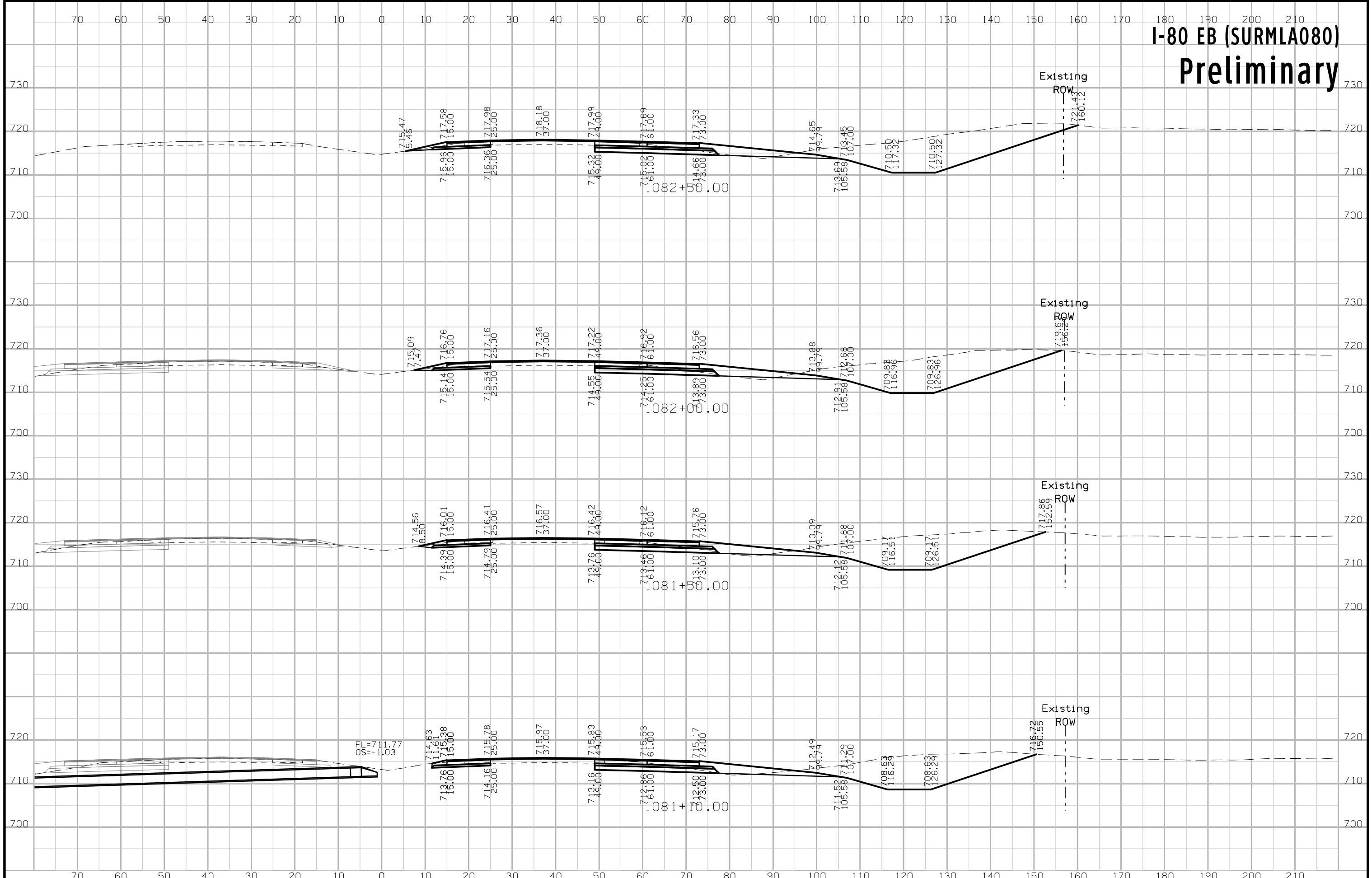

# I-80 EB (SURMLA080) Preliminary

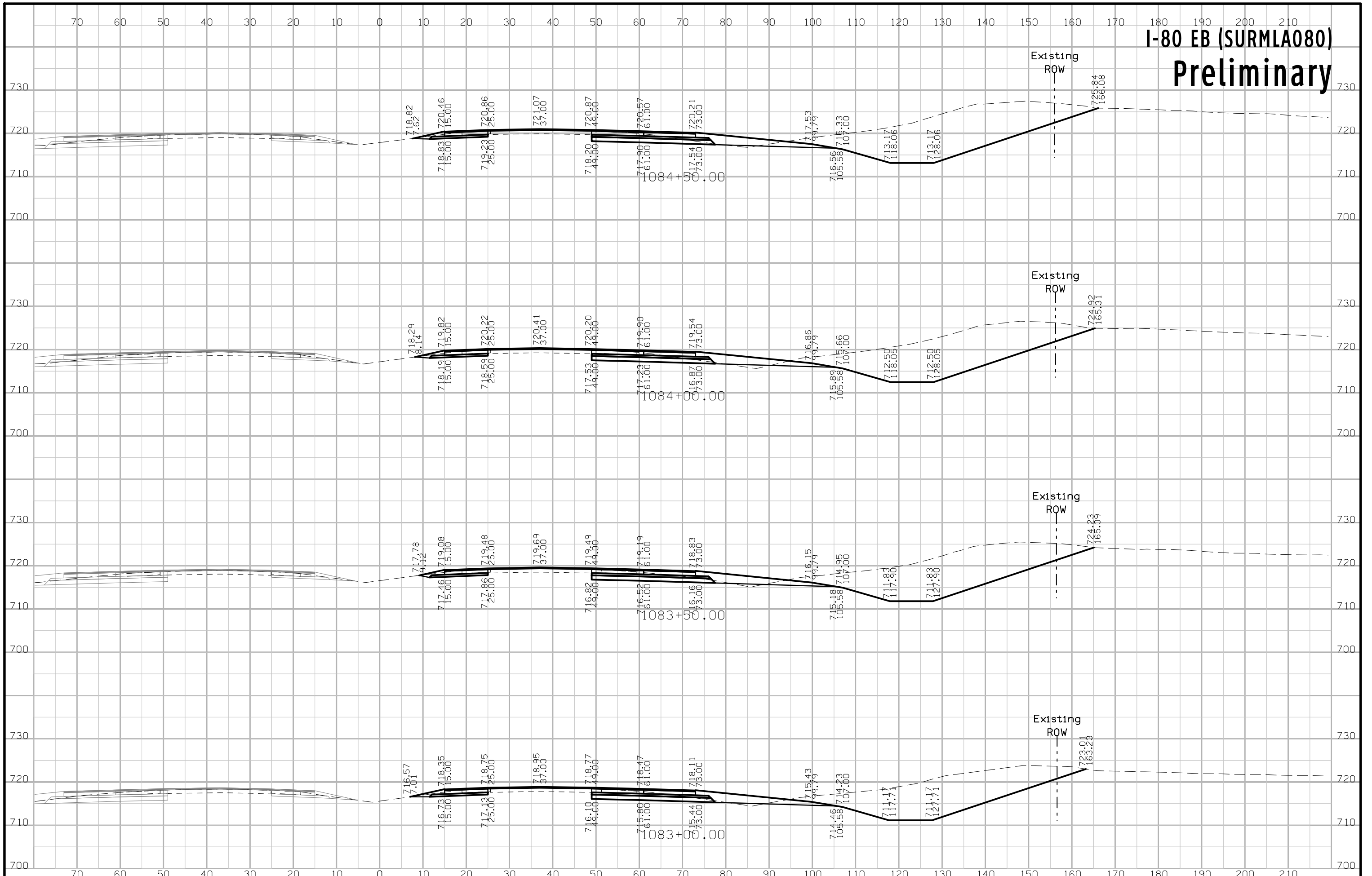

# I-80 EB (SURMLA080) Preliminary

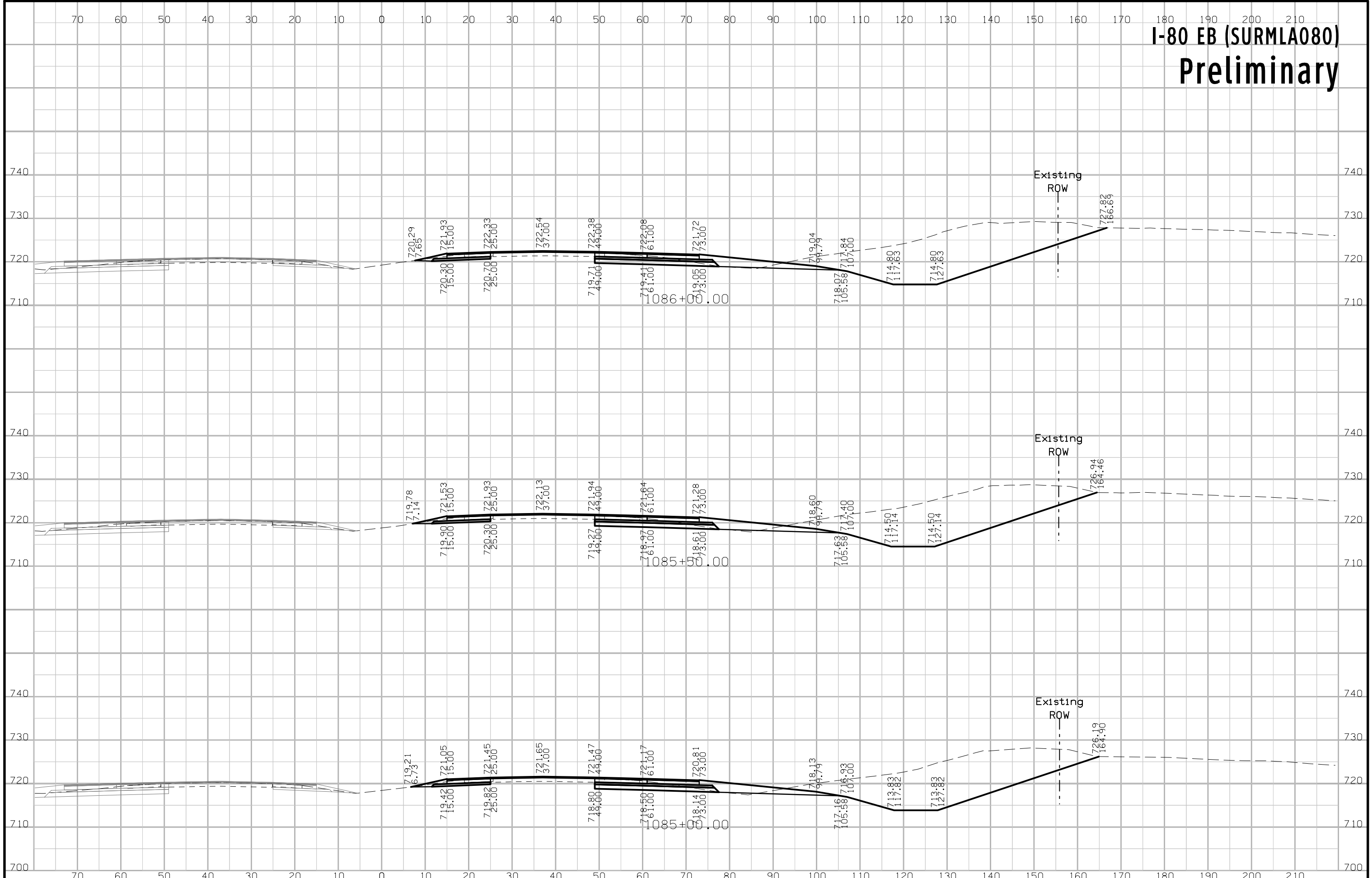

# I-80 EB (SURMLA080) Preliminary

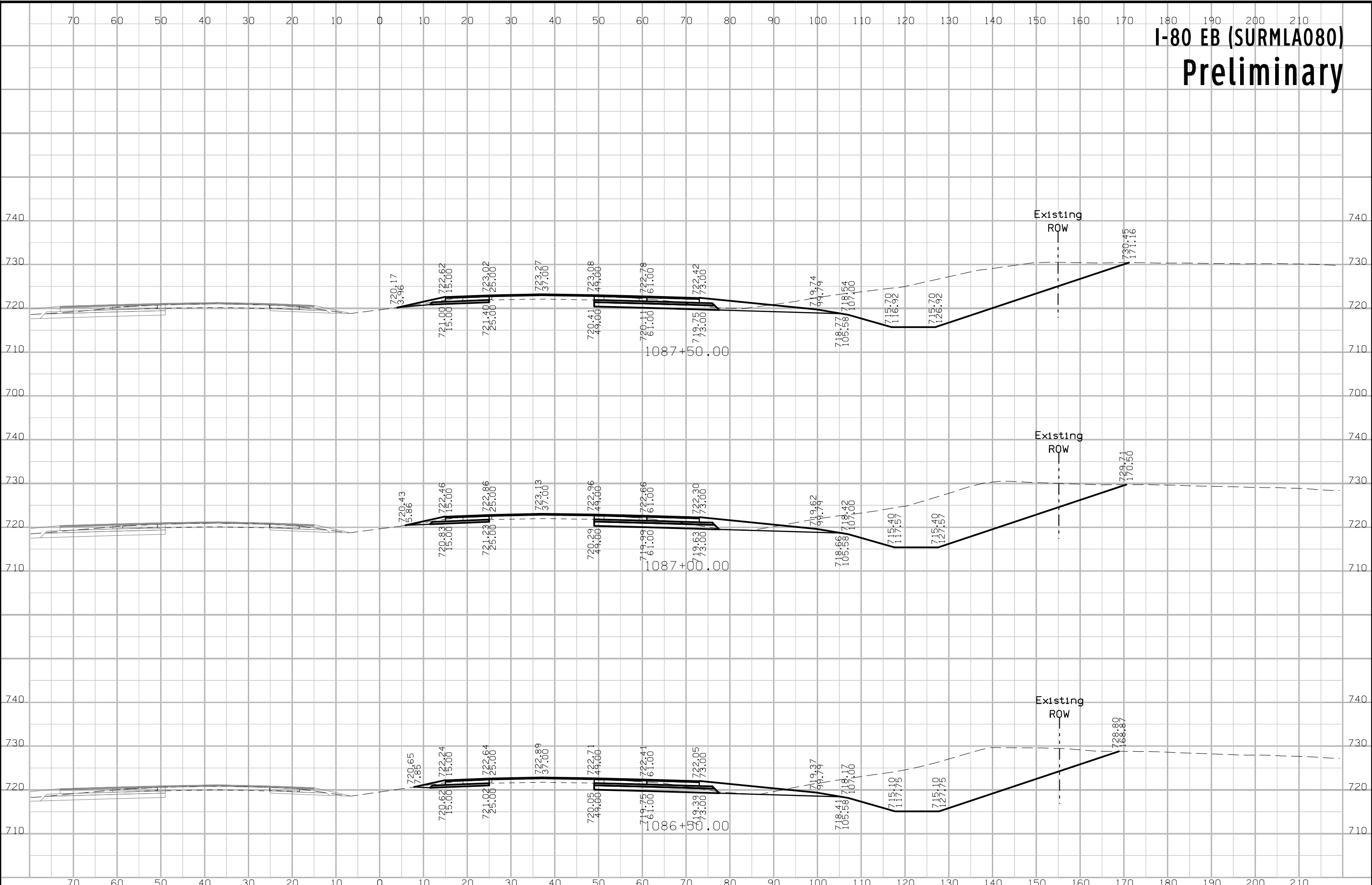

# I-80 EB (SURMLA080) Preliminary

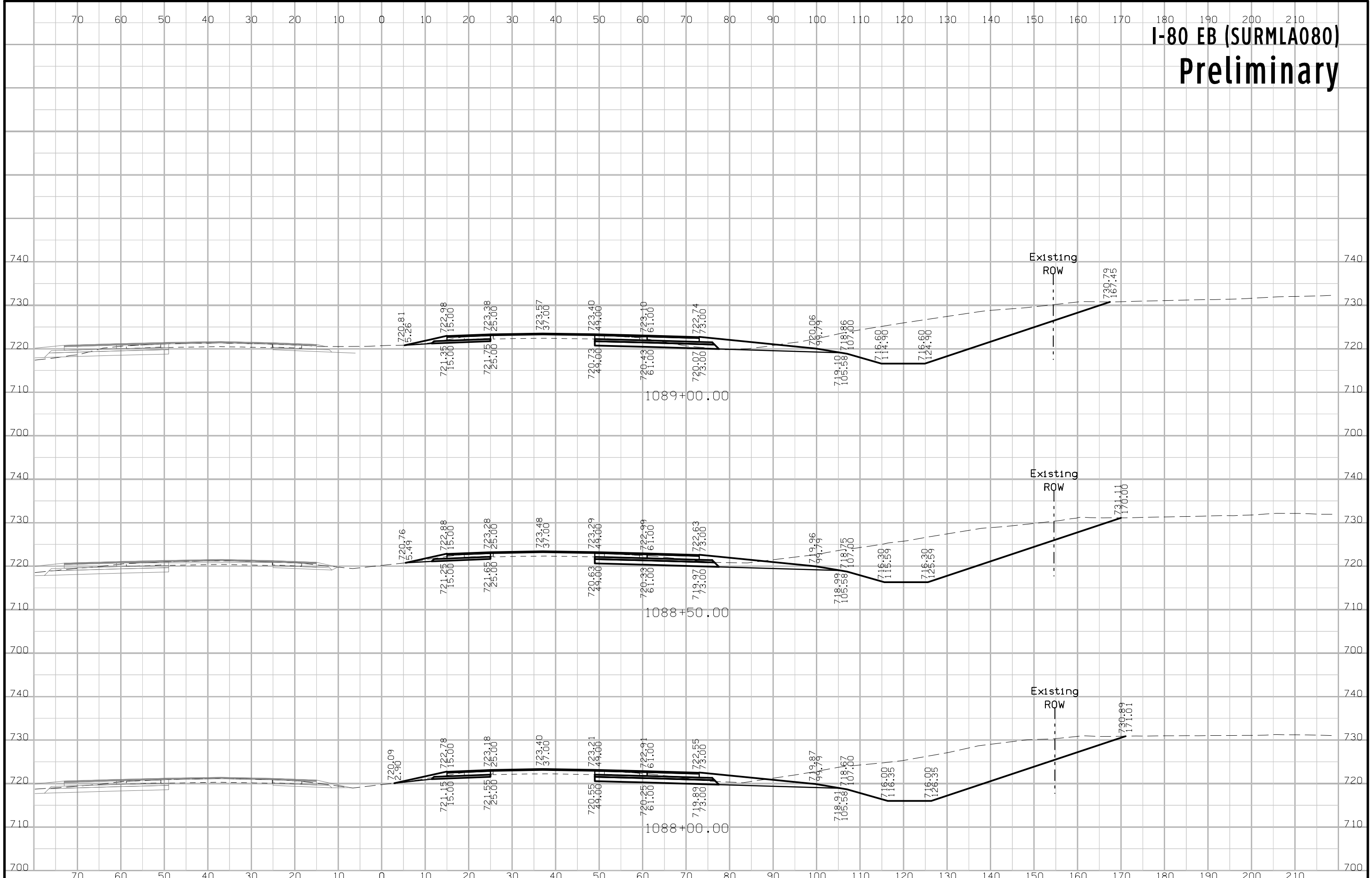

# I-80 EB (SURMLA080) Preliminary

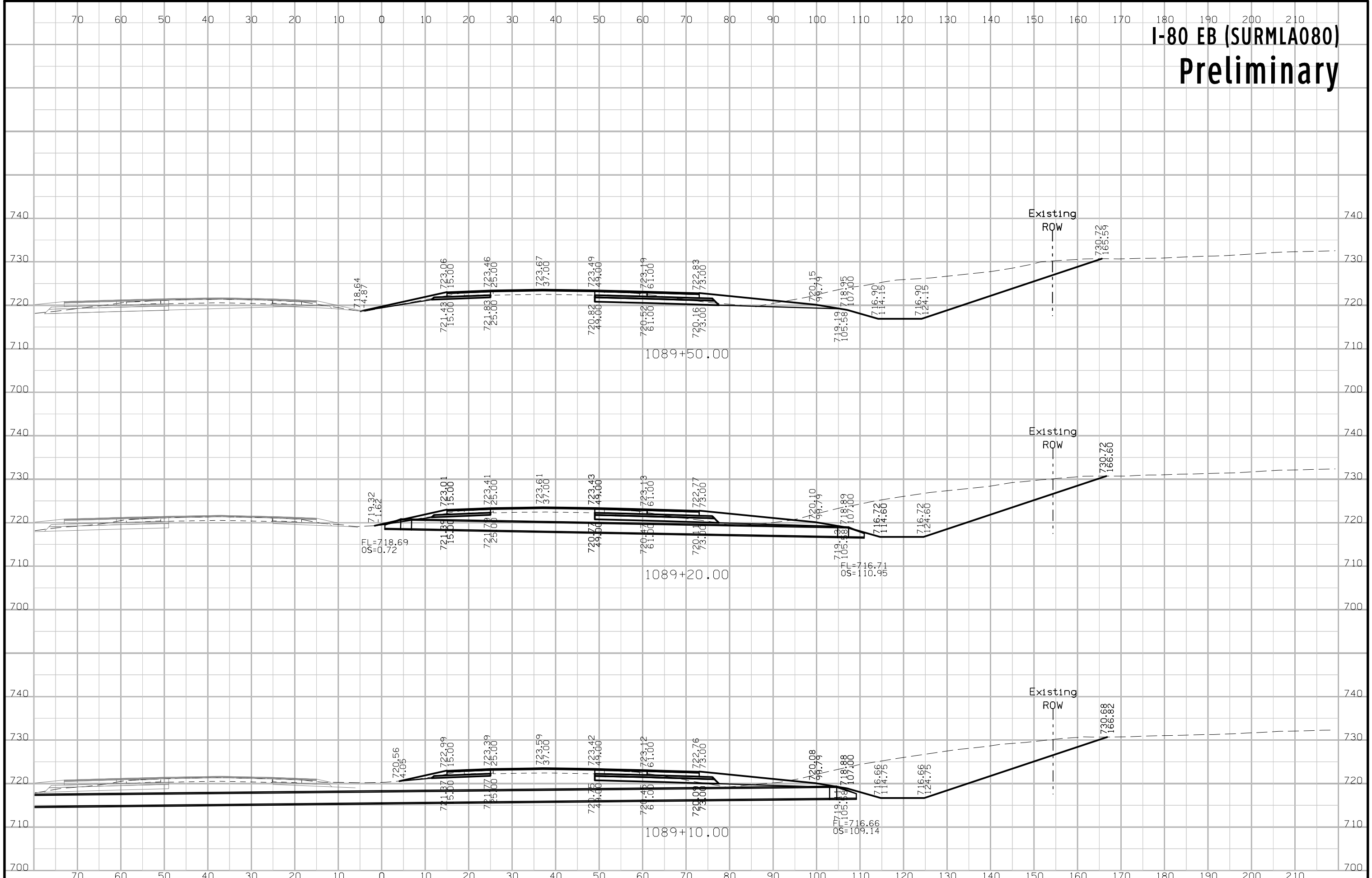

# I-80 EB (SURMLA080) Preliminary

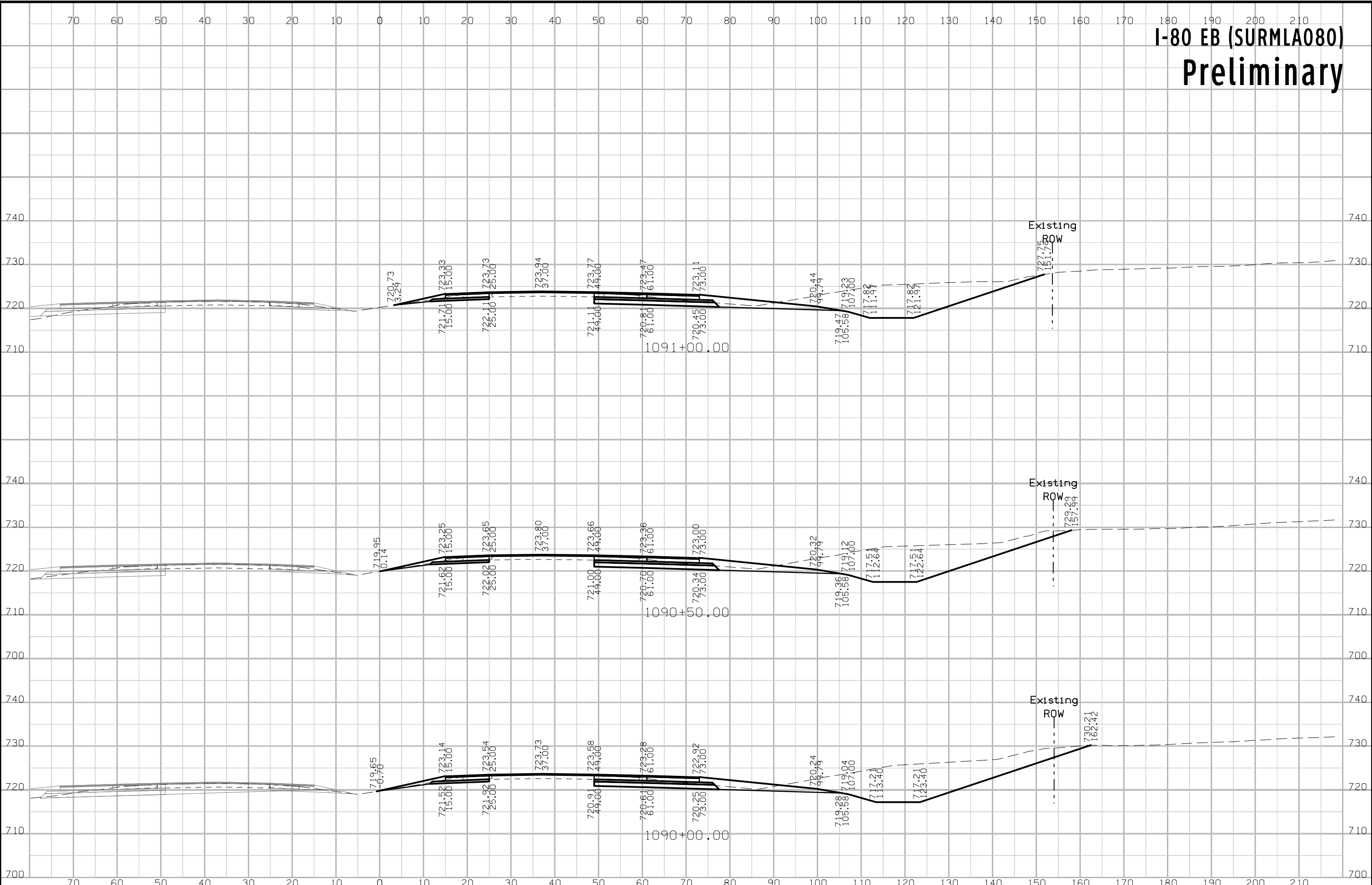



# I-80 EB (SURMLA080) Preliminary

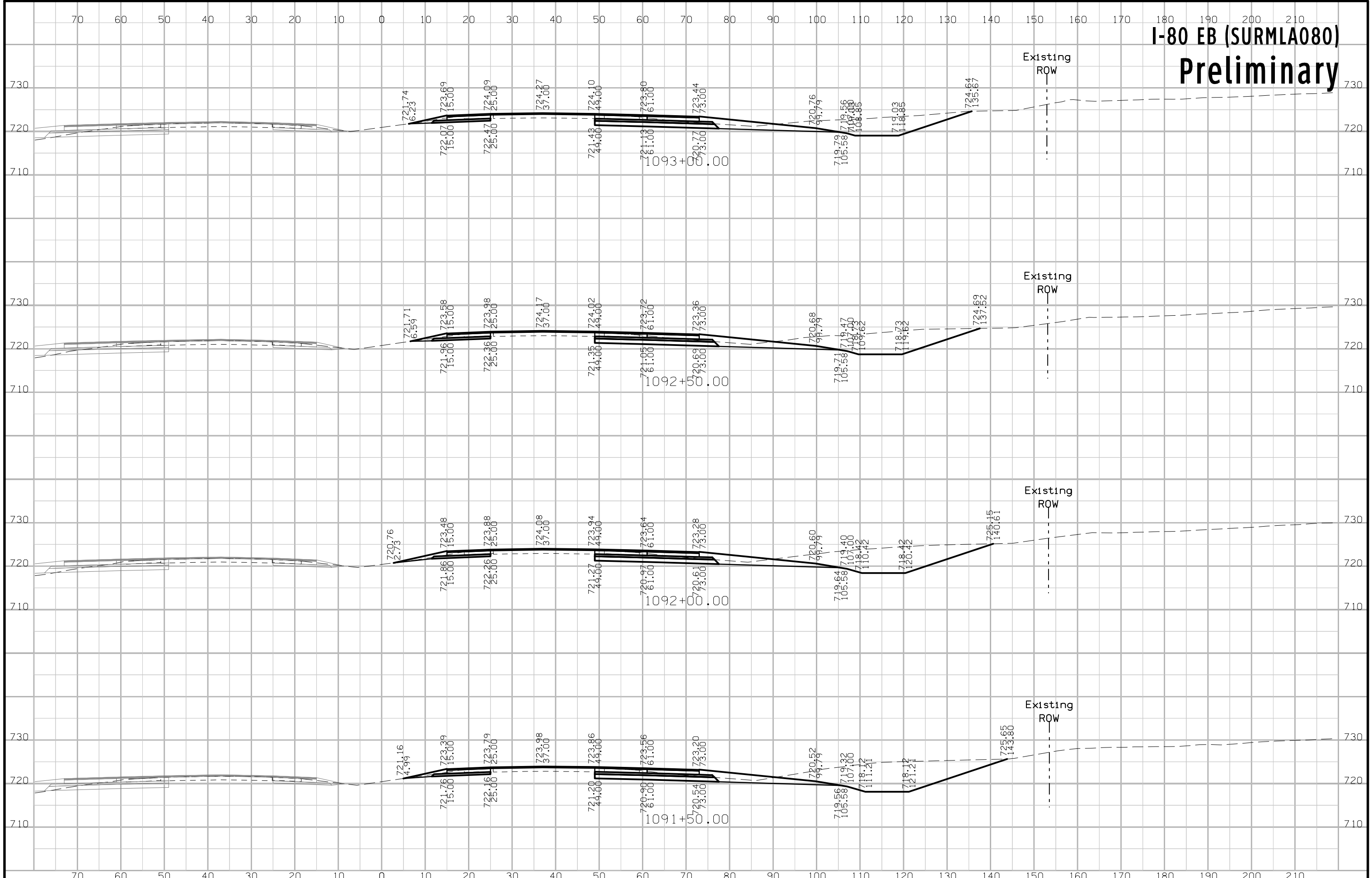

# I-80 EB (SURMLA080) Preliminary

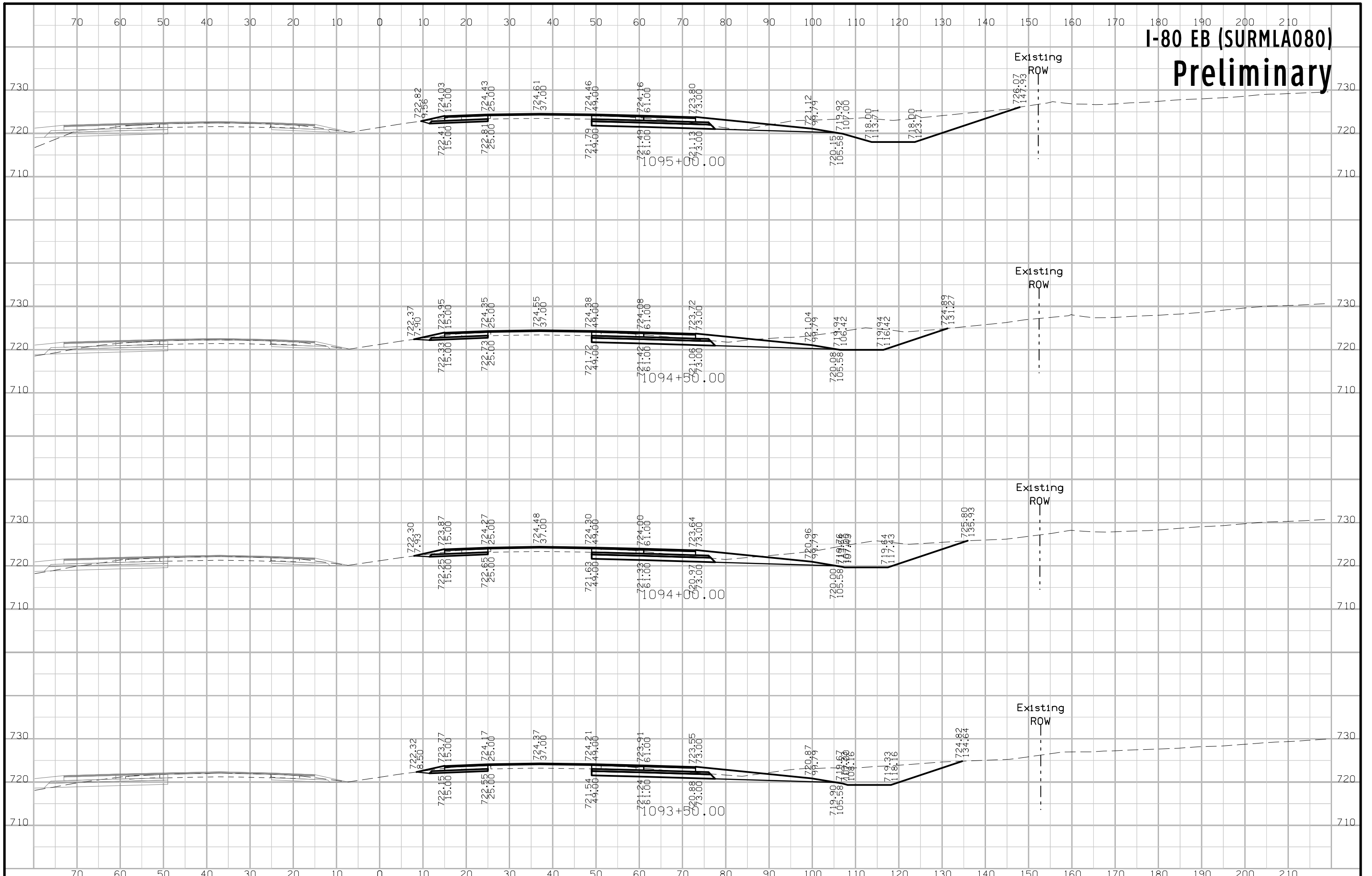

# I-80 EB (SURMLA080) Preliminary

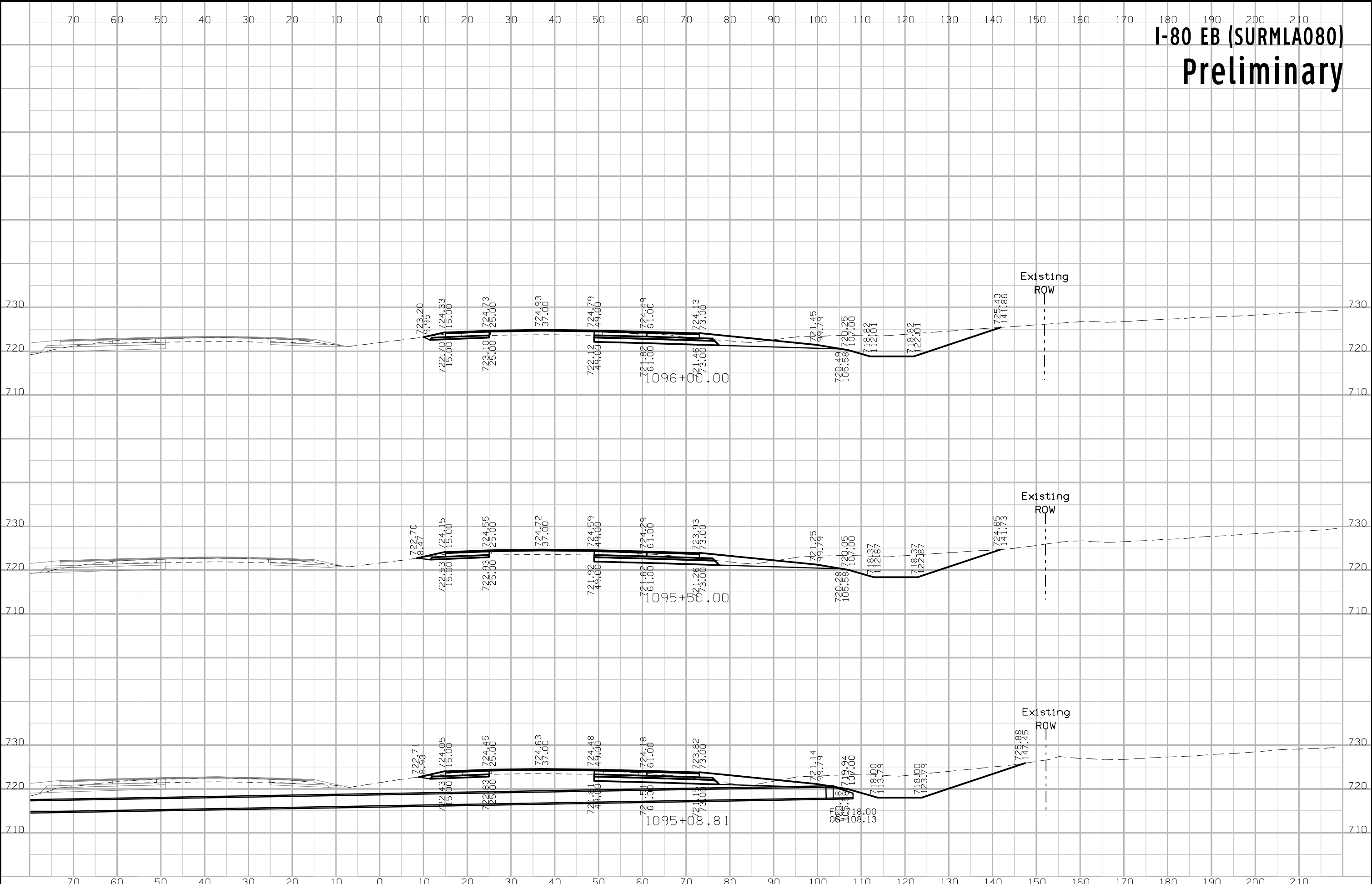

# I-80 EB (SURMLA080) Preliminary

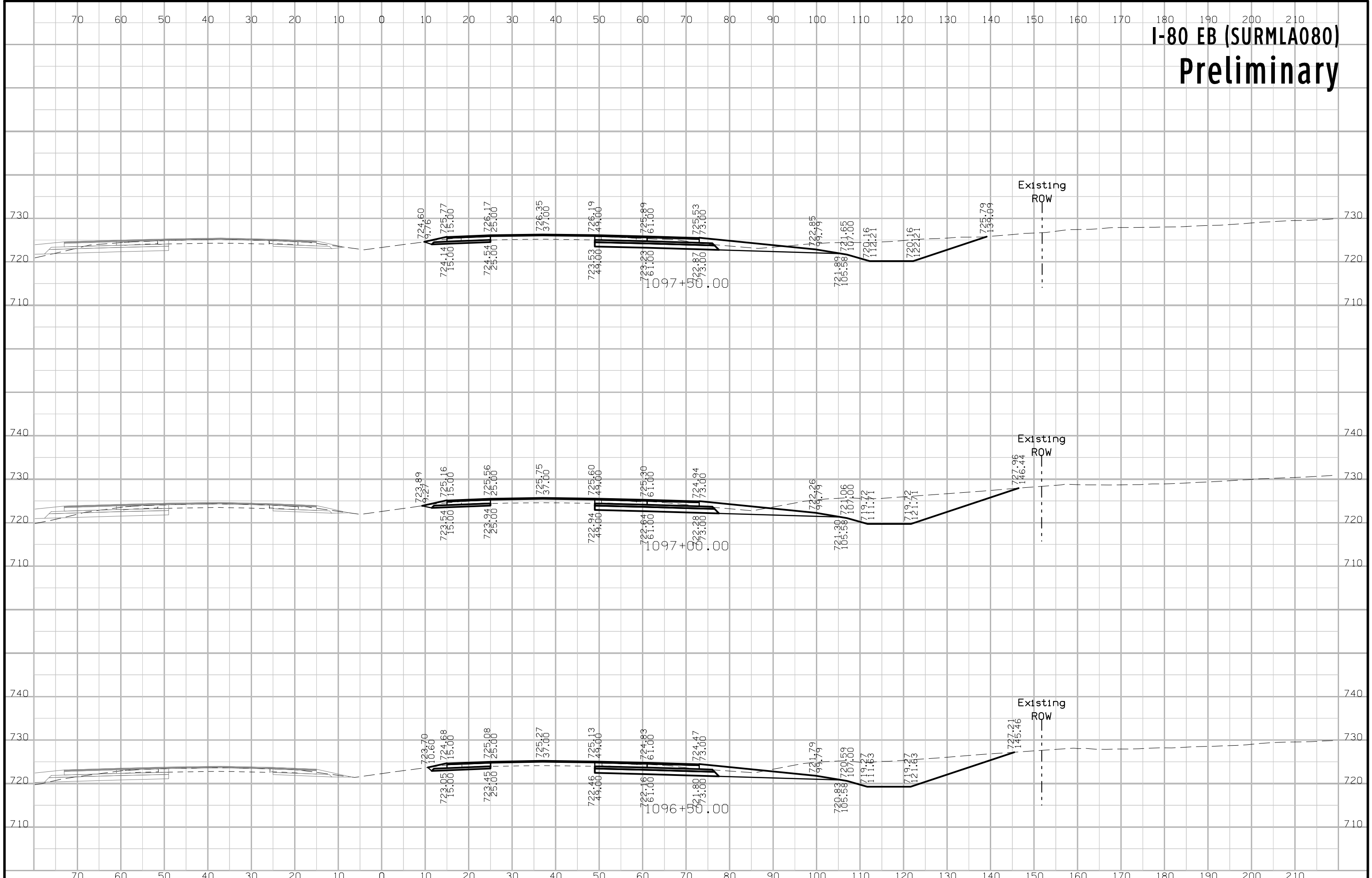

# I-80 EB (SURMLA080) Preliminary

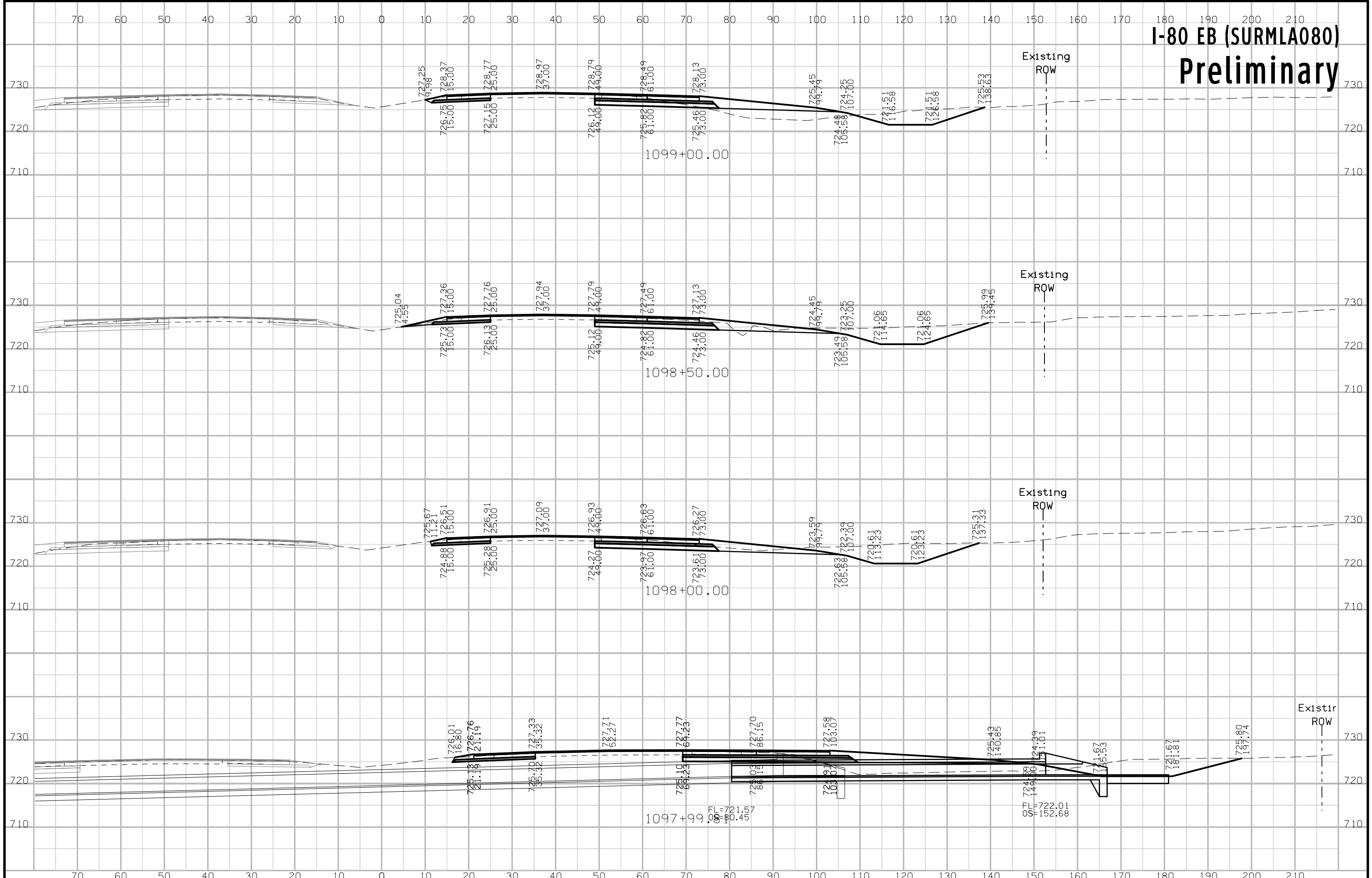

# I-80 EB (SURMLA080) Preliminary

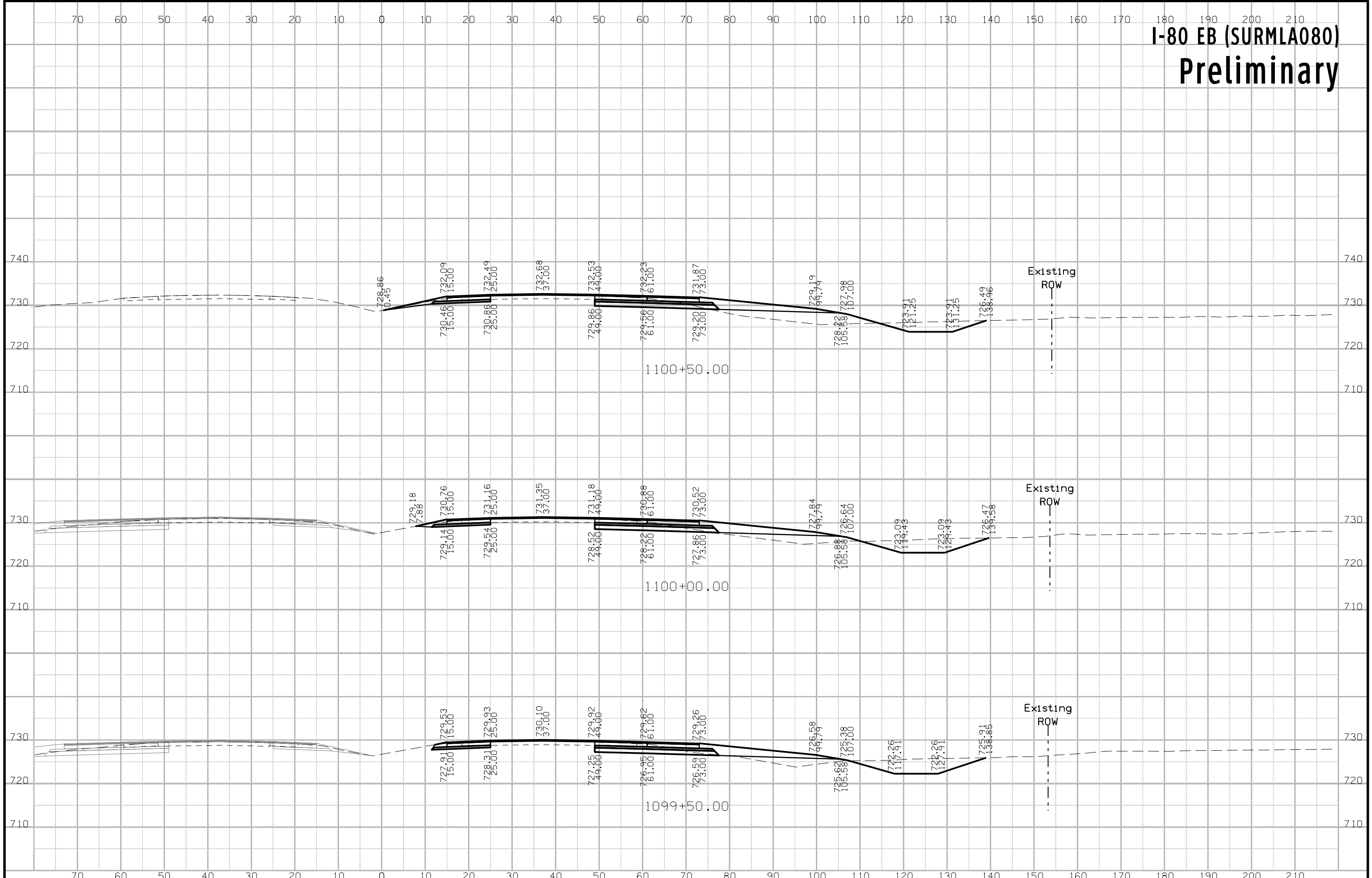

# I-80 EB (SURMLA080) Preliminary

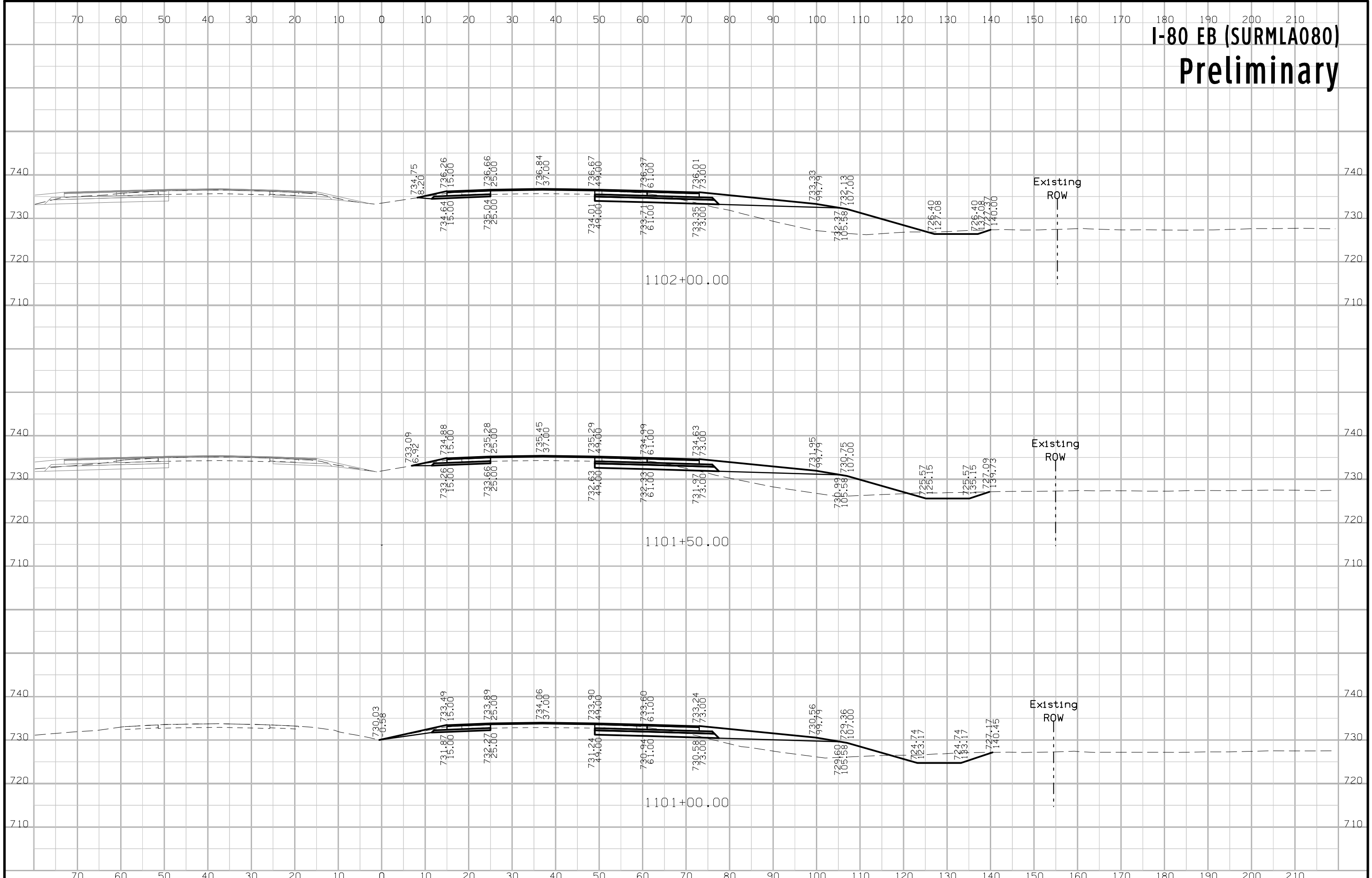

# I-80 EB (SURMLA080) Preliminary

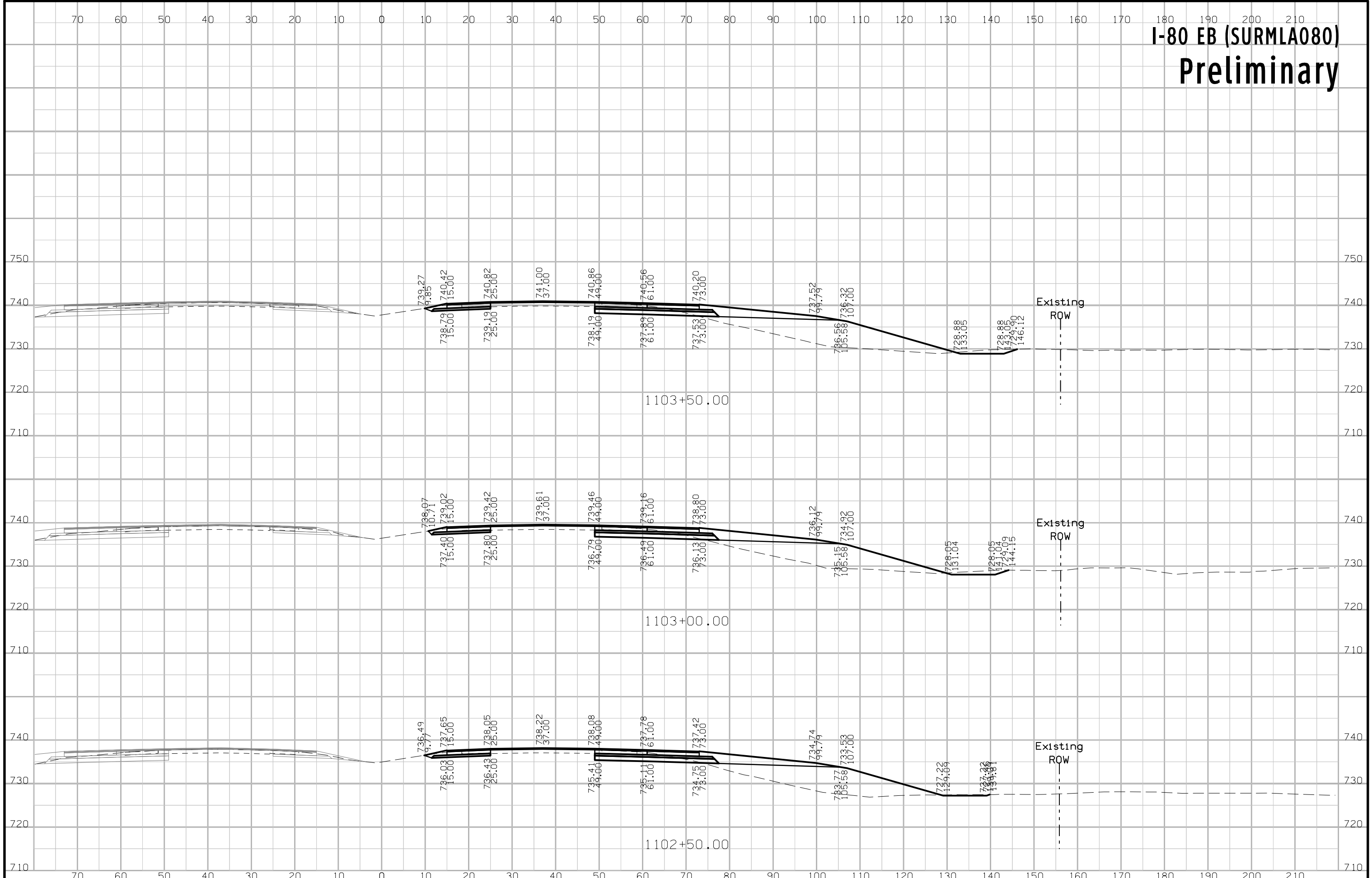



# I-80 EB (SURMLA080) Preliminary

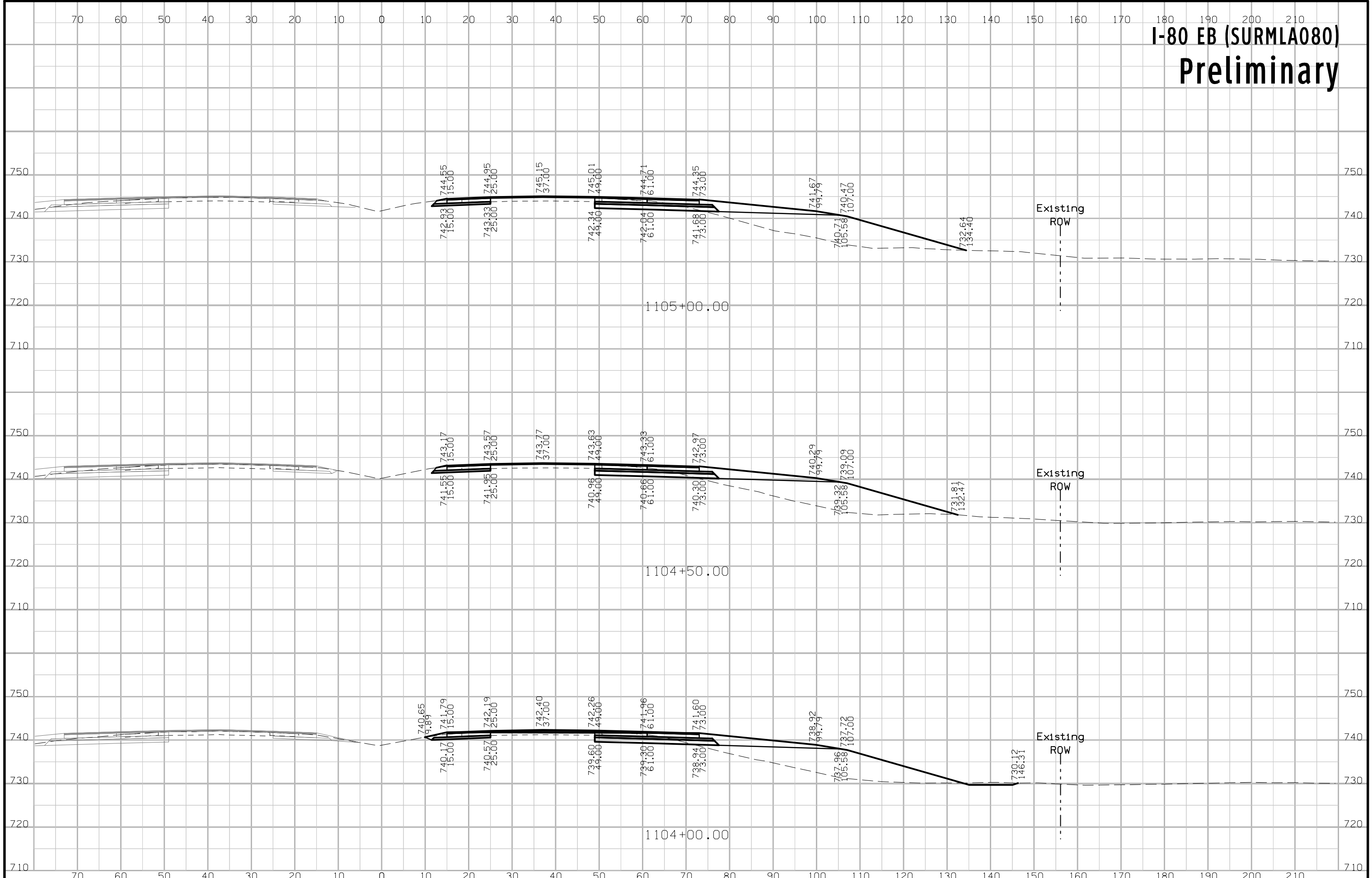

# I-80 EB (SURMLA080) Preliminary

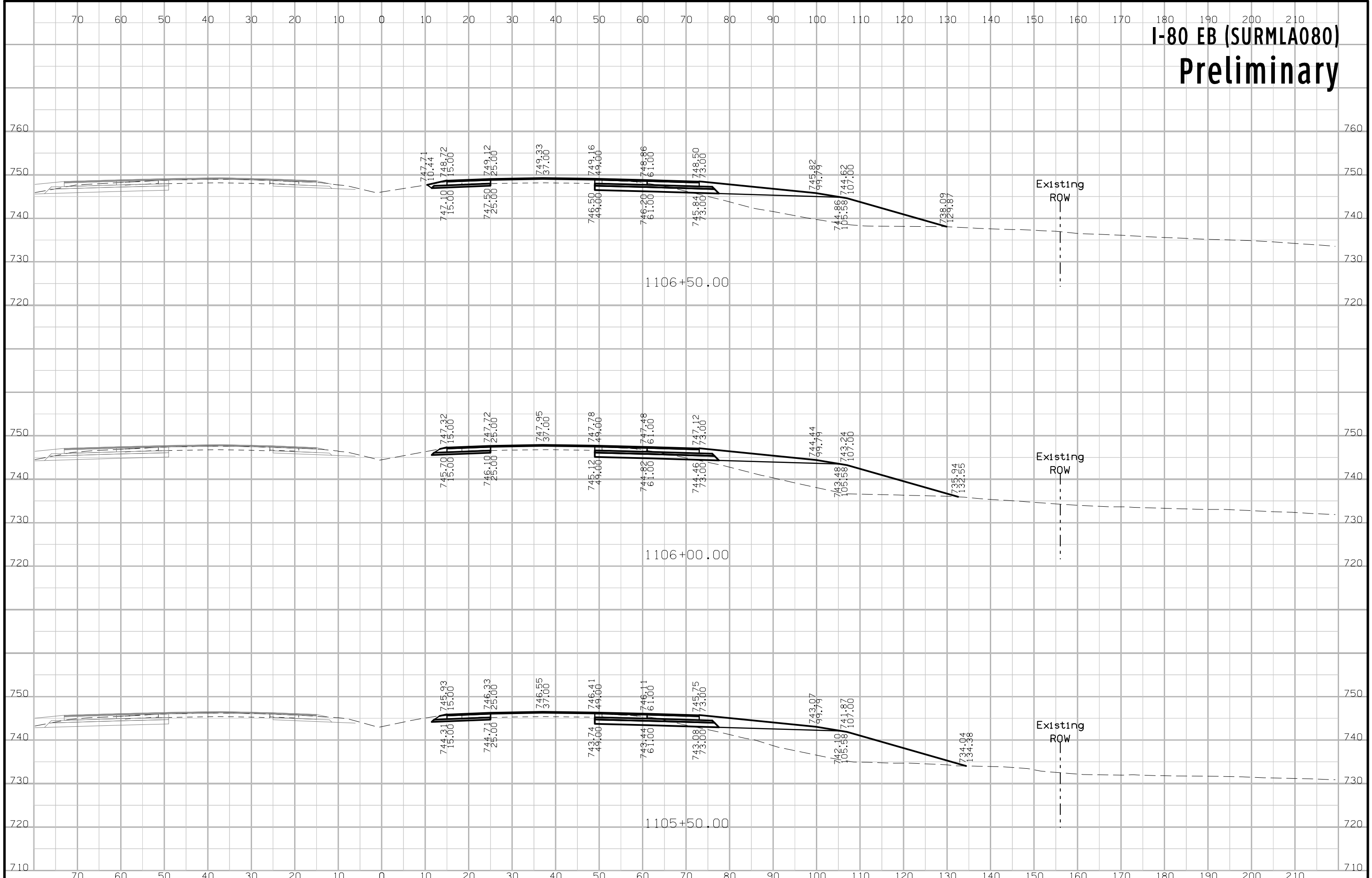

# I-80 EB (SURMLA080) Preliminary

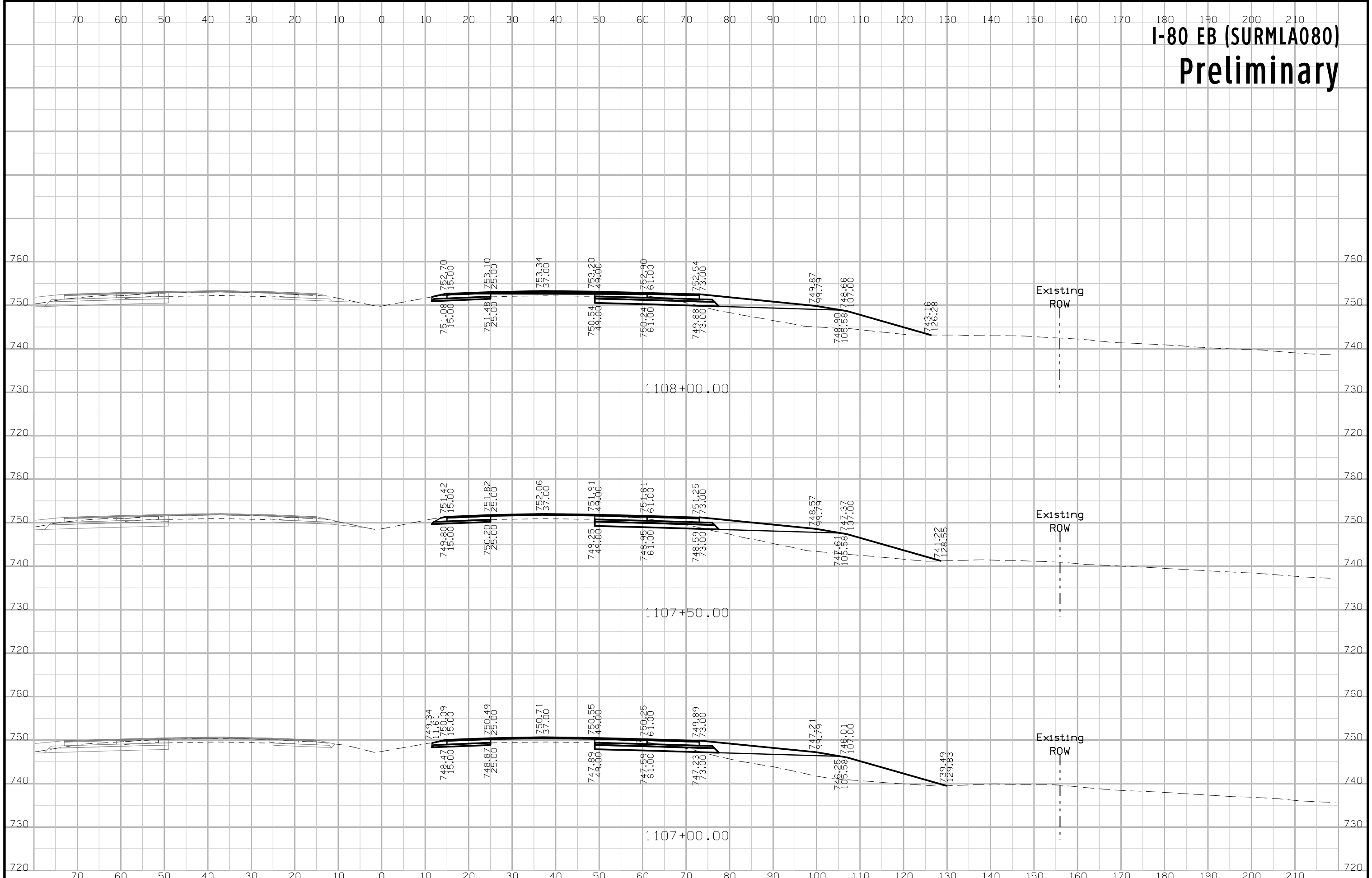

# I-80 EB (SURMLA080) Preliminary

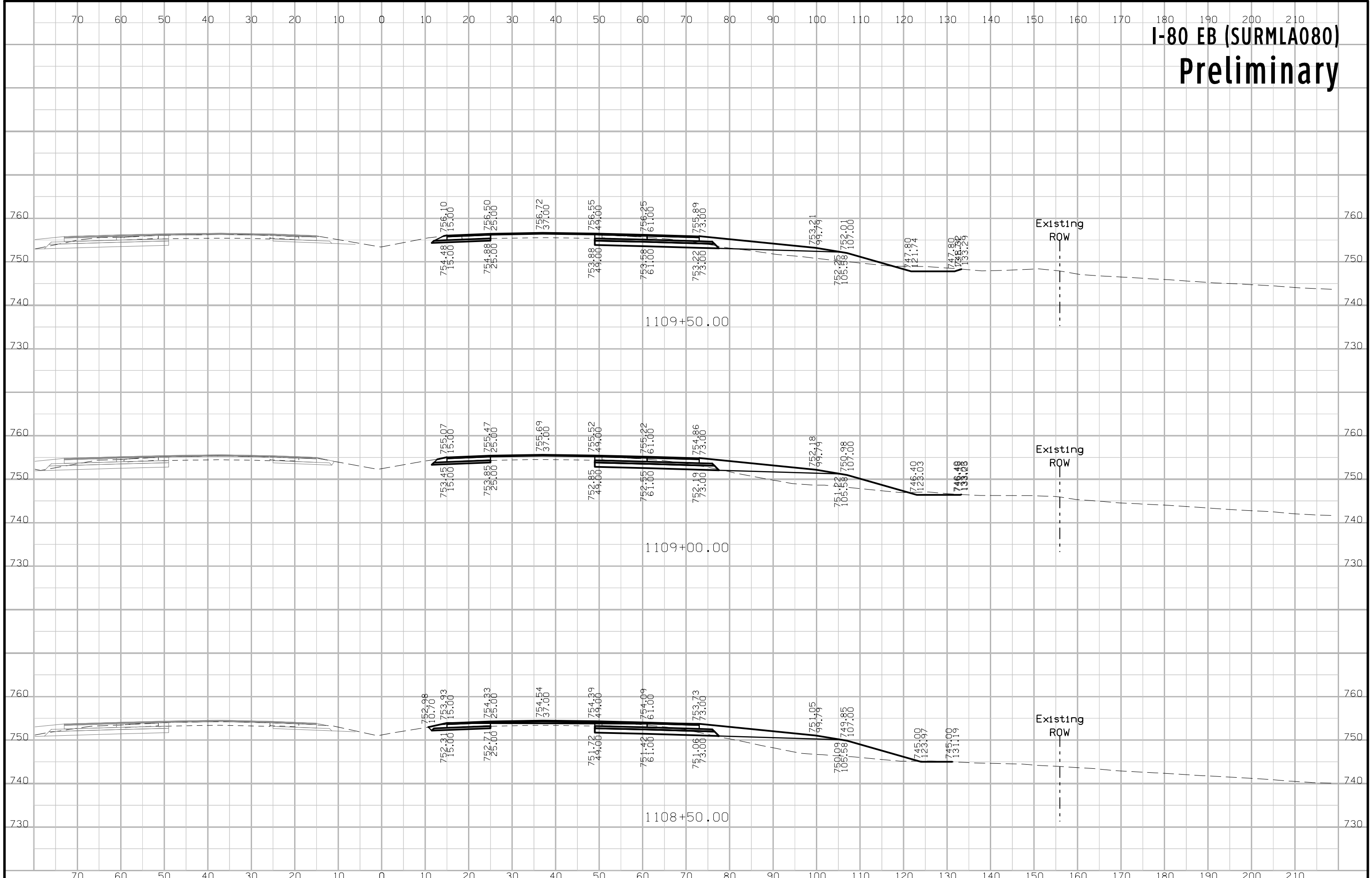

# I-80 EB (SURMLA080) Preliminary

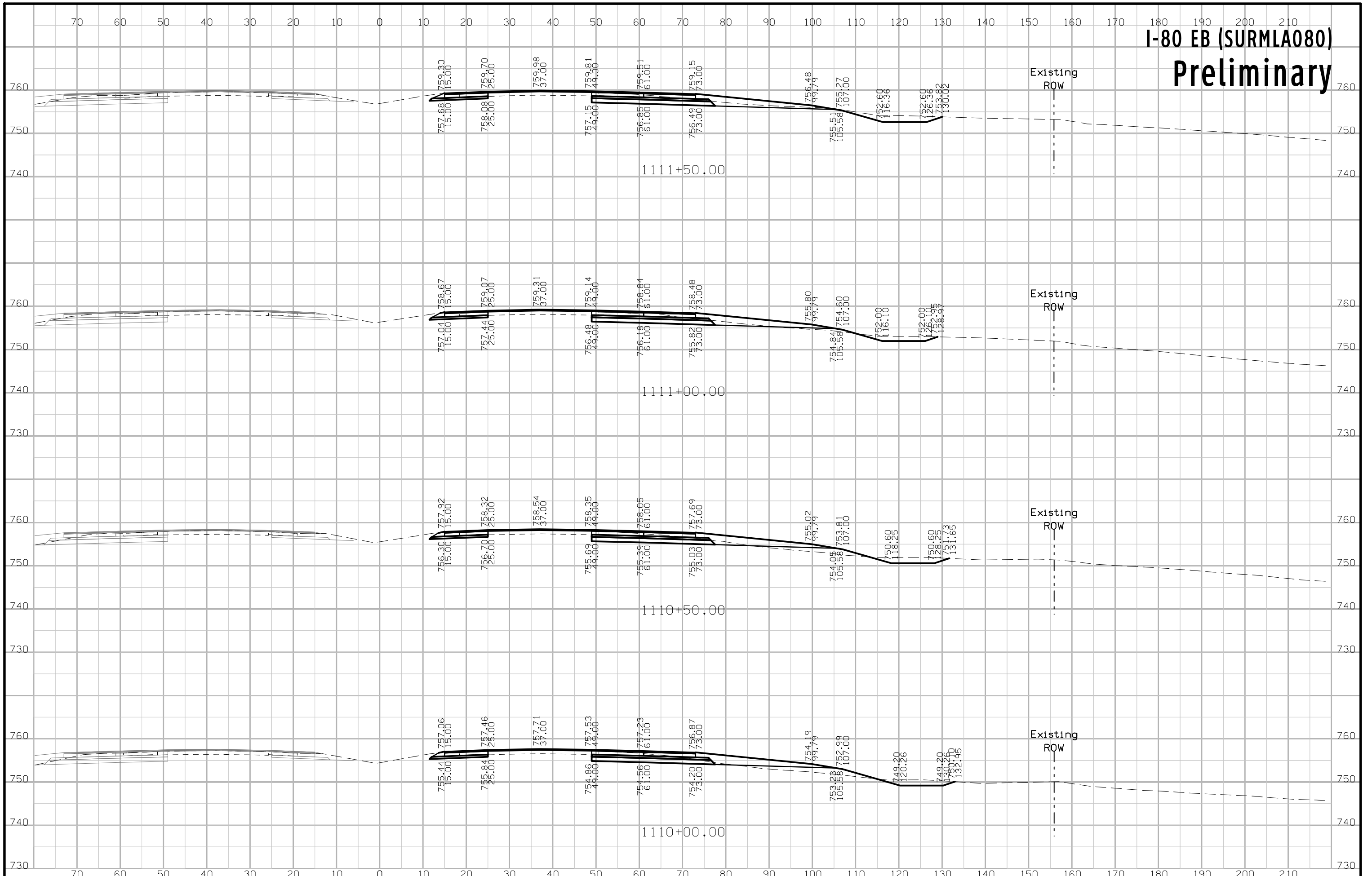

# I-80 EB (SURMLA080) Preliminary

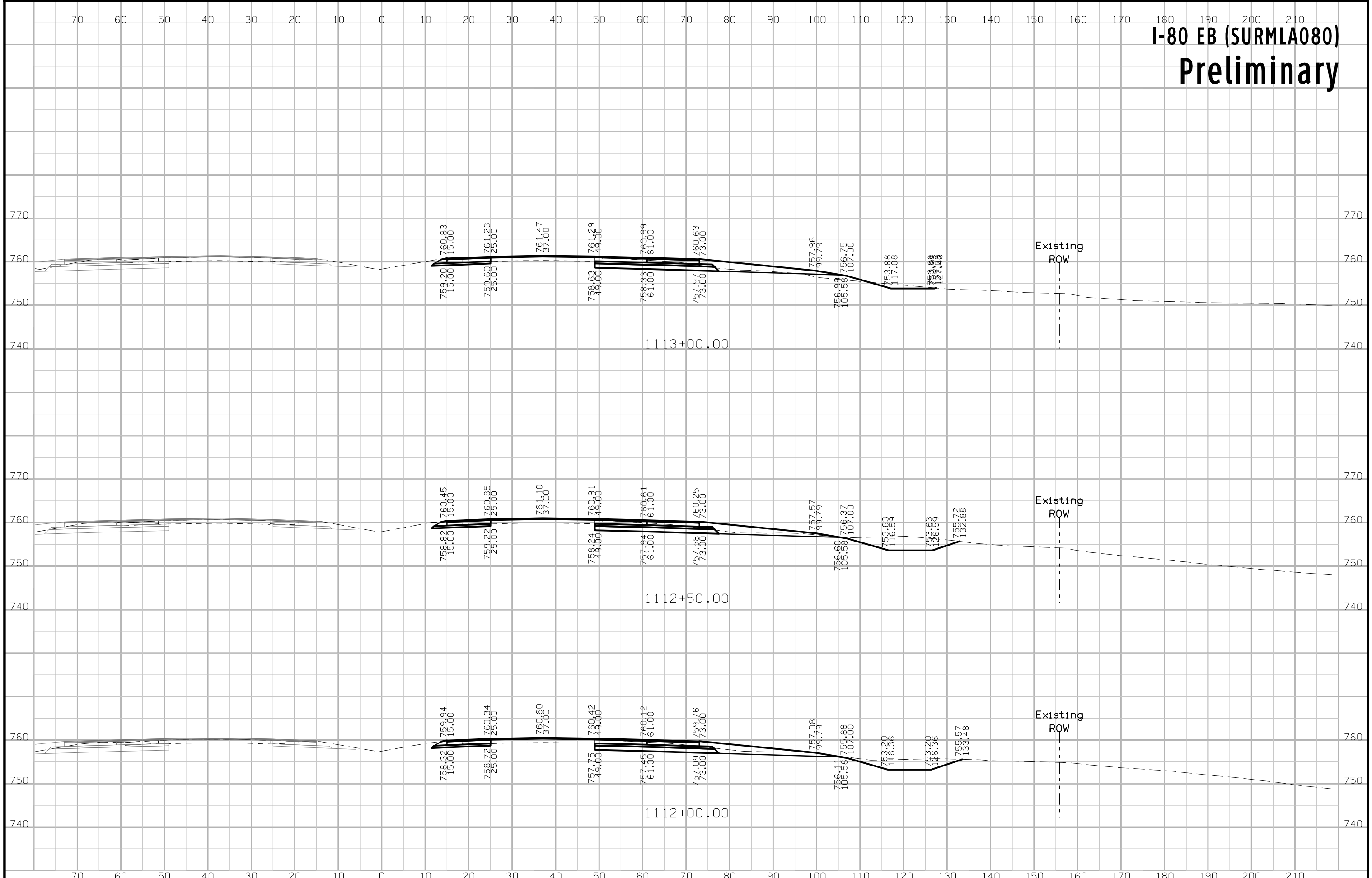

# I-80 EB (SURMLA080) Preliminary

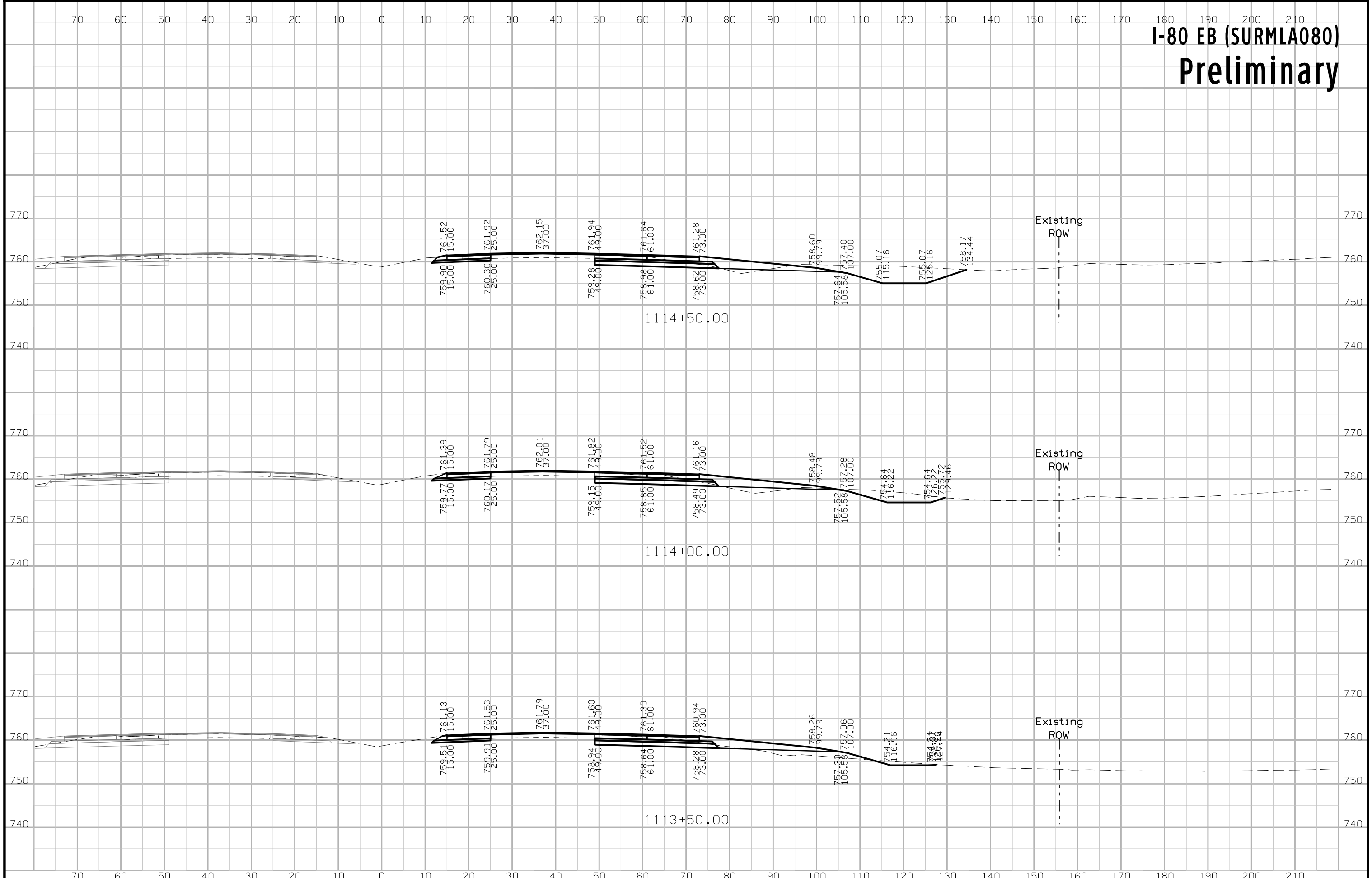

# I-80 EB (SURMLA080) Preliminary

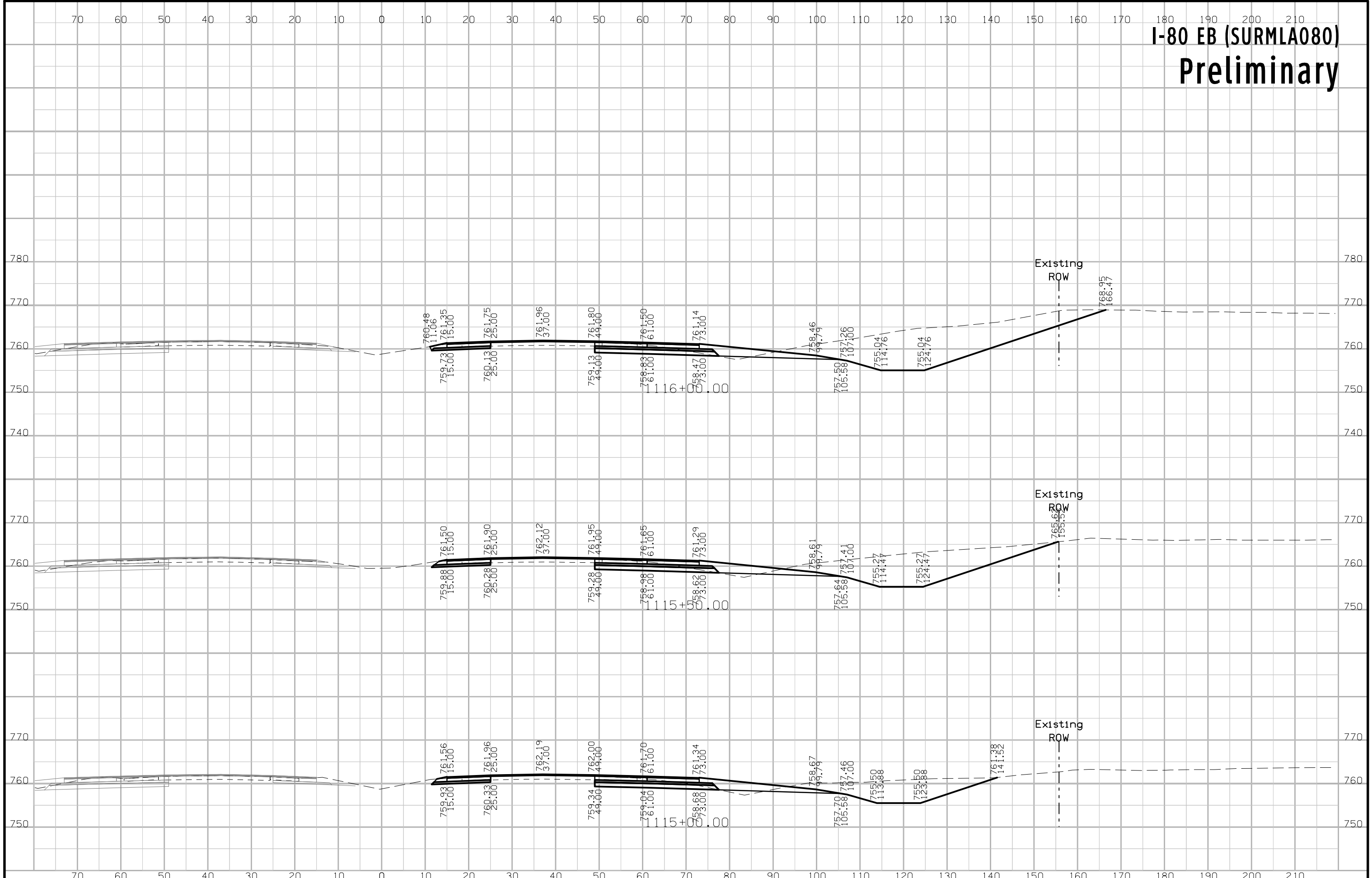



# I-80 EB (SURMLA080) Preliminary

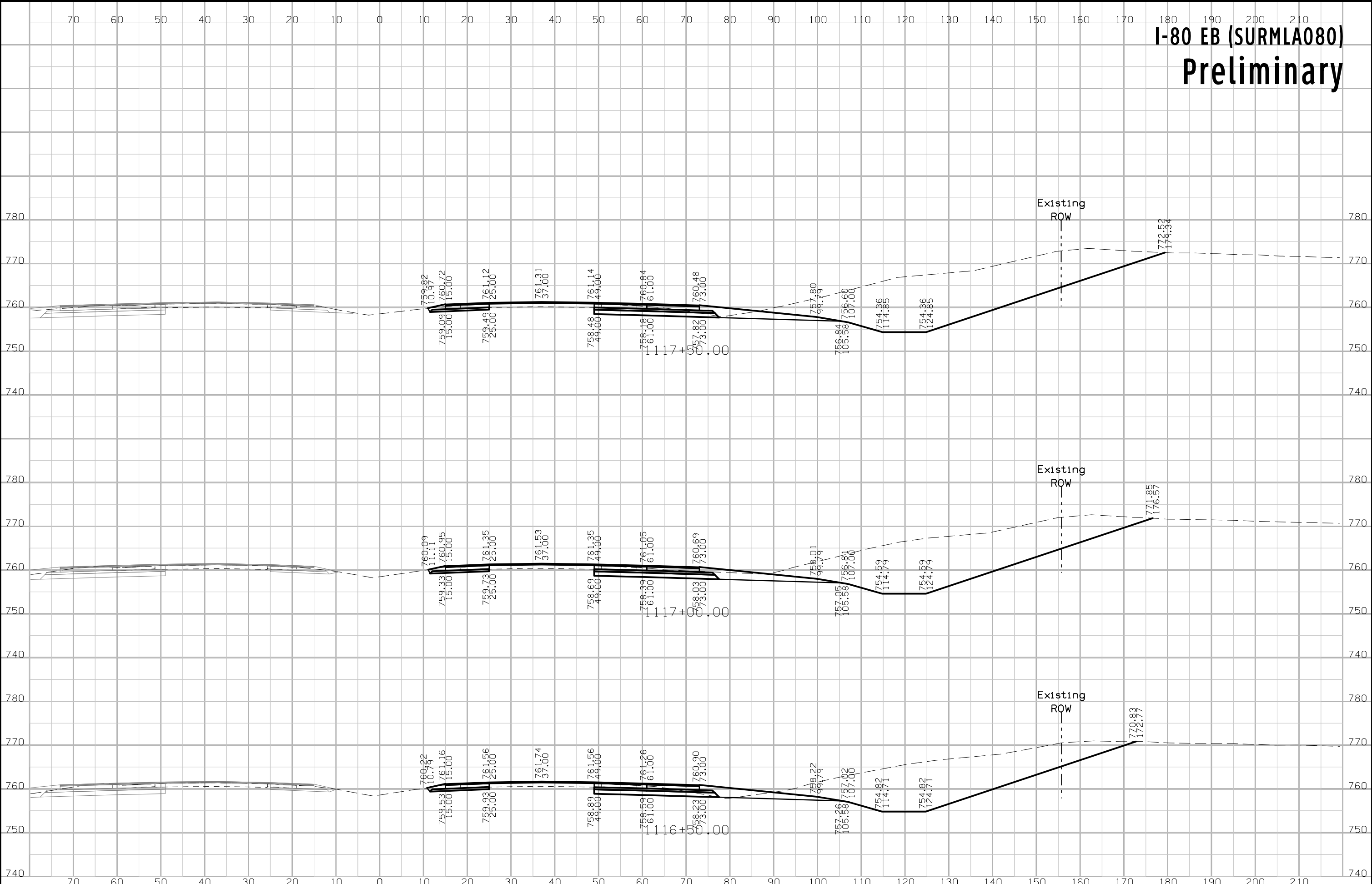

# I-80 EB (SURMLA080) Preliminary

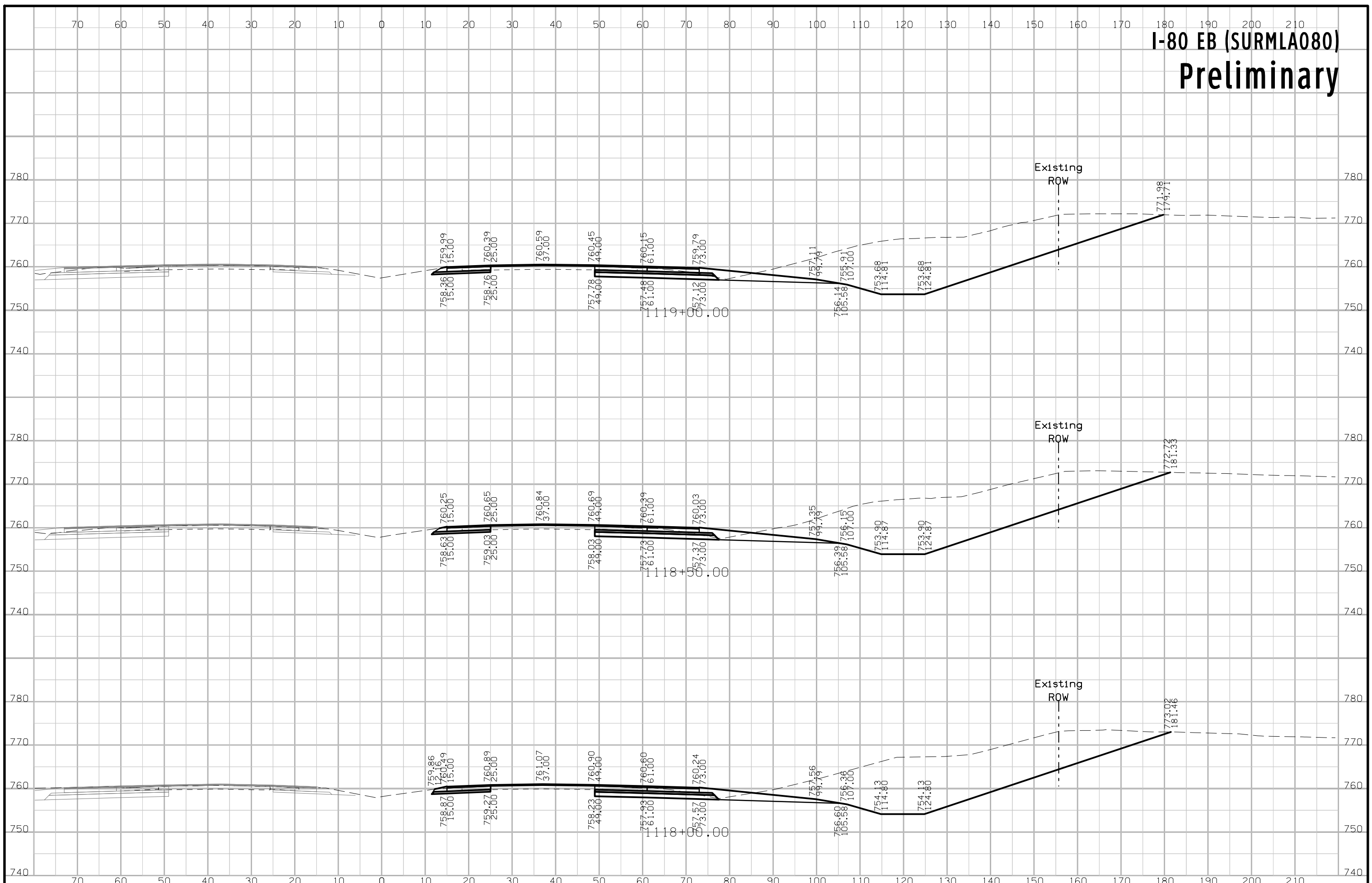

# I-80 EB (SURMLA080) Preliminary

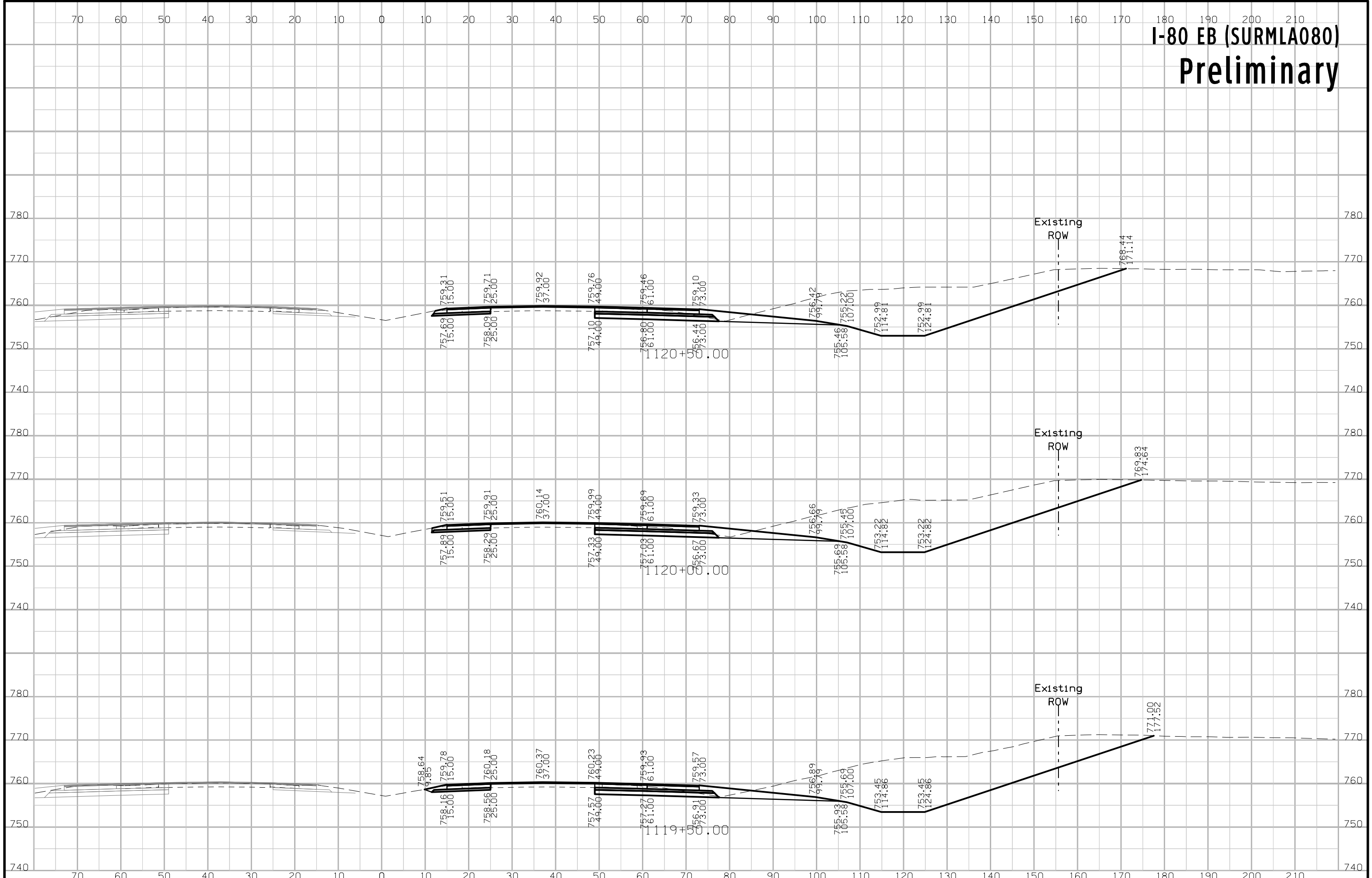

# I-80 EB (SURMLA080) Preliminary

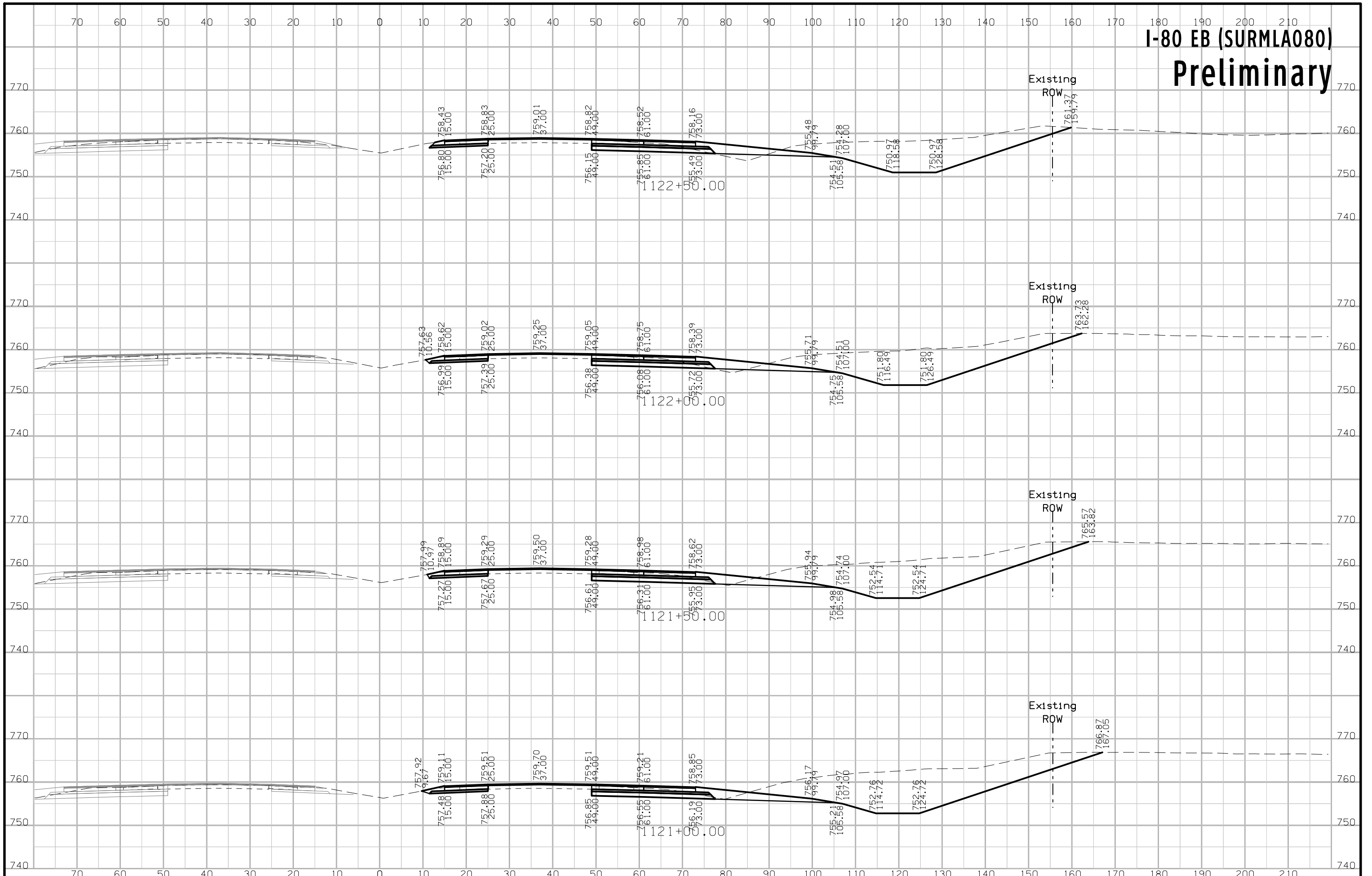

# I-80 EB (SURMLA080) Preliminary

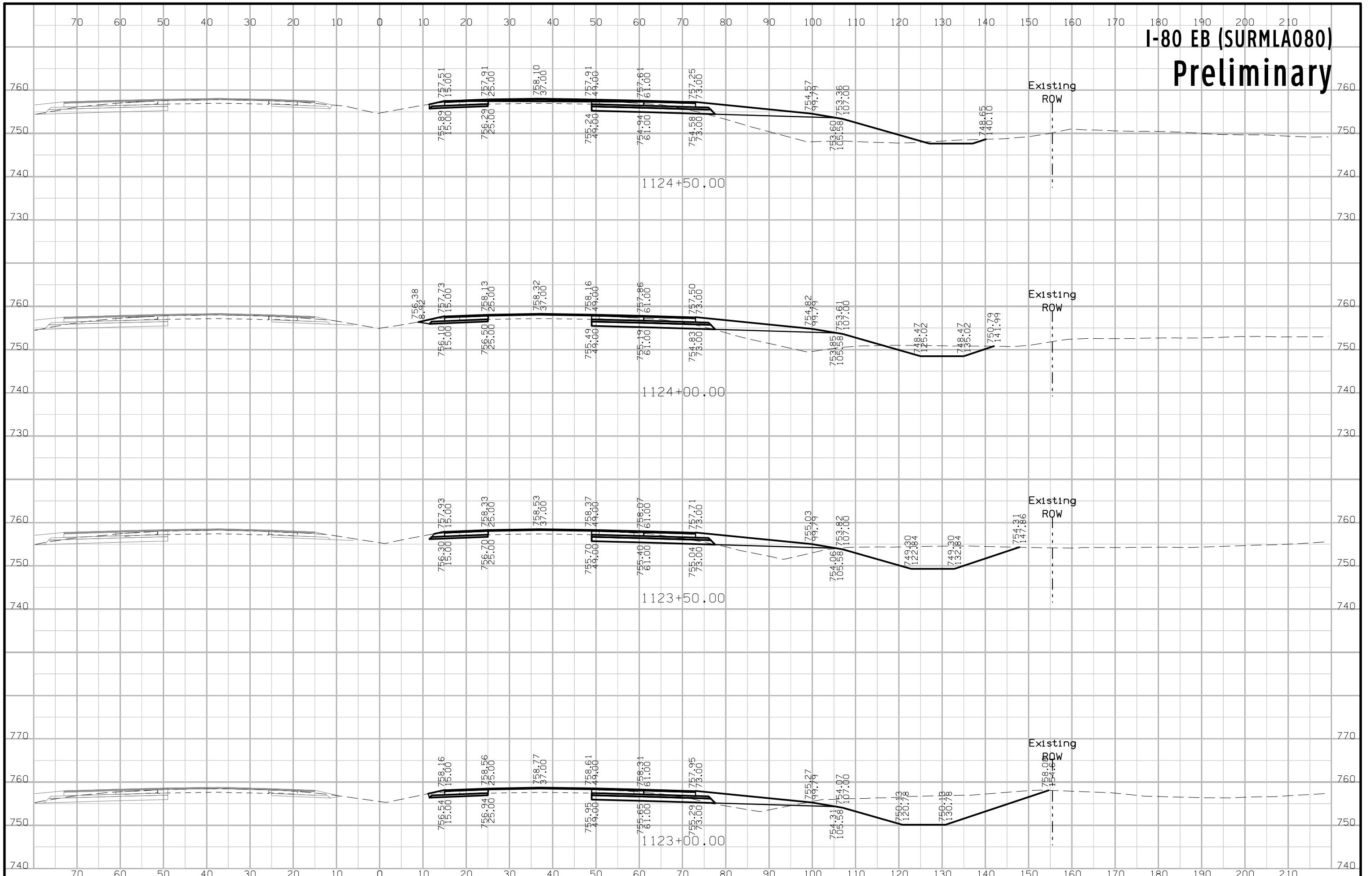

# I-80 EB (SURMLA080) Preliminary

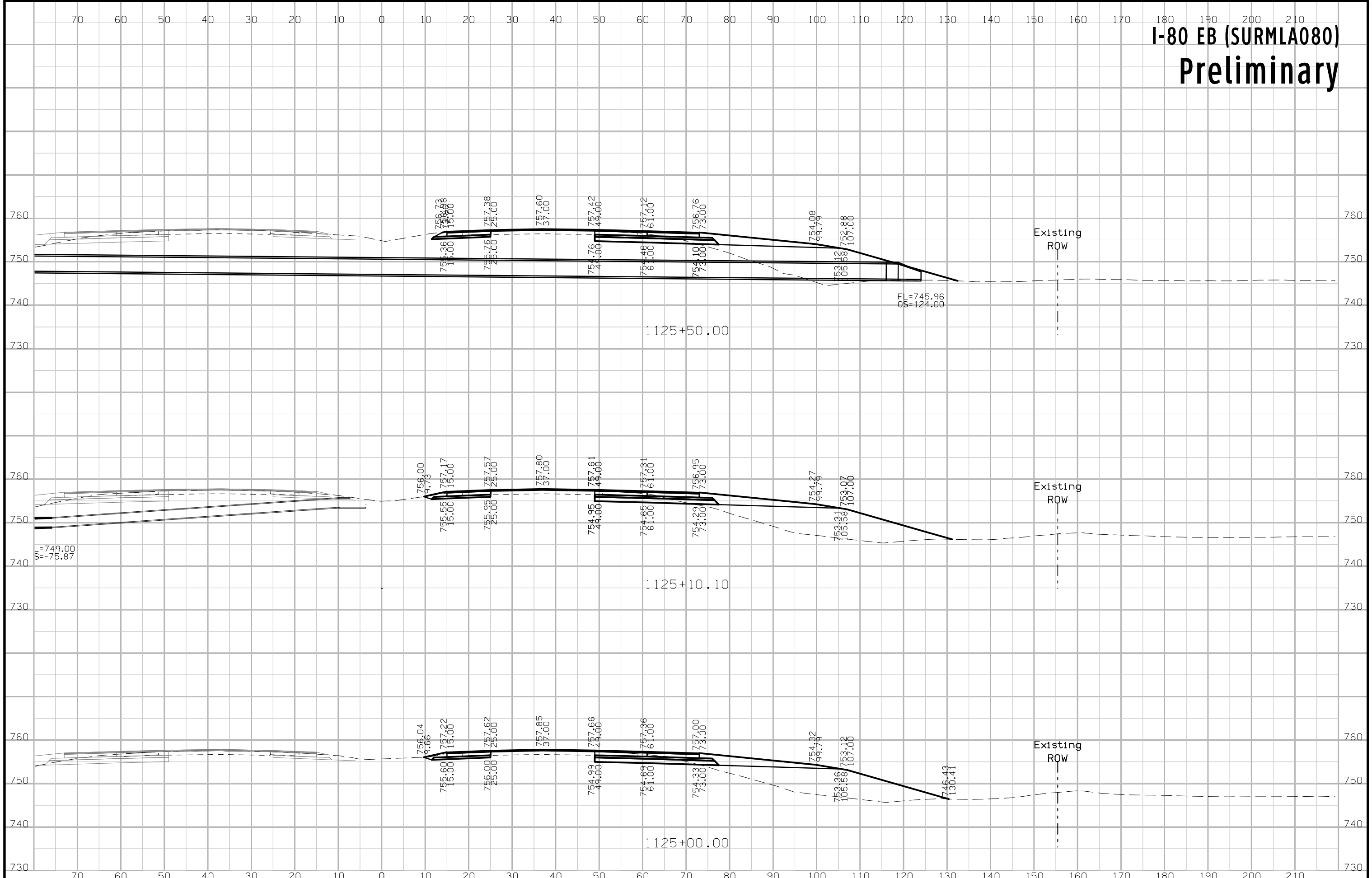

# I-80 EB (SURMLA080) Preliminary

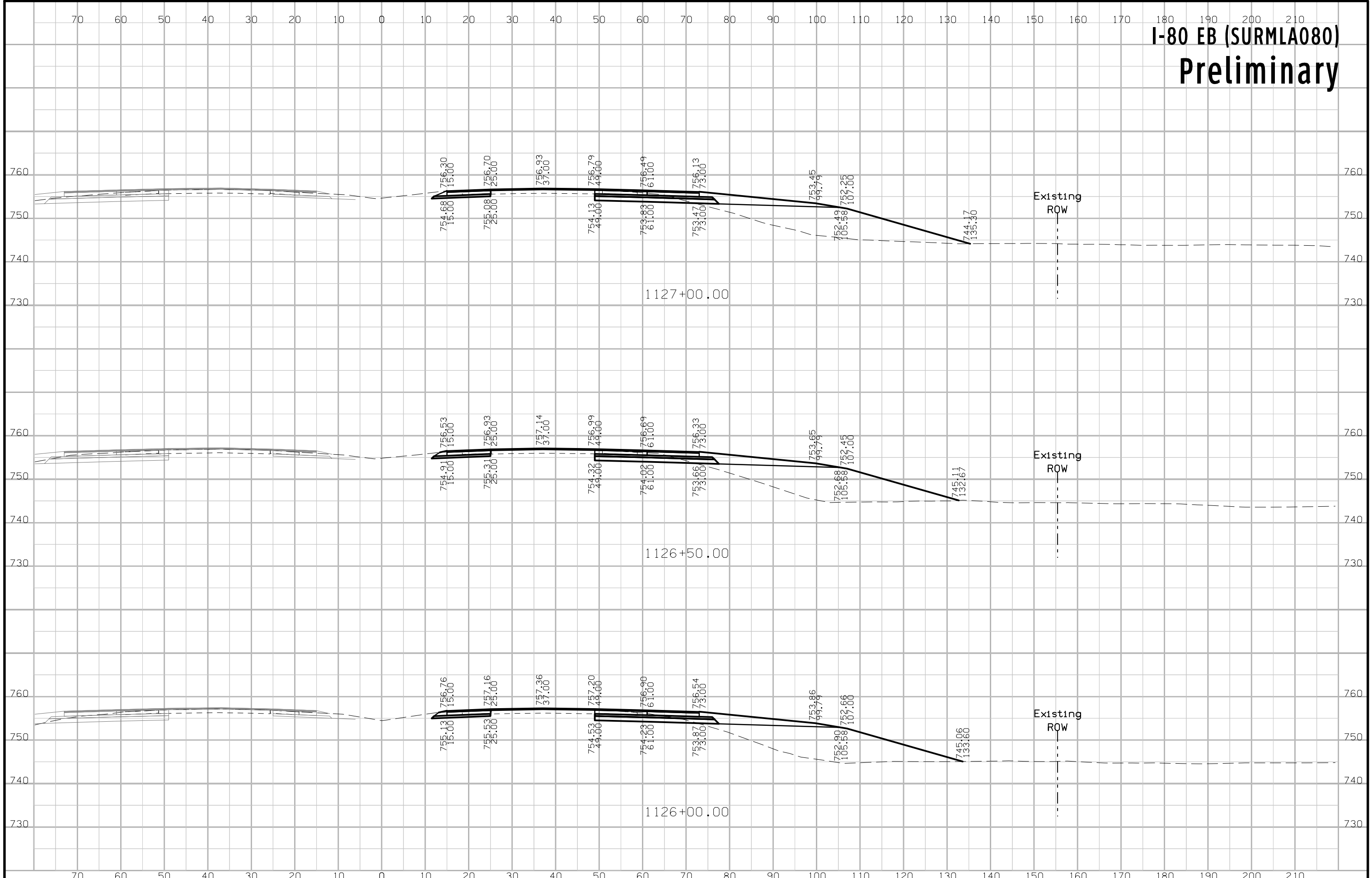

# I-80 EB (SURMLA080) Preliminary

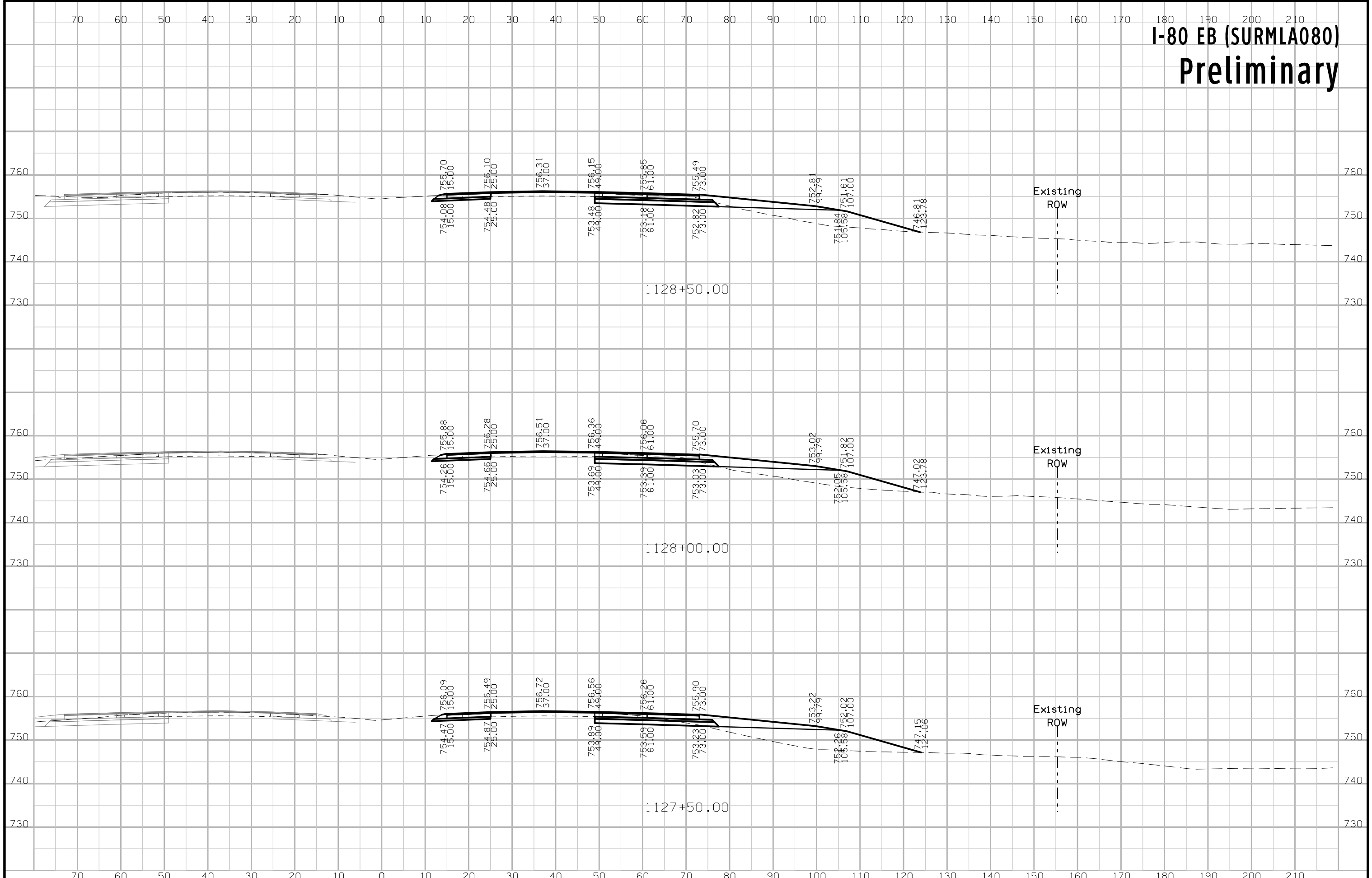



# I-80 EB (SURMLA080) Preliminary

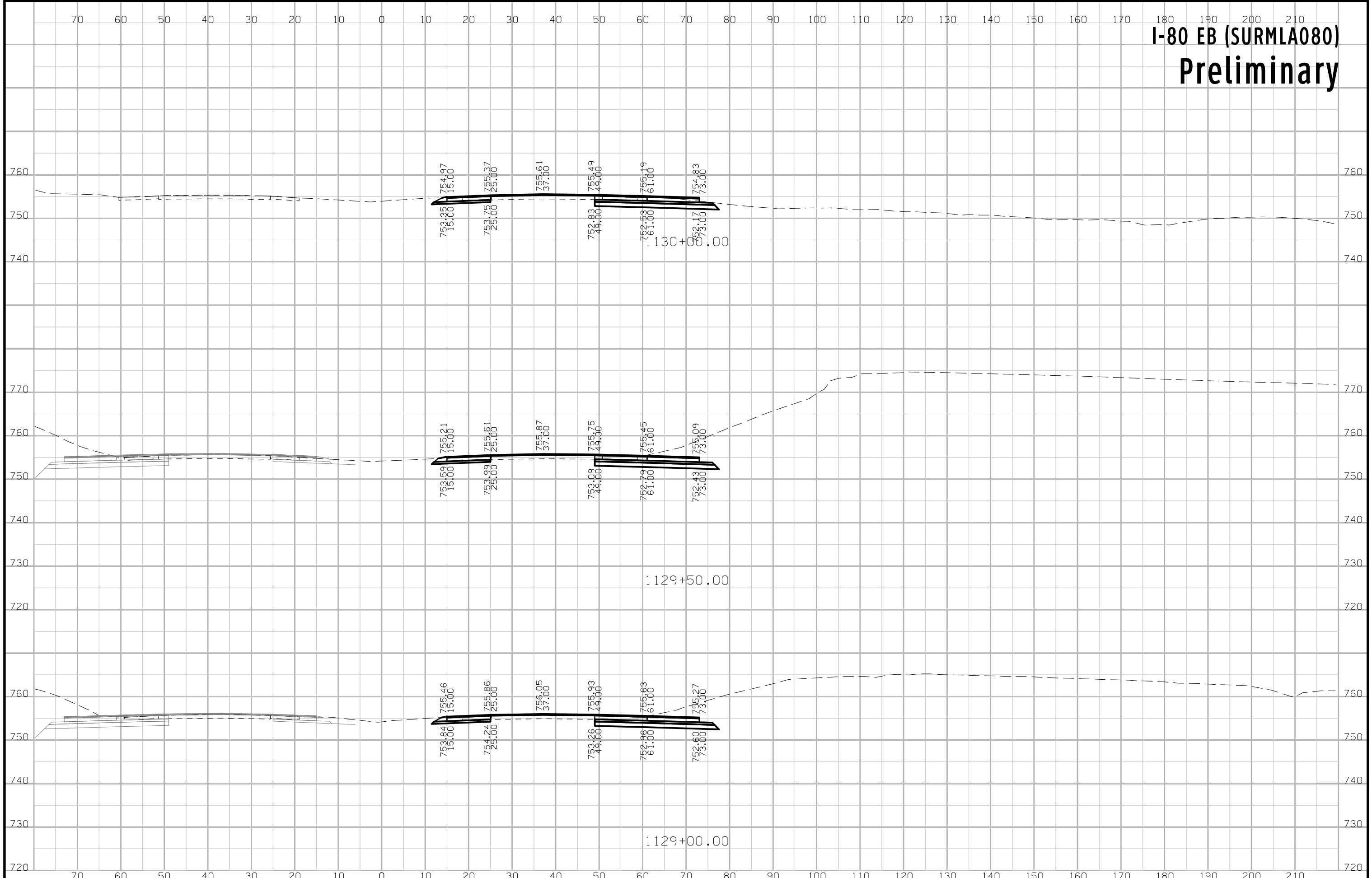

# I-80 EB (SURMLA080) Preliminary

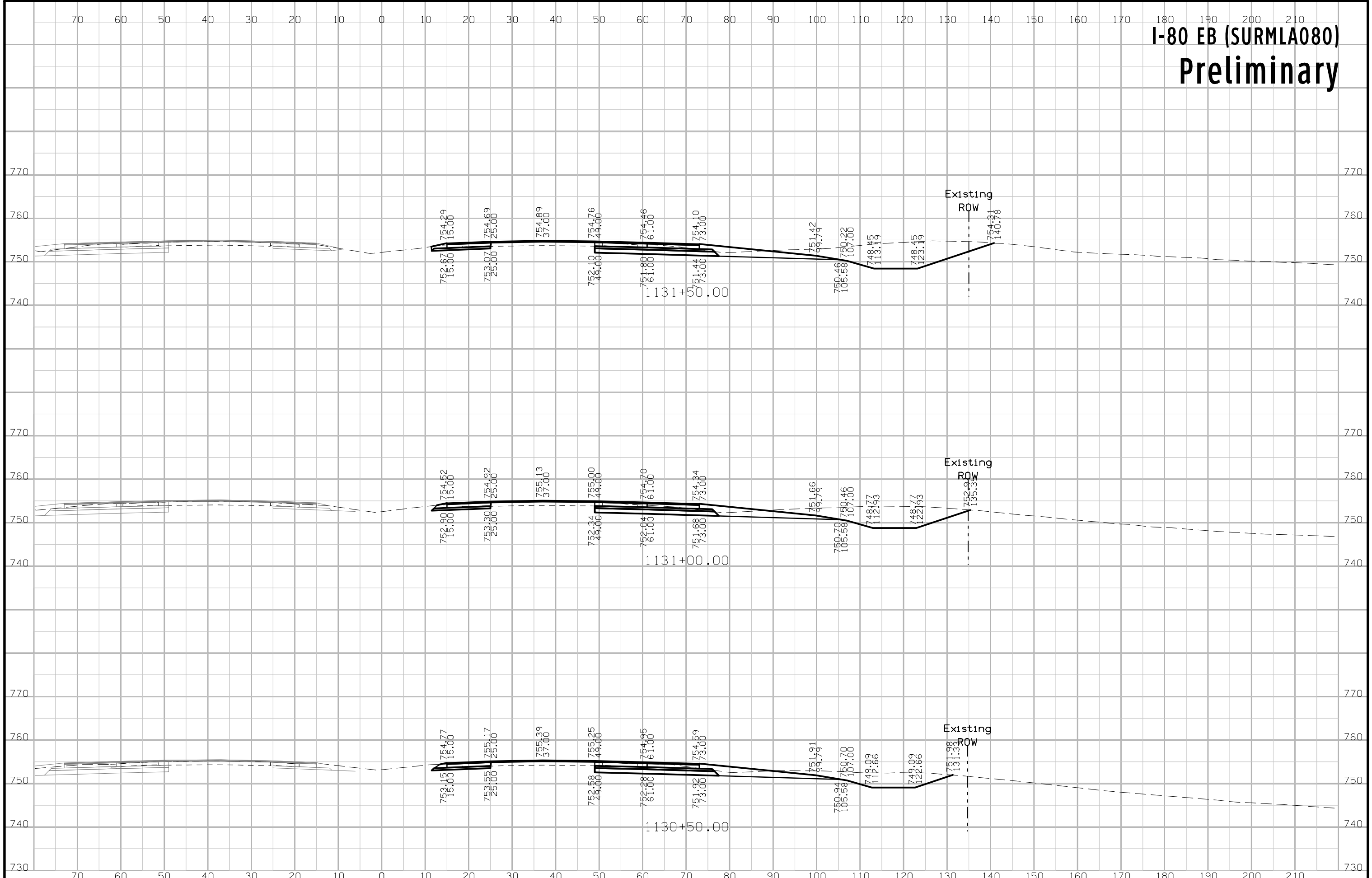

# I-80 EB (SURMLA080) Preliminary

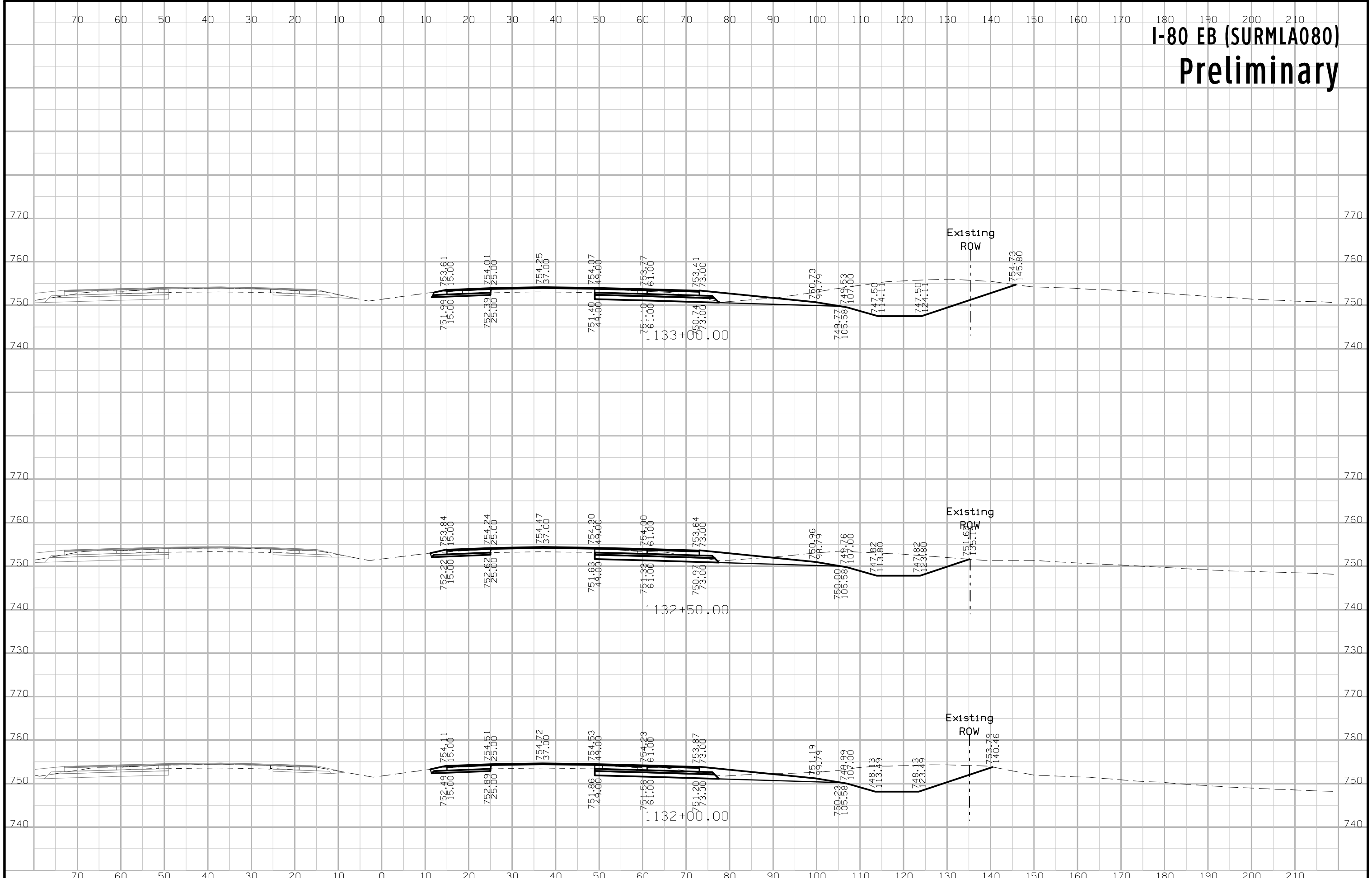

# I-80 EB (SURMLA080) Preliminary

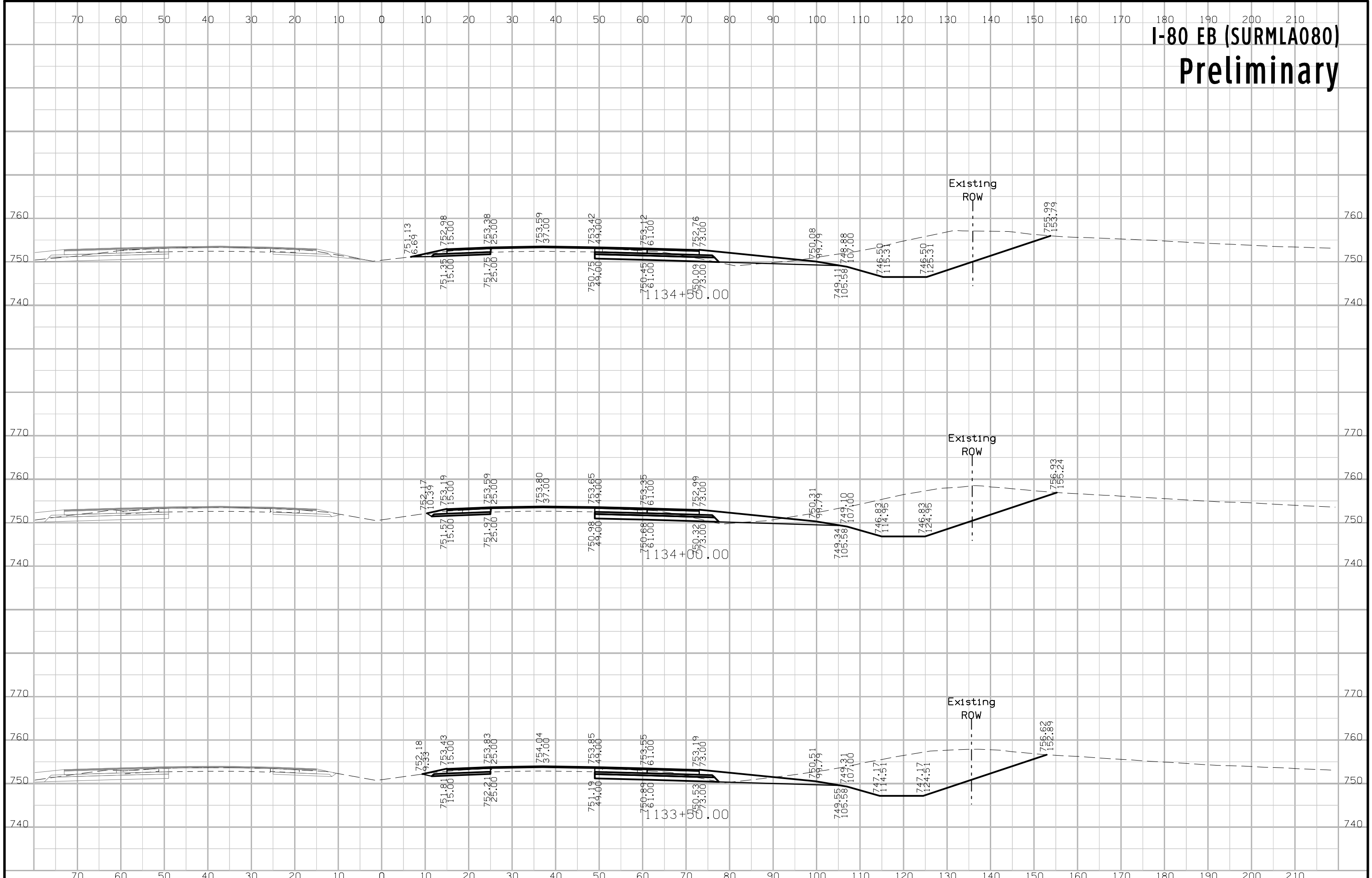

# I-80 EB (SURMLA080) Preliminary

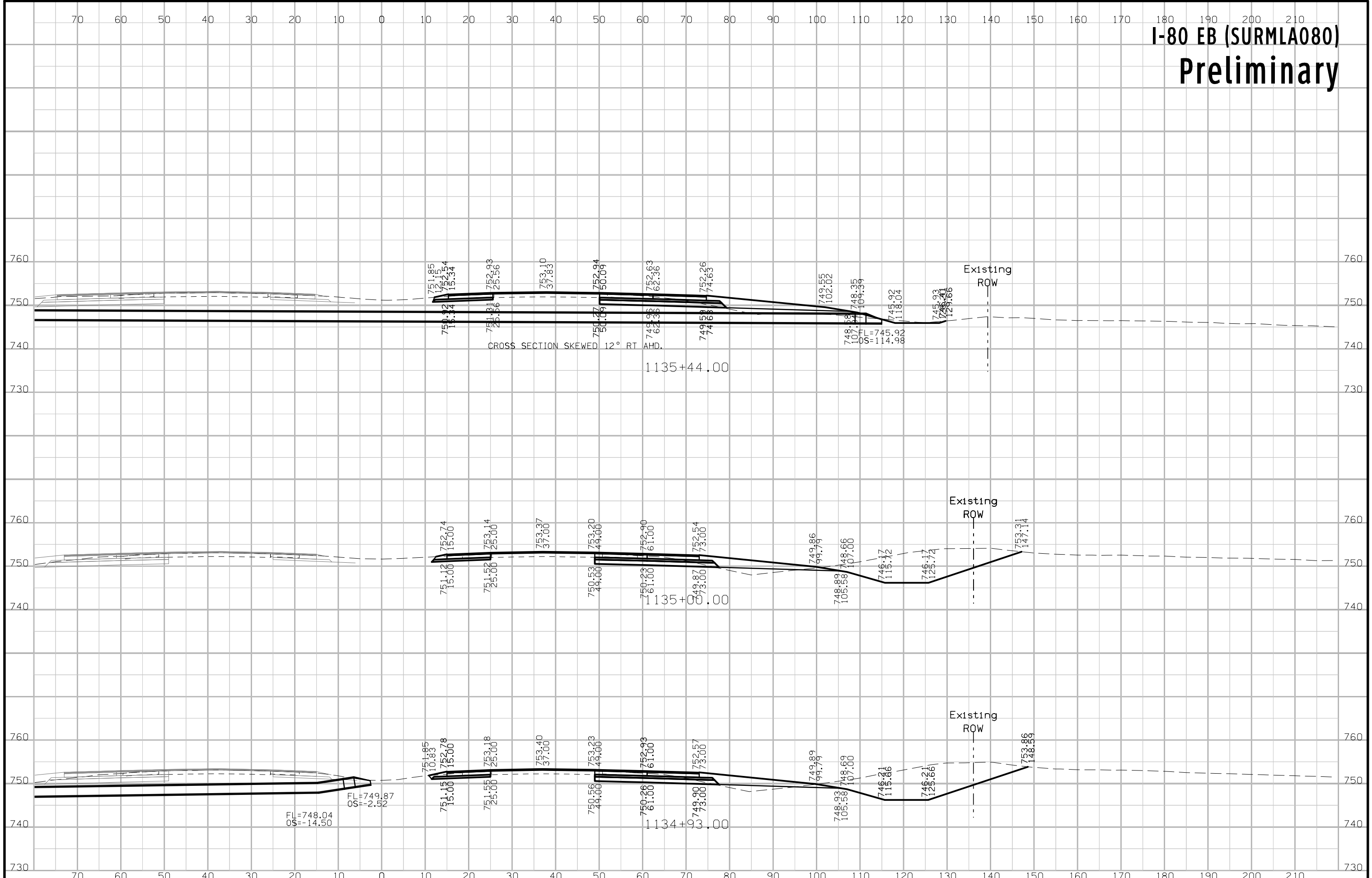

# I-80 EB (SURMLA080) Preliminary

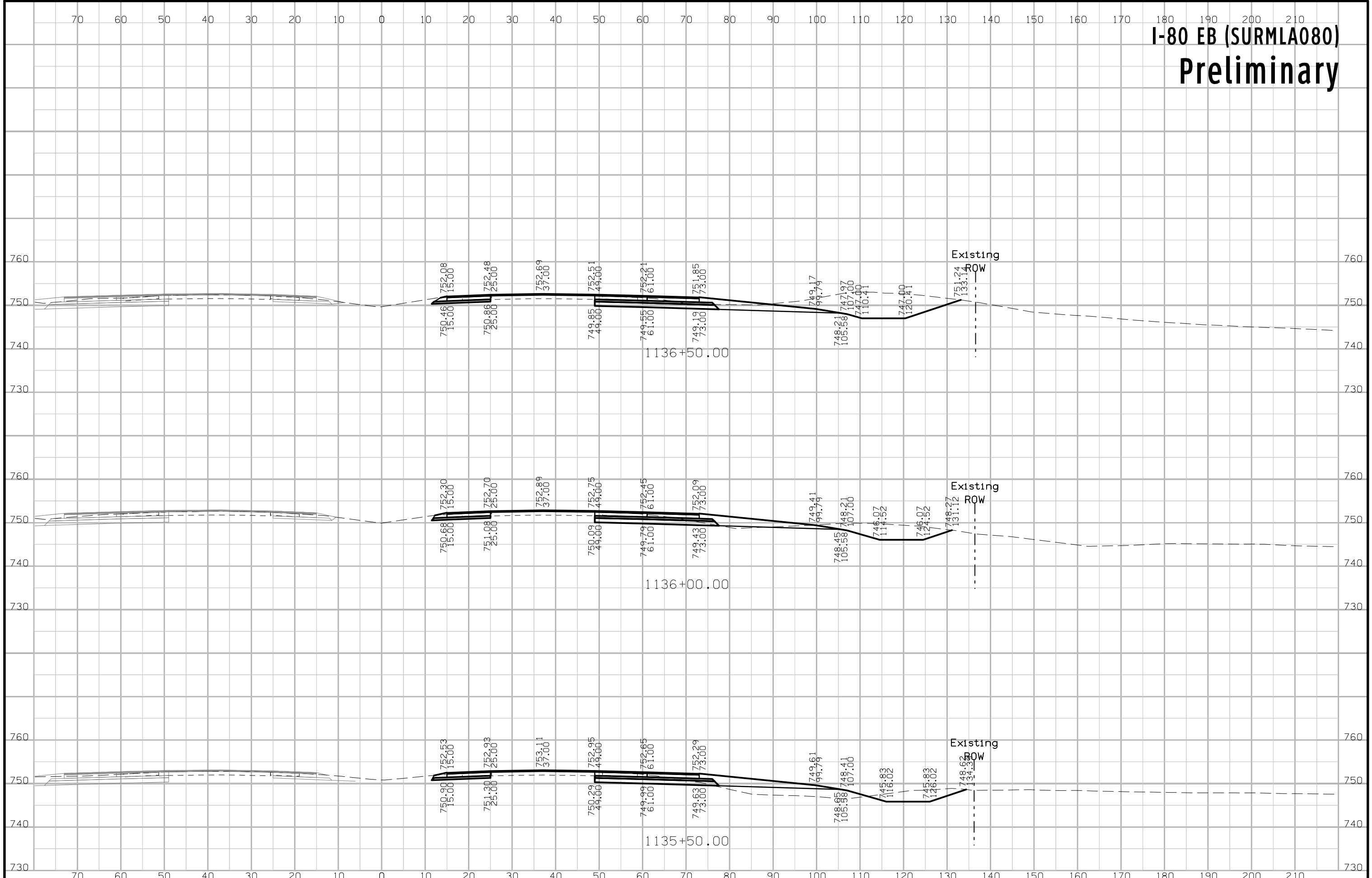

# I-80 EB (SURMLA080) Preliminary

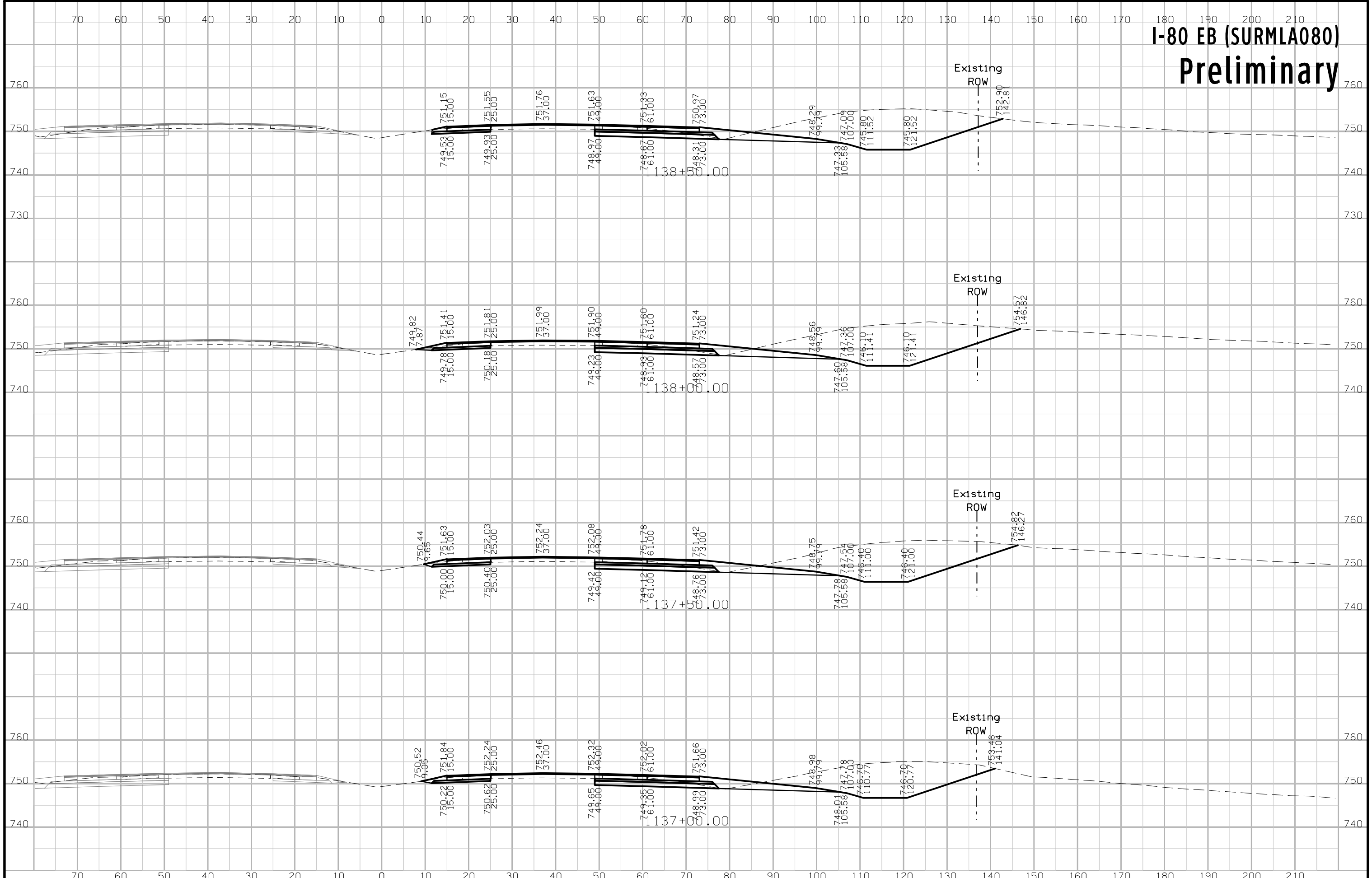

# I-80 EB (SURMLA080) Preliminary

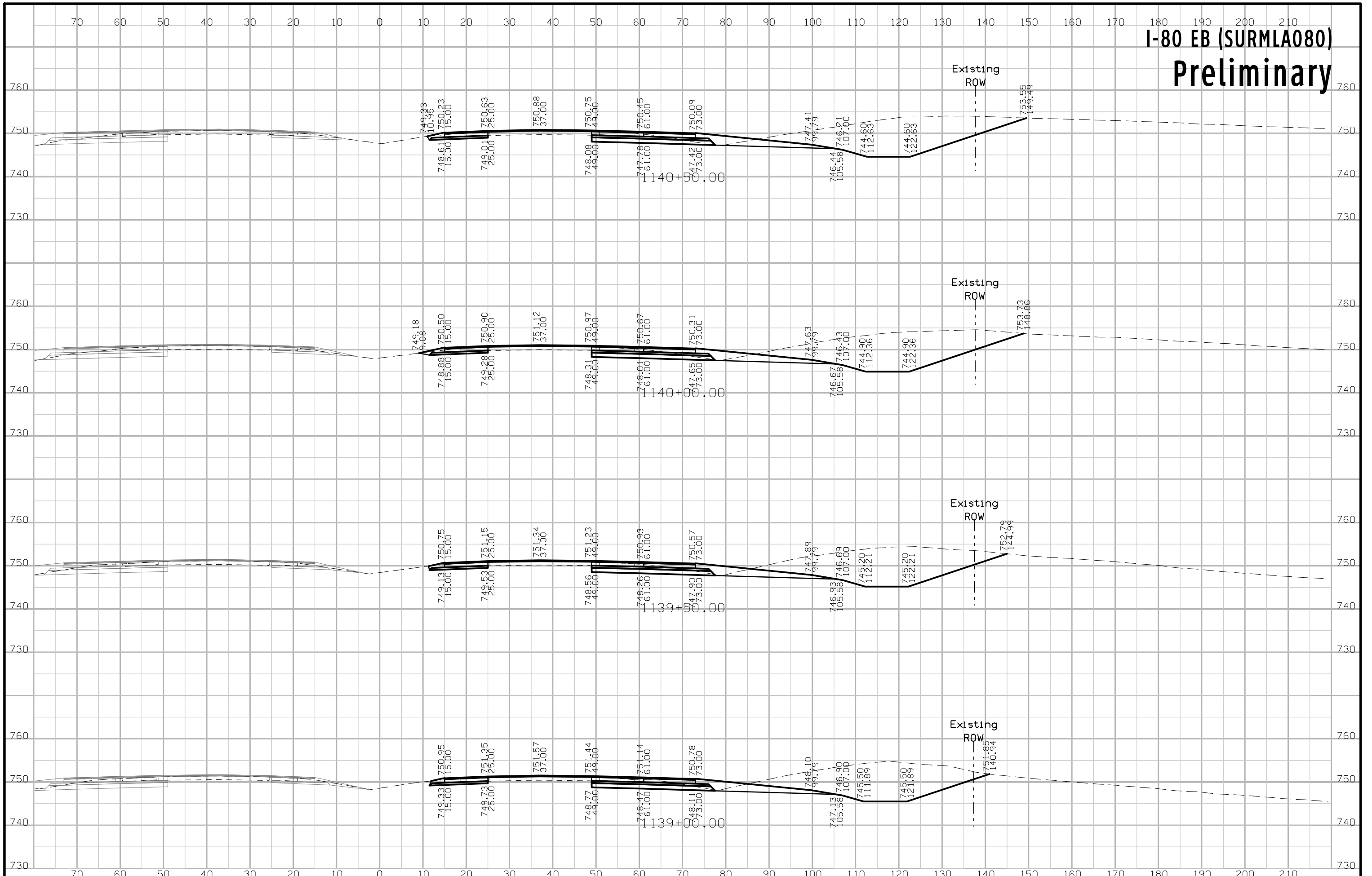



# I-80 EB (SURMLA080) Preliminary

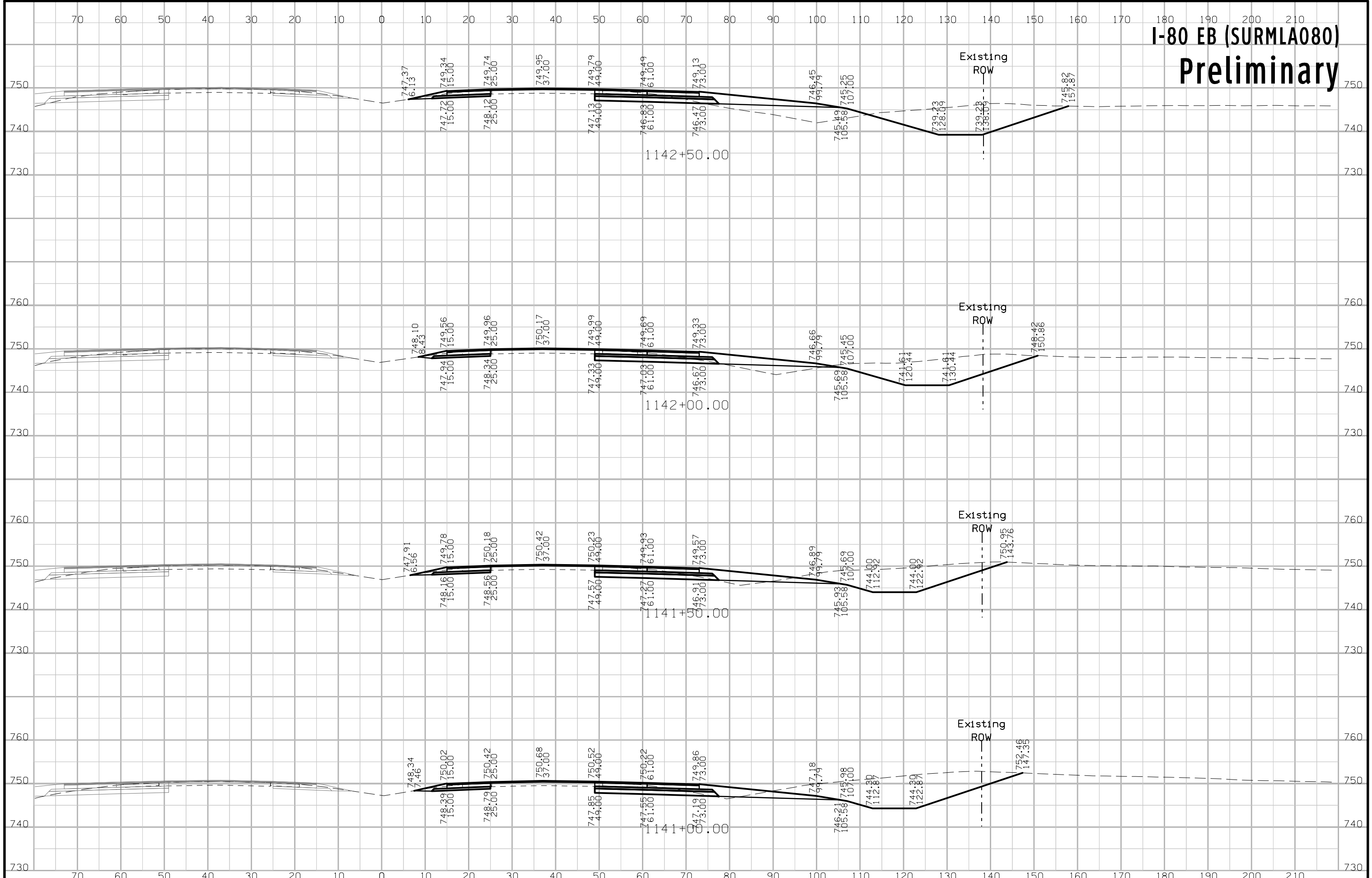

# I-80 EB (SURMLA080) Preliminary

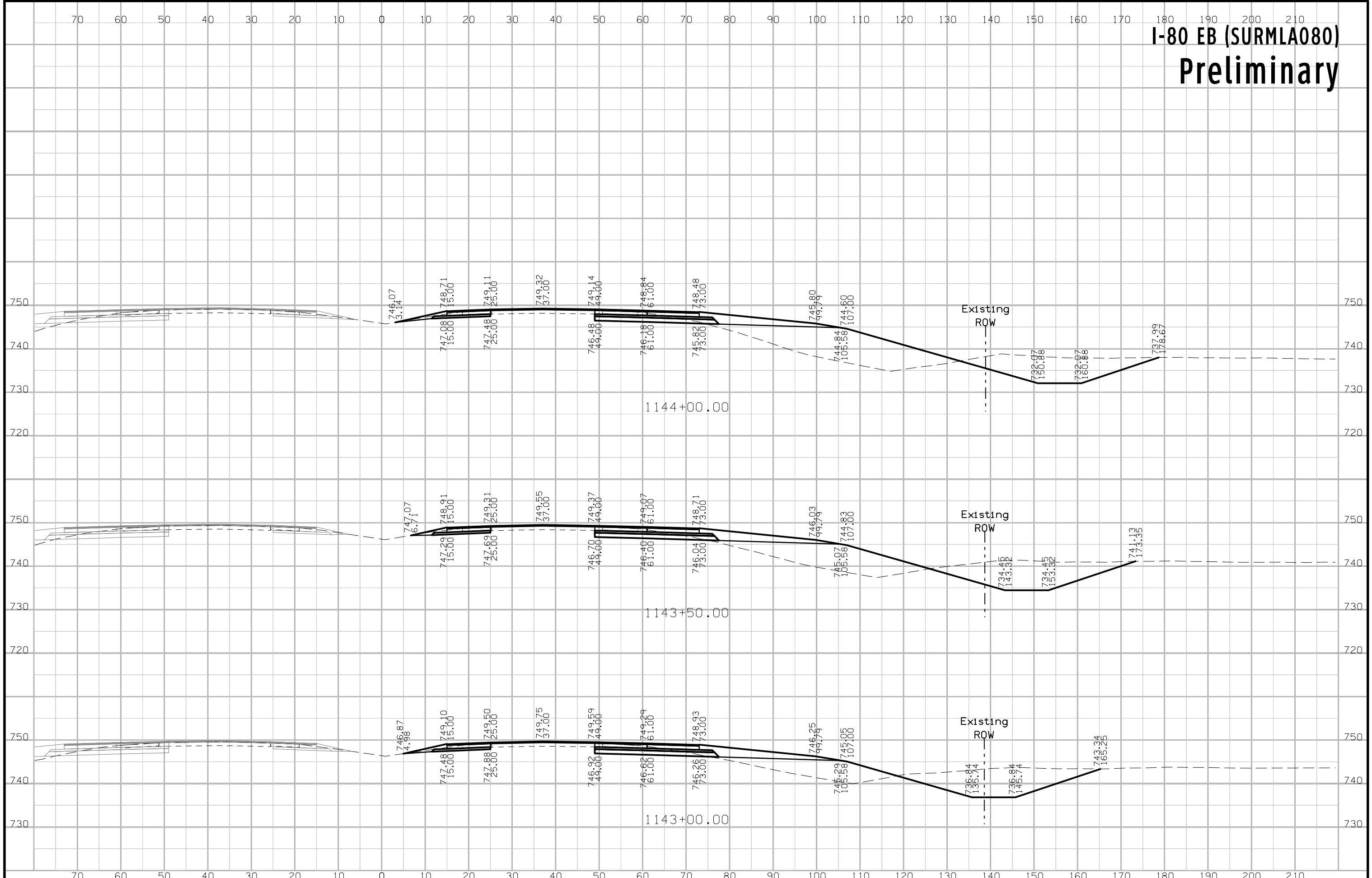

# I-80 EB (SURMLA080) Preliminary

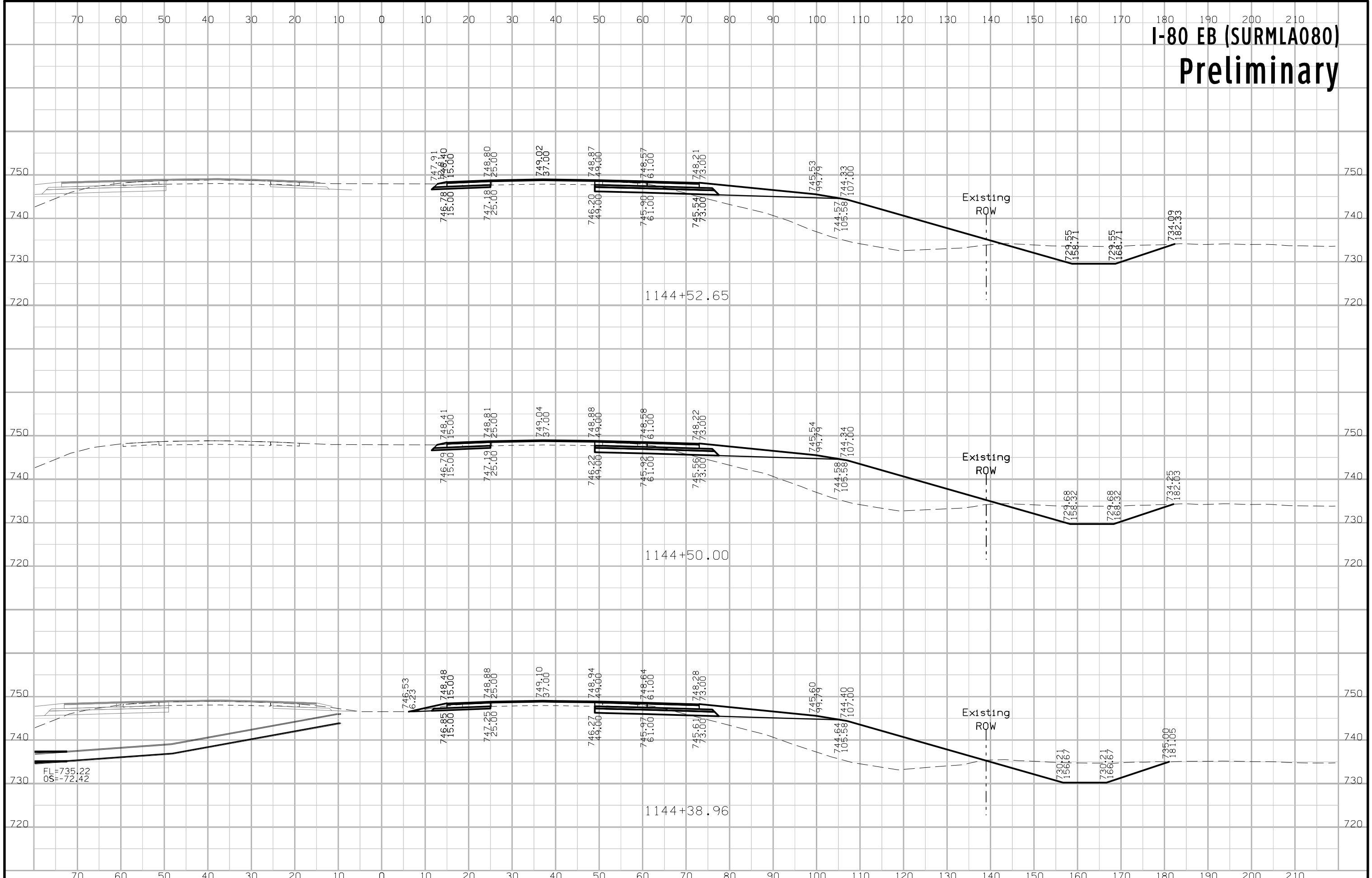

# I-80 EB (SURMLA080) Preliminary

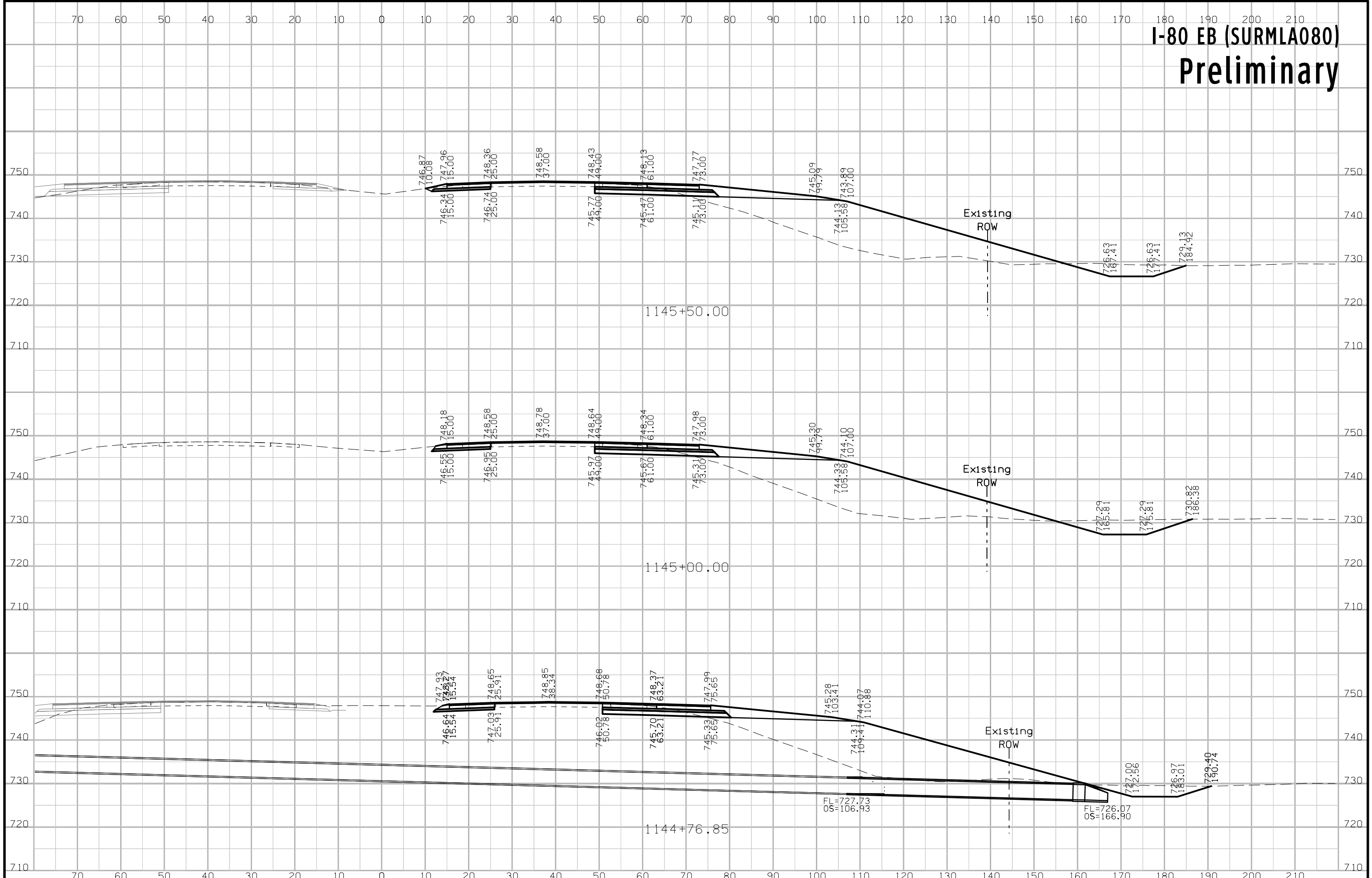

# I-80 EB (SURMLA080) Preliminary

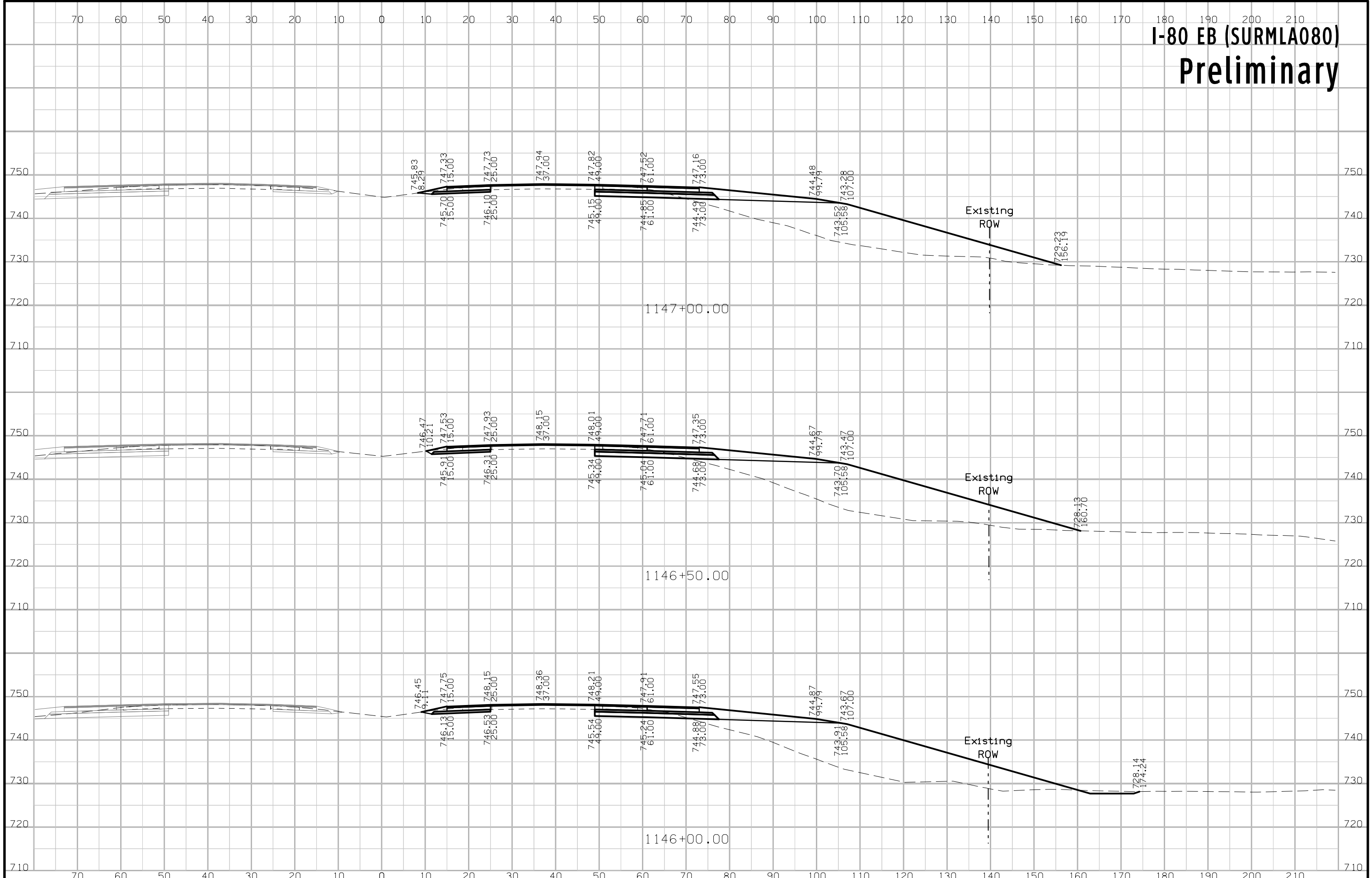

# I-80 EB (SURMLA080) Preliminary

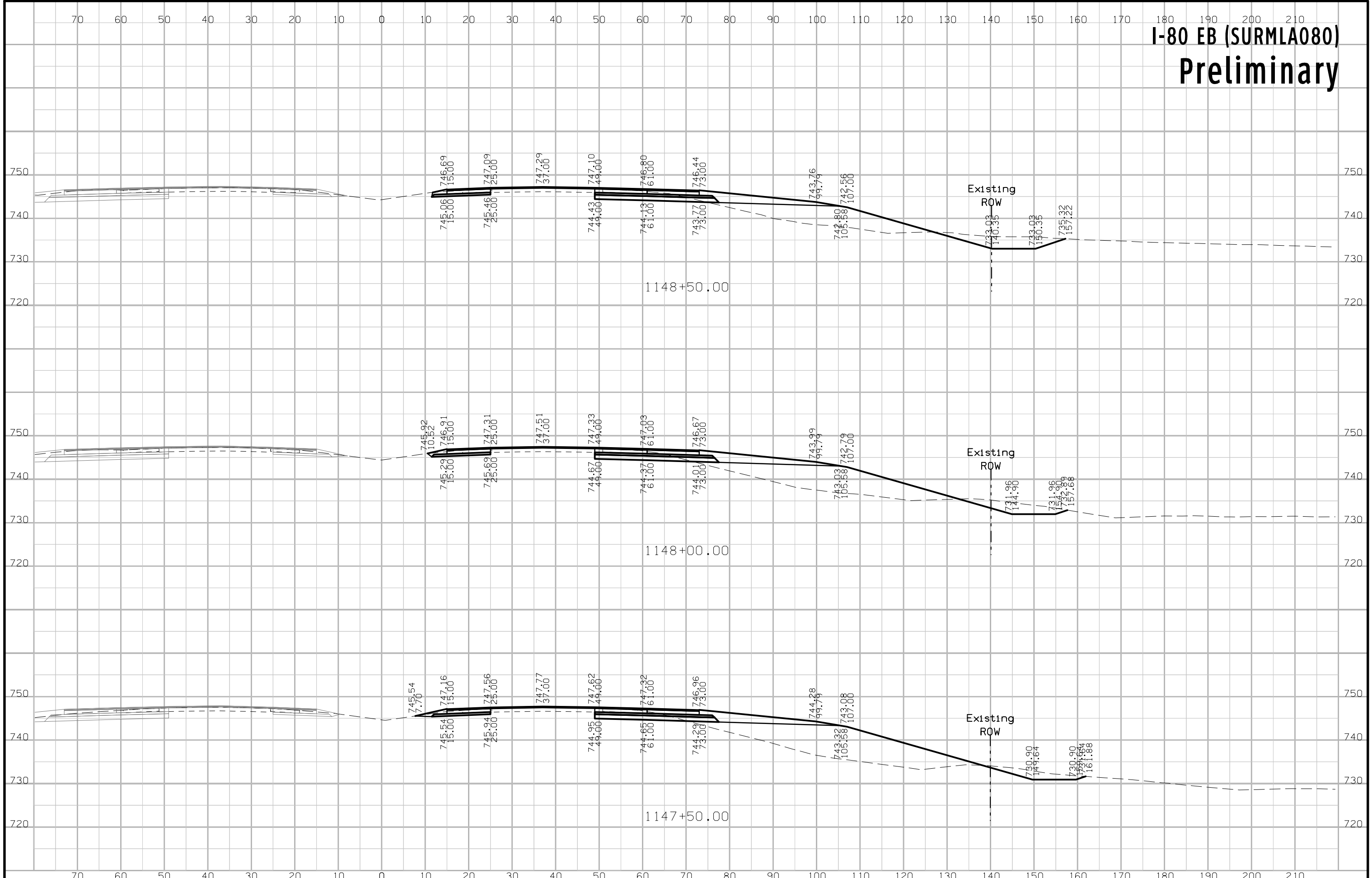

# I-80 EB (SURMLA080) Preliminary

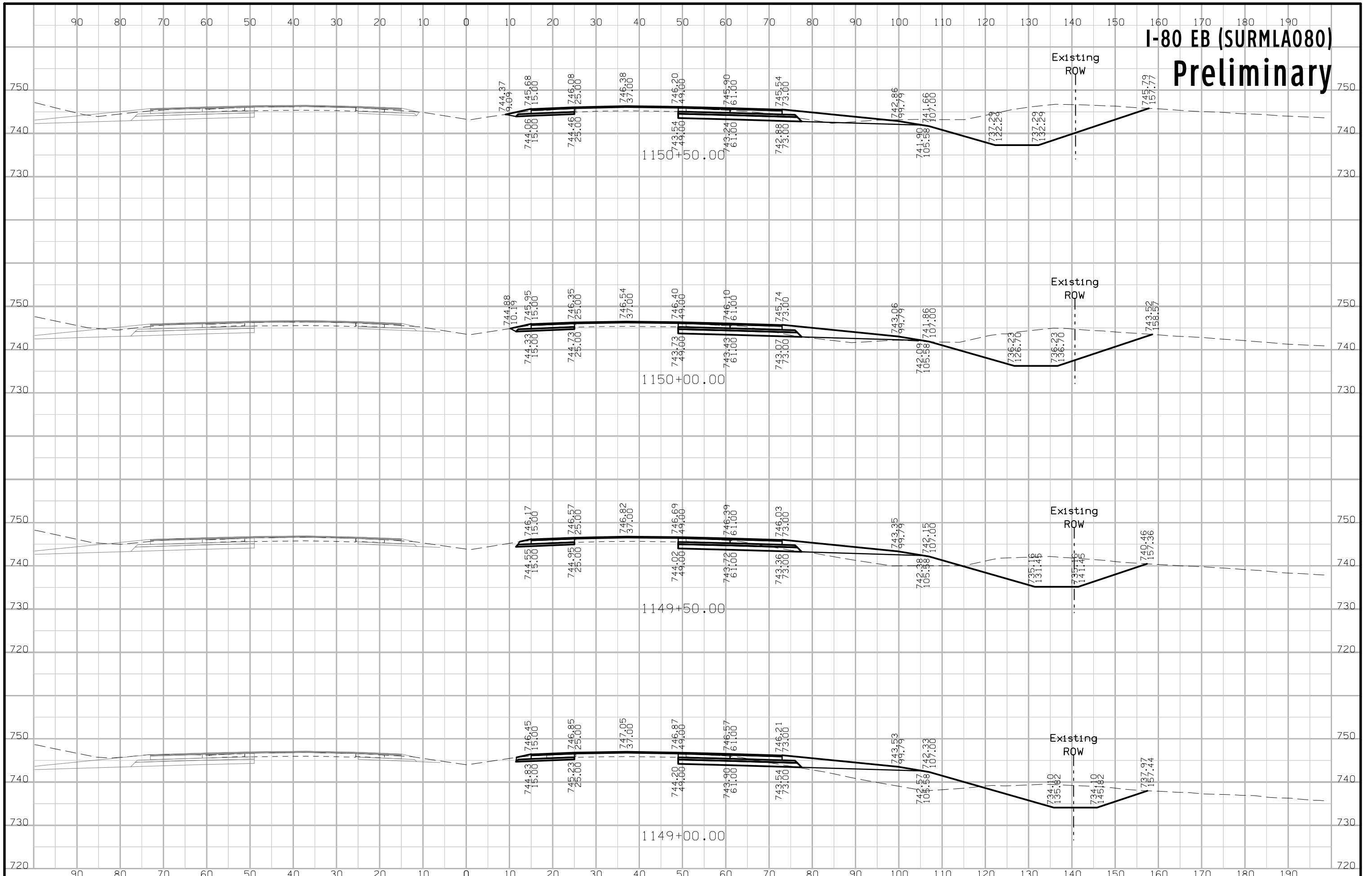

# I-80 EB (SURMLA080) Preliminary

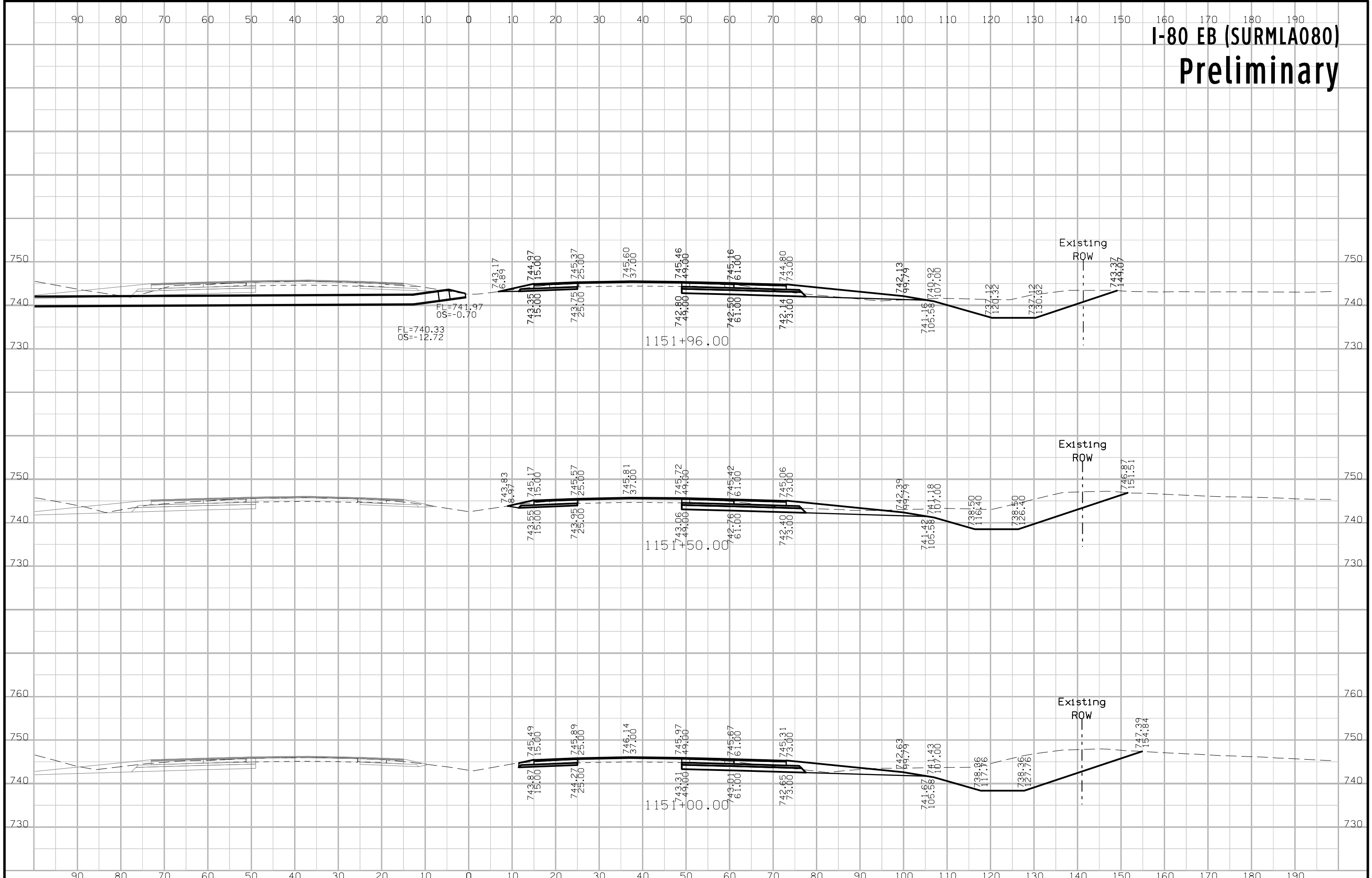



# I-80 EB (SURMLA080) Preliminary

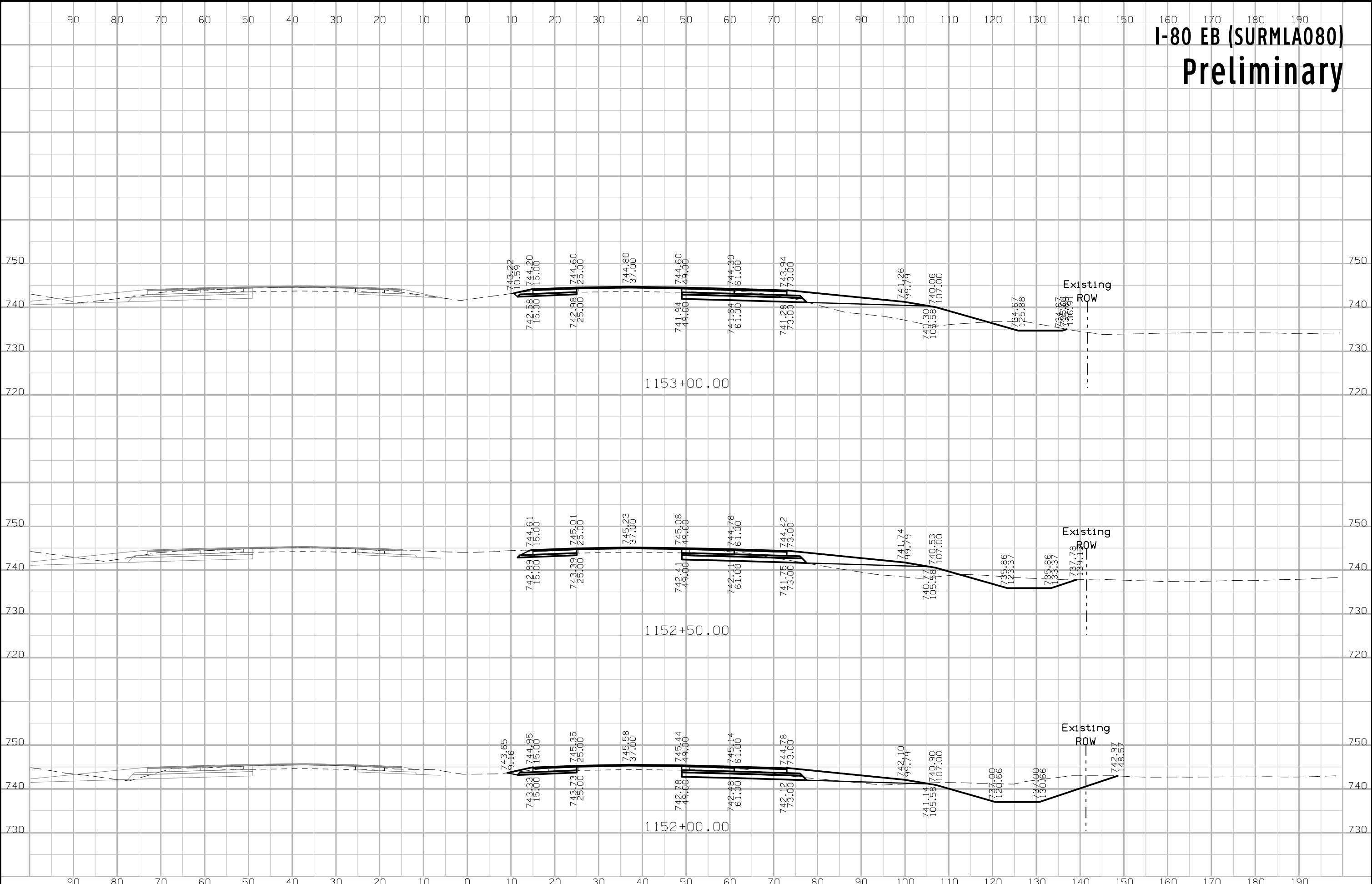

# I-80 EB (SURMLA080) Preliminary

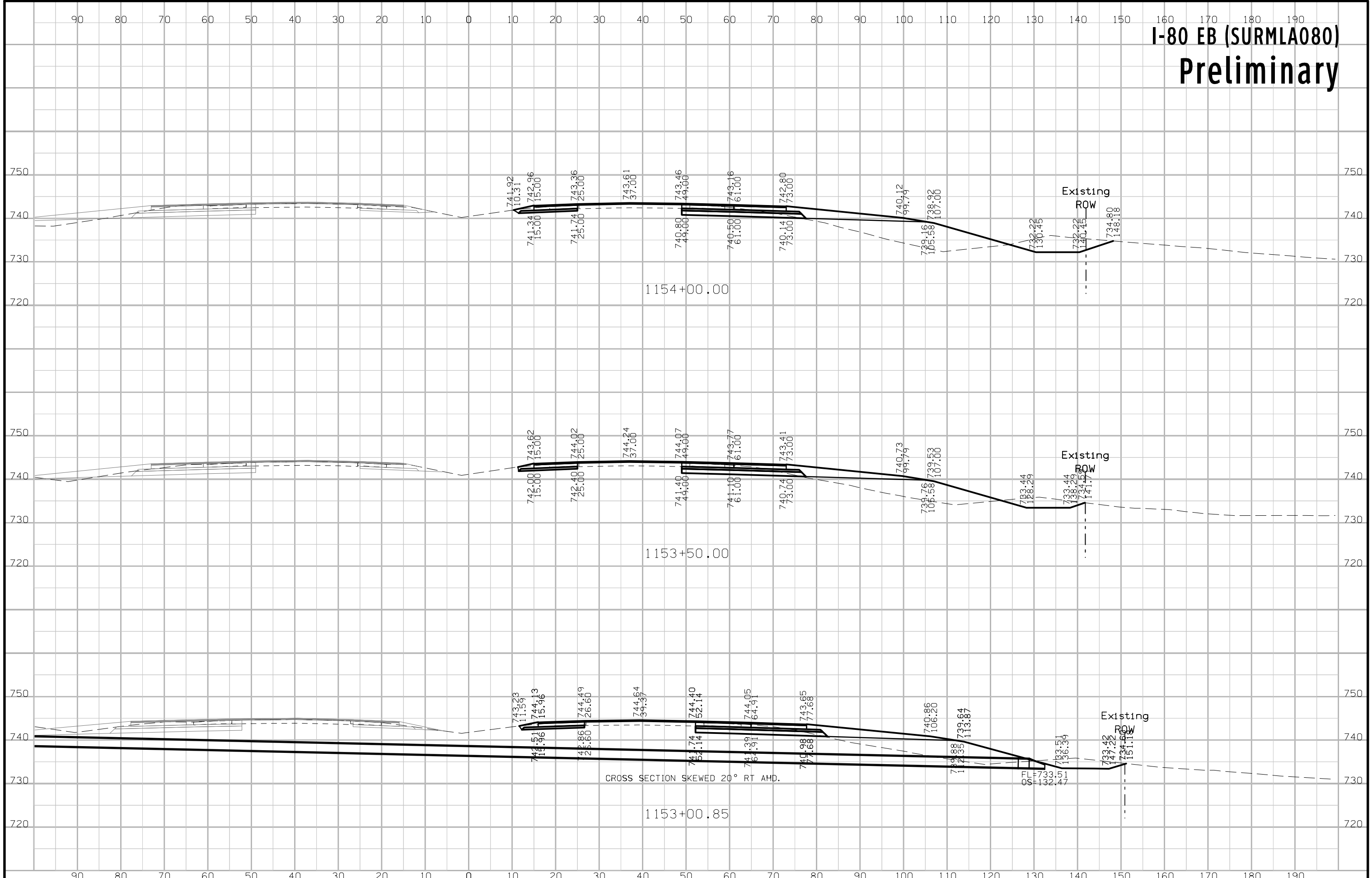

# I-80 EB (SURMLA080) Preliminary

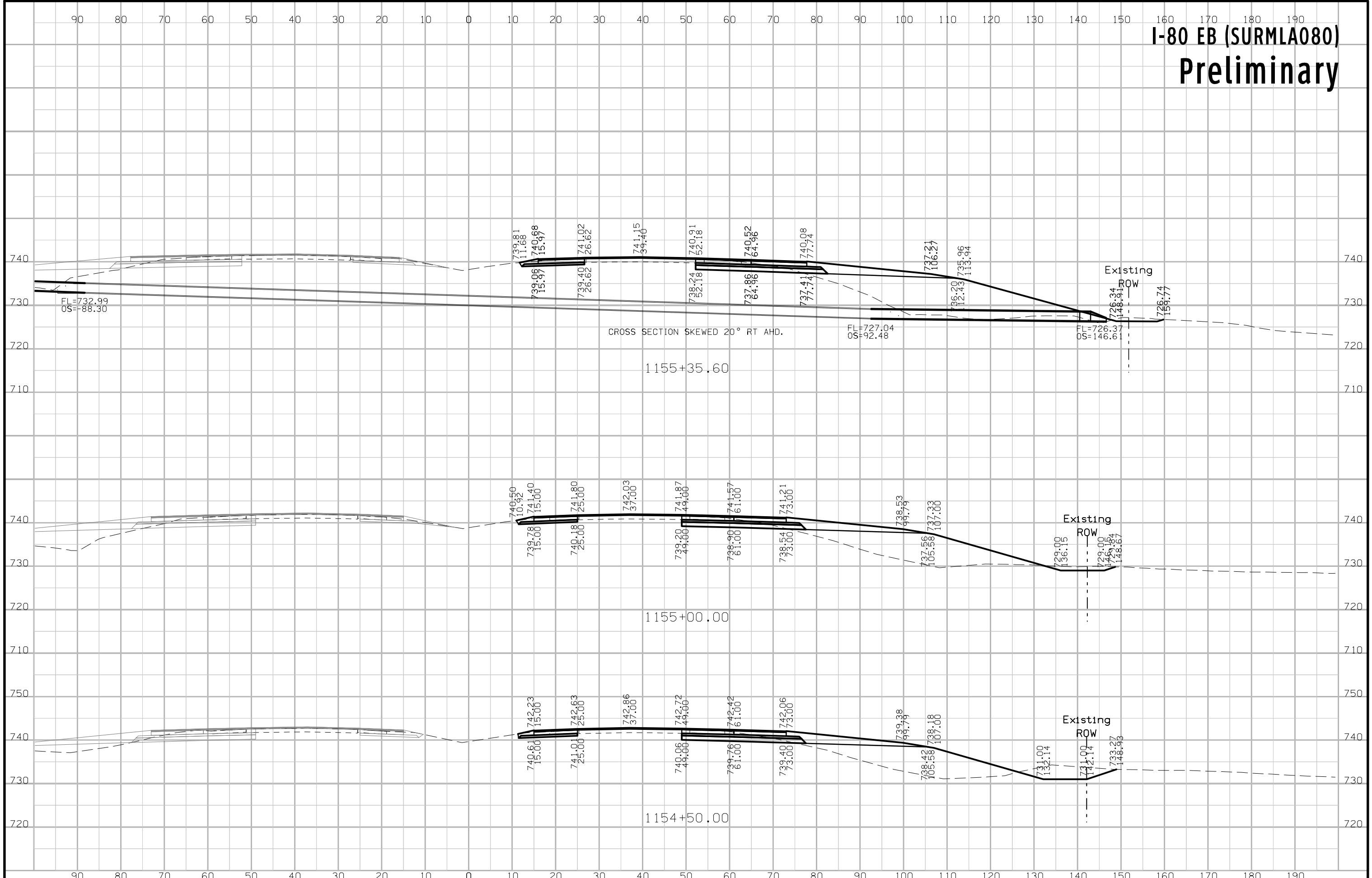

# I-80 EB (SURMLA080) Preliminary

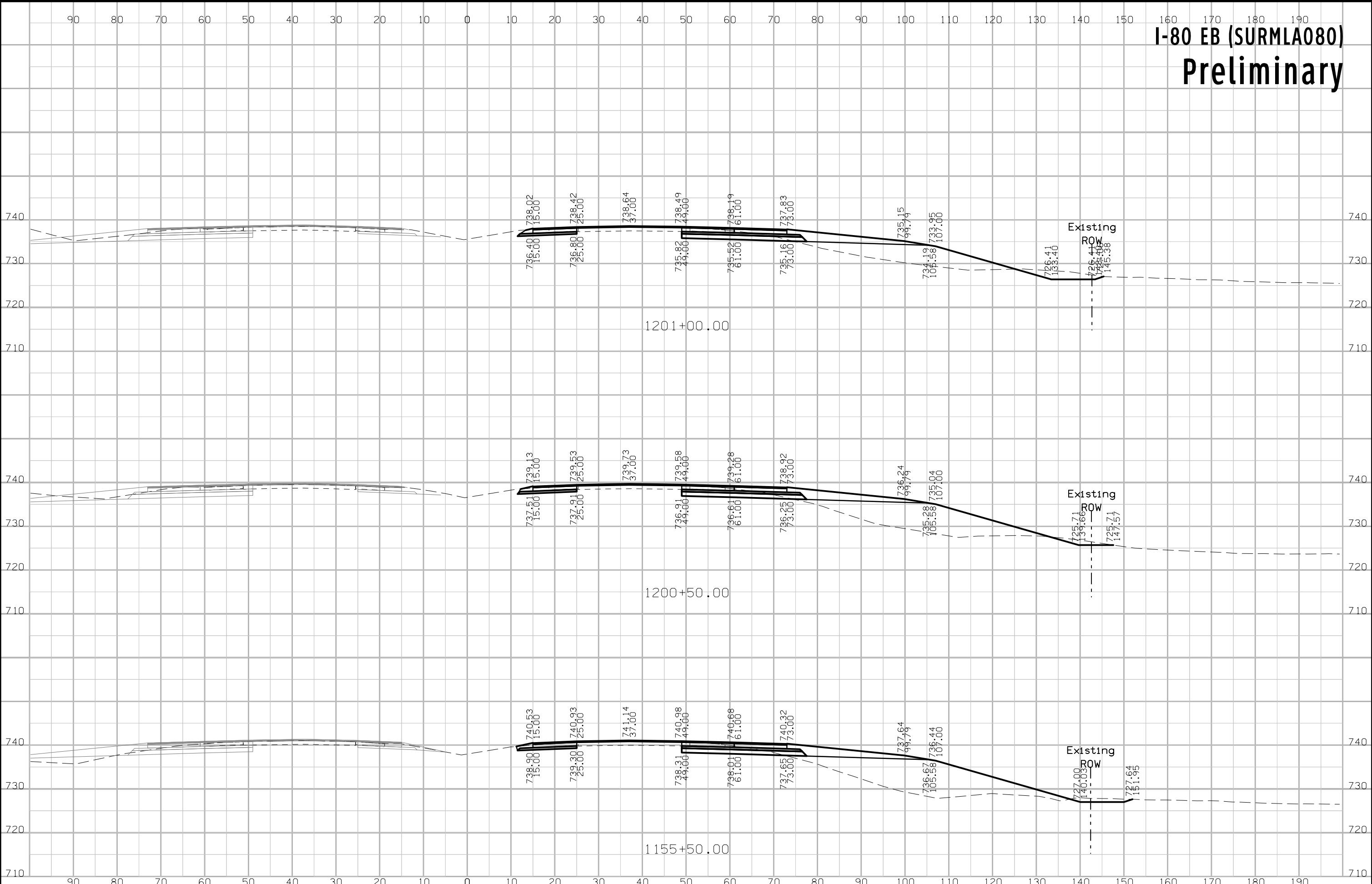

# I-80 EB (SURMLA080) Preliminary

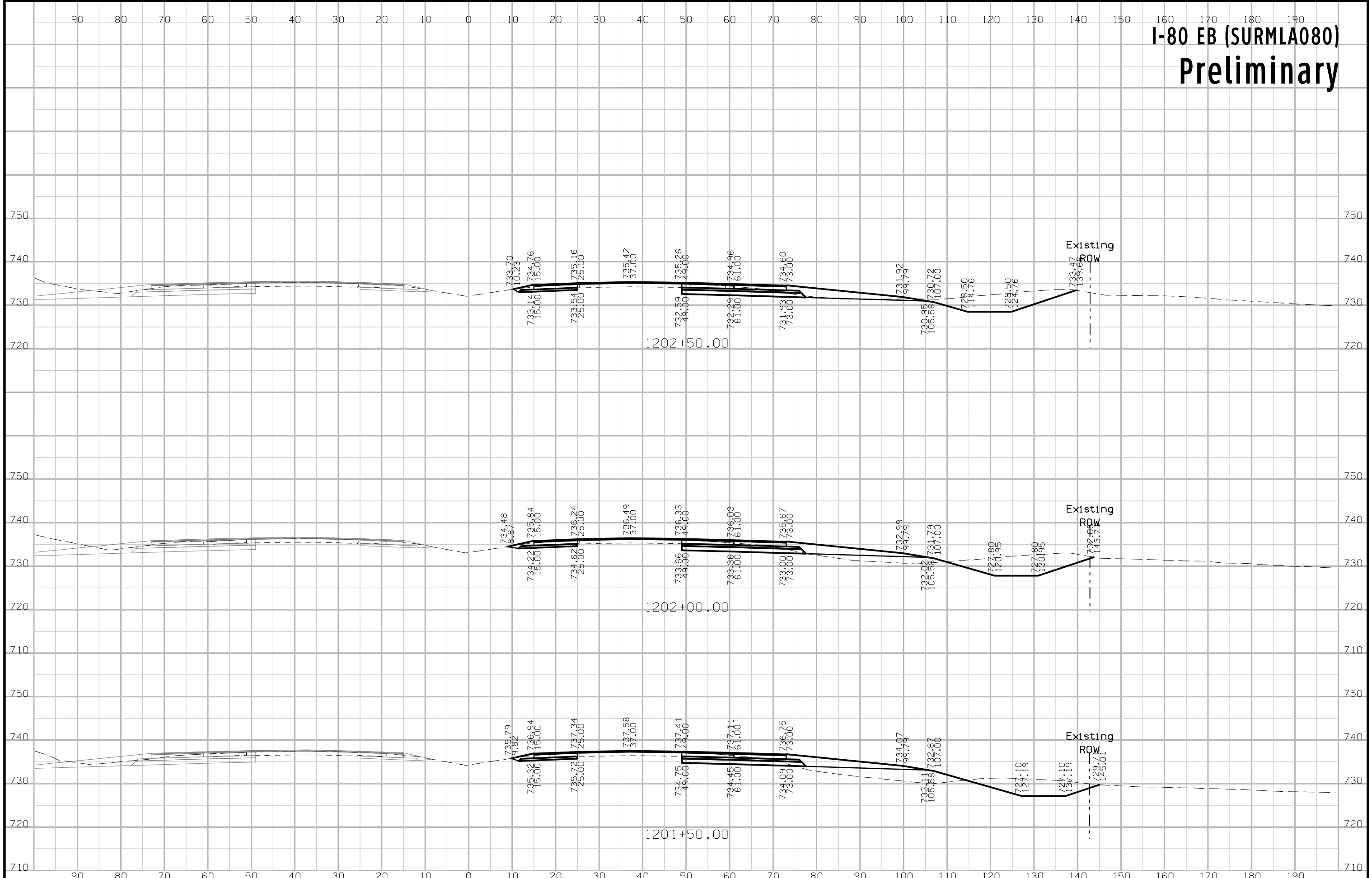

# I-80 EB (SURMLA080) Preliminary

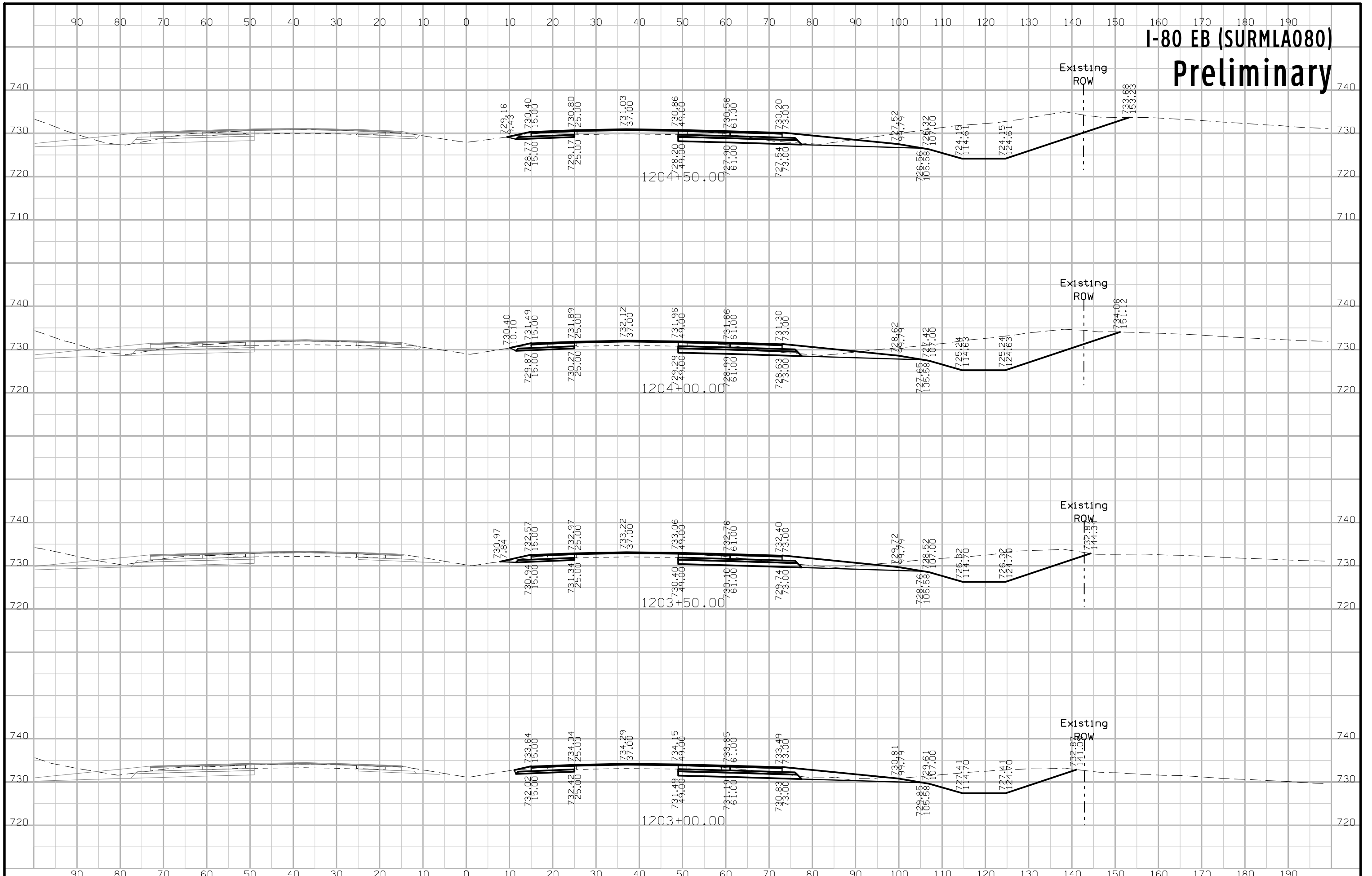

# I-80 EB (SURMLA080) Preliminary

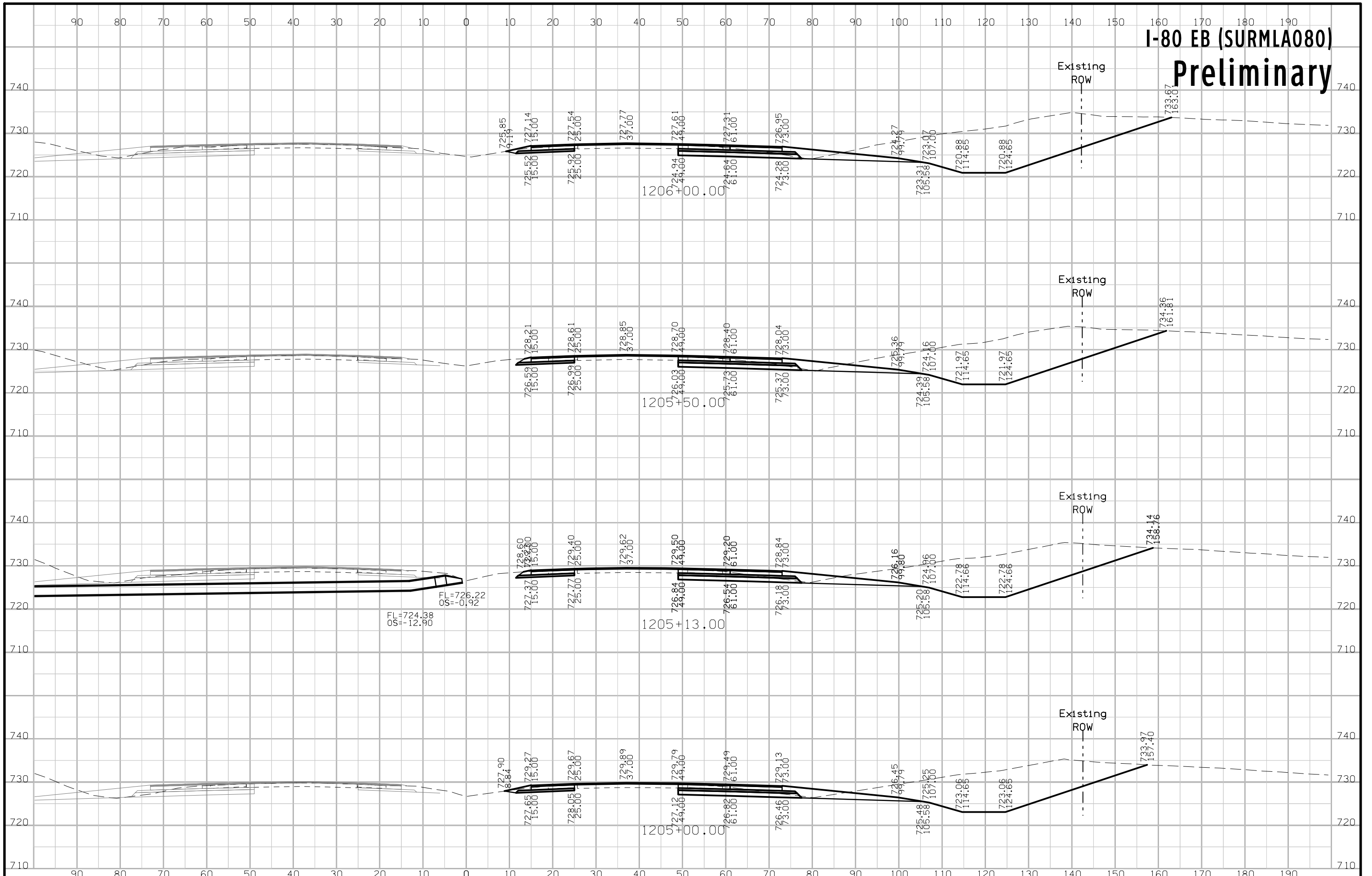

# I-80 EB (SURMLA080) Preliminary

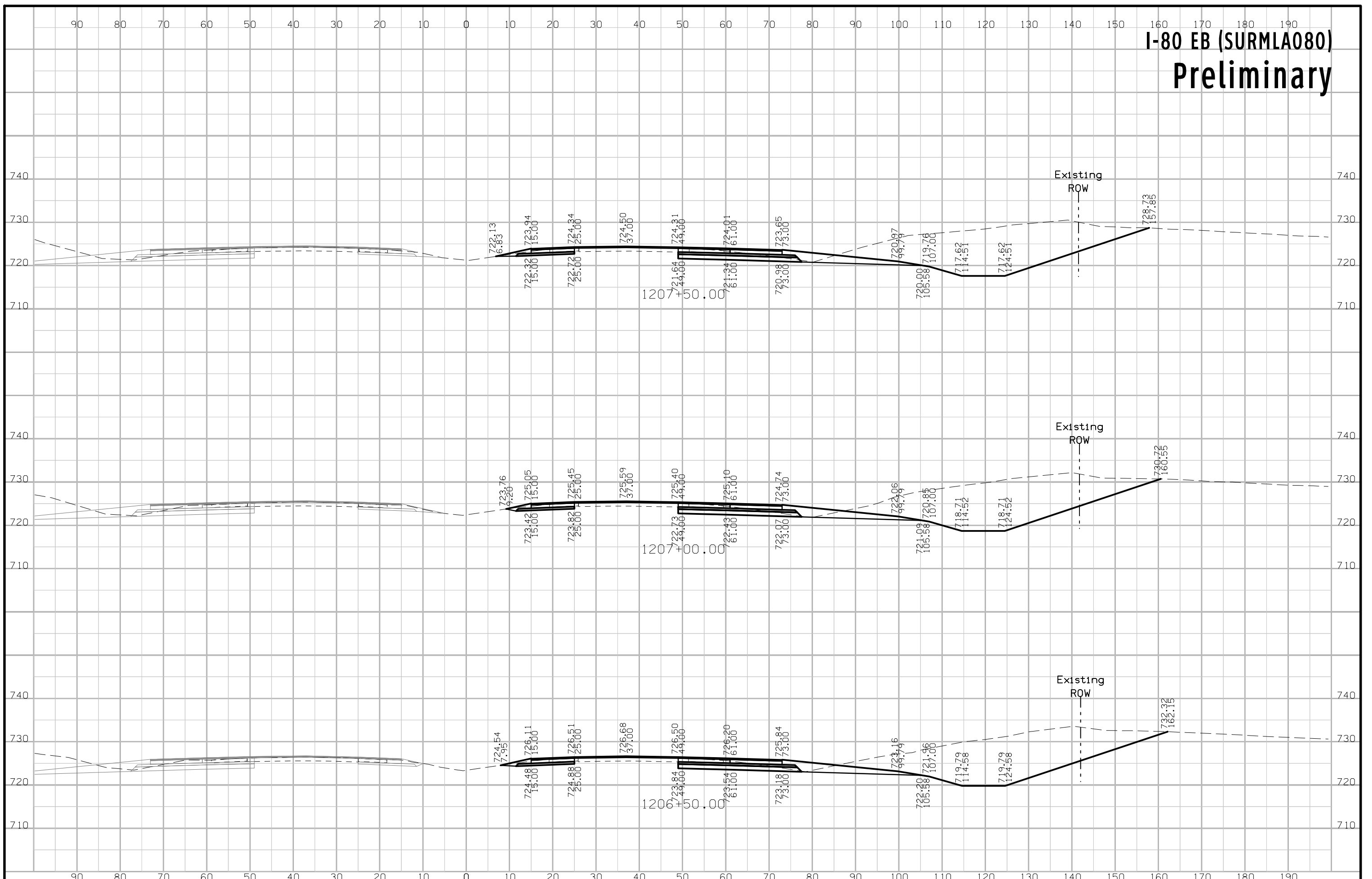



# I-80 EB (SURMLA080) Preliminary

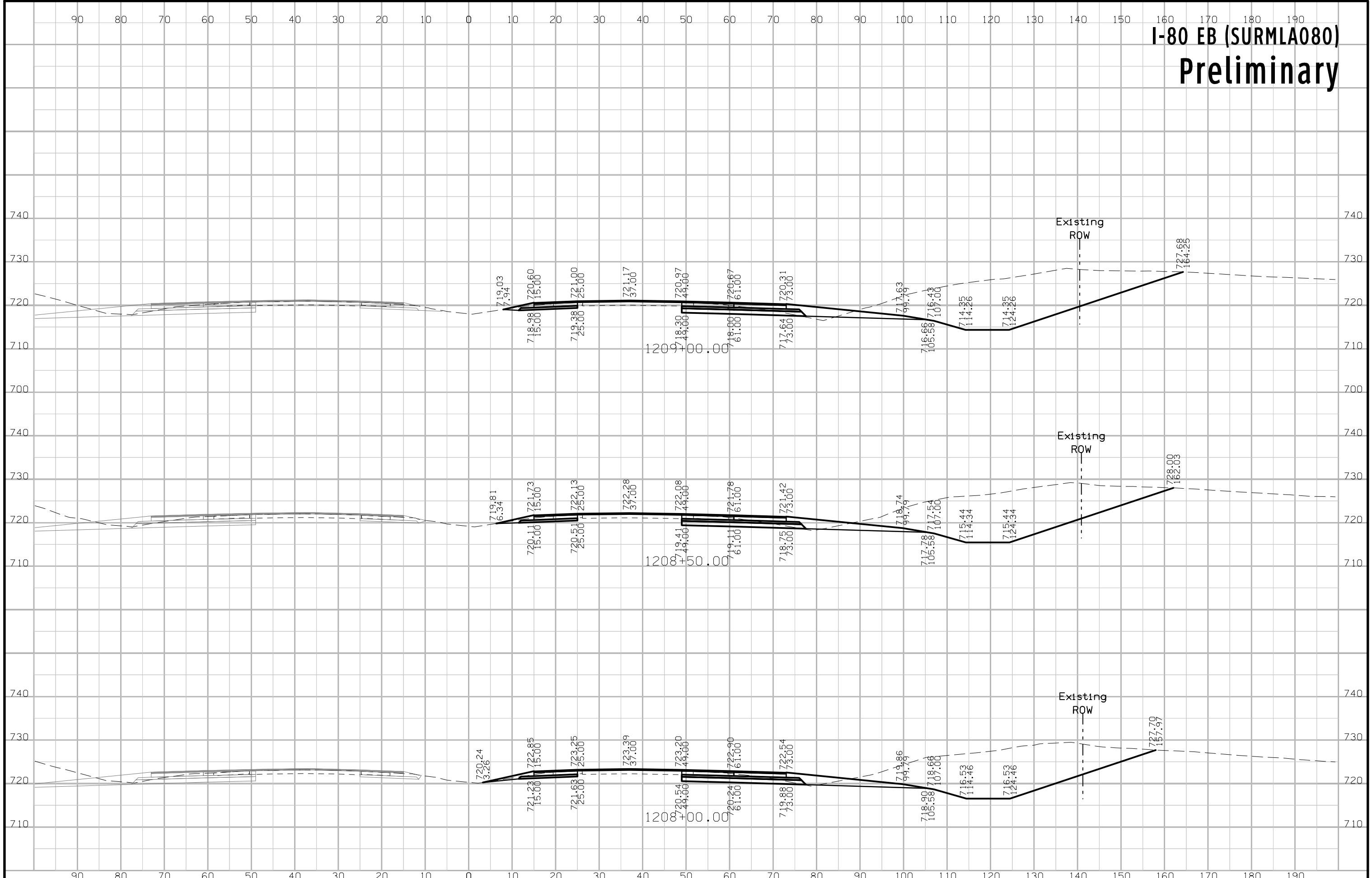

# I-80 EB (SURMLA080) Preliminary

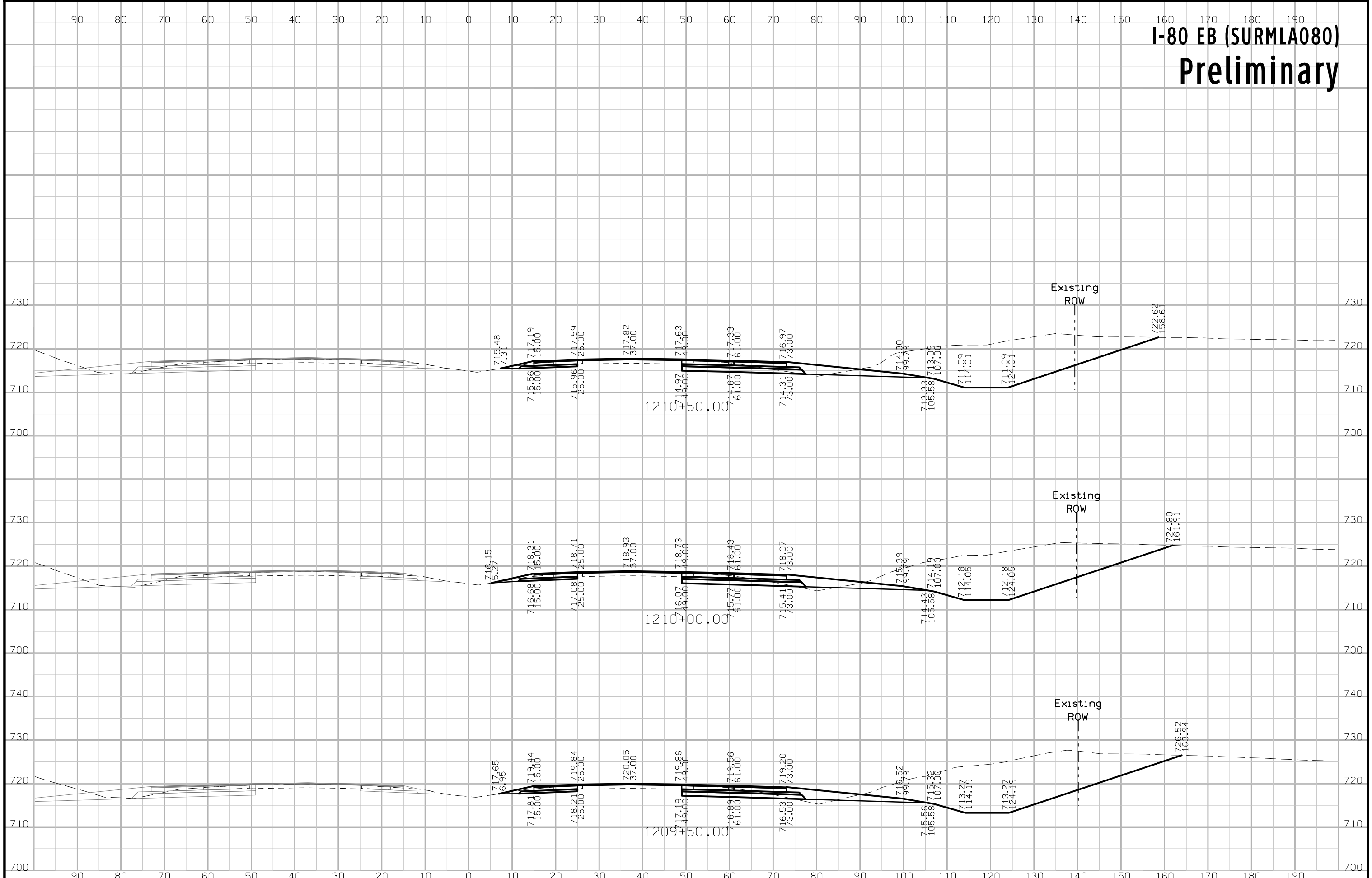

# I-80 EB (SURMLA080) Preliminary

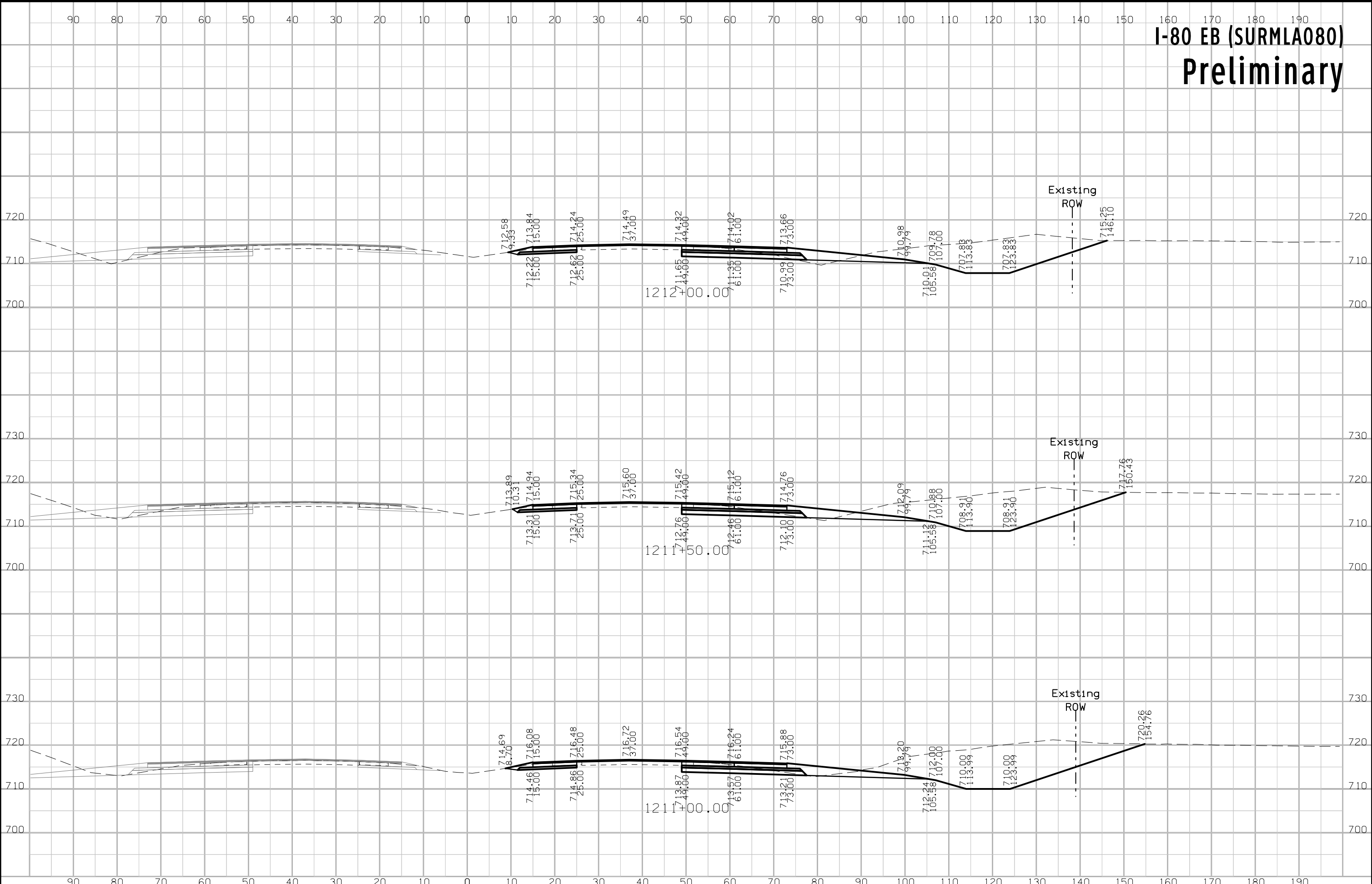

# I-80 EB (SURMLA080) Preliminary

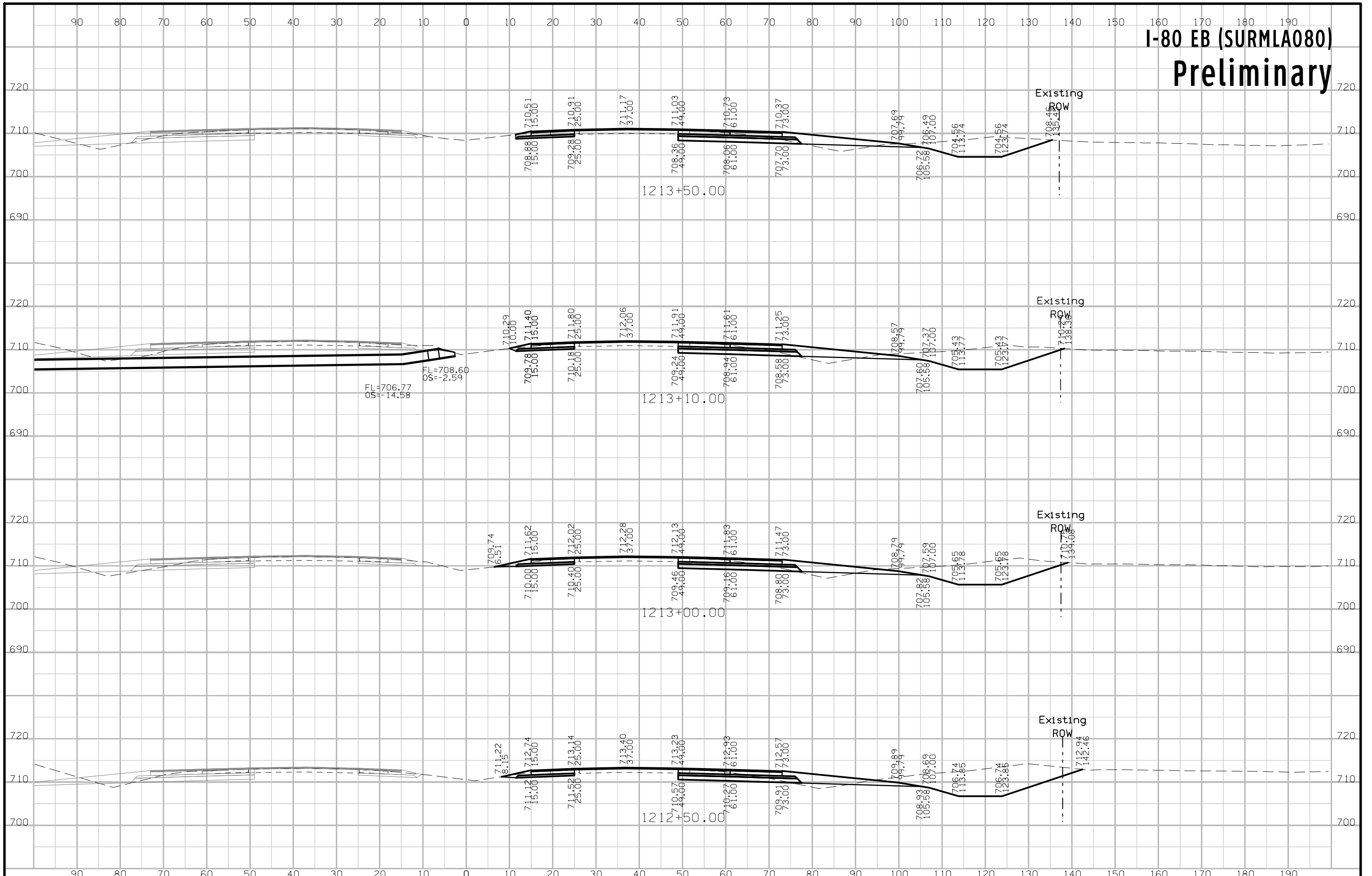

# I-80 EB (SURMLA080) Preliminary

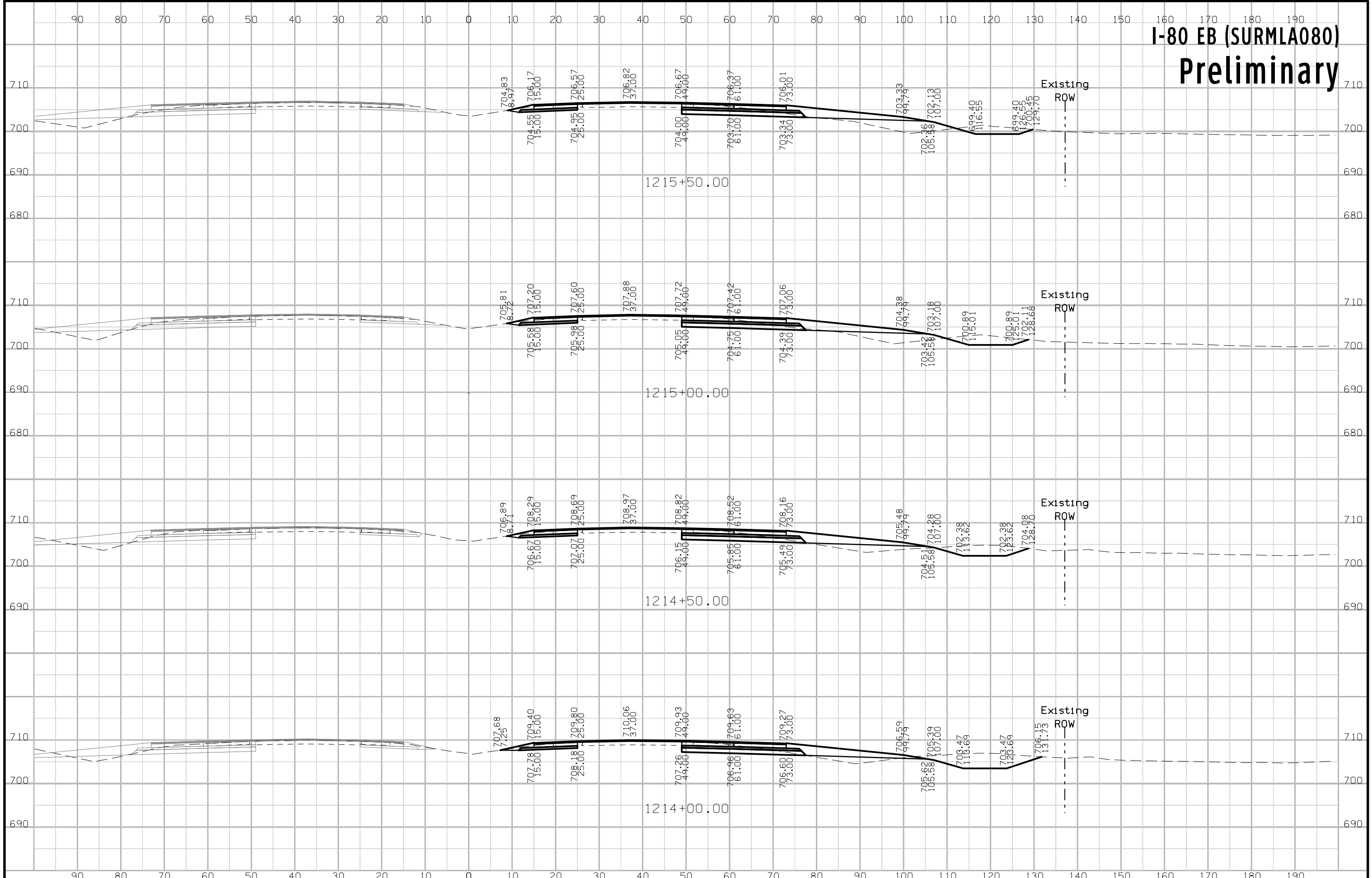

# I-80 EB (SURMLA080) Preliminary

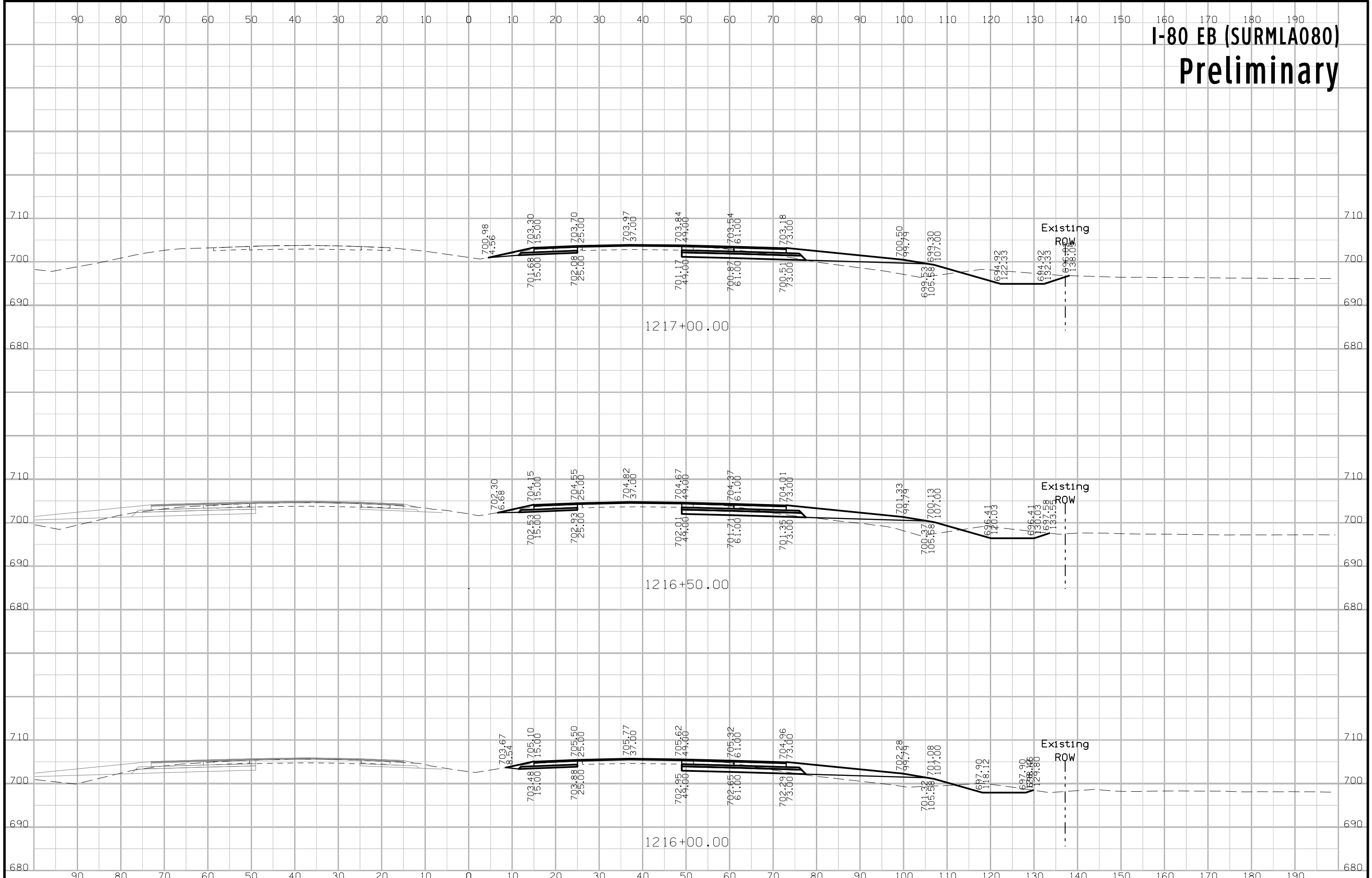

# I-80 EB (SURMLA080) Preliminary

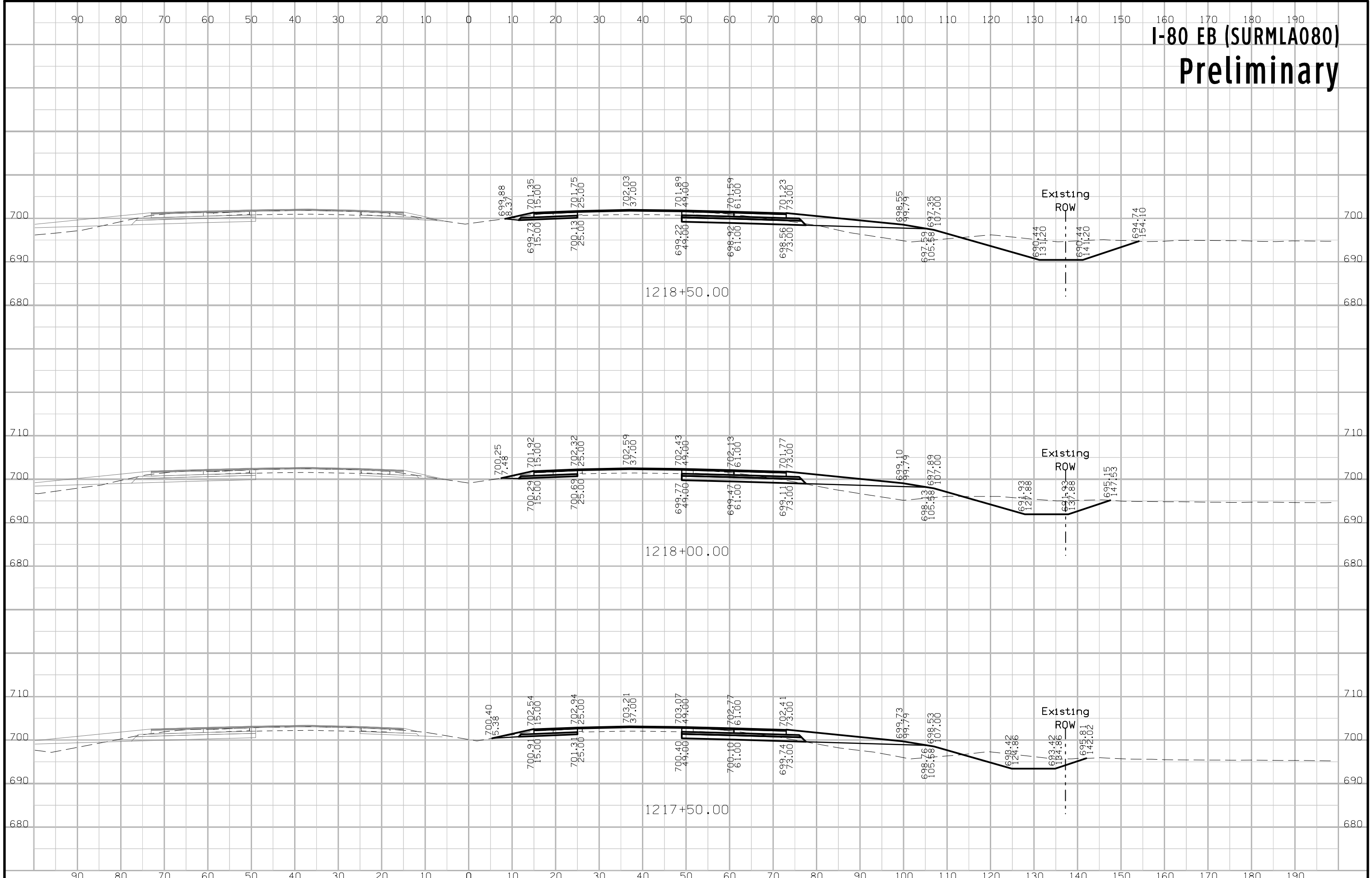

# I-80 EB (SURMLA080) Preliminary

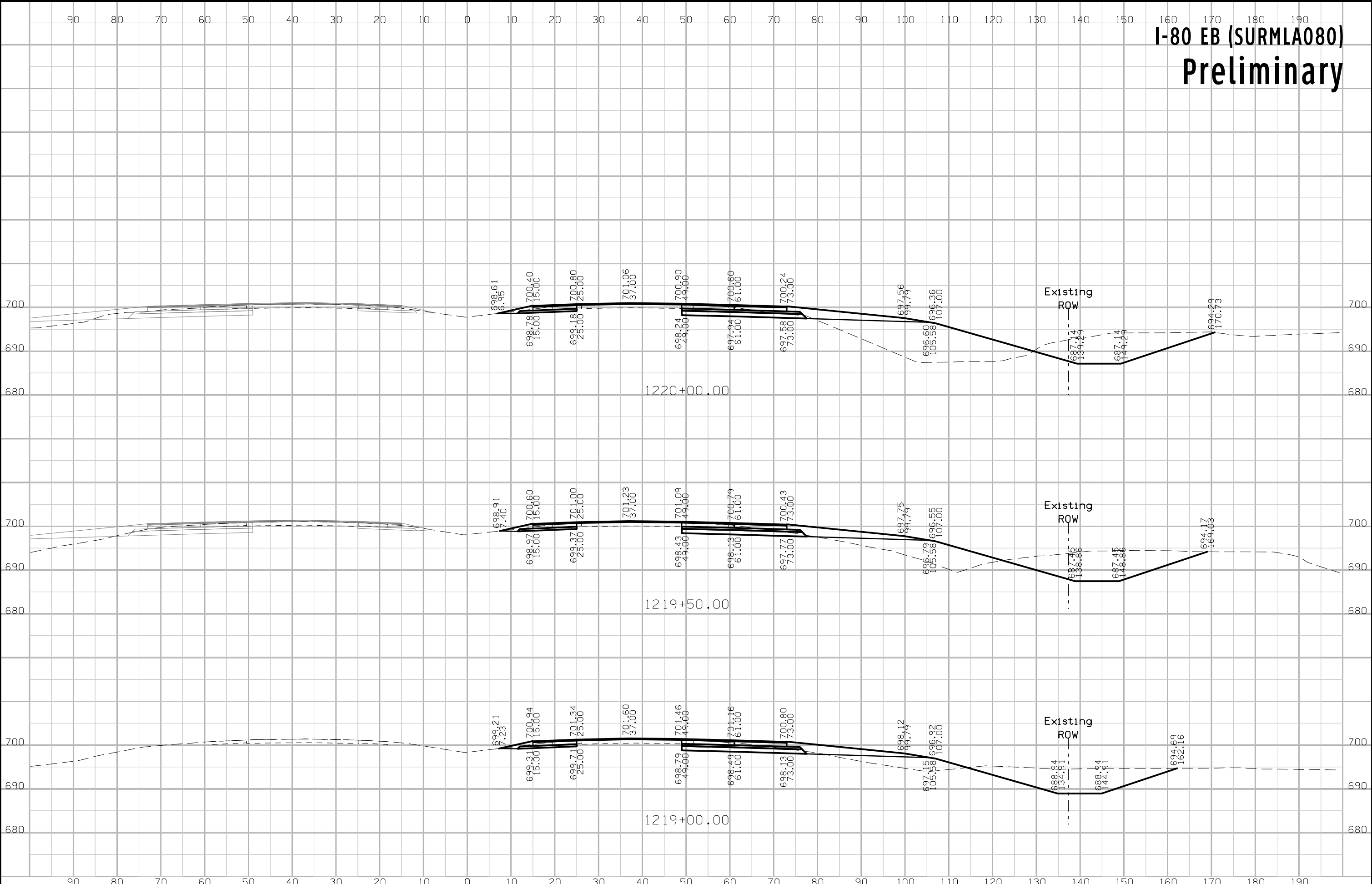



# I-80 EB (SURMLA080) Preliminary

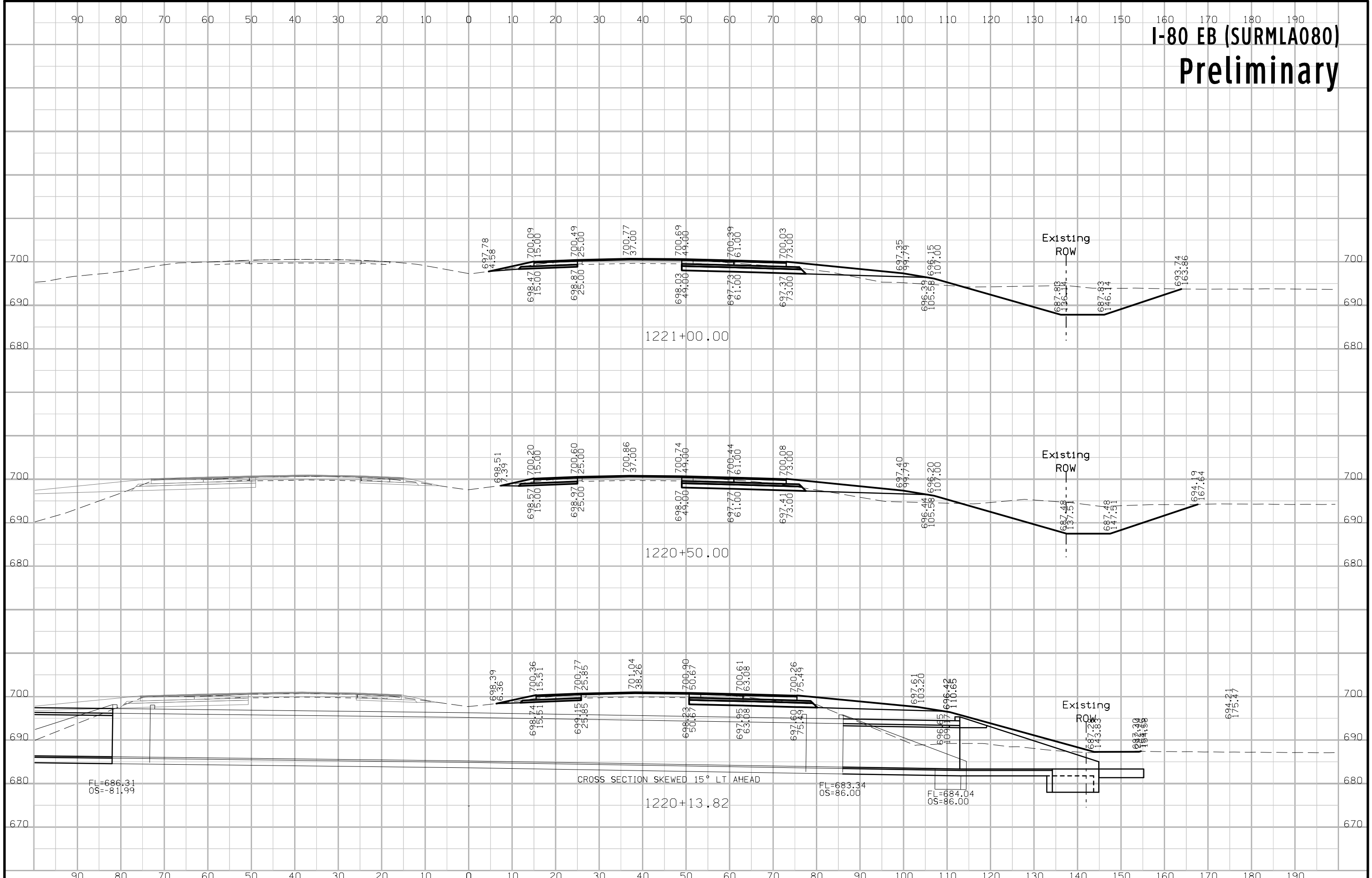

# I-80 EB (SURMLA080) Preliminary

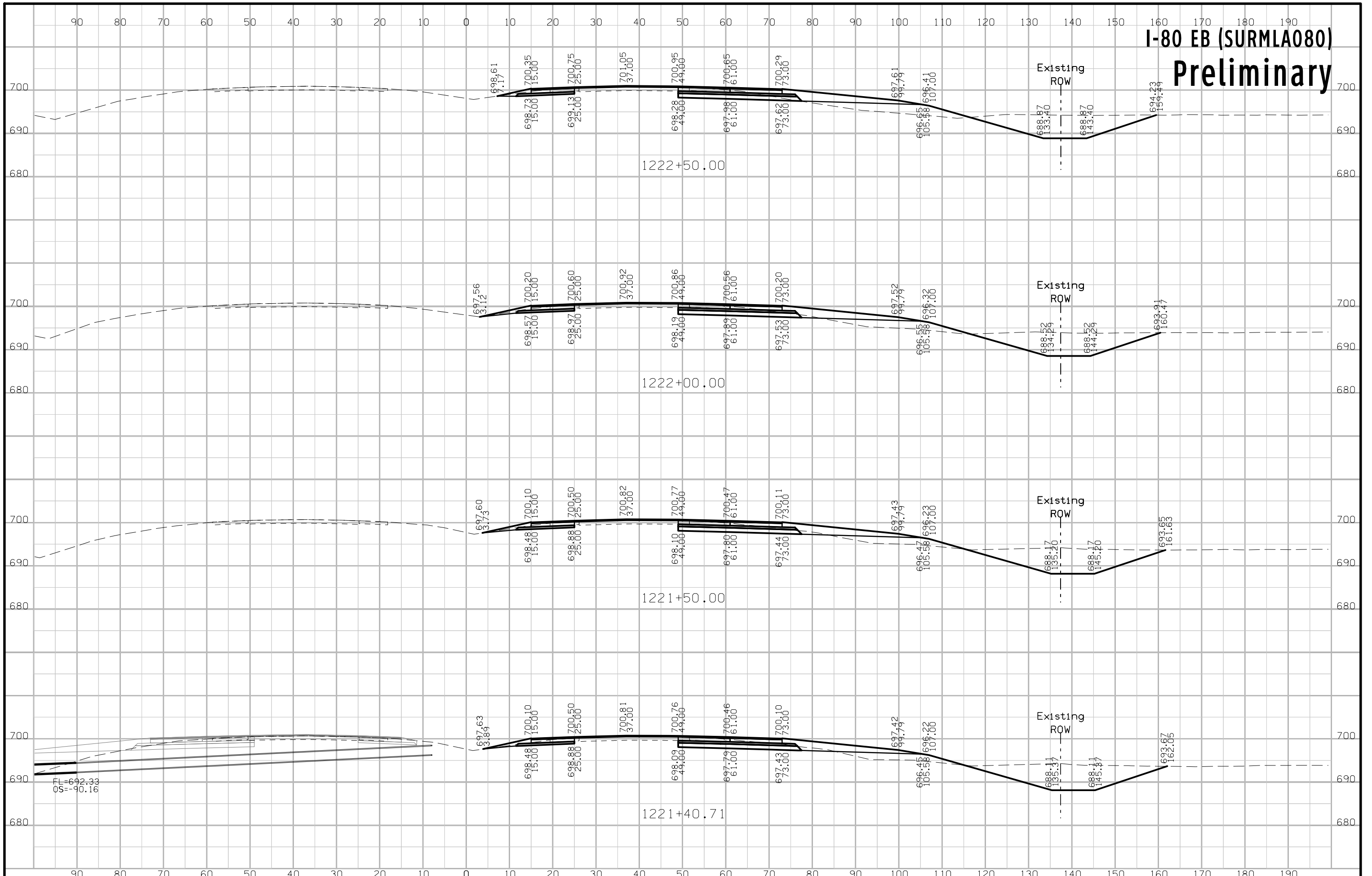

# I-80 EB (SURMLA080) Preliminary

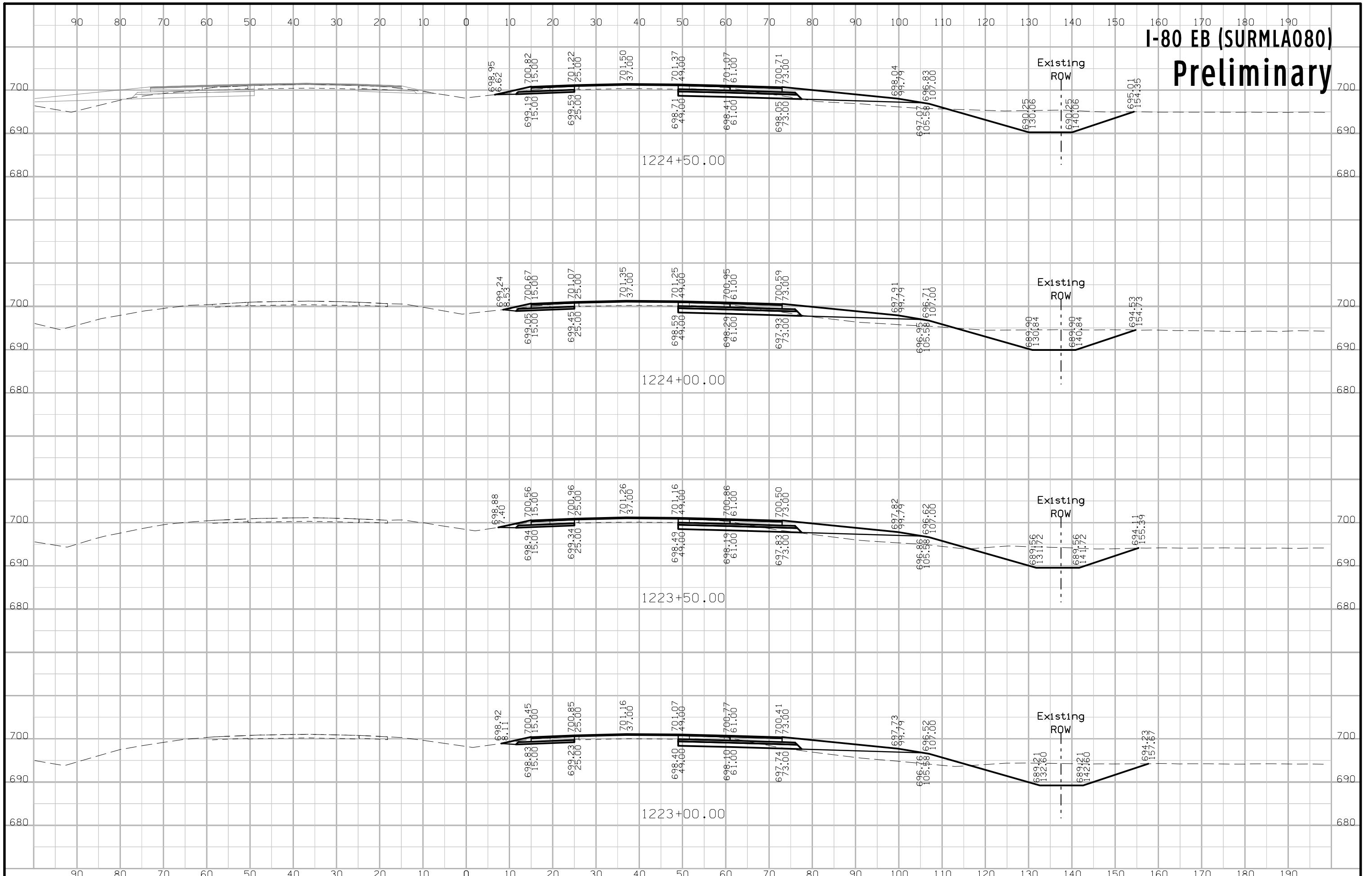

# I-80 EB (SURMLA080) Preliminary

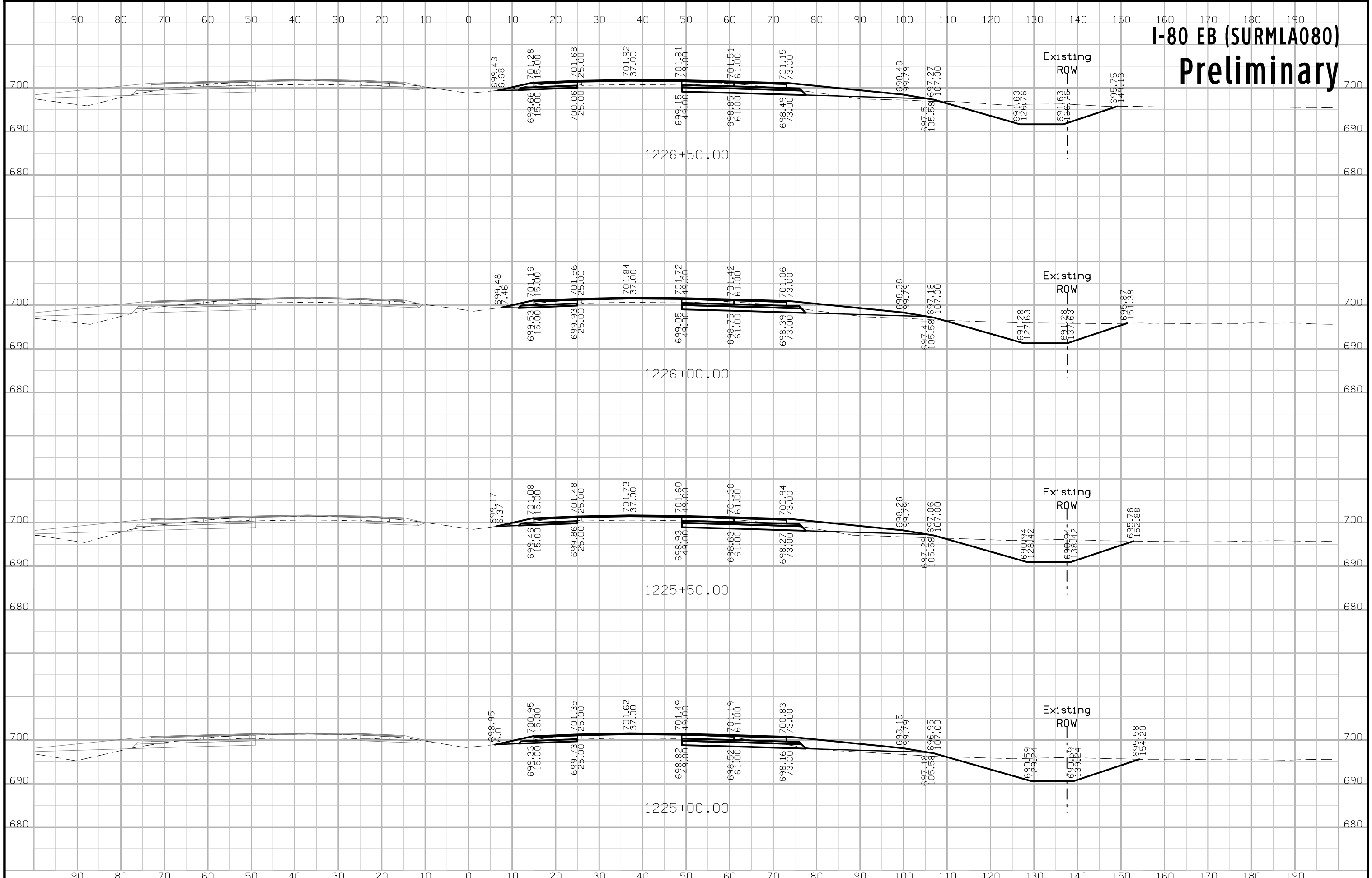

# I-80 EB (SURMLA080) Preliminary

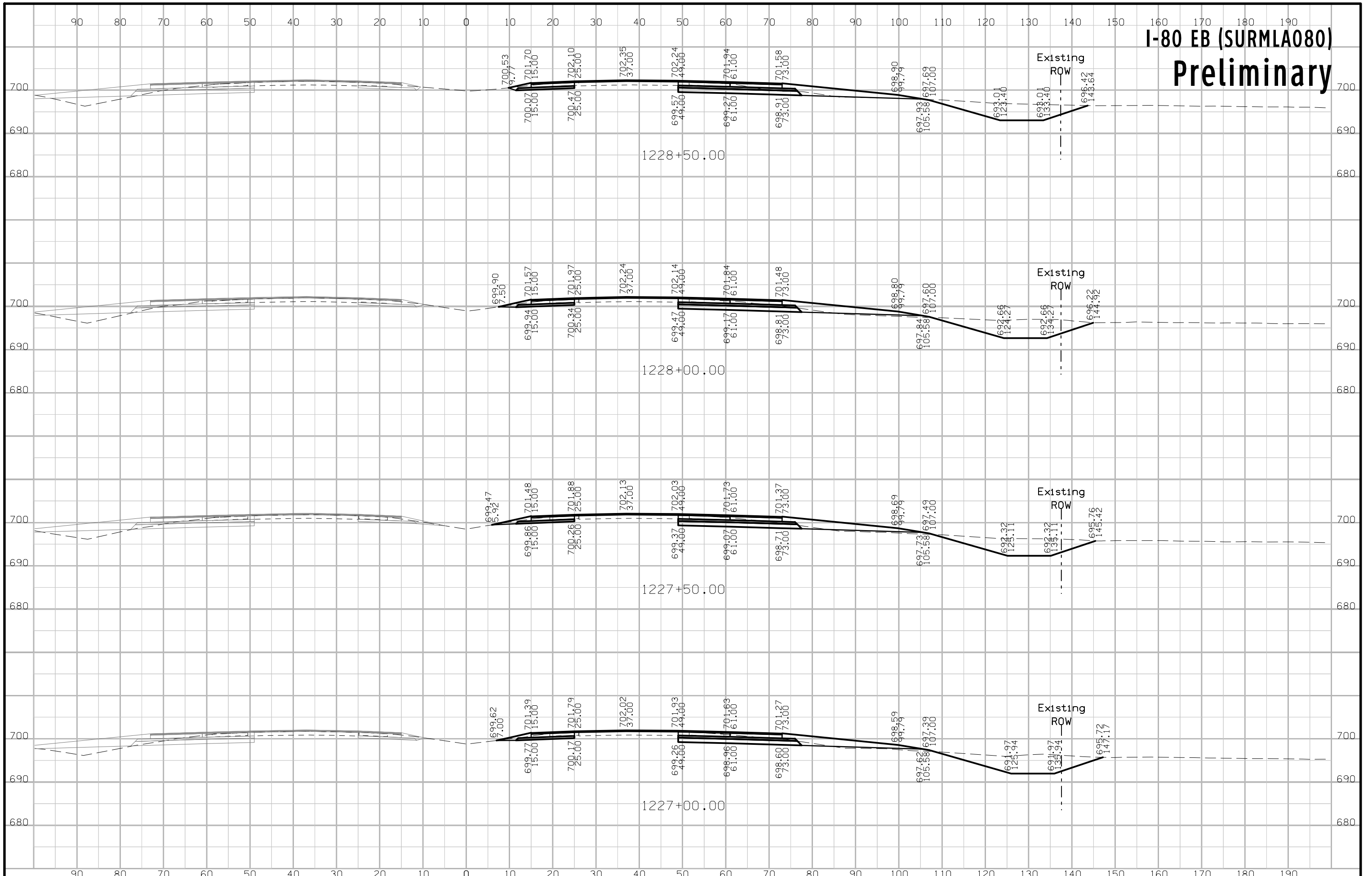

# I-80 EB (SURMLA080) Preliminary

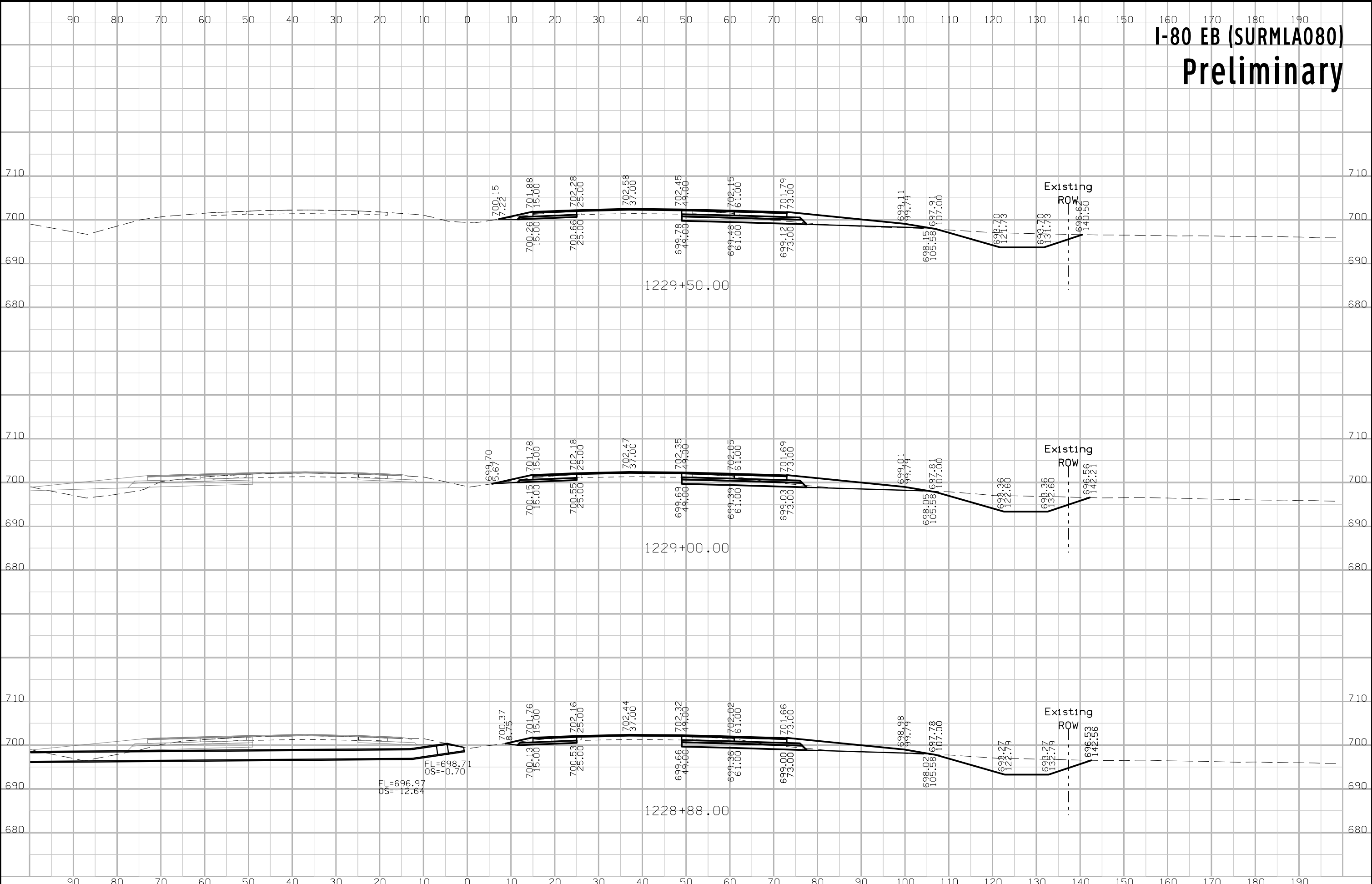

# I-80 EB (SURMLA080) Preliminary

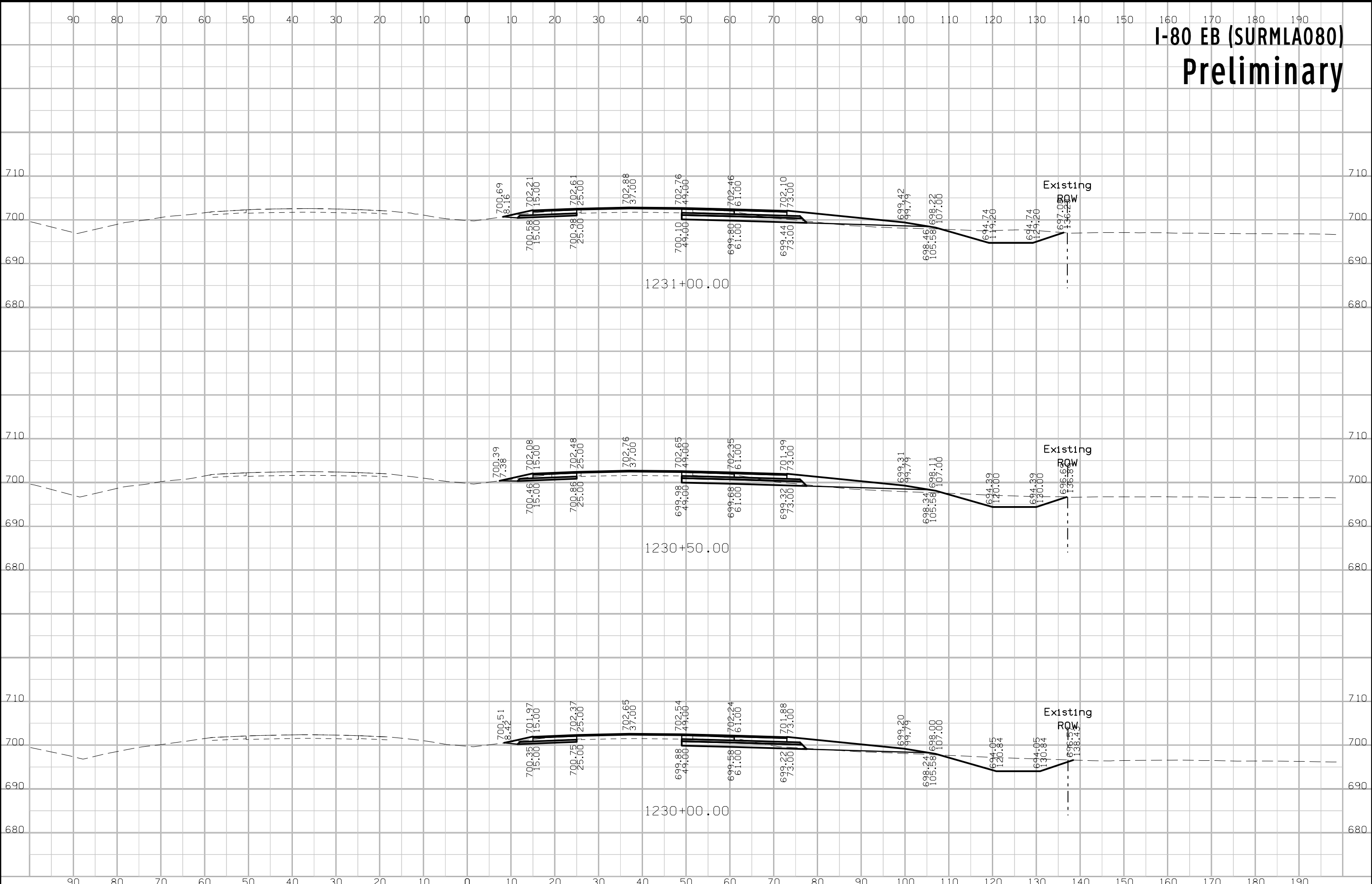

# I-80 EB (SURMLA080) Preliminary

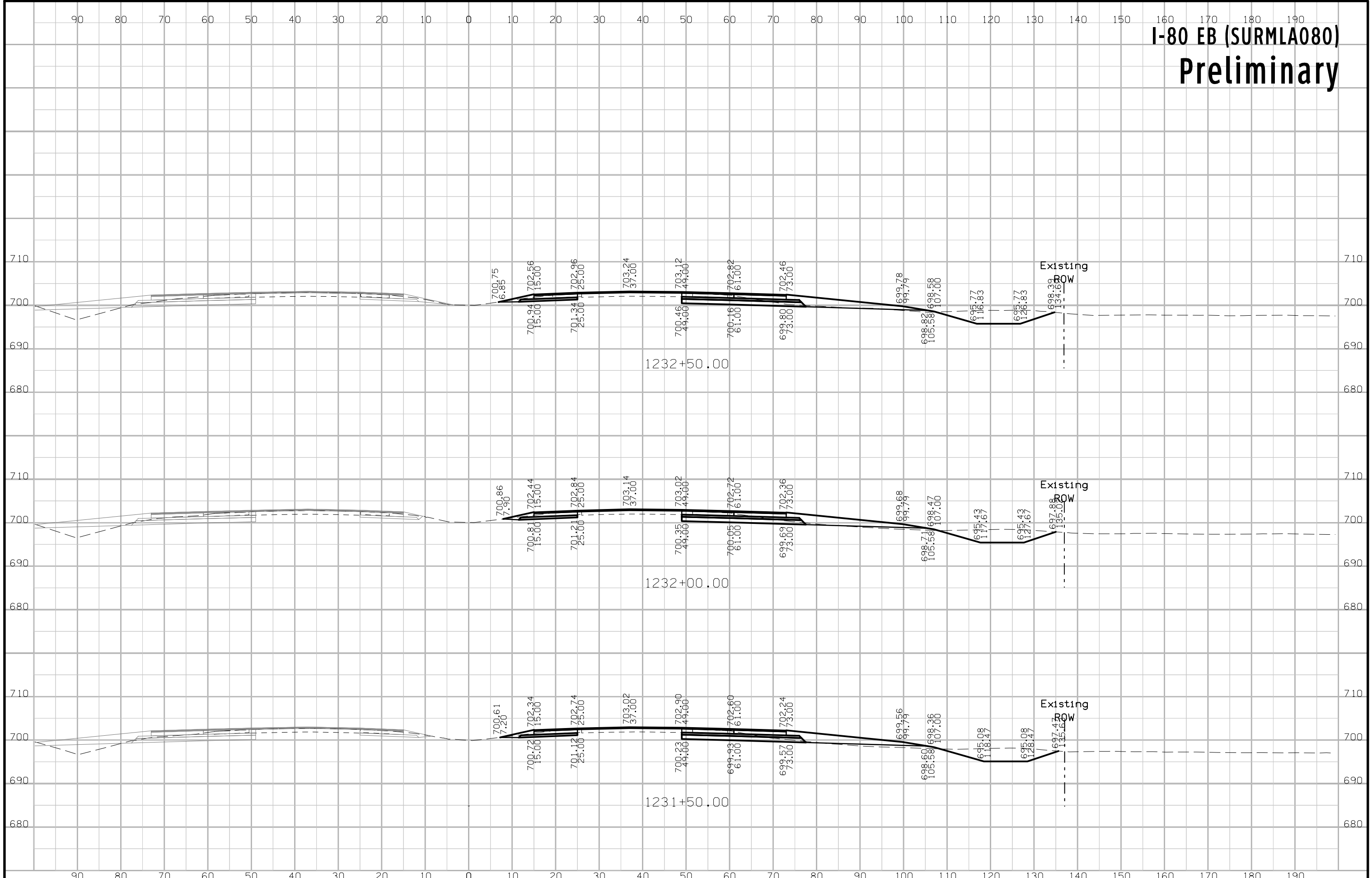



# I-80 EB (SURMLA080) Preliminary

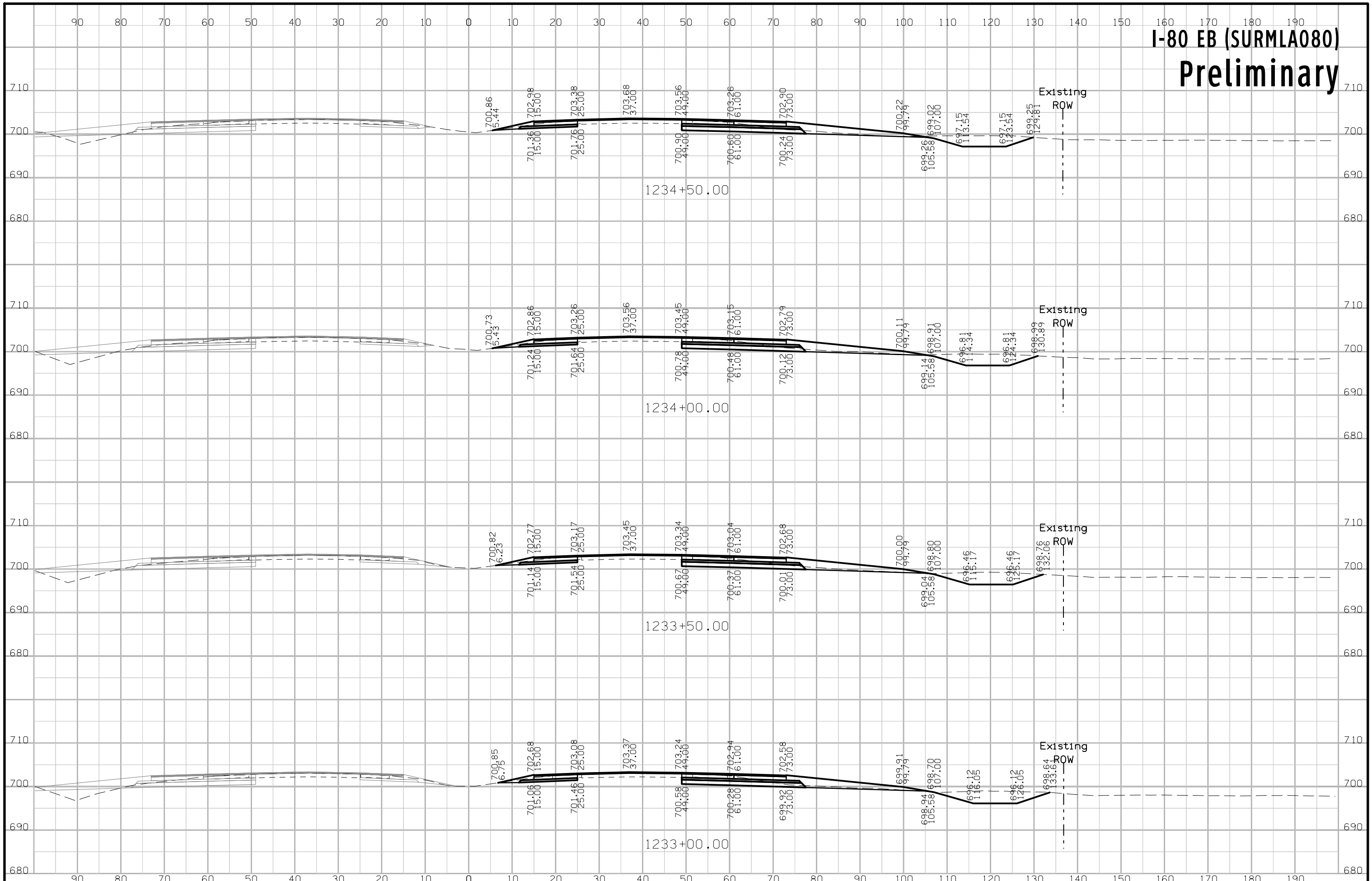

# I-80 EB (SURMLA080) Preliminary

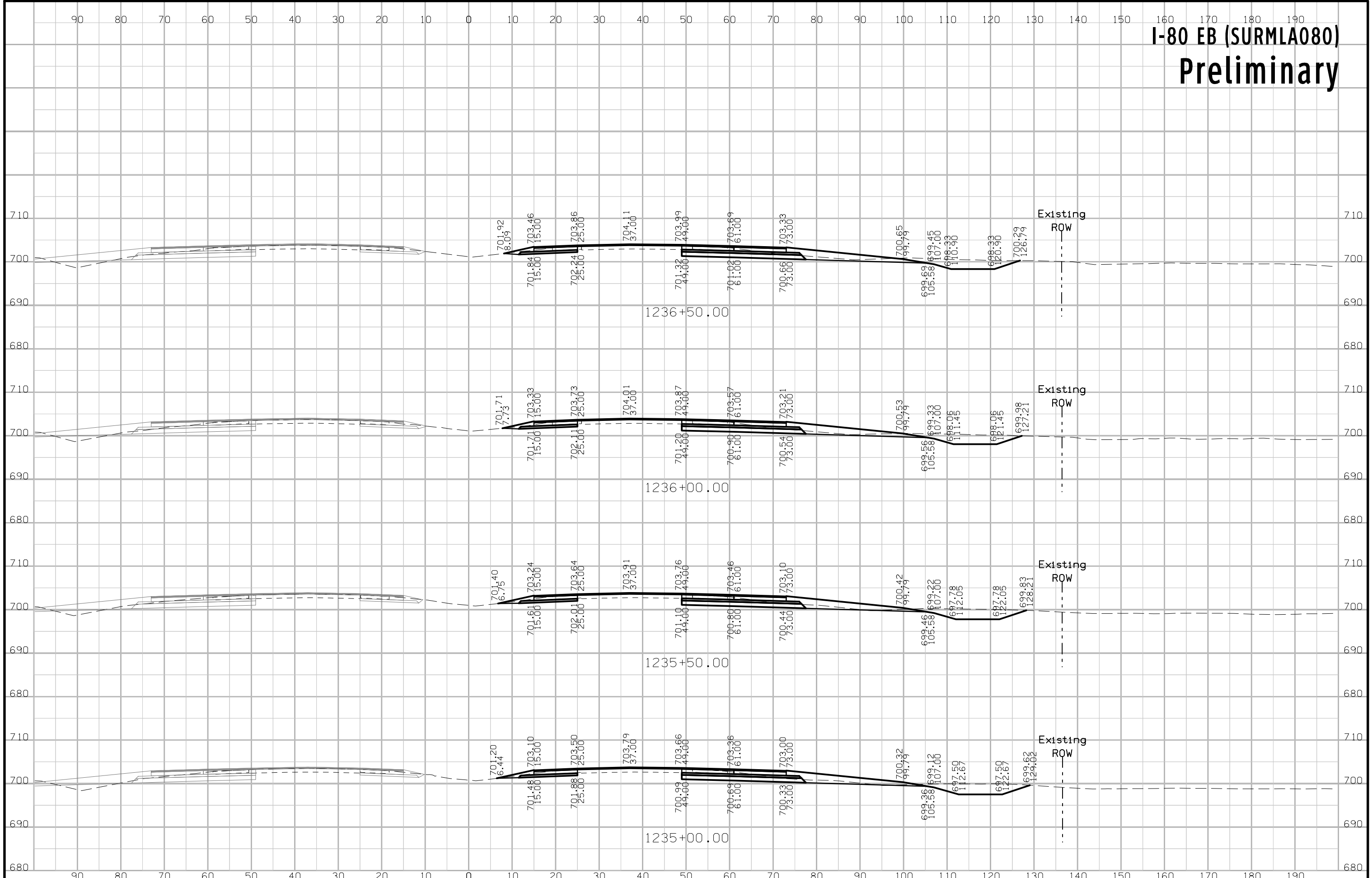

# I-80 EB (SURMLA080) Preliminary

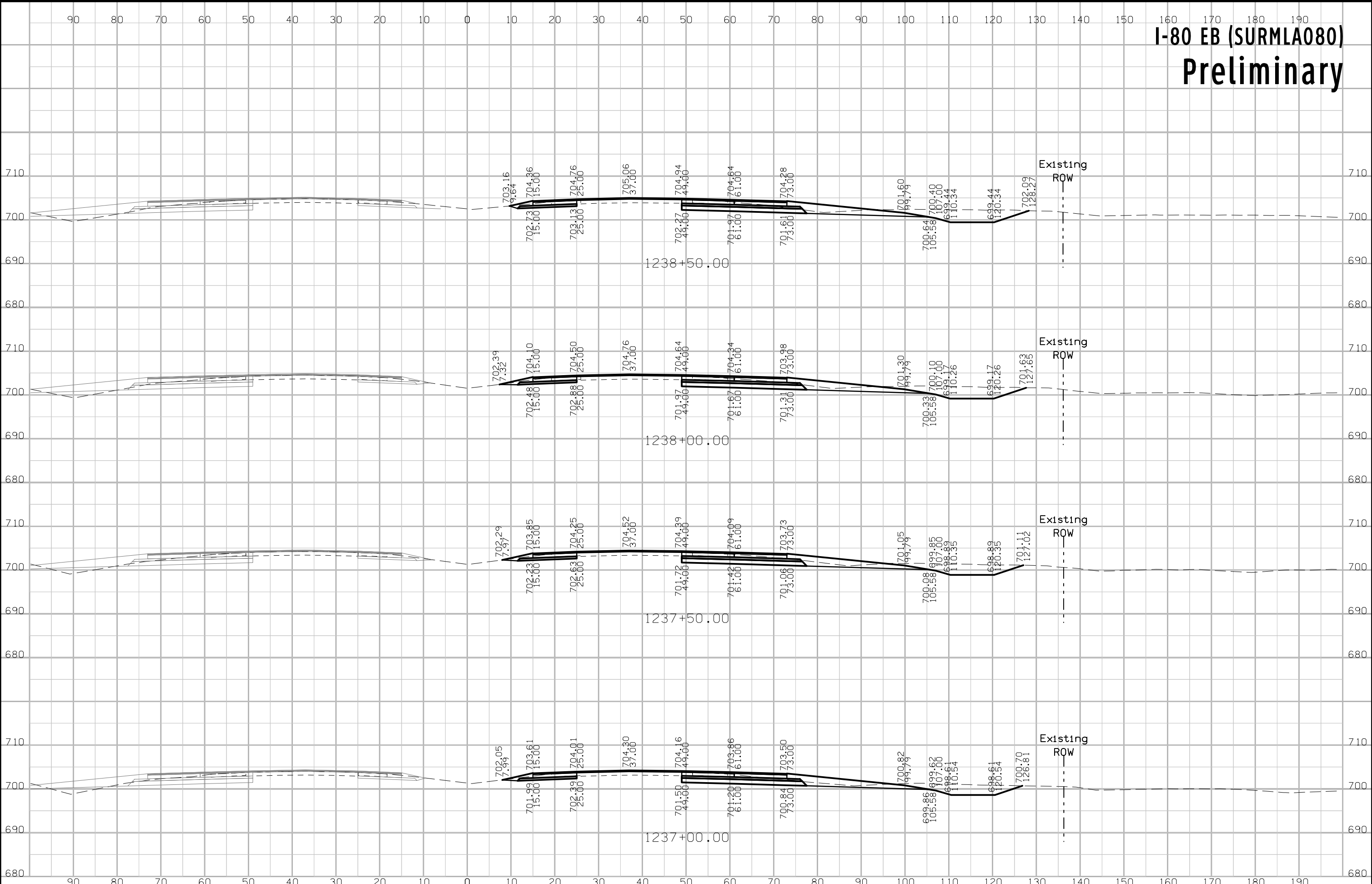

# I-80 EB (SURMLA080) Preliminary

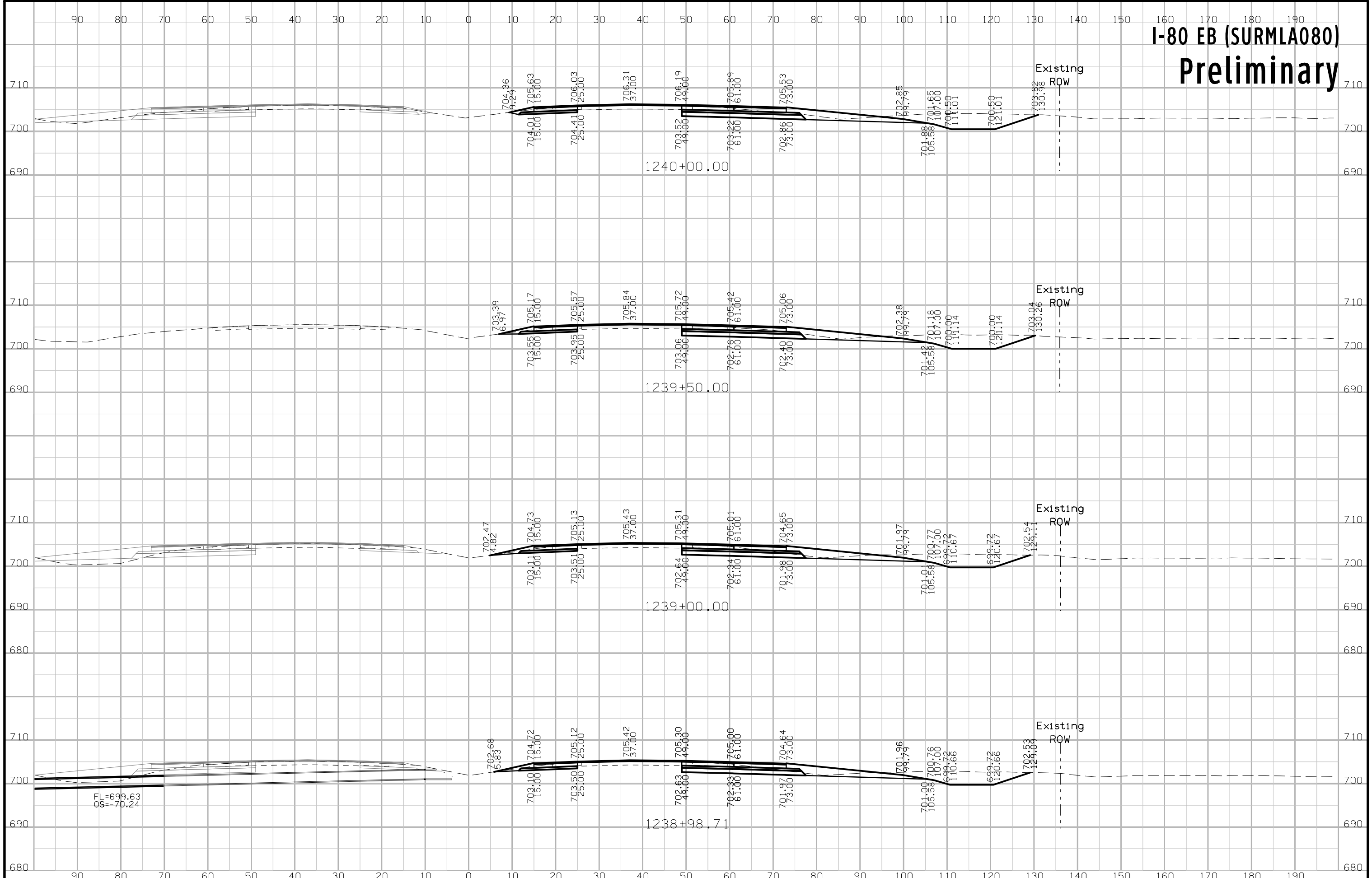

# I-80 EB (SURMLA080) Preliminary

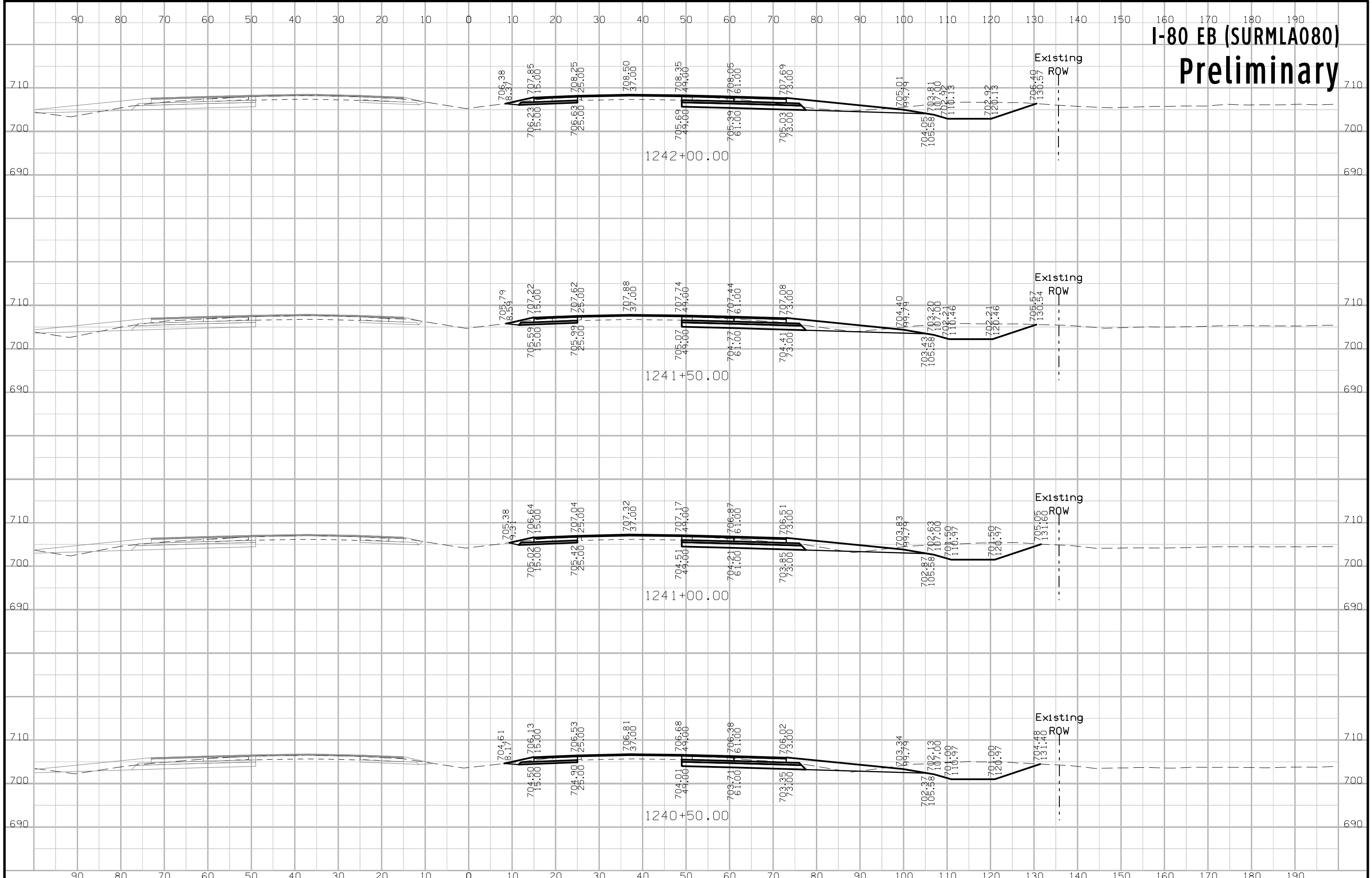

# I-80 EB (SURMLA080) Preliminary

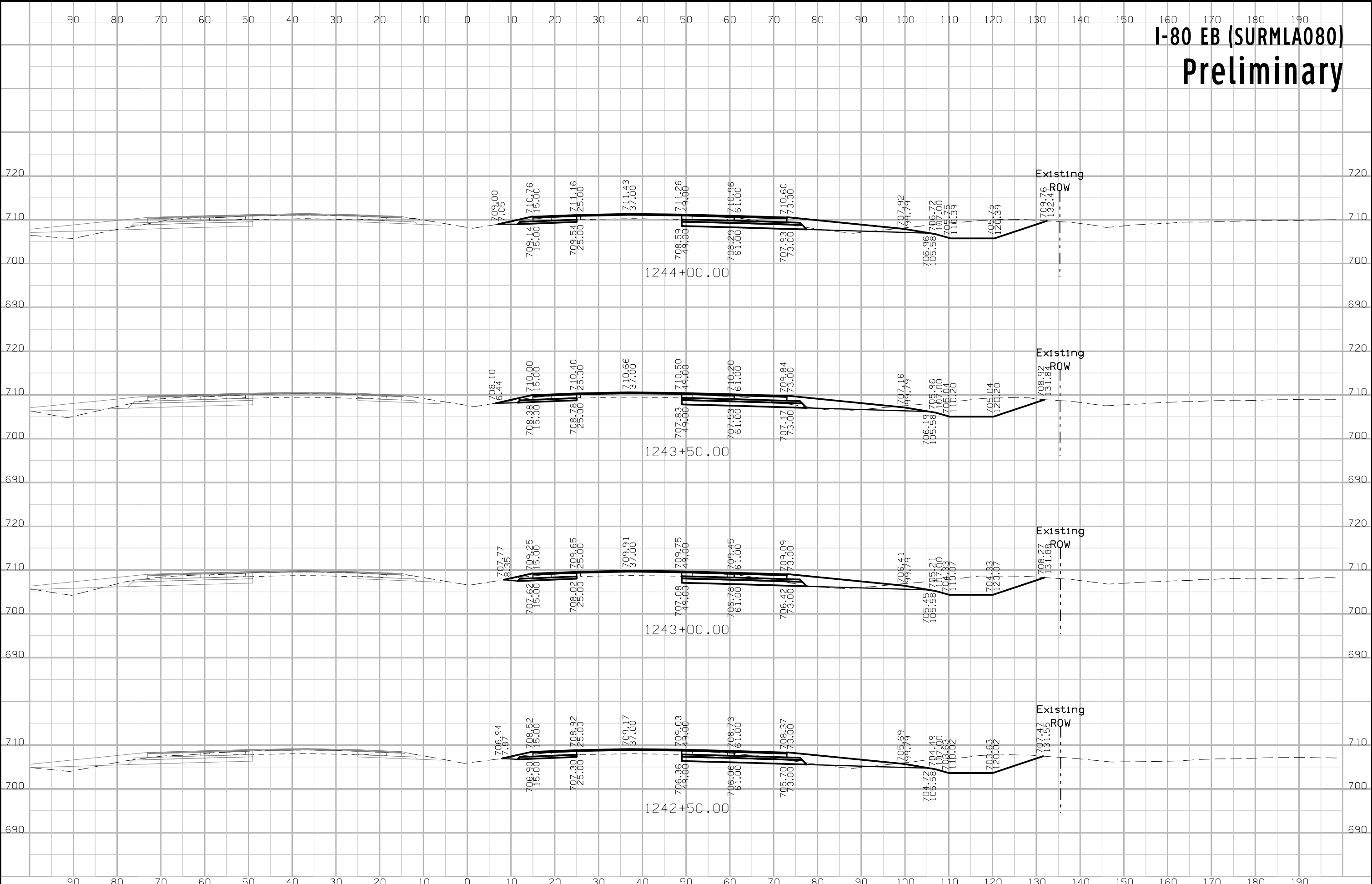

# I-80 EB (SURMLA080) Preliminary

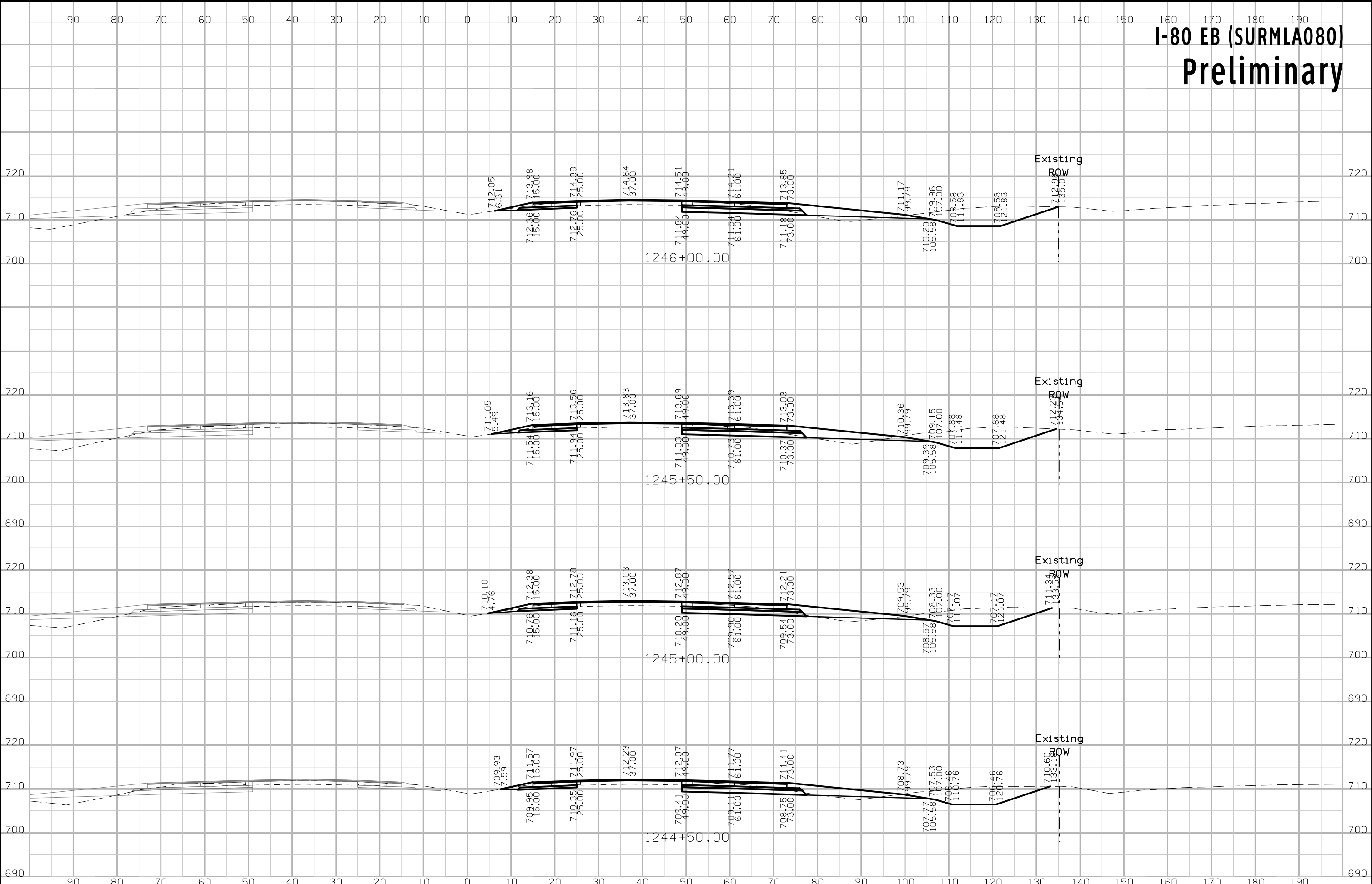

# I-80 EB (SURMLA080) Preliminary

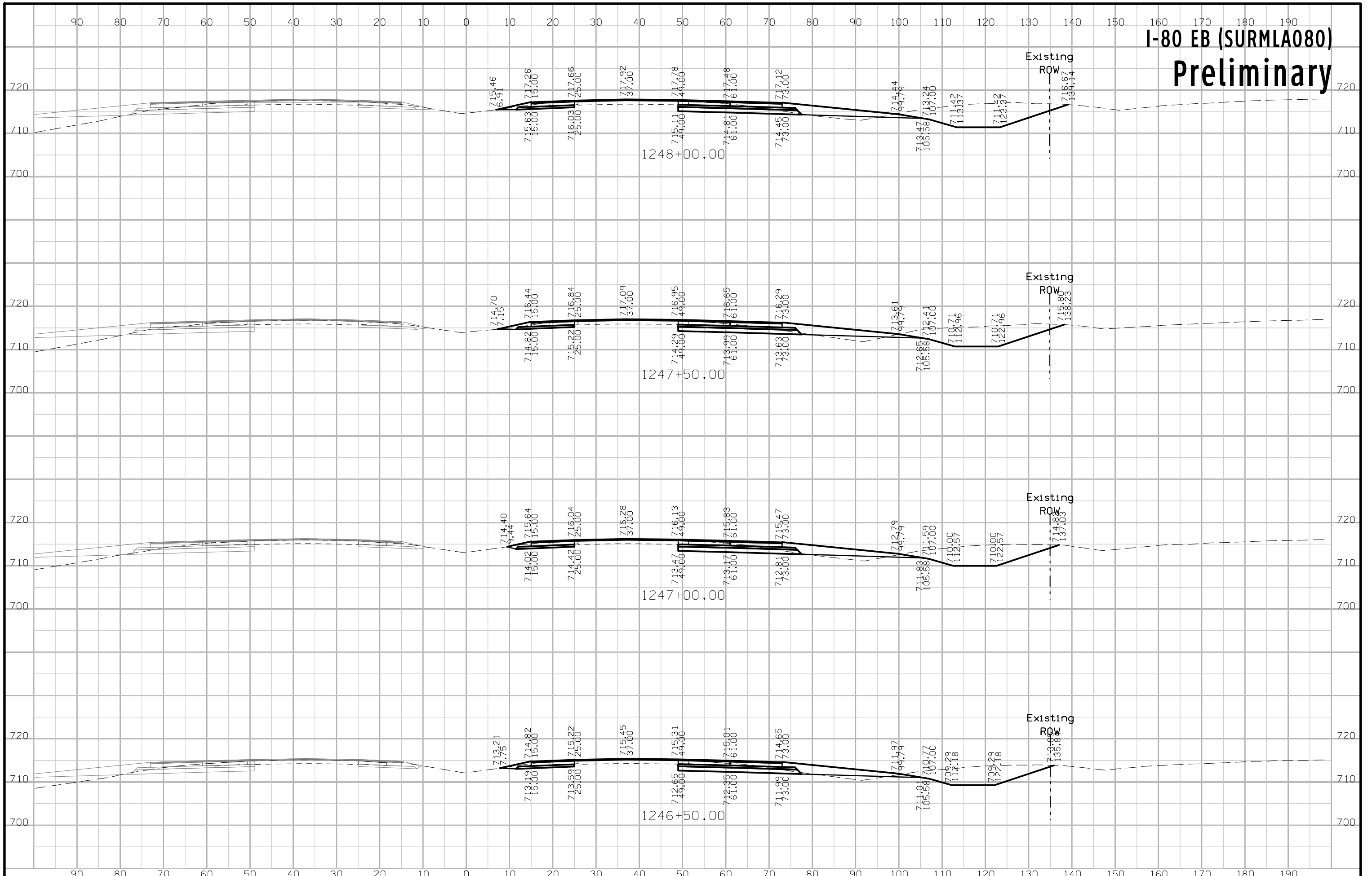



# I-80 EB (SURMLA080) Preliminary

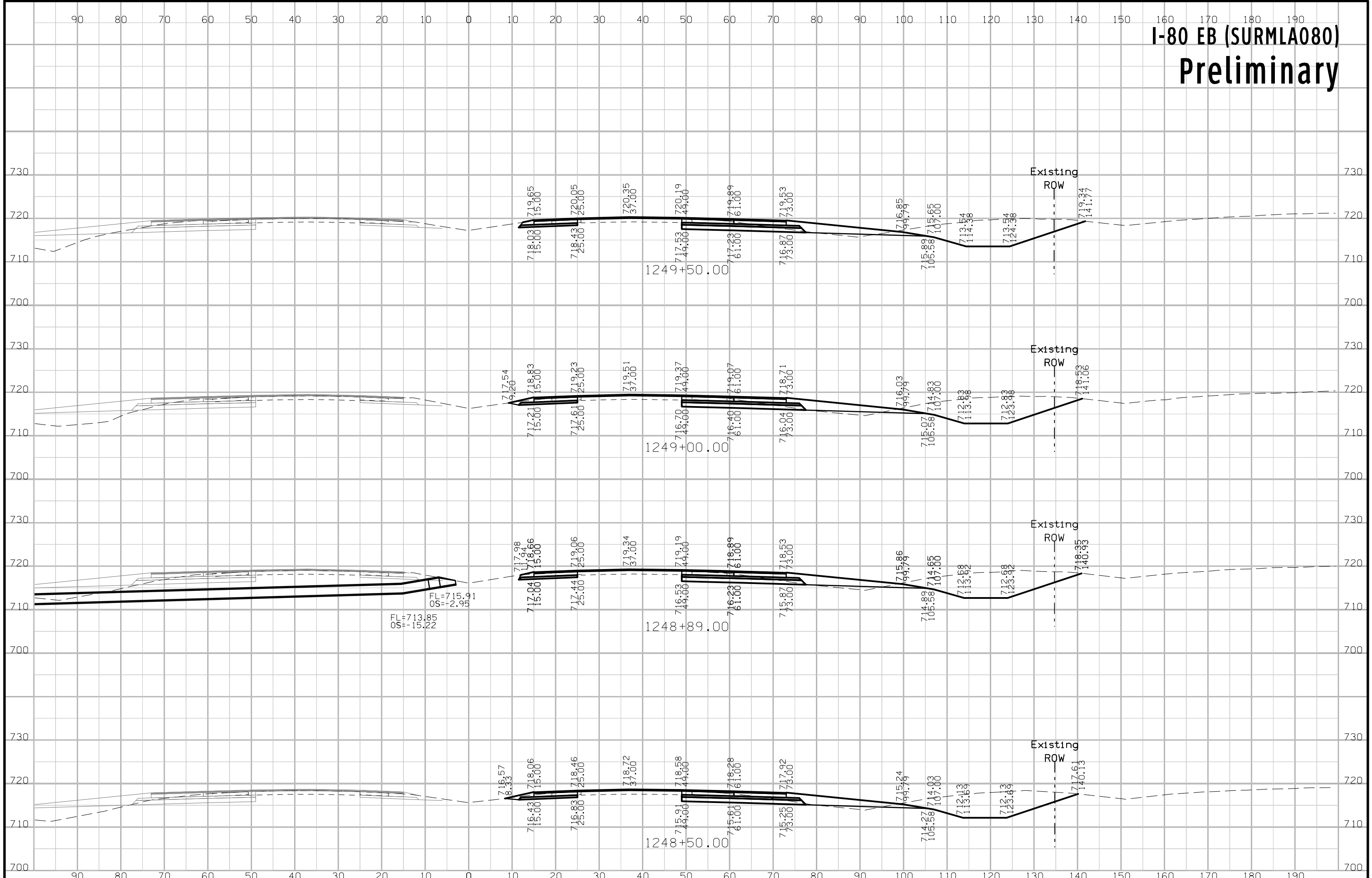

# I-80 EB (SURMLA080) Preliminary

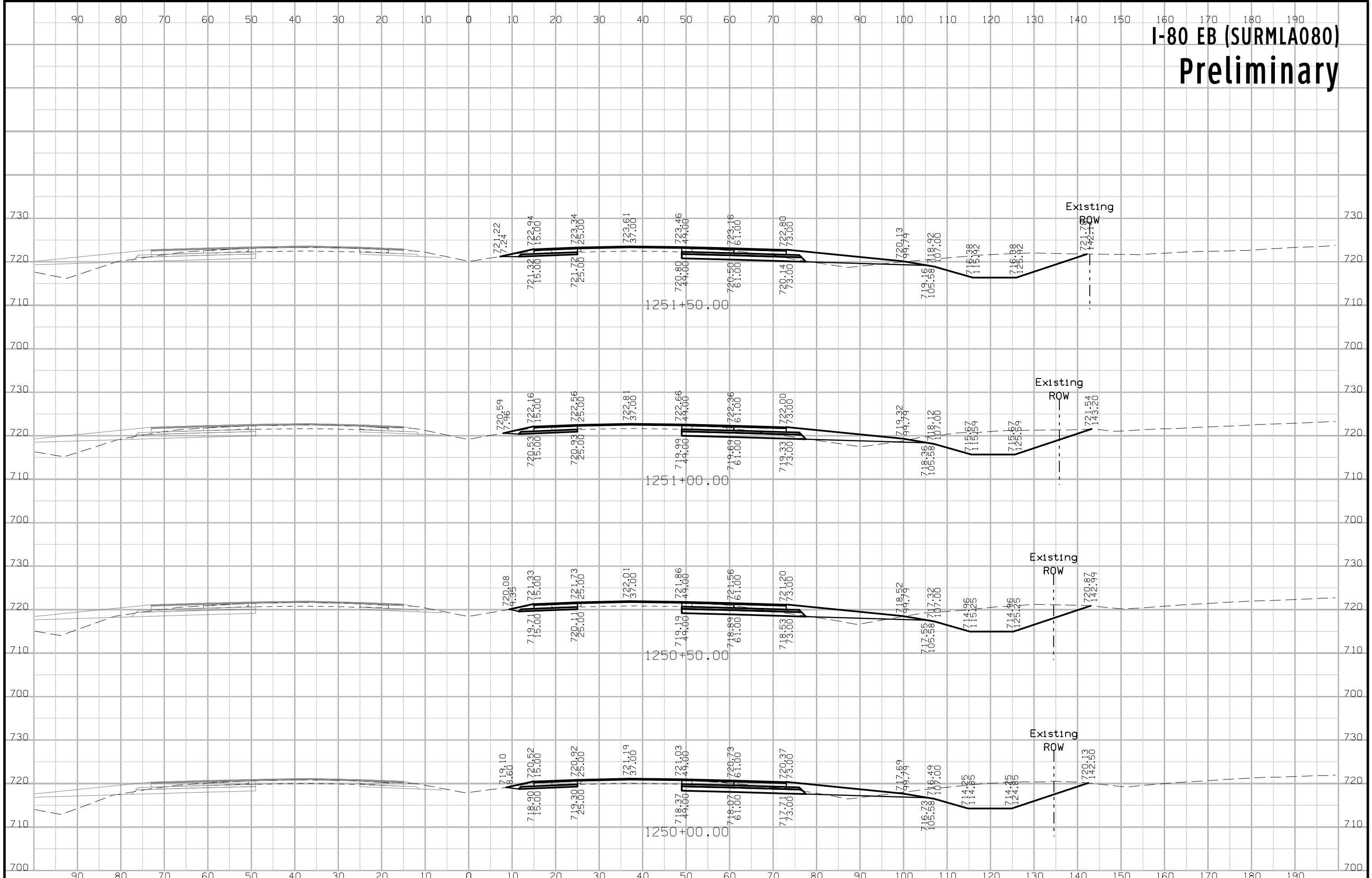

# I-80 EB (SURMLA080) Preliminary

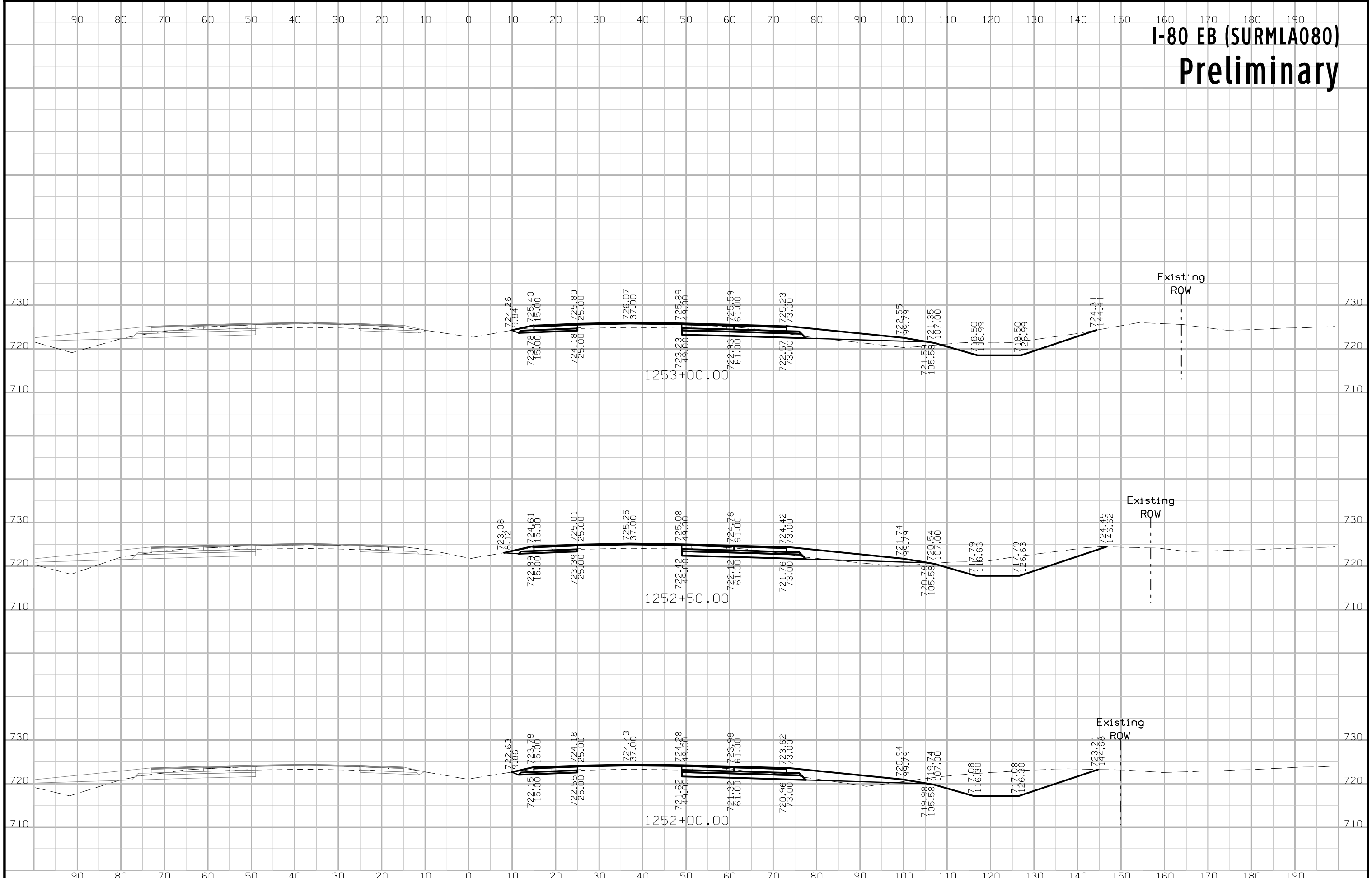

# I-80 EB (SURMLA080) Preliminary

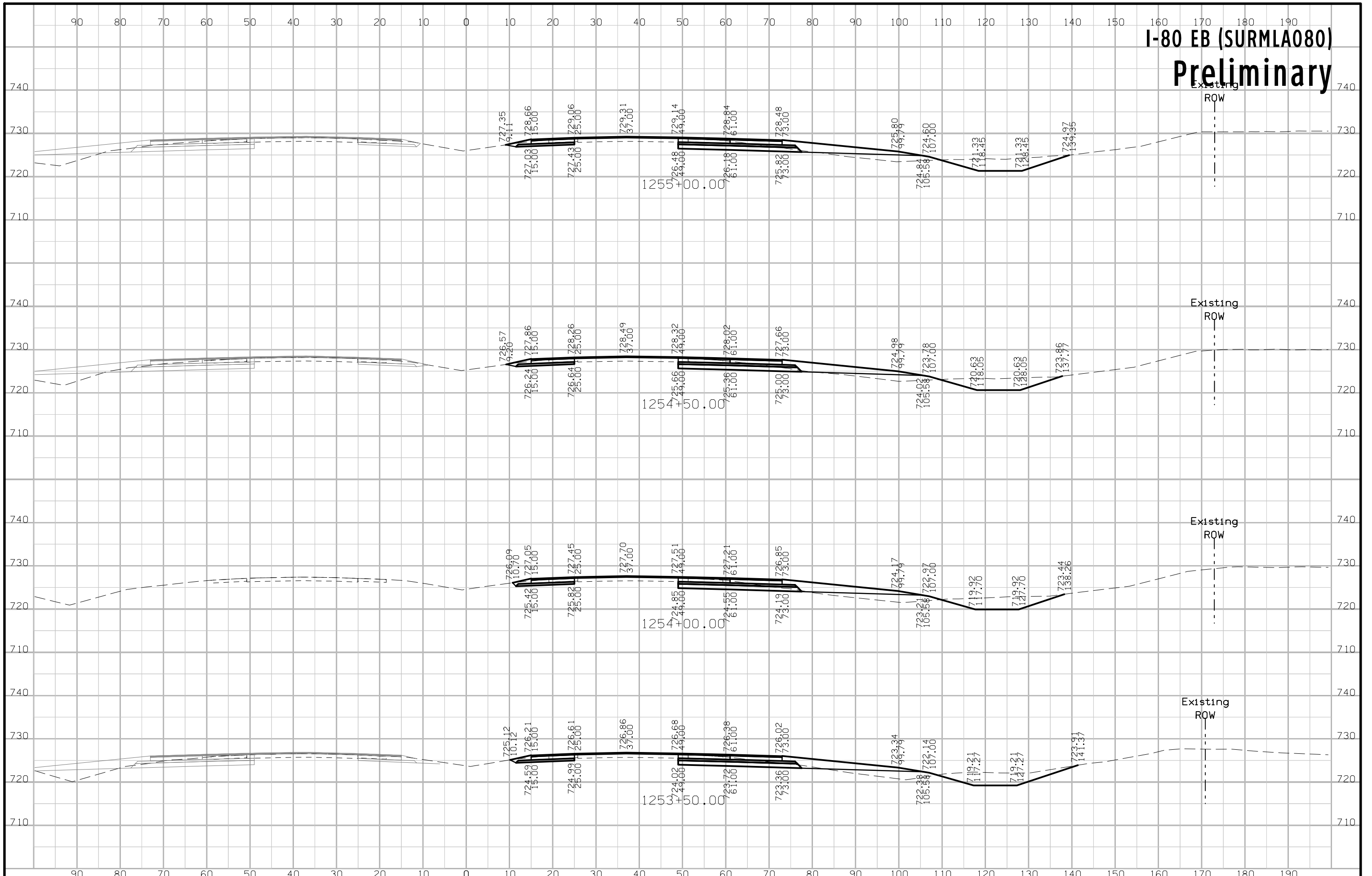

# I-80 EB (SURMLA080) Preliminary

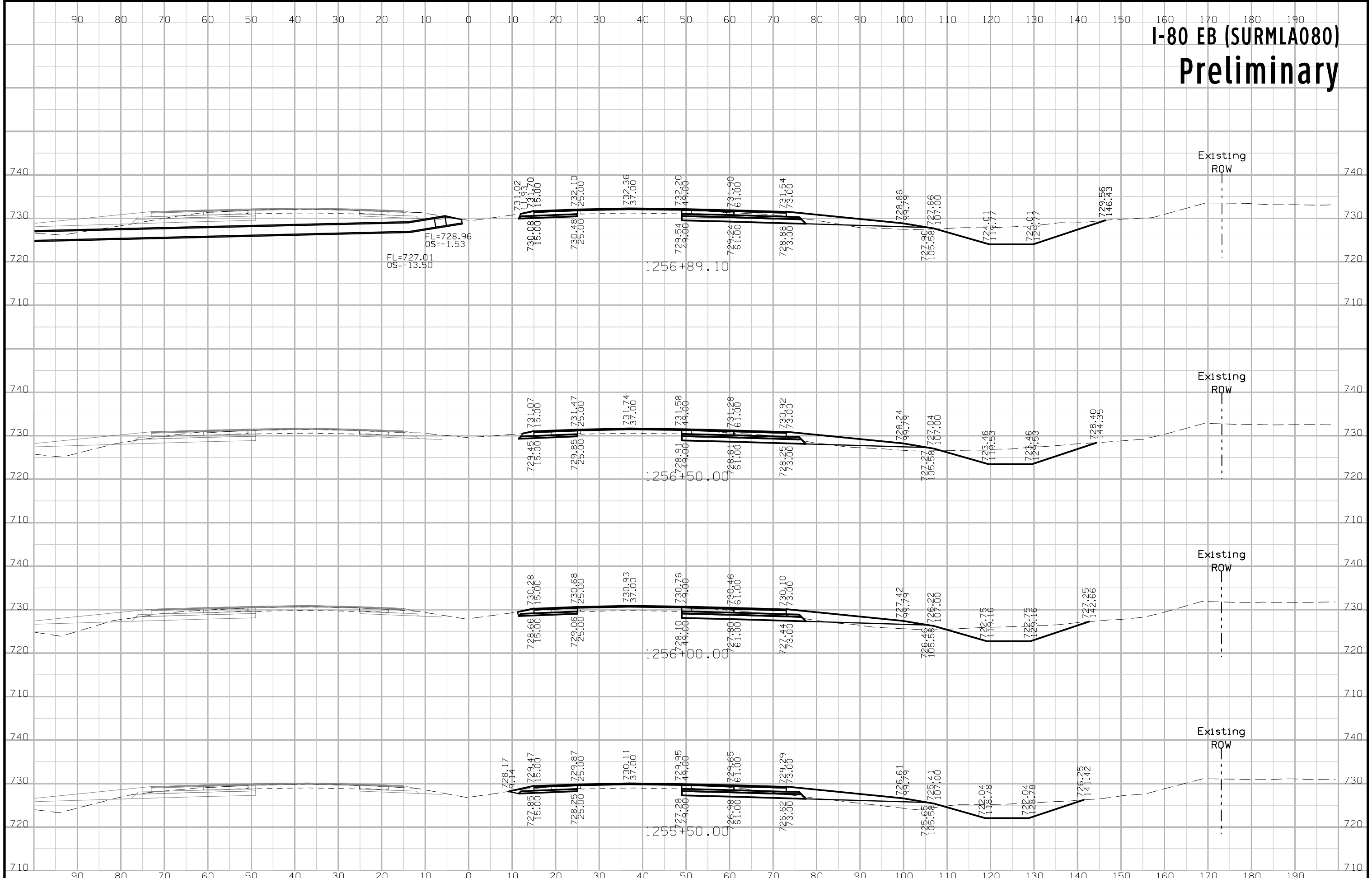

**I-80 EB (SURMLA080)**  
**Preliminary**

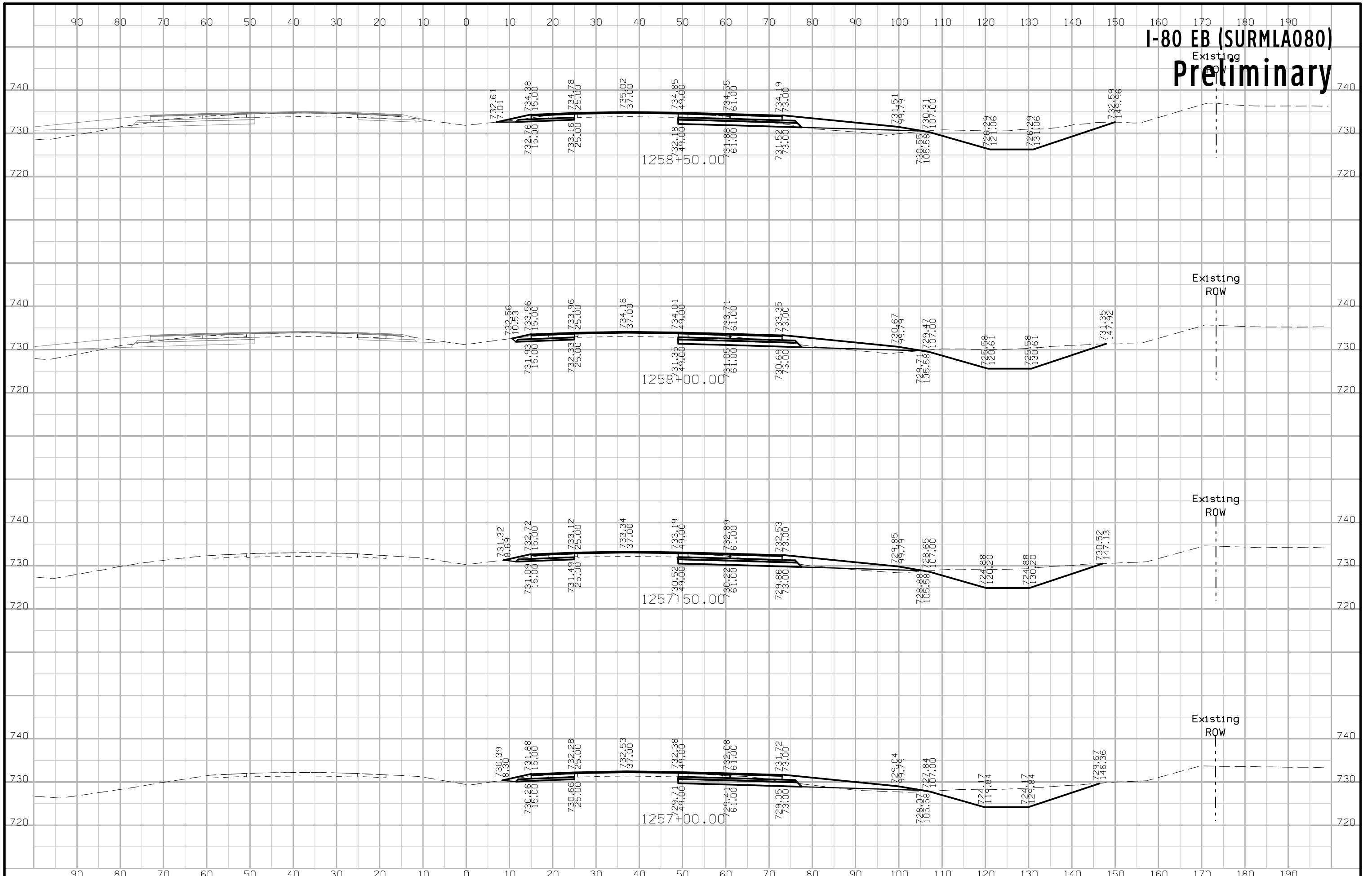

# I-80 EB (SURMLA080) Preliminary

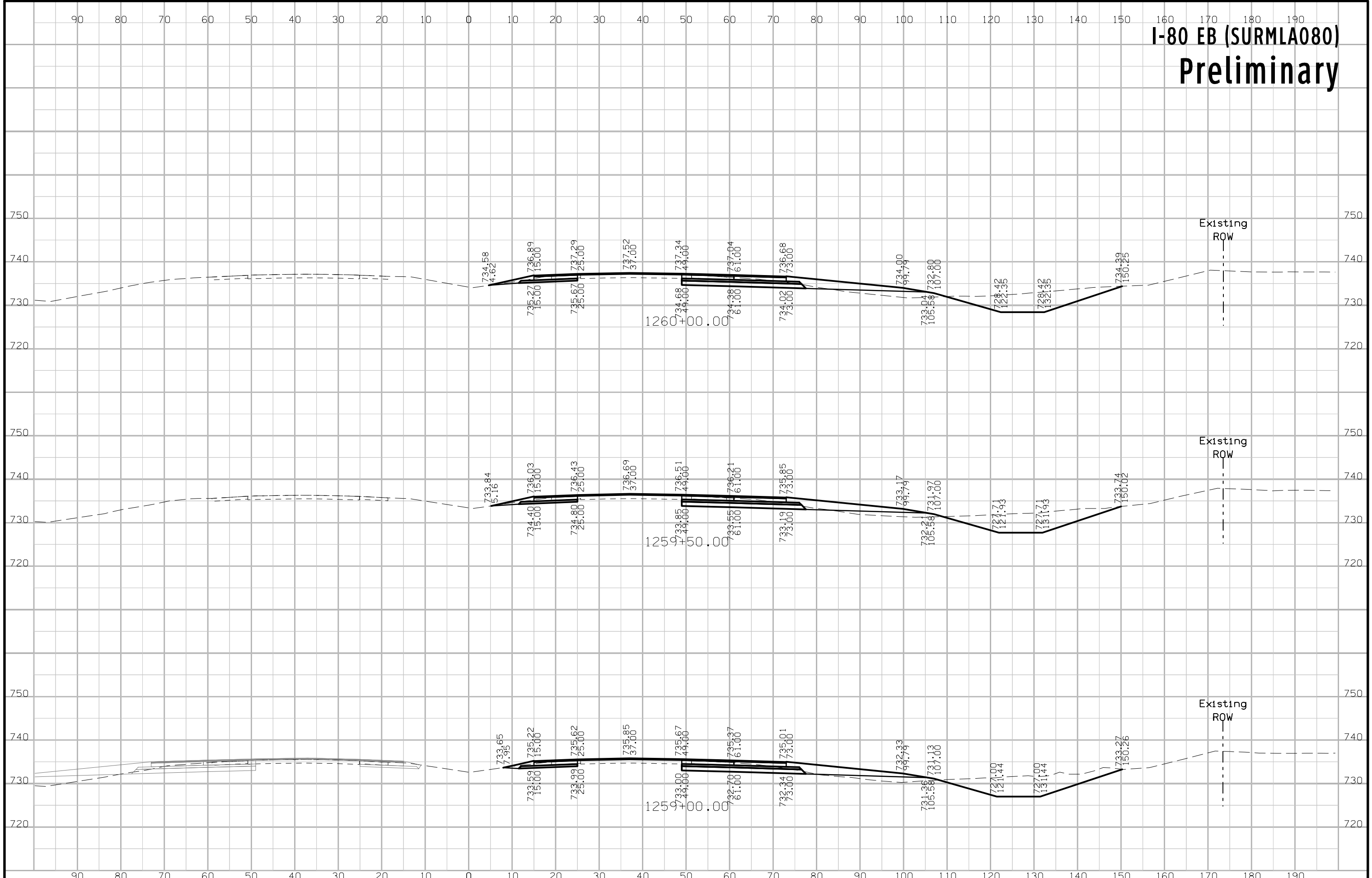

# I-80 EB (SURMLA080) Preliminary

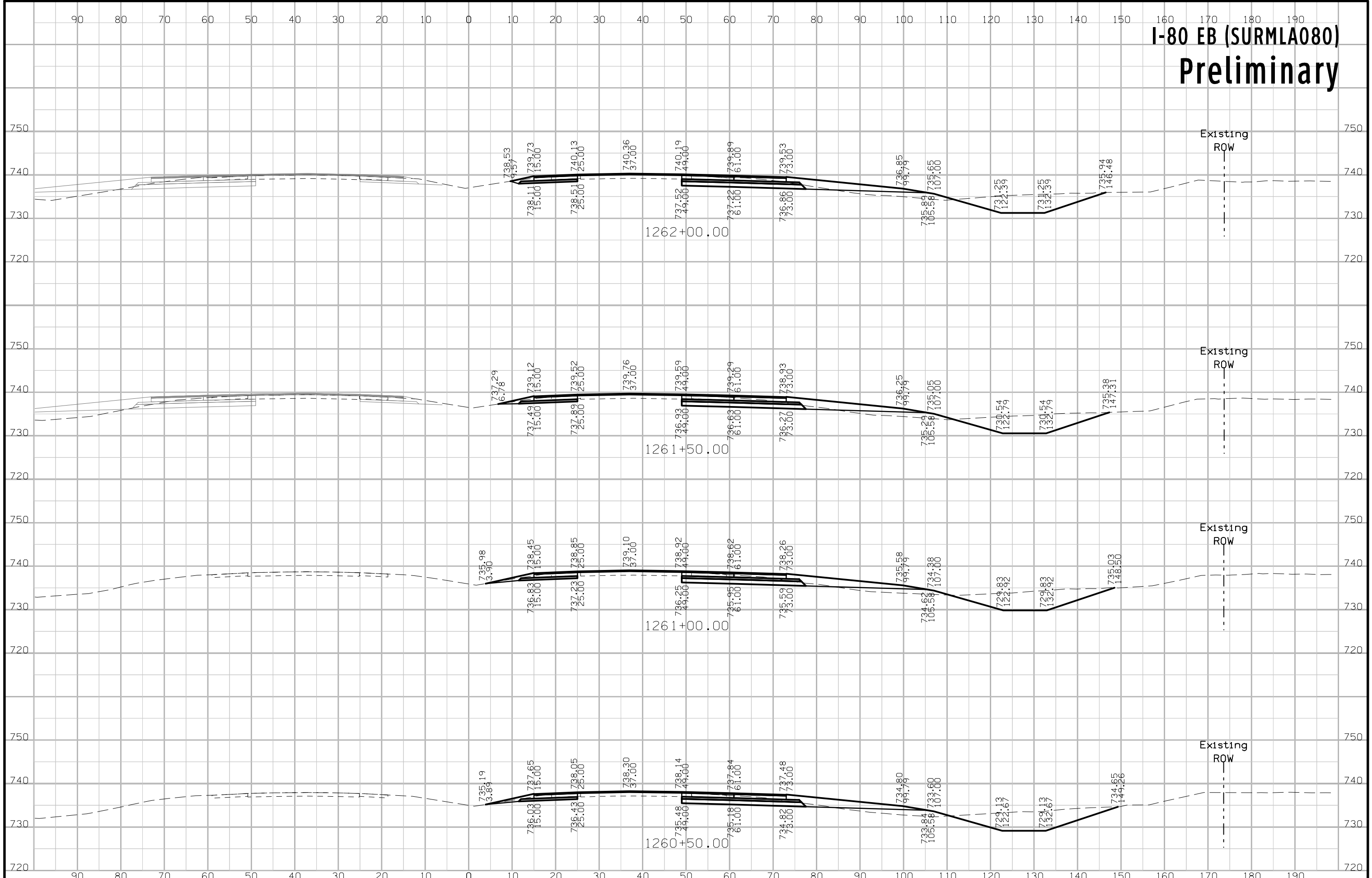



# I-80 EB (SURMLA080) Preliminary

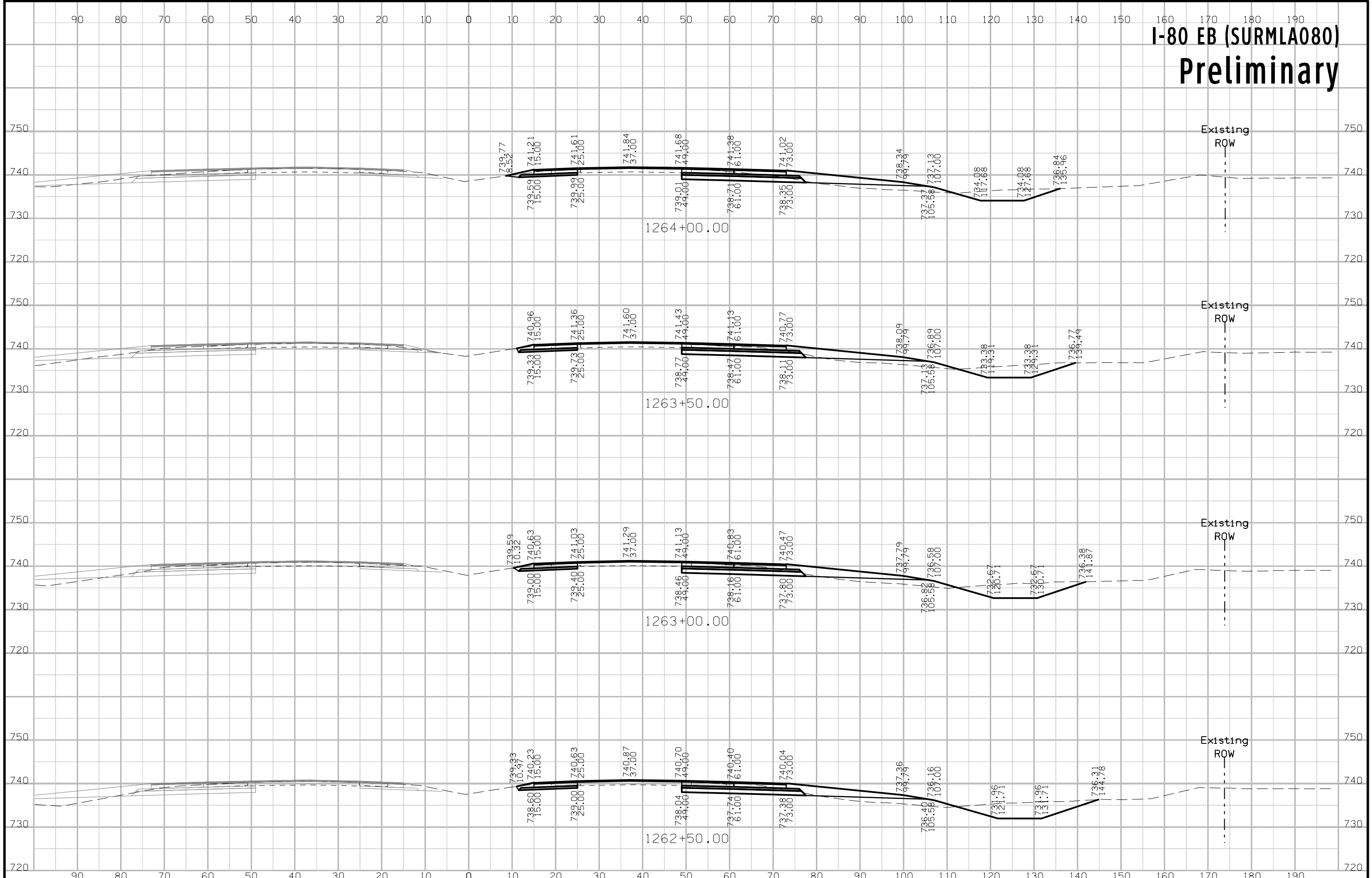

# I-80 EB (SURMLA080) Preliminary

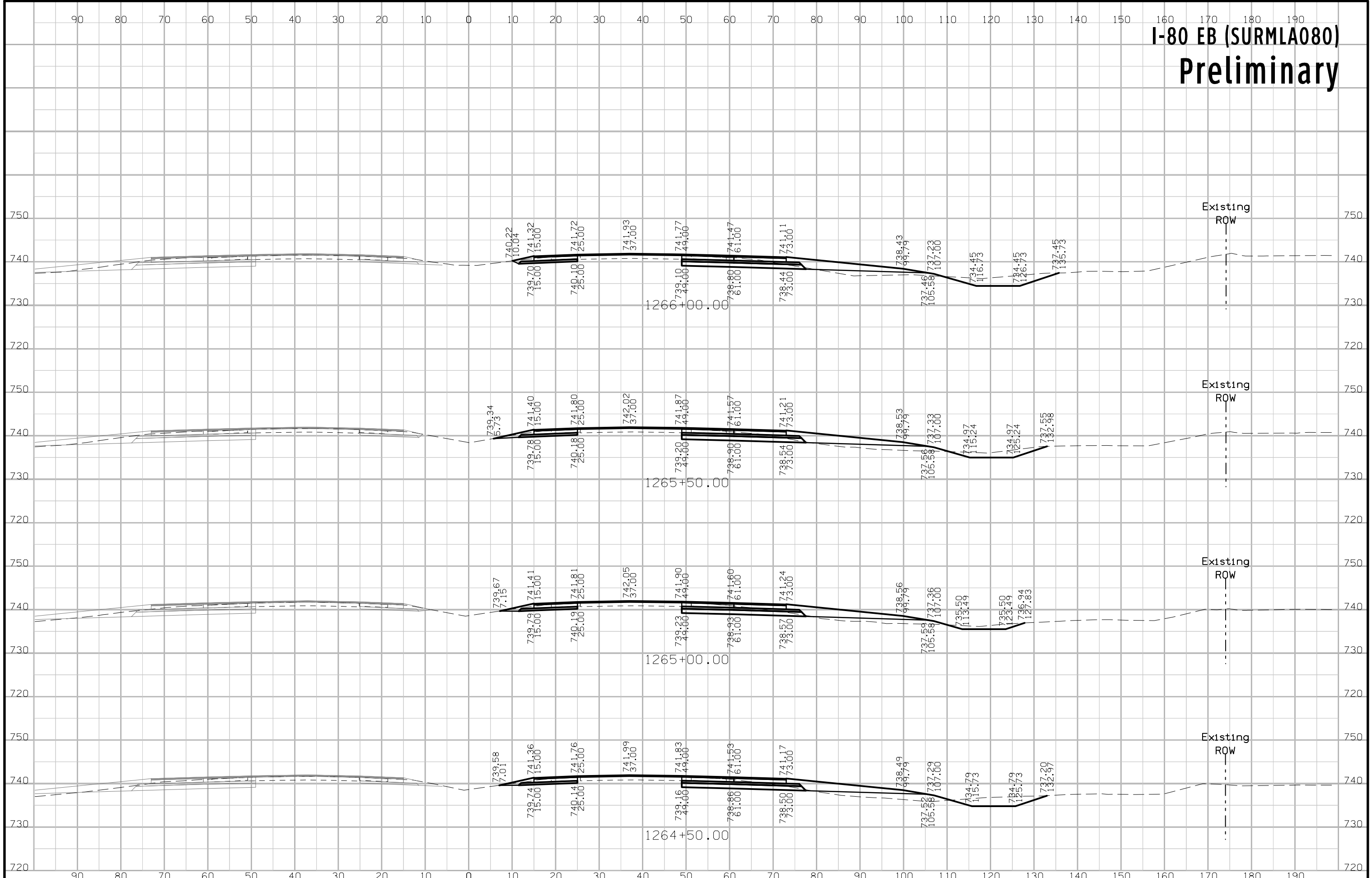

# I-80 EB (SURMLA080) Preliminary

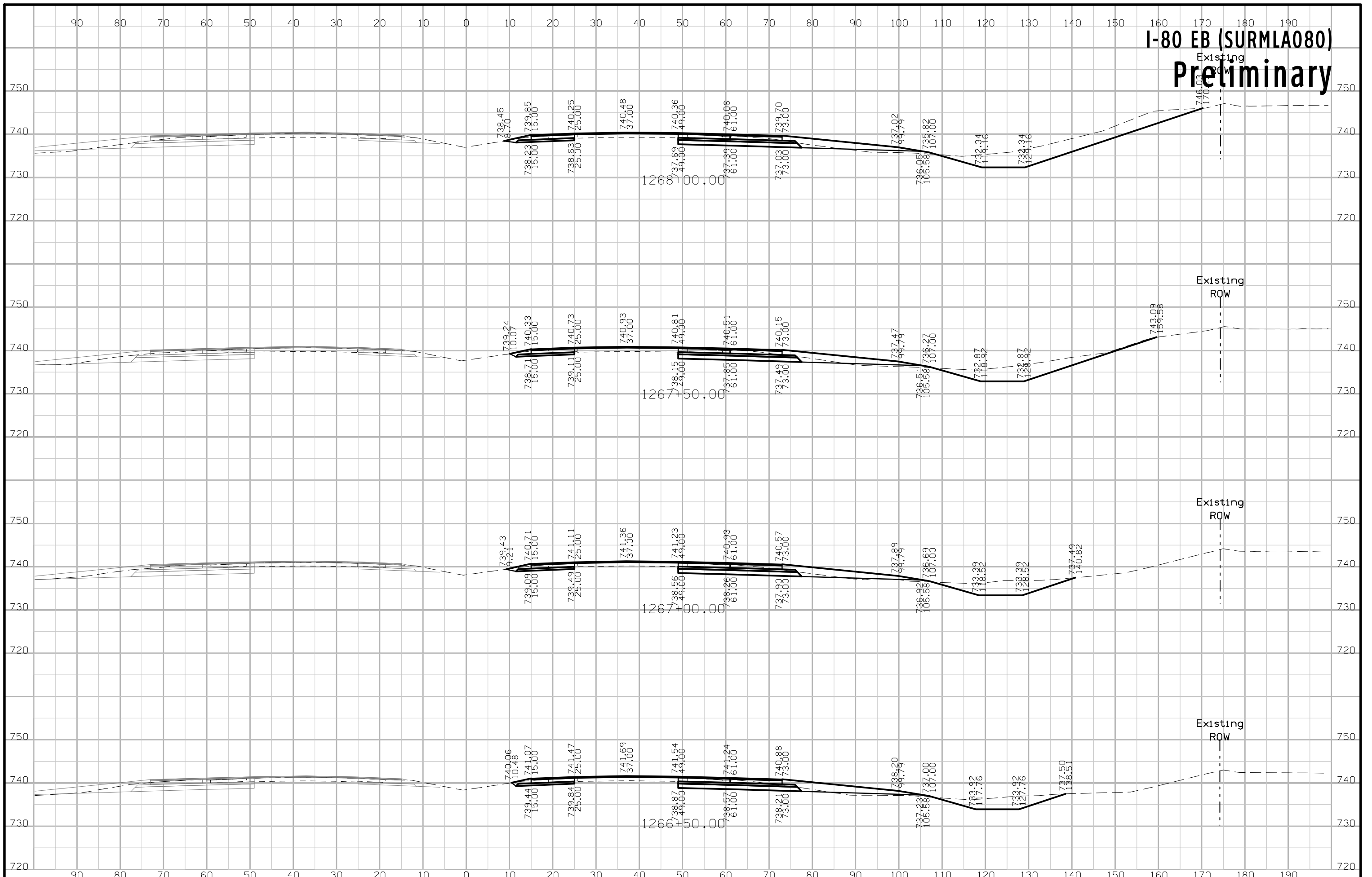

# I-80 EB (SURMLA080) Preliminary

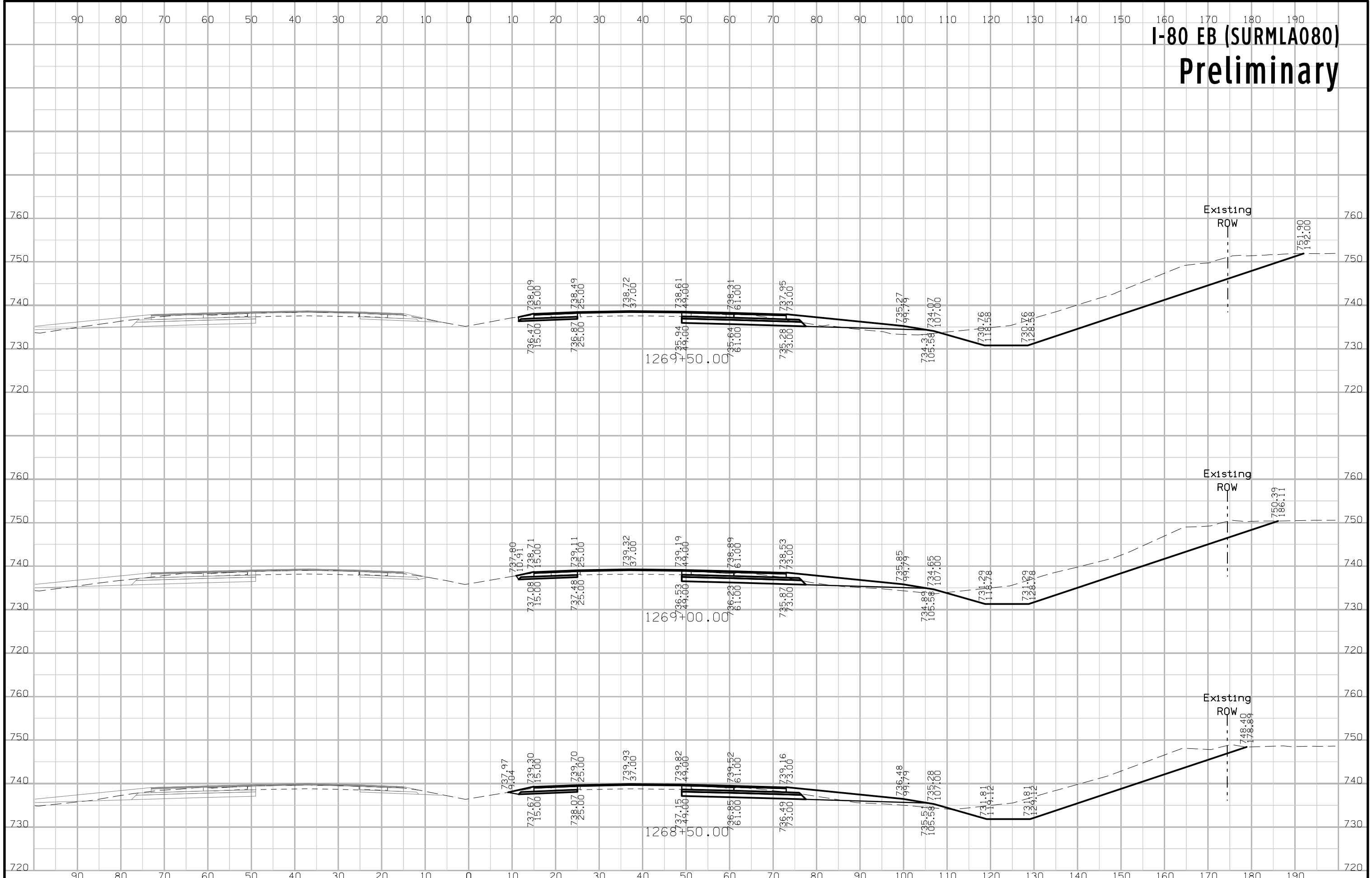

# I-80 EB (SURMLA080) Preliminary

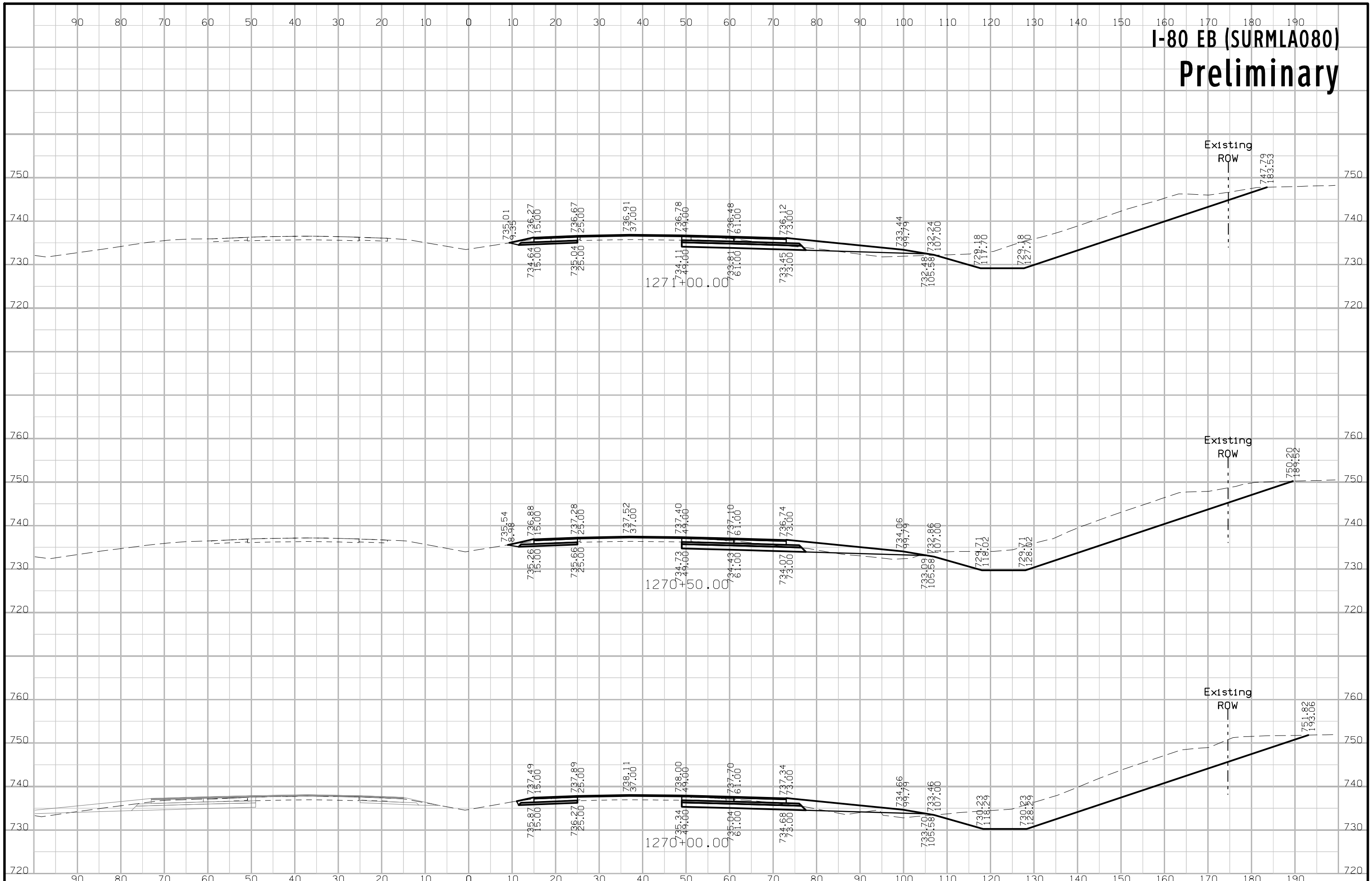

# I-80 EB (SURMLA080) Preliminary

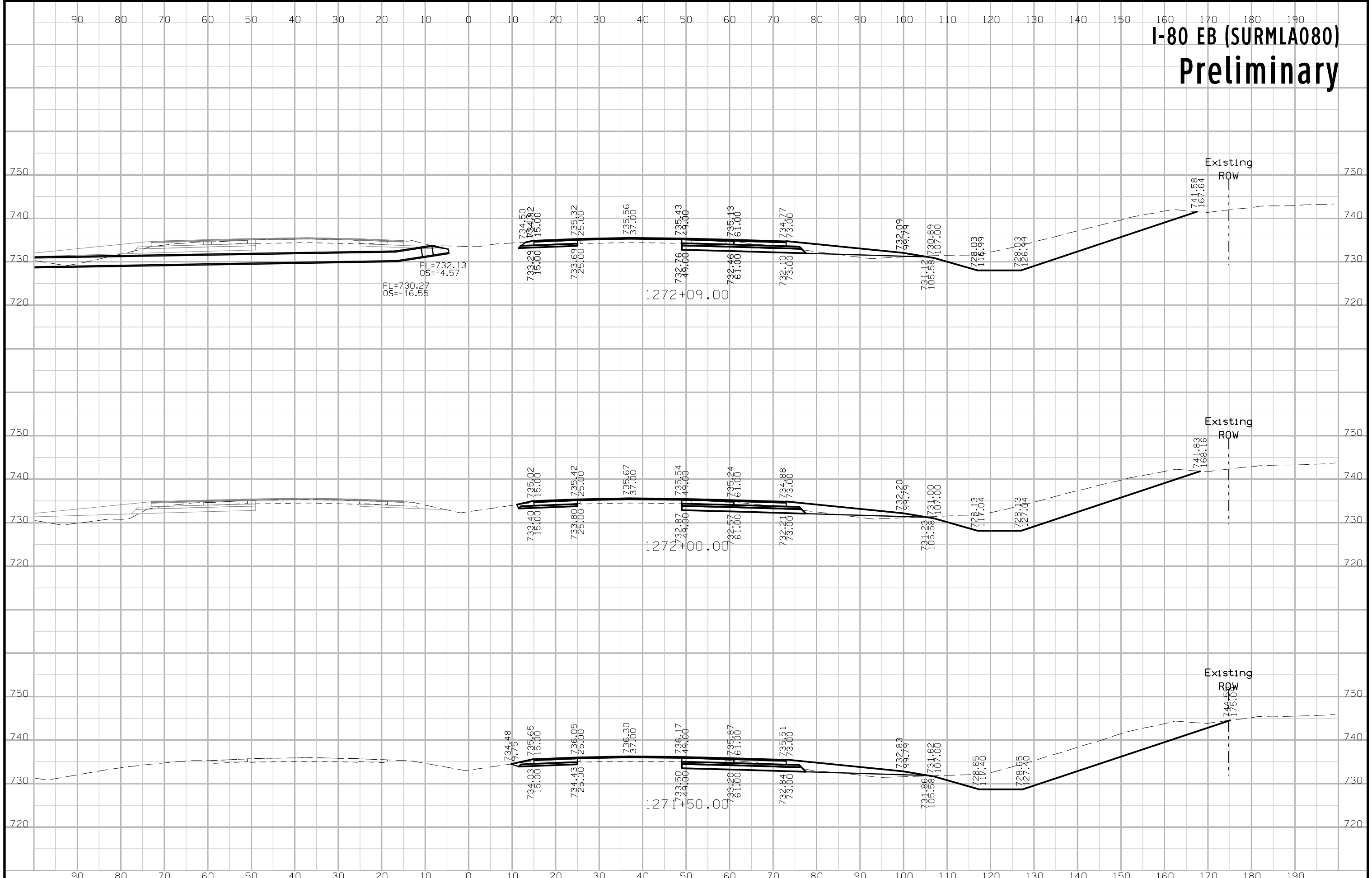

# I-80 EB (SURMLA080) Preliminary

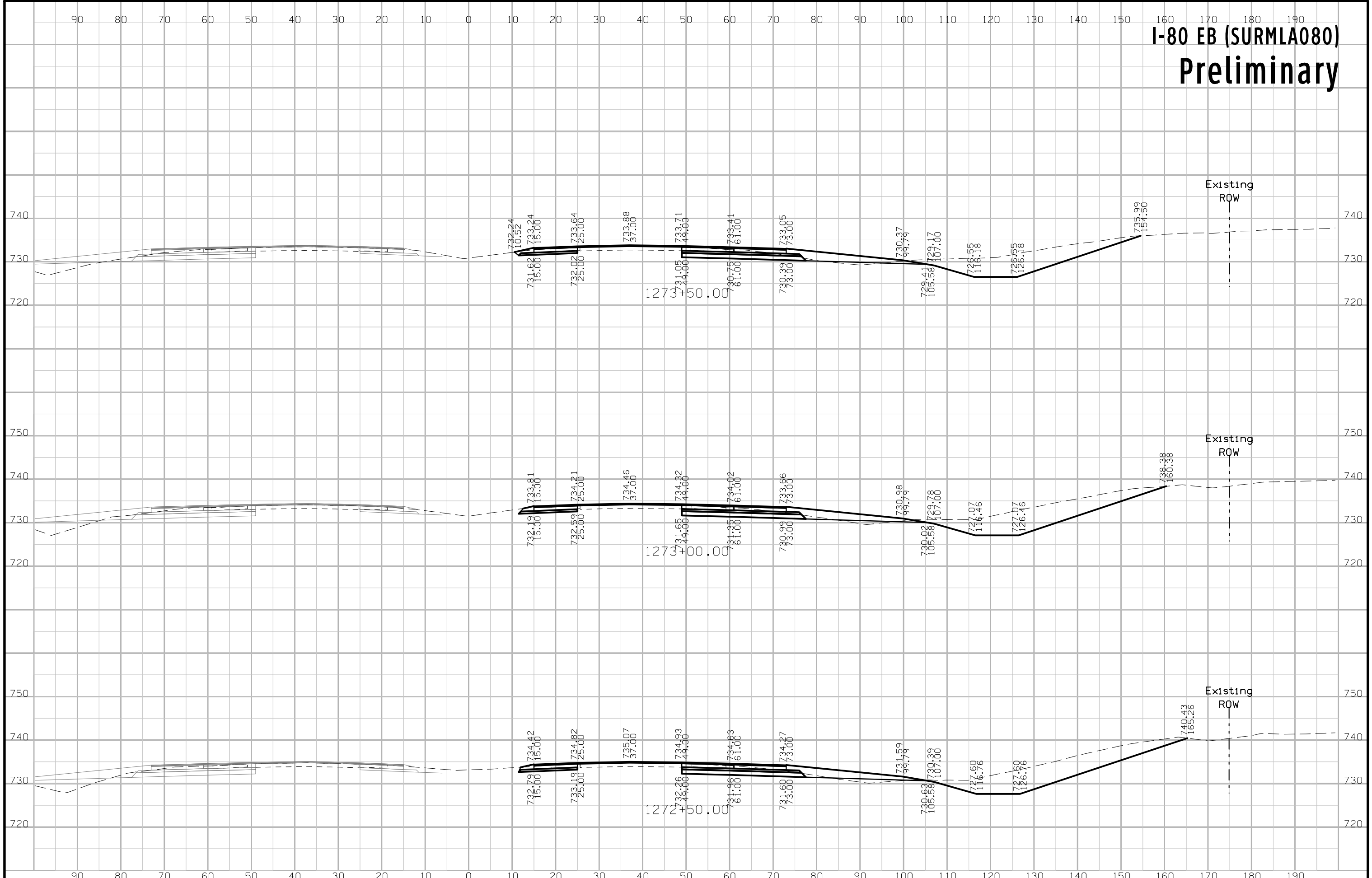

# I-80 EB (SURMLA080) Preliminary

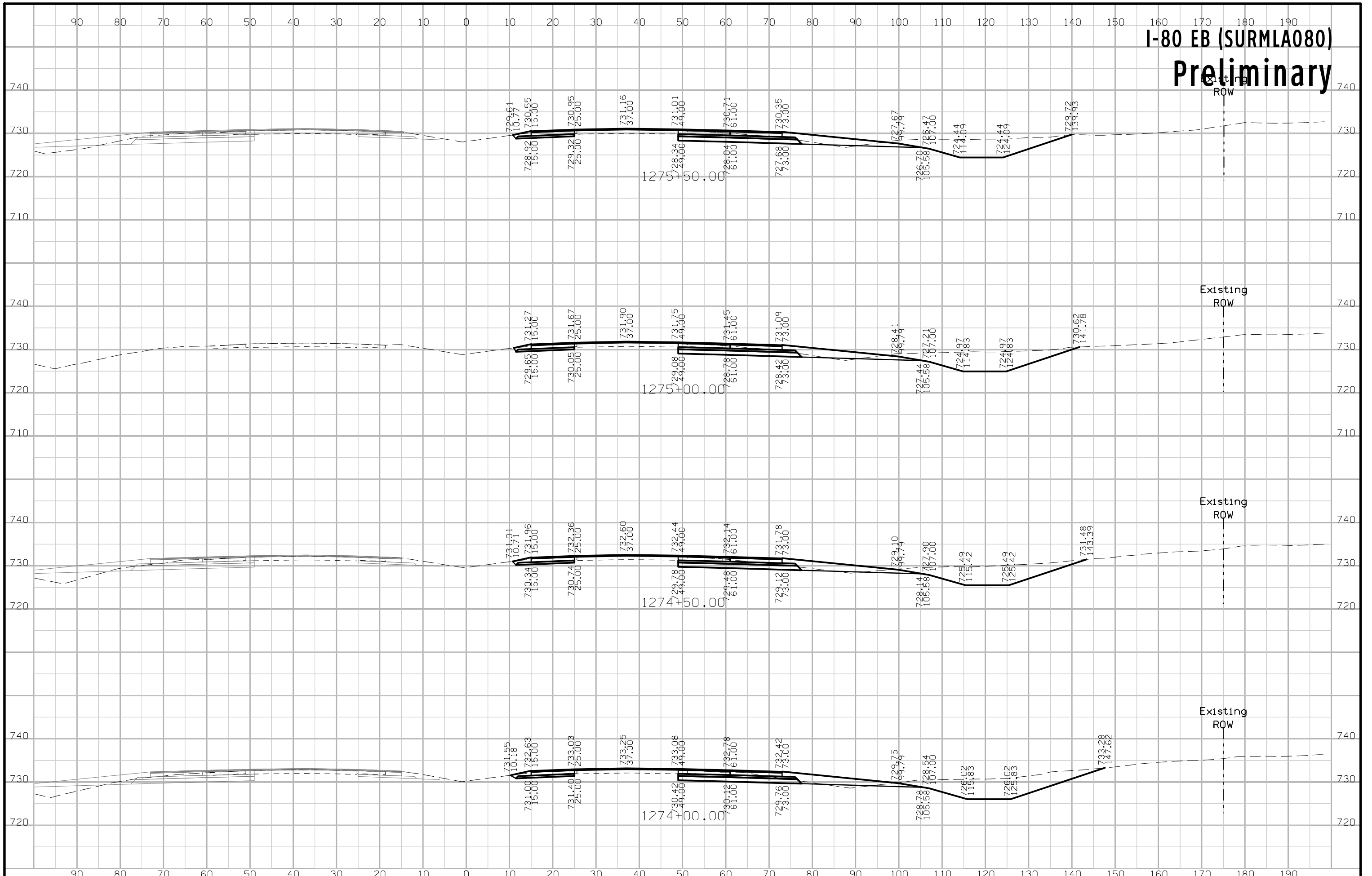



# I-80 EB (SURMLA080) Preliminary

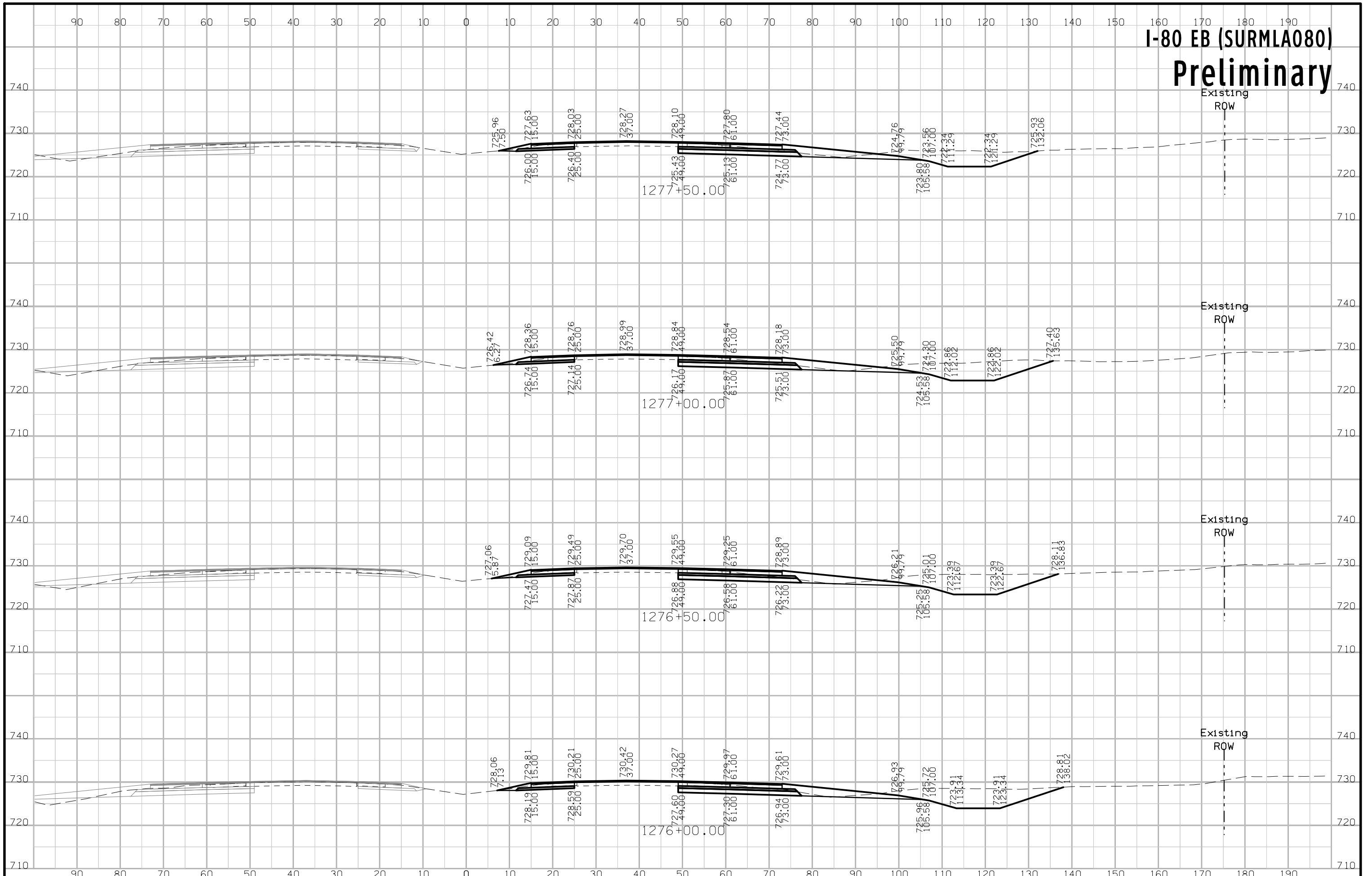

# I-80 EB (SURMLA080) Preliminary

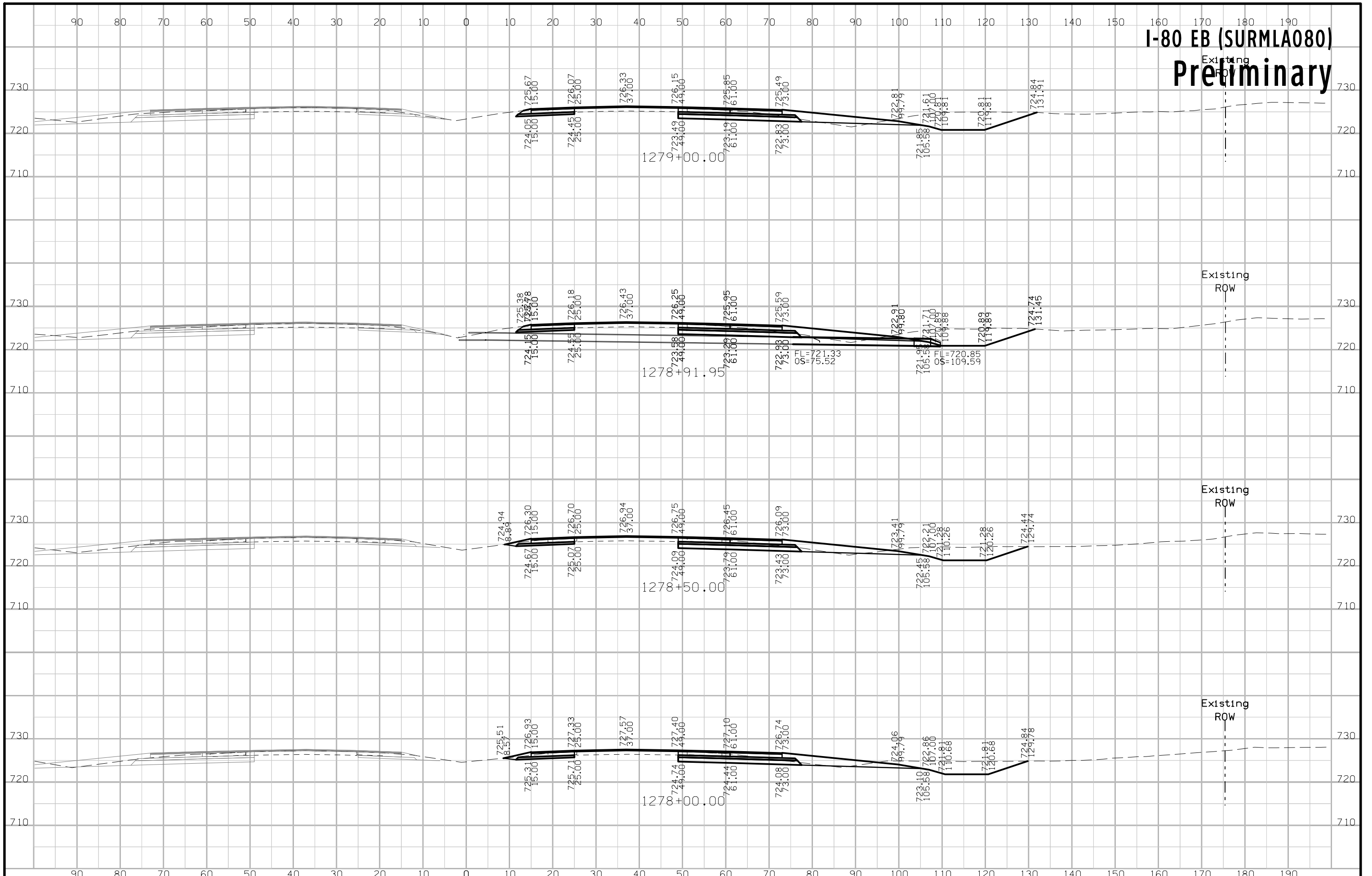

# I-80 EB (SURMLA080) Preliminary

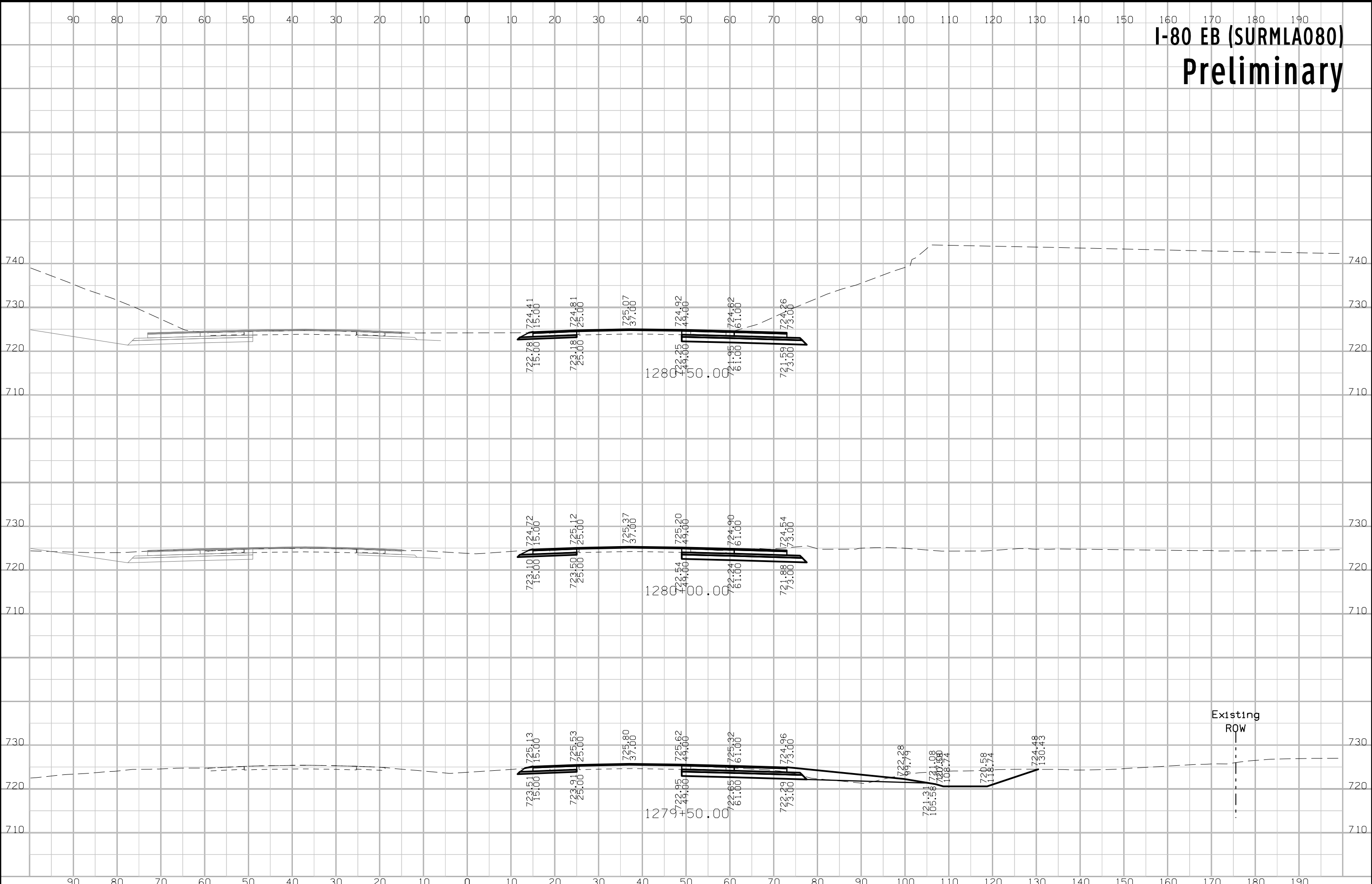

# I-80 EB (SURMLA080) Preliminary

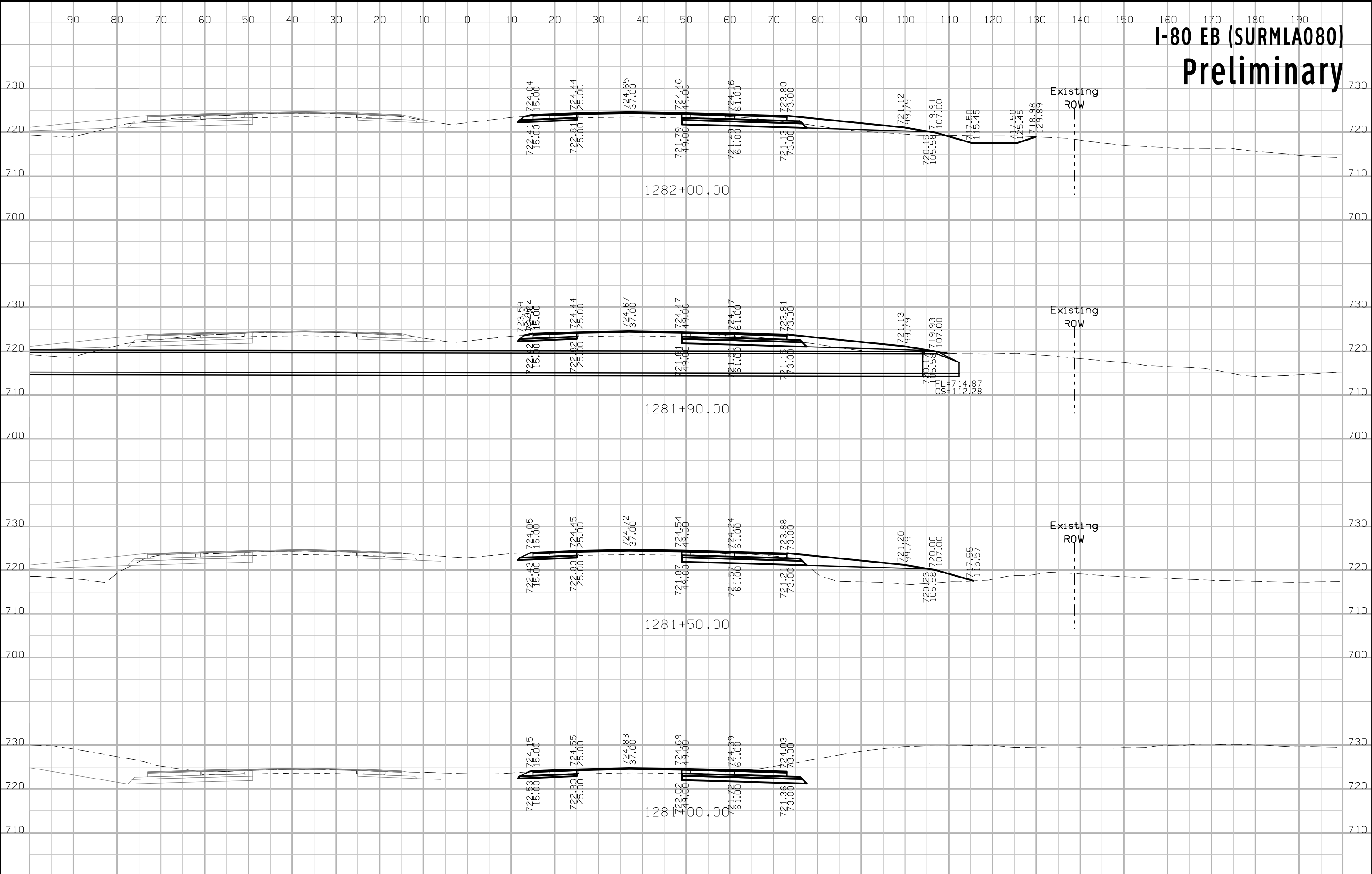

# I-80 EB (SURMLA080) Preliminary

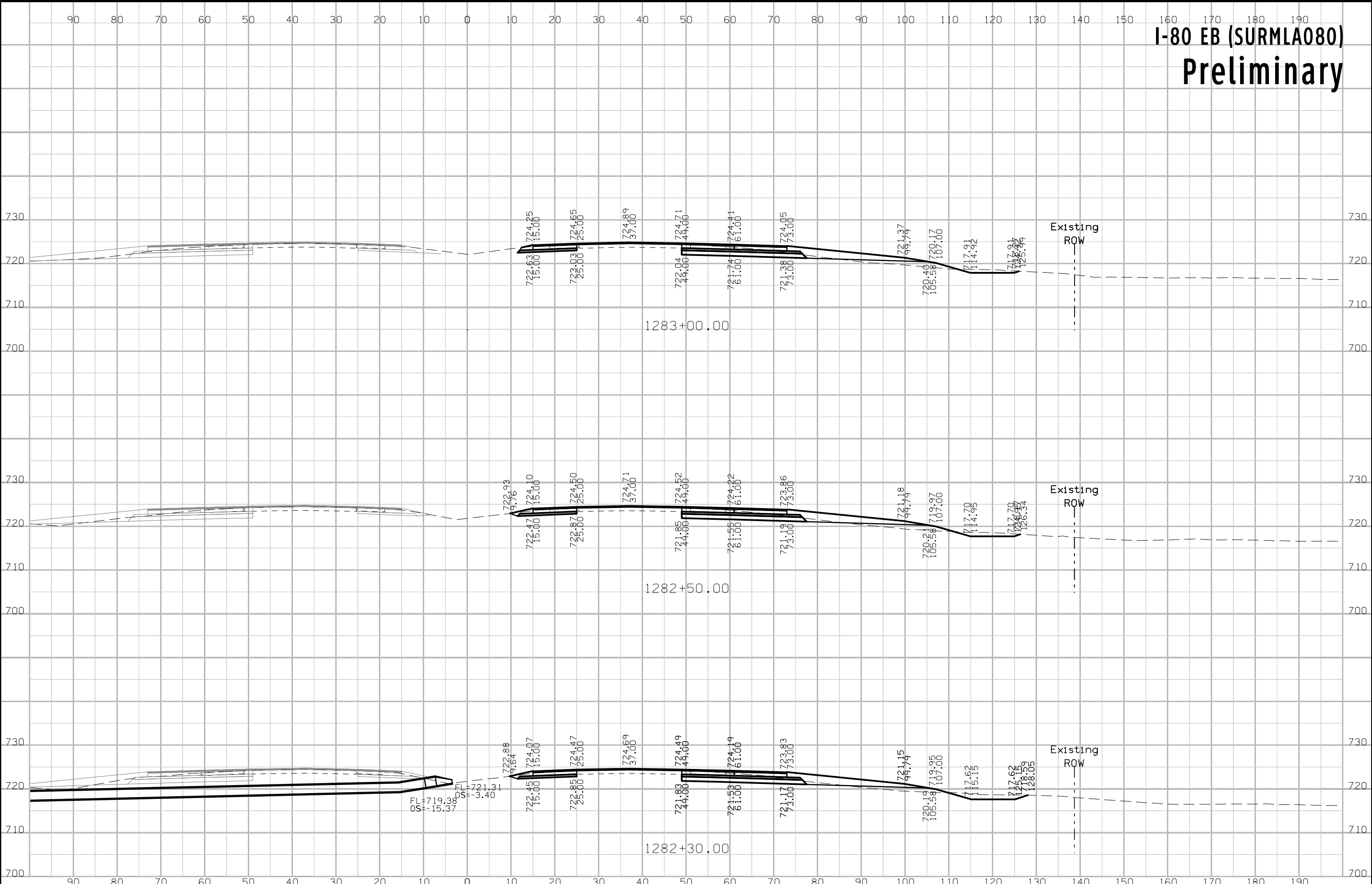

# I-80 EB (SURMLA080) Preliminary

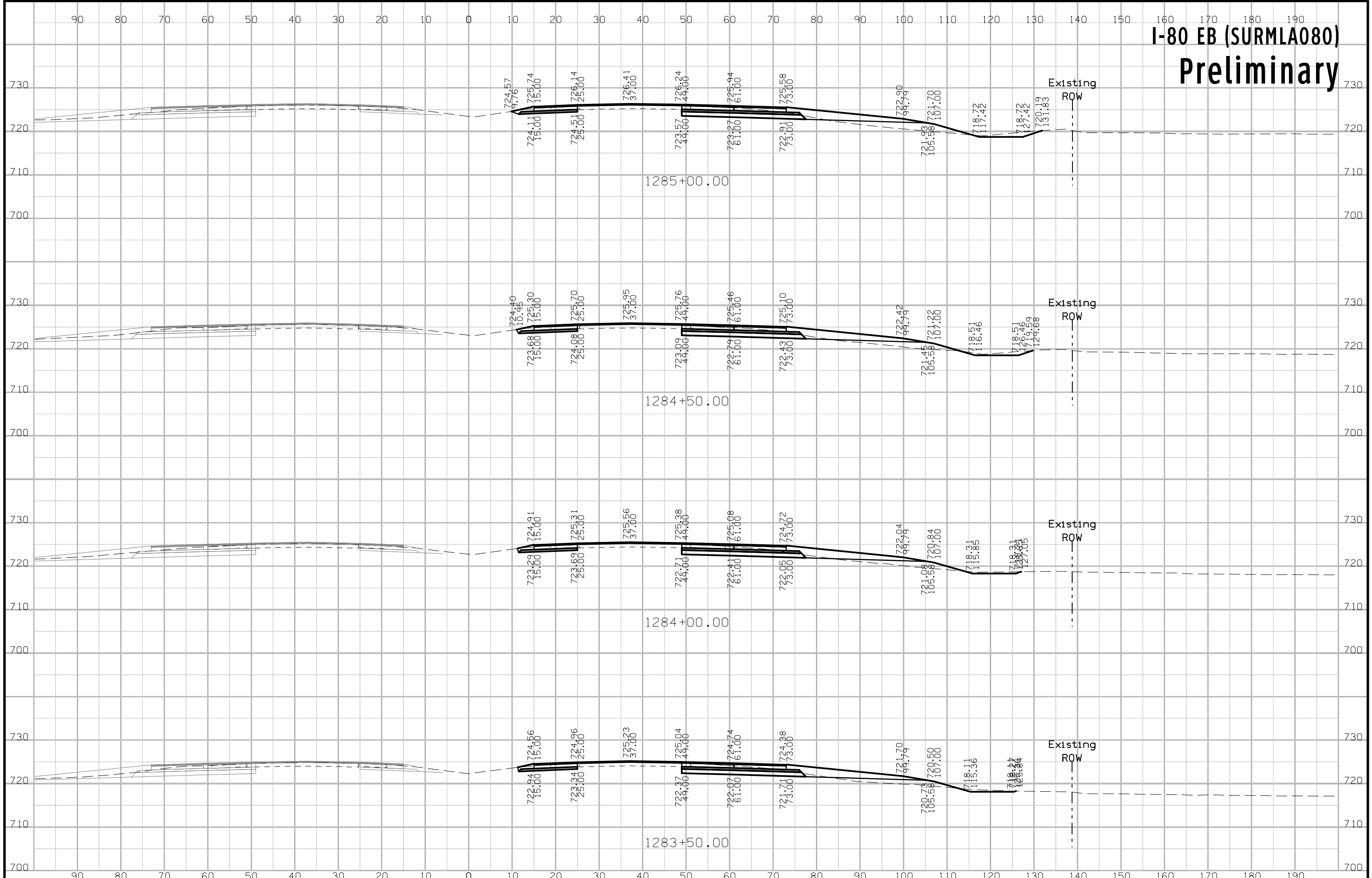

# I-80 EB (SURMLA080) Preliminary

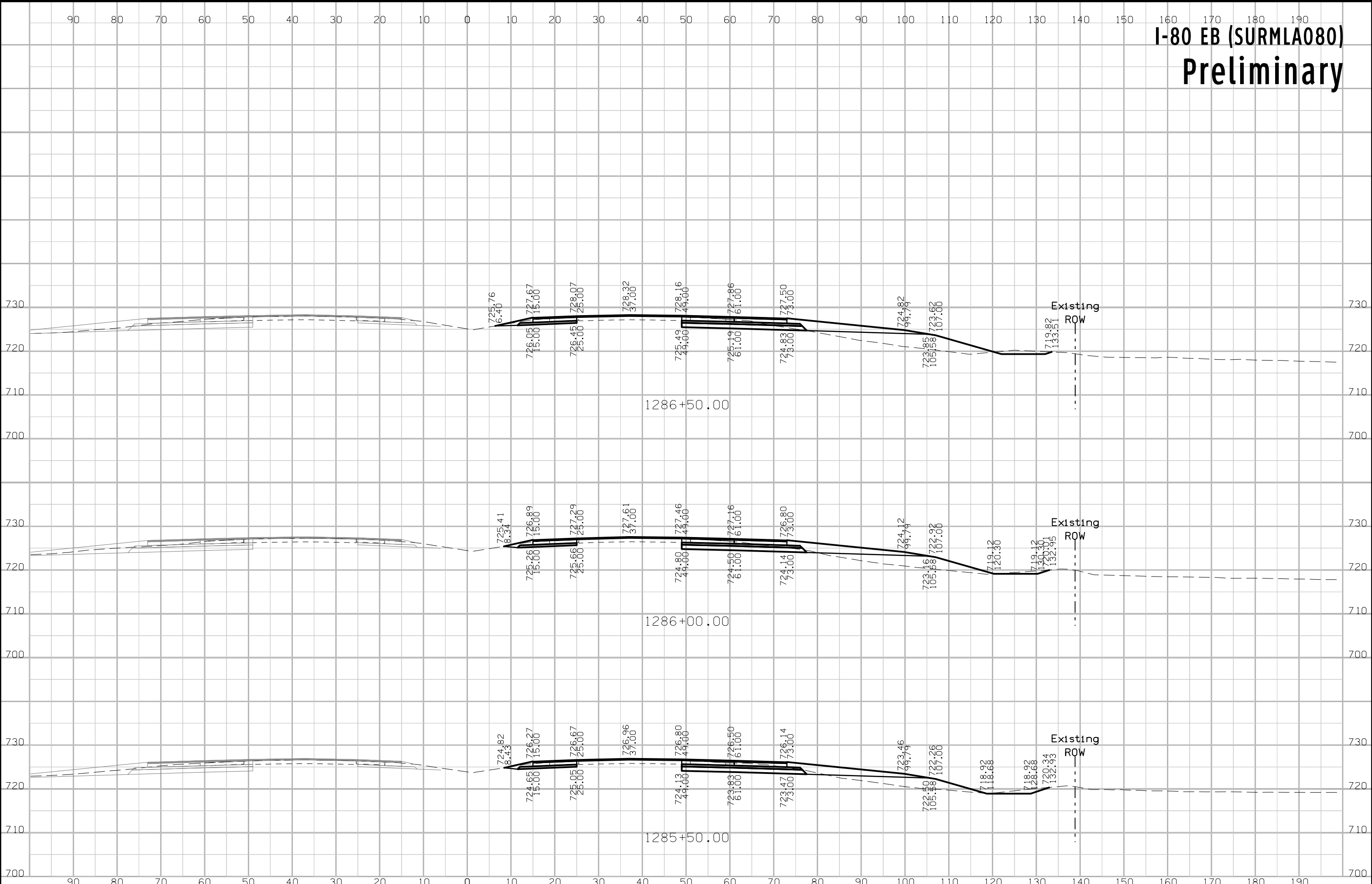

# I-80 EB (SURMLA080) Preliminary

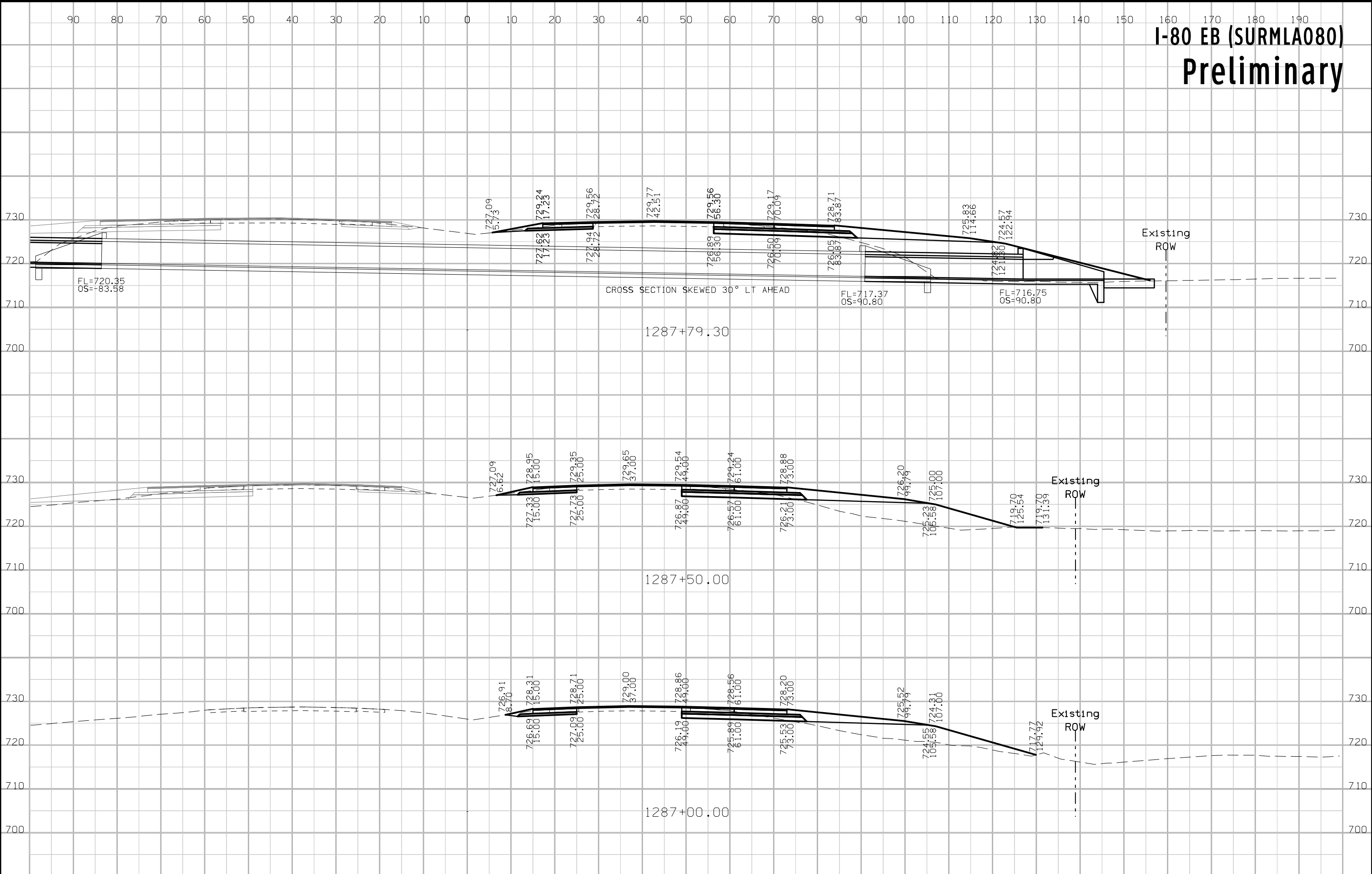



# I-80 EB (SURMLA080) Preliminary

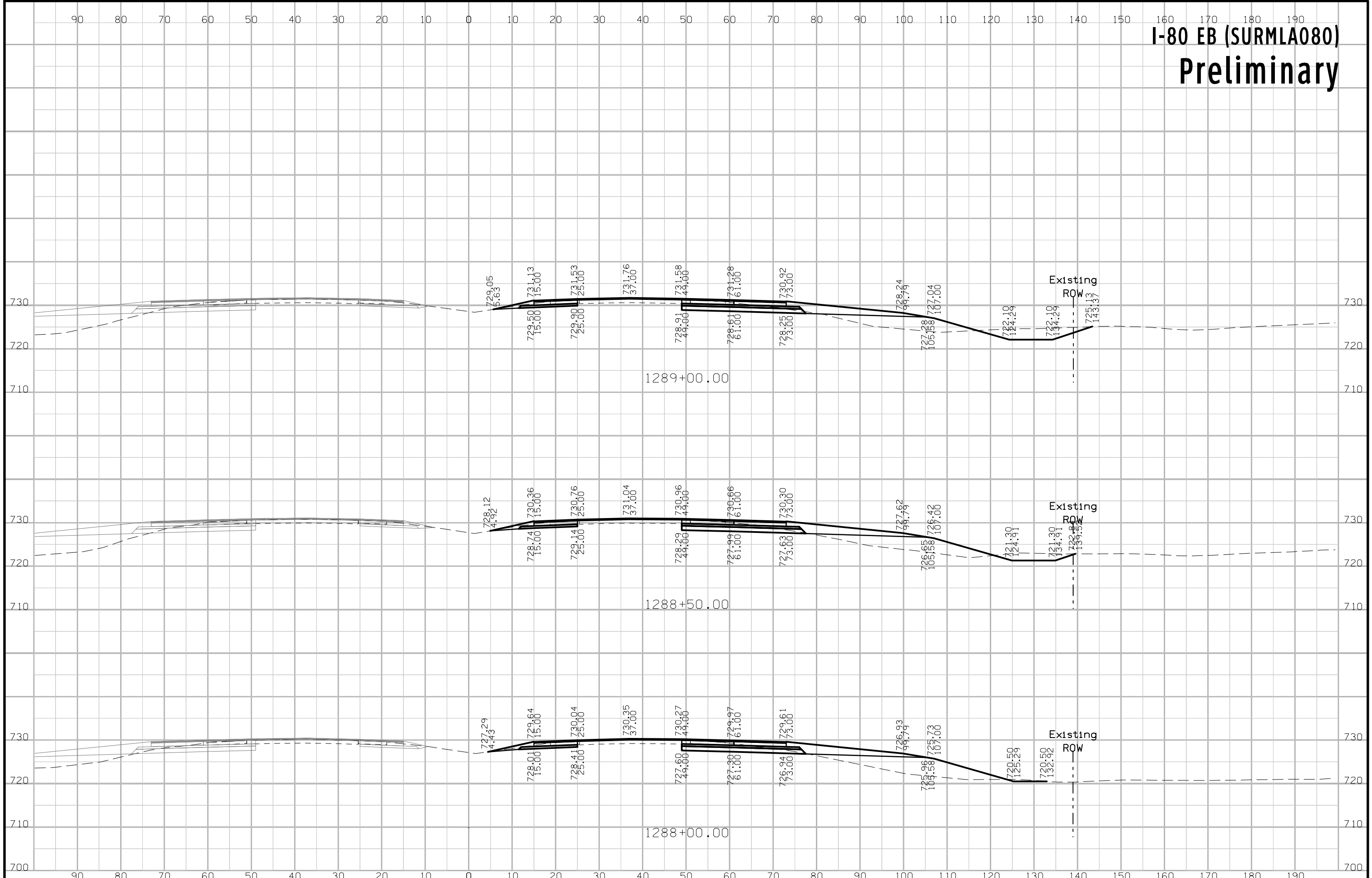

# I-80 EB (SURMLA080) Preliminary

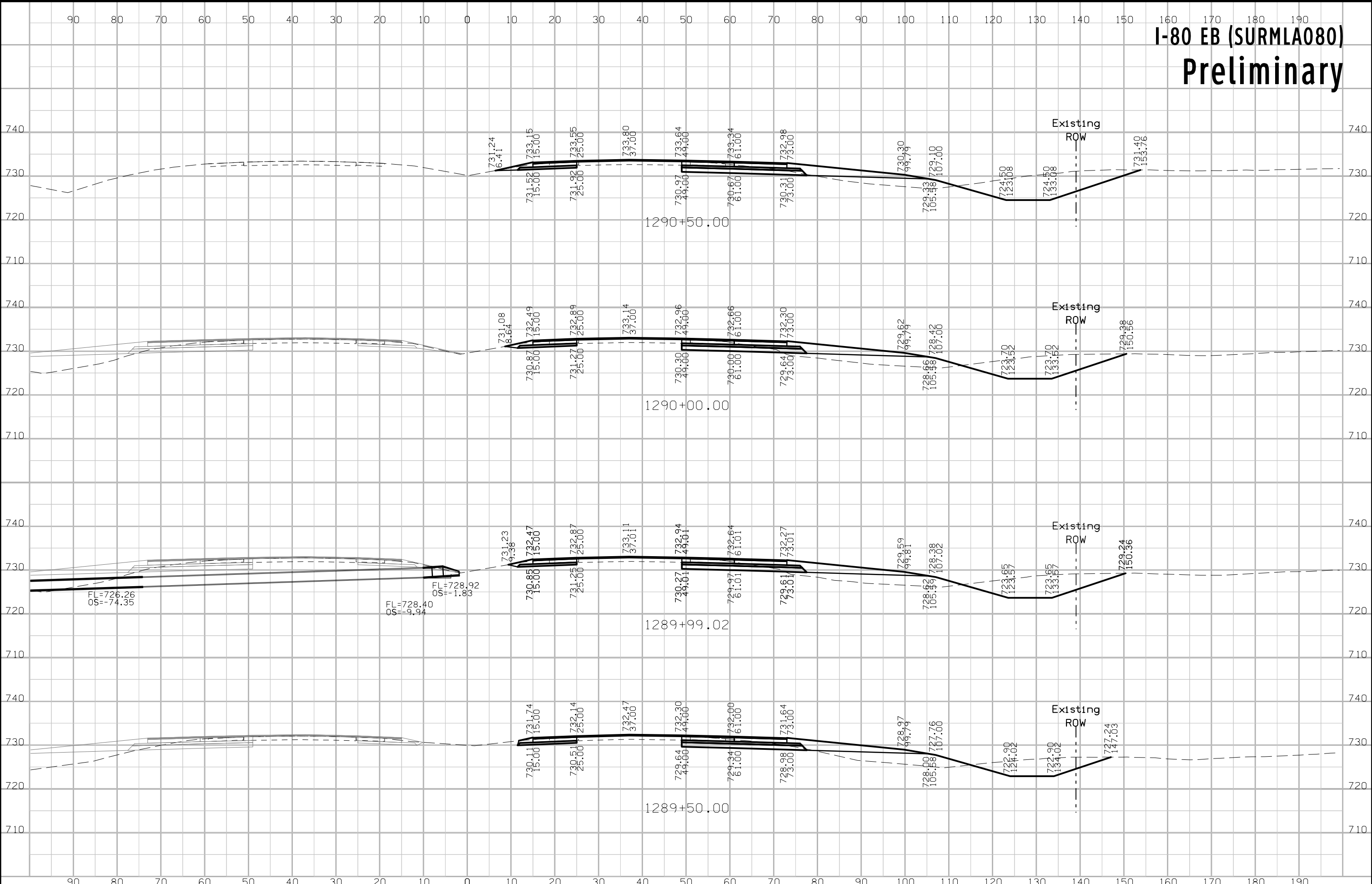

# I-80 EB (SURMLA080) Preliminary

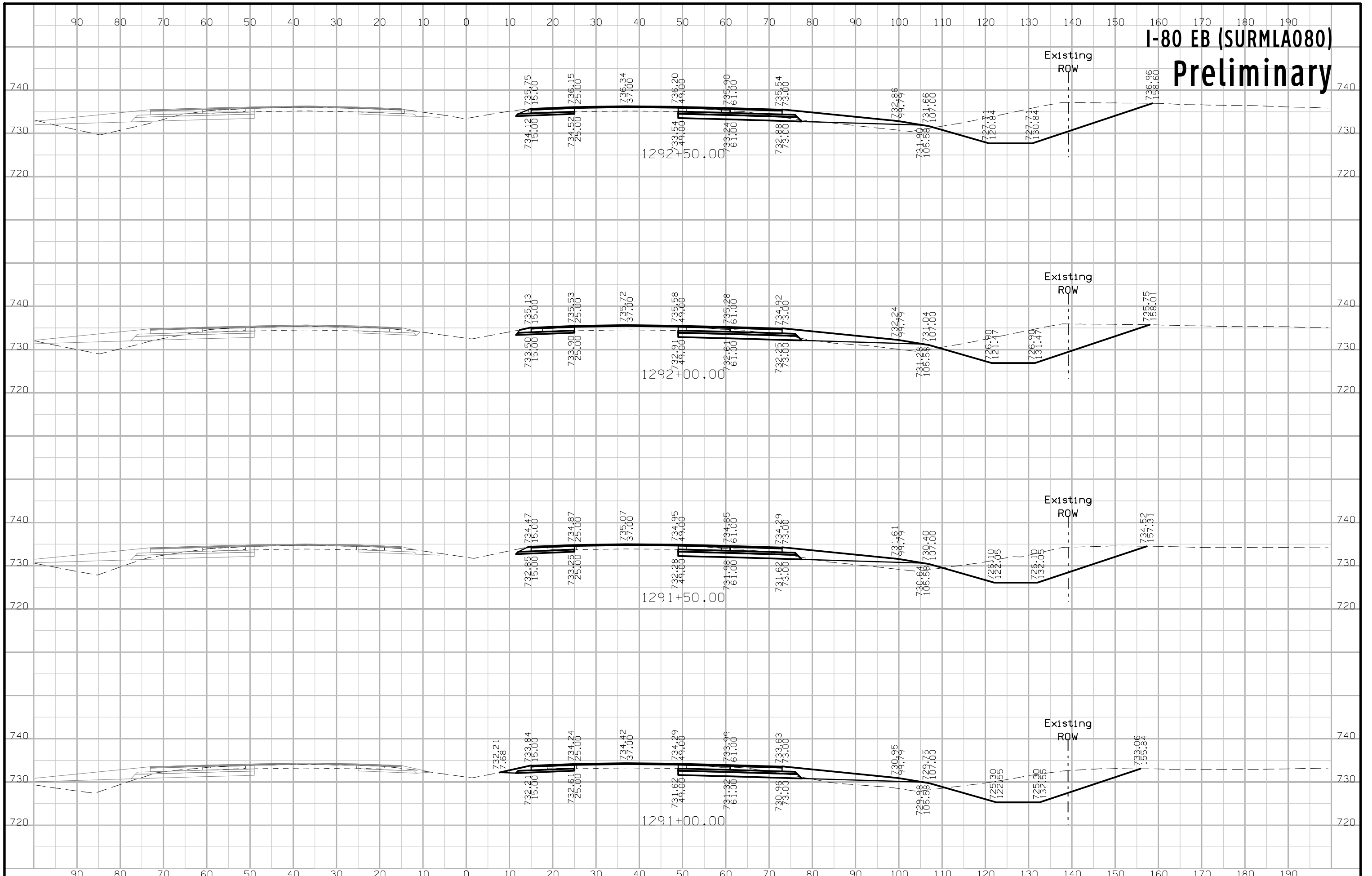

# I-80 EB (SURMLA080) Preliminary

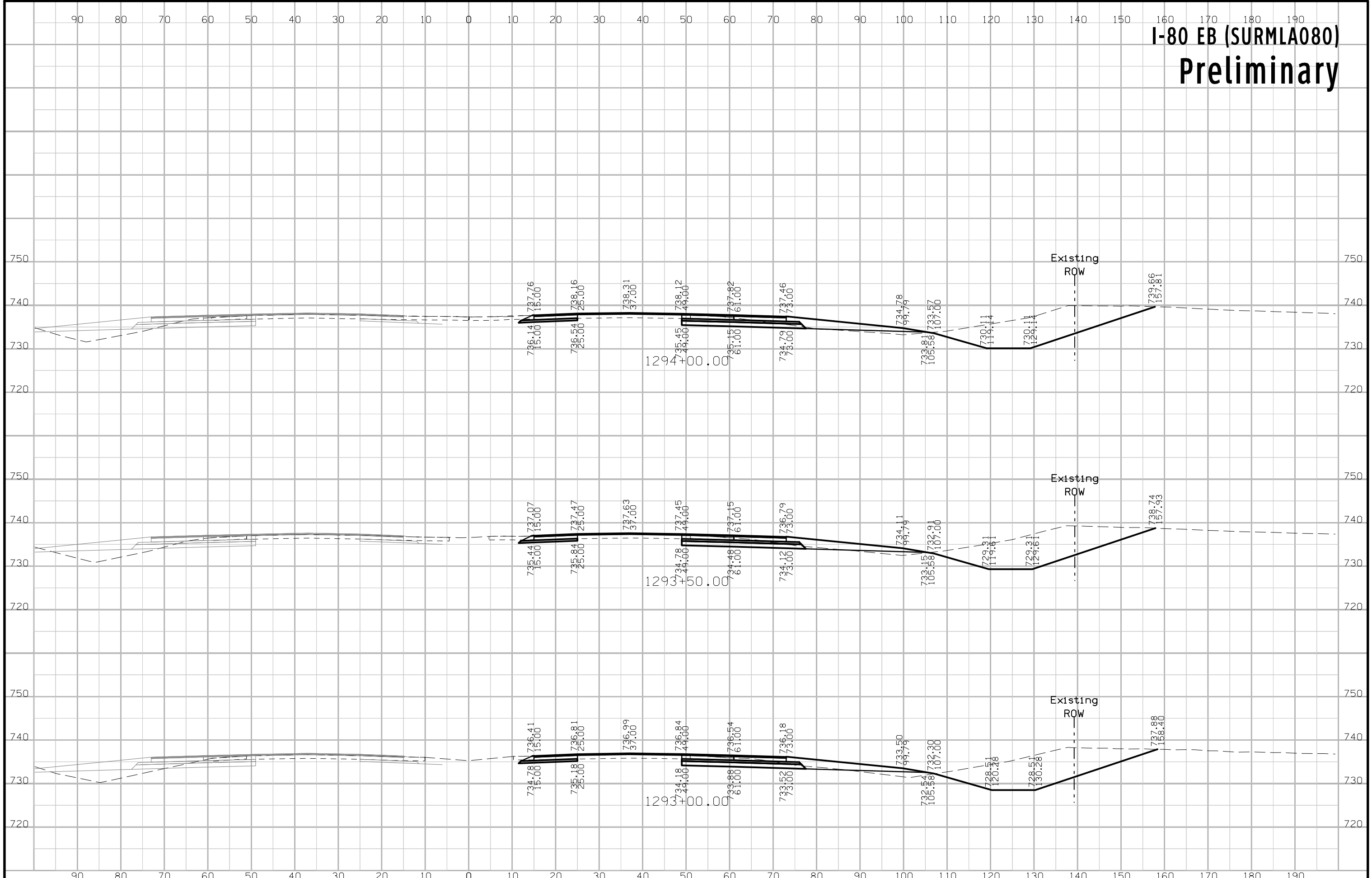

# I-80 EB (SURMLA080) Preliminary

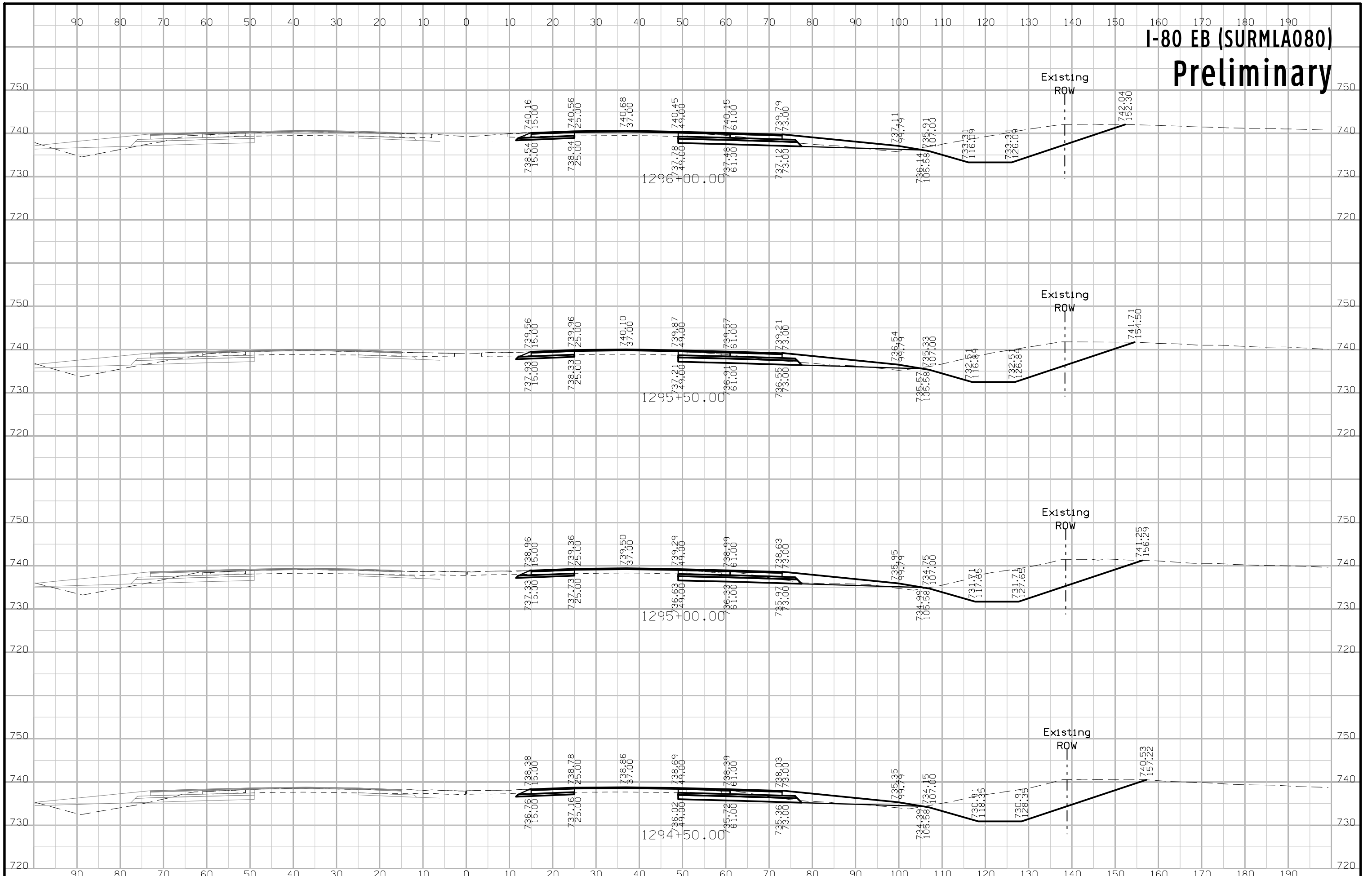

# I-80 EB (SURMLA080) Preliminary

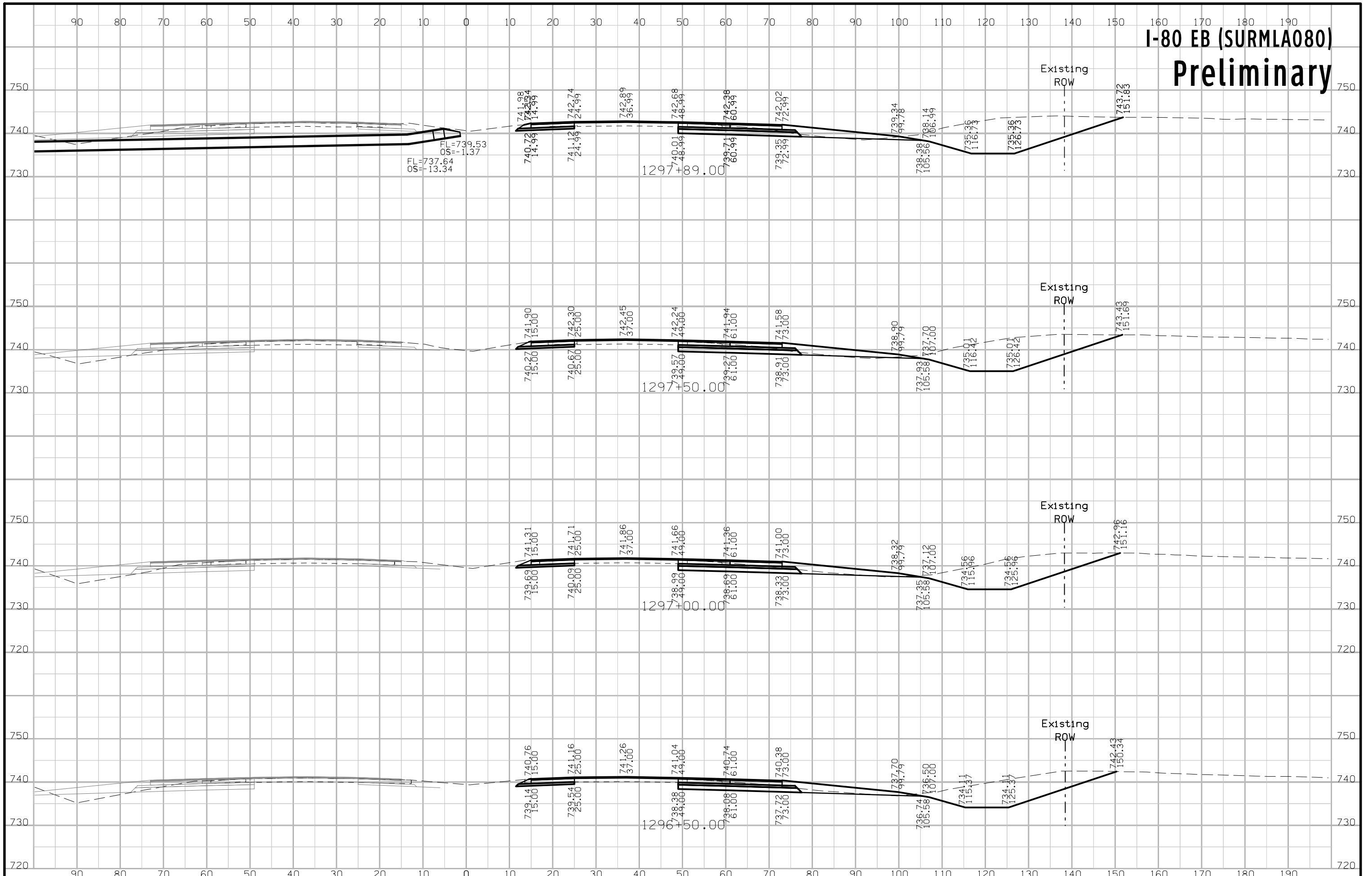

# I-80 EB (SURMLA080) Preliminary

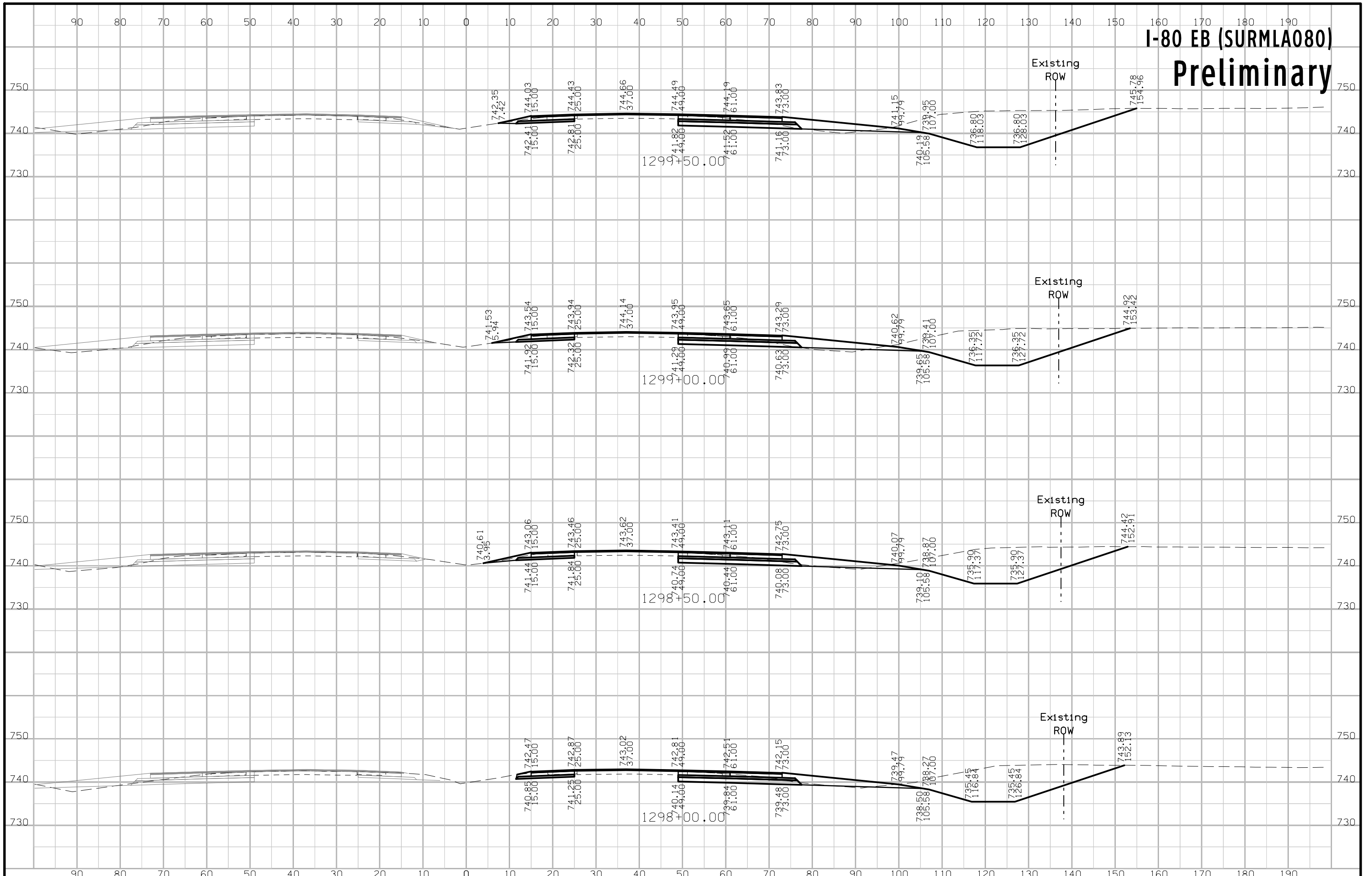

# I-80 EB (SURMLA080) Preliminary

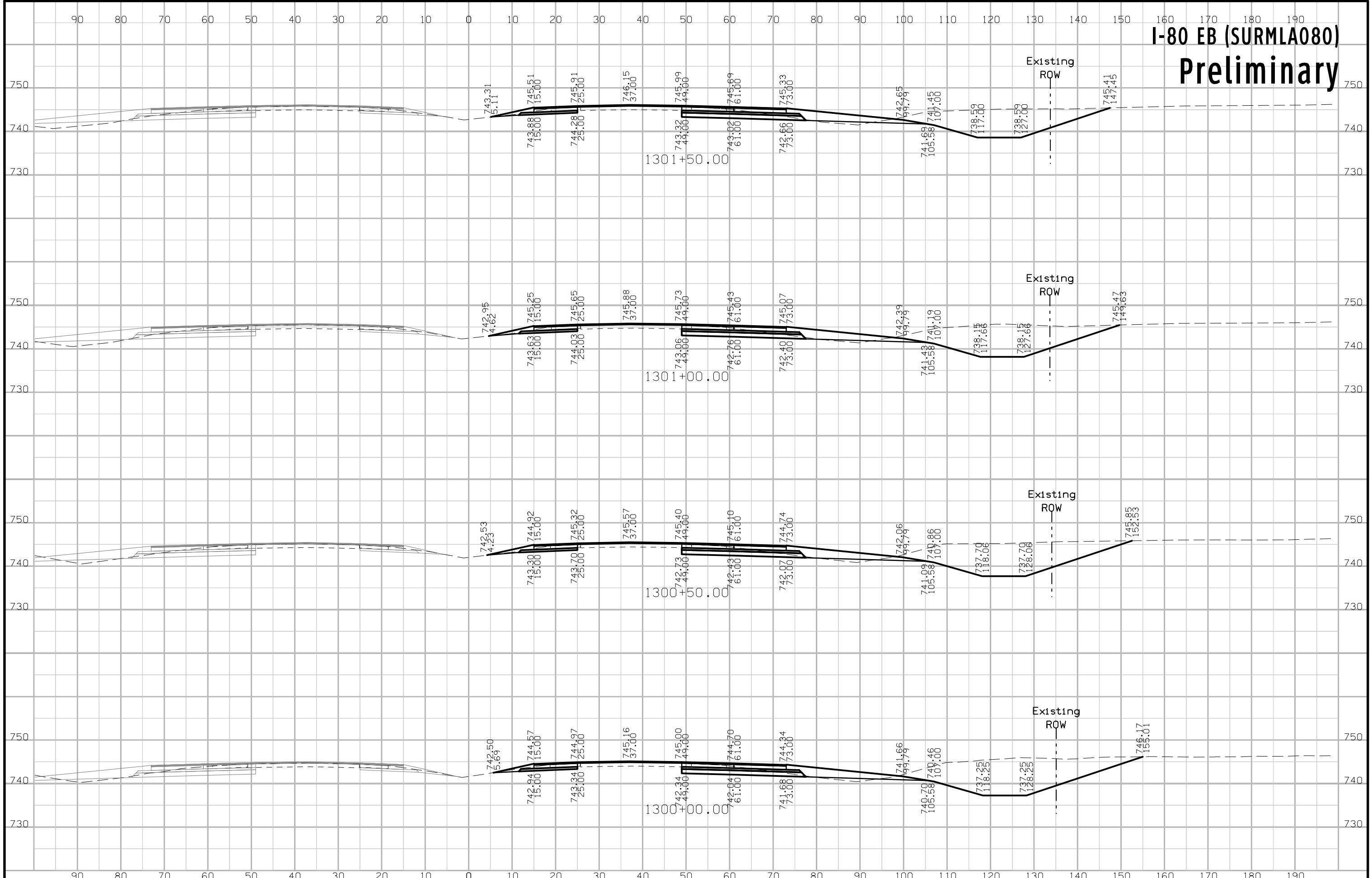



# I-80 EB (SURMLA080) Preliminary

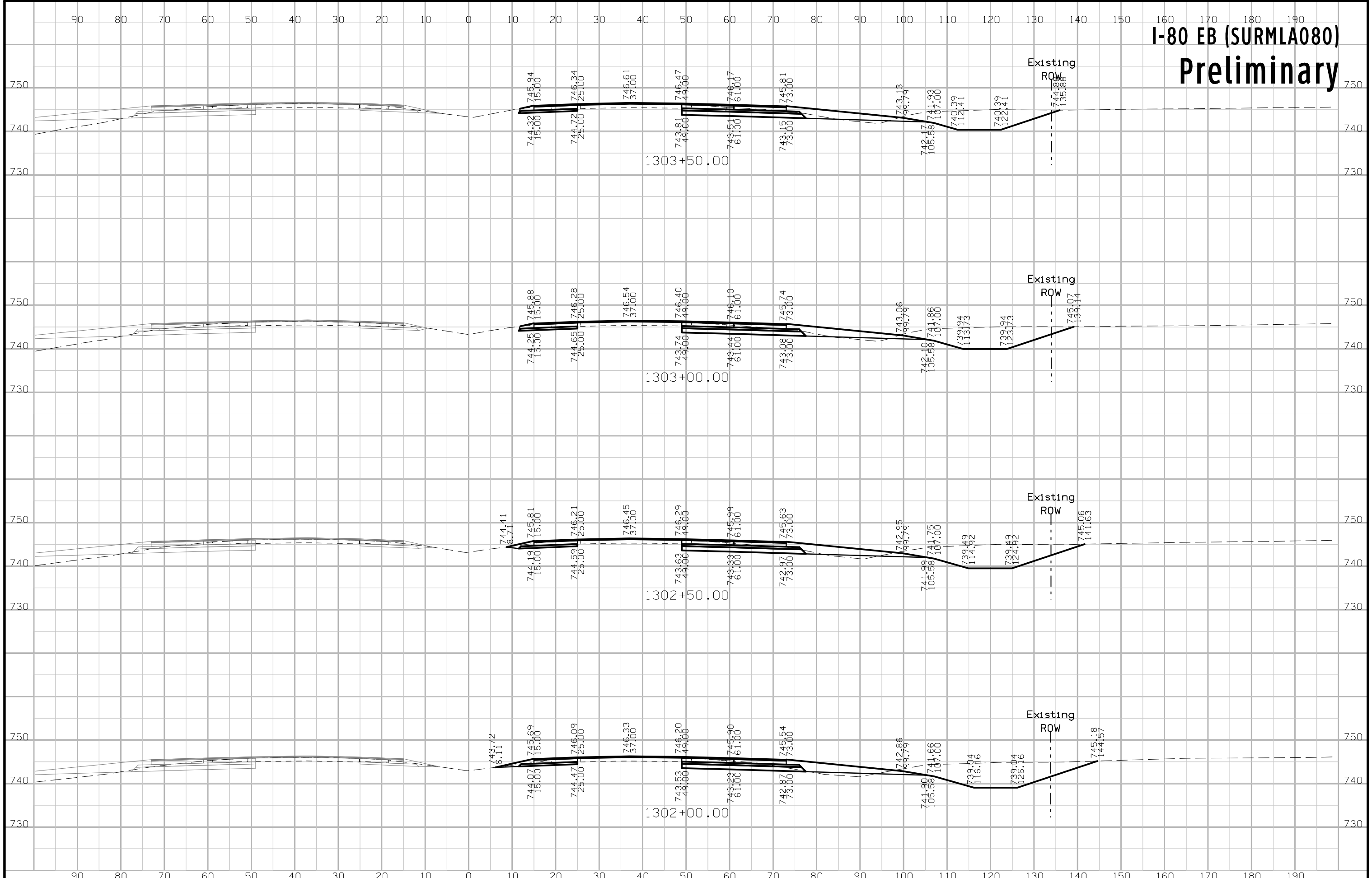

# I-80 EB (SURMLA080) Preliminary

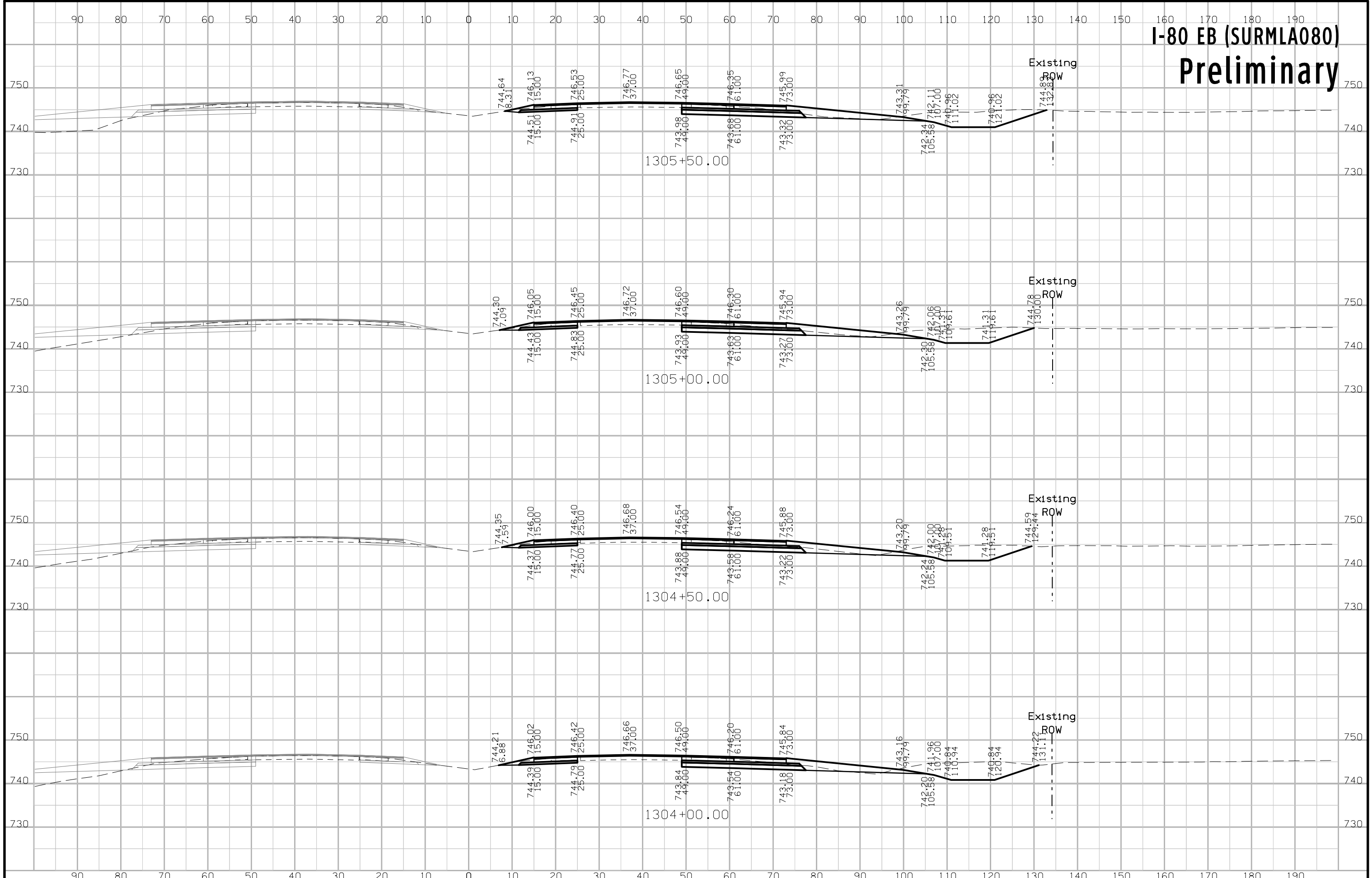

# I-80 EB (SURMLA080) Preliminary

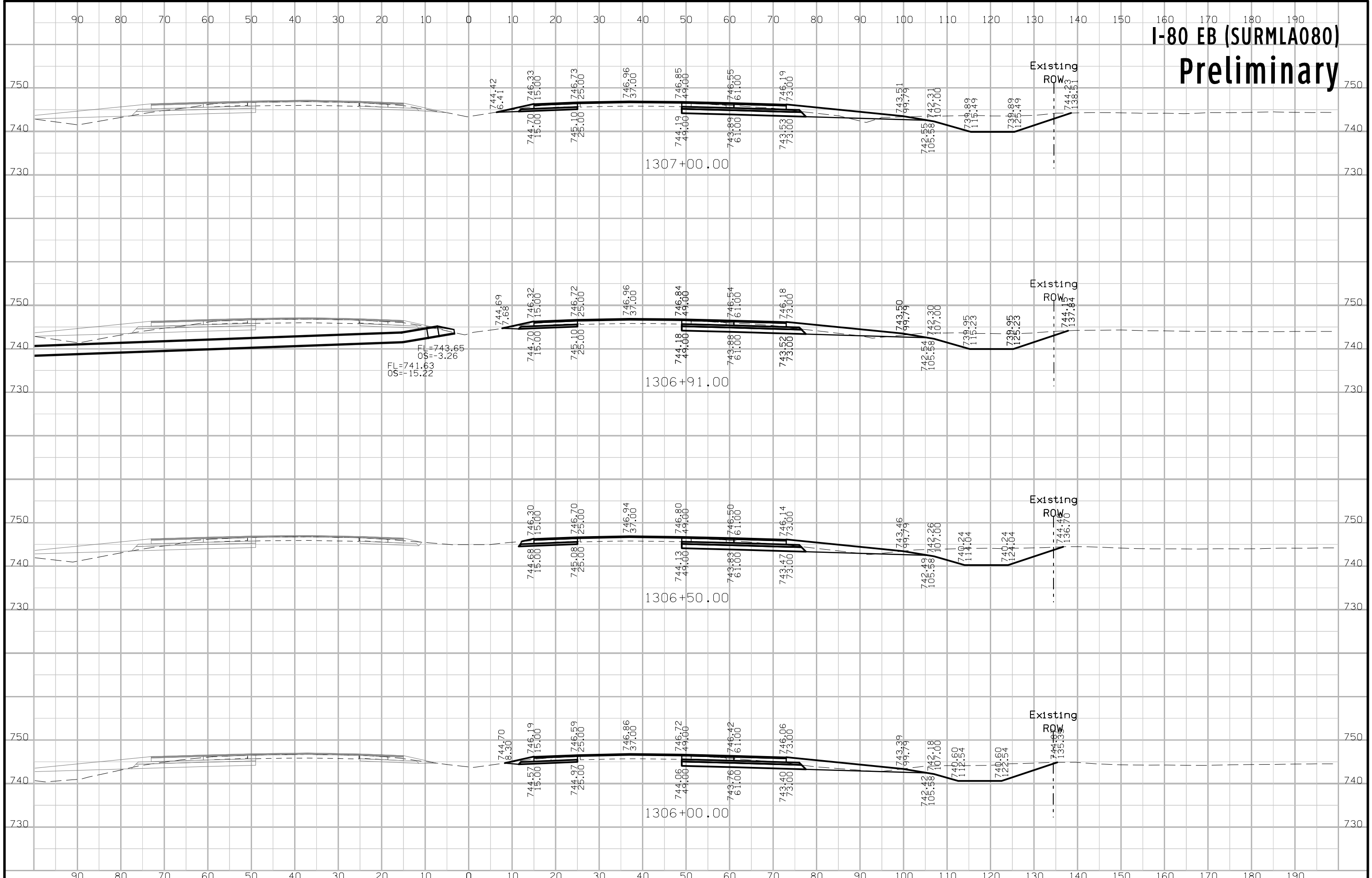

# I-80 EB (SURMLA080) Preliminary

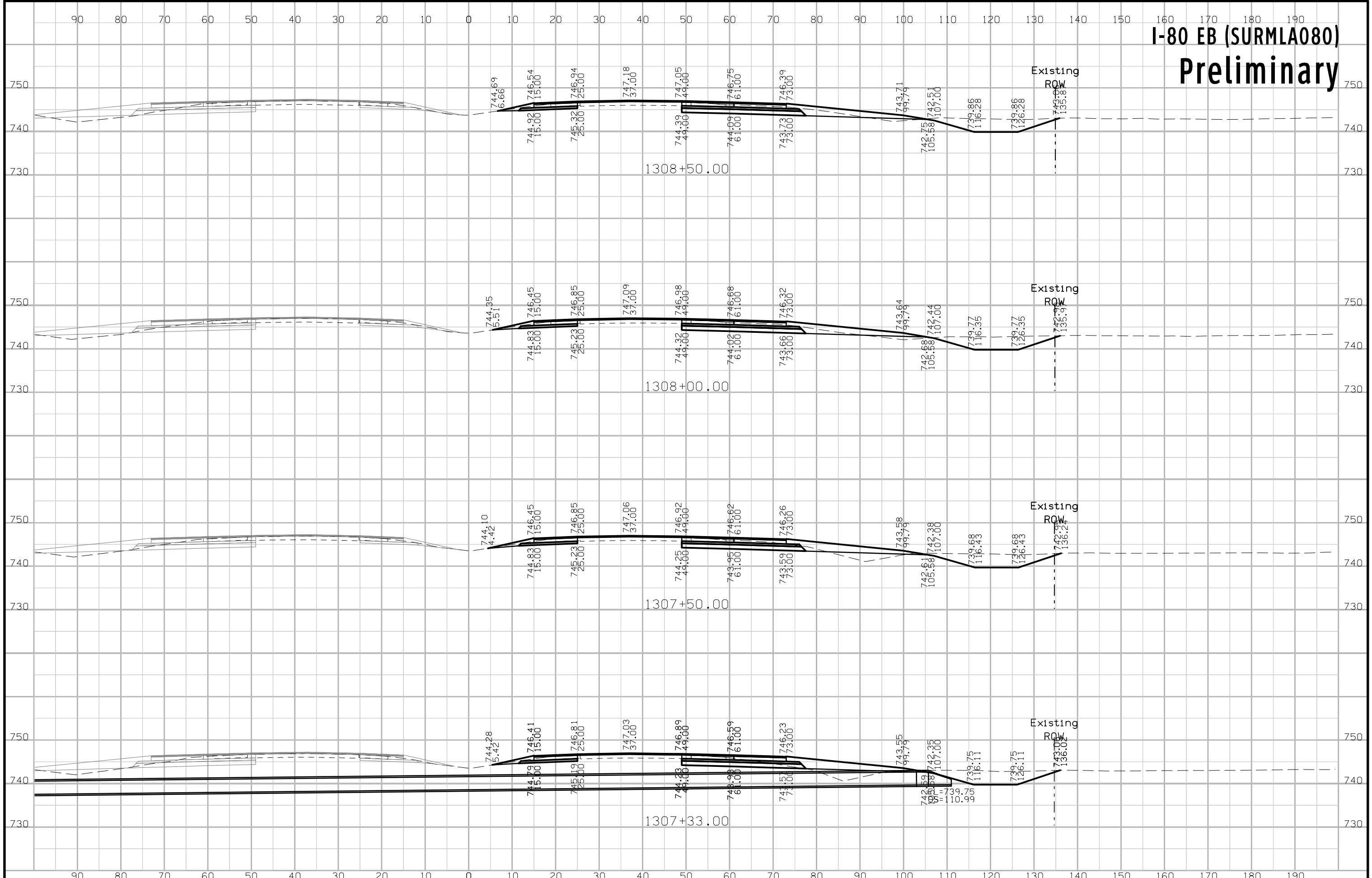

# I-80 EB (SURMLA080) Preliminary

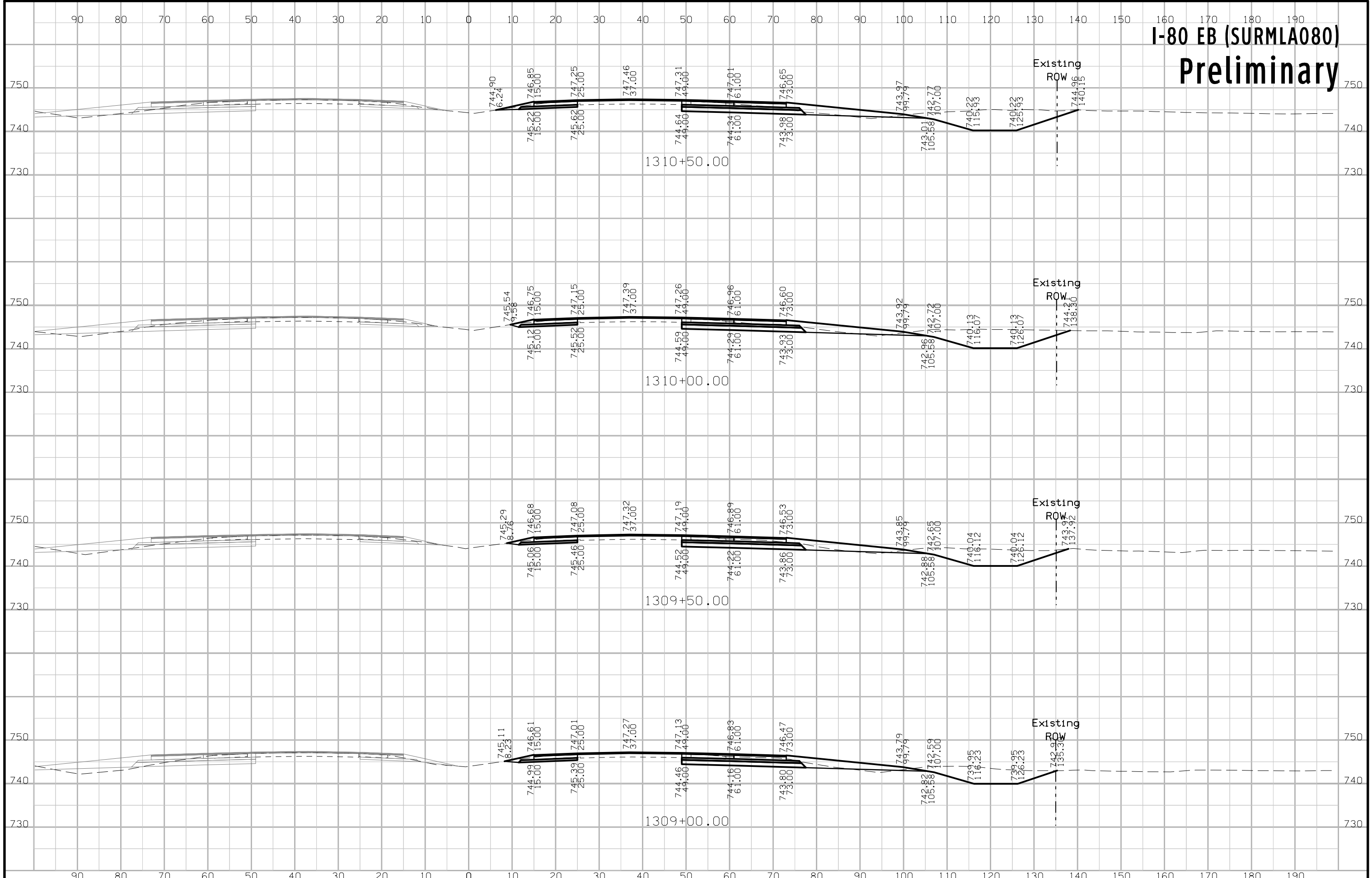

# I-80 EB (SURMLA080) Preliminary

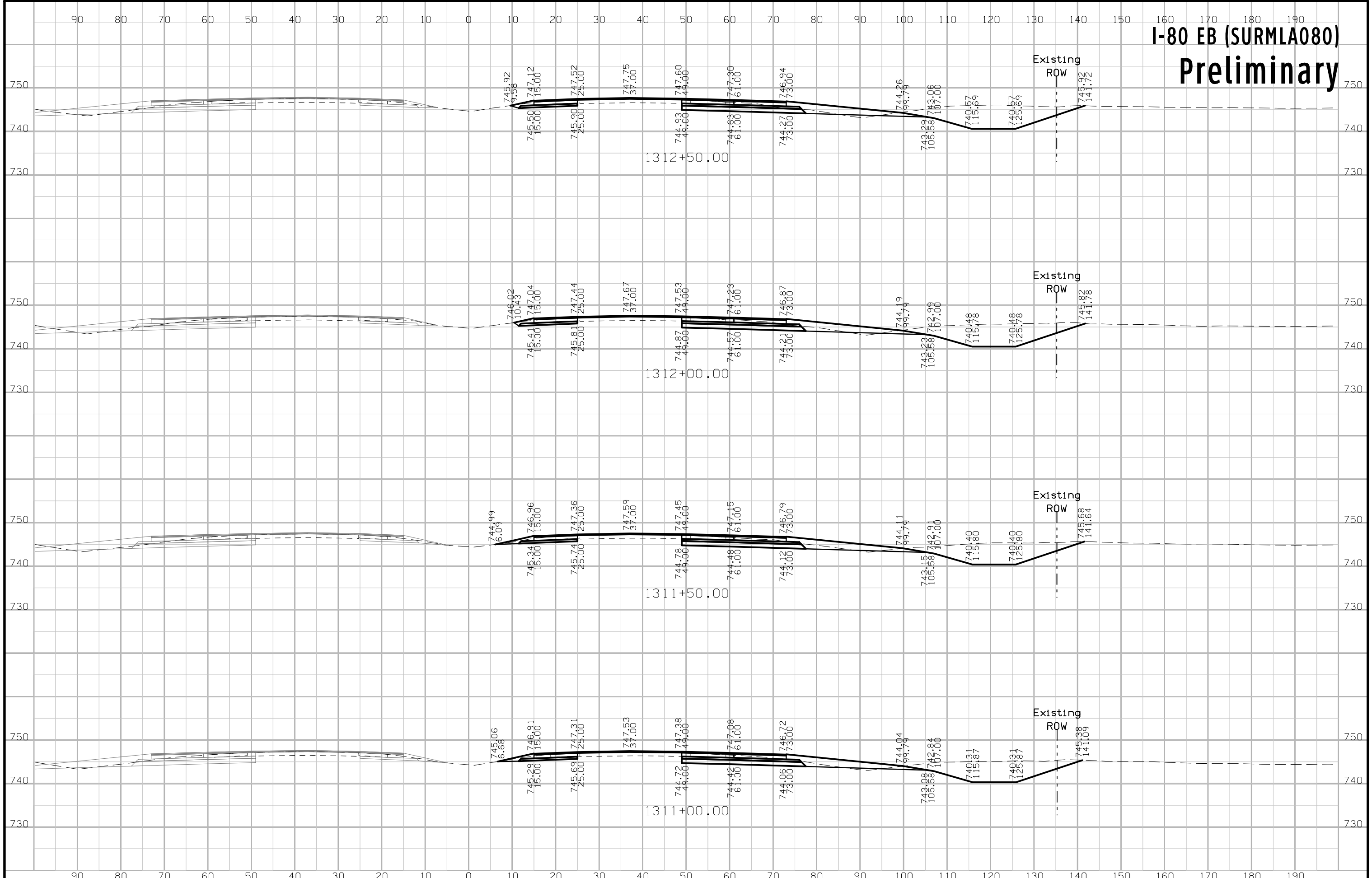

# I-80 EB (SURMLA080) Preliminary

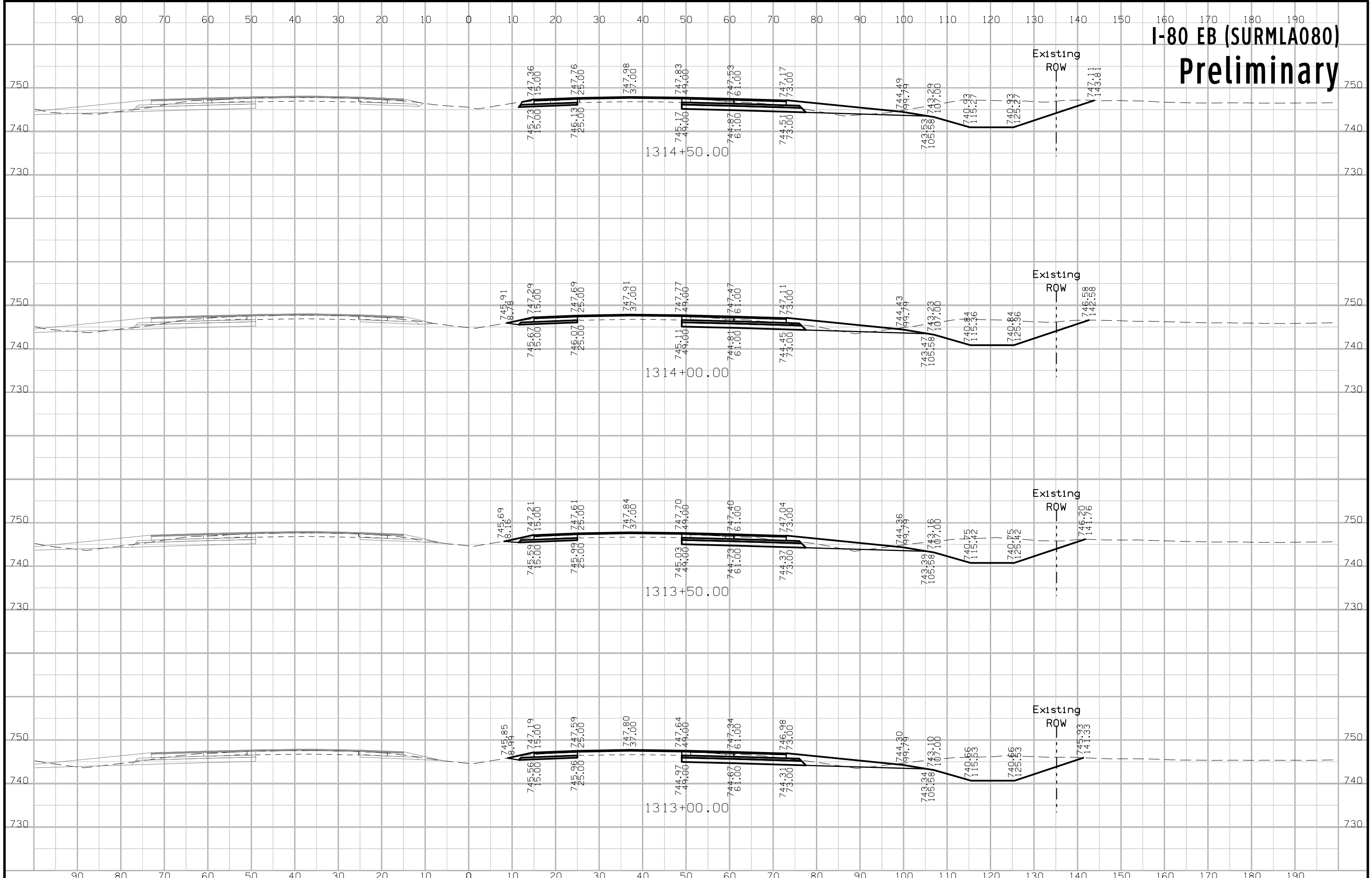

# I-80 EB (SURMLA080) Preliminary

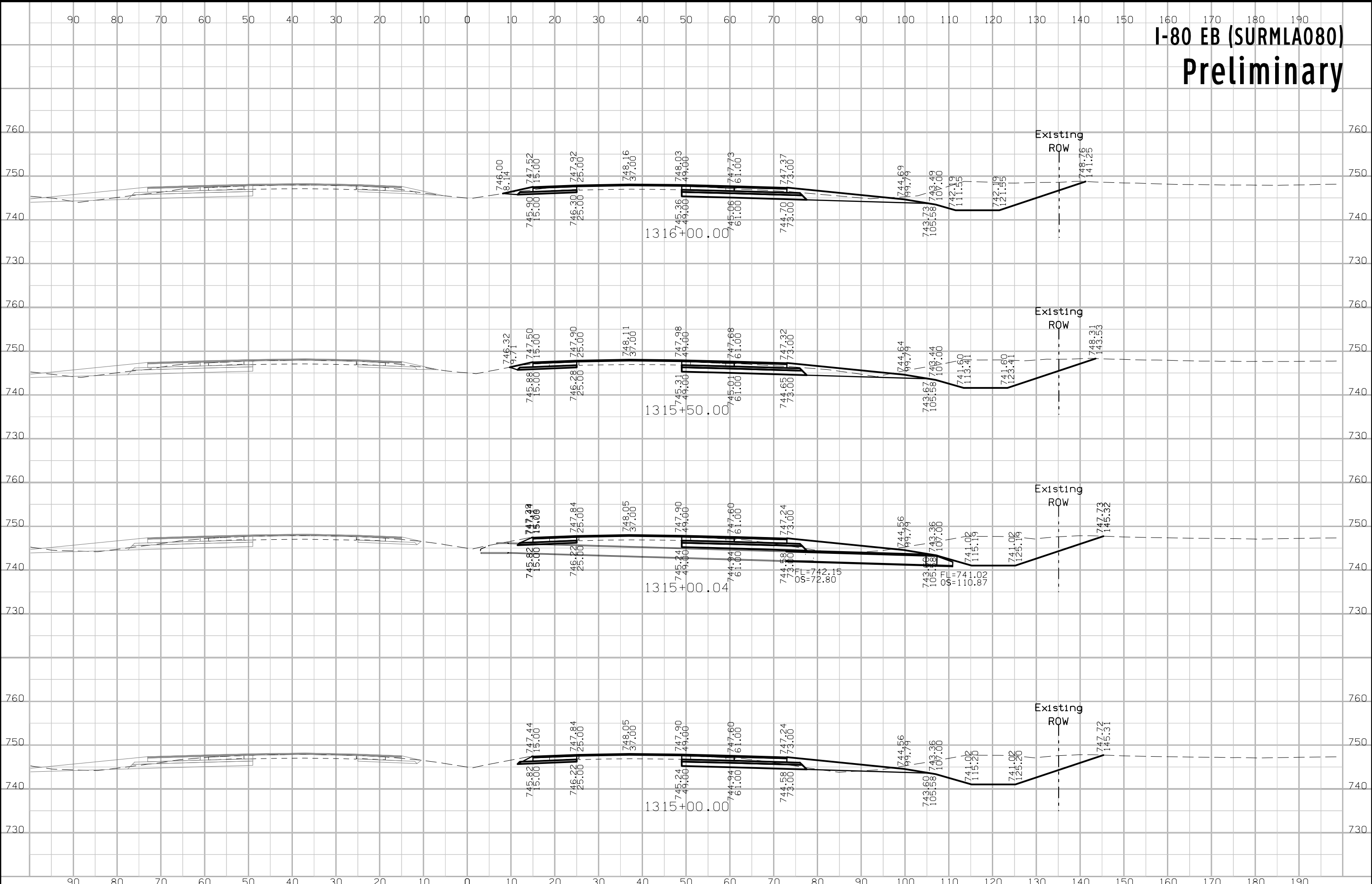



# I-80 EB (SURMLA080) Preliminary

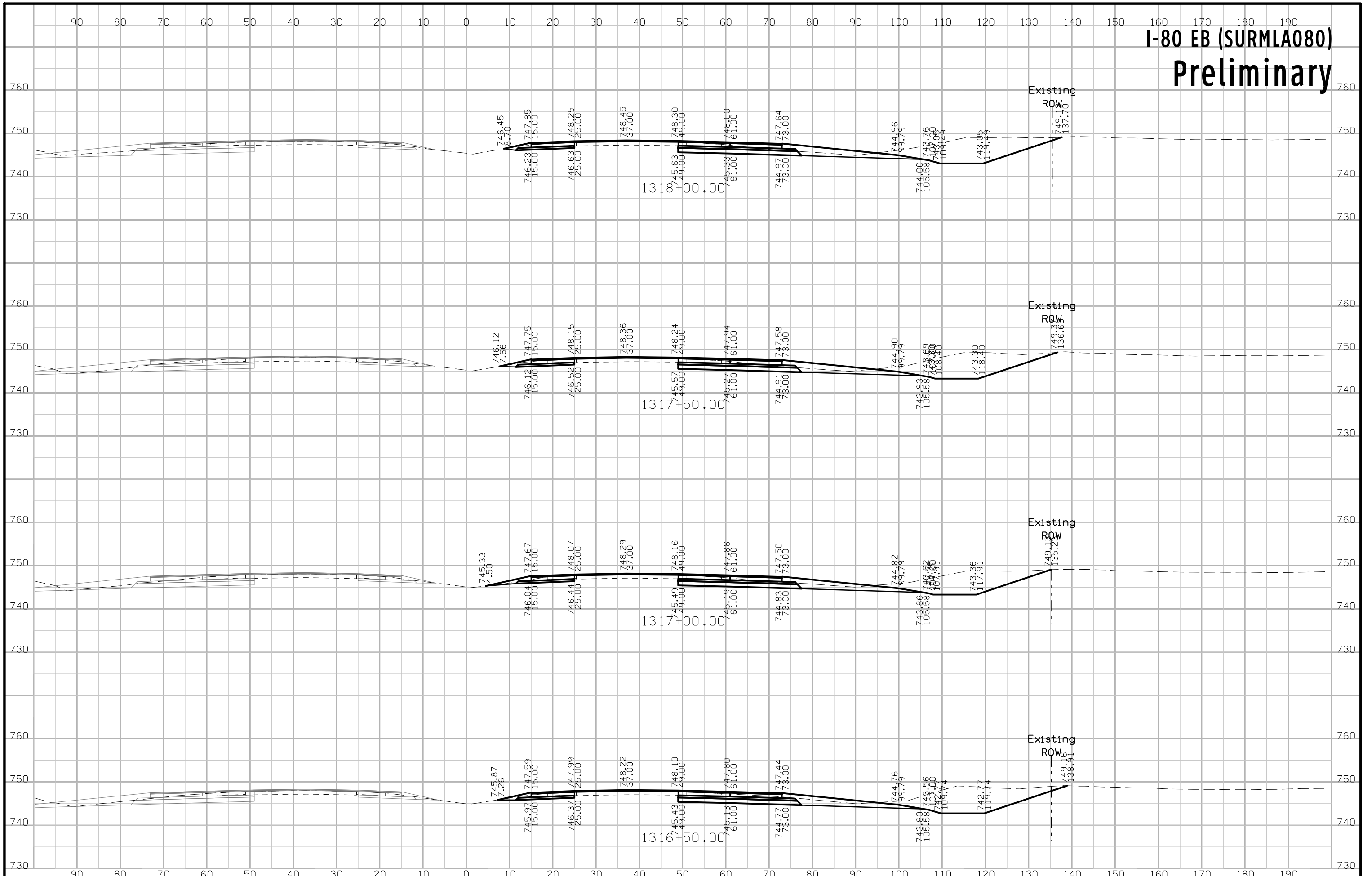

# I-80 EB (SURMLA080) Preliminary

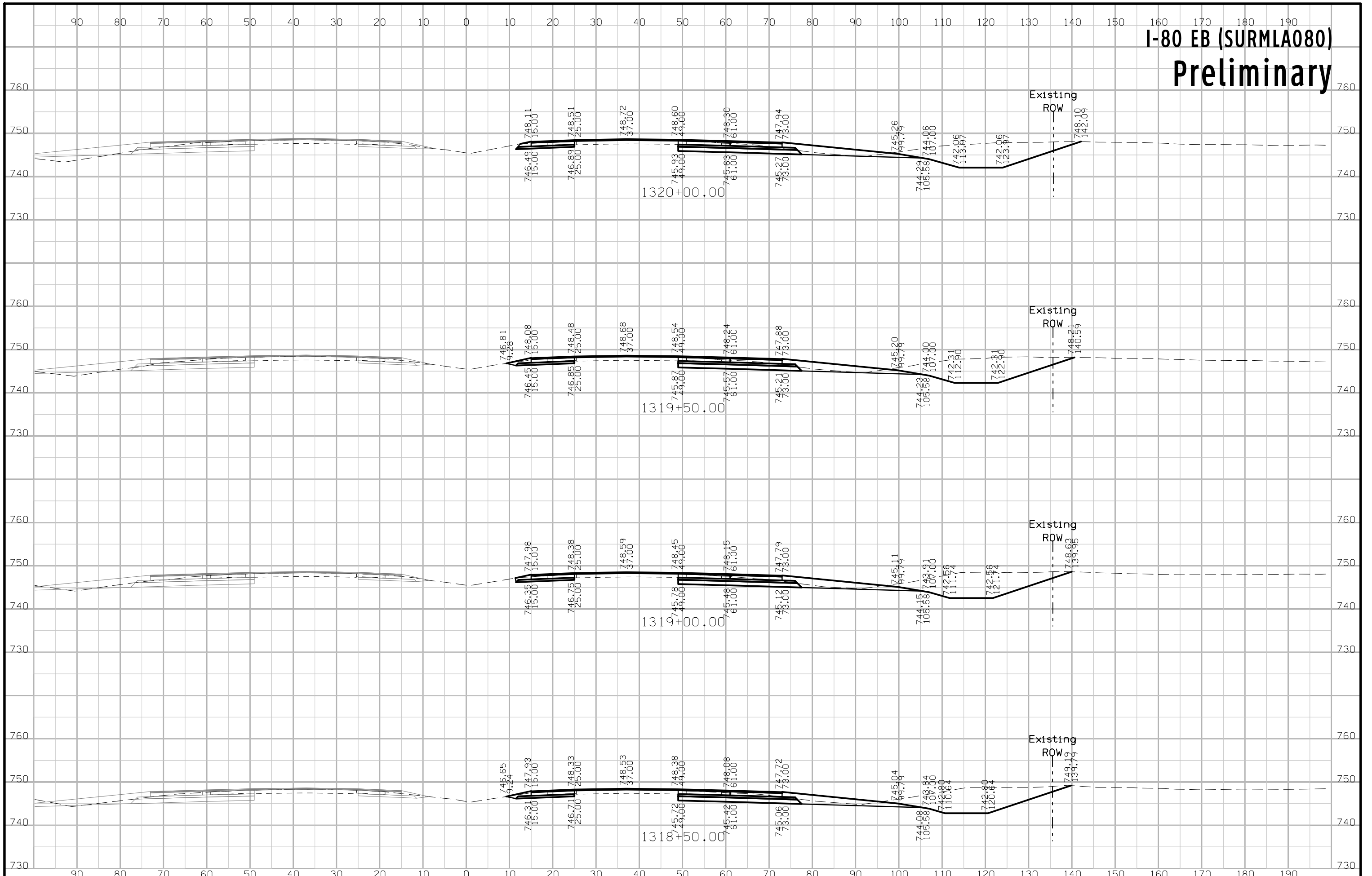

# I-80 EB (SURMLA080) Preliminary

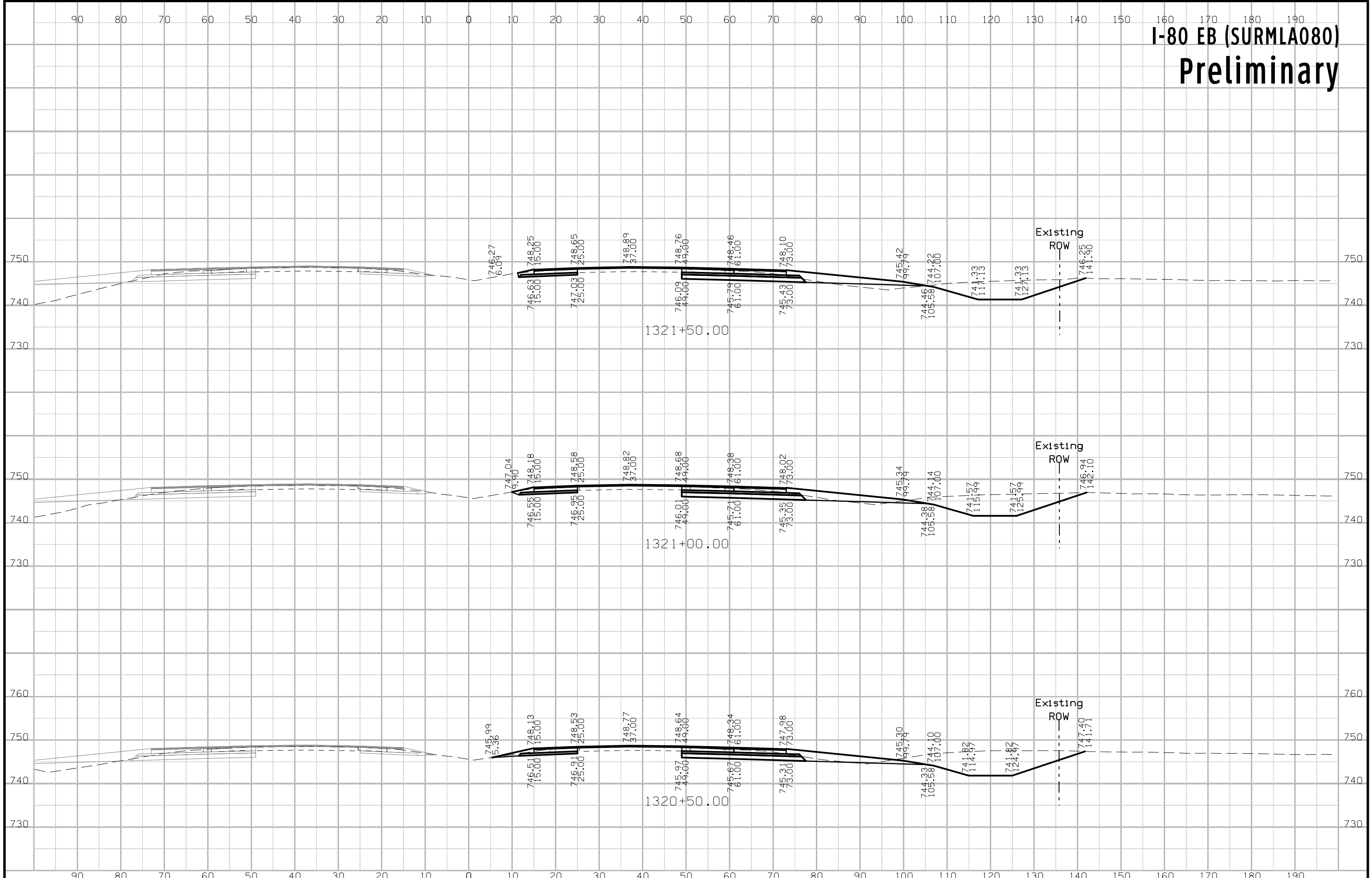

# I-80 EB (SURMLA080) Preliminary

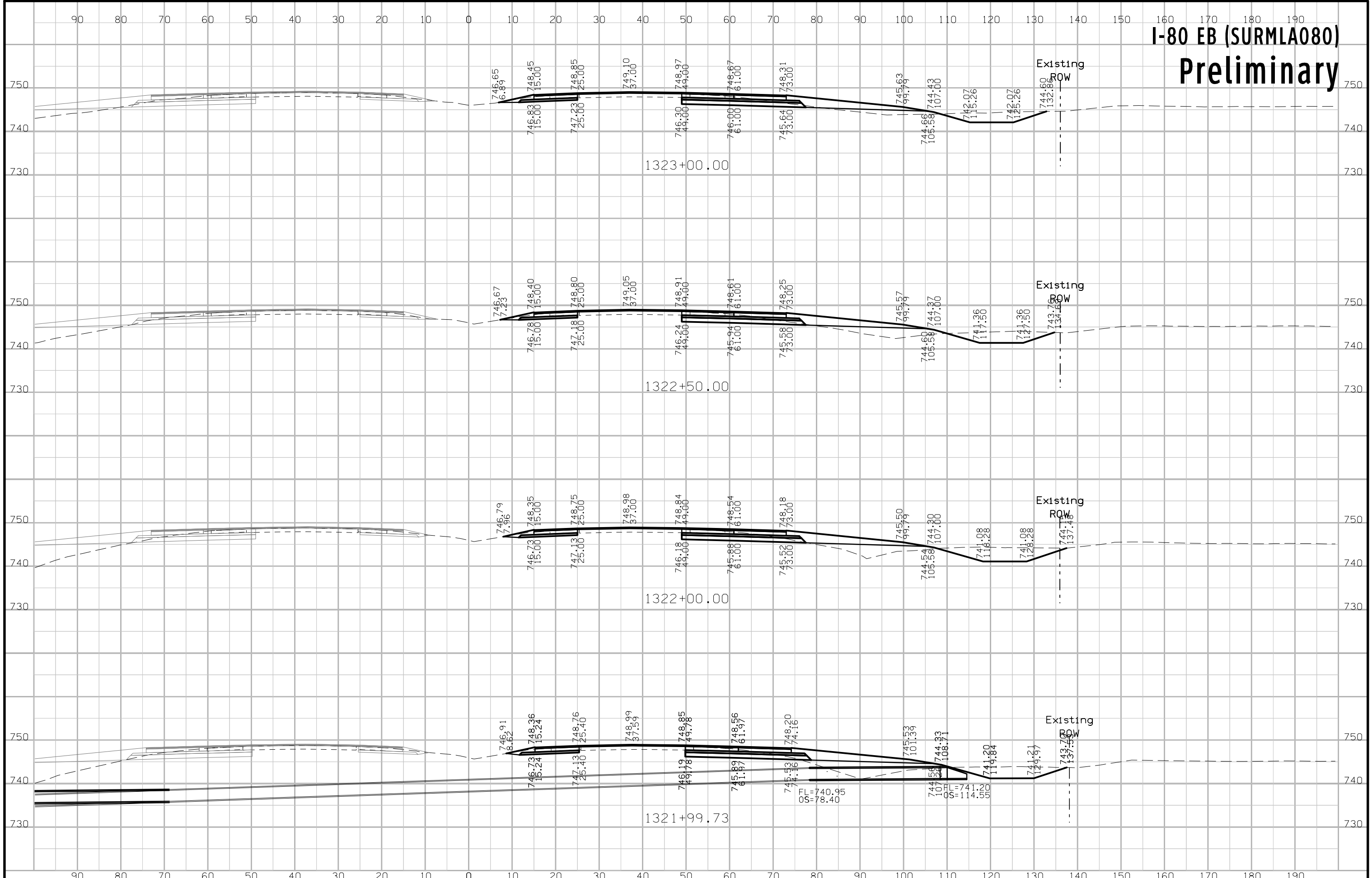

# I-80 EB (SURMLA080) Preliminary

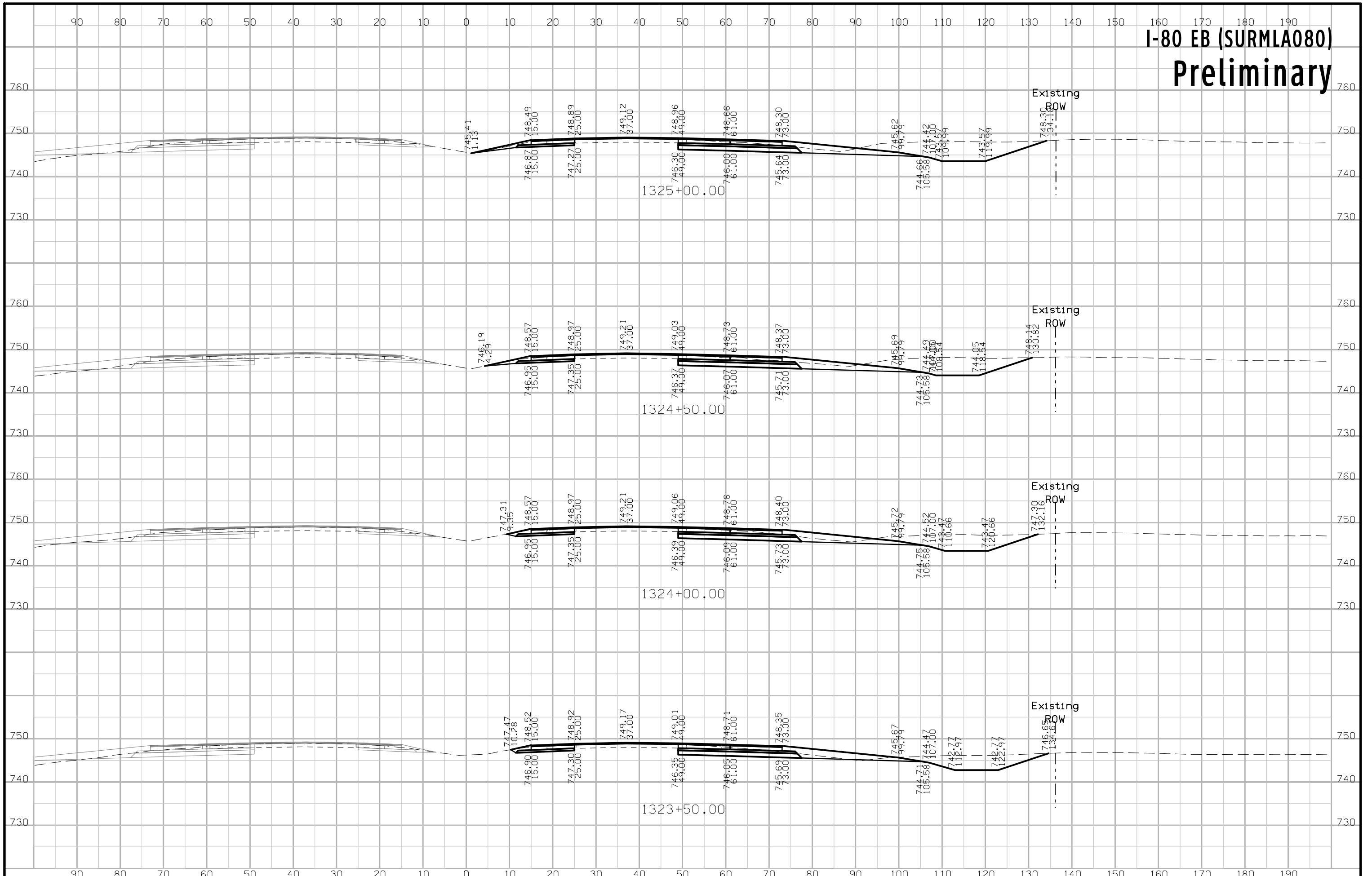

# I-80 EB (SURMLA080) Preliminary

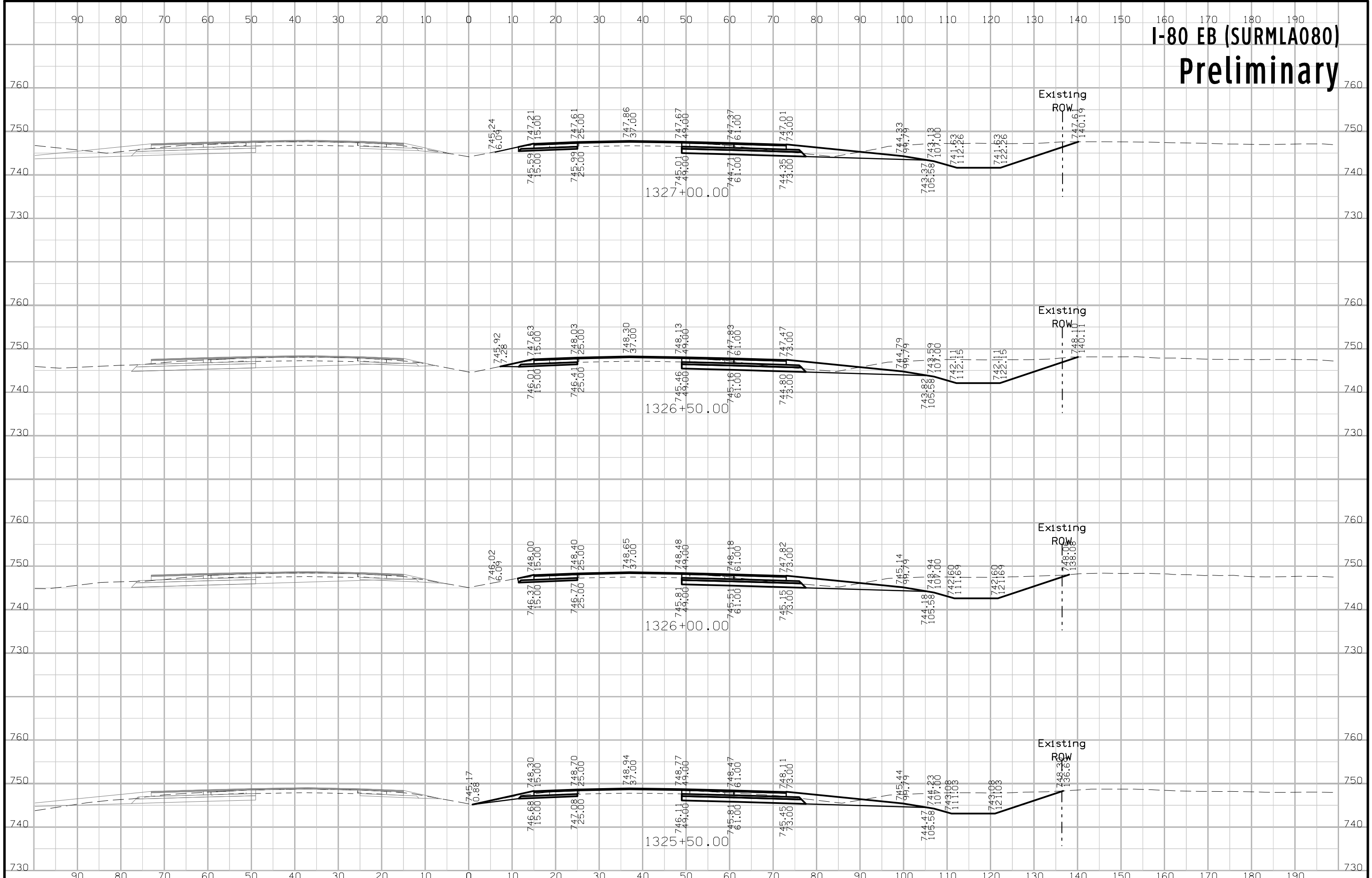

# I-80 EB (SURMLA080) Preliminary

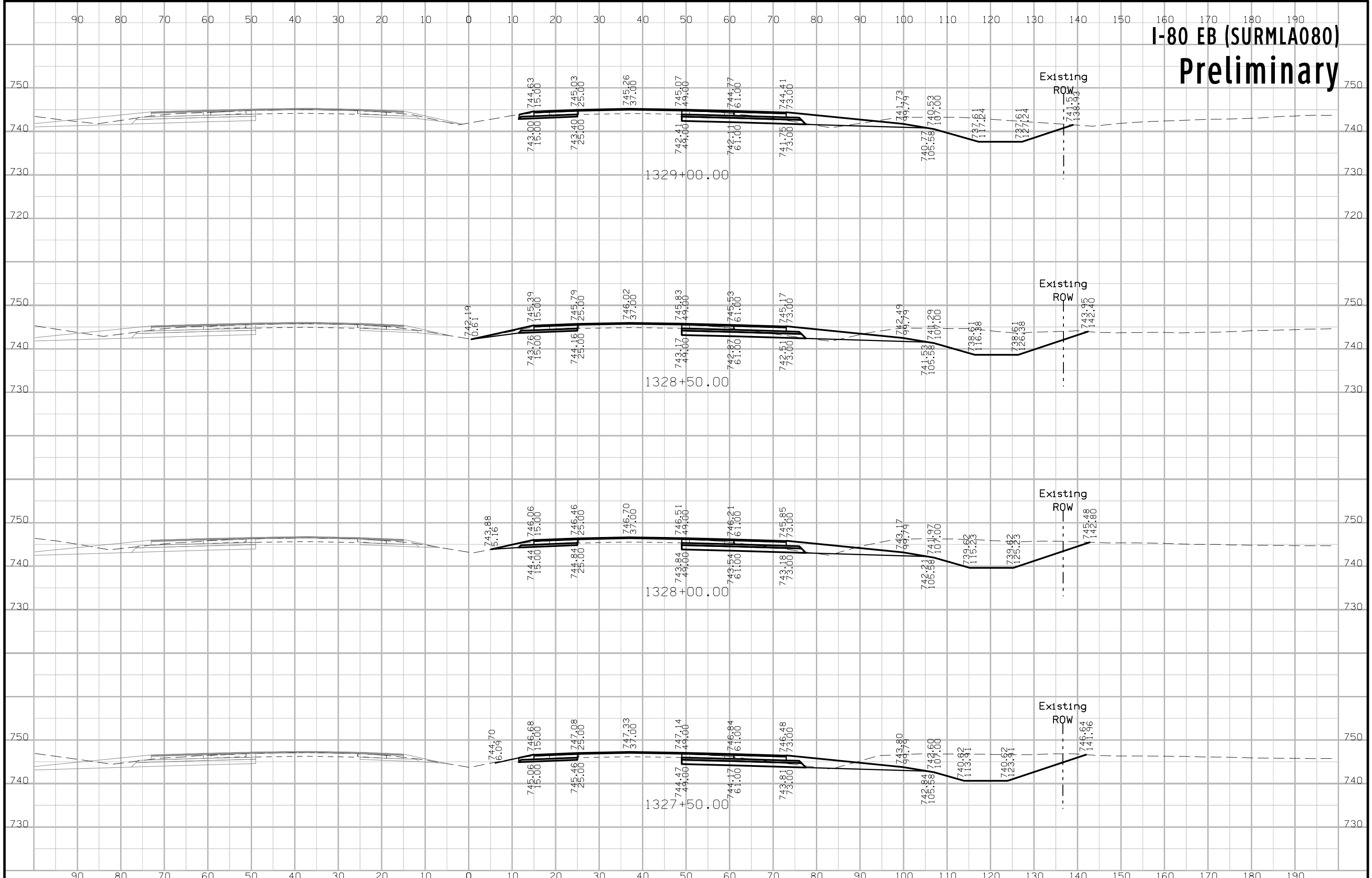

# I-80 EB (SURMLA080) Preliminary

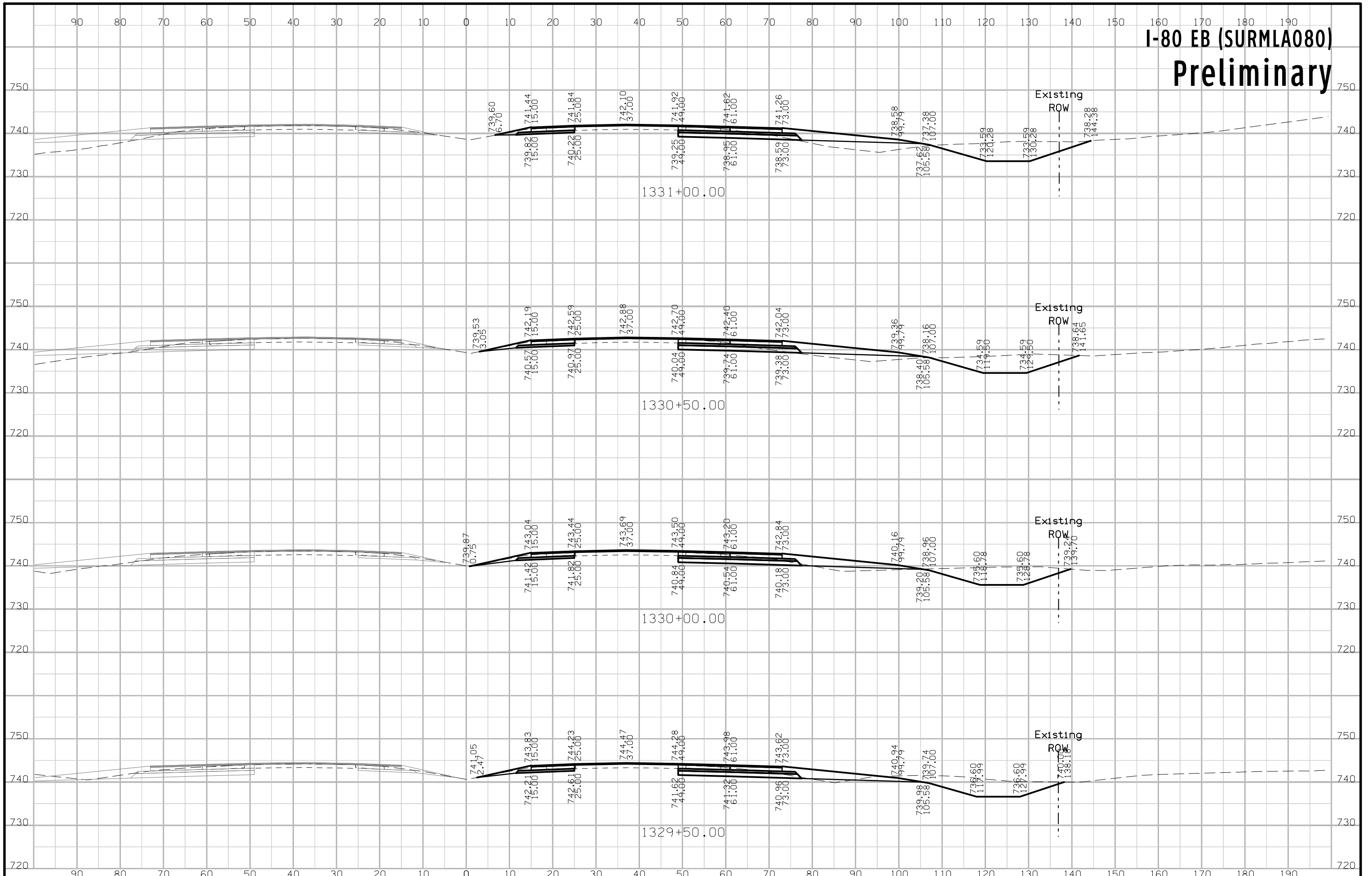



# I-80 EB (SURMLA080) Preliminary

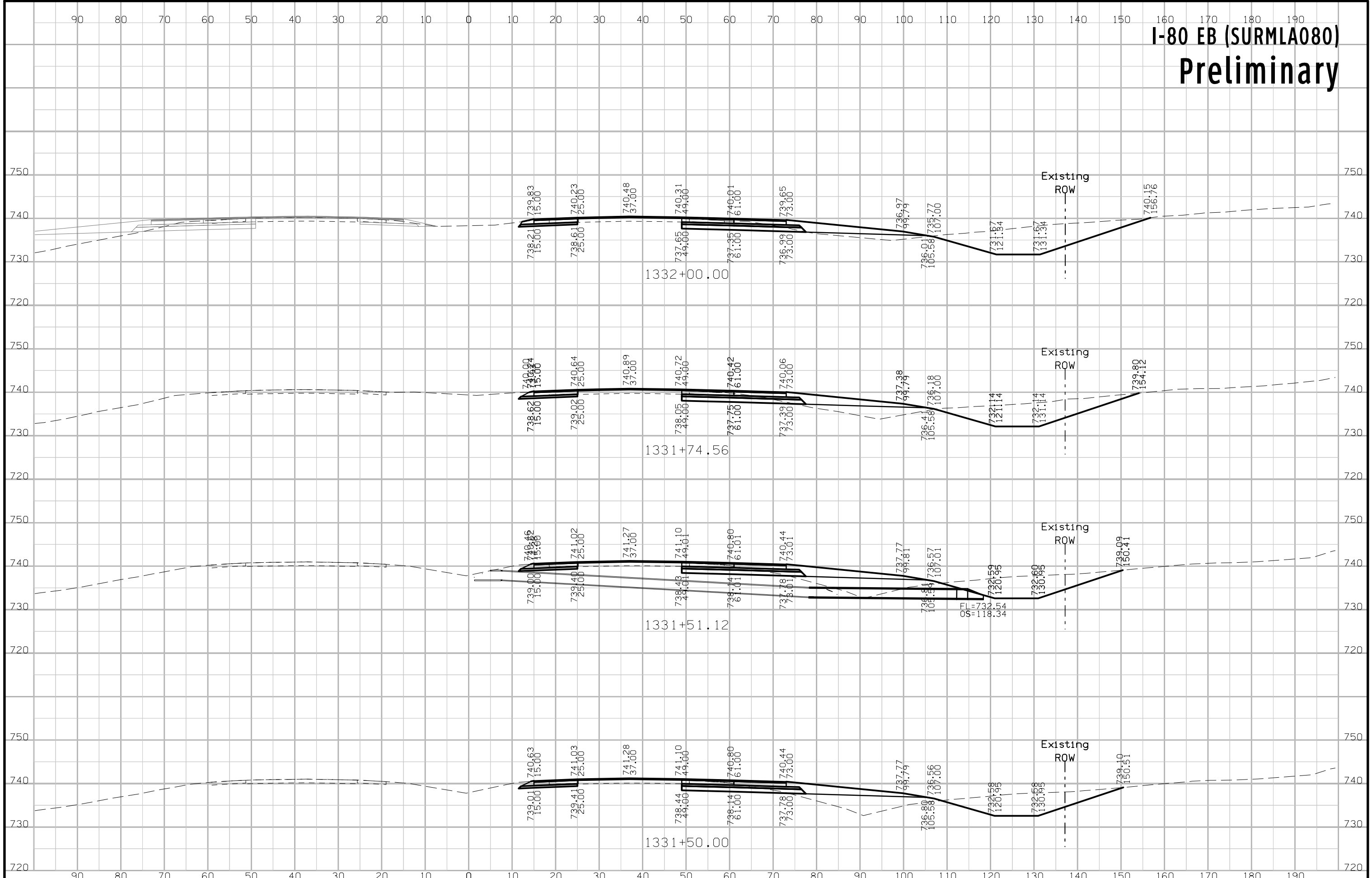

# I-80 EB (SURMLA080) Preliminary

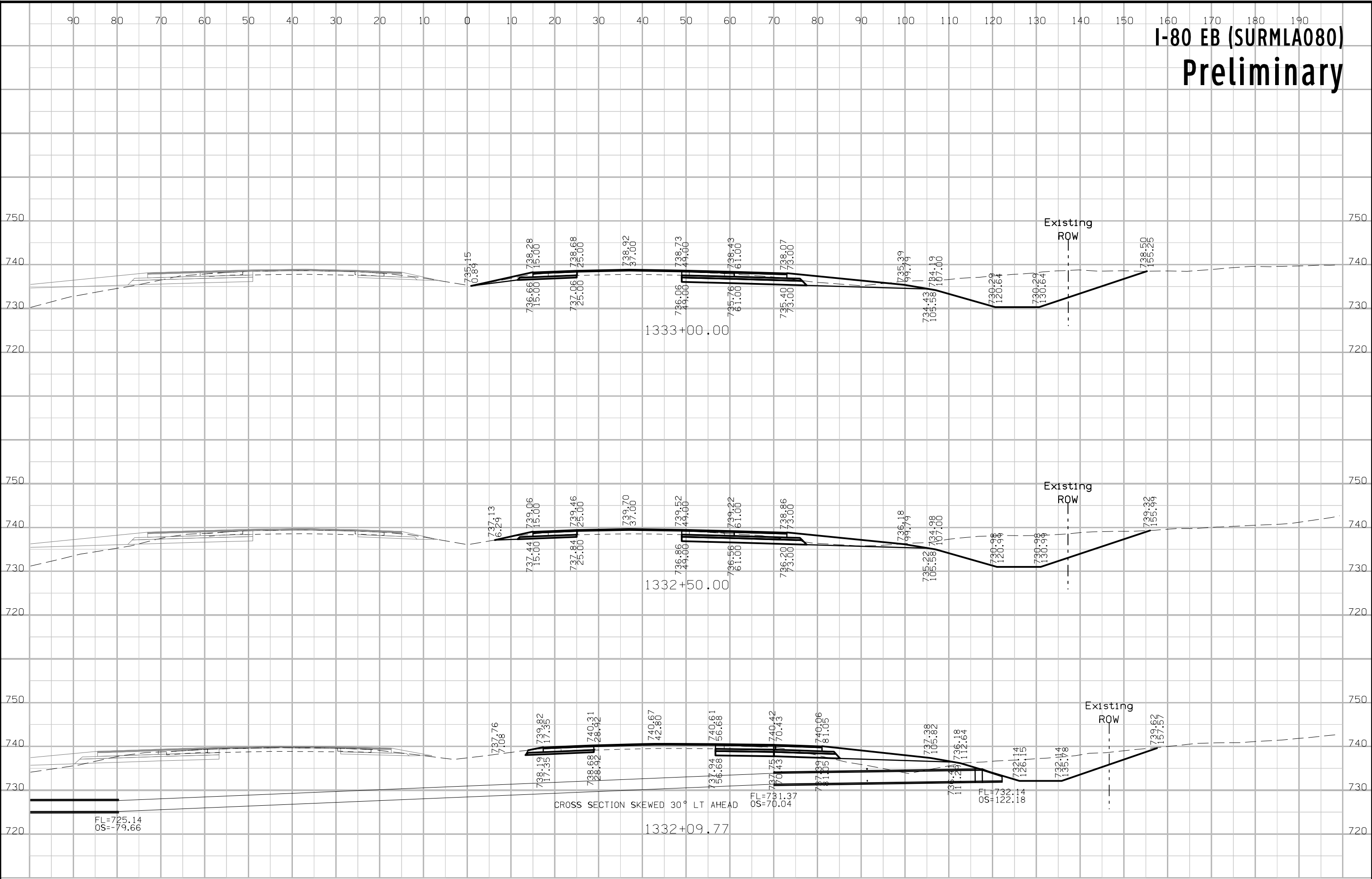

# I-80 EB (SURMLA080) Preliminary

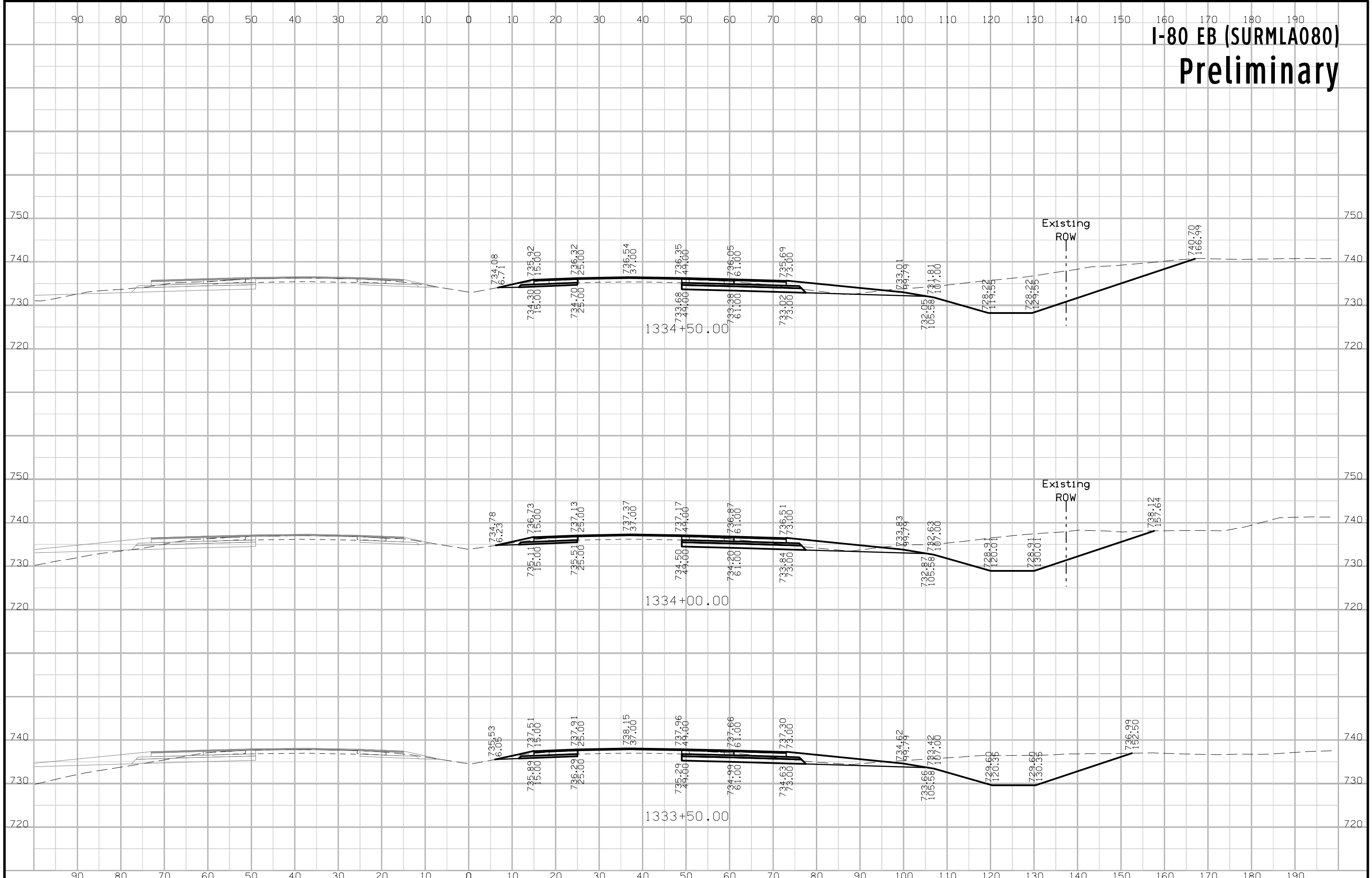

# I-80 EB (SURMLA080) Preliminary

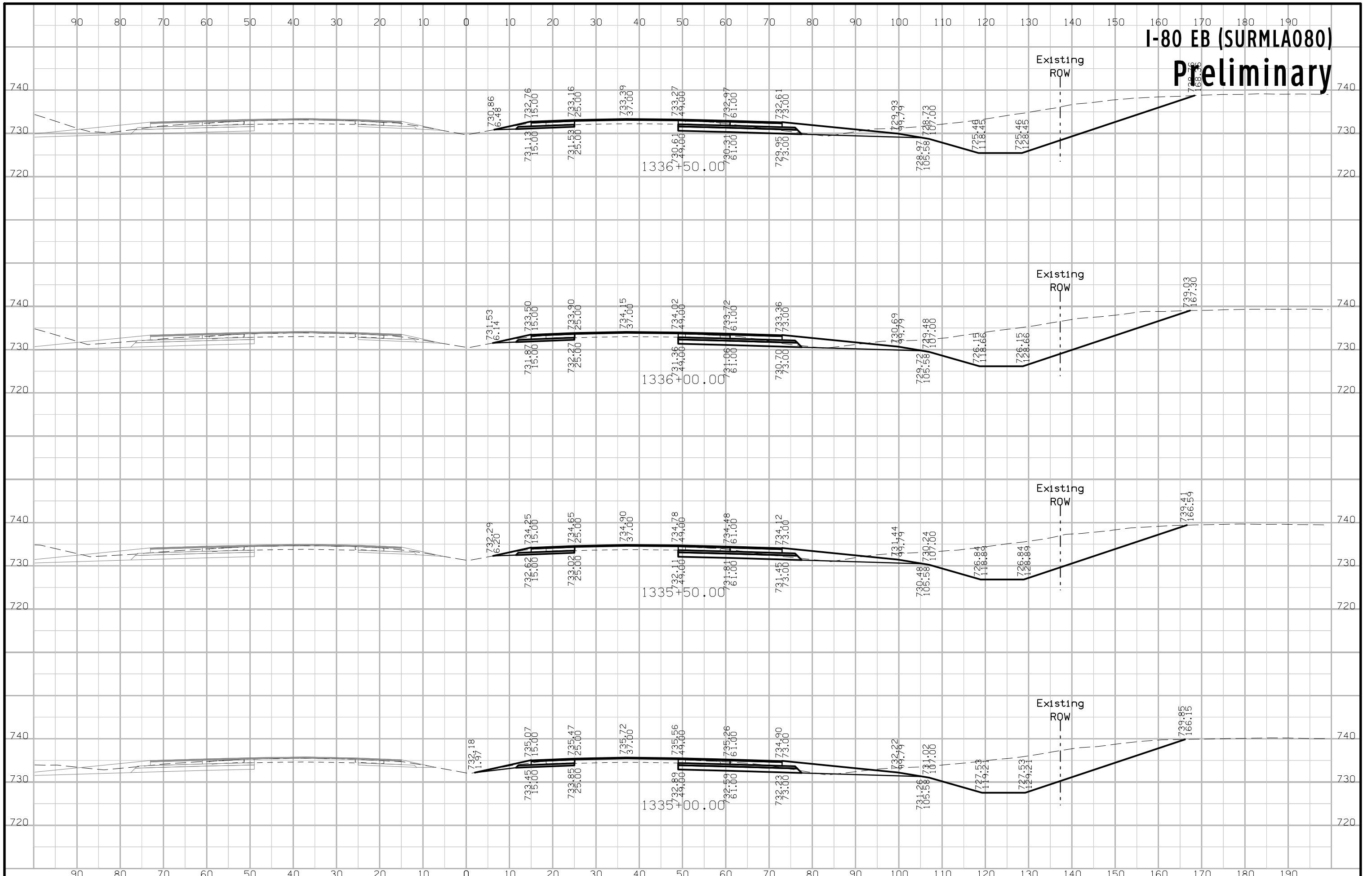

# I-80 EB (SURMLA080) Preliminary

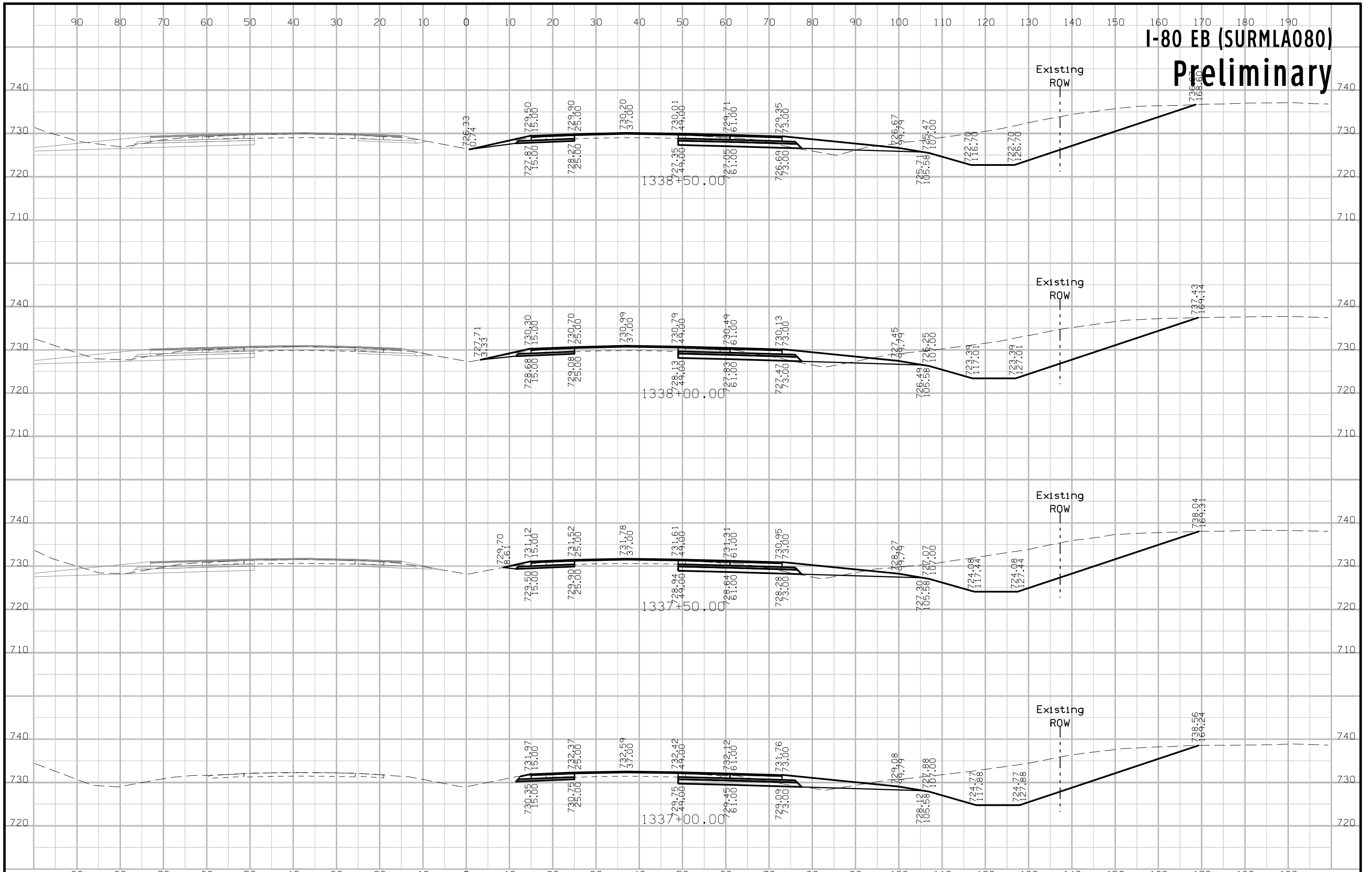

# I-80 EB (SURMLA080) Preliminary

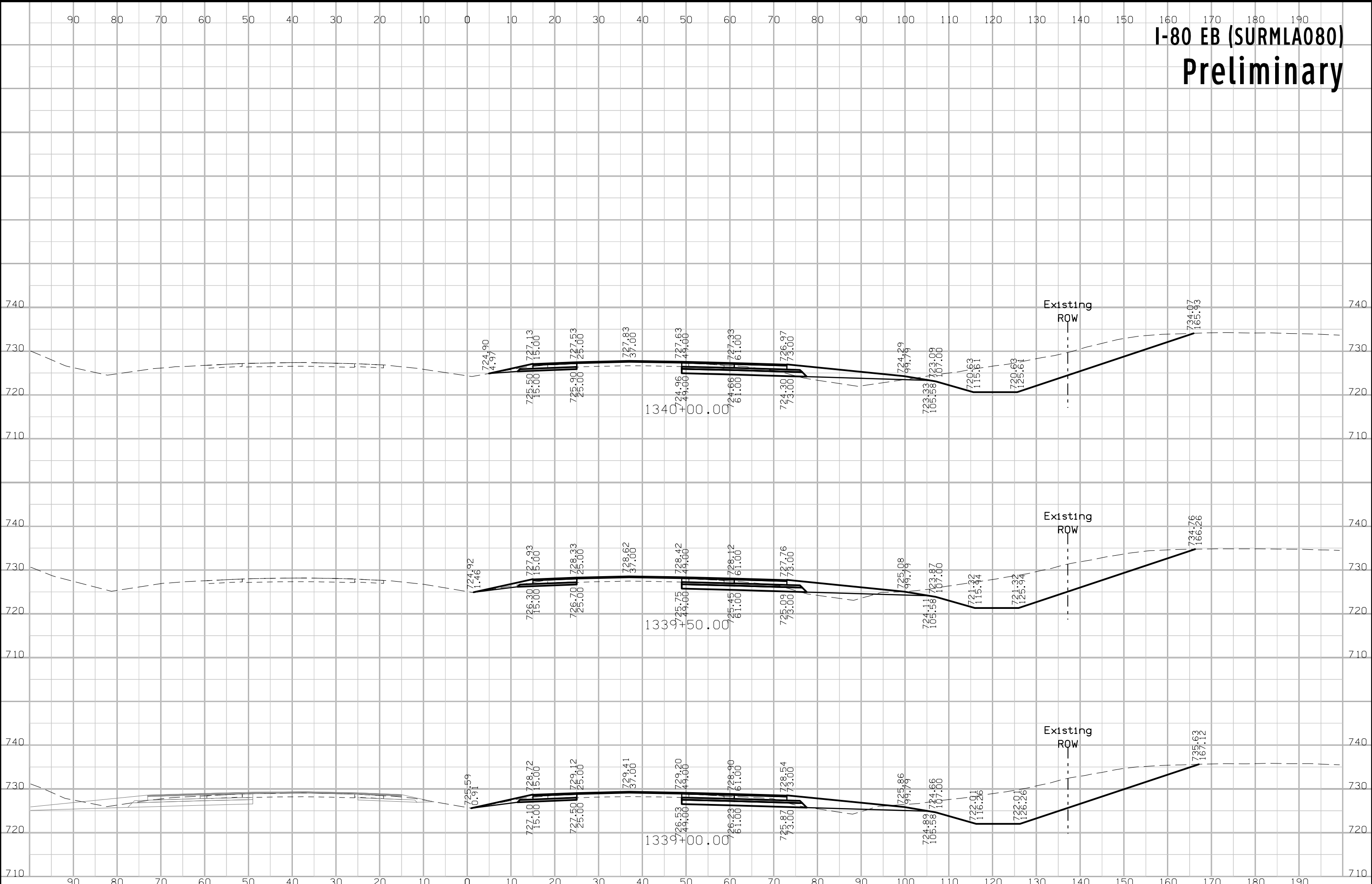

# I-80 EB (SURMLA080) Preliminary

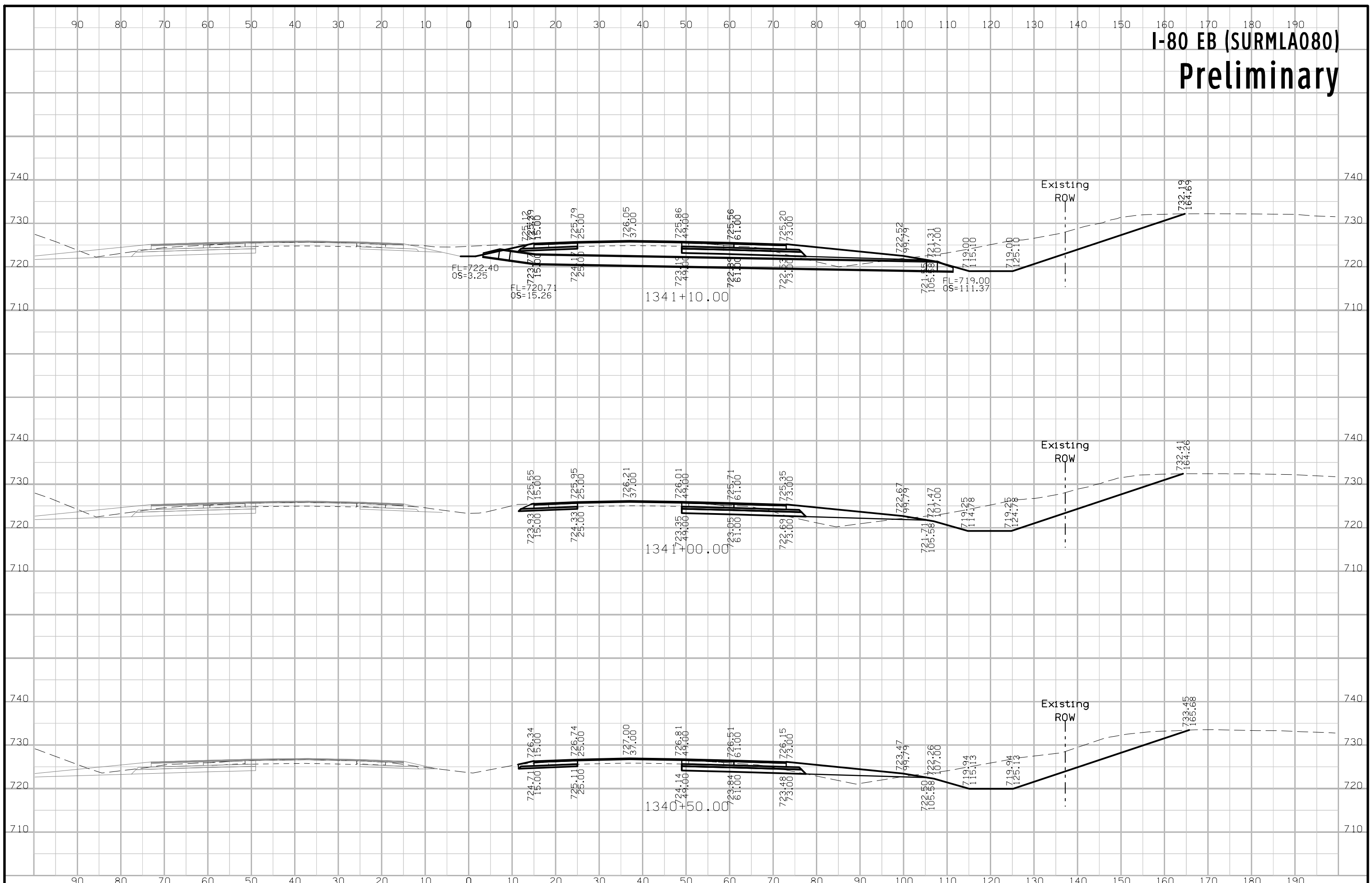

# I-80 EB (SURMLA080) Preliminary

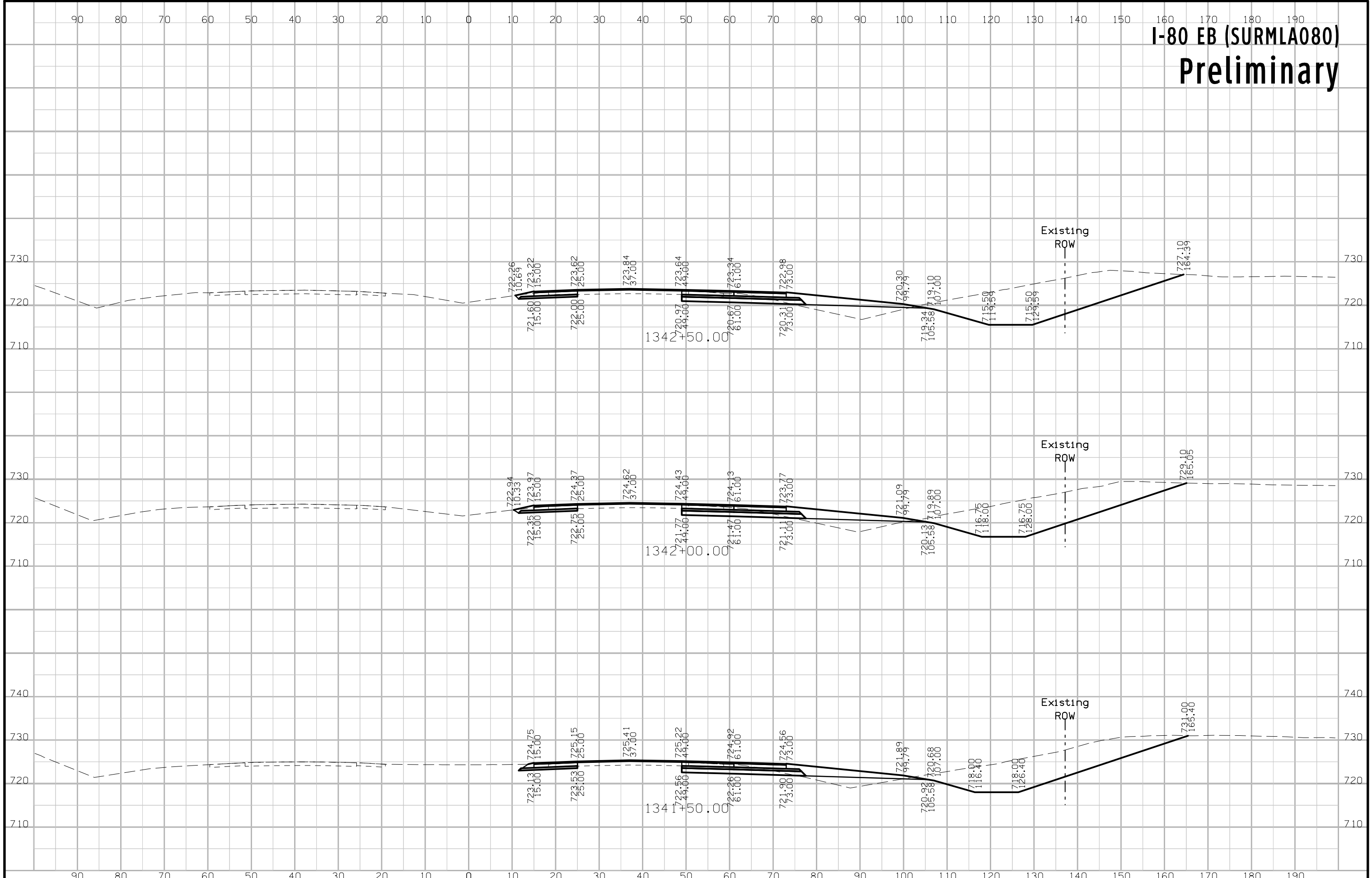



# I-80 EB (SURMLA080) Preliminary

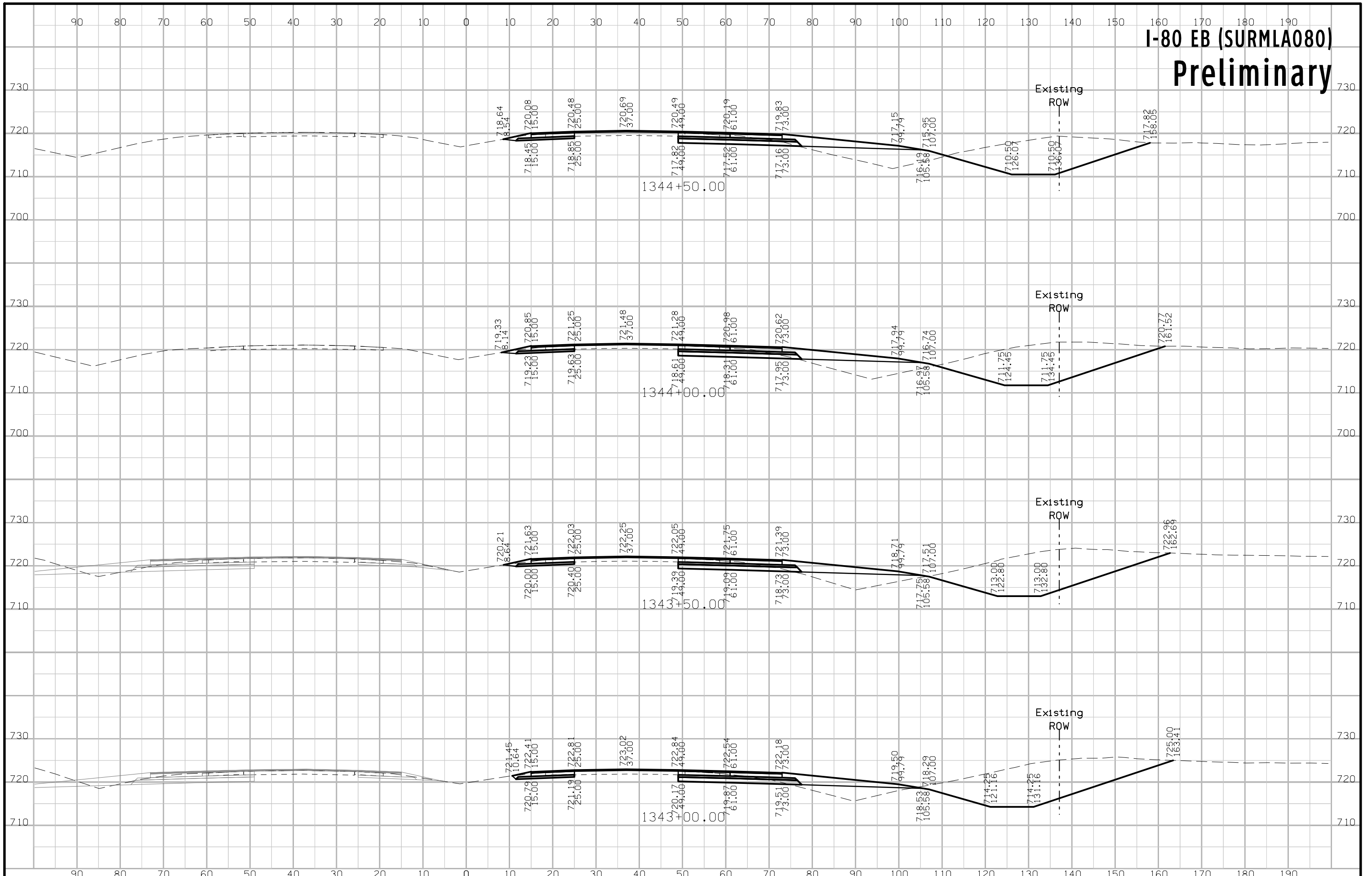

# I-80 EB (SURMLA080) Preliminary

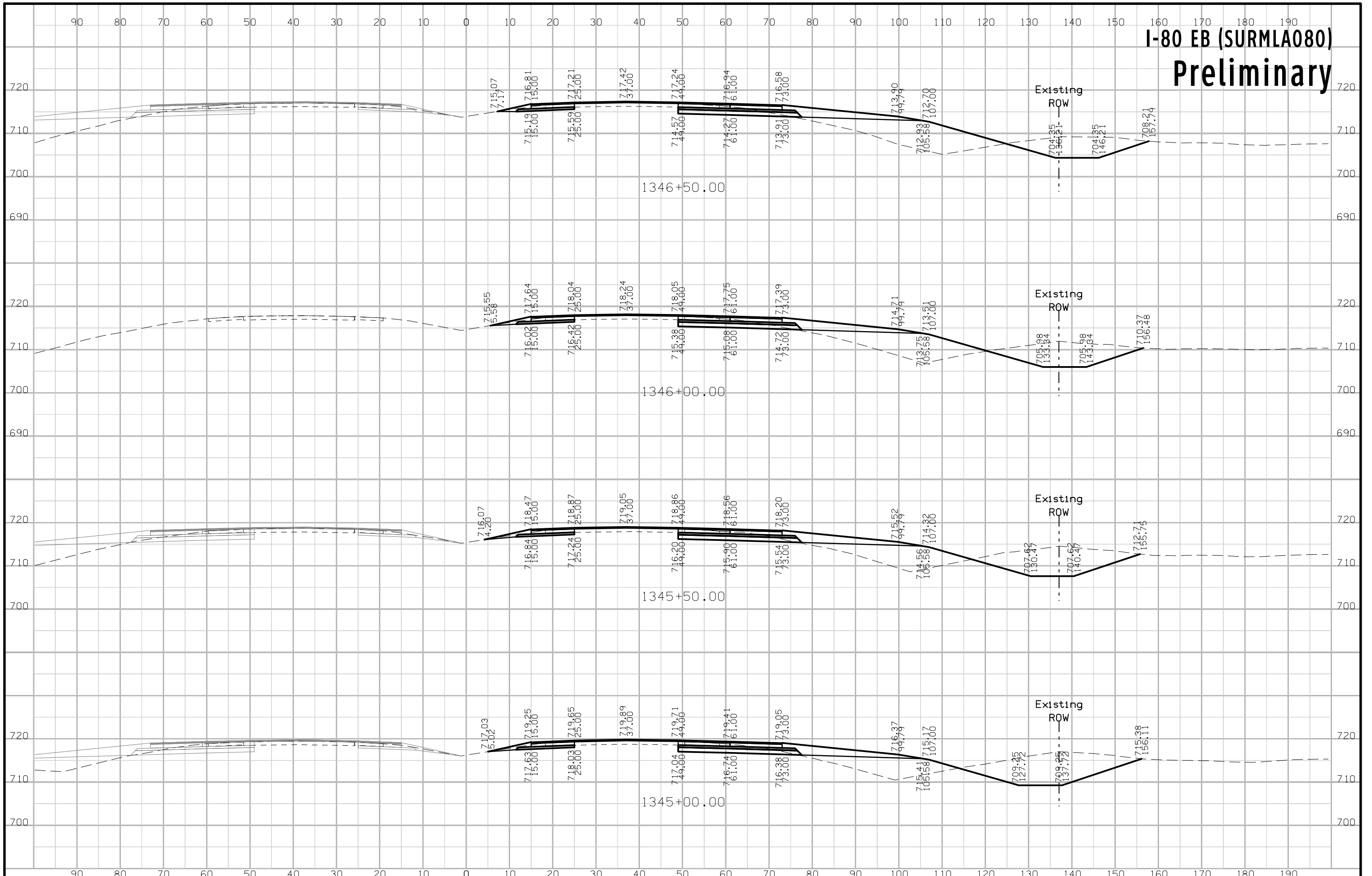

# I-80 EB (SURMLA080) Preliminary

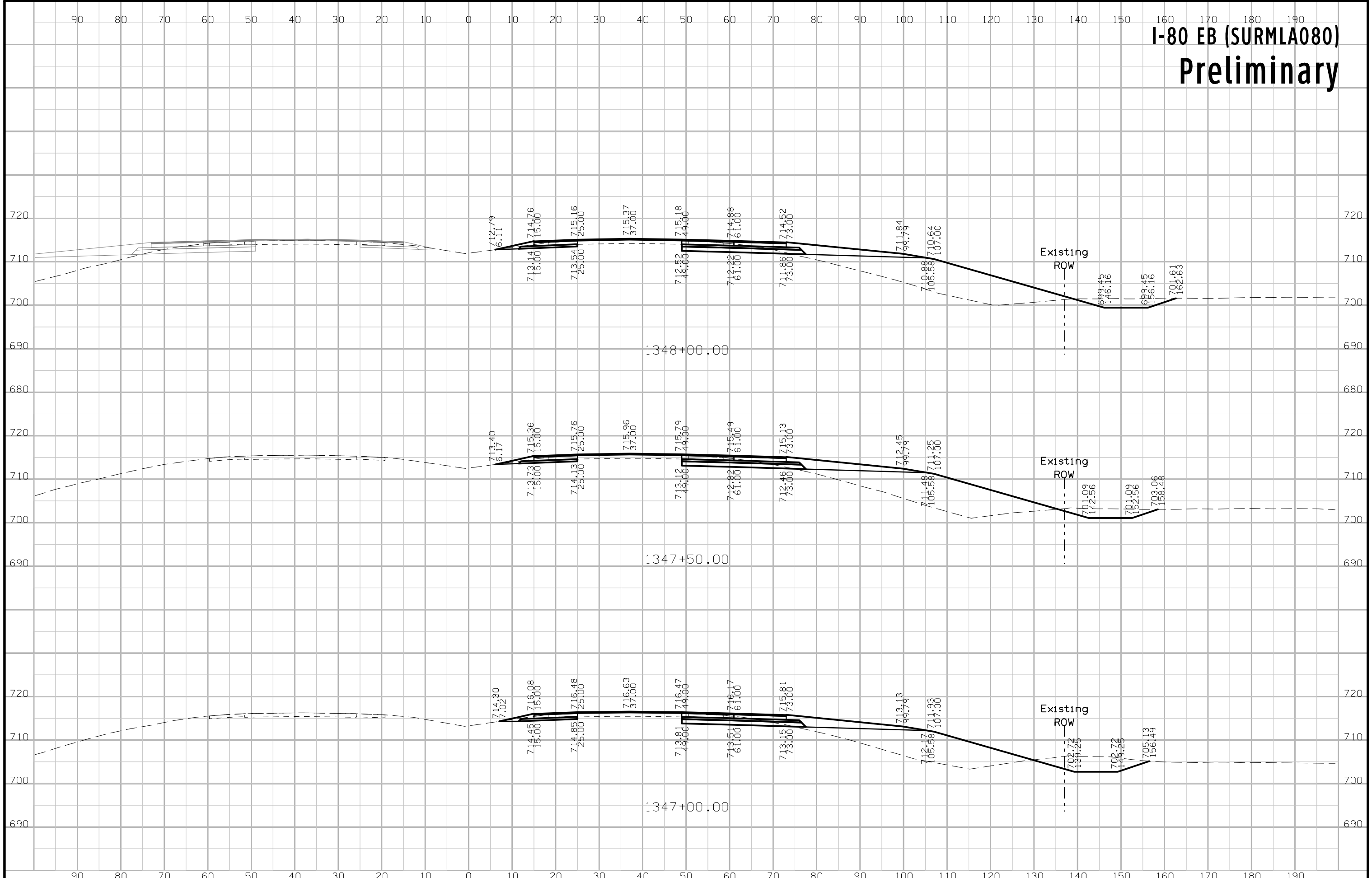

# I-80 EB (SURMLA080) Preliminary

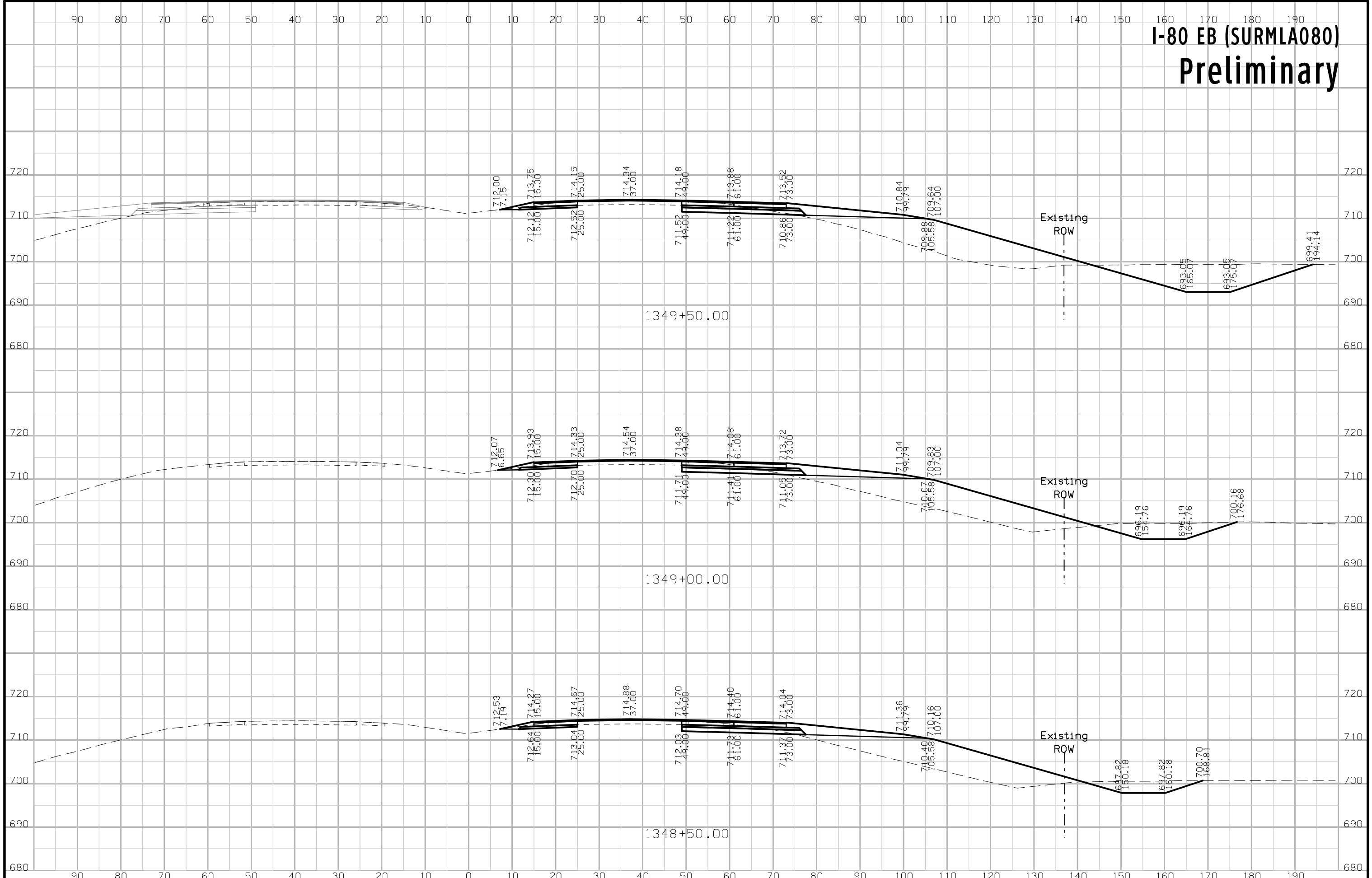

# I-80 EB (SURMLA080) Preliminary

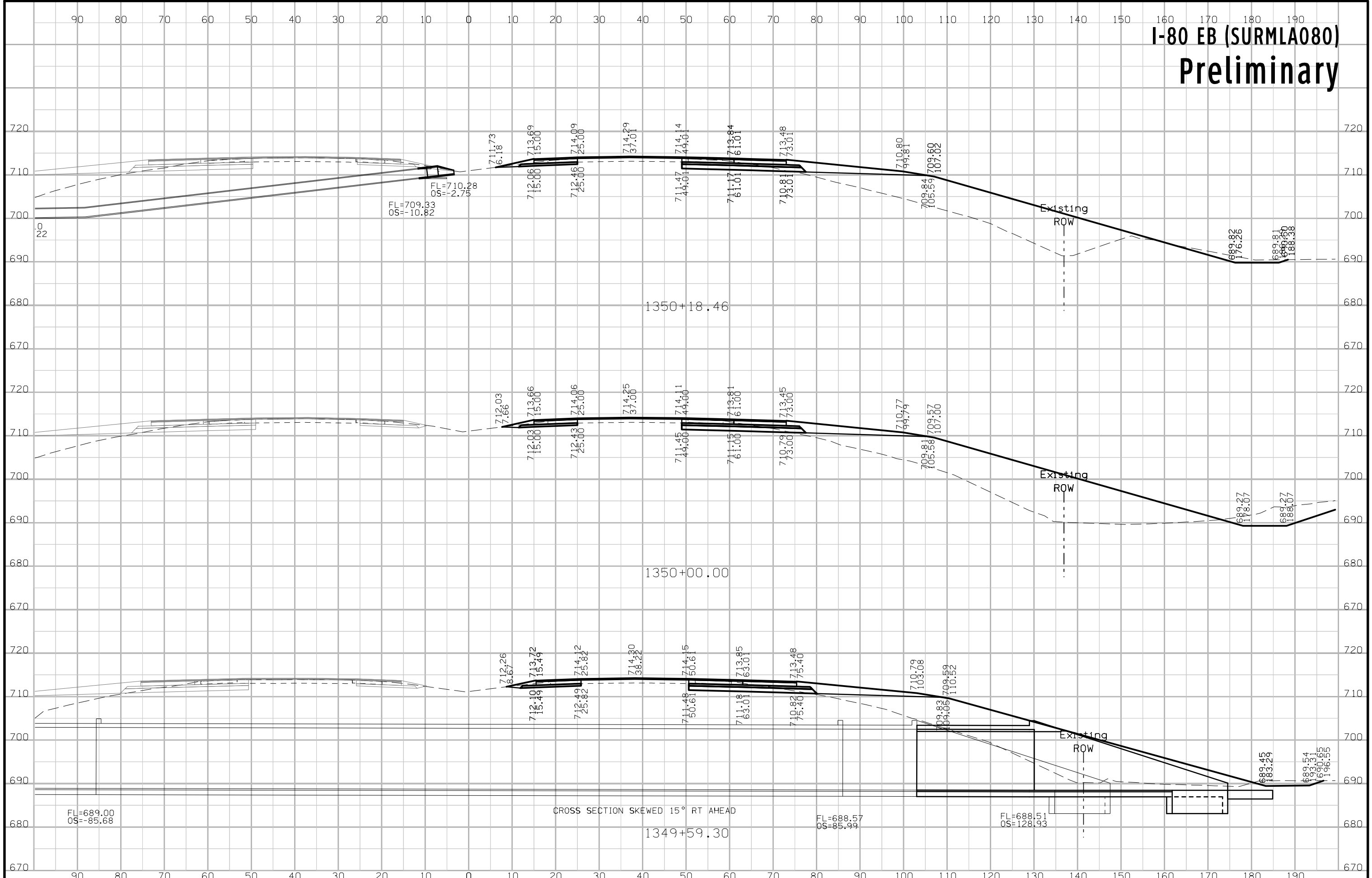

# I-80 EB (SURMLA080) Preliminary

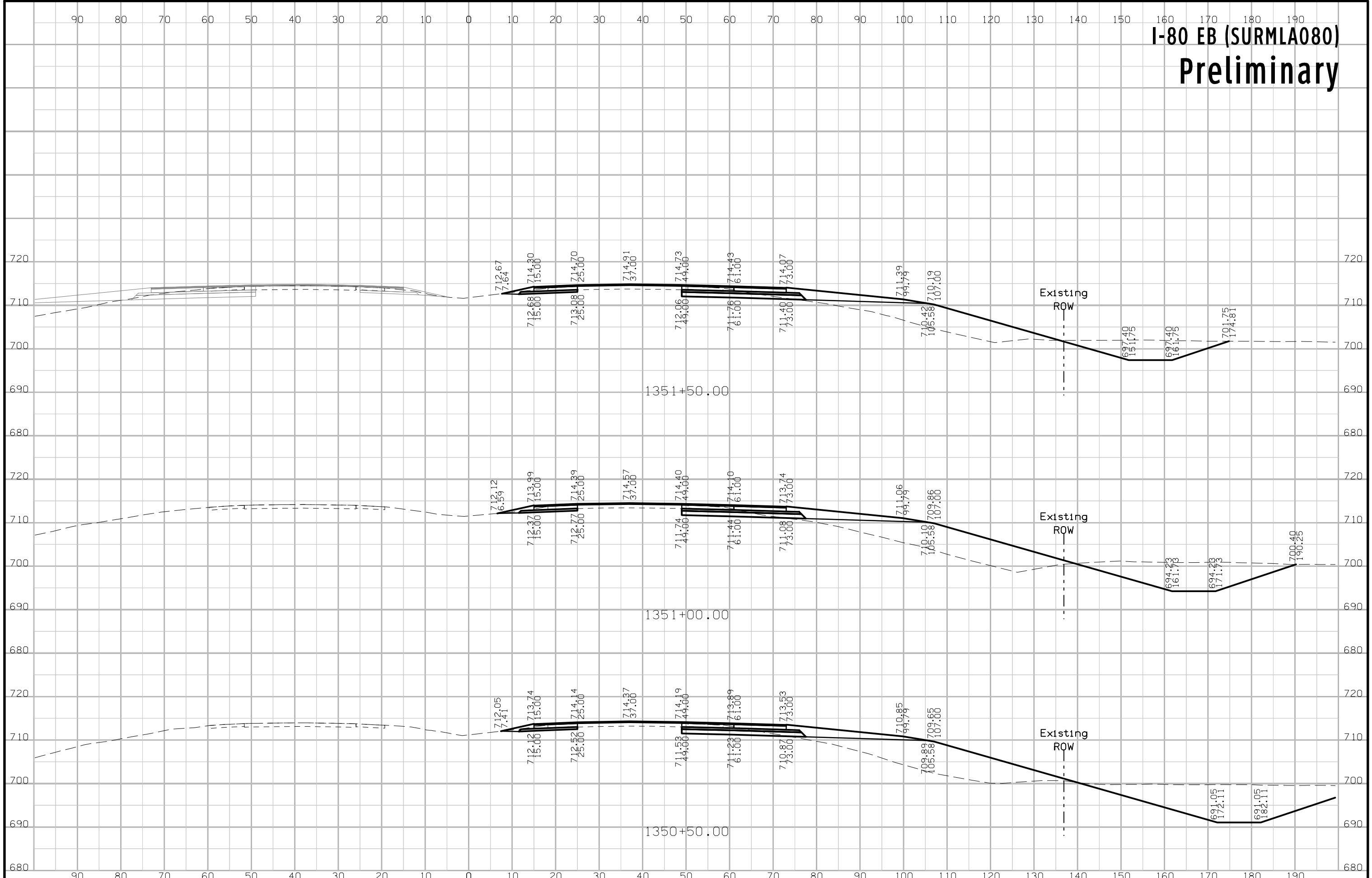

# I-80 EB (SURMLA080) Preliminary

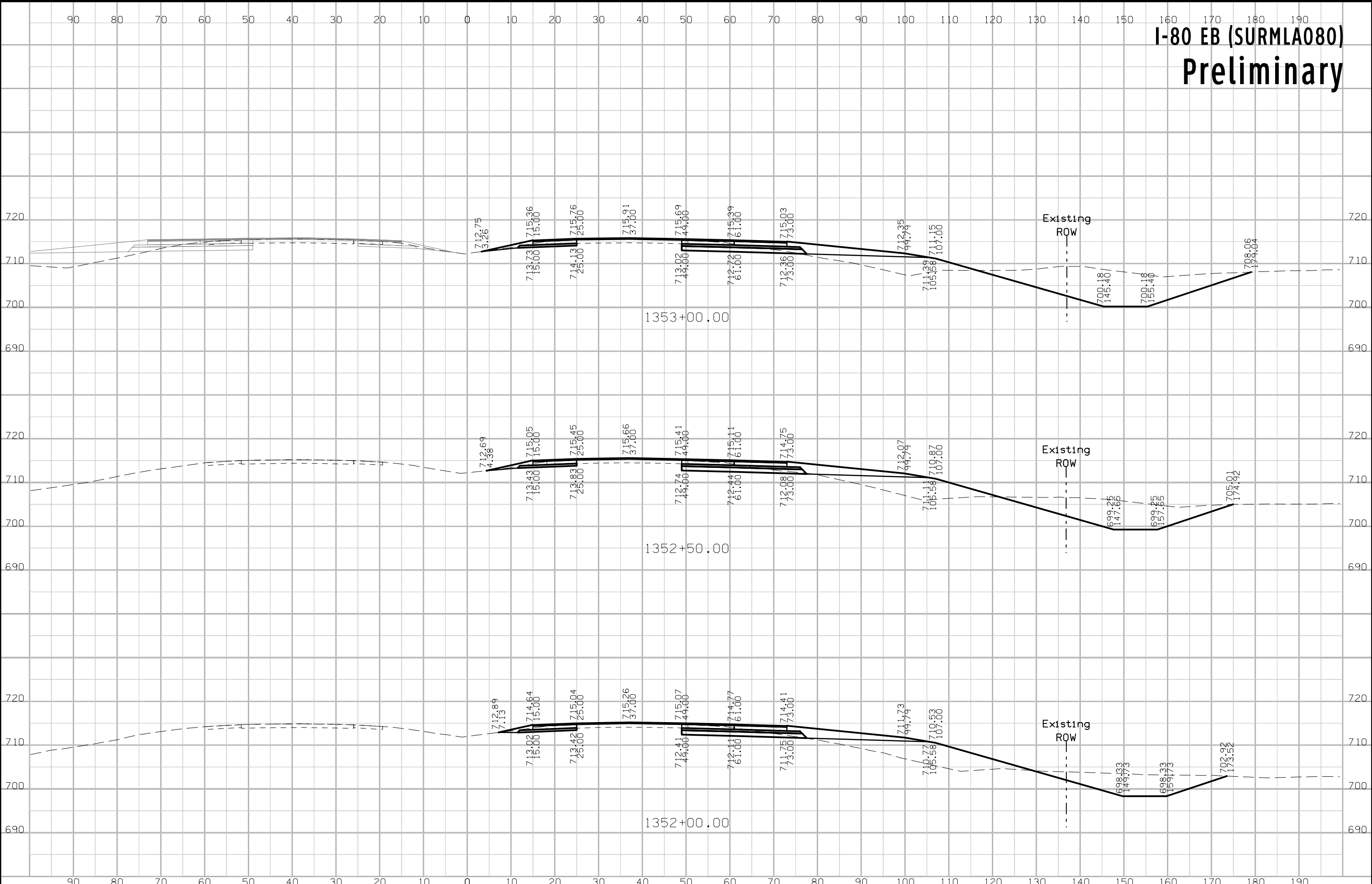

# I-80 EB (SURMLA080) Preliminary

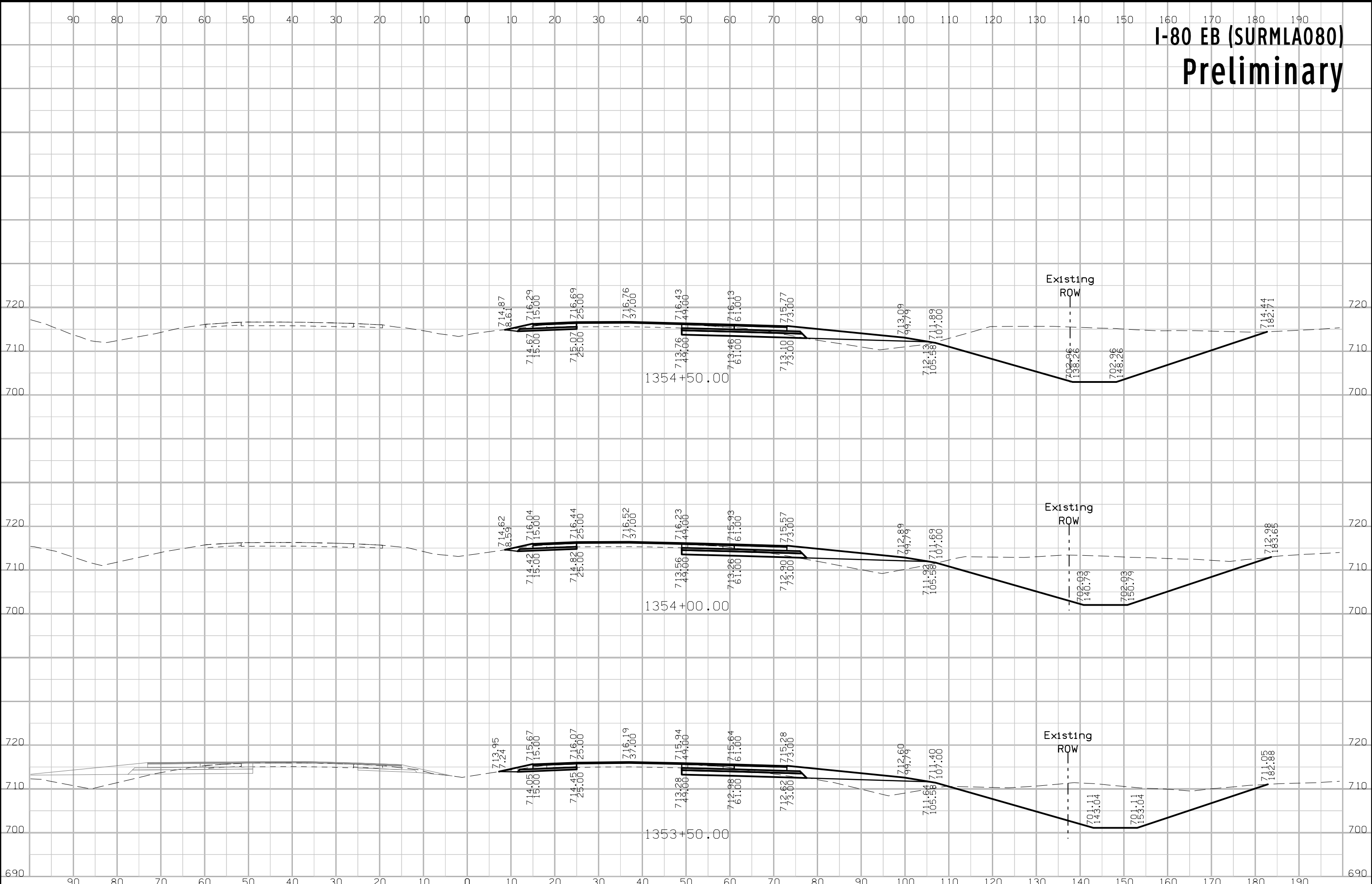



# I-80 EB (SURMLA080) Preliminary

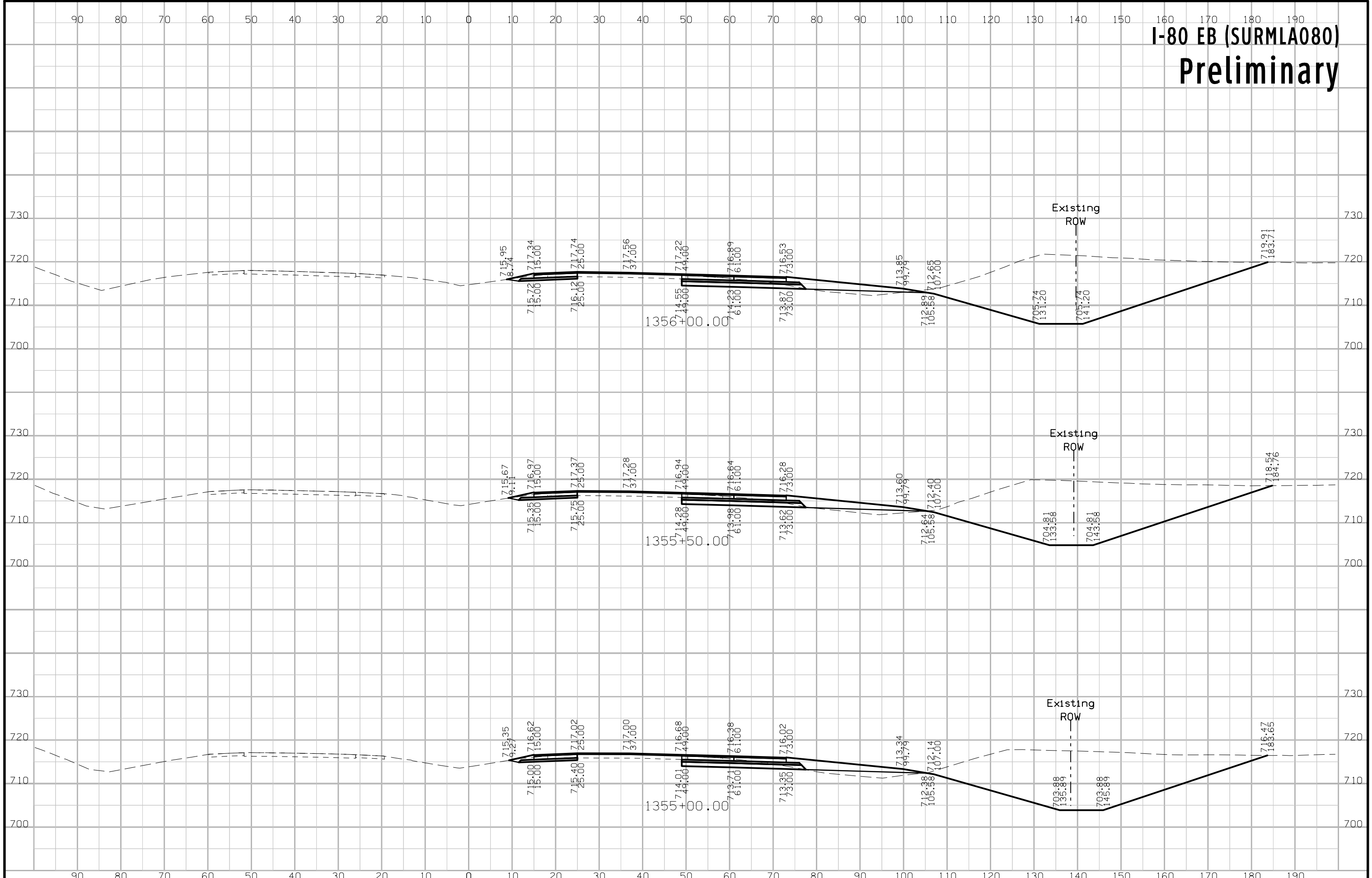

# I-80 EB (SURMLA080) Preliminary

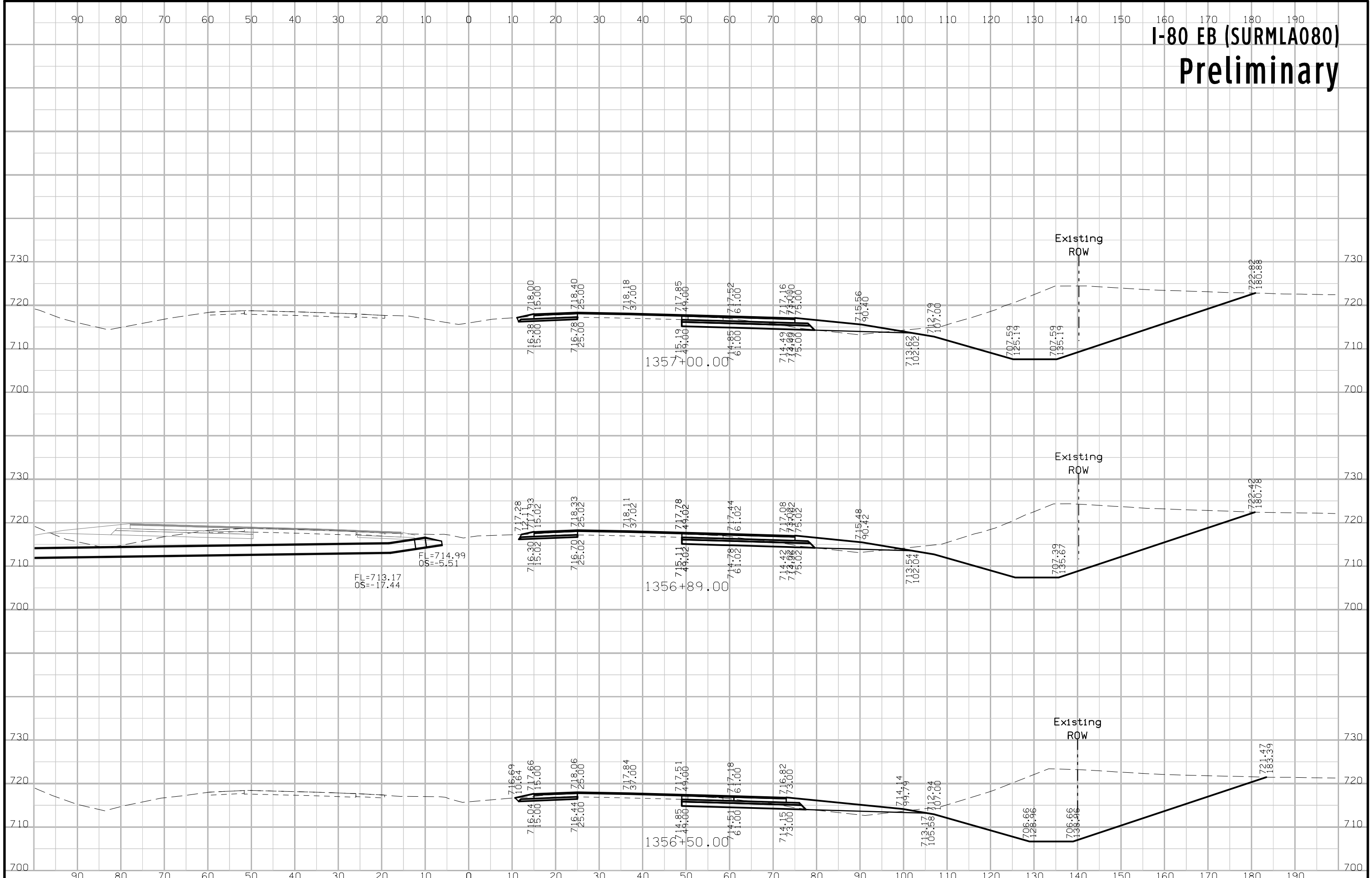

# I-80 EB (SURMLA080) Preliminary

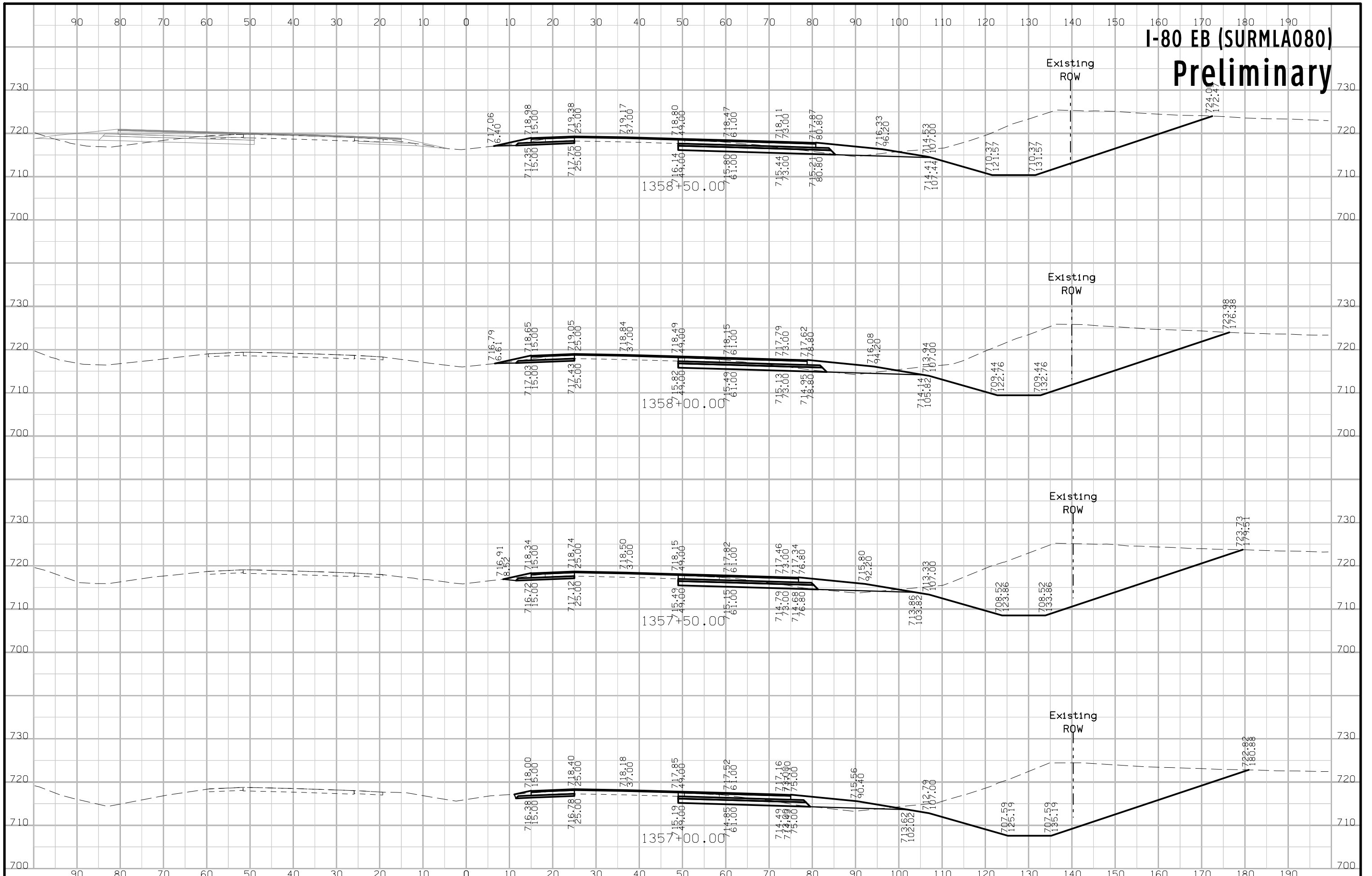

# I-80 EB (SURMLA080) Preliminary

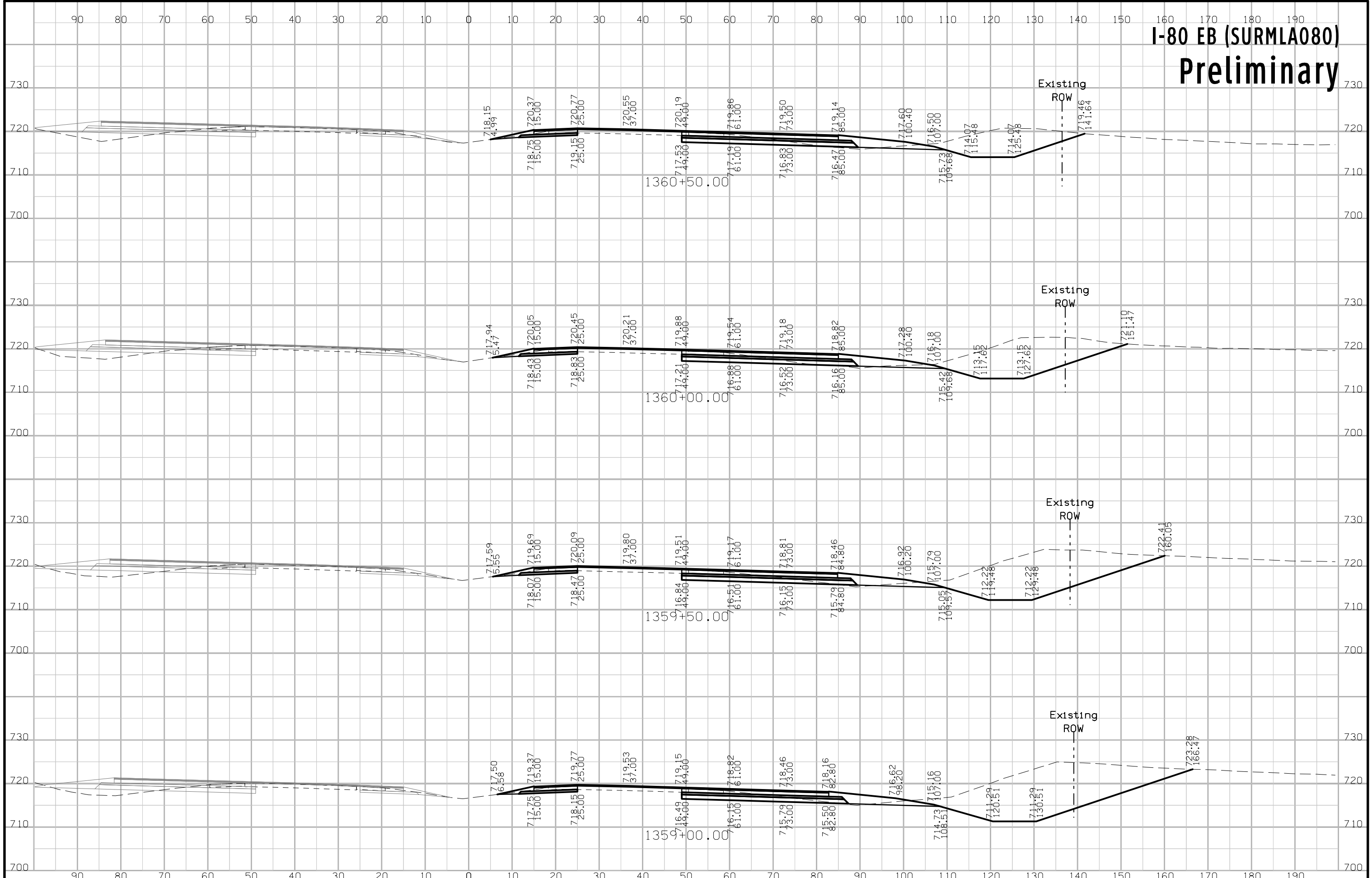

# I-80 EB (SURMLA080) Preliminary

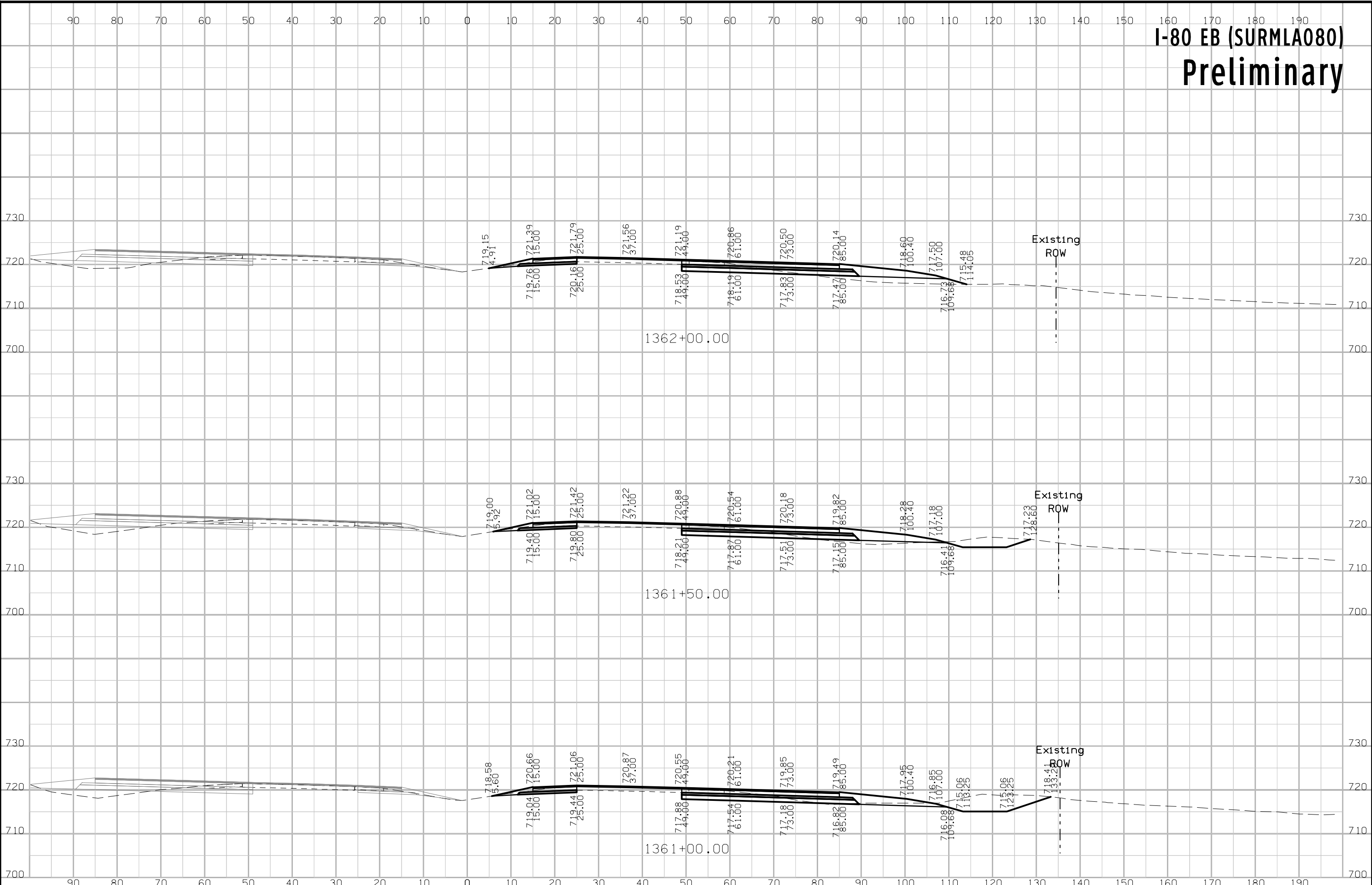

# I-80 EB (SURMLA080) Preliminary

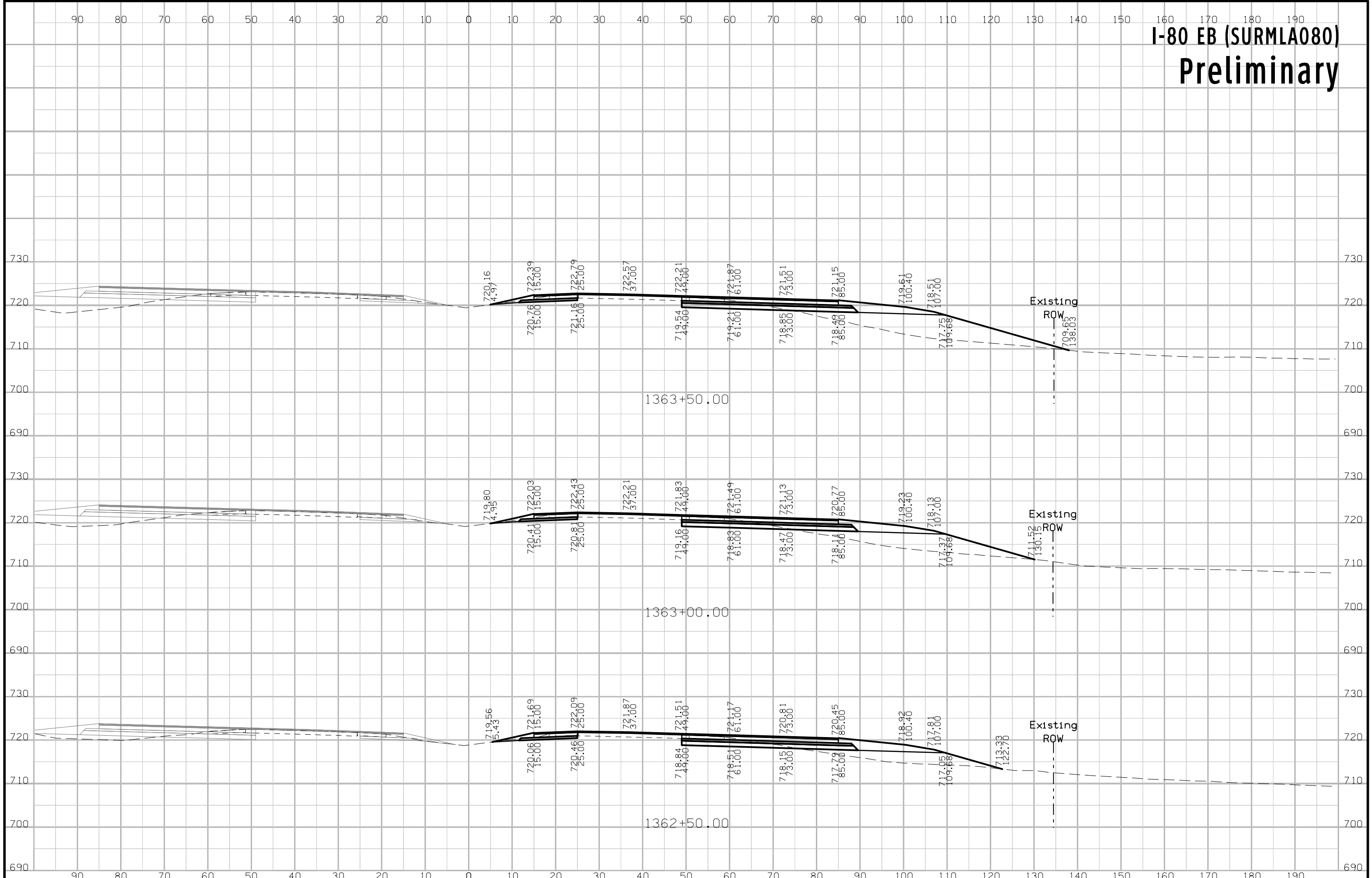

# I-80 EB (SURMLA080) Preliminary

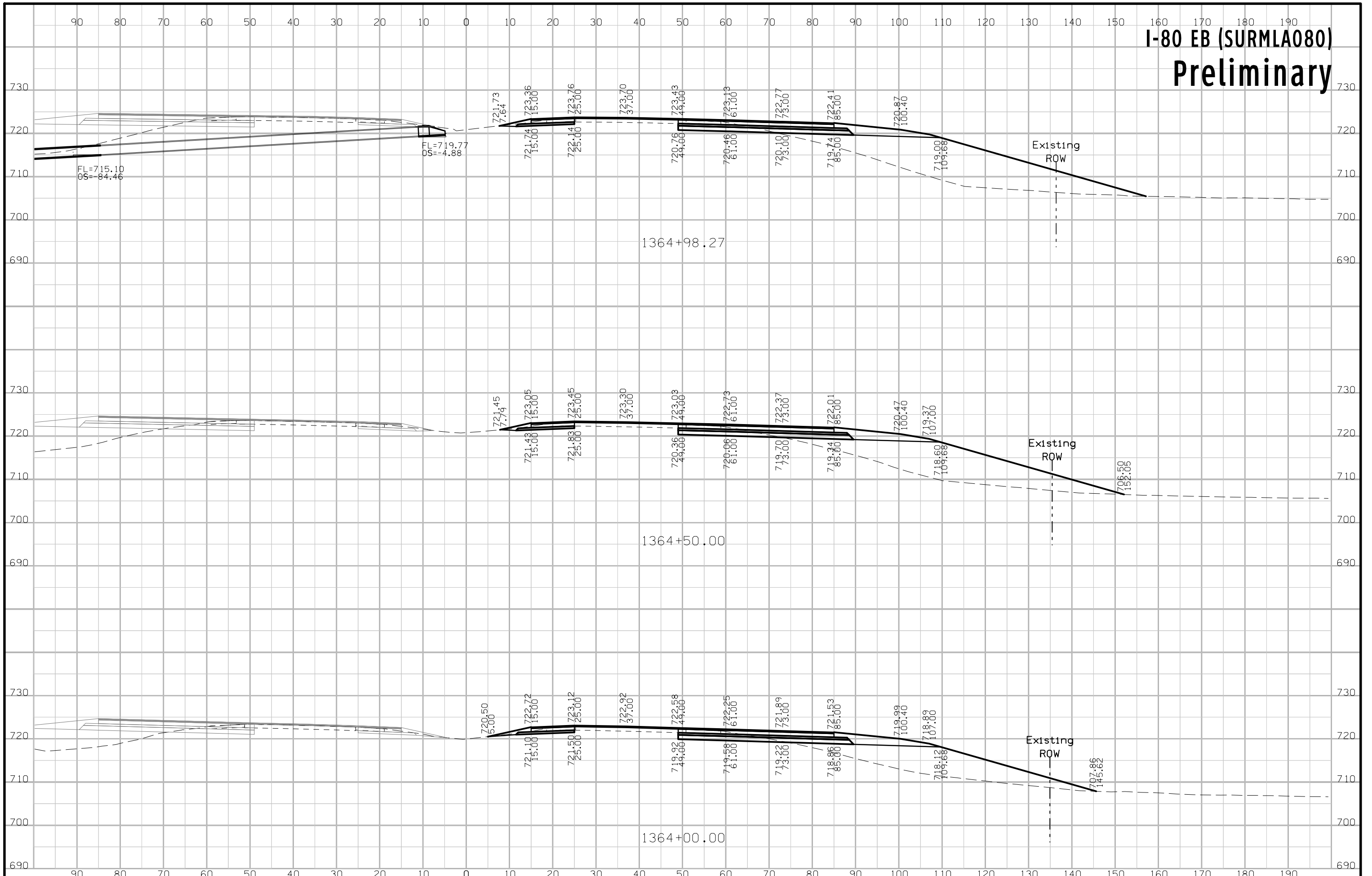

# I-80 EB (SURMLA080) Preliminary

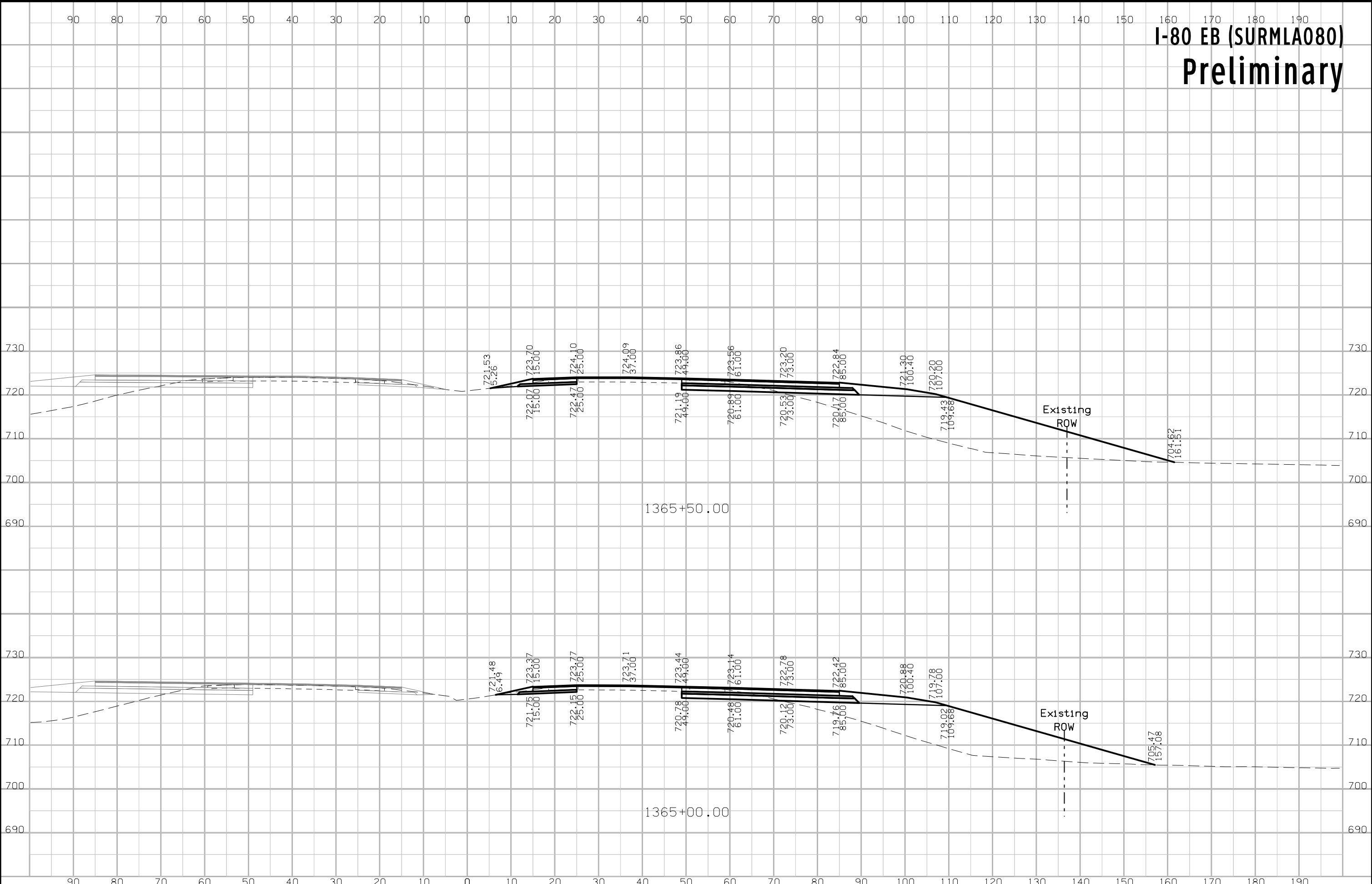



# I-80 EB (SURMLA080) Preliminary

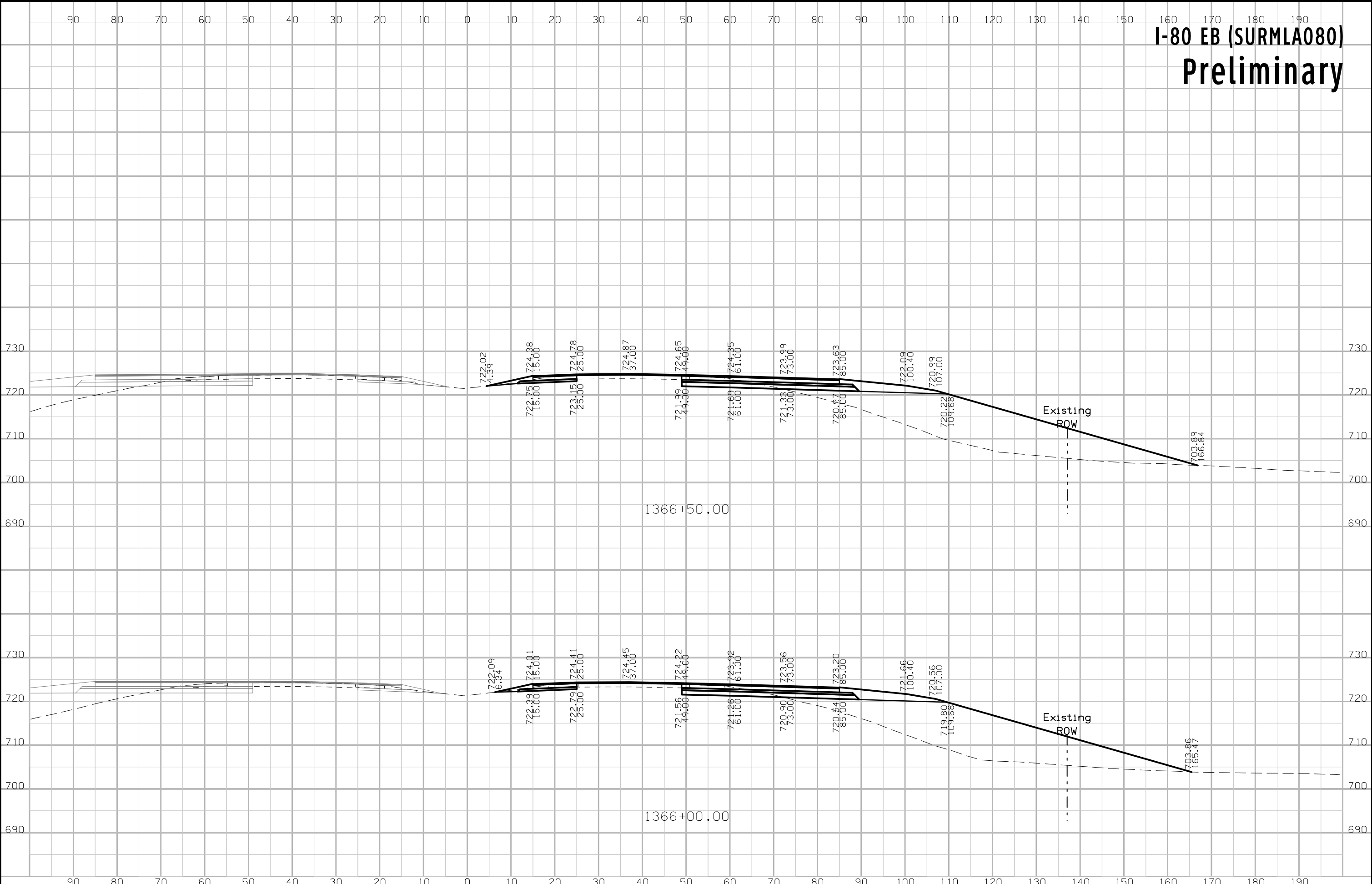

# I-80 EB (SURMLA080) Preliminary

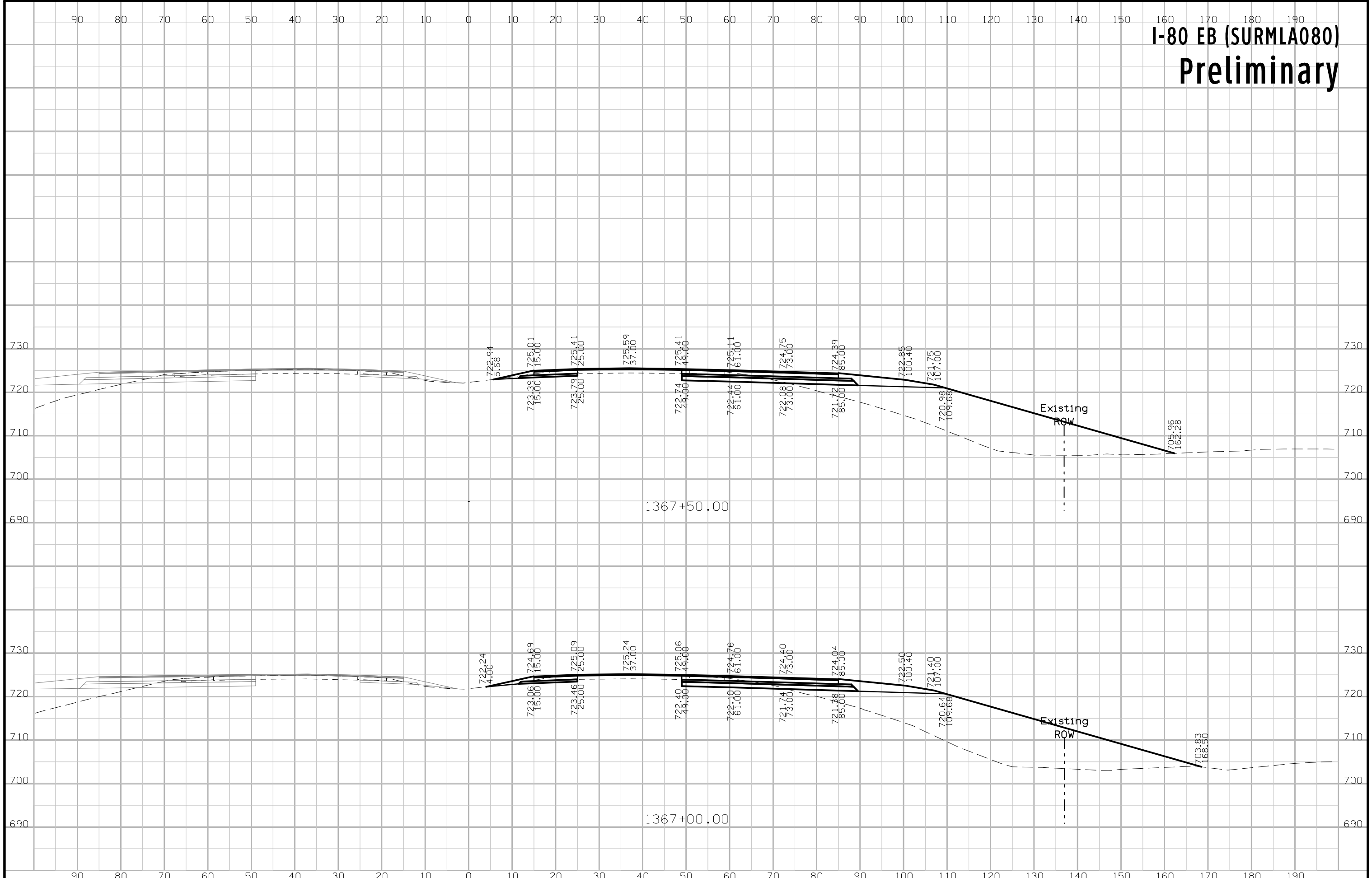

# I-80 EB (SURMLA080) Preliminary

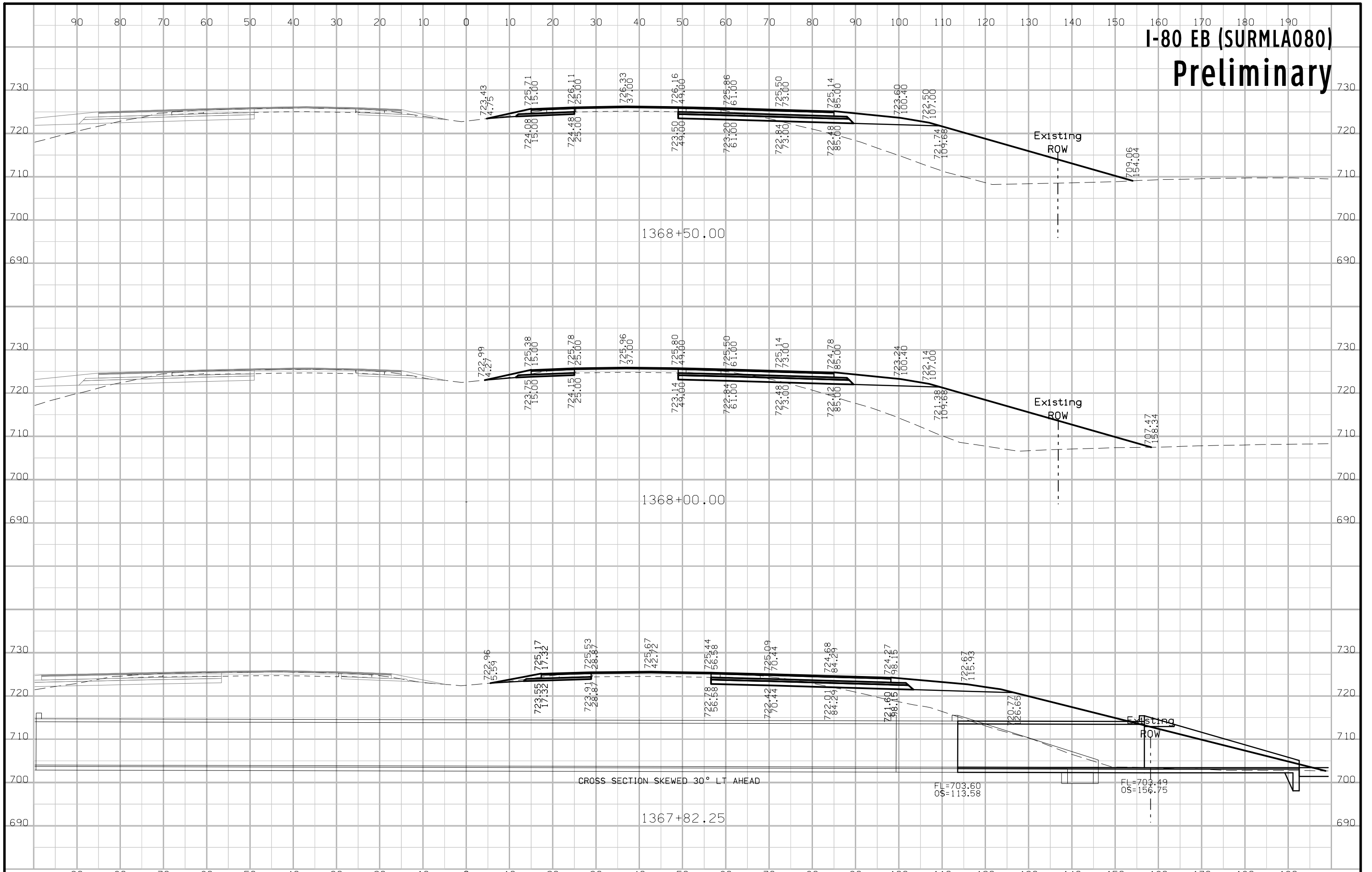

# I-80 EB (SURMLA080) Preliminary

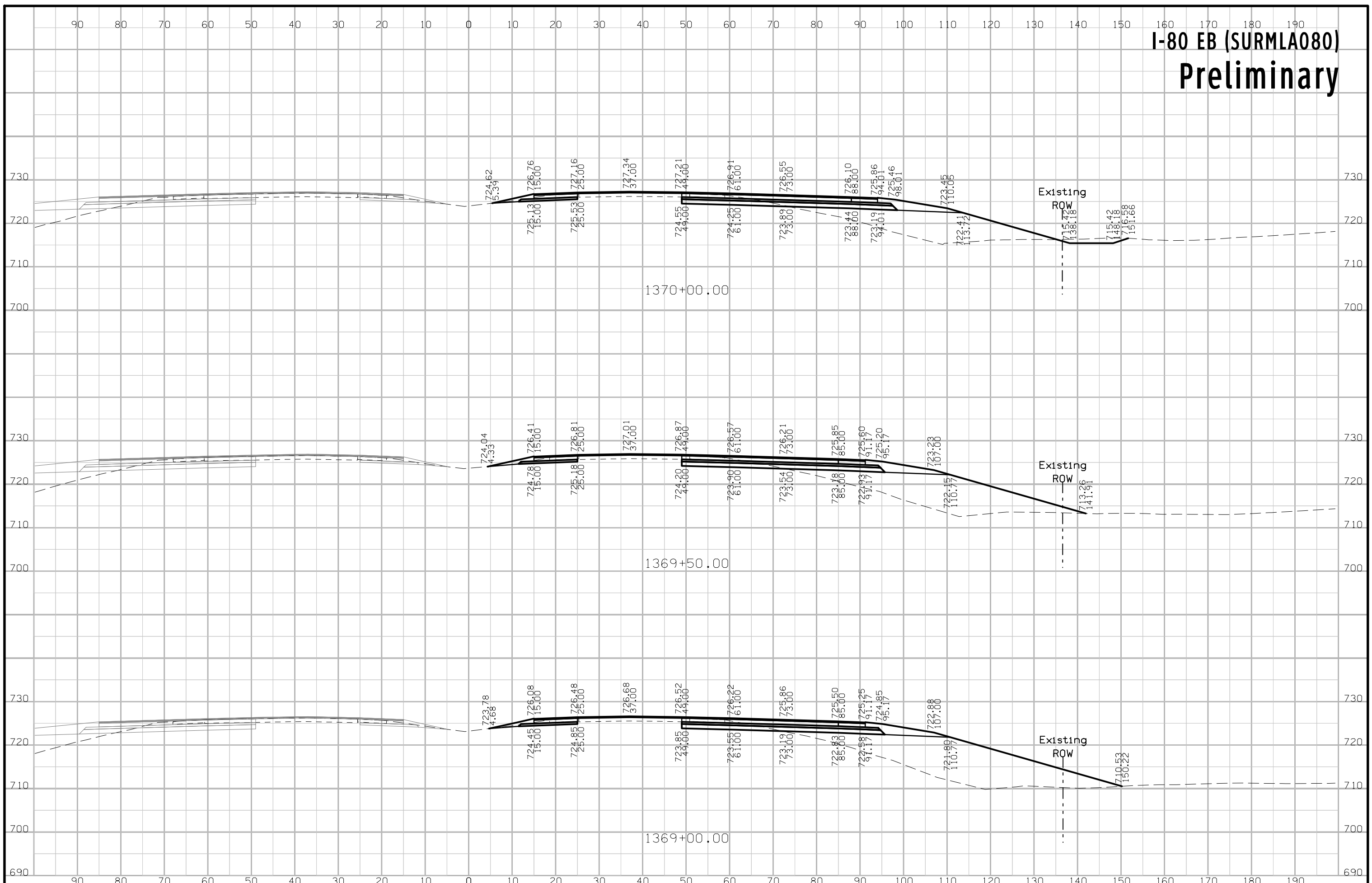

# I-80 EB (SURMLA080) Preliminary

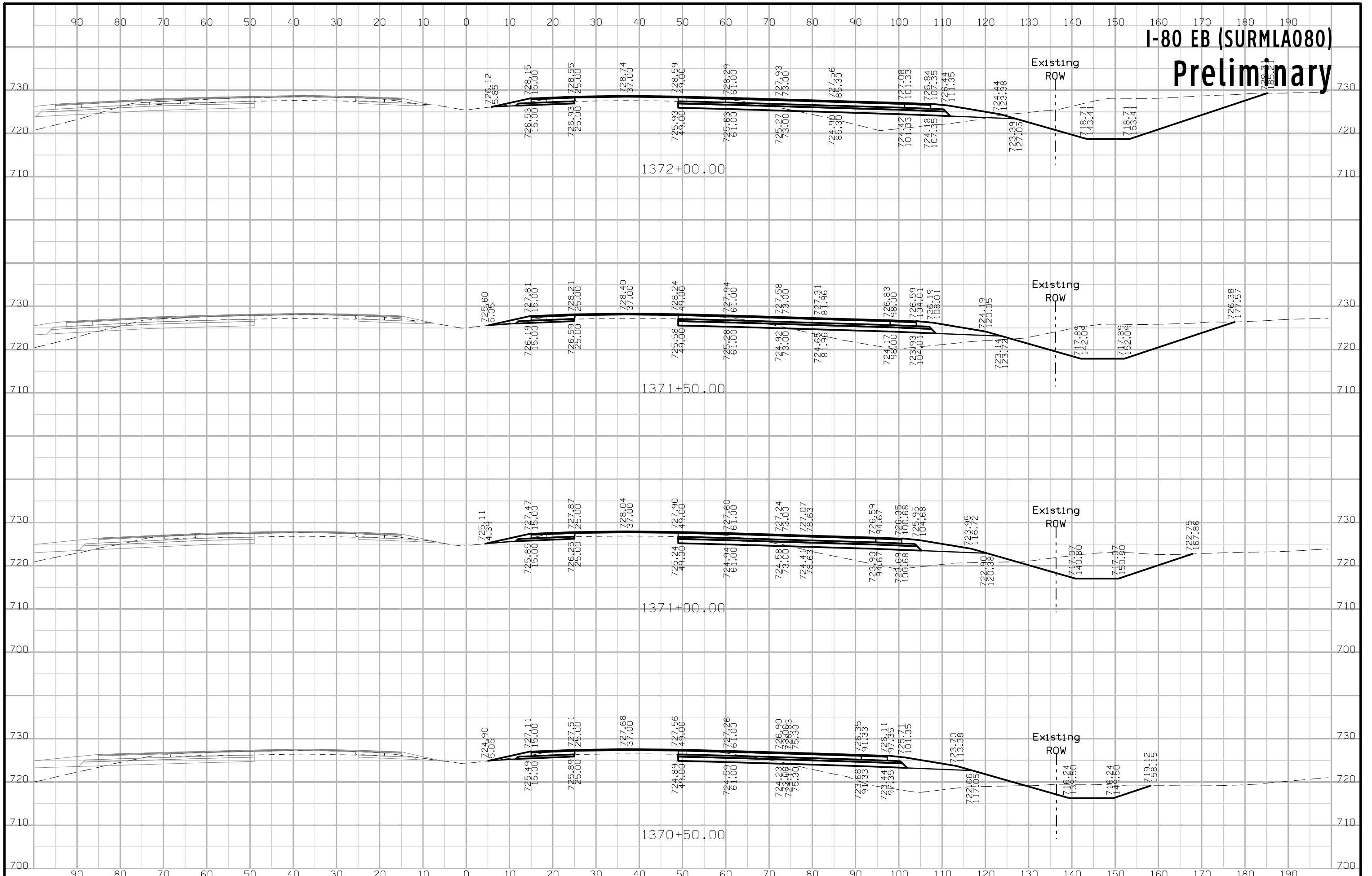

# I-80 EB (SURMLA080) Preliminary

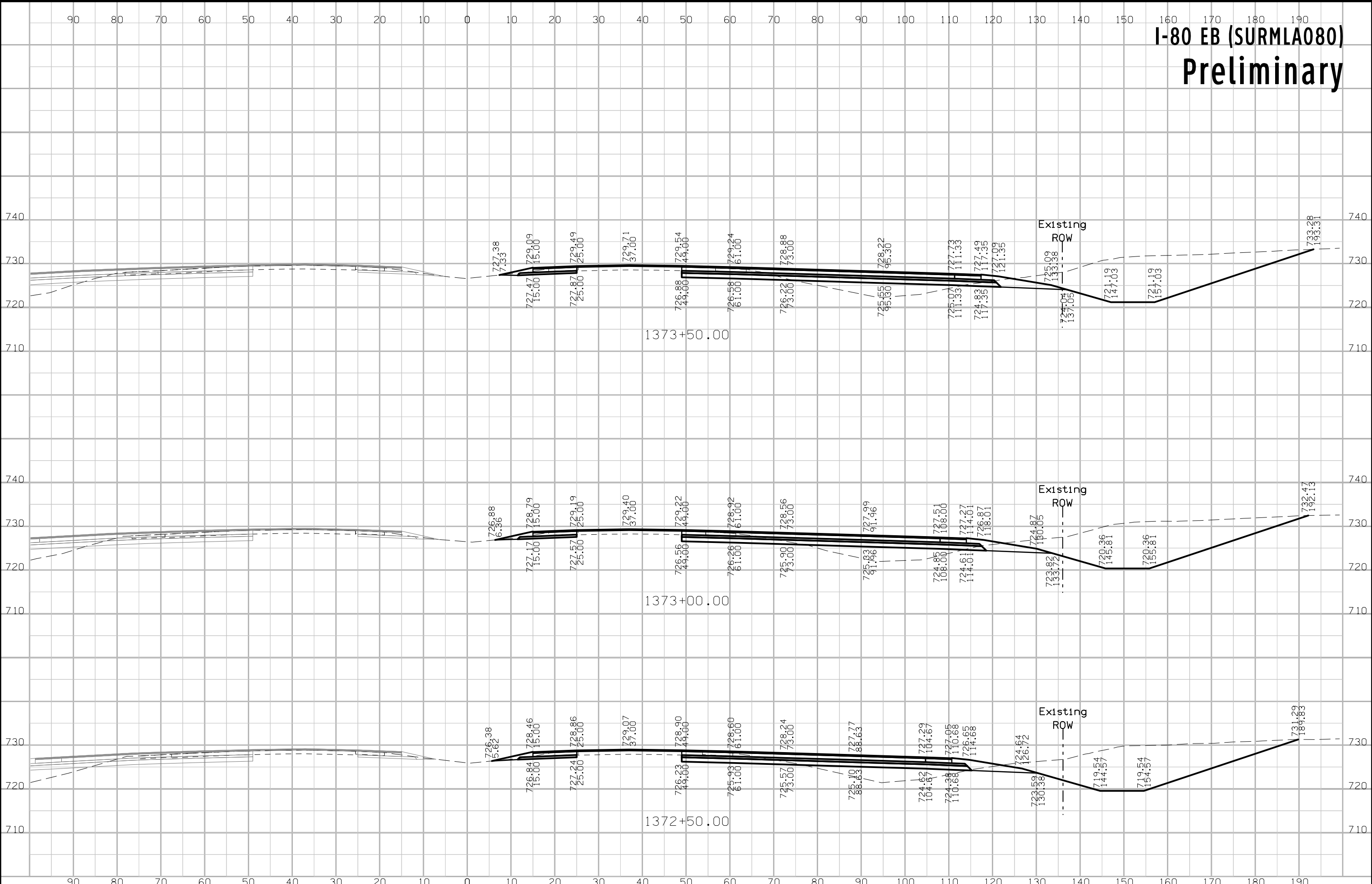

# I-80 EB (SURMLA080) Preliminary

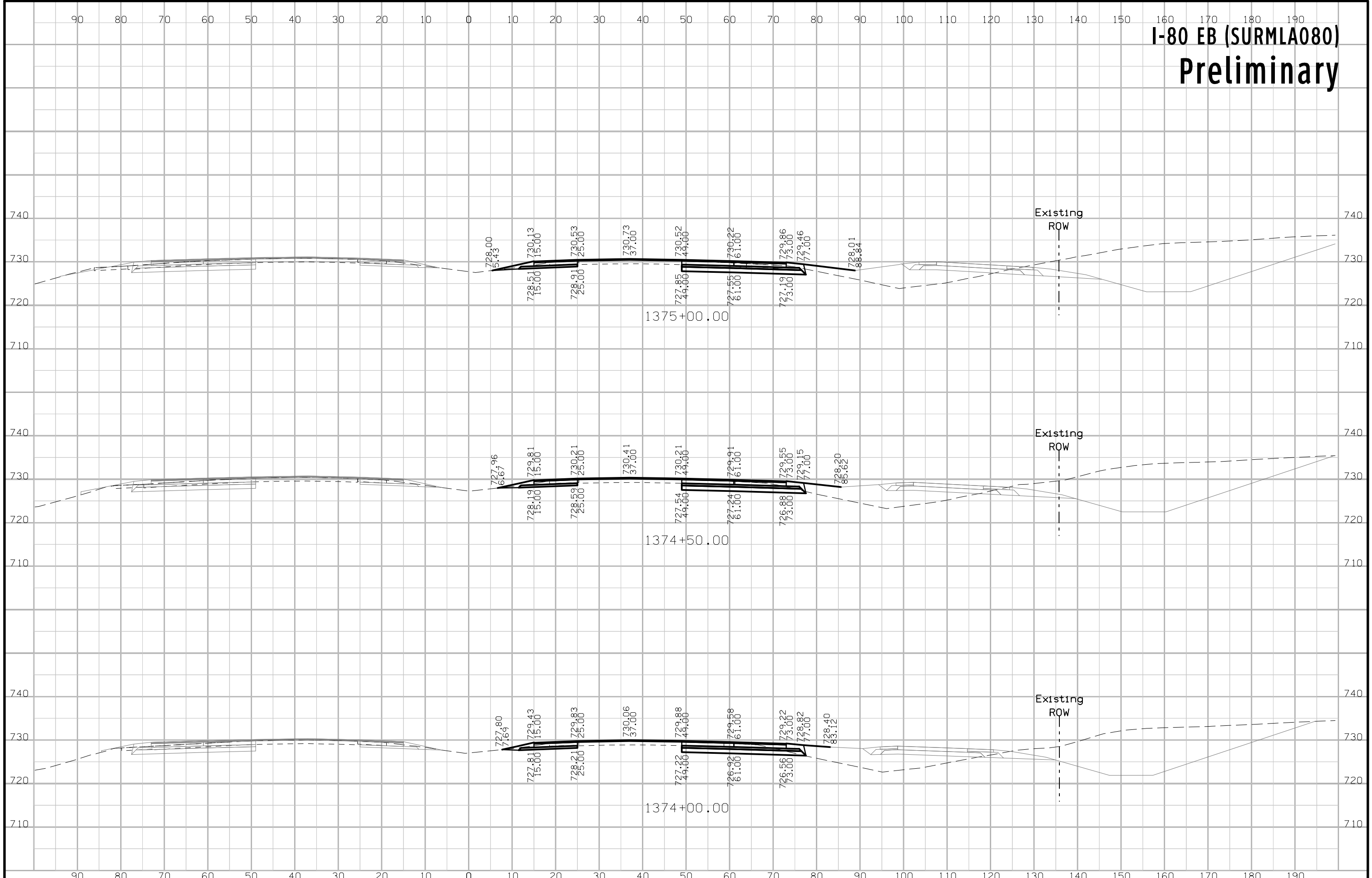

# I-80 EB (SURMLA080) Preliminary

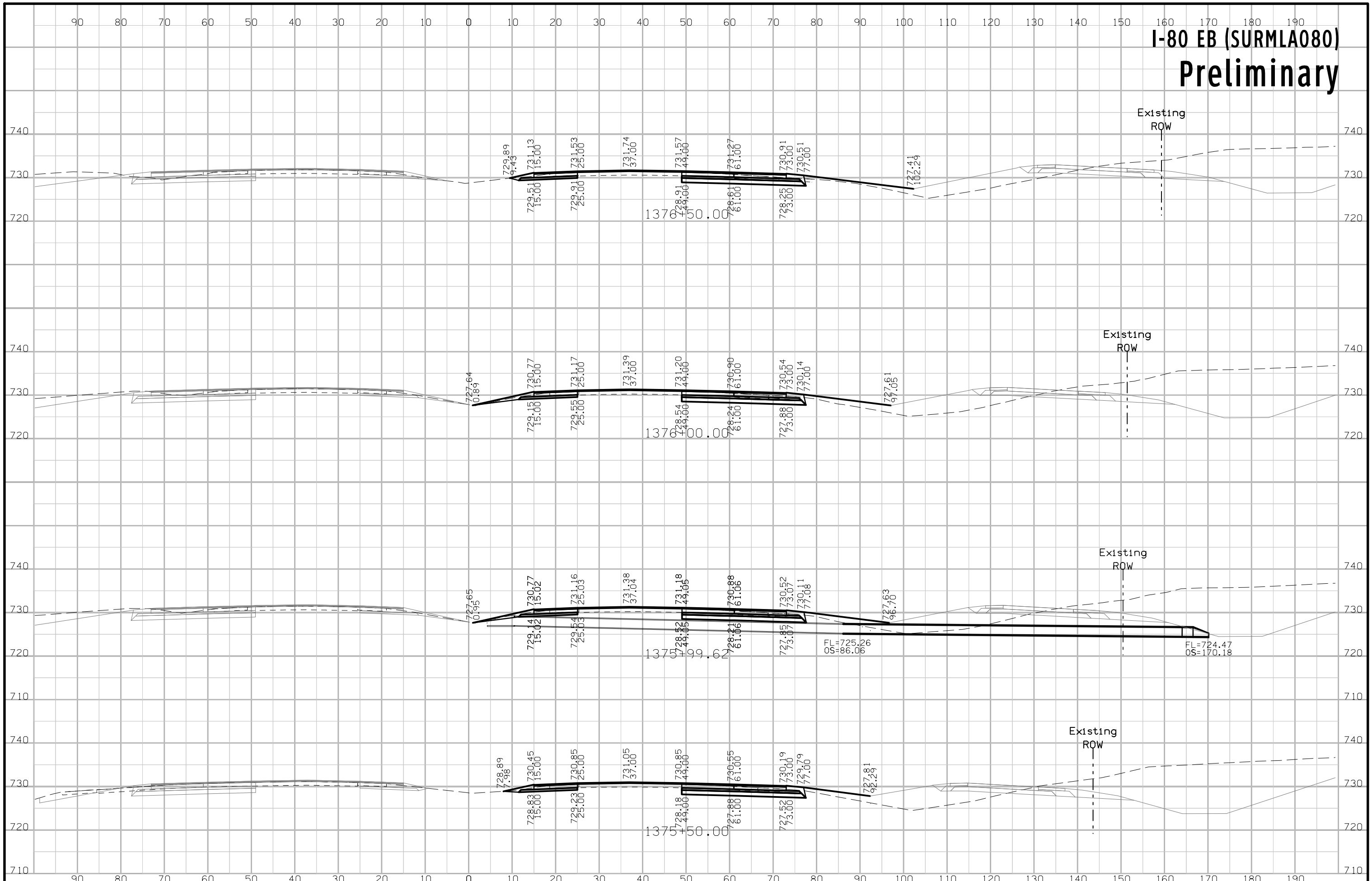



# I-80 EB (SURMLA080) Preliminary

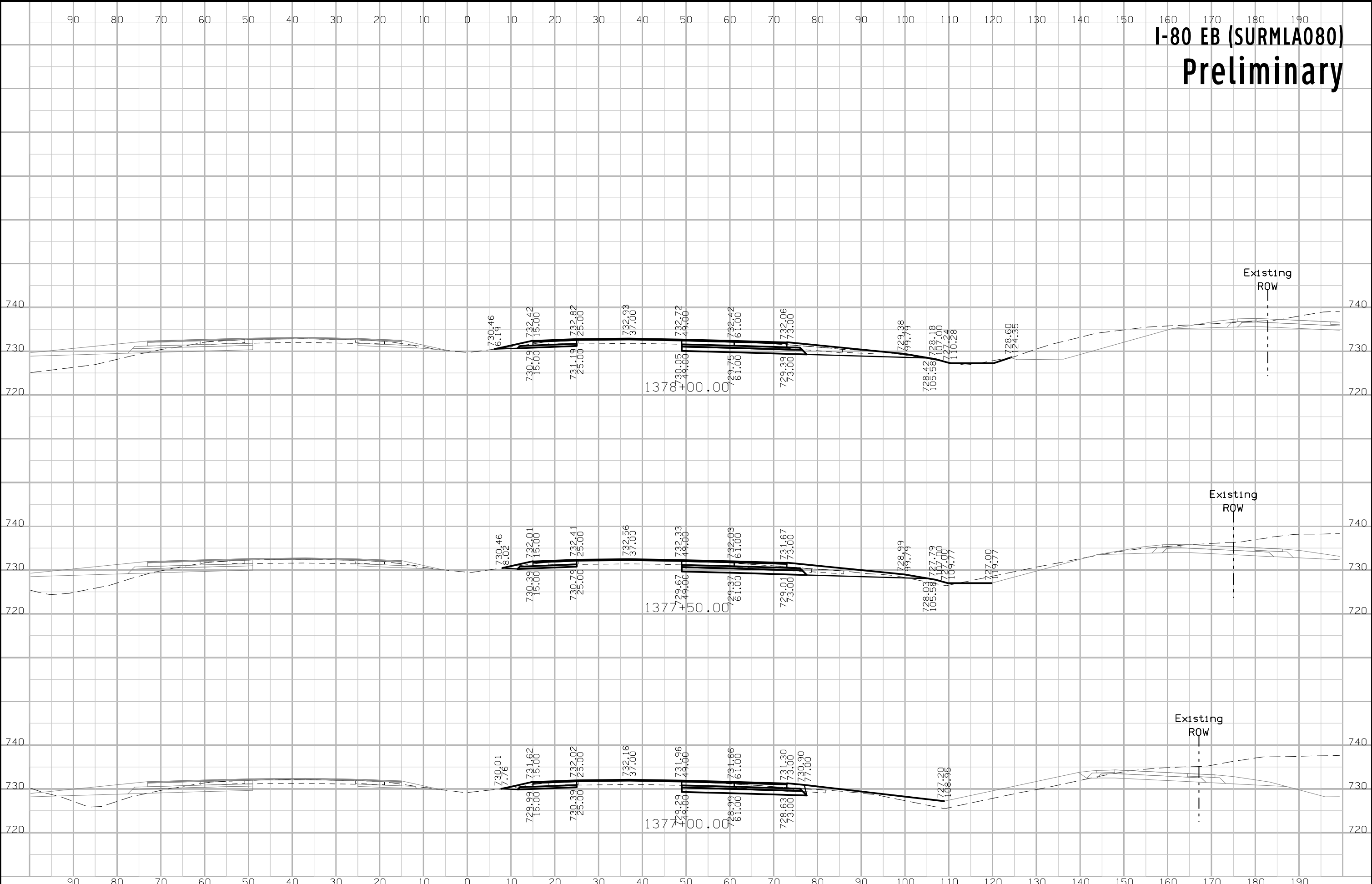

# I-80 EB (SURMLA080) Preliminary

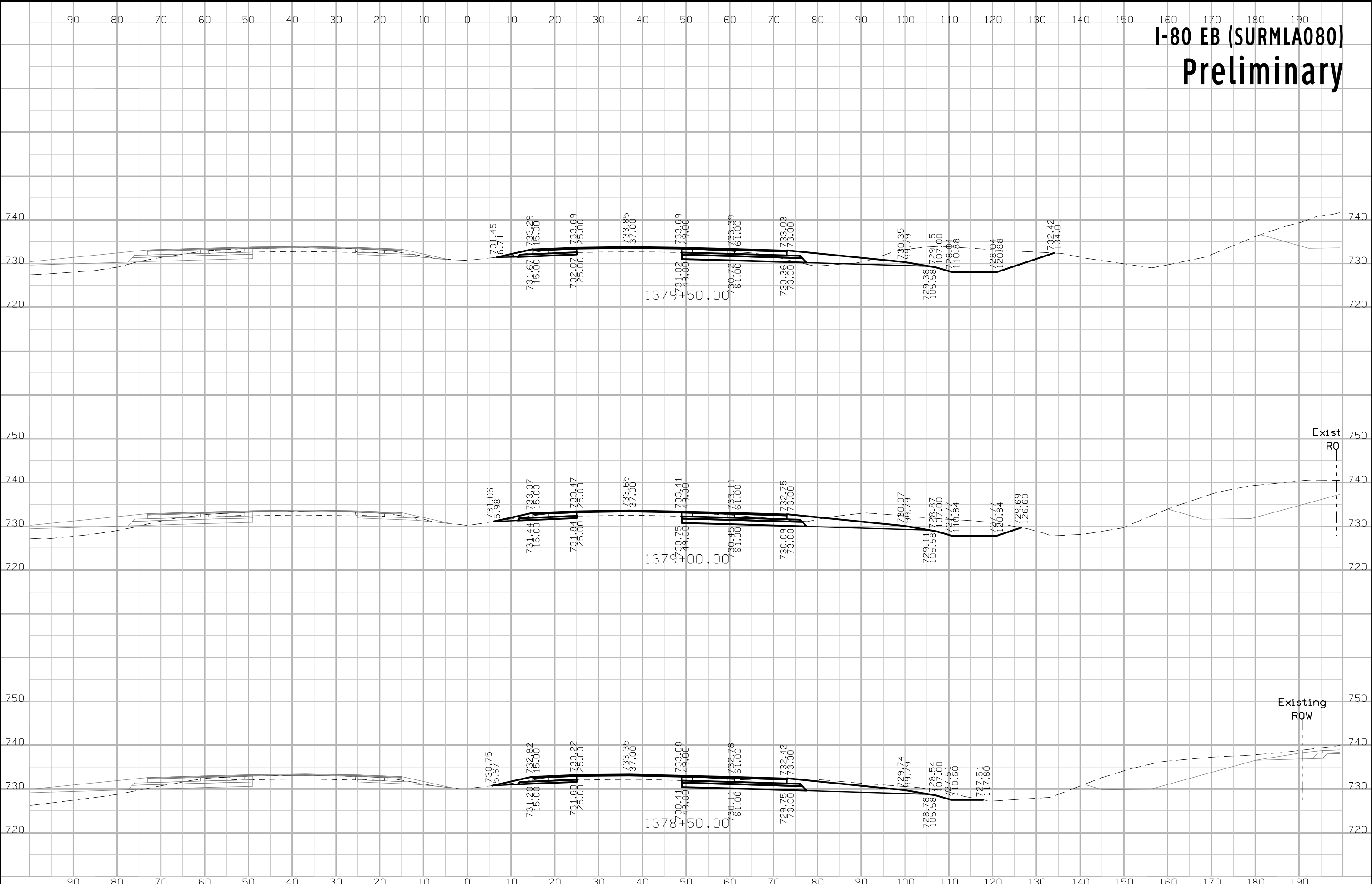

# I-80 EB (SURMLA080) Preliminary

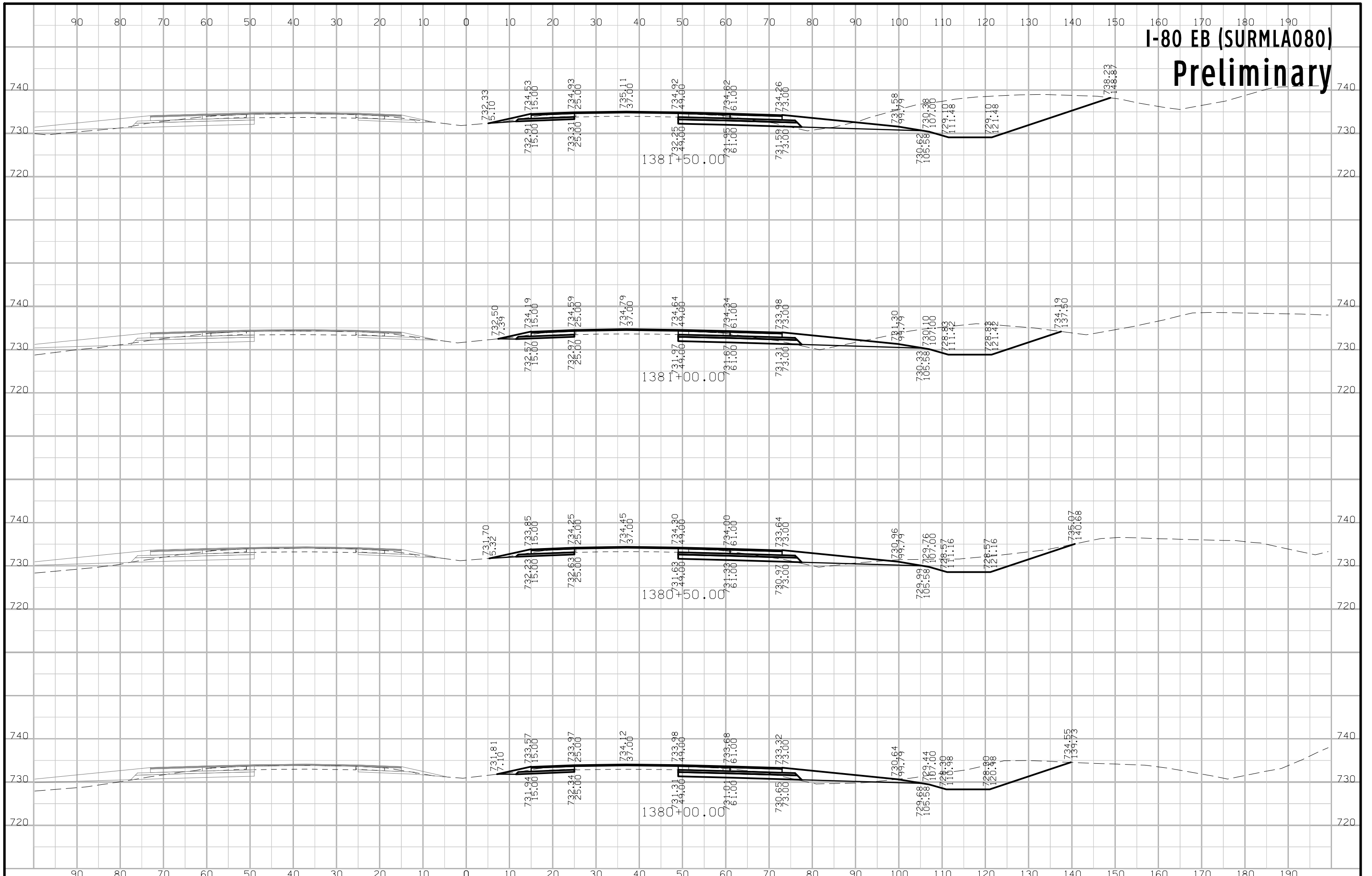

# I-80 EB (SURMLA080) Preliminary

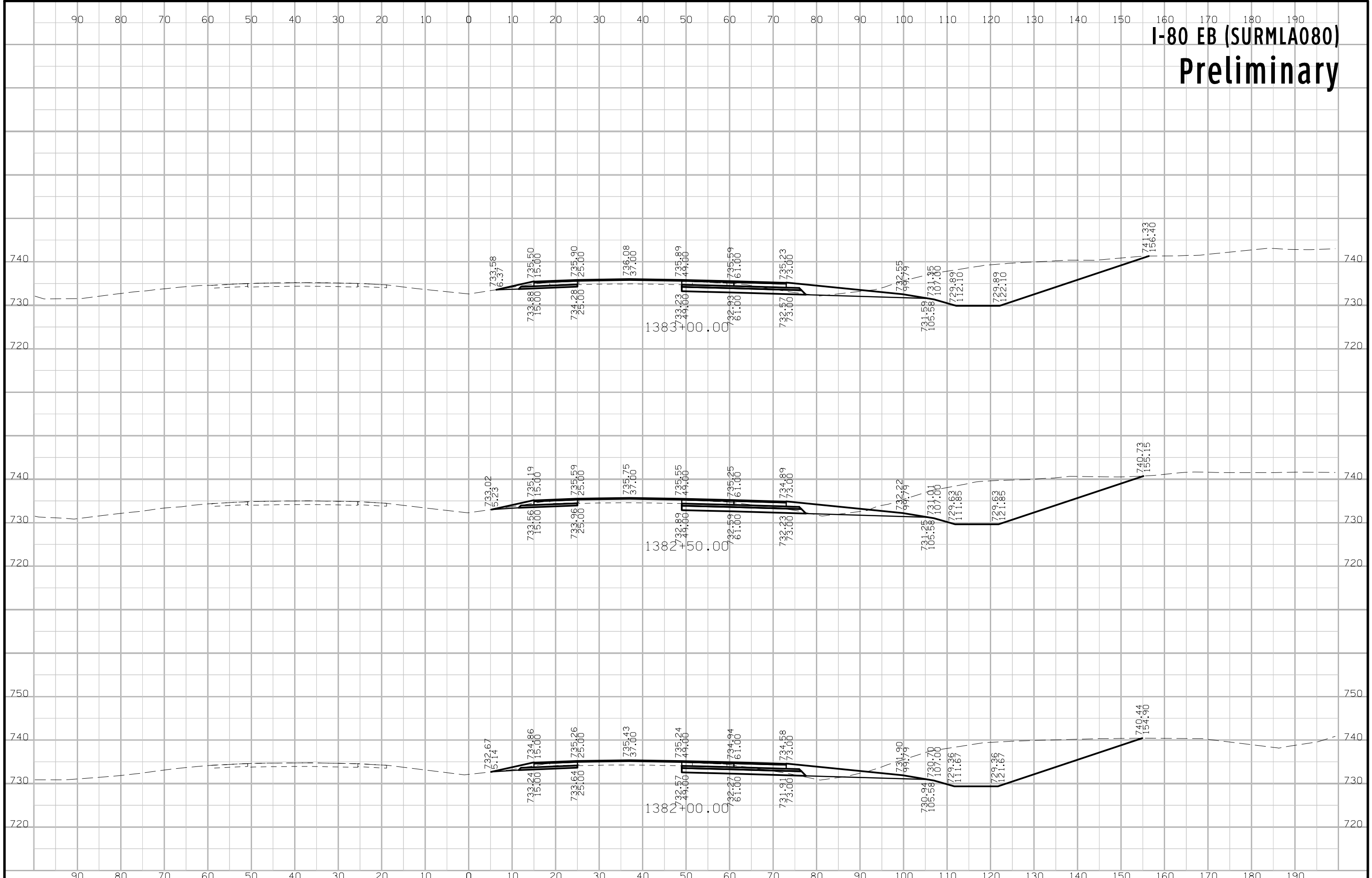

# I-80 EB (SURMLA080) Preliminary

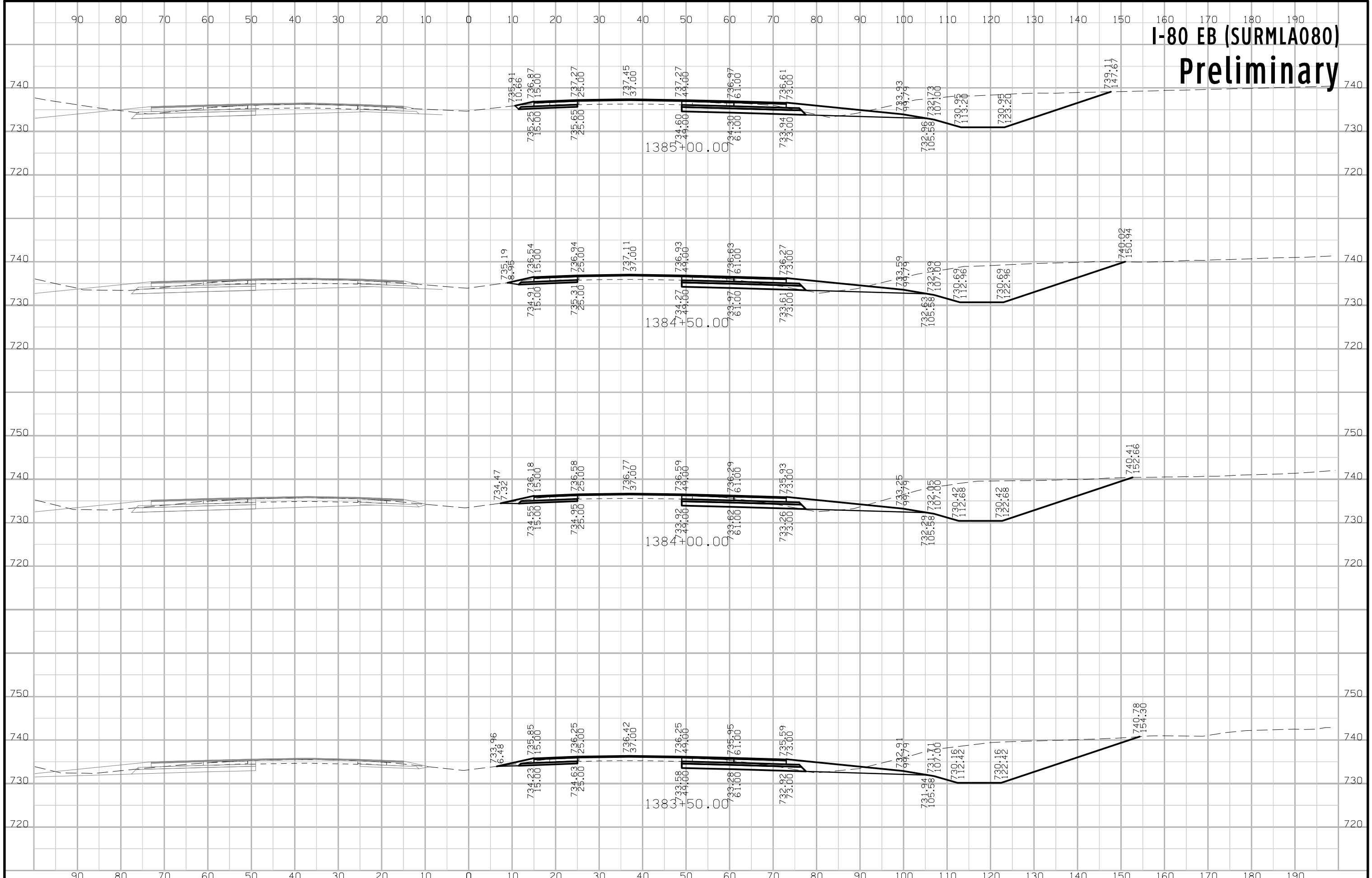

# I-80 EB (SURMLA080) Preliminary

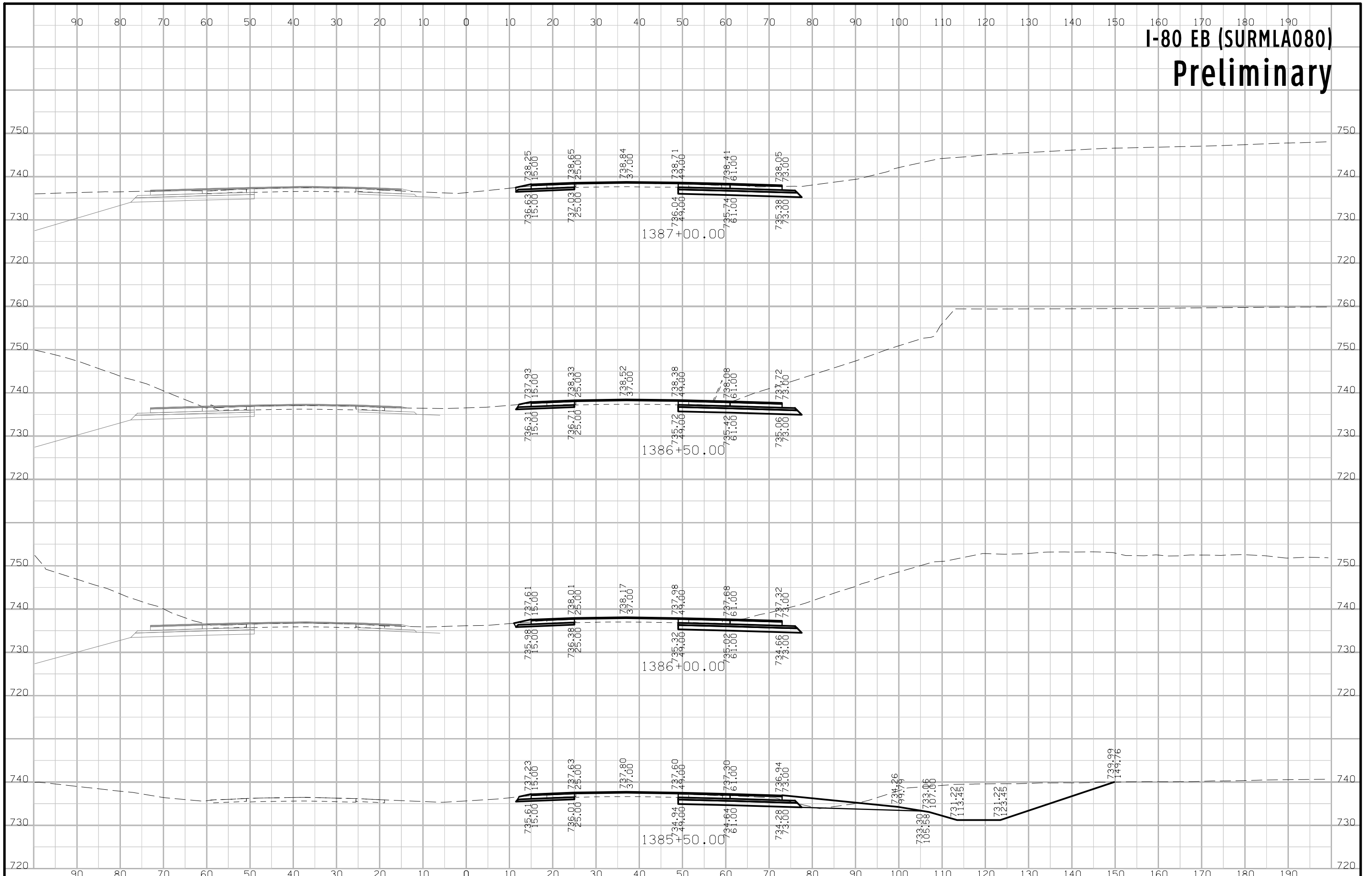

# I-80 EB (SURMLA080) Preliminary

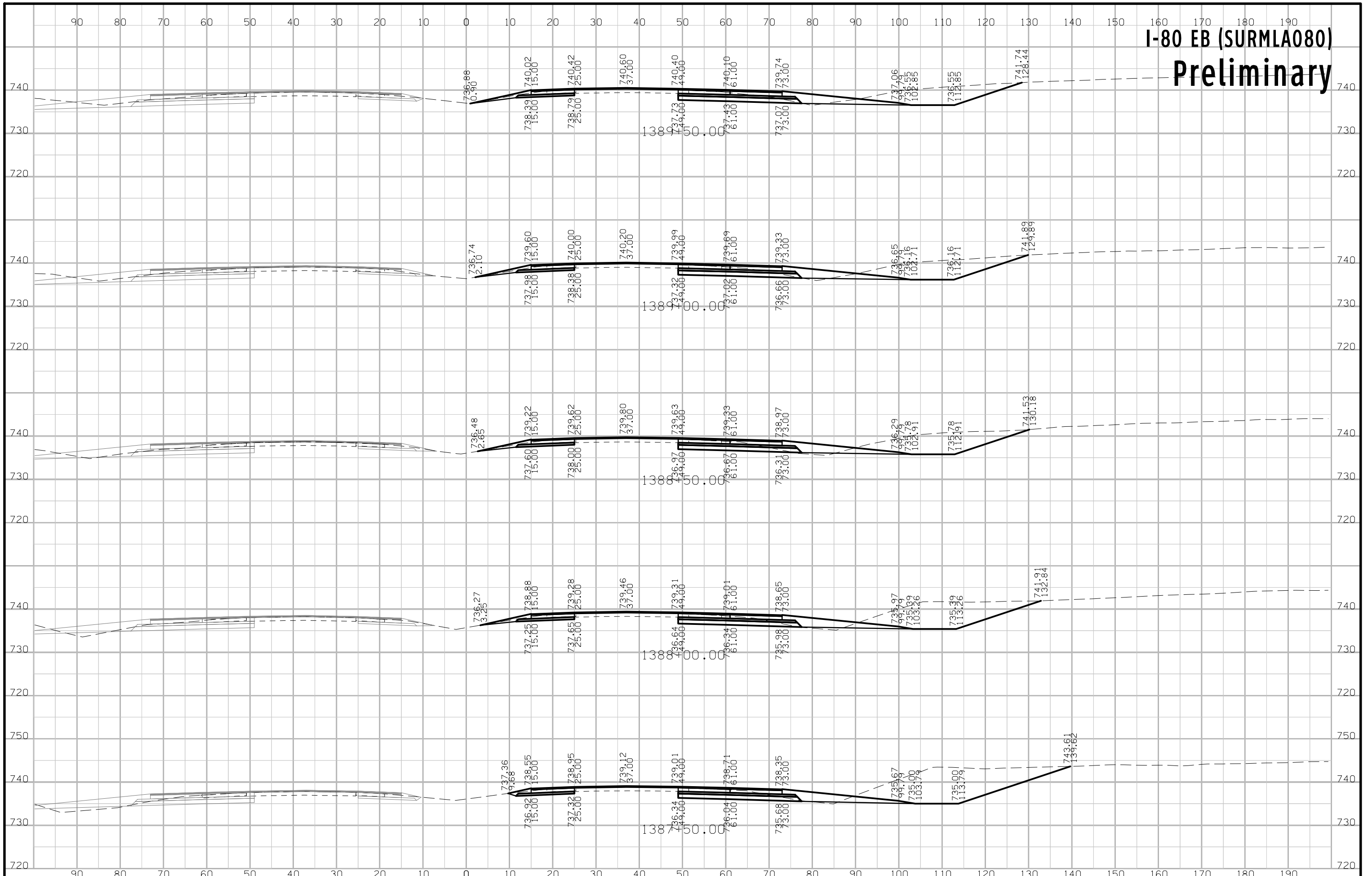

# I-80 EB (SURMLA080) Preliminary

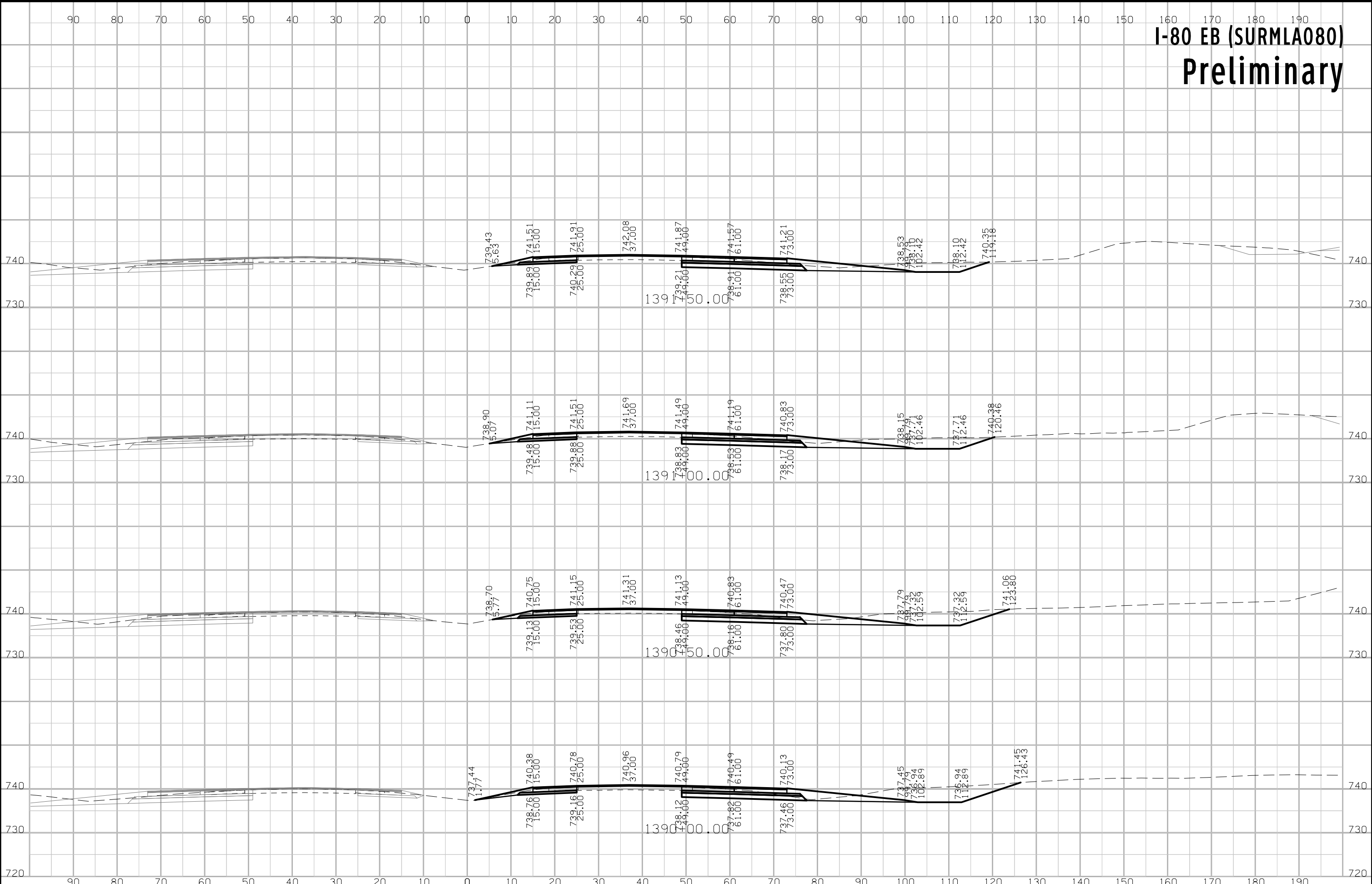



# I-80 EB (SURMLA080) Preliminary

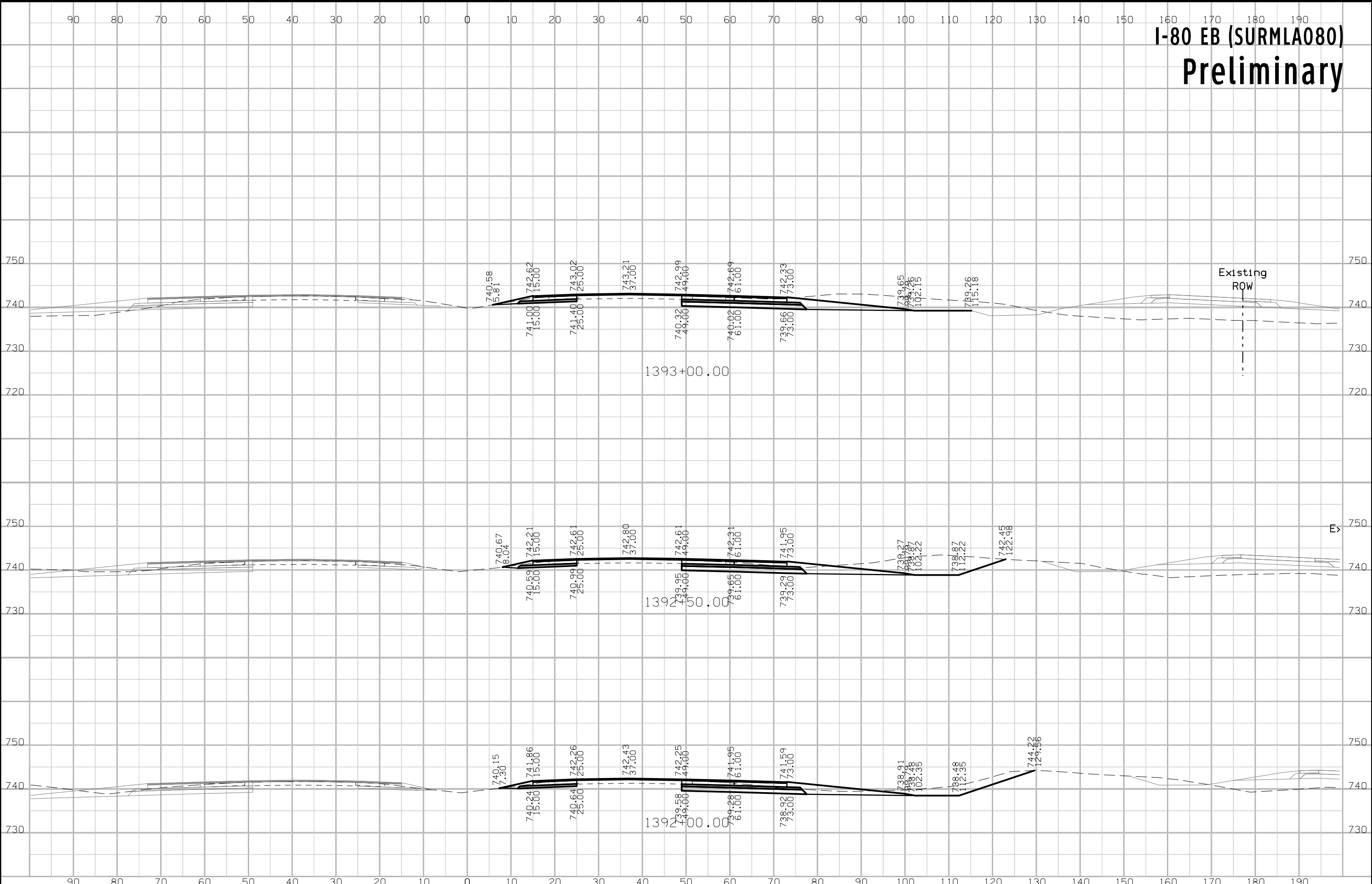

# I-80 EB (SURMLA080) Preliminary

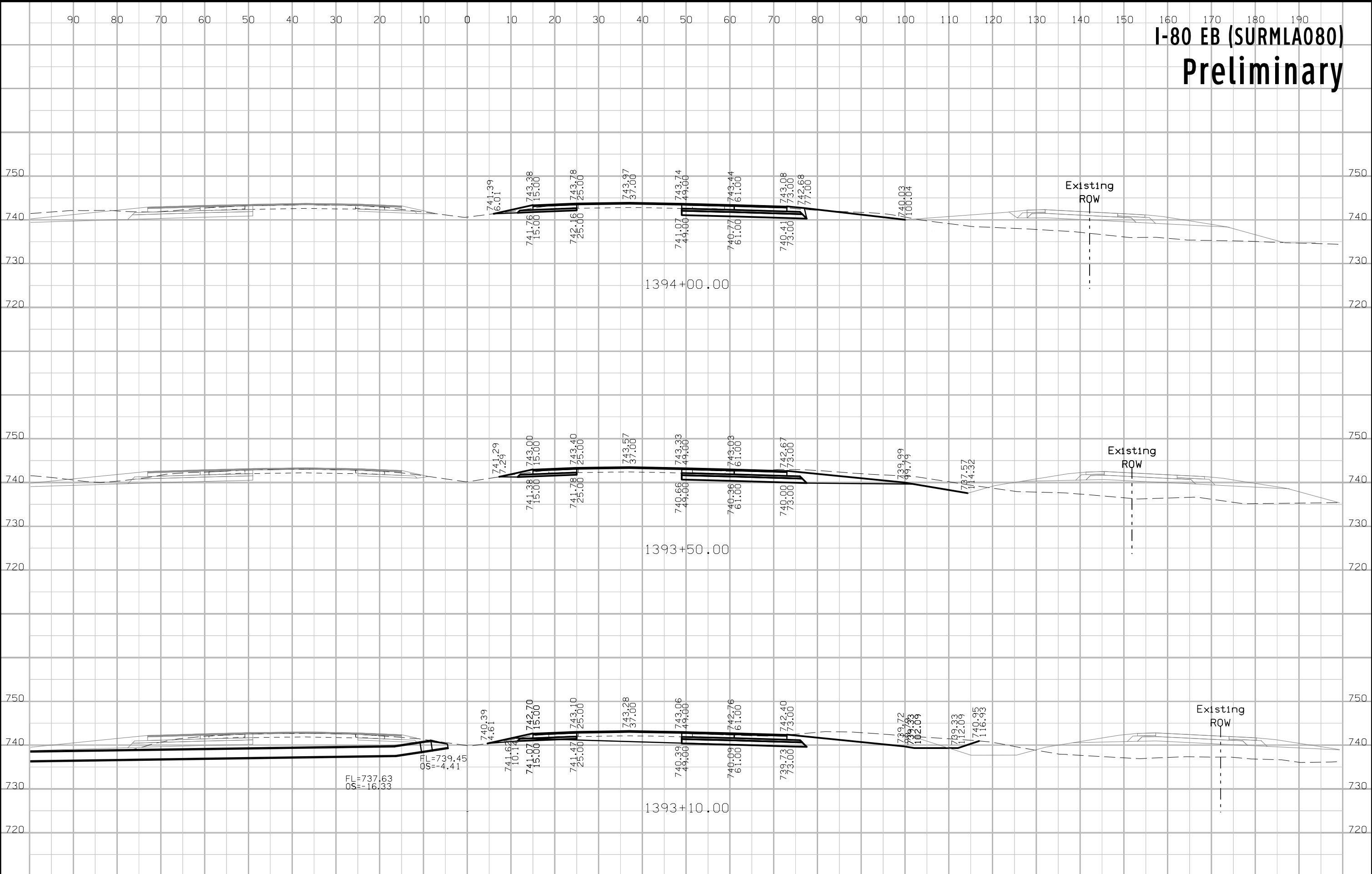

# I-80 EB (SURMLA080) Preliminary

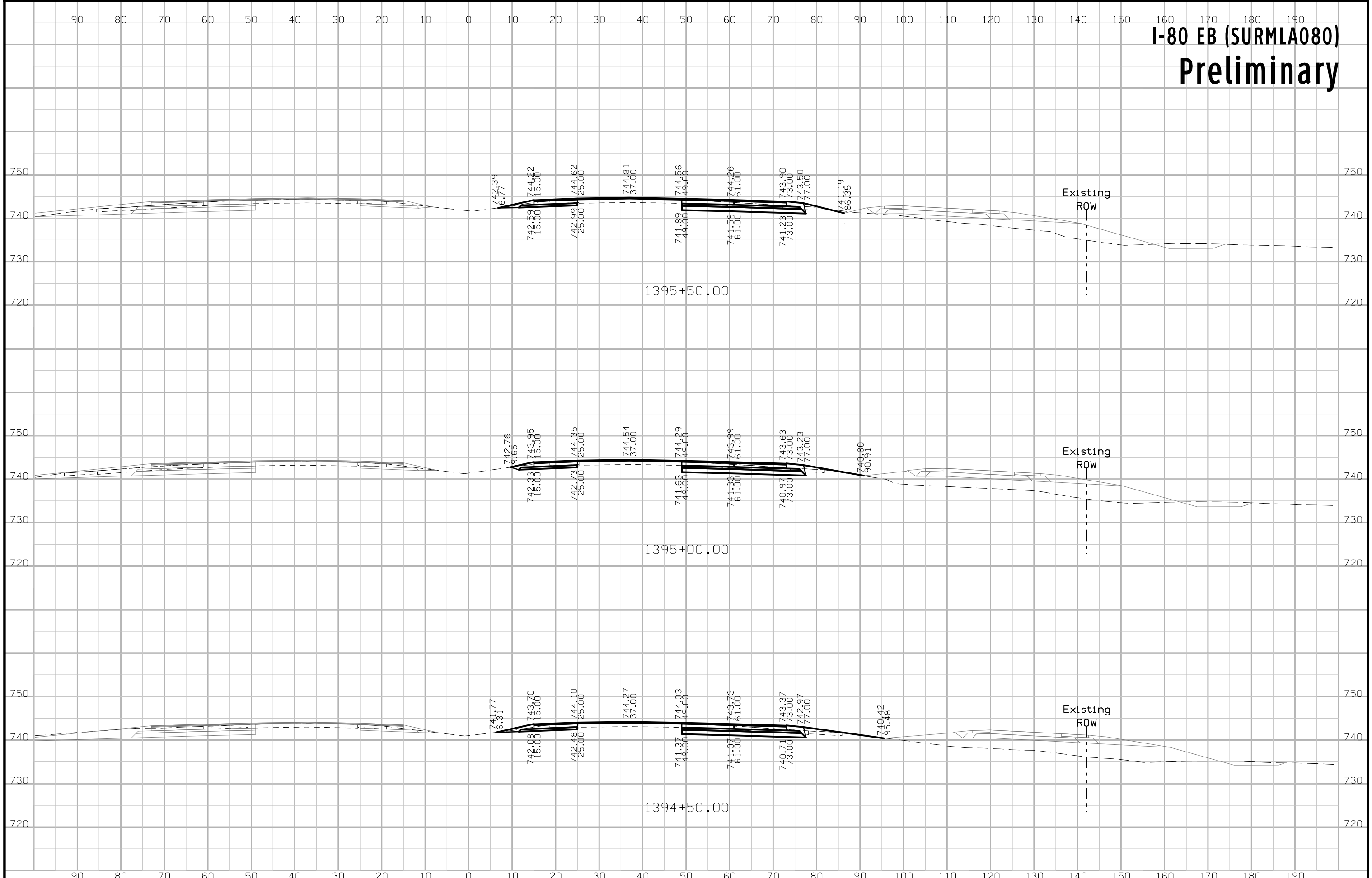

# I-80 EB (SURMLA080) Preliminary

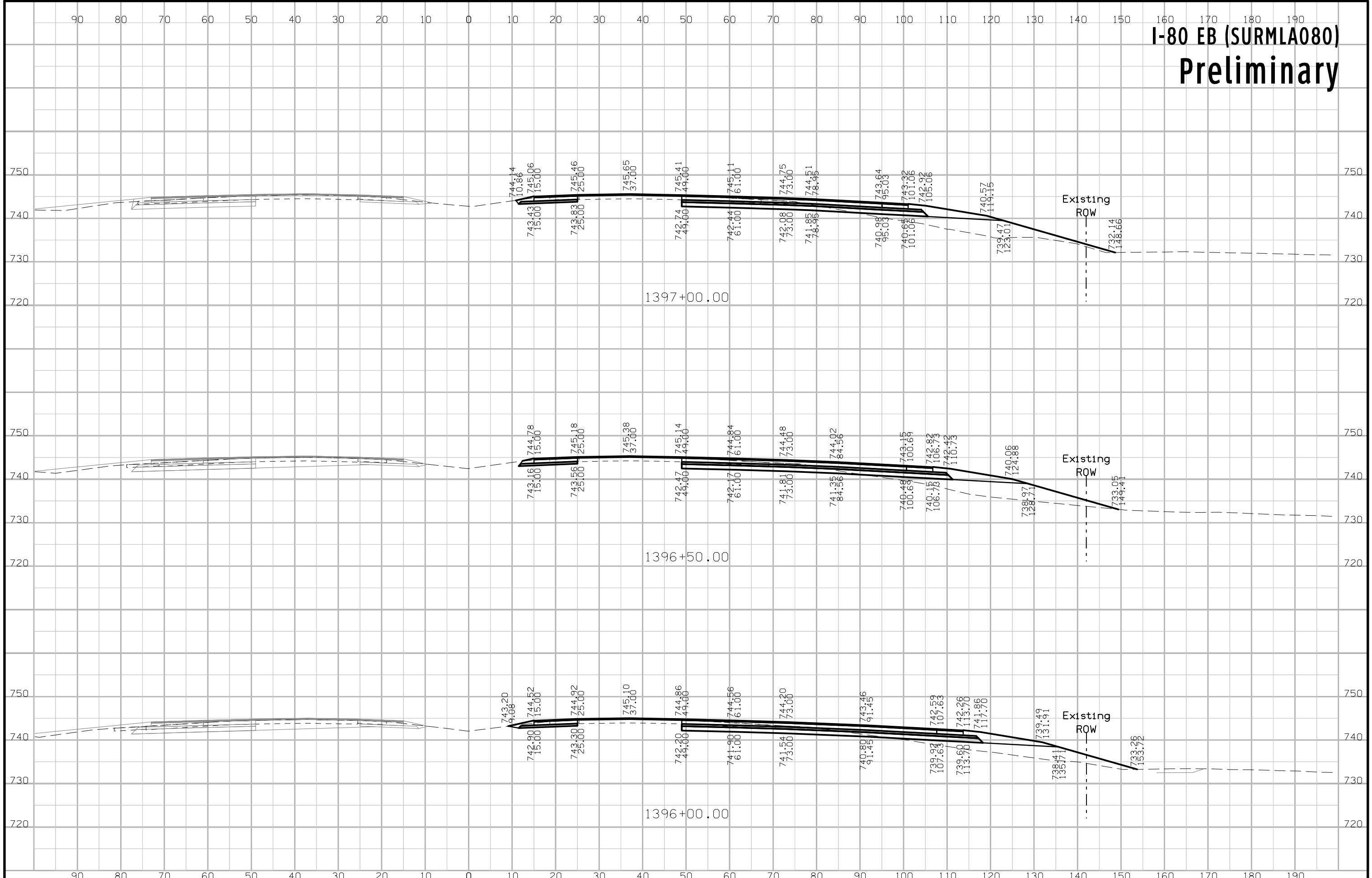

# I-80 EB (SURMLA080) Preliminary

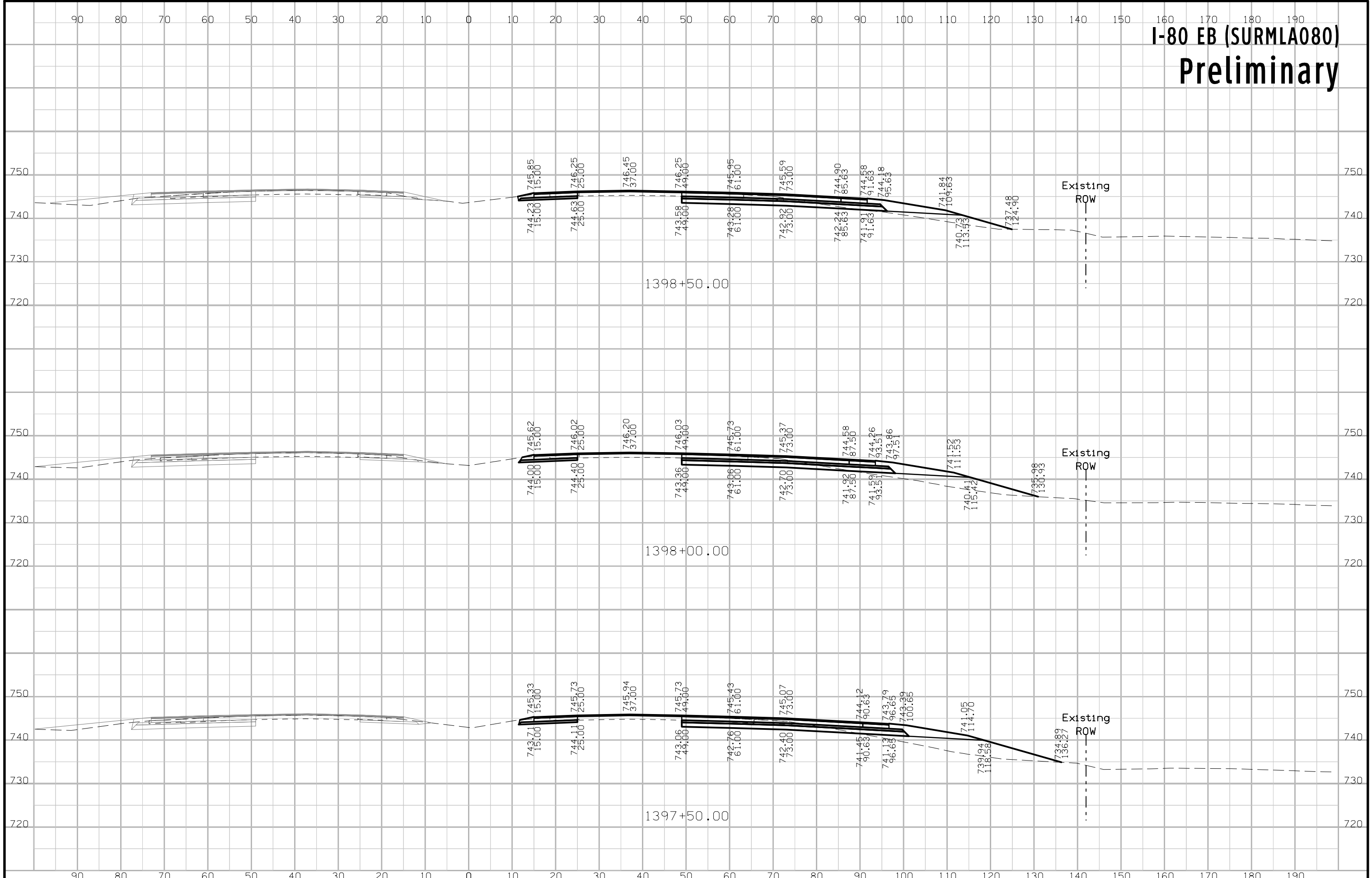

# I-80 EB (SURMLA080) Preliminary

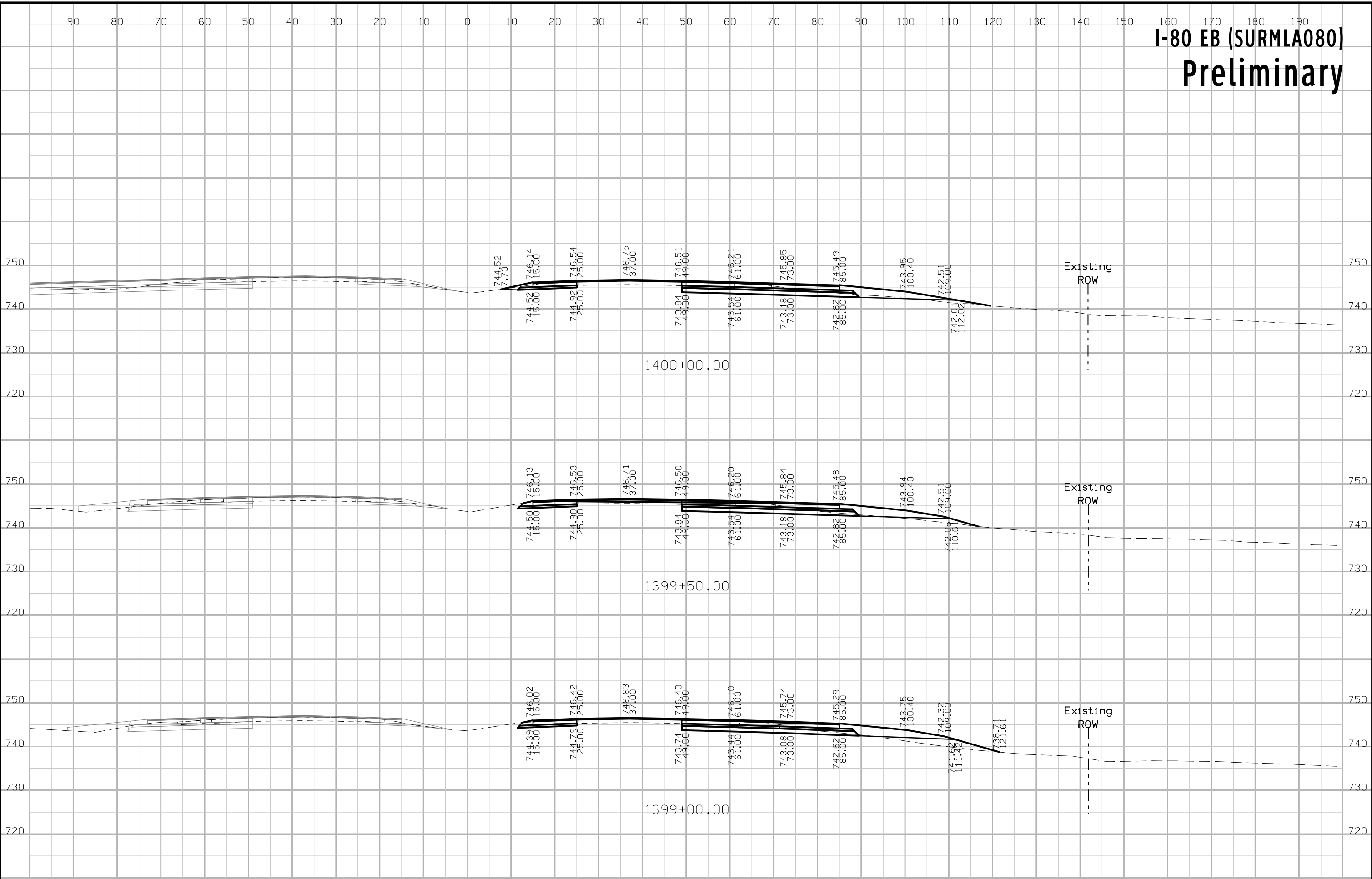

# I-80 EB (SURMLA080) Preliminary

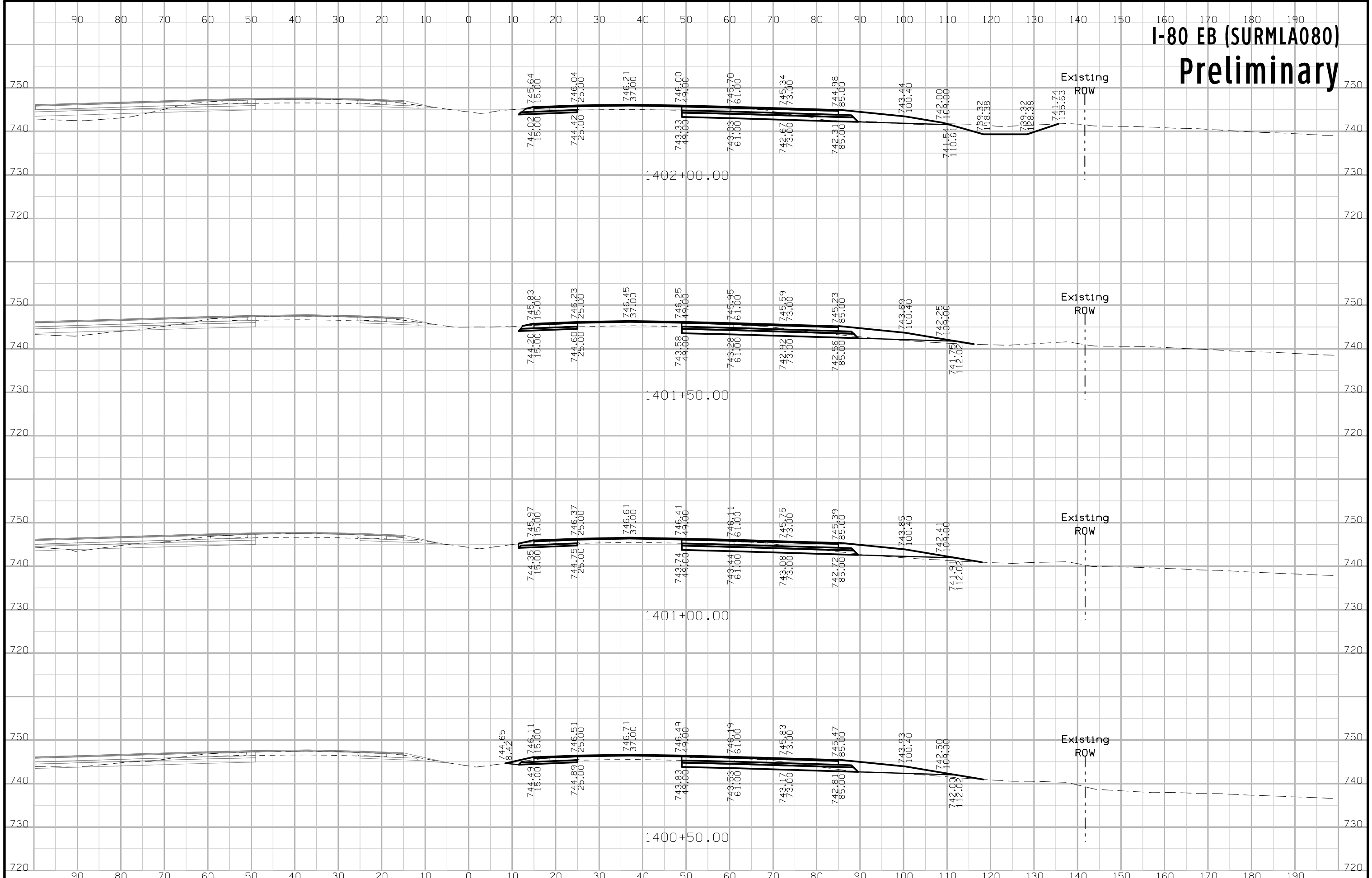

# I-80 EB (SURMLA080) Preliminary

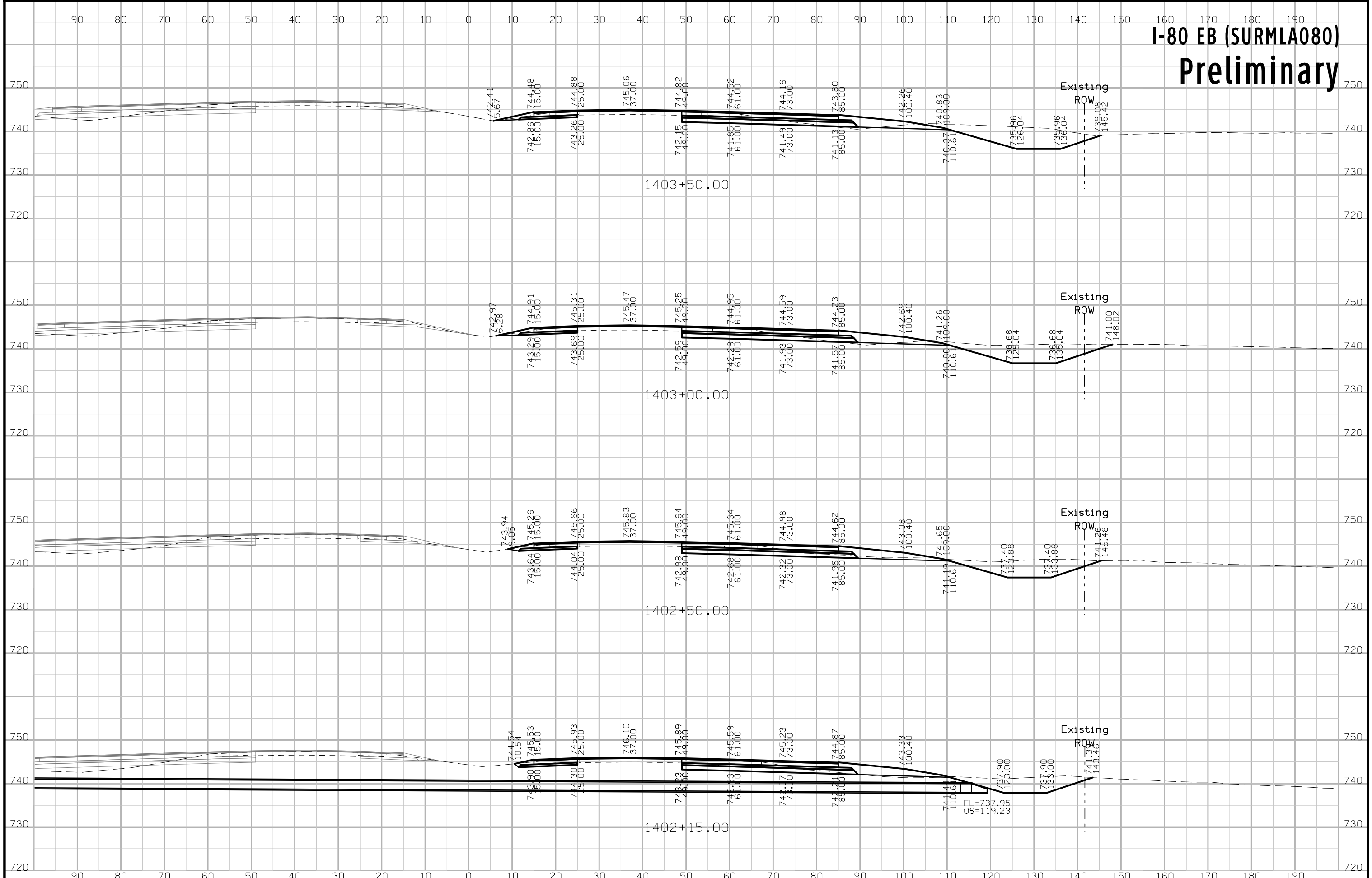



# I-80 EB (SURMLA080) Preliminary

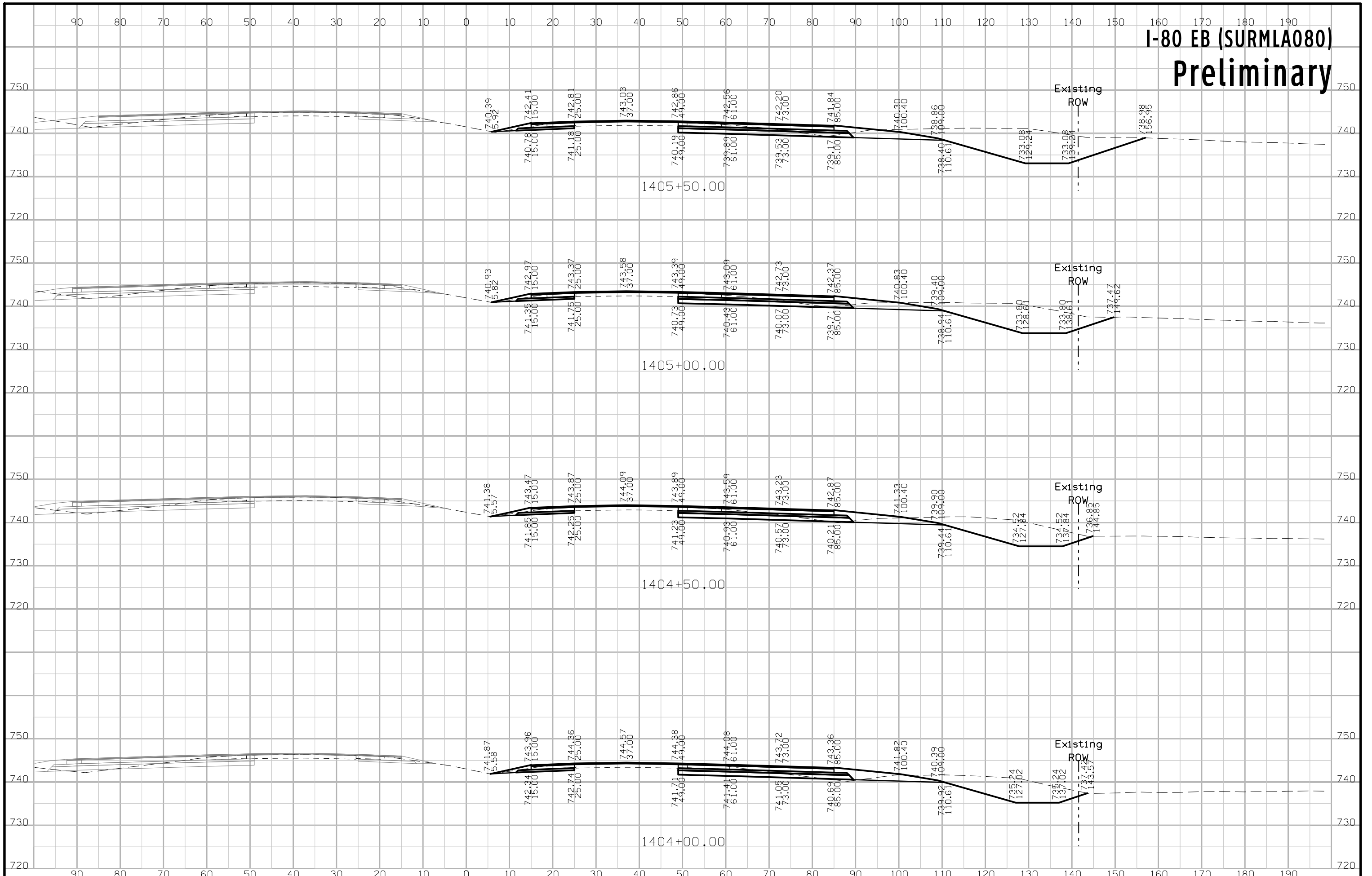

# I-80 EB (SURMLA080) Preliminary

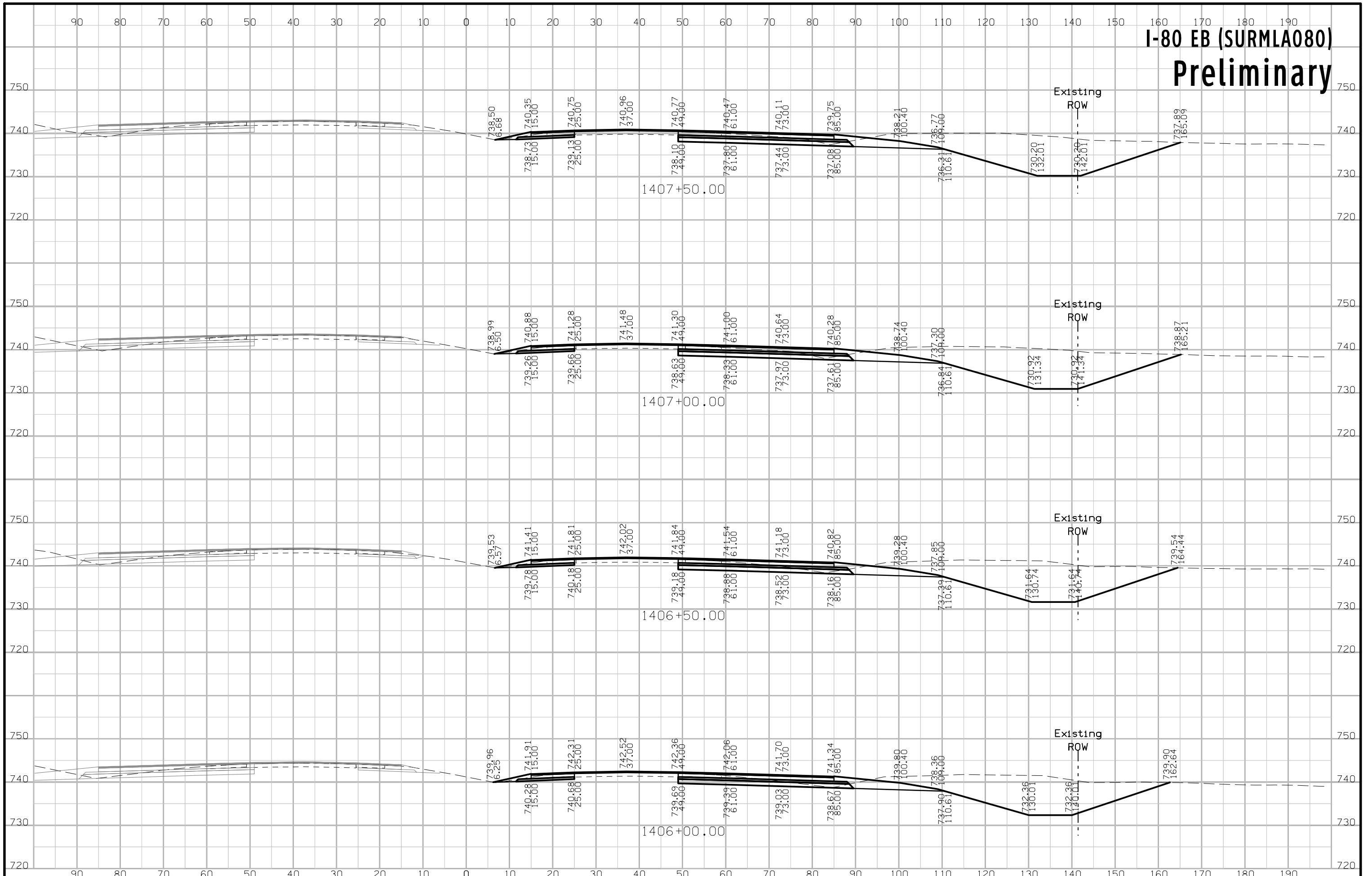

# I-80 EB (SURMLA080) Preliminary

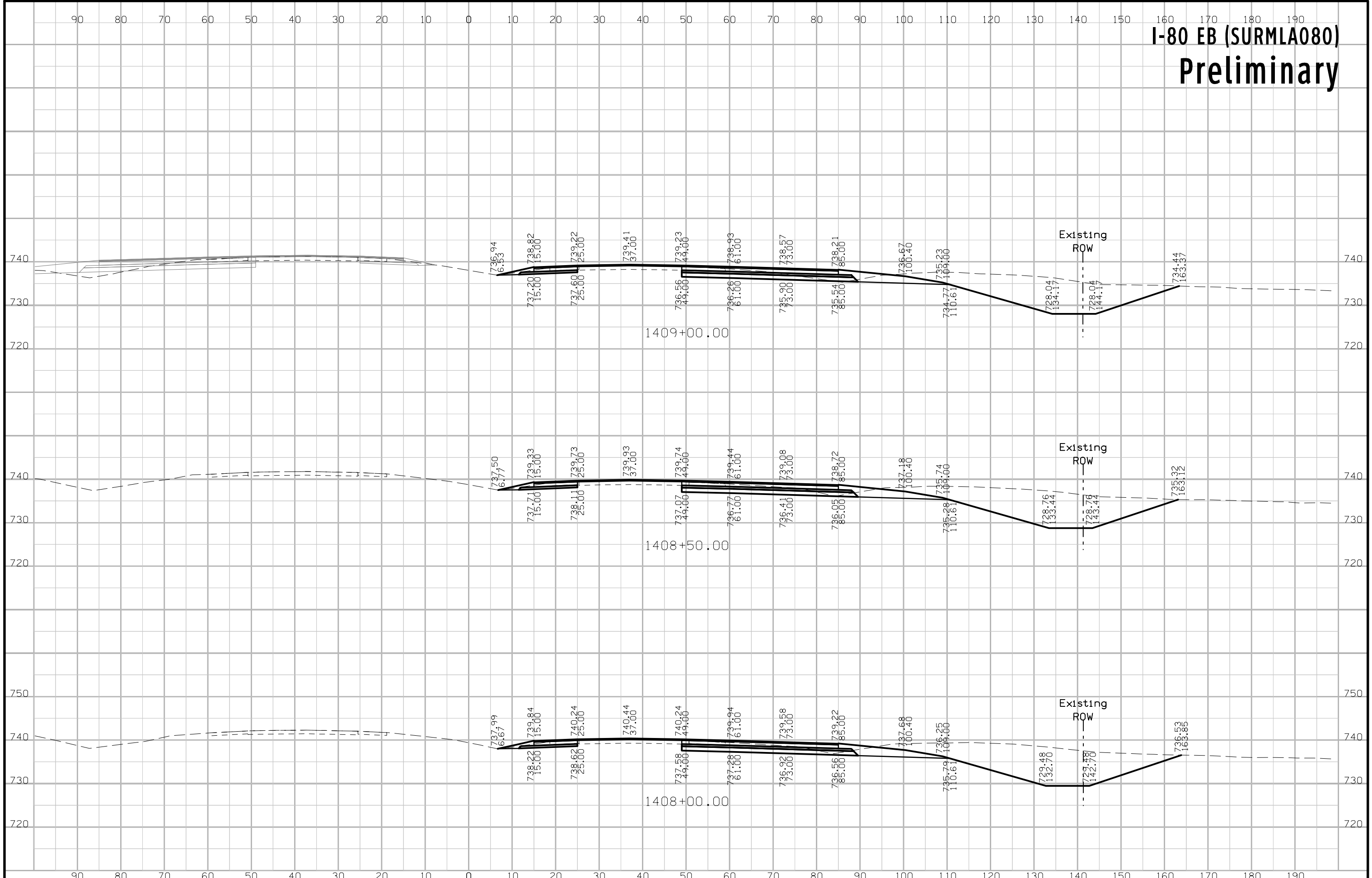

# I-80 EB (SURMLA080) Preliminary

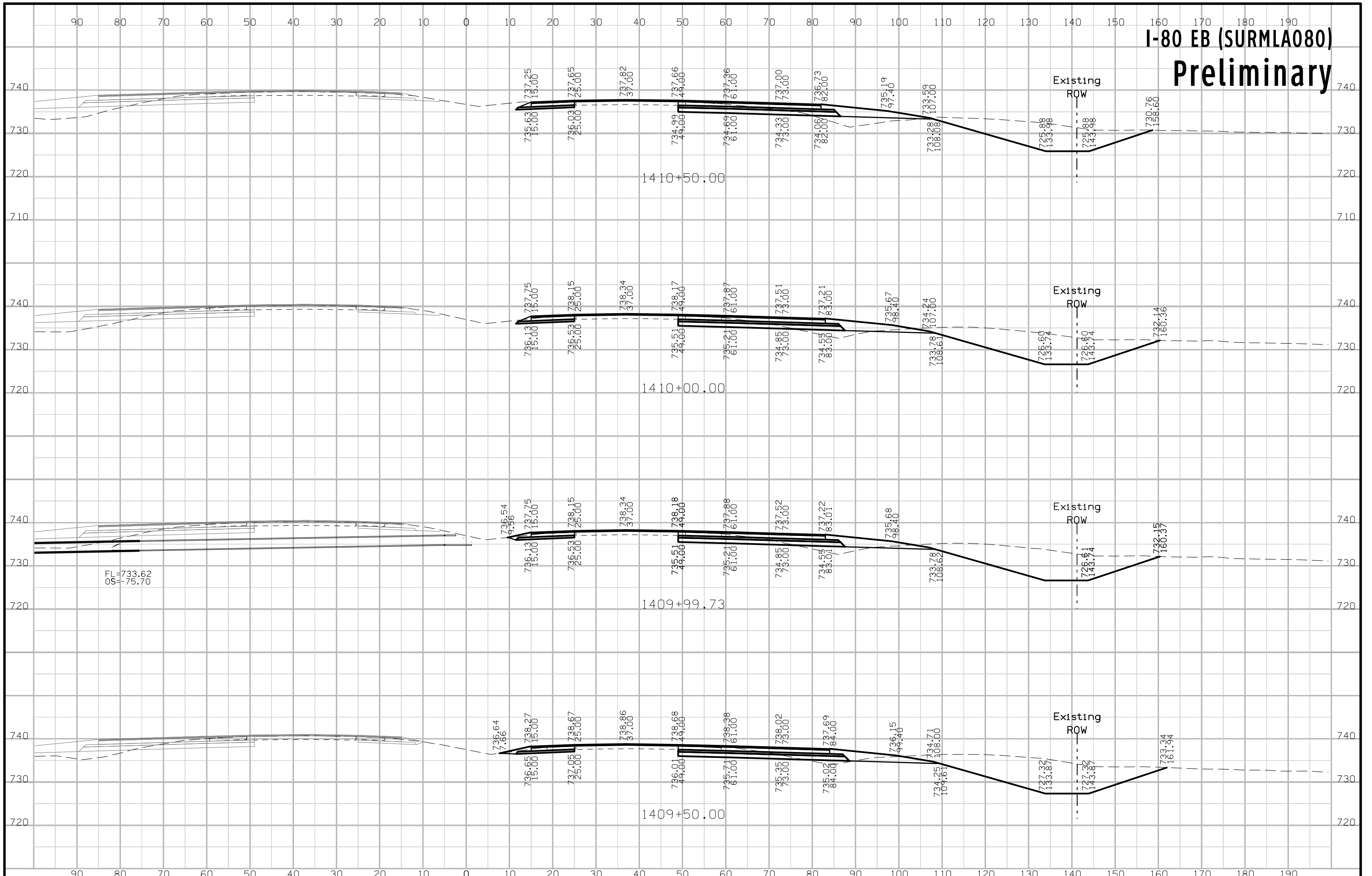

# I-80 EB (SURMLA080) Preliminary

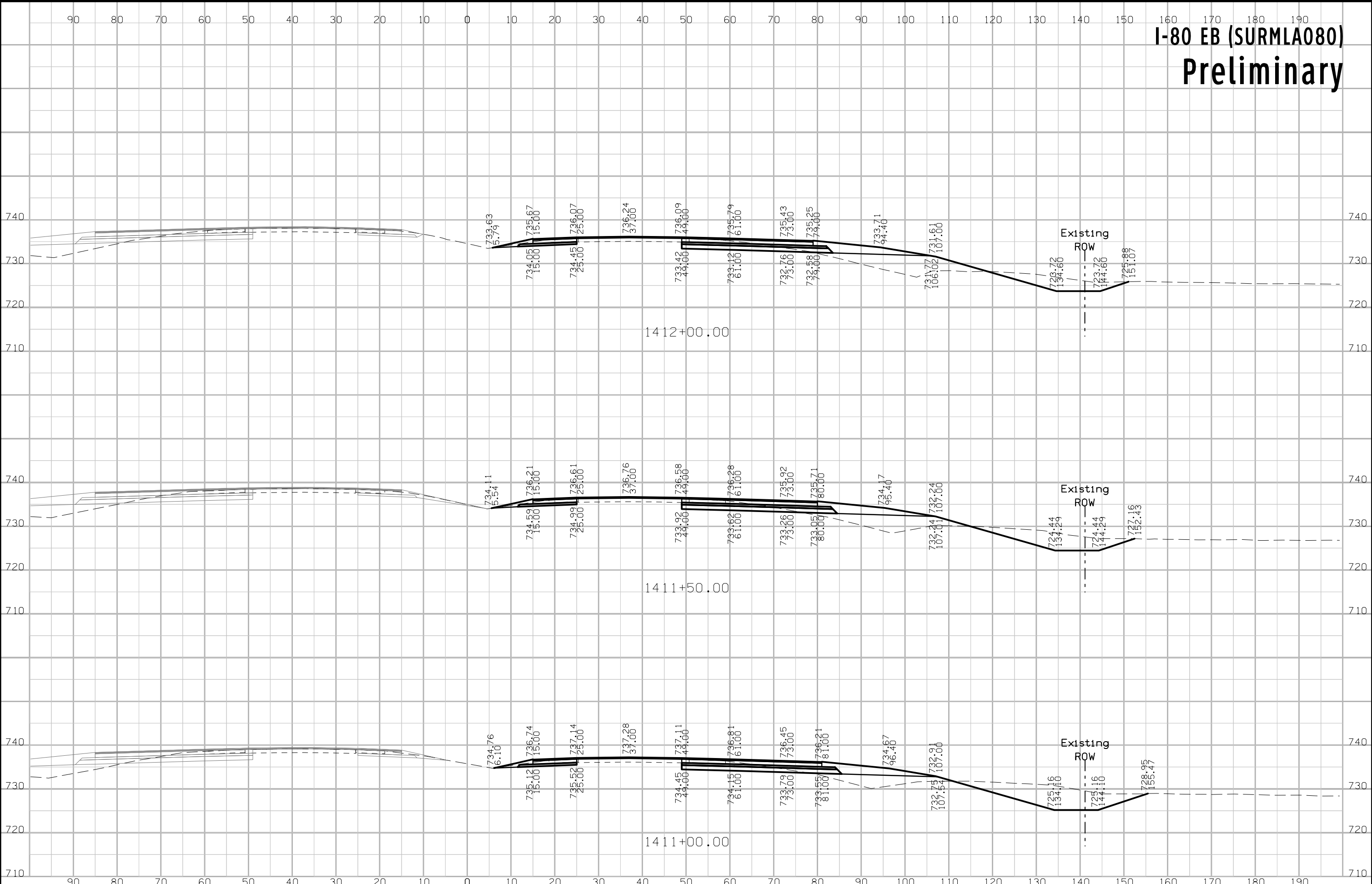

# I-80 EB (SURMLA080) Preliminary

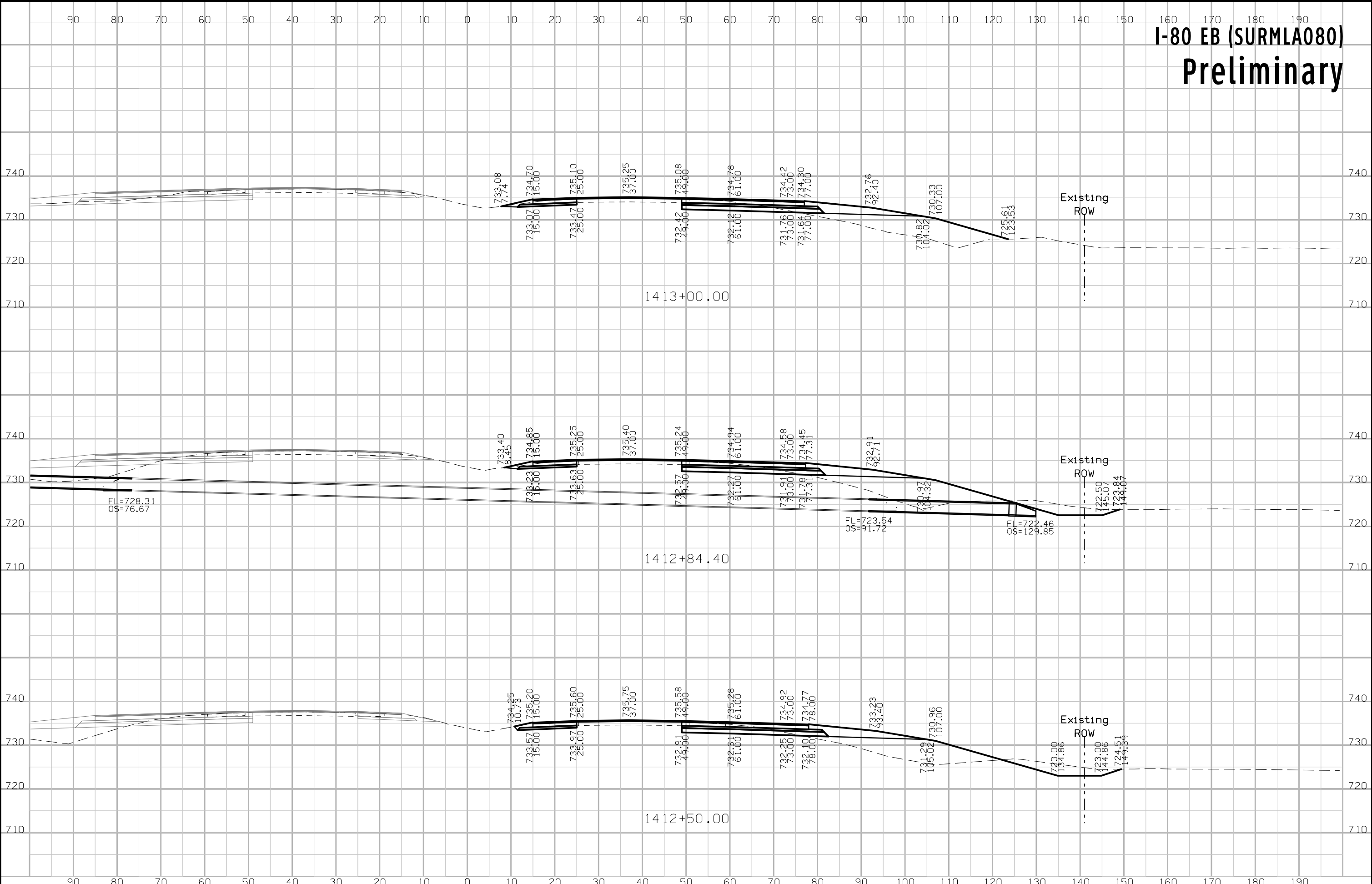

# I-80 EB (SURMLA080) Preliminary

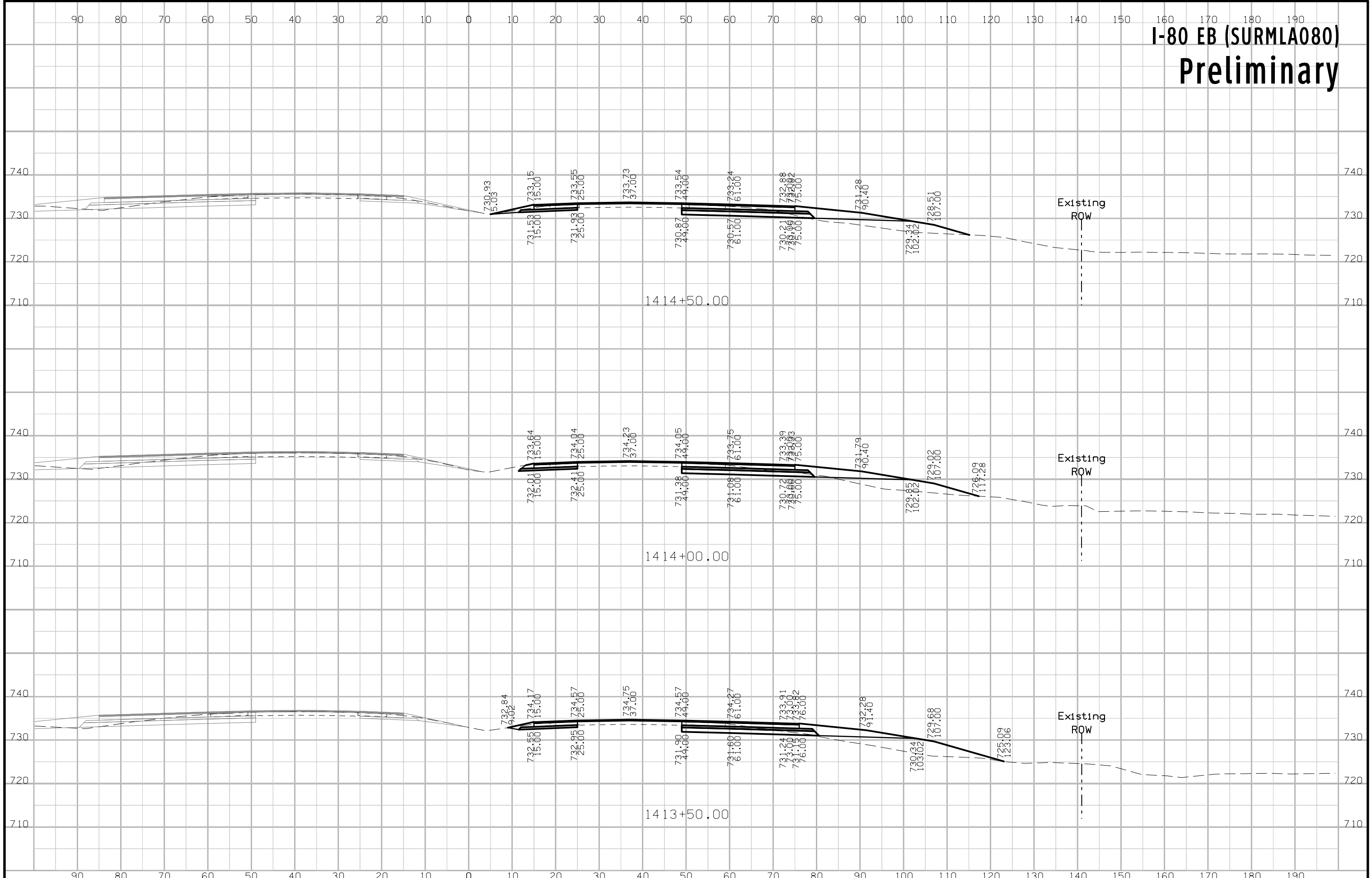

# I-80 EB (SURMLA080) Preliminary

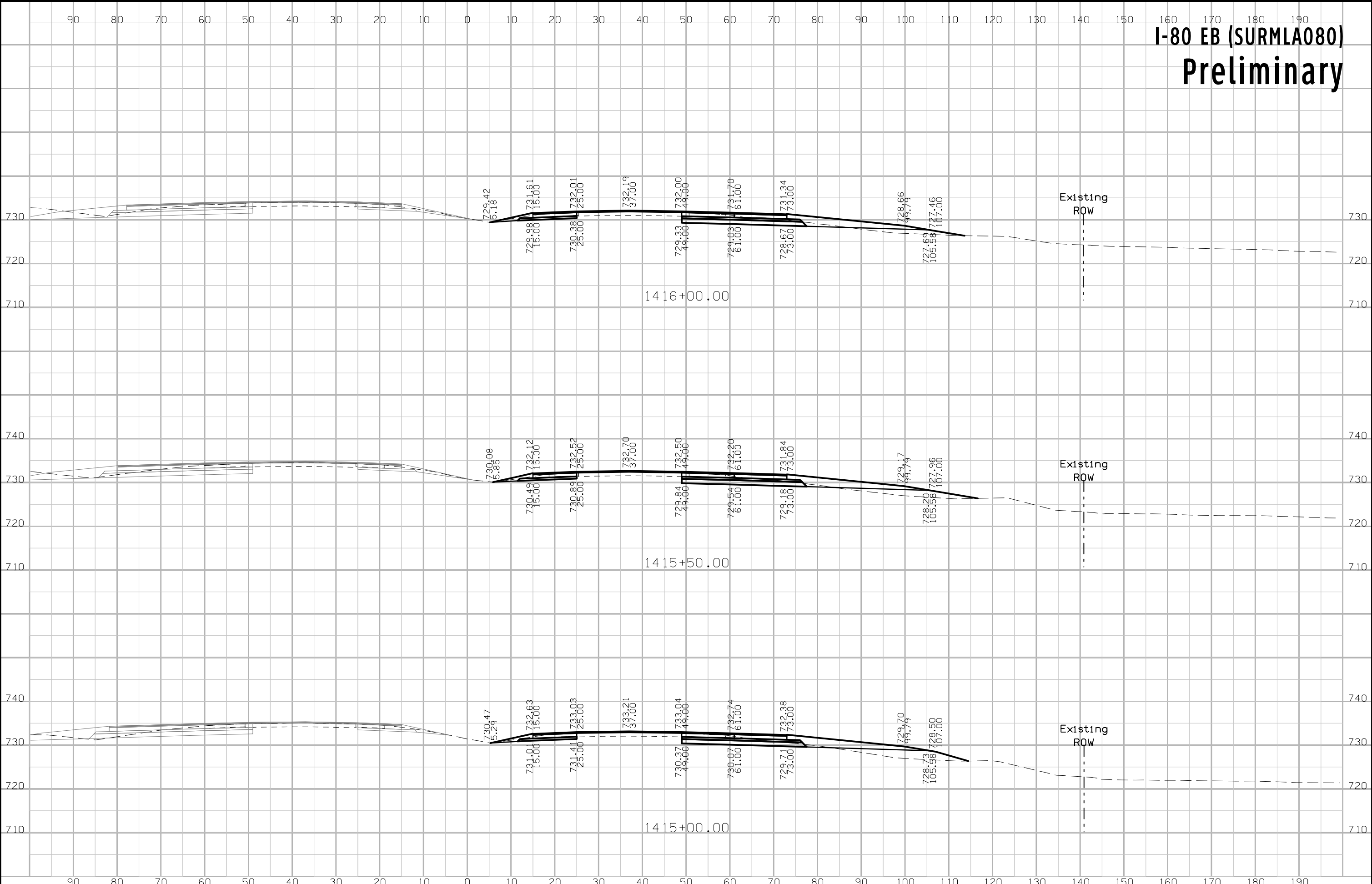



# I-80 EB (SURMLA080) Preliminary

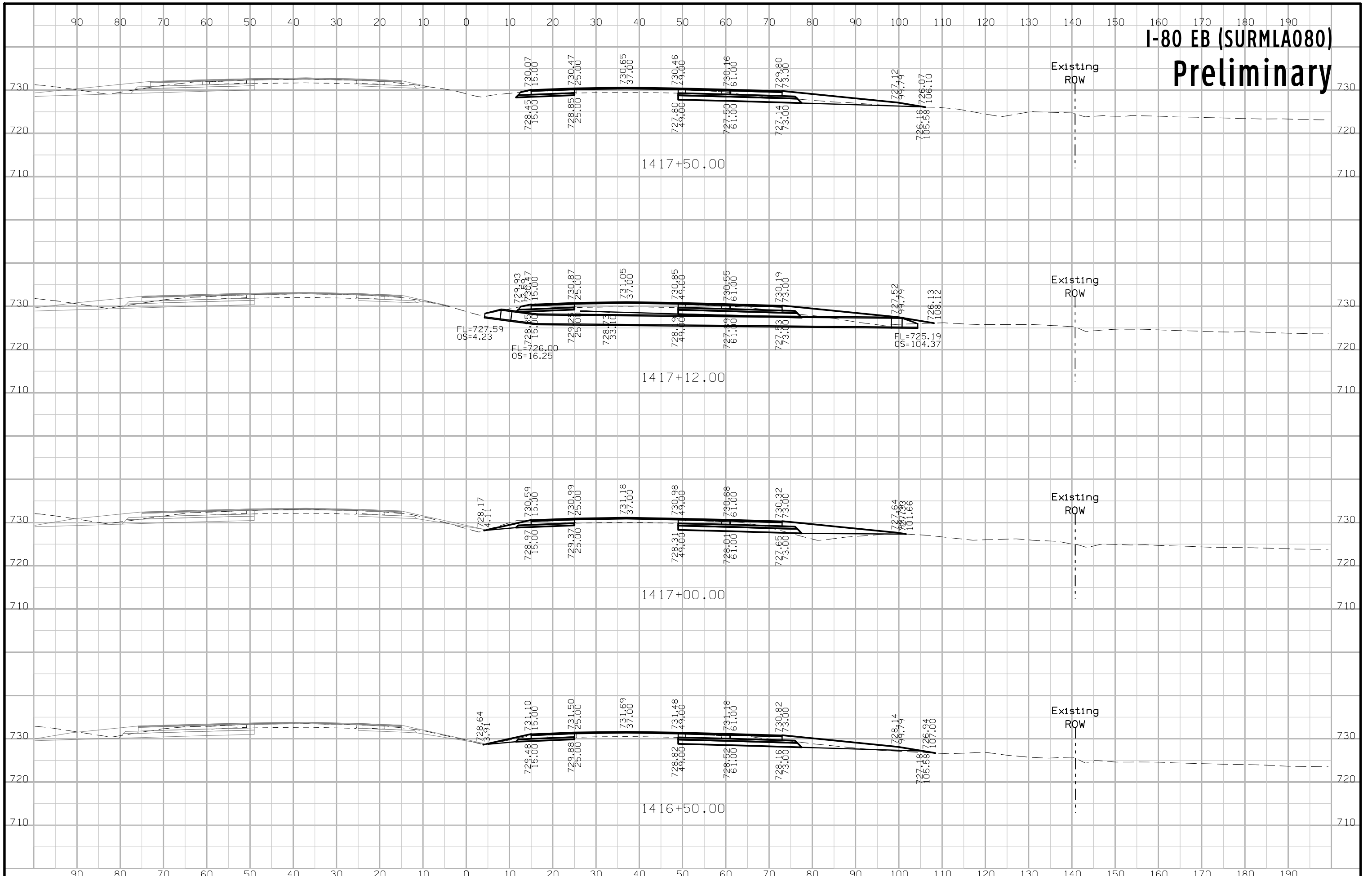

# I-80 EB (SURMLA080) Preliminary

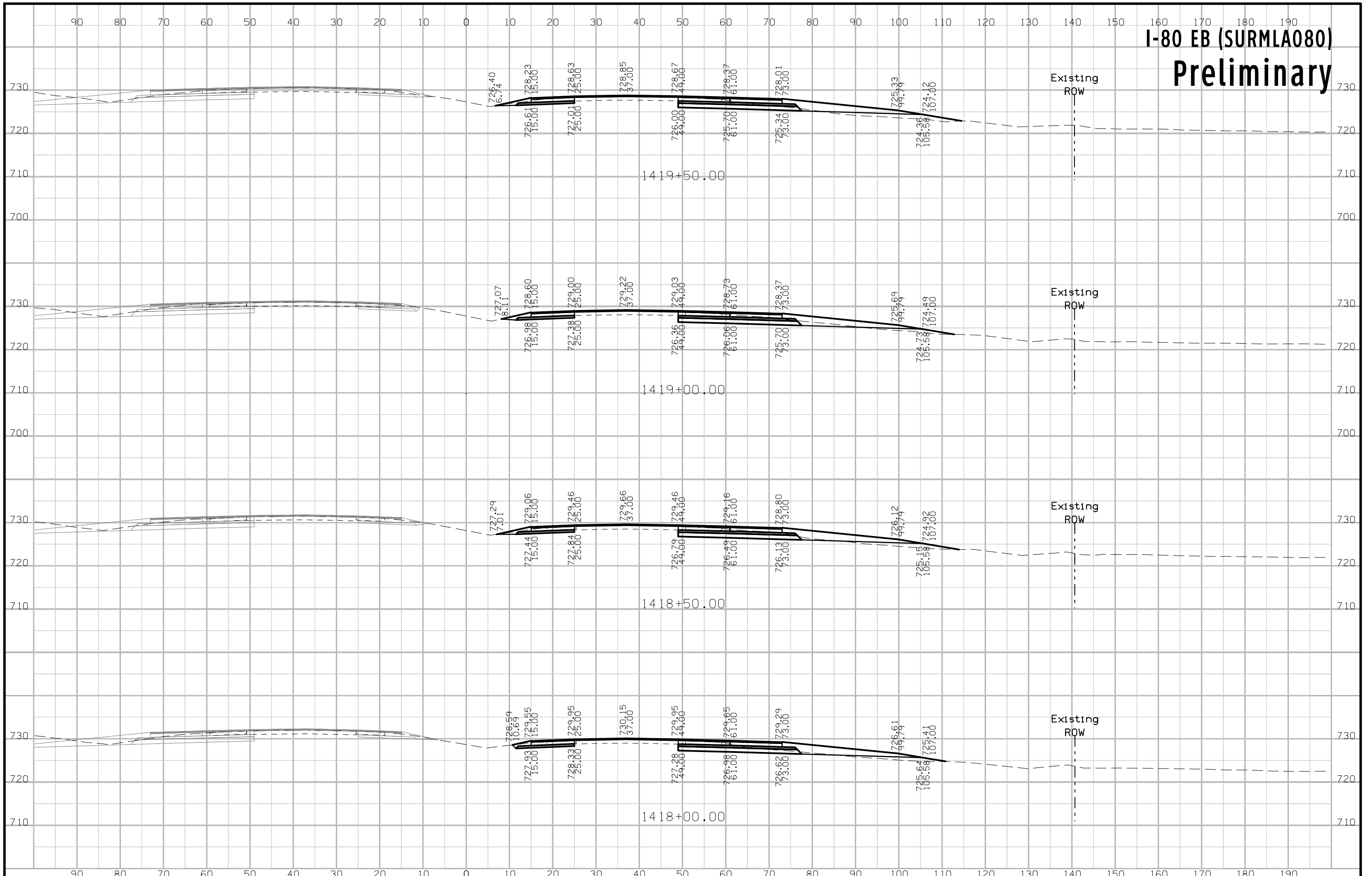

# I-80 EB (SURMLA080) Preliminary

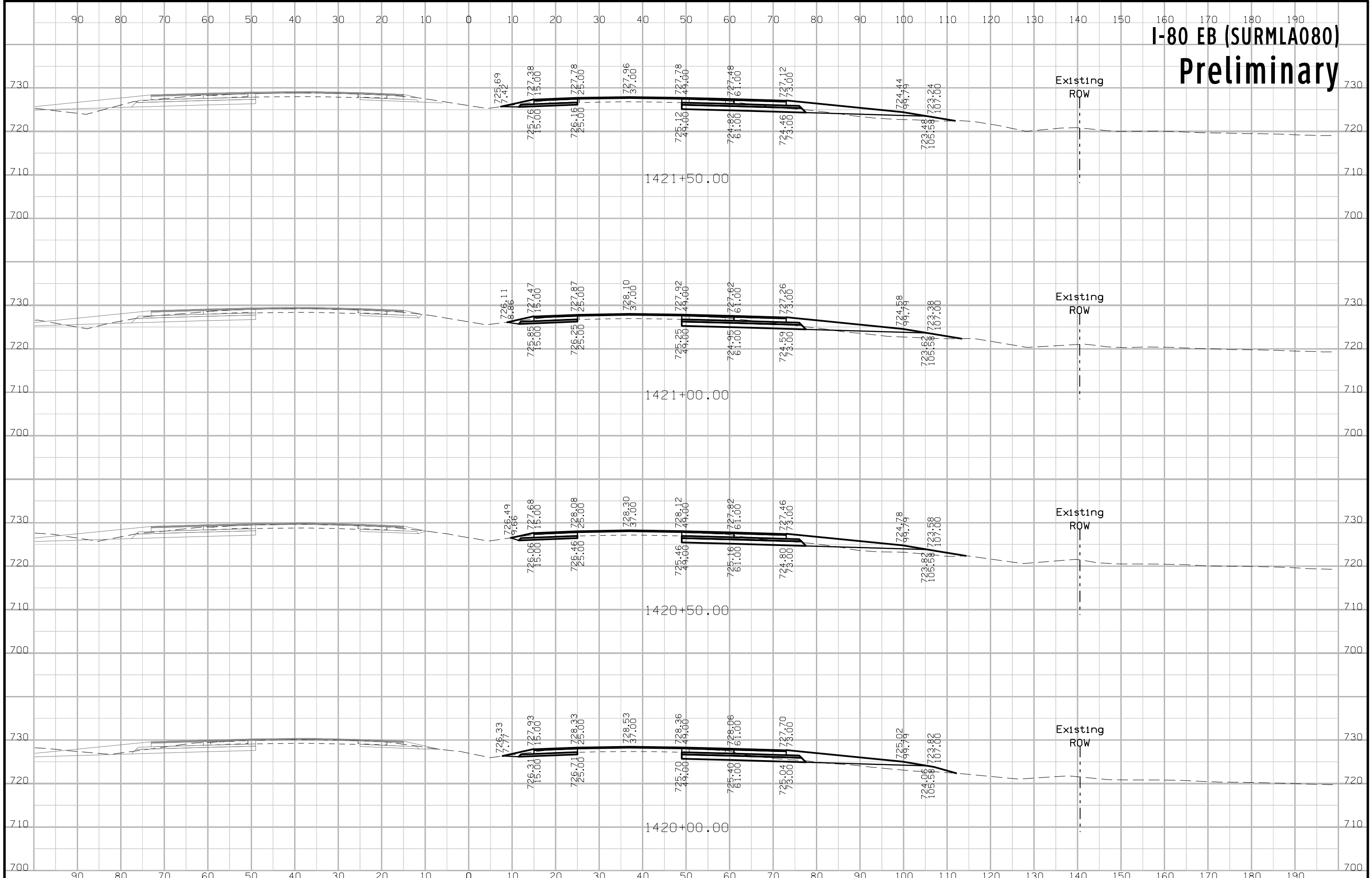

# I-80 EB (SURMLA080) Preliminary

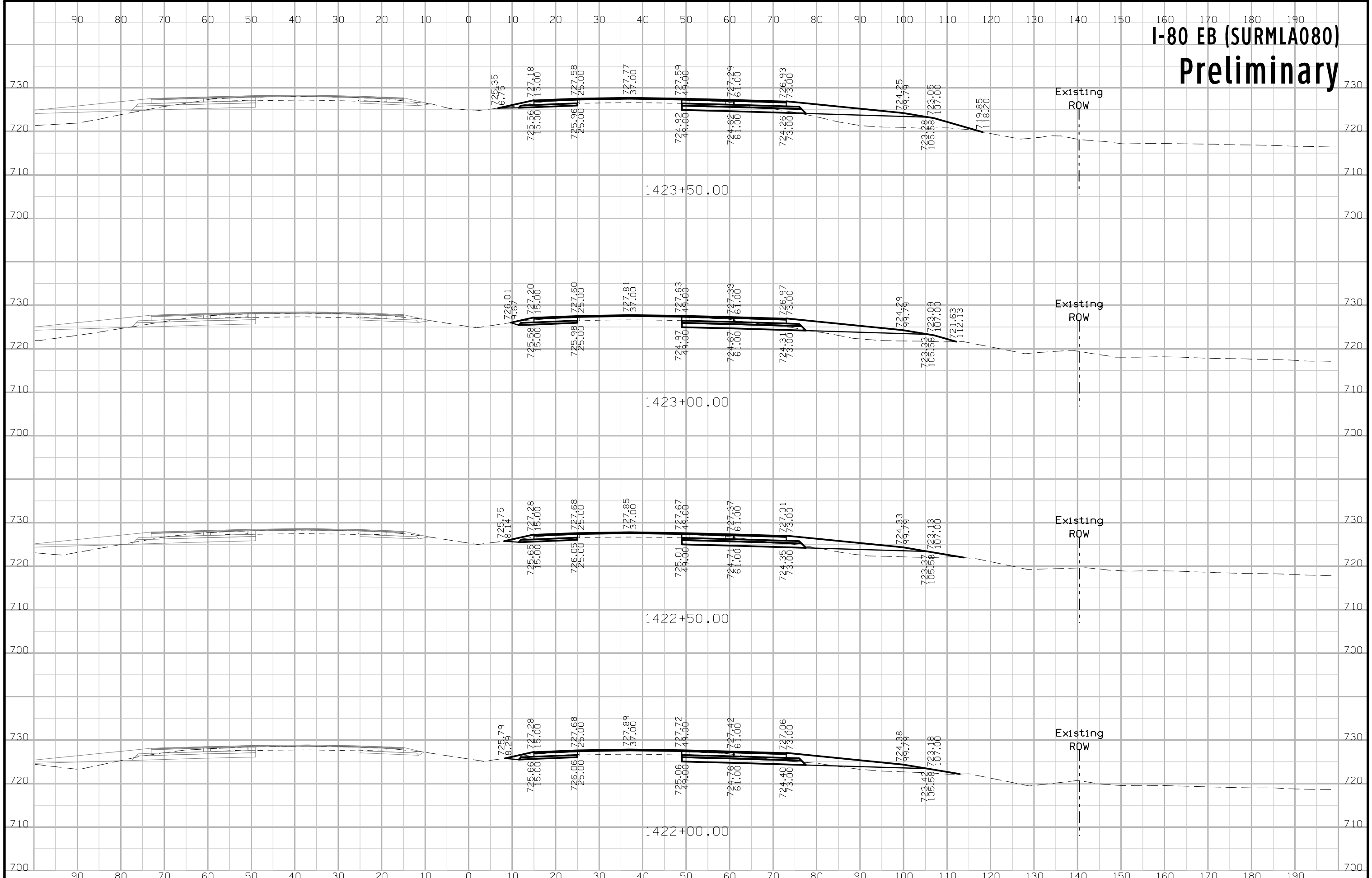

# I-80 EB (SURMLA080) Preliminary

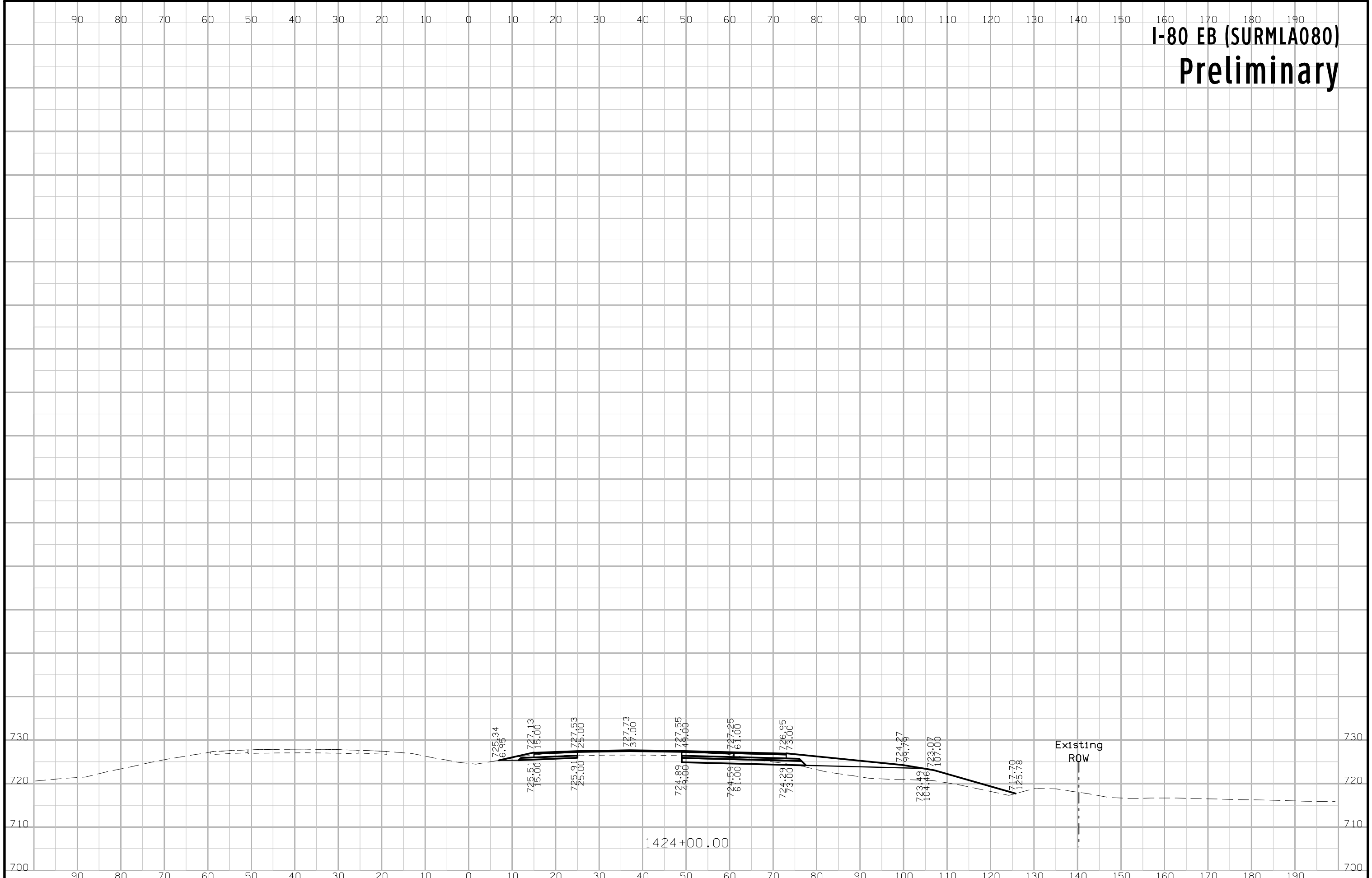

**SHEET INTENTIONALLY LEFT BLANK**

# 306th St. Preliminary

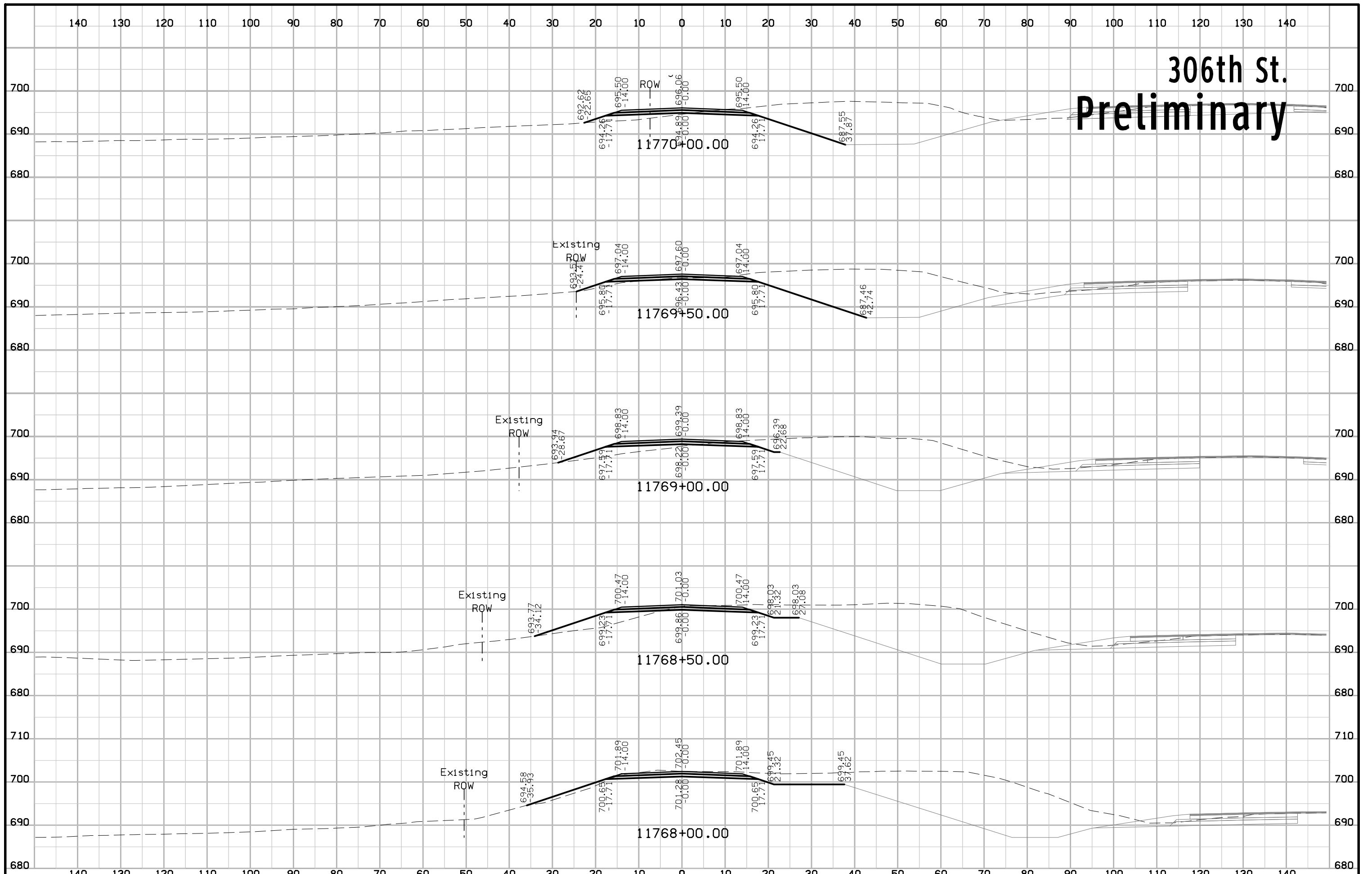

# 306th St. Preliminary

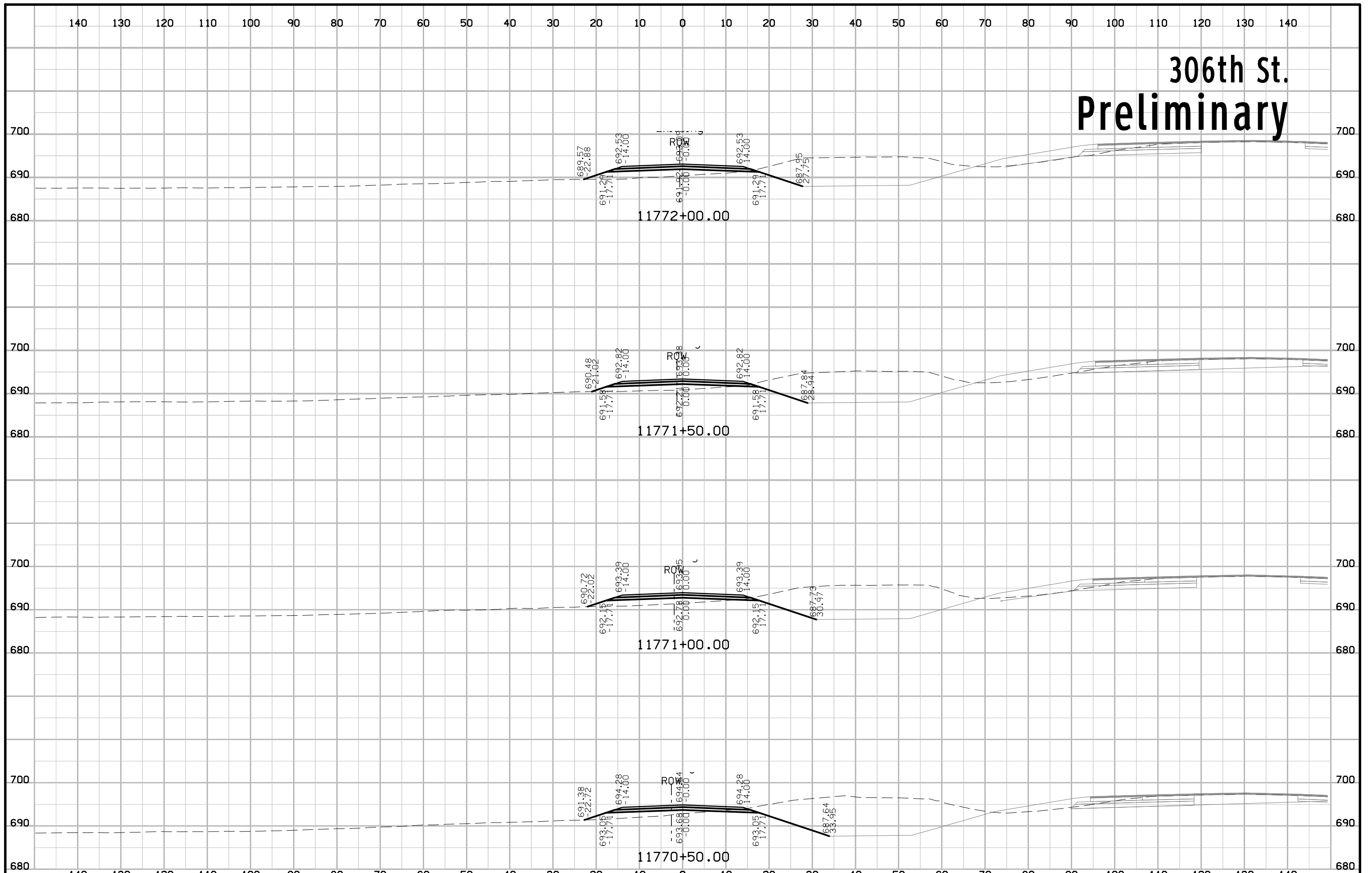



# 306th St. Preliminary

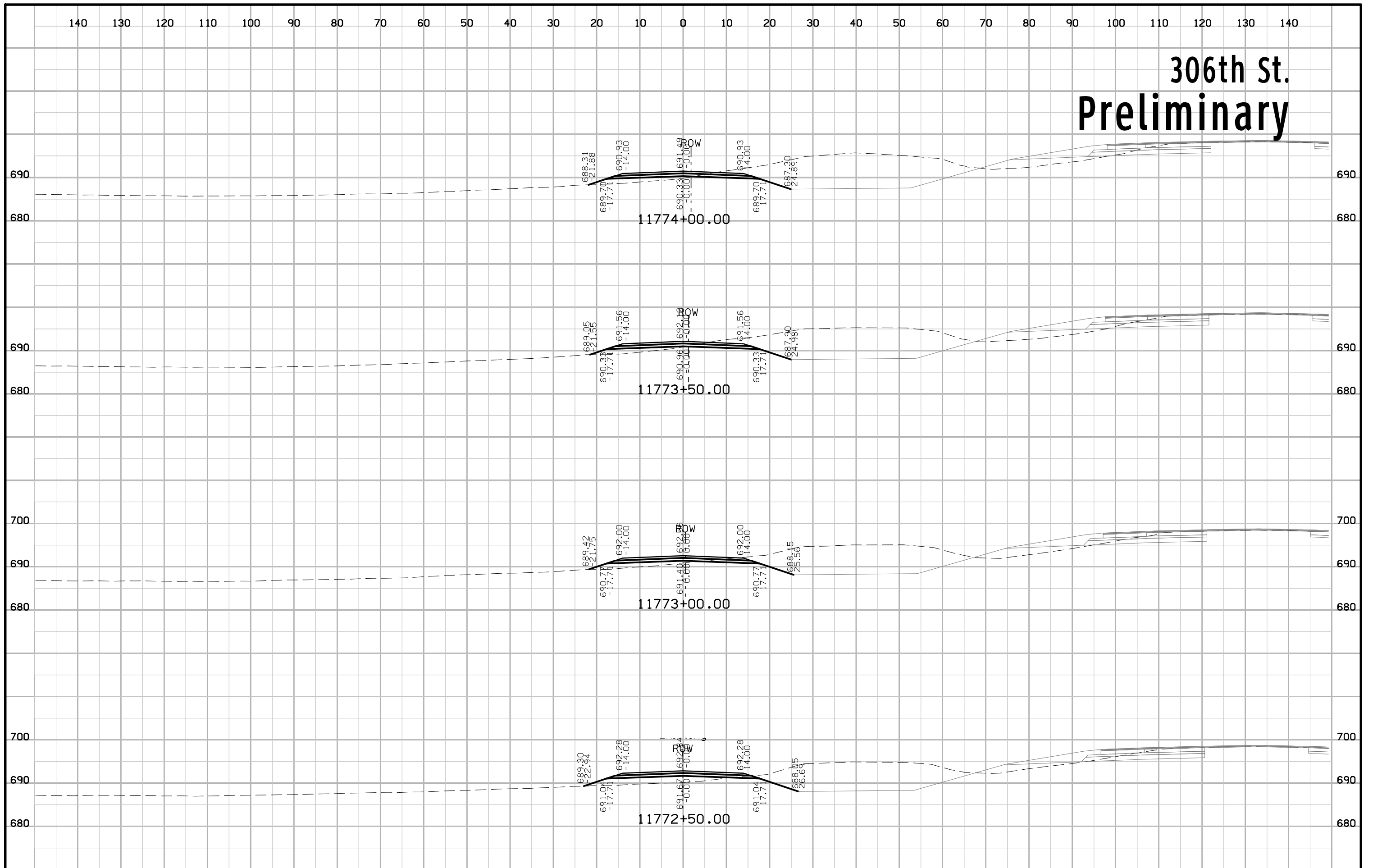

# 306th St. Preliminary

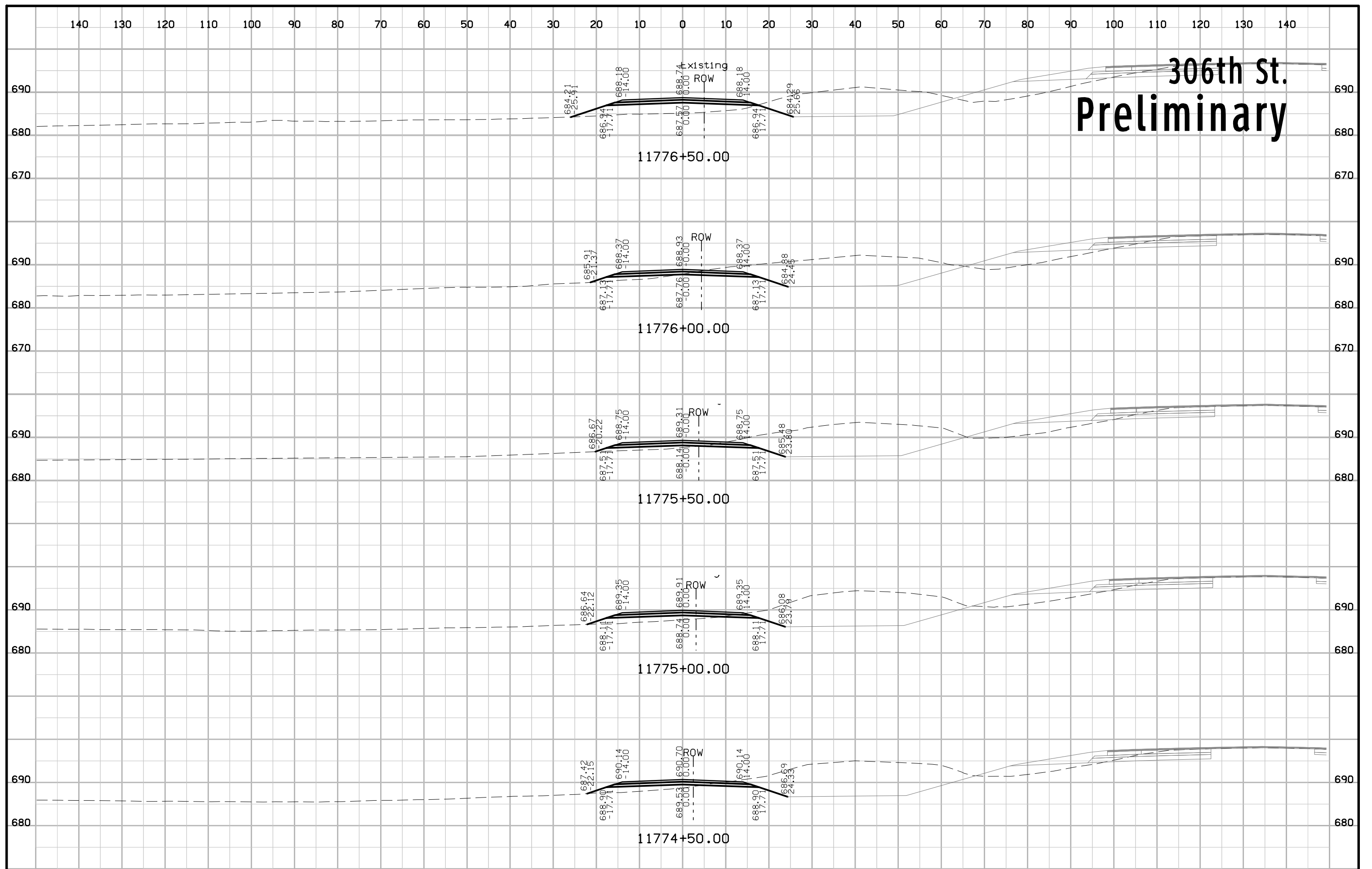

# 306th St. Preliminary

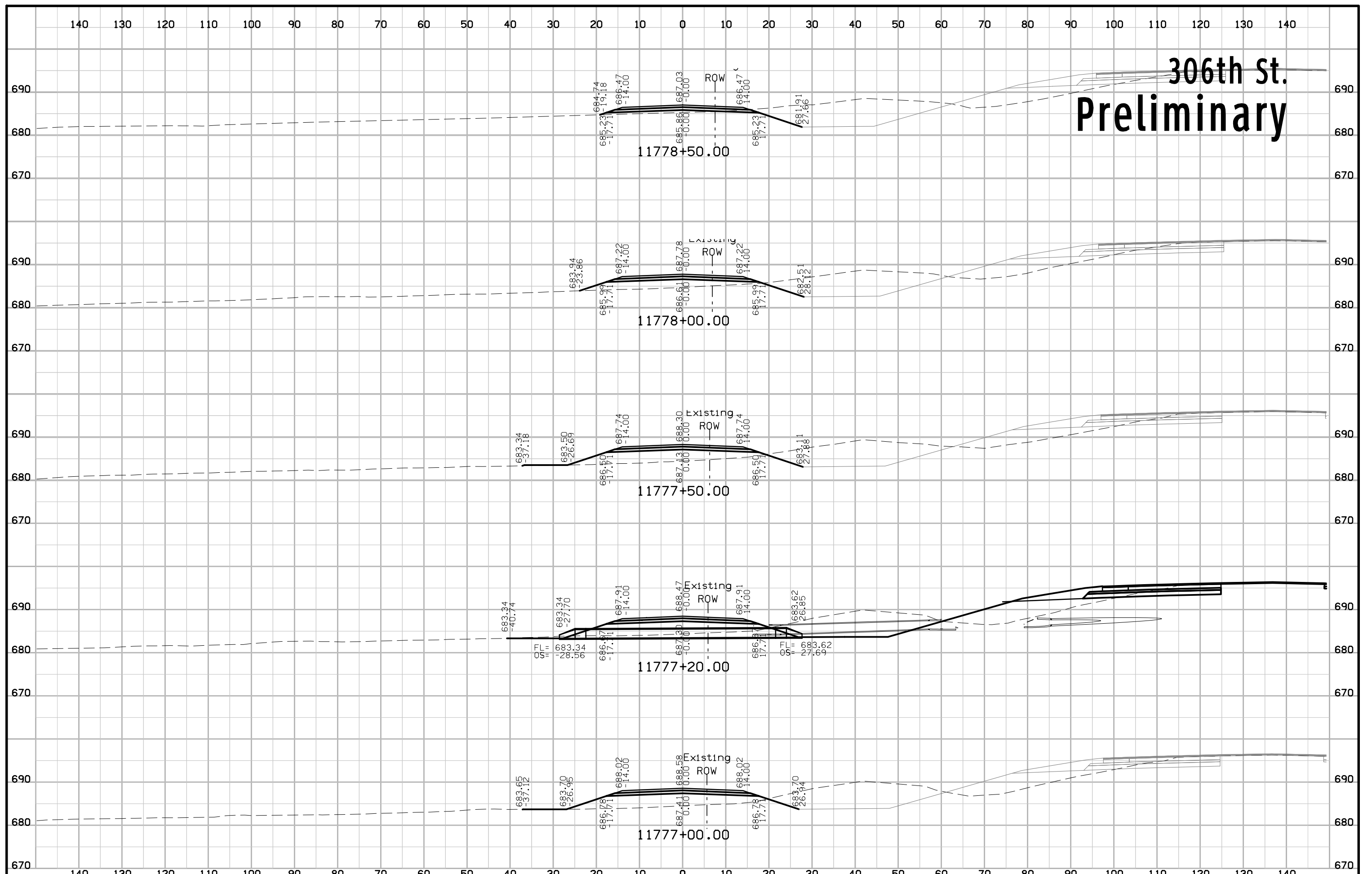

# 306th St. Preliminary

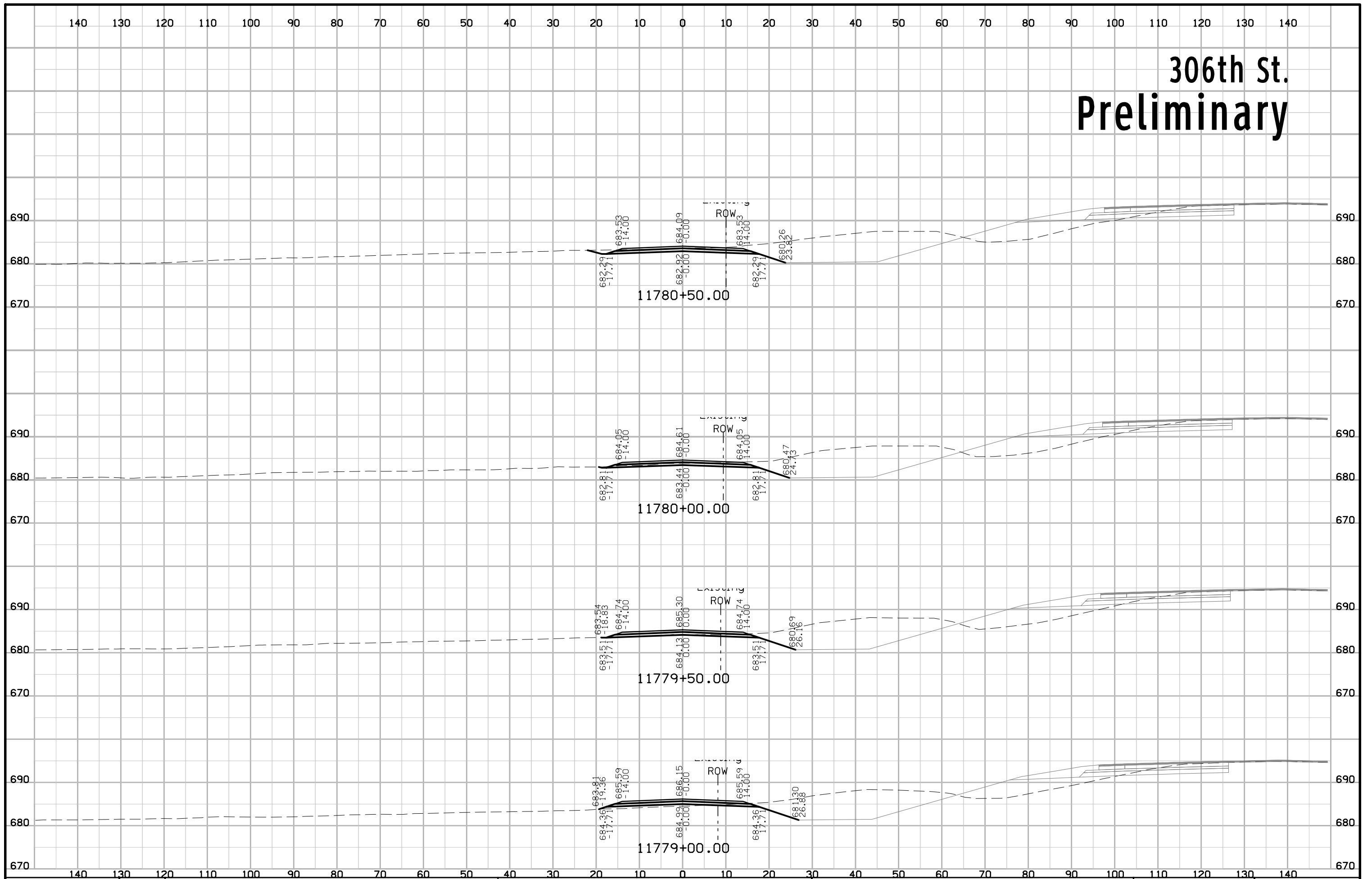

# 306th St. Preliminary

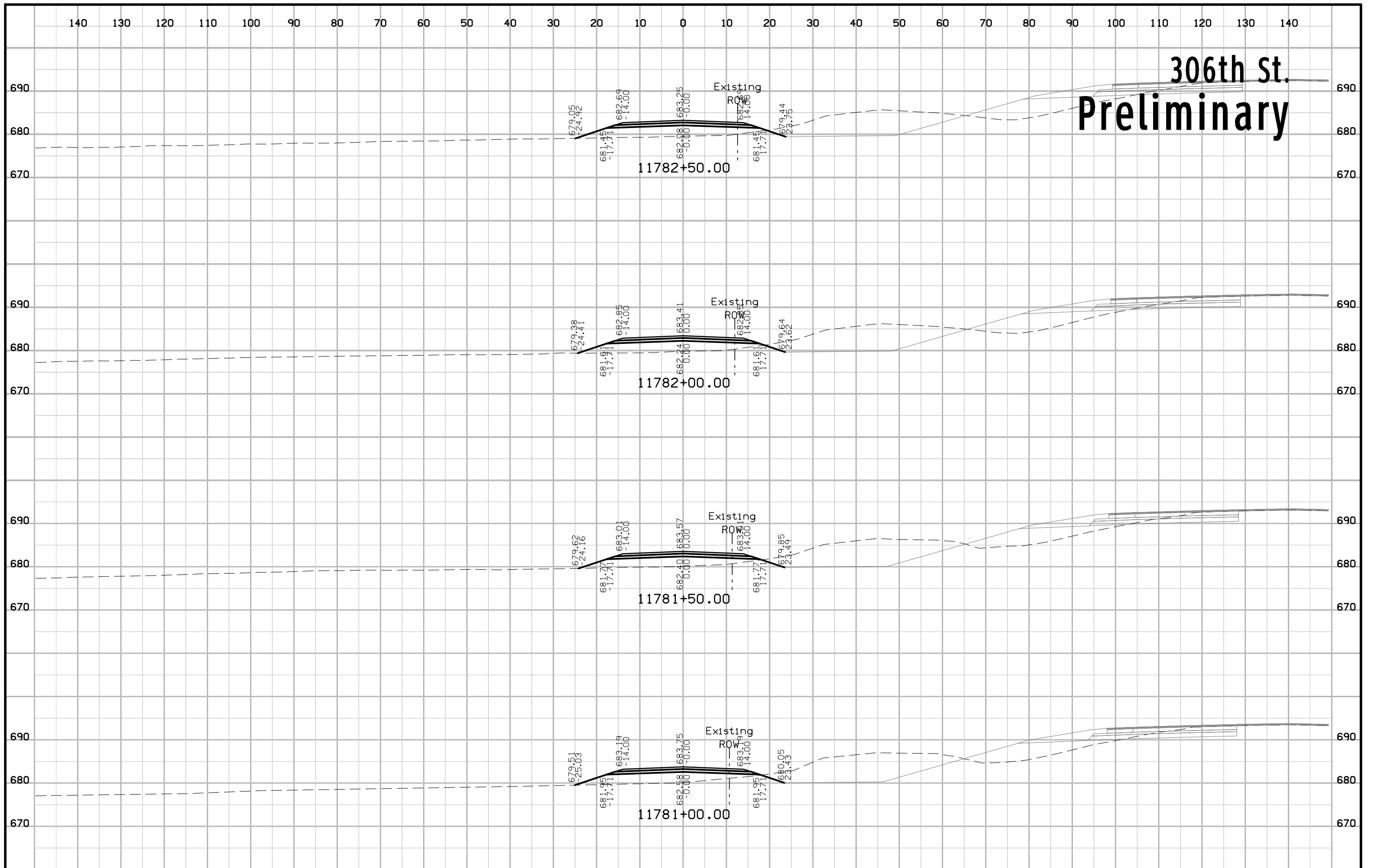

# 306th St. Preliminary

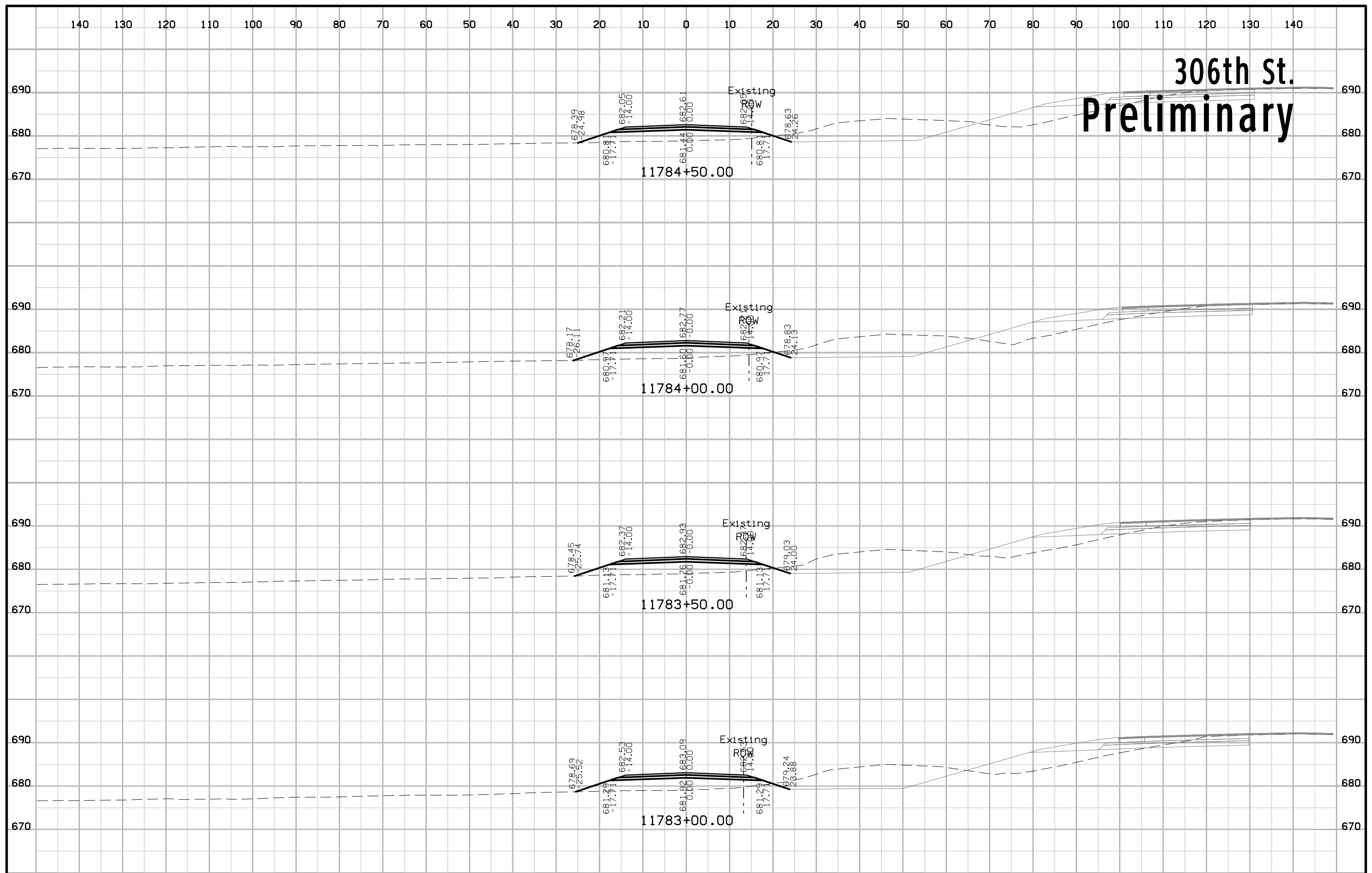

# 306th St. Preliminary

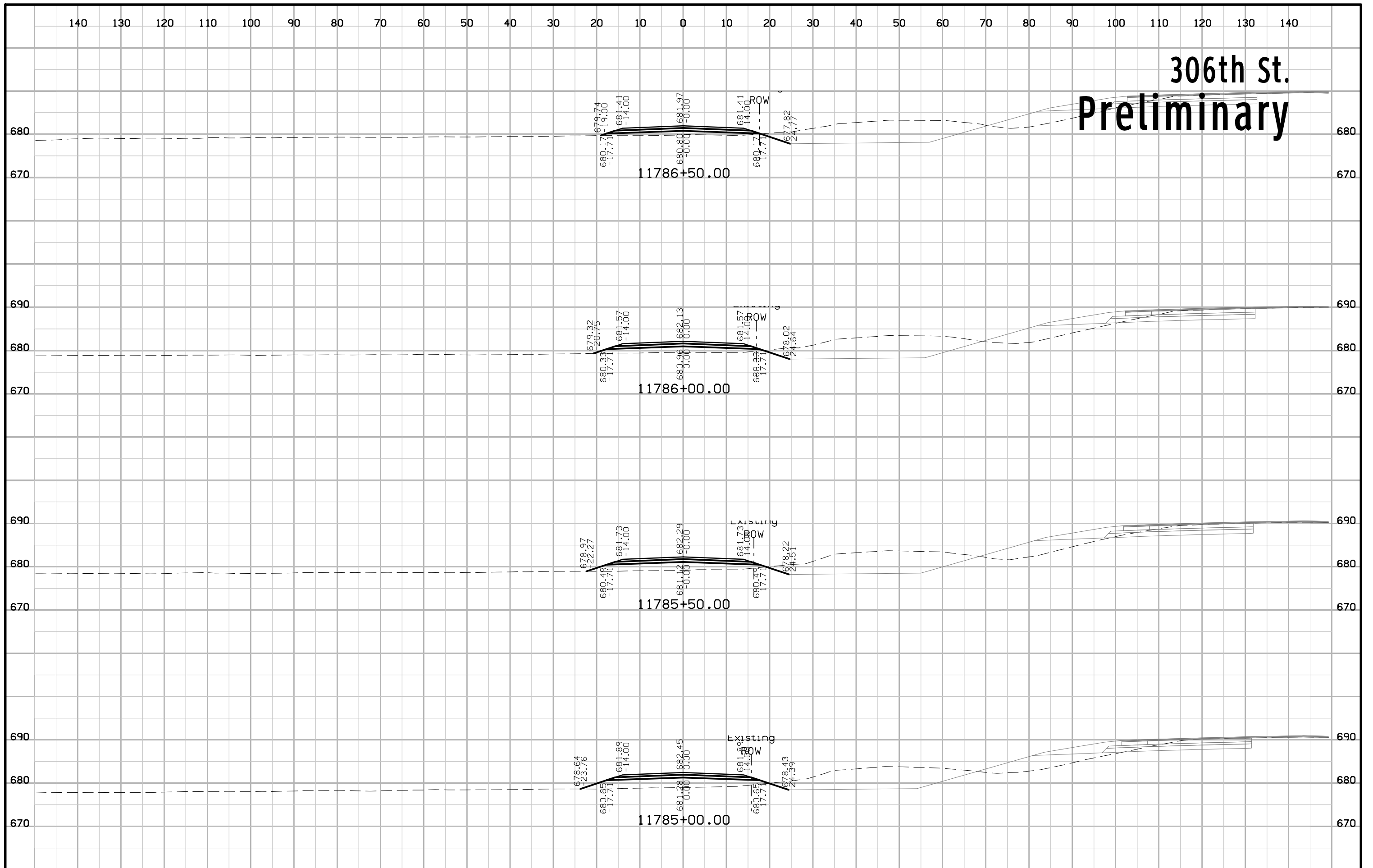

# 306th St. Preliminary

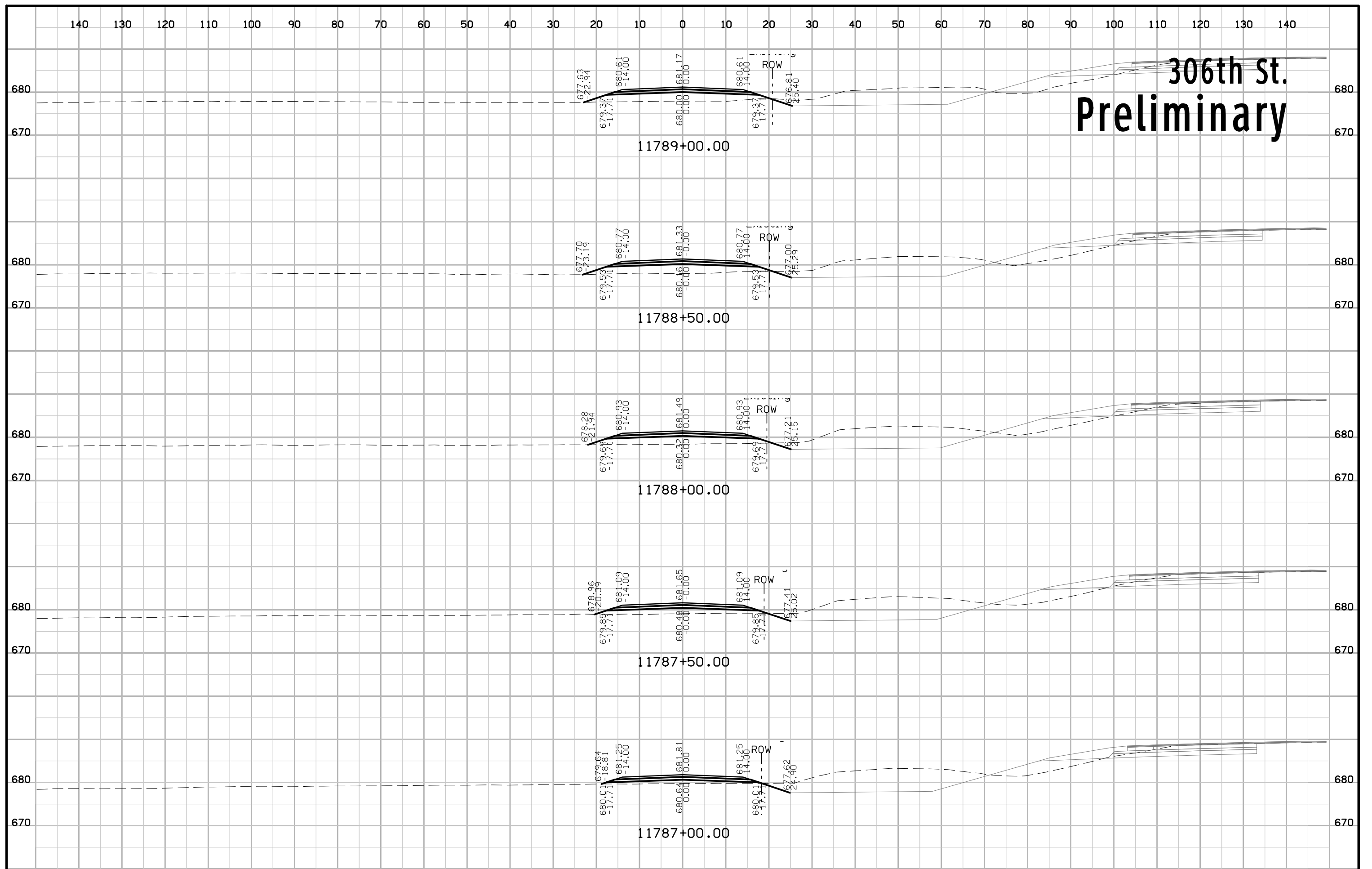



# 306th St. Preliminary

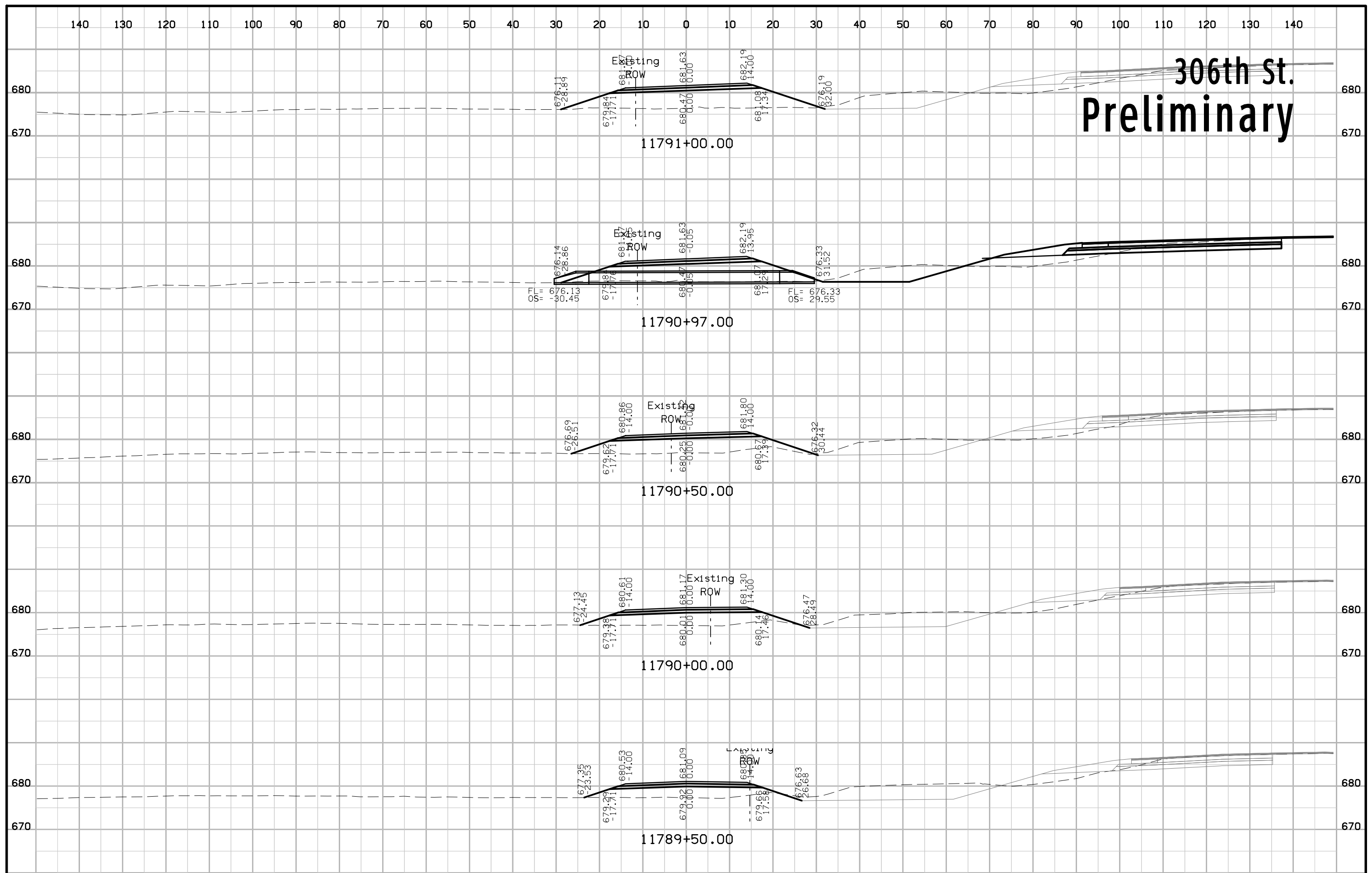

# 306th St. Preliminary

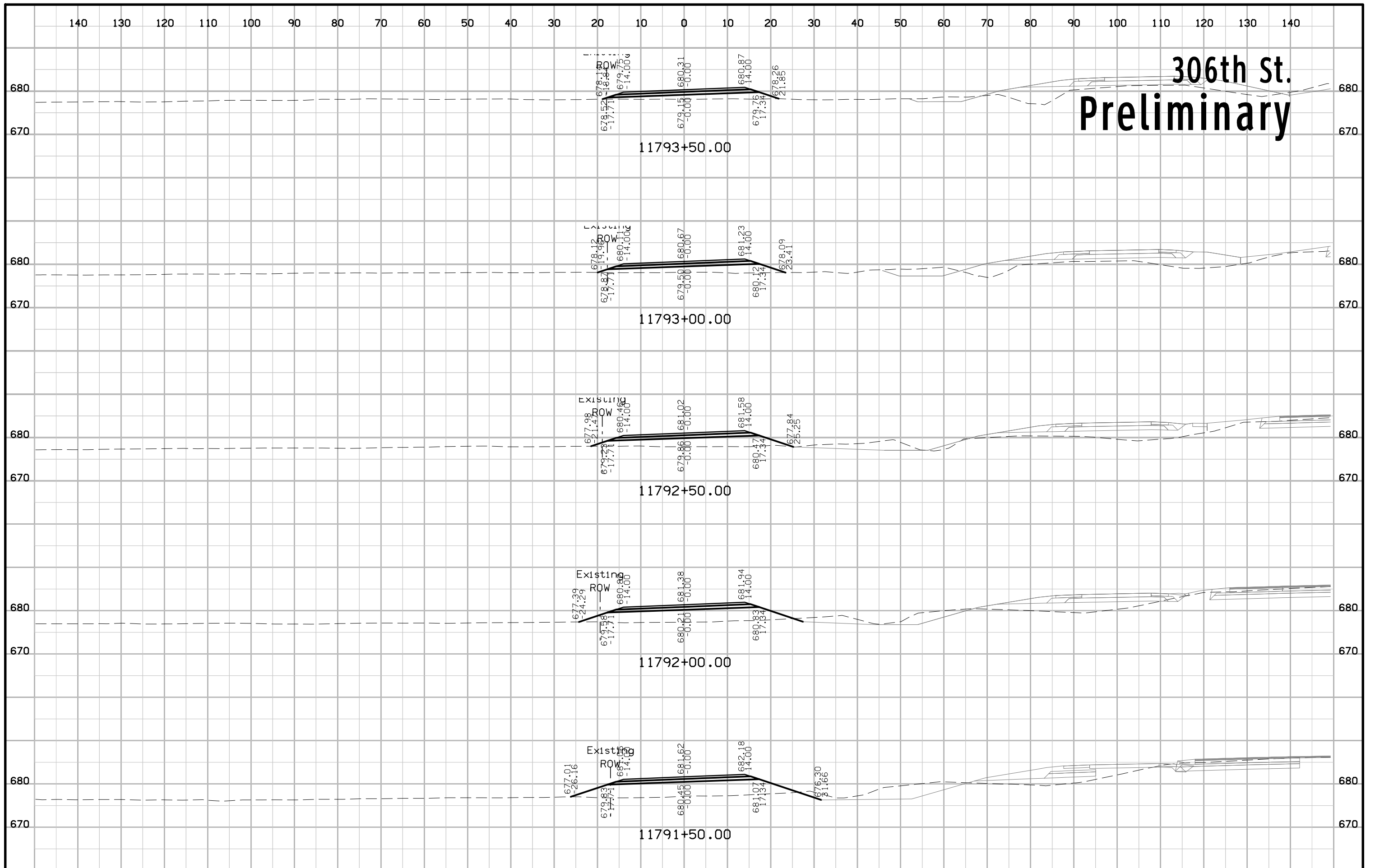

# 306th St. Preliminary

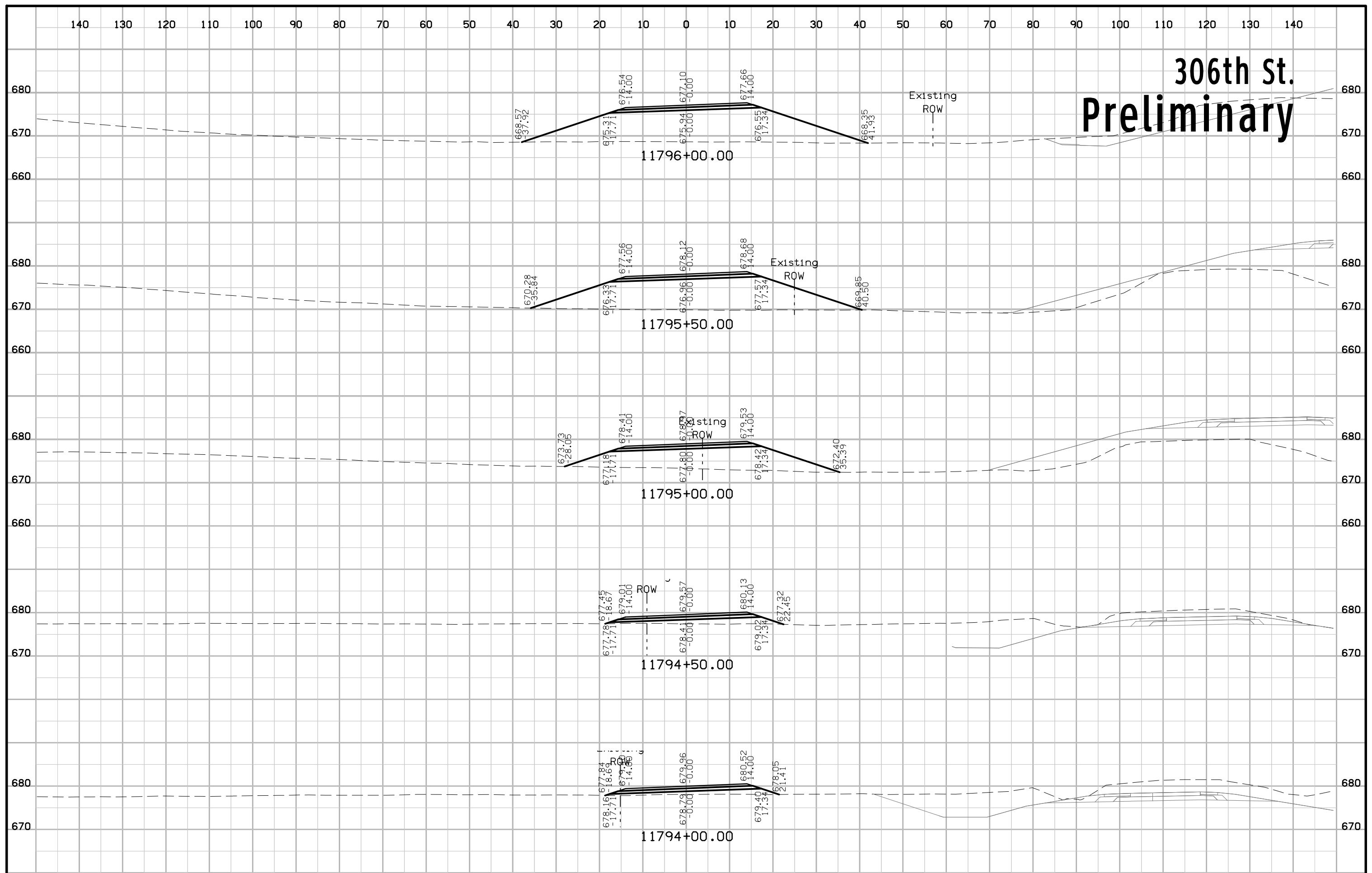

# 306th St. Preliminary

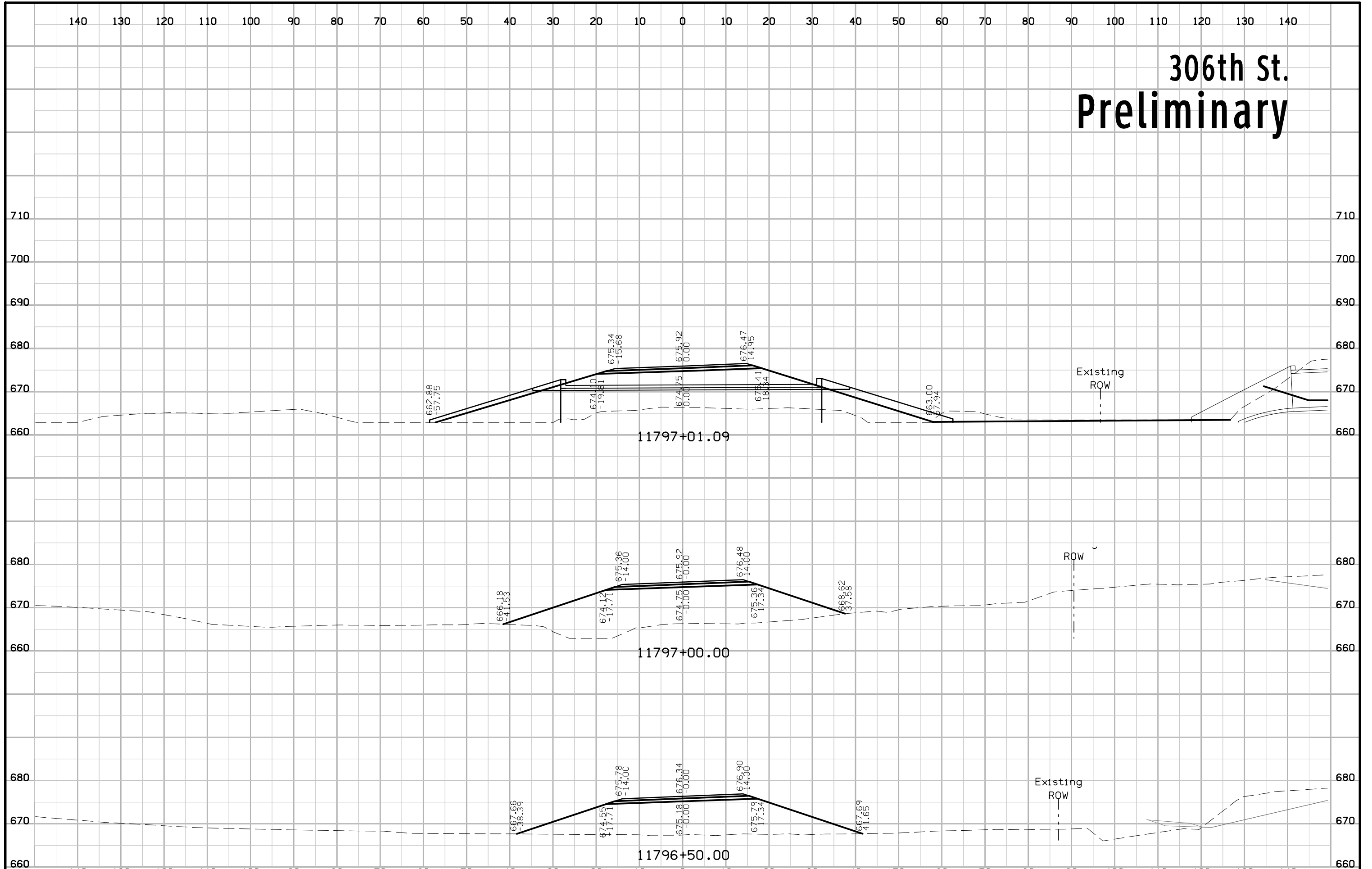

# 306th St. Preliminary

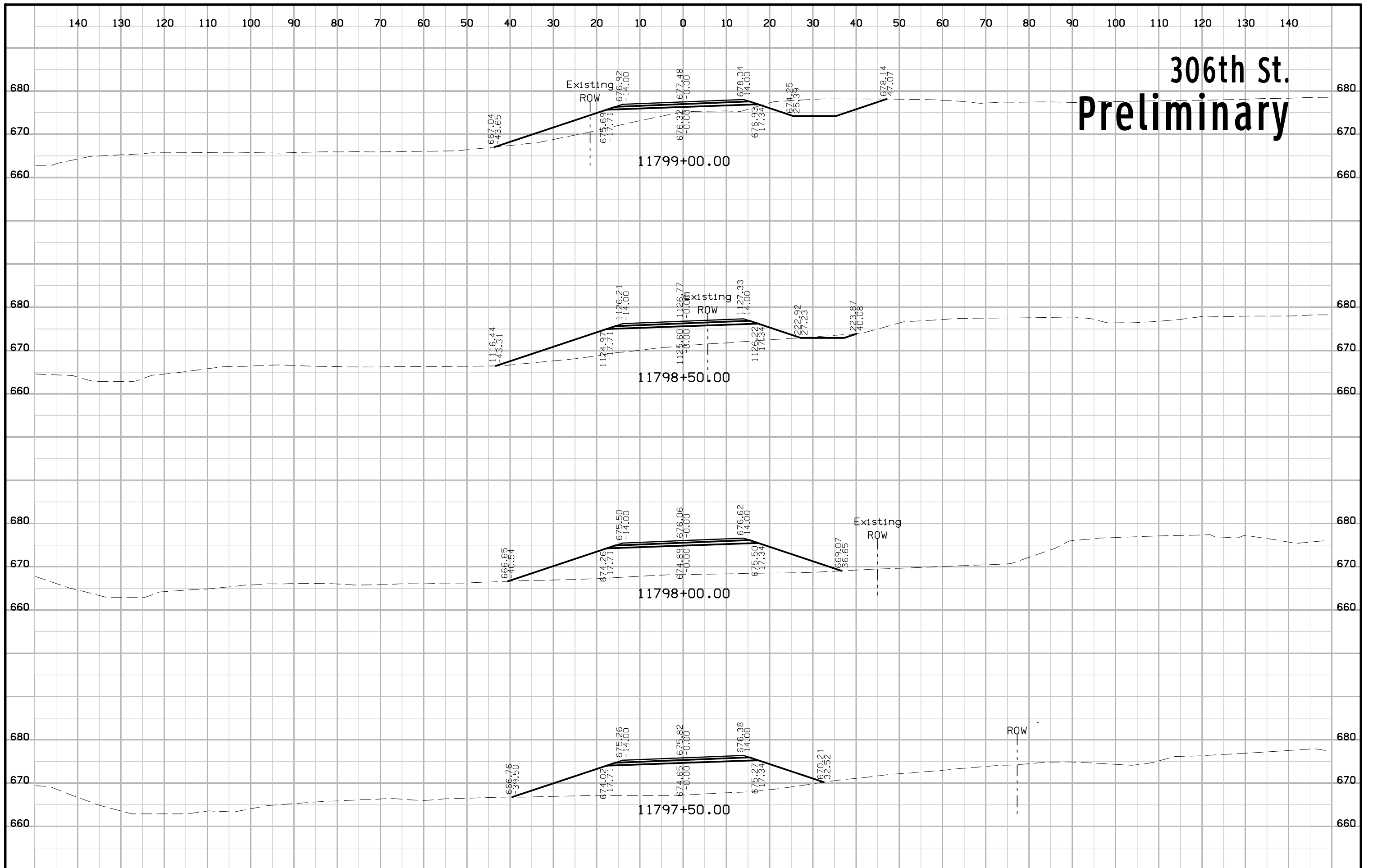

# 306th St. Preliminary

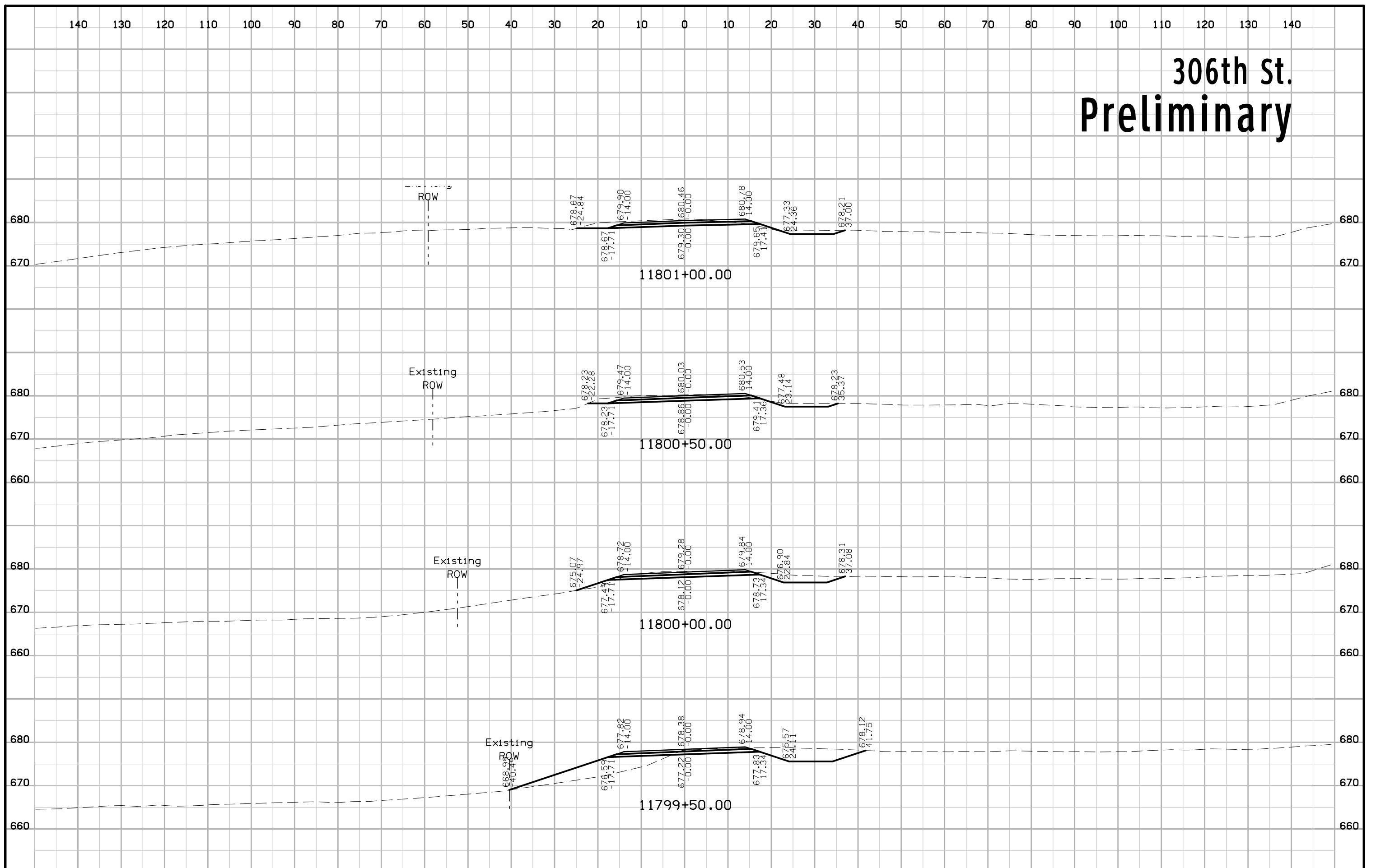

# 306th St. Preliminary

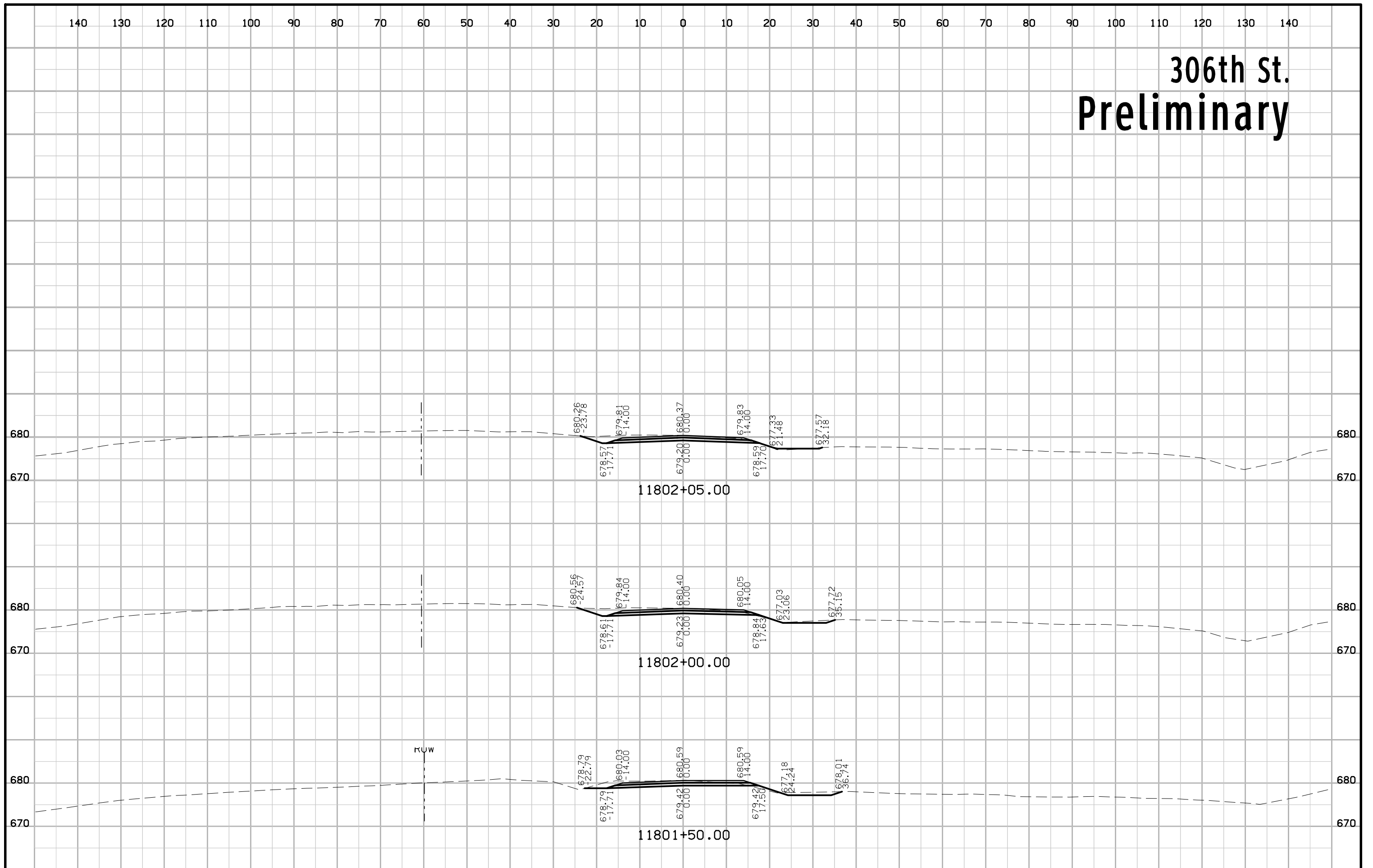

# 307th St. Preliminary

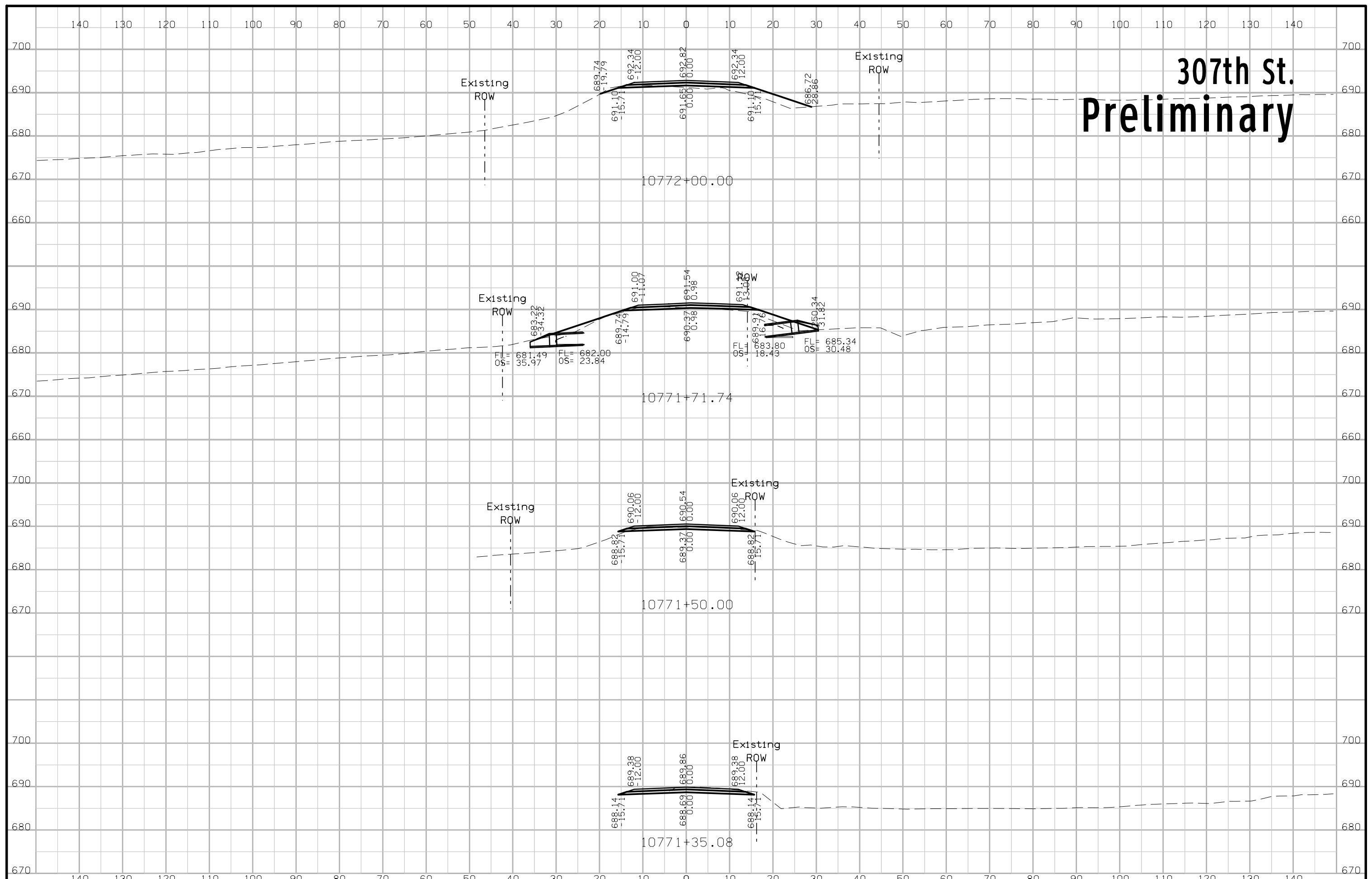



# 307th St. Preliminary

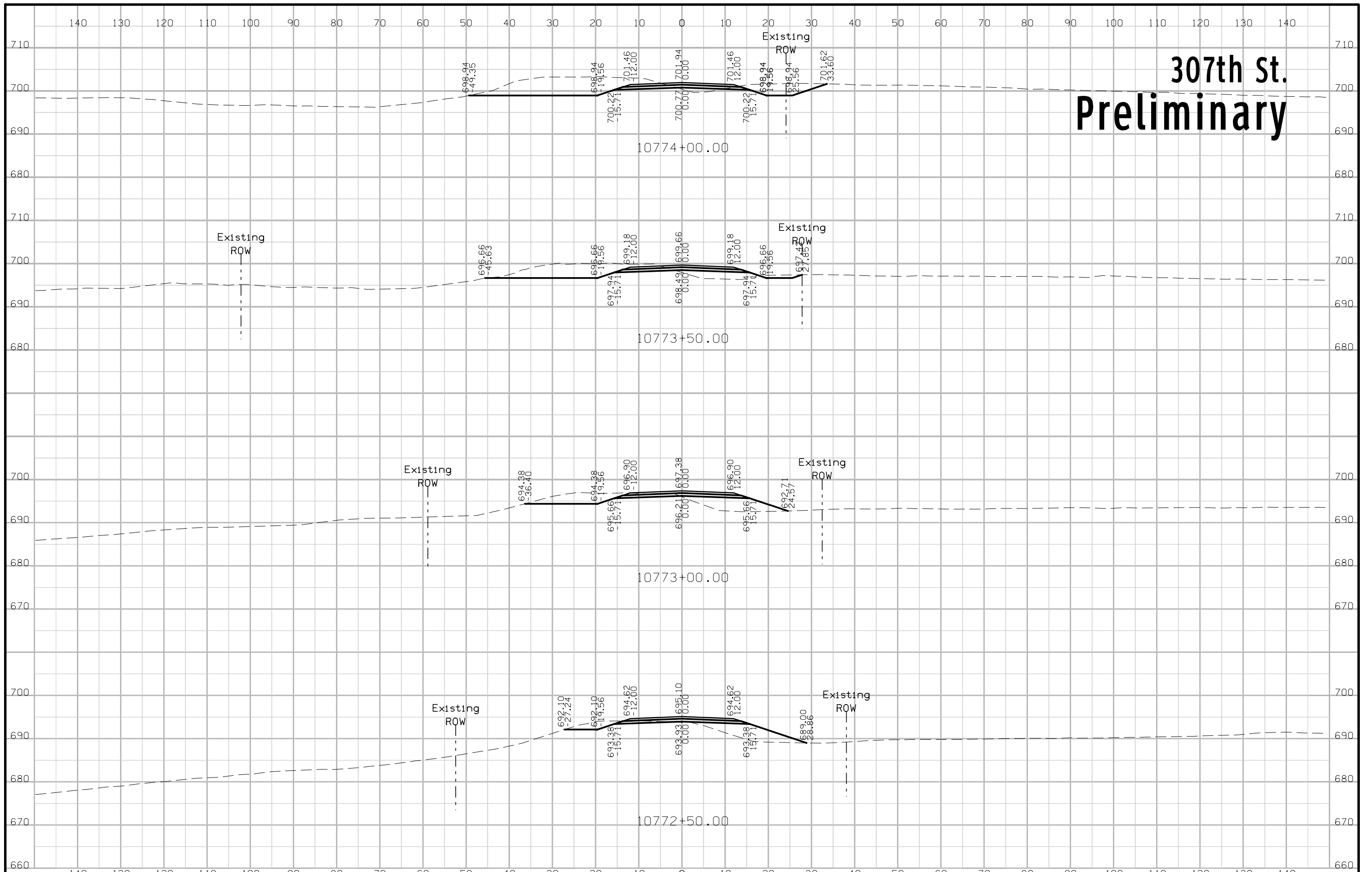

# 307th St. Preliminary

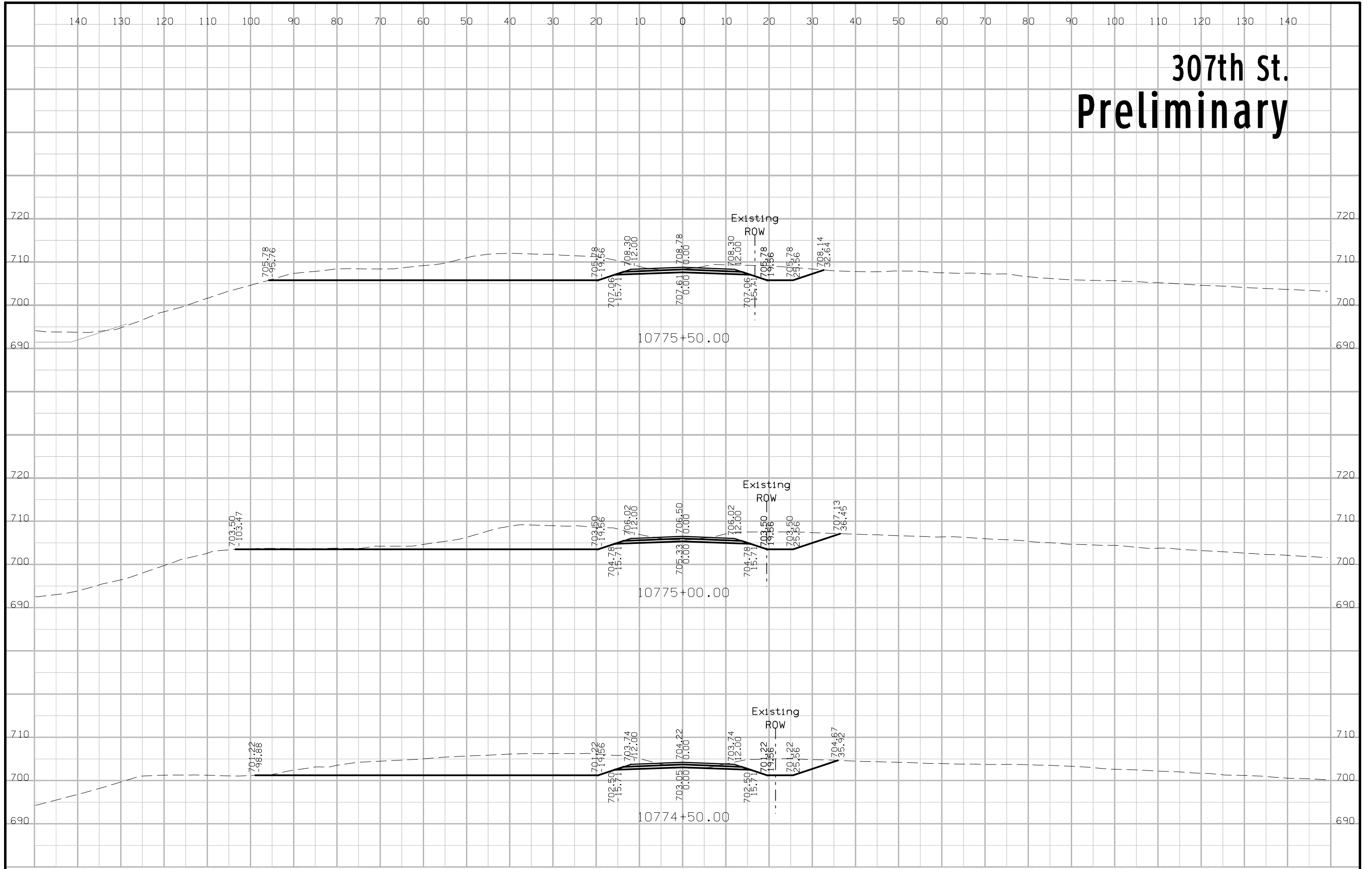

# 307th St. Preliminary

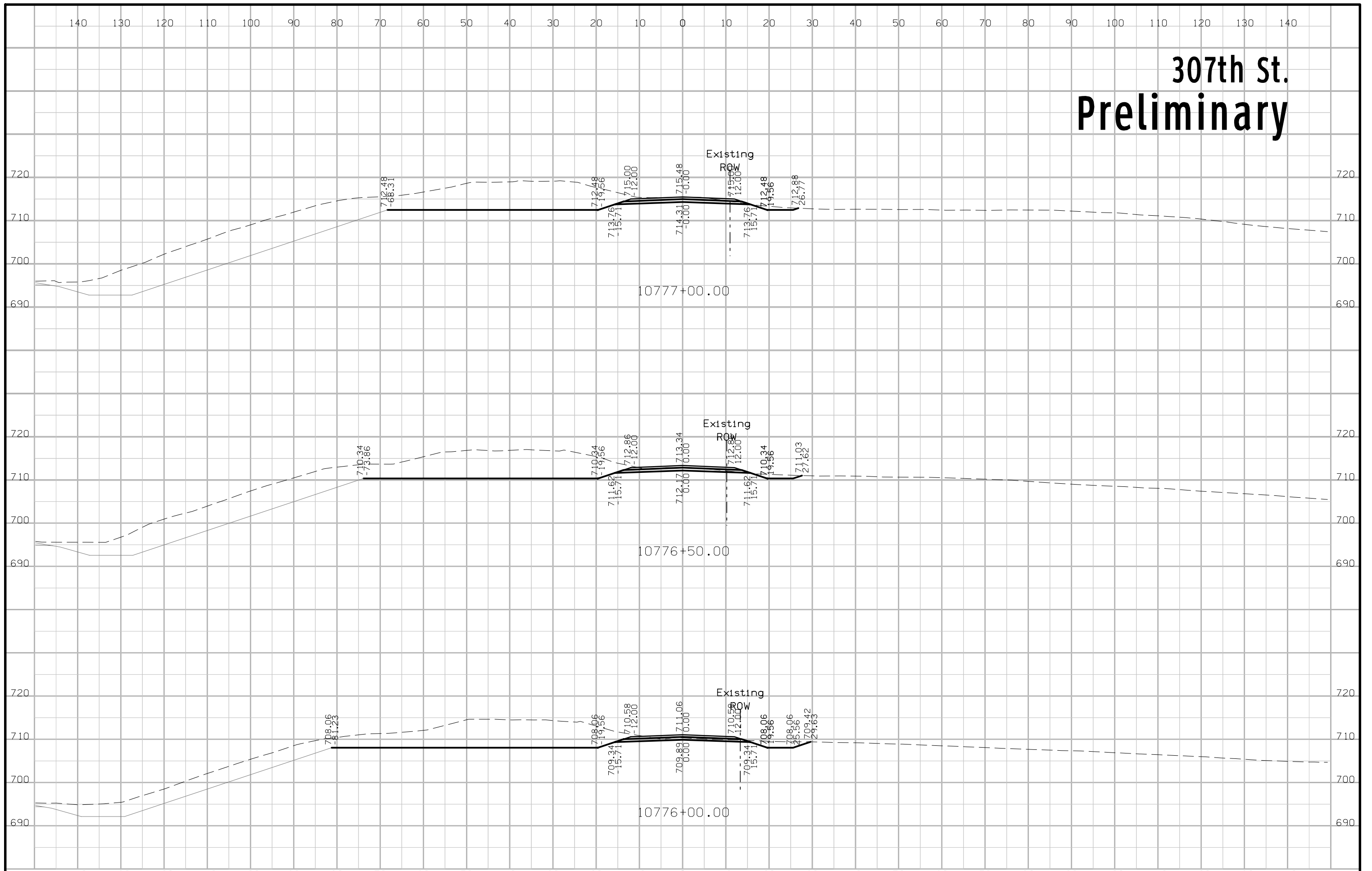

# 307th St. Preliminary

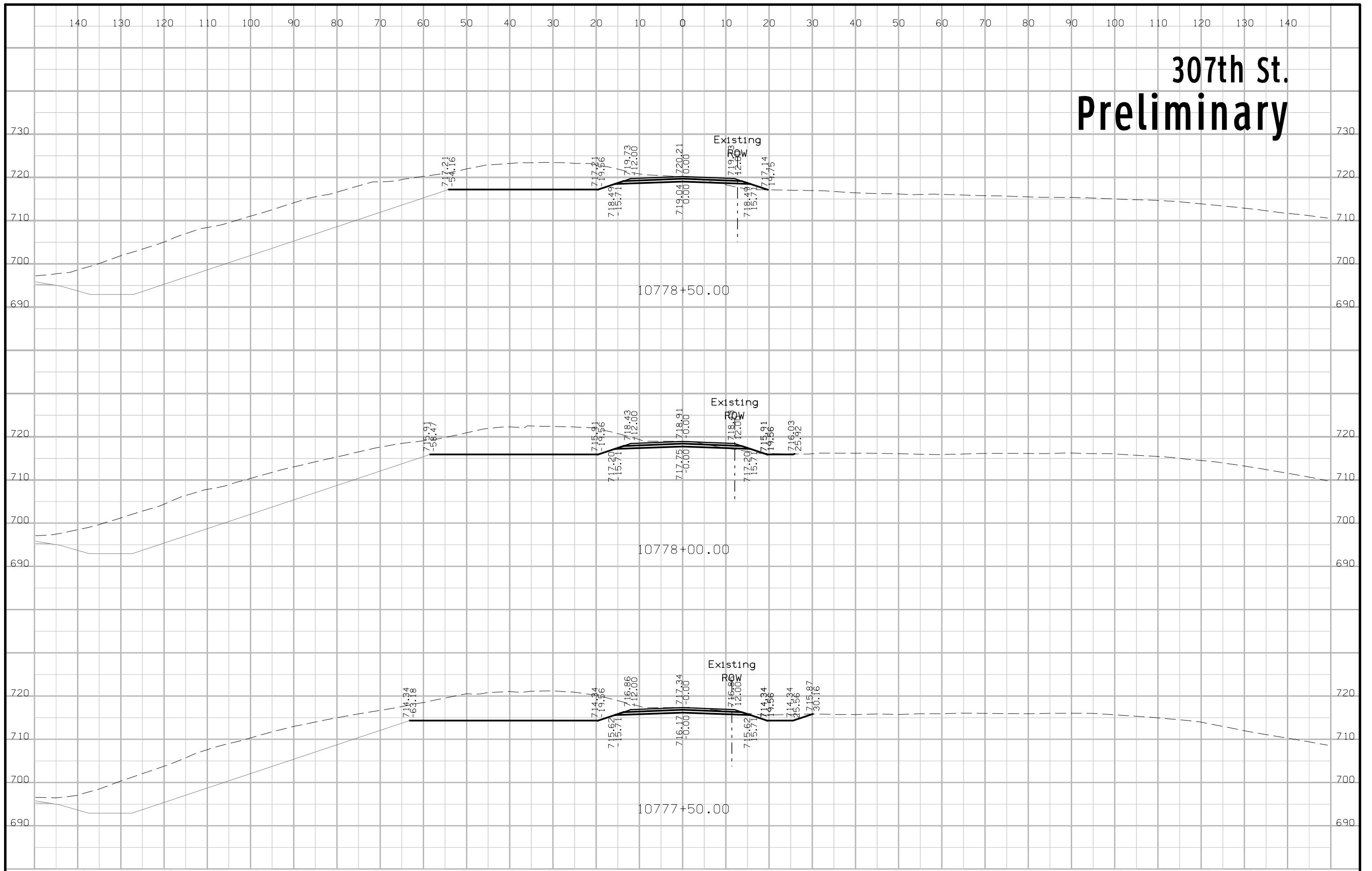

# 307th St. Preliminary

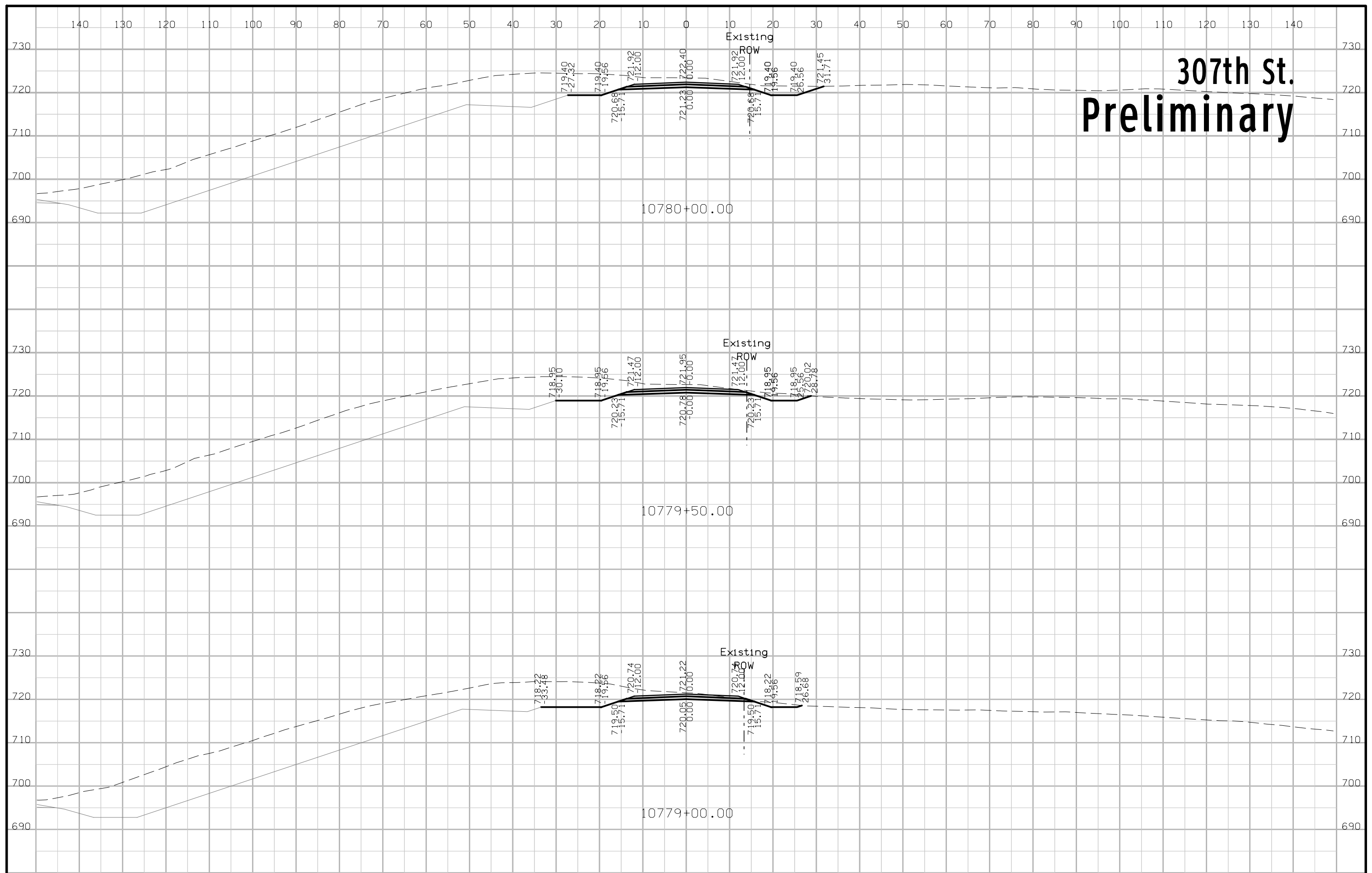

# 307th St. Preliminary

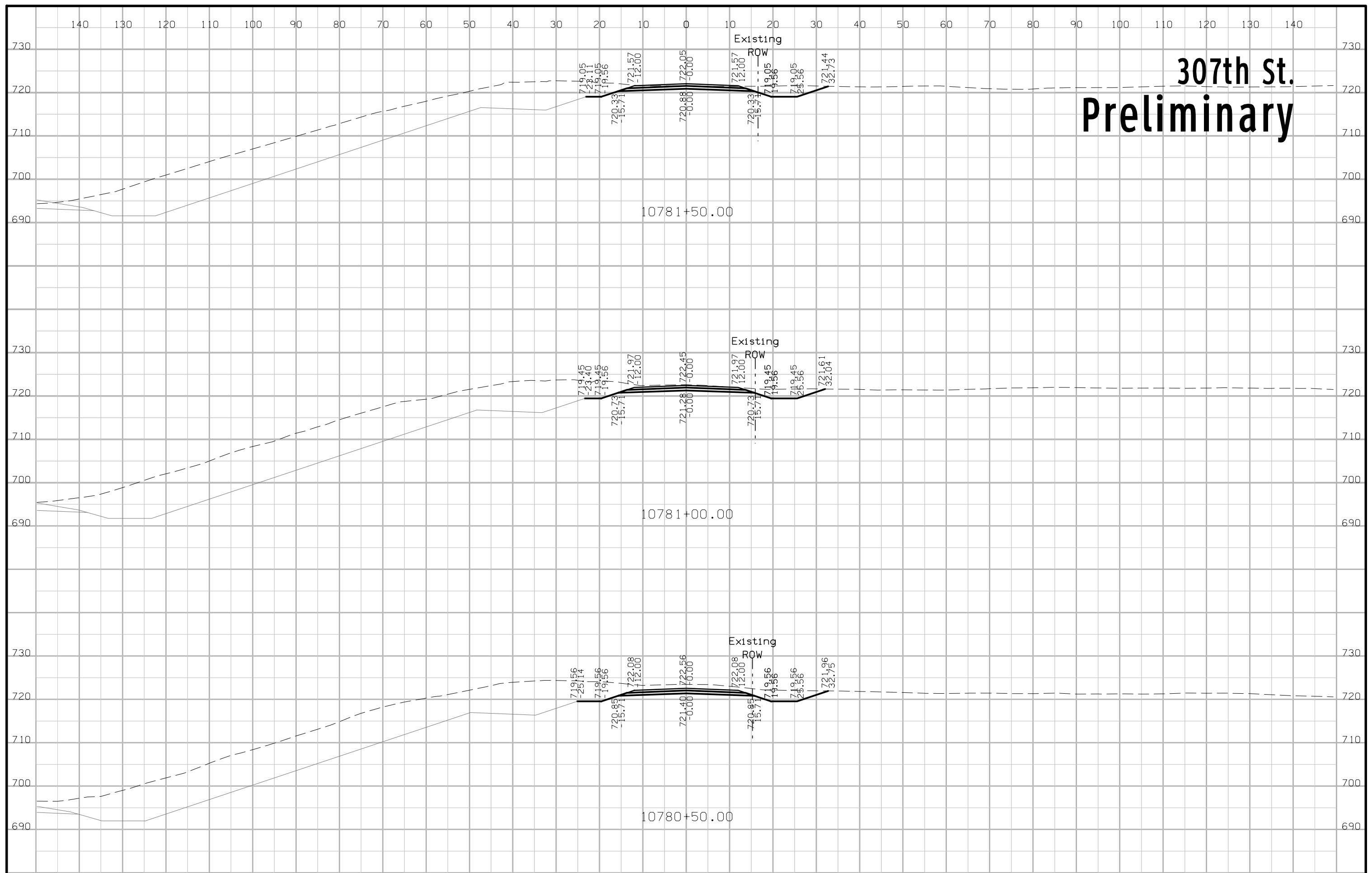

# 307th St. Preliminary

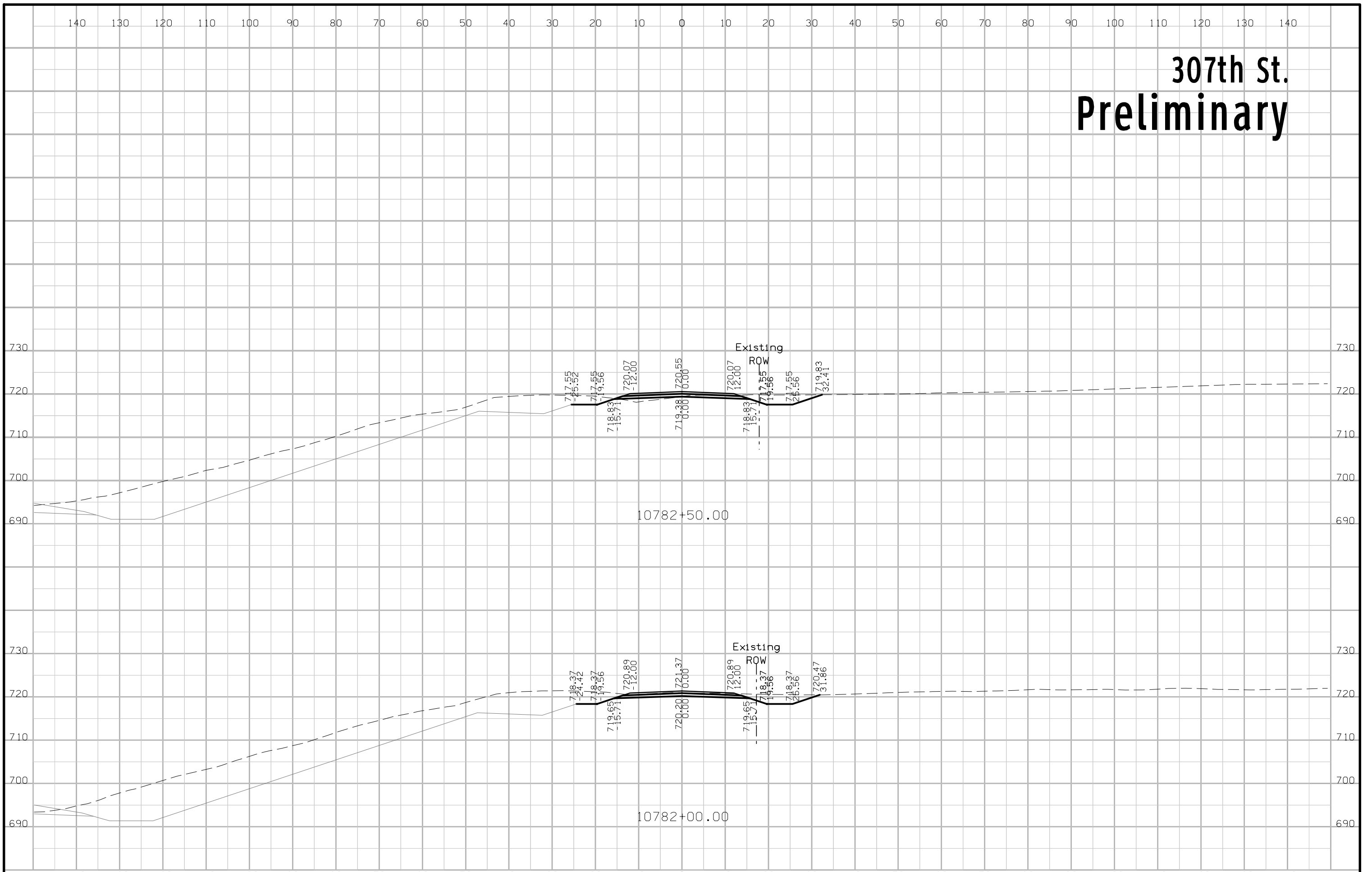

# 307th St. Preliminary

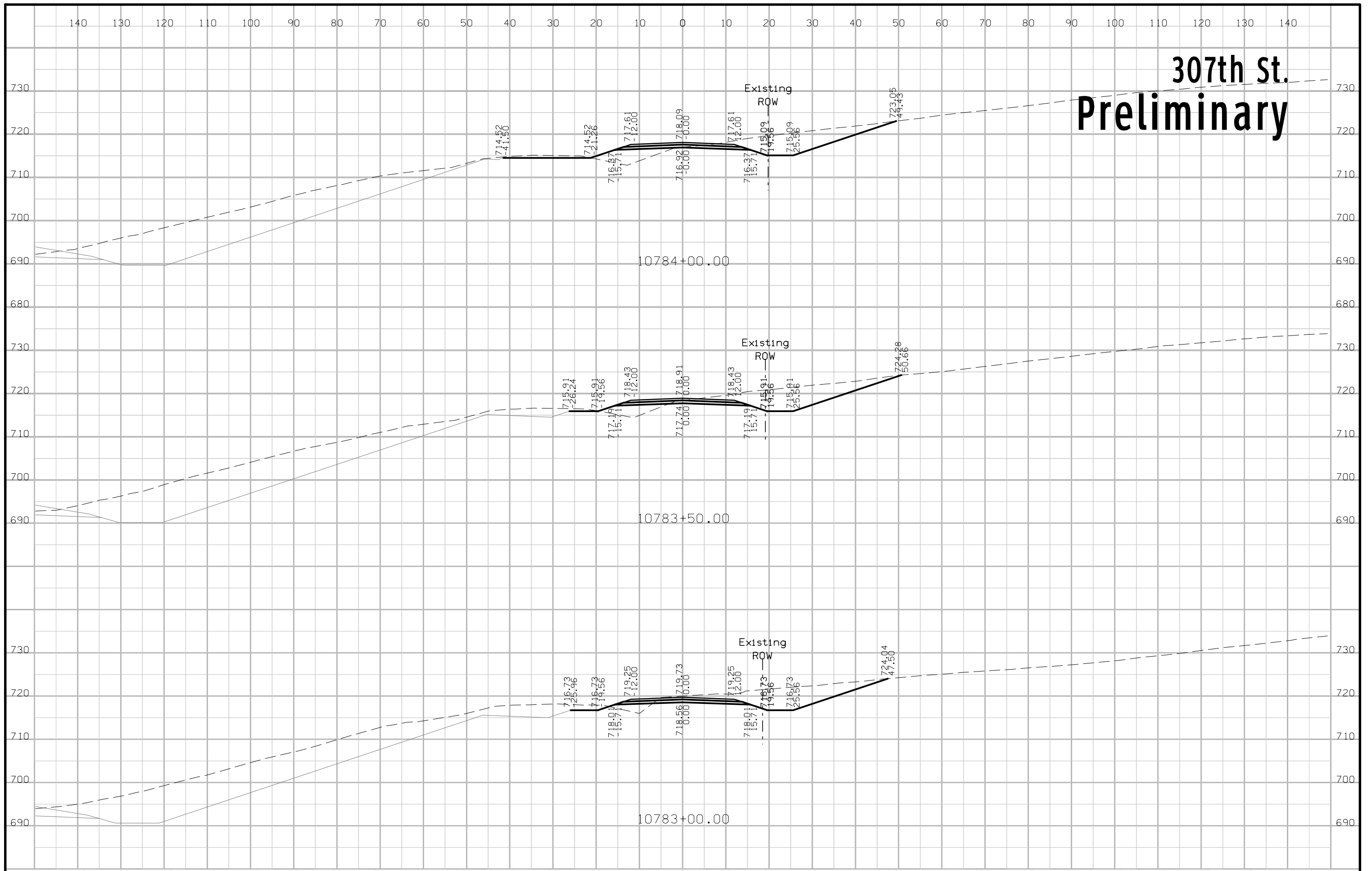



# 307th St. Preliminary

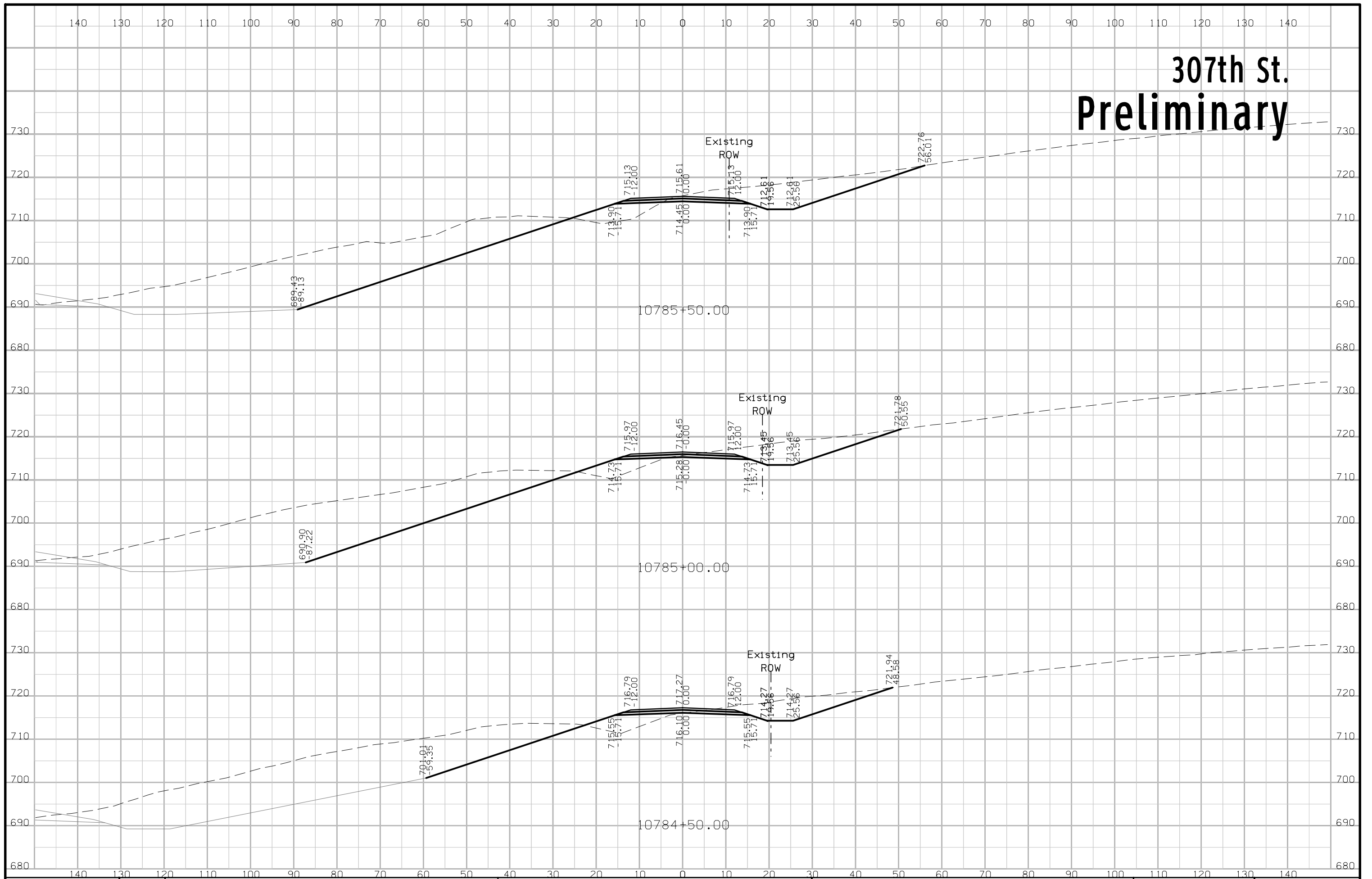

# 307th St. Preliminary

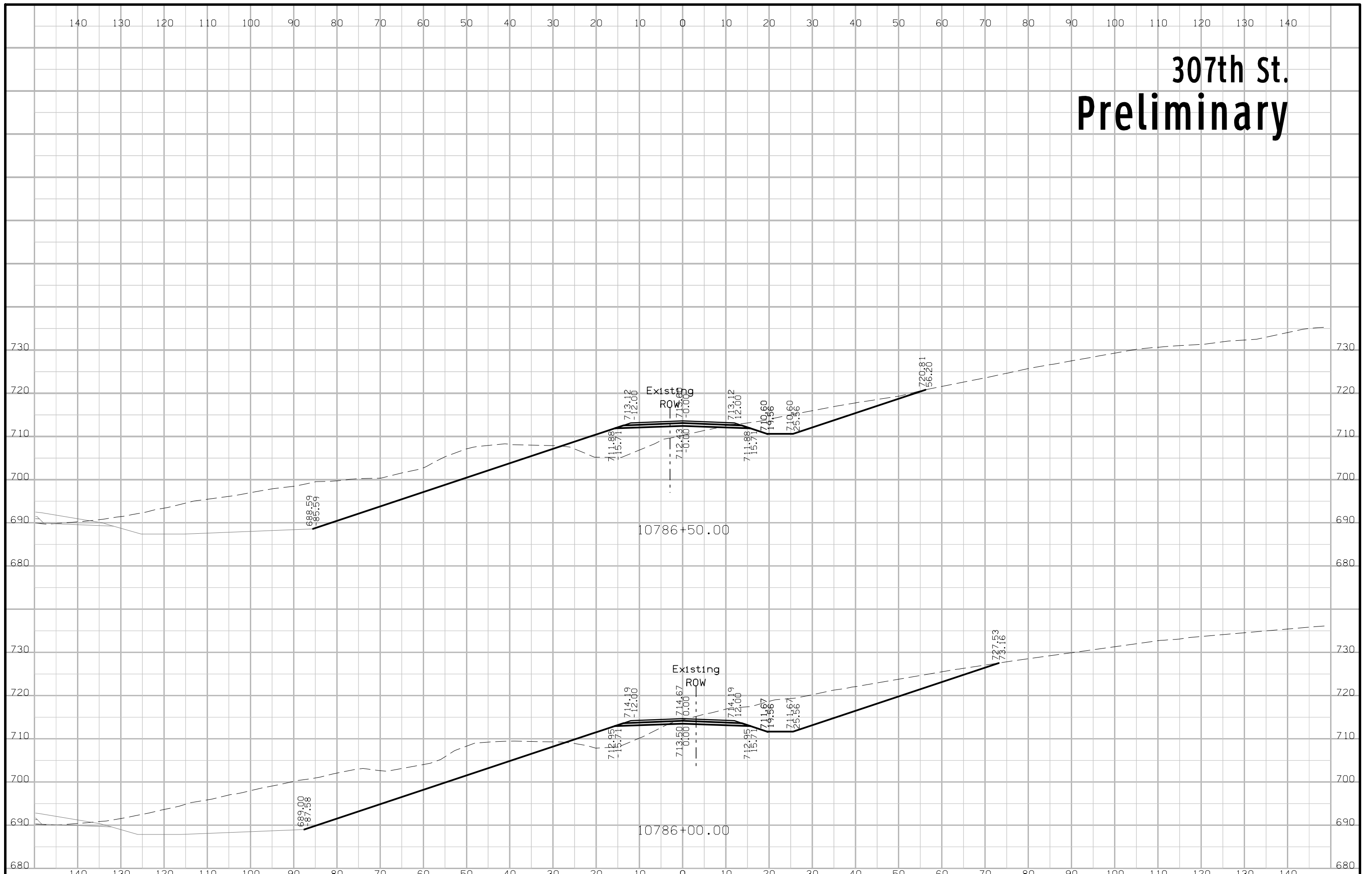

# 307th St. Preliminary

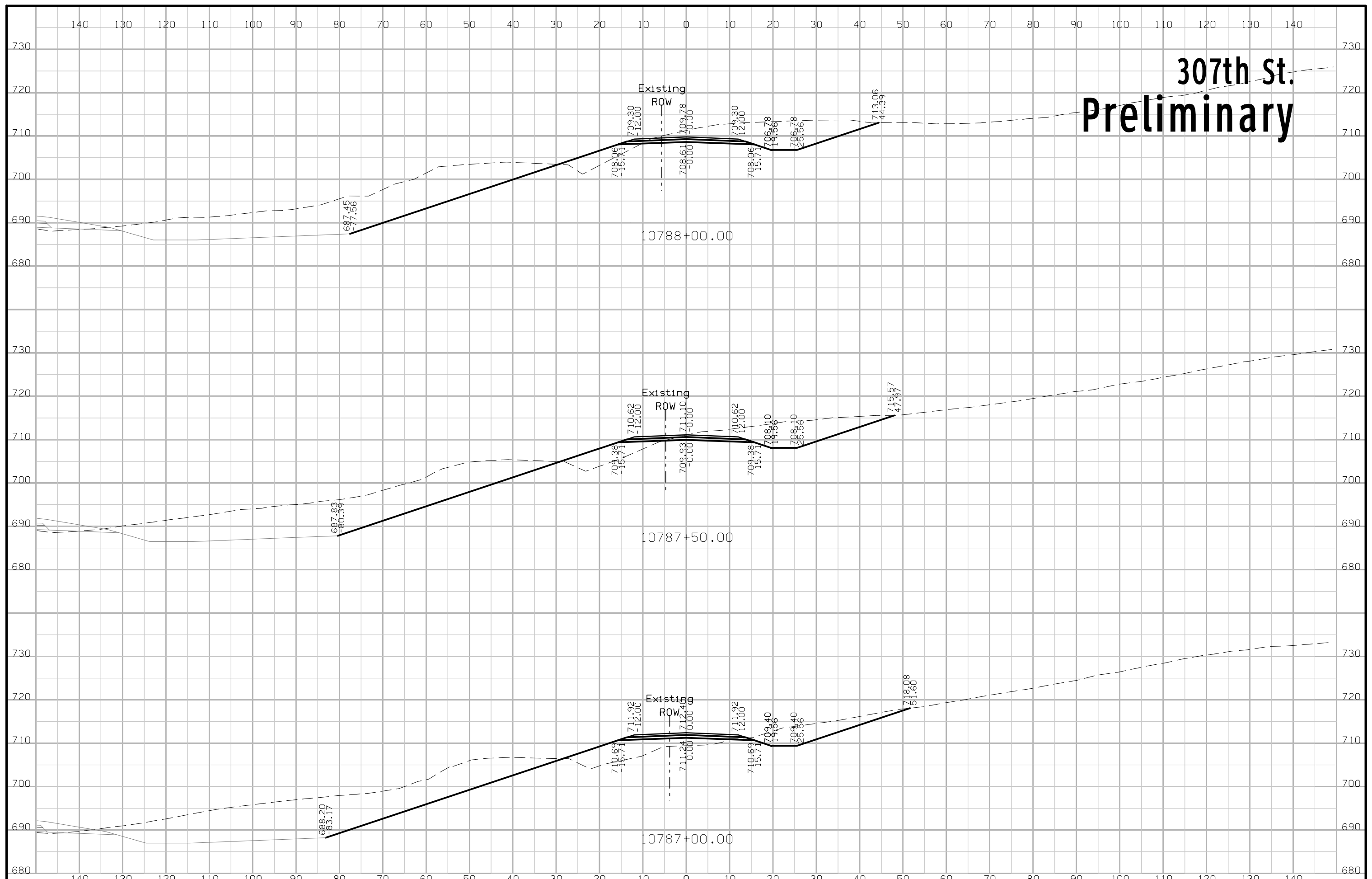

# 307th St. Preliminary

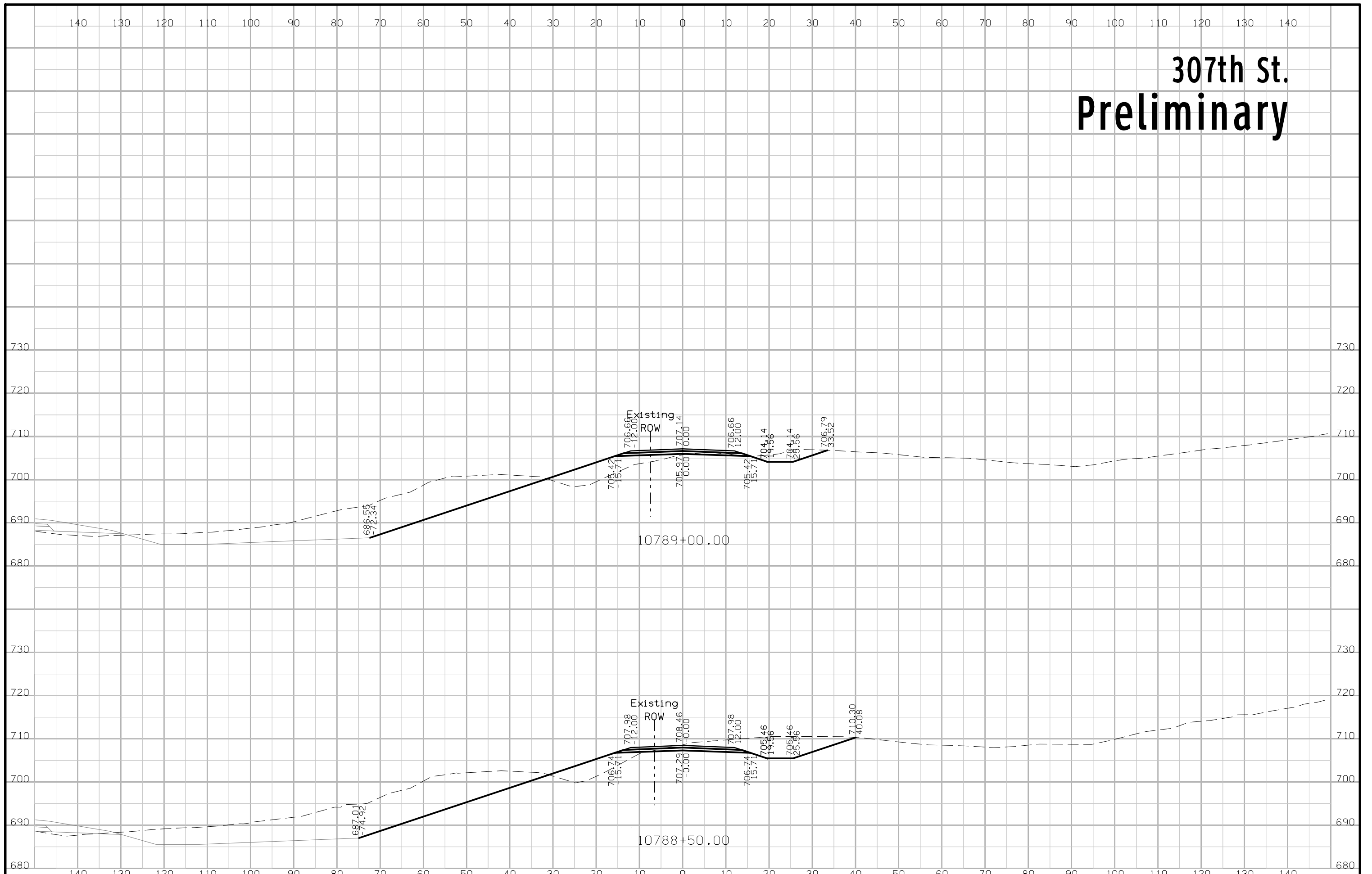

# 307th St. Preliminary

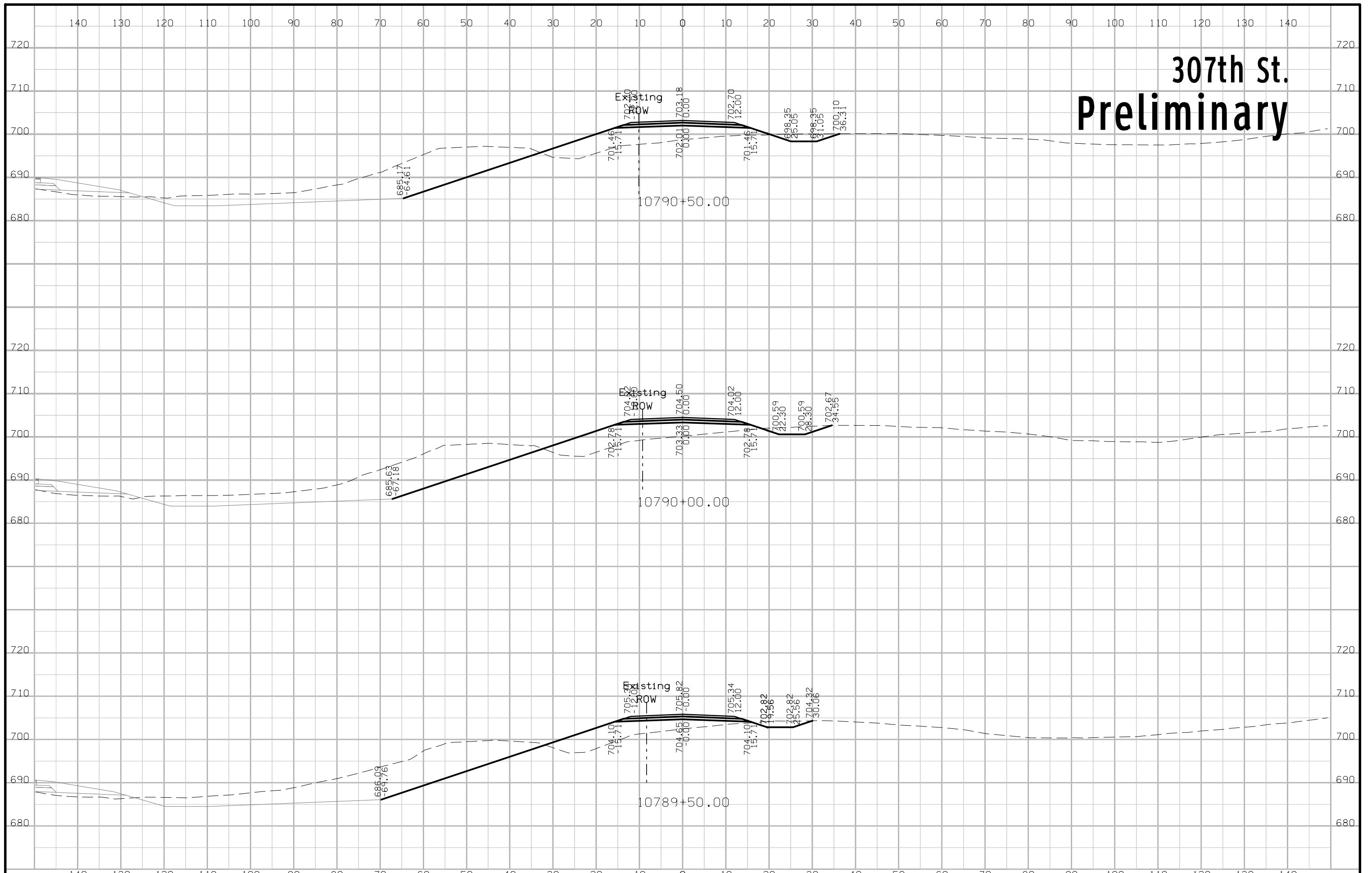

# 307th St. Preliminary

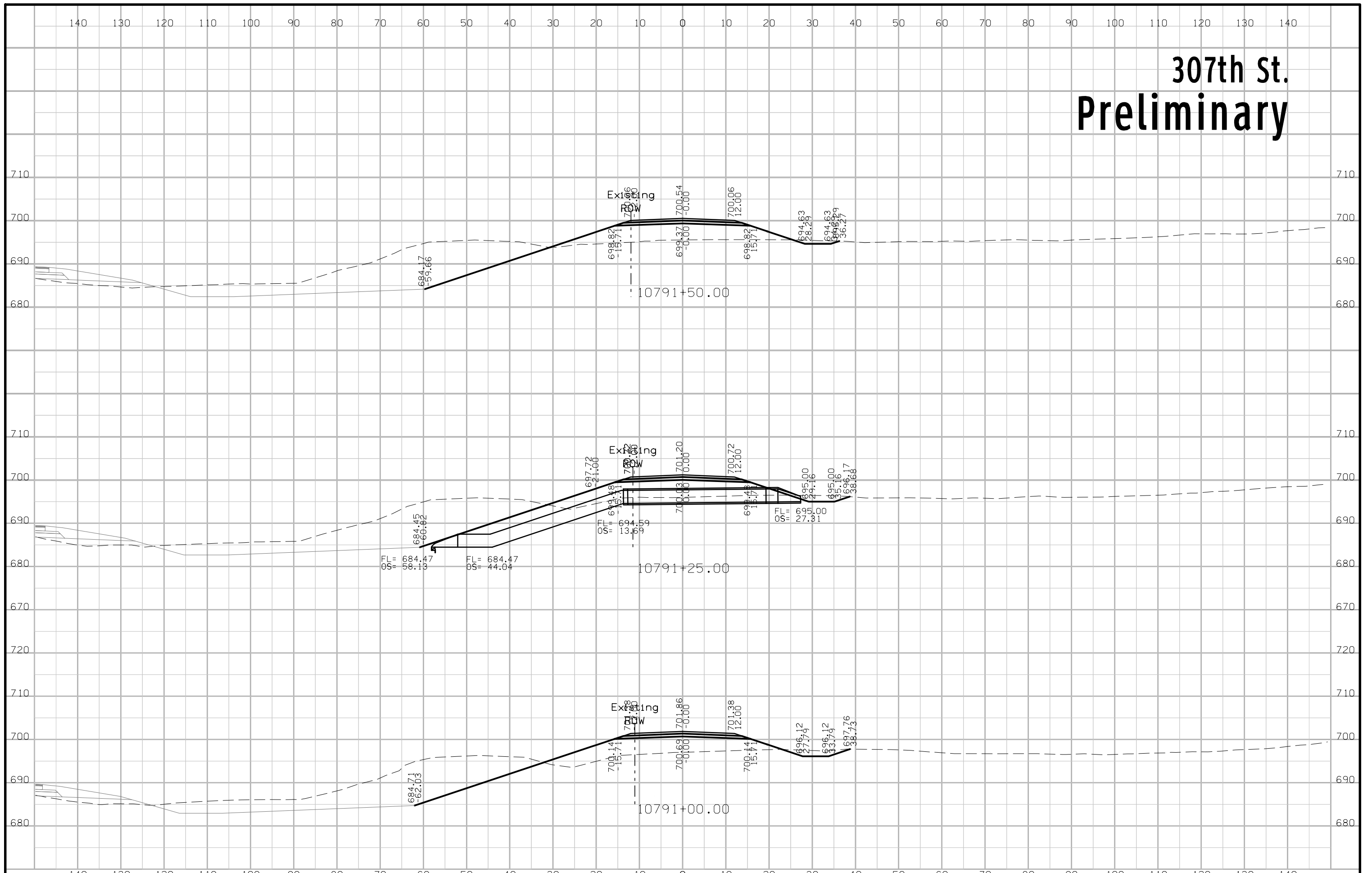

# 307th St. Preliminary

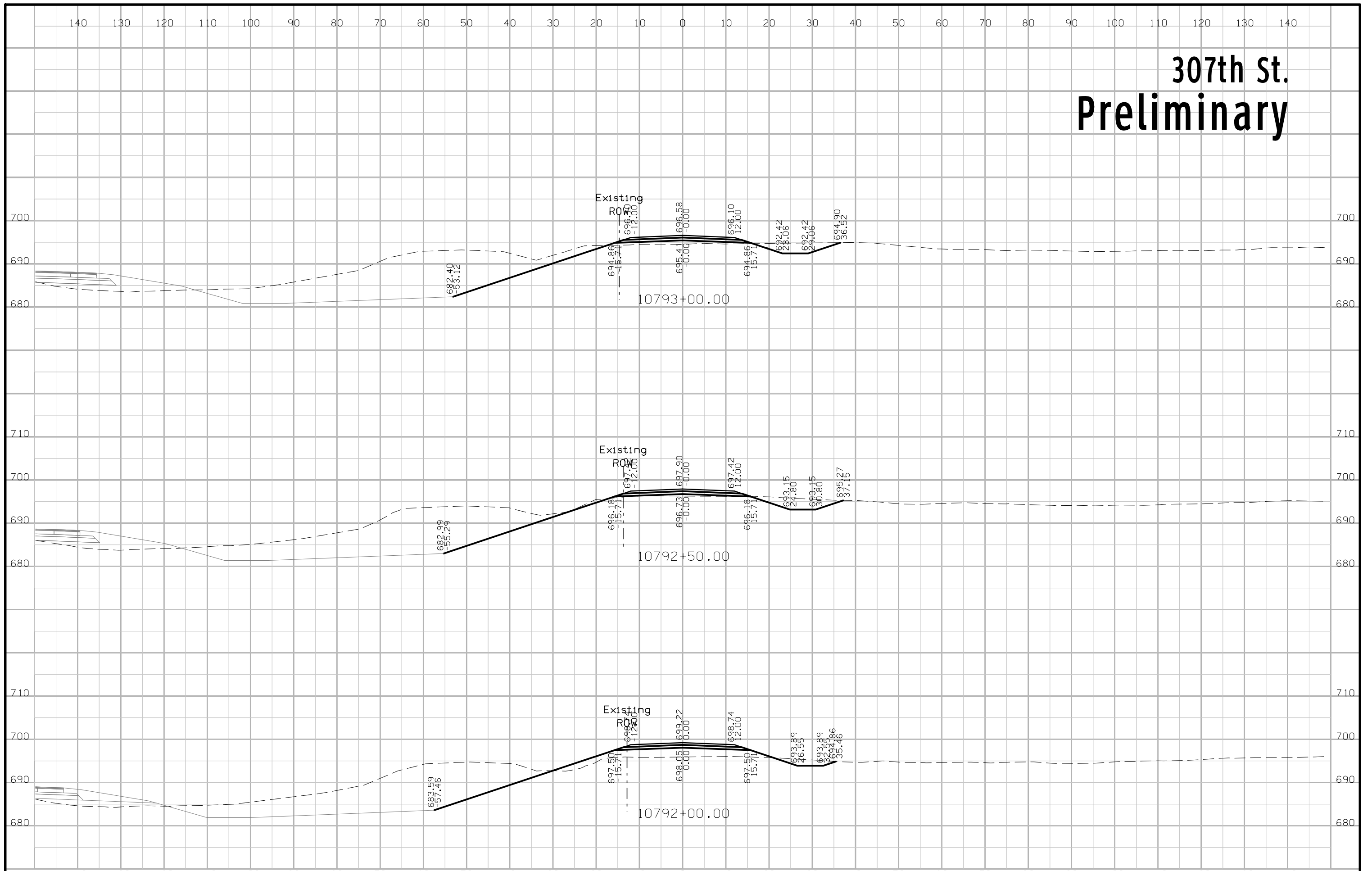

# 307th St. Preliminary

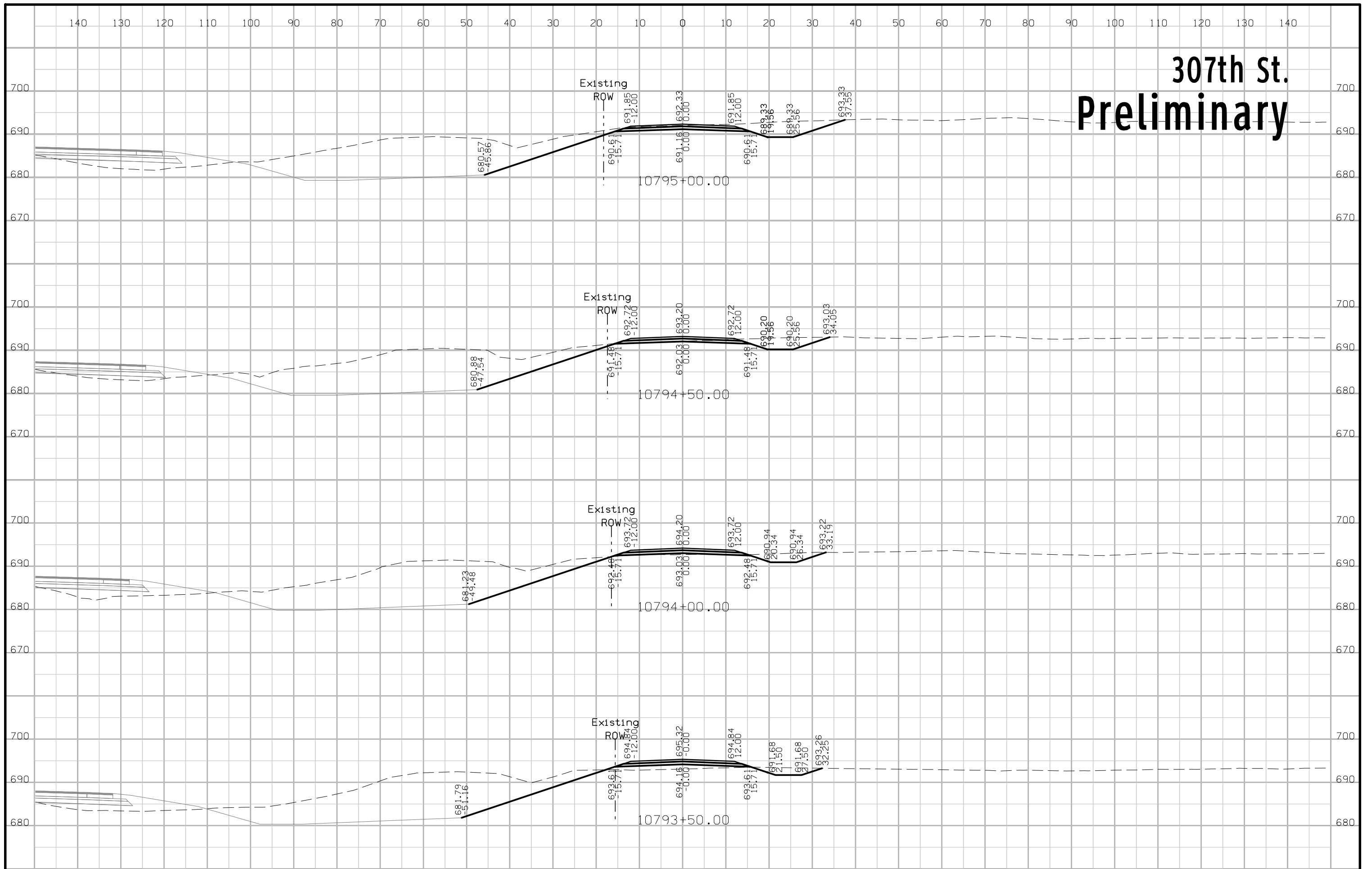



# 307th St. Preliminary

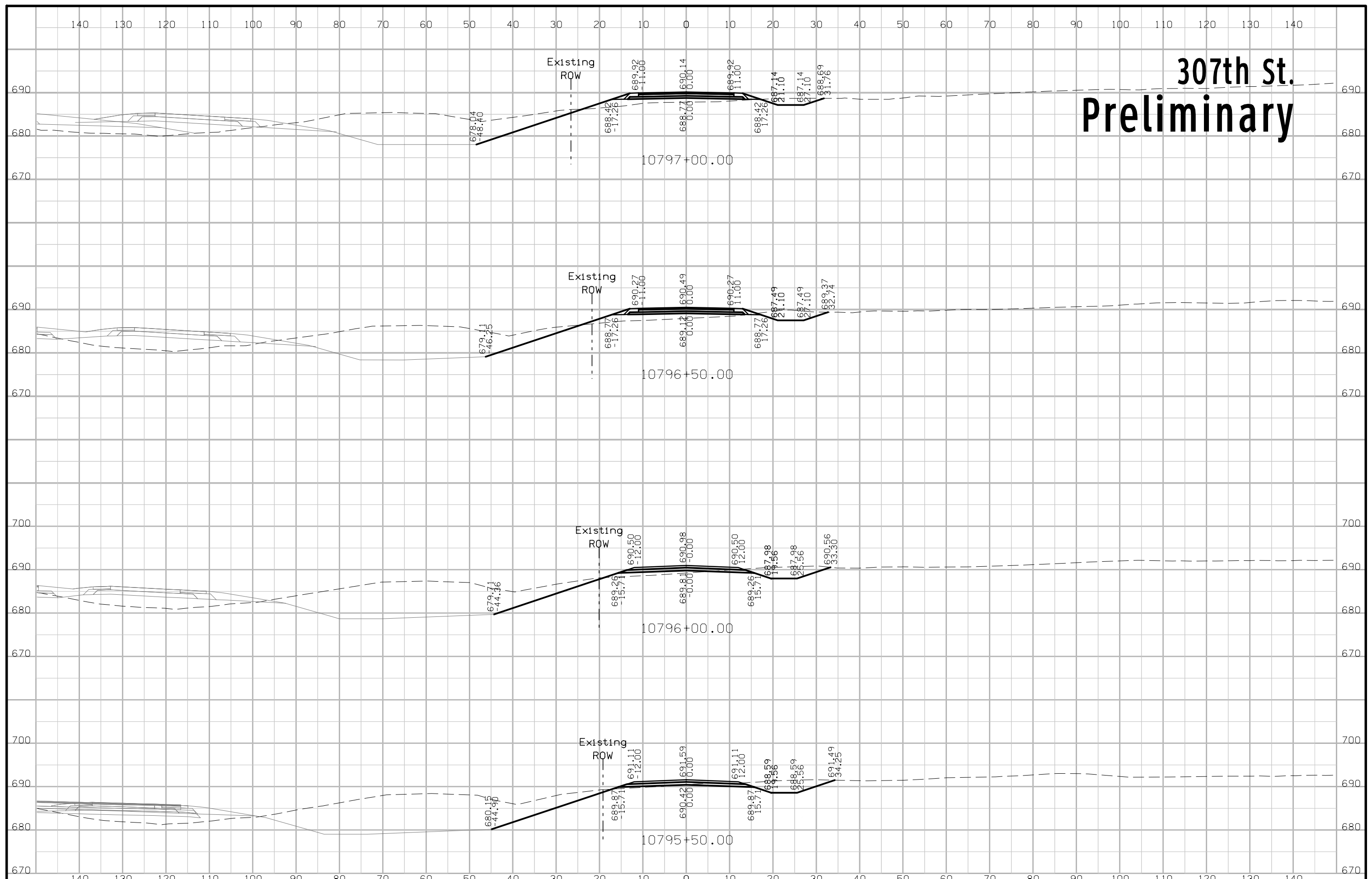

# 307th St. Preliminary

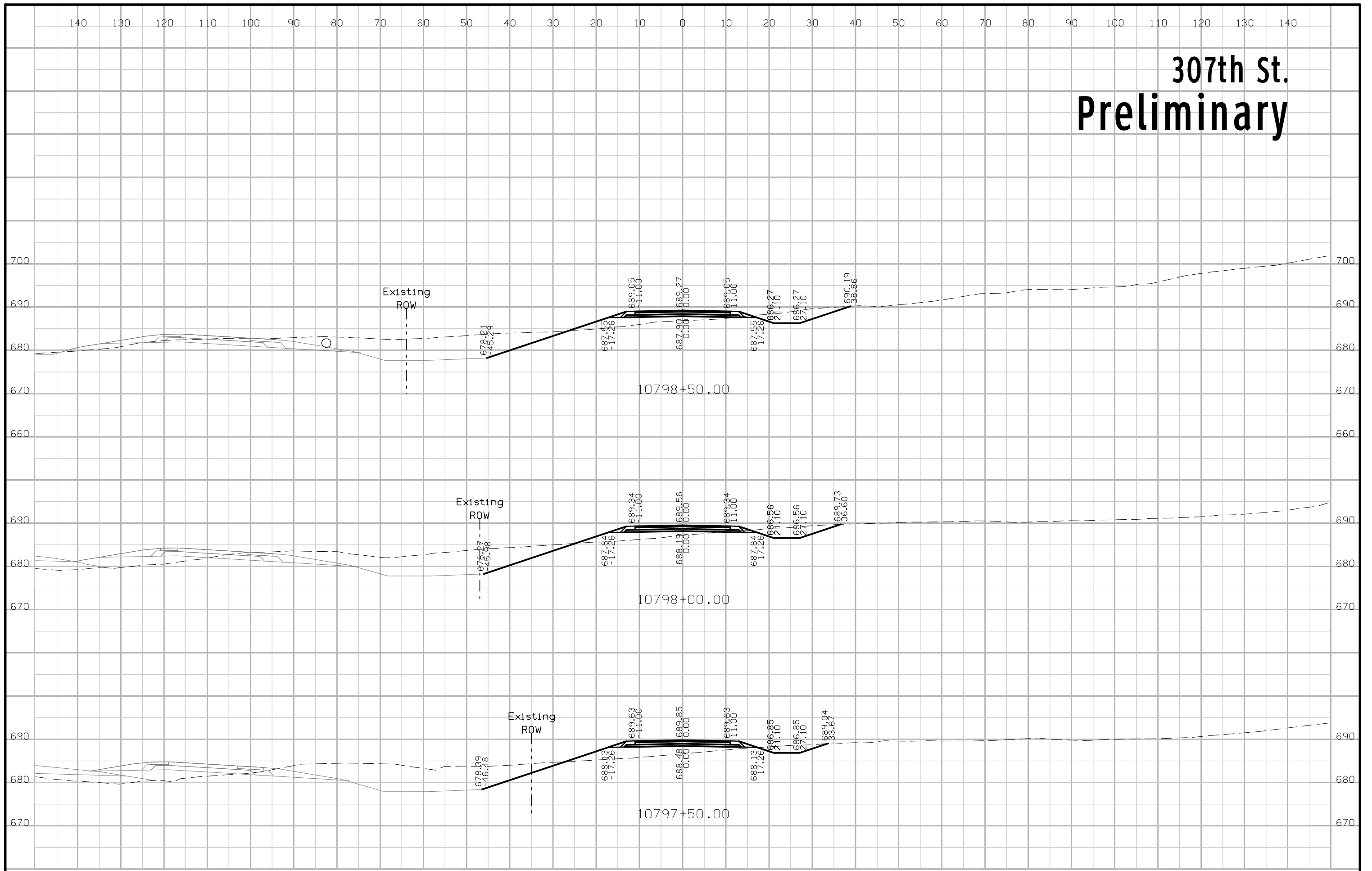

# 307th St. Preliminary

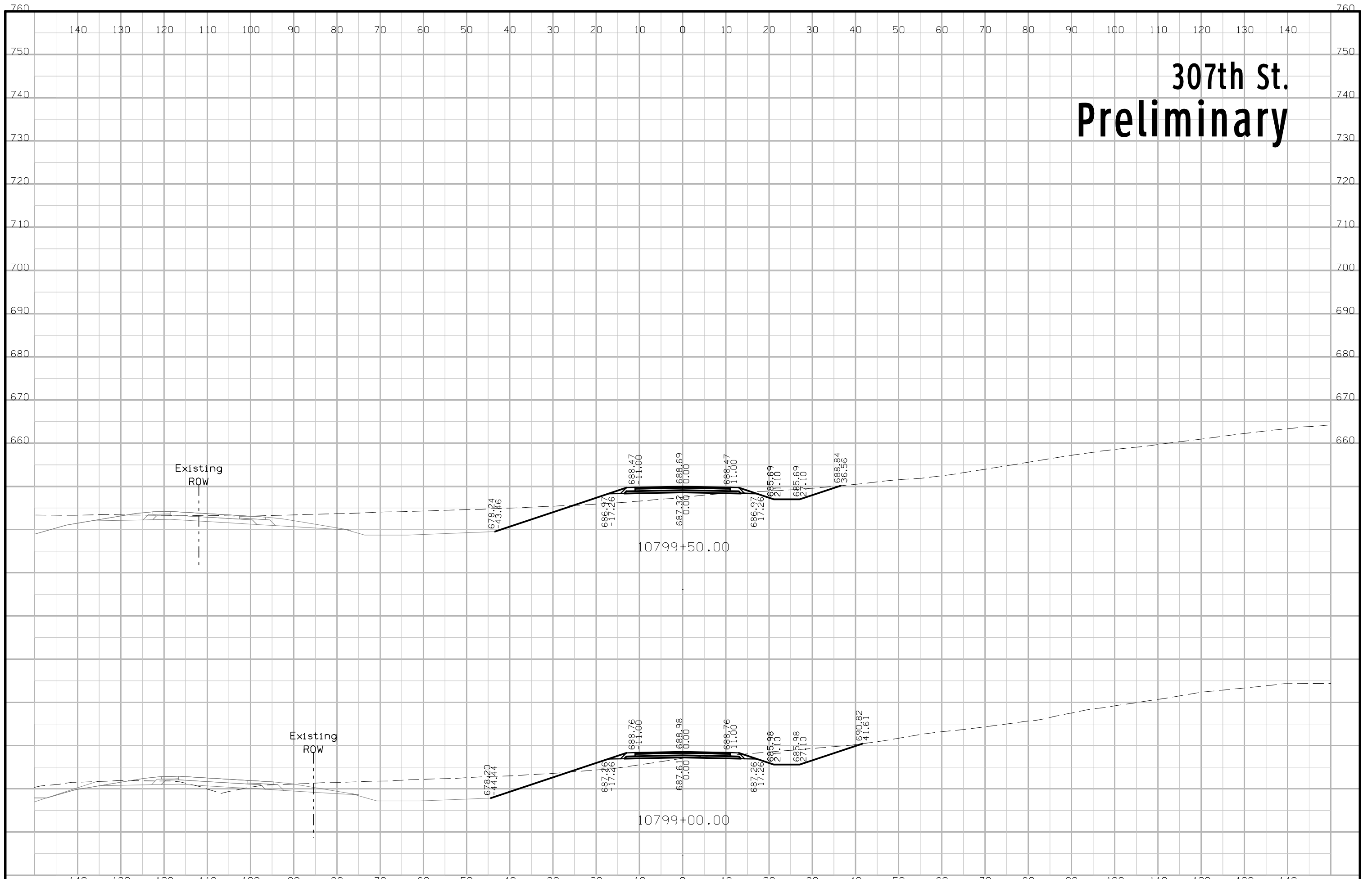

# 307th St. Preliminary

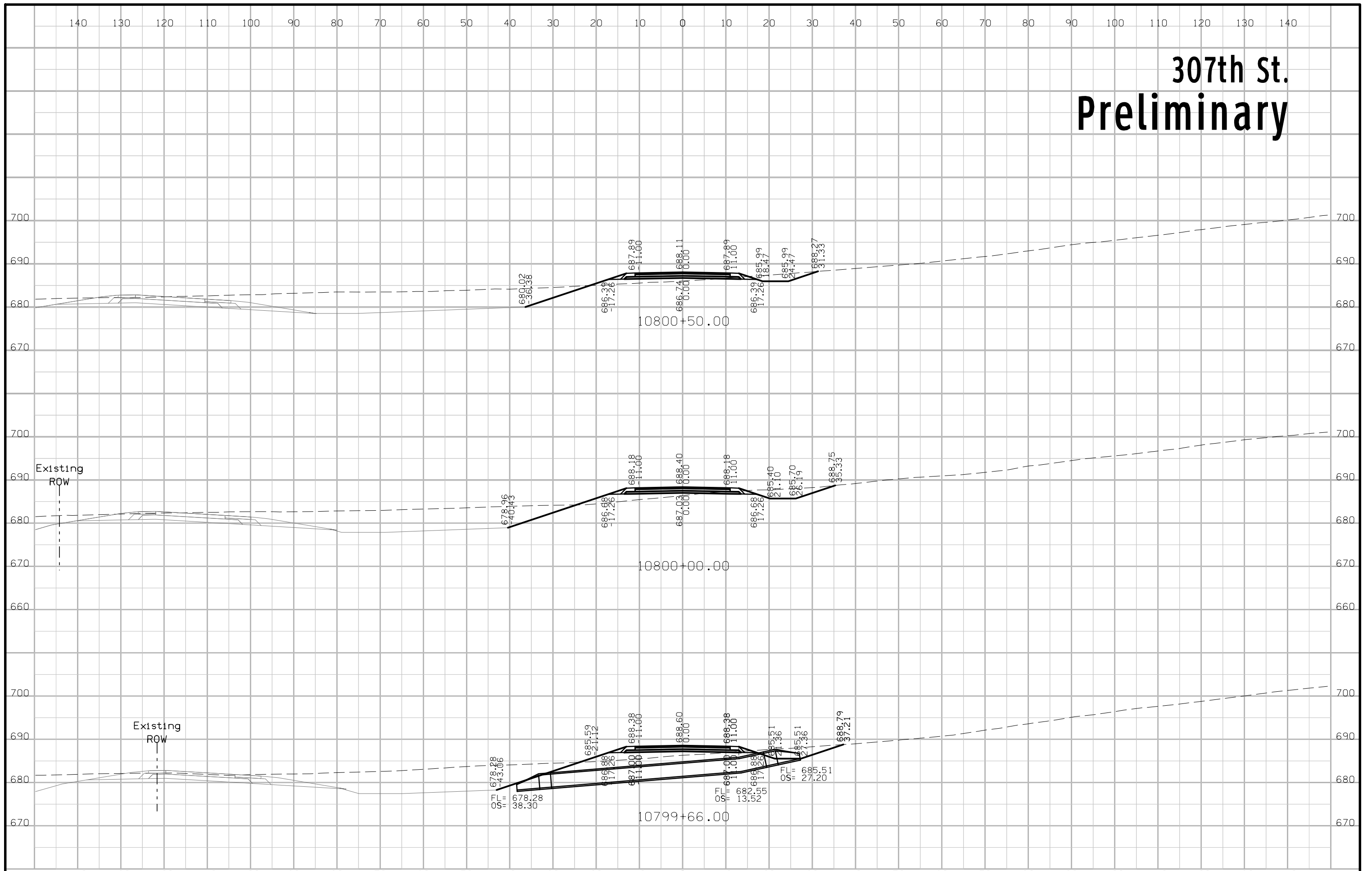

# 307th St. Preliminary

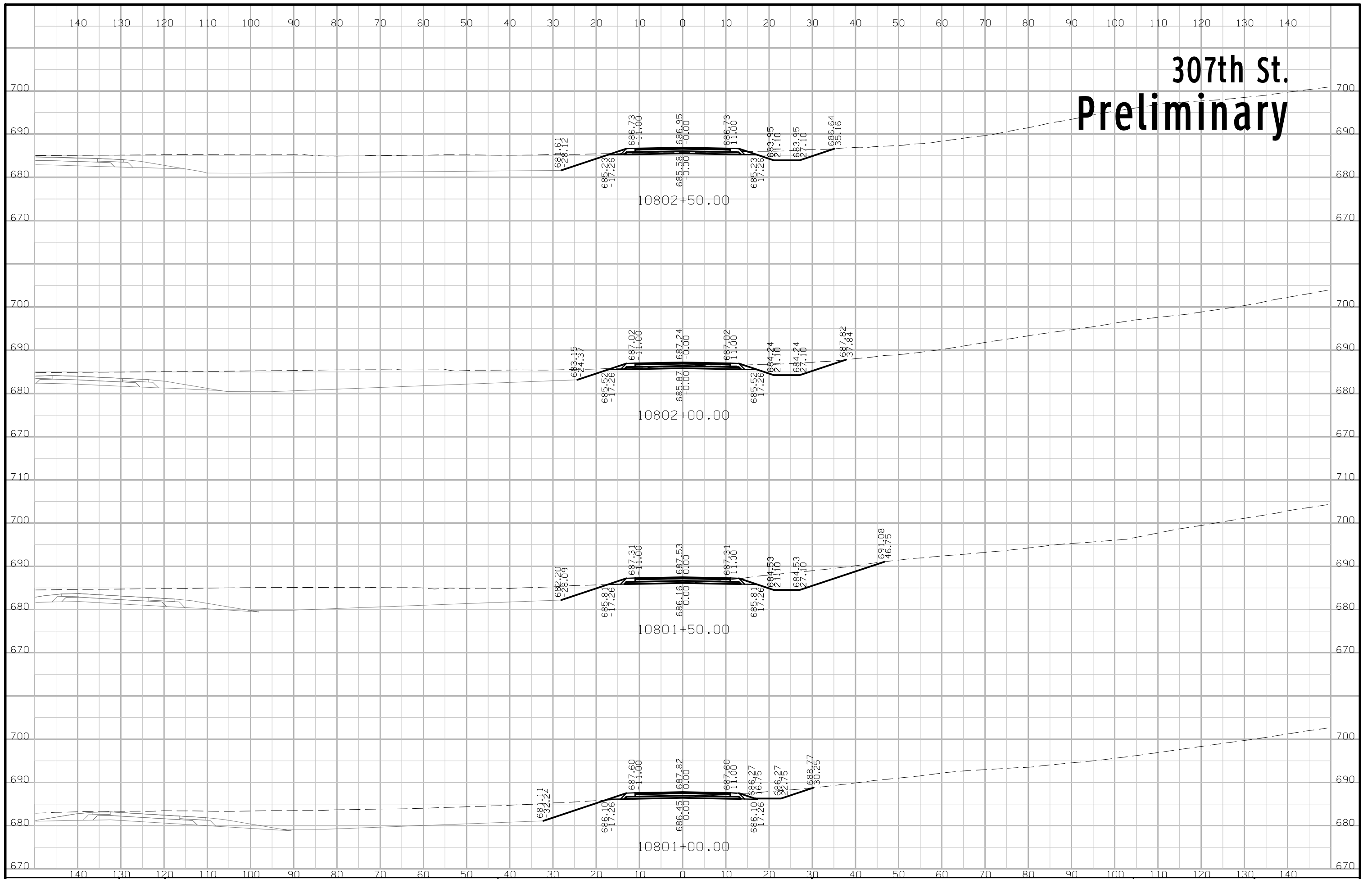

# 307th St. Preliminary

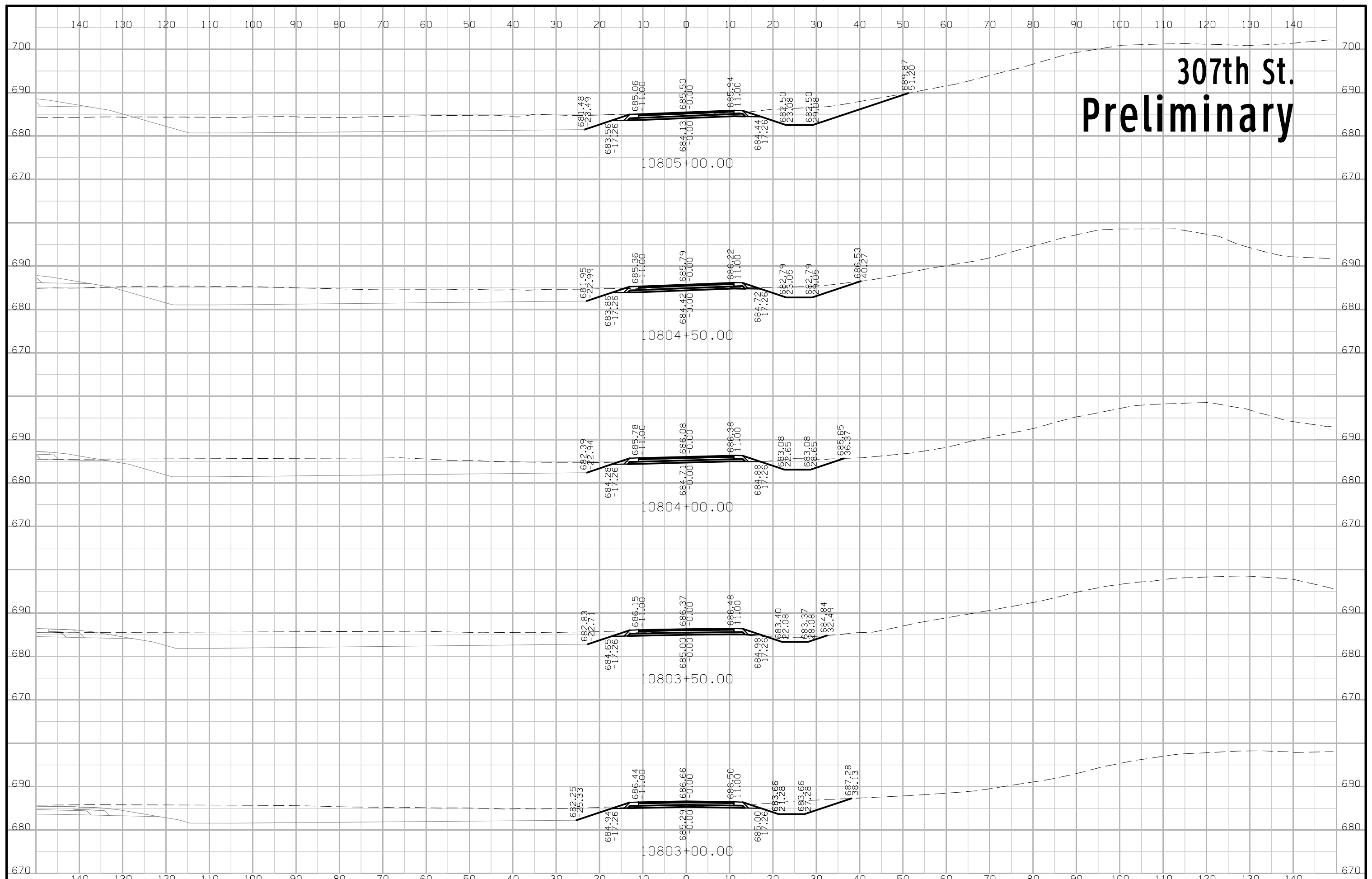

# 307th St. Preliminary

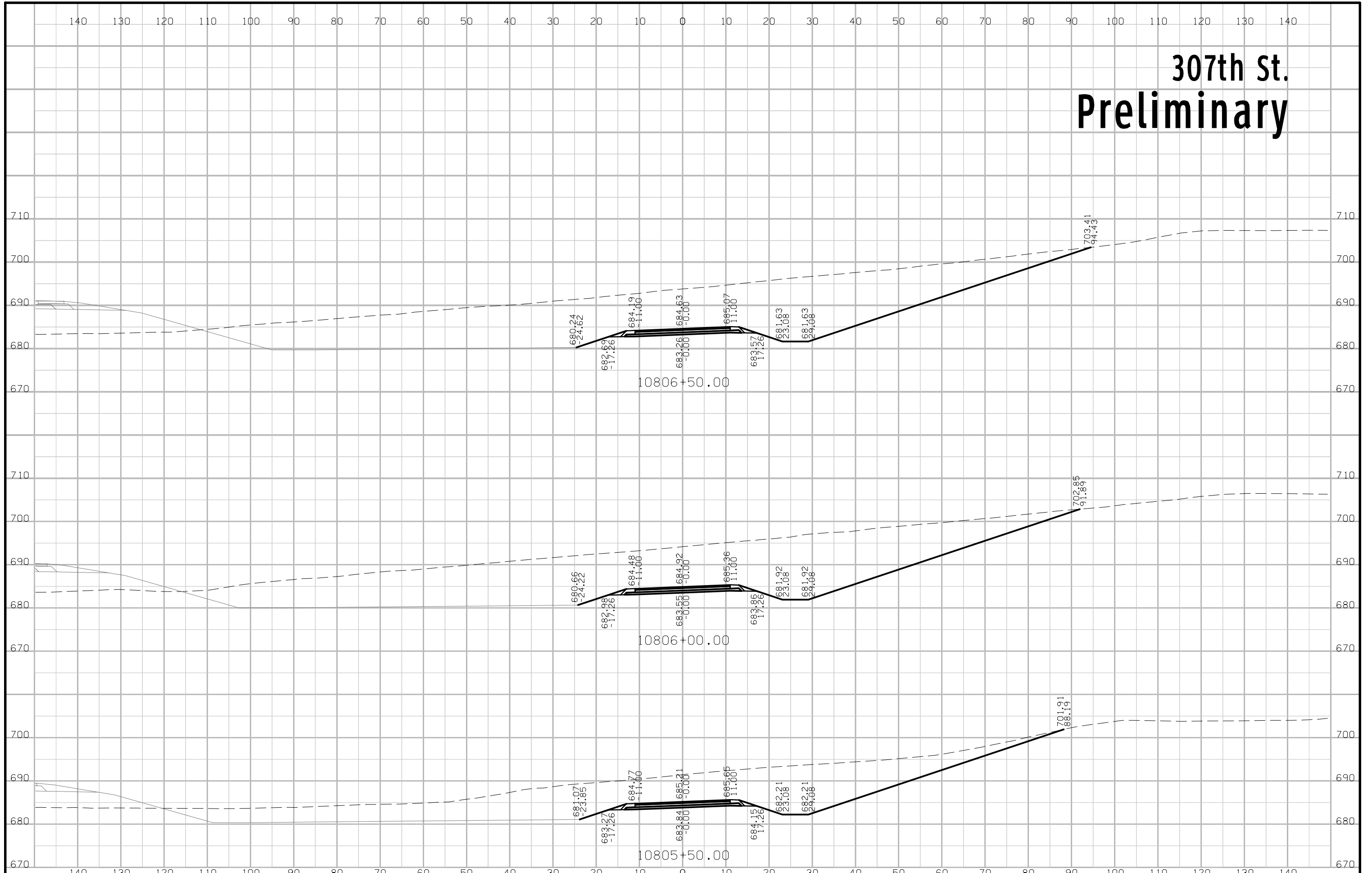

# 307th St. Preliminary

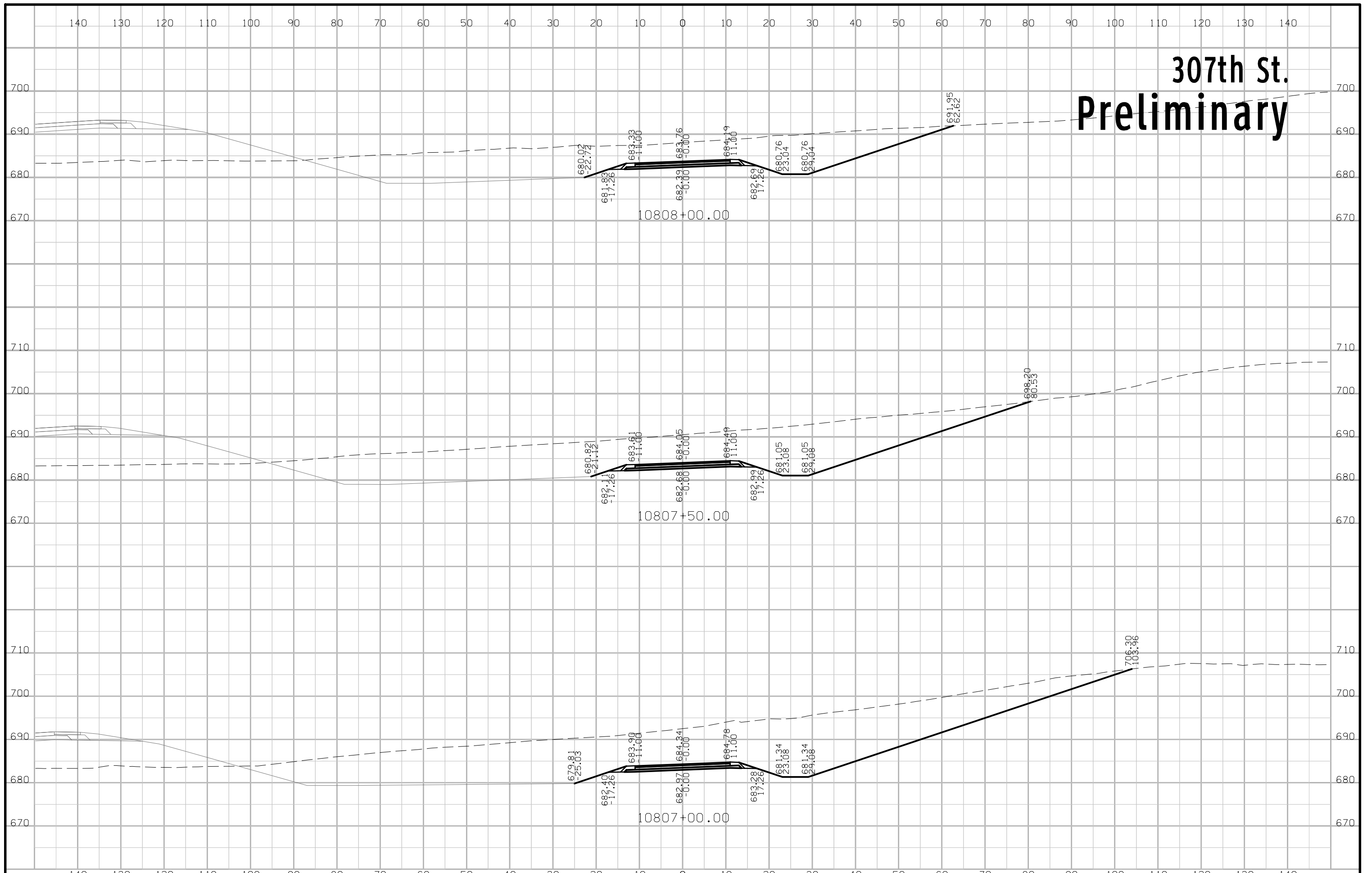



# 307th St. Preliminary

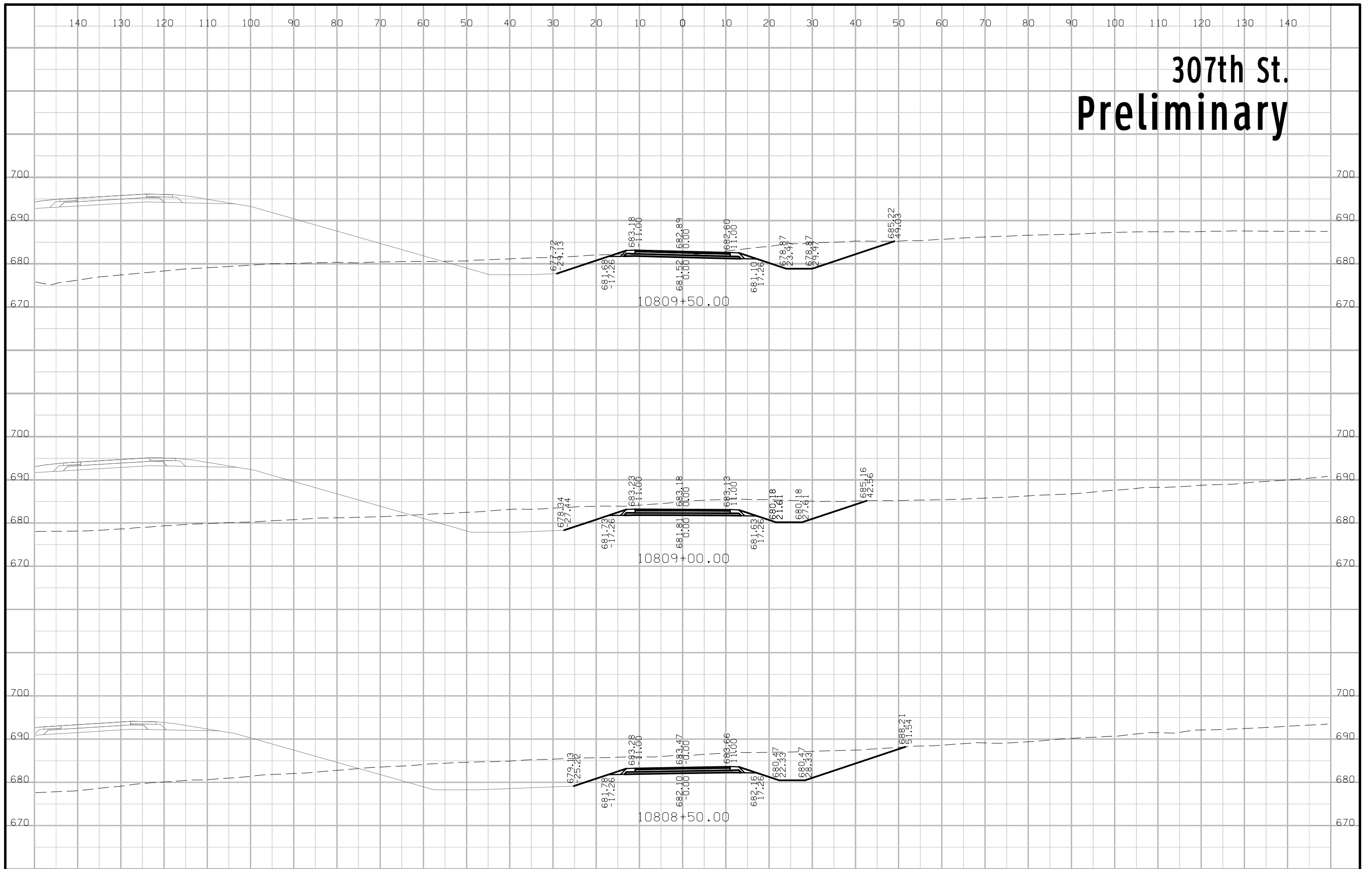

# 307th St. Preliminary

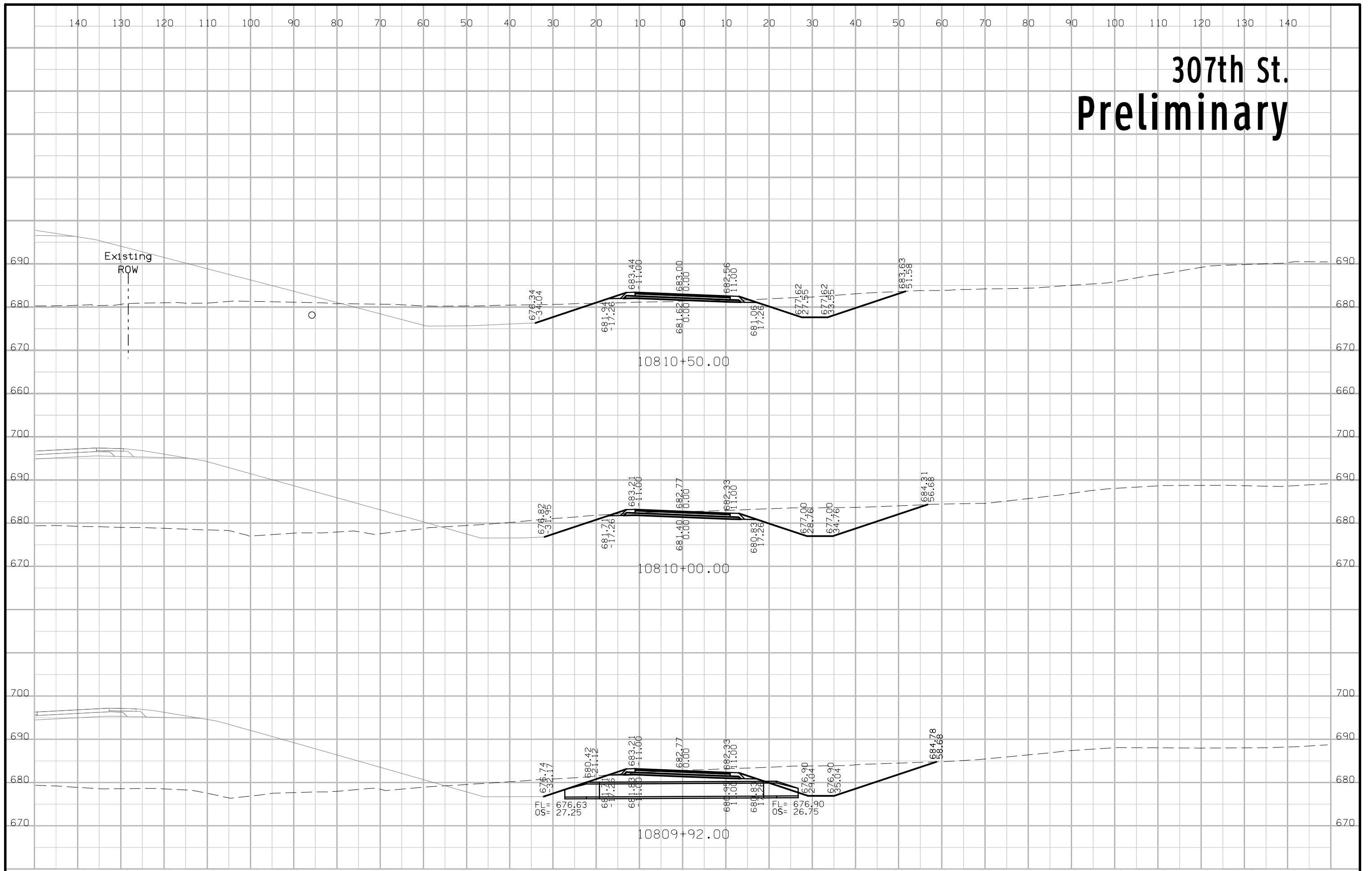

# 307th St. Preliminary

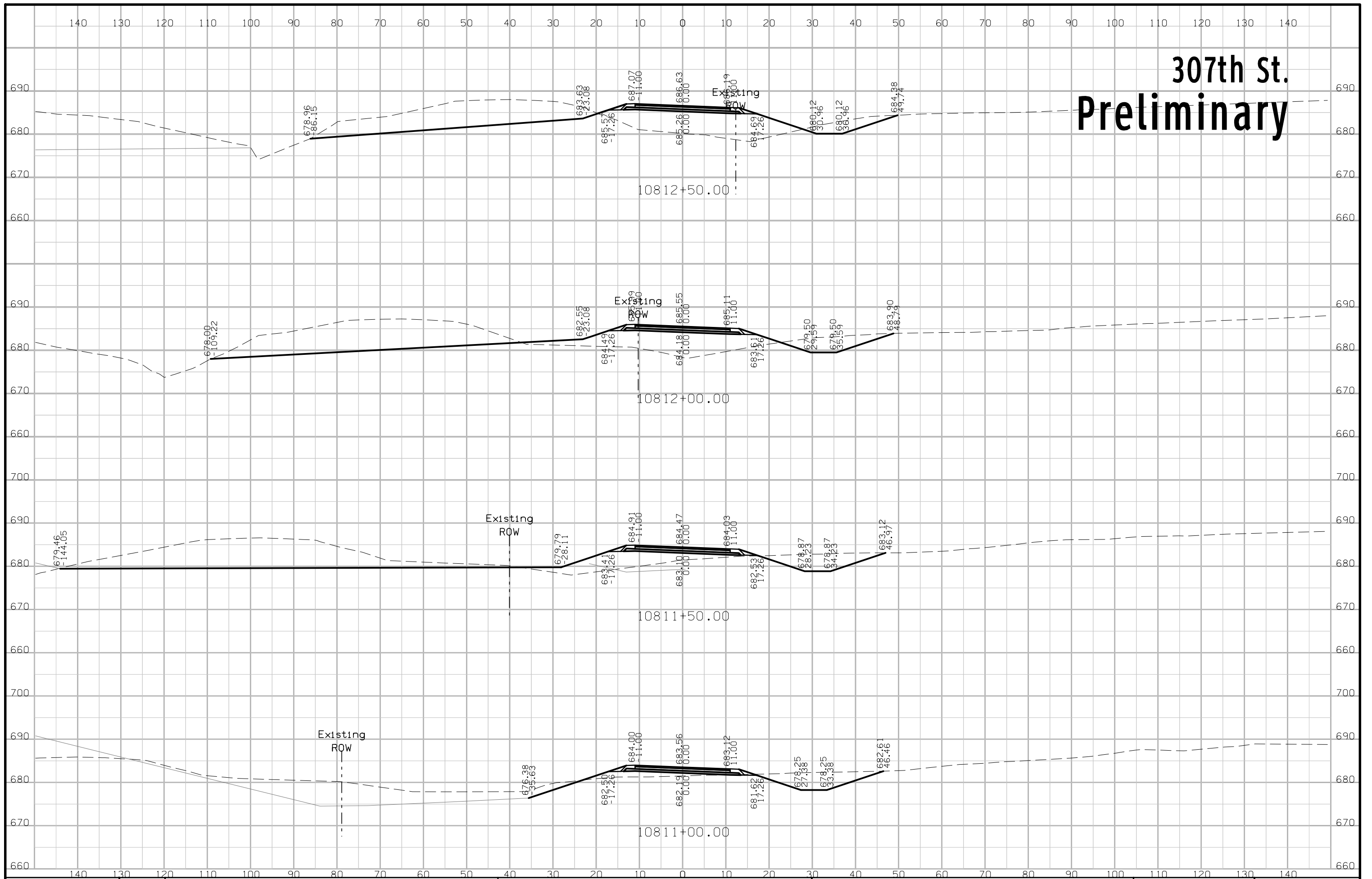

# 307th St. Preliminary

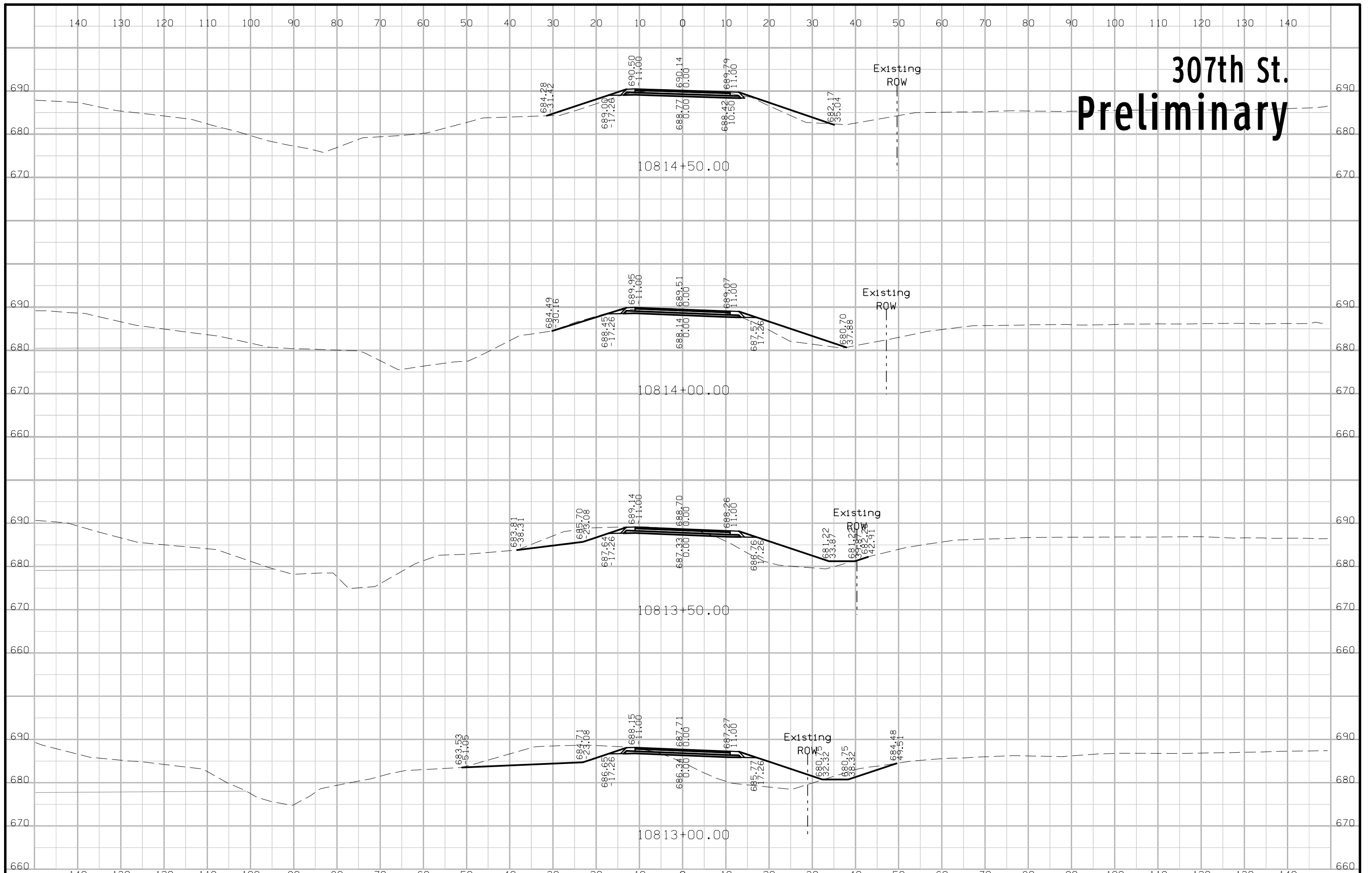

# 307th St. Preliminary

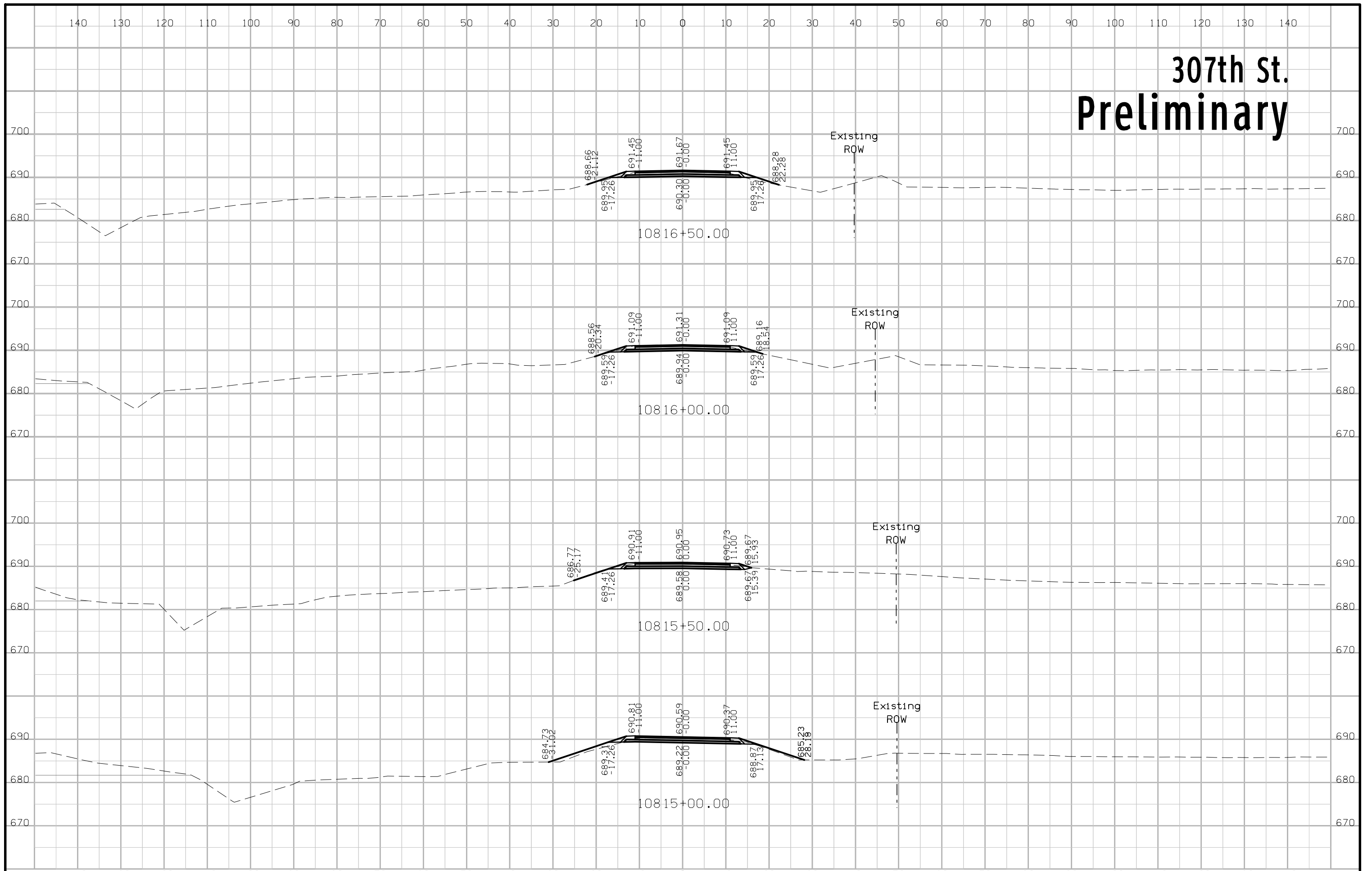

# 307th St. Preliminary

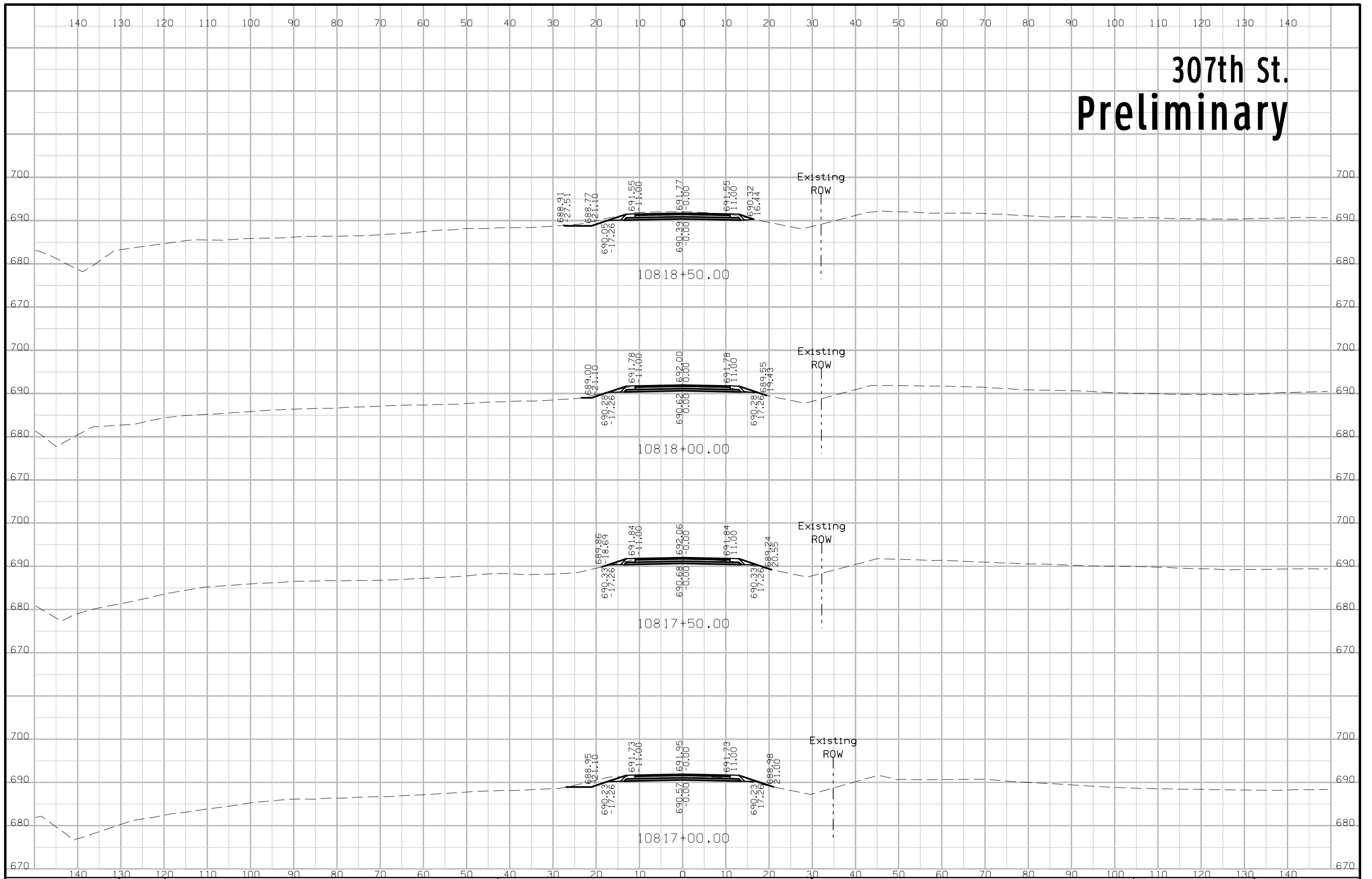

# 307th St. Preliminary

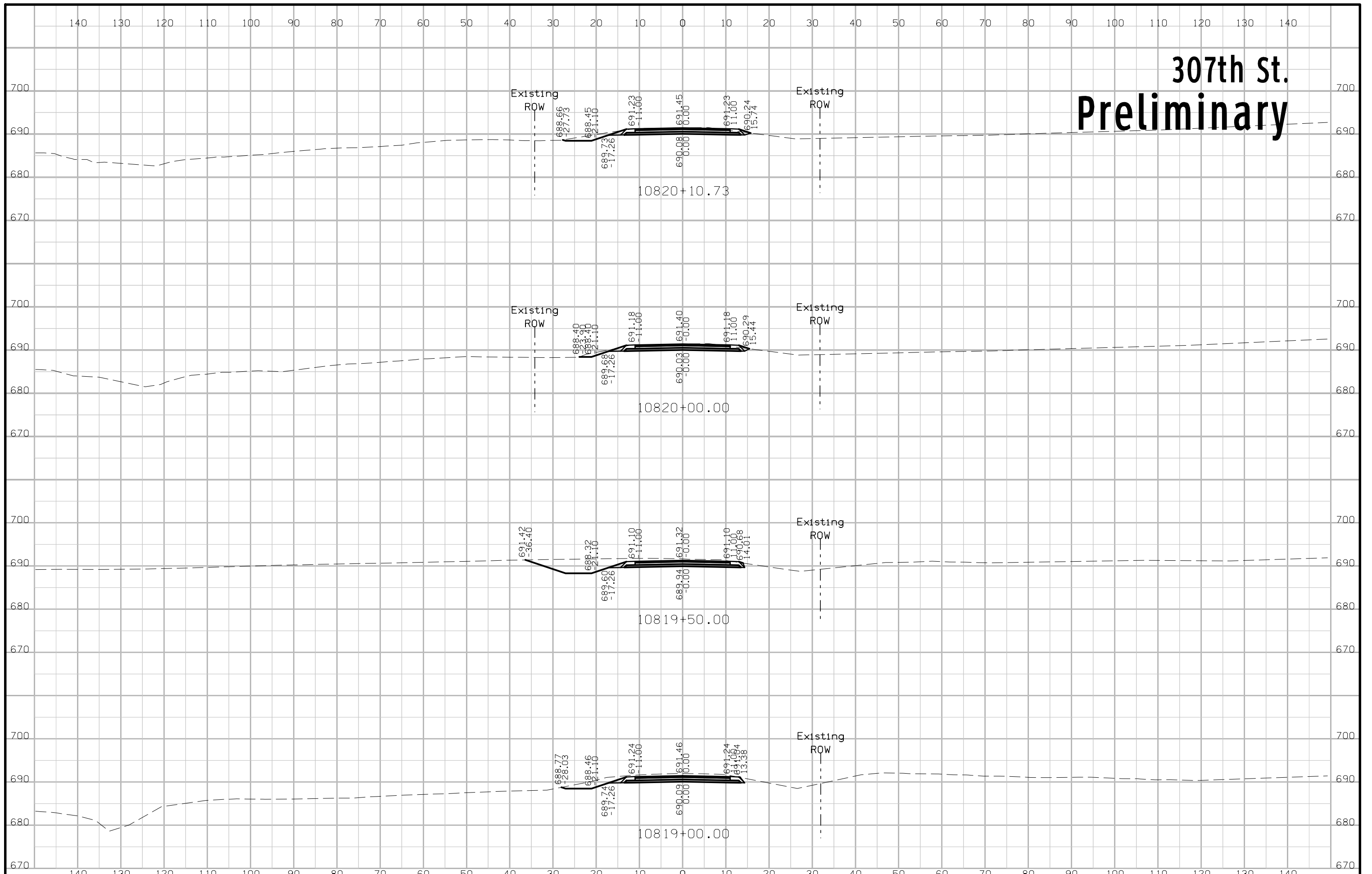

# 307th St. Preliminary

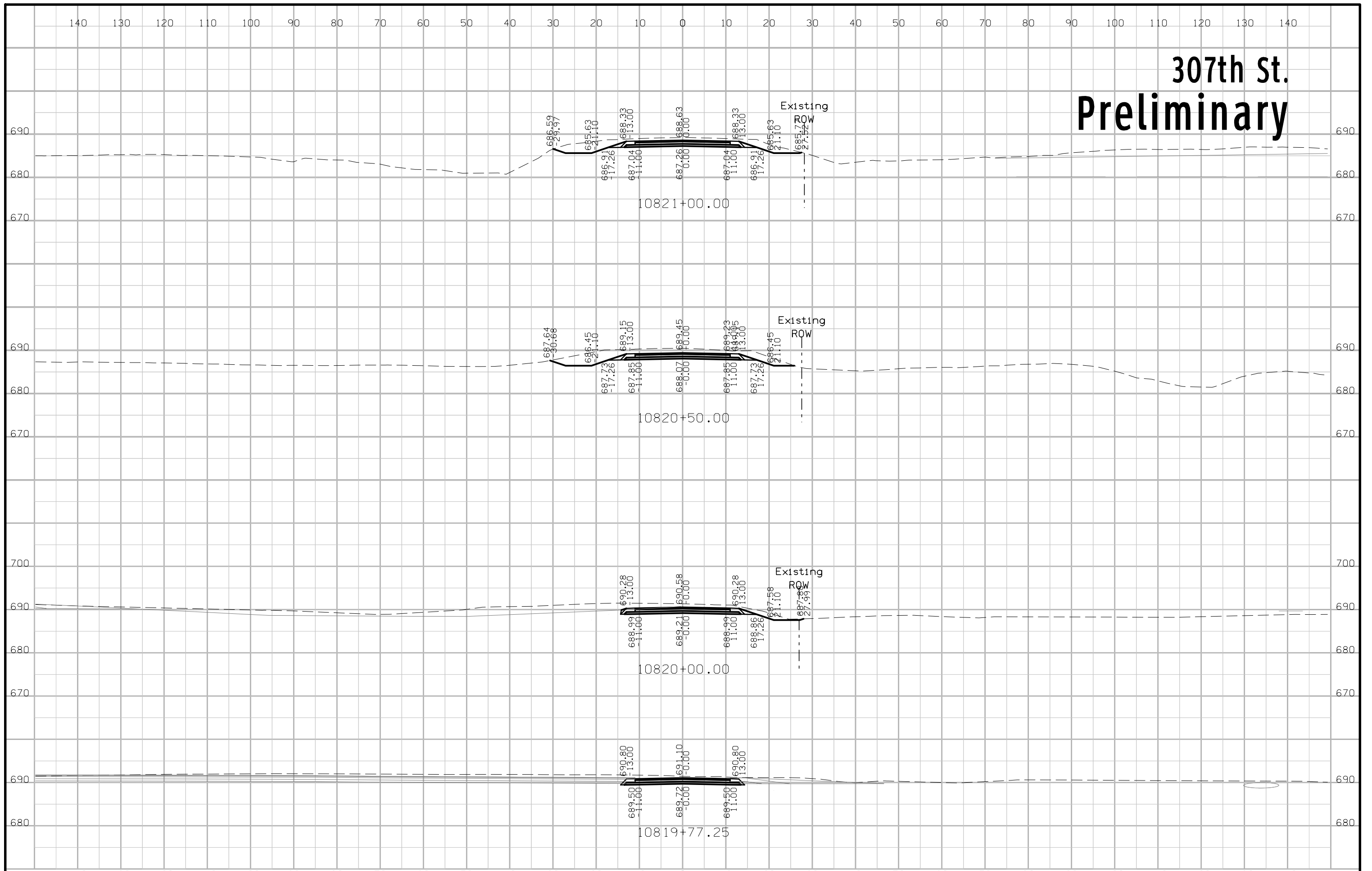



# 307th St. Preliminary

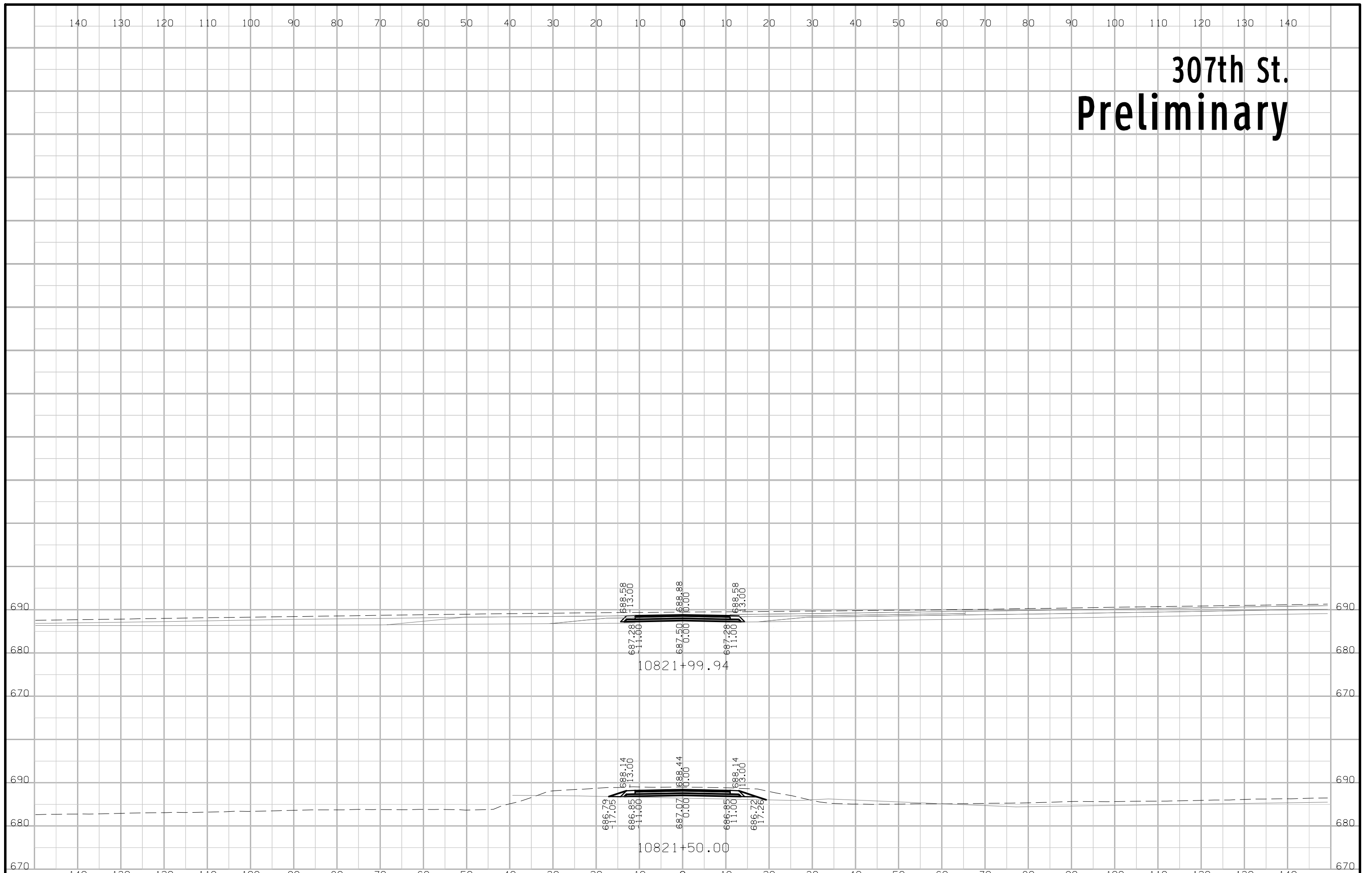

# Moscow Rd. Preliminary

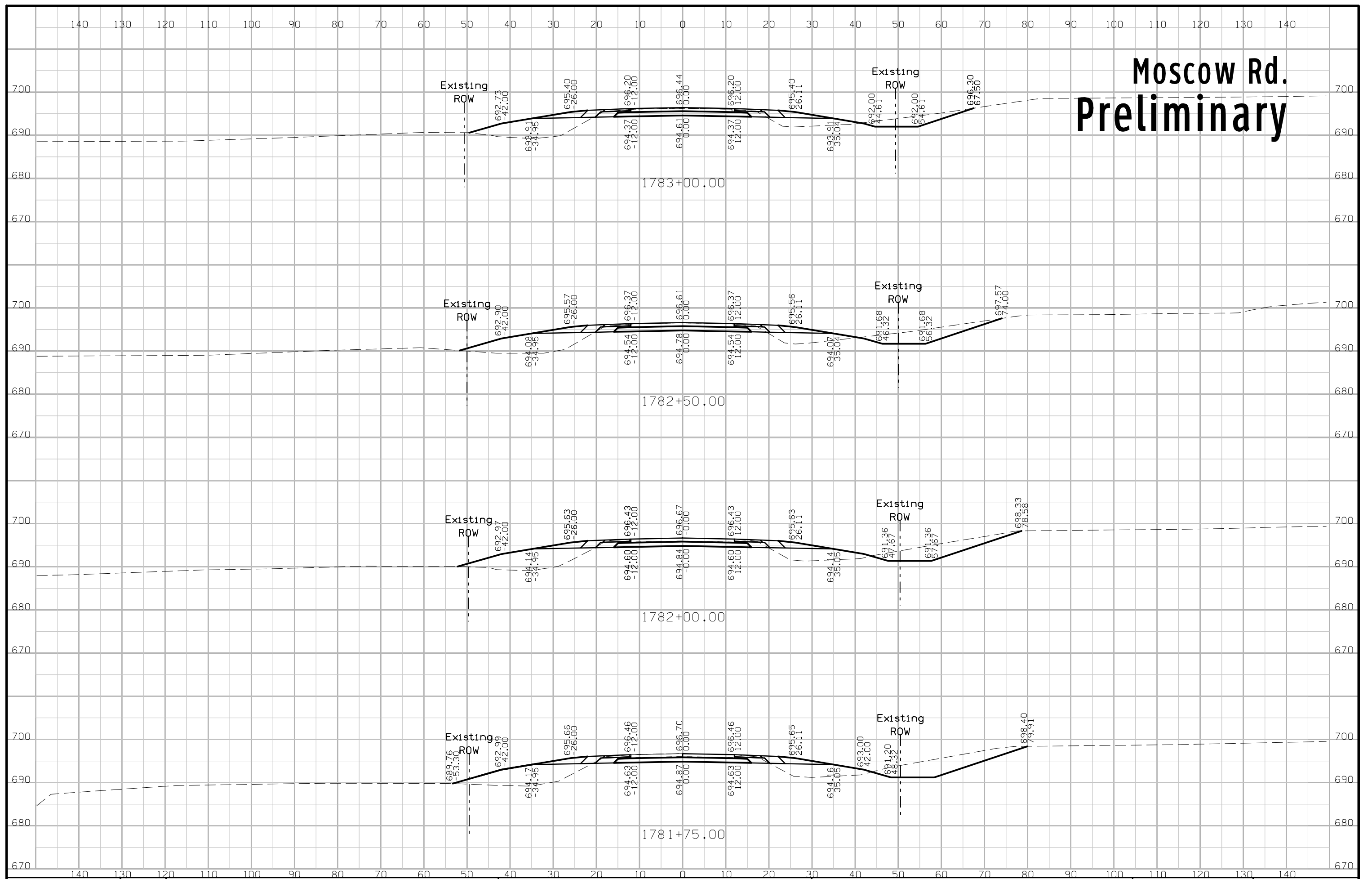

# Moscow Rd. Preliminary

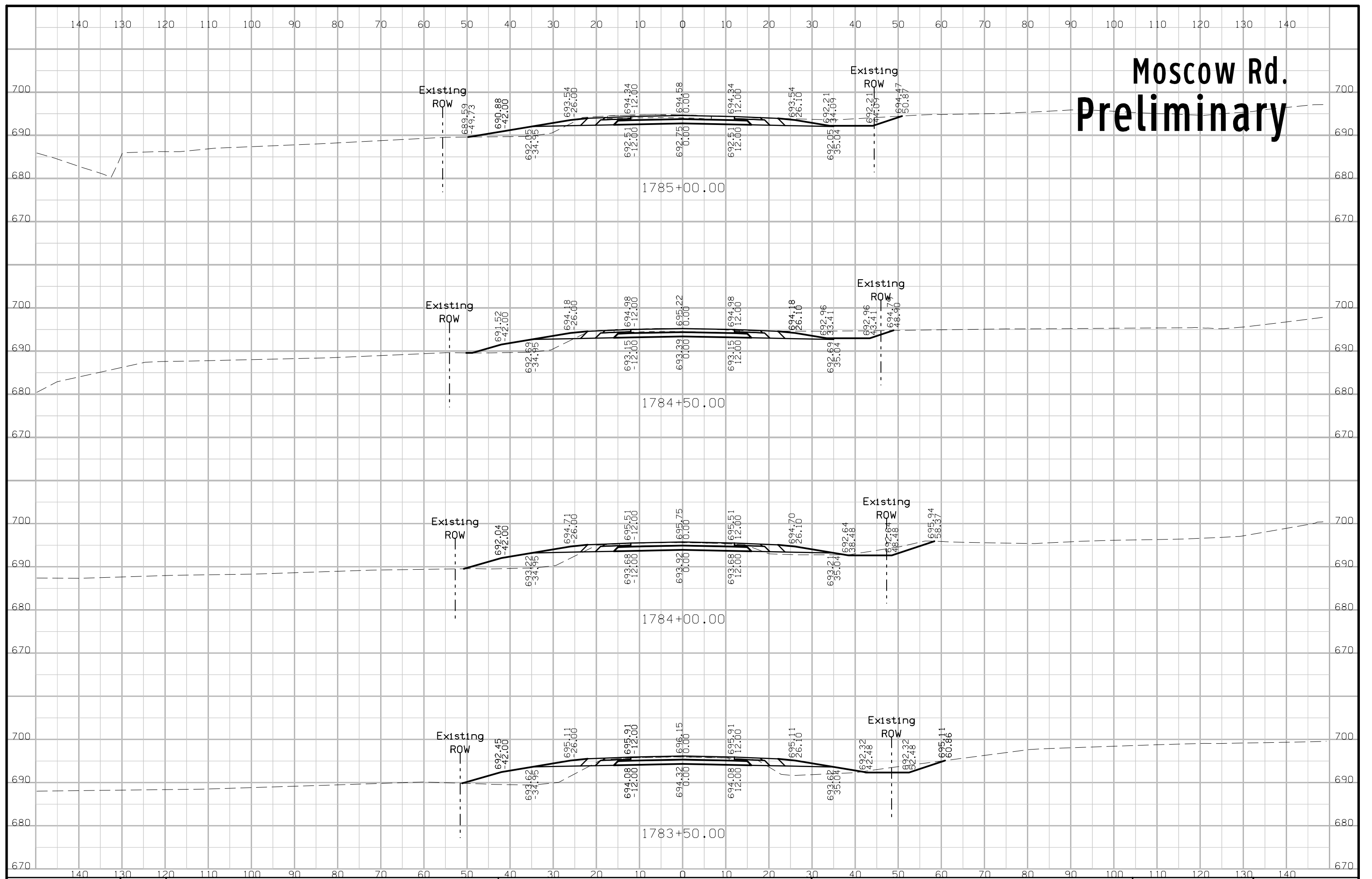

# Moscow Rd. Preliminary

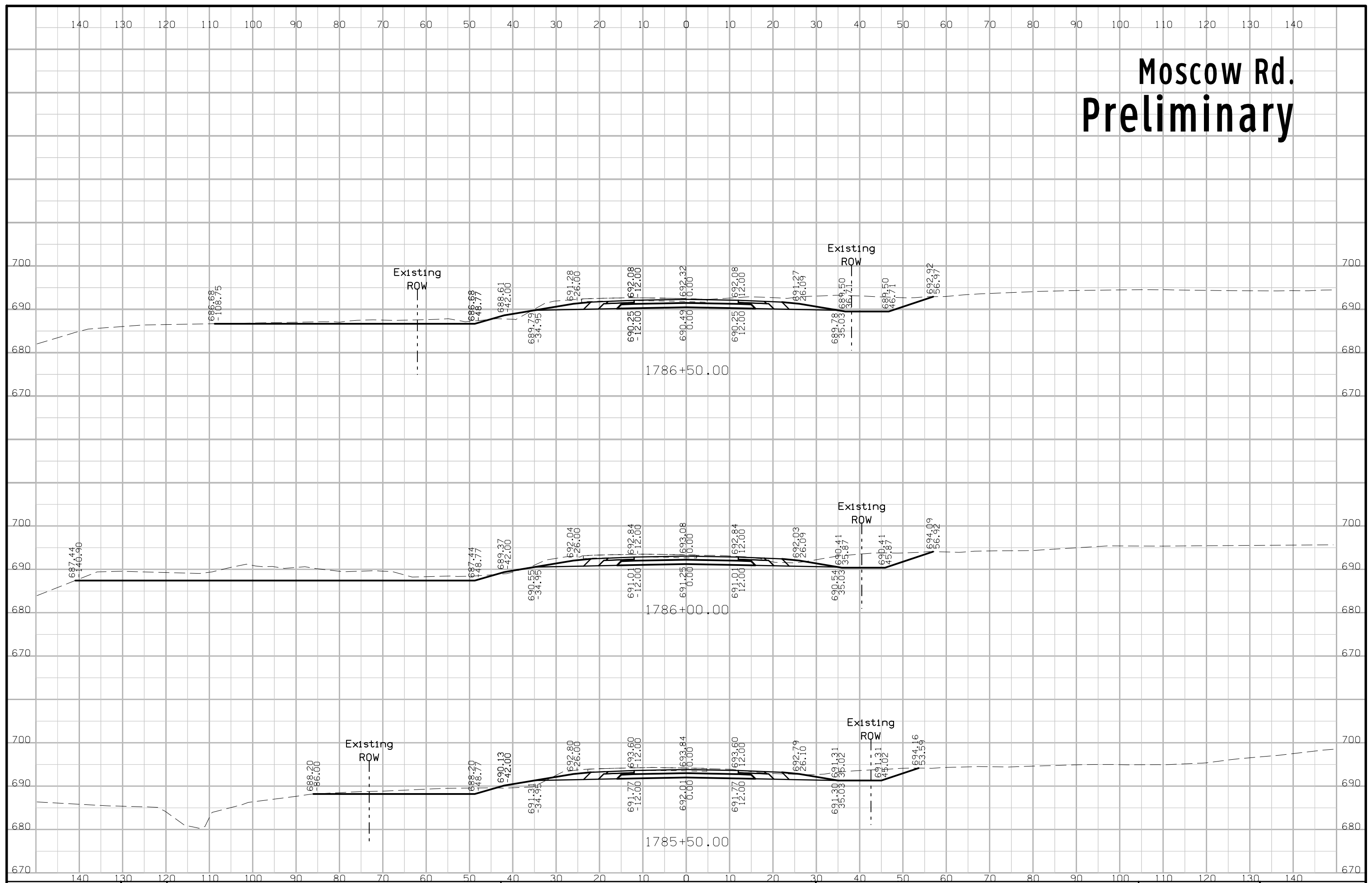

# Moscow Rd. Preliminary

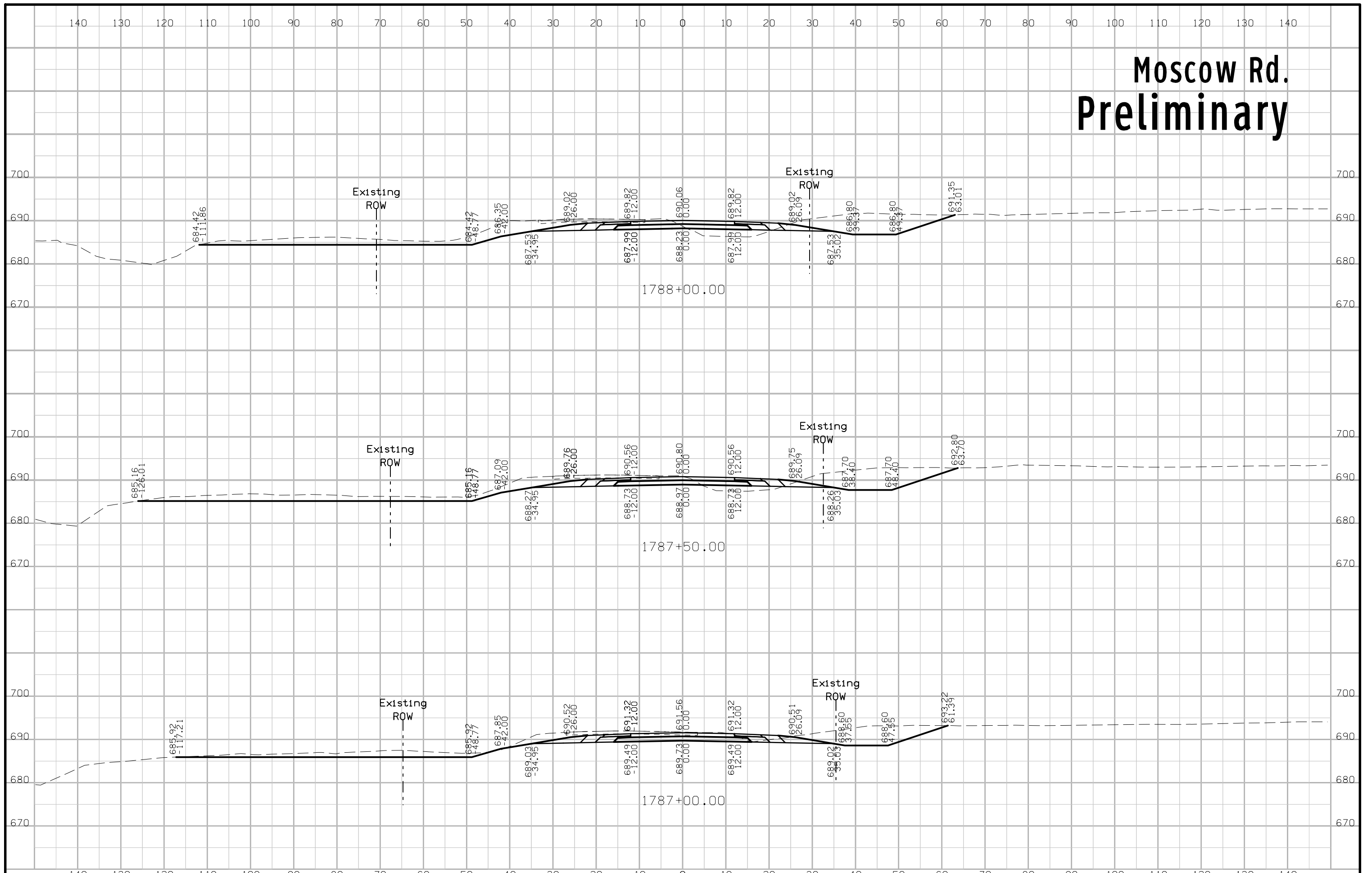

# Moscow Rd. Preliminary

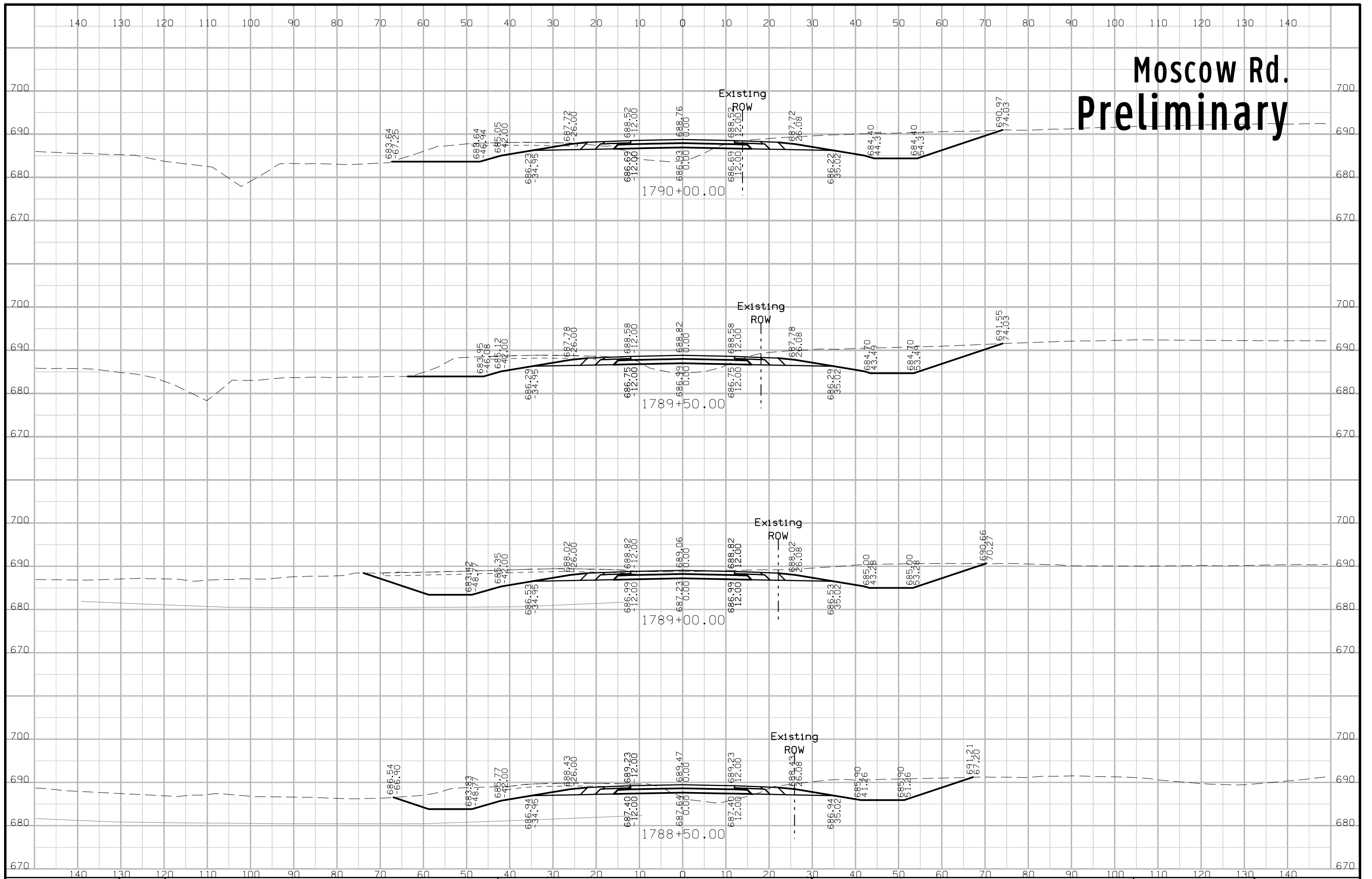

# Moscow Rd. Preliminary

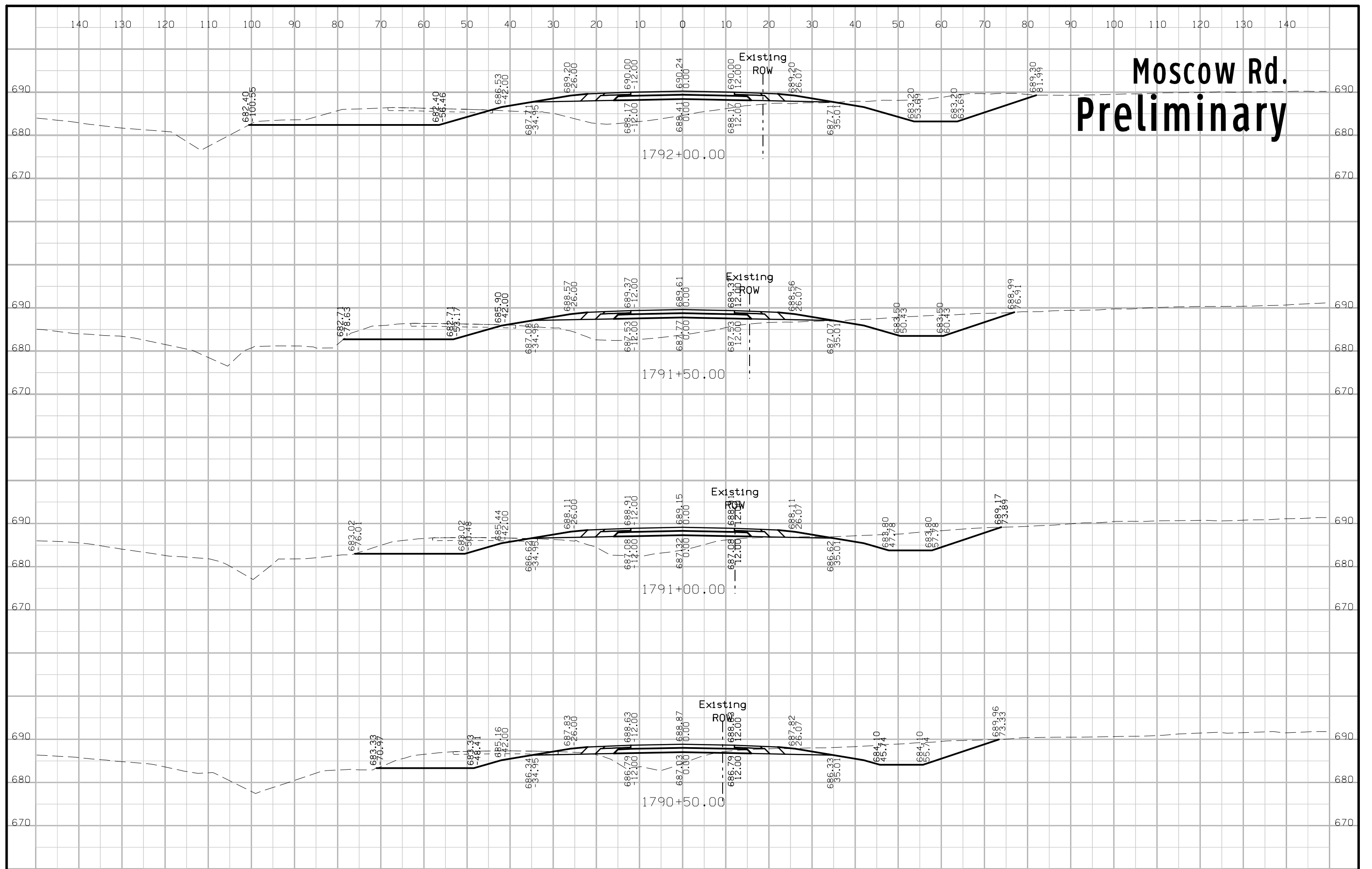

# Moscow Rd. Preliminary

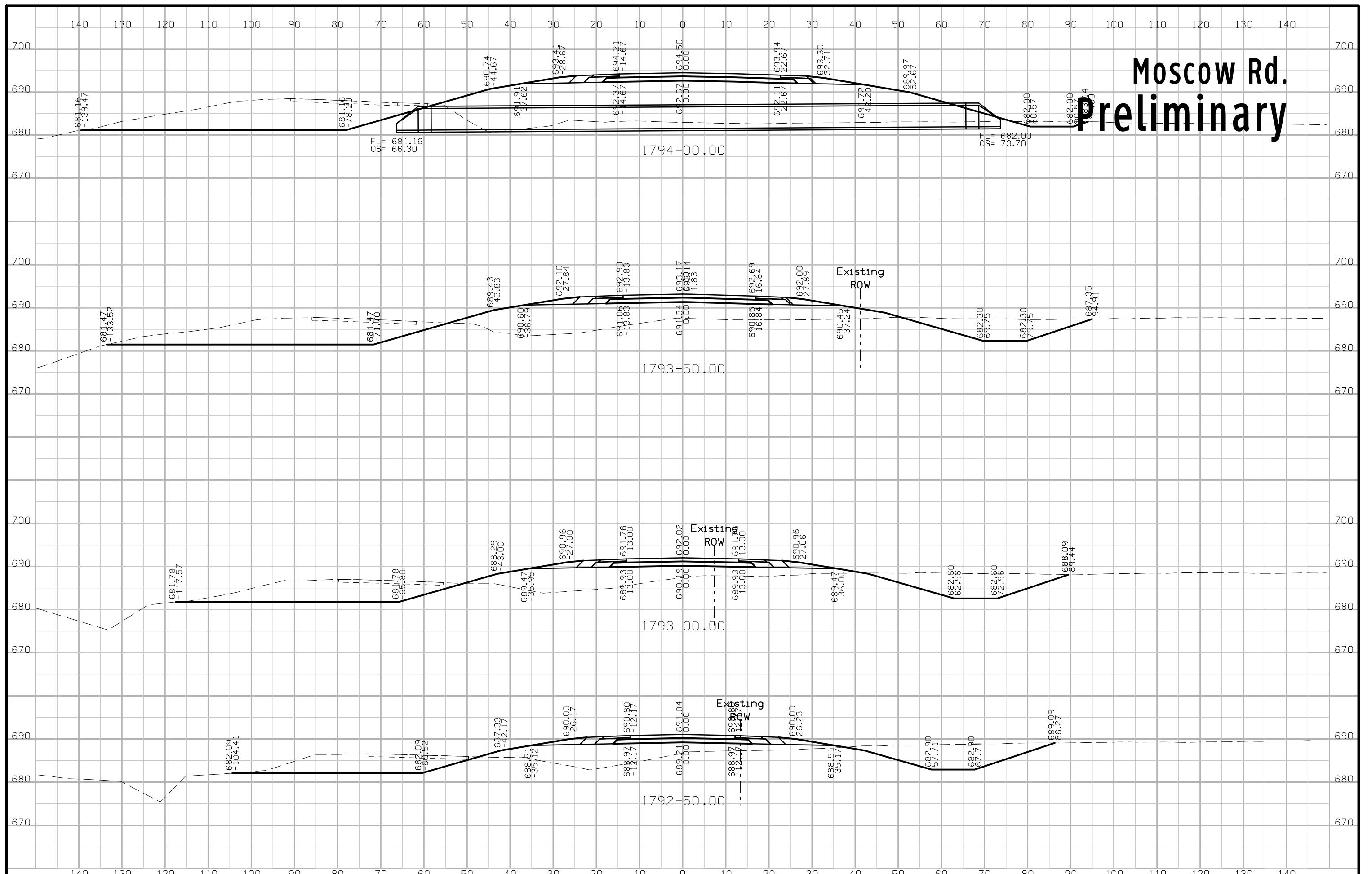



# Moscow Rd. Preliminary

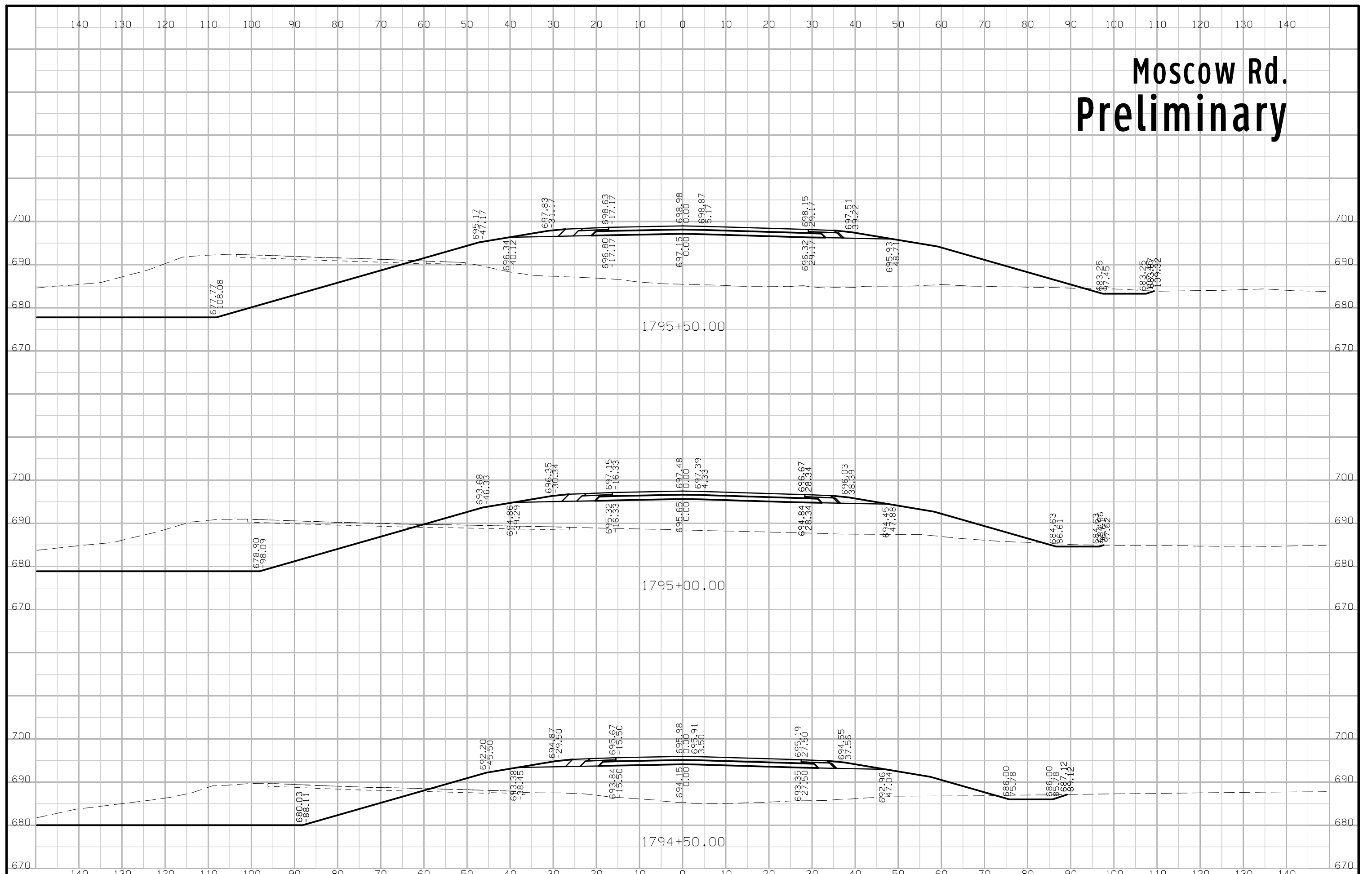

# Moscow Rd. Preliminary

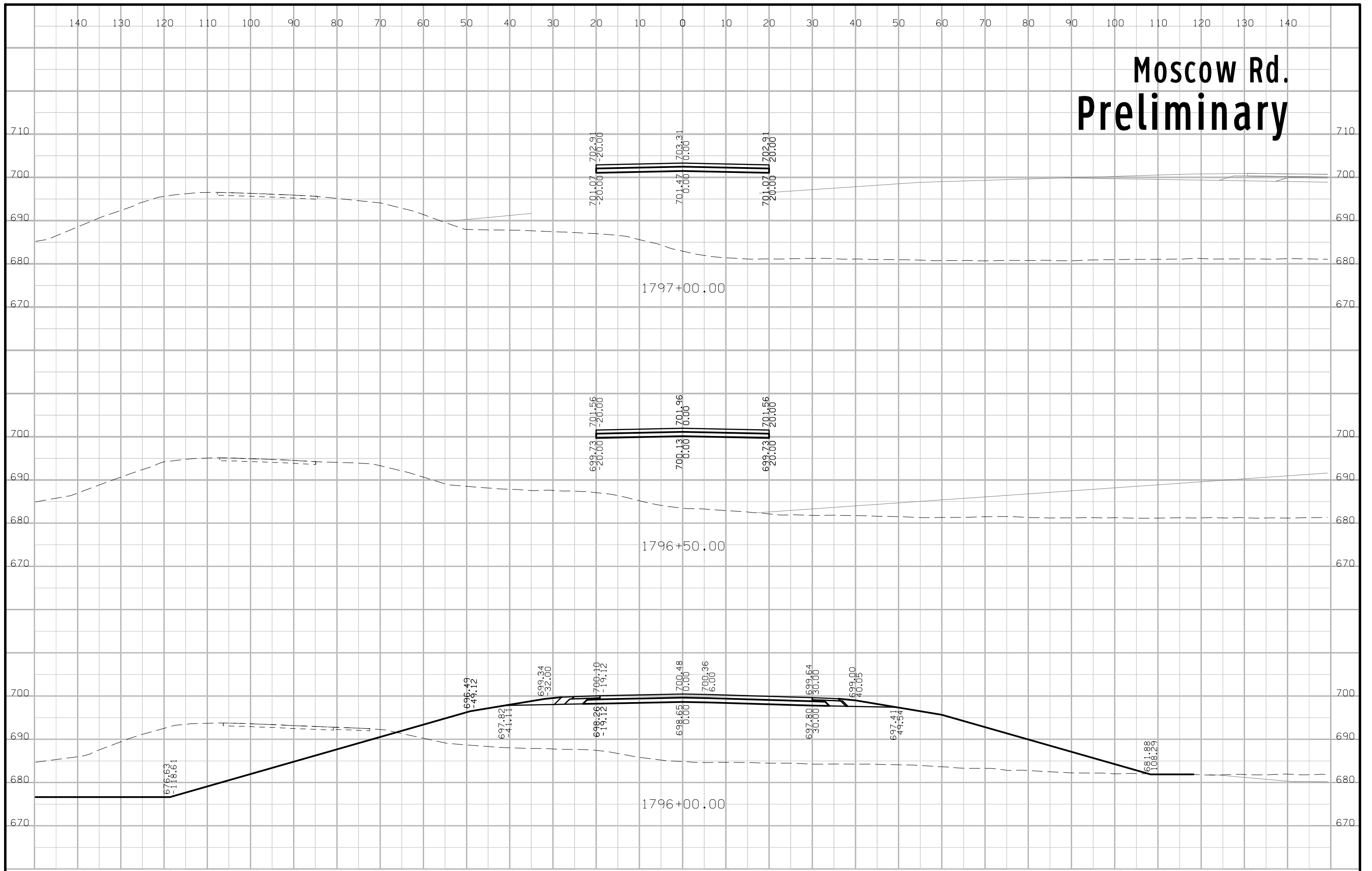

# Moscow Rd. Preliminary

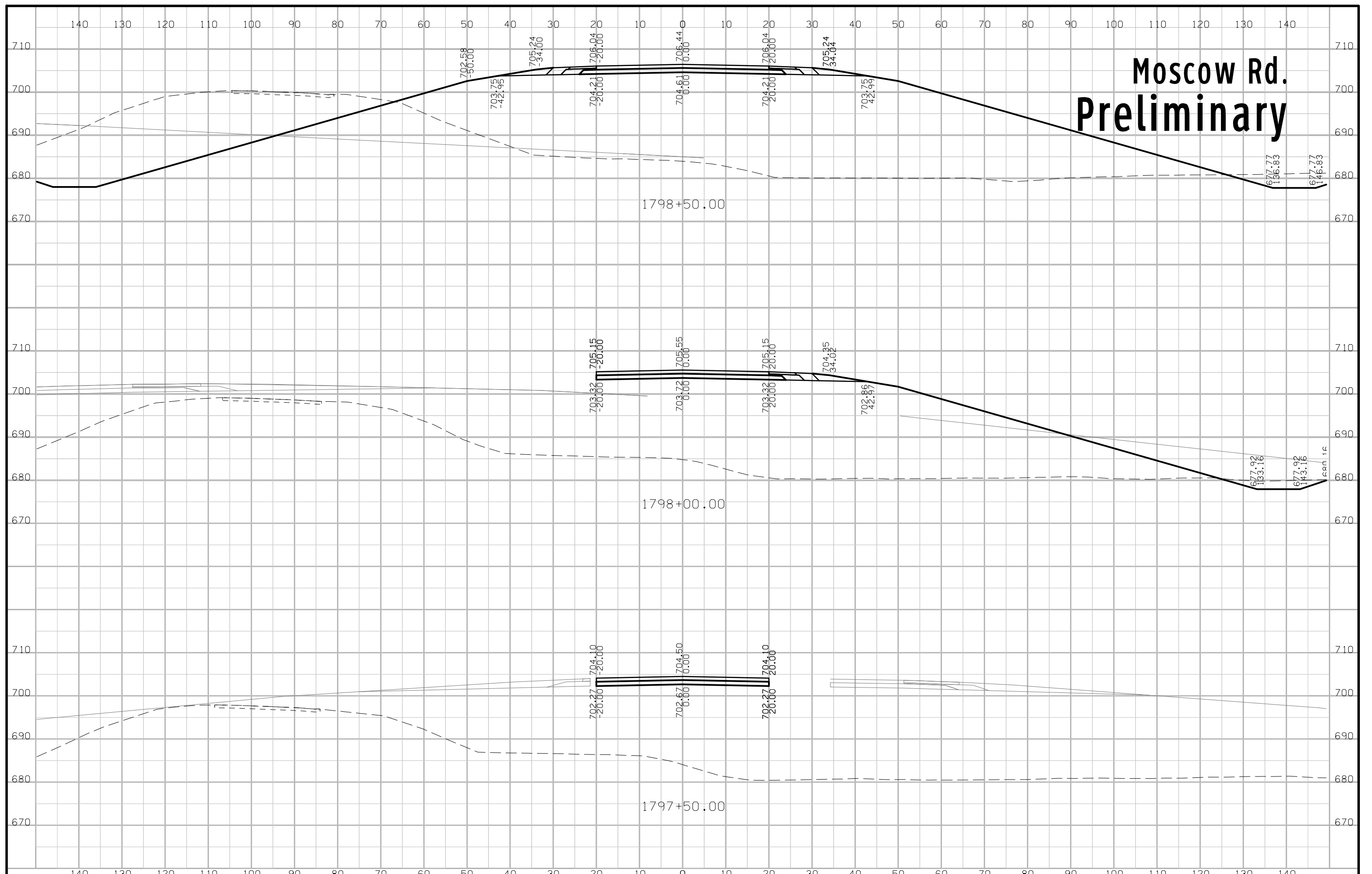

# Moscow Rd. Preliminary

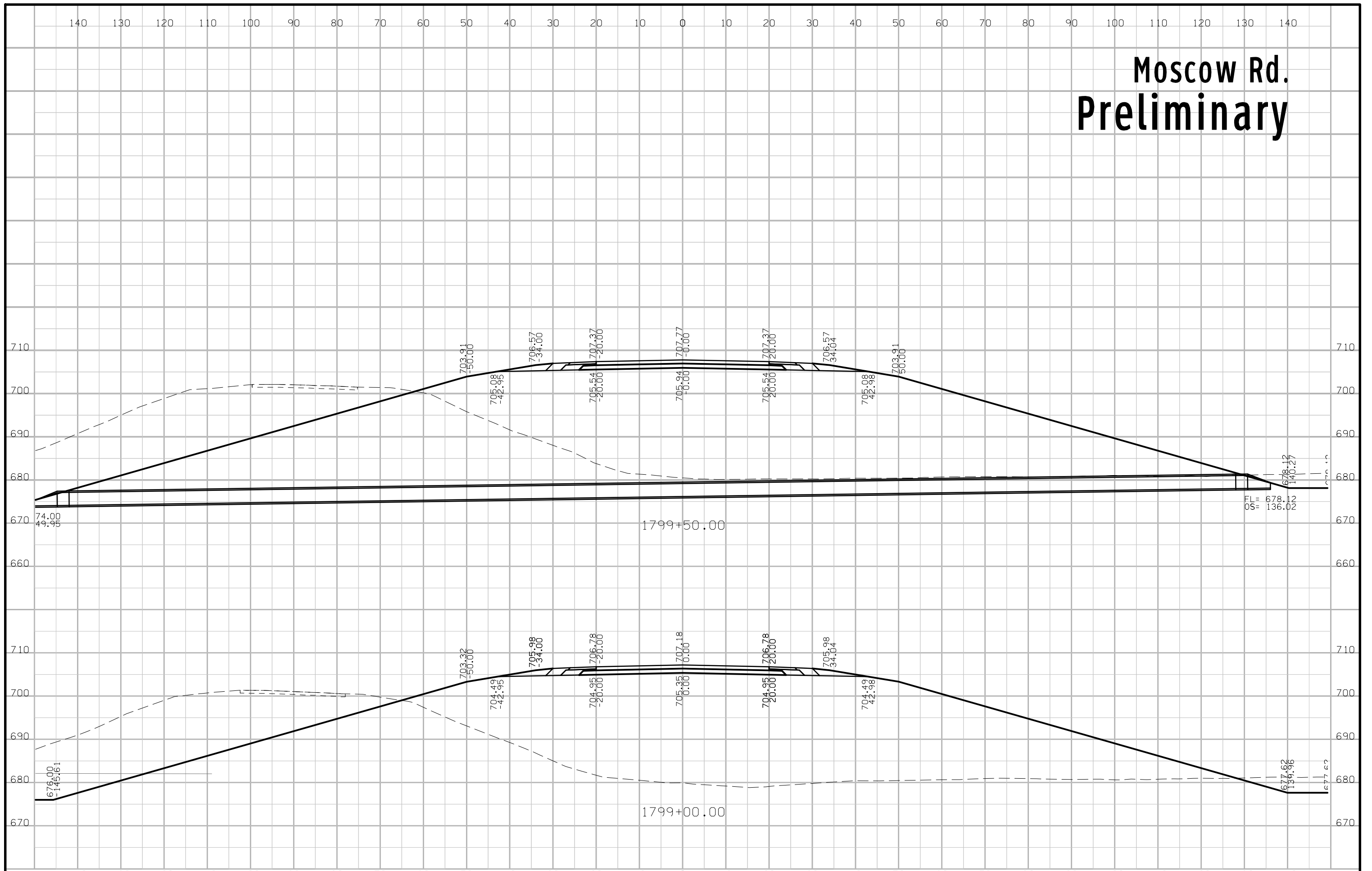

# Moscow Rd. Preliminary

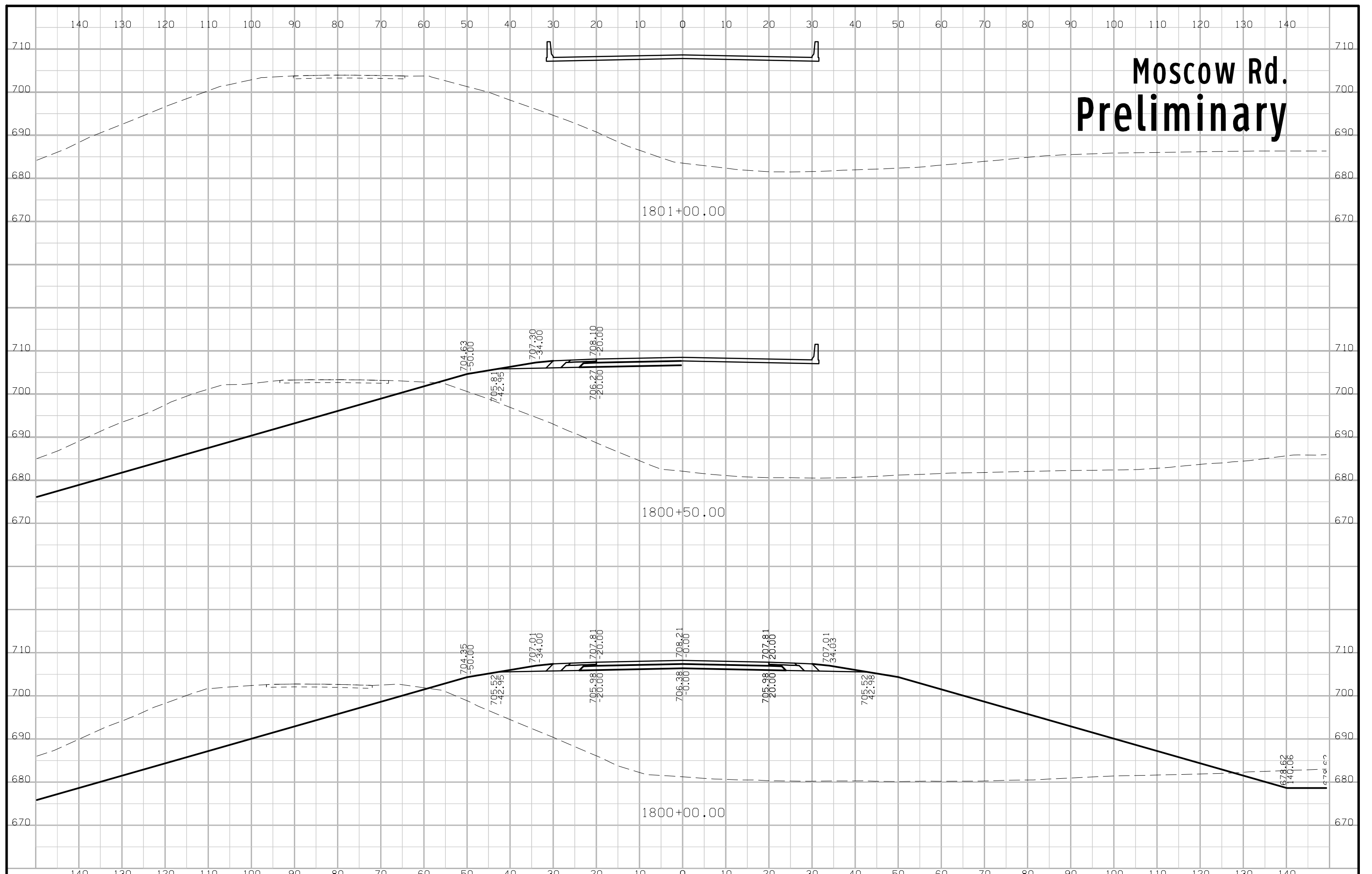

# Moscow Rd. Preliminary

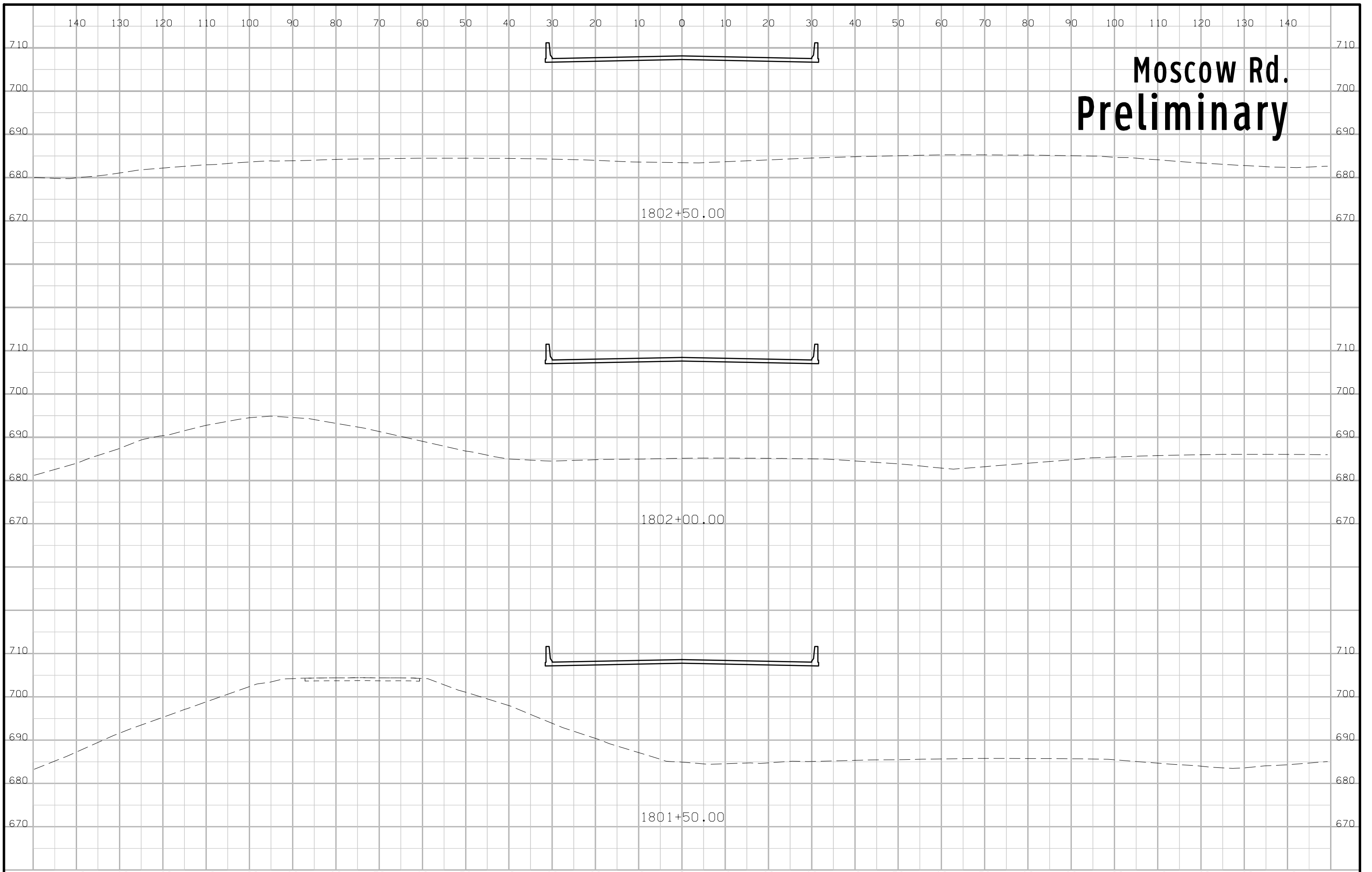

# Moscow Rd. Preliminary

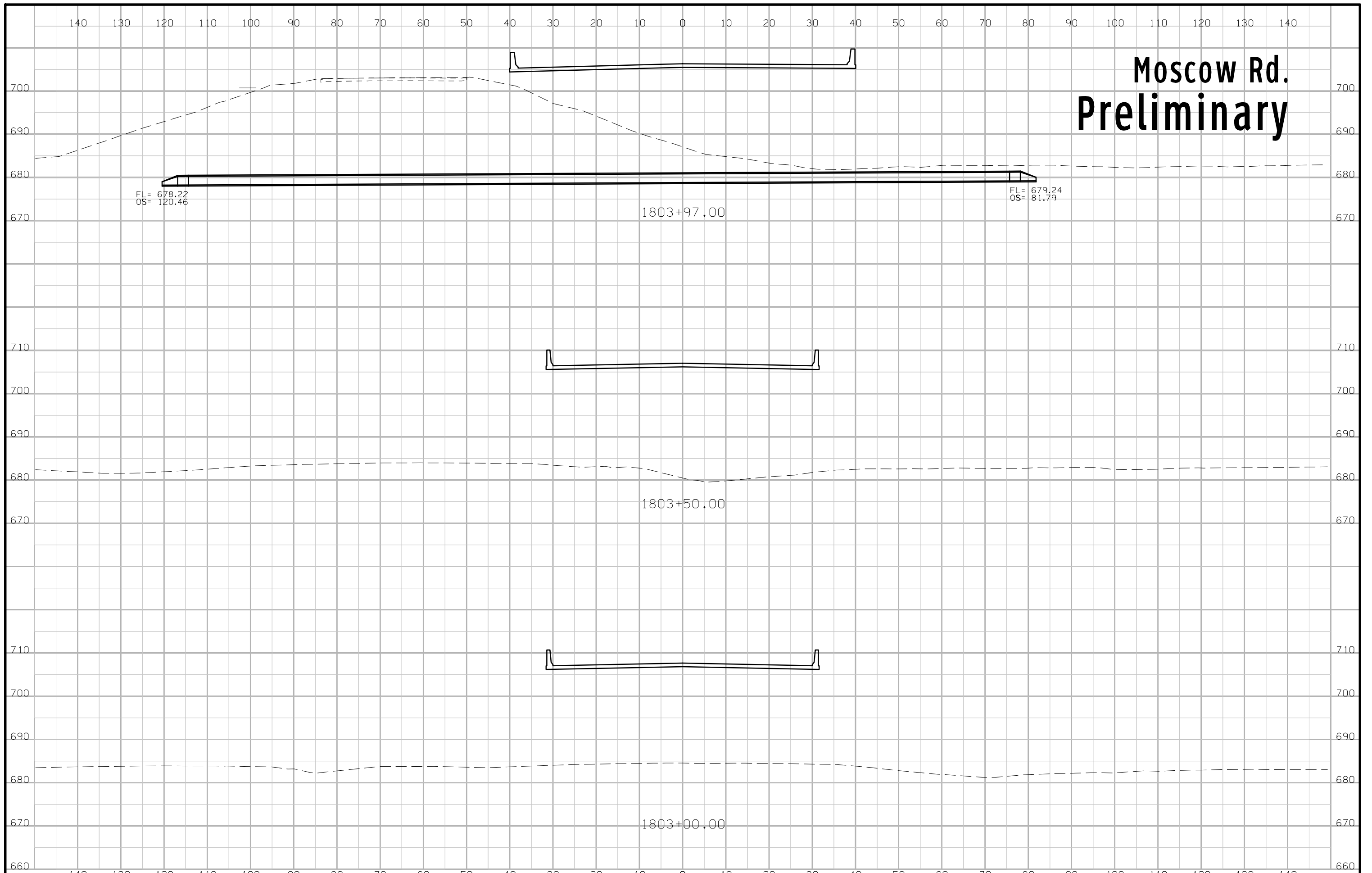

# Moscow Rd. Preliminary

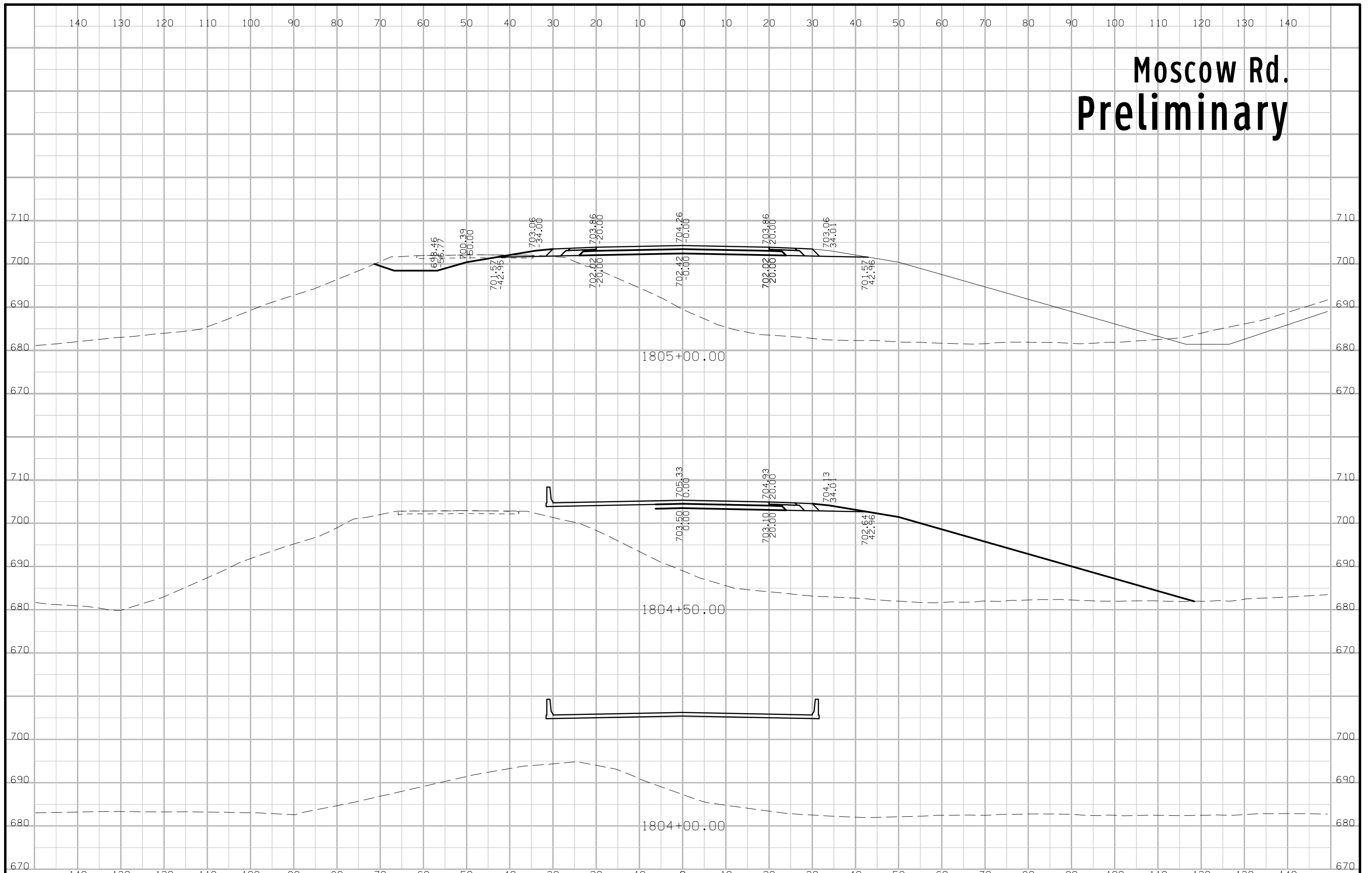



# Moscow Rd. Preliminary

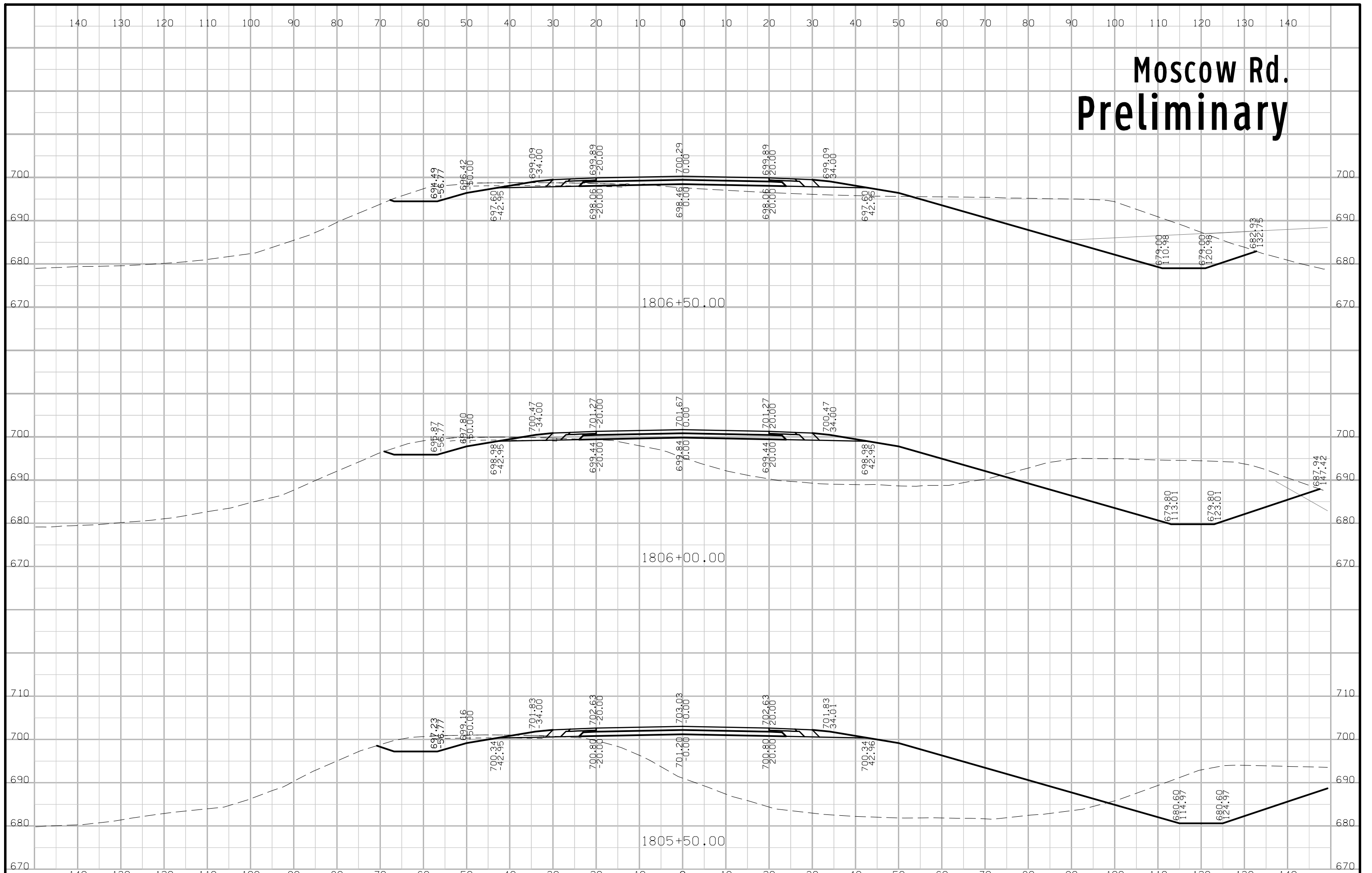

# Moscow Rd. Preliminary

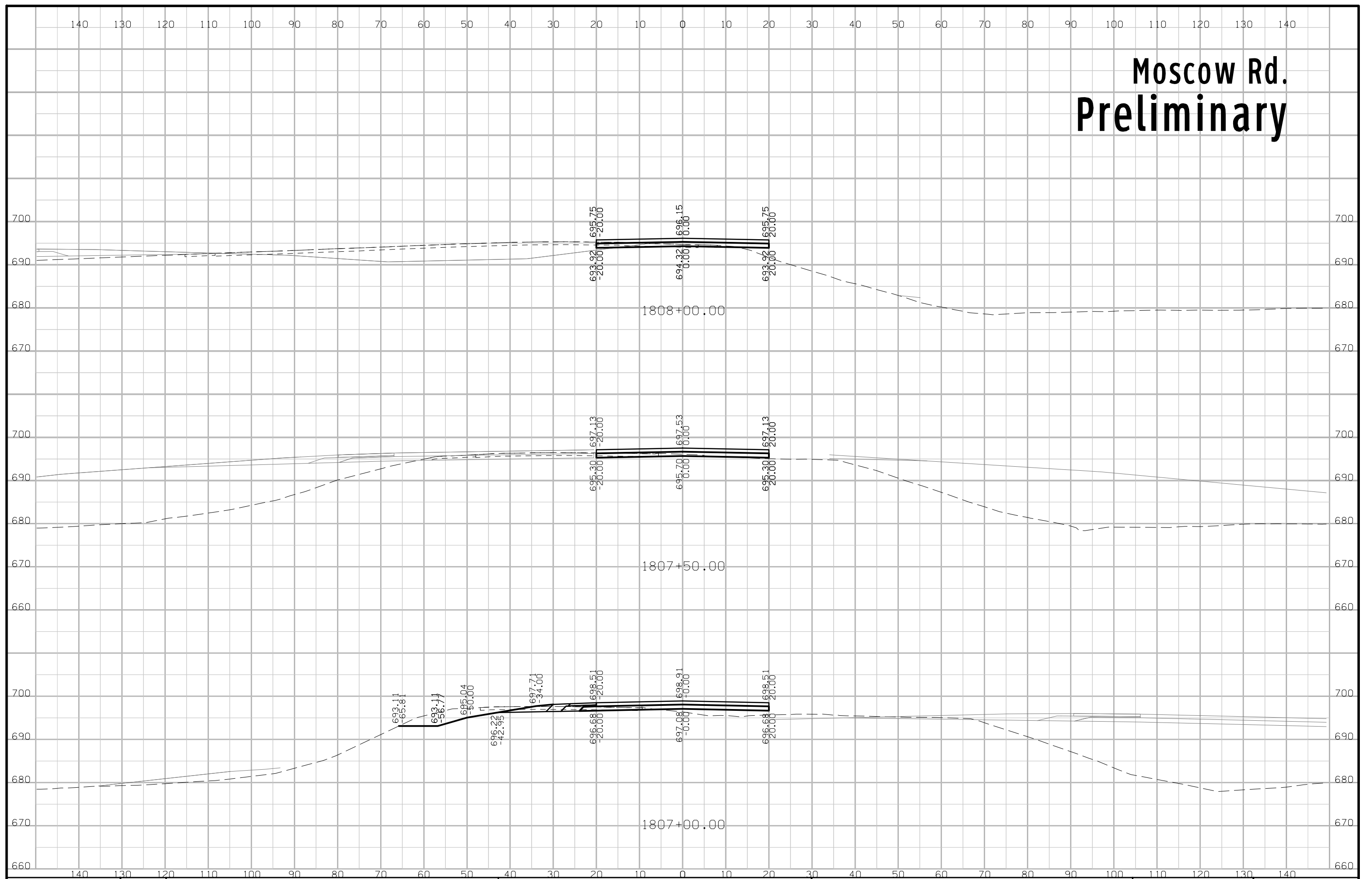

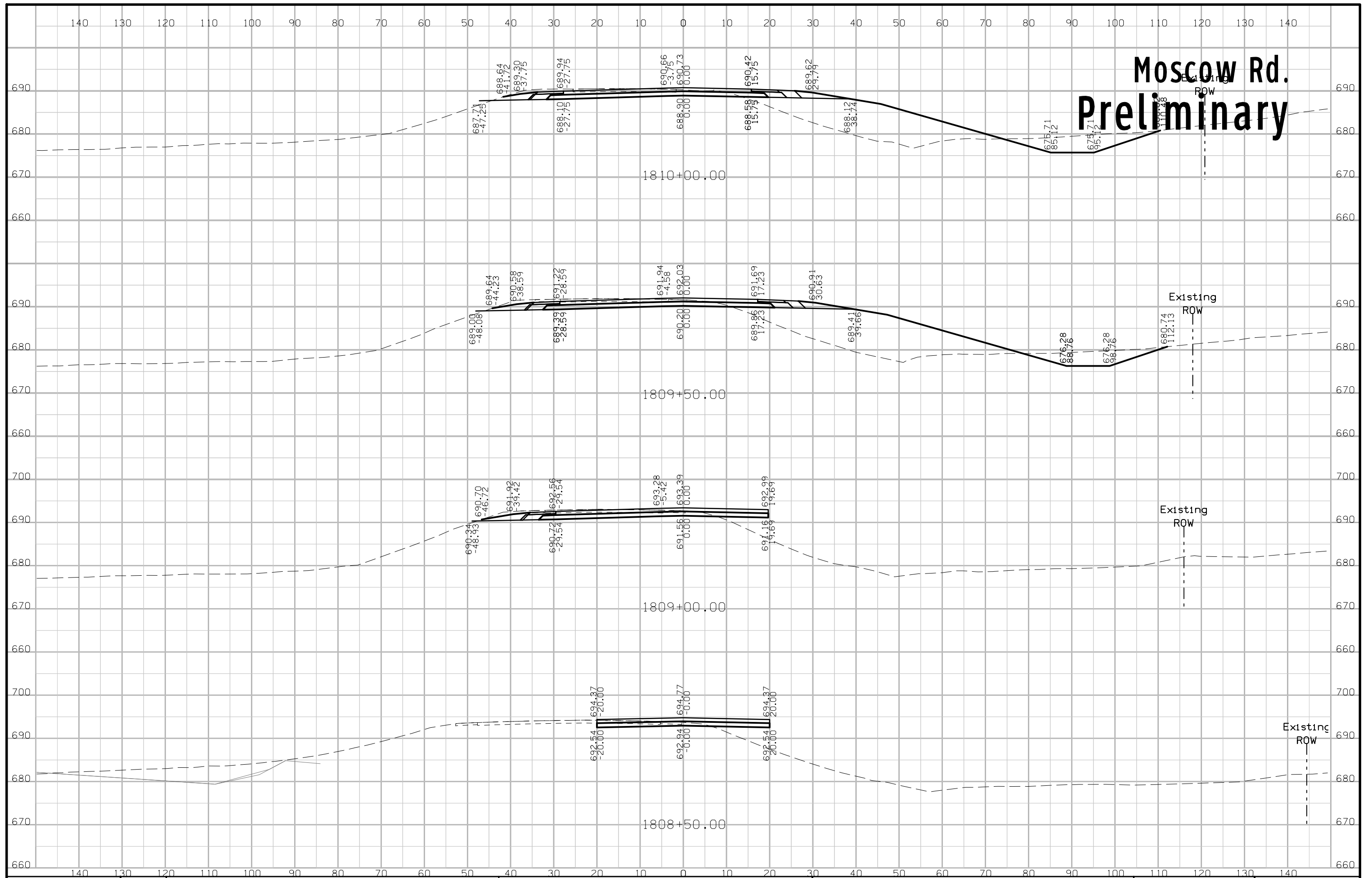

# Moscow Rd. Preliminary

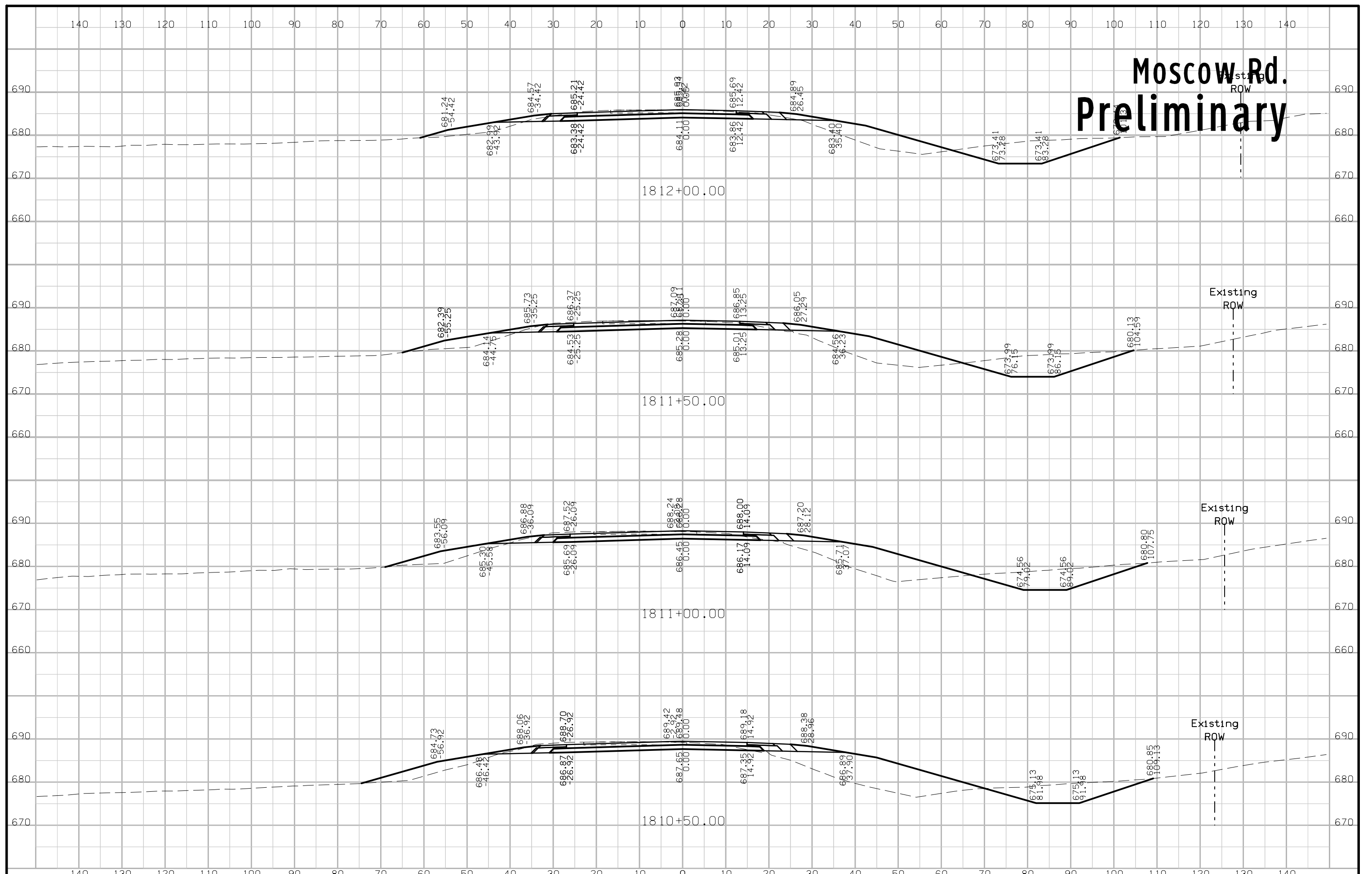

# Moscow Rd. Preliminary

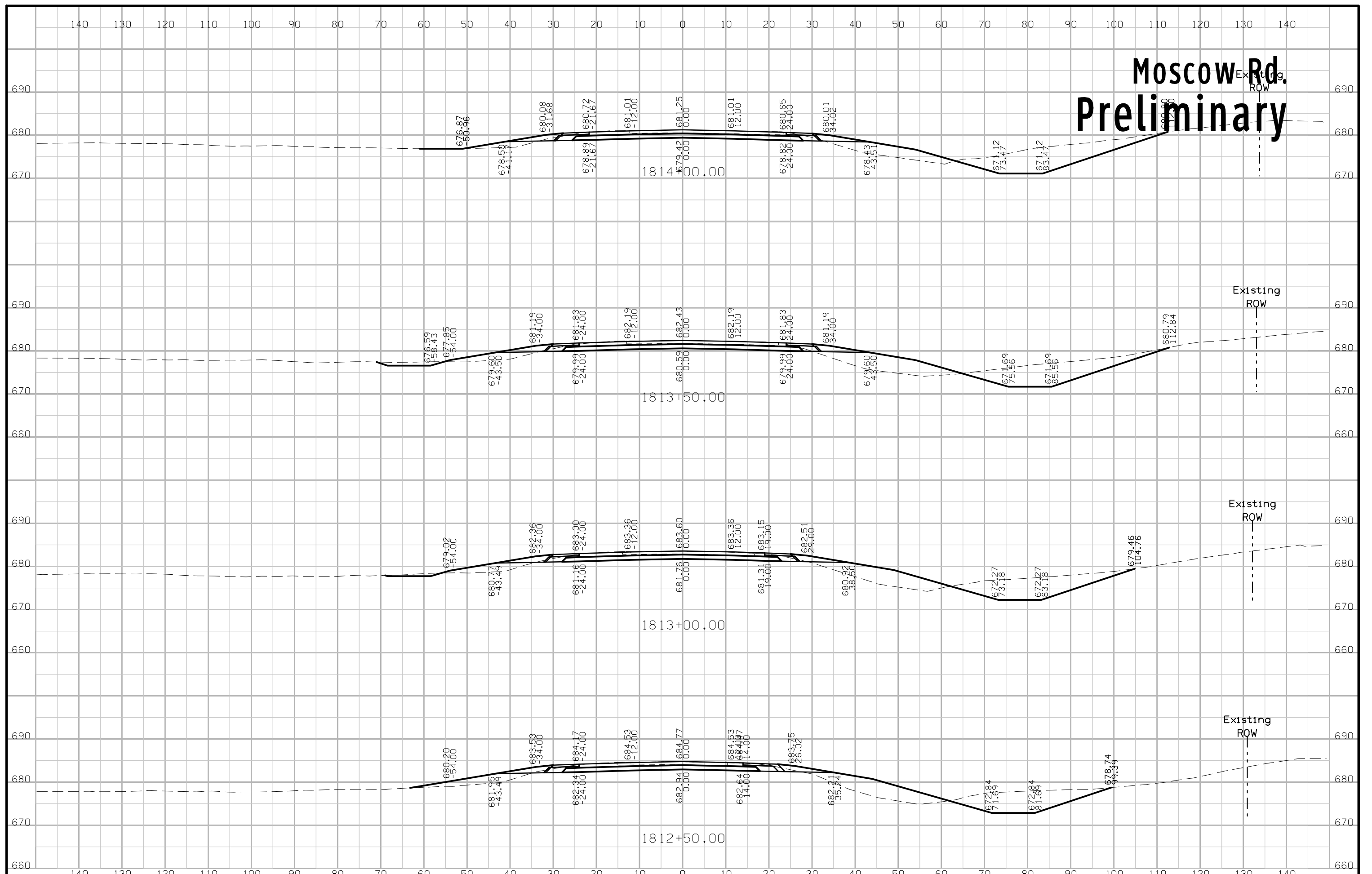

# Moscow Rd. Preliminary

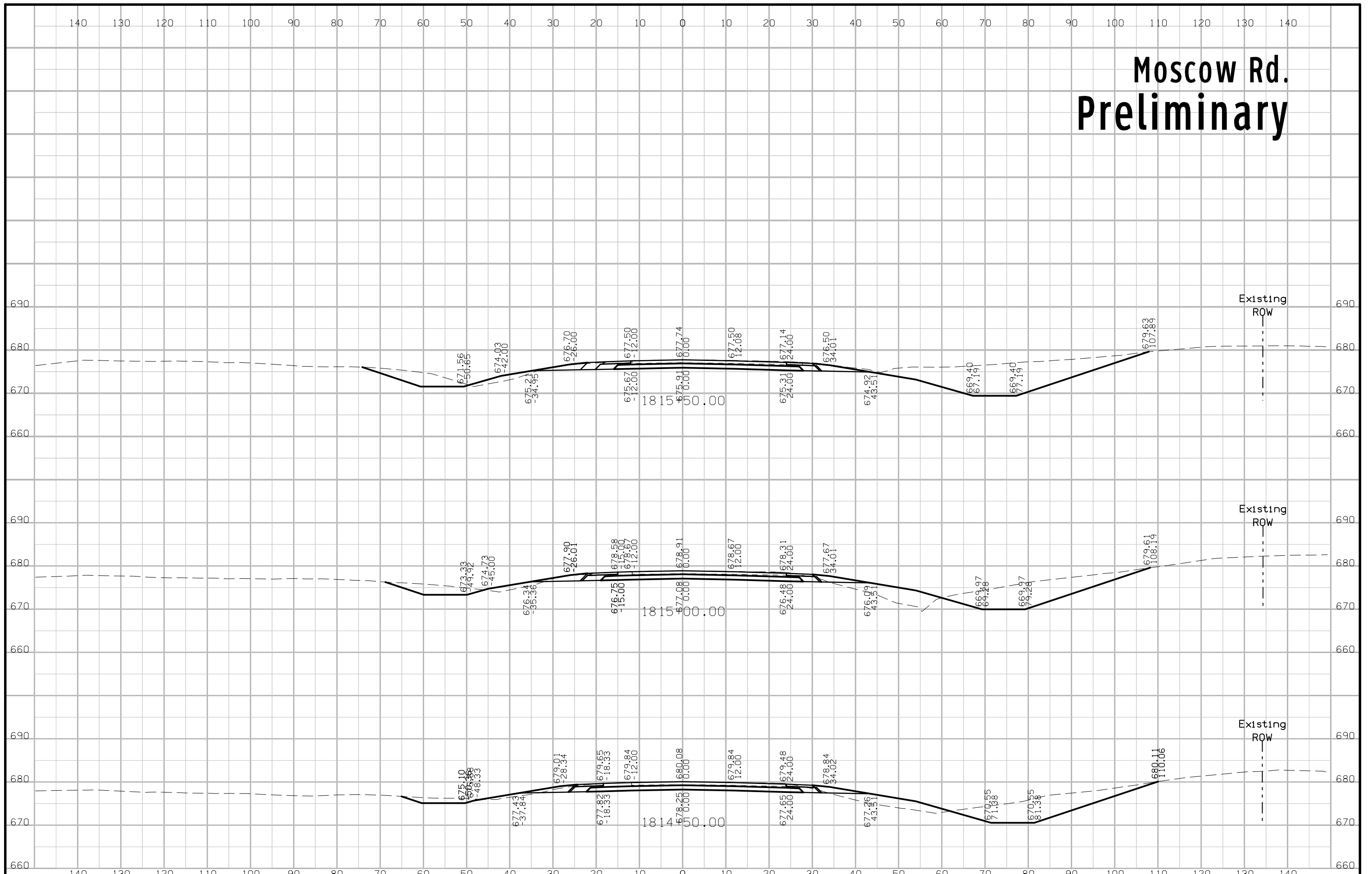

# Pine Ave./Old Muscatine Rd. Preliminary

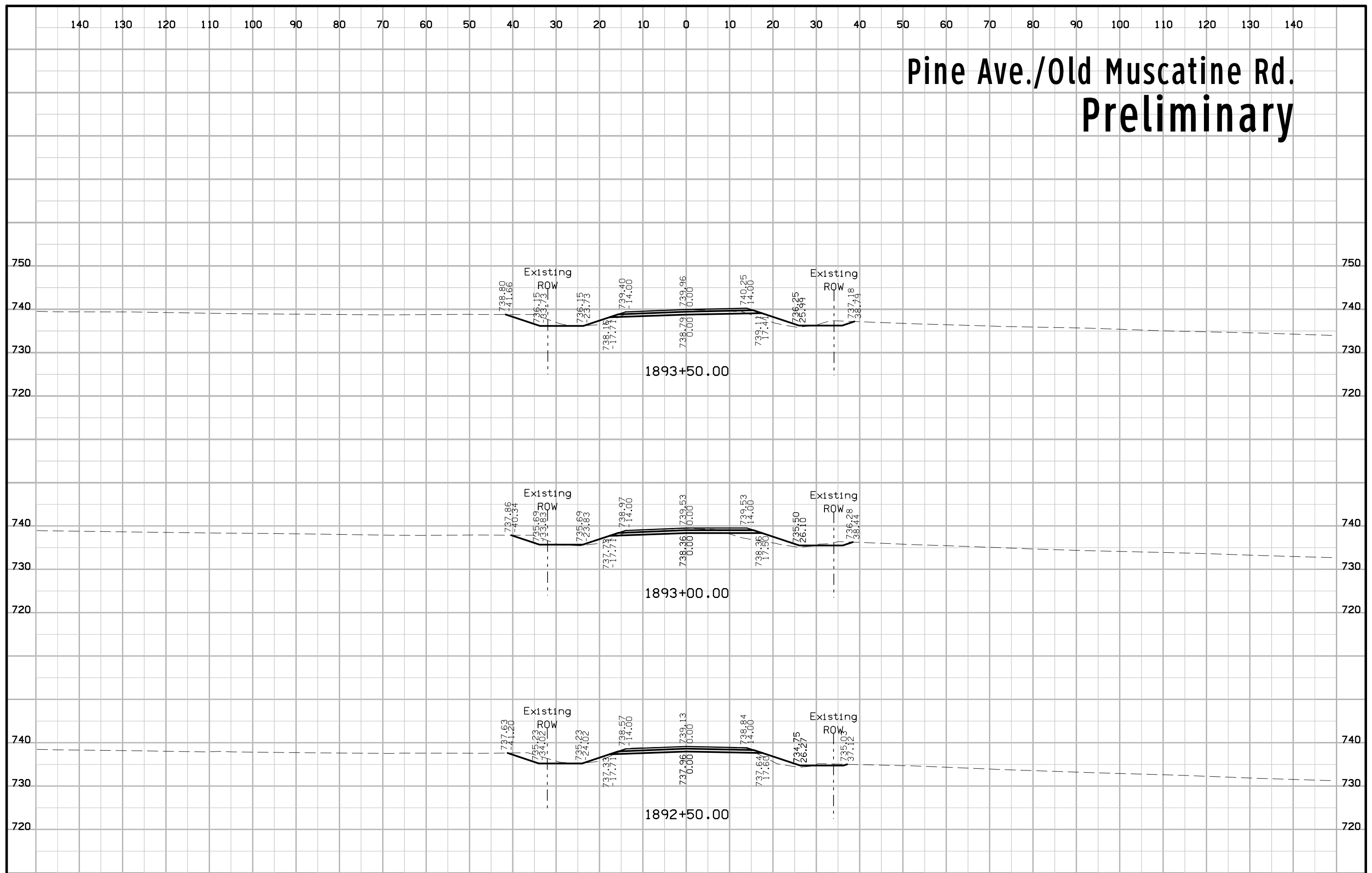

# Pine Ave./Old Muscatine Rd. Preliminary

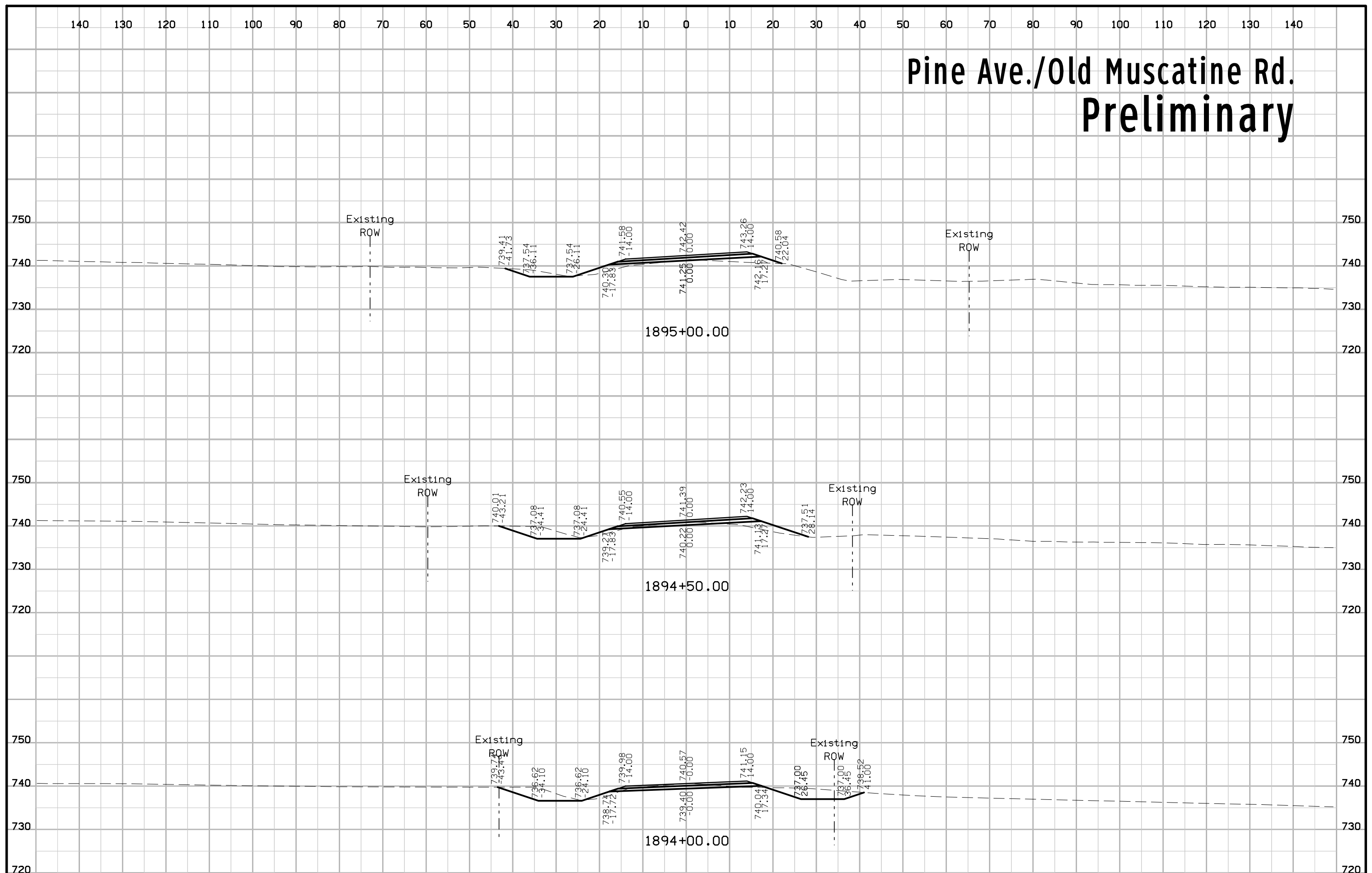



# Pine Ave./Old Muscatine Rd. Preliminary

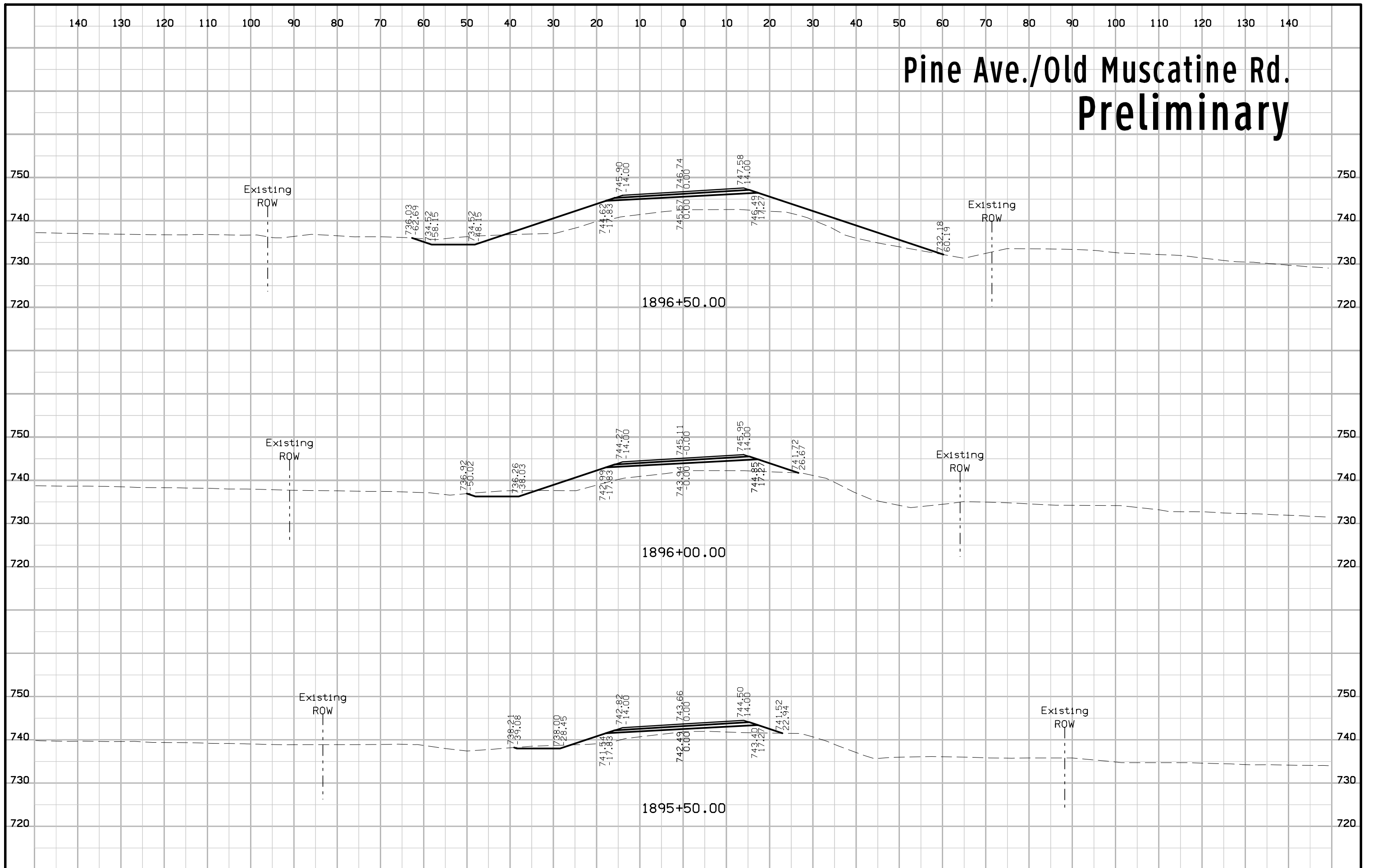

# Pine Ave./Old Muscatine Rd. Preliminary

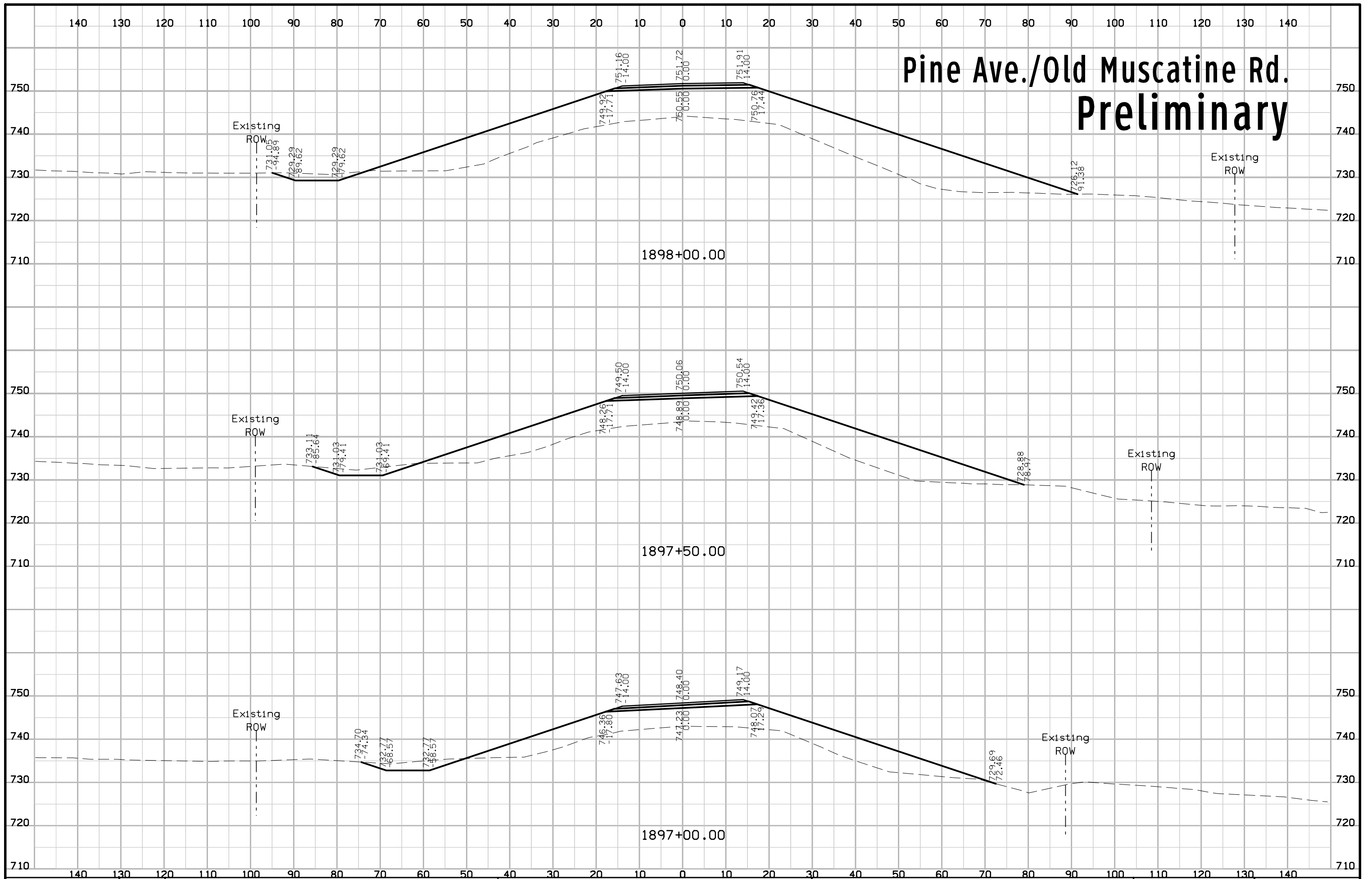

# Pine Ave./Old Muscatine Rd. Preliminary

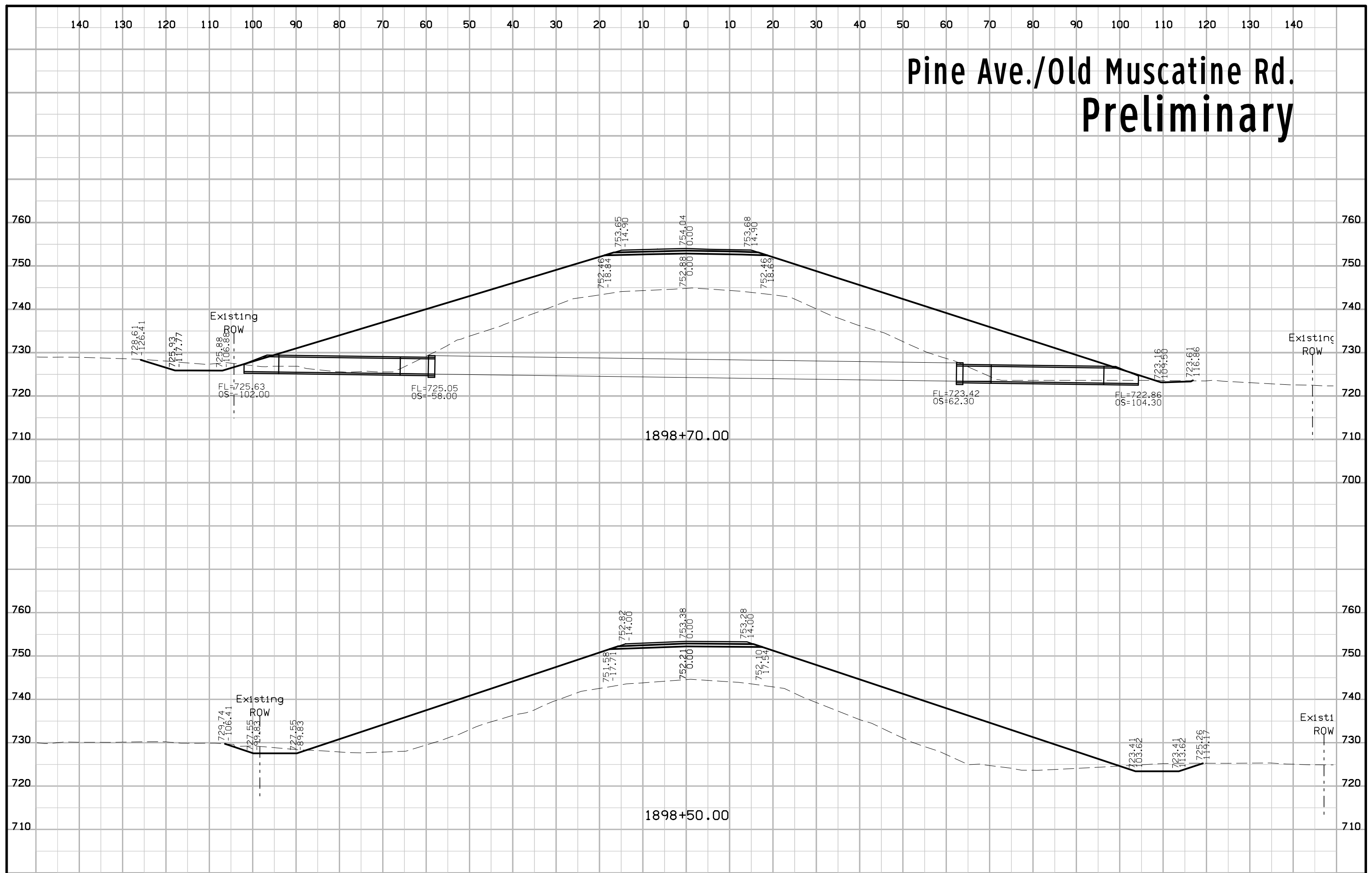

# Pine Ave./Old Muscatine Rd. Preliminary

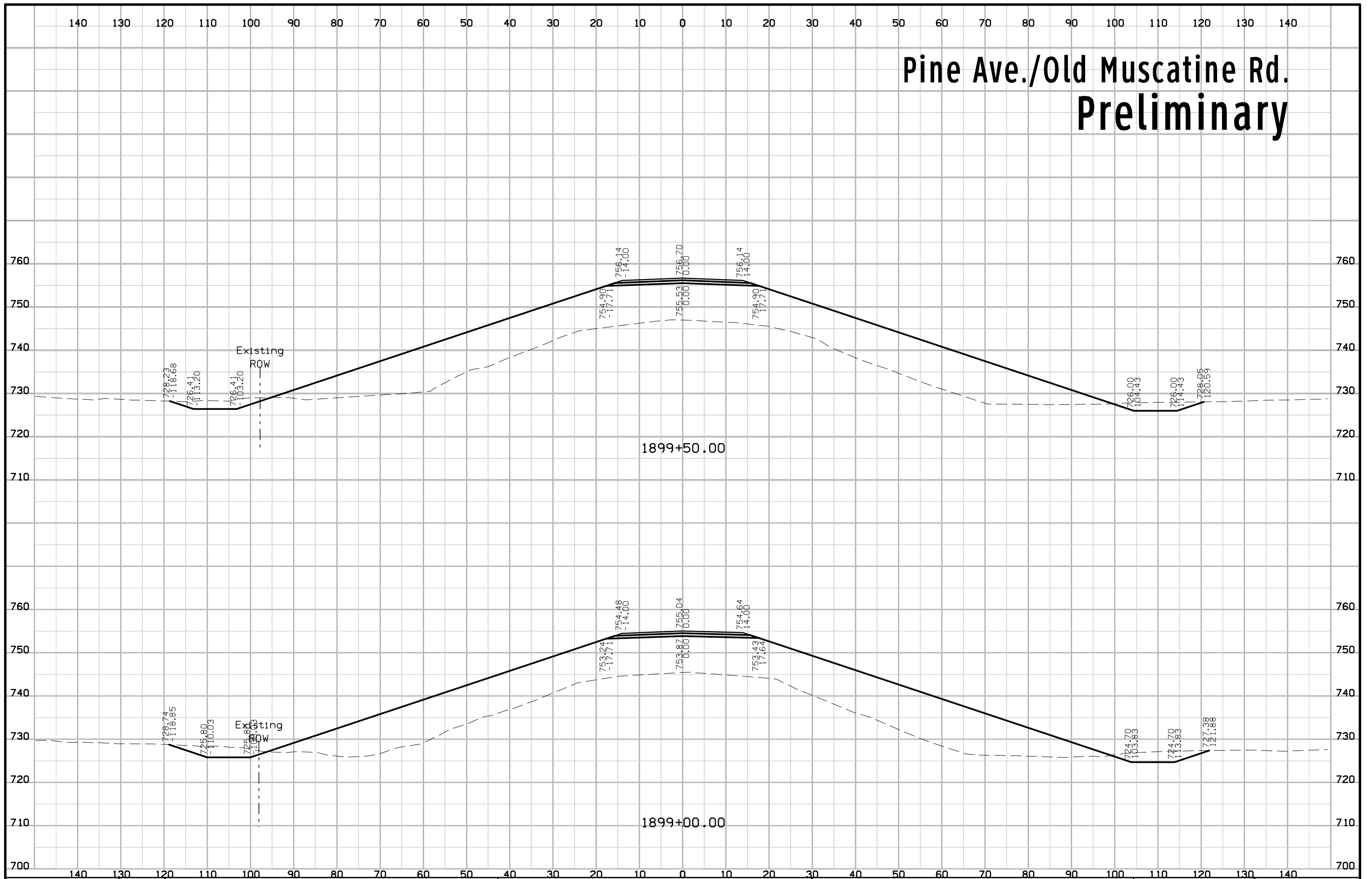

# Pine Ave./Old Muscatine Rd. Preliminary

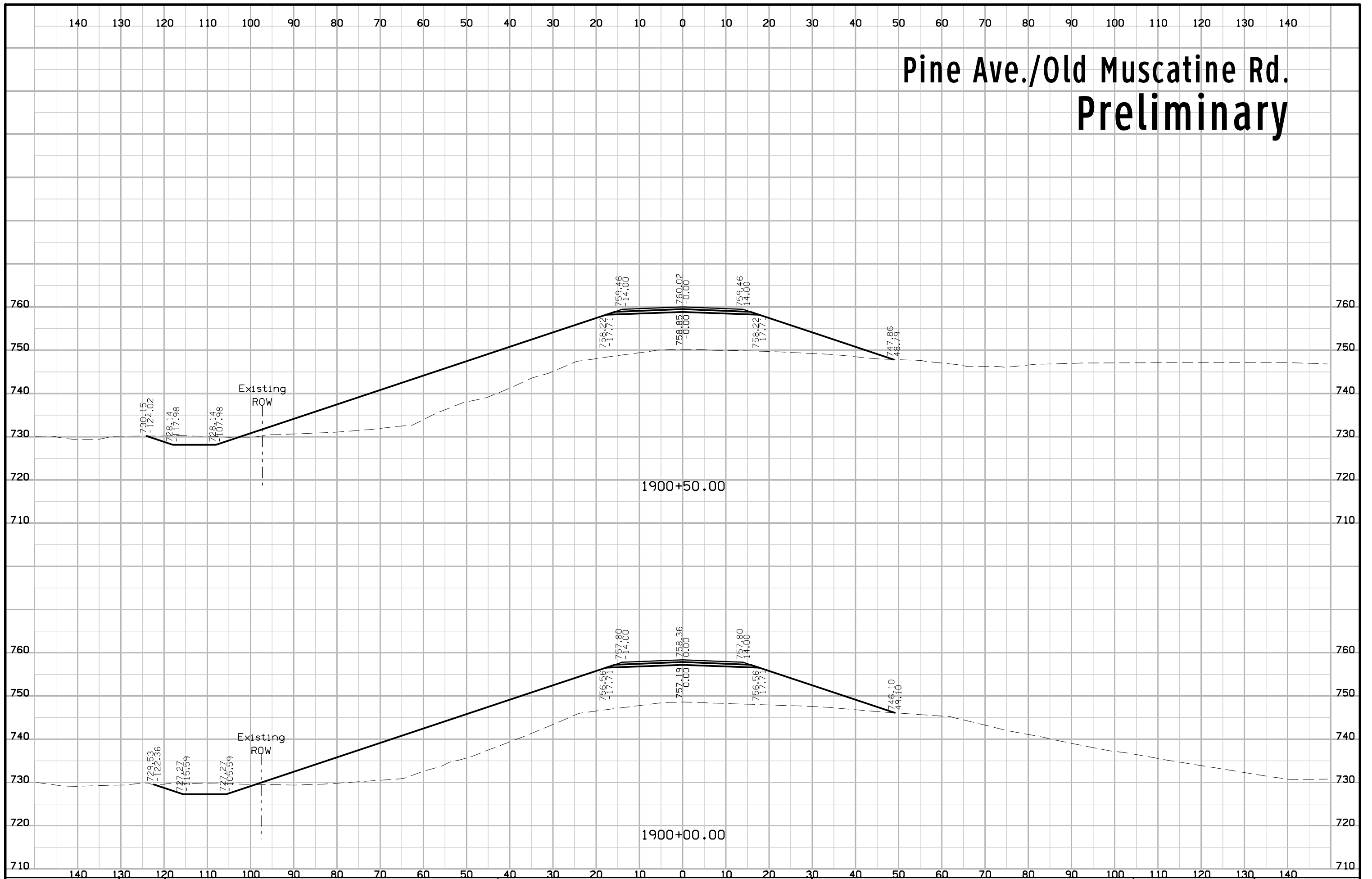

# Pine Ave./Old Muscatine Rd. Preliminary

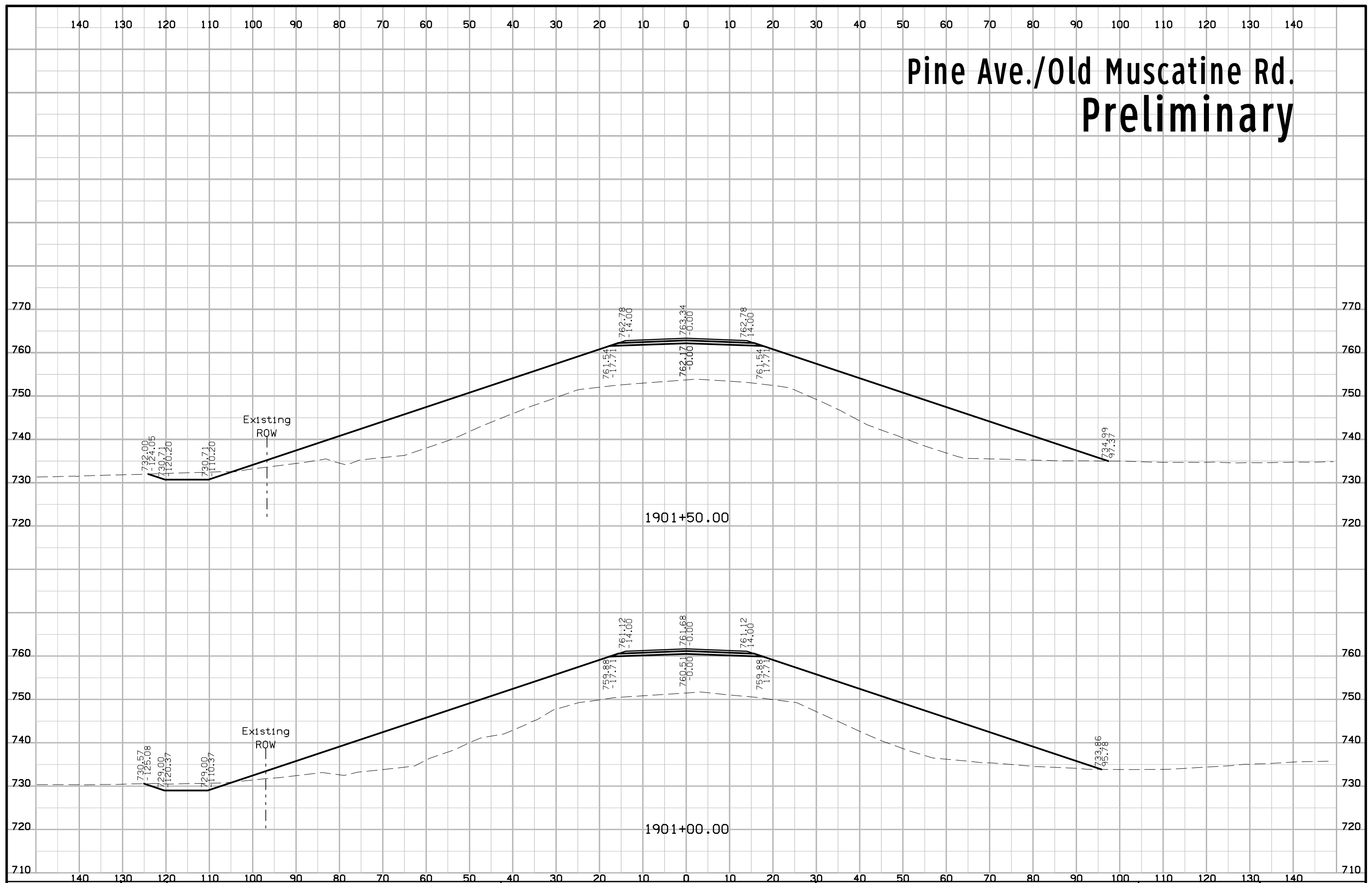

# Pine Ave./Old Muscatine Rd. Preliminary

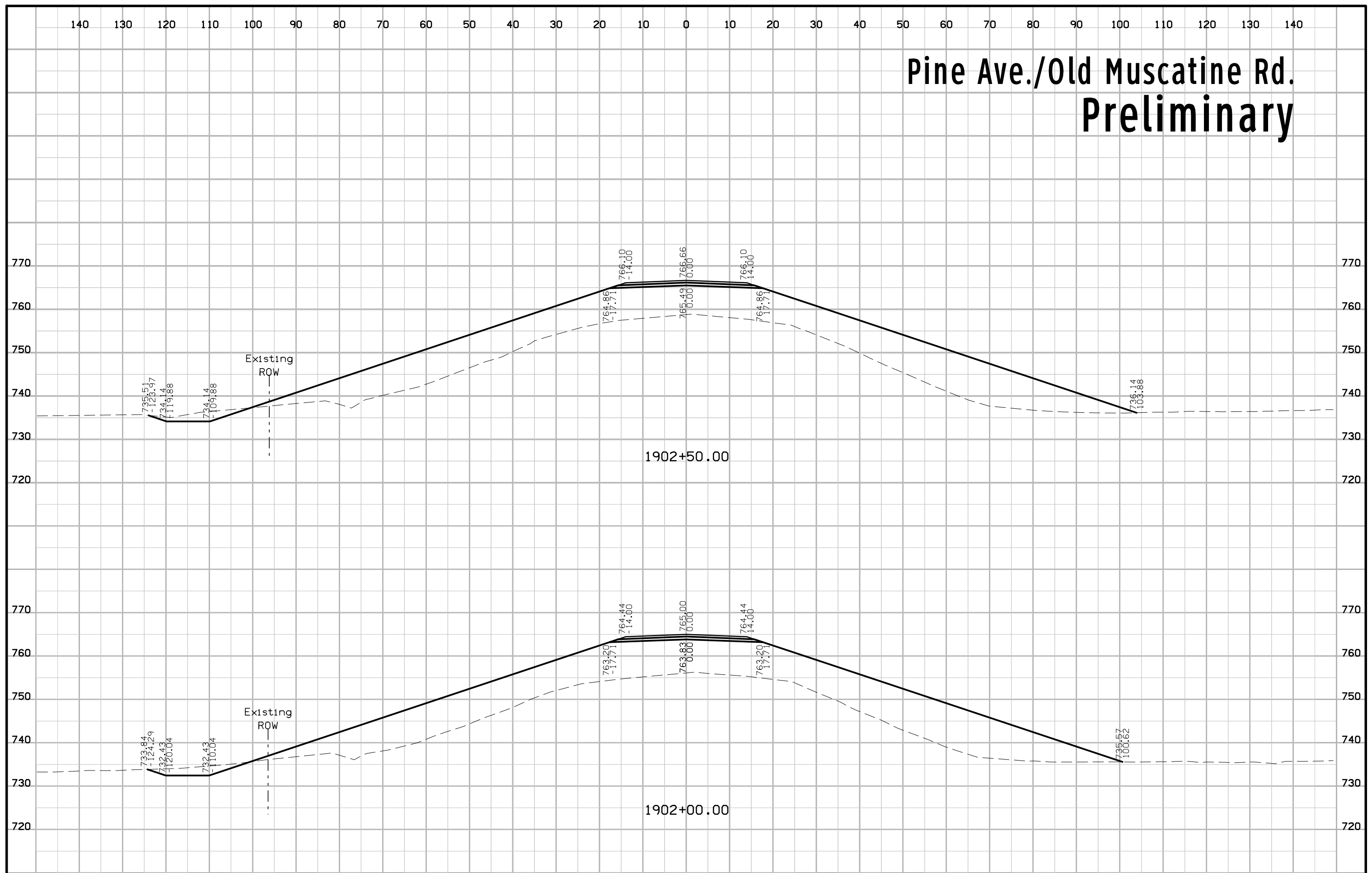

# Pine Ave./Old Muscatine Rd. Preliminary

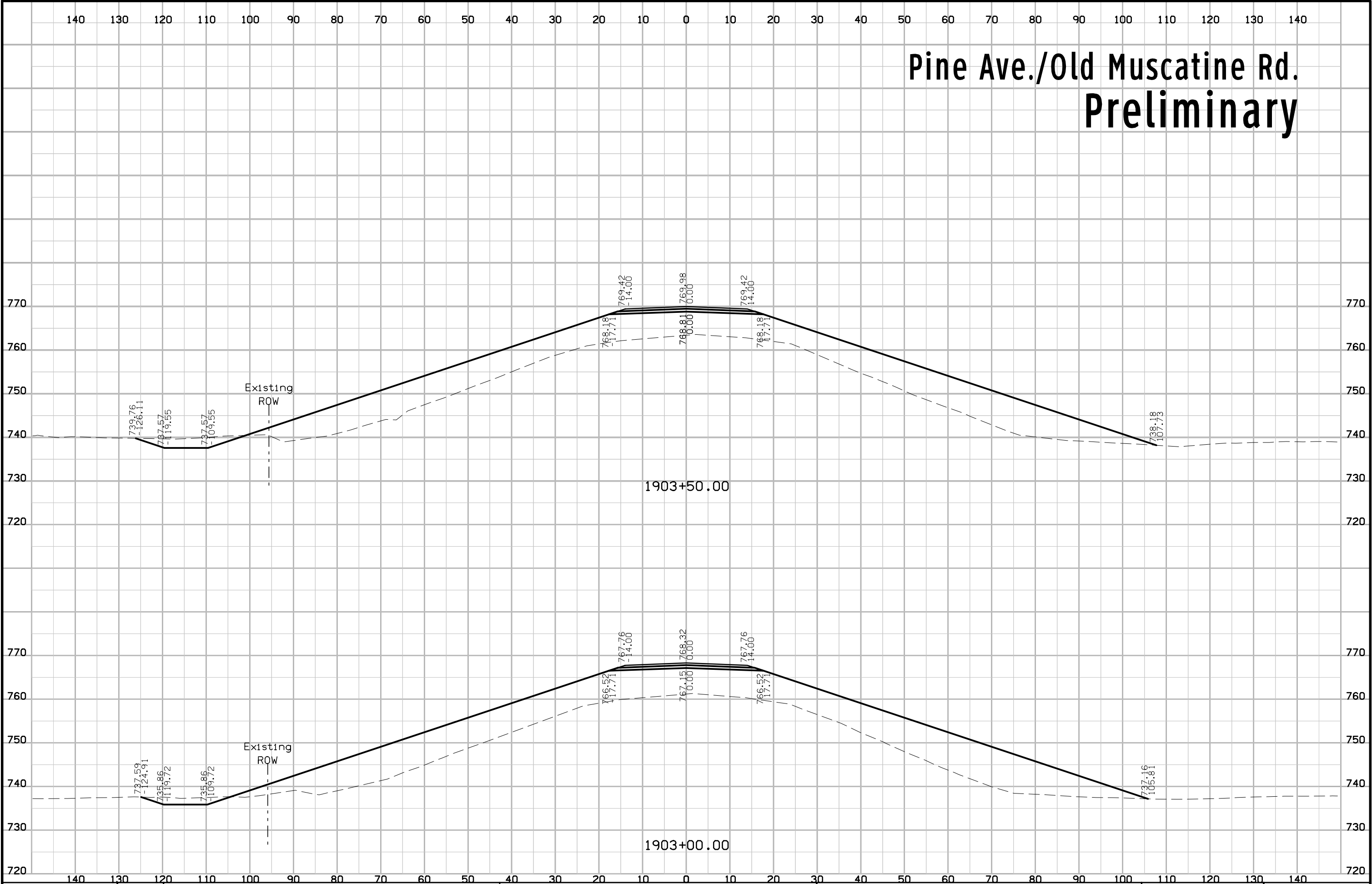



# Pine Ave./Old Muscatine Rd. Preliminary

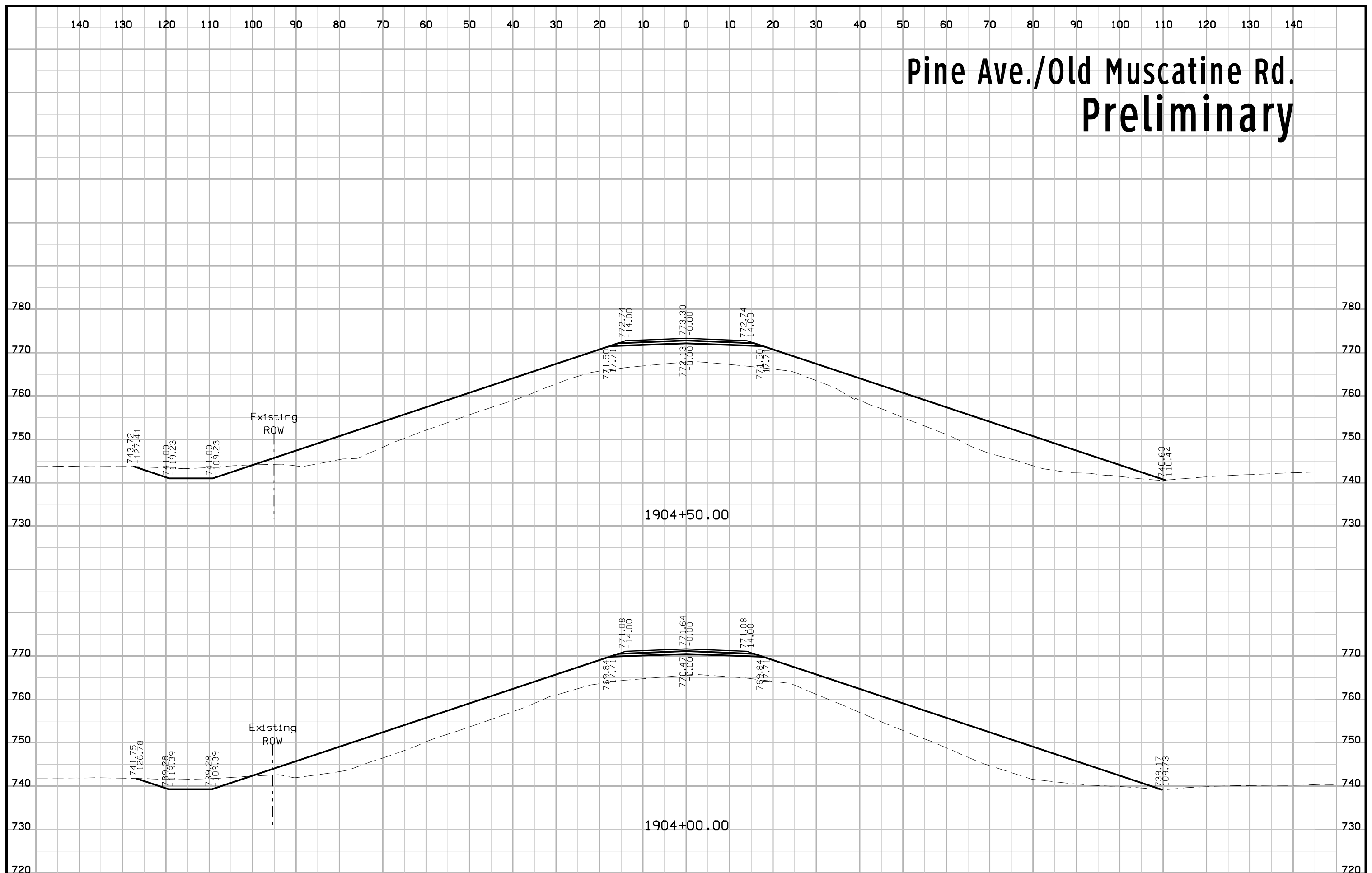

# Pine Ave./Old Muscatine Rd. Preliminary

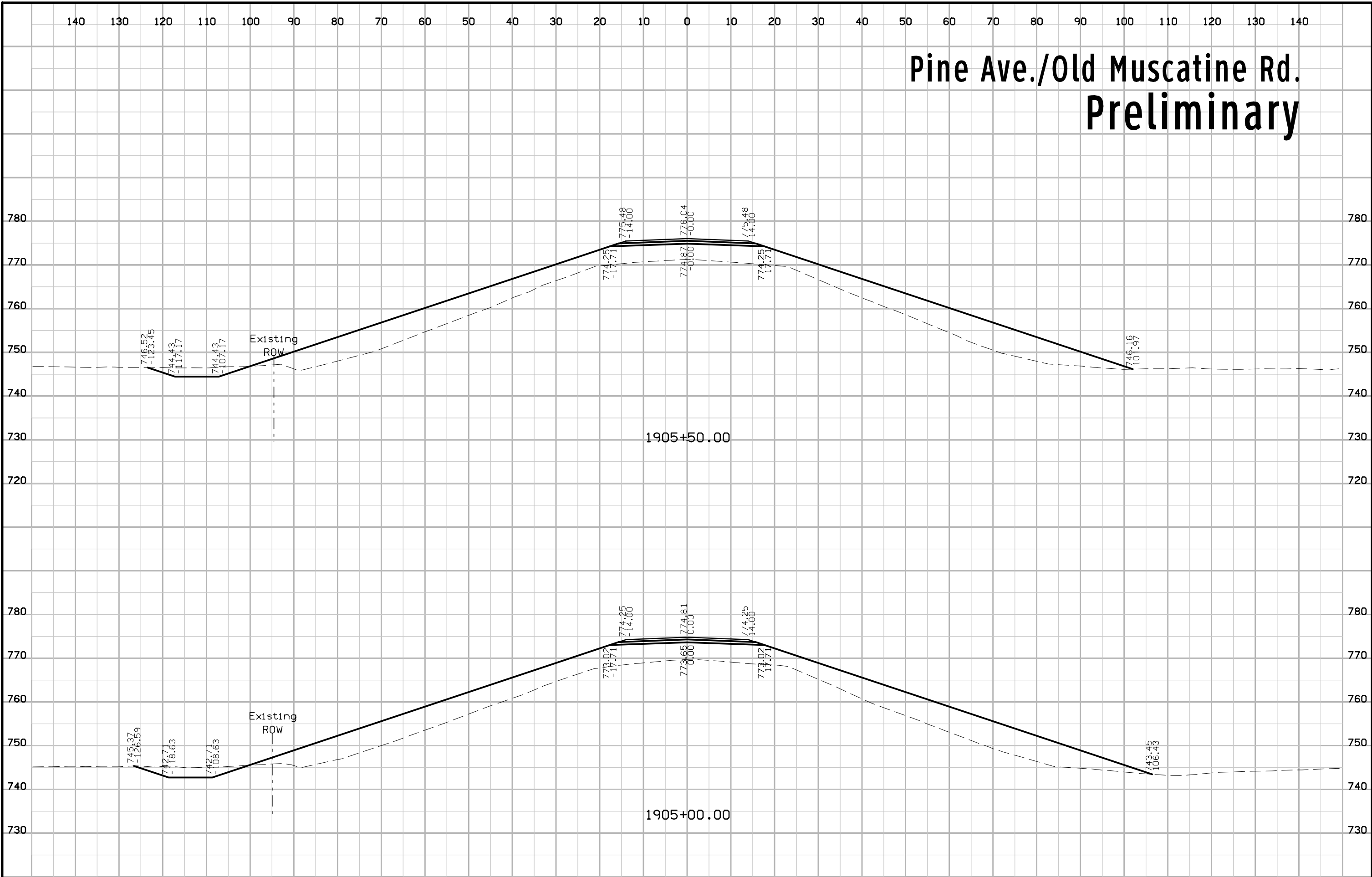

# Pine Ave./Old Muscatine Rd. Preliminary

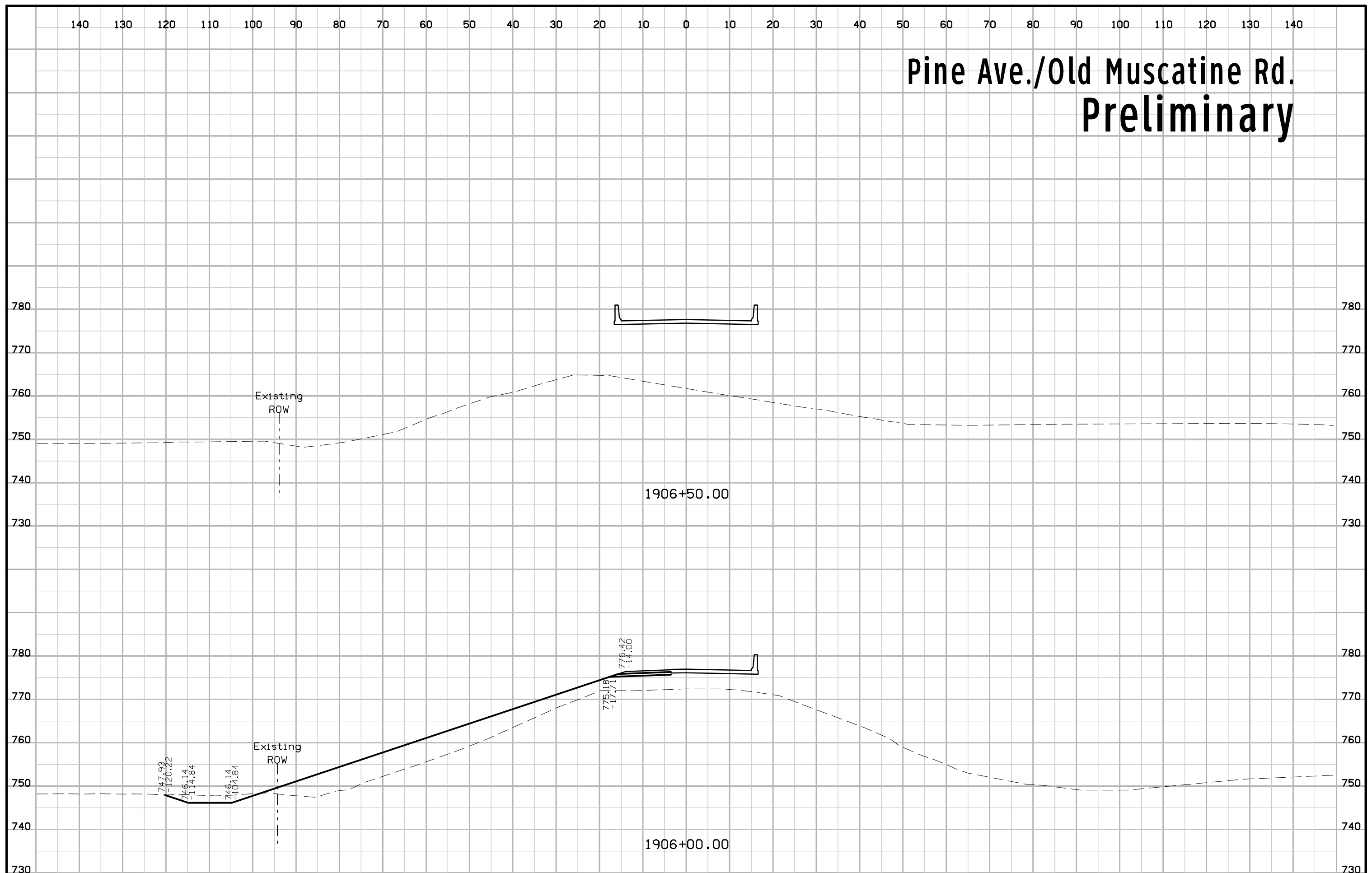

140 130 120 110 100 90 80 70 60 50 40 30 20 10 0 10 20 30 40 50 60 70 80 90 100 110 120 130 140

# Pine Ave./Old Muscatine Rd. Preliminary

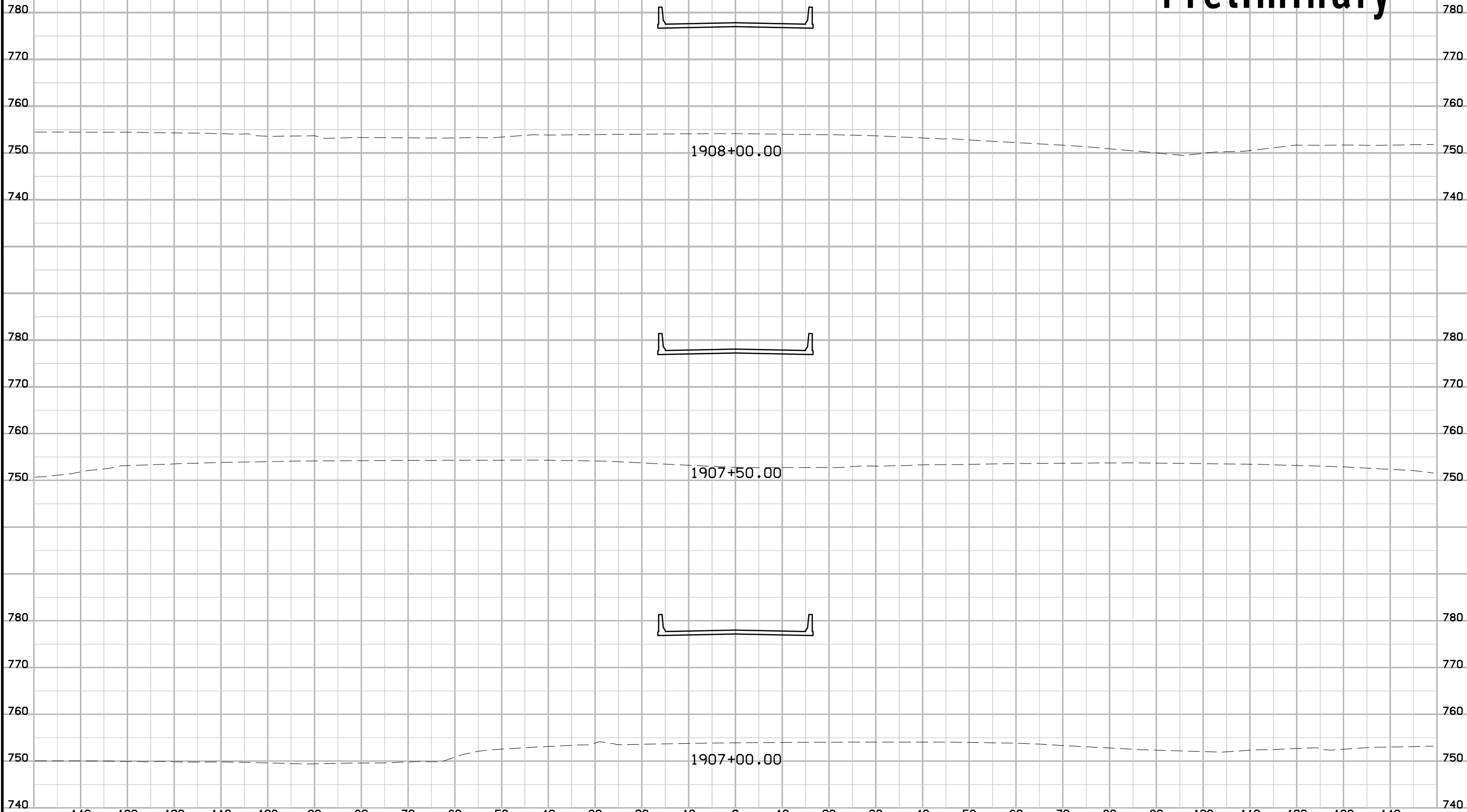

# Pine Ave./Old Muscatine Rd. Preliminary

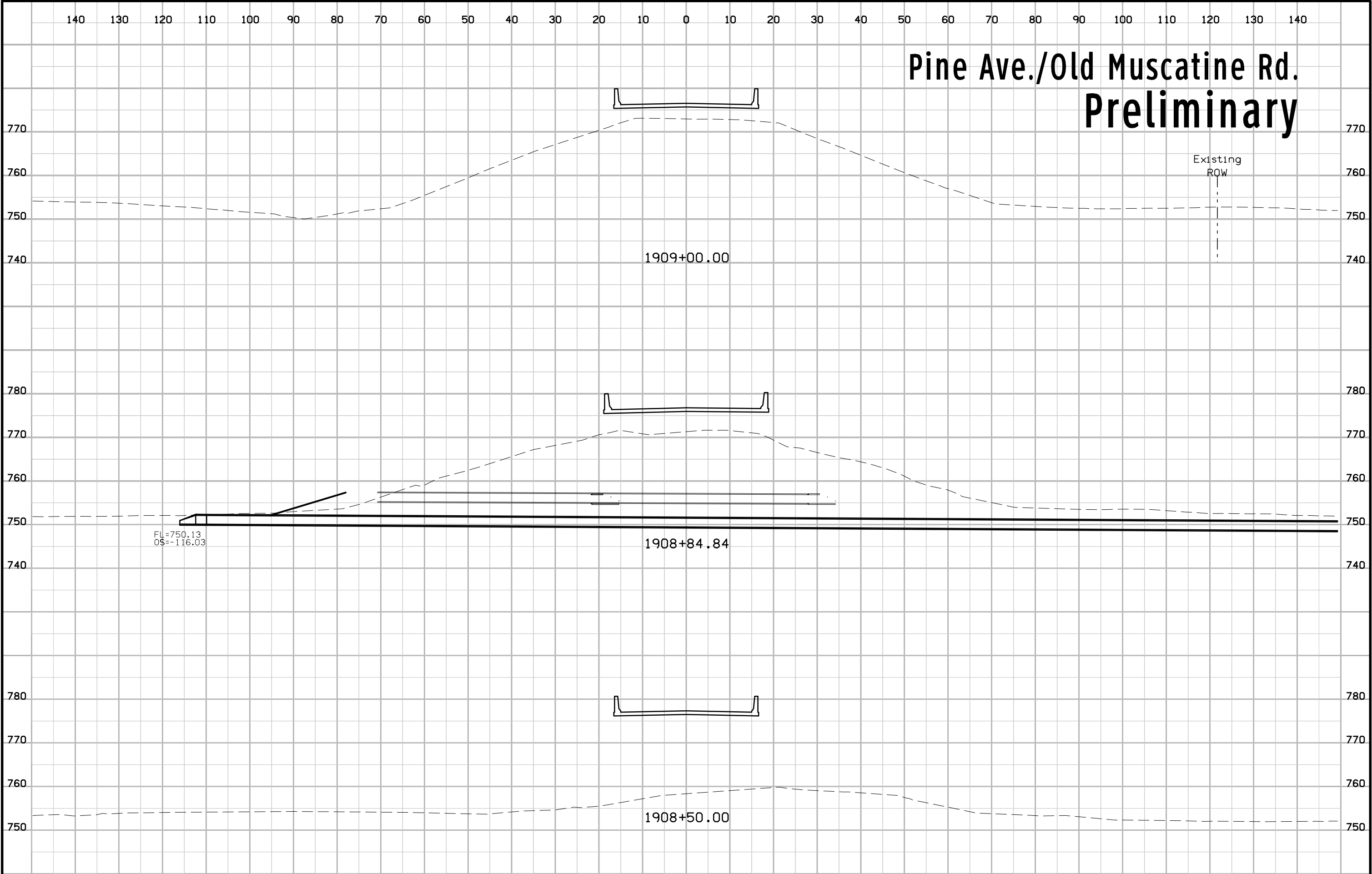

FL=750.13  
OS=-116.03

1909+00.00

1908+84.84

1908+50.00

Existing  
ROW

# Pine Ave./Old Muscatine Rd. Preliminary

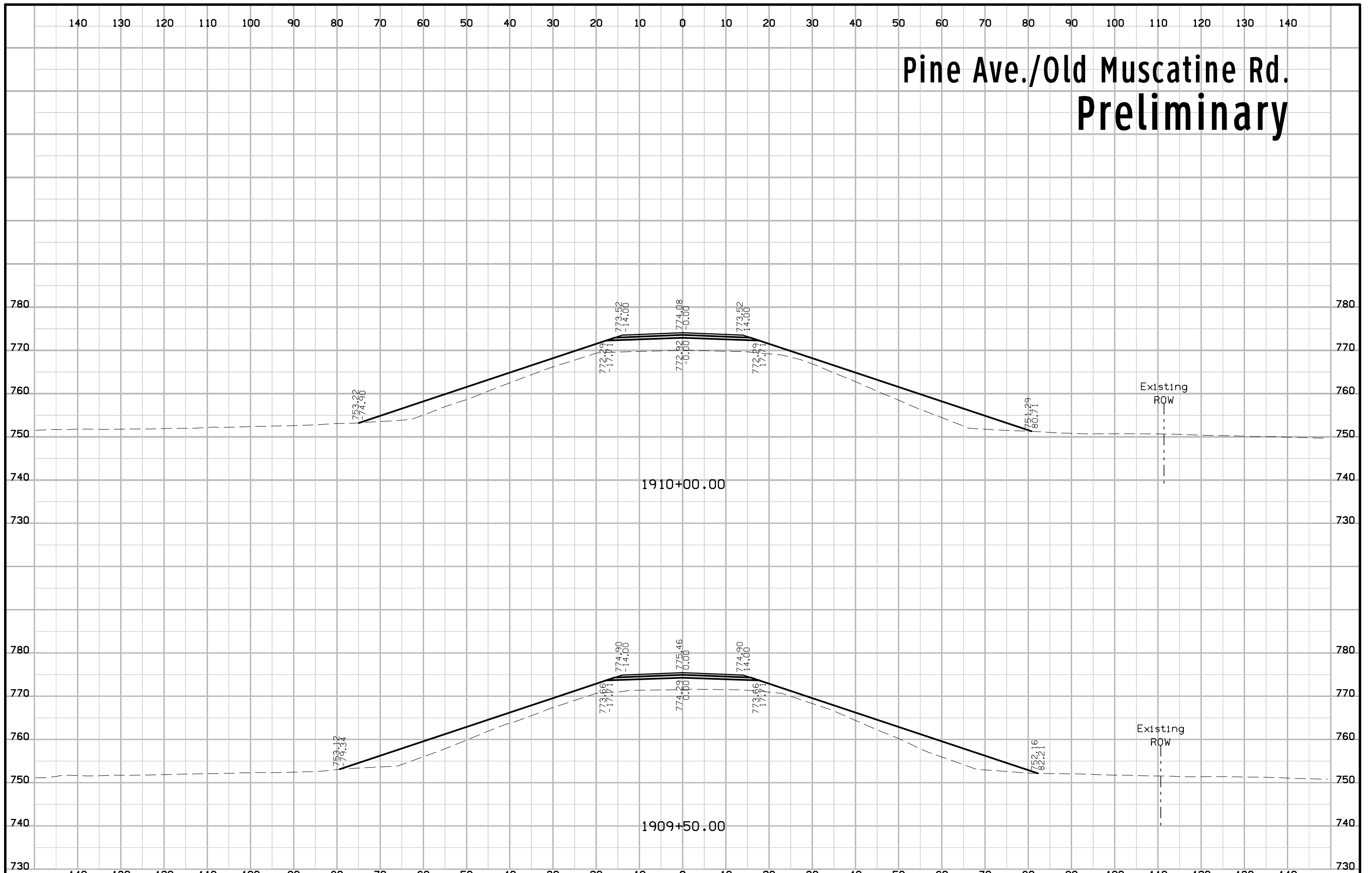

# Pine Ave./Old Muscatine Rd. Preliminary

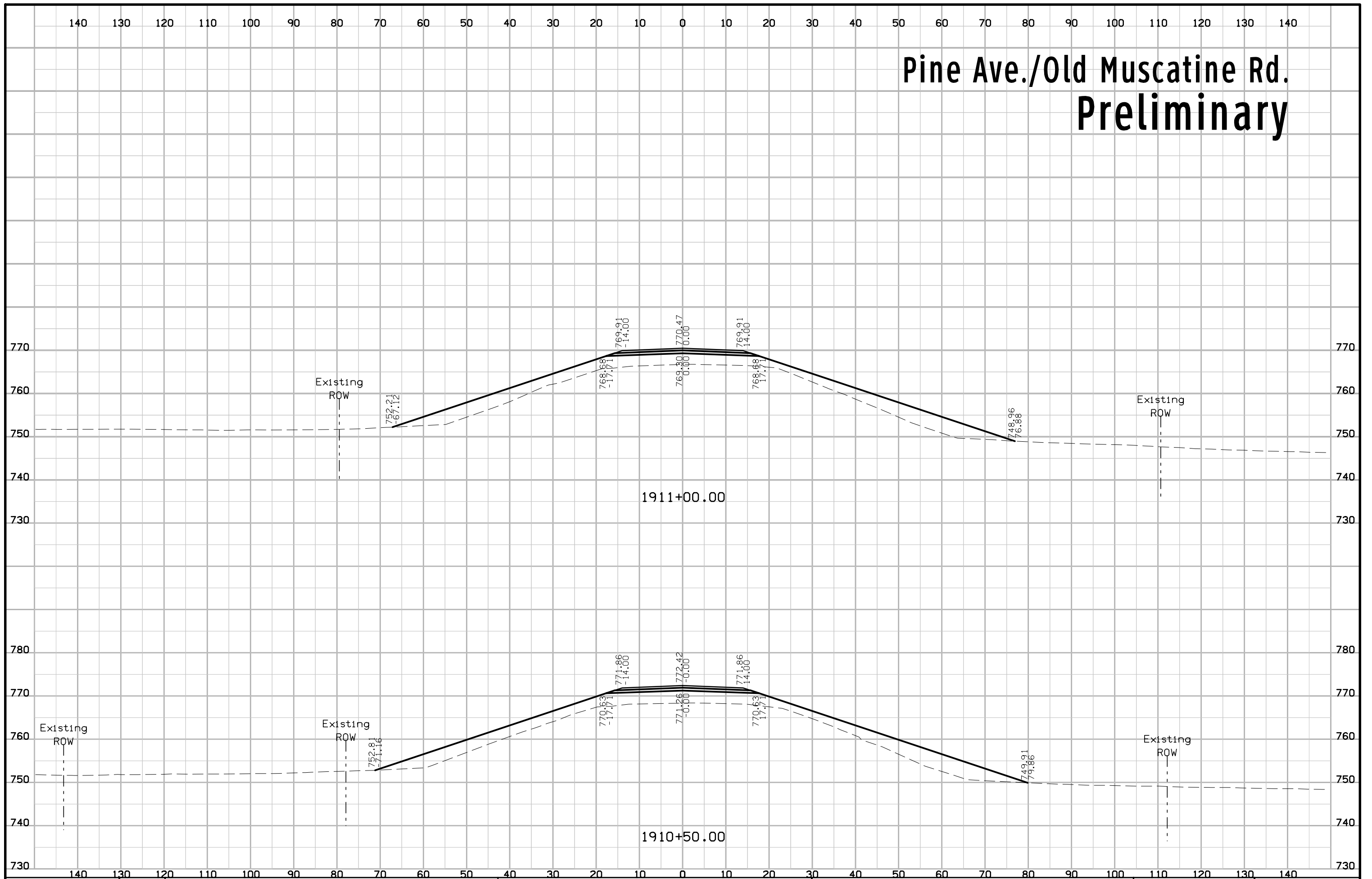

# Pine Ave./Old Muscatine Rd. Preliminary

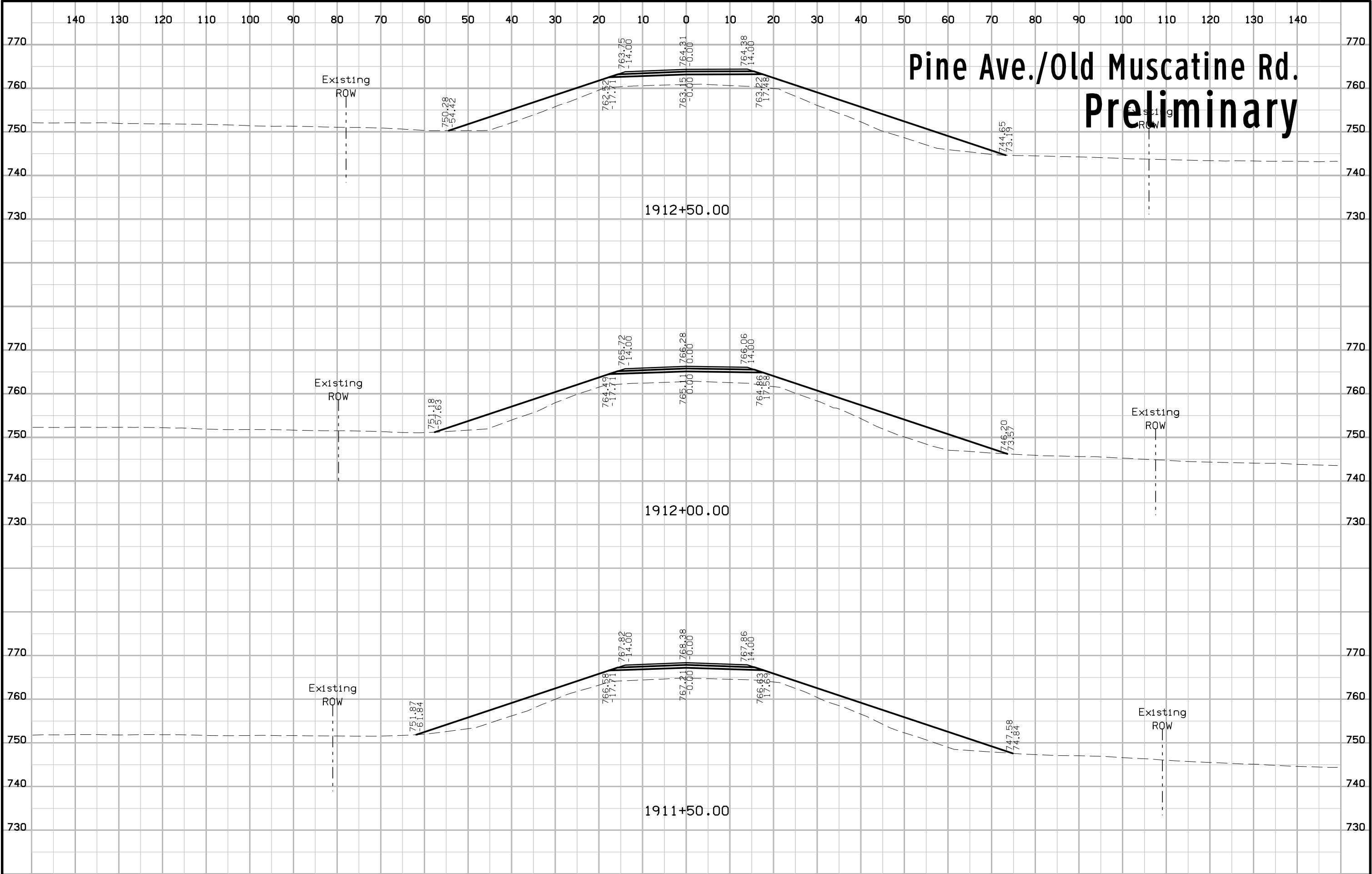



# Pine Ave./Old Muscatine Rd. Preliminary

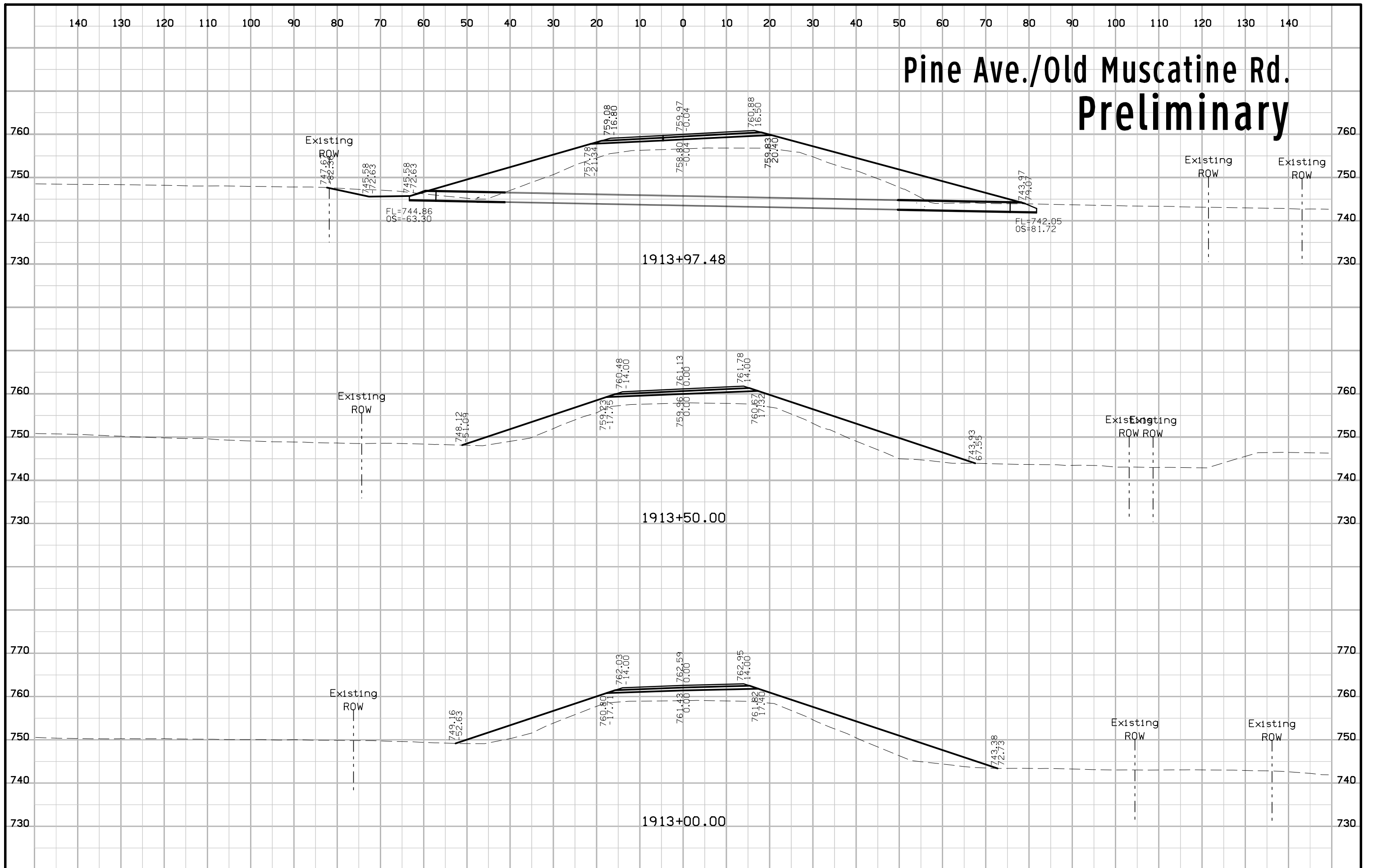

# Pine Ave./Old Muscatine Rd. Preliminary

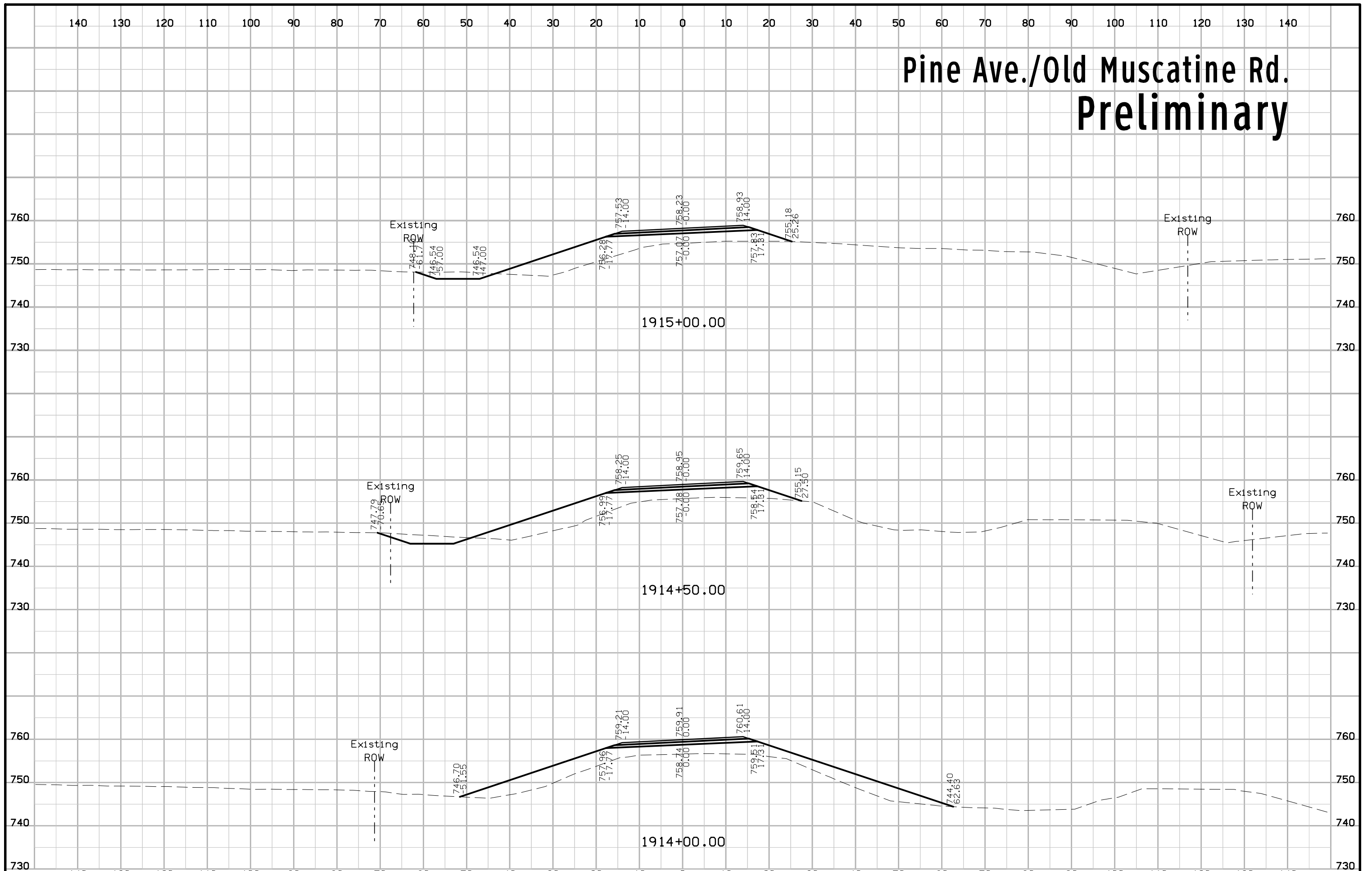

# Pine Ave./Old Muscatine Rd. Preliminary

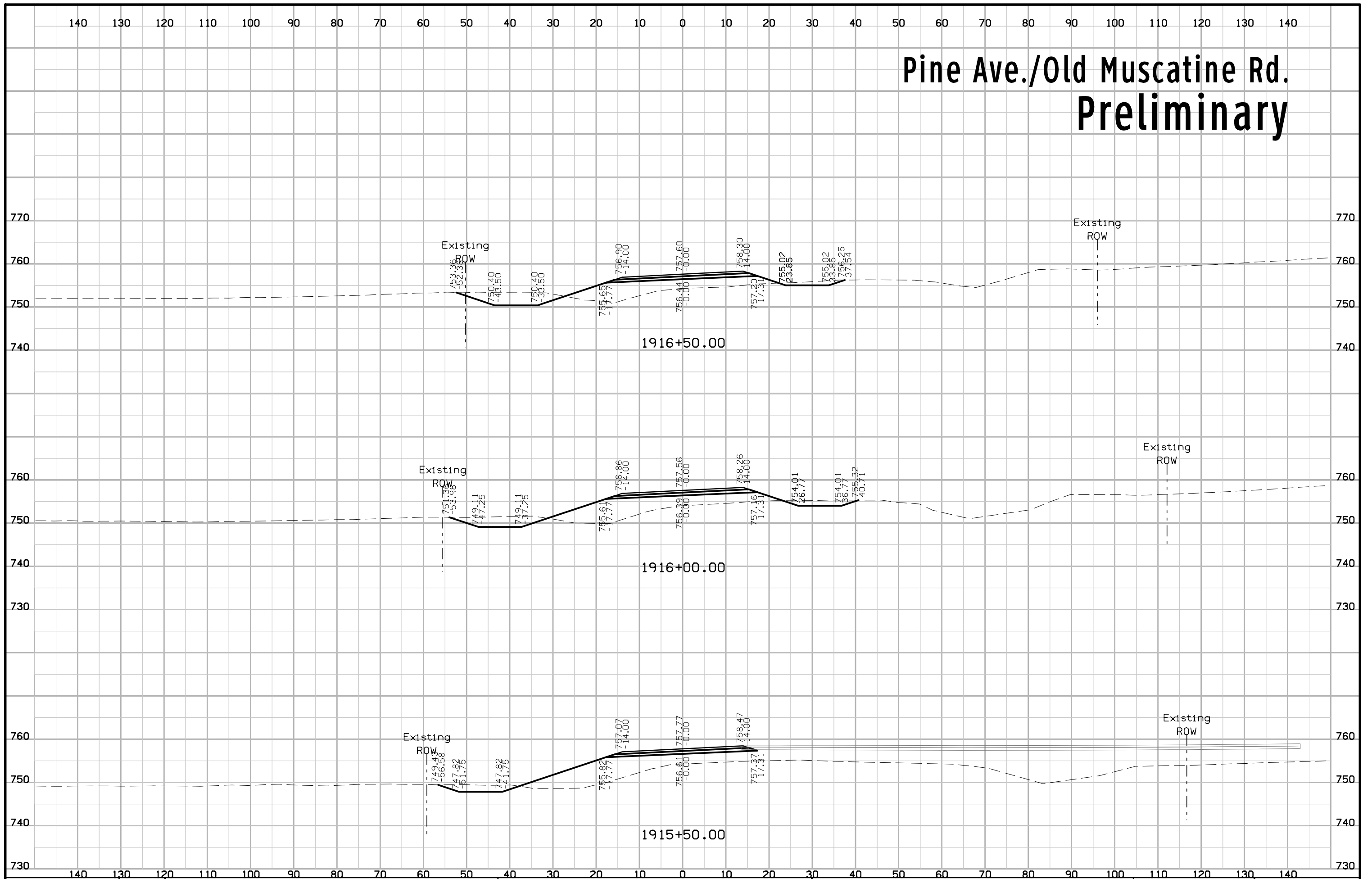

# Pine Ave./Old Muscatine Rd. Preliminary

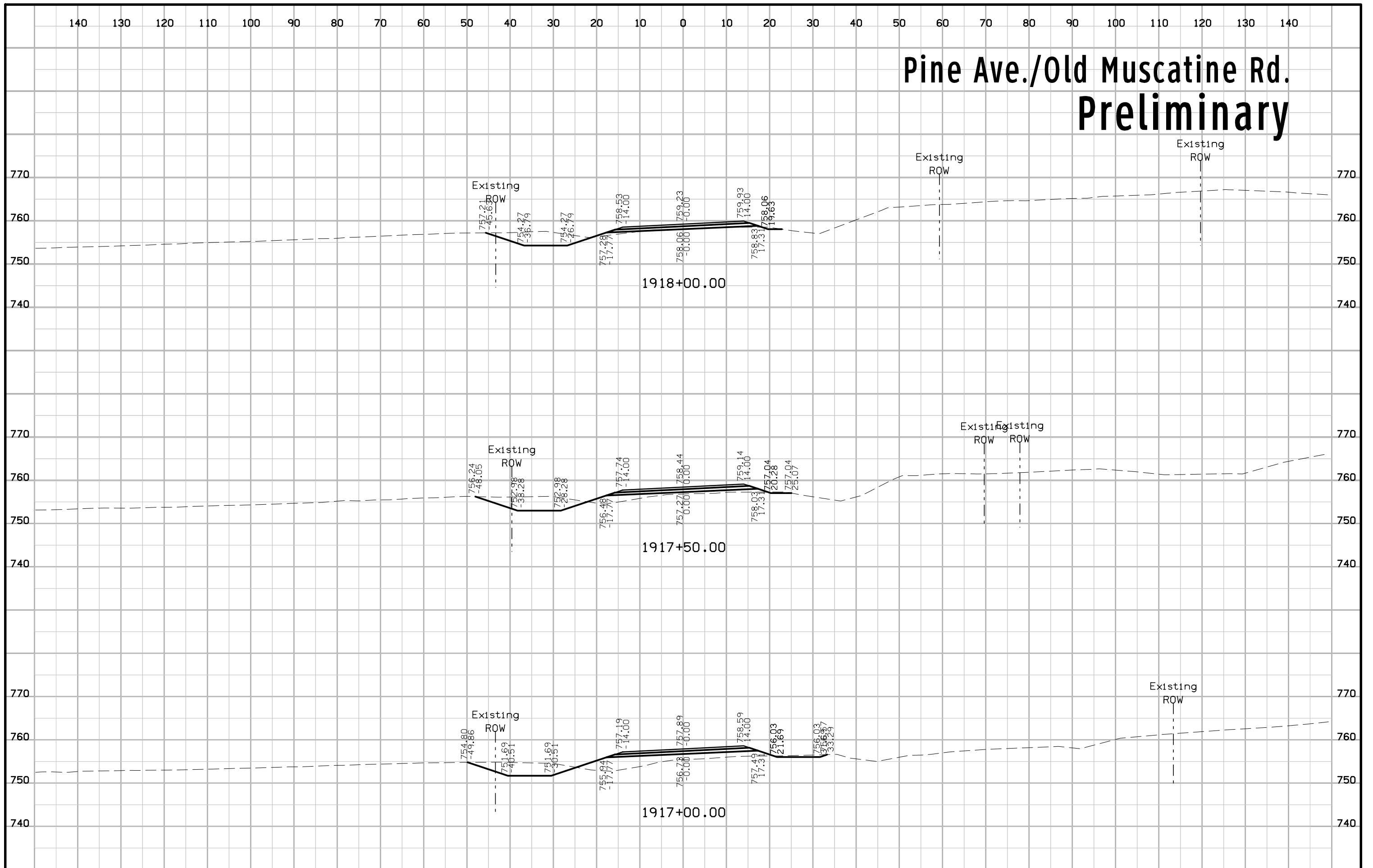

# Pine Ave./Old Muscatine Rd. Preliminary

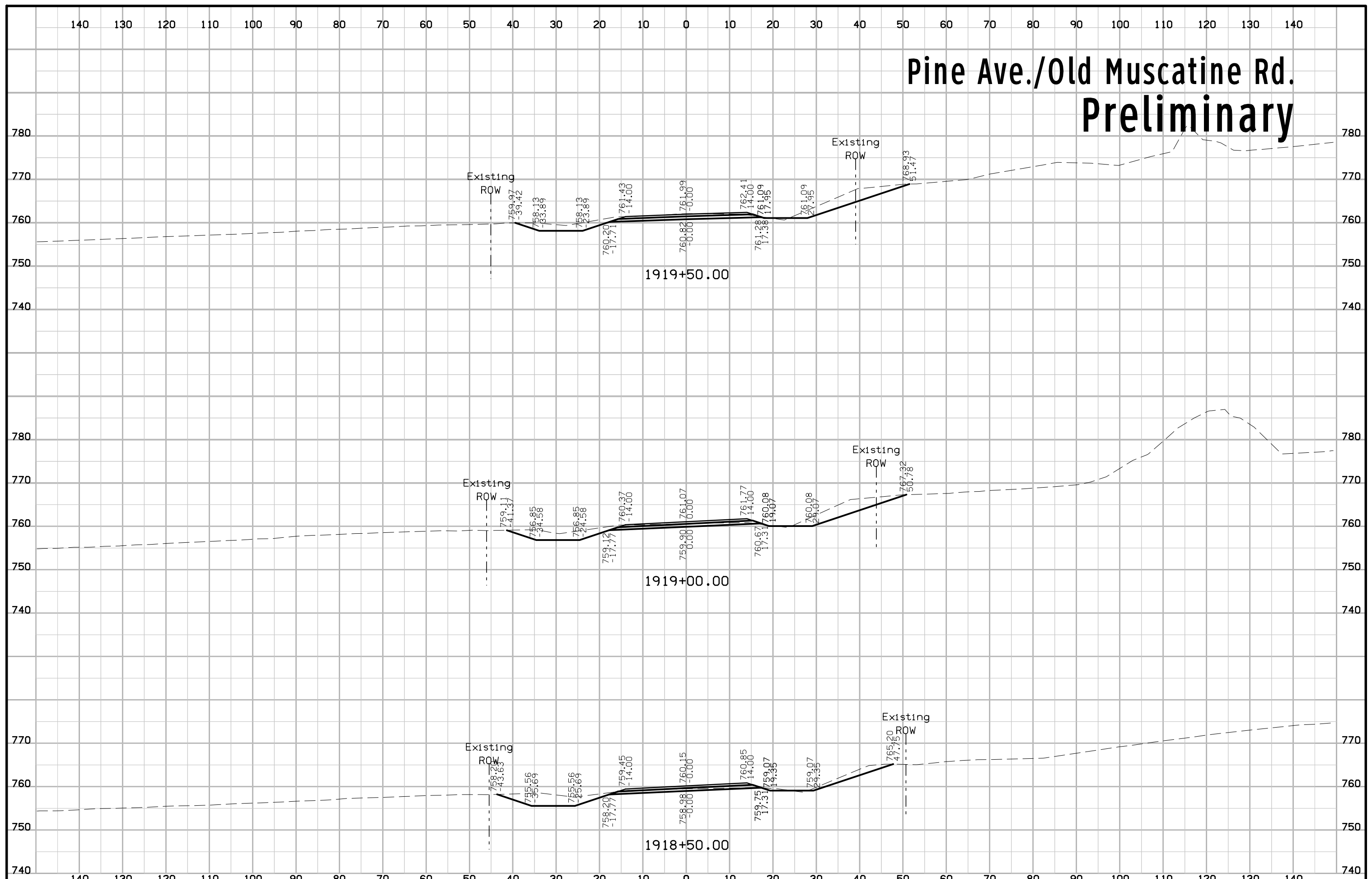

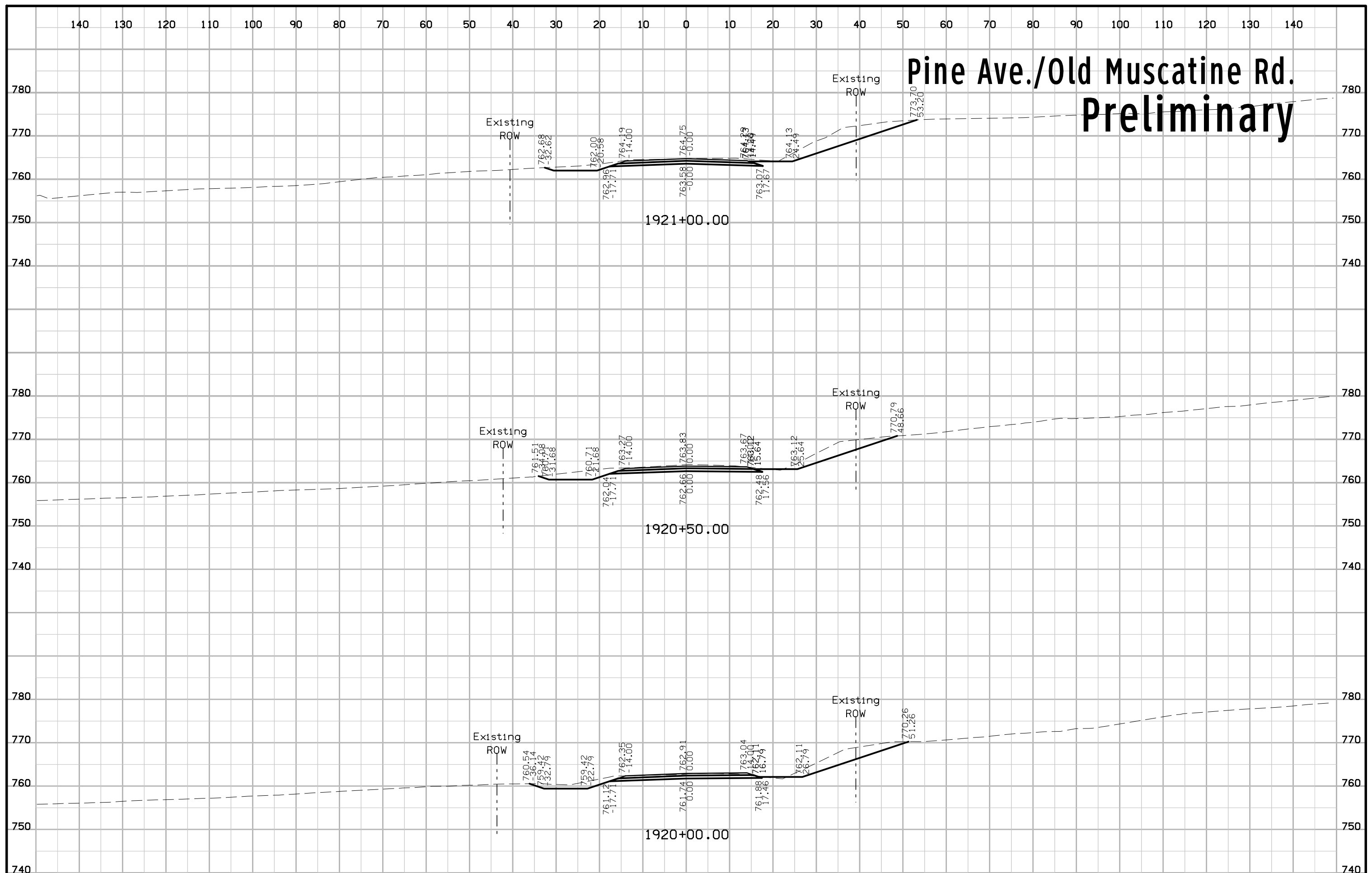

# 306th St. B Preliminary

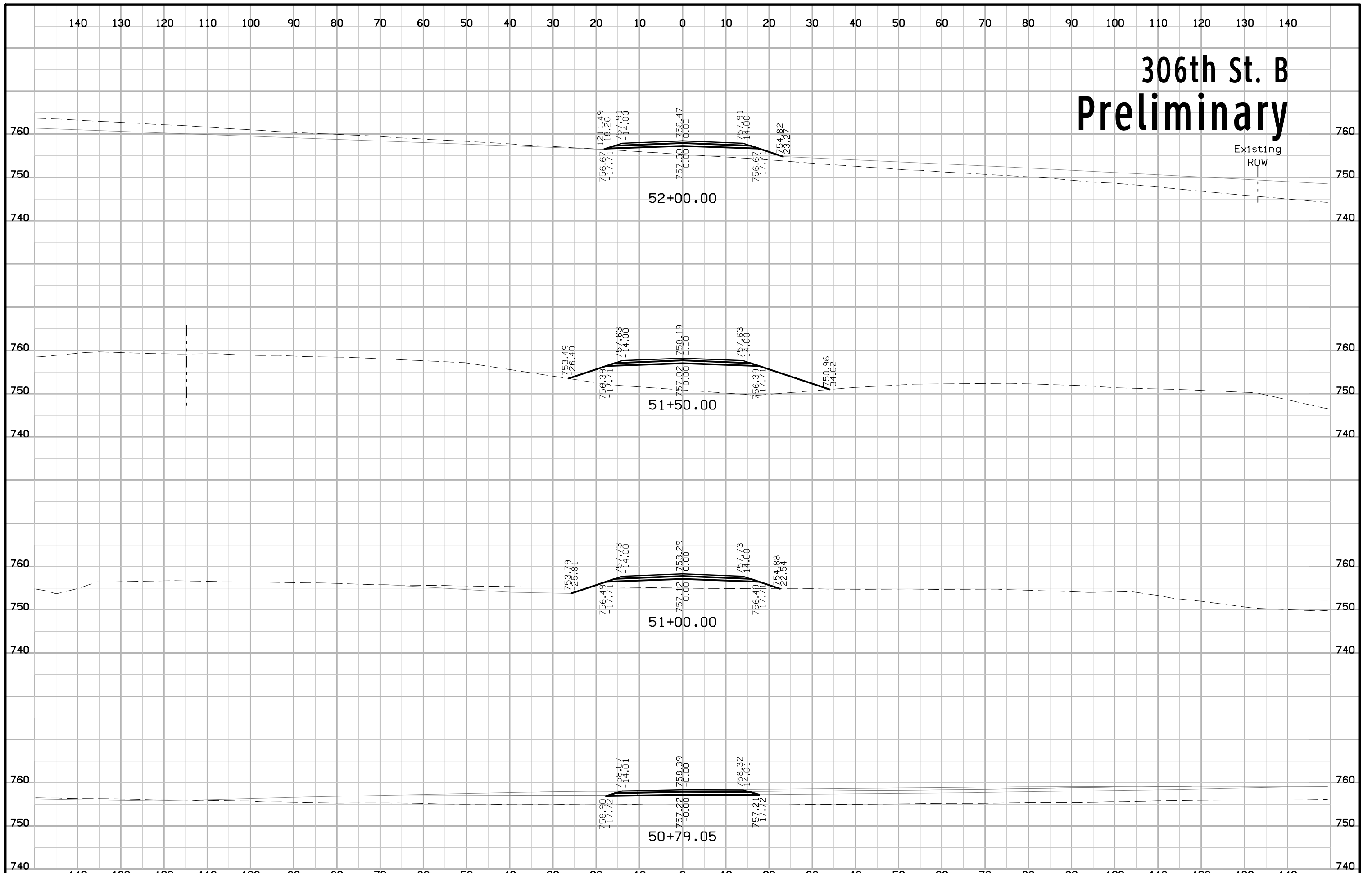

# 306th St. B Preliminary

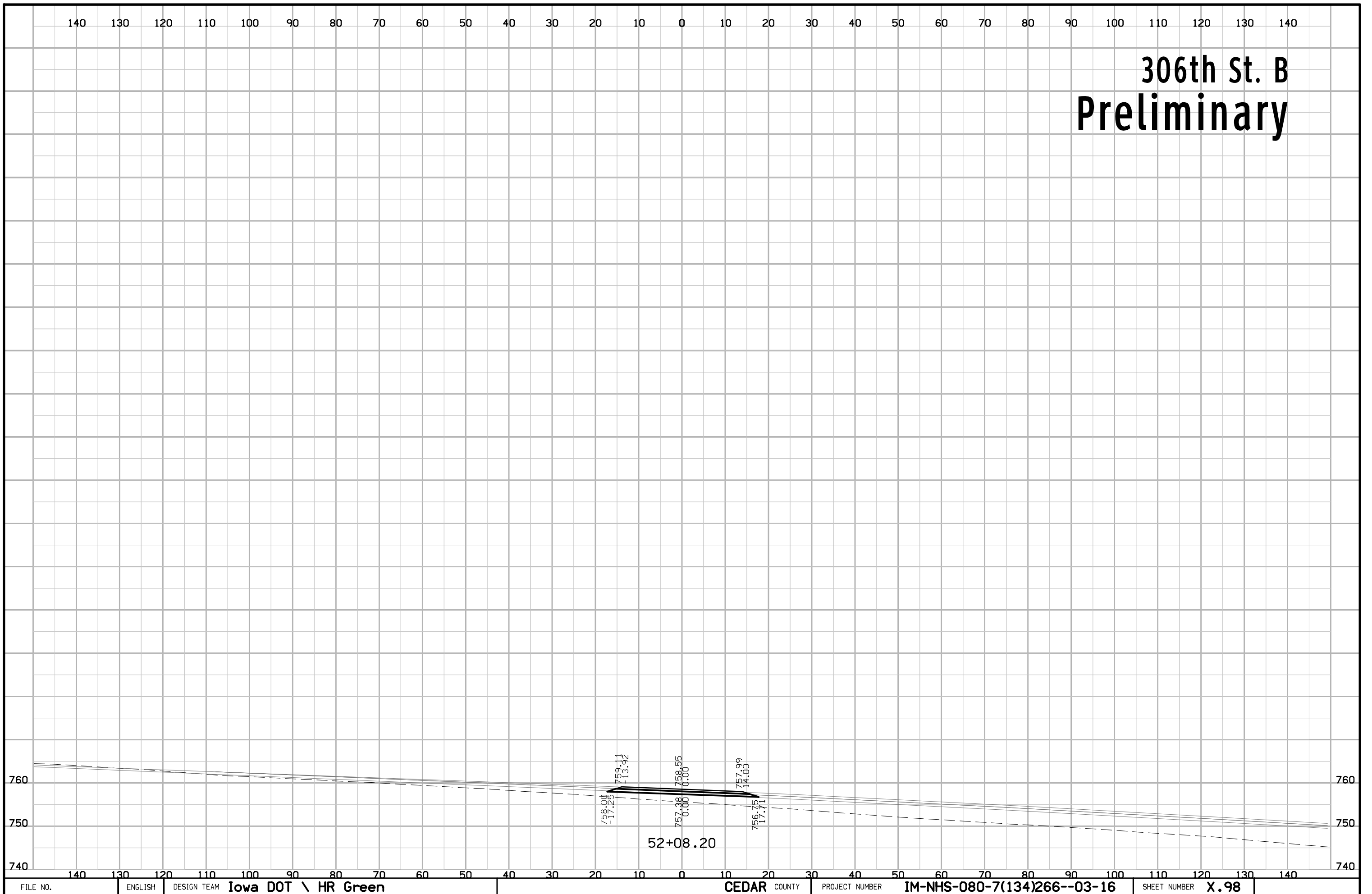



# East St. Preliminary

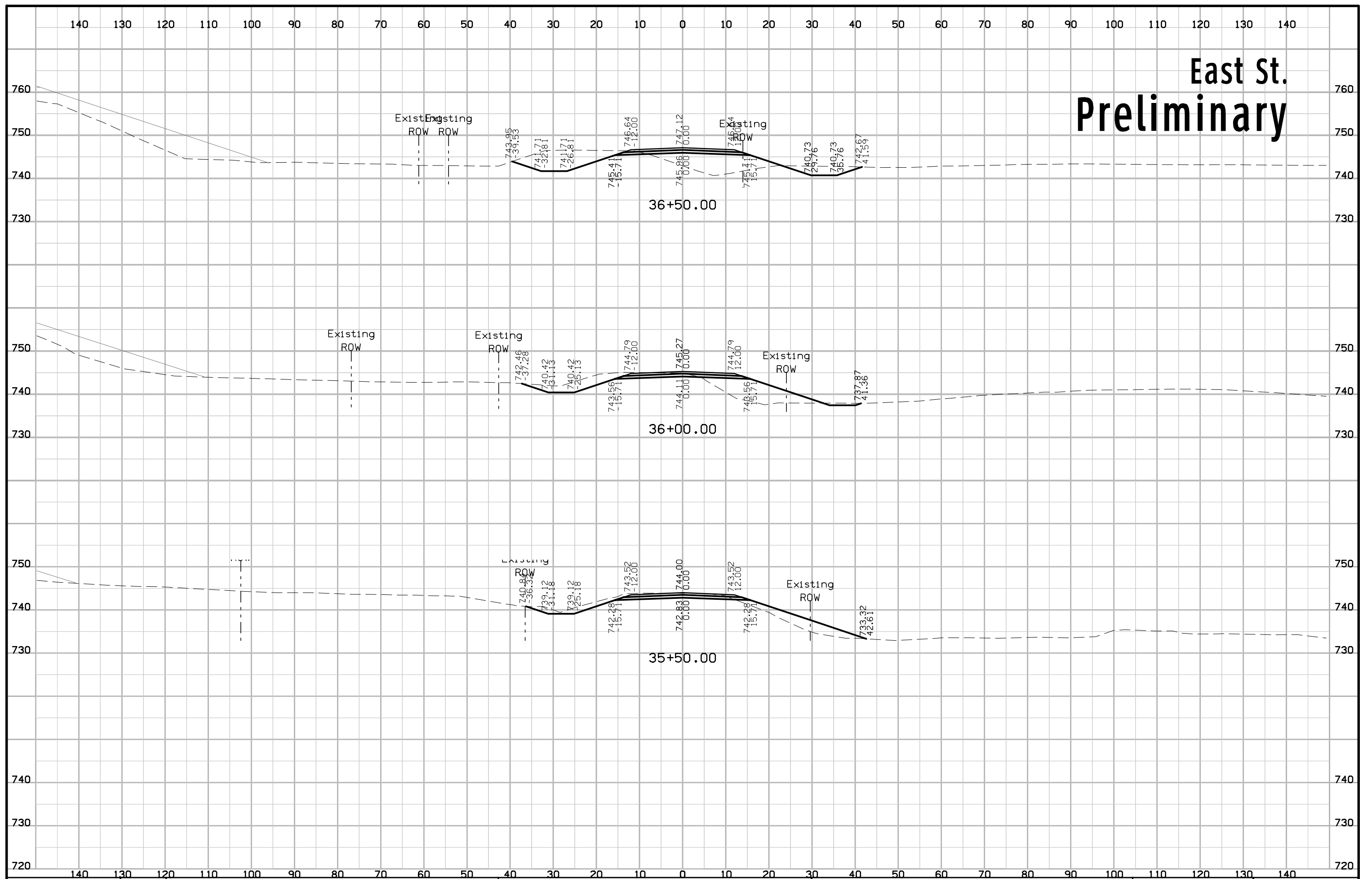

# East St. Preliminary

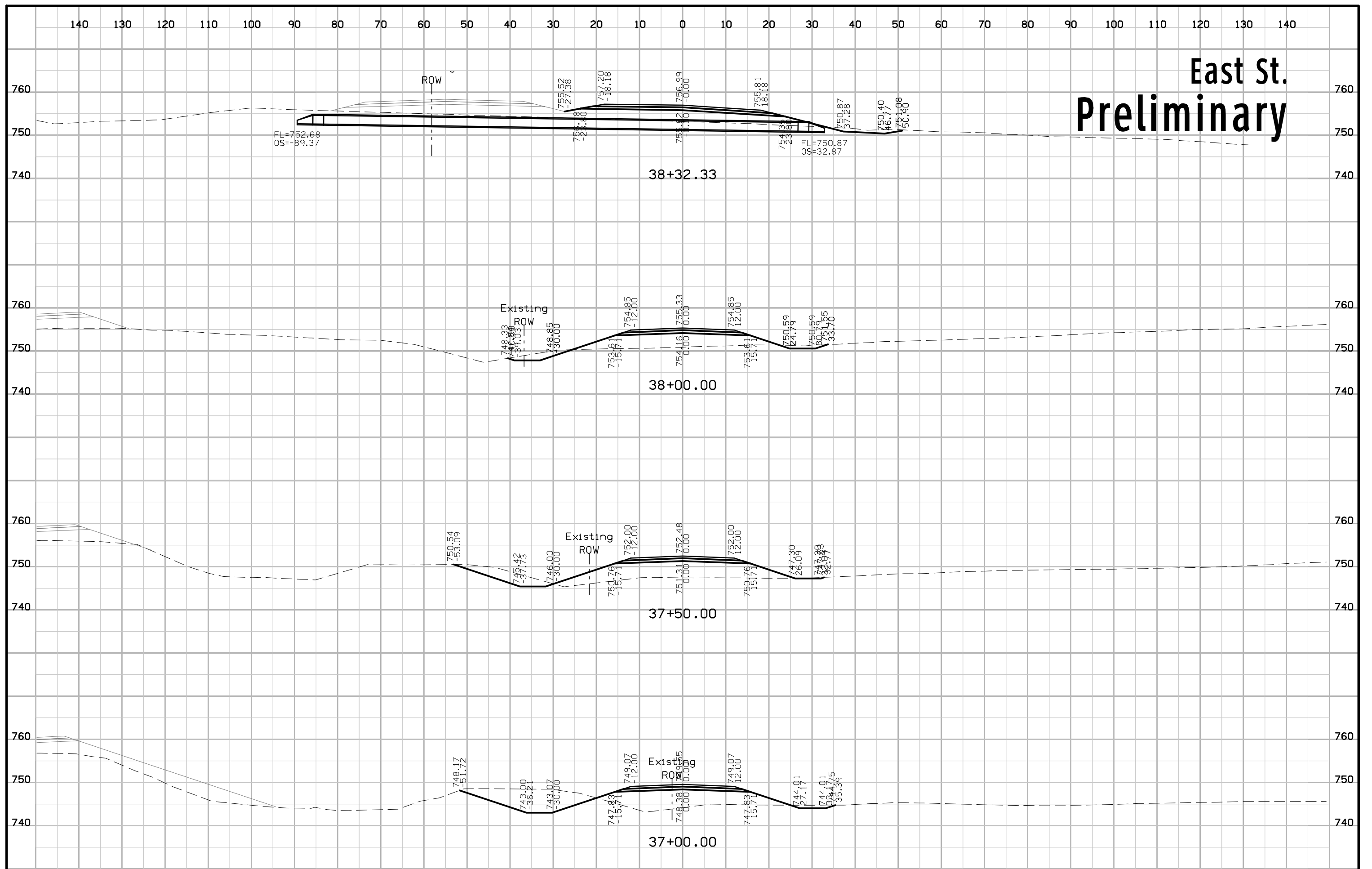

# East St. Preliminary

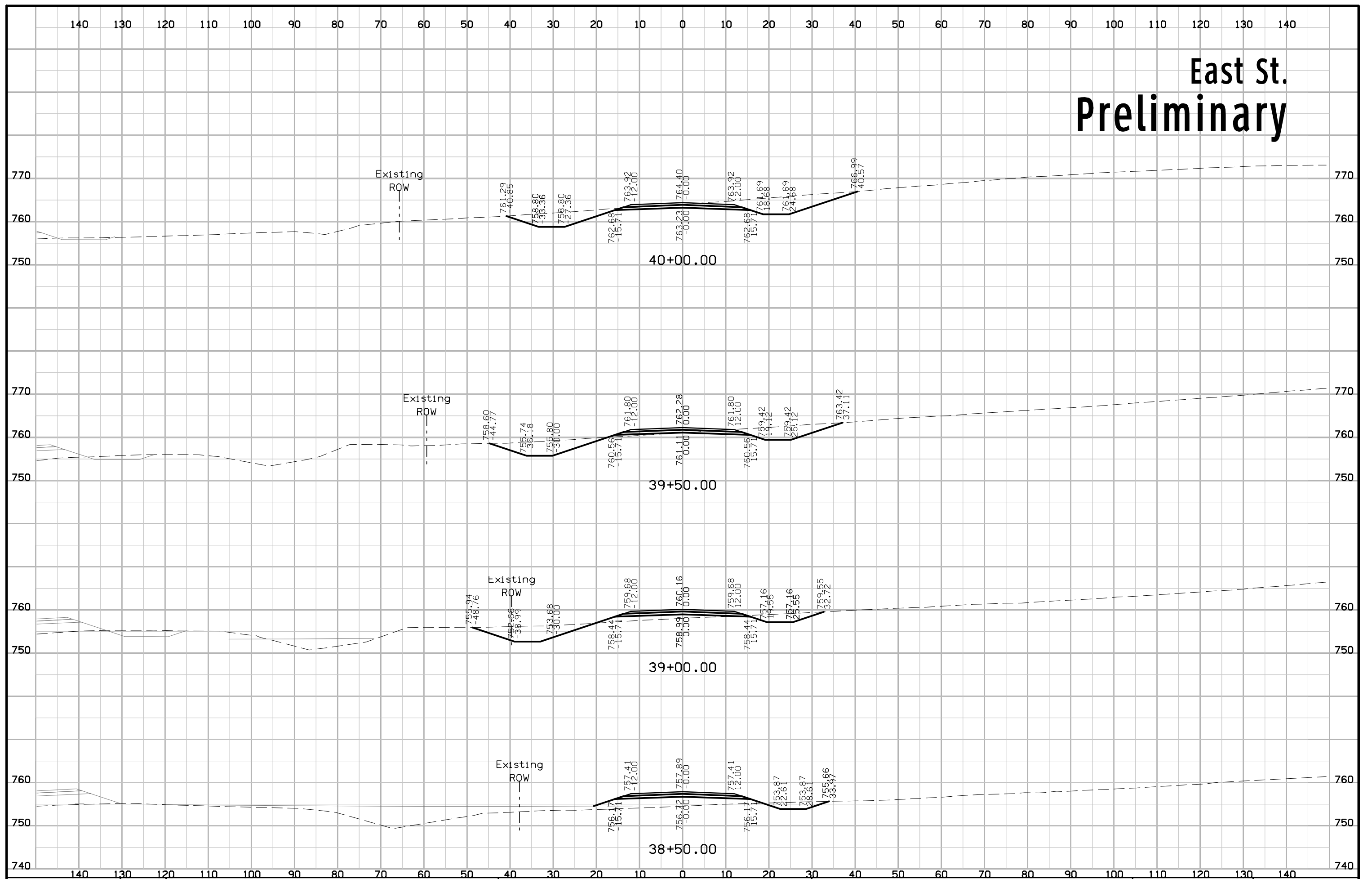

# East St. Preliminary

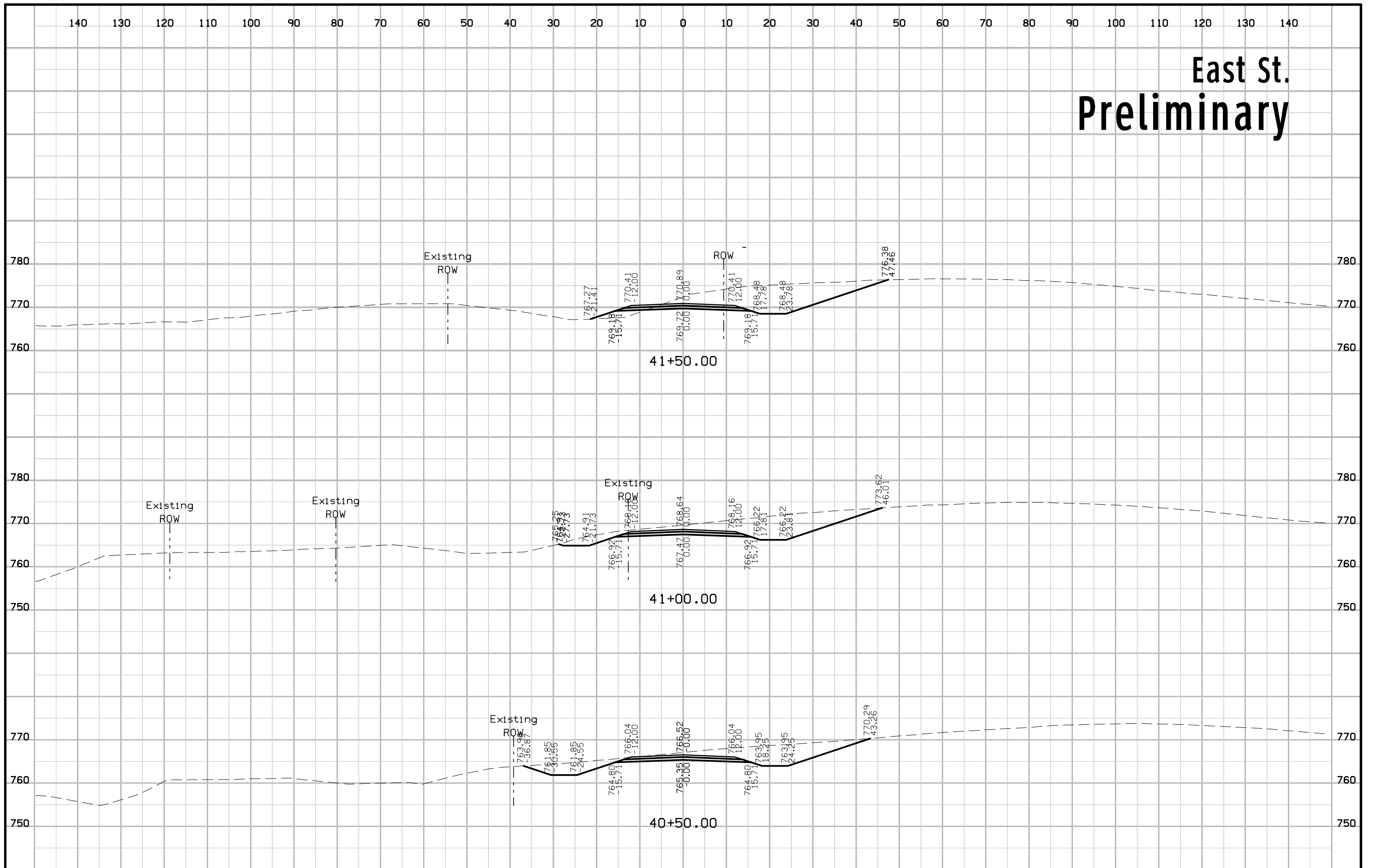

# East St. Preliminary

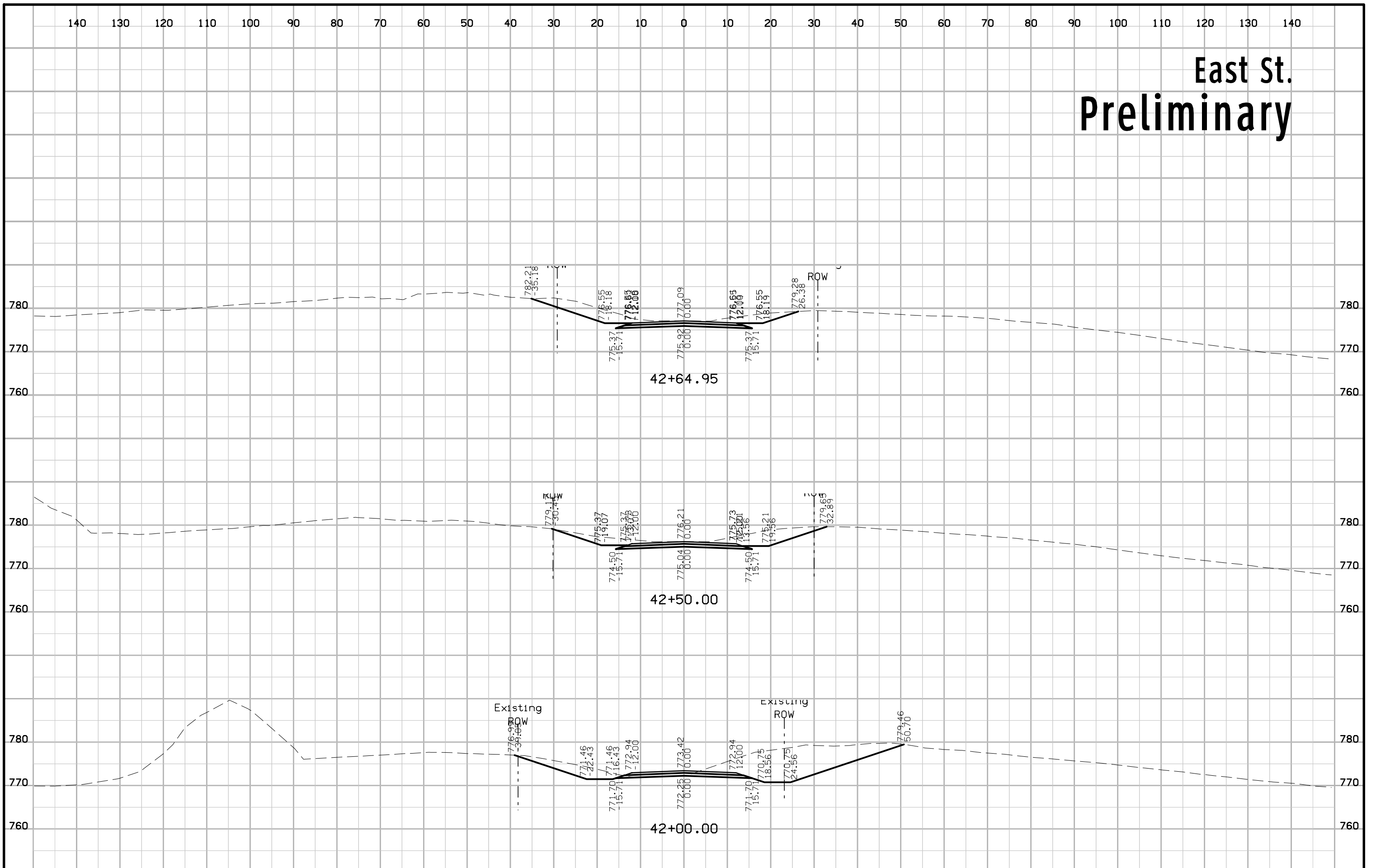

# Old Muscatine Rd. Preliminary

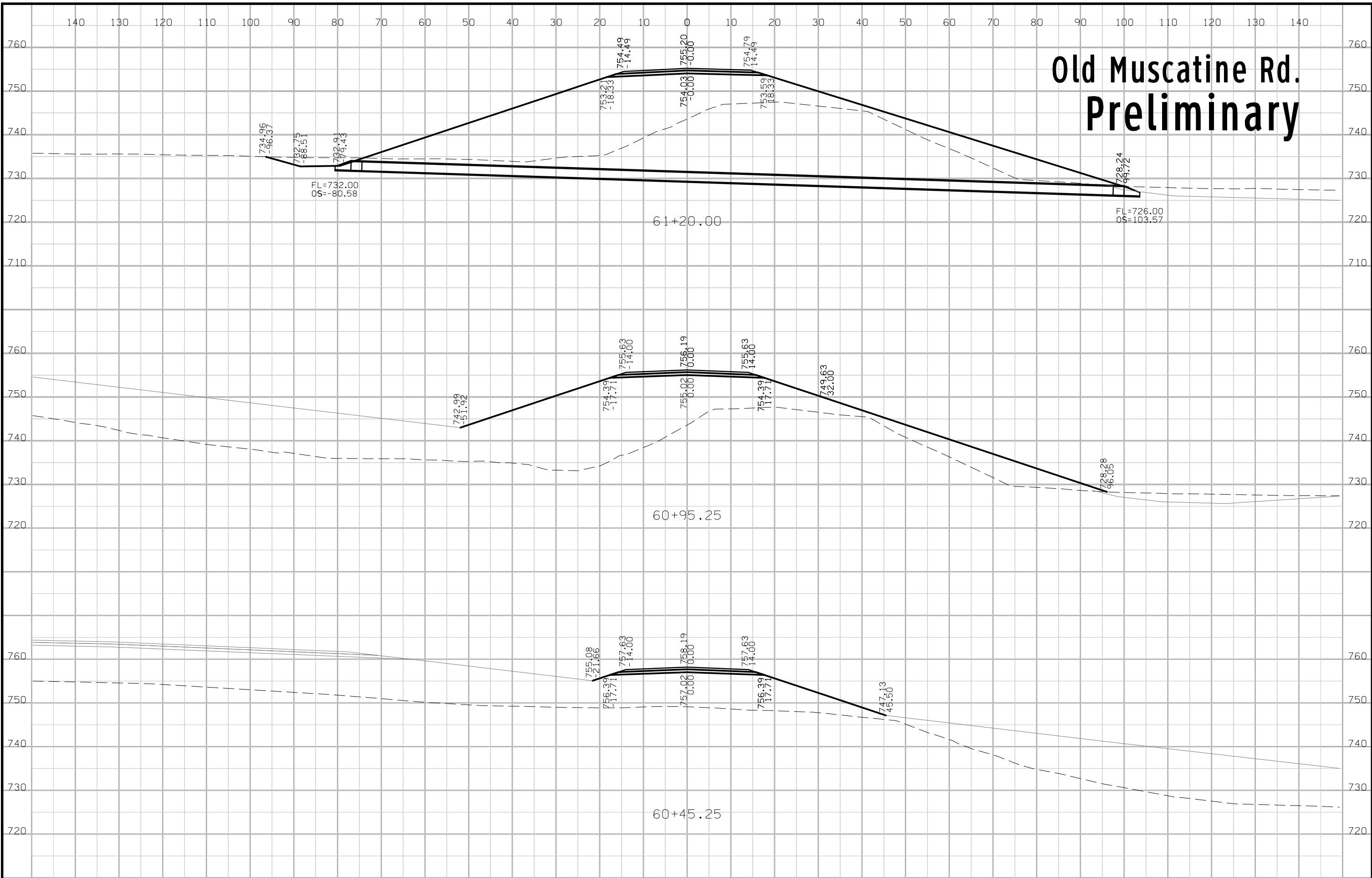

# Old Muscatine Rd. Preliminary

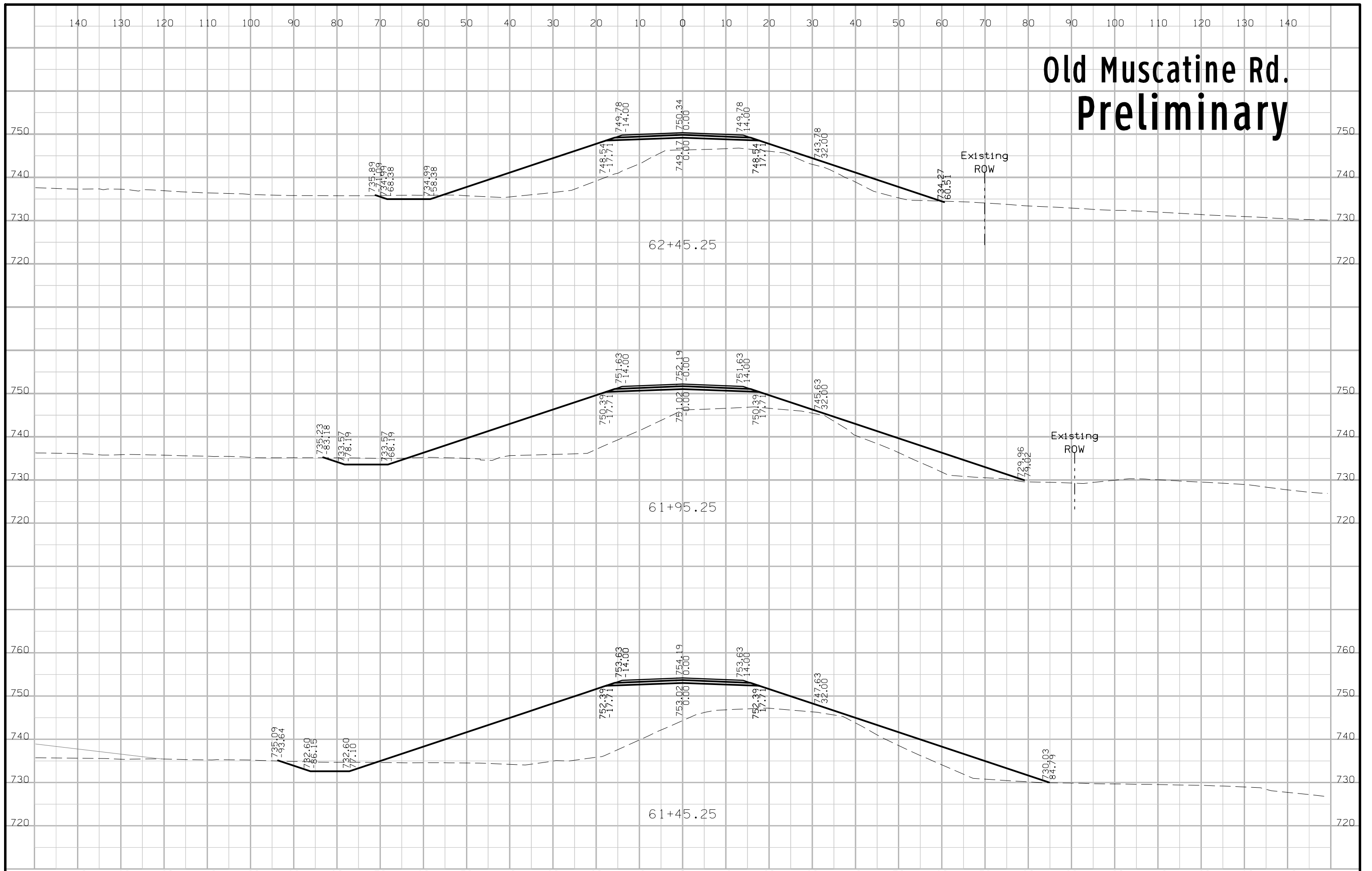

# Old Muscatine Rd. Preliminary

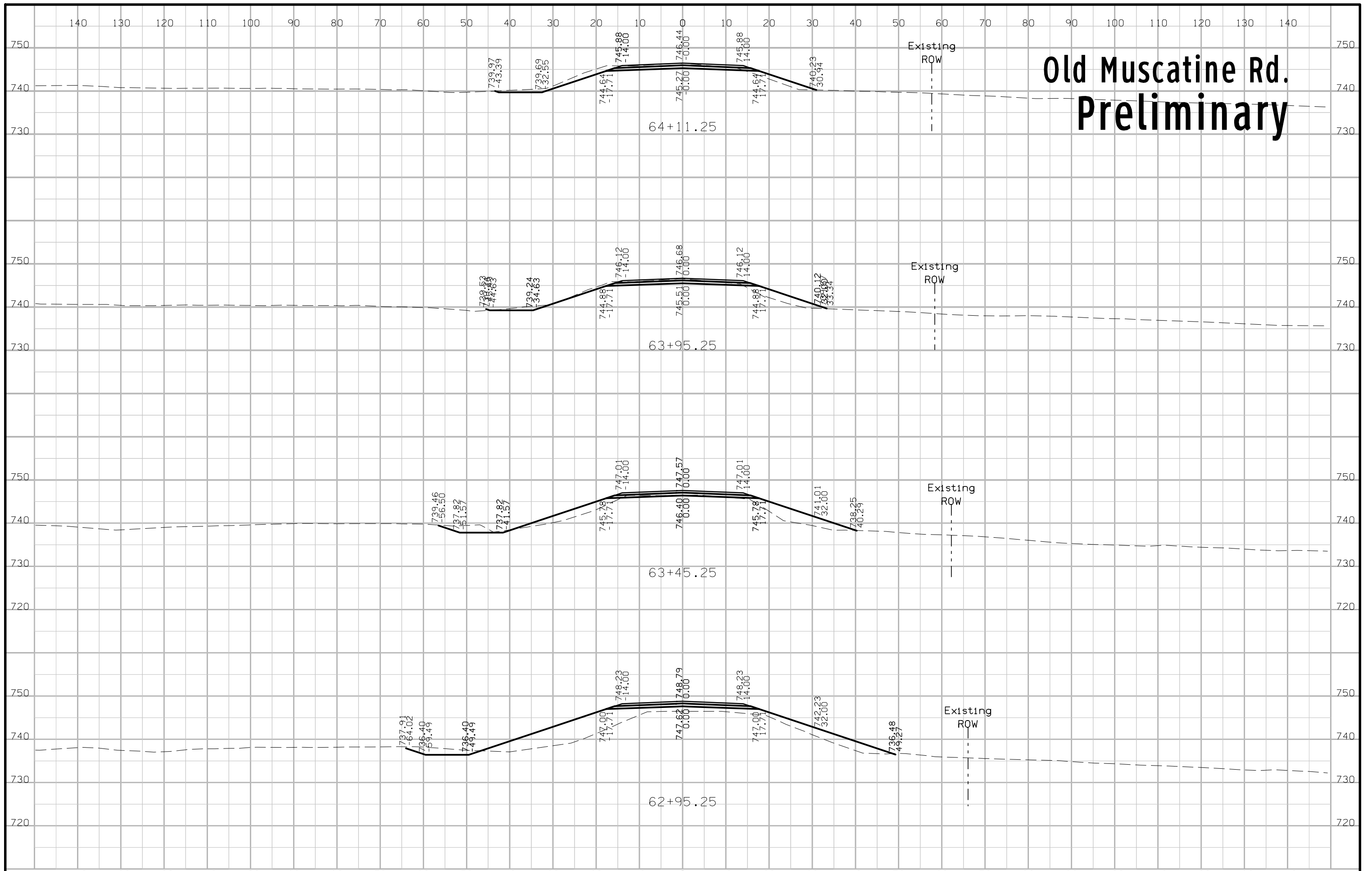



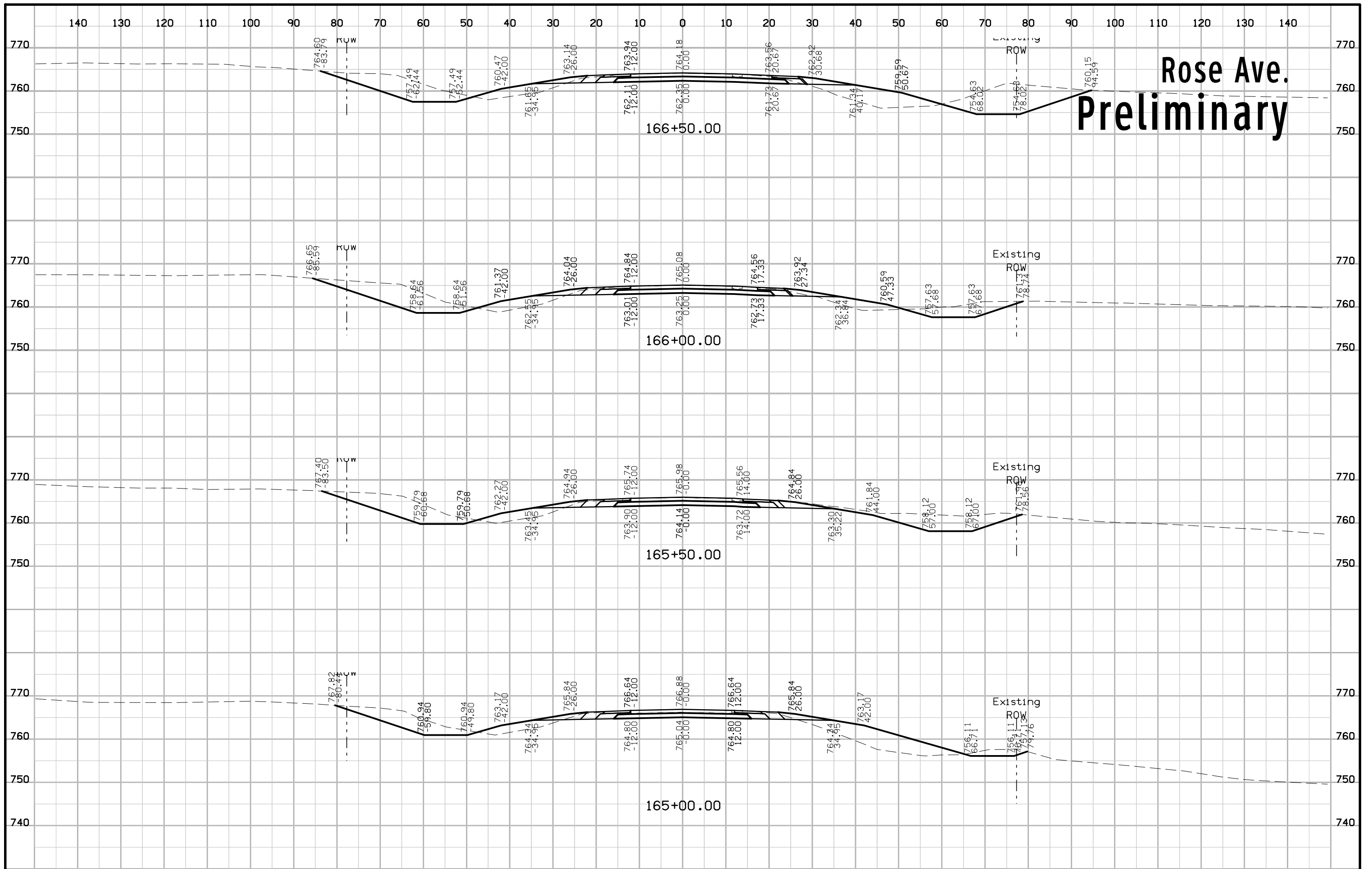

# Rose Ave. Preliminary

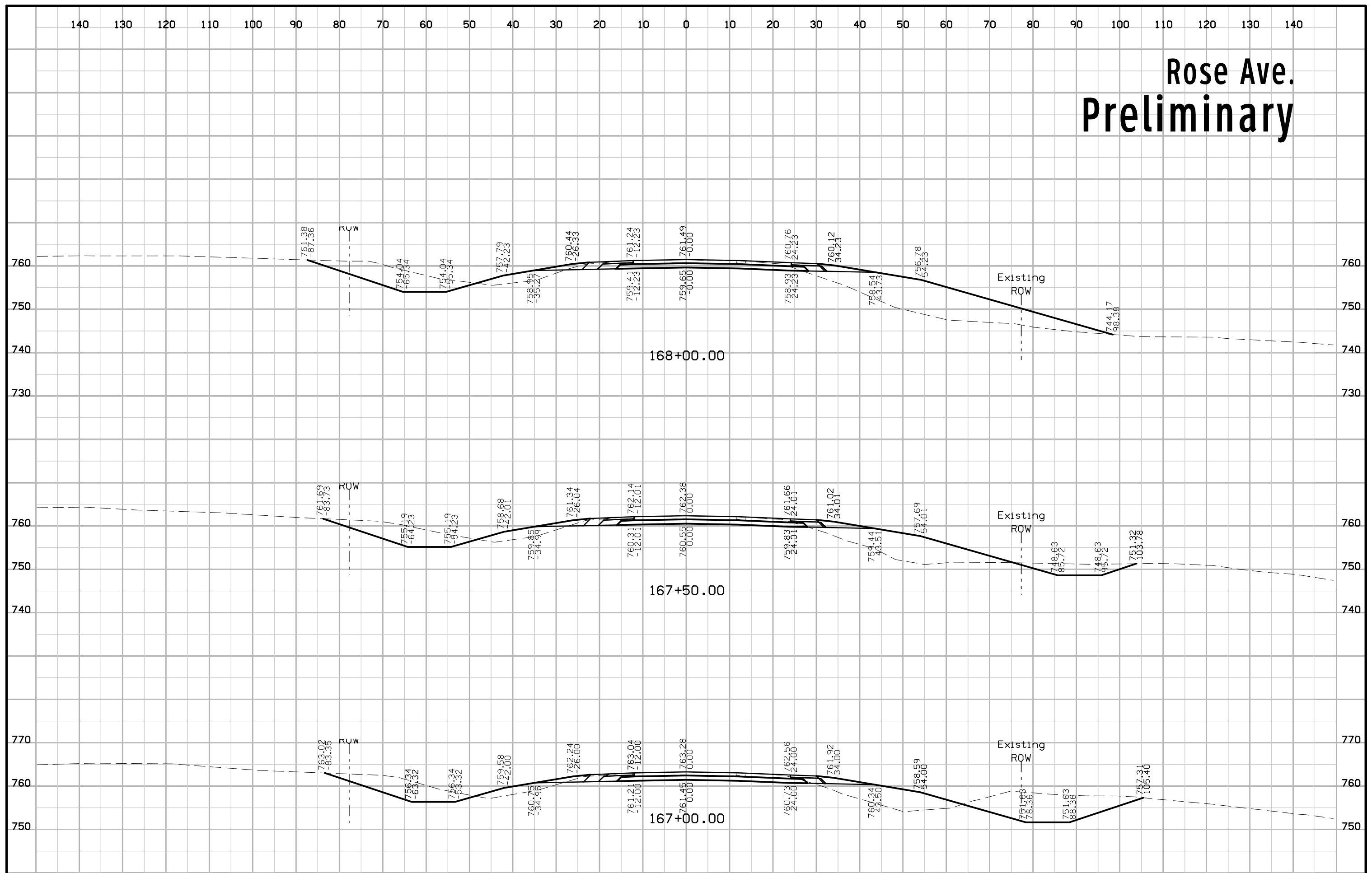

# Rose Ave. Preliminary

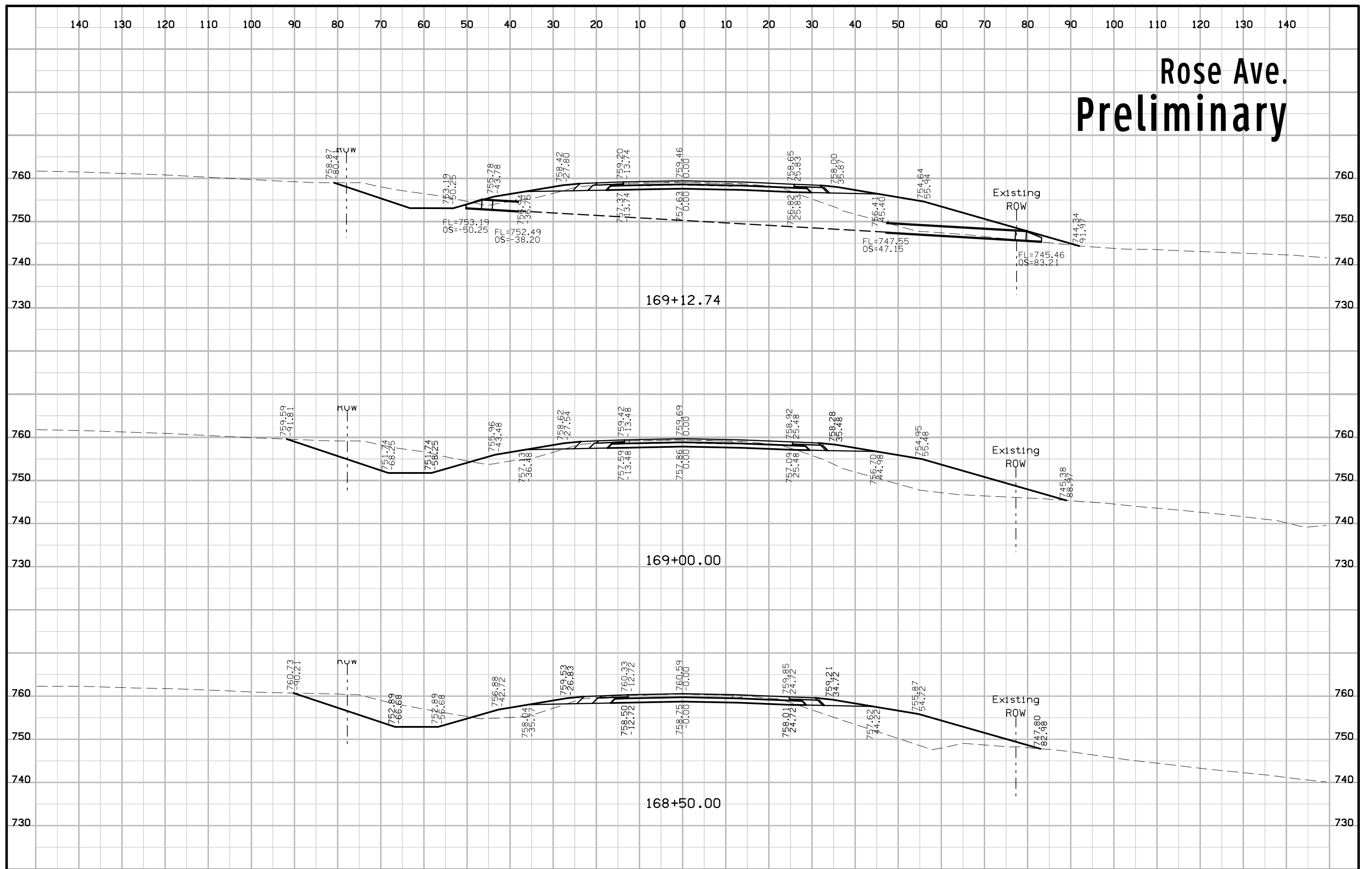

# Rose Ave. Preliminary

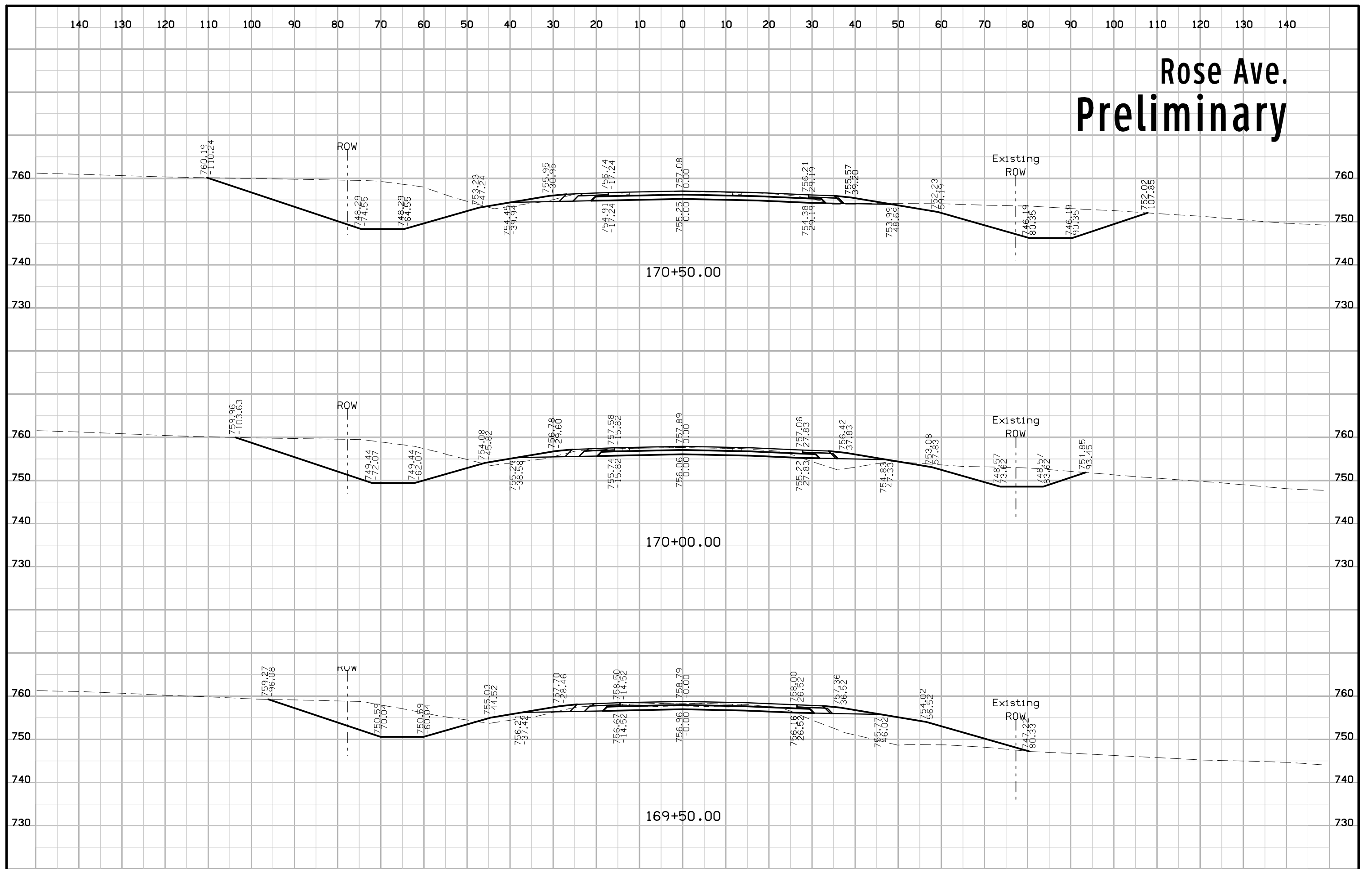

# Rose Ave. Preliminary

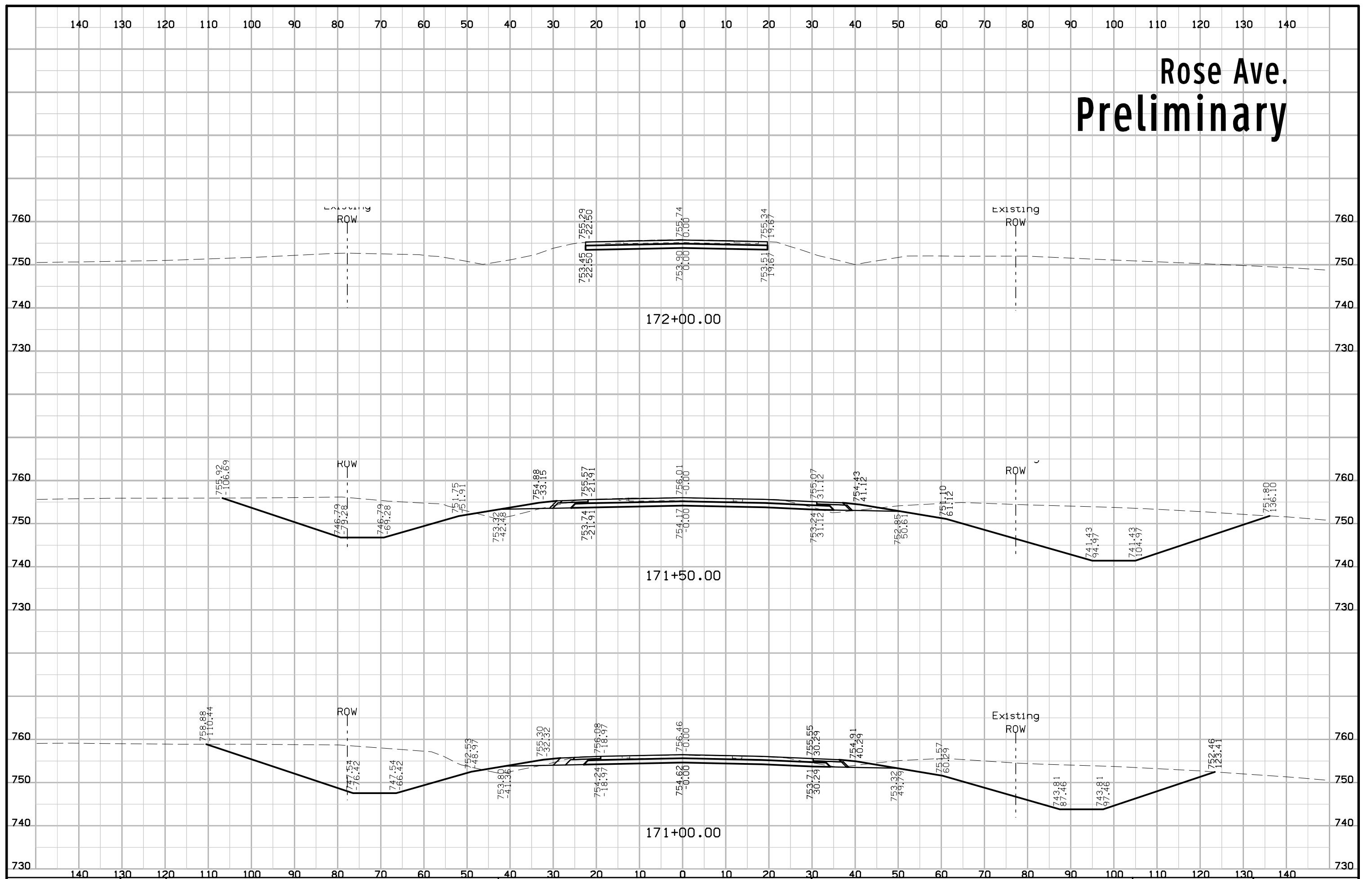

# Rose Ave. Preliminary

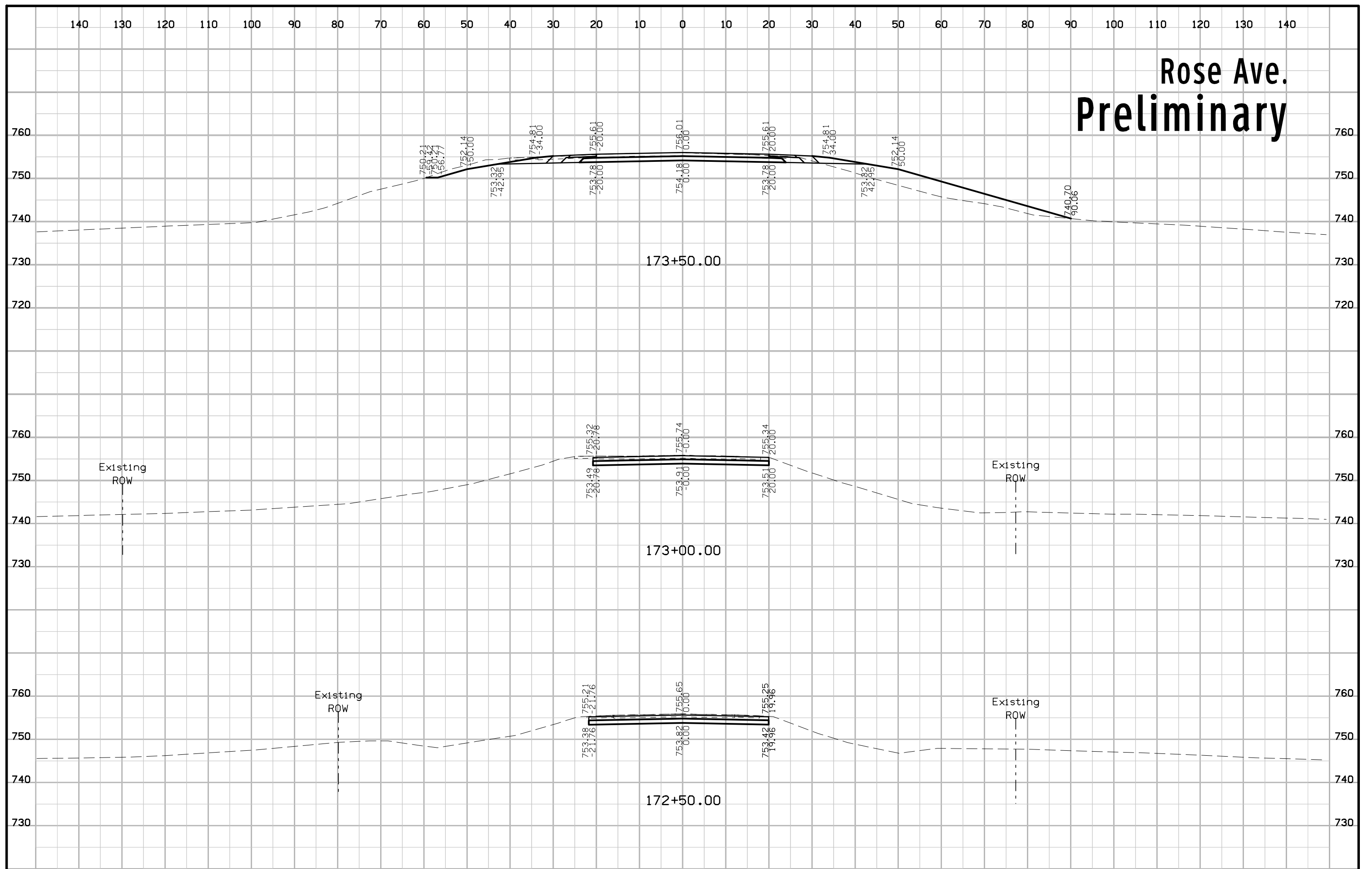

# Rose Ave. Preliminary

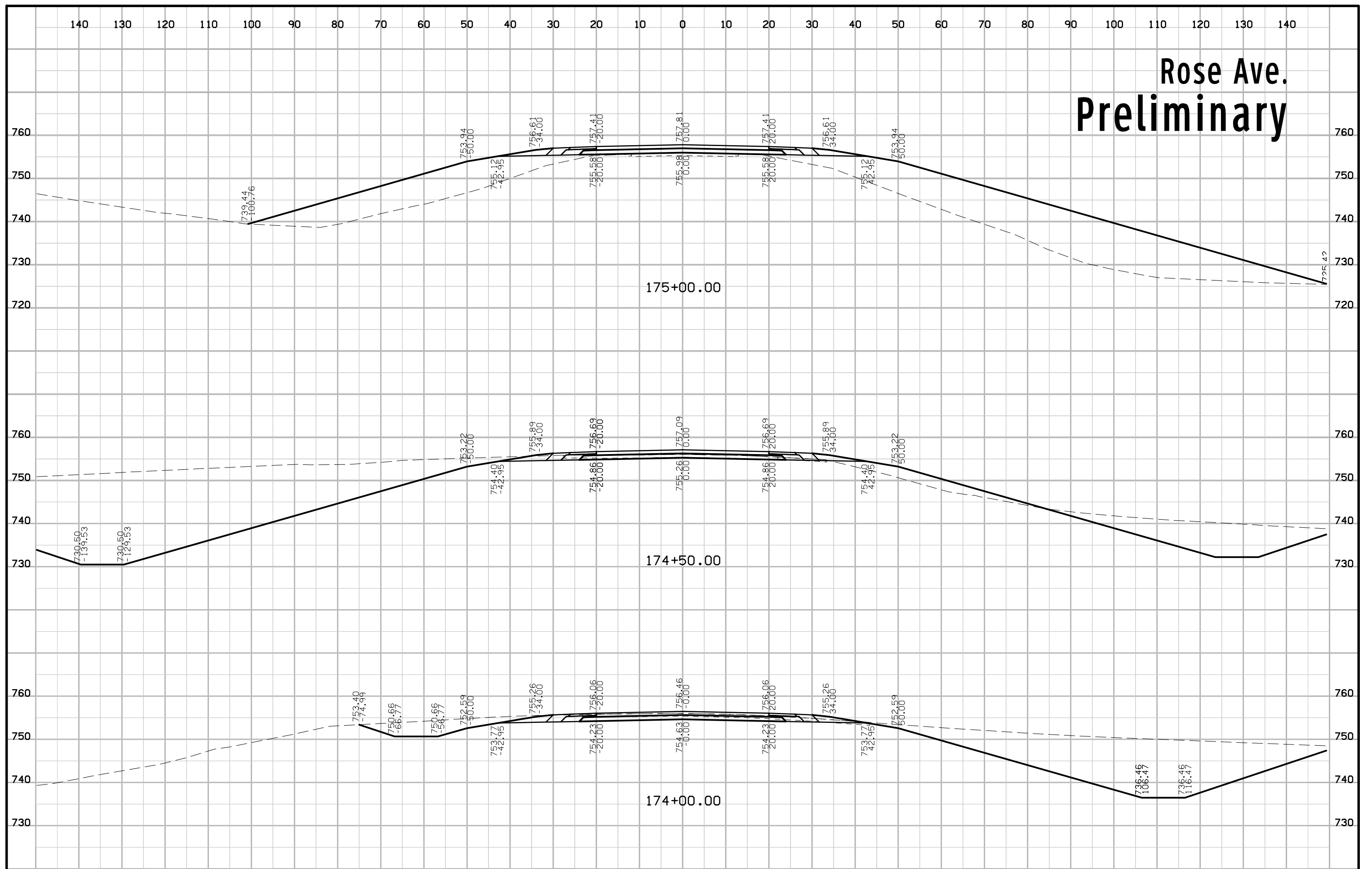

# Rose Ave. Preliminary

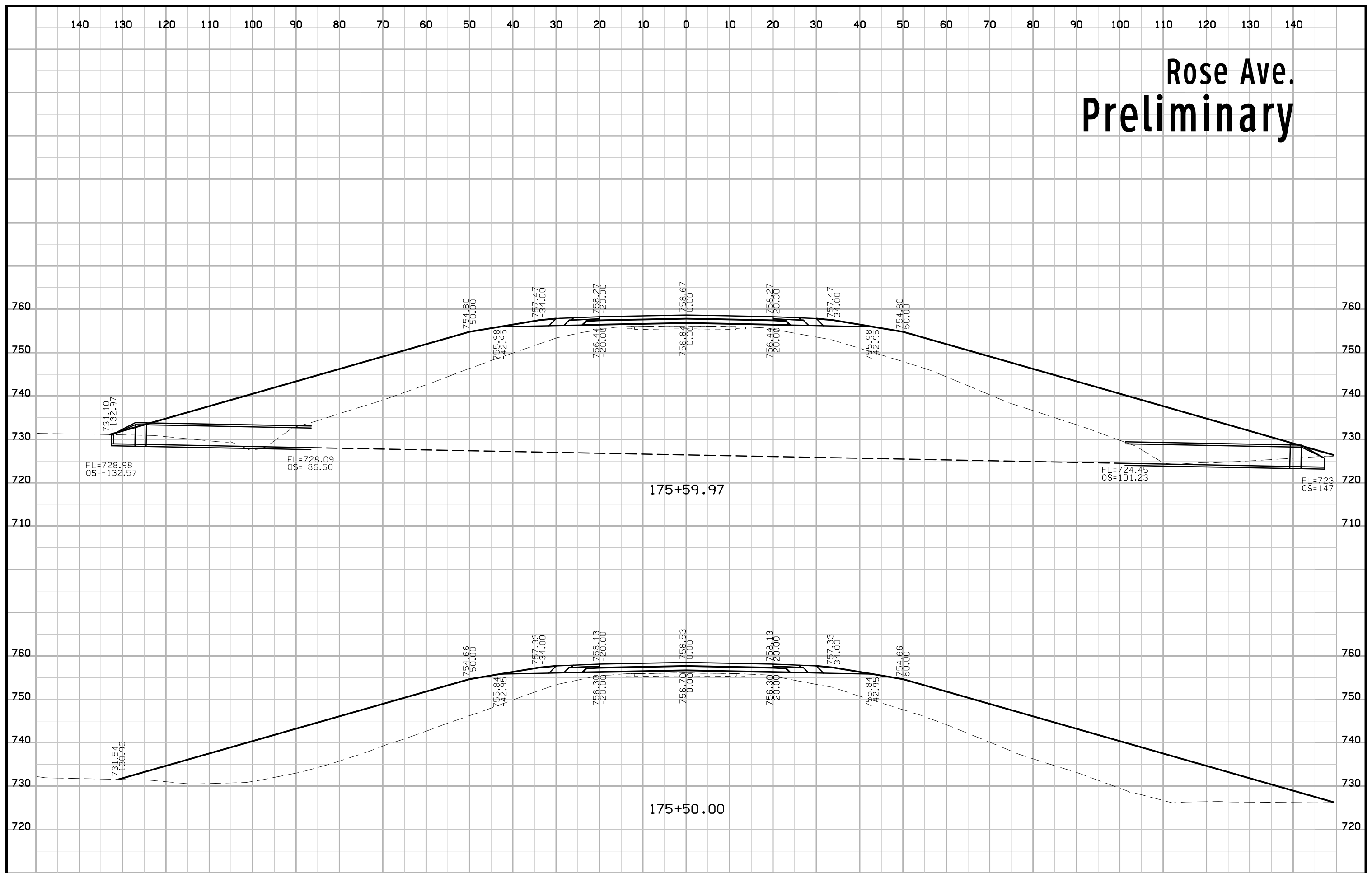



# Rose Ave. Preliminary

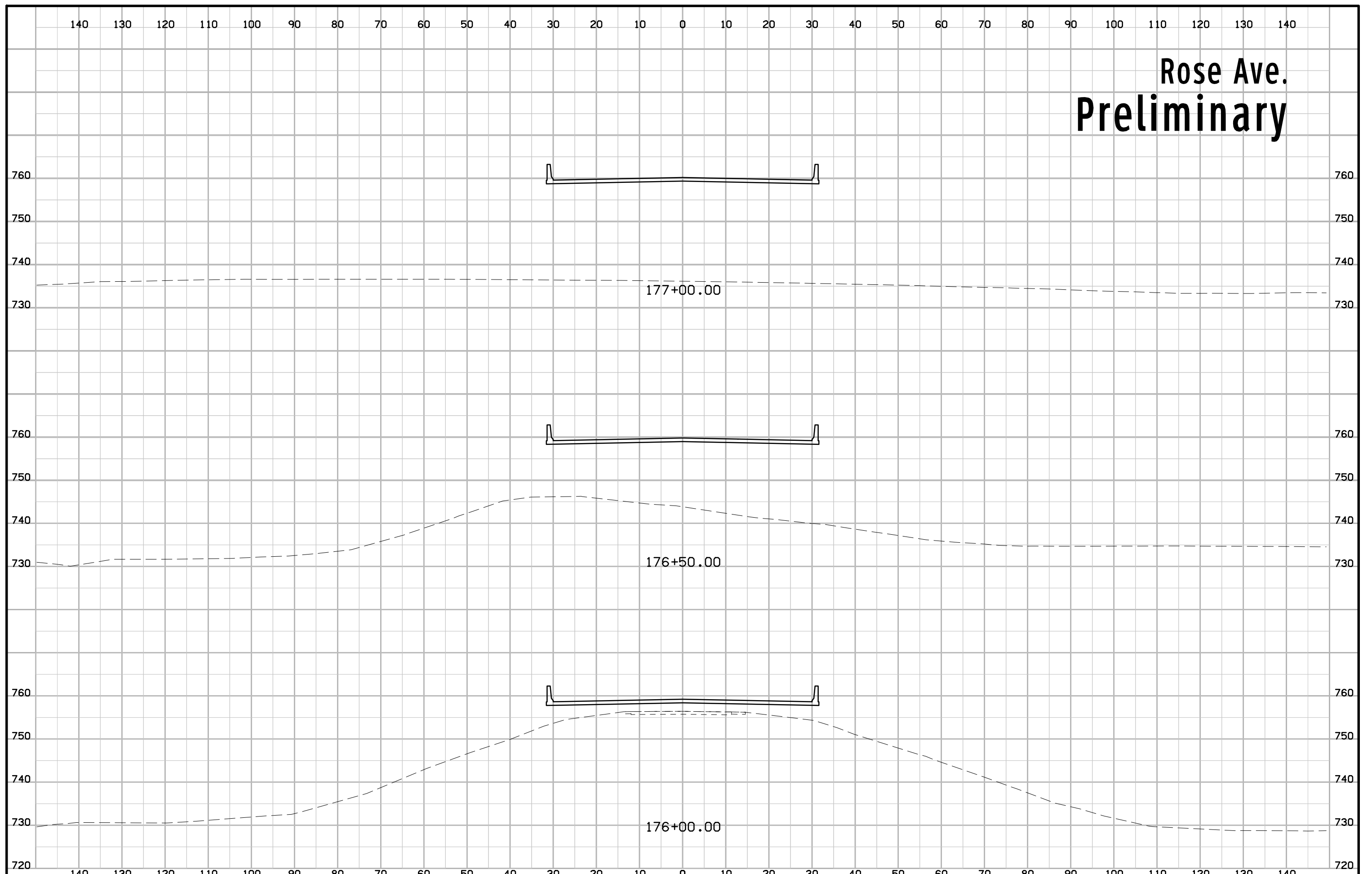

# Rose Ave. Preliminary

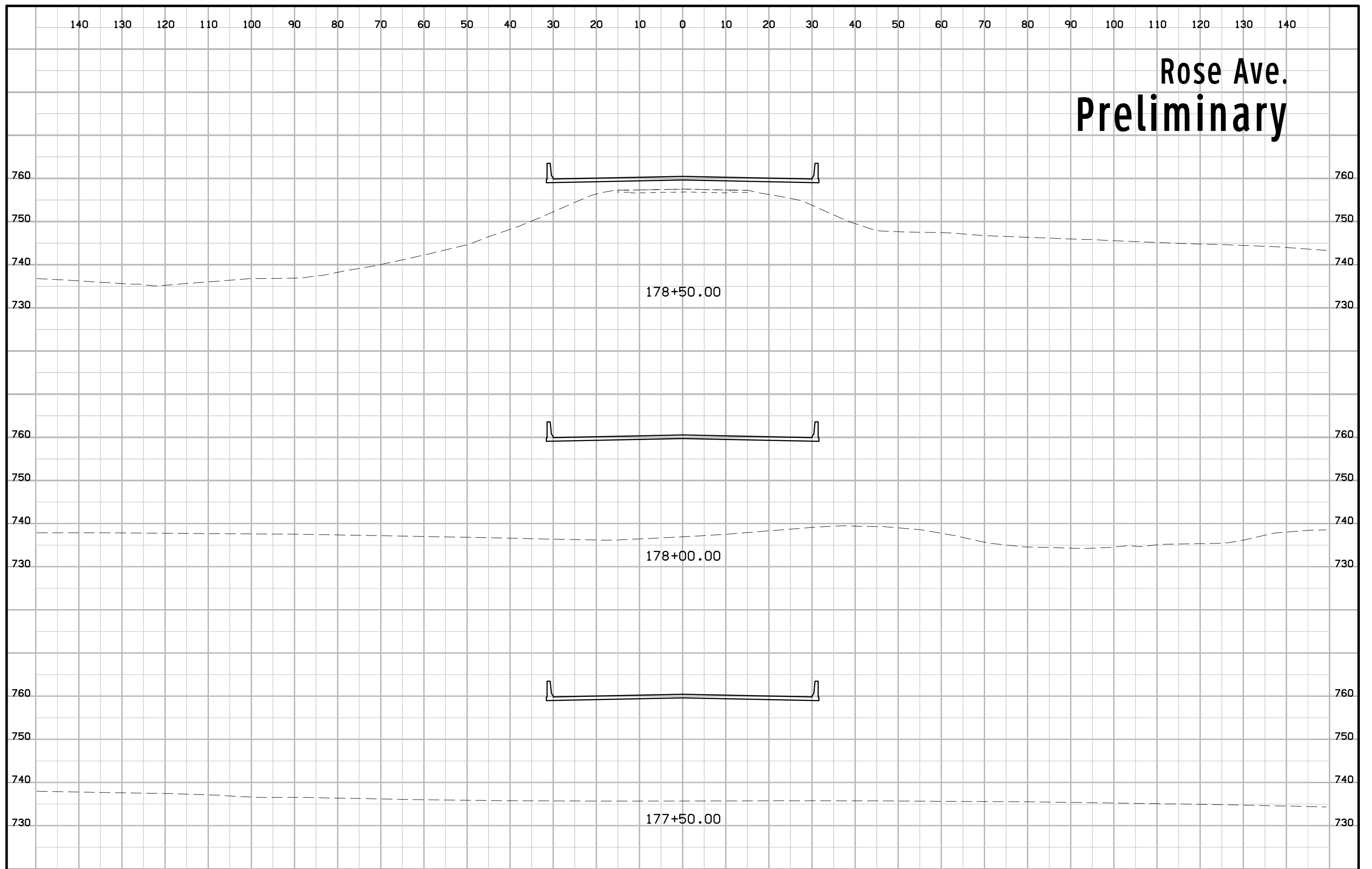

# Rose Ave. Preliminary

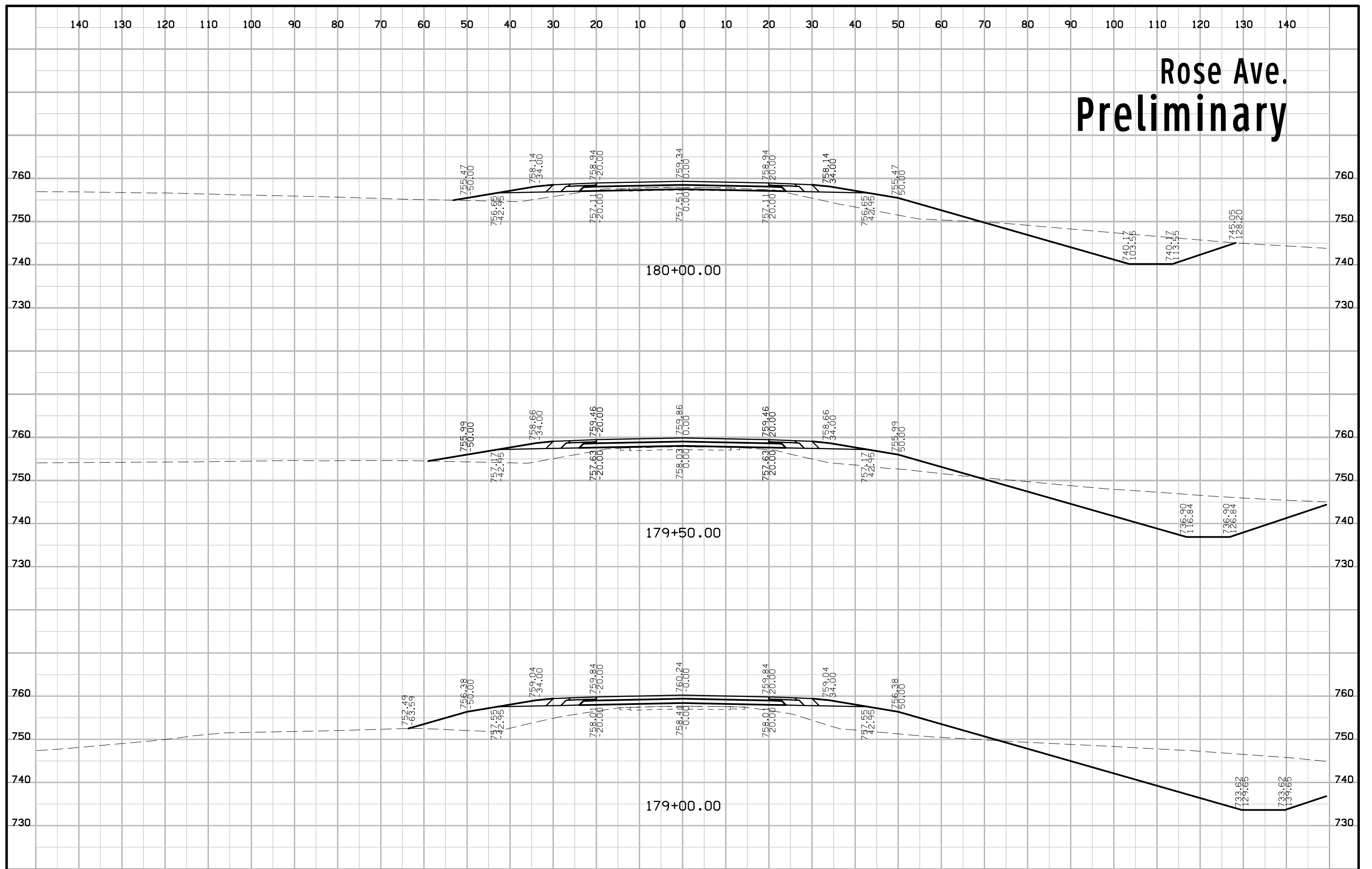

# Rose Ave. Preliminary

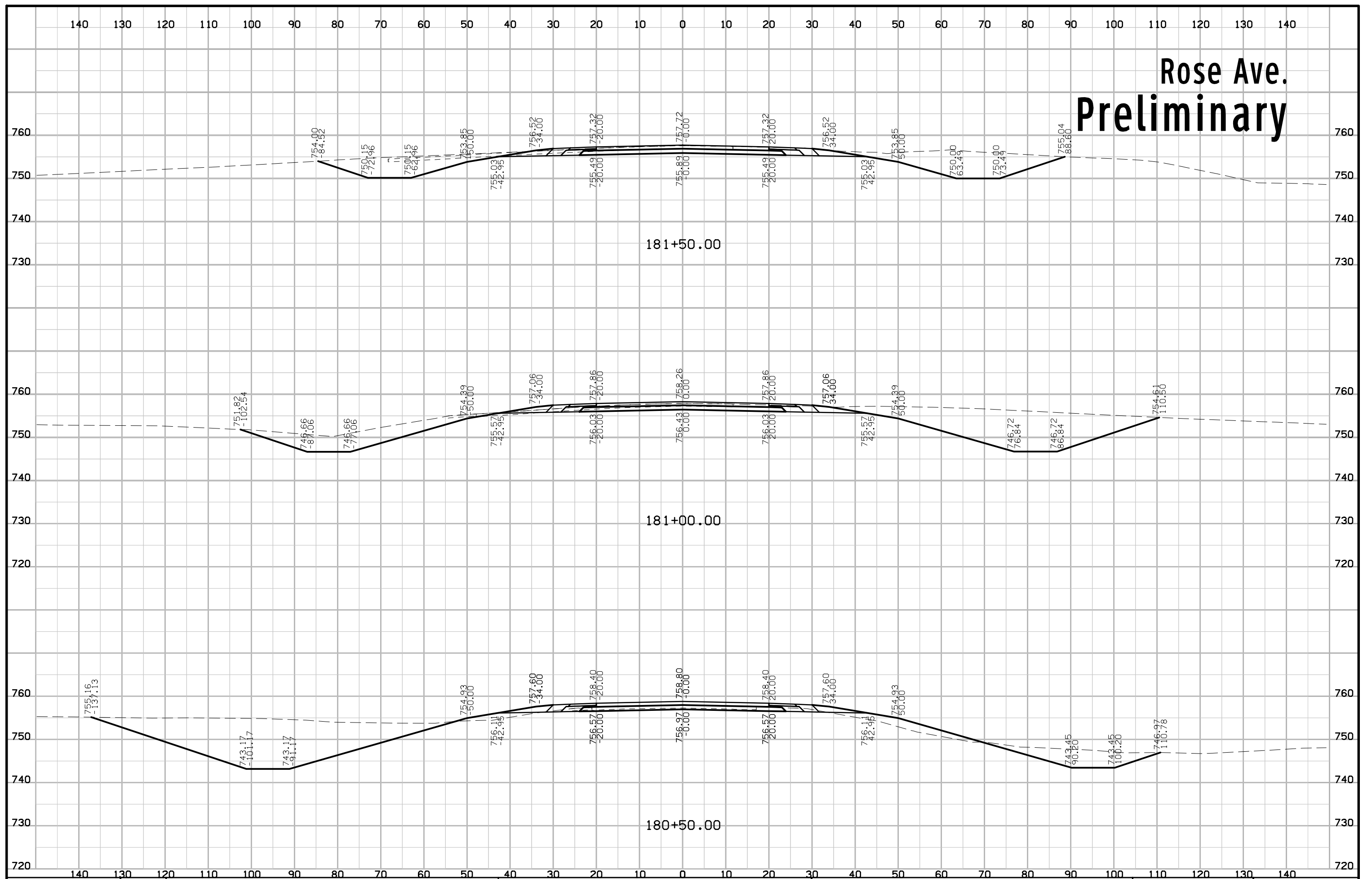

# Rose Ave. Preliminary

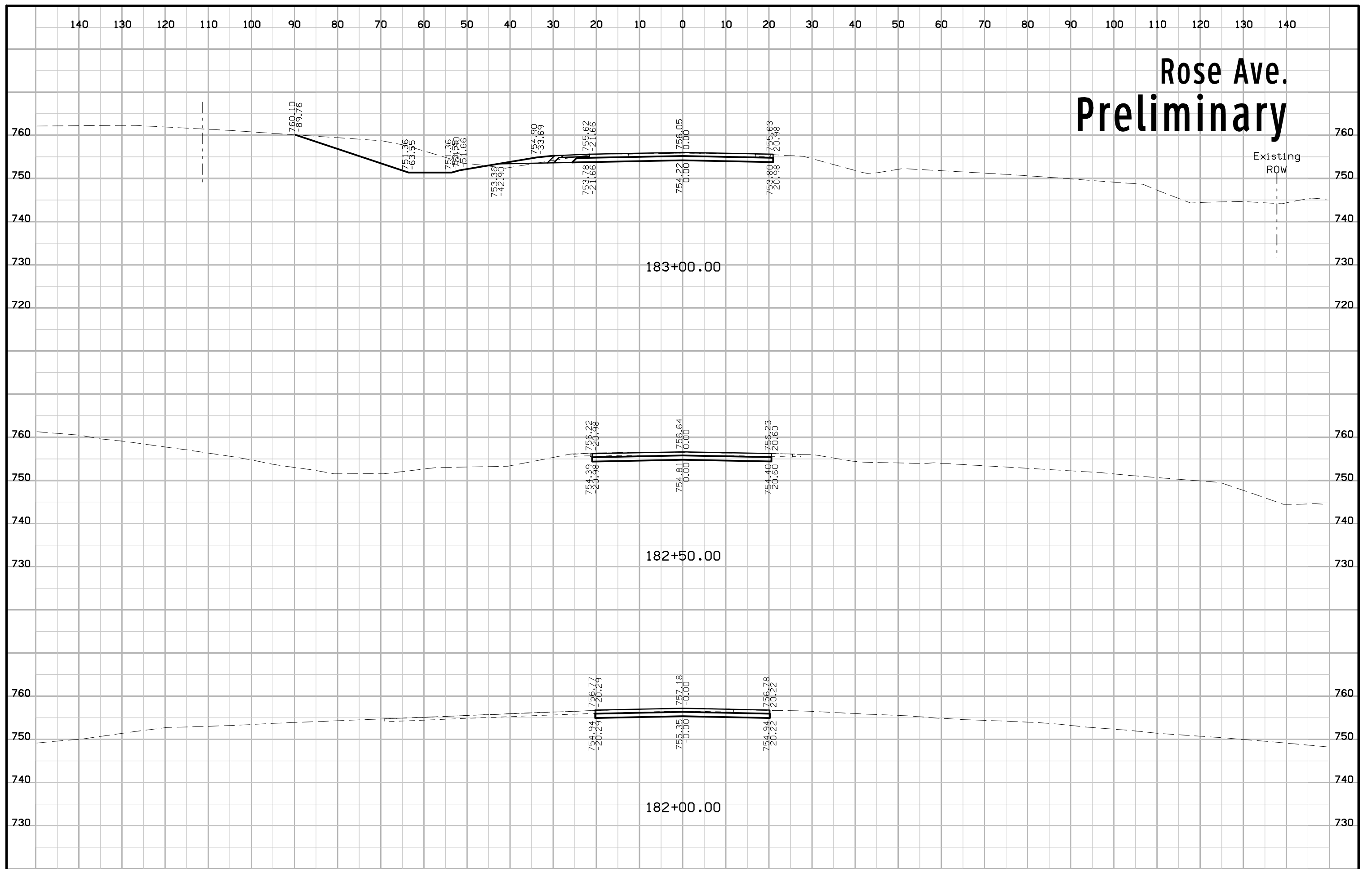

# Rose Ave. Preliminary

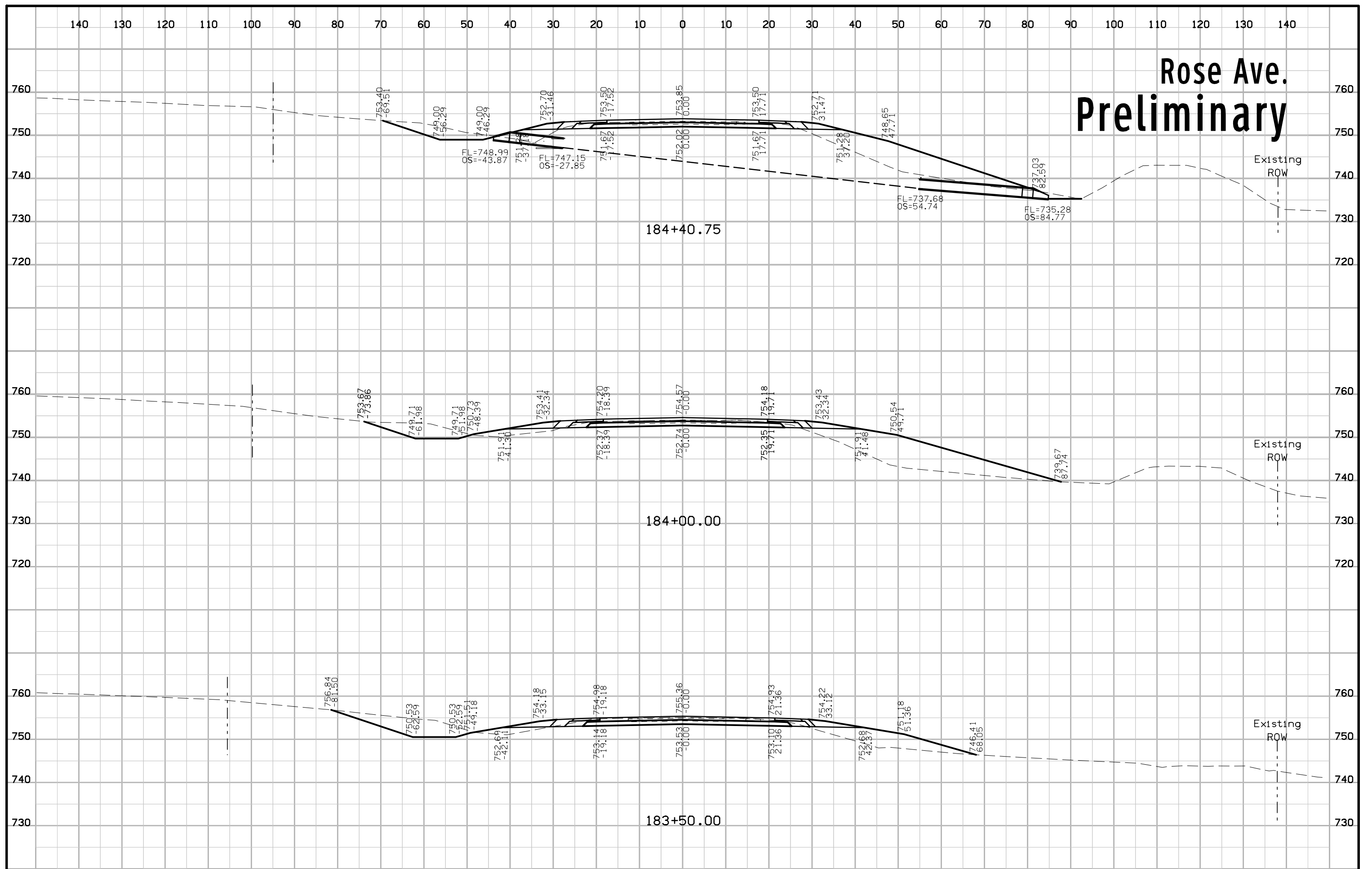

# Rose Ave. Preliminary

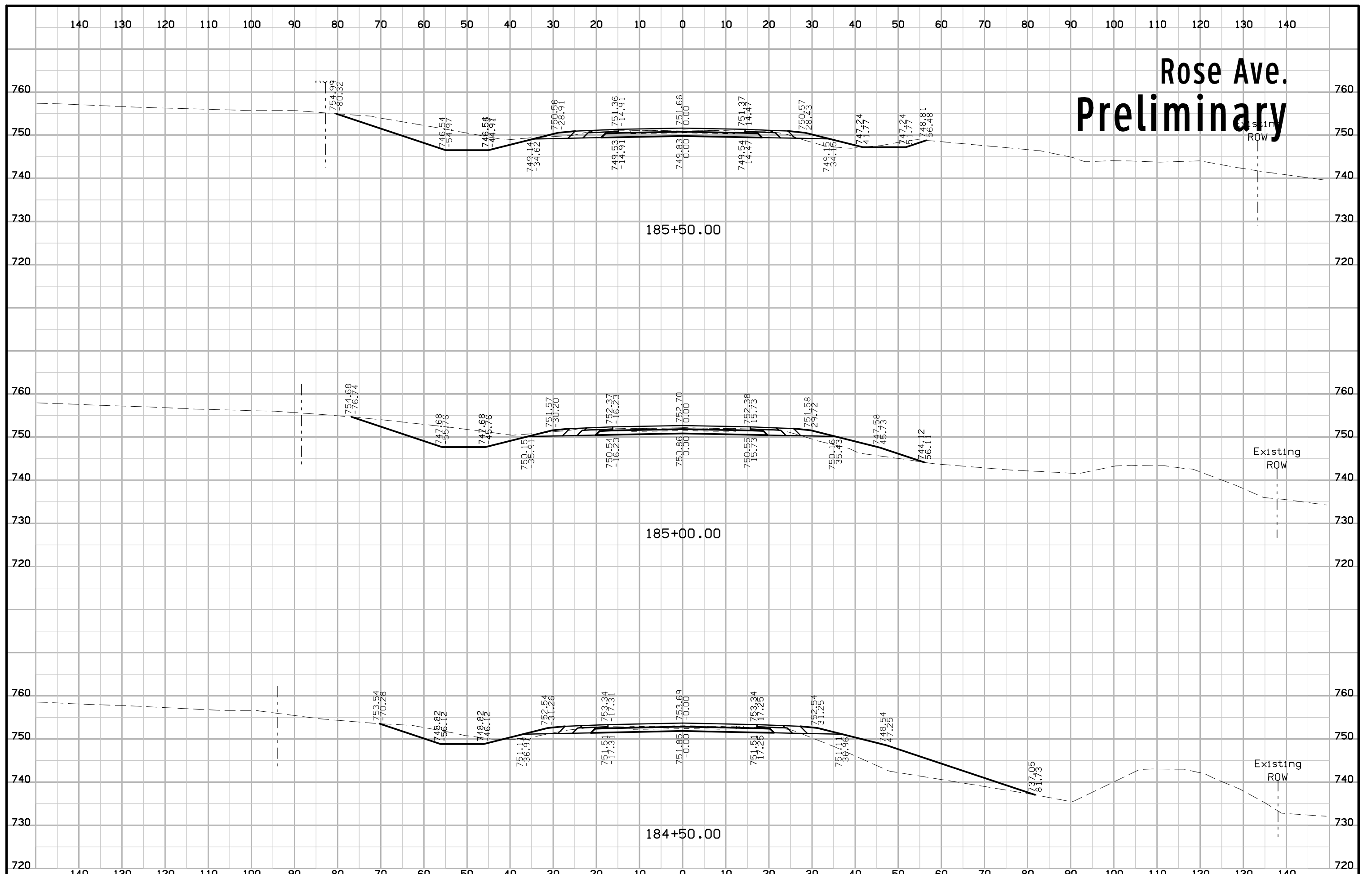

# Rose Ave. Preliminary

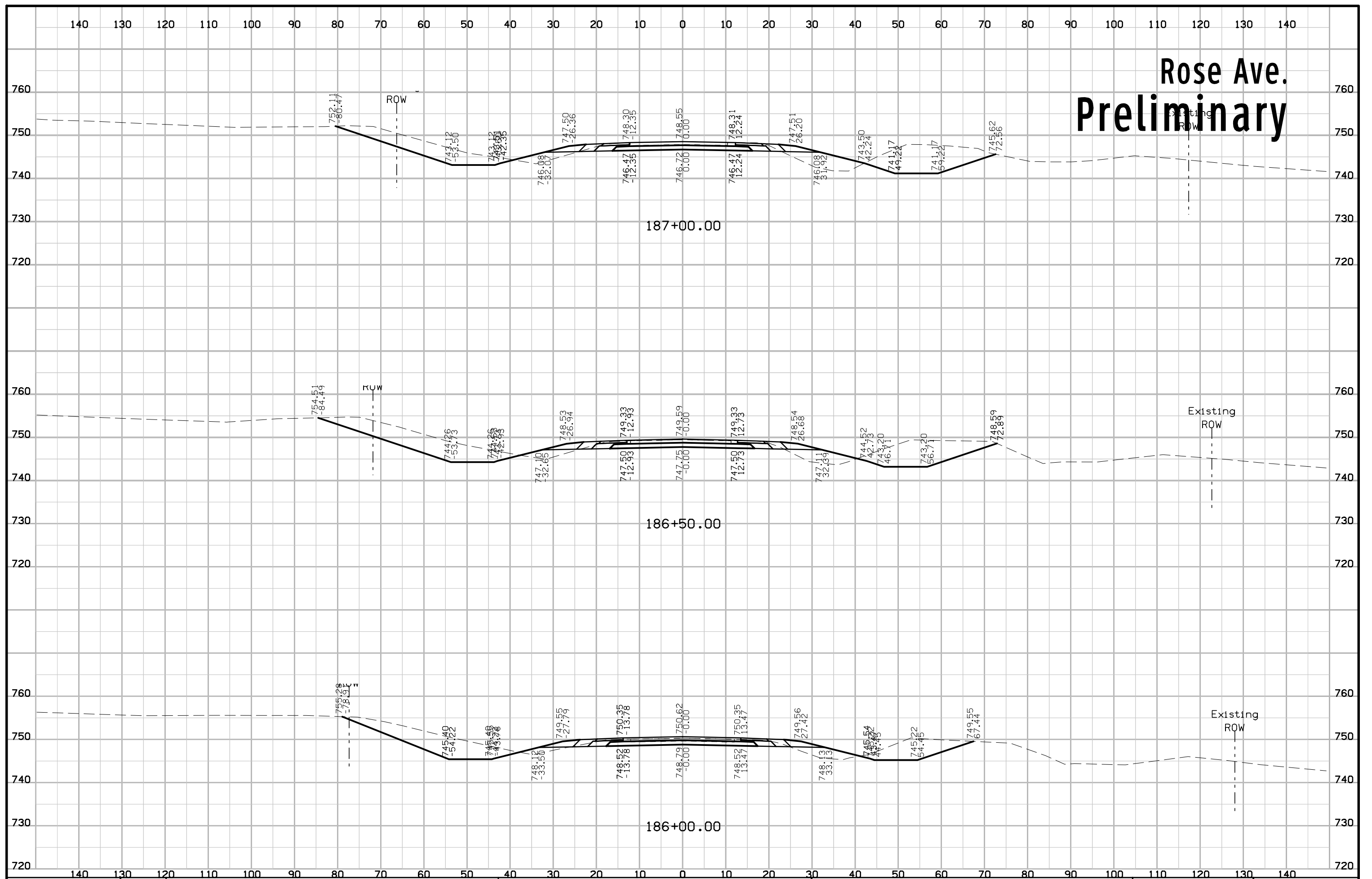



# Rose Ave. Preliminary

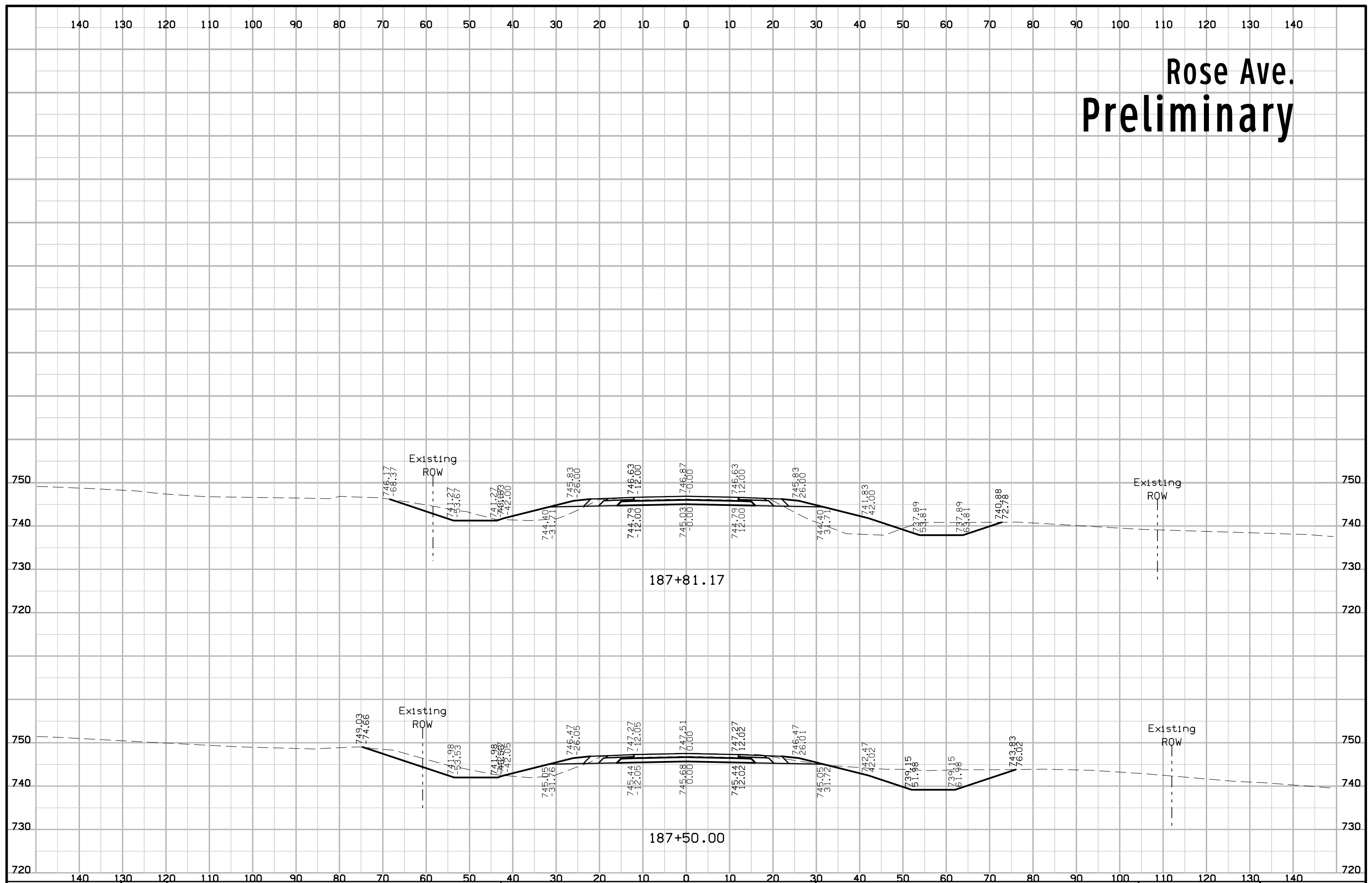

# Taylor Ave. Preliminary

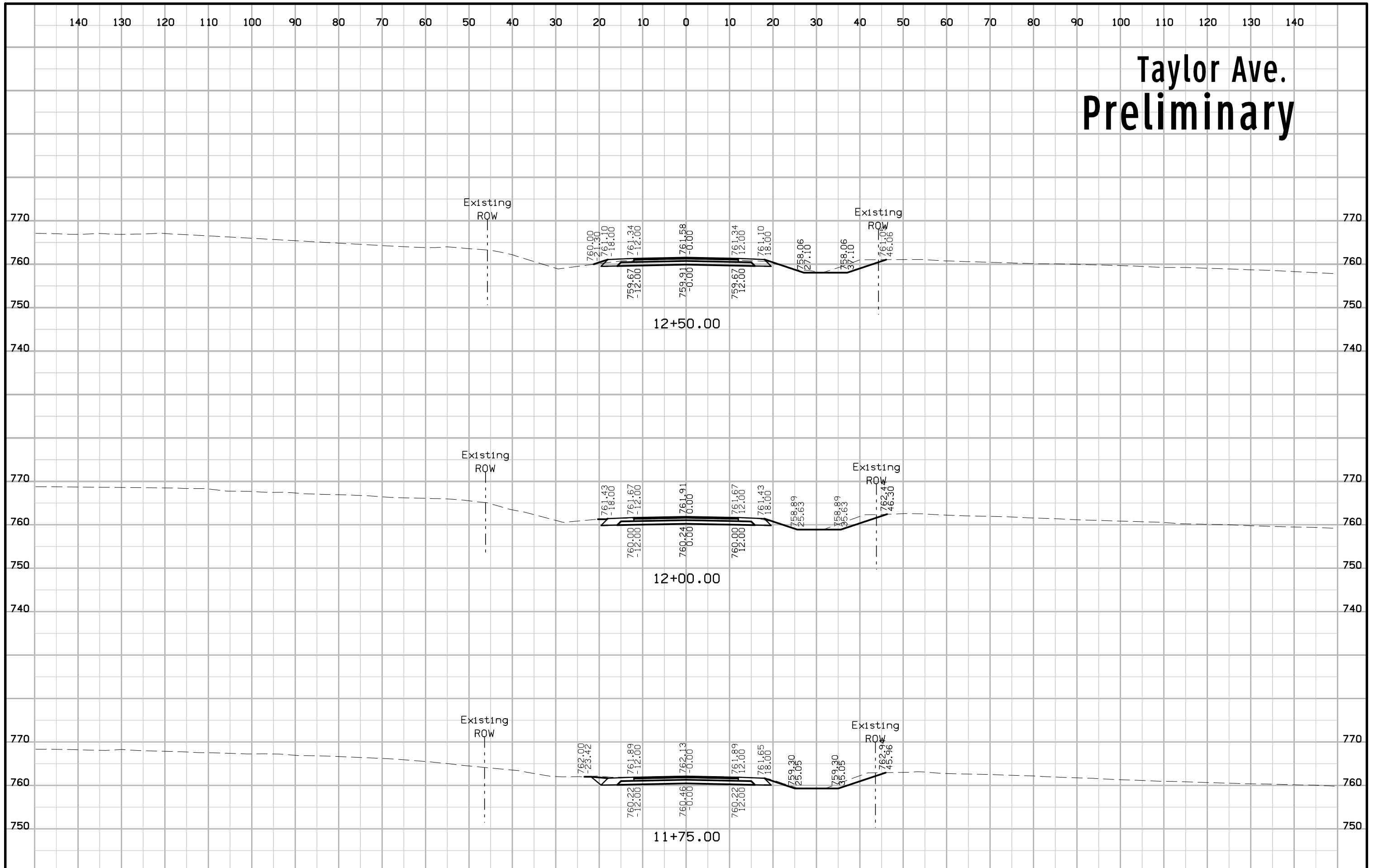

# Taylor Ave. Preliminary

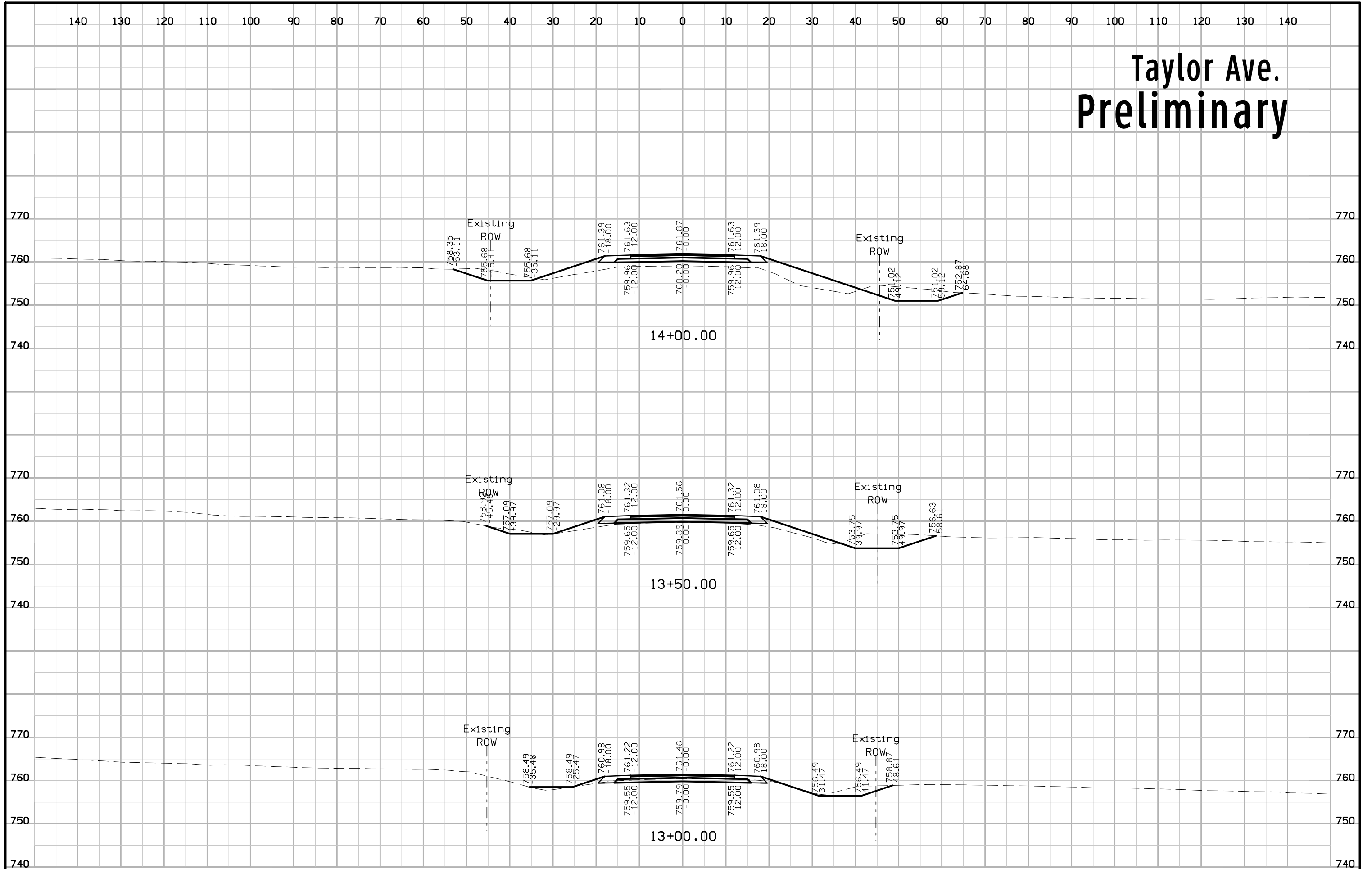

# Taylor Ave. Preliminary

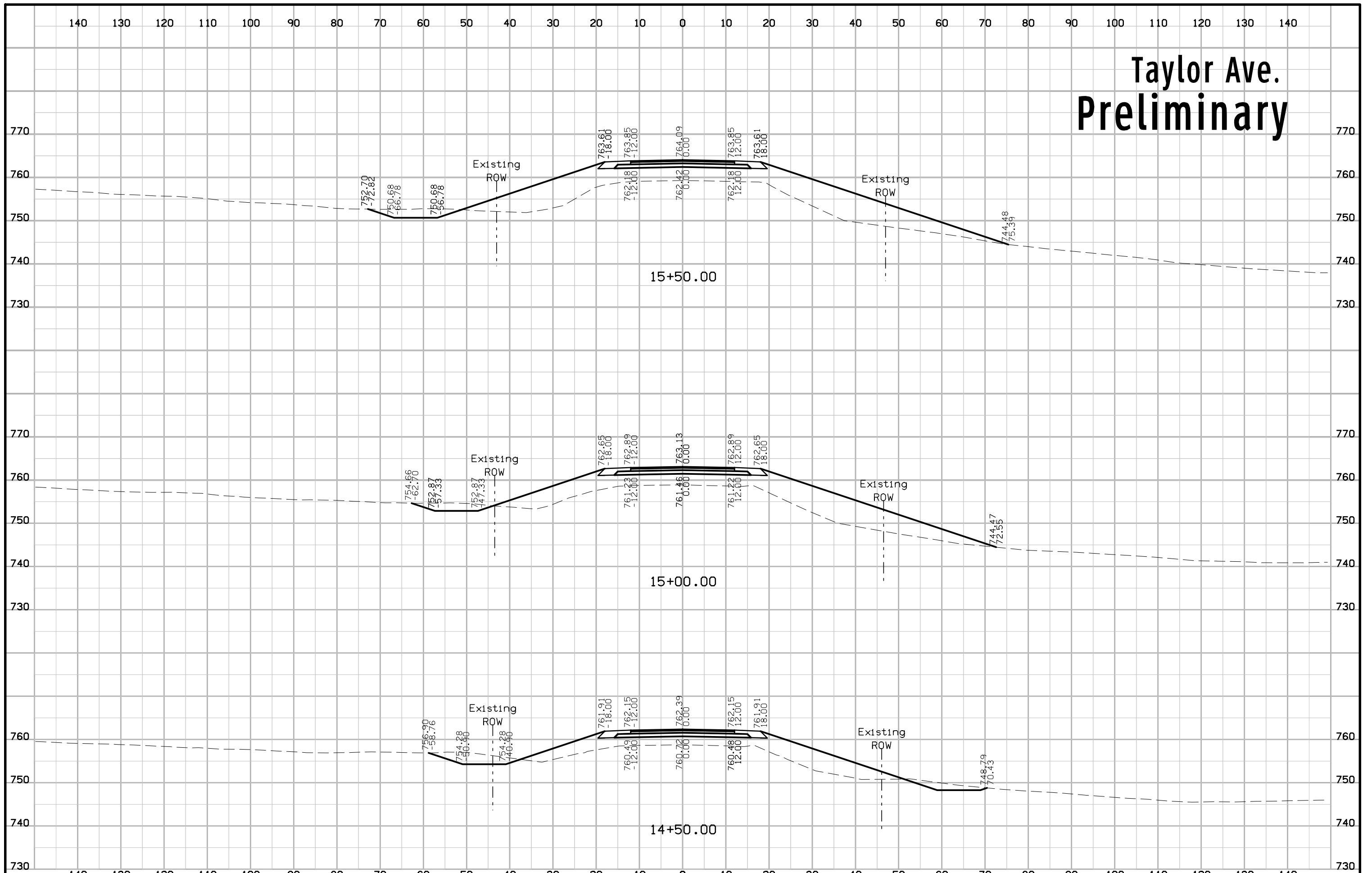

# Taylor Ave. Preliminary

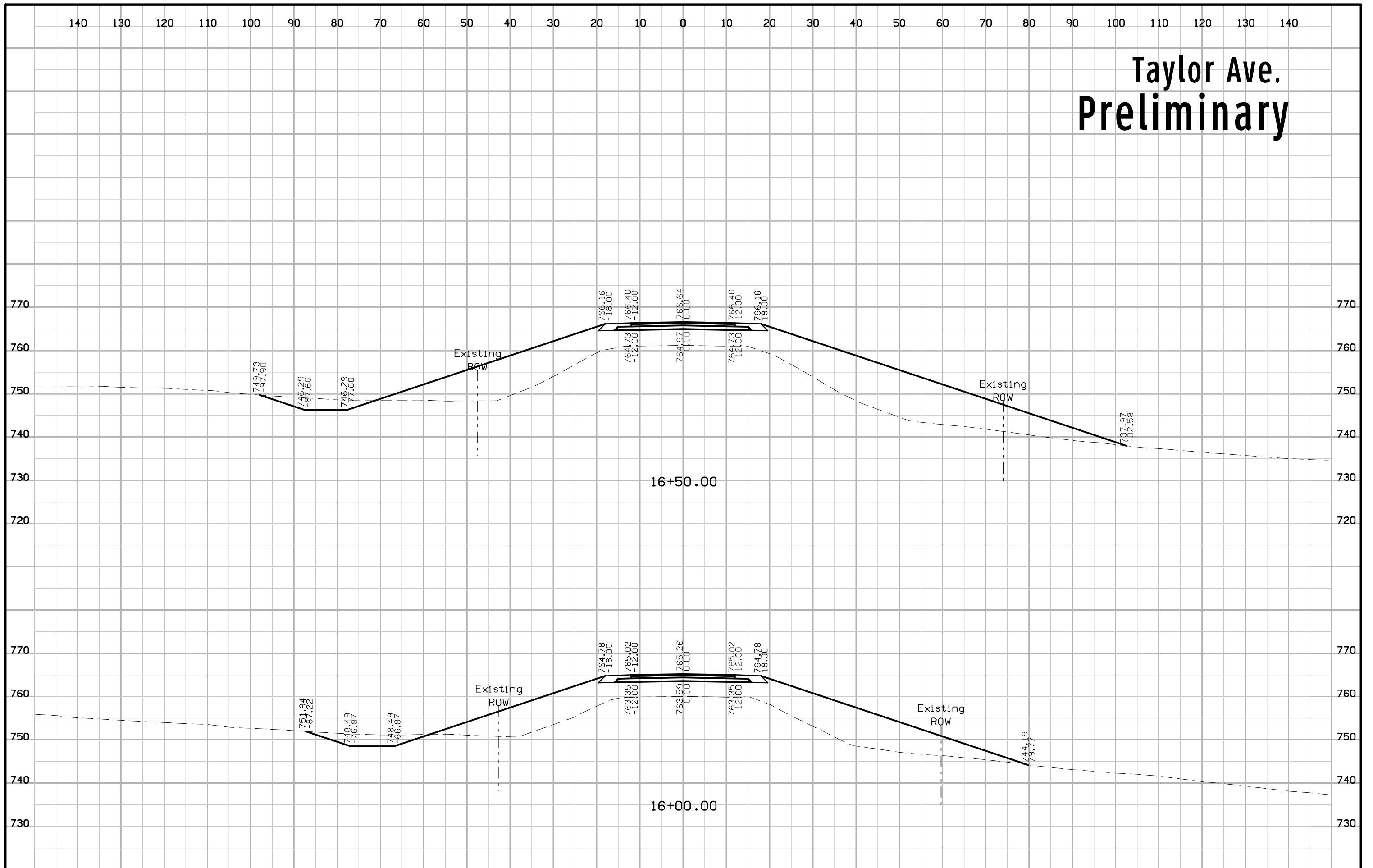

# Taylor Ave. Preliminary

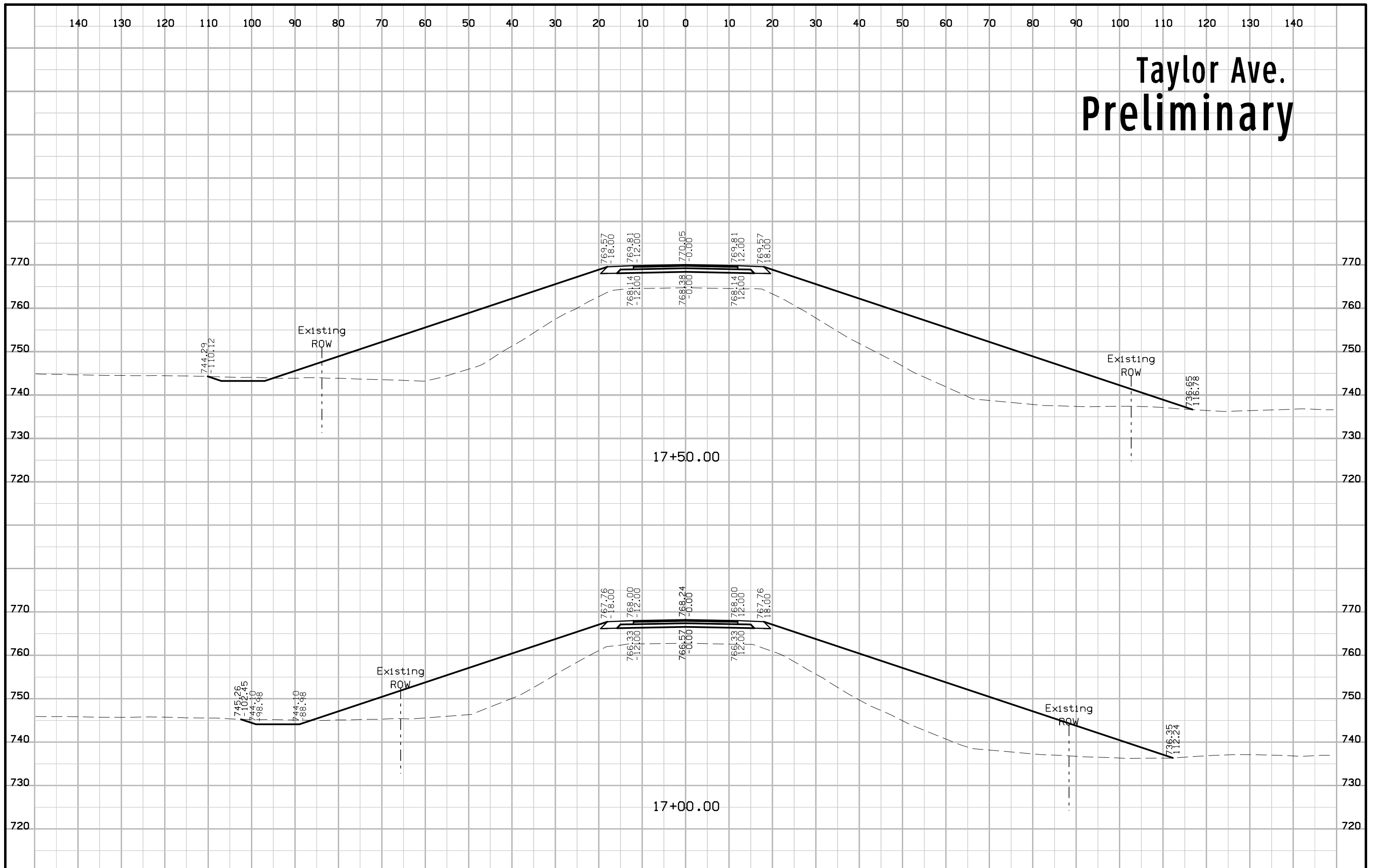

# Taylor Ave. Preliminary

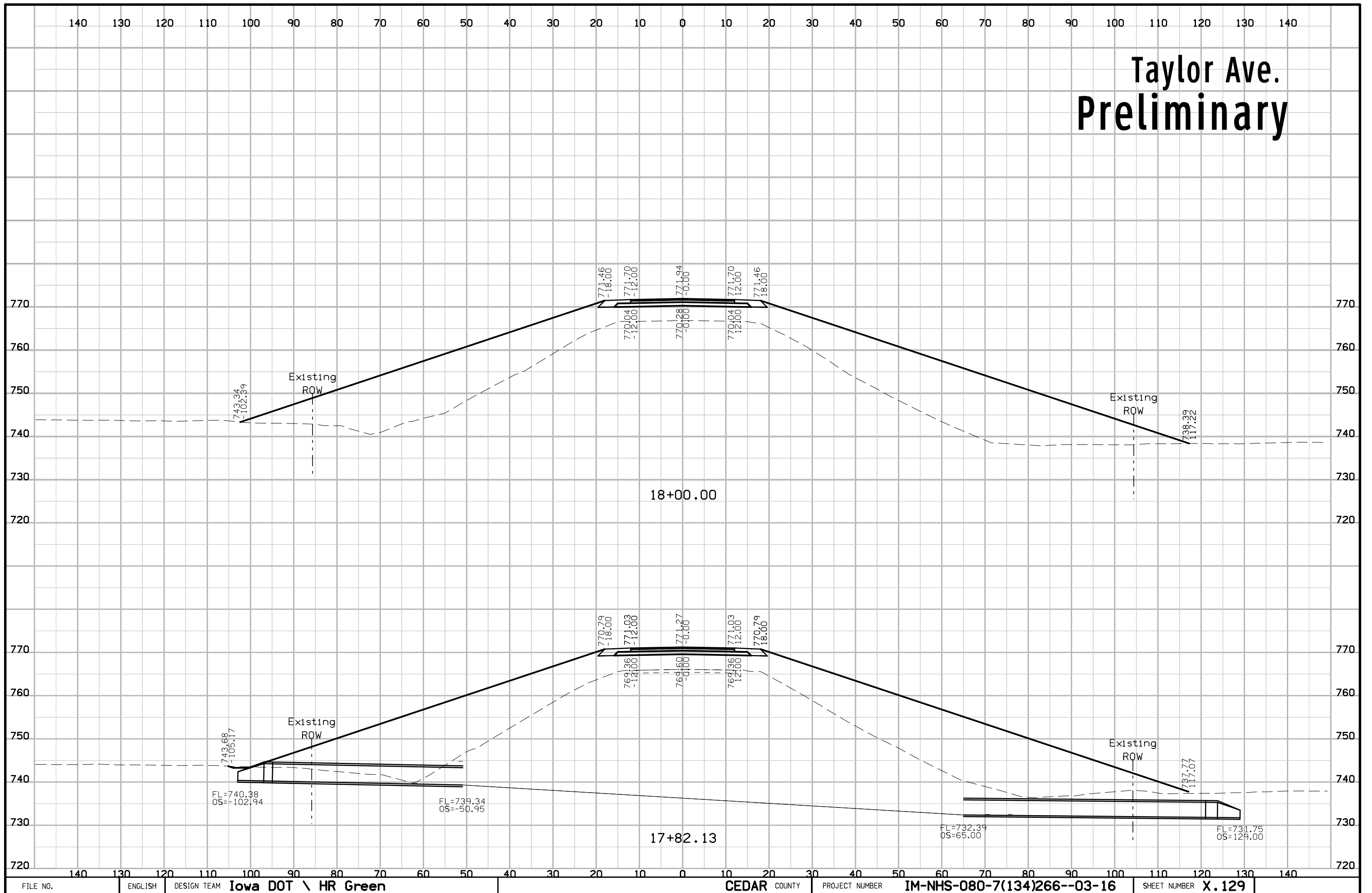

# Taylor Ave. Preliminary

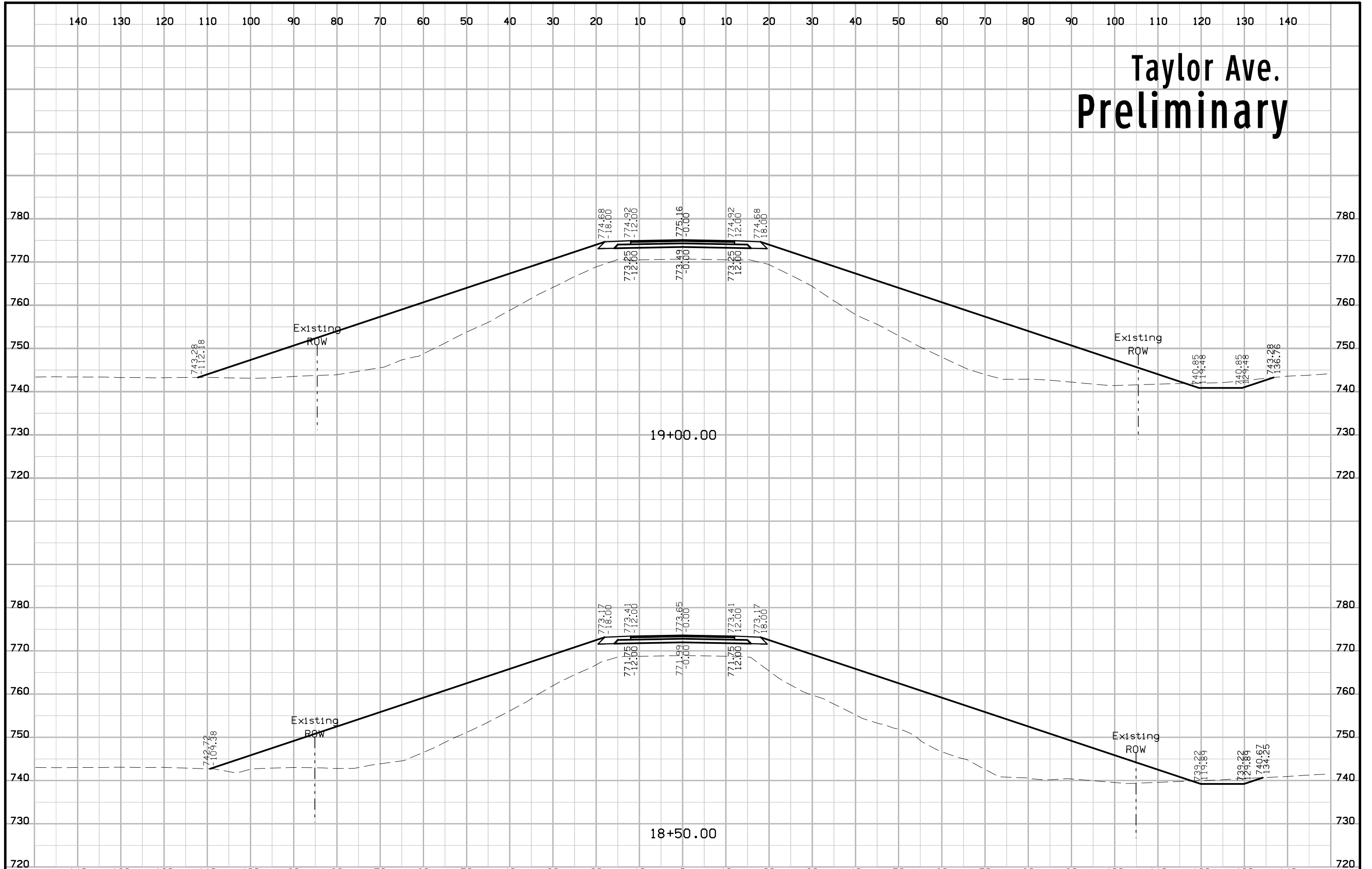



# Taylor Ave. Preliminary

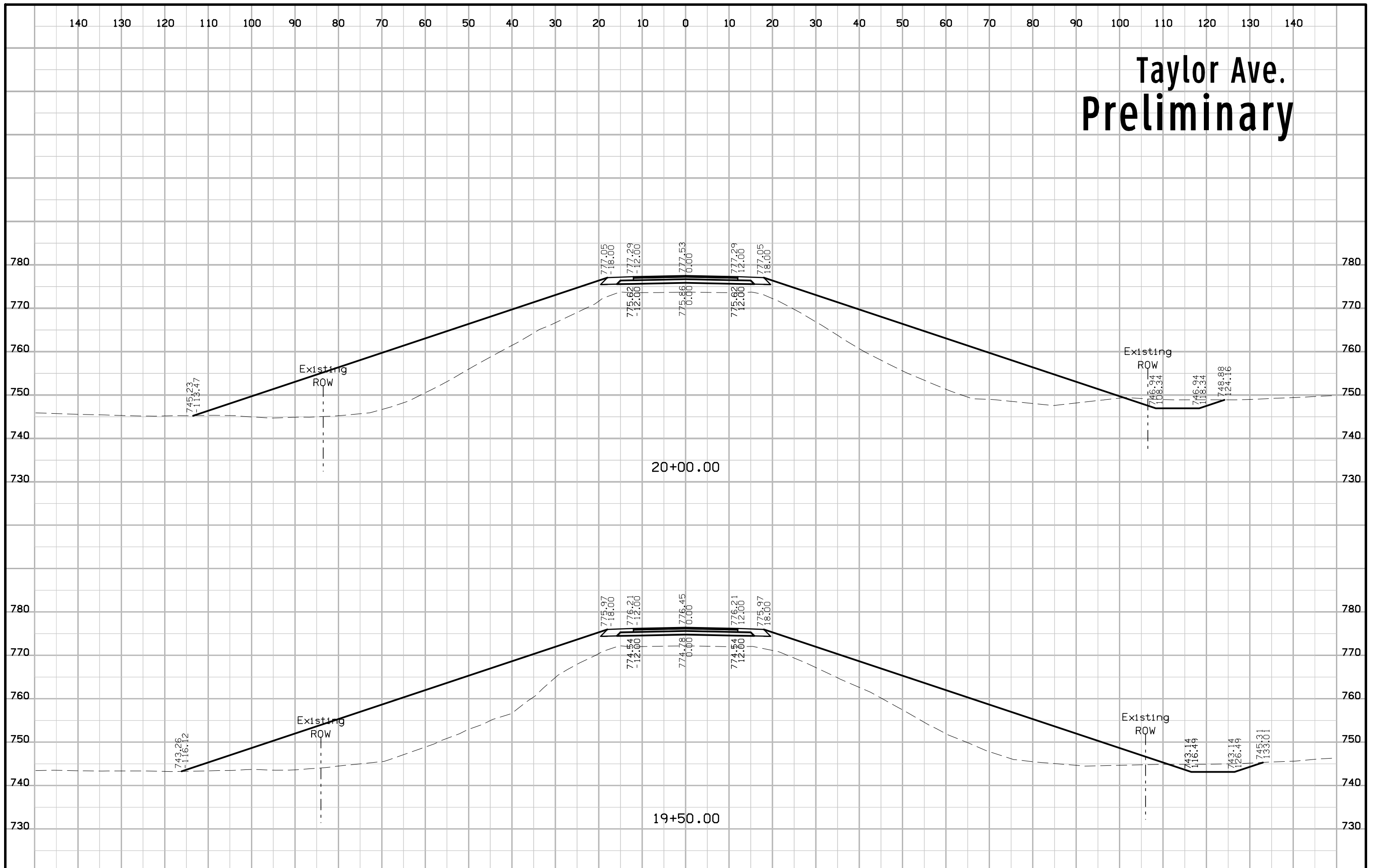

# Taylor Ave. Preliminary

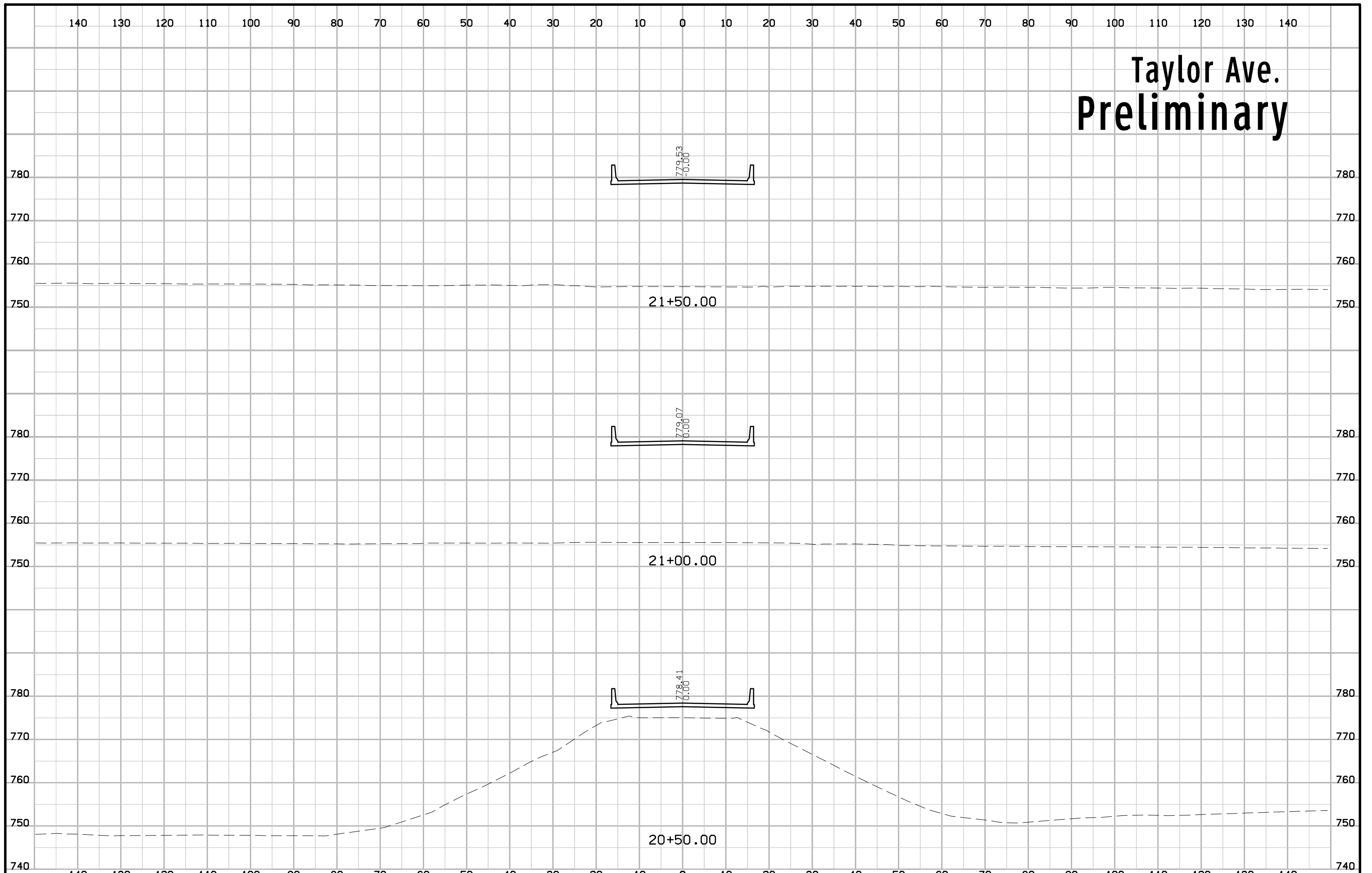

# Taylor Ave. Preliminary

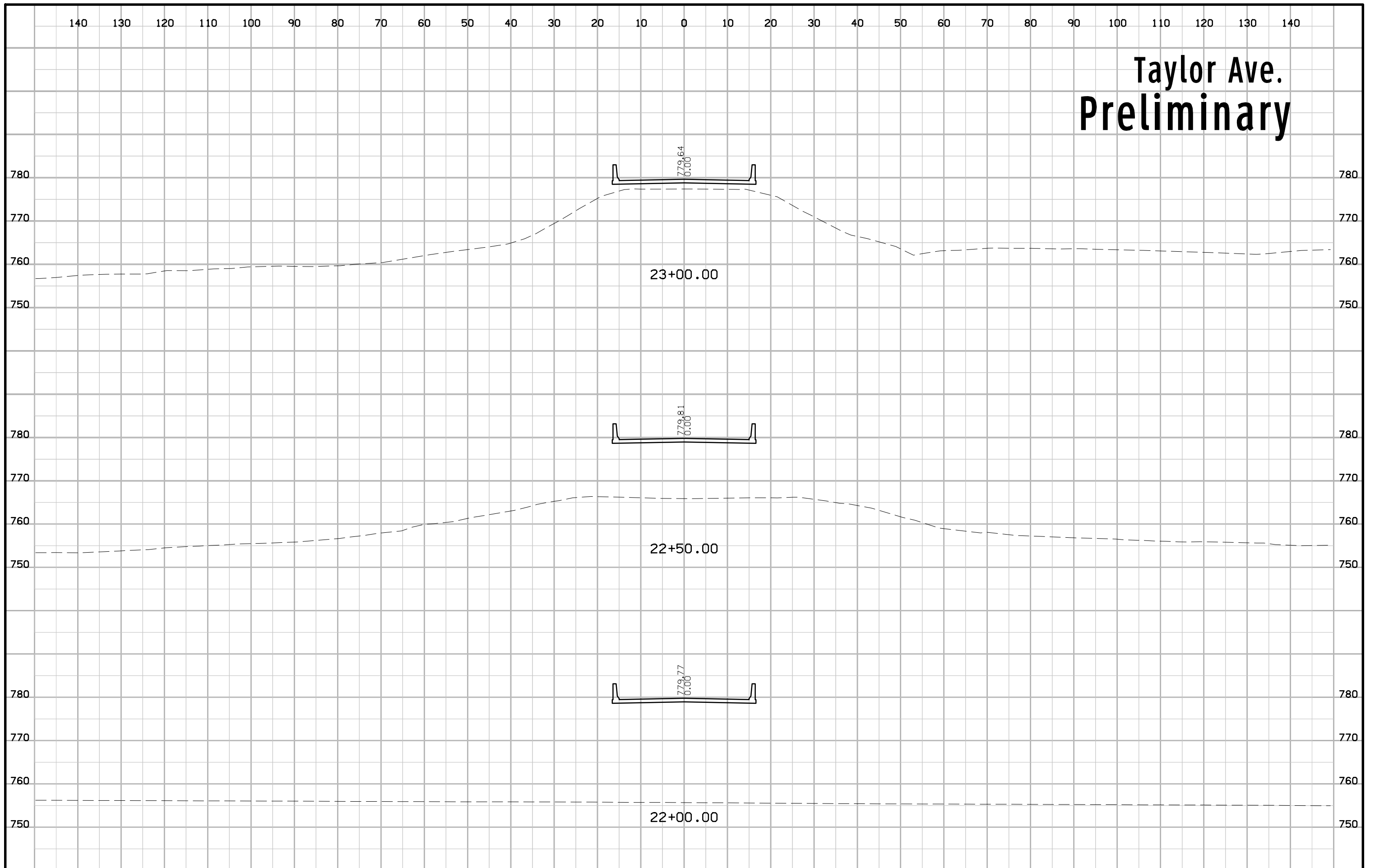

# Taylor Ave. Preliminary

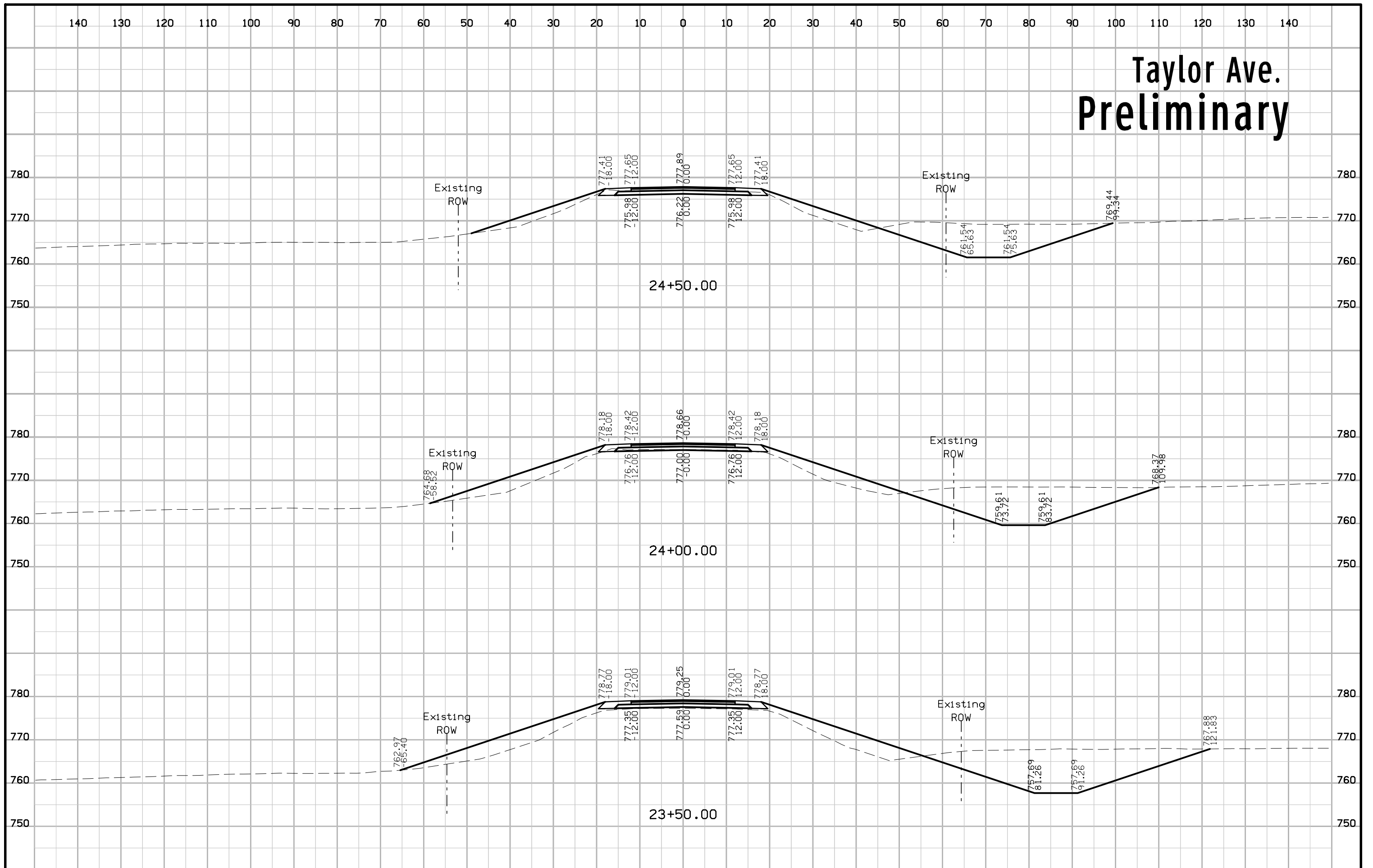

# Taylor Ave. Preliminary

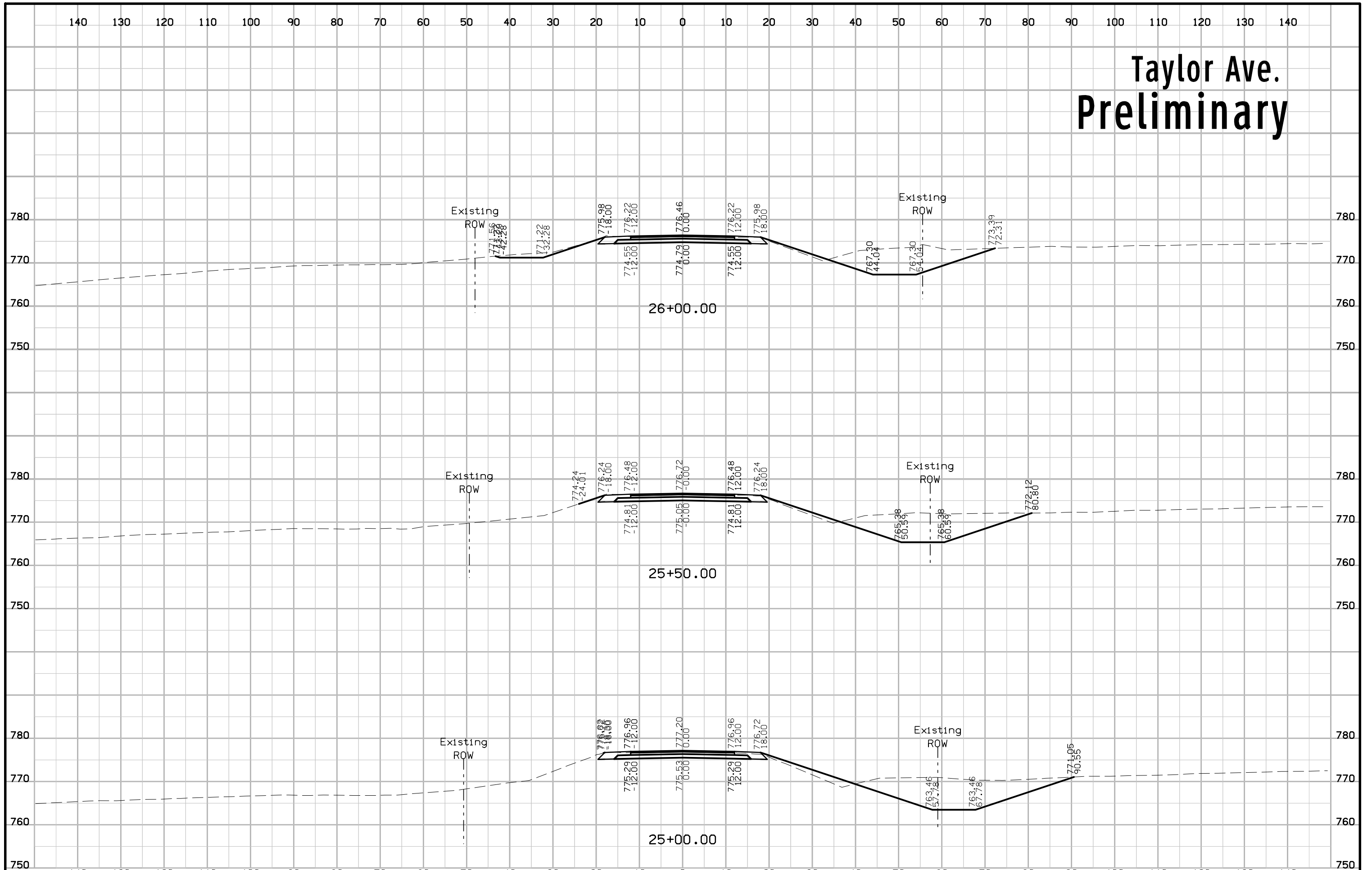

# Taylor Ave. Preliminary

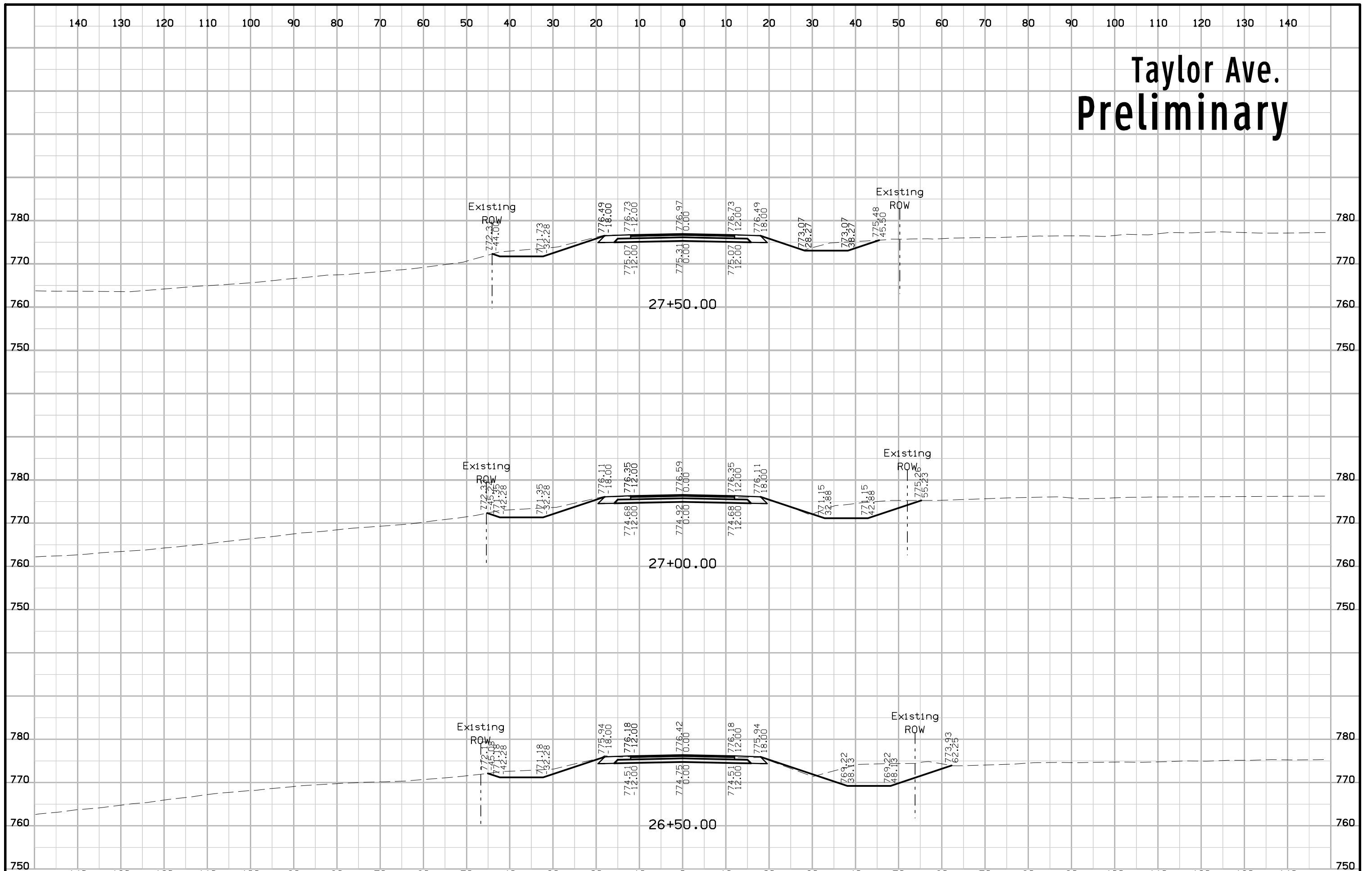

# Taylor Ave. Preliminary

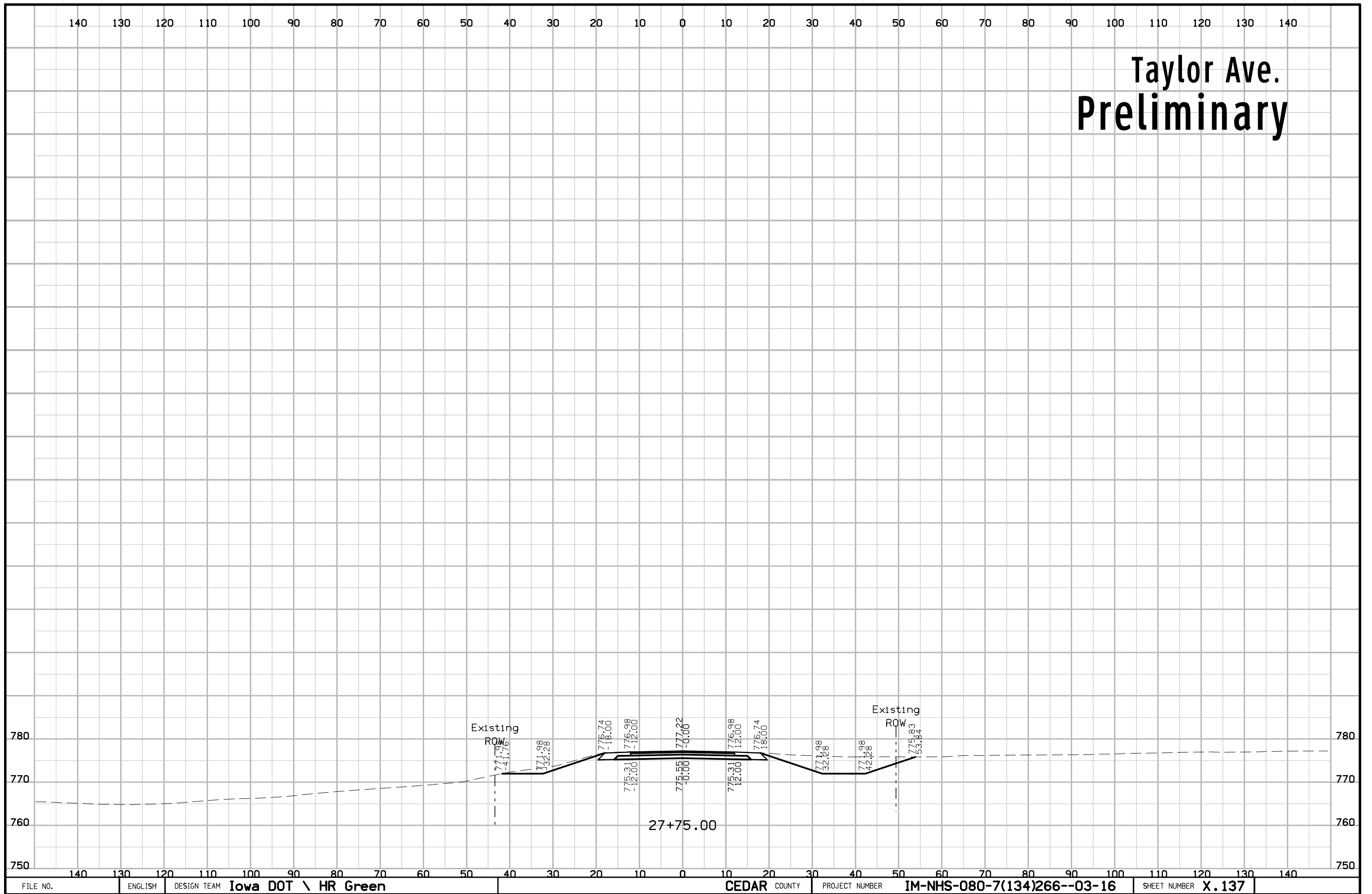

# Vermont Ave. Preliminary

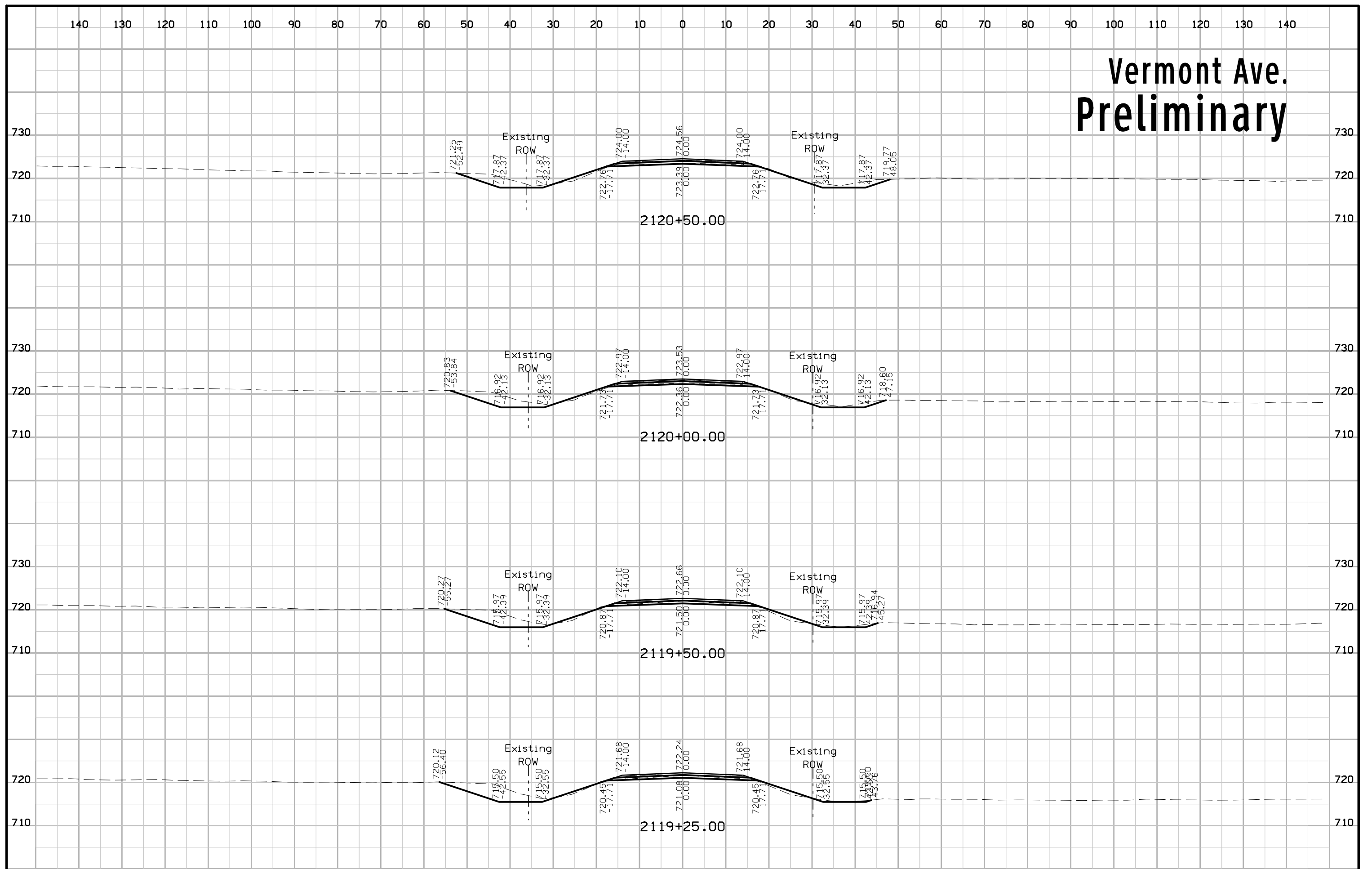



# Vermont Ave. Preliminary

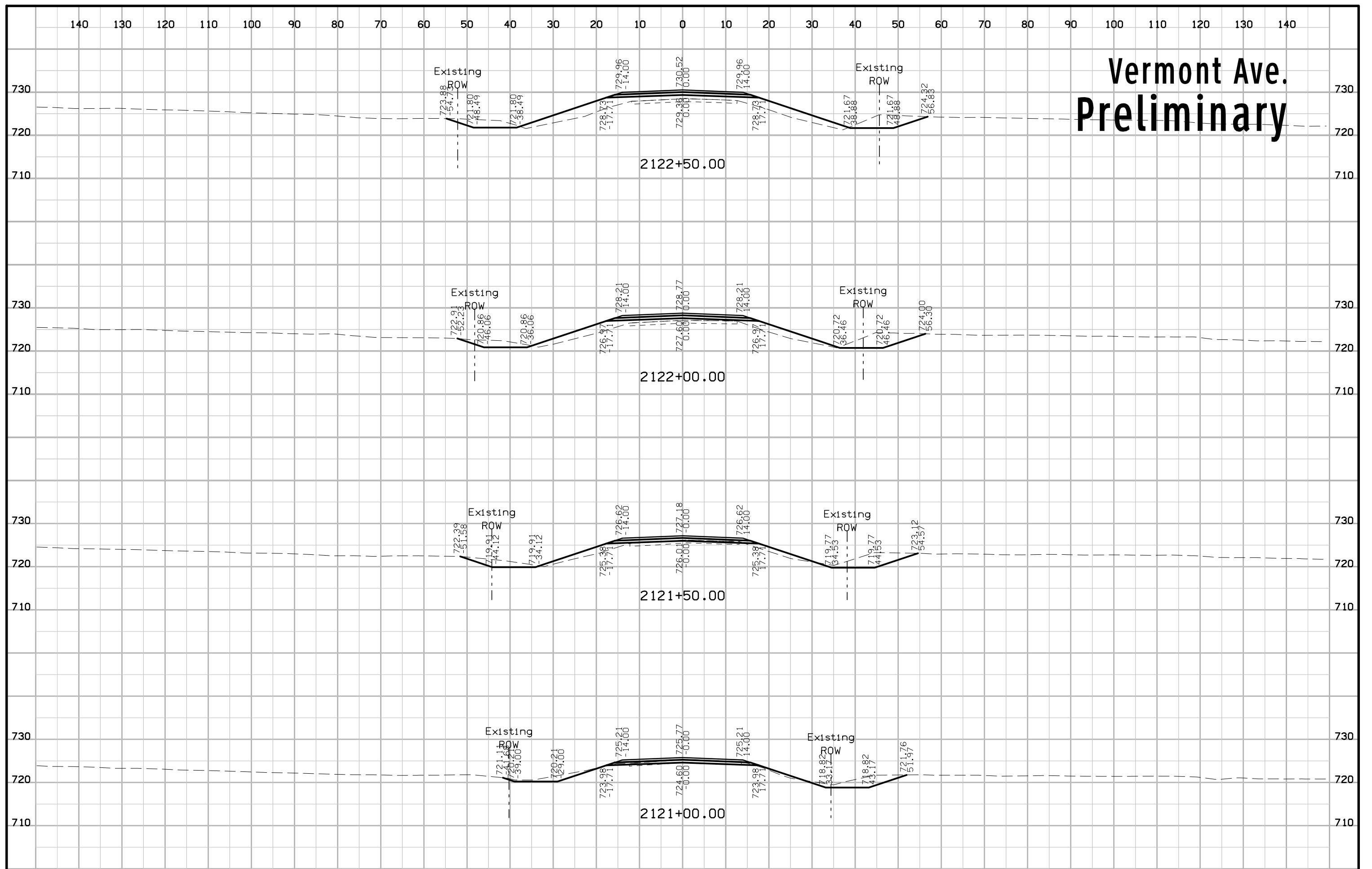

# Vermont Ave. Preliminary

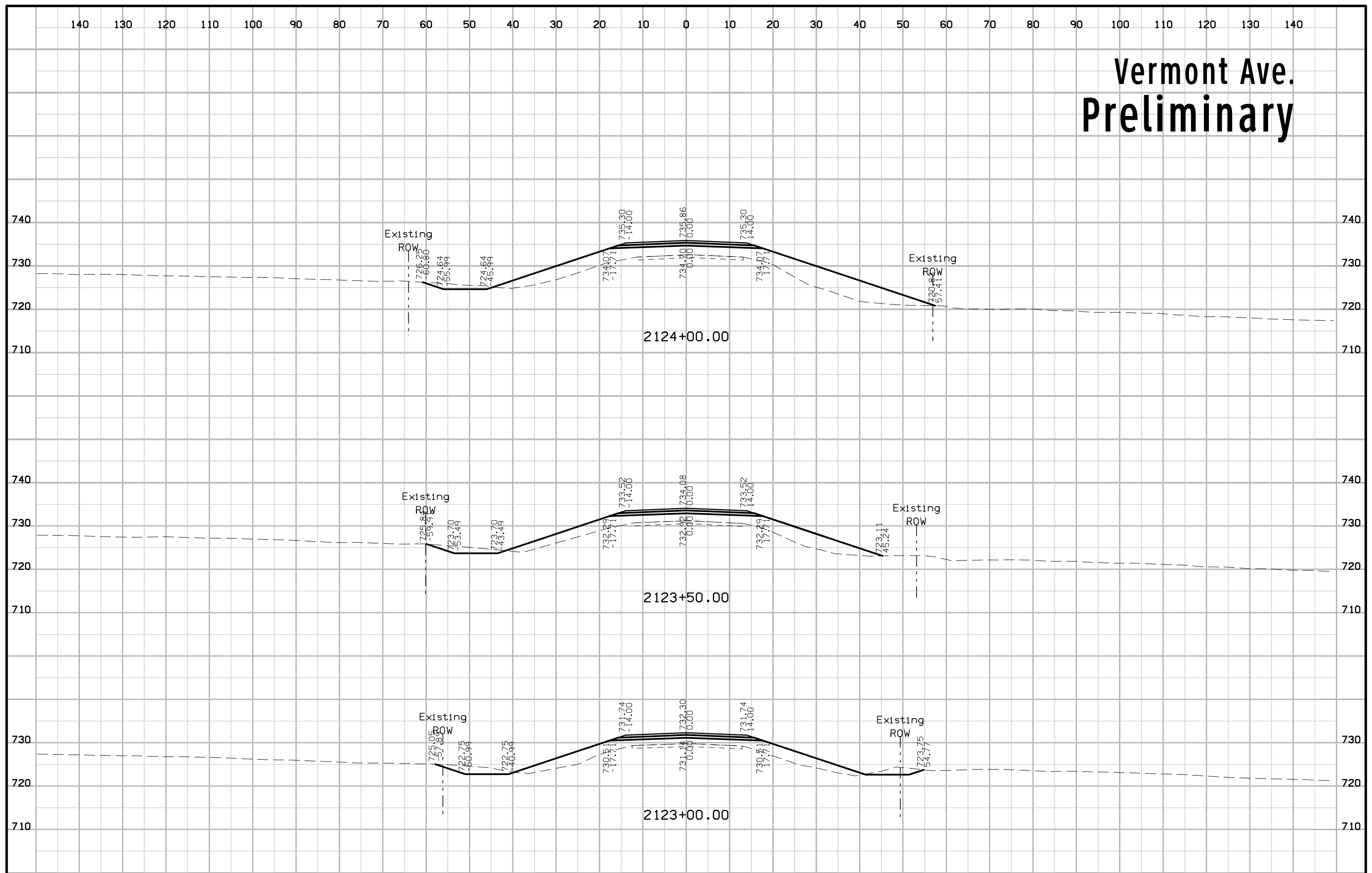

# Vermont Ave. Preliminary

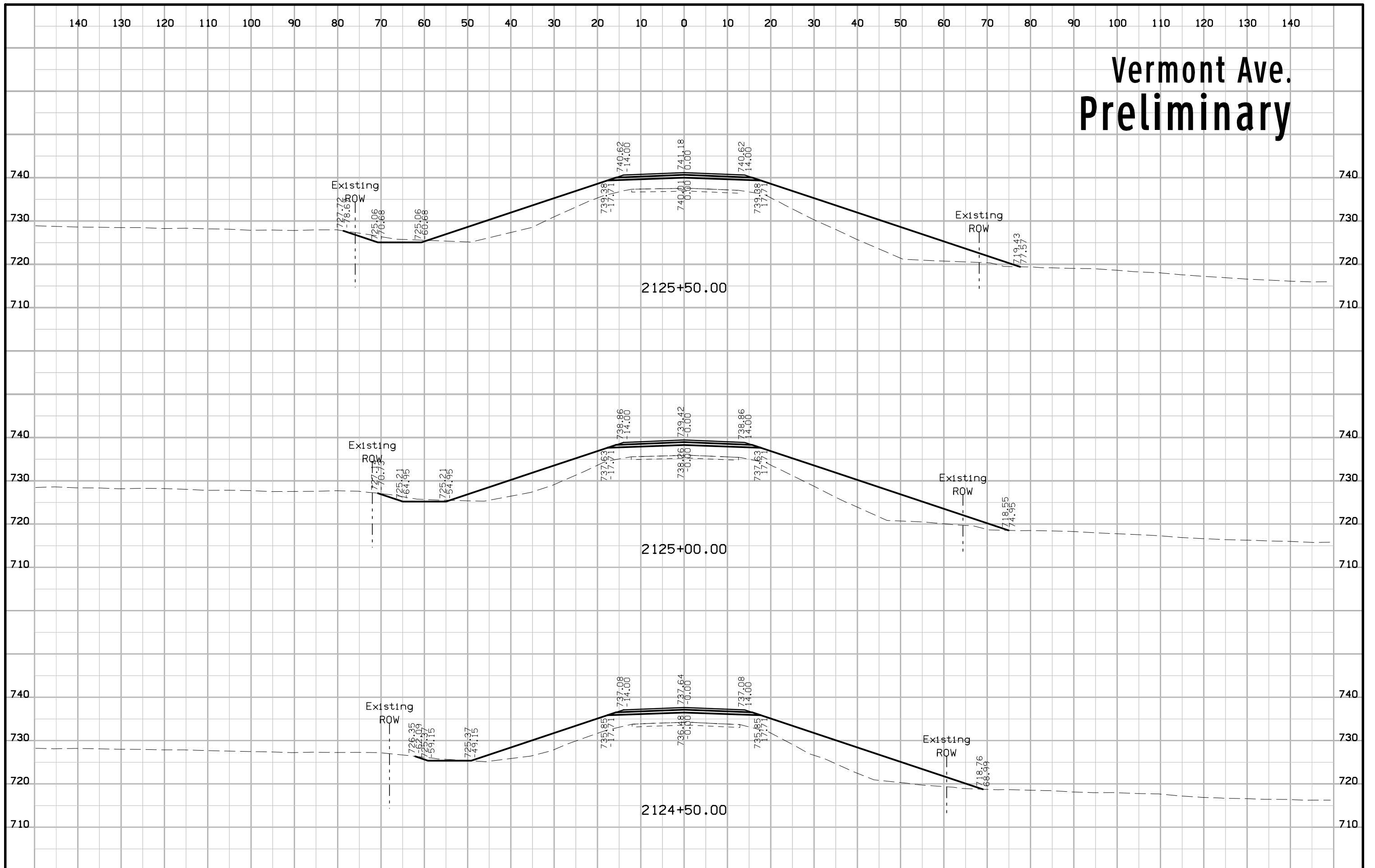

# Vermont Ave. Preliminary

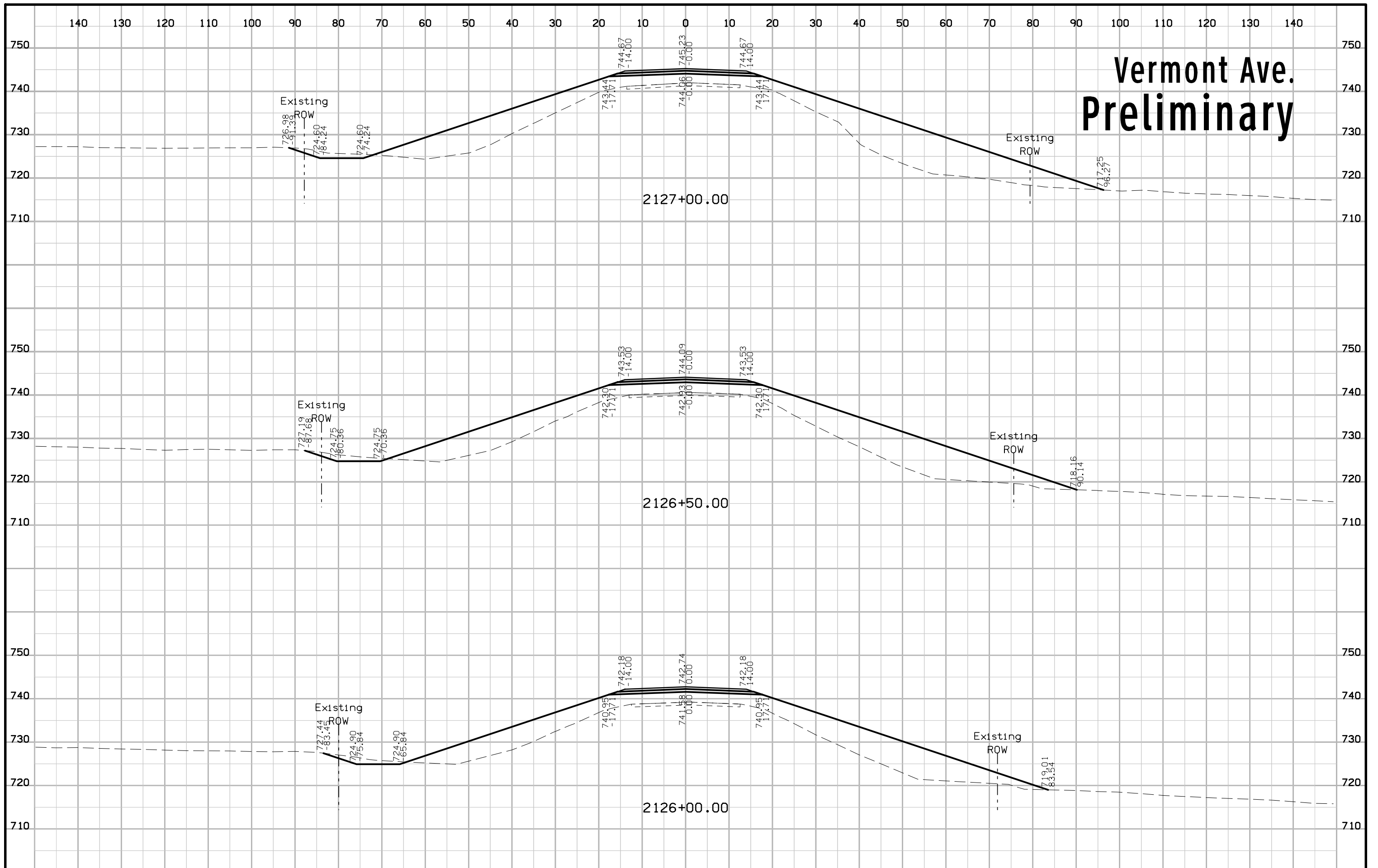

# Vermont Ave. Preliminary

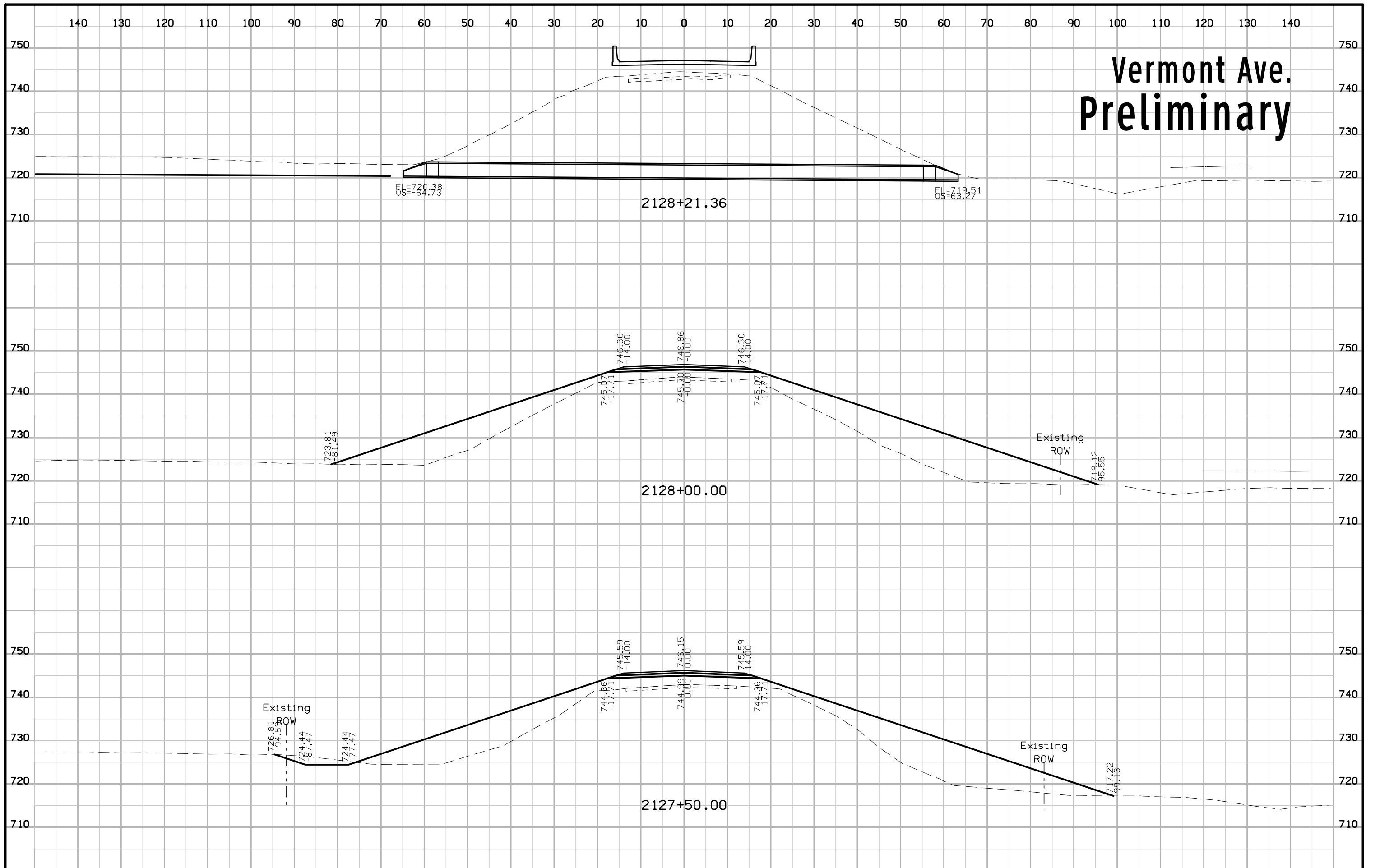

# Vermont Ave. Preliminary

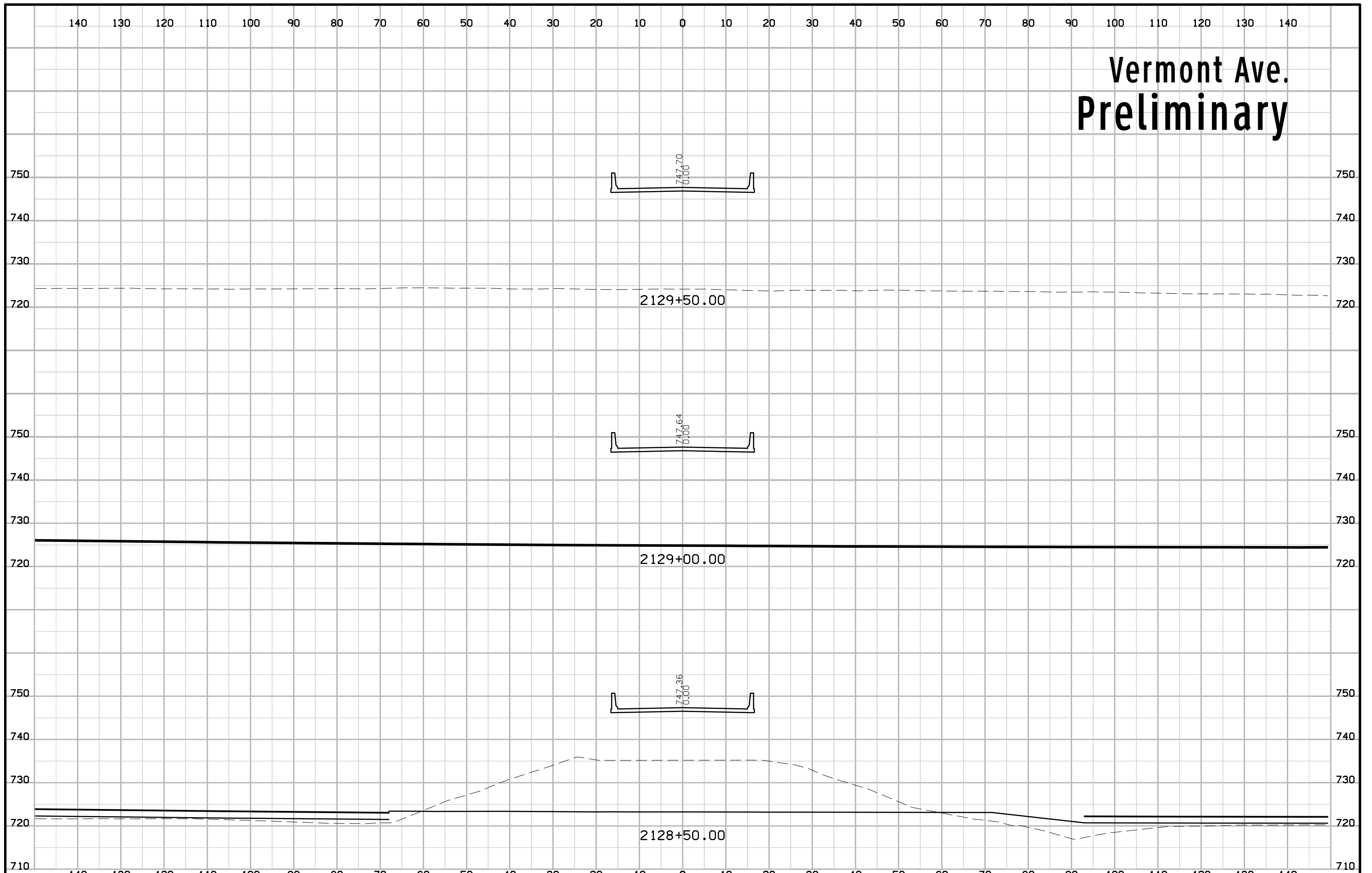

# Vermont Ave. Preliminary

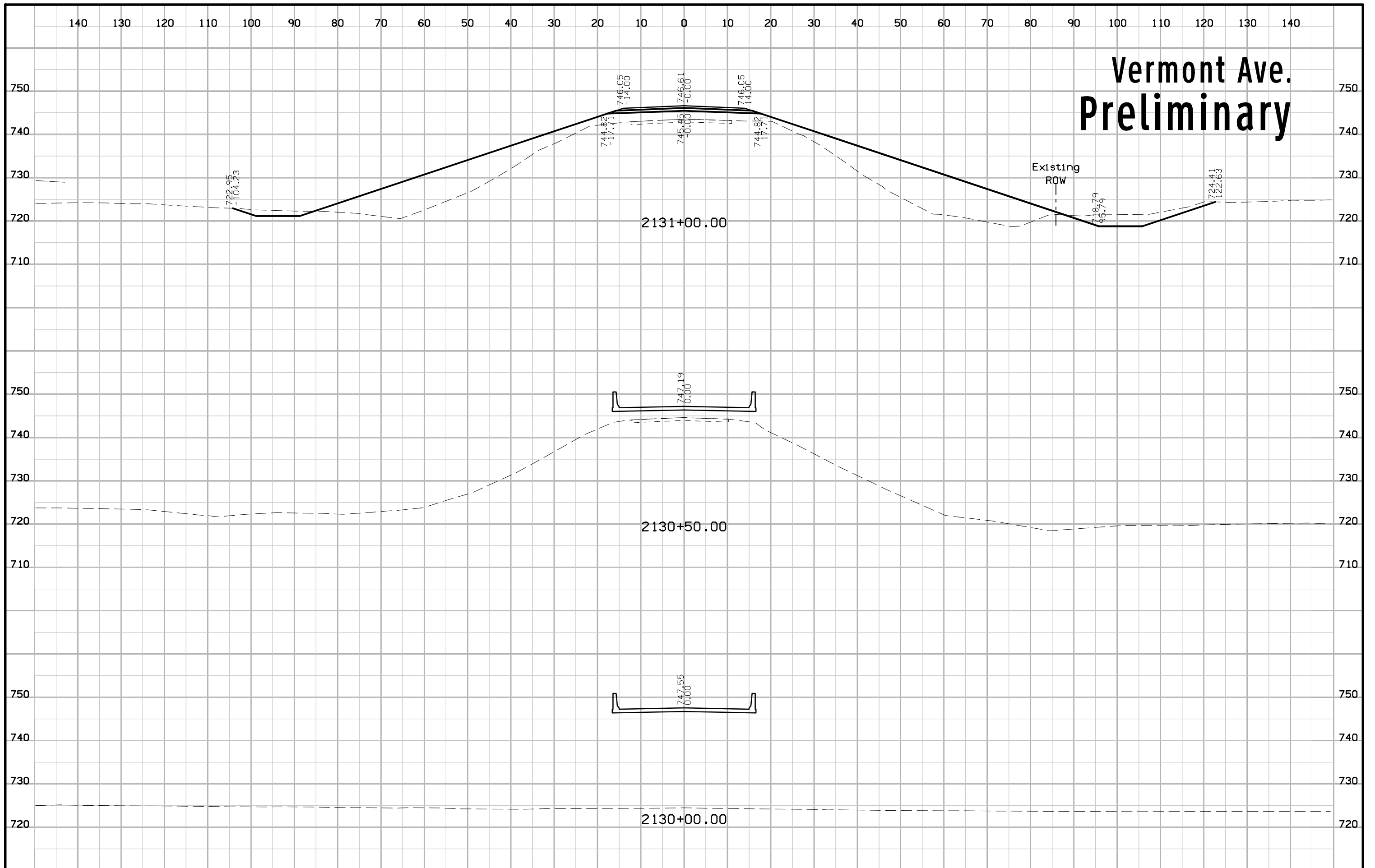

# Vermont Ave. Preliminary

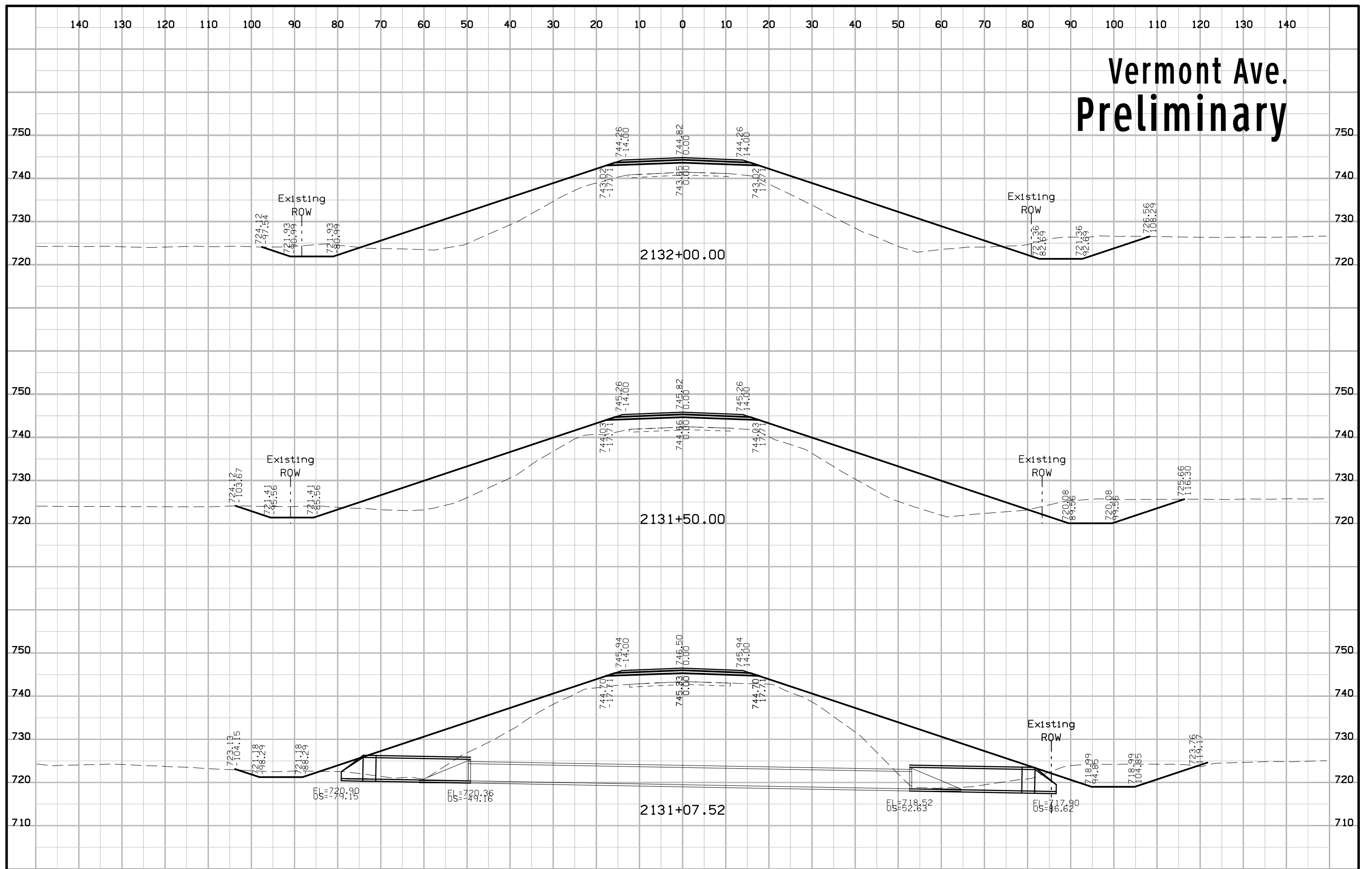



# Vermont Ave. Preliminary

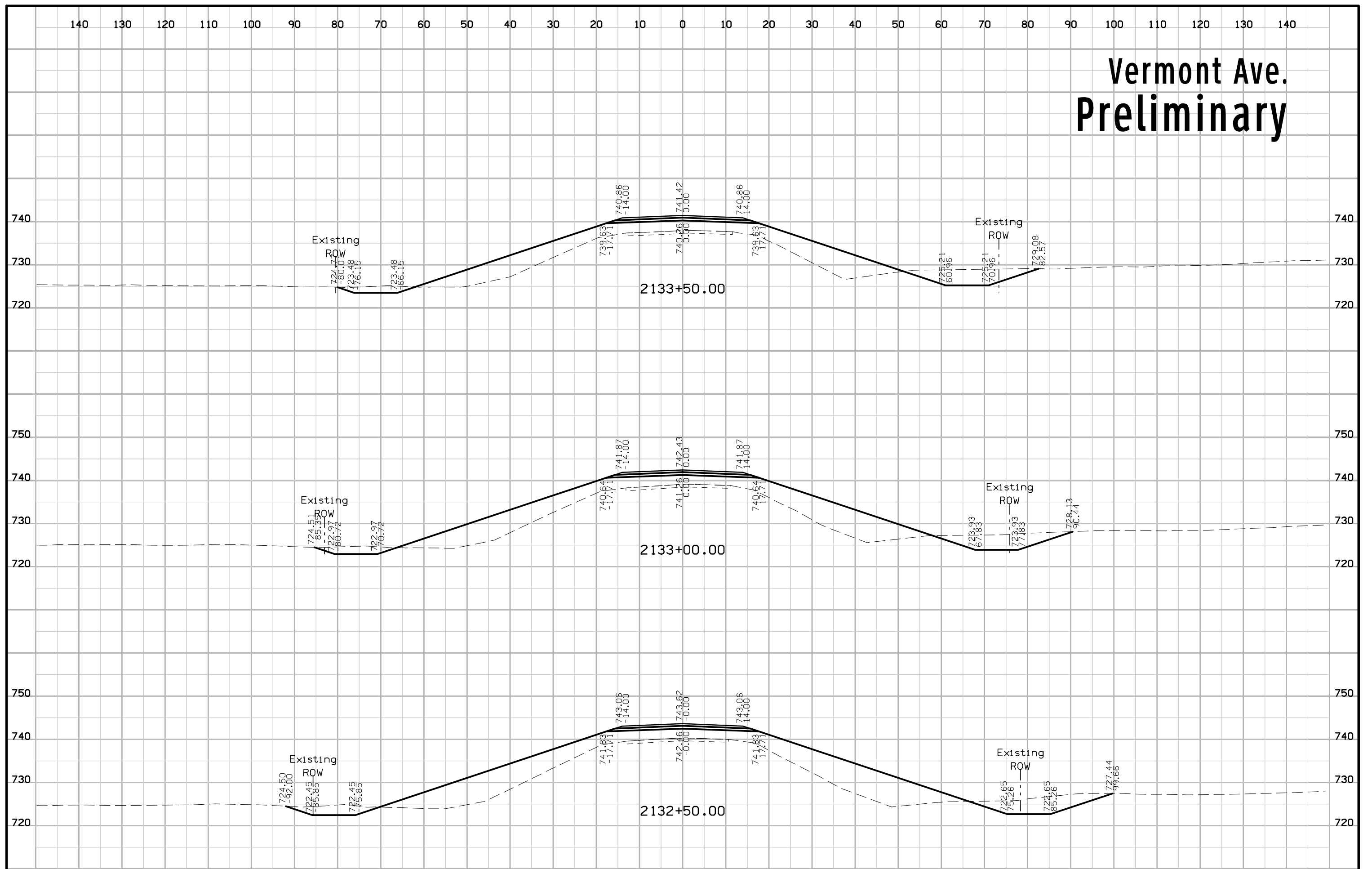

# Vermont Ave. Preliminary

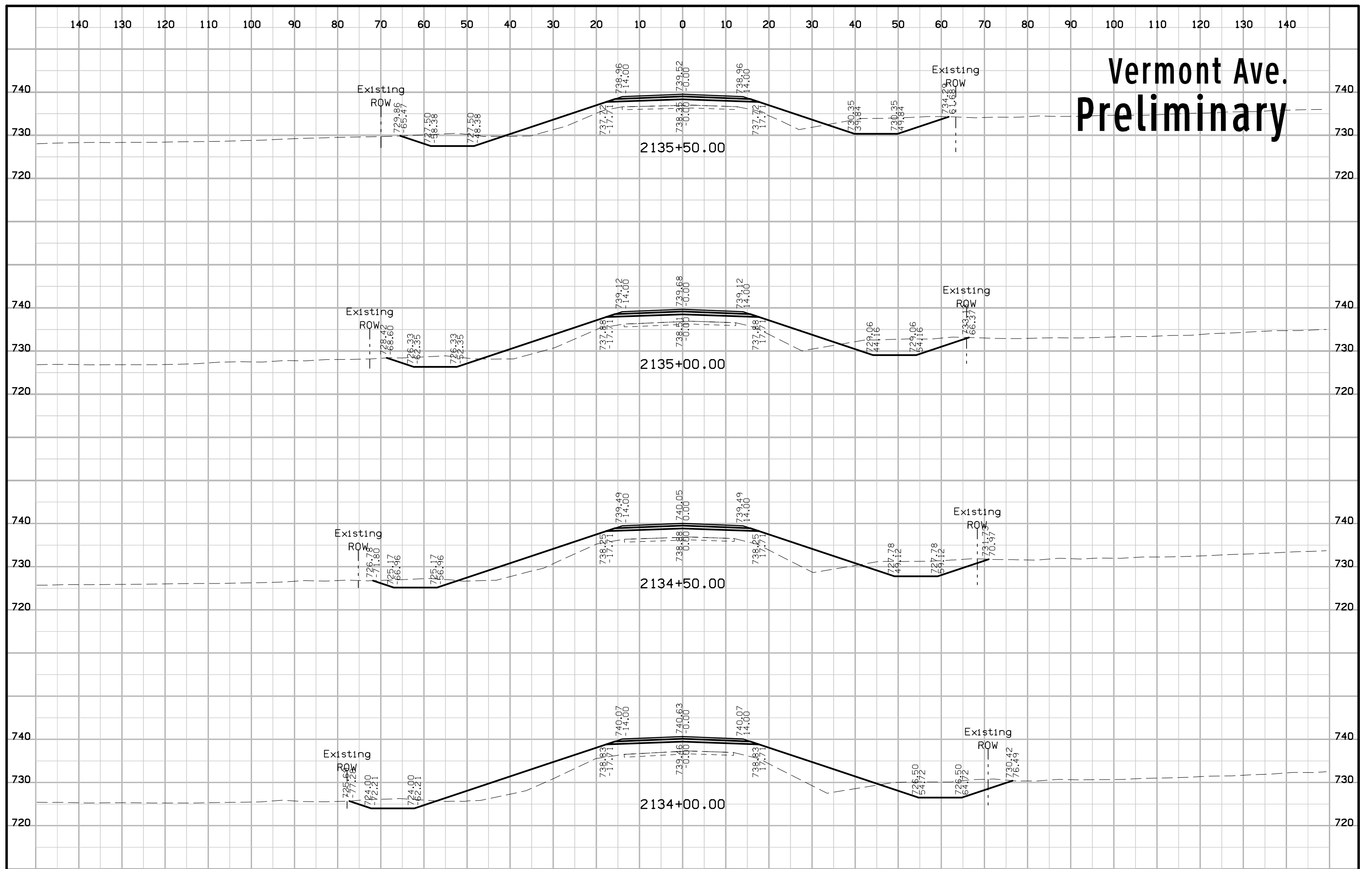

# Vermont Ave. Preliminary

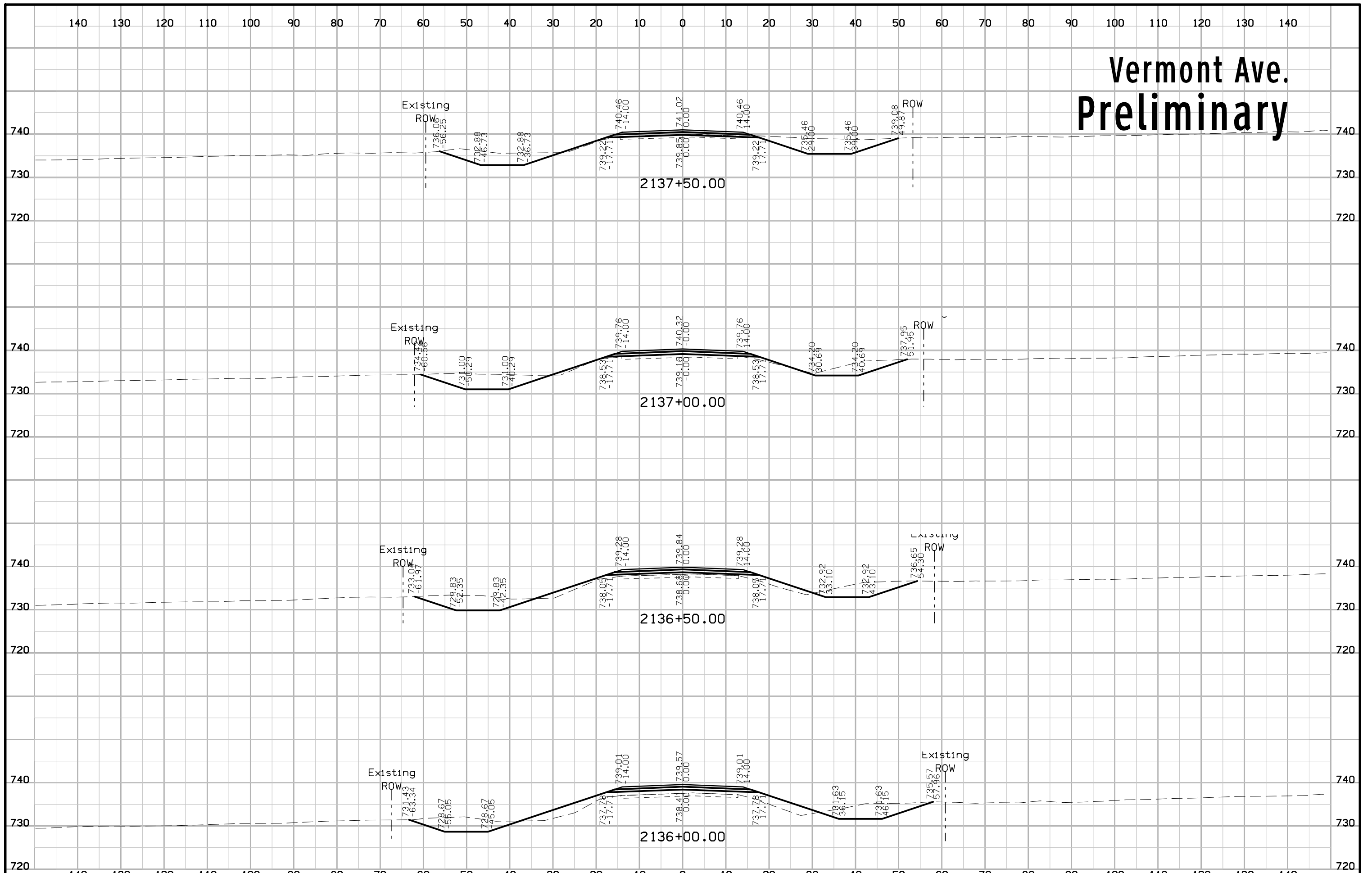

# Vermont Ave. Preliminary

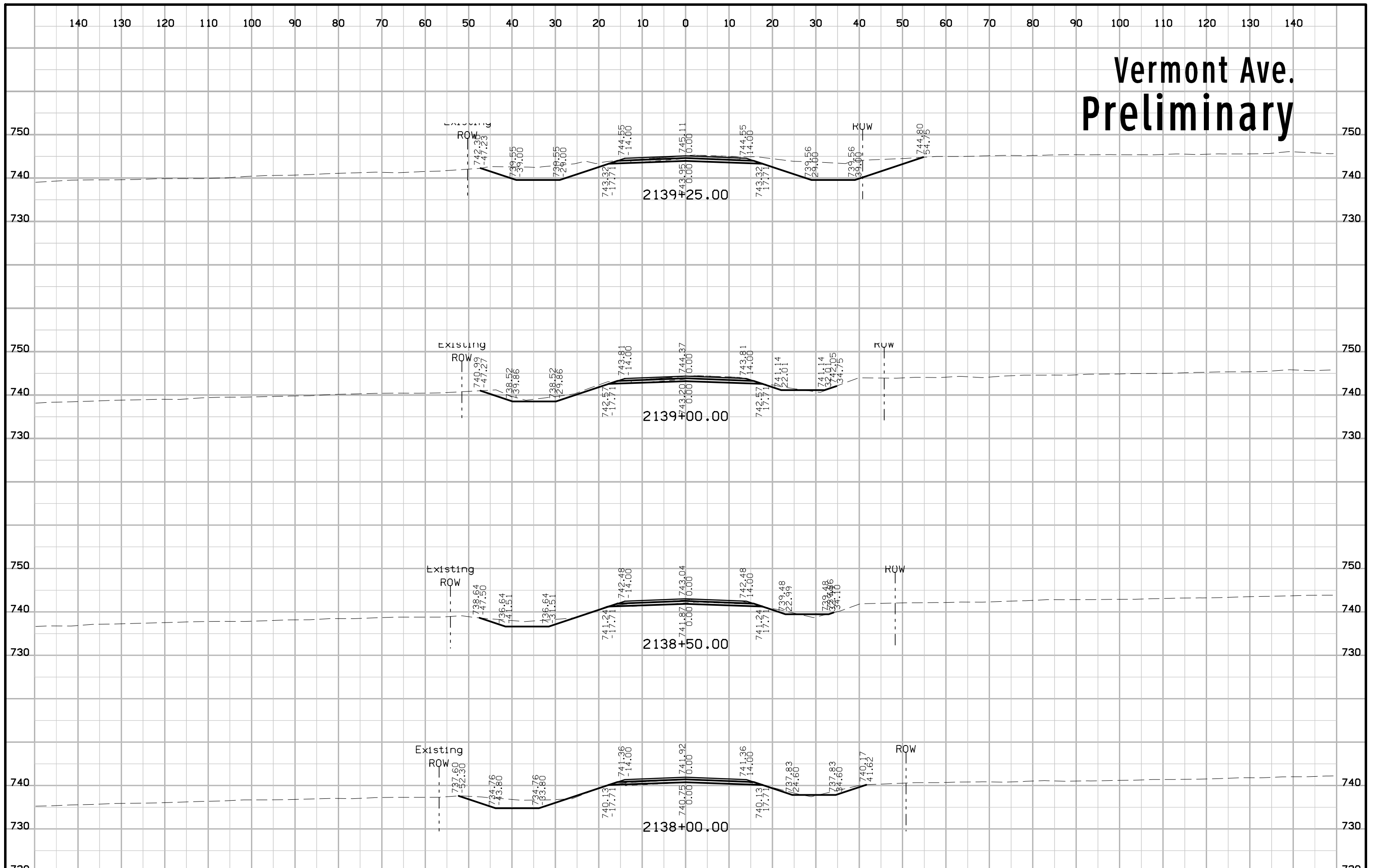

# Yankee Ave. Preliminary

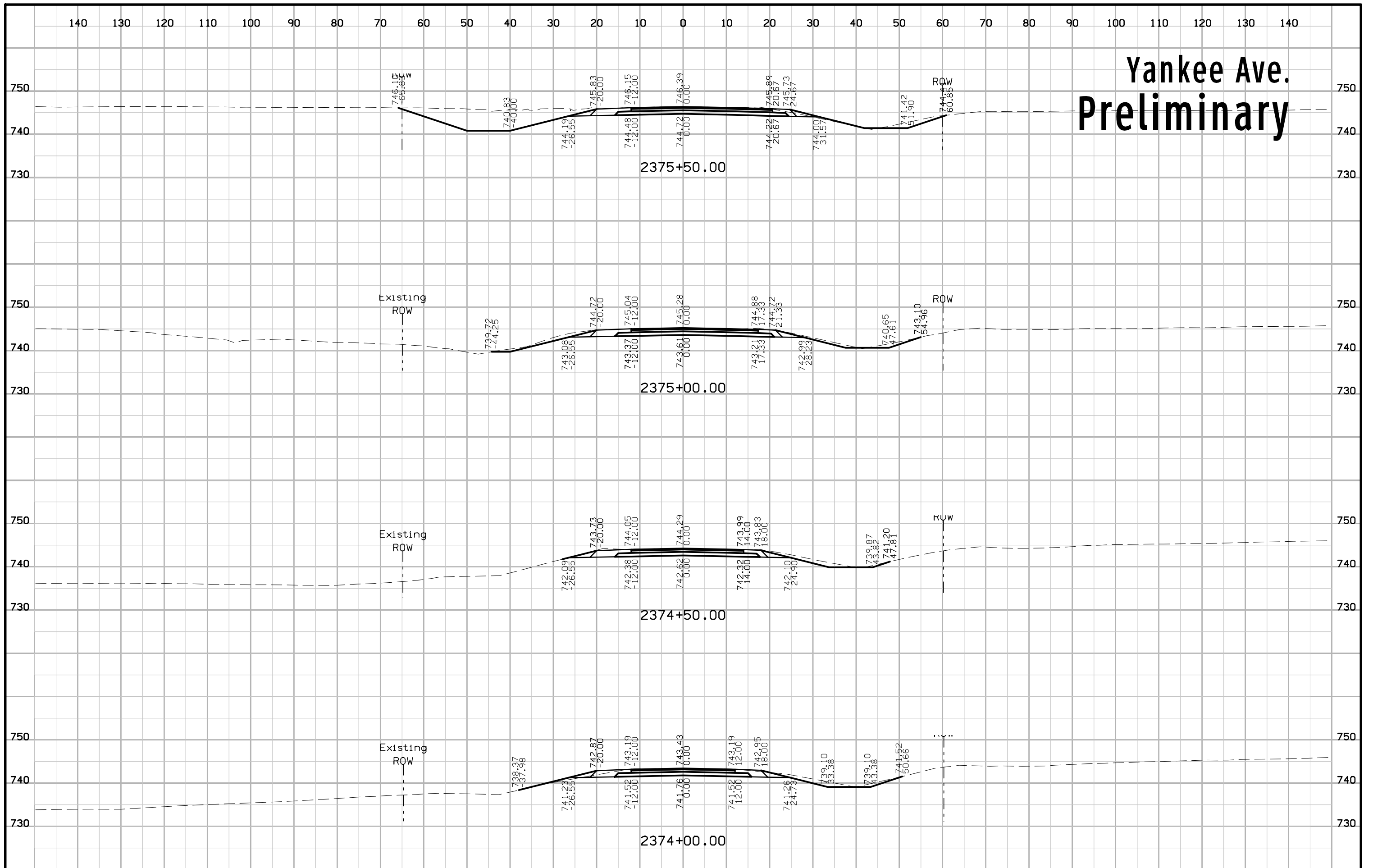

# Yankee Ave. Preliminary

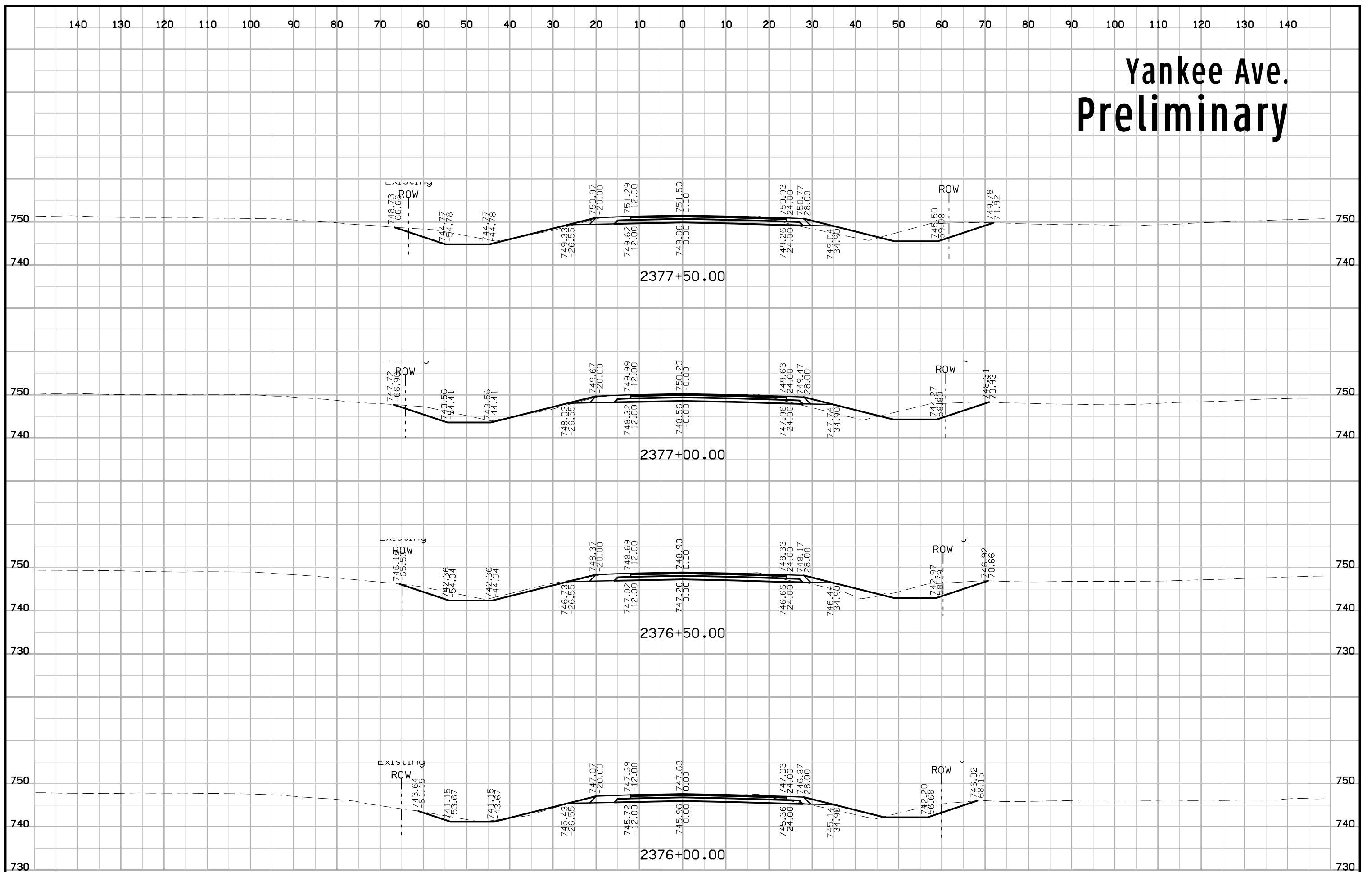

# Yankee Ave. Preliminary

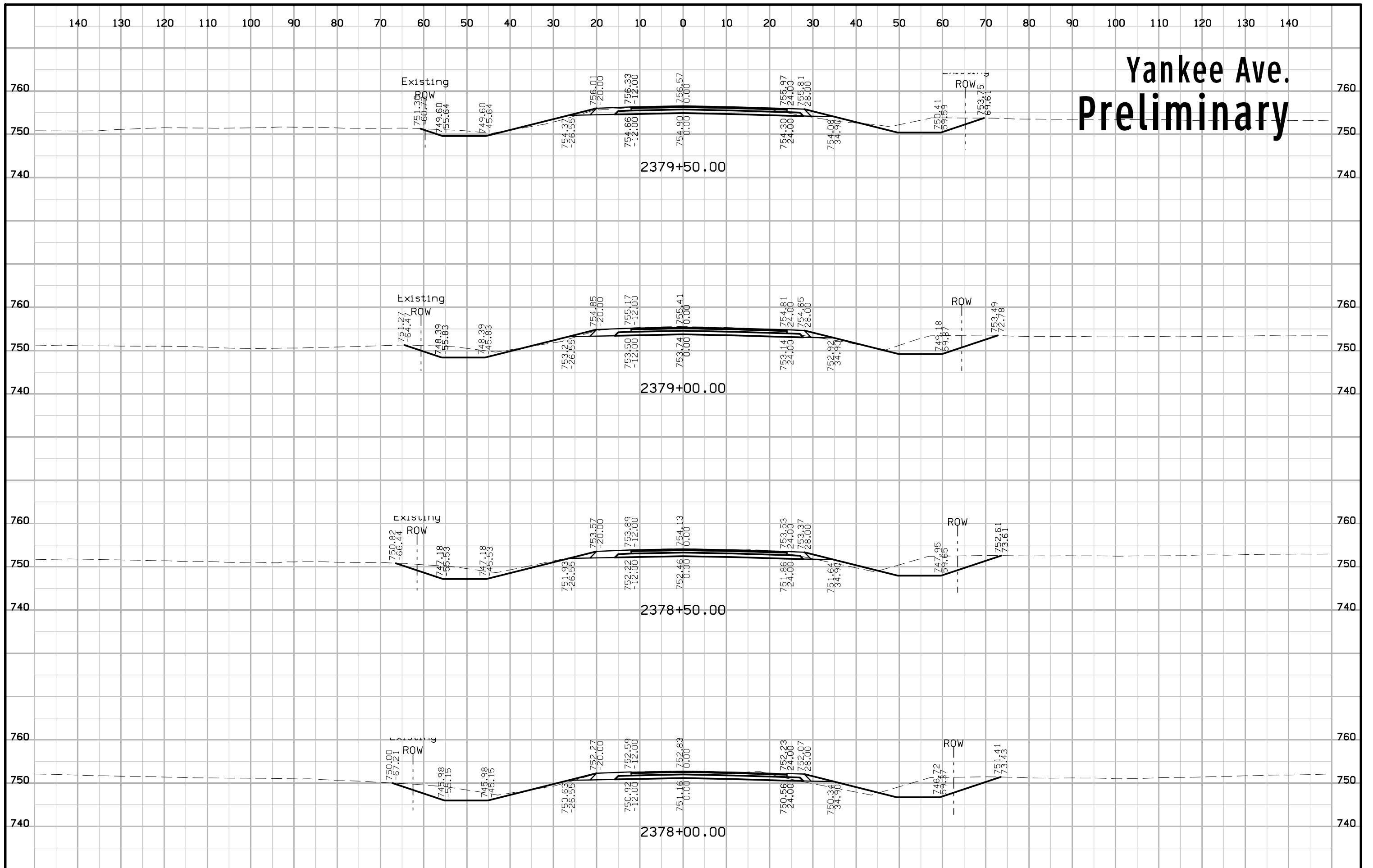

# Yankee Ave. Preliminary

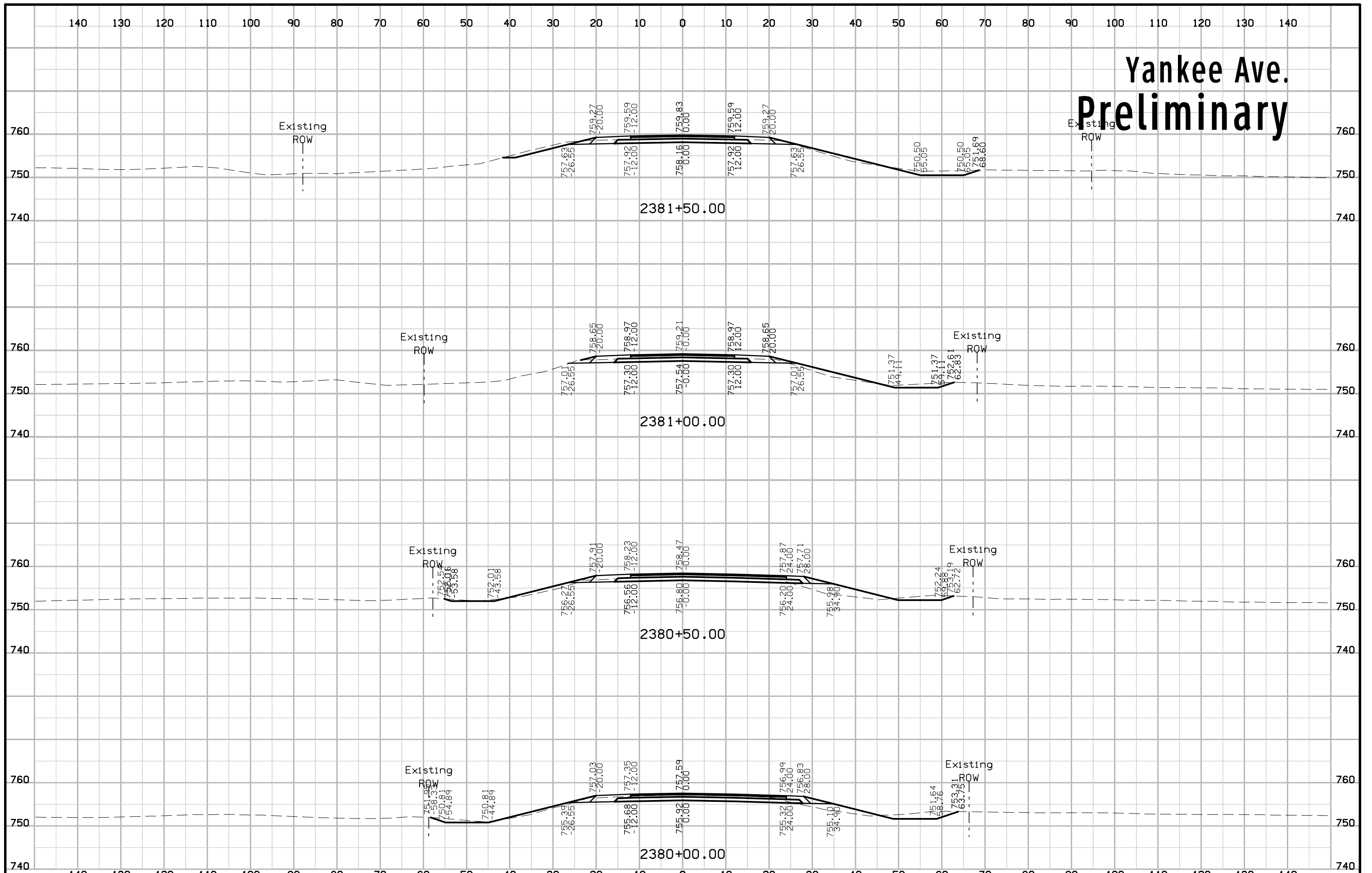



# Yankee Ave. Preliminary

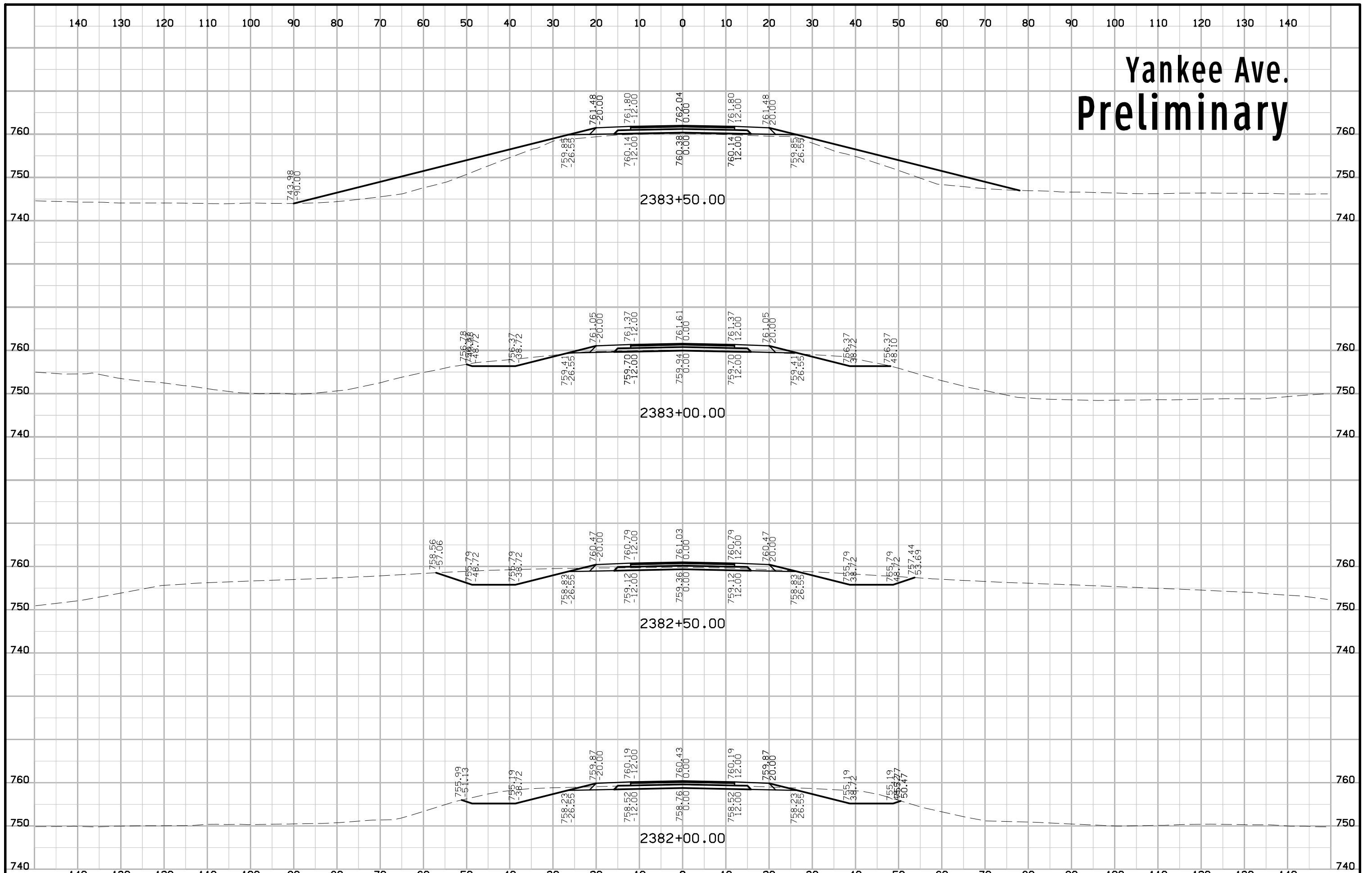

# Yankee Ave. Preliminary

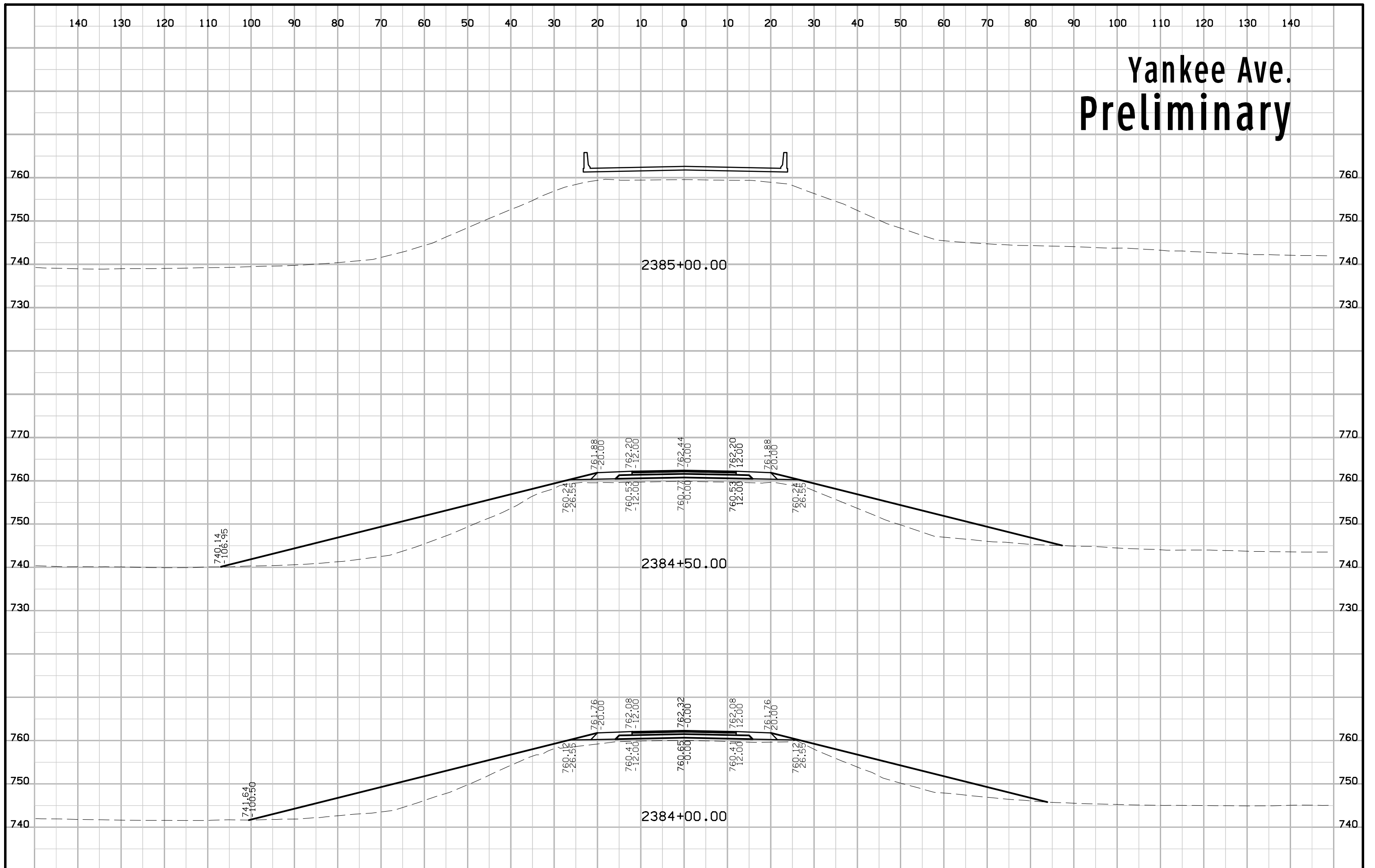

# Yankee Ave. Preliminary

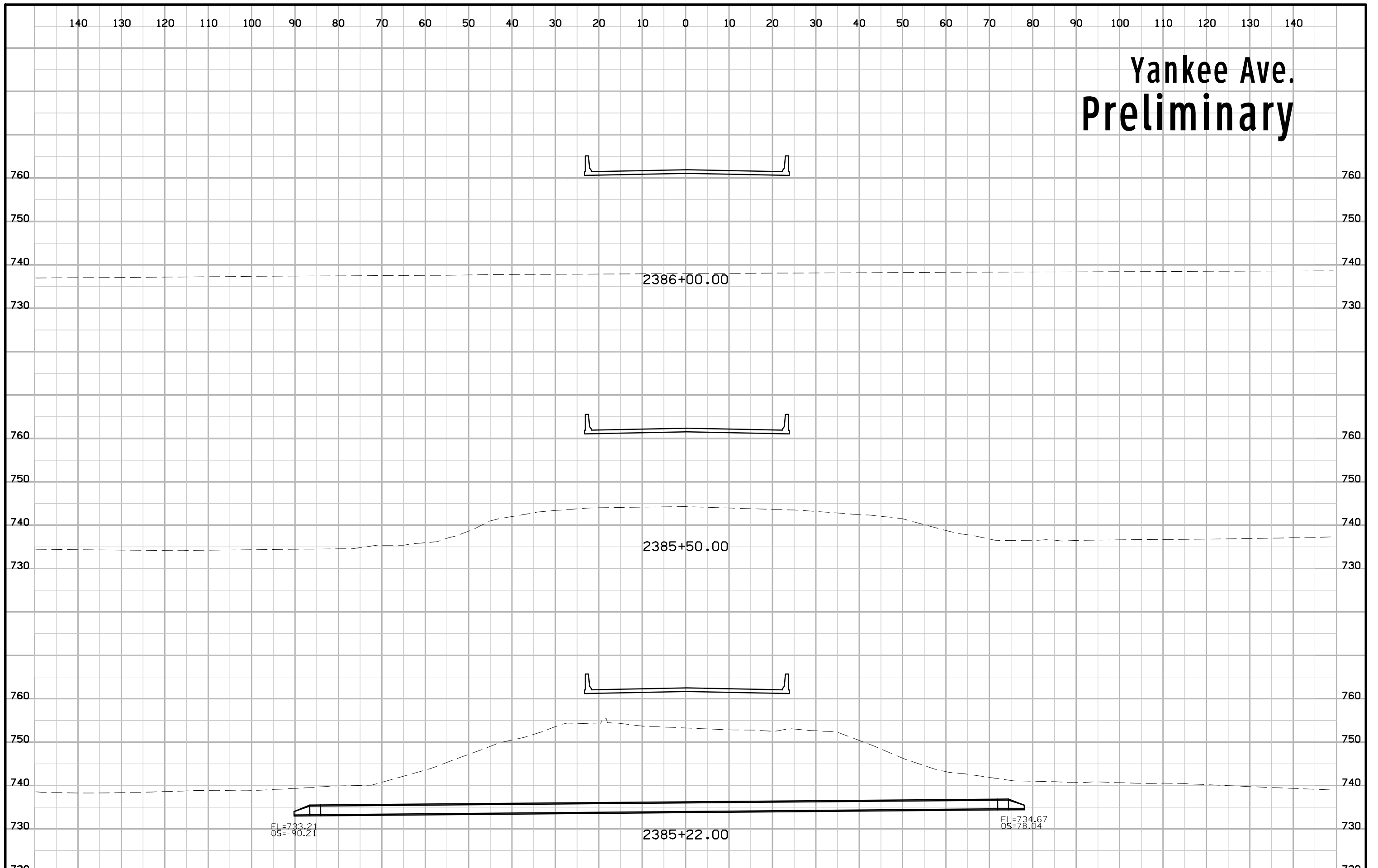

# Yankee Ave. Preliminary

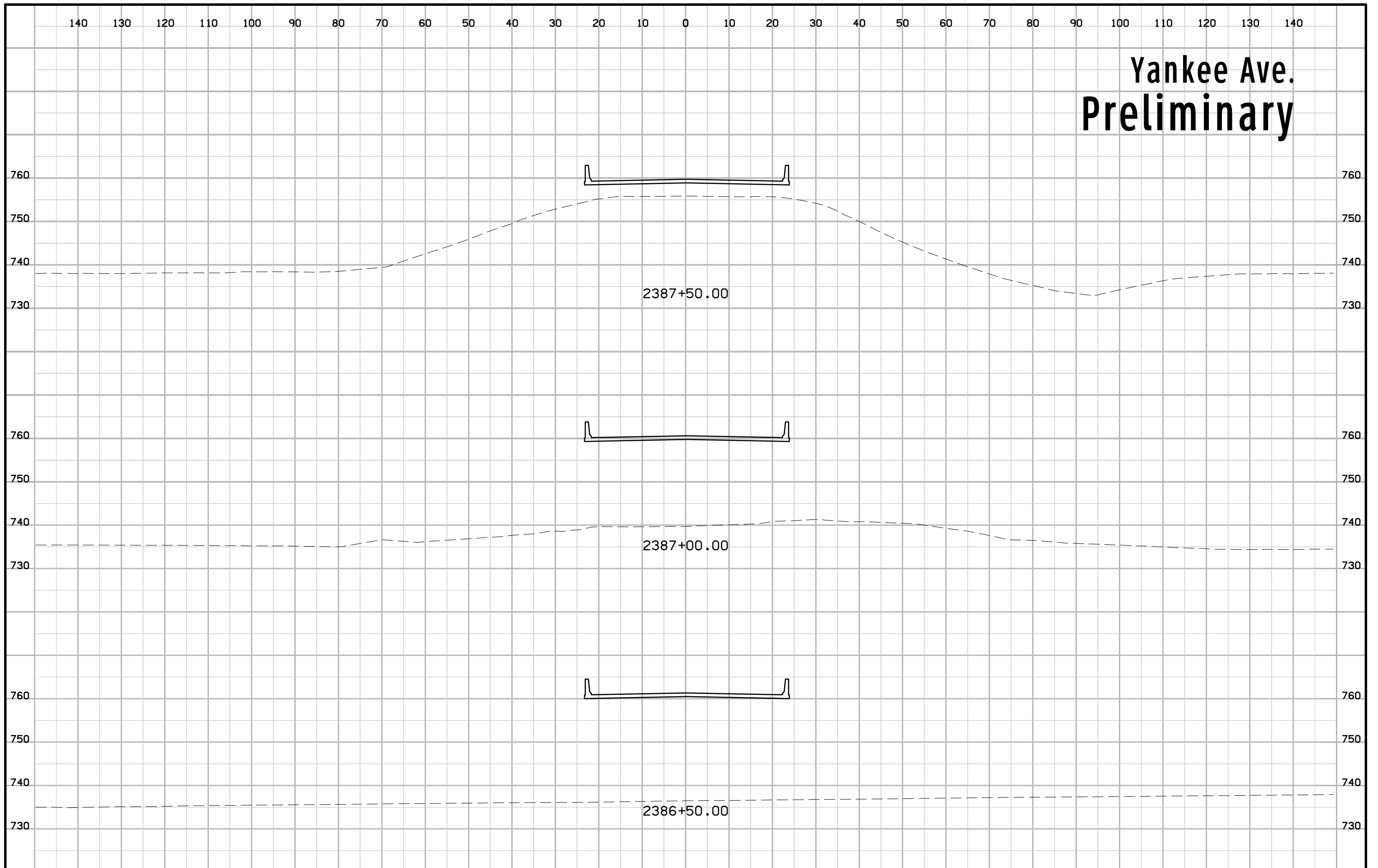

# Yankee Ave. Preliminary

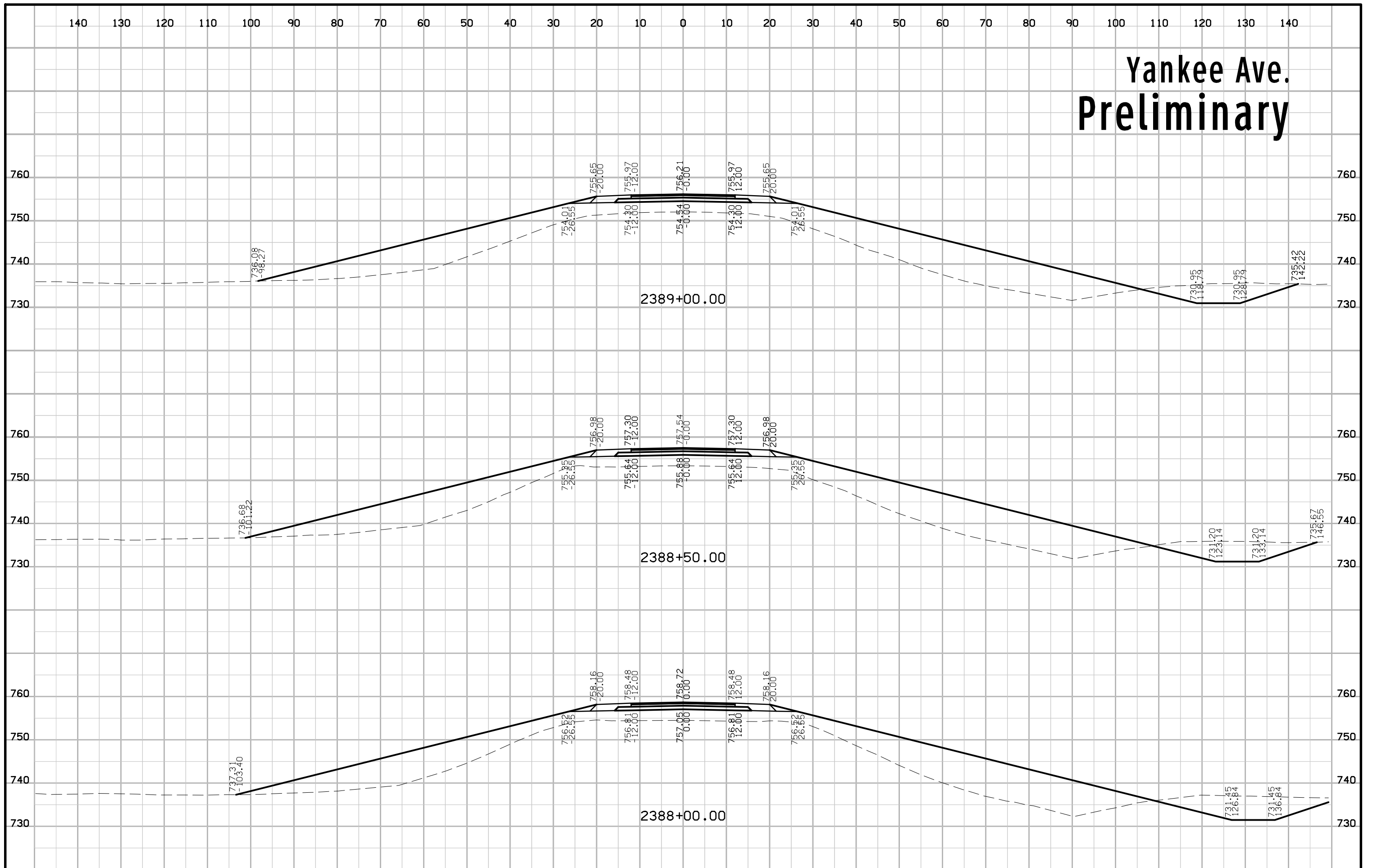

# Yankee Ave. Preliminary

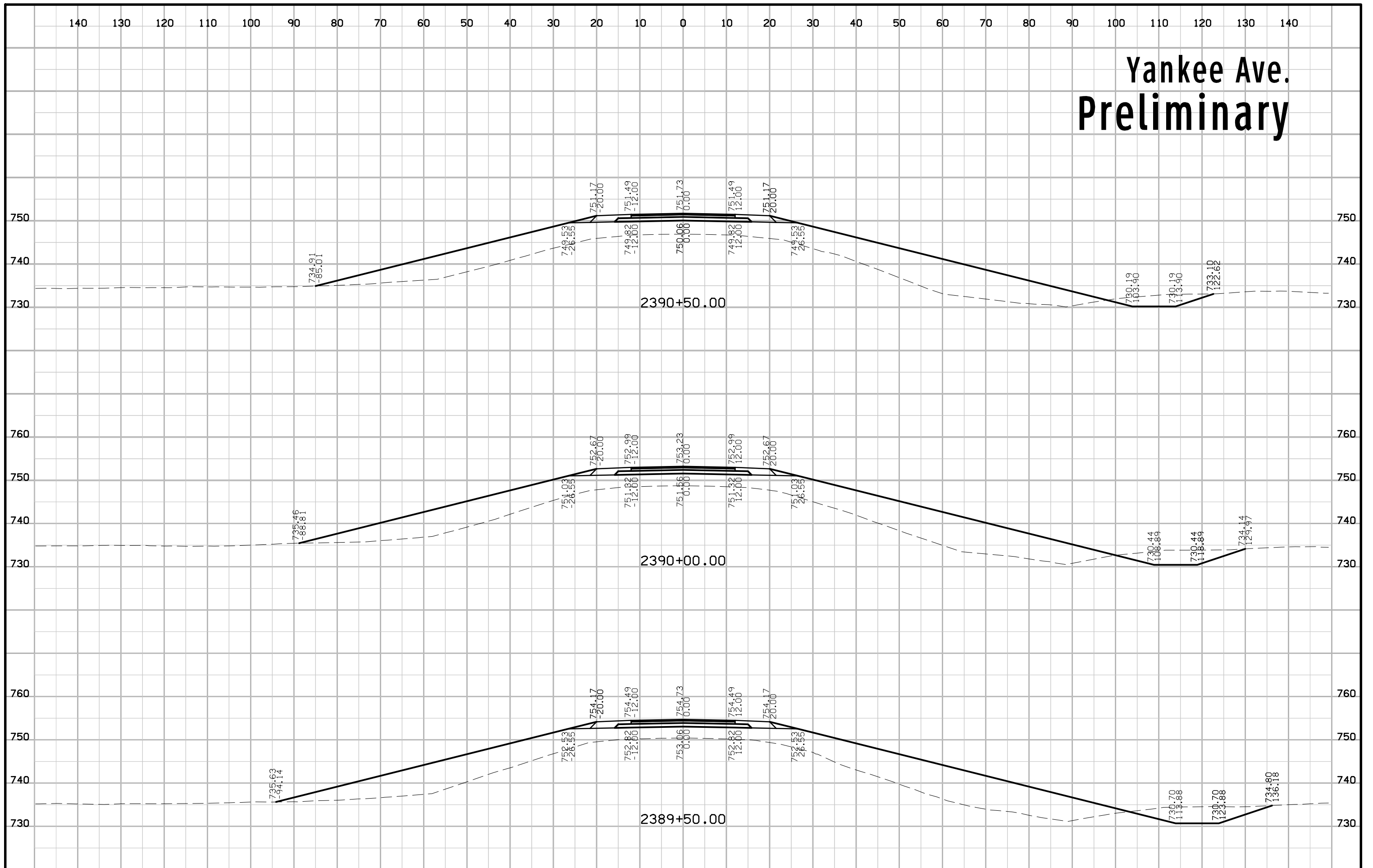

# Yankee Ave. Preliminary

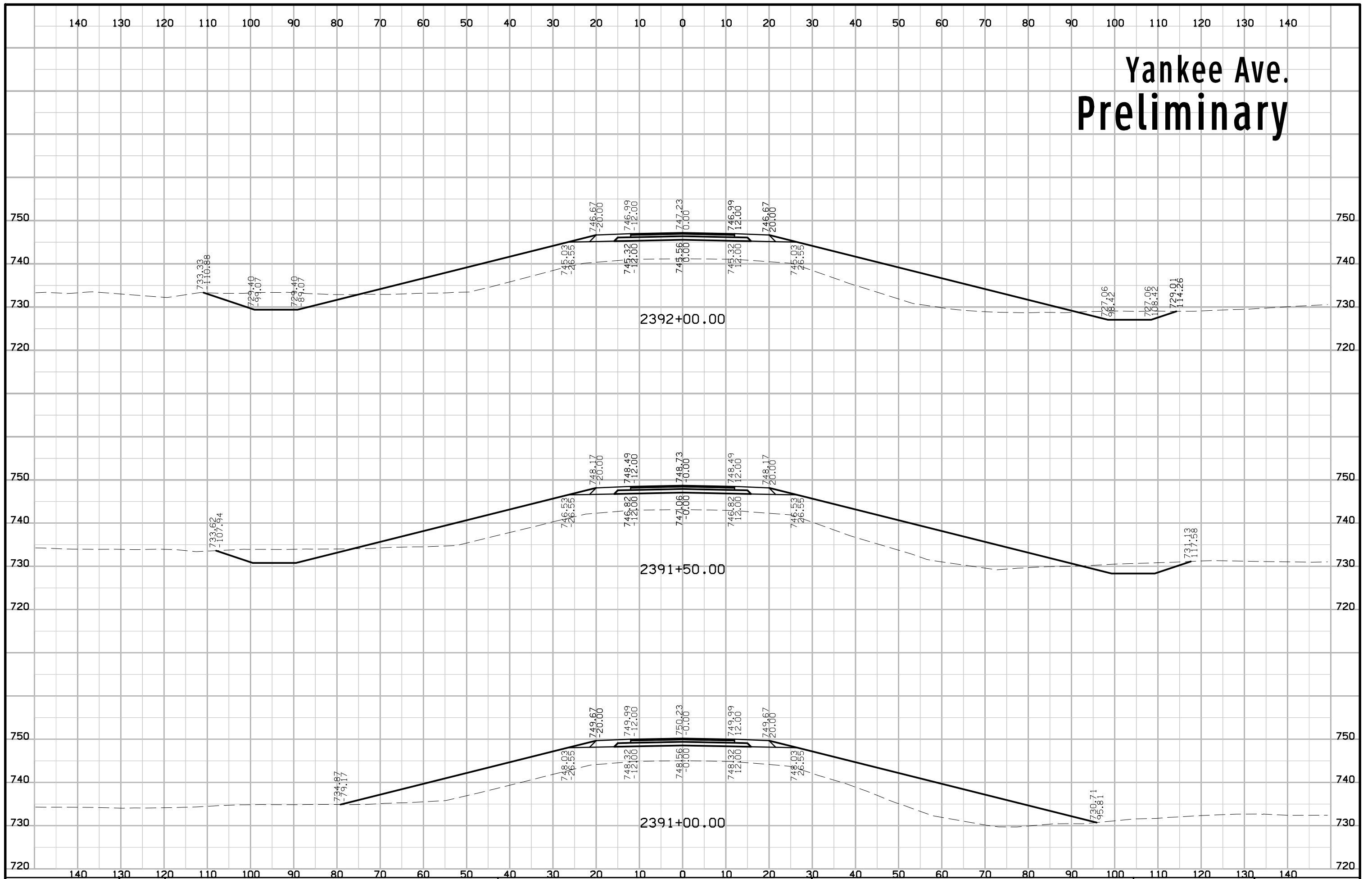

# Yankee Ave. Preliminary

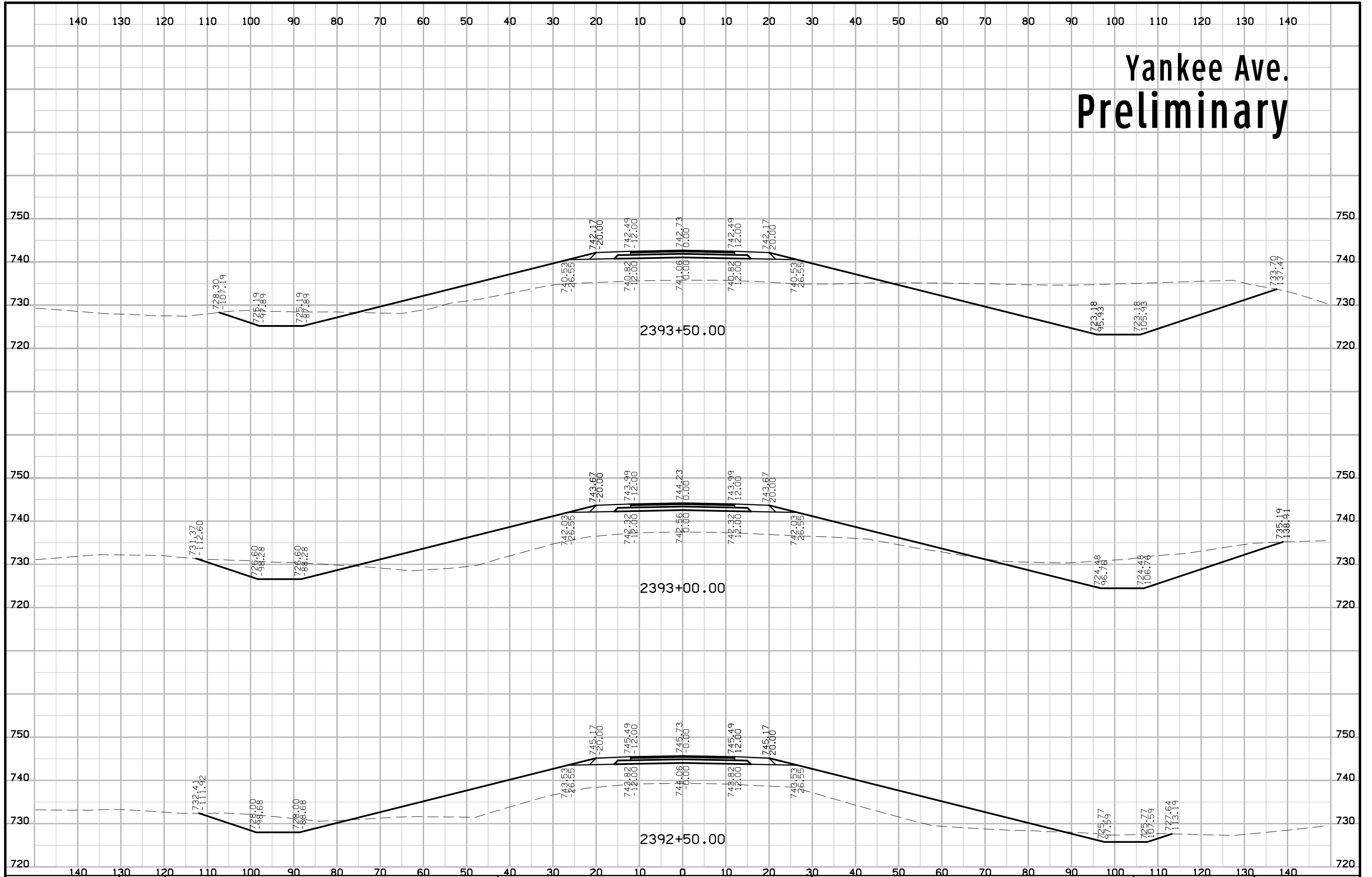



# Yankee Ave. Preliminary

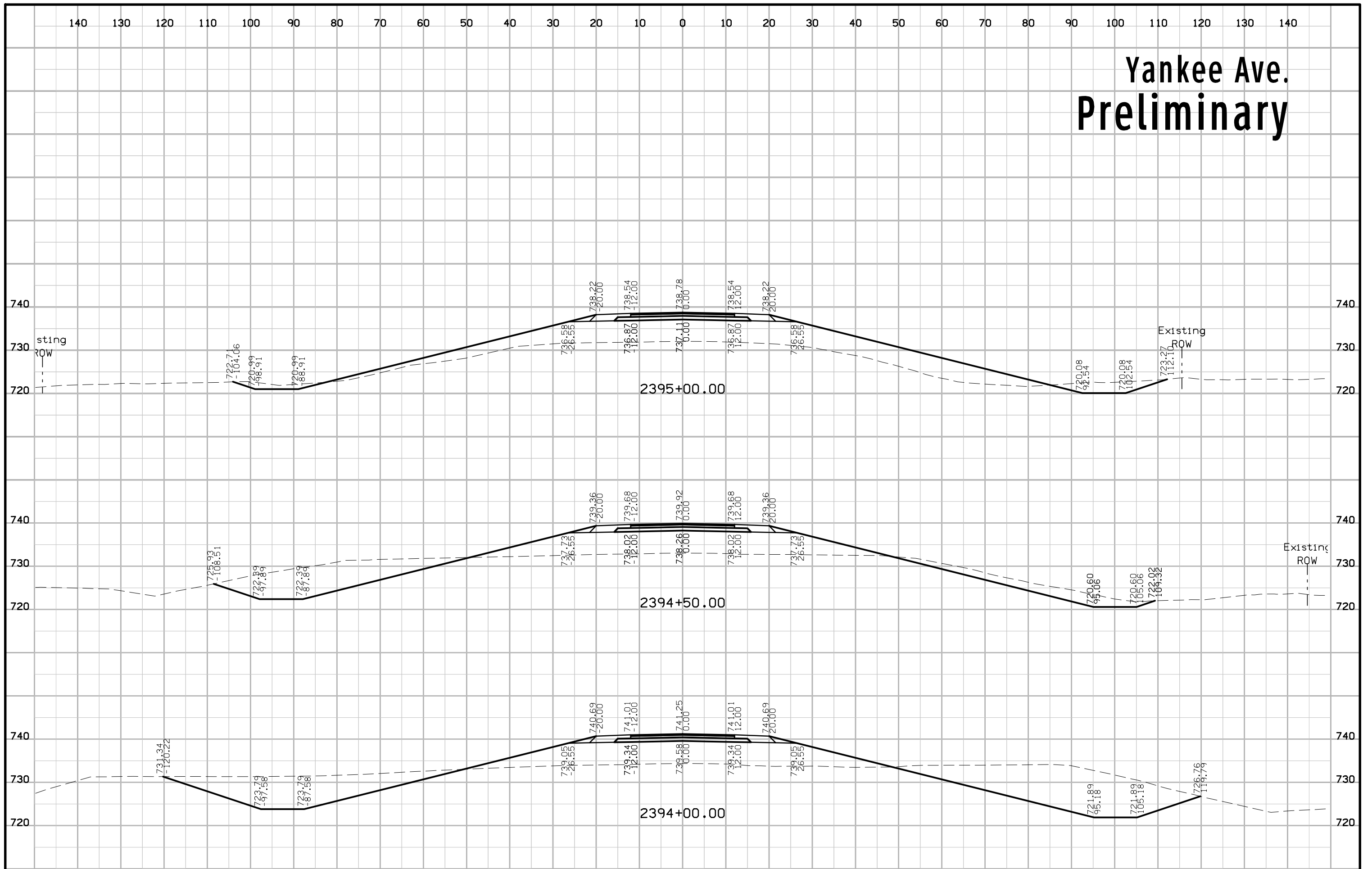

# Yankee Ave. Preliminary

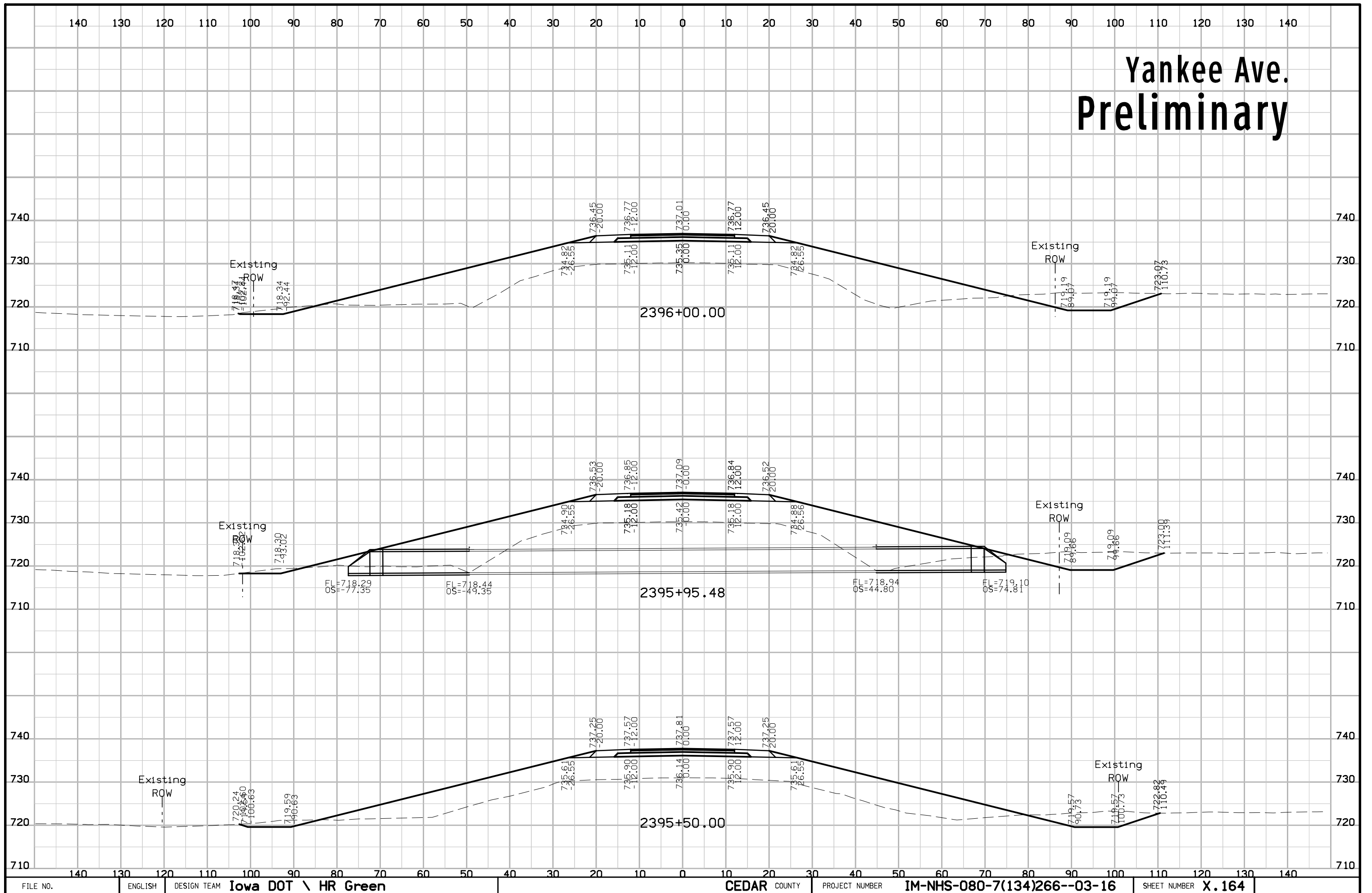

# Yankee Ave. Preliminary

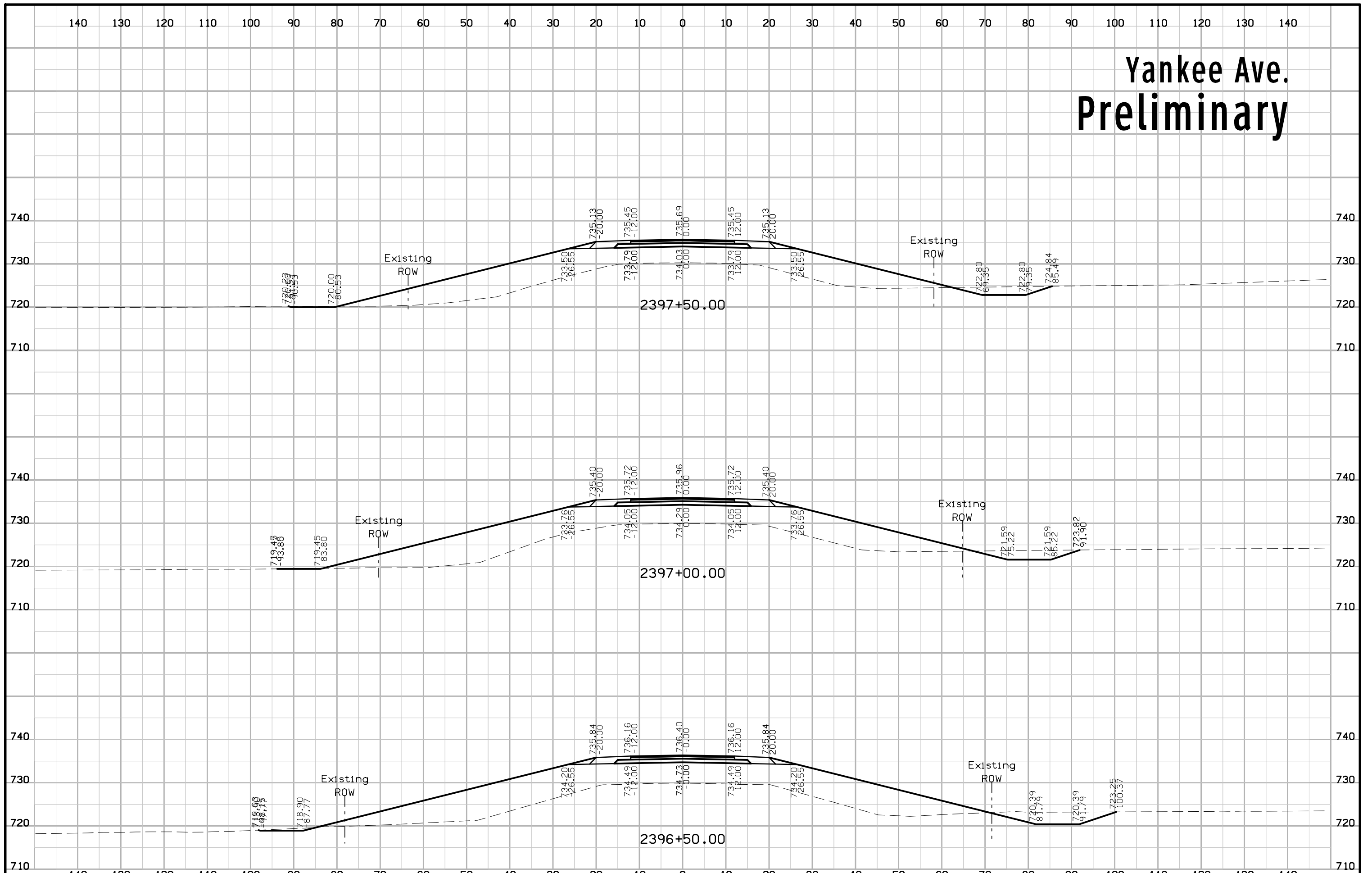

# Yankee Ave. Preliminary

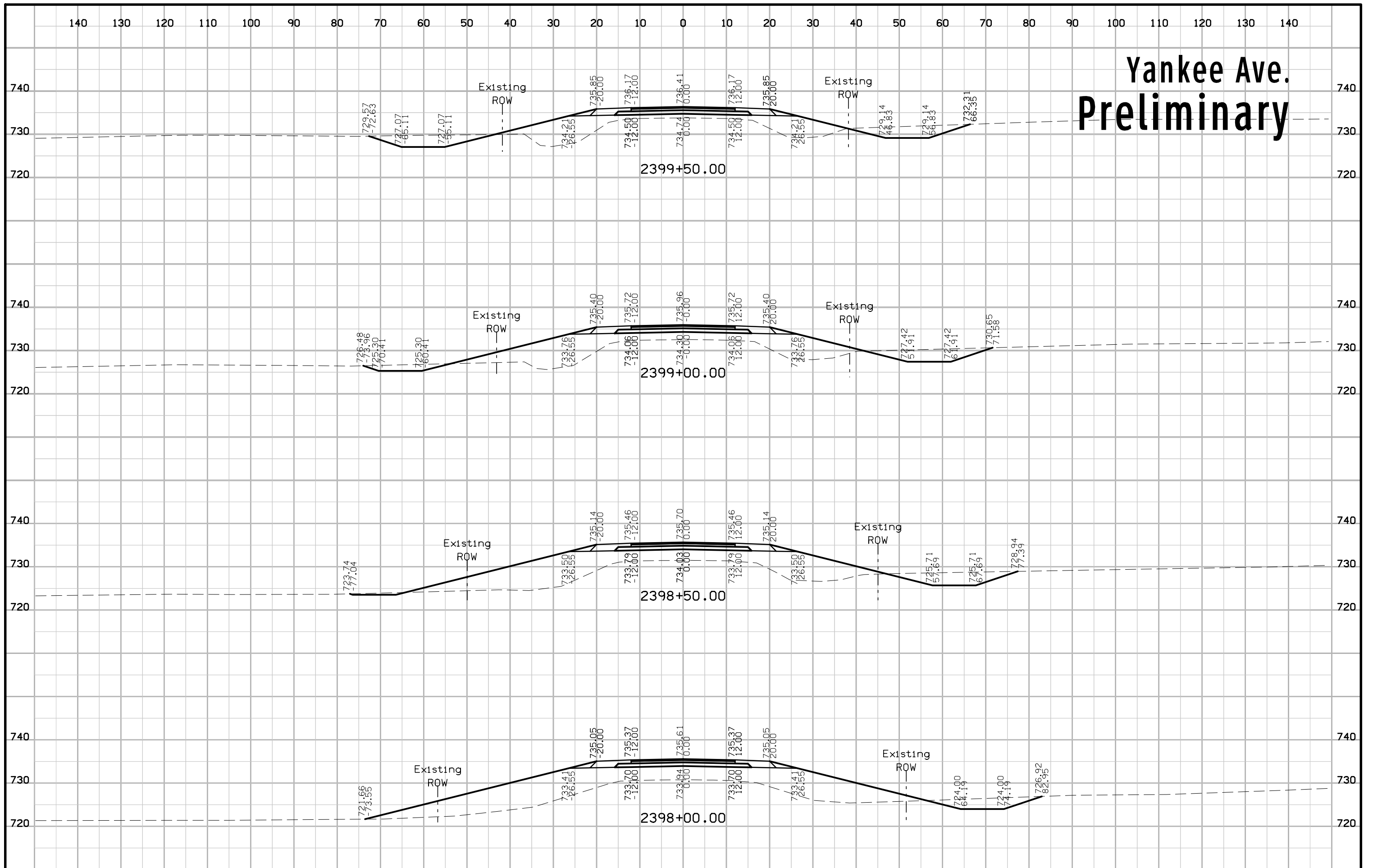

# Yankee Ave. Preliminary

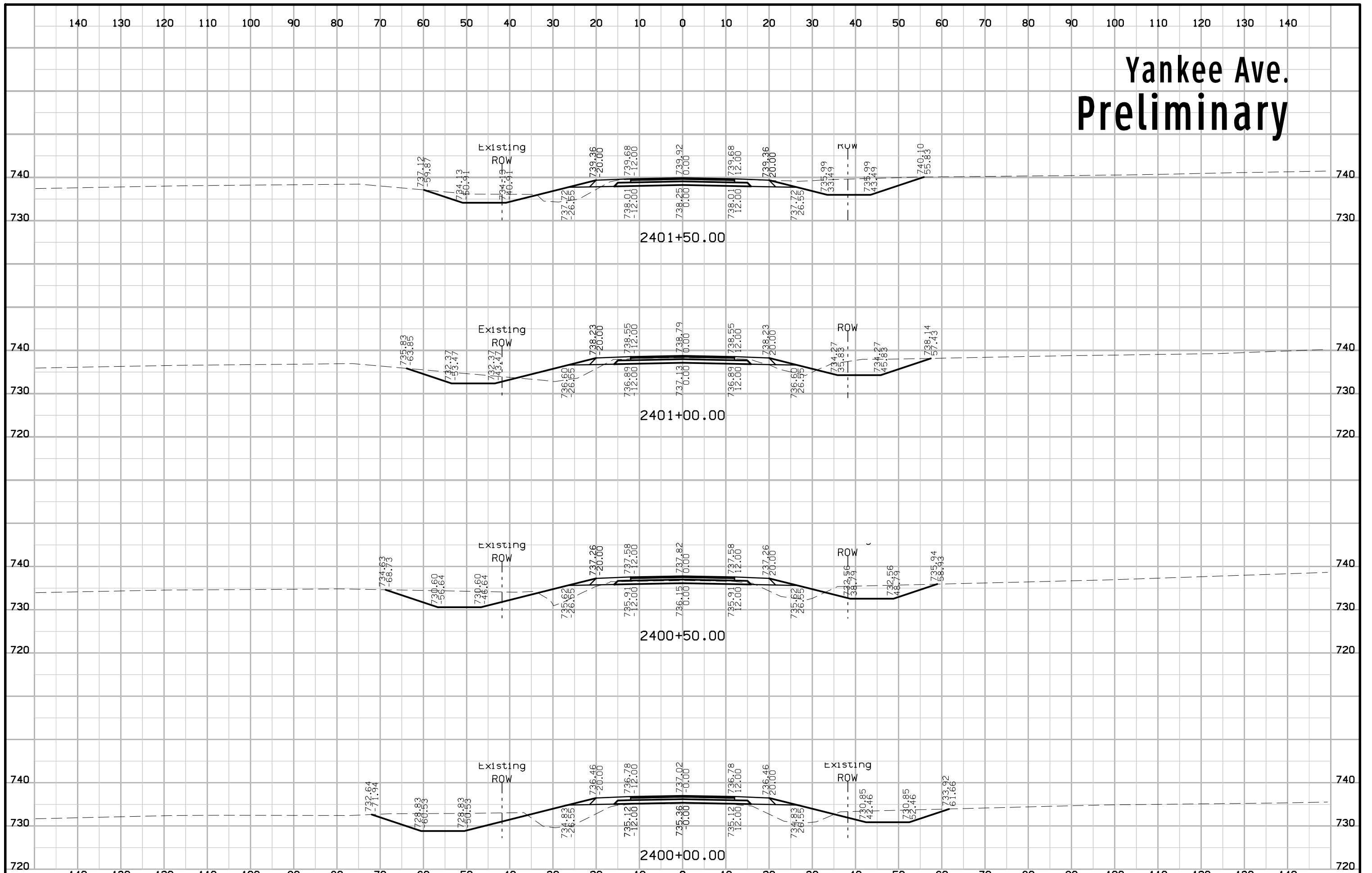

# Yankee Ave. Preliminary

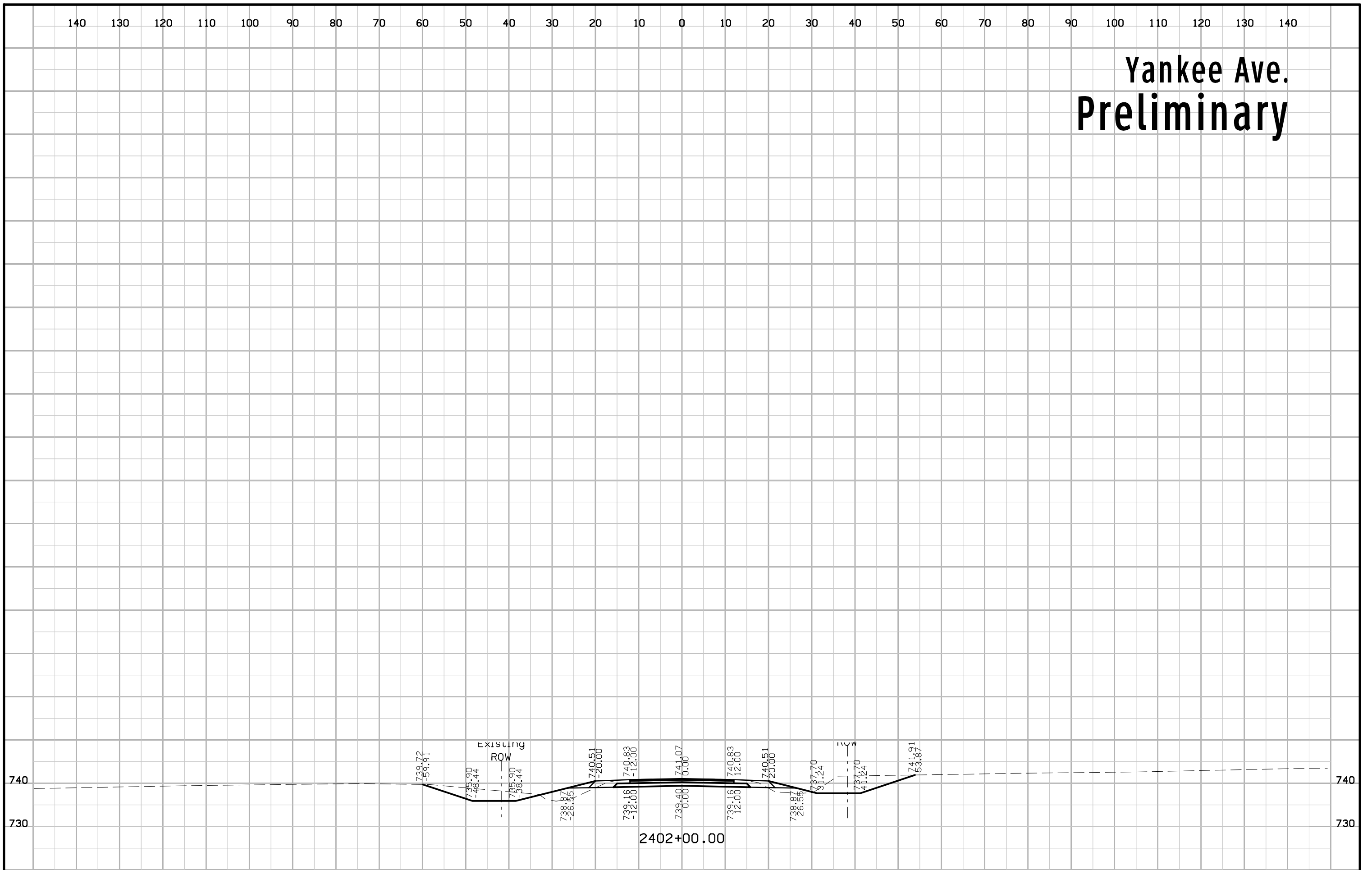

# Moscow Ramp A Preliminary

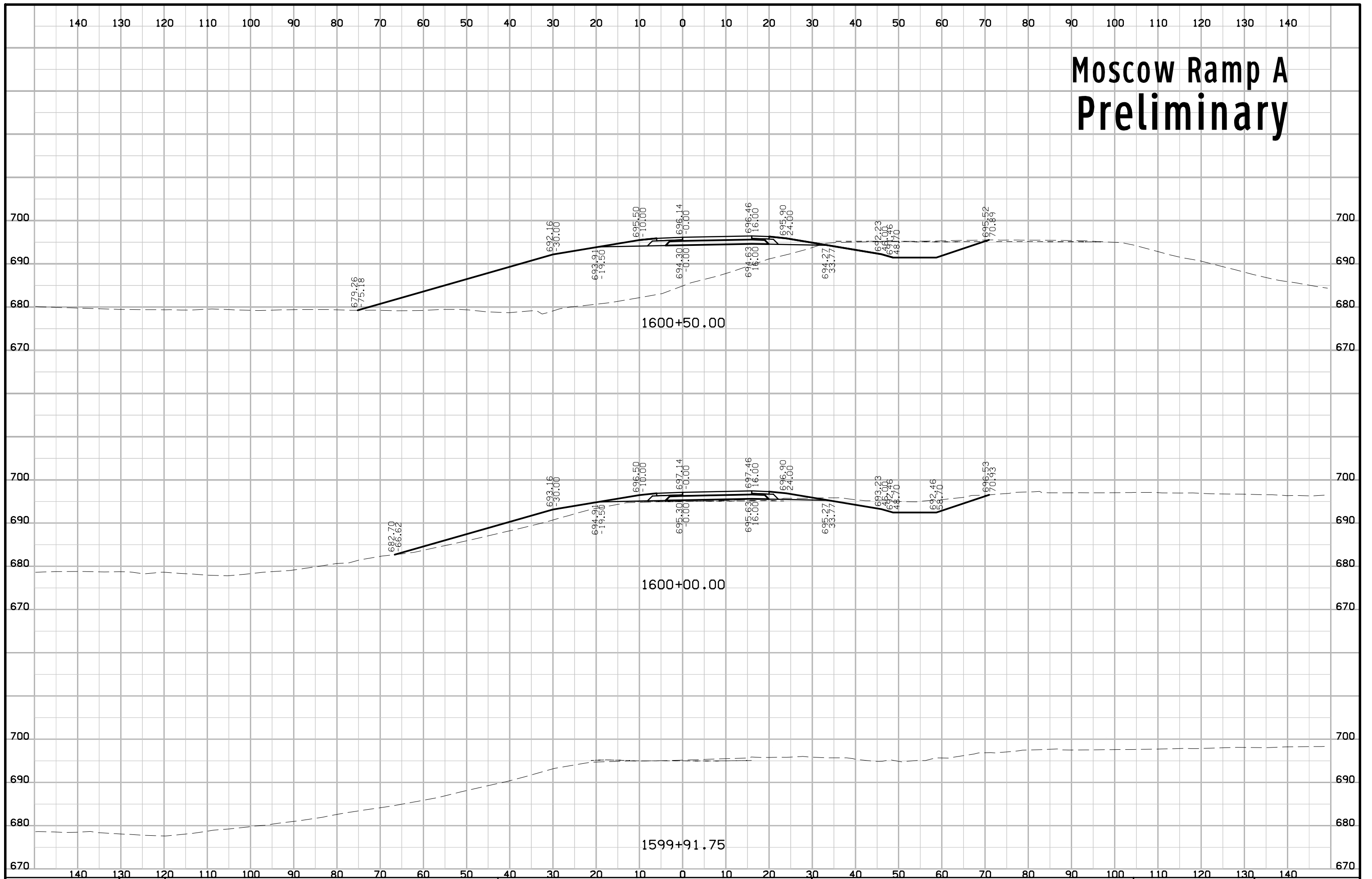

# Moscow Ramp A Preliminary

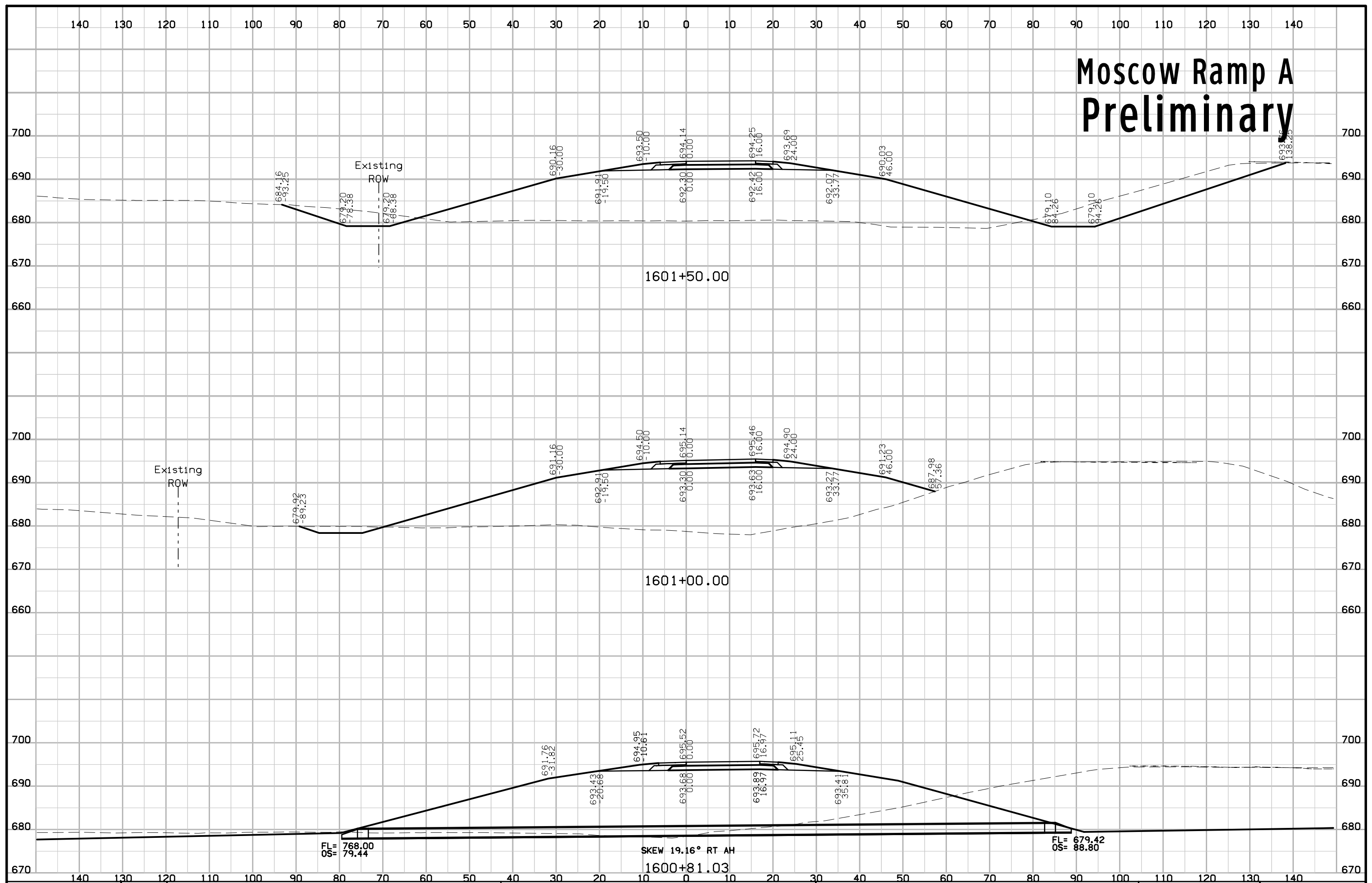



# Moscow Ramp A Preliminary

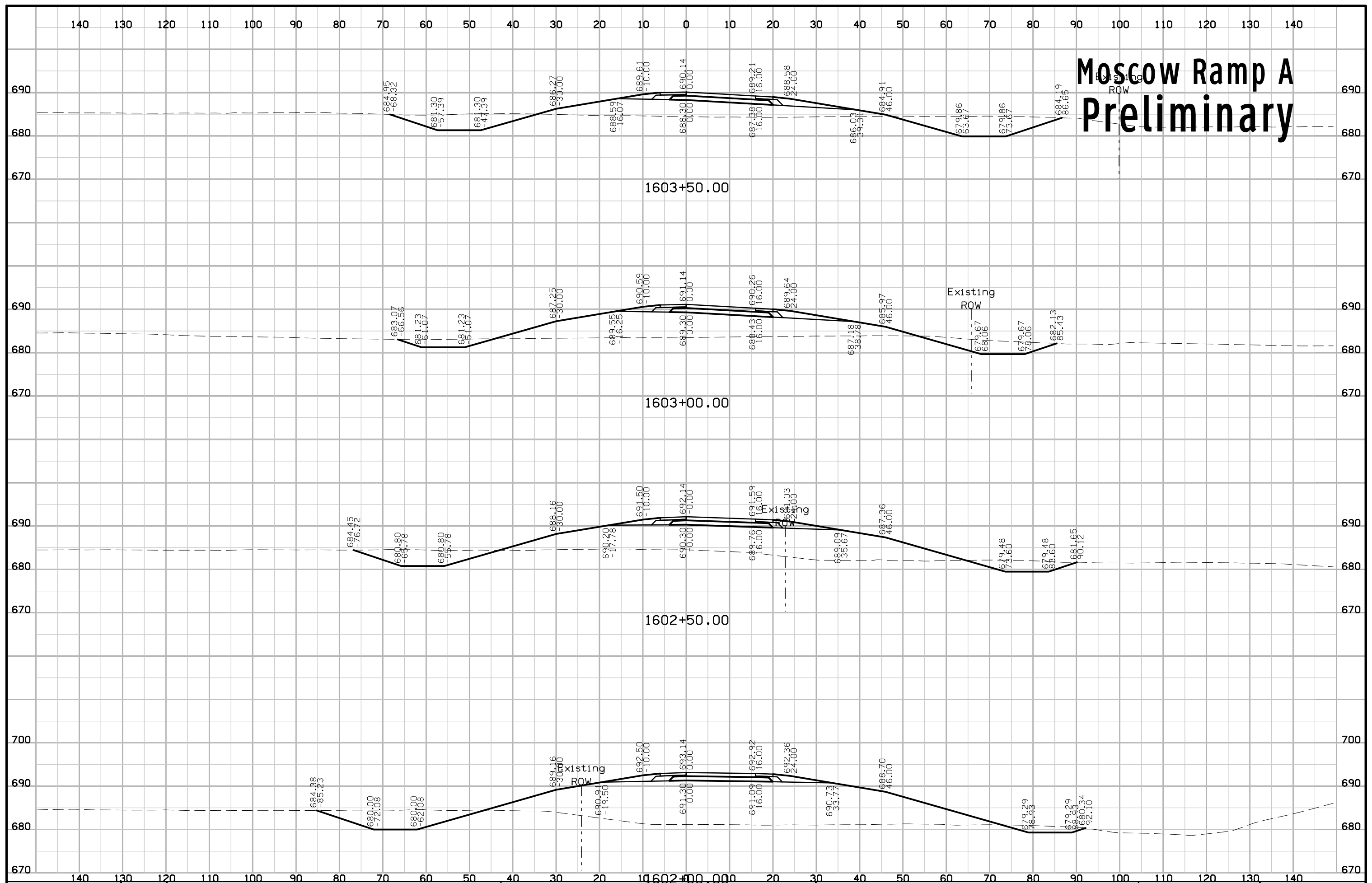

# Moscow Ramp A Preliminary

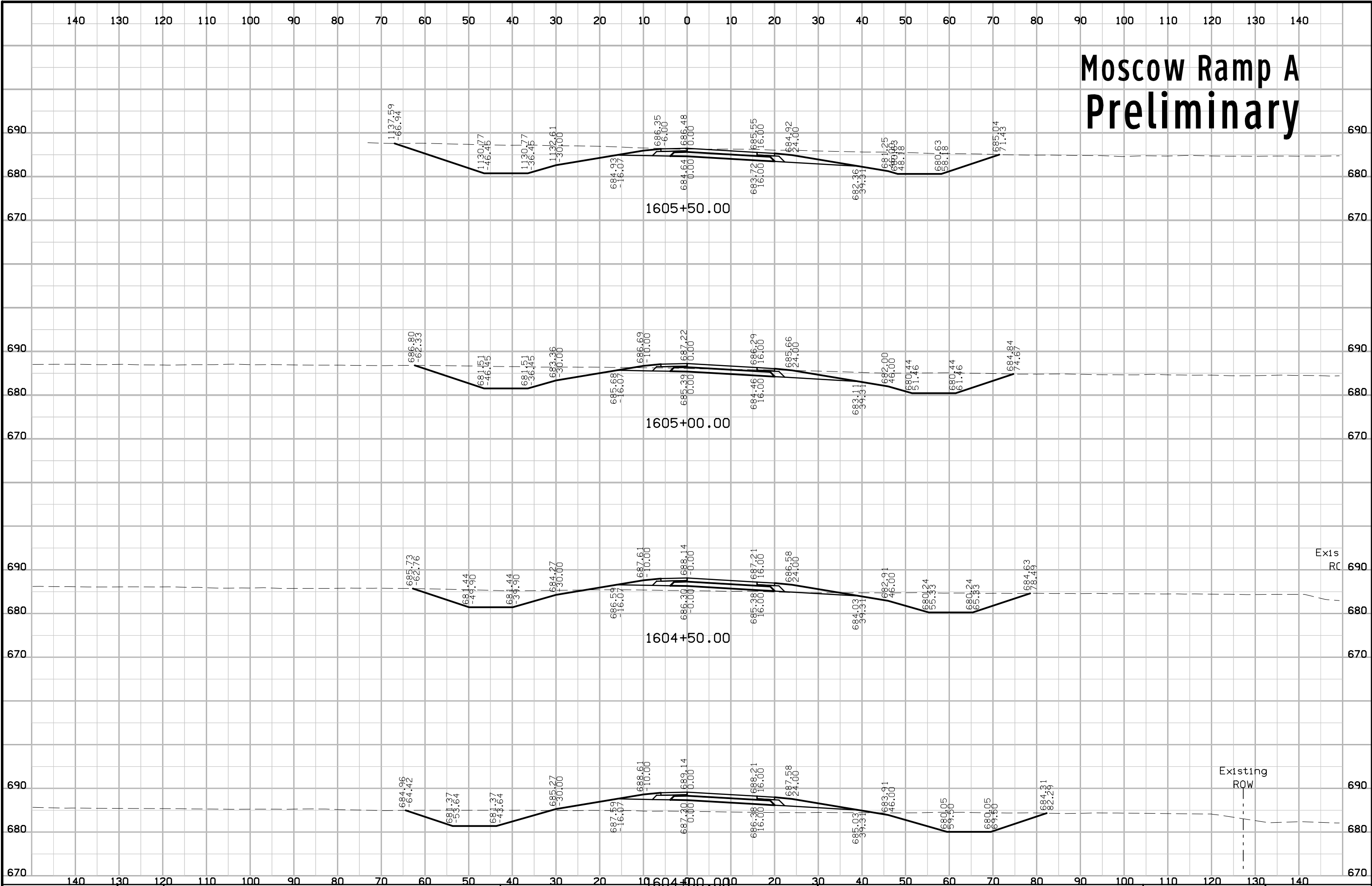

# Moscow Ramp A Preliminary

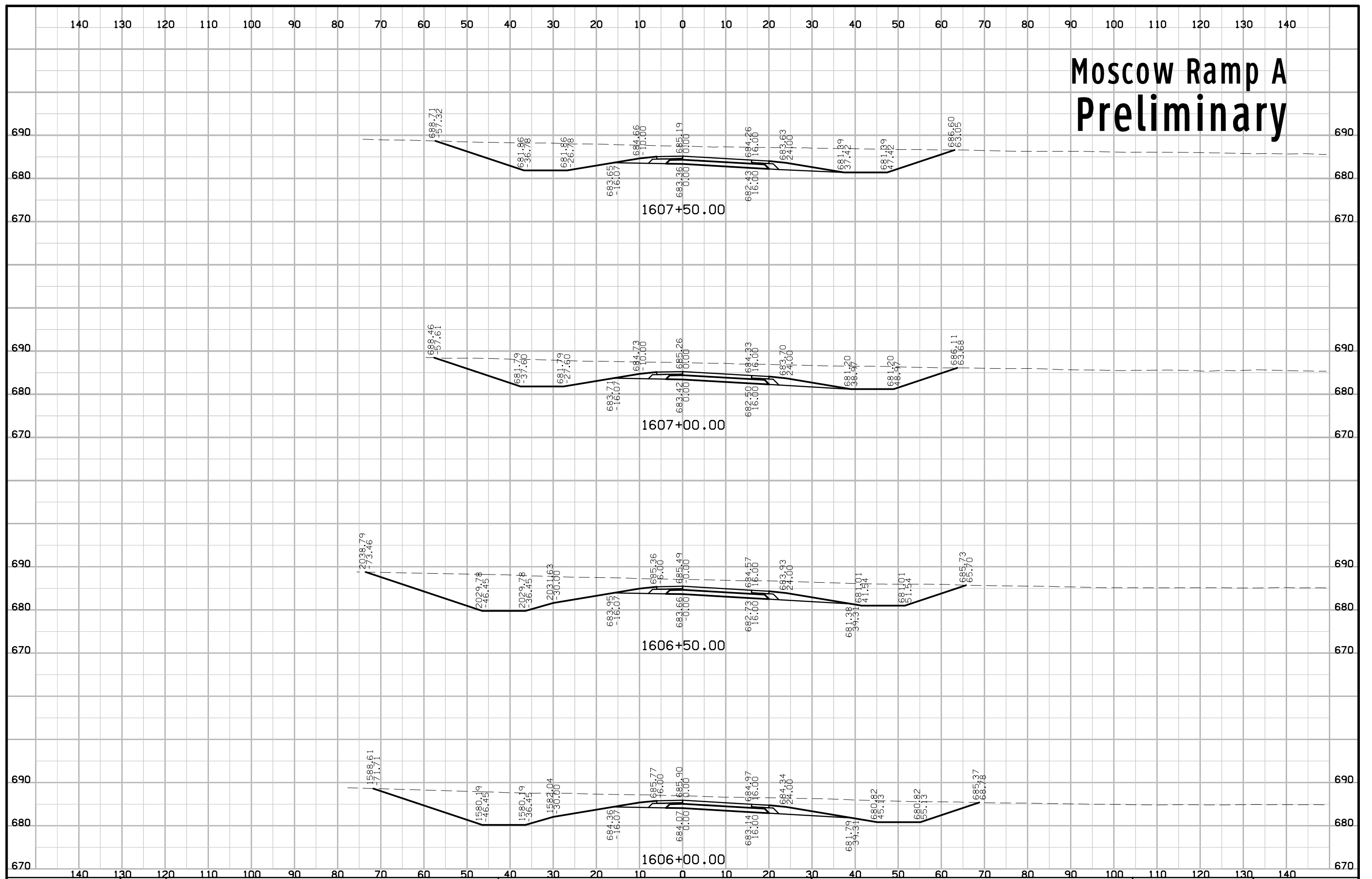

# Moscow Ramp A Preliminary

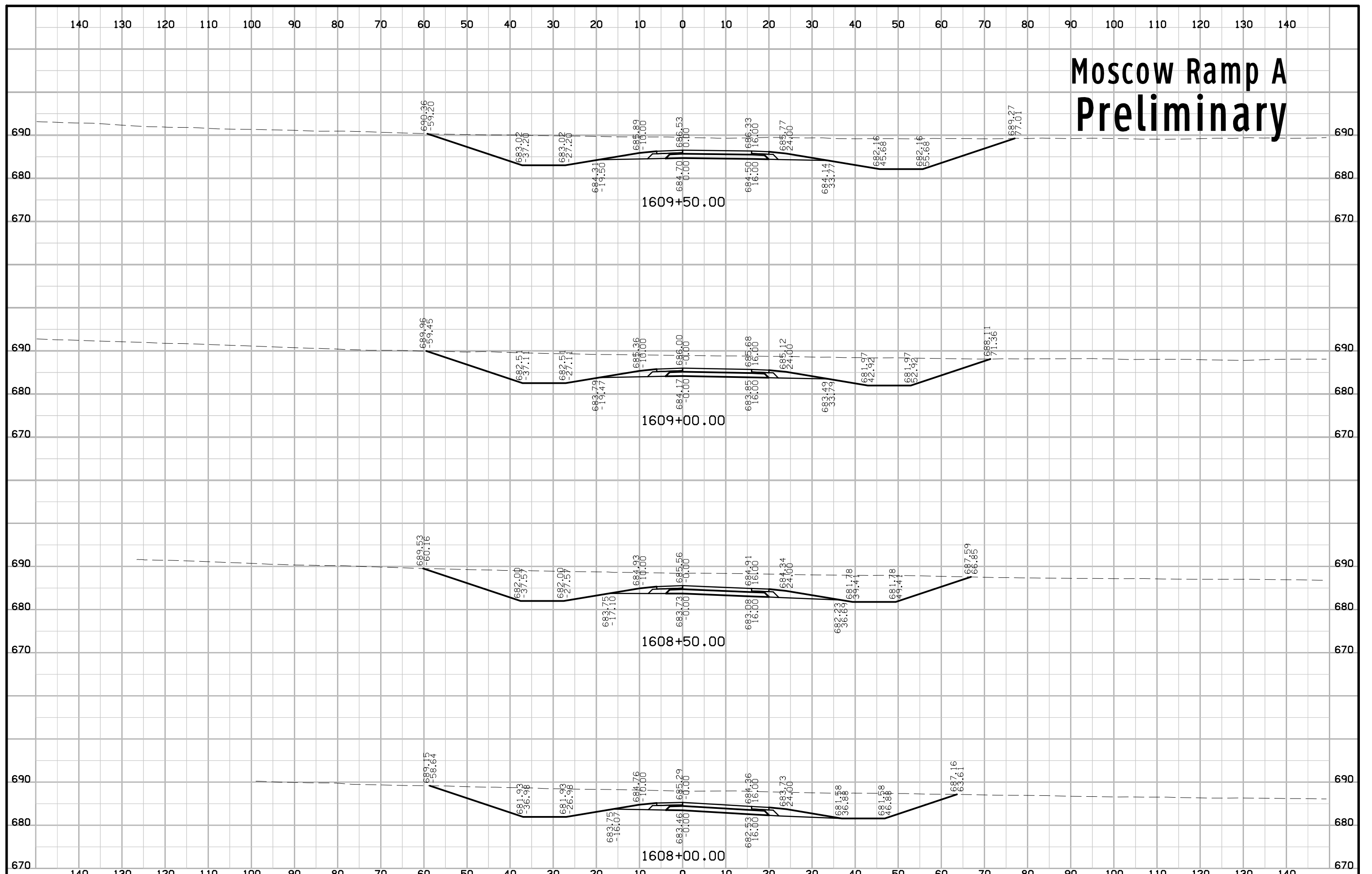

# Moscow Ramp A Preliminary

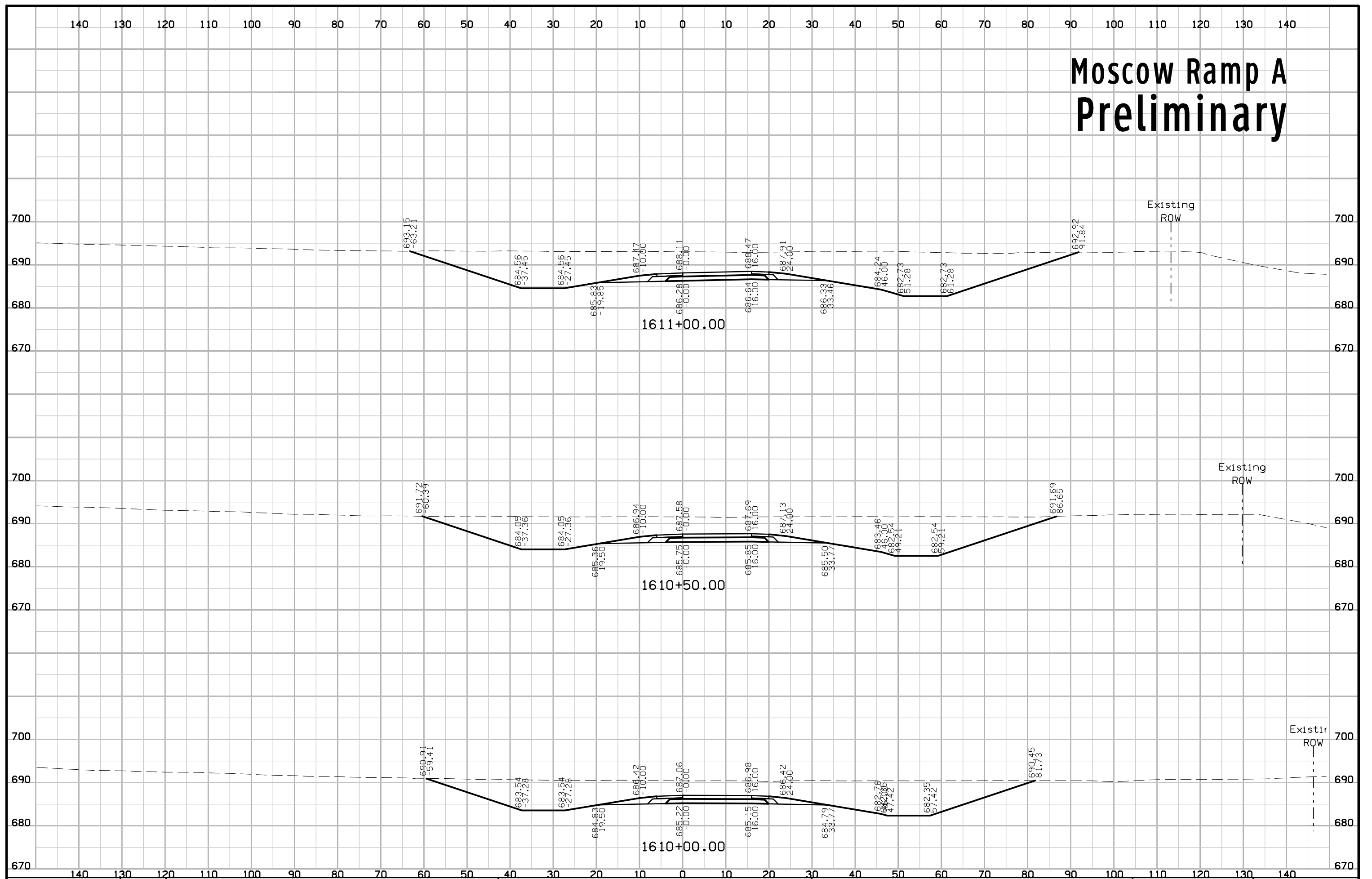

# Moscow Ramp A Preliminary

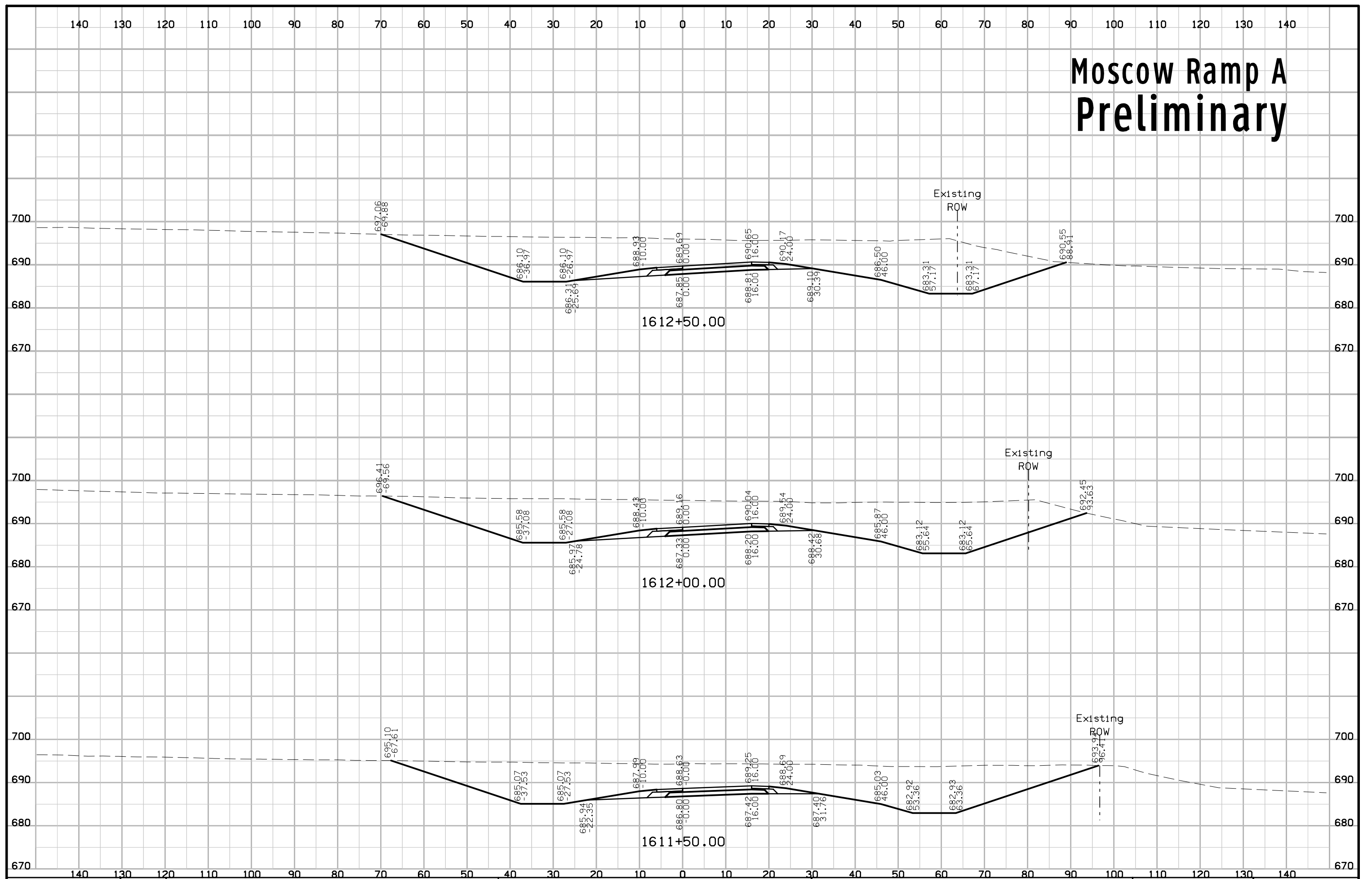

# Moscow Ramp A Preliminary

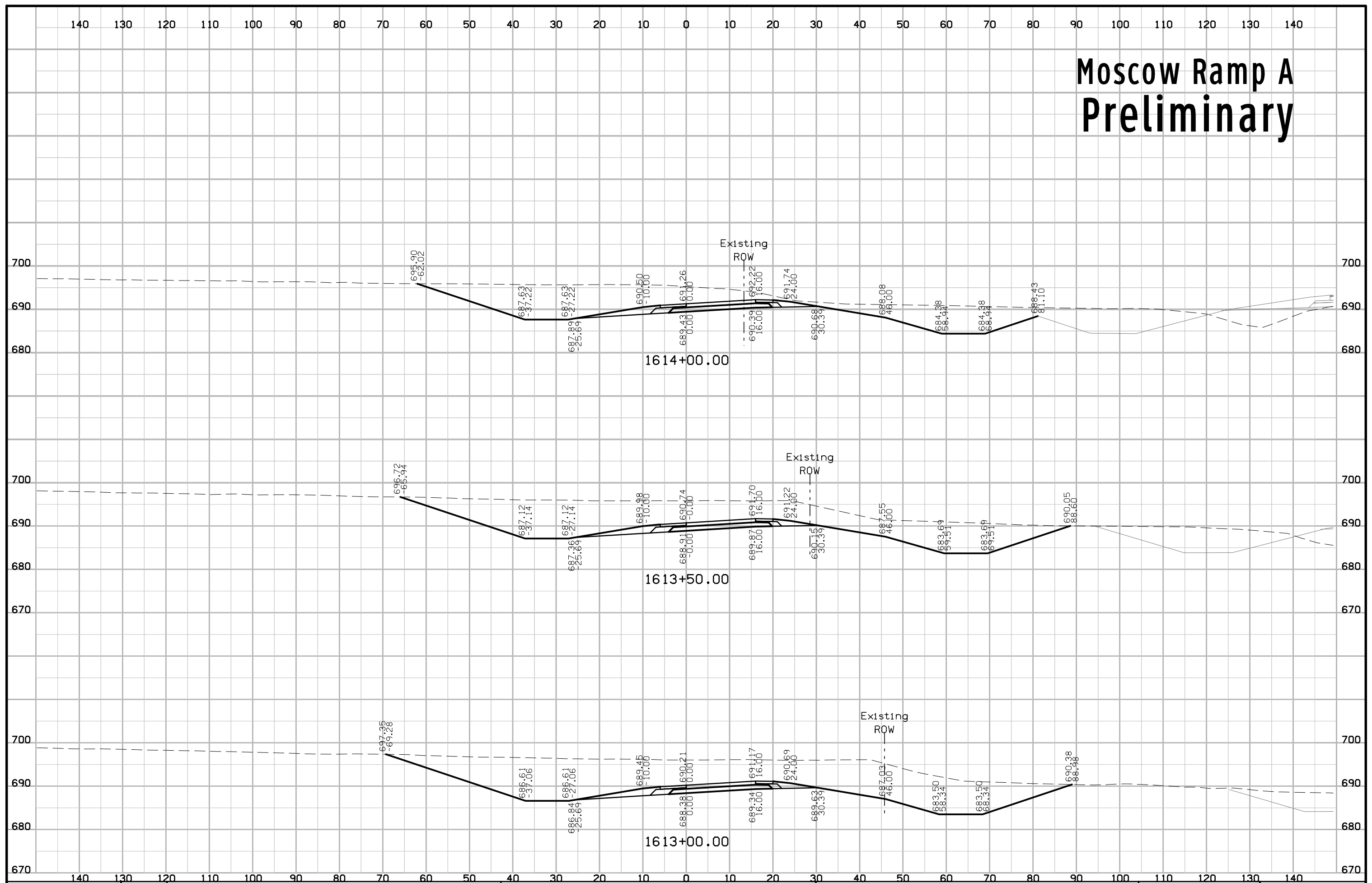

# Moscow Ramp A Preliminary

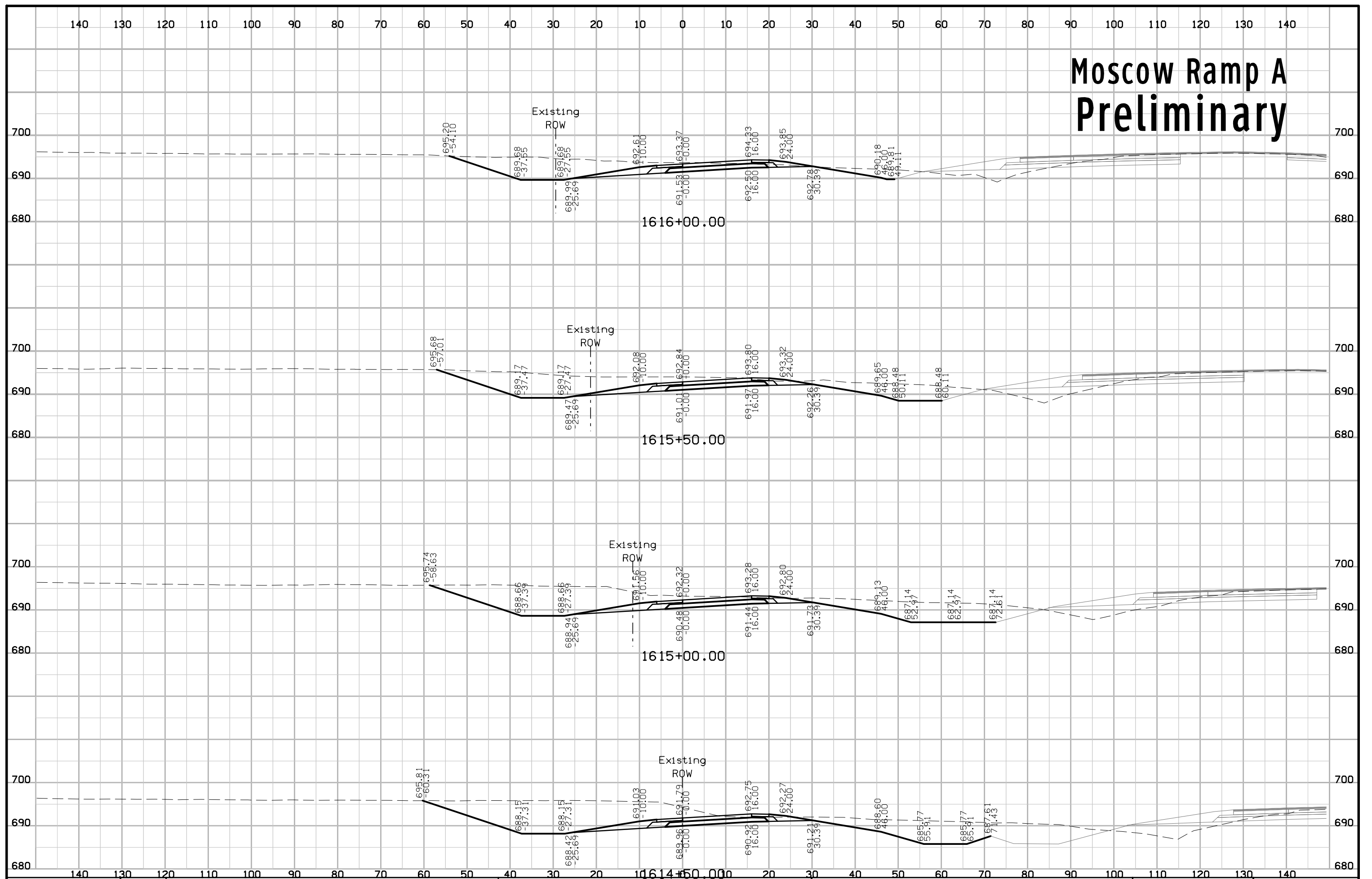



# Moscow Ramp A Preliminary

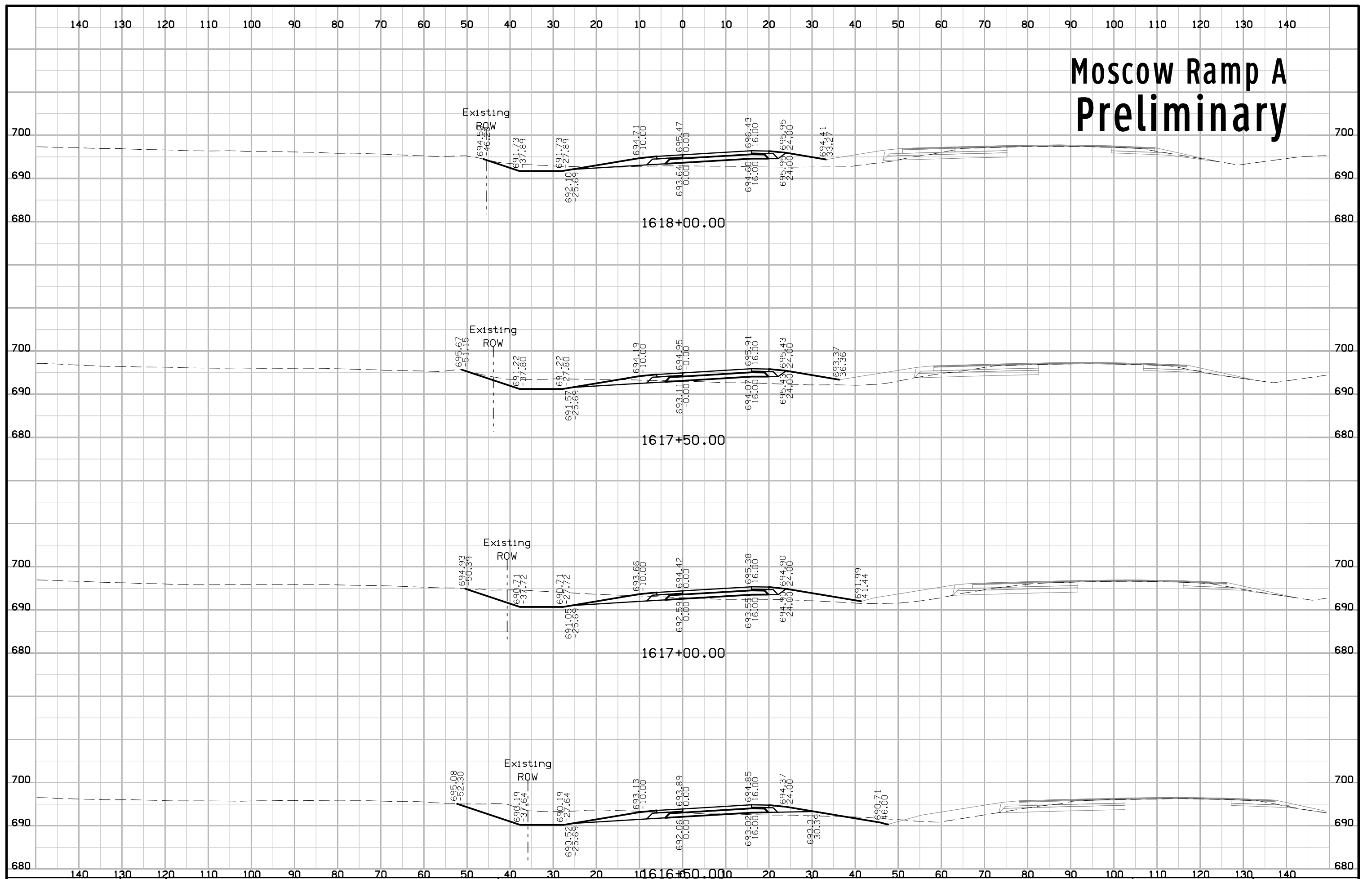

# Moscow Ramp A Preliminary

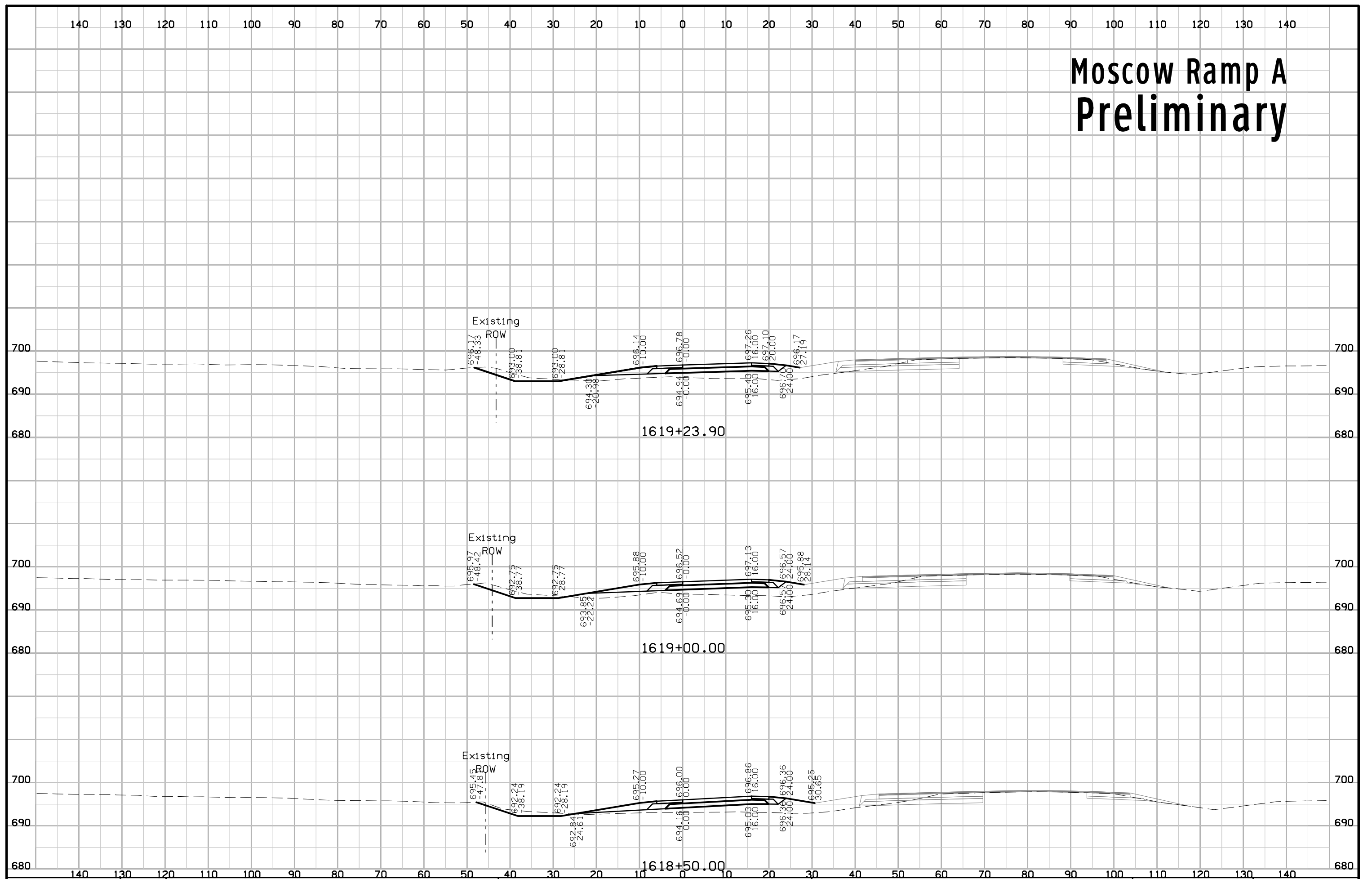

# Moscow Ramp B Preliminary

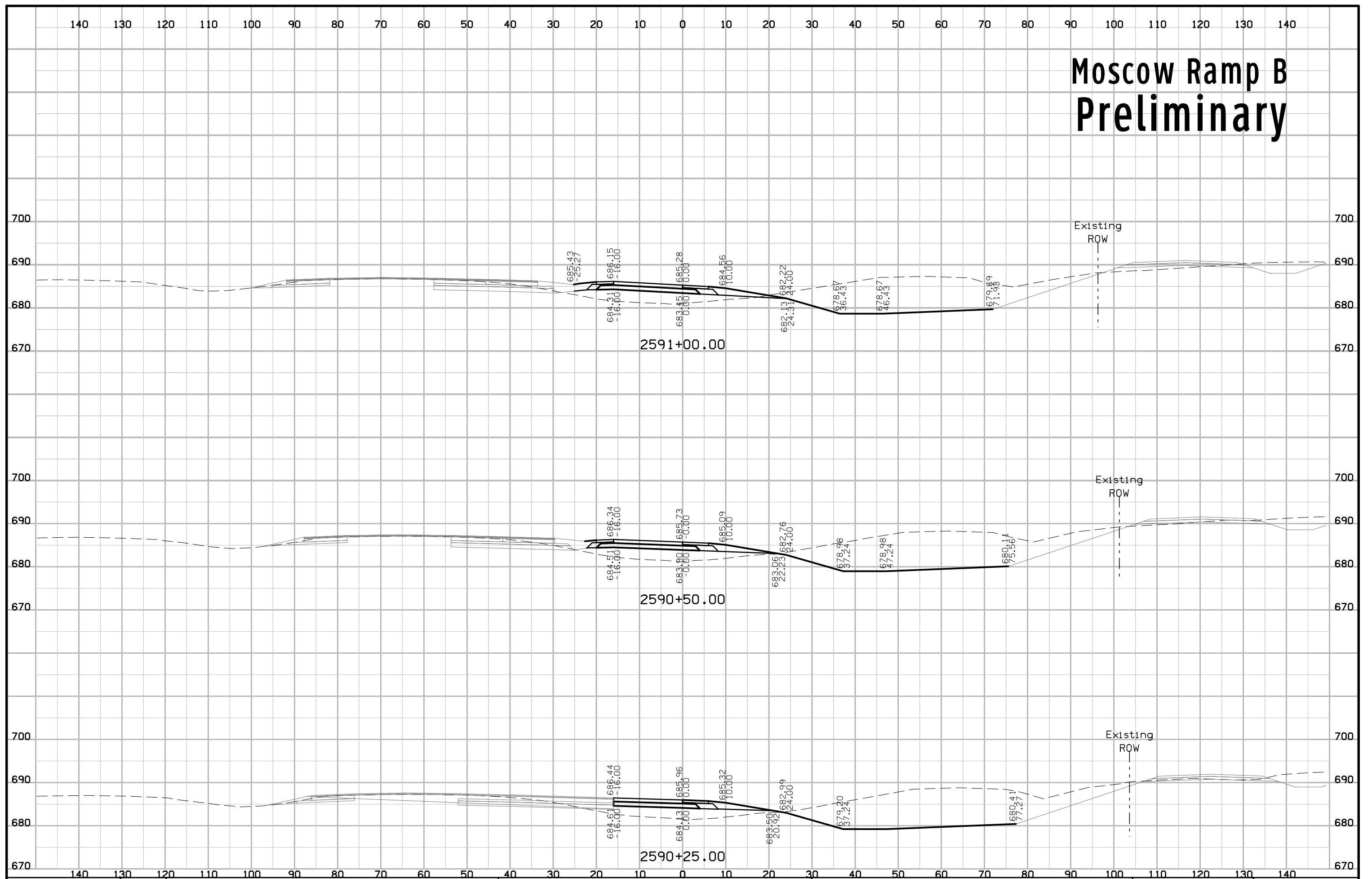

# Moscow Ramp B Preliminary

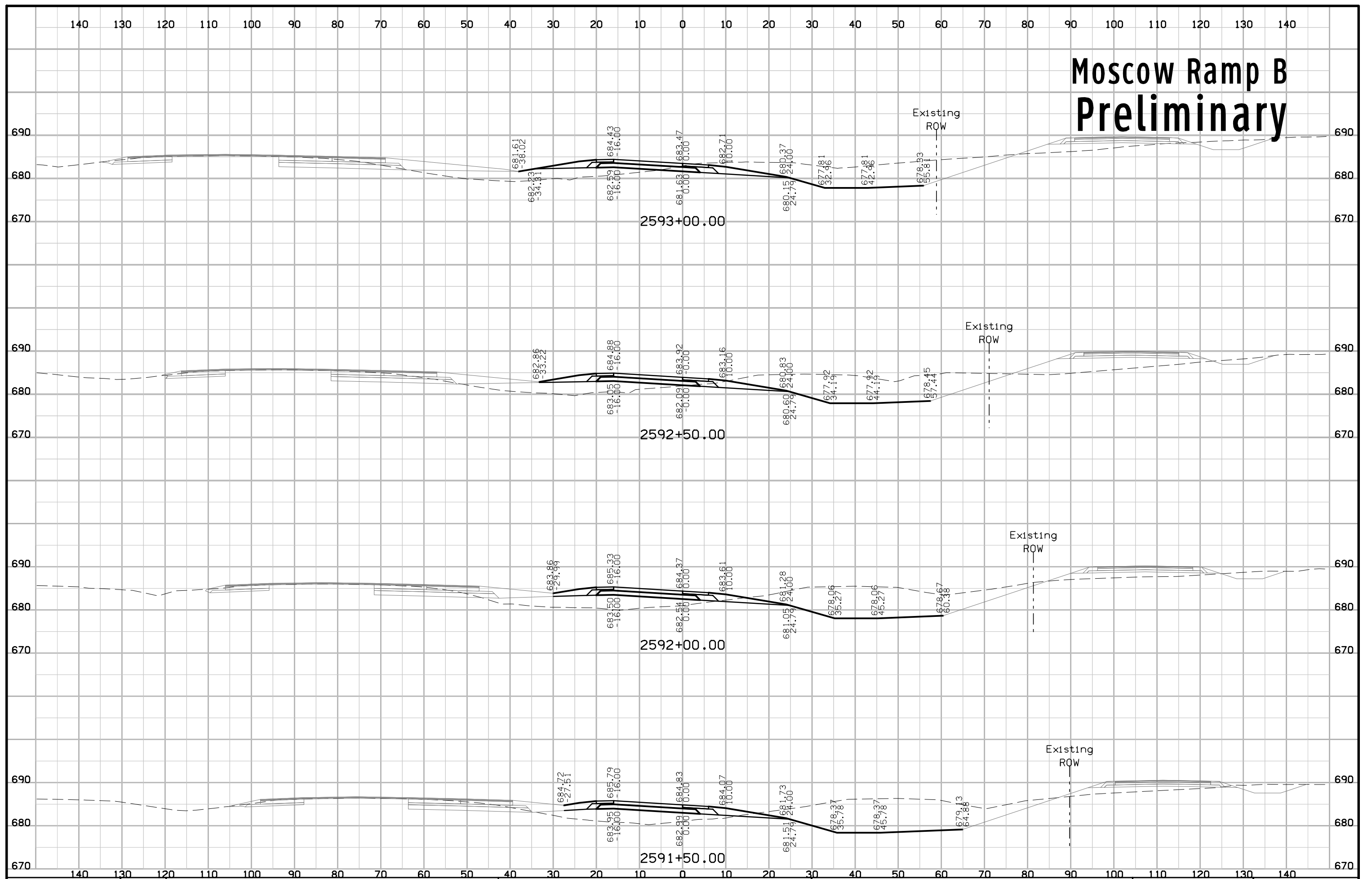

# Moscow Ramp B Preliminary

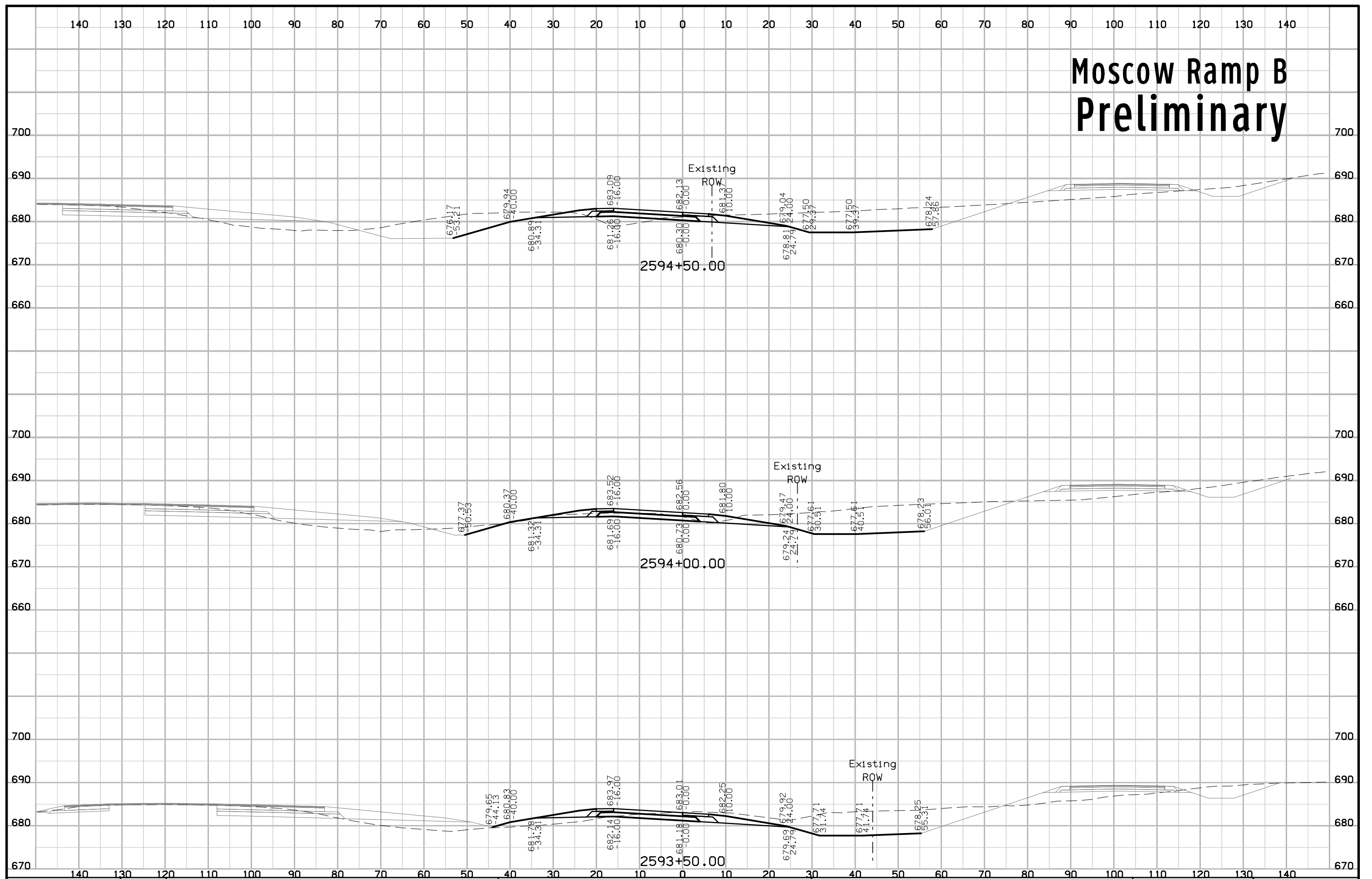

# Moscow Ramp B Preliminary

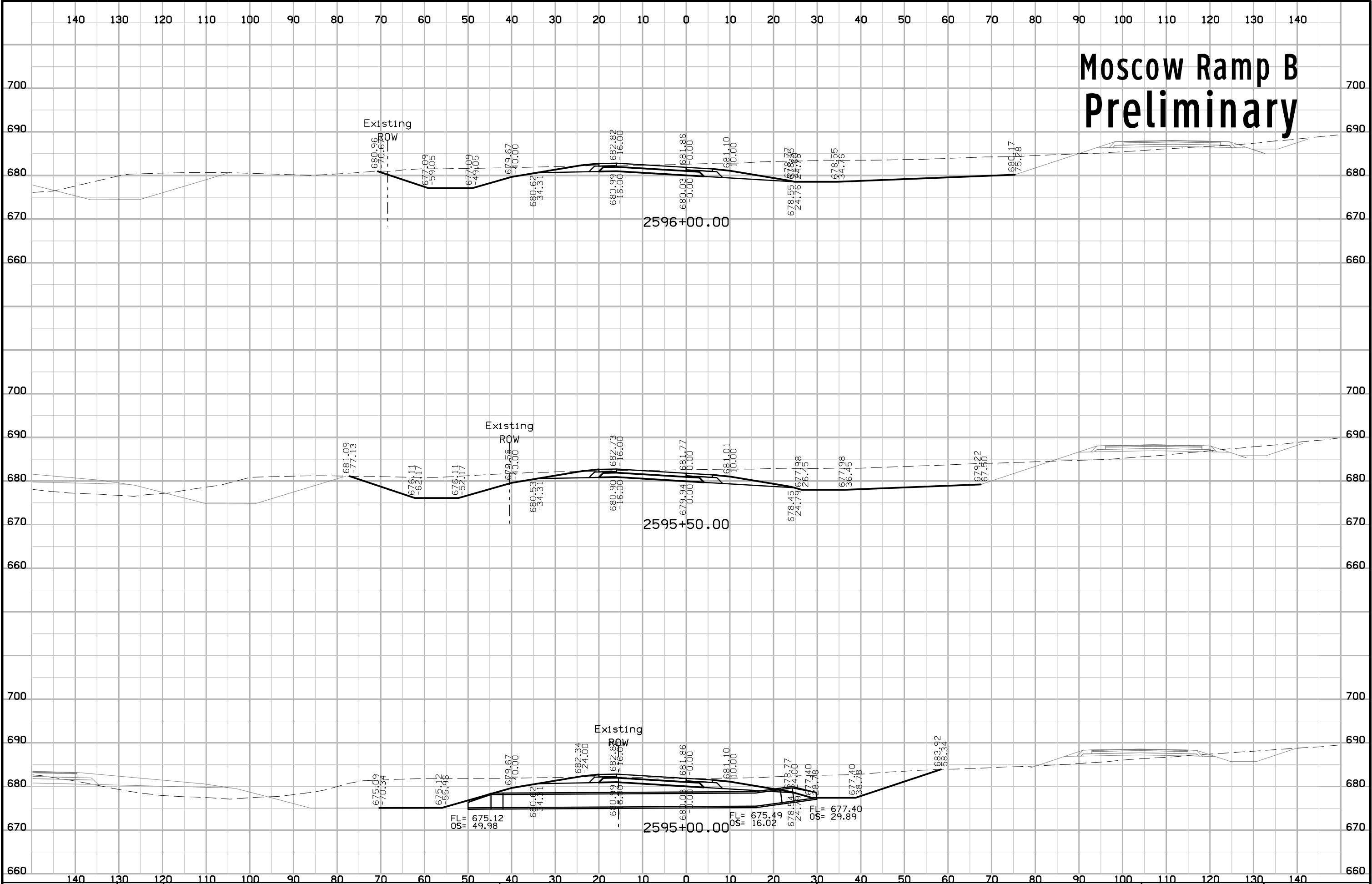

# Moscow Ramp B Preliminary

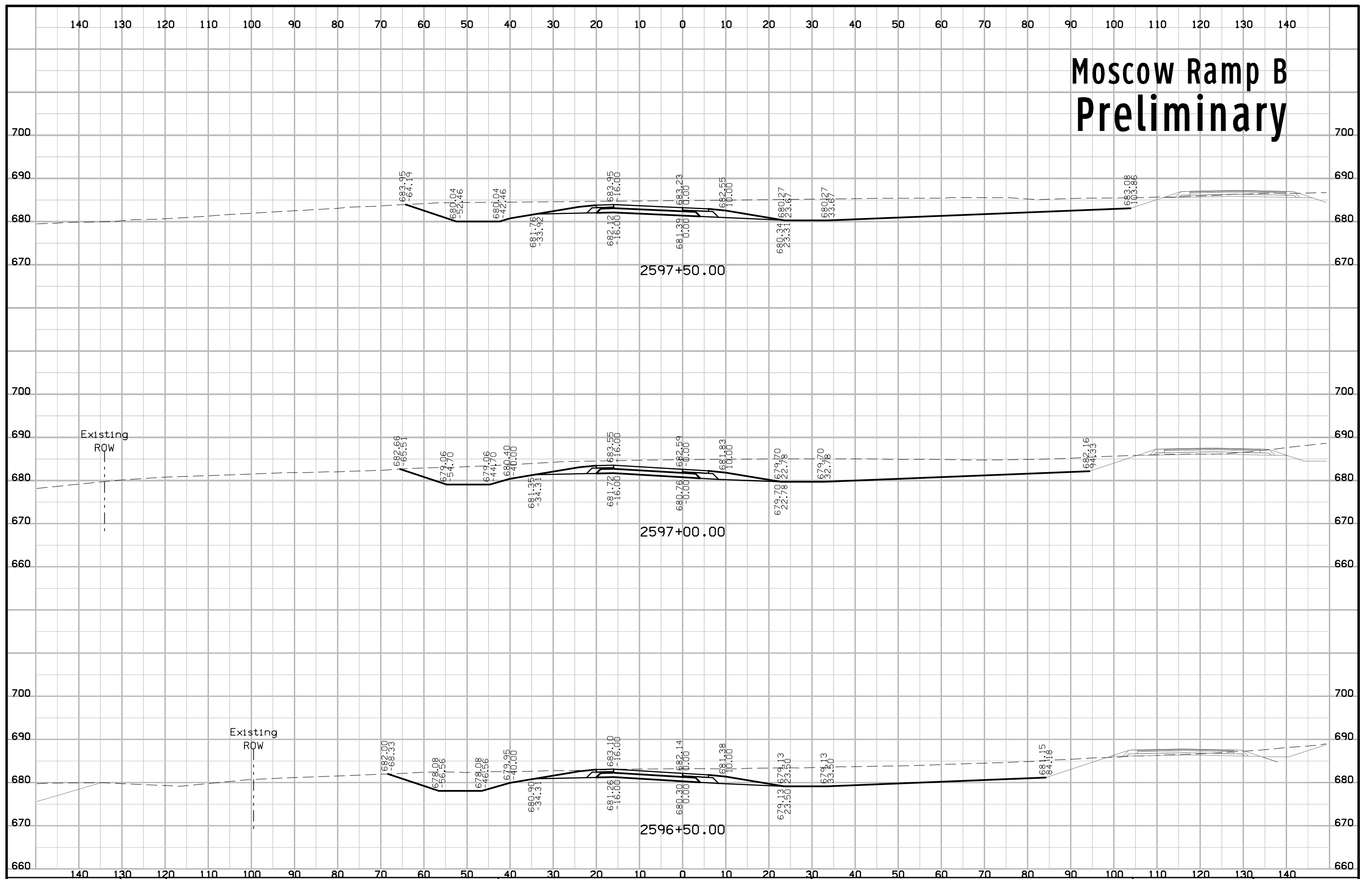

# Moscow Ramp B Preliminary

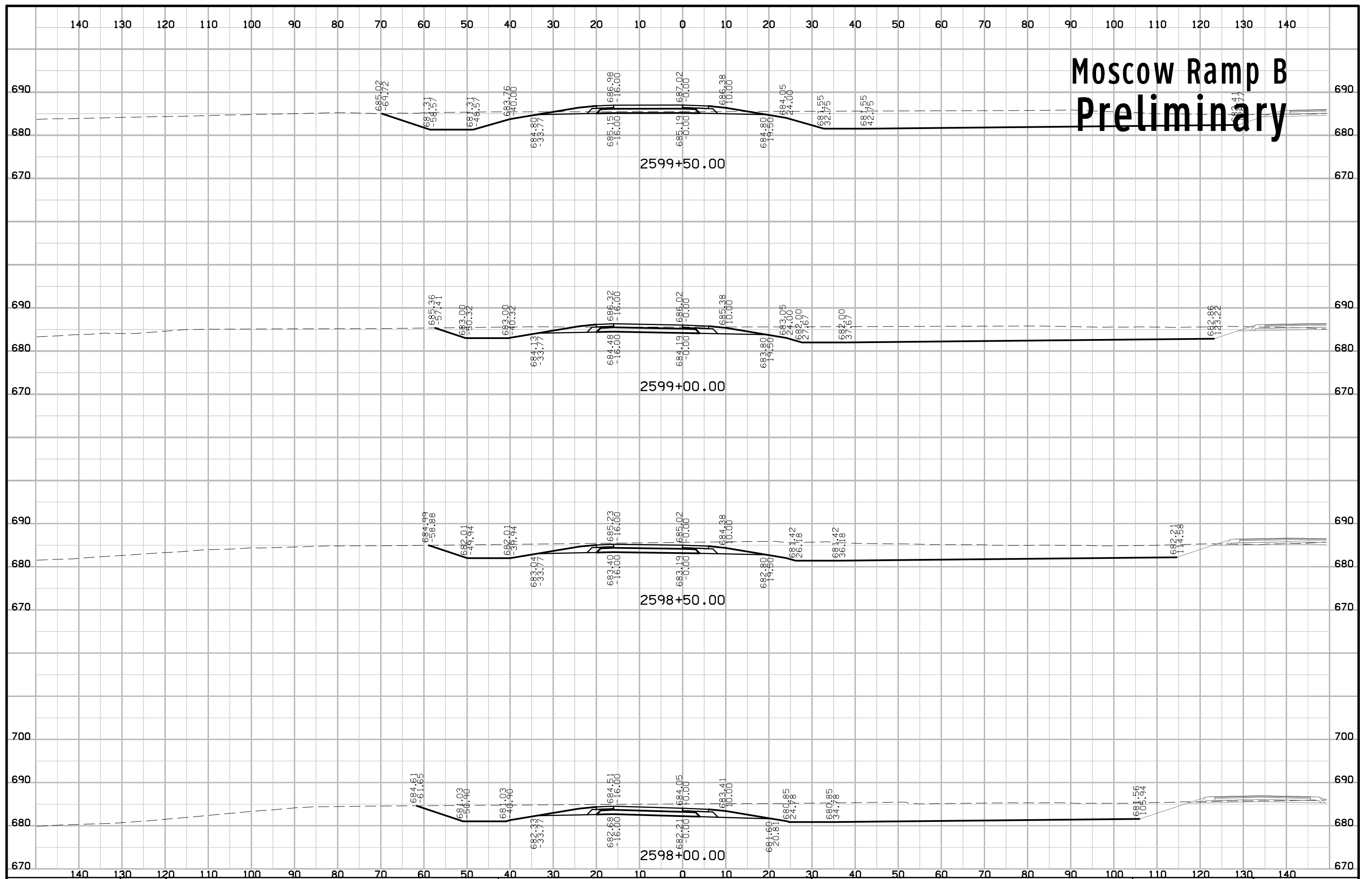



# Moscow Ramp B Preliminary

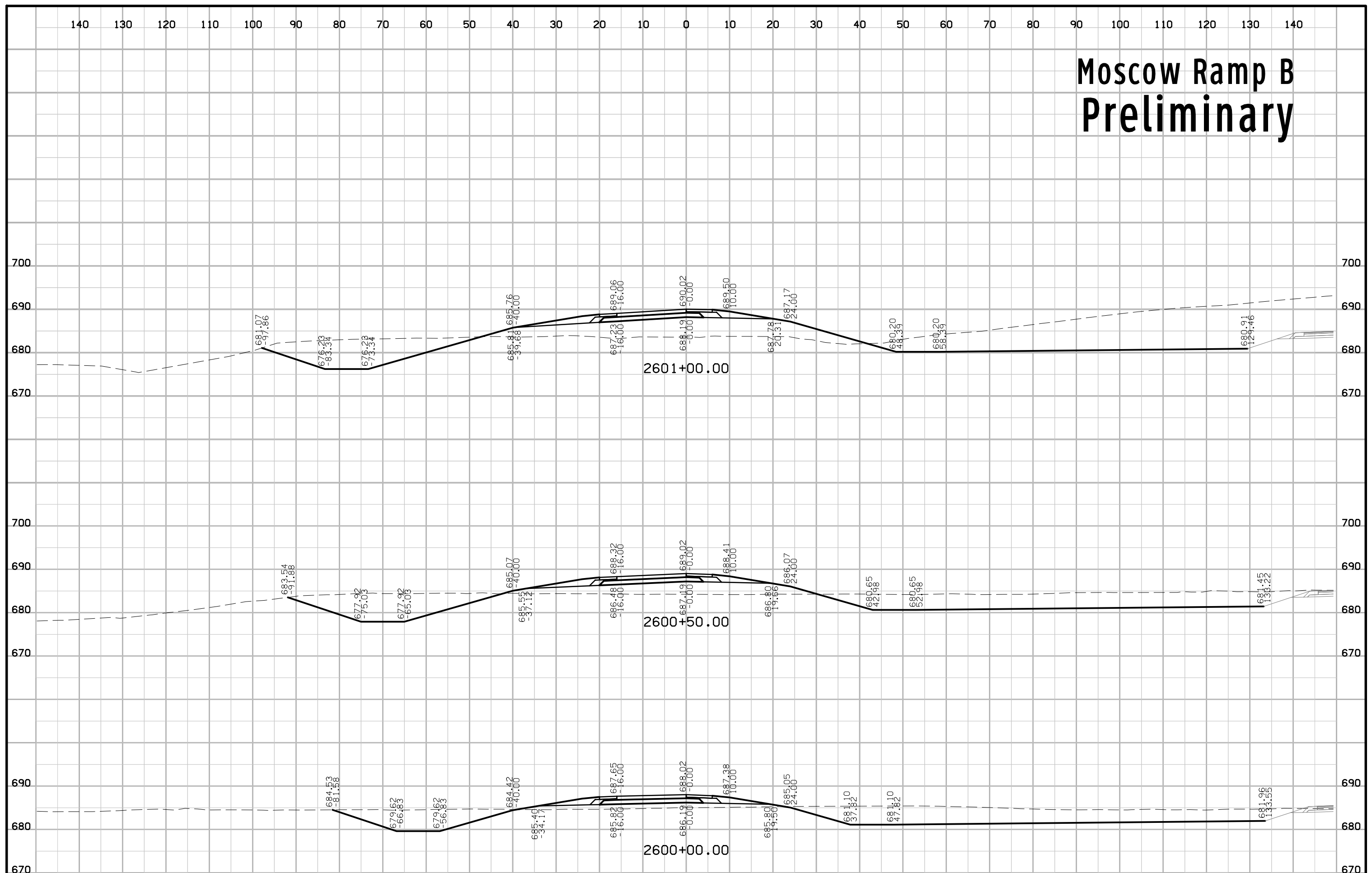

# Moscow Ramp B Preliminary

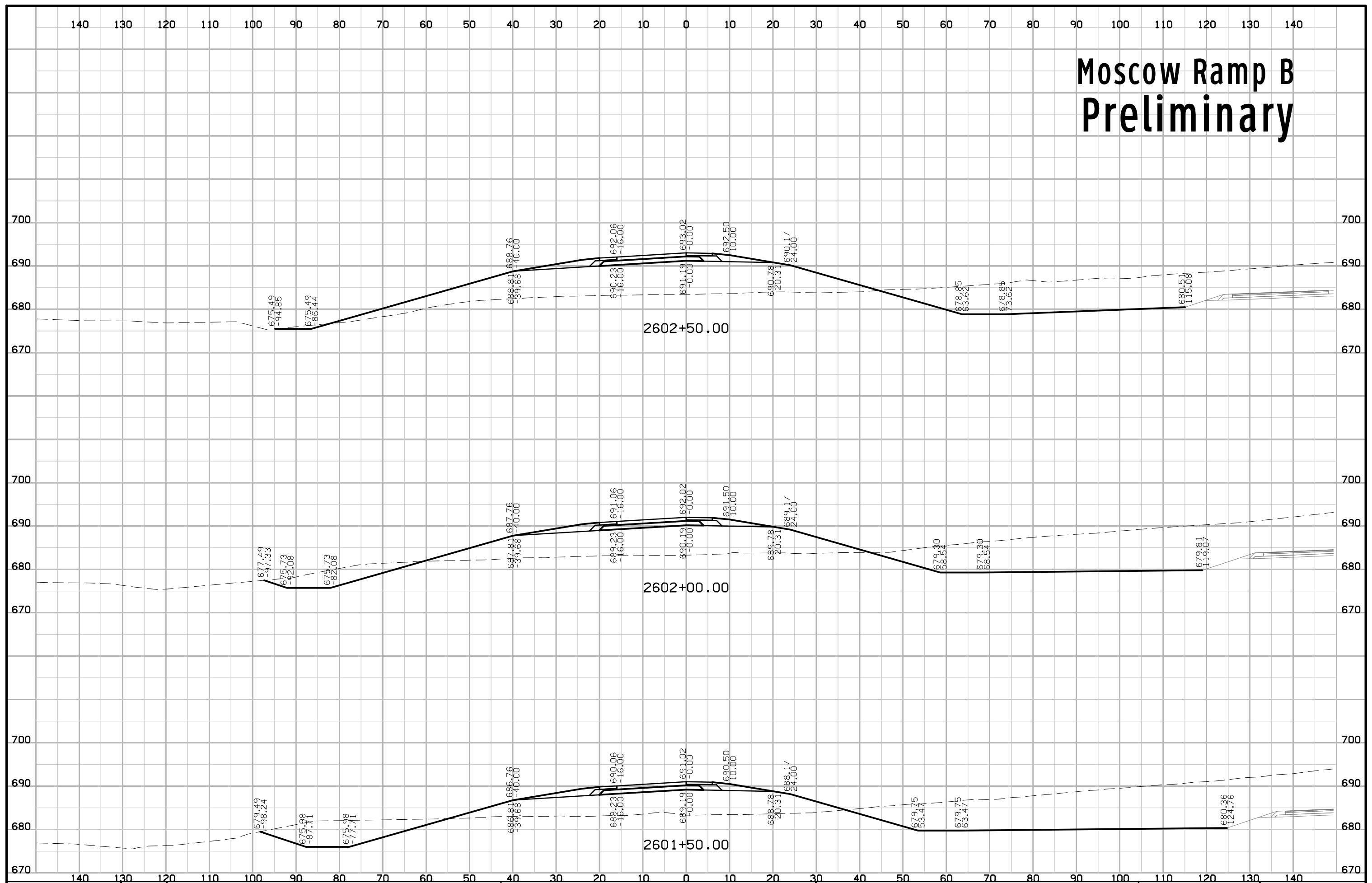

# Moscow Ramp B Preliminary

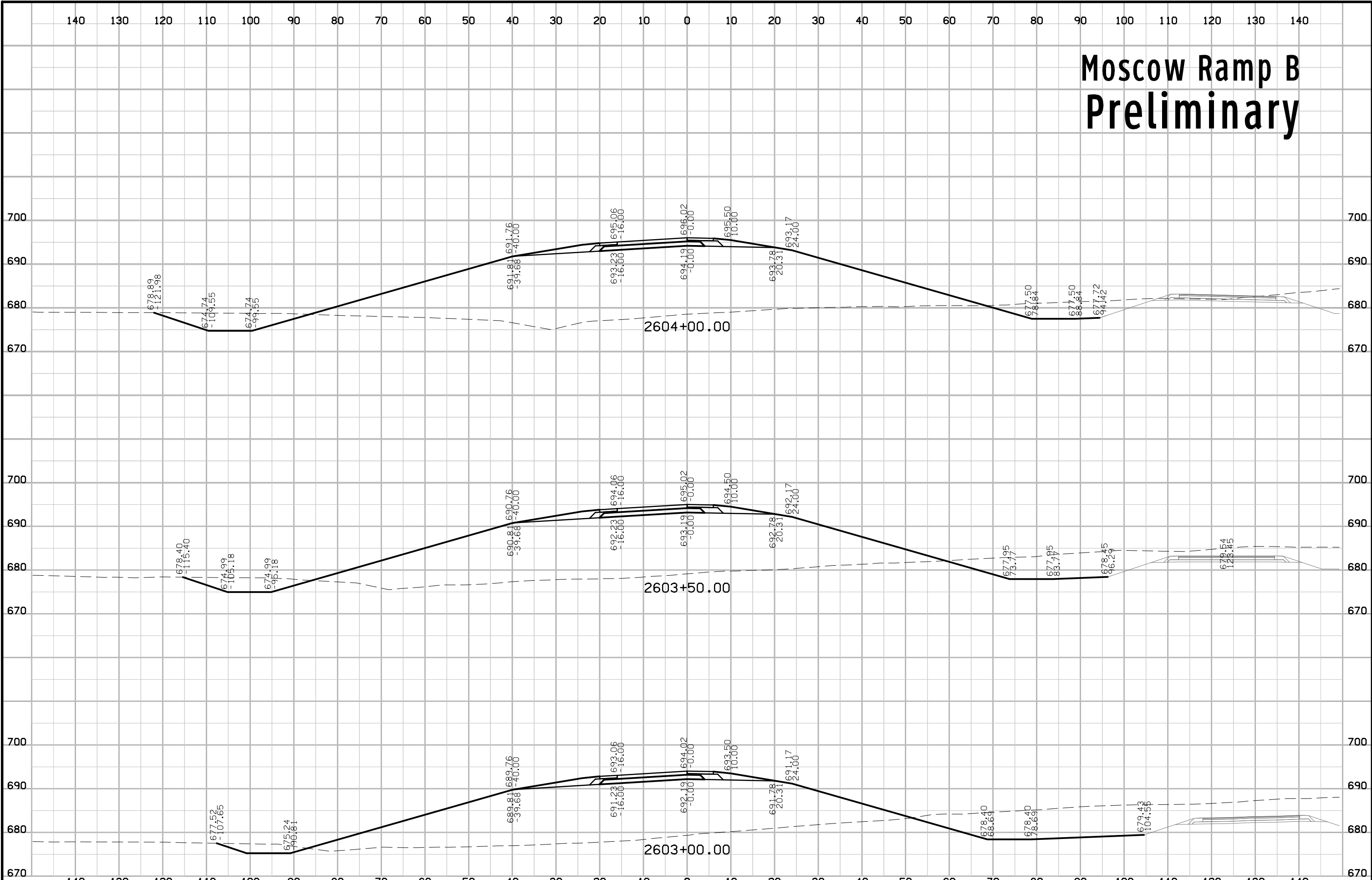

# Moscow Ramp B Preliminary

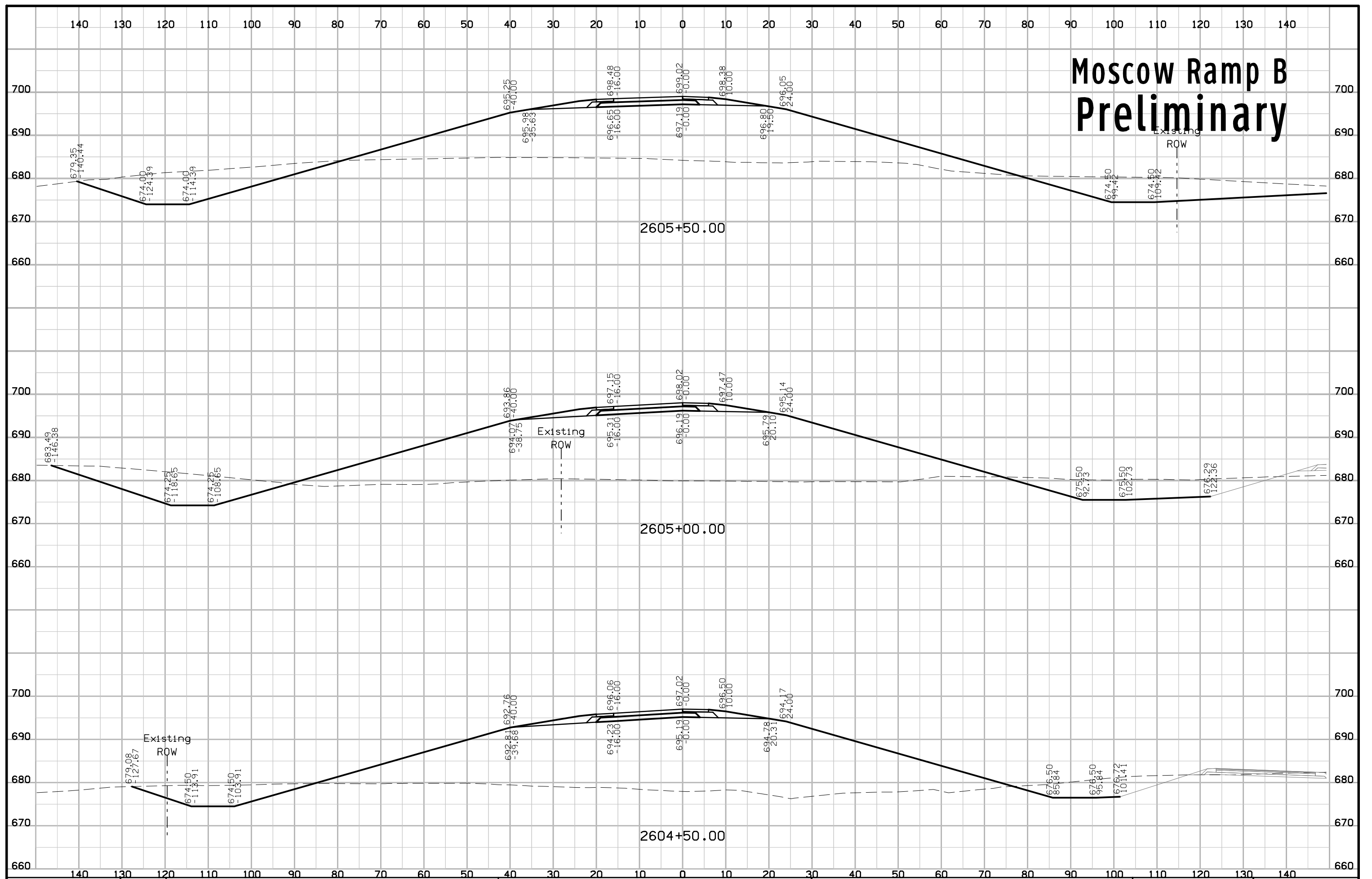

# Moscow Ramp B Preliminary

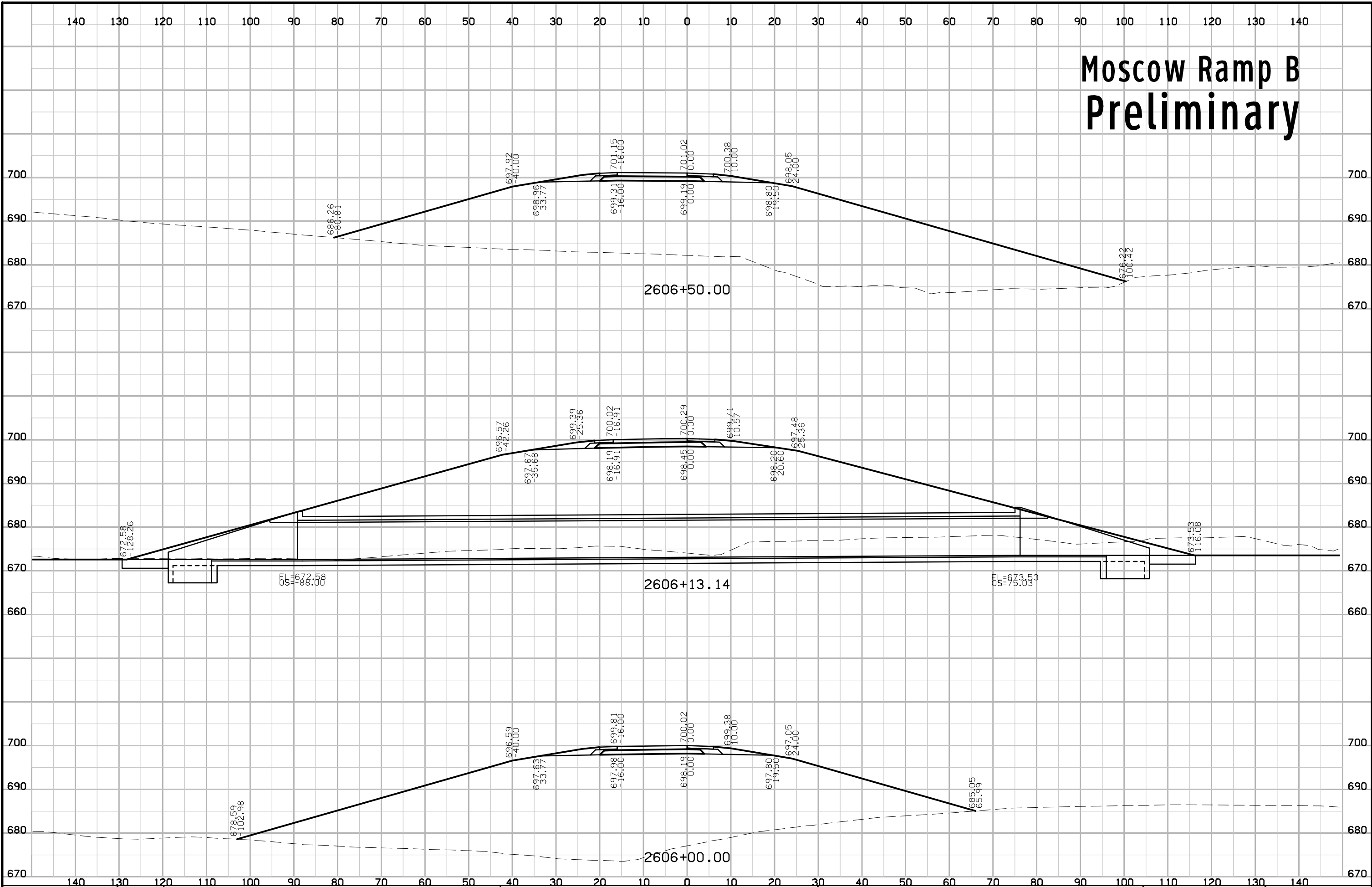

# Moscow Ramp B Preliminary

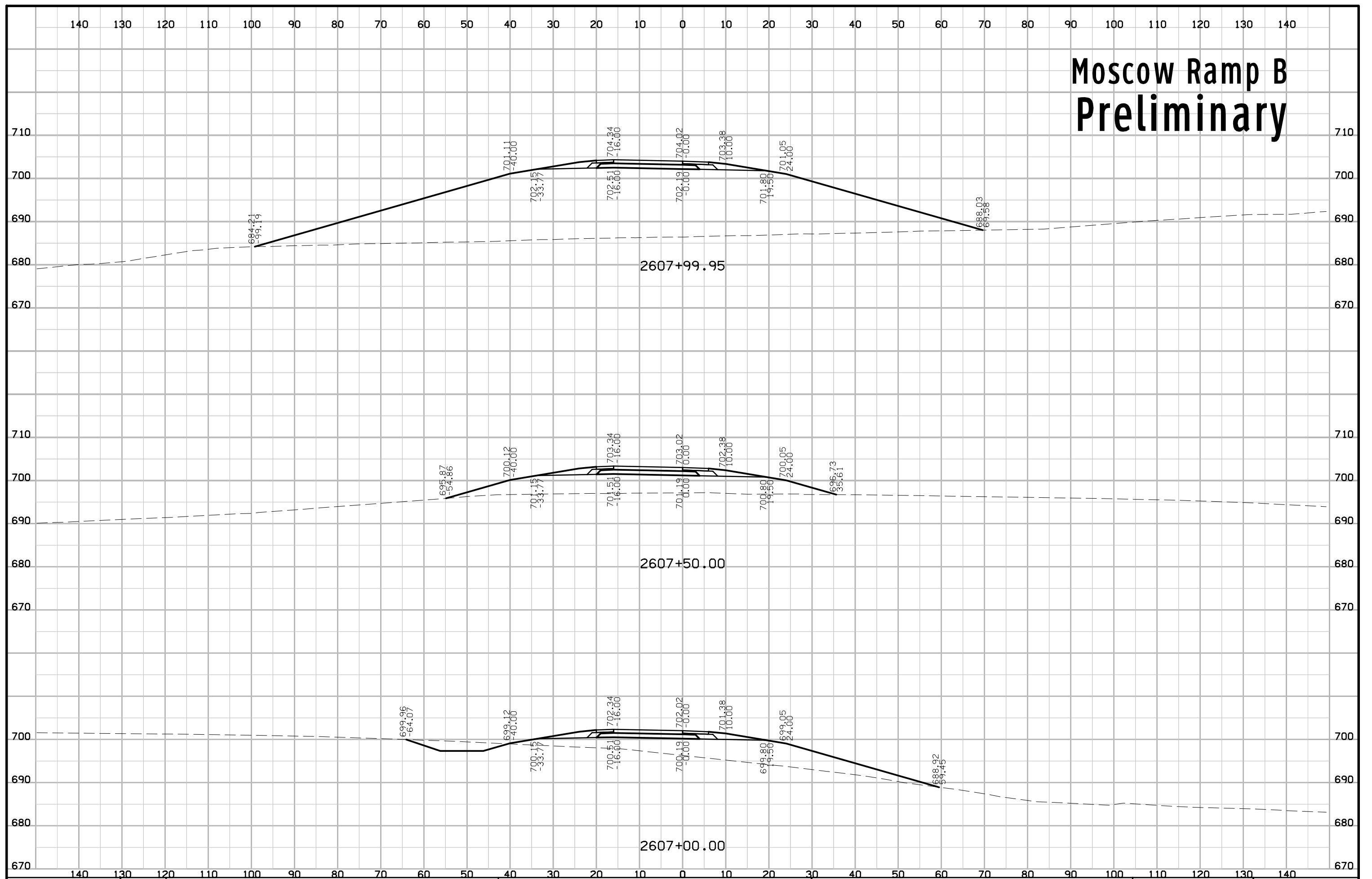

# Moscow Ramp C Preliminary

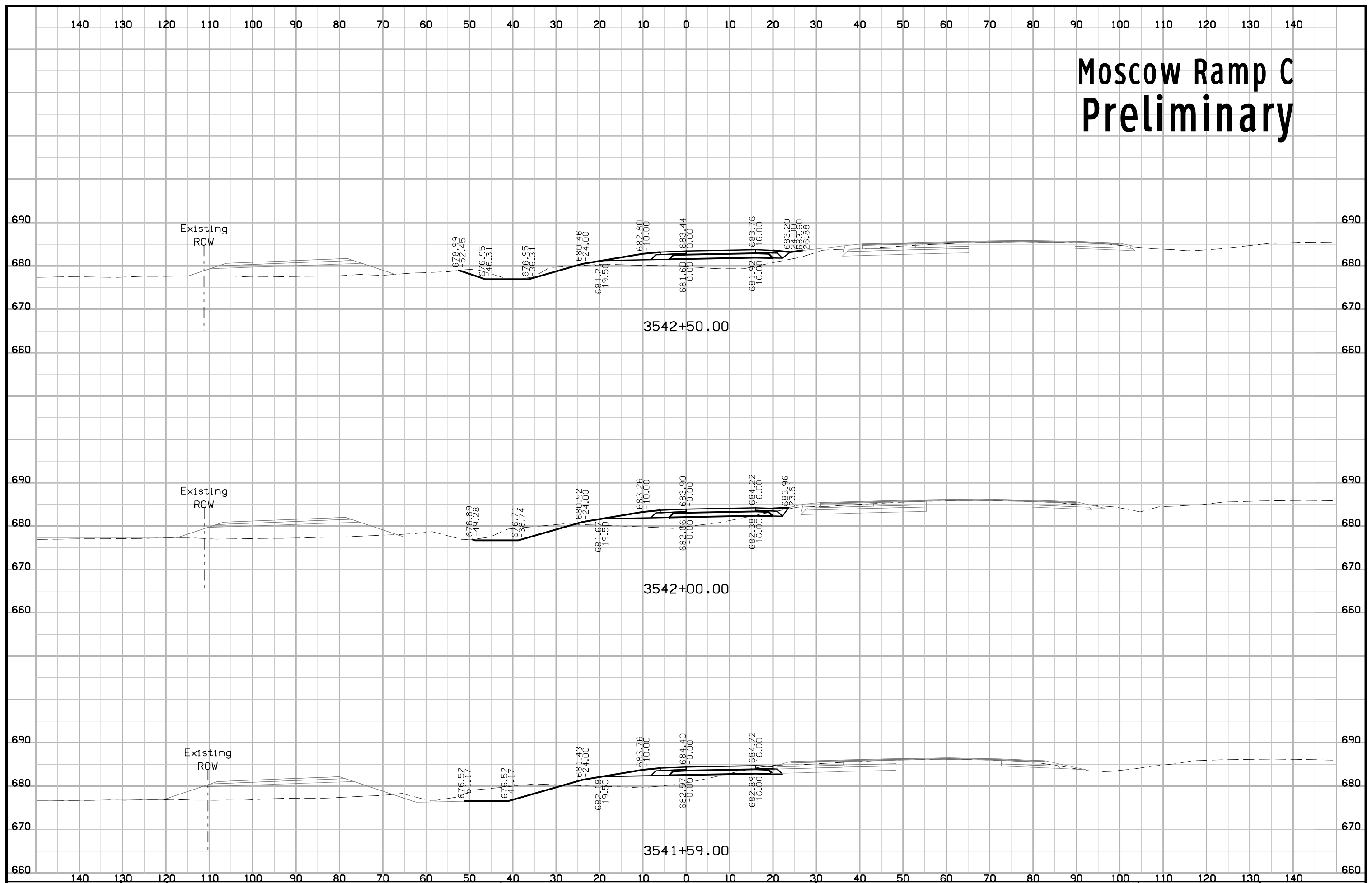

# Moscow Ramp C Preliminary

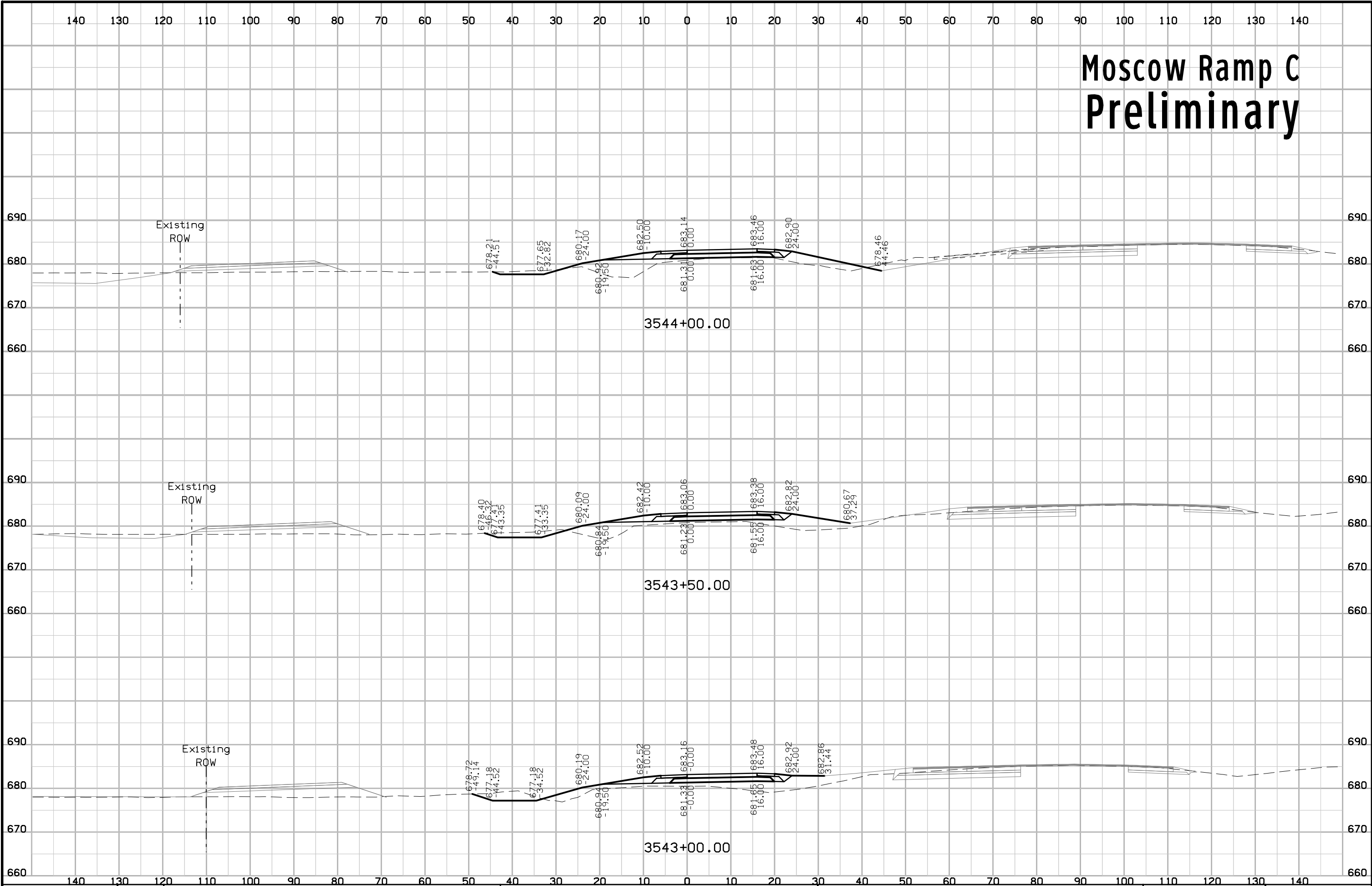



# Moscow Ramp C Preliminary

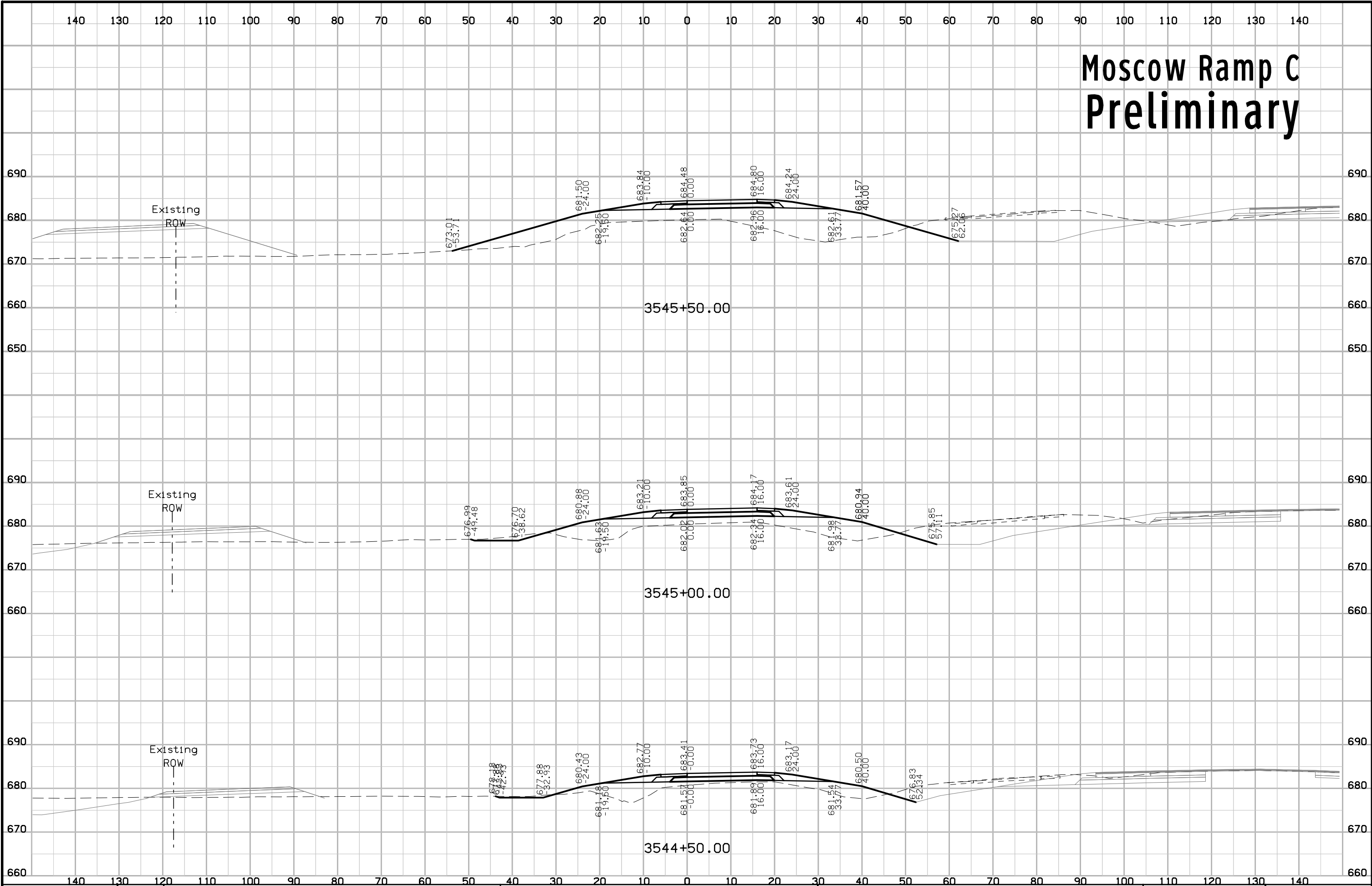

# Moscow Ramp C Preliminary

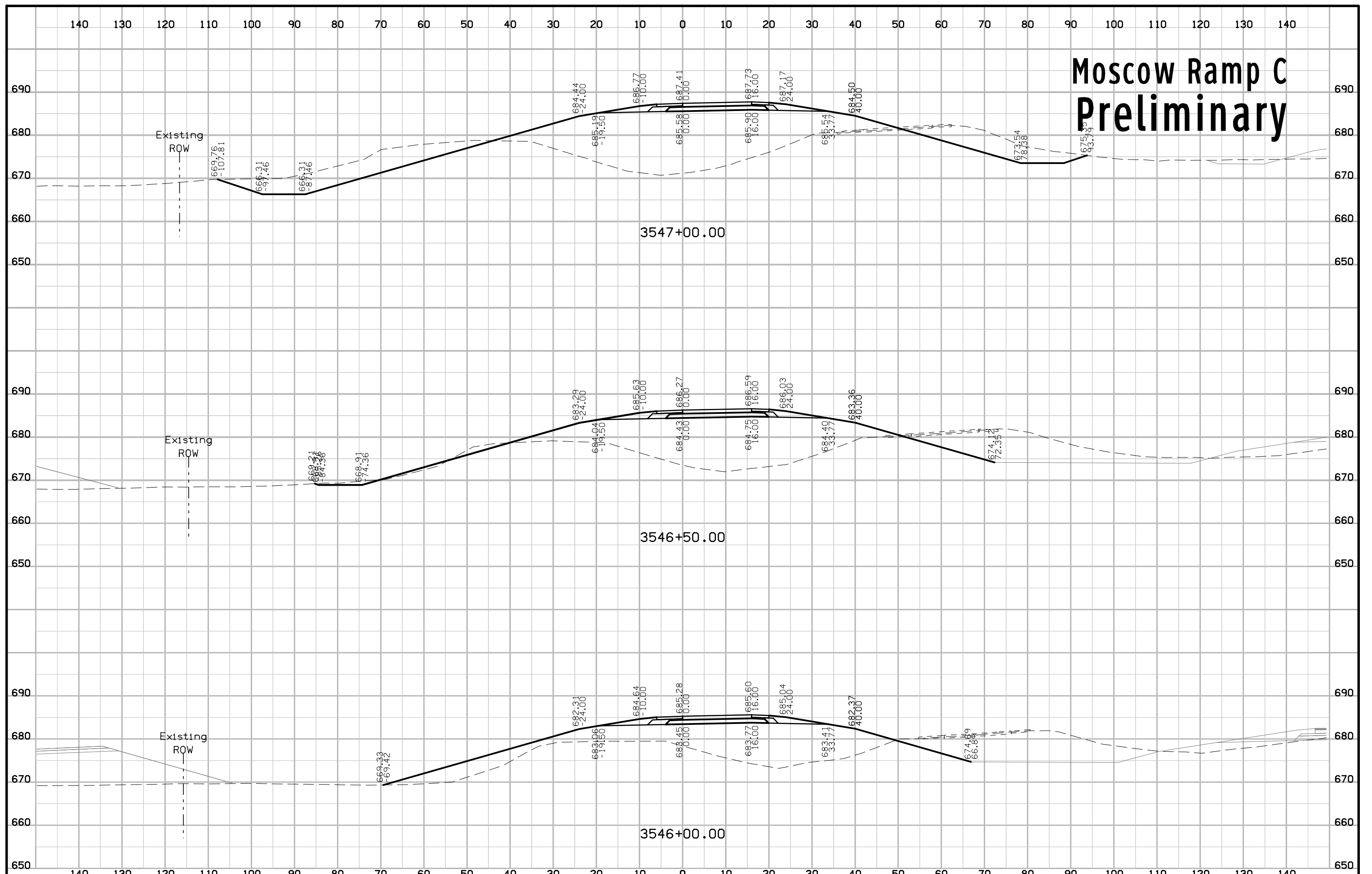

# Moscow Ramp C Preliminary

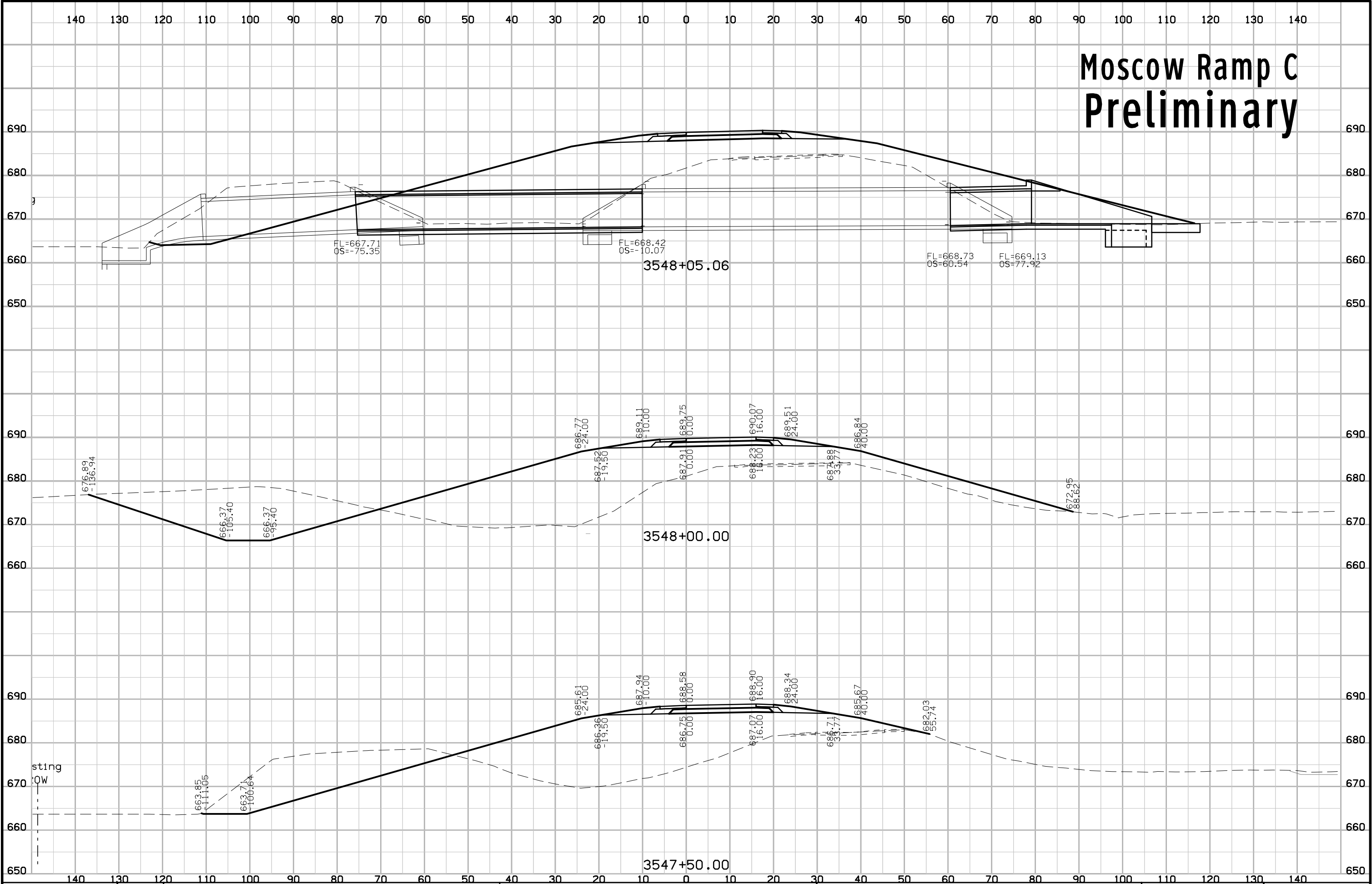

# Moscow Ramp C Preliminary

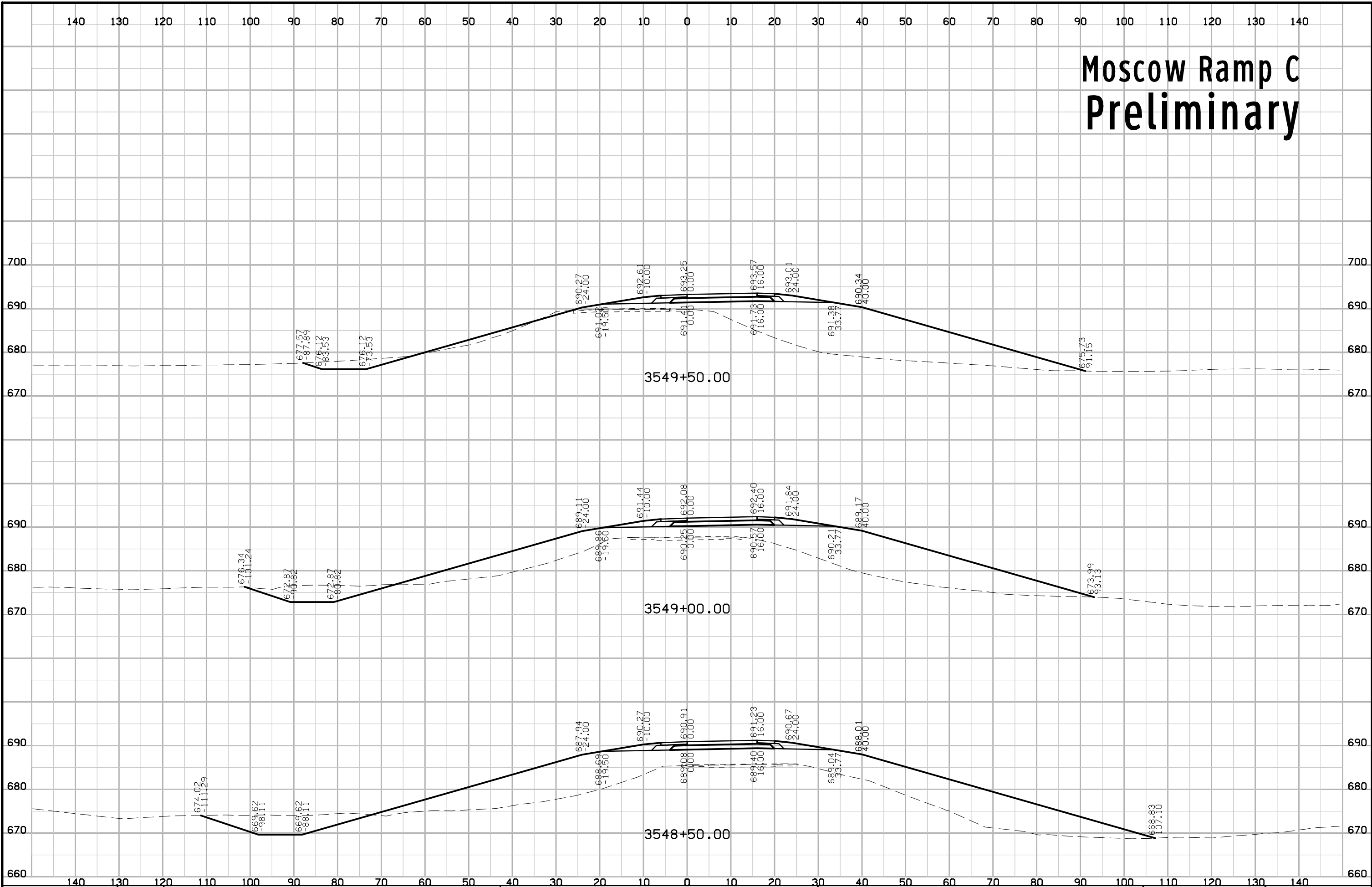

# Moscow Ramp C Preliminary

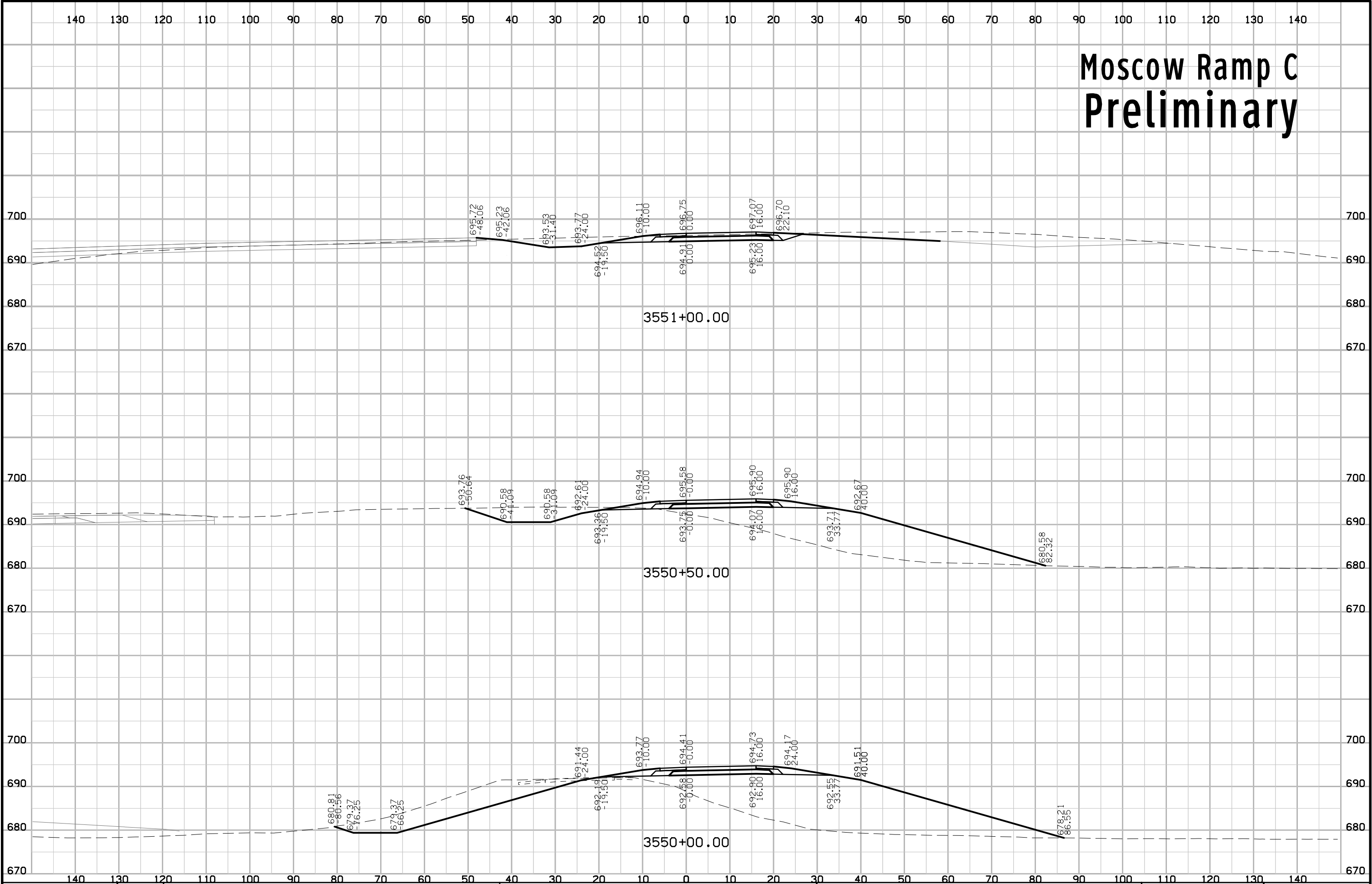

# Moscow Ramp C Preliminary

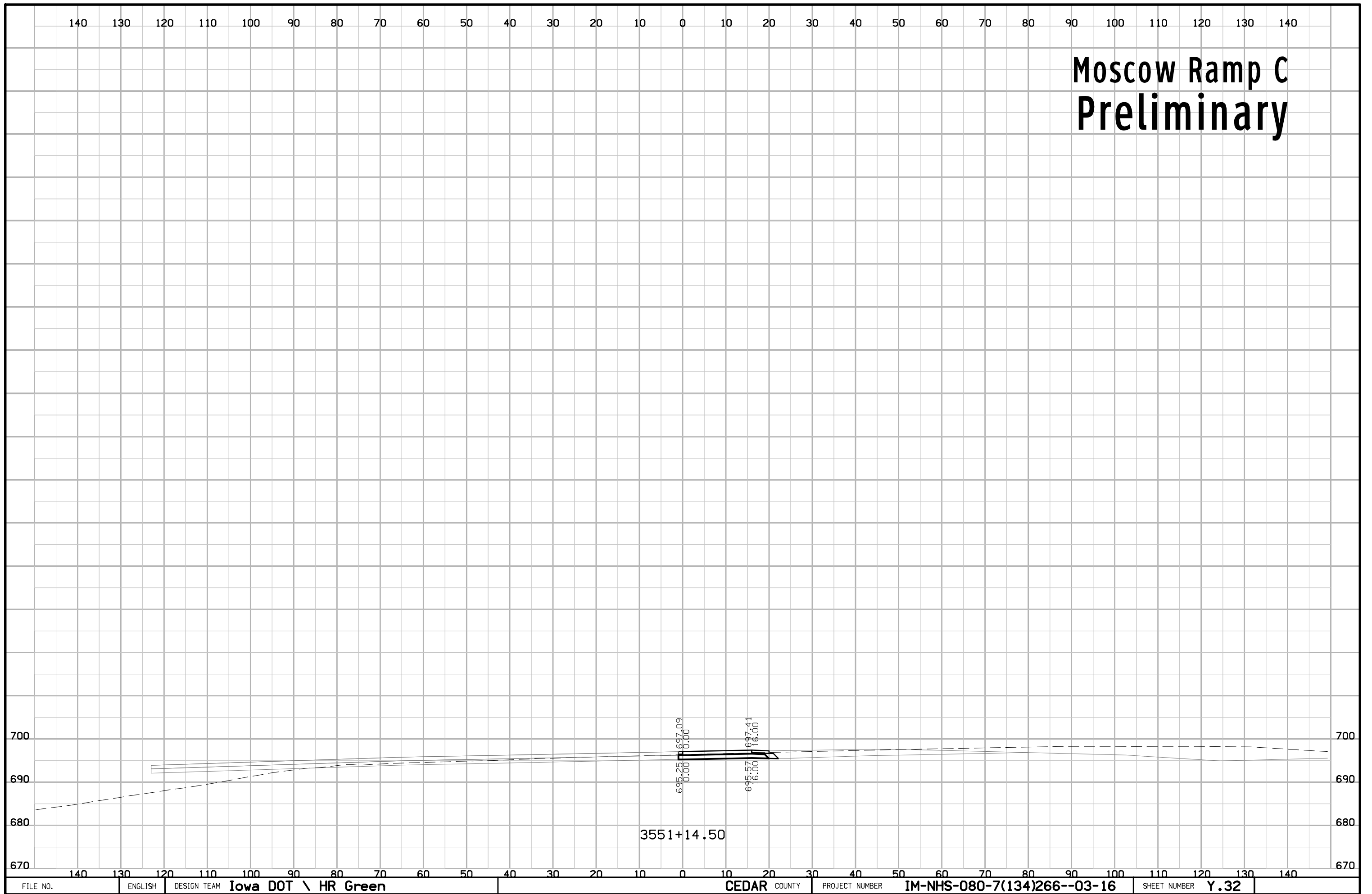

# Moscow Ramp D Preliminary

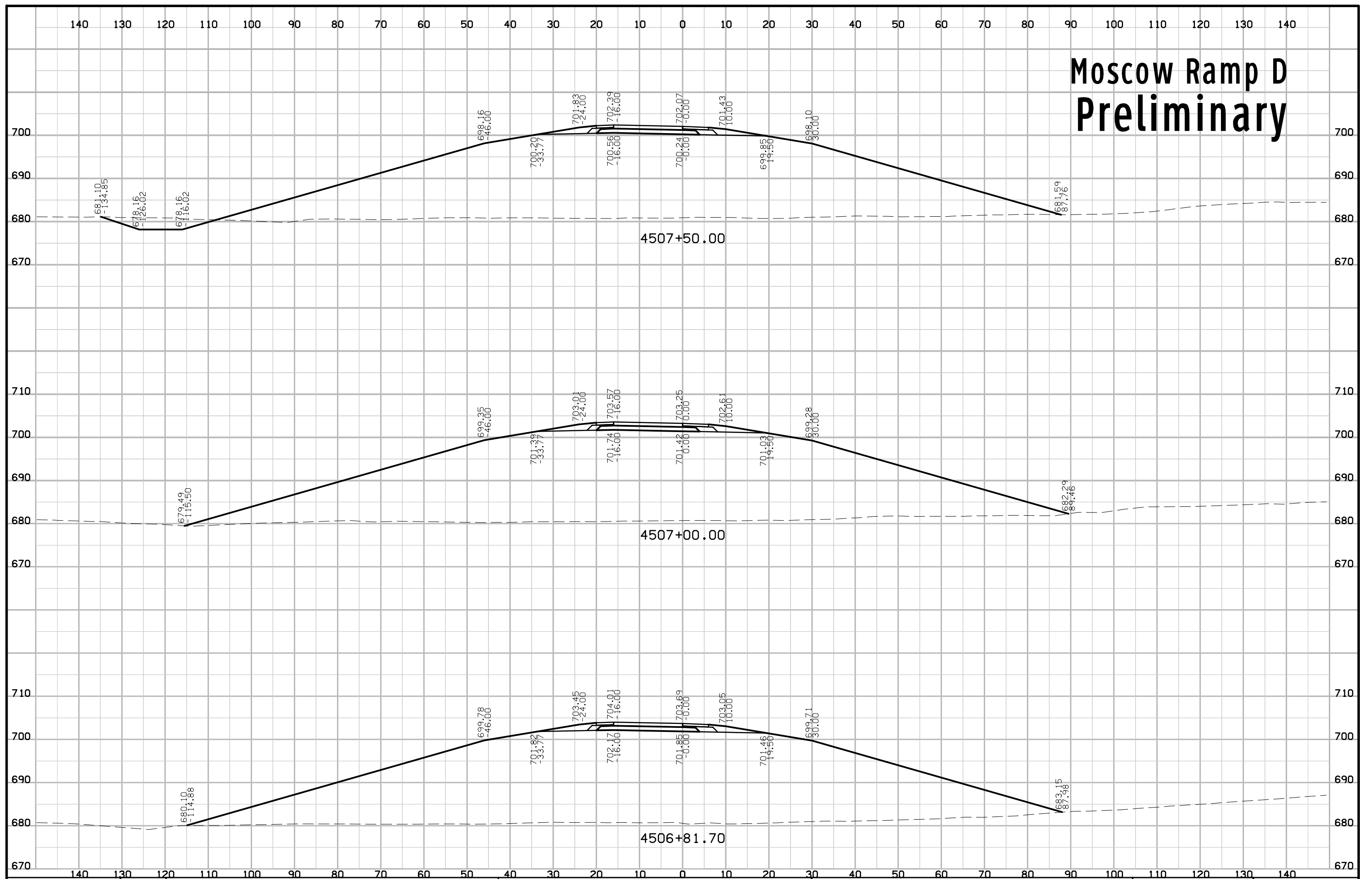

# Moscow Ramp D Preliminary

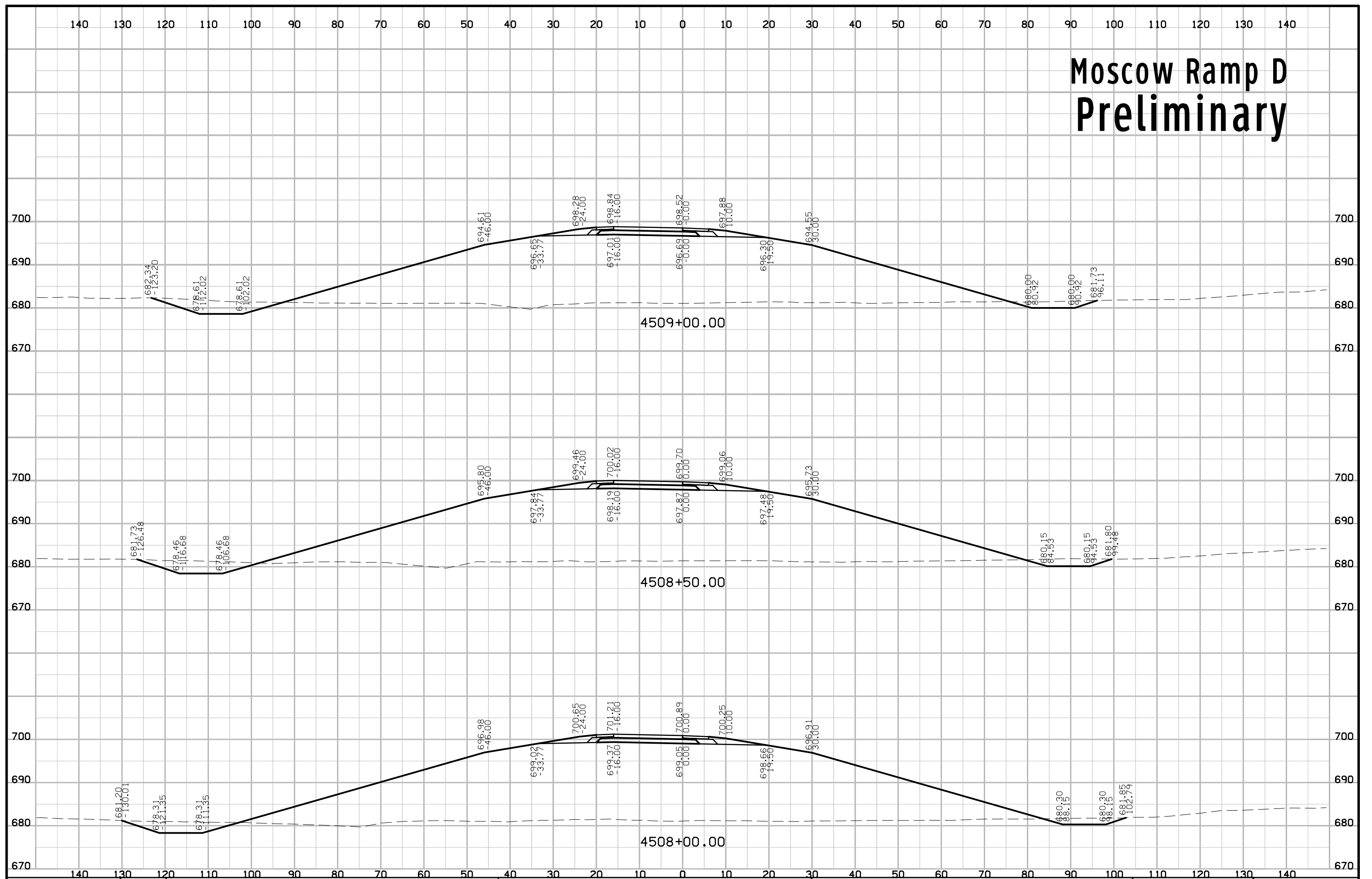



# Moscow Ramp D Preliminary

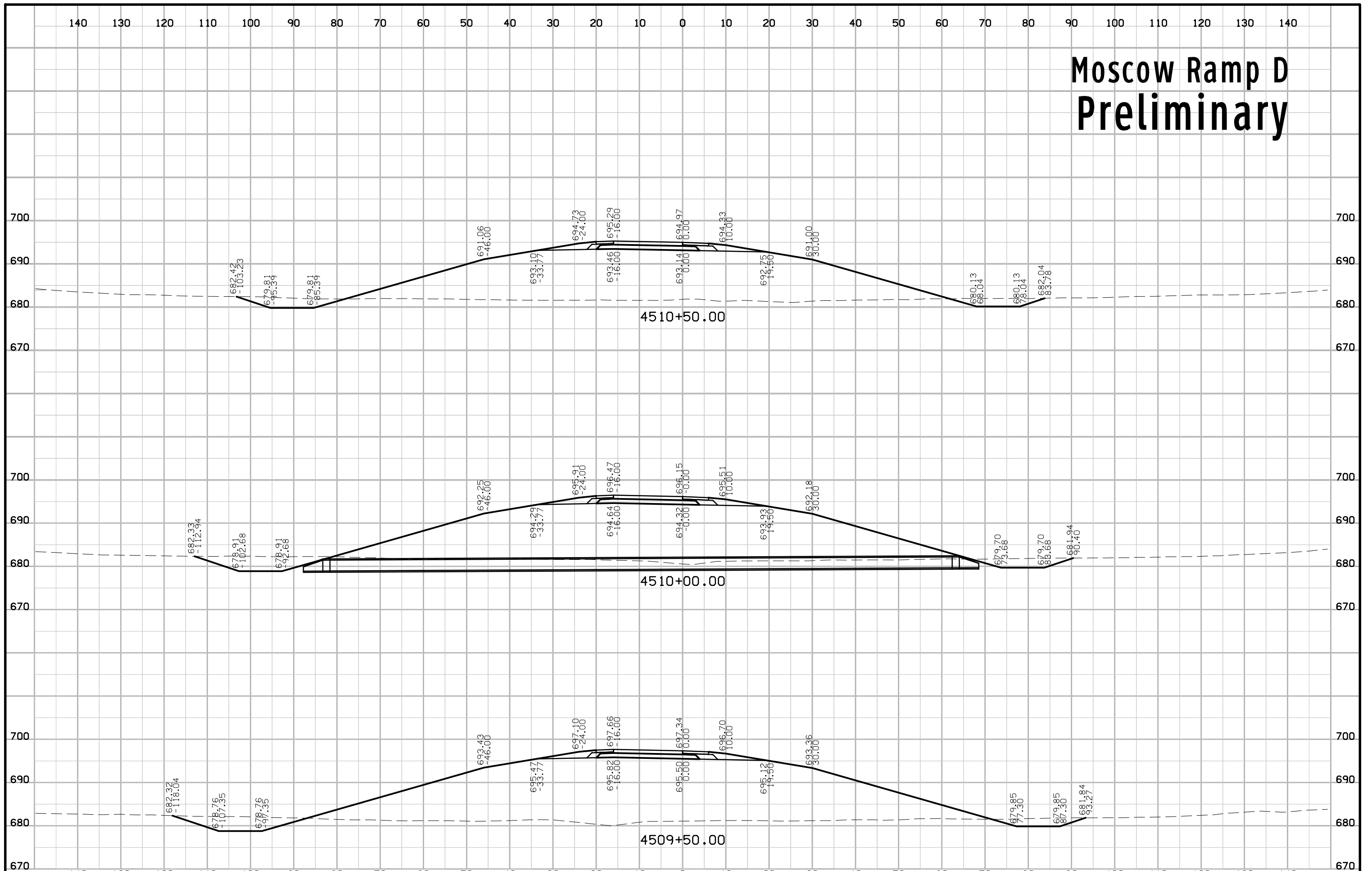

# Moscow Ramp D Preliminary

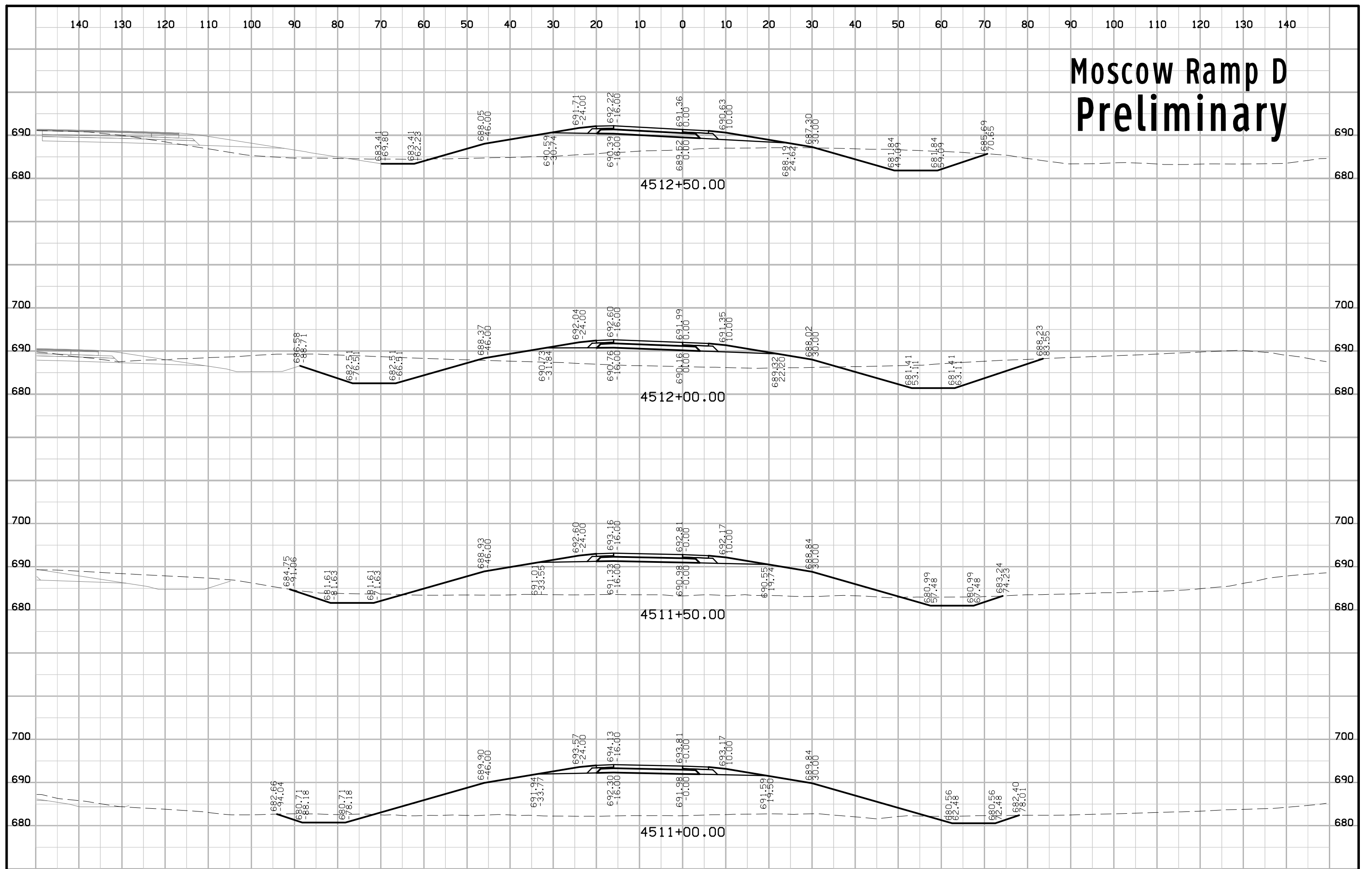

# Moscow Ramp D Preliminary

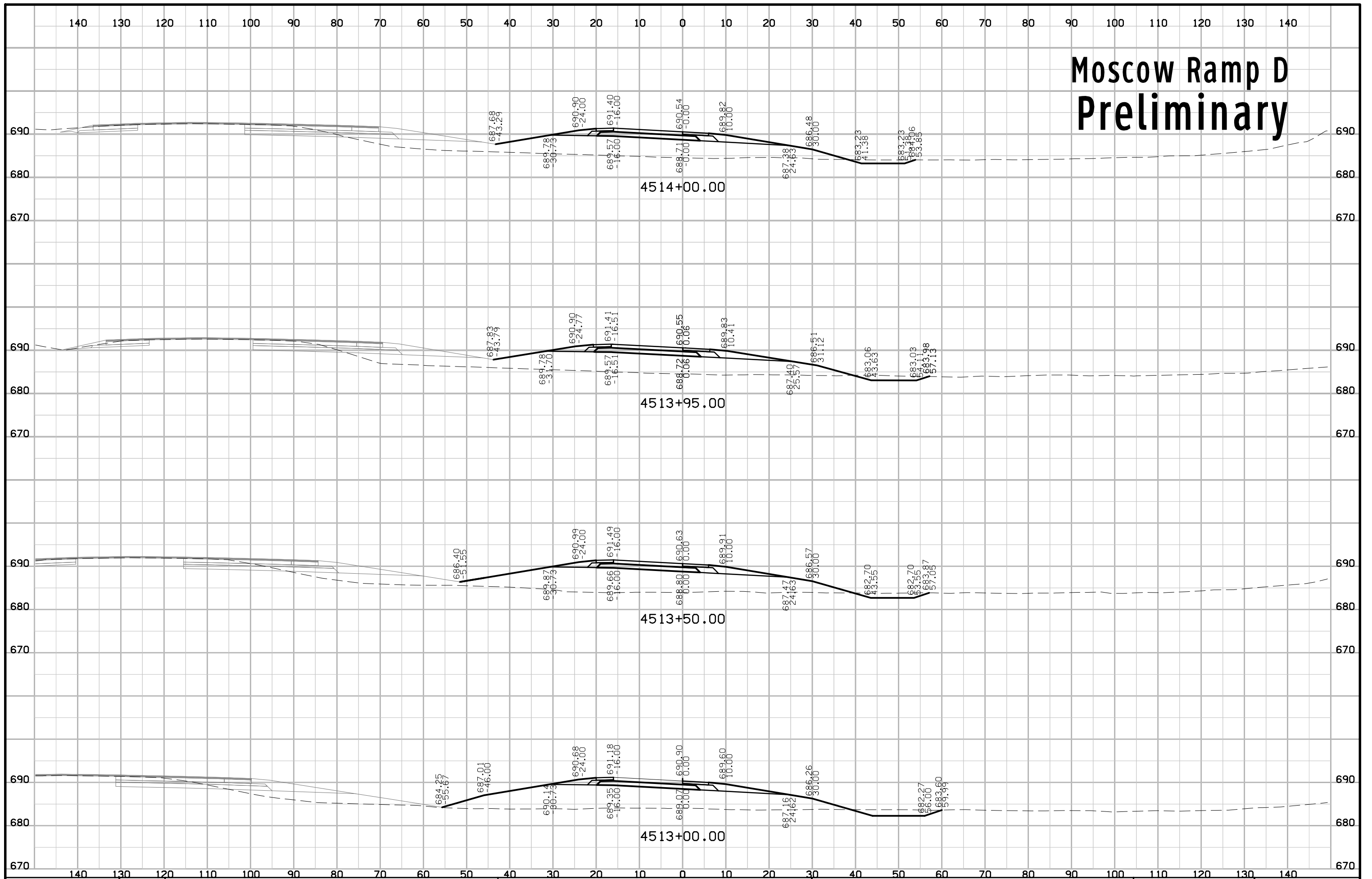

# Moscow Ramp D Preliminary

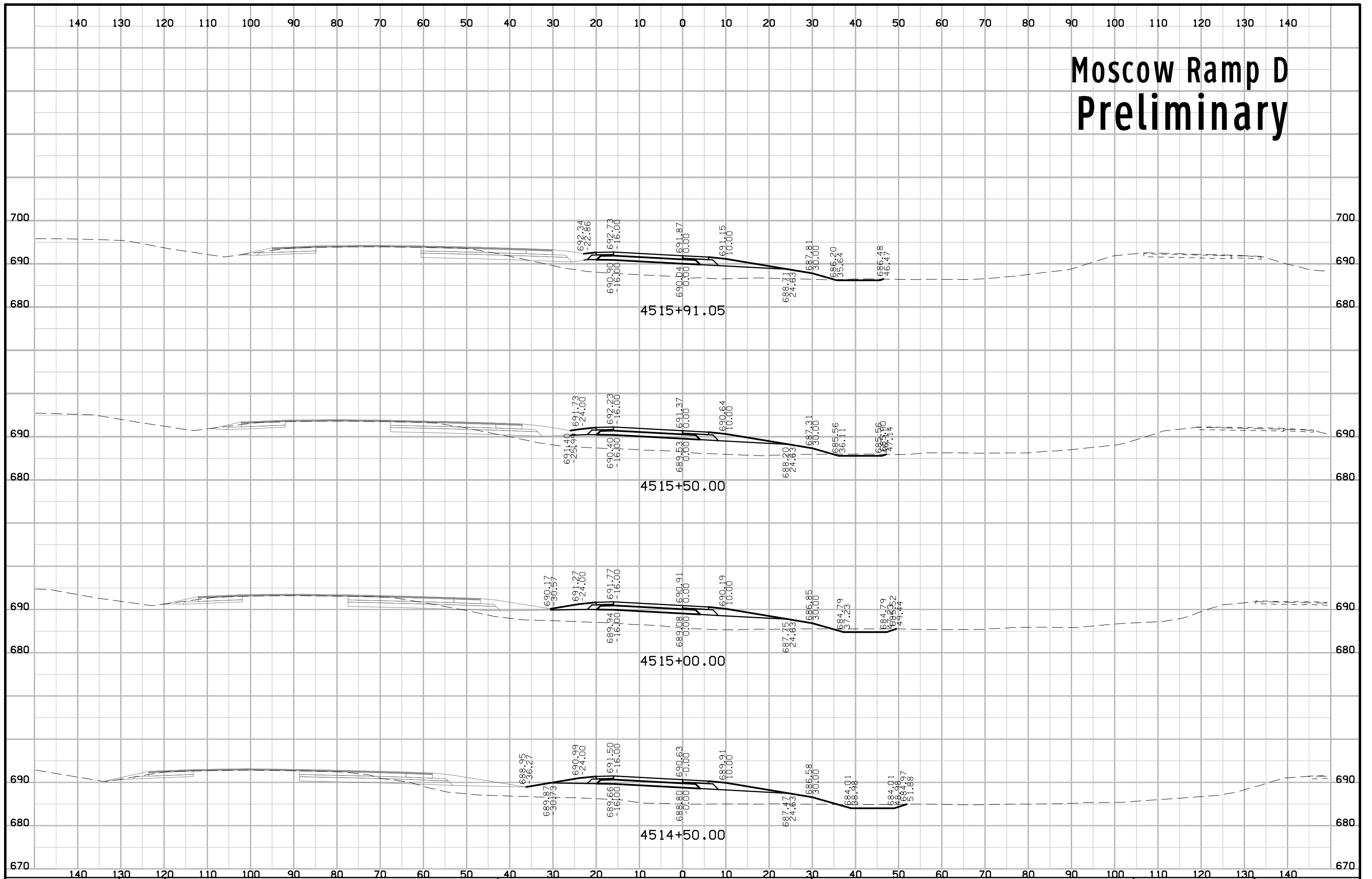

# Truck Parking Ramp A Preliminary

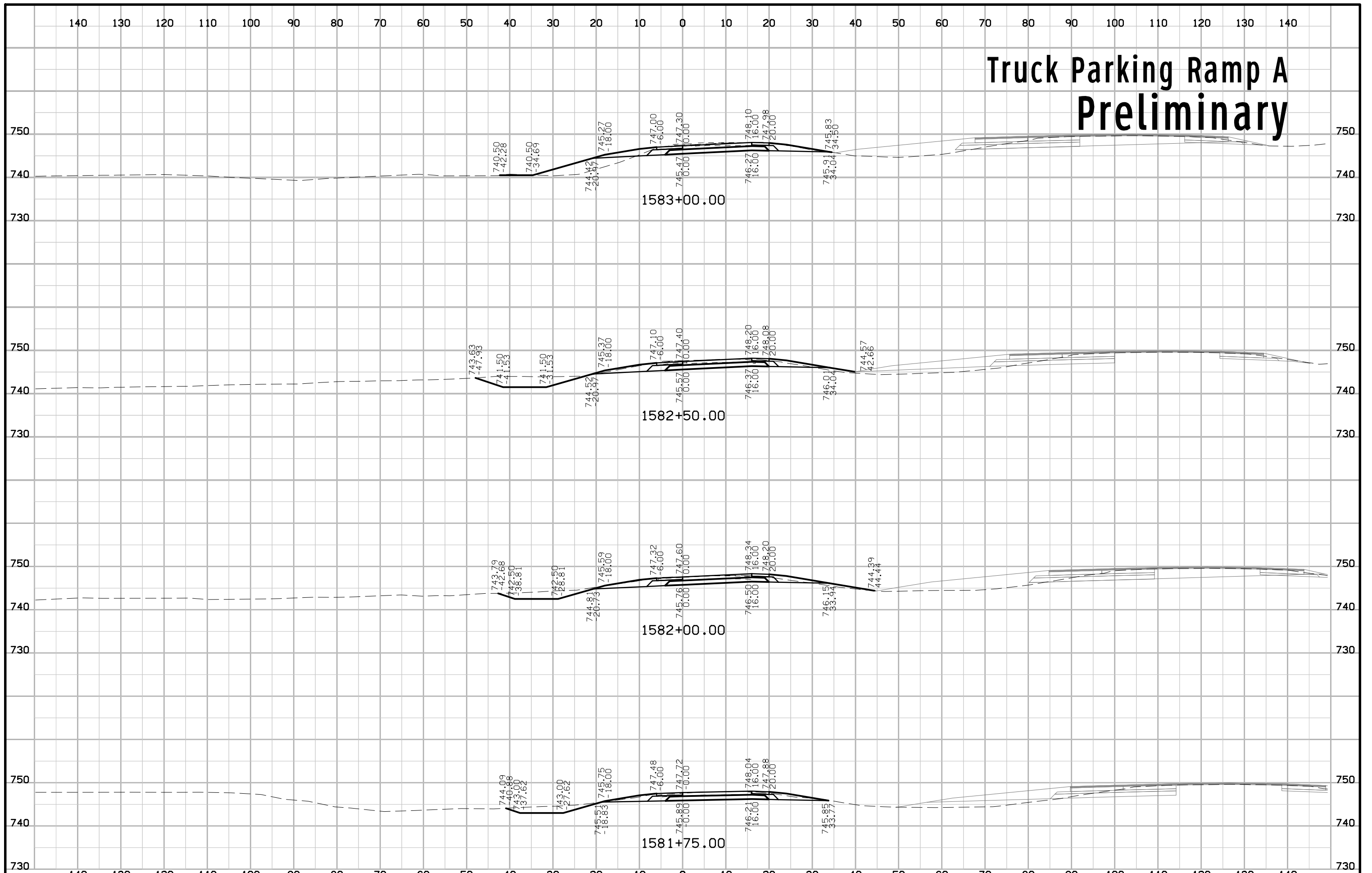

# Truck Parking Ramp A Preliminary

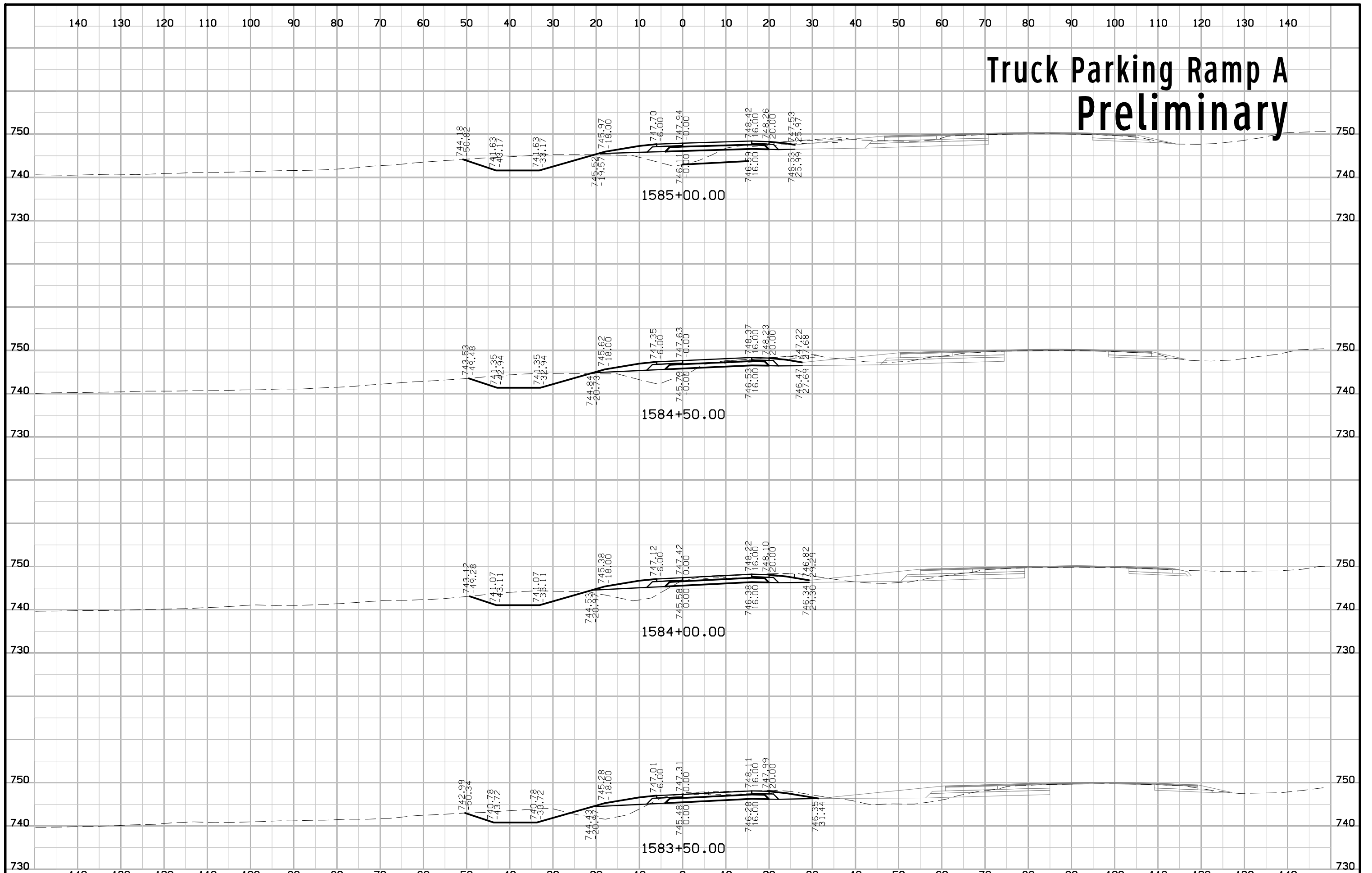

# Truck Parking Ramp A Preliminary

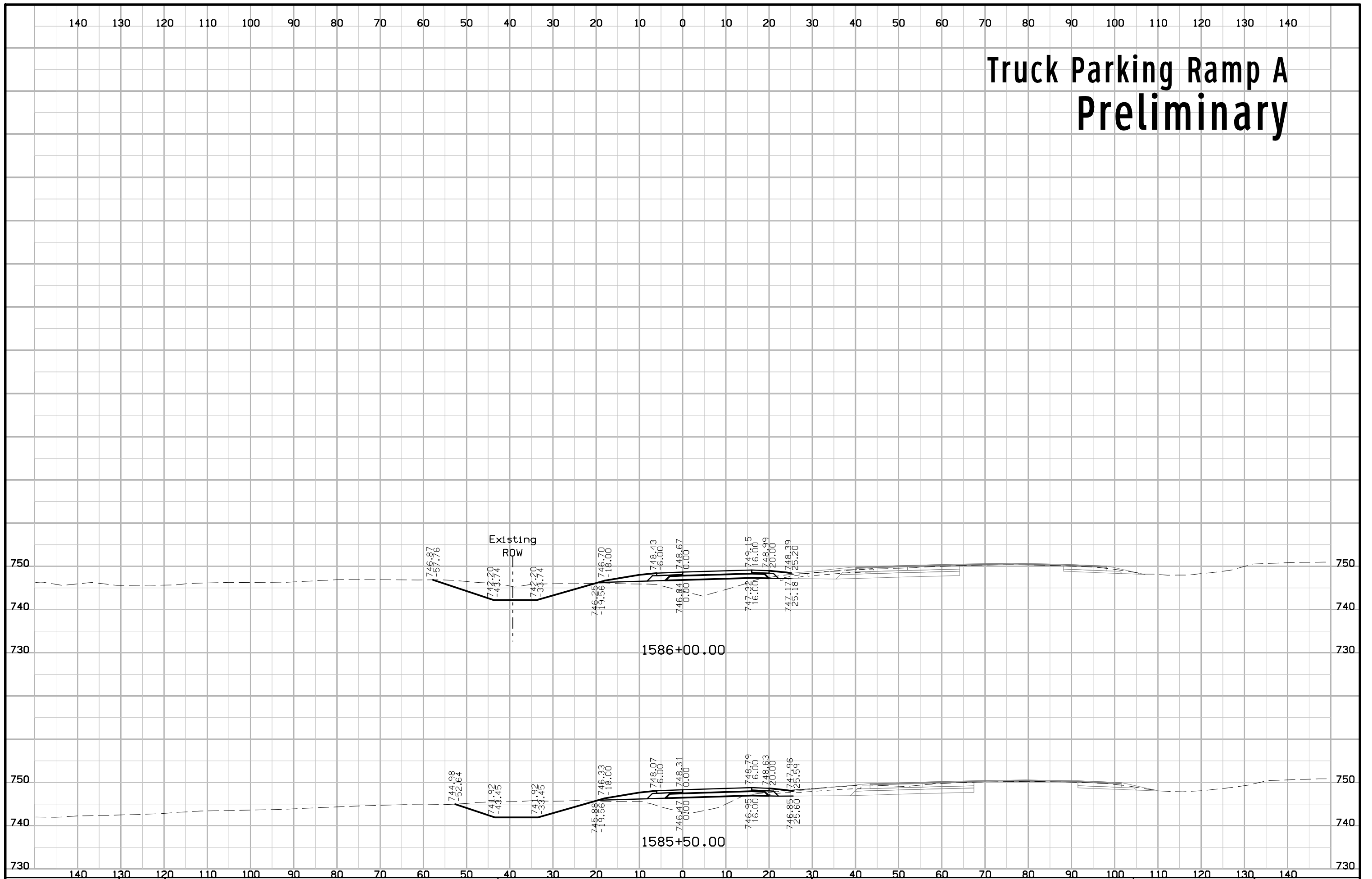

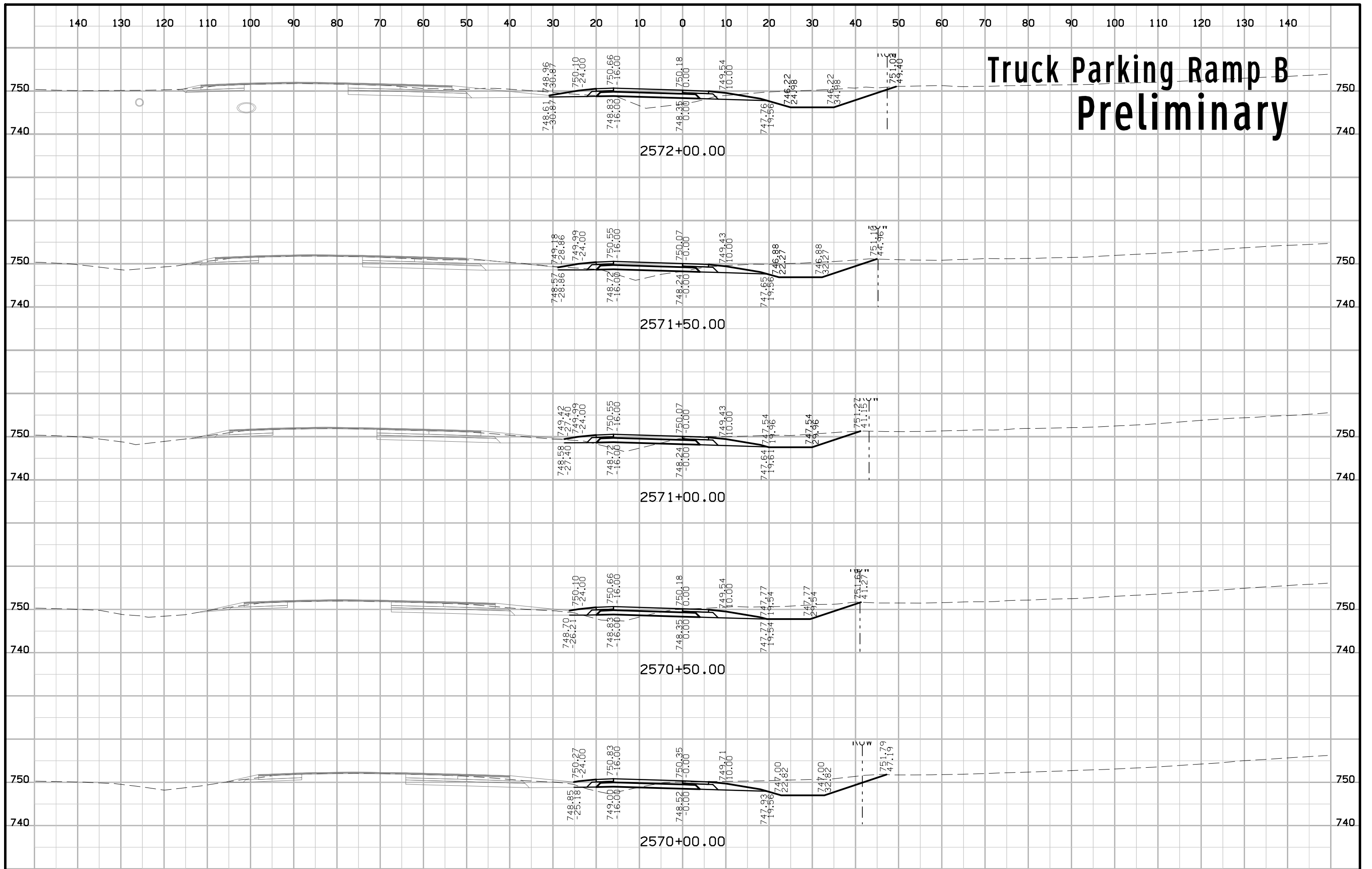



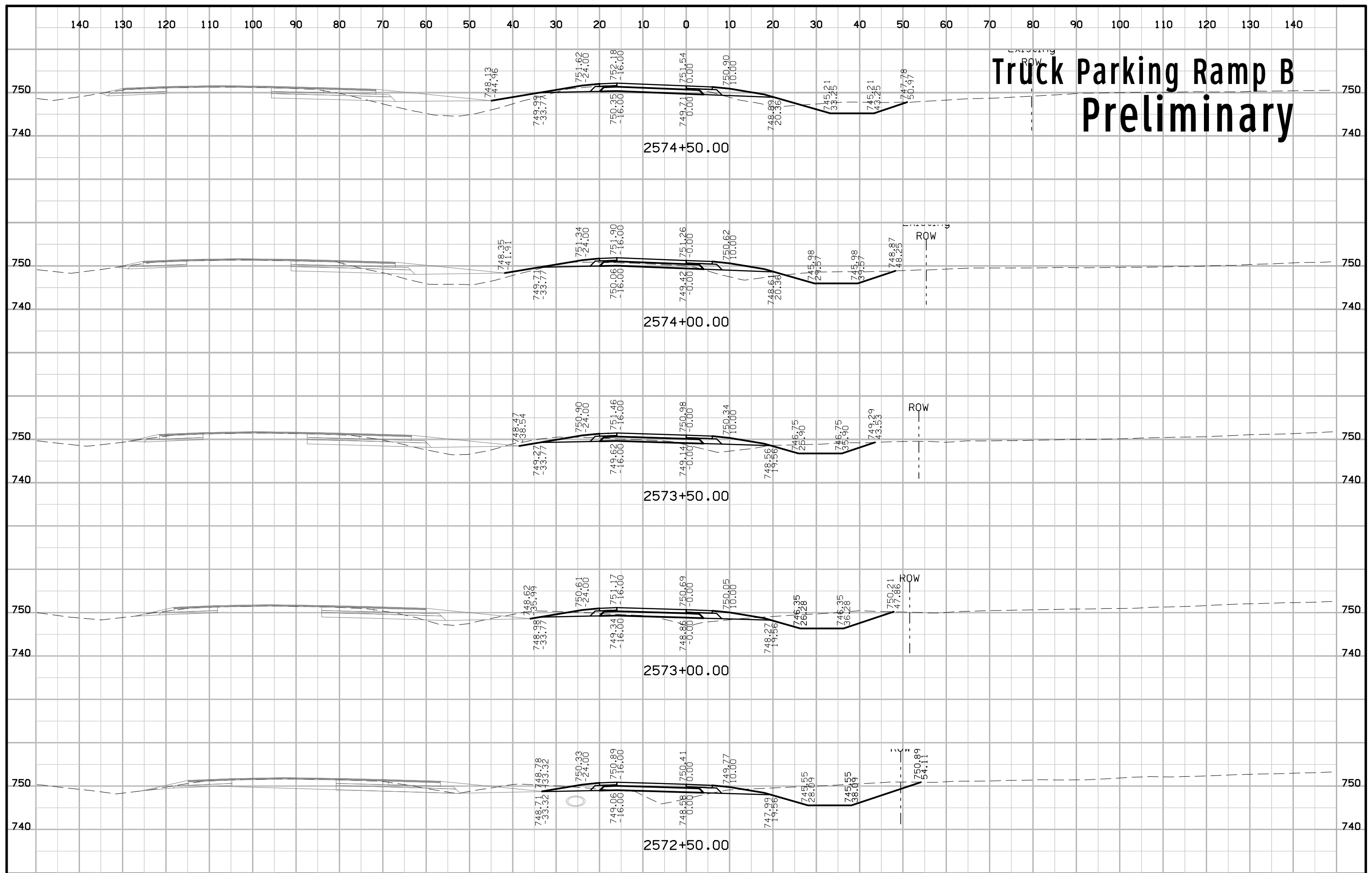

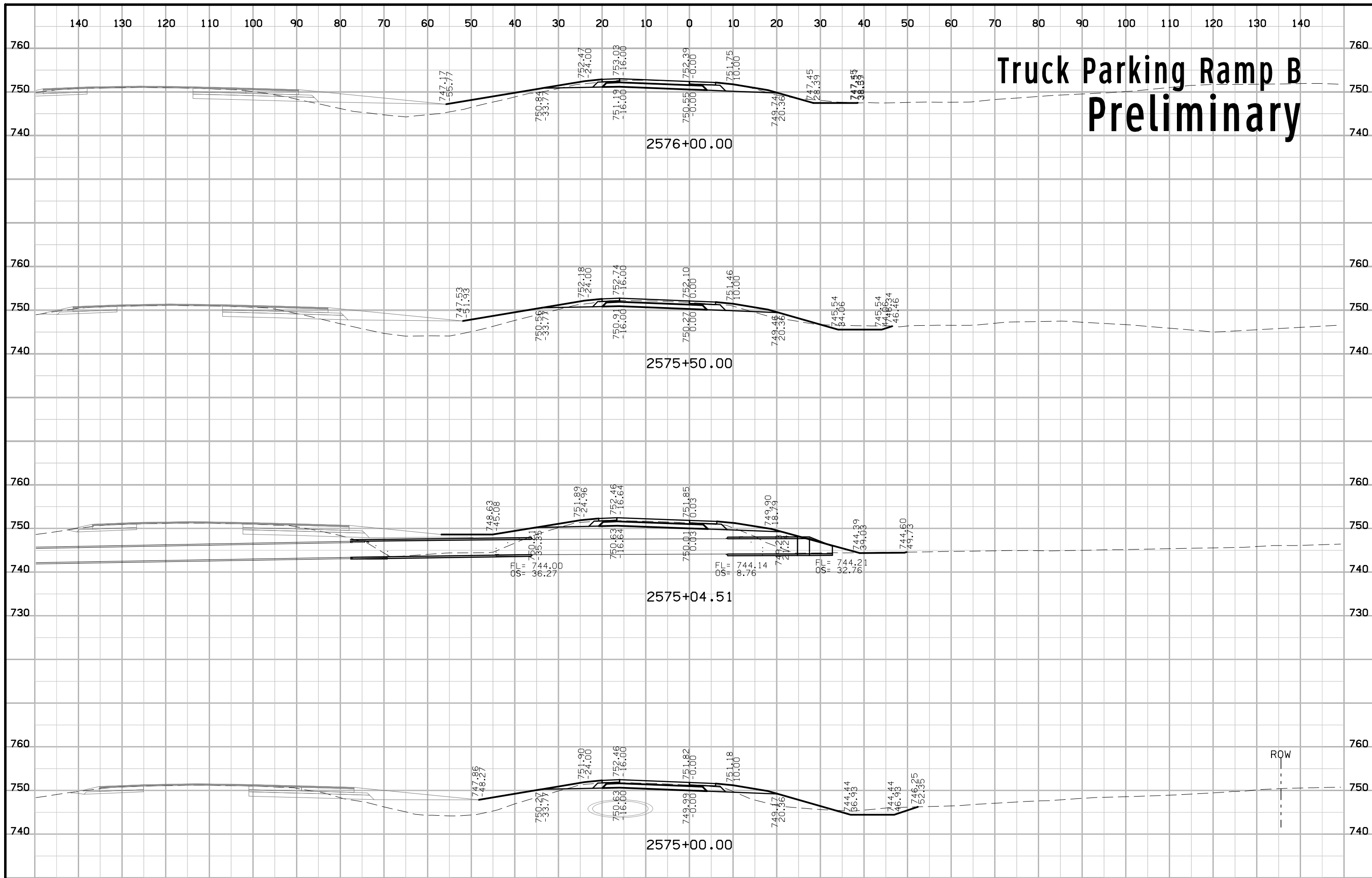

# Truck Parking Ramp B Preliminary

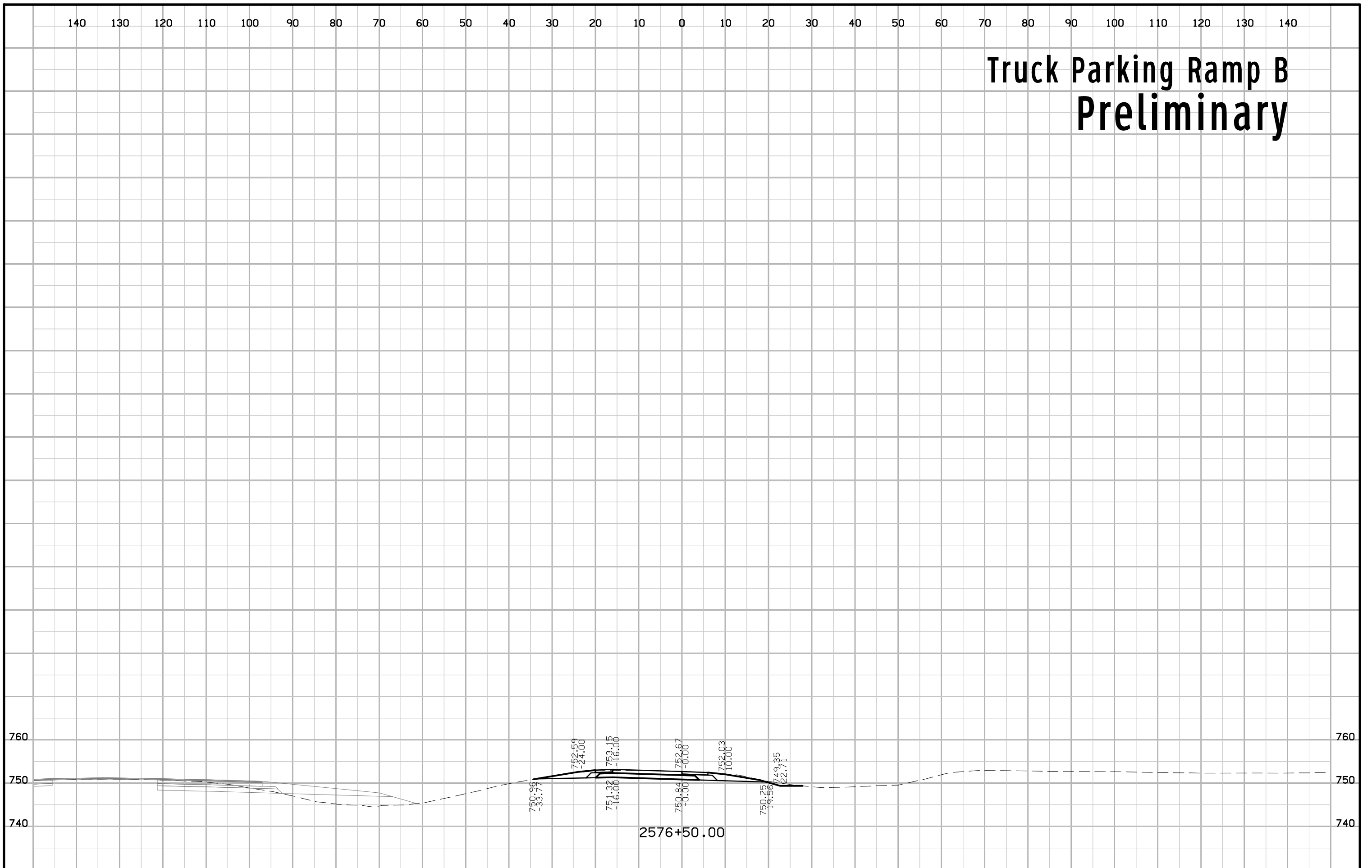

# Truck Parking Ramp C Preliminary

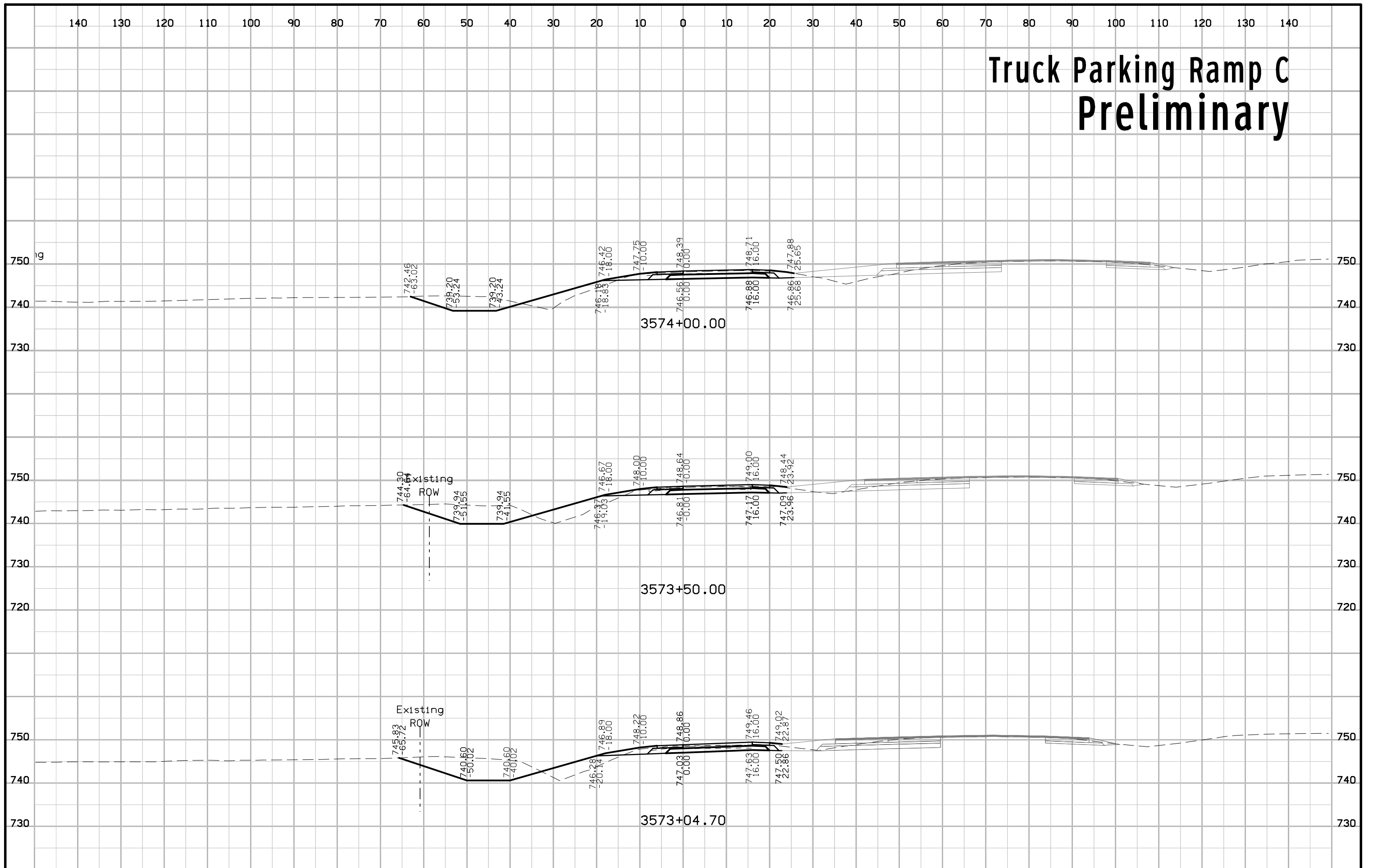

# Truck Parking Ramp C Preliminary

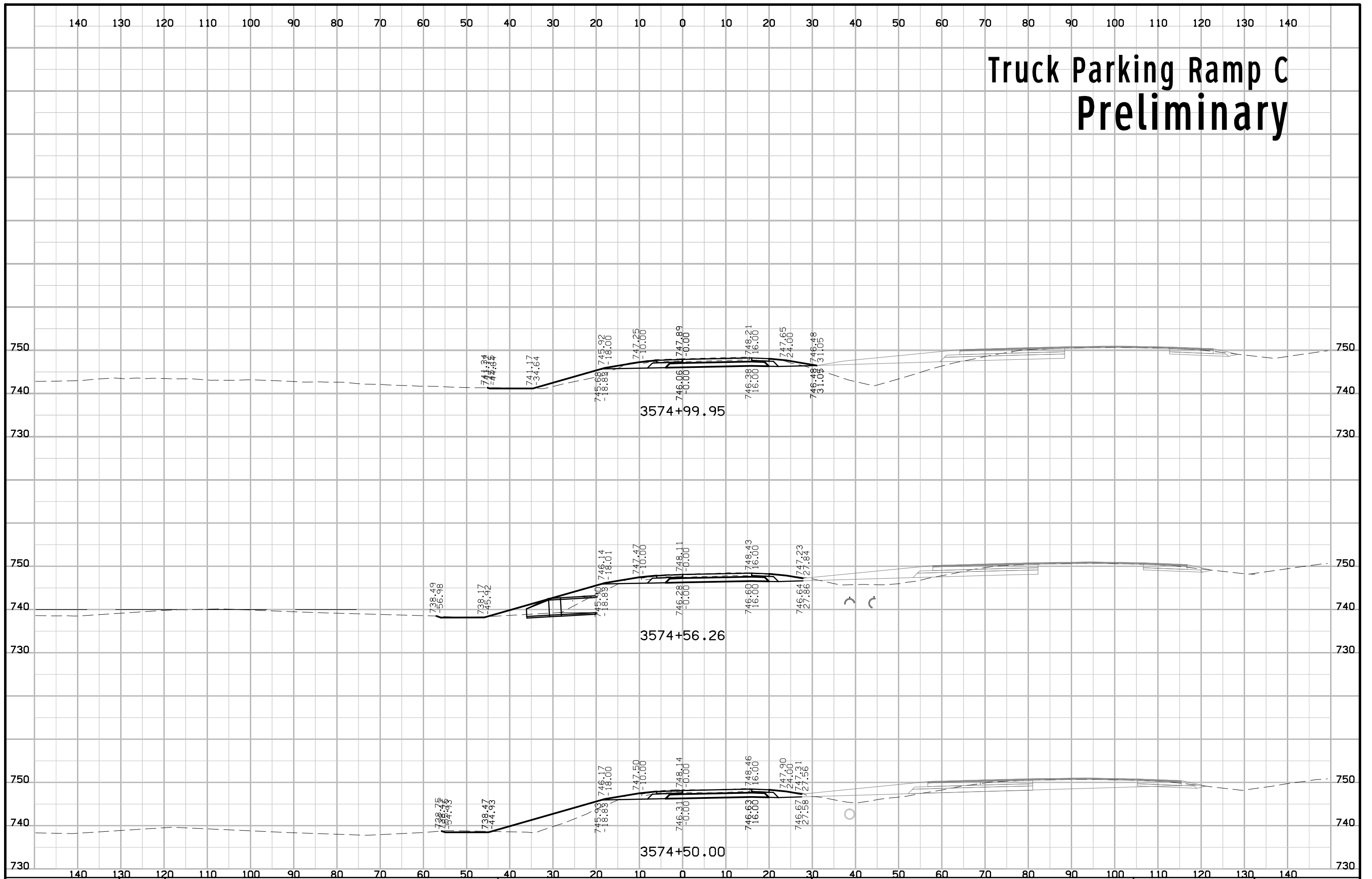

# Truck Parking Ramp D Preliminary

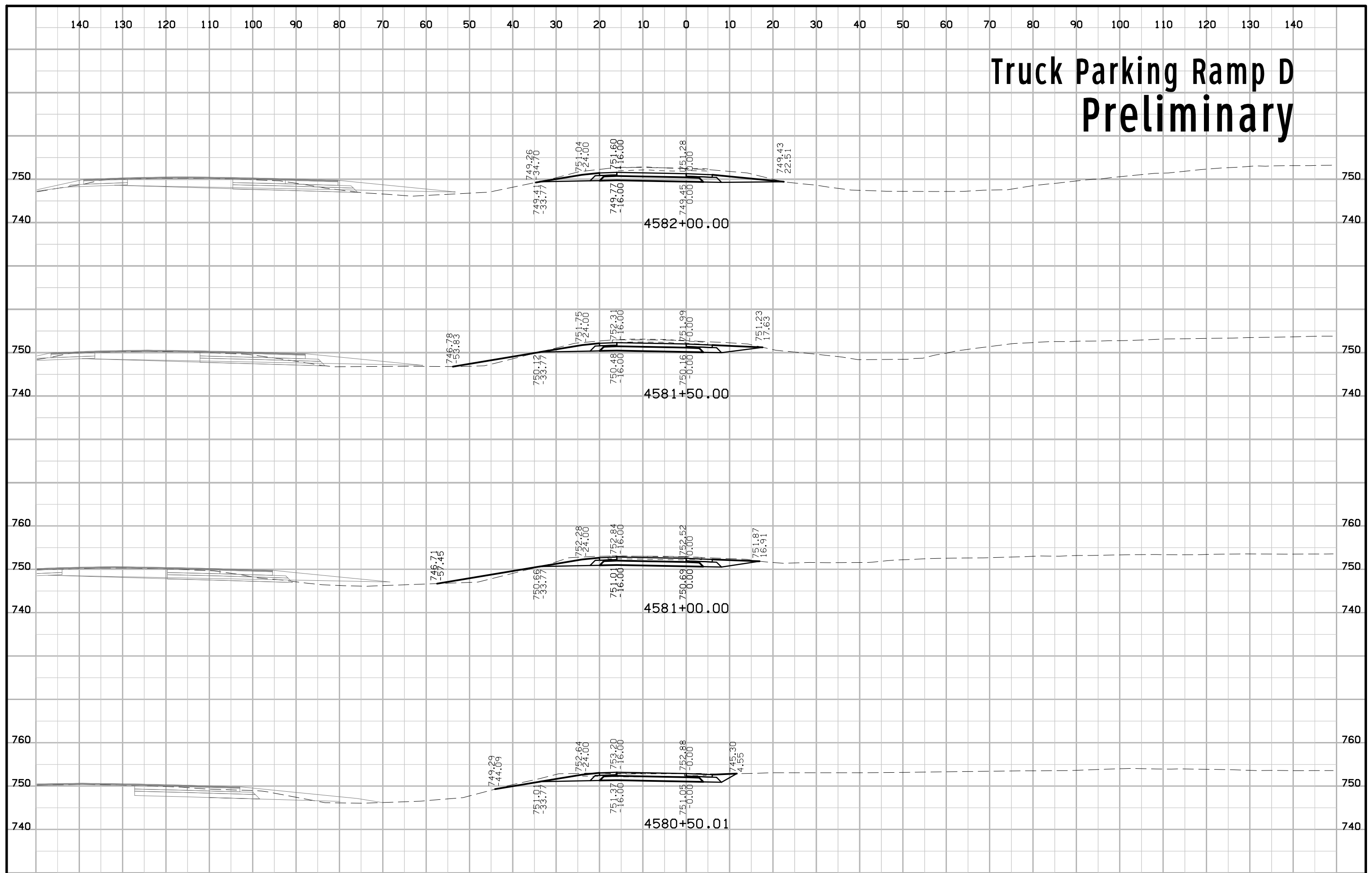

# Truck Parking Ramp D Preliminary

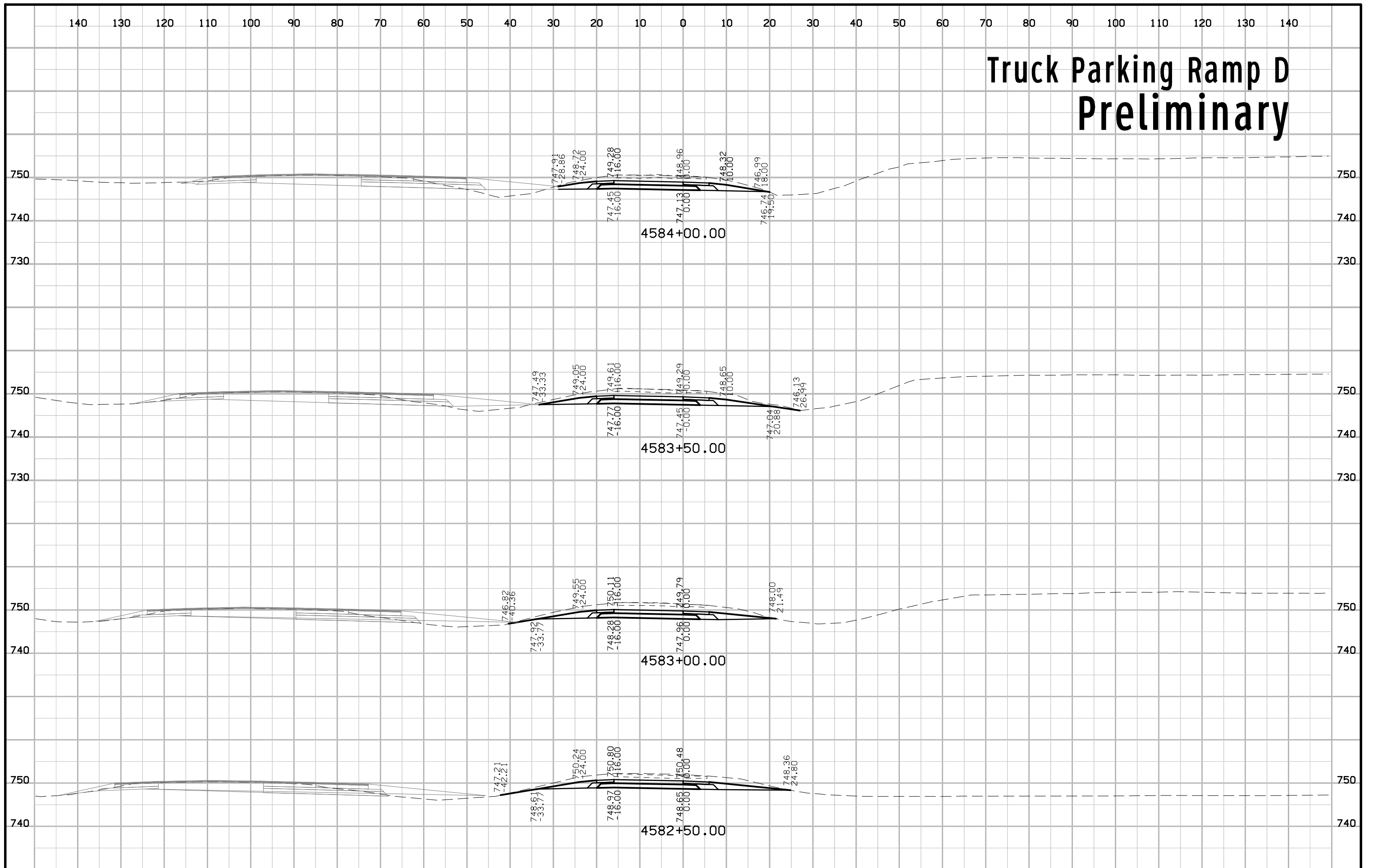

# Truck Parking Ramp D Preliminary

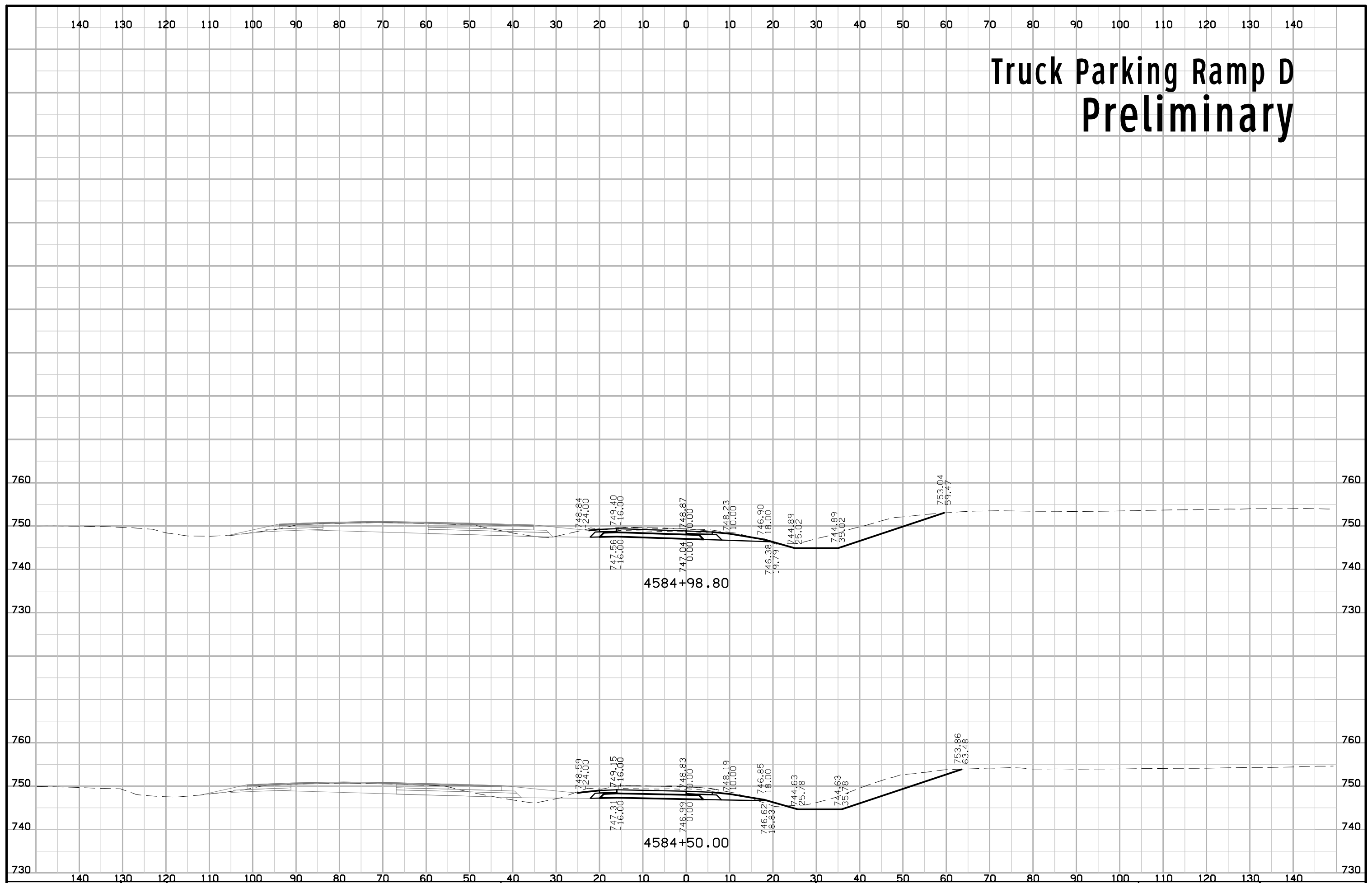



# Rest Area Ramp C Preliminary

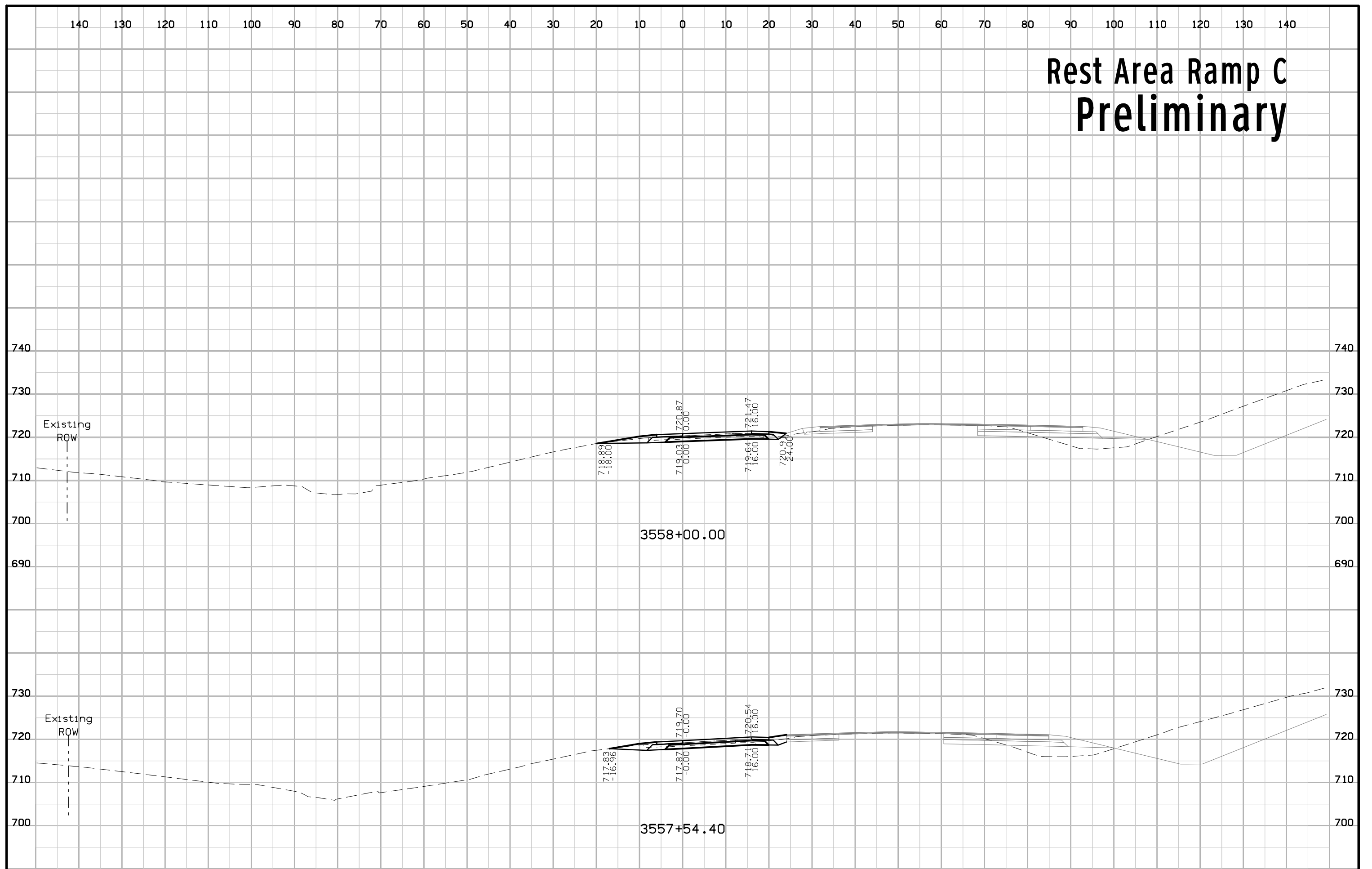

# Rest Area Ramp C Preliminary

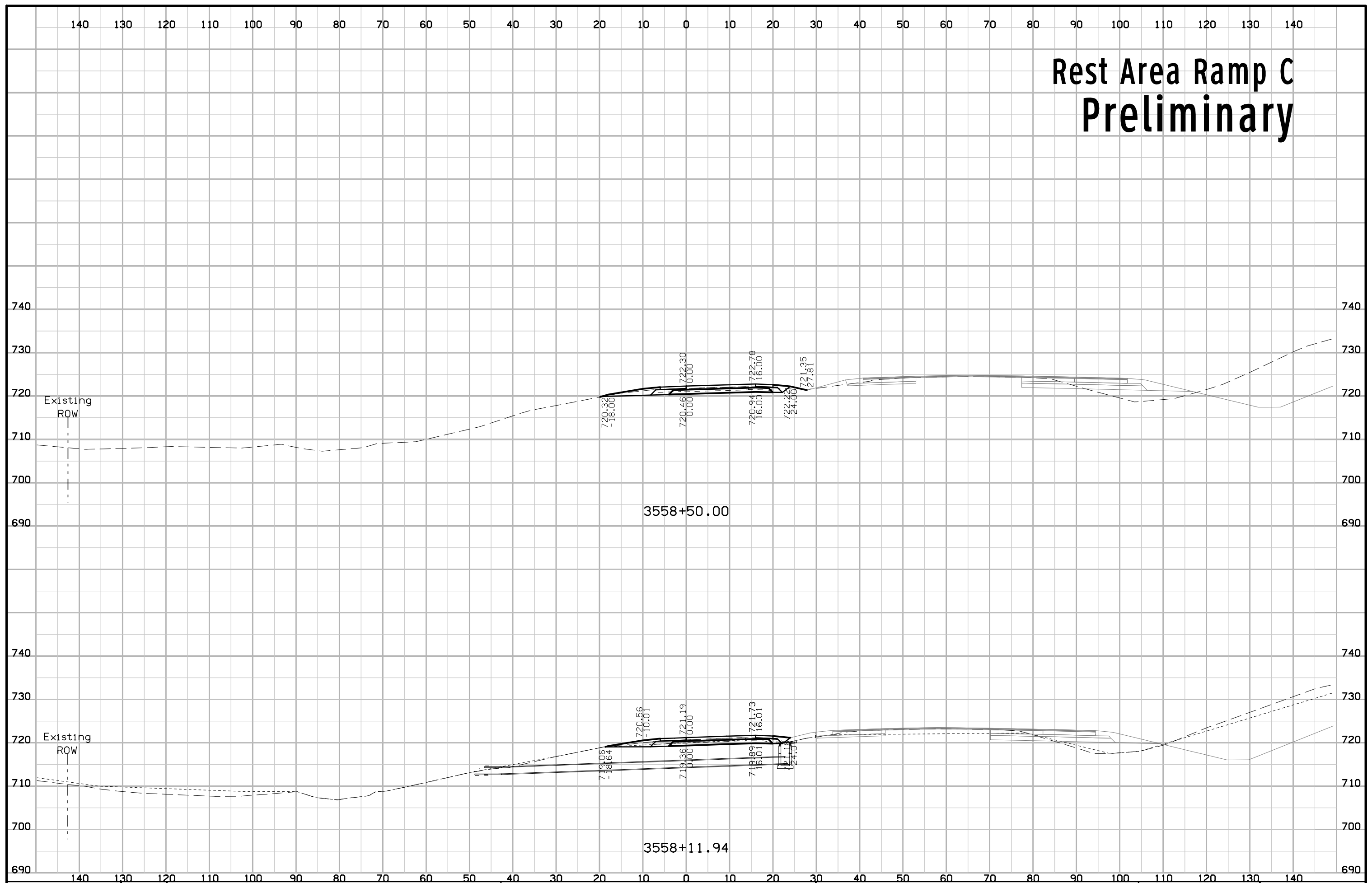

# Rest Area Ramp C Preliminary

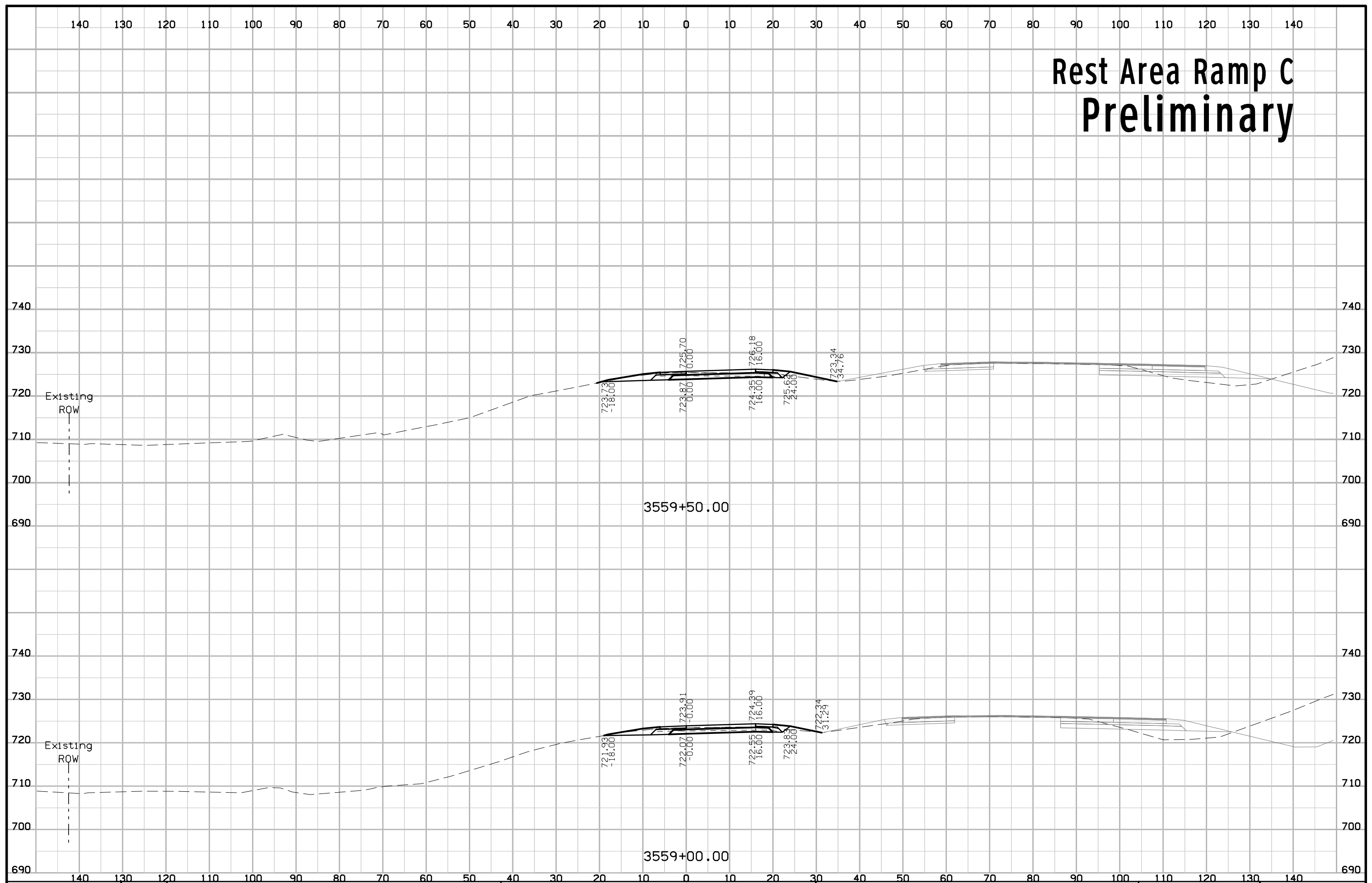

# Rest Area Ramp C Preliminary

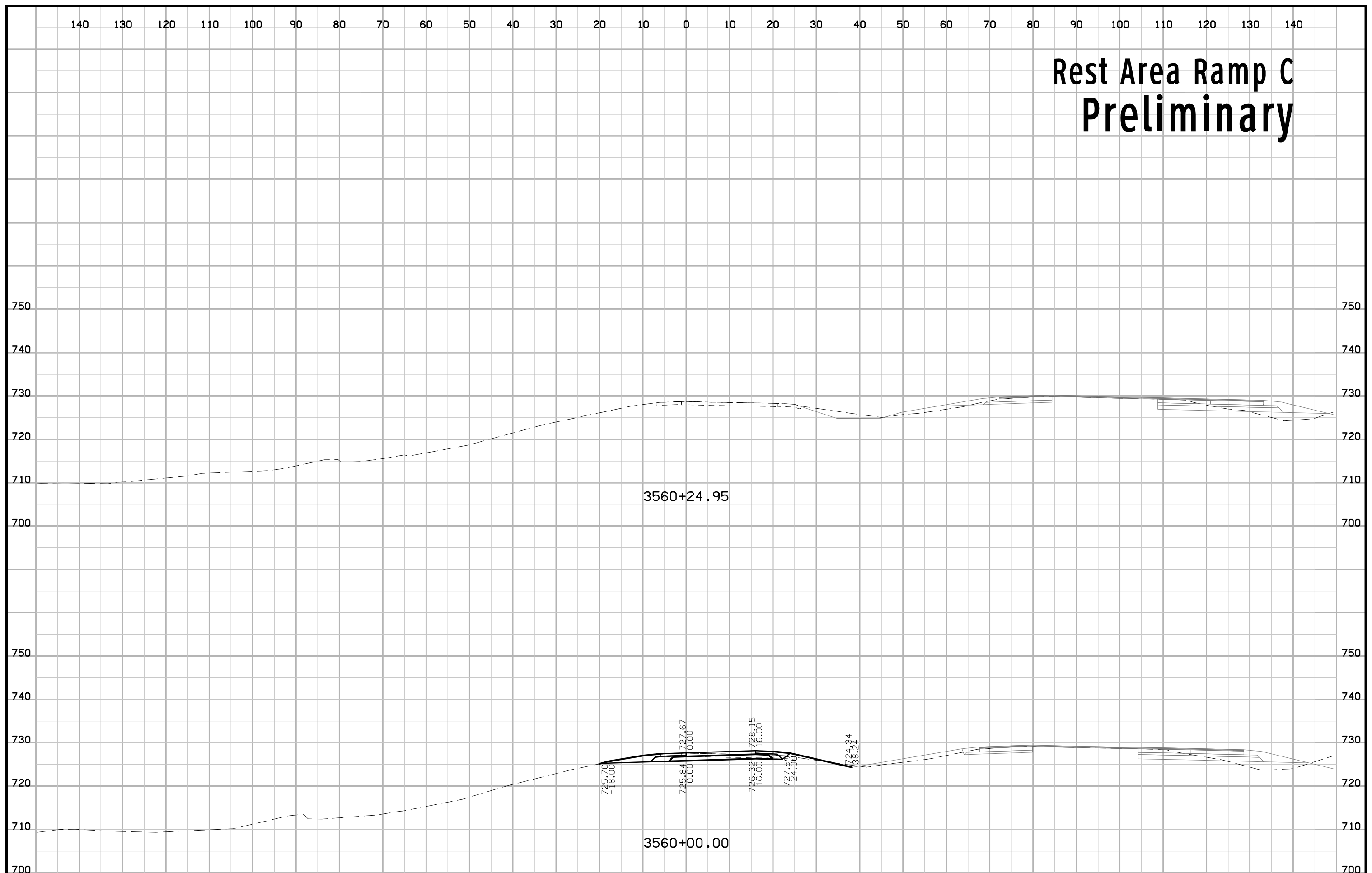

# Rest Area Ramp D Preliminary

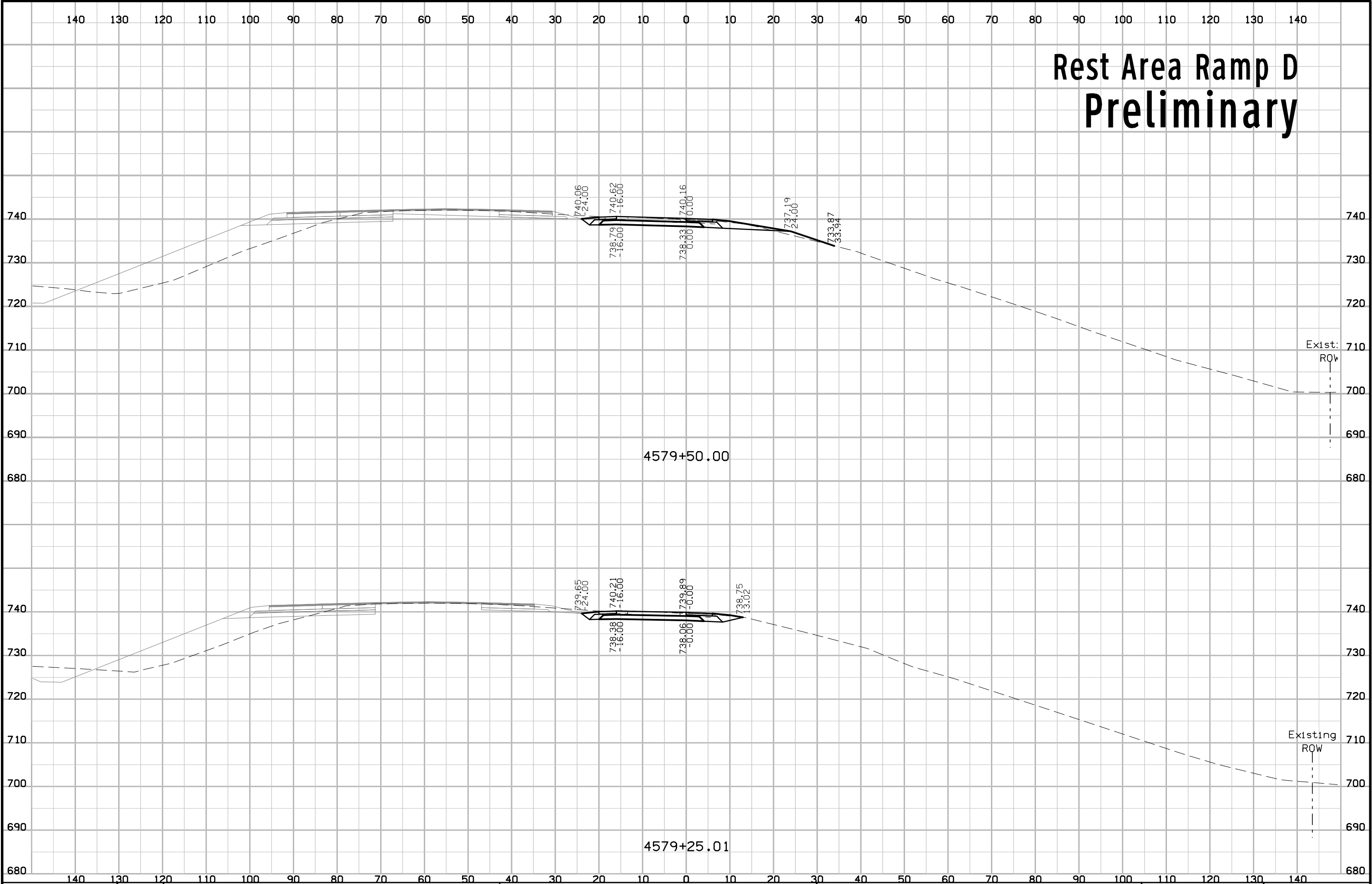

# Rest Area Ramp D Preliminary

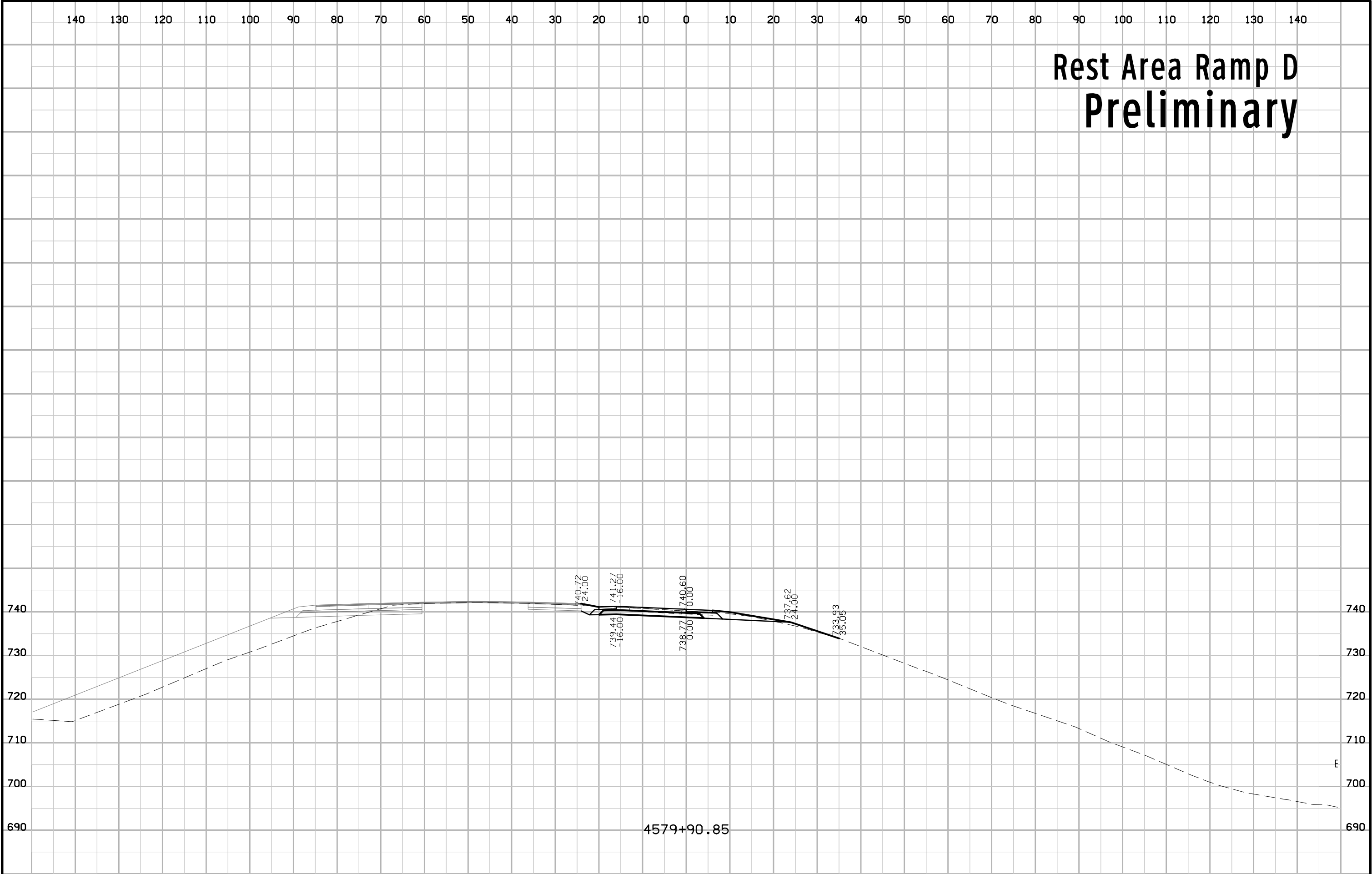

4579+90.85

E

# Rose Ramp A Preliminary

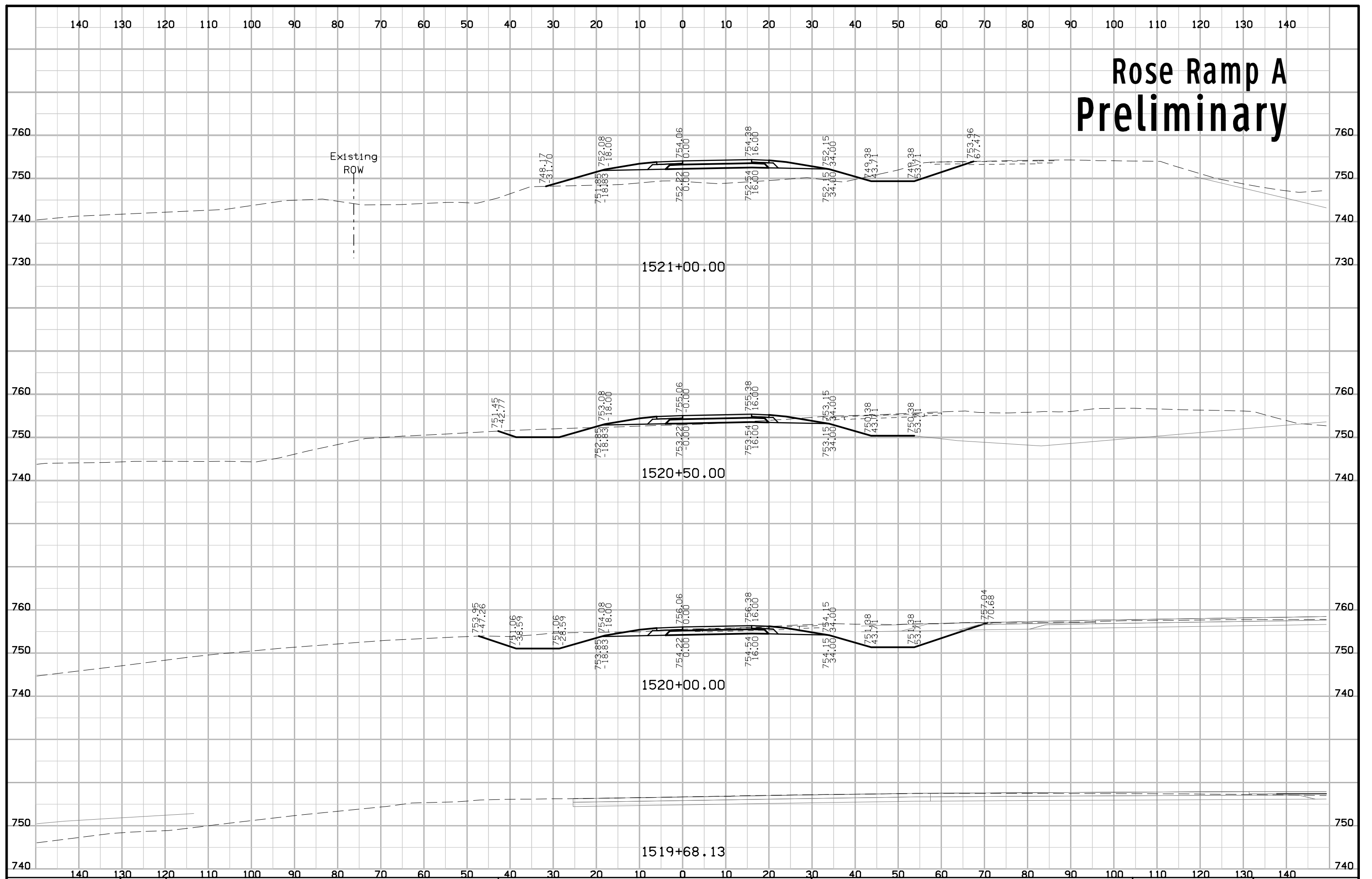

# Rose Ramp A Preliminary

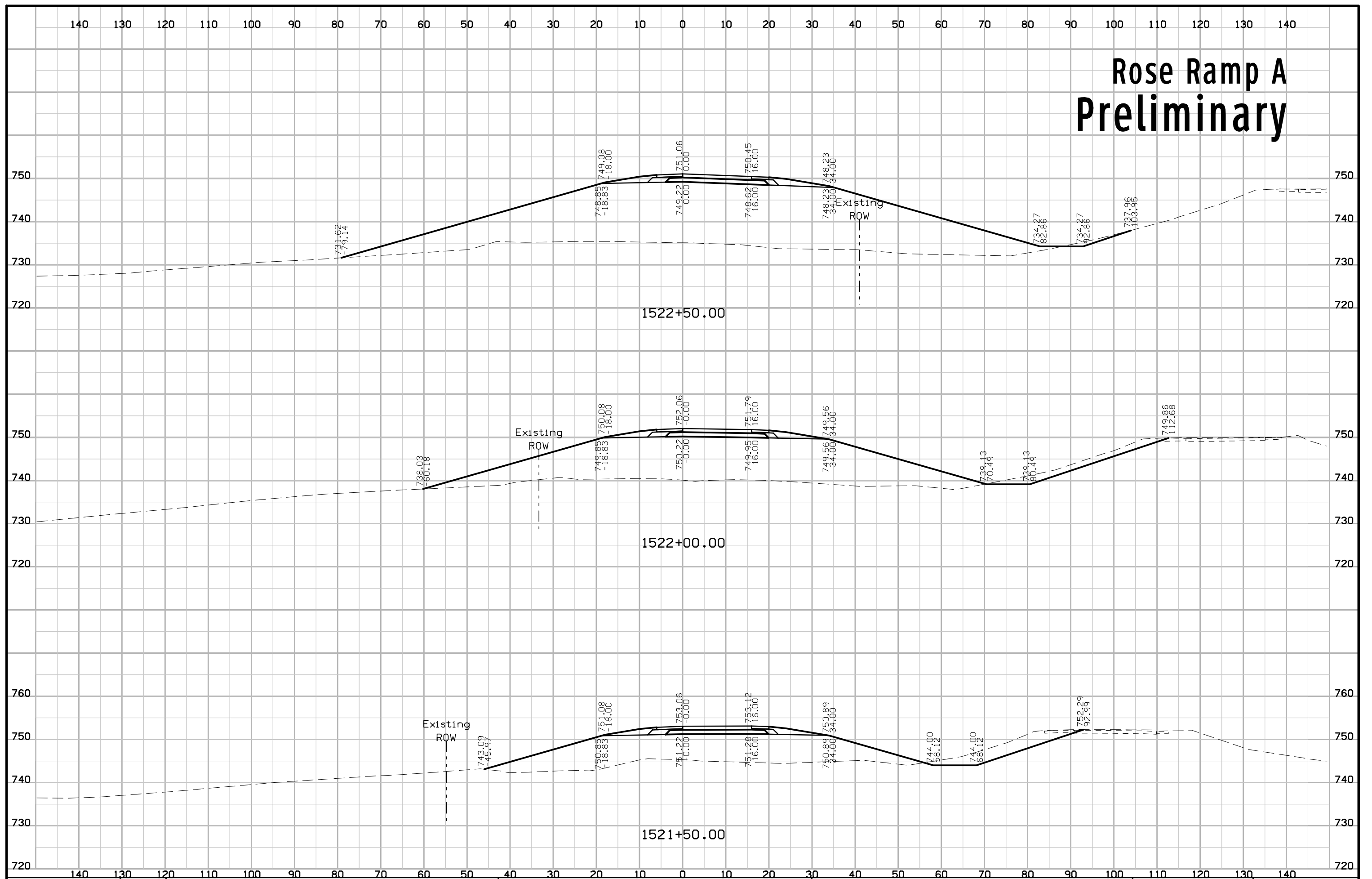



# Rose Ramp A Preliminary

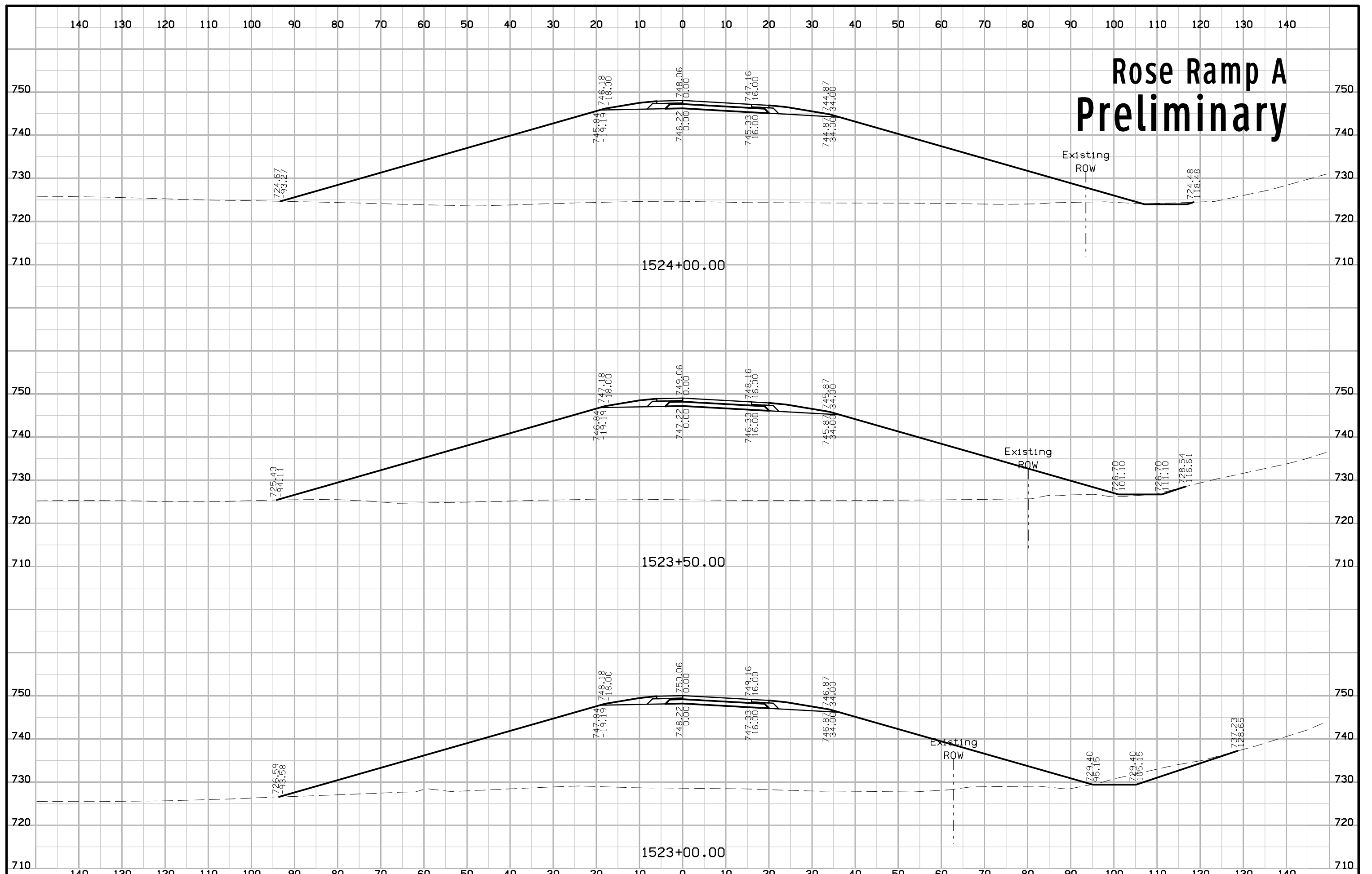

# Rose Ramp A Preliminary

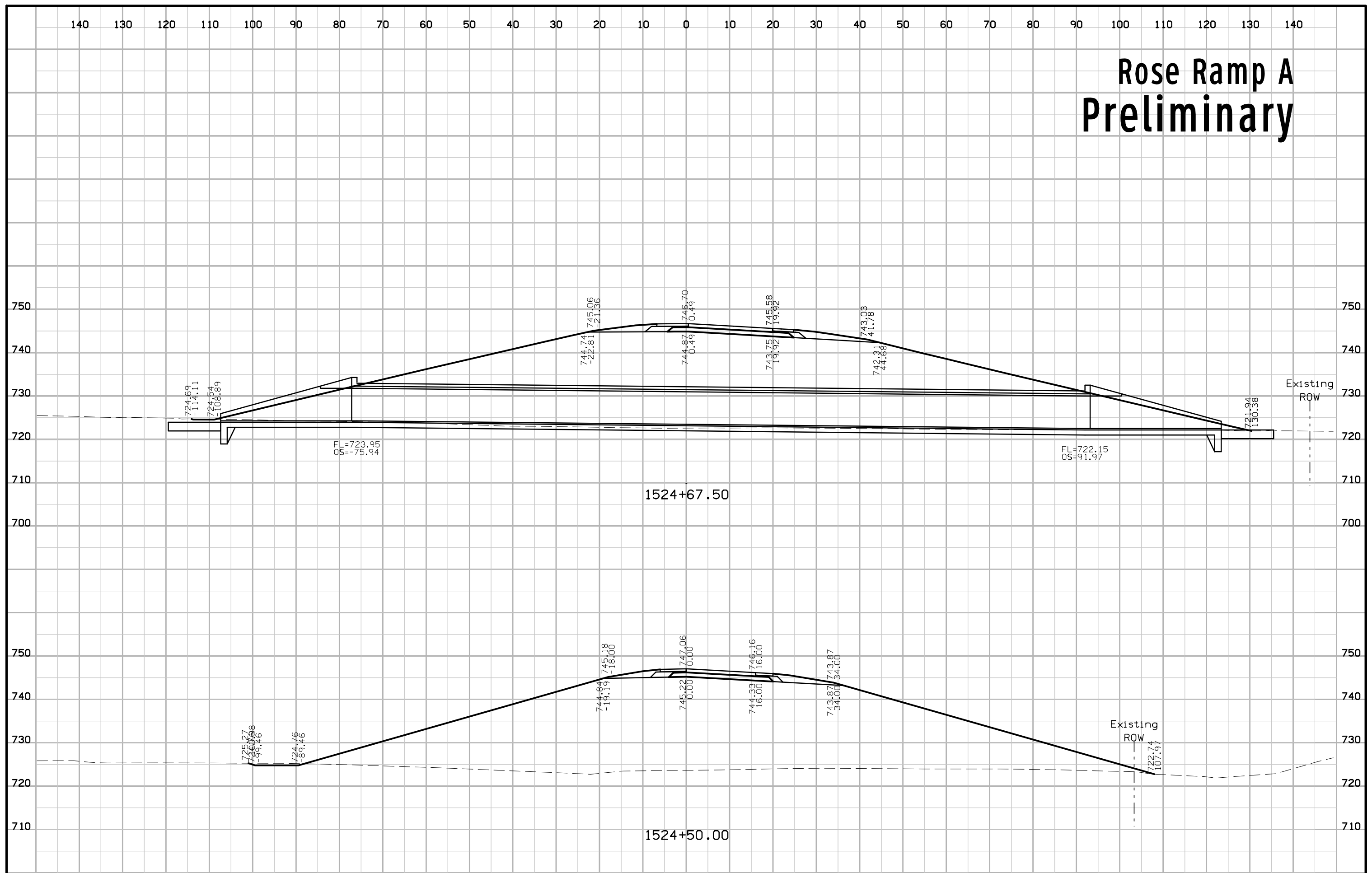

# Rose Ramp A Preliminary

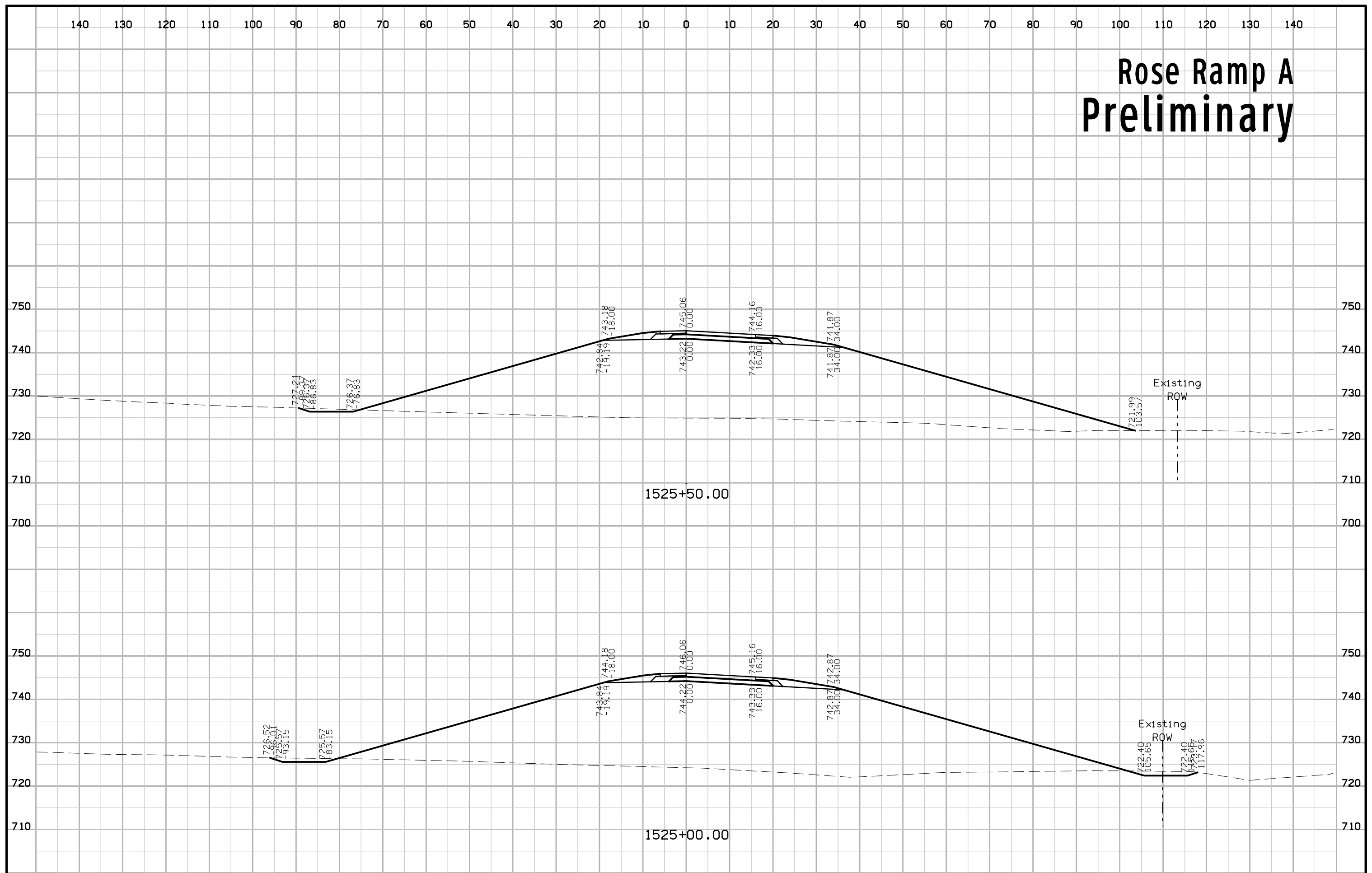

# Rose Ramp A Preliminary

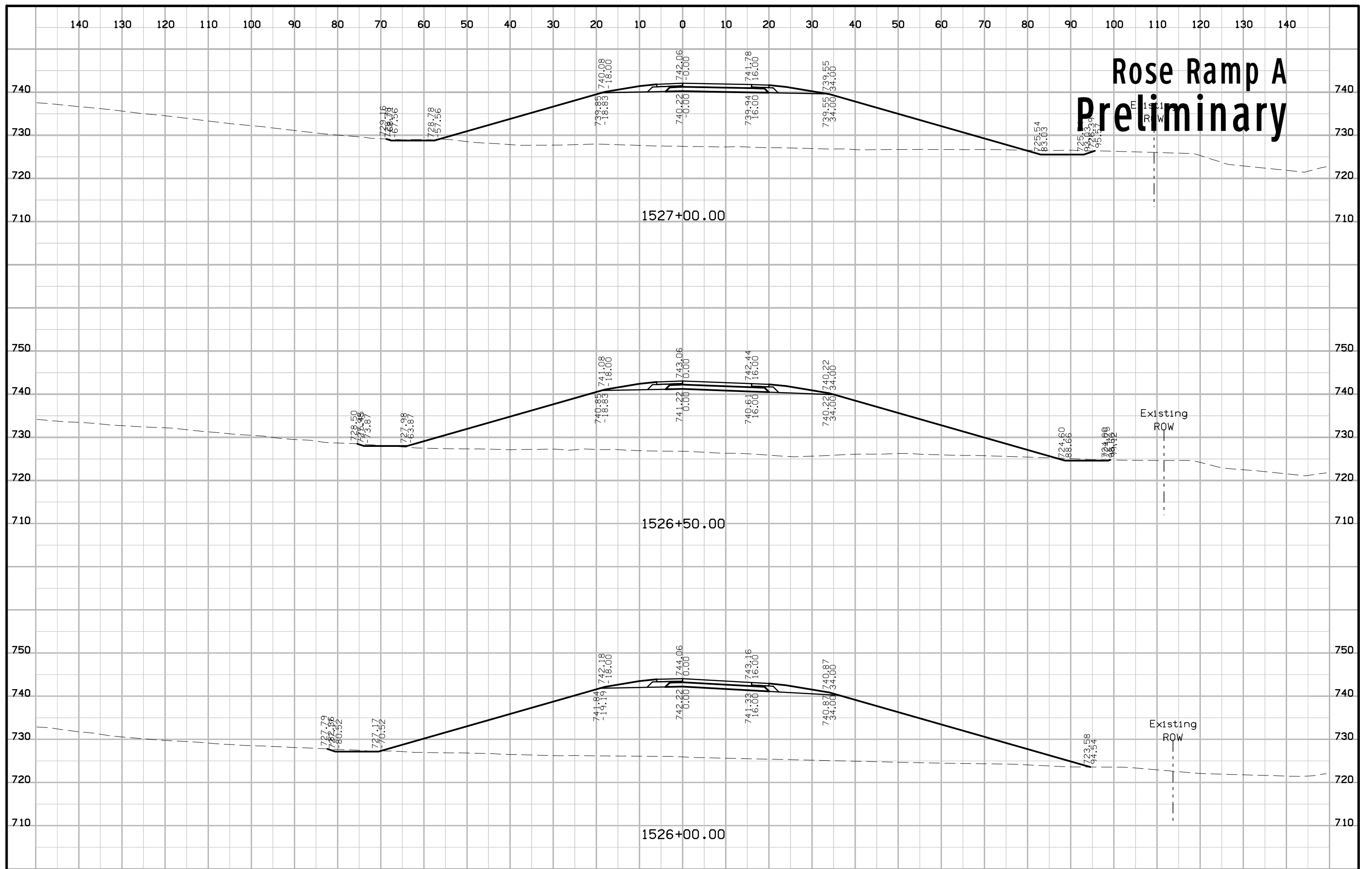

# Rose Ramp A Preliminary

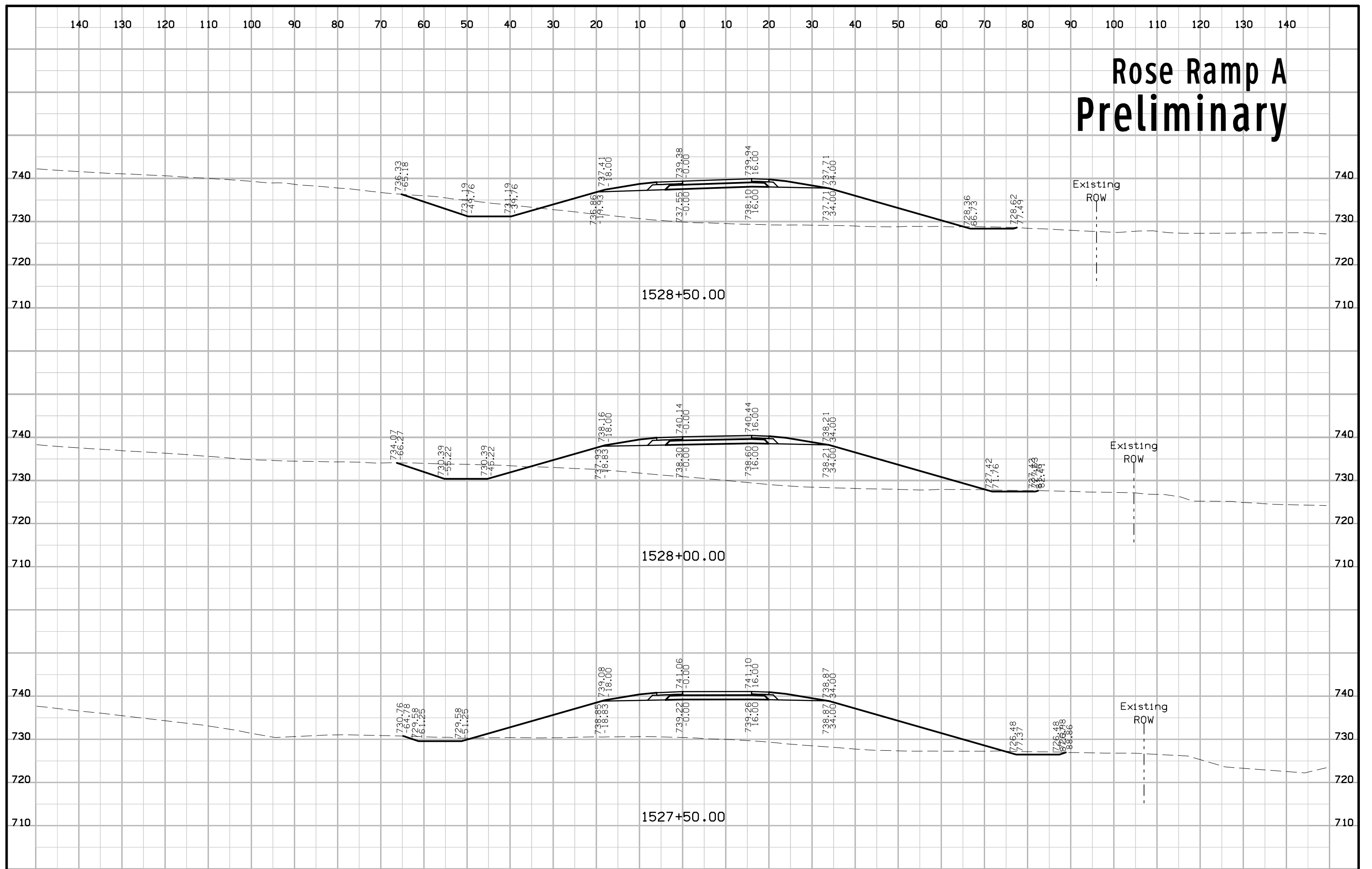

# Rose Ramp A Preliminary

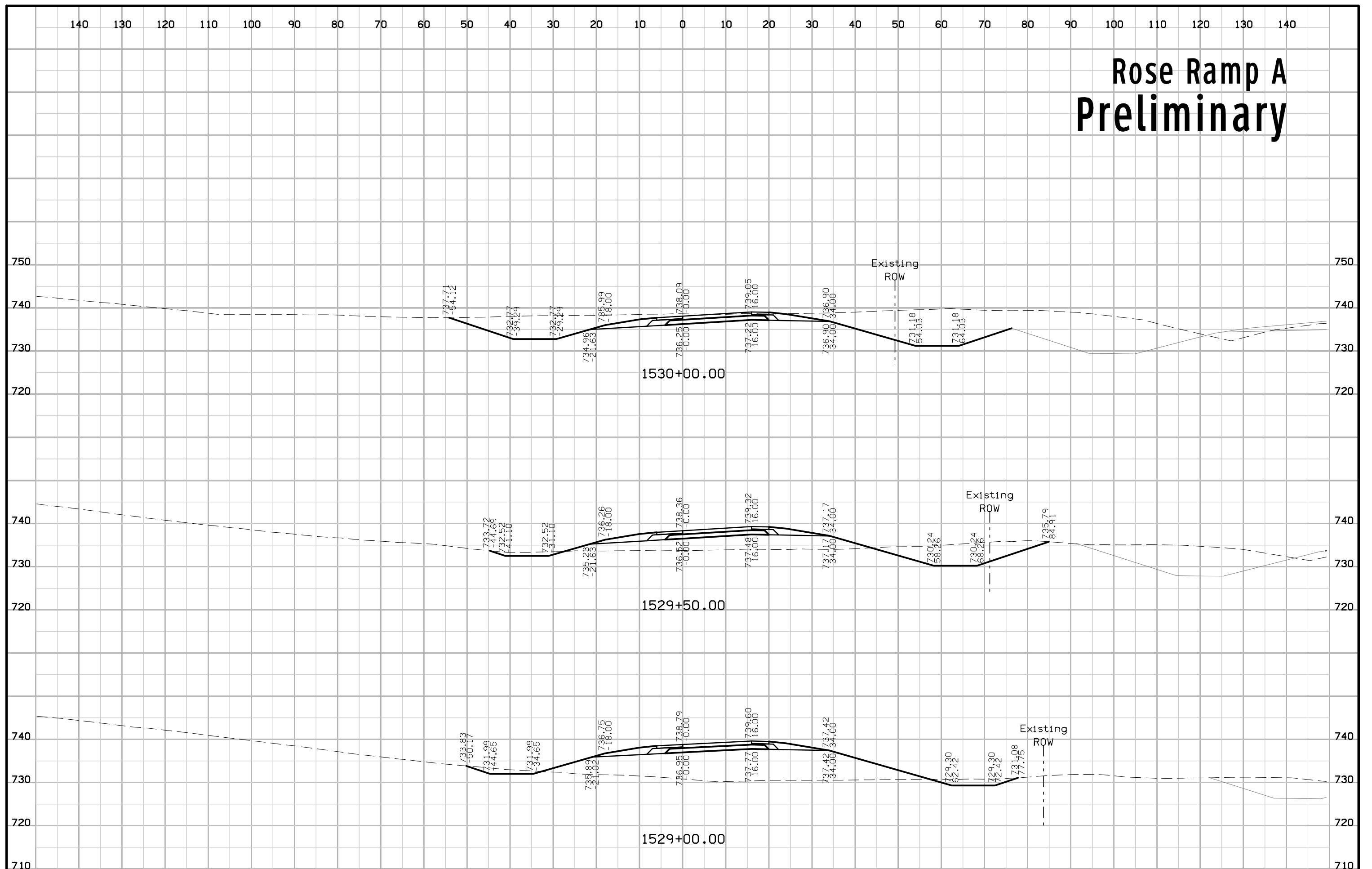

# Rose Ramp A Preliminary

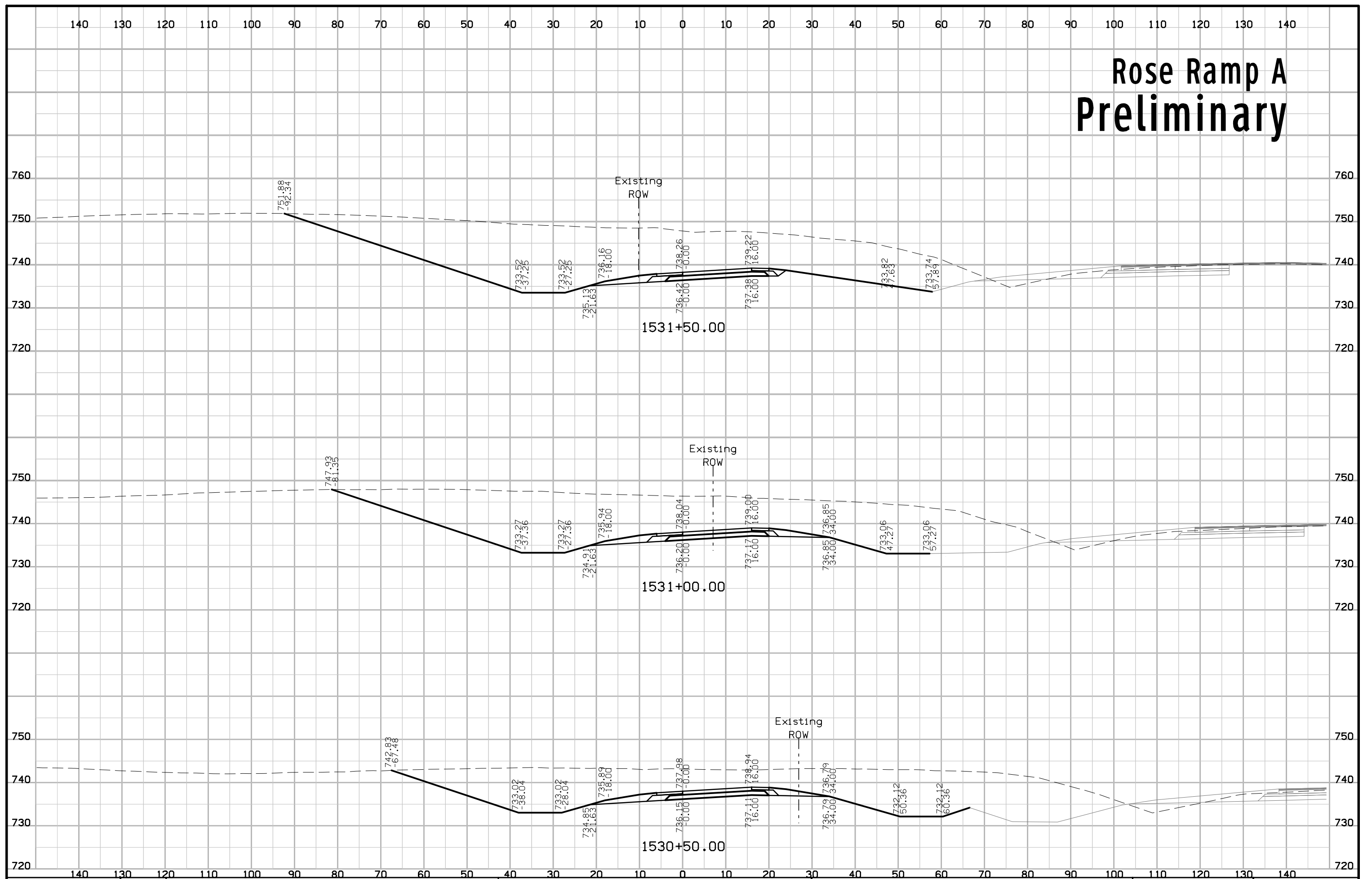

# Rose Ramp A Preliminary

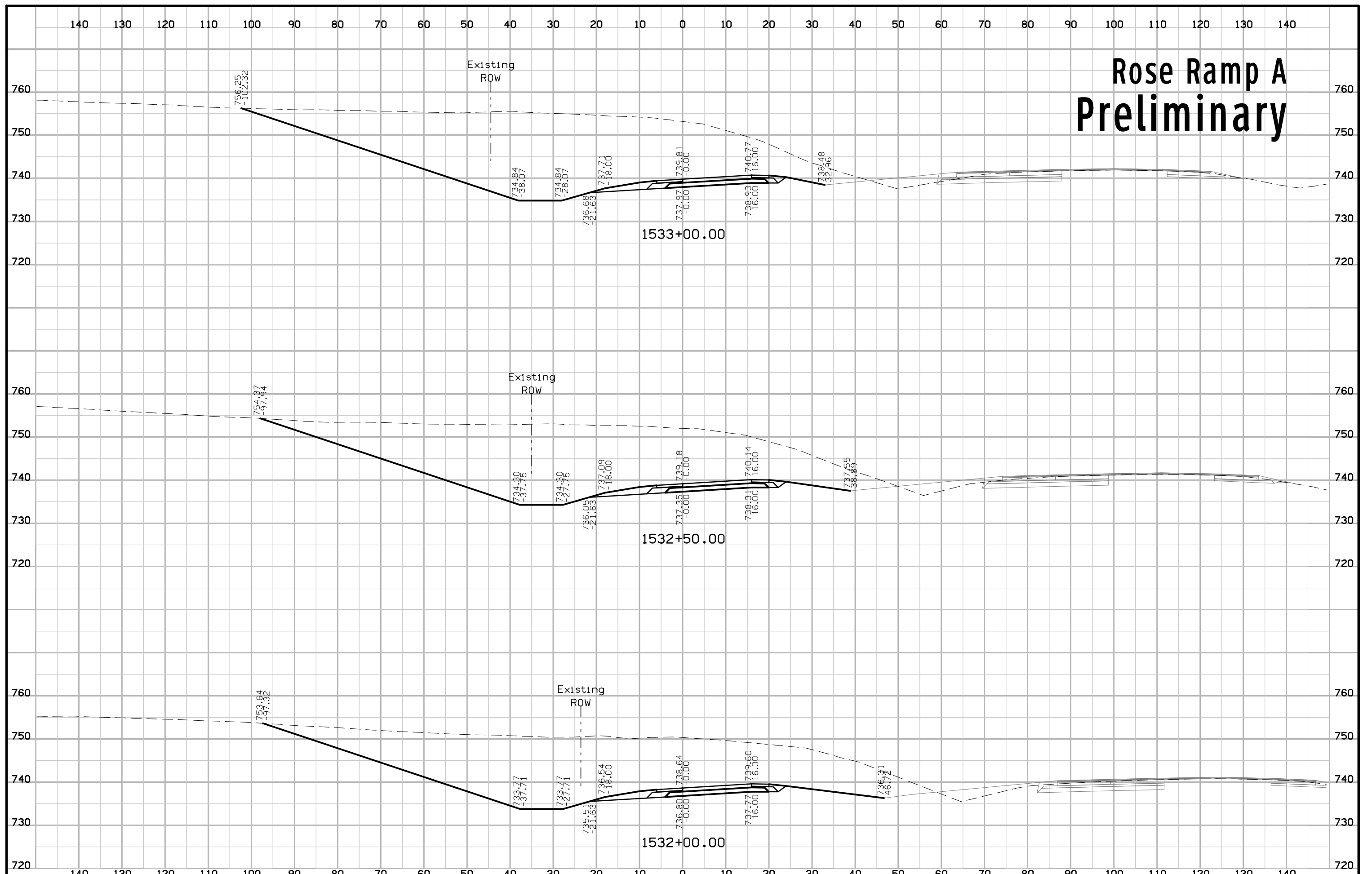



# Rose Ramp A Preliminary

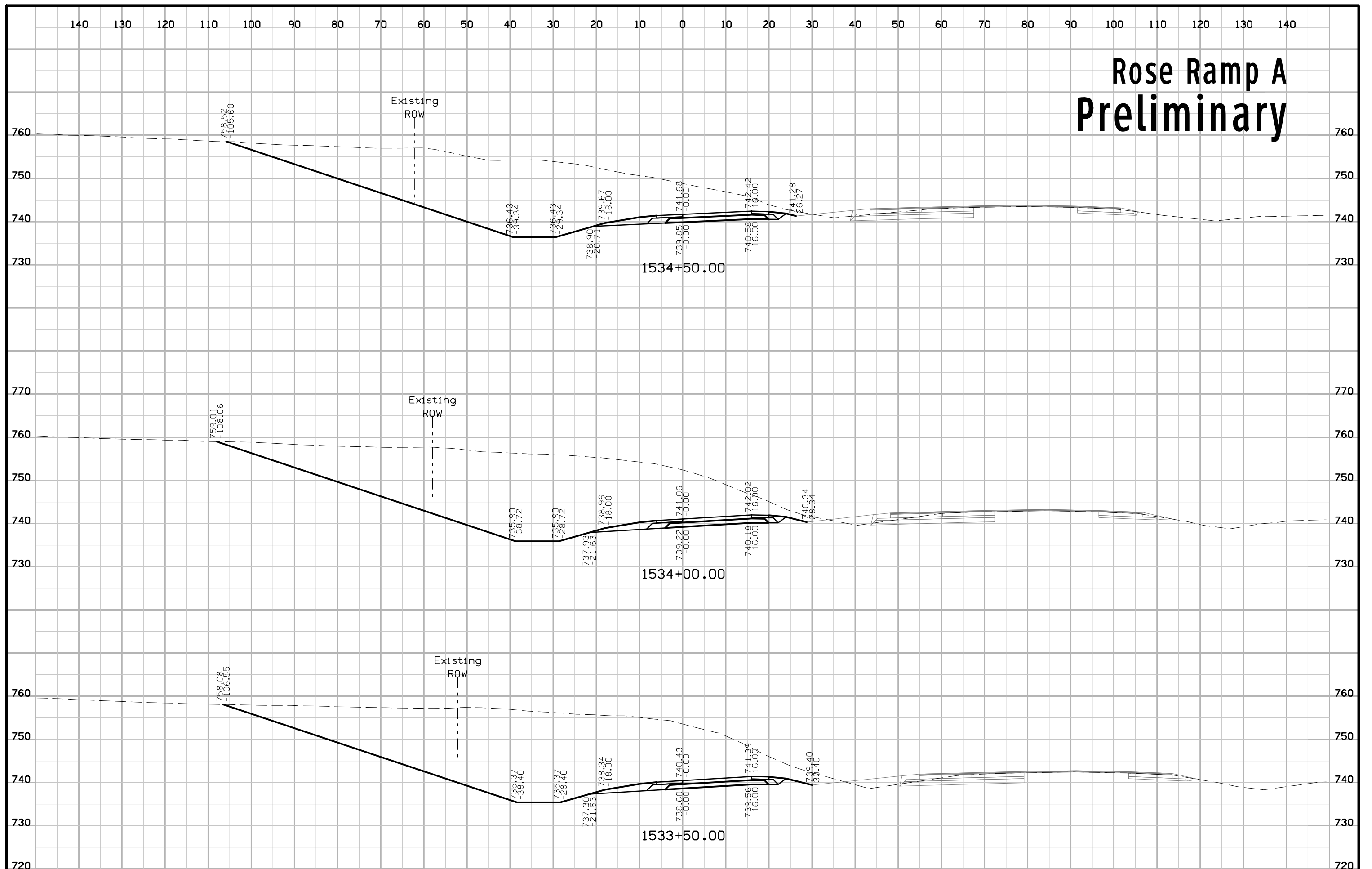

# Rose Ramp A Preliminary

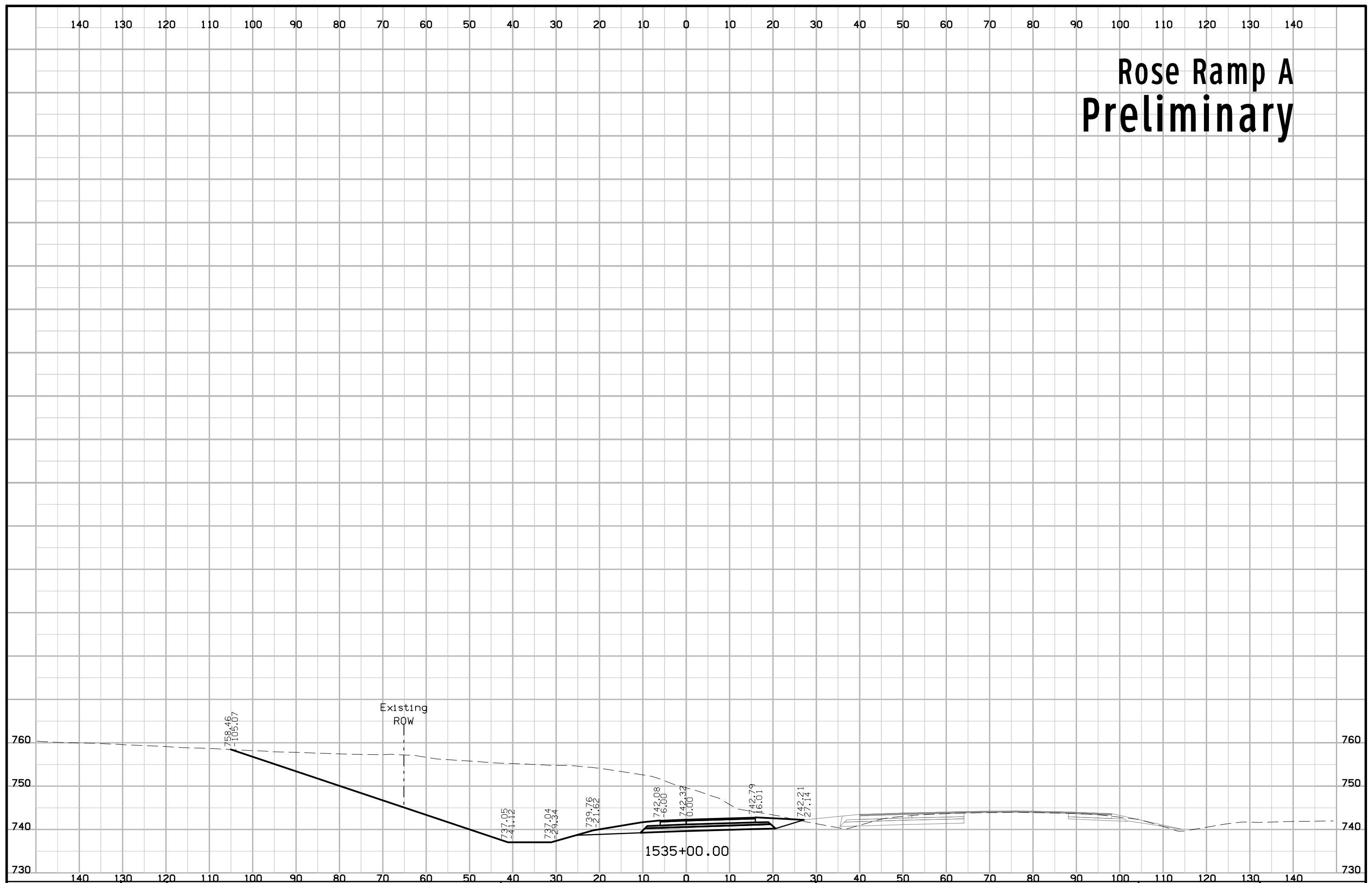

# Rose Ramp B Preliminary

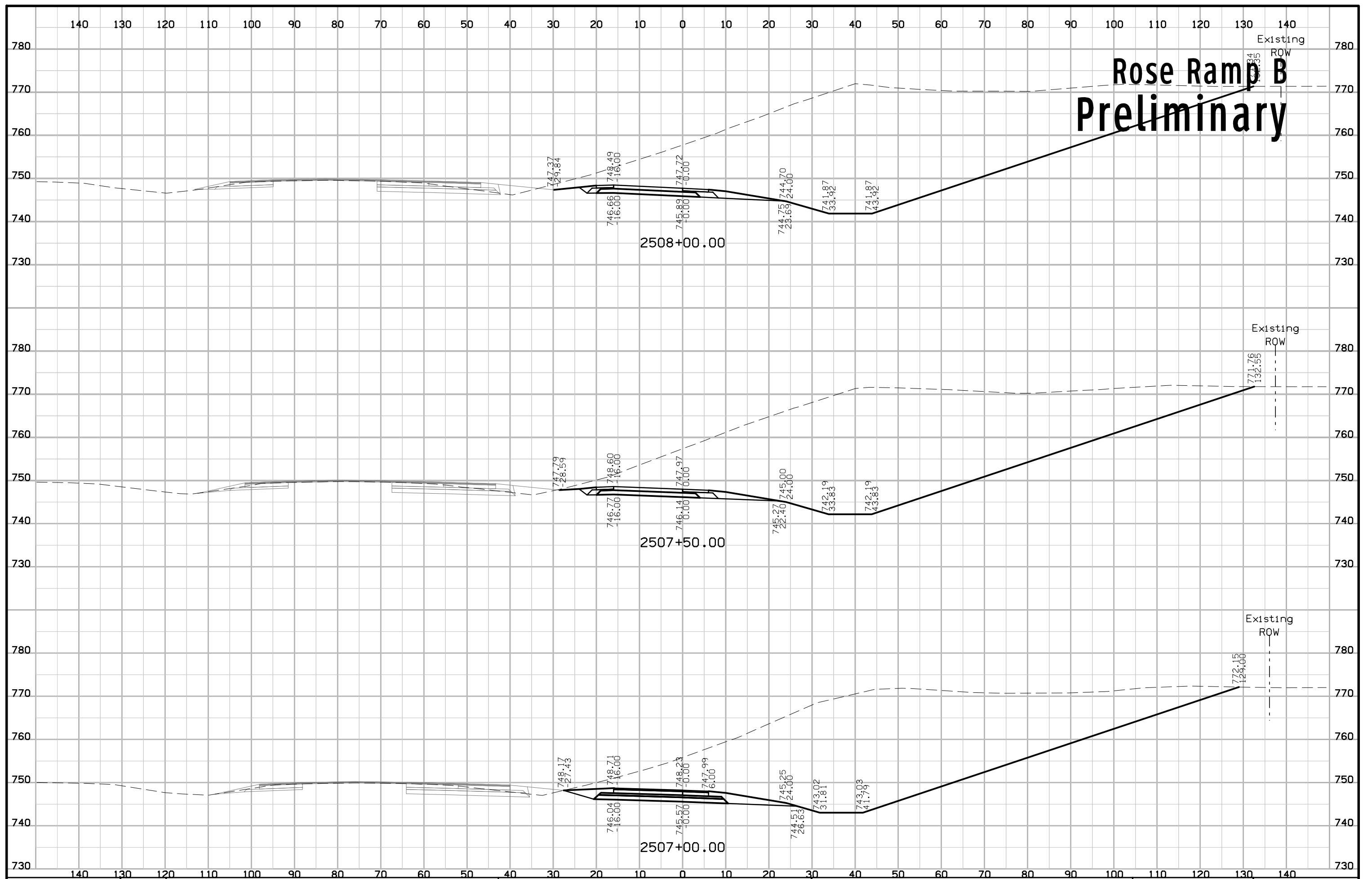

# Rose Ramp B Preliminary

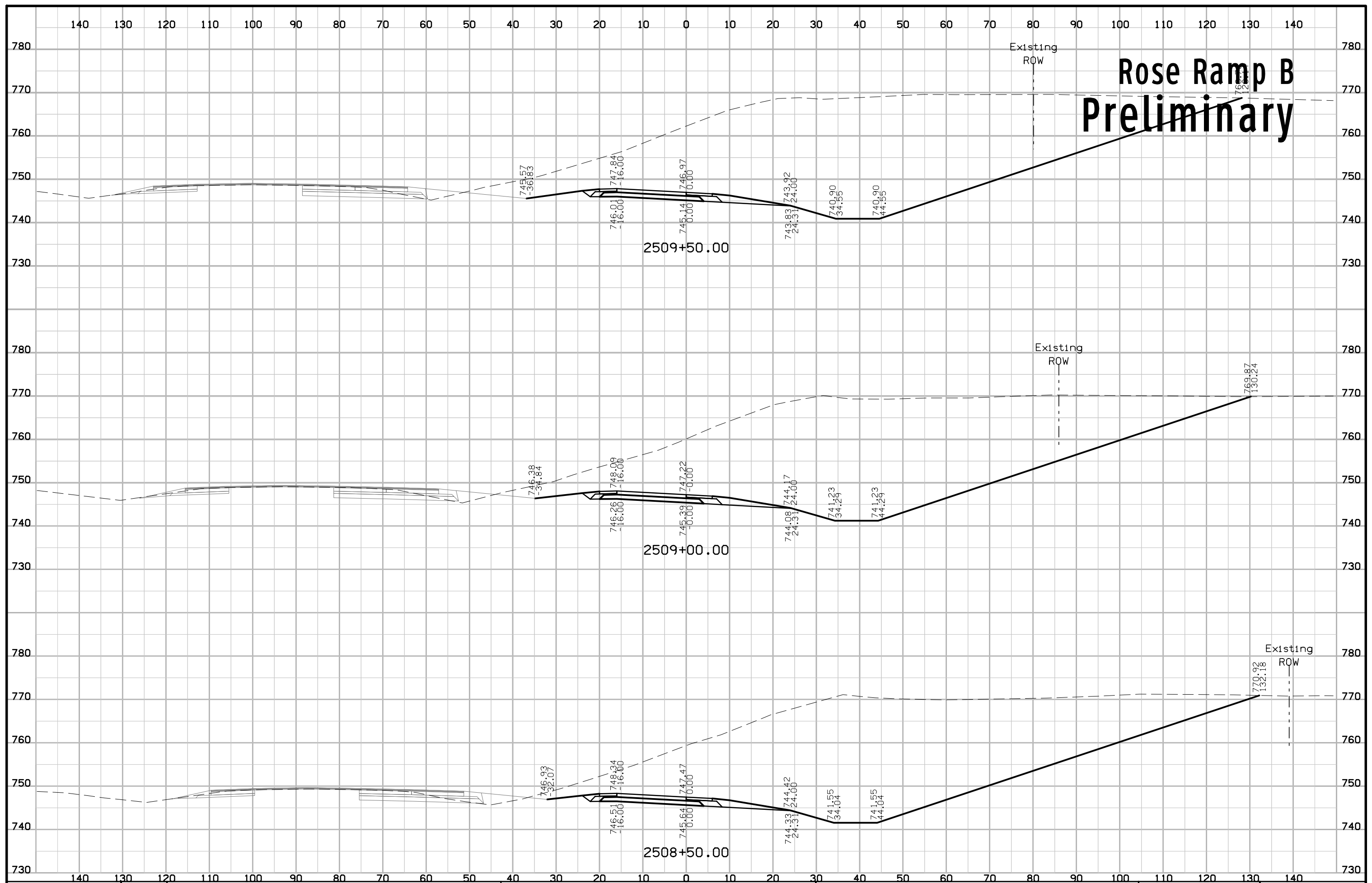

# Rose Ramp B Preliminary

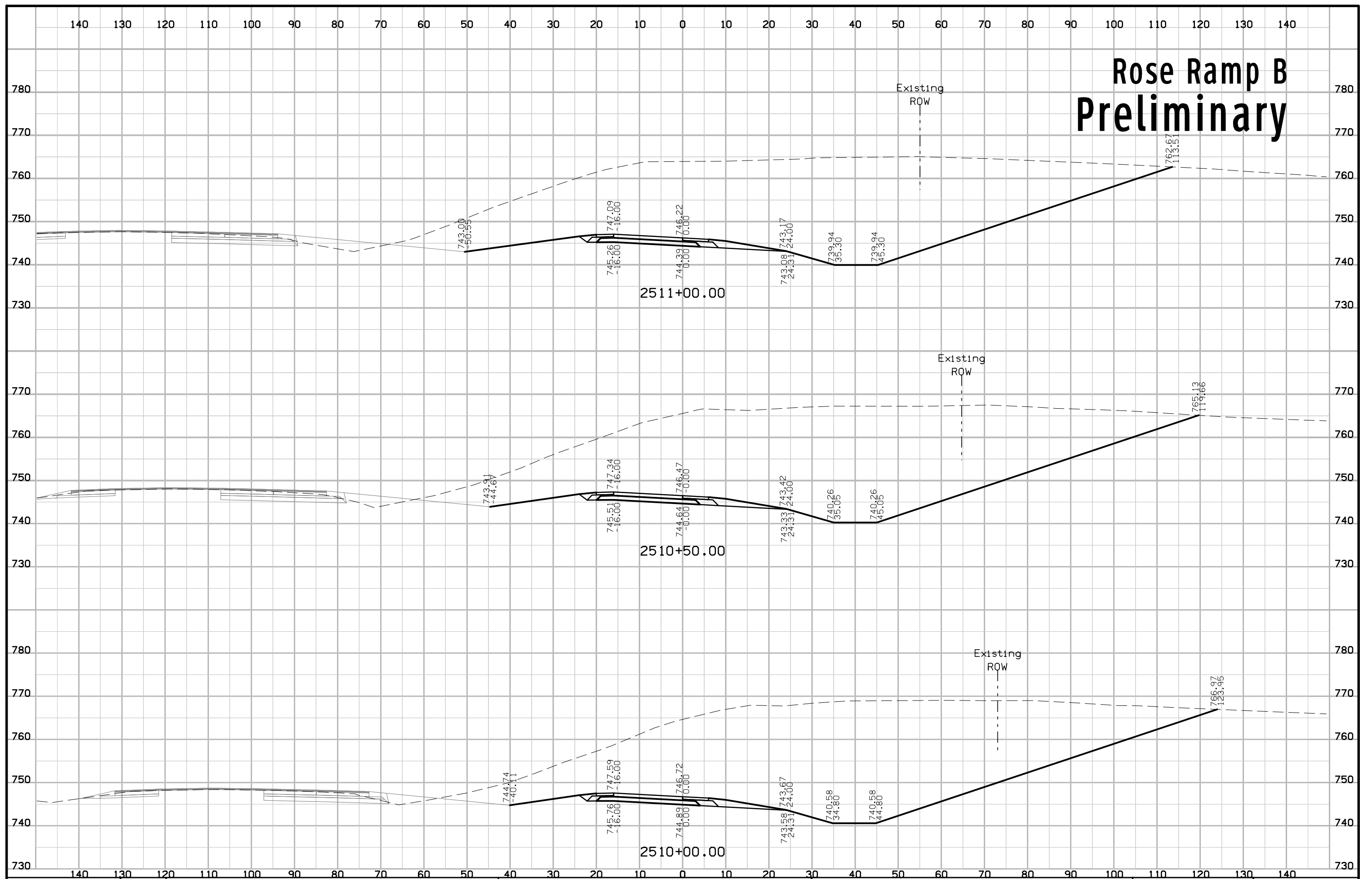

# Rose Ramp B Preliminary

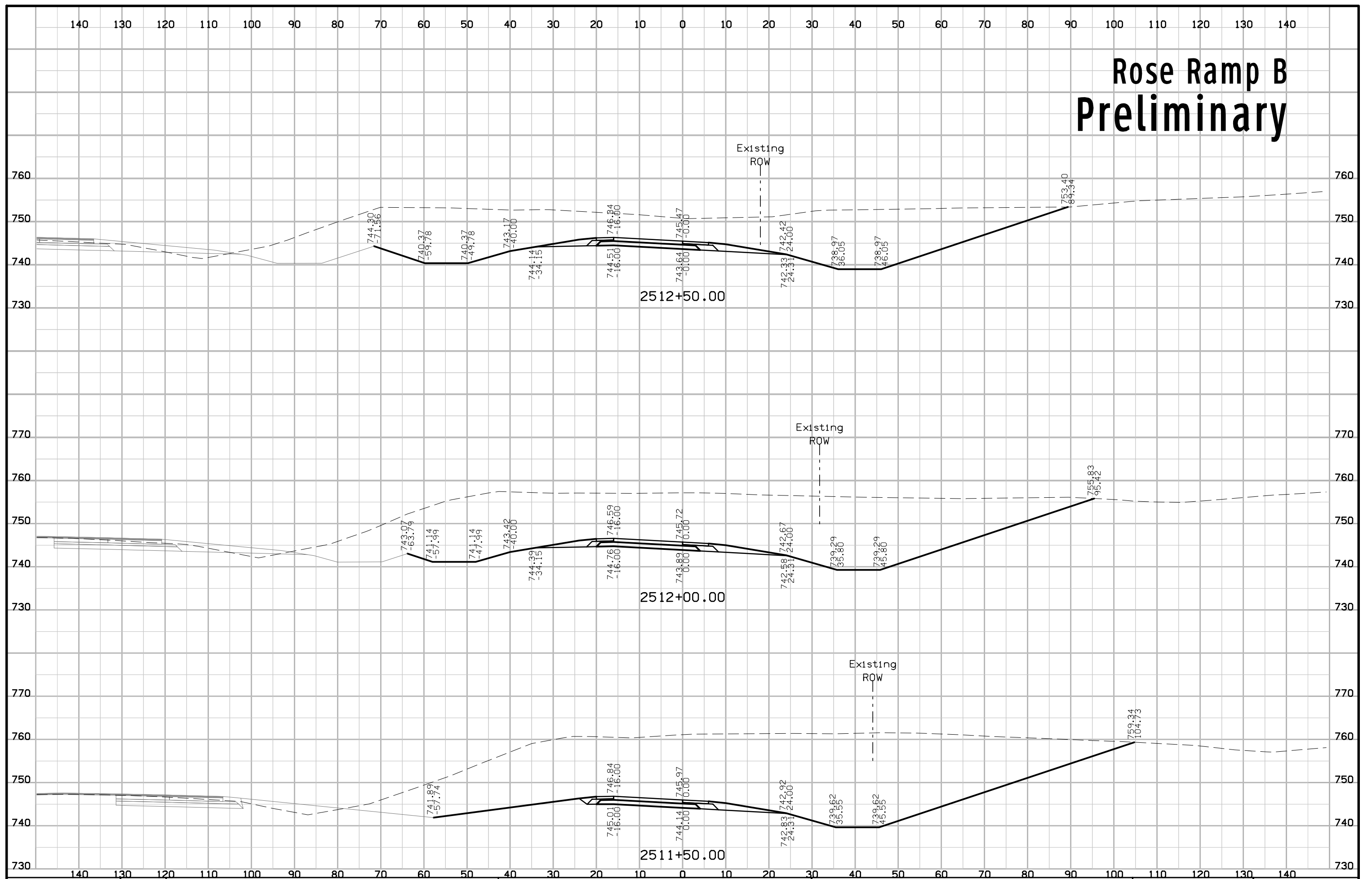

# Rose Ramp B Preliminary

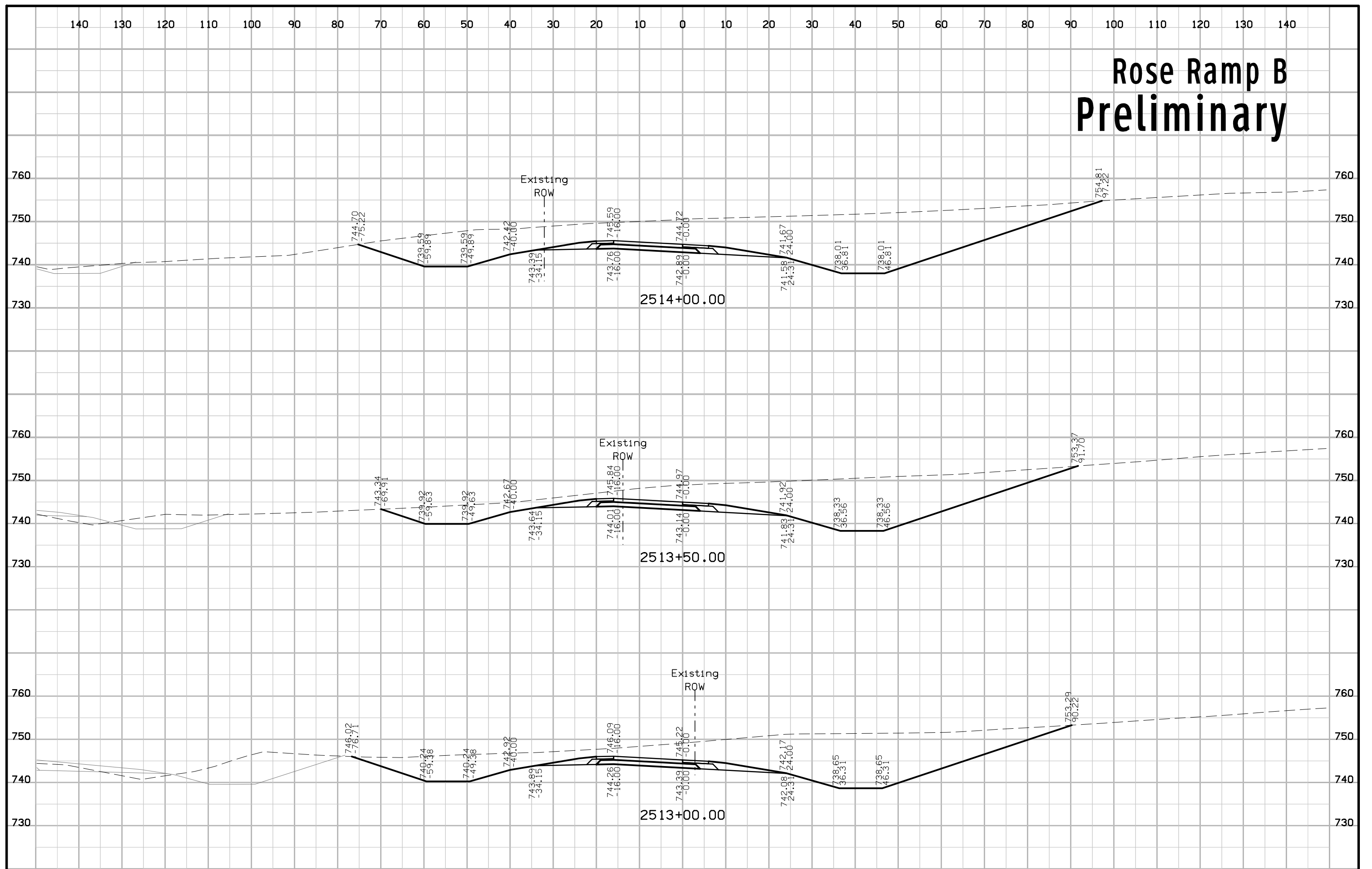

# Rose Ramp B Preliminary

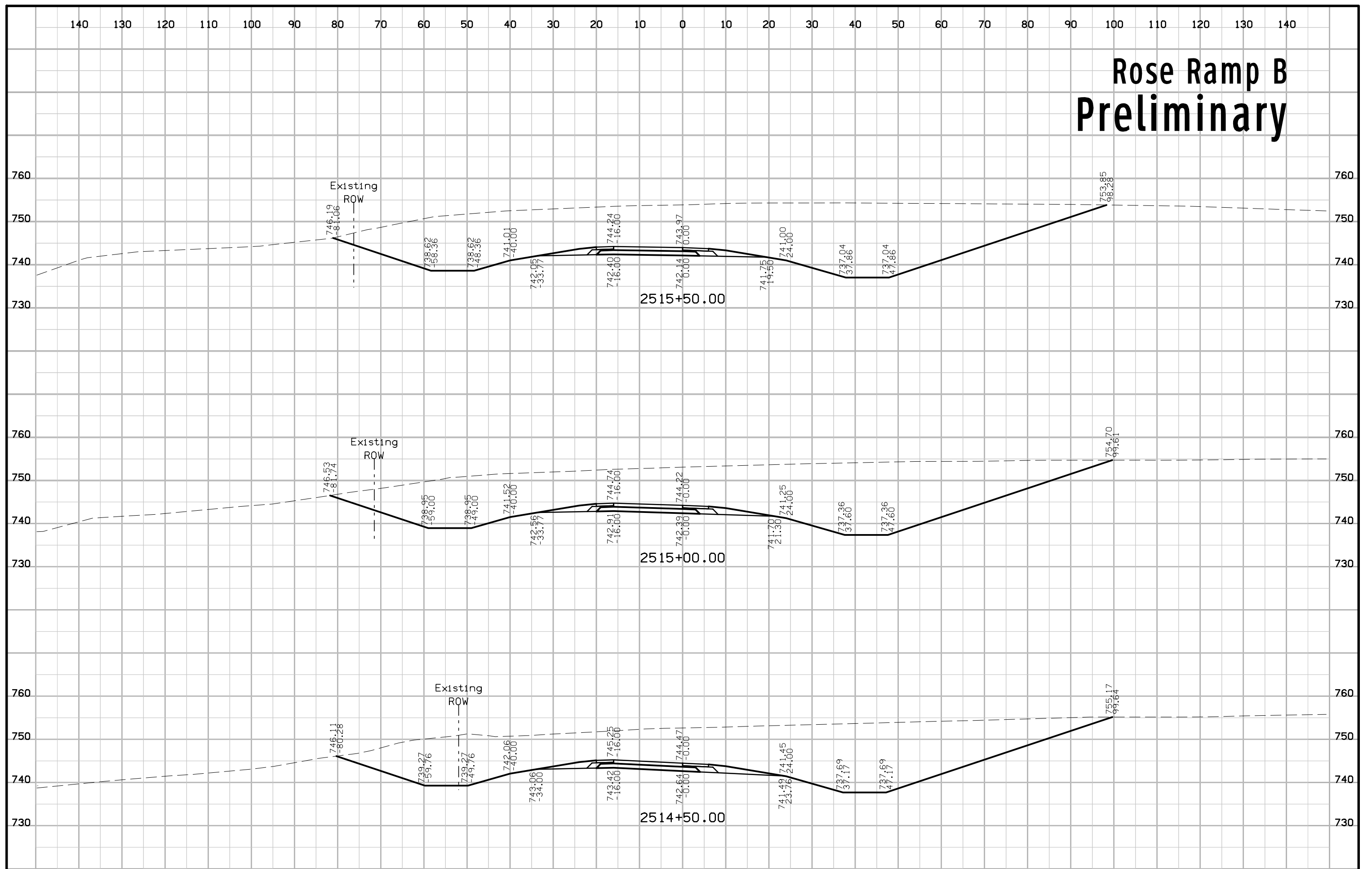



# Rose Ramp B Preliminary

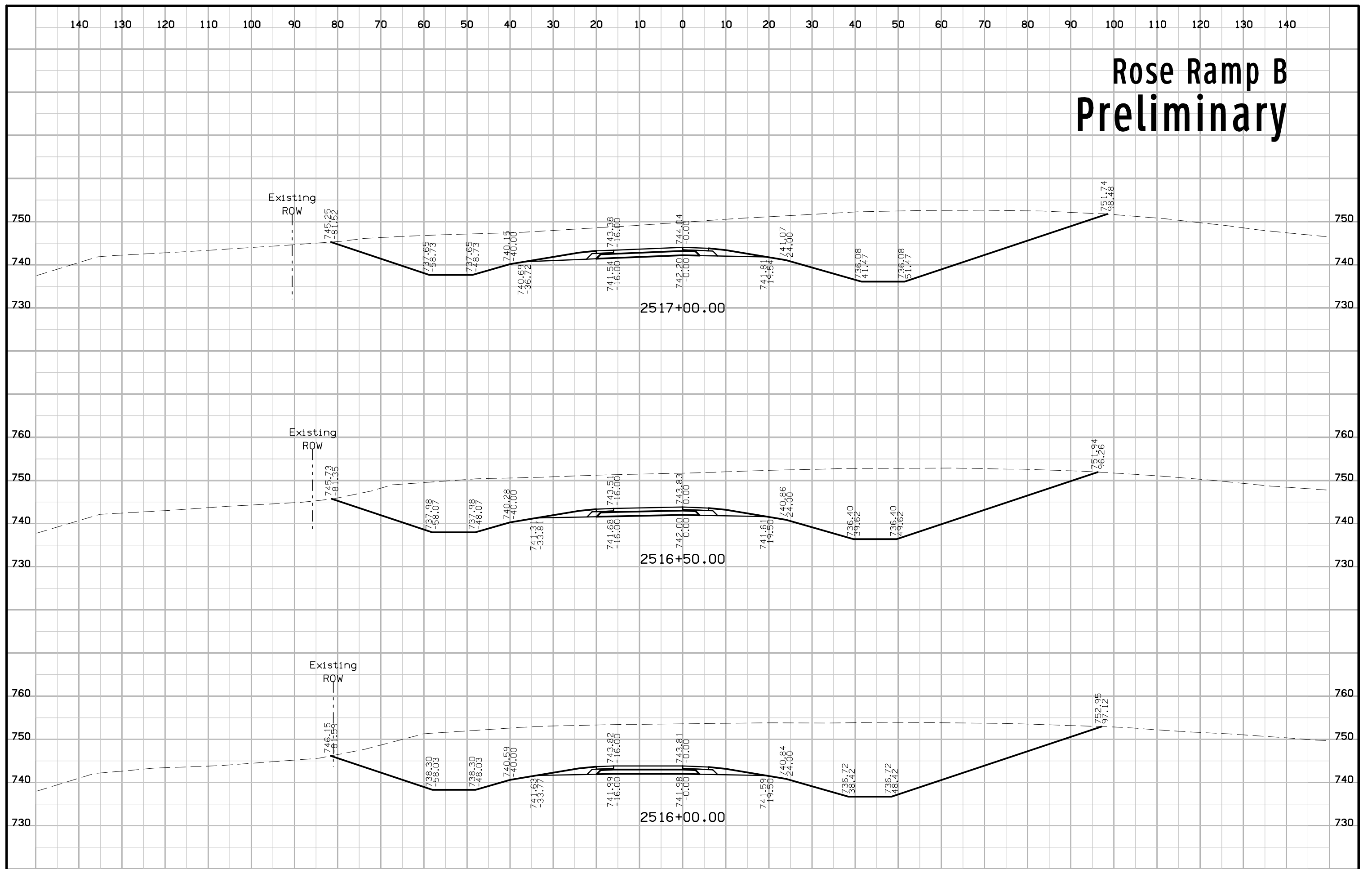

# Rose Ramp B Preliminary

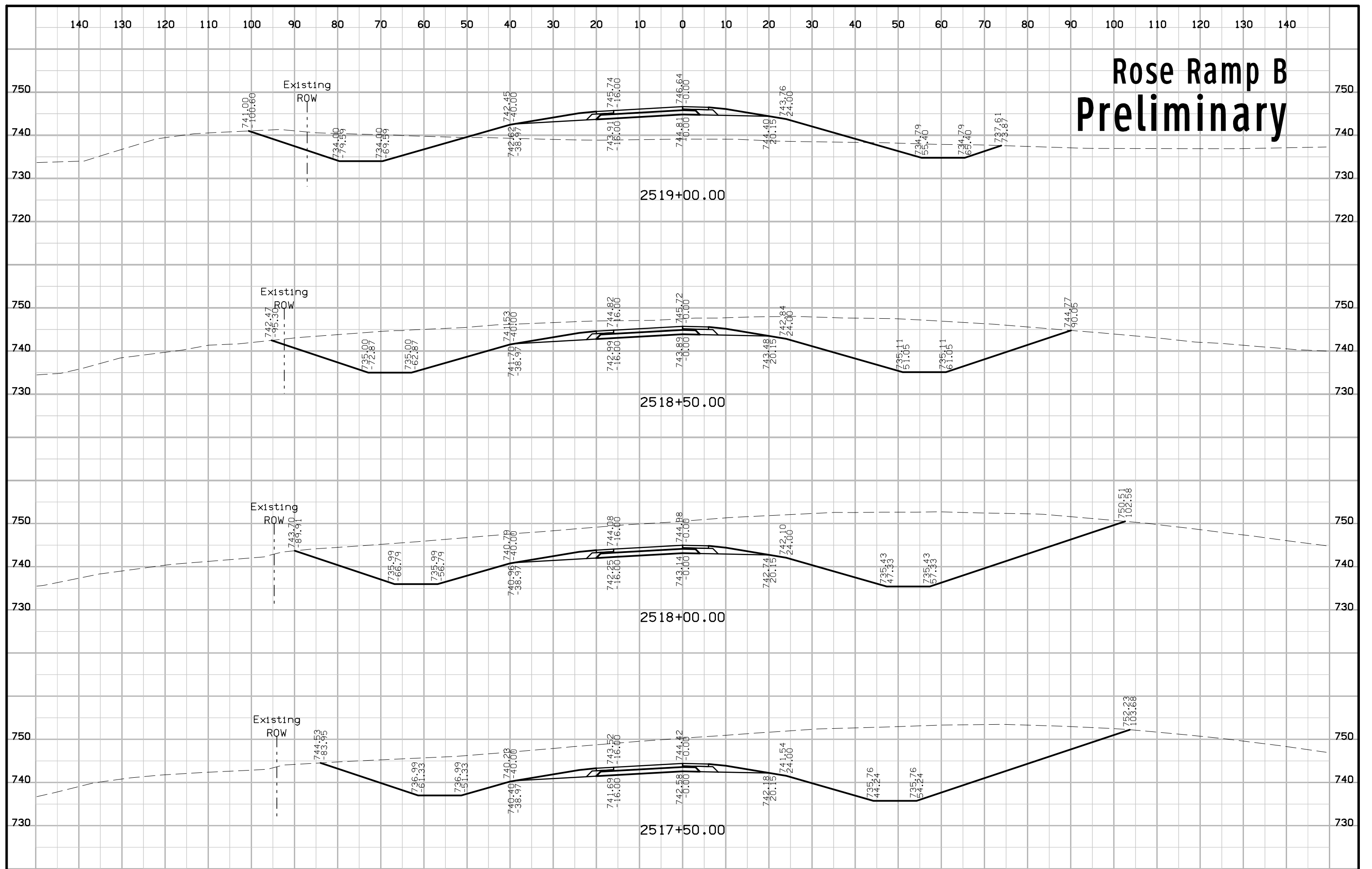

# Rose Ramp B Preliminary

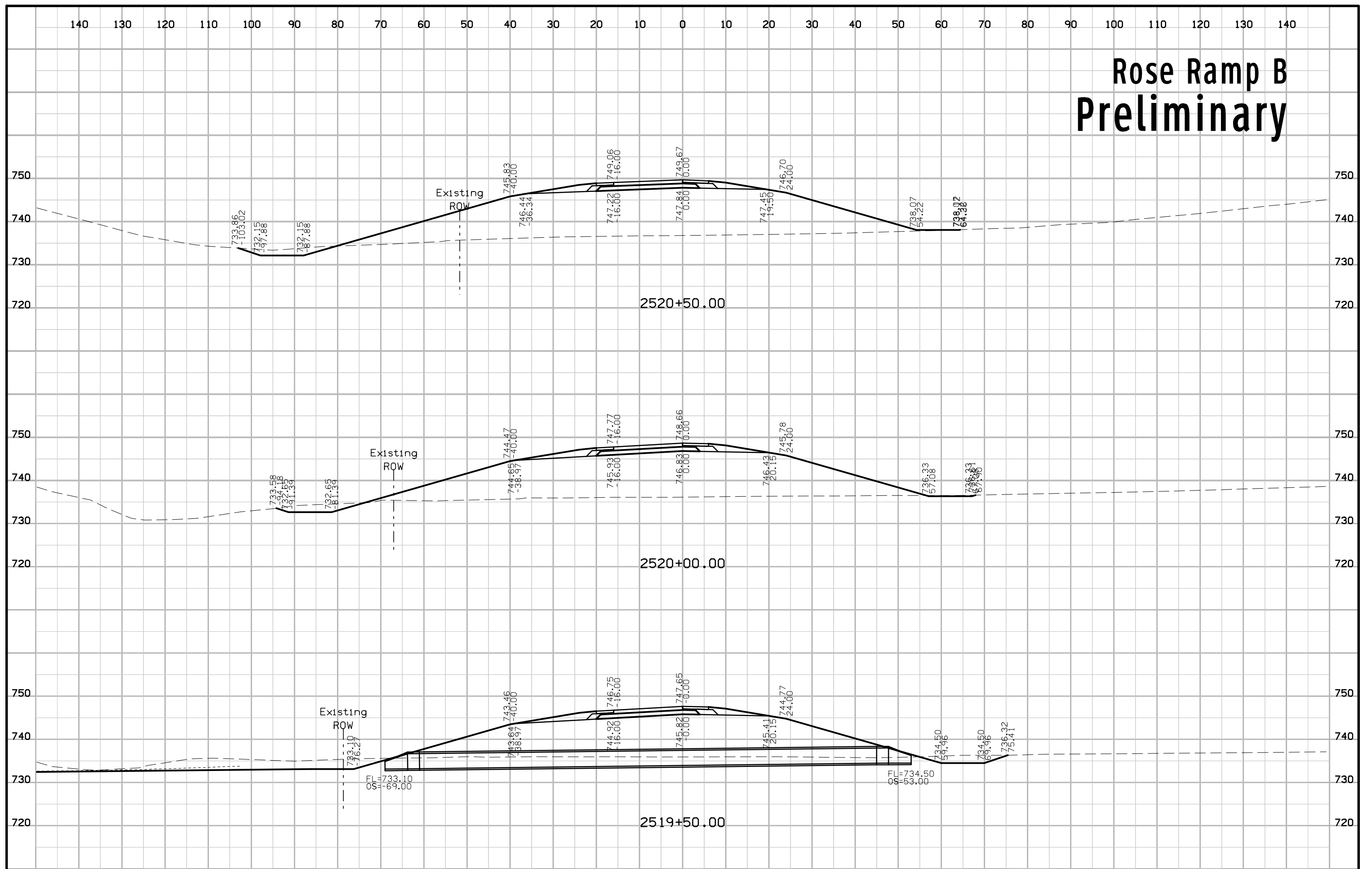

# Rose Ramp B Preliminary

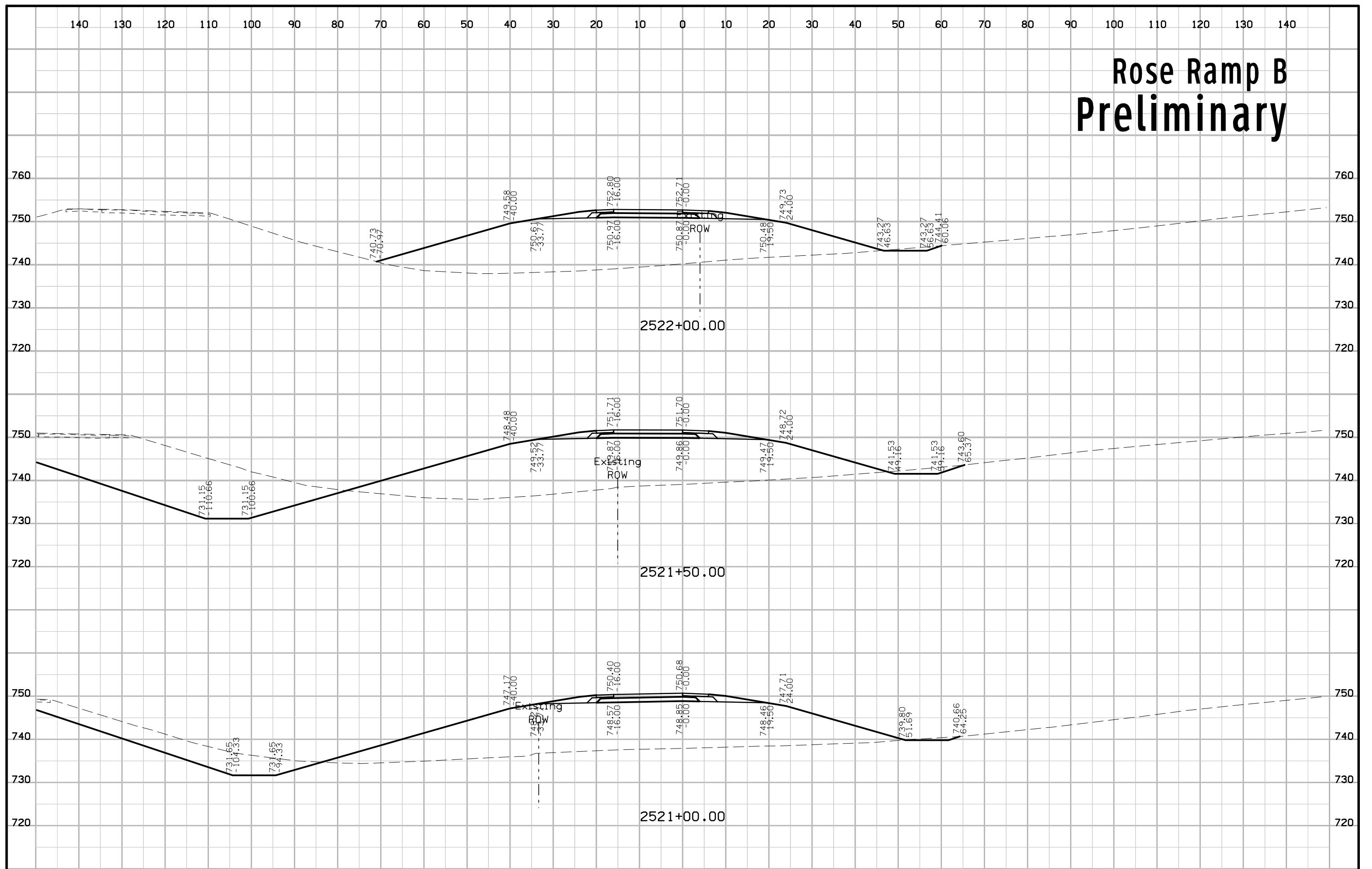

# Rose Ramp B Preliminary

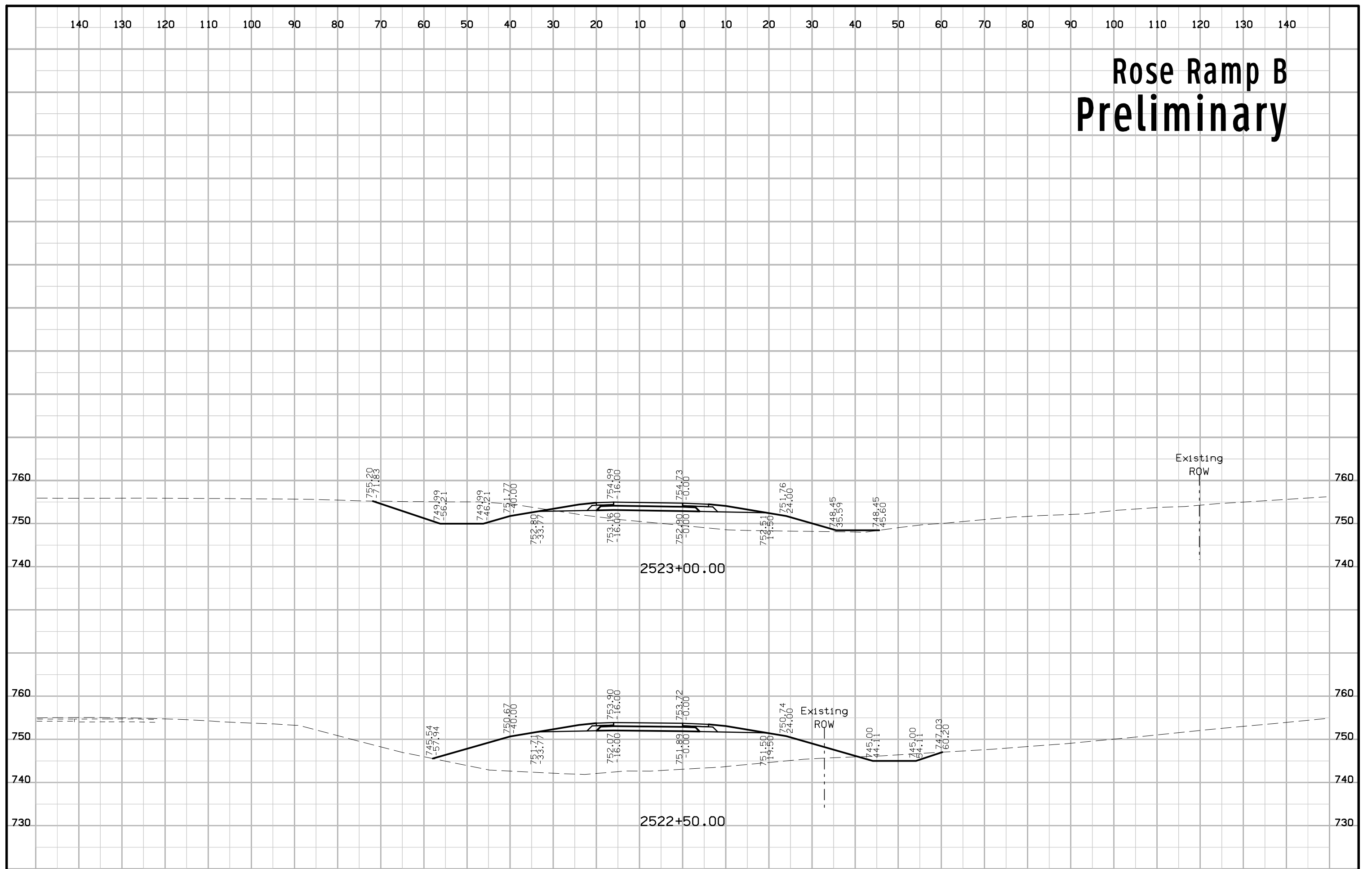

# Rose Ramp C Preliminary

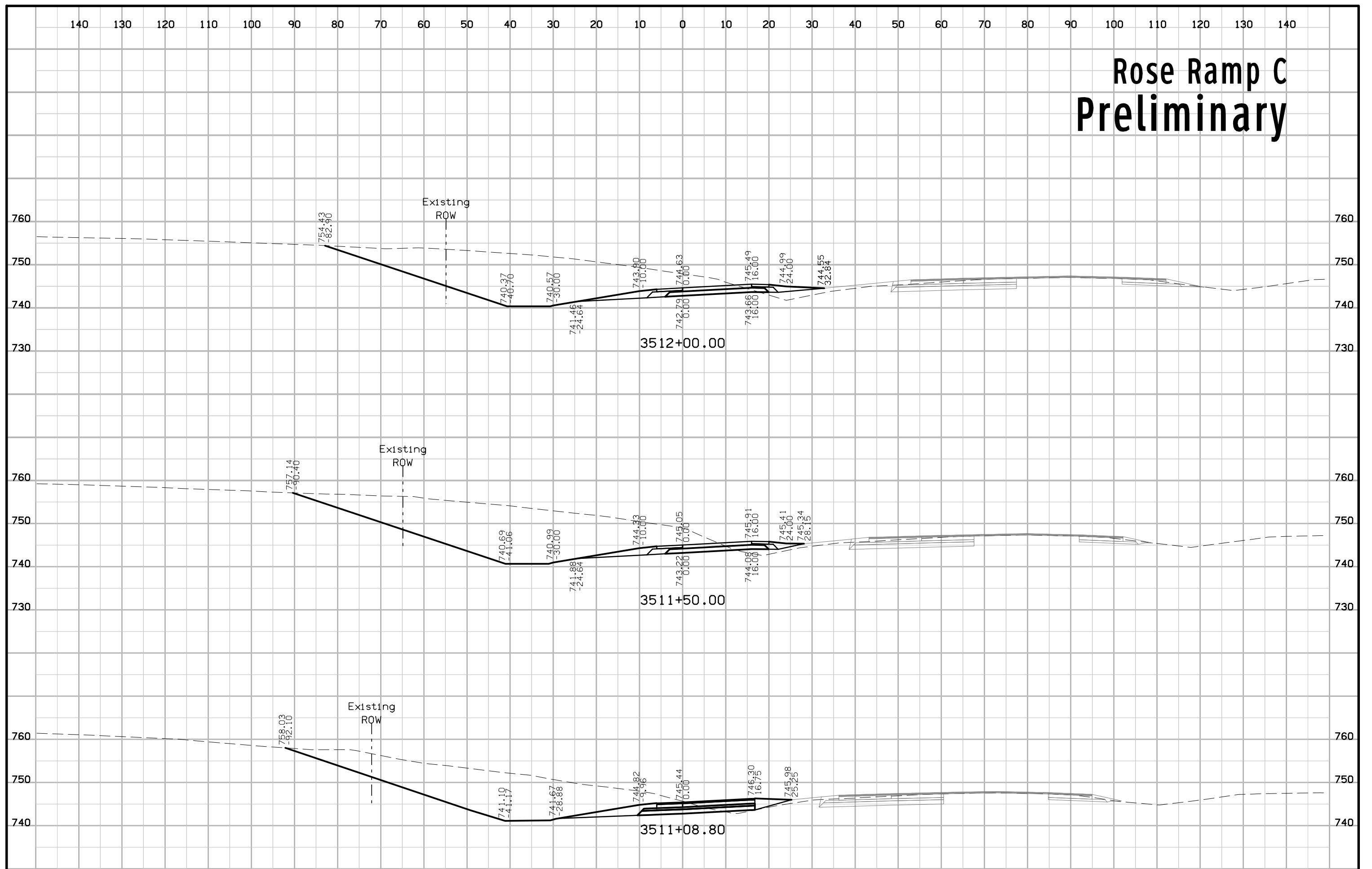

# Rose Ramp C Preliminary

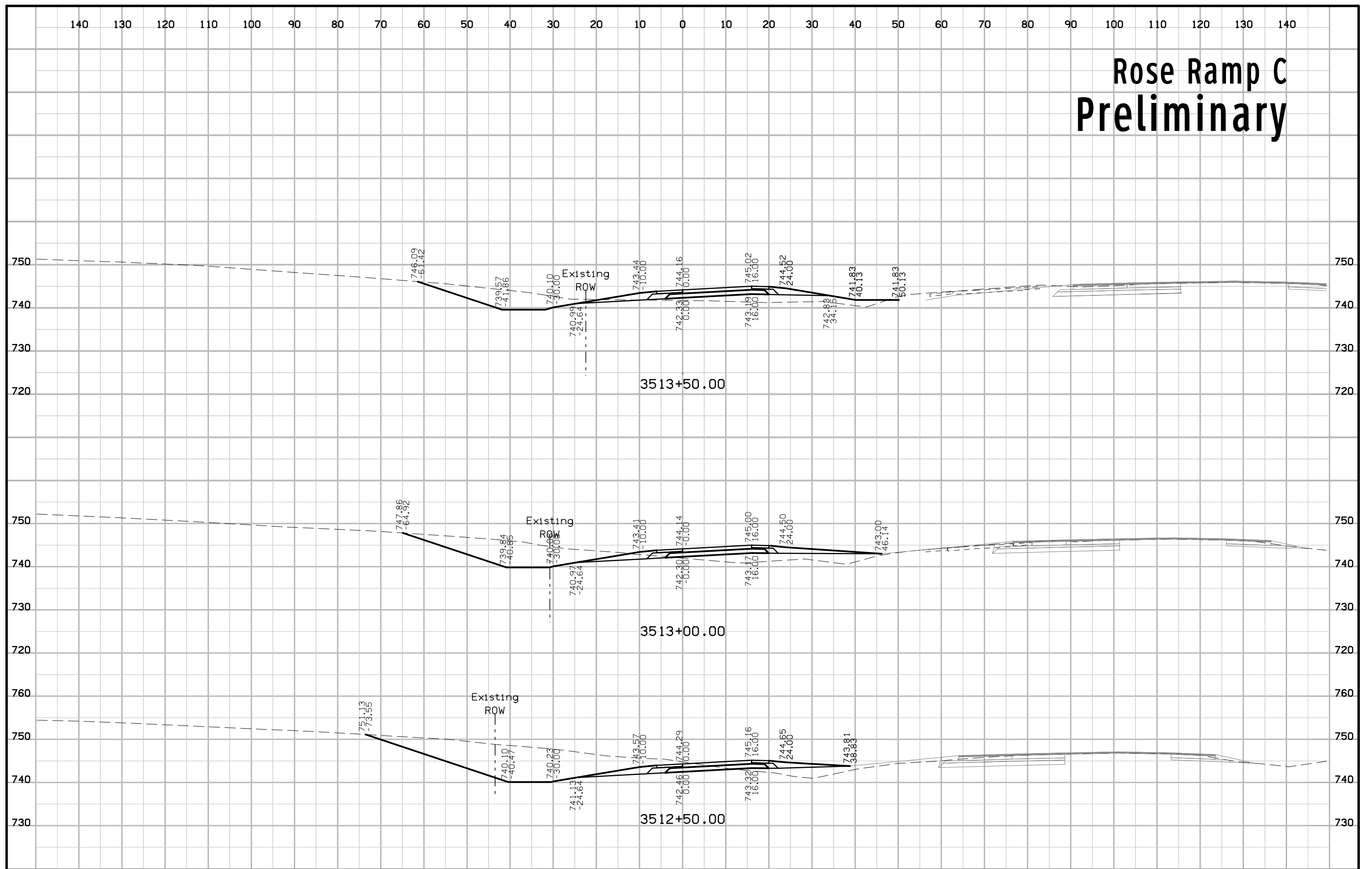

# Rose Ramp C Preliminary

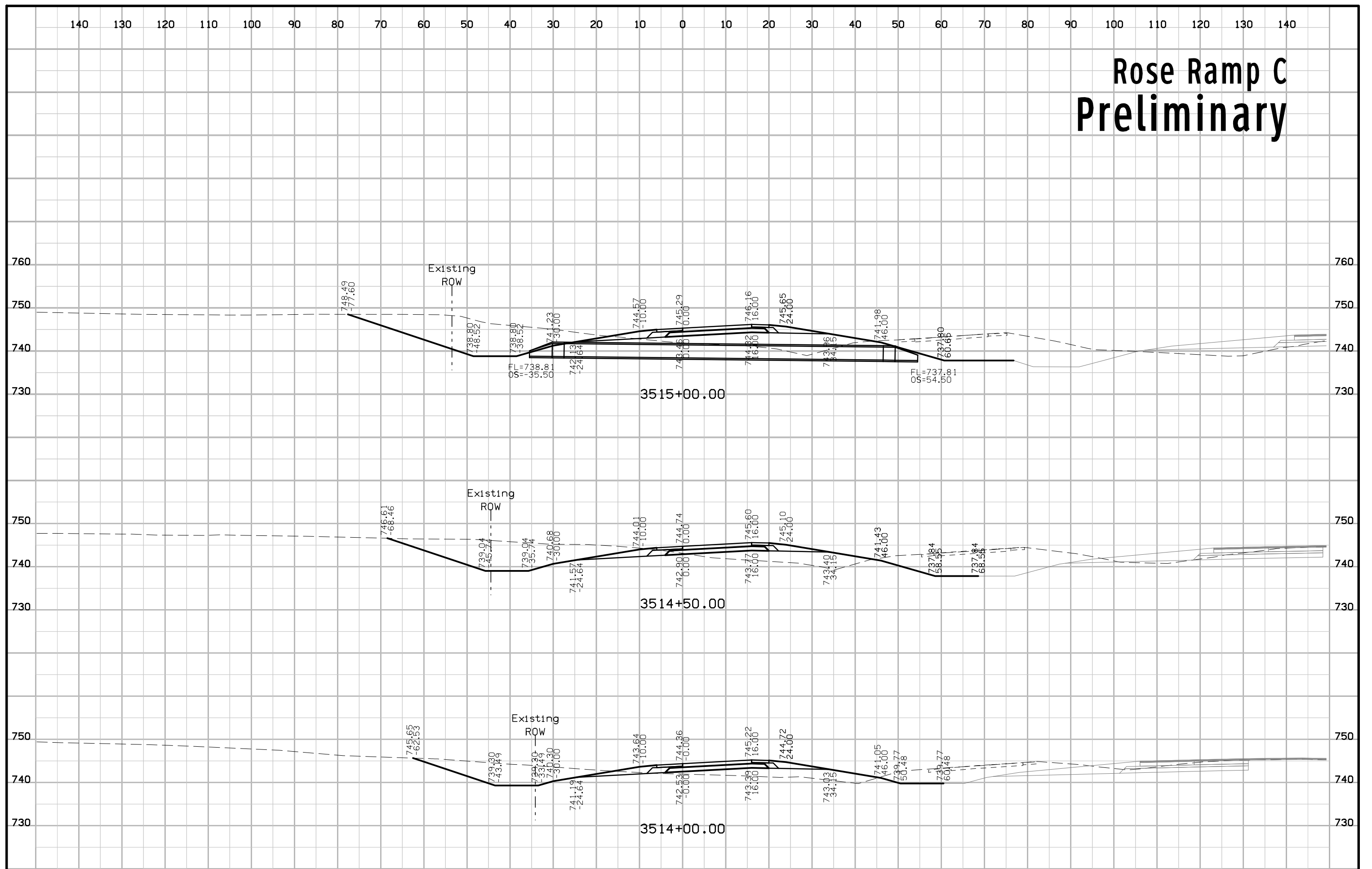



# Rose Ramp C Preliminary

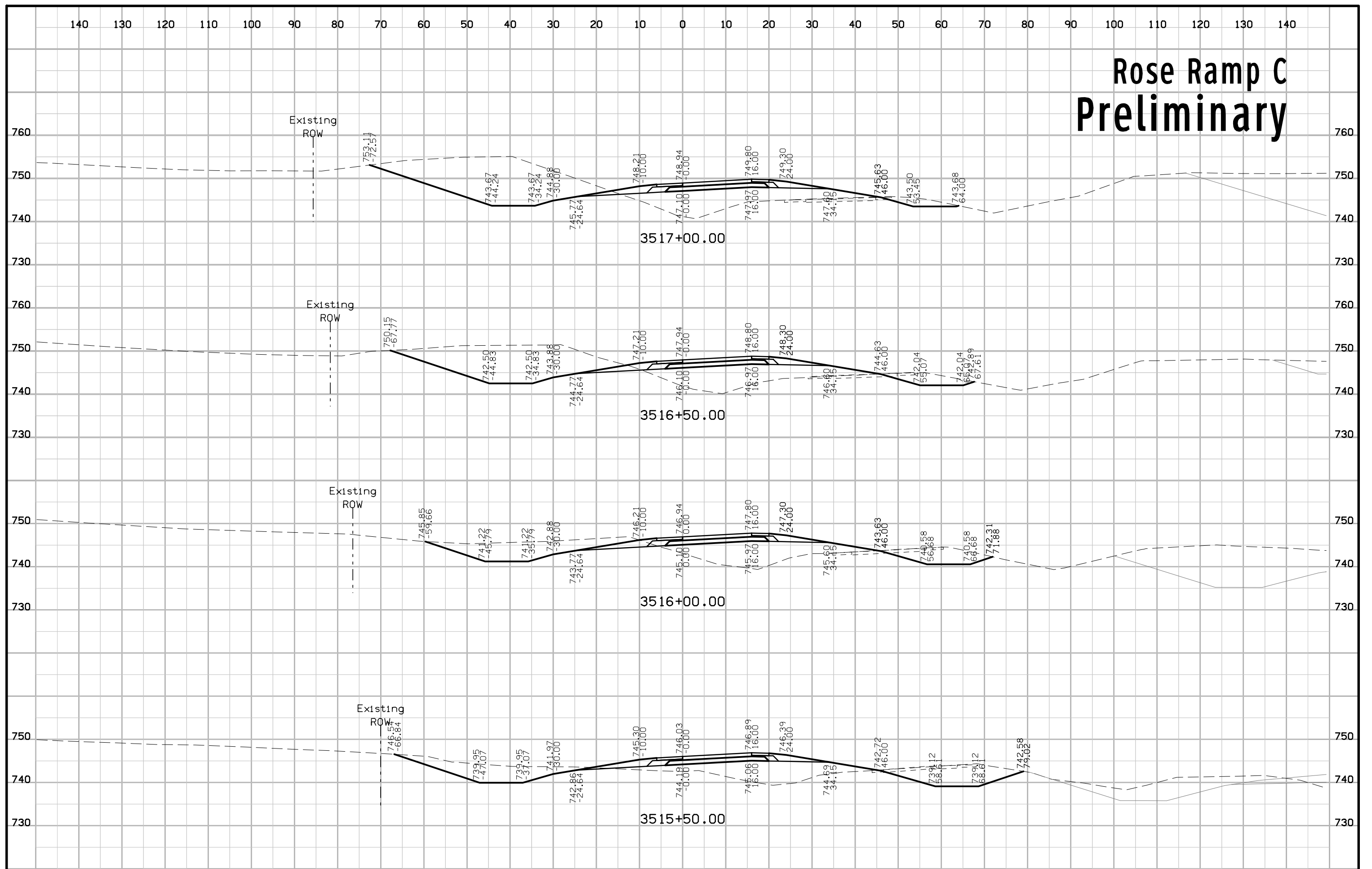

# Rose Ramp C Preliminary

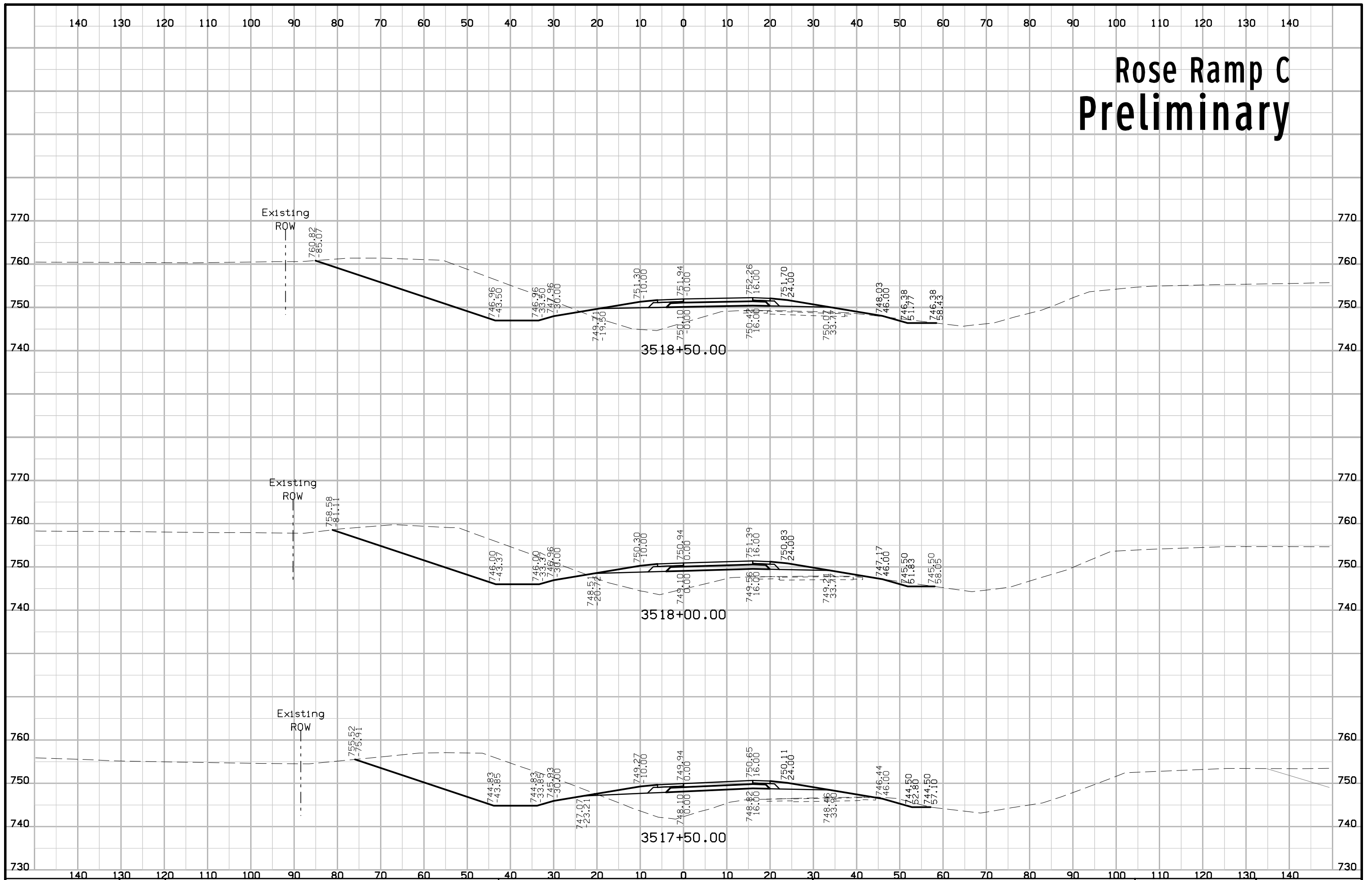

FILE NO.	ENGLISH	DESIGN TEAM	Iowa DOT \ HR Green	CEDAR COUNTY	PROJECT NUMBER	IM-NHS-080-7(134)266--03-16	SHEET NUMBER	Y.84
----------	---------	-------------	---------------------	--------------	----------------	-----------------------------	--------------	------

# Rose Ramp C Preliminary

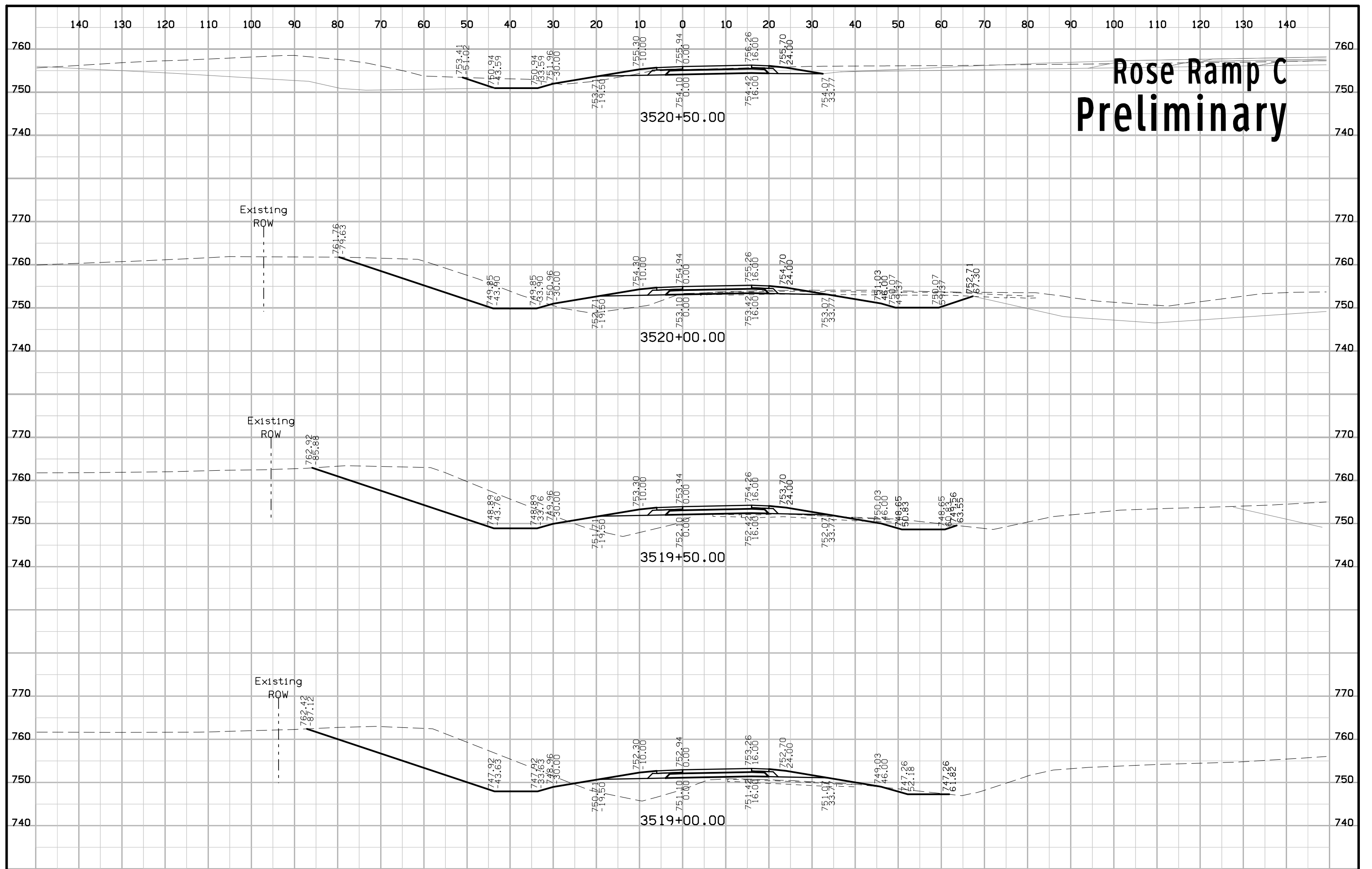

# Rose Ramp C Preliminary

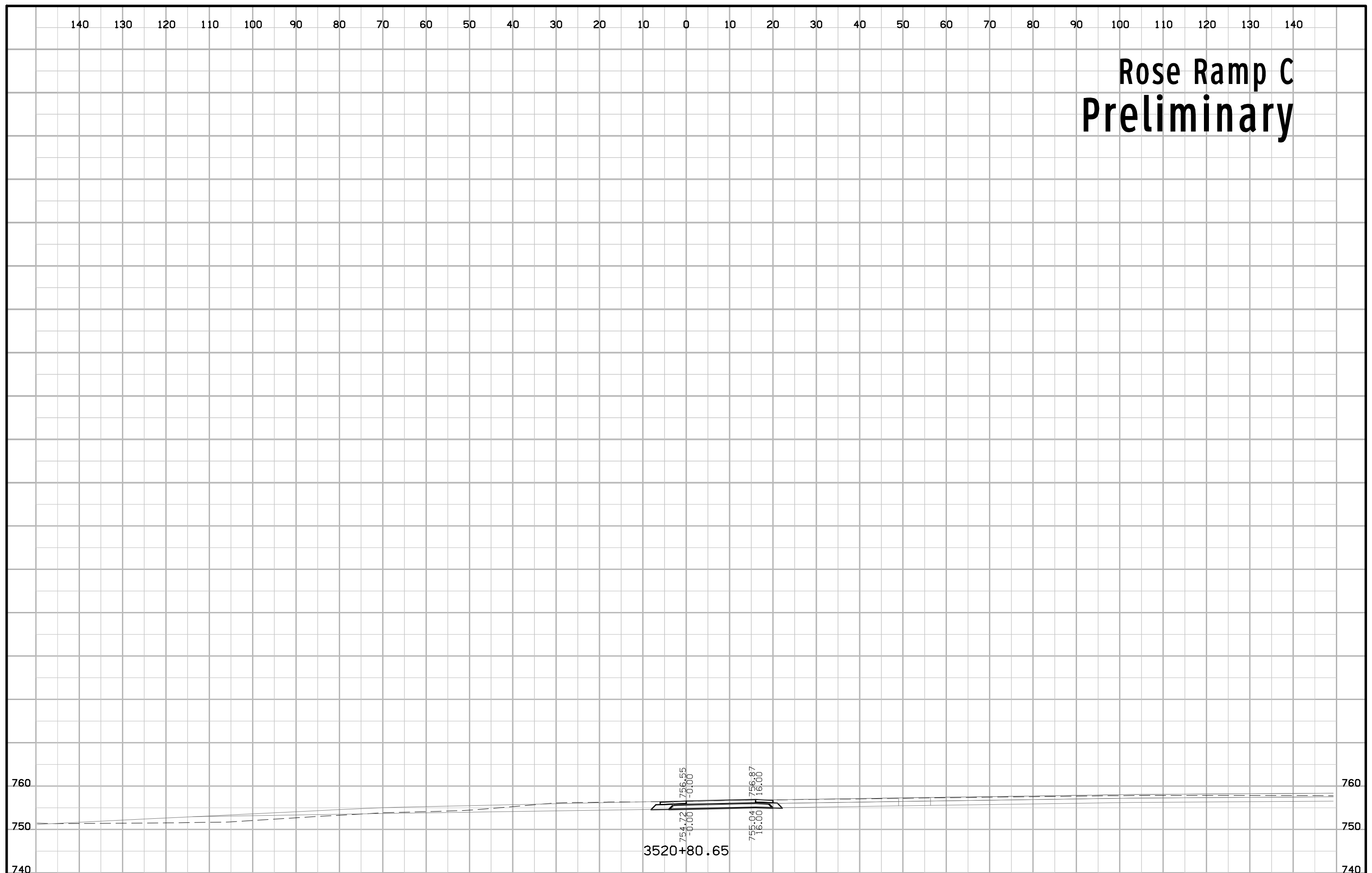

FILE NO.	ENGLISH	DESIGN TEAM	Iowa DOT \ HR Green	CEDAR COUNTY	PROJECT NUMBER	IM-NHS-080-7(134)266--03-16	SHEET NUMBER	Y.86
----------	---------	-------------	---------------------	--------------	----------------	-----------------------------	--------------	------

# Rose Ramp D Preliminary

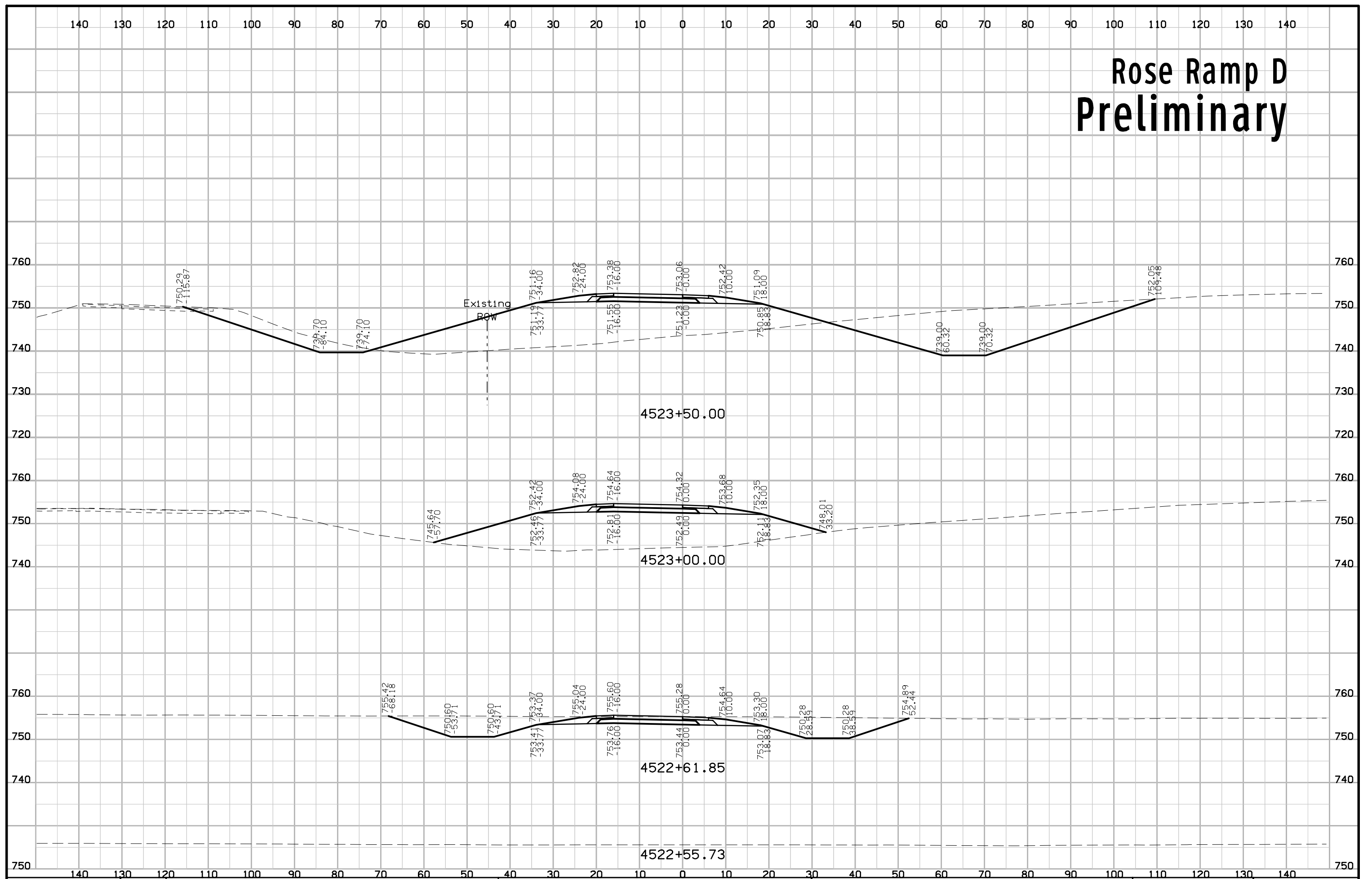

# Rose Ramp D Preliminary

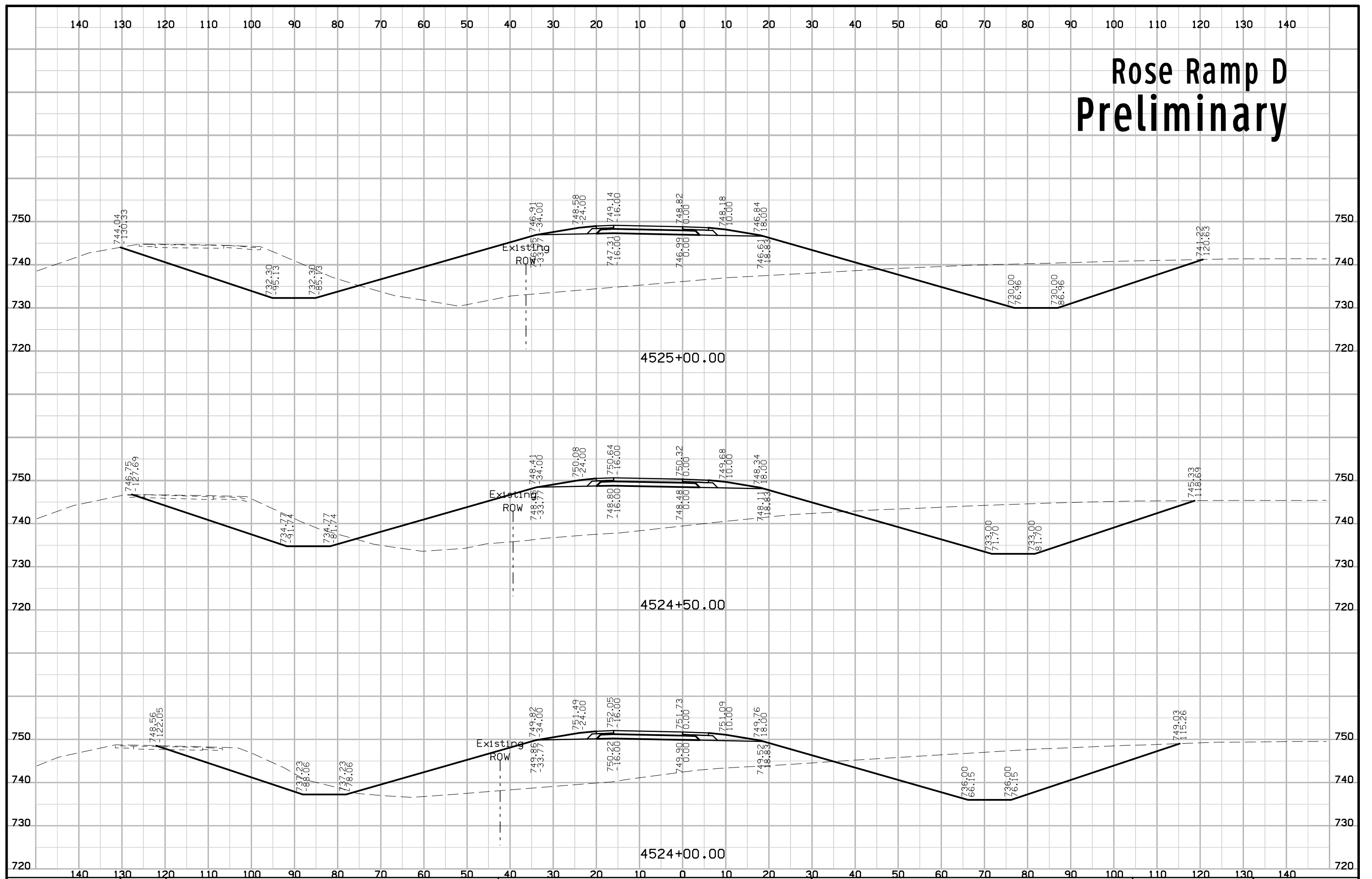

# Rose Ramp D Preliminary

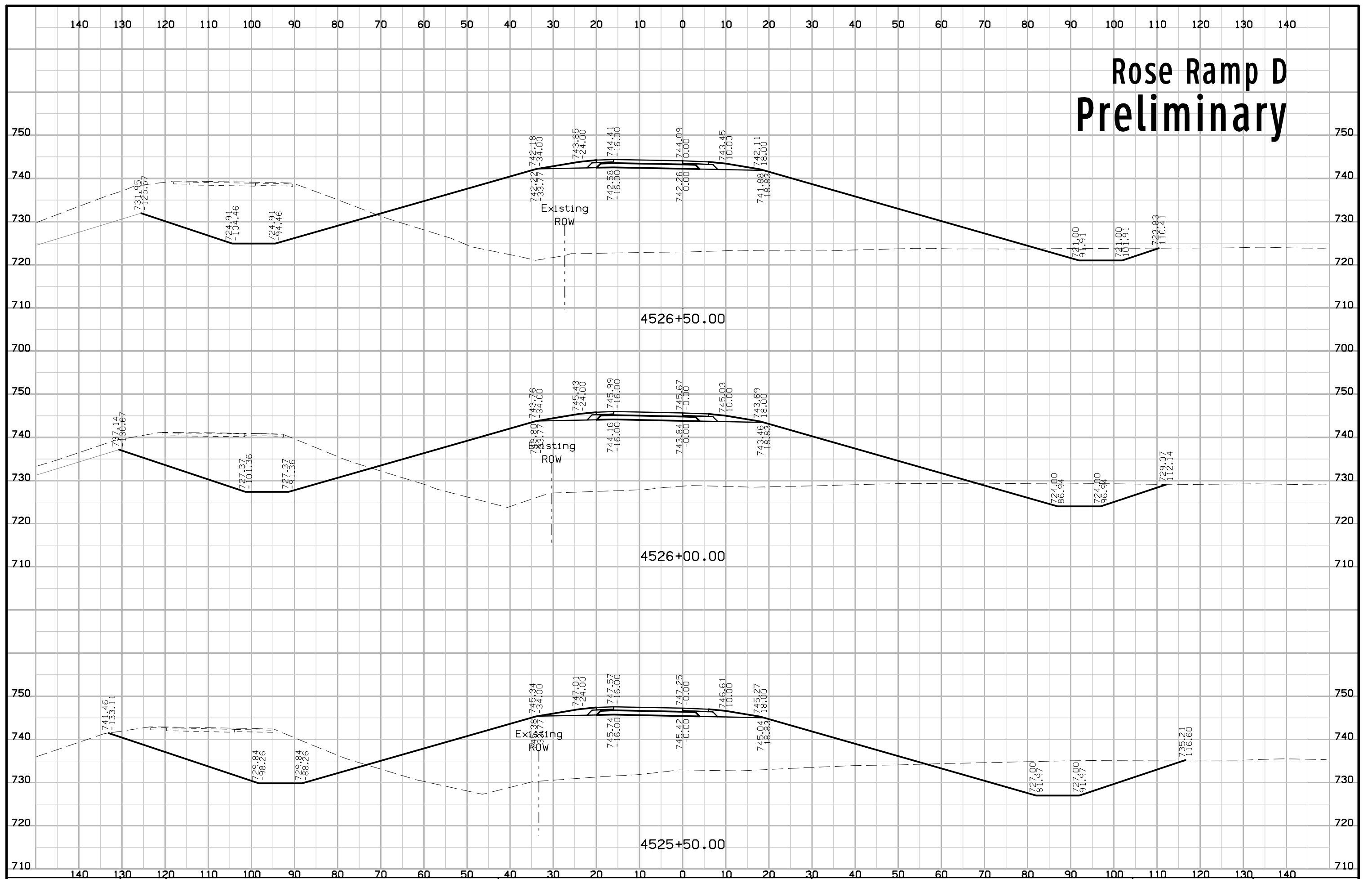

# Rose Ramp D Preliminary

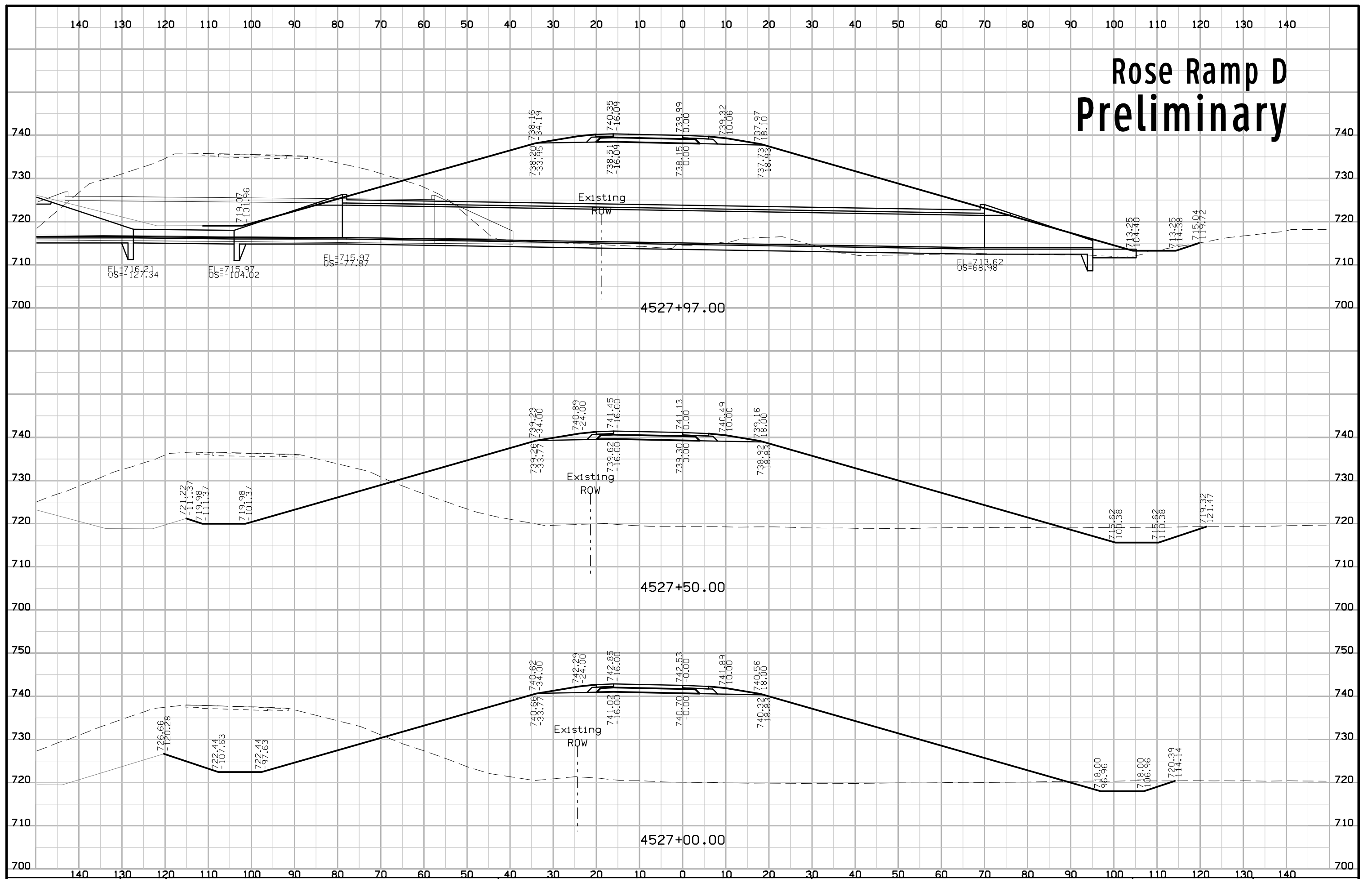



# Rose Ramp D Preliminary

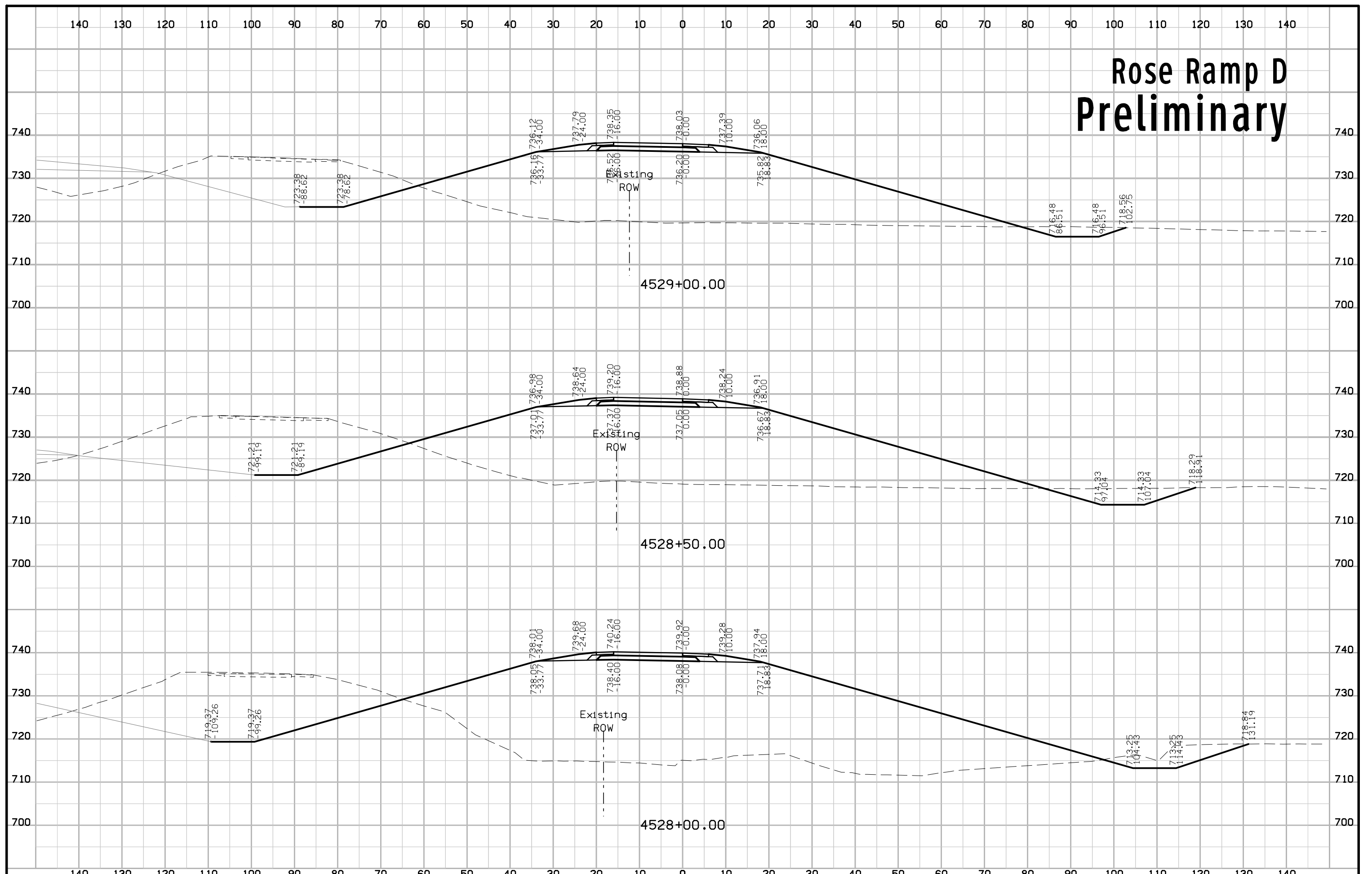

# Rose Ramp D Preliminary

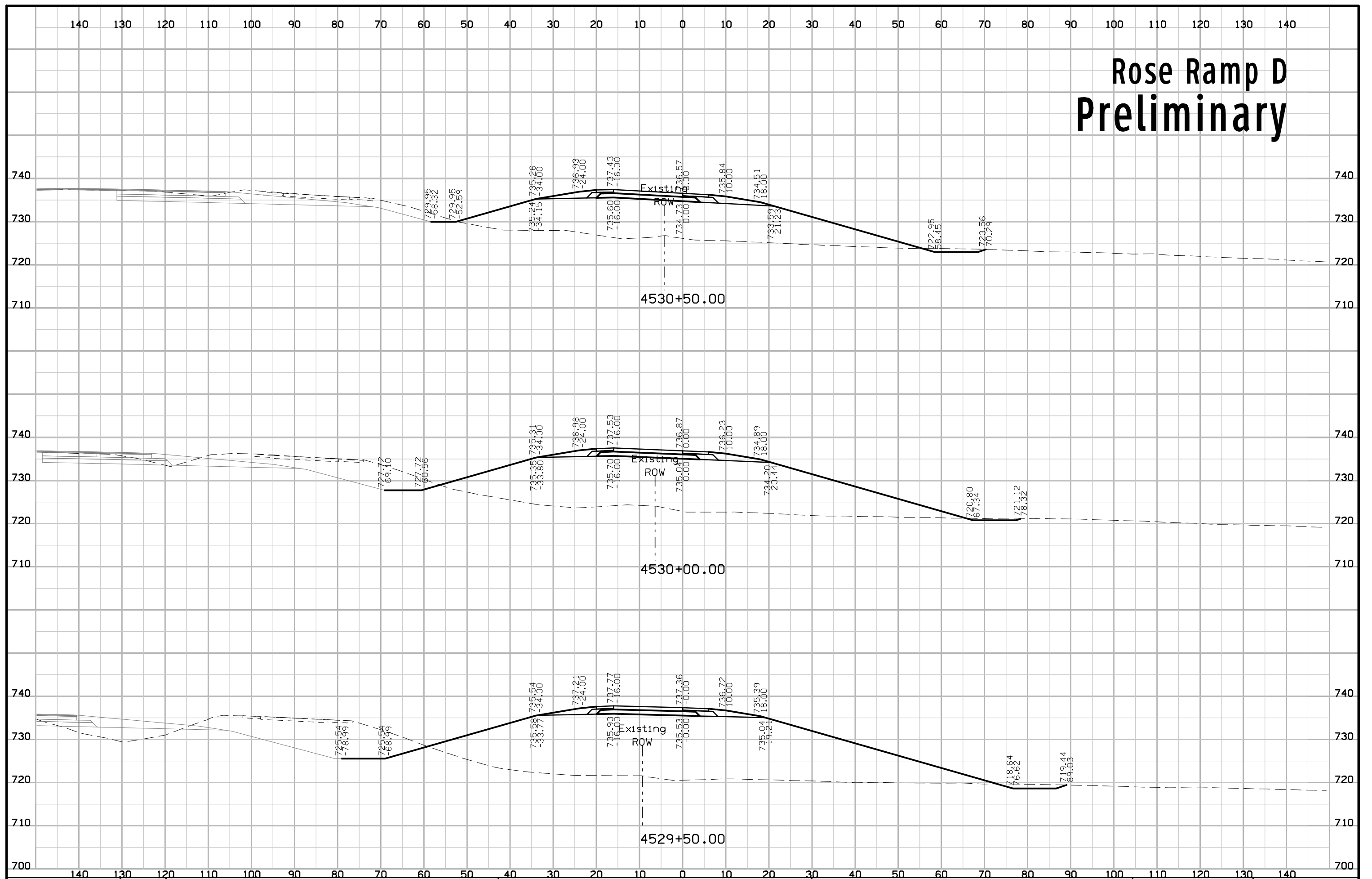

# Rose Ramp D Preliminary

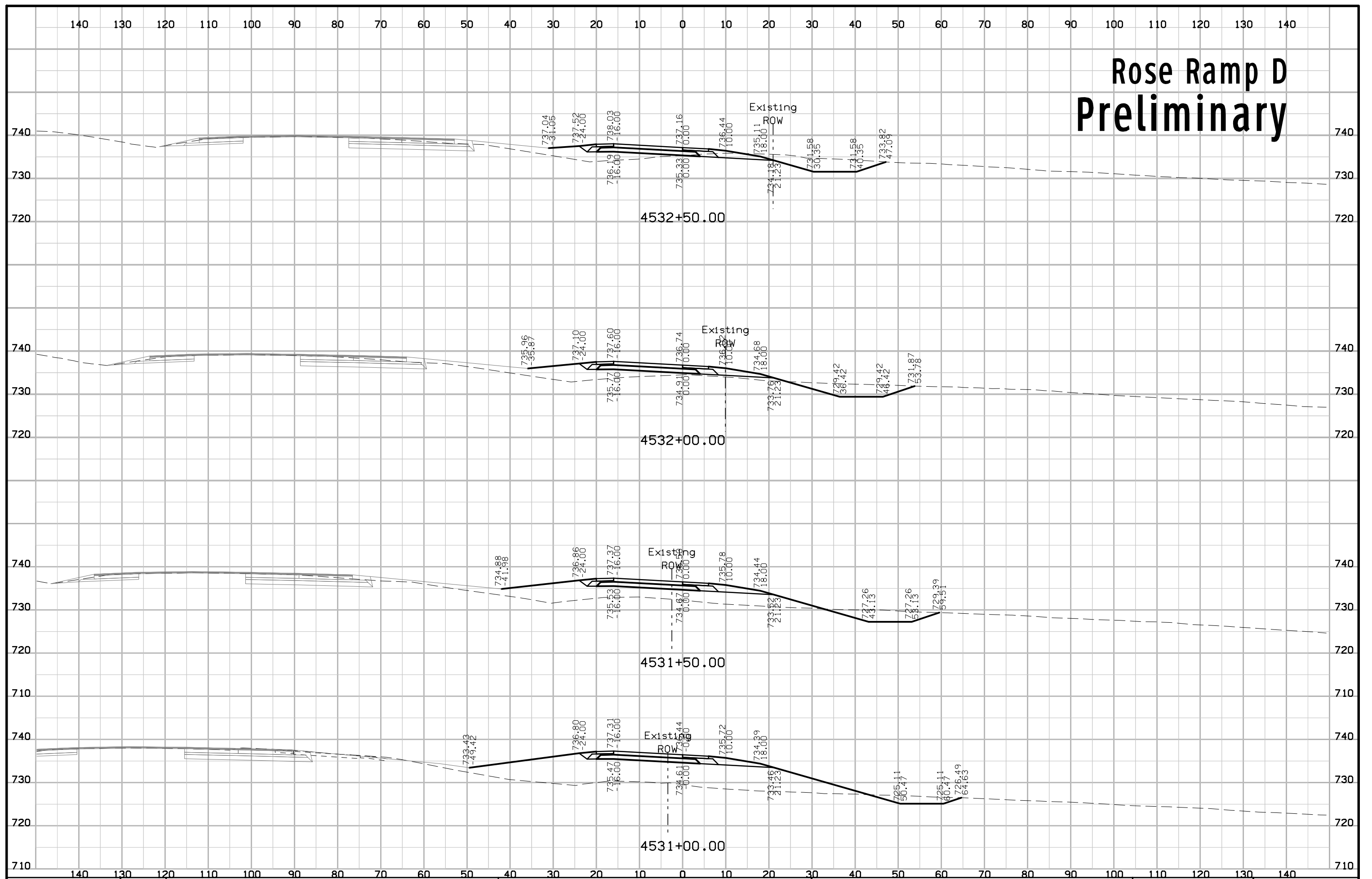

# Rose Ramp D Preliminary

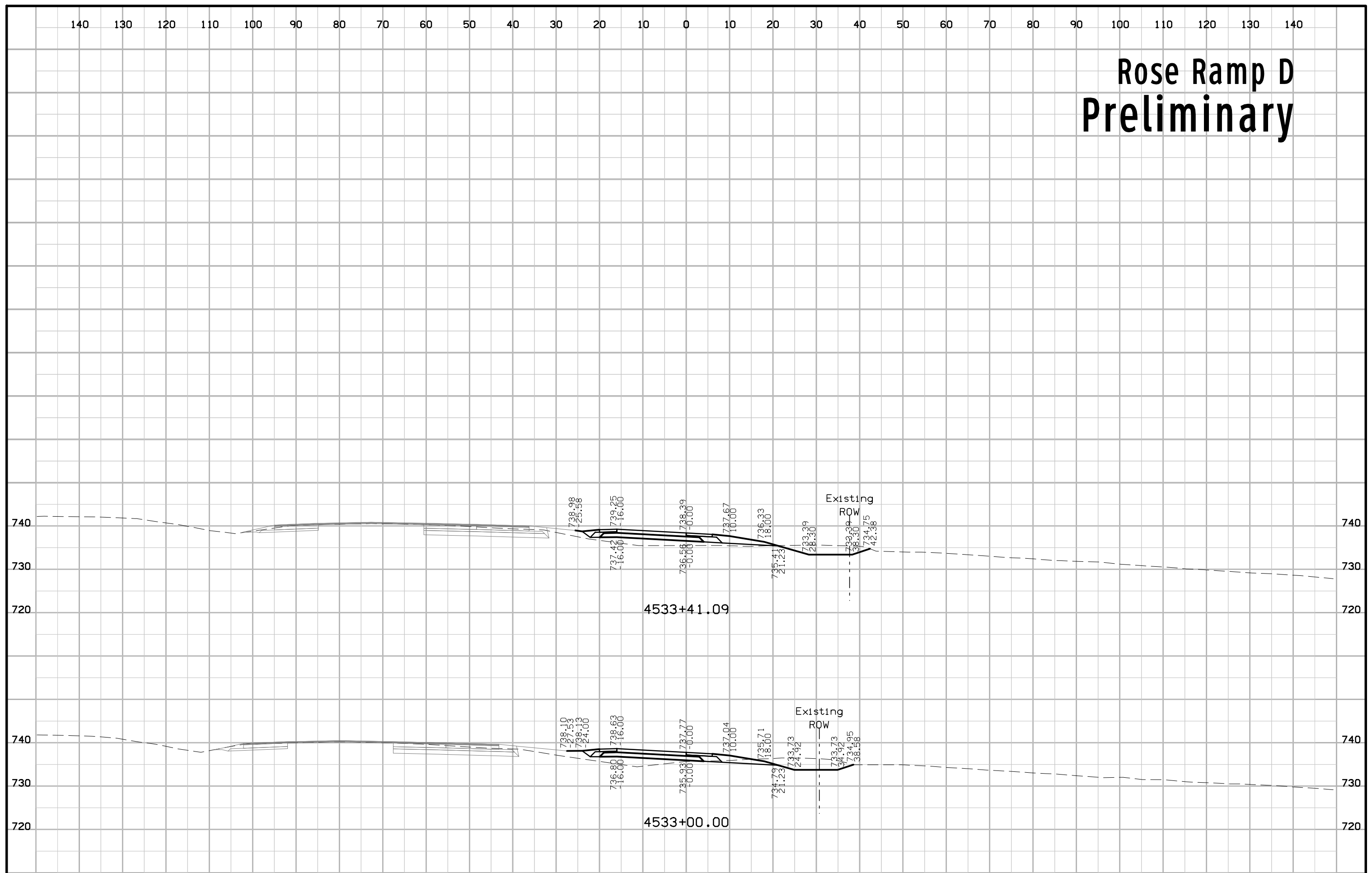

# Yankee Ramp A Preliminary

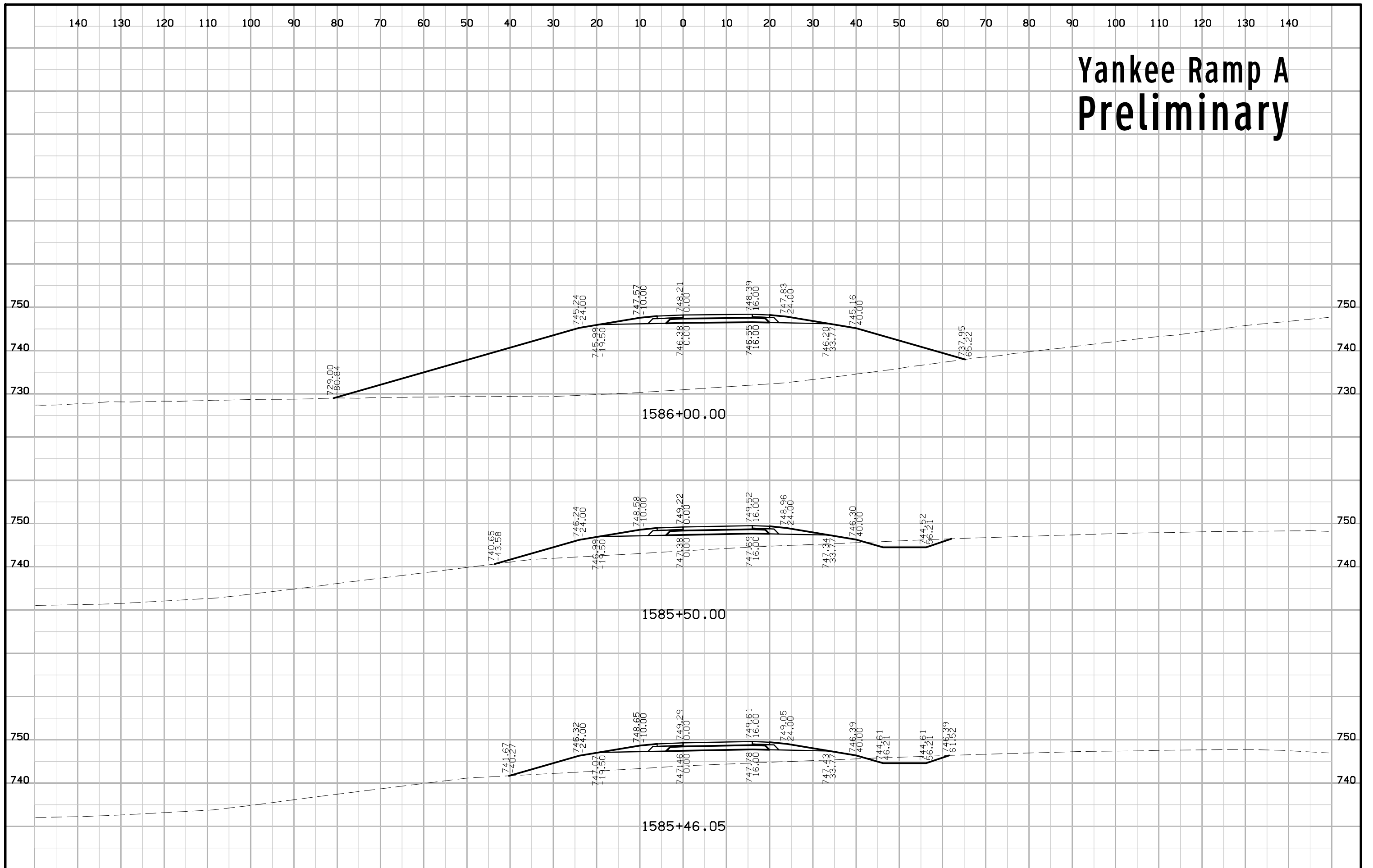

# Yankee Ramp A Preliminary

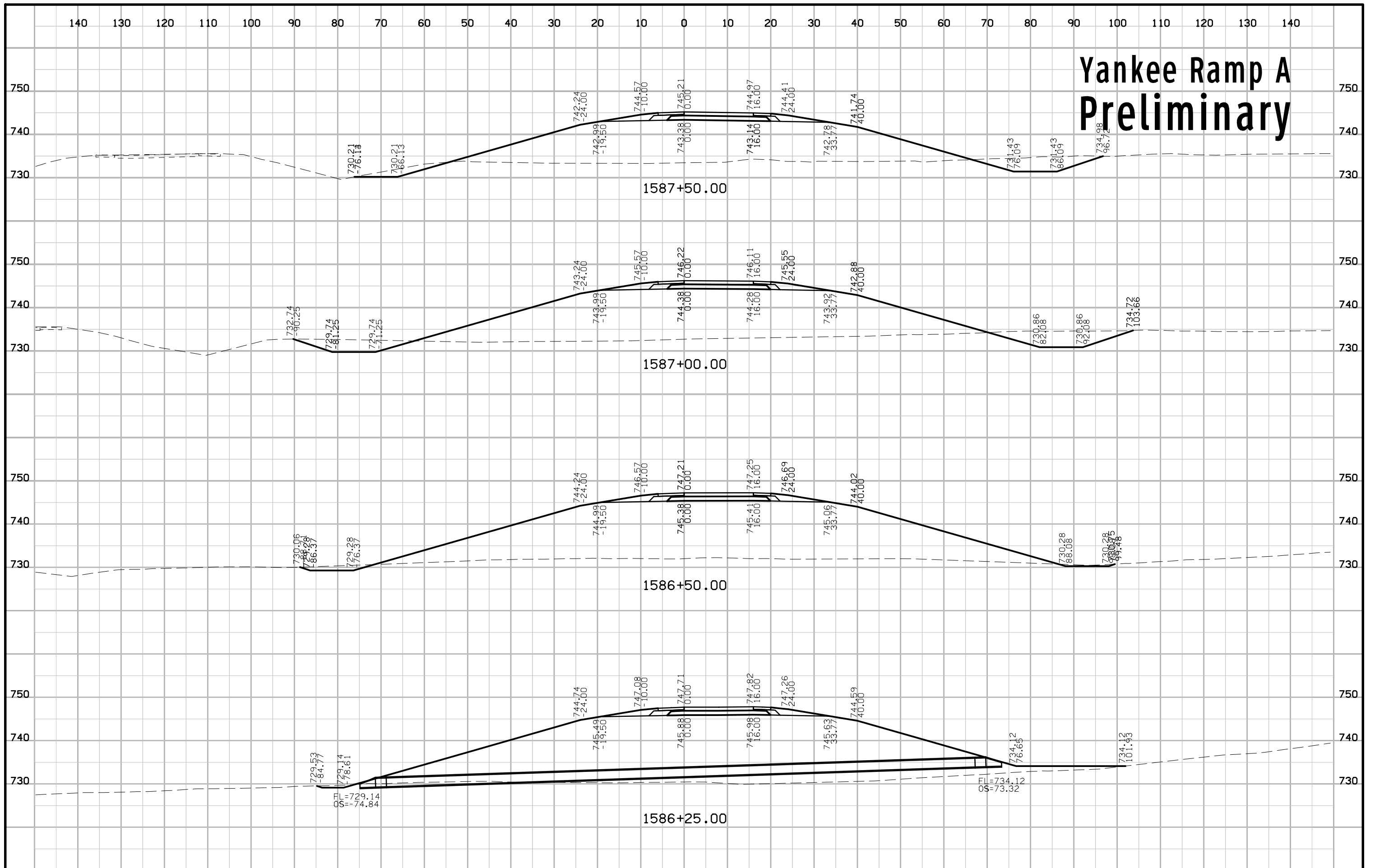

# Yankee Ramp A Preliminary

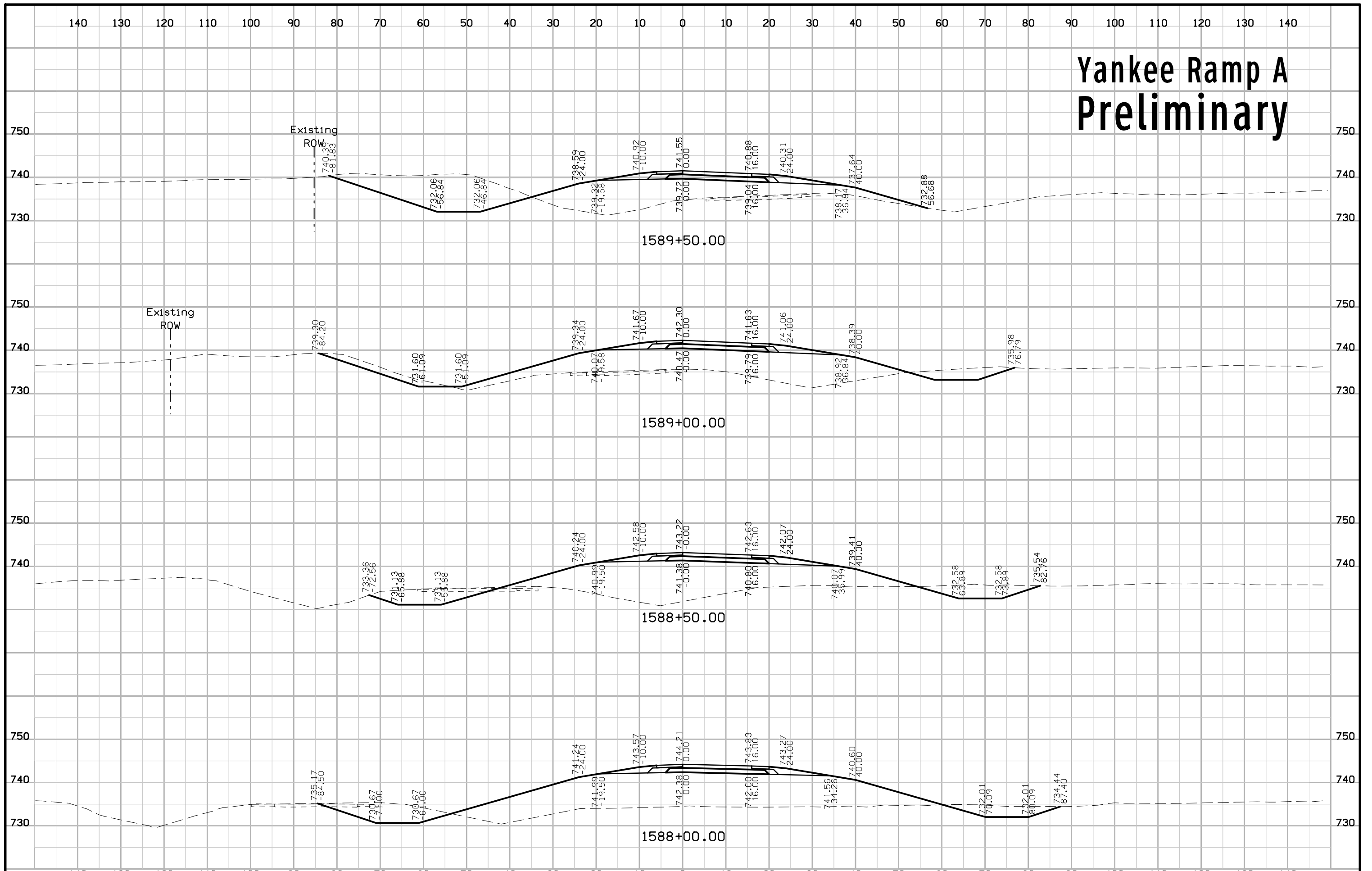

# Yankee Ramp A Preliminary

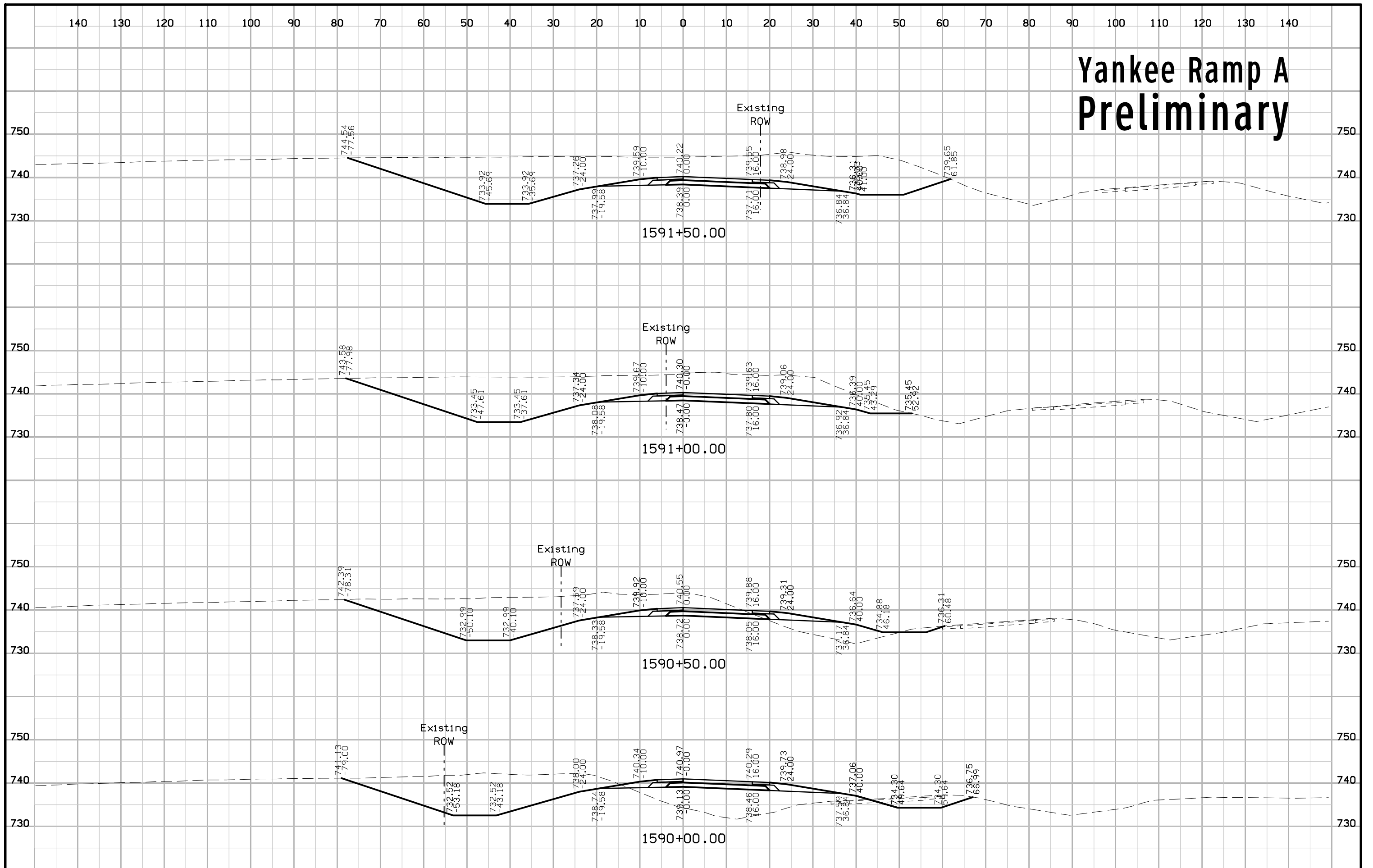



# Yankee Ramp A Preliminary

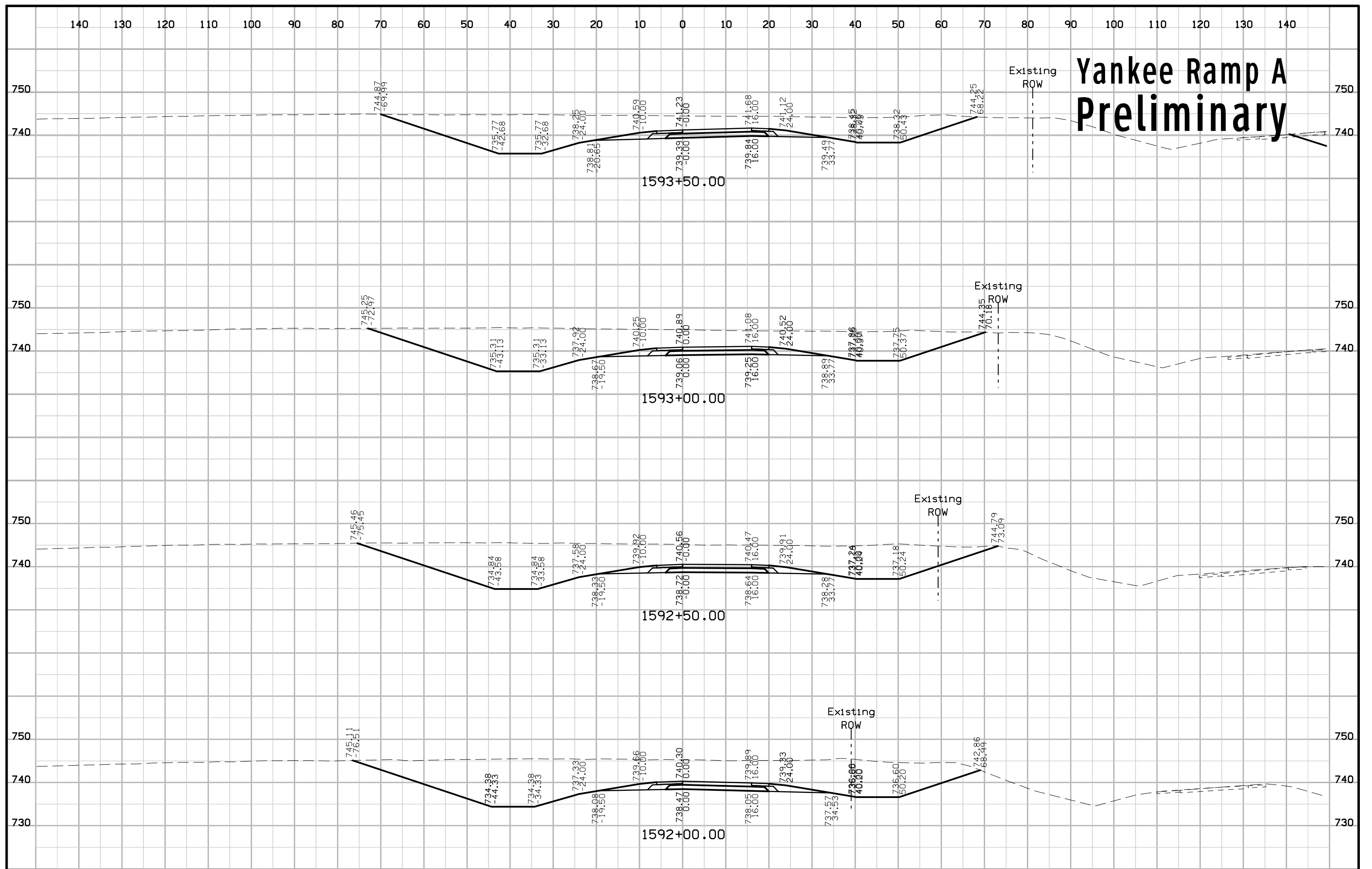

# Yankee Ramp A Preliminary

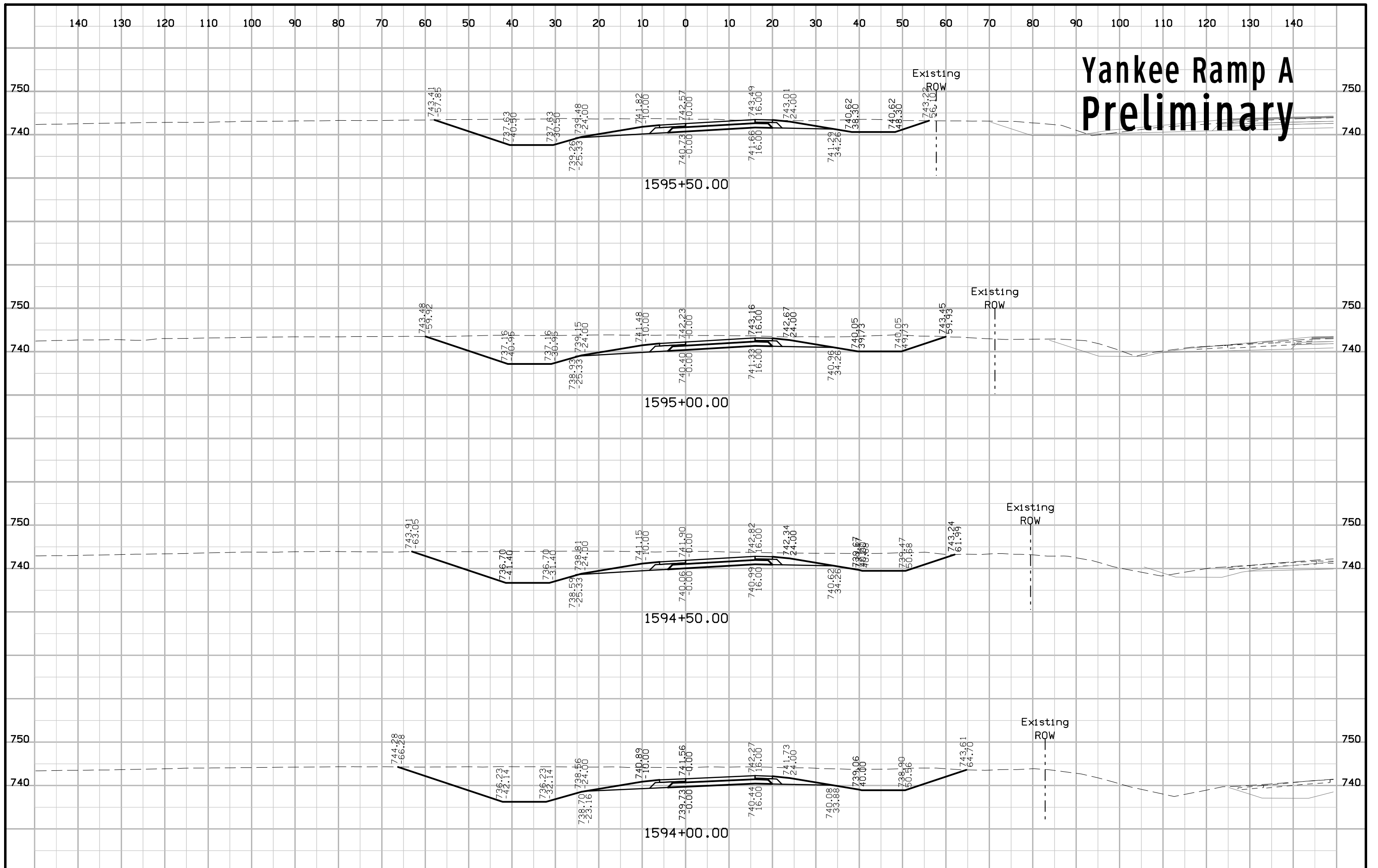

# Yankee Ramp A Preliminary

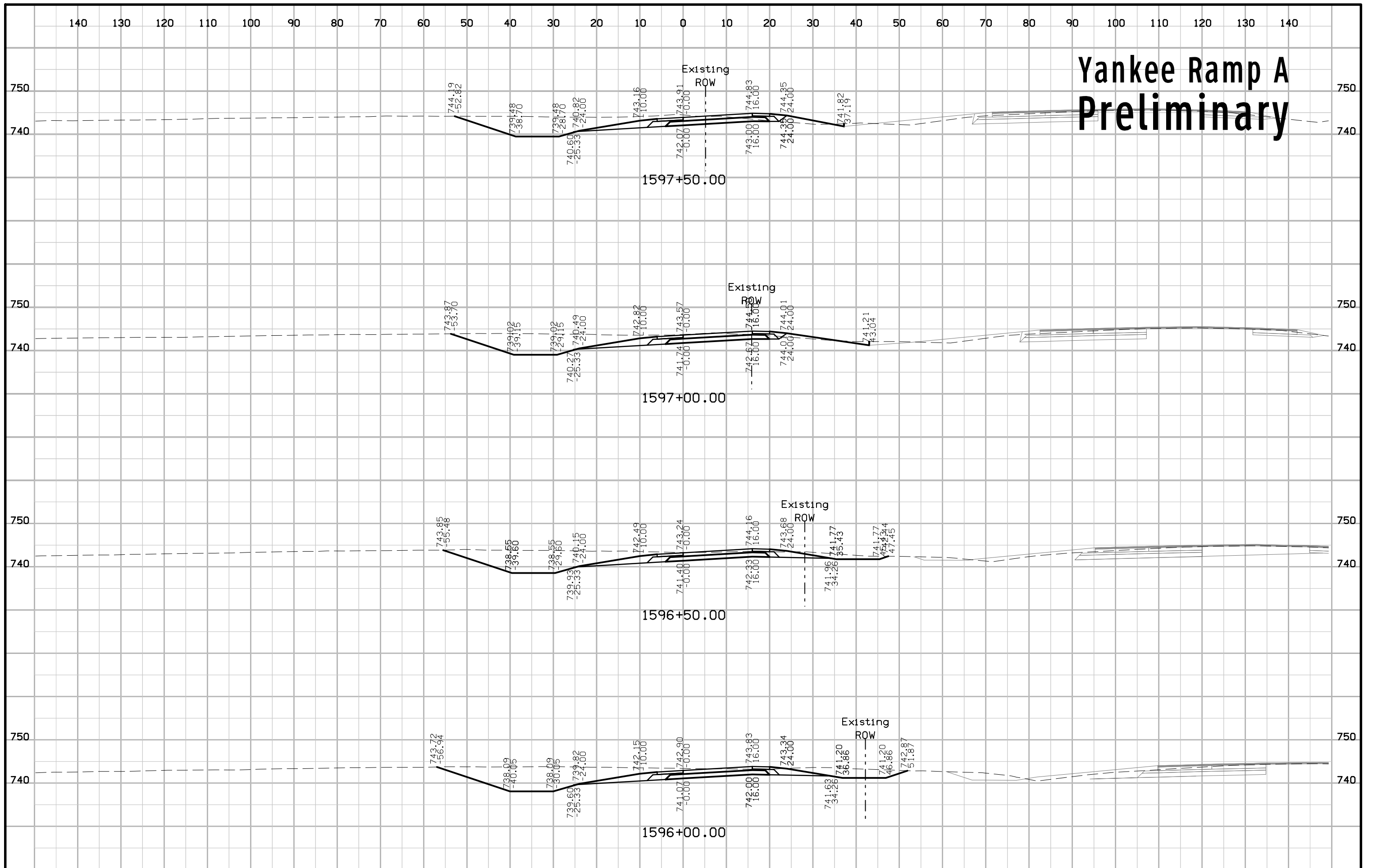

# Yankee Ramp A Preliminary

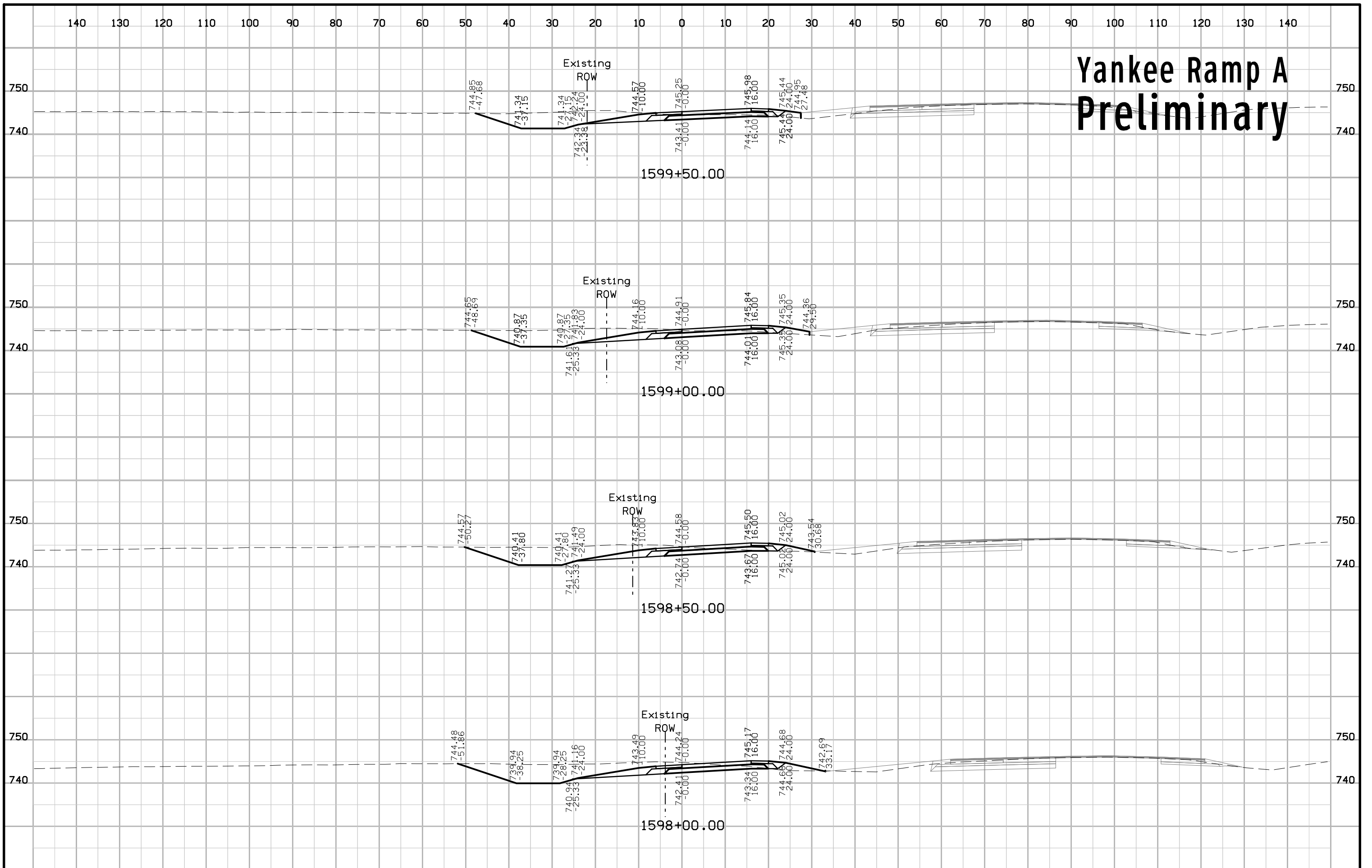

# Yankee Ramp A Preliminary

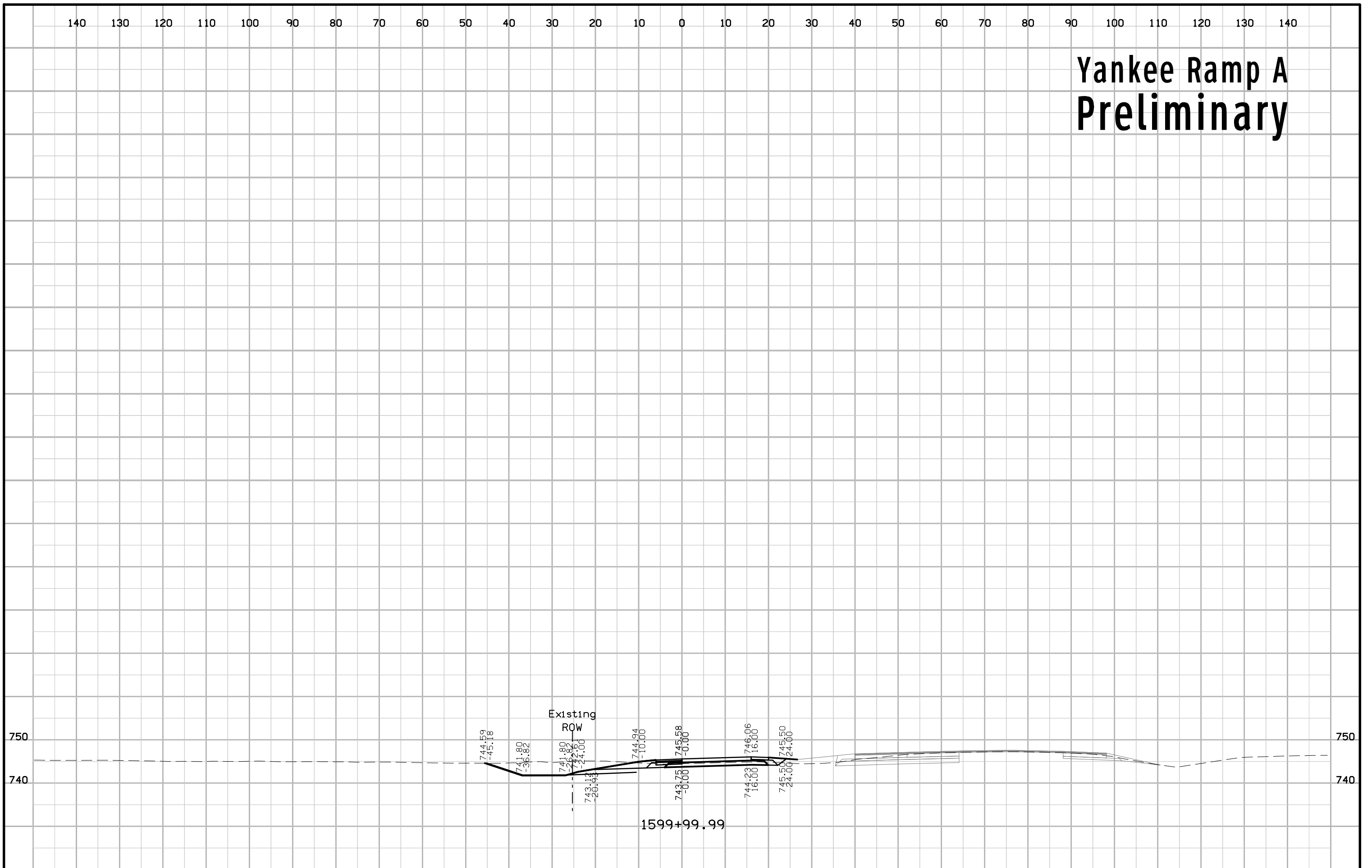

# Yankee Ramp B Preliminary

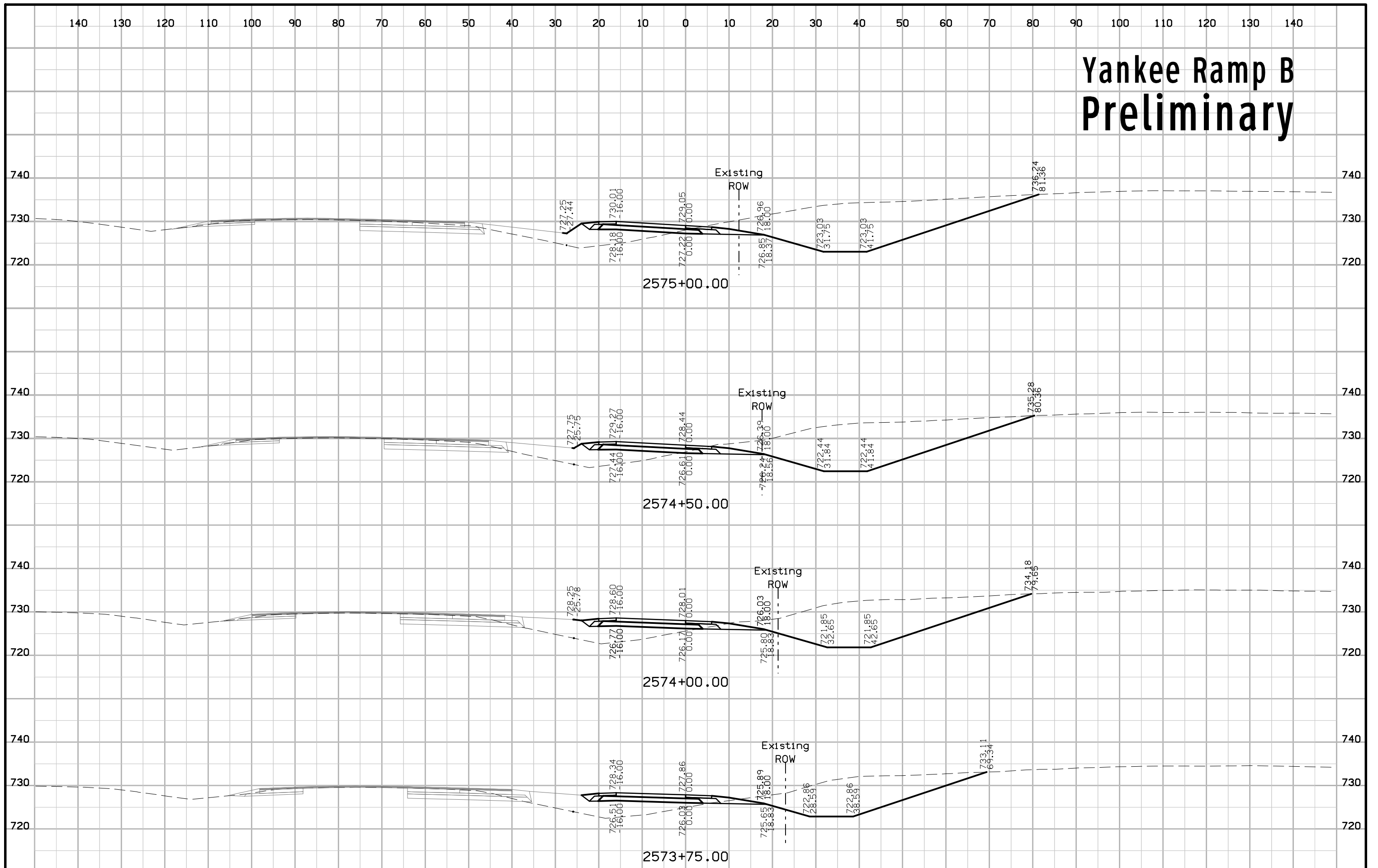

# Yankee Ramp B Preliminary

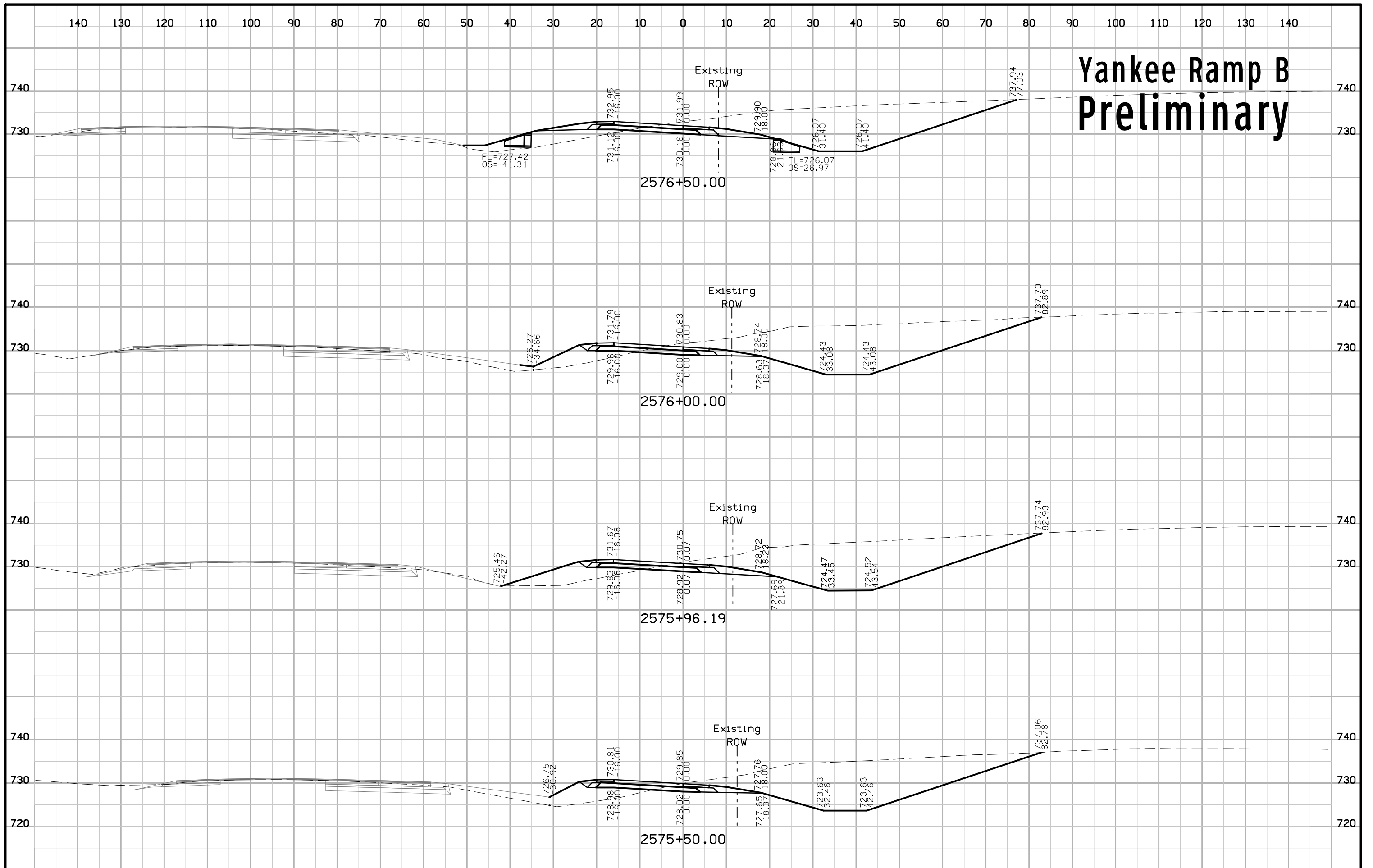

# Yankee Ramp B Preliminary

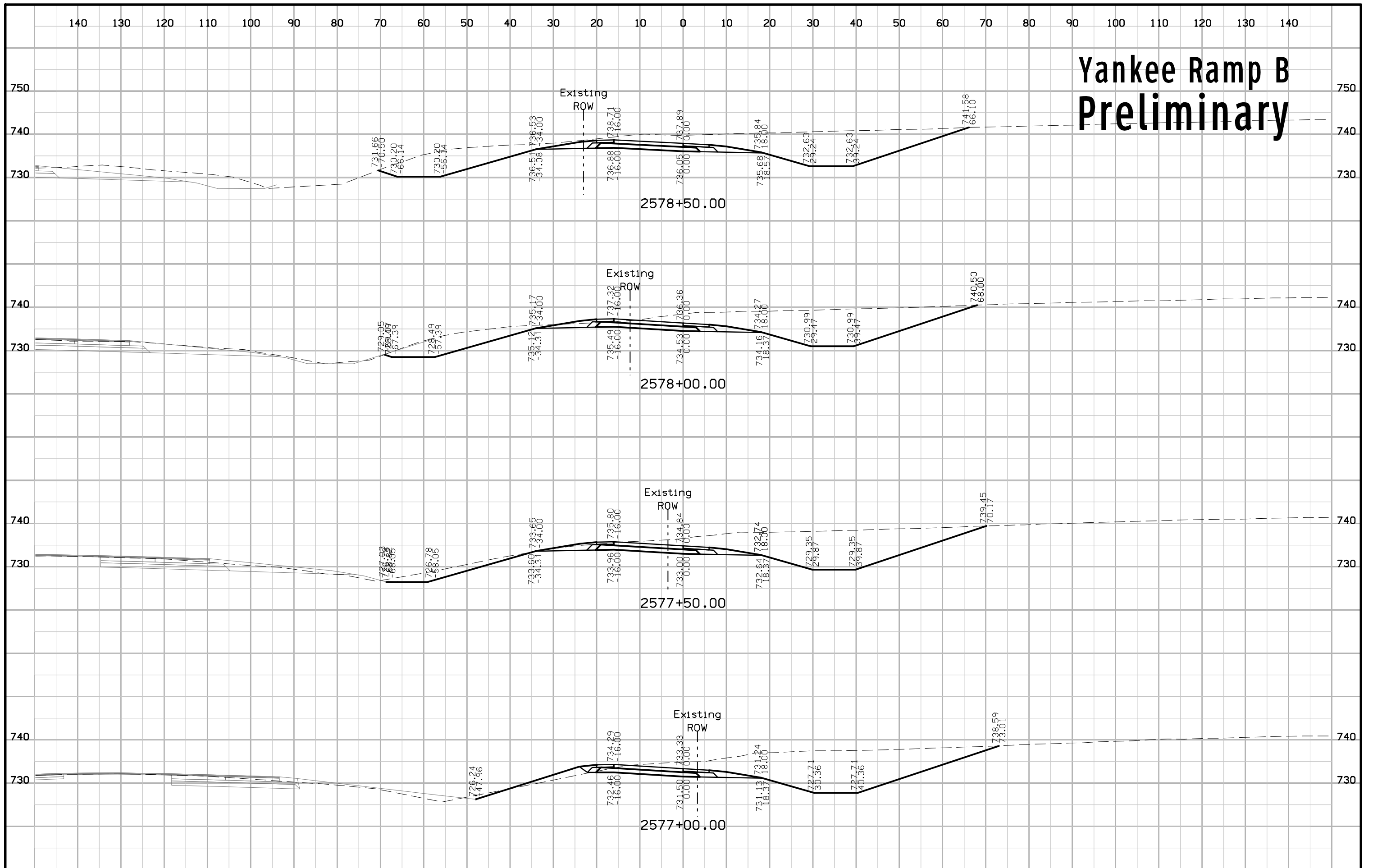



# Yankee Ramp B Preliminary

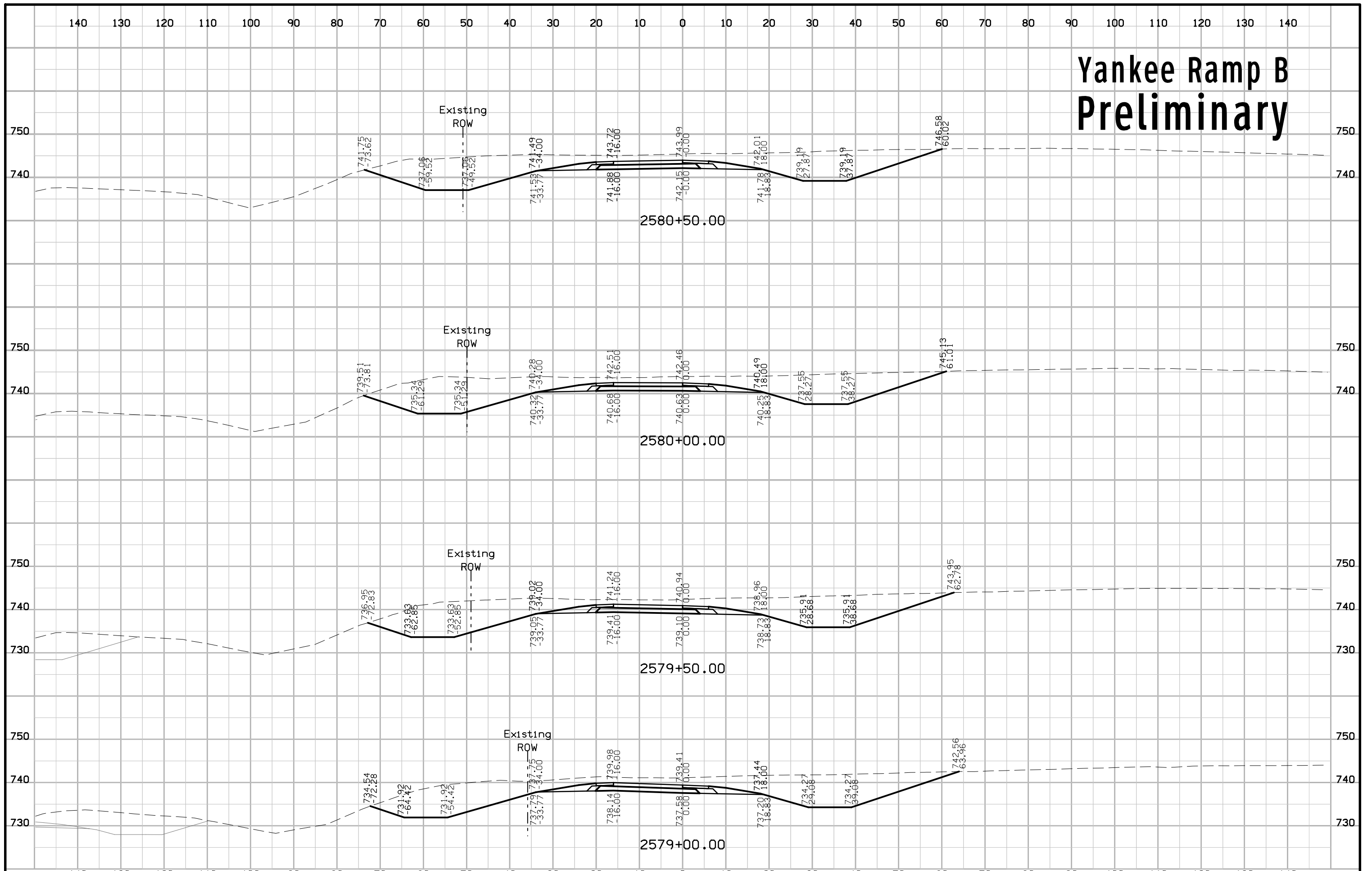

# Yankee Ramp B Preliminary

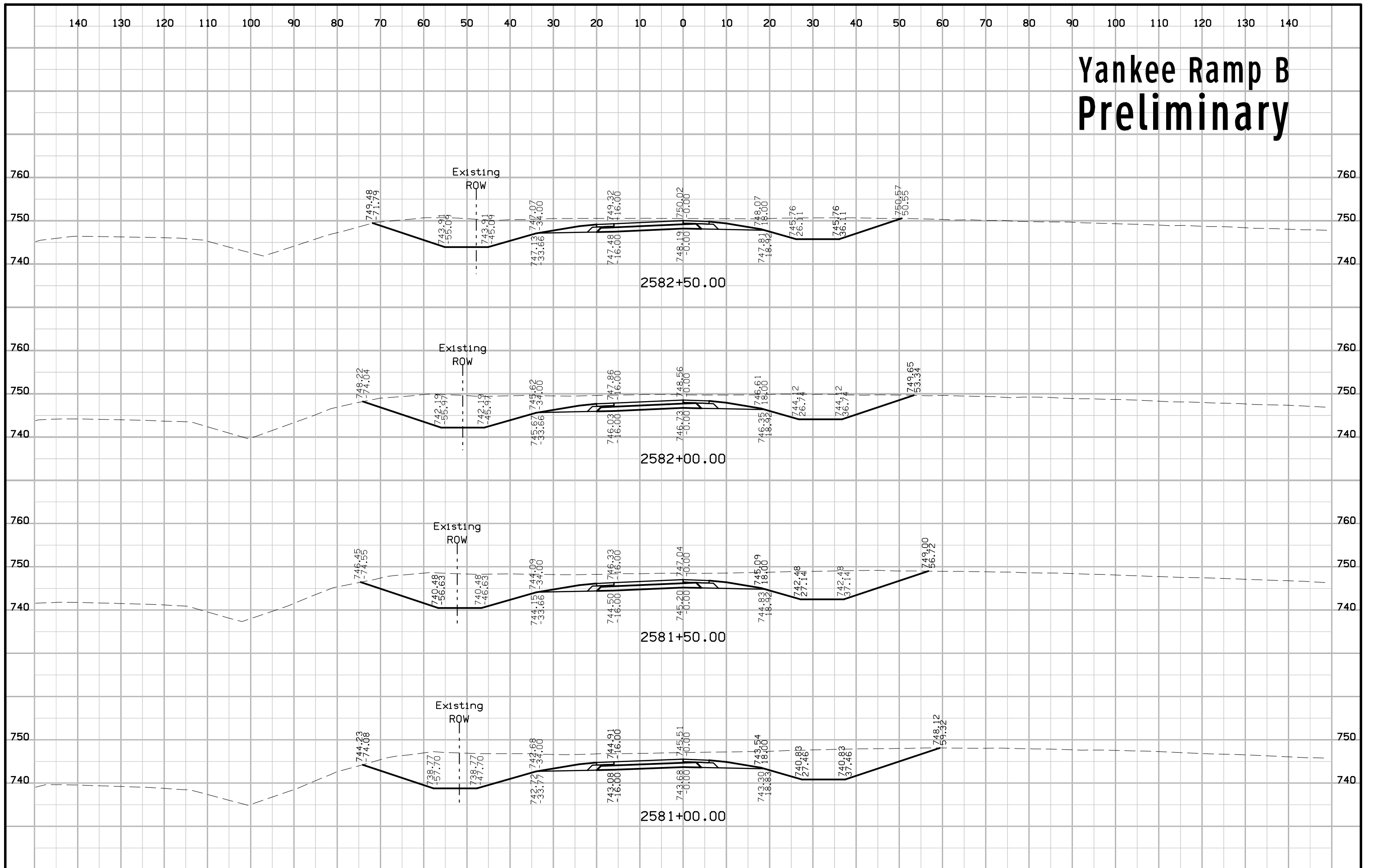

# Yankee Ramp B Preliminary

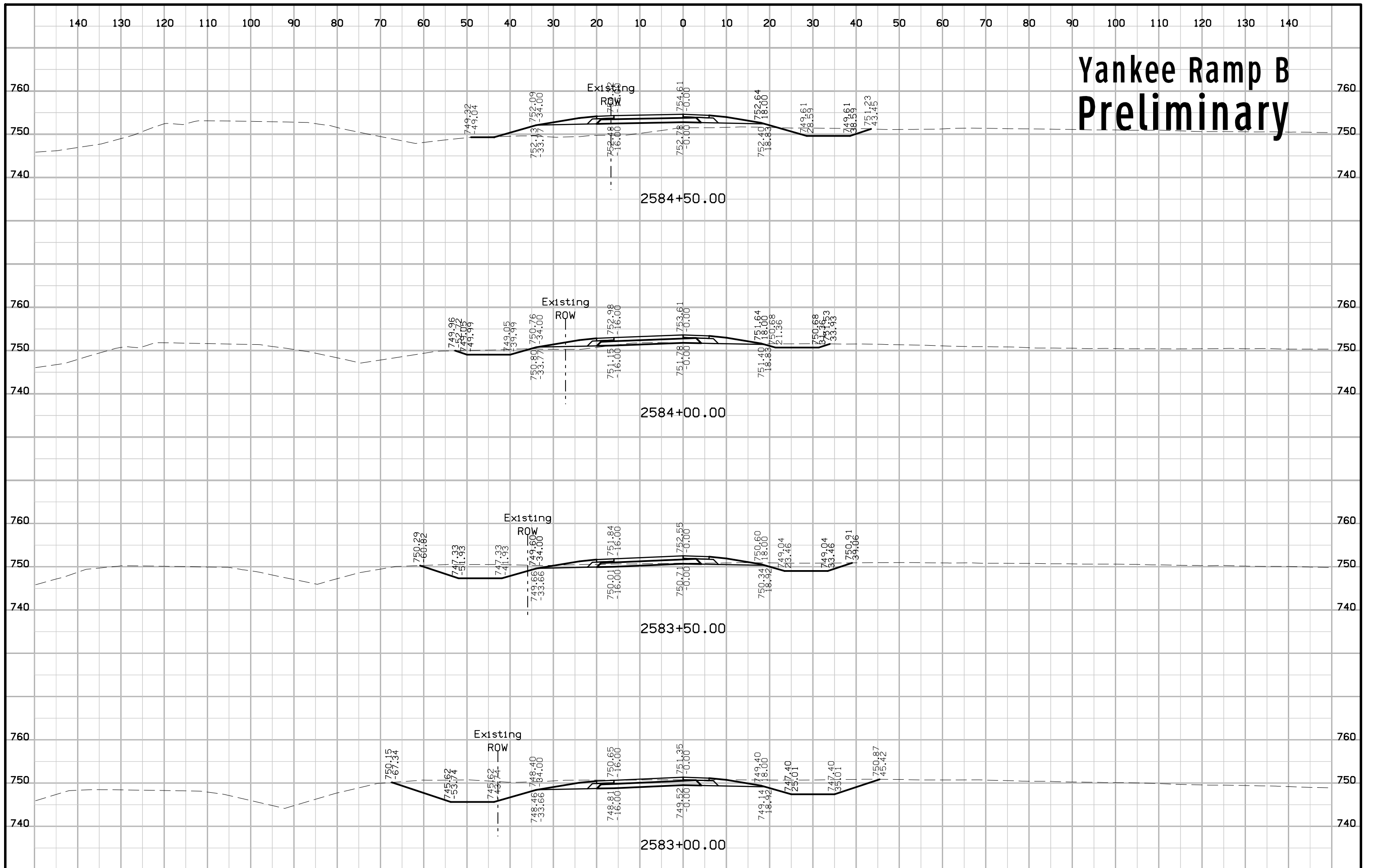

# Yankee Ramp B Preliminary

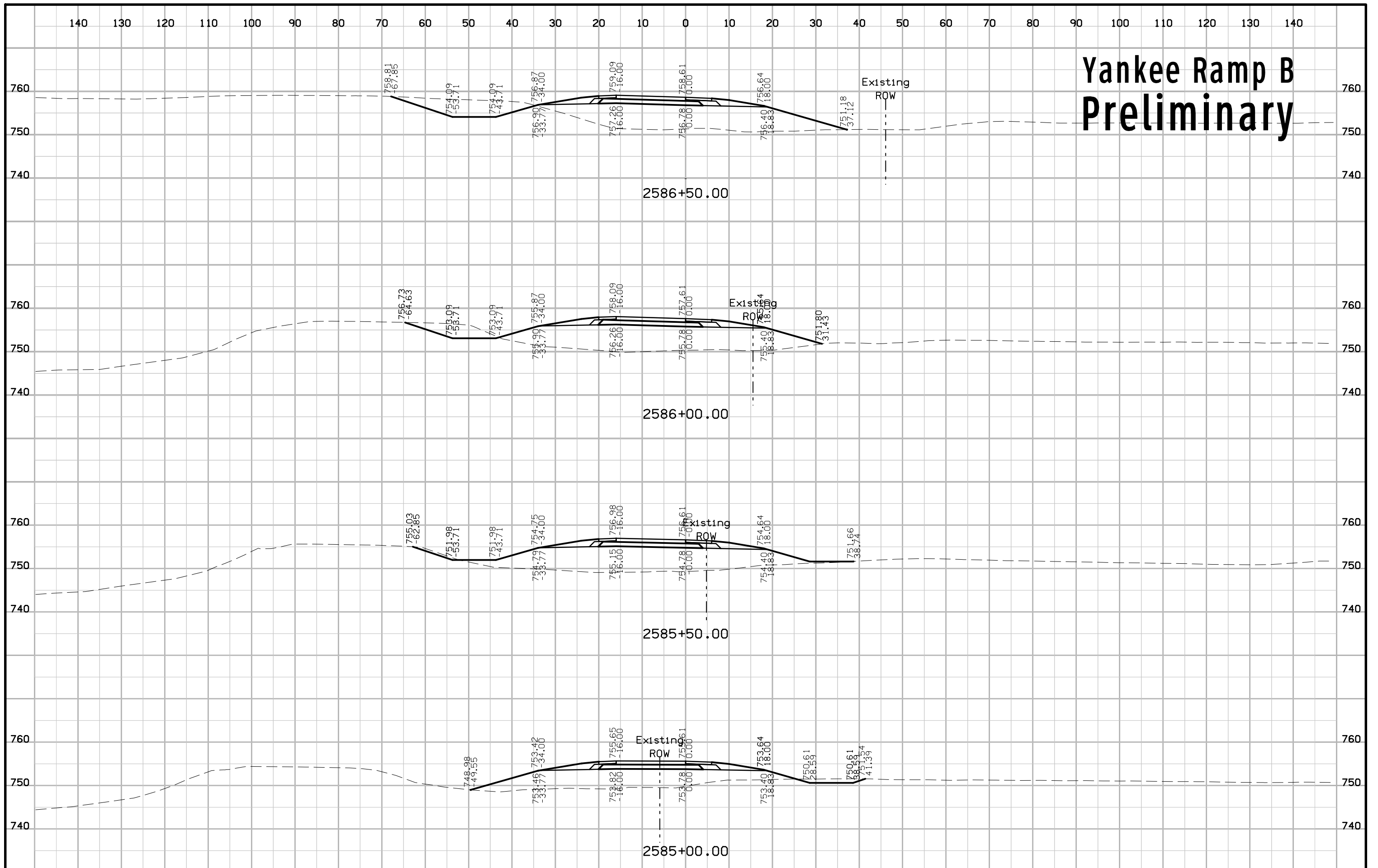

# Yankee Ramp B Preliminary

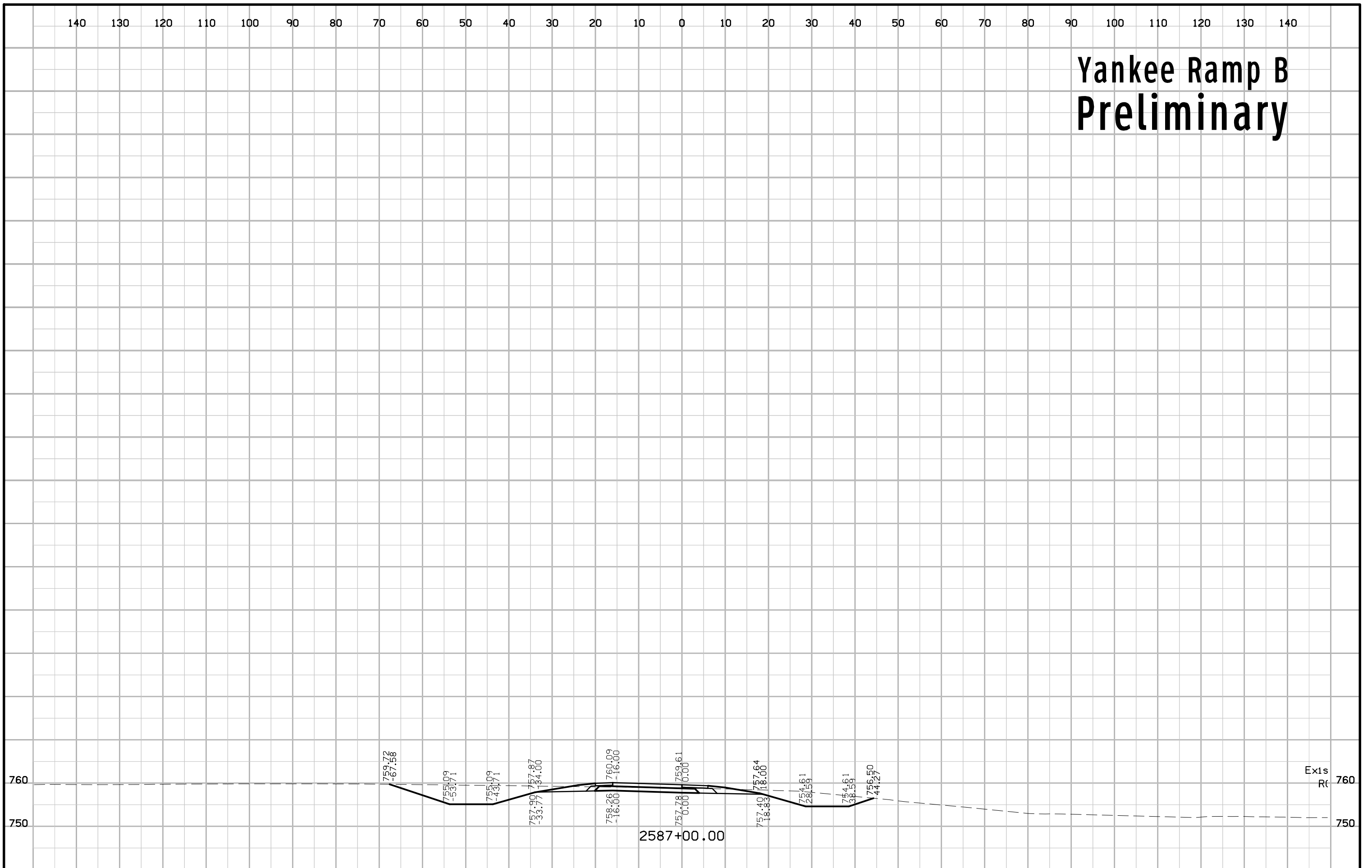

FILE NO.	ENGLISH	DESIGN TEAM	Iowa DOT \ HR Green	CEDAR COUNTY	PROJECT NUMBER	IM-NHS-080-7(134)266--03-16	SHEET NUMBER	Y.111
----------	---------	-------------	---------------------	--------------	----------------	-----------------------------	--------------	-------

# Yankee Ramp C Preliminary

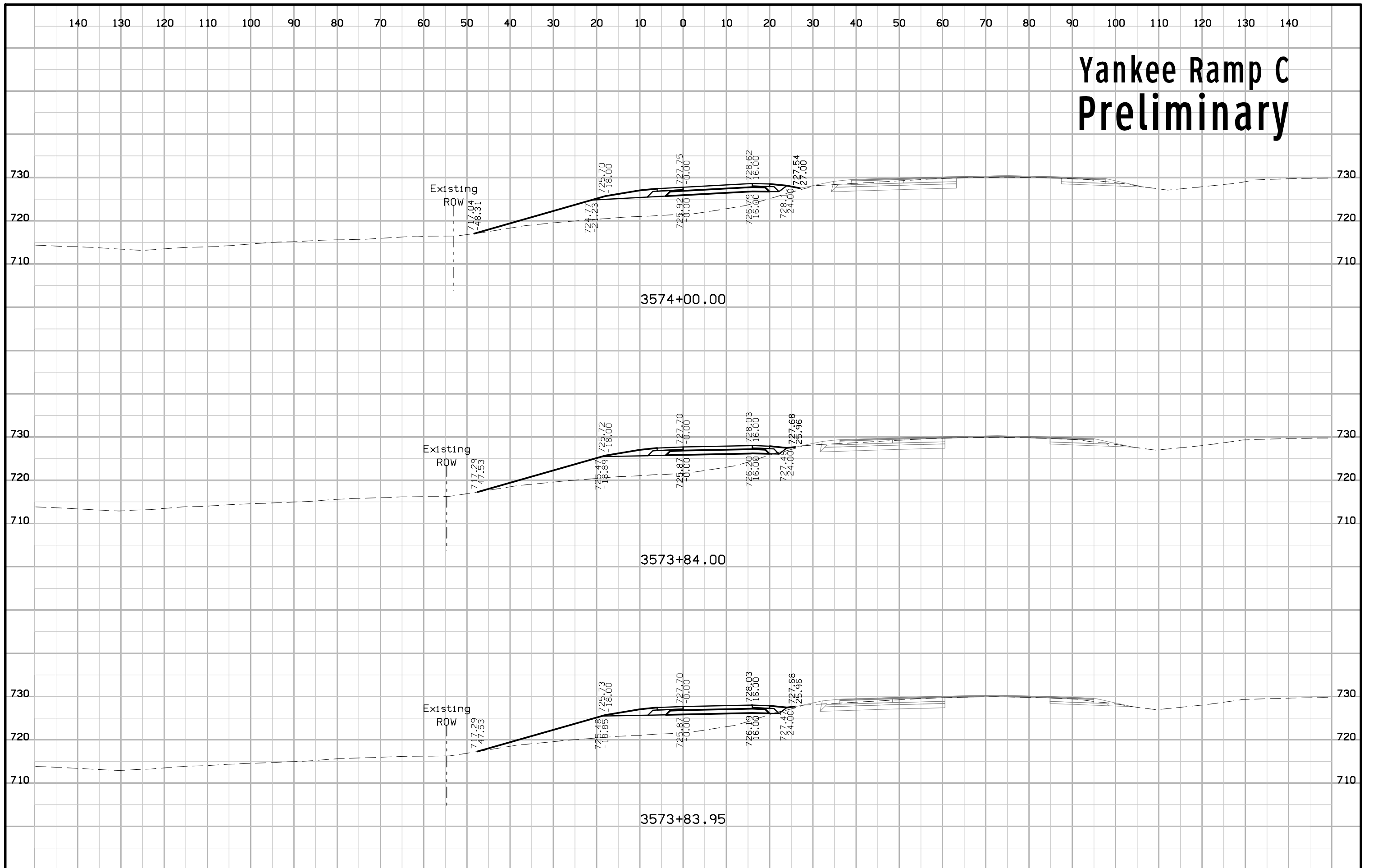

# Yankee Ramp C Preliminary

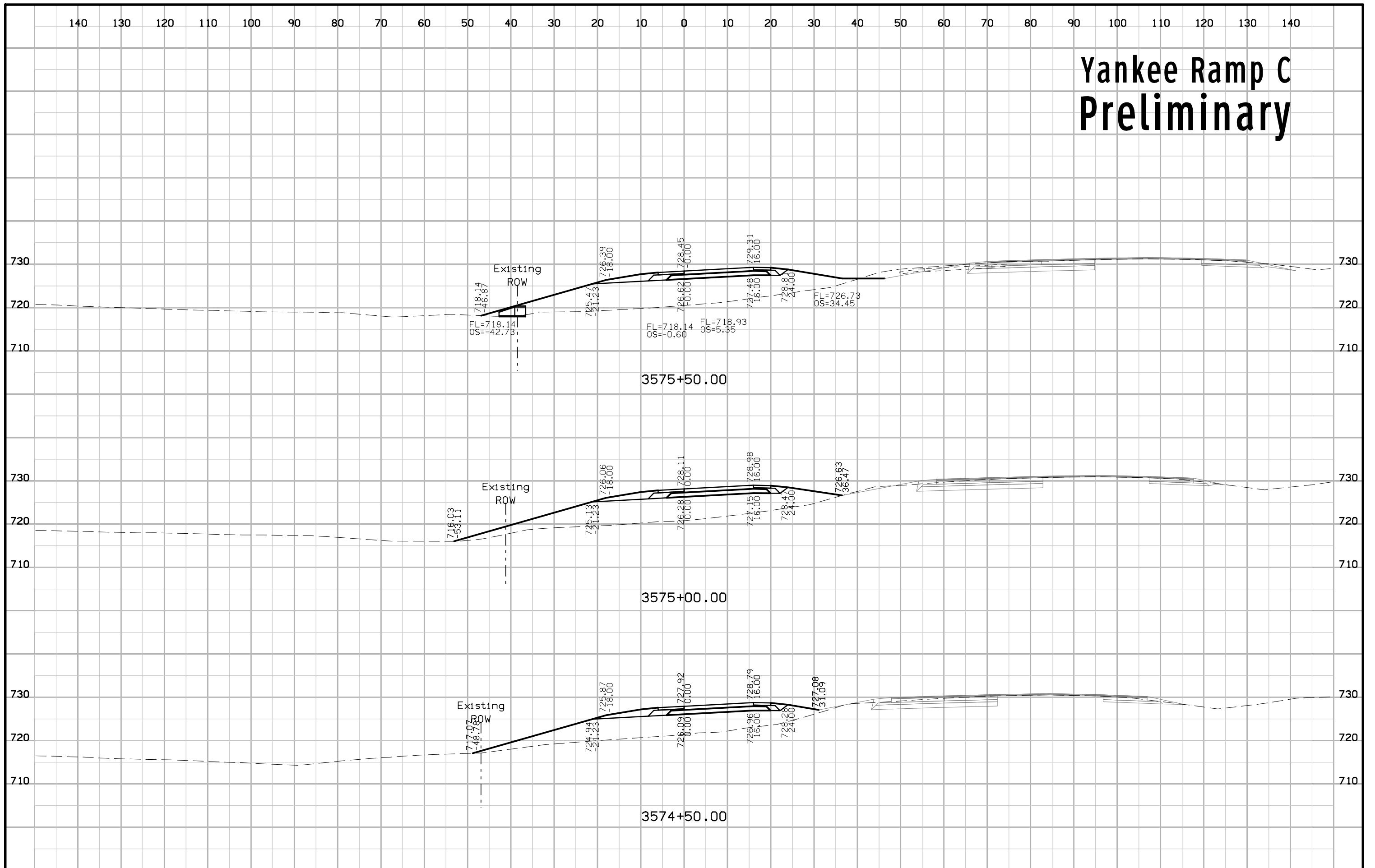

# Yankee Ramp C Preliminary

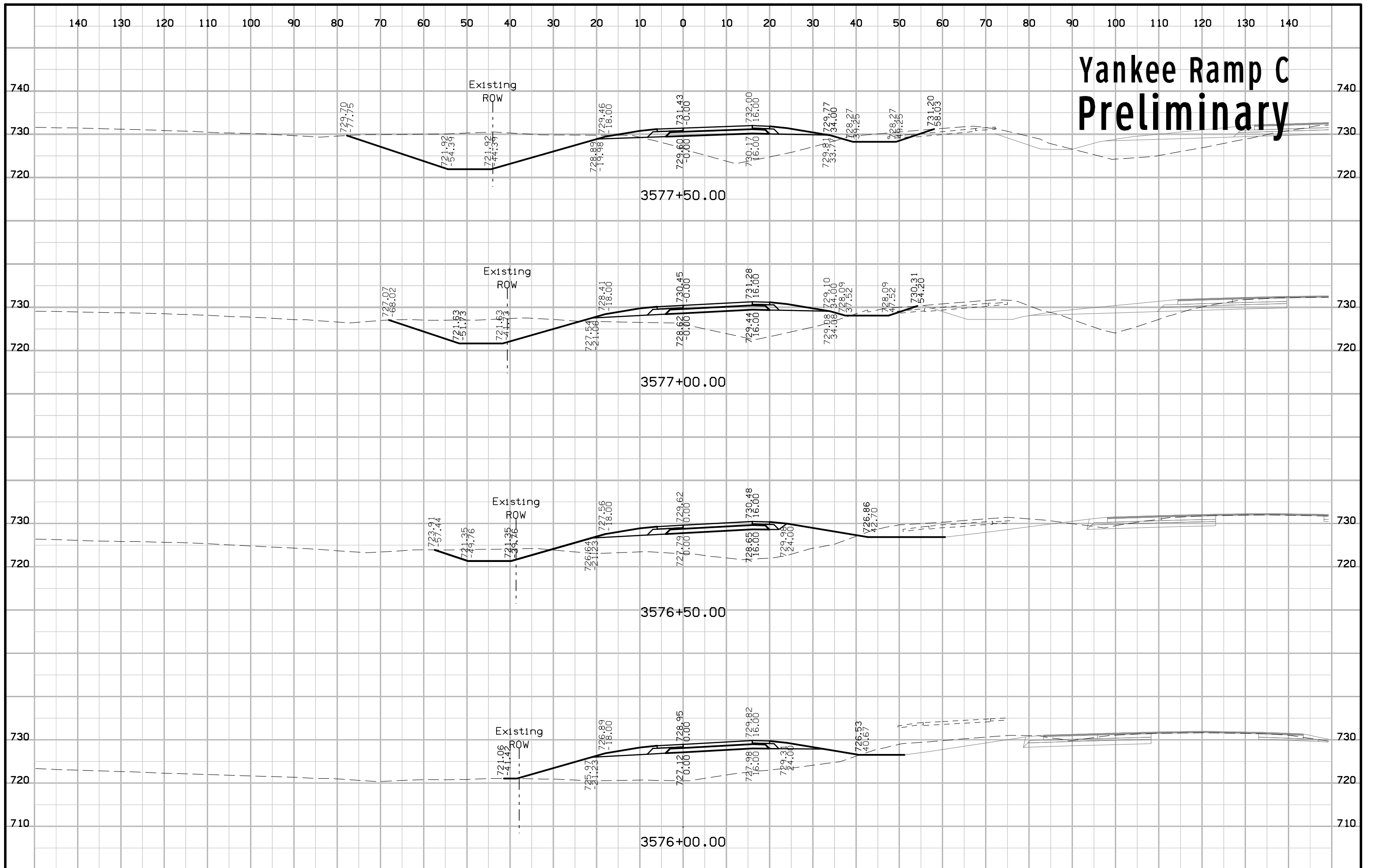



# Yankee Ramp C Preliminary

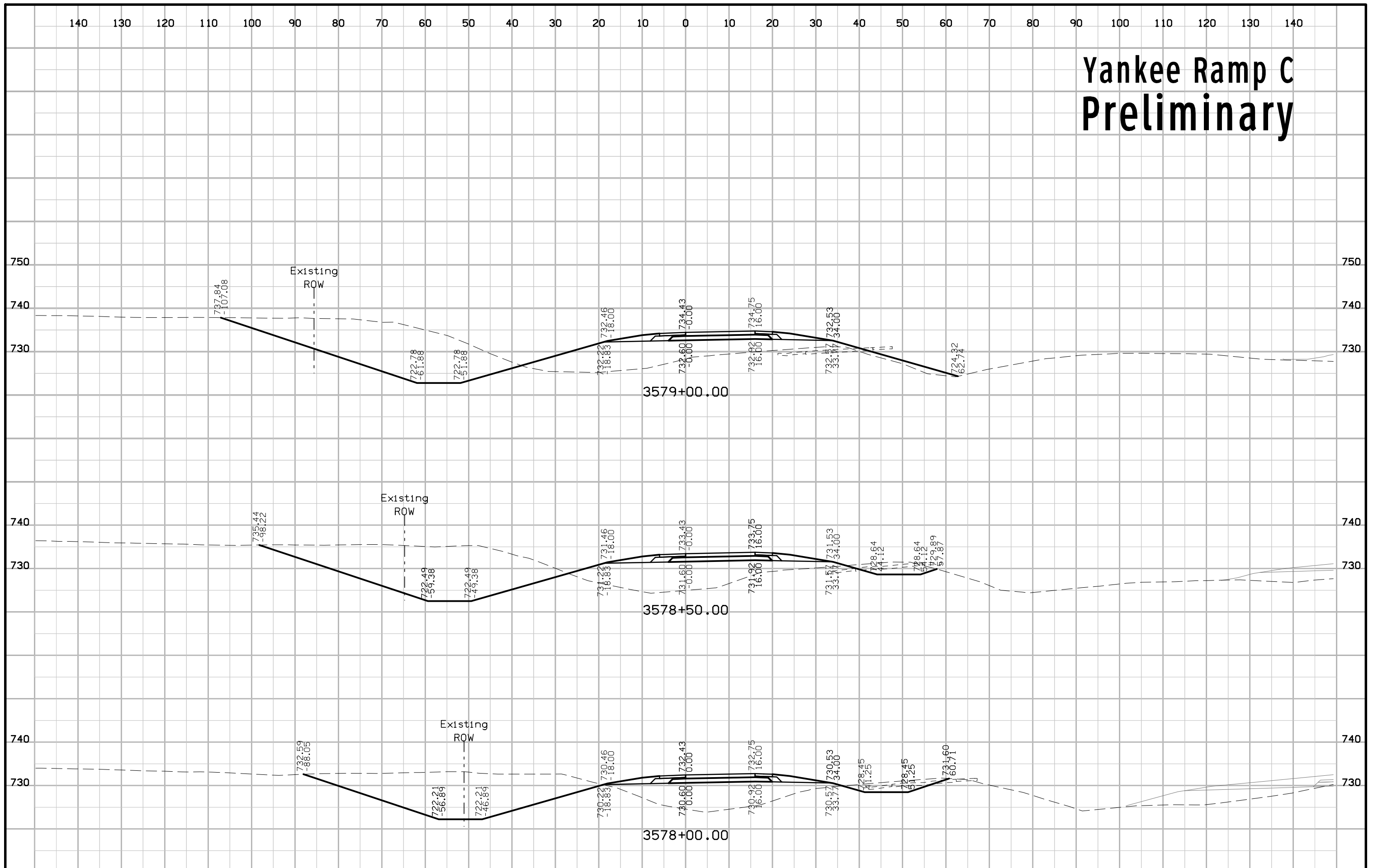

# Yankee Ramp C Preliminary

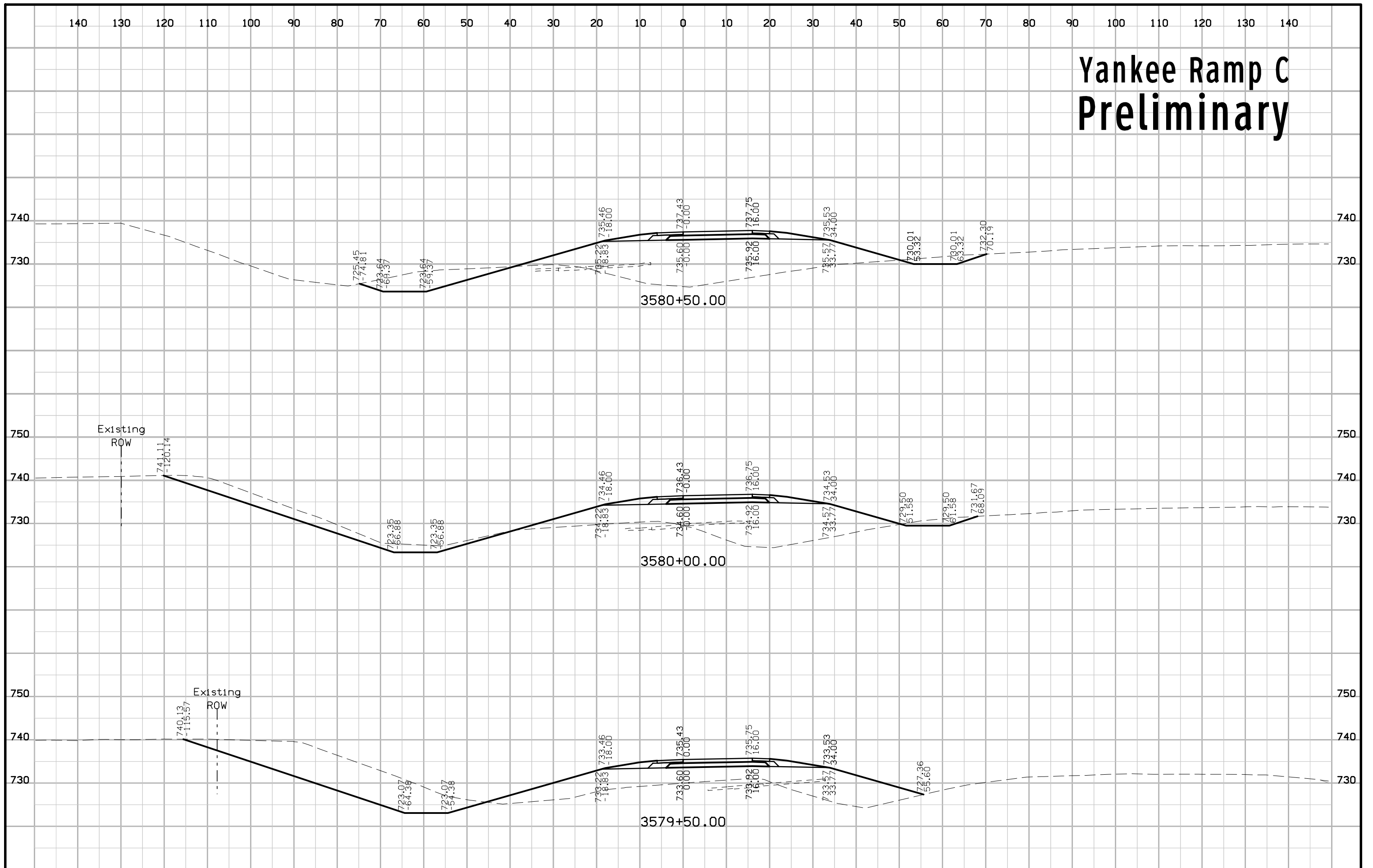

# Yankee Ramp C Preliminary

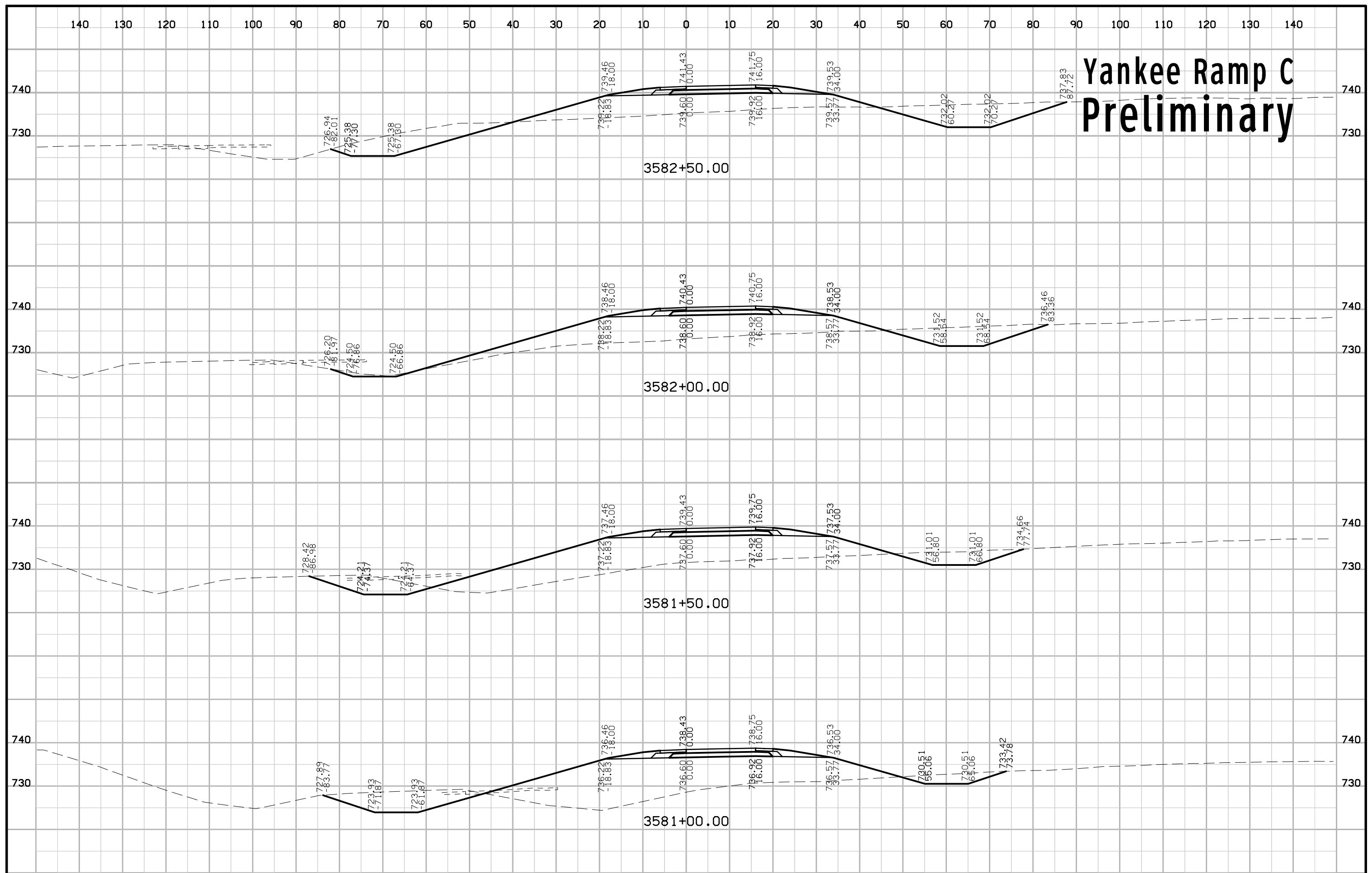

# Yankee Ramp C Preliminary

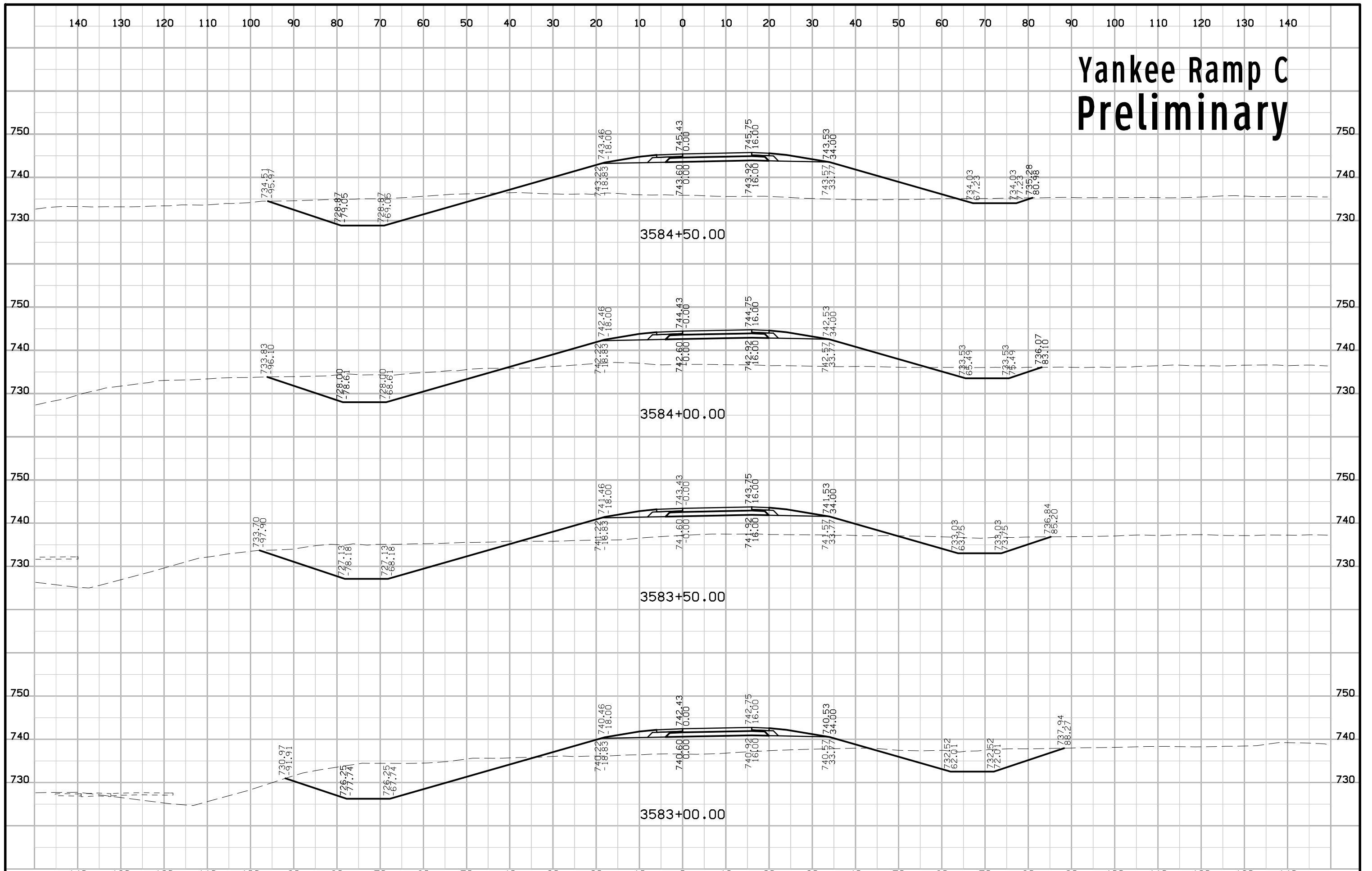

# Yankee Ramp C Preliminary

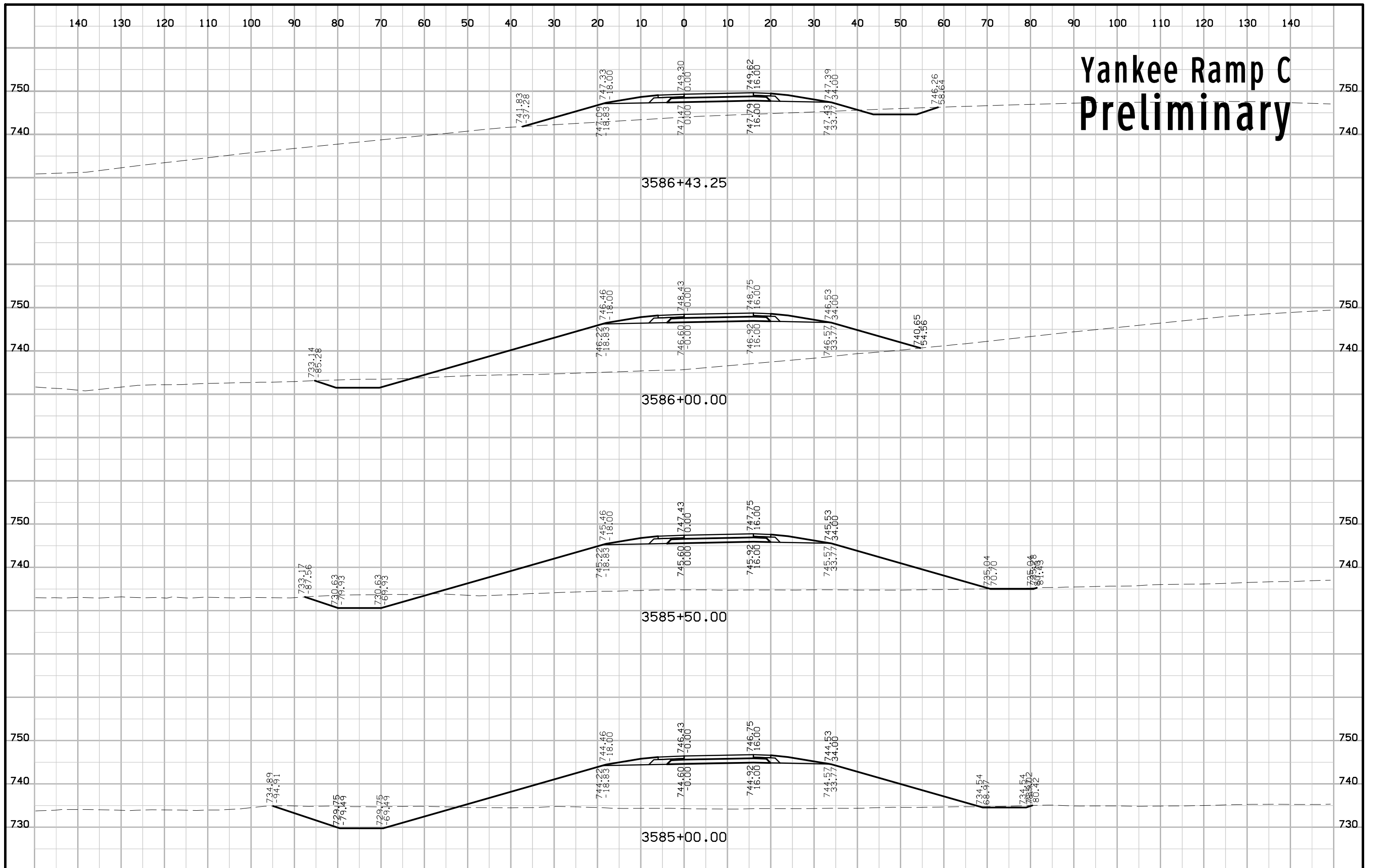

# Yankee Ramp C Preliminary

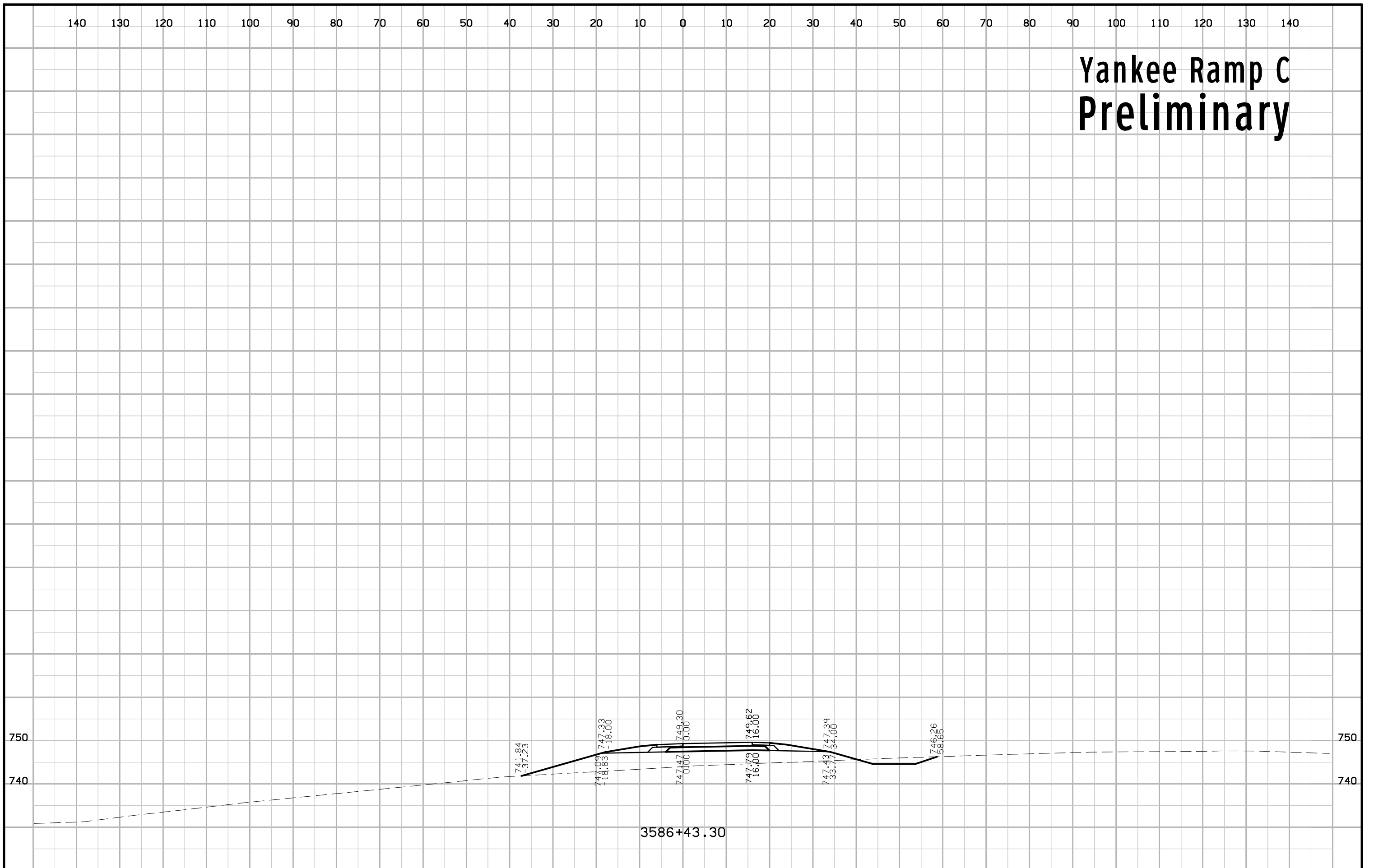

# Yankee Ramp D Preliminary

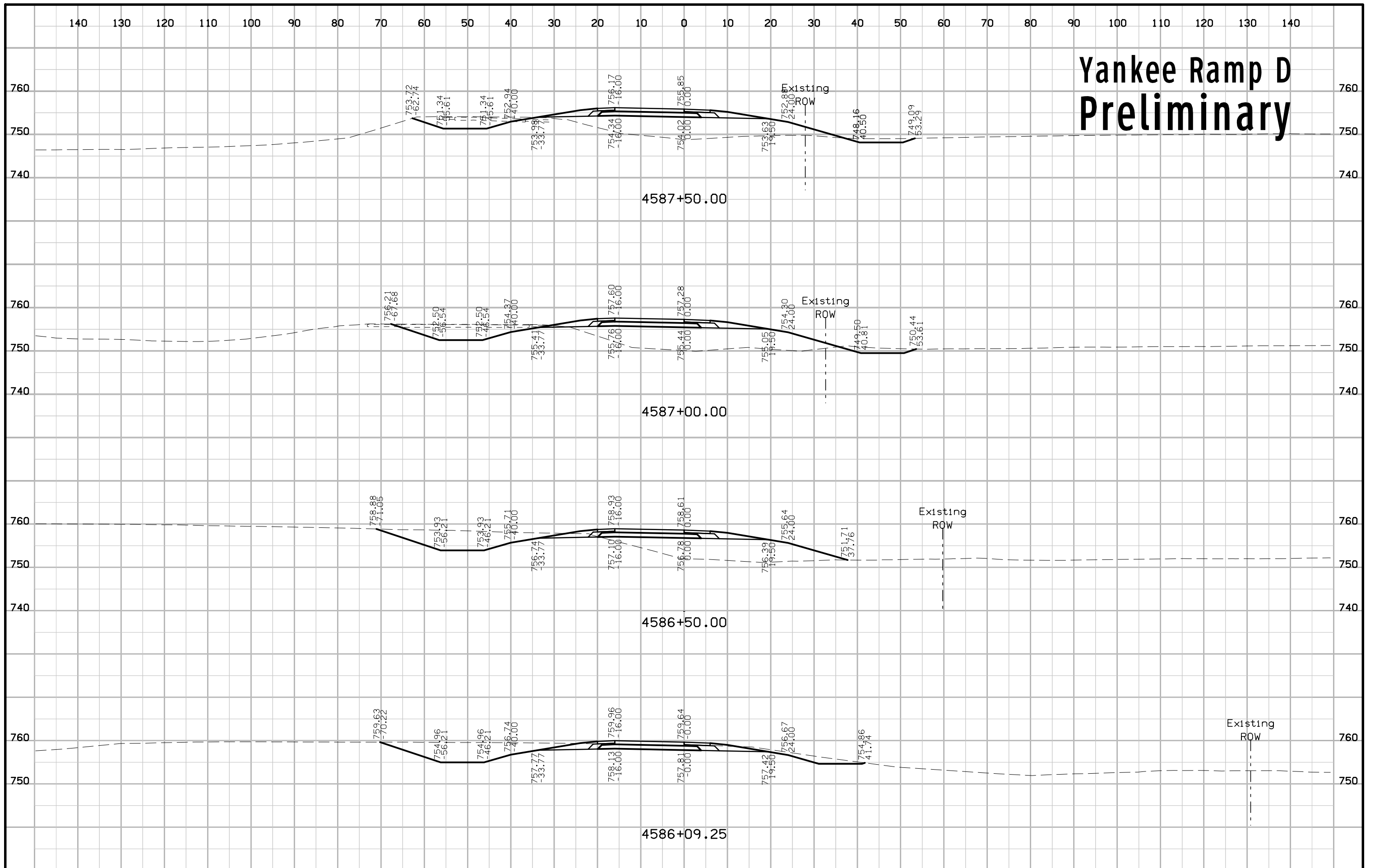

# Yankee Ramp D Preliminary

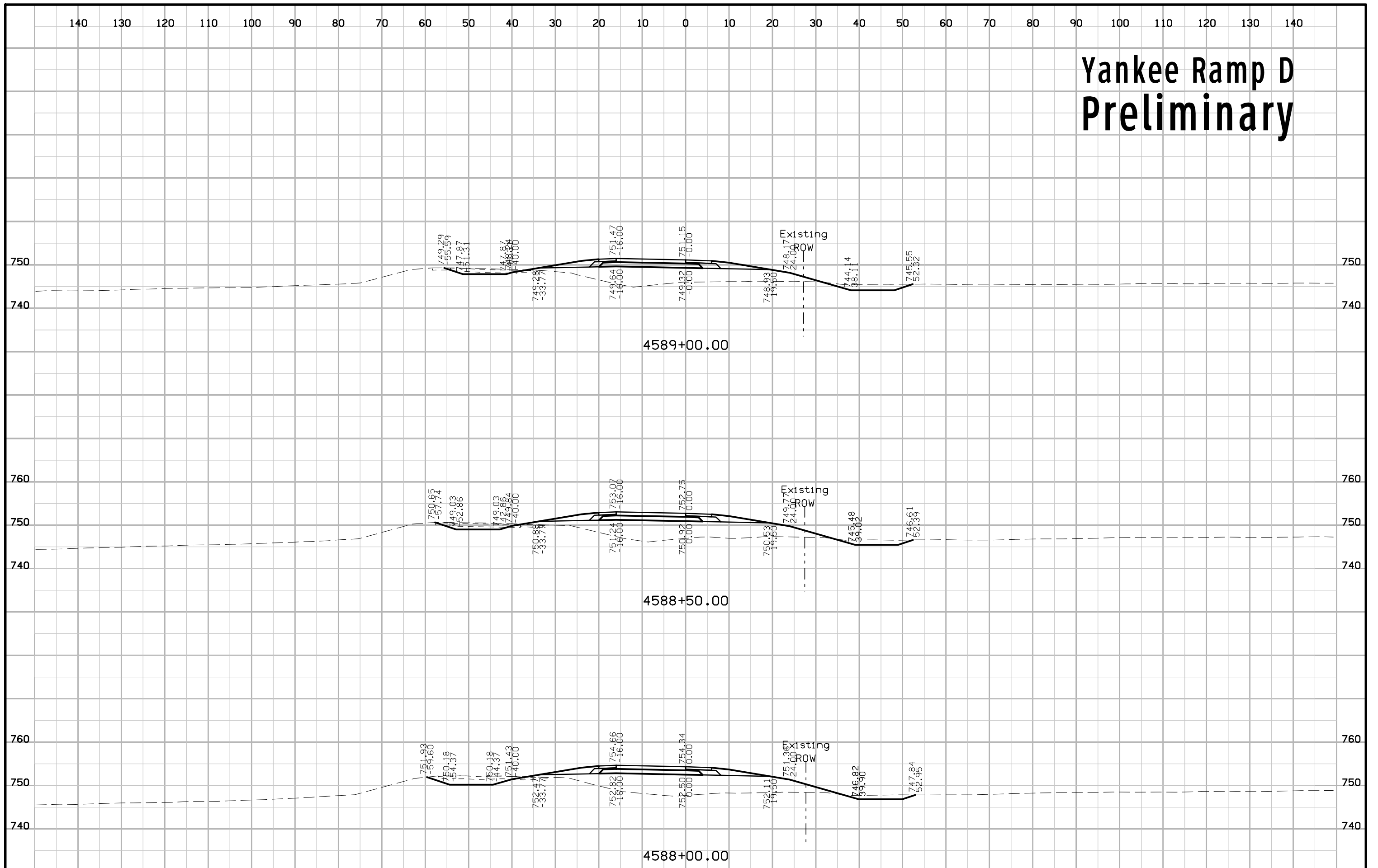



# Yankee Ramp D Preliminary

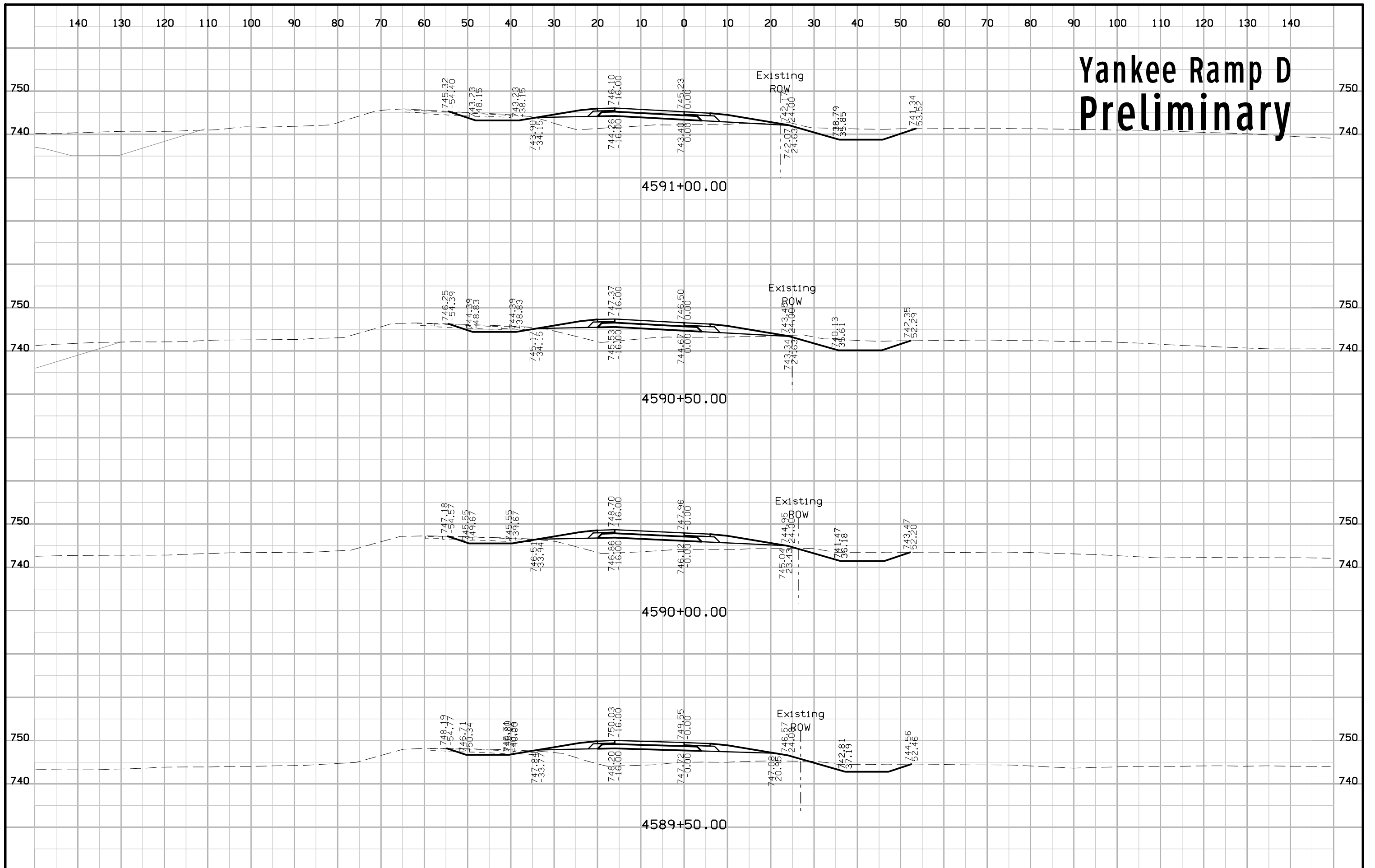

# Yankee Ramp D Preliminary

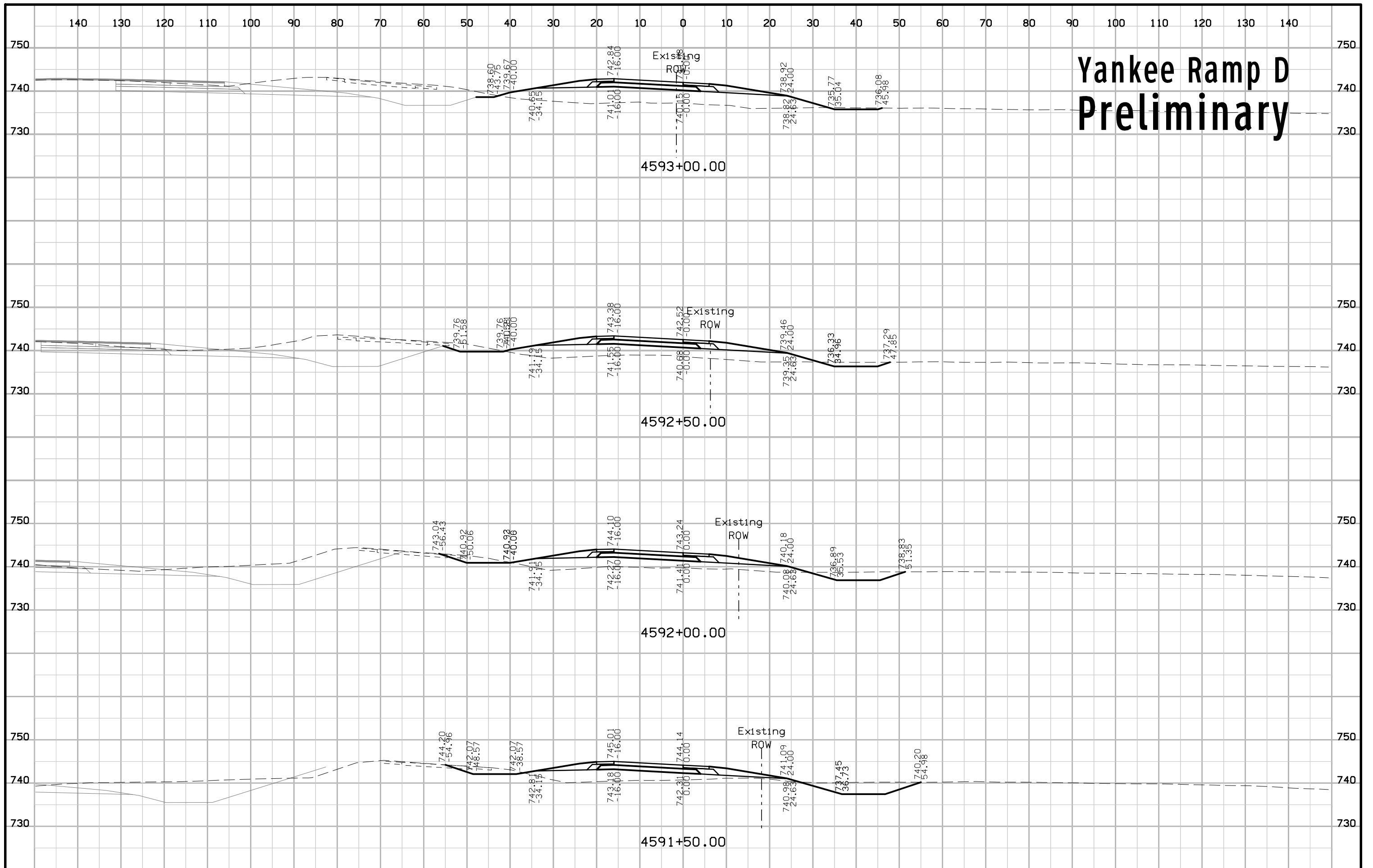

# Yankee Ramp D Preliminary

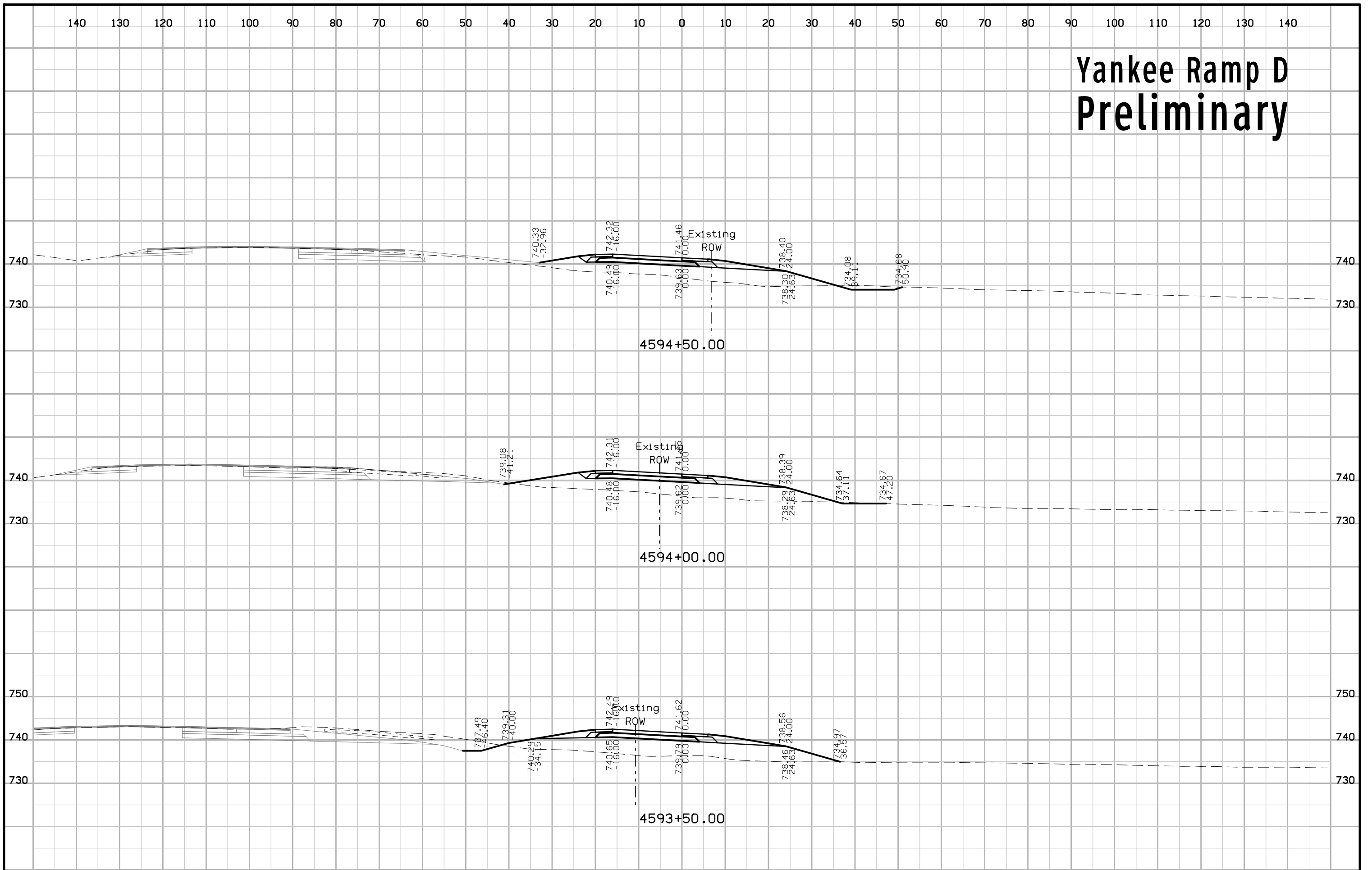

# Yankee Ramp D Preliminary

