



PLANS OF PROPOSED IMPROVEMENT ON THE

# PRIMARY ROAD SYSTEM BOONE COUNTY

## PCC Pavement - Grade and Pave

Linn St. and SE Marshall St.  
Intersection in Boone  
Location

SCALES: As Noted

Refer to the Proposal Form for list of applicable specifications.

Value Engineering Saves. Refer to Article 1105.14 of the Specifications.



REVISIONS

TOTAL

113

PROJECT IDENTIFICATION NUMBER

24-08-030-020

PROJECT NUMBER

HSIPX-030-4(113)--3L-08

R.O.W. PROJECT NUMBER

--

--

--

### INDEX OF SHEETS

No.	DESCRIPTION
<b>A Sheets</b>	<b>Title Sheets</b>
A.1	Title Sheet
A.2	Location Map Sheet
<b>B Sheets</b>	<b>Typical Cross Sections and Details</b>
* B.1 - 14	Typical Cross Sections and Details
<b>D Sheets</b>	<b>Mainline Plan and Profile Sheets</b>
* D.1	Plan & Profile Legend & Symbol Information Sheet
* D.2 - 6	US 30 P&S Sheets
<b>E Sheets</b>	<b>Side Road Plan and Profile Sheets</b>
* E.1 - 8	SR and Roundabout P&P Sheets
<b>G Sheets</b>	<b>Survey Sheets</b>
G.1 - 3	Reference Ties and Bench Marks
G.4 - 6	Horizontal Control Tab. & Super for all Alignments
<b>J Sheets</b>	<b>Traffic Control and Staging Sheets</b>
J.1	Traffic Control Plan
J.2	511 Travel Restrictions
J.3	Staging Notes
J.4	Coordinated Operations
<b>L Sheets</b>	<b>Geometric, Staking and Jointing Sheets</b>
* L.1 - 4	Geometric details
* L.5 - 9	Staking details
* L.10 - 11	Jointing details
* L.12	Edge Profiles
<b>M Sheets</b>	<b>Storm Sewer Sheets</b>
* M.1 - 4	Storm Sewer Plan and Profile Sheets "ML or SR Name"
<b>U Sheets</b>	<b>500 Series, Mod.Stds. and Detail Sheets</b>
* U.1	AutoTurn - Oversize vehicle - through traffic
<b>W Sheets</b>	<b>Mainline Cross Sections</b>
* W.1	Cross Sections Legend & Symbol Information Sheet
* W.2 - 30	US 30 Cross Sections
<b>X Sheets</b>	<b>Side Road Cross Sections</b>
* X.1 - 19	SR 30, SE Marshall St. & Crown Flair Dr. Cross Sections
<b>Y Sheets</b>	<b>Roundabout Cross Sections</b>
* Y.1 - 7	Roundabout Cross Sections
	* Color Plan Sheets

LETTING DATE  
**Dec 15 2026**

PCC Pavement - Grade and Pave  
HSIPX-030-4(113)--3L-08

**BOONE COUNTY**

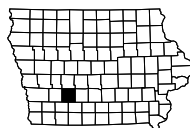
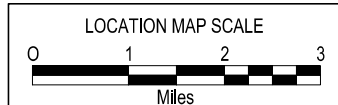
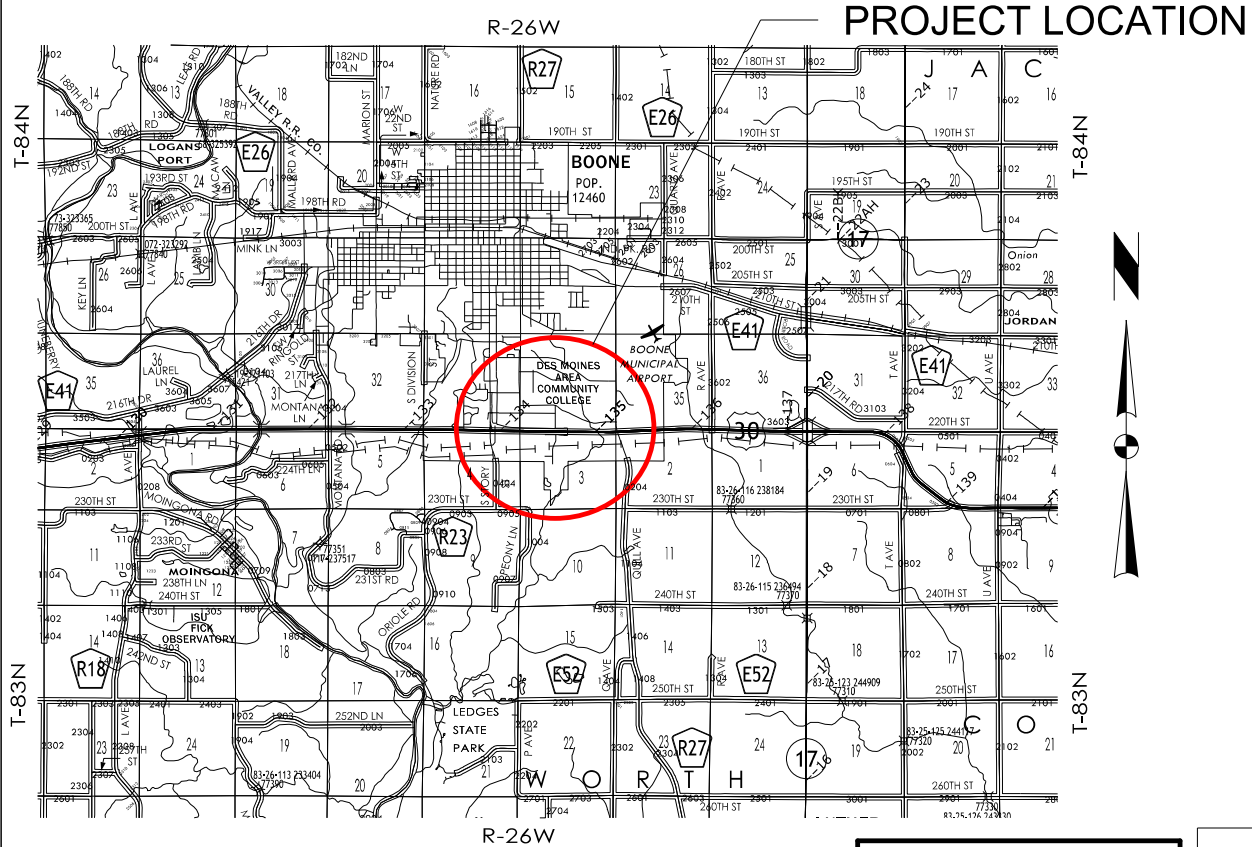

US 30 DESIGN DATA RURAL			
2019	AADT	12,066	V.P.D.
2047	AADT	14,325	V.P.D.
20	DHV	-	V.P.H.
	TRUCKS	8	%
	Total Design ESALs	-	

INDEX OF SEALS			
SHEET NO.	NAME	TYPE	BID QUANTITY SHEETS
A.1	X	Primary Signature Block	X
X	X	X	X

Schedule:  
DM5 - 09/01/2026  
D8 - 10/06/2026

PRELIMINARY PLANS

Subject to change by final design.

**D5 PLAN - 01-28-2025**

# BOONE COUNTY

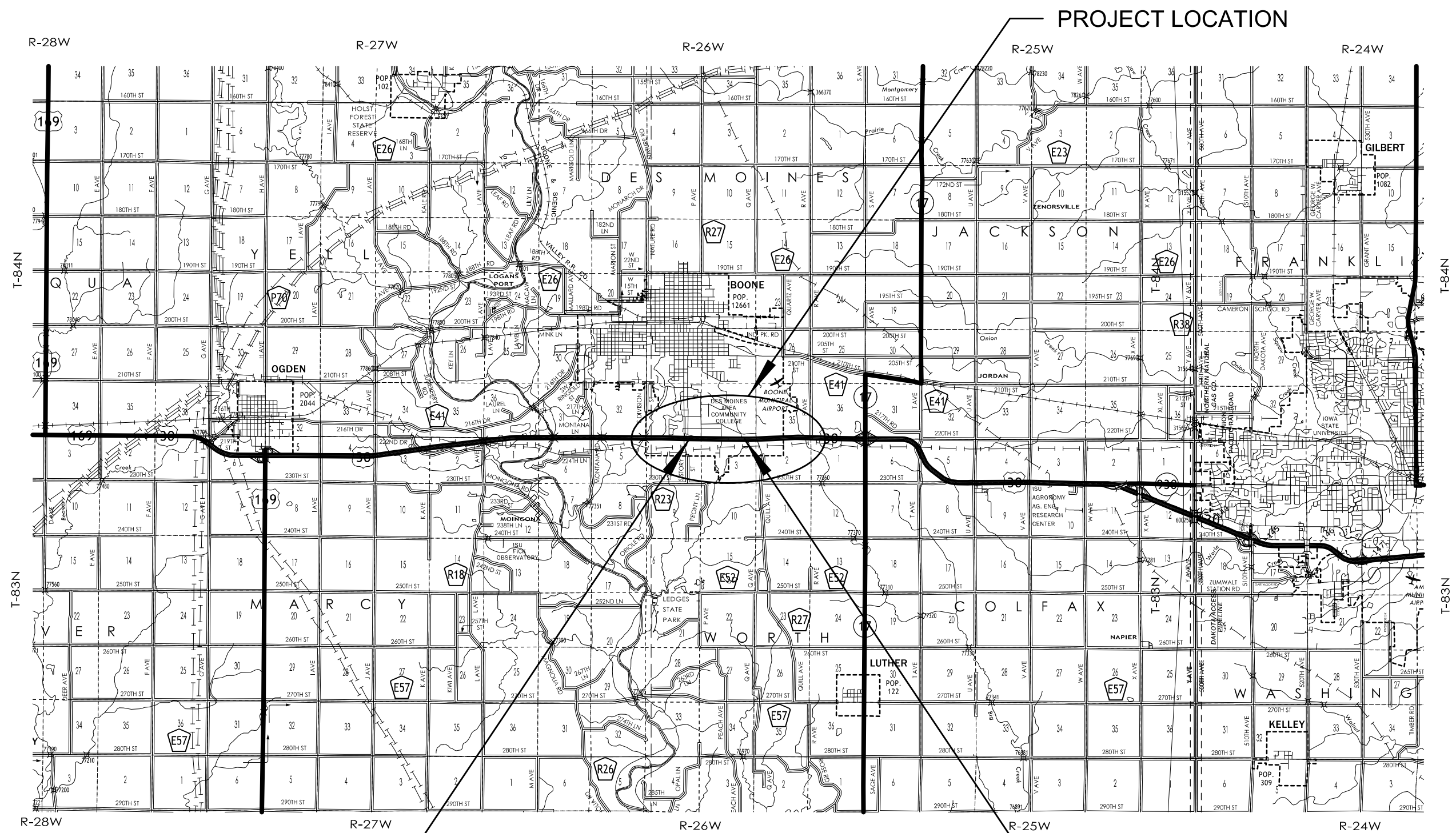

BEGIN CONSTRUCTION

END CONSTRUCTION

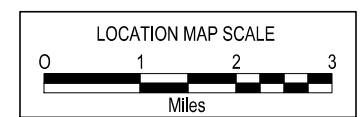

8

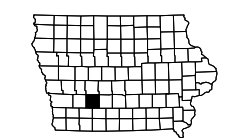

# TYPICAL CROSS SECTIONS

FED. DIST. NO.	STATE	PROJ. NO.	SHEET NO.	TOTAL SHEETS
	MO.	F-936(7)	4A	98

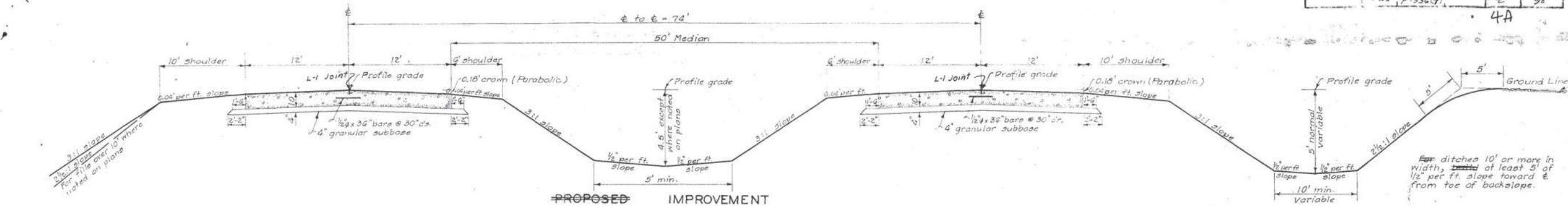

PROPOSED		IMPROVEMENT		P.T. STA 1017 + 24.89		TO P.C. STA 1053 + 64.65	
STA 826 + 28.25	TO P.C. STA 857 + 13.40	P.T. STA 1062 + 47.99	TO P.C. STA 1099 + 57.42				
P.T. STA 863 + 13.40	TO P.C. STA 906 + 00.98	P.T. STA 1105 + 70.74	TO T.S. STA 1157 + 67.90				
P.T. STA 912 + 18.58	TO P.C. STA 923 + 04.64	S.T. STA 1181 + 90.40	TO T.S. STA 1190 + 33.43				
P.T. STA 929 + 04.76	TO P.C. STA 946 + 13.25	S.T. STA 1202 + 02.60	TO T.S. STA 1214 + 25.36				
P.T. STA 952 + 25.00	TO P.C. STA 1010 + 74.80						

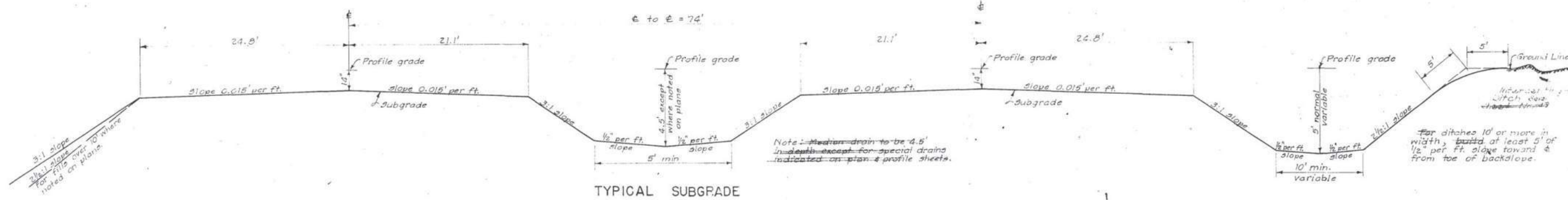

TYPICAL SUBGRADE

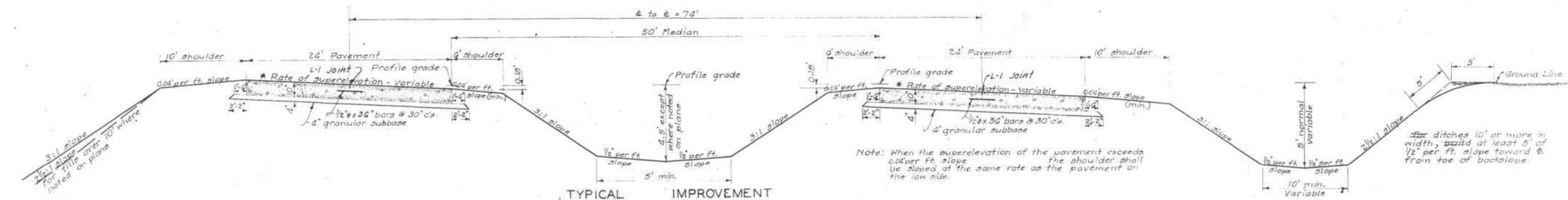

TYPICAL		IMPROVEMENT		P.C. STA 1053 + 64.65		TO P.T. STA 1062 + 47.99	
P.C. STA 857 + 13.40	TO P.T. STA 853 + 13.40	P.C. STA 1099 + 57.42	TO P.T. STA 1105 + 70.76				
P.C. STA 906 + 00.98	TO P.T. STA 912 + 18.58	T.S. STA 1157 + 67.90	TO S.T. STA 1181 + 90.40				
P.C. STA 923 + 04.64	TO P.T. STA 929 + 04.76	T.S. STA 1190 + 33.43	TO S.T. STA 1202 + 02.60				
P.C. STA 946 + 13.25	TO P.T. STA 952 + 25.00	T.S. STA 1214 + 25.36	TO C.S. STA 1222 + 94.30				
P.C. STA 1010 + 74.80	TO P.T. STA 1017 + 24.88						

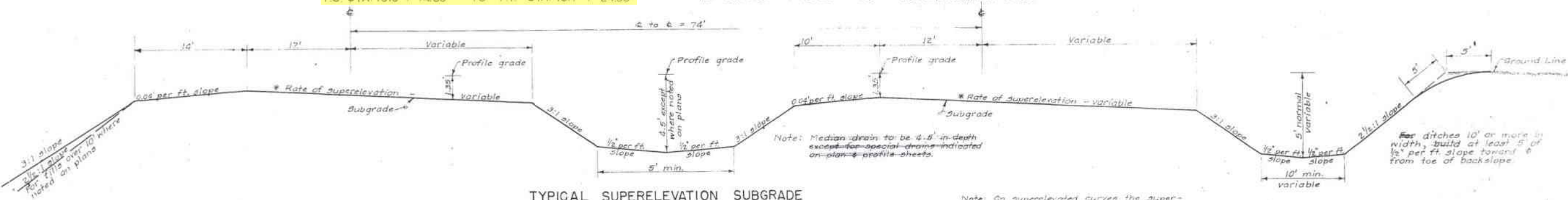

TYPICAL SUPERELEVATION SUBGRADE

HMA RESURFACING

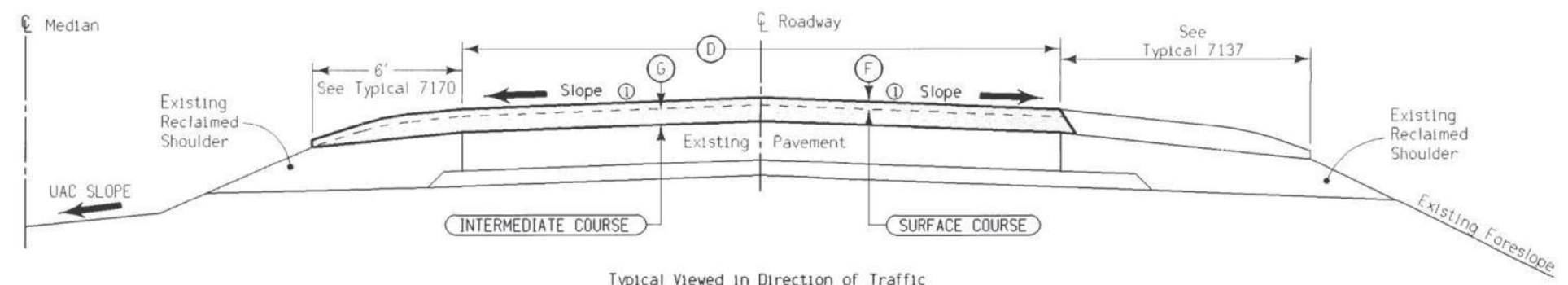

- Notes:
- Finished slope shall match existing pavement except that the maximum allowable slope is 3.0%, minimum allowable slope is 2.0%. Section may be Modified as directed by the engineer through areas of special shaping. Refer to tabulation listing of superelevated curves and Standard Road Plans for additional requirements through superelevated curves.
  - Tack Coat estimated for 2 applications.
  - Rates include quantity for Median Shoulder.
  - Refer to sheets L.01-L.07 for Paved Crossover details and quantities.
  - Includes 16.6 tons for crown correction from existing 1.5% slope to the proposed 2% slope.

DESIGN RATES	
ITEM	RATE
Surface Course	145 lbs./cu. ft.
Intermediate Course	145 lbs./cu. ft.
Tack Coat	0.05 gal./sq. yd.

(A) EQUATION:  
Sta. 2785+47.3 = Sta. 787+70.9

LOCATION		DIMENSIONS			TACK COAT	ASPHALT BINDER	HOT MIX ASPHALT (Tons)	
ROAD IDENTIFICATION	STATION TO STATION	F	G	D	Gallons ②	Tons	SURFACE	INTERMEDIATE
US 30 (EBL)	2750+00 (A) 860+13±	2.0"	2.5"	24.0'	33.64	5.44	36.42	59.08 ⑤
US 30 (WBL)	2750+00 (A) 860+13±	2.0"	2.5"	24.0'	33.64	5.44	36.42	59.08 ⑤

TYPICAL CROSS SECTION FOR HMA RESURFACING

HMA RESURFACING

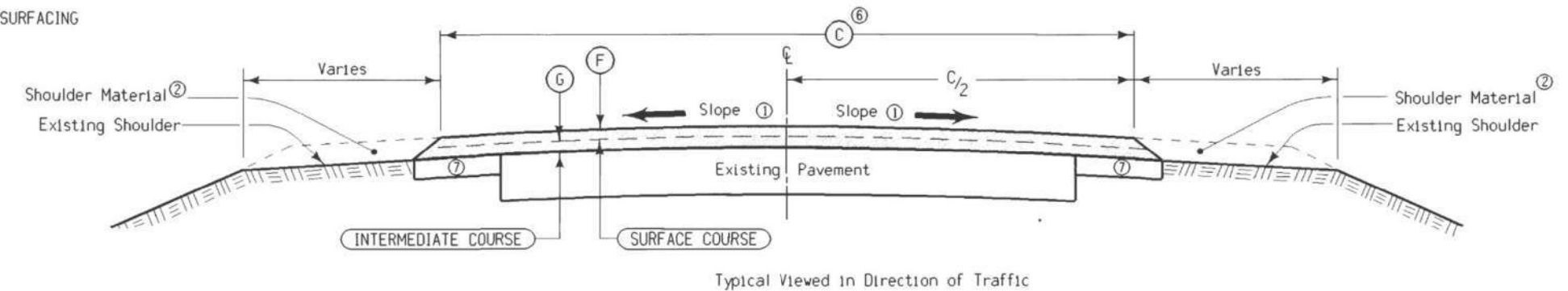

- Notes:
- Finished slope shall match existing pavement except that the maximum allowable slope is 3.0%, minimum allowable slope is 2.0%. Section may be modified as directed by the Engineer through areas of special shaping. Refer to tabulation listing of superelevated curves and Standard Road Plans for additional requirements through superelevated curves.
  - Shoulder material as specified elsewhere in these plans; refer to Typical 7151, 7151A, and 7170A.
  - Tack Coat estimated for 2 applications.
  - Refer to sheets L.01-L.07 for Paved Crossover details and quantities.
  - Includes 16.6 tons for crown correction of the existing 24' PCC pavement. (from existing 1.5% slope to the proposed 2% slope)
  - Width includes 24' pavement and 2-4' retrofit shoulders (refer to Typical 7151 and 7151A on sheet B.08).
  - Proposed Retrofit Shoulder, refer to Typical 7151 and 7151A on sheet B.08.

DESIGN RATES	
ITEM	RATE
Surface Course	145 lbs./cu. ft.
Intermediate Course	145 lbs./cu. ft.
Tack Coat	0.05 gal./sq. yd.

LOCATION		F	G	C	TACK COAT	ASPHALT BINDER	HOT MIX ASPHALT (Tons)	
ROAD IDENTIFICATION	STATION TO STATION	Inches	Inches	Feet	Gallons ③	Tons	SURFACE	INTERMEDIATE
US 30 (EBL)	860+13± 1152+00 (A)	2.0	2.5	32.0	36.16	5.95	38.95	65.67 ⑤
US 30 (WBL)	860+13± 1152+00 (A)	2.0	2.5	32.0	36.16	5.95	38.95	65.67 ⑤

(A) EQUATION:  
Sta. 1105+70.74 = Sta. 1105+63.98  
Lengthens Line 6.76'

TYPICAL CROSS SECTION HMA RESURFACING

HMA RESURFACING

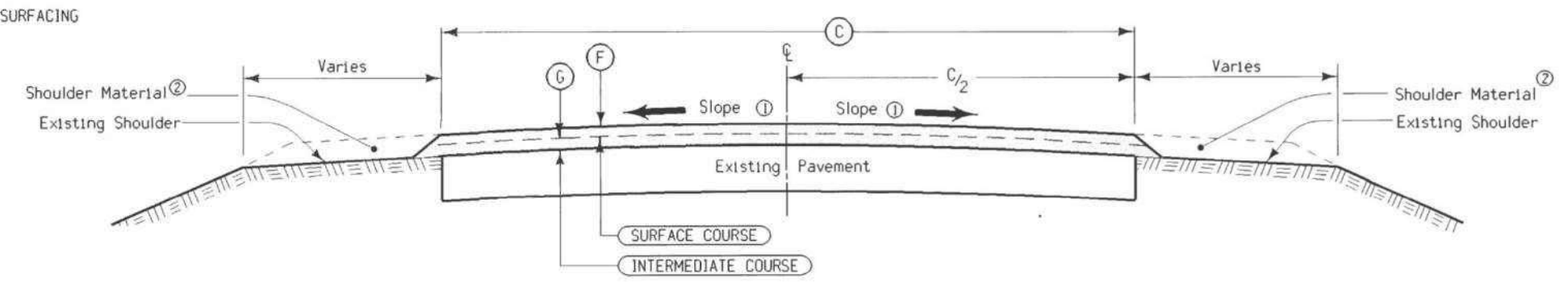

- Notes:
- Finished slope shall match existing pavement except that the maximum allowable slope is 3.0%, minimum allowable slope is 2.0%. Section may be modified as directed by the Engineer through areas of special shaping. Refer to tabulation listing of superelevated curves and Standard Road Plans for additional requirements through superelevated curves.
  - Shoulder material as specified elsewhere in these plans.
  - Tack Coat estimated for 2 applications.
  - Includes 16.6 tons for crown correction of the existing 24' PCC pavement. (from existing 1.5% slope to the proposed 2% slope)
  - (A) Width includes 24' pavement and 2-3' shoulder strengthening.

DESIGN RATES	
ITEM	RATE
Surface Course	145 lbs./cu. ft.
Intermediate Course	145 lbs./cu. ft.
Tack Coat	0.05 gal./sq. yd.

LOCATION		F	G	C	TACK COAT	ASPHALT BINDER	HOT MIX ASPHALT (Tons)	
ROAD IDENTIFICATION	STATION TO STATION	Inches	Inches	Feet	Gallons ③	Tons	SURFACE	INTERMEDIATE
IA 17	634+45 645+03	1.5	1.5	24	27.08	3.44	21.86	38.69 ④
IA 17	645+93 648+26	1.5	1.5	30 (A)	33.76	4.07	27.30	44.13 ④
IA 17	652+40 654+72	1.5	1.5	30 (A)	33.76	4.07	27.30	44.13 ④
IA 17	655+36 665+75	1.5	1.5	24	27.08	3.44	21.86	38.69 ④

TYPICAL CROSS SECTION HMA RESURFACING

DESIGN RATES	
ITEM	RATE
Surface Course	145 lbs./cu. Ft.
Intermediate Course	145 lbs./cu. Ft.
Tack Coat	0.05 gal./sq. yd.

Note:  
Normal section shown may be appropriately modified at areas specifically designated by the engineer, such as intersections or superelevated curves.  
Section view is in the direction of traffic.  
Refer to other drawings for details of shoulder design and construction.  
① Shoulder material as specified elsewhere in these plans; refer to typical 7135 for "Type 'B' Granular Surfaced Shoulder".

HMA RESURFACING

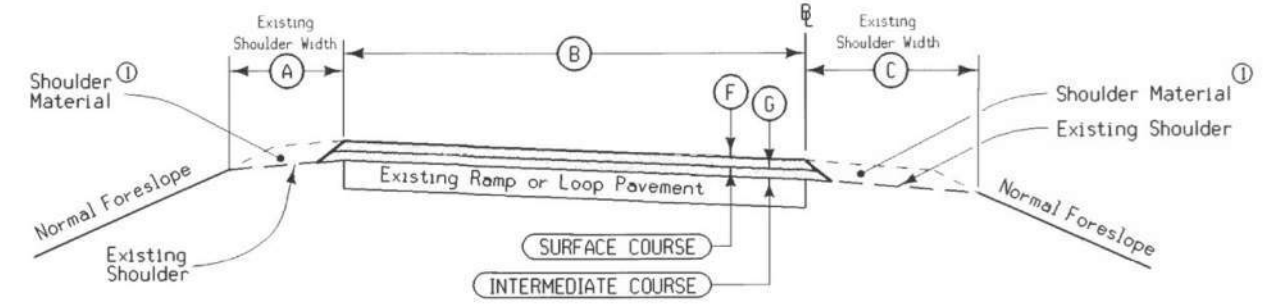

TYPICAL CROSS SECTION  
HMA RESURFACING  
RAMP or LOOP

TABLE OF DESIGN QUANTITIES Per Station

INTERCHANGE	STATION TO STATION	RAMP/ LOOP IDENT.	DENSITY			A Feet	B Feet	C Feet	G Inches	F Inches	TACK COAT Gallons ③	ASPHALT BINDER Tons	HOT MIX ASPHALT Tons	
			94%	95%	96%								SURFACE	INTERMEDIATE
1A 17	1522+66	1537+25	A	X		4	16.0	6	1.5	1.5	18.20	1.70	14.62	14.84
1A 17	2510+00	2524+84	B	X		4	16.0	6	1.5	1.5	18.20	1.70	14.62	14.84
1A 17	3511+05	3524+82	C	X		4	16.0	6	1.5	1.5	18.20	1.70	14.62	14.84
1A 17	4522+60	4535+95	D	X		4	16.0	6	1.5	1.5	18.20	1.70	14.62	14.84

HMA RESURFACING

(A) Includes 120' Taper (10:1 Ratio)

LOCATION				D	E	F	G
ROAD IDENTIFICATION	STATION TO STATION	SIDE		Feet	Feet	Inches	Inches
US 30 - EBL	2750+90±	2754+37± (A)	Lt.	12.0	6.0	2	2.5
US 30 - WBL	2752+32±	2755+80± (A)	Rt.	12.0	6.0	2	2.5
US 30 - WBL	891+90±	896+40± (A)	Lt.	12.0	6.0	2	2.5
US 30 - EBL	946+31±	950+57± (A)	Lt.	12.5	6.0	2	2.5
US 30 - WBL	947+80±	952+06± (A)	Rt.	12.5	6.0	2	2.5
US 30 - EBL	988+70±	992+73± (A)	Lt.	12.0	6.0	2	2.5
US 30 - WBL	990+90±	995+08± (A)	Rt.	12.0	6.0	2	2.5

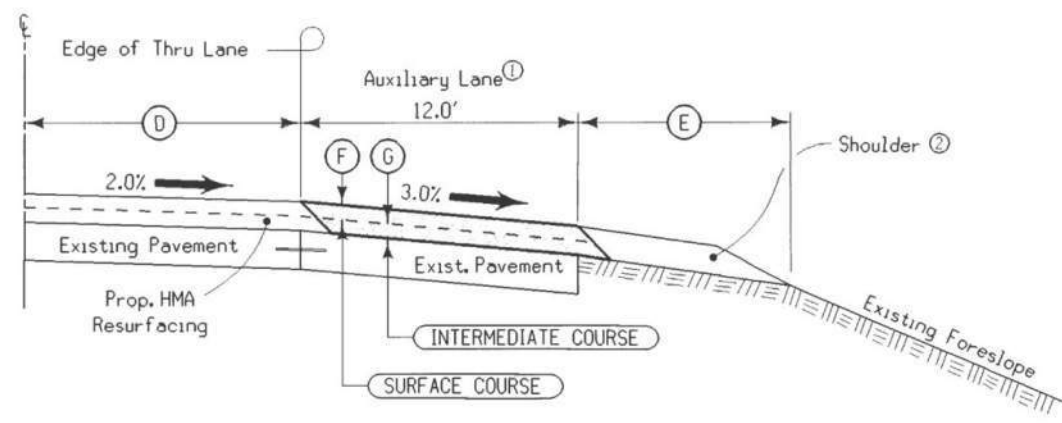

Notes:  
① Details shall be similar for construction on either side (by stationing) of roadway.  
Pavement for auxiliary lane shall be constructed according to requirements specified for through roadway pavement.  
② Refer to other drawings for details of shoulder design and construction.  
③ Refer to sheets L.06, L.07 for details of resurfacing at paved median intersections.

TYPICAL HALF SECTION  
HMA RESURFACING  
EXISTING AUXILIARY LANE

HMA RESURFACING

(A) Includes 120' Taper (10:1 Ratio)

LOCATION				D	E	F
ROAD IDENTIFICATION	MILEPOST TO MILEPOST	SIDE		Feet	Feet	Inches
US 30 - EBL (580 Ave.)	152.864	152.957 (A)	Lt.	12.0	6.0	2
US 30 - EBL (590 Ave.)	153.823	154.016 (A)	Lt.	12.0	6.0	2
US 30 - EBL (600 Ave.)	154.873	154.966 (A)	Lt.	12.0	6.0	2
US 30 - EBL (610 Ave.)	155.875	155.968 (A)	Lt.	12.0	6.0	2

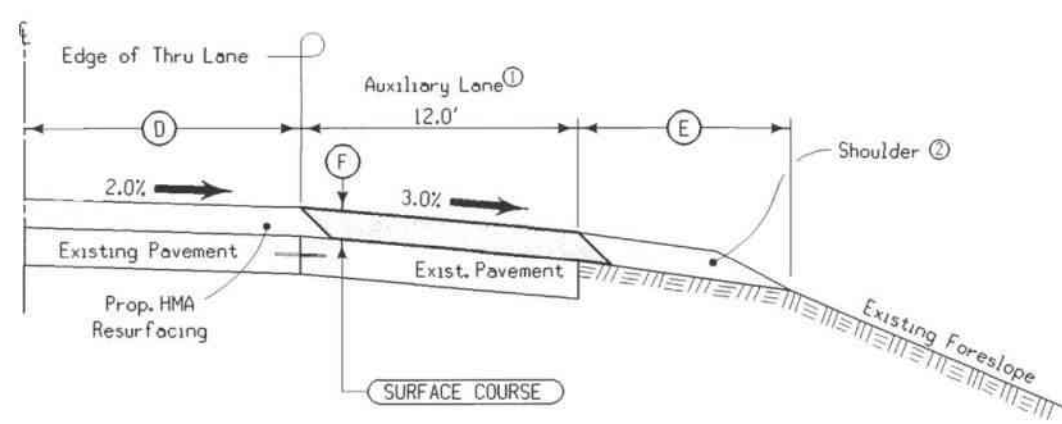

Notes:  
① Details shall be similar for construction on either side (by stationing) of roadway.  
Pavement for auxiliary lane shall be constructed according to requirements specified for through roadway pavement.  
② Refer to other drawings for details of shoulder design and construction.  
③ Refer to Typical INT-1 for details of resurfacing at paved median intersections.

TYPICAL HALF SECTION  
HMA RESURFACING  
EXISTING AUXILIARY LANE

Division 3 - Story Co.  
MP-30-1(702)151--76-85

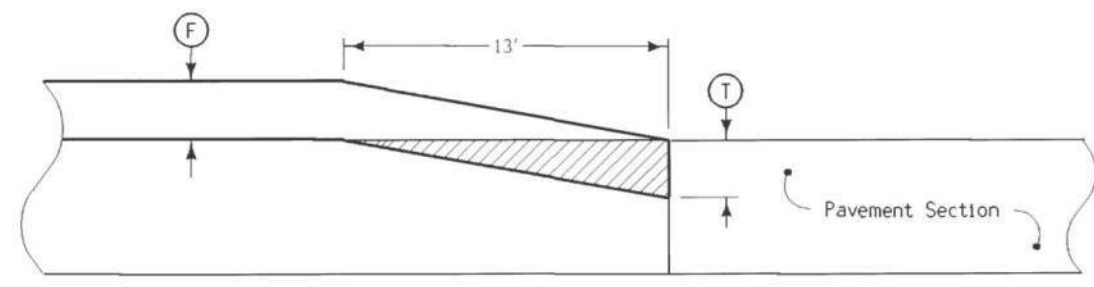
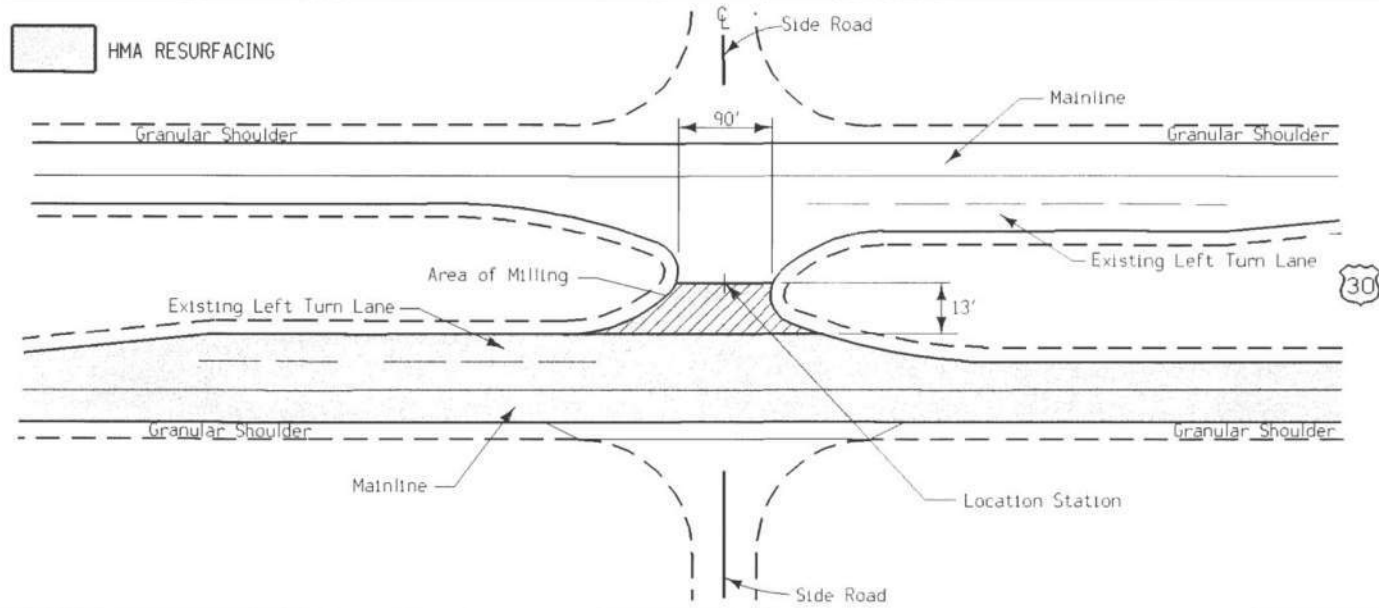

Location Station	(L) Feet	(S) Inches	(T) Inches
US 30 (580 Ave.)	100	2.0	2.0
US 30 (590 Ave.)	100	2.0	2.0
US 30 (600 Ave.)	100	2.0	2.0
US 30 (610 Ave.)	100	2.0	2.0

Division 3 - Story Co.  
MP-30-1(702)151--76-85

**EASTBOUND LANE  
HMA RESURFACING DETAILS  
Typical Intersection**

INT-1  
Not to Scale

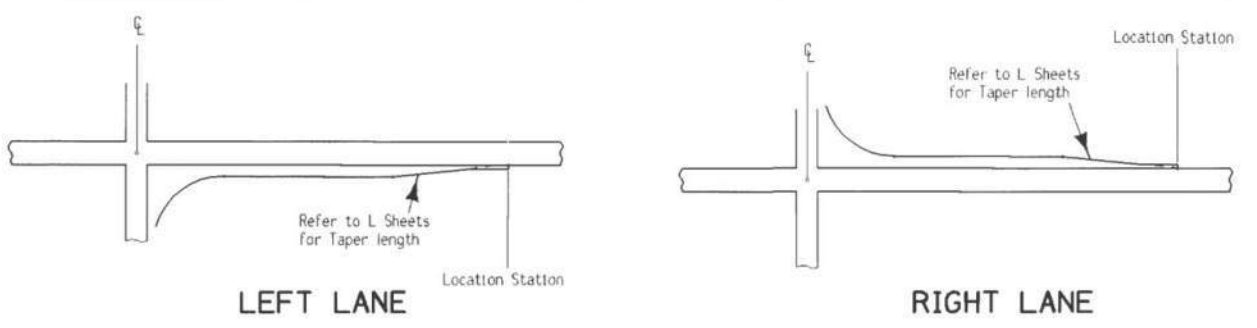

**LRTL-1**  
Notes:  
Normal section shown may be Modified appropriately in areas of super-elevated curves or other locations specifically designated by the engineer.  
See cross sections and sheets D.01, D.03-D.06 and L.01-L.05 for additional information.

- ① Pavement includes thickness of surface (2.0") and intermediate (2.5") plus base material.
- ② To be included with removal.
- ③ Material to be included in the price bid for "Embankment-In-Place" and shaping to be bid as "Earth Shoulder Finishing".
- ④ Includes taper.
- ⑤ HMA 1M (ESAL) Base

- (A) - Division 1
- (B) - Division 2
- (C) - 6:1 and/or 6:1/3:1 Barnroof (refer to cross sections)
- (D) - 207 Cu. Yds. of cut is available
- (E) - 83 Cu. Yds. of cut is available
- (F) - 237 Cu. Yds. of cut is available
- (G) - 287 Cu. Yds. of cut is available
- (H) - 82 Cu. Yds. of cut is available
- (I) - 256 Cu. Yds. of cut is available

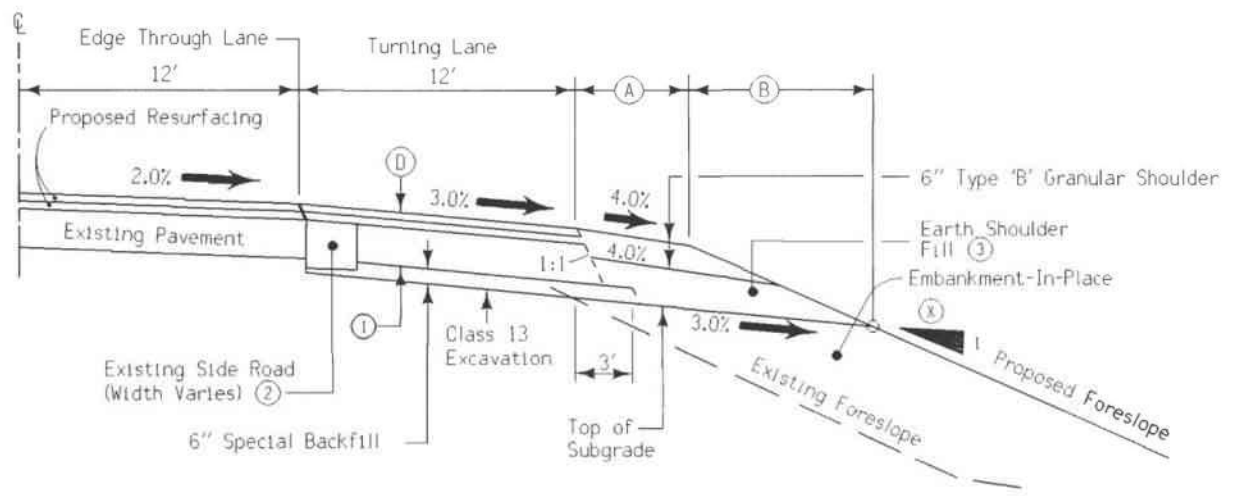

**TYPICAL HALF SECTION  
HMA LEFT/RIGHT TURNING LANE**

LOCATION STATION	SIDE	D	A	B	X	TOTAL QUANTITIES PER LOCATION									
						HOT MIX ASPHALT COURSES			TACK COAT	ASPHALT BINDER	SPECIAL BACKFILL	CLASS 13 EXCAVATION	EMBANK-IN-PLACE	SHOULDER FINISHING	GRANULAR SHOULDER
						Surface	Intermediate	Base							
(A) 2756+80 (WBL)	Rt.	10.0	6.0	9.30	(C)	24	29	67	44	7	84	24	230	1.6	49
(A) 806+11 (EBL)	Lt.	10.0	6.0	9.30	(C)	36	45	103	67	11	129	19	354	2.5	75
(A) 856+80 (EBL)	Lt.	10.0	6.0	9.30	(C)	36	45	104	68	11	130	30	357	2.5	76
(A) 863+45 (WBL)	Rt.	11.5	6.0	10.25	(C)	36	45	134	69	13	131	41	360	2.5	76
(A) 868+24 (WBL)	Lt.	11.5	6.0	10.25	(C)	112	140	413	211	39	405	326	3365 (D)	7.7	235
(B) 931+21 (EBL)	Lt.	10.0	6.0	9.30	(C)	36	45	103	67	11	129	60	185	2.5	75
(B) 962+25 (EBL)	Lt.	10.0	6.0	9.30	(C)	36	45	103	67	11	129	60	353	2.5	75
(B) 968+85 (WBL)	Rt.	10.0	6.0	9.30	(C)	36	45	103	68	11	130	60	185	2.5	75
(B) 972+60 (WBL)	Lt.	11.5	6.0	10.25	(C)	84	104	308	158	29	302	250	170 (E)	5.8	175
(B) 985+30 (EBL)	Rt.	11.5	6.0	10.25	(C)	73	91	270	138	26	265	229	85 (F)	5.0	154
(B) 998+65 (WBL)	Lt.	11.5	6.0	10.25	(C)	79	98	291	149	28	285	237	658 (G)	5.4	165
(B) 1012+20 (EBL)	Rt.	10.0	6.0	9.30	(C)	86	107	248	162	26	312	203	854	5.6	170
(B) 1012+40 (EBL)	Lt.	11.5	6.0	10.25	(C)	81	101	299	153	29	293	129	373 (H)	5.9	181
(B) 1023+10 (WBL)	Rt.	10.0	6.0	9.30	(C)	43	54	124	81	13	155	41	425	3.0	90
(B) 1026+80 (WBL)	Lt.	11.5	6.0	10.25	(C)	105	130	385	197	37	378	289	5148 (I)	7.2	219
(A) 1067+86 (EBL)	Lt.	10.0	6.0	9.30	(C)	36	45	103	68	11	129	30	354	2.5	75

Notes:  
 ① 6:1 Typical, may vary to 4:1 Maximum  
 ② Roll to a Rounded Profile

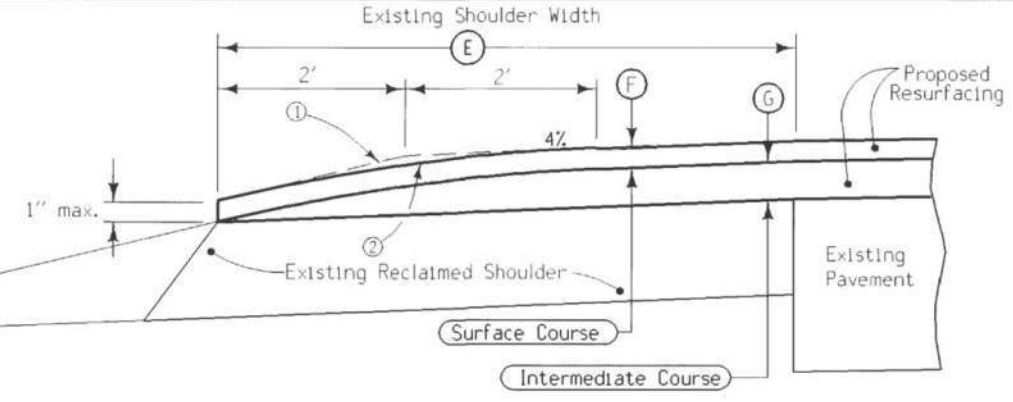

7170  
Special

(A) US 30 (EBL)  
 (B) US 30 (WBL)

STATION TO STATION		F	G	E
		Inches	Inches	Feet
2750+00 (A)	2750+90	2.0	2.5	6.0
2753+60 (A)	806+11	2.0	2.5	6.0
810+50 (A)	819+43	2.0	2.5	6.0
826+62 (A)	856+80	2.0	2.5	6.0
2750+00 (B)	2753+00	2.0	2.5	6.0
2756+80 (B)	819+13	2.0	2.5	6.0
827+57 (B)	860+00	2.0	2.5	6.0

DESIGN RATES	
ITEM	RATE
Surface Course	145 lbs./cu. ft.
Intermediate Course	145 lbs./cu. ft.
Tack Coat	0.05 gal./sq. yd.

**HMA SHOULDER RESURFACING ( MEDIAN SHOULDER )**

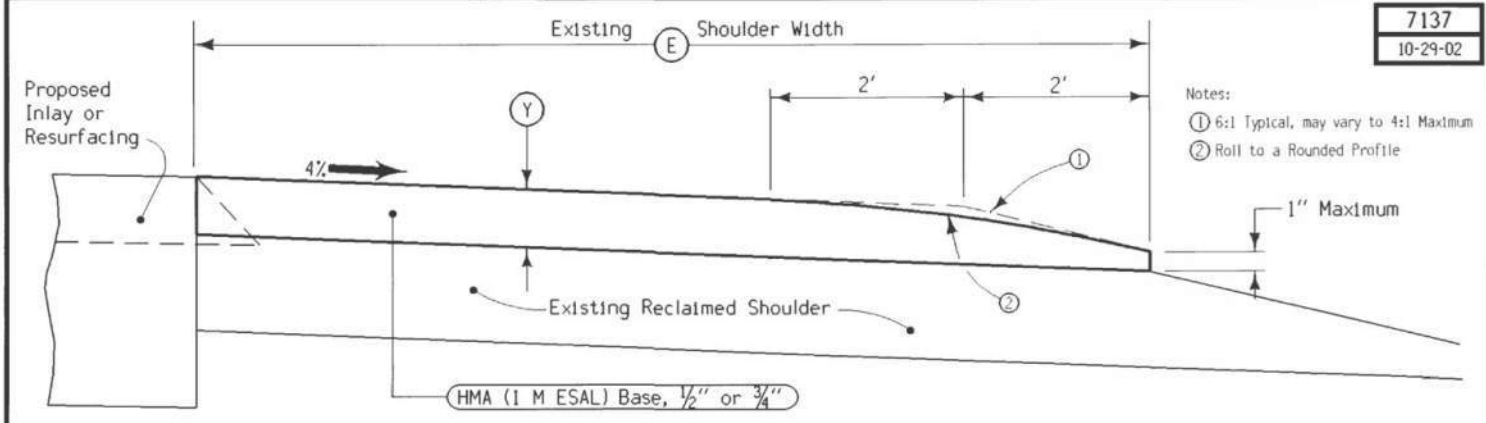

7137  
10-29-02

Notes:  
 ① 6:1 Typical, may vary to 4:1 Maximum  
 ② Roll to a Rounded Profile

STATION TO STATION		RIGHT OR LEFT / INSIDE OR OUTSIDE	Y	E	TACK COAT	ASPHALT BINDER	HOT MIX ASPHALT
			Inches	Feet	Gallons	Tons	Tons
Eastbound Lane							
2750+00	819+43	Outside	4.5	10.0	11.12	2.65	44.24
826+62	860+00	Outside	4.5	10.0	11.12	2.65	44.24
Westbound Lane							
2750+00	819+13	Outside	4.5	10.0	11.12	2.65	44.24
827+57	860+00	Outside	4.5	10.0	11.12	2.65	44.24

DESIGN RATES	
ITEM	RATE
Base Course	145 lbs./cu. ft.
Tack Coat	0.05 gal./sq. yd.

**HMA (OUTSIDE) SHOULDER RESURFACING**

DESIGN RATES	
ITEM	RATE
Surface Course	145 lbs./cu. ft.
Intermediate Course	145 lbs./cu. ft.
Tack Coat	0.05 gal./sq. yd.

Notes:  
 ① 6:1 Typical, may vary to 4:1 Maximum  
 ② Roll to a Rounded Profile

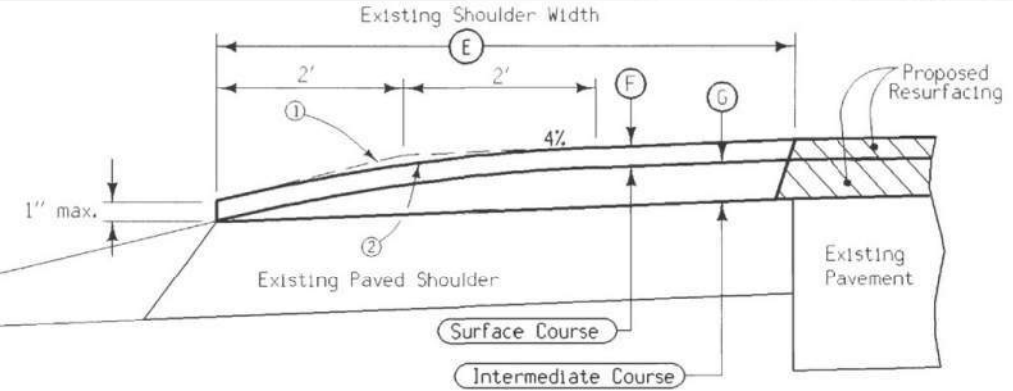

7170A  
Special

(A) US 30 (EBL) (C) Varies from 6' to 10'  
 (B) US 30 (WBL)

TABLE OF DESIGN QUANTITIES		Per Location					
STATION TO STATION	SIDE	F	G	E	ASPHALT BINDER	HOT MIX ASPHALT	
						Tons	Tons
988+57 (A)	993+50	Median	2.0	2.5	6.0	1	8
988+56 (B)	997+00	Median	2.0	2.5	6.0	2	13
991+22 (A)	991+35	Outside	2.0	2.5	(C)	0.1	0.5
992+29 (A)	993+20	Outside	2.0	2.5	7.0	0.4	2
1018+77 (A)	1019+03	Outside	2.0	2.5	(C)	0.1	0.8
1019+99 (A)	1020+98	Outside	2.0	2.5	10.0	0.8	6
949+65 (B)	995+00	Outside	2.0	2.5	10.0	4	32
990+68 (B)	991+24	Outside	2.0	2.5	6.0	0.2	1
1017+43 (B)	1018+52	Outside	2.0	2.5	10.0	0.8	6

**HMA SHOULDER RESURFACING ( MEDIAN/OUTSIDE SHOULDER )**

DESIGN RATES	
ITEM	RATE
Surface Course	145 lbs./cu. ft.
Intermediate Course	145 lbs./cu. ft.
Tack Coat	0.05 gal./sq. yd.

Notes:  
 ① 6:1 Typical, may vary to 4:1 Maximum  
 ② Roll to a Rounded Profile

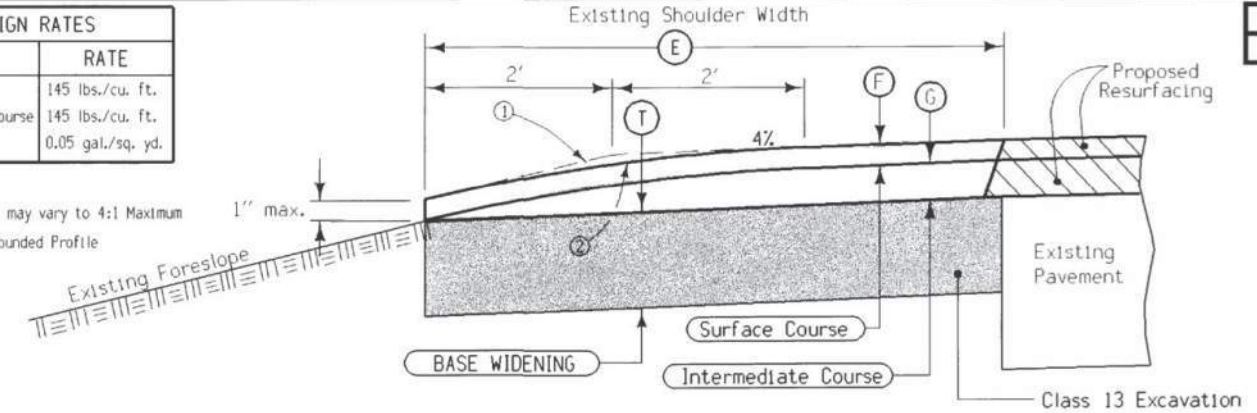

7170B  
Special

**TYPICAL CROSS SECTION HMA PAVED SHOULDER RETURN**

(A) East and west side of crossover, refer to L sheets.

TABLE OF DESIGN QUANTITIES		Per Location									
LOCATION STATION	SIDE	F	G	E	T	ASPHALT BINDER	HOT MIX ASPHALT			CLASS 13 EXCAVATION	REMARKS
							Tons	Tons	Tons		
2753+35 (A)	Median	2.0	2.5	6.0	5.5	2	7	3	18	9	Co. Rd. R18
860+13 (A)	Median	2.0	2.5	6.0	5.5	3	13	6	37	19	Montana Road
934+51 (A)	Median	2.0	2.5	6.0	5.5	4	14	6	40	21	Kate Shelley Dr.
949+19 (A)	Median	2.0	2.5	6.0	5.5	3	11	5	31	16	South Story St.
965+78 (A)	Median	2.0	2.5	6.0	5.5	3	13	6	38	19	South Linn St.
1019+23 (A)	Median	2.0	2.5	6.0	5.5	4	15	6	41	21	Snedden Dr./Out II Ave.
1071+16 (A)	Median	2.0	2.5	6.0	5.5	4	14	6	40	21	R Ave.

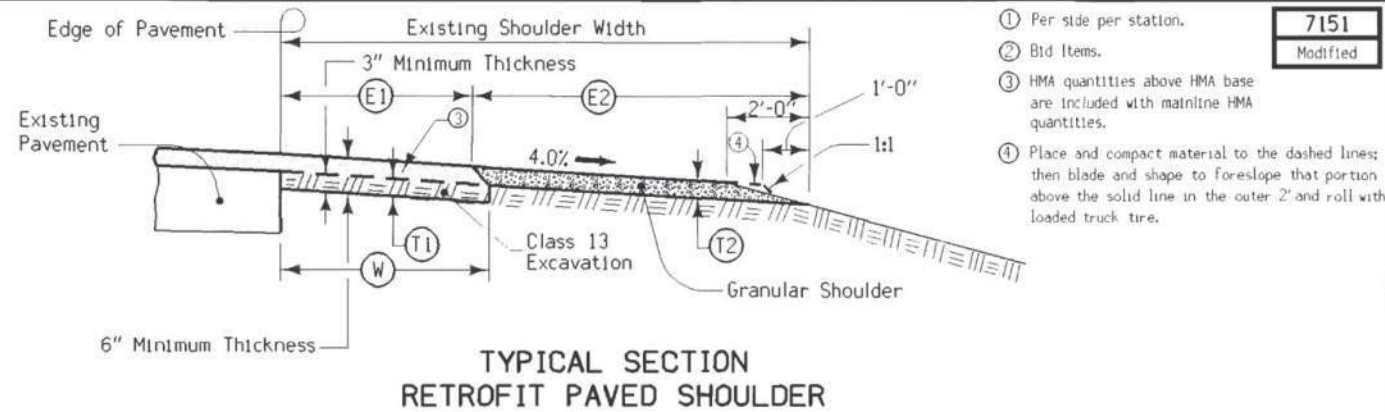

**7151**  
Modified

- ① Per side per station.
- ② Bid Items.
- ③ HMA quantities above HMA base are included with mainline HMA quantities.
- ④ Place and compact material to the dashed lines; then blade and shape to foreslope that portion above the solid line in the outer 2' and roll with loaded truck tire.

**TYPICAL SECTION  
RETROFIT PAVED SHOULDER**

LOCATION			E1	E2	T1	T2	W	QUANTITIES ①				
ROAD IDENTIFICATION	STATION TO STATION	SIDE	Feet	Feet	Inches	Inches	Feet	HMA BASE WIDENING Tons	TACK COAT Gals.	ASPHALT BINDER Tons	GRANULAR SHOULDER Tons	CLASS 13 EXCAVATION Cu. Yds.
US 30 (EBL)	861+00 - 985+30	Outside	4.0	6.0	3.0	4.5	4.38	7.94	---	0.48	18	4.05
US 30 (EBL)	992+90 - 1012+30	Outside	4.0	6.0	3.0	4.5	4.38	7.94	---	0.48	18	4.05
US 30 (EBL)	1020+98 - 1104+90	Outside	4.0	6.0	3.0	4.5	4.38	7.94	---	0.48	18	4.05
US 30 (EBL)	1145+95 - 1152+00	Outside	4.0	6.0	3.0	4.5	4.38	7.94	---	0.48	18	4.05
US 30 (WBL)	868+24 - 947+25	Outside	4.0	6.0	3.0	4.5	4.38	7.94	---	0.48	18	4.05
US 30 (WBL)	955+00 - 964+50	Outside	4.0	6.0	3.0	4.5	4.38	7.94	---	0.48	18	4.05
US 30 (WBL)	972+60 - 990+70	Outside	4.0	6.0	3.0	4.5	4.38	7.94	---	0.48	18	4.05
US 30 (WBL)	991+24 - 992+32	Outside	4.0	6.0	3.0	4.5	4.38	7.94	---	0.48	18	4.05
US 30 (WBL)	998+00 - 1017+43	Outside	4.0	6.0	3.0	4.5	4.38	7.94	---	0.48	18	4.05
US 30 (WBL)	1024+00 - 1101+05	Outside	4.0	6.0	3.0	4.5	4.38	7.94	---	0.48	18	4.05
US 30 (WBL)	1142+35 - 1152+00	Outside	4.0	6.0	3.0	4.5	4.38	7.94	---	0.48	18	4.05

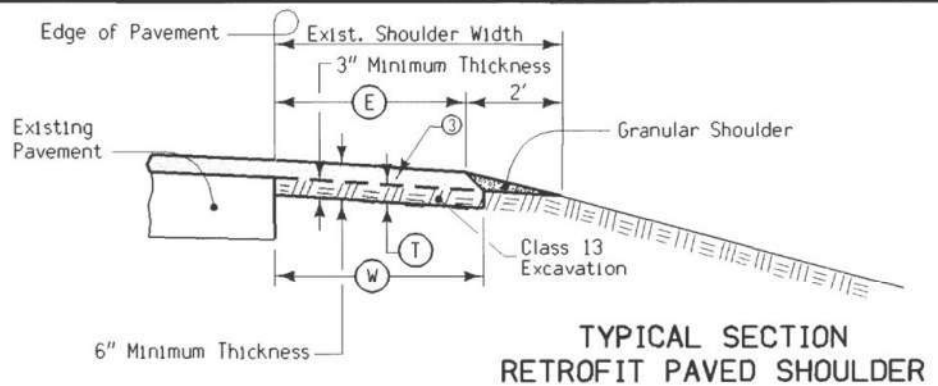

**7151A**  
Modified

- ① Per side per station.
- ② Bid Items.
- ③ HMA quantities above HMA base are included with mainline HMA quantities.

**TYPICAL SECTION  
RETROFIT PAVED SHOULDER**

LOCATION			E	T	W	QUANTITIES ①				
ROAD IDENTIFICATION	STATION TO STATION	SIDE	Feet	Inches	Feet	HMA BASE WIDENING Tons	TACK COAT Gals.	ASPHALT BINDER Tons	GRANULAR SHOULDER Tons	CLASS 13 EXCAVATION Cu. Yds.
US 30 (EBL)	860+00 - 892+30	Inside	4.0	3.0	4.38	7.94	---	0.48	4	4.05
US 30 (EBL)	893+15 - 931+21	Inside	4.0	3.0	4.38	7.94	---	0.48	4	4.05
US 30 (EBL)	935+00 - 946+31	Inside	4.0	3.0	4.38	7.94	---	0.48	4	4.05
US 30 (EBL)	950+57 - 962+25	Inside	4.0	3.0	4.38	7.94	---	0.48	4	4.05
US 30 (EBL)	966+00 - 988+57	Inside	4.0	3.0	4.38	7.94	---	0.48	4	4.05
US 30 (EBL)	993+50 - 1012+40	Inside	4.0	3.0	4.38	7.94	---	0.48	4	4.05
US 30 (EBL)	1019+70 - 1067+86	Inside	4.0	3.0	4.38	7.94	---	0.48	4	4.05
US 30 (EBL)	1071+70 - 1152+00	Inside	4.0	3.0	4.38	7.94	---	0.48	4	4.05
US 30 (WBL)	863+45 - 891+90	Inside	4.0	3.0	4.38	7.94	---	0.48	4	4.05
US 30 (WBL)	896+40 - 934+00	Inside	4.0	3.0	4.38	7.94	---	0.48	4	4.05
US 30 (WBL)	935+00 - 965+00	Inside	4.0	3.0	4.38	7.94	---	0.48	4	4.05
US 30 (WBL)	968+85 - 988+56	Inside	4.0	3.0	4.38	7.94	---	0.48	4	4.05
US 30 (WBL)	997+00 - 1018+70	Inside	4.0	3.0	4.38	7.94	---	0.48	4	4.05
US 30 (WBL)	1023+10 - 1070+50	Inside	4.0	3.0	4.38	7.94	---	0.48	4	4.05
US 30 (WBL)	1071+70 - 1152+00	Inside	4.0	3.0	4.38	7.94	---	0.48	4	4.05

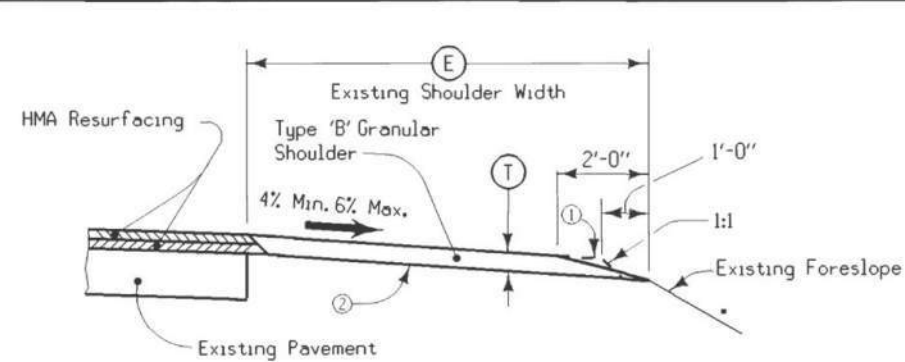

**7135**  
10-02-01

- Notes:
- Quantities have been determined on the basis of a design weight of 140 lbs. per cubic foot.
  - ① Place and compact material to the dashed lines; then blade and shape to foreslope that portion above the solid line in the outer 2' and roll with loaded truck tire.
  - ② Existing shoulder surface to be shaped to a uniform cross slope prior to placing granular shoulder material. Shape to ensure the thickness of the granular shoulder material is not less than the thickness of the resurfacing. Shaping shall be paid for in accordance with Section 2121 of the Standard Specifications.
  - ③ Tons per side per station.

**TYPICAL SECTION  
FOR TYPE 'B'  
GRANULAR SHOULDER  
ADJACENT TO HOT MIX ASPHALT  
RESURFACING**

(A) Radius Return (C) Plus 520' Taper  
(B) Taper and Radius Return (D) Plus 993' Taper

LOCATION			TONS	T	E
ROAD IDENTIFICATION	STATION TO STATION	SIDE	③	Inches	Feet
US 30 (EBL)	2750+90 - 2753+00	Median	18	4.5	6.0
US 30 (WBL)	2753+60 - 2754+60	Median	18	4.5	6.0
US 30 (EBL)	891+90 - 892+30 (A)	Median	18	4.5	6.0
US 30 (EBL)	893+15 - 893+35 (A)	Median	18	4.5	6.0
US 30 (WBL)	893+35 - 896+40	Median	18	4.5	6.0
US 30 (EBL)	946+31 - 948+57	Median	18	4.5	6.0
US 30 (WBL)	947+25 - 948+80 (B)	Outside	30	4.5	10.0
US 30 (EBL)	947+80 - 948+57 (A)	Median	18	4.5	6.0
US 30 (EBL)	949+80 - 950+57 (A)	Median	18	4.5	6.0
US 30 (WBL)	949+80 - 952+06	Median	18	4.5	6.0
IA 17	634+45 - 642+95	Lt.	23	3.0	10.0
IA 17	645+08 - 648+73	Lt.	16	3.0	7.0
IA 17	651+92 - 655+17	Lt.	16	3.0	7.0
IA 17	665+75 - 667+62	Lt.	23	3.0	10.0
IA 17	634+45 - 643+08	Rt.	23	3.0	10.0
IA 17	645+03 - 648+73	Rt.	16	3.0	7.0
IA 17	651+92 - 655+36	Rt.	16	3.0	7.0
IA 17	665+75 - 667+44	Rt.	23	3.0	10.0
IA 17 Interchange - Ramp A	1523+57 - 1537+25 (C)	Lt.	13	3.0	6.0
IA 17 Interchange - Ramp A	1524+18 - 1534+90	Rt.	8	3.0	4.0
IA 17 Interchange - Ramp B	2511+80 - 2523+33	Lt.	8	3.0	4.0
IA 17 Interchange - Ramp B	2510+00 - 2523+83 (C)	Rt.	13	3.0	6.0
IA 17 Interchange - Ramp C	3511+05 - 3523+71 (D)	Lt.	13	3.0	6.0
IA 17 Interchange - Ramp C	3513+00 - 3523+30	Rt.	8	3.0	4.0
IA 17 Interchange - Ramp D	4524+16 - 4534+00	Lt.	8	3.0	4.0
IA 17 Interchange - Ramp D	4523+59 - 4535+95 (D)	Rt.	13	3.0	6.0
IA 17 Interchange Ramp Tapers (2-520' and 2-993' in length)		Both	18	4.5	6.0

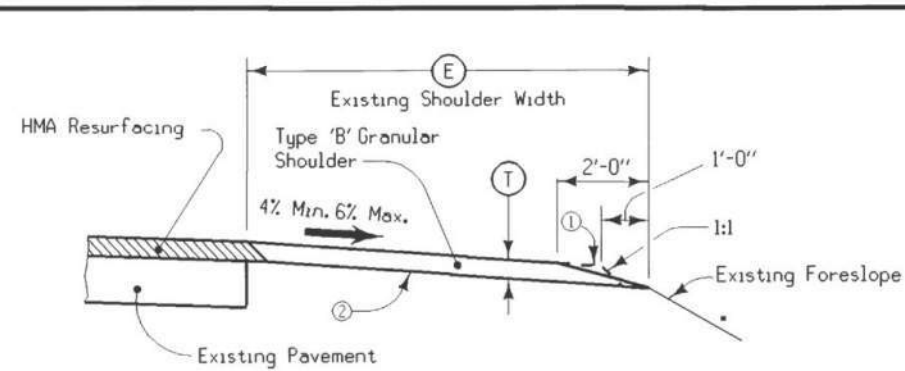

**7135C**  
Modified

- Notes:
- Quantities have been determined on the basis of a design weight of 140 lbs. per cubic foot.
  - ① Place and compact material to the dashed lines; then blade and shape to foreslope that portion above the solid line in the outer 2' and roll with loaded truck tire.
  - ② Existing shoulder surface to be shaped to a uniform cross slope prior to placing granular shoulder material. Shape to ensure the thickness of the granular shoulder material is not less than the thickness of the resurfacing. Shaping shall be paid for in accordance with Section 2121 of the Standard Specifications.
  - ③ Tons per side per station.

**TYPICAL SECTION  
FOR TYPE 'B'  
GRANULAR SHOULDER  
ADJACENT TO HOT MIX ASPHALT  
RESURFACING**

Division 3 - Story Co.  
MP-30-1(702)151--76-85

LOCATION			TONS	T	E
ROAD IDENTIFICATION	MILEPOST TO MILEPOST	SIDE	③	Inches	Feet
US 30 (WBL)	151.38 - 151.92	Outside	16	2.0	10.0
US 30 (WBL)	151.38 - 151.92	Inside	9	2.0	6.0
US 30 (EBL)	152.19 - 154.18	Outside	16	2.0	10.0
US 30 (EBL)	152.19 - 154.18	Inside	9	2.0	6.0
US 30 (EBL)	154.19 - 156.00	Outside	16	2.0	10.0
US 30 (EBL)	154.19 - 156.00	Inside	9	2.0	6.0



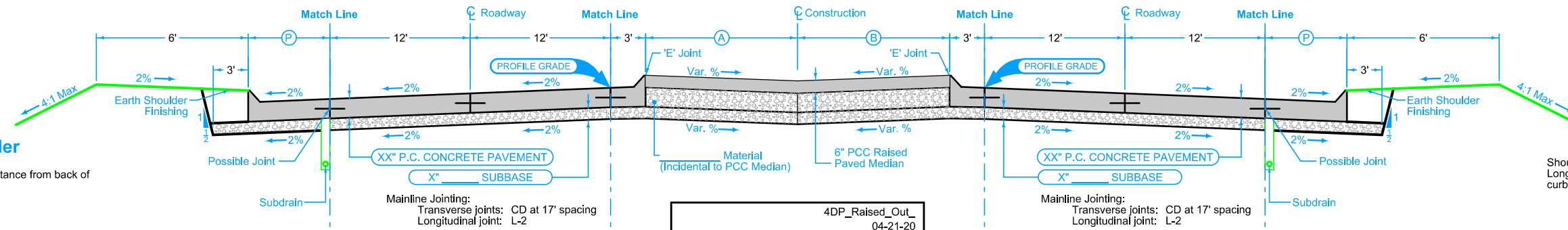

**Curbed Shoulder**

Shoulder jointing:  
Longitudinal joint not required when distance from back of curb to nearest joint is less than 16':

Transverse: C at 15' spacing  
Single pour: L-2  
Staged: KT-2

1R_Curb_10-18-22			
BEGIN STATION	END STATION	(P) Feet	Curb Type See PV-102
XXXX+XX.XX	XXXX+XX.XX	X.X	X" Sloped

Mainline Jointing:  
Transverse joints: CD at 17' spacing  
Longitudinal joint: L-2

BEGIN STATION	END STATION
XXXX+XX.XX	XXXX+XX.XX

4DP_Raised_Out_04-21-20			
BEGIN STATION	END STATION	(A) Feet	(B) Feet
XXXX+XX.XX	XXXX+XX.XX	X	X

Mainline Jointing:  
Transverse joints: CD at 17' spacing  
Longitudinal joint: L-2

BEGIN STATION	END STATION
XXXX+XX.XX	XXXX+XX.XX

**Curbed Shoulder**

Shoulder jointing:  
Longitudinal joint not required when distance from back of curb to nearest joint is less than 16':

Transverse: C at 15' spacing  
Single pour: L-2  
Staged: KT-2

1R_Curb_10-18-22			
BEGIN STATION	END STATION	(P) Feet	Curb Type See PV-102
XXXX+XX.XX	XXXX+XX.XX	X	X" Sloped

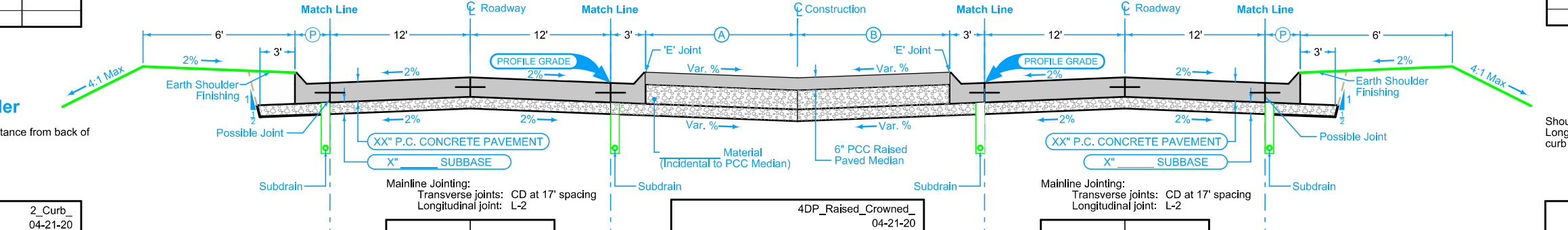

**Curbed Shoulder**

Shoulder Jointing:  
Longitudinal joint not required when distance from back of curb to nearest joint is less than 15':

Single pour: L-2  
Staged: KT-2  
Transverse: C at 17' spacing

2_Curb_04-21-20			
STATION TO STATION	(P) Feet	Curb Type See PV-102	
XXXX+XX.XX	XXXX+XX.XX	X.X	X" Sloped

Mainline Jointing:  
Transverse joints: CD at 17' spacing  
Longitudinal joint: L-2

BEGIN STATION	END STATION
XXXX+XX.XX	XXXX+XX.XX

4DP_Raised_Crowned_04-21-20			
BEGIN STATION	END STATION	(A) Feet	(B) Feet
XXXX+XX.XX	XXXX+XX.XX	X	X

Mainline Jointing:  
Transverse joints: CD at 17' spacing  
Longitudinal joint: L-2

BEGIN STATION	END STATION
XXXX+XX.XX	XXXX+XX.XX

**Curbed Shoulder**

Shoulder Jointing:  
Longitudinal joint not required when distance from back of curb to nearest joint is less than 15':

Single pour: L-2  
Staged: KT-2  
Transverse: C at 17' spacing

2_Curb_04-21-20			
STATION TO STATION	(P) Feet	Curb Type See PV-102	
XXXX+XX.XX	XXXX+XX.XX	X.X	X" Sloped

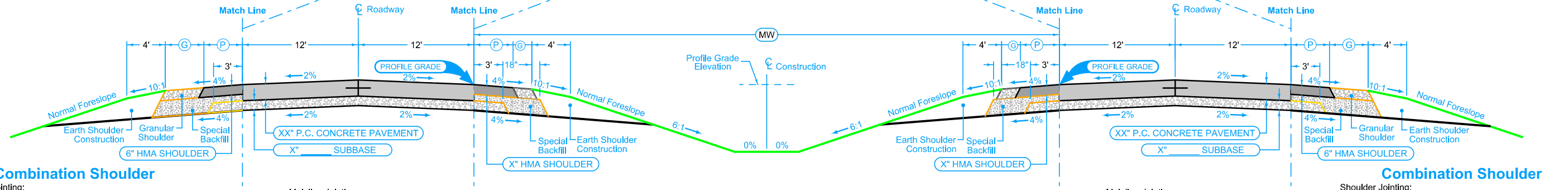

**Combination Shoulder**

Shoulder Jointing:  
Longitudinal joint: B

4_C_04-21-20					
Direction of Travel	BEGIN STATION	END STATION	(P) Feet	(G) Feet	
X	XXXX+XX.XX	XXXX+XX.XX	X	X	

Mainline Jointing:  
Transverse joints: CD at 17' spacing  
Longitudinal joint: L-2

BEGIN STATION	END STATION
XXXX+XX.XX	XXXX+XX.XX

**Combination Shoulder**

Shoulder Jointing:  
Longitudinal joint: B

4_C_04-21-20					
Direction of Travel	BEGIN STATION	END STATION	(P) Feet	(G) Feet	
X	XXXX+XX.XX	XXXX+XX.XX	X	X	

**Combination Shoulder**

Shoulder Jointing:  
Longitudinal joint: B

4_C_04-21-20					
Direction of Travel	BEGIN STATION	END STATION	(P) Feet	(G) Feet	
X	XXXX+XX.XX	XXXX+XX.XX	X	X	

Mainline Jointing:  
Transverse joints: CD at 17' spacing  
Longitudinal joint: L-2

BEGIN STATION	END STATION
XXXX+XX.XX	XXXX+XX.XX

**Combination Shoulder**

Shoulder Jointing:  
Longitudinal joint: B

4_C_04-21-20					
Direction of Travel	BEGIN STATION	END STATION	(P) Feet	(G) Feet	
X	XXXX+XX.XX	XXXX+XX.XX	X	X	

See Tab 100-24 or 100-25 for pavement quantities.  
See Tab 112-9 for shoulder quantities.

### Curbed Shoulder

Shoulder Jointing:  
 Longitudinal joint not required when distance from back of curb to nearest joint is less than 15':

Single pour: L-2  
 Staged : KT-2  
 Transverse: CD refer to L sheets for spacing

STATION TO STATION		(P) Feet	Curb Type See PV-102
XXXX+XX.XX	XXXX+XX.XX	X.X	X" Sloped

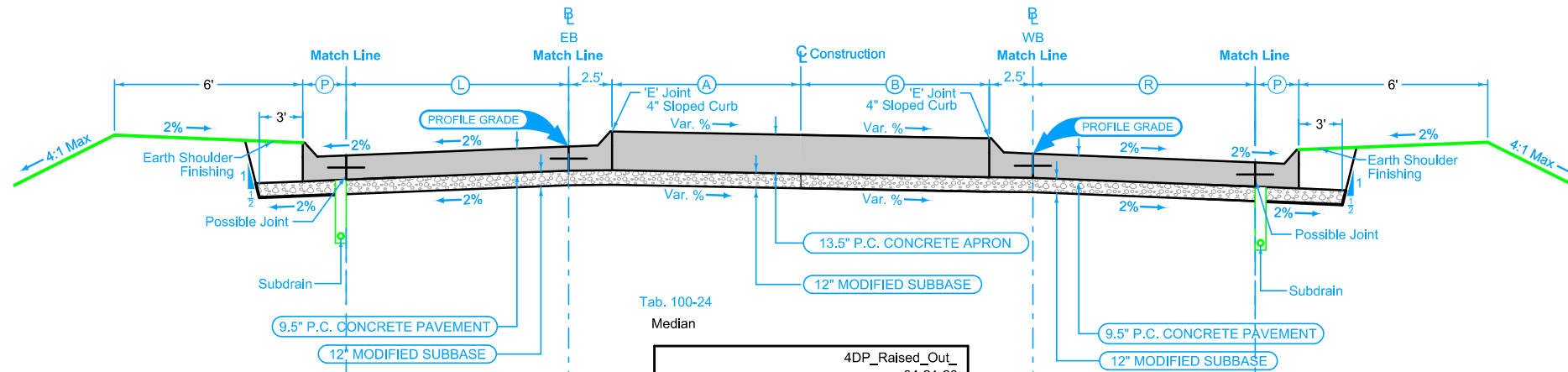

Mainline Jointing:  
 Transverse joints: CD refer to L sheets for spacing  
 Longitudinal joint: L-2

BEGIN STATION	END STATION	(L) Feet
XXXX+XX.XX	XXXX+XX.XX	X

Tab. 100-24  
 Median

4DP_Raised_Out_04-21-20			
BEGIN STATION	END STATION	(A) Feet	(B) Feet
XXXX+XX.XX	XXXX+XX.XX	X	X

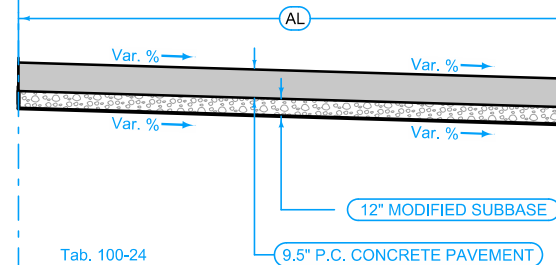

Tab. 100-24

Median Jointing:  
 Transverse joints: CD refer to L sheets for spacing  
 Longitudinal joint: L-2

STATION TO STATION		(AL) Feet
XXXX+XX.XX	XXXX+XX.XX	X

Mainline Jointing:  
 Transverse joints: CD refer to L sheets for spacing  
 Longitudinal joint: L-2

BEGIN STATION	END STATION	(R) Feet
XXXX+XX.XX	XXXX+XX.XX	X

### Curbed Shoulder

Shoulder Jointing:  
 Longitudinal joint not required when distance from back of curb to nearest joint is less than 15':

Single pour: L-2  
 Staged : KT-2  
 Transverse: CD refer to L sheets for spacing

STATION TO STATION		(P) Feet	Curb Type See PV-102
XXXX+XX.XX	XXXX+XX.XX	X.X	X" Sloped

See Tab 100-24 or 100-25 for pavement quantities.  
 See Tab 112-9 for shoulder quantities.

**SE Marshall Street**

### Curbed Shoulder

Shoulder Jointing:  
 Longitudinal joint not required when distance from back of  
 curb to nearest joint is less than 15':

Single pour: L-2  
 Staged : KT-2  
 Transverse: CD refer to L sheets for spacing

STATION TO STATION		(P) Feet	Curb Type See PV-102
XXXX+XX.XX	XXXX+XX.XX	X.X	X" Sloped

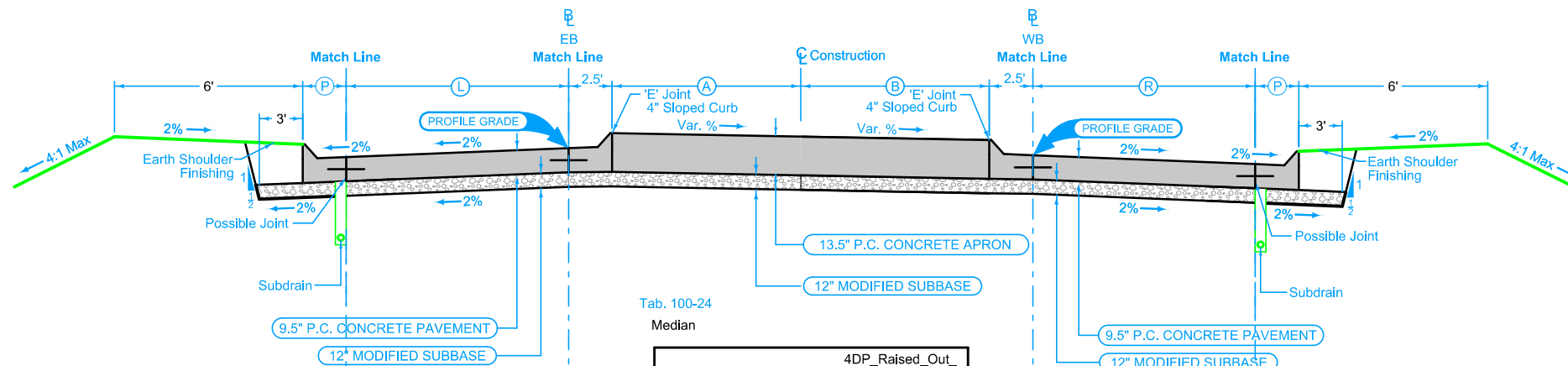

Mainline Jointing:  
 Transverse joints: CD refer to L sheets for spacing  
 Longitudinal joint: L-2

BEGIN STATION	END STATION	(L) Feet
XXXX+XX.XX	XXXX+XX.XX	X

Tab. 100-24

Median

4DP_Raised_Out_04-21-20			
BEGIN STATION	END STATION	(A) Feet	(B) Feet
XXXX+XX.XX	XXXX+XX.XX	X	X

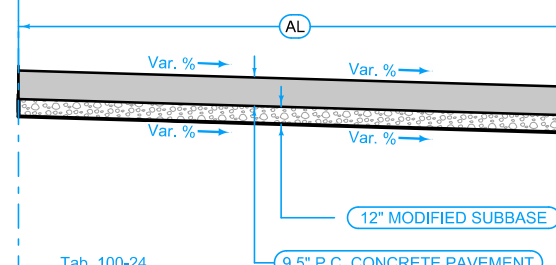

Tab. 100-24

Median Jointing:  
 Transverse joints: CD refer to L sheets for spacing  
 Longitudinal joint: L-2

STATION TO STATION		(AL) Feet
XXXX+XX.XX	XXXX+XX.XX	X

### Curbed Shoulder

Shoulder Jointing:  
 Longitudinal joint not required when distance from back of  
 curb to nearest joint is less than 15':

Single pour: L-2  
 Staged : KT-2  
 Transverse: CD refer to L sheets for spacing

STATION TO STATION		(P) Feet	Curb Type See PV-102
XXXX+XX.XX	XXXX+XX.XX	X.X	X" Sloped

Mainline Jointing:  
 Transverse joints: CD refer to L sheets for spacing  
 Longitudinal joint: L-2

BEGIN STATION	END STATION	(R) Feet
XXXX+XX.XX	XXXX+XX.XX	X

See Tab 100-24 or 100-25 for pavement quantities.  
 See Tab 112-9 for shoulder quantities.

**Crown Flair Drive**

### Curbed Shoulder

Shoulder Jointing:  
 Longitudinal joint not required when distance from back of curb to nearest joint is less than 15':

Single pour: L-2  
 Staged : KT-2  
 Transverse: C at 17' spacing

2_Curb_04-21-20			
STATION TO STATION	(P) Feet	Curb Type See PV-102	
XXXX+XX.XX	XXXX+XX.XX	X.X	X" Sloped

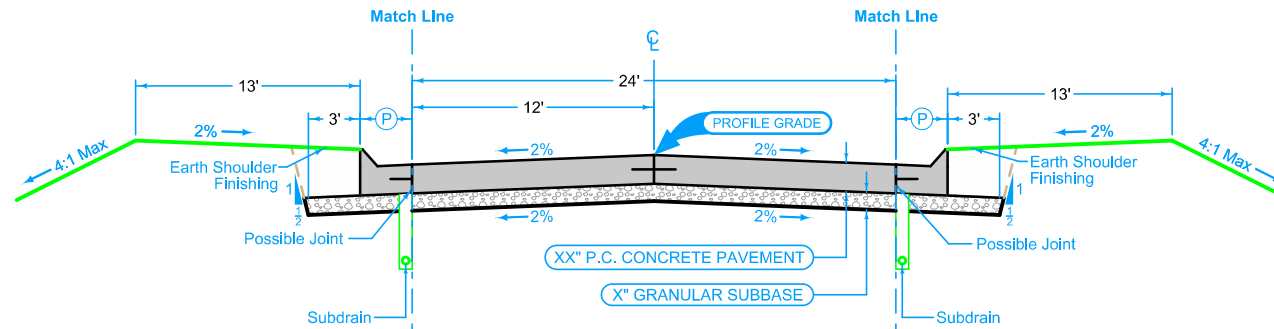

Mainline Jointing:  
 Transverse joints: CD at 17' spacing  
 Longitudinal joint: L-2

2P_04-21-20	
STATION TO STATION	
XXXX+XX.XX	XXXX+XX.XX

### Curbed Shoulder

Shoulder Jointing:  
 Longitudinal joint not required when distance from back of curb to nearest joint is less than 15':

Single pour: L-2  
 Staged : KT-2  
 Transverse: C at 17' spacing

2_Curb_04-21-20			
STATION TO STATION	(P) Feet	Curb Type See PV-102	
XXXX+XX.XX	XXXX+XX.XX	X.X	X" Sloped

See Tab 100-24 or 100-25 for pavement quantities.  
 See Tab 112-9 for shoulder quantities.

## SE Marshall Street

### Curbed Shoulder

Shoulder Jointing:  
 Longitudinal joint not required when distance from back of curb to nearest joint is less than 15':

Single pour: L-2  
 Staged : KT-2  
 Transverse: C at 17' spacing

2_Curb_04-21-20			
STATION TO STATION	(P) Feet	Curb Type See PV-102	
XXXX+XX.XX	XXXX+XX.XX	X.X	X" Sloped

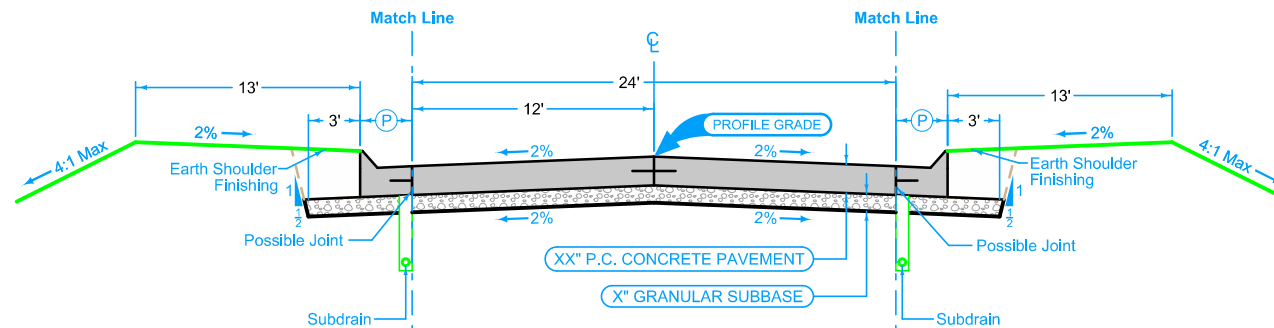

Mainline Jointing:  
 Transverse joints: CD at 17' spacing  
 Longitudinal joint: L-2

2P_04-21-20	
STATION TO STATION	
XXXX+XX.XX	XXXX+XX.XX

### Curbed Shoulder

Shoulder Jointing:  
 Longitudinal joint not required when distance from back of curb to nearest joint is less than 15':

Single pour: L-2  
 Staged : KT-2  
 Transverse: C at 17' spacing

2_Curb_04-21-20			
STATION TO STATION	(P) Feet	Curb Type See PV-102	
XXXX+XX.XX	XXXX+XX.XX	X.X	X" Sloped

See Tab 100-24 or 100-25 for pavement quantities.  
 See Tab 112-9 for shoulder quantities.

## Crown Flair Drive

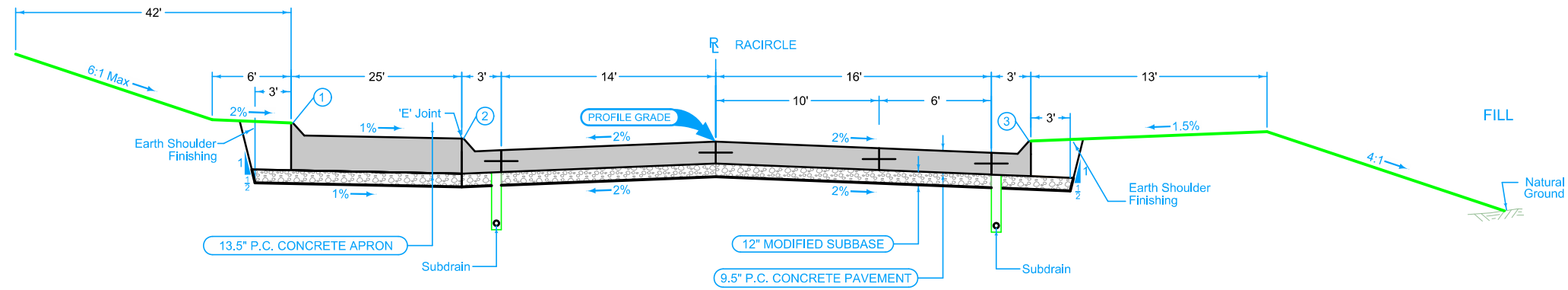

- ① 6" Standard Curb
- ② 4" Sloped Curb
- ③ 6" Sloped Curb

Note: See 'L' Sheets for Jointing Layout

Mainline Jointing:  
 Transverse joints: CD refer to L sheets for spacing  
 Longitudinal joint: L-2

LOCATION			(X)
ROAD IDENTIFICATION	STATION TO STATION		Feet
RACIRCLE	XXXX+XX.XX	XXXX+XX.XX	X.X
RACIRCLE	XXXX+XX.XX	XXXX+XX.XX	X.X

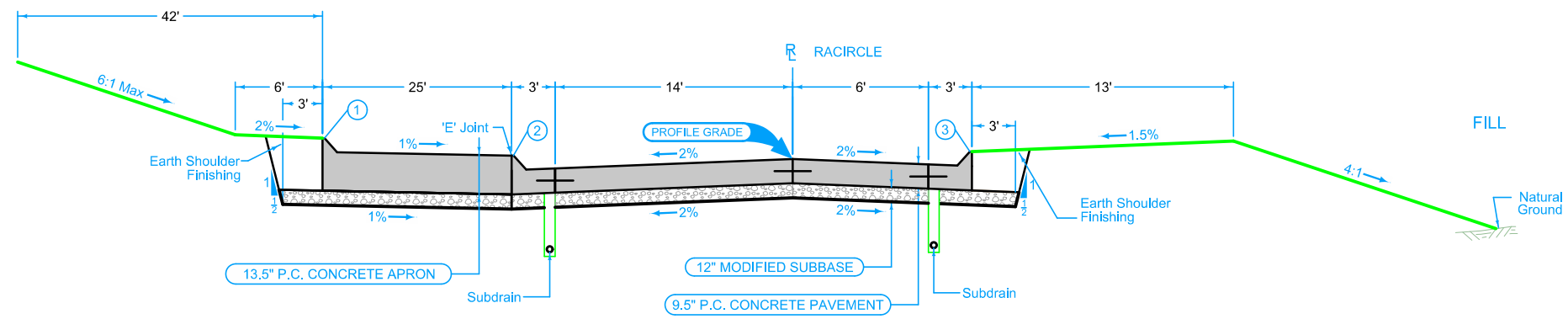

- ① 6" Standard Curb
- ② 4" Sloped Curb
- ③ 6" Sloped Curb

Note: See 'L' Sheets for Jointing Layout

Mainline Jointing:  
 Transverse joints: CD refer to L sheets for spacing  
 Longitudinal joint: L-2

LOCATION			(X)
ROAD IDENTIFICATION	STATION TO STATION		Feet
RACIRCLE	XXXX+XX.XX	XXXX+XX.XX	X.X
RACIRCLE	XXXX+XX.XX	XXXX+XX.XX	X.X

See Tab 100-24 or 100-25 for pavement quantities.  
 See Tab 112-9 for shoulder quantities.

**Roundabout**

LOCATION			DIMENSIONS				
ROAD IDENTIFICATION	STATION TO STATION		(L)	(R)	FS	BS	(DW)
							Feet
SR 30	XXXX+XX.XX	XXXX+XX.XX	X	X	X	X	X

G\_2\_GradeGran  
Modified

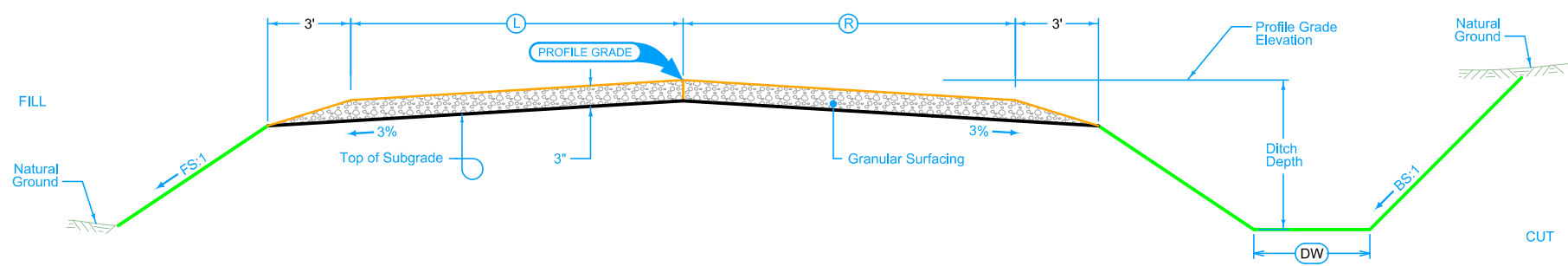

Normal section shown may be modified appropriately in areas of superelevated curves or other locations specifically designated by the Engineer.

See plan & profile sheets and cross sections for additional details of ditches and backslopes.

### GRADING AND GRANULAR SURFACING FOR PRIVATE DRIVES

LOCATION			DIMENSIONS						6" Special Backfill CY	Earth Shoulder Construction Station	Class 13 Waste CY
ROAD IDENTIFICATION	STATION TO STATION		HMA		PCC		6" Special Backfill CY	Earth Shoulder Construction Station			
	PW Feet	T Inches	SGW Feet	PW Feet	T Inches	SGW Feet					
US 30	XXXX+XX.XX	XXXX+XX.XX									
SR 30	XXXX+XX.XX	XXXX+XX.XX									

Quantity calculations based on vertical pavement edges.

Normal section shown may be modified appropriately in areas of superelevated curves or other locations specifically designated by the Engineer.

- ① Possible HMA 1:1 slope
- ② Earth Shoulder Construction shall consist of the Class 13 Excavation material from adjacent Class 13 Excavation operation. Excess Class 13 material shall be hauled off.

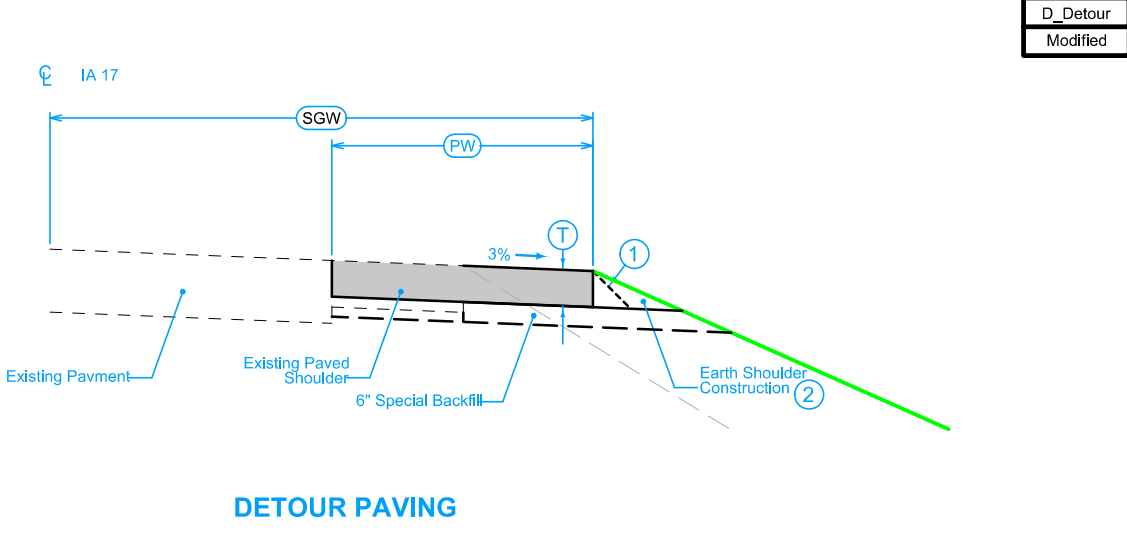

D\_Detour  
Modified

6147  
10-20-15

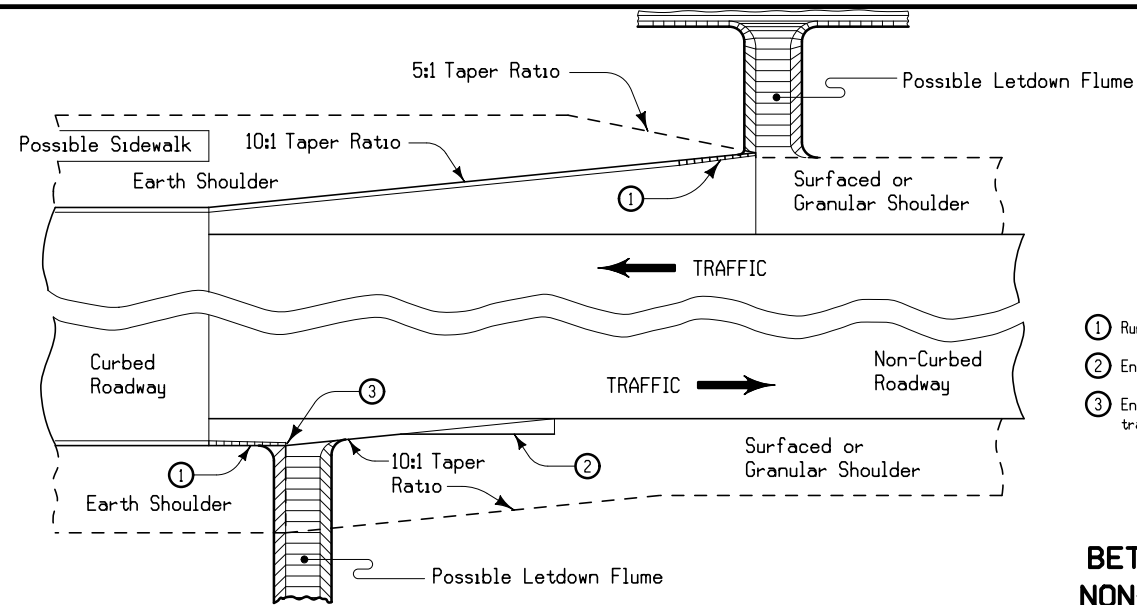

- ① Runout curb according to PV-102
- ② End of Taper Details see Typical Detail 7101
- ③ End earth shoulder at the end of the curb transition when no flume is needed.

**TRANSITION  
BETWEEN CURBED AND  
NON-CURBED ROADWAYS**

7101  
10-19-10

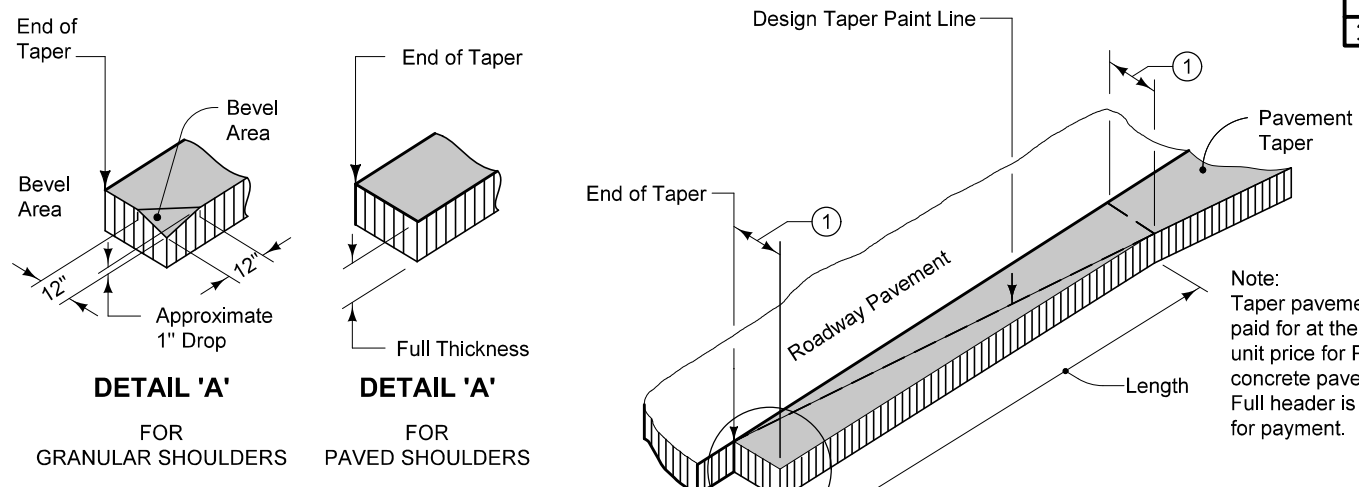

- ① Normal width is 2'-0". Construct 4'-0" width when butting into 4' wide HMA shoulders (See Typical 7154A).

**TYPICAL DETAILS OF  
PCC PAVEMENT HEADER**



**SURVEY SYMBOLS**

- AST, Above Ground Storage Tank
- BB, Billboard
- BBB, Bottom of Bridge Beam
- BCL, Bridge Centerline
- BD, Bridge Deck
- BD, Bridge Deck
- BL, Topo Breakline
- BLD, Building or Foundation
- BLS, Bridge Low Steel
- BM, Bench Mark
- BNK, Stream Bank
- BRS, Bridge
- C, Centerline BL of Road -ML or SR
- CAV, Cave
- CEL, Cell Phone Tower
- CIS, Cistern
- COM, Concrete or A/C Slab
- CP, Control Point
- CRP, Corporation Line
- CS, Curve Point
- CU, Back of Curb
- CUL, Culvert
- D, Centerline Draw or Stream -Down
- DAB, Drainage Area Boundary
- DIG, Centerline of Dike or Dam
- DTM, Photogrammetry Elev Control Check
- DU, Centerline Draw or Stream -Up
- EB, Electrical Box
- EG, Edge of Gravel Road
- ENS, Edge Paved Entrance and Park Lot
- ENT, Centerline BL of Entrance
- ENU, Edge Unpaved Entrance and Parking
- EP, Edge of Paved Roads -ML or SR
- EW, Edge of Water
- FCL, Chain Link and Security Fence
- FENO, FENO Monument
- FHD, Fire Hydrant
- FLG, Flag
- FP, Filler Pipe
- FW, Wire Fence
- FWD, Wood Fence
- GDC, Guard Rail Cable
- GDL, Guard Rail Steel
- GP, Guard Post -Less Than 4 Posts
- GRP, Guard Post -4 or More Posts
- GR, Ground Shot
- GRV, Grave
- GV, Gas Valve
- HDR, Hedge Row
- HS, Hydric Soil -Wetlands
- HT, Electrical Highline Tower
- IN, Storm Sewer Intake
- INB, Storm Sewer Beehive Intake
- LC, Lot Corner
- LIN, Miscellaneous Line
- LP, L.P. Tank
- LUM, Luminaire
- MH, Utility Access -Manhole
- MIS, Miscellaneous
- MM, Mile Marker Post
- OUT, Tile Outlet
- PC, Curve Point
- PCP, Photo Control Point
- PCT, Photo Control Target
- PI, Target Point
- PIP, Pipe Culvert
- PL, Location of Photo -Wetlands
- PLG, Location of General Photo
- PDC, Curve Point
- POST, Spiral Point
- PR, Electric Riser Pole
- PRO, Profile Shot
- PT, Curve Point
- REF, Reference Tie Point
- RET, Retaining Wall
- RIP, Rip-Rap
- ROC, Rock Outcropping
- ROW, Right of Way Mark
- RR, Centerline of Railroad Tracks
- RRB, Railroad Signal Box
- RRF, Railroad Frog
- RRR, Railroad Rail
- RRS, Railroad Signal
- RRW, Railroad Switch
- RT, Radio Tower
- S, Soil Sampling Site -Wetlands
- SBR, Size of Bridge
- SC, Spiral Point
- SCR, Section Corner
- SEP, Septic Tank
- SF, Staff Gauge -Wetlands
- SG, Staff Gauge -Wetlands
- SH, Paved Shoulder
- SHR, Shrub
- SI, Sign
- SL, Speed Limit Sign
- SLN, Section Line
- SLO, Silo
- SNK, Sink Hole
- SNP, Unpaved Shoulder
- SP, Stream Profile
- STP, Stump
- SWK, Sidewalk
- SWP, Swamp or Marsh
- TA, Tower Anchor
- TBO, Telephone Booth
- TCB, Traffic Signal Box
- TDC, Tree Deciduous
- TDL, Traffic Detection Loop
- TER, Terrace
- TEV, Evergreen Tree
- TFR, Tree Fruit
- TGP, Telegraph Pole
- TL, Tie Line
- TLNL, Tree Line Left
- TLNR, Tree Line Right
- TOP, Top of Bridge Pier
- TPA, Telephone Pole Co. 1
- TPB, Telephone Pole Co. 2
- TPC, Telephone Pole Co. 3
- TR, Telephone Riser Pole
- TRL, Trail
- TS, Spiral Point
- TSB, Telephone Switch Box
- TSG, Traffic Signal
- TSL, Traffic Signal and Luminaire
- TV, Satellite TV Dish
- TVP, TV Pedestal
- TW, Top of Water
- UB, Utility Box
- UE, Utility Elevation
- UPH, Utility Pot Hole - Quality A
- UST, Underground Tank
- UV, Underground Utility Vault
- VS, Channel Cross Section
- WC, Wild Card -Misc. Field Shot
- WEL, Well
- WHD, Water Hydrant
- WHU, RV Water Hook Up
- WM, Wind Mill
- WND, Wind Turbine
- WV, Water Valve

**UTILITY LEGEND**

- G** **GL1D, Alliant Energy Gas - Quality D**  
Billie Reid  
billiereid@alliantenergy.com  
319-786-3703
- E1** **EL1D, Alliant Energy Elec - Quality D**  
**Midland Power Cooperative Electric Distribution**  
**ITC Midwest LLC Electric Transmission**  
Billie Reid  
billiereid@alliantenergy.com  
319-786-3703
- Dan Kyle  
dkyle@midlandpower.coop  
515 370 1071
- Chad Levi  
clevi@itctransco.com  
3198999969
- G2** **GL2D, Black Hills Energy - Quality D**  
Brad Fleming  
brad.fleming@blackhillscorp.com  
402 660 0812
- F0** **F01D, CenturyLink-Lumens - Quality D**  
Steve Parker  
Steven.Parker4@lumen.com  
507 358 1978
- T1** **TL1D, CenturyLink-Lumens - Quality D**  
Steve Parker  
Steven.Parker4@lumen.com  
507 358 1978
- W** **WL1D, City of Boone - Quality D**
- ST S** **ST1D, City of Boone - Quality D**
- SAN** **SA1D, City of Boone - Quality D**
- F02** **F02D, ICN-IDOT - Quality D**  
Jason Dale  
Jason.Dale@iowadot.us  
515-239-1995
- F03** **F03D, ICN Network - Quality D**  
David Augspurger  
daugspurger@icn.state.ia.us  
515-725-4604
- F04** **F04D, Jefferson Telephone Company - Quality D**  
Duane Russell  
duane@jeffersontelecom.com  
515 386 4705
- F05** **F05D, Mediacom - Quality D**  
Jerry Broughton  
jbroughton@mediacomcc.com  
(845) 587-2521
- TV** **TV1D, Mediacom - Quality D**  
Jerry Broughton  
jbroughton@mediacomcc.com  
(845) 587-2521
- G3** **GL3D, Northern Natural Gas - Quality D**
- F06** **F06D, Ogden Telephone - Quality D**  
Joel Munson  
ogdentel@netins.net  
515-275-2050

**PLAN VIEW COLOR LEGEND OF PLAN AND PROFILE SHEETS**

LINEWORK		Design Color No.	
Green	(2)		Existing Topographic Features and Labels
Blue	(1)		Proposed Alignment, Stationing, Tic Marks, and Alignment Annotation
Magenta	(5)		Existing Utilities
SHADING		Design Color No.	Transparency
Pink, Dark	(13)		Temporary Pavement Shading 50%
Yellow	(4)		Proposed Pavement Shading 50%
Orange	(6)		Proposed Granular Shading 50%
Orange	(70)		Proposed Shoulder Granular Shading 50%
Yellow	(68)		Proposed Shoulder Paved Full Depth Shading 50%
Yellow	(132)		Proposed Shoulder Paved Partial Depth Shading 50%
Brown, Light	(236)		Grading Shading 50%
Orange, Light	(134)		Proposed Granular Entrance Shading 50%
Yellow	(220)		Proposed Paved Entrance Shading 50%
Tan	(8)		Proposed Sidewalk Shading 50%
Blue, Light	(230)		Proposed Sidewalk Landing Shading 50%
Pink	(11)		Proposed Sidewalk Ramp Shading 50%
Red	(3)		Proposed Structure Shading 50%
Red	(3)		Delineates Restricted Areas 0%

**PROFILE VIEW COLOR LEGEND OF PLAN AND PROFILE SHEETS**

LINEWORK		Design Color No.	
Green	(10)		Existing Ground Line Profile
Blue	(1)		Proposed Profile and Annotation
Magenta	(5)		Existing Utilities
Blue, Light	(230)		Proposed Ditch Grades, Left
Black	(0)		Proposed Ditch Grades, Median
Rust	(14)		Proposed Ditch Grades, Right

**Reference Point**

- Station
- Section Corner
- Ground Line Intercept
- Saw Cut
- Guardrail
- Trench Drain
- HighTension Cable Guardrail
- Sheet Pile
- Pavement Removal
- Clearing & Grubbing Area

**RIGHT-OF-WAY LEGEND**

- Proposed Right-of-Way Symbol
- Proposed Right-of-Way Line
- Existing Right of Way
- Existing and Proposed Right-of-Way
- Easement and Existing Right-of-Way
- Easement (Temporary) Symbol
- Easement (Temporary) Line
- Easement
- C/A Access Control
- Property Line Symbol
- Property Line

**PLAN AND PROFILE LEGEND AND SYMBOL INFORMATION SHEET**

(COVERS SHEET SERIES D, E, F, & K)

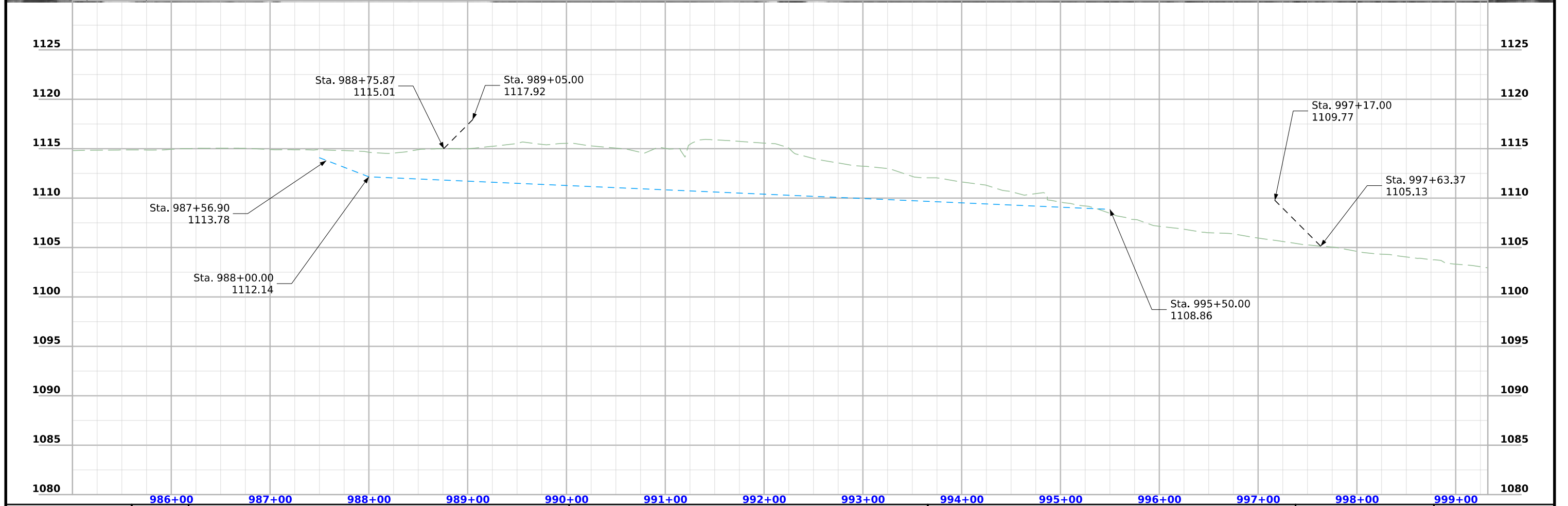
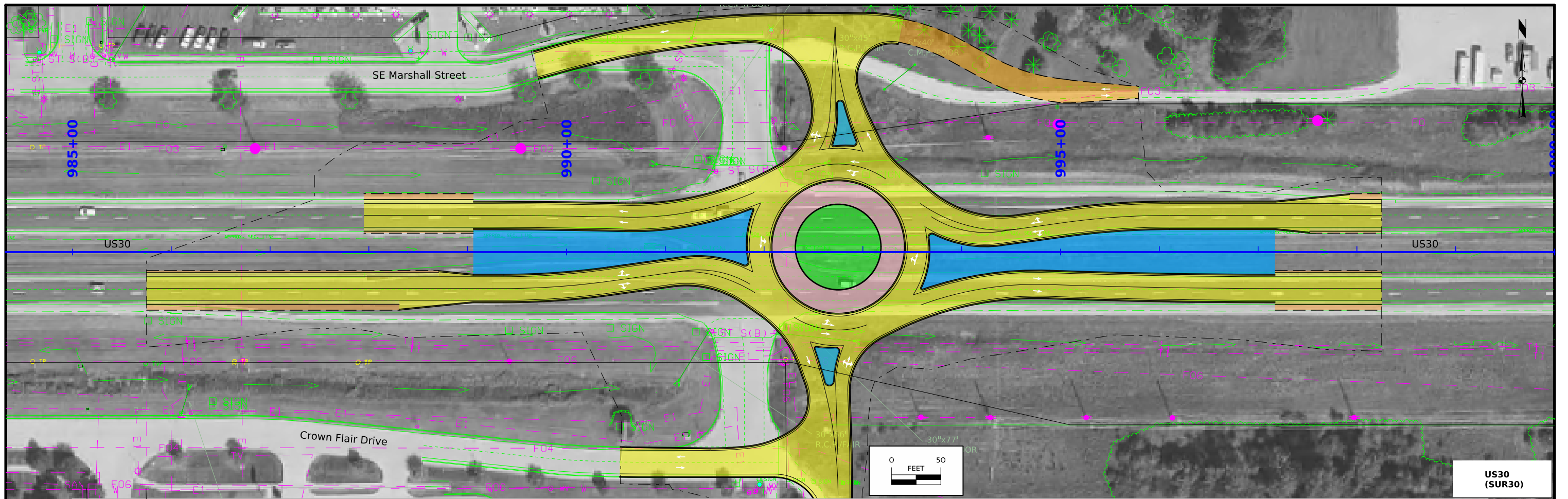

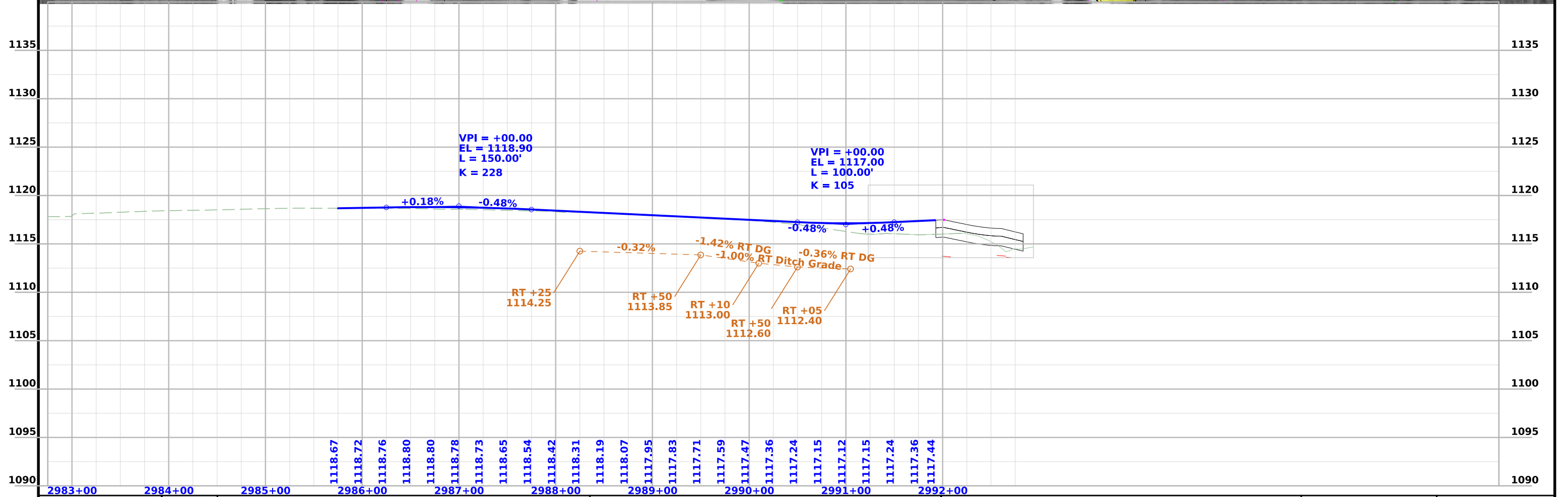
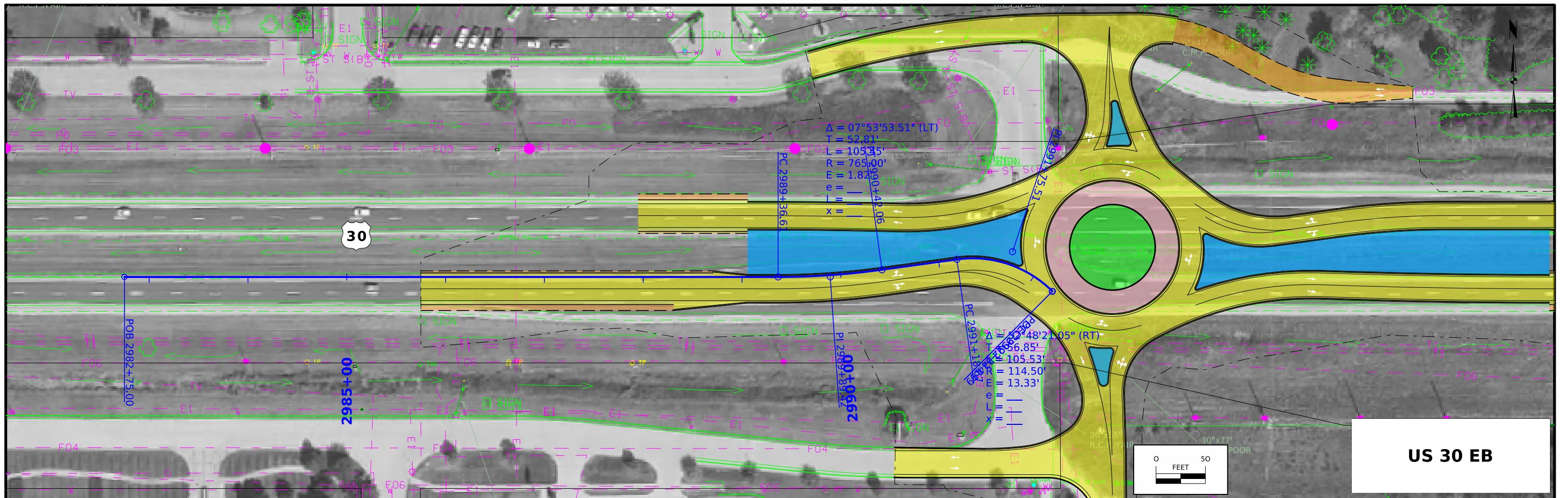

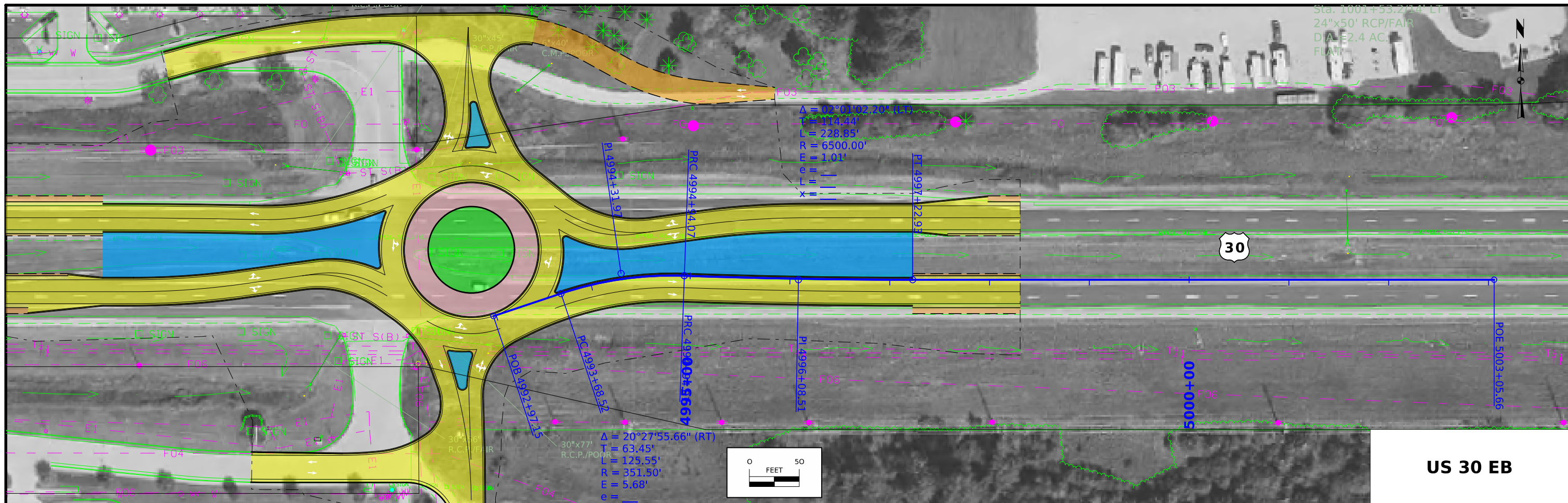

**US 30 EB**

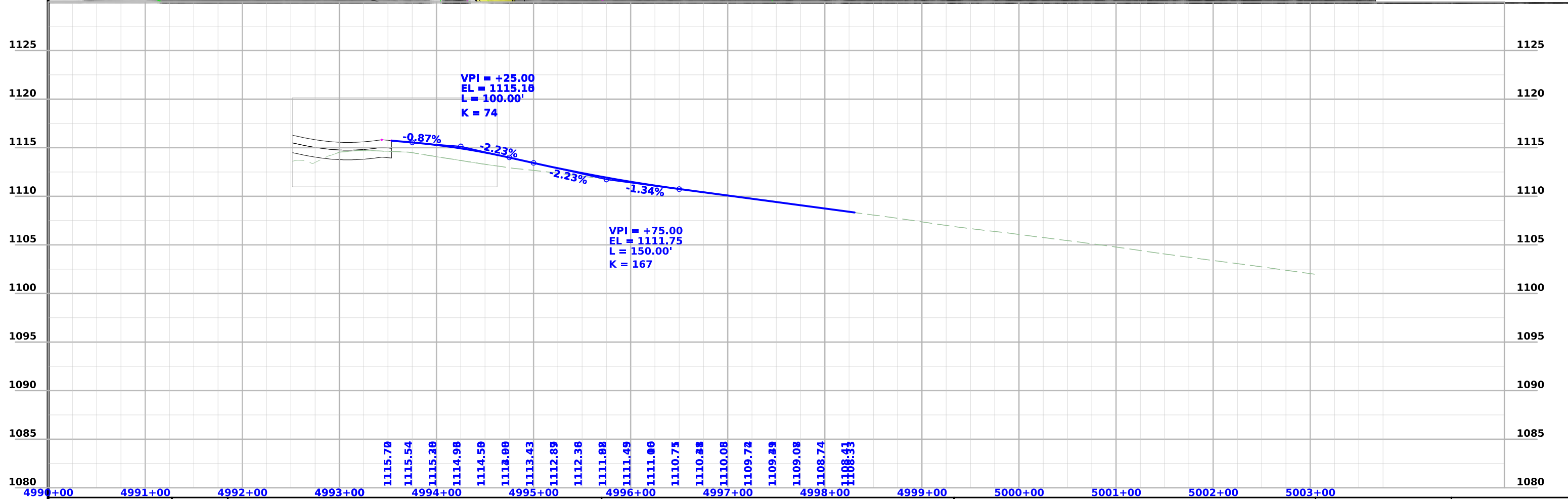

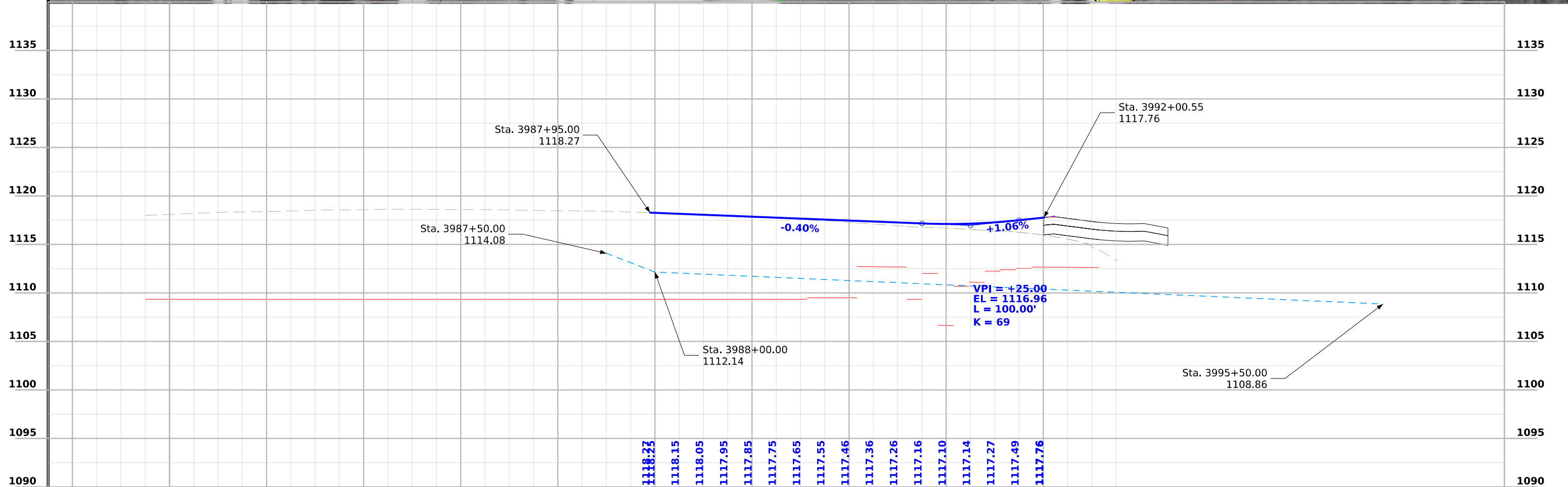
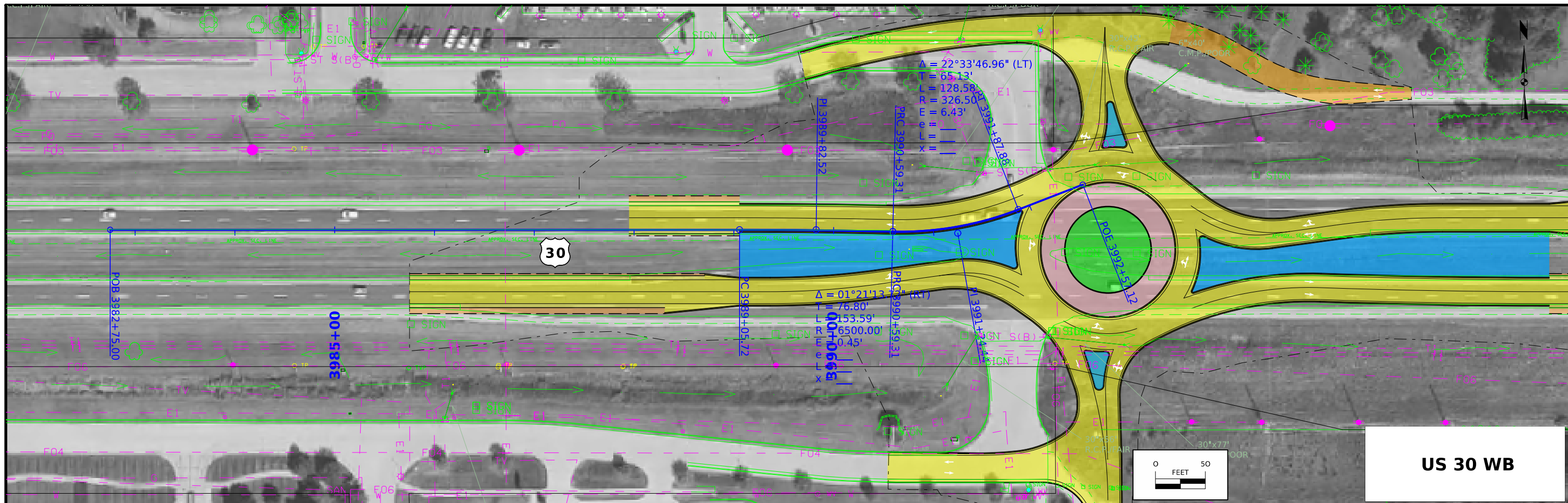

FILE NO.	ENGLISH	DESIGN TEAM	BOONE COUNTY	PROJECT NUMBER	SHEET NUMBER
		Rhoads\Tamrakar\Prindle		HSIPX-030-4(113)--3L-08	D.5

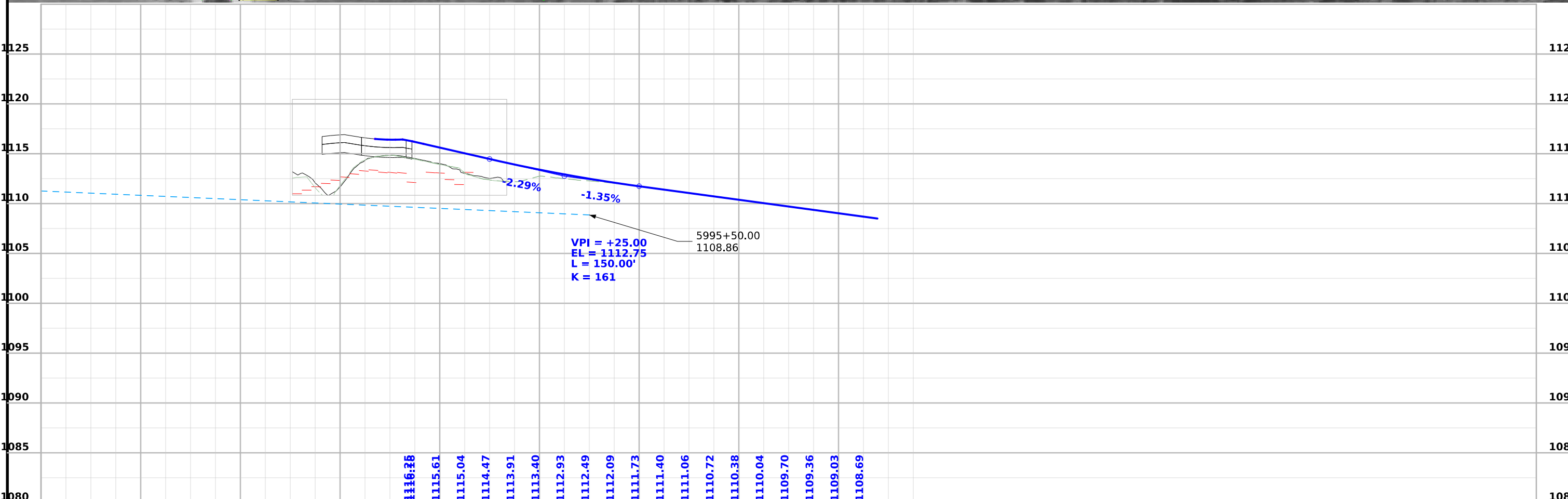
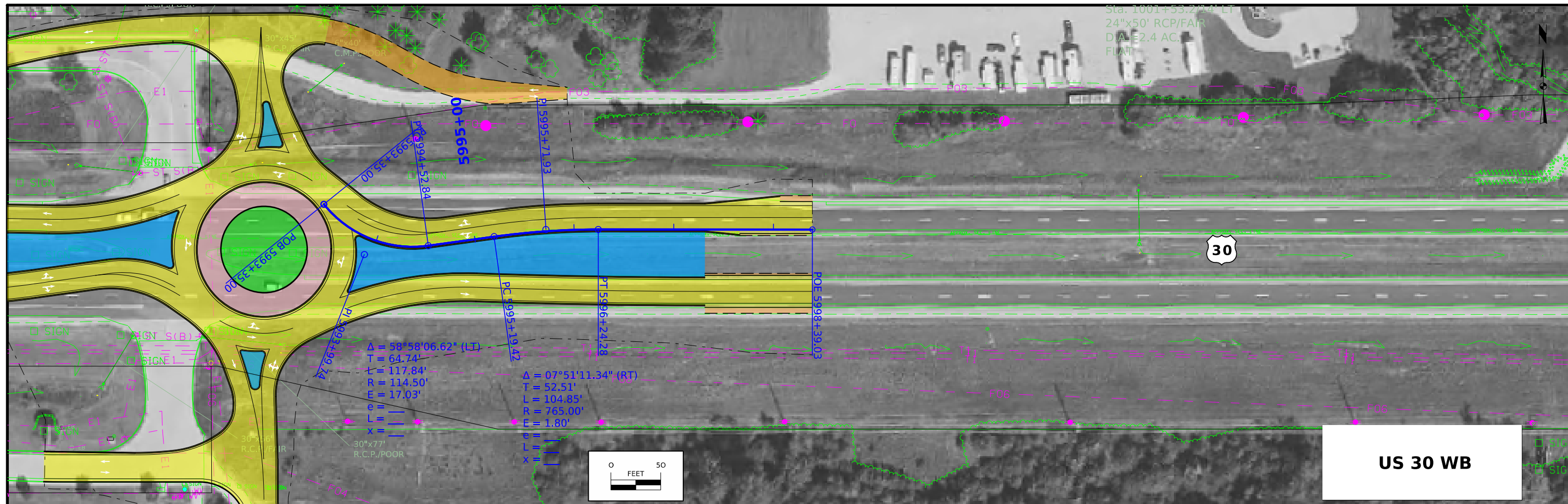

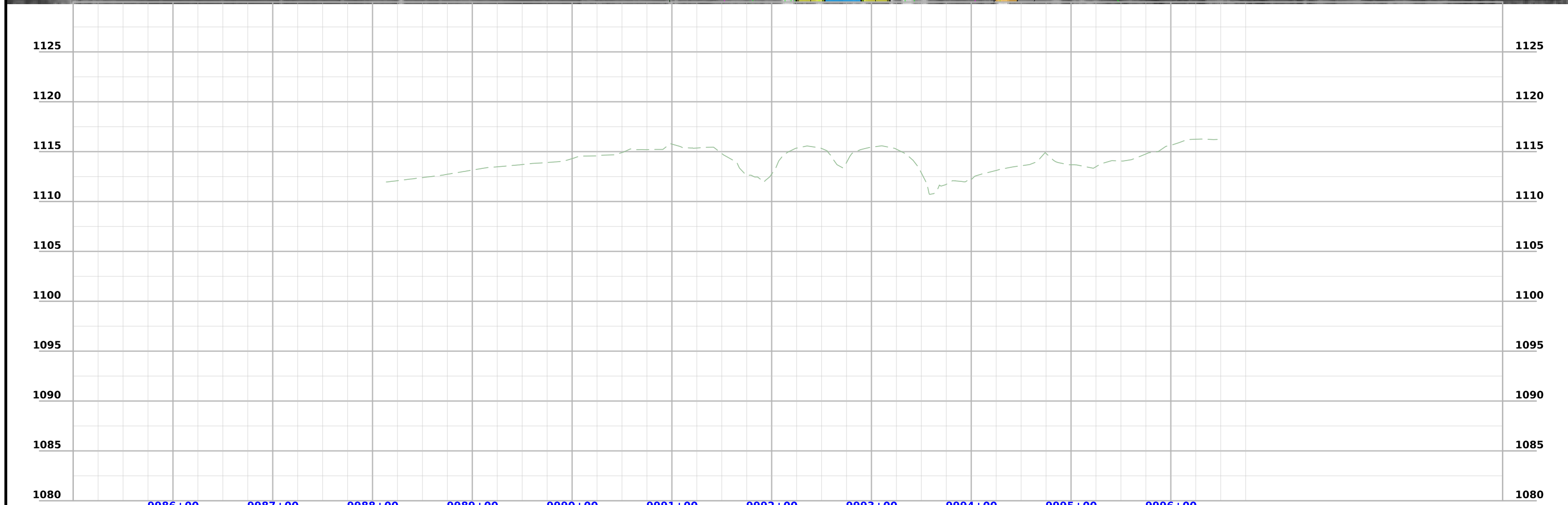
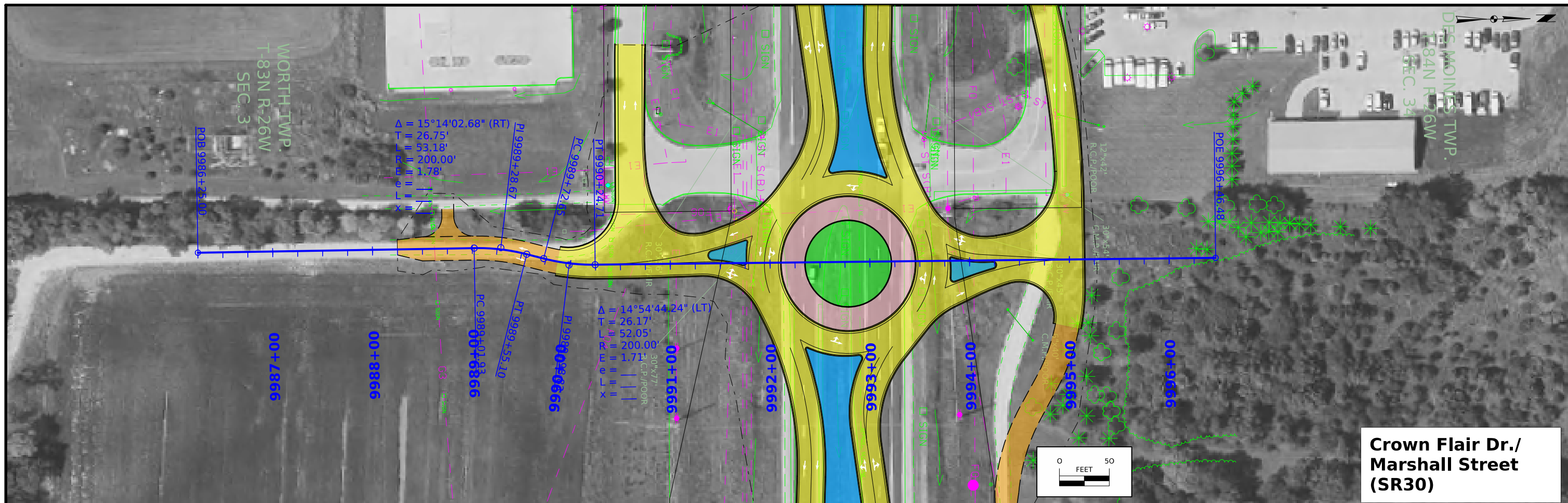

FILE NO.	ENGLISH	DESIGN TEAM Rhoads\Tamrakar\Prindle	BOONE COUNTY	PROJECT NUMBER HSIPX-030-4(113)--3L-08	SHEET NUMBER E.1
----------	---------	-------------------------------------	--------------	--	------------------

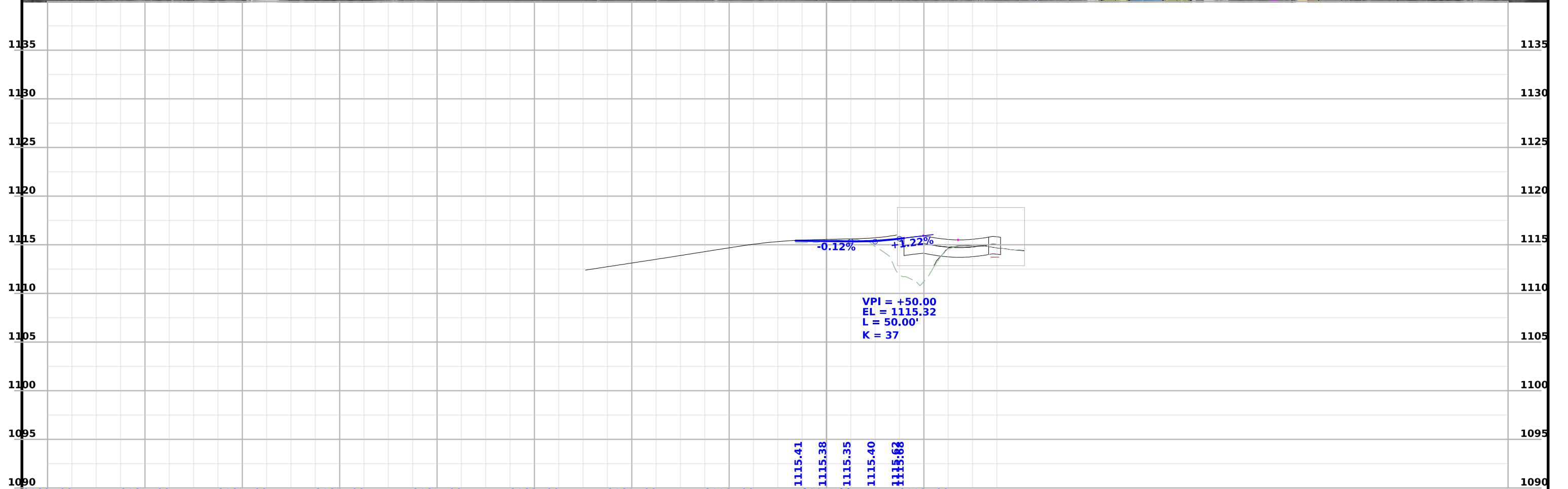

2983+00	2984+00	2985+00	2986+00	2987+00	2988+00	2989+00	2990+00	2991+00	2992+00	BOONE COUNTY	PROJECT NUMBER HSIPX-030-4(113)--3L-08	SHEET NUMBER E.2
---------	---------	---------	---------	---------	---------	---------	---------	---------	---------	--------------	--	------------------



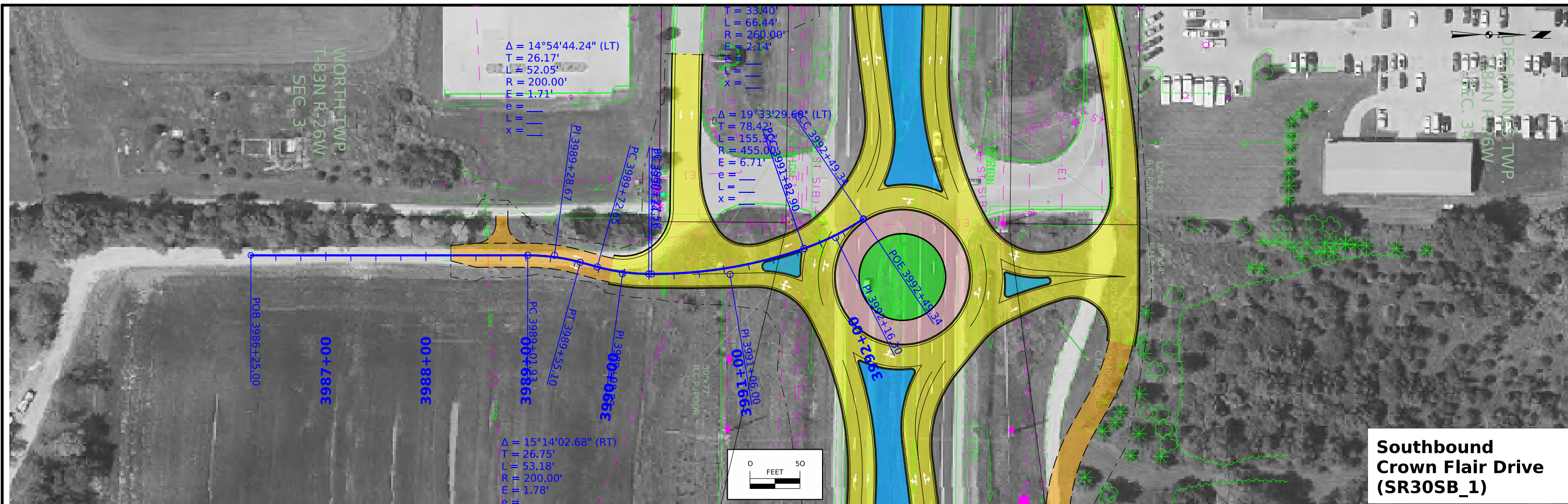

**Southbound  
Crown Flair Drive  
(SR30SB\_1)**

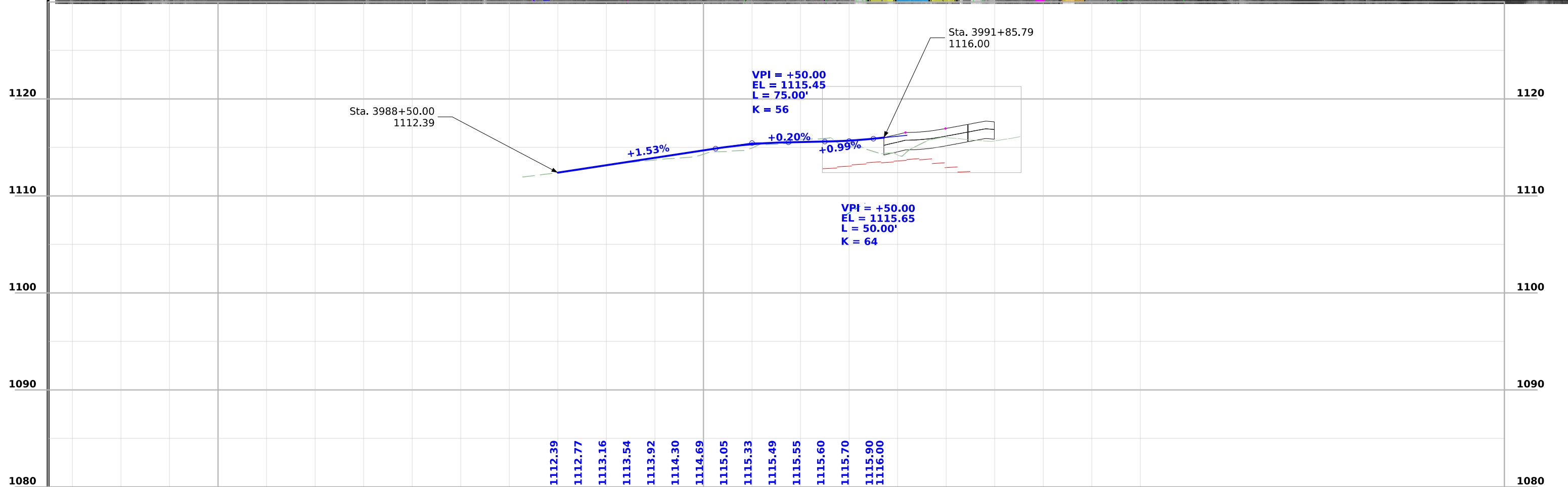

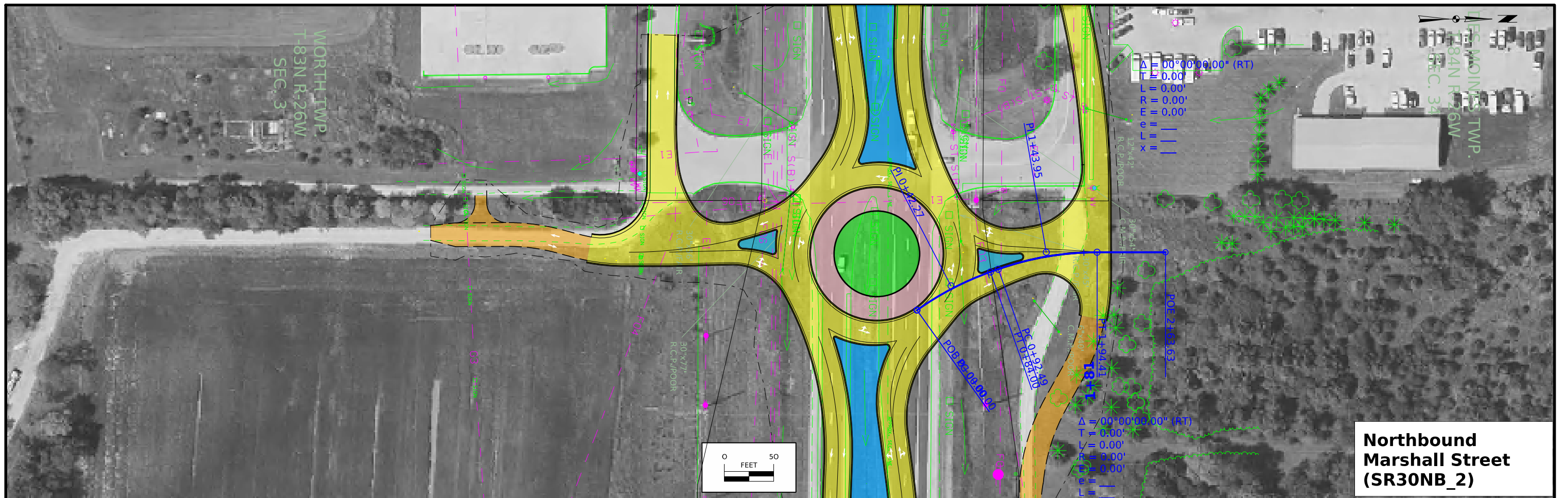

FILE NO.	ENGLISH	DESIGN TEAM	Rhoads\Tamrakar\Prindle		BOONE COUNTY	PROJECT NUMBER	HSIPX-030-4(113)--3L-08	SHEET NUMBER	E.4
----------	---------	-------------	-------------------------	--	--------------	----------------	-------------------------	--------------	-----

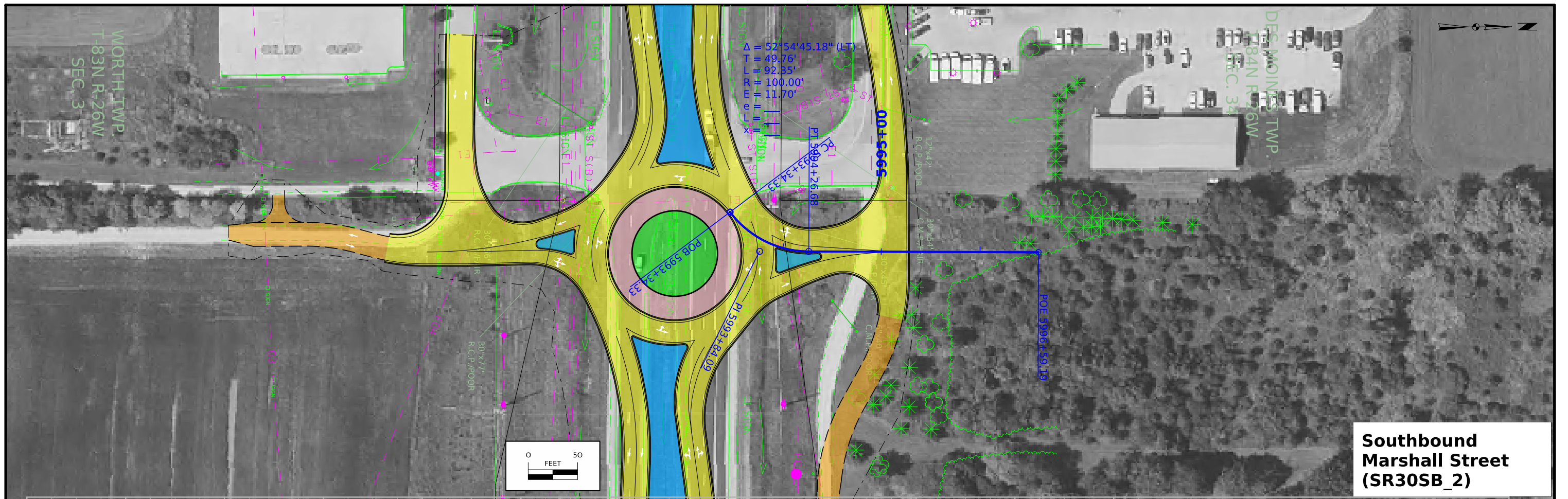

**Southbound  
Marshall Street  
(SR30SB\_2)**

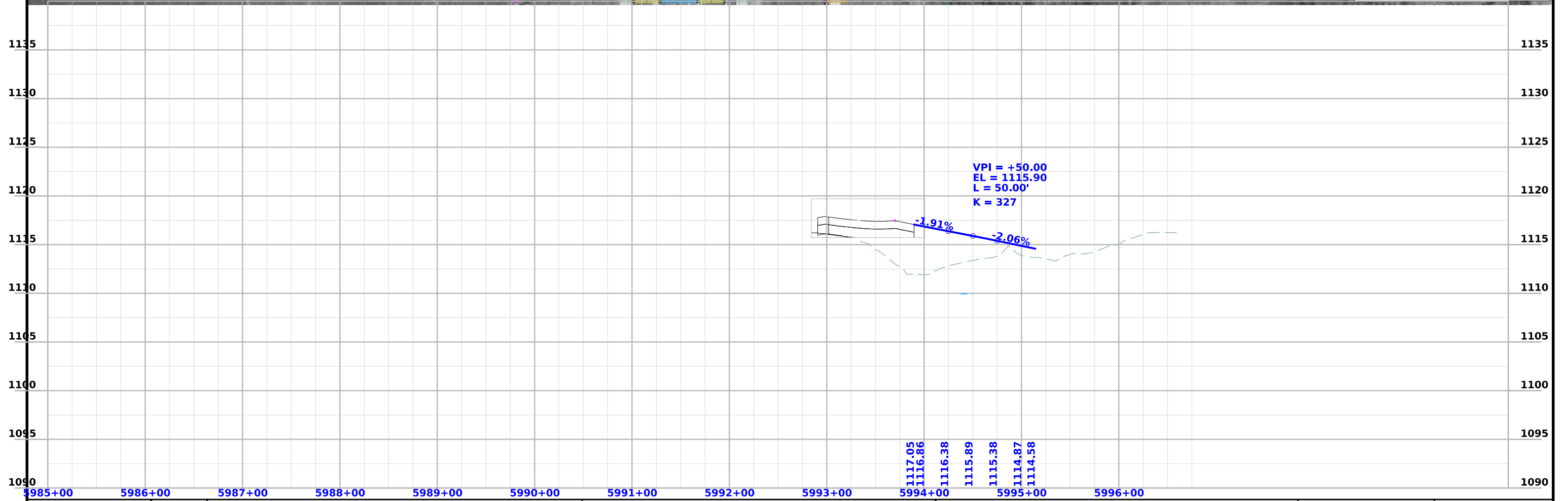

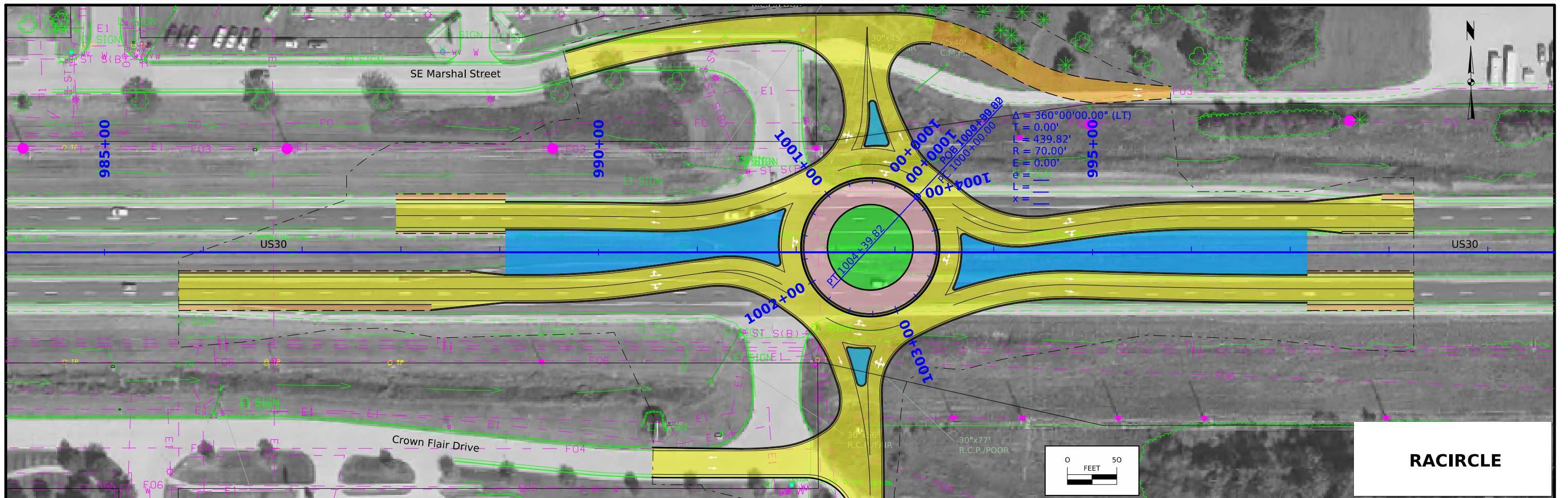

**RACIRCLE**

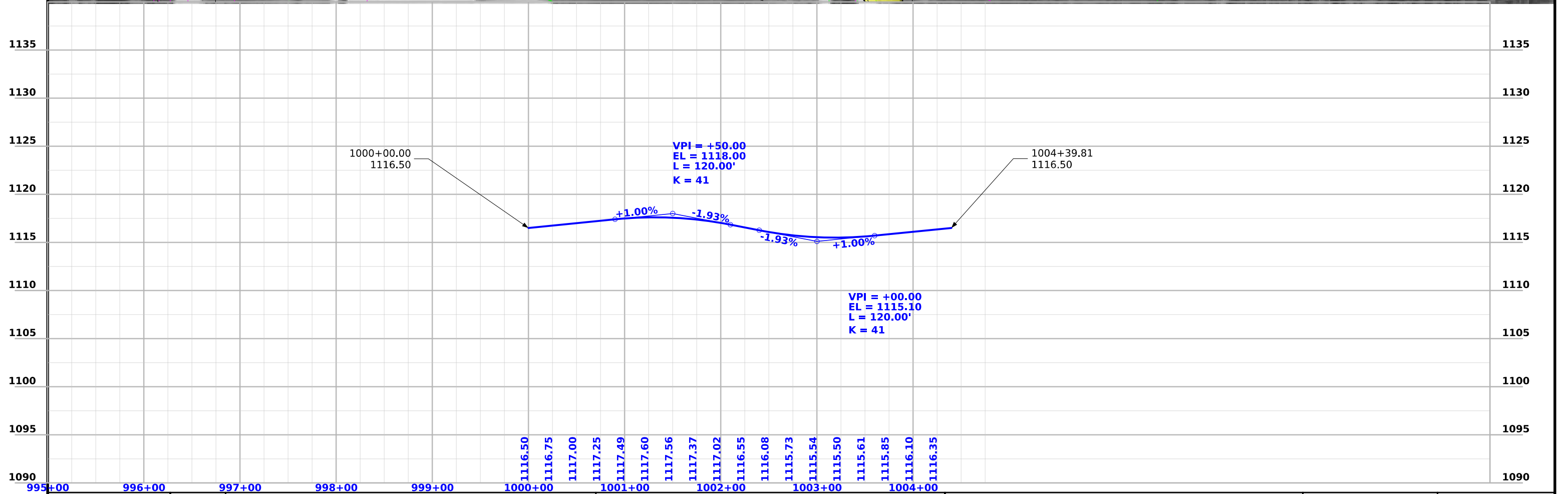
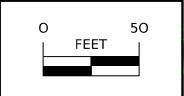

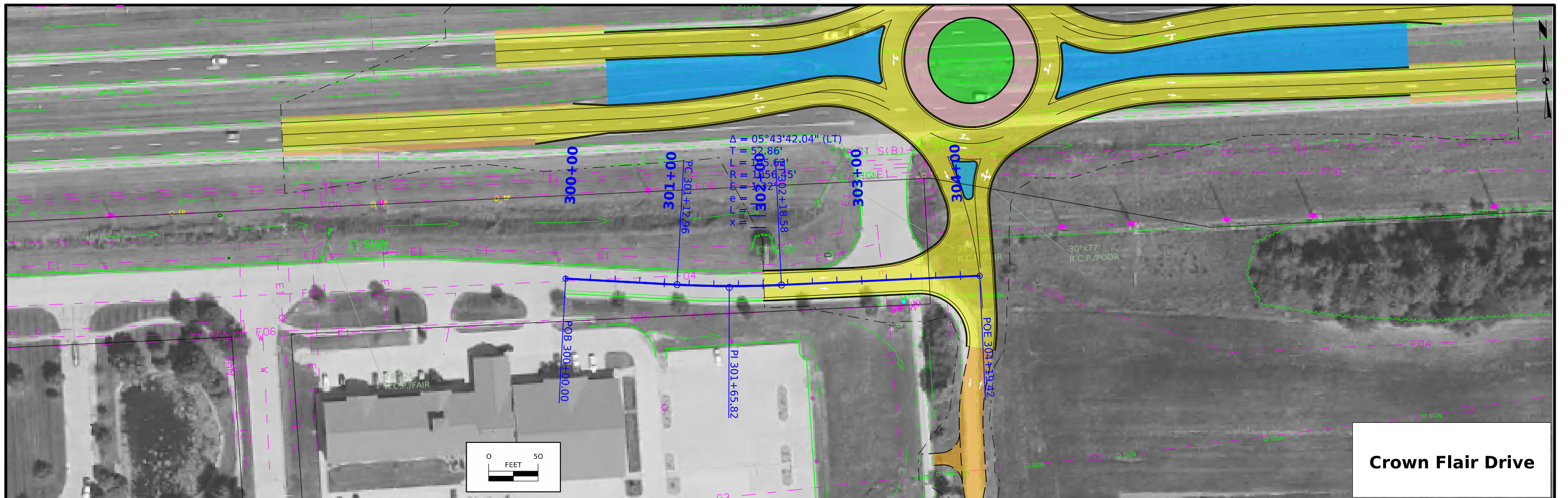

**Crown Flair Drive**

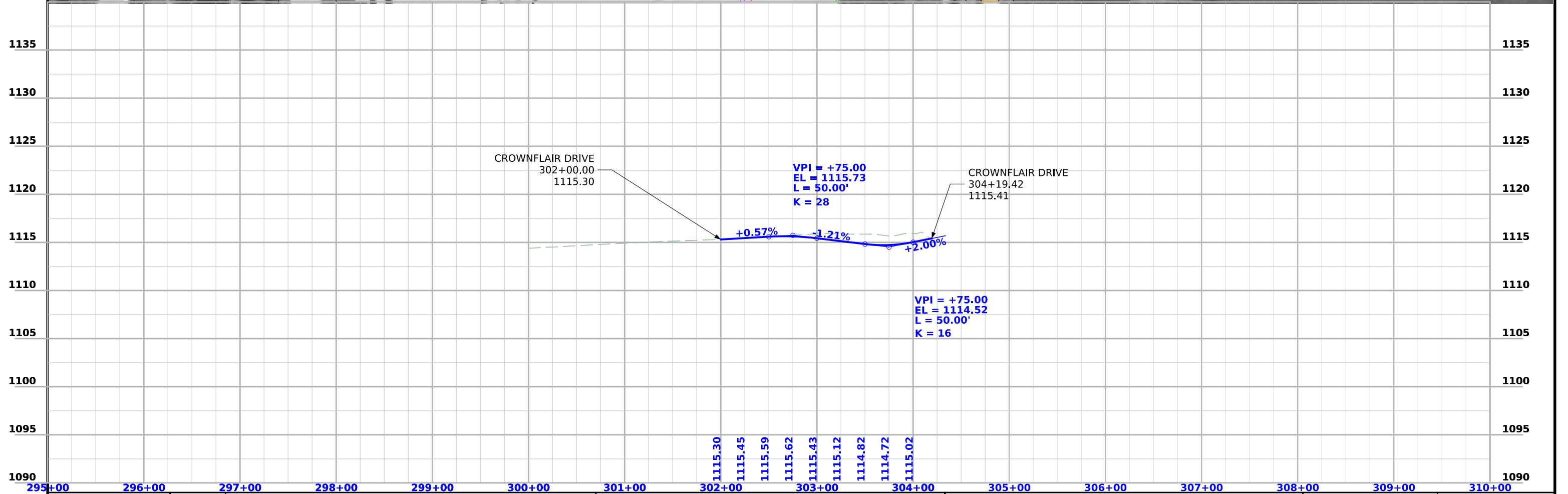

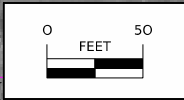
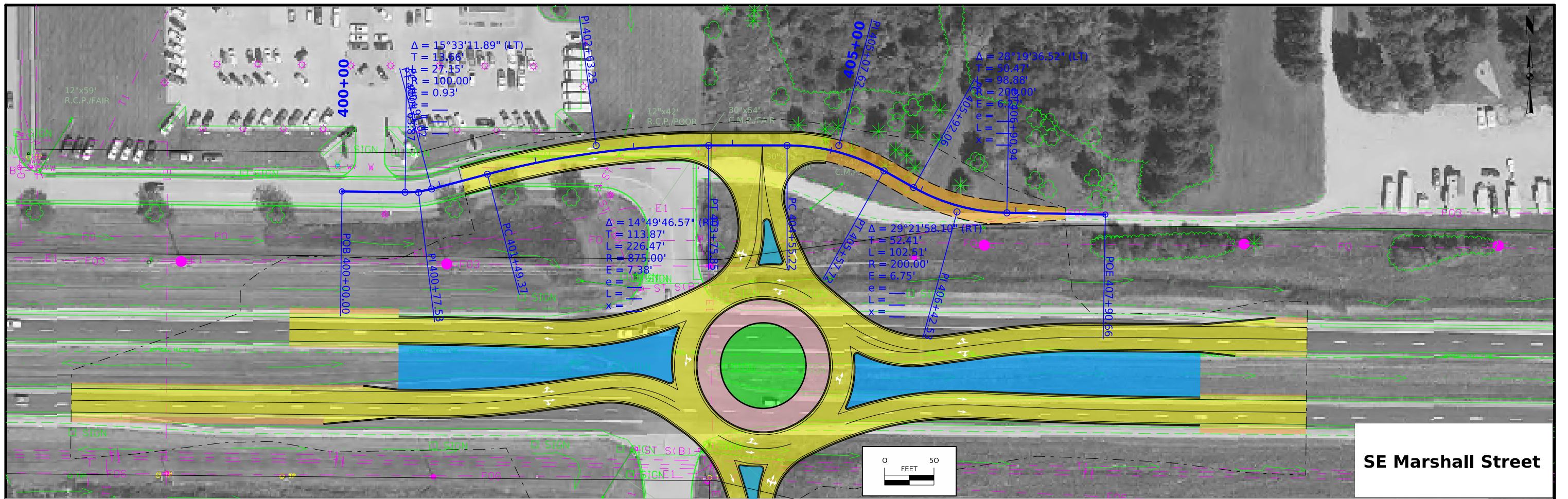

**SE Marshall Street**

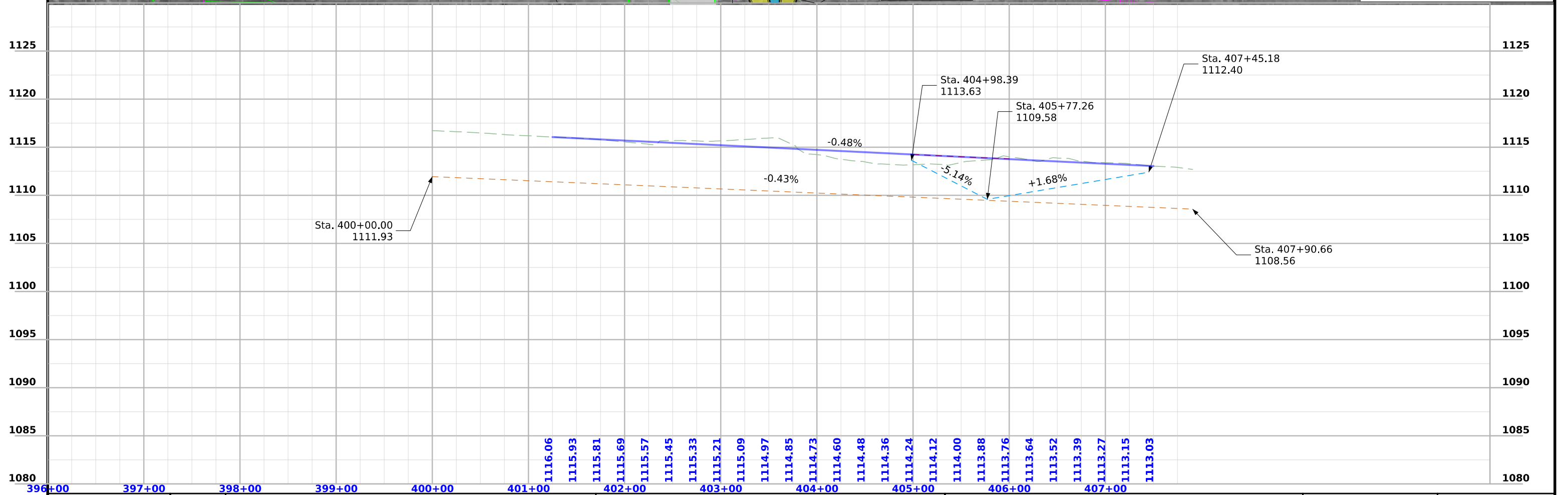

## Survey Information

### SURVEY INDEX

**County: Boone**

**PIN: 21-51-034-010**

**Project Number: NHSN-030-4(116)--2R-08**

**Location: US 30 from 0.2 miles E. of S. Story St. to Quill Ave.**

**Type of Work: Partial DTM Survey**

**Project Directory: 0803002024**

### Survey Personnel

Tom Hoyle – Lead Survey Technician  
Brad Duffy – Survey Technician  
Max Phillips - Survey Technician  
Dave Ciskowski – Survey Technician

### Date(s) of Survey

Begin Date                    03/28/2024  
End Date                      05/23/2024

### General Information

This survey is for US Hwy 30 from 0.2 mi E of South Story St. to Quill Ave. This survey includes portions of SE Marshall St. and Crown Flair Drive. This project is a Partial Field DTM, Project Control, Post Flight Photo control and SUE QLD.

### Utility Information

For logging data and other utility details see Utility Survey and Ownership Report in the Utility folder of the PrelimSurvey project directory.

### Project Control

Nearby Iowa Real Time Network reference stations were utilized to obtain horizontal and vertical control on primary project control points. Between three and five (300 epoch) five-minute observations were taken with a minimum two-hour time span between and used in a weighted average to obtain final coordinate values.

A double run level loop was run through control points 1-4. The RTN derived elevations of control points 1 - 4 were held fixed. The estimated standard error of the observed height differences from the network adjustment was 0.0157 ft/mile.

NGS mark GSVS 080 (DP4534), CP4 was tied it's record orthometric height of 1109.56 is 0.034' lower than the elevation derived by this survey of 1109.594. NGS mark GSVS 081 (DP4535) was leveled through its record orthometric height of 1113.48 is 0.011' lower than the elevation derived by this survey of 1113.491. NGS mark GSVS 082 (DP4536), CP1 was tied it's record orthometric height of 1139.78 is 0.028' lower than the elevation derived by this survey of 1139.808. Due to the proximity of NGS mark GSVS 081 (DP4535) to a tree it was not used as a primary control point on this project.

**PROJECT DATUM: NAD83(2011) for EPOCH 2010.00 (IaRTN 2019 ADJUSTMENT)**  
**COORDINATE SYSTEM: IOWA REGIONAL COORDINATE SYSTEM ZONE 8**  
**(U.S. SURVEY FOOT)**  
**VERTICAL DATUM: NAVD88**  
**GEOID MODEL: 2018**

### Alignment Information

No alignment requested.

## CONTROL POINT VICINITY MAP

This map is a guide to the vicinity of the primary project control points. Primary control is for use with RTK base stations and for RTN validation. Future surveys will use primary project control to establish temporary control as needed for construction or other surveying applications.

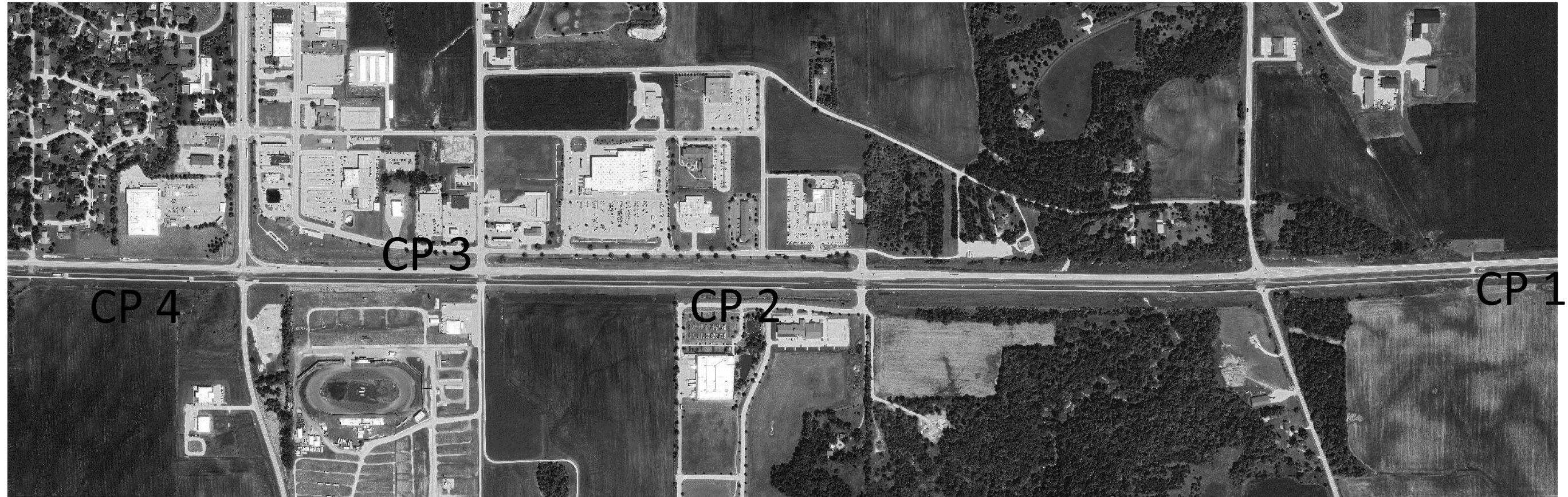

HORIZ. DATUM: NAD83(2011) for EPOCH 2010.00 (IaRTN 2019 Adjustment) - Iowa RCS Zone 08 (U.S. Survey Foot)

VERT. DATUM: NAVD88 - Geoid Model: 2018u3

Coordinate listing from next sheet will be used with IaRTN for monument recovery. No other reference ties are given.



**HORIZONTAL AND VERTICAL PROJECT CONTROL COORDINATE LISTING**  
**HORIZ. DATUM: NAD83(2011) for EPOCH 2010.00 (IaRTN 2019 Adjustment)**  
**1a. Regional Coordinate System Zone 08 (U.S. Survey Foot)**  
**VERT. DATUM: NAVD88**  
**Geoid Model: 2018u3**

Point Name	Northing	Easting	Elevation	Code-Description
CP1	7650237.6520	18464179.2860	1139.81	CP FOUND NGS STATION GSVS 082 0.27 MILES E OF QUILL AVE. 69.2' S OF THE CL OF US 30 EB LANES 140' E OF AN ELEC BOW WITH METER 69' W OF A PP 12' N OF A WITNESS POST.
CP2	7650126.9530	18458761.6880	1113.21	FENO SET FENO MONUMENT FLUSH WITH GOUND SURFACE 0.6 MILES EAST SOUTH STORY ST. 120' SOUTH OF THE CL OF THE US 30 EB LANES 78.7' SE OF A PP 36.5' E OF A LIGHT POLE 7.2' N OF CROWN FLAIR DR BACK OF CURB.
CP3	7650481.0610	18456632.8400	1109.03	FENO SET FENO MONUMENT FLUSH WITH GROUND SURFACE 0.2 MILES EAST SOUTH STORY ST. 139' NORTH OF THE CL OF THE US 30 WB LANES 161.3' NW OF A PP 33.2' S OF A MH LID ON AN INLET 28.6' S OF SE MARSHALL ST. BACK OF CURB.
CP4	7650241.0810	18454626.3000	1109.59	CP FOUND NGS STATION GSVS 080 0.2 MILES WEST SOUTH STORY ST. 62.6' S OF THE CL OF US 30 EB LANES 73' WNW OF A PP 46.4' SE OF MP 133.70 10' N OF A WITNESS POST.



**ALIGNMENT COORDINATES**

Line No.	Name	Location	Poin on Tangent Station	Point on Tangent Y Northing	Point on Tangent X Easting	Begin Spiral Station	Begin Spiral Y Northing	Begin Spiral X Easting	Begin Curve Station	Begin Curve Y Northing	Begin Curve X Easting	Simple Curve PI or Master PI Station	Simple Curve PI or Master PI Y Northing	Simple Curve PI or Master PI X Easting	End Curve Station	End Curve Y Northing	End Curve X Easting	End Spiral Station	End Spiral Y Northing	End Spiral X Easting
7.0	ML30							101074.912	76502+53.63	18461869.93	101400	76502+50.44	18462195	101724.912	76502+65.75	18462519.73				
8.0	ML30	105805.433	76504+57.87	18466595.73																
8.0	SE Marshall							40592.06	76504+56.67	18460222.21	40642.532	76504+31.91	18460266.2	40690.939	76504+31.00	18460316.66				
9.0	SE Marshall Street	40790.66	76504+29.19	18460416.37																

**SPIRAL OR CIRCULAR CURVE DATA**

Line No.	Name	Location	SCS	S	Ls	Ts	Es	Xc	Yc	L.T.	S.T.	C	T	L	R	E	Remarks
	C1	ML30										1.186	308.811	617.6	29824.175	1.599	
	C2	ML30										2.039	300.092	600.12	16864.182	2.67	
	C3	ML30										0.848	305.881	611.75	41333.989	1.132	
	C4	ML30										3.261	325.088	650	11421.359	4.626	
	C1	ML30EB_1										7.898	52.811	105.455	765	1.821	
	C2	ML30EB_1										52.806	56.846	105.527	114.5	13.335	
	C1	ML30WB_1										1.354	76.796	153.585	6500	0.454	
	C2	ML30WB_1										22.563	65.132	128.576	326.5	6.433	
	C1	ML30EB_2										20.465	63.452	125.552	351.5	5.681	
	C2	ML30EB_2										2.017	114.438	228.853	6500	1.007	
	C1	ML30WB_2										58.969	64.739	117.843	114.5	17.035	
	C2	ML30WB_2										7.853	52.509	104.853	765	1.8	
	C1	SR30										15.234	26.746	53.177	200	1.78	
	C2	SR30										14.912	26.175	52.054	200	1.706	
	C1	SR30NB_1										56.788	54.057	99.114	100	13.675	
	C1	SR30SB_1										15.234	26.746	53.177	200	1.78	
	C2	SR30SB_1										14.912	26.175	52.054	200	1.706	
	C3	SR30SB_1										19.558	78.421	155.317	455	6.709	
	C4	SR30SB_1										14.642	33.404	66.444	260	2.137	
	C1	SR30NB_2										16.042	42.274	83.995	300	2.964	
	C2	SR30NB_2										19.465	51.455	101.918	300	4.381	
	C1	SR30SB_2										52.913	49.763	92.35	100	11.698	
	C1	RETA										46.297	47.029	88.883	110	9.631	
	C2	RETA										25.677	17.092	33.611	75	1.923	
	C1	RETC										43.083	39.475	75.194	100	7.509	
	C2	RETC										35.052	33.159	64.236	105	5.111	
	C1	RETD										64.362	37.756	67.399	60	10.891	
	C2	RETD										29.429	85.349	166.928	325	11.02	
	C1	CrownFlair Drive										5.728	52.855	105.622	1056.449	1.321	
	C1	RETC_Crown										100.447	55.858	81.521	46.5	26.18	
	C1	SE Marshall										15.553	13.657	27.146	100	0.928	
	C2	SE Marshall										14.83	113.873	226.472	875	7.379	
	C3	SE Marshall										29.366	52.406	102.507	200	6.752	
	C4	SE Marshall										28.327	50.472	98.879	200	6.27	

108\_23A  
8/15/22

### TRAFFIC CONTROL PLAN

Maintain a single lane of traffic on US-30 for the duration of the project.  
Some movements between Marshall Street, Crown Flair Drive, and US-30 will be restricted during construction.  
Maintain access for all property owners adjacent to the project at all times.

**511 TRAVEL RESTRICTIONS**

Line No.	Route	Direction	County	Location Description	Feature Crossed	Object Type	Maint. Bridge No. or Structure ID or FHWA No.	Type of Restriction	Existing Measurement	Construction Measurement	Construction Measurement as Signed	Projected As Built Measurement	Remarks
1.0	US 30	Both	Boone	Intersection of US30 and Marshall / Crown Fair Dr.		Traffic Control Device		Horizontal					

108\_26A  
8/15/22

### STAGING NOTES

Staging Notes in progress.

111\_01  
10/14/22

### COORDINATED OPERATIONS

Other work in progress during the same period of time will include the construction of the projects listed. Coordinate operations with those of other contractors working within the same area.

Project	Type of Work
NHSX-030-4(119)--3H-08	PCC Pavement - Grade and New





985+00

POT STA 987+95.00 25.0' LT(ML30)  
= POT STA 3987+95.00 00.0' LT(ML30WB\_1)

ML30WB\_1

ML30

ML30EB\_1

POT STA 985+75.00 25.0' RT(ML30)  
= POT STA 2985+75.00 00.0' RT(ML30EB\_1)

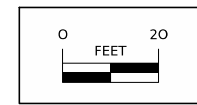

**Geometric Details**

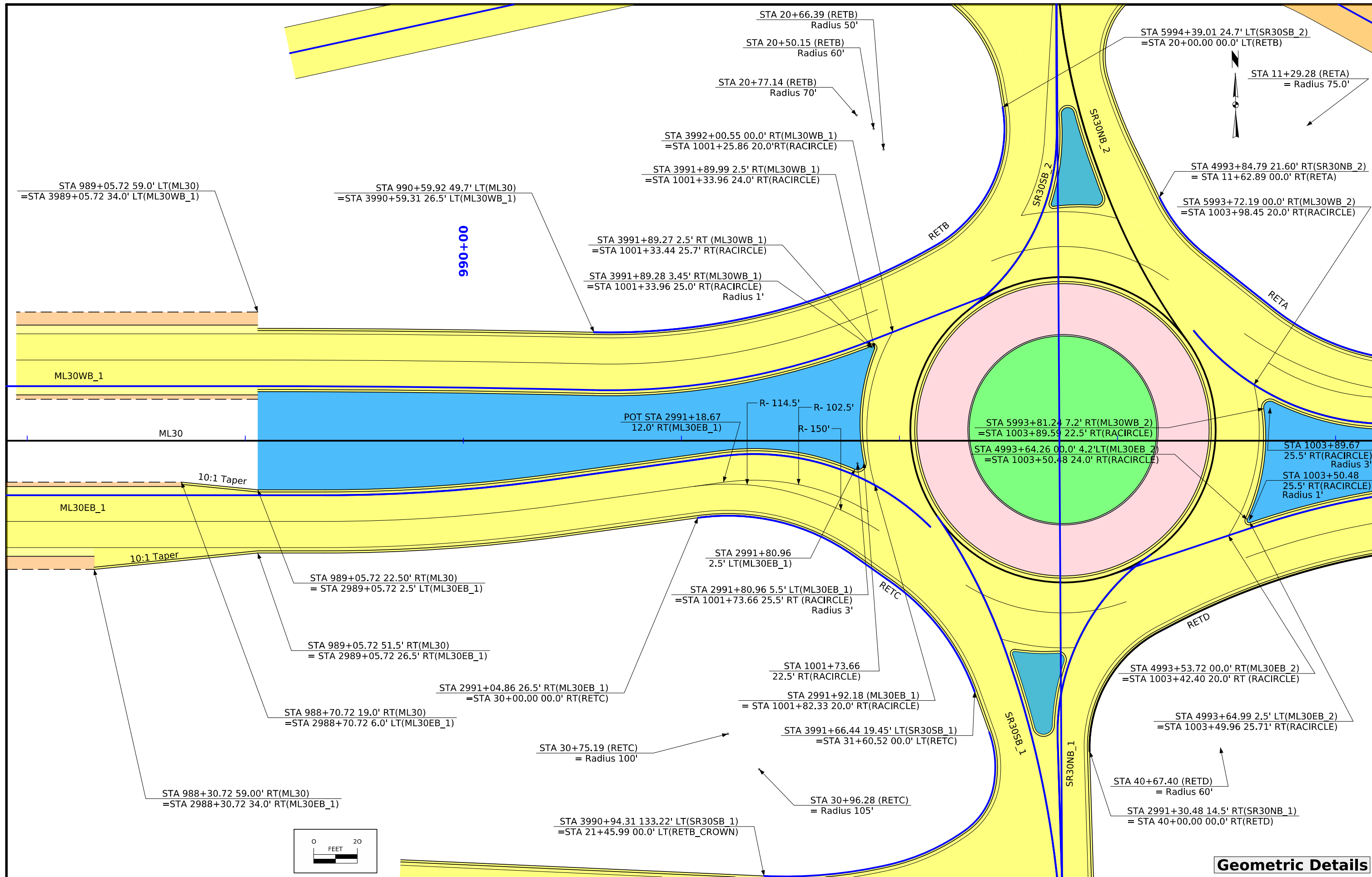

**Geometric Details**

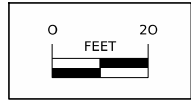
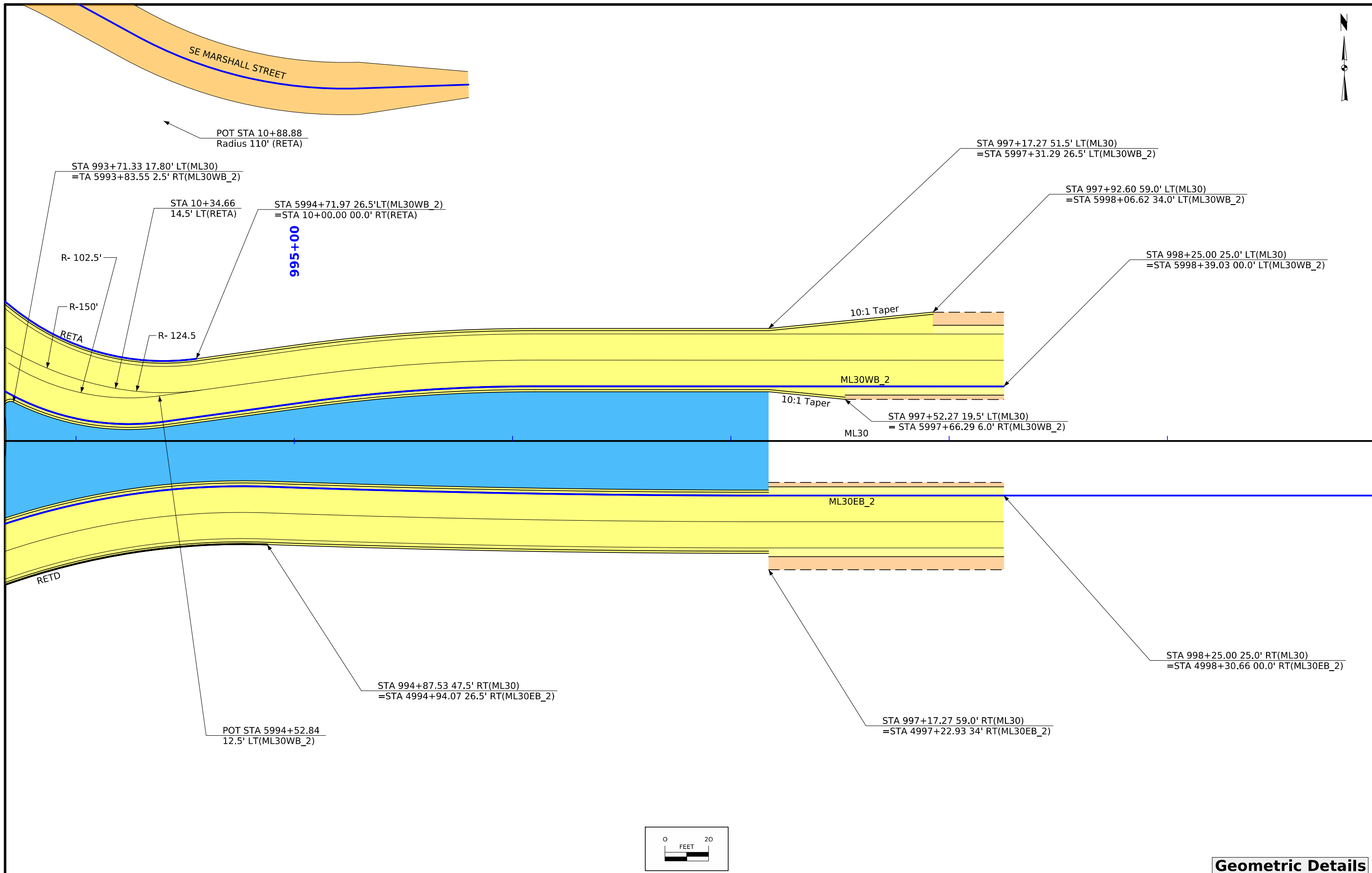

**Geometric Details**

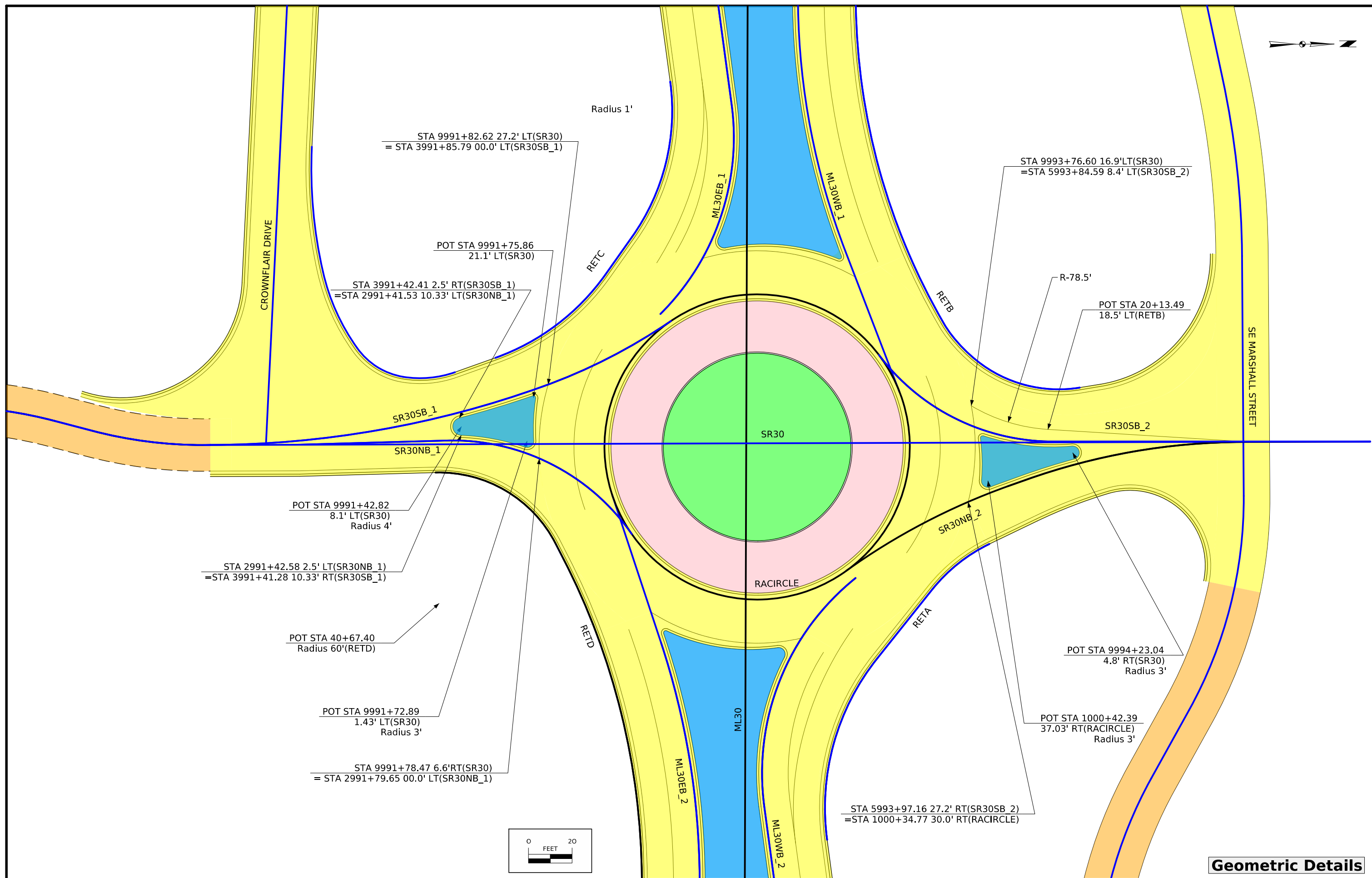
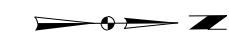

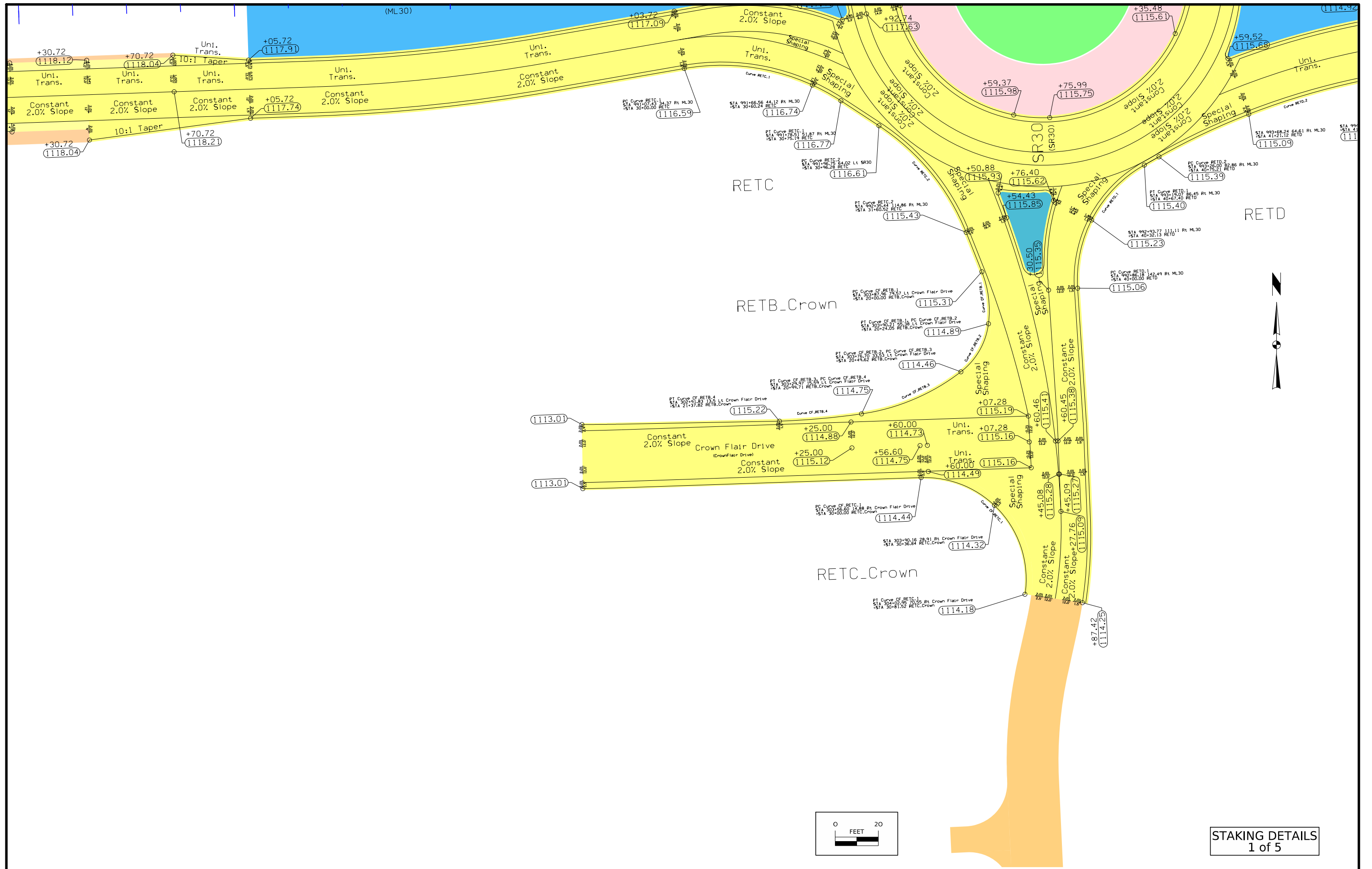

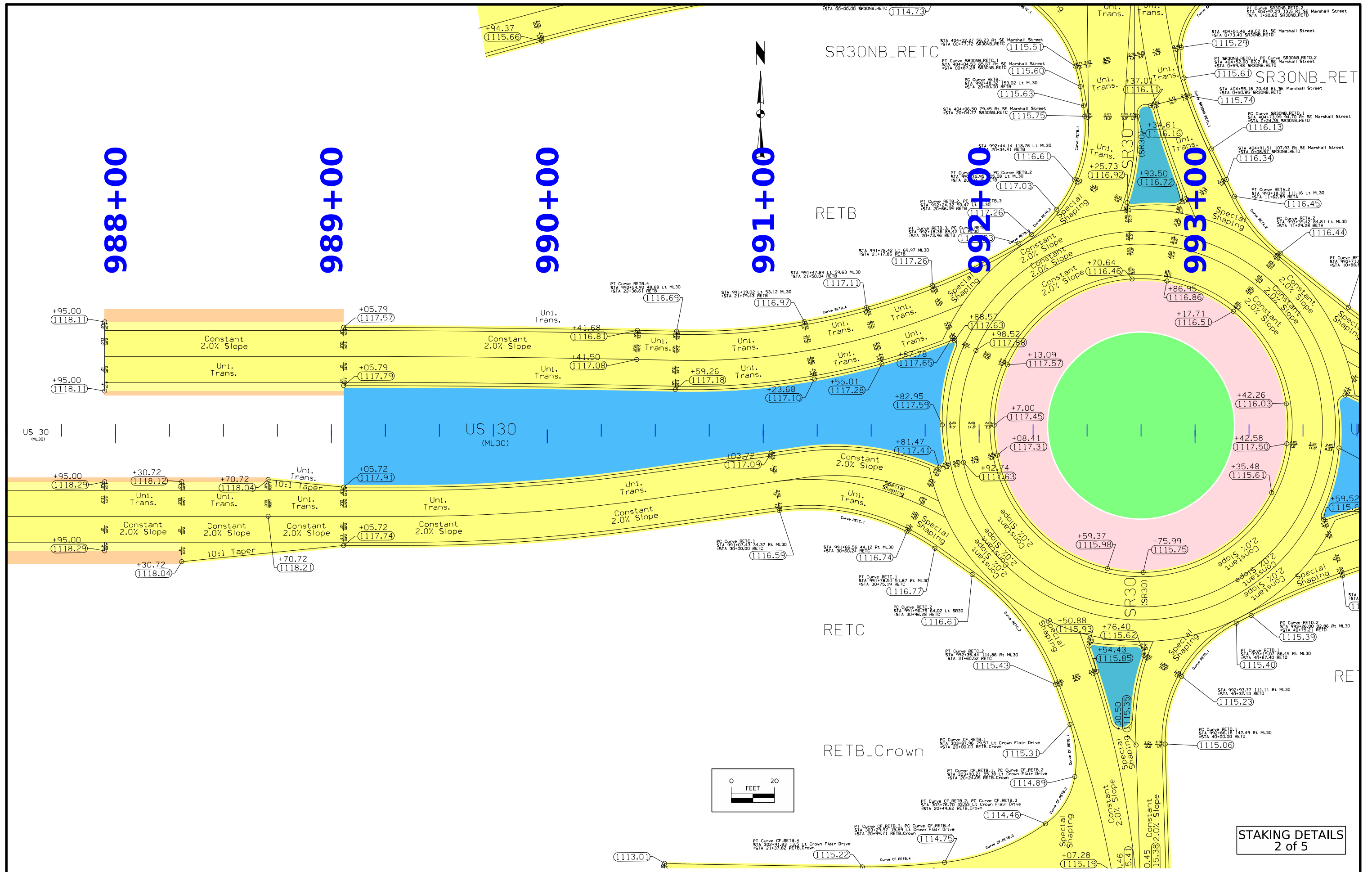

STAKING DETAILS  
2 of 5

FILE NO.	ENGLISH	DESIGN TEAM RhoadsTamrakarPrindle	BOONE COUNTY	PROJECT NUMBER HSIPX-030-4(113)--3L-08	SHEET NUMBER L.6
----------	---------	-----------------------------------	--------------	--	------------------

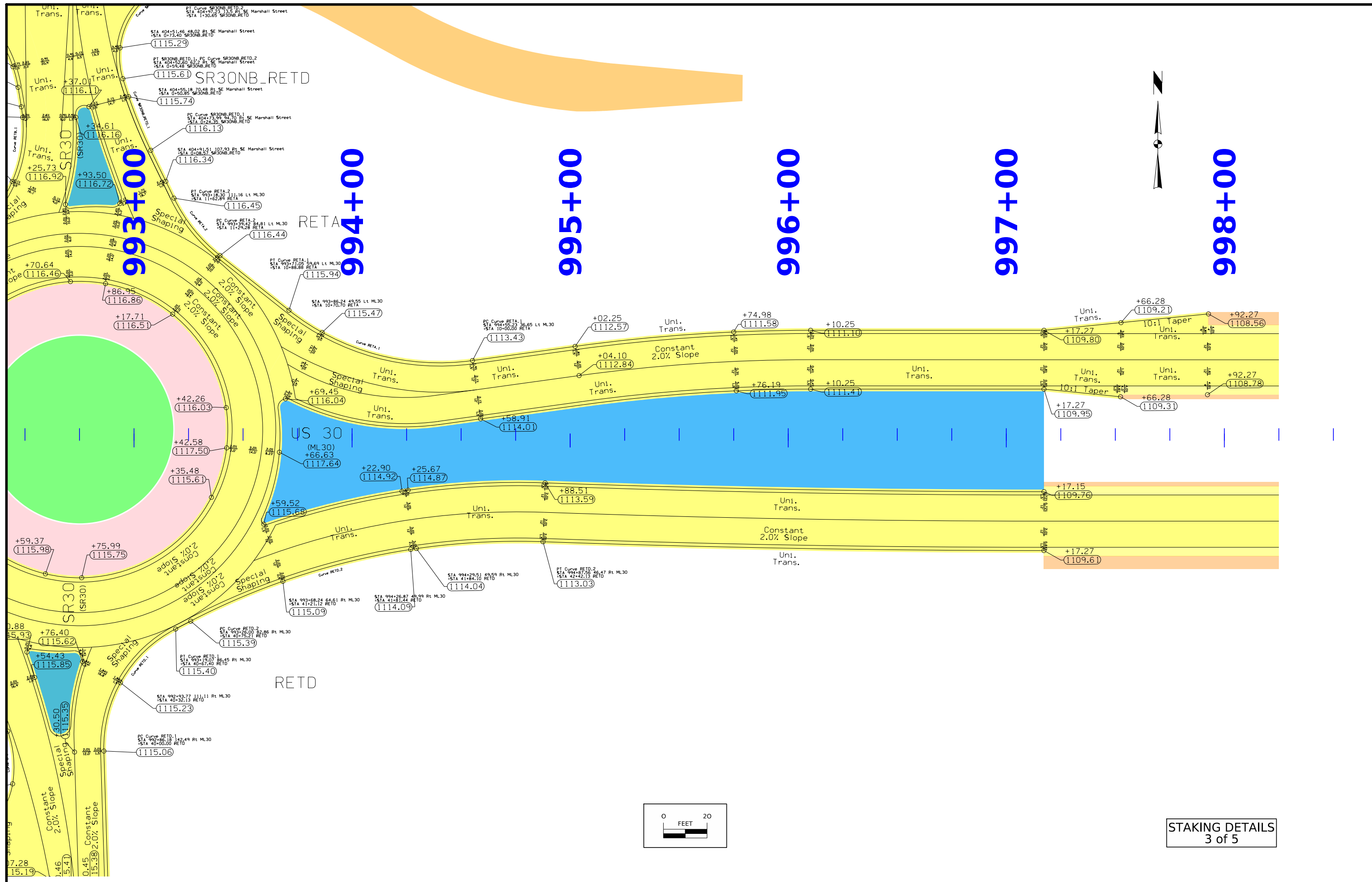

STAKING DETAILS  
3 of 5

FILE NO.	ENGLISH	DESIGN TEAM RhoadsTamrakar\Prindle	BOONE COUNTY	PROJECT NUMBER HSIPX-030-4(113)--3L-08	SHEET NUMBER L.7
----------	---------	------------------------------------	--------------	--	------------------

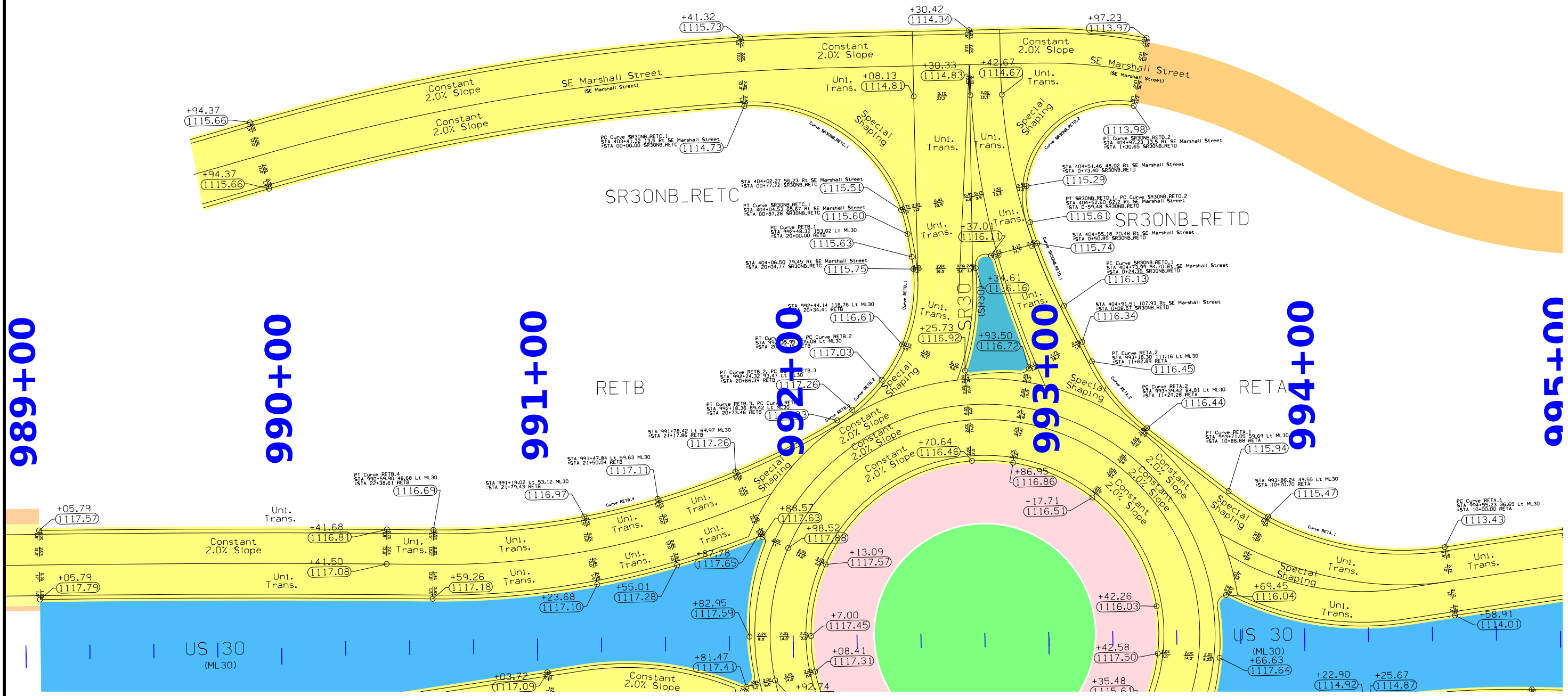
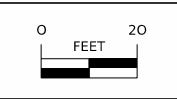



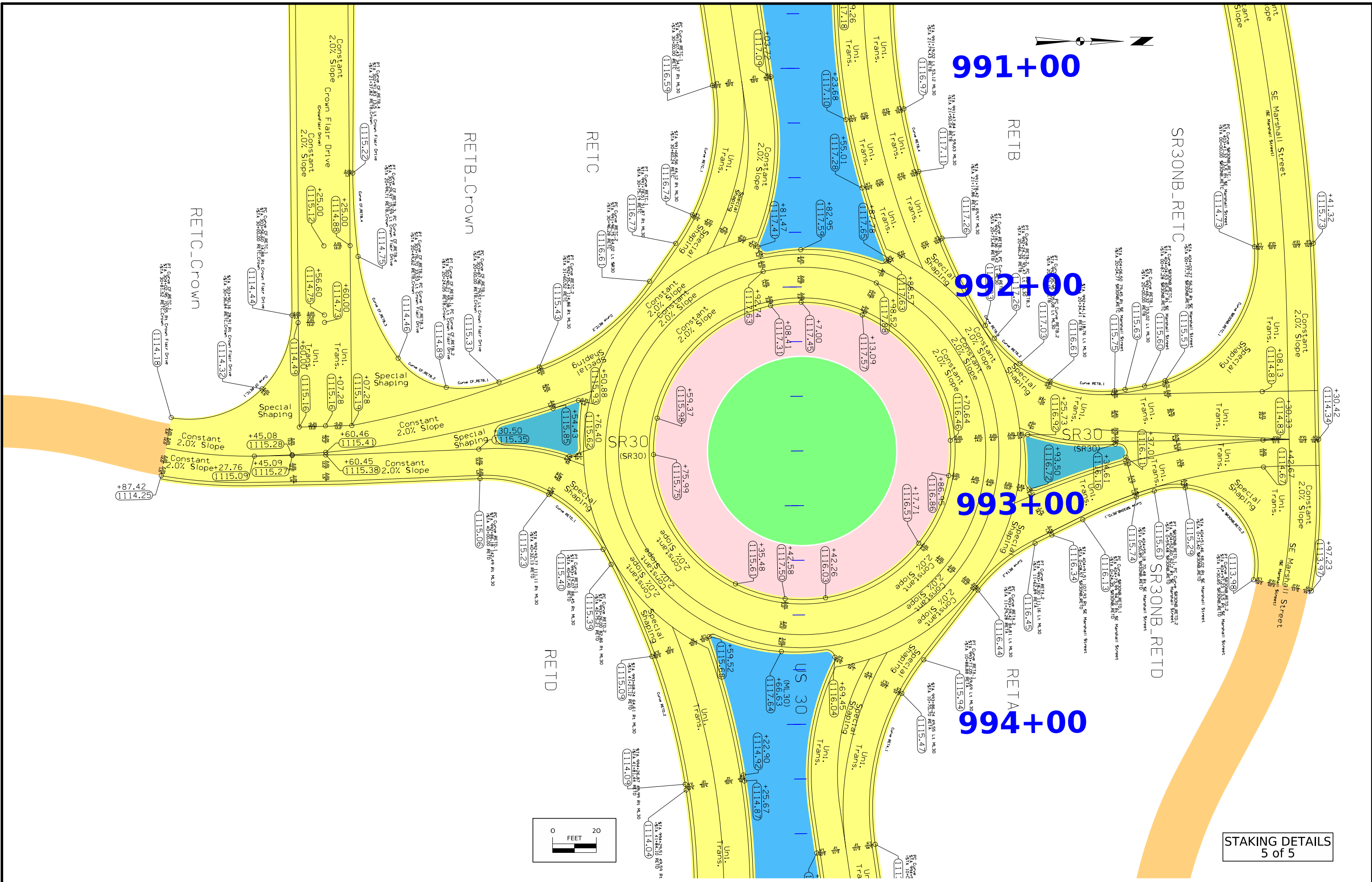

FILE NO.	ENGLISH	DESIGN TEAM RhoadsTamraka\Prindle	BOONE COUNTY	PROJECT NUMBER HSIPX-030-4(113)--3L-08	SHEET NUMBER L.9
----------	---------	-----------------------------------	--------------	--	------------------

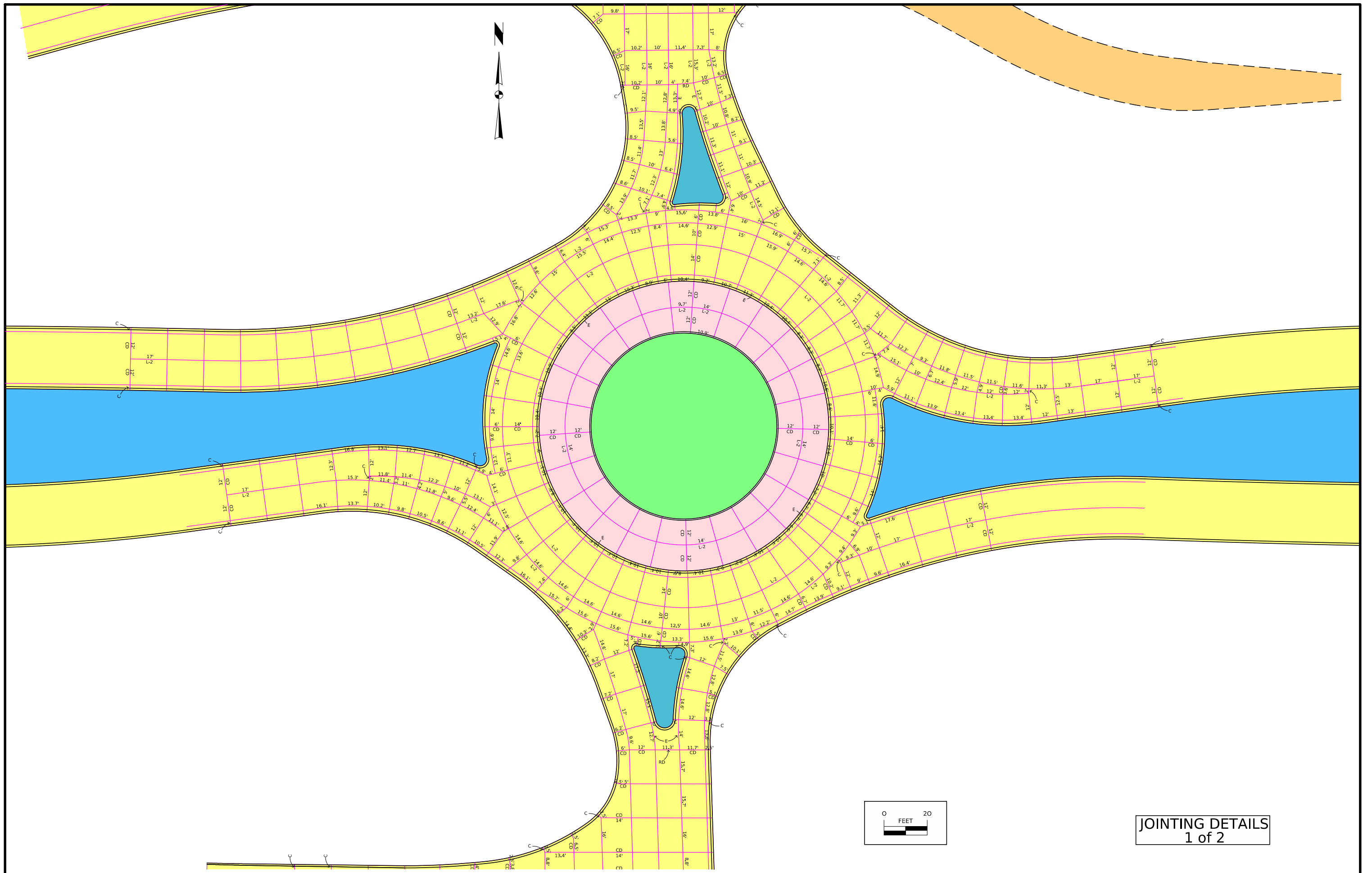

JOINTING DETAILS  
1 of 2

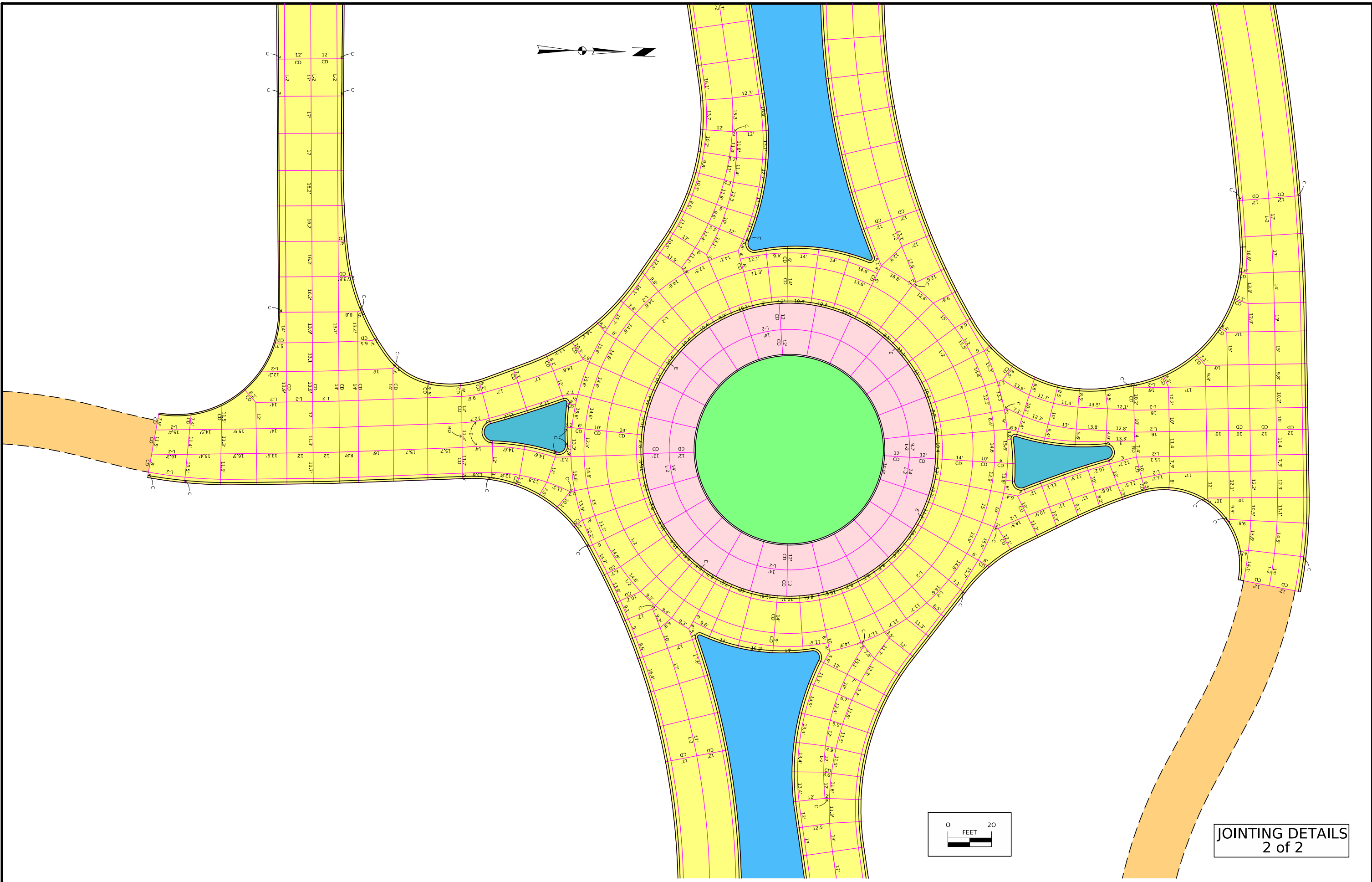
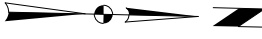

JOINTING DETAILS  
2 of 2

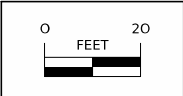

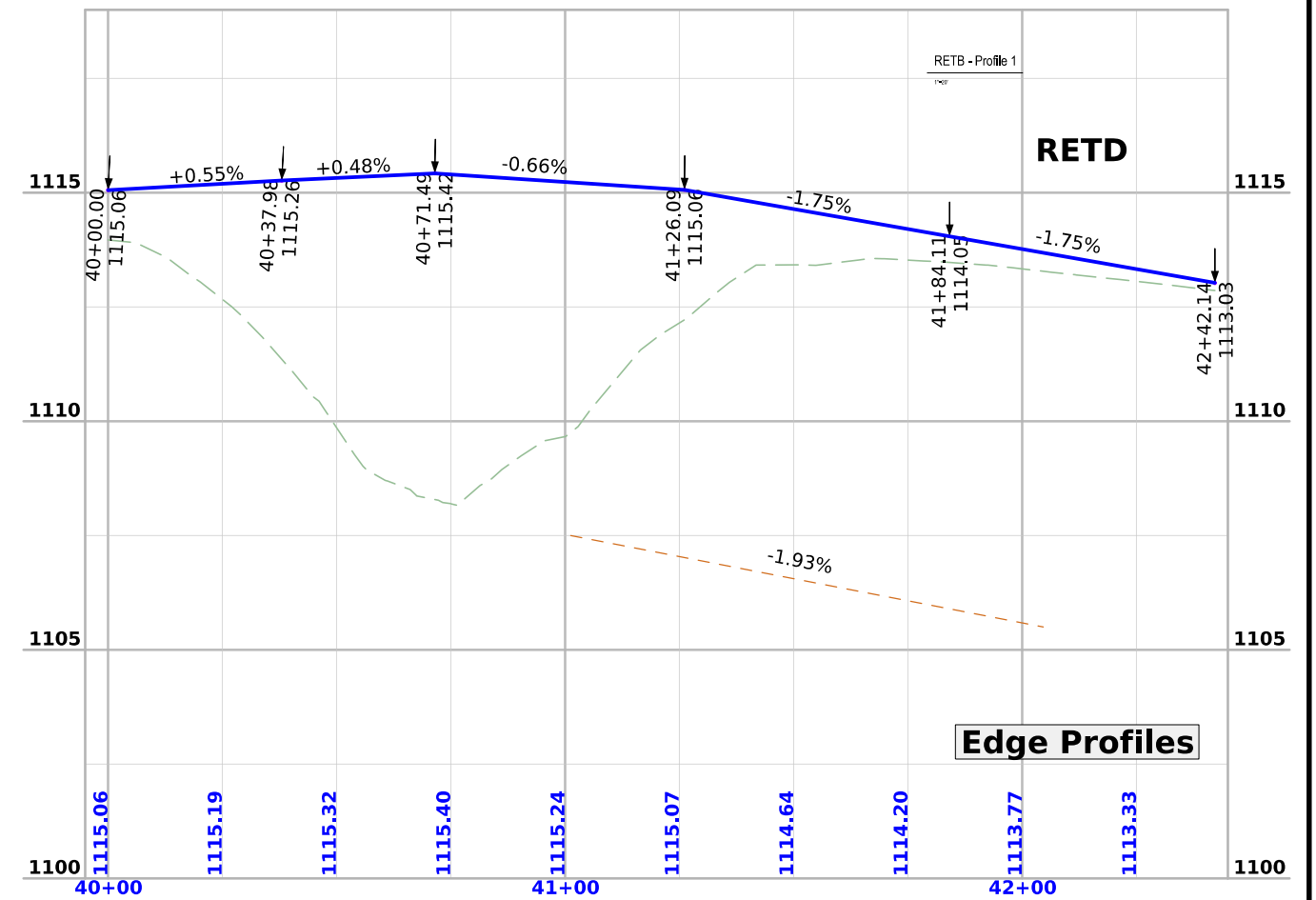
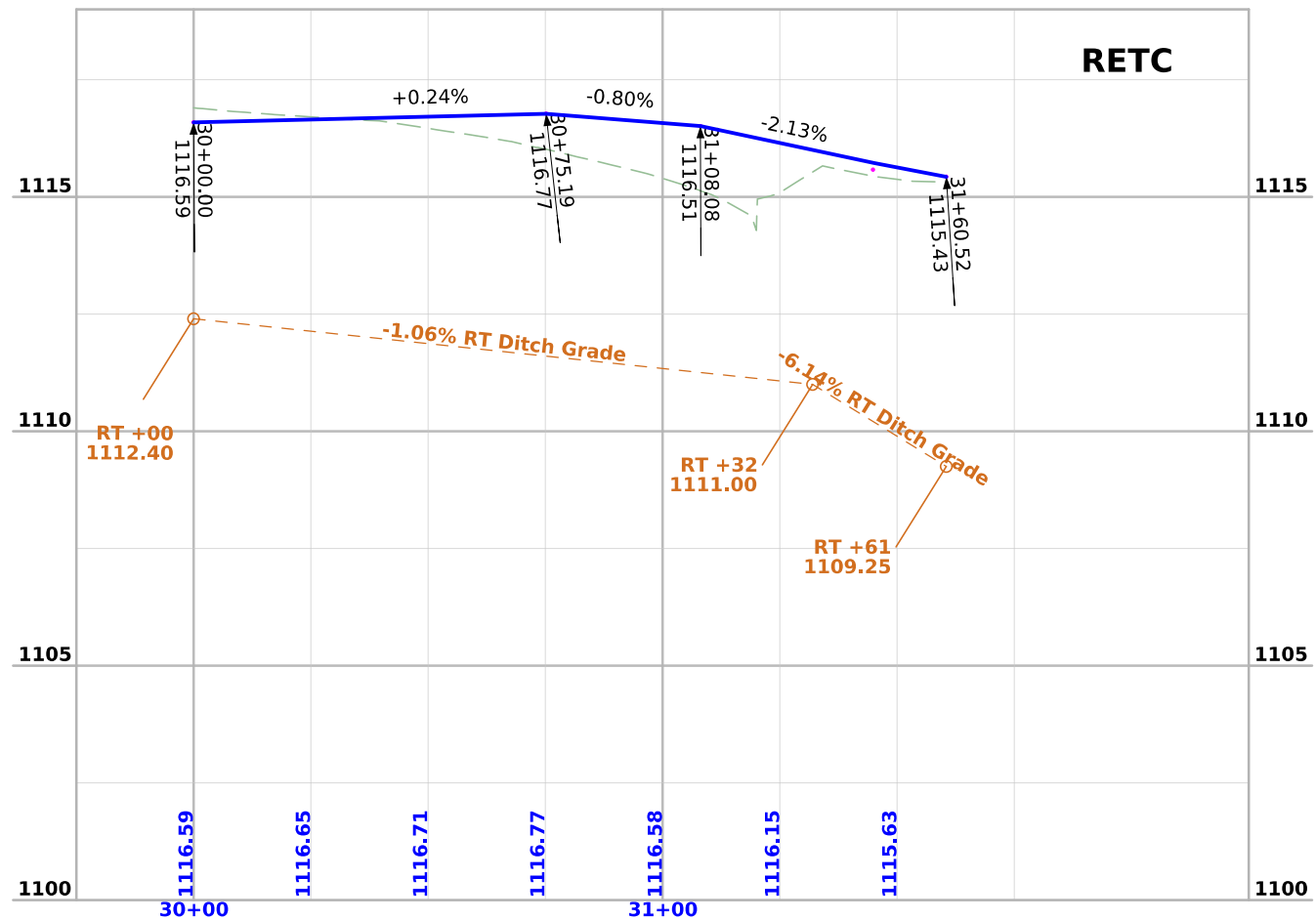
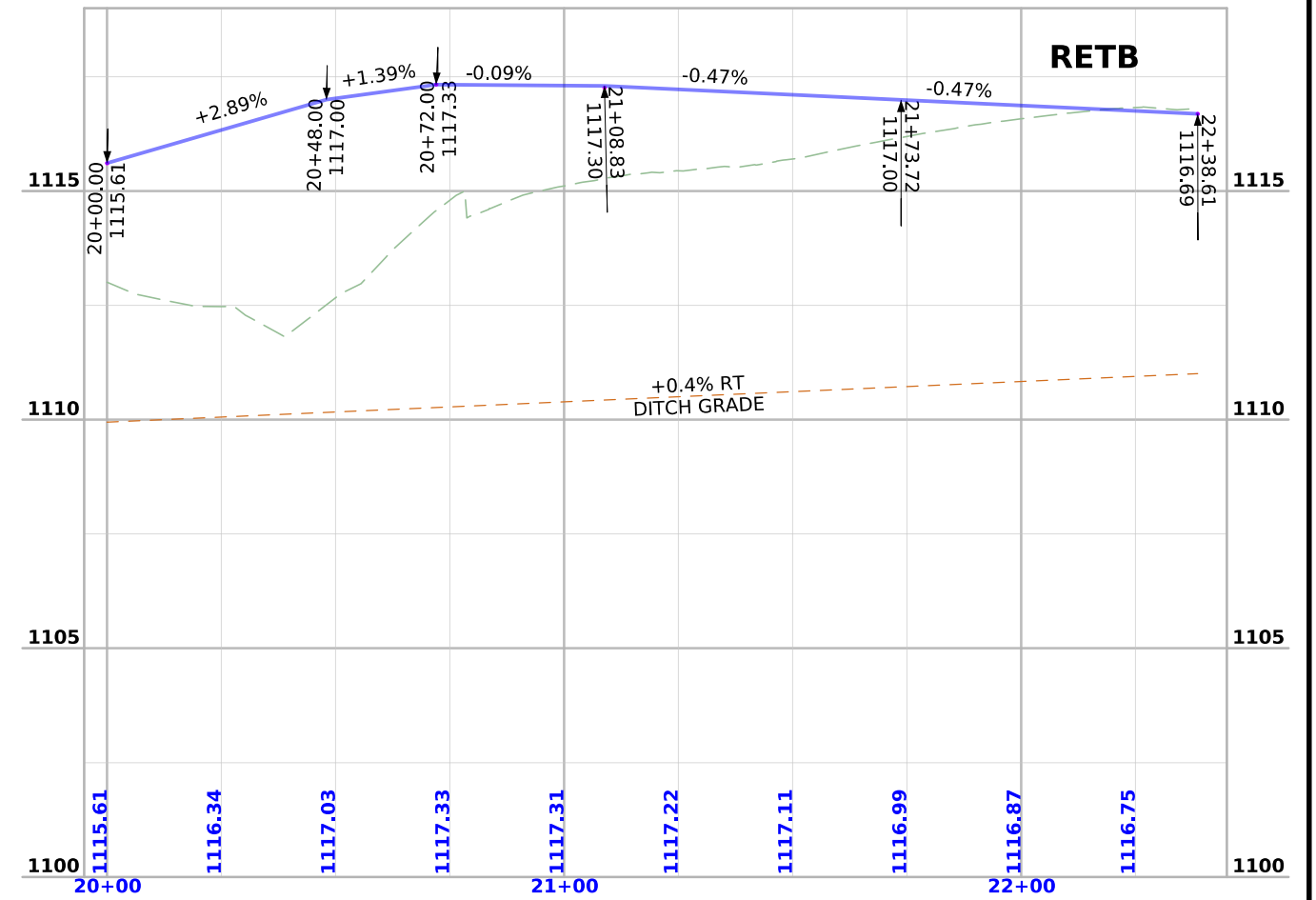
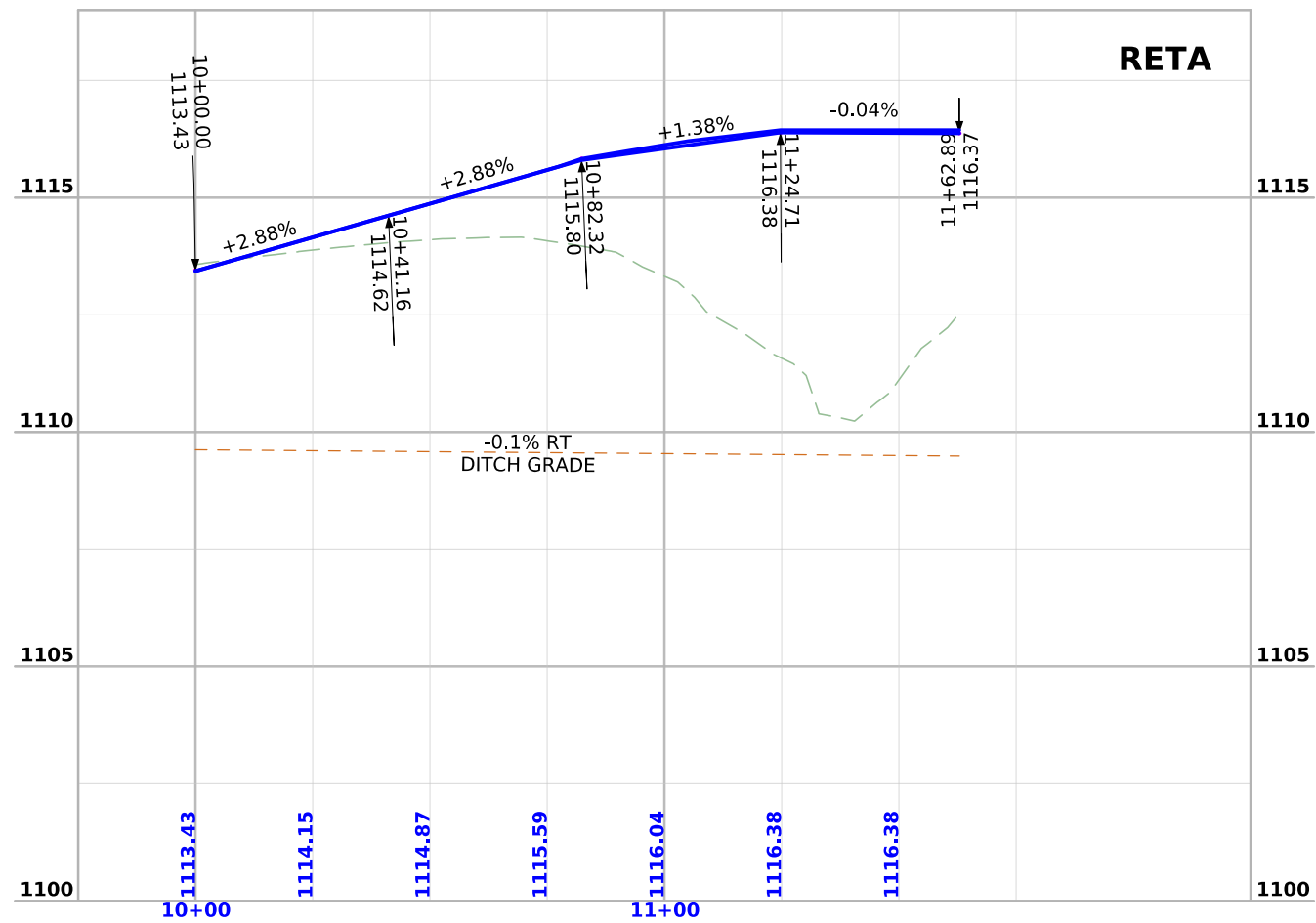

Edge Profiles

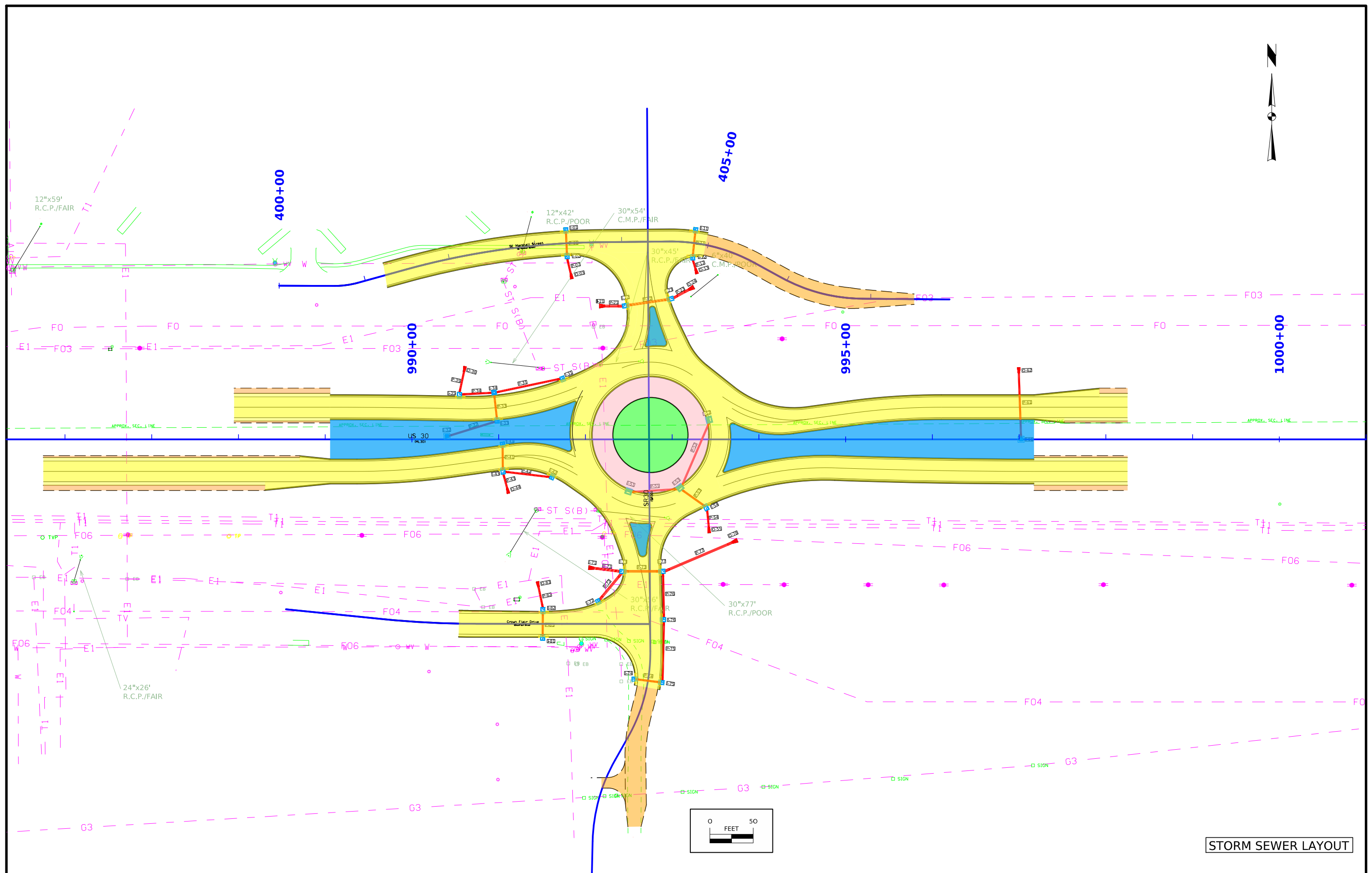

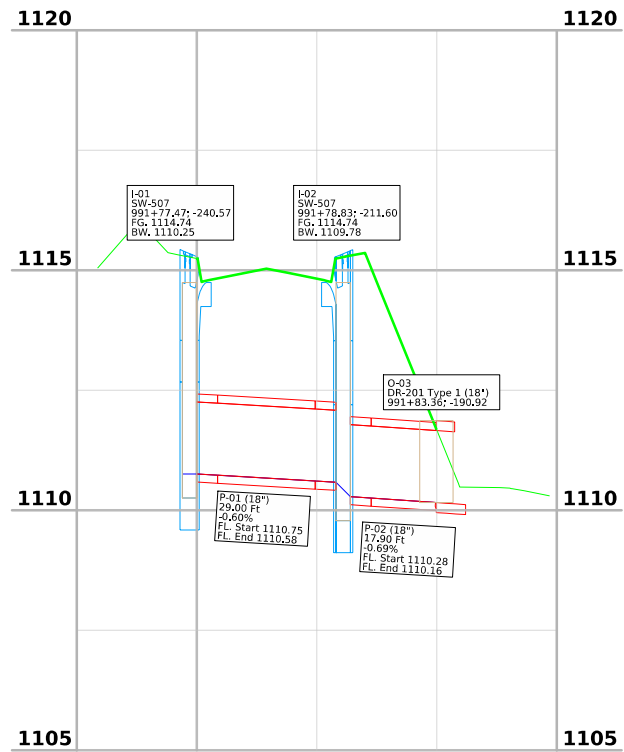

I-01 to O-03 - Profile

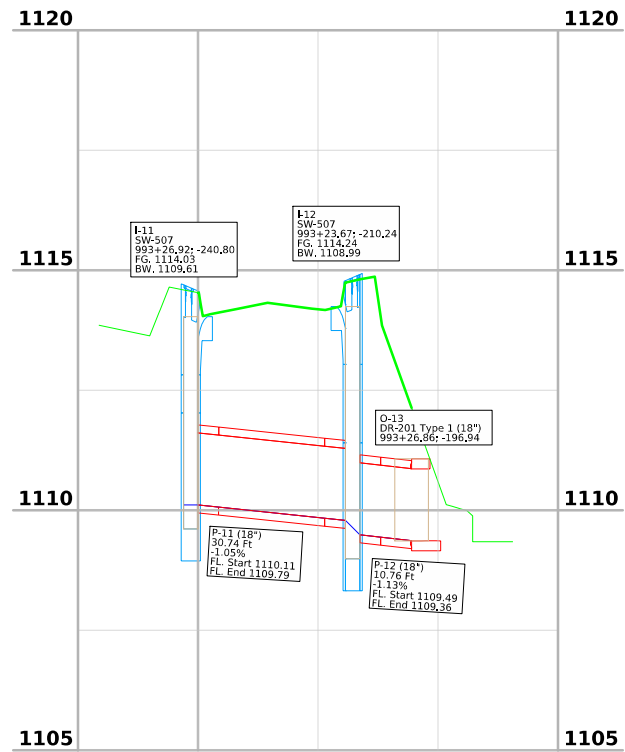

I-11 to O-13 - Profile

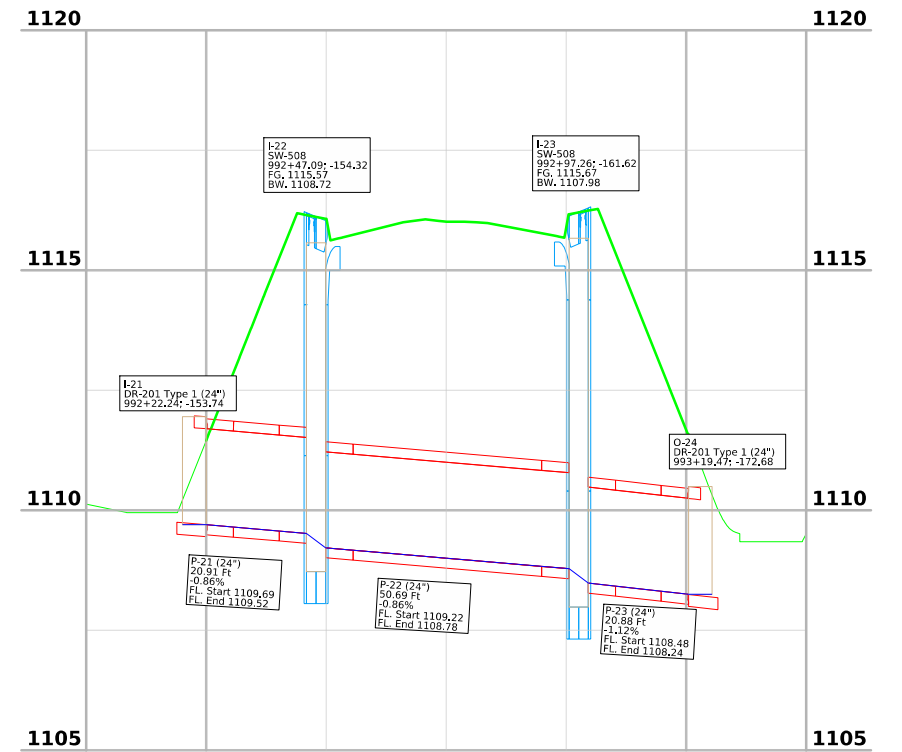

I-21 to O-24 - Profile

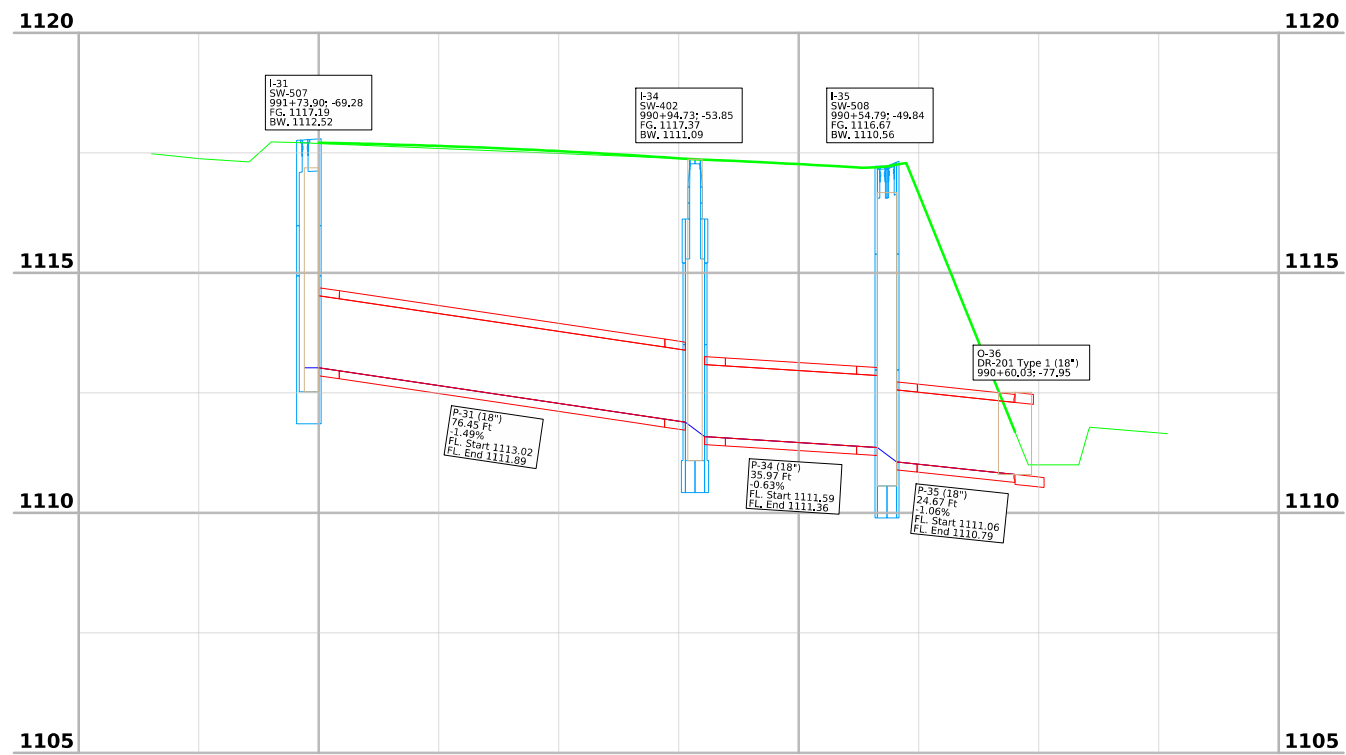

I-31 to O-36 - Profile

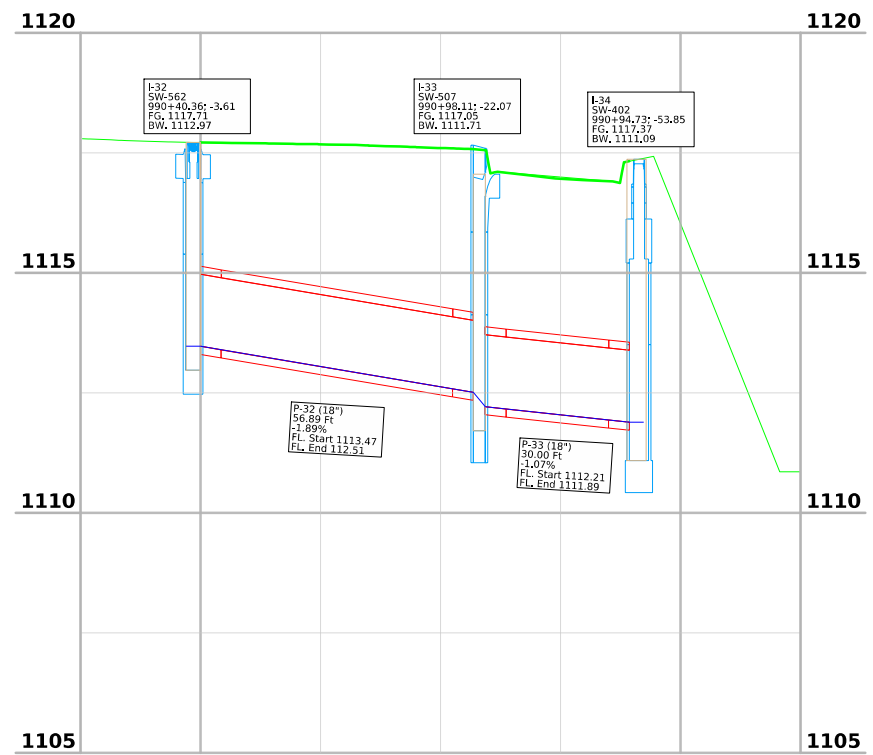

I-32 to I-34 - Profile

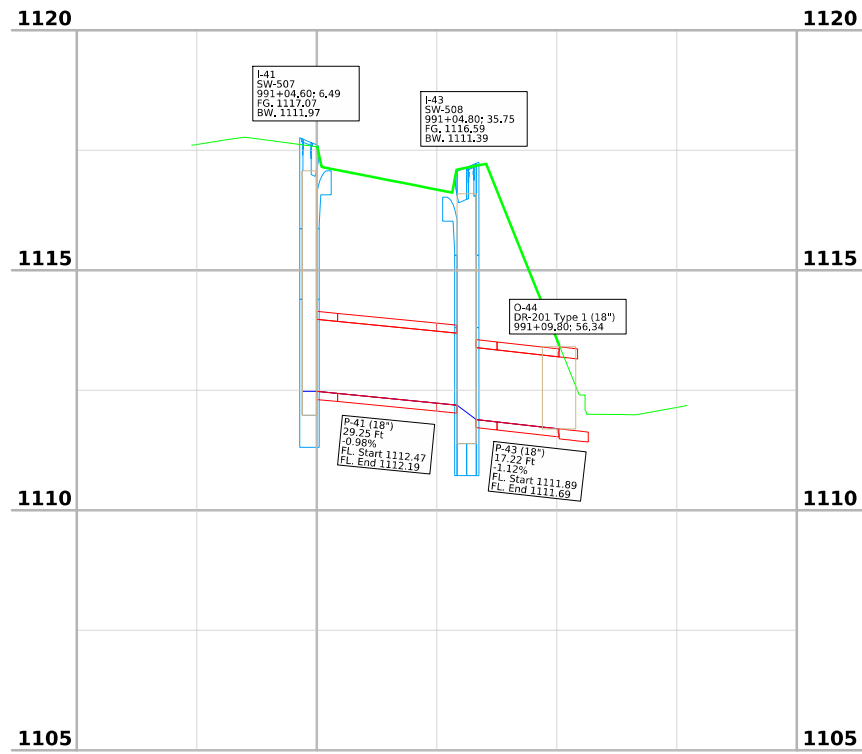

I-41 to O-44 - Profile

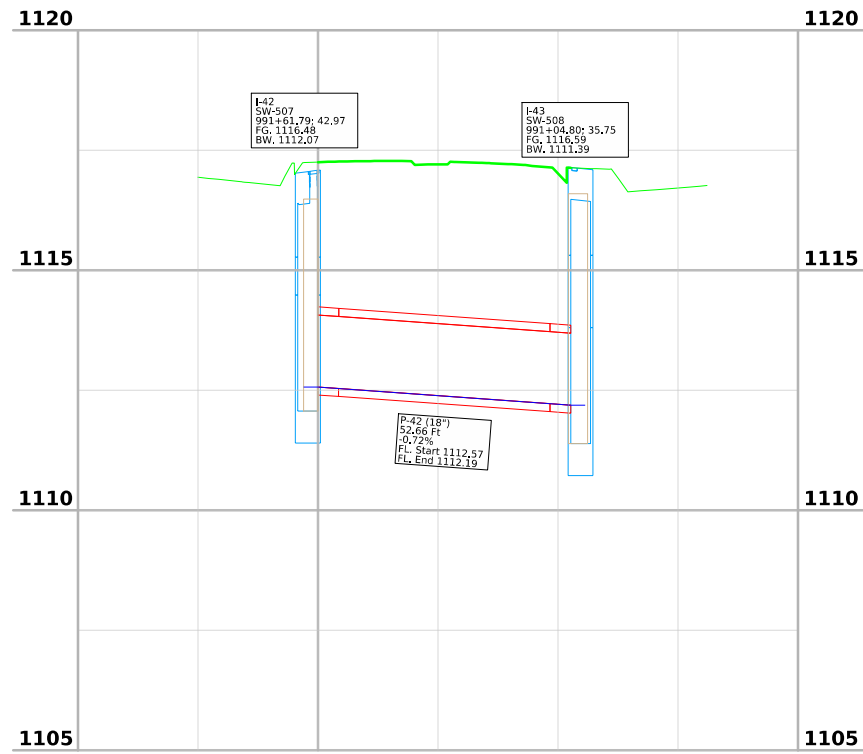

I-42 to I-44 - Profile

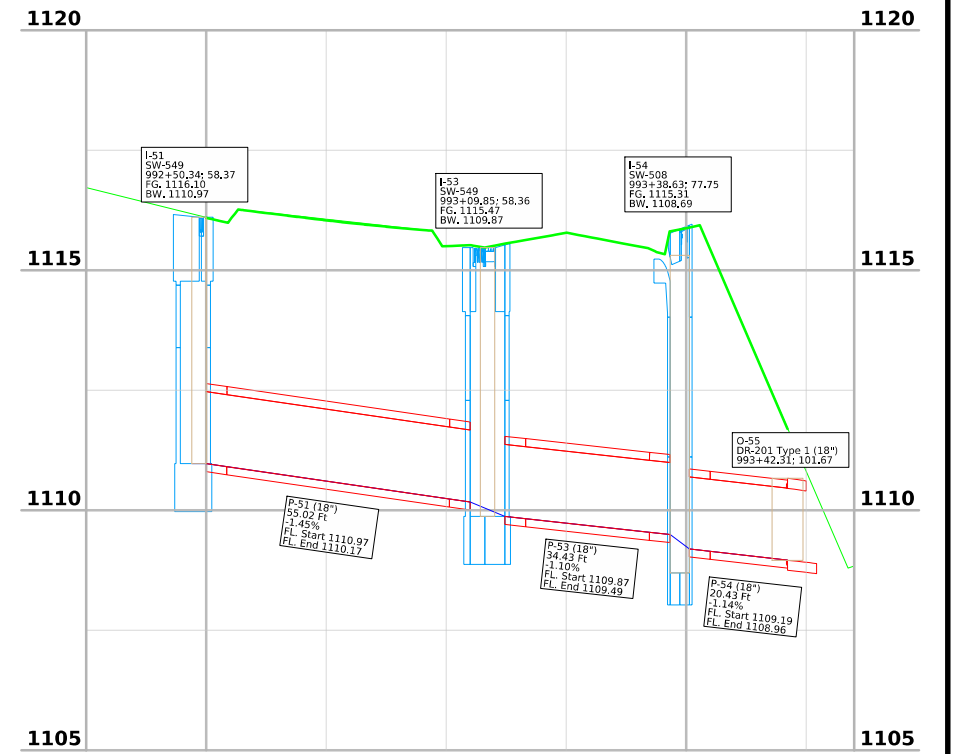

I-51 to O-58 - Profile

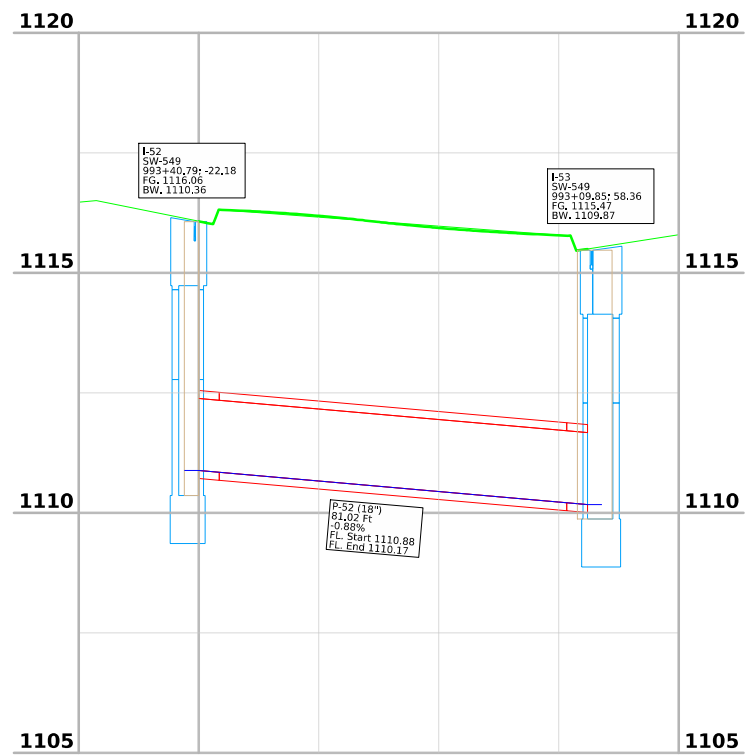

I-52 to I-53 - Profile

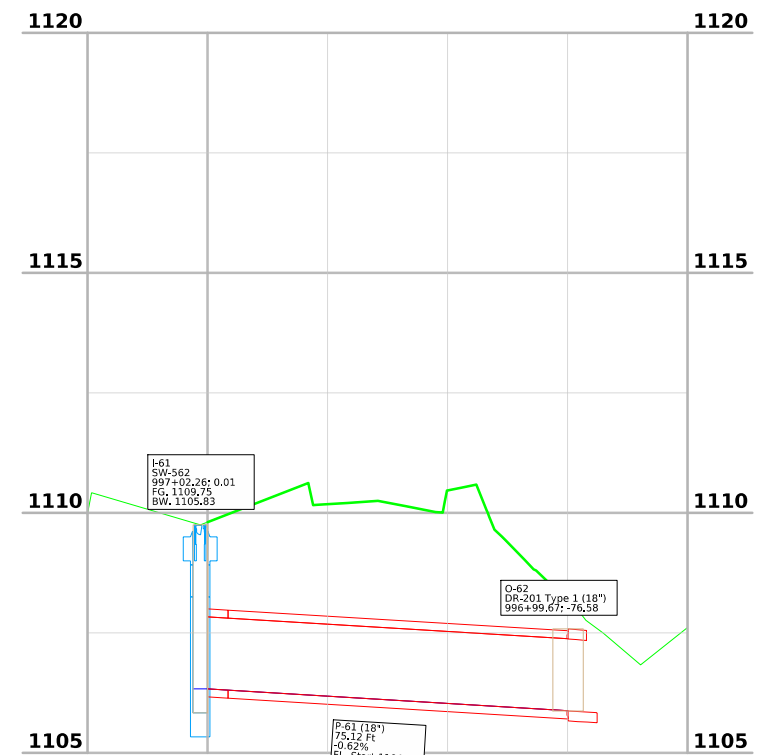

I-61 to O-62 - Profile

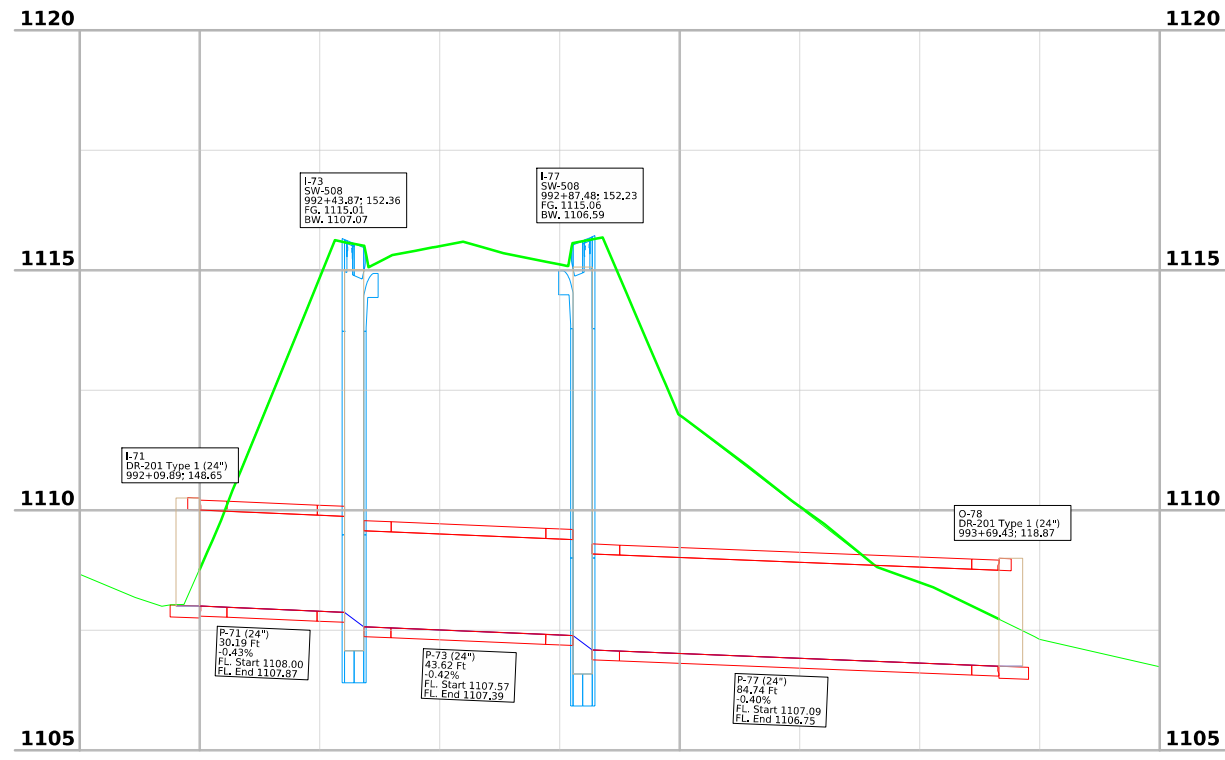

I-71 to O-78 - Profile

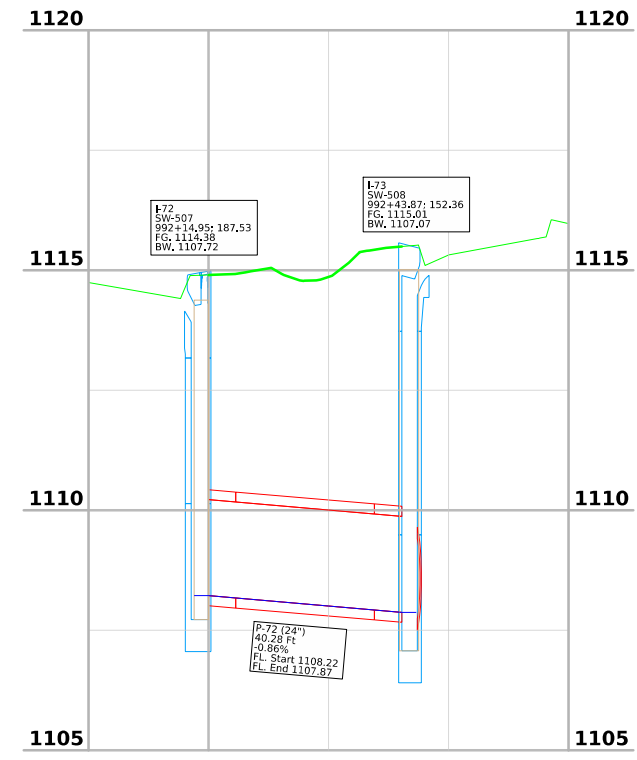

I-72 to I-73 - Profile

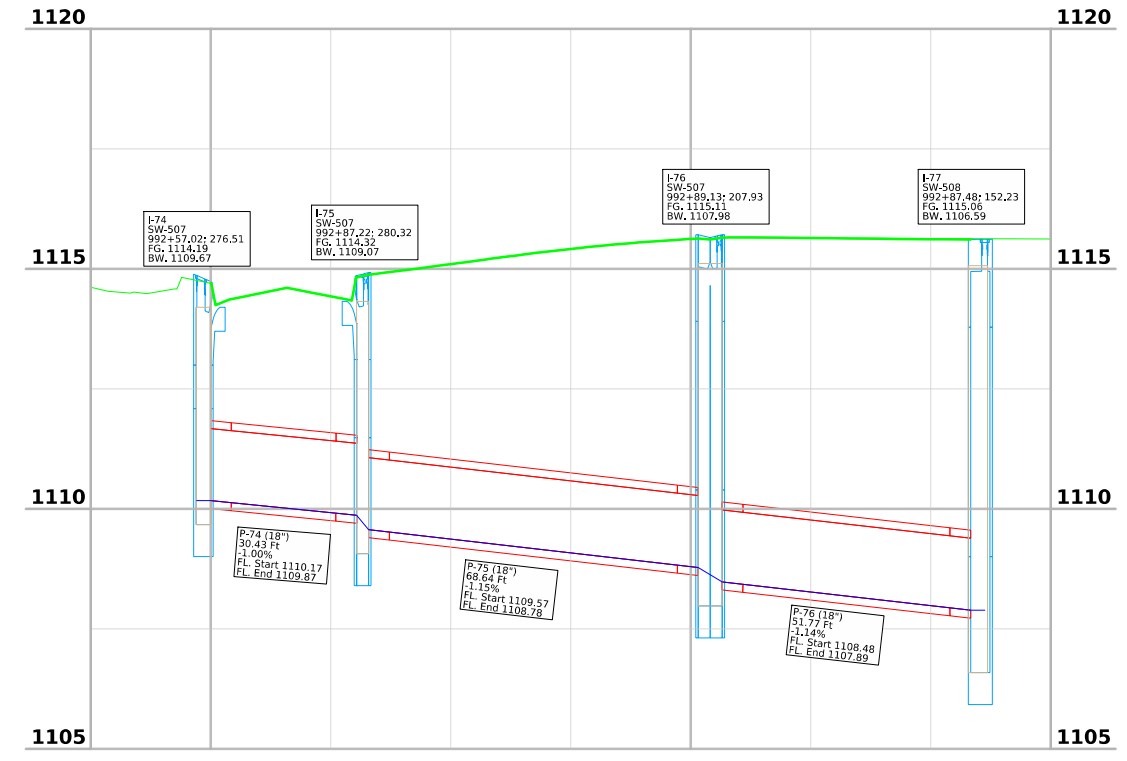

I-74 to I-77 - Profile

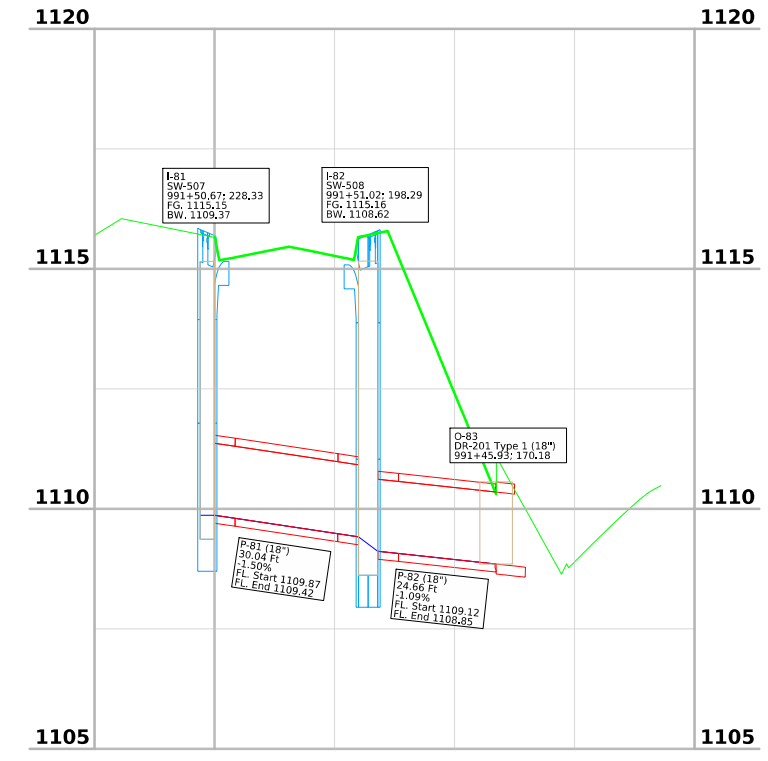

I-81 to O-83 - Profile



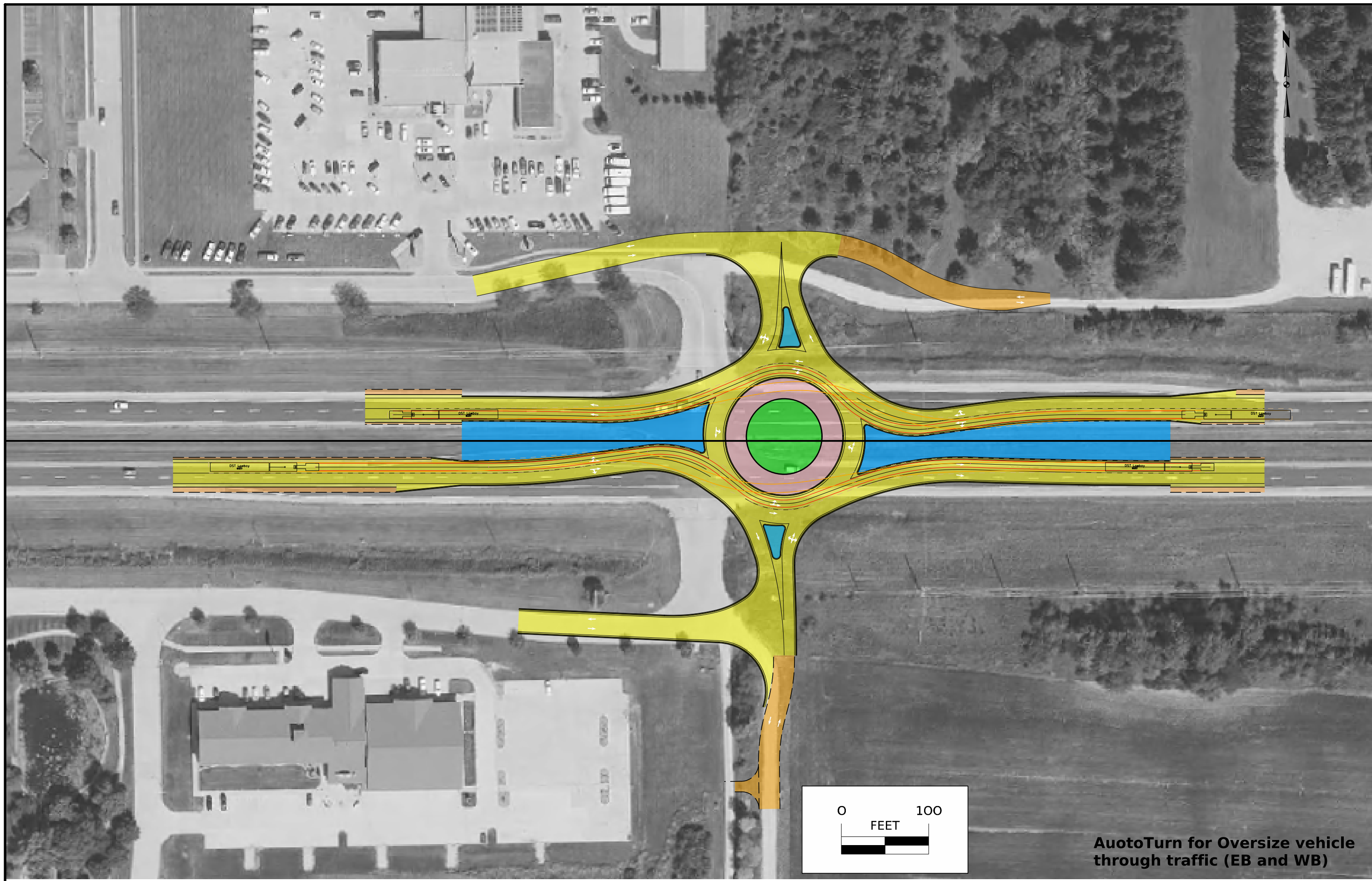

**AuotoTurn for Oversize vehicle  
through traffic (EB and WB)**

## CROSS SECTION VIEW COLOR LEGEND

Design Color No.	Feature	Design Color No.	Feature
<b>Aggregate</b>			
(64)	Choke Stone	(8)	Behind Curb Cut
(42)	Engineering Fabric	(6)	Granular
(8)	Flooded Backfill	(13)	Granular Back Fill
(92)	Macadam Stone	(48)	Rock Undercut
(20)	Modified	(8)	Shoulder Earth Fill
(12)	Plowing Shaping	(2)	Side Slopes
(14)	Porous Backfill	(226)	Side Slopes Dressing
(8)	Revetment Class A	<b>Substrata</b>	
(6)	Revetment Class B	(128)	Boulder
(62)	Revetment Class C	(209)	Boulder Removed
(188)	Revetment Class D	(48)	Broken Weathered
(28)	Revetment Class E	(210)	Broken Weathered Removed
(12)	Shoulder Special Backfill	(3)	Core Out
(12)	Special Backfill	(115)	Core Out Remove Only
(20)	Subbase	(195)	Core Out Remove and Replace
(20)	Subbase Lower	(203)	Existing Pavement
(20)	Subbase Upper	(184)	Existing Pavement Remove Only
(118)	Subgrade Treatment	(200)	Existing Pavement Remove and Replace
<b>Asphalt</b>			
(207)	HMA Base Course	(6)	Loam
(207)	HMA Interim Course	(211)	Loam Removed
(207)	HMA Surface Course	(80)	Rock
<b>Bridge</b>			
(0)	Bridge	(212)	Rock Removed
<b>Concrete</b>			
(0)	Barrier Concrete	(4)	Select Sand
(0)	Barrier Concrete Footing	(214)	Select Sand Removed
(0)	Curb Gutter	(3)	Shale
(48)	Flowable Mortar	(215)	Shale Removed
(0)	Median Concrete	(10)	Topsoil
(0)	PCC Pavement	(2)	Topsoil Remove Only
(0)	Sidewalk	(4)	Topsoil Remove and Replace
<b>Unsuitable / Waste</b>			
(0)	Existing Pavement	(3)	Unsuitable Type A
<b>Shoulder</b>			
(209)	Shoulder HMA	(216)	Unsuitable Type A Removed
(0)	Shoulder PCC	(13)	Unsuitable Type B
(6)	Shoulder Granular	(217)	Unsuitable Type B Removed
<b>Structural</b>			
(112)	Noise Wall	(11)	Unsuitable Type C
(112)	Noise Wall Footing	(218)	Unsuitable Type C Removed
(112)	Retaining Wall Back	(3)	Waste
(112)	Retaining Wall Back Excavate	(219)	Waste Removed
(112)	Retaining Wall Face		
(112)	Retaining Wall Front Excavate		
(112)	Retaining Wall Front Footing		
(112)	Retaining Wall MSE Gutter		
(112)	Retaining Wall Reinforced Earth		

**NOTES:**

Text

**NOTES:**

Text

## CROSS SECTIONS LEGEND AND INFORMATION SHEET

(COVERS SHEET SERIES W, X, Y, & Z)

# US30\_EB\_1

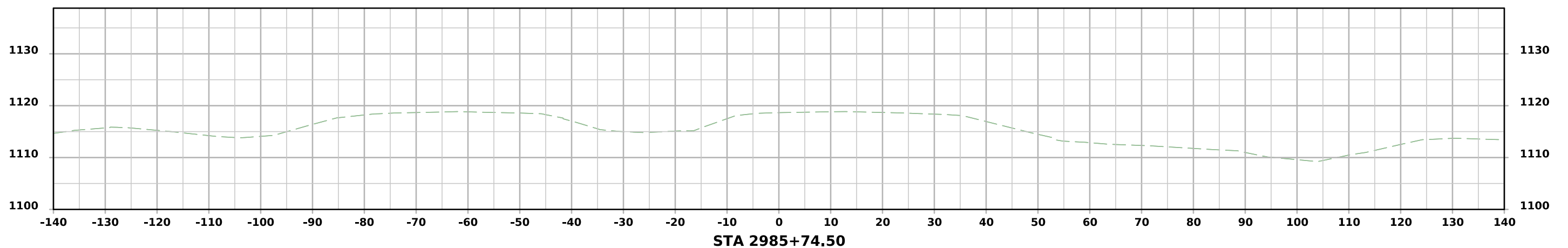
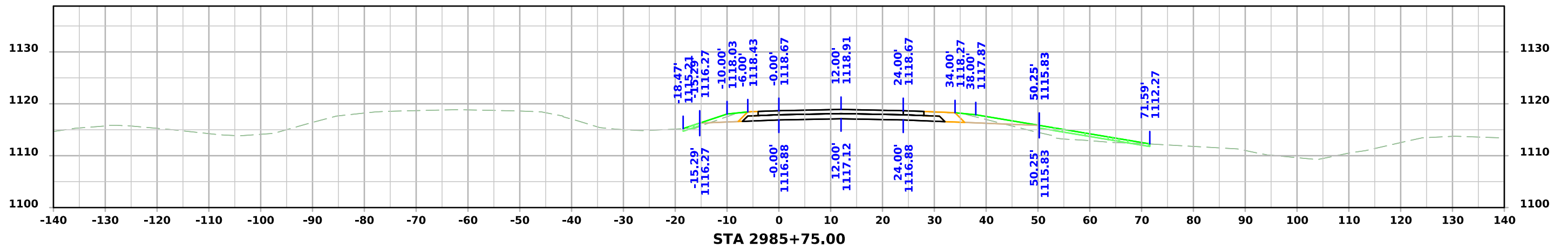
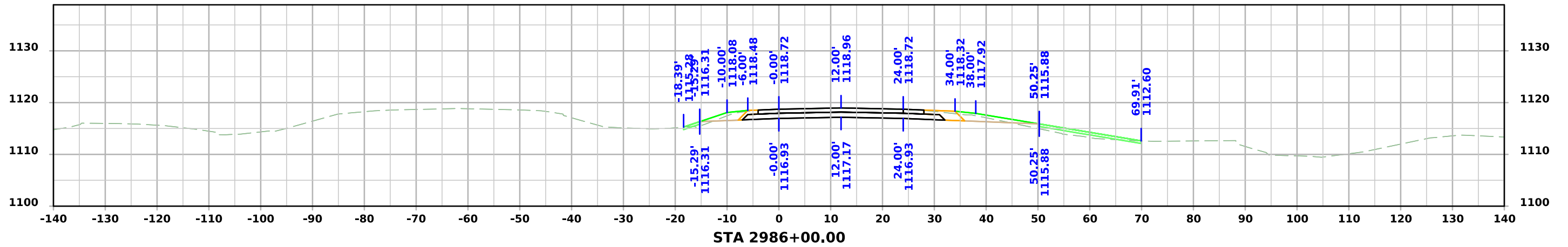

# US30\_EB\_1

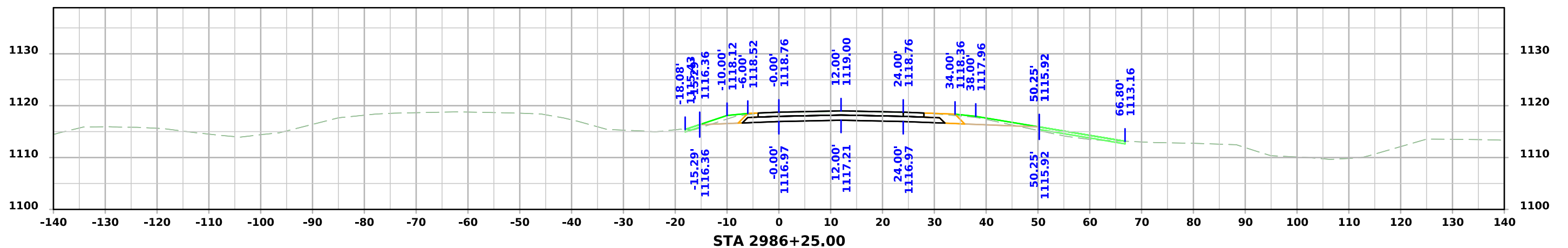
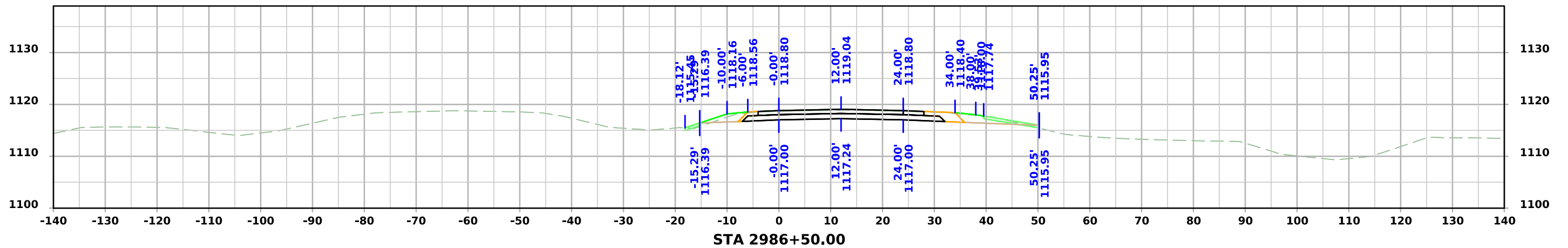
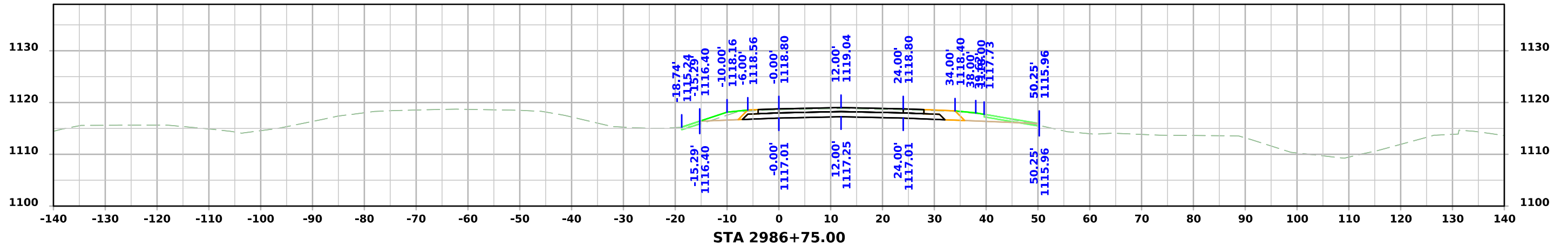

# US30\_EB\_1

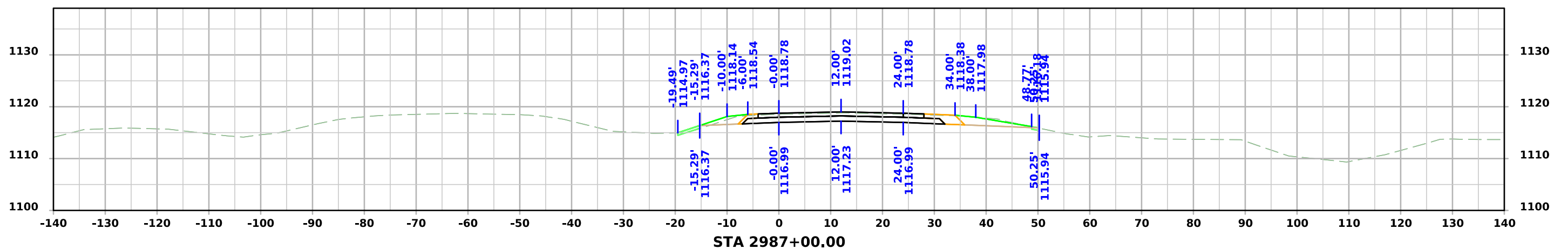
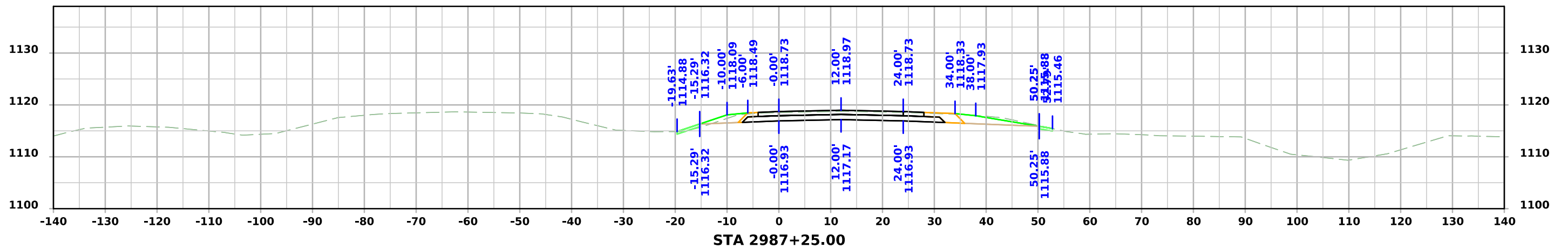
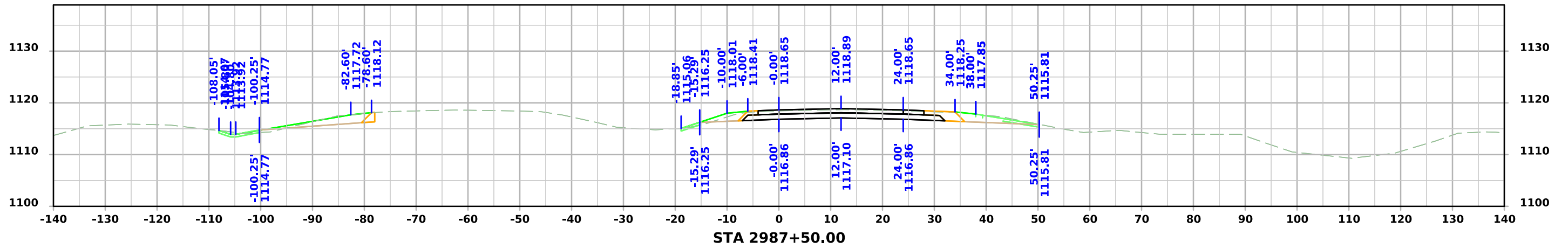

# US30\_EB\_1

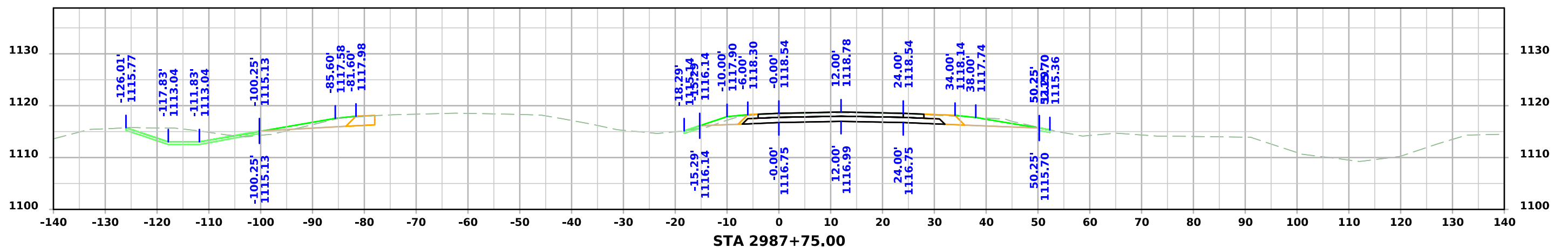
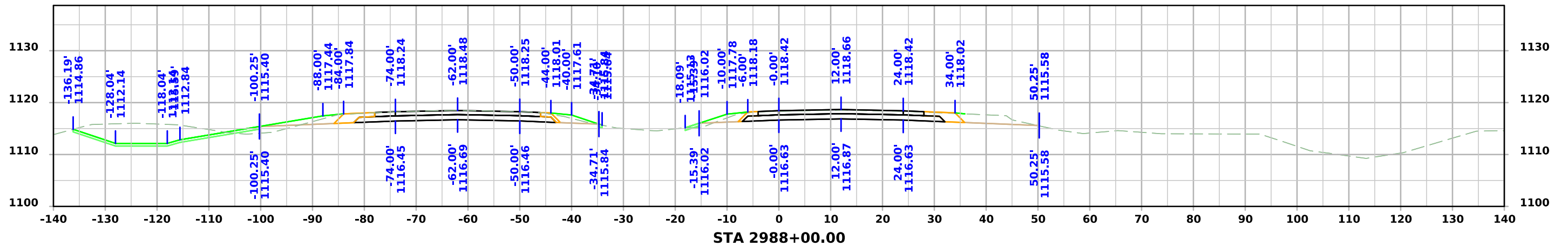
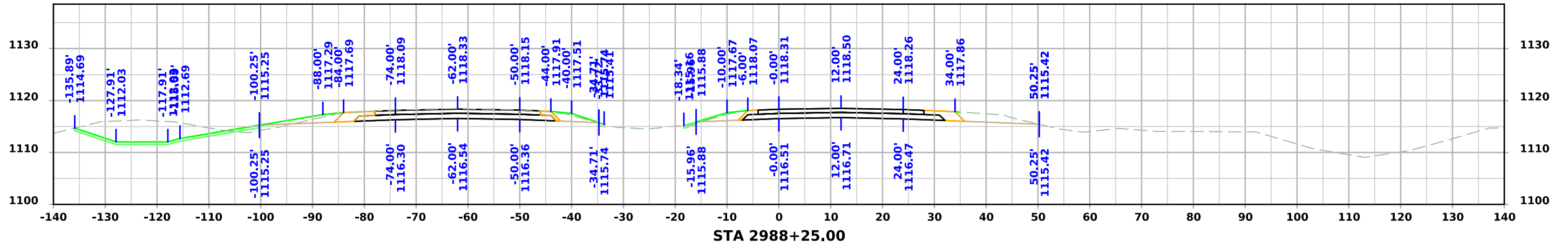

# US30\_EB\_1

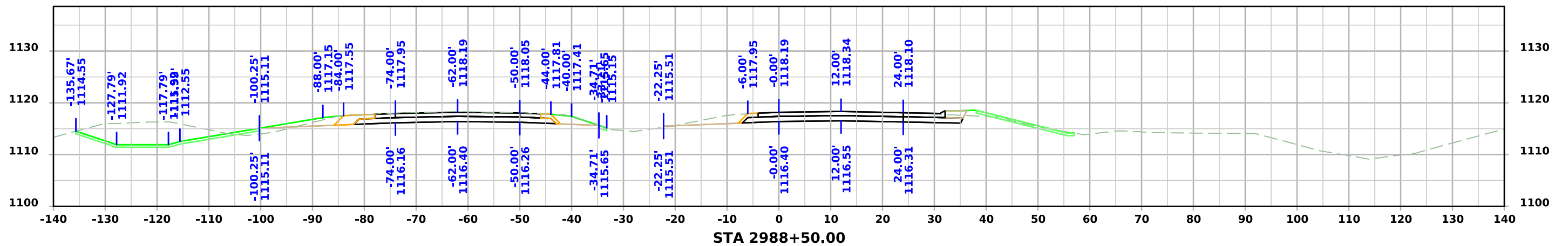
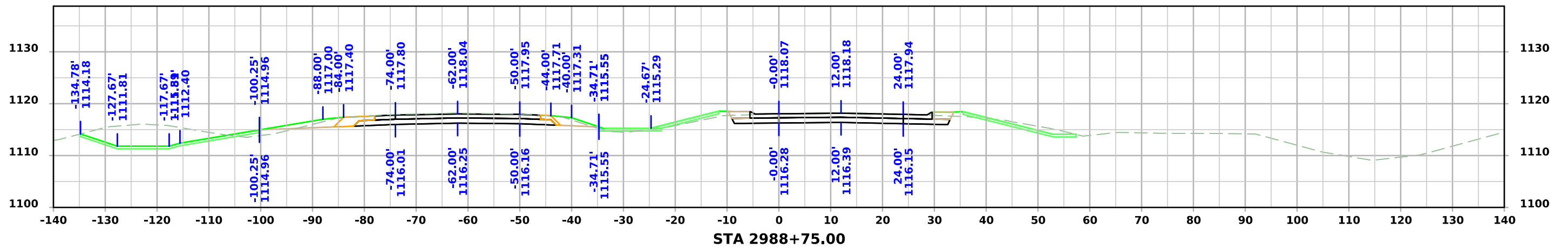
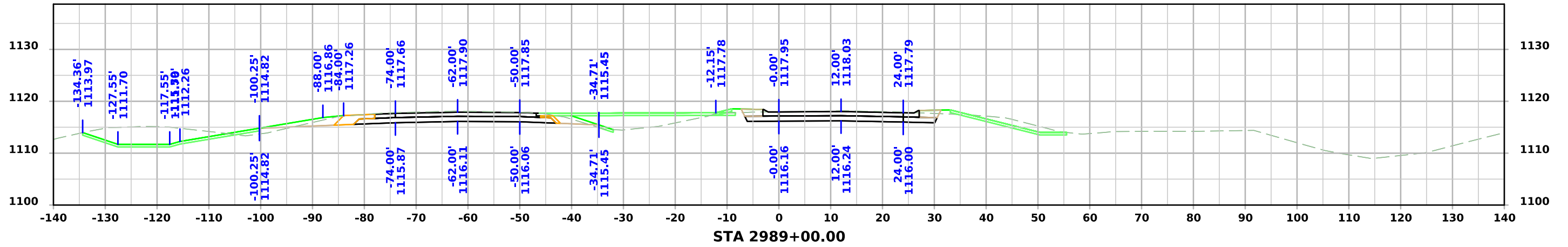

# US30\_EB\_1

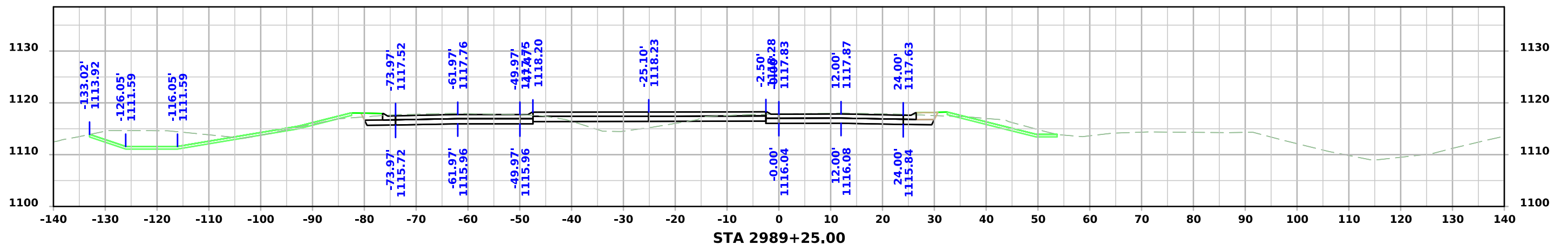
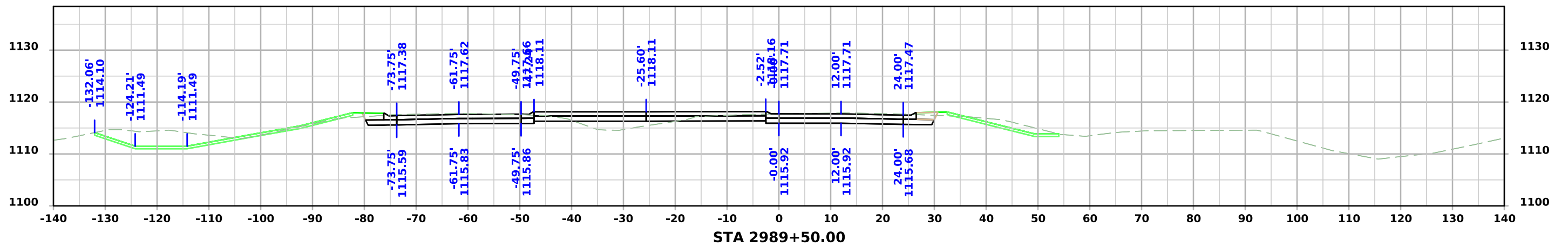
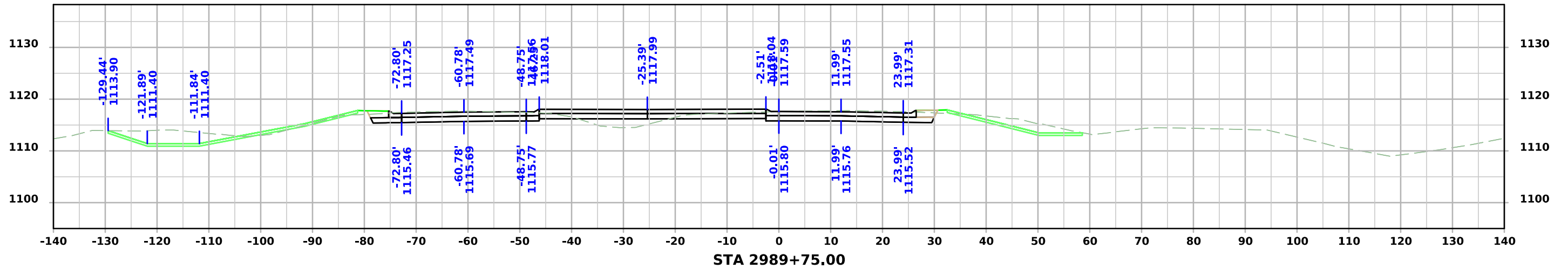



# US30\_EB\_1

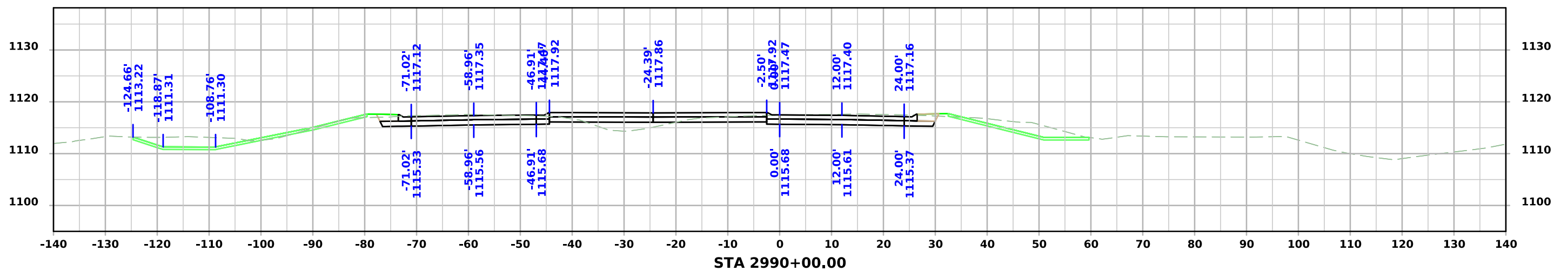
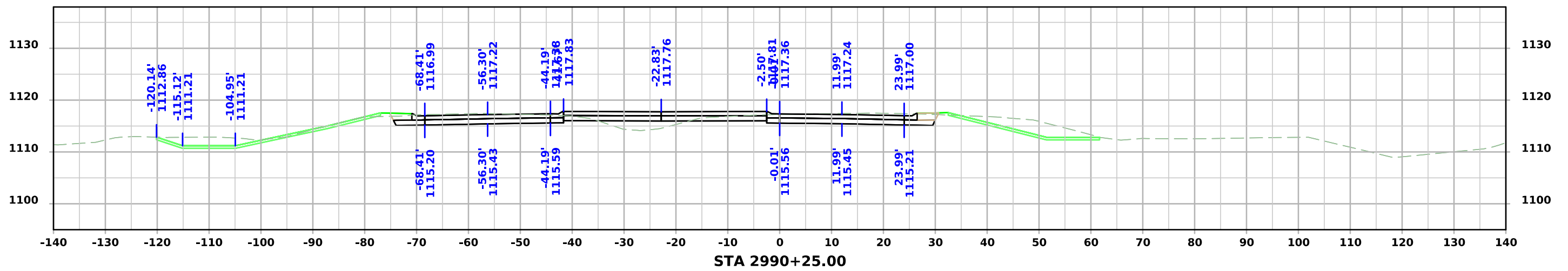
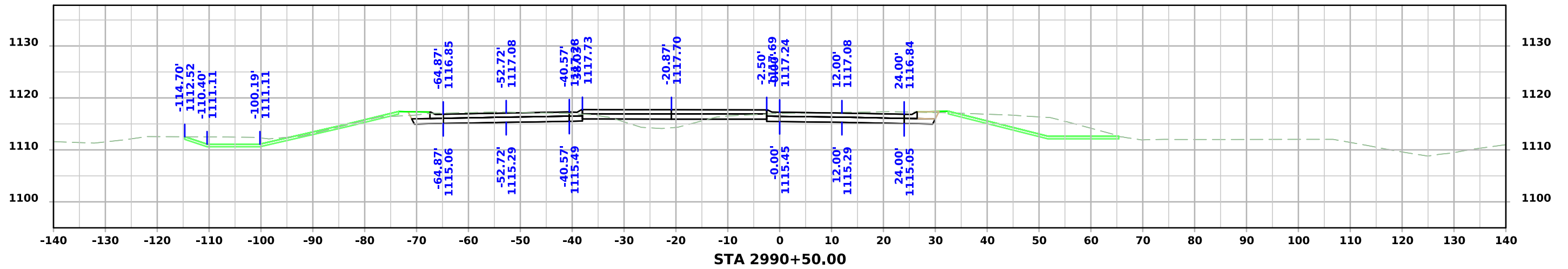

# US30\_EB\_1

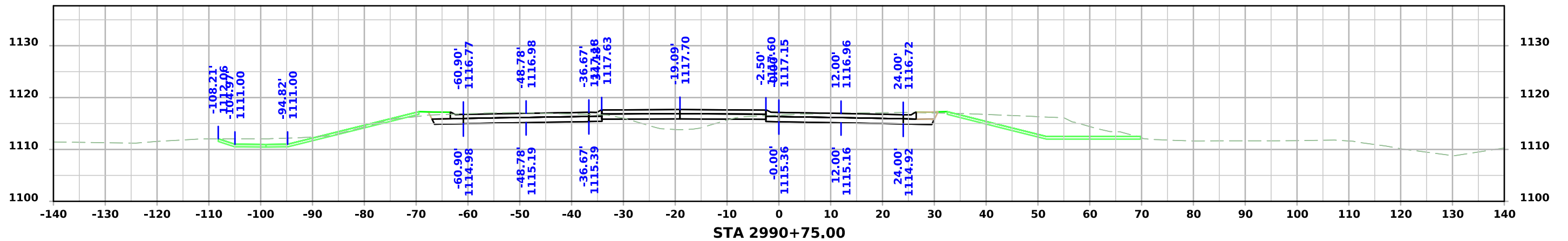
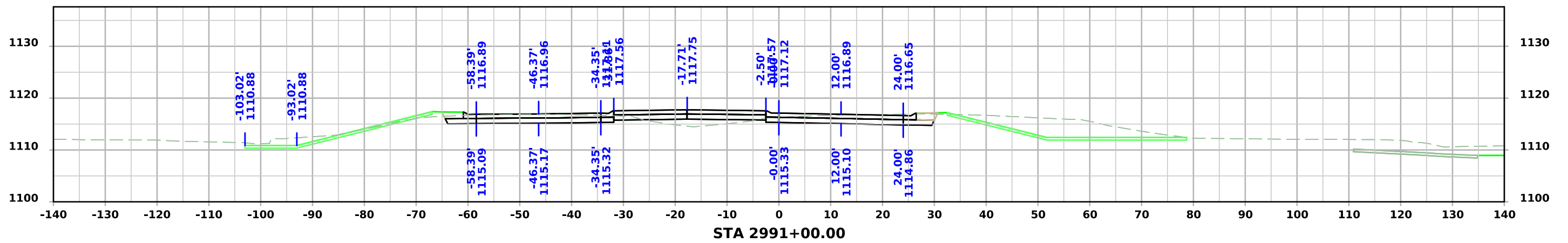
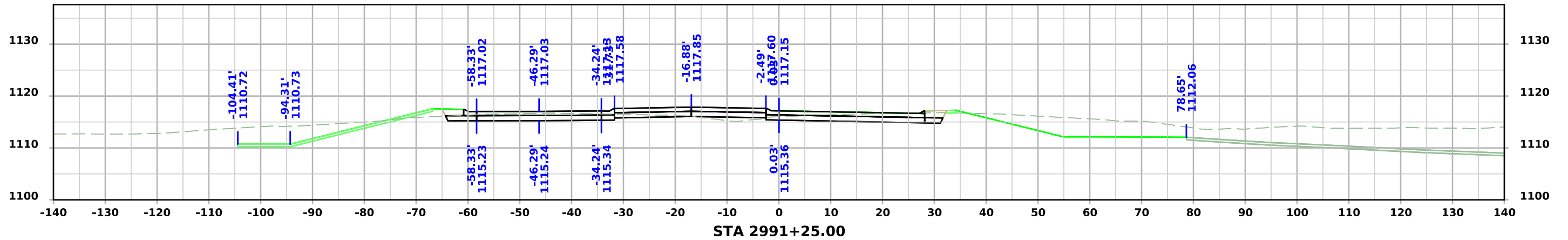

# US30\_EB\_1

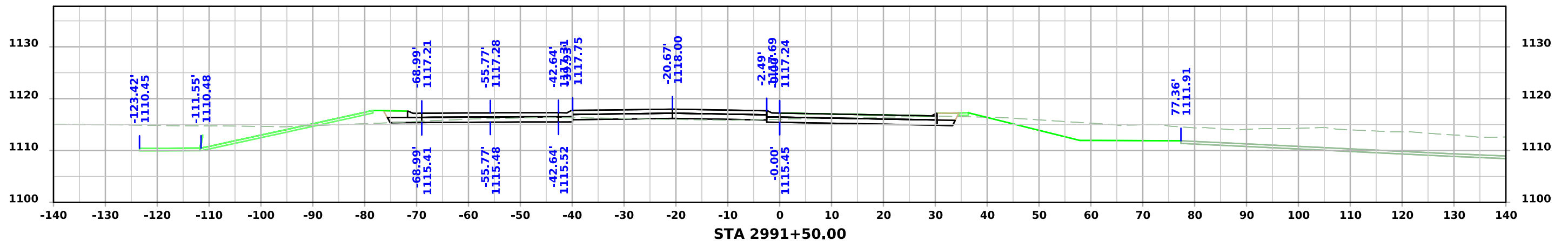
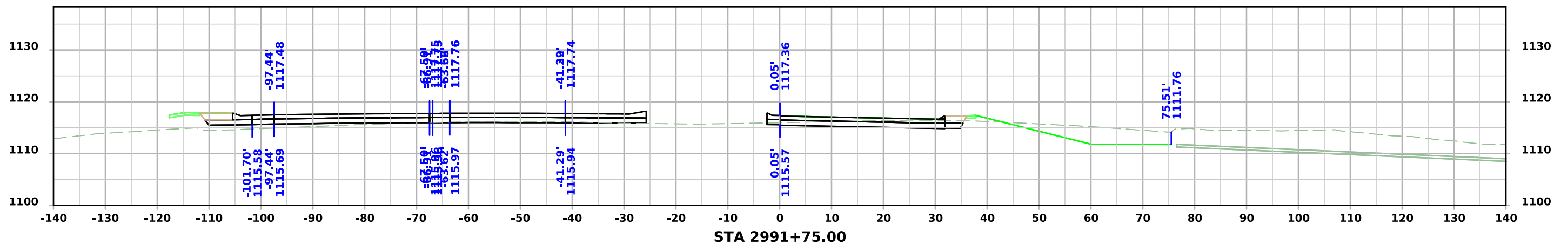
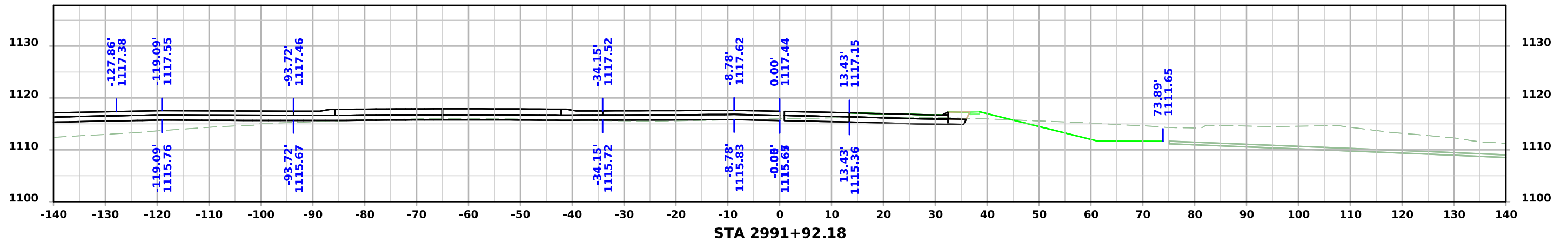

# US30\_EB\_2

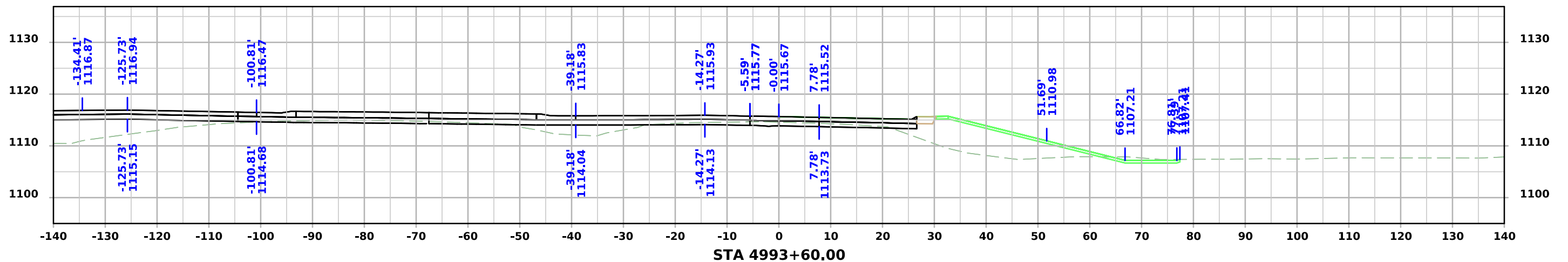
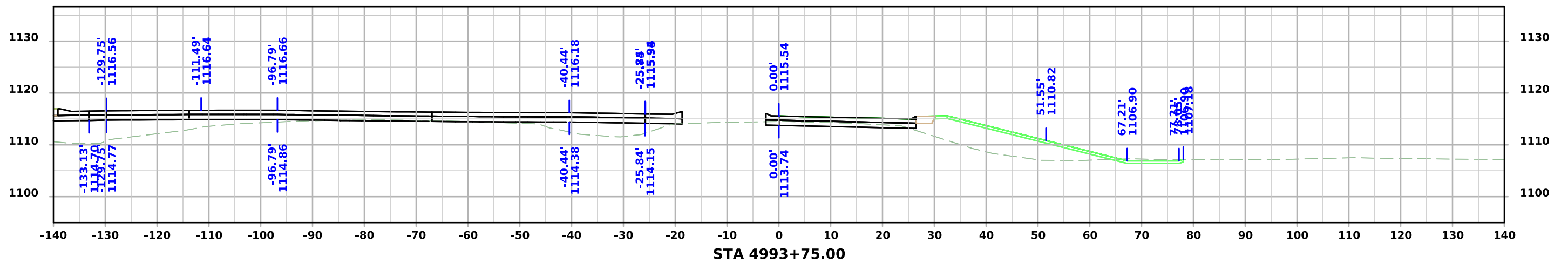
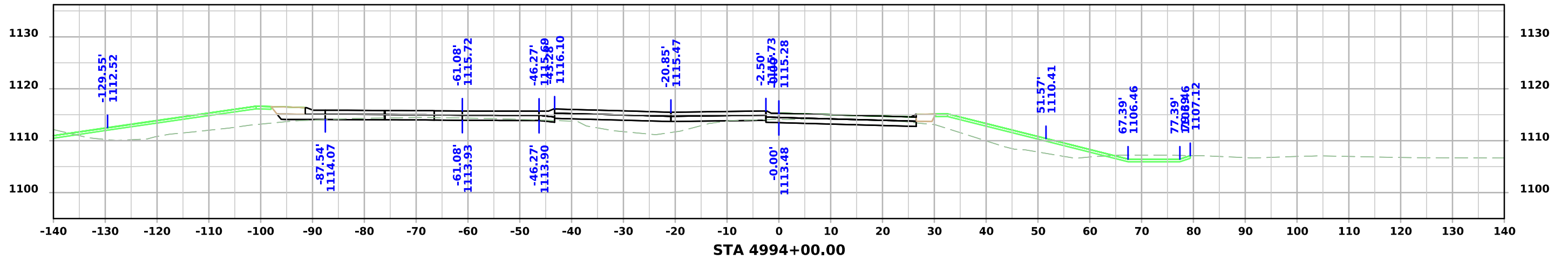

# US30\_EB\_2

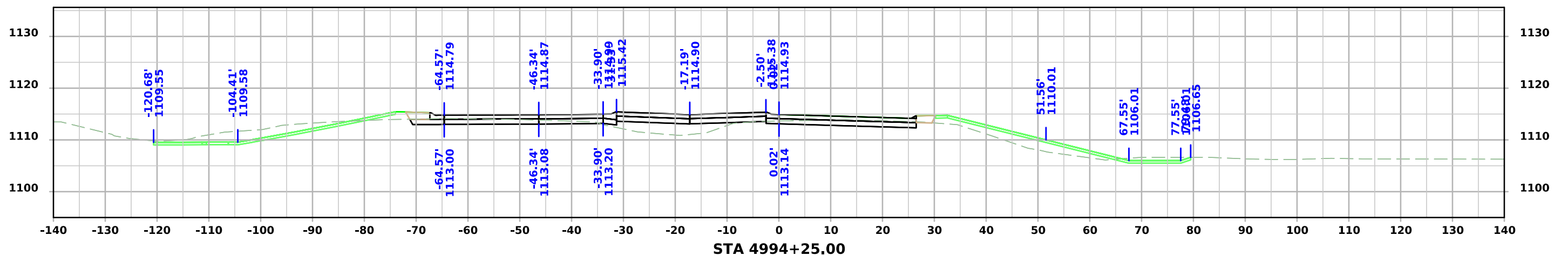
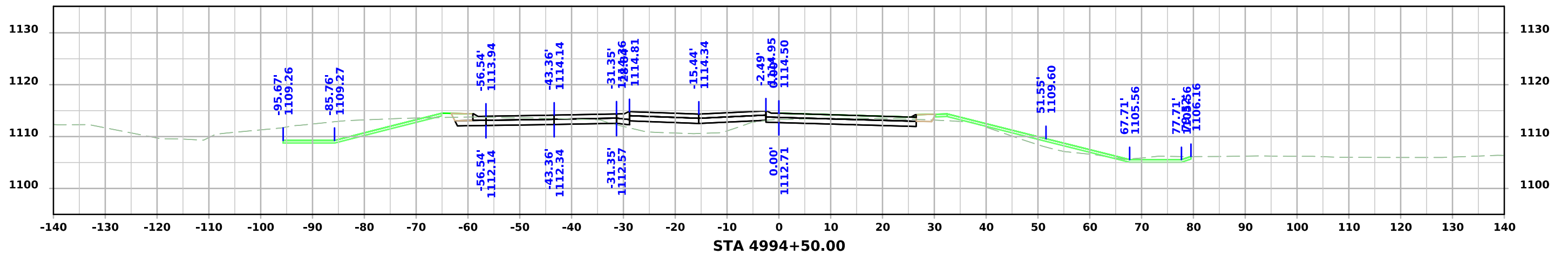
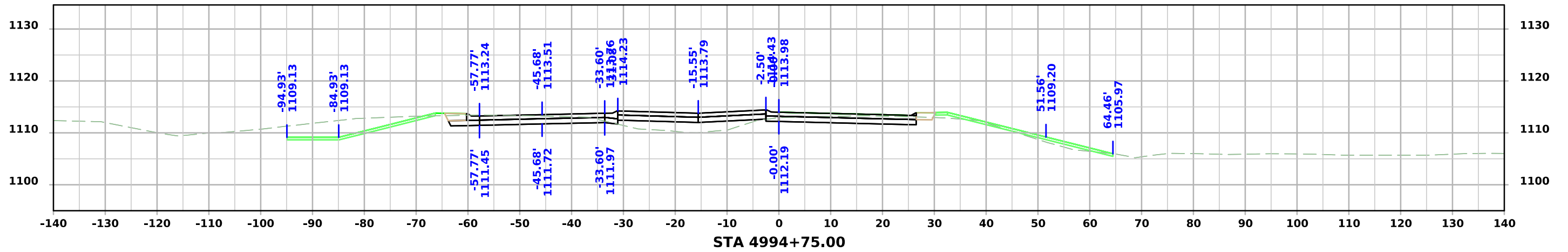

# US30\_EB\_2

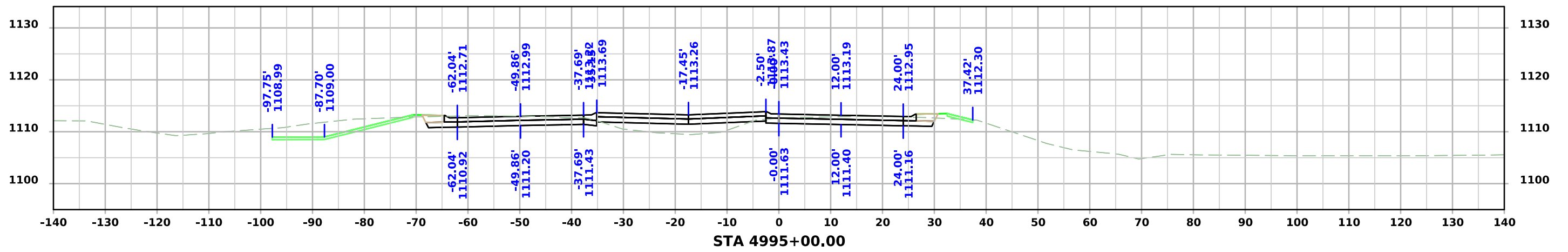
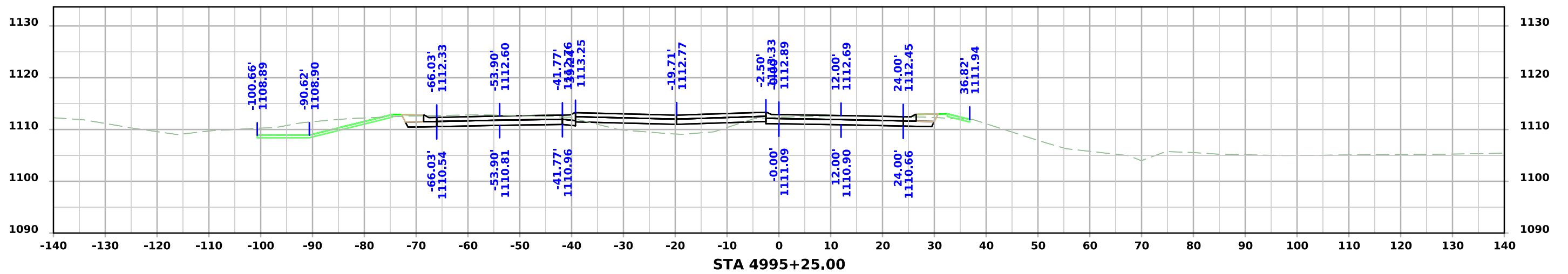
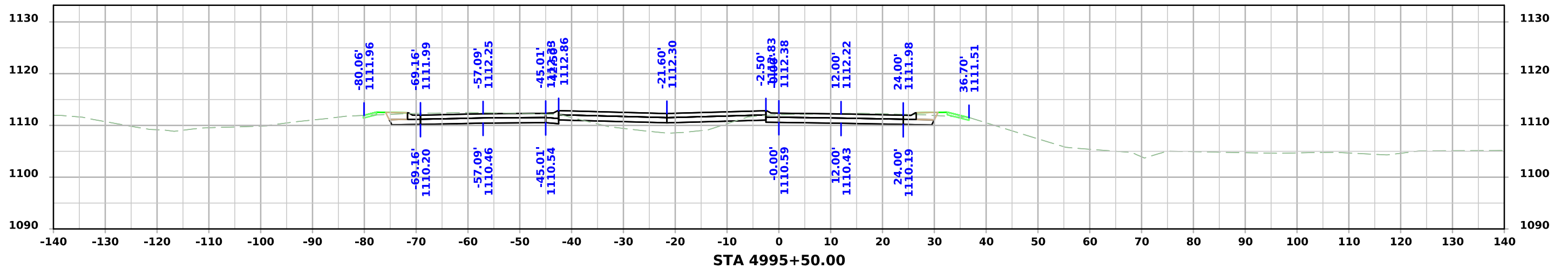

# US30\_EB\_2

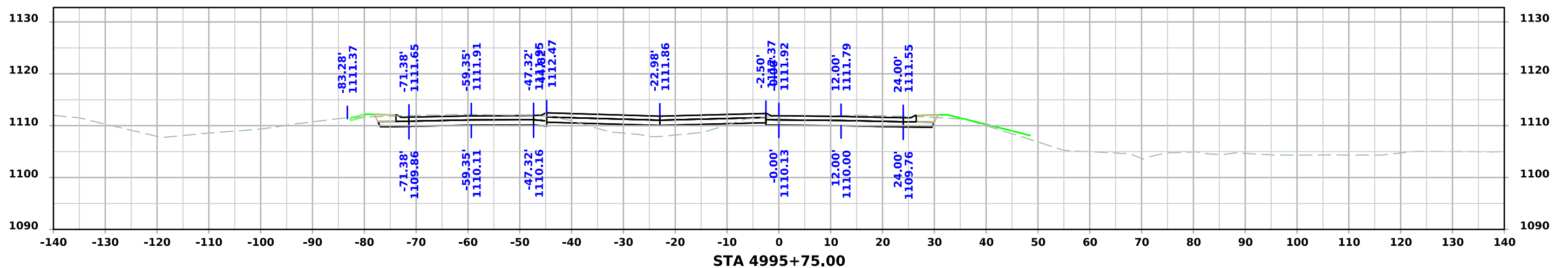
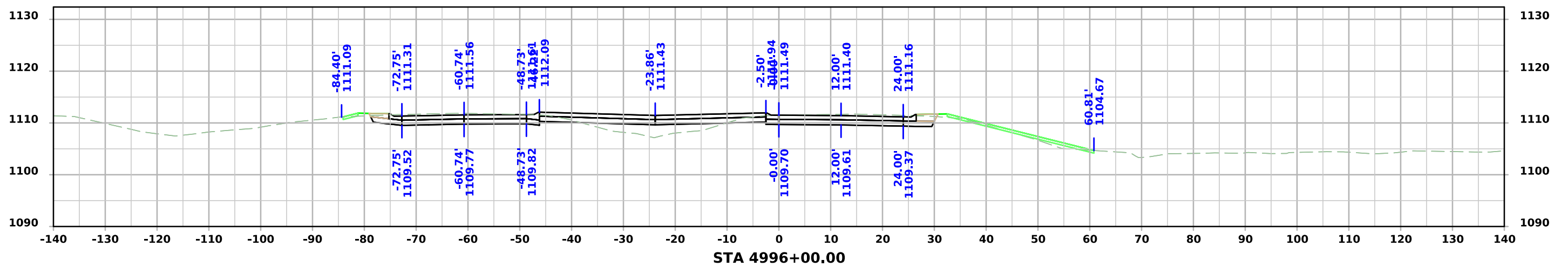
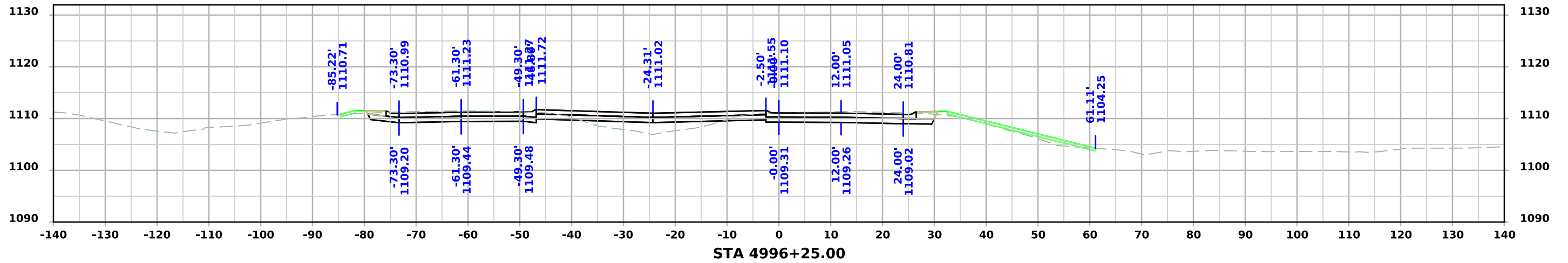

# US30\_EB\_2

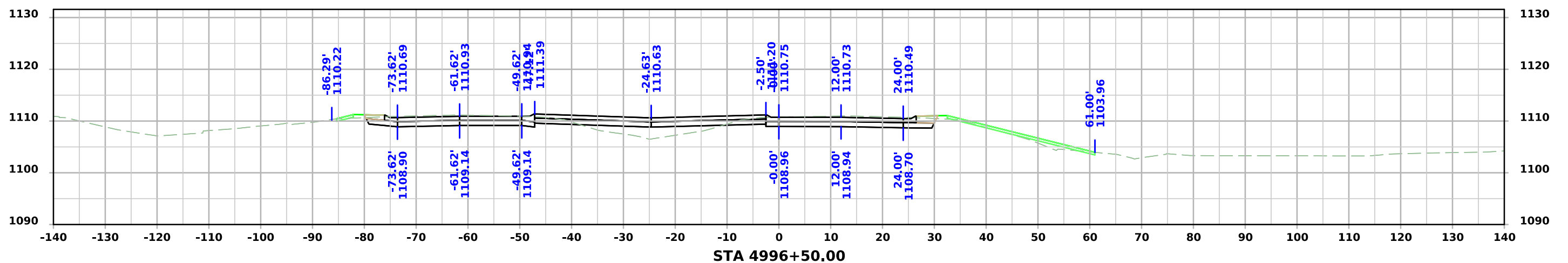
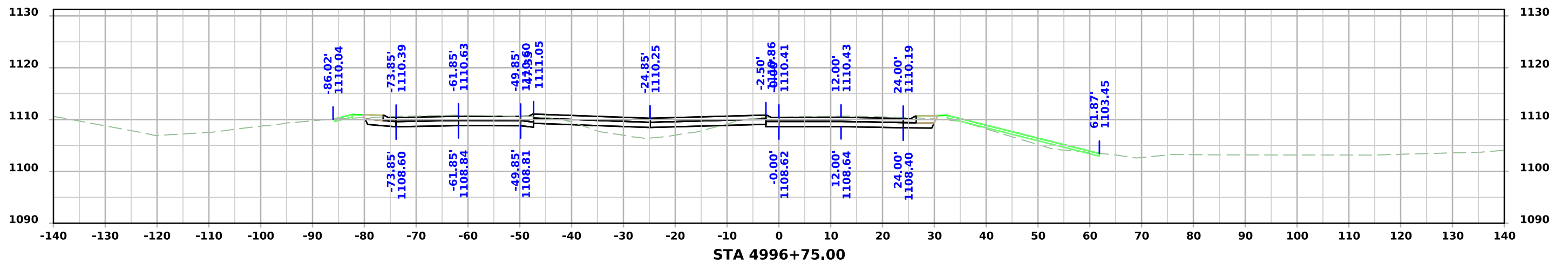
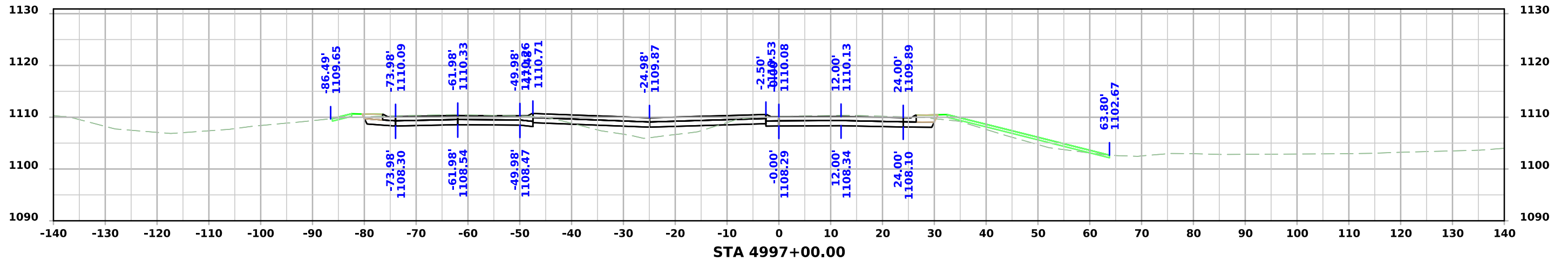



# US30\_EB\_2

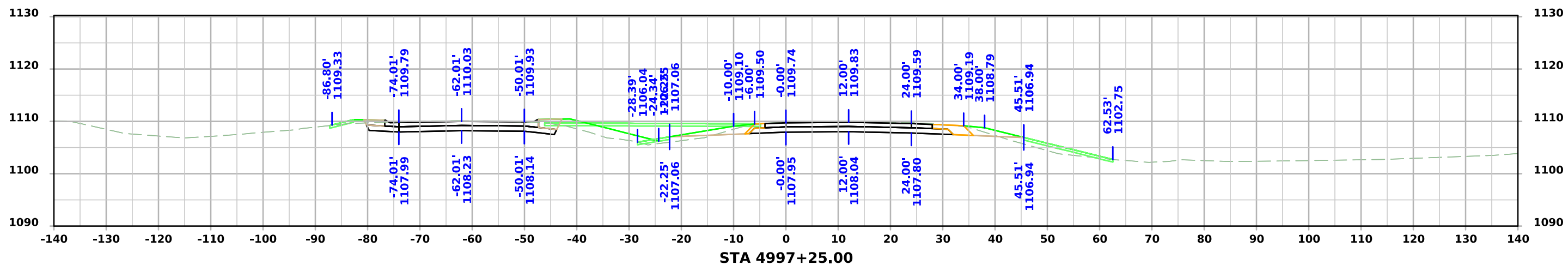
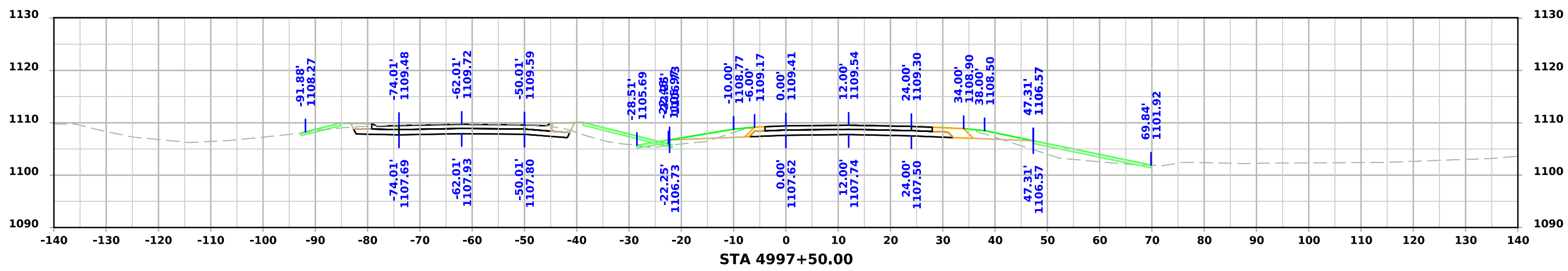
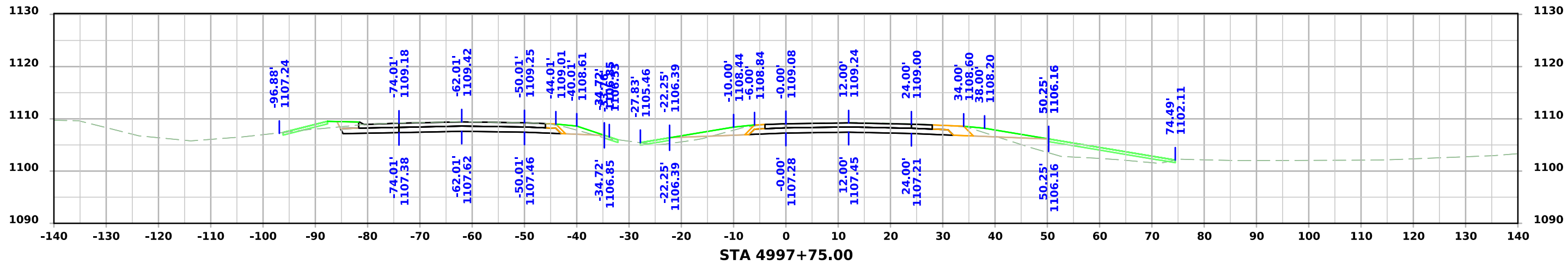

# US30\_EB\_2

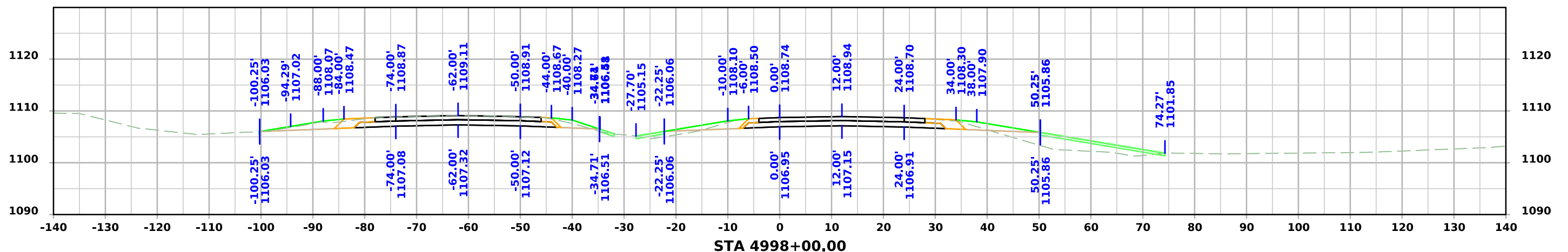
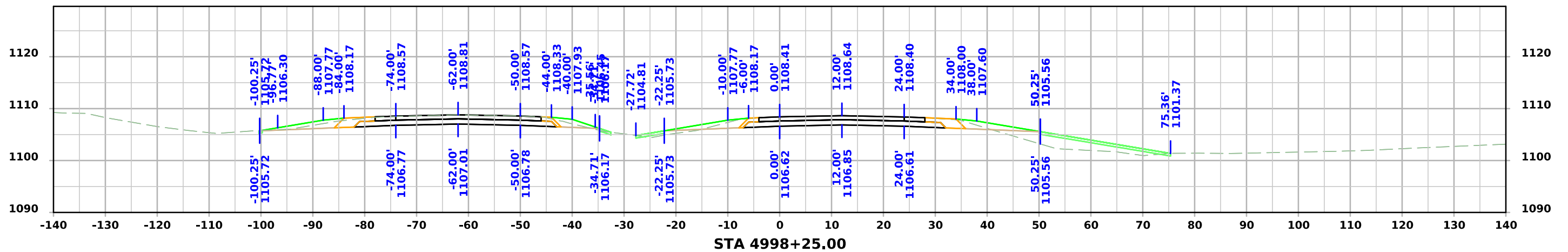
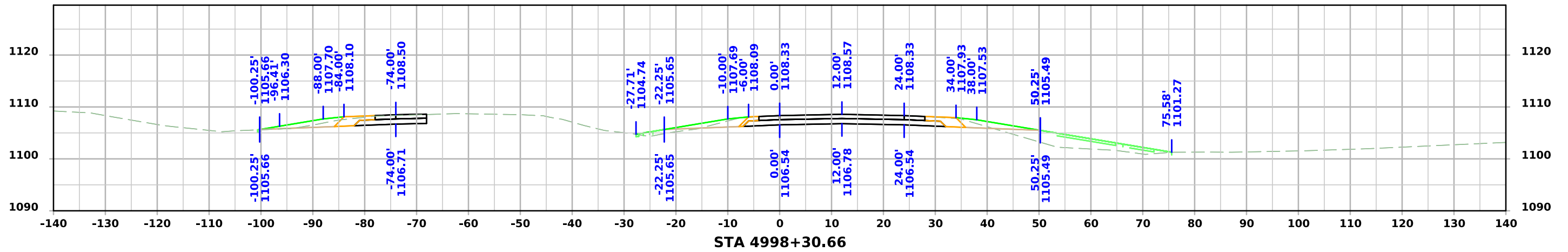

# US30 WB\_1

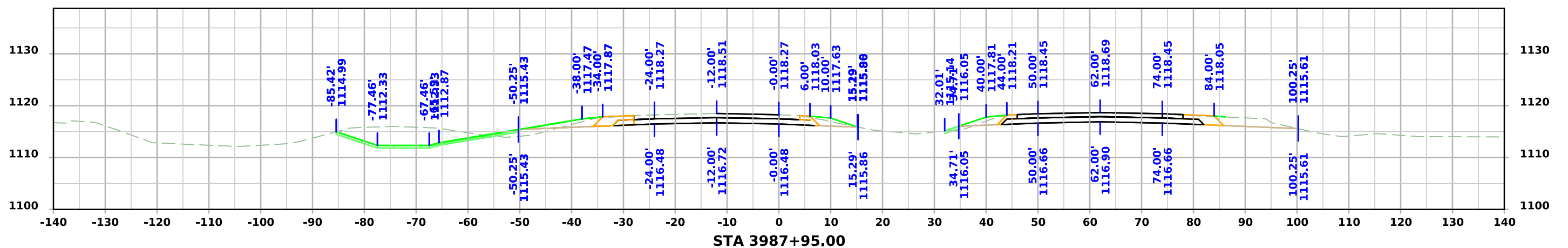
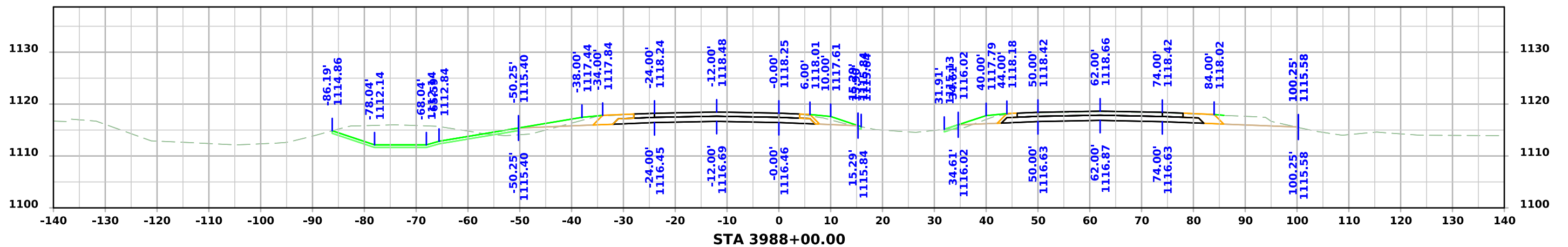
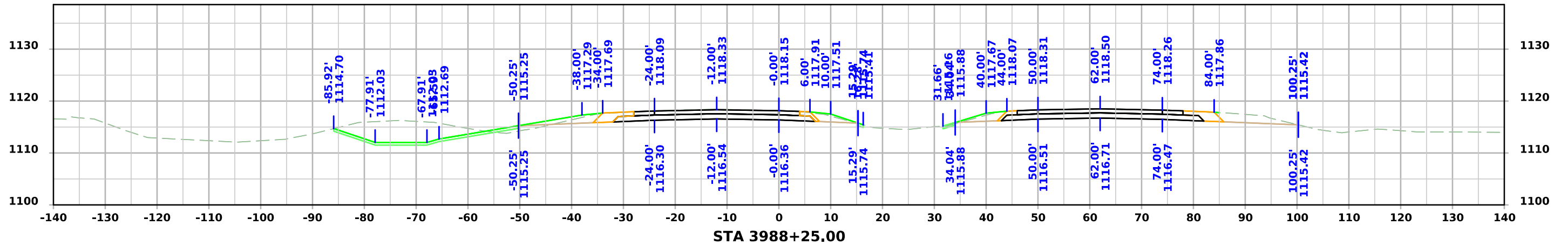

# US30 WB\_1

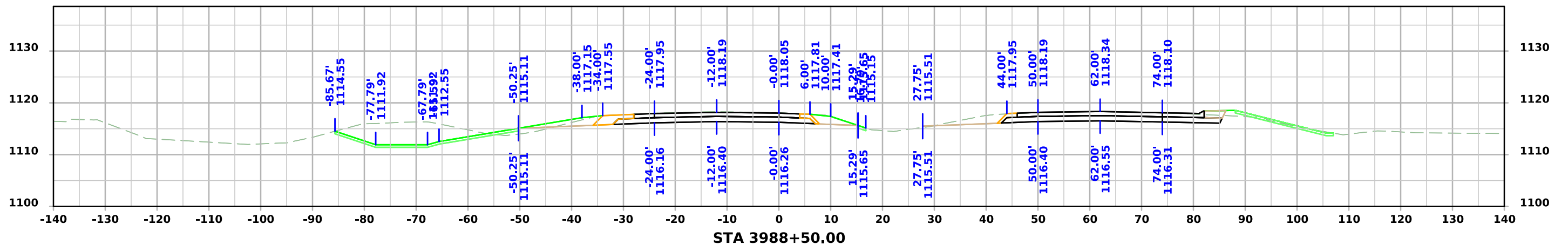
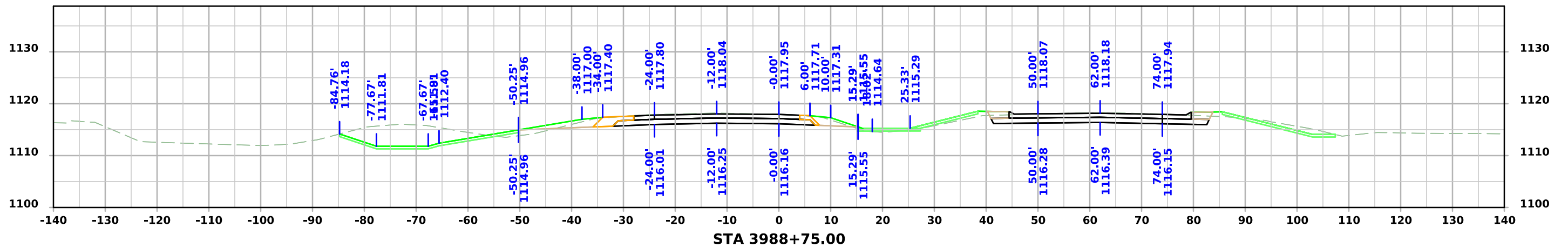
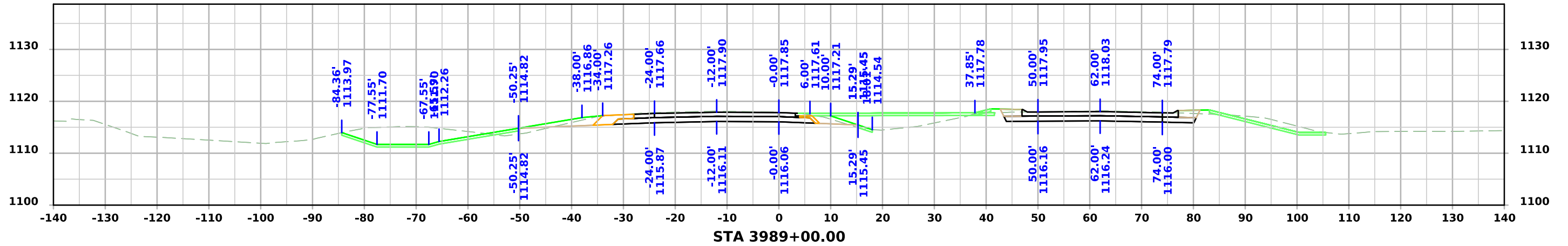

# US30 WB\_1

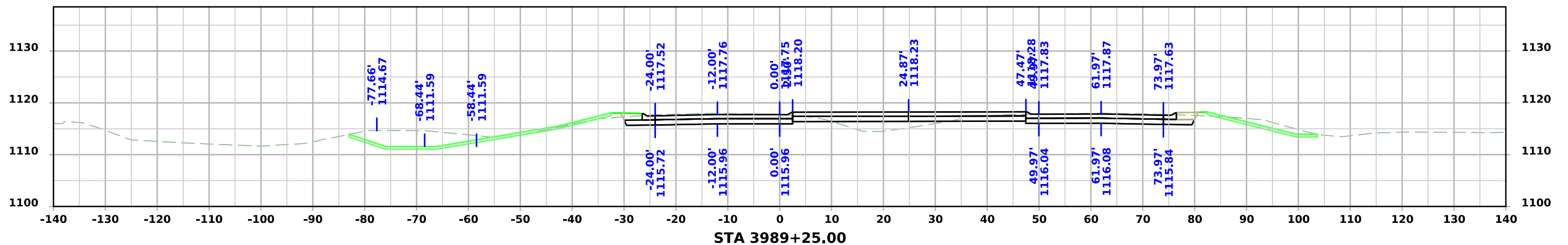
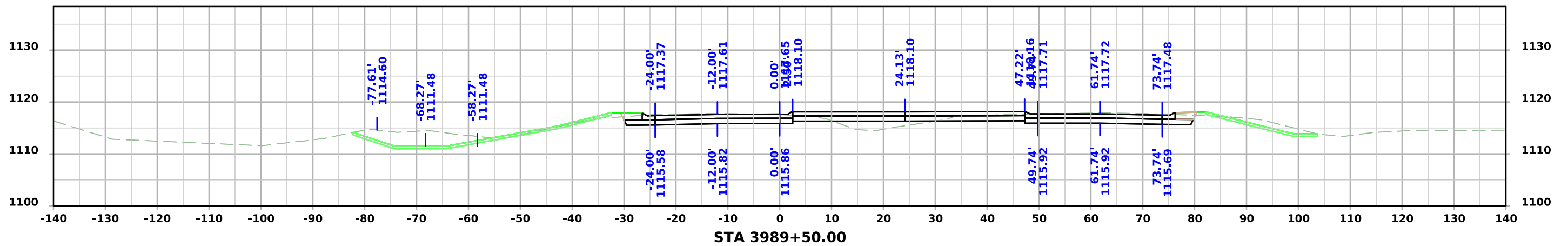
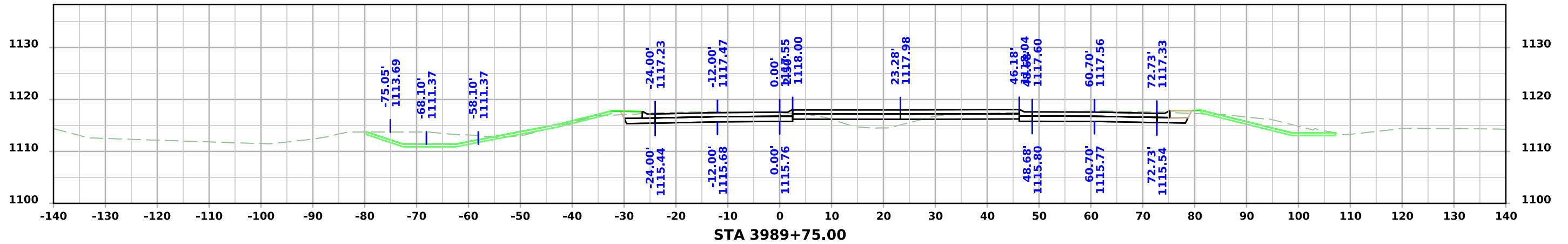

# US30 WB\_1

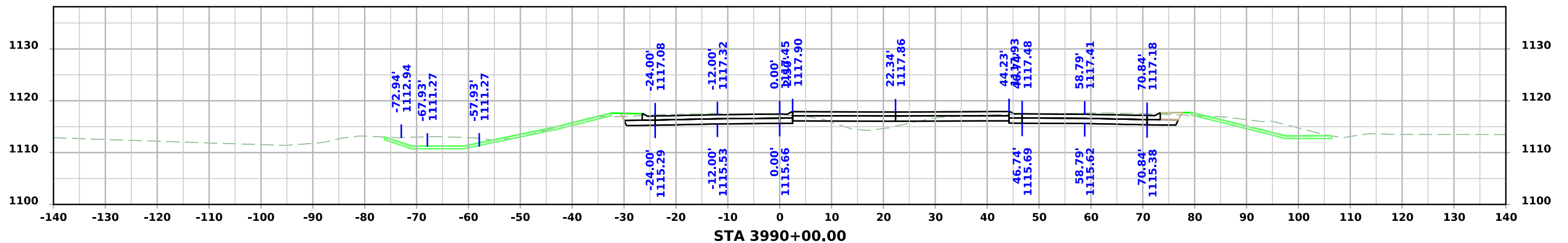
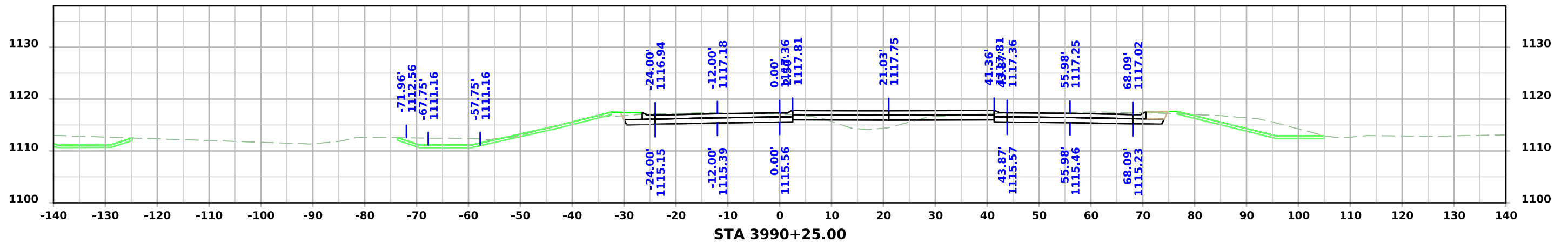
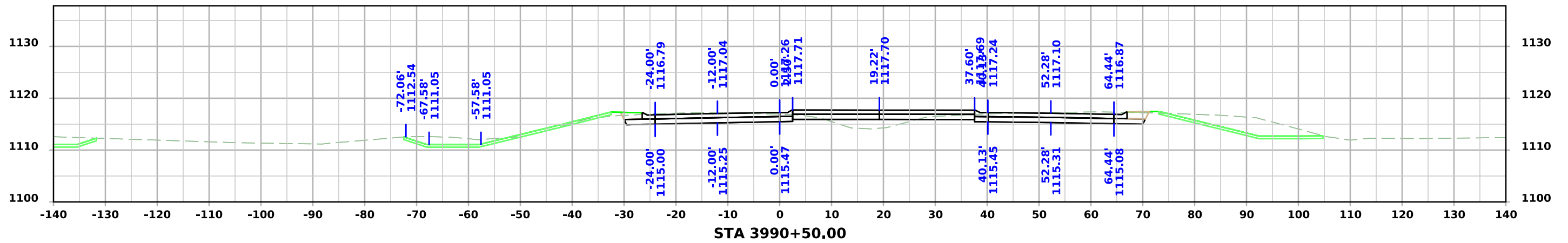

# US30 WB\_1

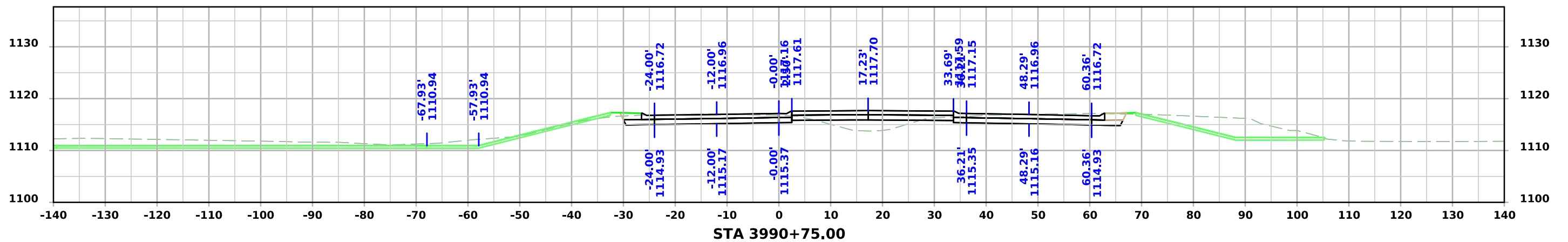
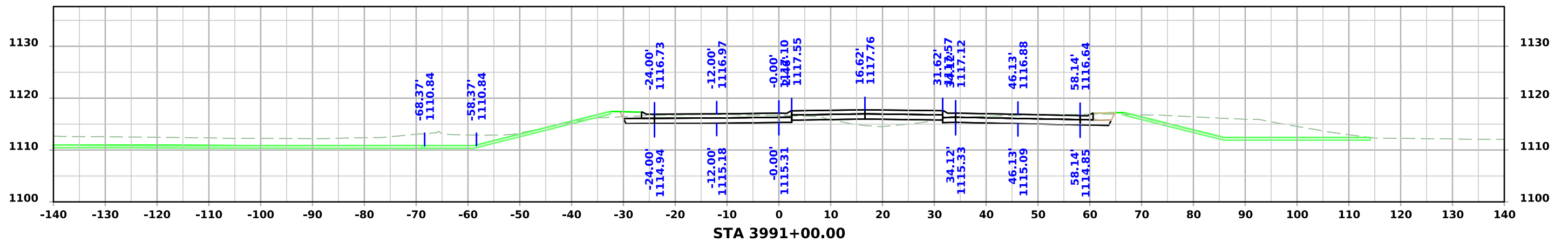
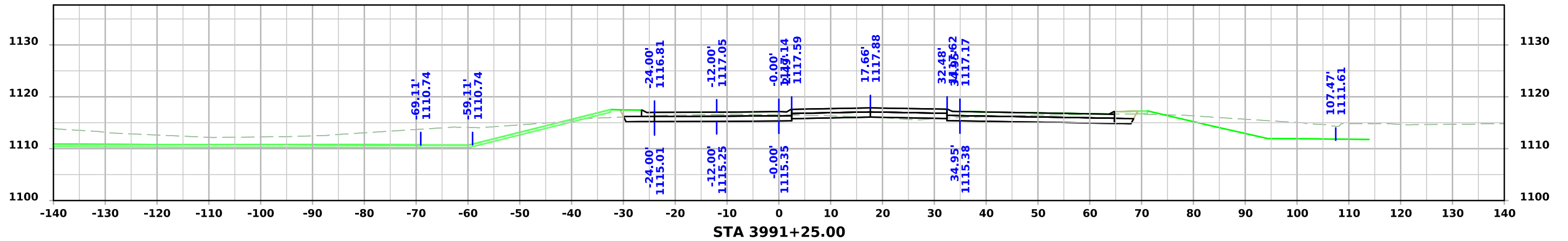

# US30 WB\_1

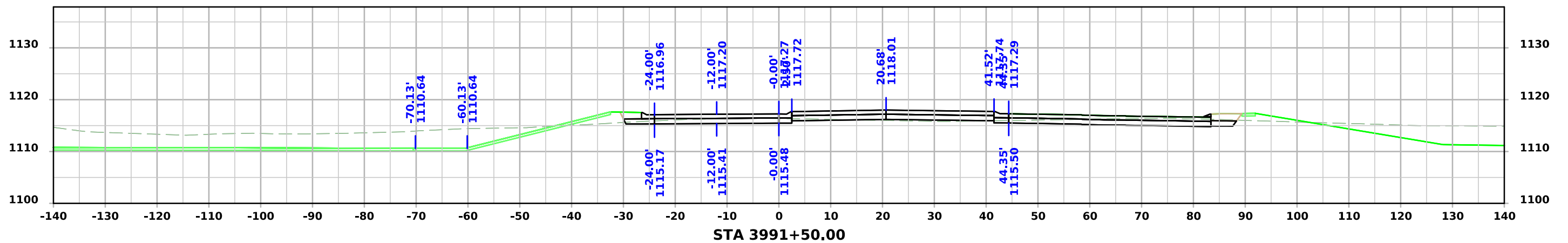



# US30 WB\_2

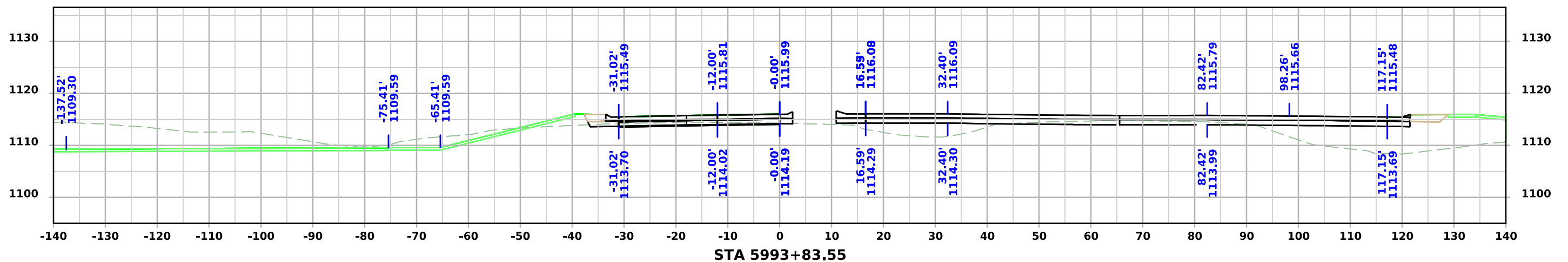
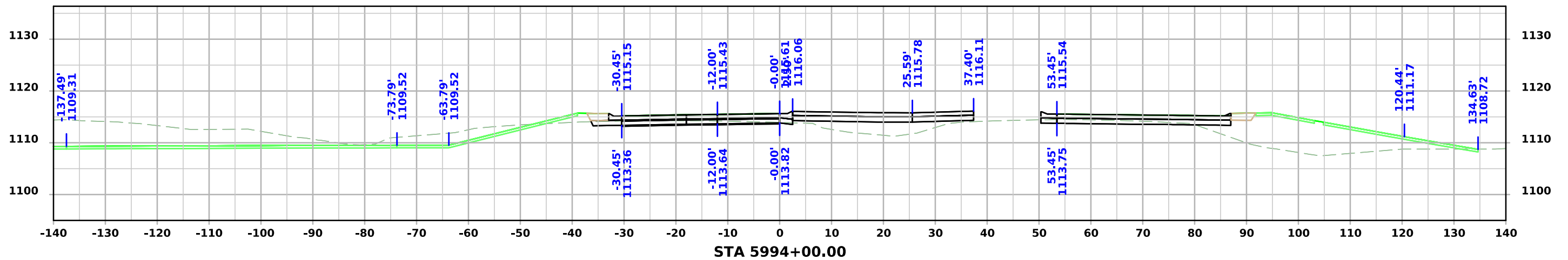
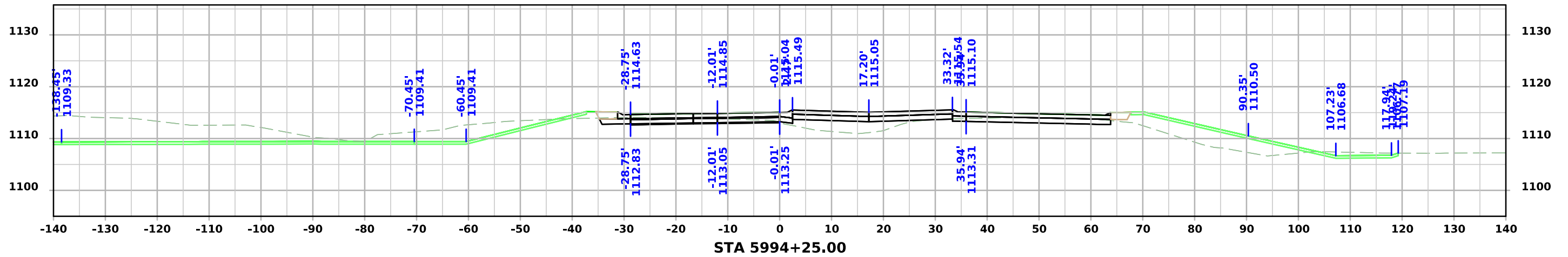

# US30 WB\_2

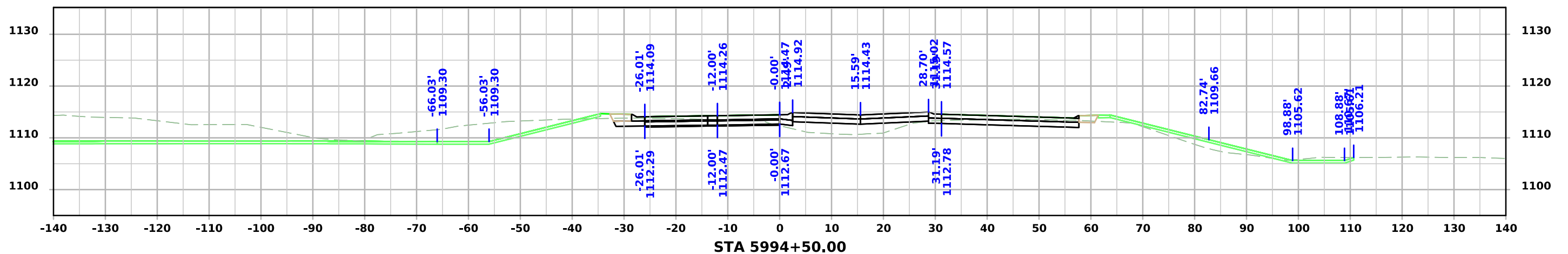
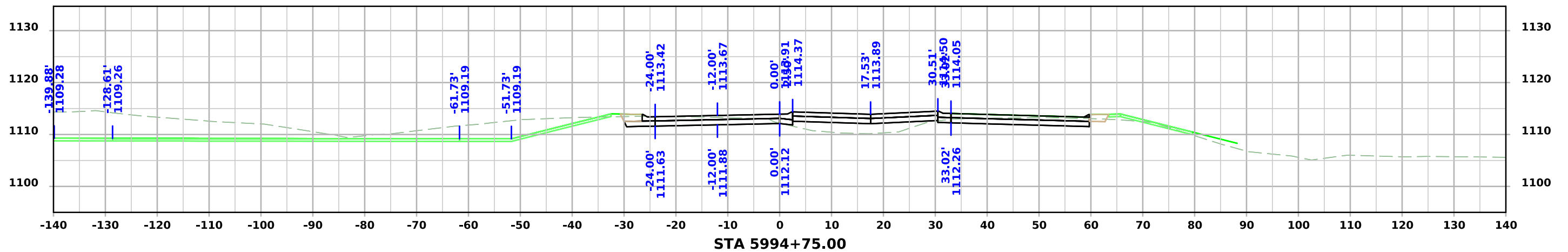
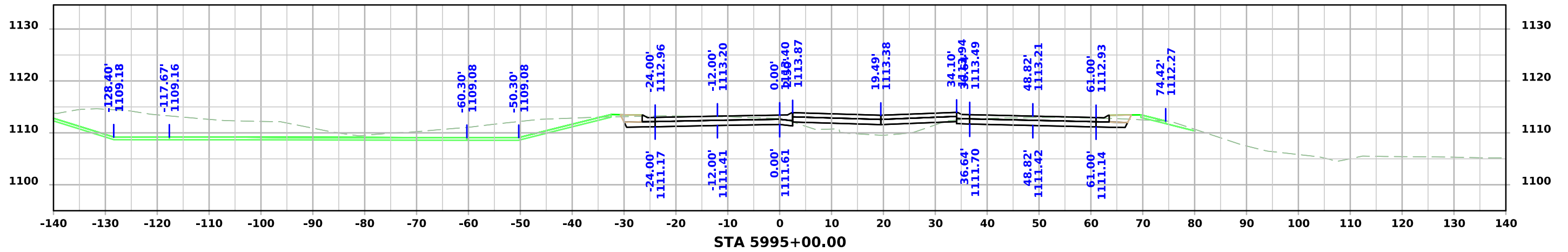

# US30 WB\_2

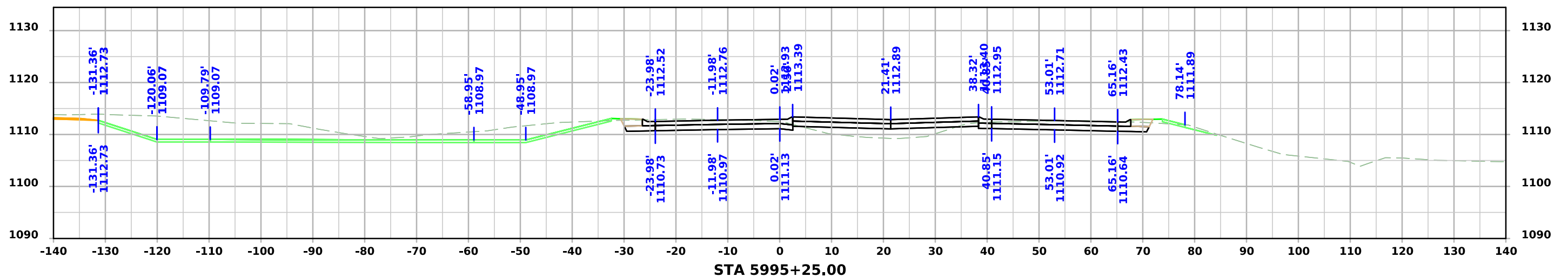
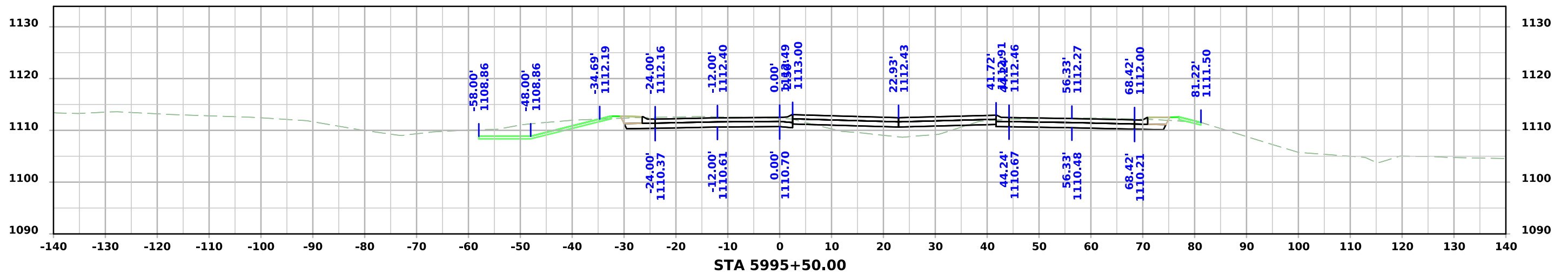
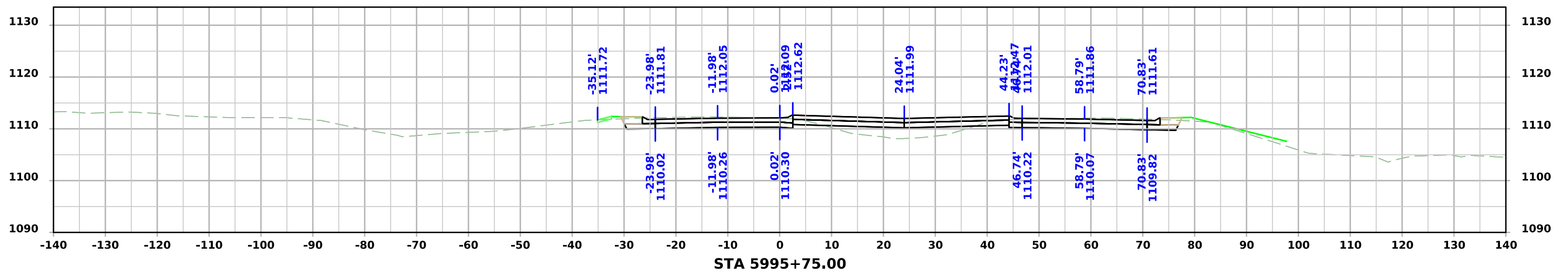

# US30 WB\_2

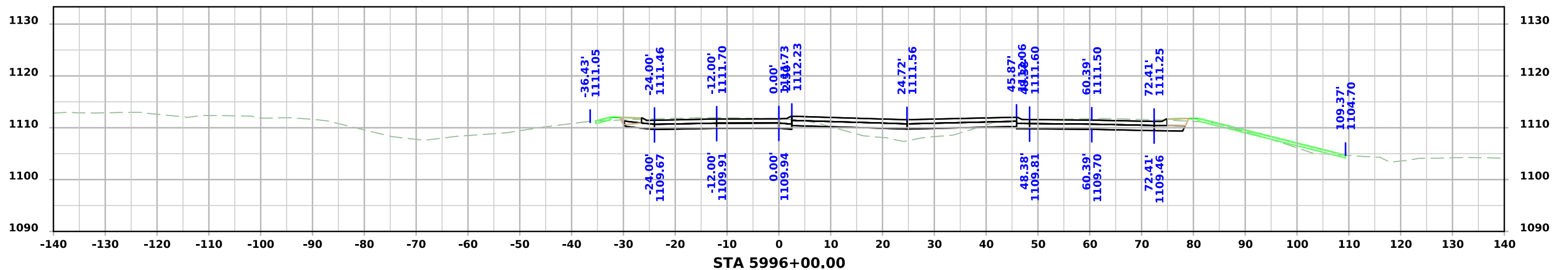
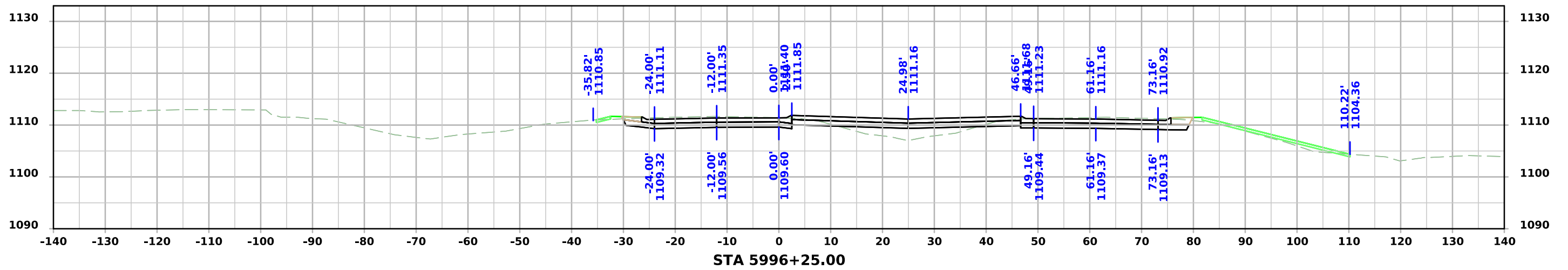
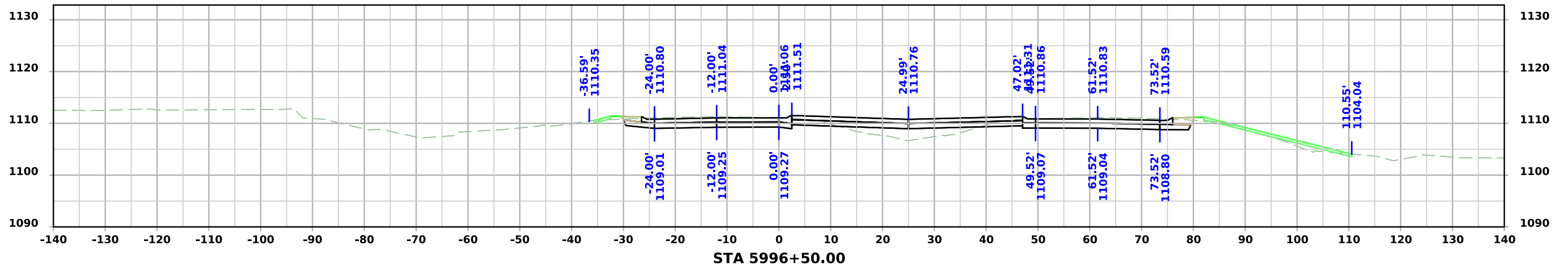

# US30 WB\_2

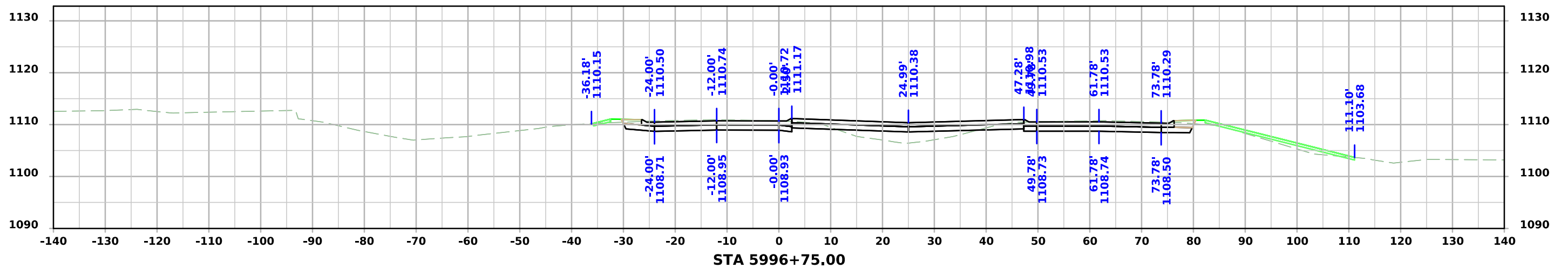
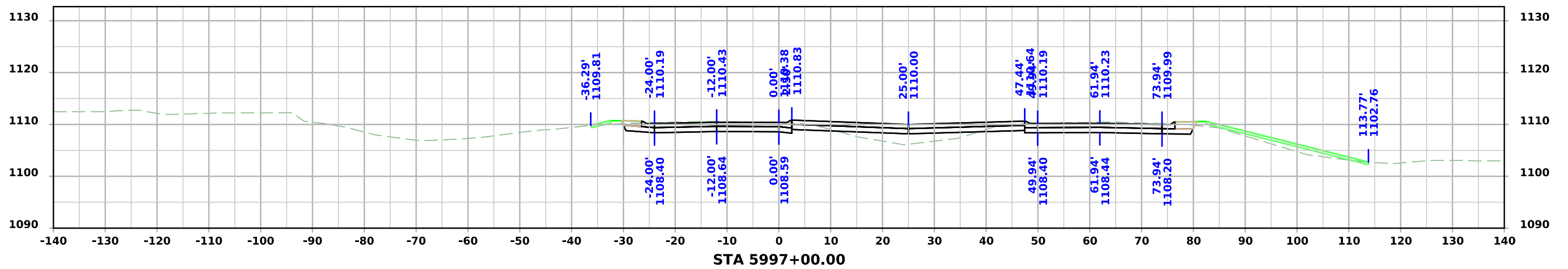
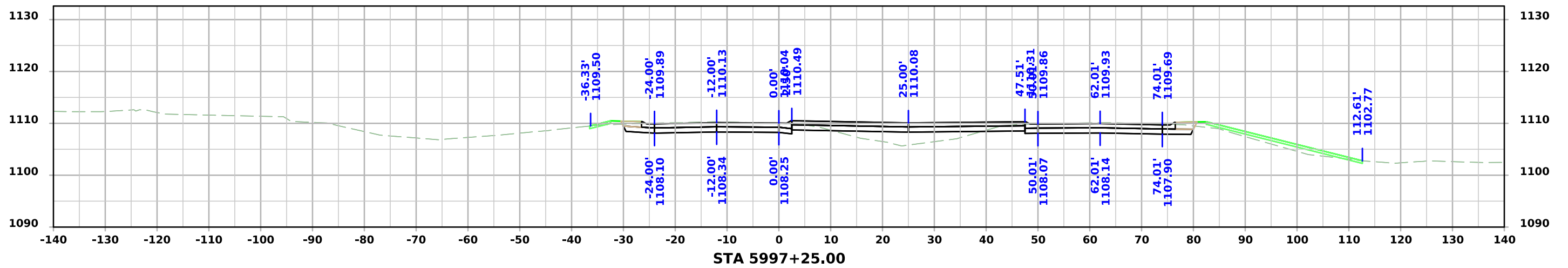

# US30 WB\_2

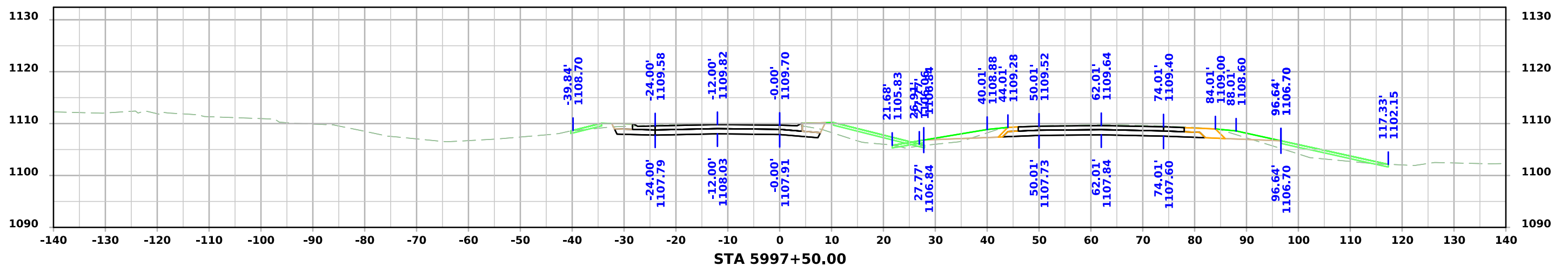
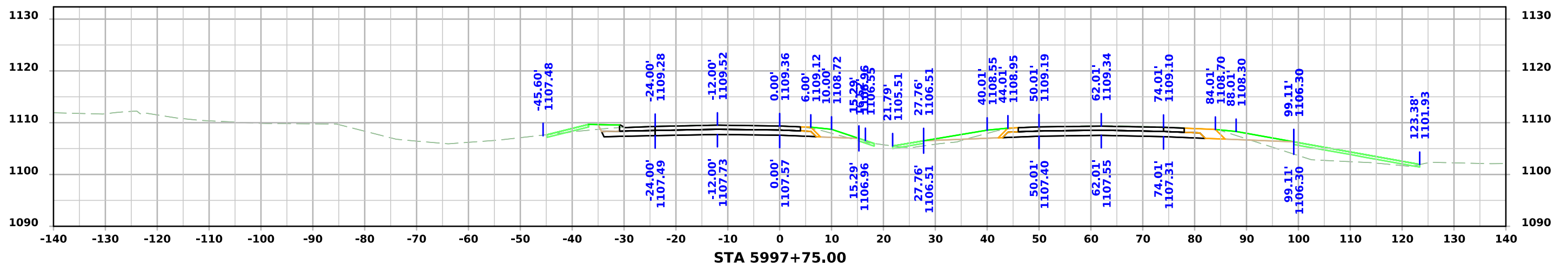
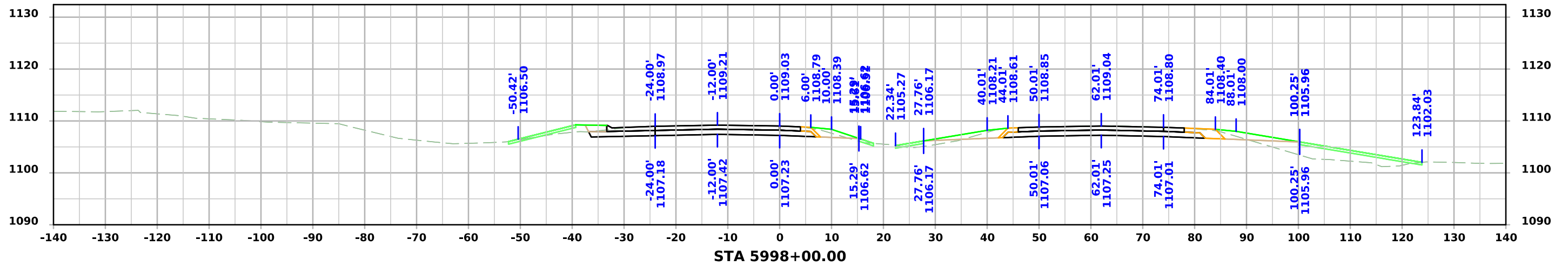

# US30 WB\_2

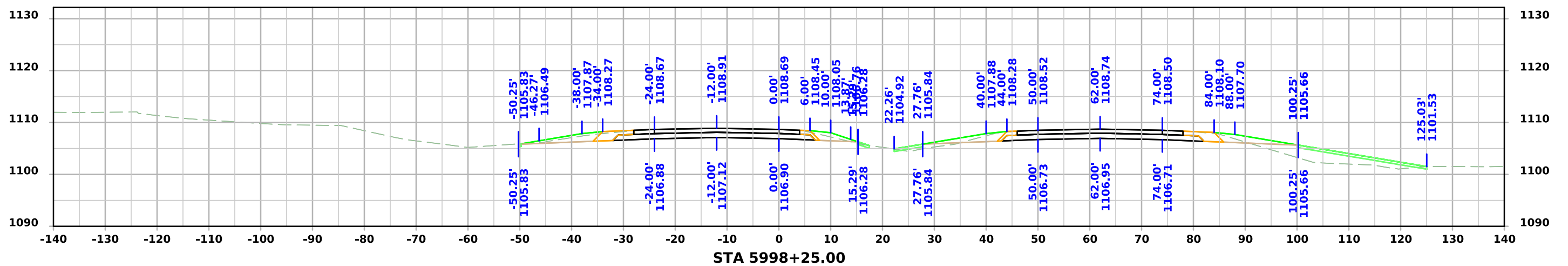
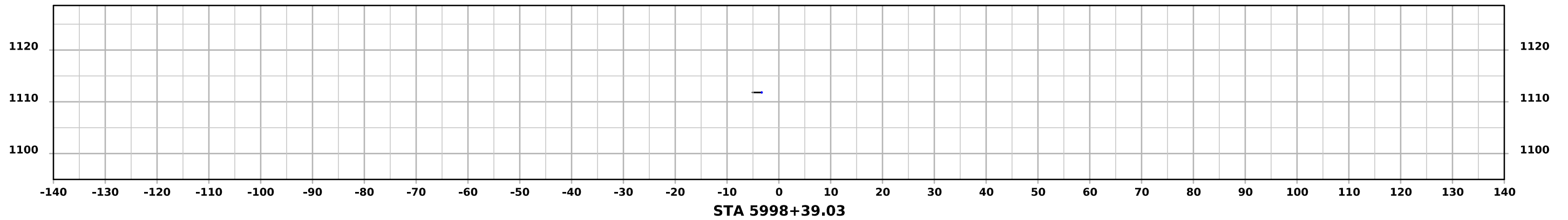

# SR30

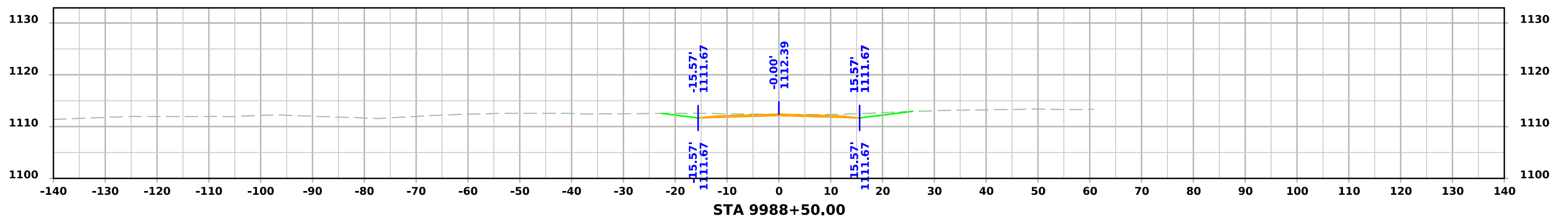
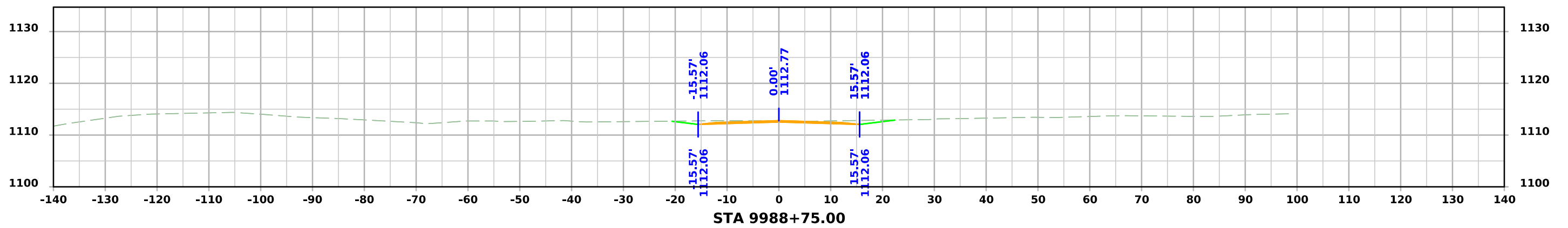
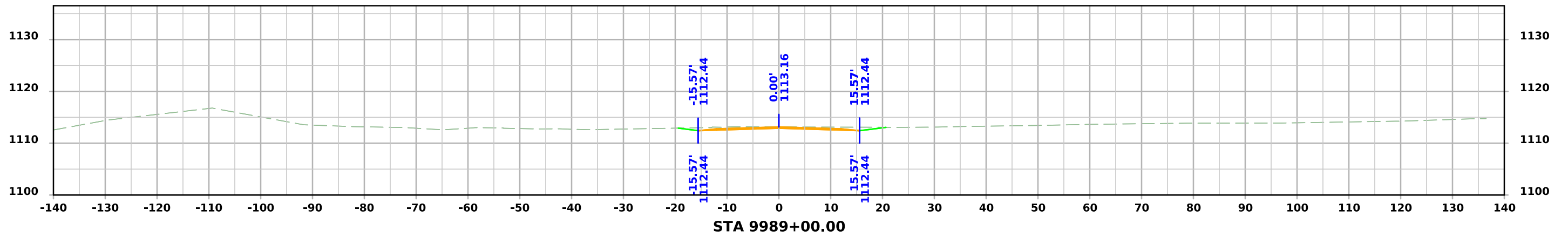



# SR30

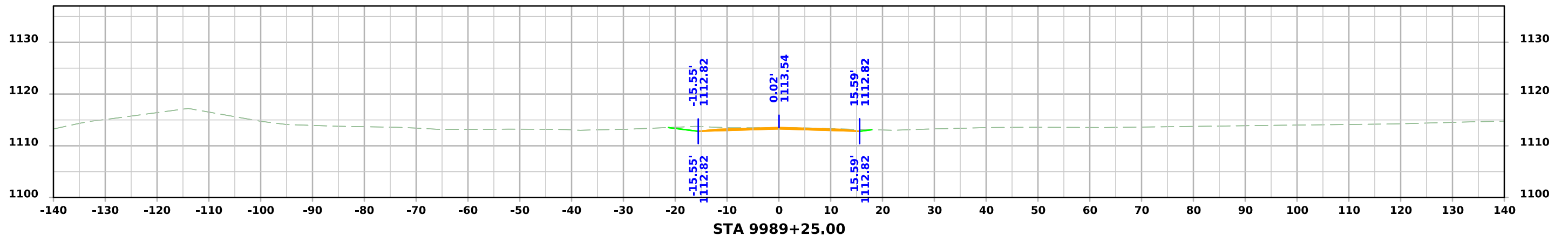
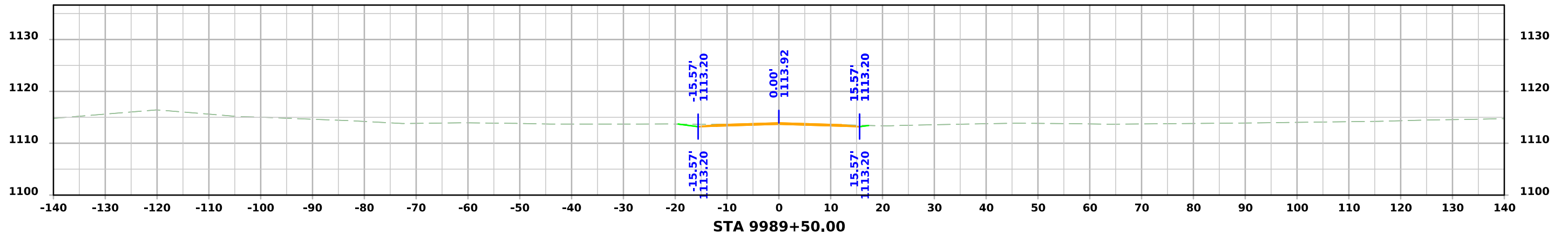
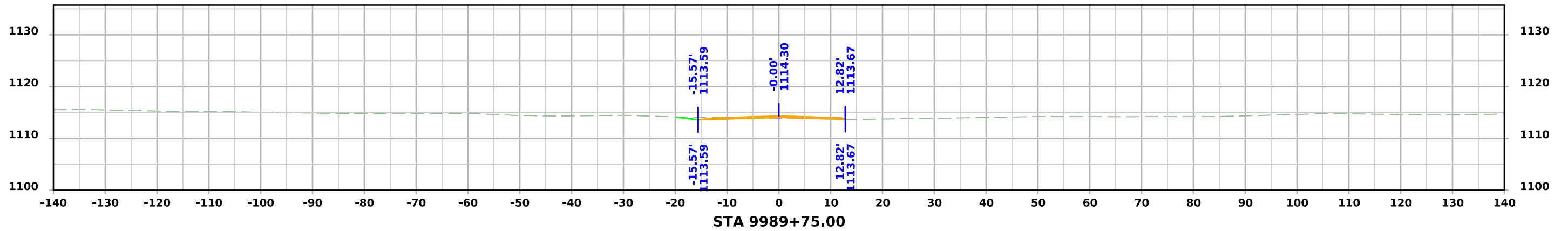

# SR30

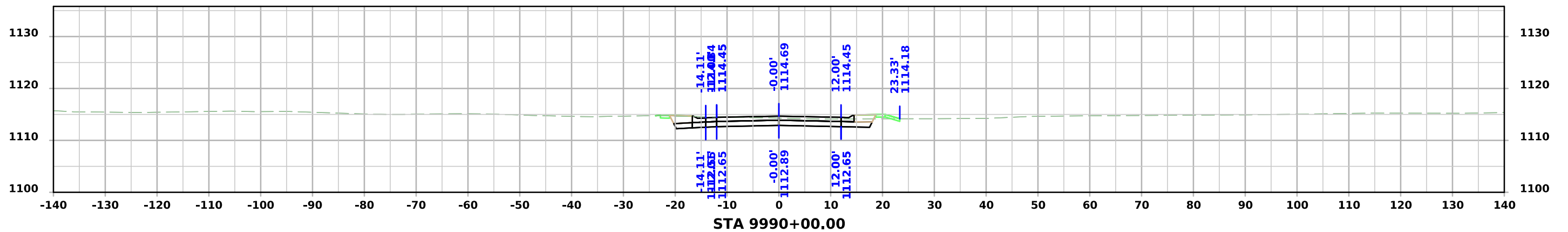
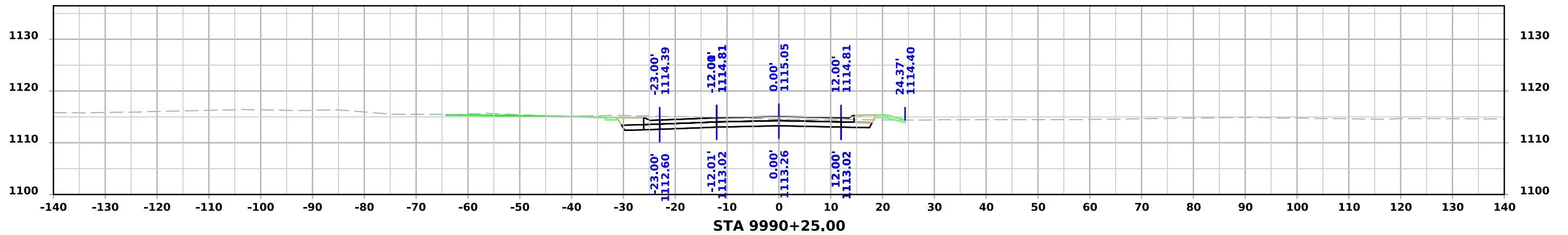
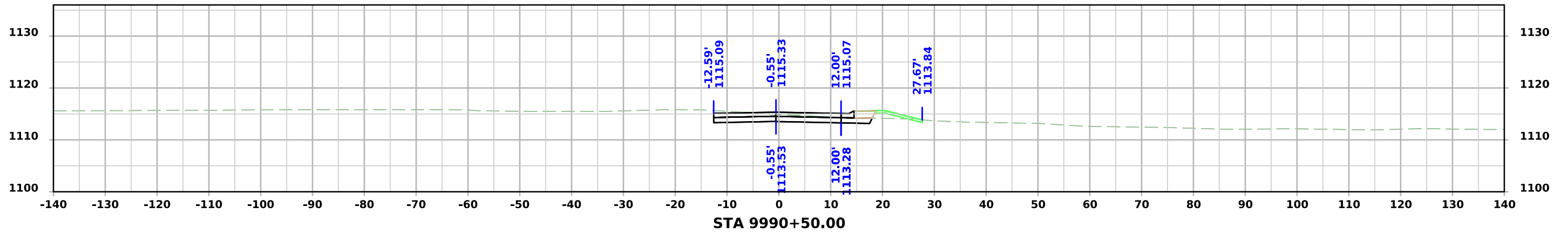

# SR30

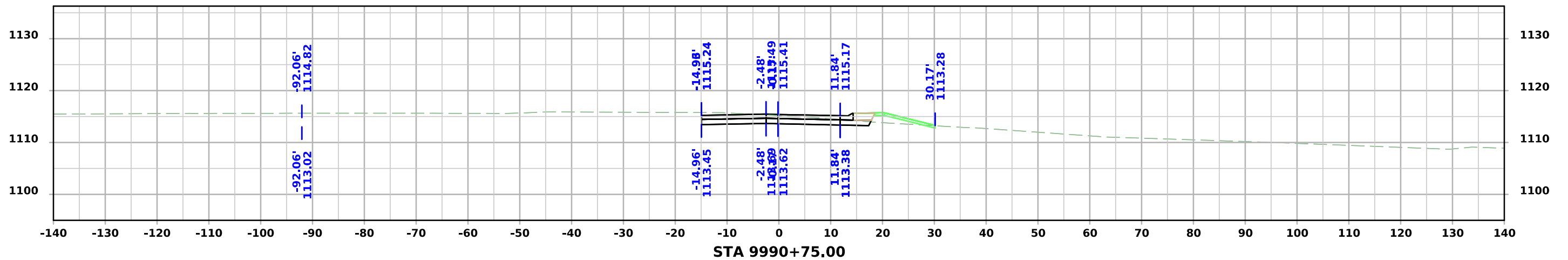
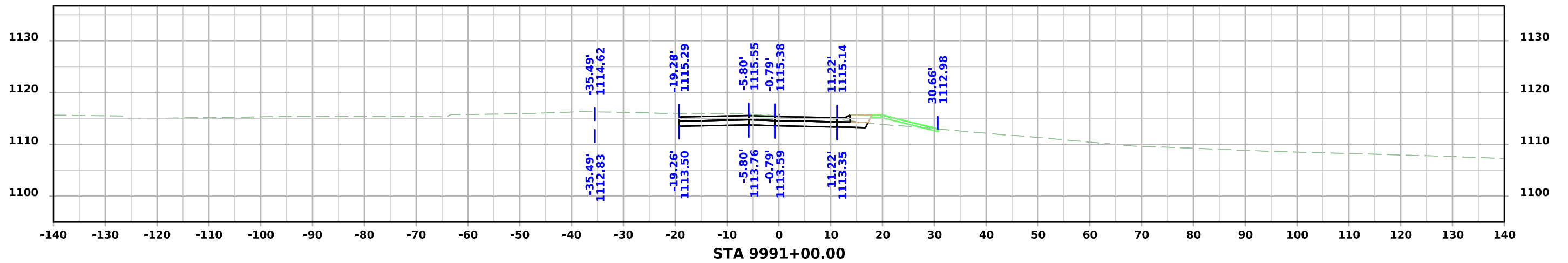
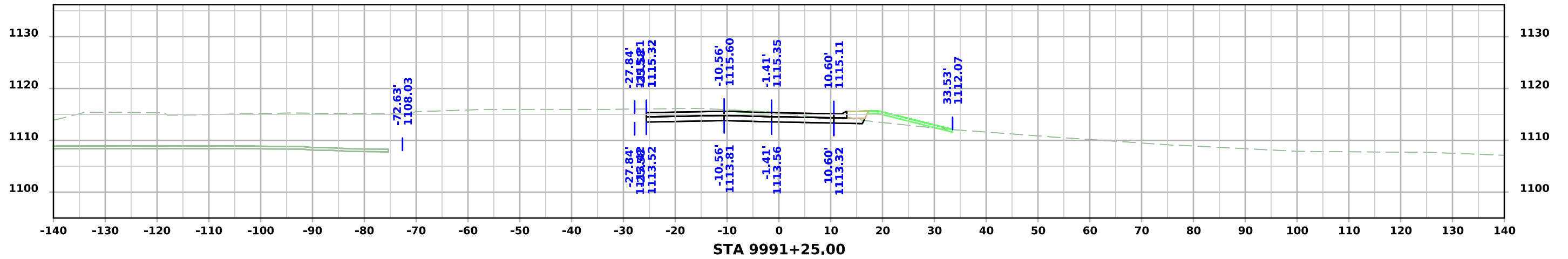

# SR30

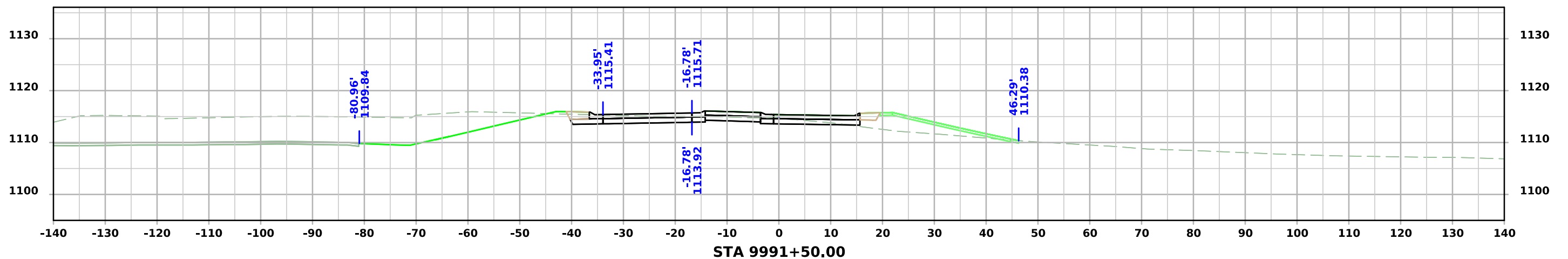
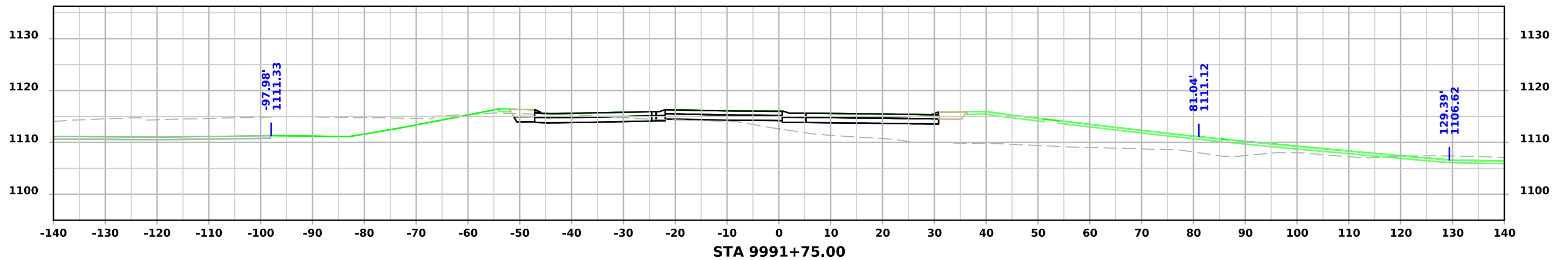
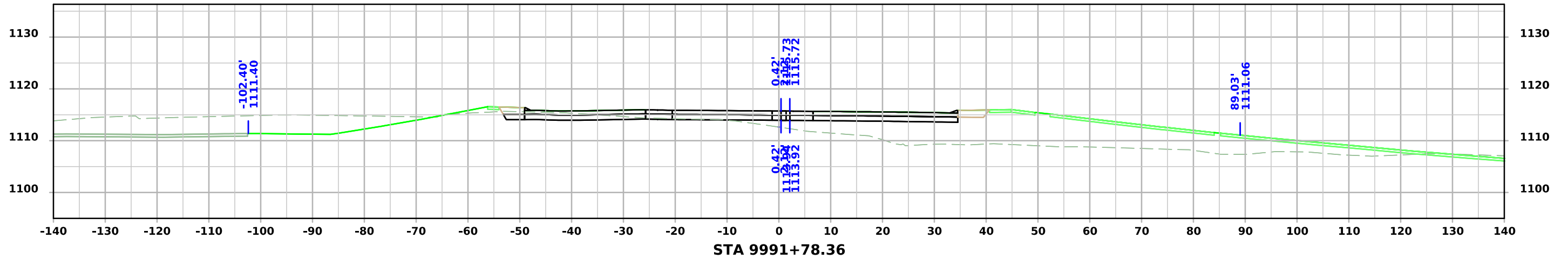

# SR30\_2

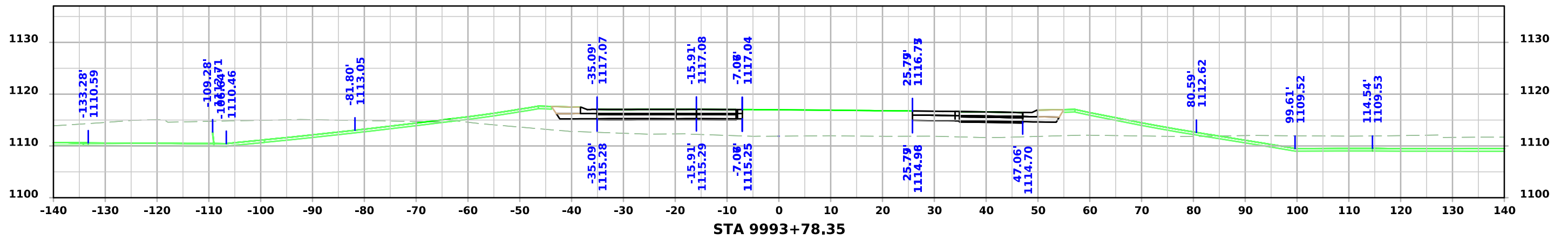
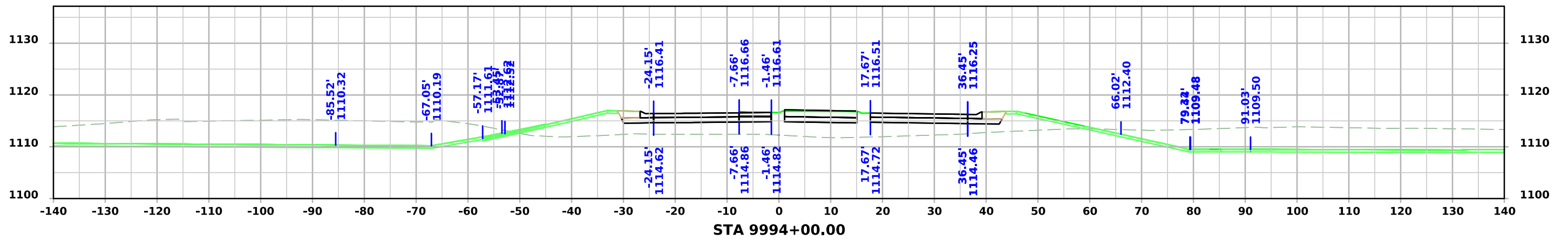
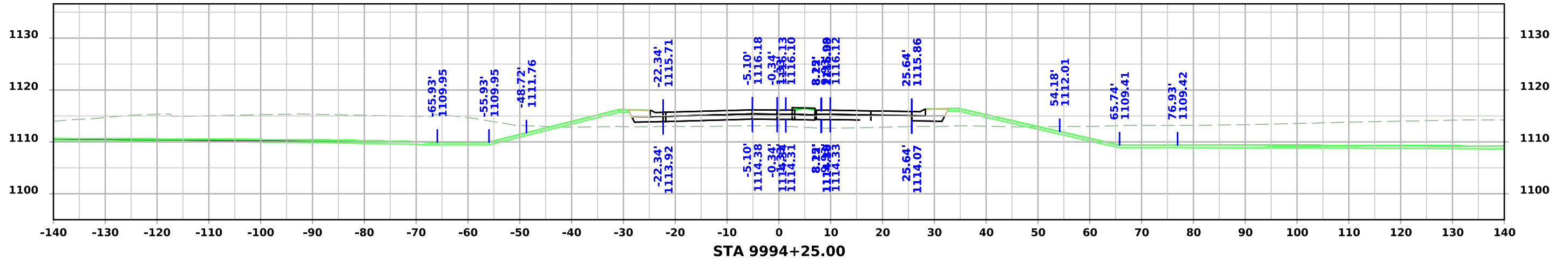

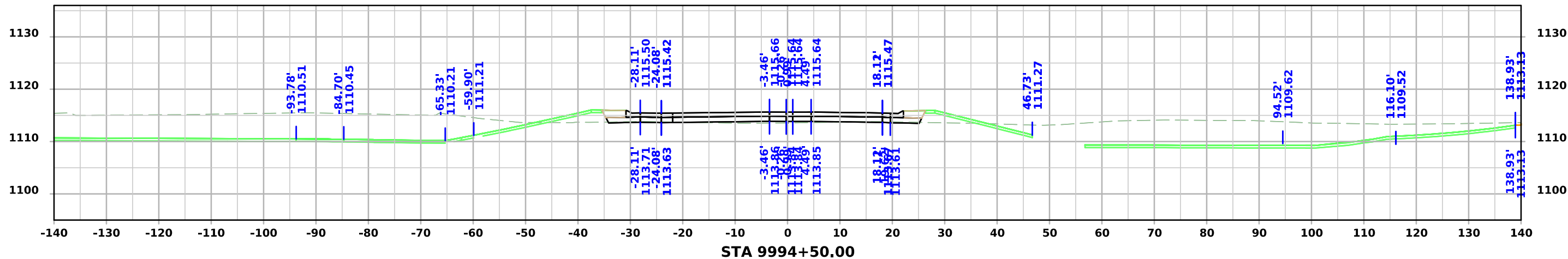

# SE Marshall Street

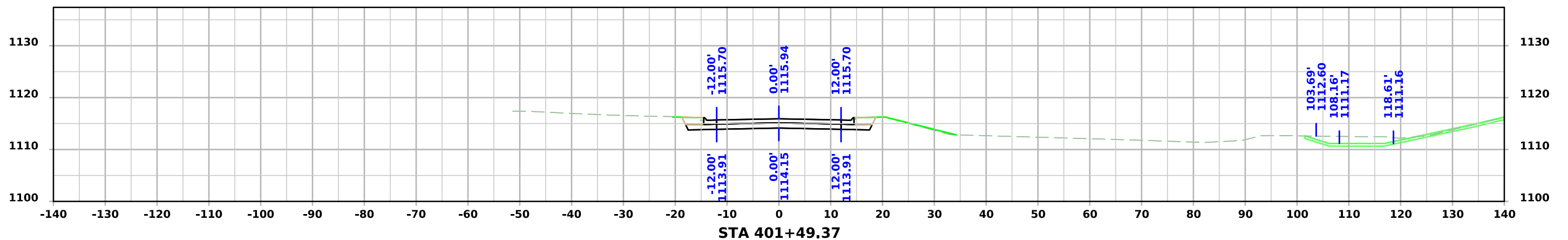
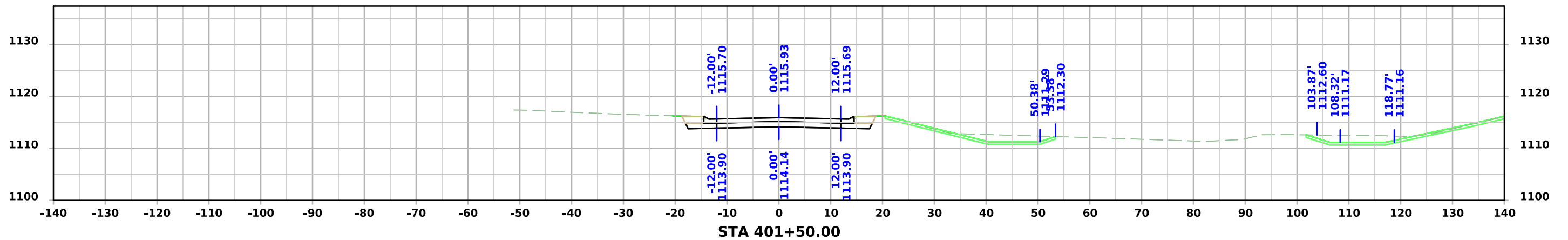
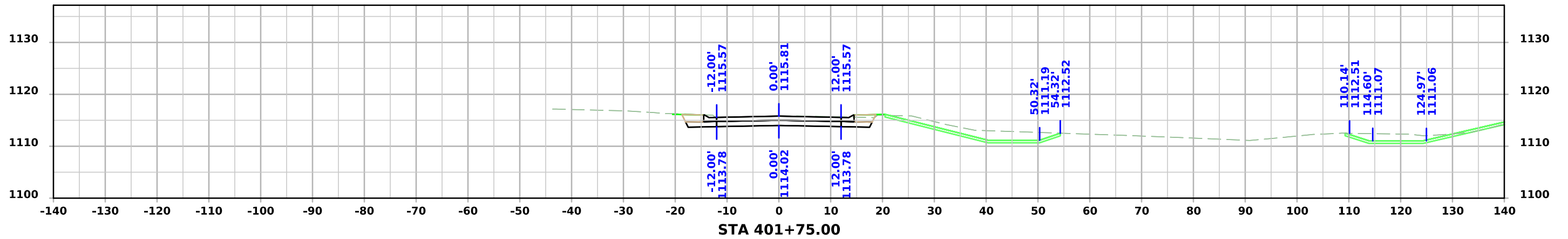

# SE Marshall Street

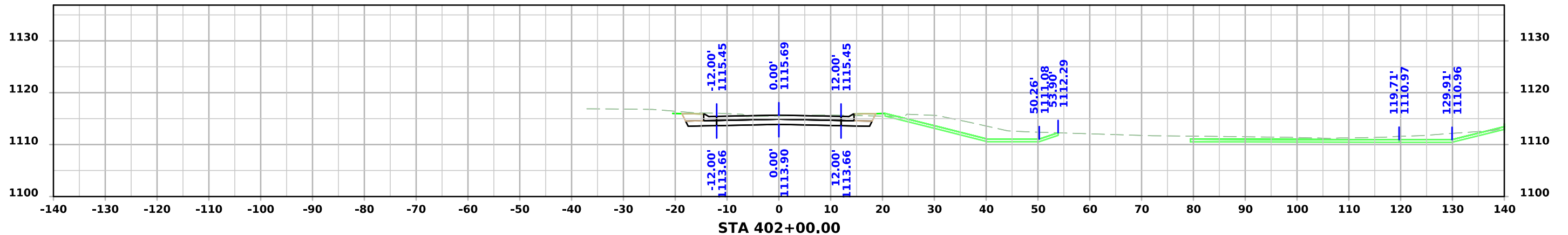
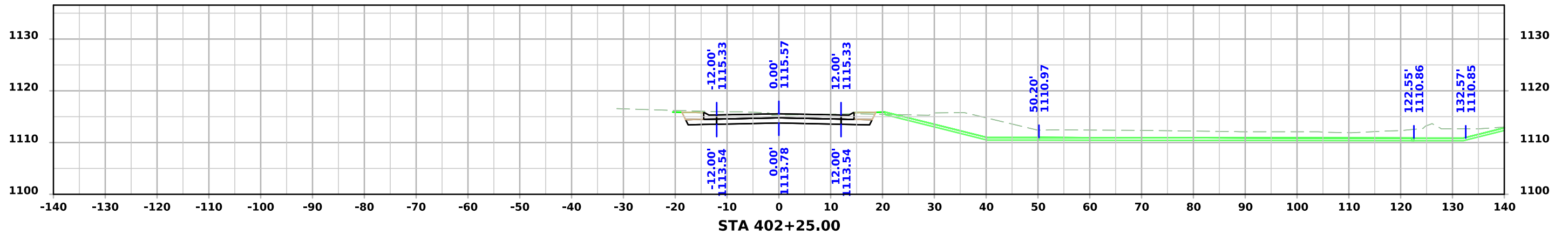
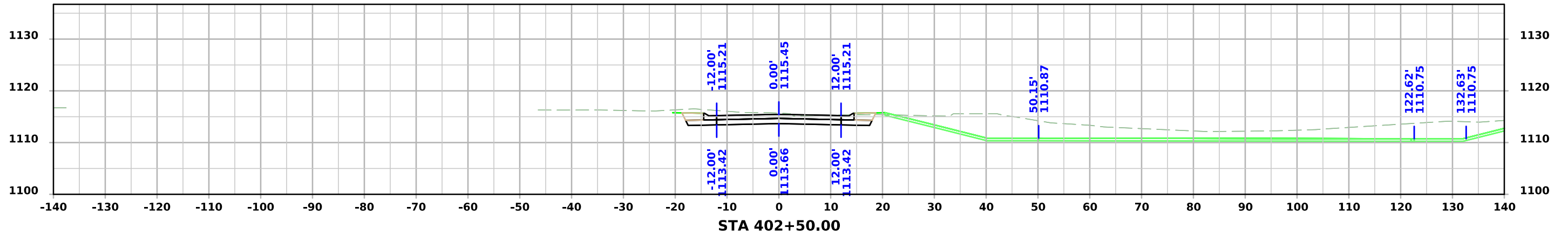



# SE Marshall Street

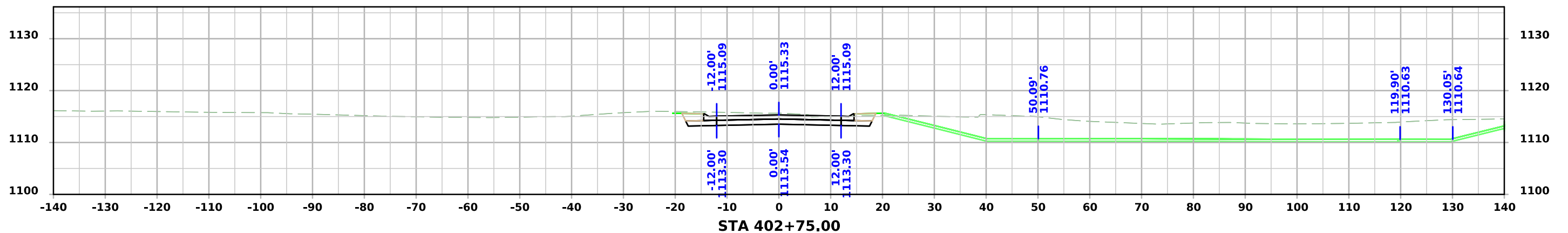
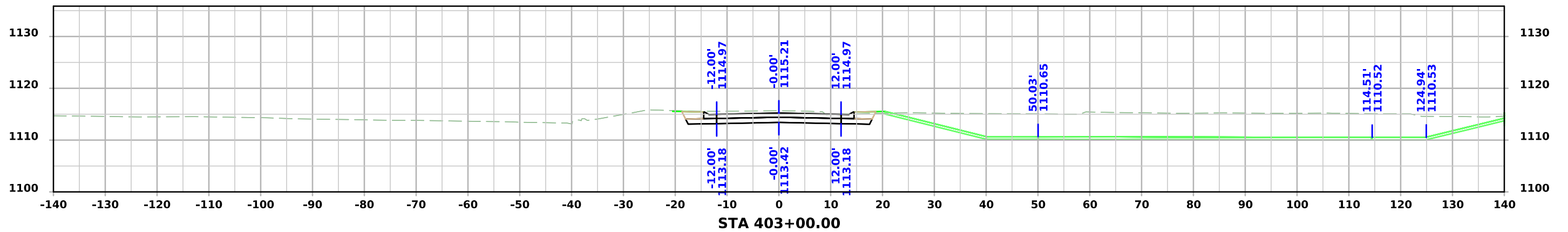
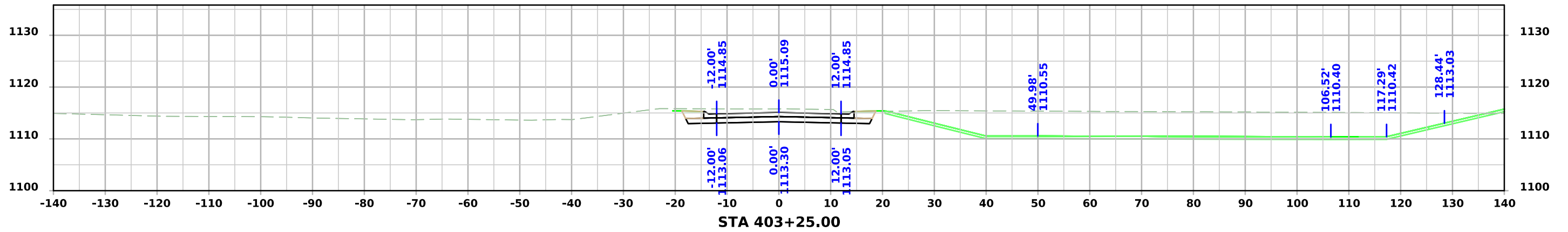

# SE Marshall Street

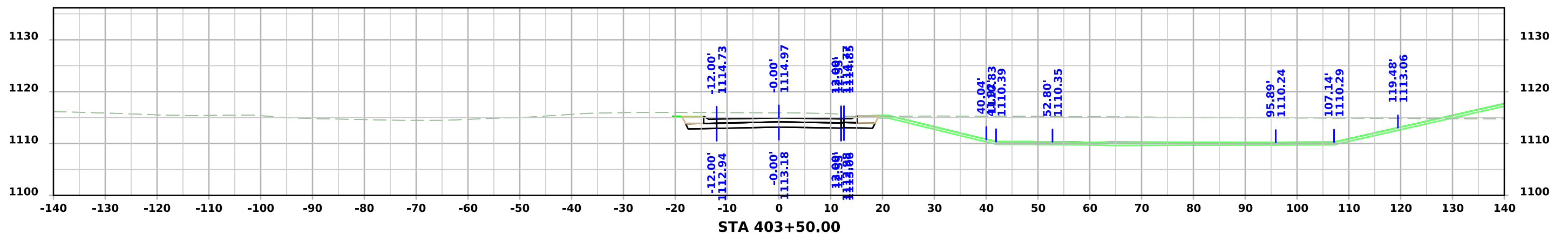
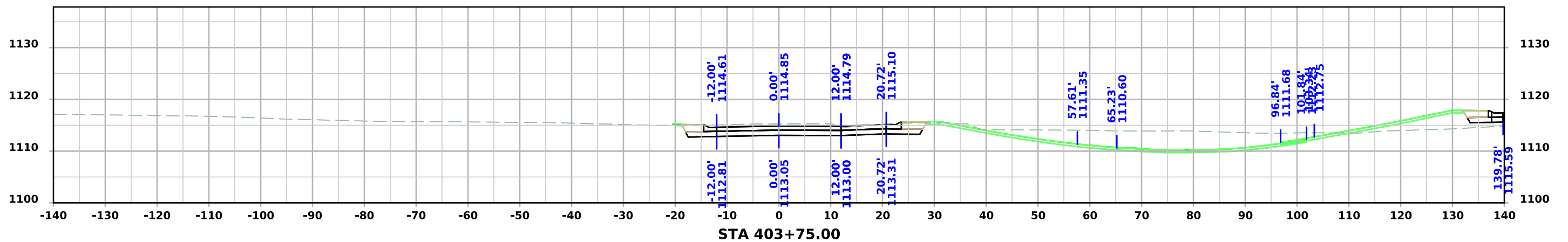
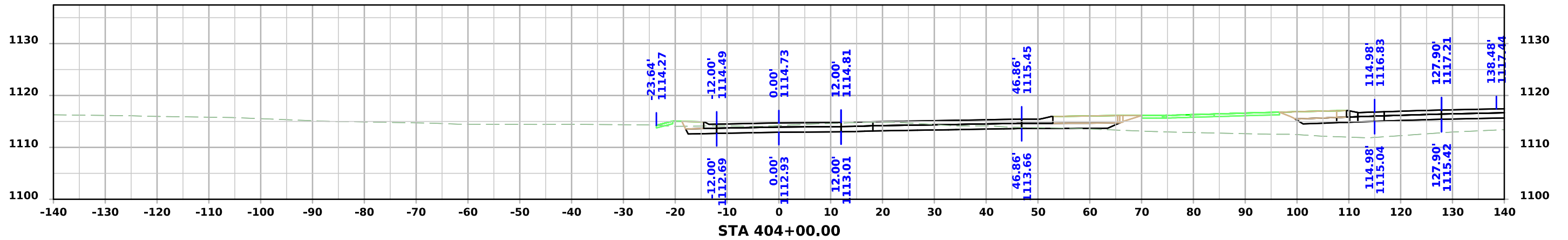

# SE Marshall Street

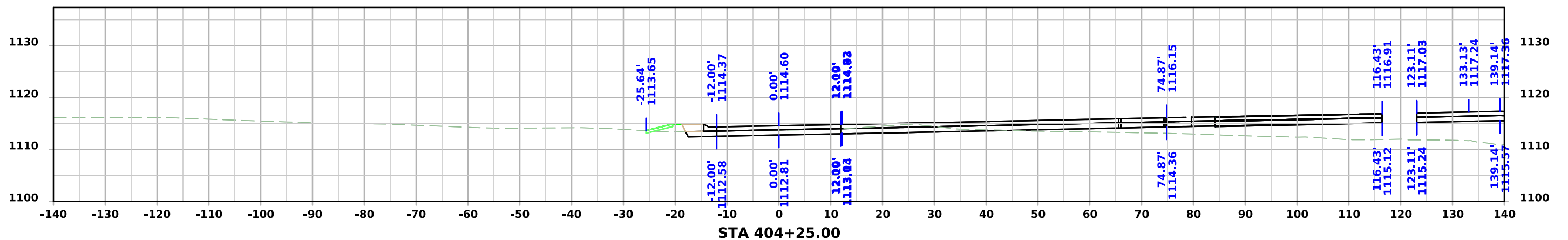
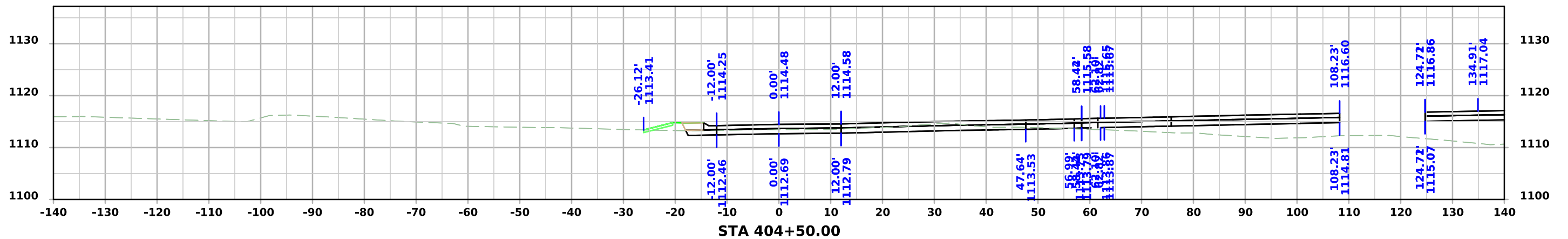
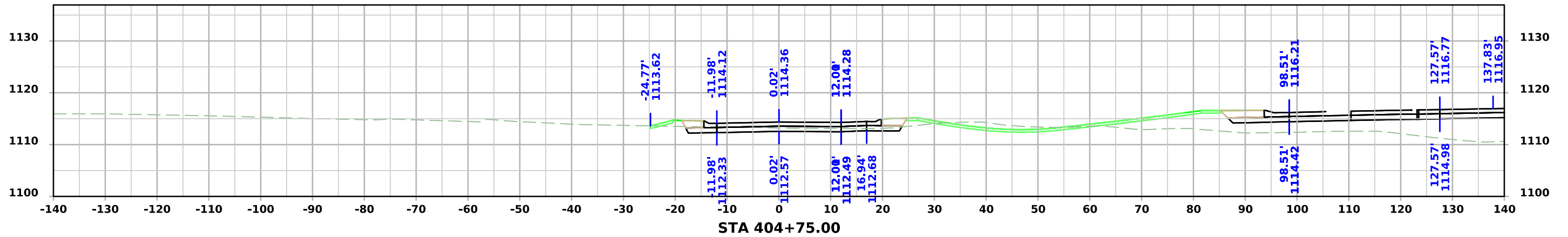

# SE Marshall Street

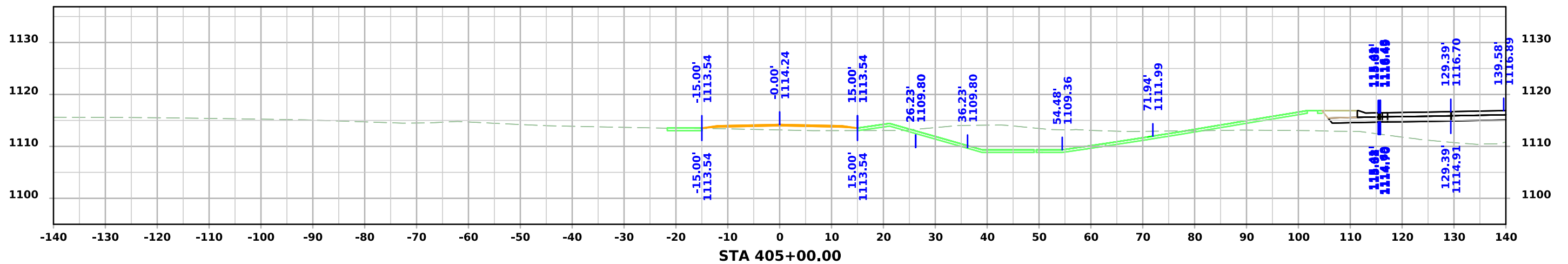
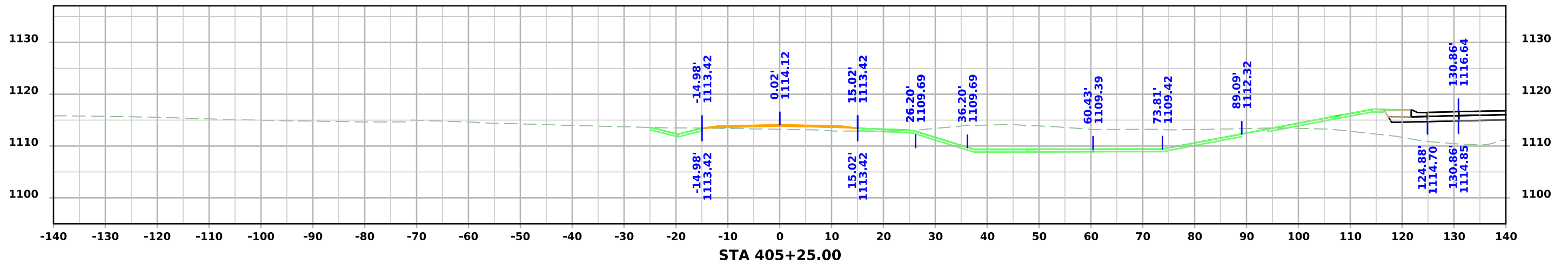
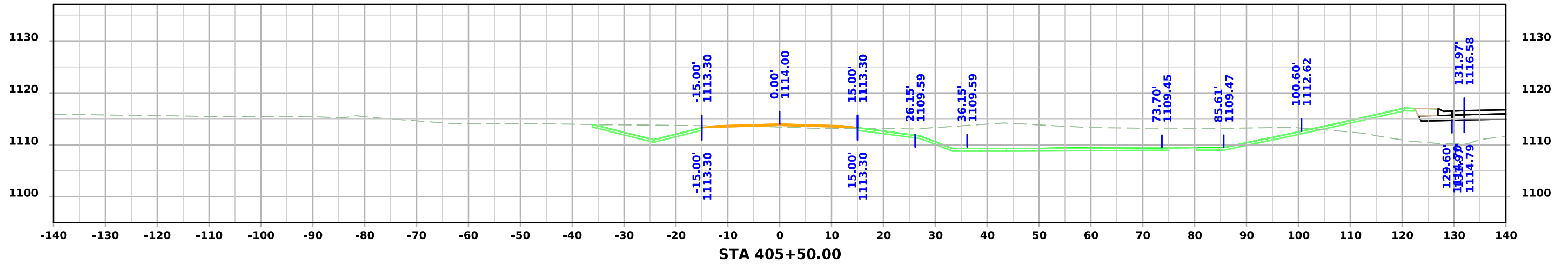

# SE Marshall Street

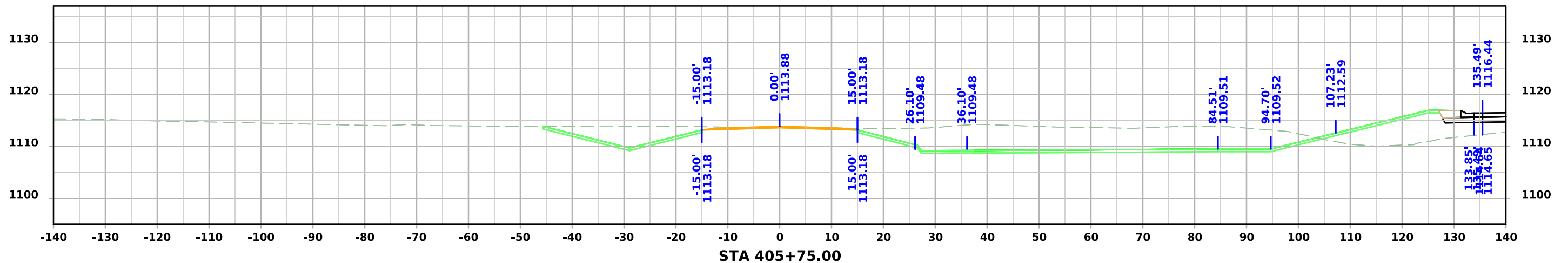
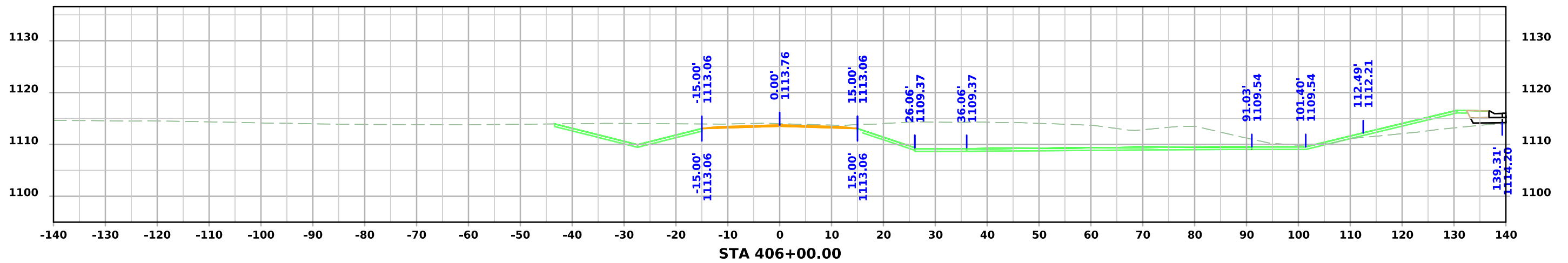
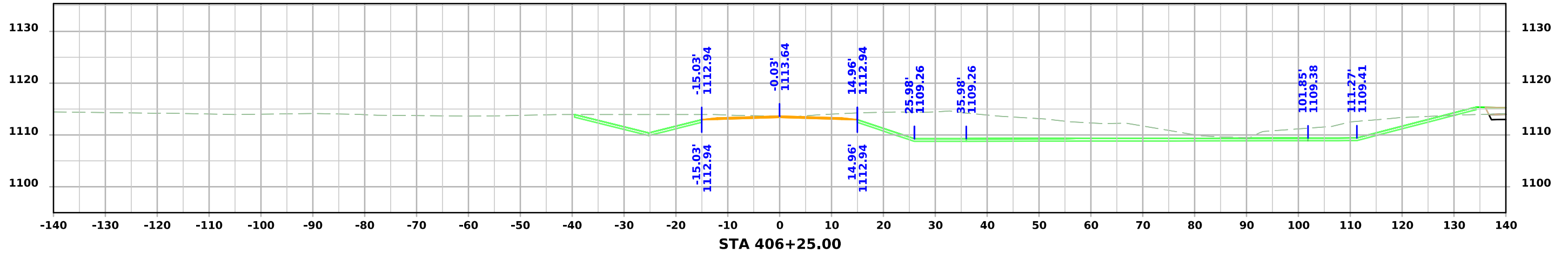

# SE Marshall Street

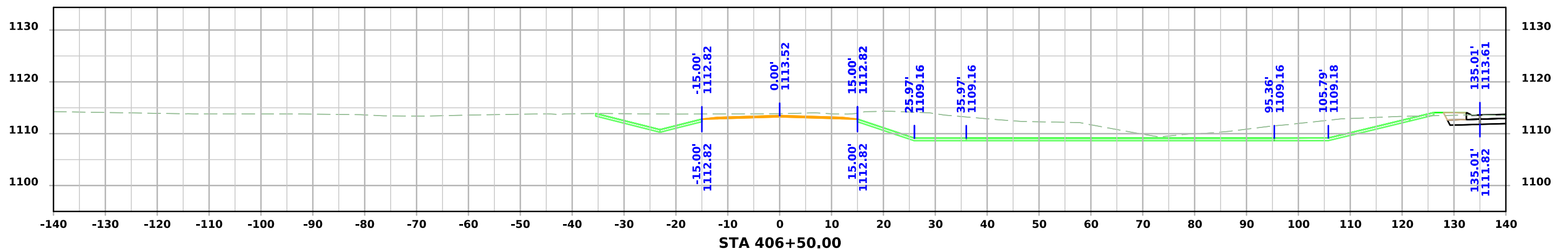
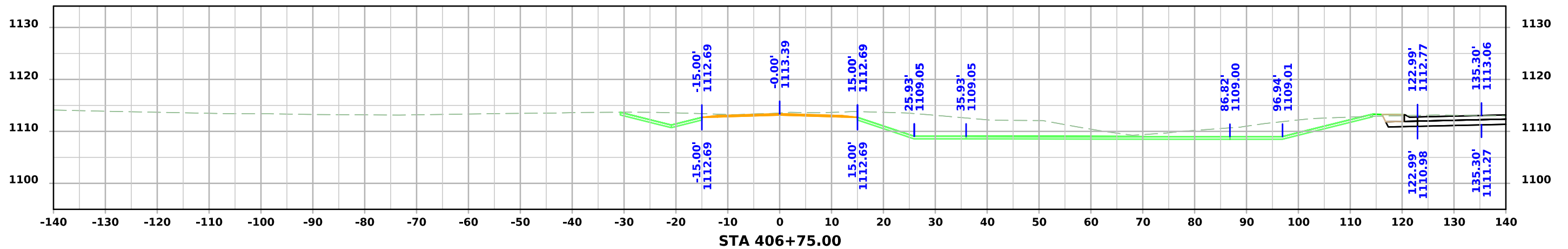
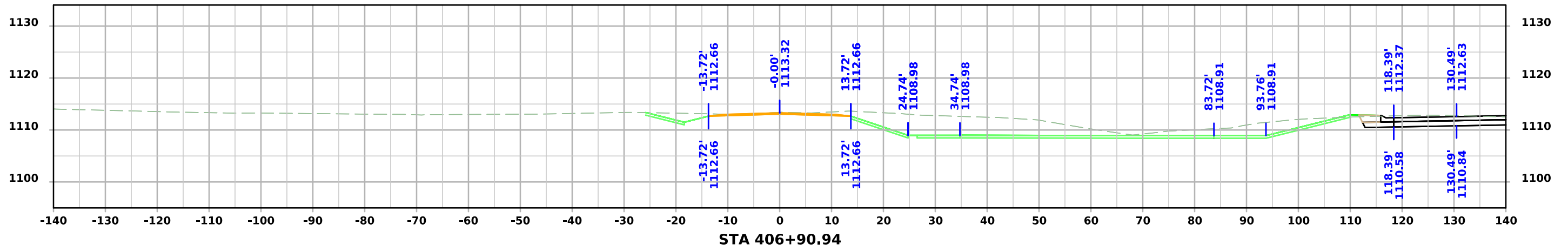

# Crown Flair Dr.

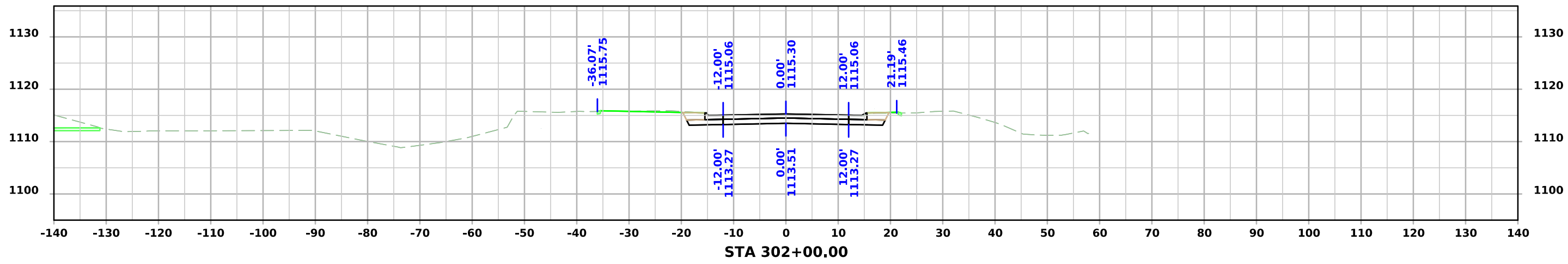
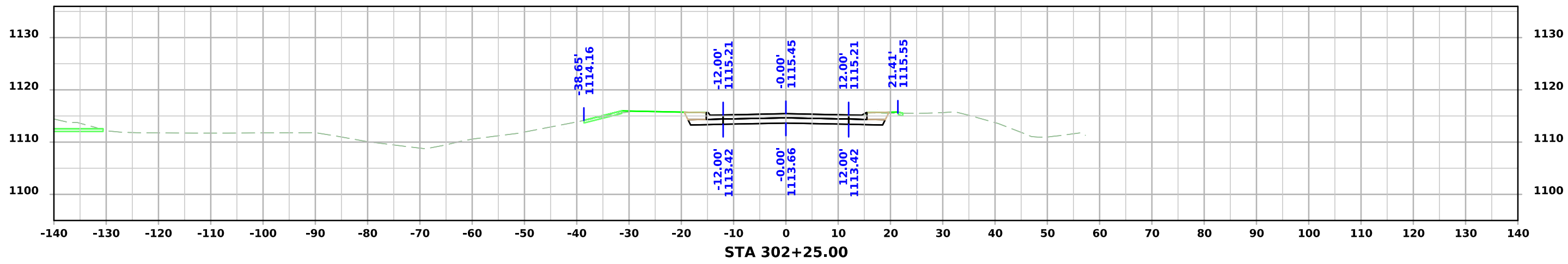
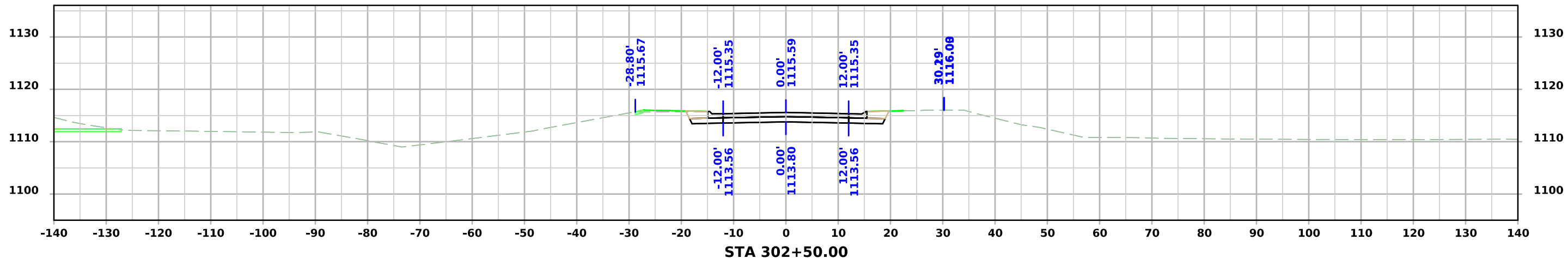

# Crown Flair Dr.

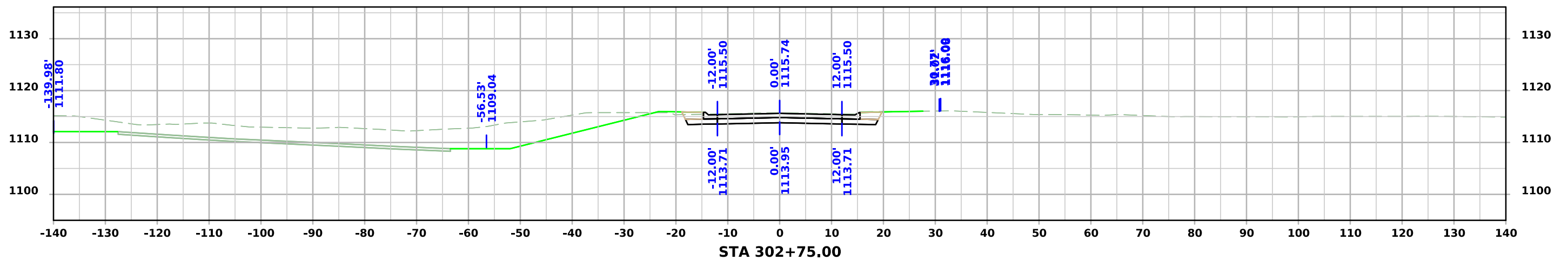
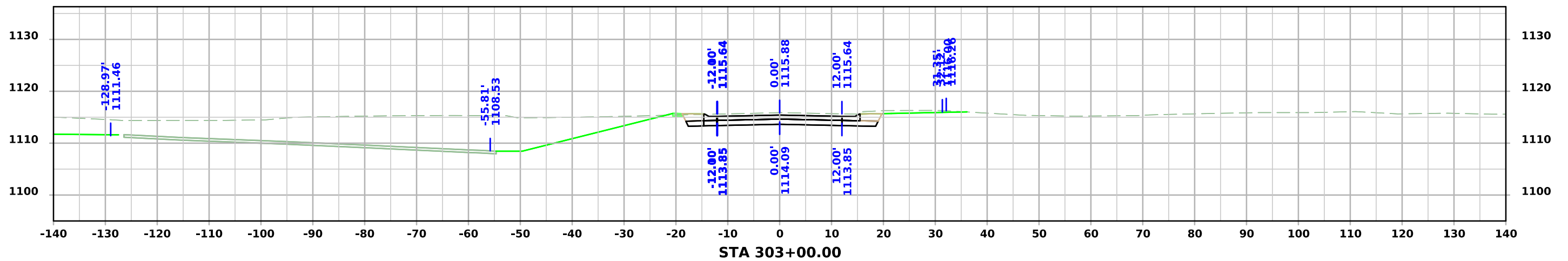
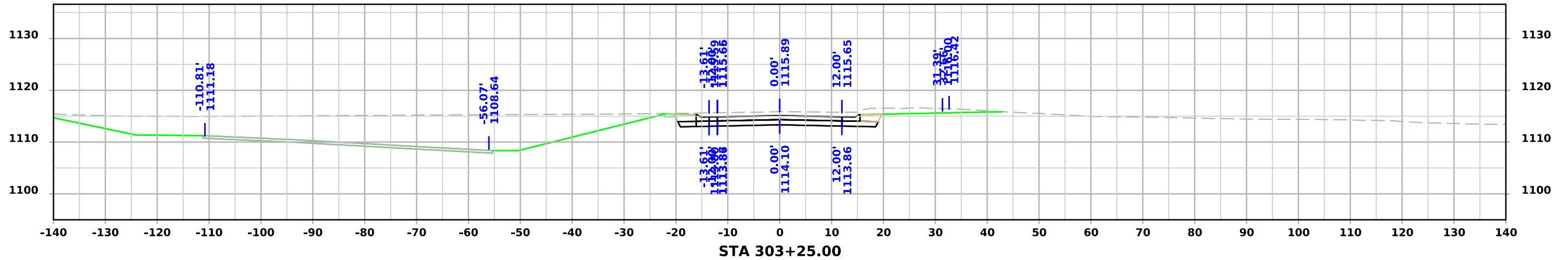



# Crown Flair Dr.

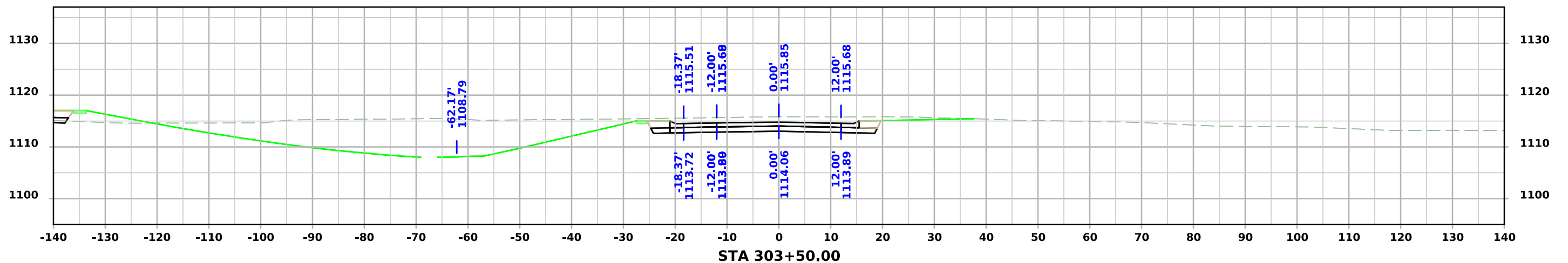
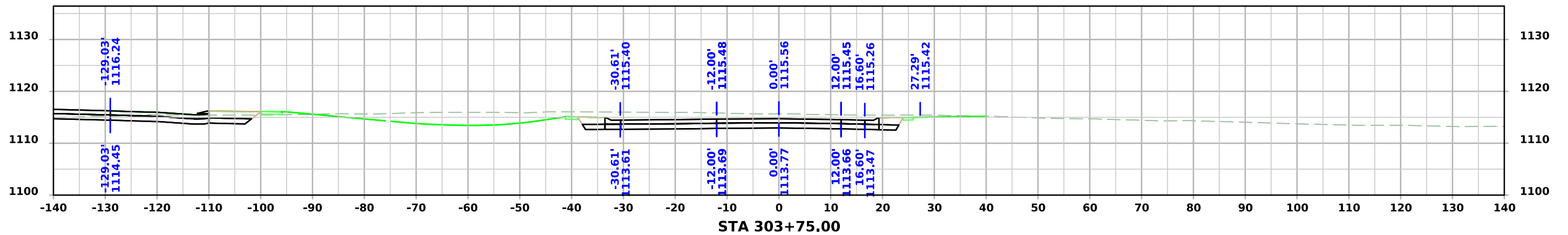
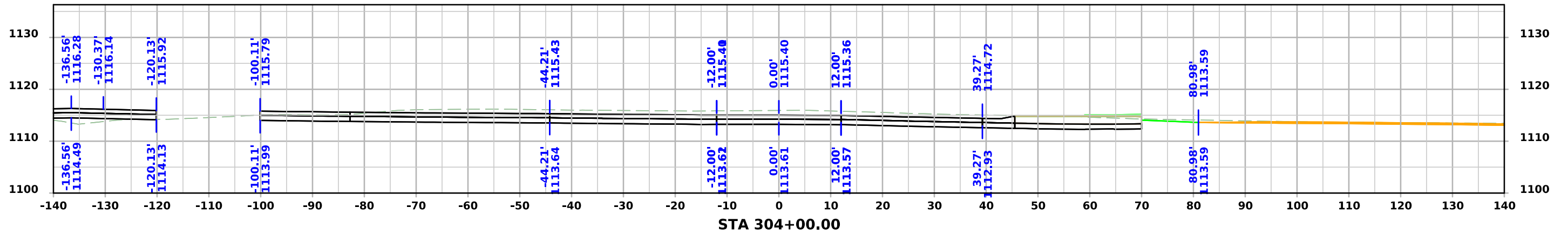

# Crown Flair Dr.

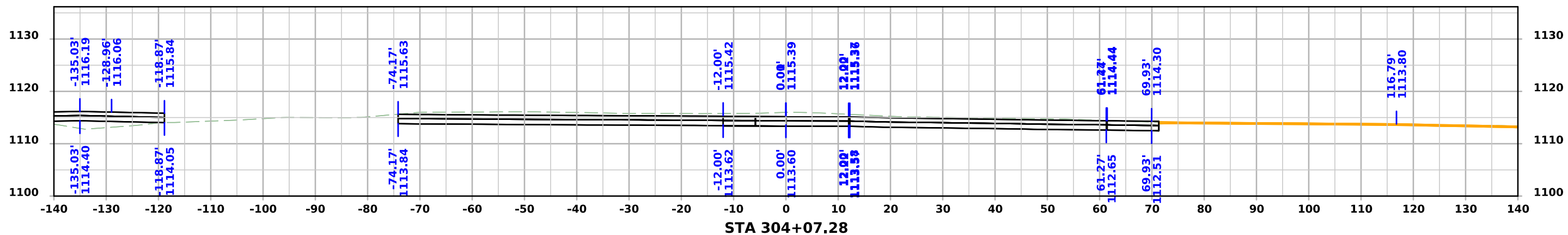

STA 304+07.28

# RA Circle

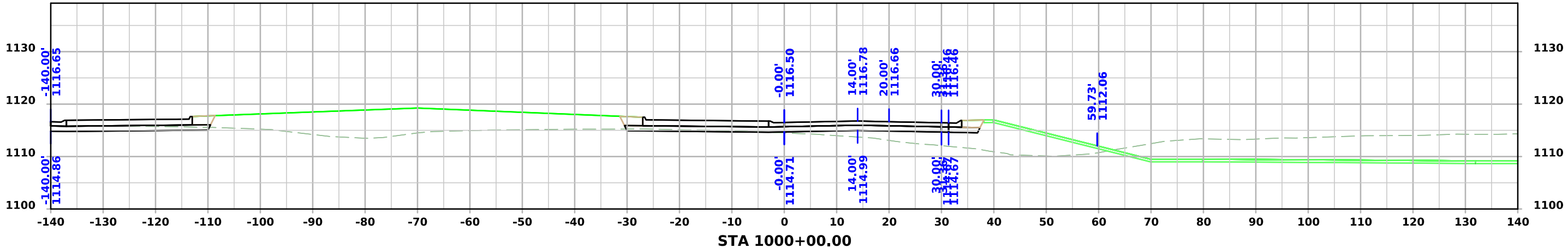
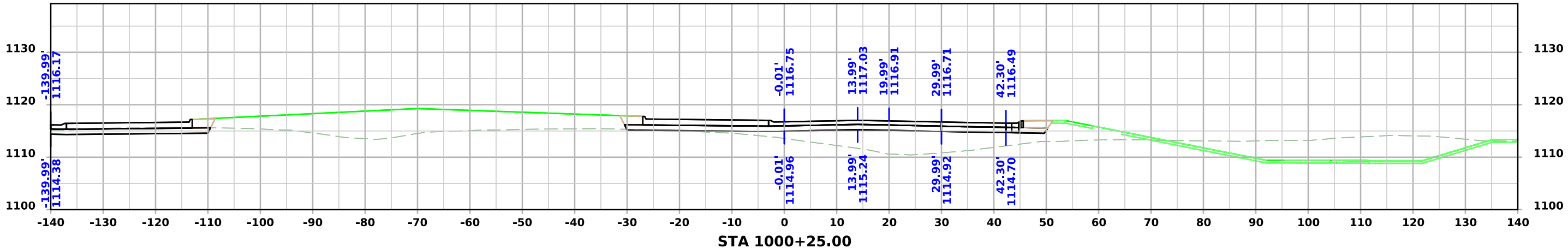
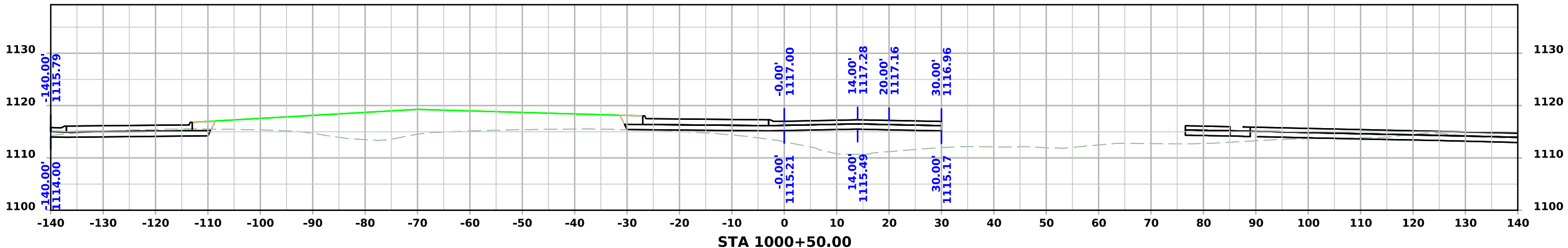

# RA Circle

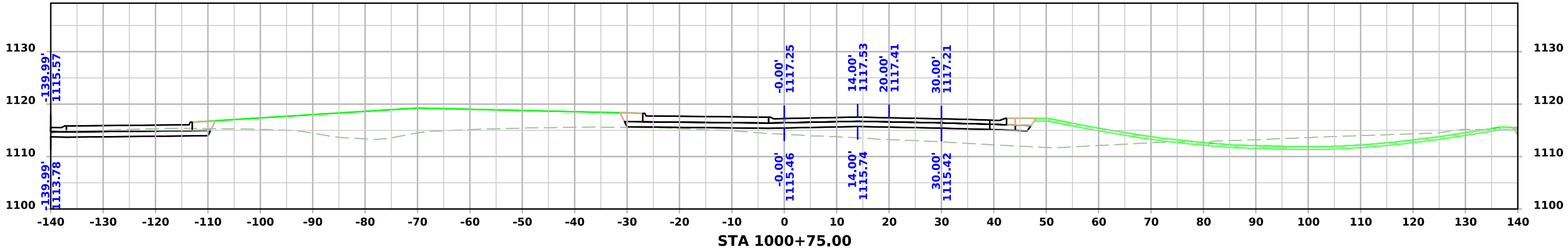
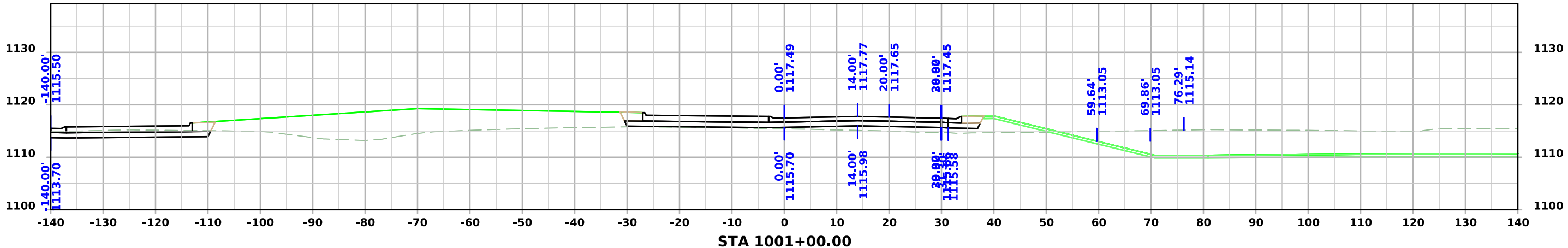
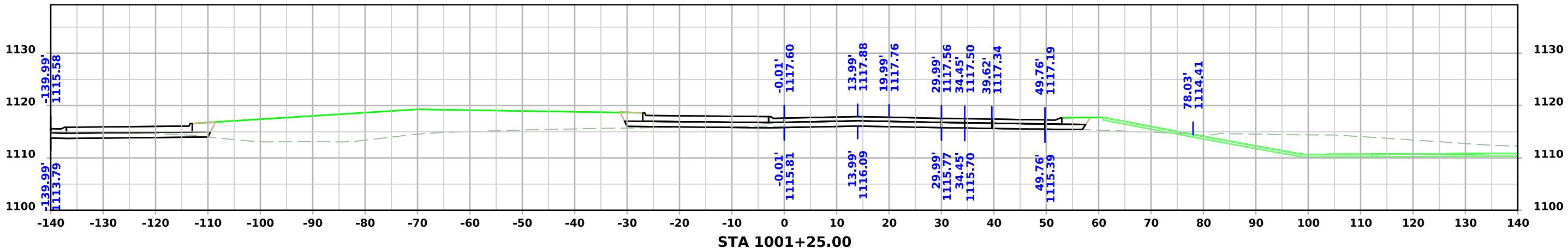

# RA Circle

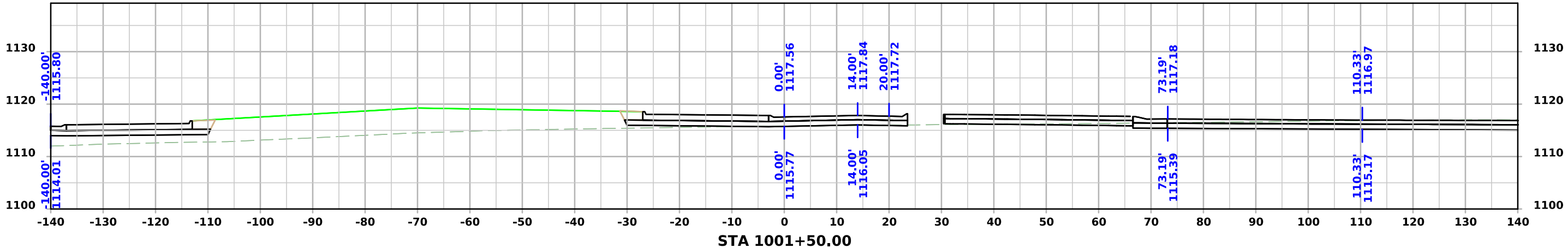
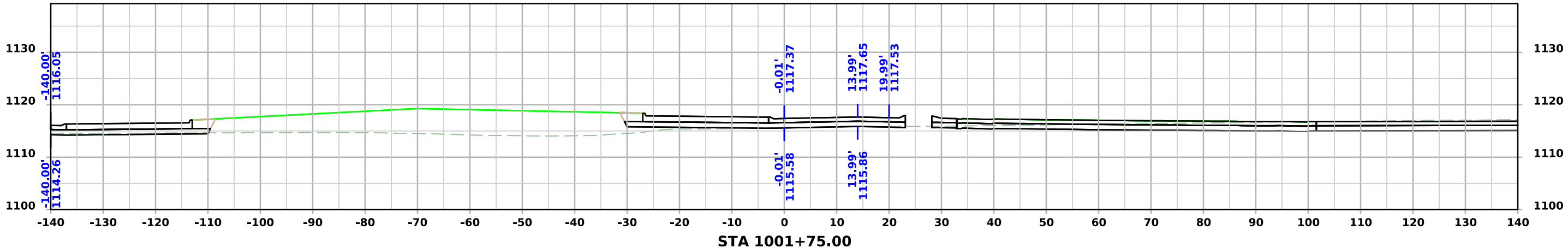
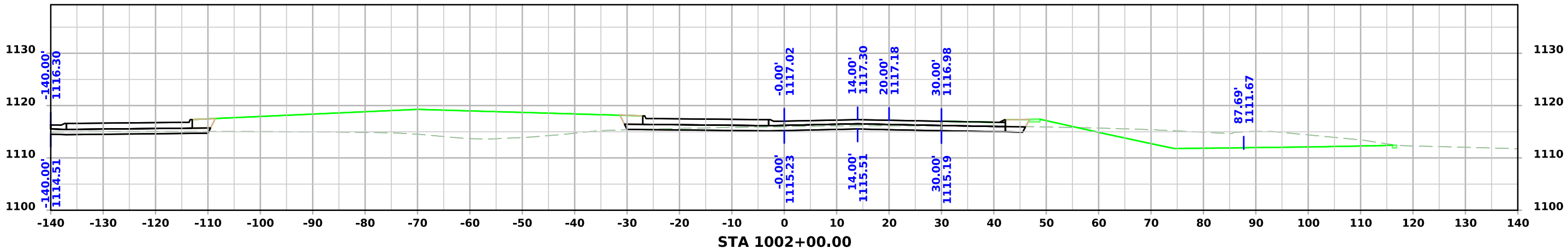

# RA Circle

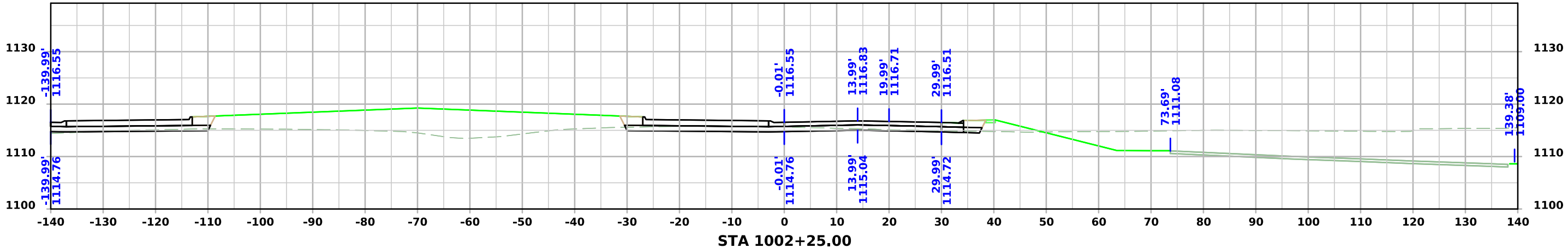
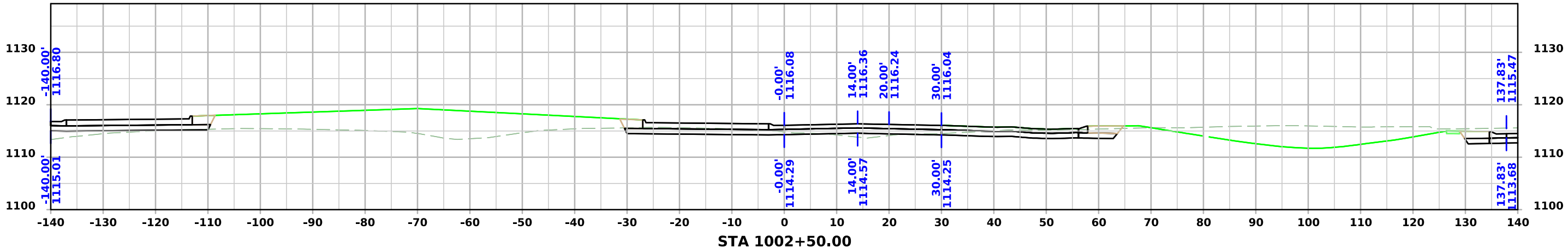
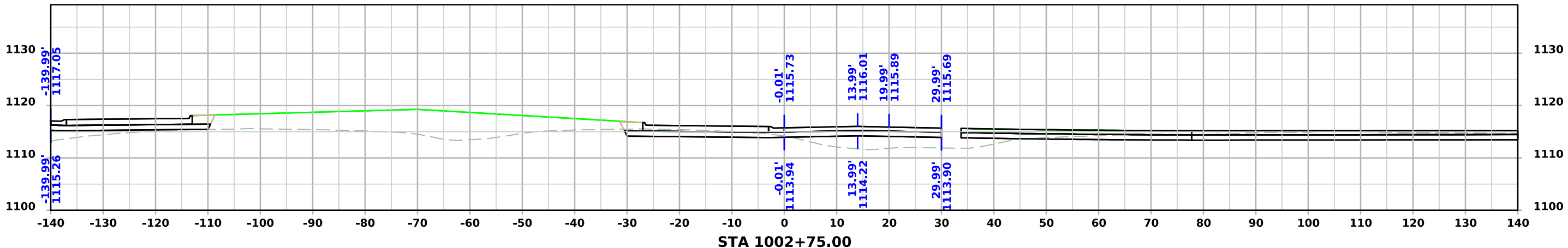

# RA Circle

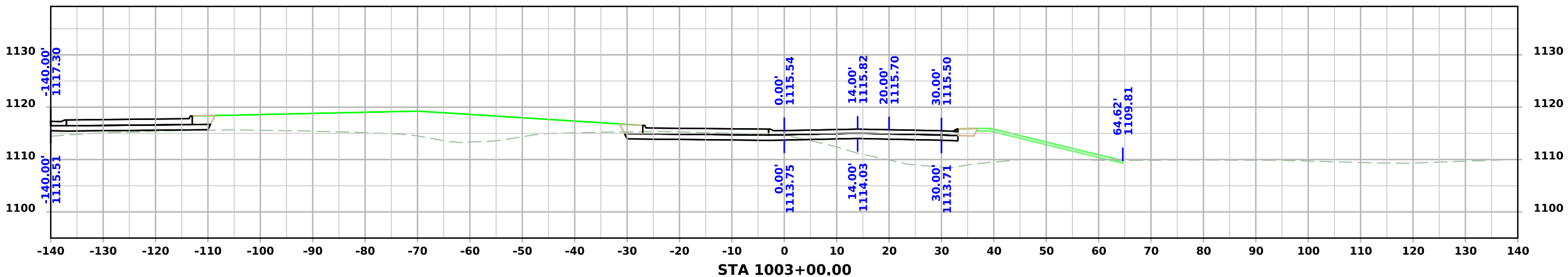
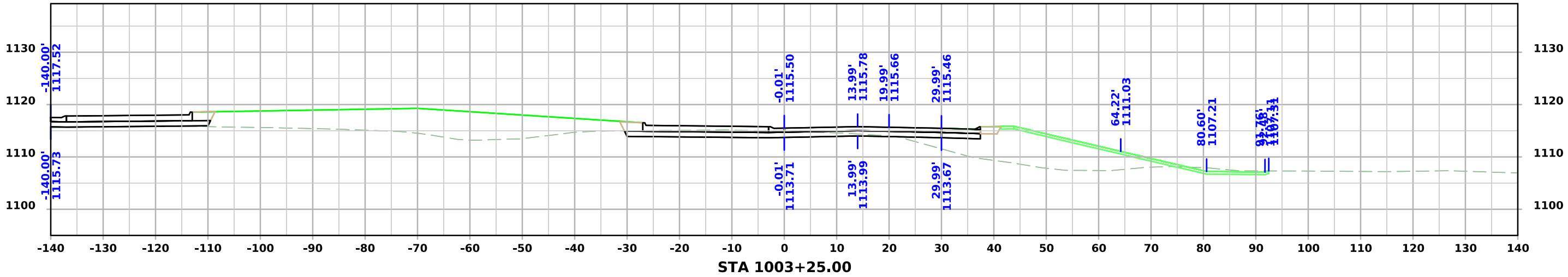
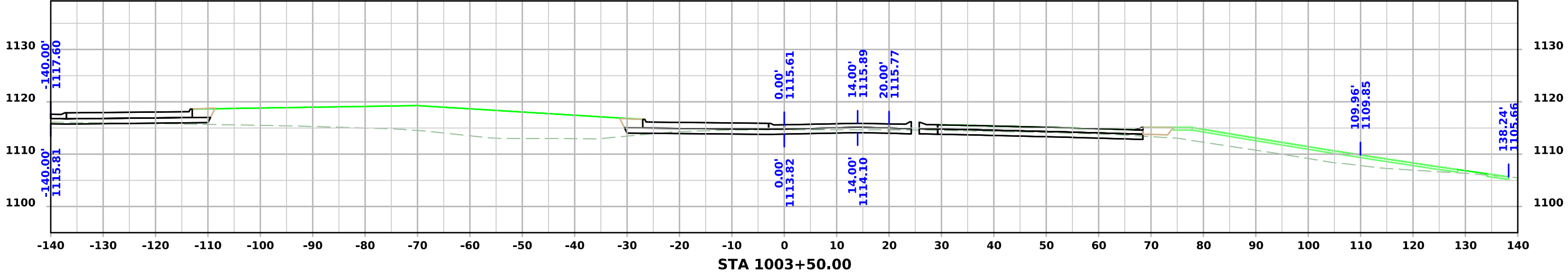

# RA Circle

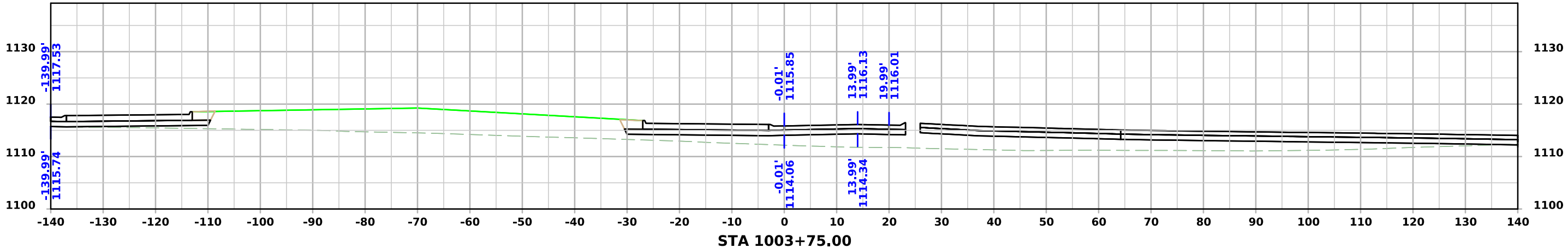
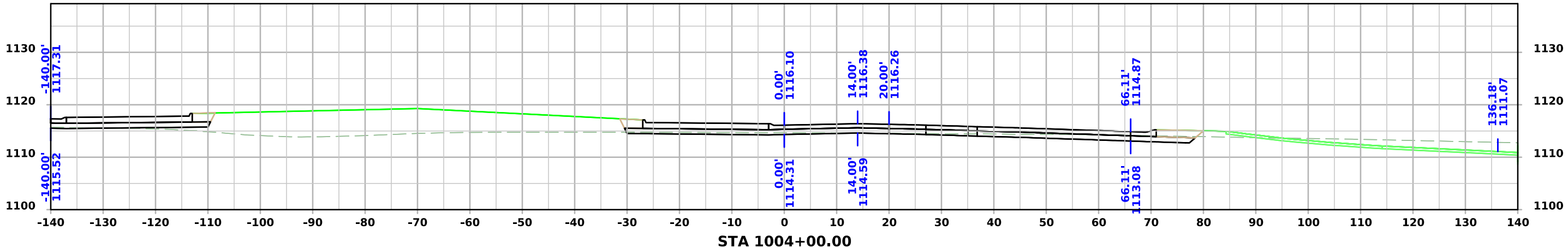
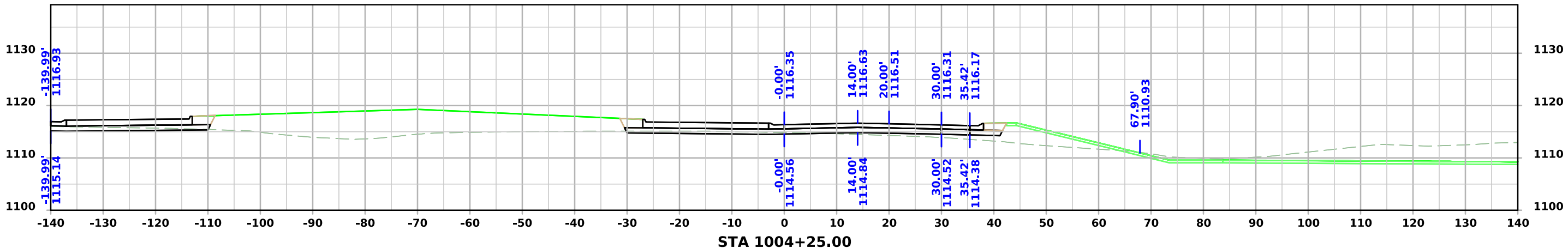



# RA Circle

