



Iowa Department of Transportation
Highway Division

PLANS OF PROPOSED IMPROVEMENT ON THE

INTERSTATE ROAD SYSTEM
WOODBURY COUNTY
PCC PAVEMENT - NEW

REVISIONS

TOTAL

200

PROJECT IDENTIFICATION NUMBER

04-97-029-040

PROJECT NUMBER

IM-029-6(186)136--13-97

R.O.W. PROJECT NUMBER

IMN-029-6(159)136--0E-97

LETTING DATE
12/18/2012

PCC PAVEMENT - NEW
IM-029-6(186)136--13-97

PRELIMINARY EARTHWORK (D5)

I-29	Cut = 33946	Fill = 5234
D-51	Cut = 53444	Fill = 204093
Ramp A	Cut = 5063	Fill = 33039
Ramp B	Cut = 1729	Fill = 38915
Ramp C	Cut = 5065	Fill = 60192
Ramp D	Cut = 7618	Fill = 32069
Burnett Ave	Cut = 1152	Fill = 536
Liberty Lane	Cut = 7365	Fill = 8507
Entrance 21473	Cut = 0	Fill = 834
Project Total	Cut = 115382	Fill = 383419

SCALES: As Noted

Refer to the Proposal Form for list of applicable specifications.

Value Engineering Saves. Refer to Article 1105.15 of the Specifications.

NO MILEAGE SUMMARY



INDEX OF SHEETS

No.	DESCRIPTION
A Sheets	Title Sheets
A.1	Title Sheet
A.2	Location Map
B Sheets	Typical Cross Sections and Details
B.1 - 10	Typical Cross Sections and Details
D Sheets	Mainline Plan and Profile Sheets
* D.1	Legend Sheet
* D.2 - 4	Interstate 29
E Sheets	Side Road Plan and Profile Sheets
* E.1	County Road D-51/260th Street
* E.3	Burnett Avenue
* E.4	Liberty Lane
G Sheets	Survey Sheets
G.1 - 2	Reference Ties and Bench Marks
G.3 - 6	Horizontal Control Tab. for Mainline and Side Roads
G.7	Superelevation Tab. for Mainline and Side Roads
J Sheets	Traffic Control and Staging Sheets
* J.1	Traffic Control Plan
* J.1	Staging Notes Stage
* J.1	Tabulation of Special Events
K Sheets	Interchange Sheets
* K.1 - 2	Interchange Layout Sheets
* K.3	D-51 RAMP "A" Plan and Profile Sheet
* K.4	D-51 RAMP "B" Plan and Profile Sheet
* K.5	D-51 RAMP "C" Plan and Profile Sheet
* K.6	D-51 RAMP "D" Plan and Profile Sheet
V Sheets	Bridge and Culvert Situation Plans
V.1	Bridge and Culvert Situation Plans
W Sheets	Mainline Cross Sections
W.1	Legend Sheet
W.2 - 48	Mainline Cross Sections
X Sheets	Side Road Cross Sections
X.1 - 48	County Road D-51/260th Street Cross Sections
X.49 - 50	Burnett Avenue Cross Sections
X.51 - 65	County Road D-51/260th Street Cross Sections
X.66 - 67	Entrance Sta. 64176+37 Cross Sections
Y Sheets	Ramp Cross Sections
Y.1 - 9	D-51 RAMP "A" Cross Sections
Y.10 - 19	D-51 RAMP "A" Cross Sections
Y.20 - 36	D-51 RAMP "A" Cross Sections
Y.37 - 50	D-51 RAMP "A" Cross Sections
	* Color Plan Sheets

For Project Location Map
Refer to Sheet A.2

260th St/D-51

I-29

DESIGN DATA RURAL			
2011 AADT	1,760	V.P.D.	
2031 AADT	2,610	V.P.D.	
20 -- DHV	--	V.P.H.	
TRUCKS	34 %		
Total Design ESALs	--		

DESIGN DATA RURAL			
2011 AADT	20,300	V.P.D.	
2031 AADT	35,400	V.P.D.	
20 -- DHV	--	V.P.H.	
TRUCKS	18 %		
Total Design ESALs	--		

INDEX OF SEALS		
SHEET NO.	NAME	TYPE
A.1	Paul W. Flattery	Primary Signature Block
X	X	X

PRELIMINARY PLANS

Subject to change by final design.

D5 PLAN - Date: June XX, 2011

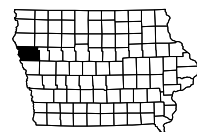

ENGLISH

IOWA DOT

DESIGN TEAM Flattery\Bell

WOODBURY COUNTY

PROJECT NUMBER

IM-029-6(186)136--13-97

SHEET NUMBER

A.1

Project Location
260th St./D-51 Over I-29

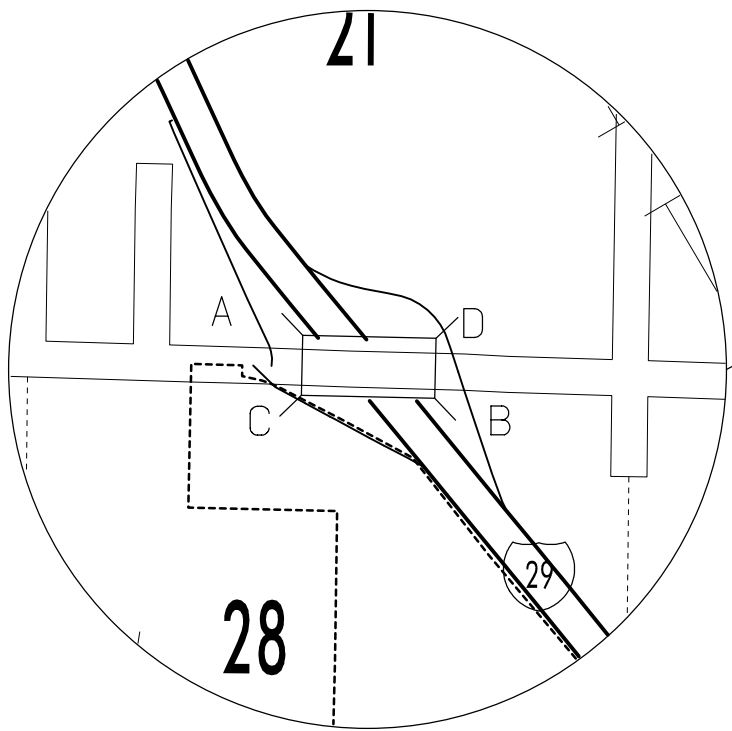

260th St./D-51/I-29 Interchange

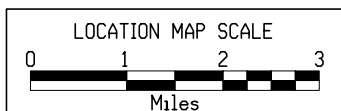
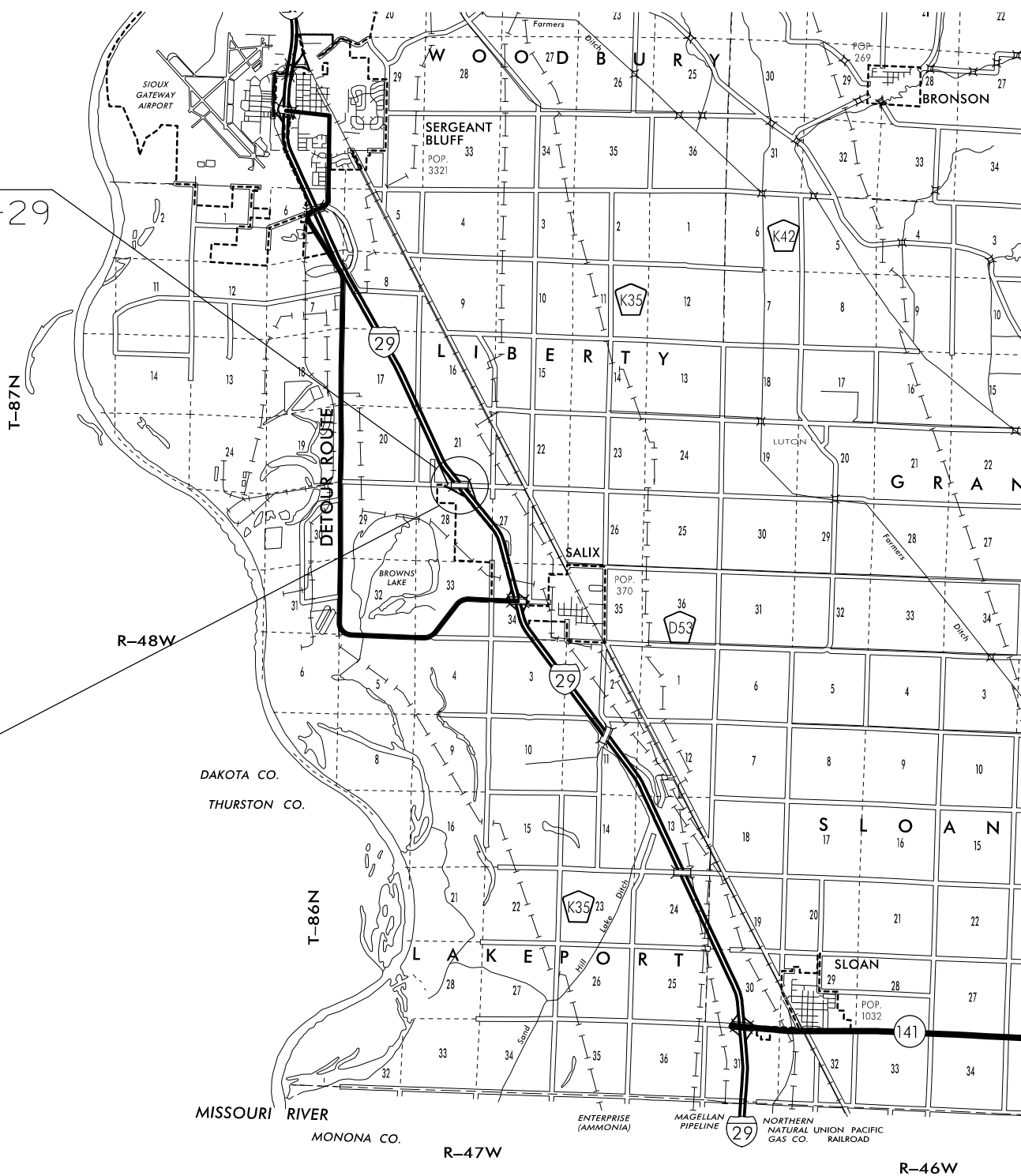

LOCATION			DIMENSIONS			
ROAD IDENTIFICATION	STATION TO STATION		(L) Feet	(R) Feet	(X) Inches	(BW) Feet
Co. Rd. D-51	21466+75.00	21479+50.00	(1)	(1)	22	16.5
Co. Rd. D-51	21479+50.00	21503+25.00	41.2	41.2	22	16.5
Co. Rd. D-51	21503+25.00	21516+50.00	(2)	(2)	22	16.5
			(1) 33.22 - 41.23			
			(2) 41.23 - 33.22			
Burnett Ave.	301+08.30	303+50.00	29.9	29.9	22	16.5

Normal section shown may be modified appropriately in areas of superelevated curves or other locations specifically designated by the Engineer.

See Plan & Profile sheets and cross sections for additional details of ditches and backstops.

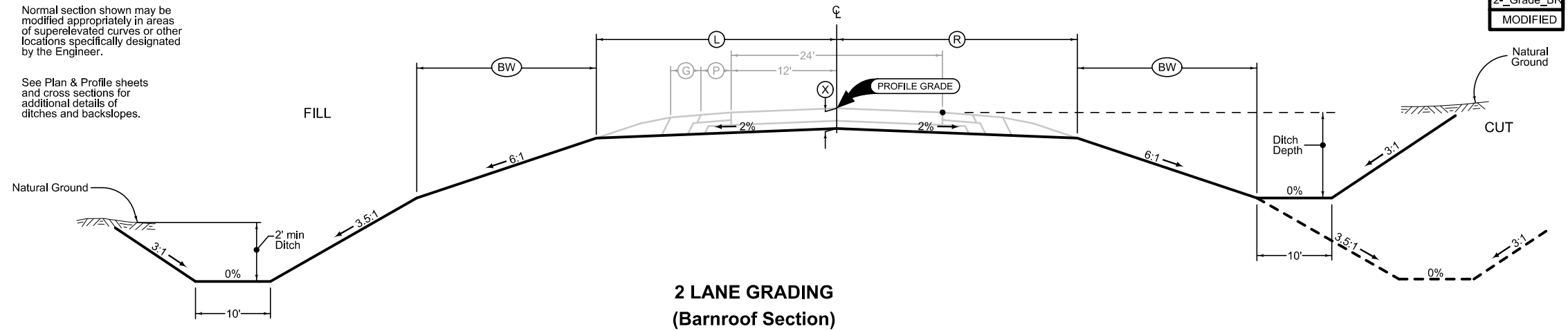

2-Grade_BR
MODIFIED

LOCATION			DIMENSIONS					
INTERCHANGE	RAMP	STATION TO STATION		(L) Feet	(R) Feet	(X) Inches	(BW) _L Feet	(BW) _R Feet
I-29 & D-51	A	5497+15.47	5499+40.00	41.8	19.5	22	16.9	16.7
I-29 & D-51	A	5499+40.00	5500+60.00	(1)	19.5	22	16.9	16.7
I-29 & D-51	A	5500+60.00	5509+50.00	33.8	19.5	22	16.9	16.7
I-29 & D-51	B	2578+40.00	2590+02.41	33.8	19.5	22	16.9	16.7
I-29 & D-51	C	3582+30.00	3600+62.79	33.8	19.5	22	16.9	16.7
I-29 & D-51	C	7+79.70	9+52.22	--	35.5	22	--	16.7
I-29 & D-51	D	4488+69.94	4506+75.00	33.8	19.5	22	16.9	16.7
				(1) 33.8 - 41.8				

Section view is in direction of traffic.

Normal sections shown may be appropriately modified for areas specifically designated by the Engineer such as intersections or superelevated curves.

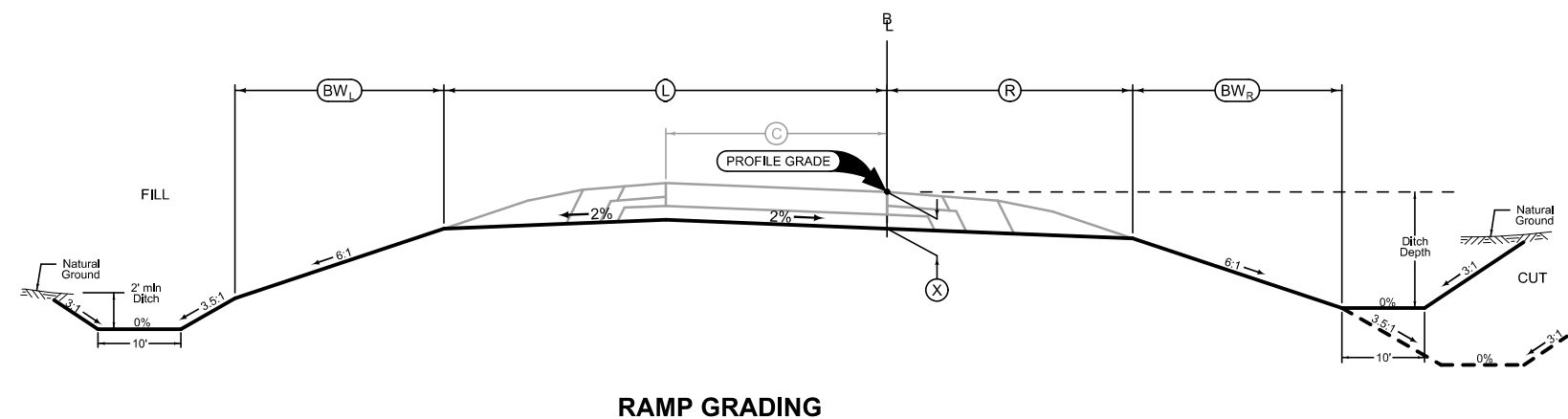

1R_Grade
10-19-10

LOCATION			DIMENSIONS			
ROAD IDENTIFICATION	STATION TO STATION		(L) Feet	(R) Feet	FS	BS
Liberty Lane	200+27.90	214+72.46	14.0	14.0	4	3
Entrance 21476	100+00.00	101+24.71	7.0	7.0	4	3

Normal section shown may be modified appropriately in areas of superelevated curves or other locations specifically designated by the Engineer.

See plan & profile sheets and cross sections for additional details of ditches and backstops.

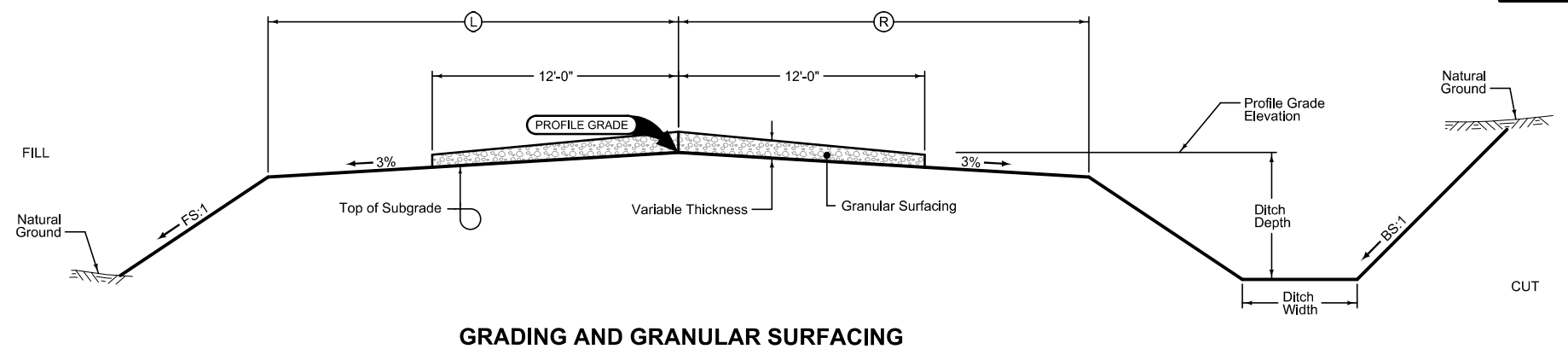

2-GradeGran
10-19-10

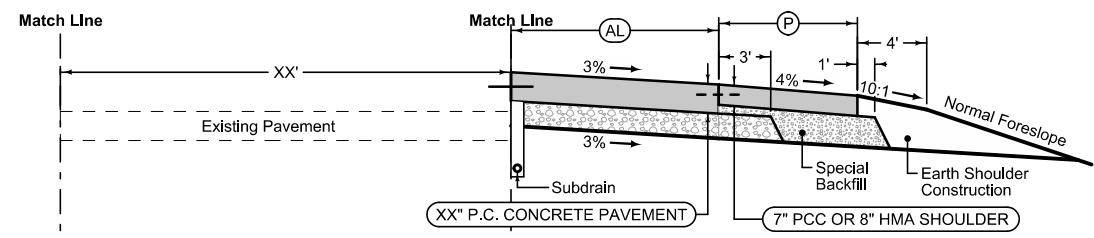

Auxiliary Lane

Longitudinal joint: L or KT
 Transverse joint: Match Mainline

Direction of Travel	BEGIN STATION	END STATION	(AL) Feet	(P) Feet
Ramp A	SB 1512+42.25	1521+00.06	20.0 - 0.0	6.0 - 10.0
Ramp B	NB 1472+40.00	1475+20.00	0.0 - 18.7	10.0 - 6.0
Ramp C	SB 1470+00.00	1480+00.00	0.0 - 20.0	10.0 - 6.0
Ramp D	NB 1506+75.00	1516+75.00	20.0 - 0.0	6.0 - 10.0

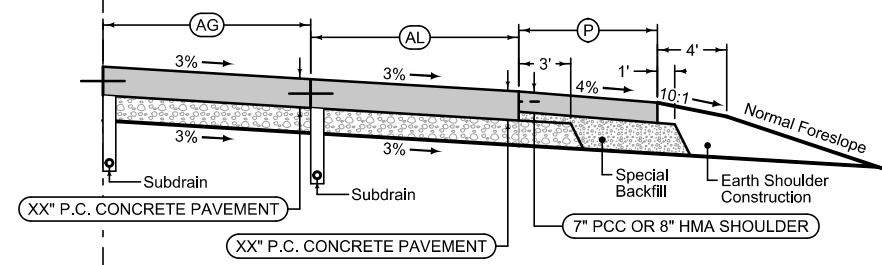

Auxiliary Lane

Longitudinal joint: L or KT
 Transverse joint: Match Mainline

Direction of Travel	BEGIN STATION	END STATION	(AG) Feet	(AL) Feet	(P) Feet
Ramp A	SB 1509+50.00	1512+42.25	24.0 - 4.0	16.0	6.0
Ramp B	NB 1475+20.00	1478+40.00	2.6 - 24.0	16.0	6.0
Ramp C	SB 1480+00.00	1482+30.00	4.0 - 21.8	16.0	6.0
Ramp D	NB 1504+45.00	1506+75.00	21.8 - 4.0	16.0	6.0

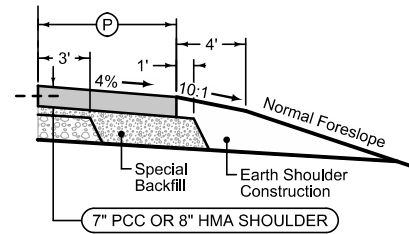

Paved Shoulder Alternates

PCC Shoulder Jointing:
 Longitudinal joint: BT-1 or BT-3
 Transverse joints: C at 20' spacing
 HMA Shoulder Jointing:
 Longitudinal joint: B

Direction of Travel	BEGIN STATION	END STATION	(P) Feet
Ramp C	SB 1521+00.00	1524+00.00	10.0
Ramp C	SB 1482+30.00	1485+45.00	10.0

Section view is in direction of traffic.

Normal sections shown may be appropriately modified for areas specifically designated by the Engineer such as intersections or super-elevated curves.

See Tab 100-24 for pavement quantities.

See Tab 112-9 for shoulder quantities.

INTERSTATE 29

Granular Shoulder

STATION TO STATION		Ⓞ Feet
21466+75.00	21485+60.00	8
21488+00.00	21491+??.??	8
21496+??.??	21499+10.73	8
21500+70.00	21516+50.00	8

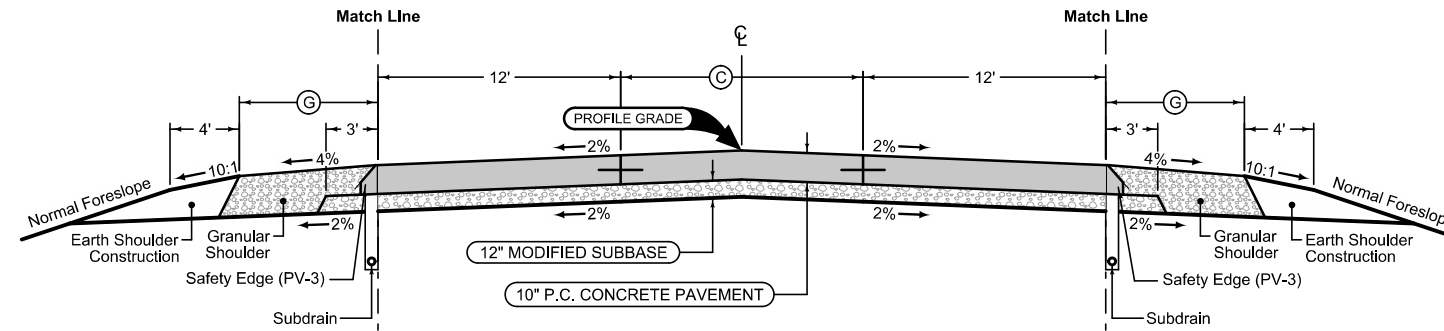

Granular Shoulder

STATION TO STATION		Ⓞ Feet
21466+75.00	21479+70.00	8
21484+51.06	21487+59.25	8
21488+40.07	21490+??.??	8
21495+??.??	21499+74.79	8
21501+90.00	21516+50.00	8

STATION TO STATION		Ⓞ Feet
21466+75.00	21467+50.00	0
21467+50.00	21479+50.00	0-16
21479+50.00	21503+25.00	16
21503+25.00	21515+89.00	16-0
21515+89.00	21516+50.00	0

Mainline Jointing:
 Transverse joints: CD at 20' spacing
 Longitudinal joint: L-2

See Tab 100-24 for pavement quantities.
 See Tab 112-9 for shoulder quantities.

260th St./Co. Rd. D-51

Paved Shoulder Alternates

PCC Shoulder Jointing:
 Longitudinal joint: BT-1 or BT-3
 Transverse joints: C at 20' spacing
 HMA Shoulder Jointing:
 Longitudinal joint: B

BEGIN STATION	END STATION	(P) Feet
5509+50.00	5500+60.00	4

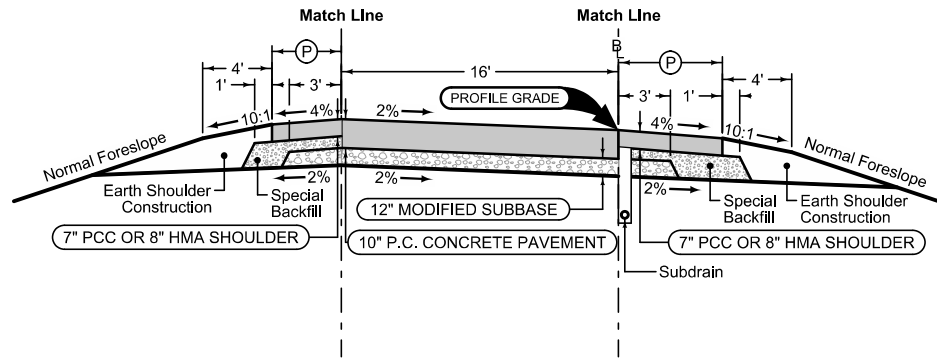

Section shown in the direction of traffic.

Ramp Jointing:
 Transverse joints: CD at 20' spacing.

BEGIN STATION	END STATION
5509+50.00	5497+15.47

Paved Shoulder Alternates

PCC Shoulder Jointing:
 Longitudinal joint: BT-1 or BT-3
 Transverse joints: C at 20' spacing
 HMA Shoulder Jointing:
 Longitudinal joint: B

BEGIN STATION	END STATION	(P) Feet
5509+50.00	5497+15.47	6

Auxiliary Lane

Longitudinal joint: L or KT
 Transverse joint: Match Mainline

STATION TO STATION	(AL) Feet	(P) Feet	(G) Feet
5500+60.00	5499+40.00	0-8	4
5499+40.00	5497+15.47	8	4

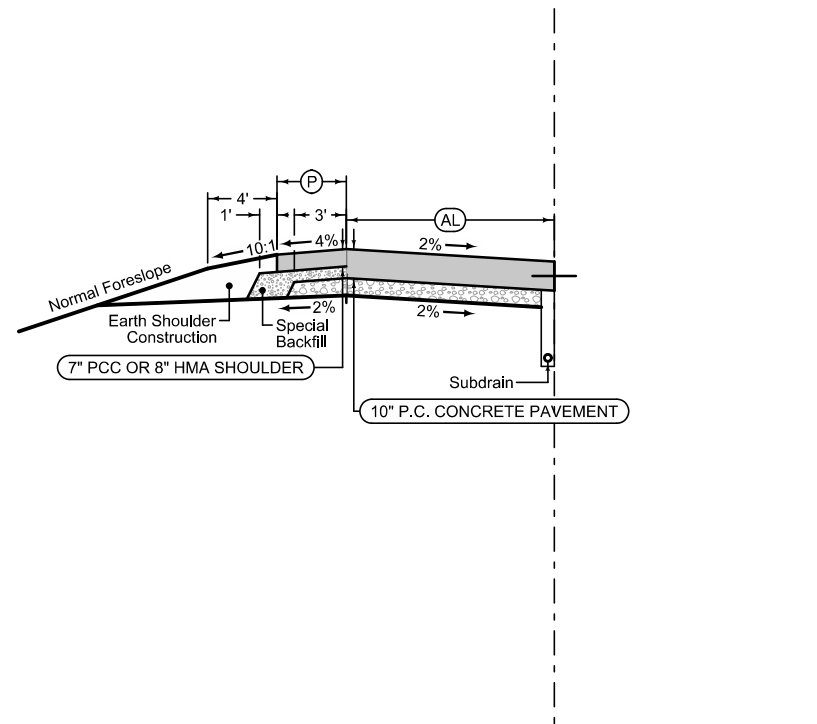

See Tab 100-24 for pavement quantities.
 See Tab 112-9 for shoulder quantities.

RAMP 'A'

Paved Shoulder Alternates

PCC Shoulder Jointing:
 Longitudinal joint: BT-1 or BT-3
 Transverse joints: C at 20' spacing
 HMA Shoulder Jointing:
 Longitudinal joint: B

BEGIN STATION	END STATION	(P) Feet
2578+40.00	2590+02.41	4

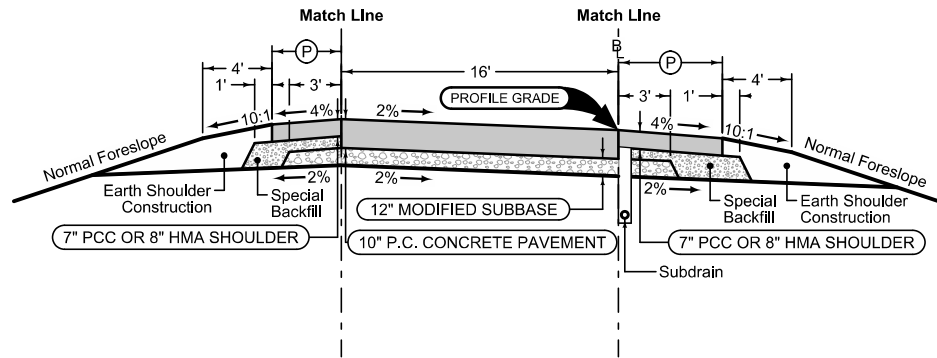

Section shown in the direction of traffic.

Ramp Jointing:
 Transverse joints: CD at 20' spacing.

BEGIN STATION	END STATION
2578+40.00	2590+02.41

Paved Shoulder Alternates

PCC Shoulder Jointing:
 Longitudinal joint: BT-1 or BT-3
 Transverse joints: C at 20' spacing
 HMA Shoulder Jointing:
 Longitudinal joint: B

BEGIN STATION	END STATION	(P) Feet
2578+40.00	2590+02.41	6

See Tab 100-24 for pavement quantities.
 See Tab 112-9 for shoulder quantities.

RAMP 'B'

Paved Shoulder Alternates

PCC Shoulder Jointing:
 Longitudinal joint: BT-1 or BT-3
 Transverse joints: C at 20' spacing
 HMA Shoulder Jointing:
 Longitudinal joint: B

BEGIN STATION	END STATION	(P) Feet
3600+62.79	3582+28.45	4

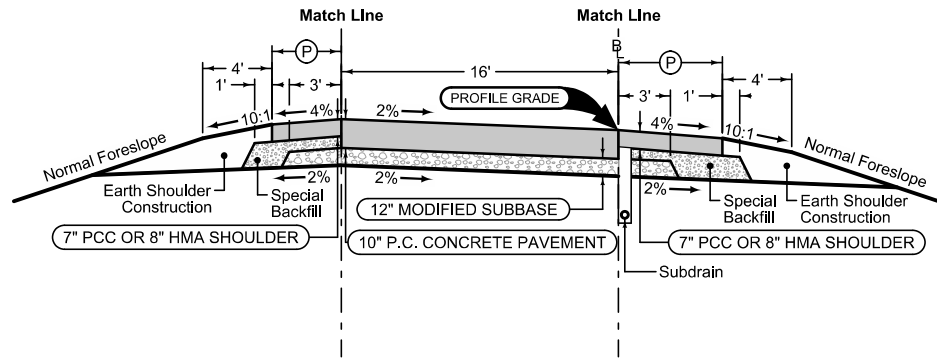

Section shown in the direction of traffic.

Ramp Jointing:
 Transverse joints: CD at 20' spacing.

BEGIN STATION	END STATION
3600+62.79	3596+20.27
3596+20.27*	3588+40.00*
3588+40.00	3582+30.00

RAMPC_OR

* Ramp width transitions include taper/gore of RMPC_FL3.

Paved Shoulder Alternates

PCC Shoulder Jointing:
 Longitudinal joint: BT-1 or BT-3
 Transverse joints: C at 20' spacing
 HMA Shoulder Jointing:
 Longitudinal joint: B

BEGIN STATION	END STATION	(P) Feet
3600+62.79	3582+30.00	6

Paved Shoulder Alternates

PCC Shoulder Jointing:
 Longitudinal joint: BT-1 or BT-3
 Transverse joints: C at 20' spacing
 HMA Shoulder Jointing:
 Longitudinal joint: B

BEGIN STATION	END STATION	(P) Feet
9+19.84	7+79.70	4

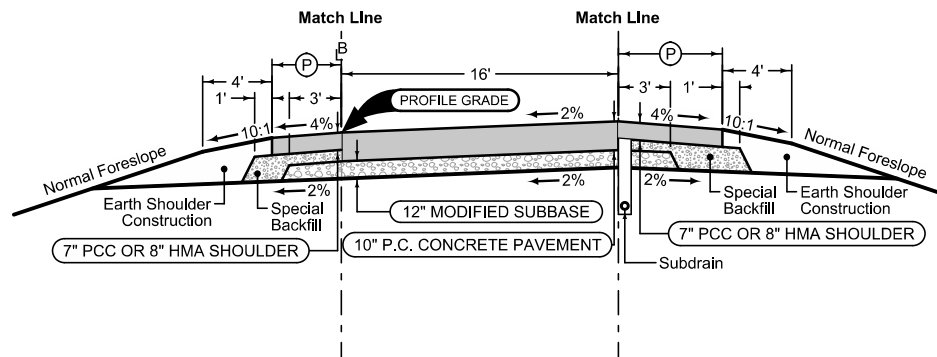

Section shown in the direction of traffic.

Ramp Jointing:
 Transverse joints: CD at 20' spacing.

BEGIN STATION	END STATION
9+52.22	7+79.70

RMPC_FL3

Paved Shoulder Alternates

PCC Shoulder Jointing:
 Longitudinal joint: BT-1 or BT-3
 Transverse joints: C at 20' spacing
 HMA Shoulder Jointing:
 Longitudinal joint: B

BEGIN STATION	END STATION	(P) Feet
9+64.92	7+79.70	6

See Tab 100-24 for pavement quantities.

See Tab 112-9 for shoulder quantities.

RAMP 'C'

Paved Shoulder Alternates

PCC Shoulder Jointing:
 Longitudinal joint: BT-1 or BT-3
 Transverse joints: C at 20' spacing
 HMA Shoulder Jointing:
 Longitudinal joint: B

BEGIN STATION	END STATION	(P) Feet
4488+69.91	4504+46.33	4

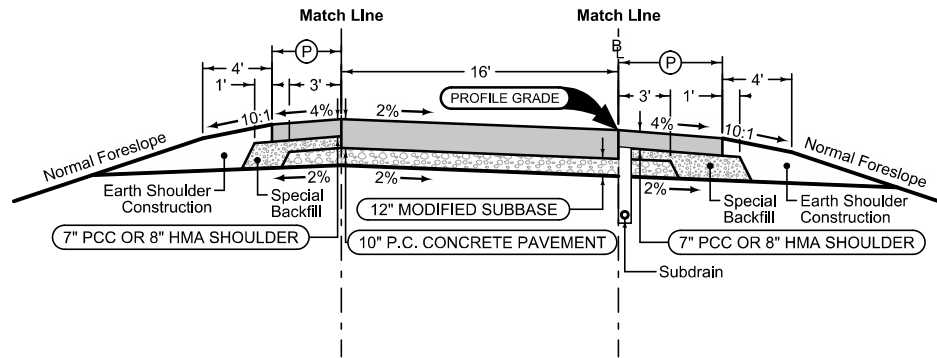

Section shown in the direction of traffic.

Ramp Jointing:
 Transverse joints: CD at 20' spacing.

BEGIN STATION	END STATION
4488+69.94	4504+46.33

Paved Shoulder Alternates

PCC Shoulder Jointing:
 Longitudinal joint: BT-1 or BT-3
 Transverse joints: C at 20' spacing
 HMA Shoulder Jointing:
 Longitudinal joint: B

BEGIN STATION	END STATION	(P) Feet
4488+69.94	4504+46.33	6

See Tab 100-24 for pavement quantities.
 See Tab 112-9 for shoulder quantities.

RAMP 'D'

1101
04-30-02

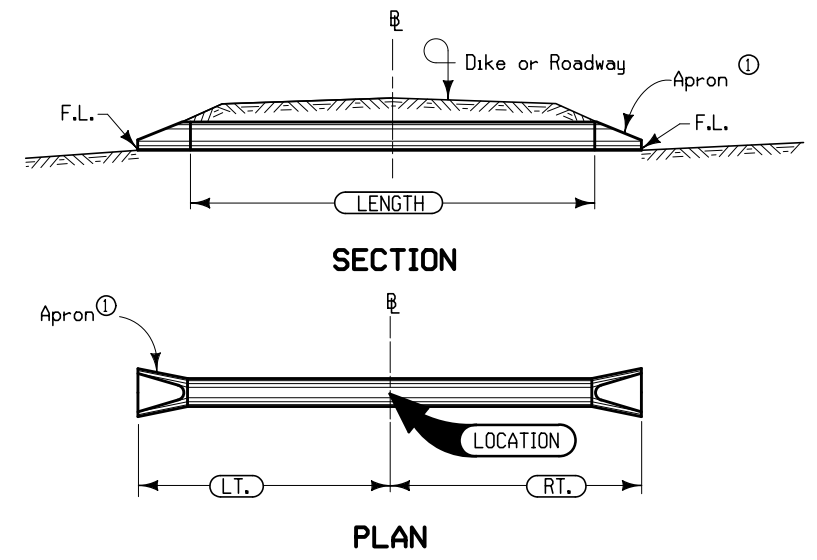

Notes:
 CL shall be CL of roadway, dike, survey, or other; as detailed on plans.
 Skew angle is the angle which one end of the pipe is ahead (by stationing) of line perpendicular to the CL (example skew Rt. ahead 30°).
 Refer to tabular listing and other plans for additional information.
 ① See Standard Road Plan RF-3 For Conc. or RF-5 for Metal.

PIPE CULVERT

1301
10-03-00

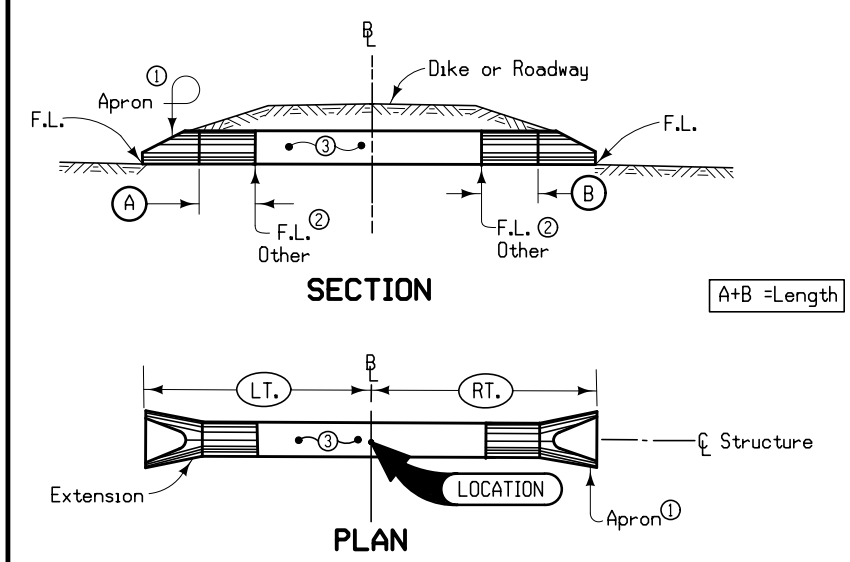

Notes:
 CL shall be CL of roadway, dike, survey, or other; as detailed on plans.
 Extension shall be on line of existing structure to Lt., Rt. or both as specified. Adaptors may be required, see Standard Road Plan RF-2.
 Refer to tabular listing and other plans for additional information.
 ① See Standard Road Plan RF-3 for concrete, RF-5 for metal.
 ② Optional type "D" section only when specified in tabulation.
 ③ Existing structure.

PIPE EXTENSION

2117
04-15-08

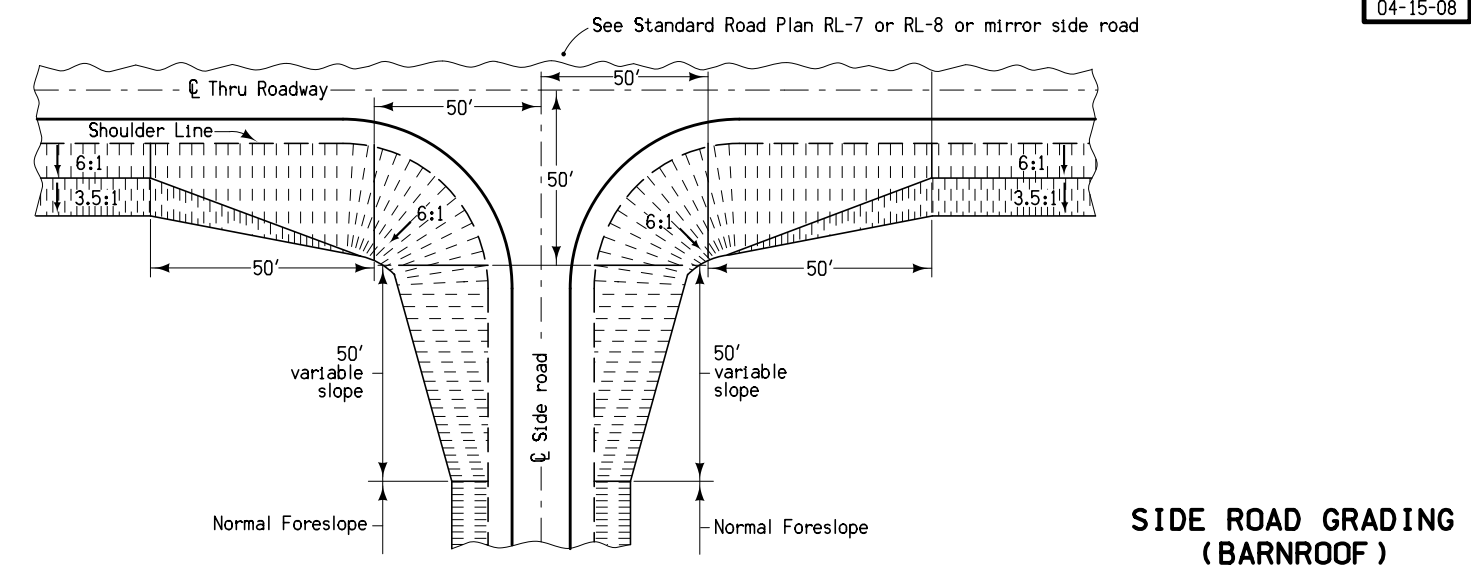

SIDE ROAD GRADING (BARNROOF)

1501
04-20-10

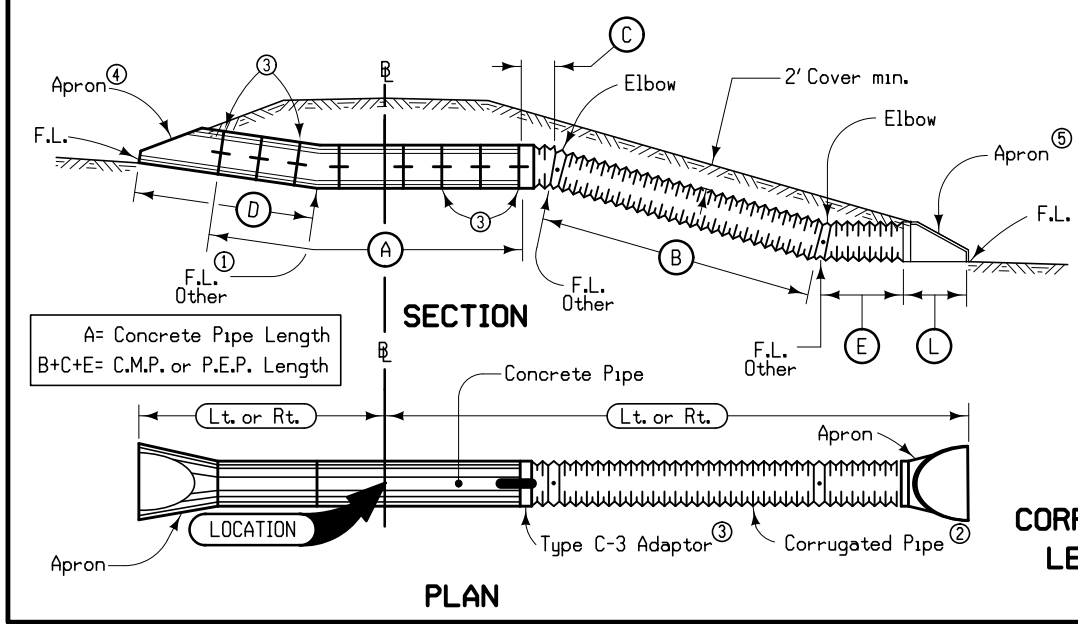

CL shall be CL of roadway, dike, survey, or other; as detailed on plans.
 Skew angle is the angle which one end of the pipe is ahead (by stationing) of a line perpendicular to the CL.
 Refer to Tabulation 104-3.
 ① Optional D section only when specified in tabulation.
 ② Standard type joint couplings are required. (See Materials I.M. 441)
 ③ See RF-2 & RF-14.
 ④ See RF-3.
 ⑤ See RF-5 for Metal and Polyethylene.

CORRUGATED PIPE - CONCRETE LETDOWN STRUCTURE WITH METAL APRON

4302
04-03-01

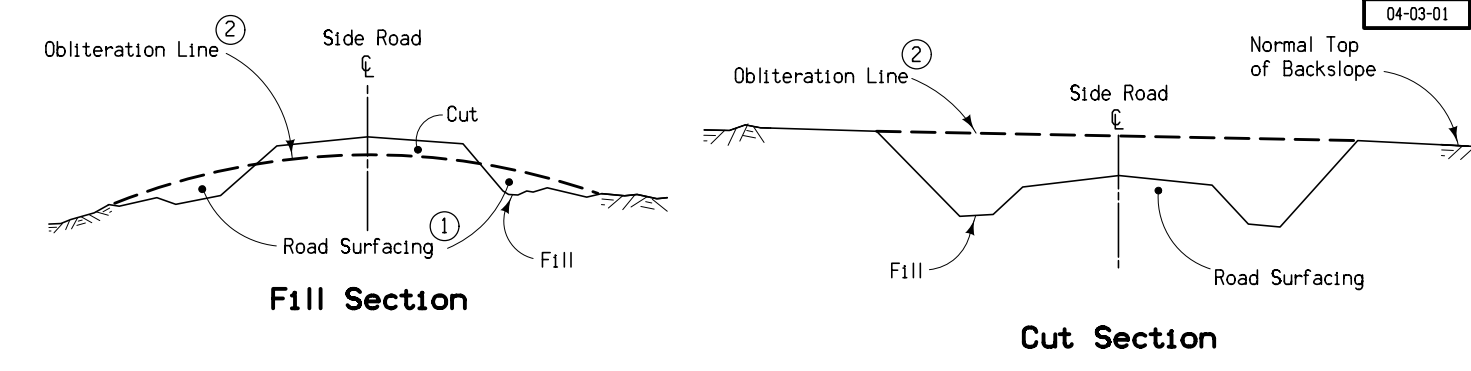

TYPICAL DETAILS FOR OBLITERATION EXISTING ROADBED

① Existing road surfacing (granular material) shall be placed as shown unless otherwise directed by the Engineer or provided for in the detail project plans.
 ② When specified, the upper 1' to be suitable for vegetation (grass or crops).
 Note:
 The work of obliterating or reshaping old roadbeds shall be done at the direction of the Engineer.

4101
04-20-10

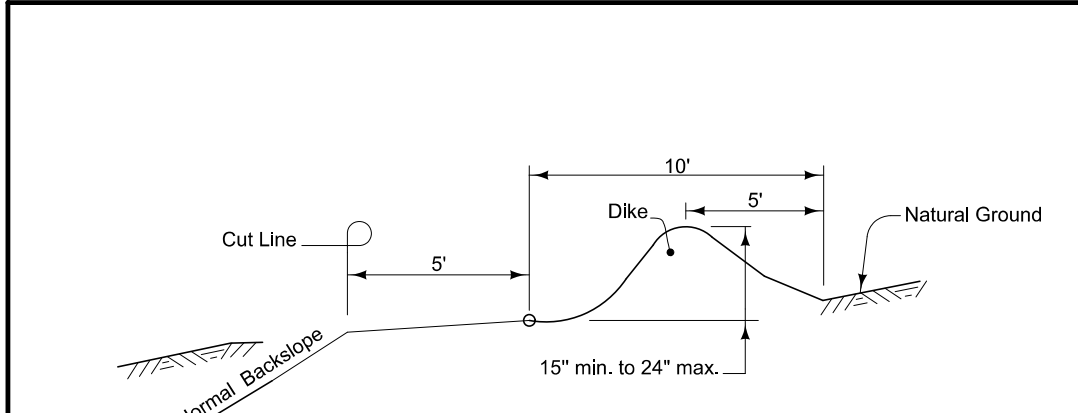

TYPICAL CROSS SECTION INTERCEPTING DITCH

Refer to plans for locations of intercepting ditches. Dike for intercepting ditch shall be made by taking earth from roadway side. Do not excavate back of dike.

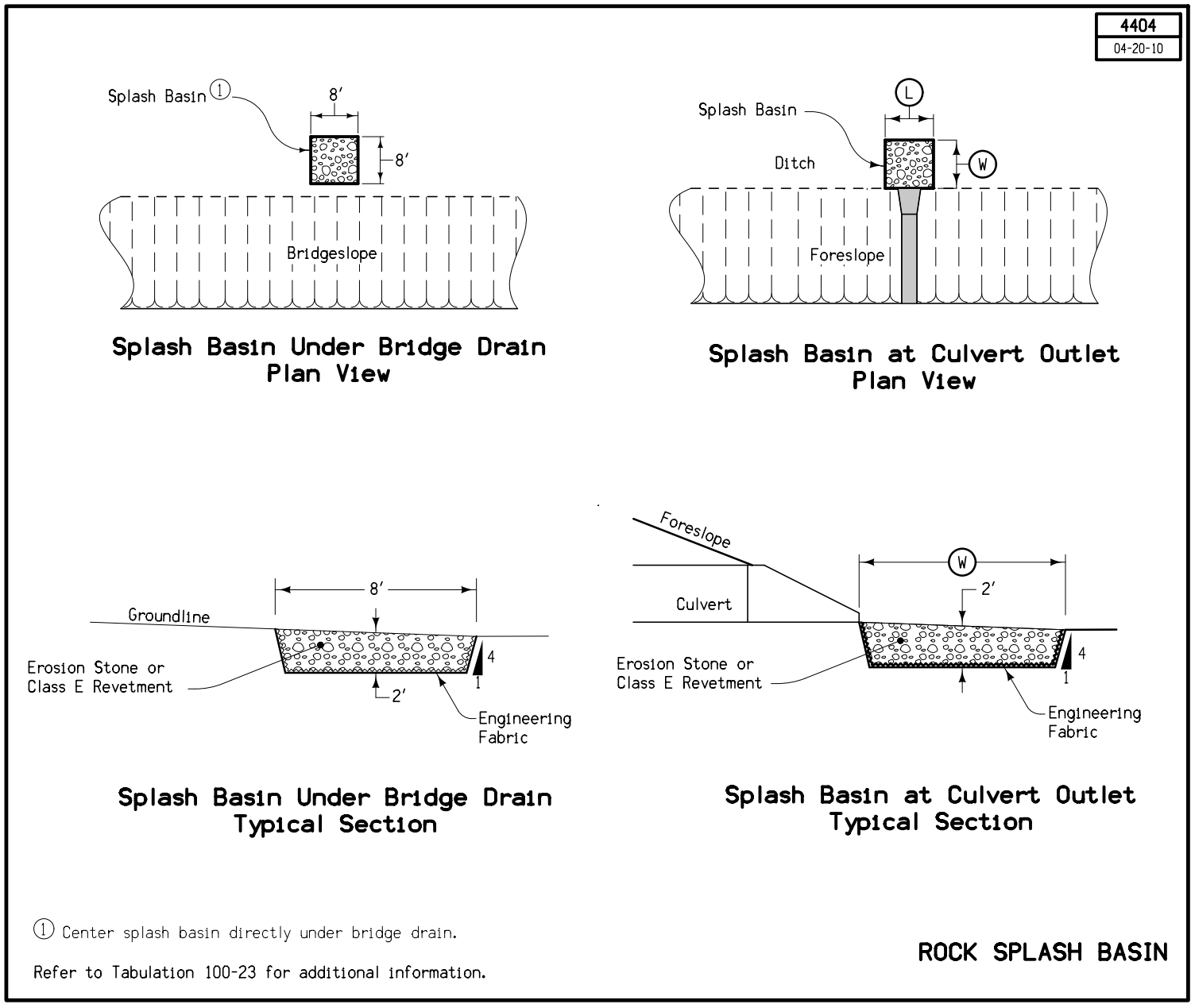
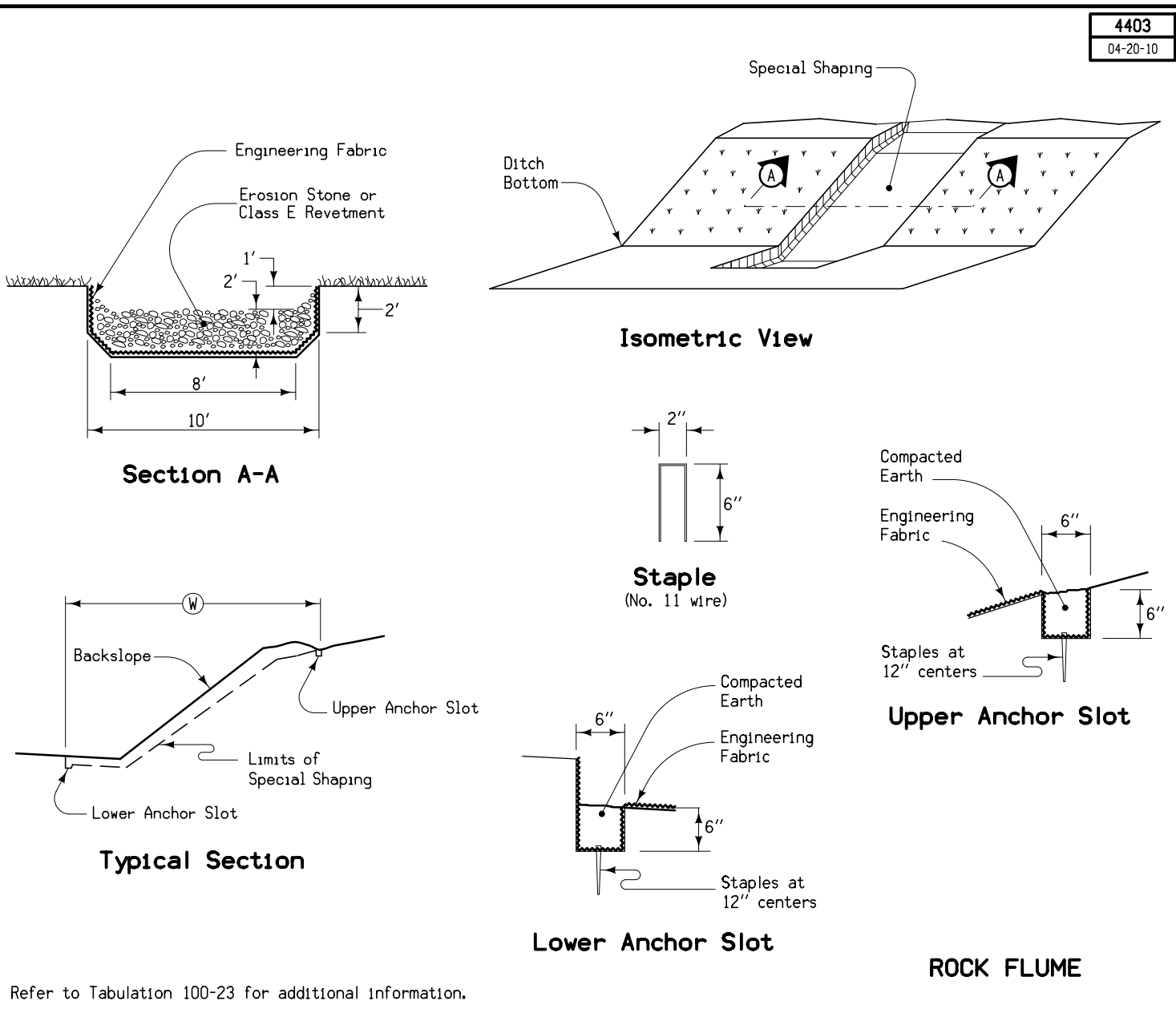
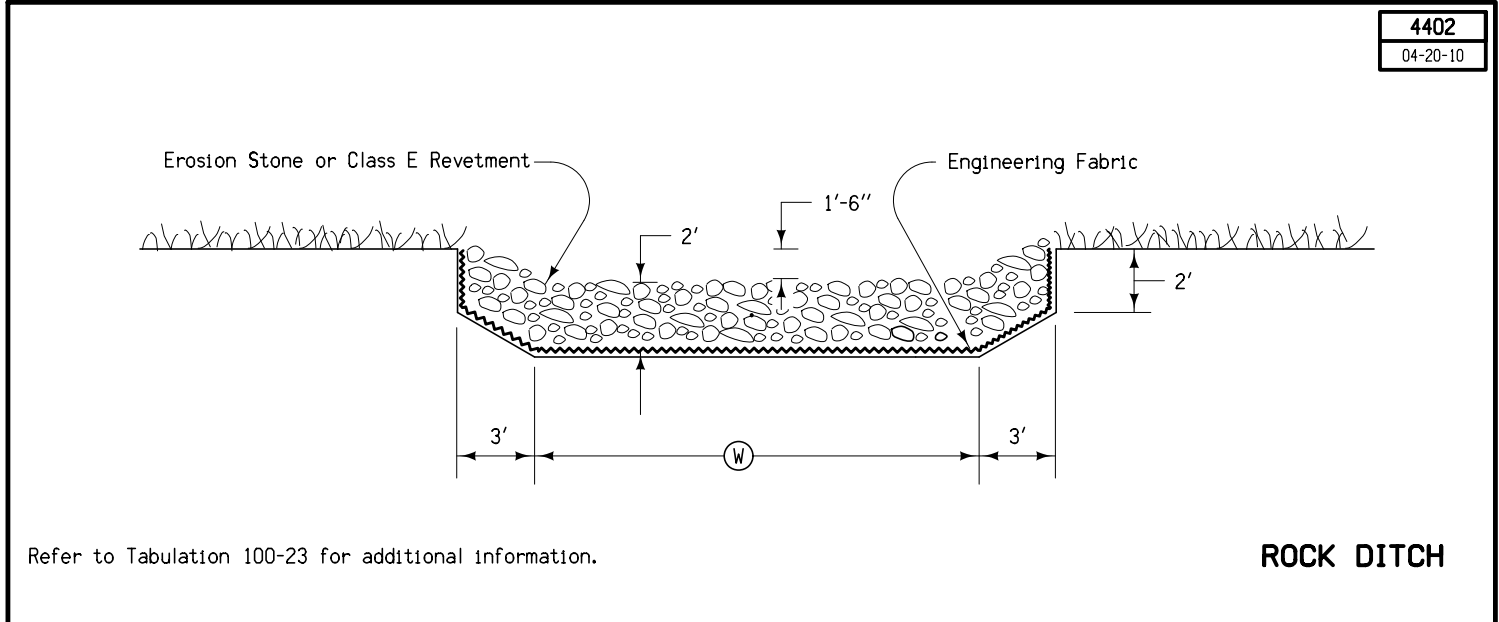
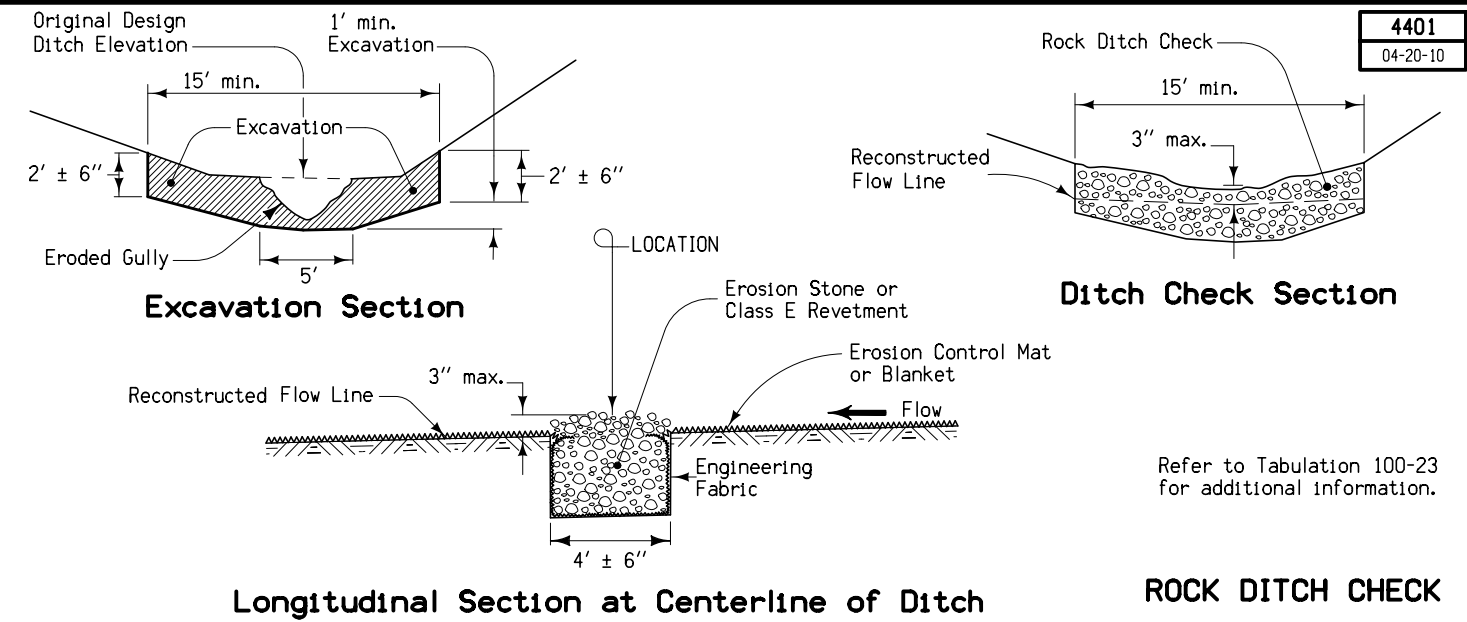

4405
04-20-10

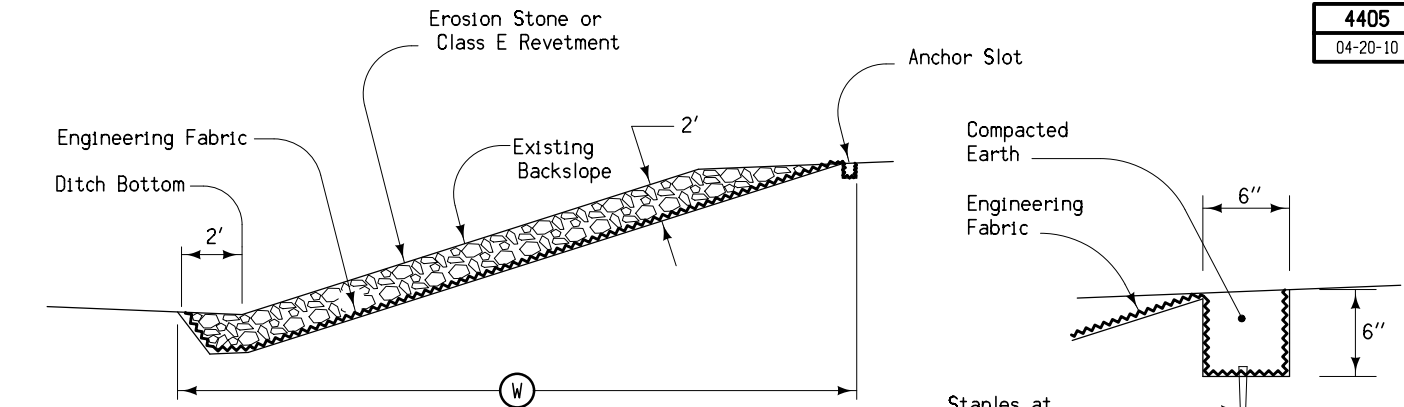

Typical Section

Anchor Slot

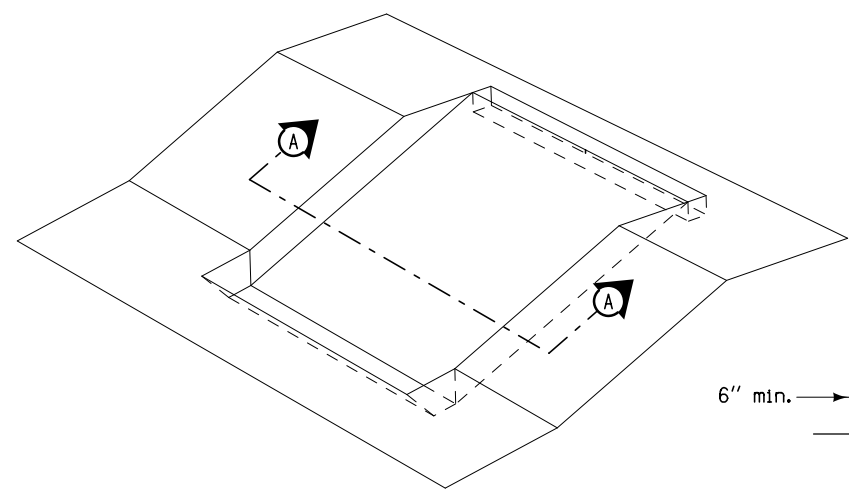

Isometric View

Staple
(No. 11 wire)

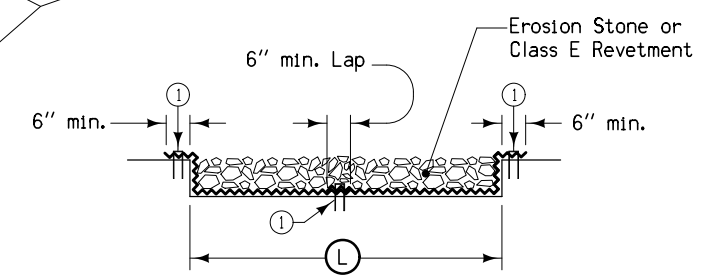

Section A-A

ROCK SLOPE PROTECTION

① Staples at 12" centers
Refer to Tabulation 100-23 for additional information.

7145
04-15-03

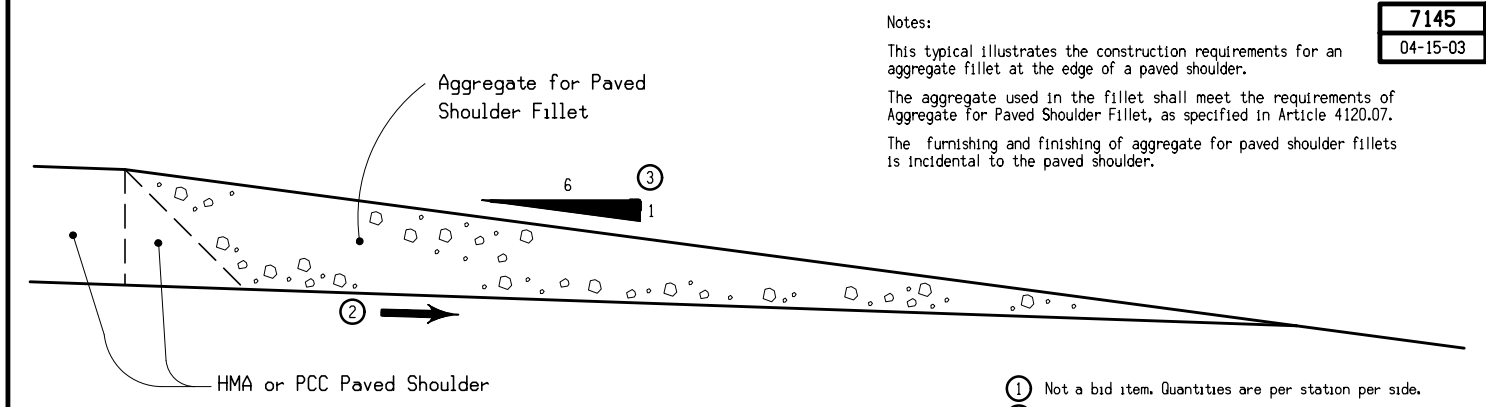

Notes:
This typical illustrates the construction requirements for an aggregate fillet at the edge of a paved shoulder.
The aggregate used in the fillet shall meet the requirements of Aggregate for Paved Shoulder Fillet, as specified in Article 4120.07.
The furnishing and finishing of aggregate for paved shoulder fillets is incidental to the paved shoulder.

- ① Not a bid item. Quantities are per station per side.
- ② Match slope of under side of shoulder pavement.
- ③ 6:1 Slope minimum.

AGGREGATE FOR PAVED SHOULDER FILLET

LOCATION			QUANTITIES ①	
ROAD IDENTIFICATION	STATION TO STATION	SIDE	AGGREGATE FOR PAVED SHOULDER FILLET	
			PCC Tons	HMA Tons

7146
04-15-03

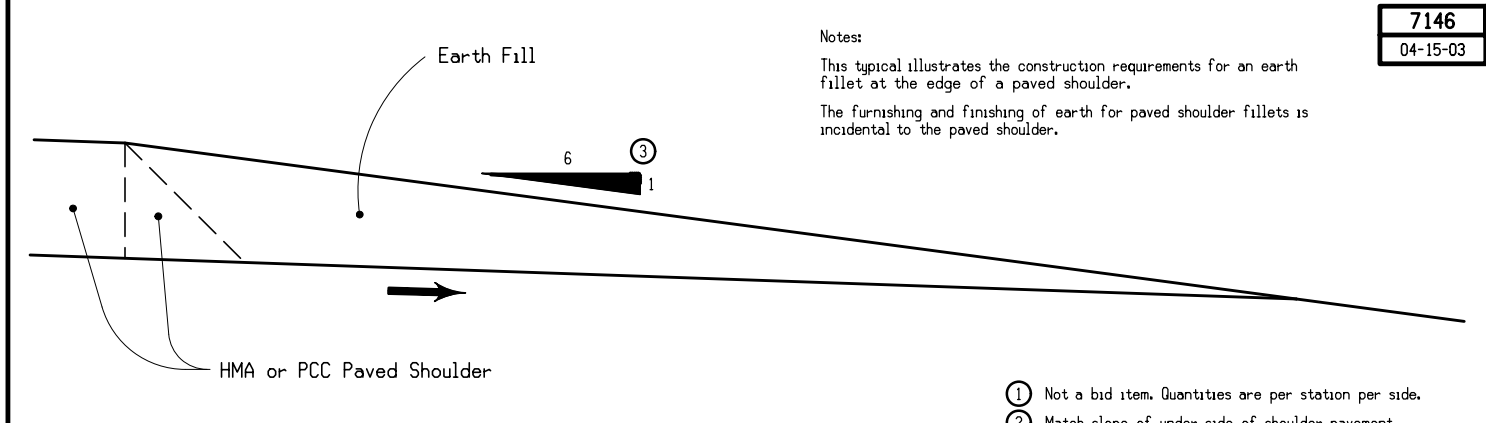

Notes:
This typical illustrates the construction requirements for an earth fillet at the edge of a paved shoulder.
The furnishing and finishing of earth for paved shoulder fillets is incidental to the paved shoulder.

- ① Not a bid item. Quantities are per station per side.
- ② Match slope of under side of shoulder pavement.
- ③ 6:1 Slope minimum.

EARTH FOR PAVED SHOULDER FILLET

LOCATION			QUANTITIES ①	
ROAD IDENTIFICATION	STATION TO STATION	SIDE	EARTH FILL	
			PCC Cu. Yds.	HMA Cu. Yds.

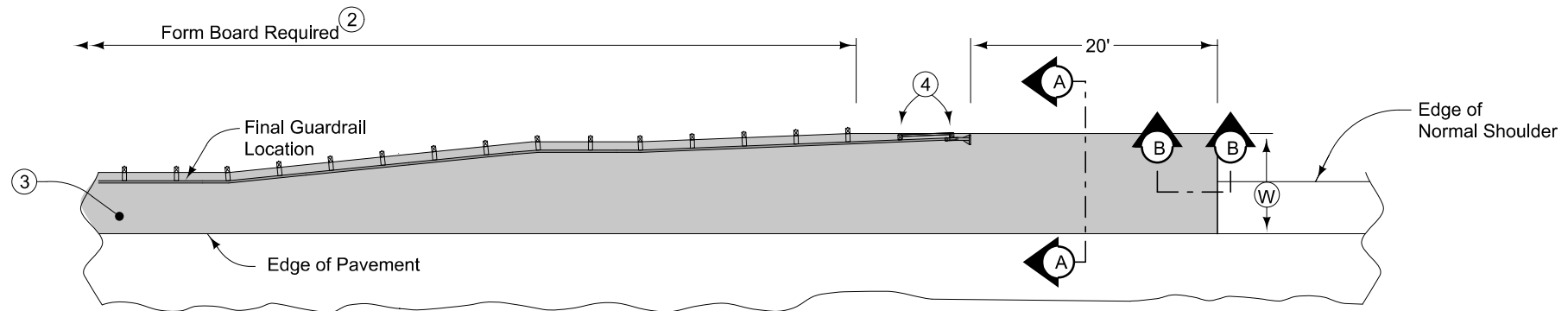

6" HMA Paved Shoulder at guardrail. 7" PCC may be substituted with the following jointing layout:

Match mainline pavement joint spacing. When mainline pavement is 8" or greater in thickness, place additional transverse joints in shoulder at mid-panel of the mainline pavement. Place longitudinal joint at W/2 from edge of mainline pavement when W is greater than 10' wide. Terminate longitudinal joint at transverse joint less than 10' in length.

Compaction of HMA is required to face of guardrail post. Hand compaction will be allowed under guardrail. Removal & reinstallation of guardrail will be allowed with no additional payment.

Location			Ⓟ Feet	Subgrade ^① Treatment		Paved Shoulder SY	Remarks
Road Identification	Station To Station	Side		Special Backfill Tons	Modified Subbase CY		

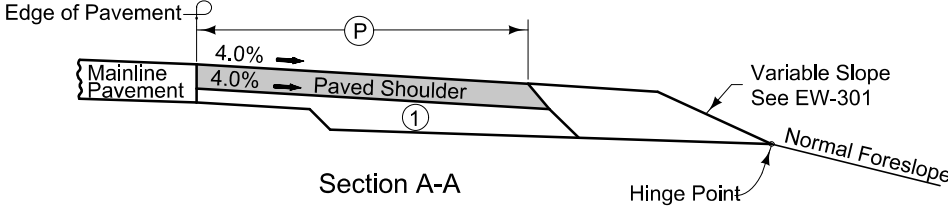
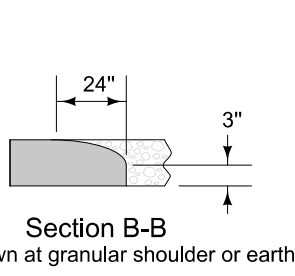
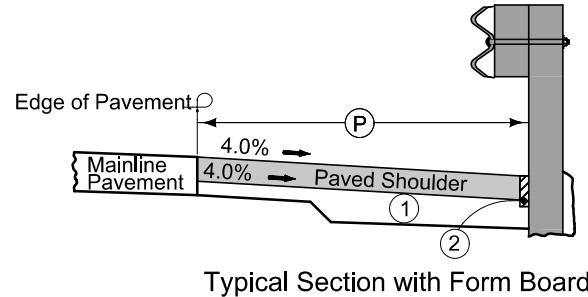

PAVED SHOULDER AT GUARDRAIL

- ① 6" subgrade treatment.
- ② When guardrail posts are installed prior to construction of paved shoulder, nail 1" x 6" untreated form boards along the face of guardrail posts for the length shown. This board is to prevent shoulder material from contacting the sides of the posts and altering the function of the guardrail. Form board not required for final 2 posts.
- ③ Continue paved shoulder to existing paved shoulder or 20' beyond the end of guardrail.
- ④ Shoulder may be notched for final 2 posts or post sleeves may be installed through pavement.

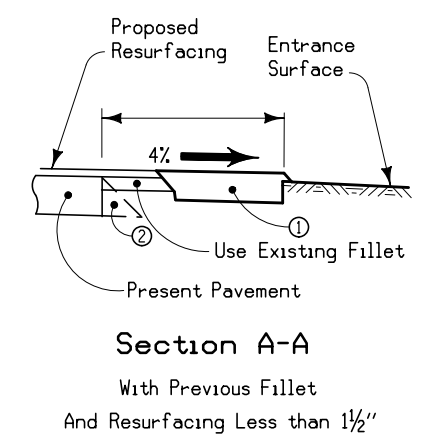
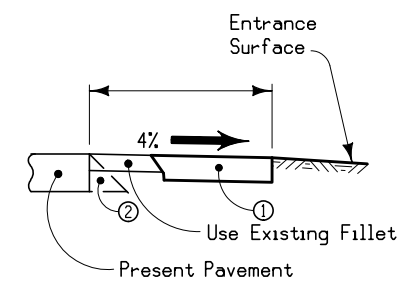
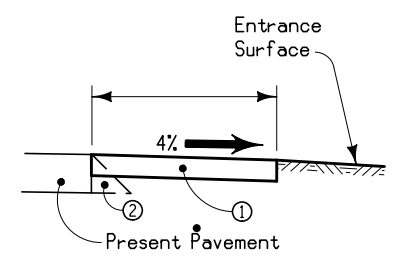
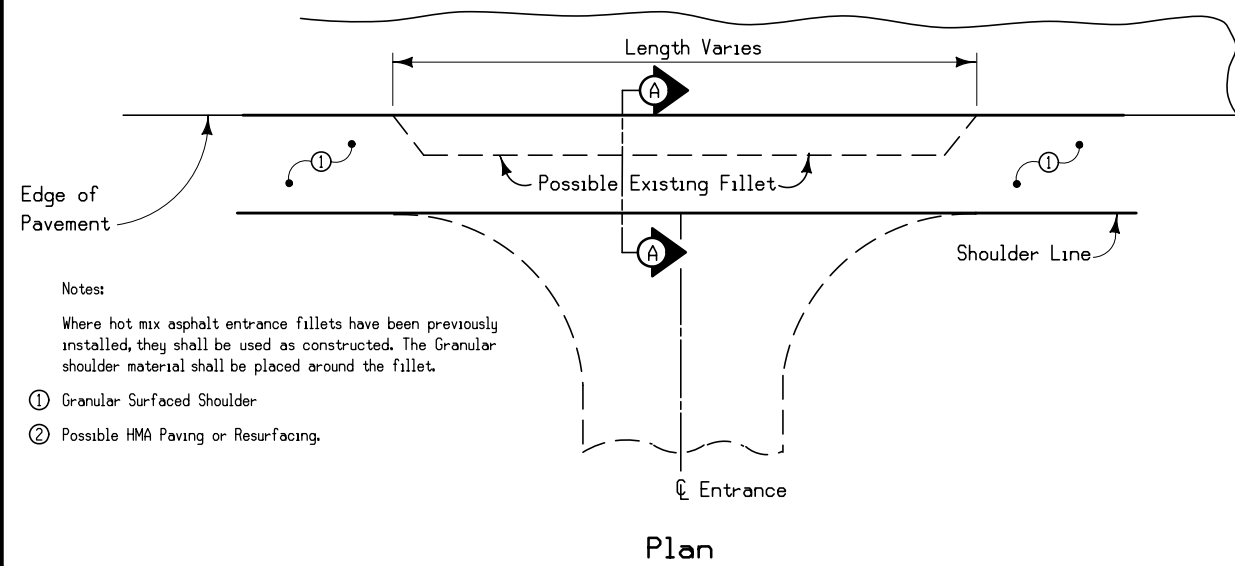

GRANULAR SHOULDER CONSTRUCTION THRU ENTRANCES

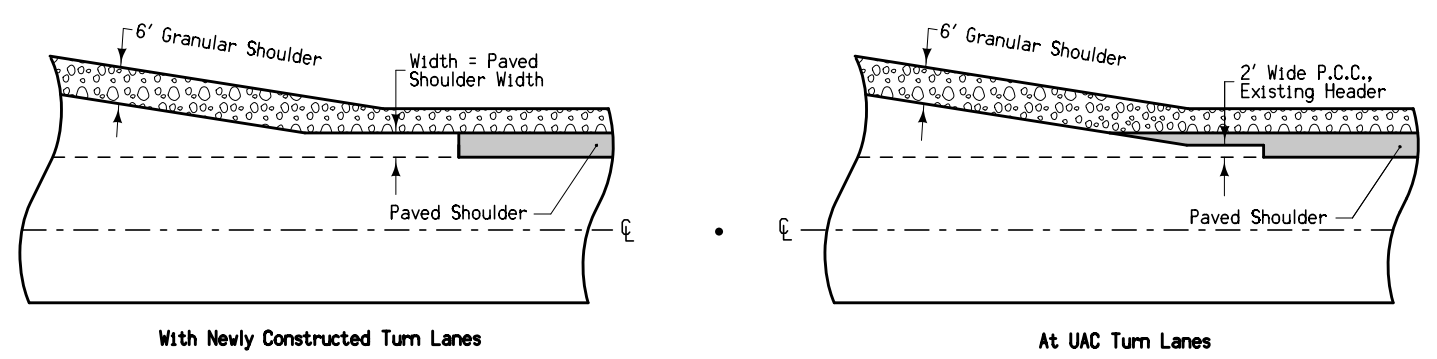

PAVED SHOULDER
DETAIL AT
TURN LANES

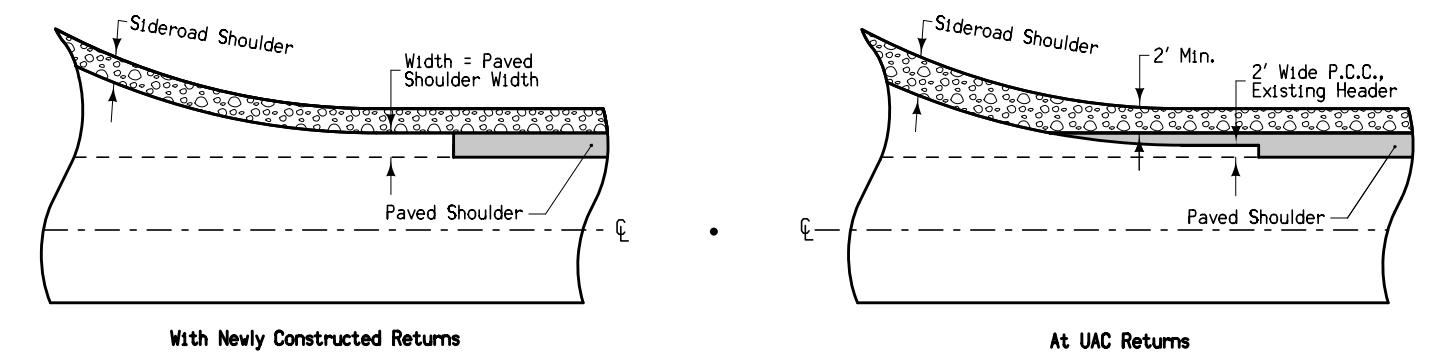

PAVED SHOULDER
DETAIL AT RETURNS

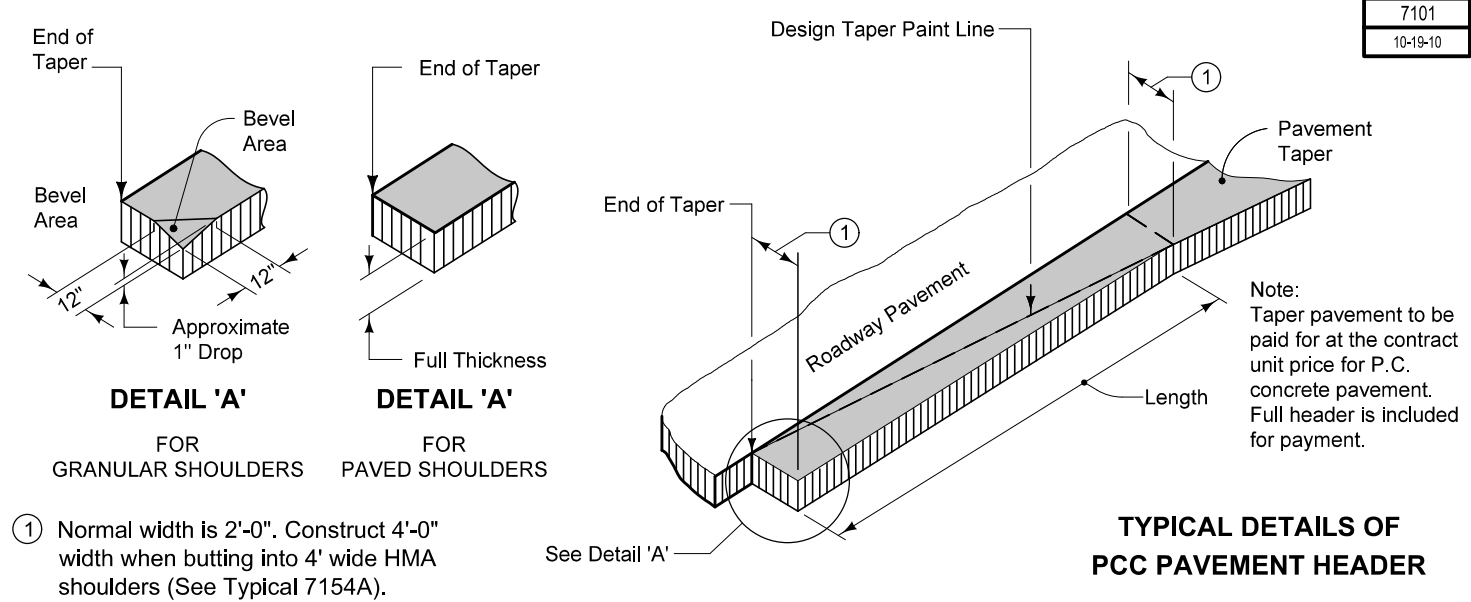

PROJECT SYMBOLS

- OUT tile outlet
- ⊗ INB intake-beehive
- TPD telephone pedestal
- ⊕ AST Above Ground Storage Tank
- Flg FLG flag poles
- MIS miscellaneous
- TDC tree deciduous
- WHD water hydrant
- GP guard post (less than 4 posts)
- PR power riser pole
- TV satellite tv dish
- ★ TEV evergreen tree
- TFR fruit tree
- LP L.P. tank
- SEP septic tank
- PPA power pole 1st co.
- LUM luminaire
- MH manhole
- HT highline tower
- MM mile marker post
- EB electrical box
- ⊗ WEL well
- SIGN SL speed limit sign
- UST buried tanks
- LC lot corner
- COR Column Round
- CUL culvert
- ← DU cl of draw upstream
- D cl of draw or stream
- PIP pipes (cast iron, steel, tile, etc)
- BL break line field survey
- x- FW fence wire
- LIN miscellaneous line
- BLD foundation or building
- RET retaining walls
- TOP Top of Bridge Piers
- CON concrete or a/c slab
- EP edge of paved roads
- T1 le TIL tile line
- GDL guard rails
- BRG bridge
- SF Silt Fence (Wetlands)
- BLS bridge low steel
- ENT cl of entrance
- E2 ELB buried electric line 2nd co.
- EG edge of gravel road
- SH shoulder paved
- ENU edge unpaved entrance & parking
- SWK sidewalk
- CU curb or center island
- SNP Shoulder Non-Paved
- DIK cl of dike or dam
- GU gutter
- ENP edge paved entrance & parking
- BNK stream bank
- FO FOA fiber optics 1st co.
- T1 TLA buried telephone line 1st co.
- E1 ELA buried electric line 1st co.

UTILITY LEGEND

- Woodbury Rural Electric
- T Long Lines
- F0-1 Long Lines
- E Woodbury Rural Electric
- E2 Iowa Dept. of Transportation

PLAN VIEW COLOR LEGEND OF PLAN AND PROFILE SHEETS

- Green (2) Existing Topographic Features and Labels
- Blue (1) Proposed Alignment, Stationing, Tic Marks, and Alignment Annotation
- Purple (5) Existing Utilities
- Yellow (4) Highlight for Critical Notes or Features
- Red (3) Delineates Restricted Areas
- Lavender (9) Temporary Pavement Shading
- Gray, Light (48) Proposed Pavement Shading
- Gray, Med (80) Proposed Granular Shading
- Gray, Dark (112) Proposed Grade and Pave Shading
- Brown, Light (237) Grading Shading

PROFILE VIEW COLOR LEGEND OF PLAN AND PROFILE SHEETS

- Green (2) Existing Ground Line Profile
- Blue (1) Proposed Profile and Annotation
- Purple (5) Existing Utilities
- Blue, Light (230) Proposed Ditch Grades, Left
- Black (0) Proposed Ditch Grades, Median
- Rust (14) Proposed Ditch Grades, Right

CONVENTIONAL SIGNS

- Reference Point
- Station
- ▲ Section Corner
- ▨ Clearing & Grubbing Area
- ▩ Pavement Removal

RIGHT-OF-WAY LEGEND

- ▲ Proposed Right-of-Way
- △ Existing Right-of-Way
- ▲ Existing and Proposed Right-of-Way
- ▲ Easement and Existing Right-of-Way
- Borrow
- Easement (Temporary)
- Easement
- ✕ Excess
- Property Line
- A/C Access Control

**PLAN AND PROFILE
LEGEND AND SYMBOL
INFORMATION SHEET**

(COVERS SHEET SERIES D, E, & K)

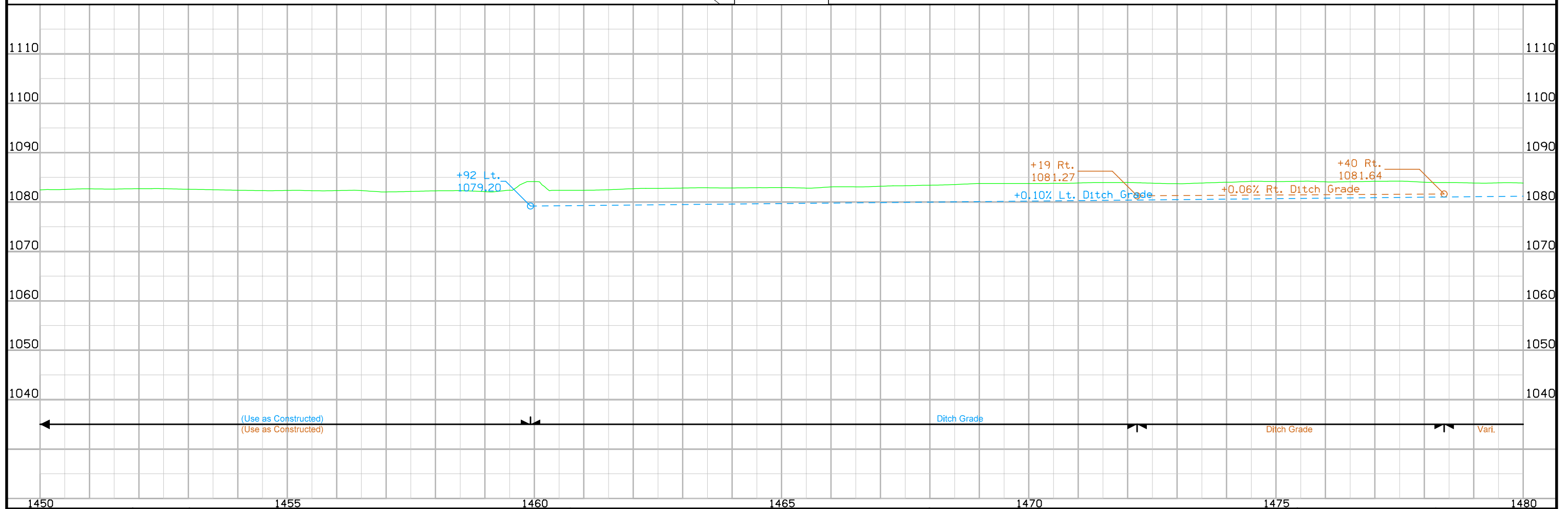
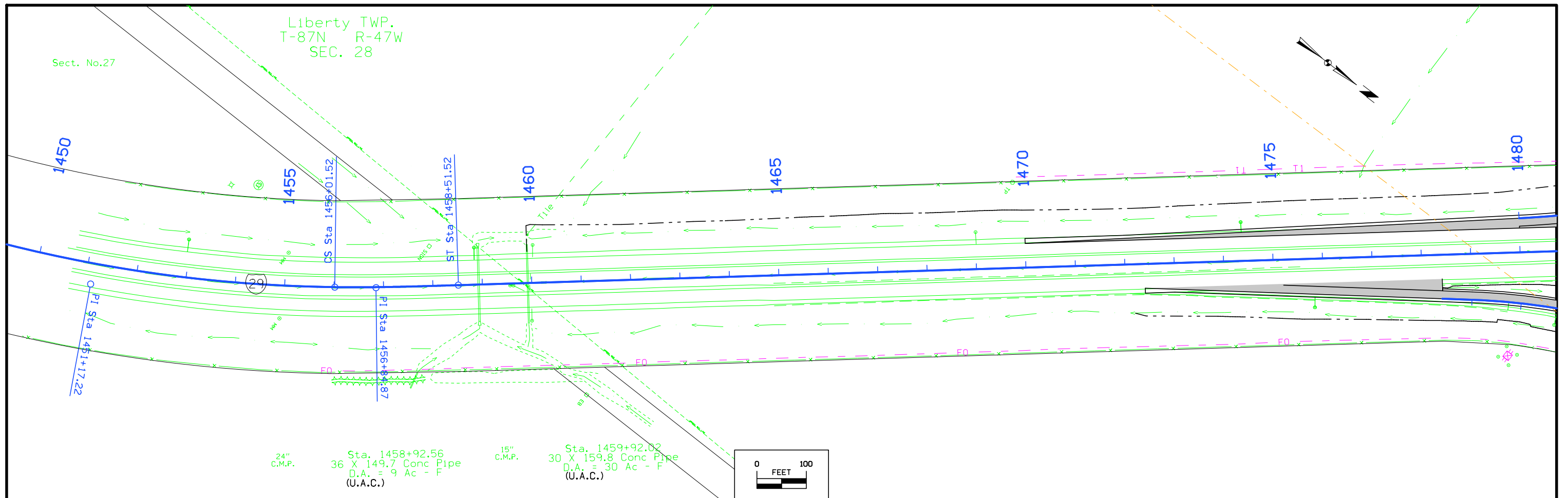

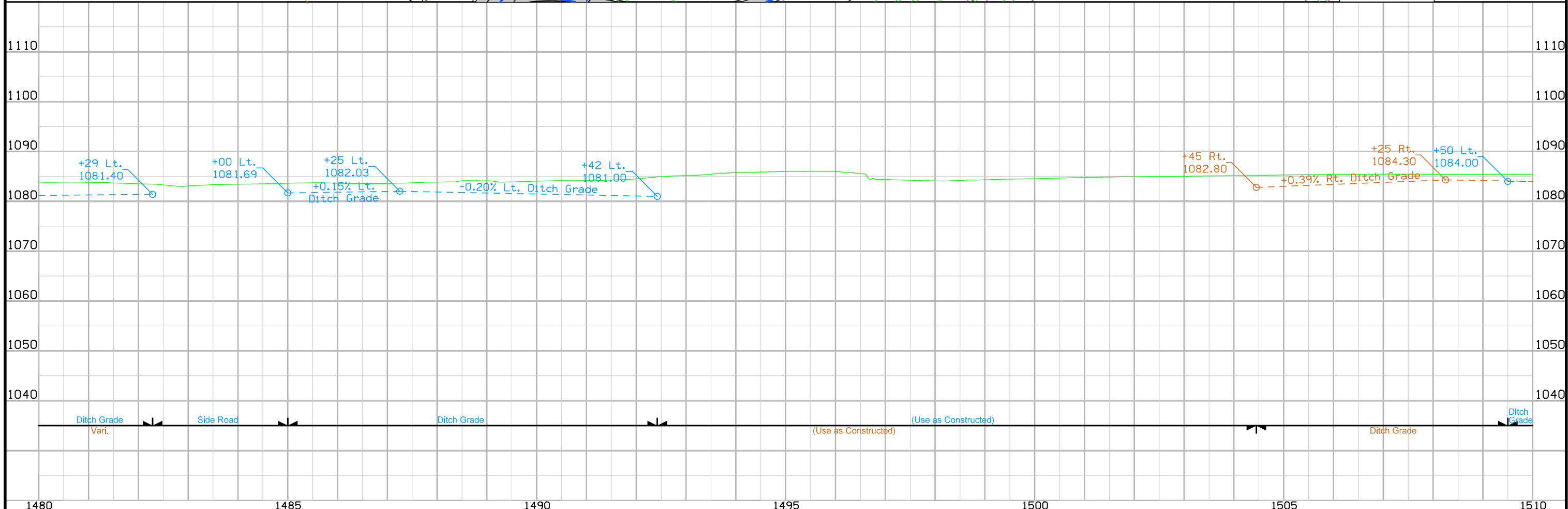
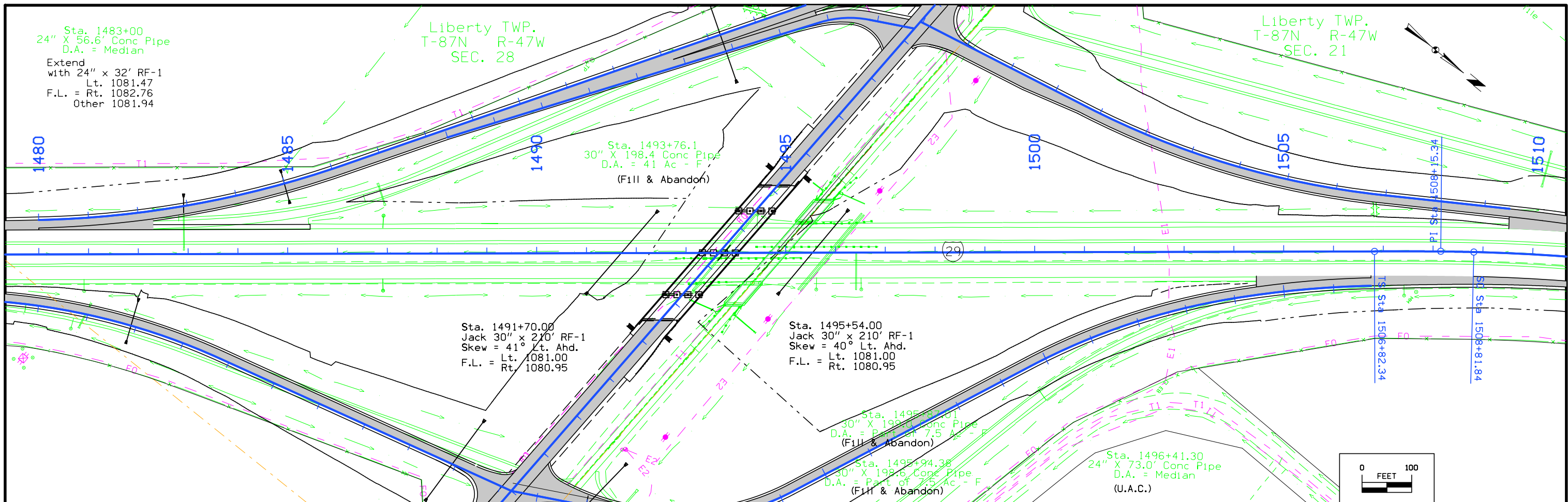

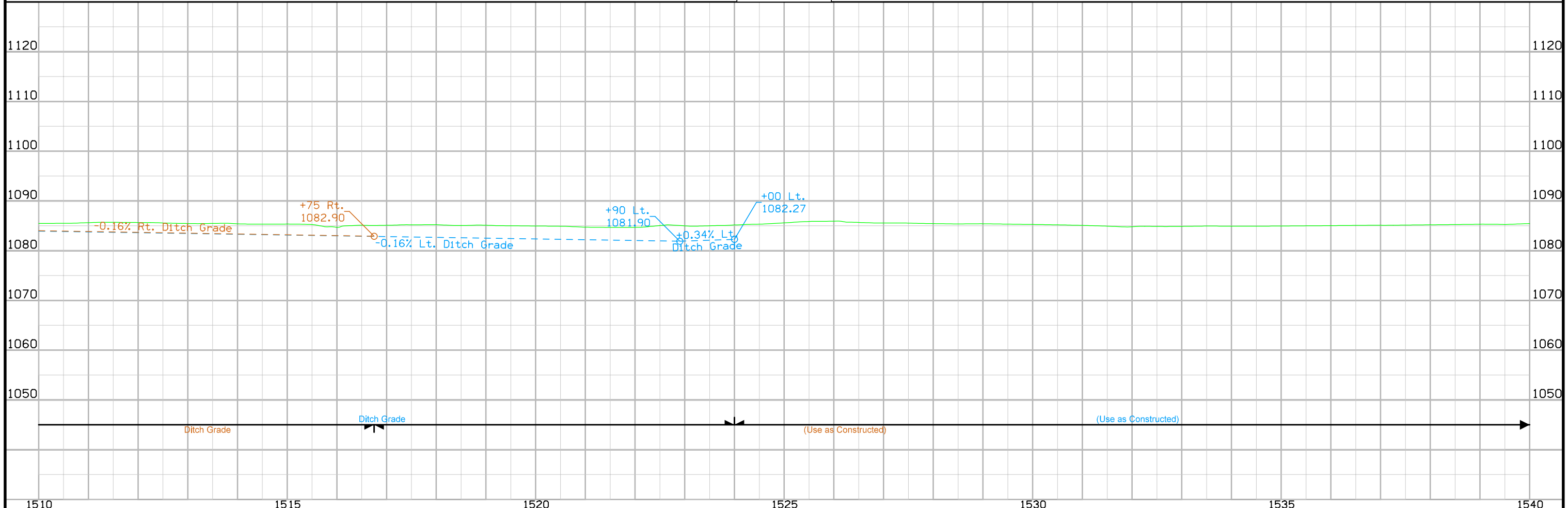
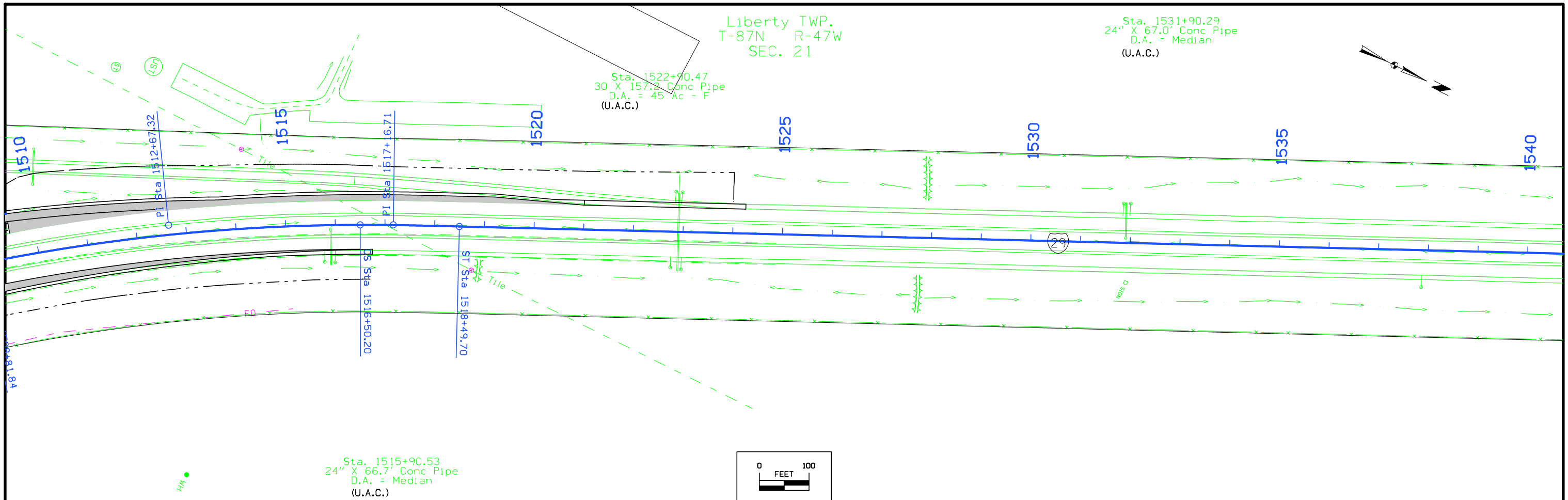

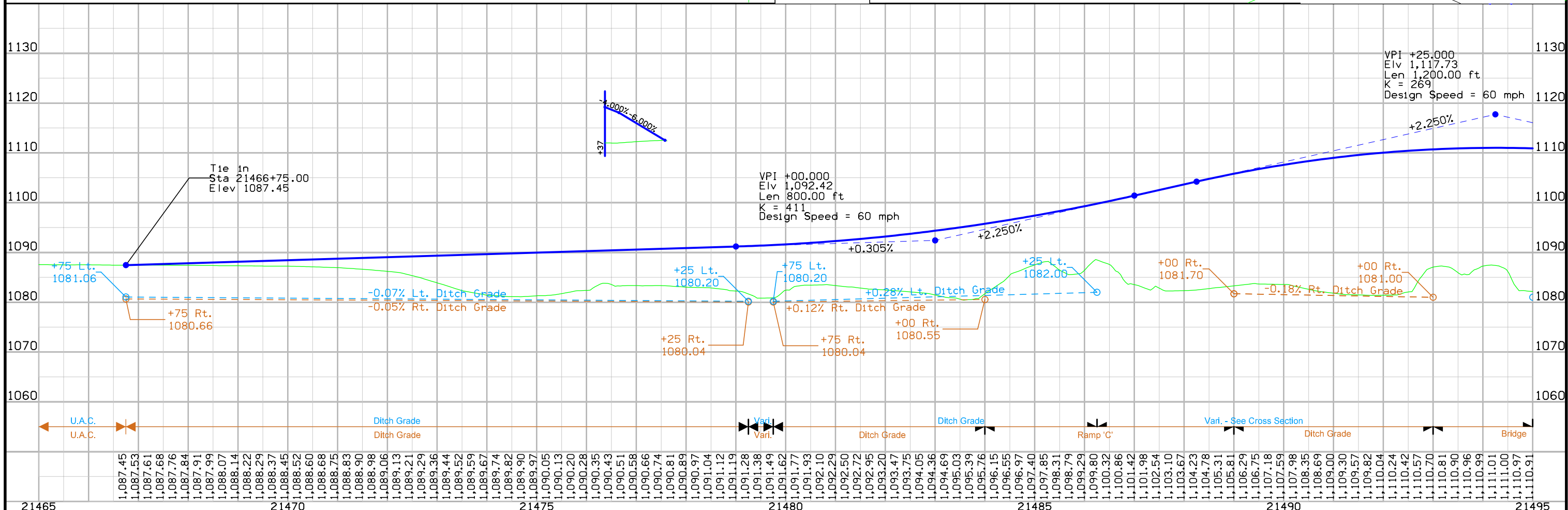
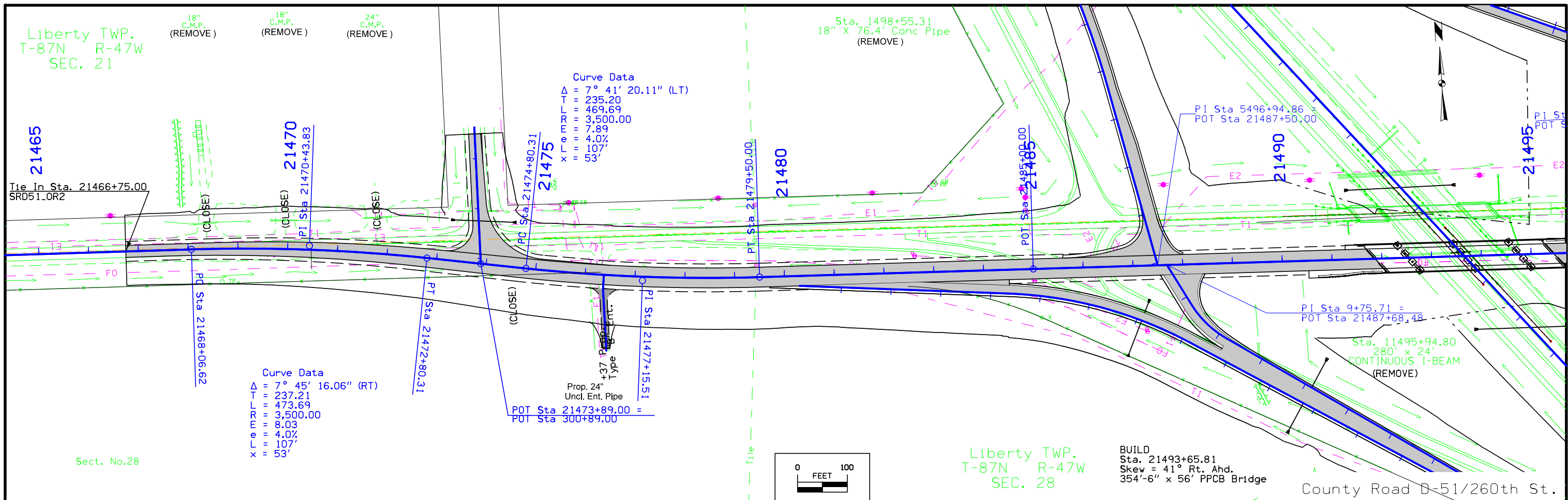

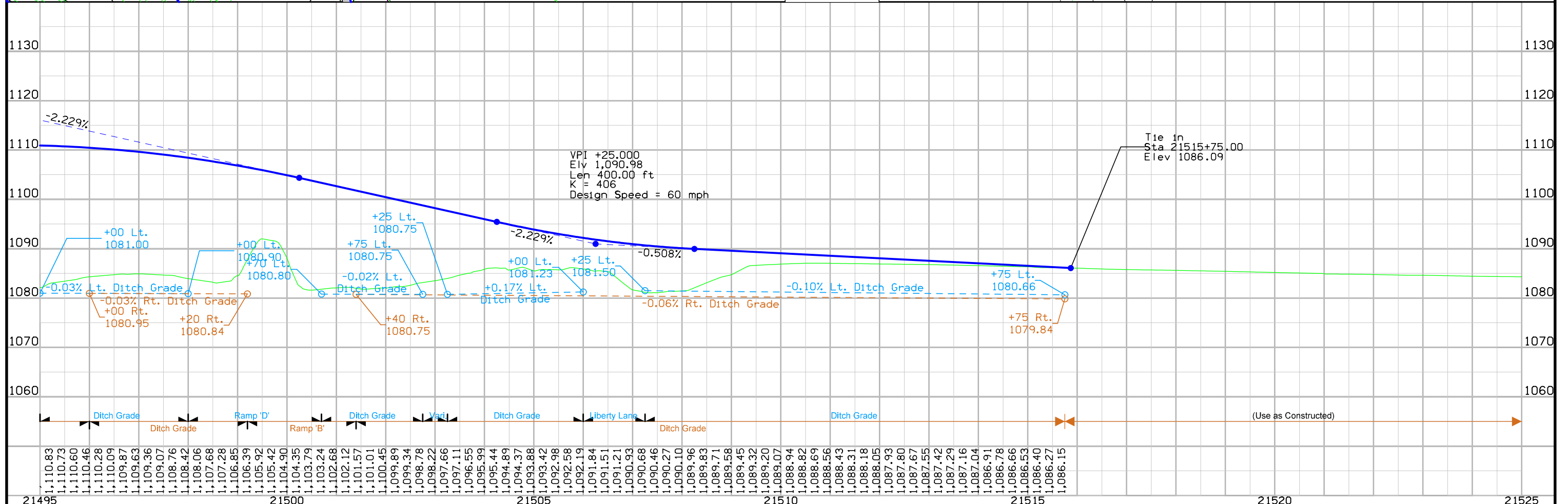
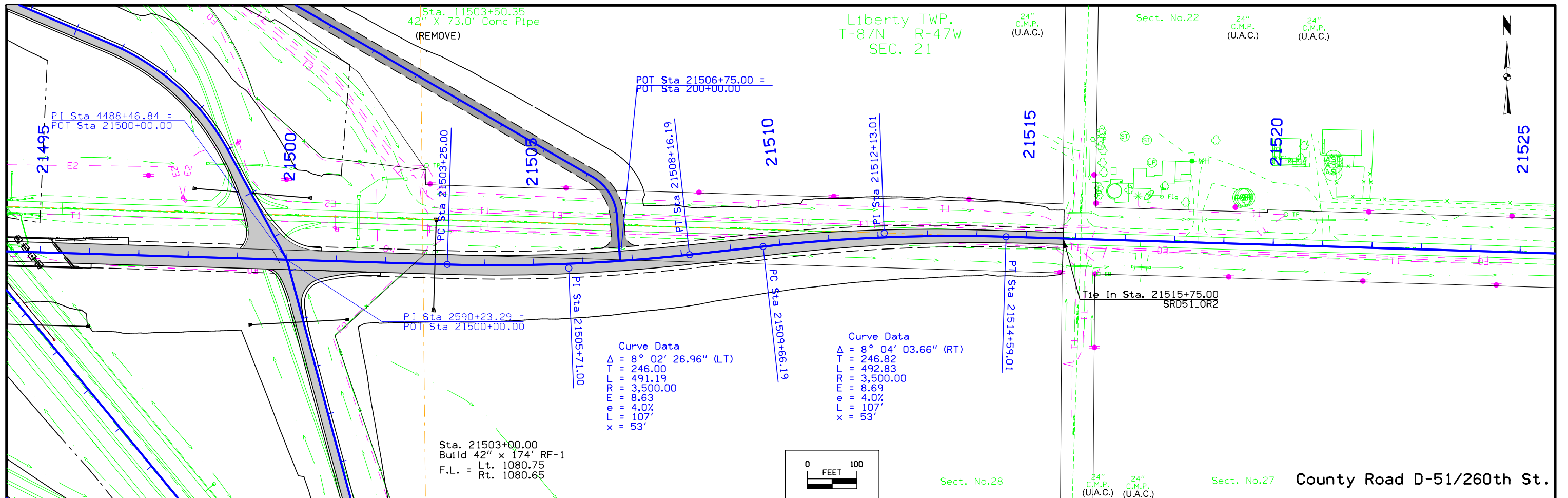

Liberty TWP.
T-87N R-47W
SEC. 21

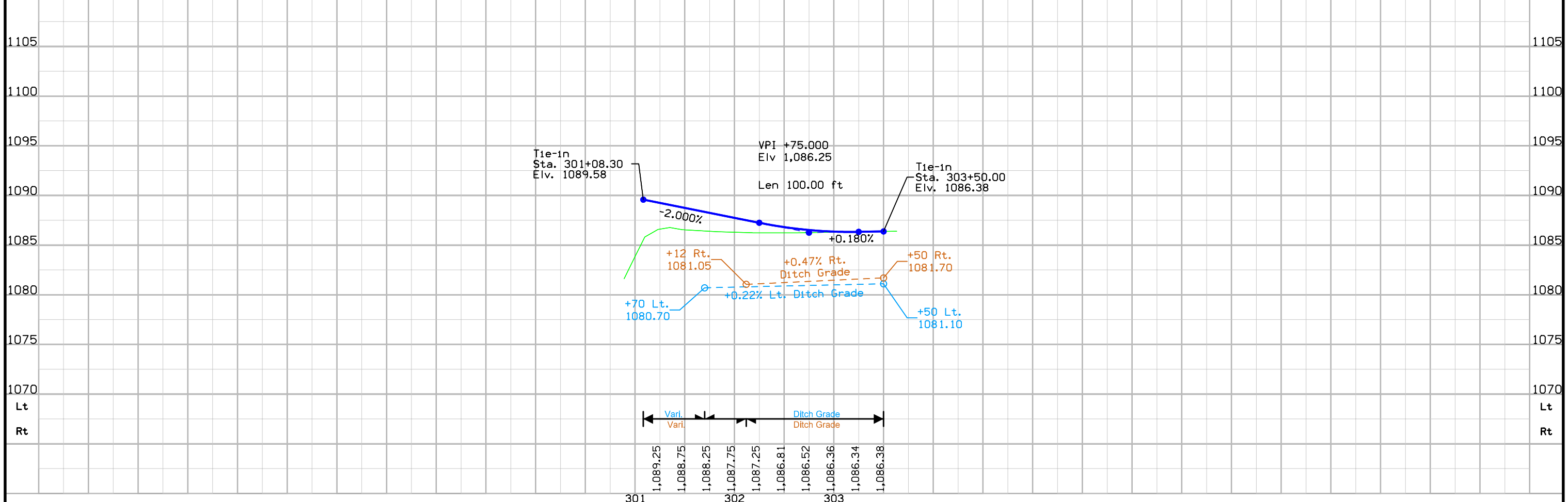
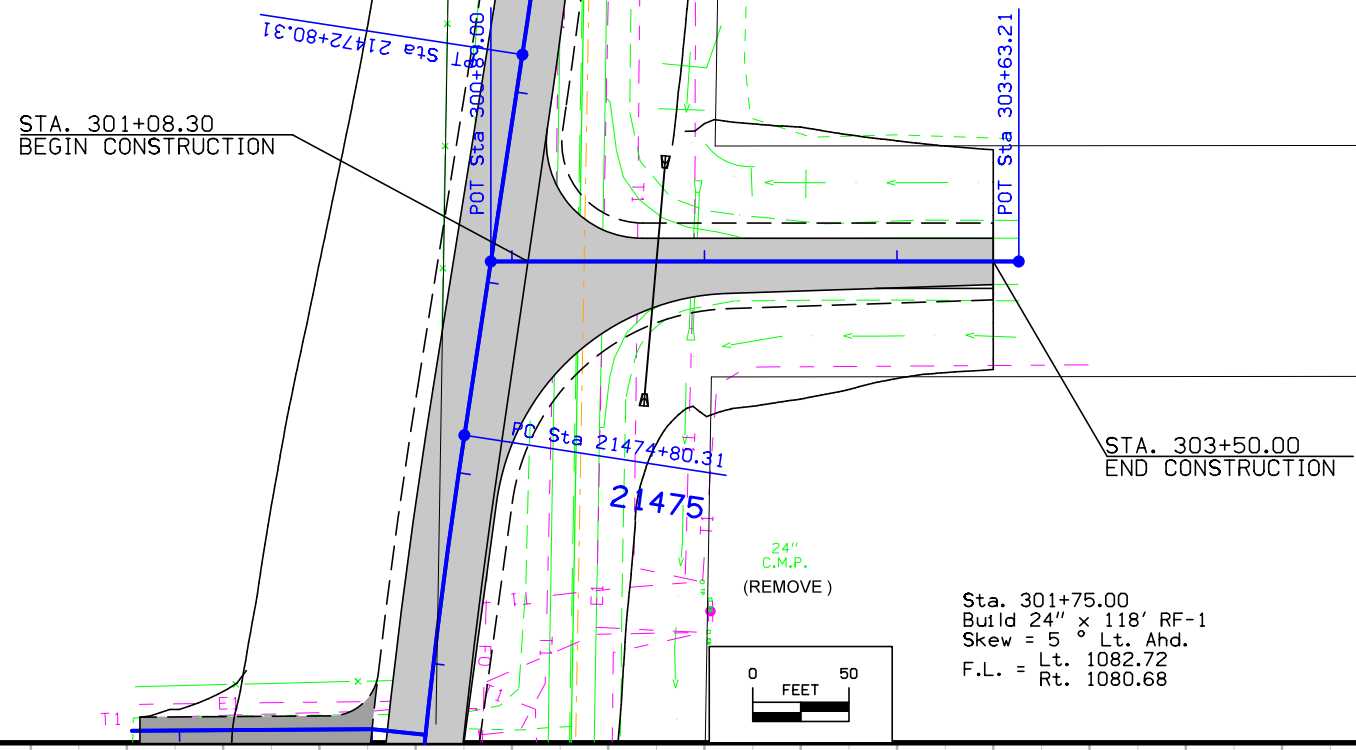
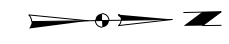

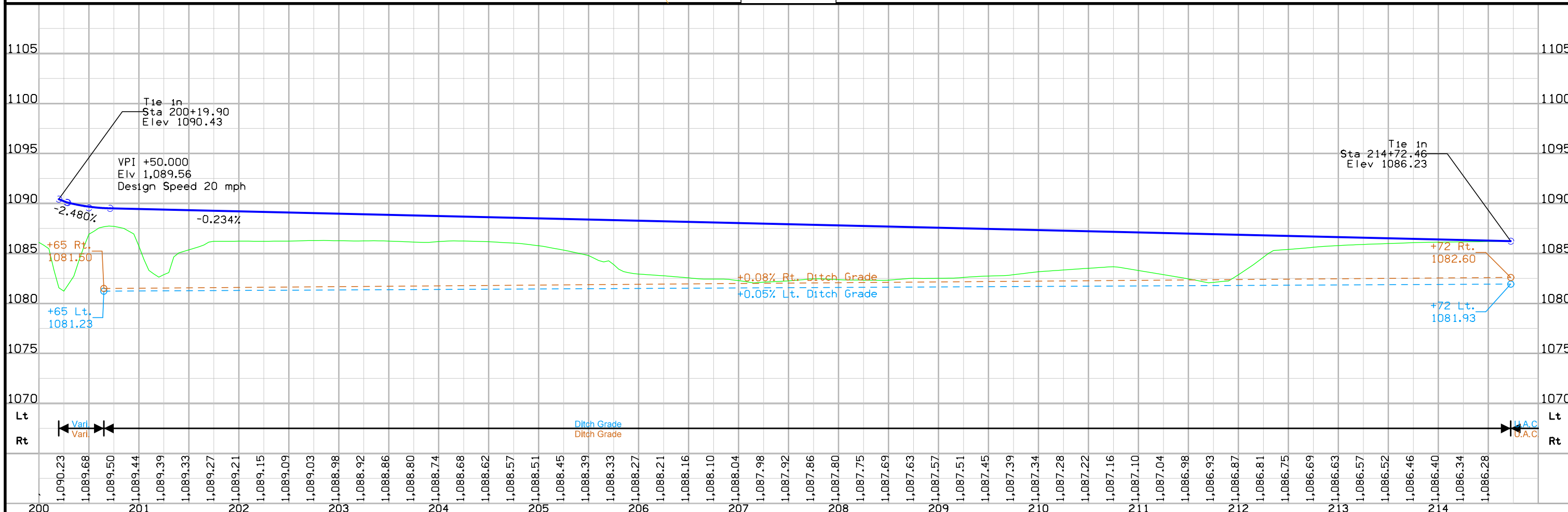
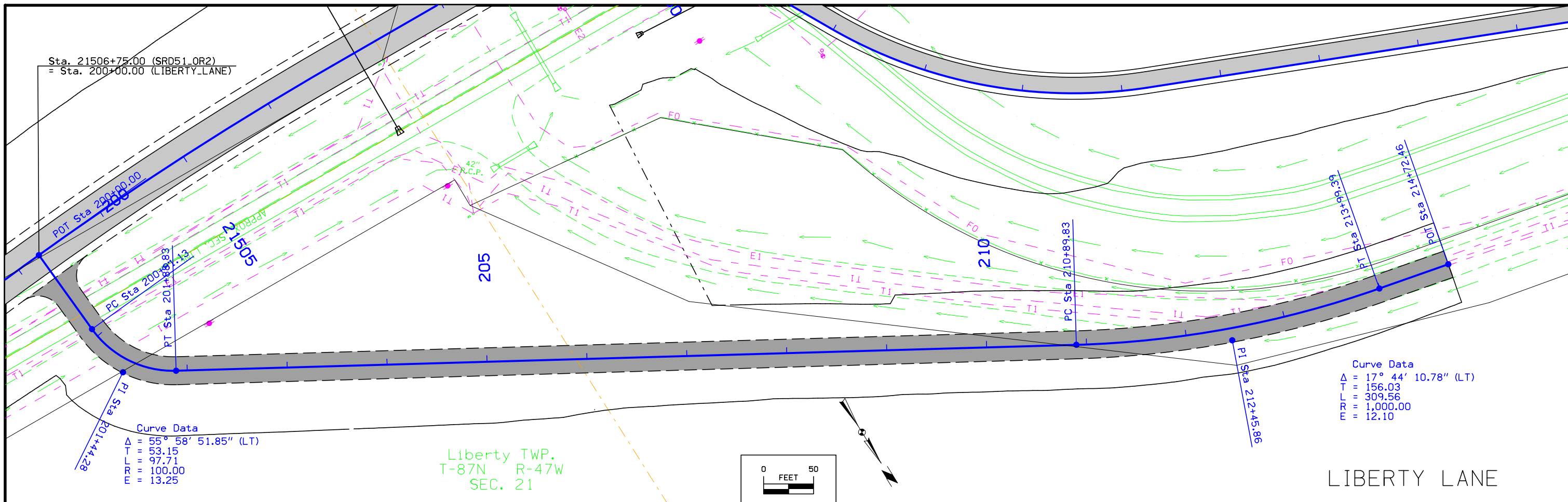

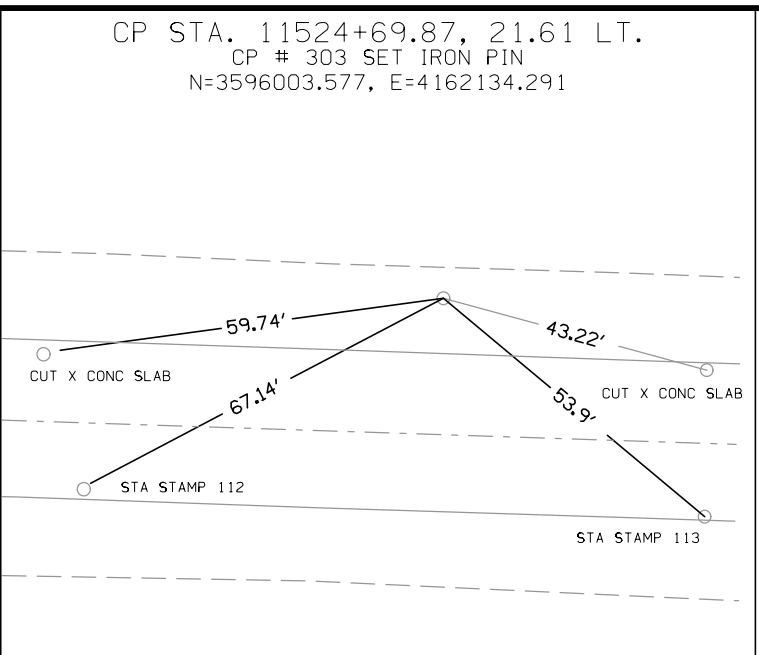
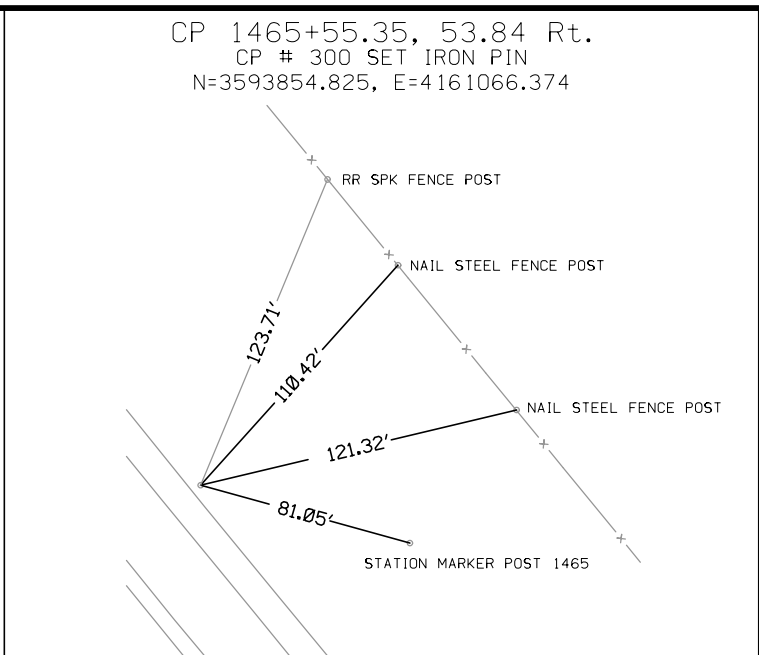
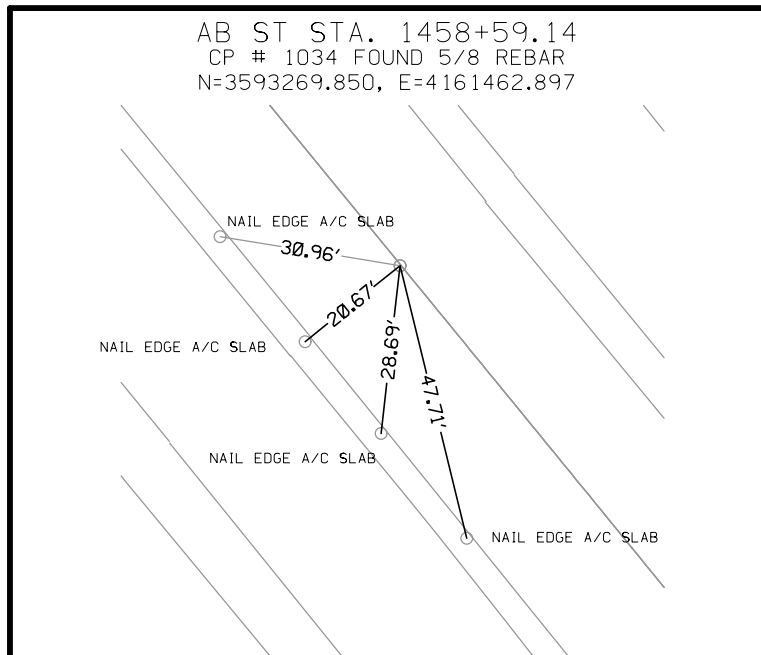

General Information

All measurements for this survey are in US survey feet.

Coordinates for this project are project specific coordinates. The coordinates are relative to Iowa North state plane coordinates (NAD83-1996) scaled around a point at 3589600.000N, 4163400.000E, 1080.000EL. A ground scale factor (1/combine factor) of 1.0000829856 was used to project the state plane coordinates to project coordinates.

Vertical Datum

Vertical datum for this survey is relative to NAVD88.

A 3-wire level loop was run along I-29 from BM #553 (NGS BM T181) Northwesterly to BM #557 (NGS BM D181) with additional benches set between these two BM's. The error of closure of the level loop was less than the allowable, so the level loop and the additional BM's were adjusted.

A 3-wire level loop was run along I-29 from BM #503 southeasterly to BM #550 (NGS BM K181) with additional benches set between these two BM's. The error of closure of the level loop was less than the allowable, so the level loop and the additional BM's were adjusted.

Vertical Equations are as follows:

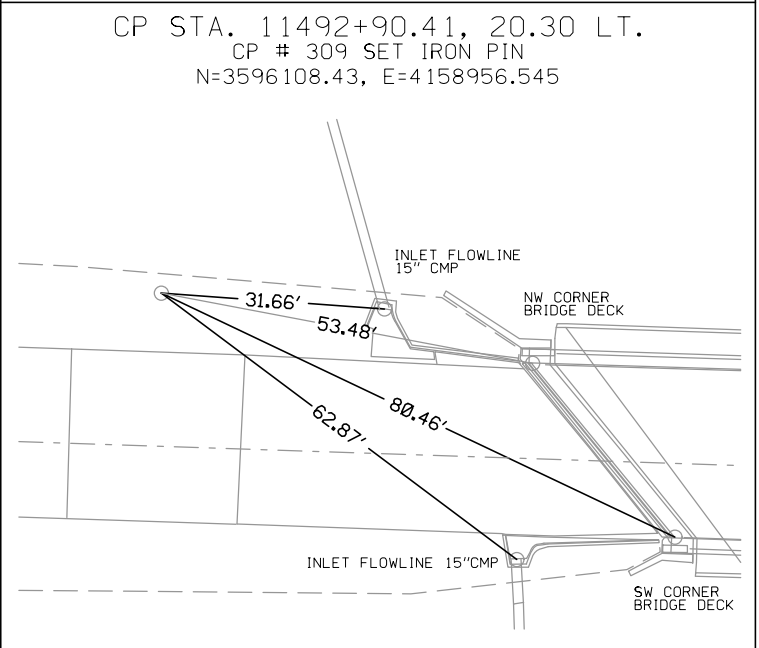
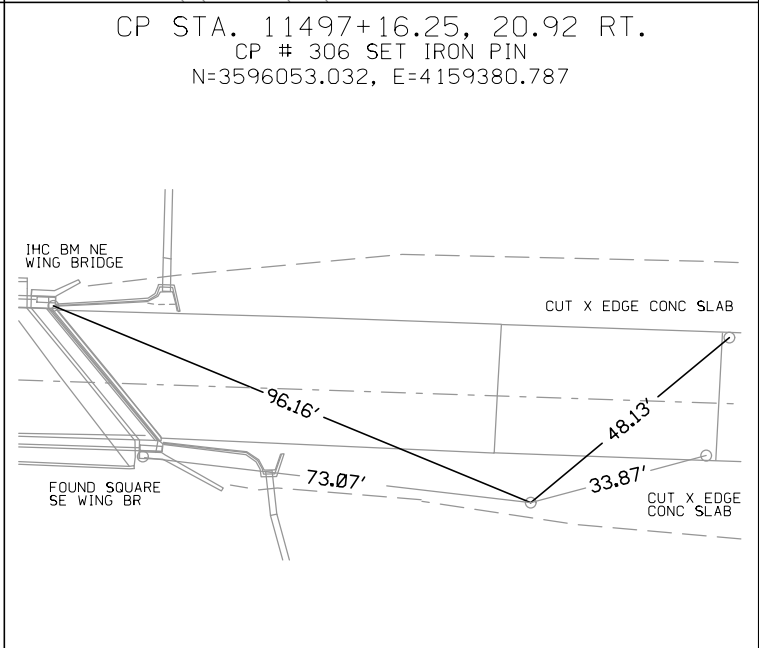
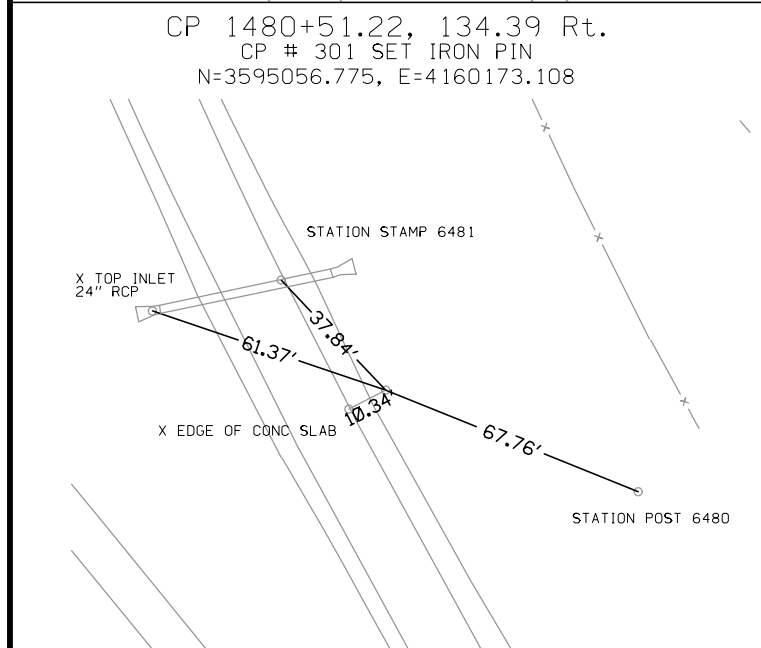

No benchmarks from the previous plans were found, so there are no vertical equations.

Horizontal Datum

The horizontal alignment for this survey is a retrace of As-built Plans, Project # I-29-6(8)122, I-29-6(9)29 and I-29-6(10)136. Stationing was established at POT Sta. 1499+57.87. Stationing was then backed southeasterly to the BOP and carried forward to the EOP.

Equations are as follows:

POT Sta. 1472+84.45 This Survey
= POT Sta. 1472+83.44 As-built Plans Project # I-29-6(8)122
= PI STA 1451+22.19 this survey
= PI STA 1451+22.19 Project # IM-029-6(183)132-13-97
= PI STA 1451+29.77 Asbuilt Plans Project # I-29-6(10)136
= PI STA 1512+68.68 this survey
= PI STA 1512+68.68 Project # IM-029-6(183)132-13-97
= PI STA 1512+77.92 Asbuilt Plans Project # INP-29-6(30)138-15-97

Point No.	Northing	Easting	Elevation	M.L. Station	Offset	Feature	Description
508	3592684.4710	4161968.4450	1080.6832	1450+93.54	92.8178	BM	CUT X NW BOLT W.LEG PORT NEAL LANDING SIGN
509	3593969.1090	4161113.7490	1084.5508	1466+13.74	172.8509	BM	SET RR SPK W. SIDE FENCE POST
510	3595076.5500	4160114.9820	1083.5484	1481+03.35	101.9560	BM	CUT X TOP INLET 24IN.
516	3597117.4440	4158536.1250	1086.4798	1506+82.67	173.8044	BM	SET RR SPK W.SIDE BRACE POST
517	3598439.2070	4157464.5450	1082.8071	1523+89.00	-103.0806	BM	CUT X SE BOLT EAST LEG PORT NEAL LANDING SIGN
518	3599516.7080	4157270.7070	1083.5054	1534+48.42	172.9822	BM	SET RR SPK W SIDE BRACE POST
521	3600874.2560	4156541.3650	1082.6431	1549+86.70	80.4220	BM	CUT X TOP 30 IN.RCP
519	3600874.2560	4156541.3650	1082.8629	1549+86.70	80.4220	BM	CUT X TOP 30 IN.RCP

Point No.	Northing	Easting	Elevation	S.R. Station	Offset	Feature	Description
511	3596119.1850	4160160.7570	1085.7868	11504+93.58	-71.1920	BM	SET RR SPK S.SIDE PO.POLE
512	3596055.4100	4162060.4910	1084.0138	11523+94.37	-70.9360	BM	SET RR SPK W. SIDE POWER POLE
513	3596178.9880	4158356.8650	1084.6679	11486+88.74	-71.1236	BM	SET RR SPK S.SIDE POWER POLE
515	3596257.2080	4155946.2800	1086.0541	11462+76.94	-70.6047	BM	SET RR SPK S.SIDE POWER POLE
514	3596209.8370	4157447.6910	1085.4265	11477+79.05	-72.2097	BM	SET RR SPK N.SIDE POWER POLE
504	3596061.4690	4159308.1670	1104.8700	11496+43.39	14.9099	BM	FOUND SQUARE SE WING BRIDGE
520	3596091.1450	4160977.7010	1086.3526	11513+11.01	-70.3974	BM	SET RR SPK S.SIDE POWER POLE

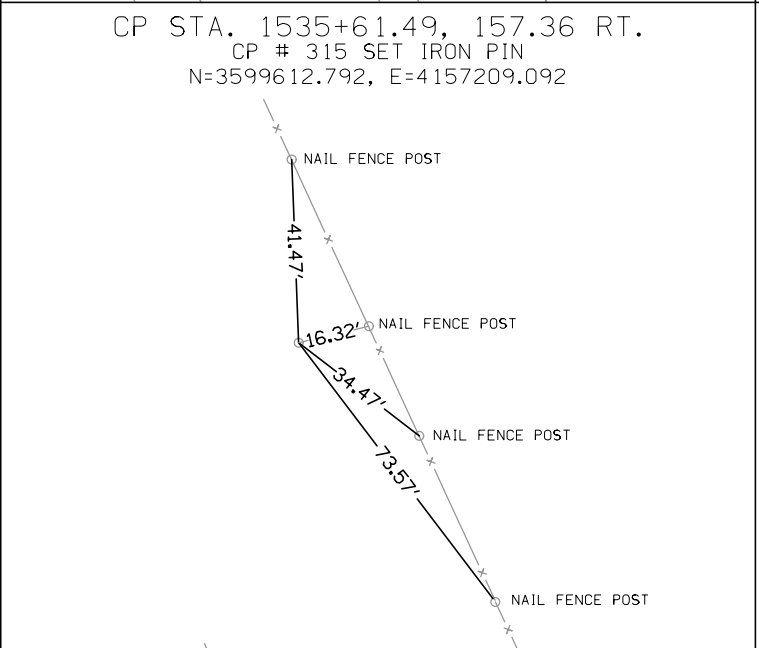
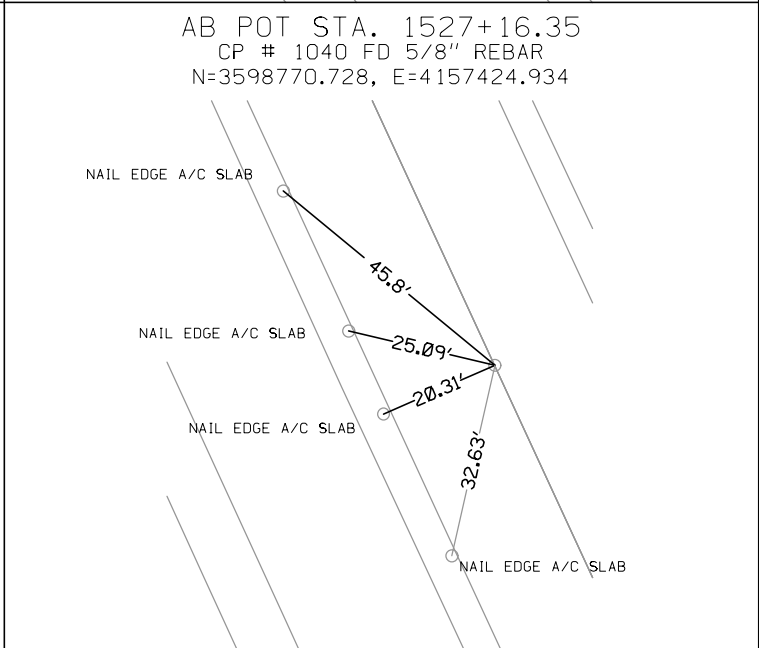
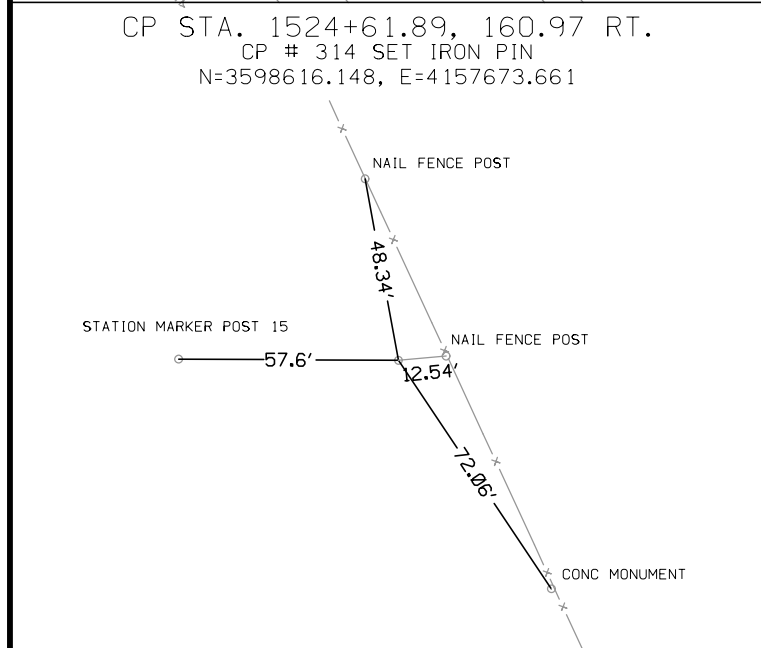
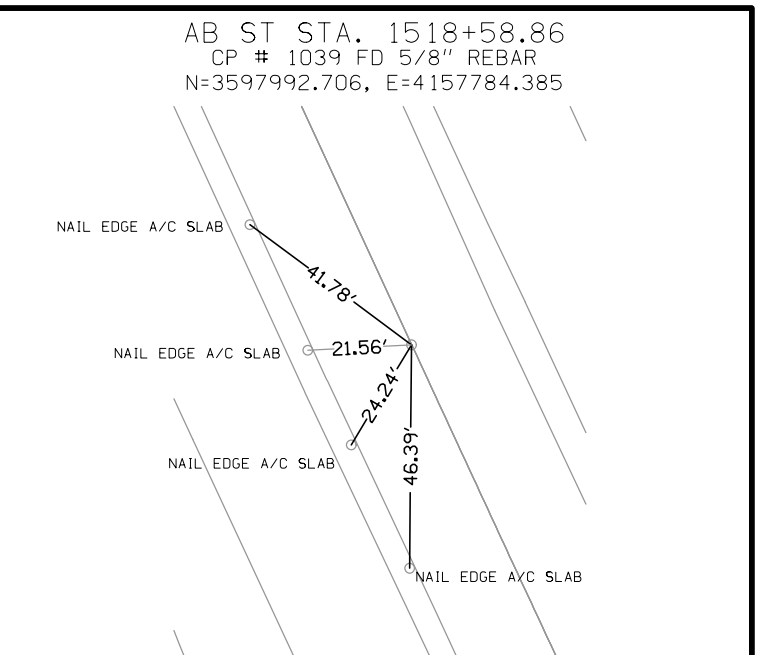
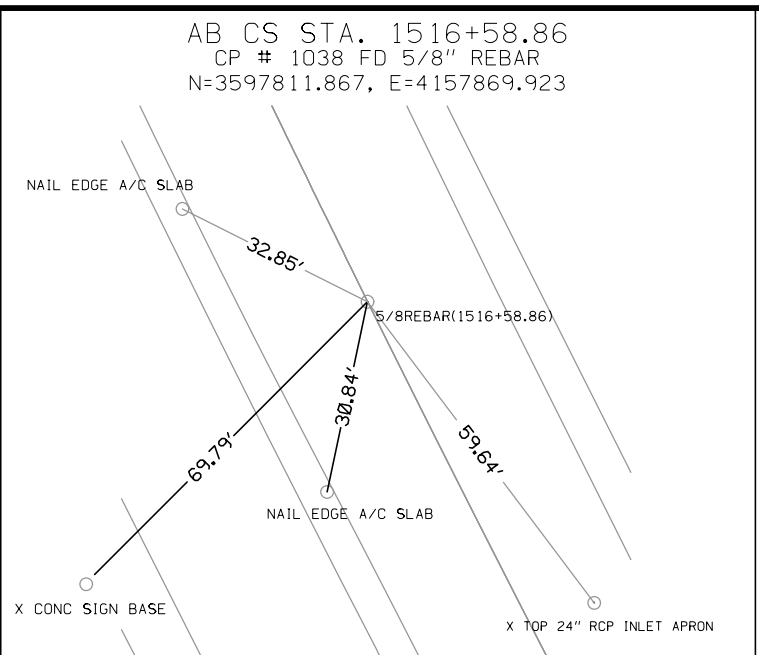
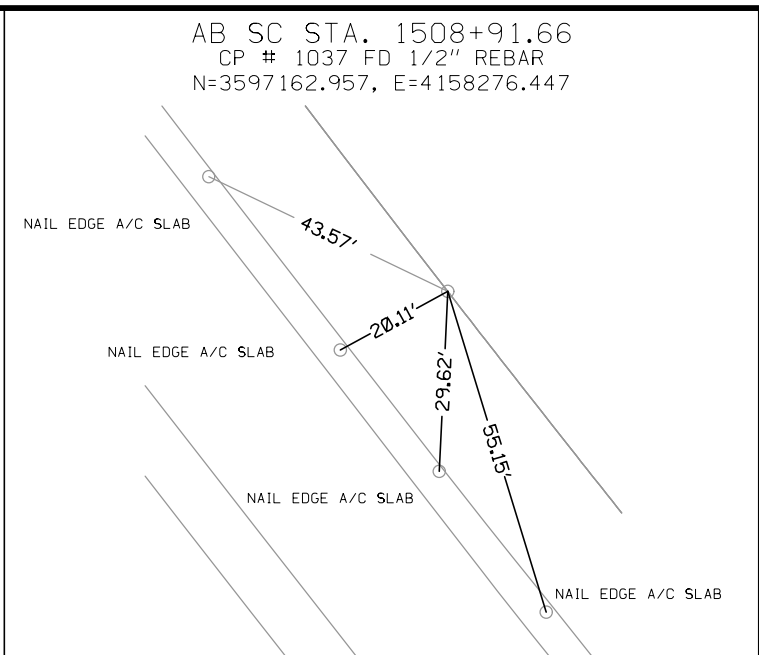
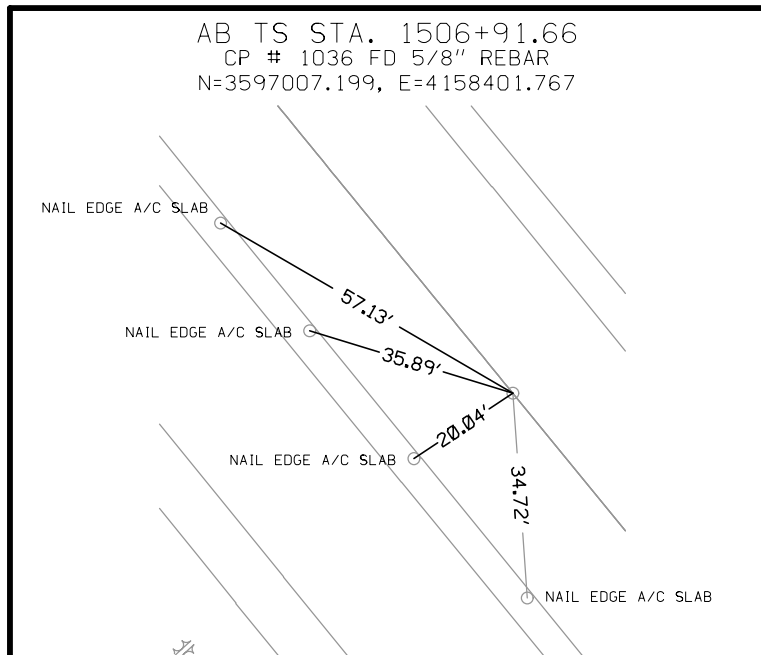

ALIGNMENT COORDINATES

101-16
10-20-09

Name	Location	Point on Tangent		Begin Spiral		Begin Curve		Simple Curve PI or Master PI of SCS			End Curve		End Spiral			
		Station	Coordinates		Station	Coordinates		Station	Coordinates		Station	Coordinates		Station	Coordinates	
			Y (Northing)	X (Easting)		Y (Northing)	X (Easting)		Y (Northing)	X (Easting)		Y (Northing)	X (Easting)		Y (Northing)	X (Easting)
Interstate 29 (ML029)																
I059		1385+95.36	3,586,379.06	4,163,600.12												
CUR1B					1443+73.31	3,591,966.42	4,162,128.33									
CUR1								1446+23.31	3,592,207.20	4,162,061.14						
CUR1A					1456+01.52	3,593,074.26	4,161,618.60									
CUR2B					1506+82.34	3,597,007.05	4,158,401.88									
CUR2								1508+81.84	3,597,162.48	4,158,276.81						
CUR2A					1516+50.20	3,597,812.55	4,157,869.62									
I058		1586+41.90	3,604,158.53	4,154,934.98												
Ramp A (051A)																
20211		5496+94.86	3,596,008.99	4,158,620.66												
20212								5500+69.63	3,596,375.46	4,158,542.23						
20213		5509+50.00	3,597,163.37	4,158,164.23												
Ramp B (051B)																
20221		2578+40.00	3,594,864.61	4,160,271.84												
20222								2579+00.00	3,594,913.46	4,160,236.99						
20223		2590+23.29	3,595,967.56	4,159,869.97												
Ramp C (051C)																
20431		3580+00.00	3,594,888.27	4,160,048.22												
20433								3580+00.00	3,594,888.27	4,160,048.22						
20432								3596+84.38	3,595,850.51	4,158,674.53						
20434		3604+83.72	3,596,012.86	4,157,900.39												
Ramp C Left Turn (051CL)																
20451		0+00.00	3,595,419.90	4,159,401.04												
20452								7+84.04	3,595,854.36	4,158,748.37						
20453		9+75.31	3,596,008.38	4,158,639.13												
Ramp D (051D)																
20241		4488+46.84	3,595,967.56	4,159,869.97												
20242								4490+96.84	3,596,188.09	4,159,752.22						
20243								4499+66.31	3,596,617.54	4,159,016.80						
20244								4503+95.00	3,596,845.48	4,158,655.92						
County Road D51/260th (SRD51_0R2)																
21301		21459+32.44	3,596,190.86	4,155,812.20												
21302								21468+06.62	3,596,162.89	4,156,685.93						
21303								21474+80.31	3,596,082.47	4,157,354.12						
21305		21485+00.00	3,596,017.28	4,158,370.80												
21306								21503+25.00	3,595,956.79	4,160,194.79						
21307								21509+66.19	3,595,991.01	4,160,834.38						
21308		21526+73.31	3,595,968.31	4,162,540.08												
Burnett Ave (BURNETT_AVE)																
22300		300+89.00	3,596,097.68	4,157,264.08												
22301		303+63.21	3,596,371.85	4,157,268.44												
Liberty Lane (LIBERTY_LANE)																
LL1		200+00.00	3,595,962.69	4,160,544.60												
LIBERTY_LANE-1								200+91.13	3,596,053.62	4,160,538.56						
LIBERTY_LANE-2								210+89.83	3,596,586.91	4,159,710.57						
LL2		214+72.46	3,596,714.97	4,159,352.07												
Entrance Sta. 21476+37 (ENT21476)																
ENT1		100+00.00	3,596,032.10	4,157,505.98												
ENT2		101+24.71	3,595,907.39	4,157,504.89												
Left EOP Transition, West of Interchange (L.REV.W)																
22310		0+00.00	3,596,055.49	4,157,821.76												
22311								0+00.00	3,596,055.49	4,157,821.76						
22312								6+44.64	3,596,130.28	4,157,182.05						
22313		11+99.40	3,596,176.69	4,156,629.72												
Right EOP Transition, West of Interchange (R.REV.W)																
22320		0+00.00	3,596,015.51	4,157,820.44												
22321								0+00.00	3,596,015.51	4,157,820.44						
22322								6+93.70	3,596,101.23	4,157,132.83						
22323		12+00.63	3,596,152.71	4,156,628.96												

ALIGNMENT COORDINATES

101-16
10-20-09

Name	Location	Point on Tangent			Begin Spiral			Begin Curve			Simple Curve PI or Master PI of SCS			End Curve			End Spiral		
		Station	Coordinates		Station	Coordinates		Station	Coordinates		Station	Coordinates		Station	Coordinates		Station	Coordinates	
			Y (Northing)	X (Easting)		Y (Northing)	X (Easting)		Y (Northing)	X (Easting)		Y (Northing)	X (Easting)		Y (Northing)	X (Easting)		Y (Northing)	X (Easting)
22330		0+00.00	3,595,976.78	4,160,195.46															
22331								0+00.00	3,595,976.78	4,160,195.46	2+33.28	3,595,969.05	4,160,428.61	4+65.87	3,595,992.33	4,160,660.72			
22332								6+15.87	3,596,007.30	4,160,809.97	8+49.97	3,596,030.66	4,161,042.91	10+83.38	3,596,022.79	4,161,276.88			
22333		12+74.39	3,596,016.37	4,161,467.78															
22340		0+00.00	3,595,936.80	4,160,194.13															
22341								0+00.00	3,595,936.80	4,160,194.13	2+58.18	3,595,928.25	4,160,452.17	5+15.43	3,595,957.65	4,160,708.68			
22342								6+65.43	3,595,974.73	4,160,857.70	9+24.44	3,596,004.22	4,161,115.02	11+82.50	3,595,995.52	4,161,373.88			
22343		12+75.64	3,595,992.39	4,161,466.97															
20556		0+00.00	3,596,027.32	4,158,671.29															
20557								0+00.00	3,596,027.32	4,158,671.29	0+17.18	3,596,033.75	4,158,655.36	0+33.10	3,596,048.62	4,158,646.75			
20558								0+33.10	3,596,048.62	4,158,646.75	0+64.80	3,596,076.05	4,158,630.85	0+95.98	3,596,107.05	4,158,624.22			
20559		0+95.98	3,596,107.05	4,158,624.22															
20551		0+00.00	3,596,035.28	4,158,431.43															
20552								0+00.00	3,596,035.28	4,158,431.43	0+62.51	3,596,033.21	4,158,493.91	1+24.23	3,596,048.24	4,158,554.58			
20553								1+24.23	3,596,048.24	4,158,554.58	1+71.48	3,596,059.61	4,158,600.44	2+02.30	3,596,106.66	4,158,596.12			
20554								2+02.30	3,596,106.66	4,158,596.12	2+32.16	3,596,136.39	4,158,593.39	2+61.94	3,596,165.58	4,158,587.15			
20555		2+61.94	3,596,165.58	4,158,587.15															
20566		0+00.00	3,595,882.95	4,159,875.73															
20567								0+00.00	3,595,882.95	4,159,875.73	0+24.49	3,595,906.63	4,159,869.49	0+48.78	3,595,928.41	4,159,858.30			
20568								0+48.78	3,595,928.41	4,159,858.30	0+63.19	3,595,941.22	4,159,851.72	0+76.83	3,595,948.57	4,159,839.33			
20569		0+76.83	3,595,948.57	4,159,839.33															
20561		0+00.00	3,595,809.67	4,159,911.60															
20562								0+00.00	3,595,809.67	4,159,911.60	0+33.07	3,595,841.65	4,159,903.17	0+66.02	3,595,874.52	4,159,899.50			
20563								0+66.02	3,595,874.52	4,159,899.50	1+09.95	3,595,918.18	4,159,894.63	1+38.11	3,595,928.62	4,159,937.31			
20564								1+38.11	3,595,928.62	4,159,937.31	1+99.96	3,595,943.33	4,159,997.39	2+61.05	3,595,941.28	4,160,059.21			
20565		2+61.05	3,595,941.28	4,160,059.21															
20391		0+00.00	3,595,805.41	4,158,821.91															
20392								0+00.00	3,595,805.41	4,158,821.91	0+43.86	3,595,829.71	4,158,785.40	0+87.65	3,595,857.12	4,158,751.16			
20393								0+87.65	3,595,857.12	4,158,751.16	1+18.76	3,595,876.55	4,158,726.87	1+49.37	3,595,902.45	4,158,709.64			
20394								1+49.37	3,595,902.45	4,158,709.64	1+99.69	3,595,944.34	4,158,681.76	2+38.01	3,595,986.02	4,158,709.95			
20395		2+38.01	3,595,986.02	4,158,709.95															
20581		0+00.00	3,595,985.23	4,159,940.60															
20582								0+00.00	3,595,985.23	4,159,940.60	0+09.85	3,595,985.56	4,159,930.75	0+19.69	3,595,986.75	4,159,920.97			
20583								0+19.69	3,595,986.75	4,159,920.97	0+54.54	3,595,990.94	4,159,886.37	0+86.76	3,596,015.73	4,159,861.88			
20584								0+86.76	3,596,015.73	4,159,861.88	1+41.32	3,596,054.54	4,159,823.53	1+95.12	3,596,102.67	4,159,797.83			
20585		1+95.12	3,596,102.67	4,159,797.83															
20586		0+00.00	3,595,990.54	4,159,780.68															
20587								0+00.00	3,595,990.54	4,159,780.68	0+23.89	3,596,008.55	4,159,796.37	0+44.57	3,596,032.07	4,159,792.21			
20588								0+44.57	3,596,032.07	4,159,792.21	1+16.15	3,596,102.56	4,159,779.75	1+86.54	3,596,165.70	4,159,746.04			
20589		1+86.54	3,596,165.70	4,159,746.04															
20582												5° 00' 48.46" RT	9.85'	19.69'	225.00'	0.22'			
20583												38° 25' 51.59" RT	34.85'	67.07'	100.00'	5.90'			
20584												16° 33' 19.95" RT	54.56'	108.36'	375.00'	3.95'			

SPIRAL OR CIRCULAR CURVE DATA

101-17
04-19-11

Name	Location	Δ _{scs}	Horizontal Alignment Data												Remarks				
			Spiral Data						Curve Data										
			θs	Ls	Ts	Es	Xc	Yc	L.T.	S.T.	Δ _c	T	L	R		E			
Ramp A Return (D51A.RET.1)																			
CUR1																			
CUR2																			
Ramp A (D51A)																			
20212																			
Ramp B Return (D51B.RET.2)																			
20222																			
Ramp C (D51C)																			
20433																			
20432																			
Ramp C Left Turn (D51CL)																			
20452																			
Ramp D (D51D)																			
20242																			
20243																			
20244																			
County Road D51/260th (SRD51.0R2)																			
21302																			
21303																			
21306																			
21307																			
Liberty Lane (LIBERTY_LANE)																			
LIBERTY_LANE-1																			
LIBERTY_LANE-2																			
Left EOP Transition, West of Interchange (L.REV.W)																			
22311																			
22312																			
Right EOP Transition, West of Interchange (R.REV.W)																			
22321																			
22322																			
Left EOP Transition, East of Interchange (L.REV.E)																			
22331																			
22332																			
Right EOP Transition, East of Interchange (R.REV.E)																			
22341																			
22342																			
Ramp A Return (D51A.RET.1)																			
20557																			
20558																			
Ramp A Return (D51A.RET.2)																			
20552																			
20553																			
20554																			
Ramp B Return (D51B.RET.3)																			
20567																			
20568																			
Ramp B Return (D51B.RET.4)																			
20562																			
20563																			
20564																			
Ramp C Return (D51C.RET.4)																			
20392																			
20393																			
20394																			

SUPERELEVATION DATA

See PV-300 Series

Road Identification	Circular Curve or Spiral Curve Name	Radius	Superelevation Data			Standard Road Plan	Section A-A	Section B-B	Section C-C	Section D-D	Section E-E	Section F-F	Case A	Case B	Case C	Case S	Case T	Case U	Remarks
			e %	L FT	x FT														
D51	21302	3500	4.0	107	53	PV-301	21466+78.72	21467+31.72	21467+84.72	21468+38.72			21468+06.62			21468+38.72	21468+38.72		Review
							21474+08.21	21473+55.21	21473+02.21	21472+48.21			21472+80.31			21472+48.21	21472+48.21		Review
D51	21303	3500	4.0	107	53	PV-301	21473+52.41	21474+05.41	21474+58.41	21475+12.41			21474+80.31			21475+12.41	21475+12.41		Review
							21480+77.90	21480+24.90	21479+71.90	21479+17.90			21479+50.00			21479+17.90	21479+17.90		Review
D51	21306	3500	4.0	107	53	PV-301	21501+97.10	21502+50.10	21503+03.10	21503+57.10			21503+25.00			21503+57.10	21503+57.10		Review
							21509+44.09	21508+91.09	21508+38.09	21507+84.09			21508+16.19			21507+84.09	21507+84.09		Review
D51	21307	3500	4.0	107	53	PV-301	21508+38.29	21508+91.29	21509+44.29	21509+98.29			21509+66.19			21509+98.29	21509+98.29		Review
							21515+86.91	21515+33.91	21514+80.91	21514+26.91			21514+59.01			21514+26.91	21514+26.91		Review
D51 Ramp A	20212	1700	5.8	180	62	PV-303	5500+05.63		5500+69.63	5501+23.63					5500+67.77	5500+67.77			
D51 Ramp A	20212	1700	5.8	180	62	PV-303	5508+78.00	5508+16.00	5506+90.00	5506+36.00					5506+91.86	5506+91.86			
D51 Ramp B	20222	1330	6.0	186	62	PV-303	2578+31.80		2579+00.00	2579+55.80					2578+93.80	2578+93.80			
							2584+49.60		2583+81.40	2583+25.60					2583+87.60	2583+87.60			
D51 Ramp C	20433	2000	5.4	168	62	PV-303			3580+00.00	3580+50.40					3580+06.84	3580+06.84			
							3586+76.65		3586+21.05	3585+70.65					3586+14.21	3586+14.21			
D51 Ramp C	20432	833	6.0	168	56	PV-303	3596+22.78		3596+84.38	3597+34.78					3596+78.78	3596+78.78			
									3600+62.79	3600+12.39					3600+68.39	3600+68.39			
D51 Ramp D	20242	485	6.0	144	48	PV-303	4489+48.04	4489+96.04	4490+96.84	4491+40.04					4490+92.04	4490+92.04			
							4495+74.55	4495+26.55	4494+25.75	4493+82.55					4494+30.55	4494+30.55			
D51 Ramp D	20243	1330	5.4	151	56	PV-303	4499+16.61		4499+66.31	4500+11.61					4499+72.46	4499+72.46			
D51 Ramp D	20244	2000	5.4	168	62	PV-303													
									4506+75.00	4506+24.60					4506+68.16	4506+68.16			

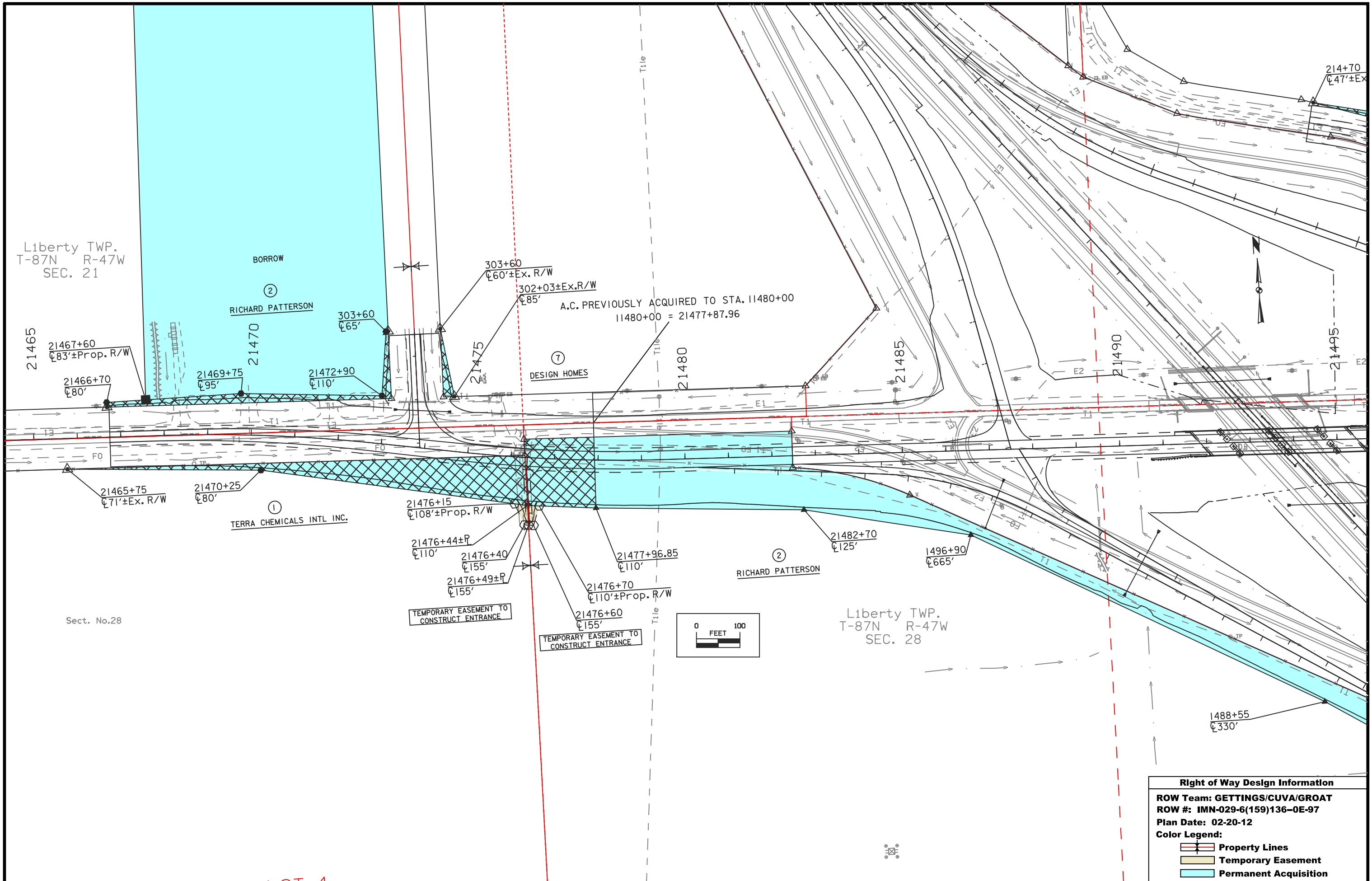

SW1/4 SE1/4
SEC 21-87-47

SE1/4 SE1/4
SEC 21-87-47

NE1/4 NE1/4
SEC 28-87-47

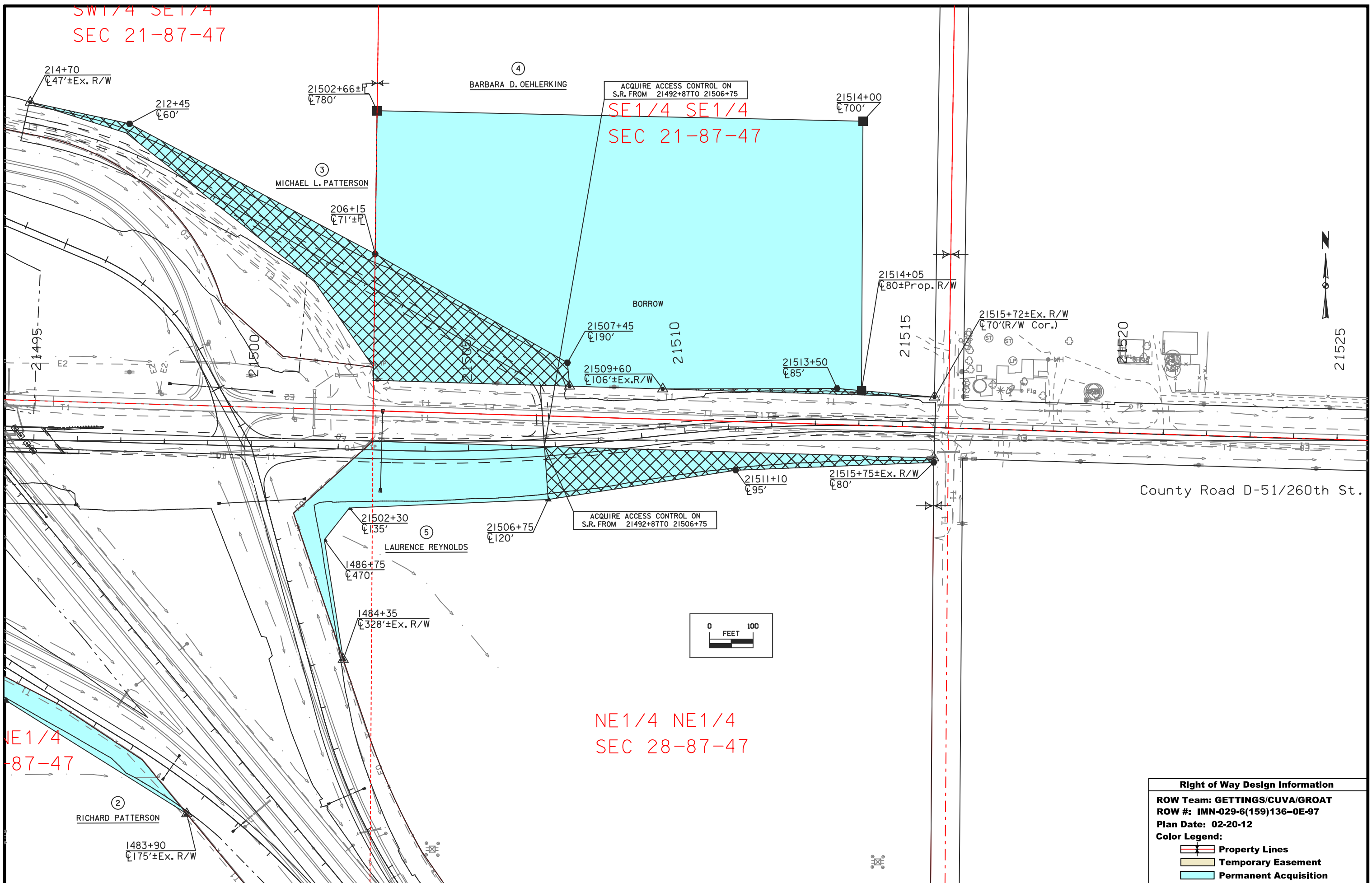

Right of Way Design Information	
ROW Team:	GETTINGS/CUVA/GROAT
ROW #:	IMN-029-6(159)136-0E-97
Plan Date:	02-20-12
Color Legend:	
	Property Lines
	Temporary Easement
	Permanent Acquisition

PARCEL CHECK BY PROJ UPDATED 02/21/12 13:37

PAGE: 1

AND: 2

R2360003 PARCEL CHECK LIST BY PROJECT NUMBER

COUNTY : WOODBURY PROJECT NO. : IMN-029-6(159)136--0E-97

PIN: 04-97-029040-00

CONSTRUCTION NO.: IM-029-6(186)136--13-97

ASSIGNED TO: NLC

DESCRIPTION : I-29/260th St./Co. Rd. D-51 Interchange 1.8 Miles N. Of Salix

PARCEL	KEY	OWNER	TYPE	R/W W.D OR EASE.	BORROW W.D OR EASE.	HOUSE OR
--------	-----	-------	------	------------------	---------------------	----------

0001	26307	TERRA CHEMICALS INTERNATIONAL INC.	FEE WOODBURY COUNTY	1.00	EASE ACRE	
0002	26308	RICHARD PATTERSON	FEE WOODBURY COUNTY	0.85	EASE ACRE	18.97 WD
			STATE OF IOWA	3.80	WD ACRE	
0003	26309	MICHAEL L. PATTERSON	FEE WOODBURY COUNTY	1.50	EASE ACRE	
0004	26310	BARBARA D. OEHLERKING	FEE WOODBURY COUNTY	1.95	EASE ACRE	14.22 WD
			STATE OF IOWA			
0005	26311	LAURENCE REYNOLDS	FEE WOODBURY COUNTY	1.09	EASE ACRE	
			STATE OF IOWA	1.09	EASE ACRE	
				1.86	WD ACRE	
0007	26312	DESIGN HOMES	FEE WOODBURY COUNTY	0.04	EASE ACRE	

COUNTY of WOODBURY

5.30 EASEMENT ACRES

STATE OF IOWA

3.80 WARRANTY DEED ACRES

33.19 BORROW WARRANTY DEED ACRES

6 TOTAL PARCELS ON PROJECT

108-23A
08-01-08

TRAFFIC CONTROL PLAN

Traffic on I-29 will be maintained at all times with the exception of short closure periods for removing the existing bridge and construction the new bridge.

The interchange at 260th Street/County Road D-51 and I-29 will be closed to all traffic and detoured to the Salix interchange at M.P. 134 or Sergeant Bluff interchange at M.P. 141.

108-26A
08-01-08

STAGING NOTES

It is not the intent of the sequence of construction to confine the Contractor's activities to the area of the suggested stages alone. It is understood that some of the various steps, though listed in numerical order, may occur simultaneously. Therefore, the Contractor may conduct several operations concurrently on the project, provided that the existing traffic is maintained and that these operations do not conflict with the staging indicated here in.

It is recognized that as various activities related to the construction progress, certain situations may arise which will preclude adhering to the original construction sequence or, which in the opinion of the Contractor, would readily adhere itself to a more efficient staging operation. Should this occur, and the Contractor desires to deviate from the original plan, they shall submit an alternate plan for approval by the Engineer.

The staging shown is one method for construction for the project. If the contractor should desire to deviate from the staging as shown, he should avail himself of Article 1105.15 of the Standard Specifications to request changes. Maintenance of traffic shall be according to Tab. 108-23; no deviations from the intent of the traffic control plan will be acceptable for Value Engineering proposal acceptance.

102-15
08-01-08

TABULATION OF SPECIAL EVENTS

Event	Location	Date
NONE PROVIDED		

Liberty TWP.
T-87N R-47W
SEC. 28

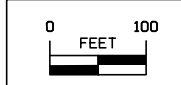
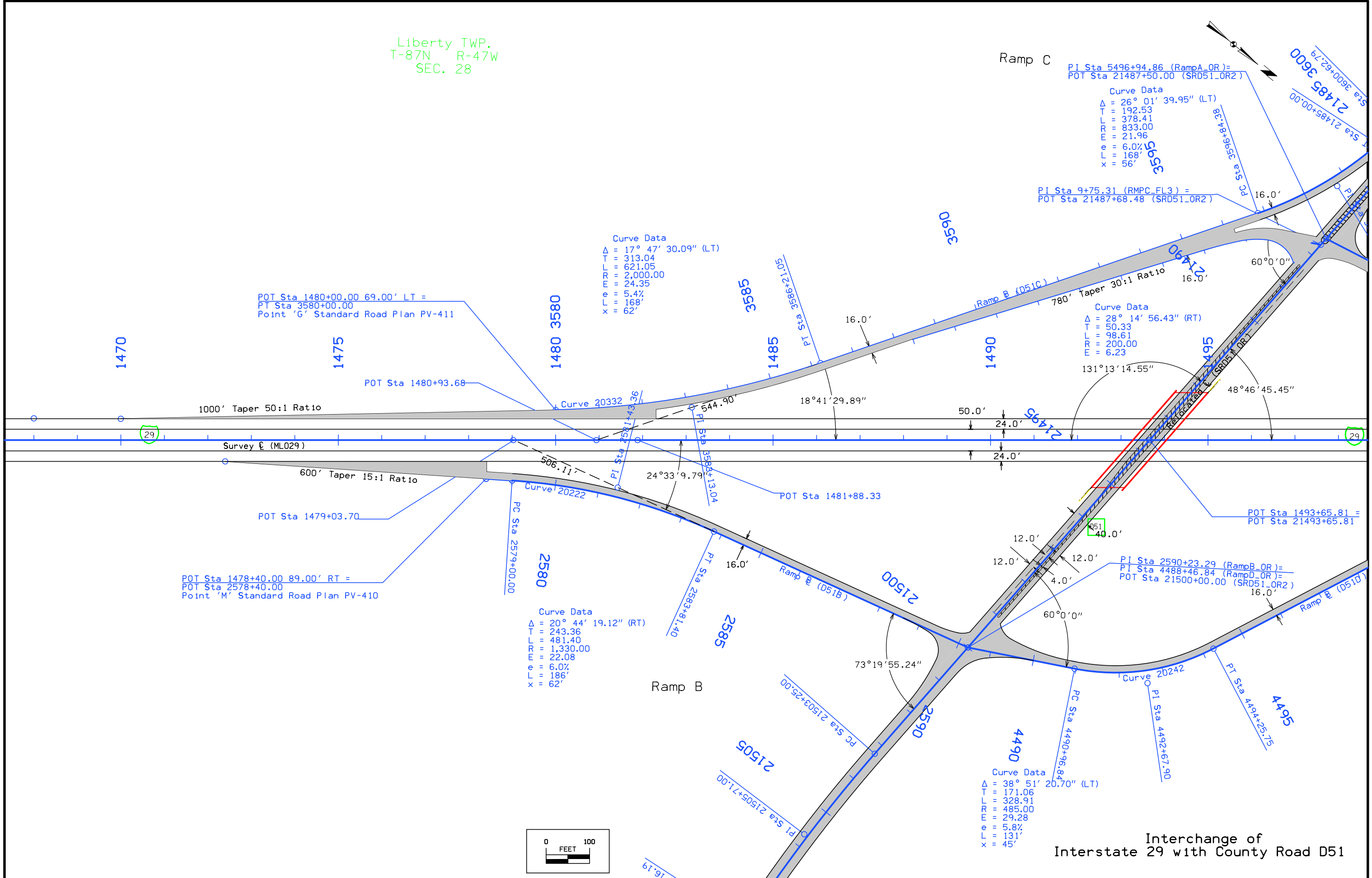

Interchange of
Interstate 29 with County Road D51

Liberty TWP.
T-87N R-47W
SEC. 21

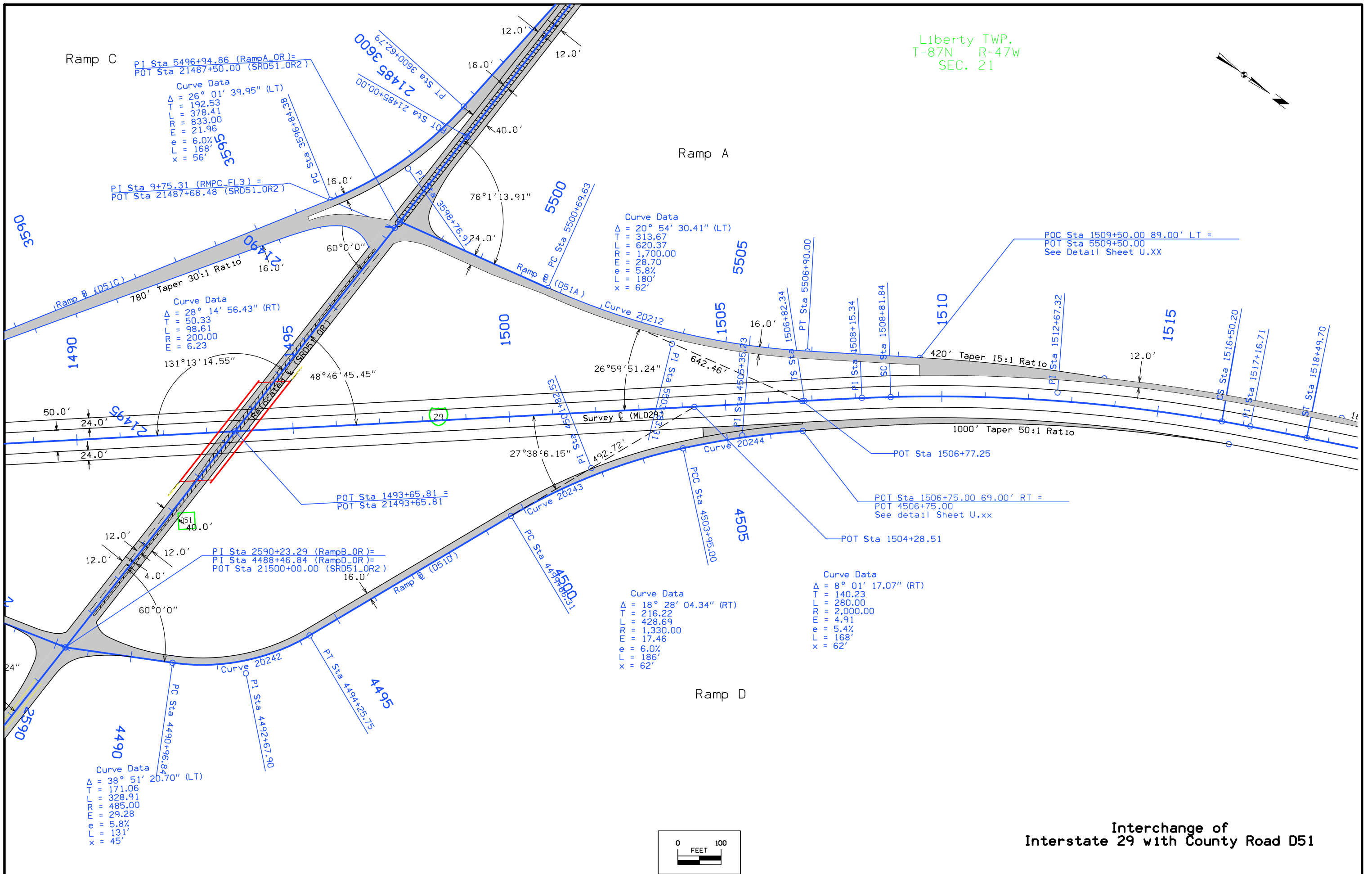
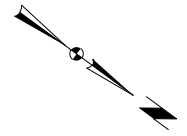

Interchange of
Interstate 29 with County Road D51

Liberty TWP.
T-87N R-47W
SEC. 21

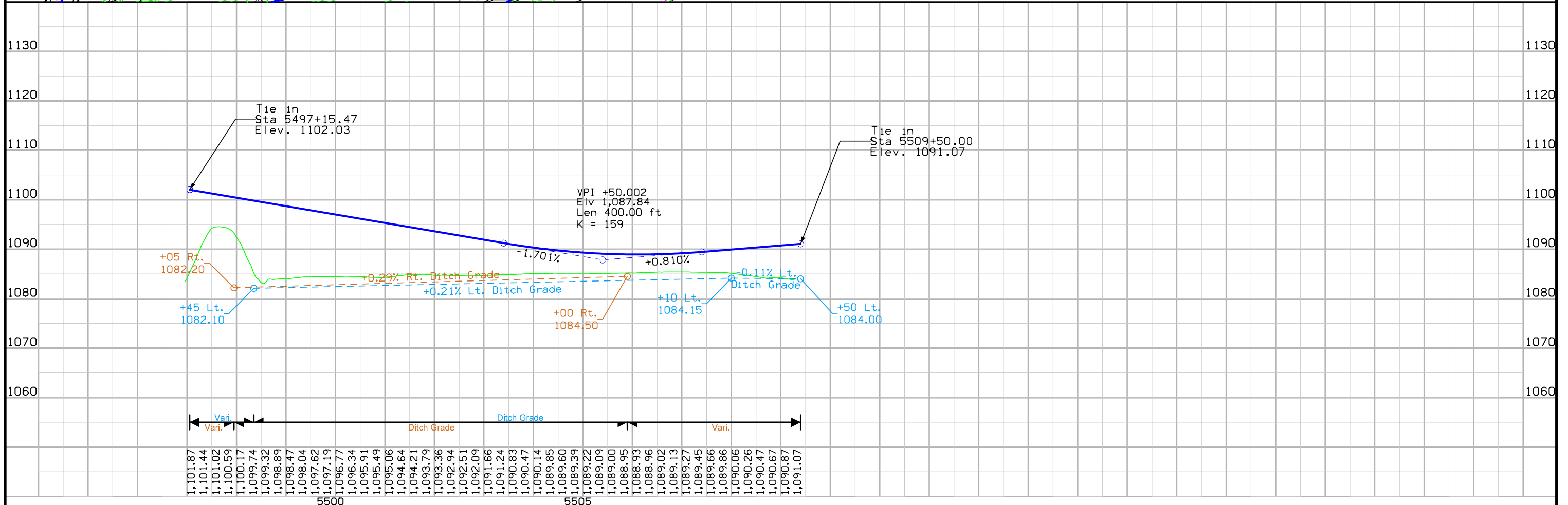
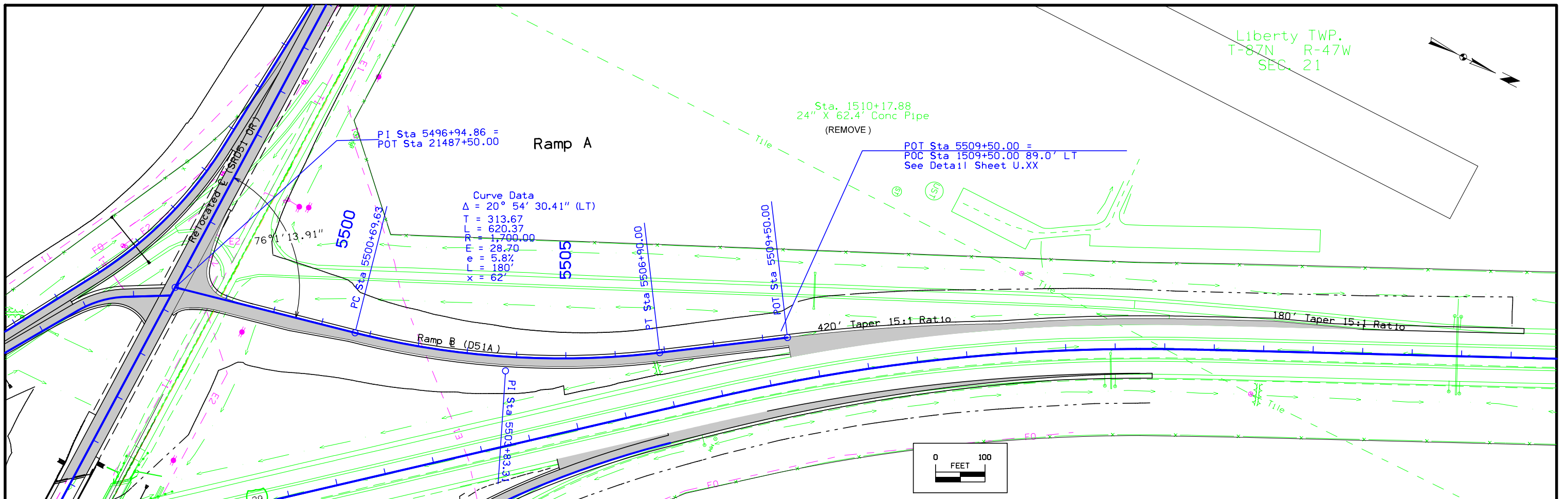

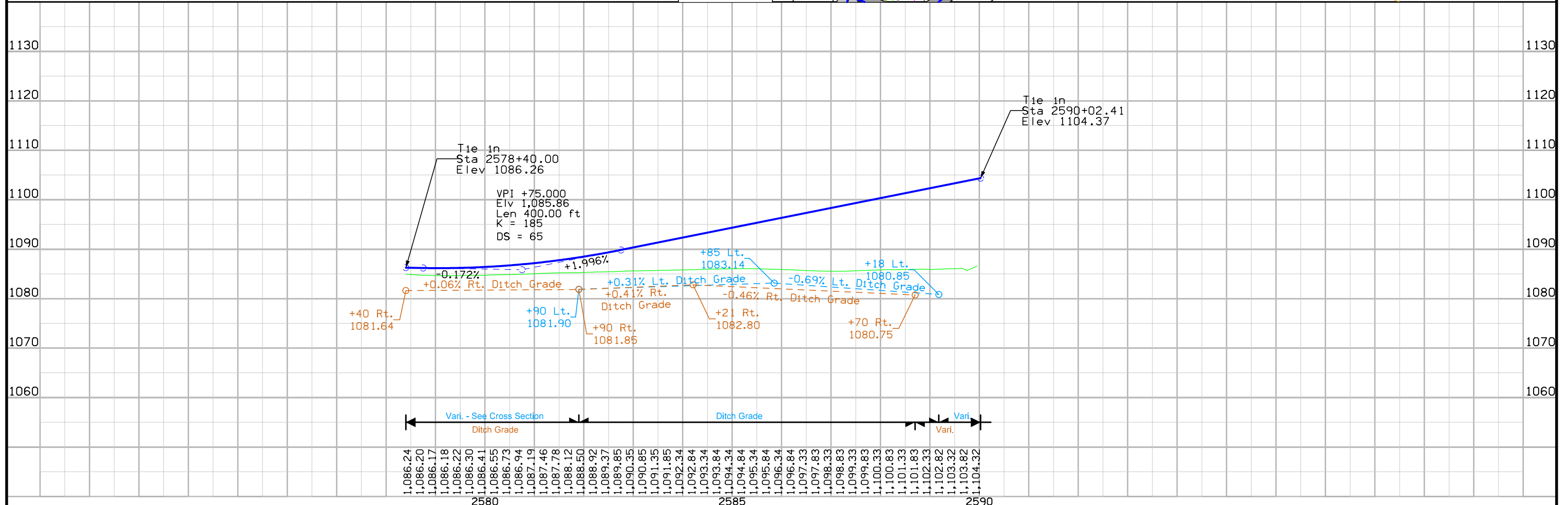
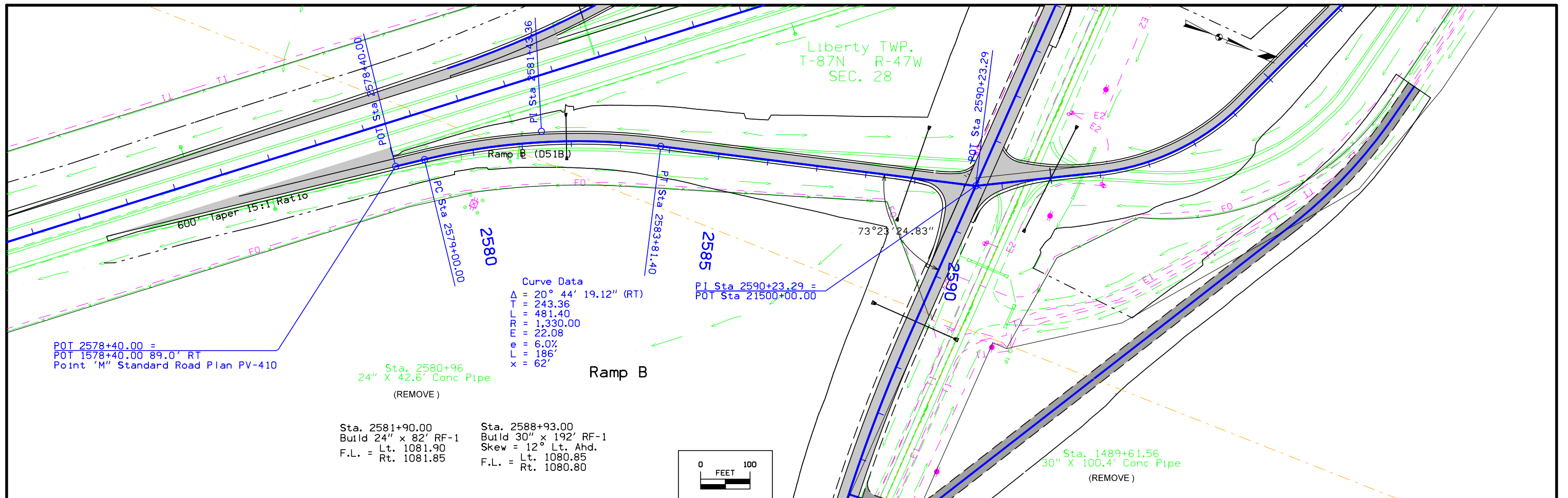

Liberty TWP.
T-87N R-47W
SEC. 28

Sta. 3585+00.00
Build 24" x 58' RF-1
F.L. = Lt. 1081.65
Rt. 1081.70

Sta. 3586+78
24" X 34.4' Conc Pipe
(REMOVE)

Sta. 3595+22
30" X 72.4' Conc Pipe
(REMOVE)

Sta. 3594+25.00
Build 30" x 158' RF-1
F.L. = Lt. 1082.00
Rt. 1081.90
+50 Prop.
Type "M" Dike
Elev. =1084.00

Sta. 3597+90.00
Build 30" x 158' RF-1
F.L. = Rt. 1095.60
Other 1093.65
Other 1092.09
Other 1082.31
Build 24" x 58' CMP
F.L. = Lt. 1081.40
Other 1081.90

Curve Data
Δ = 17° 47' 30.09" (LT)
T = 313.04
L = 621.05
M = 2,000.00
P = 24.35
e = 5.4%
x = 168'
y = 62'

Curve Data
Δ = 26° 01' 39.95" (LT)
T = 192.53
L = 378.41
M = 833.00
P = 21.96
e = 6.0%
x = 168'
y = 56'

Curve Data
Δ = 28° 14' 56.43" (RT)
T = 50.33
L = 98.61
M = 200.00
P = 6.23

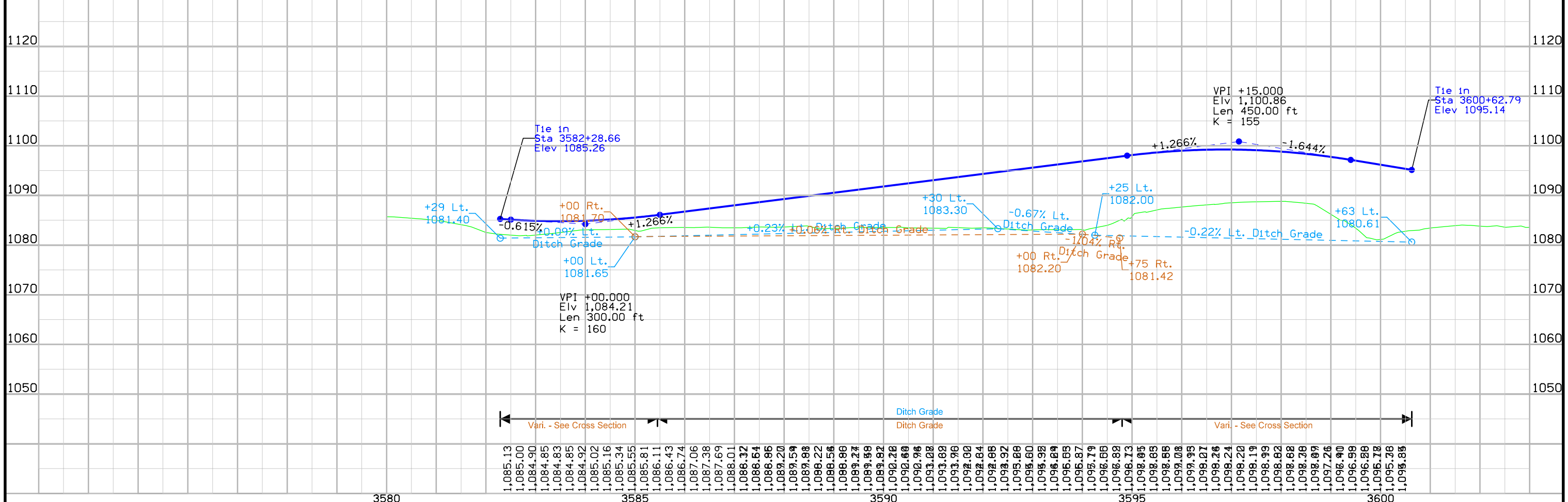
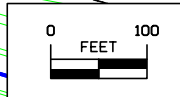
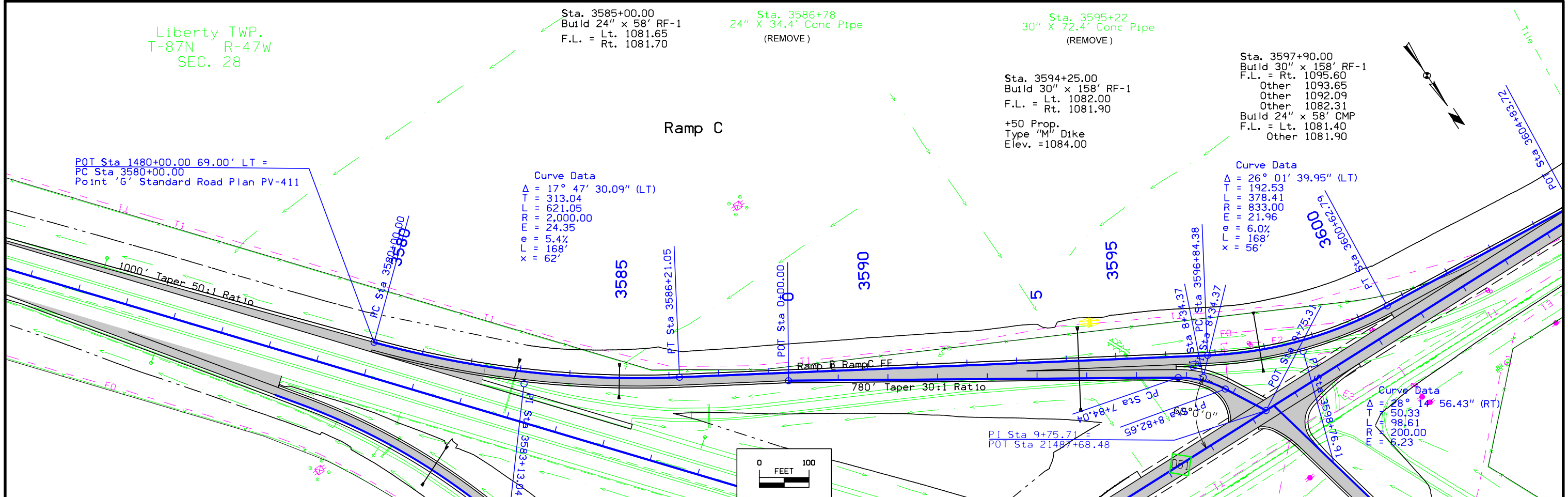

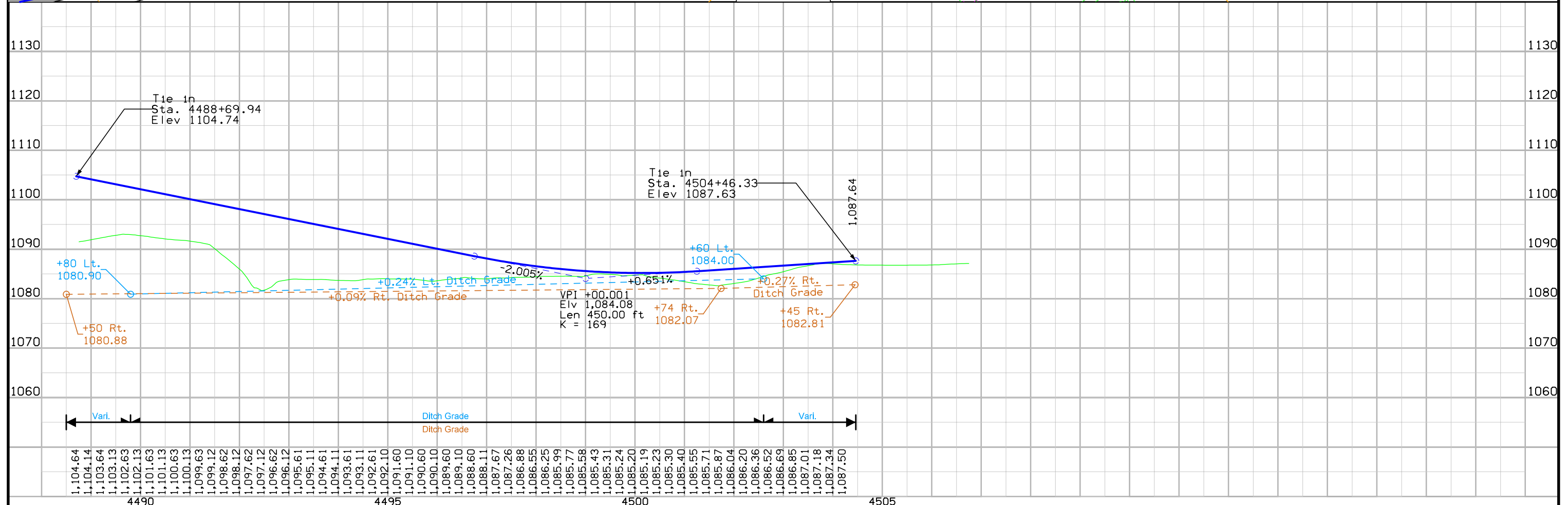
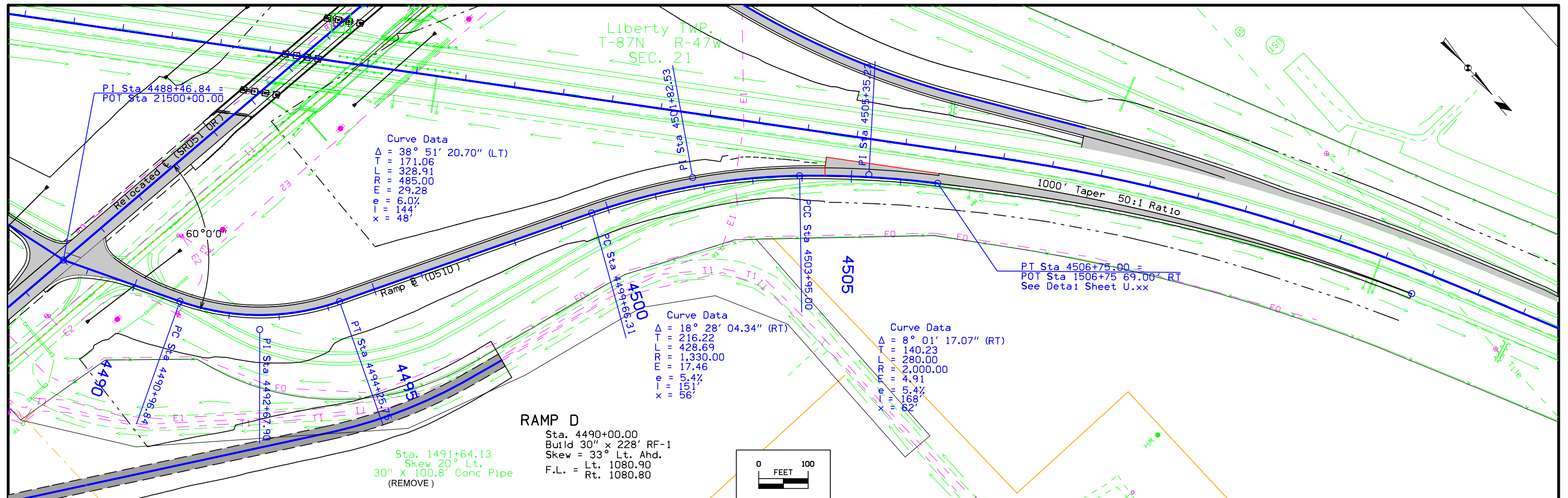

LEGEND OF CROSS SECTION SHEETS (ROAD)

- - - - - - Existing Ground Line
- ===== Proposed Template
- ===== Proposed Topsoil Placement
- - - - - Additional Topsoil Removal
- ===== Subgrade Treatment
- - - - - Granular Shoulder
- ===== Pavement
- - - - - Existing Pipe\R/CB
- ===== Proposed Pipe\R/CB
- ===== Proposed Dike
- ===== All Elements Associated with Proposed Entrances

LEGEND OF CROSS SECTION SHEETS (SOILS)

- TS----- Topsoil (Class 10)
- TS A----- Topsoil (Type A Disposal)
- TS B----- Topsoil (Type B Disposal)
- TS C----- Topsoil (Type C Disposal)
- CL 10----- Class 10 Materials
- SEL LO----- Select Loams And Clay-Loams
- SEL SA----- Select Sand
- UNS A----- Unsuitable Type A Disposal
- UNS B----- Unsuitable Type B Disposal
- UNS C----- Unsuitable Type C Disposal
- SHALE----- Shale
- WASTE----- Waste
- B&W LS----- Broken and Weathered Rock
- ROCK----- Solid Rock
- BLDRS----- Boulders

Note: All layer lines and descriptions identify layers above the line.

Note: Vertical or near vertical lines connecting soil layers at edges of cross sections are only for the purpose of calculating template quantities and do not depict soil stratification.

**CROSS SECTION
LEGEND AND SYMBOL
INFORMATION SHEET**

(COVERS SHEET SERIES W, X, & Y)

I-29 D5 Submittal

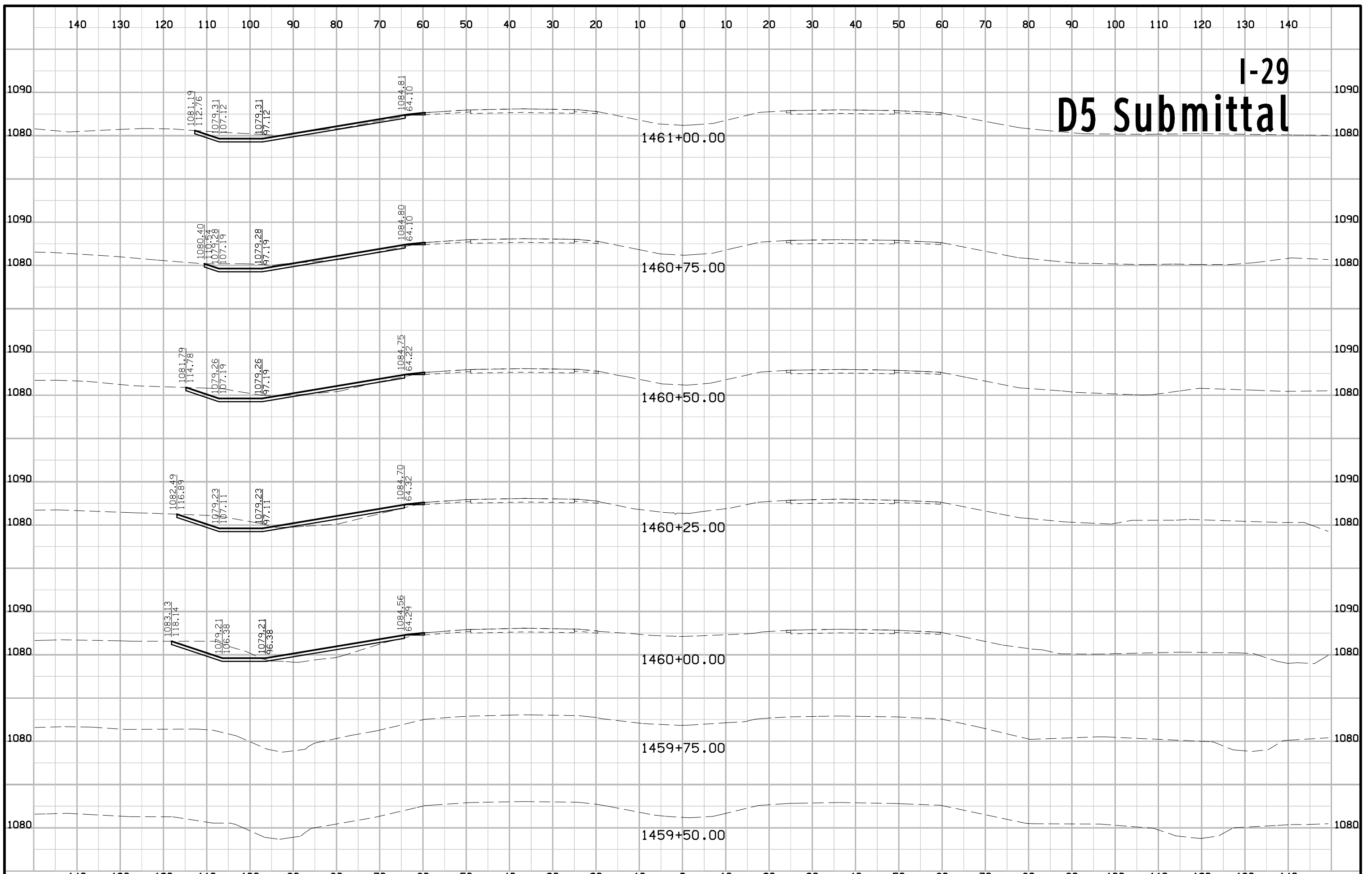

I-29 D5 Submittal

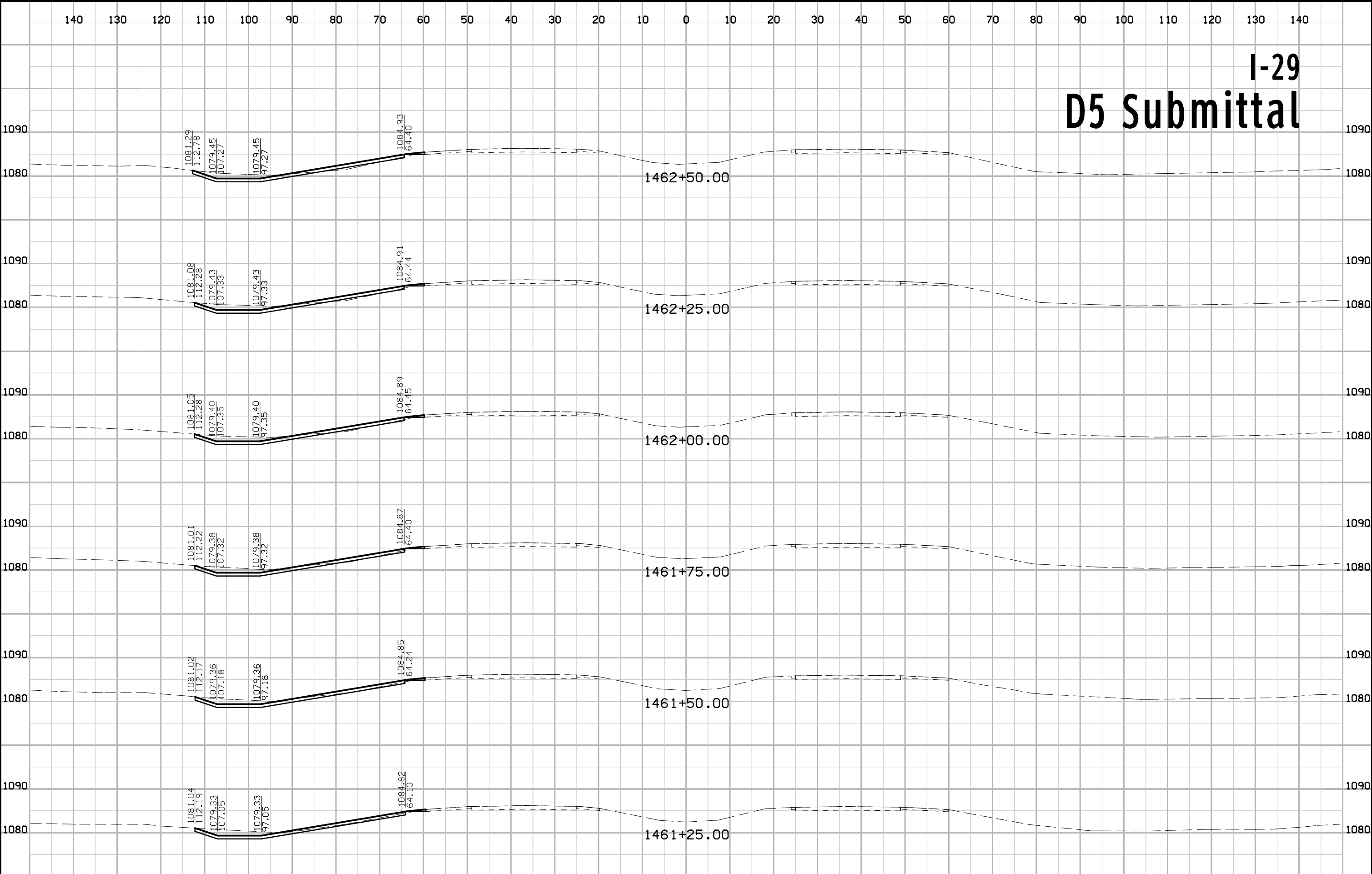

I-29 D5 Submittal

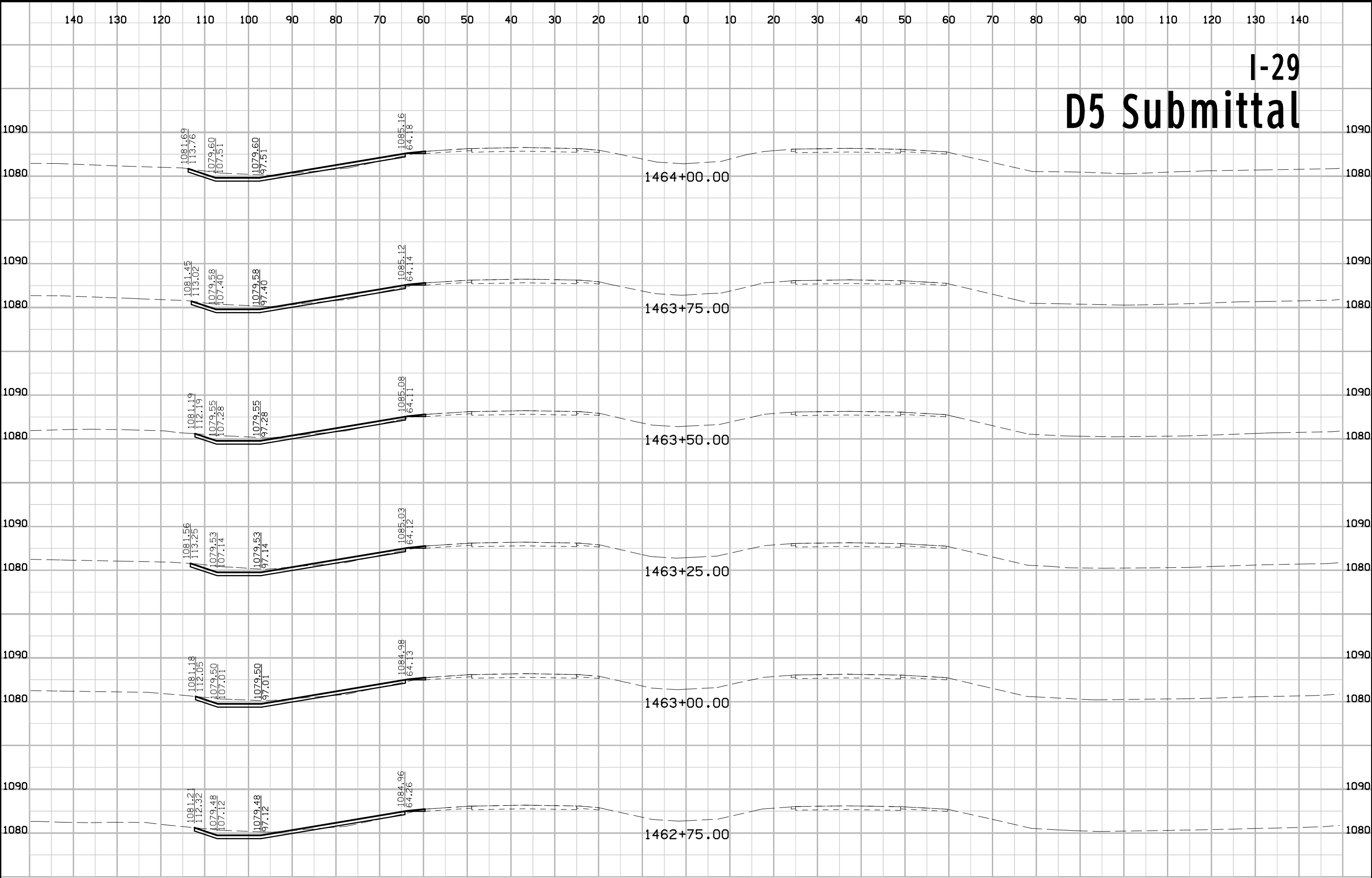

I-29 D5 Submittal

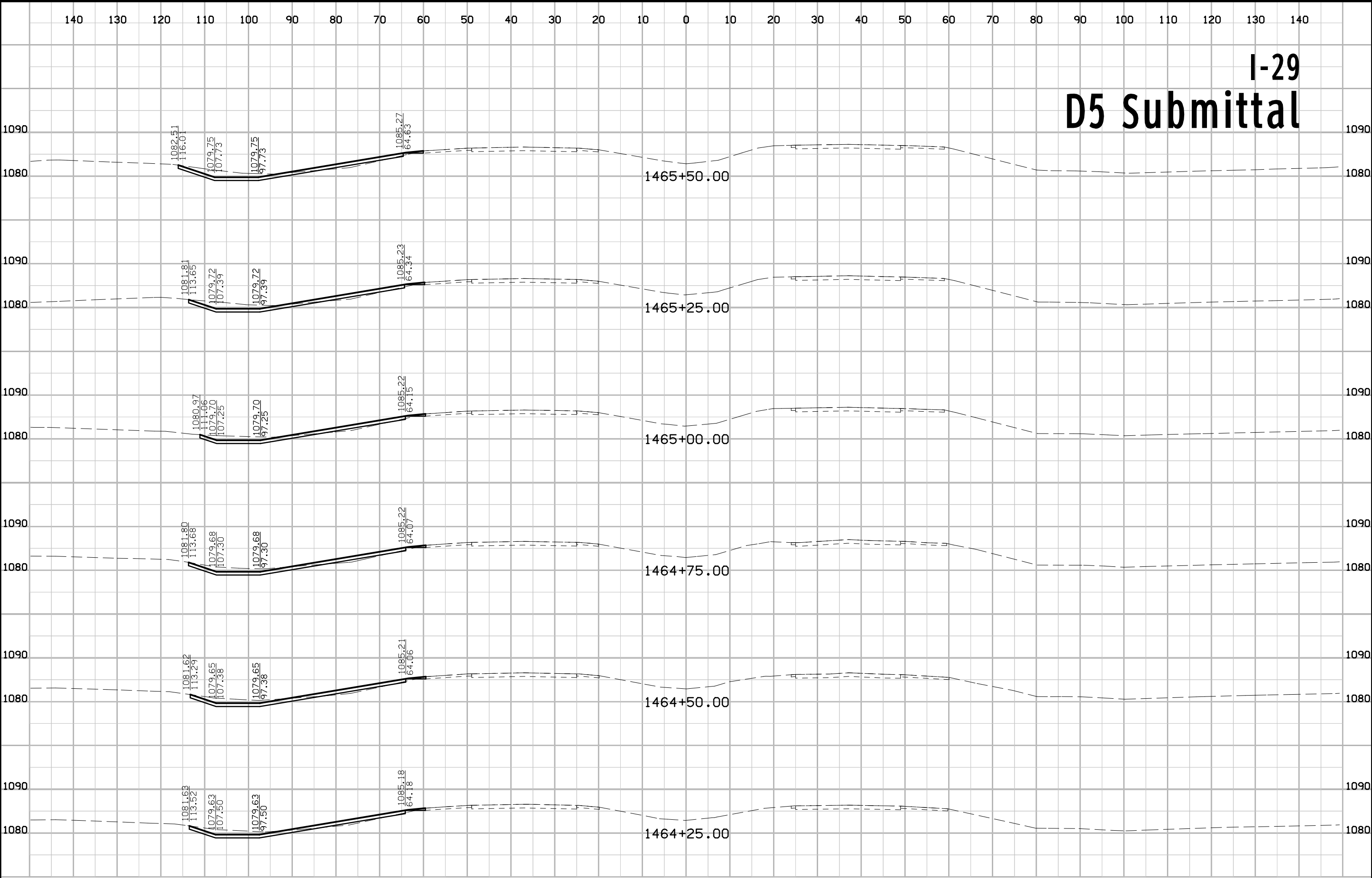

I-29 D5 Submittal

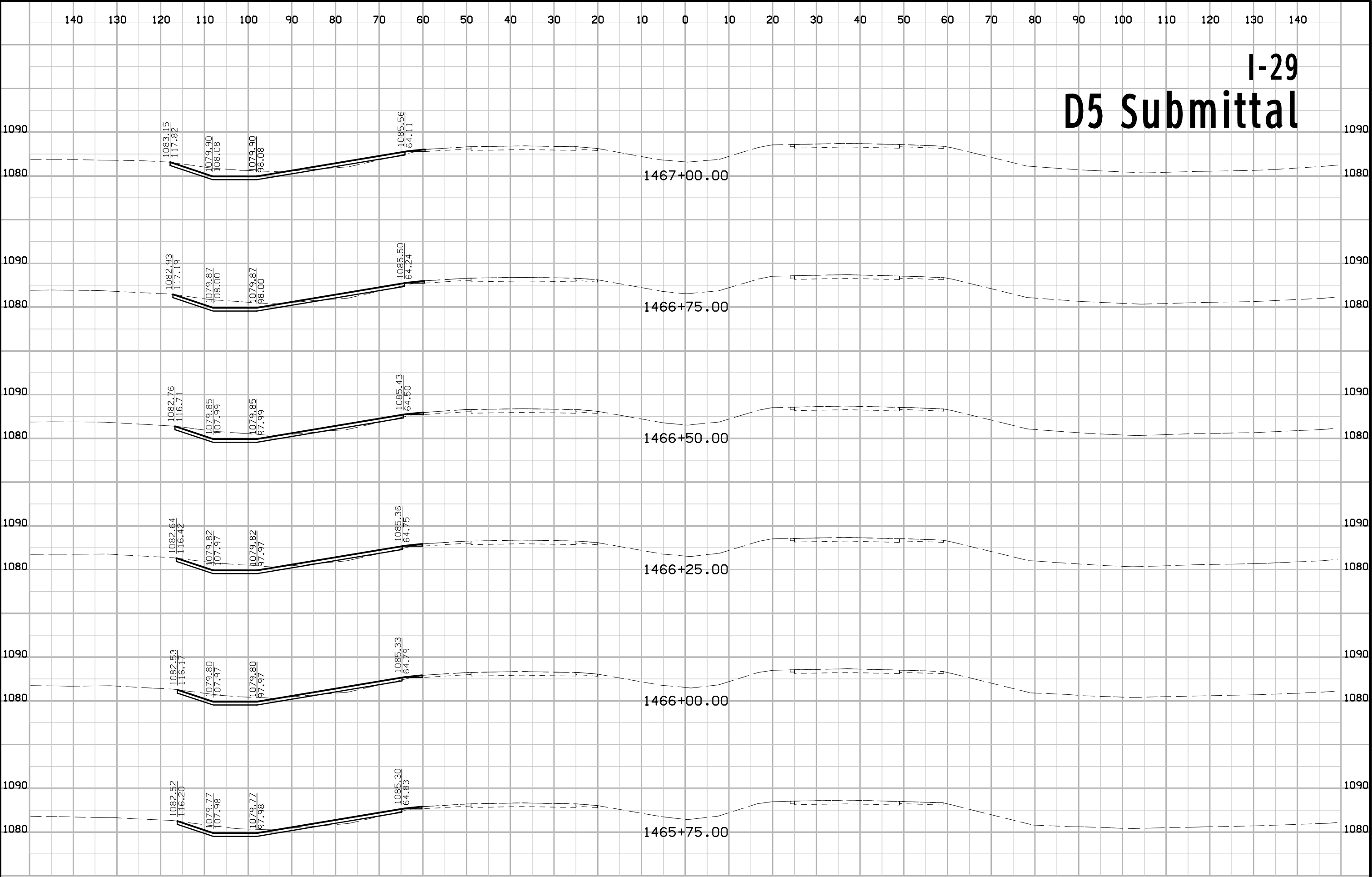

I-29 D5 Submittal

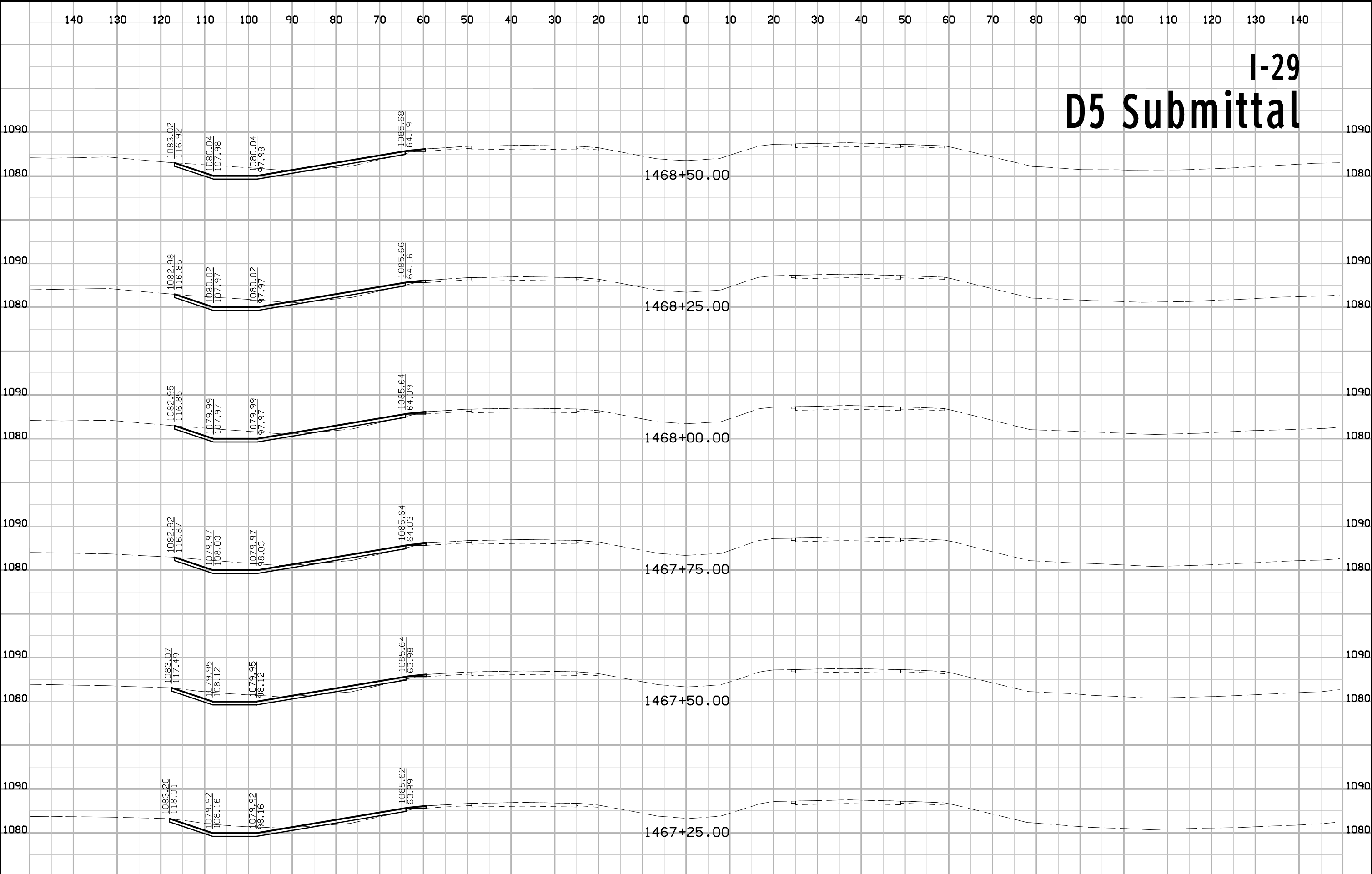

I-29 D5 Submittal

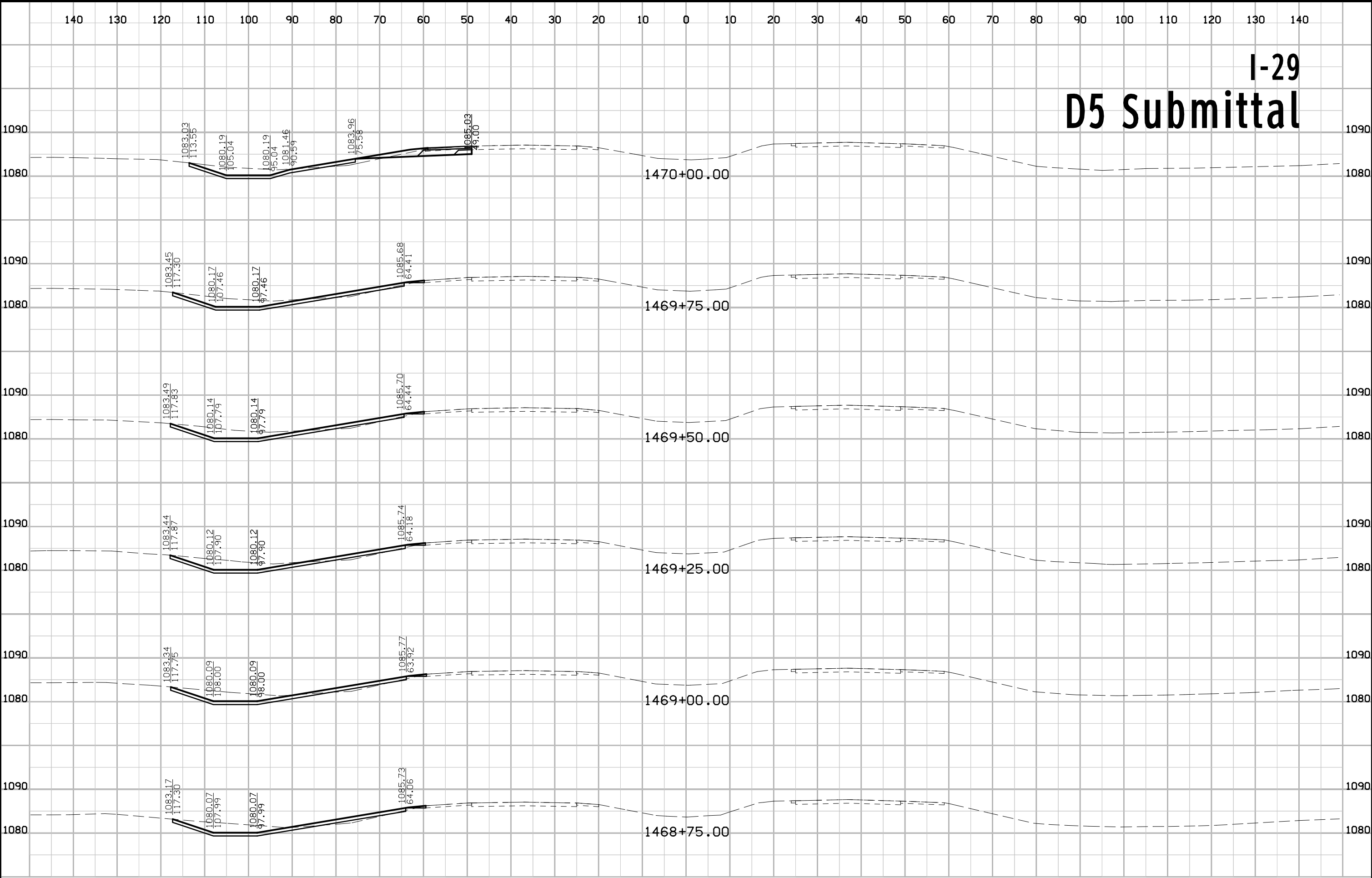

I-29 D5 Submittal

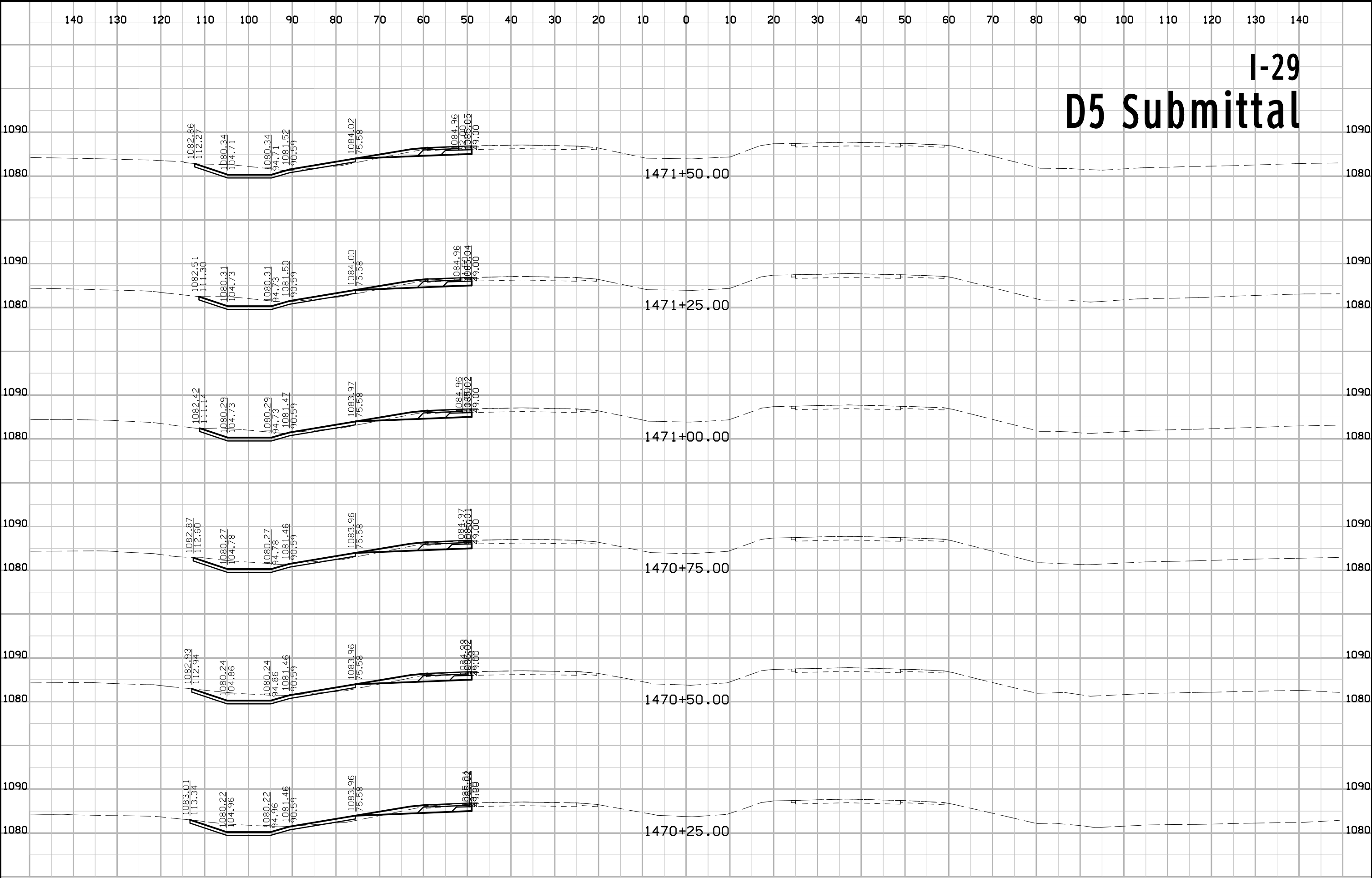

I-29 D5 Submittal

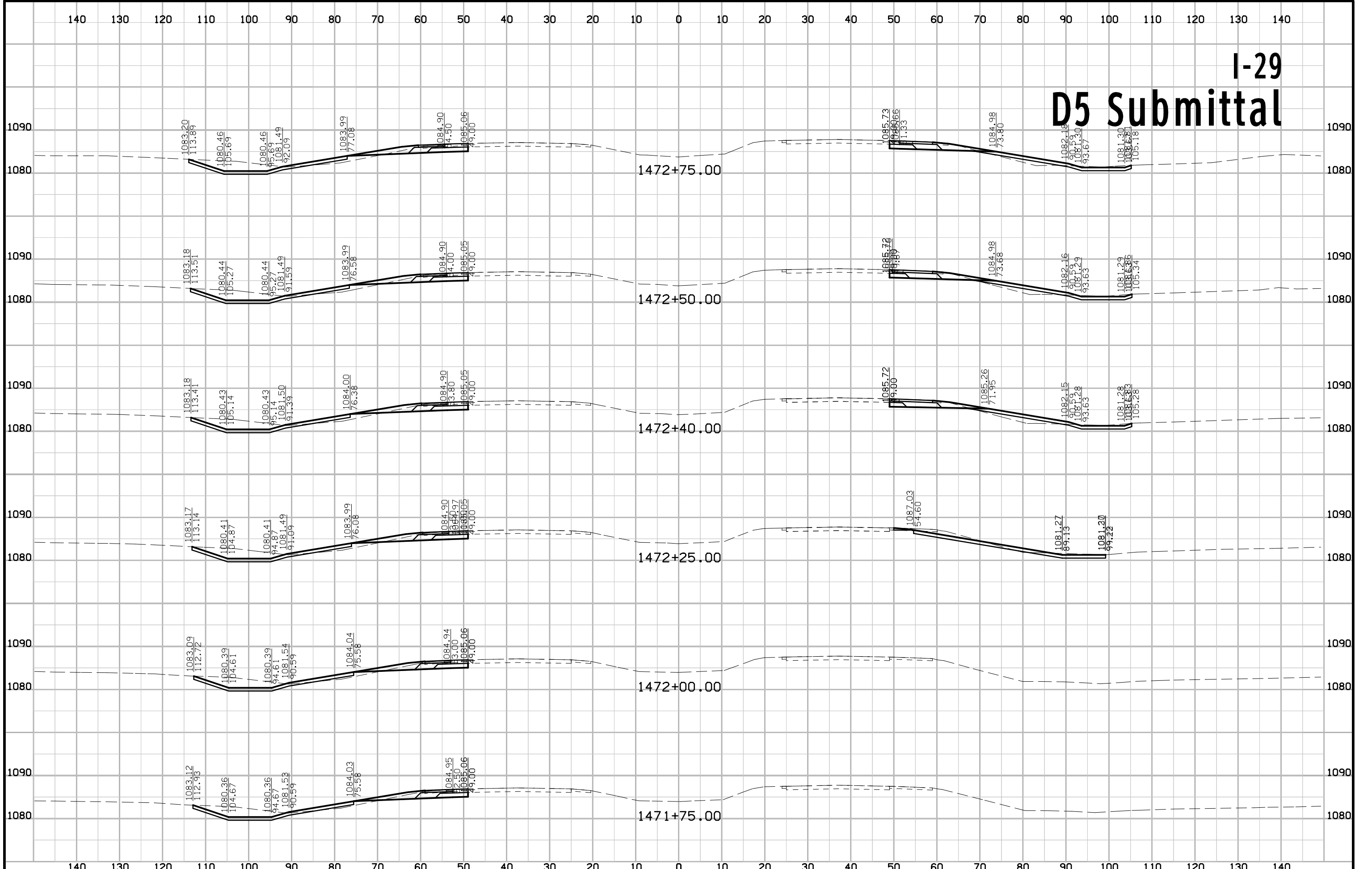

I-29 D5 Submittal

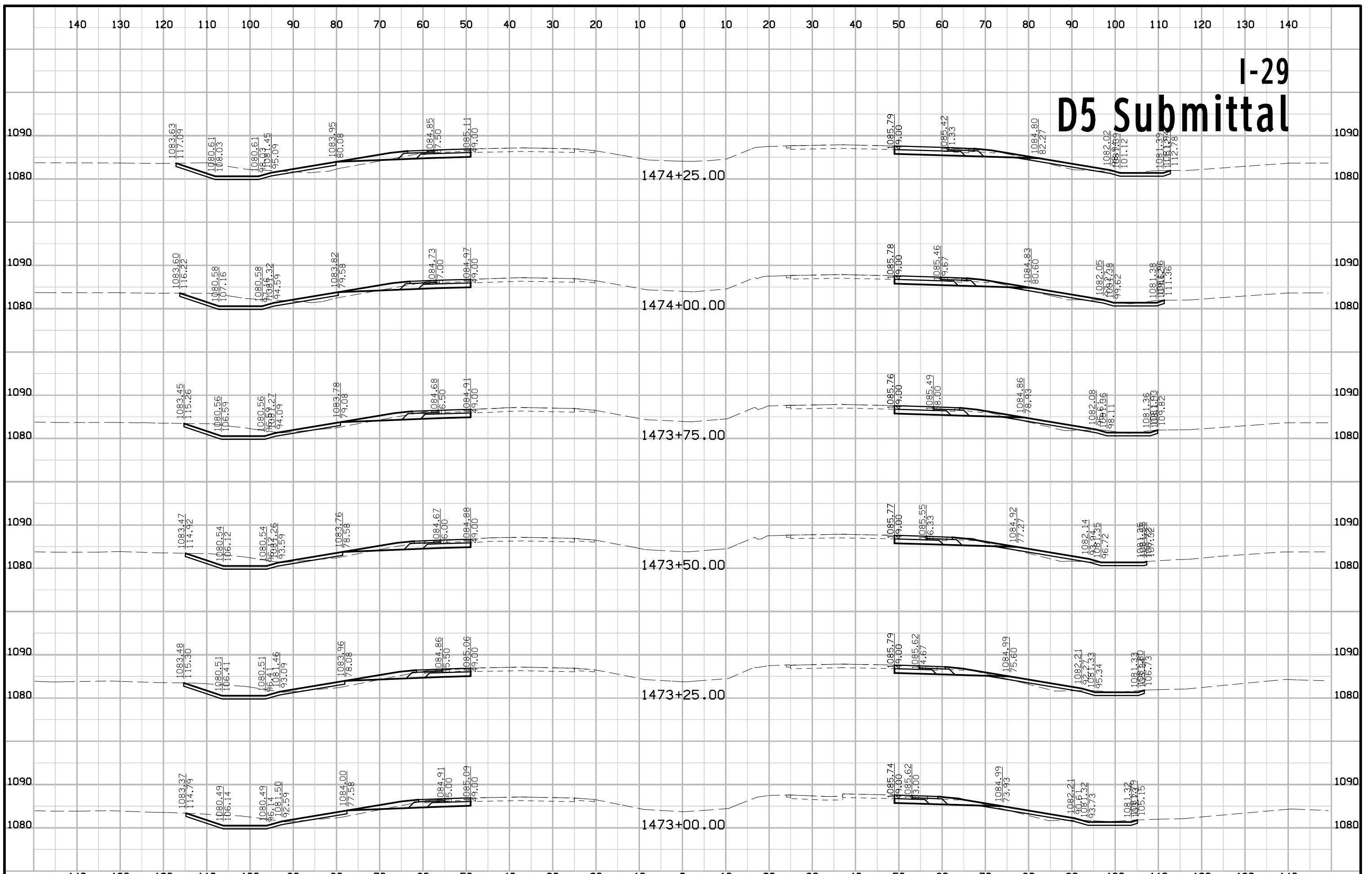

I-29 D5 Submittal

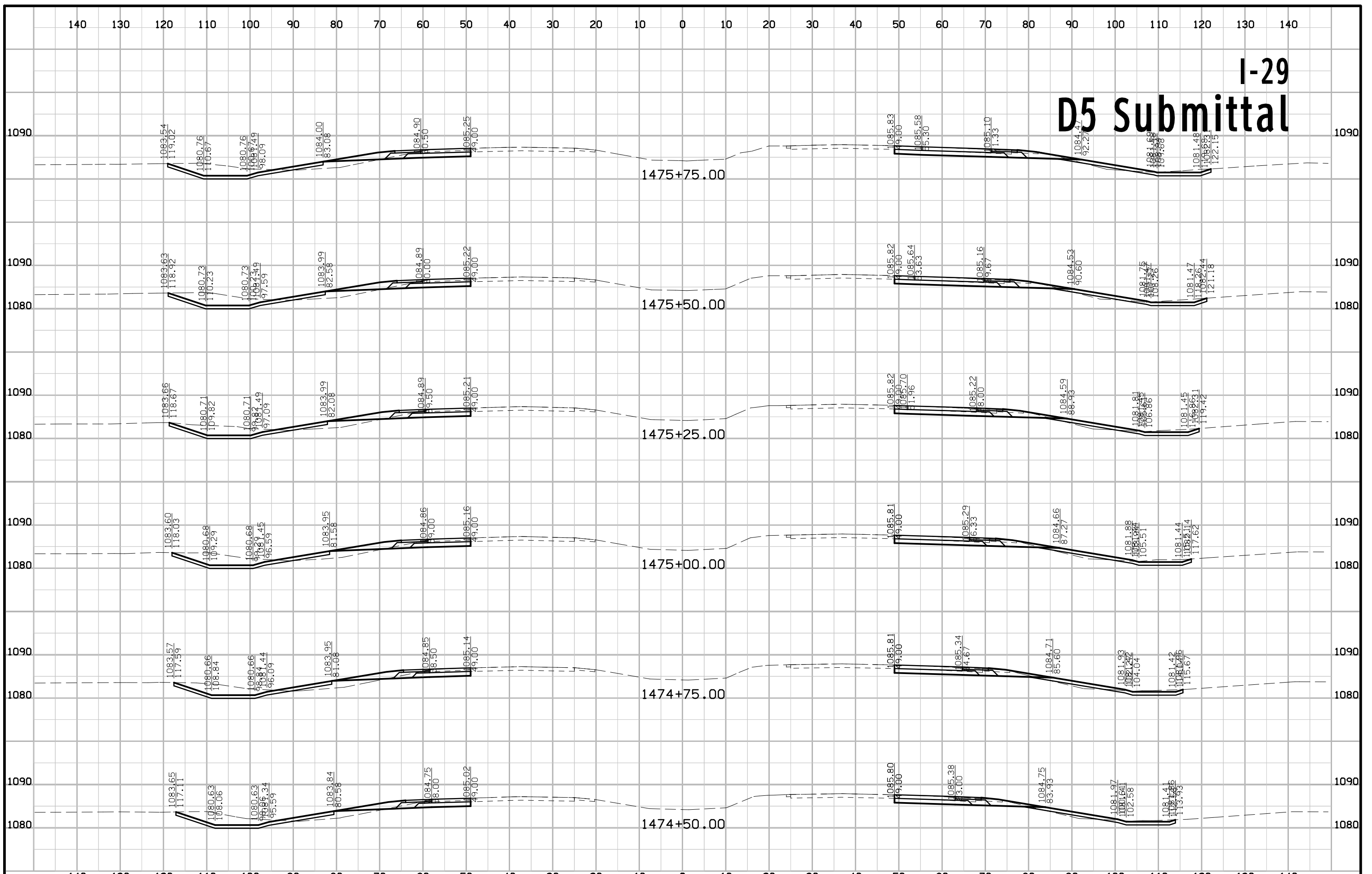

I-29 D5 Submittal

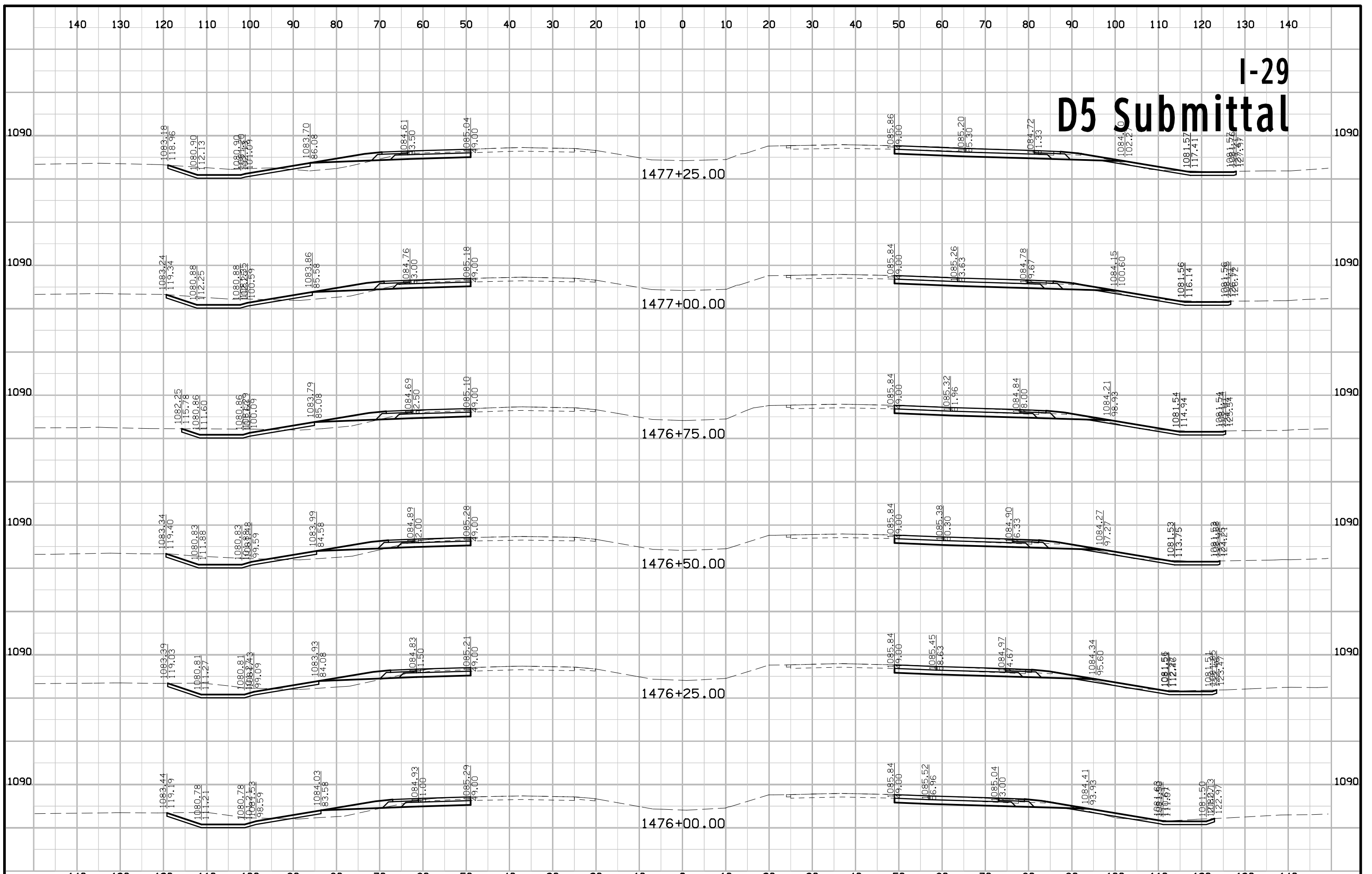

I-29 D5 Submittal



I-29 D5 Submittal

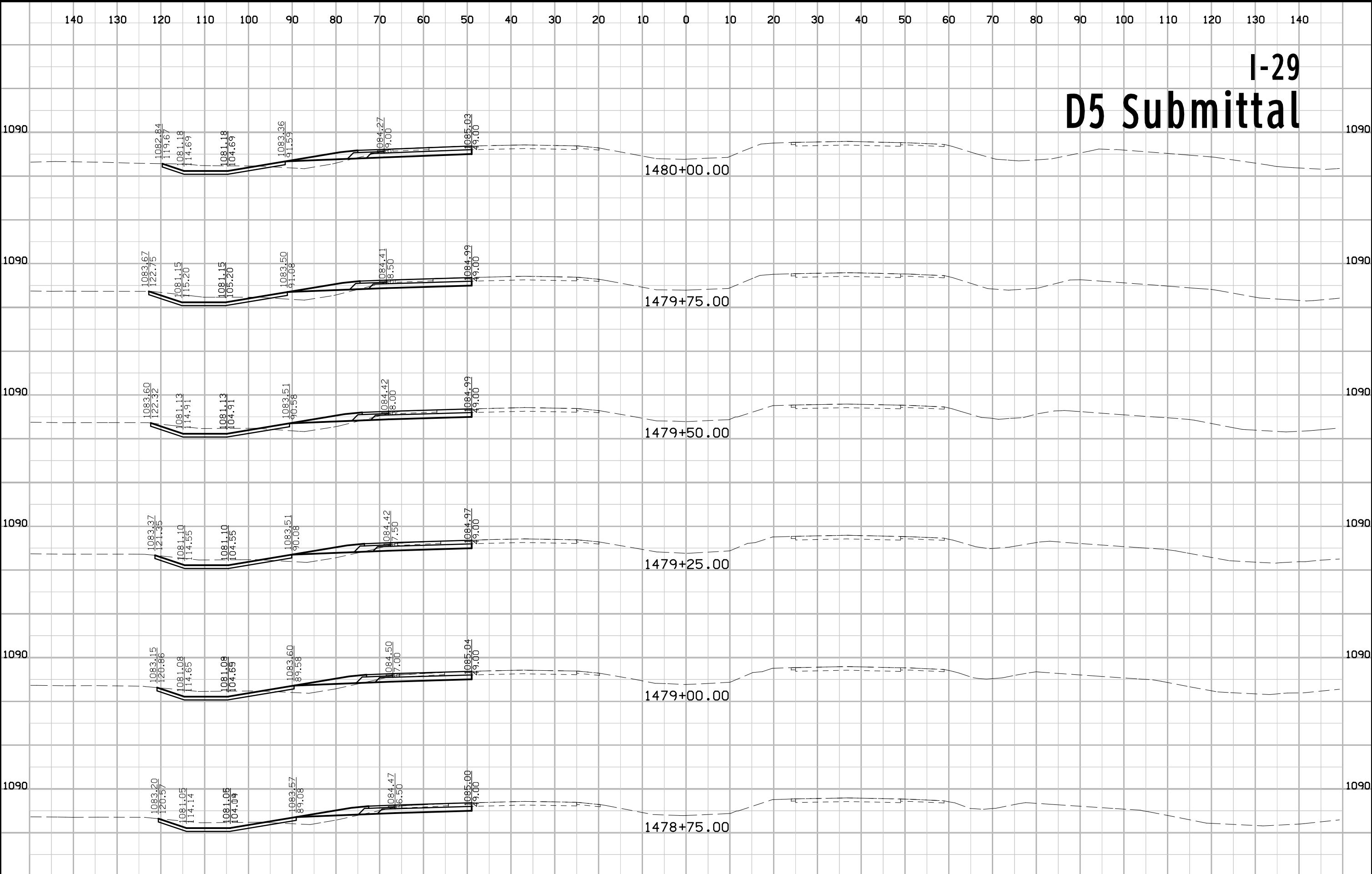

I-29 D5 Submittal

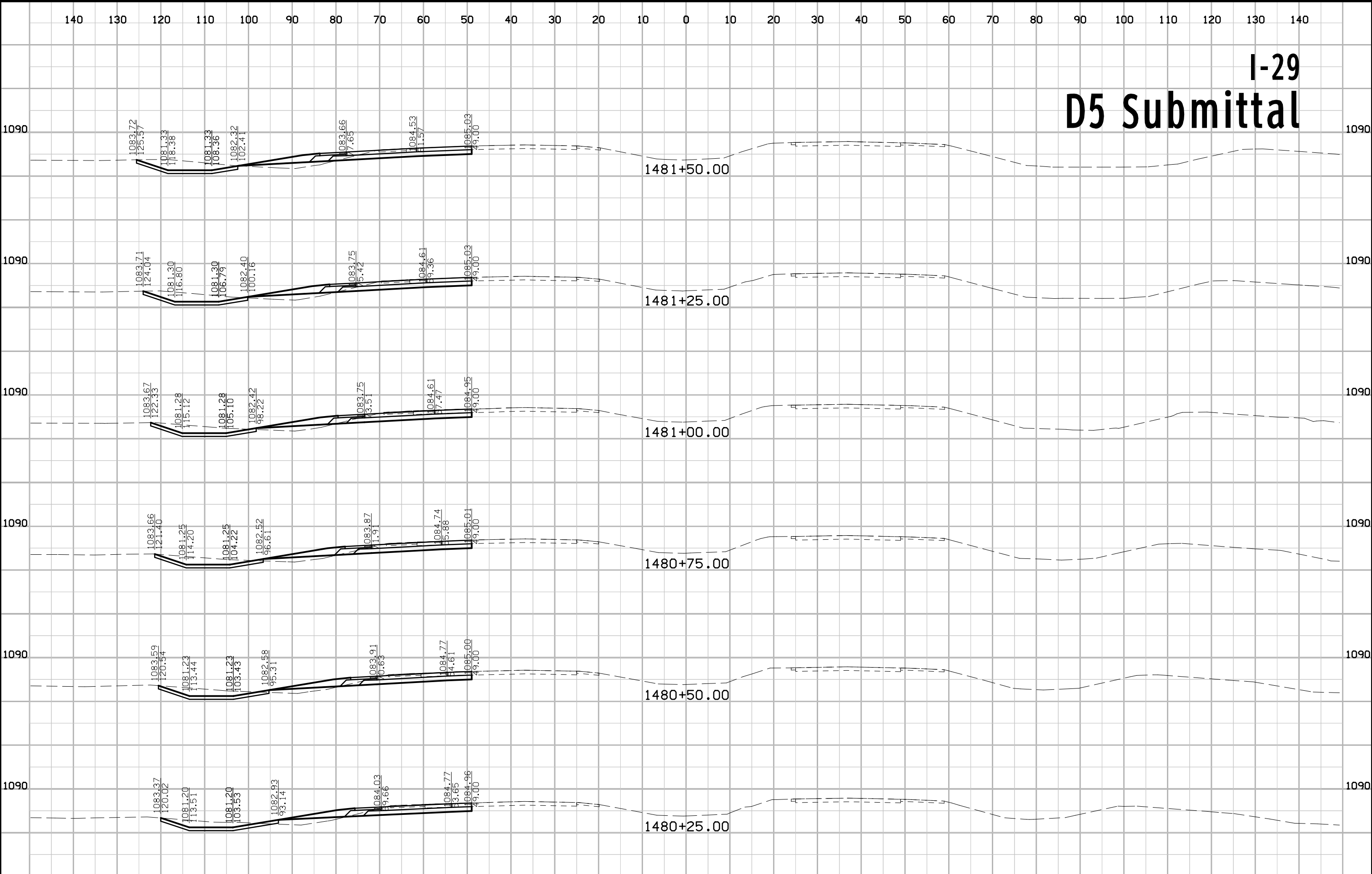

I-29 D5 Submittal



I-29 D5 Submittal

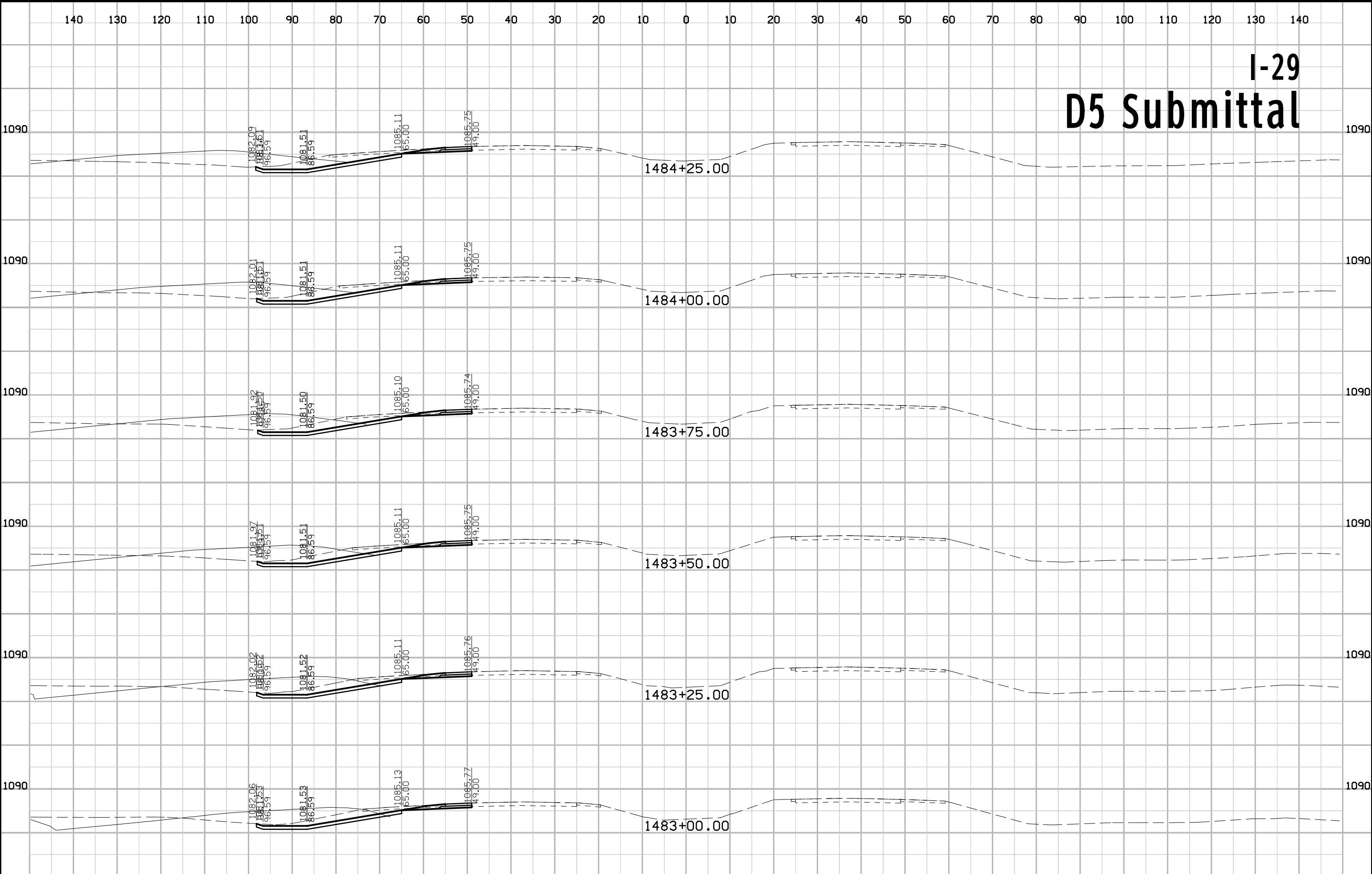

I-29 D5 Submittal

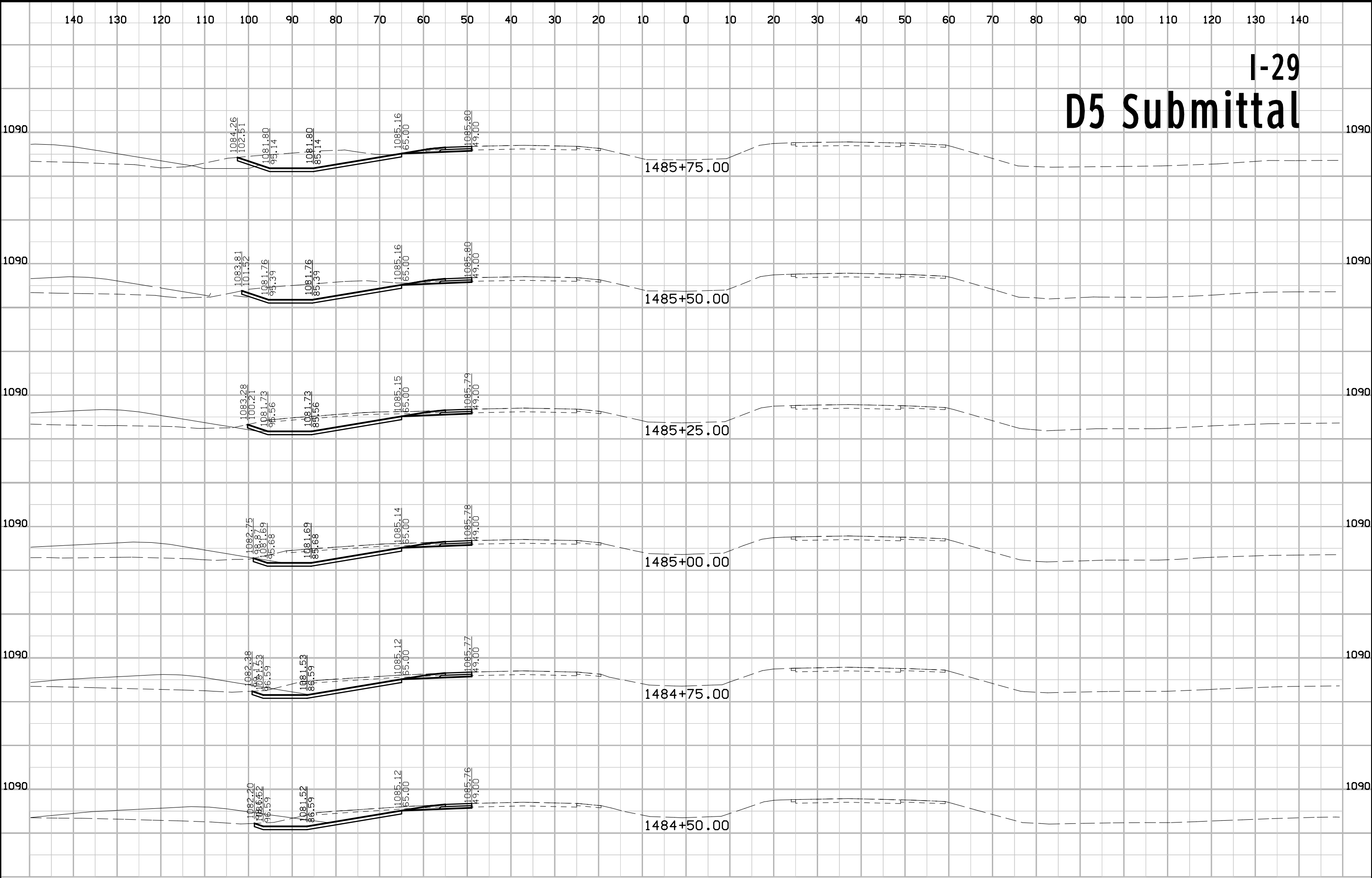

I-29 D5 Submittal

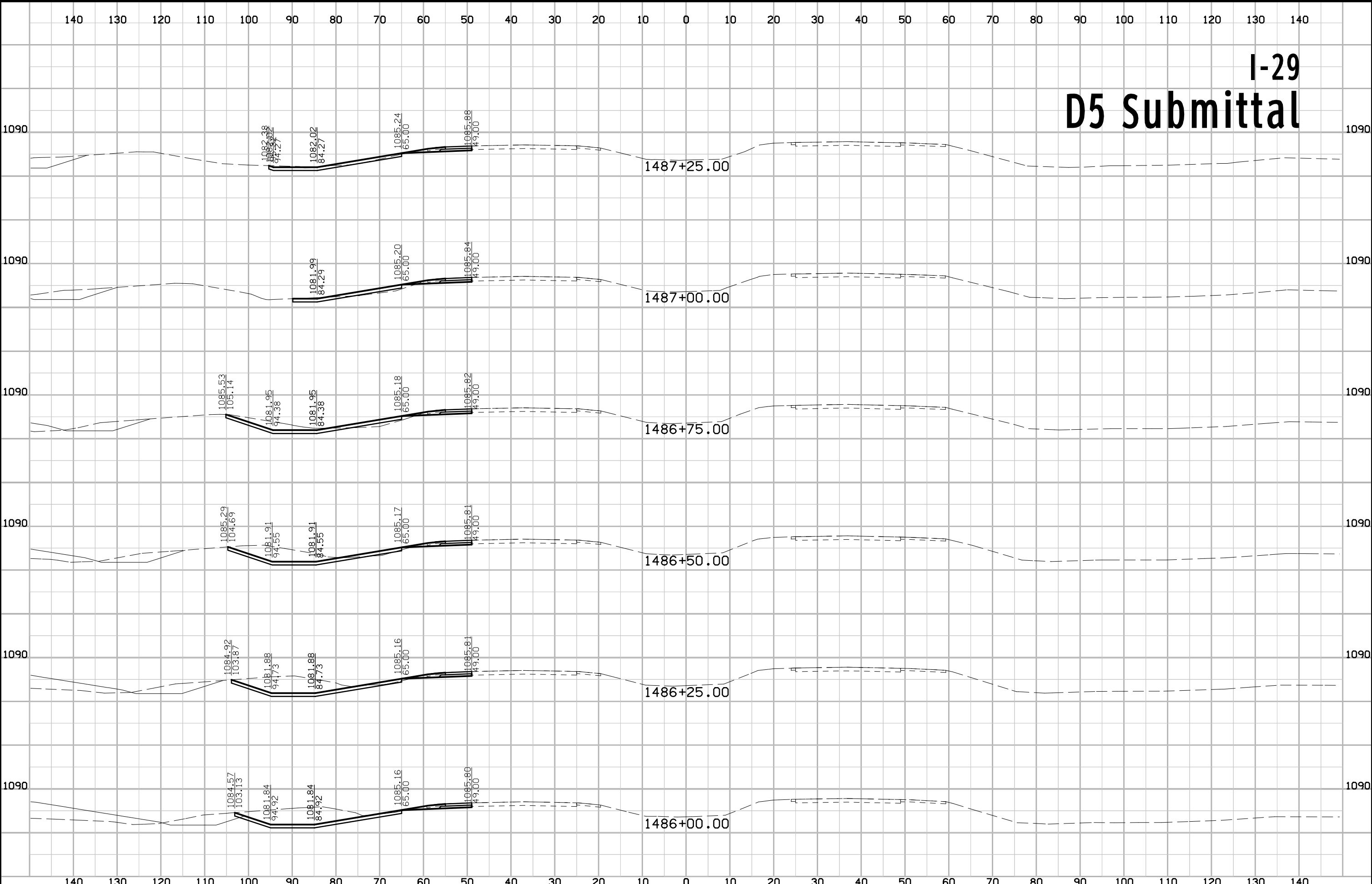

I-29 D5 Submittal

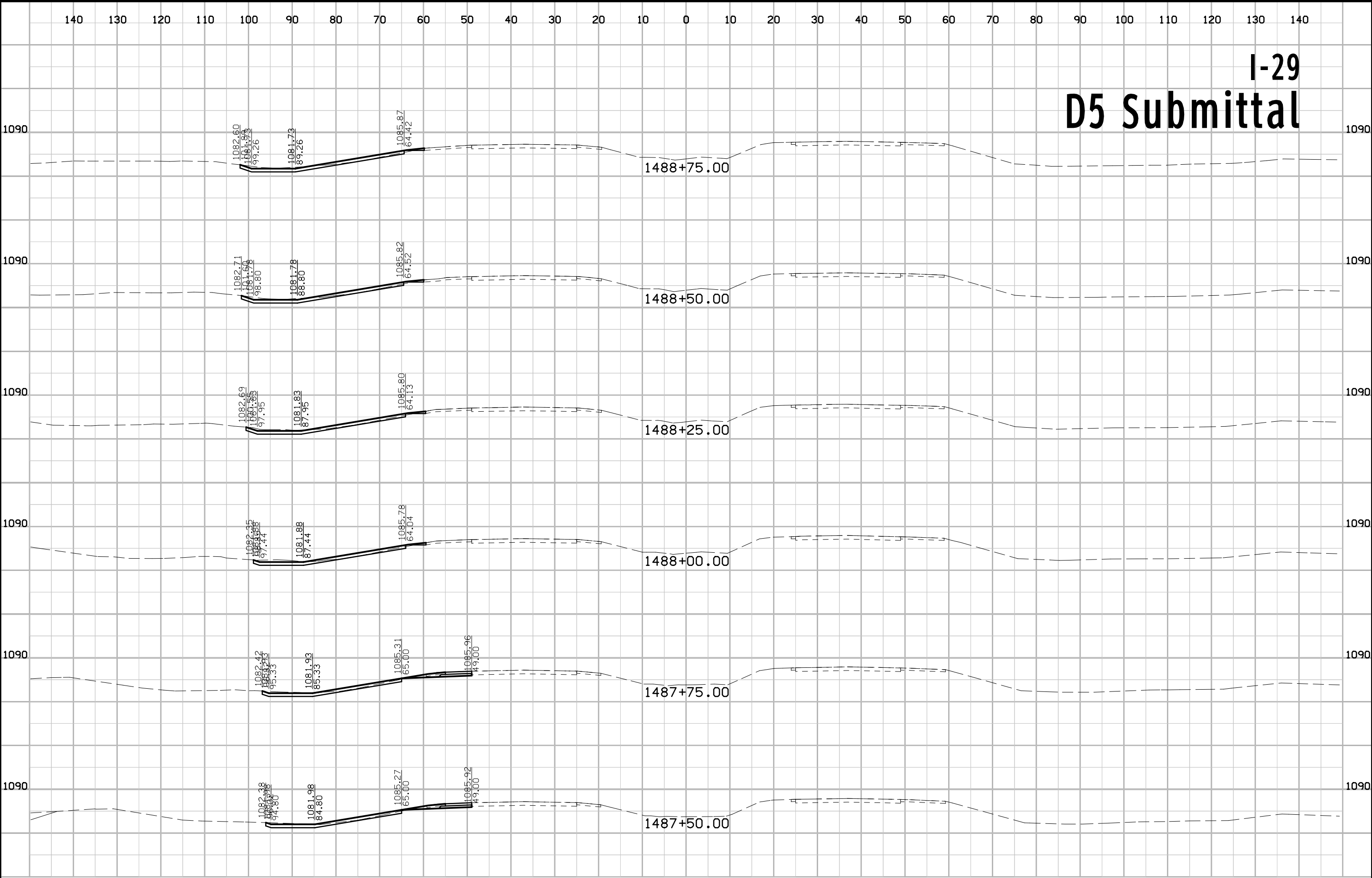

I-29 D5 Submittal

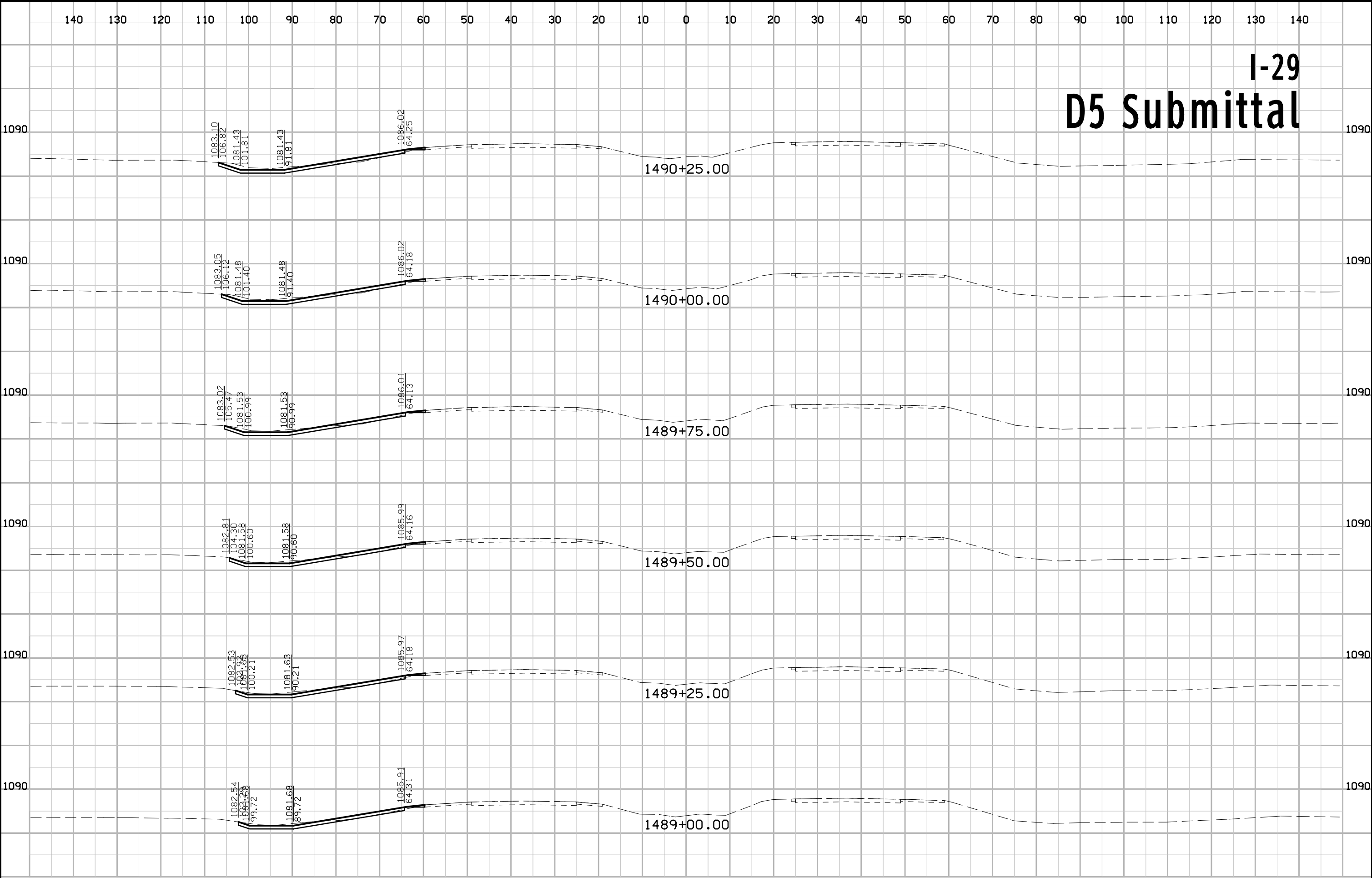

I-29 D5 Submittal

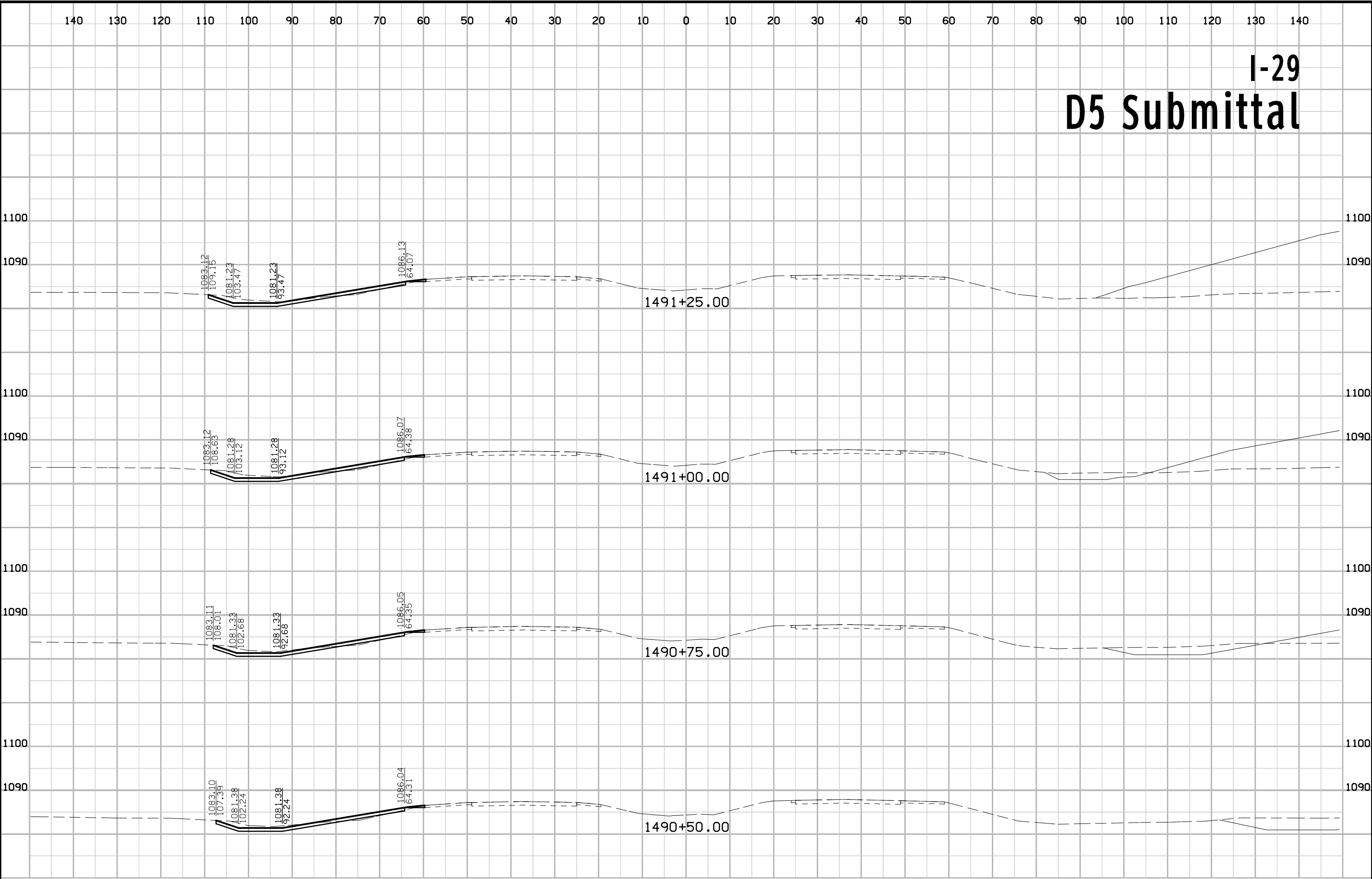

I-29 D5 Submittal

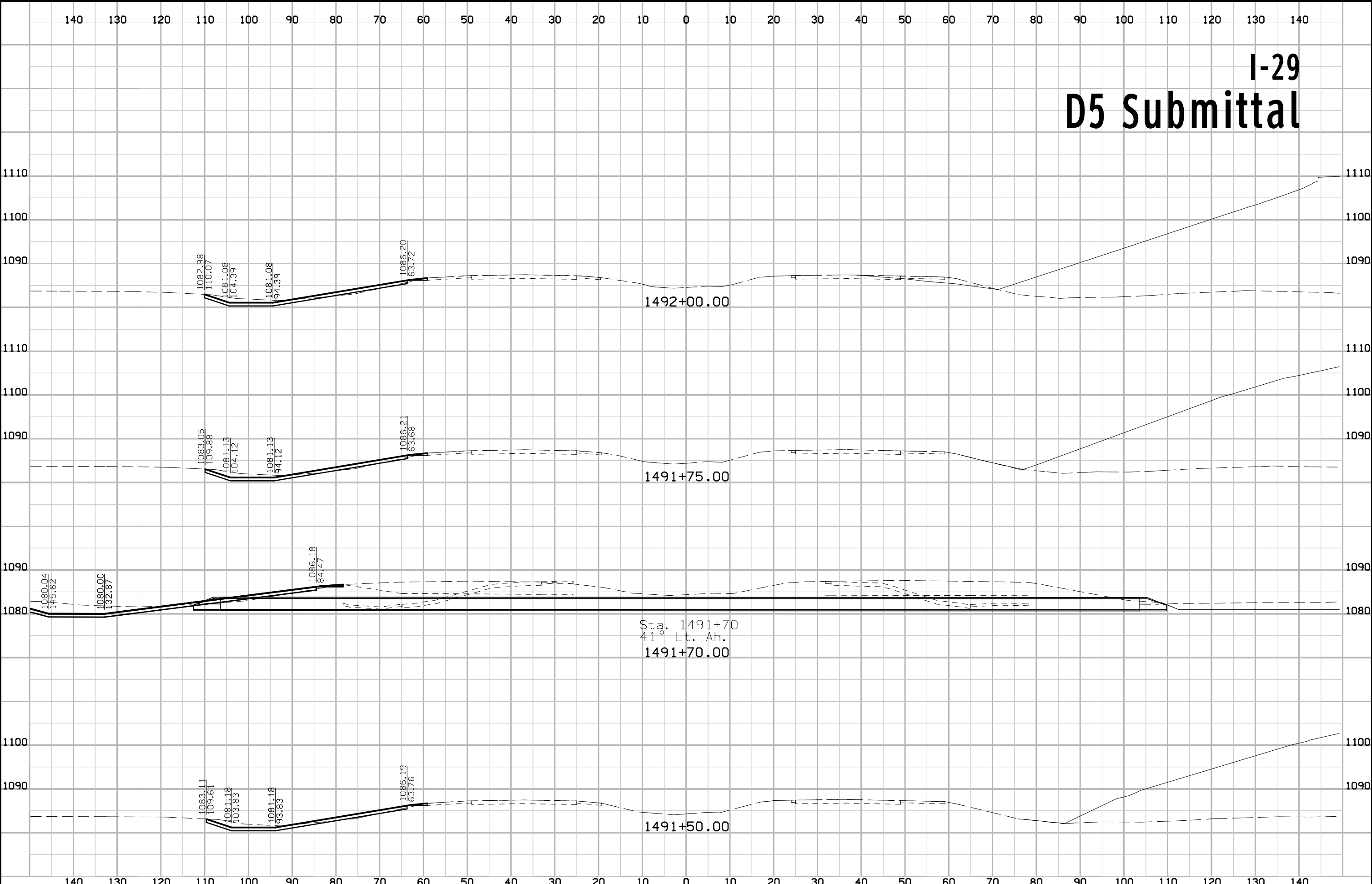

Sta. 1491+70
41° Lt. Ah.
1491+70.00

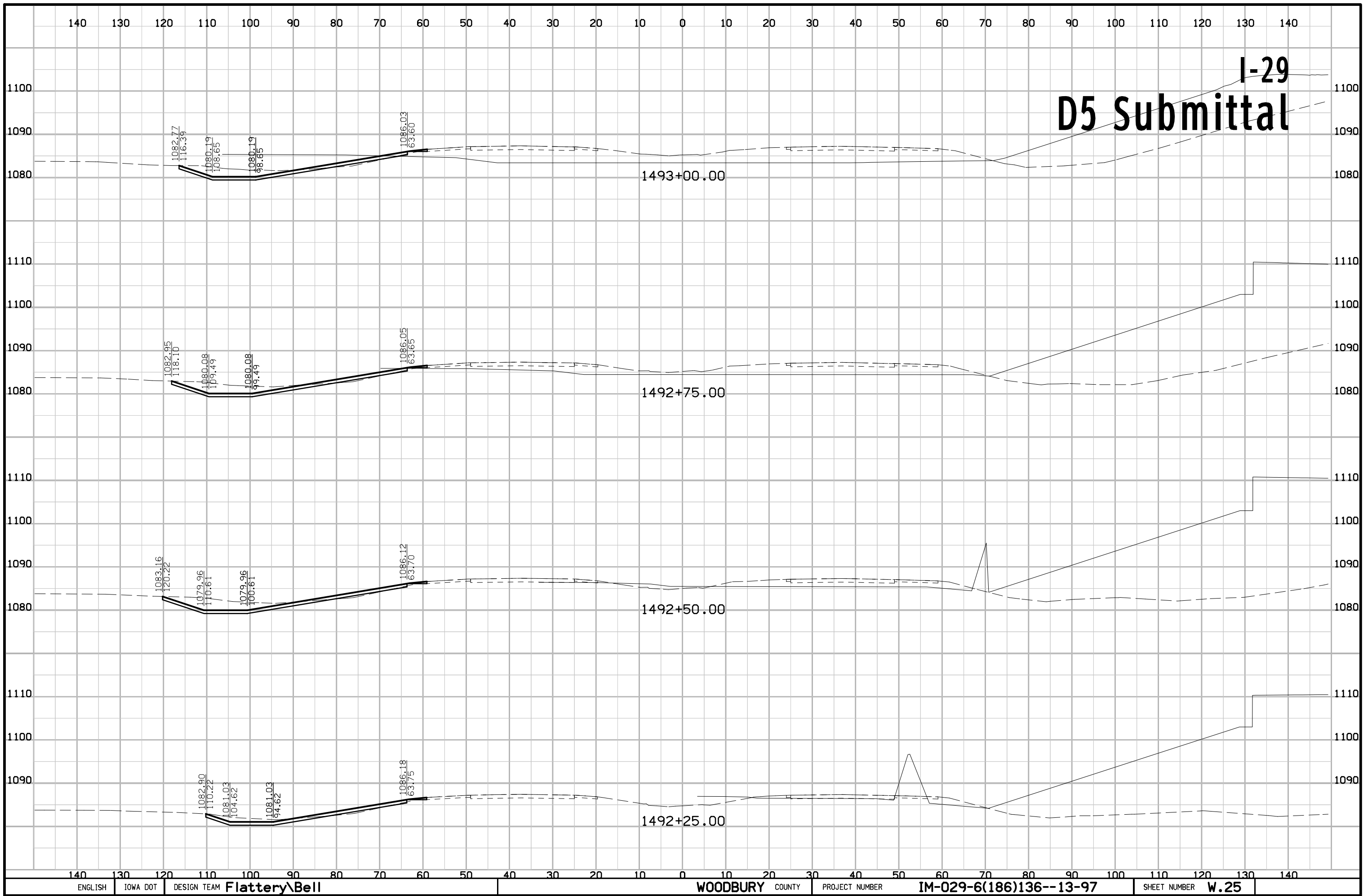

I-29 D5 Submittal

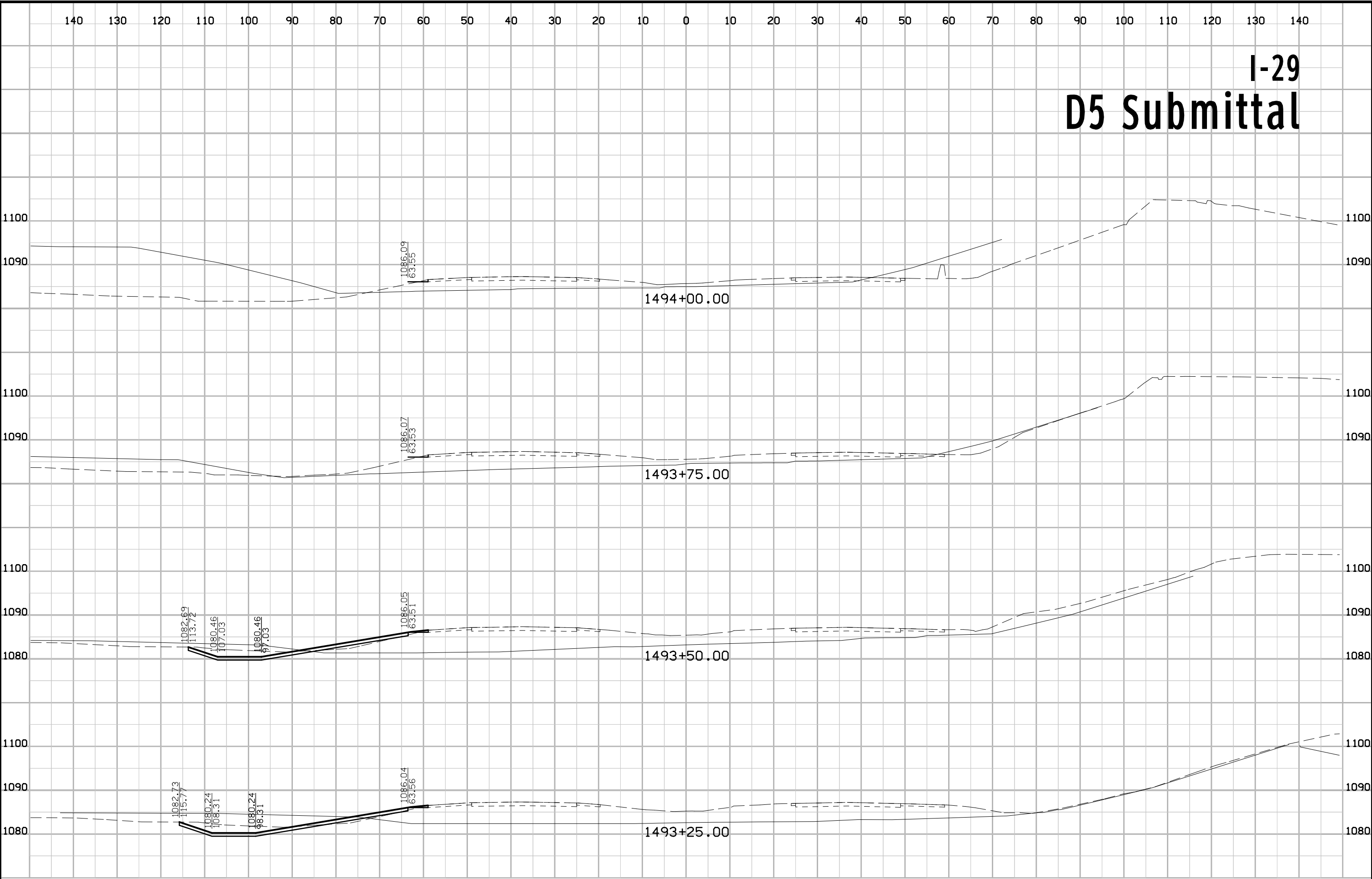

I-29 D5 Submittal

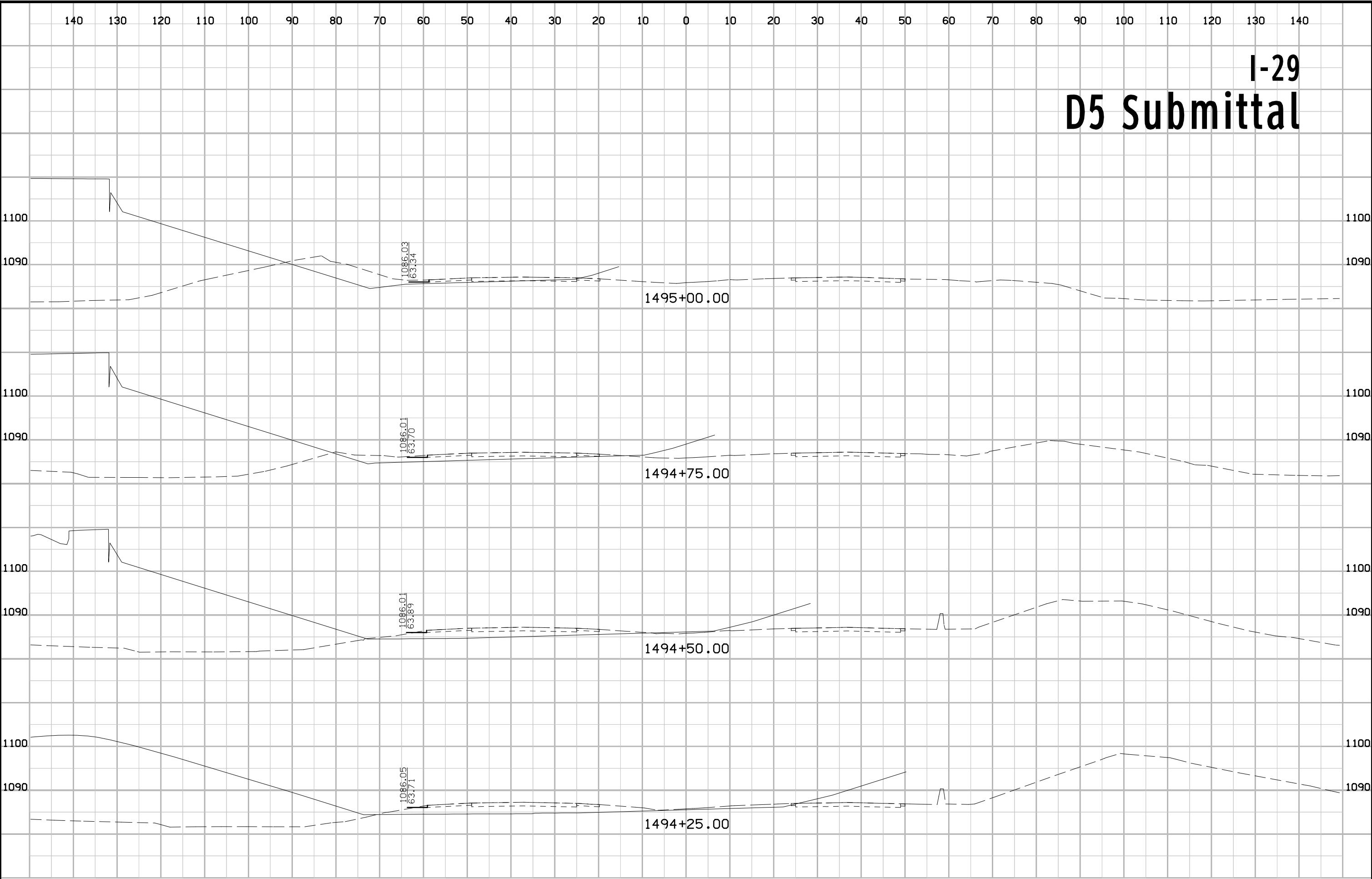

I-29 D5 Submittal

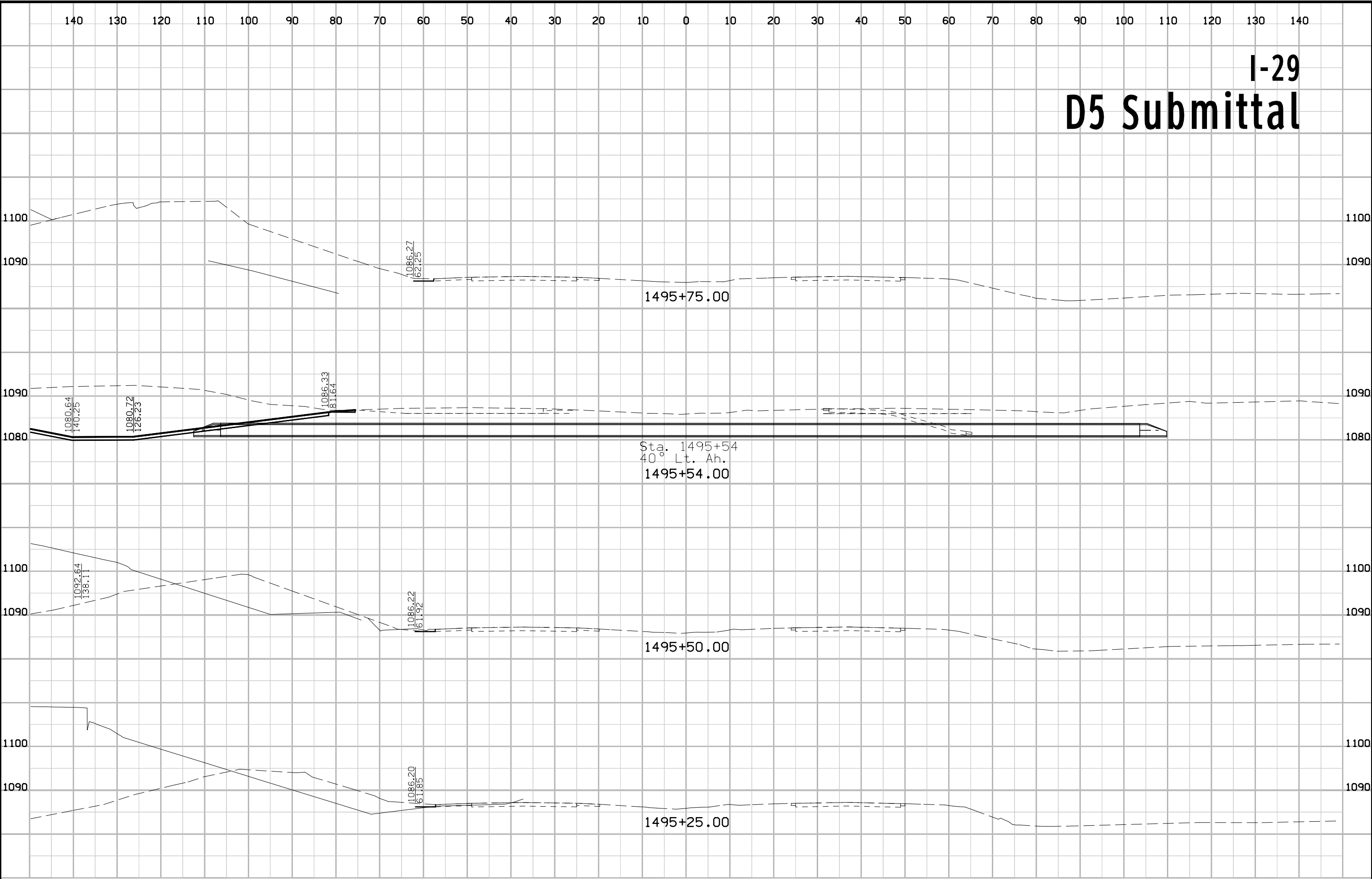

I-29 D5 Submittal

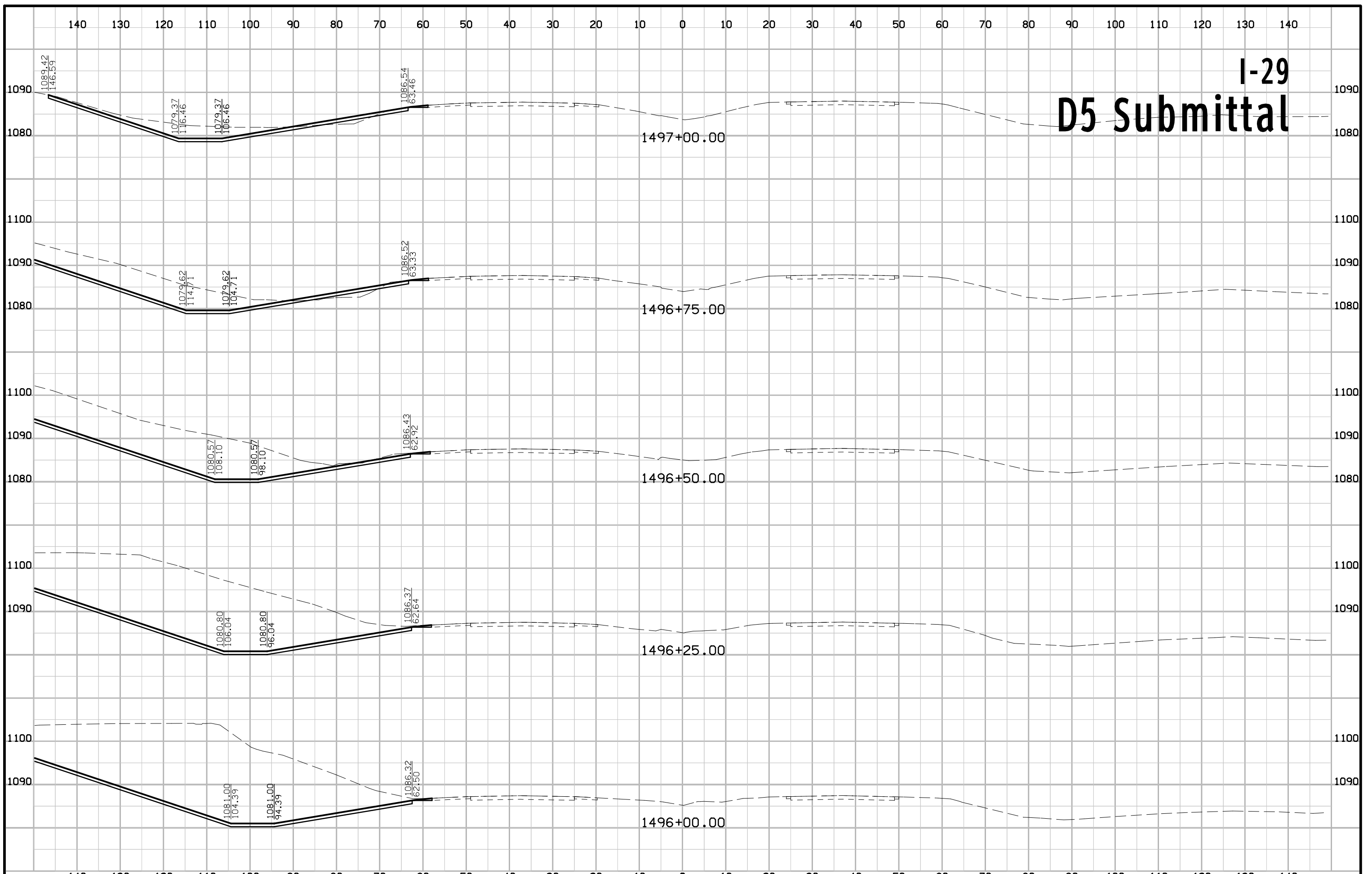

I-29 D5 Submittal

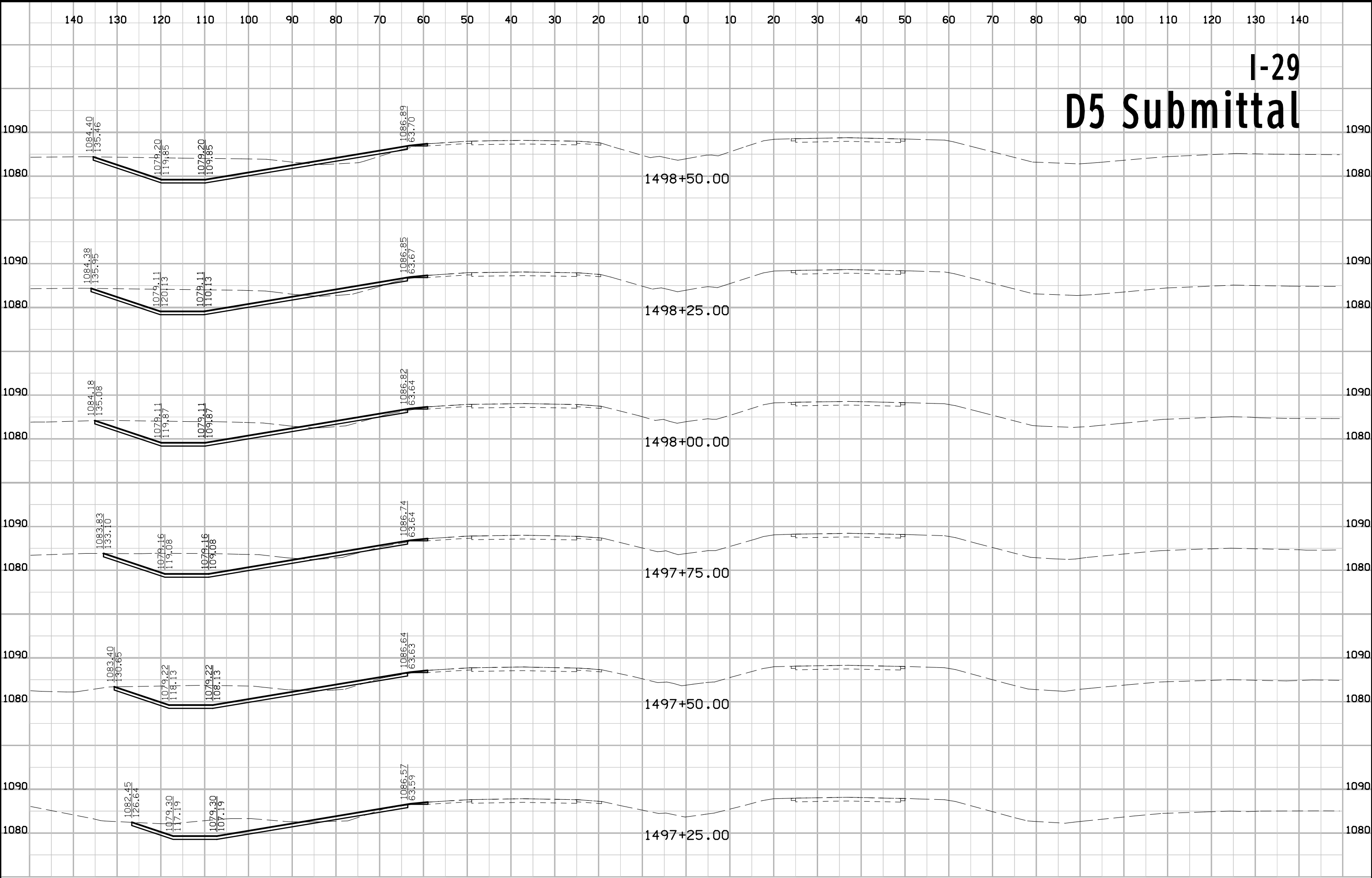

I-29 D5 Submittal

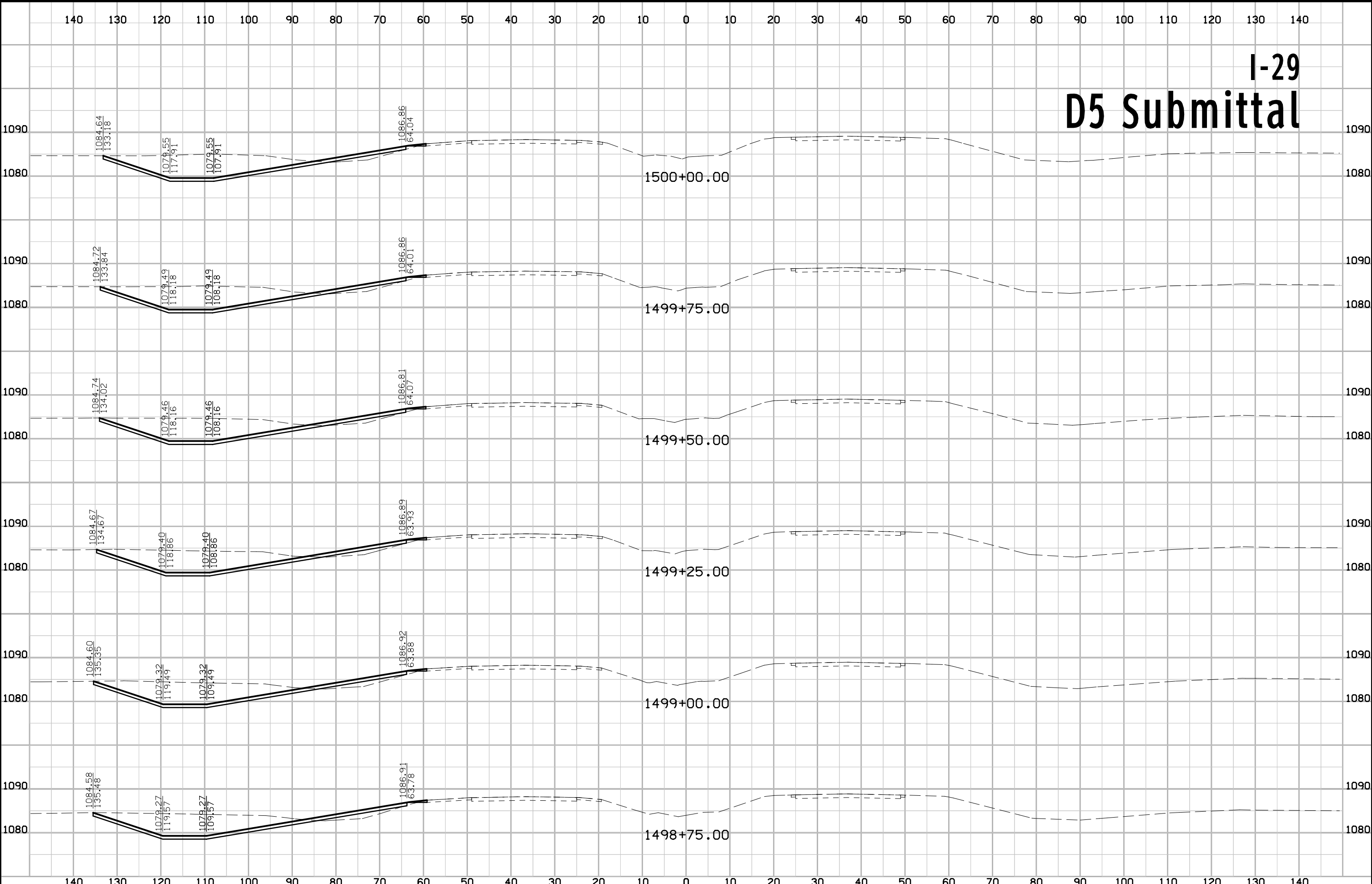

I-29 D5 Submittal

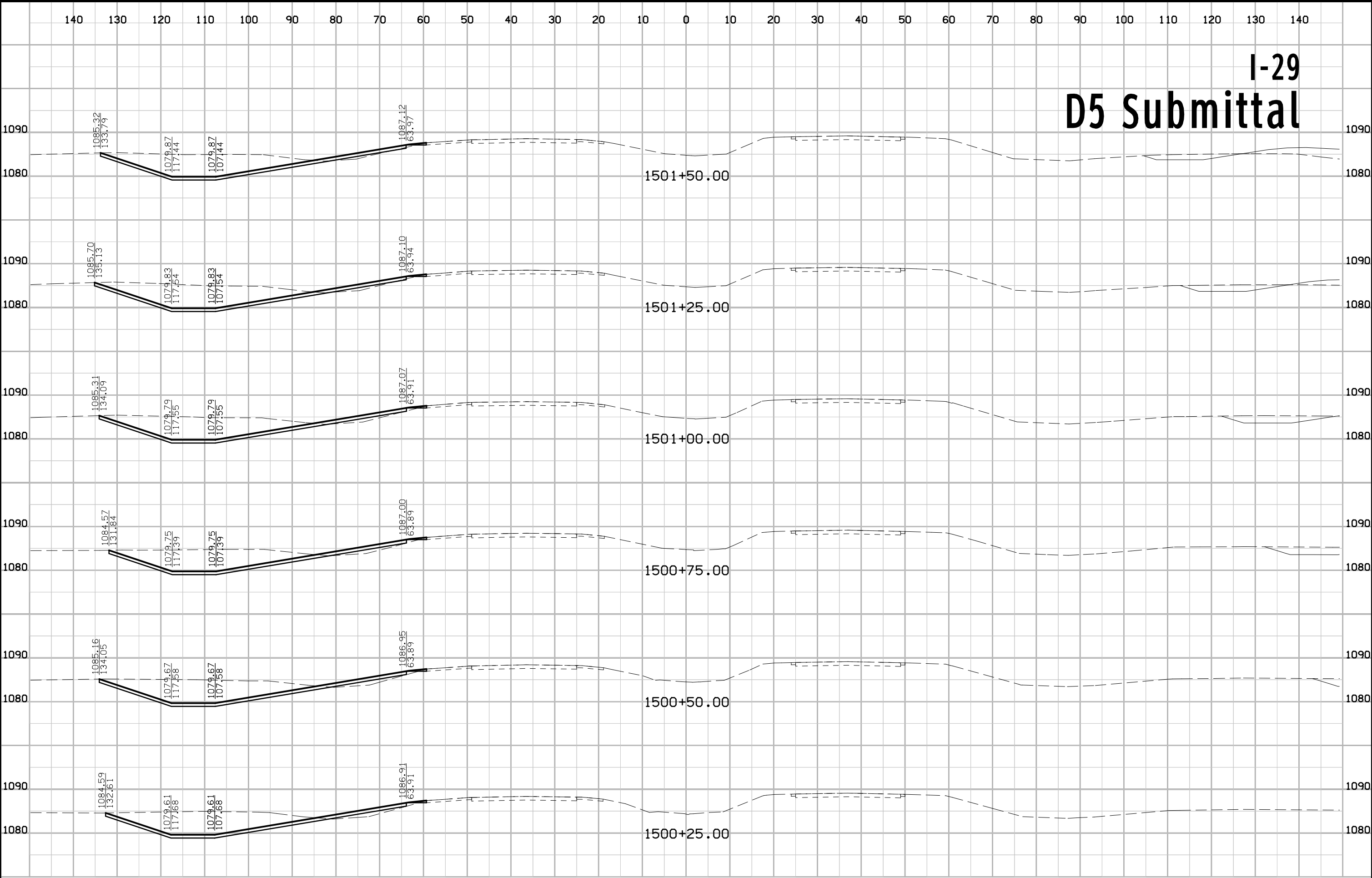

I-29 D5 Submittal

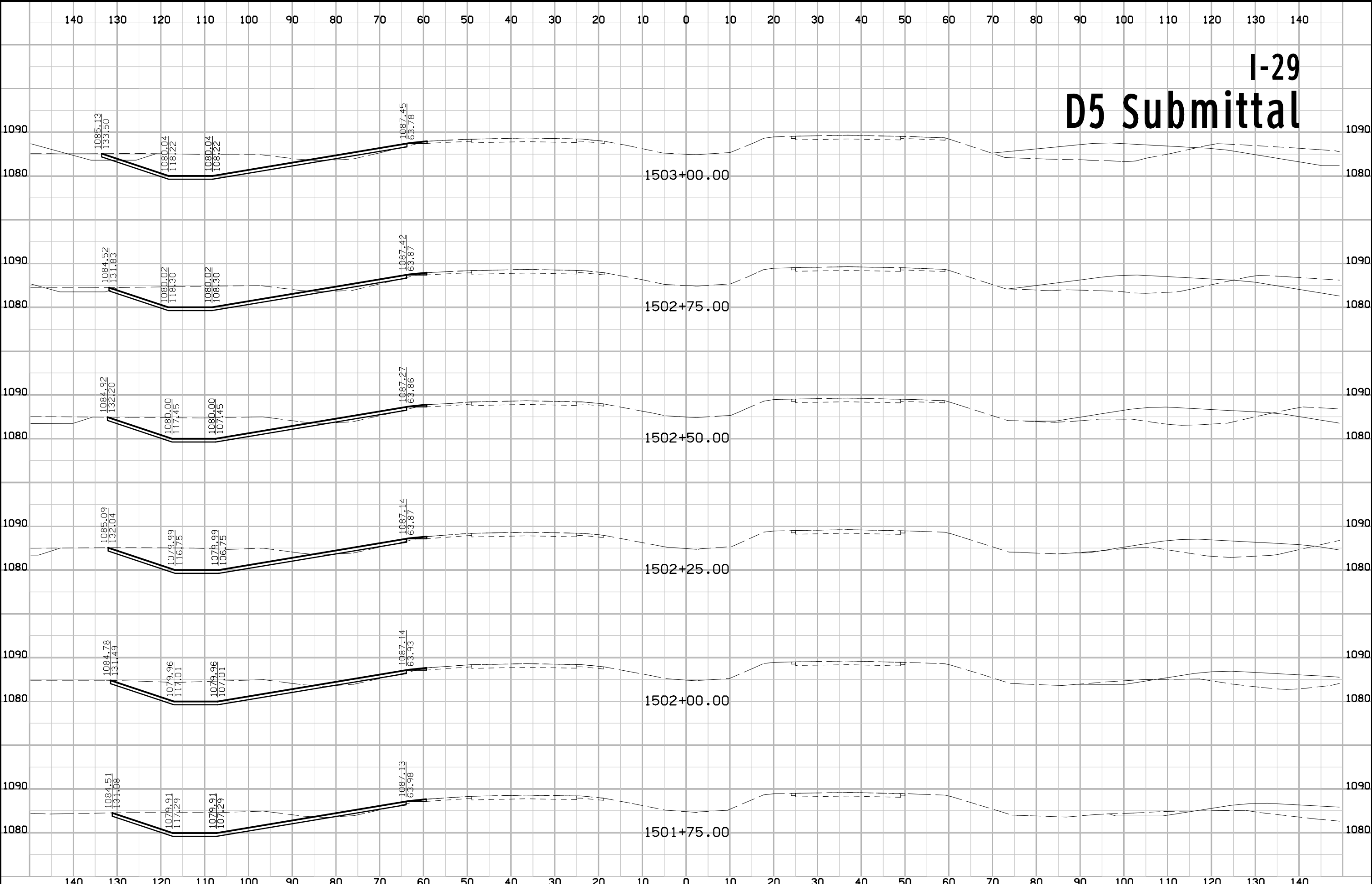

I-29 D5 Submittal

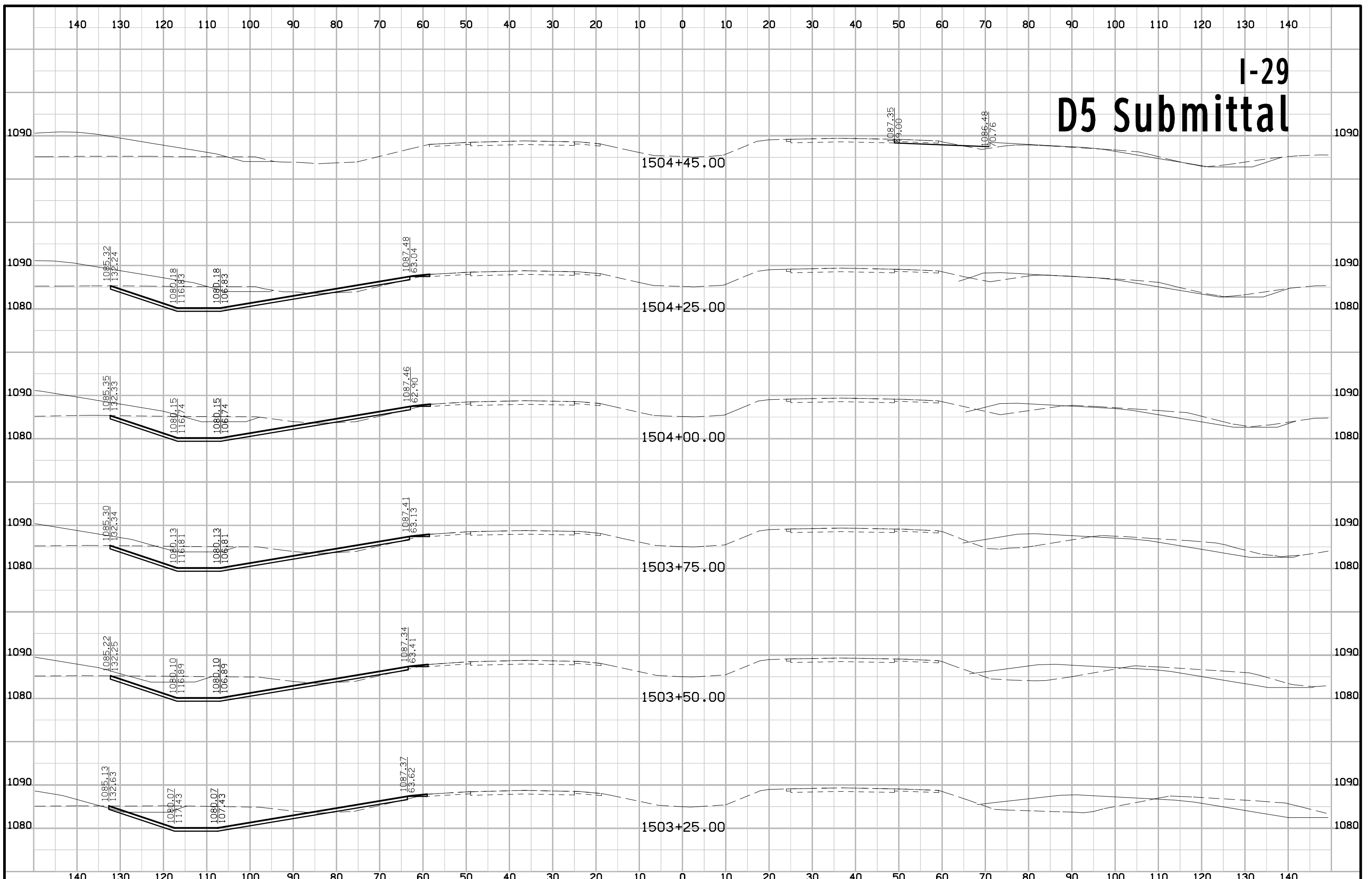

I-29 D5 Submittal

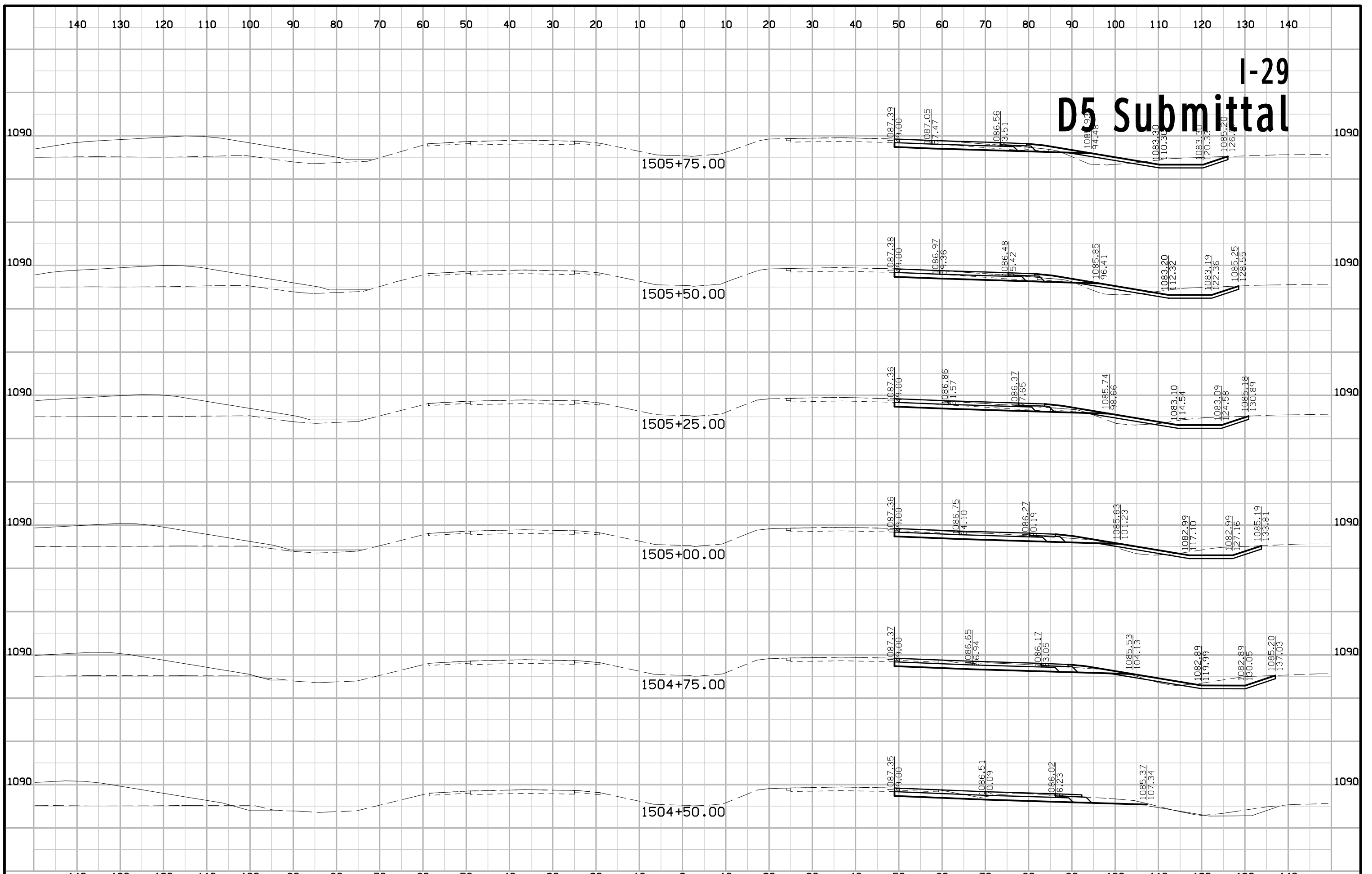

I-29 D5 Submittal

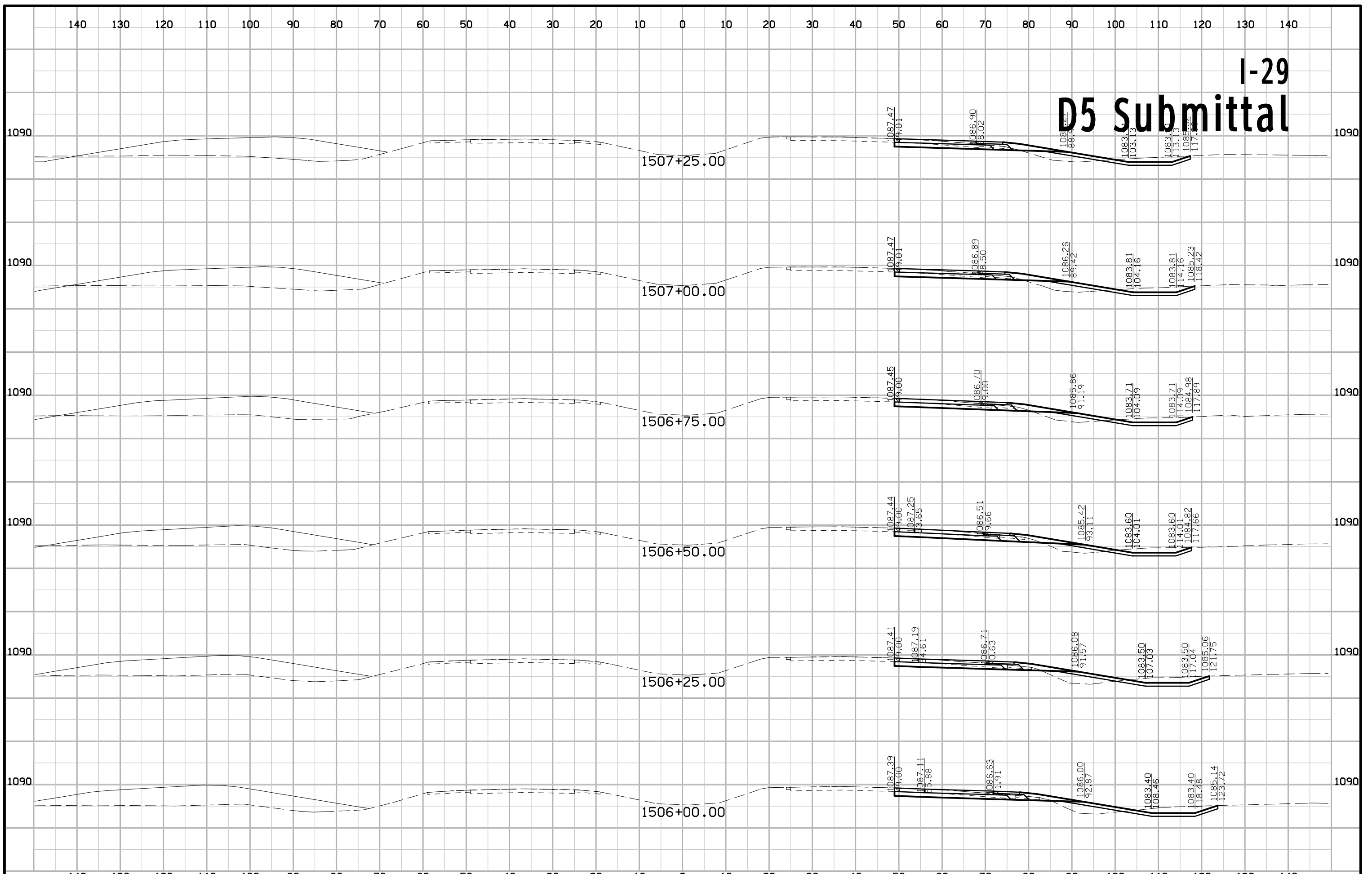

I-29 D5 Submittal

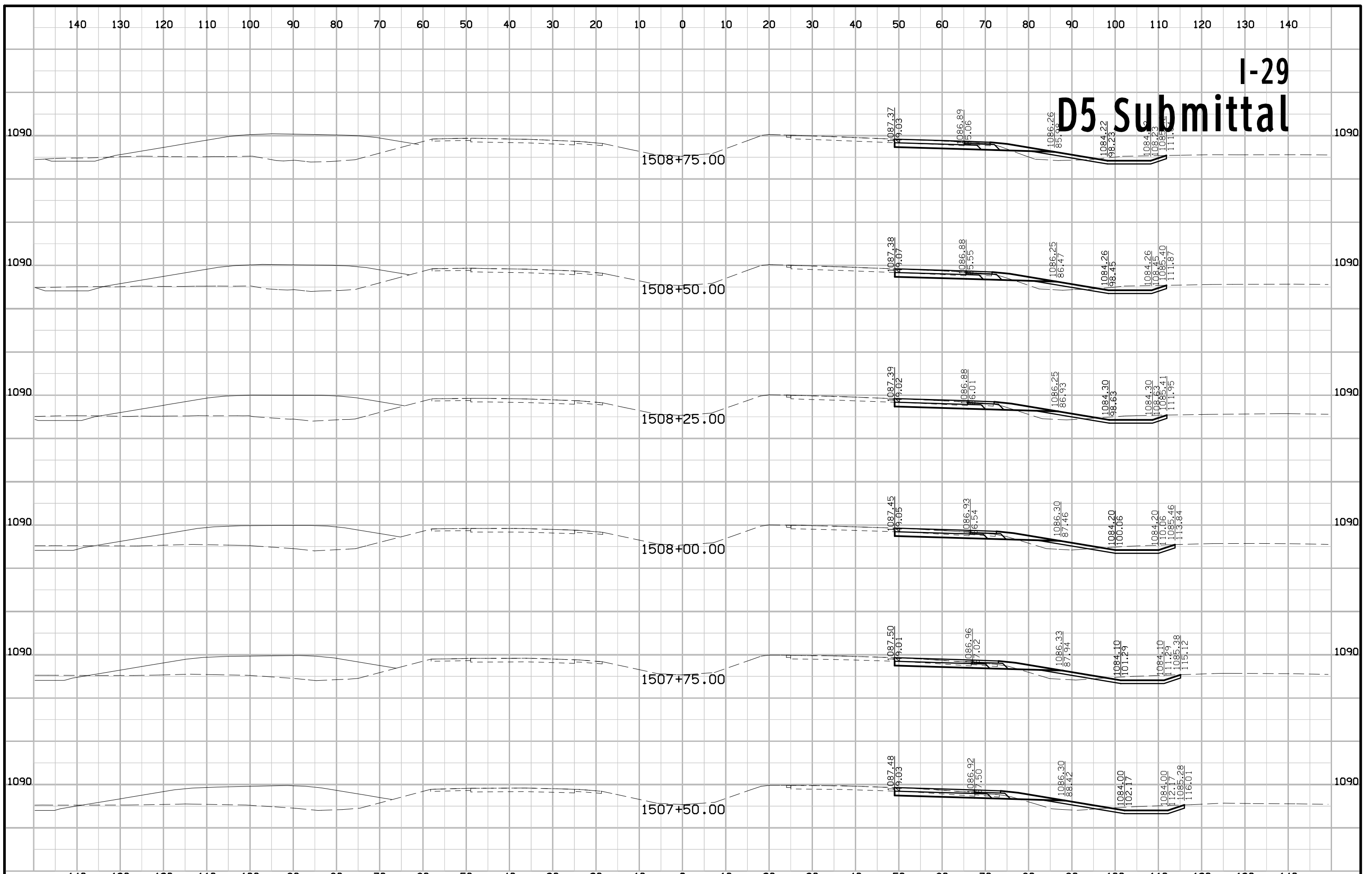

I-29 D5 Submittal

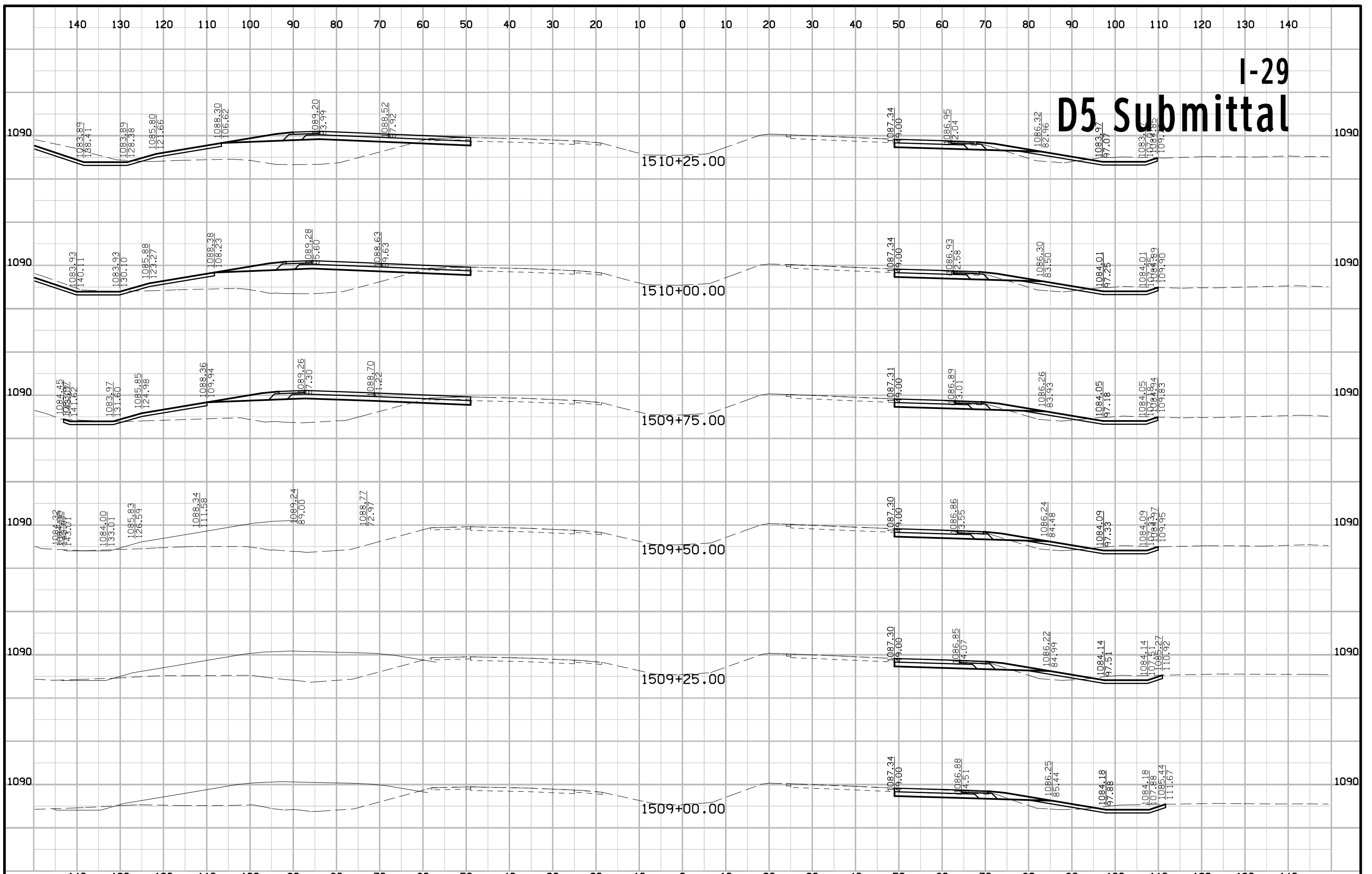

I-29 D5 Submittal

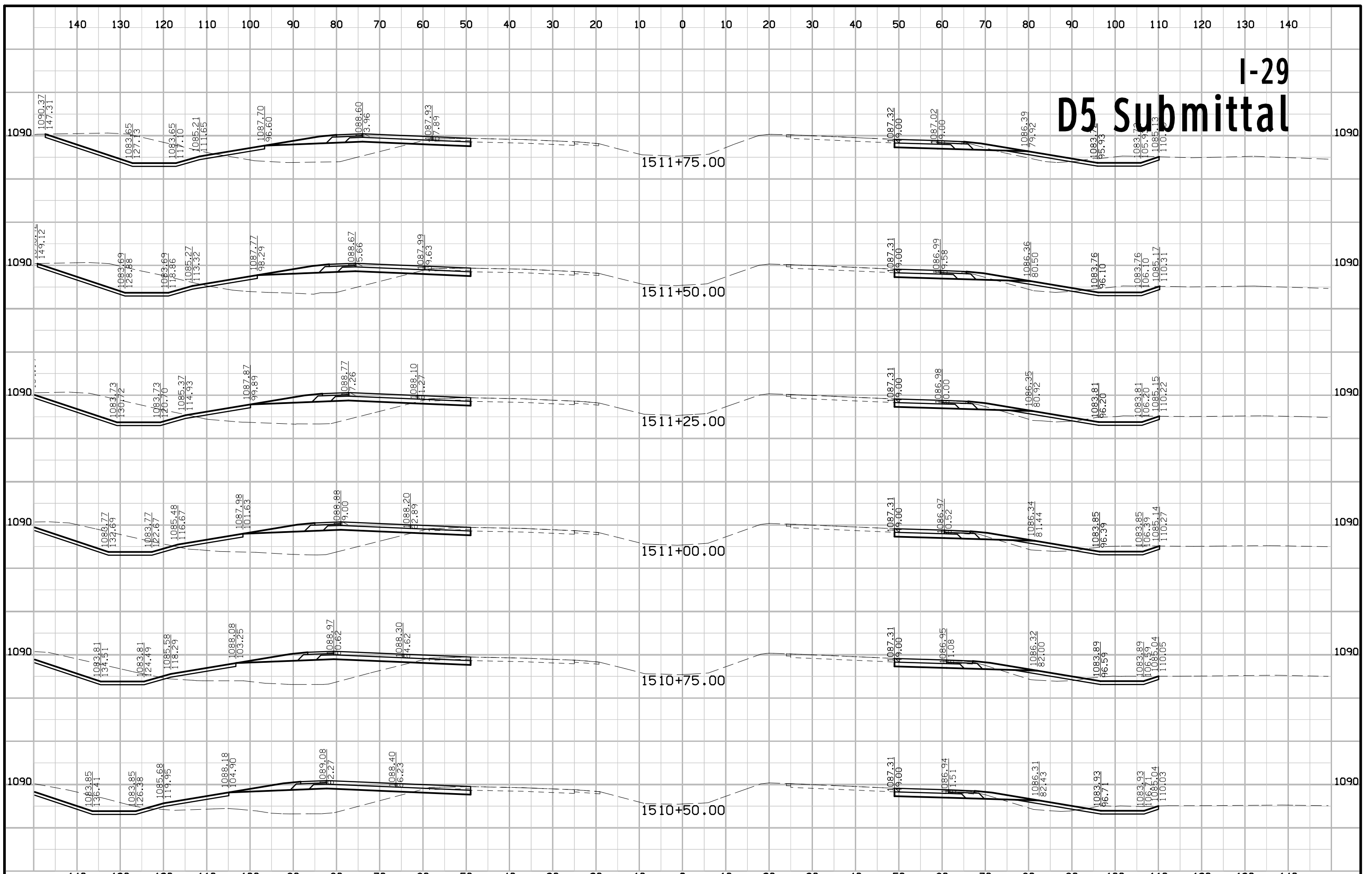

I-29 D5 Submittal

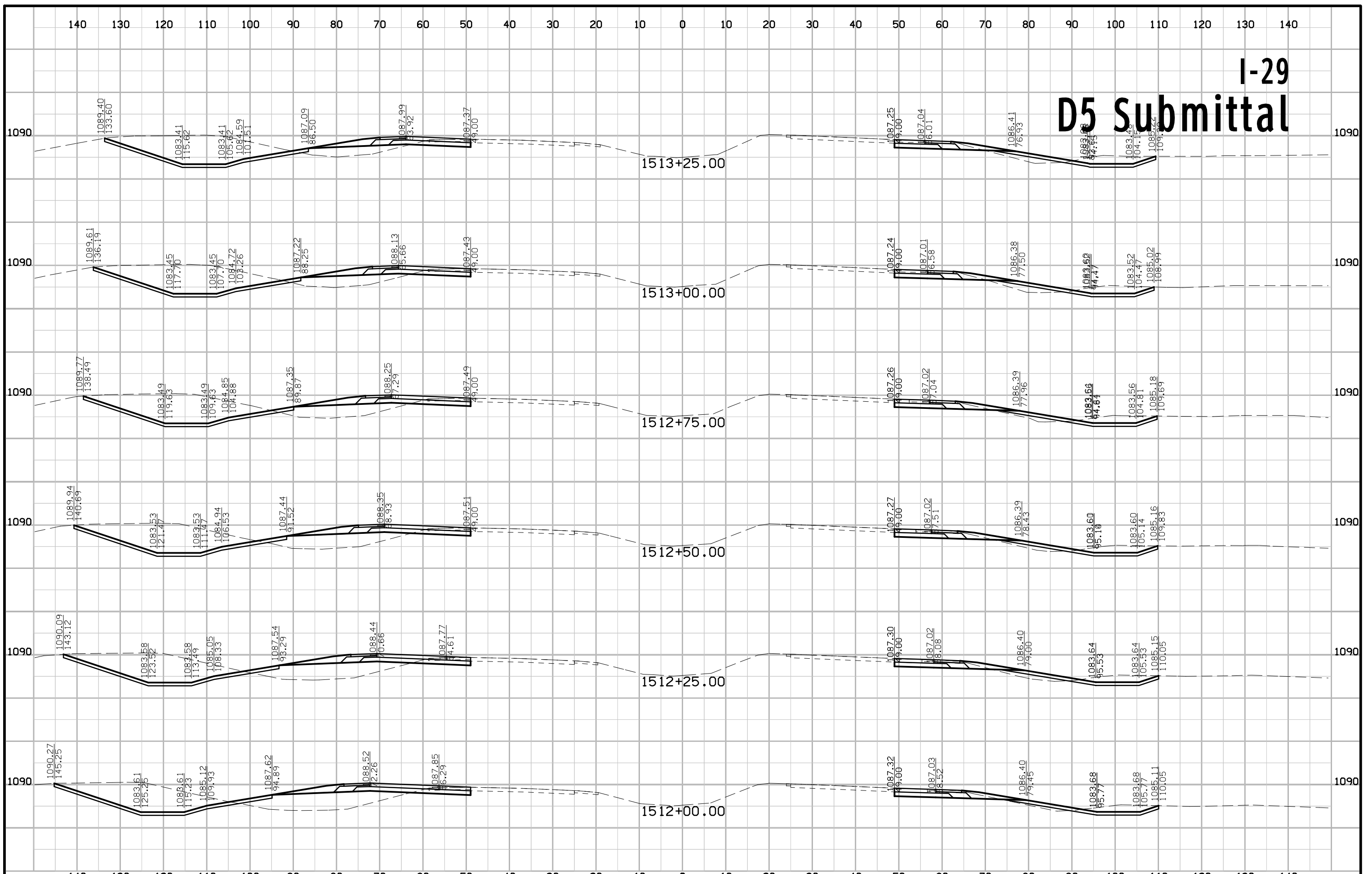

I-29 D5 Submittal

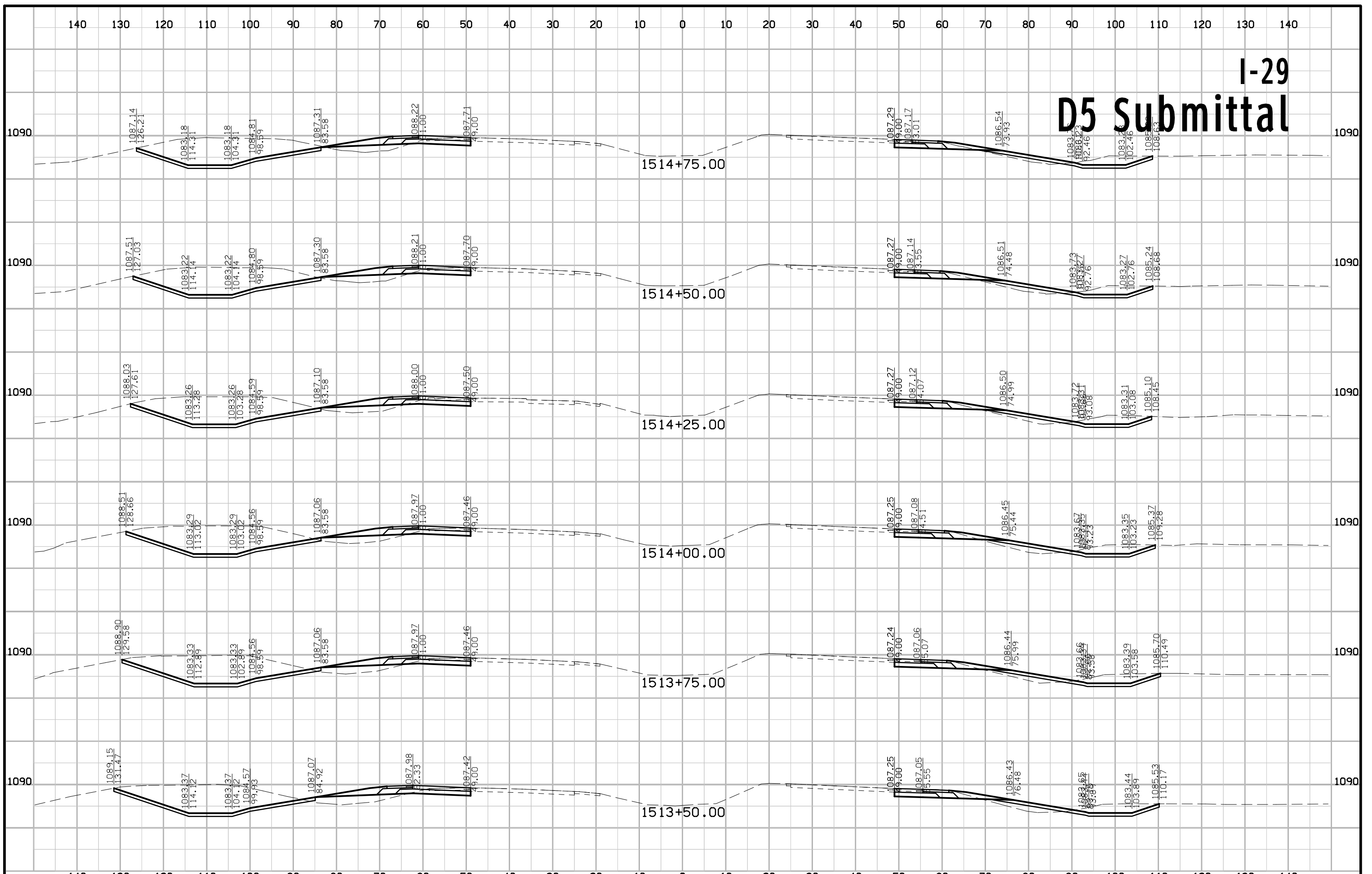

I-29 D5 Submittal

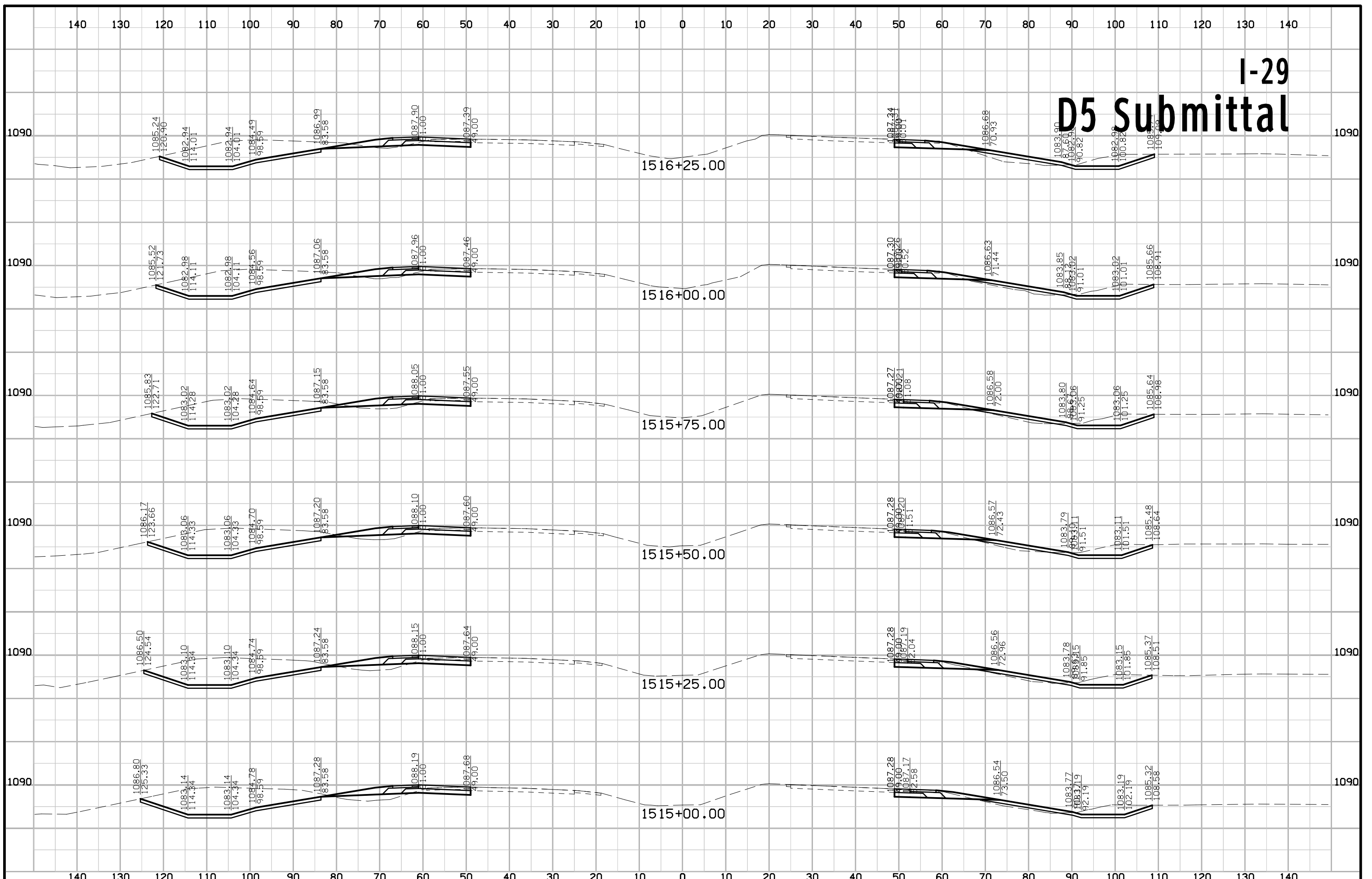

I-29 D5 Submittal

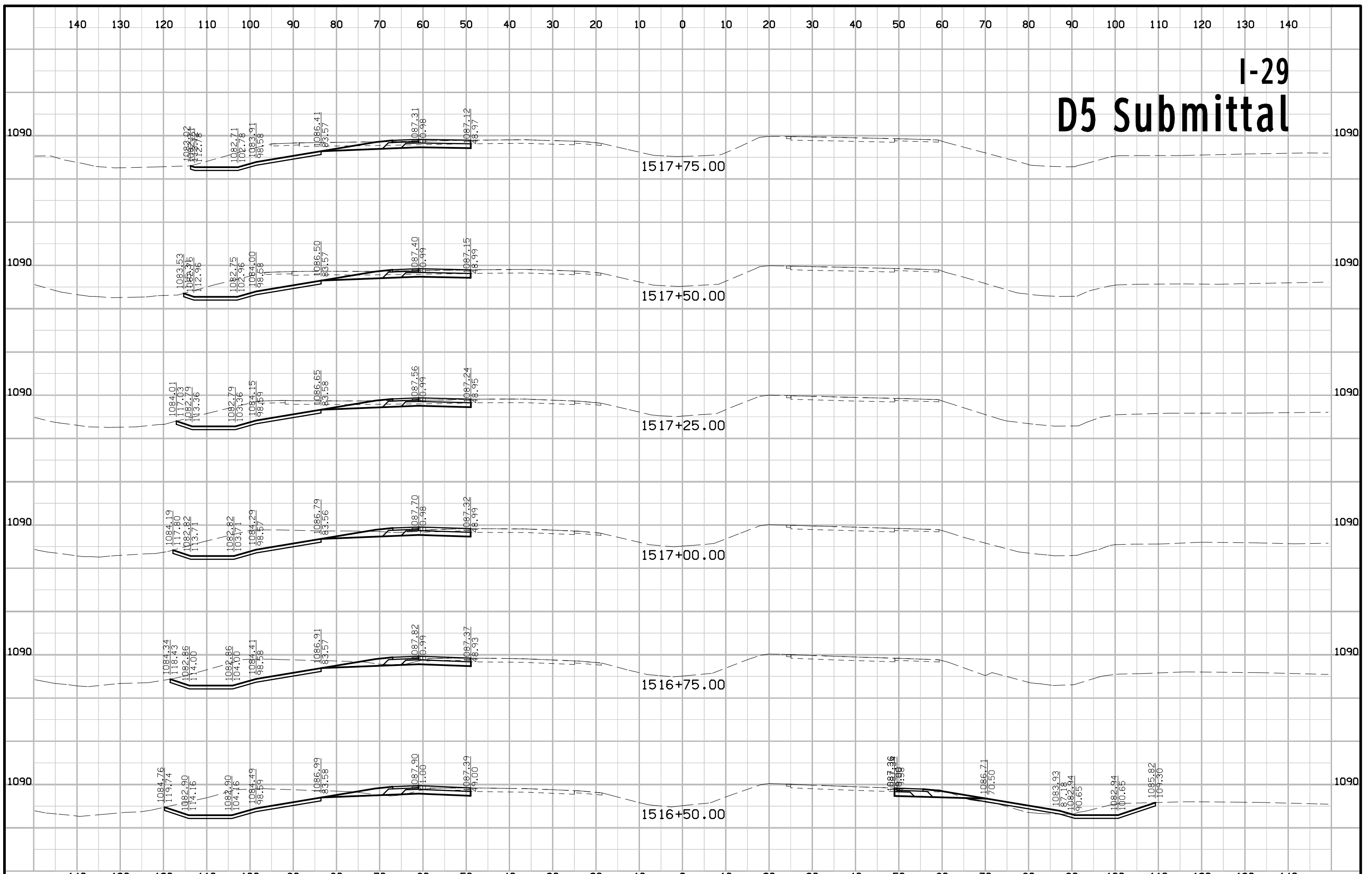

I-29 D5 Submittal

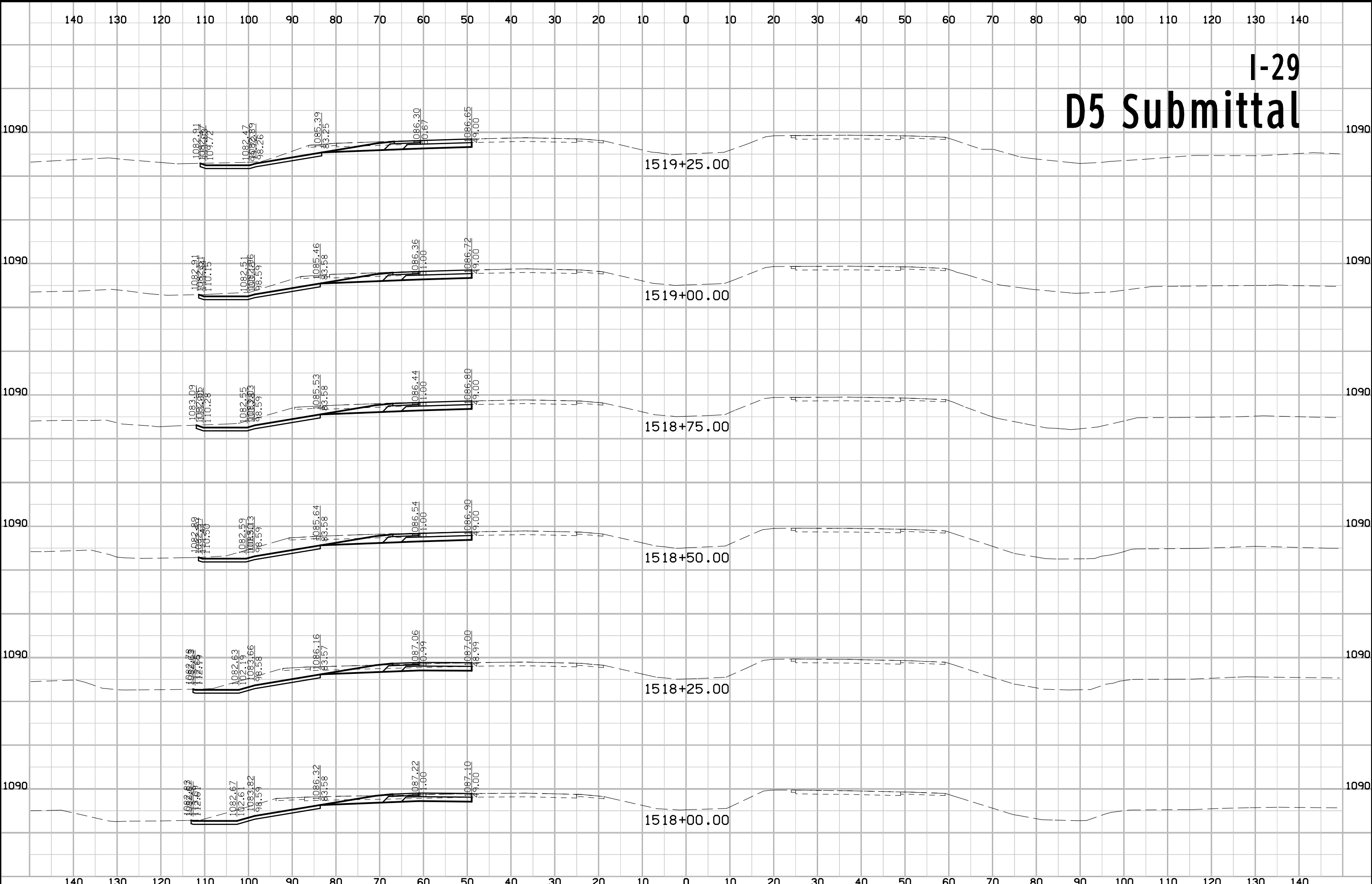

I-29 D5 Submittal



I-29 D5 Submittal

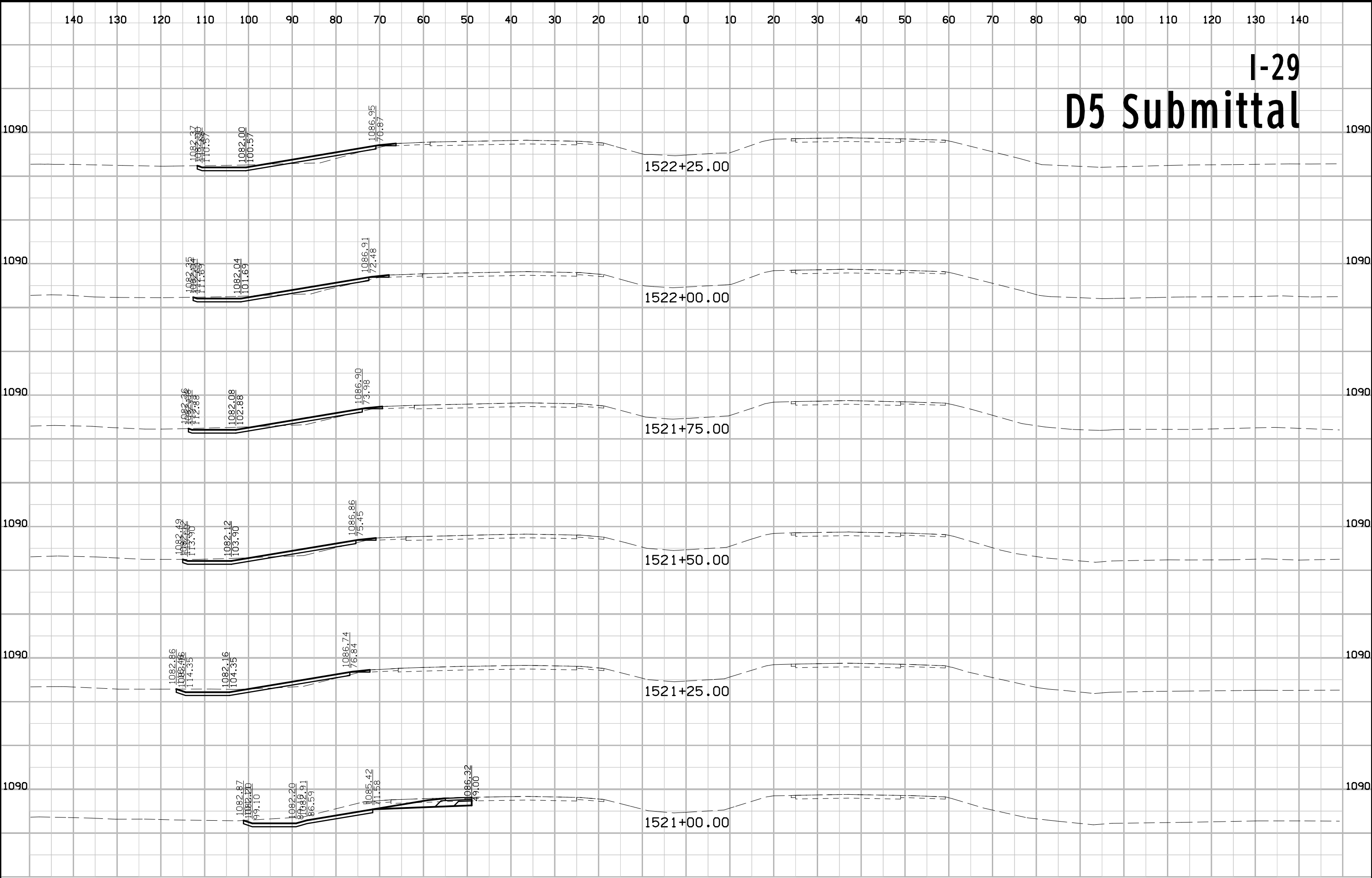

I-29 D5 Submittal

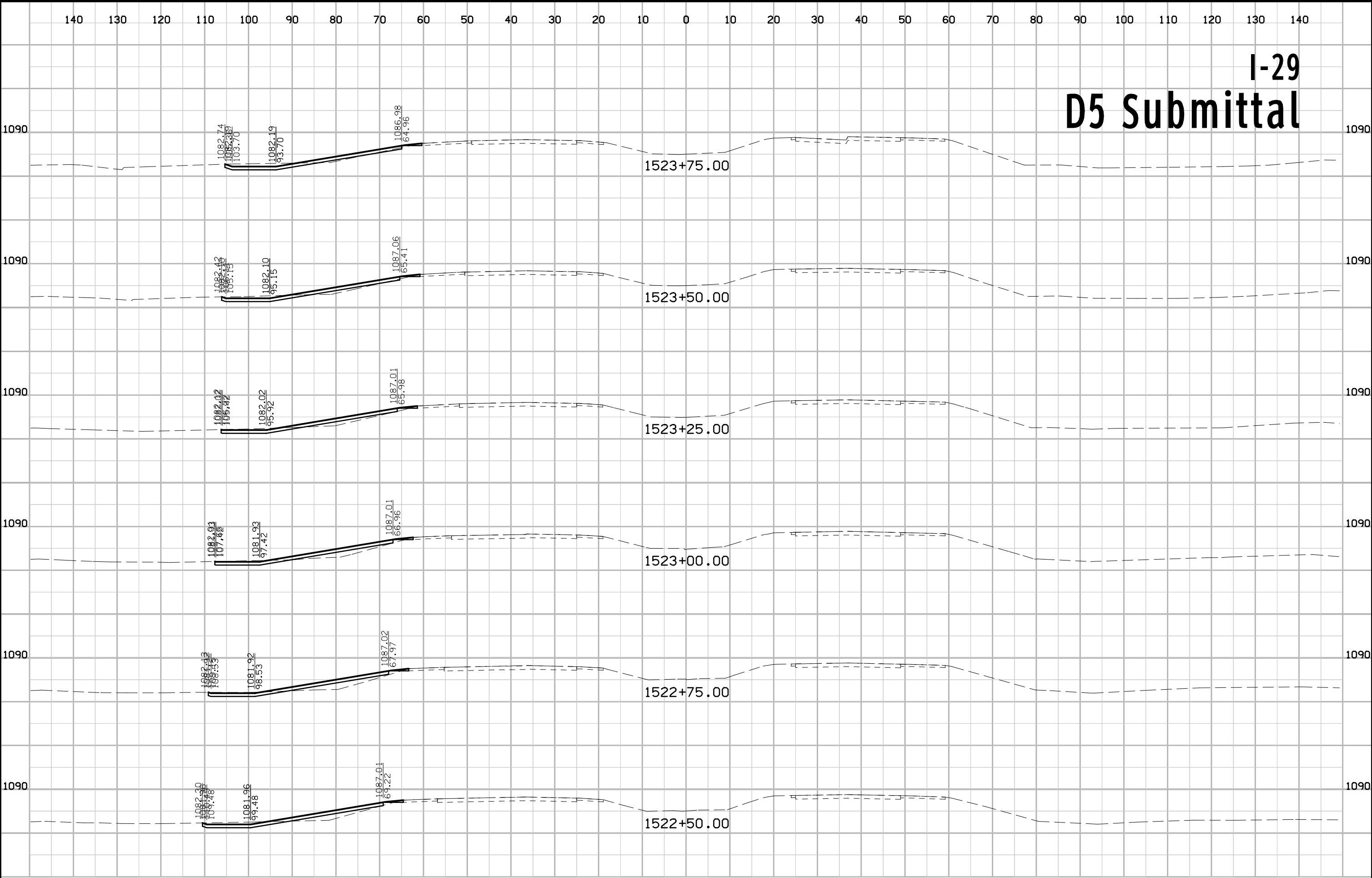

I-29 D5 Submittal

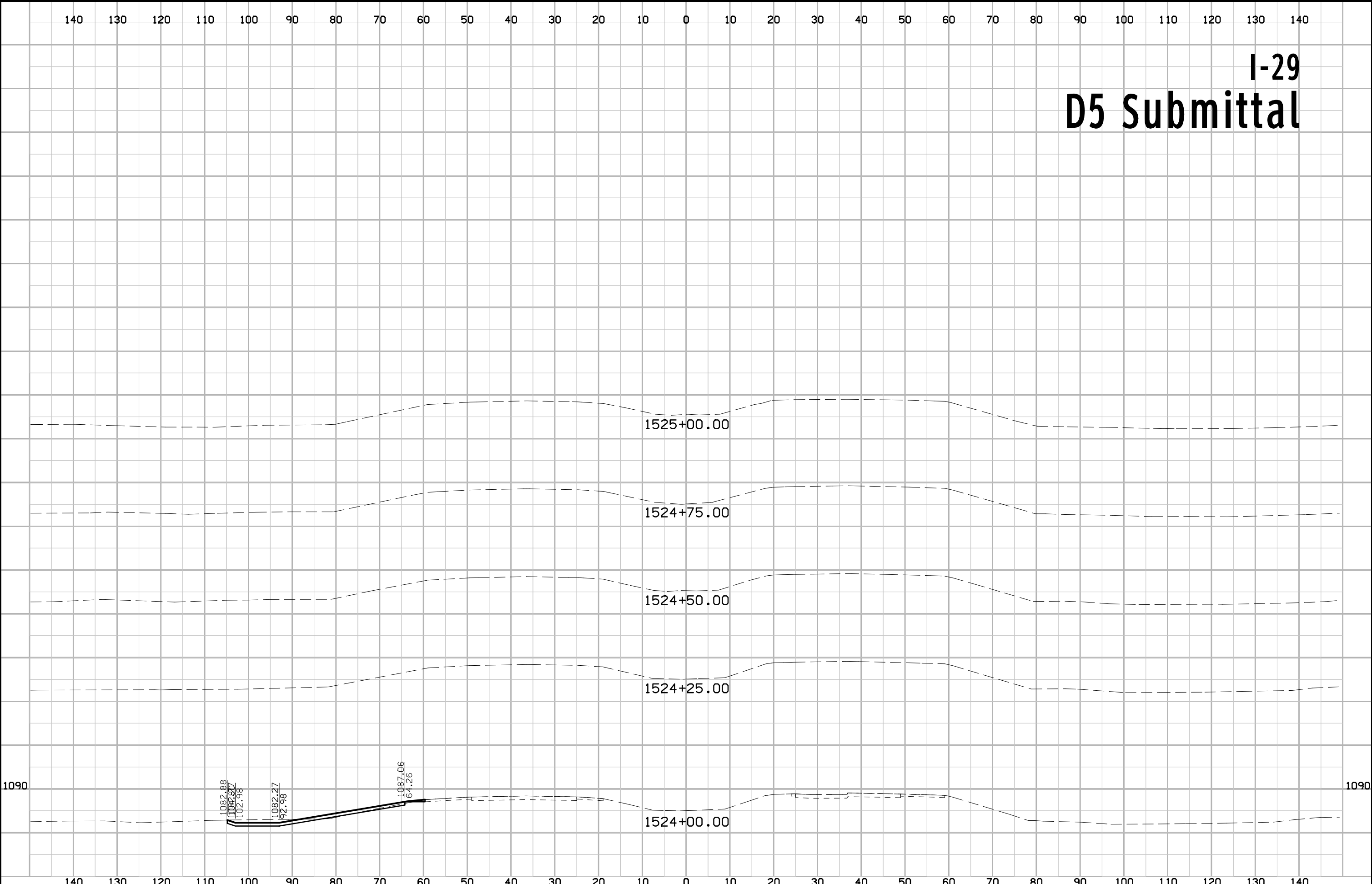

D51/260th St. D5 Submittal

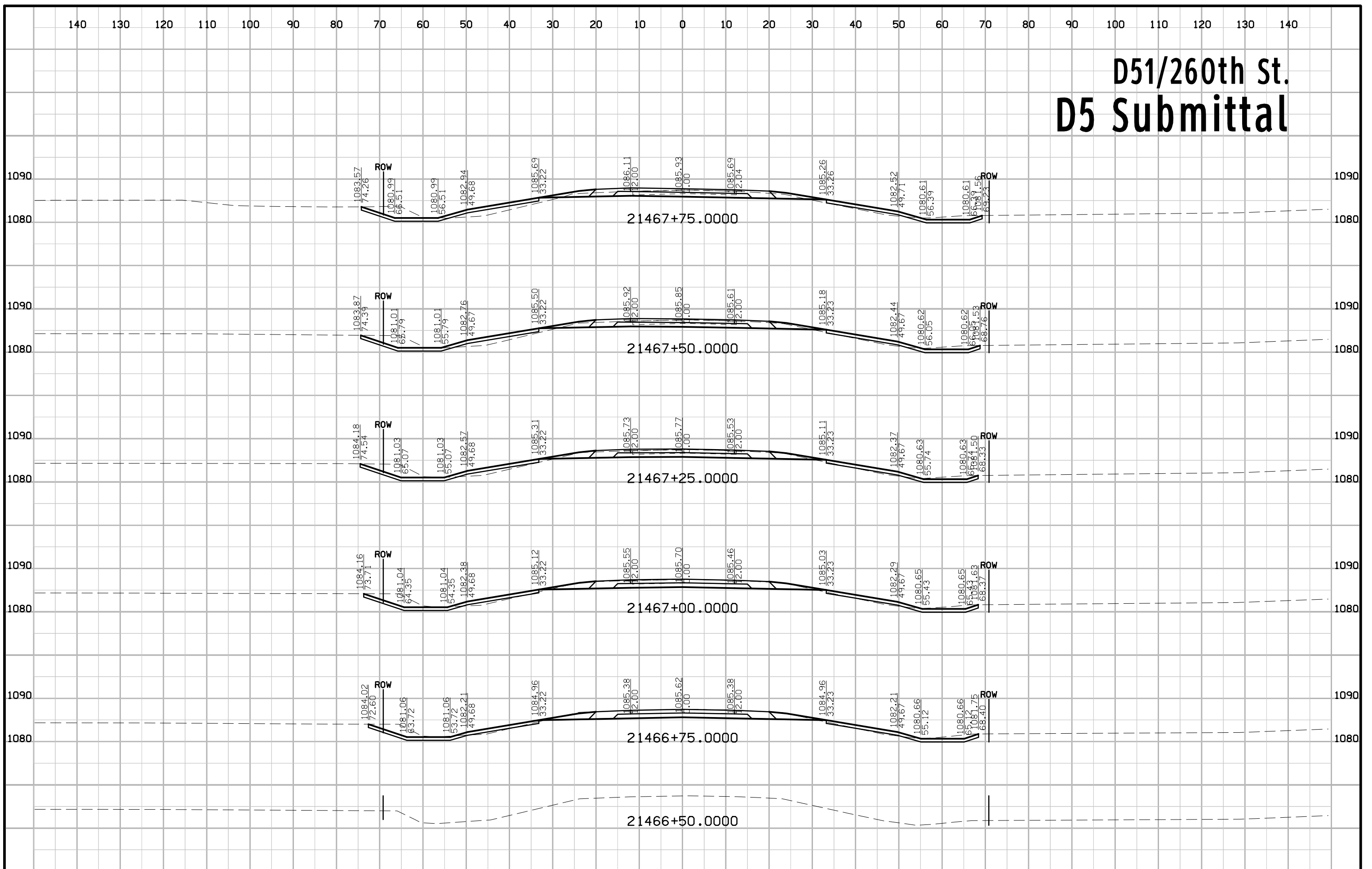

D51/260th St. D5 Submittal

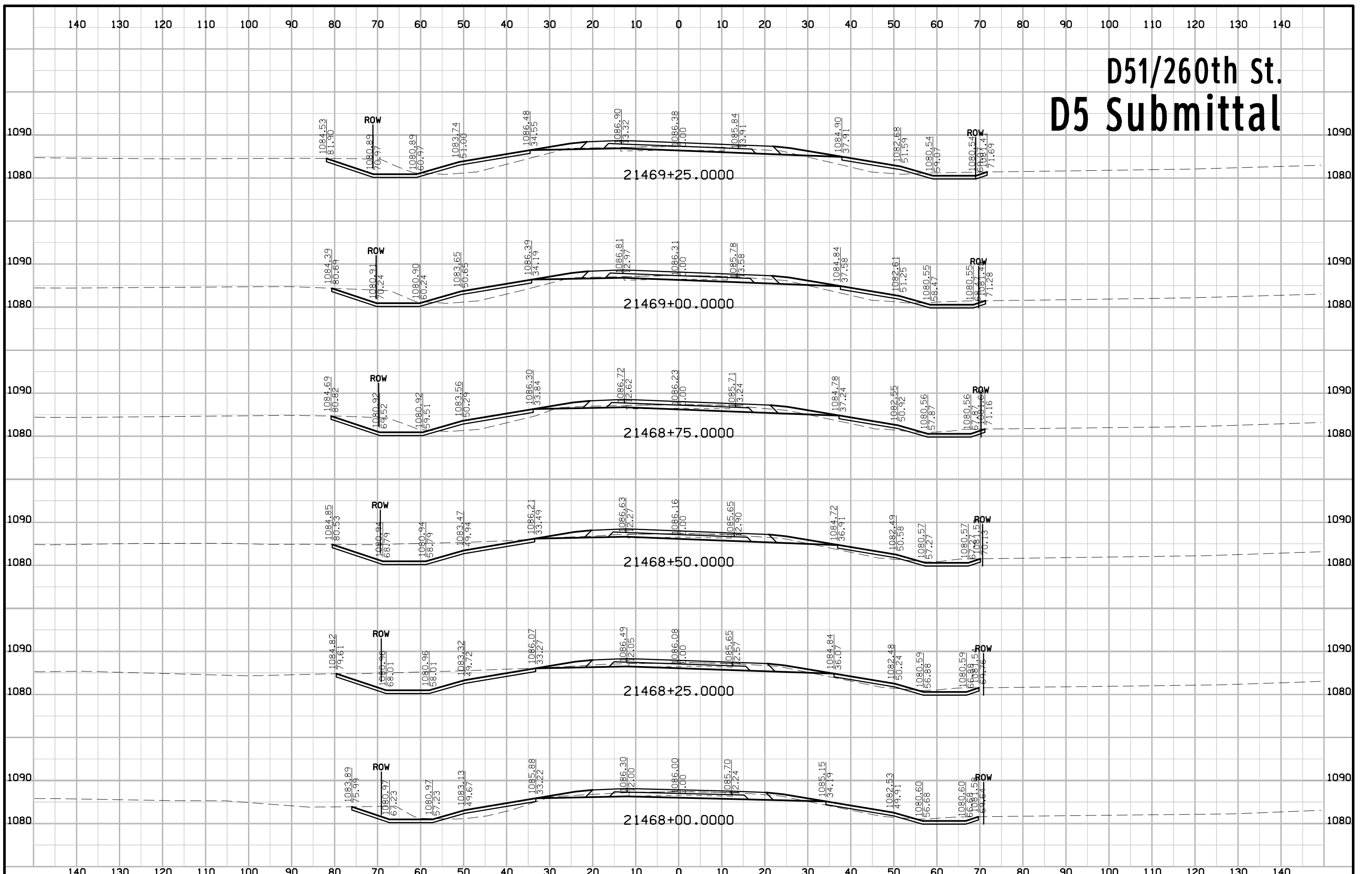

D51/260th St. D5 Submittal

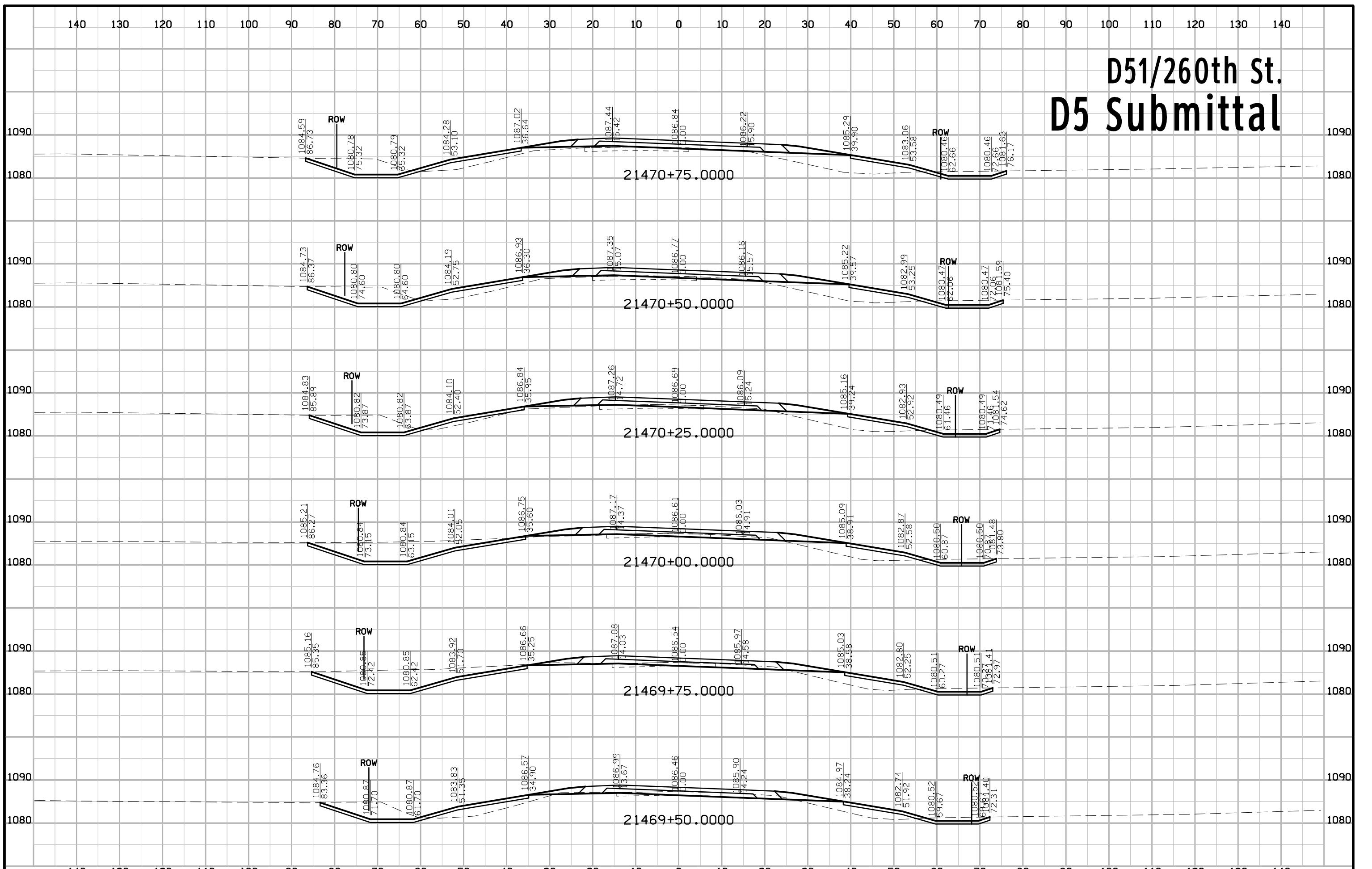

D51/260th St. D5 Submittal

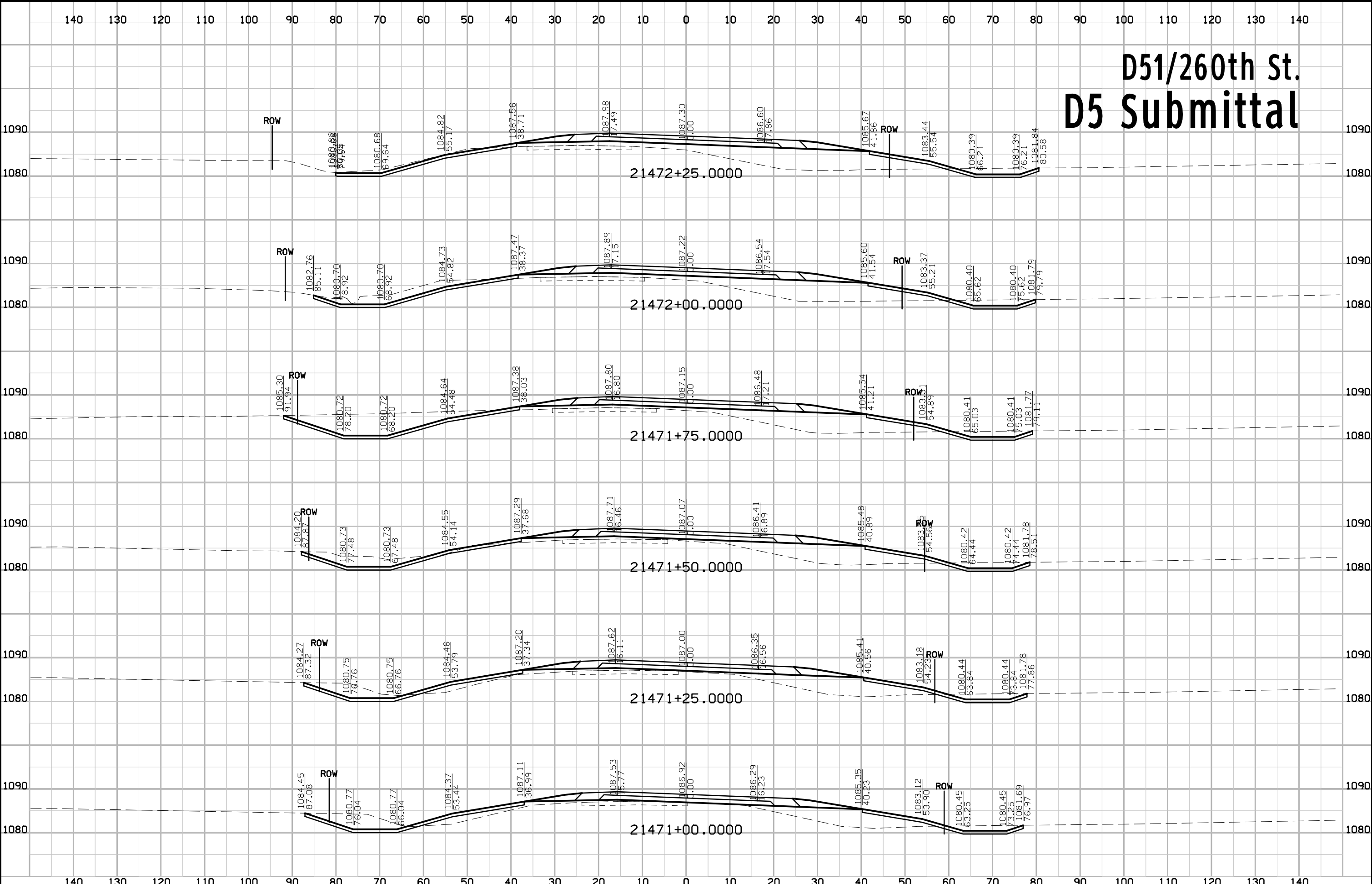

D51/260th St. D5 Submittal

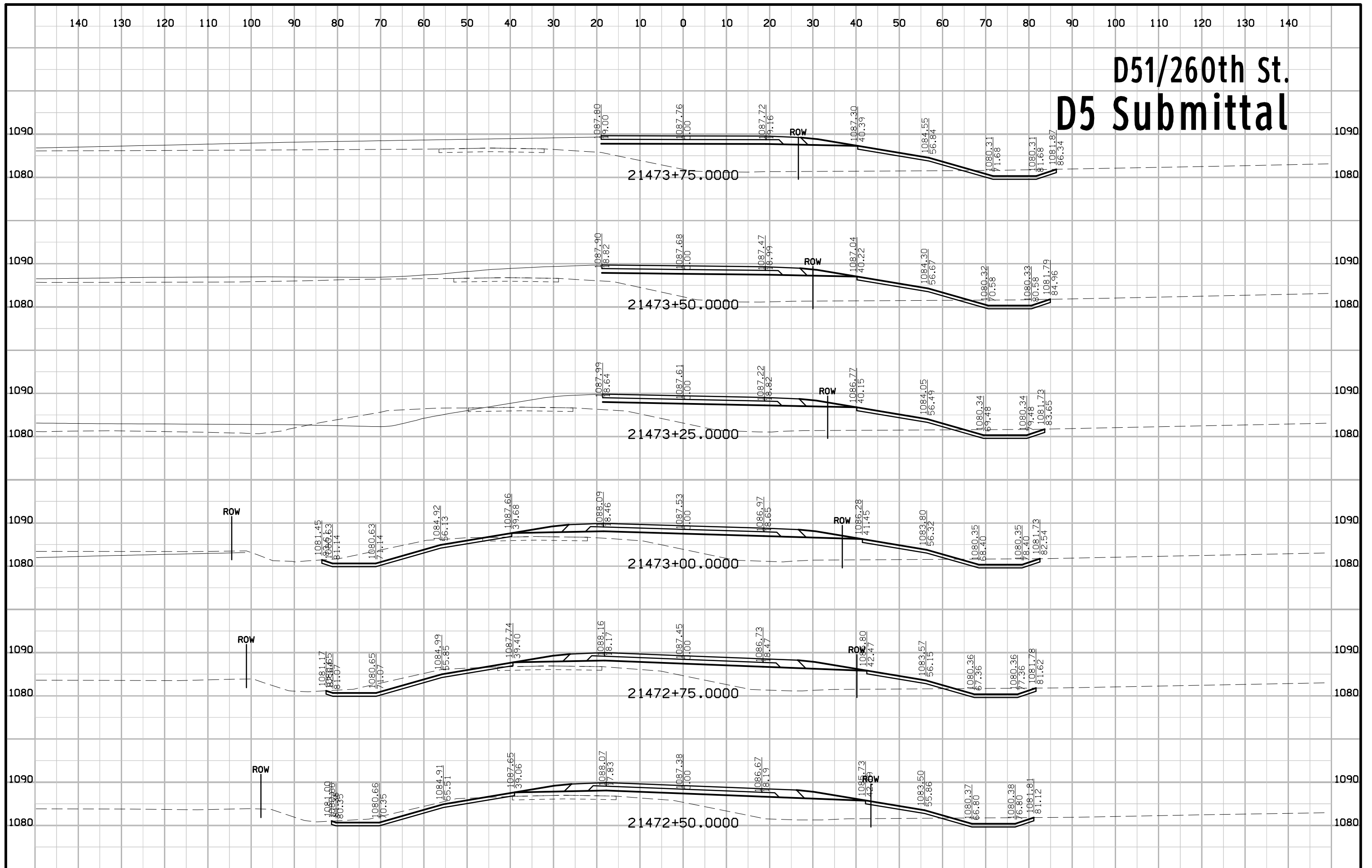

D51/260th St. D5 Submittal

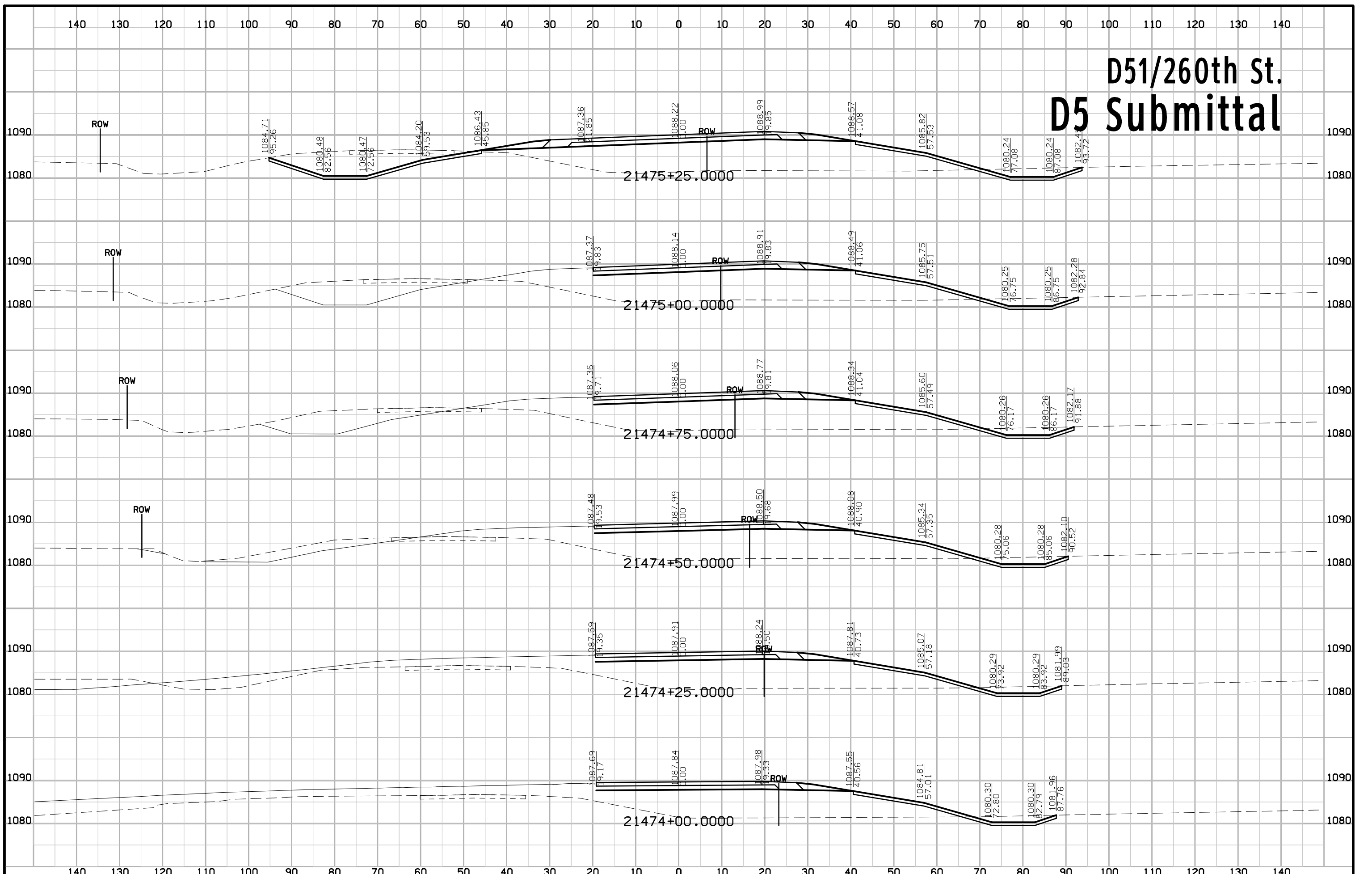

D51/260th St. D5 Submittal

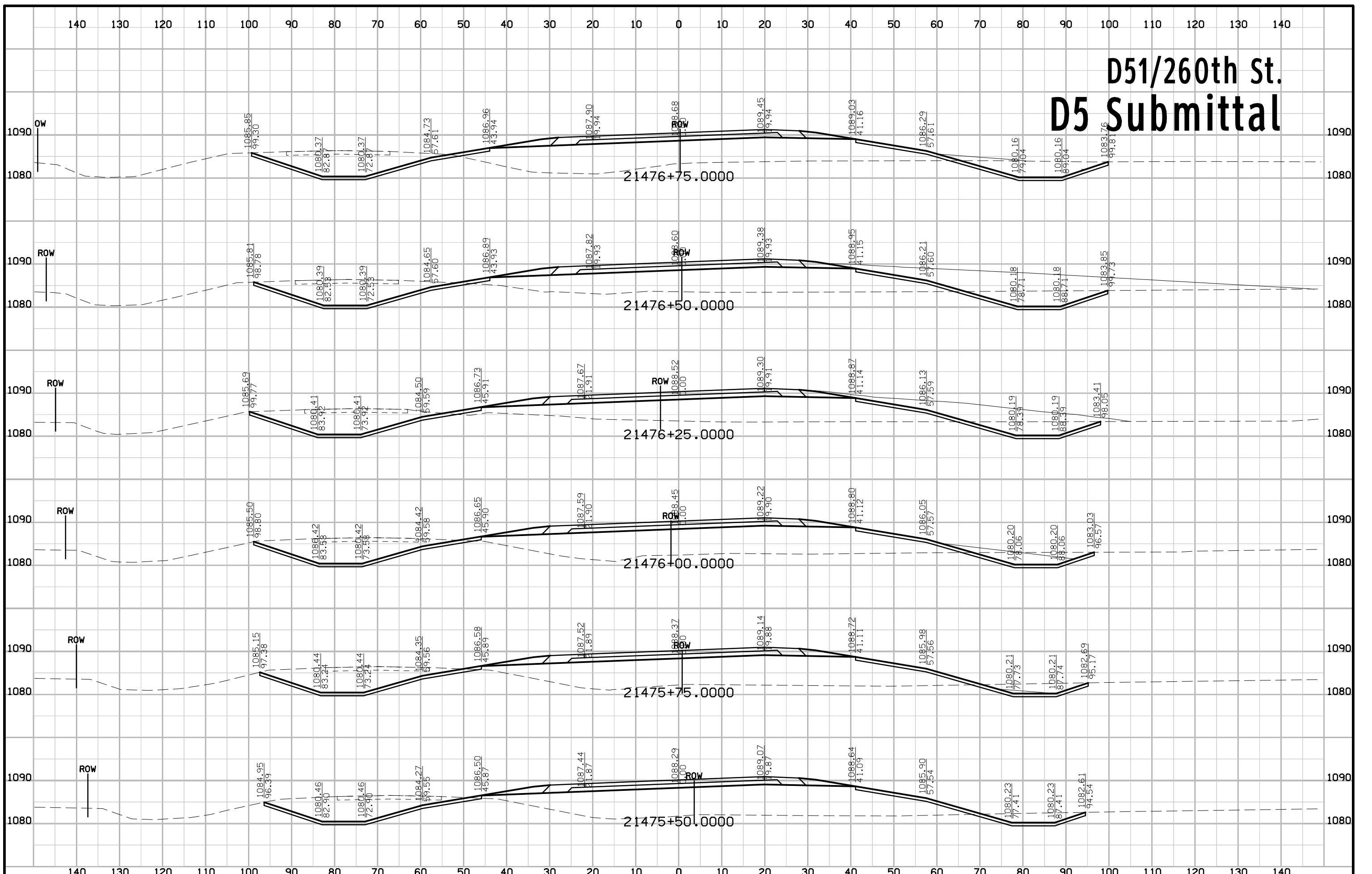

D51/260th St. D5 Submittal

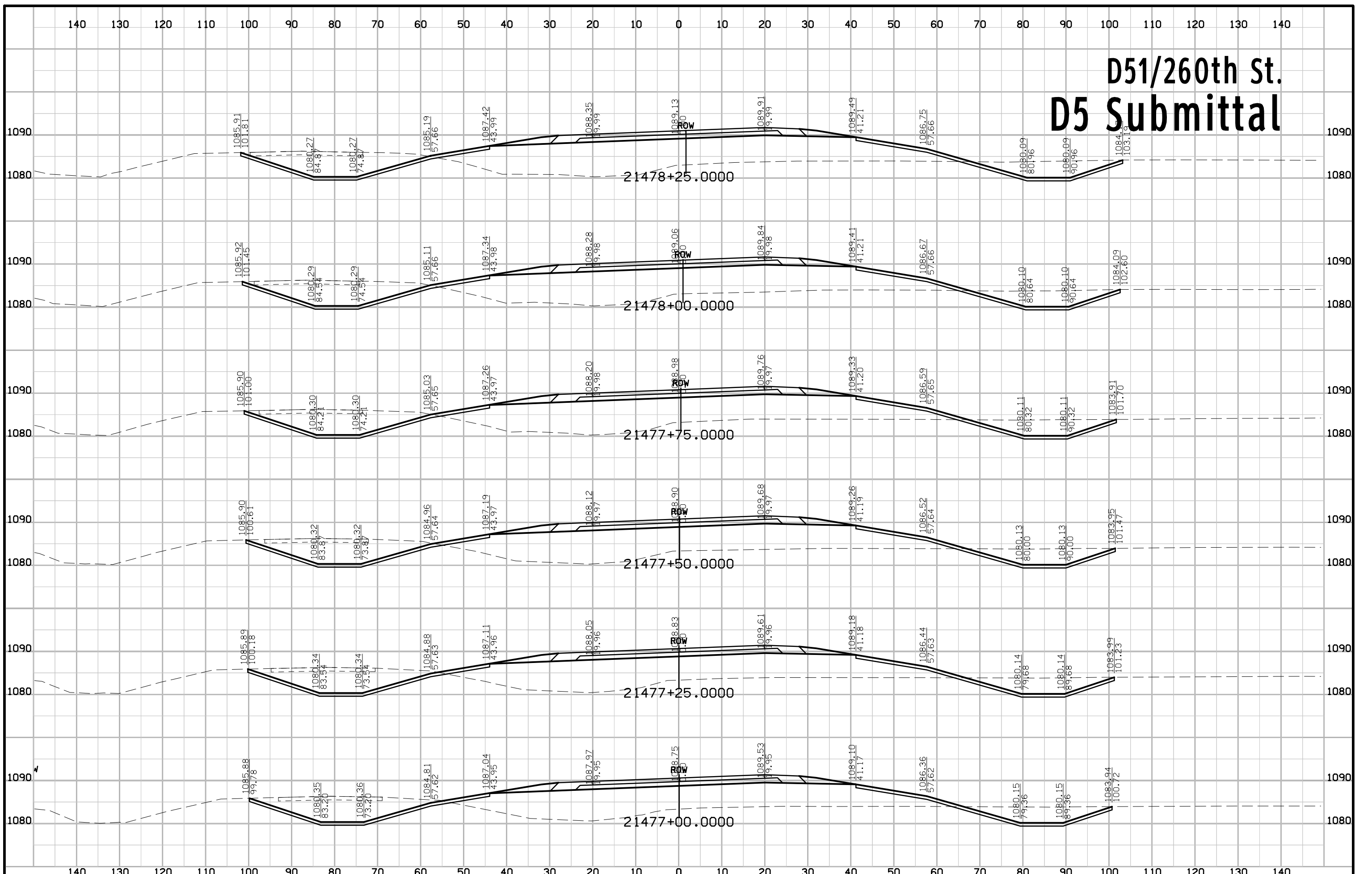

D51/260th St. D5 Submittal

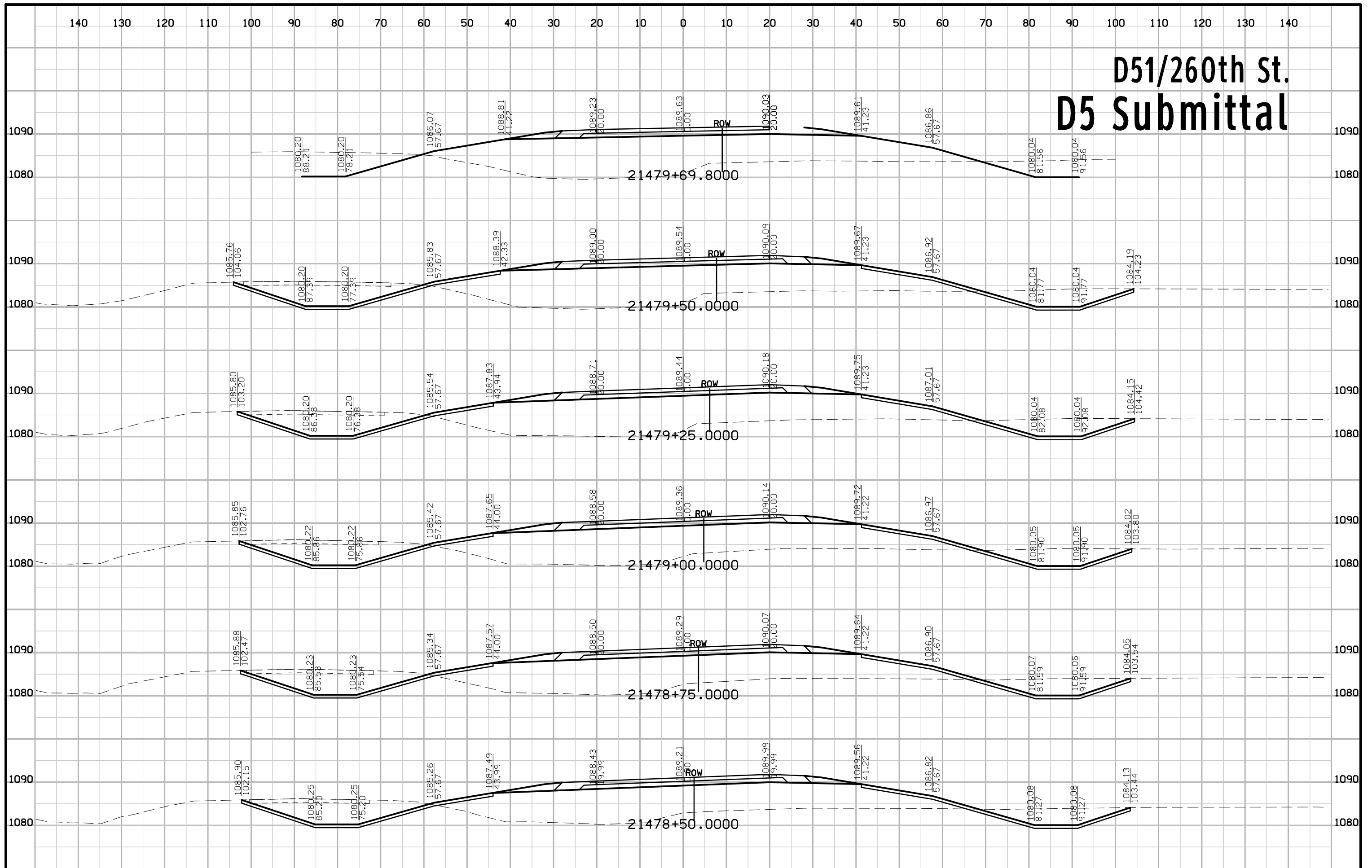

D51/260th St. D5 Submittal

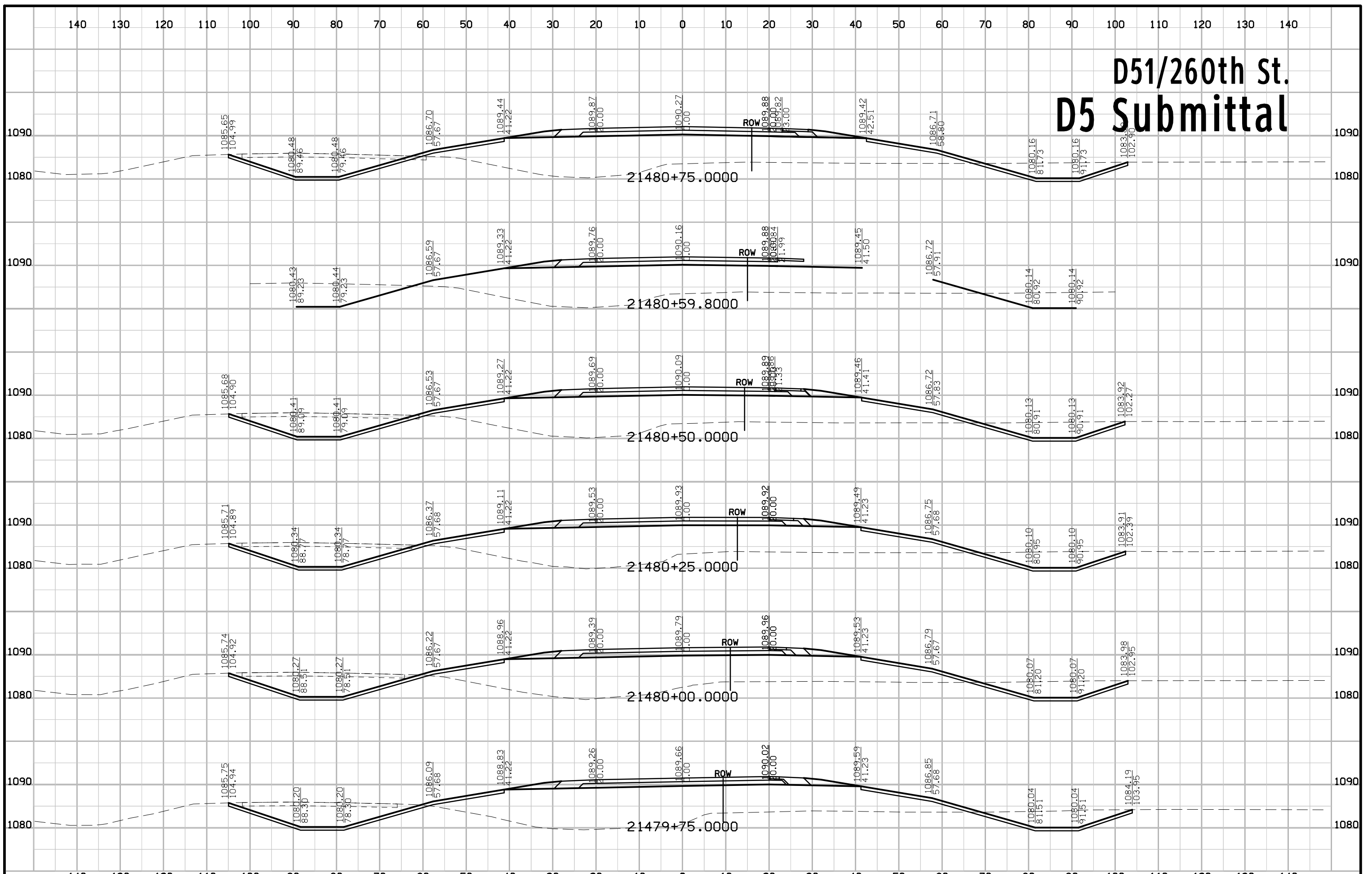

D51/260th St. D5 Submittal

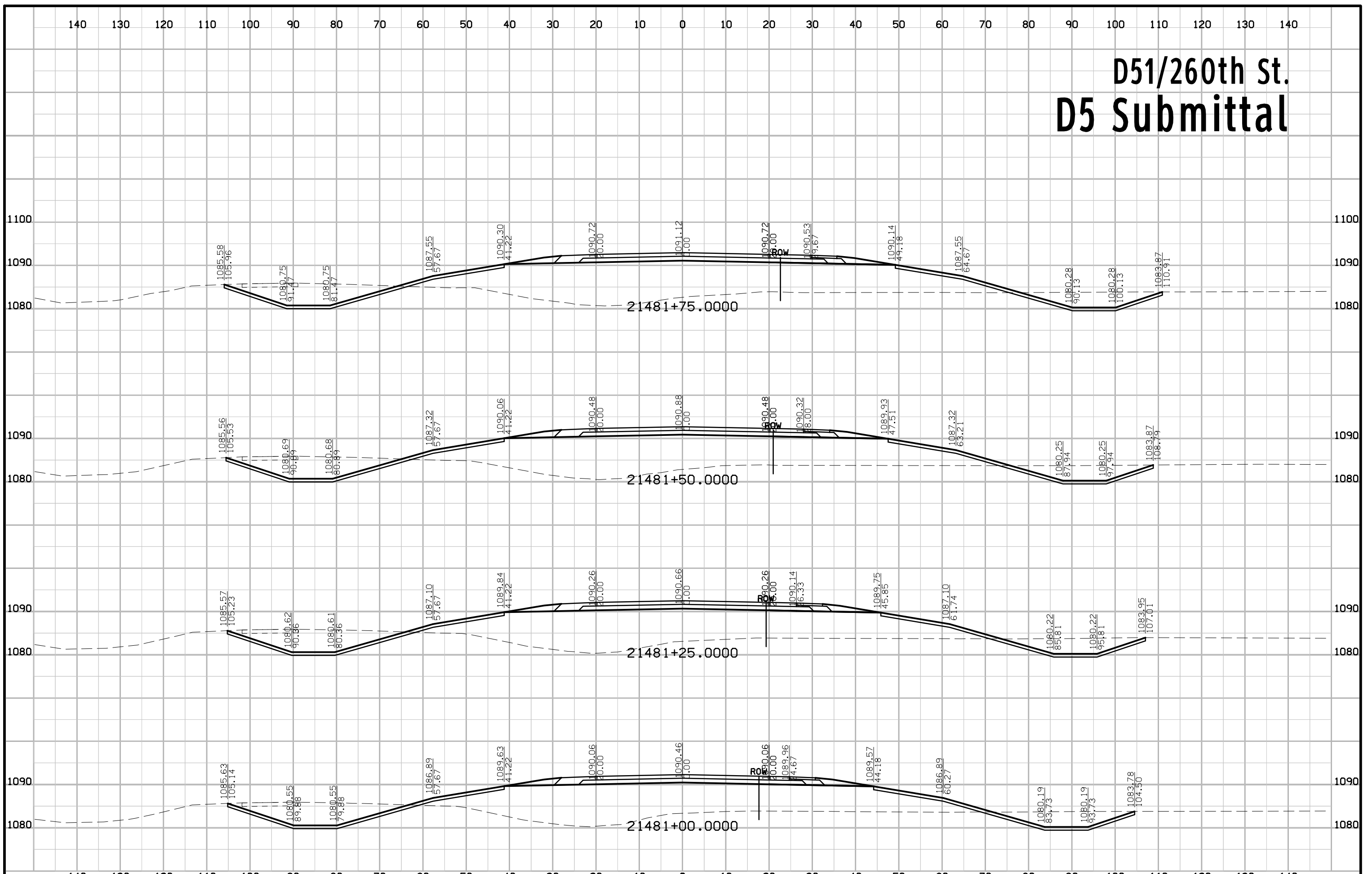

D51/260th St. D5 Submittal

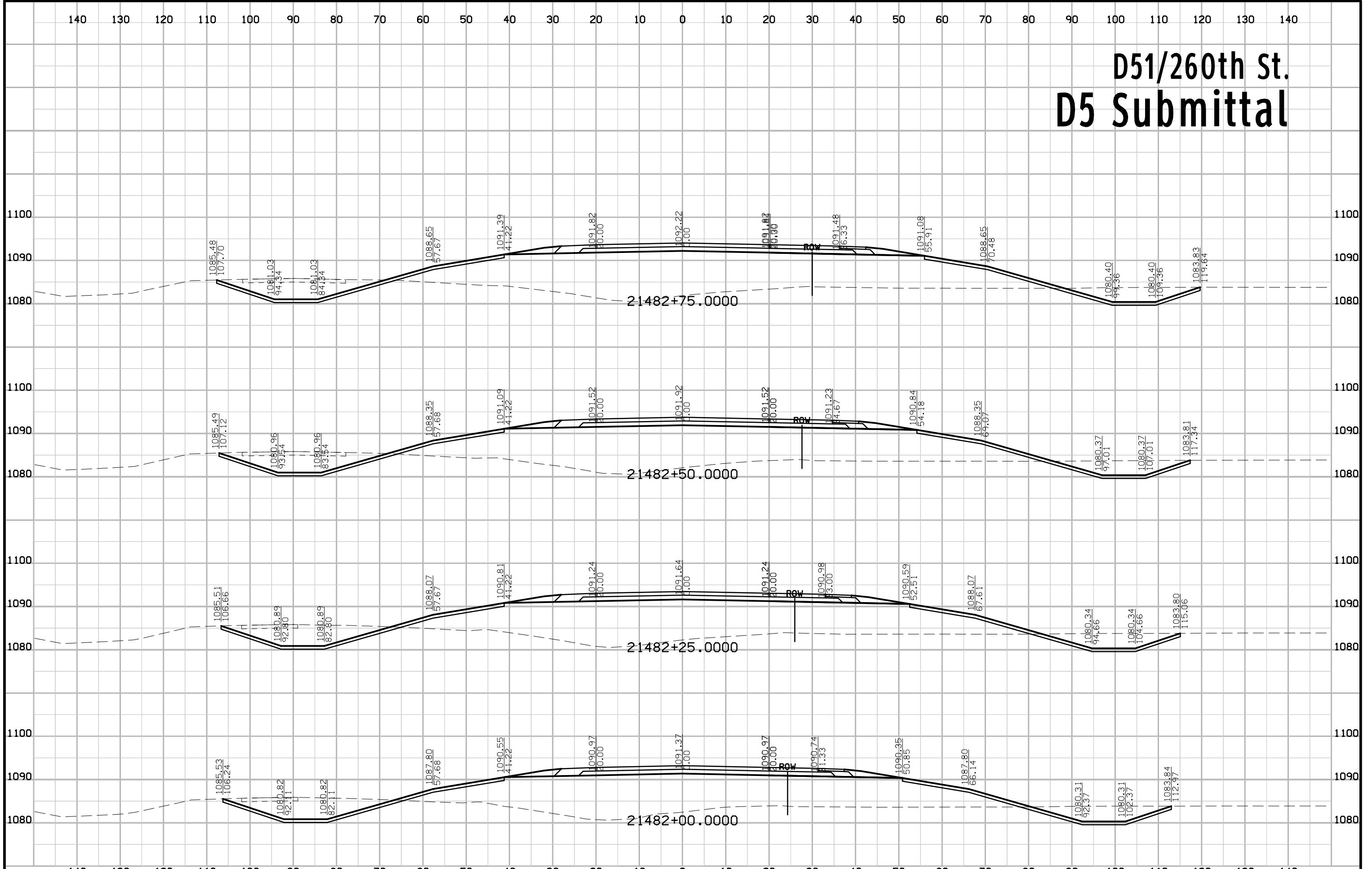

D51/260th St. D5 Submittal

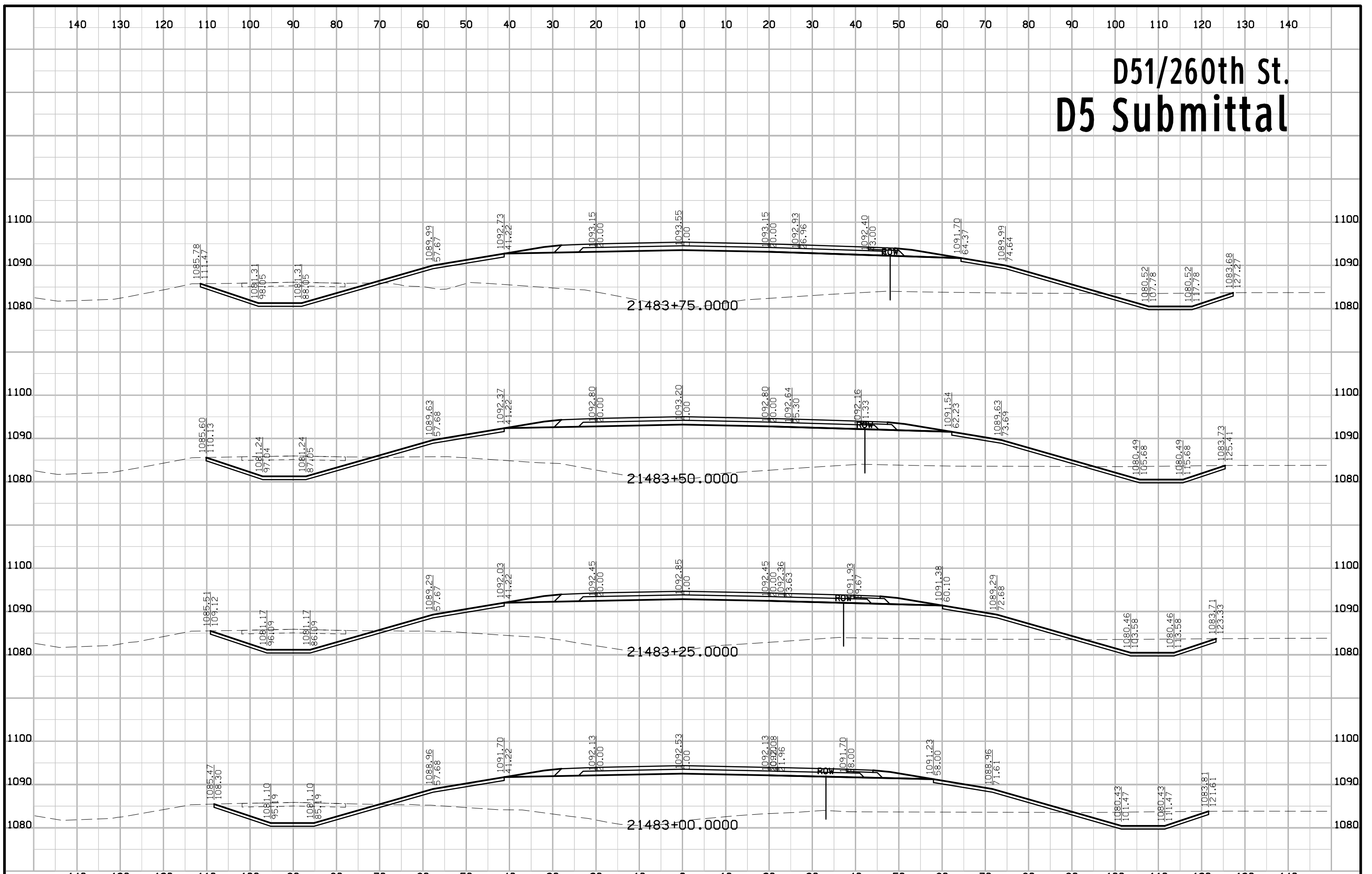

D51/260th St. D5 Submittal

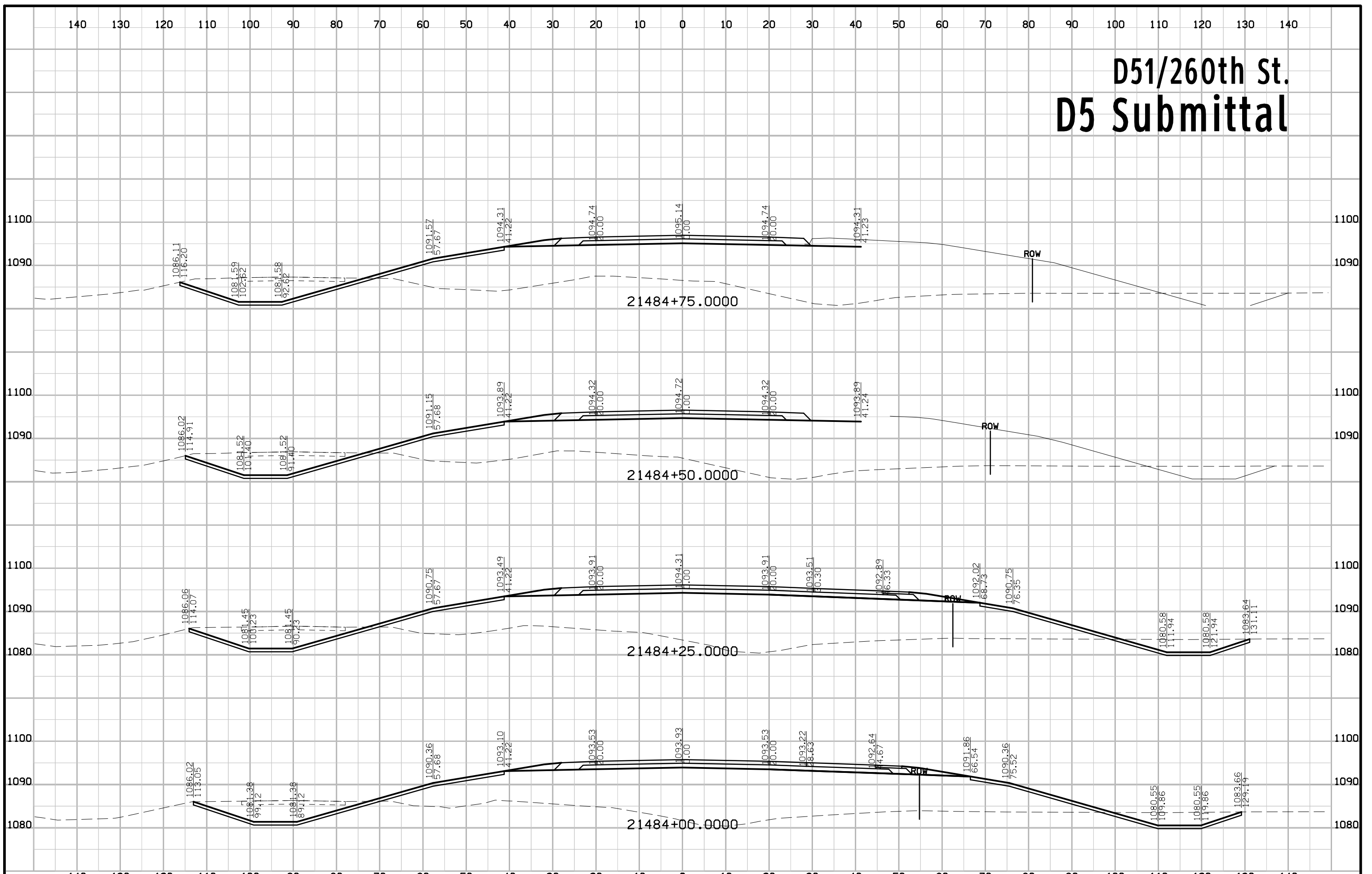

D51/260th St. D5 Submittal

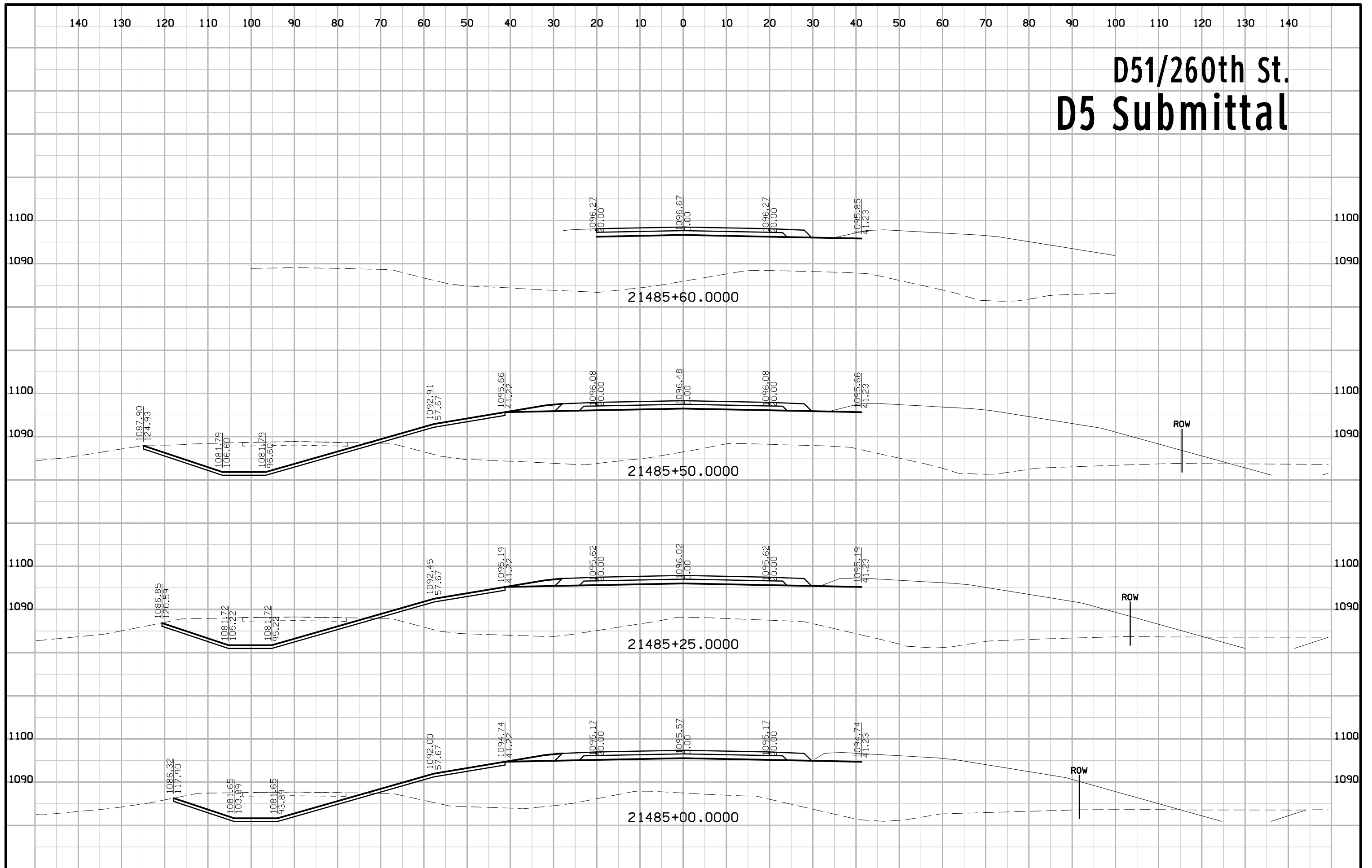

D51/260th St. D5 Submittal

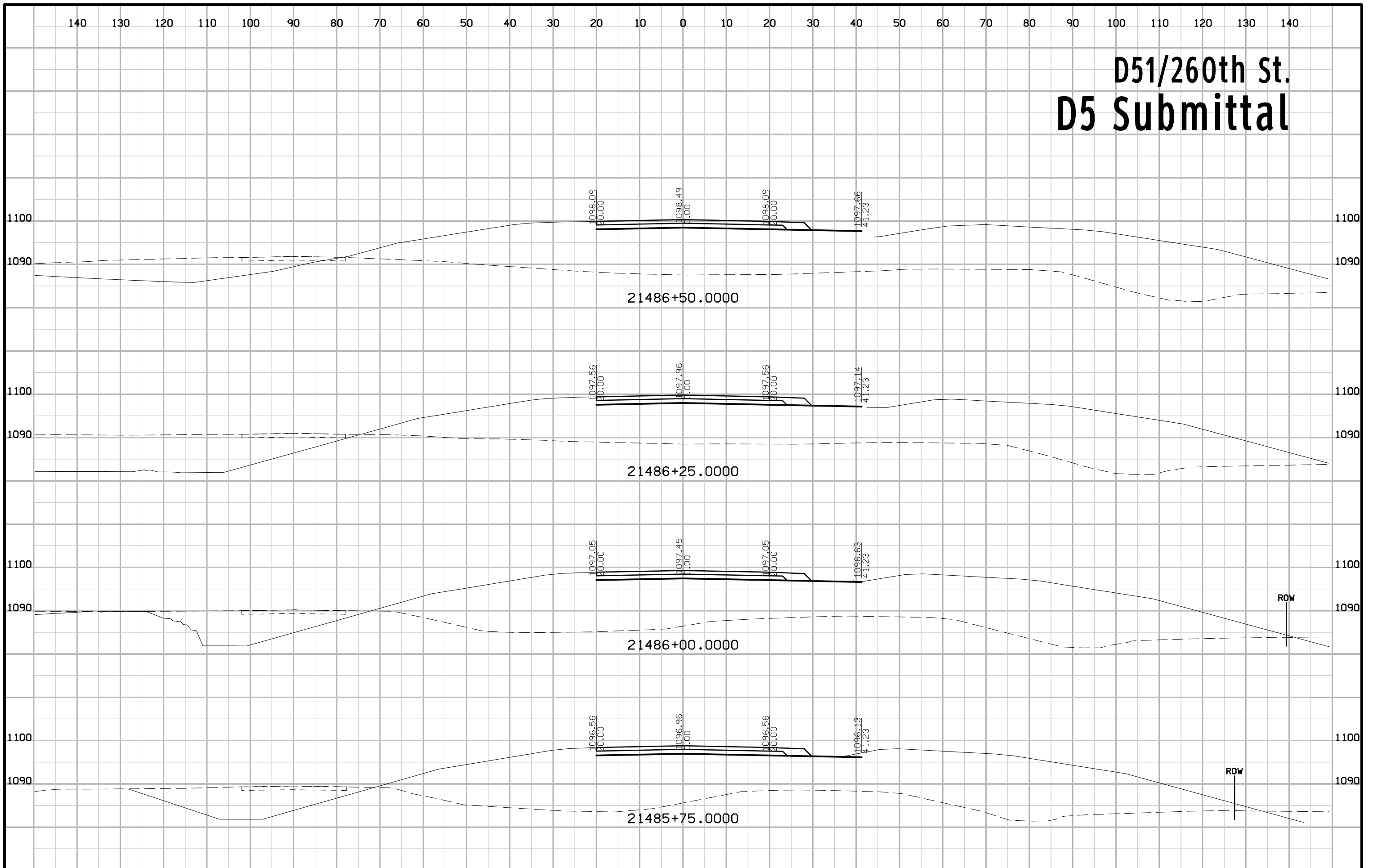

D51/260th St. D5 Submittal

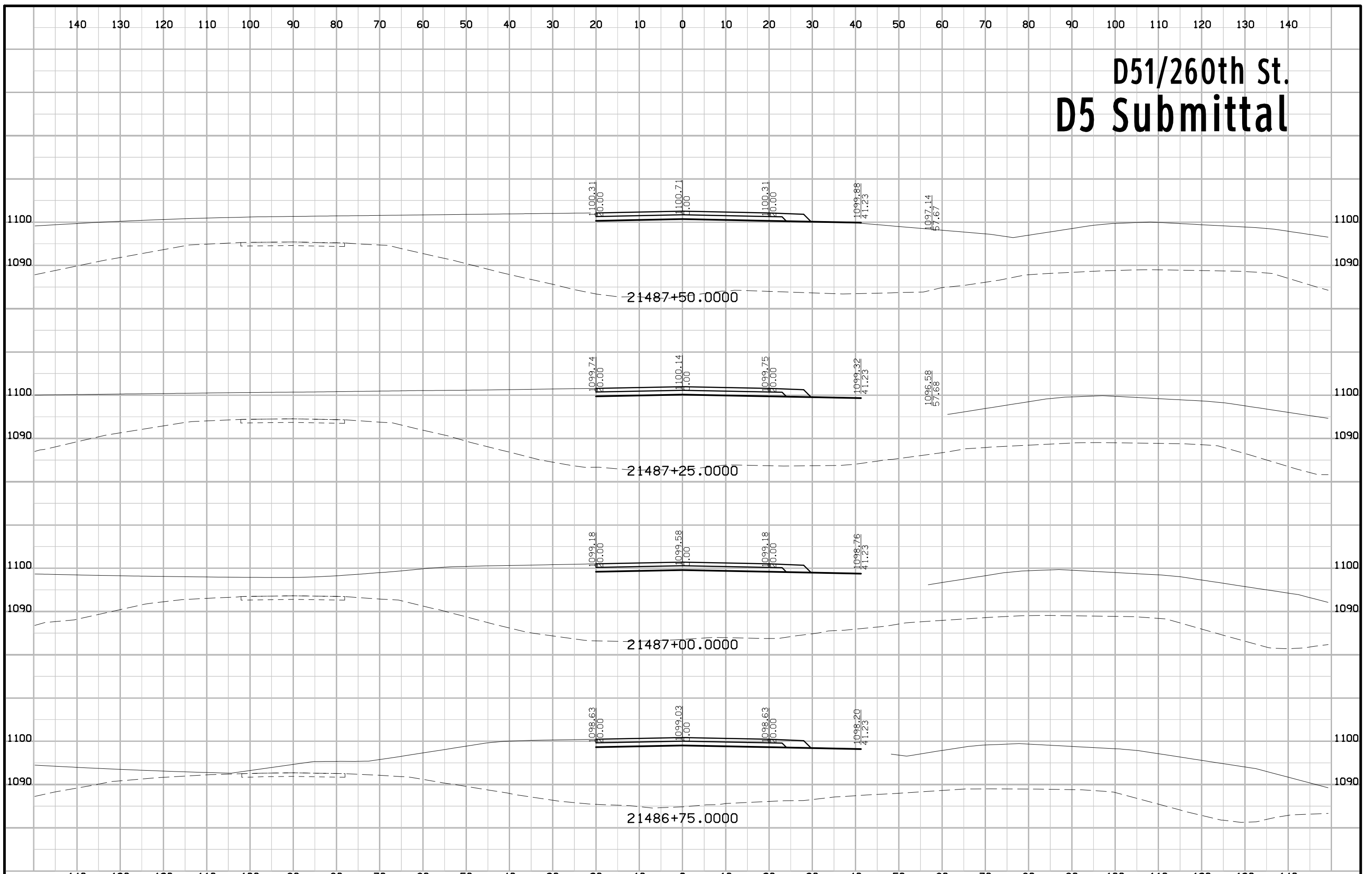

D51/260th St. D5 Submittal

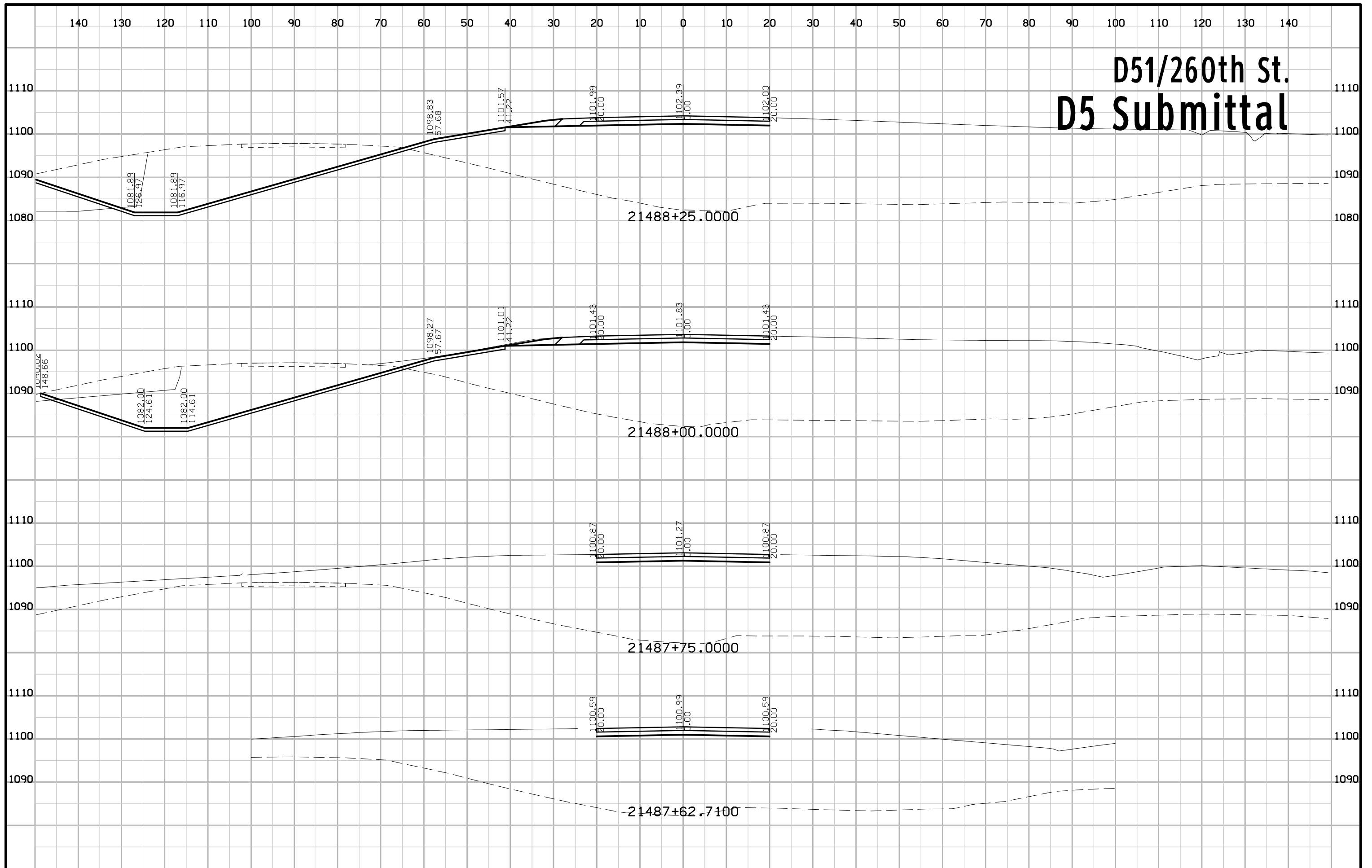

D51/260th St. D5 Submittal

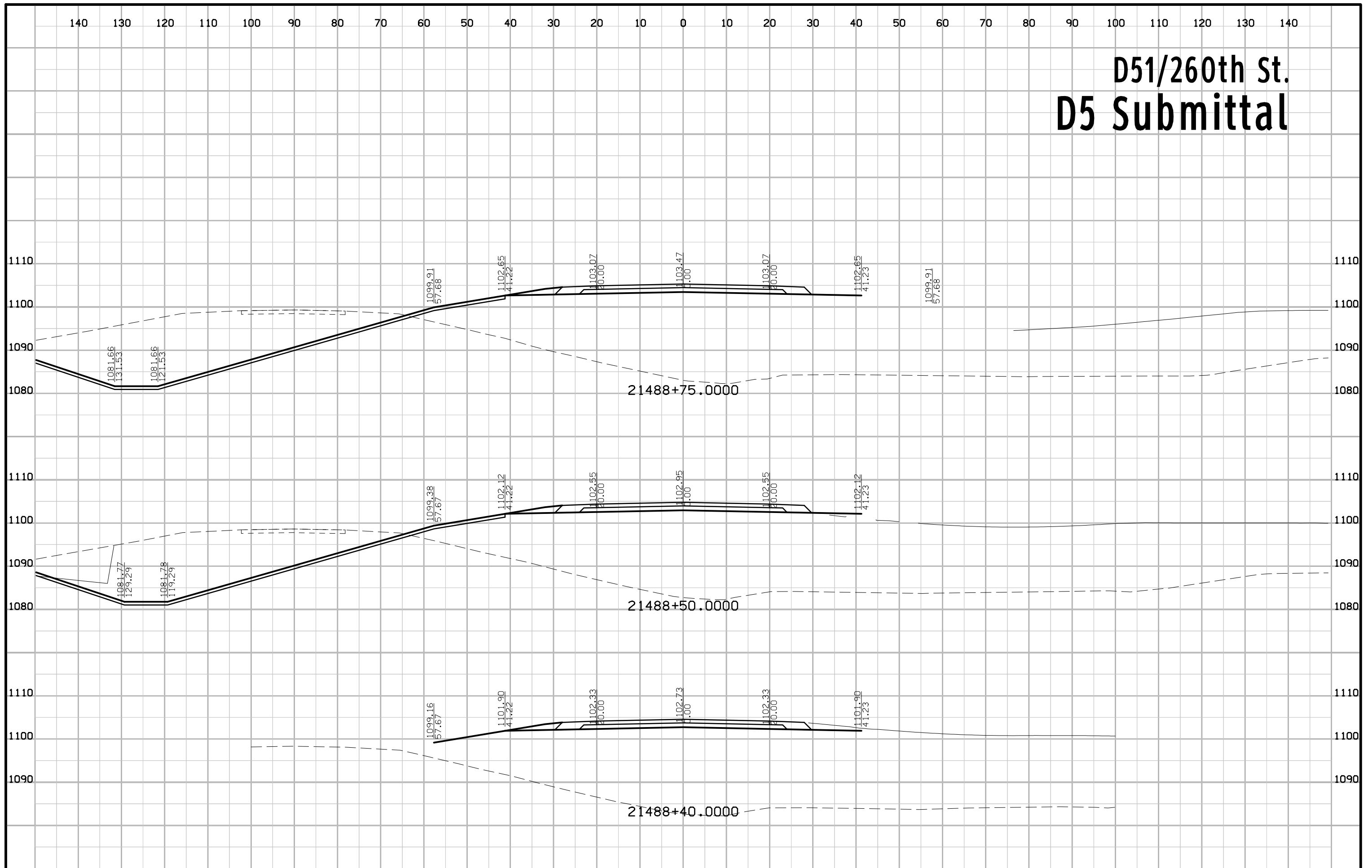

D51/260th St. D5 Submittal

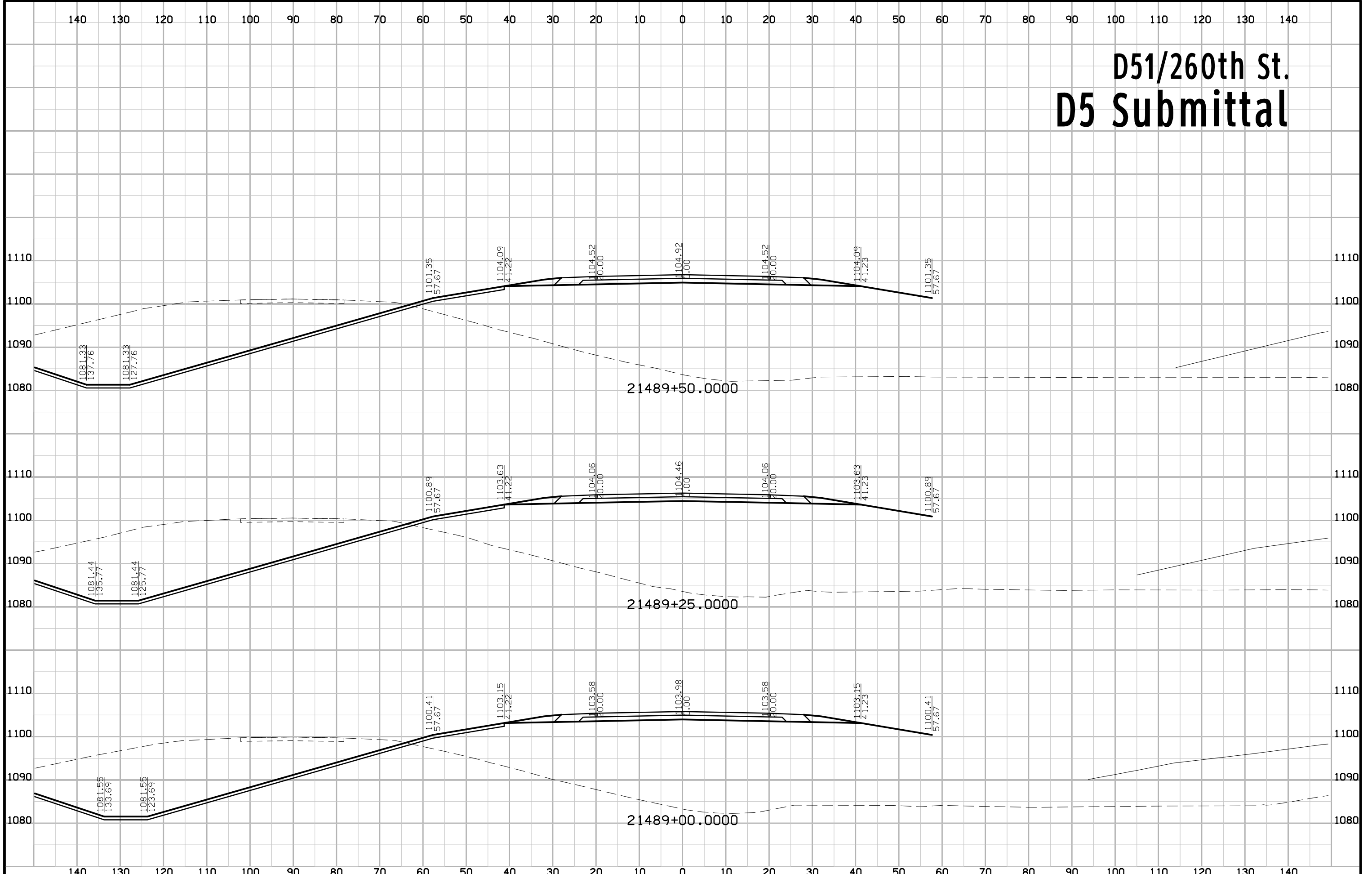

D51/260th St. D5 Submittal

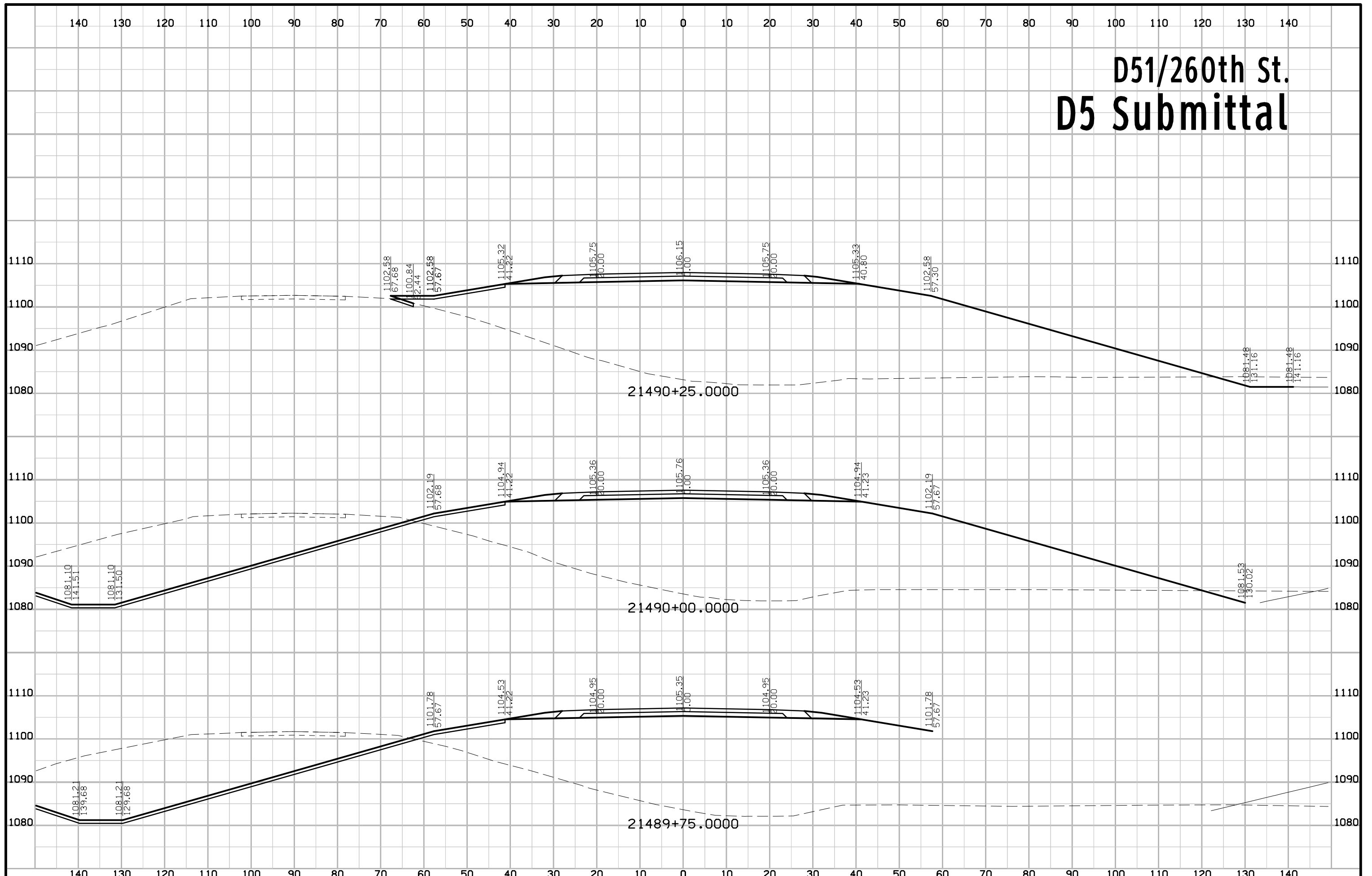

D51/260th St. D5 Submittal

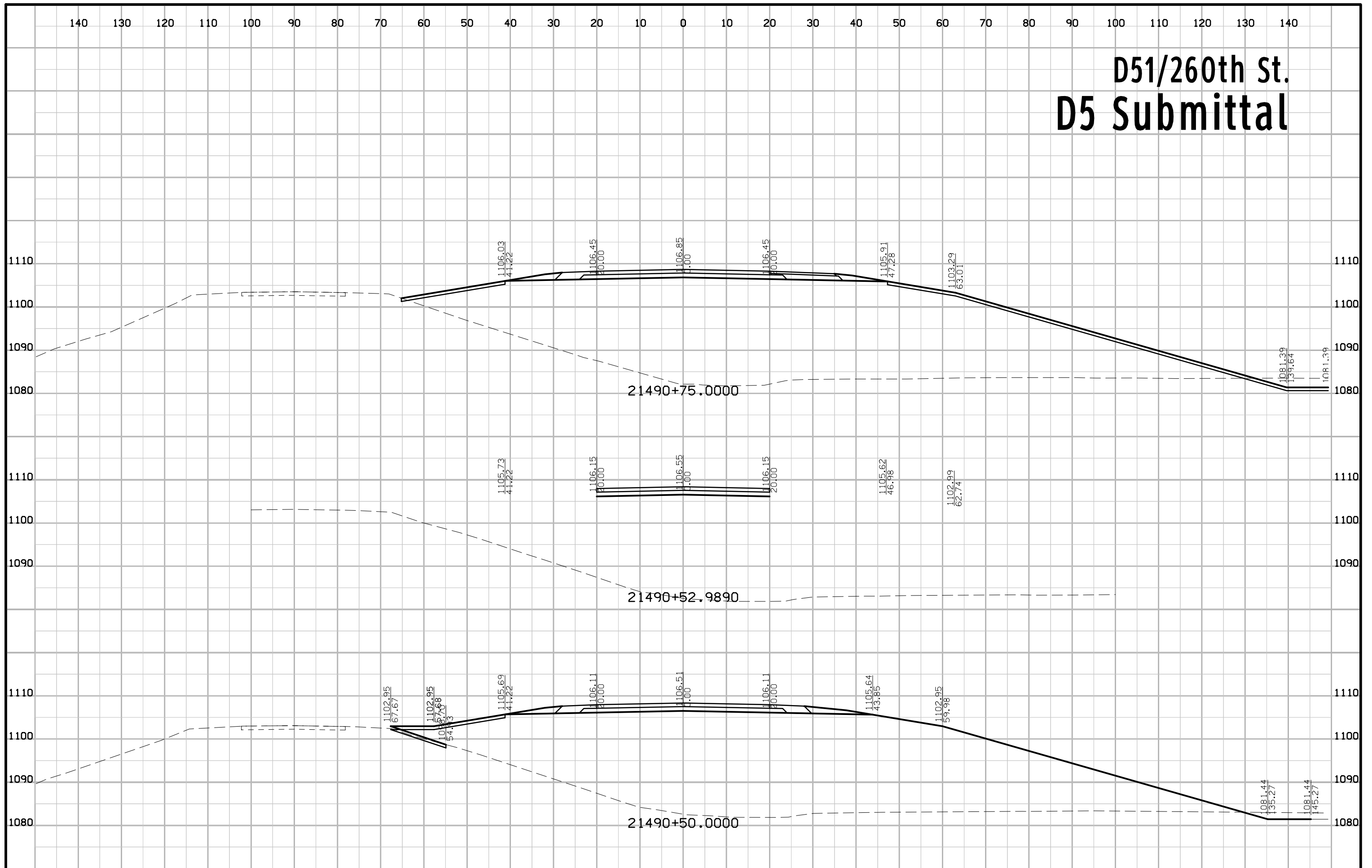

D51/260th St. D5 Submittal

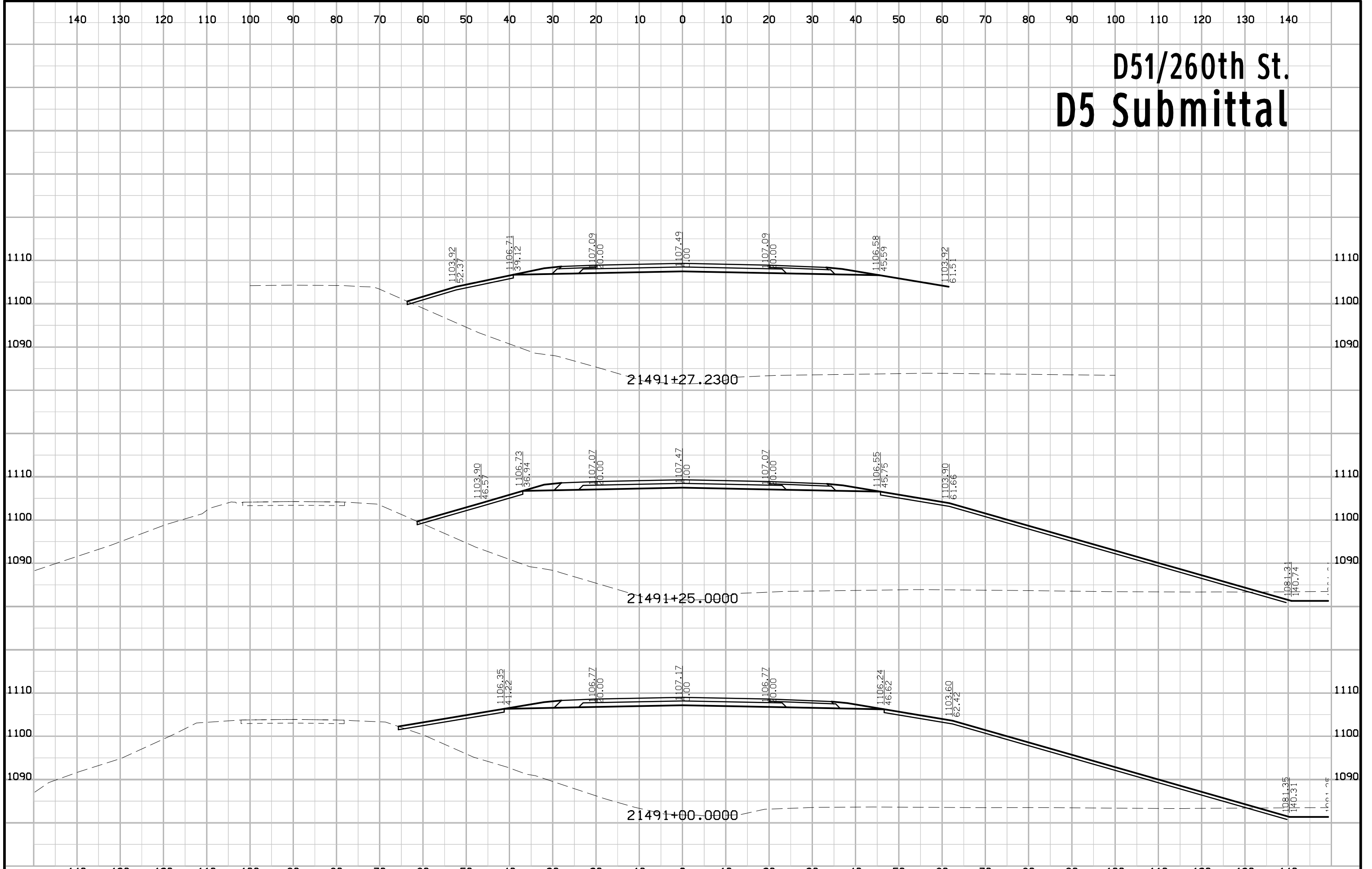

D51/260th St. D5 Submittal

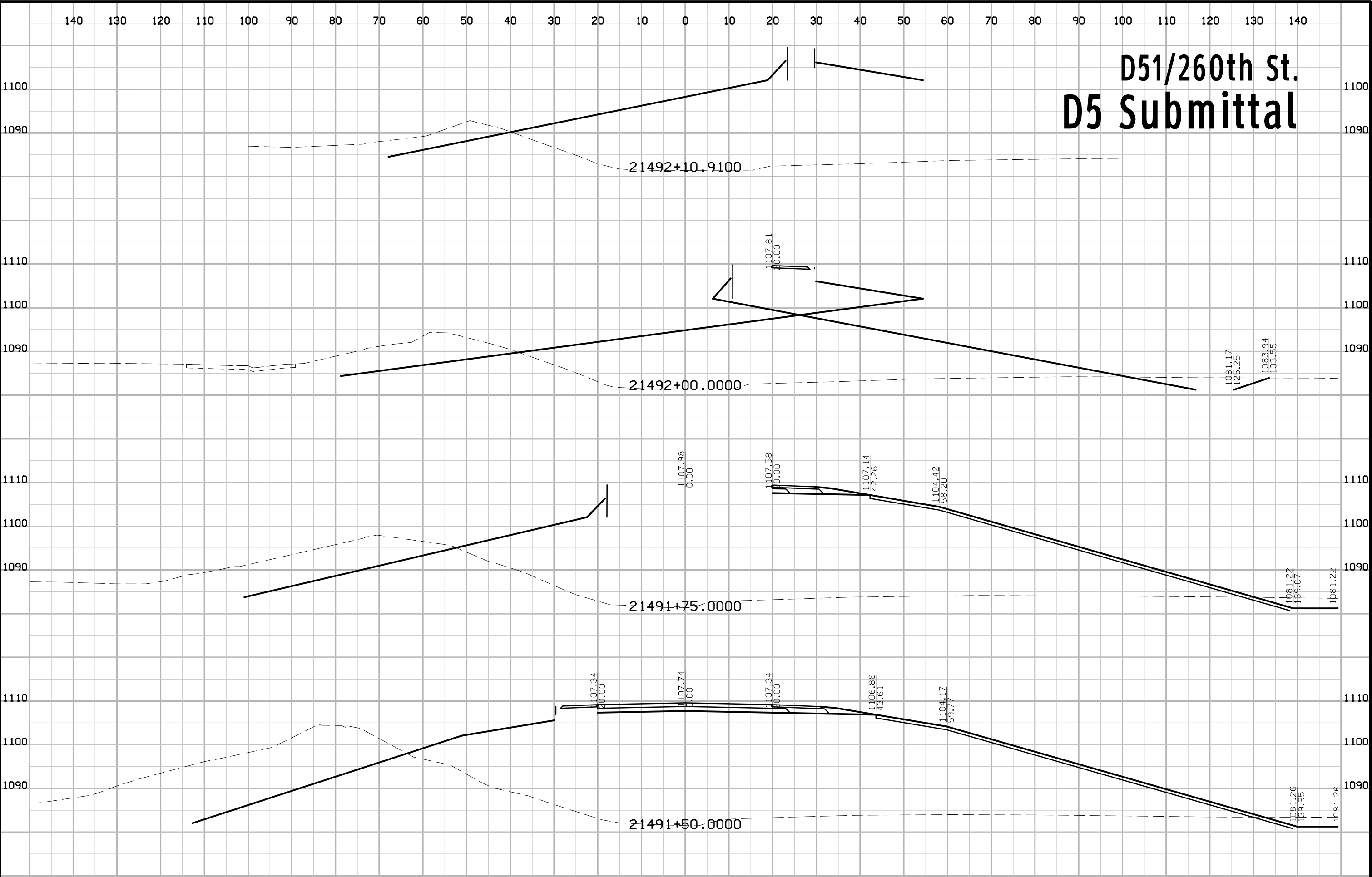

D51/260th St. D5 Submittal

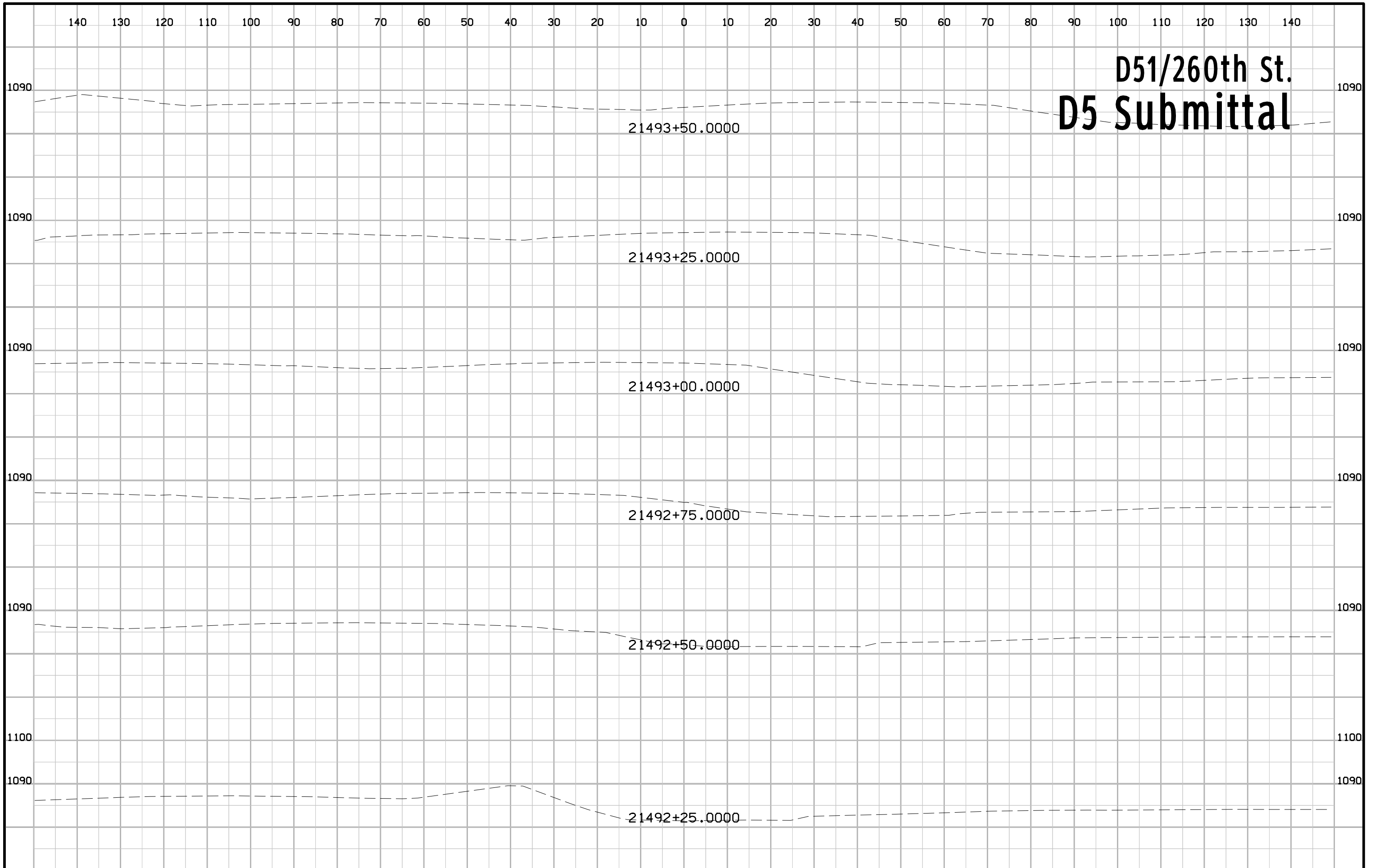

D51/260th St. D5 Submittal

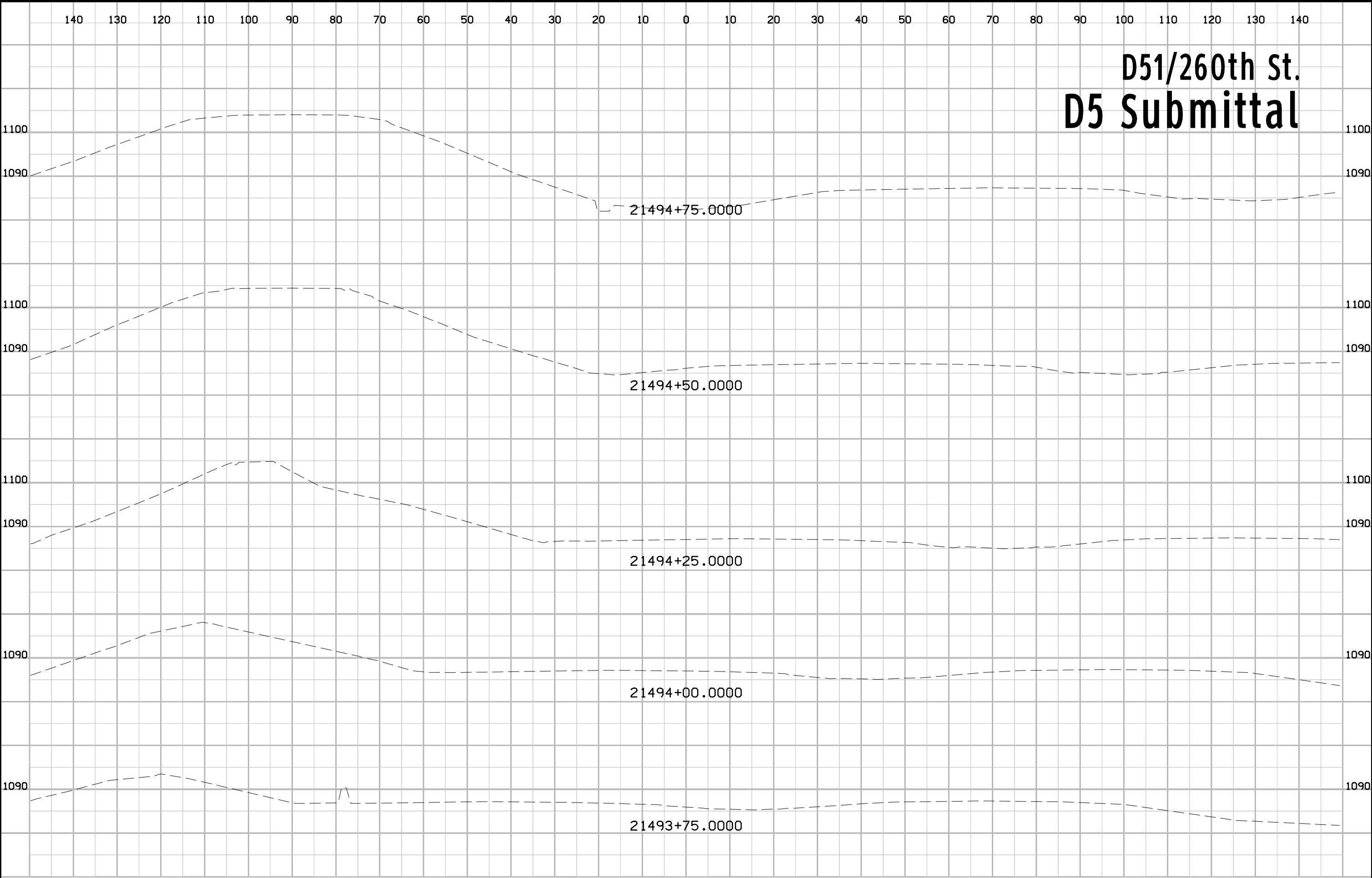

D51/260th St. D5 Submittal

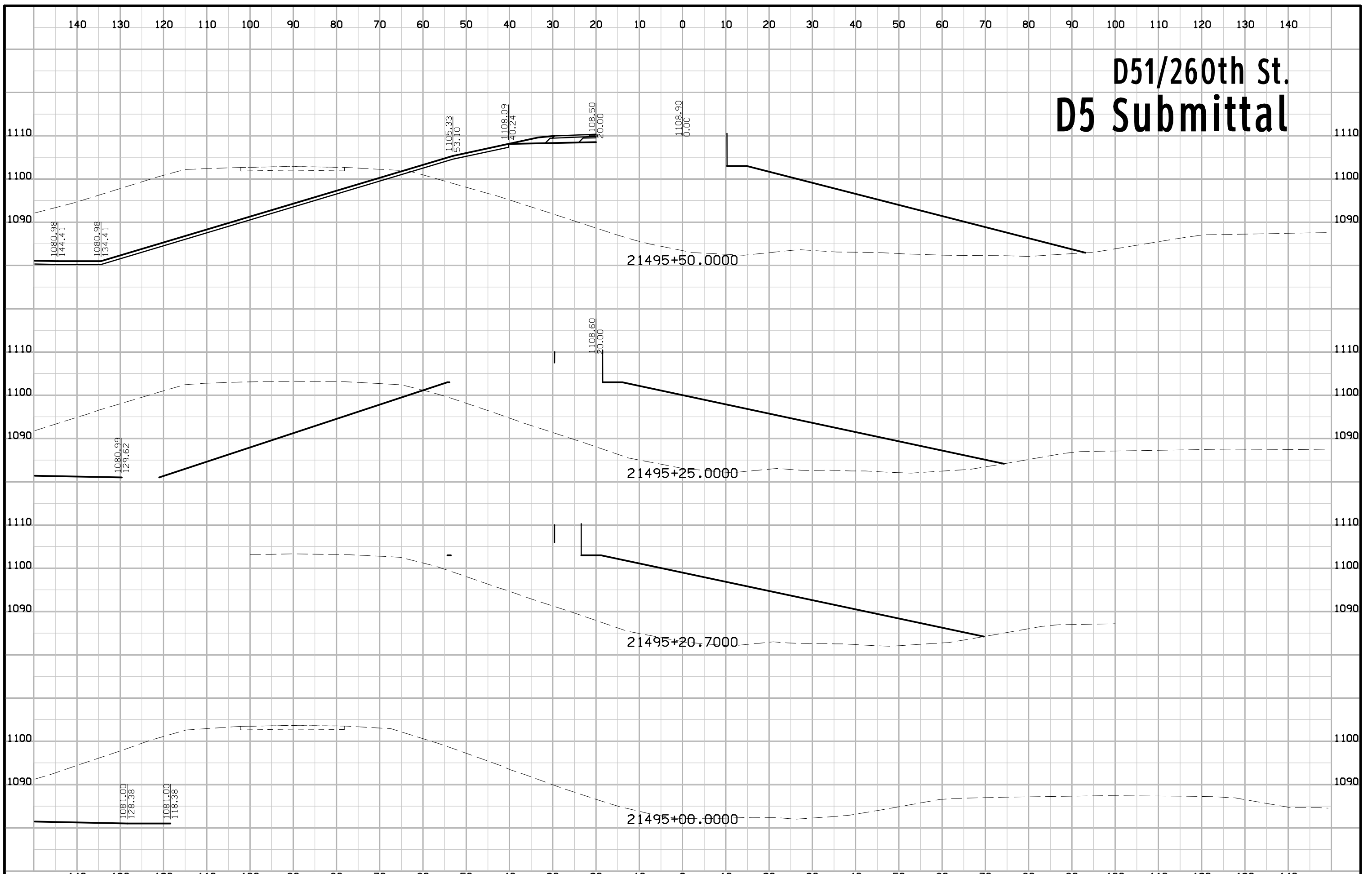

D51/260th St. D5 Submittal

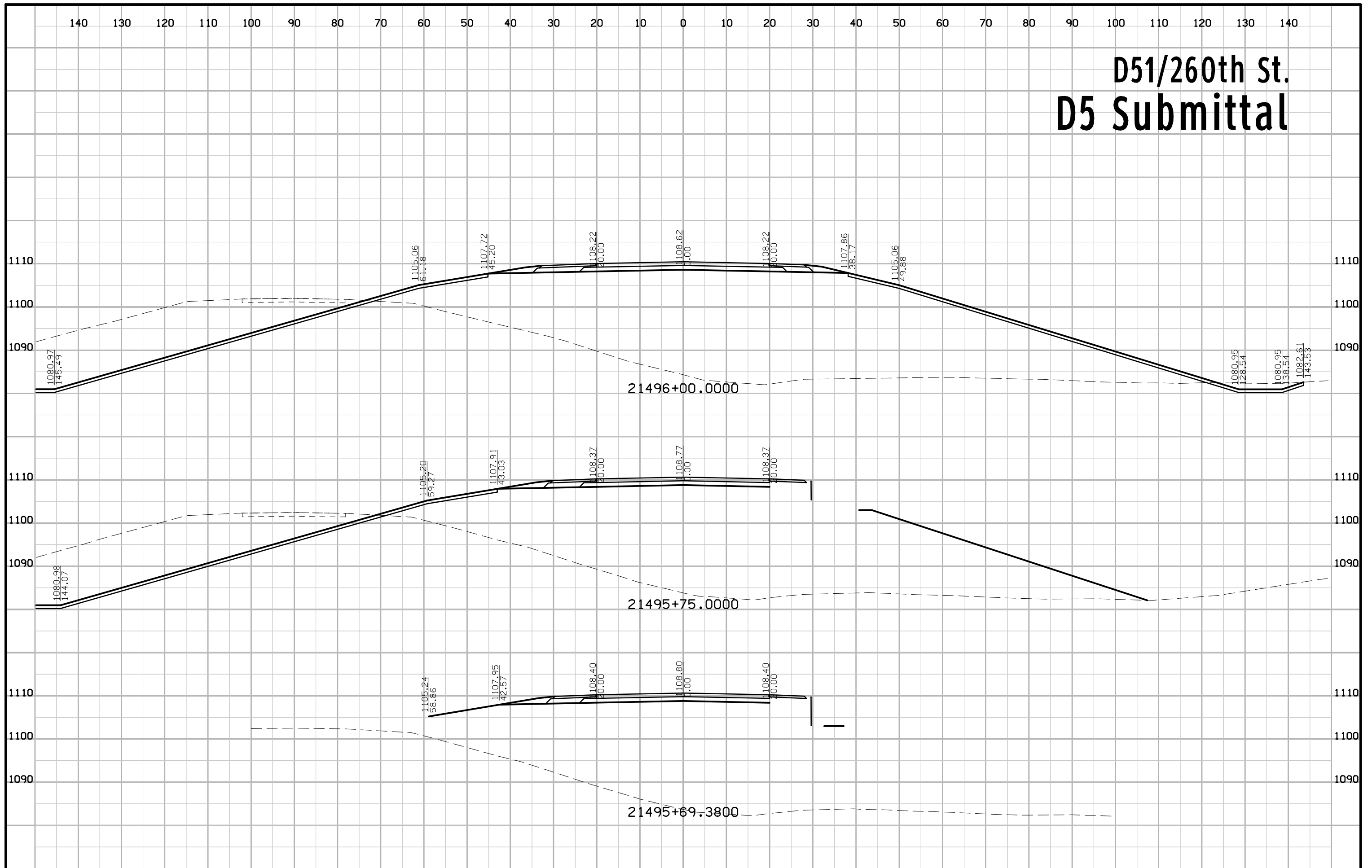

D51/260th St. D5 Submittal

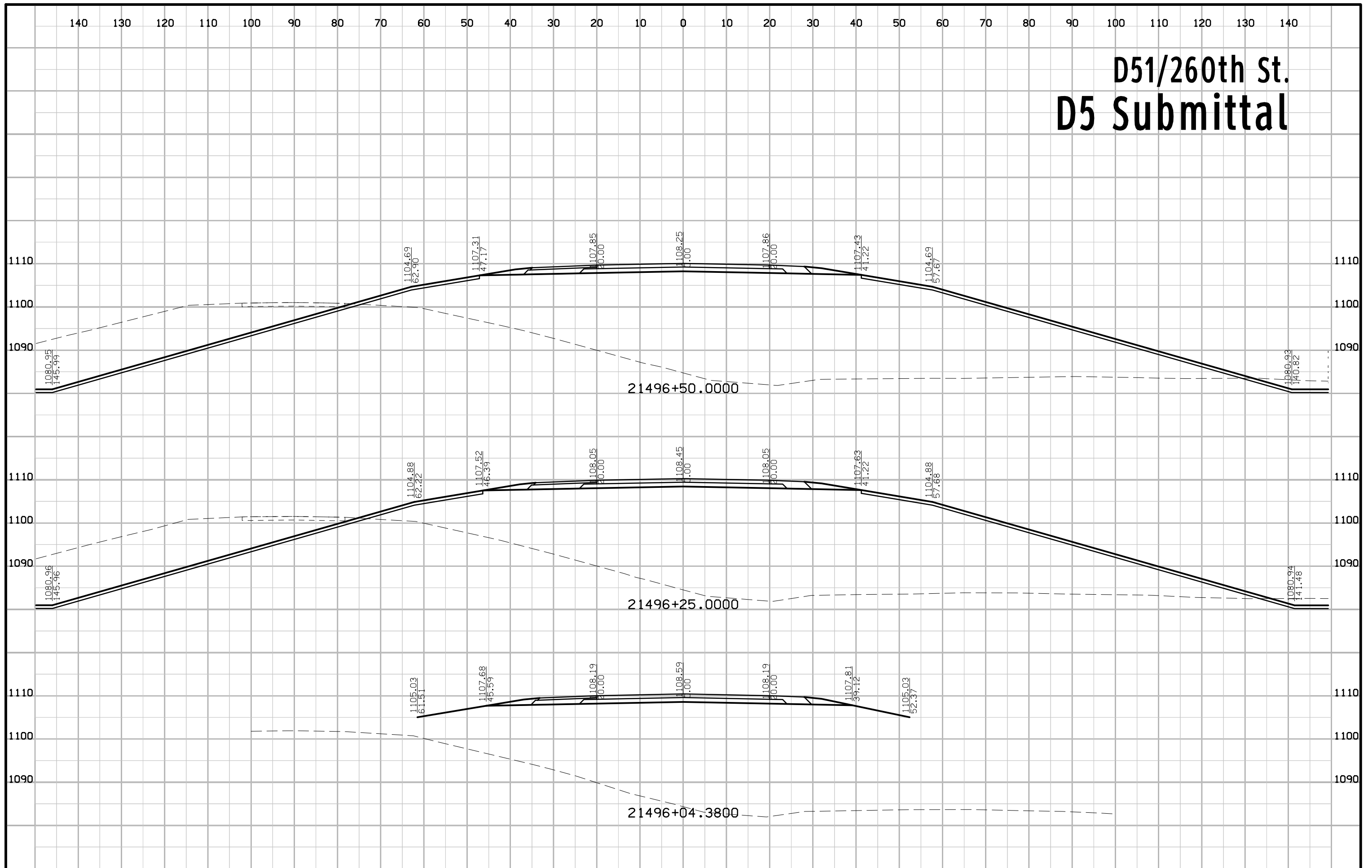

D51/260th St. D5 Submittal

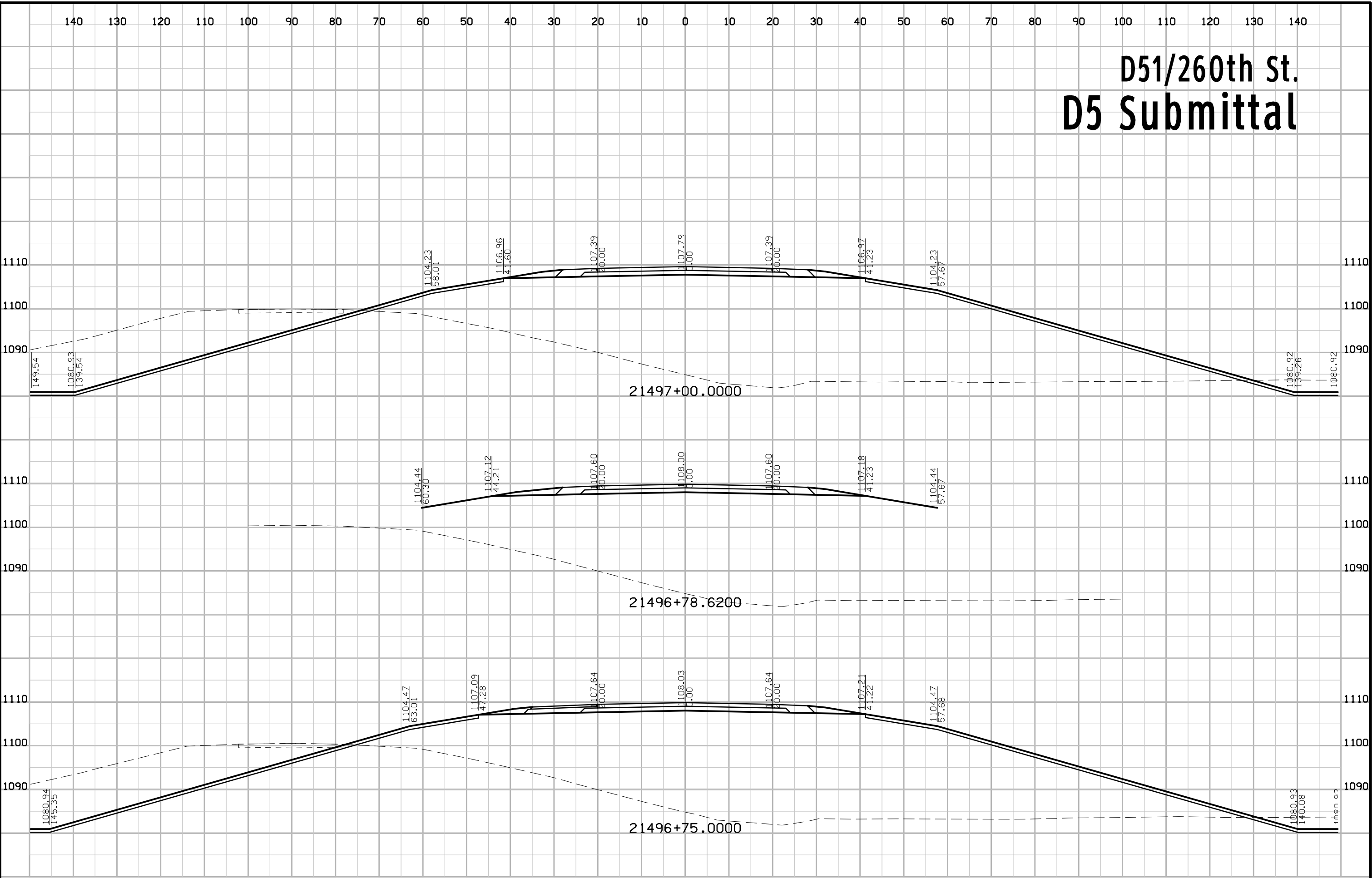

D51/260th St. D5 Submittal

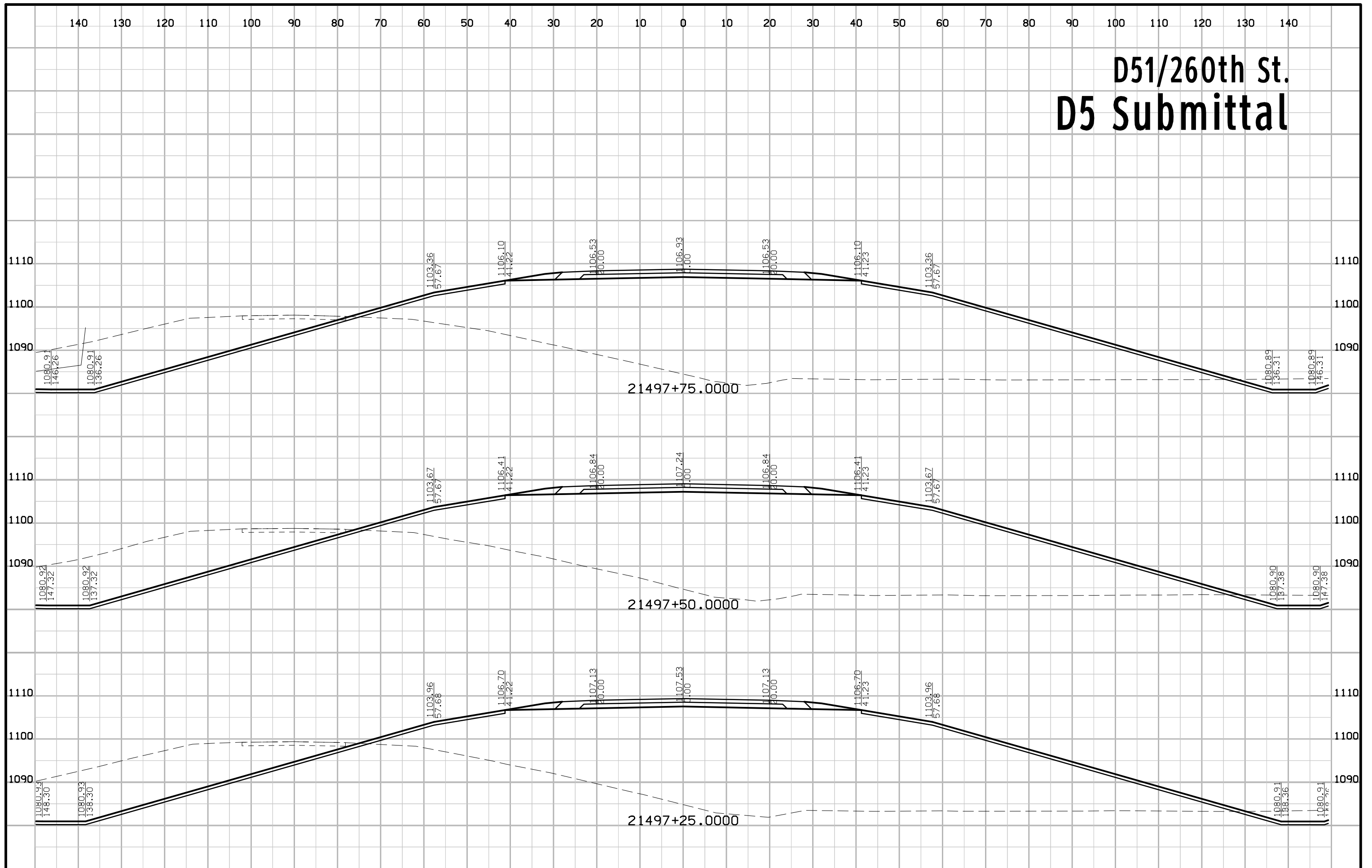

D51/260th St. D5 Submittal

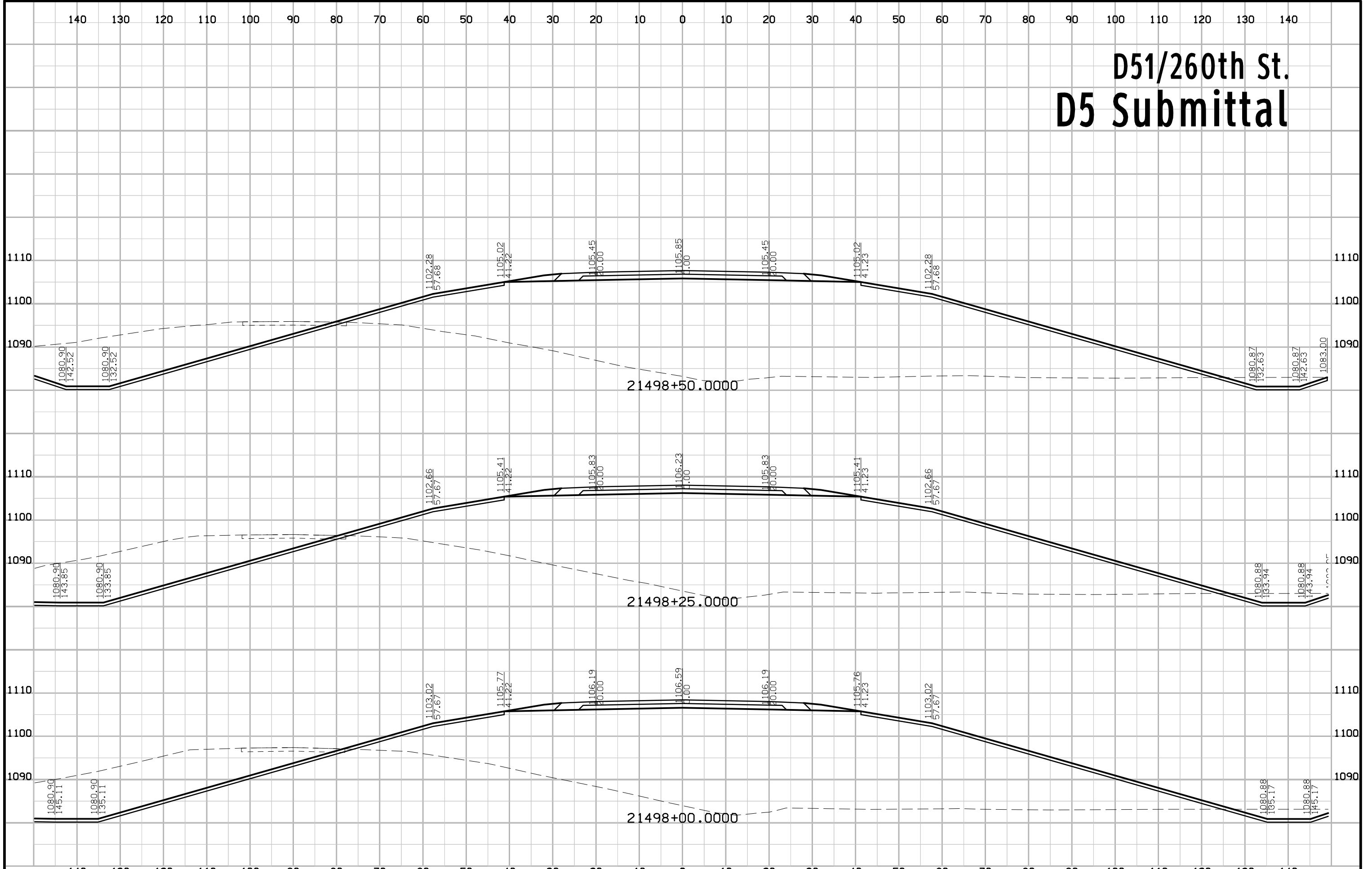

D51/260th St. D5 Submittal

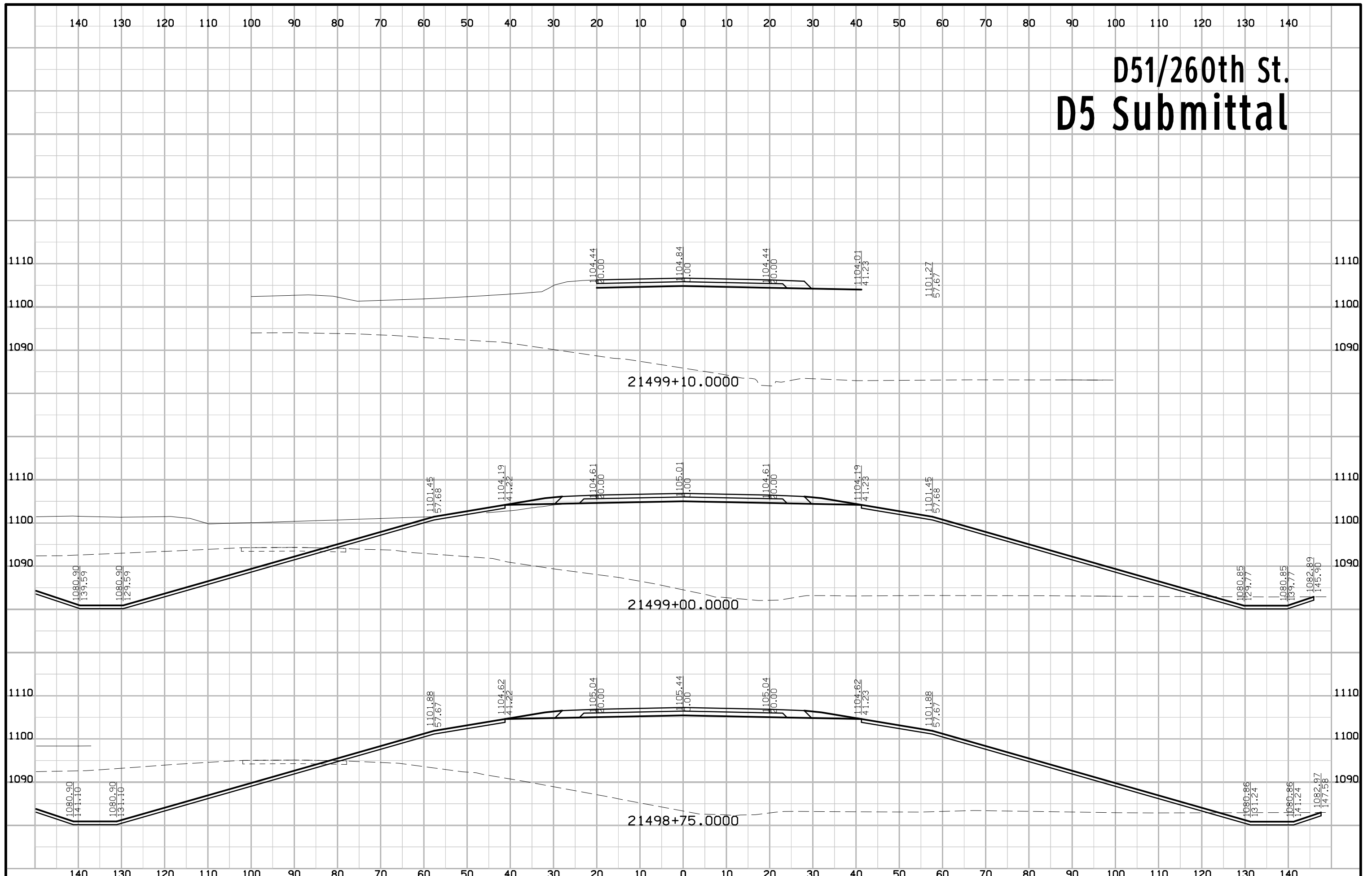

D51/260th St. D5 Submittal

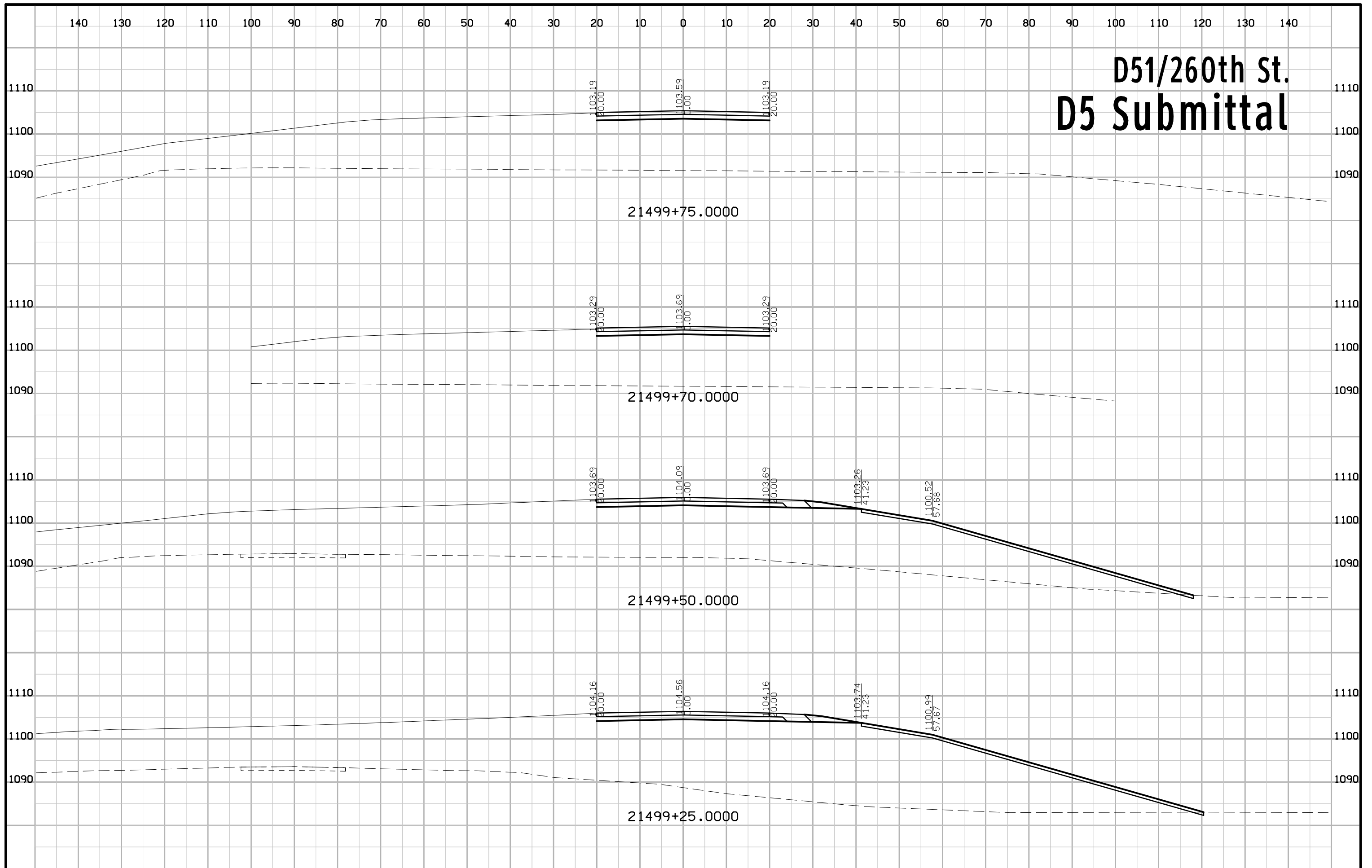

D51/260th St. D5 Submittal

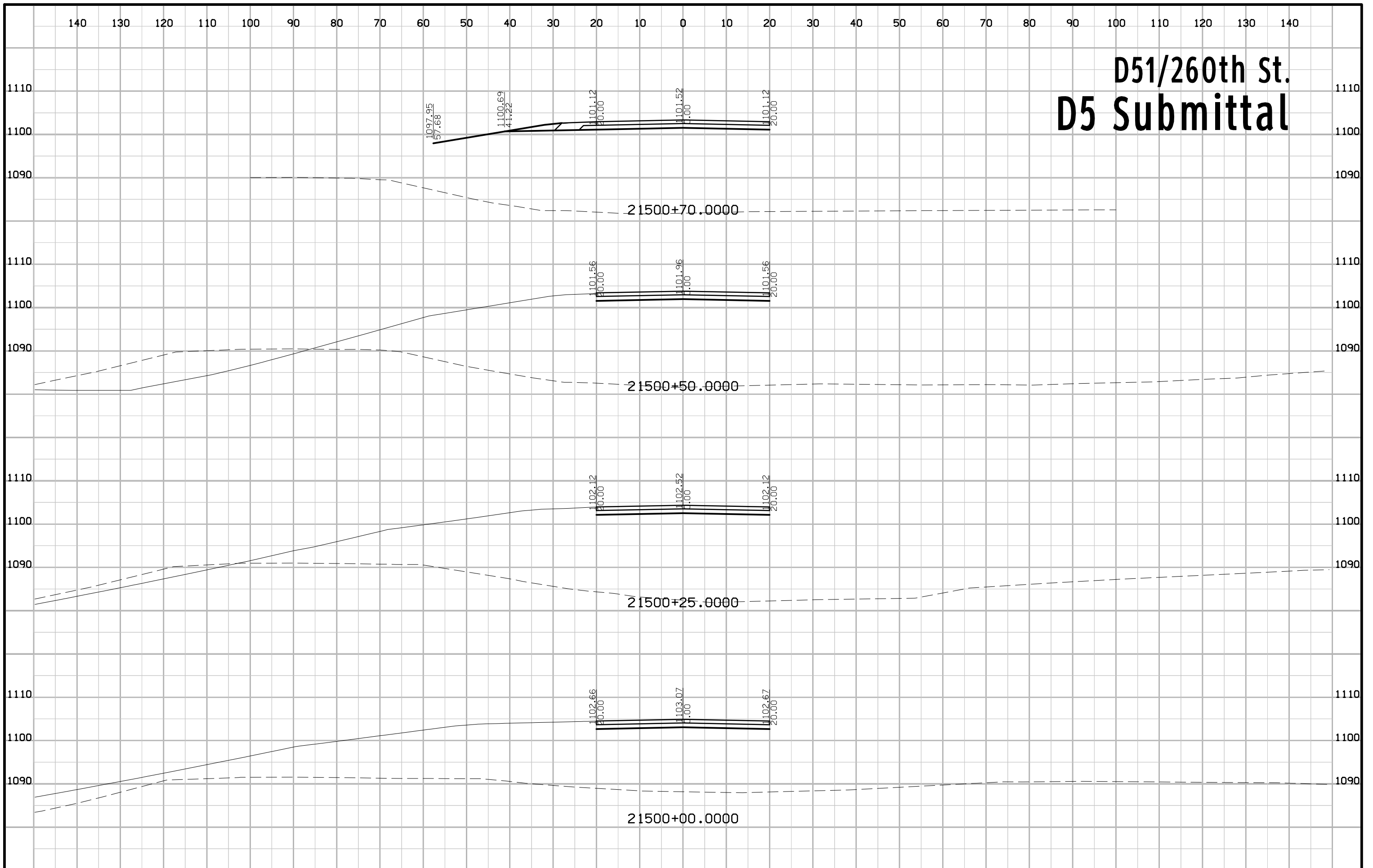

D51/260th St. D5 Submittal

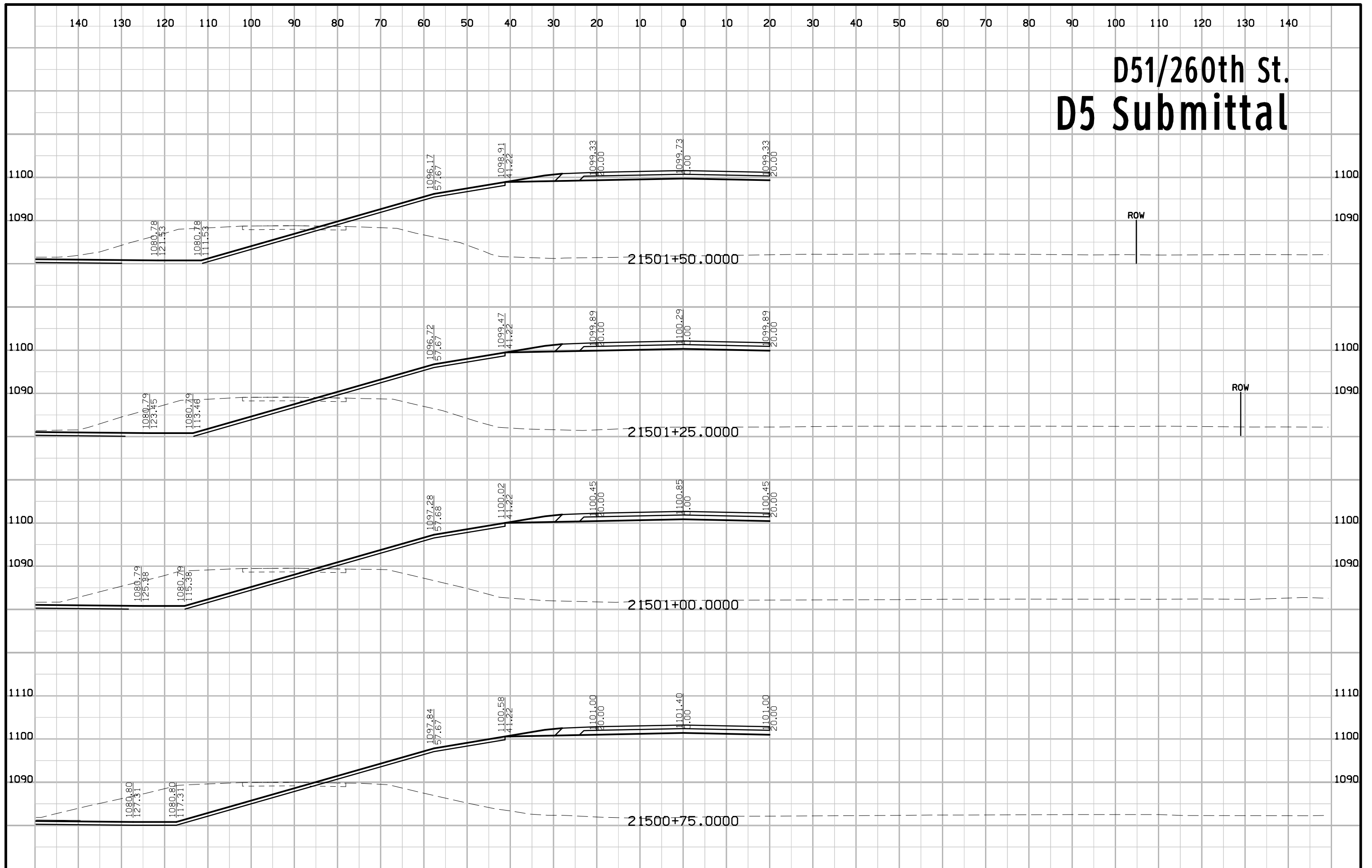

D51/260th St. D5 Submittal

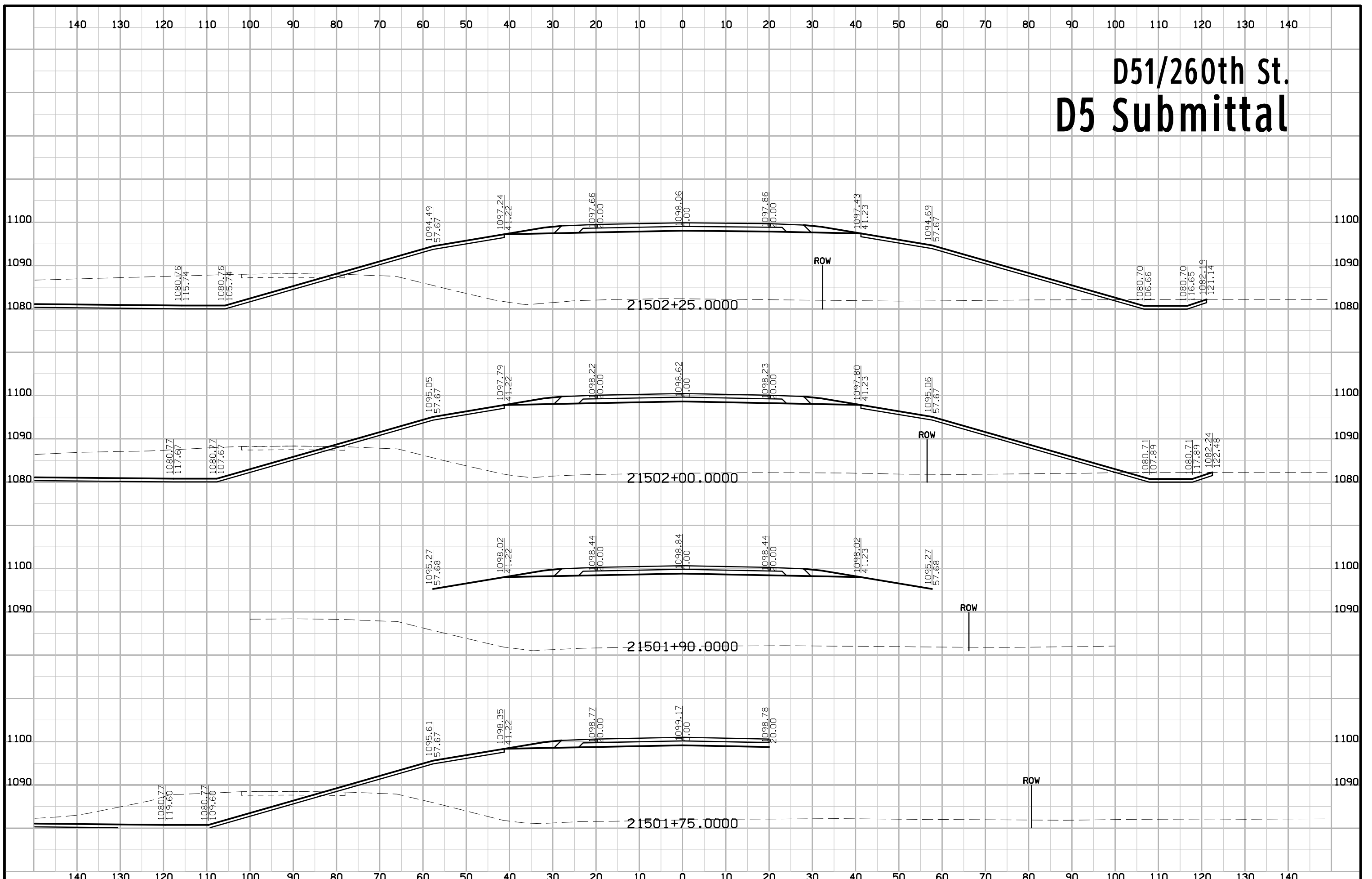

D51/260th St. D5 Submittal

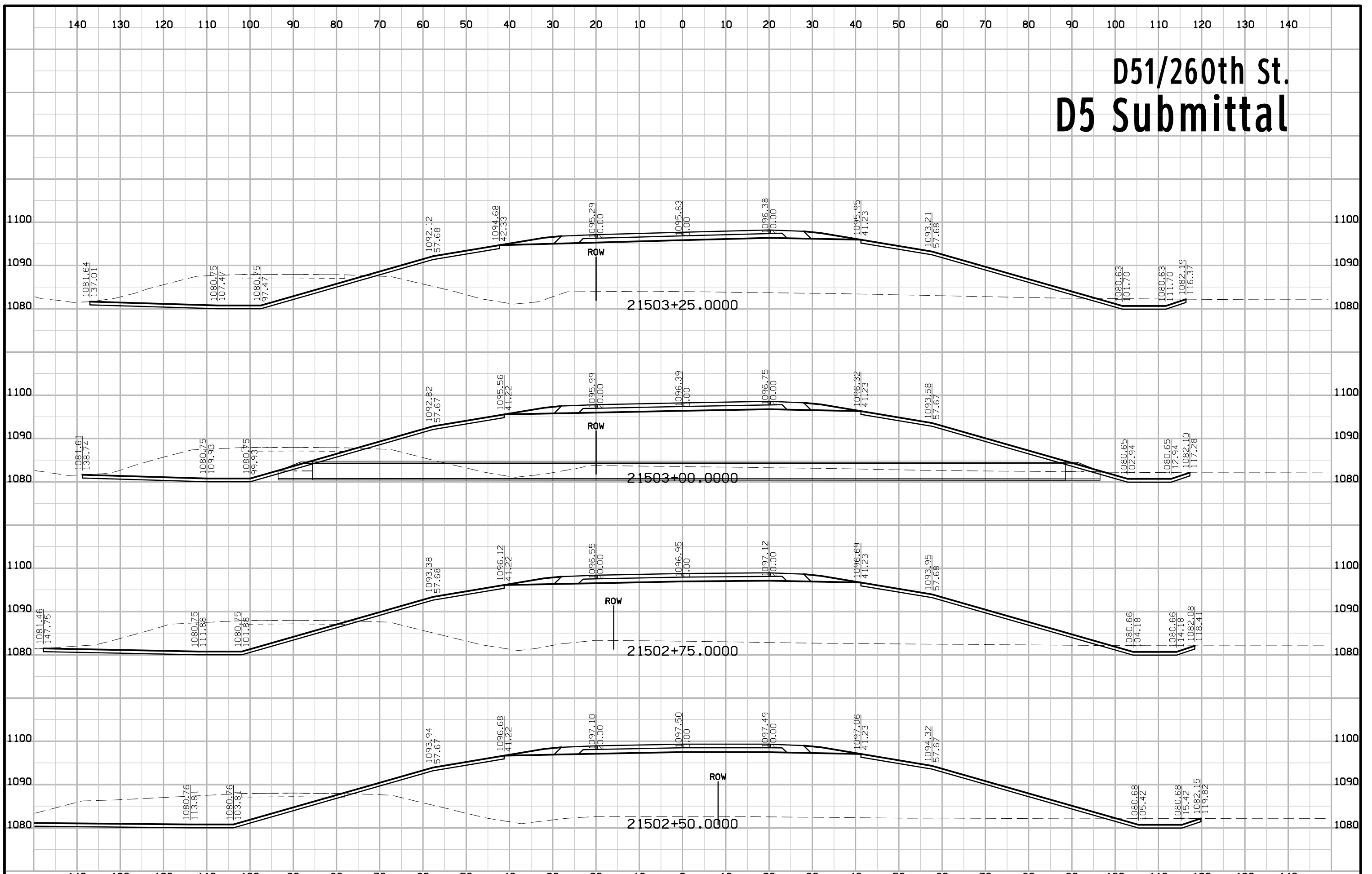

D51/260th St. D5 Submittal

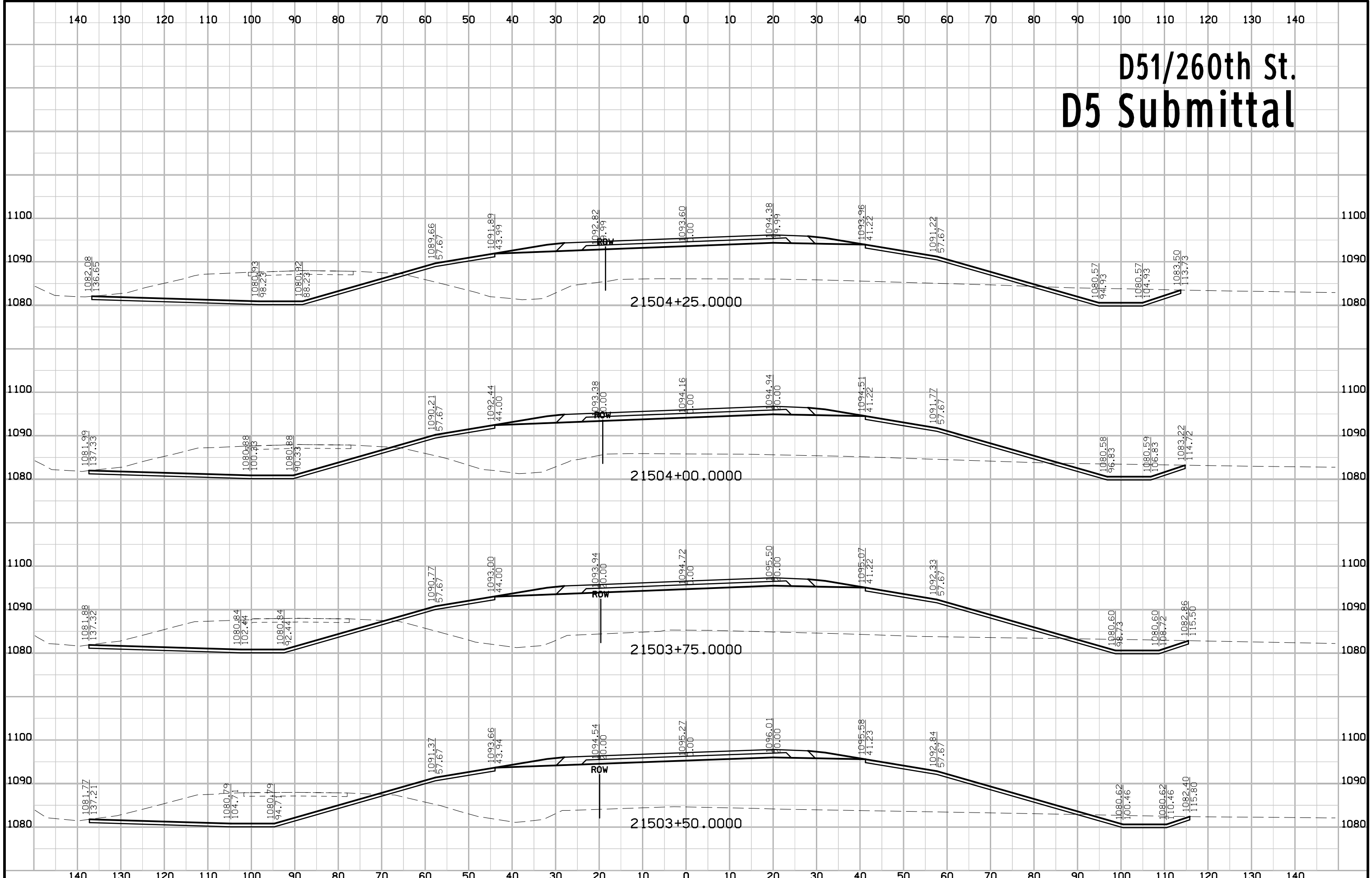

D51/260th St. D5 Submittal

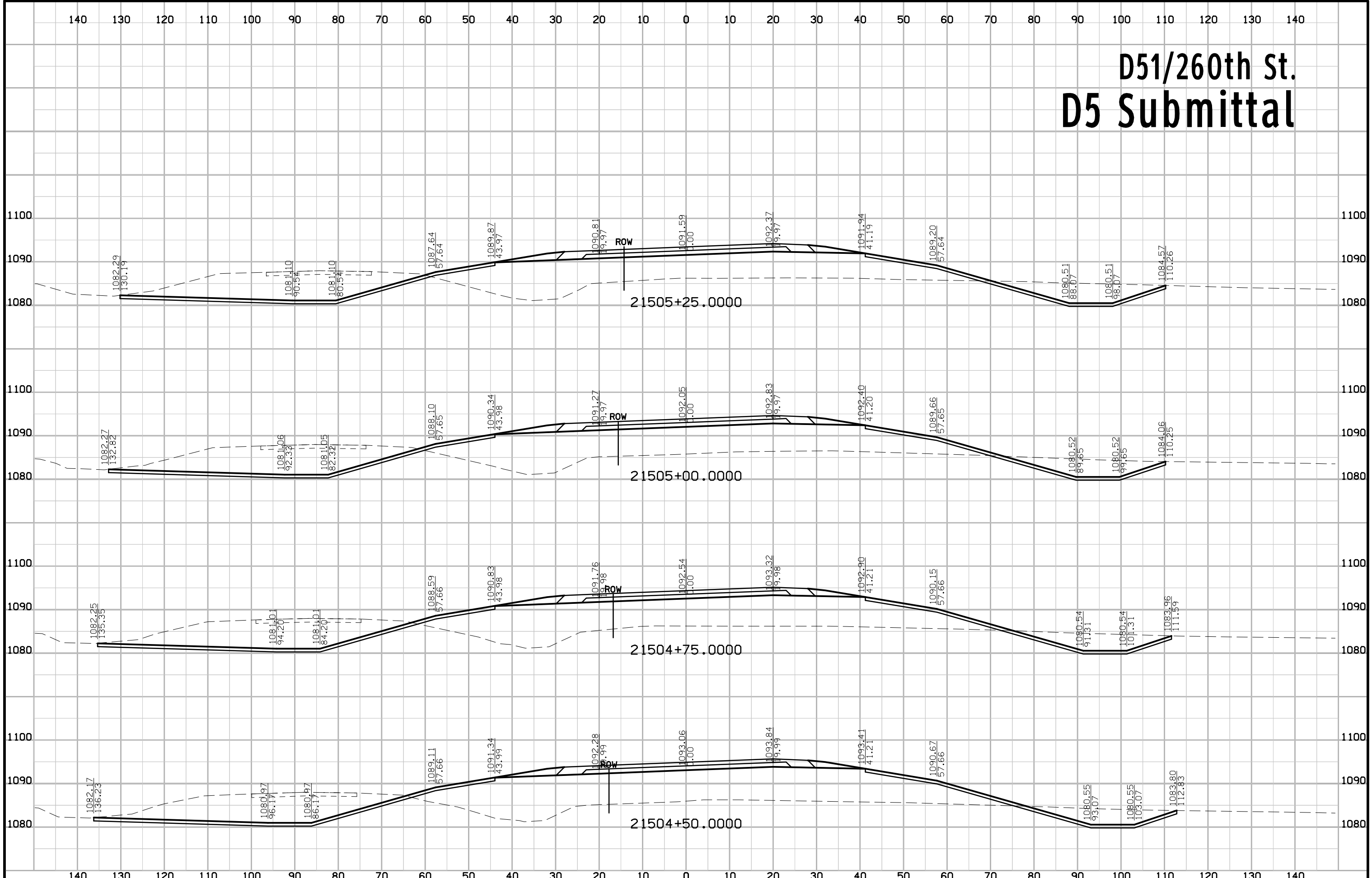

D51/260th St. D5 Submittal

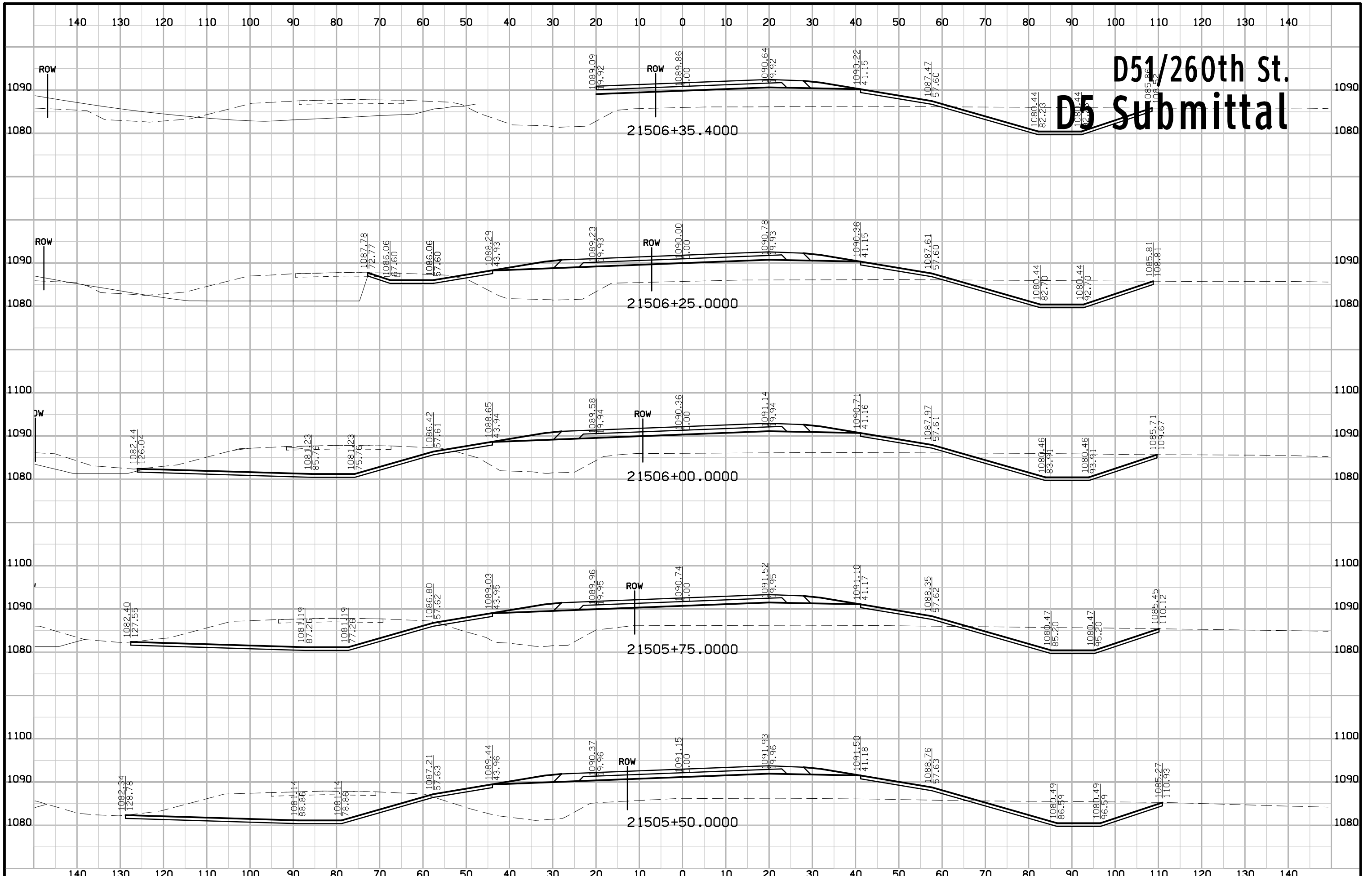

D51/260th St. D5 Submittal

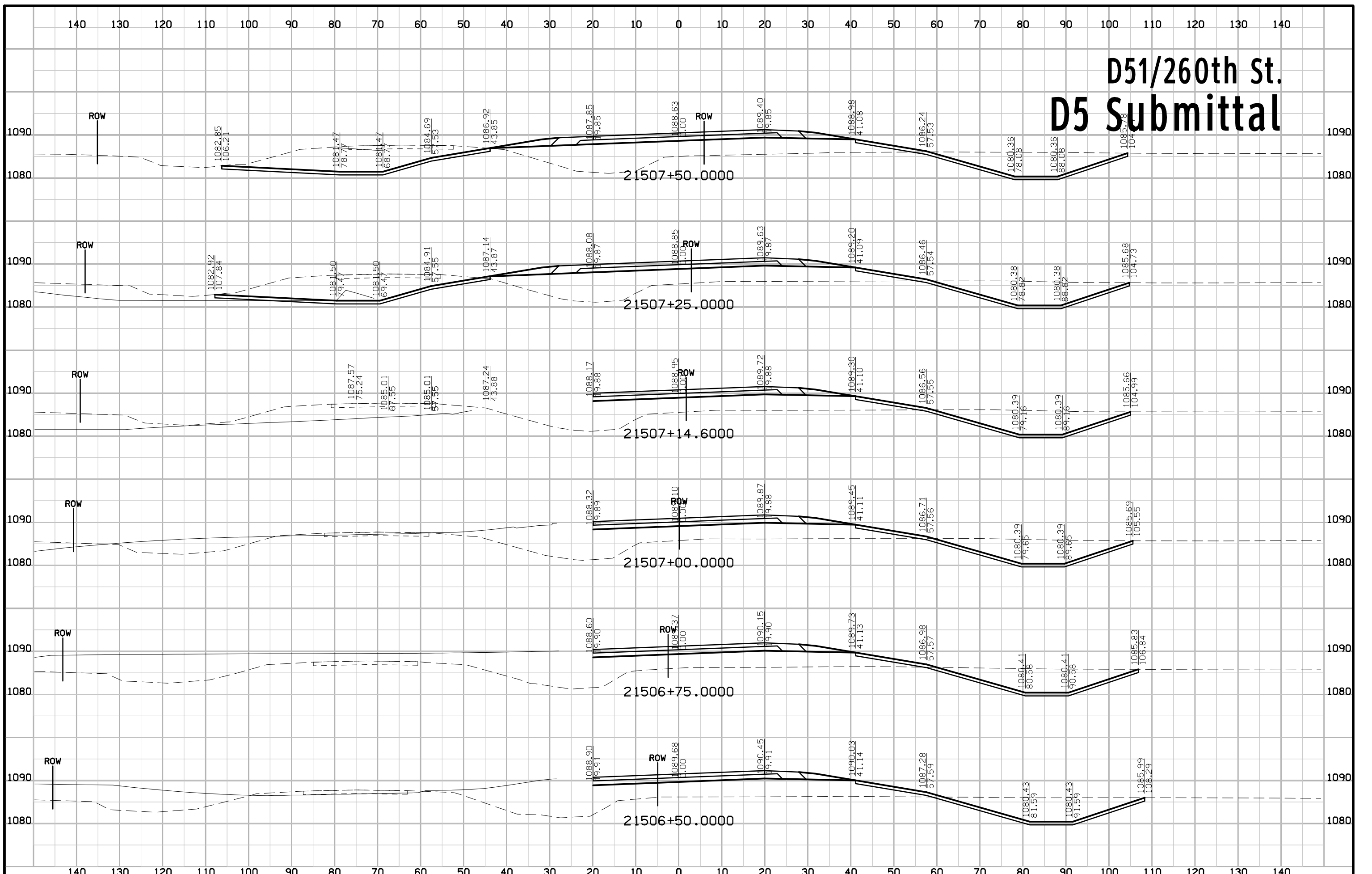

D51/260th St. D5 Submittal

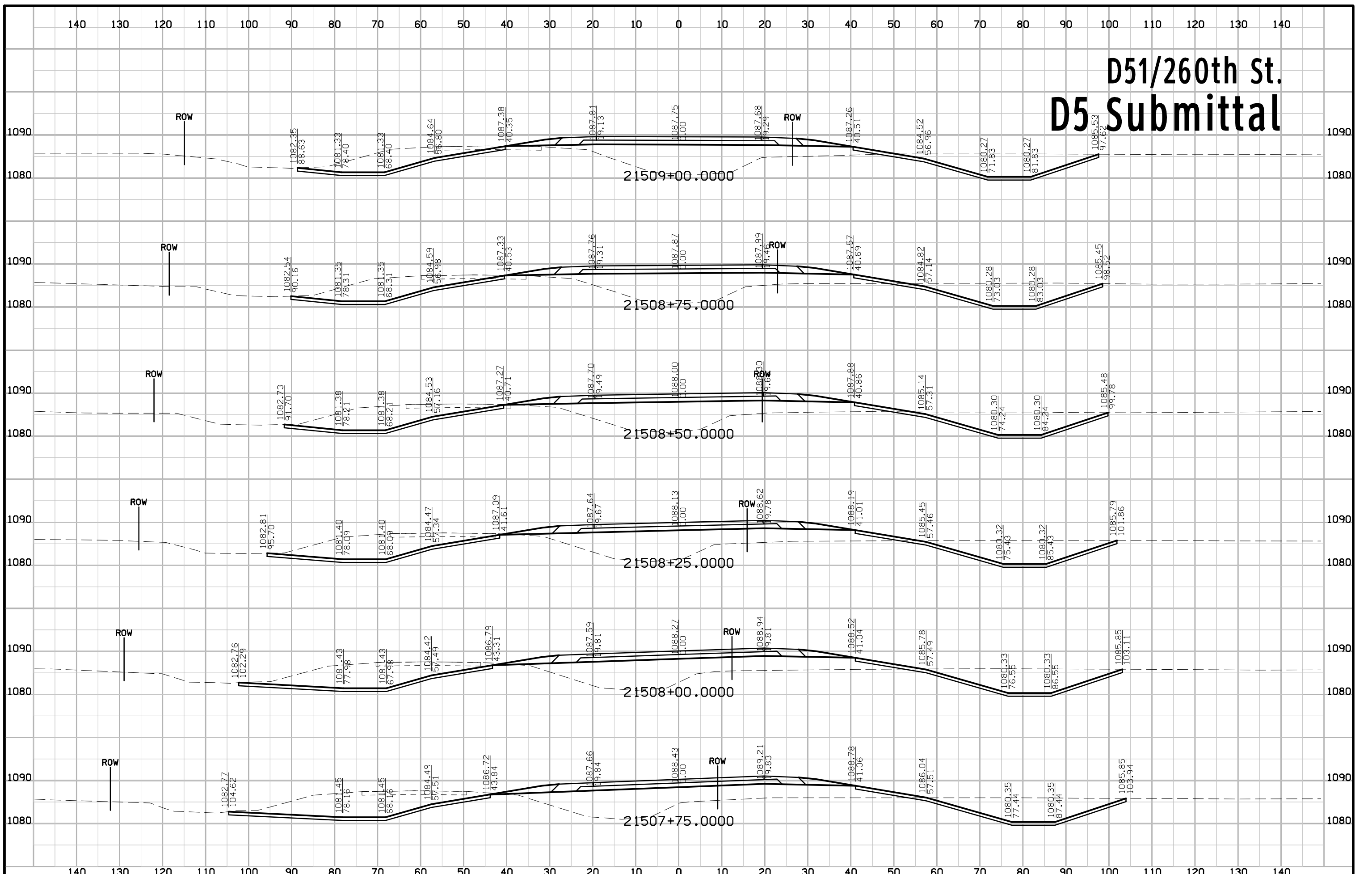

D51/260th St. D5 Submittal

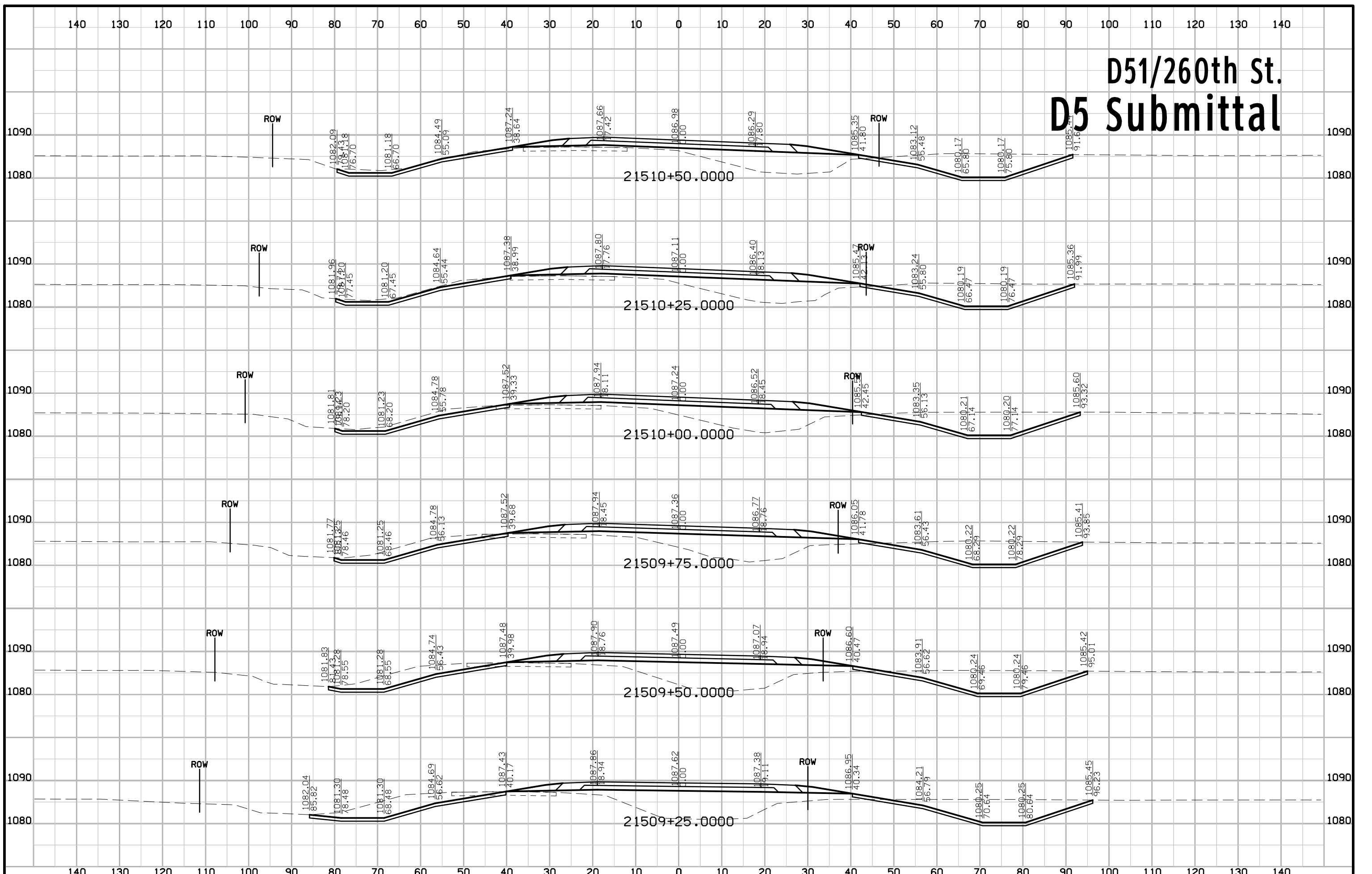

D51/260th St. D5 Submittal

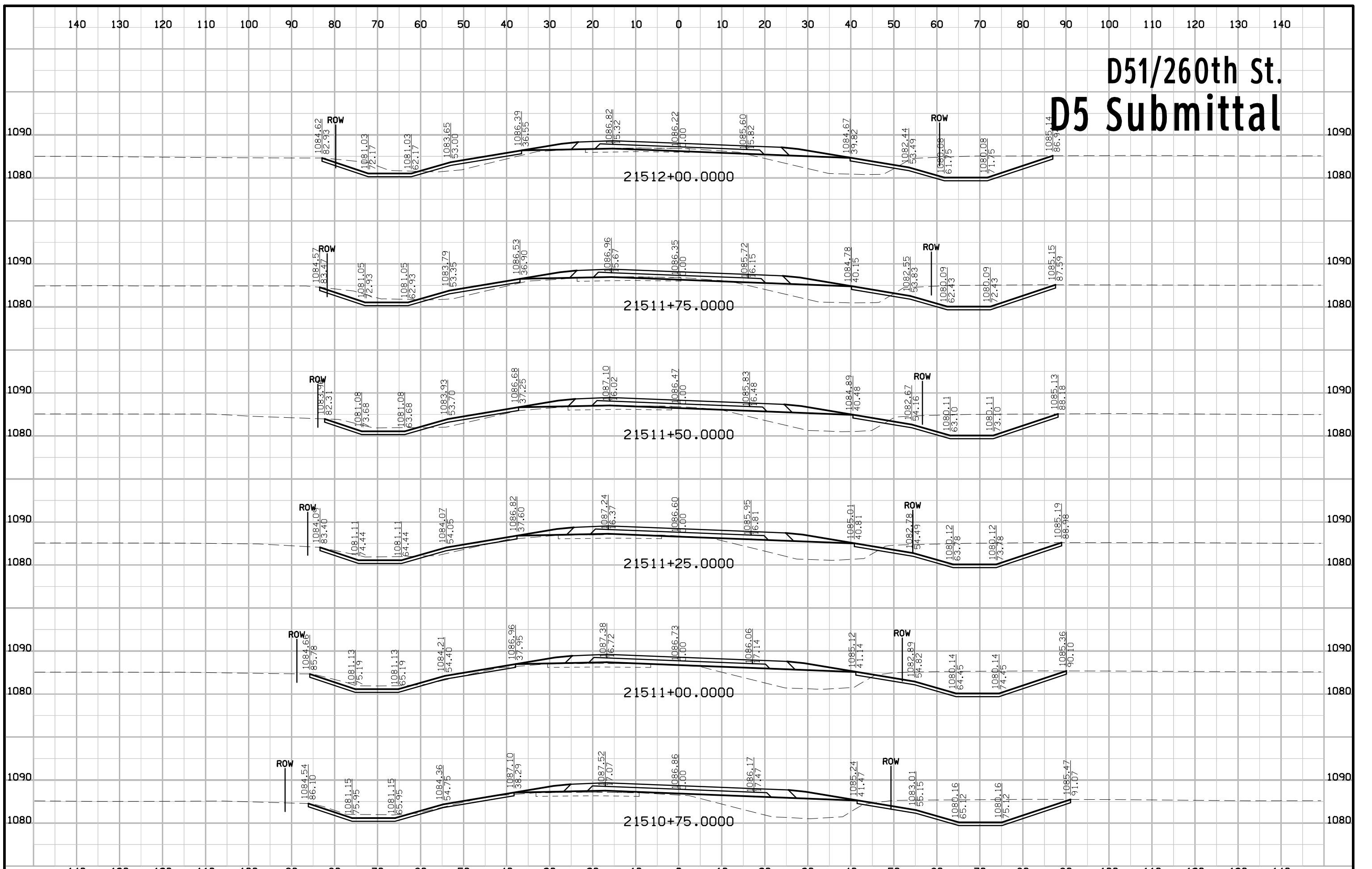

D51/260th St. D5 Submittal

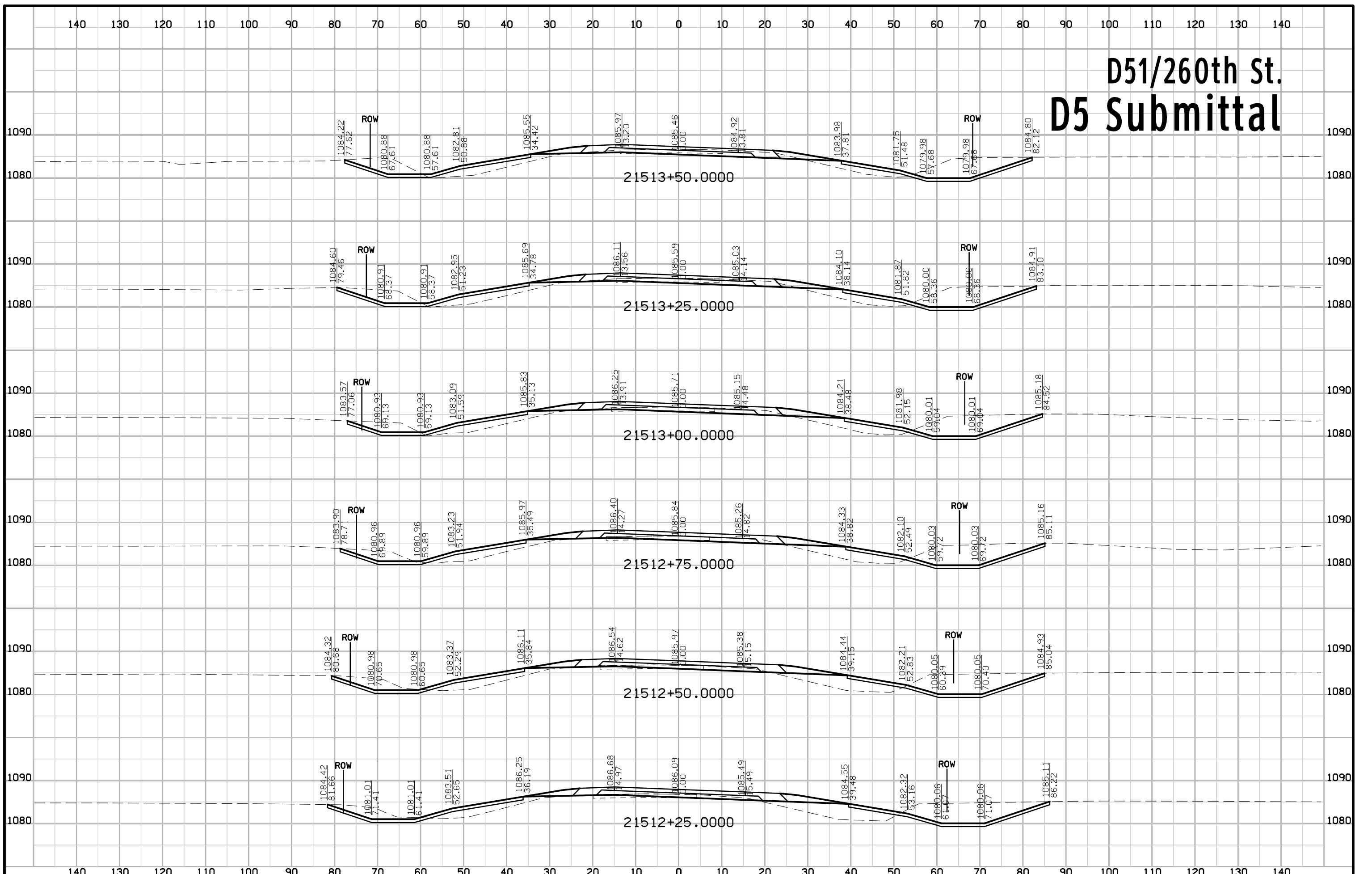

D51/260th St. D5 Submittal

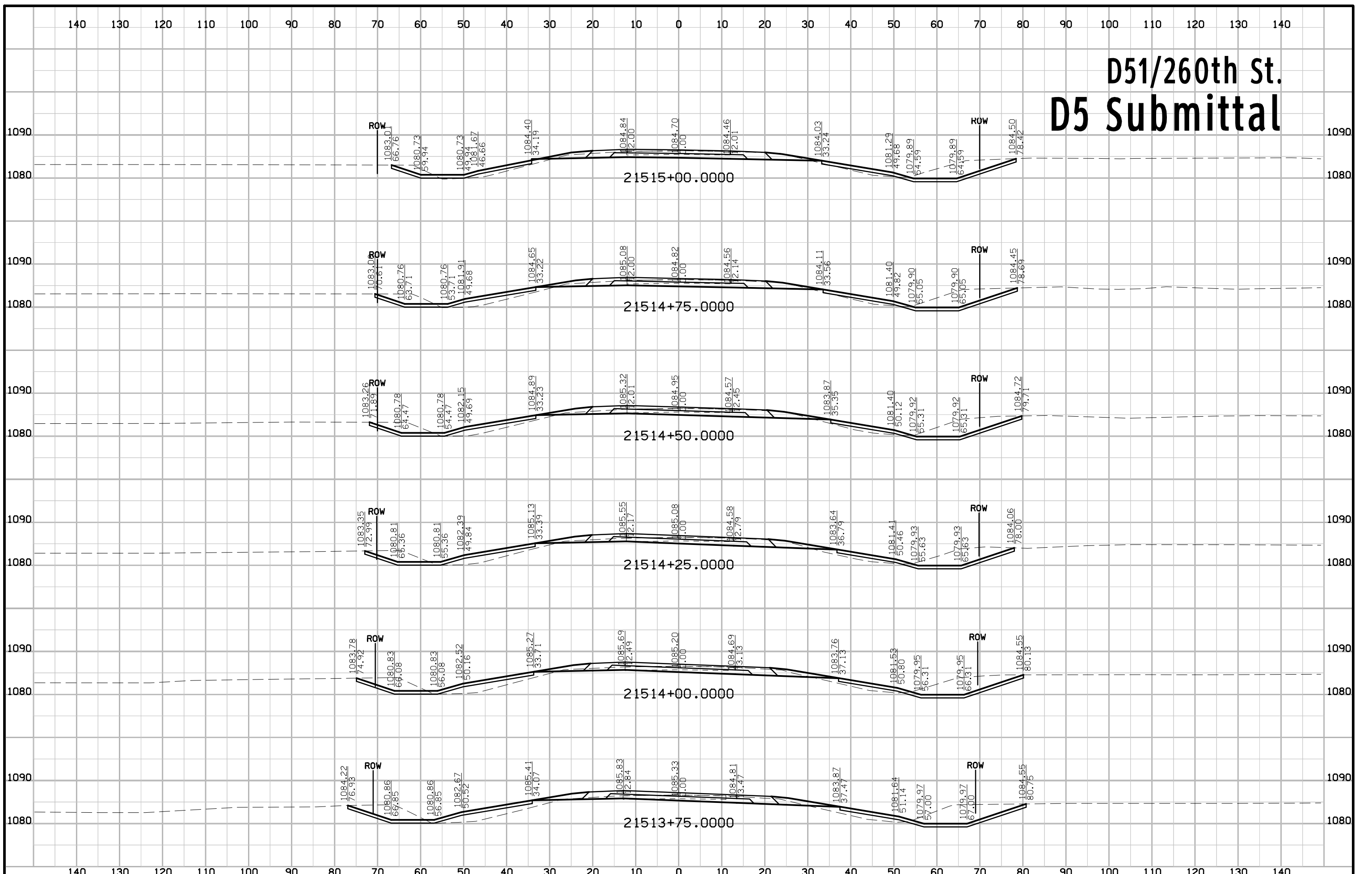

D51/260th St. D5 Submittal

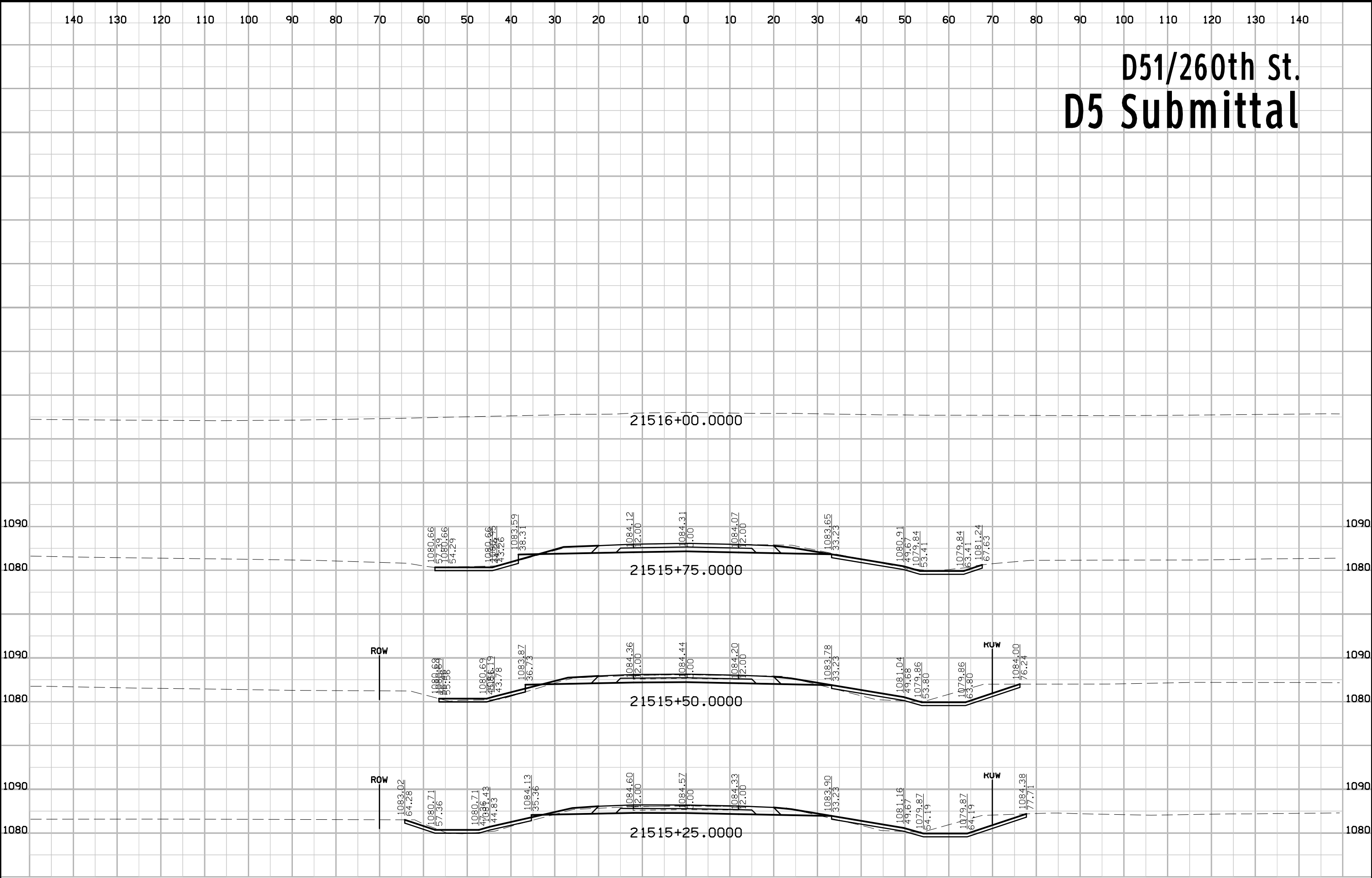

Burnett Ave. D5 Submittal

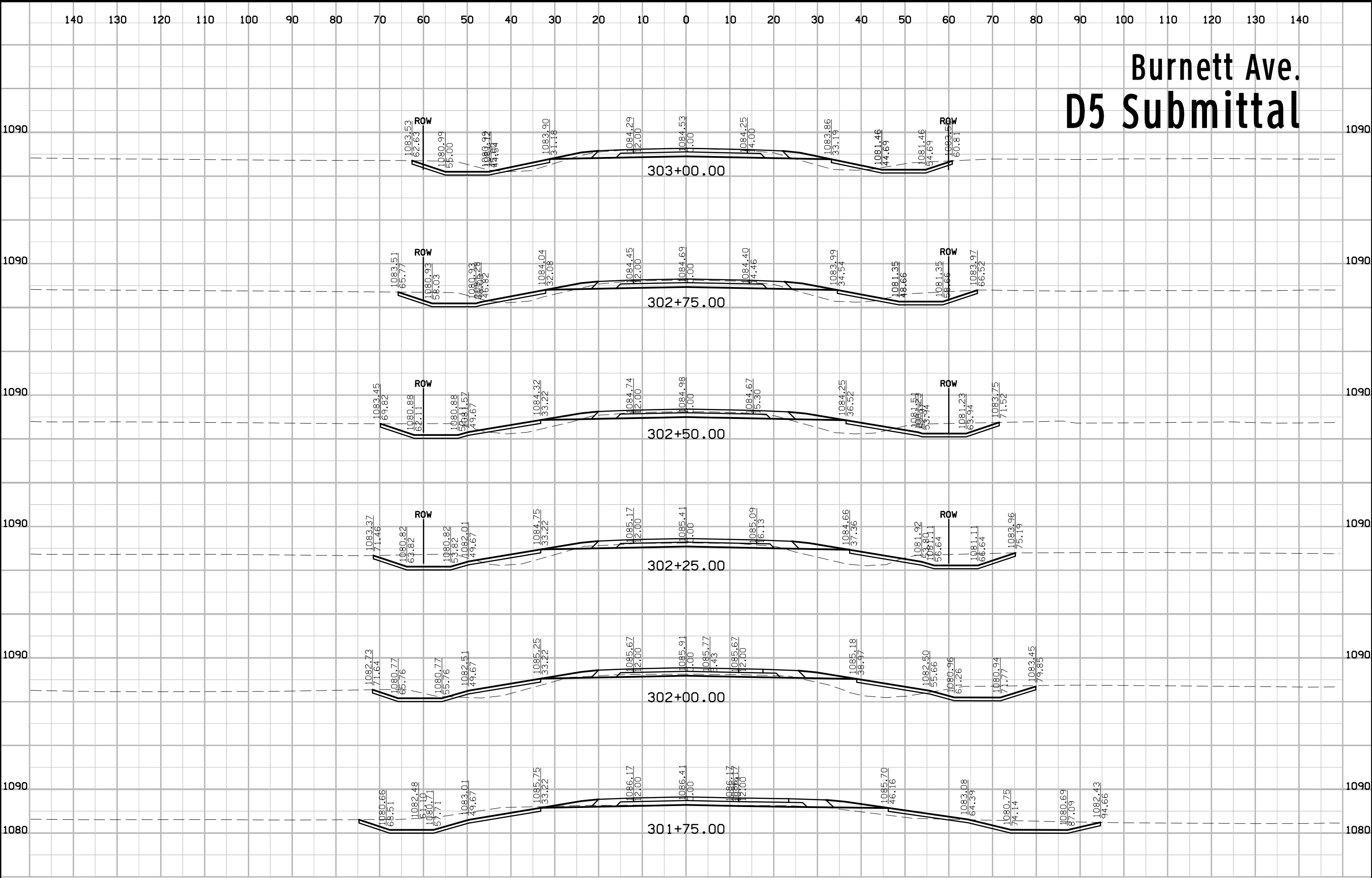

Burnett Ave. D5 Submittal

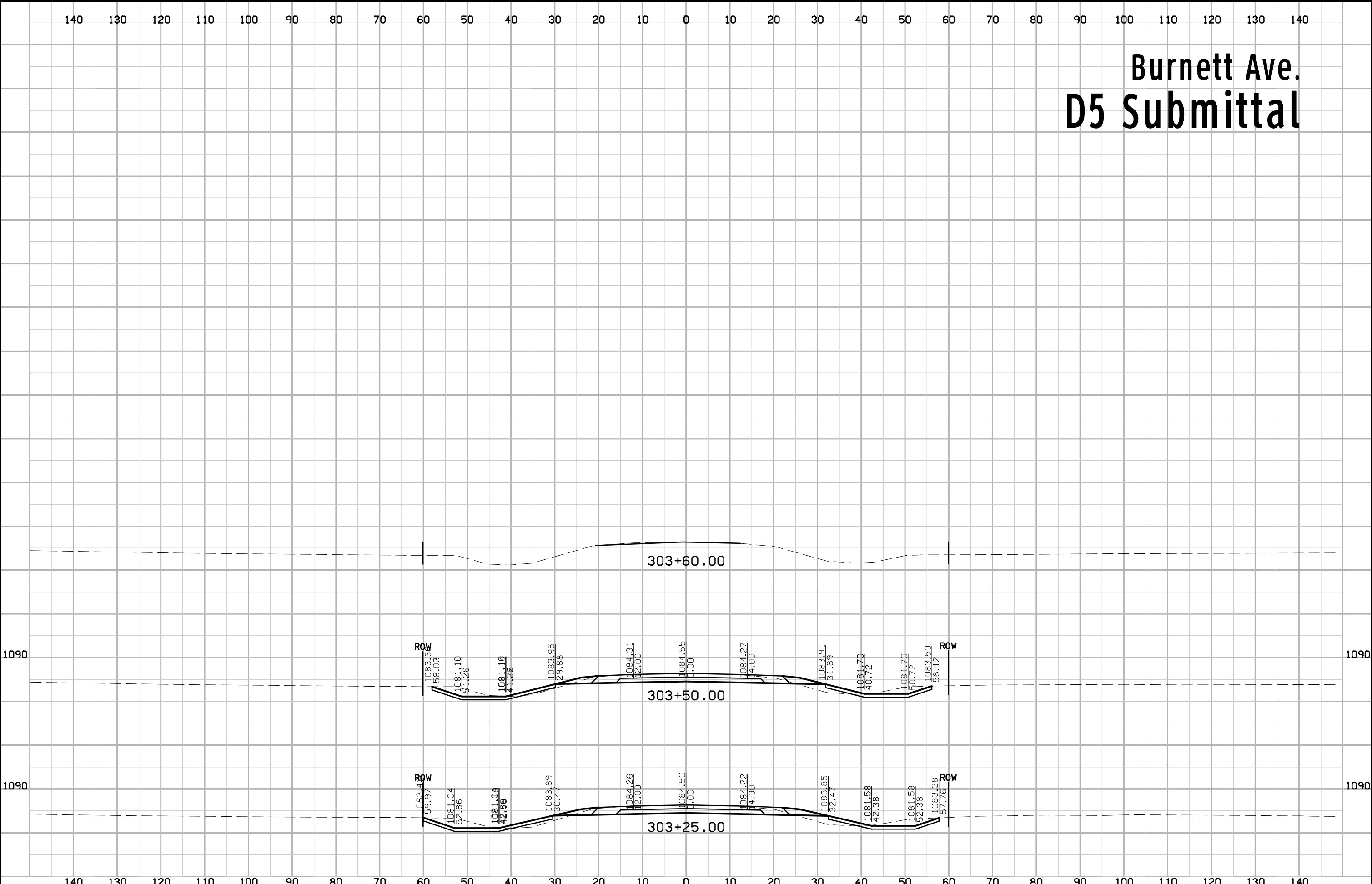

Liberty Lane D5 Submittal

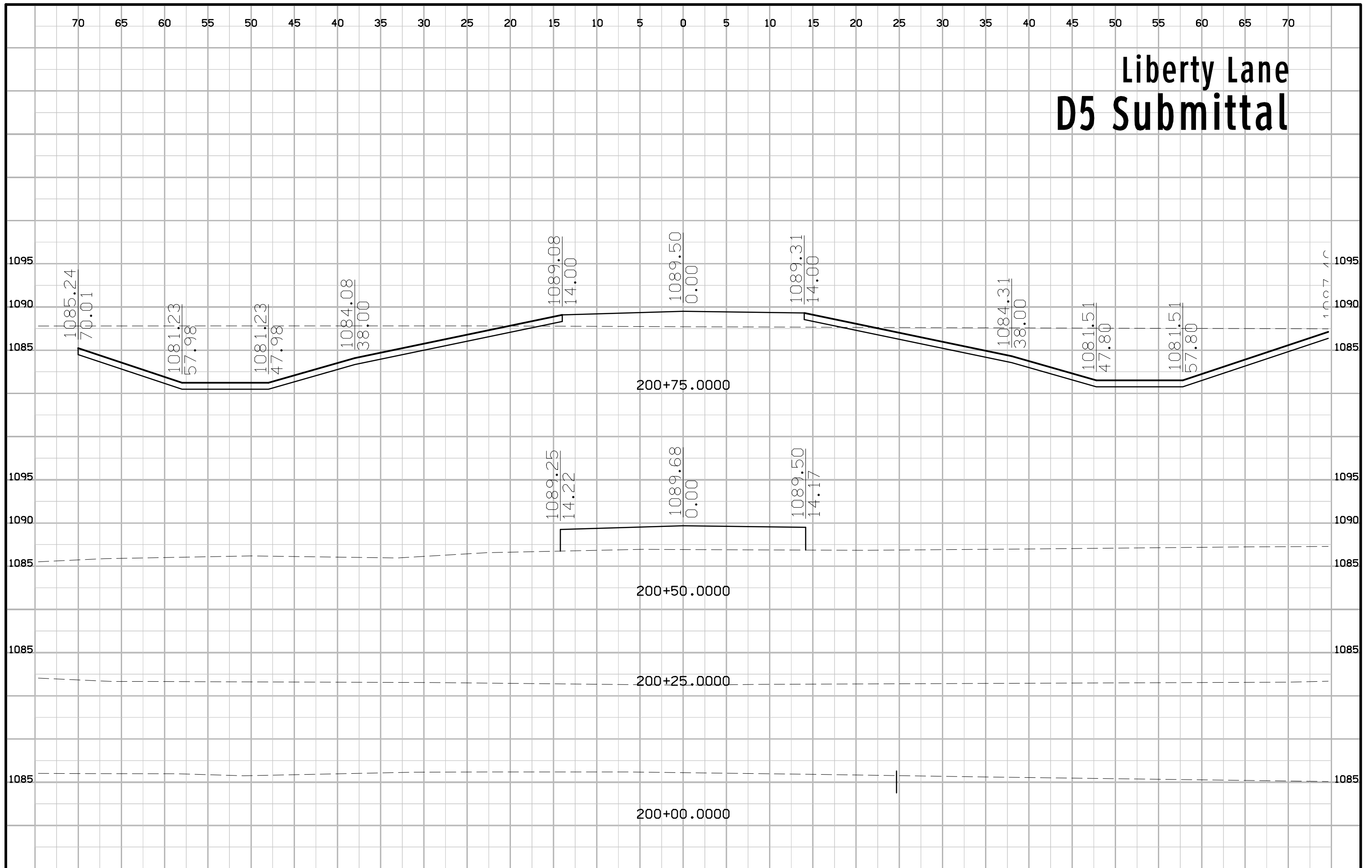

Liberty Lane D5 Submittal

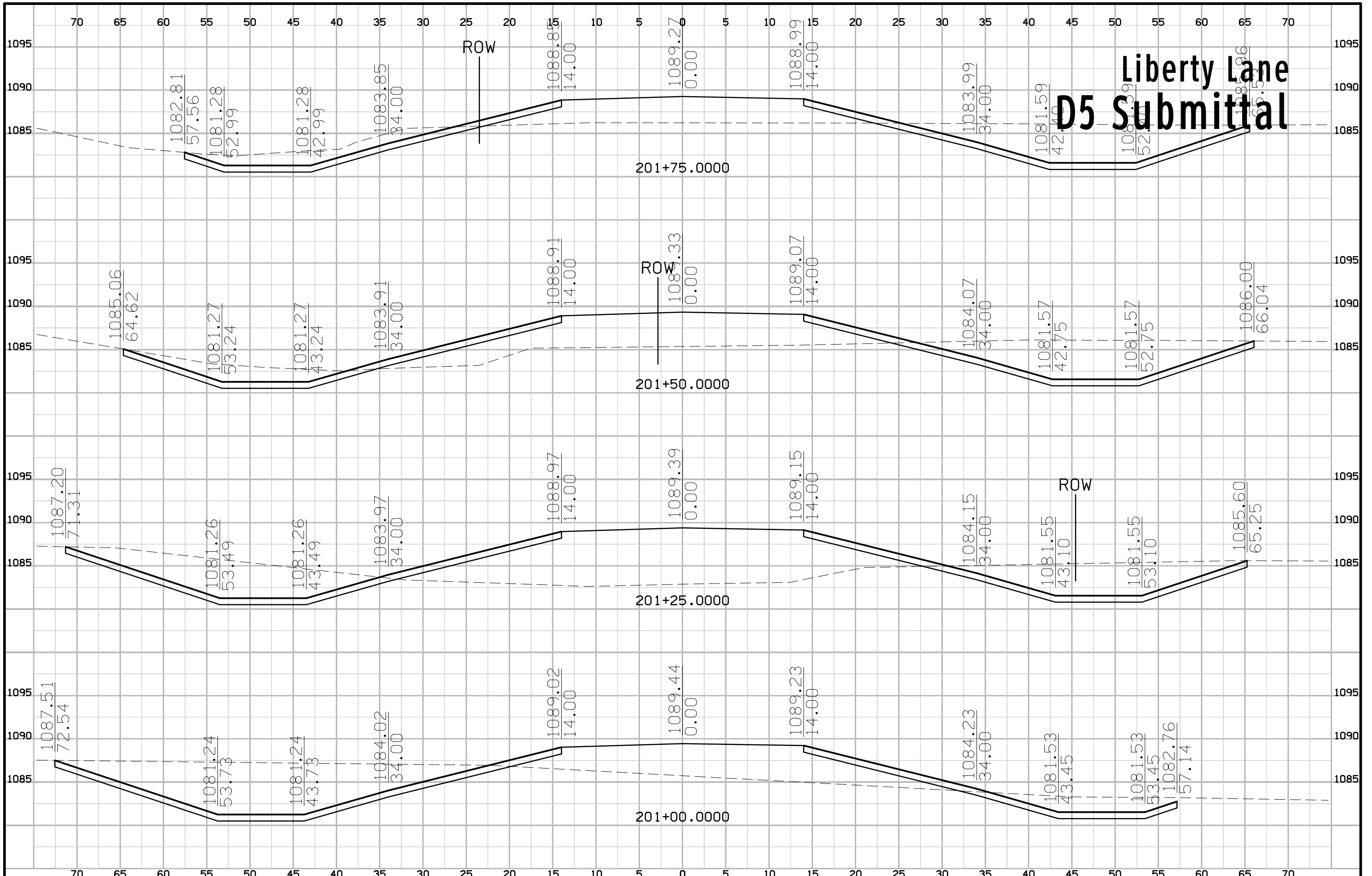

Liberty Lane D5 Submittal

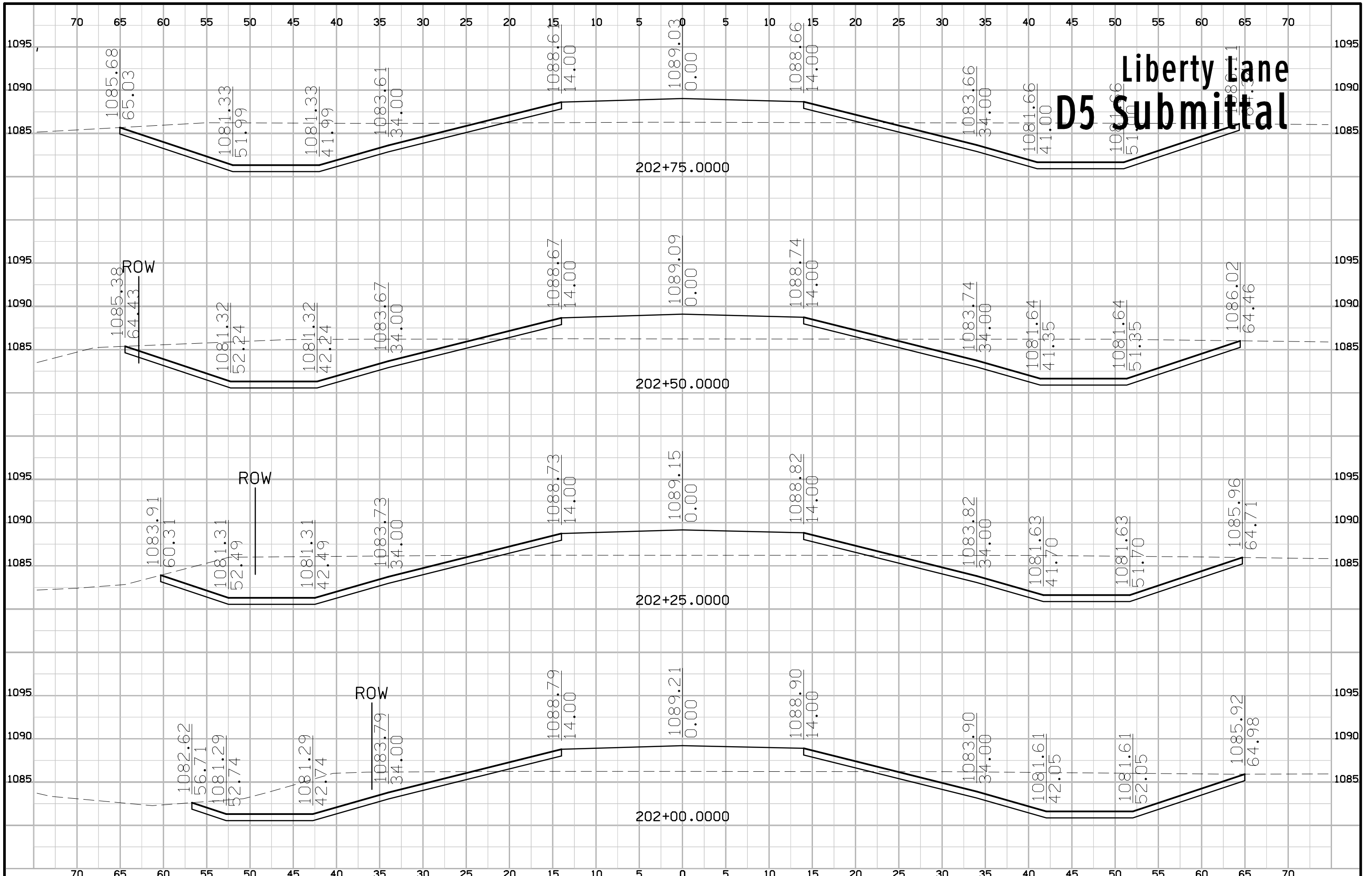

Liberty Lane D5 Submittal

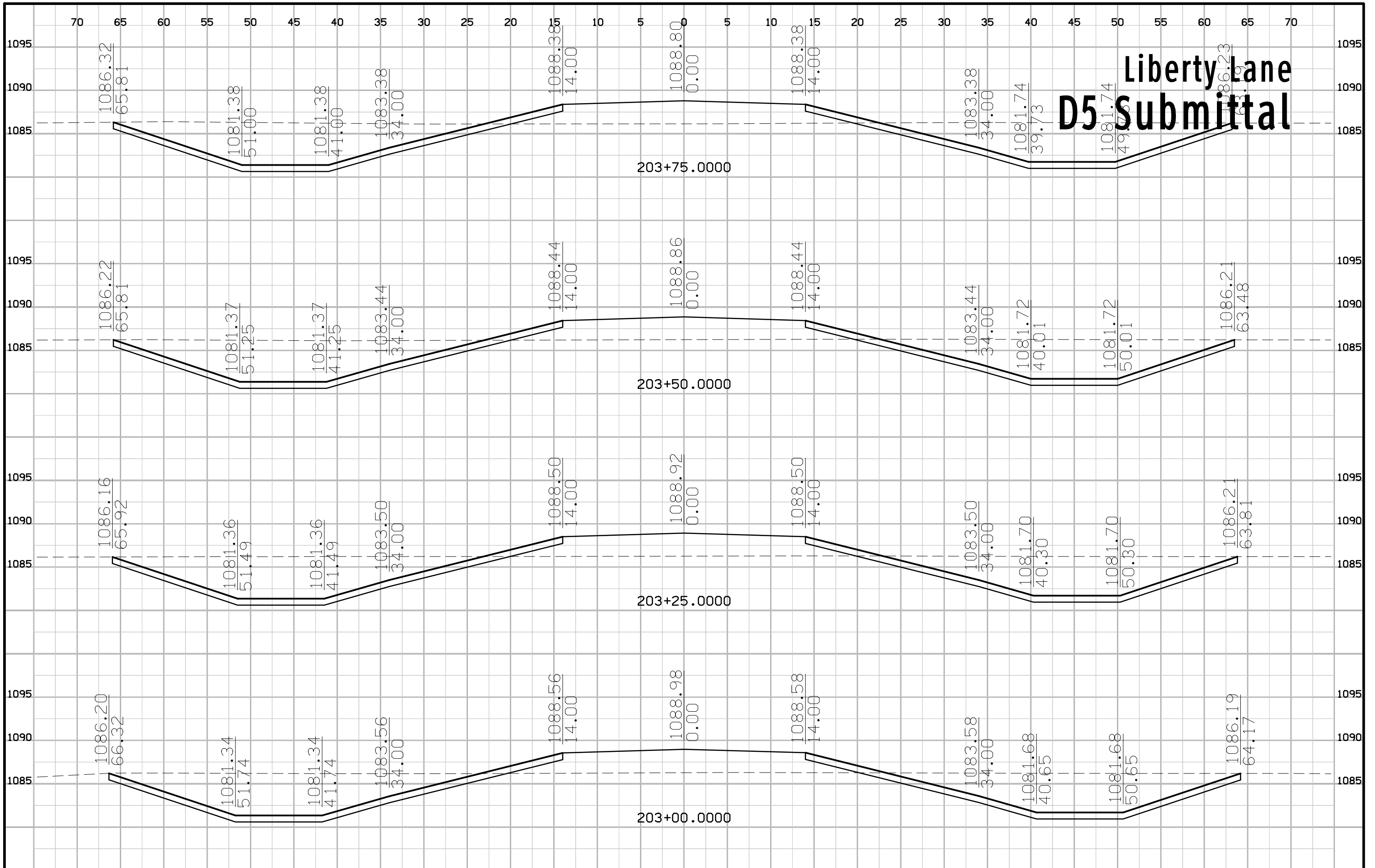

Liberty Lane D5 Submittal

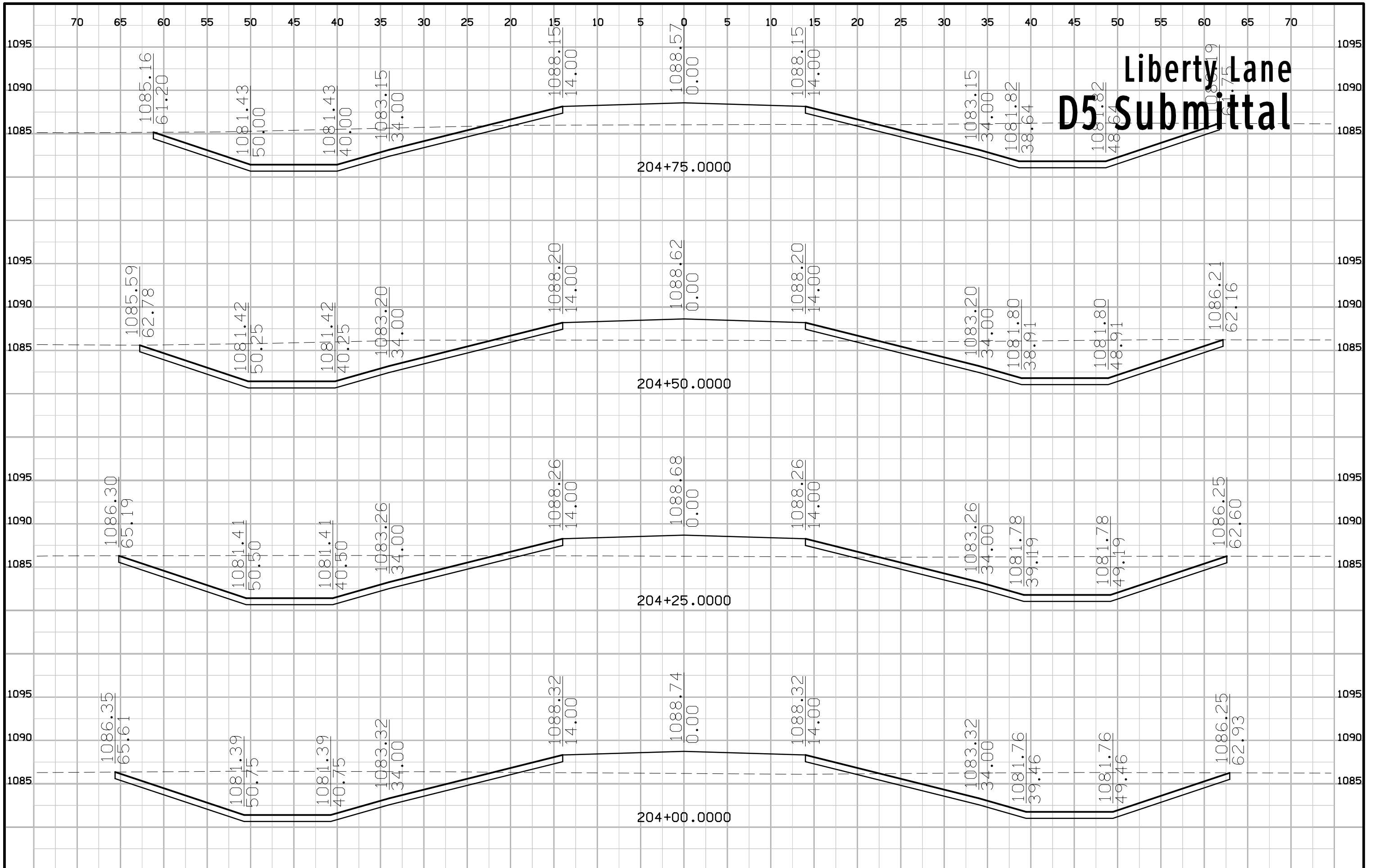

Liberty Lane D5 Submittal

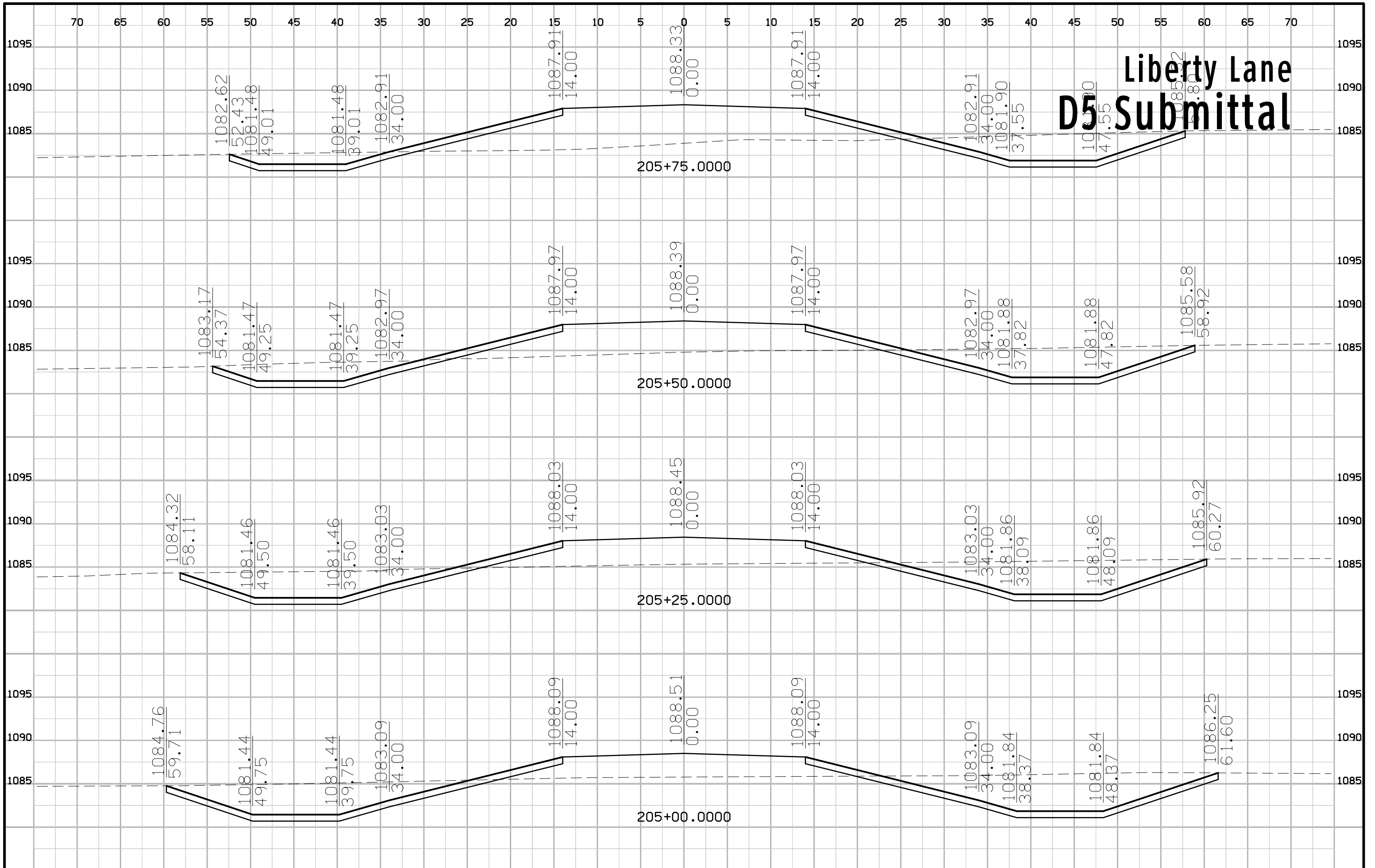

Liberty Lane D5 Submittal

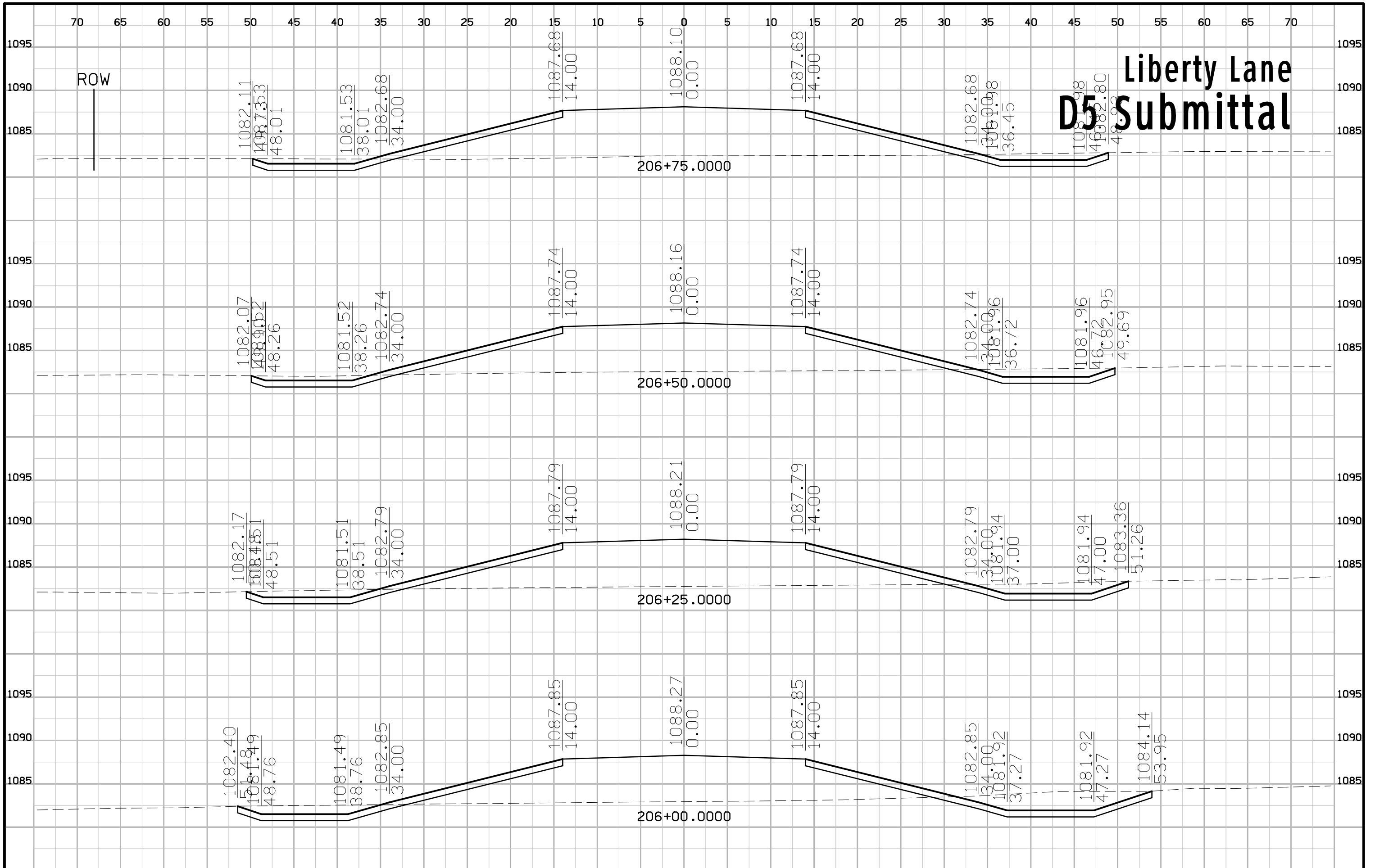

ROW

Liberty Lane D5 Submittal

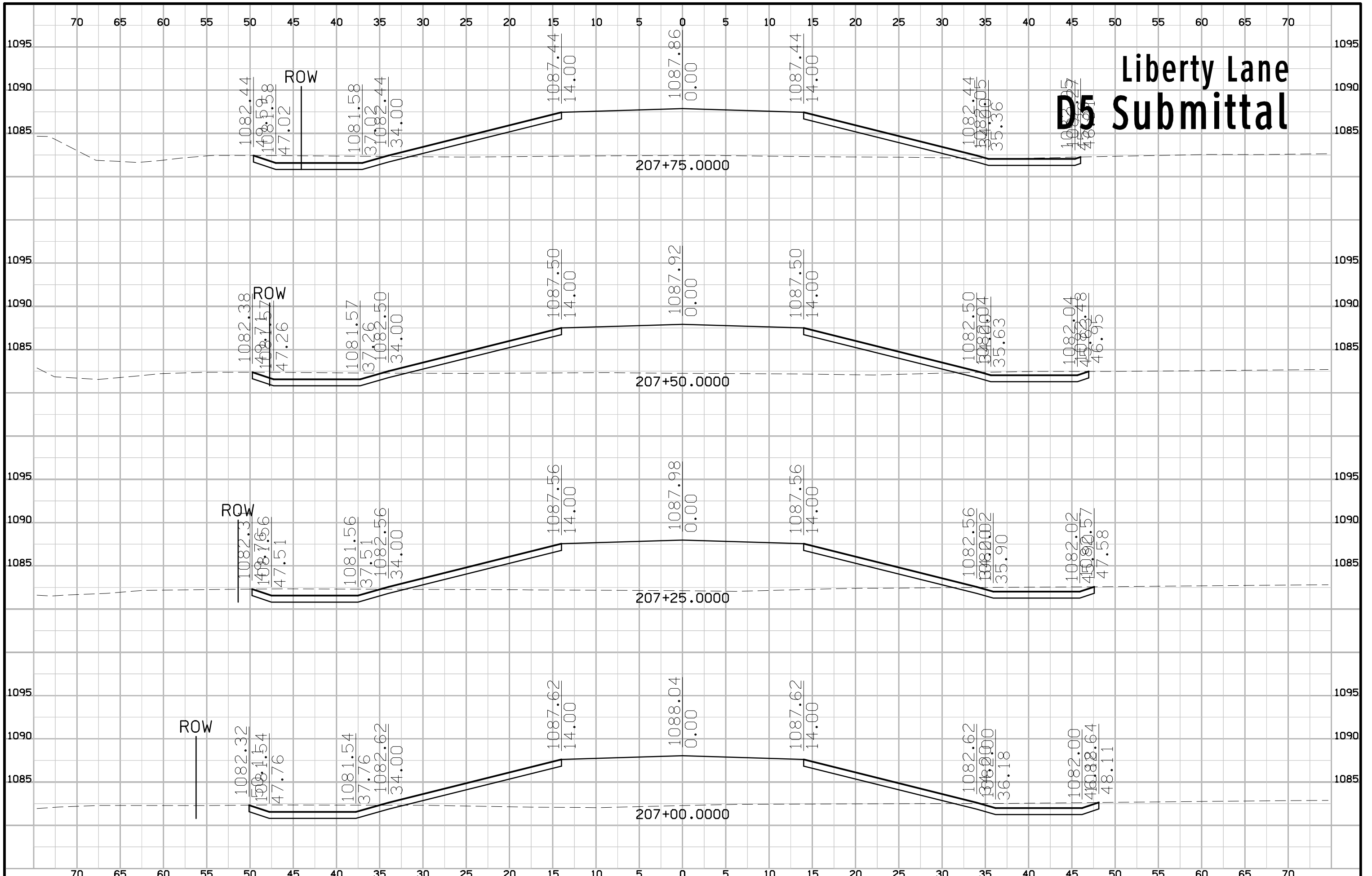

Liberty Lane D5 Submittal

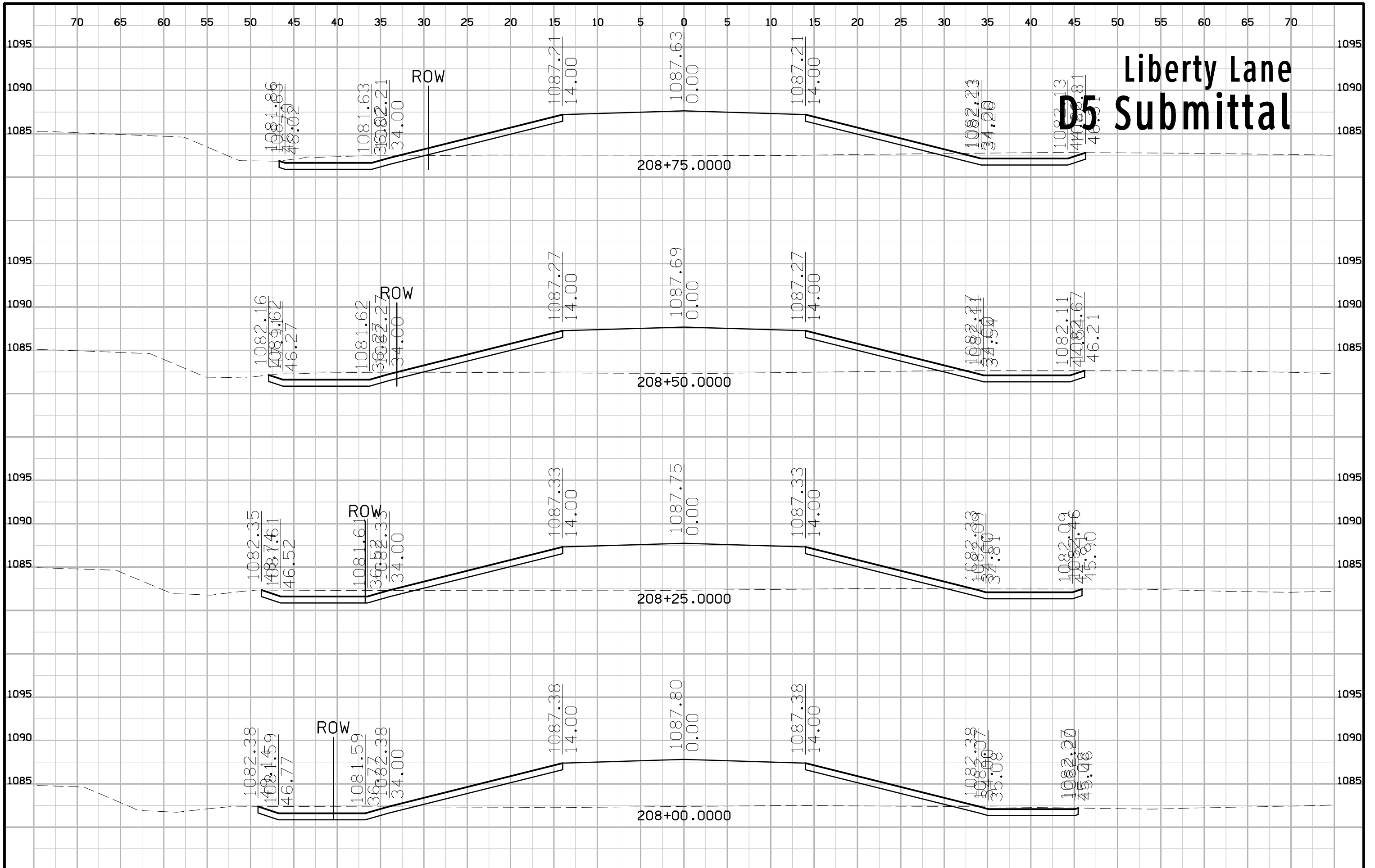

Liberty Lane D5 Submittal

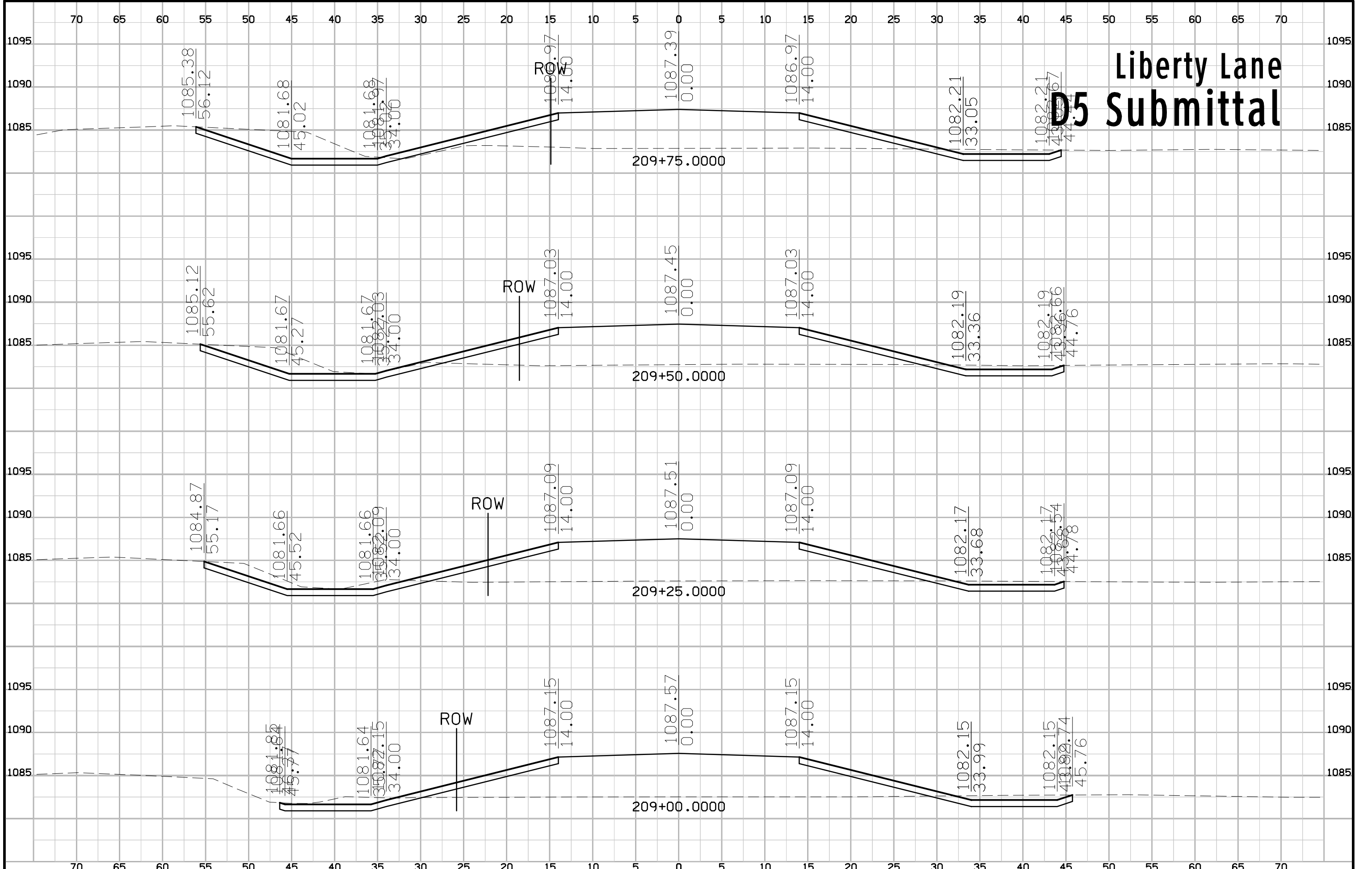

Liberty Lane D5 Submittal

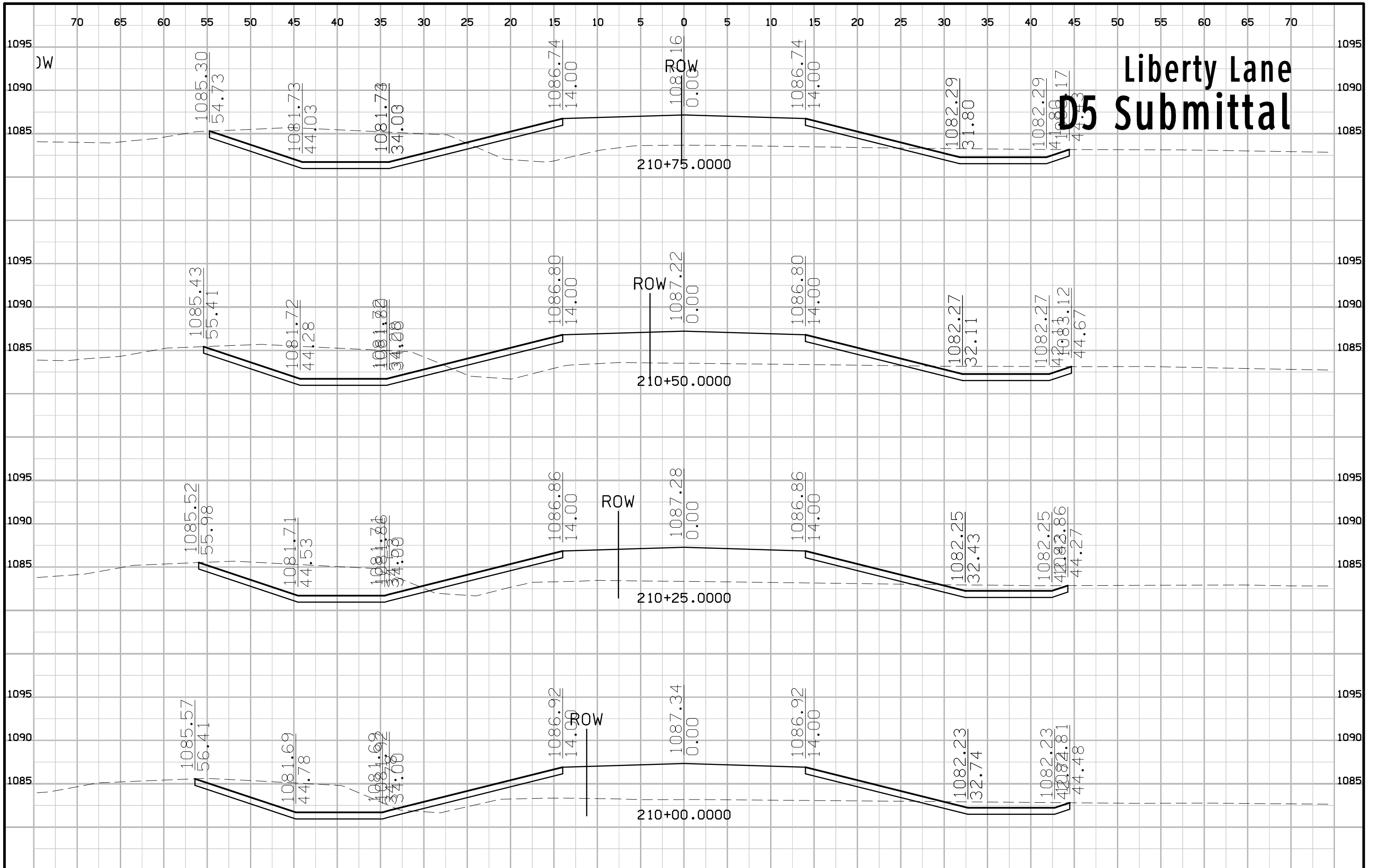

Liberty Lane D5 Submittal

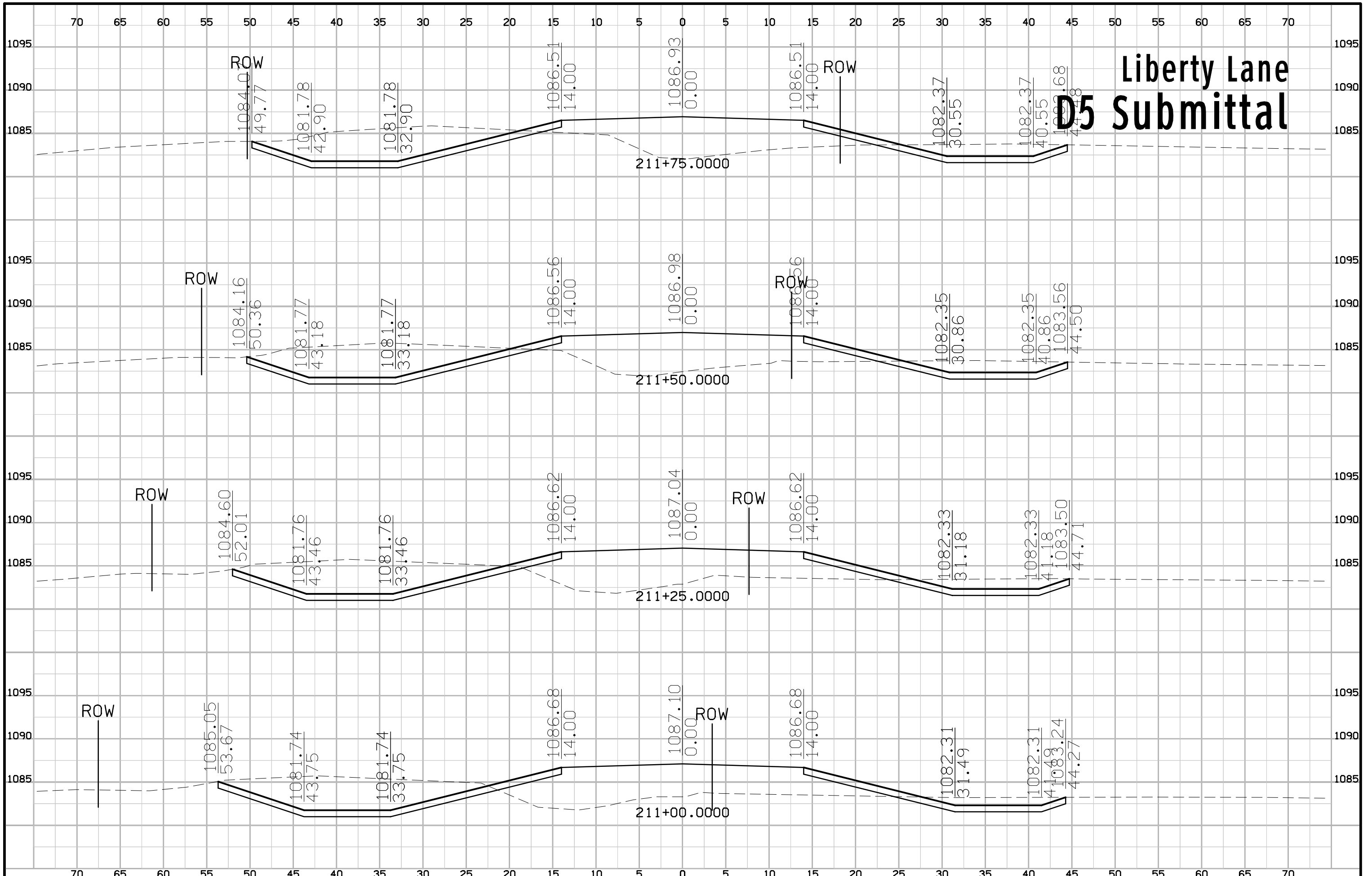

Liberty Lane D5 Submittal

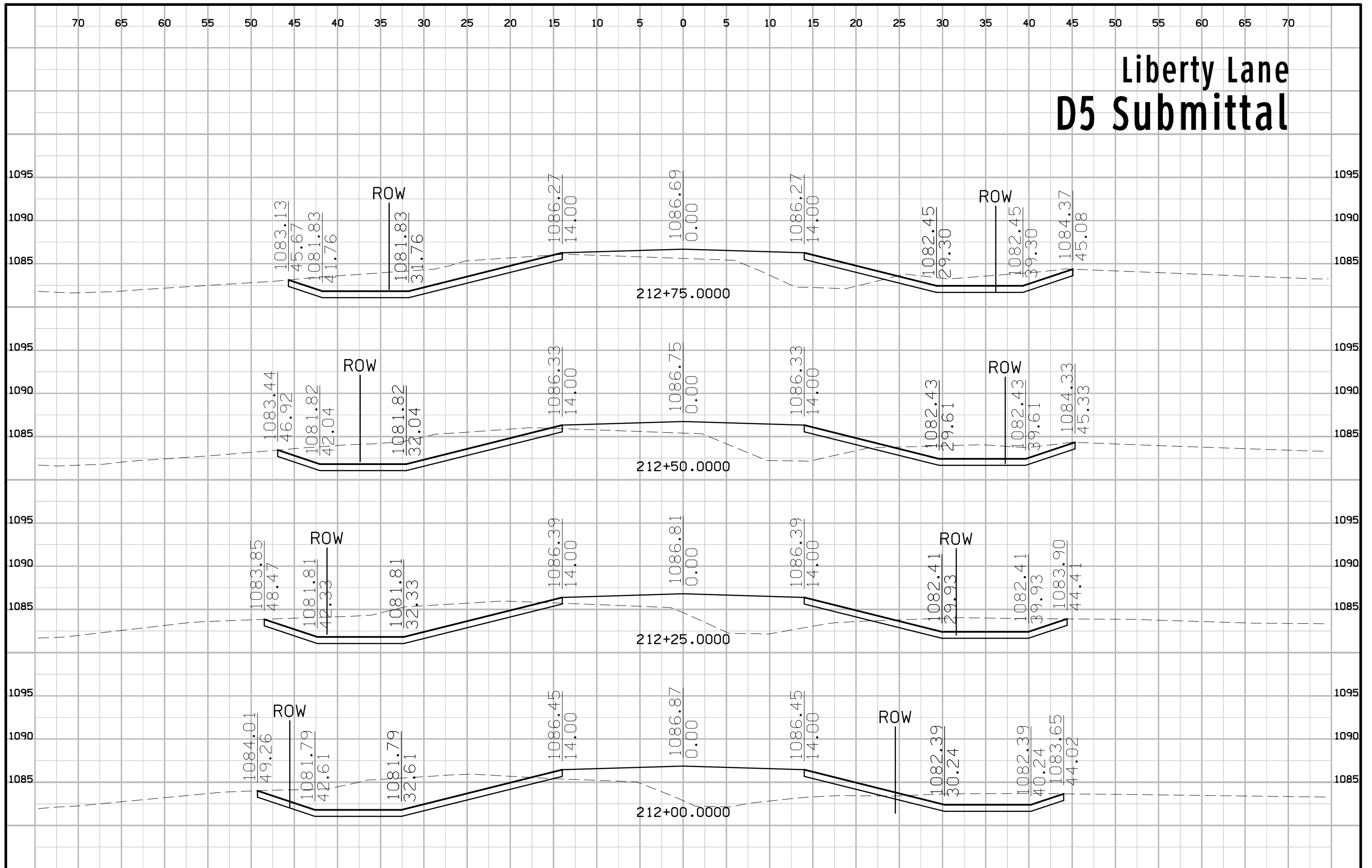

Liberty Lane D5 Submittal

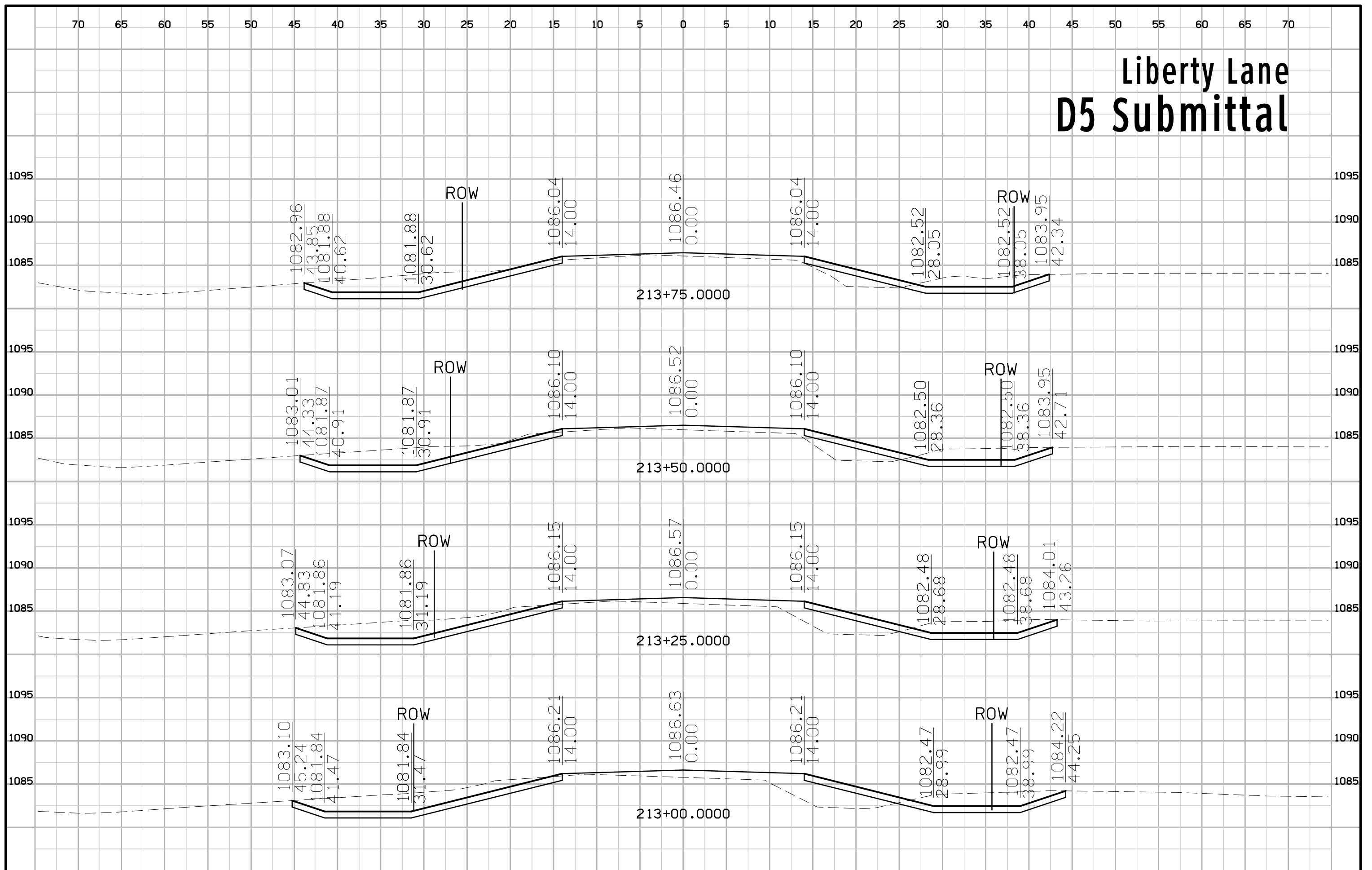

Liberty Lane D5 Submittal

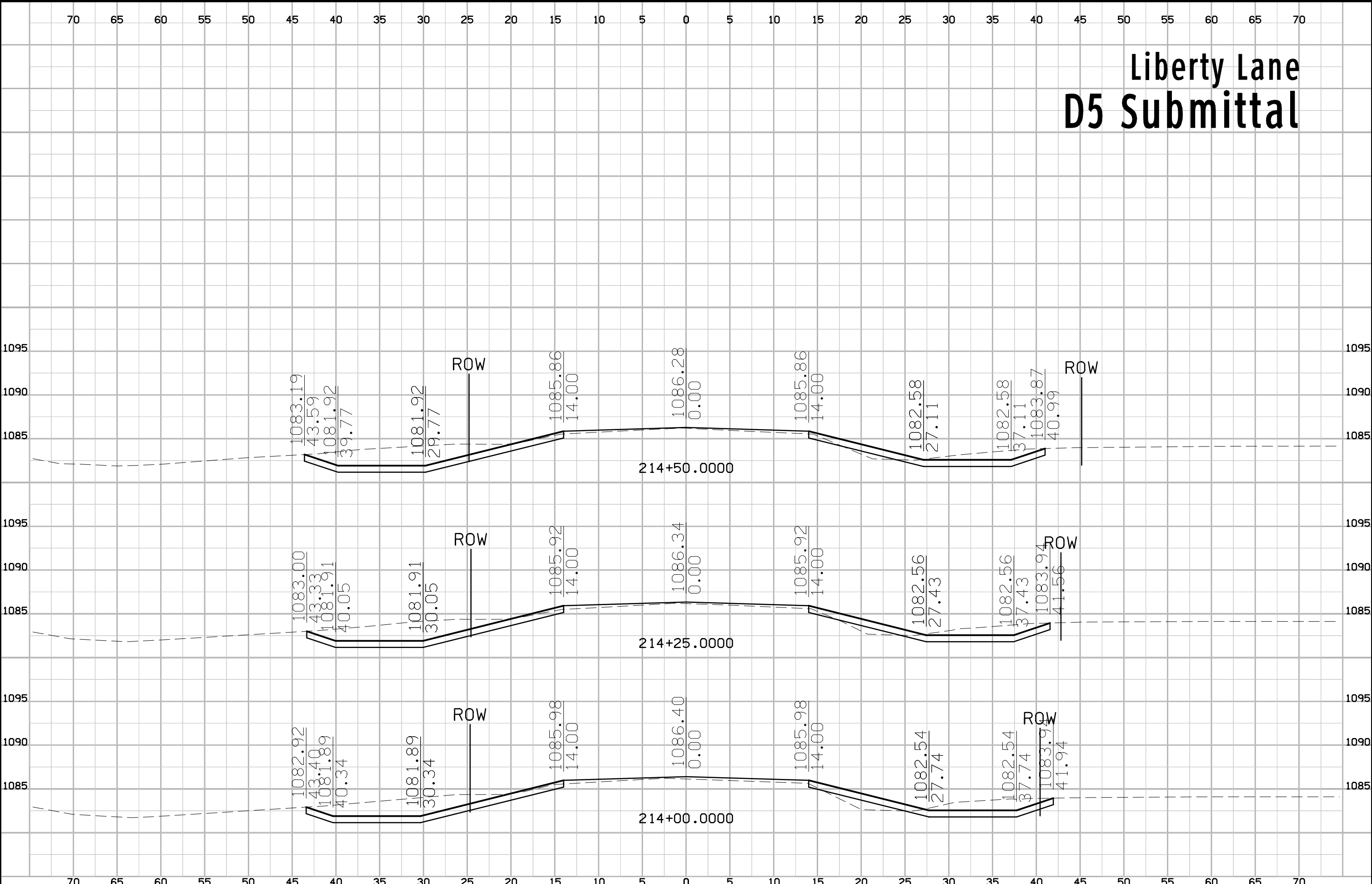

Entrance Sta. 21476+37 D5 Submittal

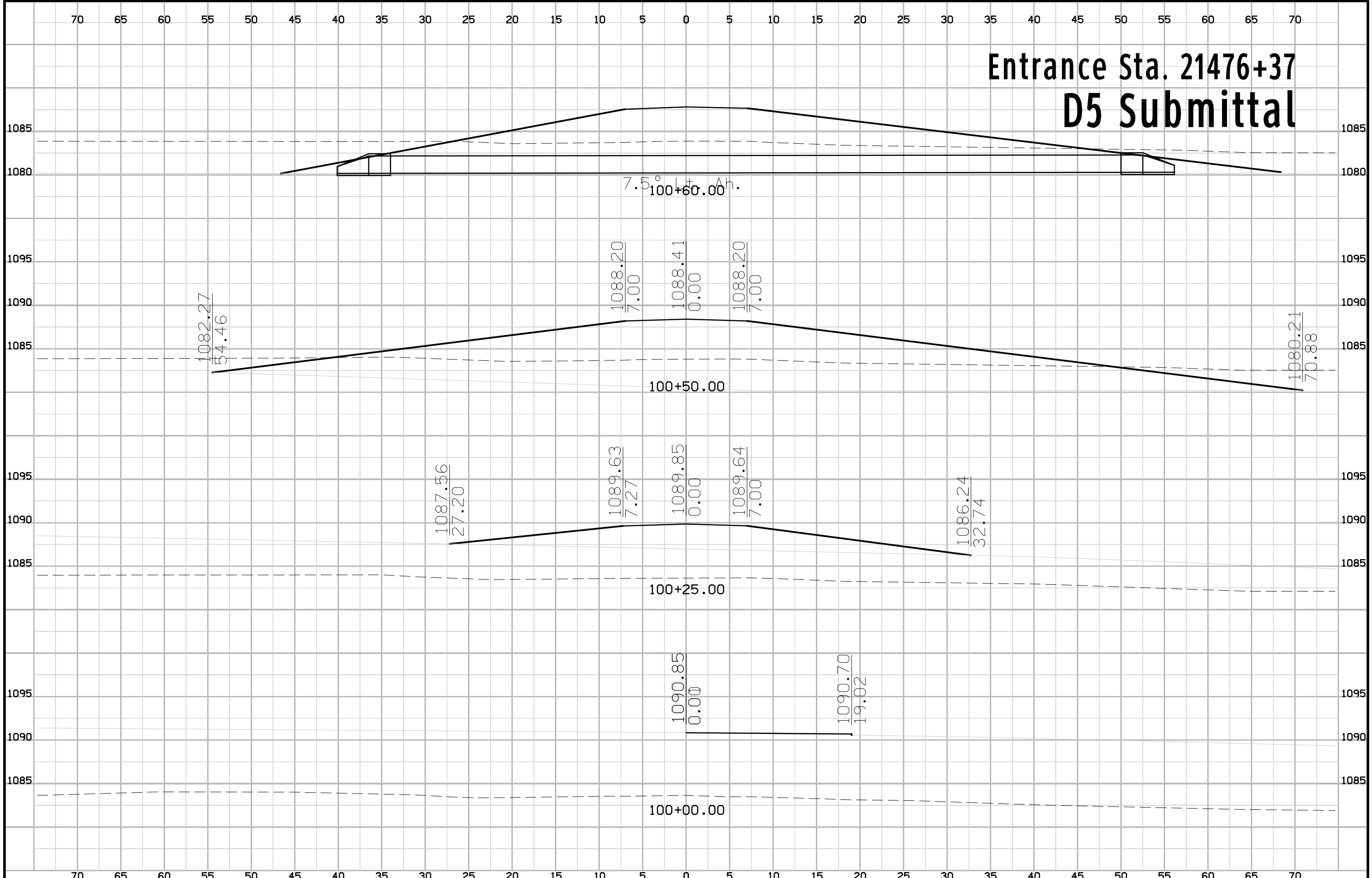

Entrance Sta. 21476+37 D5 Submittal

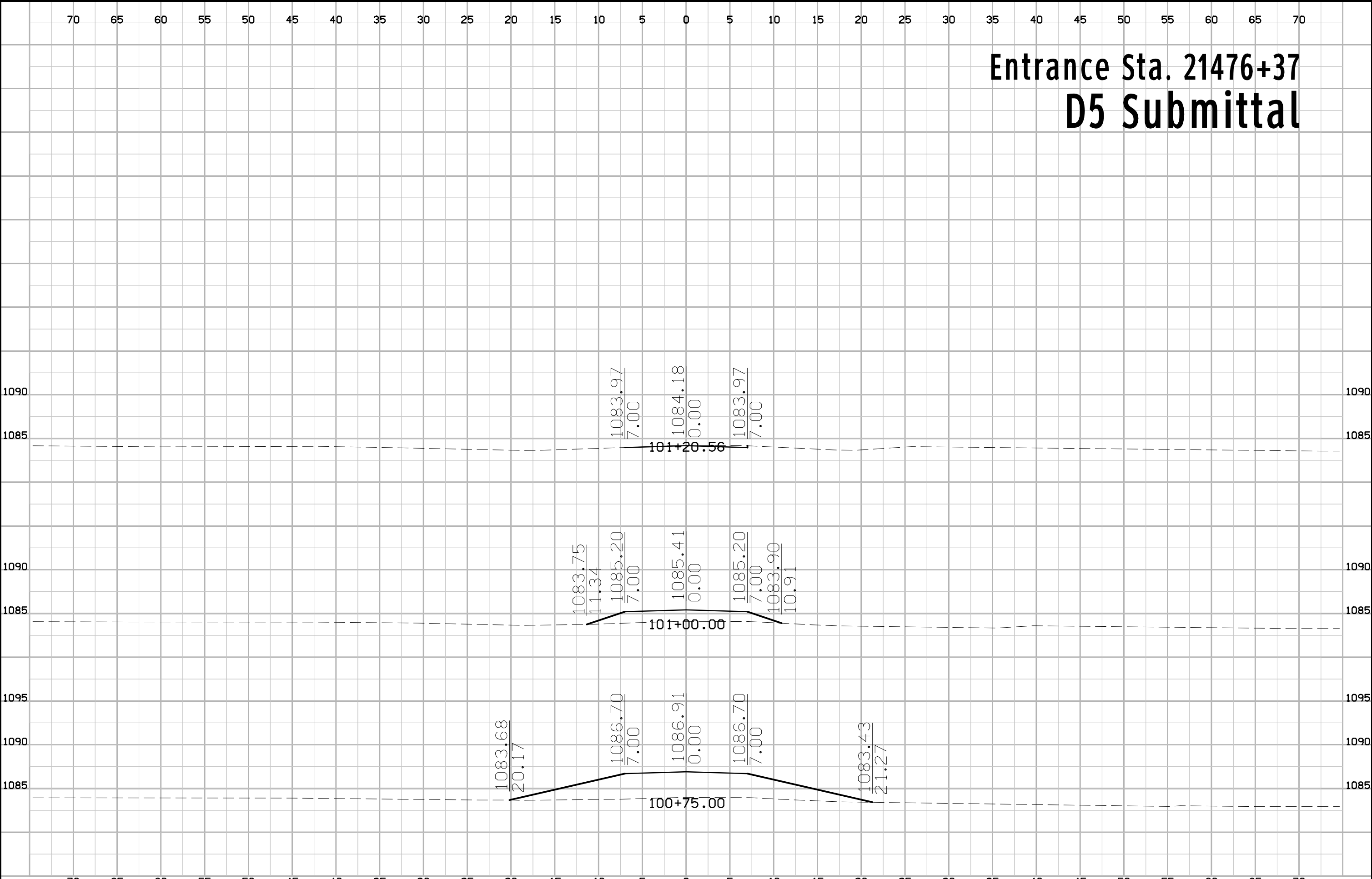

D51 Ramp A D5 Submittal

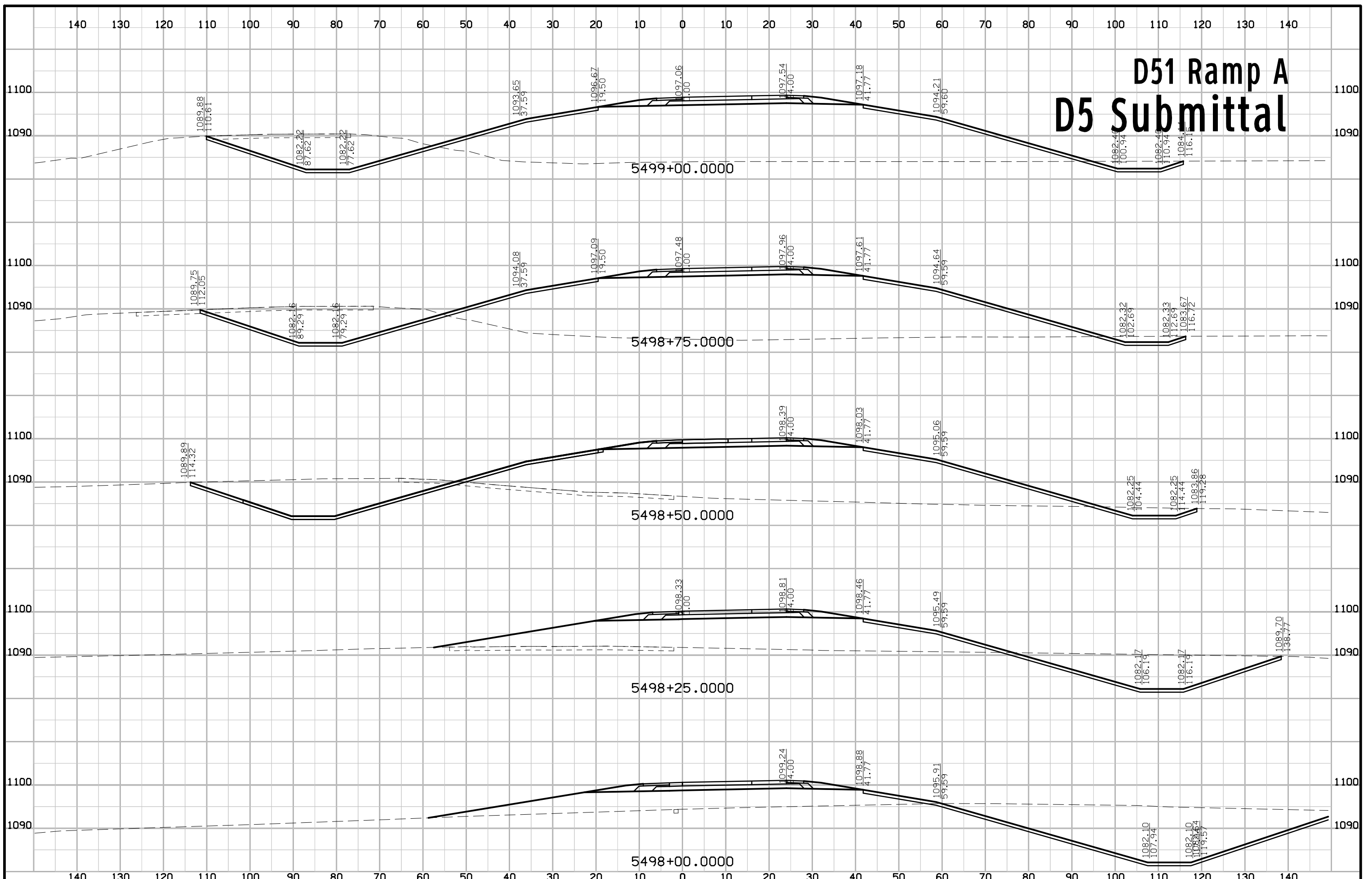

D51 Ramp A D5 Submittal

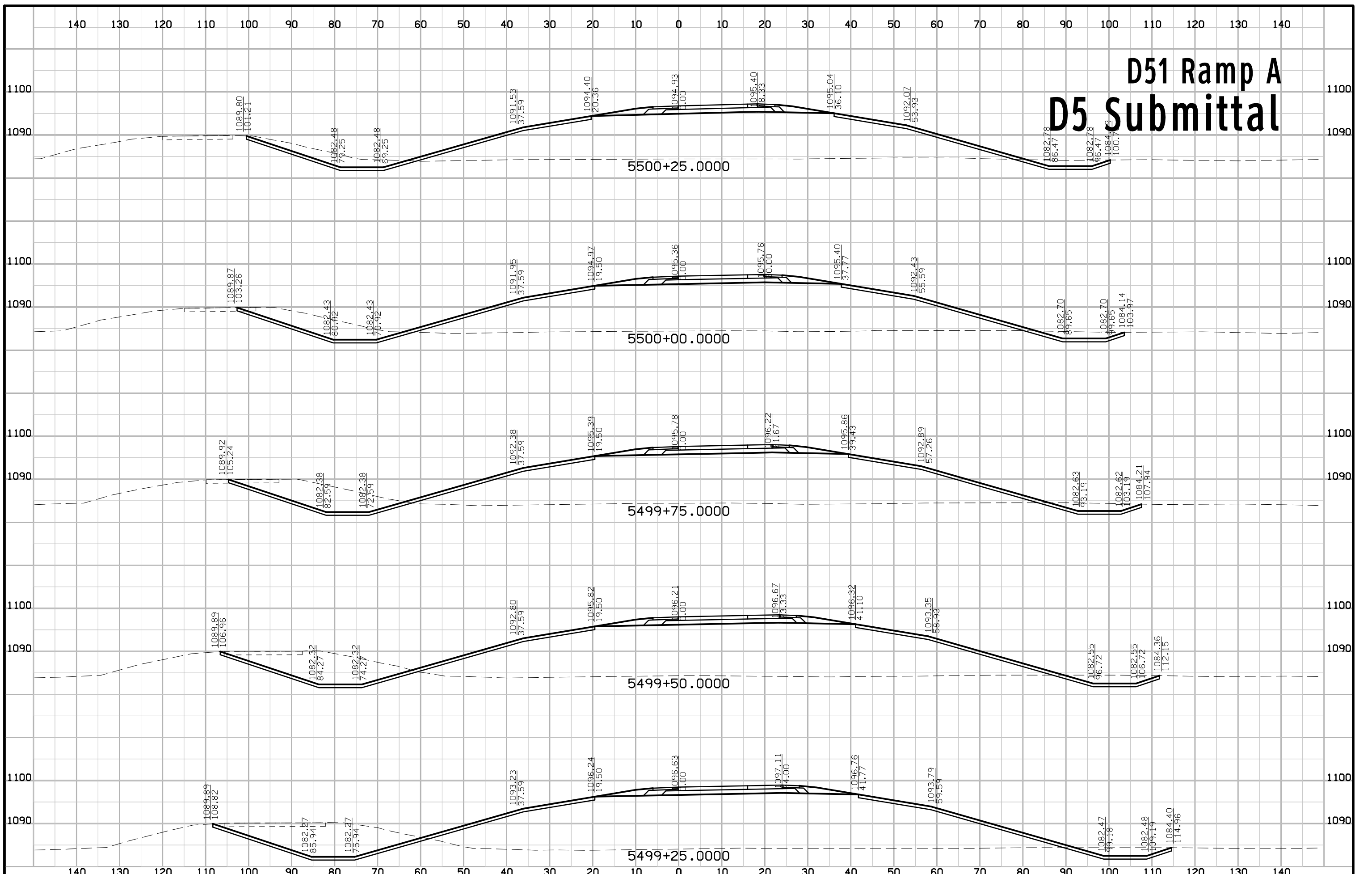

D51 Ramp A D5 Submittal

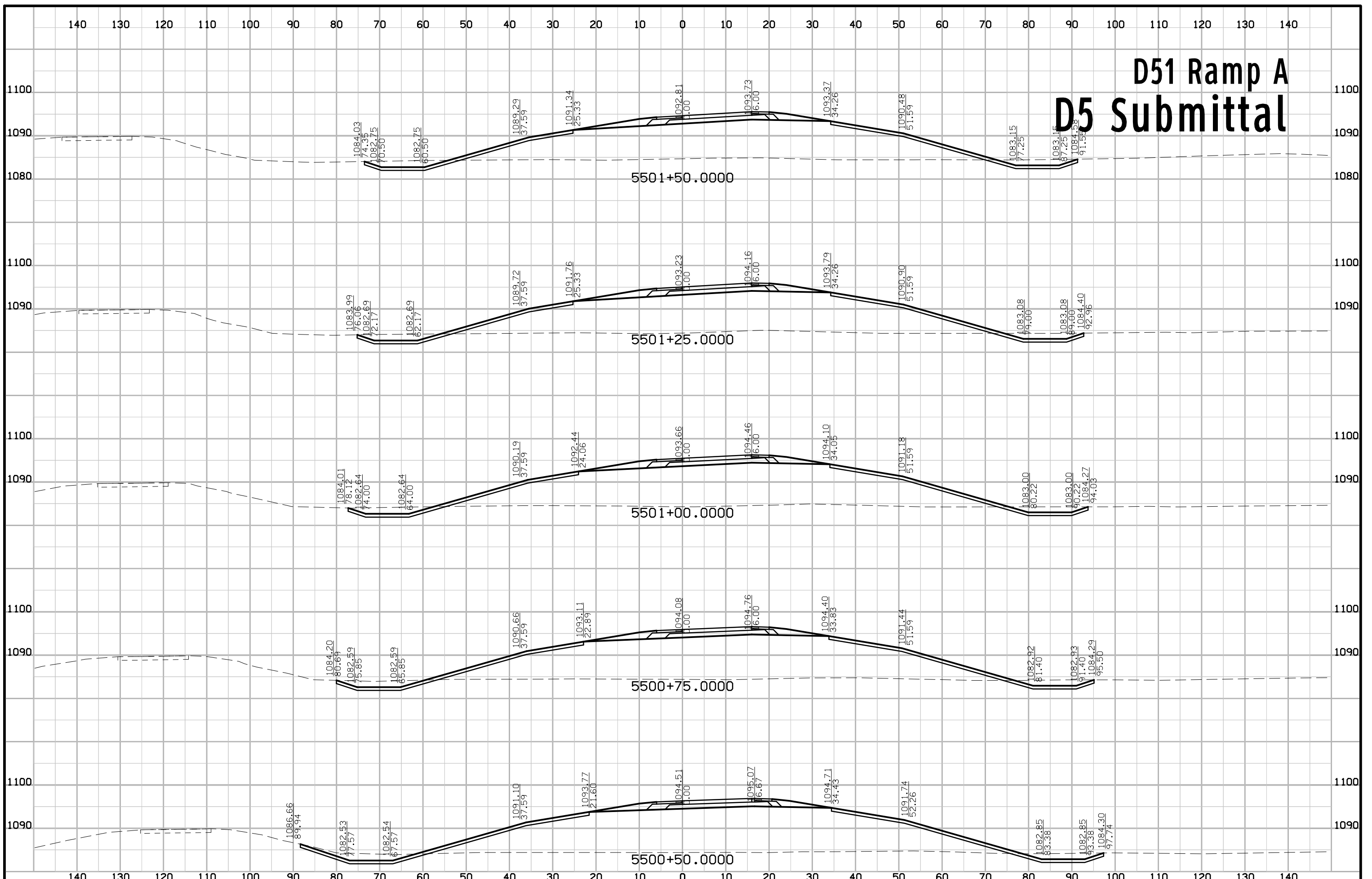

D51 Ramp A D5 Submittal

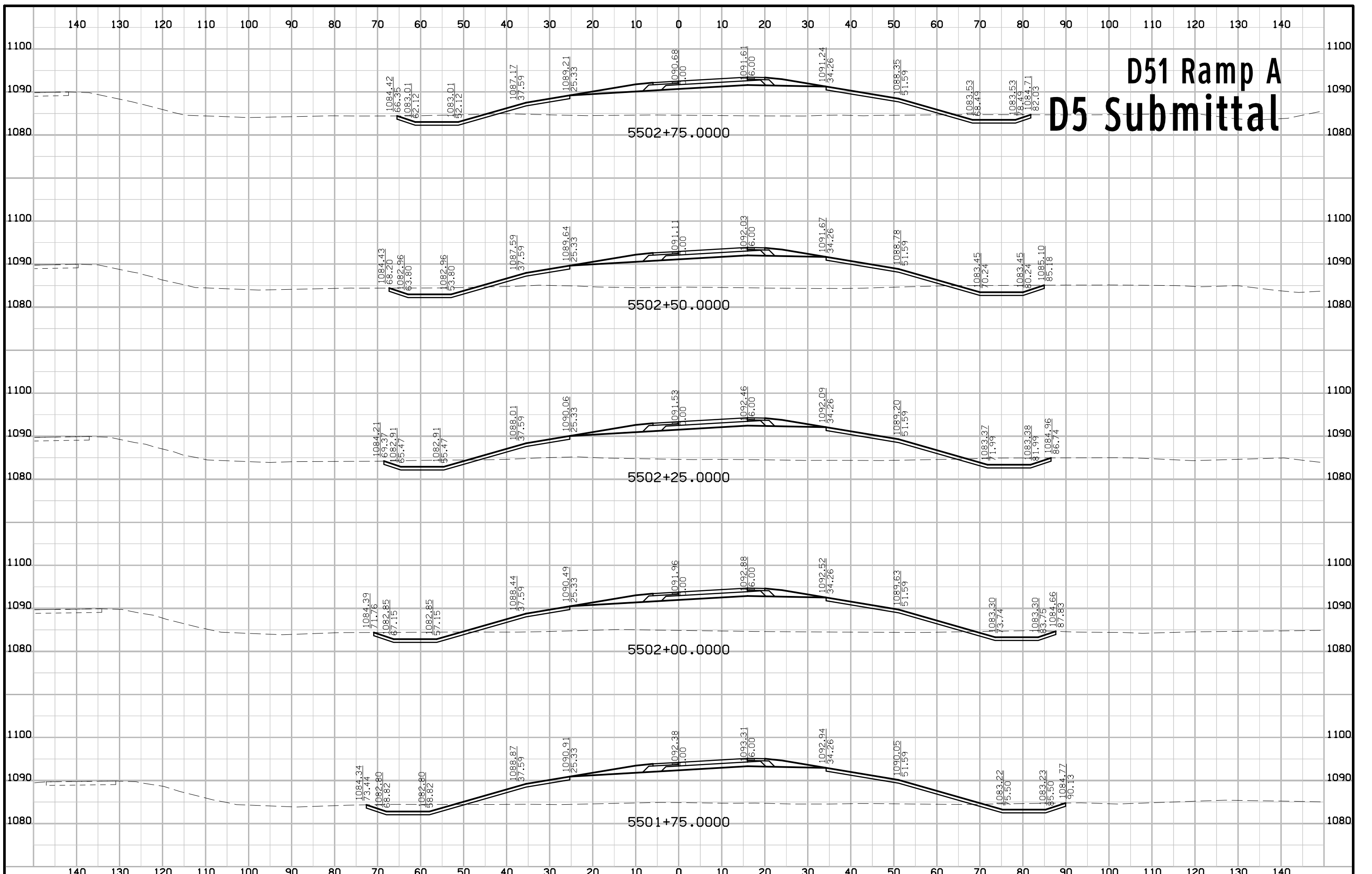

D51 Ramp A D5 Submittal

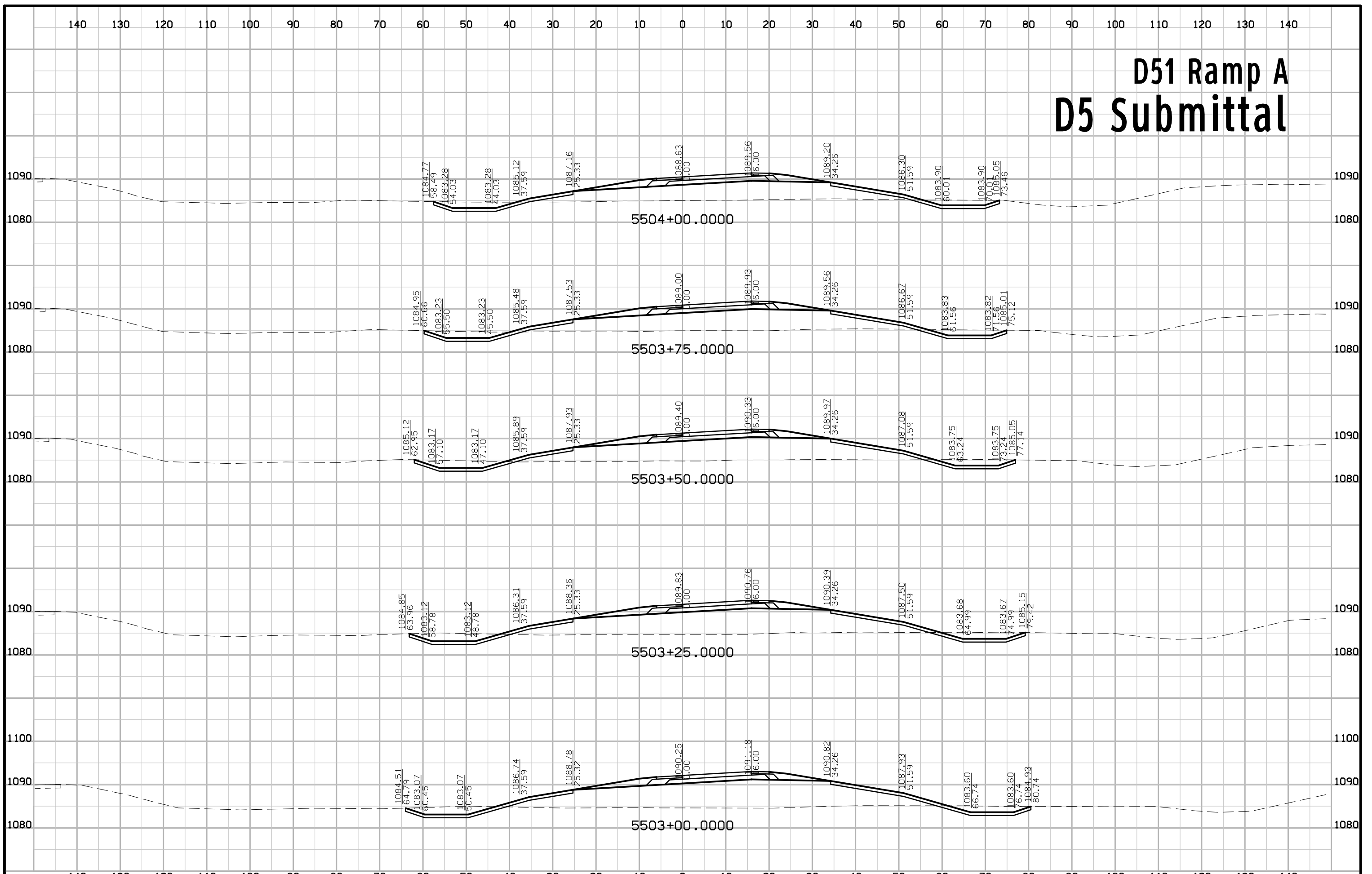

D51 Ramp A D5 Submittal

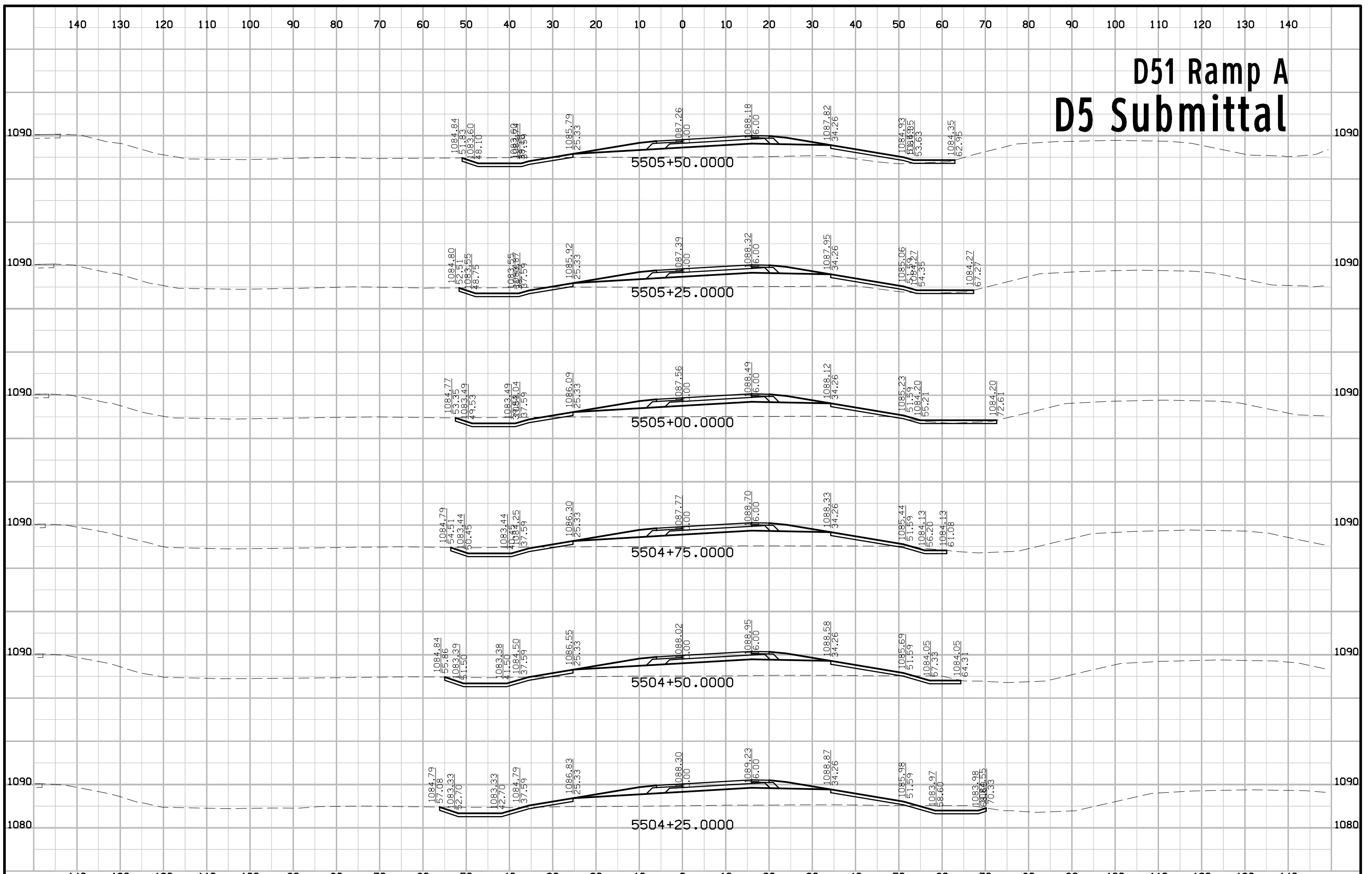

D51 Ramp A D5 Submittal

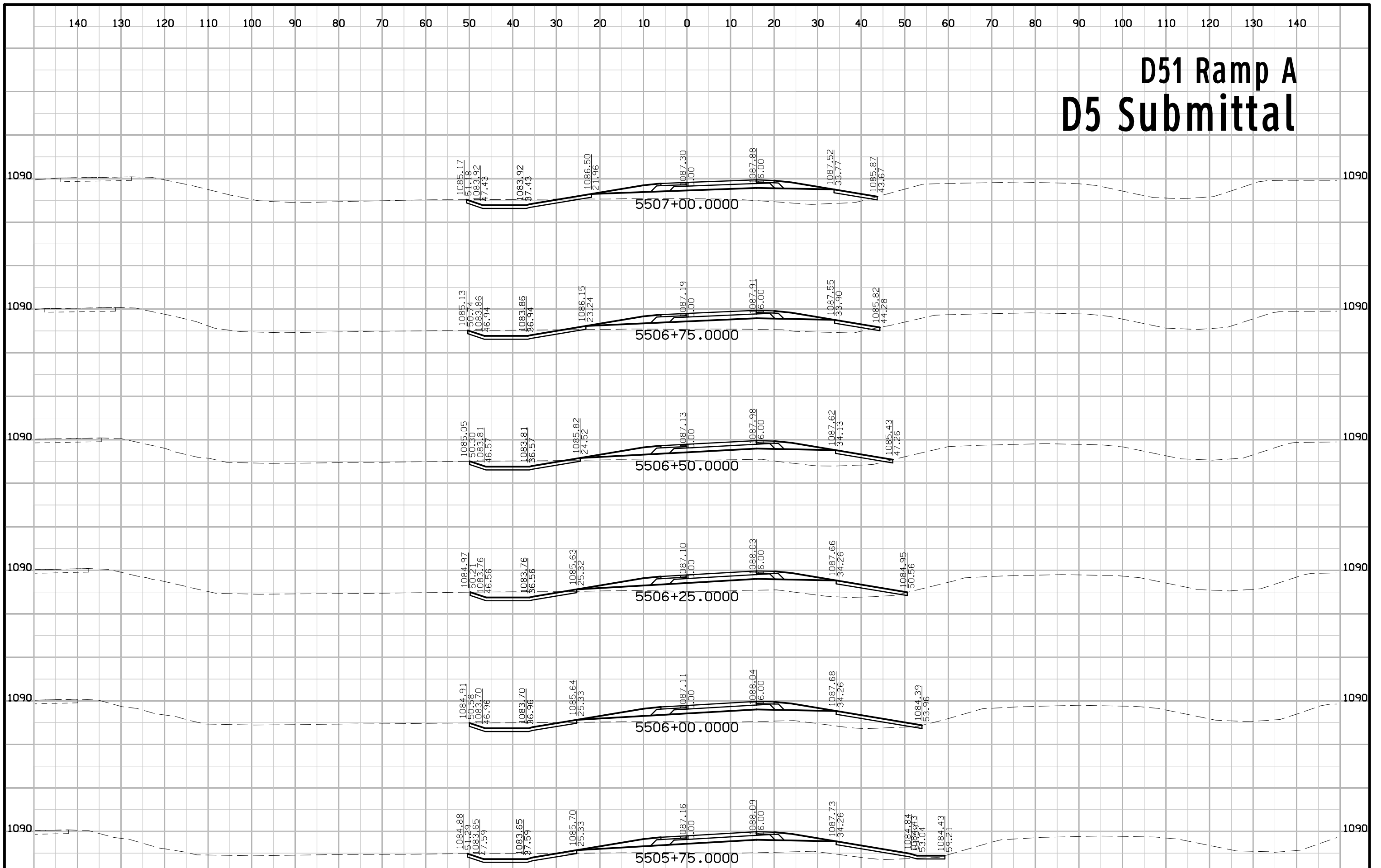

D51 Ramp A D5 Submittal

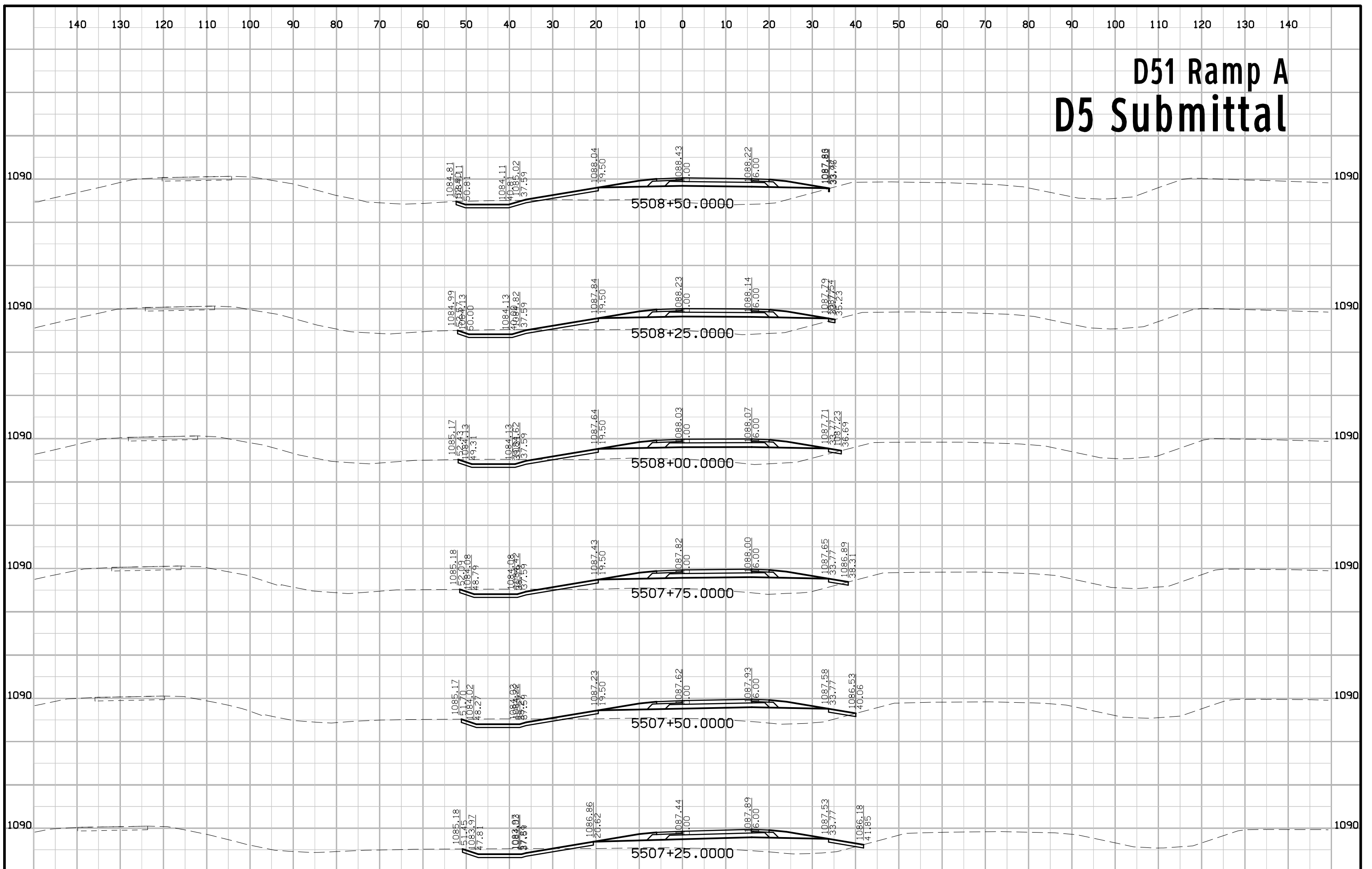

D51 Ramp A D5 Submittal

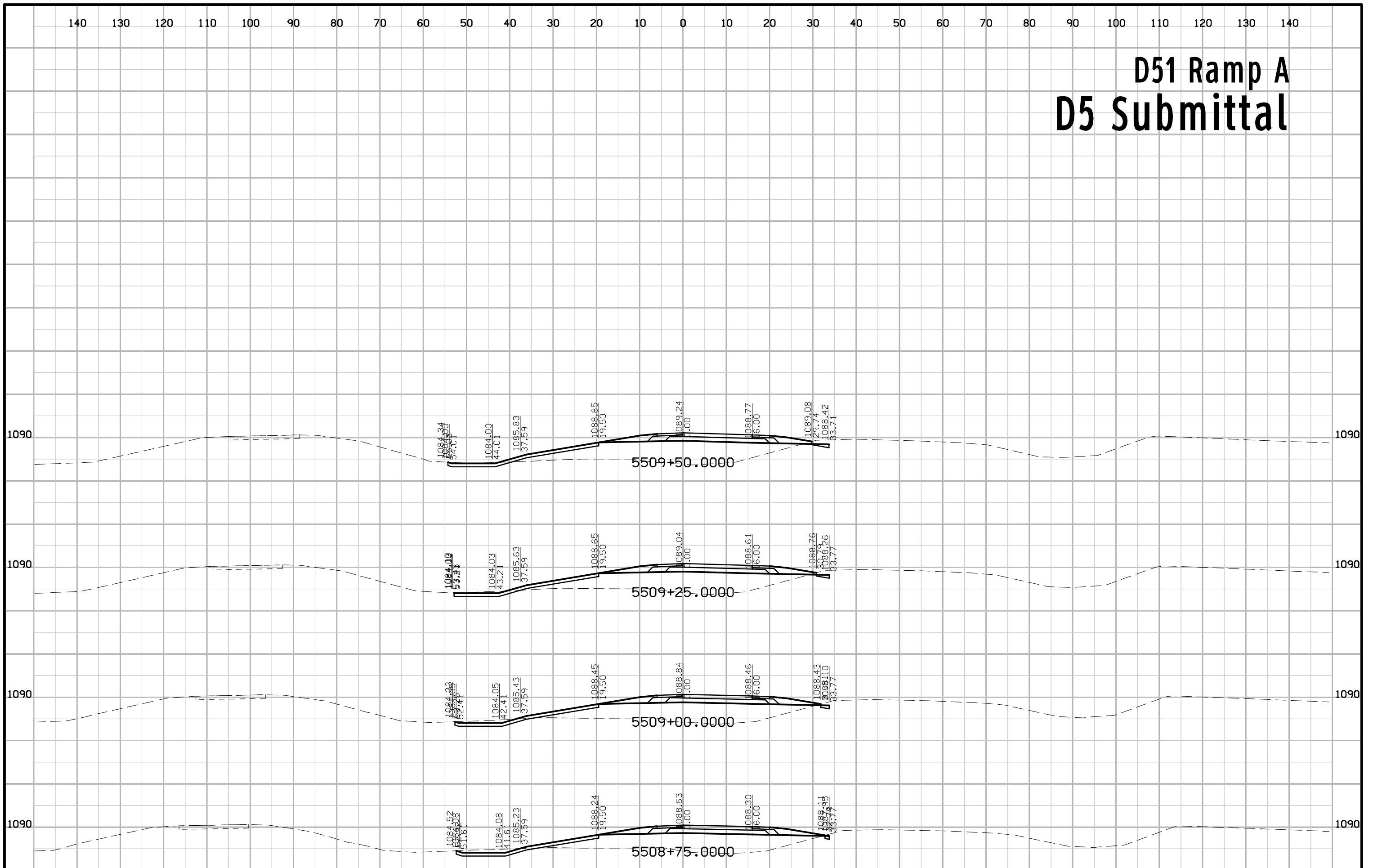

D51 Ramp B D5 Submittal

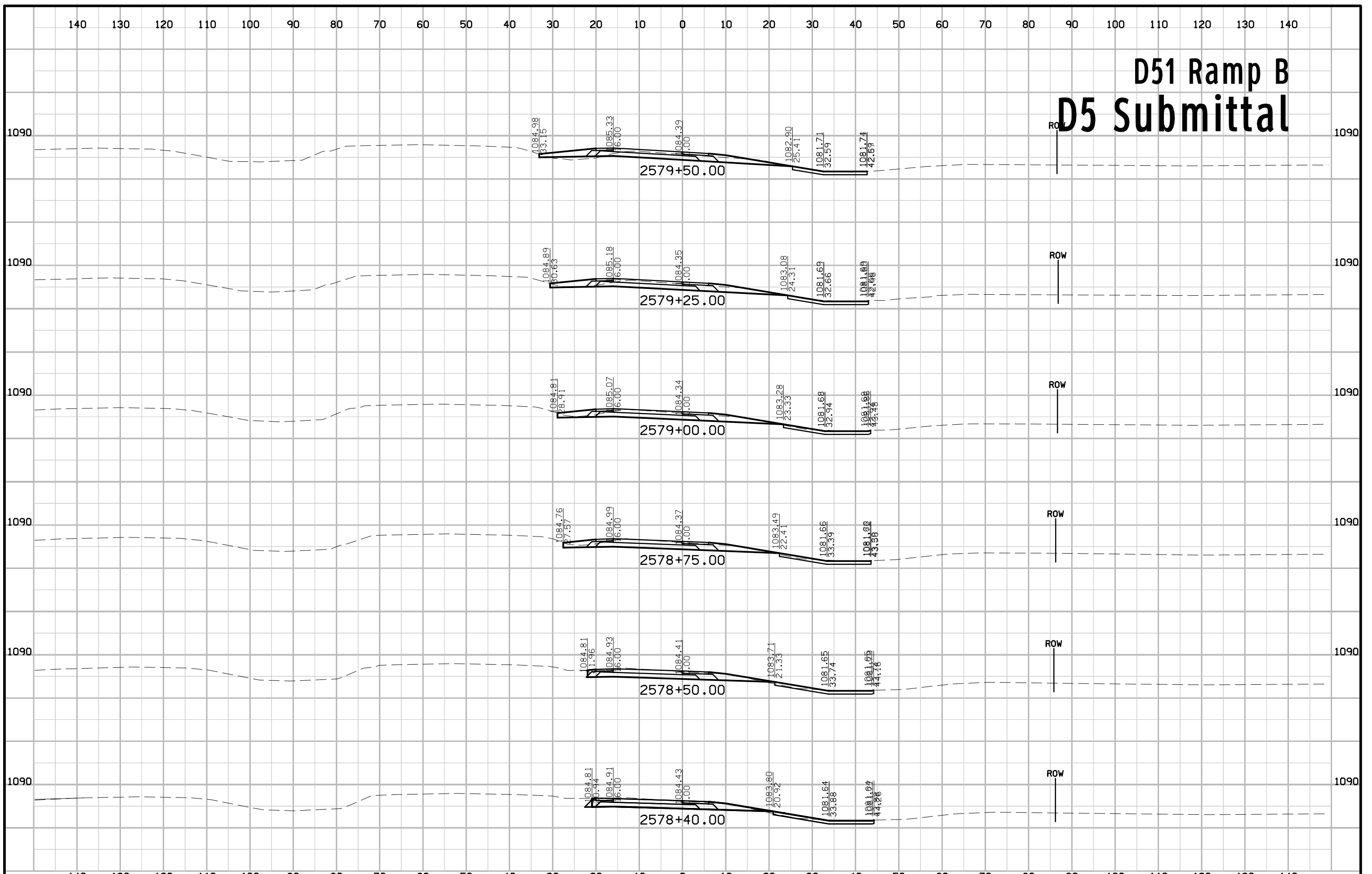

D51 Ramp B D5 Submittal

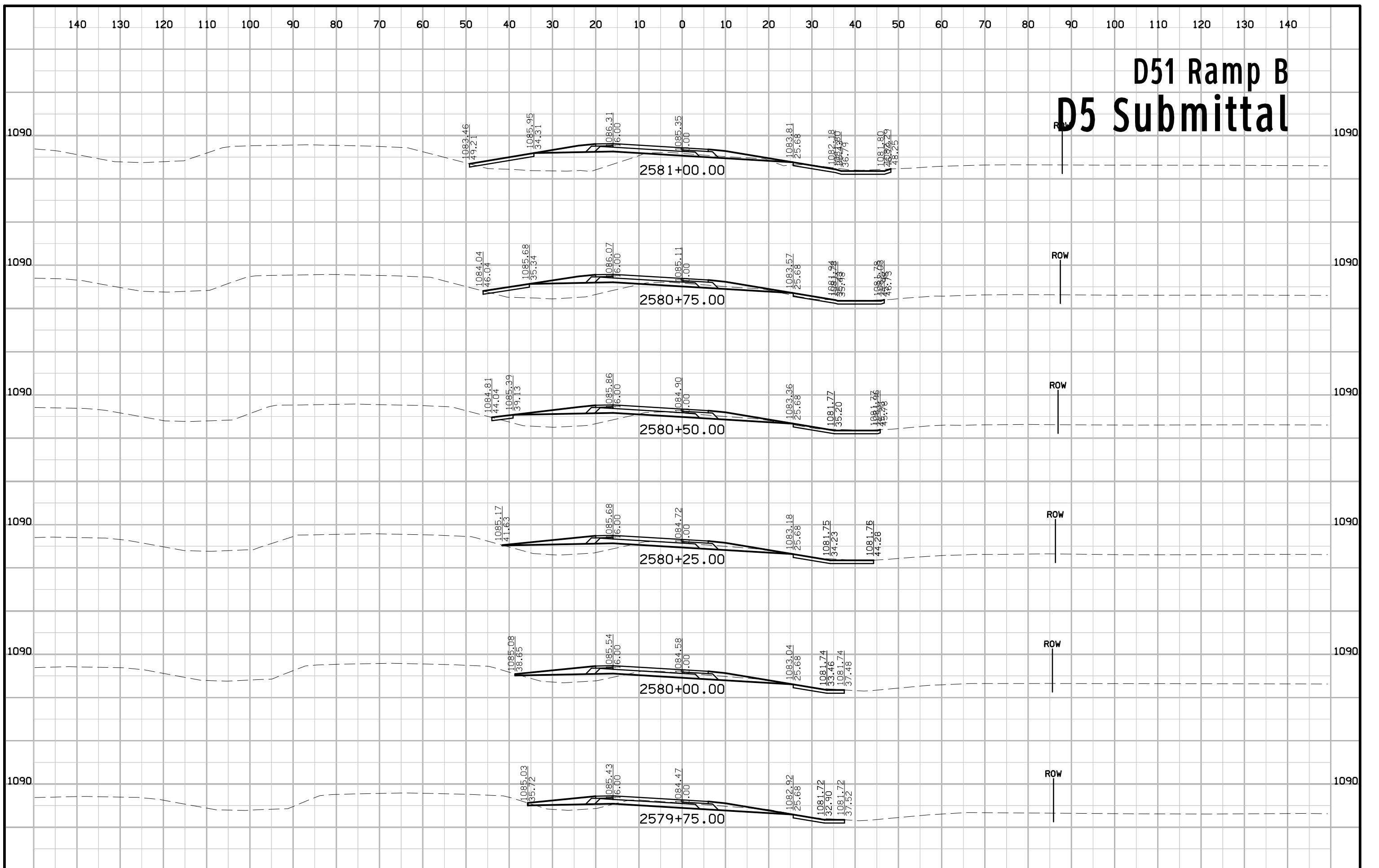

D51 Ramp B D5 Submittal

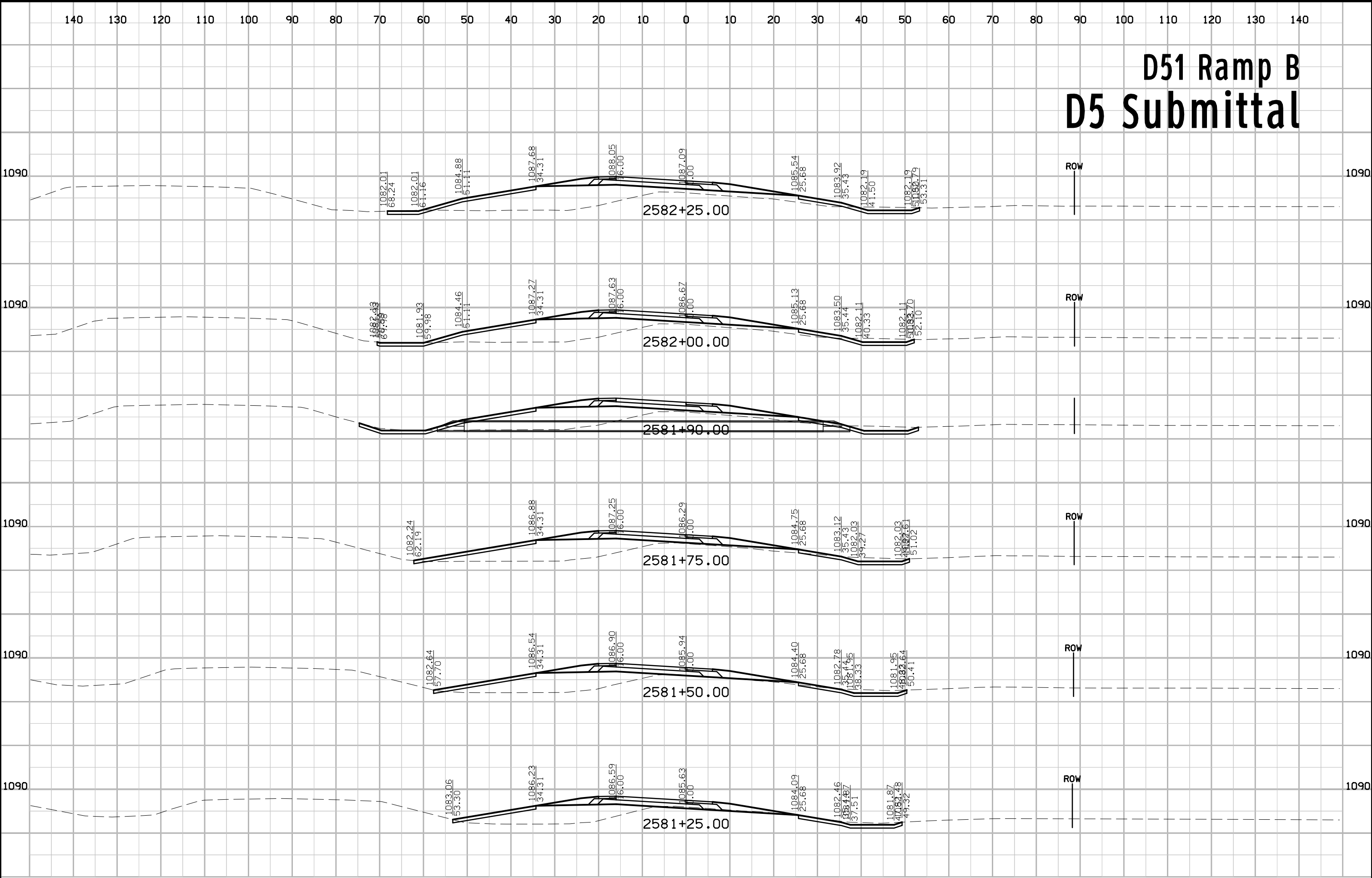

D51 Ramp B D5 Submittal

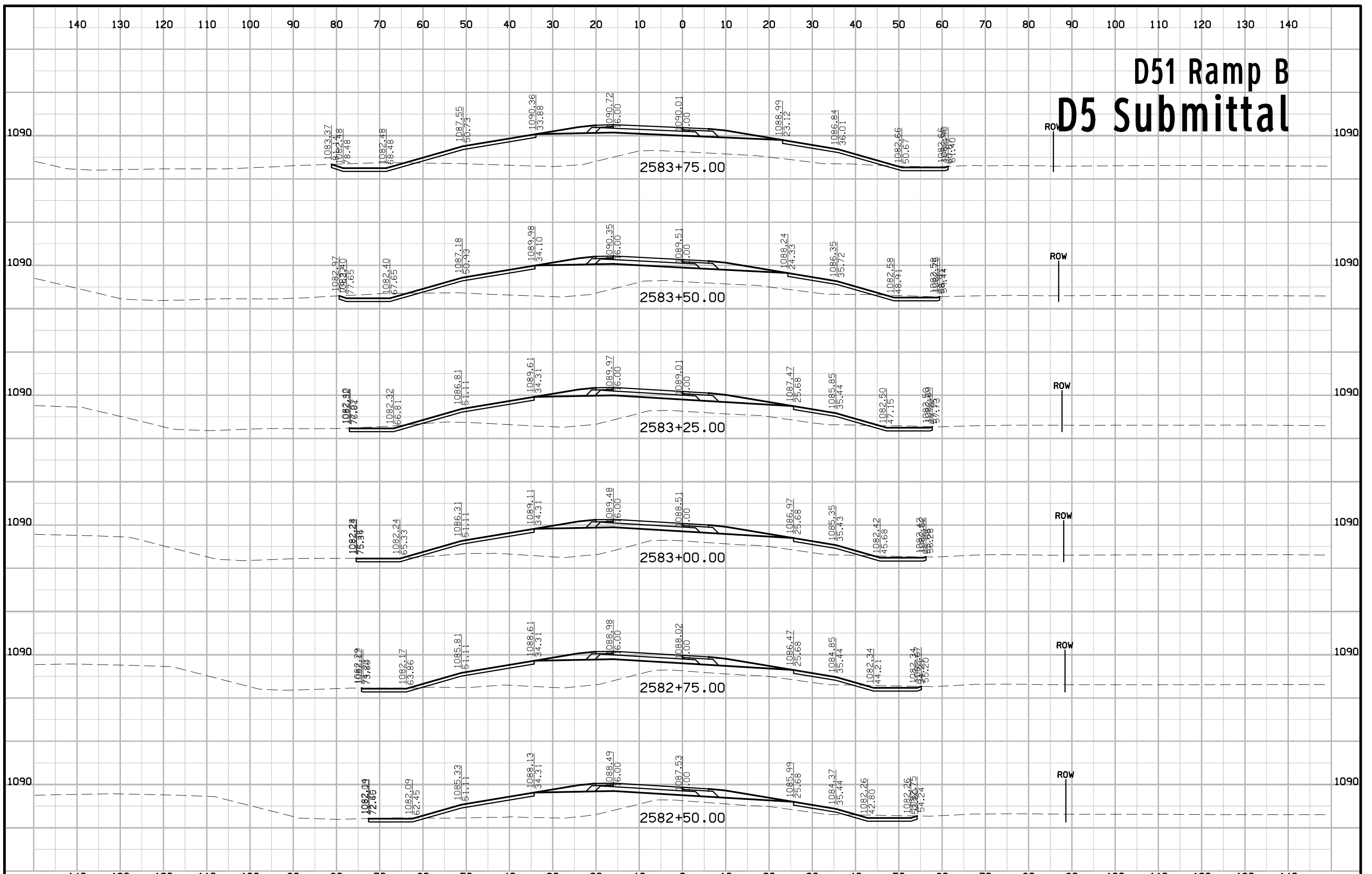

D51 Ramp B D5 Submittal

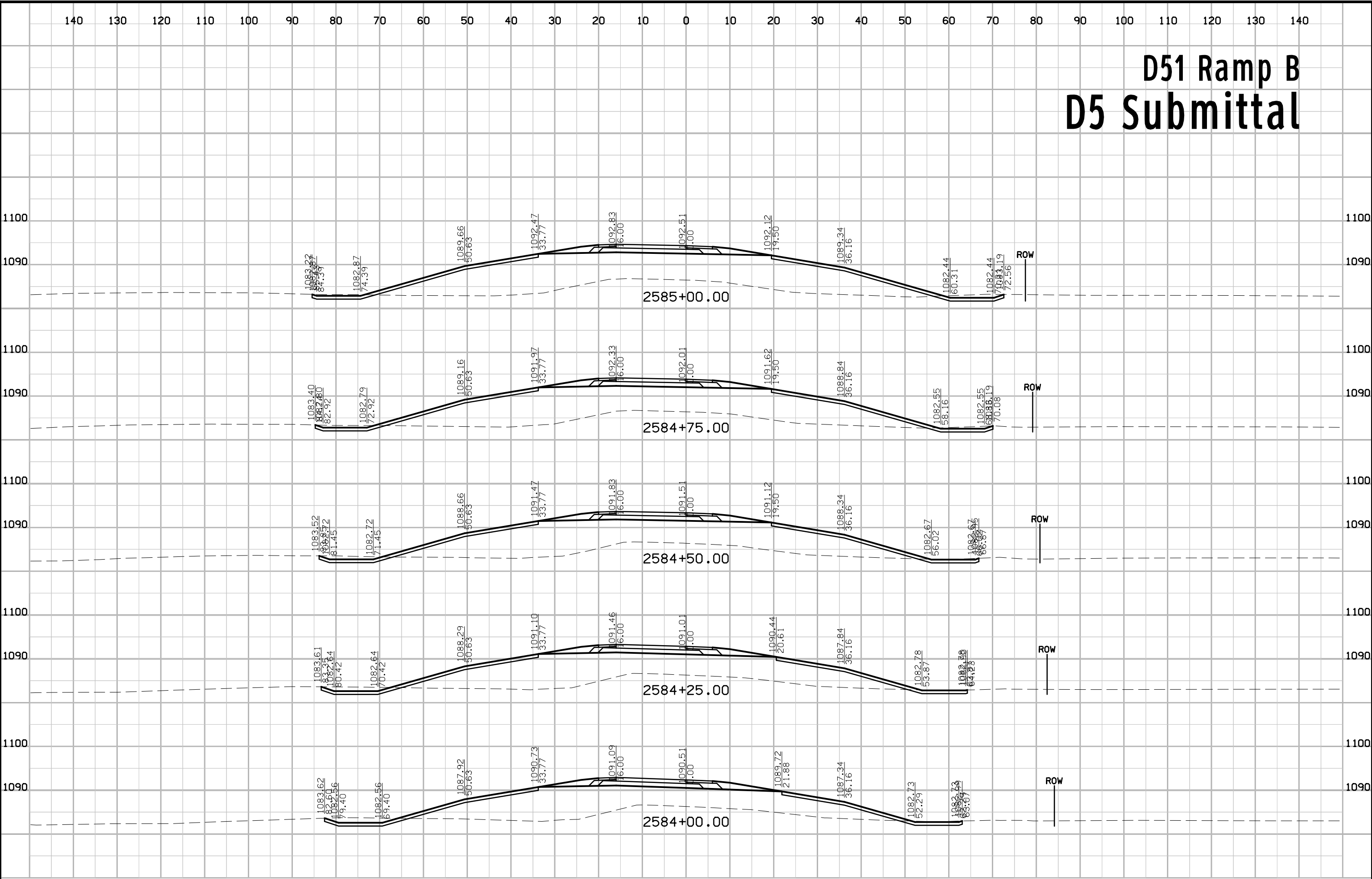

D51 Ramp B D5 Submittal

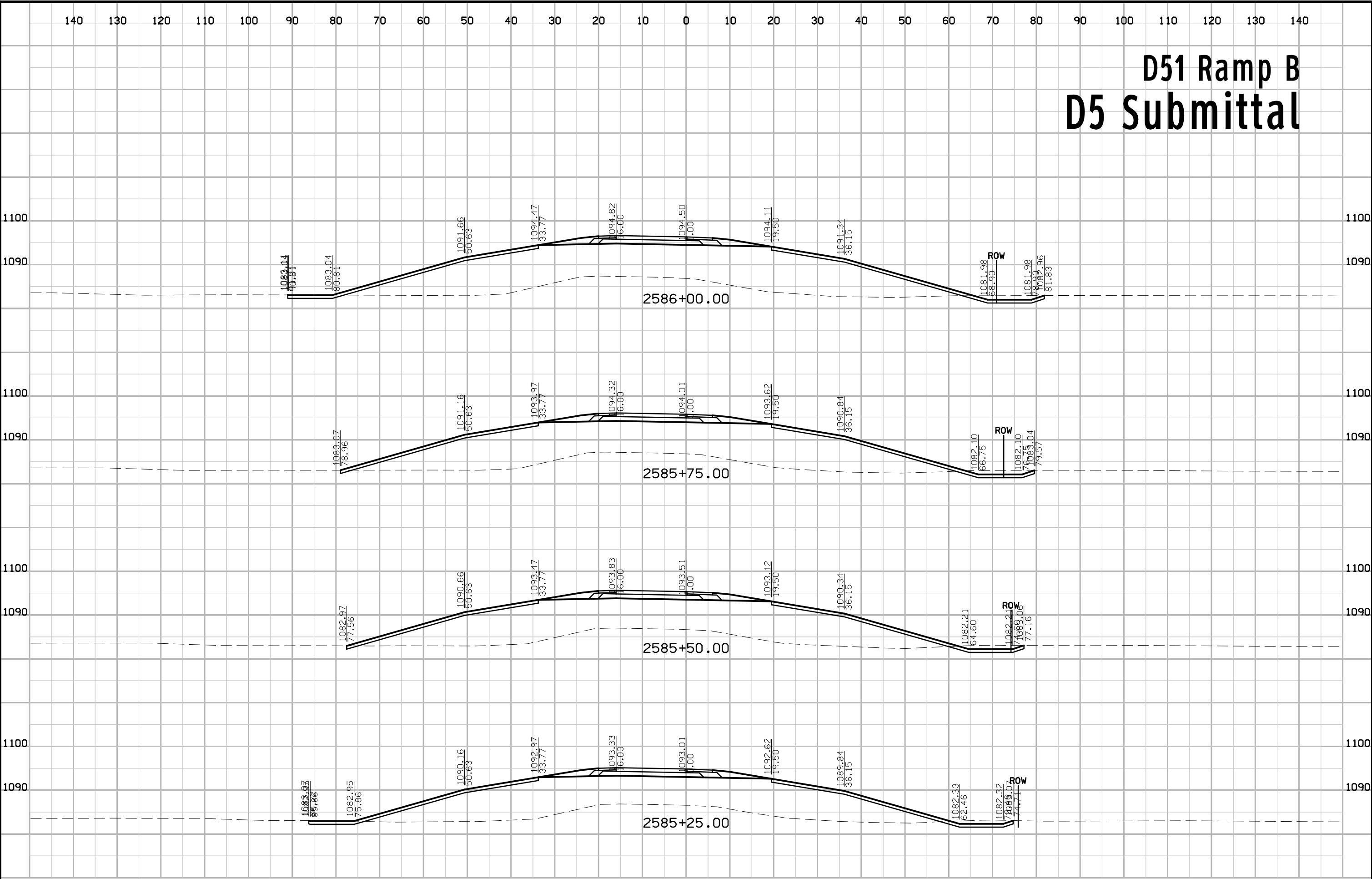

D51 Ramp B D5 Submittal

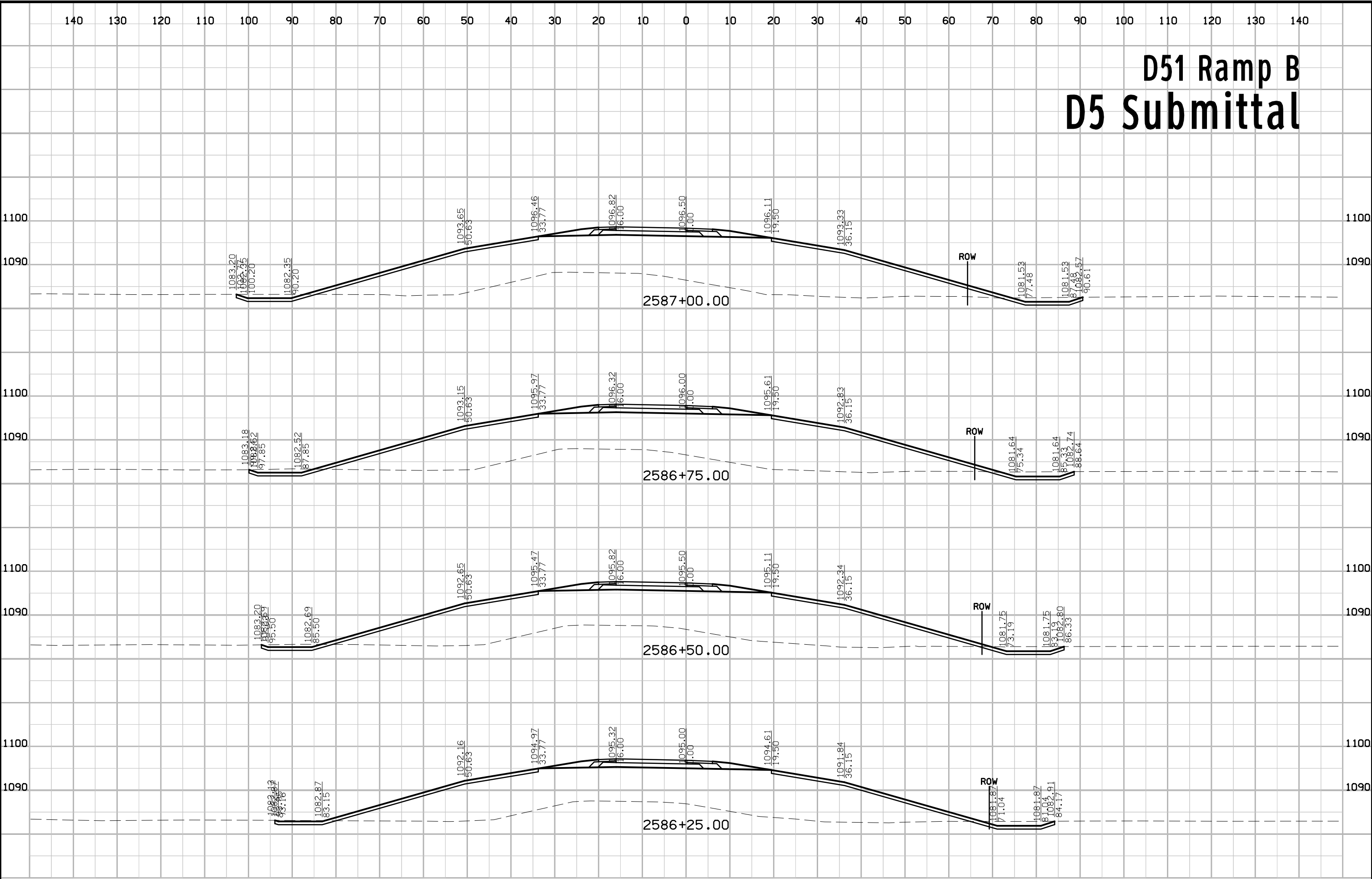

D51 Ramp B D5 Submittal

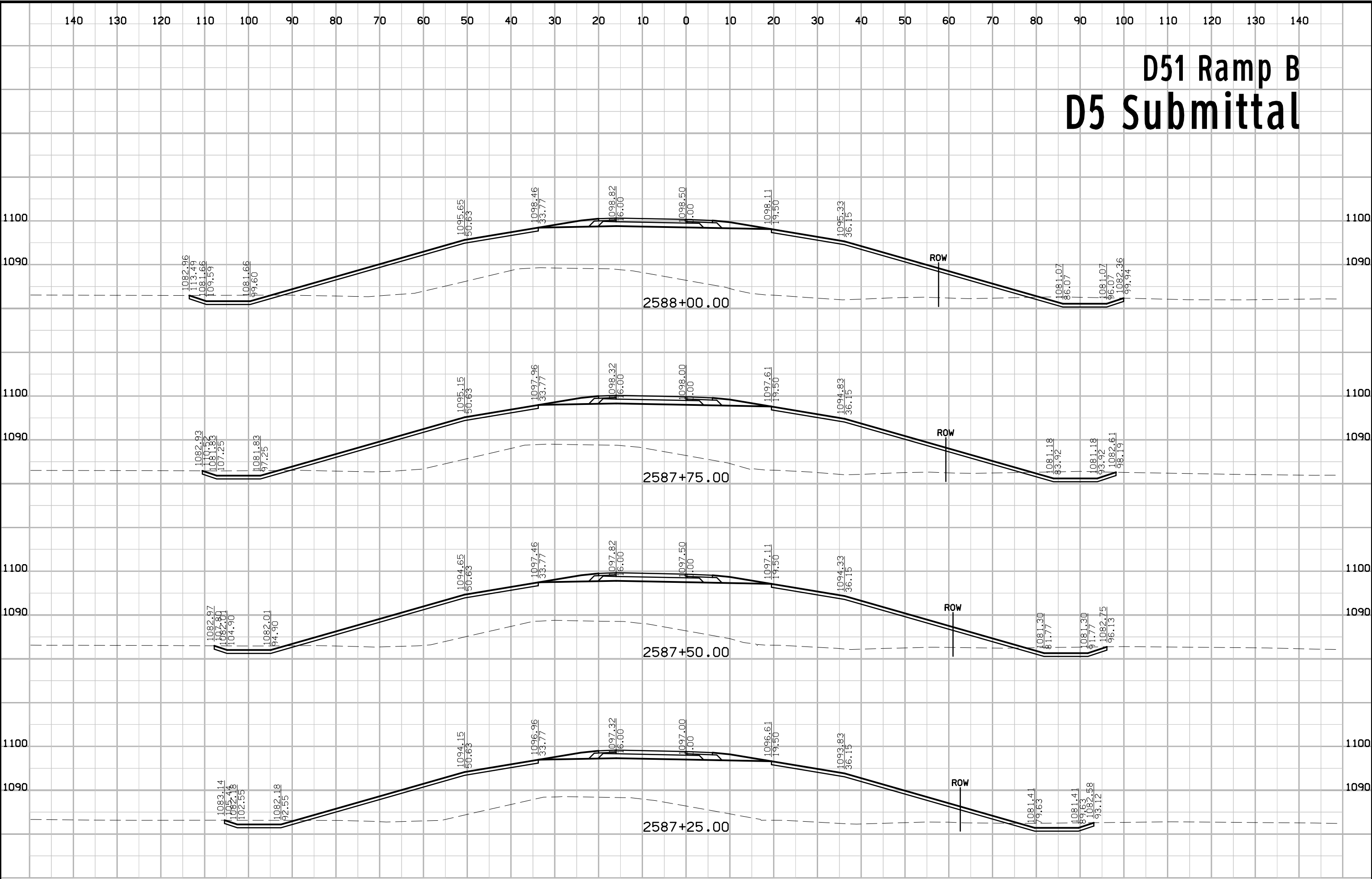

D51 Ramp B D5 Submittal

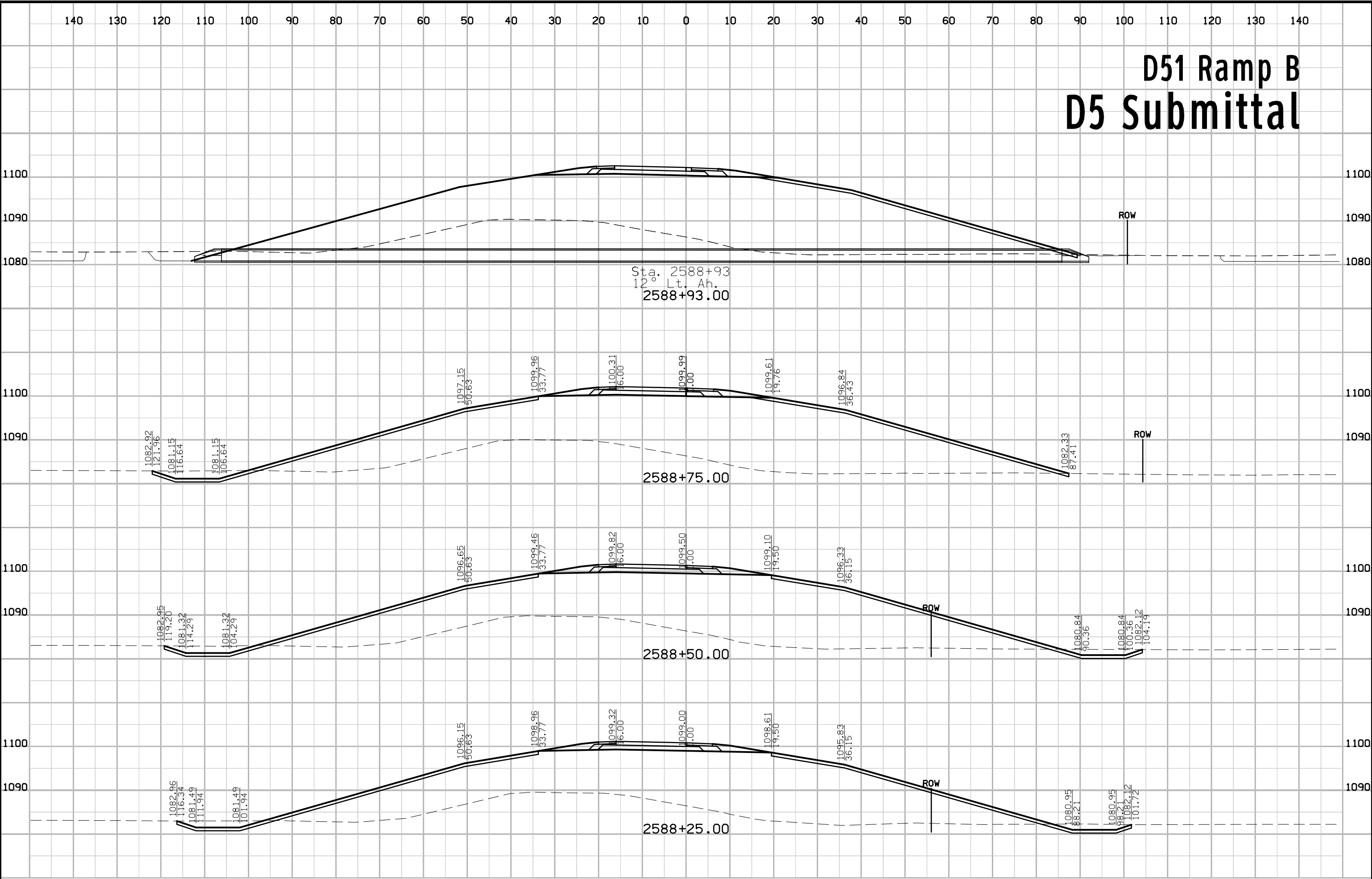

D51 Ramp B D5 Submittal

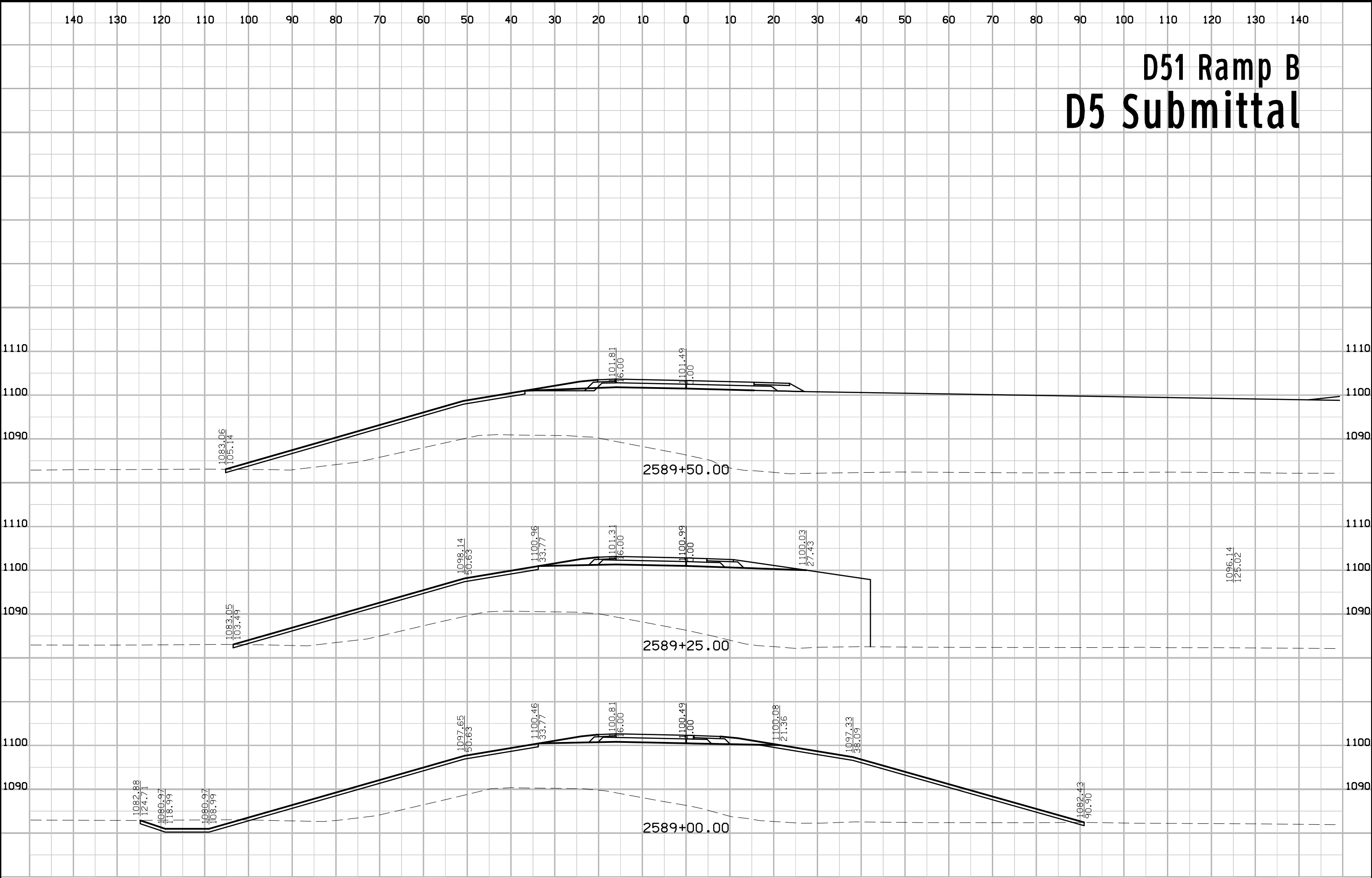

D51 Ramp C D5 Submittal

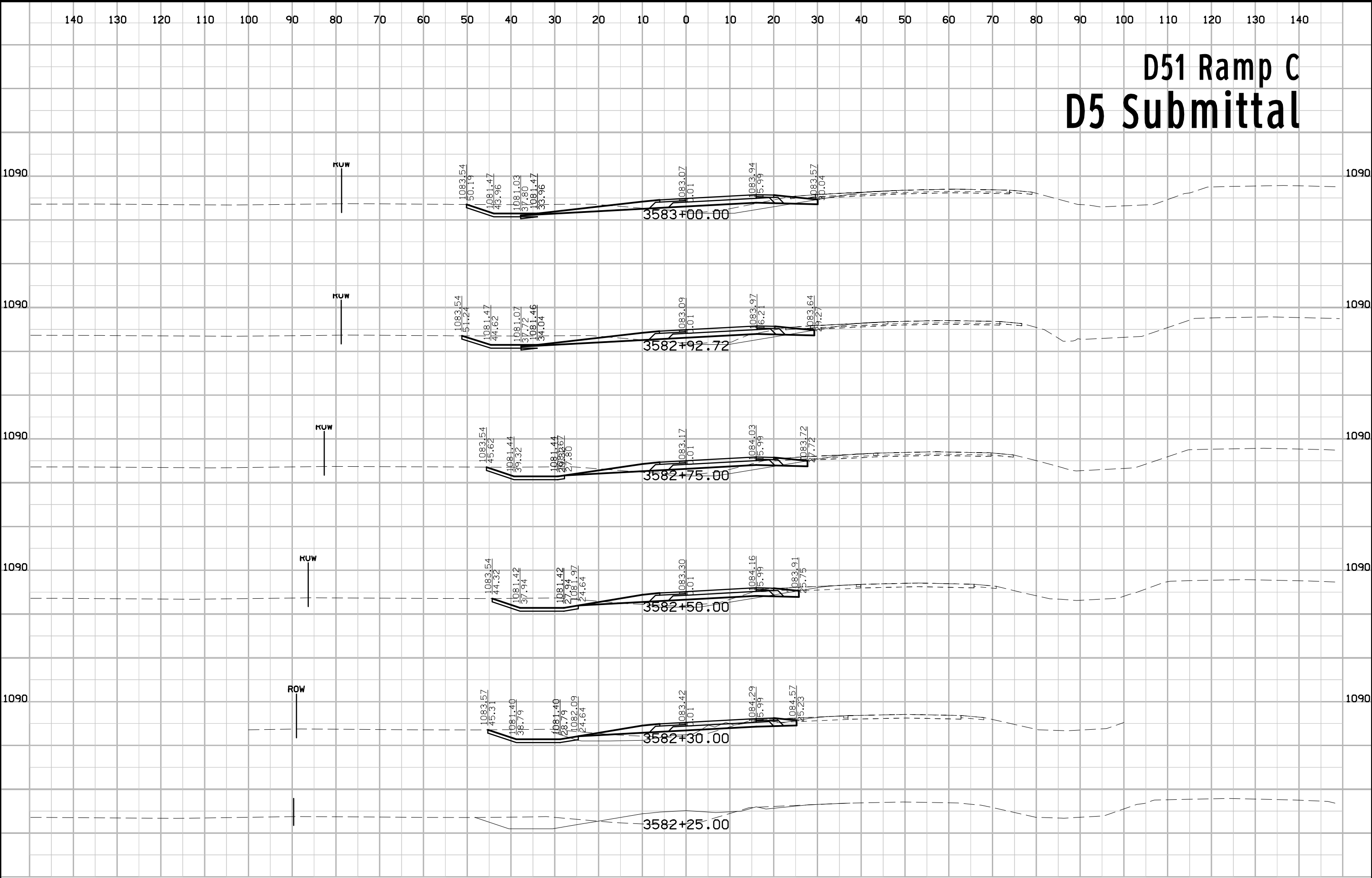

D51 Ramp C D5 Submittal

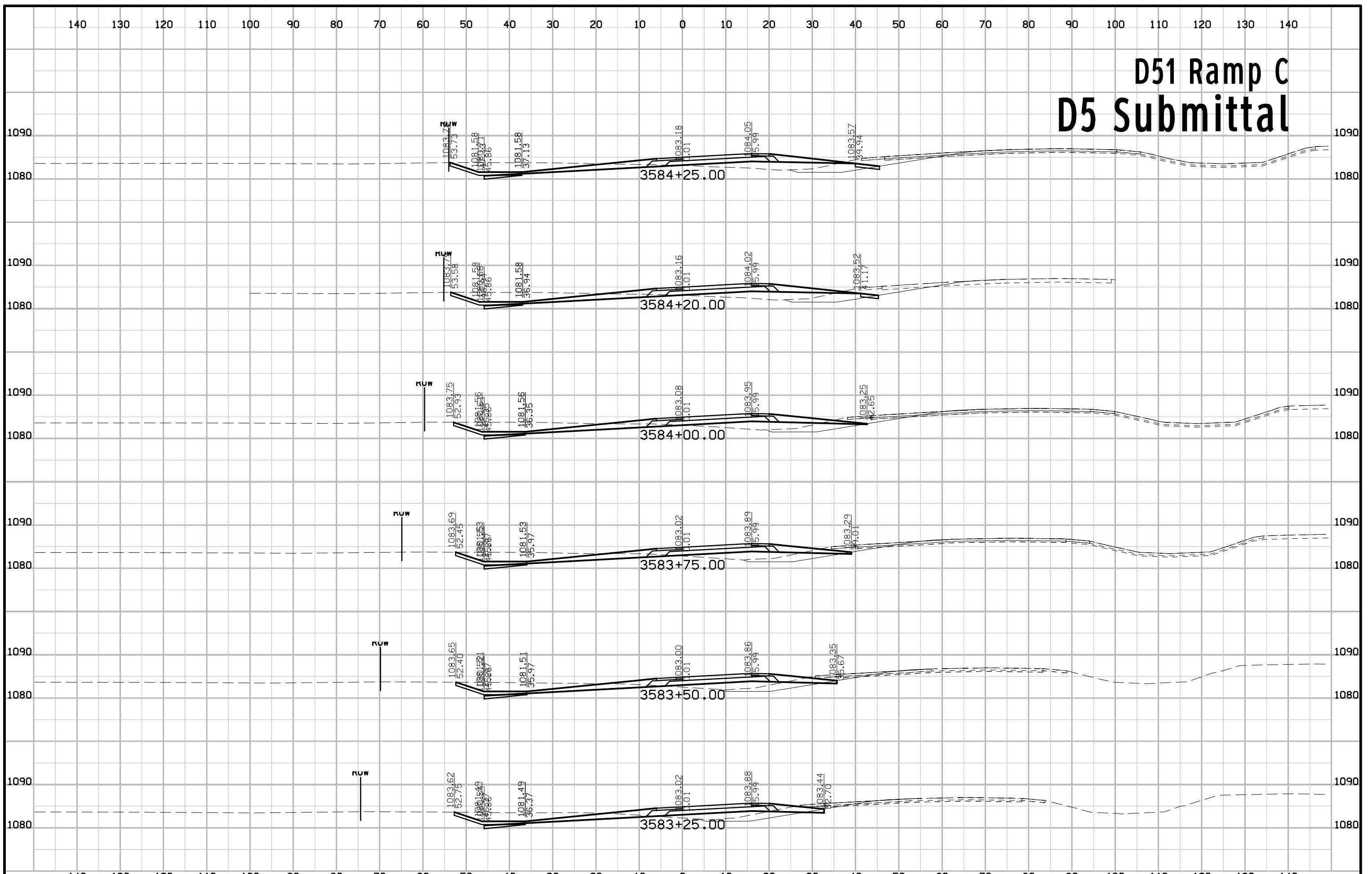

D51 Ramp C D5 Submittal

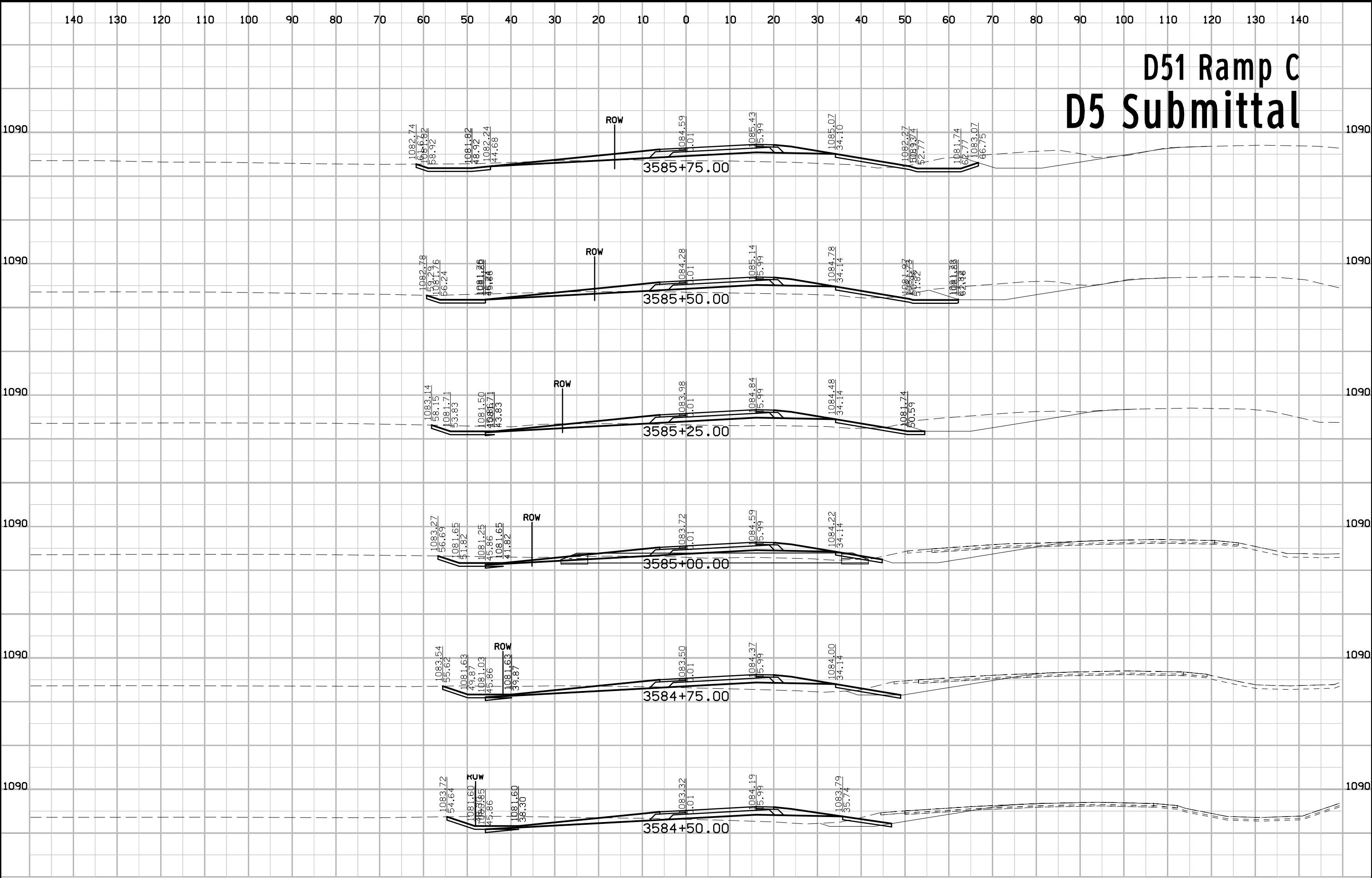

D51 Ramp C D5 Submittal

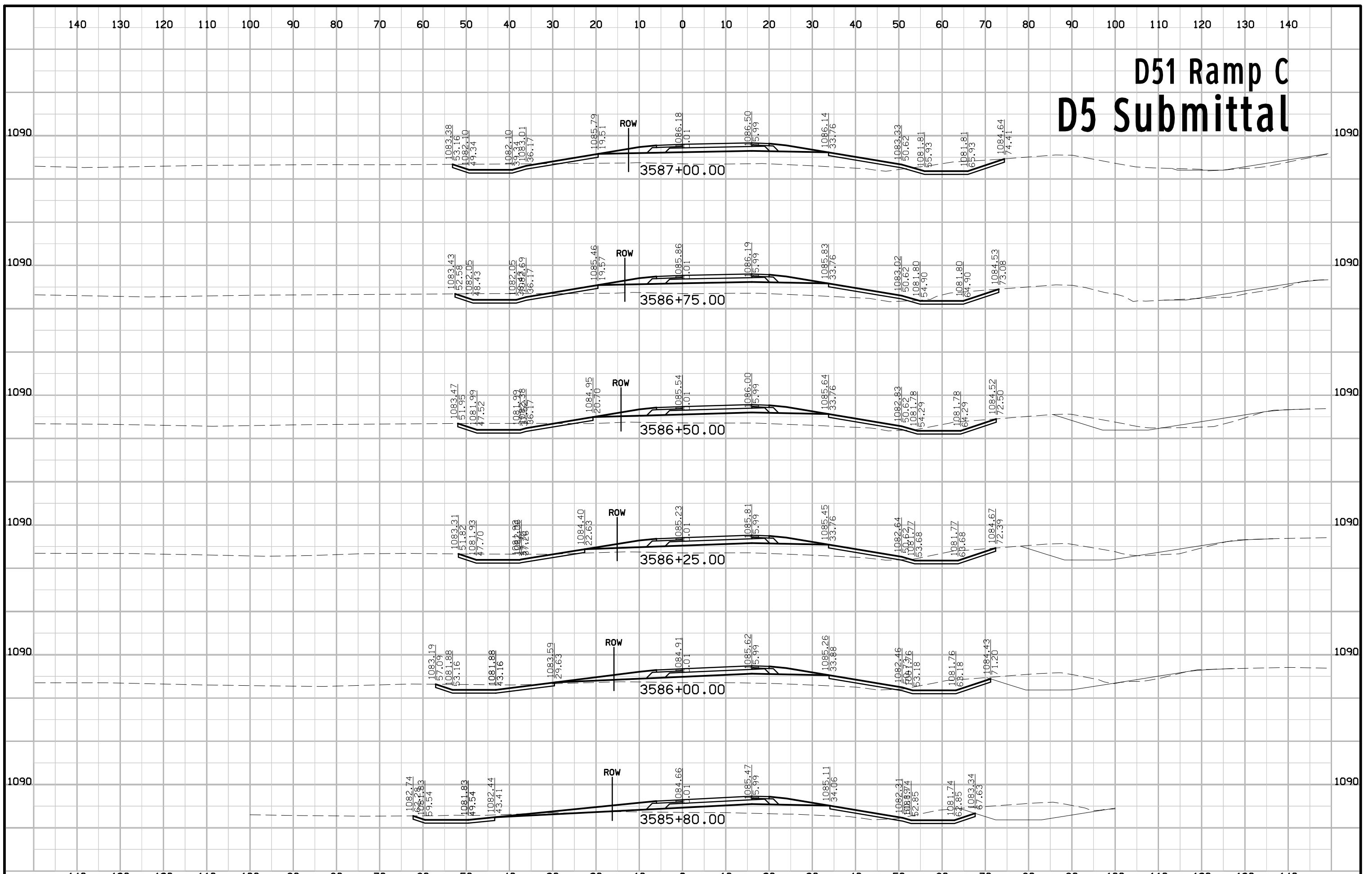

D51 Ramp C D5 Submittal

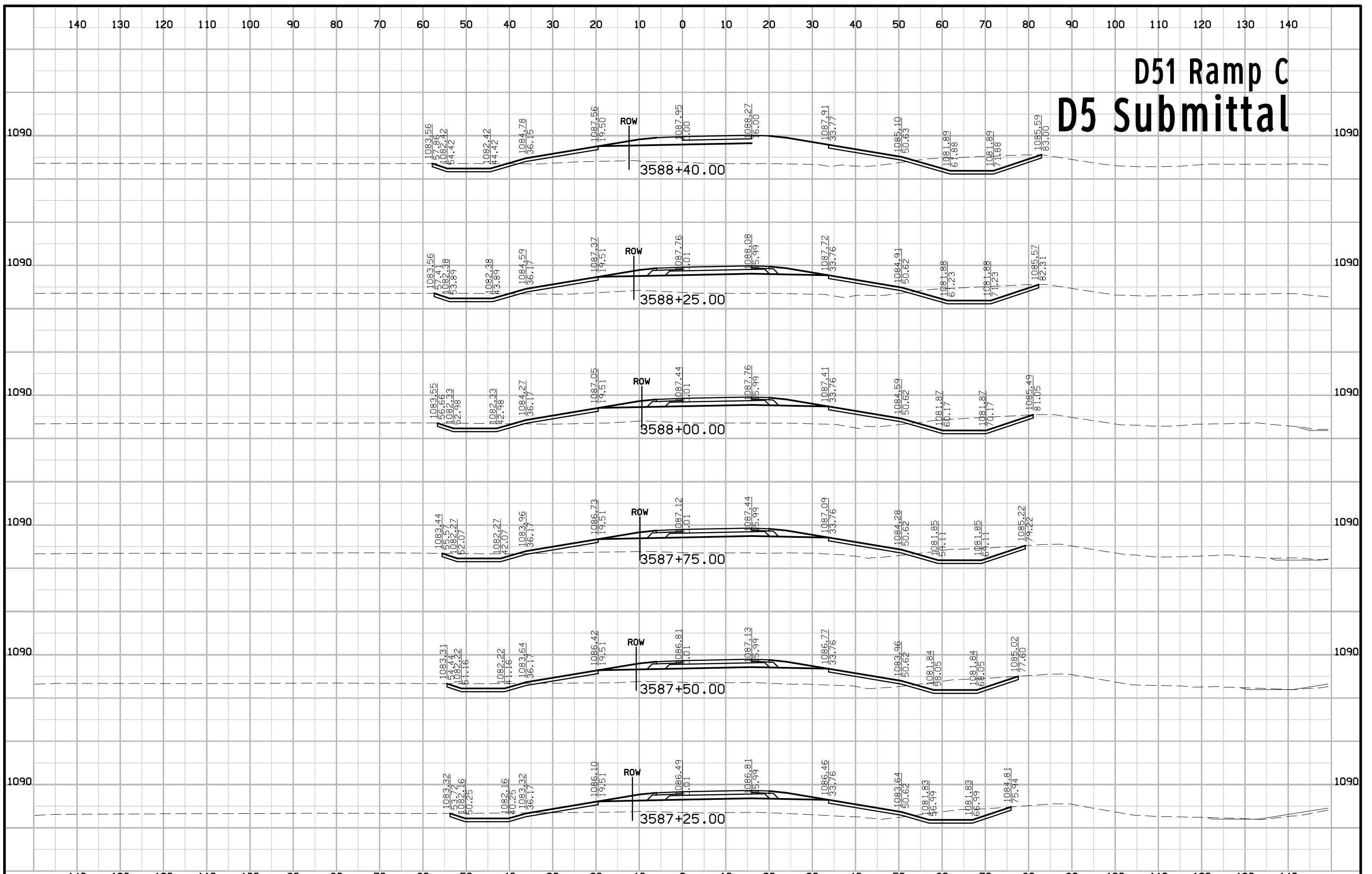

D51 Ramp C D5 Submittal

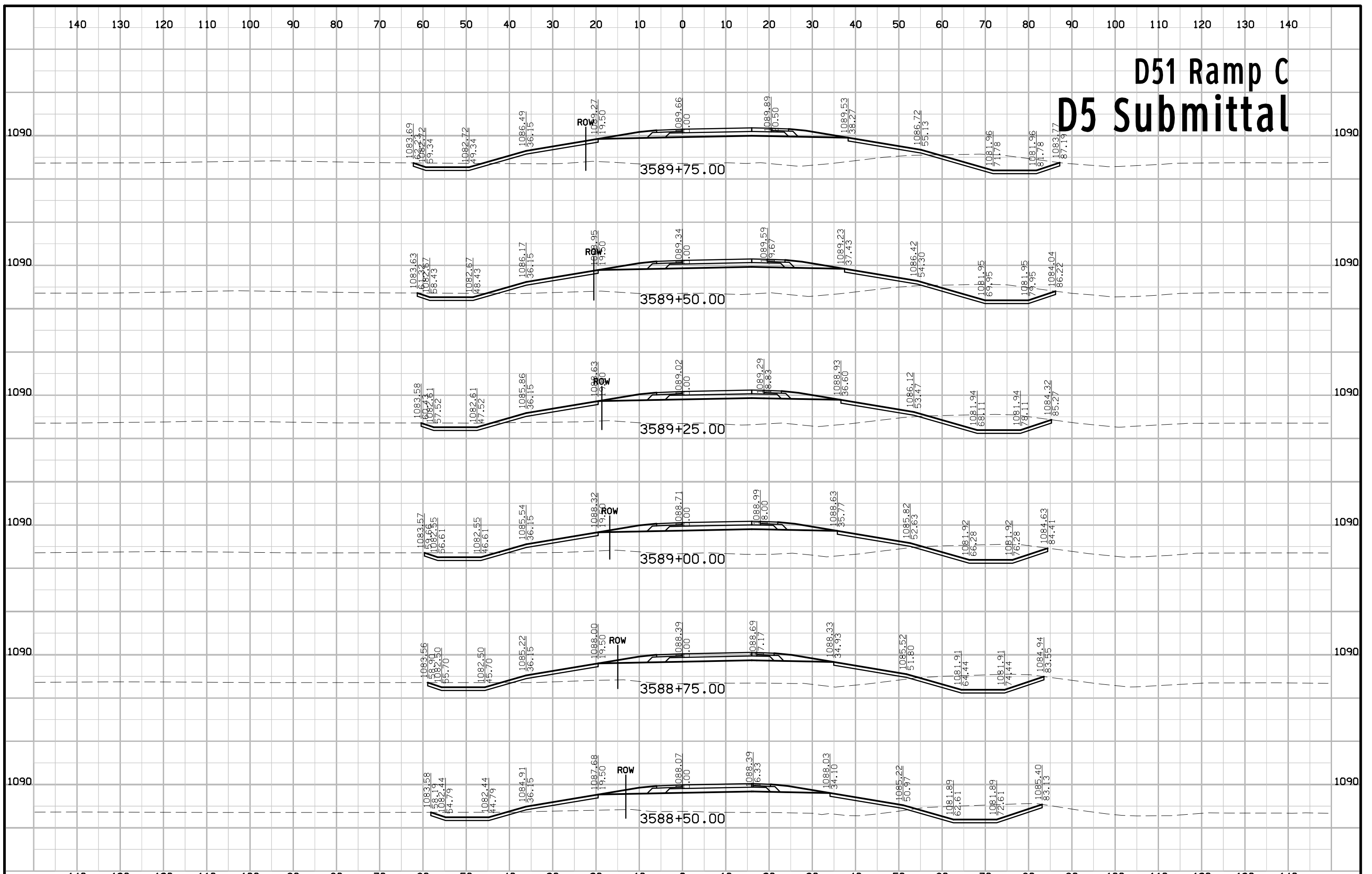

D51 Ramp C D5 Submittal

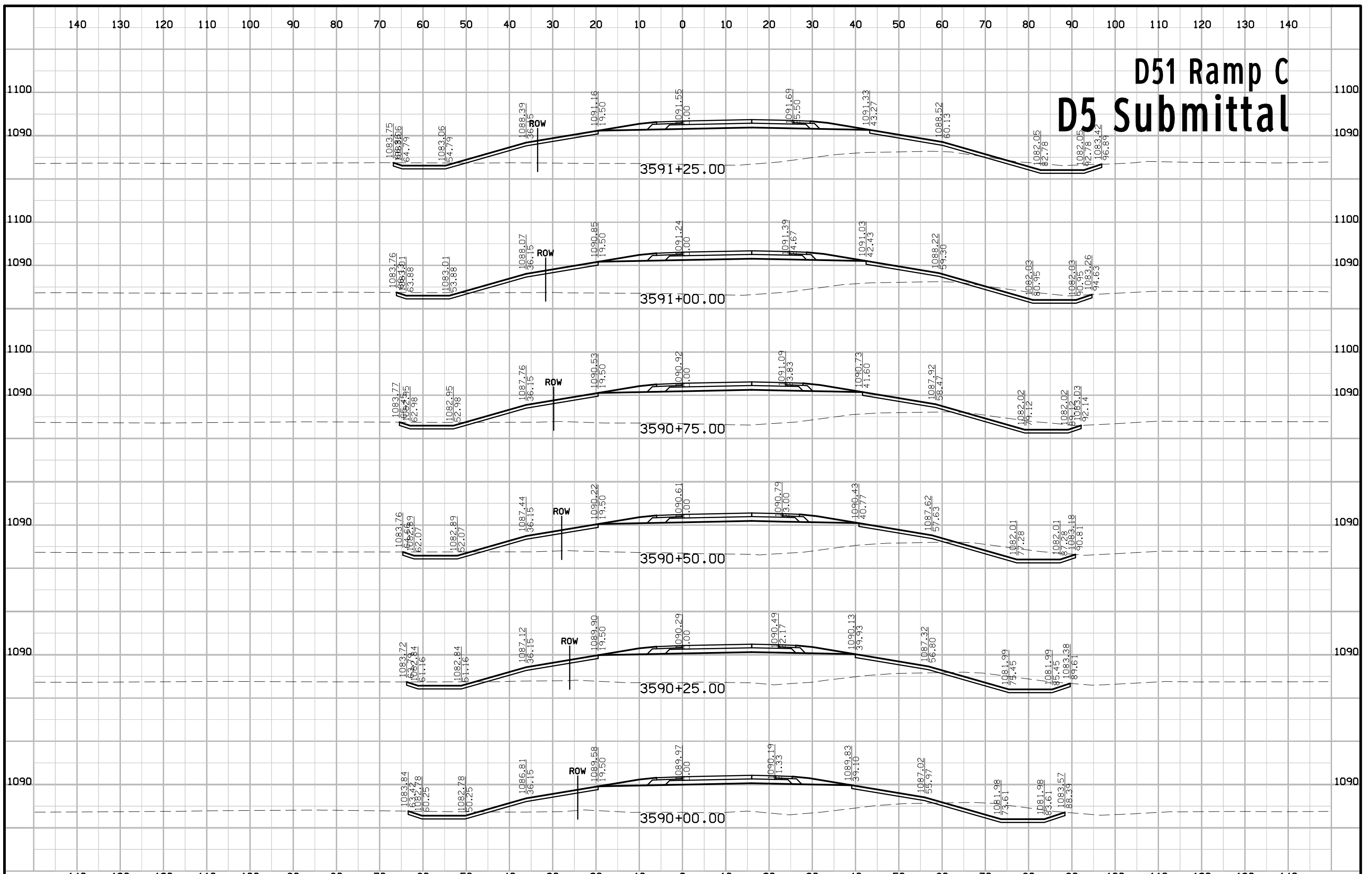

D51 Ramp C D5 Submittal

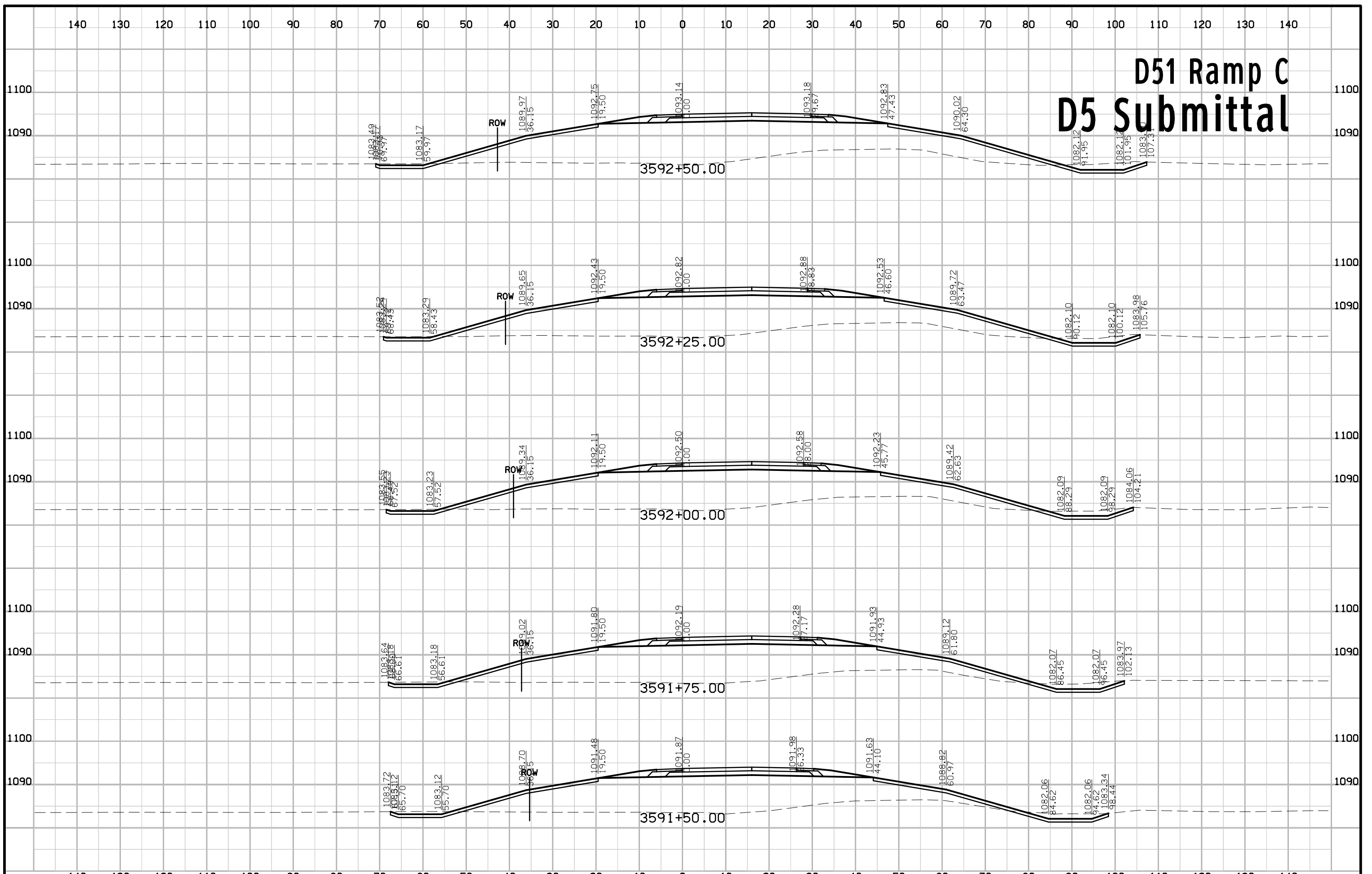

D51 Ramp C D5 Submittal

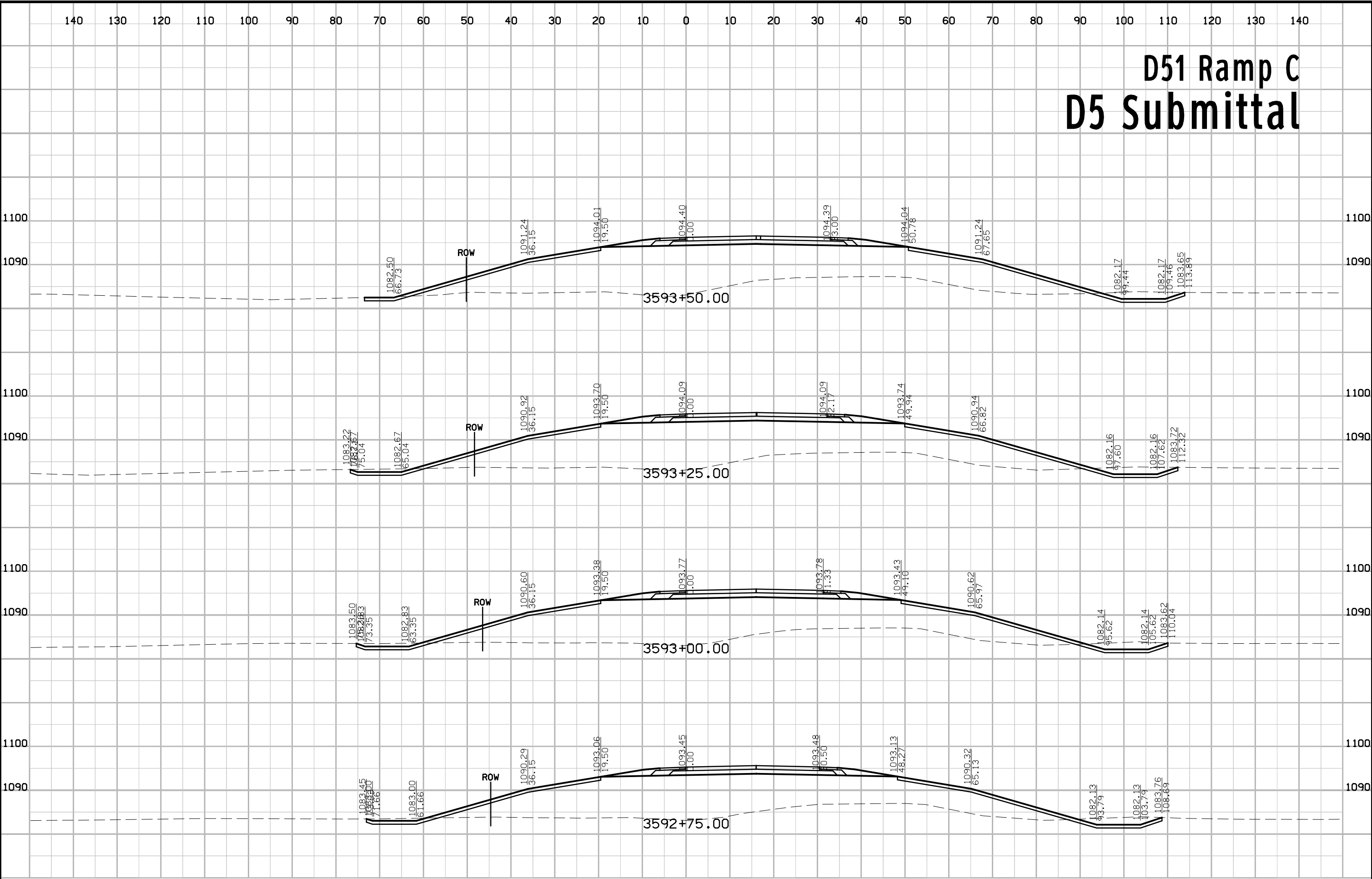

D51 Ramp C D5 Submittal

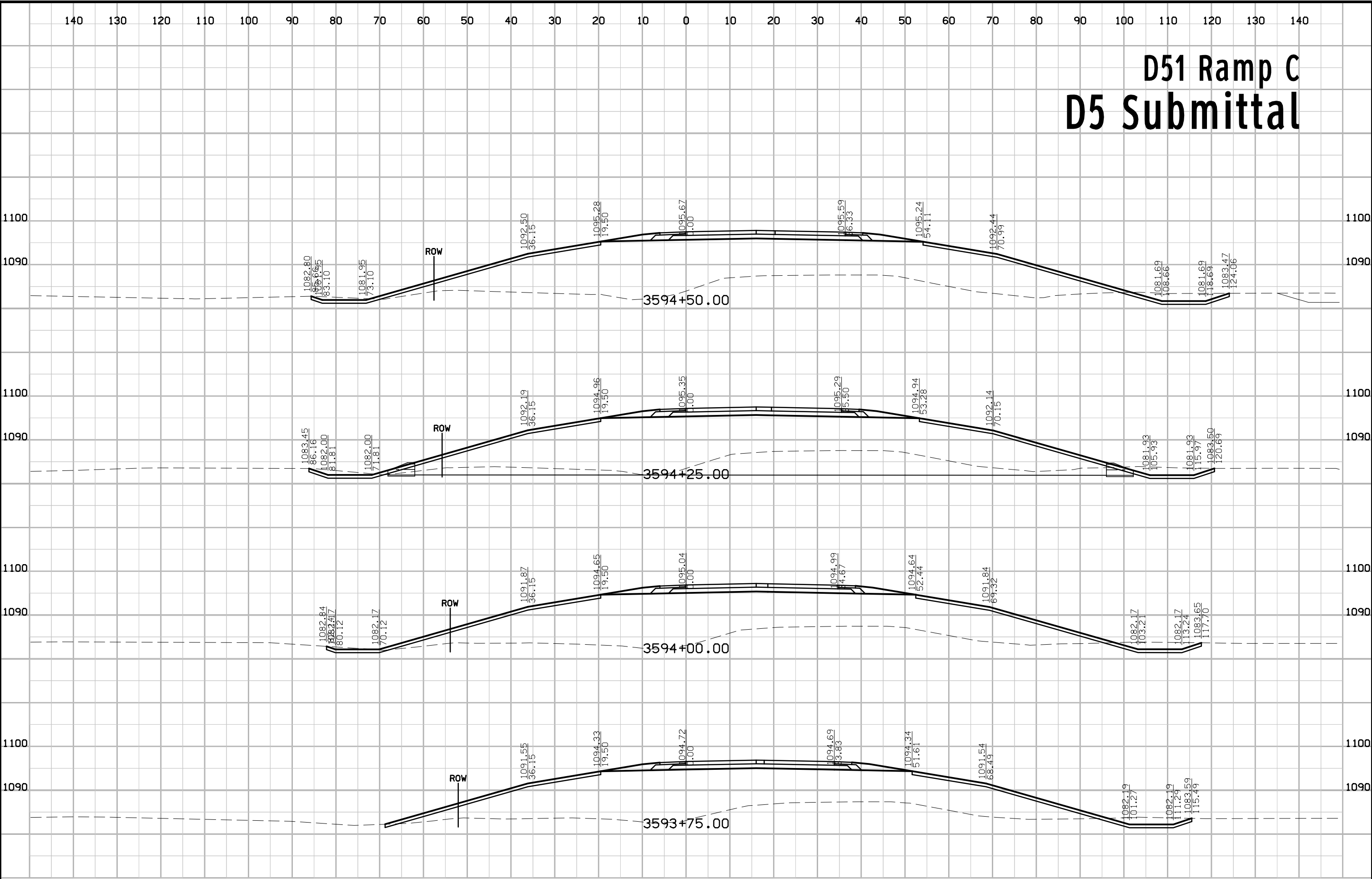

D51 Ramp C D5 Submittal

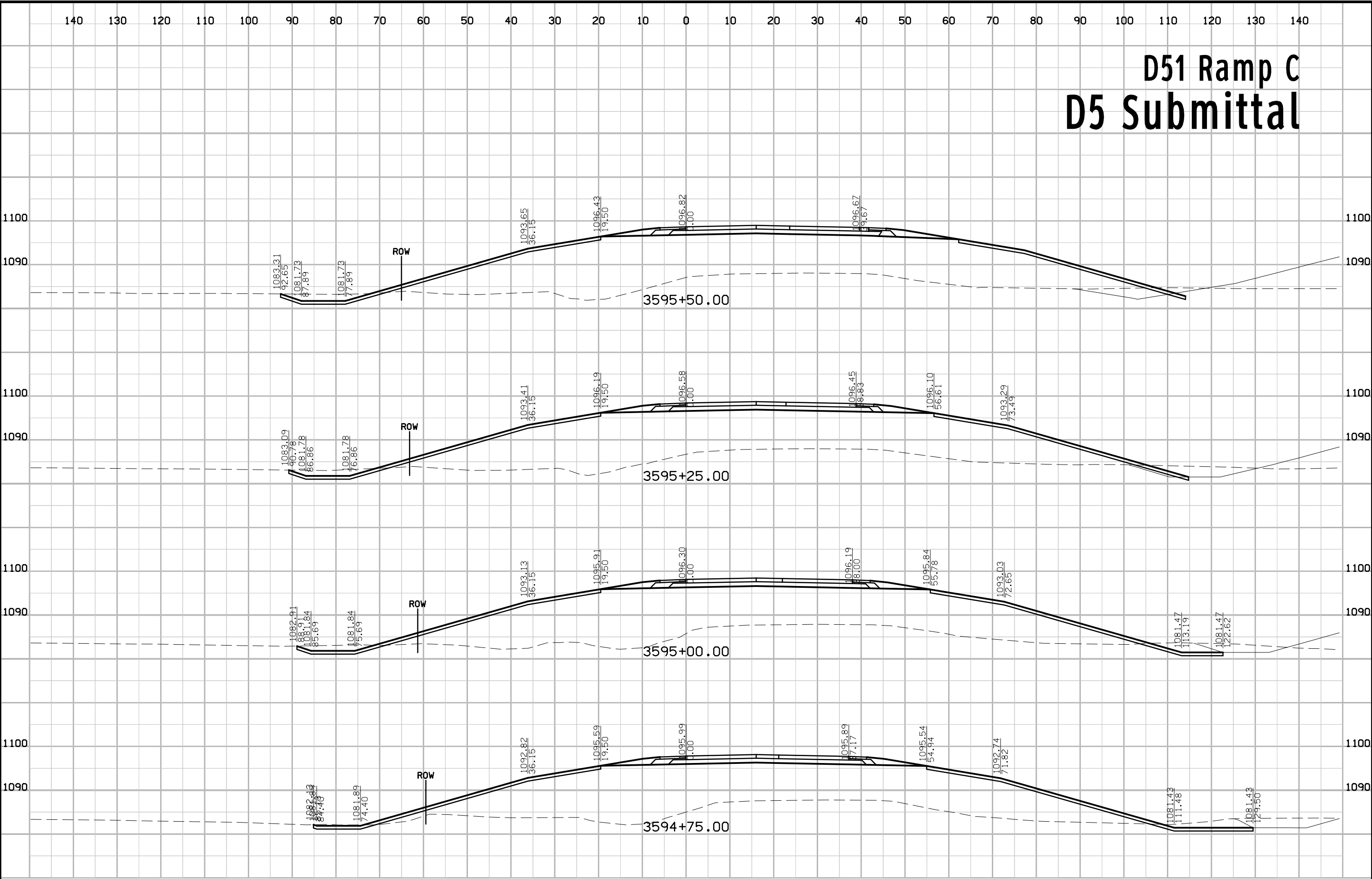

D51 Ramp C D5 Submittal

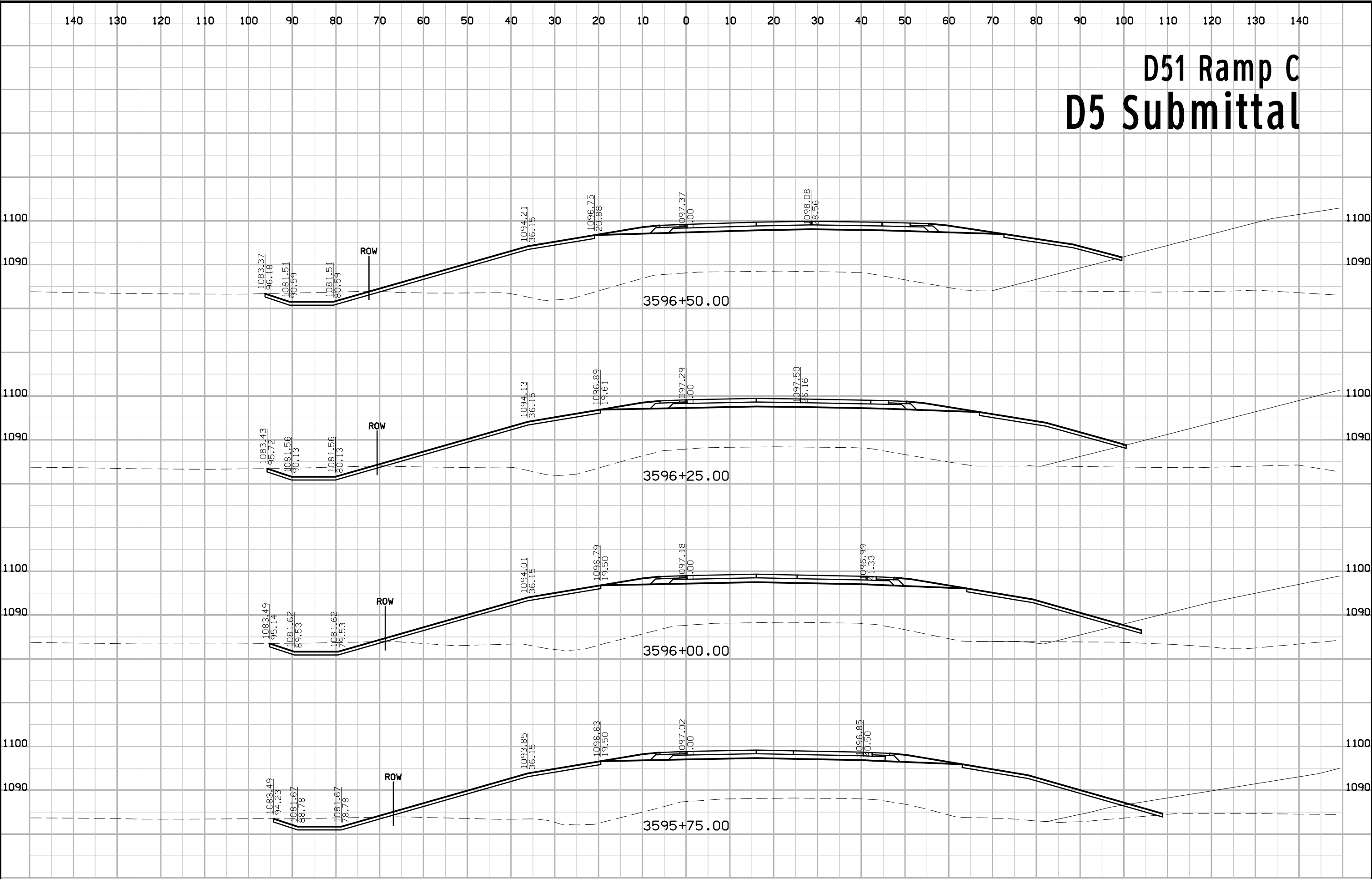

D51 Ramp C D5 Submittal

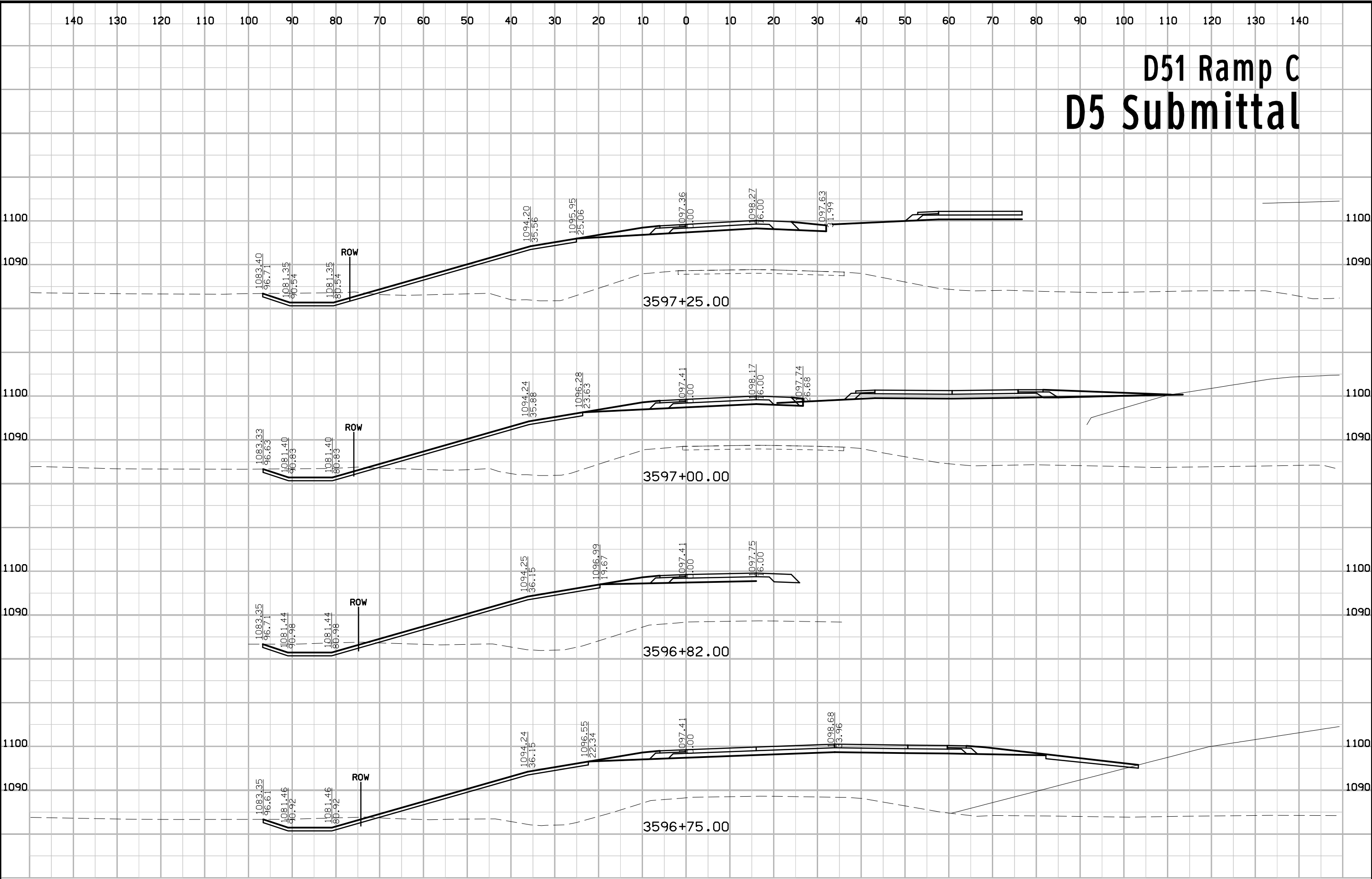

D51 Ramp C D5 Submittal

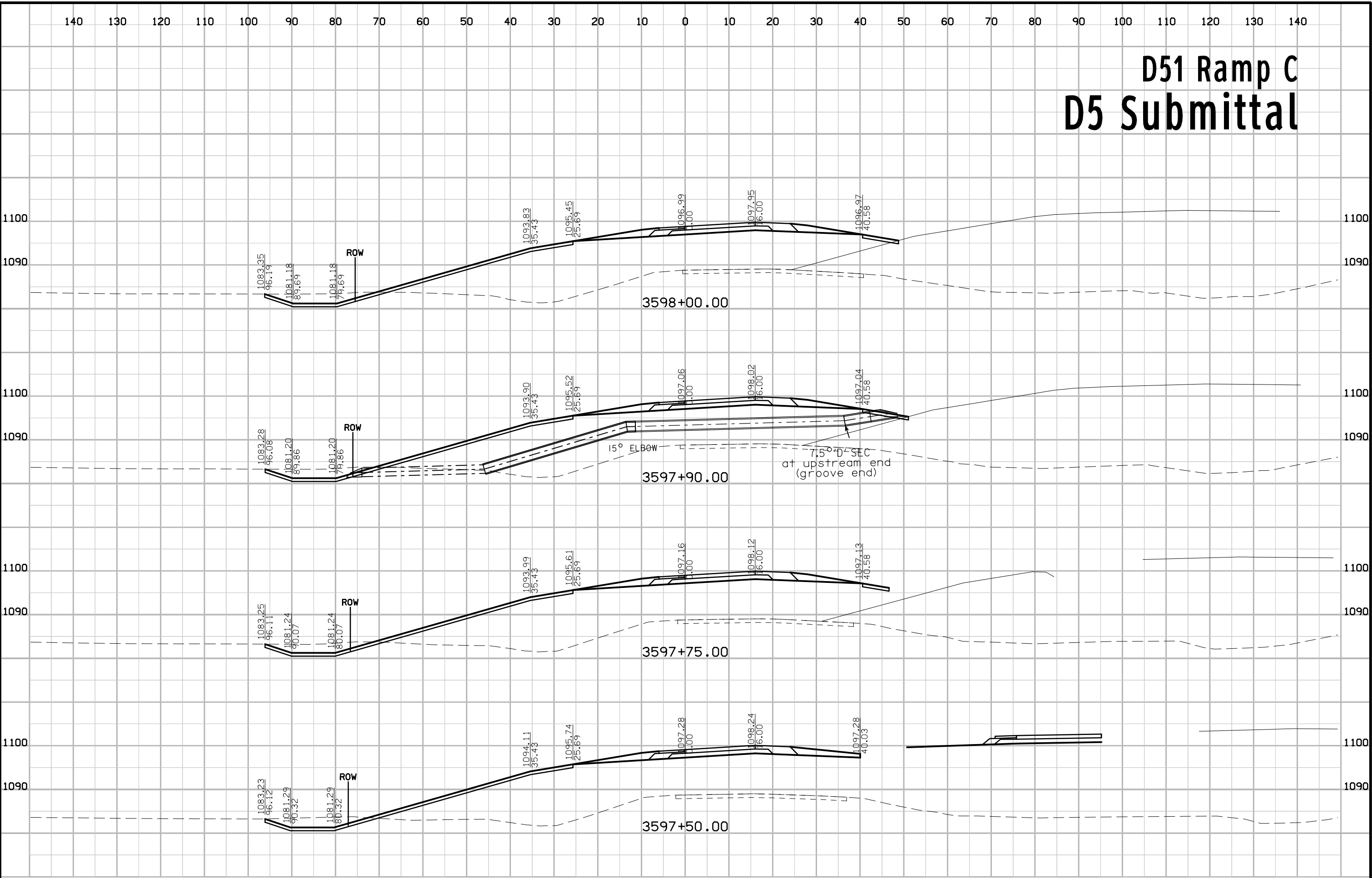

D51 Ramp C D5 Submittal

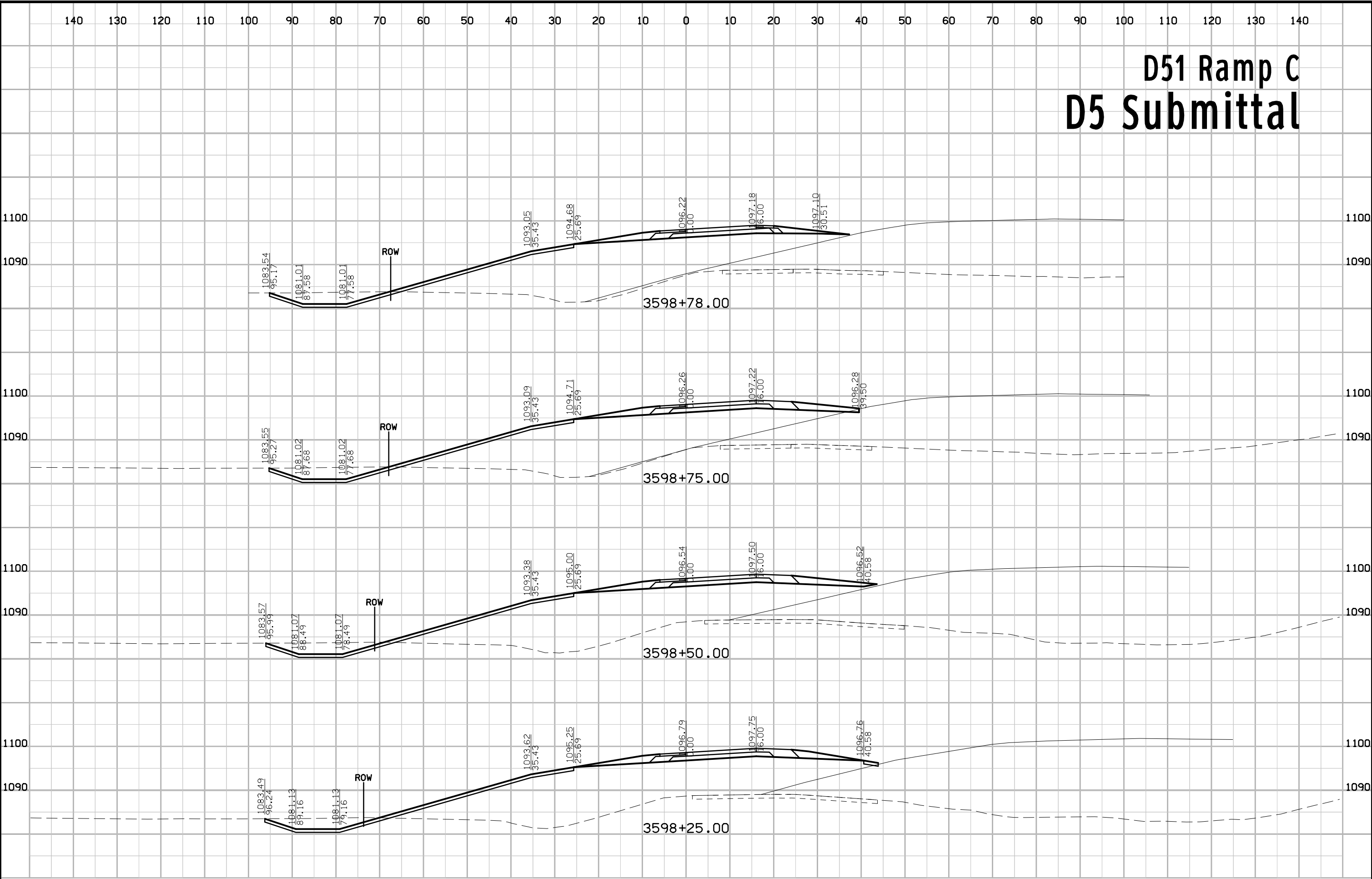

D51 Ramp C D5 Submittal

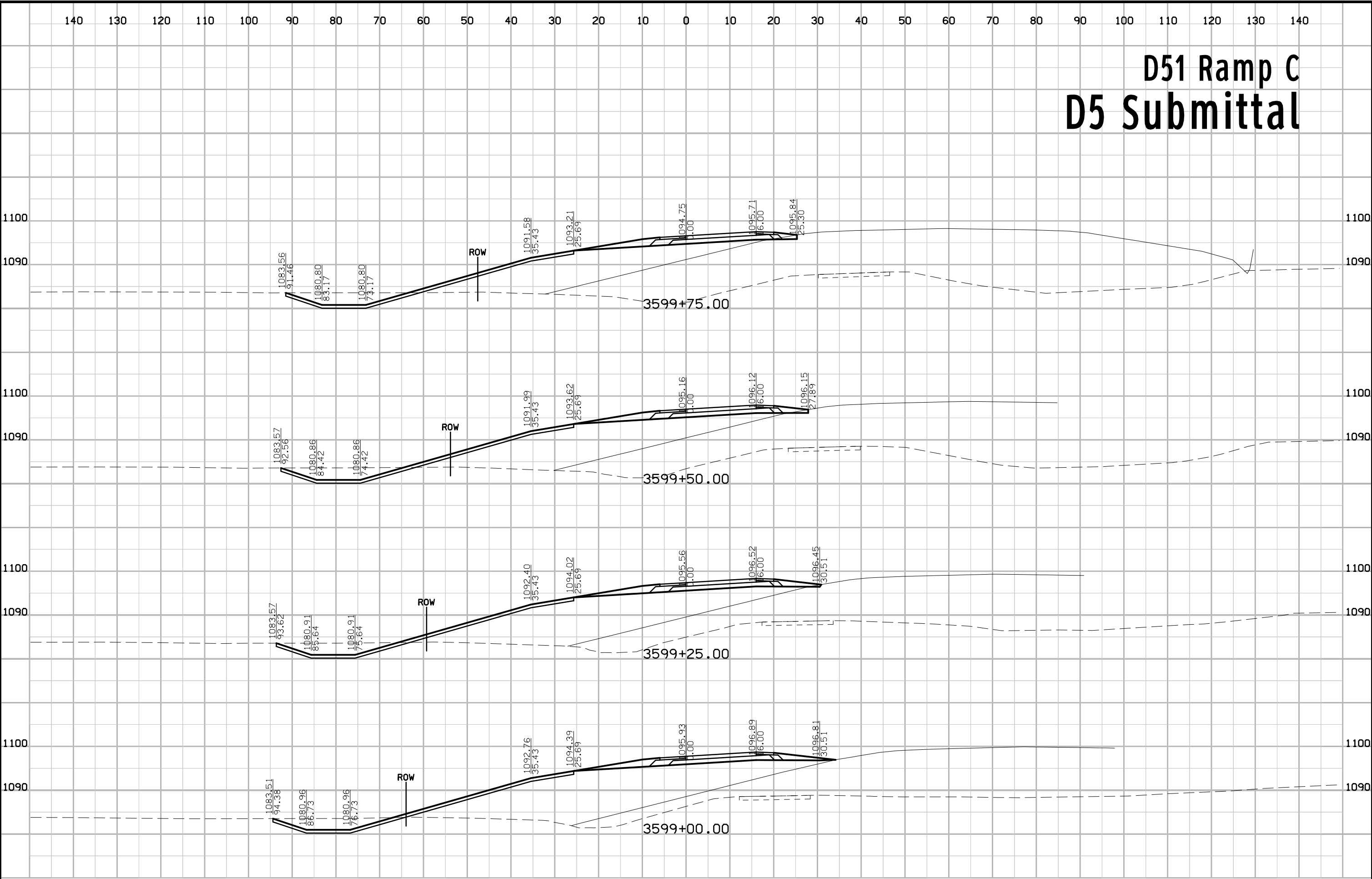

D51 Ramp C D5 Submittal

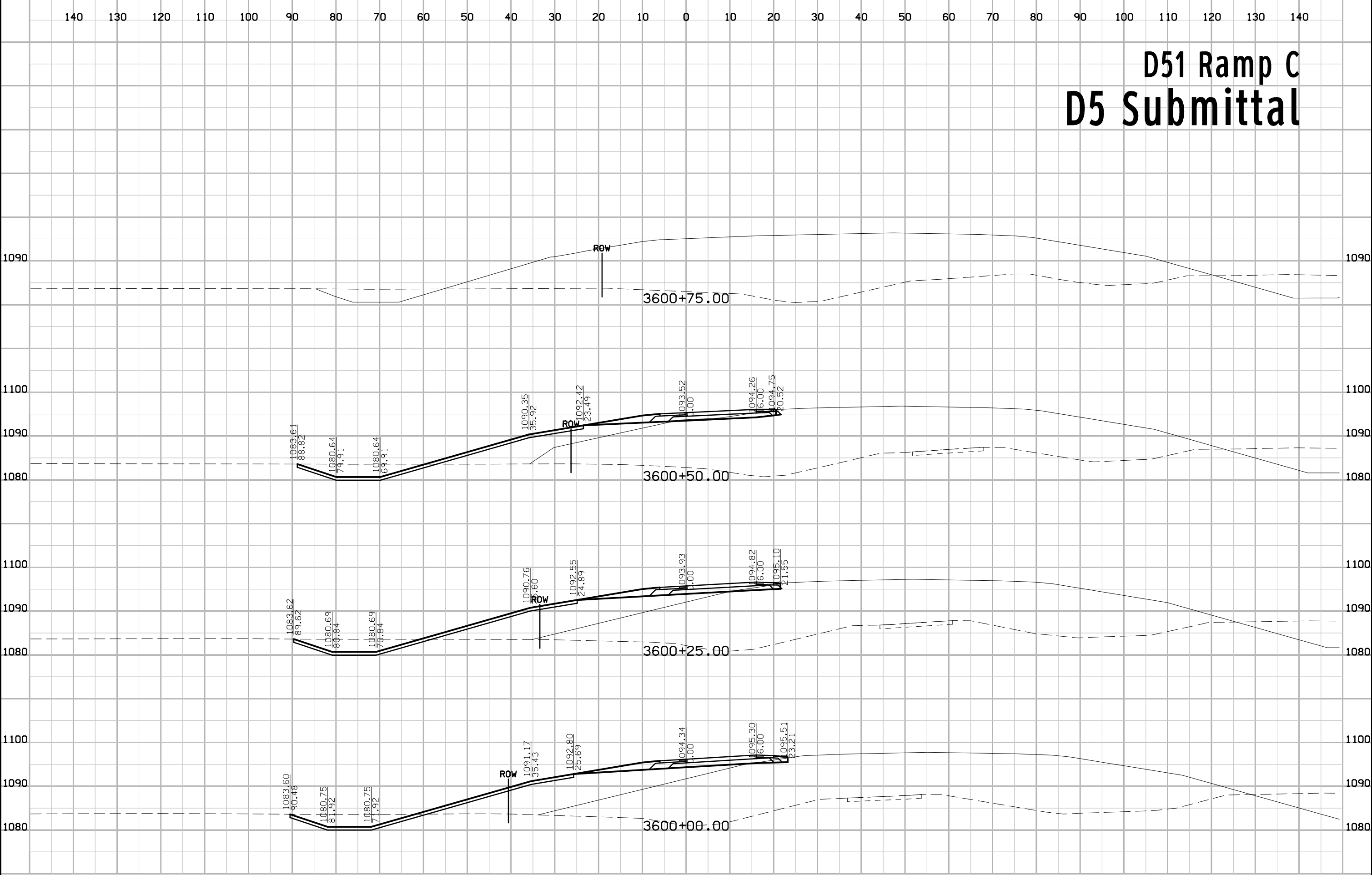

D51 Ramp D D5 Submittal

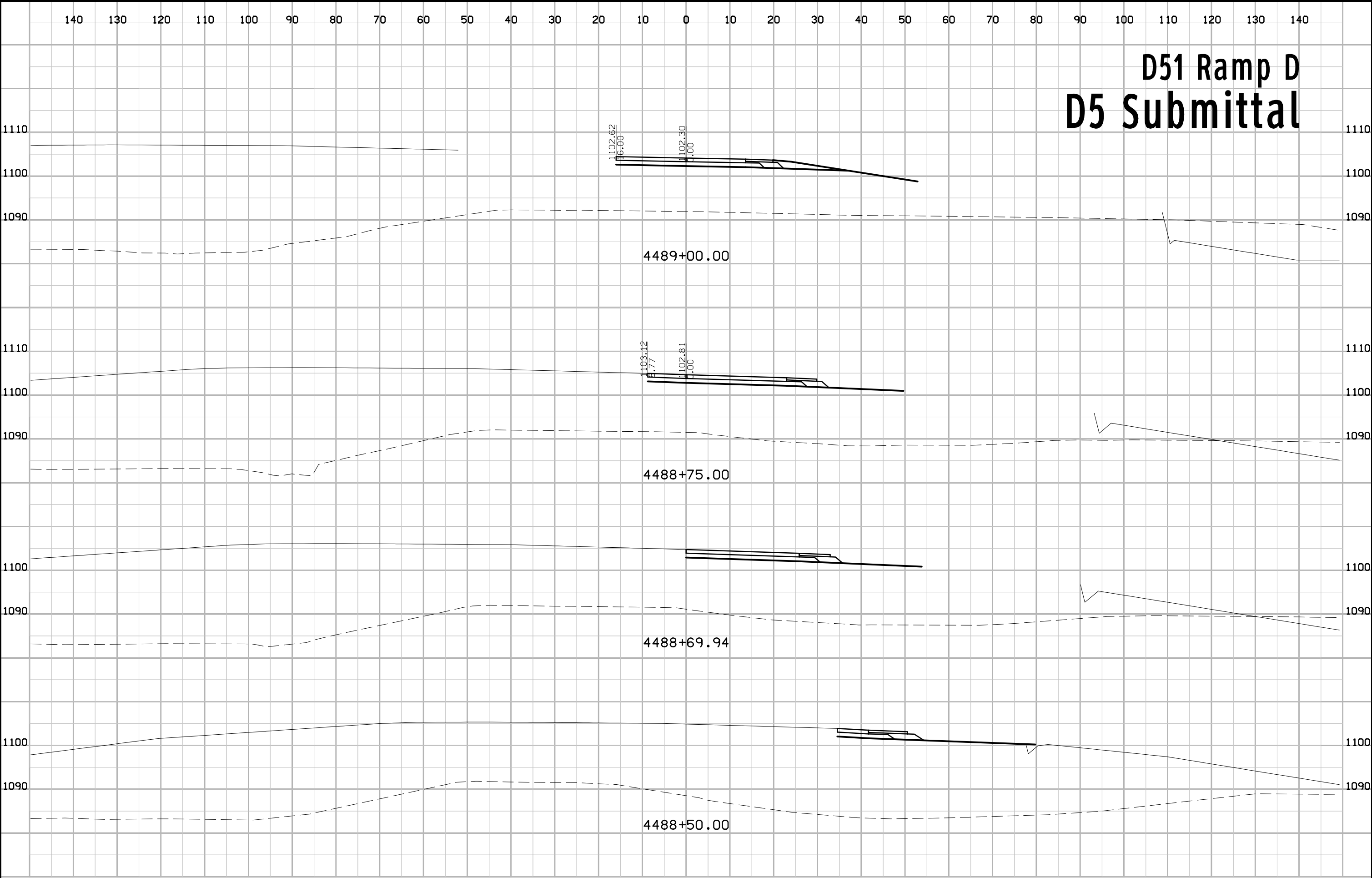

D51 Ramp D D5 Submittal

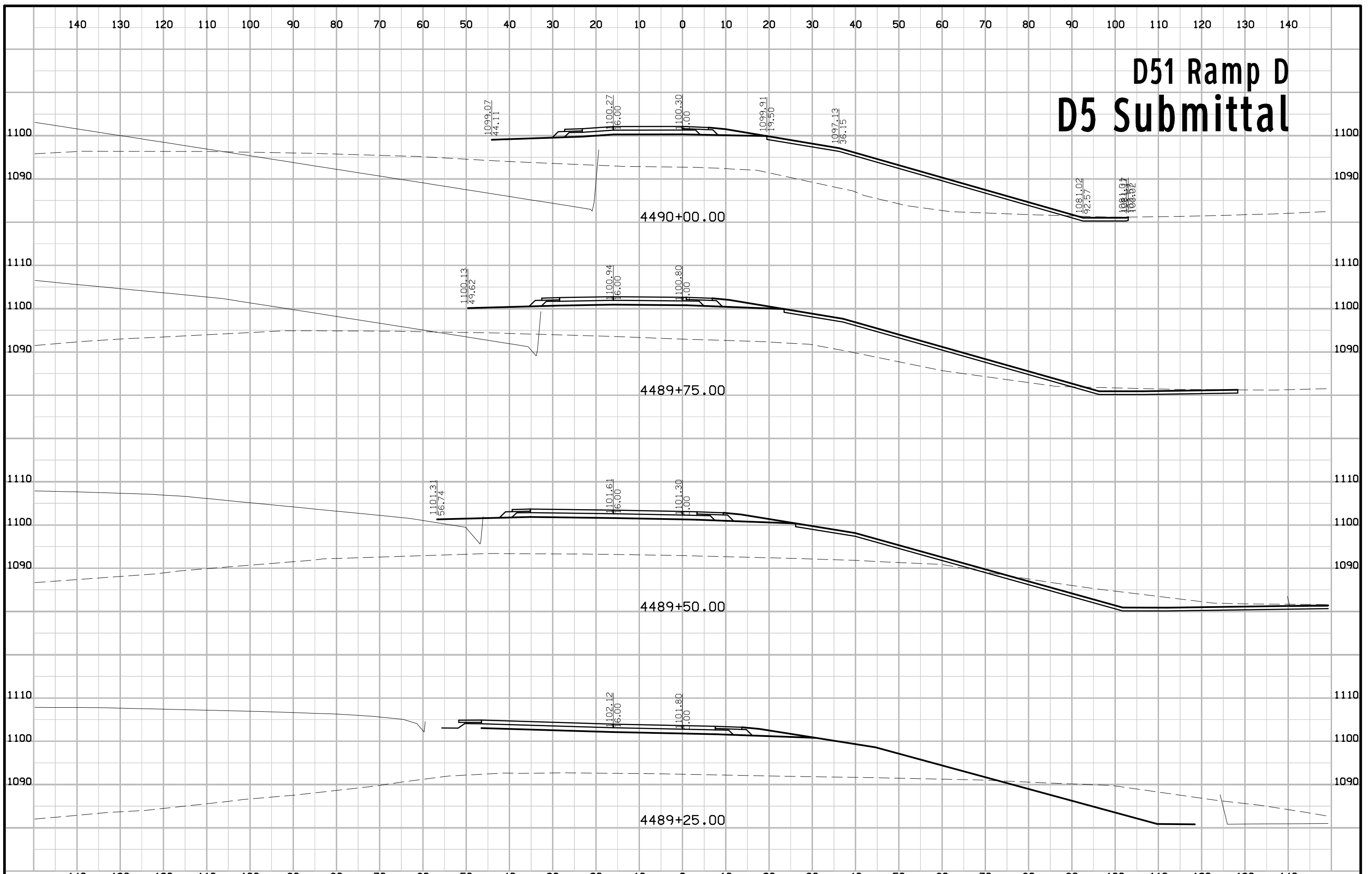

D51 Ramp D D5 Submittal

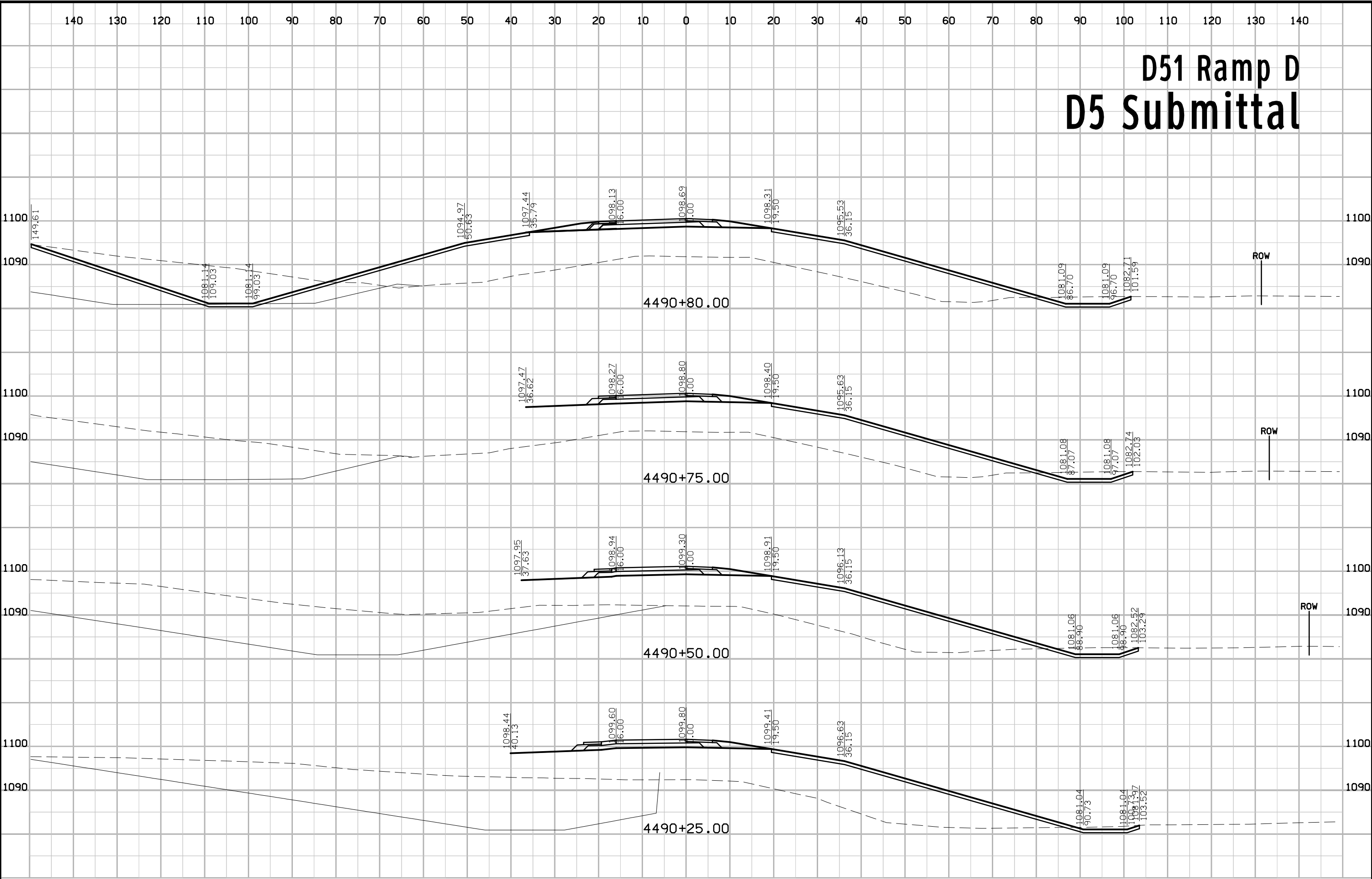

D51 Ramp D D5 Submittal

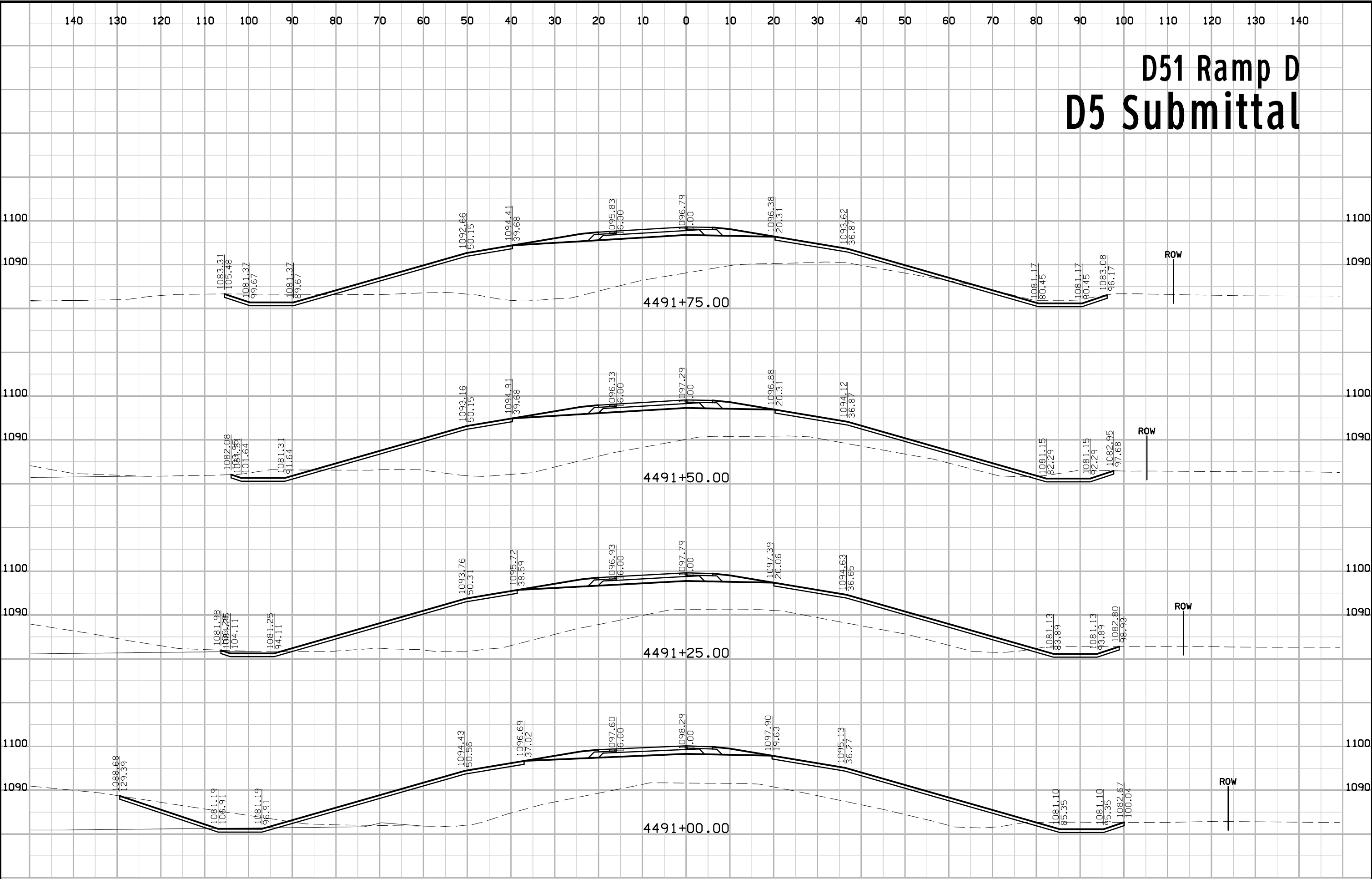

D51 Ramp D D5 Submittal

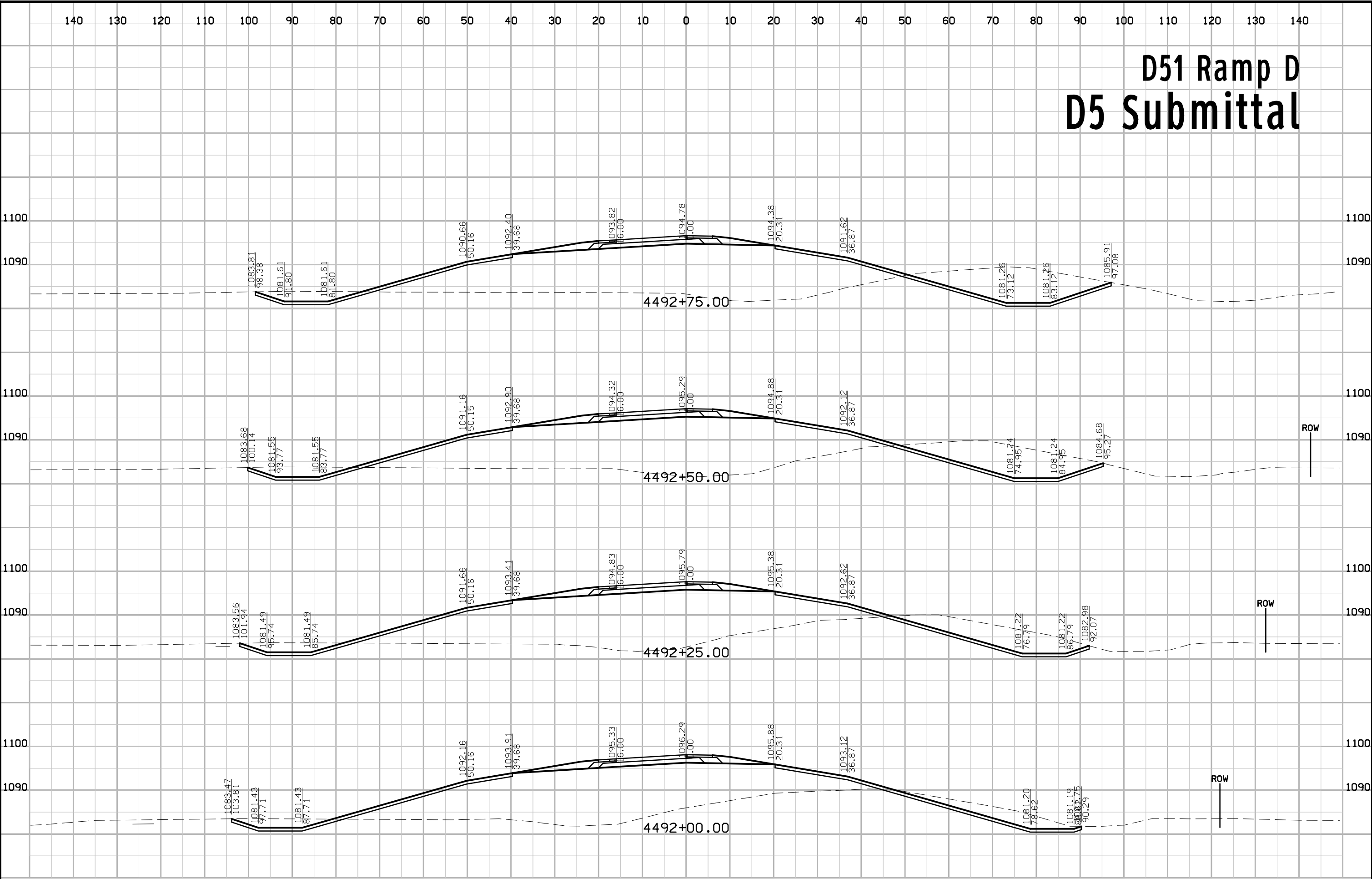

D51 Ramp D D5 Submittal

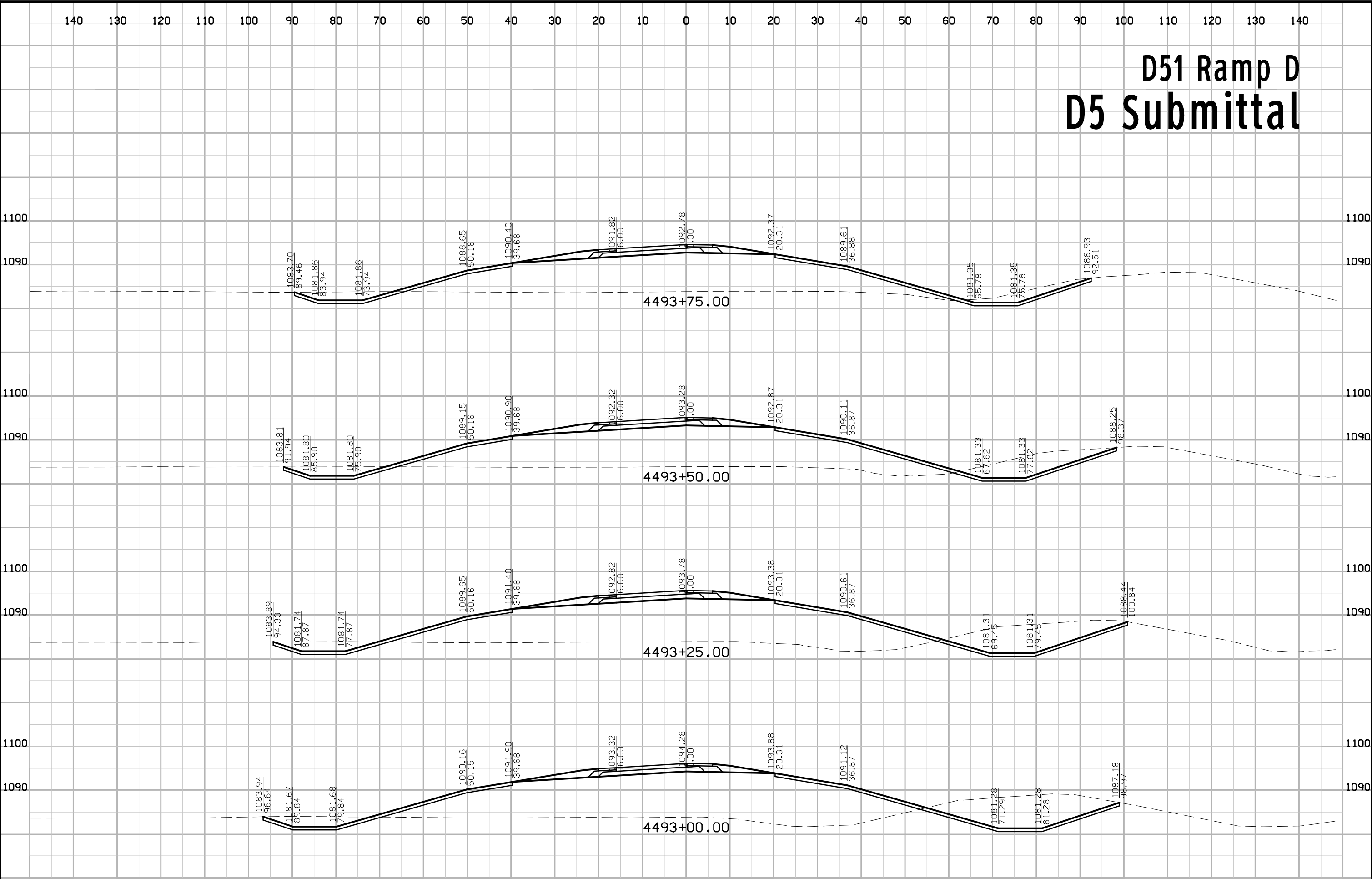

D51 Ramp D D5 Submittal

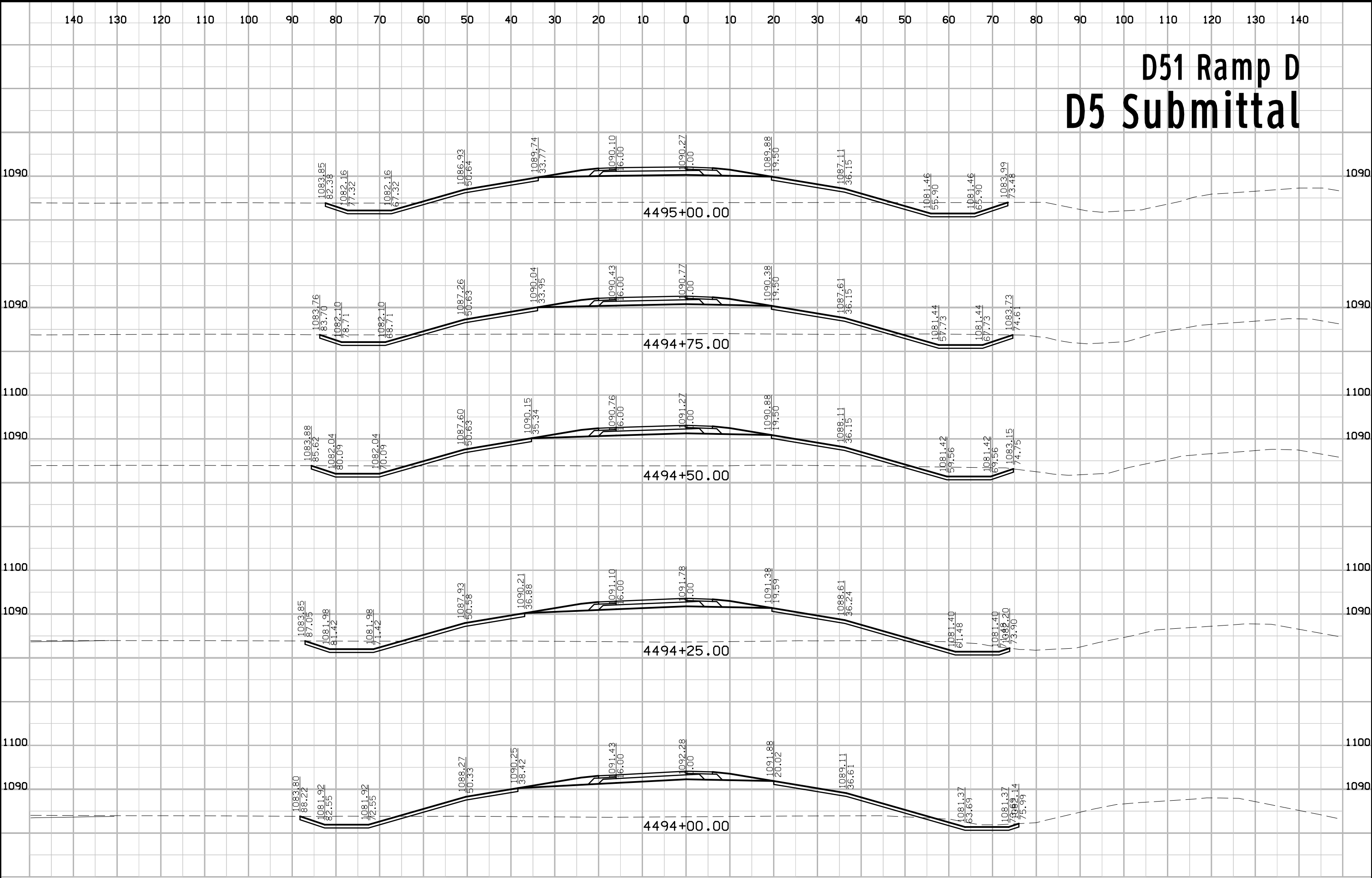

D51 Ramp D D5 Submittal

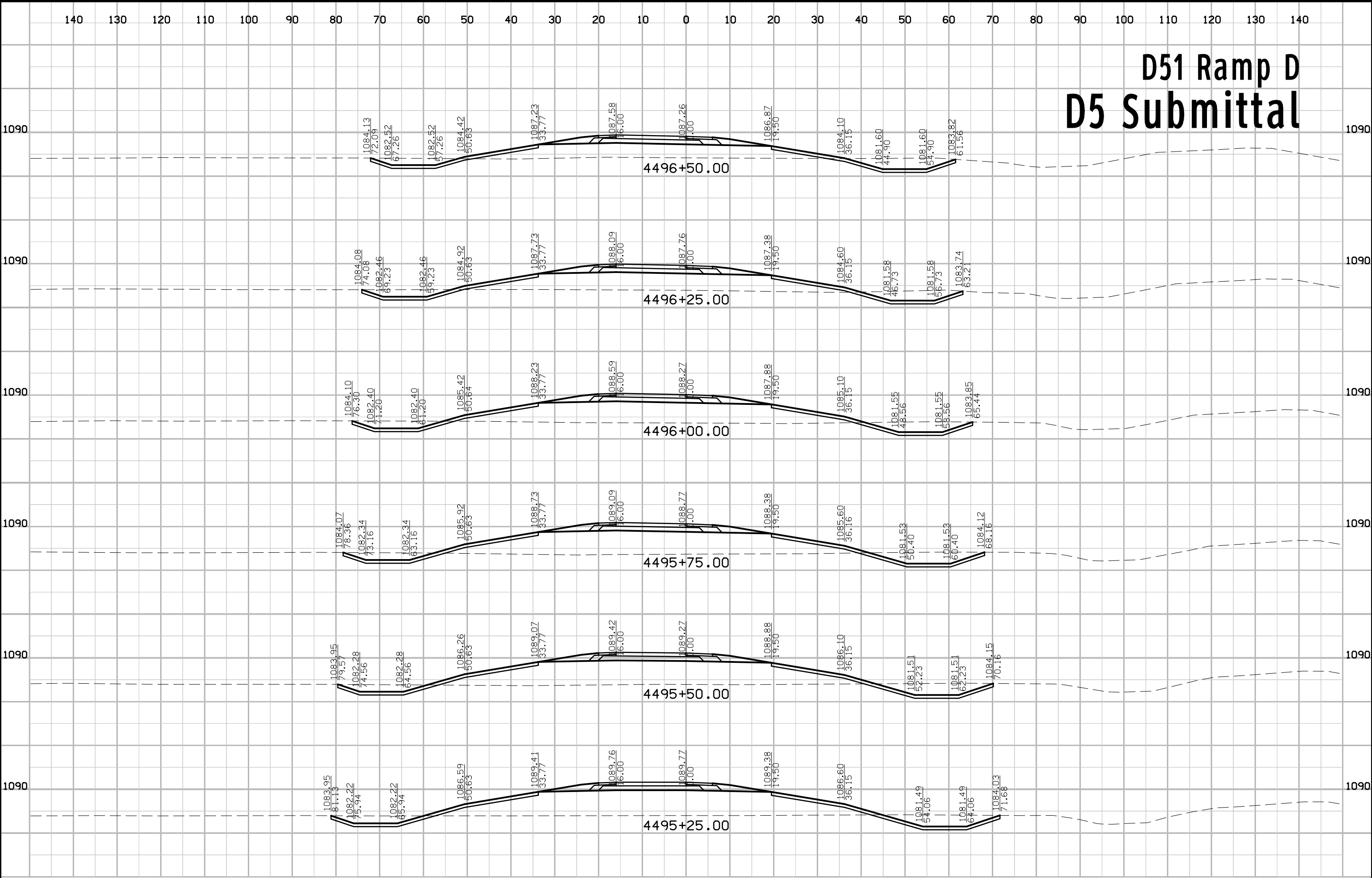

D51 Ramp D D5 Submittal

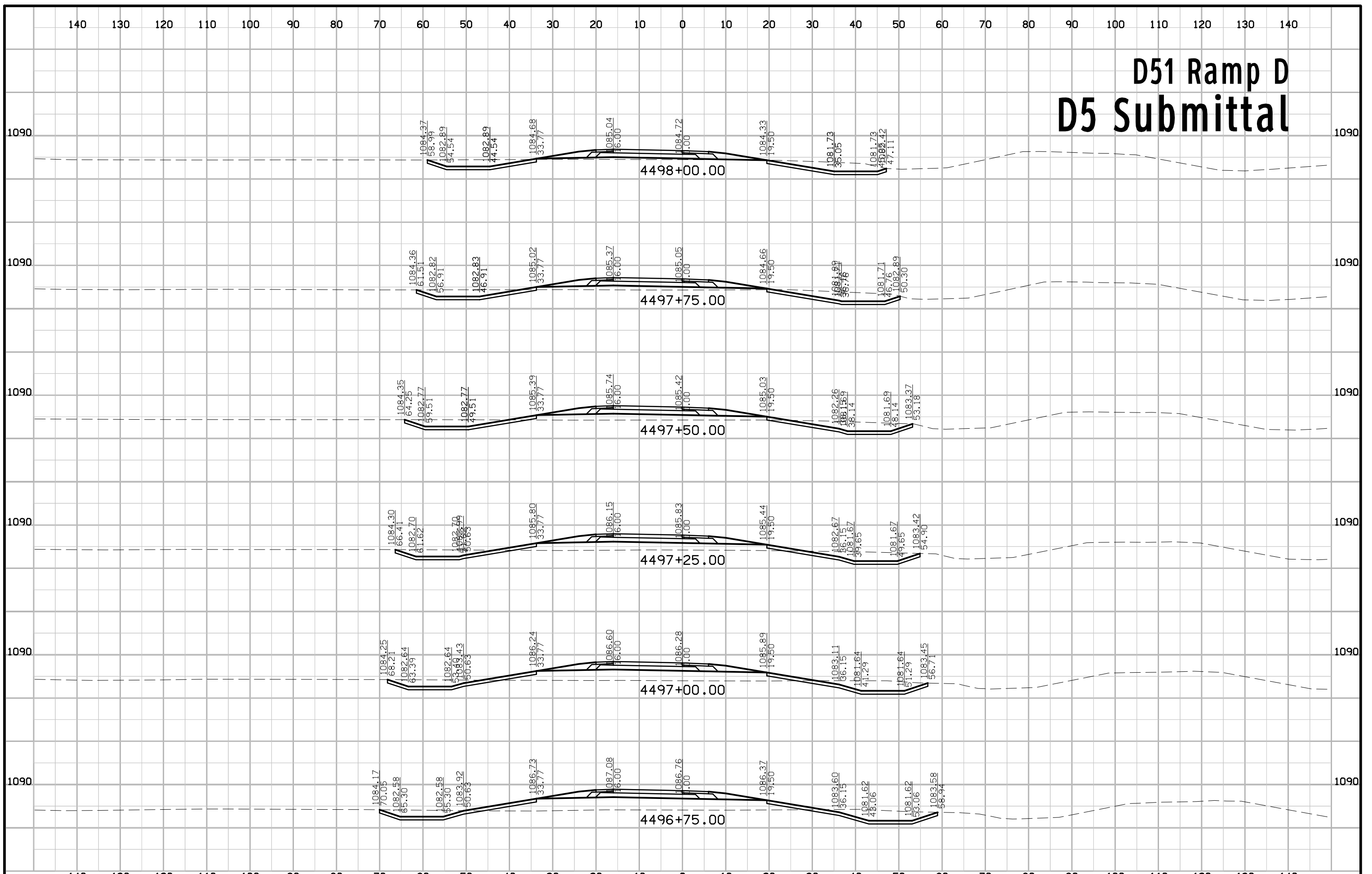

D51 Ramp D D5 Submittal

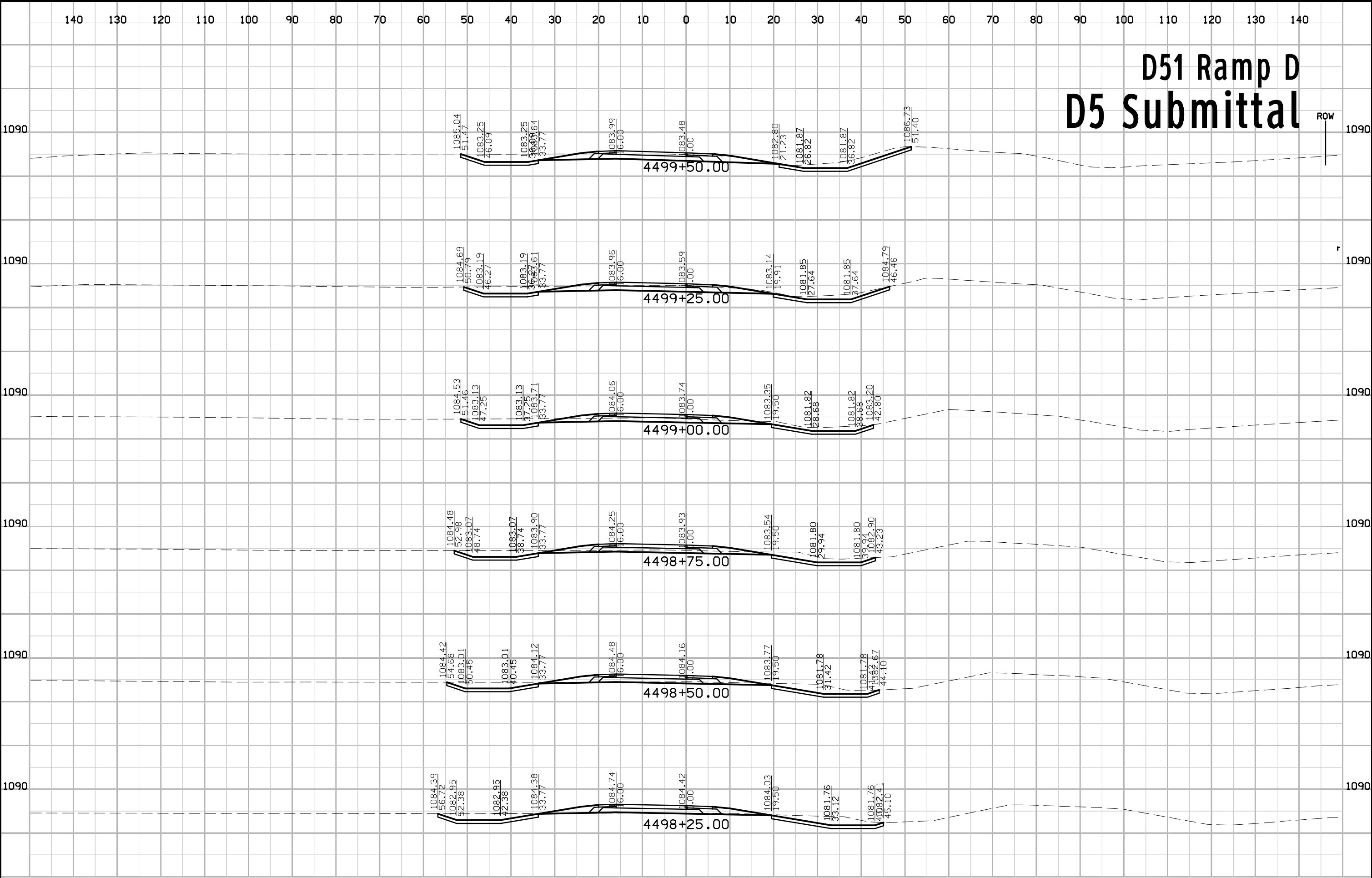

ROW

D51 Ramp D D5 Submittal

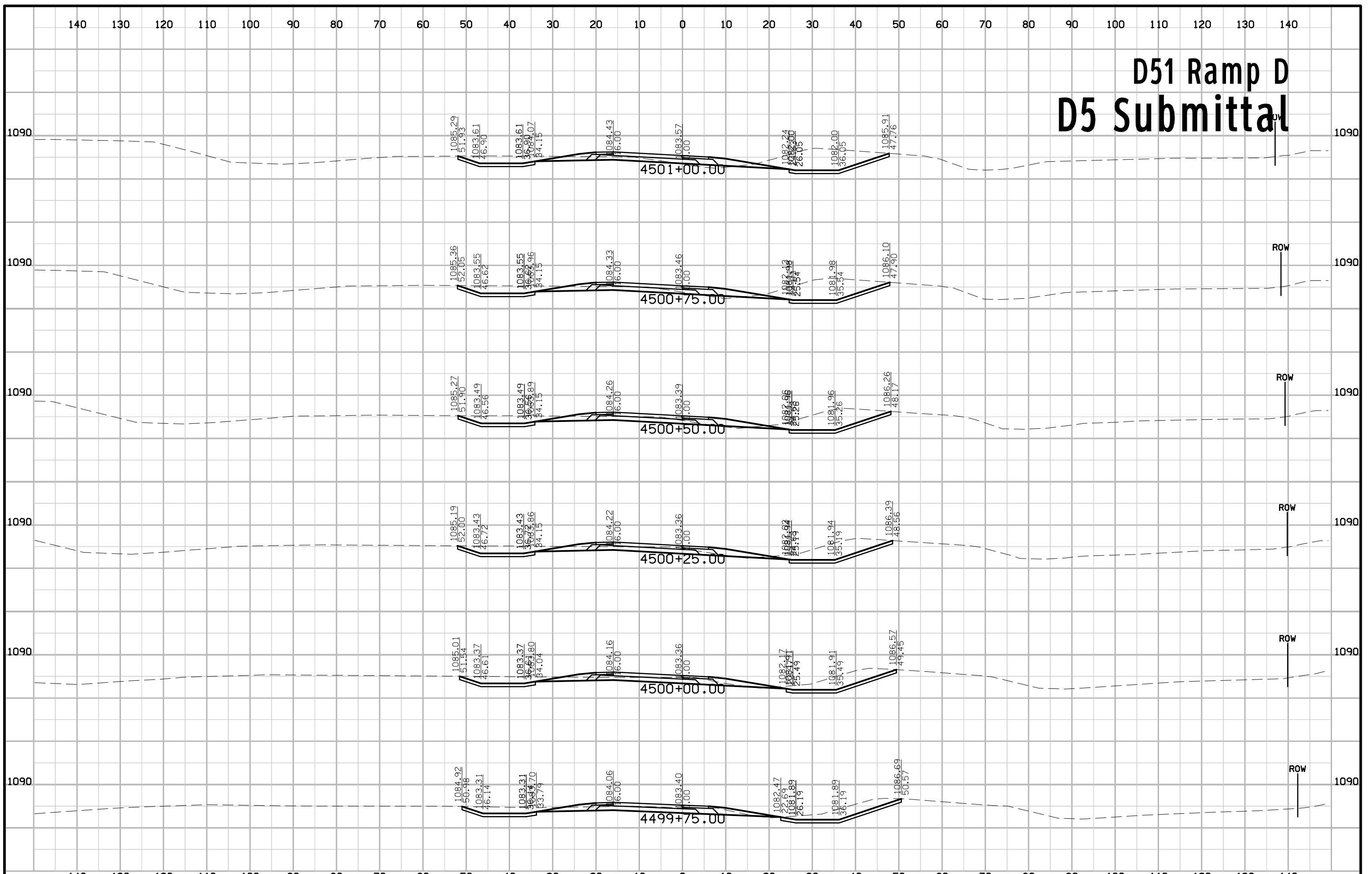

D51 Ramp D D5 Submittal

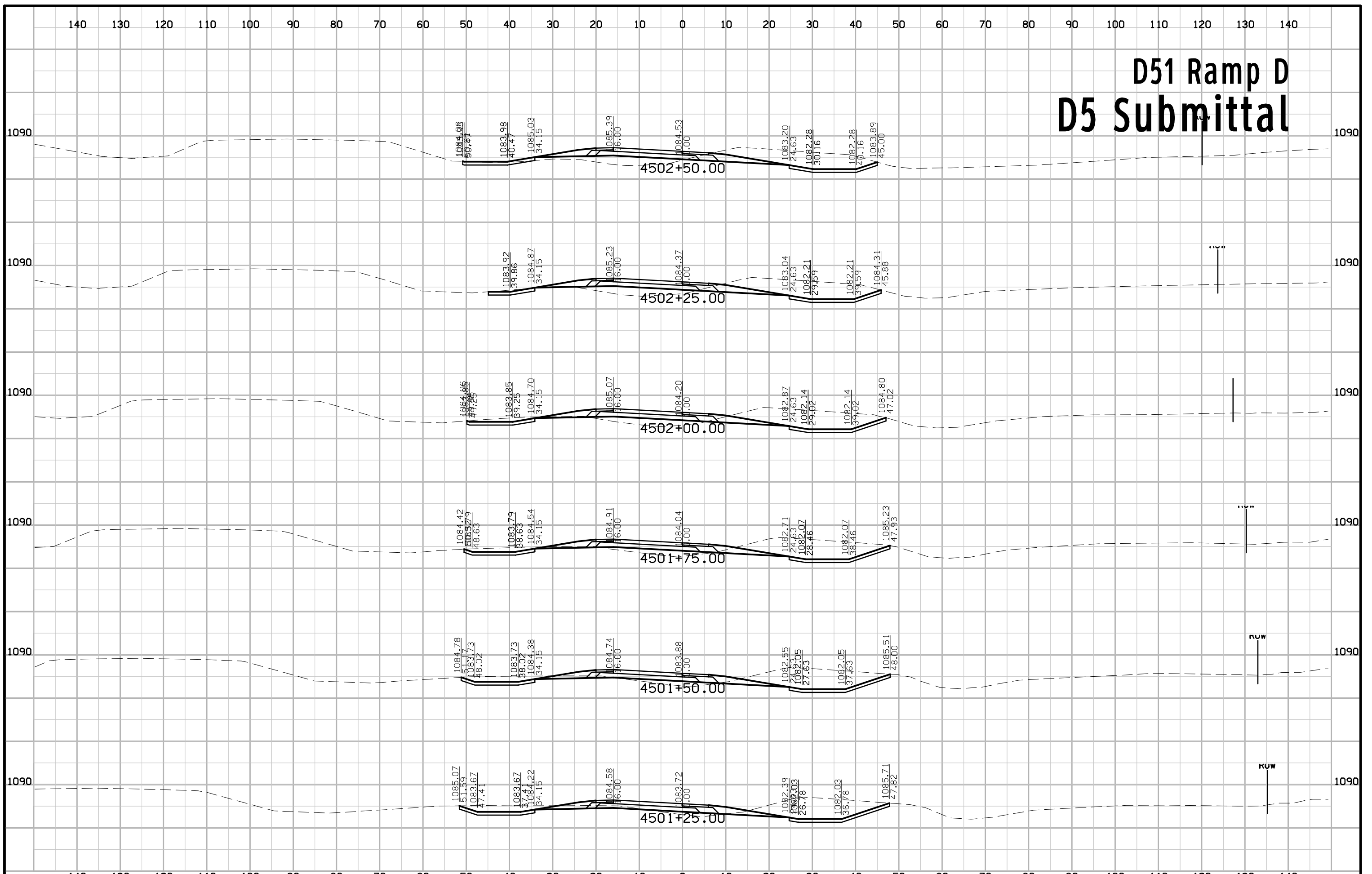

D51 Ramp D D5 Submittal

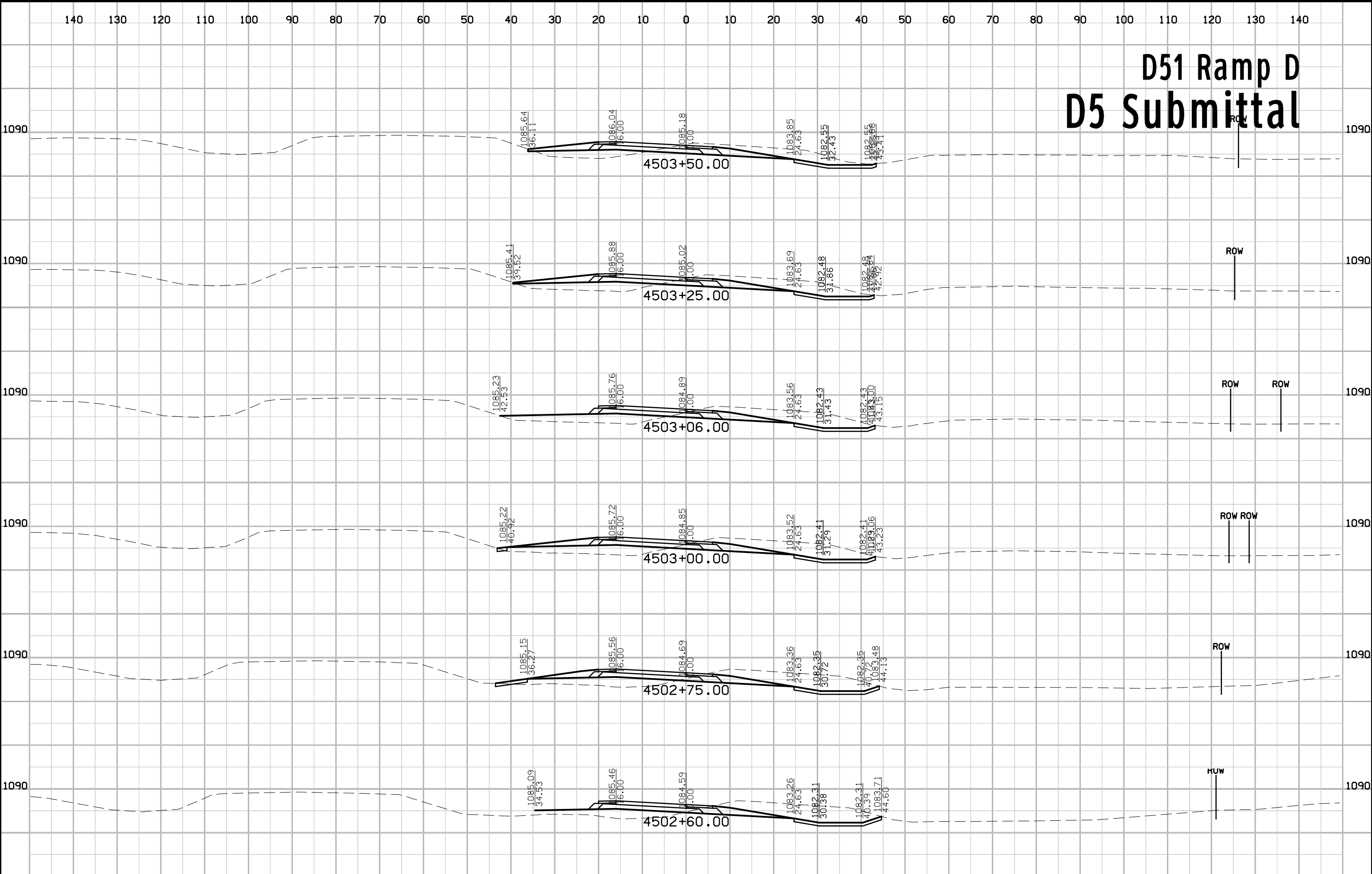

D51 Ramp D D5 Submittal

