



Iowa Department of Transportation  
Highway Division

PLANS OF PROPOSED IMPROVEMENT ON THE

INTERSTATE ROAD SYSTEM  
**WOODBURY COUNTY**  
PCC PAVEMENT - NEW

REVISIONS

TOTAL

193

PROJECT IDENTIFICATION NUMBER

04-97-029-040

PROJECT NUMBER

IM-029-6(186)136--13-97

R.O.W. PROJECT NUMBER

IMN-029-6(159)136--0E-97

LETTING DATE  
12/17/2013

PCC PAVEMENT - NEW  
IM-029-6(186)136--13-97

PRELIMINARY EARTHWORK (D5)

I-29	Cut = 33946	Fill = 5234
D-51	Cut = 53444	Fill = 204093
Ramp A	Cut = 5063	Fill = 33039
Ramp B	Cut = 1729	Fill = 38915
Ramp C	Cut = 5065	Fill = 60192
Ramp D	Cut = 7618	Fill = 32069
Burnett Ave	Cut = 1152	Fill = 536
Liberty Lane	Cut = 7365	Fill = 8507
Entrance 21473	Cut = 0	Fill = 834
Project Total	Cut = 115382	Fill = 383419

SCALES: As Noted

Refer to the Proposal Form for list of applicable specifications.

Value Engineering Saves. Refer to Article 1105.15 of the Specifications.

**NO MILEAGE SUMMARY**



INDEX OF SHEETS

No.	DESCRIPTION
<b>A Sheets</b>	<b>Title Sheets</b>
A.1	Title Sheet
A.2	Location Map
<b>B Sheets</b>	<b>Typical Cross Sections and Details</b>
B.1 - 10	Typical Cross Sections and Details
<b>D Sheets</b>	<b>Mainline Plan and Profile Sheets</b>
* D.1	Legend Sheet
* D.2 - 4	Interstate 29
<b>E Sheets</b>	<b>Side Road Plan and Profile Sheets</b>
* E.1 - 2	County Road D-51/260th Street
* E.3	Burnett Avenue
* E.4	Liberty Lane
<b>G Sheets</b>	<b>Survey Sheets</b>
G.1 - 2	Reference Ties and Bench Marks
G.3 - 6	Horizontal Control Tab. for Mainline and Side Roads
G.7	Superelevation Tab. for Mainline and Side Roads
<b>J Sheets</b>	<b>Traffic Control and Staging Sheets</b>
* J.1	Traffic Control Plan
* J.1	Staging Notes Stage
* J.1	Tabulation of Special Events
<b>K Sheets</b>	<b>Interchange Sheets</b>
* K.1 - 2	Interchange Layout Sheets
* K.3	D-51 RAMP "A" Plan and Profile Sheet
* K.4	D-51 RAMP "B" Plan and Profile Sheet
* K.5	D-51 RAMP "C" Plan and Profile Sheet
* K.6	D-51 RAMP "D" Plan and Profile Sheet
<b>V Sheets</b>	<b>Bridge and Culvert Situation Plans</b>
V.1	Bridge and Culvert Situation Plans
<b>W Sheets</b>	<b>Mainline Cross Sections</b>
W.1	Legend Sheet
W.2 - 48	Mainline Cross Sections
<b>X Sheets</b>	<b>Side Road Cross Sections</b>
X.1 - 46	County Road D-51/260th Street Cross Sections
X.47 - 48	Burnett Avenue Cross Sections
X.49 - 58	Liberty Lane Cross Sections
X.59 - 60	Entrance Sta. 64176+37 Cross Sections
<b>Y Sheets</b>	<b>Ramp Cross Sections</b>
Y.1 - 9	D-51 RAMP "A" Cross Sections
Y.10 - 19	D-51 RAMP "B" Cross Sections
Y.20 - 36	D-51 RAMP "C" Cross Sections
Y.37 - 50	D-51 RAMP "D" Cross Sections
	* Color Plan Sheets

For Project Location Map  
Refer to Sheet A.2

260th St/D-51

I-29

DESIGN DATA RURAL			
2011 AADT	1,760	V.P.D.	
2031 AADT	2,610	V.P.D.	
20 -- DHV	--	V.P.H.	
TRUCKS	34 %		
Total Design ESALs	--		

DESIGN DATA RURAL			
2011 AADT	20,300	V.P.D.	
2031 AADT	35,400	V.P.D.	
20 -- DHV	--	V.P.H.	
TRUCKS	18 %		
Total Design ESALs	--		

INDEX OF SEALS		
SHEET NO.	NAME	TYPE
A.1	Paul W. Flattery	Primary Signature Block
X	X	X

**PRELIMINARY PLANS**

Subject to change by final design.

Revised D5 PLAN -  
September 12, 2012

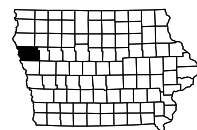

ENGLISH

IOWA DOT

DESIGN TEAM Flattery\Bell

WOODBURY COUNTY

PROJECT NUMBER

IM-029-6(186)136--13-97

SHEET NUMBER

A.1

Project Location  
260th St./D-51 Over I-29

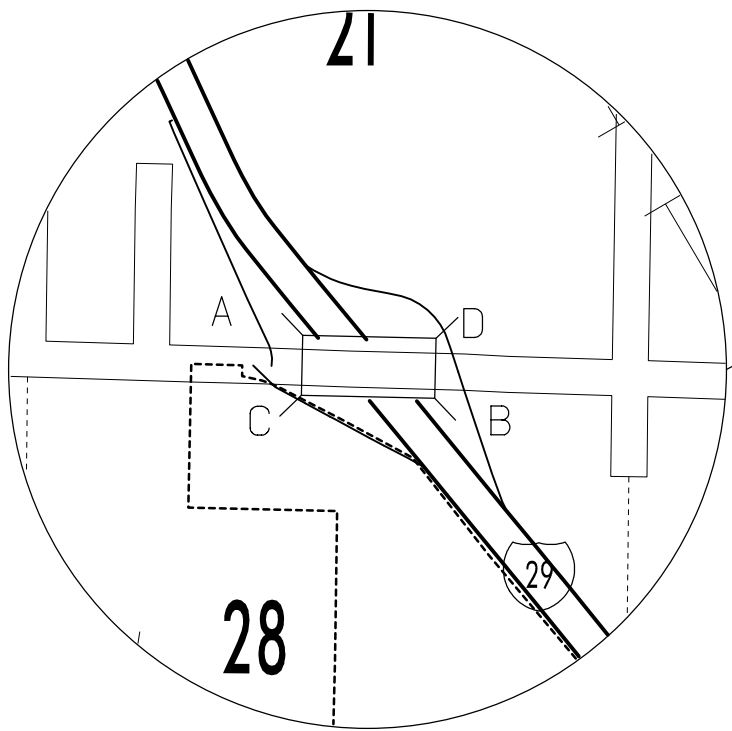

260th St./D-51/I-29 Interchange

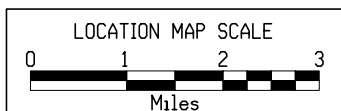
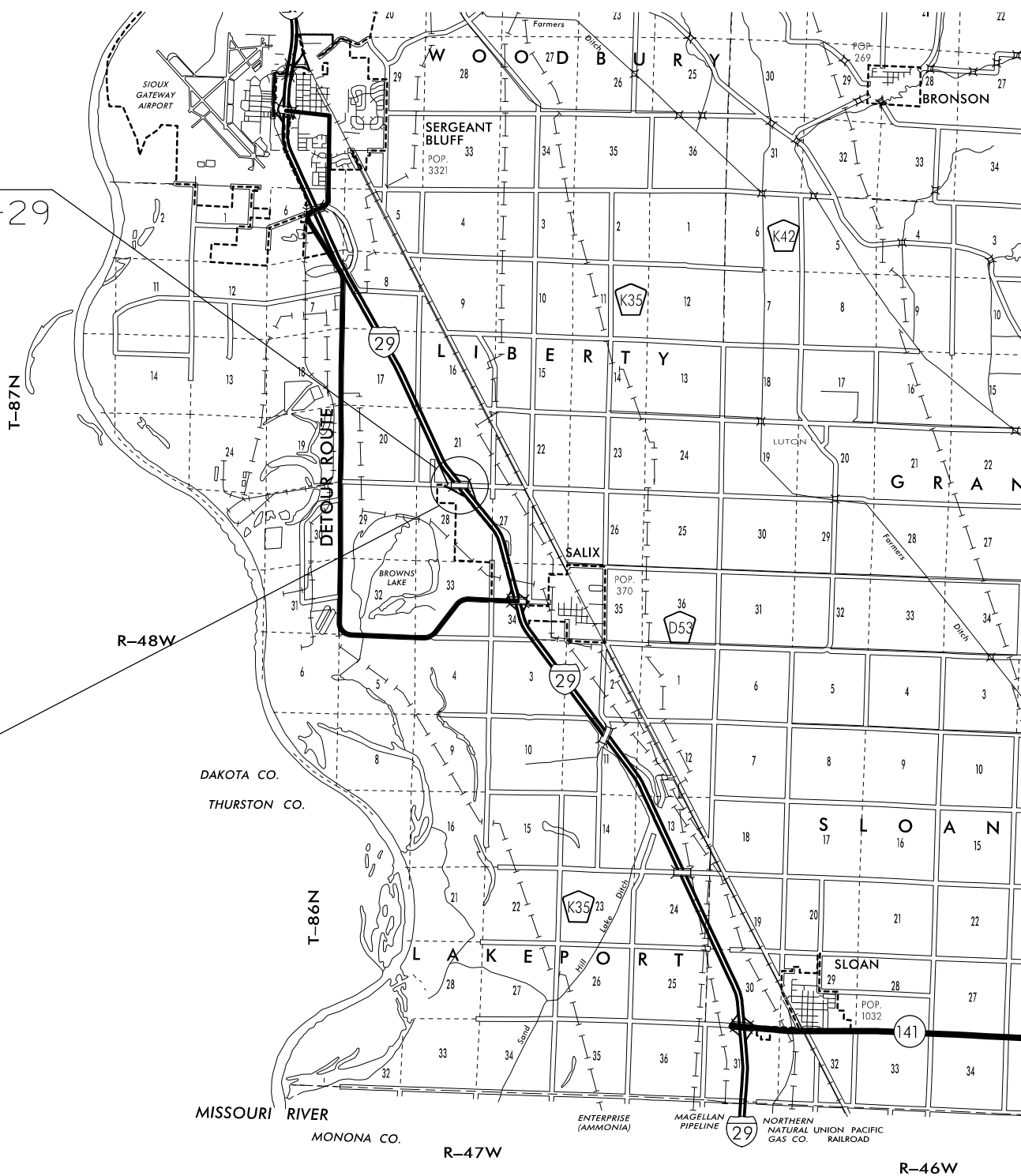

LOCATION			DIMENSIONS			
ROAD IDENTIFICATION	STATION TO STATION		(L) Feet	(R) Feet	(X) Inches	(BW) Feet
Co. Rd. D-51	21466+75.00	21479+50.00	(1)	(1)	22	16.5
Co. Rd. D-51	21479+50.00	21503+25.00	41.2	41.2	22	16.5
Co. Rd. D-51	21503+25.00	21516+50.00	(2)	(2)	22	16.5
			(1) 33.22 - 41.23			
			(2) 41.23 - 33.22			
Burnett Ave.	301+08.30	303+50.00	29.9	29.9	22	16.5

Normal section shown may be modified appropriately in areas of superelevated curves or other locations specifically designated by the Engineer.

See Plan & Profile sheets and cross sections for additional details of ditches and backstops.

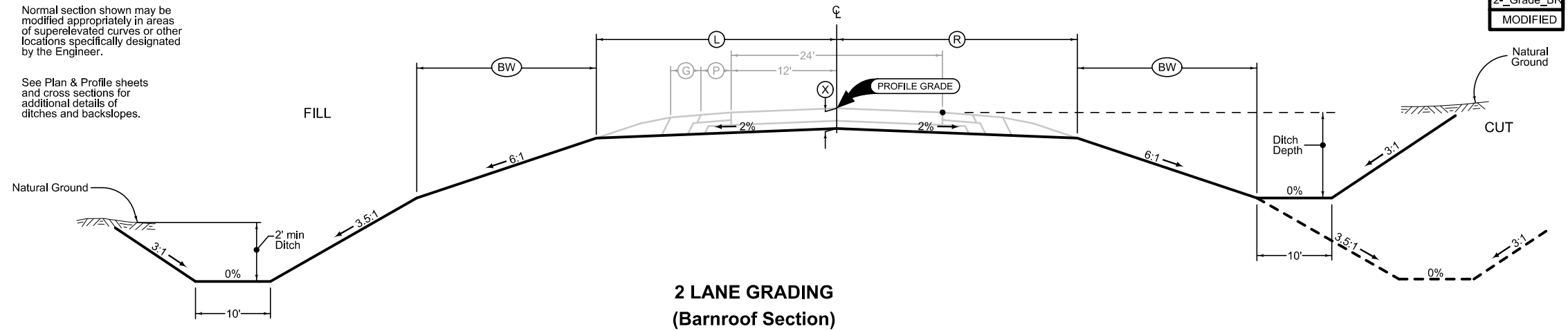

2-Grade\_BR  
MODIFIED

LOCATION			DIMENSIONS					
INTERCHANGE	RAMP	STATION TO STATION		(L) Feet	(R) Feet	(X) Inches	(BW) Feet	(BW) Feet
I-29 & D-51	A	5497+15.47	5499+40.00	41.8	19.5	22	16.9	16.7
I-29 & D-51	A	5499+40.00	5500+60.00	(1)	19.5	22	16.9	16.7
I-29 & D-51	A	5500+60.00	5509+50.00	33.8	19.5	22	16.9	16.7
I-29 & D-51	B	2578+40.00	2590+02.41	33.8	19.5	22	16.9	16.7
I-29 & D-51	C	3582+30.00	3600+62.79	33.8	19.5	22	16.9	16.7
I-29 & D-51	C	7+79.70	9+52.22	--	35.5	22	--	16.7
I-29 & D-51	D	4488+69.94	4506+75.00	33.8	19.5	22	16.9	16.7
				(1) 33.8 - 41.8				

Section view is in direction of traffic.

Normal sections shown may be appropriately modified for areas specifically designated by the Engineer such as intersections or superelevated curves.

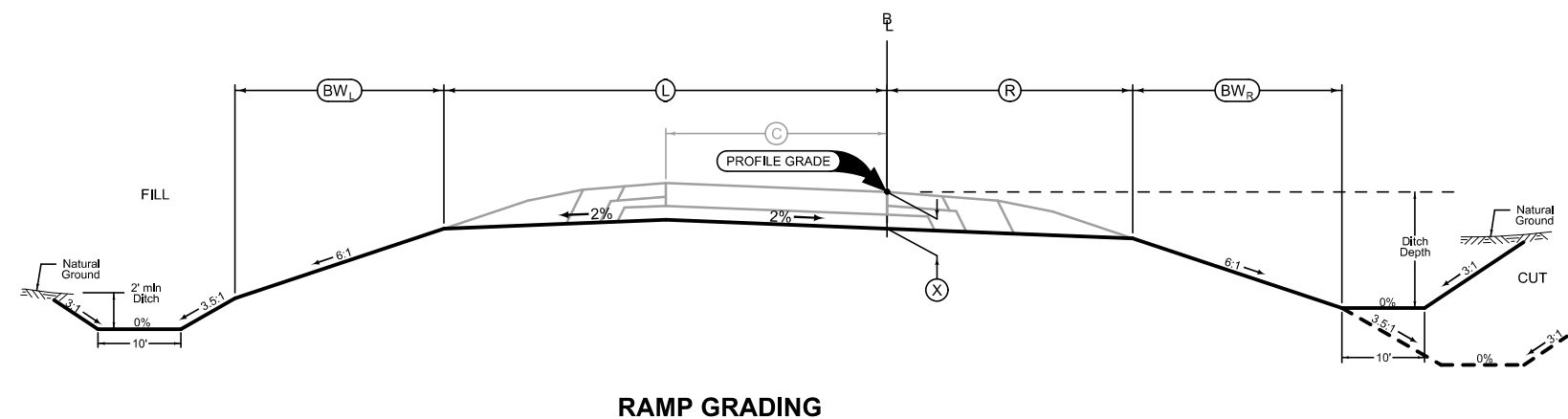

1R\_Grade  
10-19-10

LOCATION			DIMENSIONS			
ROAD IDENTIFICATION	STATION TO STATION		(L) Feet	(R) Feet	FS	BS
Liberty Lane	200+27.90	214+72.46	14.0	14.0	4	3
Entrance 21476	100+00.00	101+24.71	7.0	7.0	4	3

Normal section shown may be modified appropriately in areas of superelevated curves or other locations specifically designated by the Engineer.

See plan & profile sheets and cross sections for additional details of ditches and backstops.

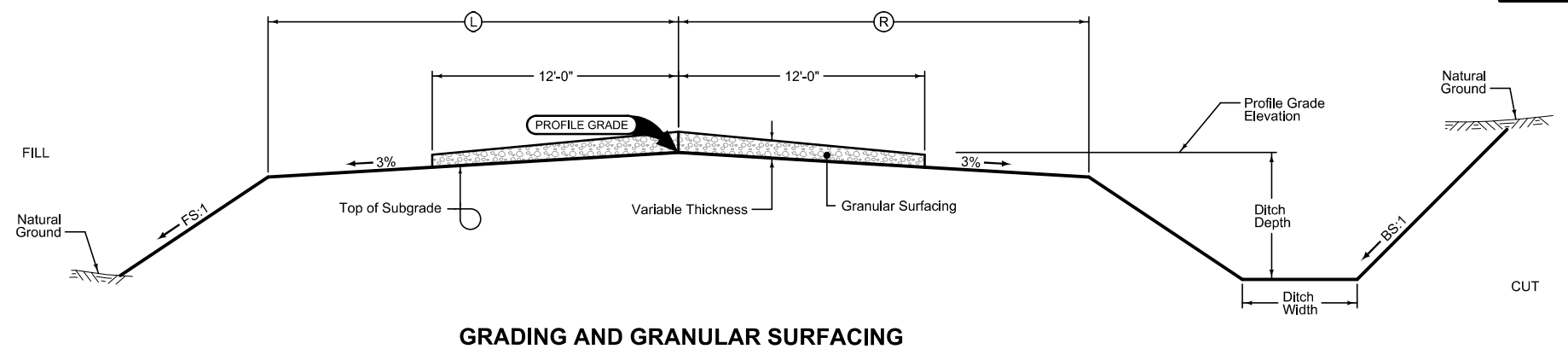

2-GradeGran  
10-19-10

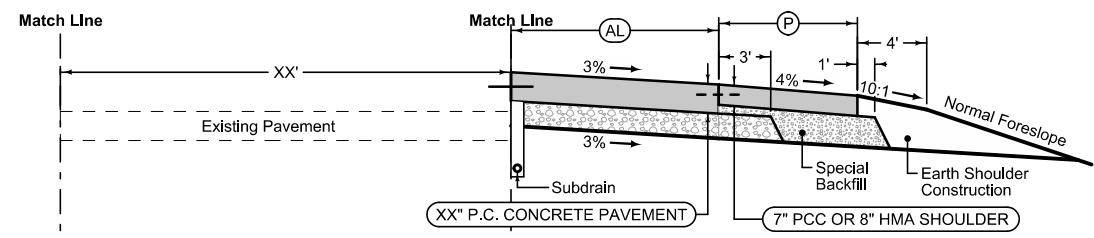

**Auxiliary Lane**

Longitudinal joint: L or KT  
 Transverse joint: Match Mainline

Direction of Travel	BEGIN STATION	END STATION	(AL) Feet	(P) Feet
Ramp A	SB 1512+42.25	1521+00.06	20.0 - 0.0	6.0 - 10.0
Ramp B	NB 1472+40.00	1475+20.00	0.0 - 18.7	10.0 - 6.0
Ramp C	SB 1470+00.00	1480+00.00	0.0 - 20.0	10.0 - 6.0
Ramp D	NB 1506+75.00	1516+75.00	20.0 - 0.0	6.0 - 10.0

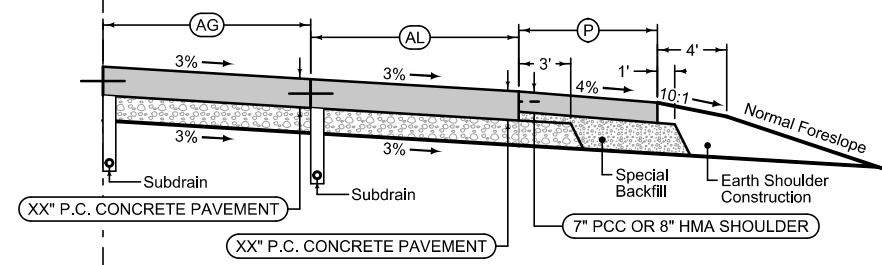

**Auxiliary Lane**

Longitudinal joint: L or KT  
 Transverse joint: Match Mainline

Direction of Travel	BEGIN STATION	END STATION	(AG) Feet	(AL) Feet	(P) Feet
Ramp A	SB 1509+50.00	1512+42.25	24.0 - 4.0	16.0	6.0
Ramp B	NB 1475+20.00	1478+40.00	2.6 - 24.0	16.0	6.0
Ramp C	SB 1480+00.00	1482+30.00	4.0 - 21.8	16.0	6.0
Ramp D	NB 1504+45.00	1506+75.00	21.8 - 4.0	16.0	6.0

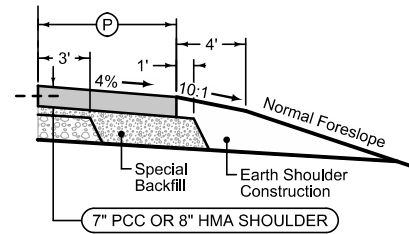

**Paved Shoulder Alternates**

PCC Shoulder Jointing:  
 Longitudinal joint: BT-1 or BT-3  
 Transverse joints: C at 20' spacing  
 HMA Shoulder Jointing:  
 Longitudinal joint: B

Direction of Travel	BEGIN STATION	END STATION	(P) Feet
Ramp C	SB 1521+00.00	1524+00.00	10.0
Ramp C	SB 1482+30.00	1485+45.00	10.0

Section view is in direction of traffic.

Normal sections shown may be appropriately modified for areas specifically designated by the Engineer such as intersections or super-elevated curves.

See Tab 100-24 for pavement quantities.

See Tab 112-9 for shoulder quantities.

**INTERSTATE 29**

**Granular Shoulder**

STATION TO STATION		Ⓞ Feet
21466+75.00	21485+60.00	8
21488+00.00	21491+??.??	8
21496+??.??	21499+10.73	8
21500+70.00	21516+50.00	8

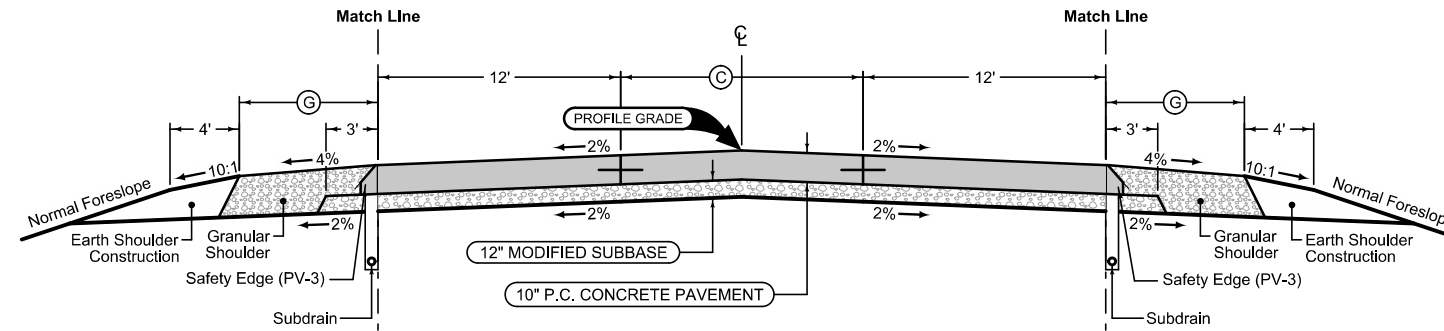

**Granular Shoulder**

STATION TO STATION		Ⓞ Feet
21466+75.00	21479+70.00	8
21484+51.06	21487+59.25	8
21488+40.07	21490+??.??	8
21495+??.??	21499+74.79	8
21501+90.00	21516+50.00	8

STATION TO STATION		Ⓞ Feet
21466+75.00	21467+50.00	0
21467+50.00	21479+50.00	0-16
21479+50.00	21503+25.00	16
21503+25.00	21515+89.00	16-0
21515+89.00	21516+50.00	0

Mainline Jointing:  
 Transverse joints: CD at 20' spacing  
 Longitudinal joint: L-2

See Tab 100-24 for pavement quantities.  
 See Tab 112-9 for shoulder quantities.

**260th St./Co. Rd. D-51**

**Paved Shoulder Alternates**

PCC Shoulder Jointing:  
 Longitudinal joint: BT-1 or BT-3  
 Transverse joints: C at 20' spacing  
 HMA Shoulder Jointing:  
 Longitudinal joint: B

BEGIN STATION	END STATION	(P) Feet
5509+50.00	5500+60.00	4

**Paved Shoulder Alternates**

PCC Shoulder Jointing:  
 Longitudinal joint: BT-1 or BT-3  
 Transverse joints: C at 20' spacing  
 HMA Shoulder Jointing:  
 Longitudinal joint: B

BEGIN STATION	END STATION	(P) Feet
5509+50.00	5497+15.47	6

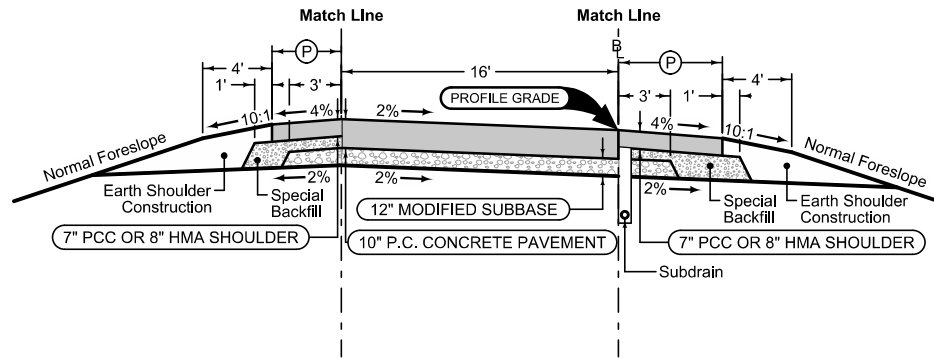

Section shown in the direction of traffic.

Ramp Jointing:  
 Transverse joints: CD at 20' spacing.

BEGIN STATION	END STATION
5509+50.00	5497+15.47

**Auxiliary Lane**

Longitudinal joint: L or KT  
 Transverse joint: Match Mainline

STATION TO STATION	(AL) Feet	(P) Feet	(G) Feet	
5500+60.00	5499+40.00	0-8	4	-
5499+40.00	5497+15.47	8	4	-

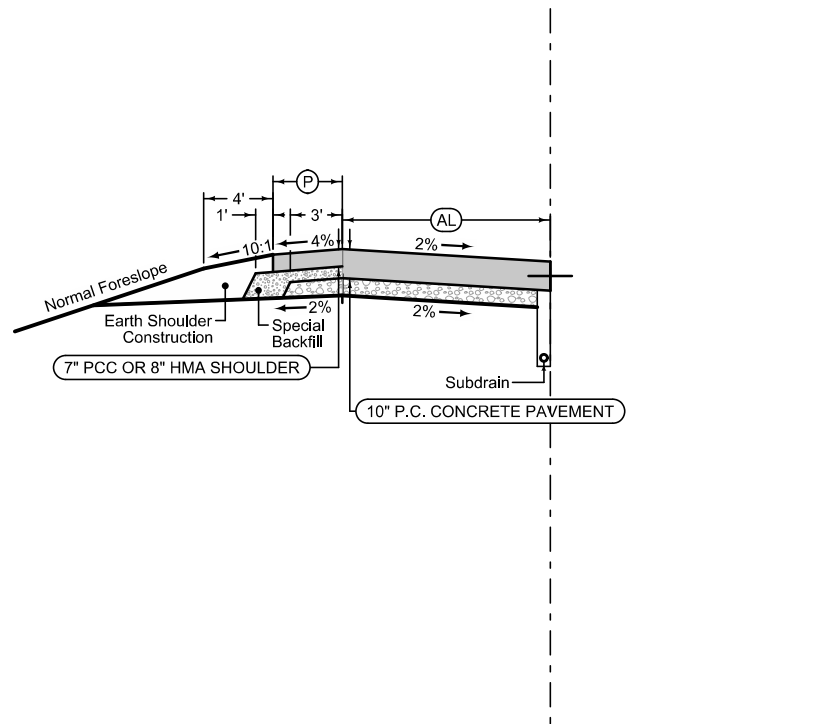

See Tab 100-24 for pavement quantities.  
 See Tab 112-9 for shoulder quantities.

**RAMP 'A'**

**Paved Shoulder Alternates**

PCC Shoulder Jointing:  
 Longitudinal joint: BT-1 or BT-3  
 Transverse joints: C at 20' spacing  
 HMA Shoulder Jointing:  
 Longitudinal joint: B

BEGIN STATION	END STATION	(P) Feet
2578+40.00	2590+02.41	4

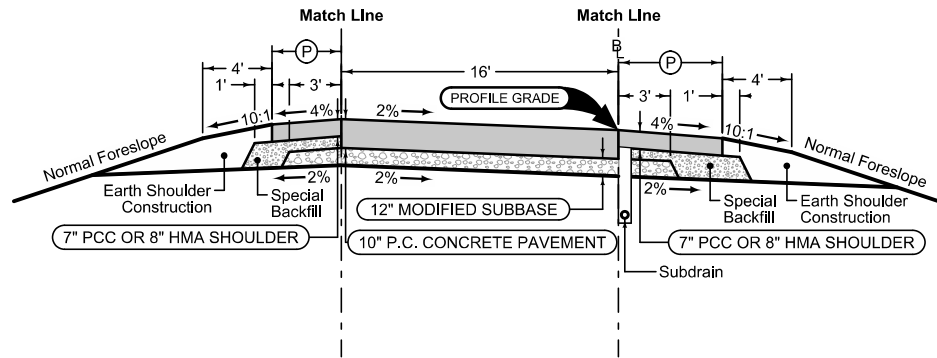

Section shown in the direction of traffic.

Ramp Jointing:  
 Transverse joints: CD at 20' spacing.

BEGIN STATION	END STATION
2578+40.00	2590+02.41

**Paved Shoulder Alternates**

PCC Shoulder Jointing:  
 Longitudinal joint: BT-1 or BT-3  
 Transverse joints: C at 20' spacing  
 HMA Shoulder Jointing:  
 Longitudinal joint: B

BEGIN STATION	END STATION	(P) Feet
2578+40.00	2590+02.41	6

See Tab 100-24 for pavement quantities.  
 See Tab 112-9 for shoulder quantities.

**RAMP 'B'**

**Paved Shoulder Alternates**

PCC Shoulder Jointing:  
 Longitudinal joint: BT-1 or BT-3  
 Transverse joints: C at 20' spacing  
 HMA Shoulder Jointing:  
 Longitudinal joint: B

BEGIN STATION	END STATION	(P) Feet
3600+62.79	3582+28.45	4

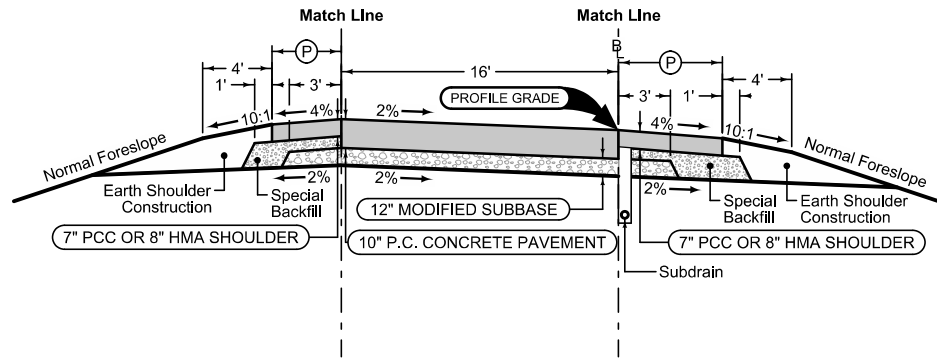

Section shown in the direction of traffic.

Ramp Jointing:  
 Transverse joints: CD at 20' spacing.

BEGIN STATION	END STATION
3600+62.79	3596+20.27
3596+20.27*	3588+40.00*
3588+40.00	3582+30.00

RAMPC\_OR

\* Ramp width transitions include taper/gore of RMPC\_FL3.

**Paved Shoulder Alternates**

PCC Shoulder Jointing:  
 Longitudinal joint: BT-1 or BT-3  
 Transverse joints: C at 20' spacing  
 HMA Shoulder Jointing:  
 Longitudinal joint: B

BEGIN STATION	END STATION	(P) Feet
3600+62.79	3582+30.00	6

**Paved Shoulder Alternates**

PCC Shoulder Jointing:  
 Longitudinal joint: BT-1 or BT-3  
 Transverse joints: C at 20' spacing  
 HMA Shoulder Jointing:  
 Longitudinal joint: B

BEGIN STATION	END STATION	(P) Feet
9+19.84	7+79.70	4

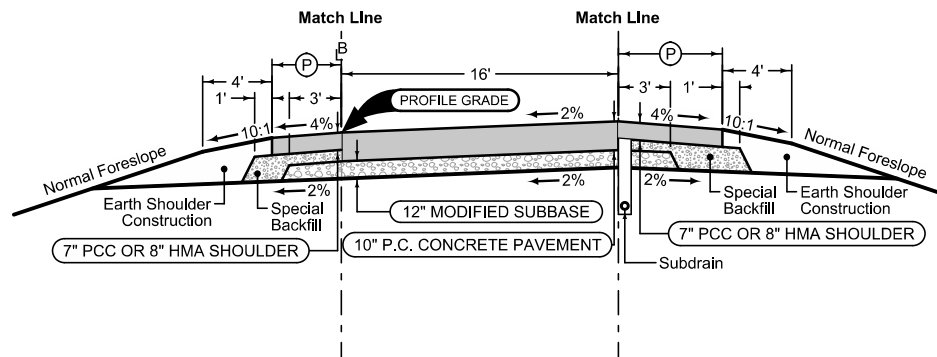

Section shown in the direction of traffic.

Ramp Jointing:  
 Transverse joints: CD at 20' spacing.

BEGIN STATION	END STATION
9+52.22	7+79.70

RMPC\_FL3

**Paved Shoulder Alternates**

PCC Shoulder Jointing:  
 Longitudinal joint: BT-1 or BT-3  
 Transverse joints: C at 20' spacing  
 HMA Shoulder Jointing:  
 Longitudinal joint: B

BEGIN STATION	END STATION	(P) Feet
9+64.92	7+79.70	6

See Tab 100-24 for pavement quantities.

See Tab 112-9 for shoulder quantities.

**RAMP 'C'**



**Paved Shoulder Alternates**

PCC Shoulder Jointing:  
 Longitudinal joint: BT-1 or BT-3  
 Transverse joints: C at 20' spacing  
 HMA Shoulder Jointing:  
 Longitudinal joint: B

BEGIN STATION	END STATION	(P) Feet
4488+69.91	4504+46.33	4

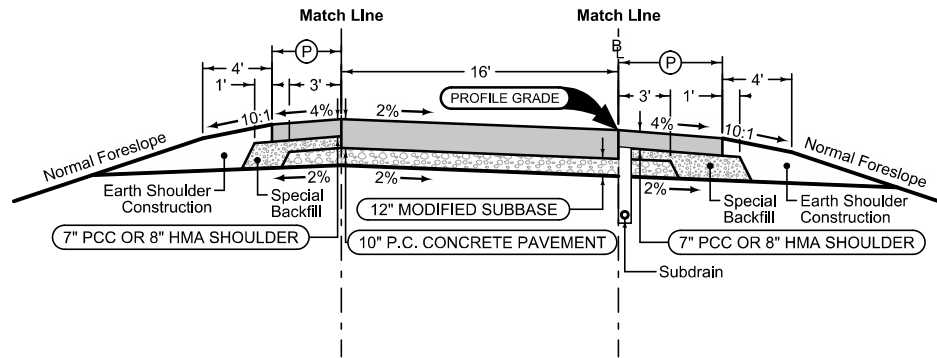

Section shown in the direction of traffic.

Ramp Jointing:  
 Transverse joints: CD at 20' spacing.

BEGIN STATION	END STATION
4488+69.94	4504+46.33

**Paved Shoulder Alternates**

PCC Shoulder Jointing:  
 Longitudinal joint: BT-1 or BT-3  
 Transverse joints: C at 20' spacing  
 HMA Shoulder Jointing:  
 Longitudinal joint: B

BEGIN STATION	END STATION	(P) Feet
4488+69.94	4504+46.33	6

See Tab 100-24 for pavement quantities.  
 See Tab 112-9 for shoulder quantities.

**RAMP 'D'**

1101  
04-30-02

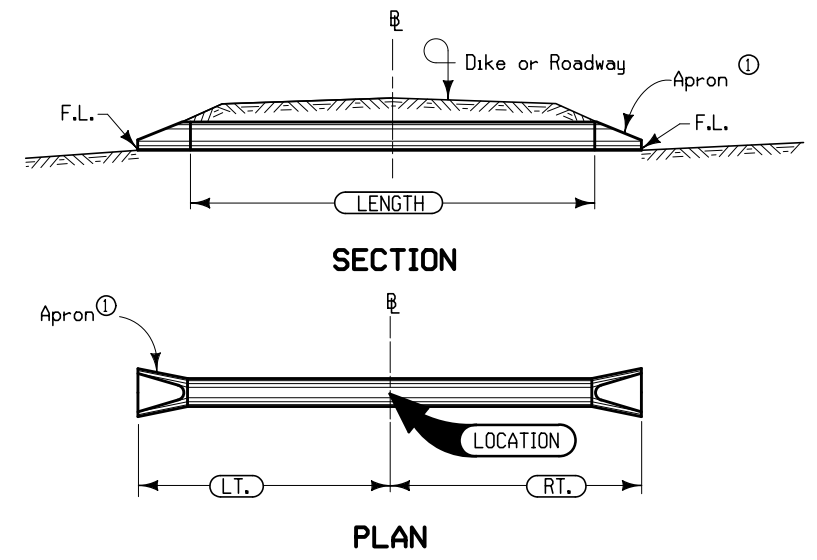

Notes:  
 R shall be C of roadway, dike, survey, or other; as detailed on plans.  
 Skew angle is the angle which one end of the pipe is ahead (by stationing) of line perpendicular to the R (example skew Rt. ahead 30°).  
 Refer to tabular listing and other plans for additional information.  
 ① See Standard Road Plan RF-3 For Conc. or RF-5 for Metal.

PIPE CULVERT

1301  
10-03-00

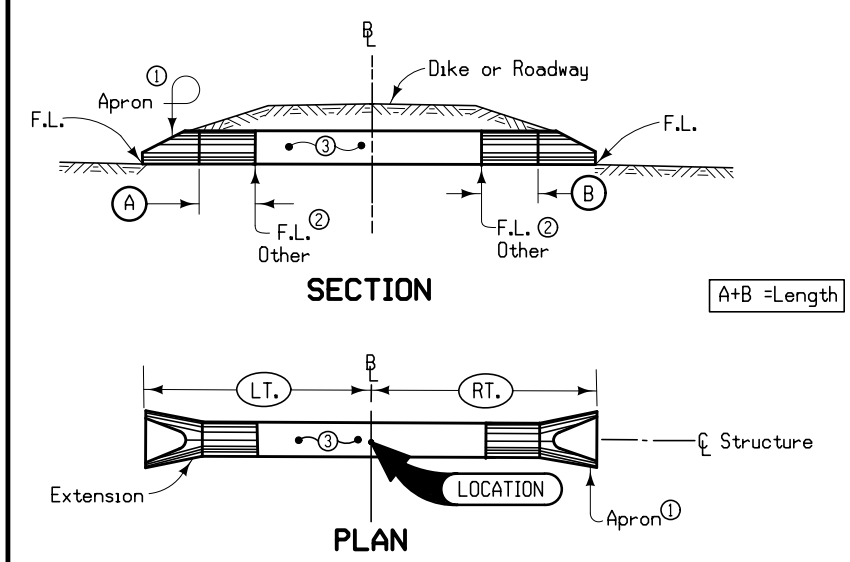

Notes:  
 R shall be C of roadway, dike, survey, or other; as detailed on plans.  
 Extension shall be on line of existing structure to Lt., Rt. or both as specified. Adaptors may be required, see Standard Road Plan RF-2.  
 Refer to tabular listing and other plans for additional information.  
 ① See Standard Road Plan RF-3 for concrete, RF-5 for metal.  
 ② Optional type "D" section only when specified in tabulation.  
 ③ Existing structure.

PIPE EXTENSION

2117  
04-15-08

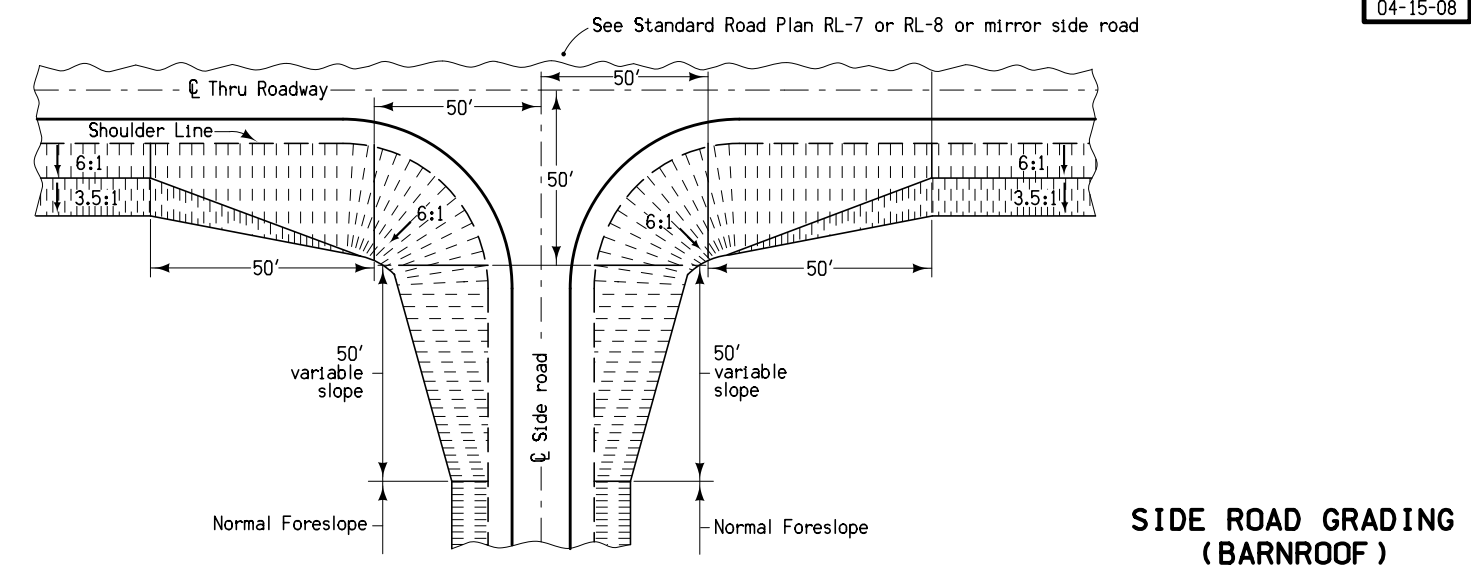

SIDE ROAD GRADING (BARNROOF)

1501  
04-20-10

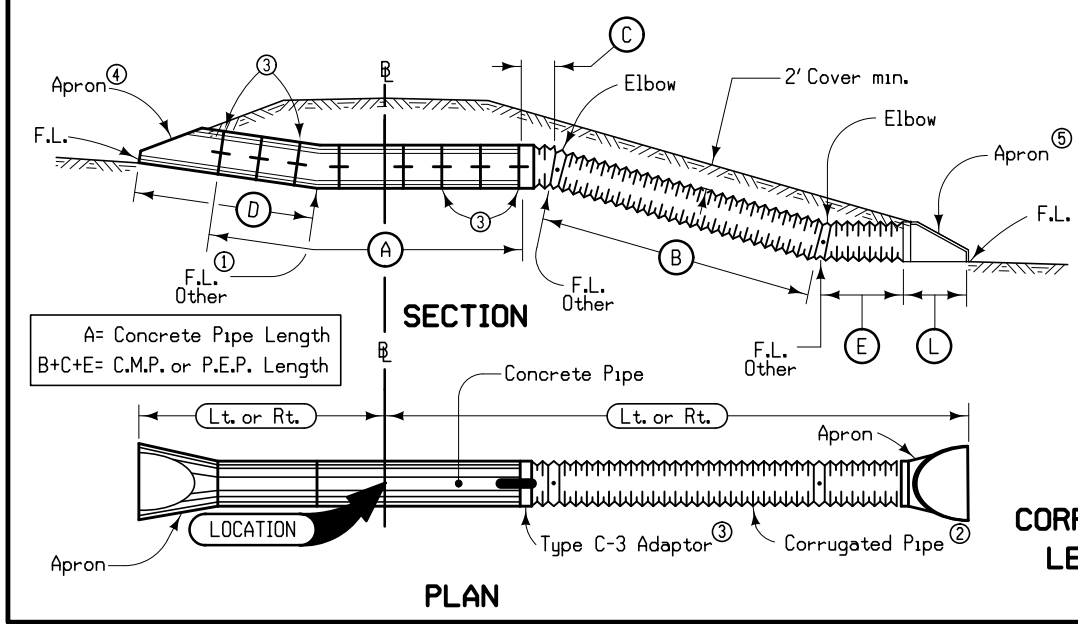

R shall be C of roadway, dike, survey, or other; as detailed on plans.  
 Skew angle is the angle which one end of the pipe is ahead (by stationing) of a line perpendicular to the R.  
 Refer to Tabulation 104-3.  
 ① Optional D section only when specified in tabulation.  
 ② Standard type joint couplings are required. (See Materials I.M. 441)  
 ③ See RF-2 & RF-14.  
 ④ See RF-3.  
 ⑤ See RF-5 for Metal and Polyethylene.

CORRUGATED PIPE - CONCRETE LETDOWN STRUCTURE WITH METAL APRON

4302  
04-03-01

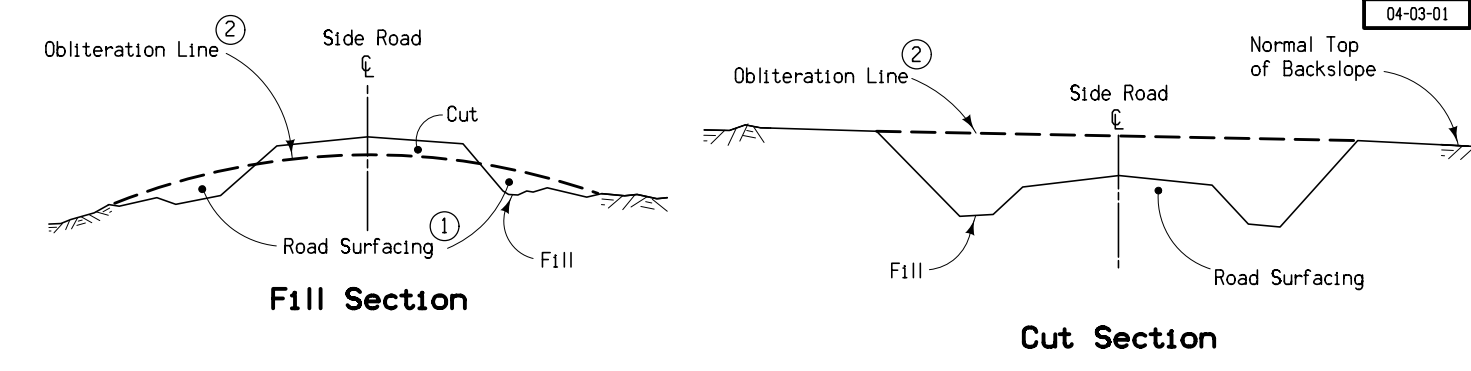

① Existing road surfacing (granular material) shall be placed as shown unless otherwise directed by the Engineer or provided for in the detail project plans.  
 ② When specified, the upper 1' to be suitable for vegetation (grass or crops).  
 Note:  
 The work of obliterating or reshaping old roadbeds shall be done at the direction of the Engineer.

TYPICAL DETAILS FOR OBLITERATION EXISTING ROADBED

4101  
04-20-10

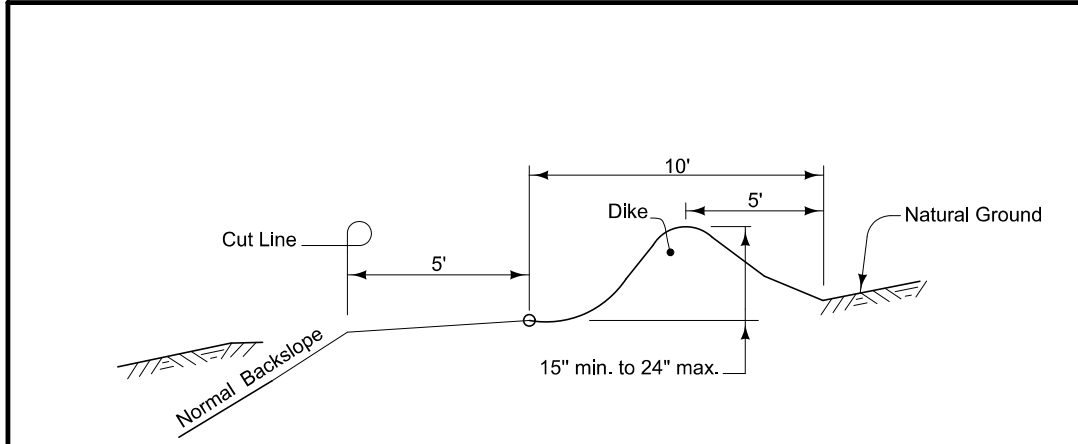

Refer to plans for locations of intercepting ditches. Dike for intercepting ditch shall be made by taking earth from roadway side. Do not excavate back of dike.

TYPICAL CROSS SECTION INTERCEPTING DITCH

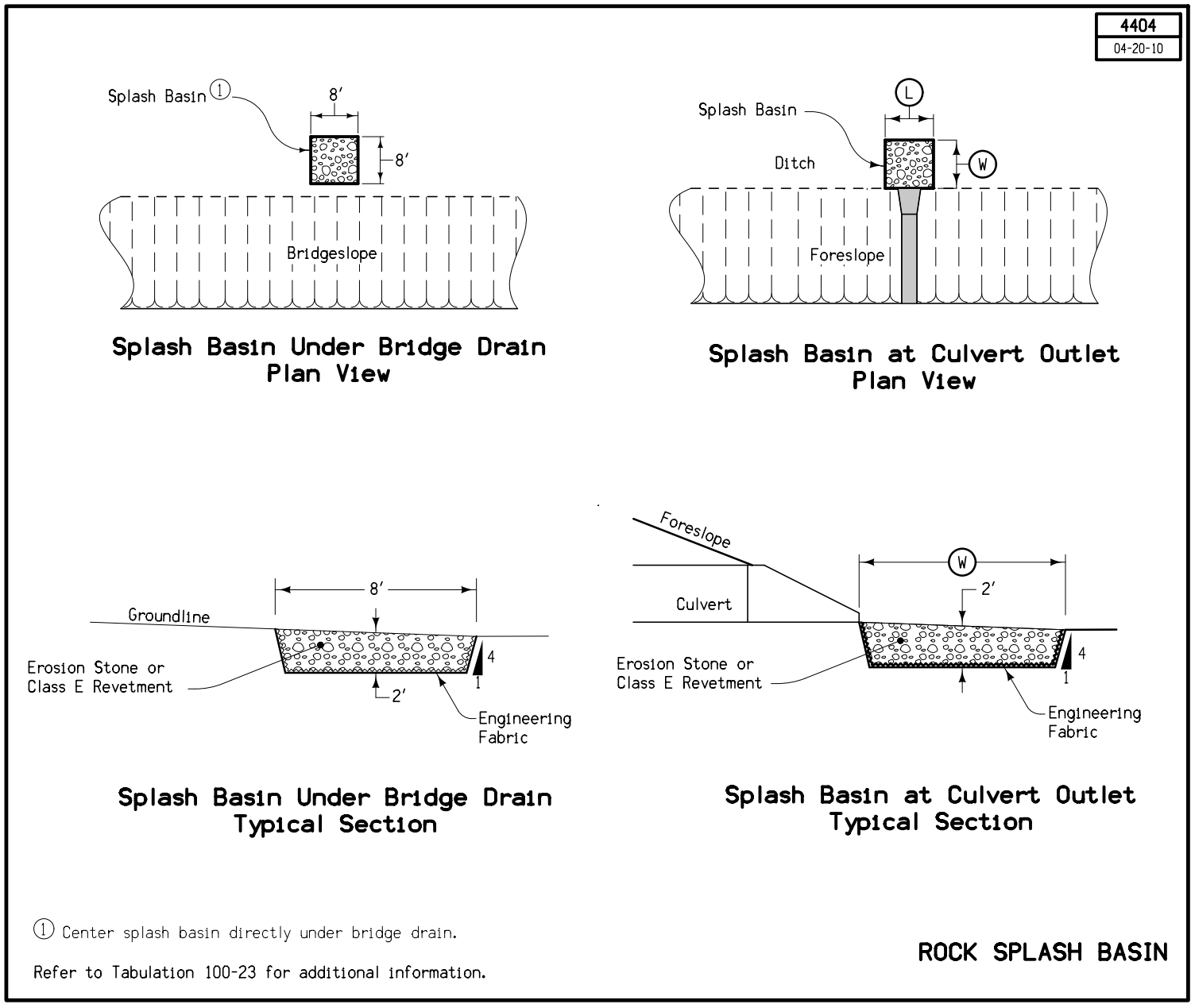
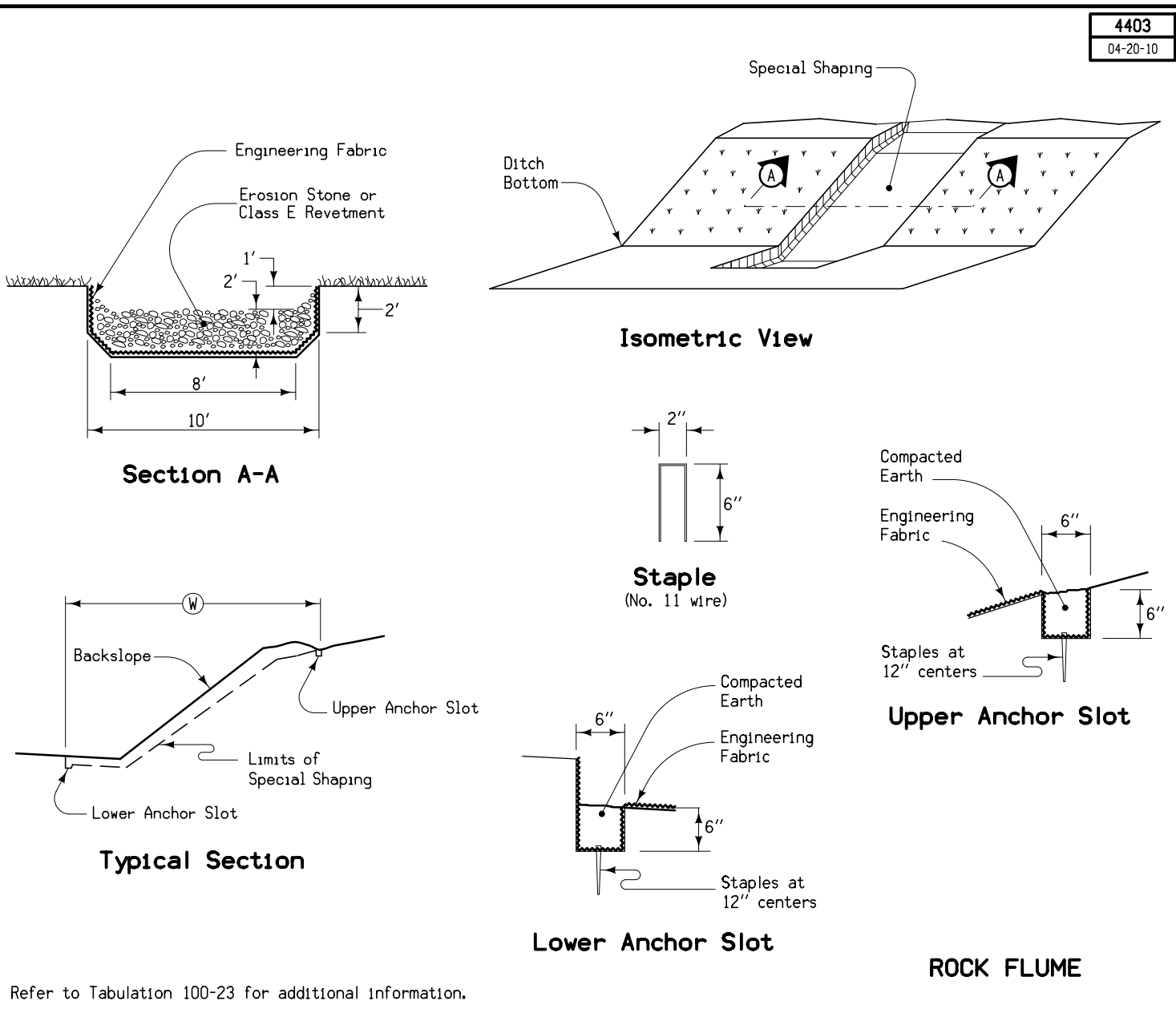
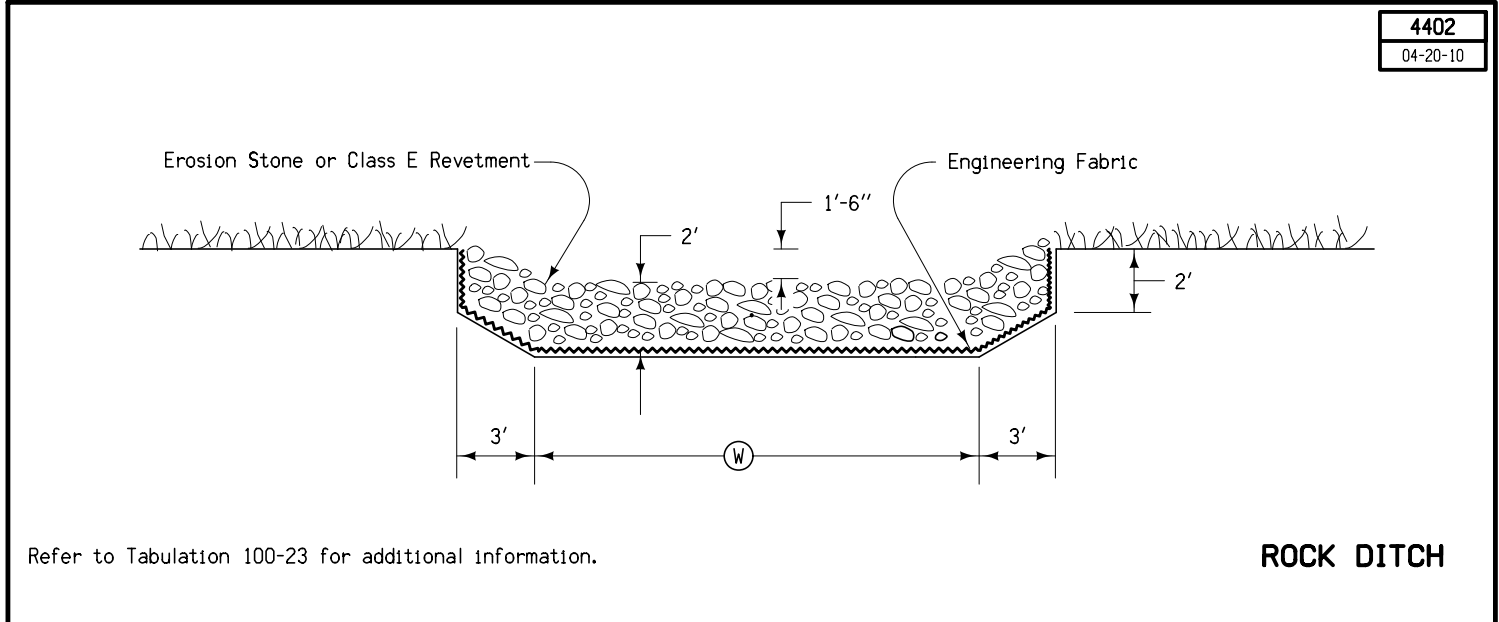
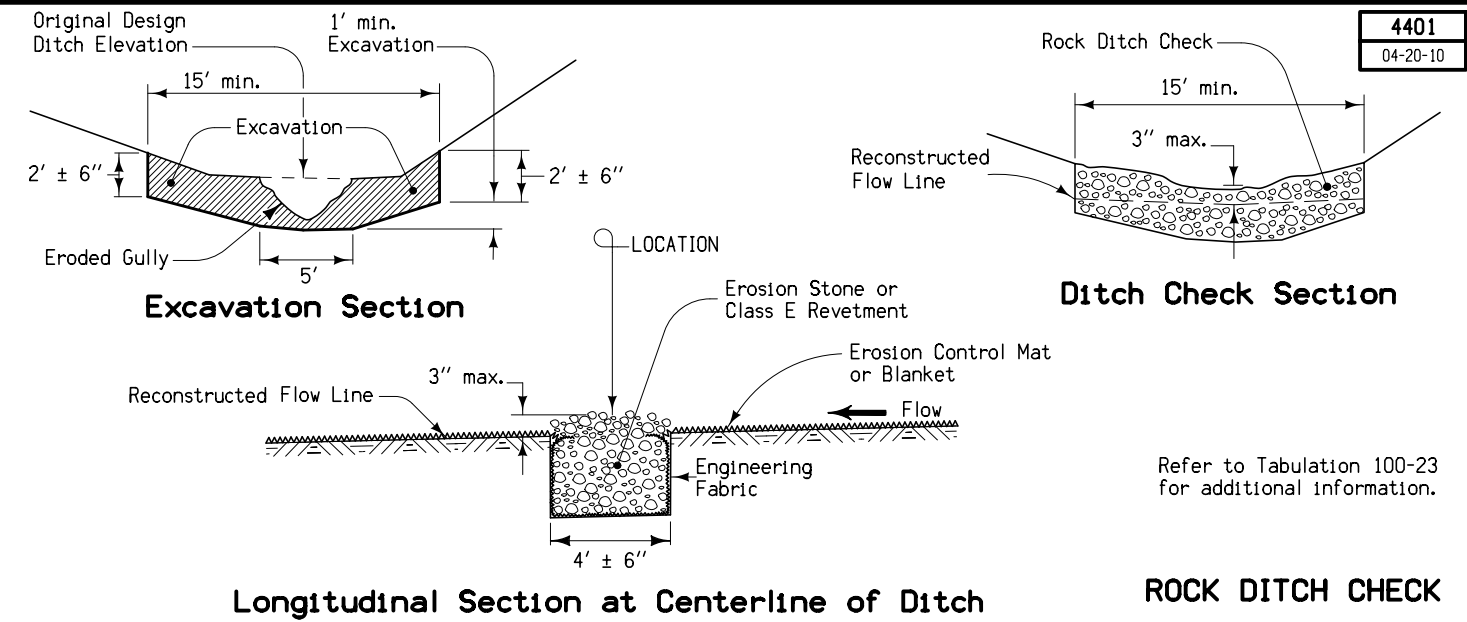

4405  
04-20-10

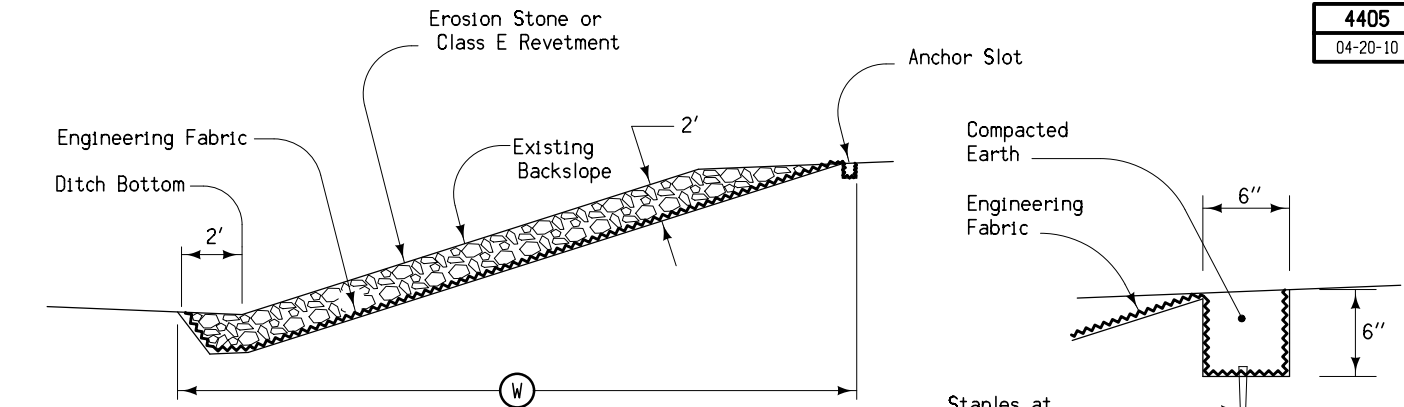

Typical Section

Anchor Slot

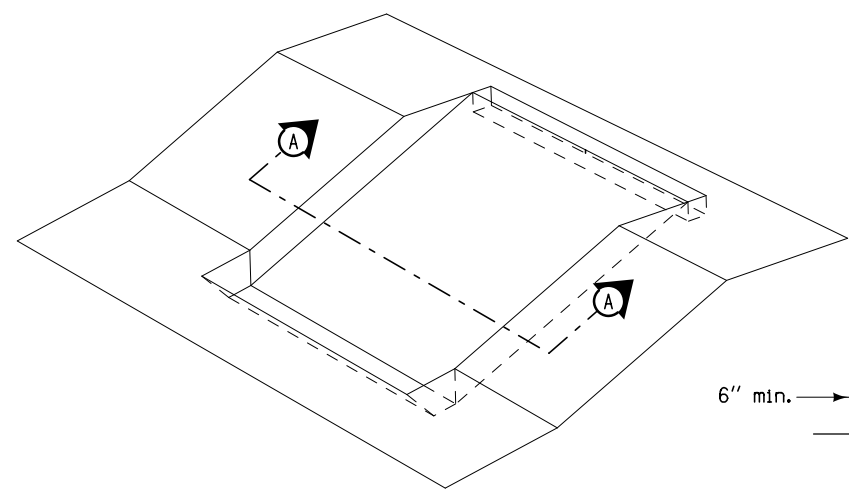

Isometric View

Staple  
(No. 11 wire)

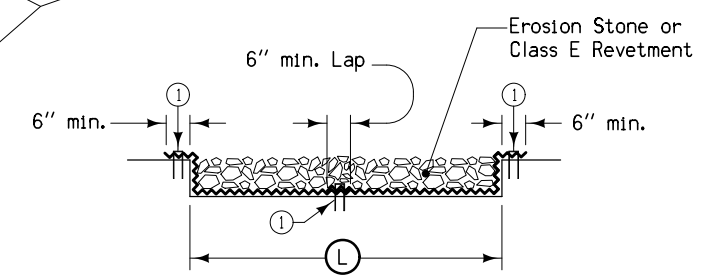

Section A-A

ROCK SLOPE PROTECTION

① Staples at 12" centers  
Refer to Tabulation 100-23 for additional information.

7145  
04-15-03

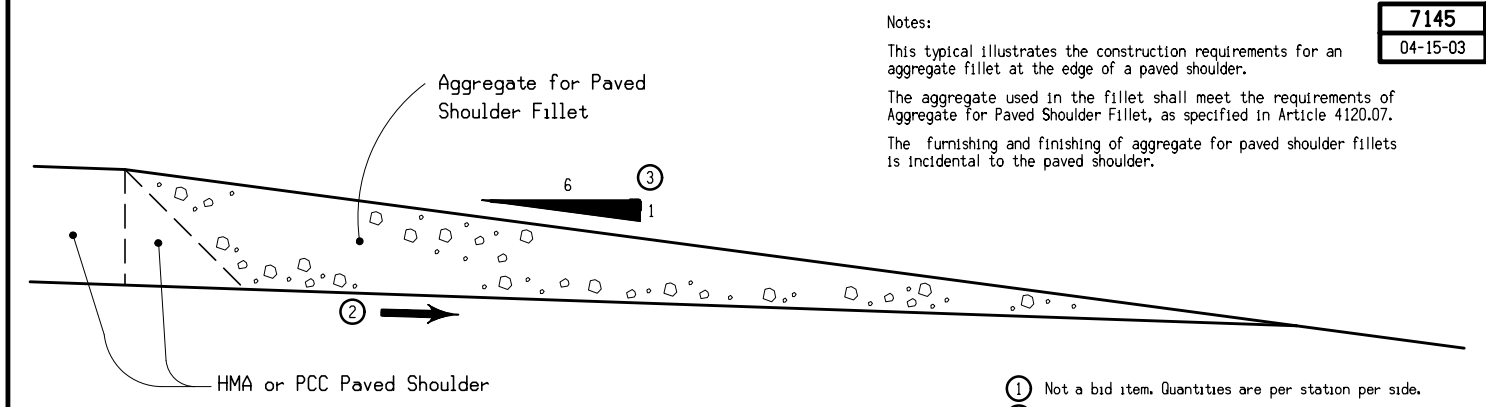

Notes:  
This typical illustrates the construction requirements for an aggregate fillet at the edge of a paved shoulder.  
The aggregate used in the fillet shall meet the requirements of Aggregate for Paved Shoulder Fillet, as specified in Article 4120.07.  
The furnishing and finishing of aggregate for paved shoulder fillets is incidental to the paved shoulder.

- ① Not a bid item. Quantities are per station per side.
- ② Match slope of under side of shoulder pavement.
- ③ 6:1 Slope minimum

AGGREGATE FOR PAVED SHOULDER FILLET

LOCATION			QUANTITIES ①	
ROAD IDENTIFICATION	STATION TO STATION	SIDE	AGGREGATE FOR PAVED SHOULDER FILLET	
			PCC Tons	HMA Tons

7146  
04-15-03

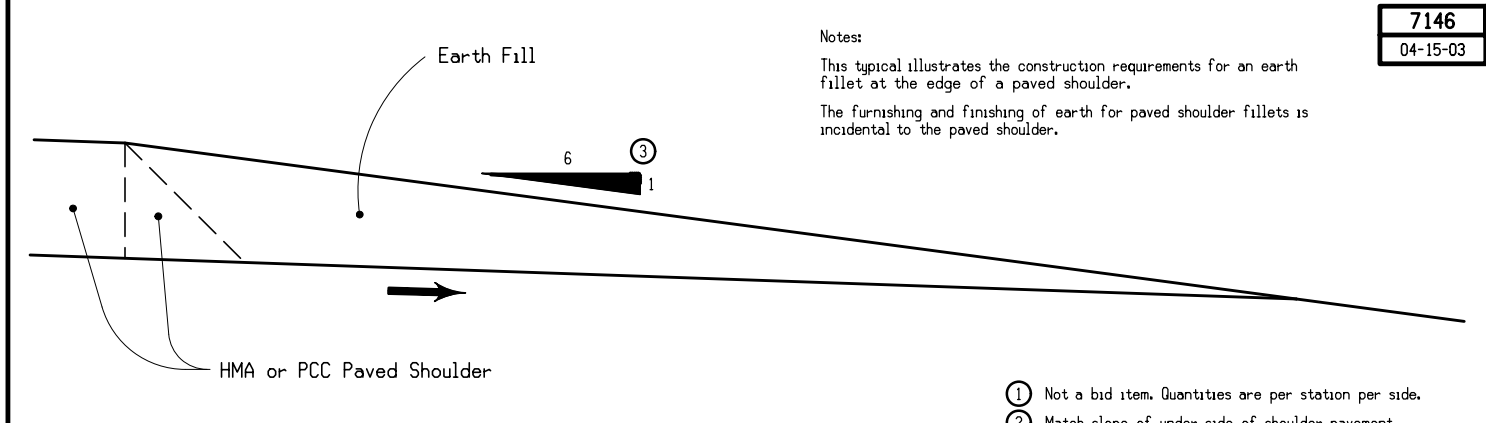

Notes:  
This typical illustrates the construction requirements for an earth fillet at the edge of a paved shoulder.  
The furnishing and finishing of earth for paved shoulder fillets is incidental to the paved shoulder.

- ① Not a bid item. Quantities are per station per side.
- ② Match slope of under side of shoulder pavement.
- ③ 6:1 Slope minimum.

EARTH FOR PAVED SHOULDER FILLET

LOCATION			QUANTITIES ①	
ROAD IDENTIFICATION	STATION TO STATION	SIDE	EARTH FILL	
			PCC Cu. Yds.	HMA Cu. Yds.

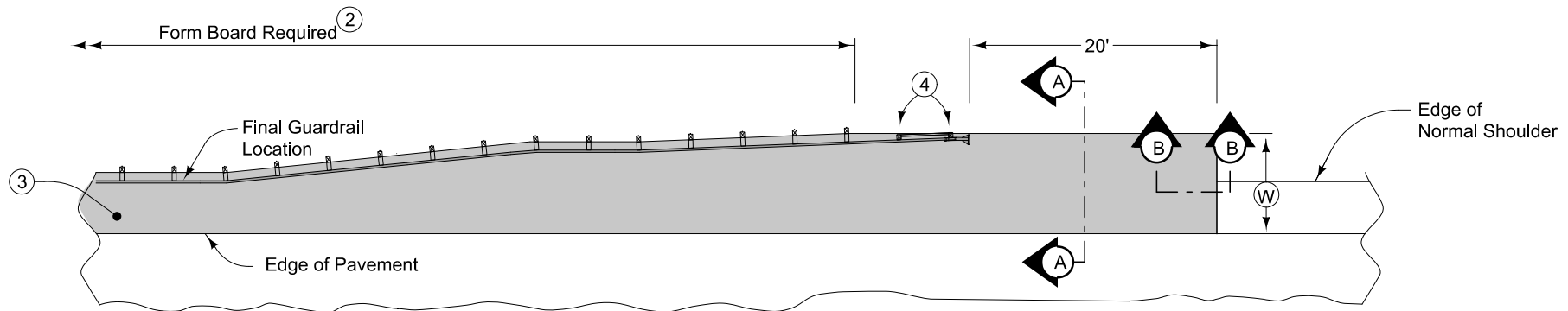

6" HMA Paved Shoulder at guardrail. 7" PCC may be substituted with the following jointing layout:

Match mainline pavement joint spacing. When mainline pavement is 8" or greater in thickness, place additional transverse joints in shoulder at mid-panel of the mainline pavement. Place longitudinal joint at W/2 from edge of mainline pavement when W is greater than 10' wide. Terminate longitudinal joint at transverse joint less than 10' in length.

Compaction of HMA is required to face of guardrail post. Hand compaction will be allowed under guardrail. Removal & reinstallation of guardrail will be allowed with no additional payment.

- ① 6" subgrade treatment.
- ② When guardrail posts are installed prior to construction of paved shoulder, nail 1" x 6" untreated form boards along the face of guardrail posts for the length shown. This board is to prevent shoulder material from contacting the sides of the posts and altering the function of the guardrail. Form board not required for final 2 posts.
- ③ Continue paved shoulder to existing paved shoulder or 20' beyond the end of guardrail.
- ④ Shoulder may be notched for final 2 posts or post sleeves may be installed through pavement.

Location			P	Subgrade Treatment ①		Paved Shoulder SY	Remarks
Road Identification	Station To Station	Side		Feet	Special Backfill Tons		

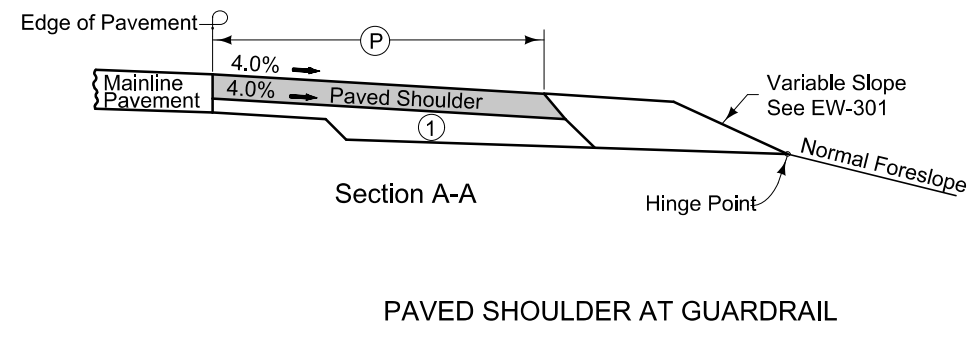
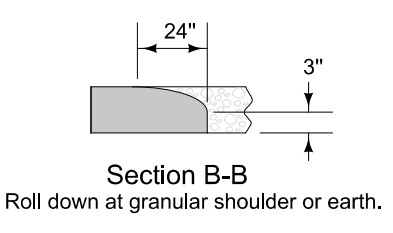
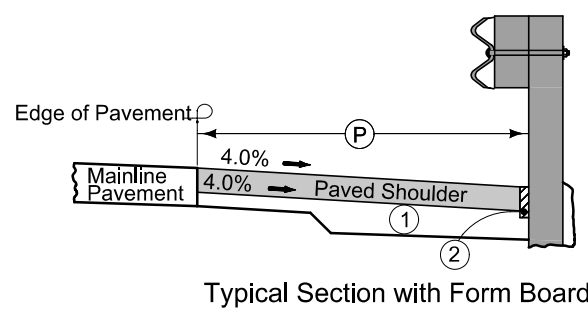

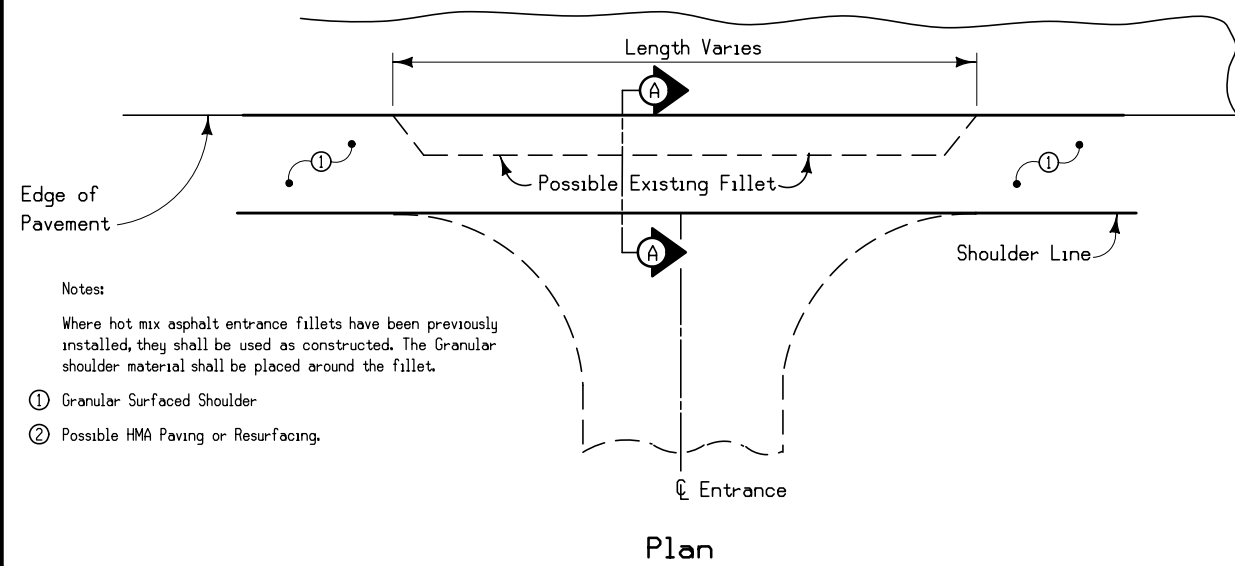

Notes:  
Where hot mix asphalt entrance fillets have been previously installed, they shall be used as constructed. The Granular shoulder material shall be placed around the fillet.

① Granular Surfaced Shoulder  
② Possible HMA Paving or Resurfacing.

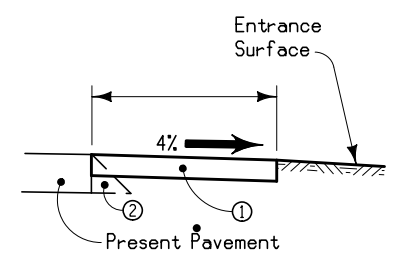

Section A-A  
Without Fillet

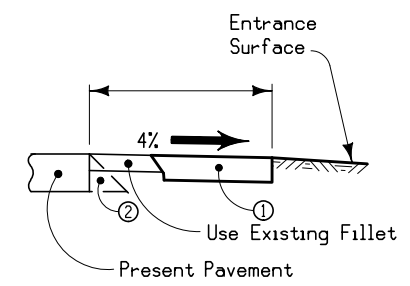

Section A-A  
With Previous Fillet

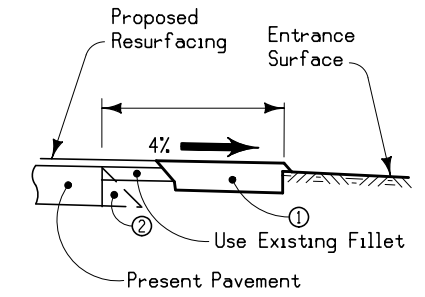

Section A-A  
With Previous Fillet  
And Resurfacing Less than 1/2"

GRANULAR SHOULDER CONSTRUCTION THRU ENTRANCES

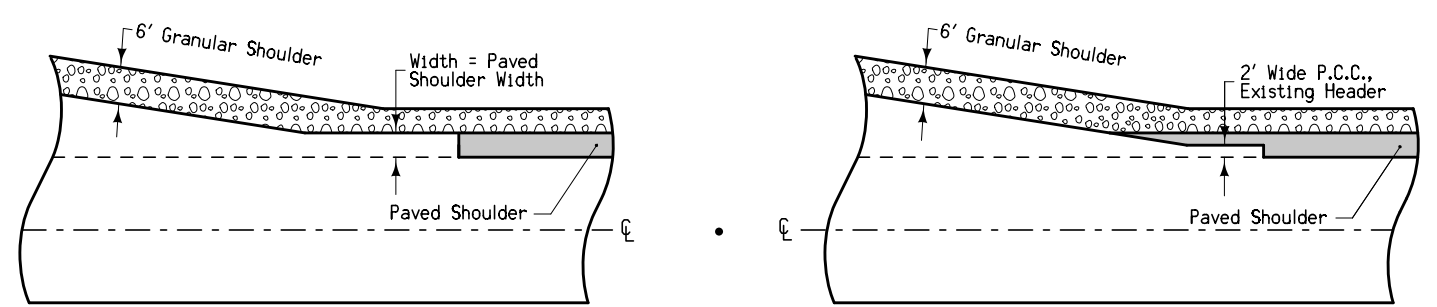

With Newly Constructed Turn Lanes      At UAC Turn Lanes

PAVED SHOULDER  
DETAIL AT  
TURN LANES

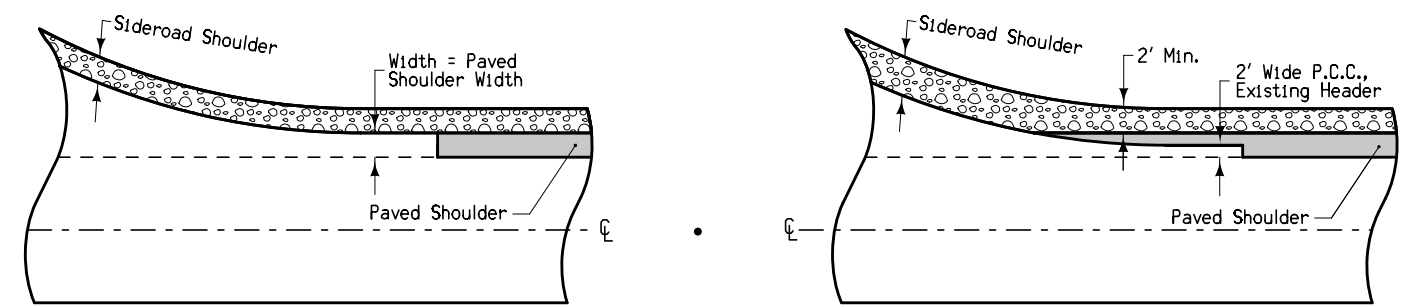

With Newly Constructed Returns      At UAC Returns

PAVED SHOULDER  
DETAIL AT RETURNS

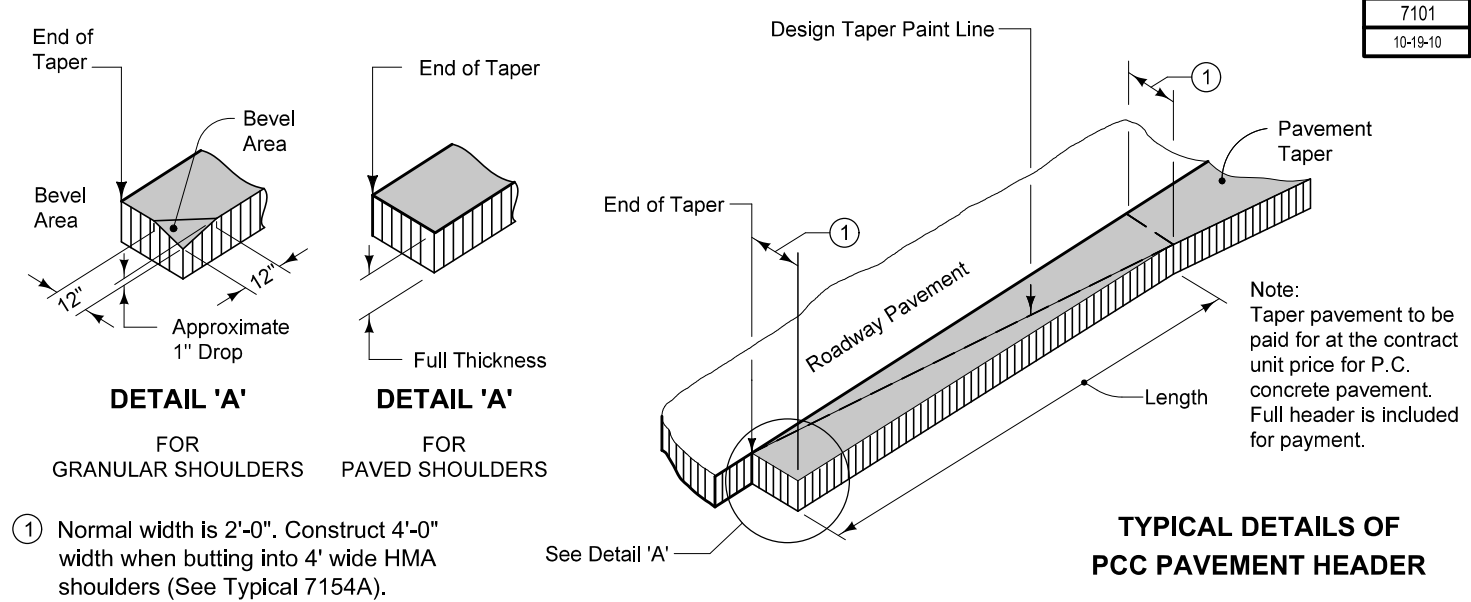

① Normal width is 2'-0". Construct 4'-0" width when butting into 4' wide HMA shoulders (See Typical 7154A).

TYPICAL DETAILS OF  
PCC PAVEMENT HEADER

**PROJECT SYMBOLS**

- OUT tile outlet
- ⊗ INB intake-beehive
- TPD telephone pedestal
- ⊕ AST Above Ground Storage Tank
- Flg FLG flag poles
- MIS miscellaneous
- TDC tree deciduous
- WHD water hydrant
- GP guard post (less than 4 posts)
- PR power riser pole
- TV satellite tv dish
- ★ TEV evergreen tree
- TFR fruit tree
- LP L.P. tank
- SEP septic tank
- PPA power pole 1st co.
- LUM luminaire
- MH manhole
- HT highline tower
- MM mile marker post
- EB electrical box
- ⊗ WEL well
- SIGN SL speed limit sign
- UST buried tanks
- LC lot corner
- COR Column Round
- CUL culvert
- ← DU cl of draw upstream
- D cl of draw or stream
- PIP pipes(cast iron,steel,tile,etc)
- - - BL break line field survey
- x - FW fence wire
- LIN miscellaneous line
- BLD foundation or building
- RET retaining walls
- TOP Top of Bridge Piers
- CON concrete or a/c slab
- EP edge of paved roads
- T1 le TIL tile line
- GDL guard rails
- BRG bridge
- SF Silt Fence (Wetlands)
- BLS bridge low steel
- ENT cl of entrance
- E2 ELB buried electric line 2nd co.
- EG edge of gravel road
- SH shoulder paved
- ENU edge unpaved entrance & parking
- SWK sidewalk
- CU curb or center island
- SNP Shoulder Non-Paved
- DIK cl of dike or dam
- GU gutter
- ENP edge paved entrance & parking
- BNK stream bank
- FO FOA fiber optics 1st co.
- T1 TLA buried telephone line 1st co.
- E1 ELA buried electric line 1st co.

**UTILITY LEGEND**

- Woodbury Rural Electric
- T Long Lines
- F0-1 Long Lines
- E Woodbury Rural Electric
- E2 Iowa Dept. of Transportation

**PLAN VIEW COLOR LEGEND OF PLAN AND PROFILE SHEETS**

- Green (2) Existing Topographic Features and Labels
- Blue (1) Proposed Alignment, Stationing, Tic Marks, and Alignment Annotation
- Purple (5) Existing Utilities
- Yellow (4) Highlight for Critical Notes or Features
- Red (3) Delineates Restricted Areas
- Lavender (9) Temporary Pavement Shading
- Gray, Light (48) Proposed Pavement Shading
- Gray, Med (80) Proposed Granular Shading
- Gray, Dark (112) Proposed Grade and Pave Shading
- Brown, Light (237) Grading Shading

**PROFILE VIEW COLOR LEGEND OF PLAN AND PROFILE SHEETS**

- Green (2) Existing Ground Line Profile
- Blue (1) Proposed Profile and Annotation
- Purple (5) Existing Utilities
- Blue, Light (230) Proposed Ditch Grades, Left
- Black (0) Proposed Ditch Grades, Median
- Rust (14) Proposed Ditch Grades, Right

**CONVENTIONAL SIGNS**

- Reference Point
- Station
- ▲ Section Corner
- ▨ Clearing & Grubbing Area
- ▩ Pavement Removal

**RIGHT-OF-WAY LEGEND**

- ▲ Proposed Right-of-Way
- △ Existing Right-of-Way
- ▲ Existing and Proposed Right-of-Way
- ▲ Easement and Existing Right-of-Way
- Borrow
- Easement (Temporary)
- Easement
- ✕ Excess
- Property Line
- A/C Access Control

**PLAN AND PROFILE  
LEGEND AND SYMBOL  
INFORMATION SHEET**

(COVERS SHEET SERIES D, E, & K)

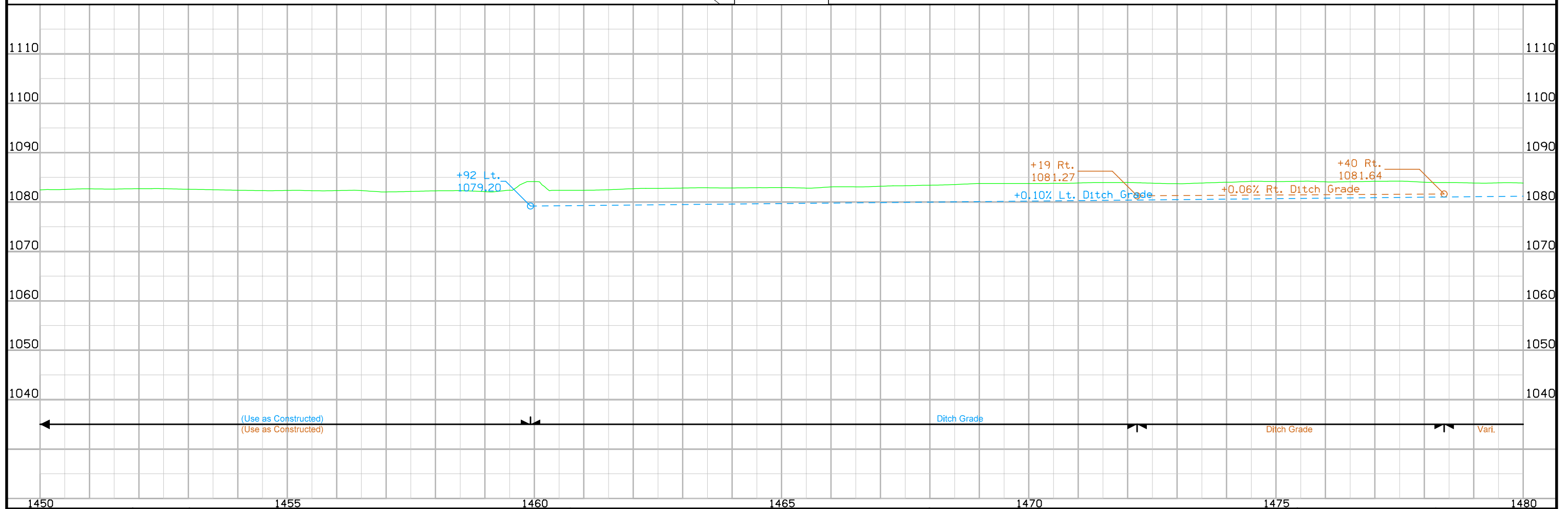
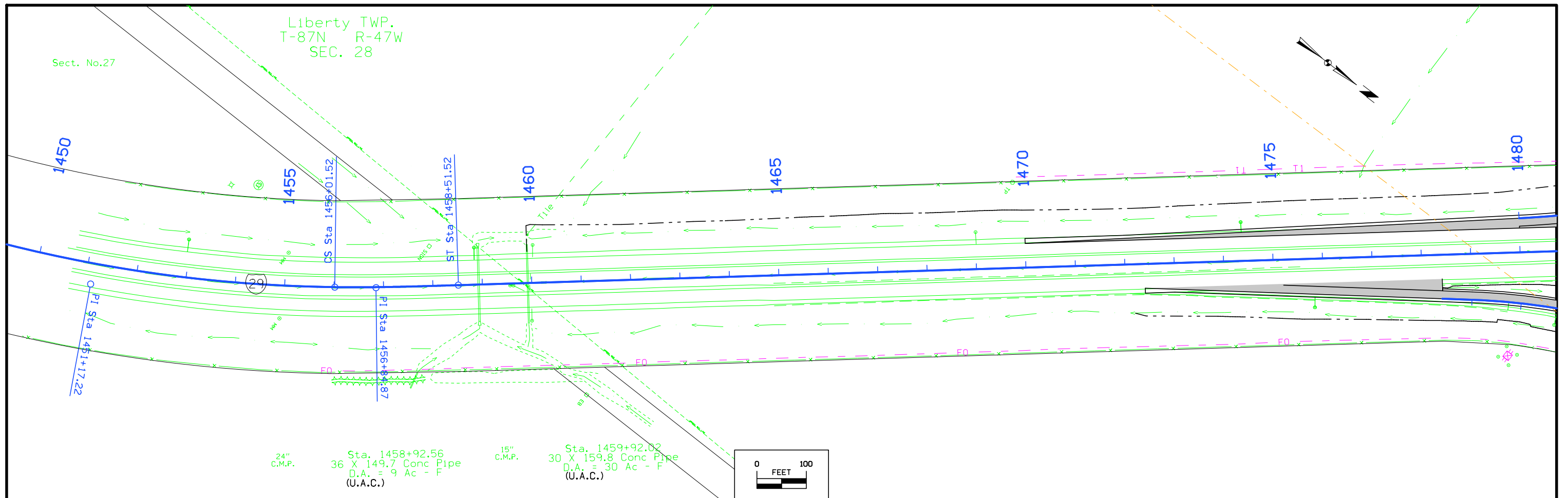



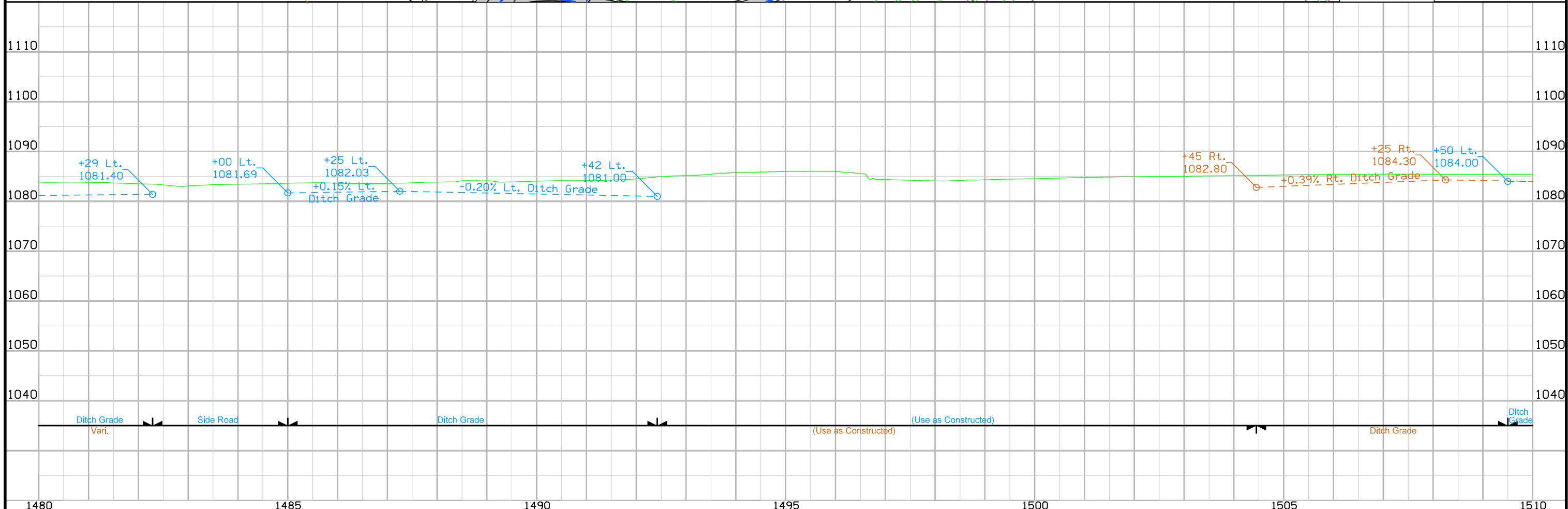
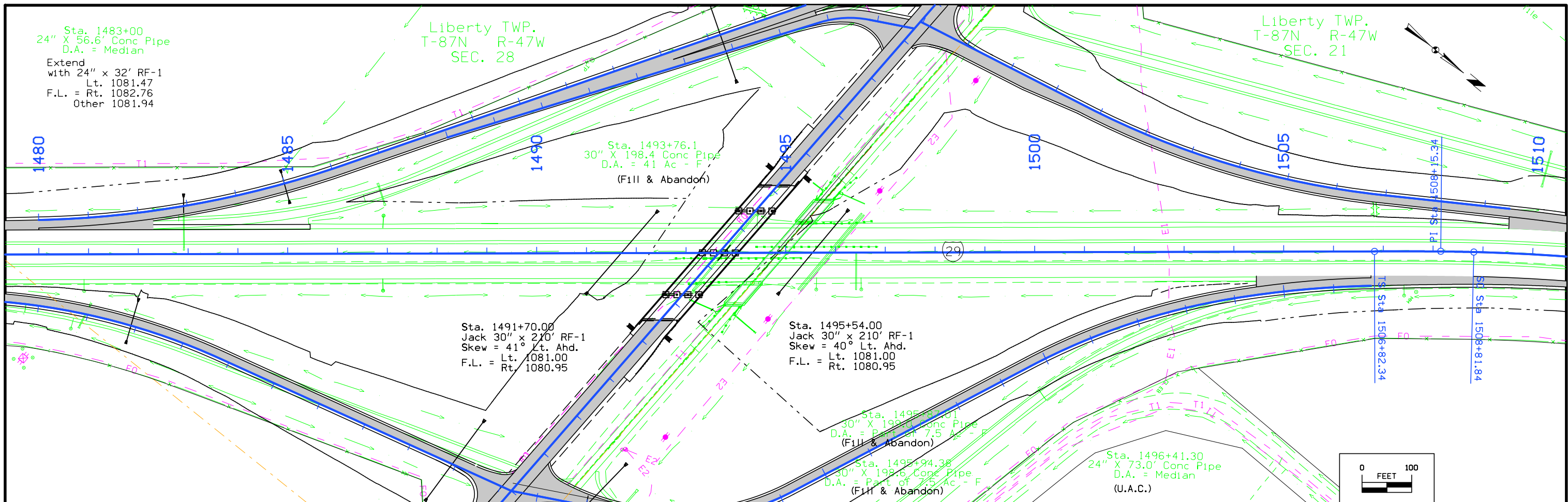

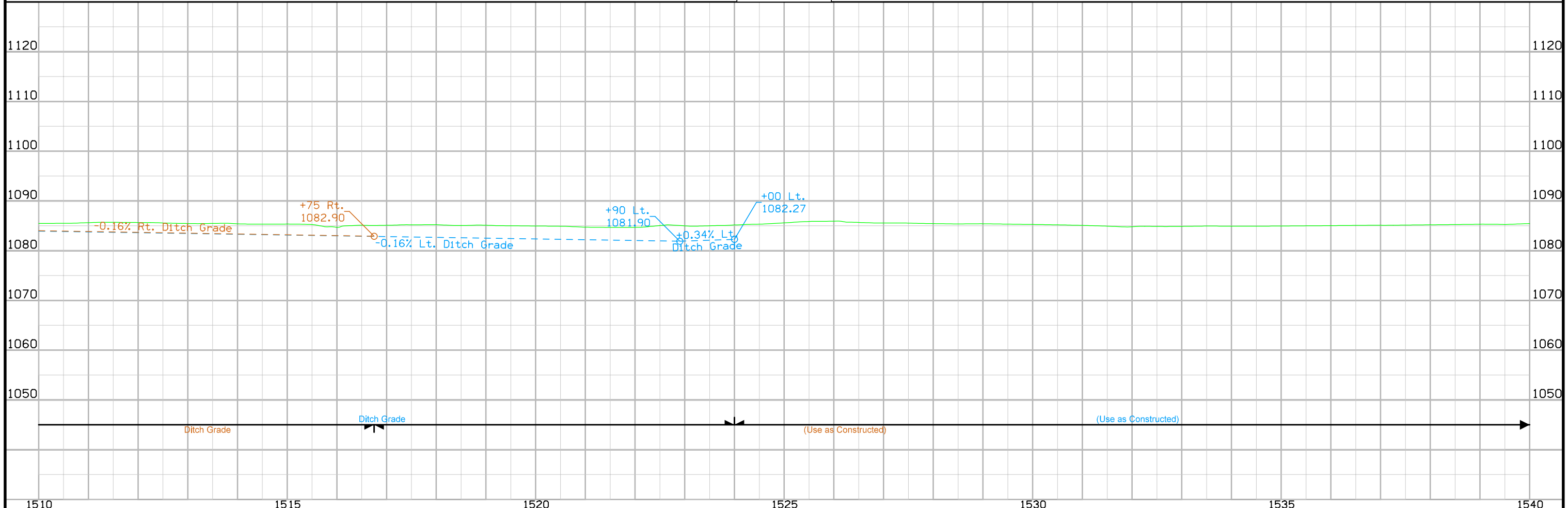
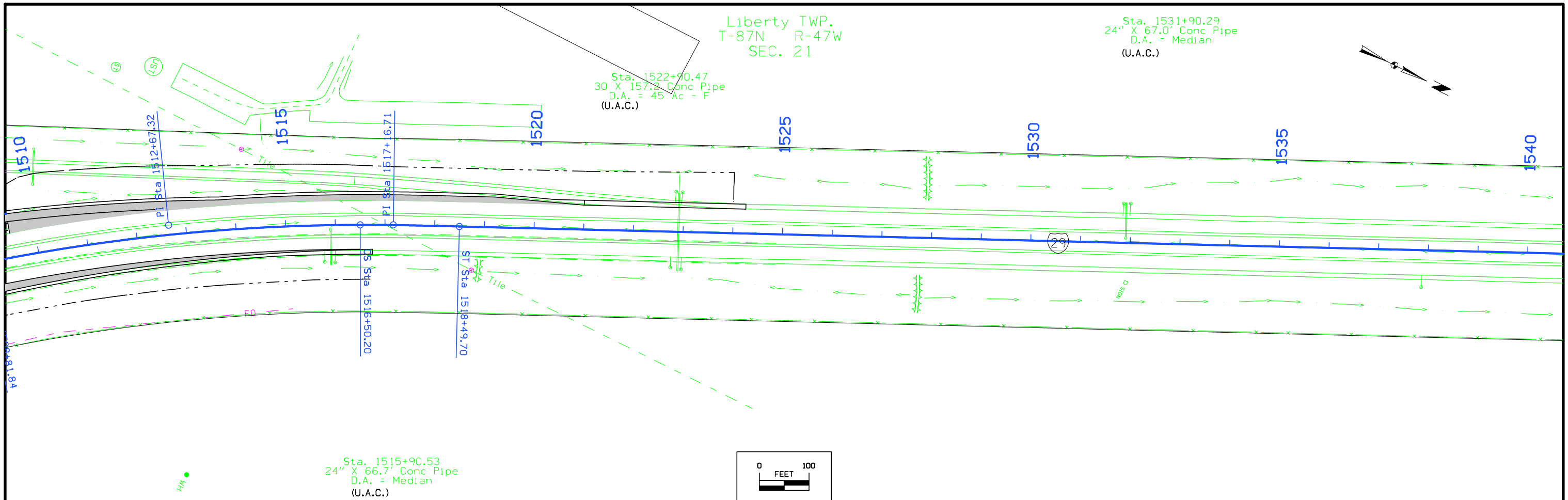

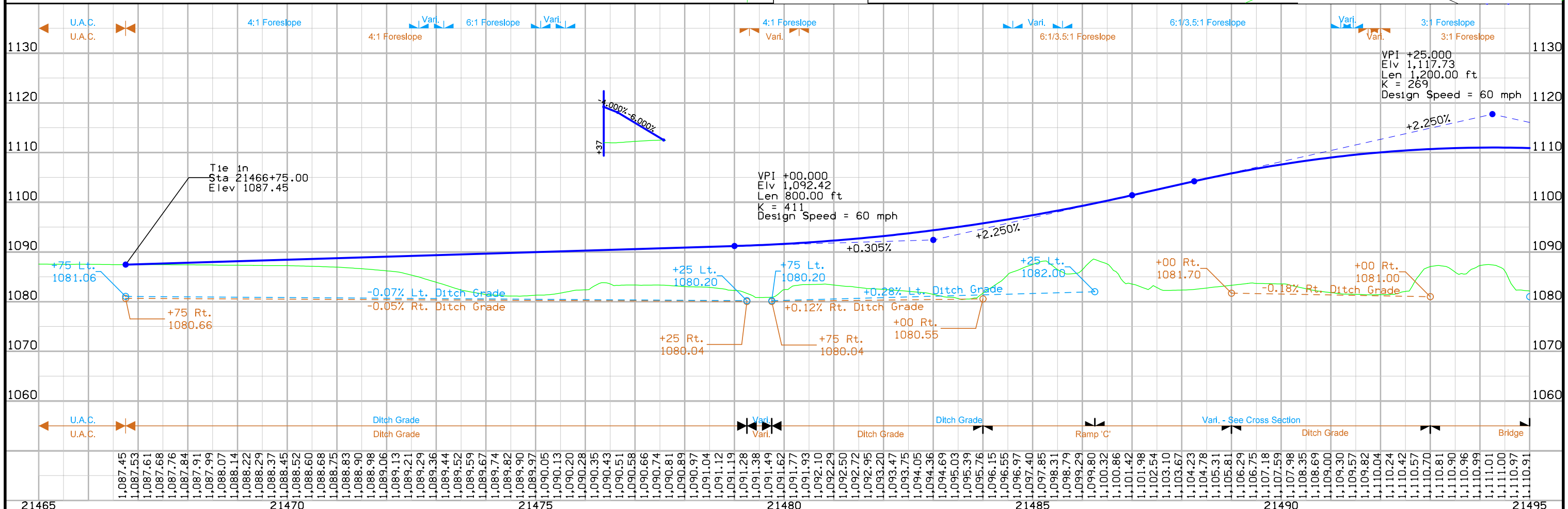
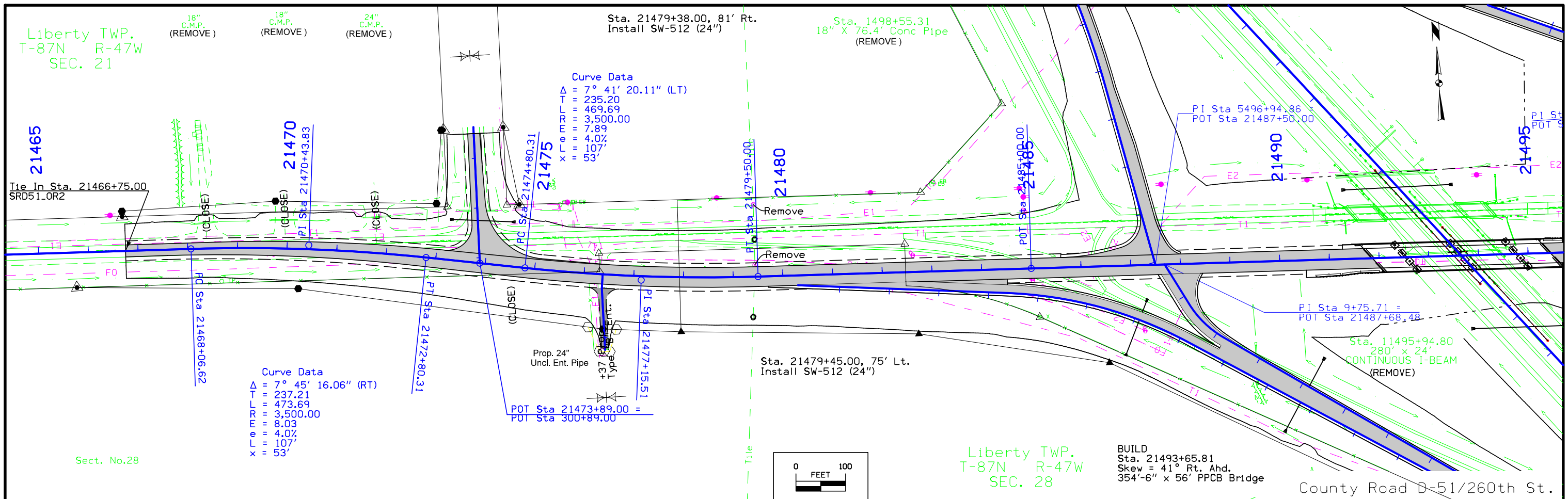

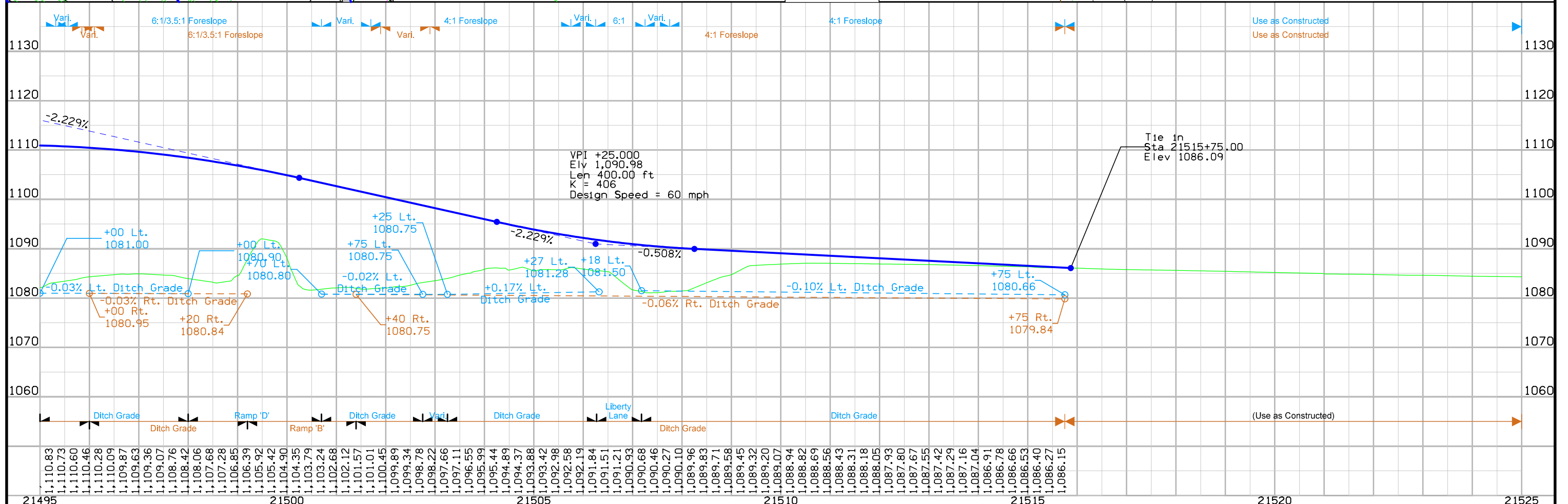
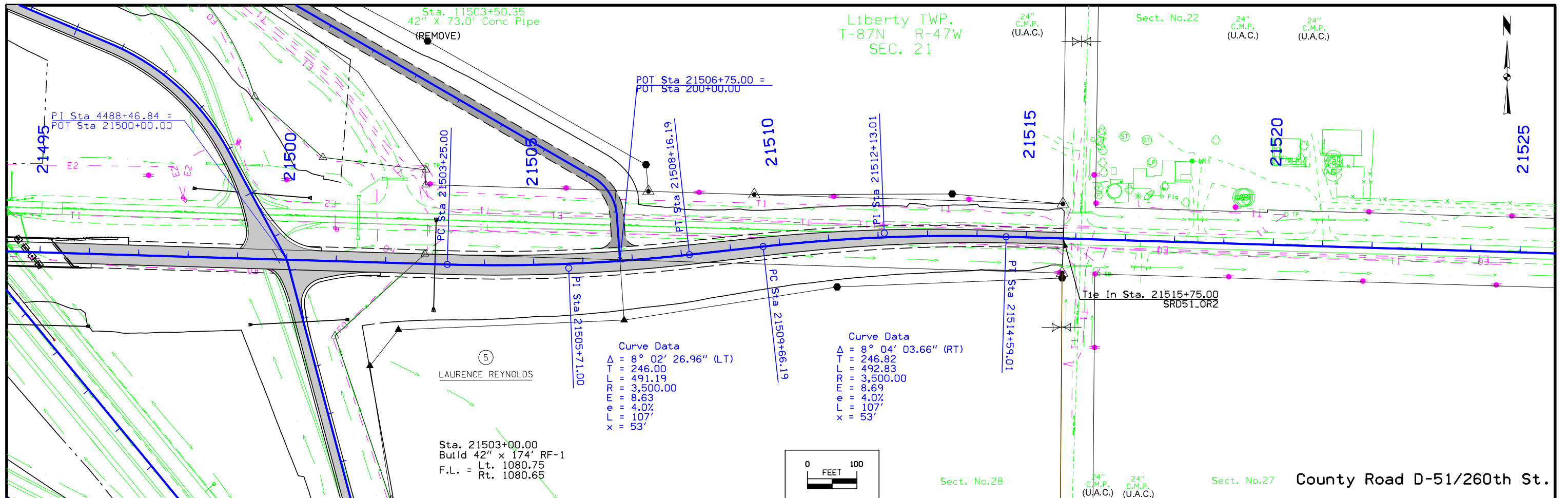

Liberty TWP.  
T-87N R-47W  
SEC. 21

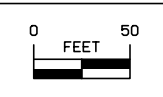
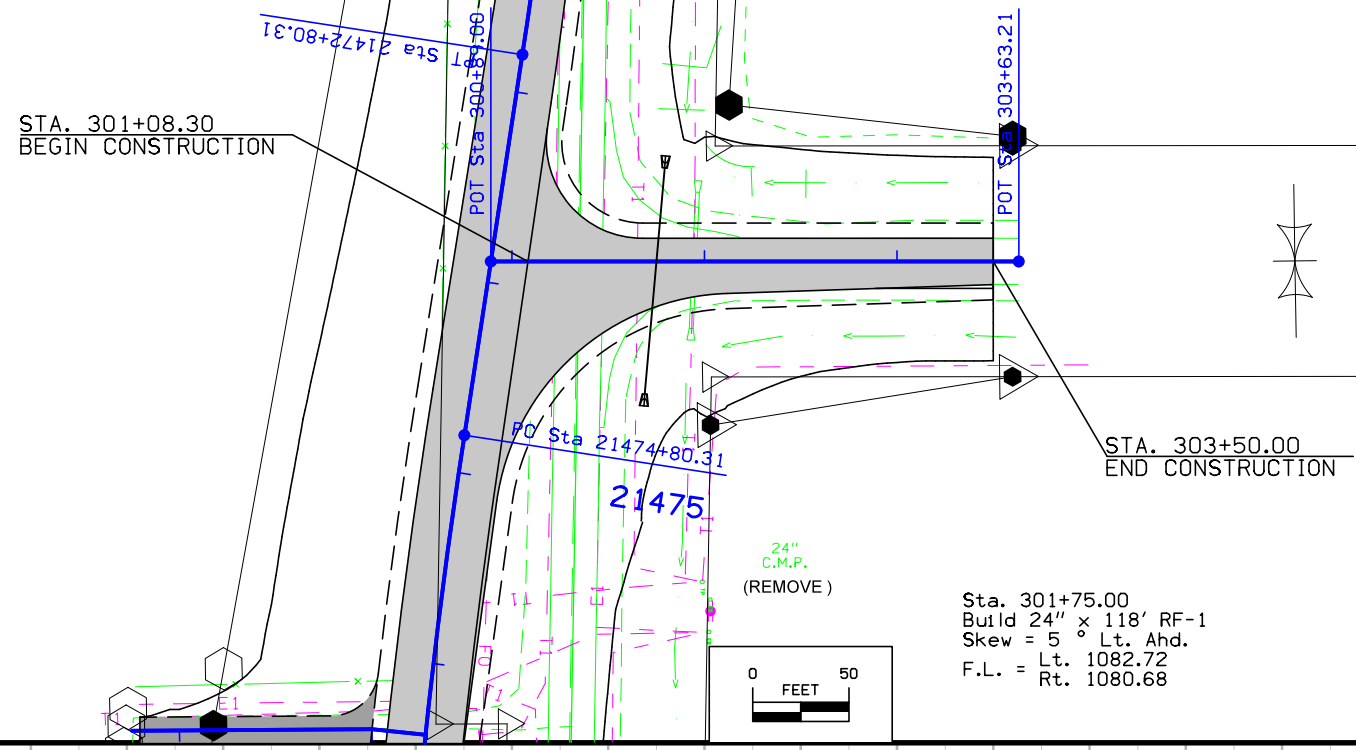
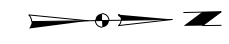

Sta. 301+75.00  
Build 24" x 118' RF-1  
Skew = 5° Lt. Ahd.  
F.L. = Lt. 1082.72  
Rt. 1080.68

Burnett Ave.

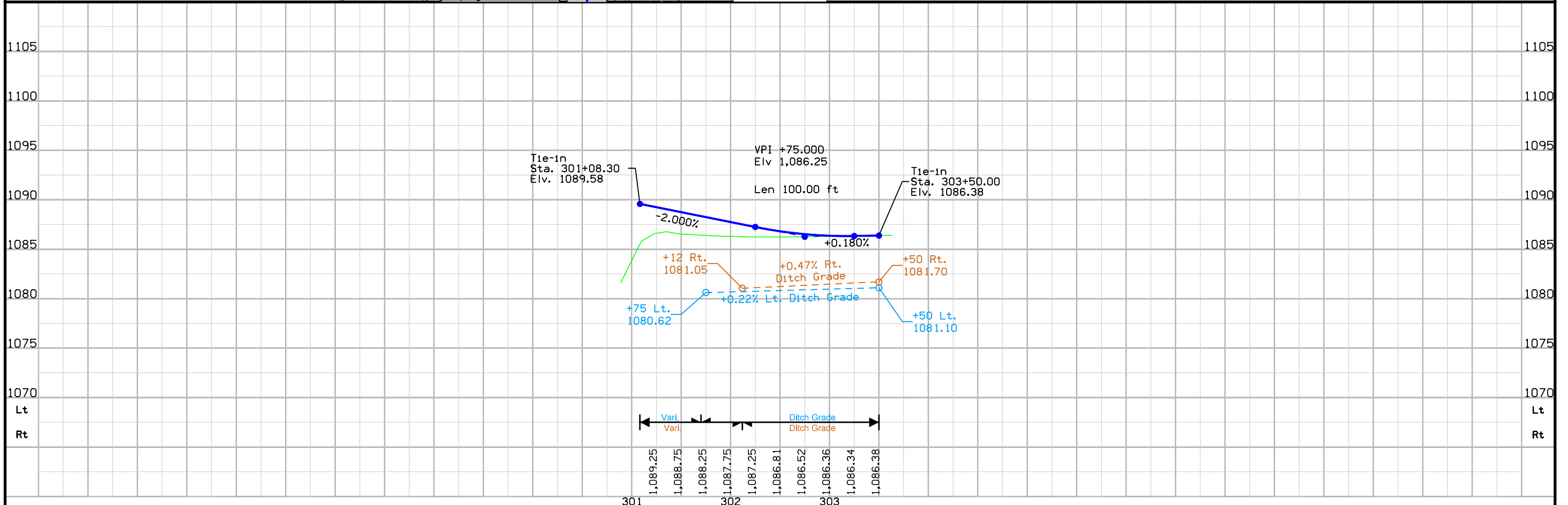

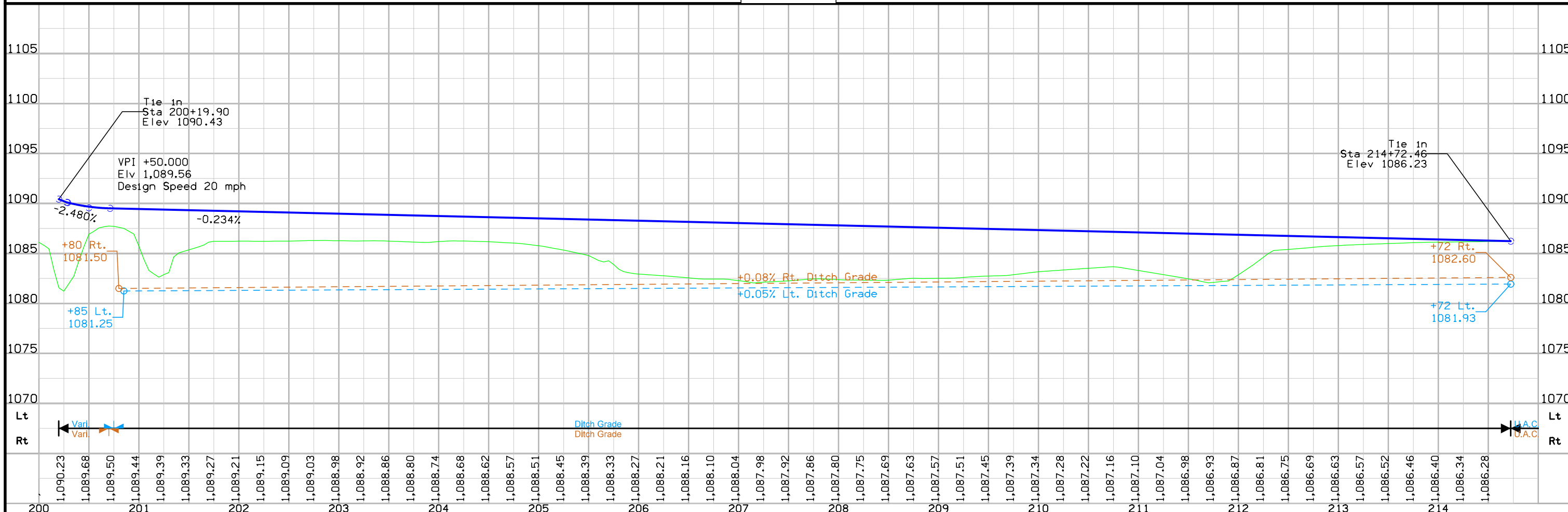
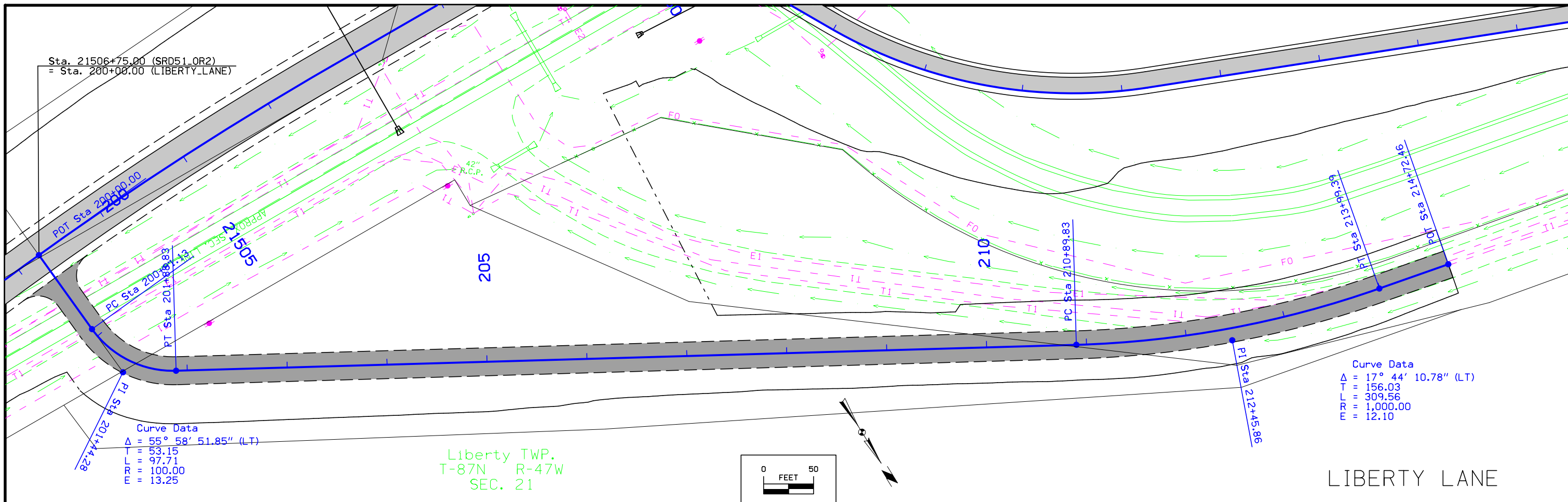

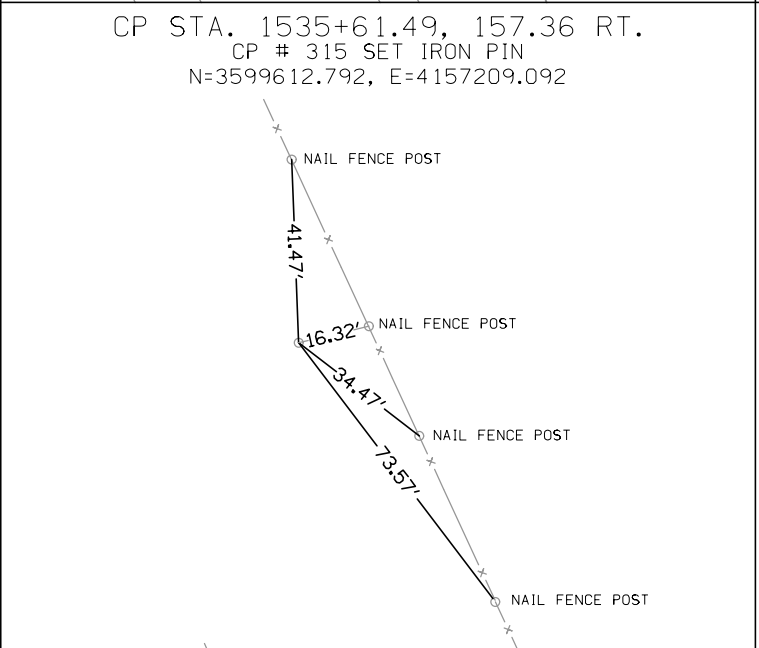
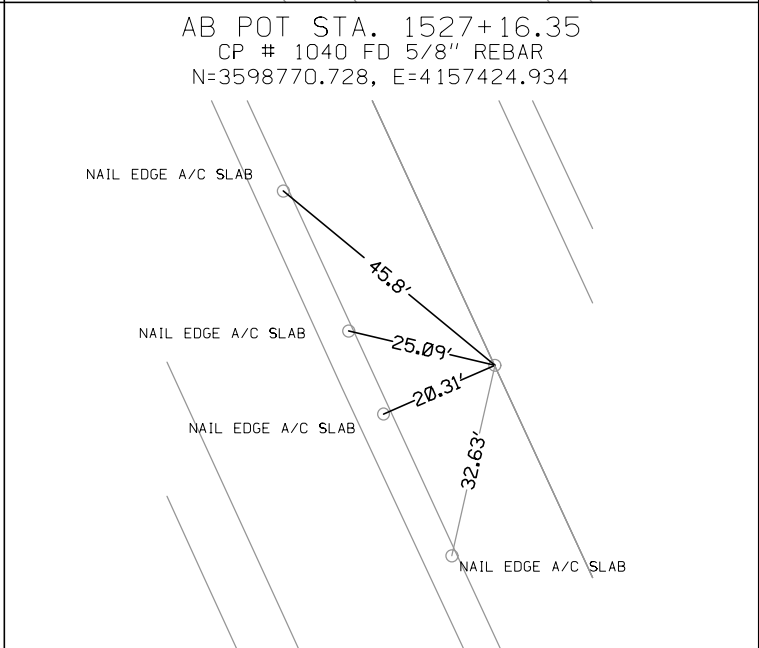
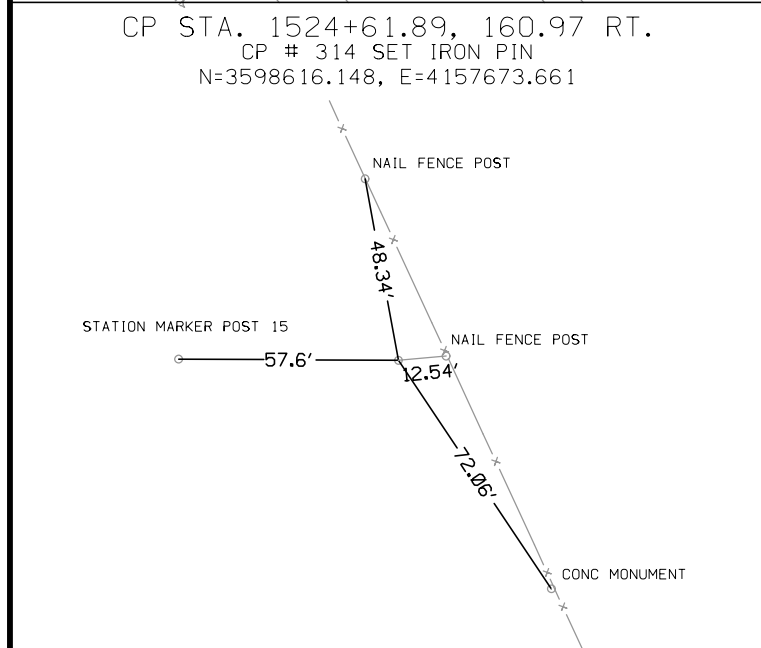
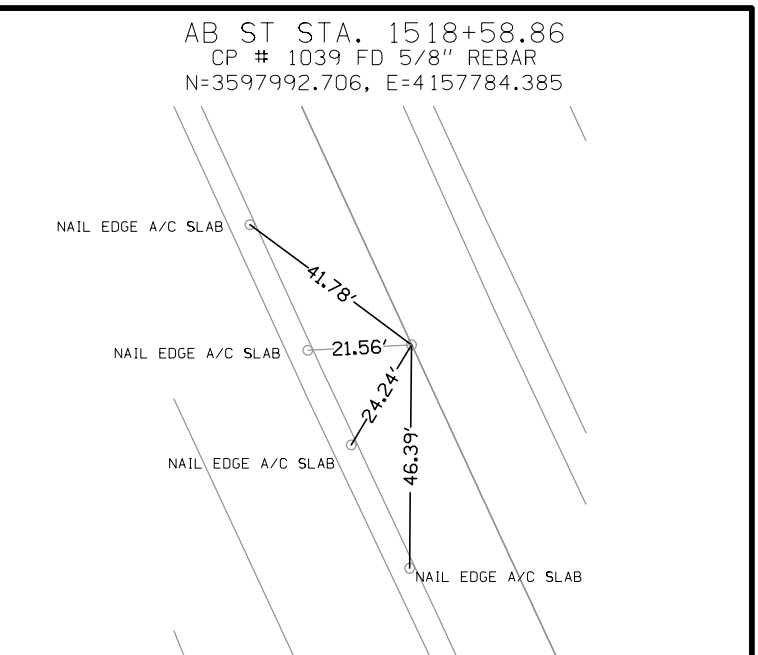
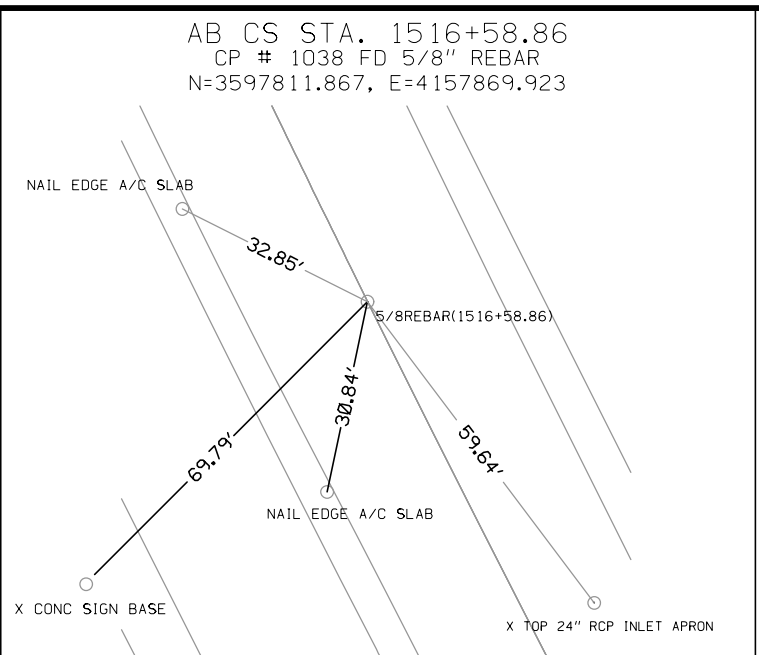
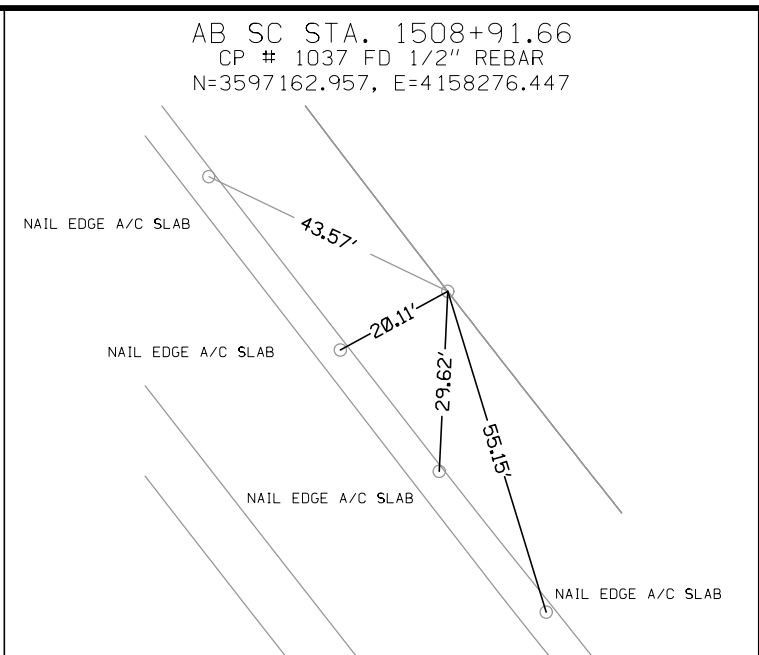
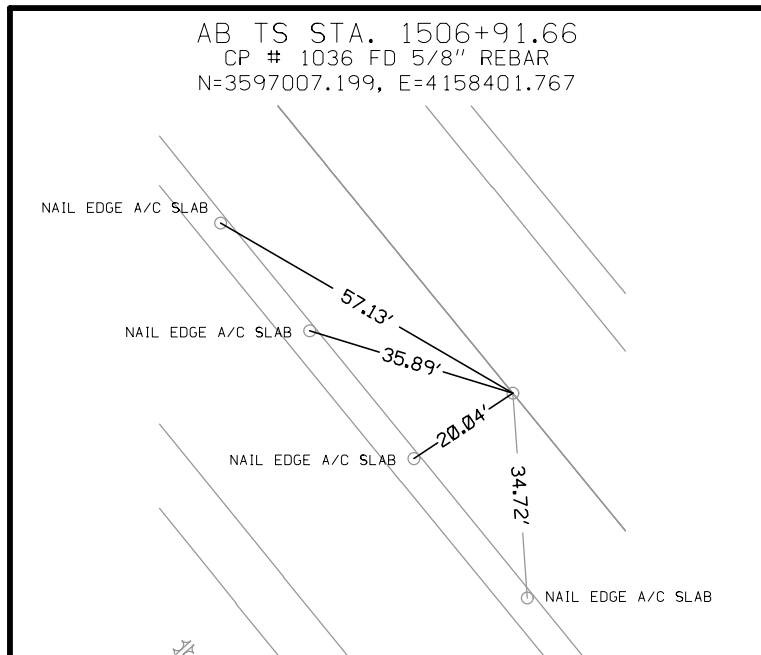

### ALIGNMENT COORDINATES

101-16  
10-20-09

Name	Location	Point on Tangent		Begin Spiral		Begin Curve		Simple Curve PI or Master PI of SCS			End Curve		End Spiral			
		Station	Coordinates		Station	Coordinates		Station	Coordinates		Station	Coordinates		Station	Coordinates	
			Y (Northing)	X (Easting)		Y (Northing)	X (Easting)		Y (Northing)	X (Easting)		Y (Northing)	X (Easting)		Y (Northing)	X (Easting)
Interstate 29 (ML029)																
I059		1385+95.36	3,586,379.06	4,163,600.12												
CUR1B					1443+73.31	3,591,966.42	4,162,128.33									
CUR1								1446+23.31	3,592,207.20	4,162,061.14						
CUR1A					1456+01.52	3,593,074.26	4,161,618.60									
CUR2B					1506+82.34	3,597,007.05	4,158,401.88									
CUR2								1508+81.84	3,597,162.48	4,158,276.81						
CUR2A					1516+50.20	3,597,812.55	4,157,869.62									
I058		1586+41.90	3,604,158.53	4,154,934.98												
Ramp A (051A)																
20211		5496+94.86	3,596,008.99	4,158,620.66												
20212								5500+69.63	3,596,375.46	4,158,542.23						
20213		5509+50.00	3,597,163.37	4,158,164.23												
Ramp B (051B)																
20221		2578+40.00	3,594,864.61	4,160,271.84												
20222								2579+00.00	3,594,913.46	4,160,236.99						
20223		2590+23.29	3,595,967.56	4,159,869.97												
Ramp C (051C)																
20431		3580+00.00	3,594,888.27	4,160,048.22												
20433								3580+00.00	3,594,888.27	4,160,048.22						
20432								3596+84.38	3,595,850.51	4,158,674.53						
20434		3604+83.72	3,596,012.86	4,157,900.39												
Ramp C Left Turn (051CL)																
20451		0+00.00	3,595,419.90	4,159,401.04												
20452								7+84.04	3,595,854.36	4,158,748.37						
20453		9+75.31	3,596,008.38	4,158,639.13												
Ramp D (051D)																
20241		4488+46.84	3,595,967.56	4,159,869.97												
20242								4490+96.84	3,596,188.09	4,159,752.22						
20243								4499+66.31	3,596,617.54	4,159,016.80						
20244								4503+95.00	3,596,845.48	4,158,655.92						
County Road D51/260th (SRD51.0R2)																
21301		21459+32.44	3,596,190.86	4,155,812.20												
21302								21468+06.62	3,596,162.89	4,156,685.93						
21303								21474+80.31	3,596,082.47	4,157,354.12						
21305		21485+00.00	3,596,017.28	4,158,370.80												
21306								21503+25.00	3,595,956.79	4,160,194.79						
21307								21509+66.19	3,595,991.01	4,160,834.38						
21308		21526+73.31	3,595,968.31	4,162,540.08												
Burnett Ave (BURNETT_AVE)																
22300		300+89.00	3,596,097.68	4,157,264.08												
22301		303+63.21	3,596,371.85	4,157,268.44												
Liberty Lane (LIBERTY_LANE)																
LL1		200+00.00	3,595,962.69	4,160,544.60												
LIBERTY_LANE-1								200+91.13	3,596,053.62	4,160,538.56						
LIBERTY_LANE-2								210+89.83	3,596,586.91	4,159,710.57						
LL2		214+72.46	3,596,714.97	4,159,352.07												
Entrance Sta. 21476+37 (ENT21476)																
ENT1		100+00.00	3,596,032.10	4,157,505.98												
ENT2		101+24.71	3,595,907.39	4,157,504.89												
Left EOP Transition, West of Interchange (L.REV.W)																
22310		0+00.00	3,596,055.49	4,157,821.76												
22311								0+00.00	3,596,055.49	4,157,821.76						
22312								6+44.64	3,596,130.28	4,157,182.05						
22313		11+99.40	3,596,176.69	4,156,629.72												
Right EOP Transition, West of Interchange (R.REV.W)																
22320		0+00.00	3,596,015.51	4,157,820.44												
22321								0+00.00	3,596,015.51	4,157,820.44						
22322								6+93.70	3,596,101.23	4,157,132.83						
22323		12+00.63	3,596,152.71	4,156,628.96												



**ALIGNMENT COORDINATES**

101-16  
10-20-09

Name	Location	Point on Tangent			Begin Spiral			Begin Curve			Simple Curve PI or Master PI of SCS			End Curve			End Spiral		
		Station	Coordinates		Station	Coordinates		Station	Coordinates		Station	Coordinates		Station	Coordinates		Station	Coordinates	
			Y (Northing)	X (Easting)		Y (Northing)	X (Easting)		Y (Northing)	X (Easting)		Y (Northing)	X (Easting)		Y (Northing)	X (Easting)		Y (Northing)	X (Easting)
22330		0+00.00	3,595,976.78	4,160,195.46															
22331								0+00.00	3,595,976.78	4,160,195.46	2+33.28	3,595,969.05	4,160,428.61	4+65.87	3,595,992.33	4,160,660.72			
22332								6+15.87	3,596,007.30	4,160,809.97	8+49.97	3,596,030.66	4,161,042.91	10+83.38	3,596,022.79	4,161,276.88			
22333		12+74.39	3,596,016.37	4,161,467.78															
22340		0+00.00	3,595,936.80	4,160,194.13															
22341								0+00.00	3,595,936.80	4,160,194.13	2+58.18	3,595,928.25	4,160,452.17	5+15.43	3,595,957.65	4,160,708.68			
22342								6+65.43	3,595,974.73	4,160,857.70	9+24.44	3,596,004.22	4,161,115.02	11+82.50	3,595,995.52	4,161,373.88			
22343		12+75.64	3,595,992.39	4,161,466.97															
20556		0+00.00	3,596,027.32	4,158,671.29															
20557								0+00.00	3,596,027.32	4,158,671.29	0+17.18	3,596,033.75	4,158,655.36	0+33.10	3,596,048.62	4,158,646.75			
20558								0+33.10	3,596,048.62	4,158,646.75	0+64.80	3,596,076.05	4,158,630.85	0+95.98	3,596,107.05	4,158,624.22			
20559		0+95.98	3,596,107.05	4,158,624.22															
20551		0+00.00	3,596,035.28	4,158,431.43															
20552								0+00.00	3,596,035.28	4,158,431.43	0+62.51	3,596,033.21	4,158,493.91	1+24.23	3,596,048.24	4,158,554.58			
20553								1+24.23	3,596,048.24	4,158,554.58	1+71.48	3,596,059.61	4,158,600.44	2+02.30	3,596,106.66	4,158,596.12			
20554								2+02.30	3,596,106.66	4,158,596.12	2+32.16	3,596,136.39	4,158,593.39	2+61.94	3,596,165.58	4,158,587.15			
20555		2+61.94	3,596,165.58	4,158,587.15															
20566		0+00.00	3,595,882.95	4,159,875.73															
20567								0+00.00	3,595,882.95	4,159,875.73	0+24.49	3,595,906.63	4,159,869.49	0+48.78	3,595,928.41	4,159,858.30			
20568								0+48.78	3,595,928.41	4,159,858.30	0+63.19	3,595,941.22	4,159,851.72	0+76.83	3,595,948.57	4,159,839.33			
20569		0+76.83	3,595,948.57	4,159,839.33															
20561		0+00.00	3,595,809.67	4,159,911.60															
20562								0+00.00	3,595,809.67	4,159,911.60	0+33.07	3,595,841.65	4,159,903.17	0+66.02	3,595,874.52	4,159,899.50			
20563								0+66.02	3,595,874.52	4,159,899.50	1+09.95	3,595,918.18	4,159,894.63	1+38.11	3,595,928.62	4,159,937.31			
20564								1+38.11	3,595,928.62	4,159,937.31	1+99.96	3,595,943.33	4,159,997.39	2+61.05	3,595,941.28	4,160,059.21			
20565		2+61.05	3,595,941.28	4,160,059.21															
20391		0+00.00	3,595,805.41	4,158,821.91															
20392								0+00.00	3,595,805.41	4,158,821.91	0+43.86	3,595,829.71	4,158,785.40	0+87.65	3,595,857.12	4,158,751.16			
20393								0+87.65	3,595,857.12	4,158,751.16	1+18.76	3,595,876.55	4,158,726.87	1+49.37	3,595,902.45	4,158,709.64			
20394								1+49.37	3,595,902.45	4,158,709.64	1+99.69	3,595,944.34	4,158,681.76	2+38.01	3,595,986.02	4,158,709.95			
20395		2+38.01	3,595,986.02	4,158,709.95															
20581		0+00.00	3,595,985.23	4,159,940.60															
20582								0+00.00	3,595,985.23	4,159,940.60	0+09.85	3,595,985.56	4,159,930.75	0+19.69	3,595,986.75	4,159,920.97			
20583								0+19.69	3,595,986.75	4,159,920.97	0+54.54	3,595,990.94	4,159,886.37	0+86.76	3,596,015.73	4,159,861.88			
20584								0+86.76	3,596,015.73	4,159,861.88	1+41.32	3,596,054.54	4,159,823.53	1+95.12	3,596,102.67	4,159,797.83			
20585		1+95.12	3,596,102.67	4,159,797.83															
20586		0+00.00	3,595,990.54	4,159,780.68															
20587								0+00.00	3,595,990.54	4,159,780.68	0+23.89	3,596,008.55	4,159,796.37	0+44.57	3,596,032.07	4,159,792.21			
20588								0+44.57	3,596,032.07	4,159,792.21	1+16.15	3,596,102.56	4,159,779.75	1+86.54	3,596,165.70	4,159,746.04			
20589		1+86.54	3,596,165.70	4,159,746.04															
20582												5° 00' 48.46" RT	9.85'	19.69'	225.00'	0.22'			
20583												38° 25' 51.59" RT	34.85'	67.07'	100.00'	5.90'			
20584												16° 33' 19.95" RT	54.56'	108.36'	375.00'	3.95'			

### SPIRAL OR CIRCULAR CURVE DATA

101-17  
04-19-11

Name	Location	Δ <sub>scs</sub>	Horizontal Alignment Data													Remarks				
			Spiral Data						Curve Data											
			θs	Ls	Ts	Es	Xc	Yc	L.T.	S.T.	Δ <sub>c</sub>	T	L	R	E					
Ramp A Return (D51A.RET.1) CUR1 CUR2															19° 33' 51.07" LT	493.91'	978.21'	2,864.79'	42.27'	
															11° 31' 31.87" RT	385.48'	768.37'	3,819.72'	19.40'	
Ramp A (D51A) 20212															20° 54' 30.41" LT	313.67'	620.37'	1,700.00'	28.70'	
Ramp B Return (D51D.RET.2) 20222															20° 44' 19.12" RT	243.36'	481.40'	1,330.00'	22.08'	
Ramp C (D51C) 20433 20432															17° 47' 30.09" LT	313.04'	621.05'	2,000.00'	24.35'	
															26° 01' 39.95" LT	192.53'	378.41'	833.00'	21.96'	
Ramp C Left Turn (D51CL) 20452															28° 14' 56.43" RT	50.33'	98.61'	200.00'	6.23'	
Ramp D (D51D) 20242 20243 20244															38° 51' 20.70" LT	171.06'	328.91'	485.00'	29.28'	
															18° 28' 04.34" RT	216.22'	428.69'	1,330.00'	17.46'	
															8° 01' 17.07" RT	140.23'	280.00'	2,000.00'	4.91'	
County Road D51/260th (SRD51.0R2) 21302 21303 21306 21307															7° 45' 16.06" RT	237.21'	473.69'	3,500.00'	8.03'	
															7° 41' 20.11" LT	235.20'	469.69'	3,500.00'	7.89'	
															8° 02' 26.96" LT	246.00'	491.19'	3,500.00'	8.63'	
															8° 04' 03.66" RT	246.82'	492.83'	3,500.00'	8.69'	
Liberty Lane (LIBERTY_LANE) LIBERTY_LANE-1 LIBERTY_LANE-2															55° 58' 51.85" LT	53.15'	97.71'	100.00'	13.25'	
															17° 44' 10.78" LT	156.03'	309.56'	1,000.00'	12.10'	
Left EOP Transition, West of Interchange (L.REV.W) 22311 22312															7° 16' 44.07" RT	222.62'	444.64'	3,500.00'	7.07'	
															7° 20' 40.02" LT	224.63'	448.65'	3,500.00'	7.20'	
Right EOP Transition, West of Interchange (R.REV.W) 22321 22322															8° 04' 54.87" RT	247.26'	493.70'	3,500.00'	8.72'	
															8° 08' 50.82" LT	249.27'	497.70'	3,500.00'	8.87'	
Left EOP Transition, East of Interchange (L.REV.E) 22331 22332															7° 37' 34.88" LT	233.28'	465.87'	3,500.00'	7.77'	
															7° 39' 11.57" RT	234.10'	467.51'	3,500.00'	7.82'	
Right EOP Transition, East of Interchange (R.REV.E) 22341 22342															8° 26' 15.84" LT	258.18'	515.43'	3,500.00'	9.51'	
															8° 27' 52.53" RT	259.01'	517.07'	3,500.00'	9.57'	
Ramp A Return (D51A.RET.1) 20557 20558															37° 55' 40.20" RT	17.18'	33.10'	50.00'	2.87'	
															18° 00' 48.45" RT	31.70'	62.88'	200.00'	2.50'	
Ramp A Return (D51A.RET.2) 20552 20553 20554															15° 49' 03.82" LT	62.51'	124.23'	450.00'	4.32'	
															81° 19' 37.93" LT	47.25'	78.07'	55.00'	17.51'	
															6° 50' 04.34" LT	29.86'	59.64'	500.00'	0.89'	
Ramp B Return (D51B.RET.3) 20567 20568															12° 25' 17.66" LT	24.49'	48.78'	225.00'	1.33'	
															32° 08' 51.10" LT	14.41'	28.05'	50.00'	2.03'	
Ramp B Return (D51B.RET.4) 20562 20563 20564															8° 24' 21.67" RT	33.07'	66.02'	450.00'	1.21'	
															82° 36' 33.87" RT	43.93'	72.09'	50.00'	16.56'	
															15° 39' 09.22" RT	61.85'	122.93'	450.00'	4.23'	
Ramp C Return (D51C.RET.4) 20392 20393 20394															5° 01' 20.06" RT	43.86'	87.65'	1,000.00'	0.96'	
															17° 40' 51.61" RT	31.11'	61.72'	200.00'	2.40'	
															67° 42' 56.38" RT	50.32'	88.64'	75.00'	15.32'	



**SUPERELEVATION DATA**

See PV-300 Series

Road Identification	Circular Curve or Spiral Curve Name	Radius	Superelevation Data			Standard Road Plan	Section A-A	Section B-B	Section C-C	Section D-D	Section E-E	Section F-F	Case A	Case B	Case C	Case S	Case T	Case U	Remarks
			e %	L FT	x FT														
D51	21302	3500	4.0	107	53	PV-301	21466+78.72	21467+31.72	21467+84.72	21468+38.72			21468+06.62			21468+38.72	21468+38.72		Review
							21474+08.21	21473+55.21	21473+02.21	21472+48.21			21472+80.31			21472+48.21	21472+48.21		Review
D51	21303	3500	4.0	107	53	PV-301	21473+52.41	21474+05.41	21474+58.41	21475+12.41			21474+80.31			21475+12.41	21475+12.41		Review
							21480+77.90	21480+24.90	21479+71.90	21479+17.90			21479+50.00			21479+17.90	21479+17.90		Review
D51	21306	3500	4.0	107	53	PV-301	21501+97.10	21502+50.10	21503+03.10	21503+57.10			21503+25.00			21503+57.10	21503+57.10		Review
							21509+44.09	21508+91.09	21508+38.09	21507+84.09			21508+16.19			21507+84.09	21507+84.09		Review
D51	21307	3500	4.0	107	53	PV-301	21508+38.29	21508+91.29	21509+44.29	21509+98.29			21509+66.19			21509+98.29	21509+98.29		Review
							21515+86.91	21515+33.91	21514+80.91	21514+26.91			21514+59.01			21514+26.91	21514+26.91		Review
D51 Ramp A	20212	1700	5.8	180	62	PV-303	5500+05.63		5500+69.63	5501+23.63						5500+67.77	5500+67.77		
D51 Ramp A	20212	1700	5.8	180	62	PV-303	5508+78.00	5508+16.00	5506+90.00	5506+36.00						5506+91.86	5506+91.86		
D51 Ramp B	20222	1330	6.0	186	62	PV-303	2578+31.80		2579+00.00	2579+55.80						2578+93.80	2578+93.80		
							2584+49.60		2583+81.40	2583+25.60						2583+87.60	2583+87.60		
D51 Ramp C	20433	2000	5.4	168	62	PV-303			3580+00.00	3580+50.40						3580+06.84	3580+06.84		
							3586+76.65		3586+21.05	3585+70.65						3586+14.21	3586+14.21		
D51 Ramp C	20432	833	6.0	168	56	PV-303	3596+22.78		3596+84.38	3597+34.78						3596+78.78	3596+78.78		
									3600+62.79	3600+12.39						3600+68.39	3600+68.39		
D51 Ramp D	20242	485	6.0	144	48	PV-303	4489+48.04	4489+96.04	4490+96.84	4491+40.04						4490+92.04	4490+92.04		
							4495+74.55	4495+26.55	4494+25.75	4493+82.55						4494+30.55	4494+30.55		
D51 Ramp D	20243	1330	5.4	151	56	PV-303	4499+16.61		4499+66.31	4500+11.61						4499+72.46	4499+72.46		
D51 Ramp D	20244	2000	5.4	168	62	PV-303													
									4506+75.00	4506+24.60						4506+68.16	4506+68.16		

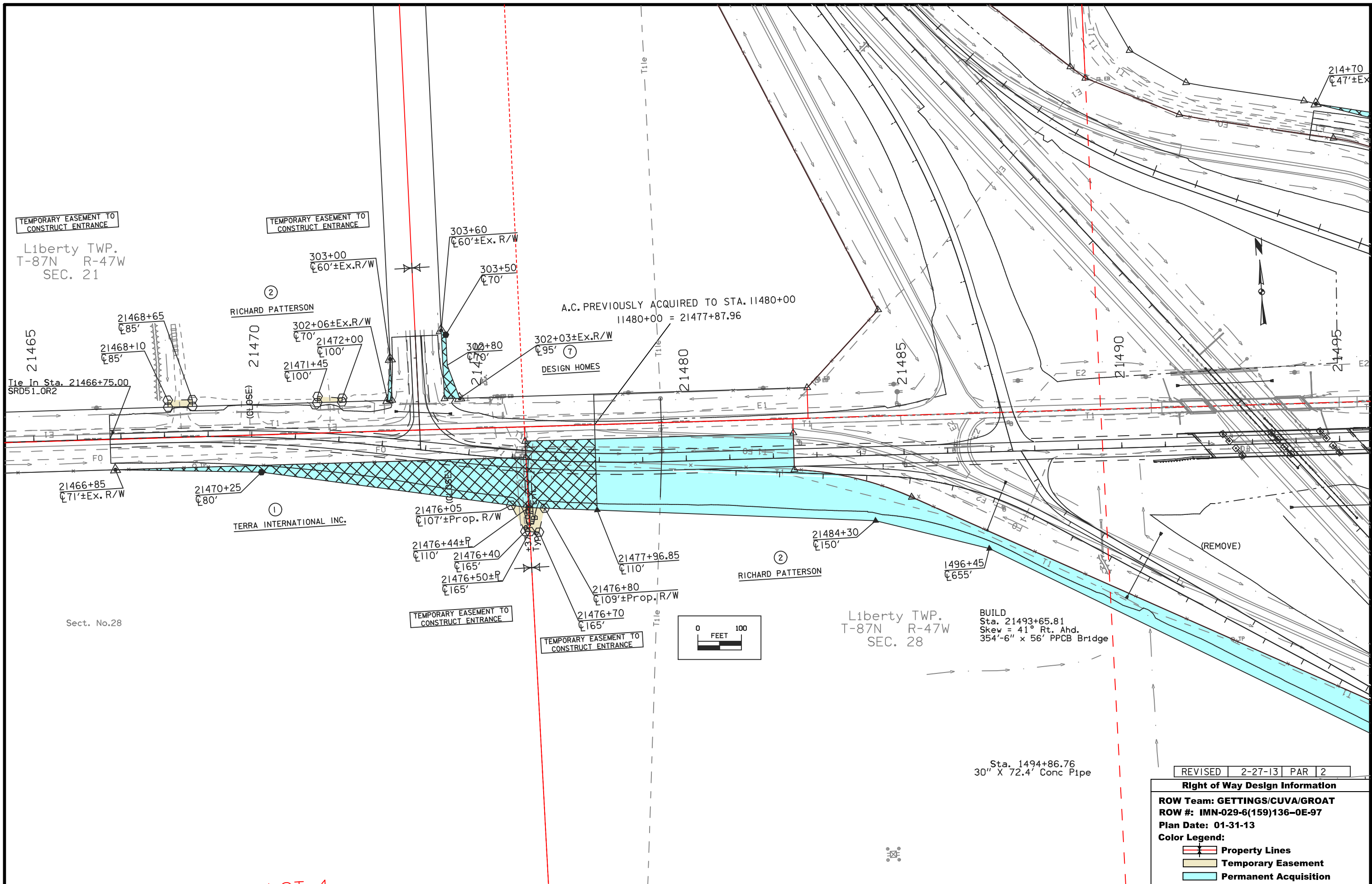

TEMPORARY EASEMENT TO CONSTRUCT ENTRANCE

Liberty TWP.  
T-87N R-47W  
SEC. 21

TEMPORARY EASEMENT TO CONSTRUCT ENTRANCE

② RICHARD PATTERSON

A.C. PREVIOUSLY ACQUIRED TO STA. 11480+00  
11480+00 = 21477+87.96

DESIGN HOMES

① TERRA INTERNATIONAL INC.

② RICHARD PATTERSON

Liberty TWP.  
T-87N R-47W  
SEC. 28

BUILD  
Sta. 21493+65.81  
Skew = 41° Rt. Ahd.  
354'-6" x 56' PPCB Bridge

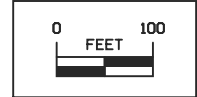

Sta. 1494+86.76  
30" X 72.4' Conc Pipe

REVISED 2-27-13 PAR 2

**Right of Way Design Information**

**ROW #:** GETTINGS/CUVA/GROAT  
**ROW #:** IMN-029-6(159)136-0E-97  
**Plan Date:** 01-31-13

- Color Legend:**
- Property Lines
  - Temporary Easement
  - Permanent Acquisition

SW1/4 SE1/4  
SEC 21-87-47

ACQUIRE ACCESS CONTROL ON  
S.R. FROM 21500+67 TO 21506+75  
SE1/4 SE1/4  
SEC 21-87-47

NE1/4 NE1/4  
SEC 28-87-47

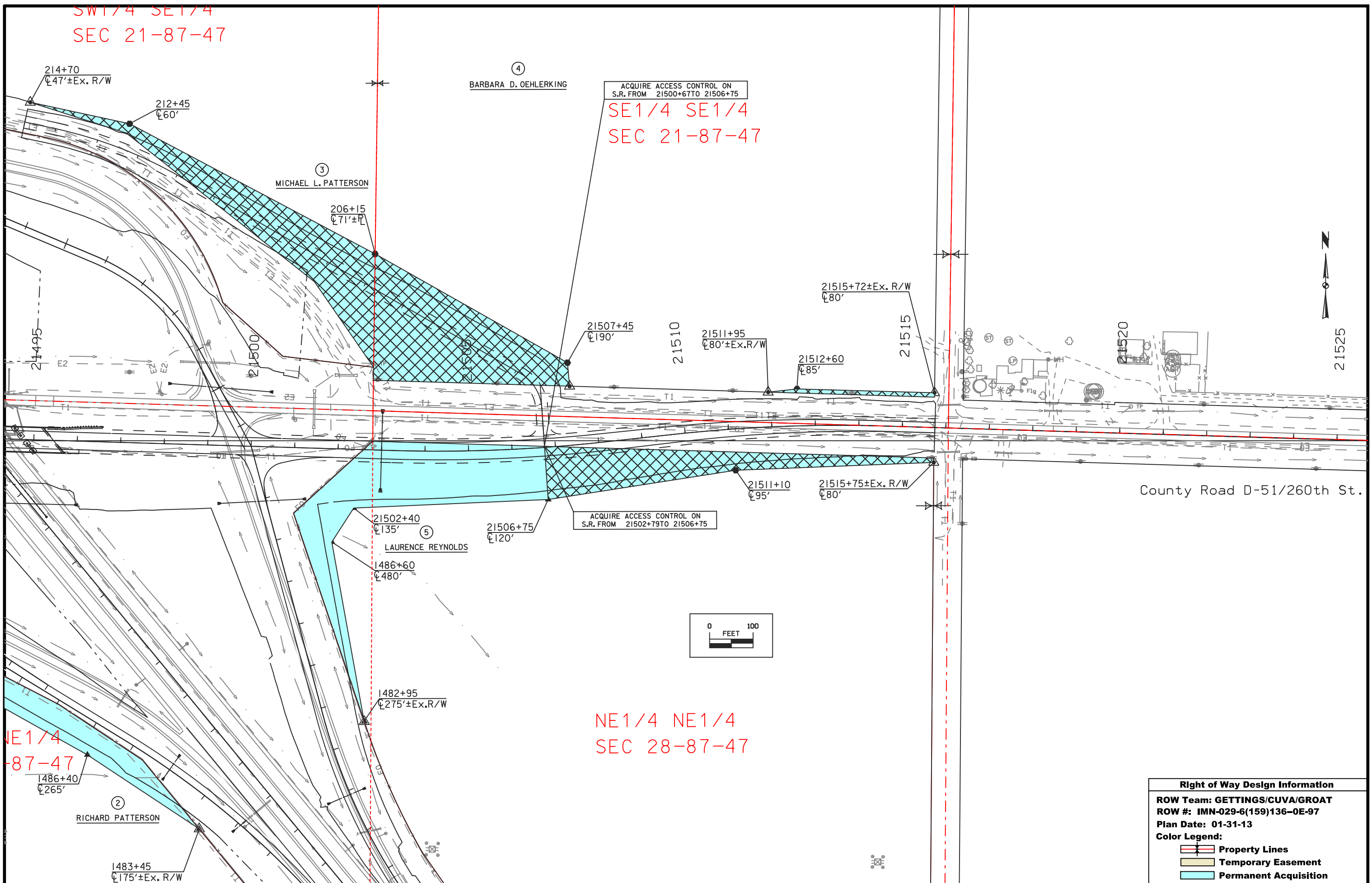

County Road D-51/260th St.

Right of Way Design Information	
ROW Team: GETTINGS/CUVA/GROAT	
ROW #: IMN-029-6(159)136-0E-97	
Plan Date: 01-31-13	
Color Legend:	
	Property Lines
	Temporary Easement
	Permanent Acquisition

PARCEL CHECK BY PROJ UPDATED 02/21/12 13:37

PAGE: 1

AND: 2

R2360003 PARCEL CHECK LIST BY PROJECT NUMBER

COUNTY : WOODBURY PROJECT NO. : IMN-029-6(159)136--0E-97

PIN: 04-97-029040-00

CONSTRUCTION NO.: IM-029-6(186)136--13-97

ASSIGNED TO: NLC

DESCRIPTION : I-29/260th St./Co. Rd. D-51 Interchange 1.8 Miles N. Of Salix

PARCEL	KEY	OWNER	TYPE	R/W W.D OR EASE.	BORROW W.D OR EASE.	HOUSE OR
--------	-----	-------	------	------------------	---------------------	----------

0001	26307	TERRA CHEMICALS INTERNATIONAL INC.	FEE WOODBURY COUNTY	1.00	EASE ACRE	
0002	26308	RICHARD PATTERSON	FEE WOODBURY COUNTY	18.97	WD	
			STATE OF IOWA	0.85	EASE ACRE	
				3.80	WD ACRE	
0003	26309	MICHAEL L. PATTERSON	FEE WOODBURY COUNTY	1.50	EASE ACRE	
0004	26310	BARBARA D. OEHLERKING	FEE WOODBURY COUNTY	14.22	WD	
			STATE OF IOWA	1.95	EASE ACRE	
0005	26311	LAURENCE REYNOLDS	FEE WOODBURY COUNTY	1.09	EASE ACRE	
			STATE OF IOWA	1.09	EASE ACRE	
				1.86	WD ACRE	
0007	26312	DESIGN HOMES	FEE WOODBURY COUNTY	0.04	EASE ACRE	

COUNTY of WOODBURY

5.30 EASEMENT ACRES

STATE OF IOWA

3.80 WARRANTY DEED ACRES

33.19 BORROW WARRANTY DEED ACRES

6 TOTAL PARCELS ON PROJECT

108-23A  
08-01-08

### TRAFFIC CONTROL PLAN

Traffic on I-29 will be maintained at all times with the exception of short closure periods for removing the existing bridge and construction the new bridge.

The interchange at 260th Street/County Road D-51 and I-29 will be closed to all traffic and detoured to the Salix interchange at M.P. 134 or Sergeant Bluff interchange at M.P. 141.

108-26A  
08-01-08

### STAGING NOTES

It is not the intent of the sequence of construction to confine the Contractor's activities to the area of the suggested stages alone. It is understood that some of the various steps, though listed in numerical order, may occur simultaneously. Therefore, the Contractor may conduct several operations concurrently on the project, provided that the existing traffic is maintained and that these operations do not conflict with the staging indicated here in.

It is recognized that as various activities related to the construction progress, certain situations may arise which will preclude adhering to the original construction sequence or, which in the opinion of the Contractor, would readily adhere itself to a more efficient staging operation. Should this occur, and the Contractor desires to deviate form the original plan, they shall submit an alternate plan for approval by the Engineer.

The staging shown is one method for construction for the project. If the contractor should desire to deviate from the staging as shown, he should avail himself of Article 1105.15 of the Standard Specifications to request changes. Maintenance of traffic shall be according to Tab. 108-23; no deviations from the intent of the traffic control plan will be acceptable for Value Engineering proposal acceptance.

102-15  
08-01-08

### TABULATION OF SPECIAL EVENTS

Event	Location	Date
NONE PROVIDED		



Liberty TWP.  
T-87N R-47W  
SEC. 28

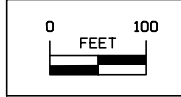
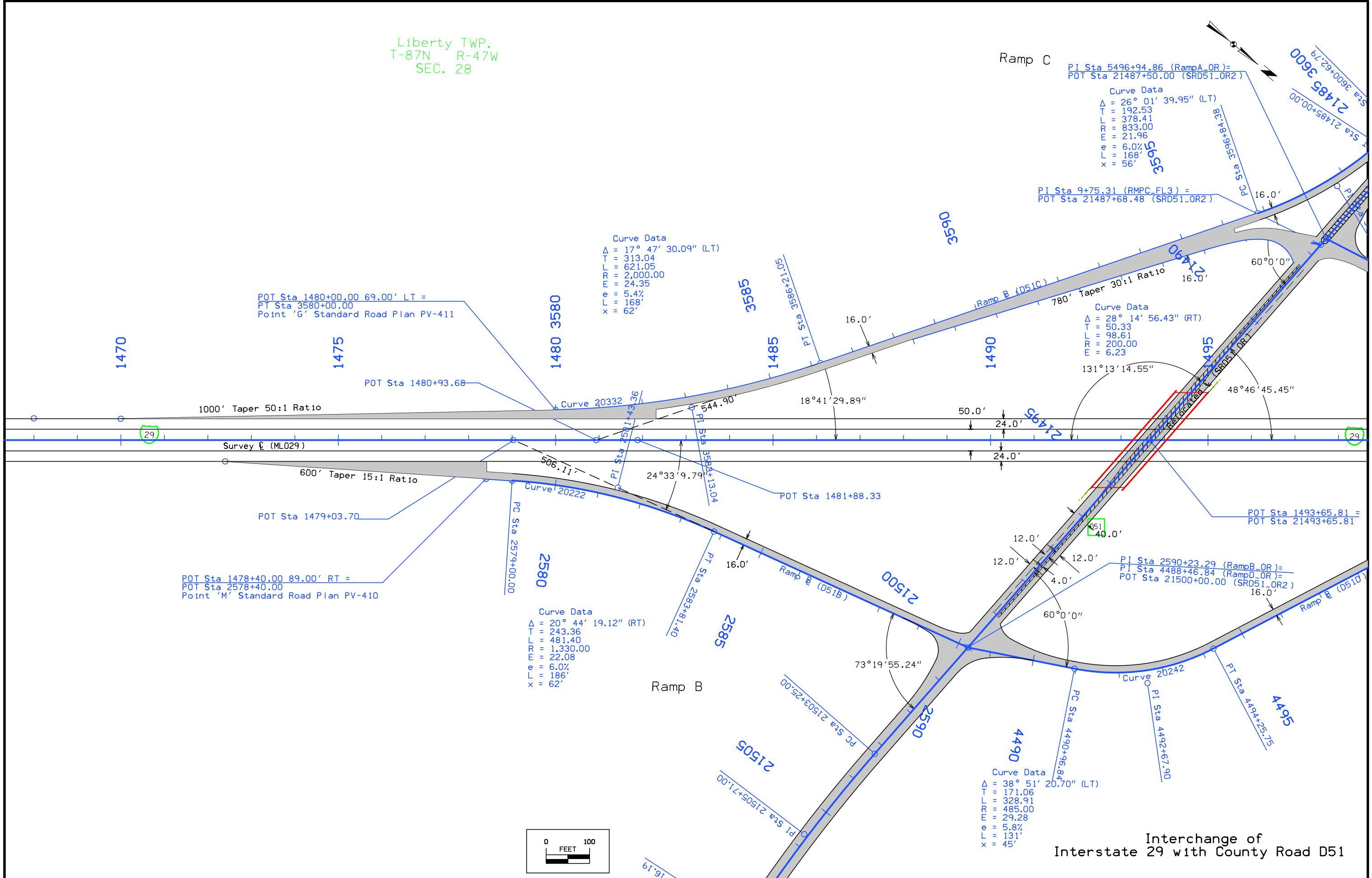

Interchange of  
Interstate 29 with County Road D51

Liberty TWP.  
T-87N R-47W  
SEC. 21

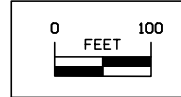
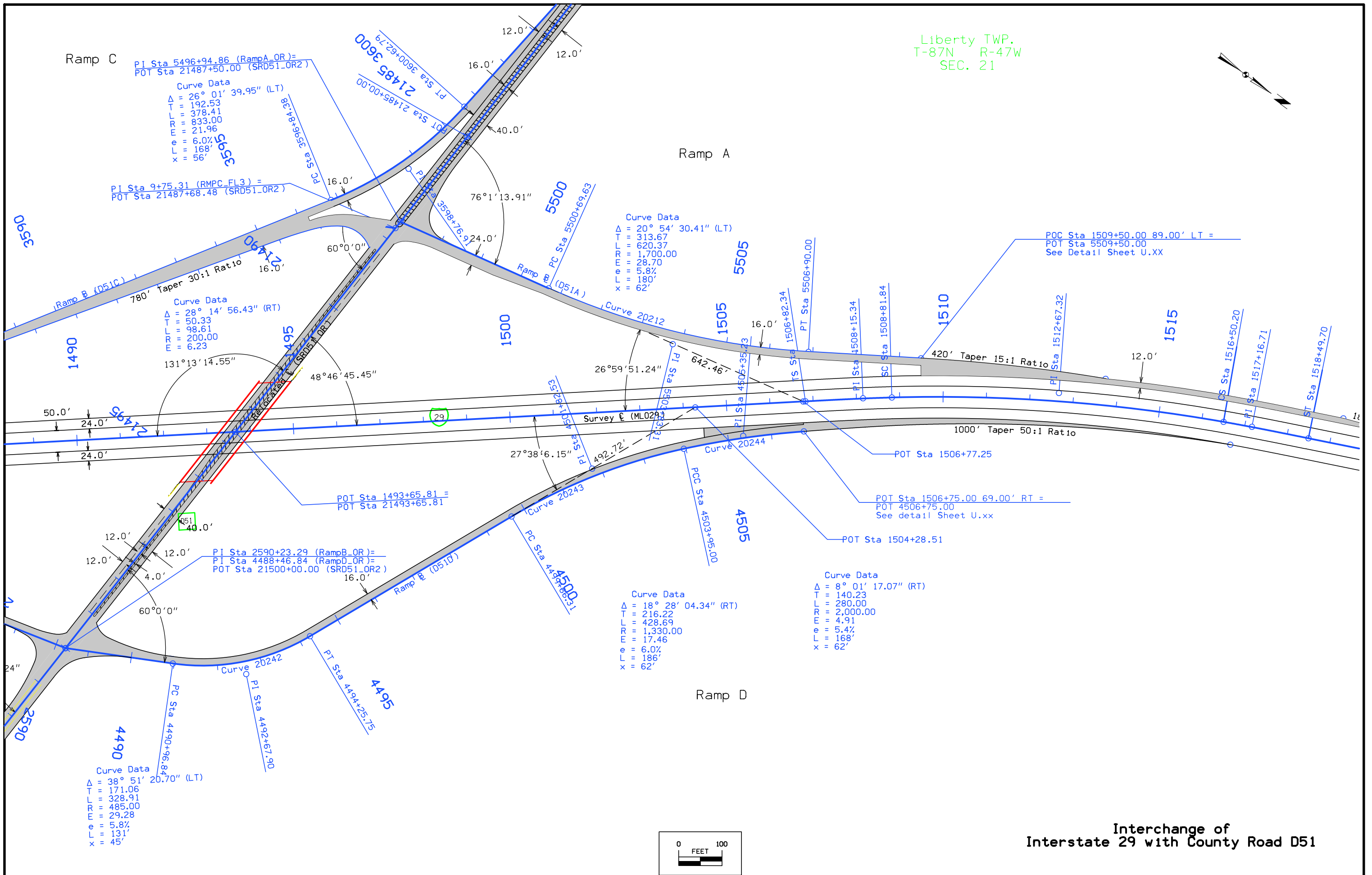
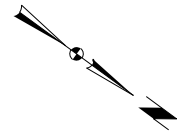

Interchange of  
Interstate 29 with County Road D51

Liberty TWP.  
T-87N R-47W  
SEC. 21

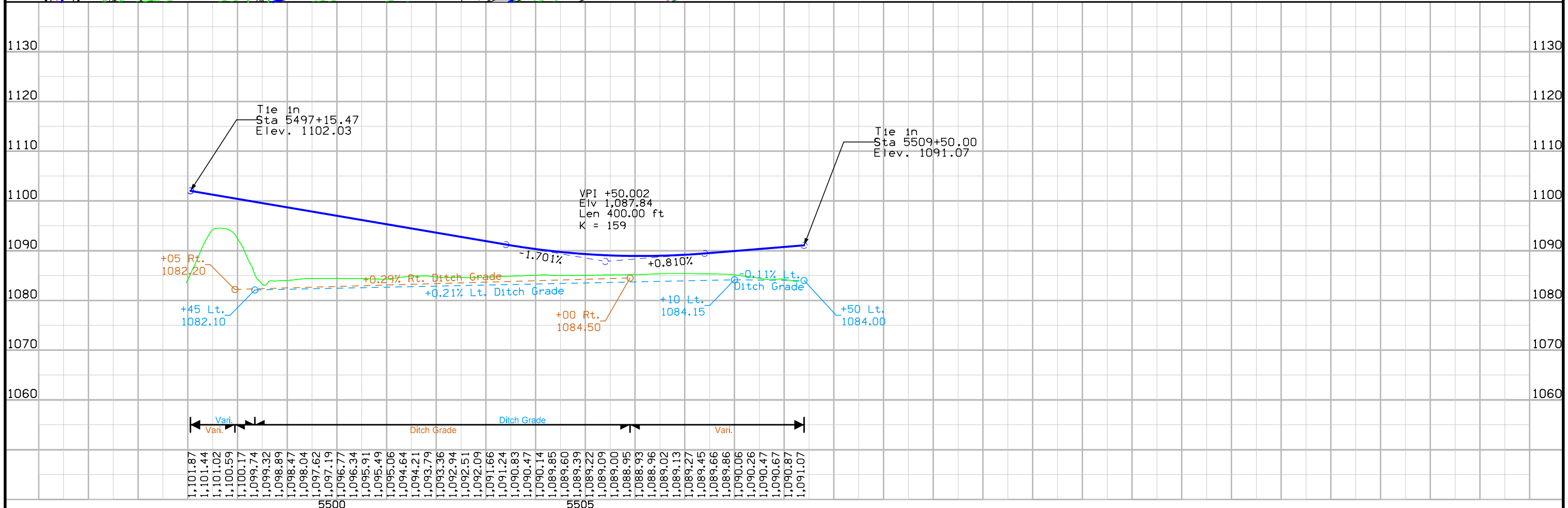
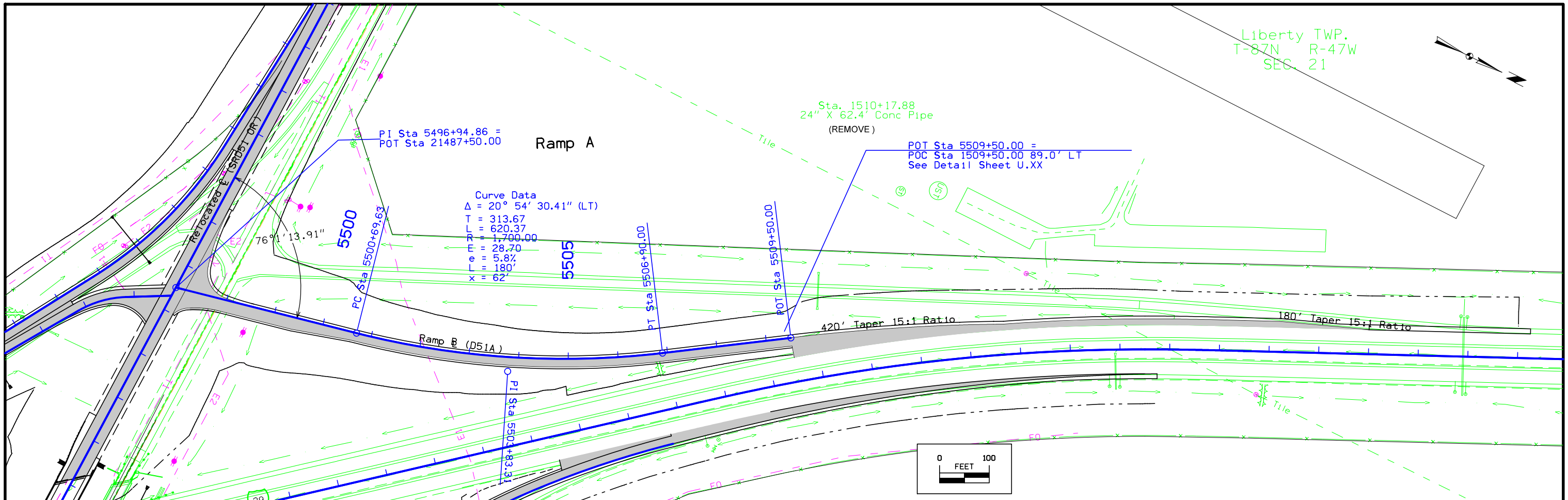

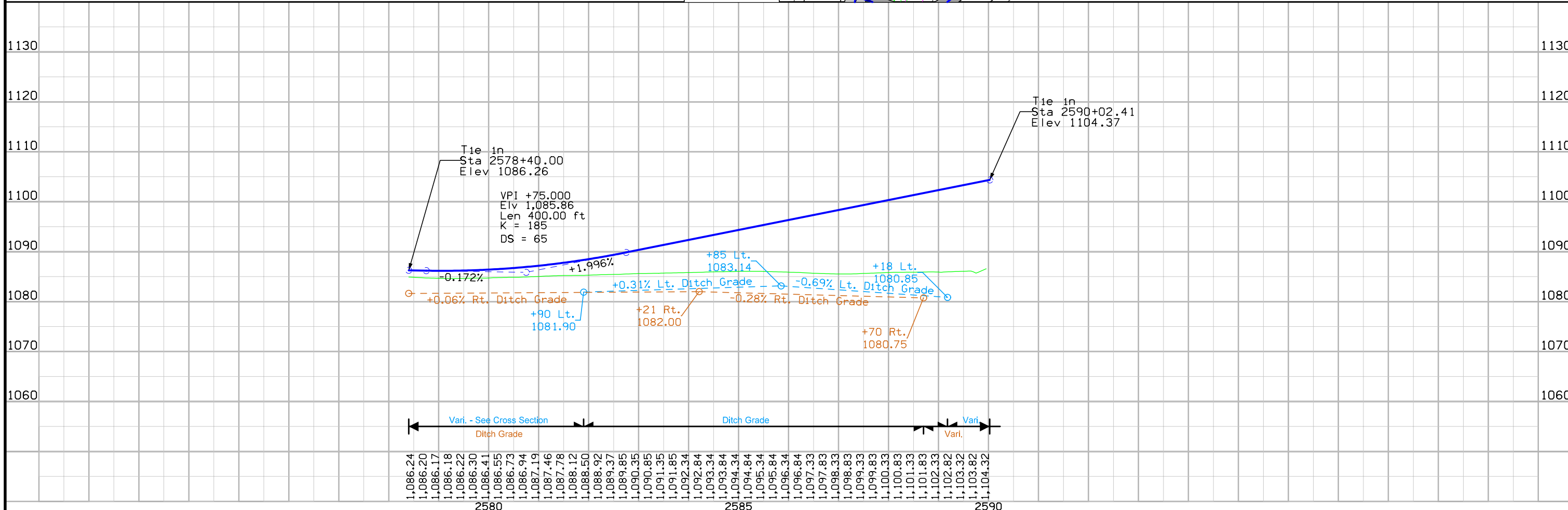
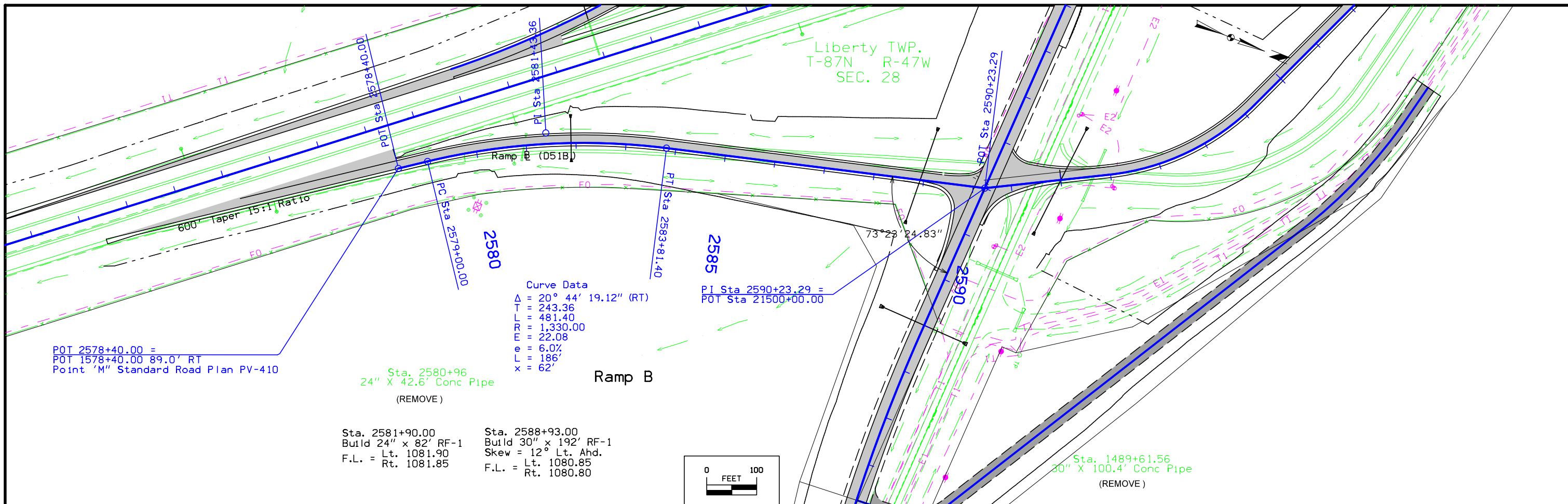

Liberty TWP.  
T-87N R-47W  
SEC. 28

Sta. 3585+00.00  
Build 24" x 58' RF-1  
F.L. = Lt. 1081.65  
Rt. 1081.70

Sta. 3586+78  
24" X 34.4' Conc Pipe  
(REMOVE)

Sta. 3595+22  
30" X 72.4' Conc Pipe  
(REMOVE)

Sta. 3594+25.00  
Build 30" x 158' RF-1  
F.L. = Lt. 1082.00  
Rt. 1081.90  
+50 Prop.  
Type "M" Dike  
Elev. =1084.00

Sta. 3597+90.00  
Build 30" x 158' RF-1  
F.L. = Rt. 1095.60  
Other 1093.65  
Other 1092.09  
Other 1082.31  
Build 24" x 58' CMP  
F.L. = Lt. 1081.40  
Other 1081.90

Curve Data  
Δ = 17° 47' 30.09" (LT)  
T = 313.04  
L = 621.05  
R = 2,000.00  
M = 24.35  
e = 5.4%  
x = 168'  
y = 62'

Curve Data  
Δ = 26° 01' 39.95" (LT)  
T = 192.53  
L = 378.41  
R = 833.00  
M = 21.96  
e = 6.0%  
x = 168'  
y = 56'

Curve Data  
Δ = 28° 14' 56.43" (RT)  
T = 50.33  
L = 98.61  
R = 200.00  
M = 6.23

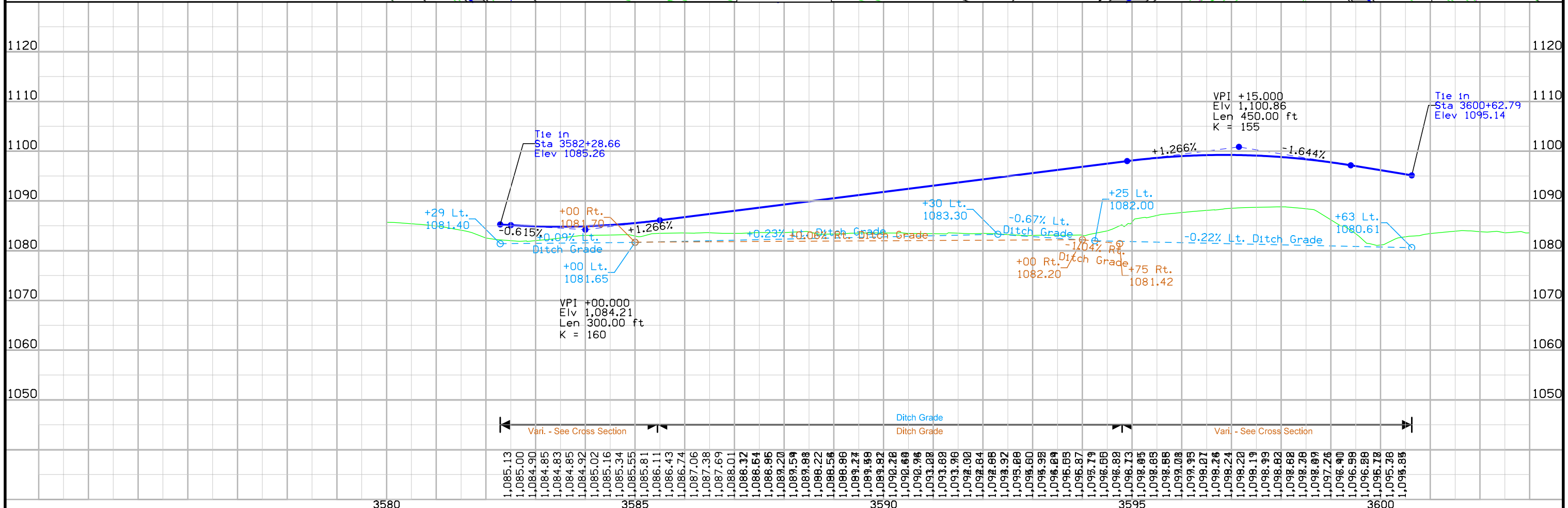
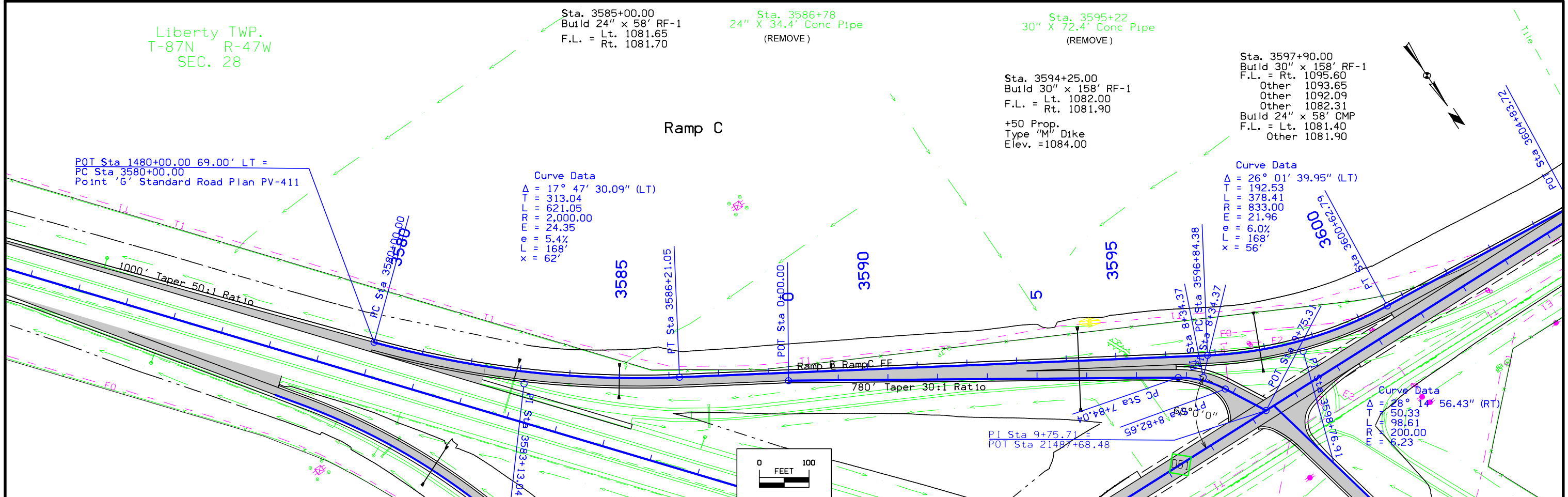

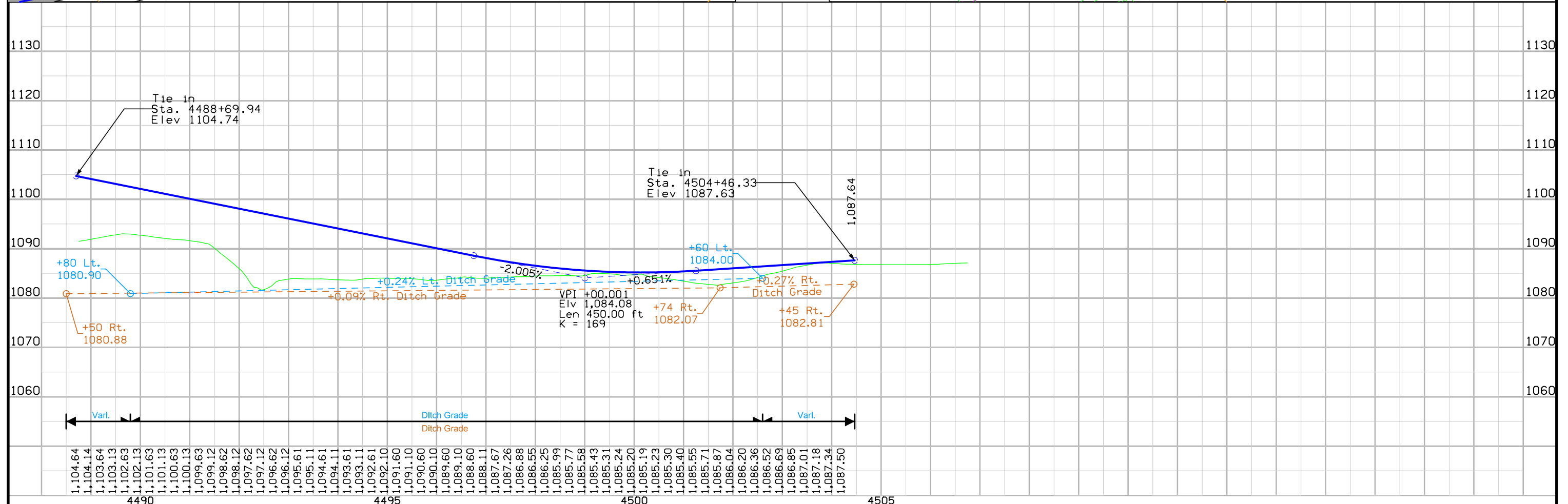
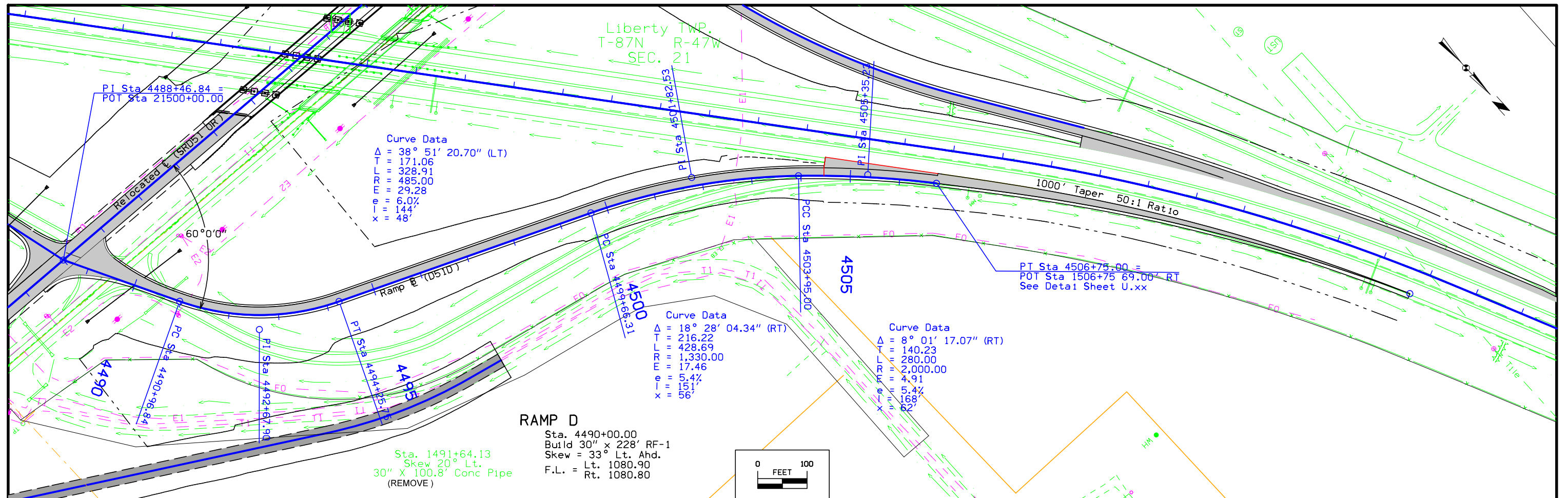

**LEGEND OF CROSS SECTION SHEETS (ROAD)**

- - - - - - Existing Ground Line
- ===== Proposed Template
- ===== Proposed Topsoil Placement
- - - - - Additional Topsoil Removal
- ===== Subgrade Treatment
- - - - - Granular Shoulder
- ===== Pavement
- - - - - Existing Pipe\R/CB
- ===== Proposed Pipe\R/CB
- ===== Proposed Dike
- ===== All Elements Associated with Proposed Entrances

**LEGEND OF CROSS SECTION SHEETS (SOILS)**

- TS----- Topsoil (Class 10)
- TS A----- Topsoil (Type A Disposal)
- TS B----- Topsoil (Type B Disposal)
- TS C----- Topsoil (Type C Disposal)
- CL 10----- Class 10 Materials
- SEL LO----- Select Loams And Clay-Loams
- SEL SA----- Select Sand
- UNS A----- Unsuitable Type A Disposal
- UNS B----- Unsuitable Type B Disposal
- UNS C----- Unsuitable Type C Disposal
- SHALE----- Shale
- WASTE----- Waste
- B&W LS----- Broken and Weathered Rock
- ROCK----- Solid Rock
- BLDRS----- Boulders

Note: All layer lines and descriptions identify layers above the line.

Note: Vertical or near vertical lines connecting soil layers at edges of cross sections are only for the purpose of calculating template quantities and do not depict soil stratification.

**CROSS SECTION  
LEGEND AND SYMBOL  
INFORMATION SHEET**

(COVERS SHEET SERIES W, X, & Y)

# I-29 D5 Submittal

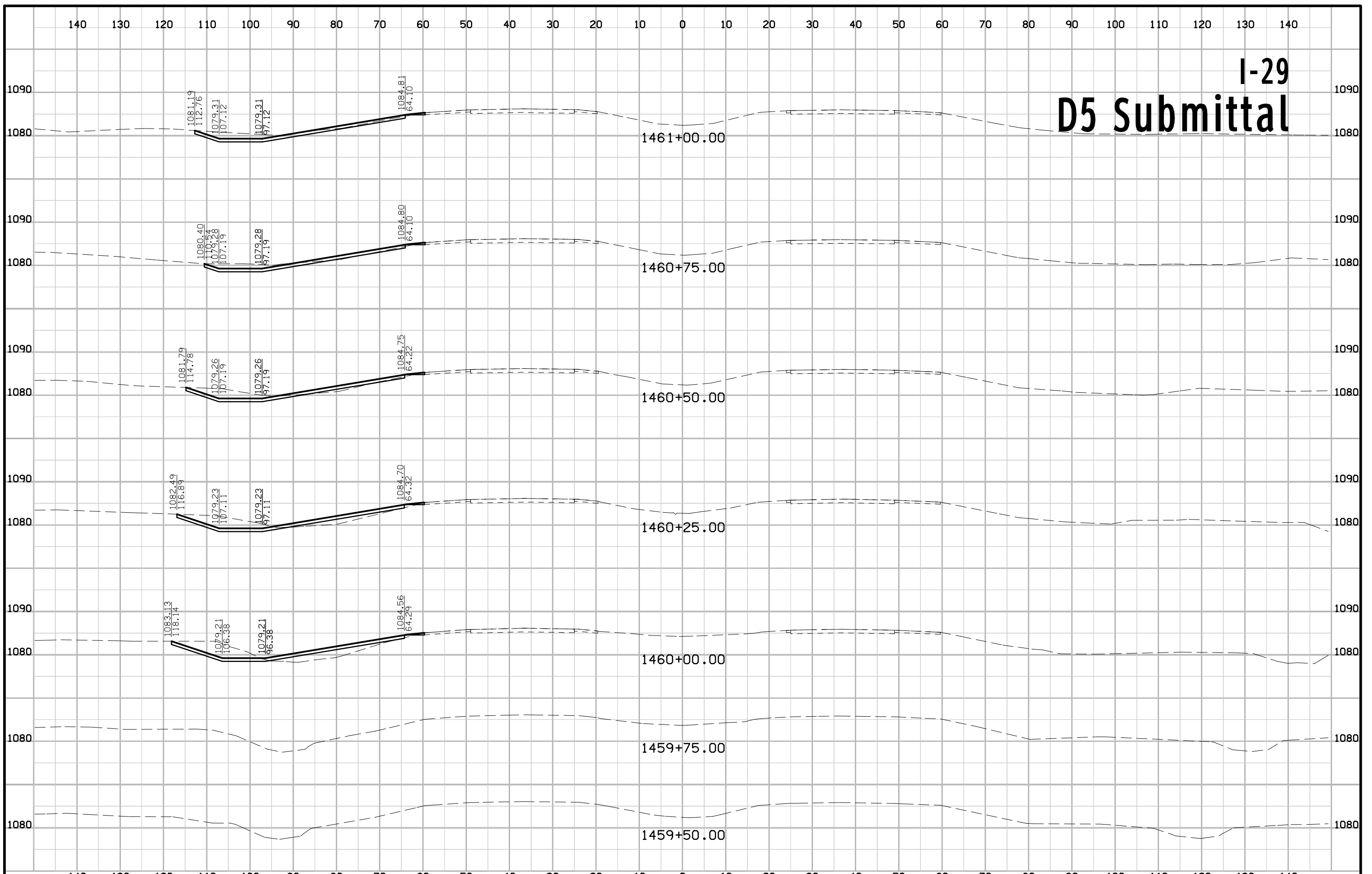



# I-29 D5 Submittal

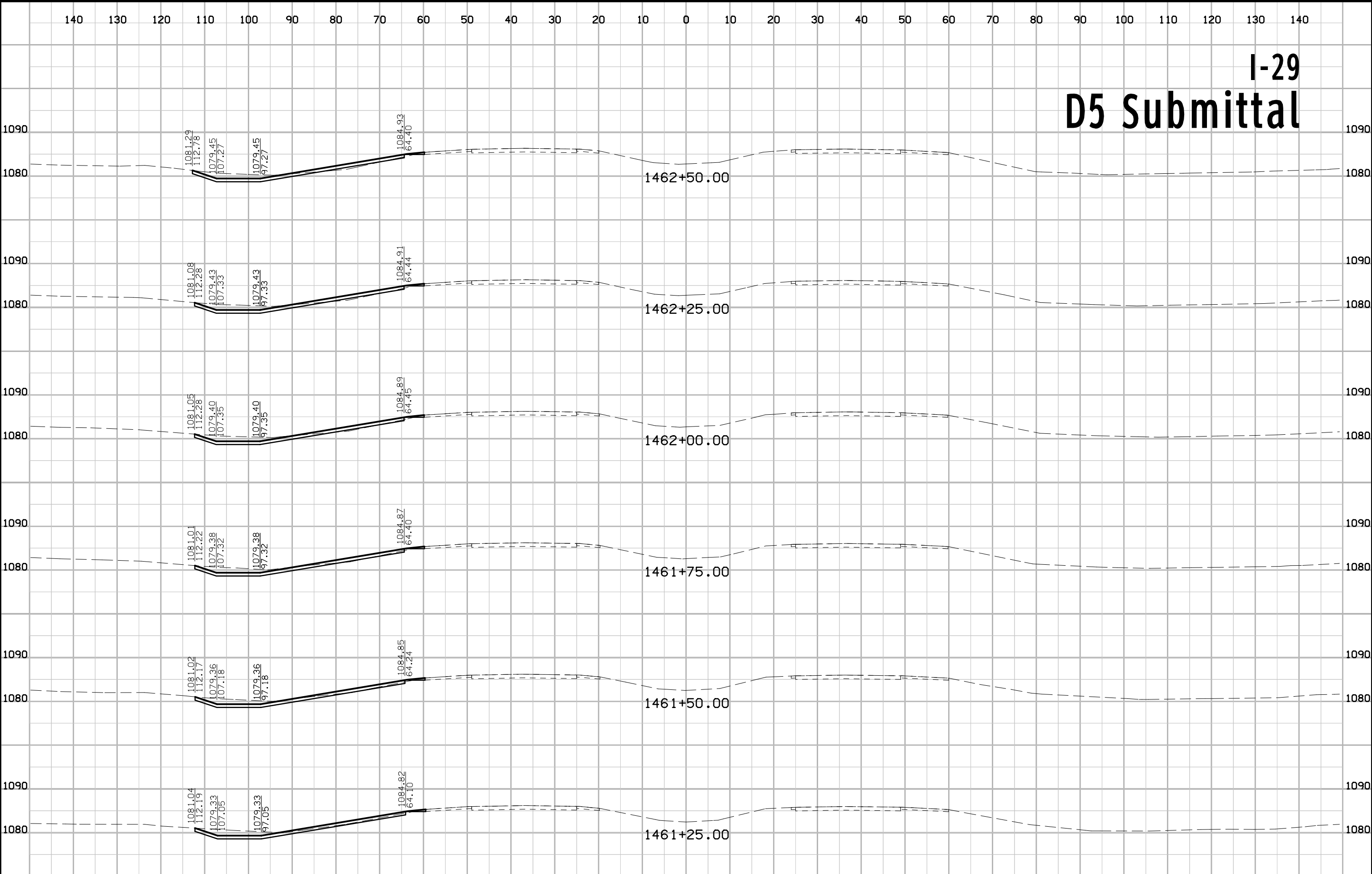

# I-29 D5 Submittal

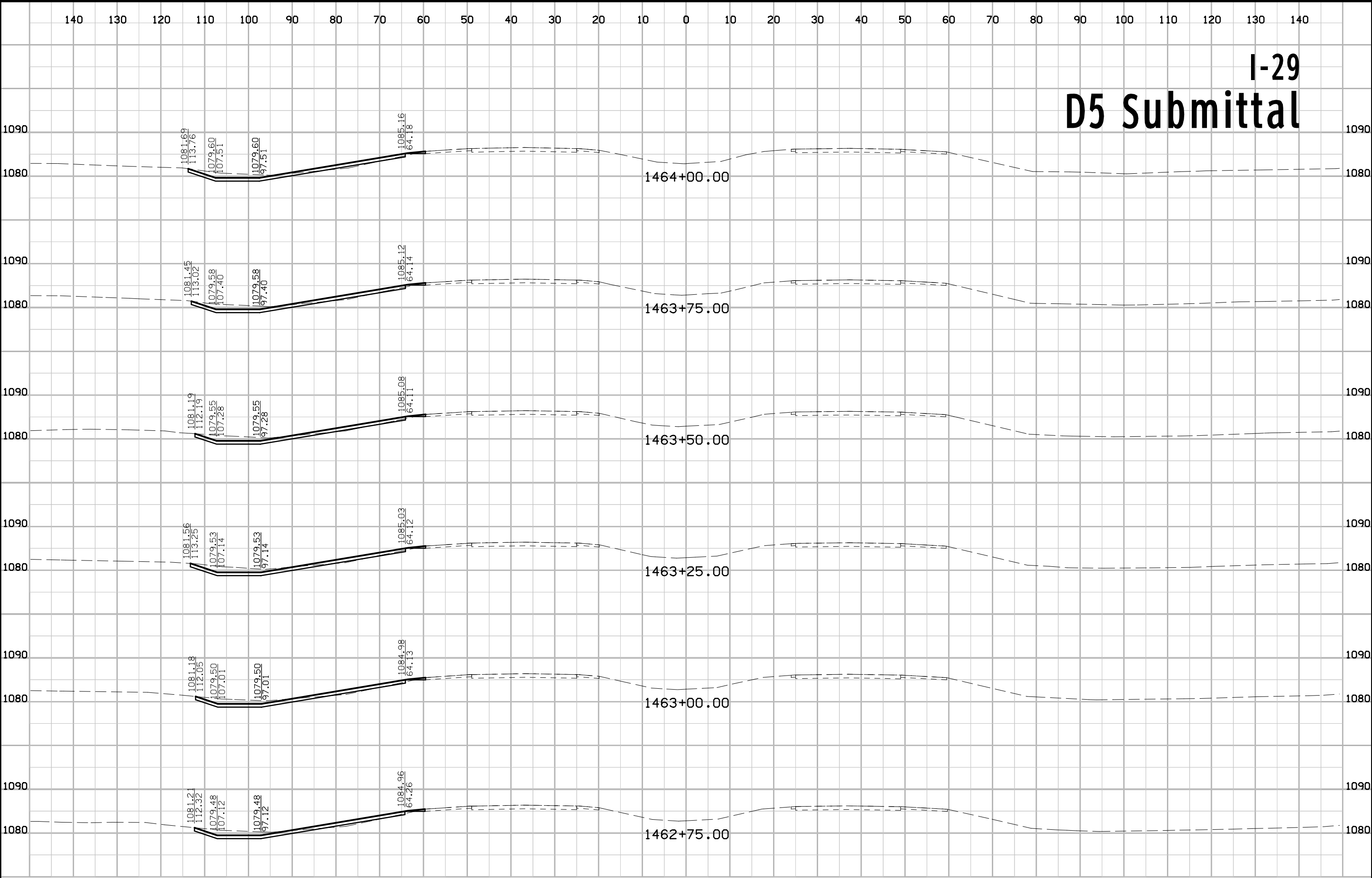

# I-29 D5 Submittal

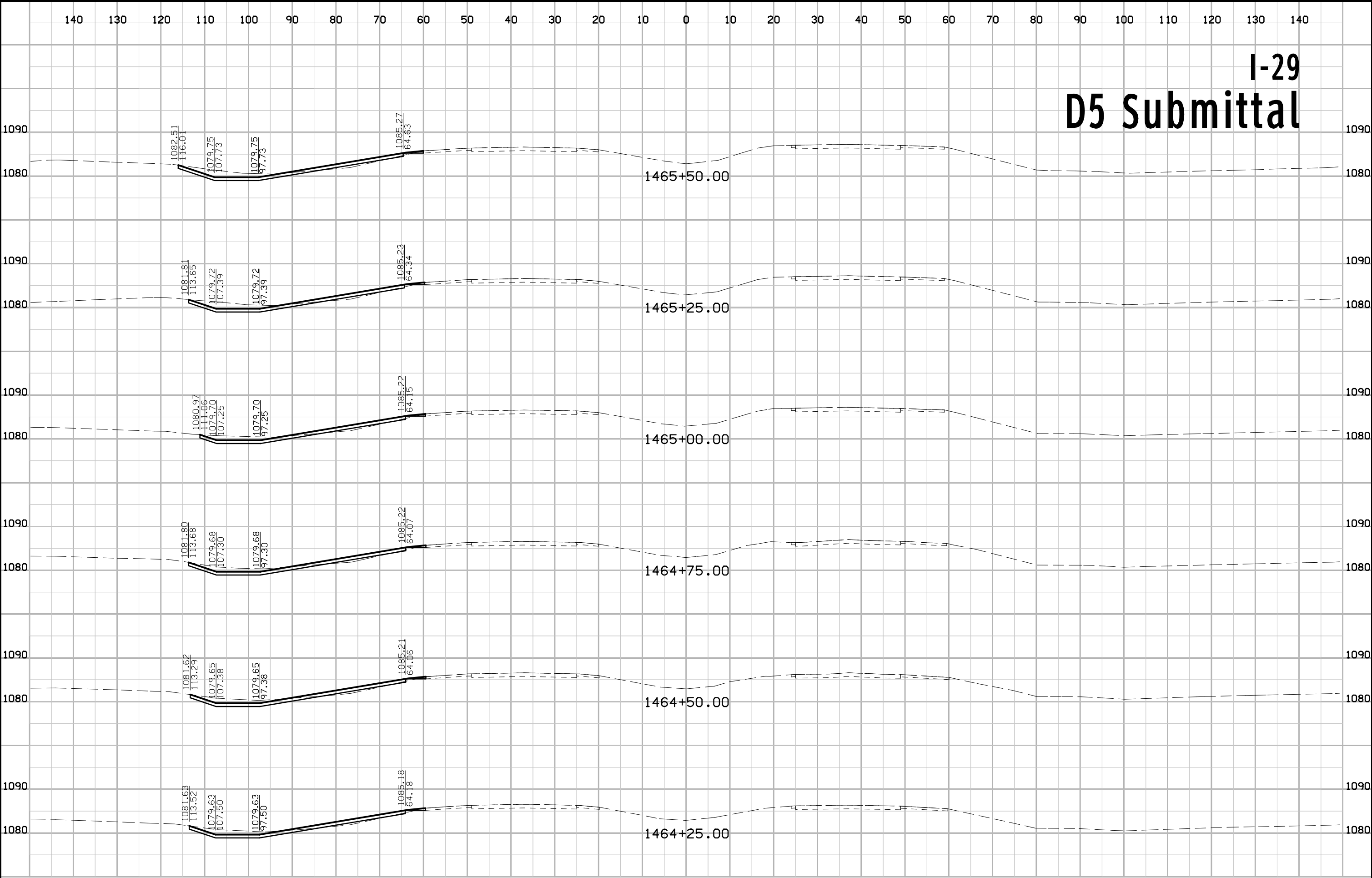

# I-29 D5 Submittal

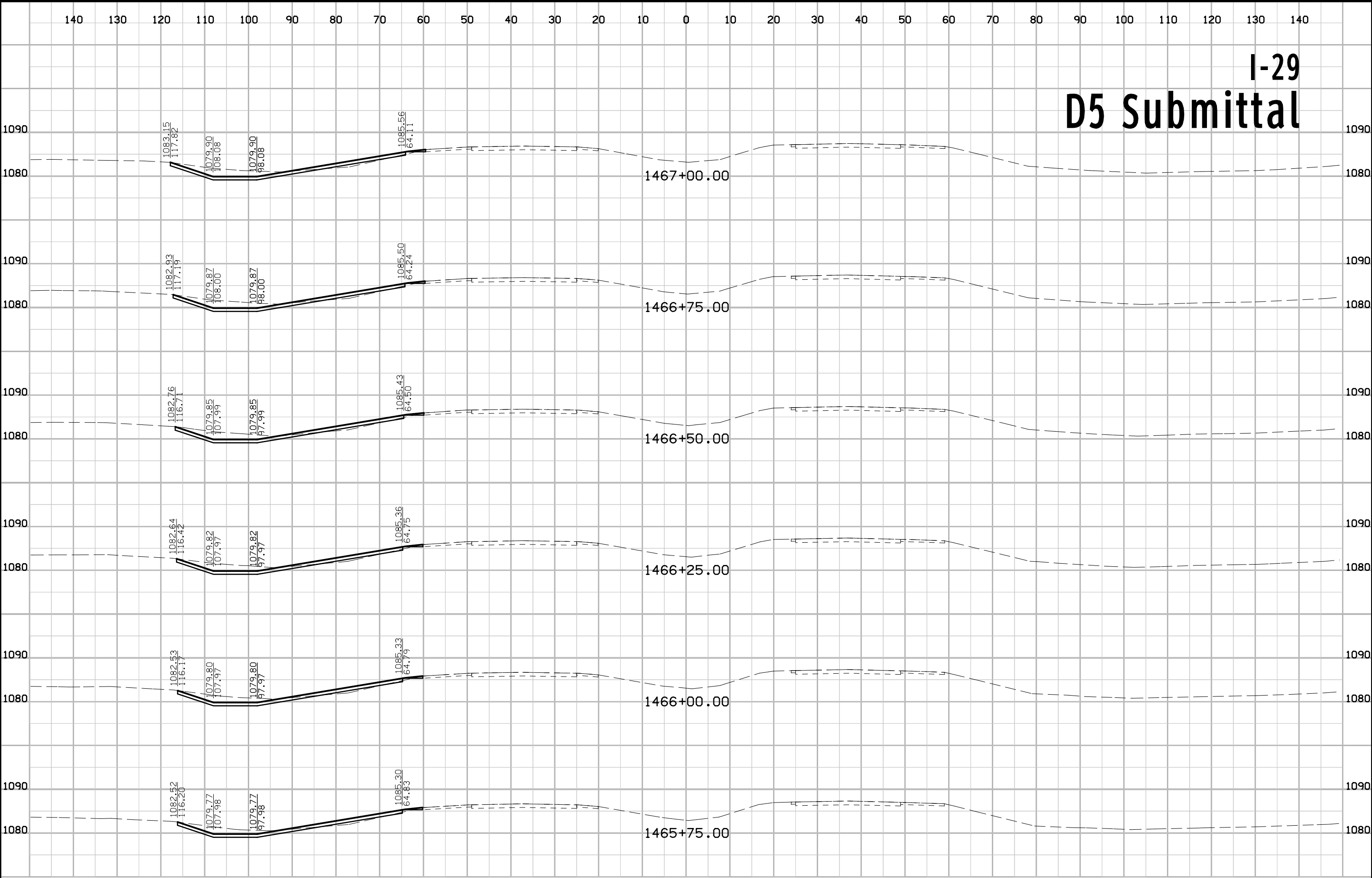

# I-29 D5 Submittal

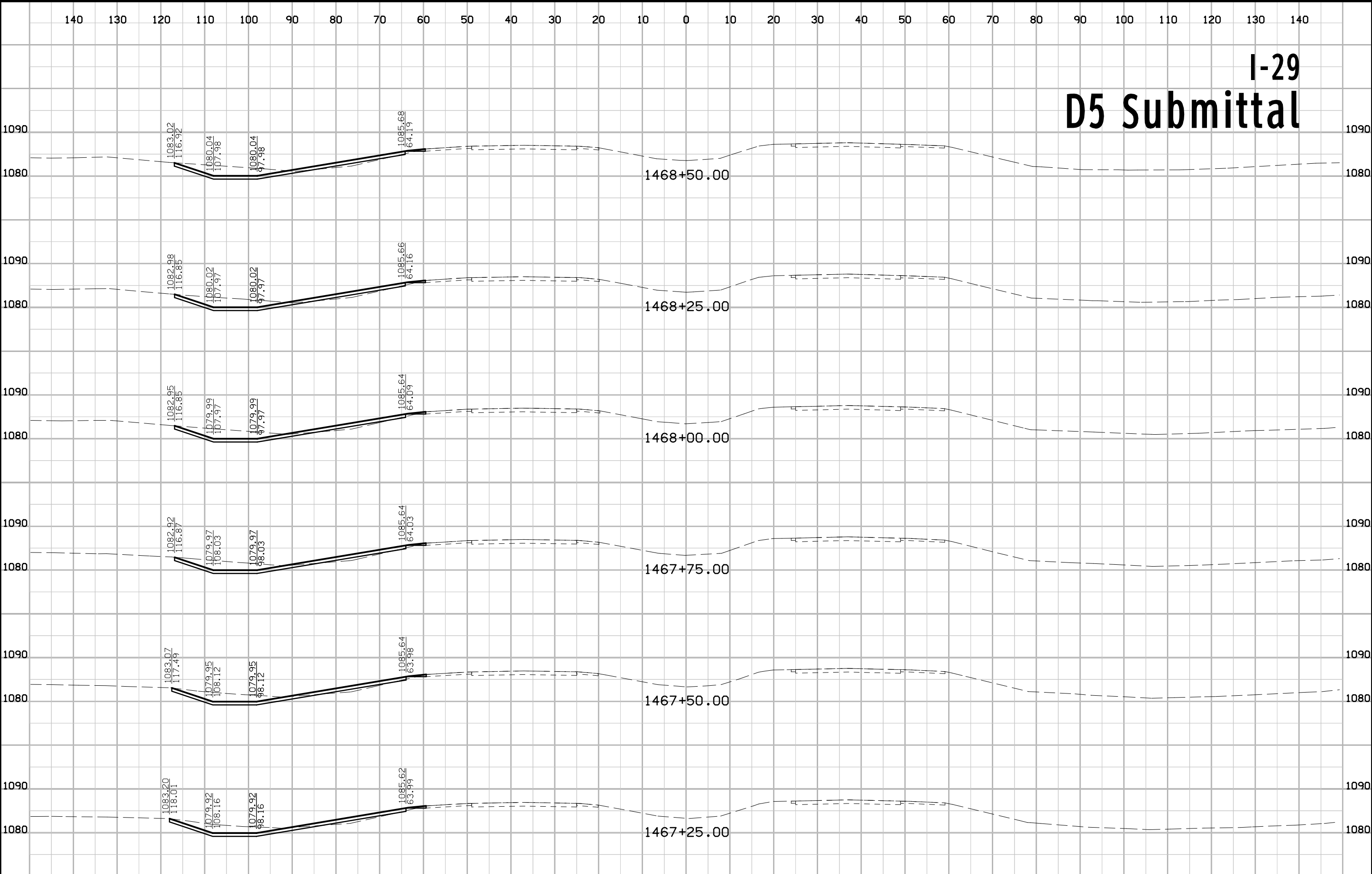

# I-29 D5 Submittal

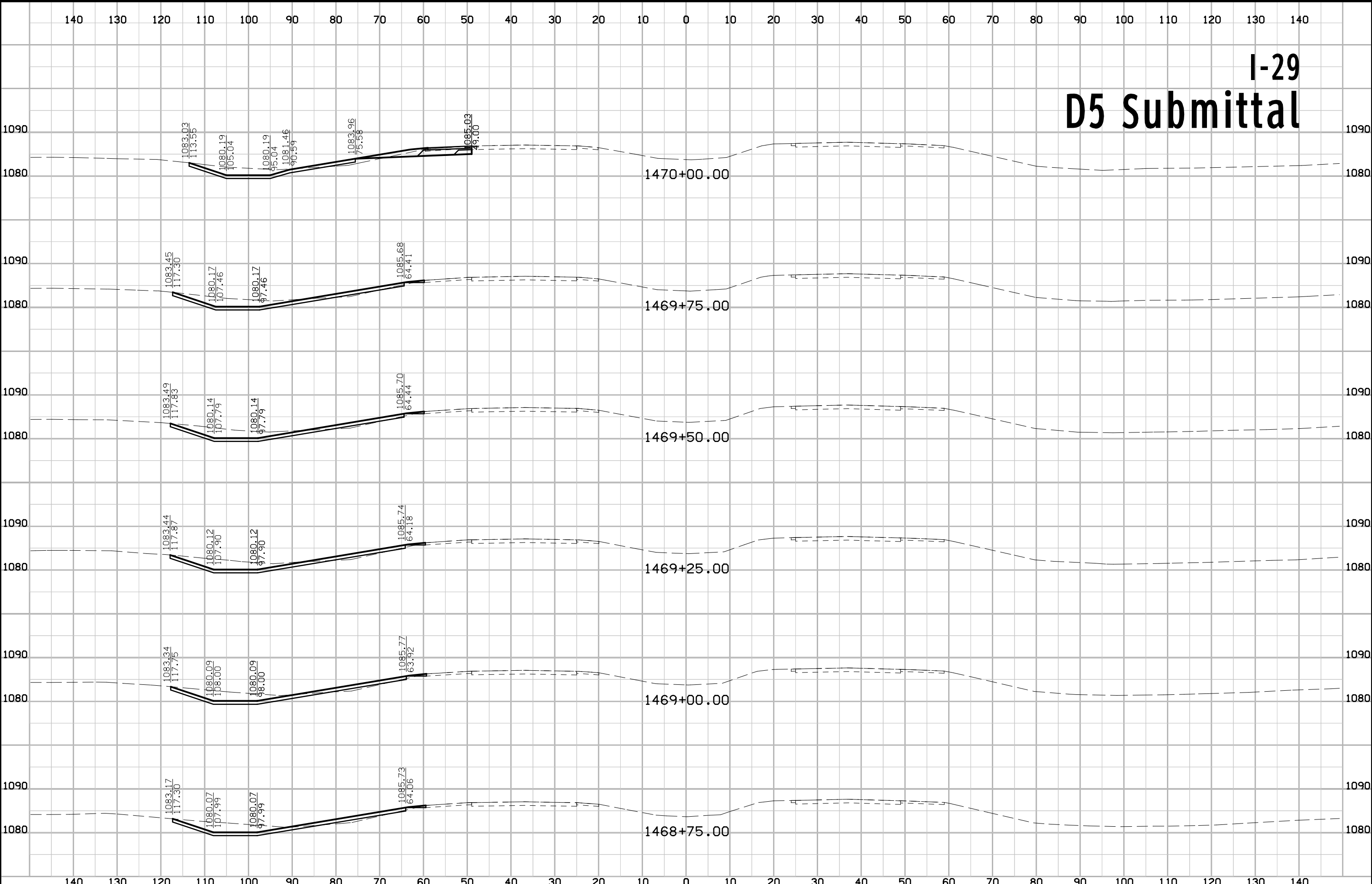

# I-29 D5 Submittal

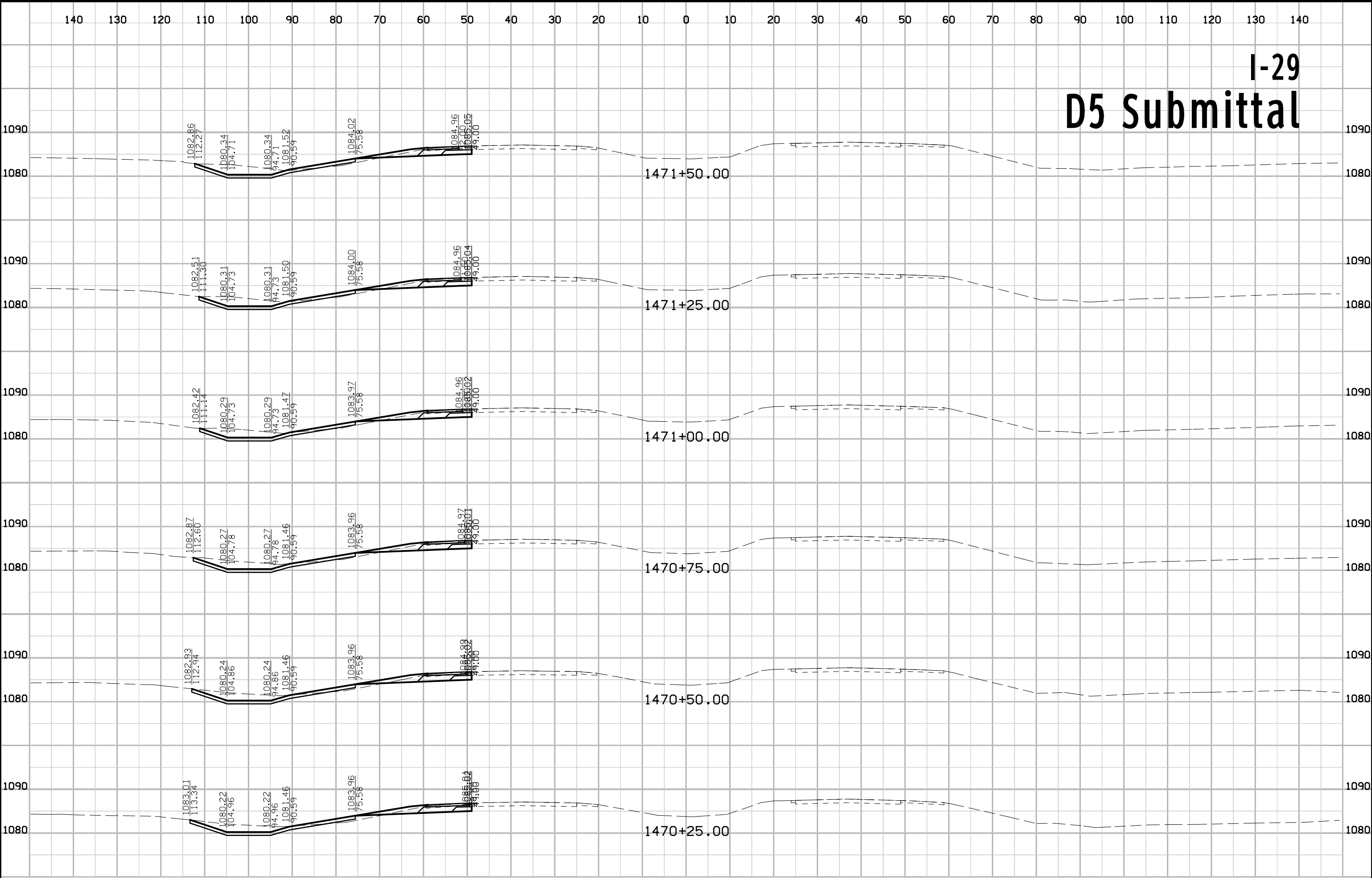

# I-29 D5 Submittal

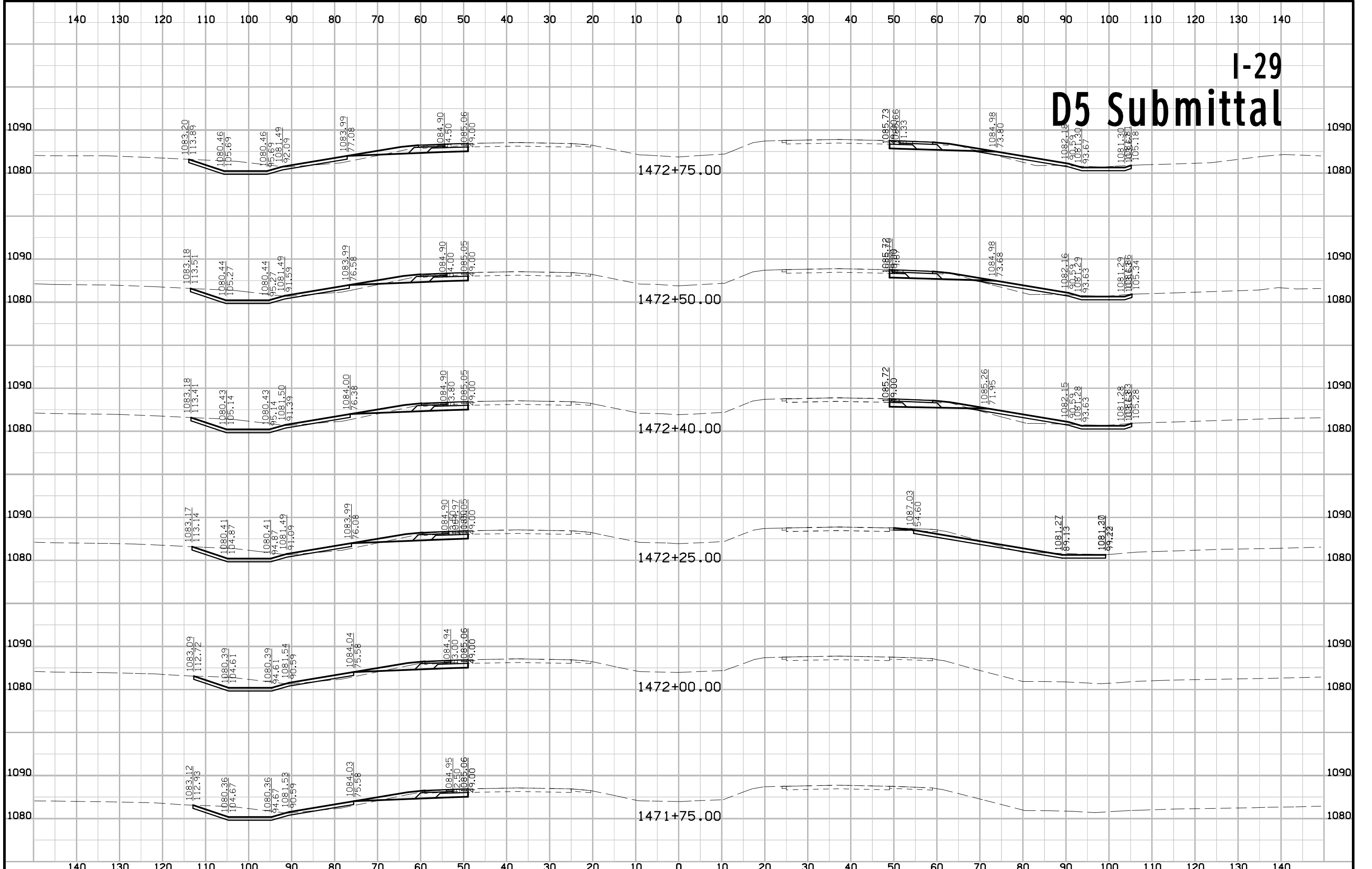



# I-29 D5 Submittal

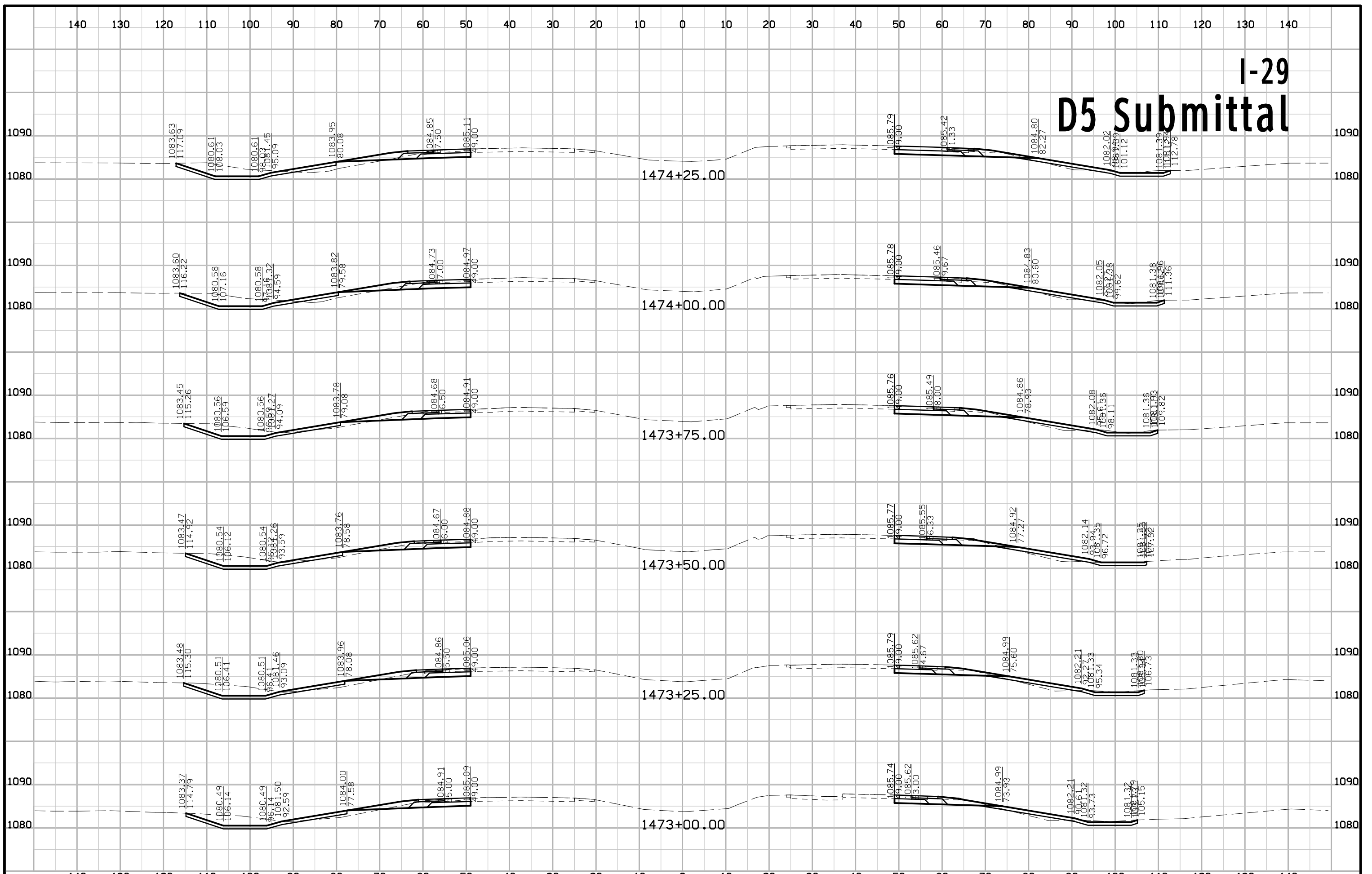

# I-29 D5 Submittal

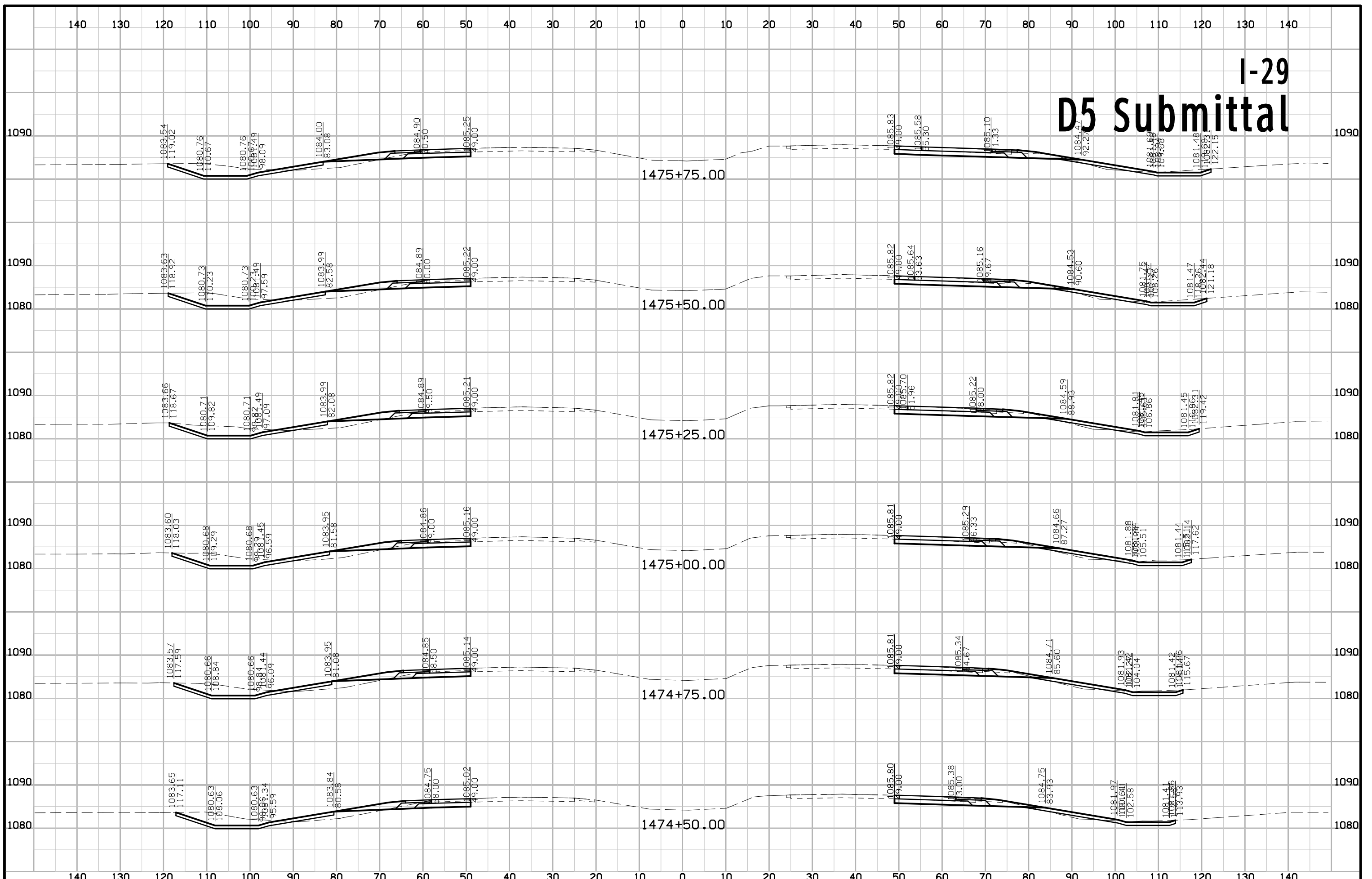

# I-29 D5 Submittal

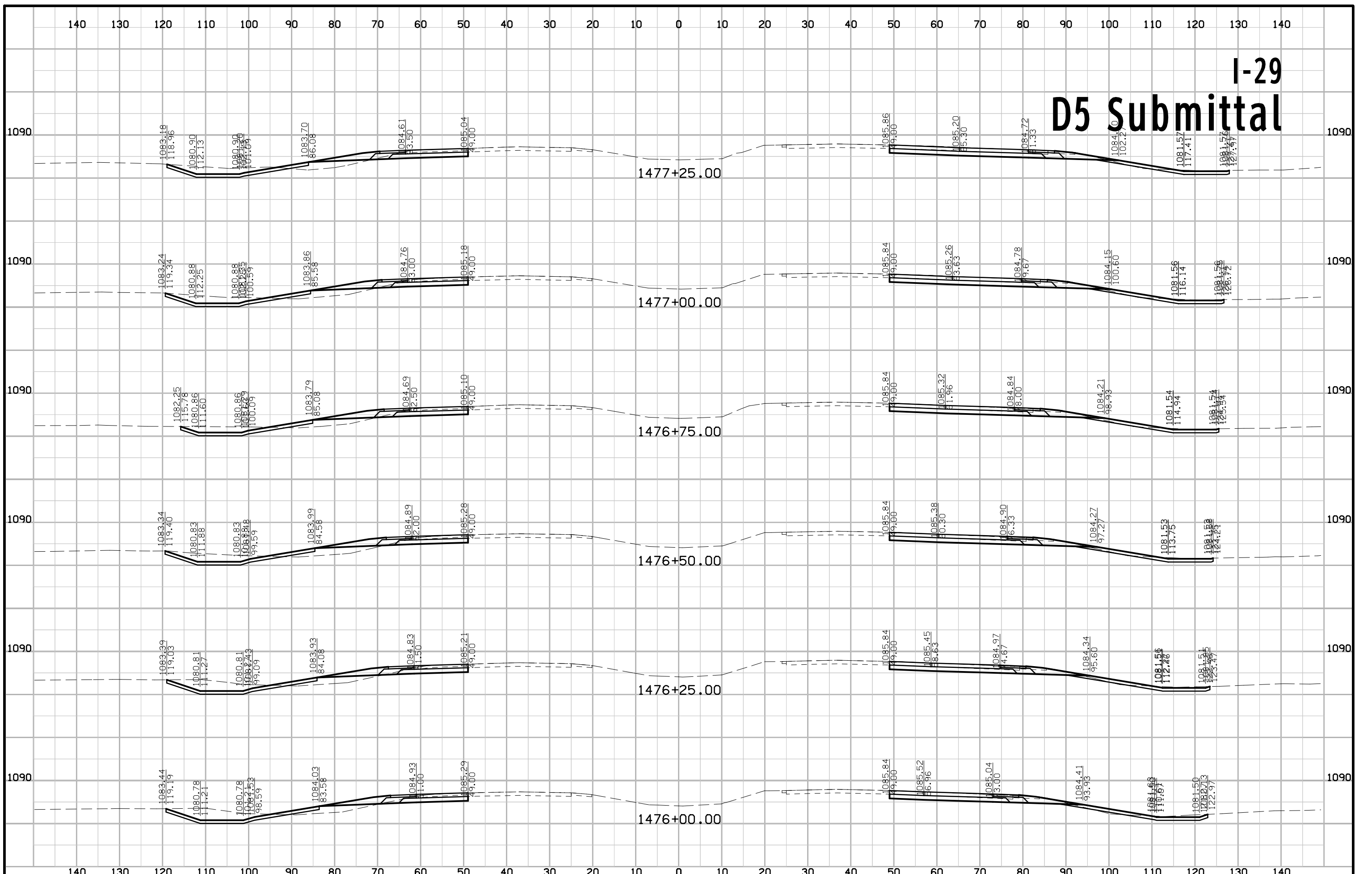

# I-29 D5 Submittal

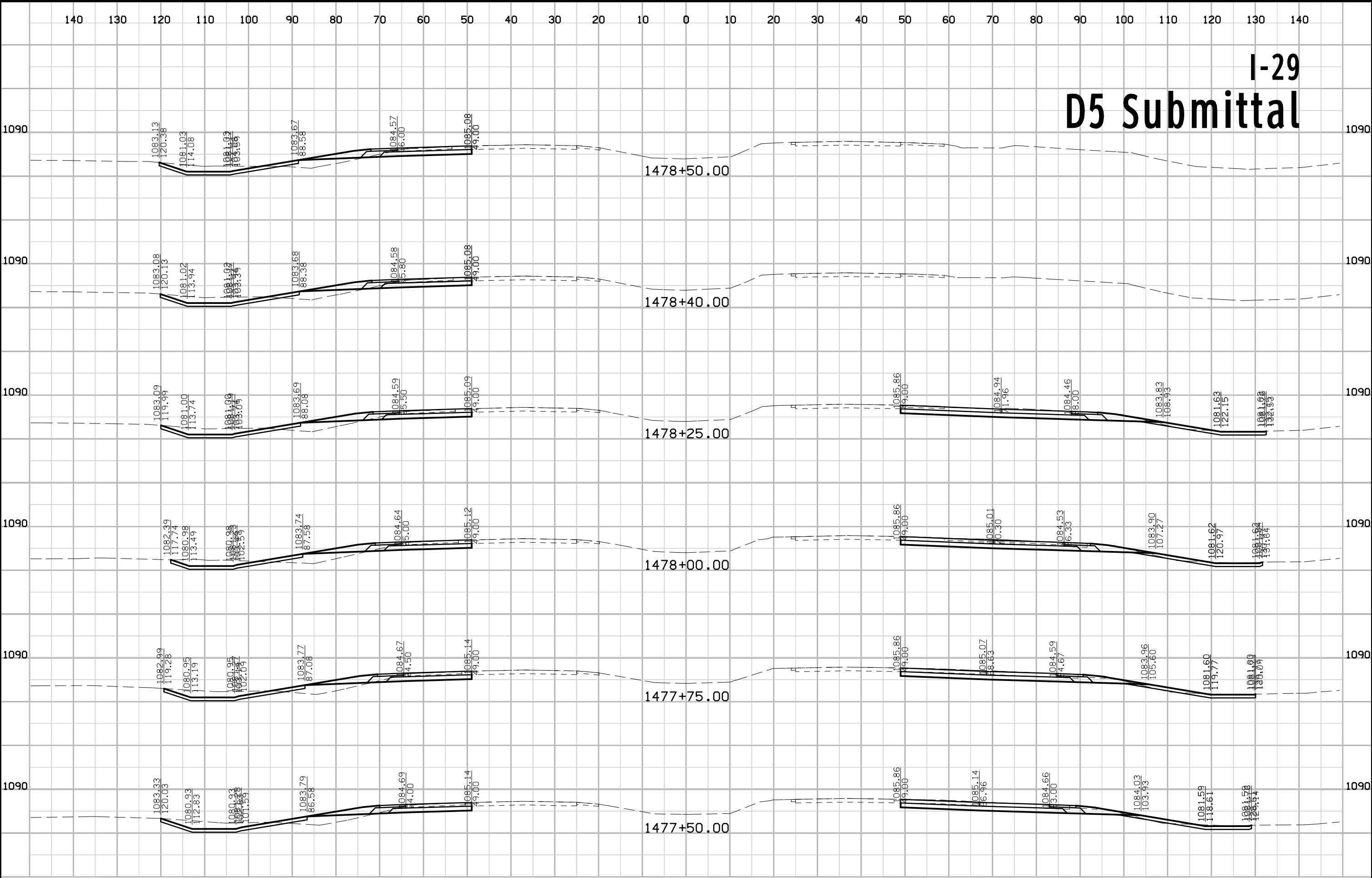

# I-29 D5 Submittal

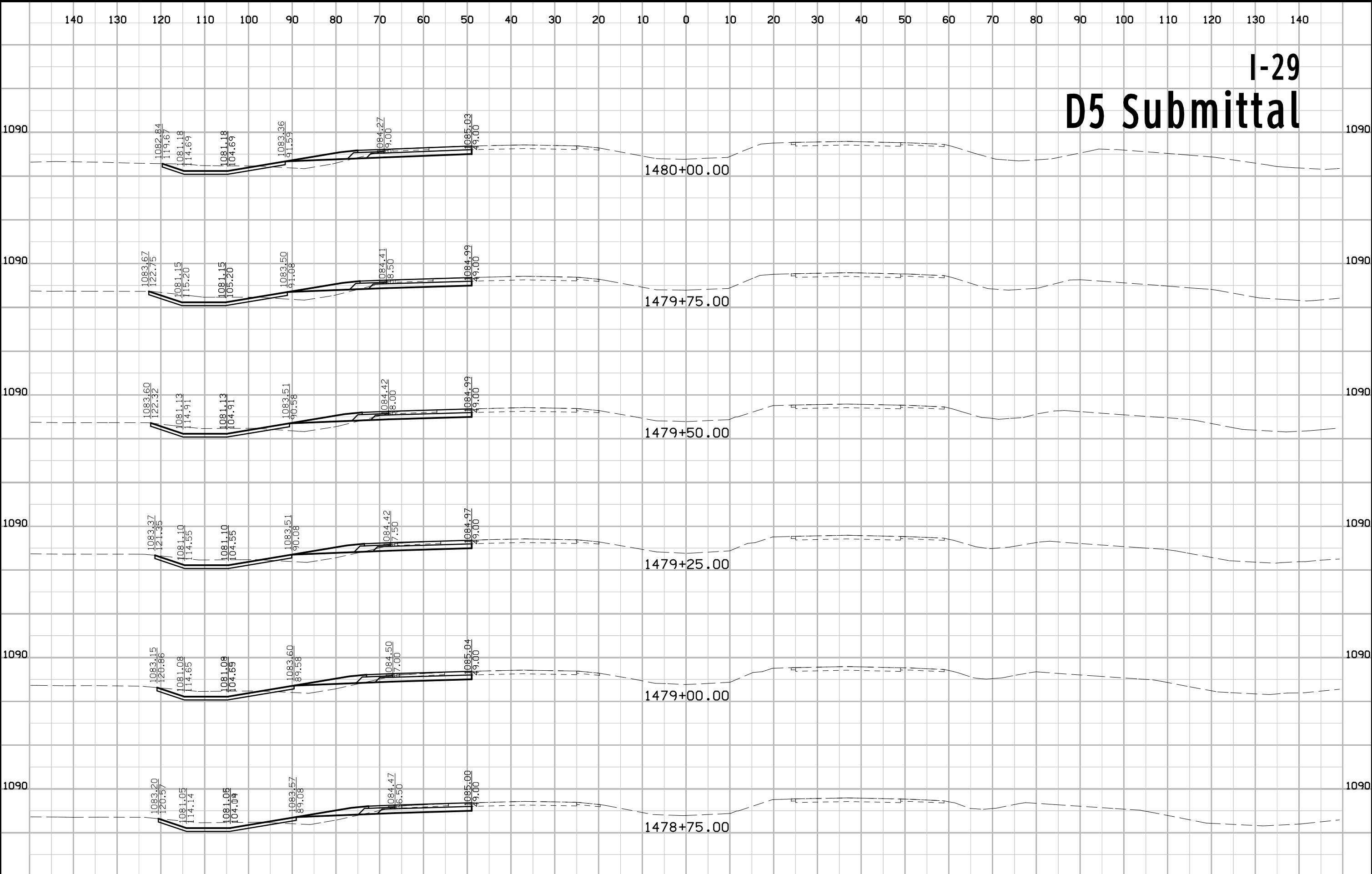

# I-29 D5 Submittal

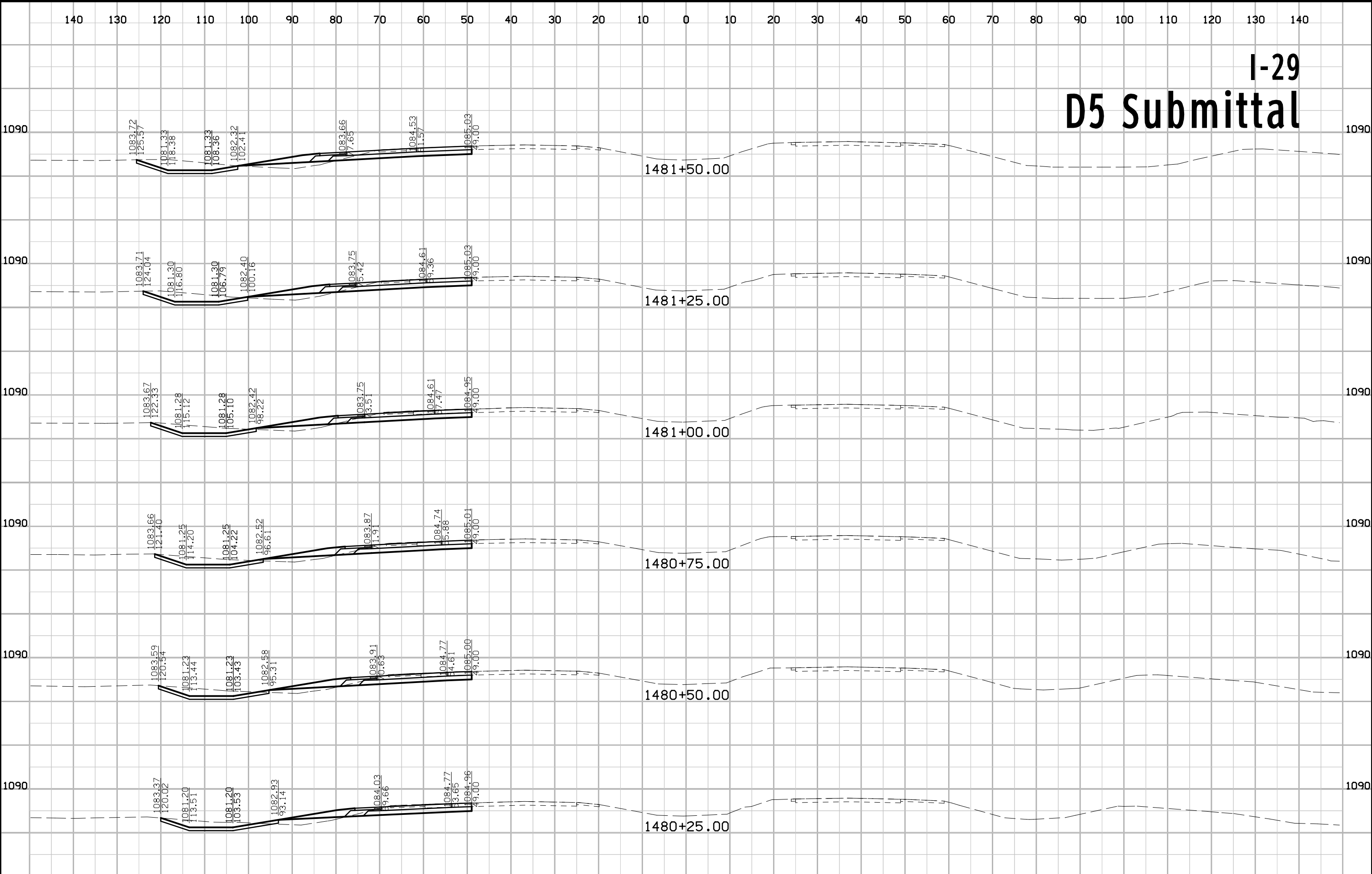

# I-29 D5 Submittal



# I-29 D5 Submittal

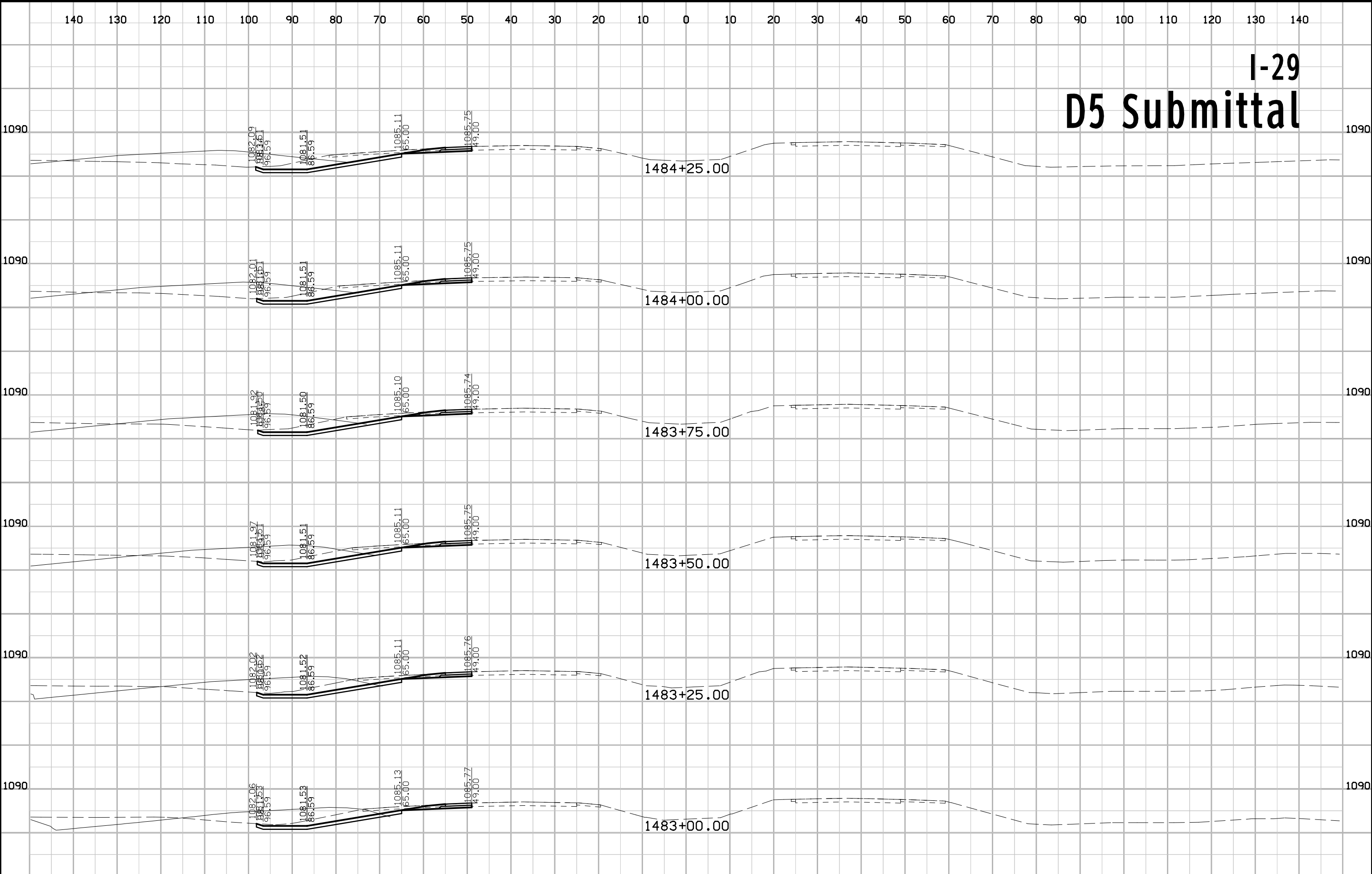



# I-29 D5 Submittal

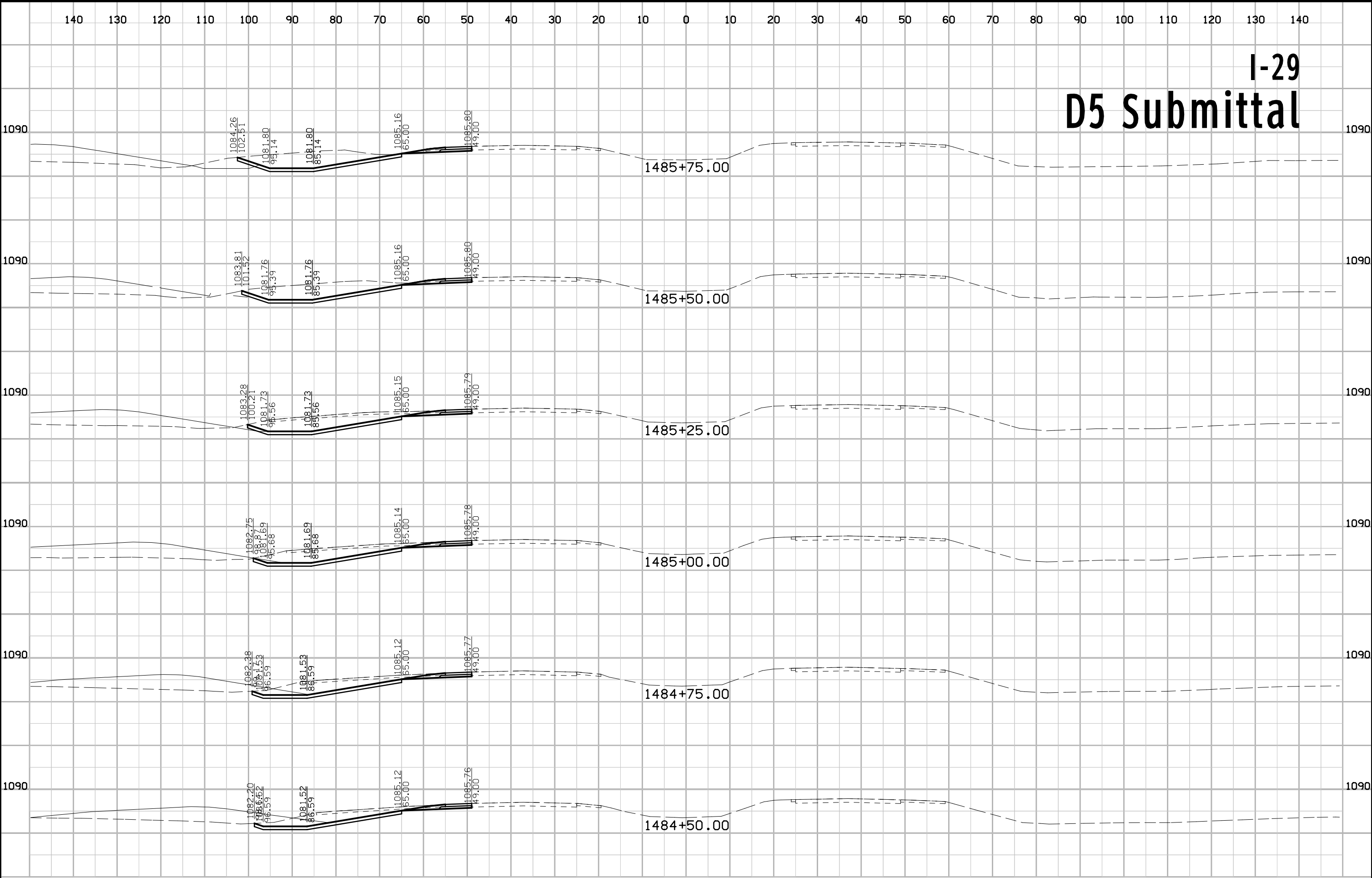

# I-29 D5 Submittal

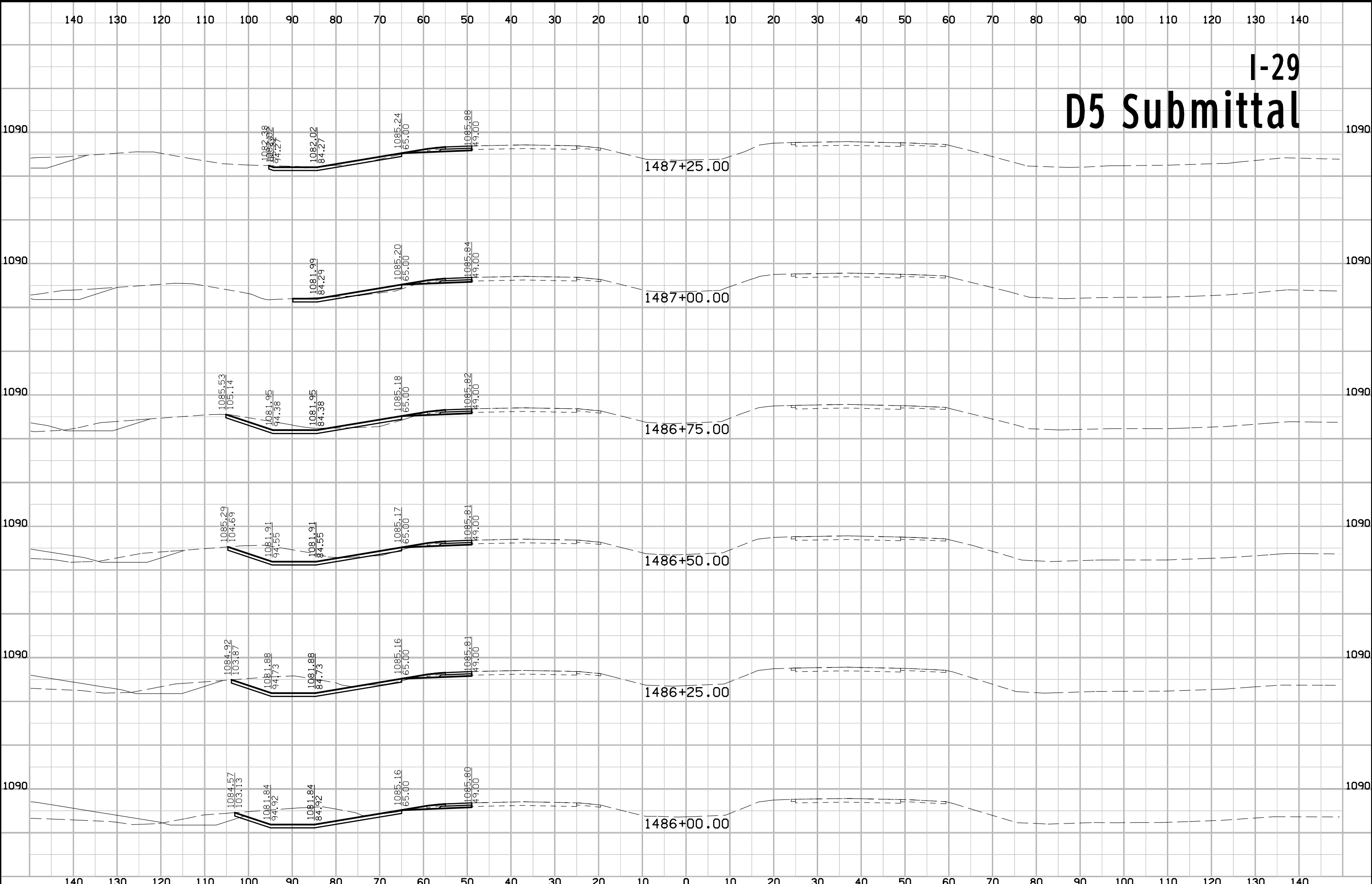

# I-29 D5 Submittal

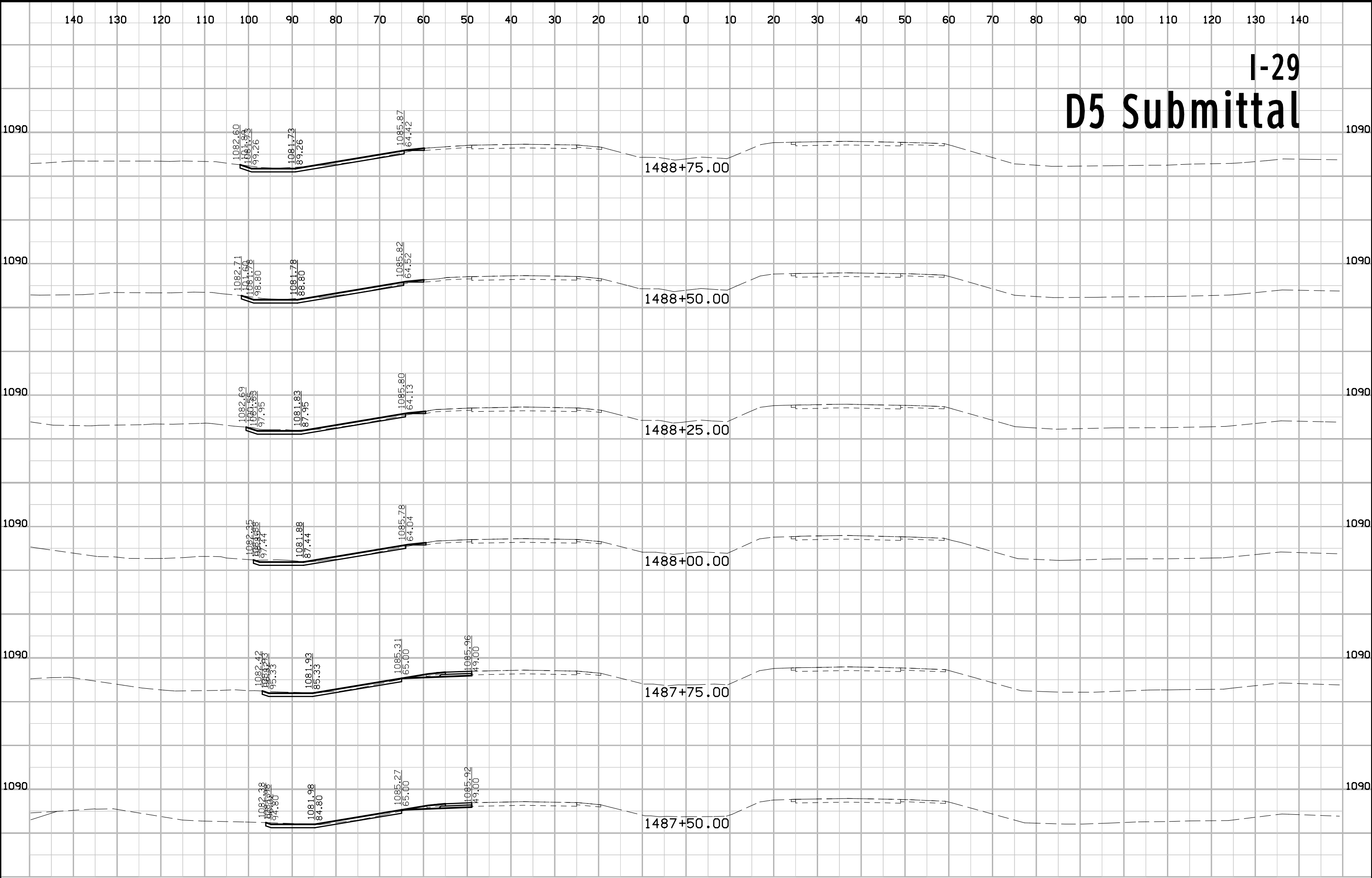

# I-29 D5 Submittal

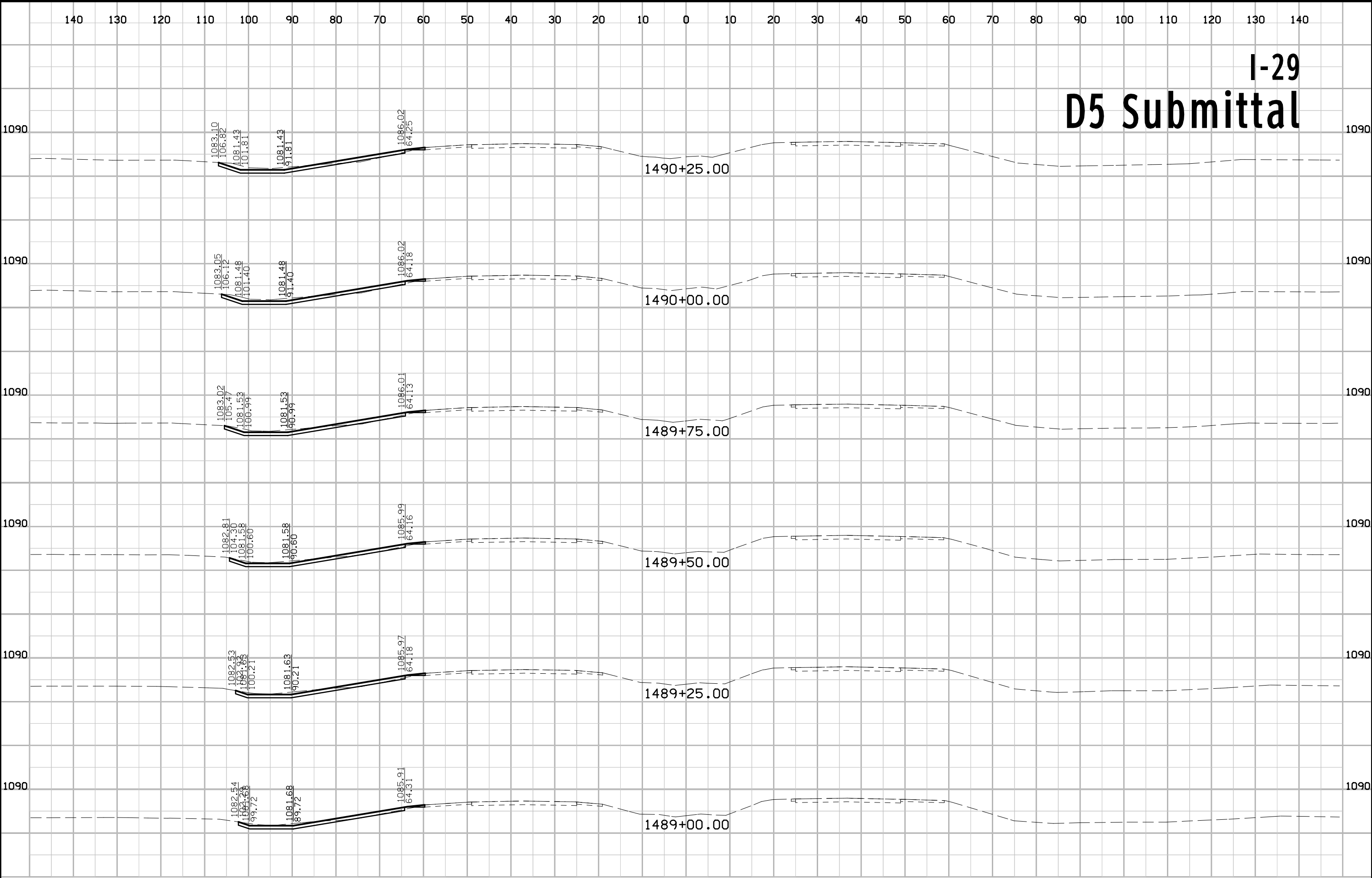

# I-29 D5 Submittal

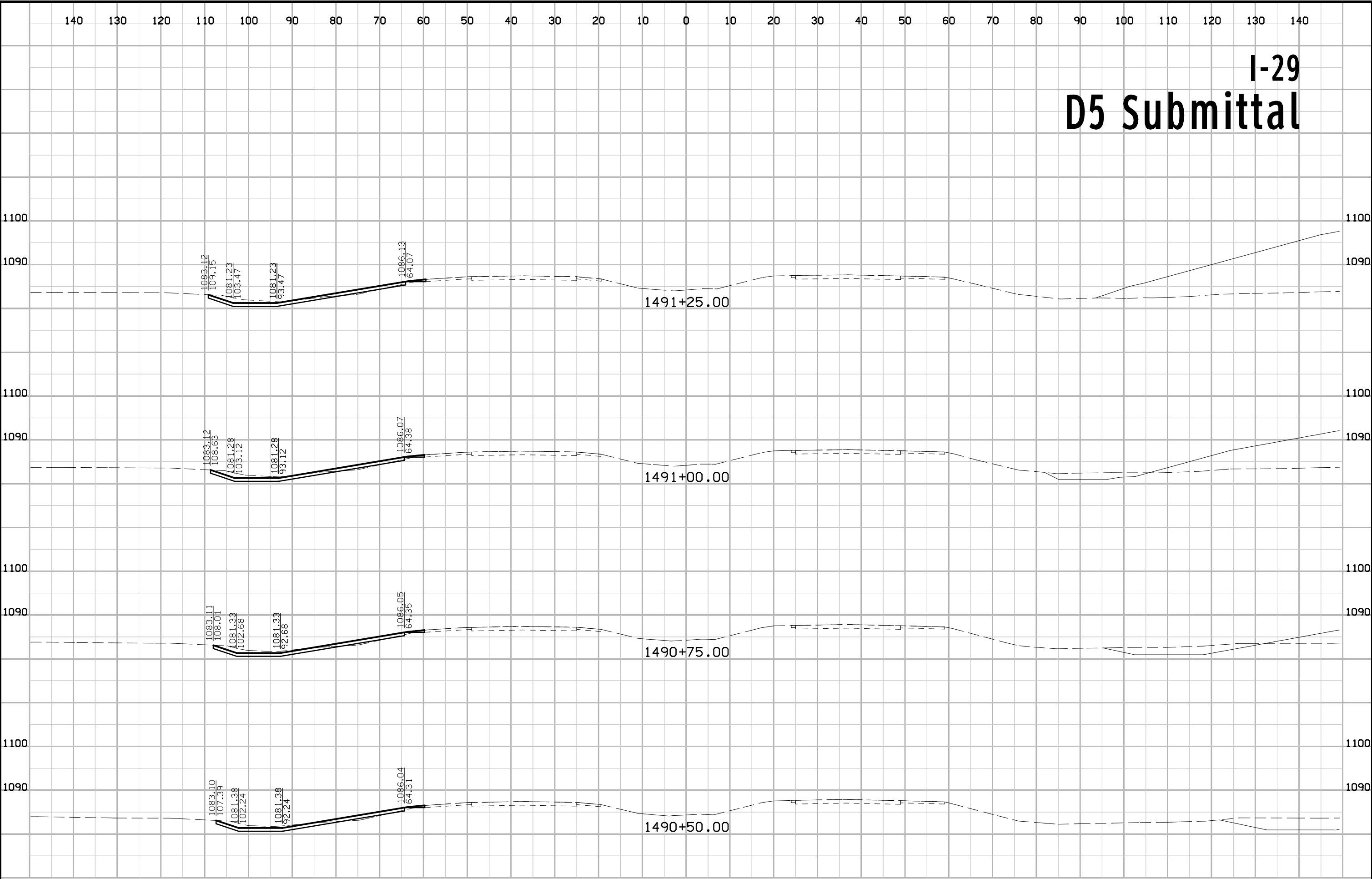

# I-29 D5 Submittal

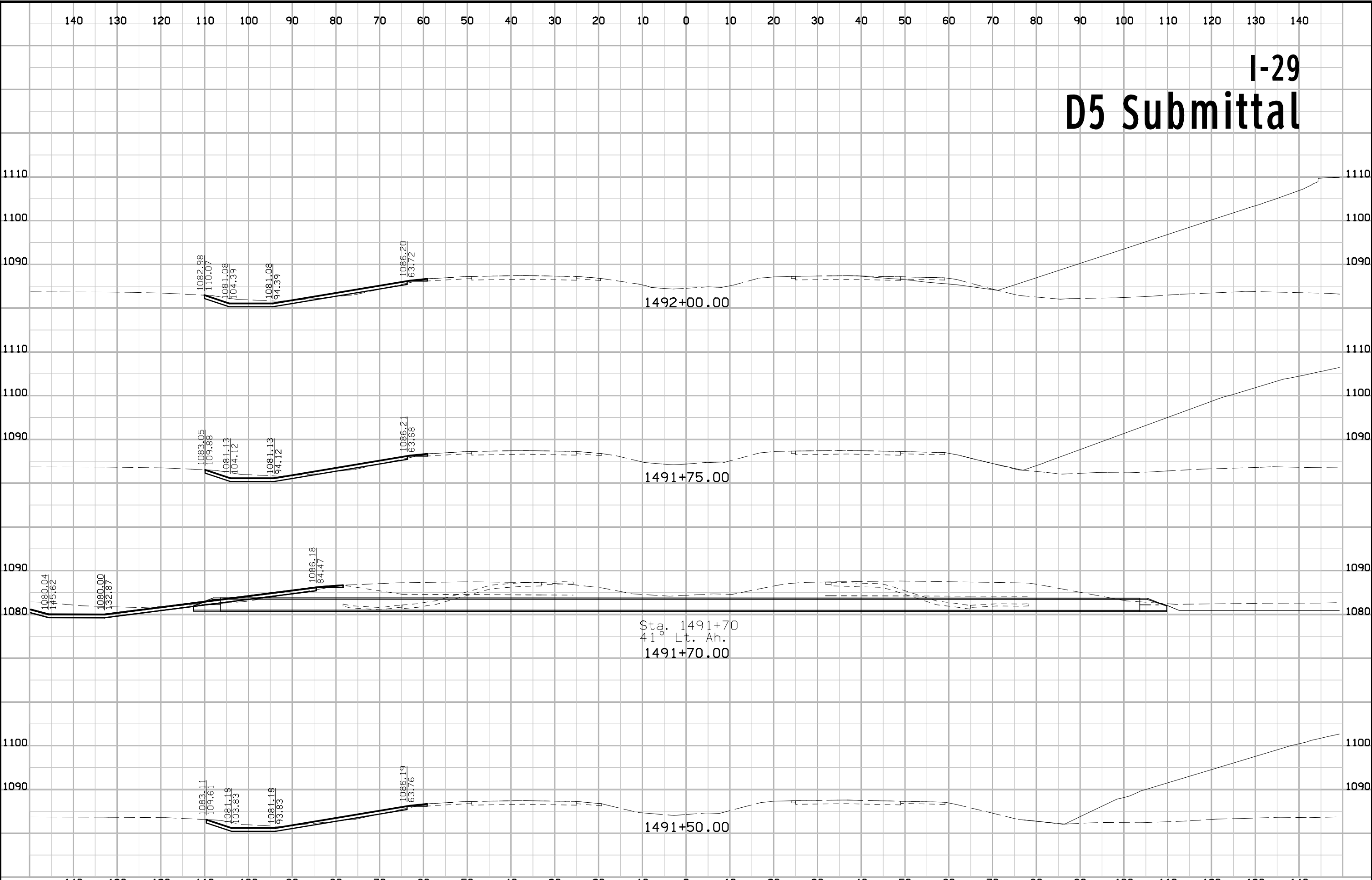

Sta. 1491+70  
41° Lt. Ah.  
1491+70.00

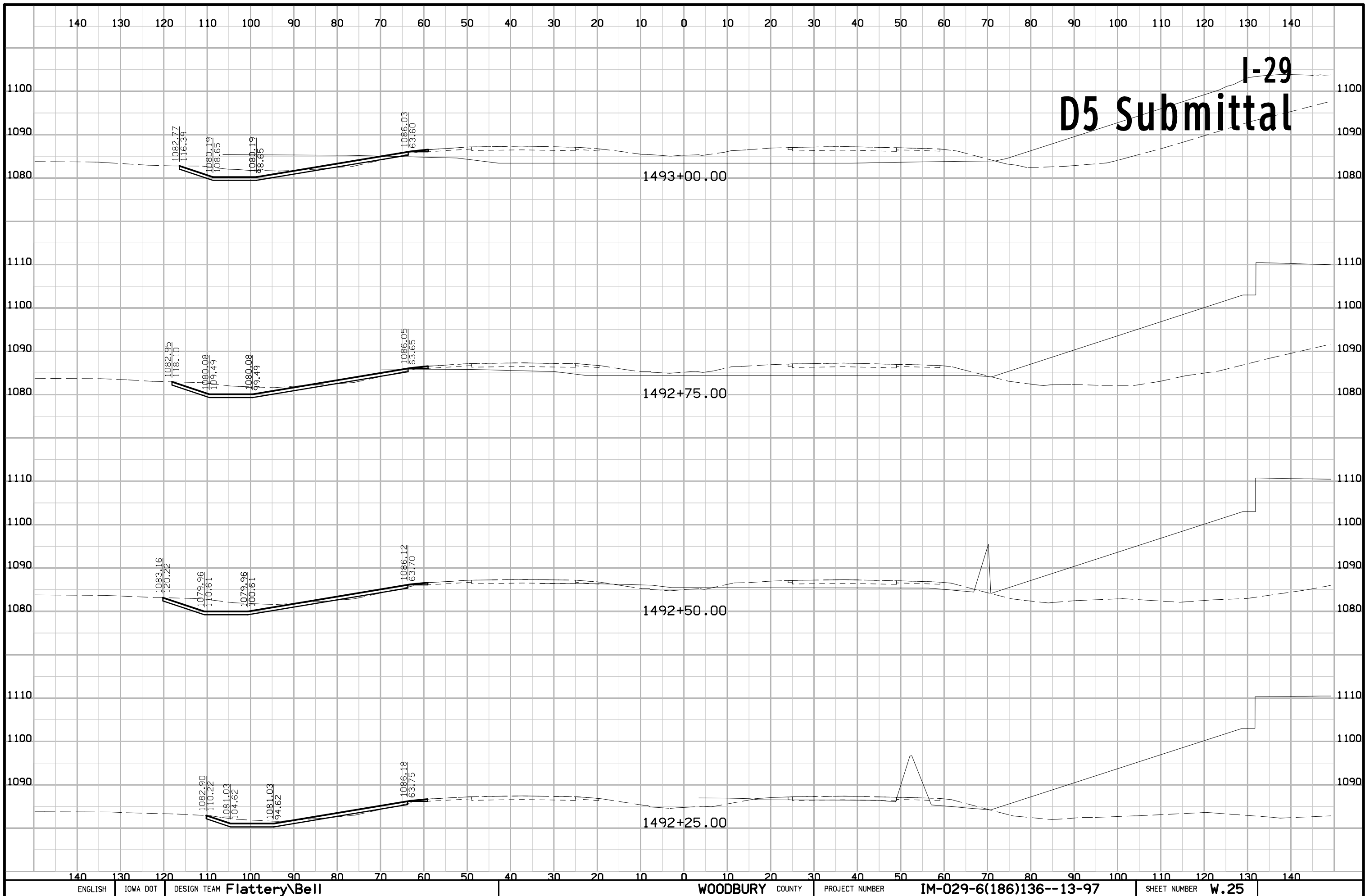

# I-29 D5 Submittal

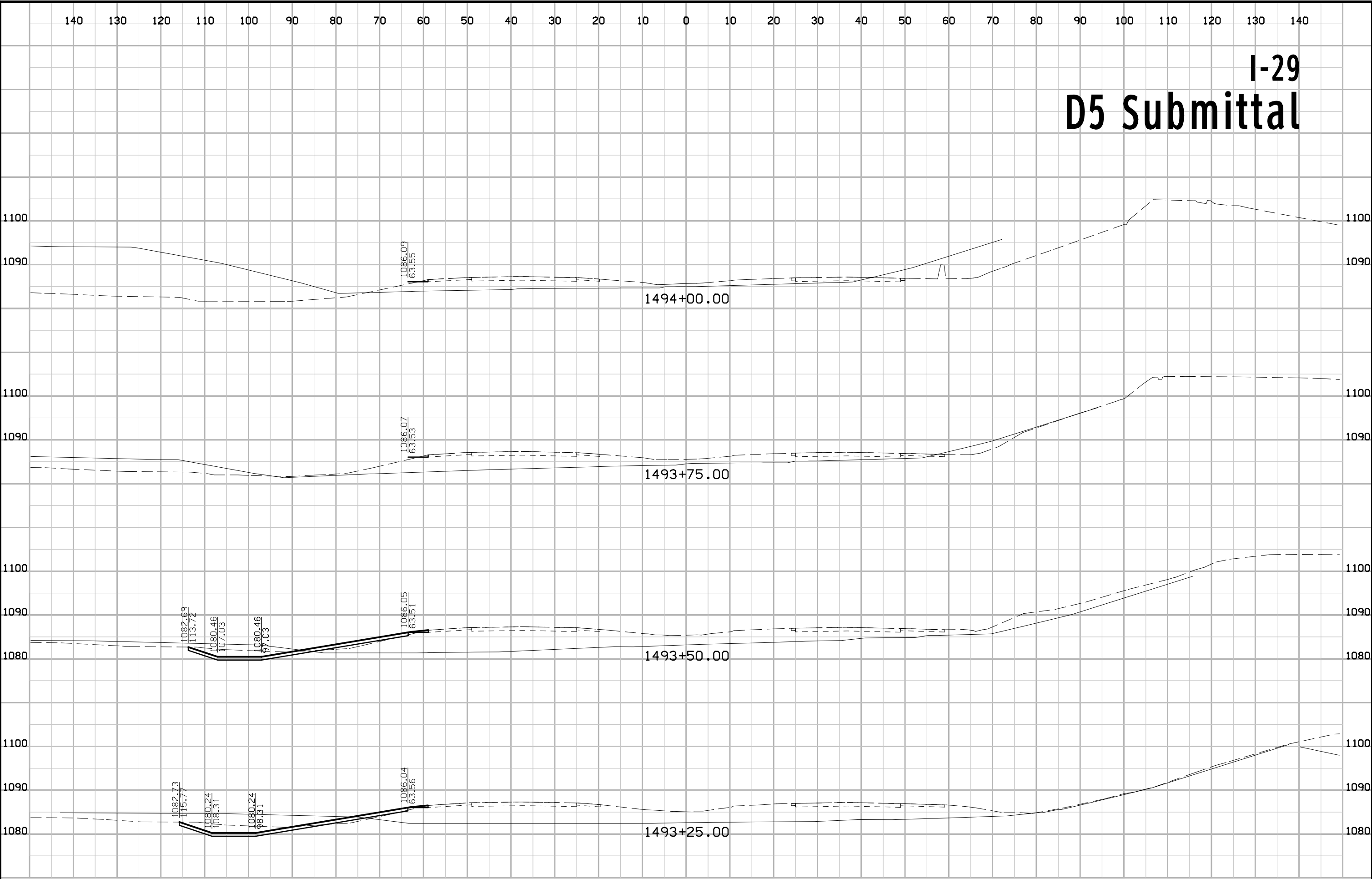



# I-29 D5 Submittal

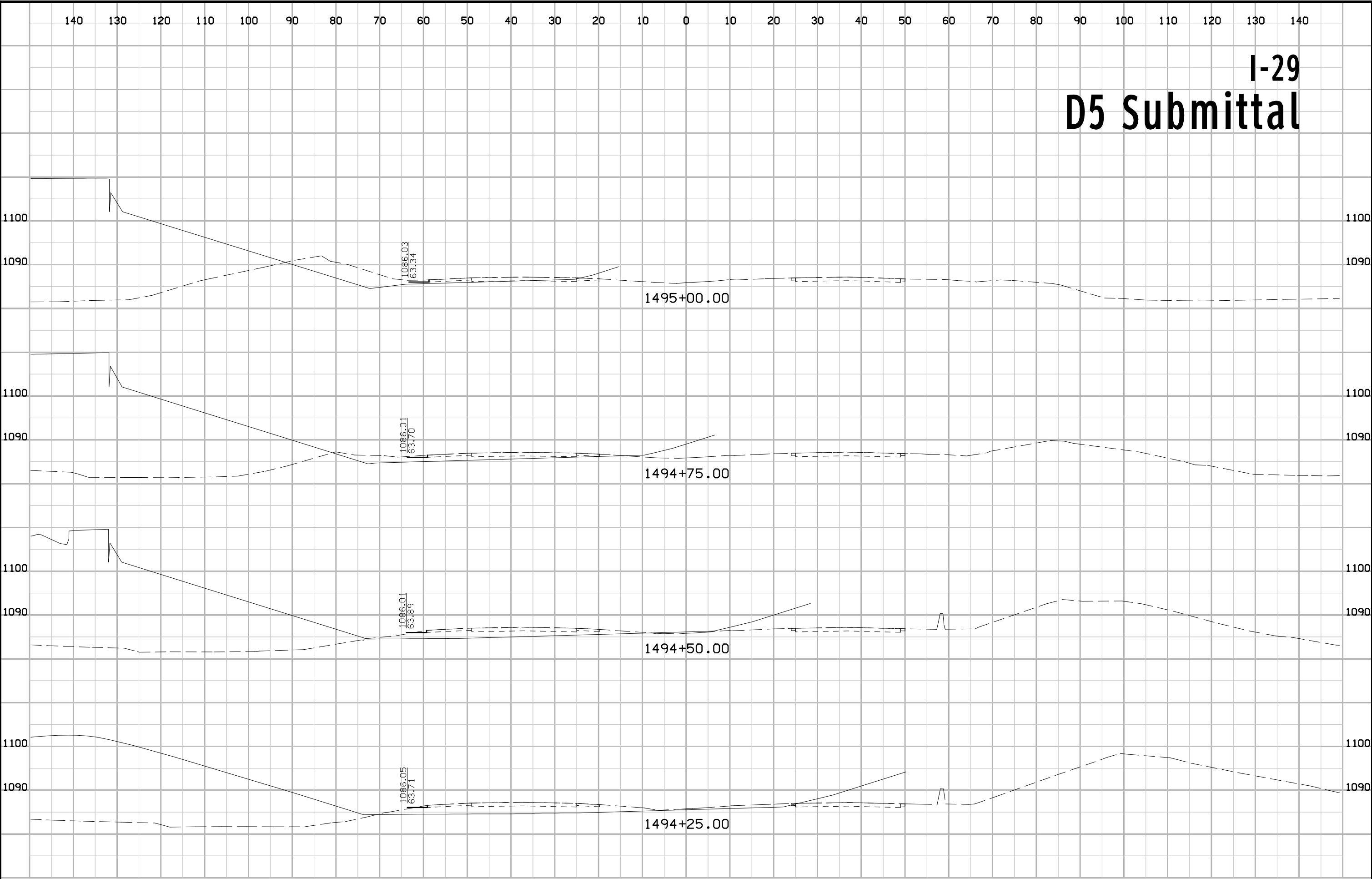

# I-29 D5 Submittal

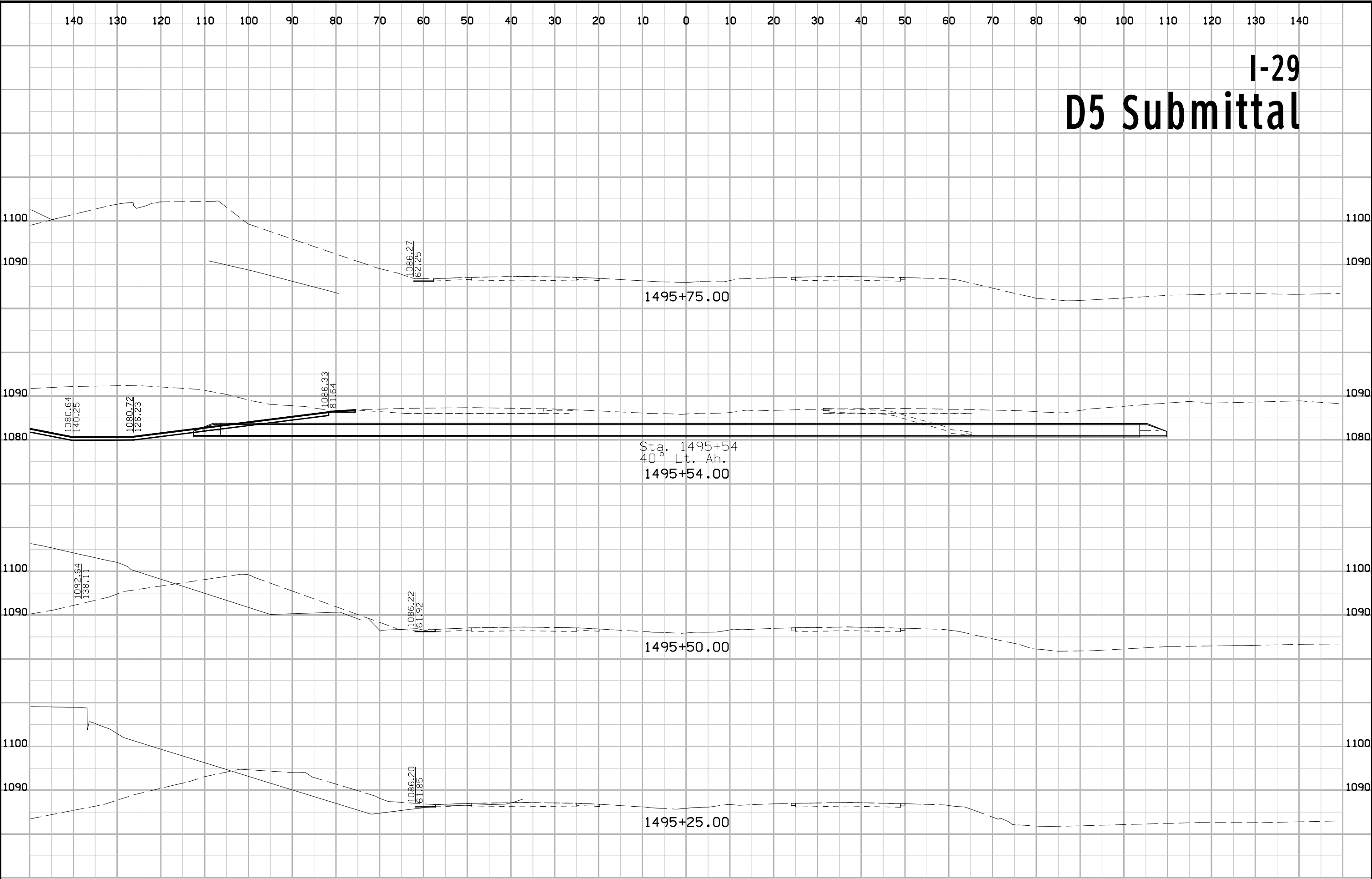

# I-29 D5 Submittal

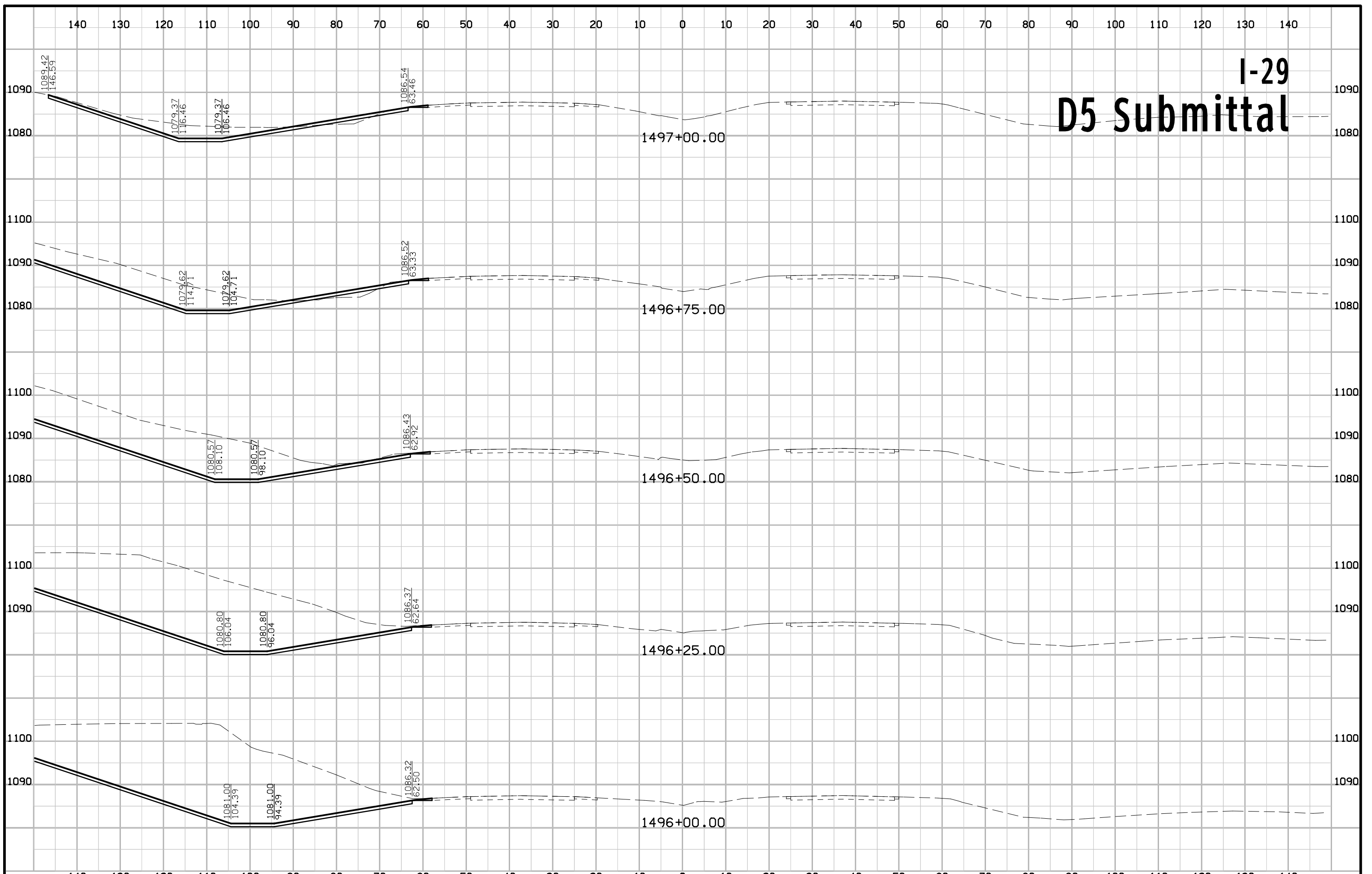

# I-29 D5 Submittal

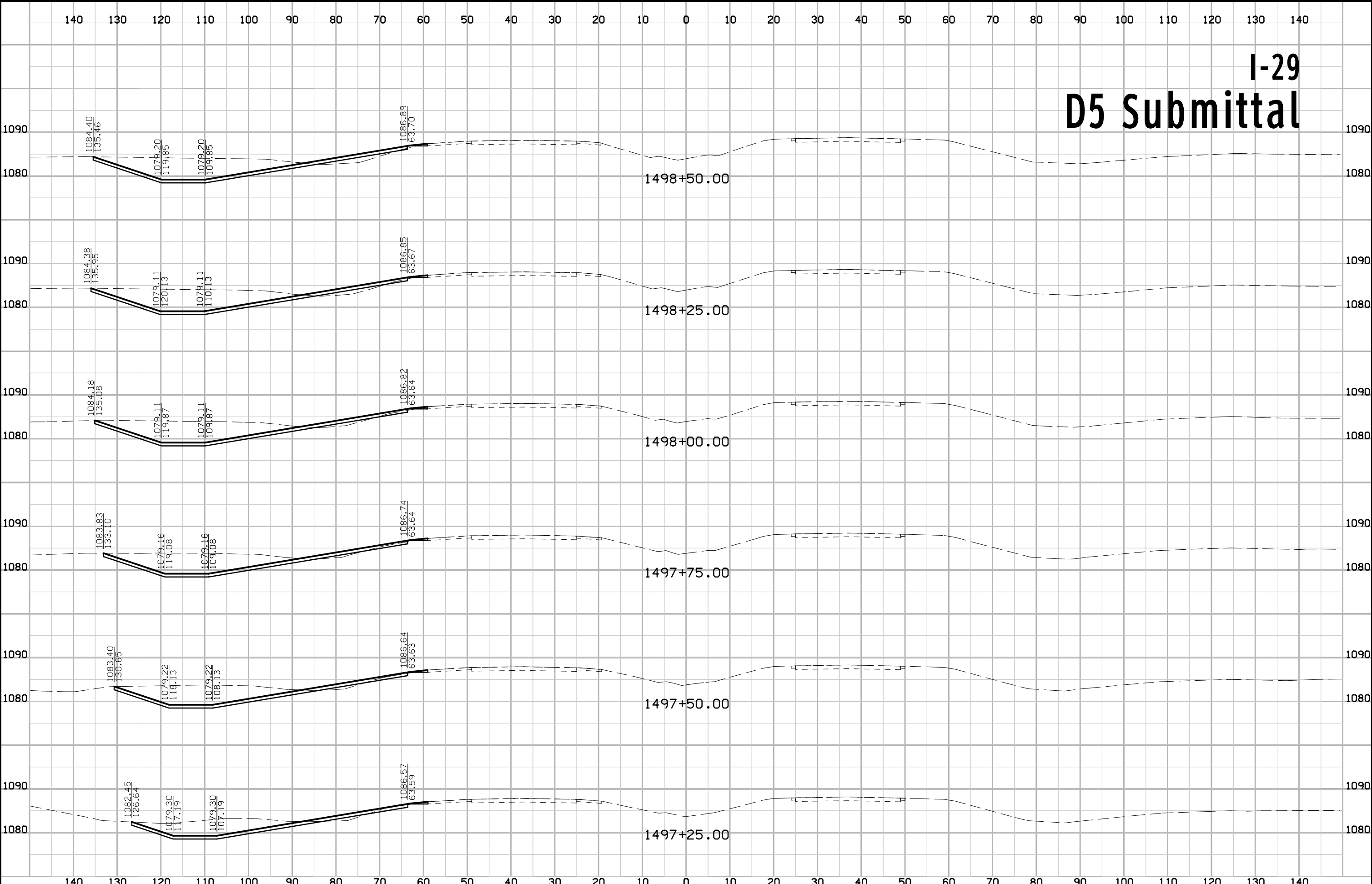

# I-29 D5 Submittal

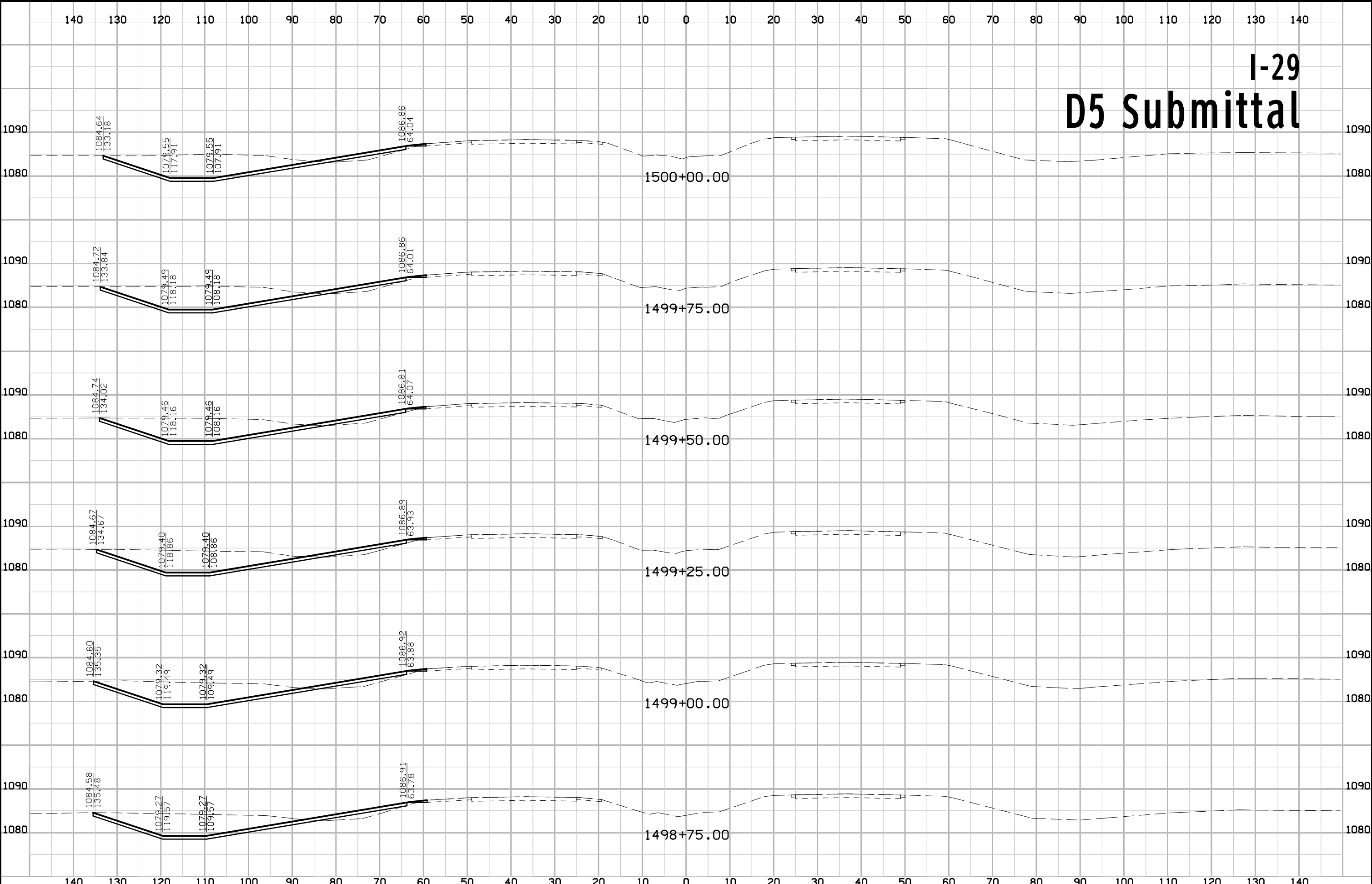

# I-29 D5 Submittal

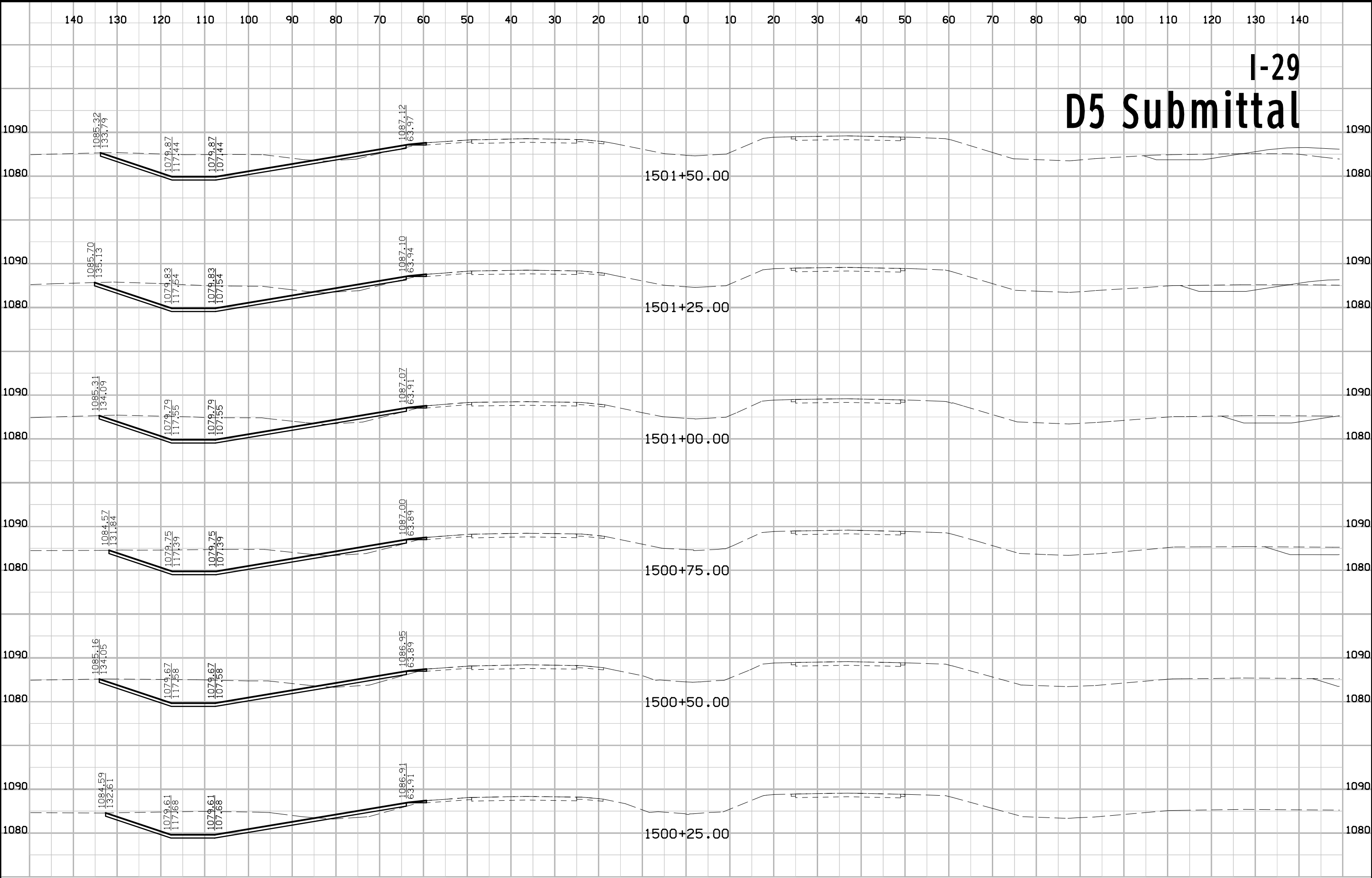

# I-29 D5 Submittal

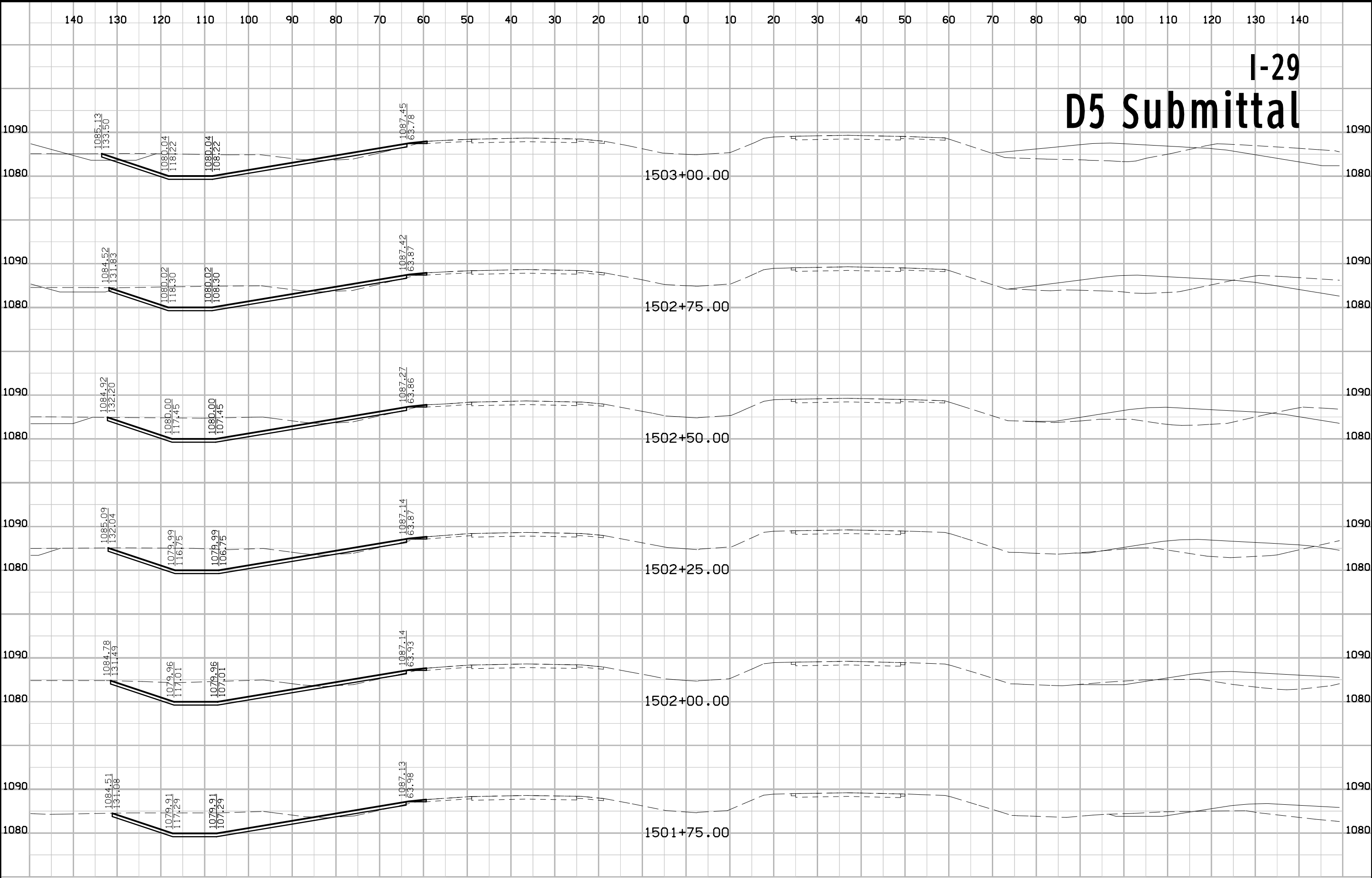

# I-29 D5 Submittal

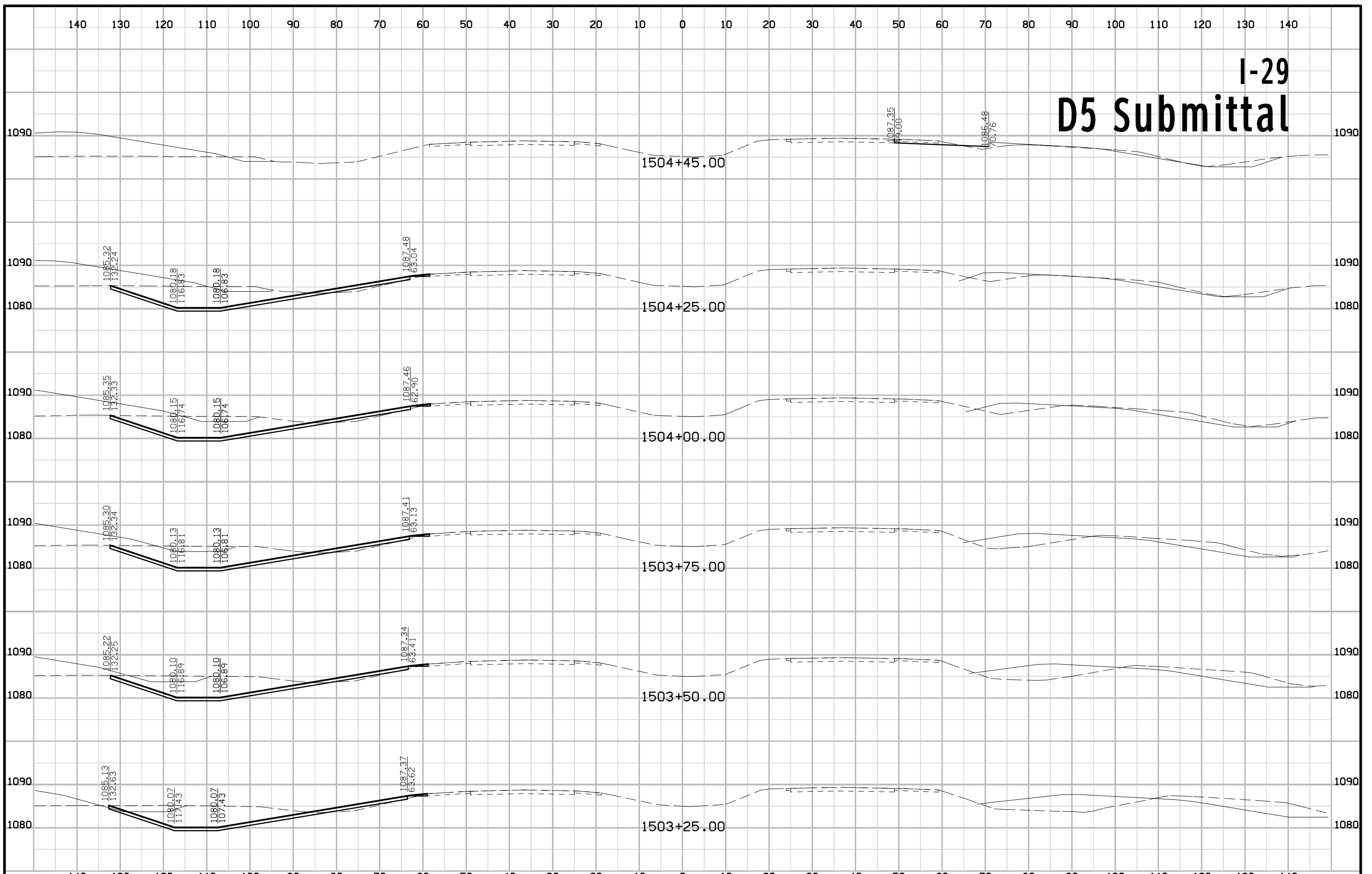



# I-29 D5 Submittal

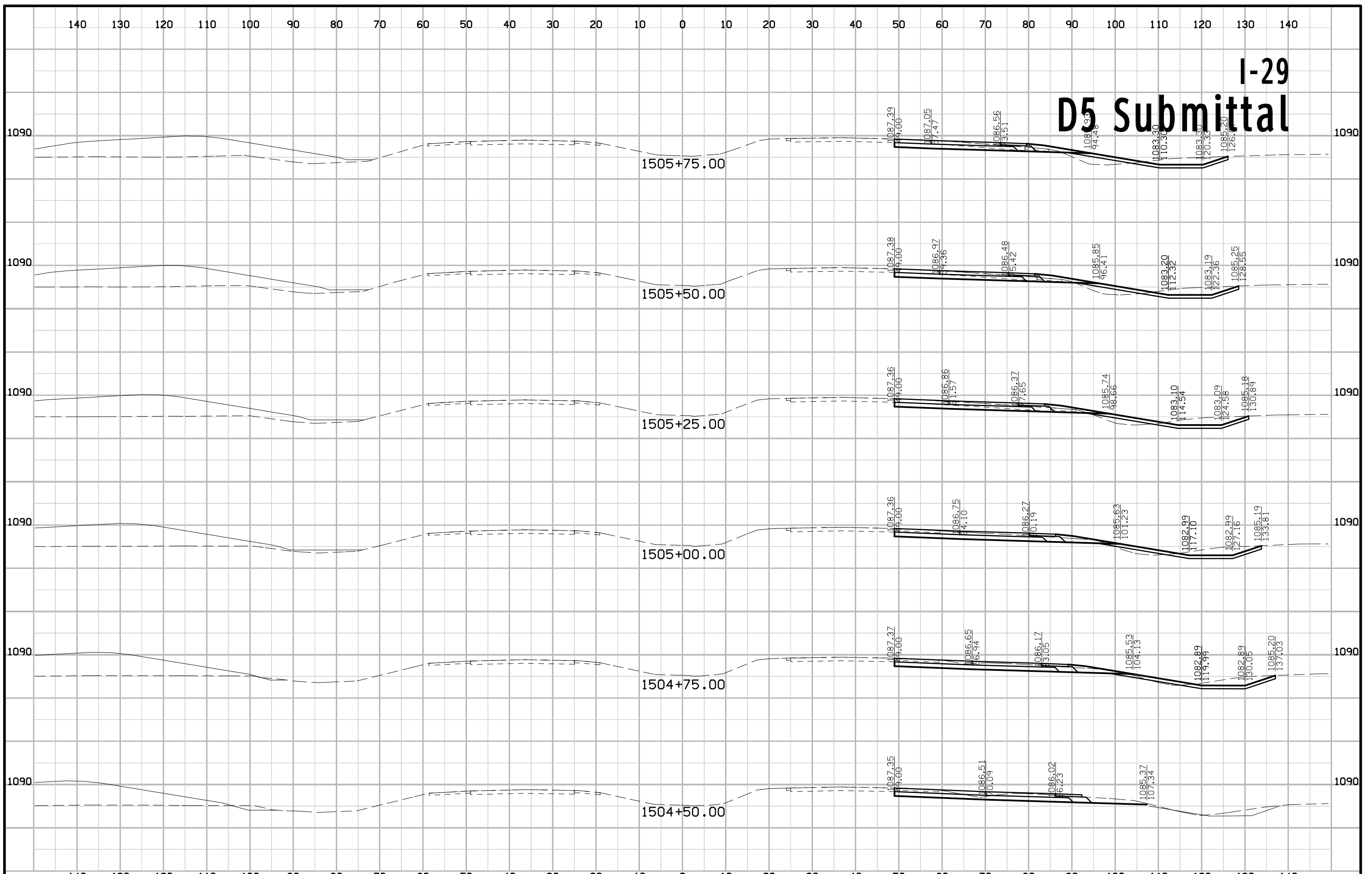

# I-29 D5 Submittal

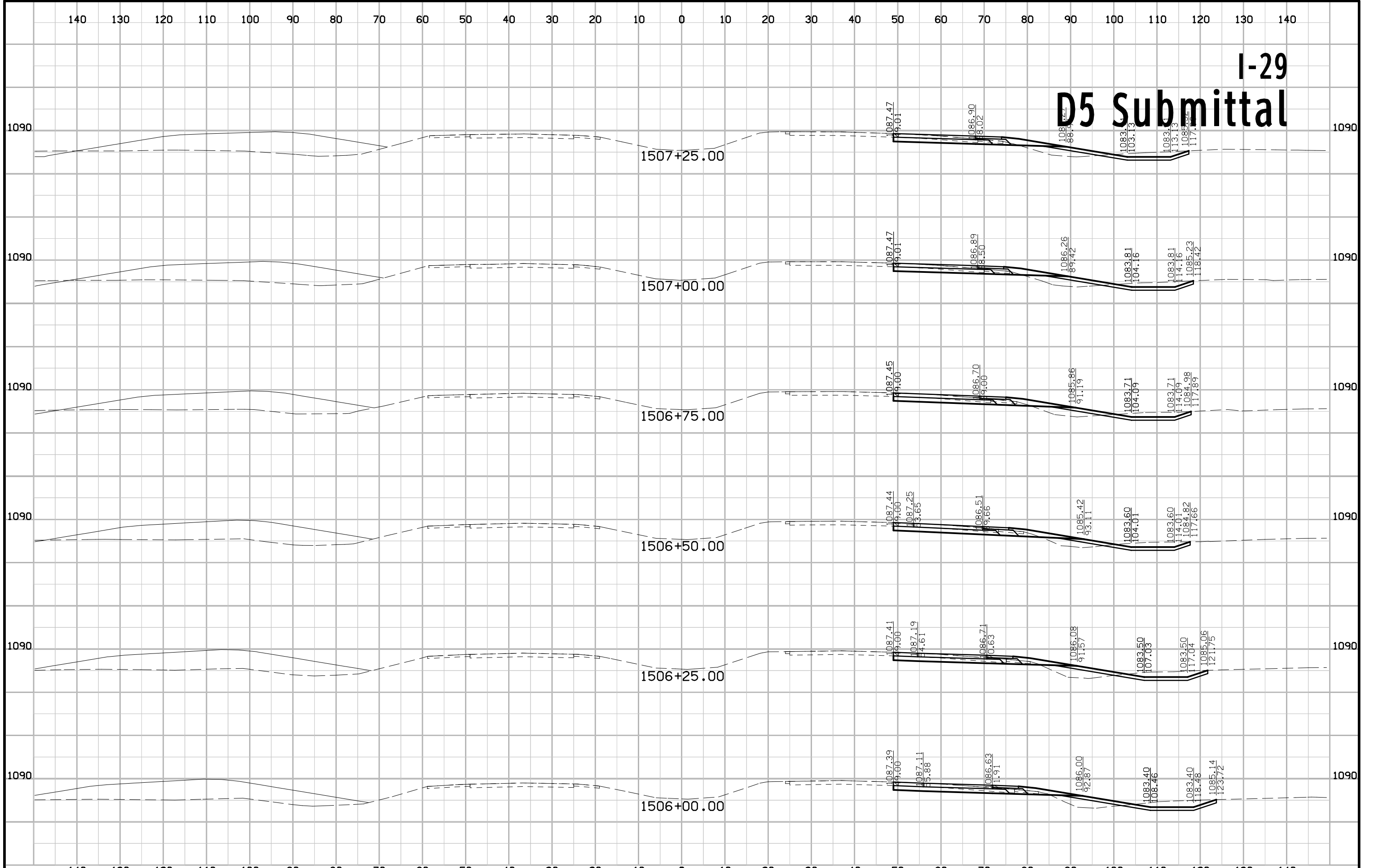

# I-29 D5 Submittal

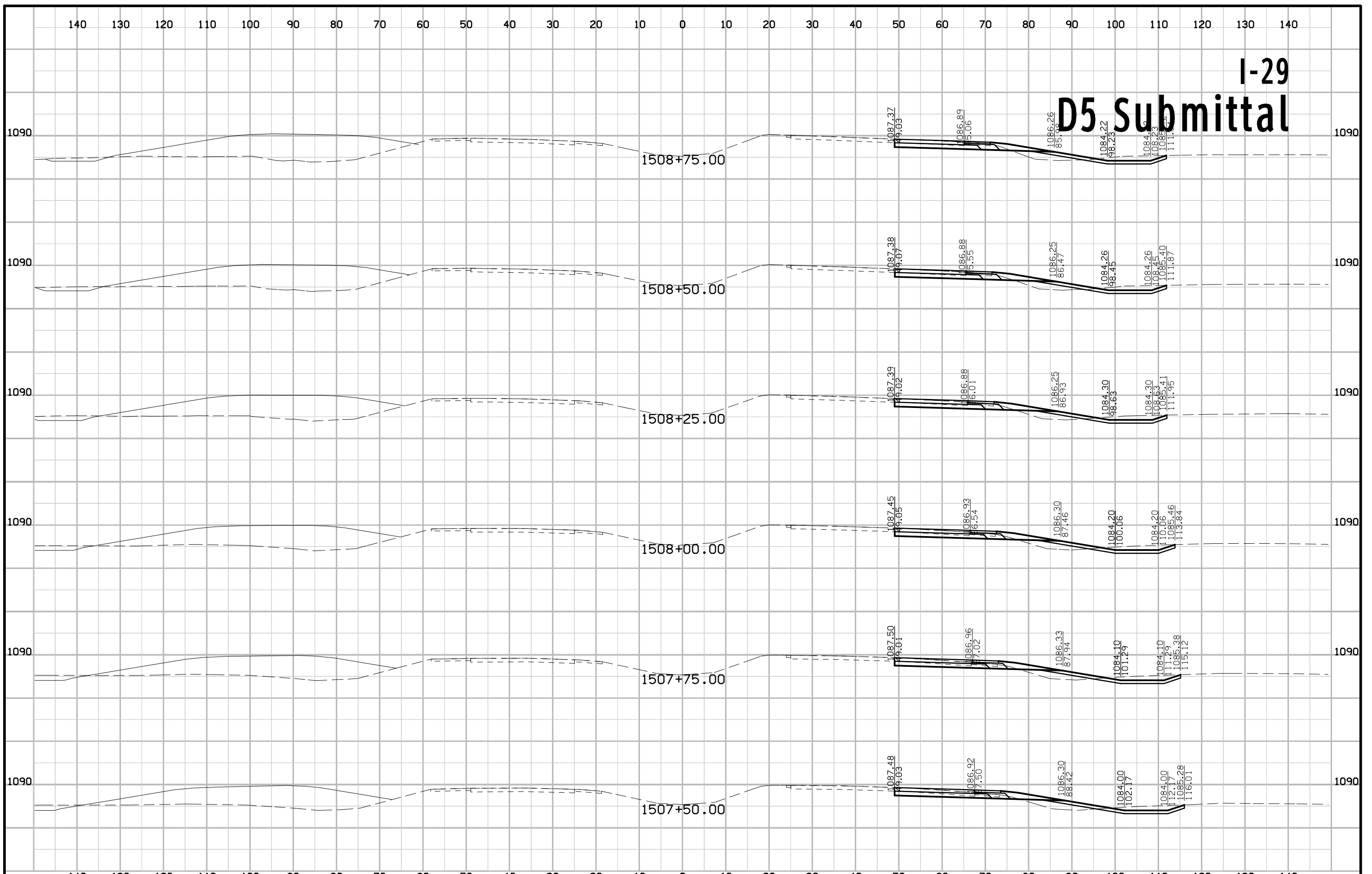

# I-29 D5 Submittal

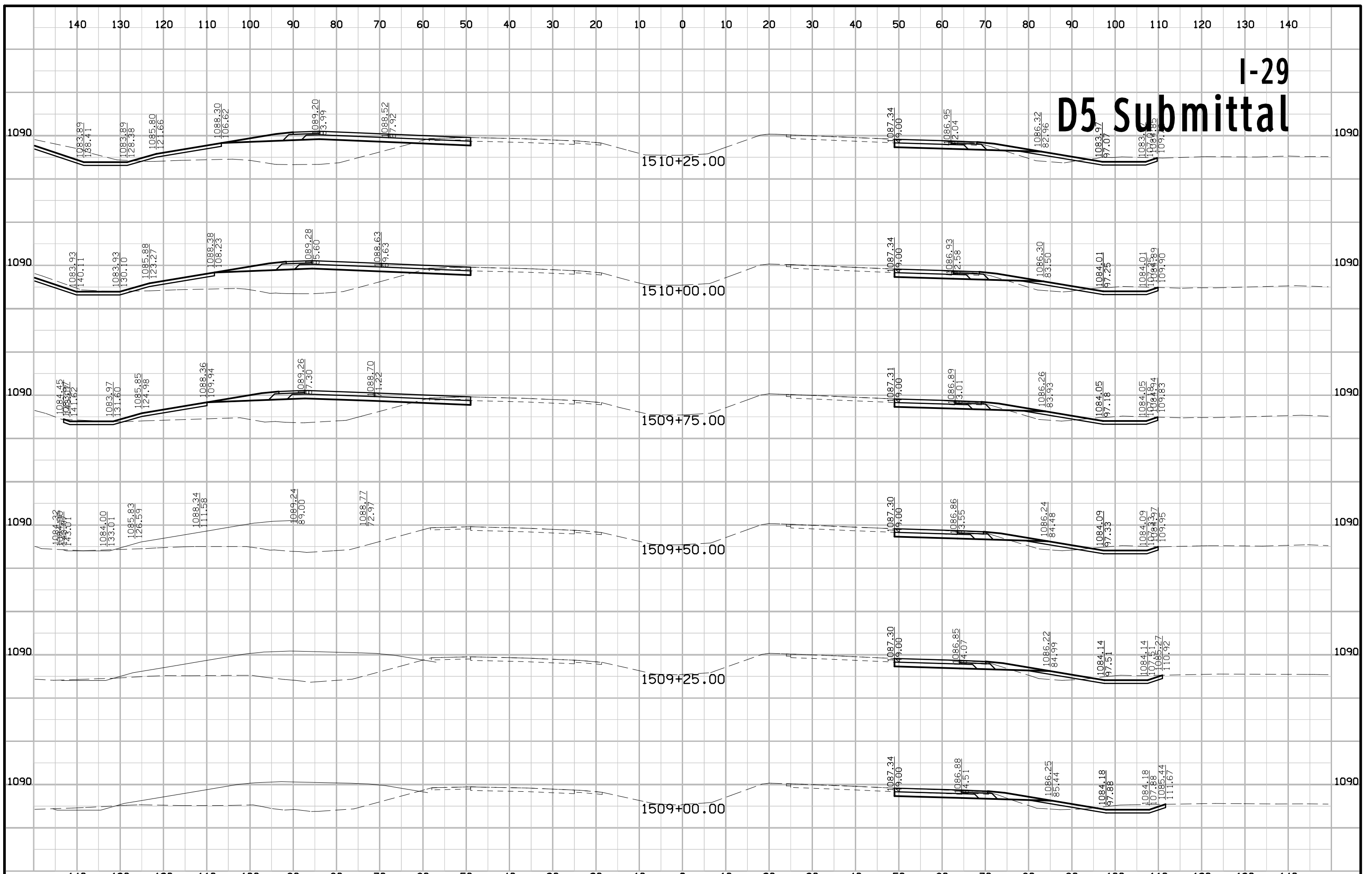

# I-29 D5 Submittal

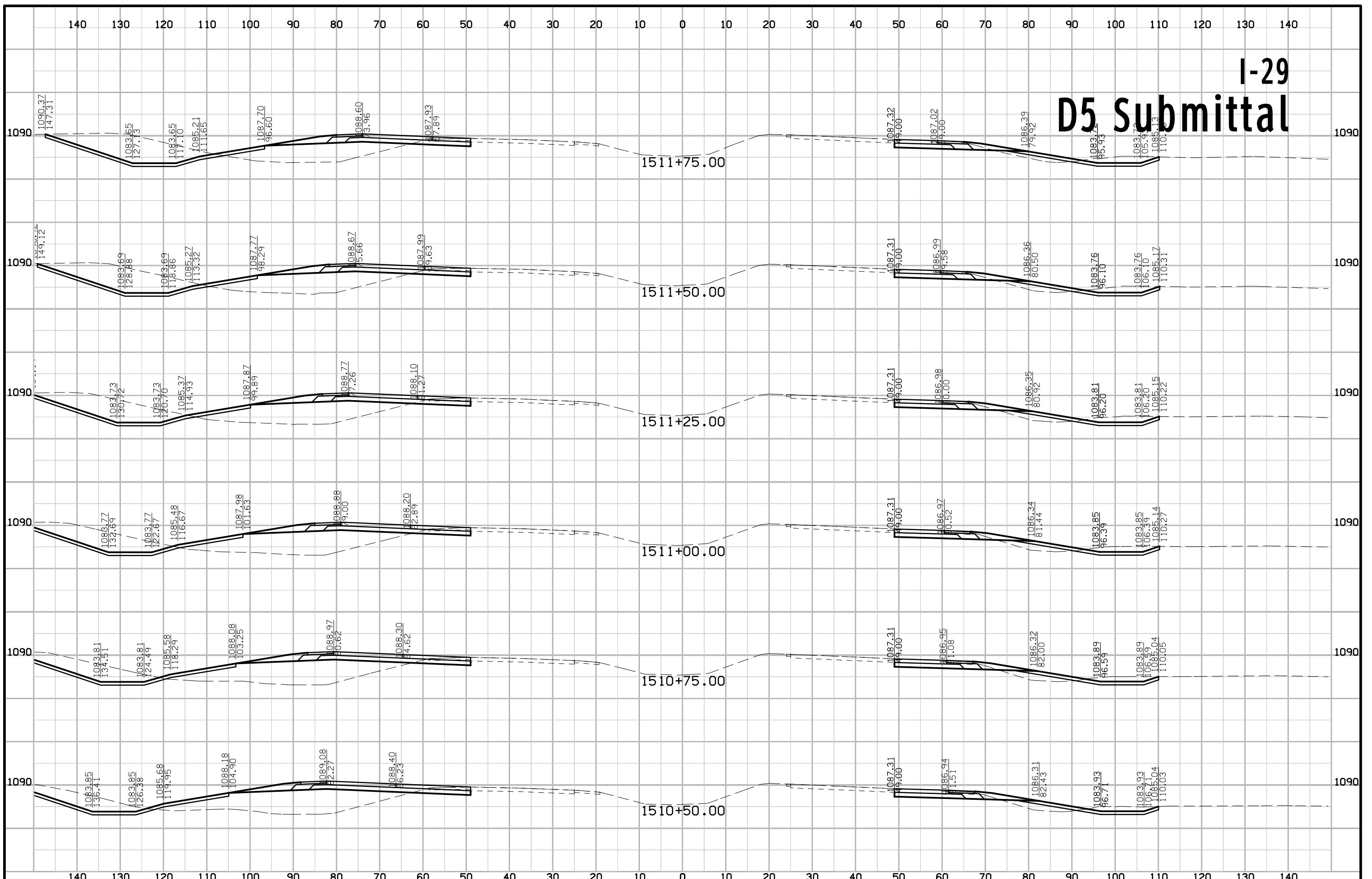

# I-29 D5 Submittal

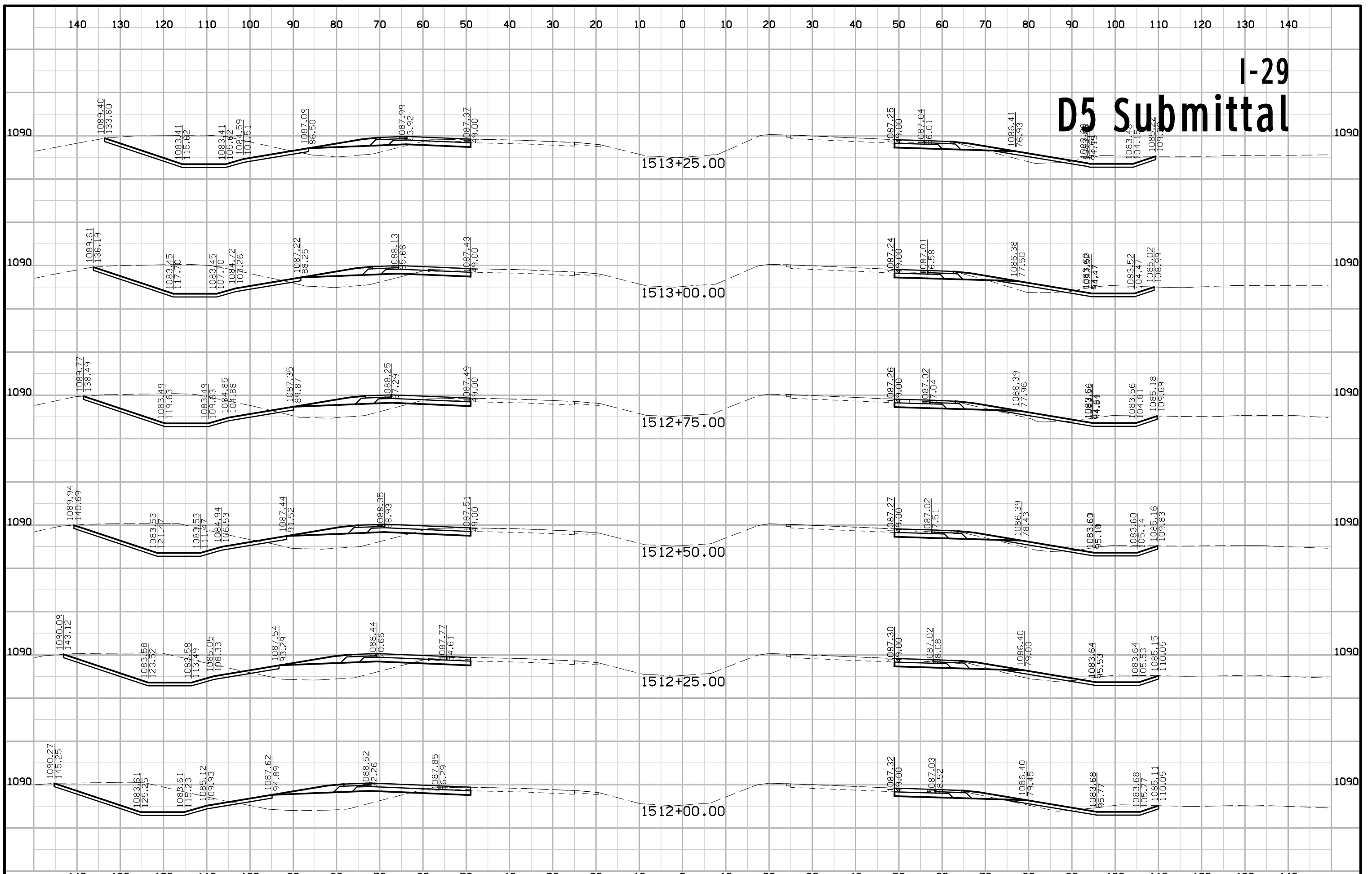

# I-29 D5 Submittal



# I-29 D5 Submittal

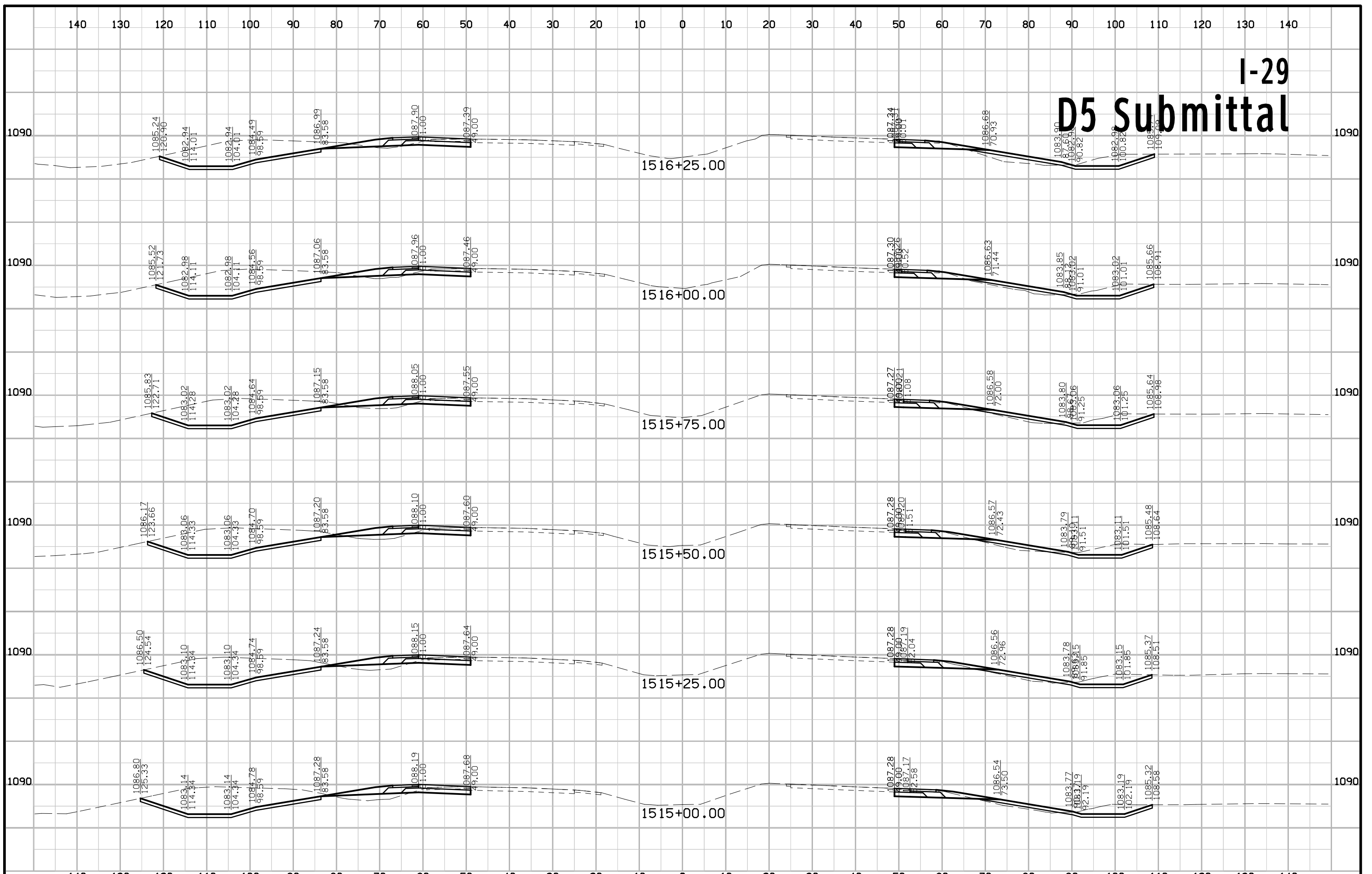



# I-29 D5 Submittal

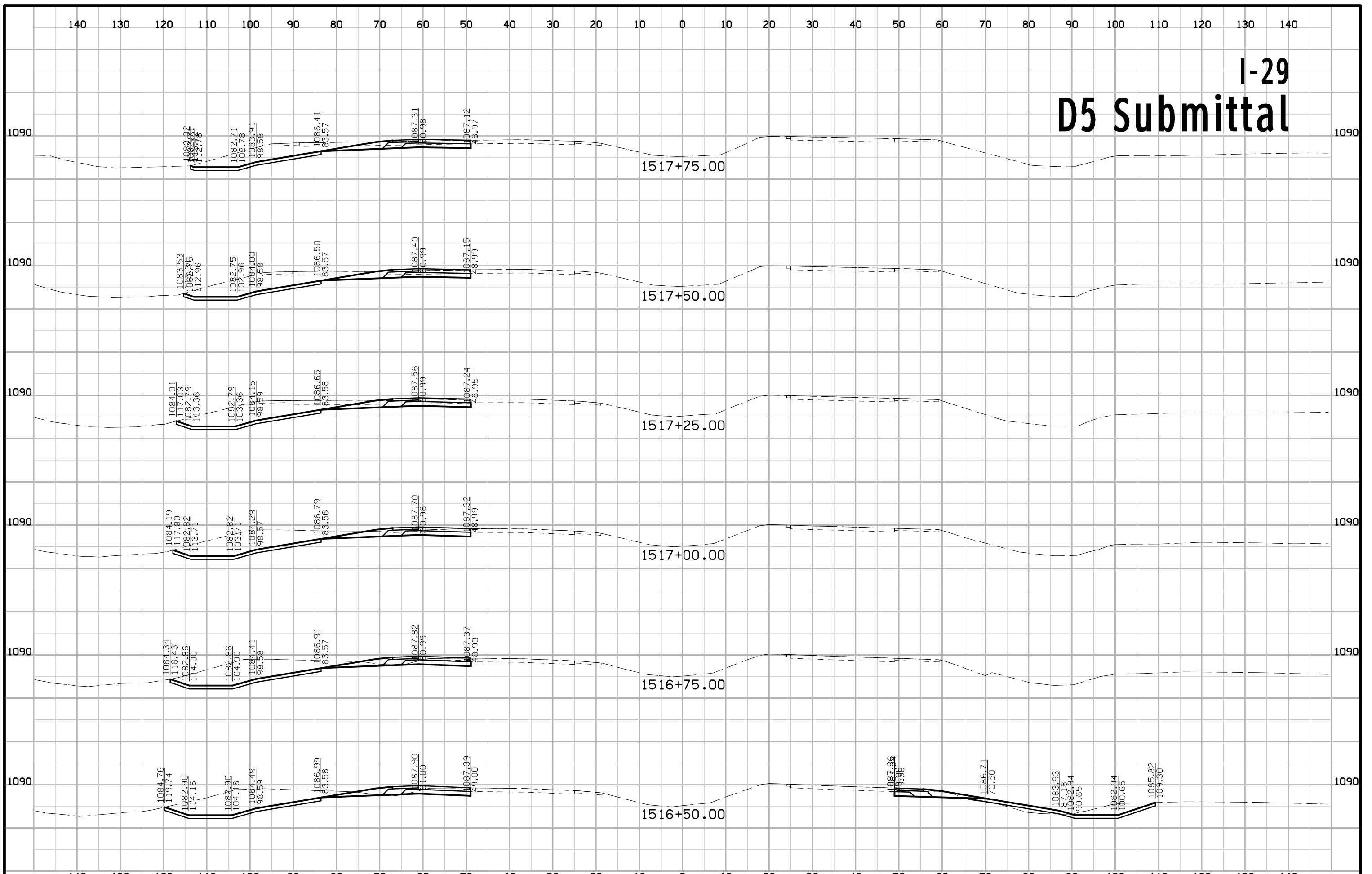

# I-29 D5 Submittal

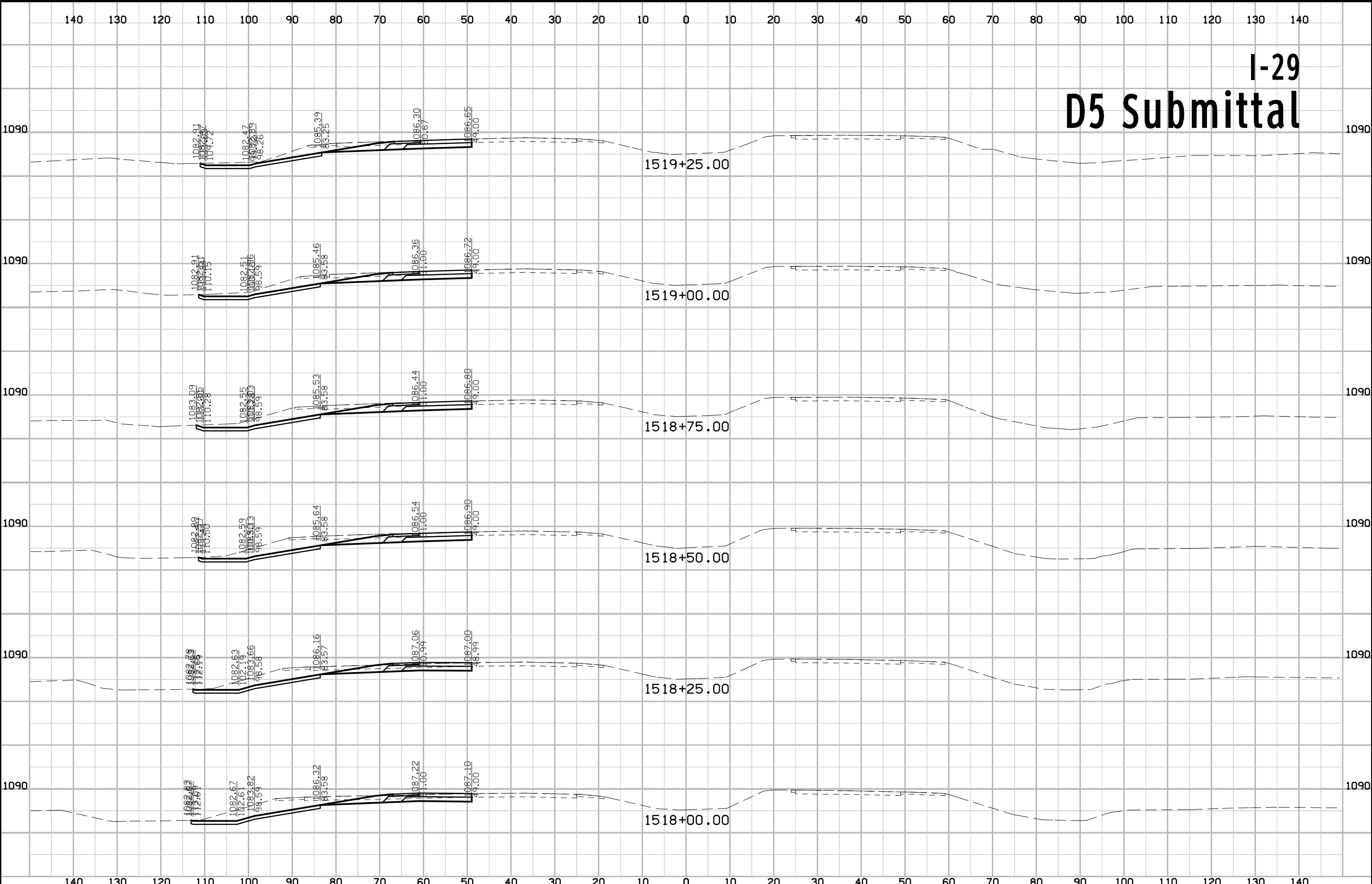

# I-29 D5 Submittal

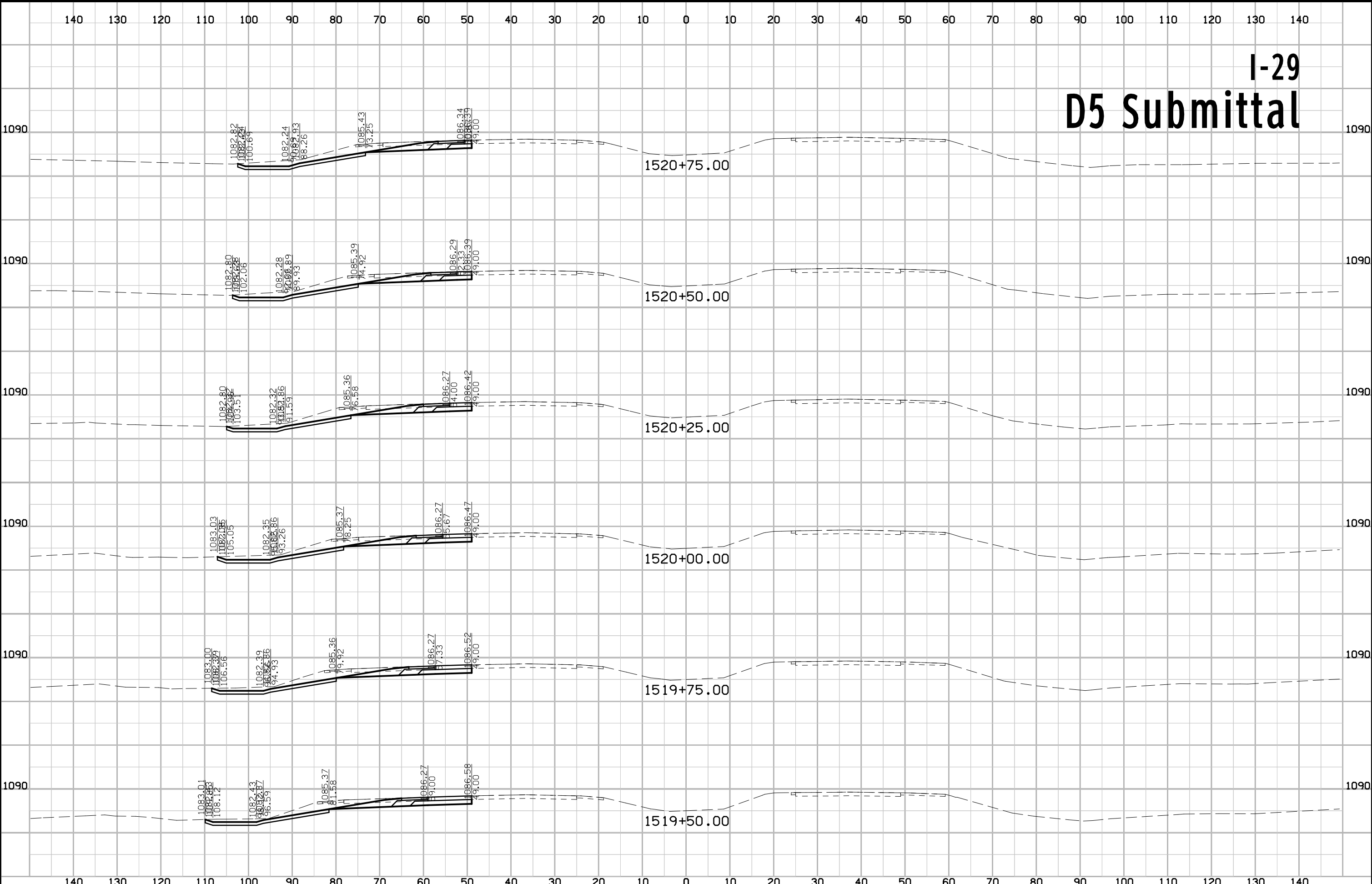

# I-29 D5 Submittal

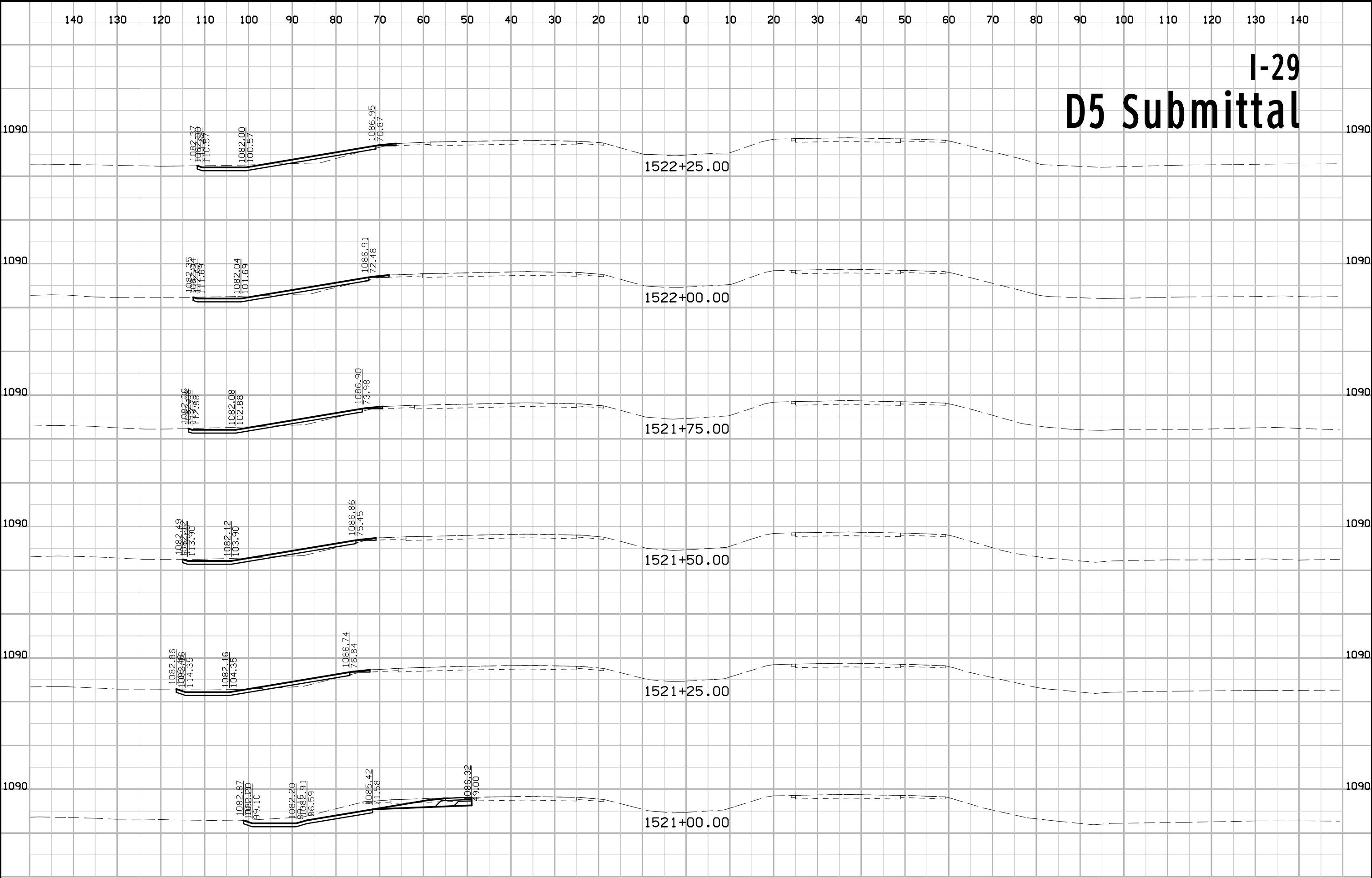

# I-29 D5 Submittal

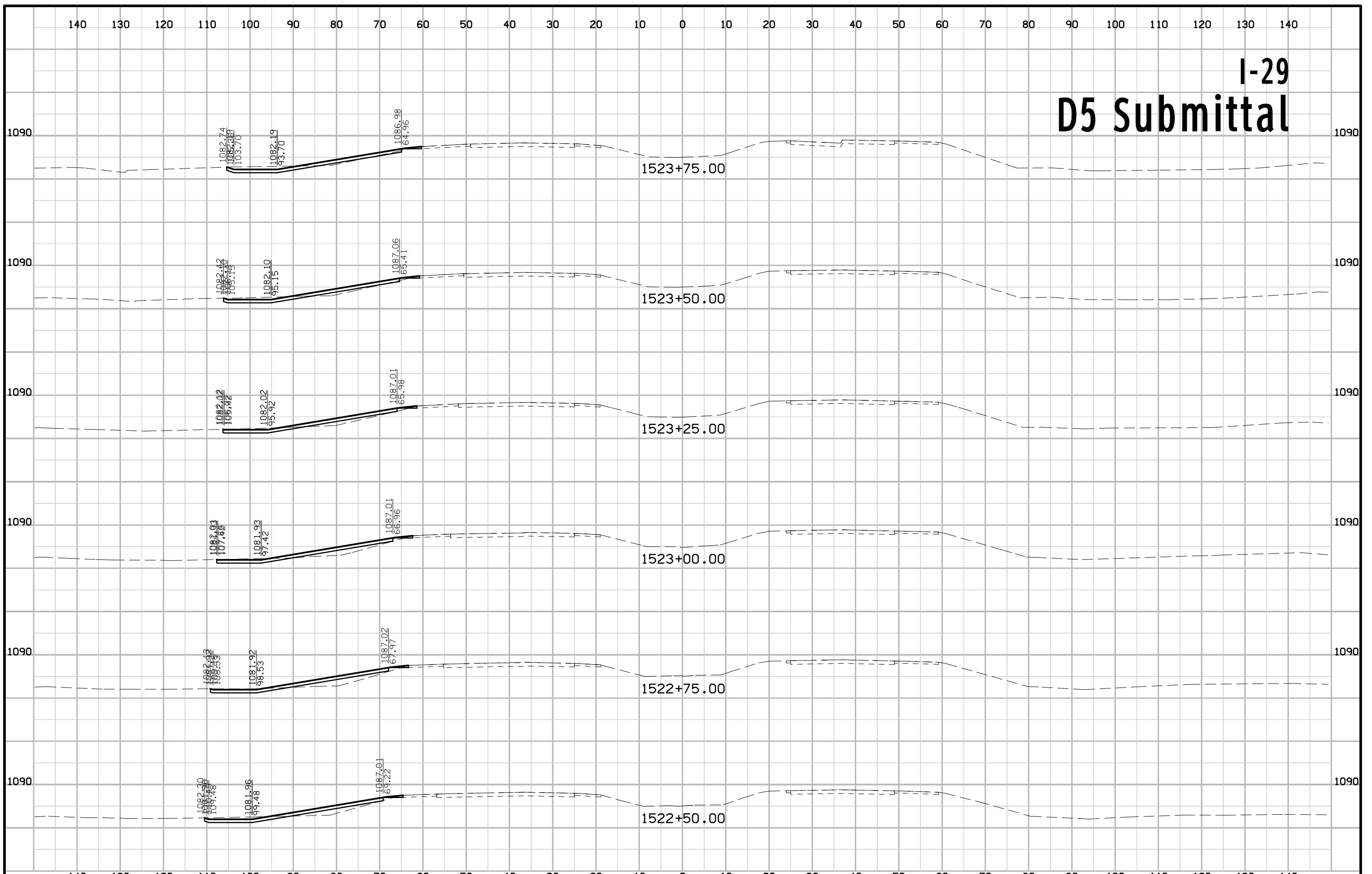

# I-29 D5 Submittal

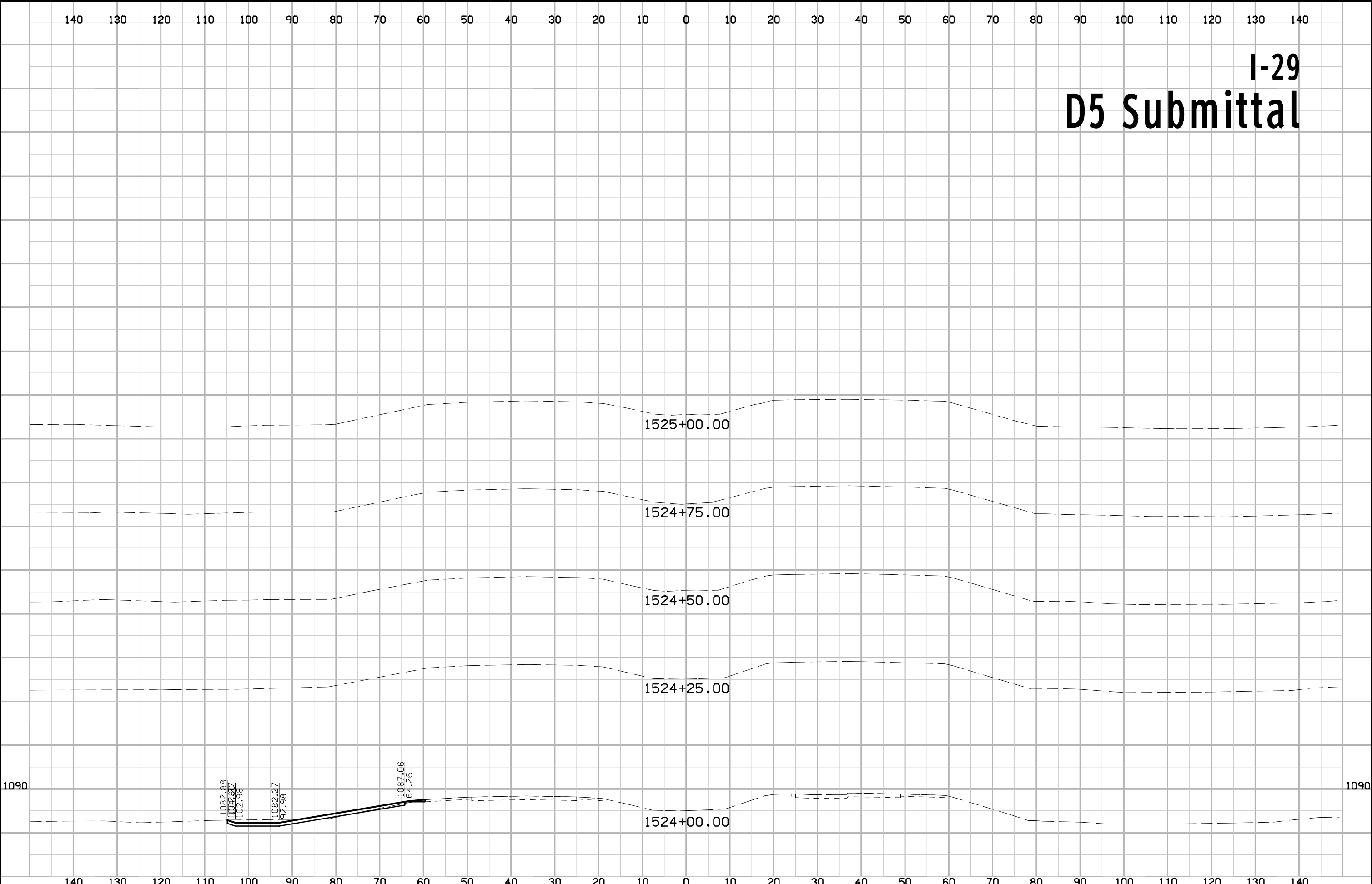

# D51/260th St. D5 Submittal

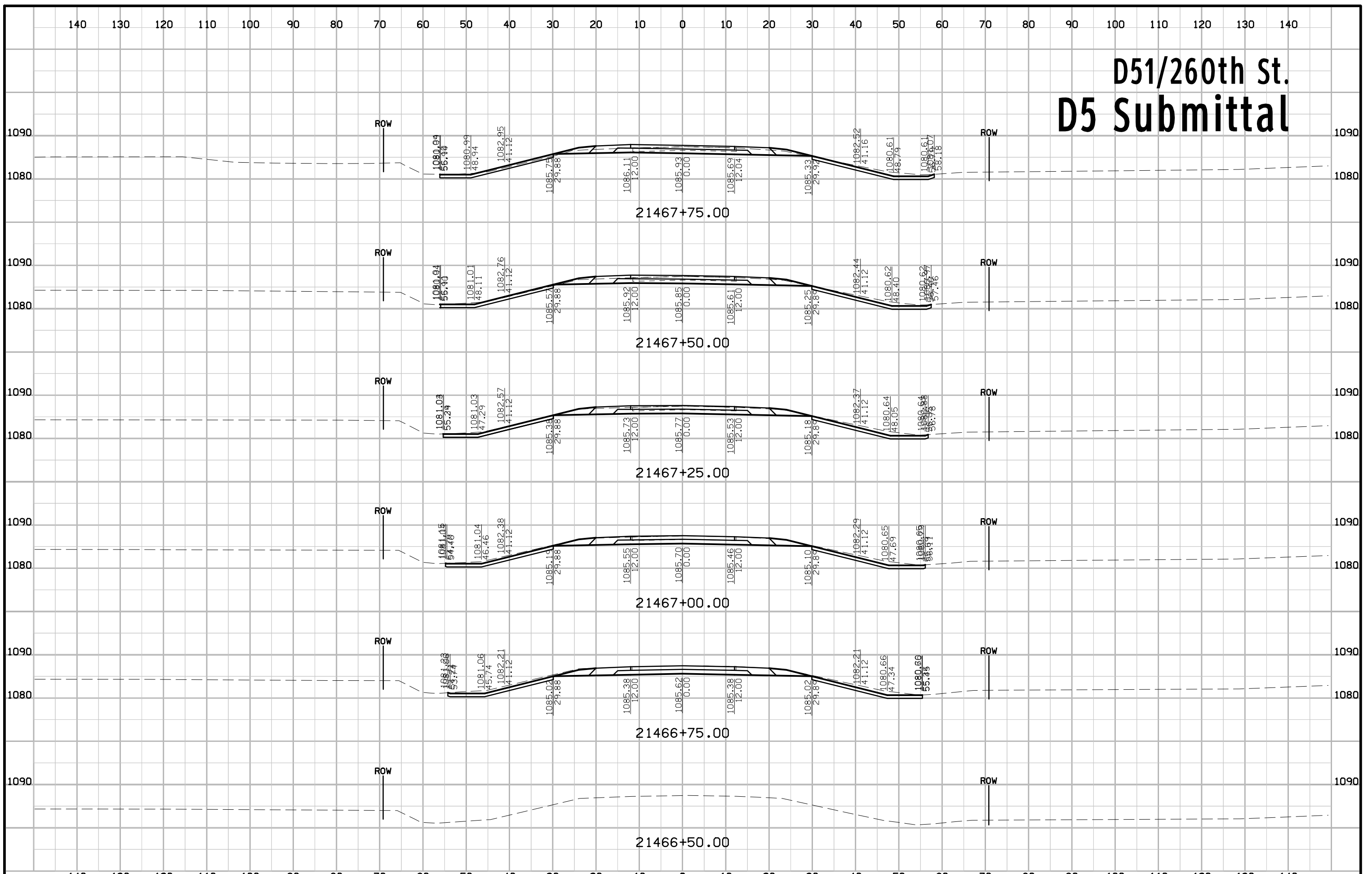

# D51/260th St. D5 Submittal

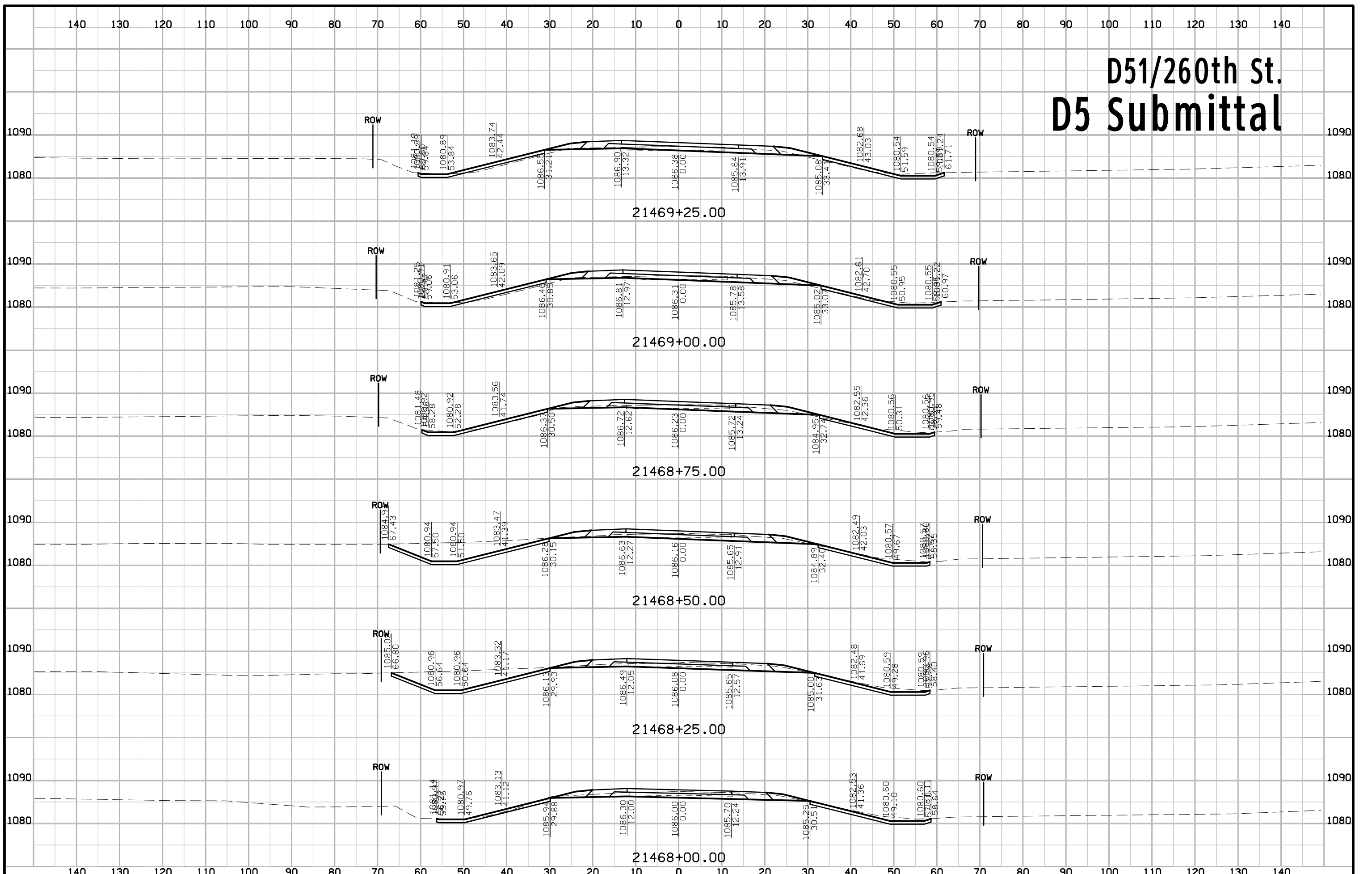



# D51/260th St. D5 Submittal

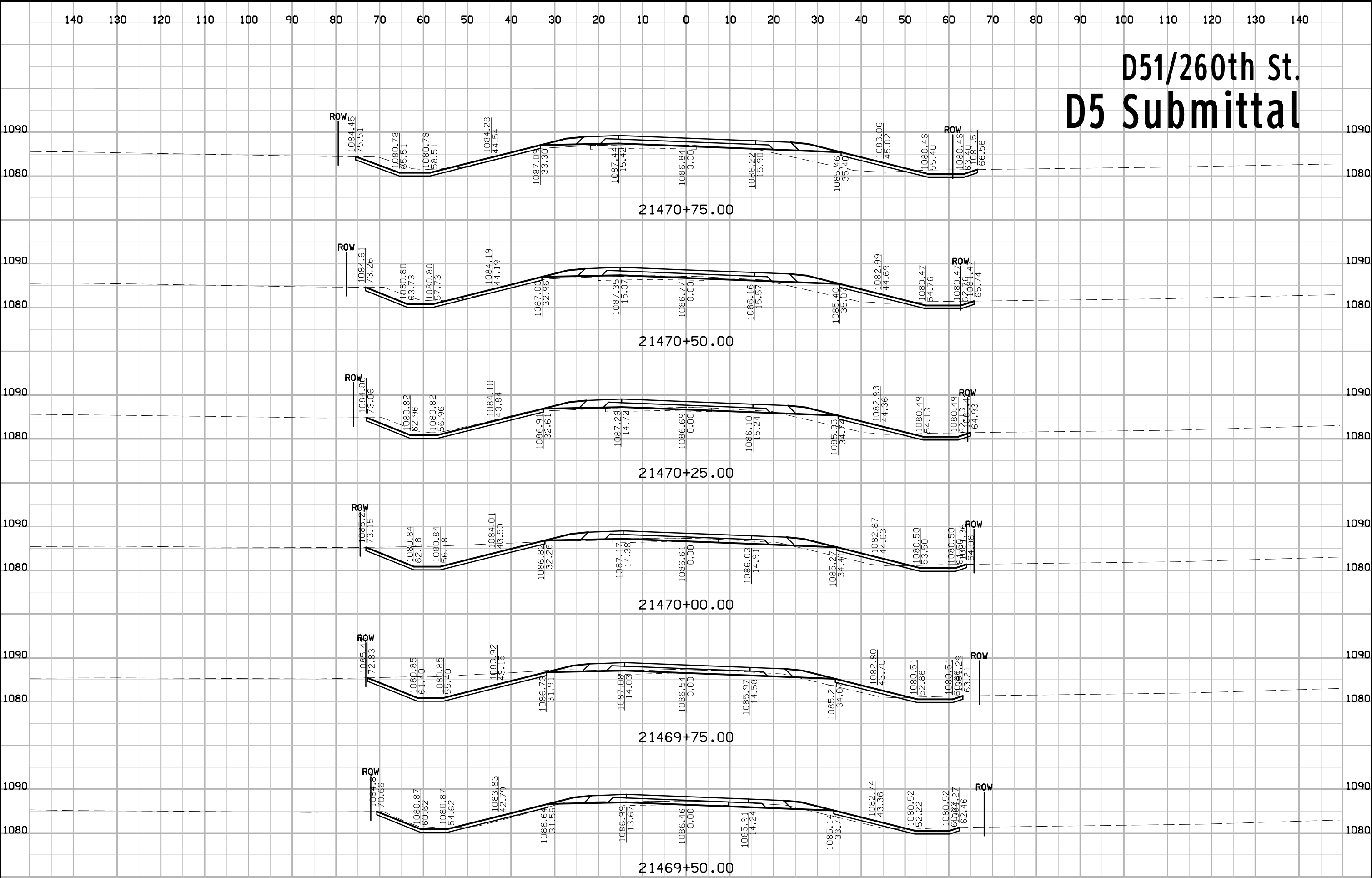

# D51/260th St. D5 Submittal

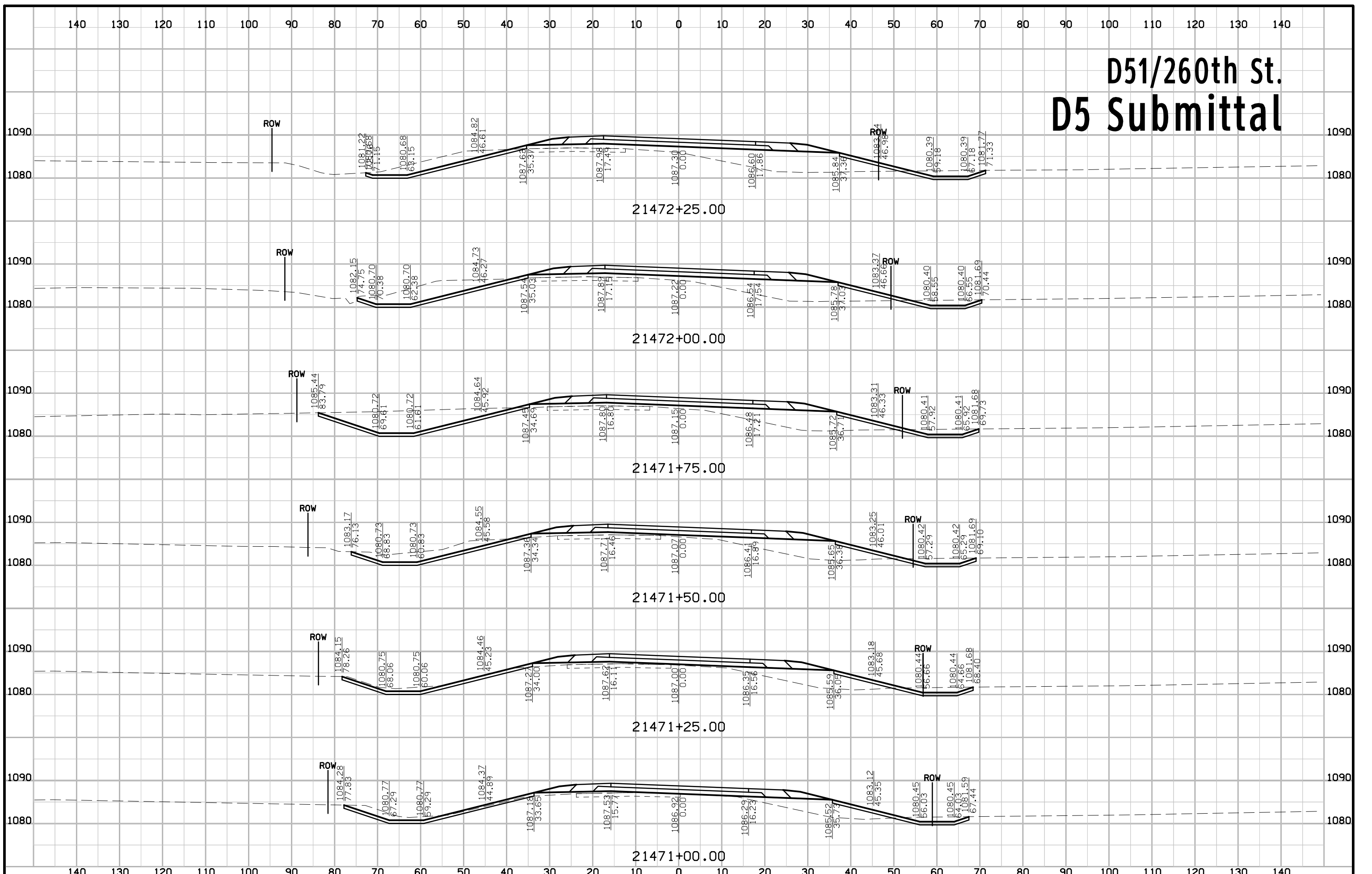

# D51/260th St. D5 Submittal

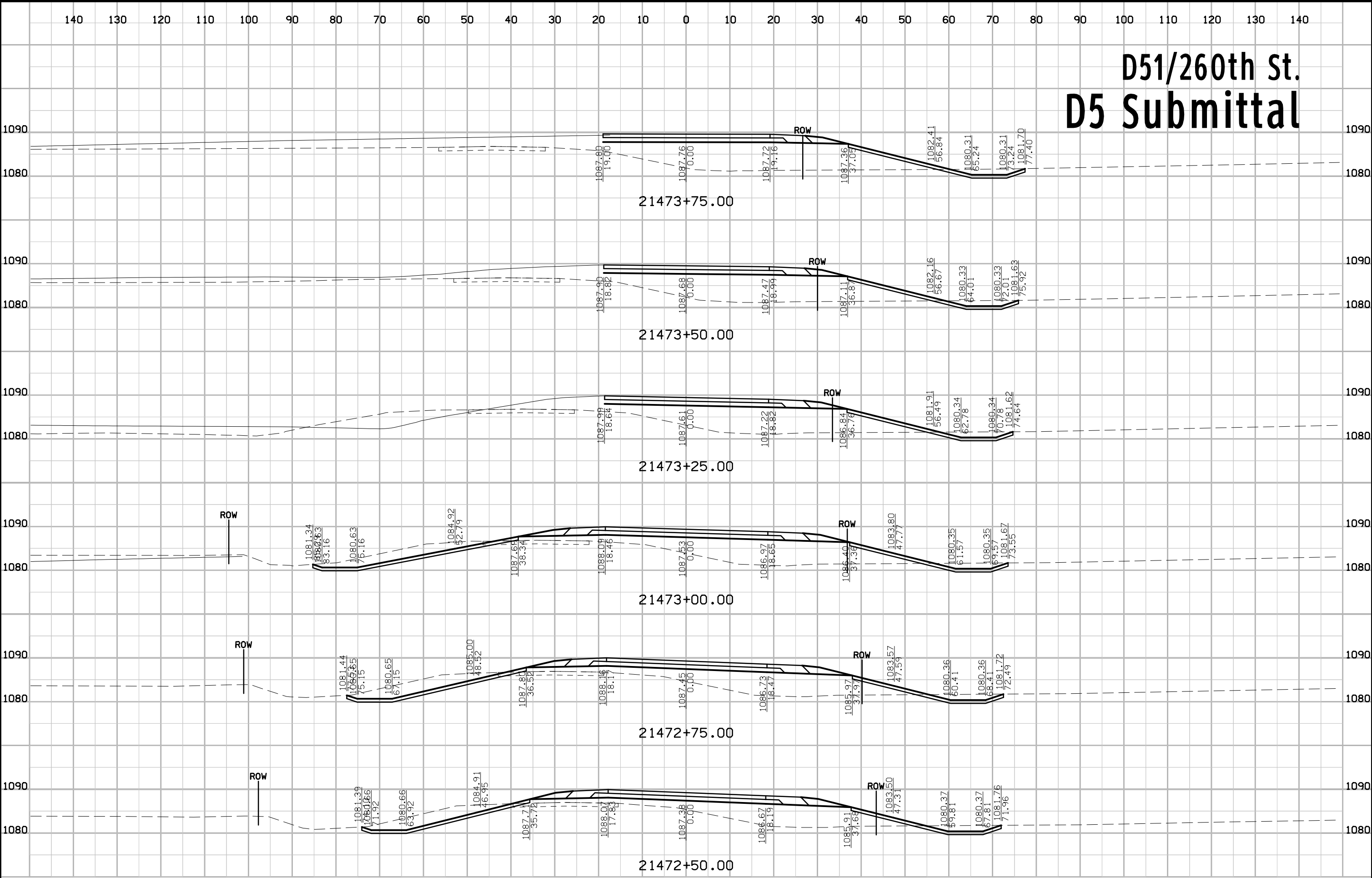

# D51/260th St. D5 Submittal

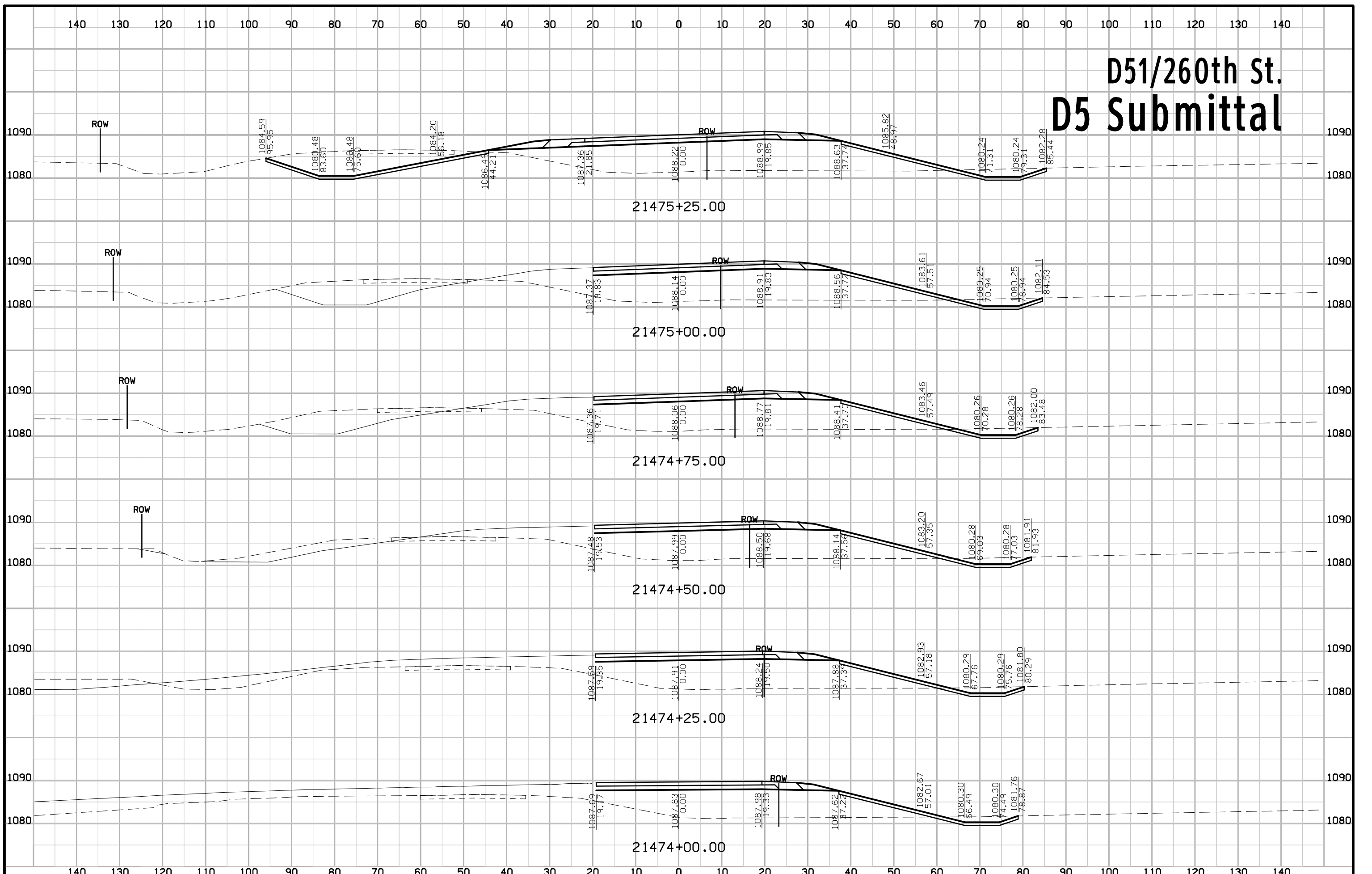

# D51/260th St. D5 Submittal

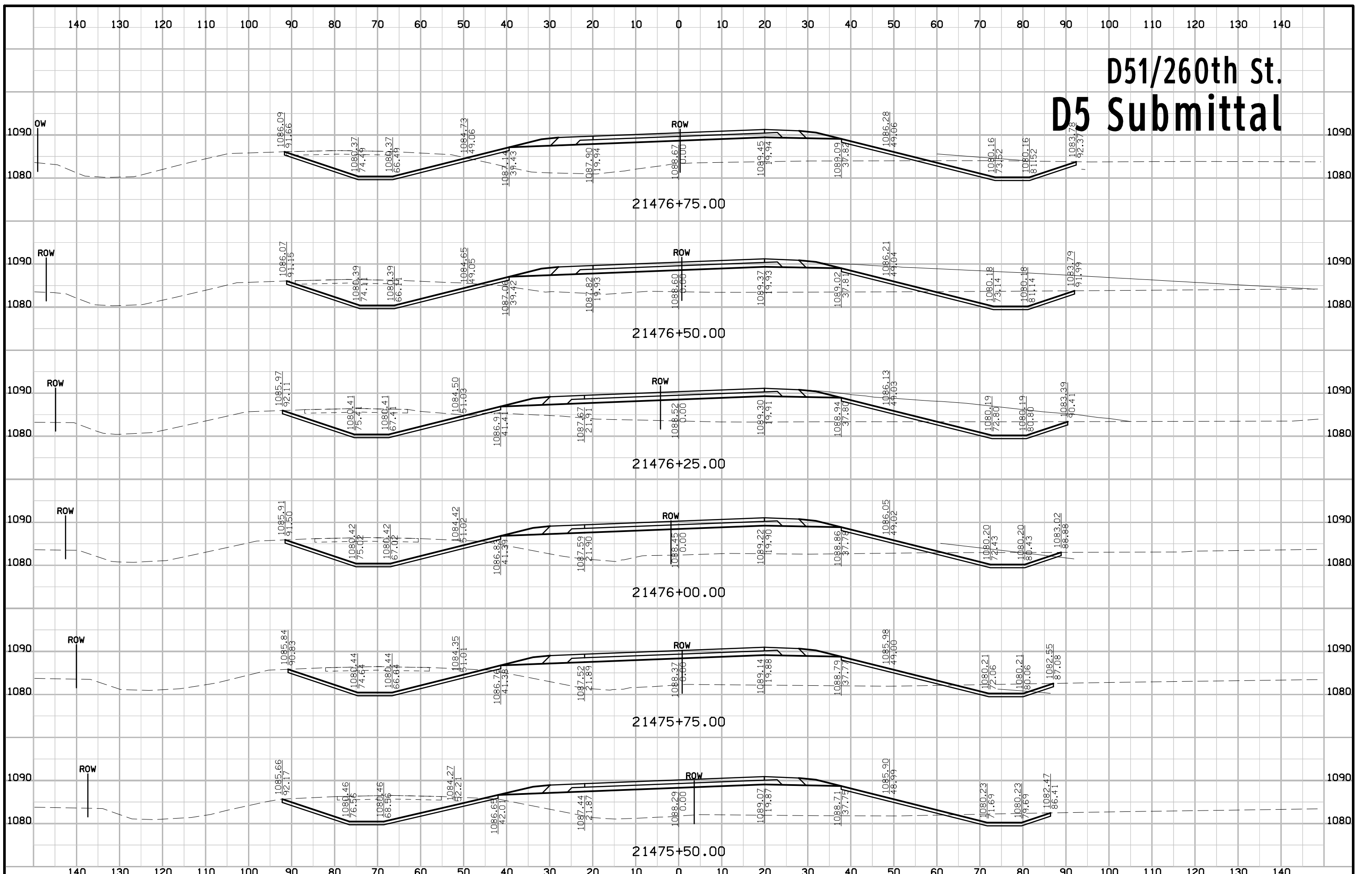

# D51/260th St. D5 Submittal

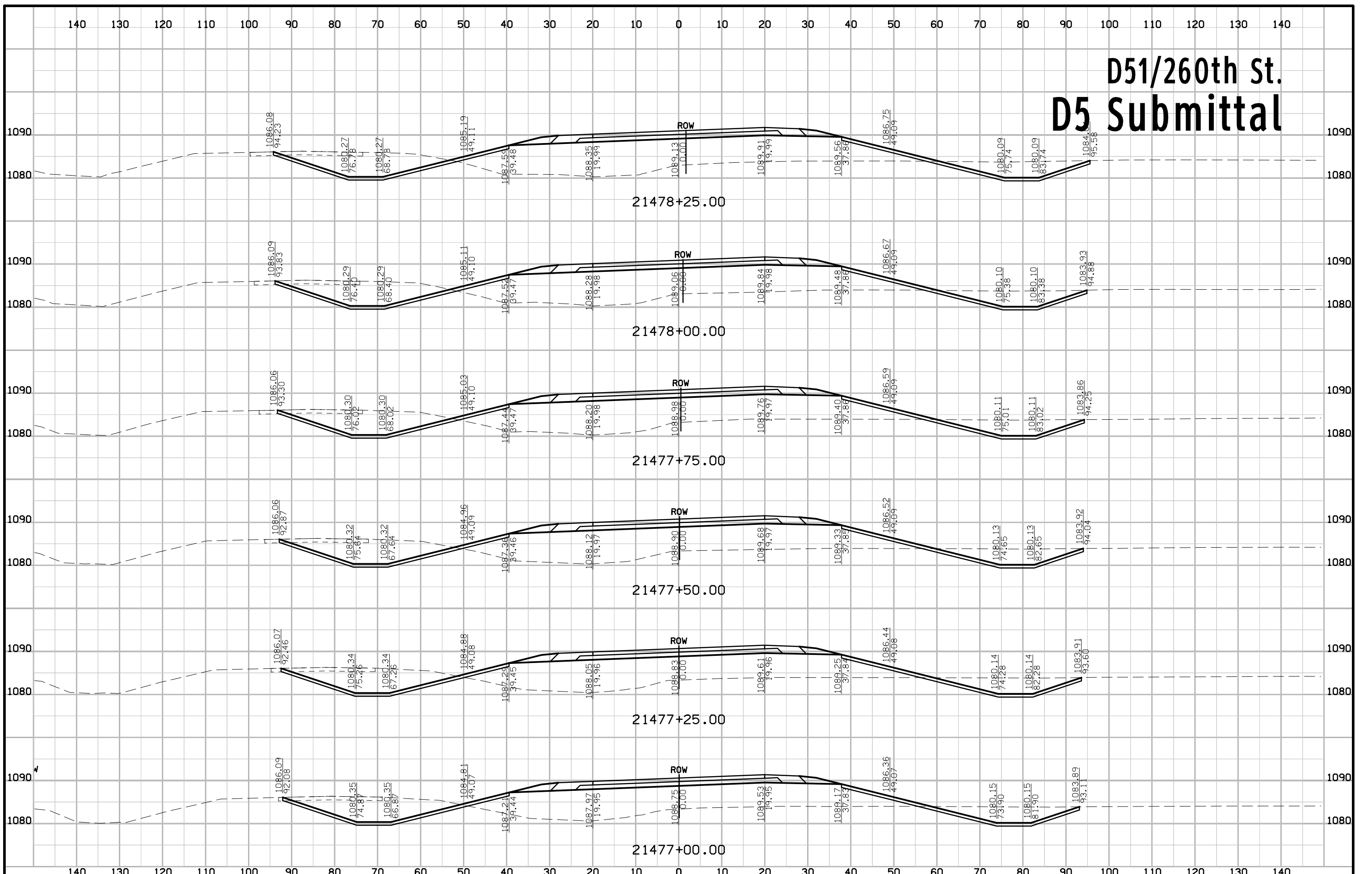

# D51/260th St. D5 Submittal

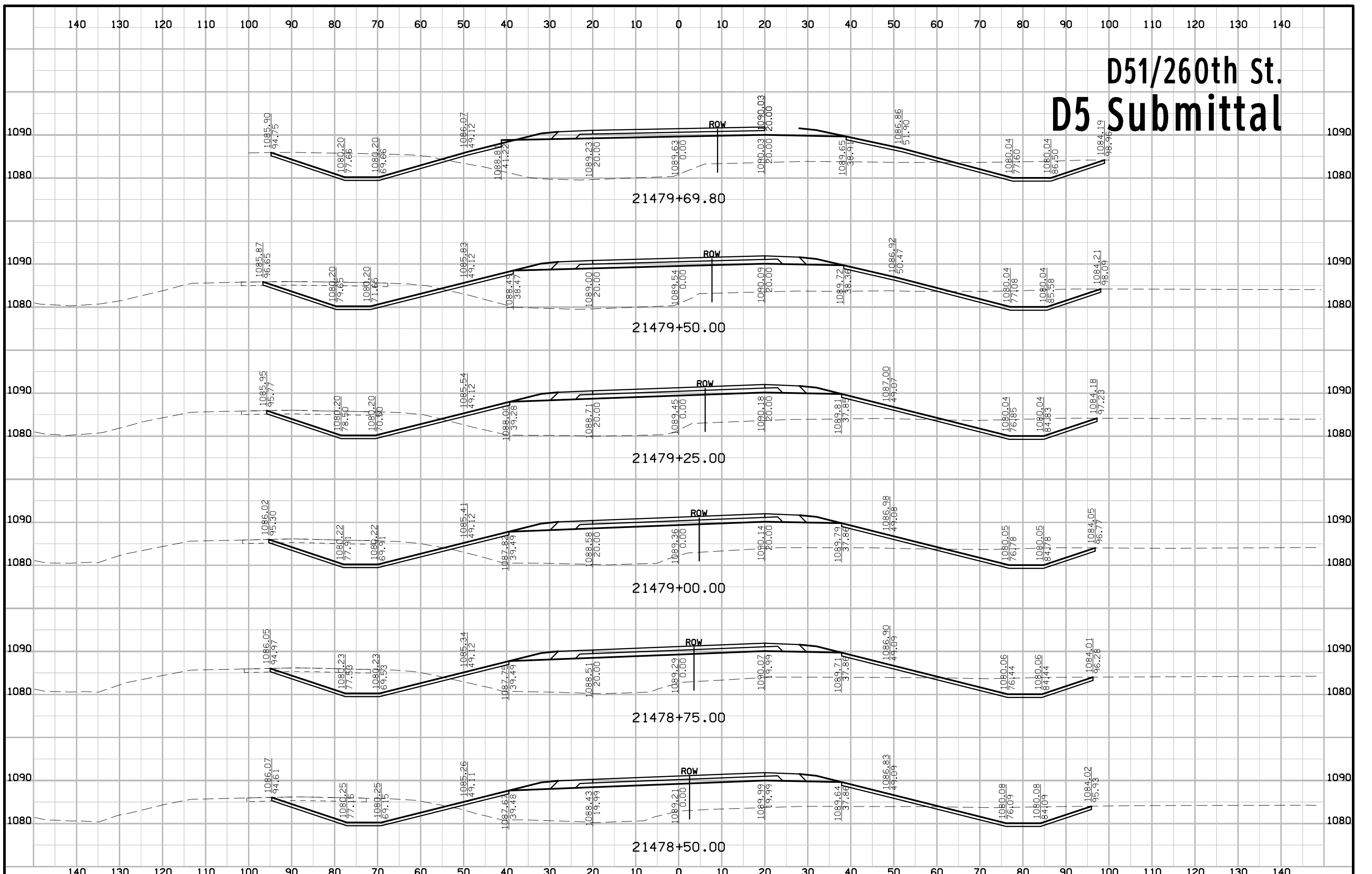

# D51/260th St. D5 Submittal

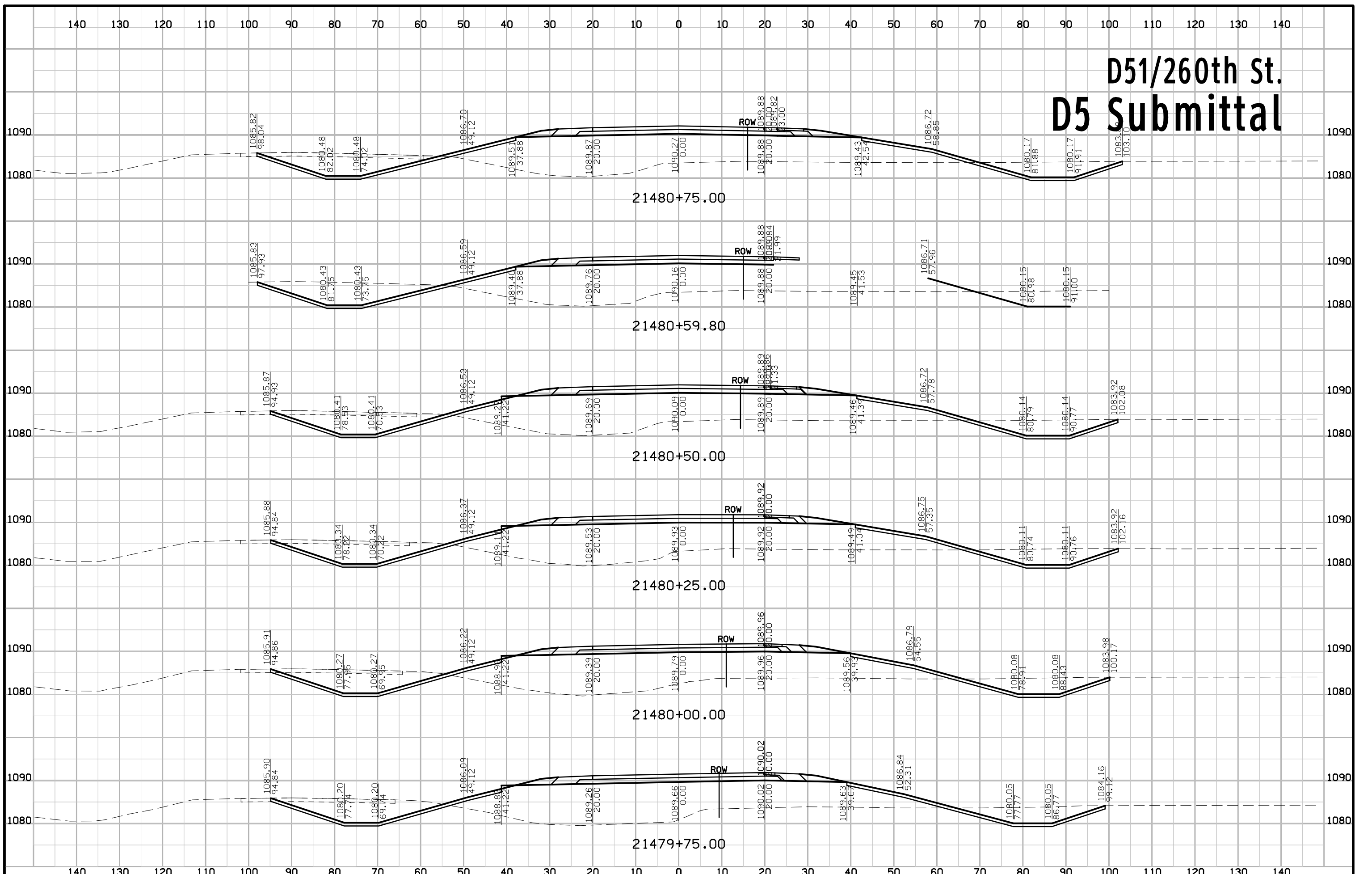



# D51/260th St. D5 Submittal

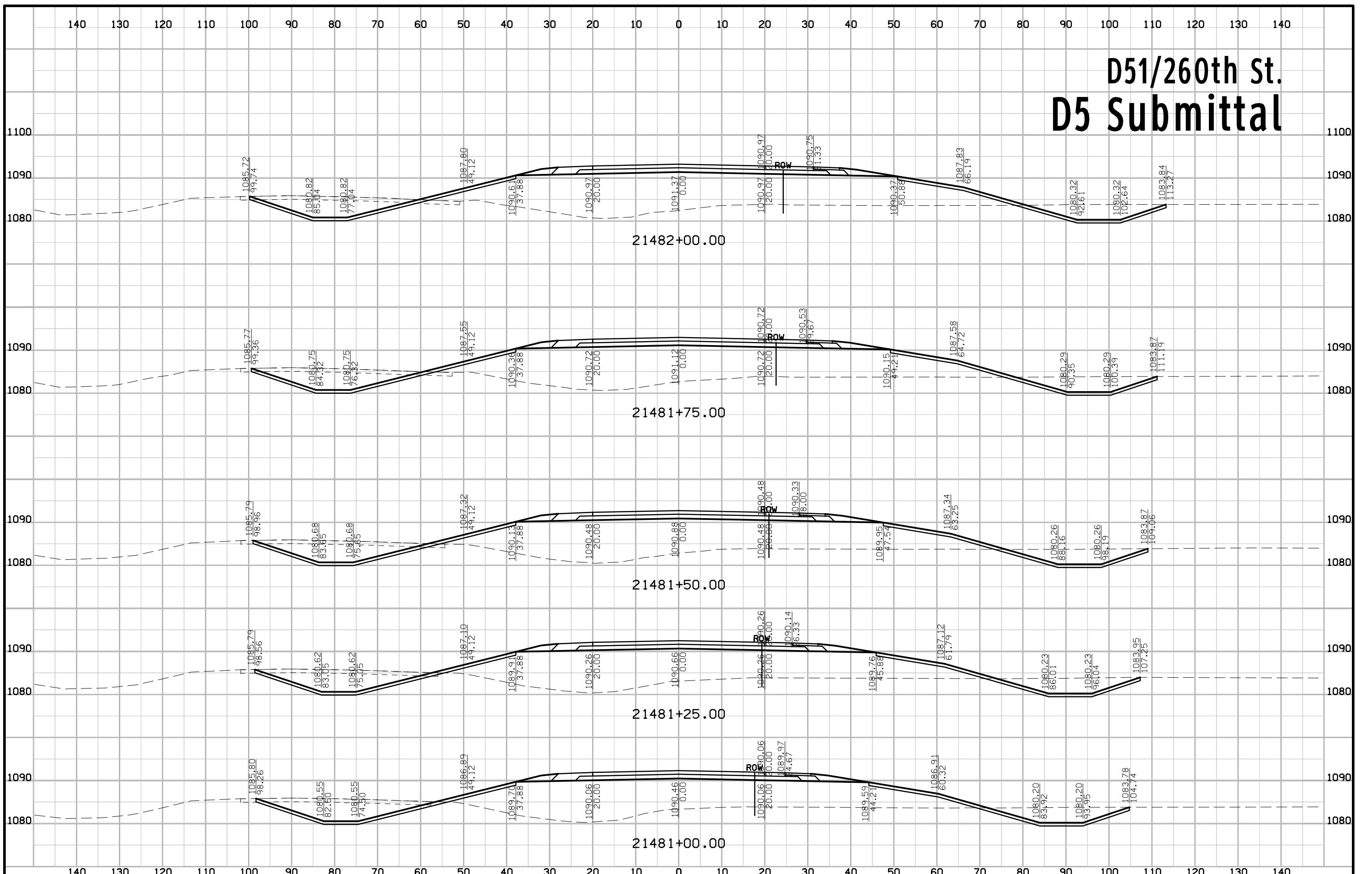

# D51/260th St. D5 Submittal

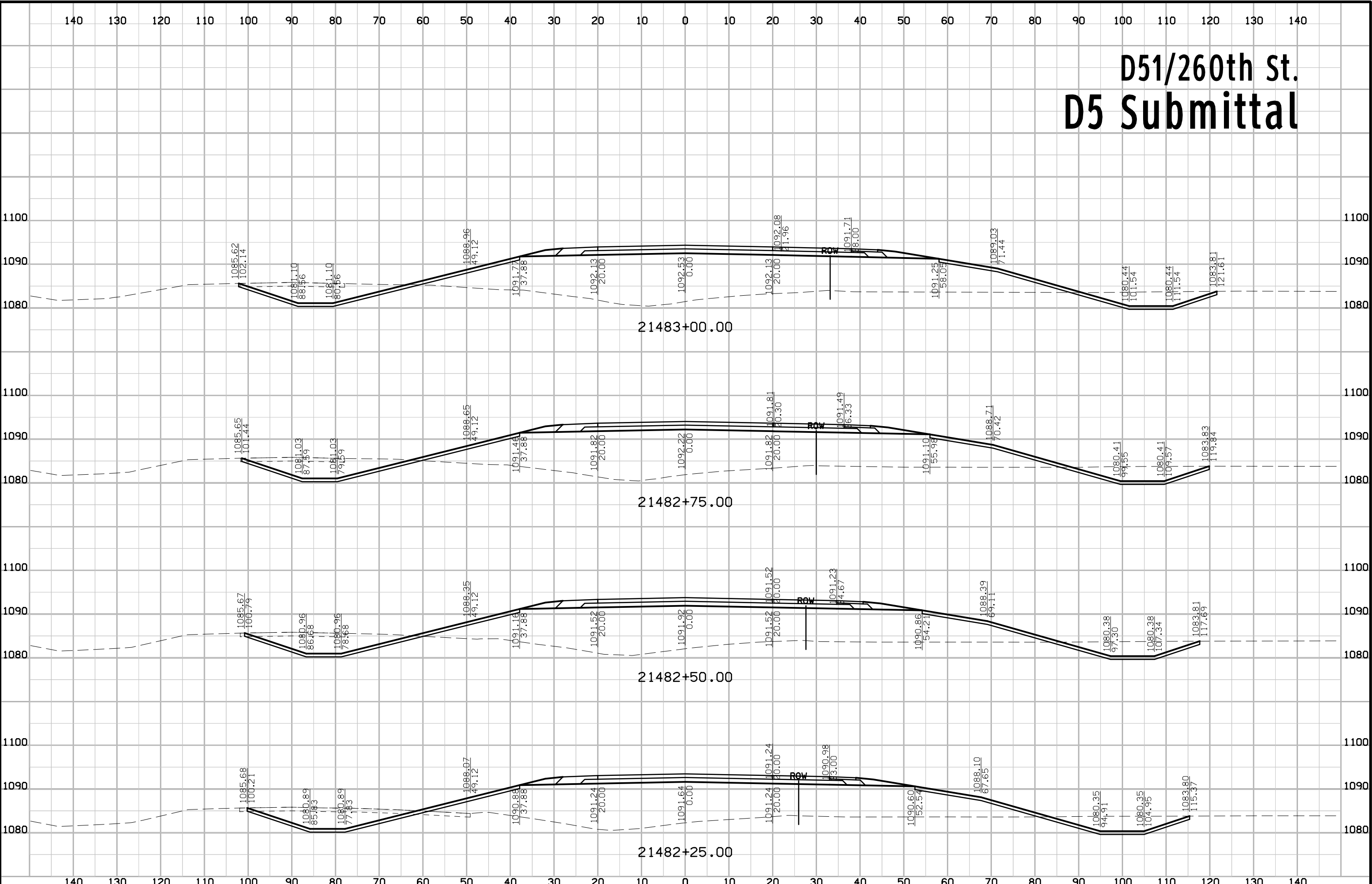

# D51/260th St. D5 Submittal

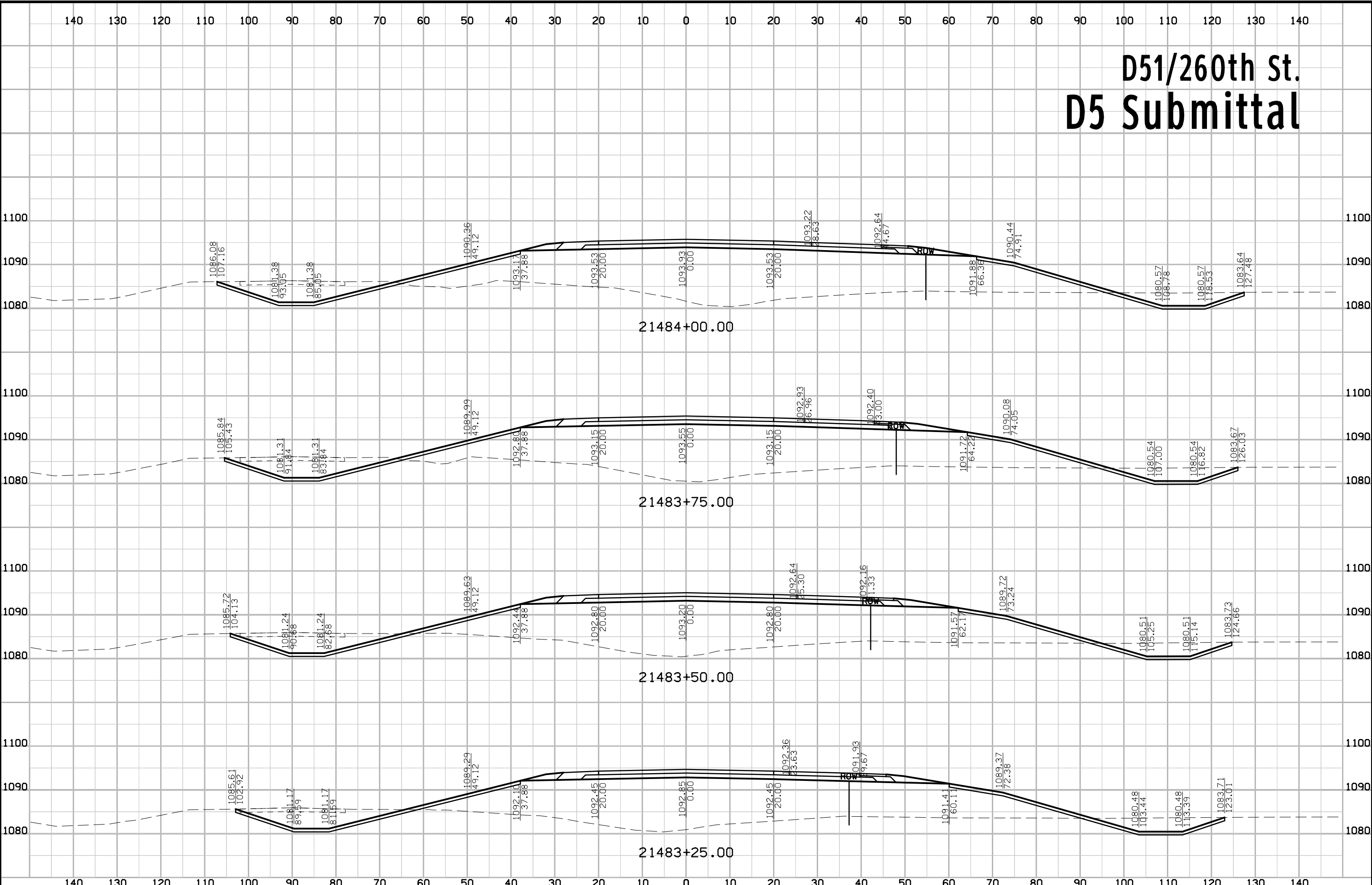

# D51/260th St. D5 Submittal

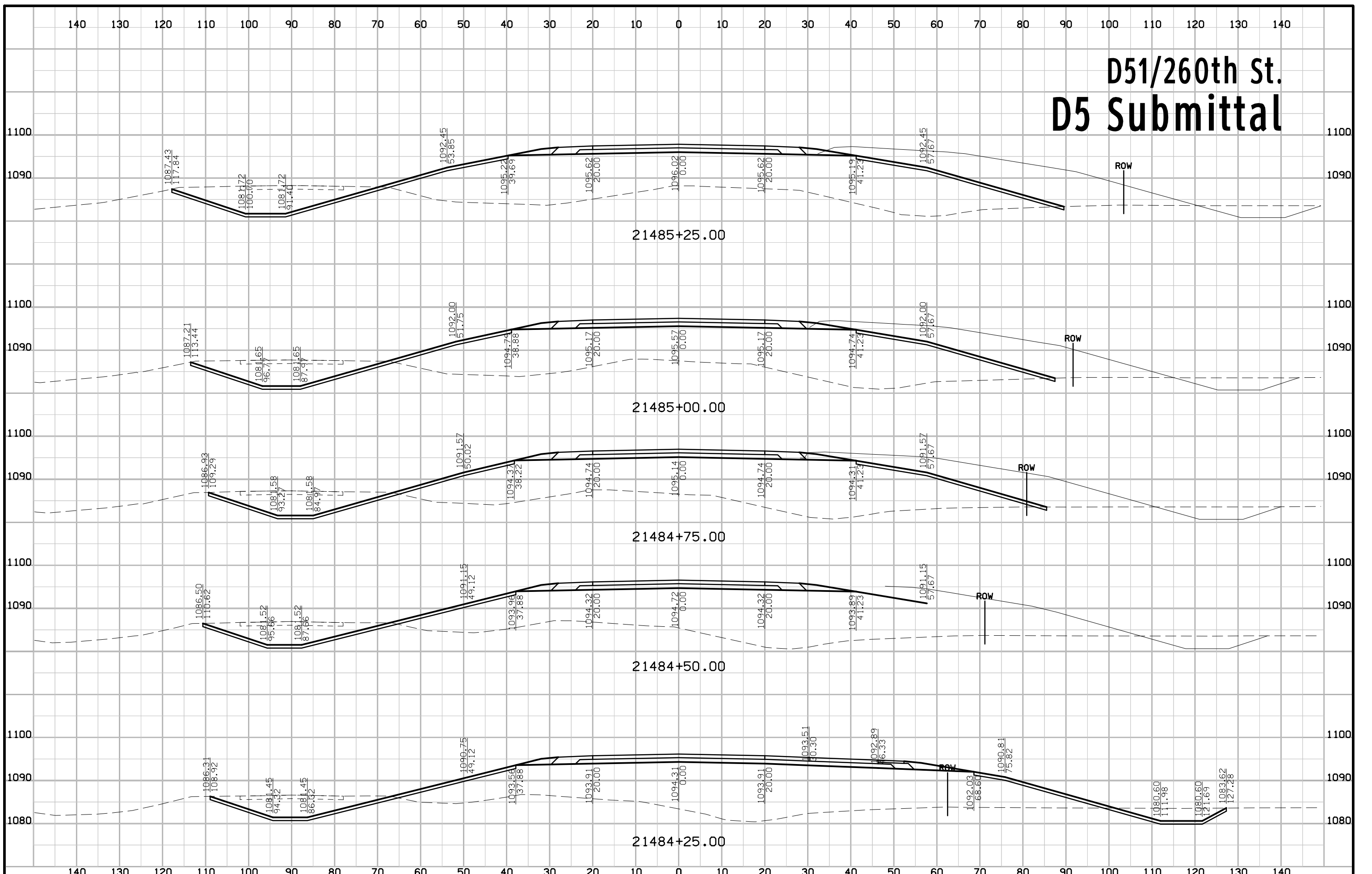

# D51/260th St. D5 Submittal

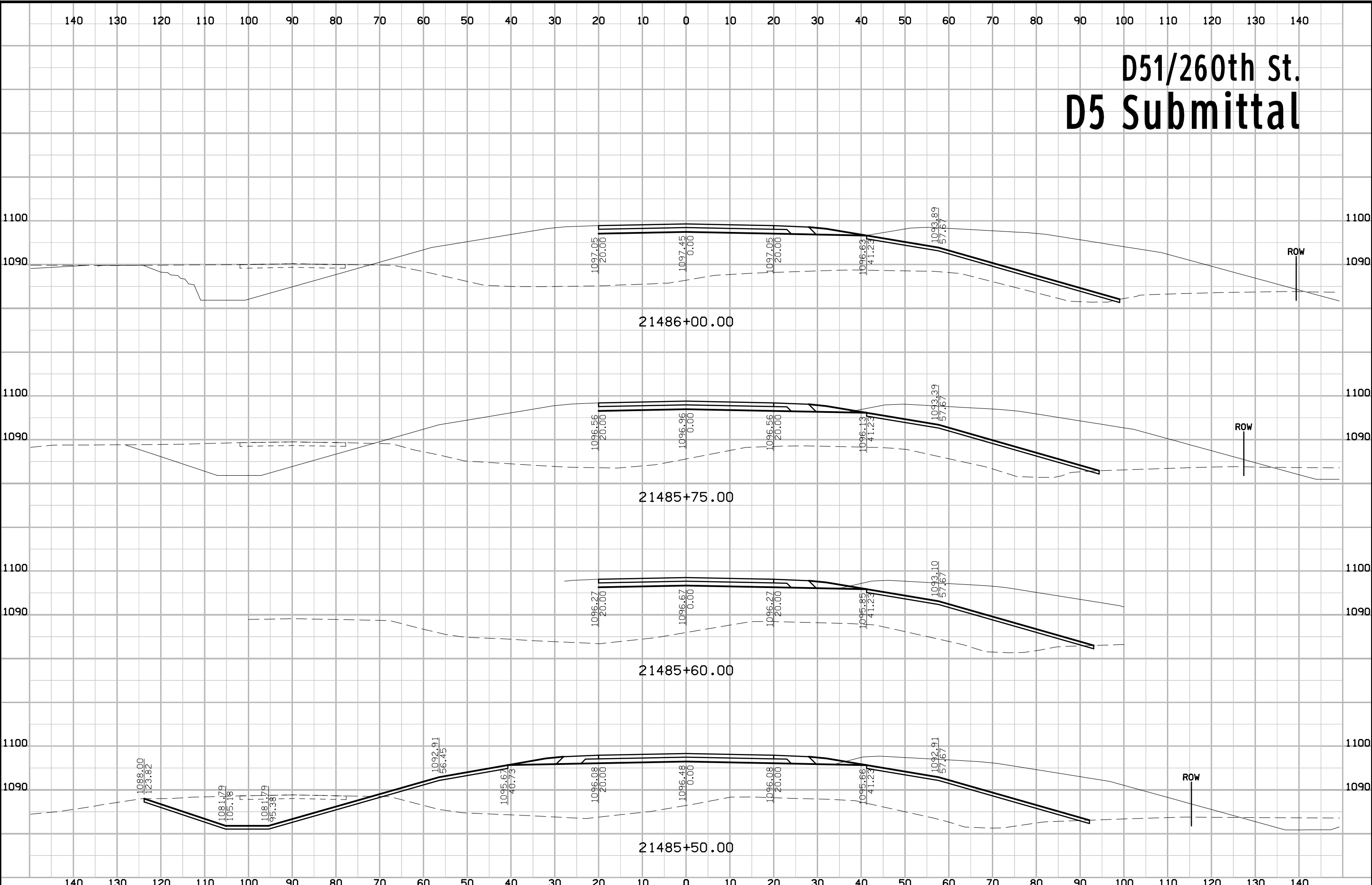

# D51/260th St. D5 Submittal

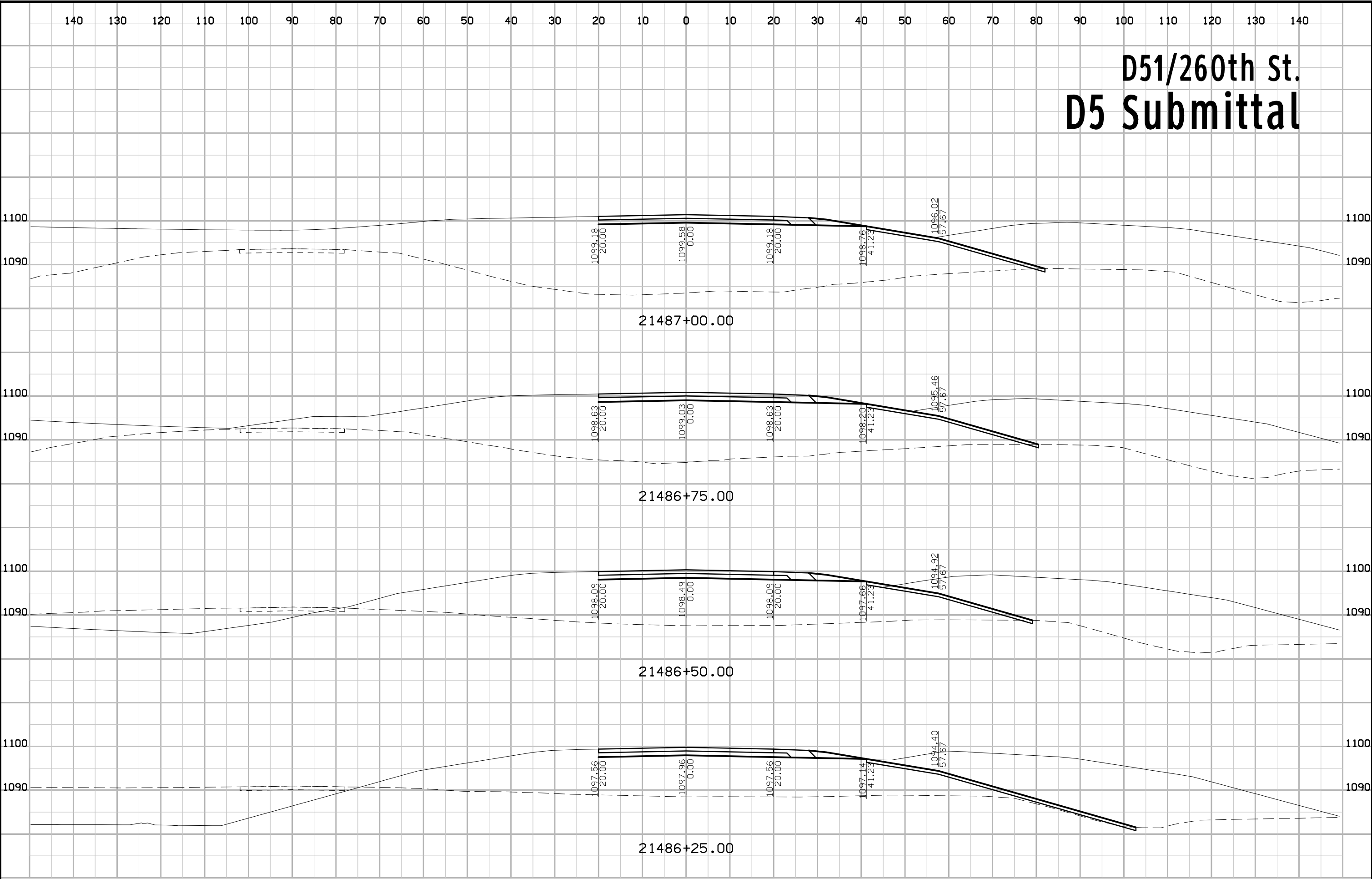

# D51/260th St. D5 Submittal

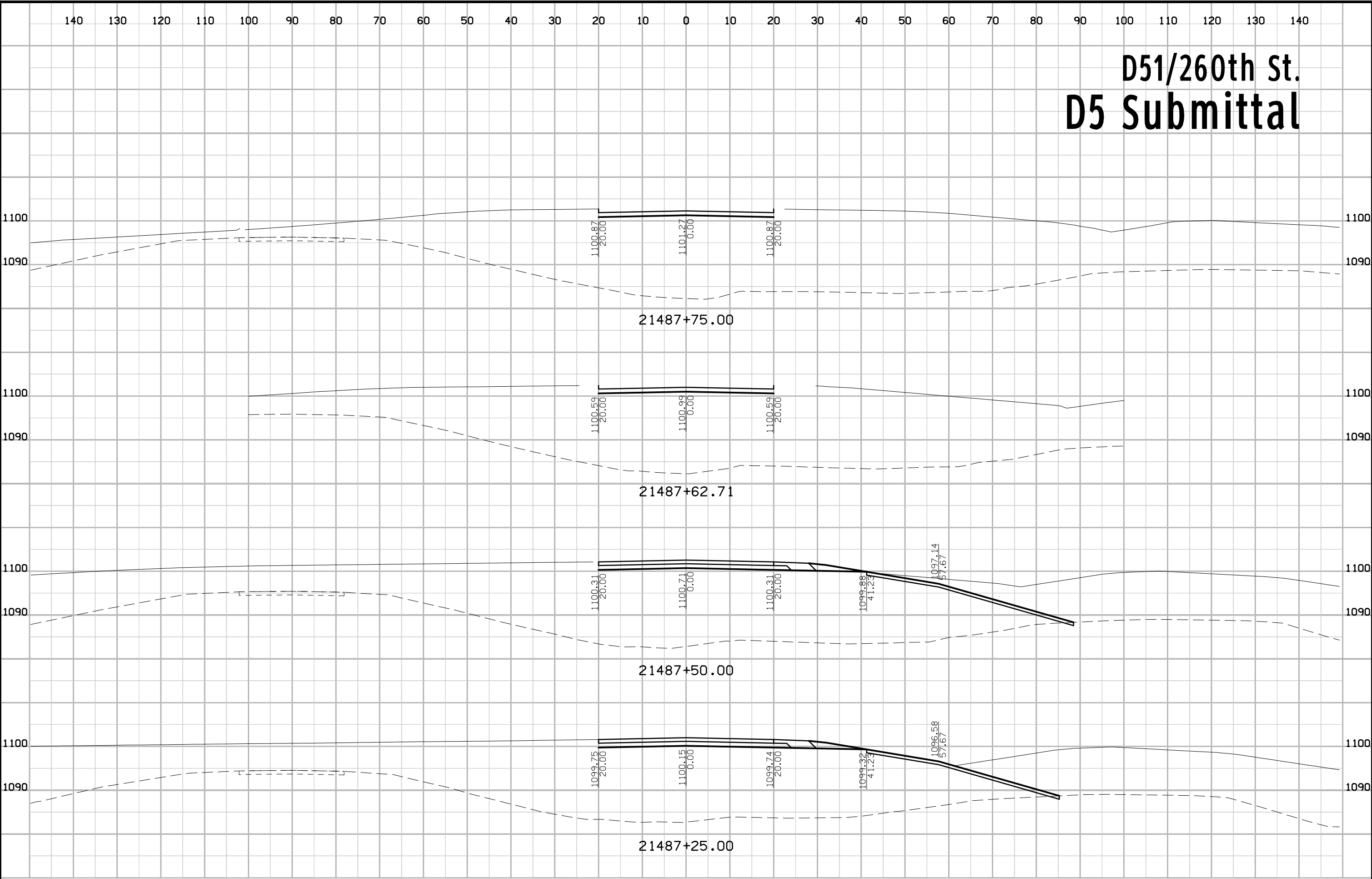

# D51/260th St. D5 Submittal

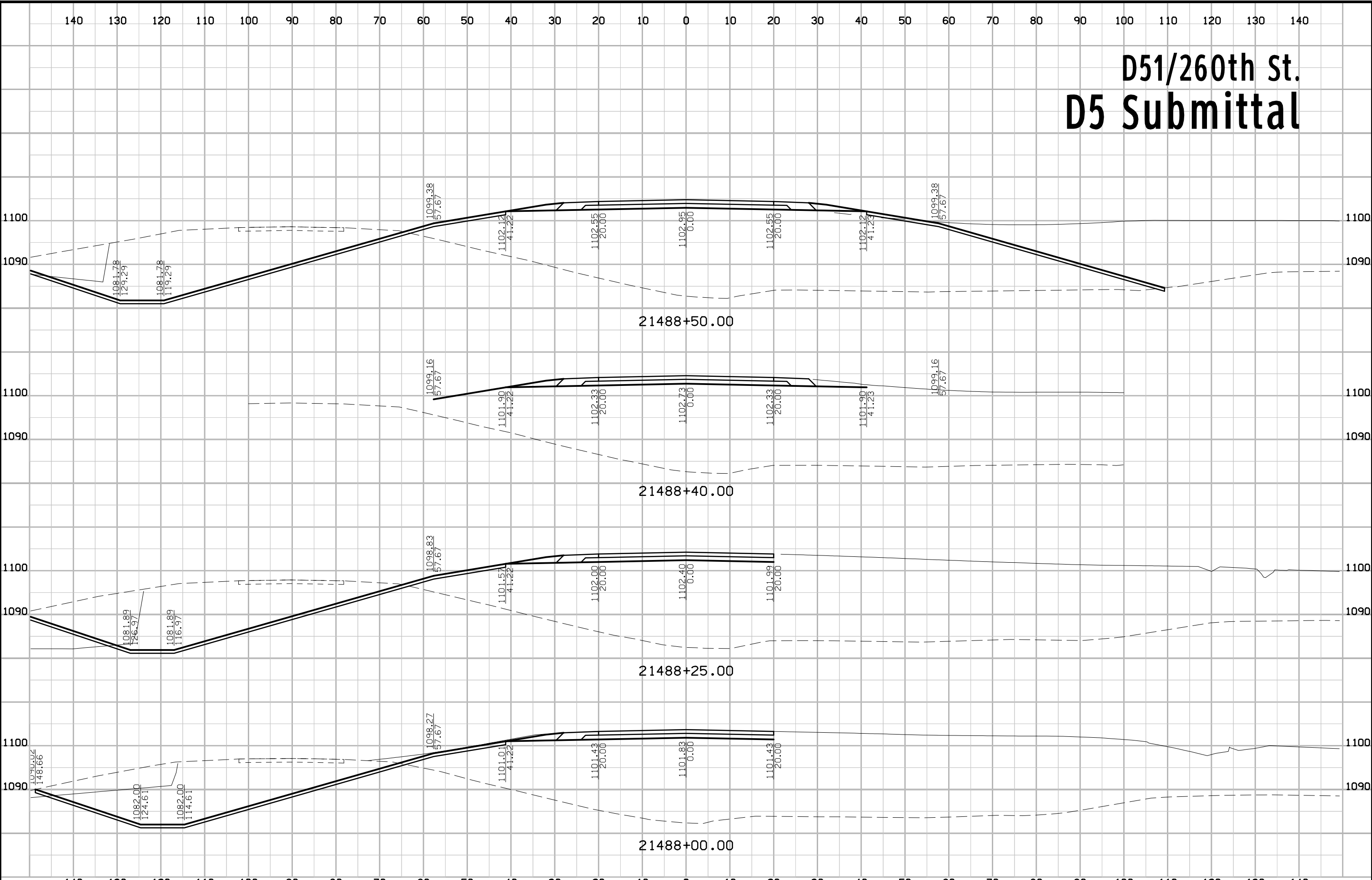



# D51/260th St. D5 Submittal

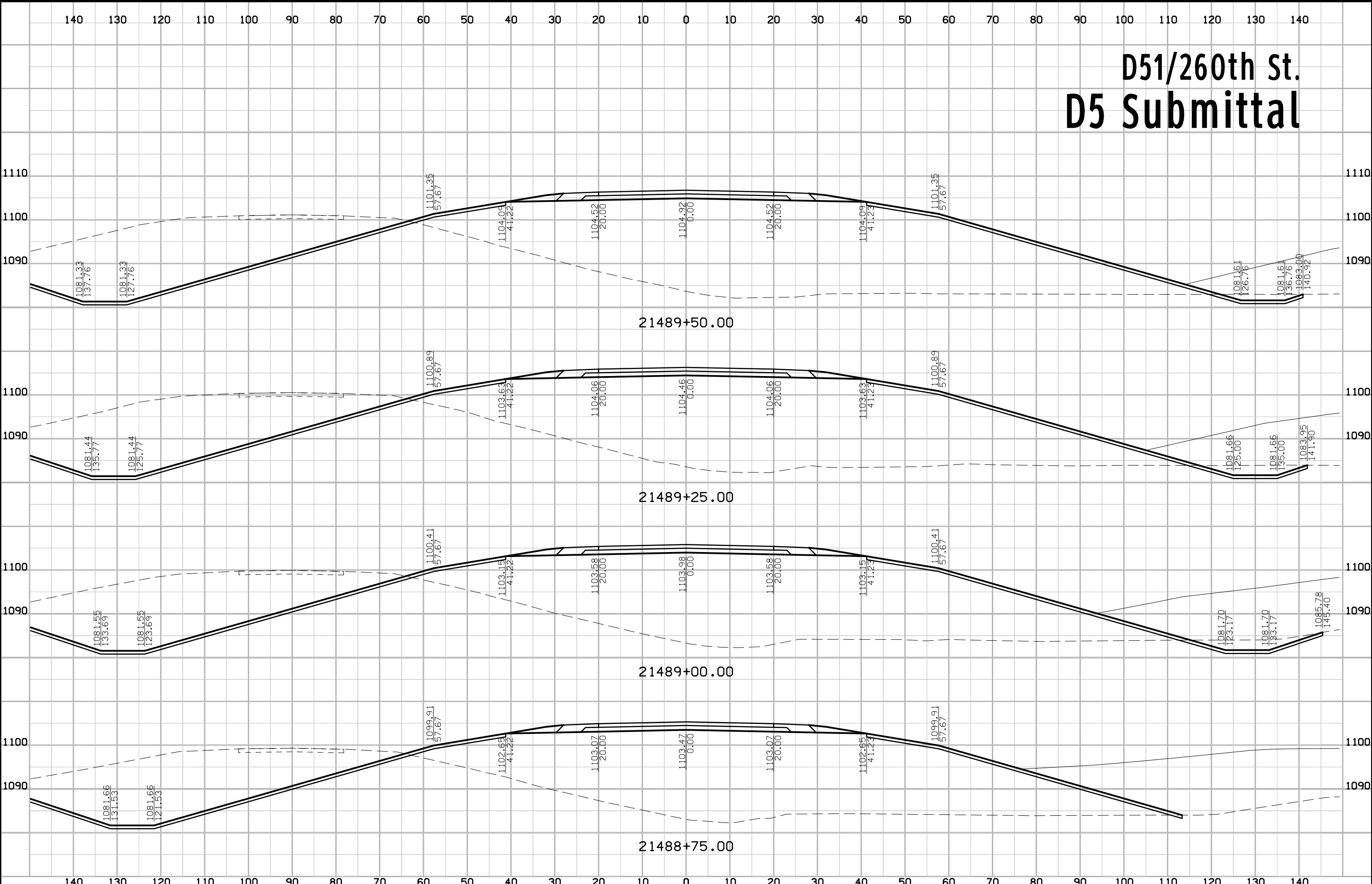

# D51/260th St. D5 Submittal

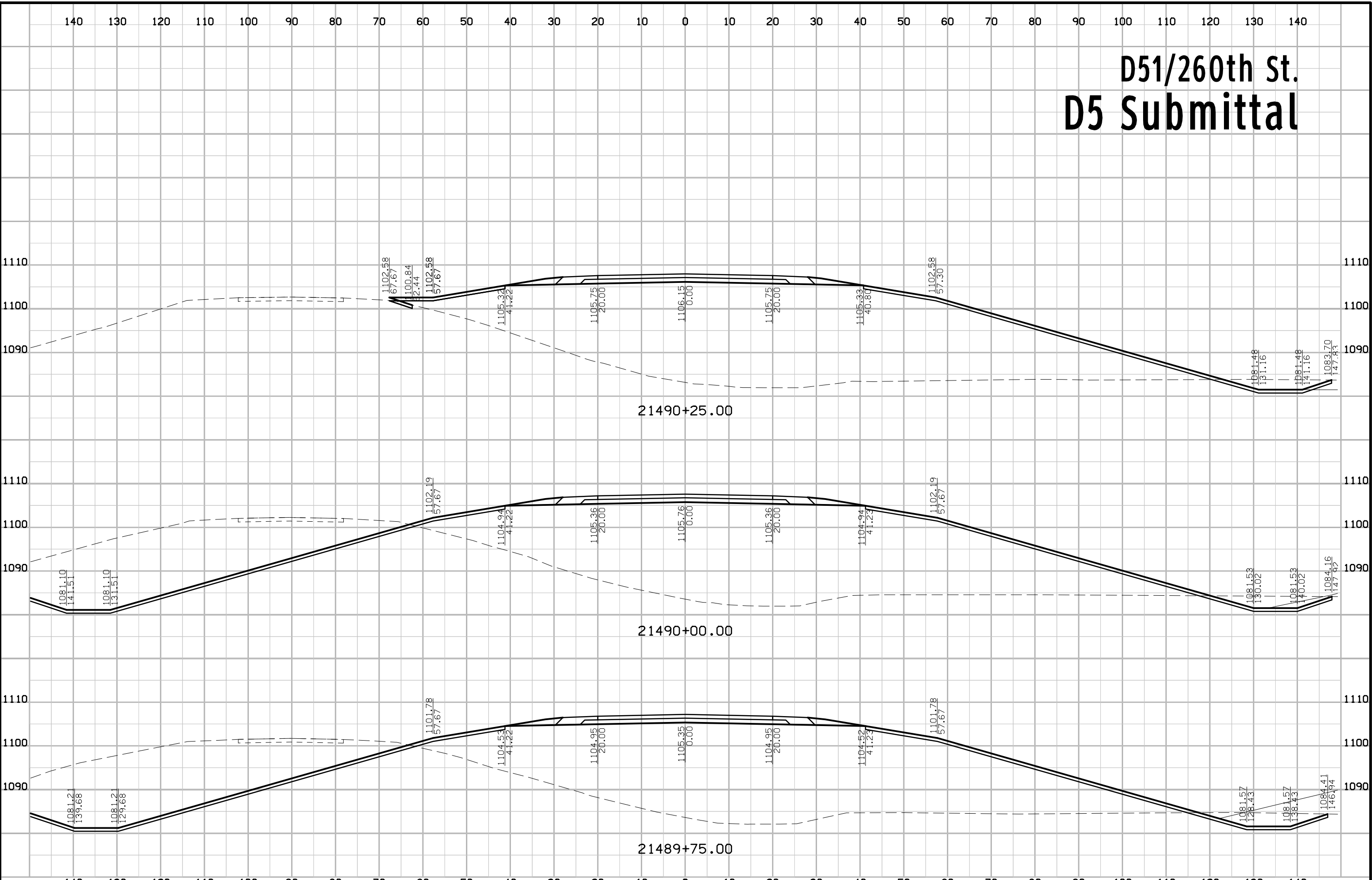

# D51/260th St. D5 Submittal

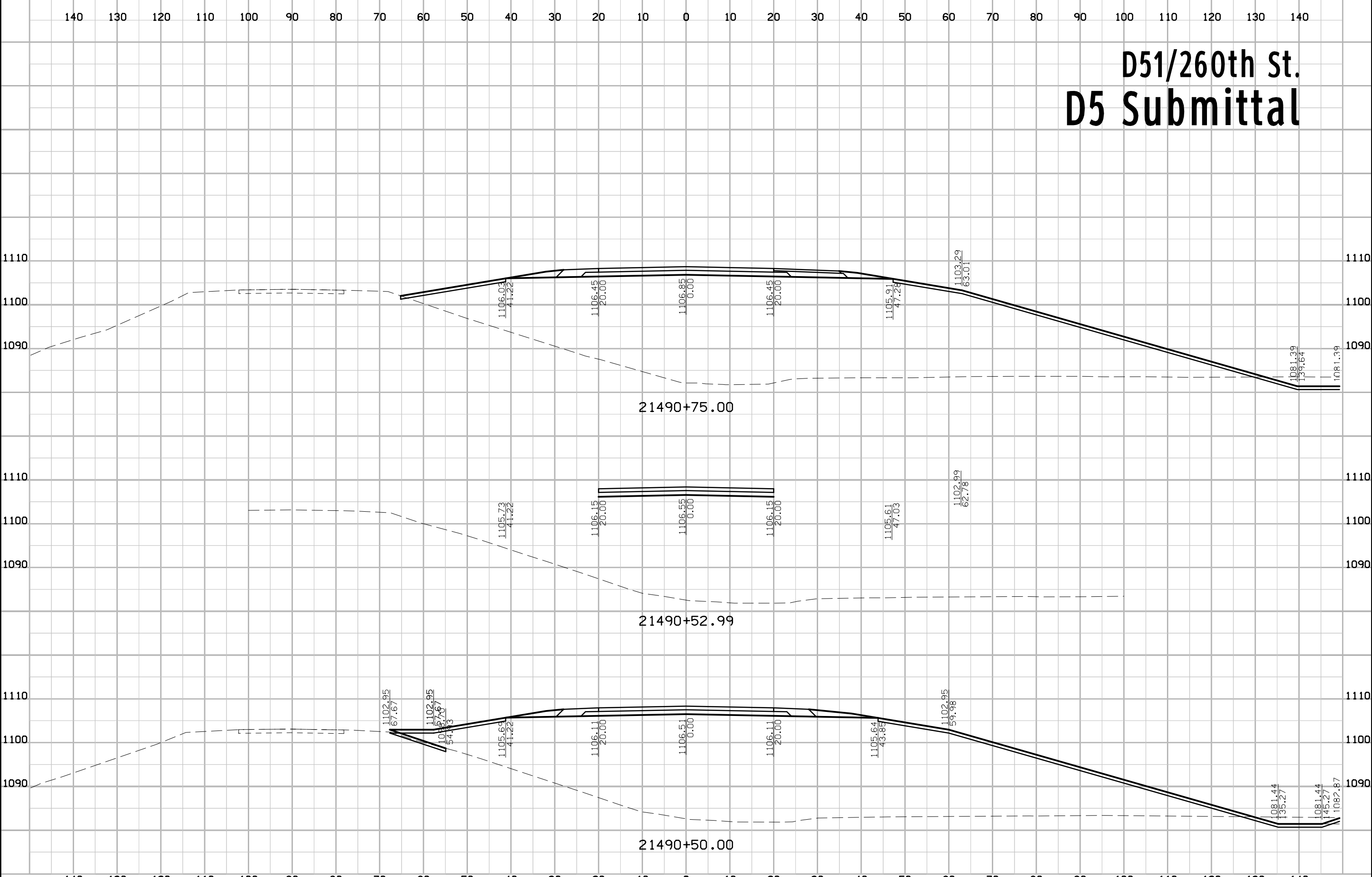

# D51/260th St. D5 Submittal

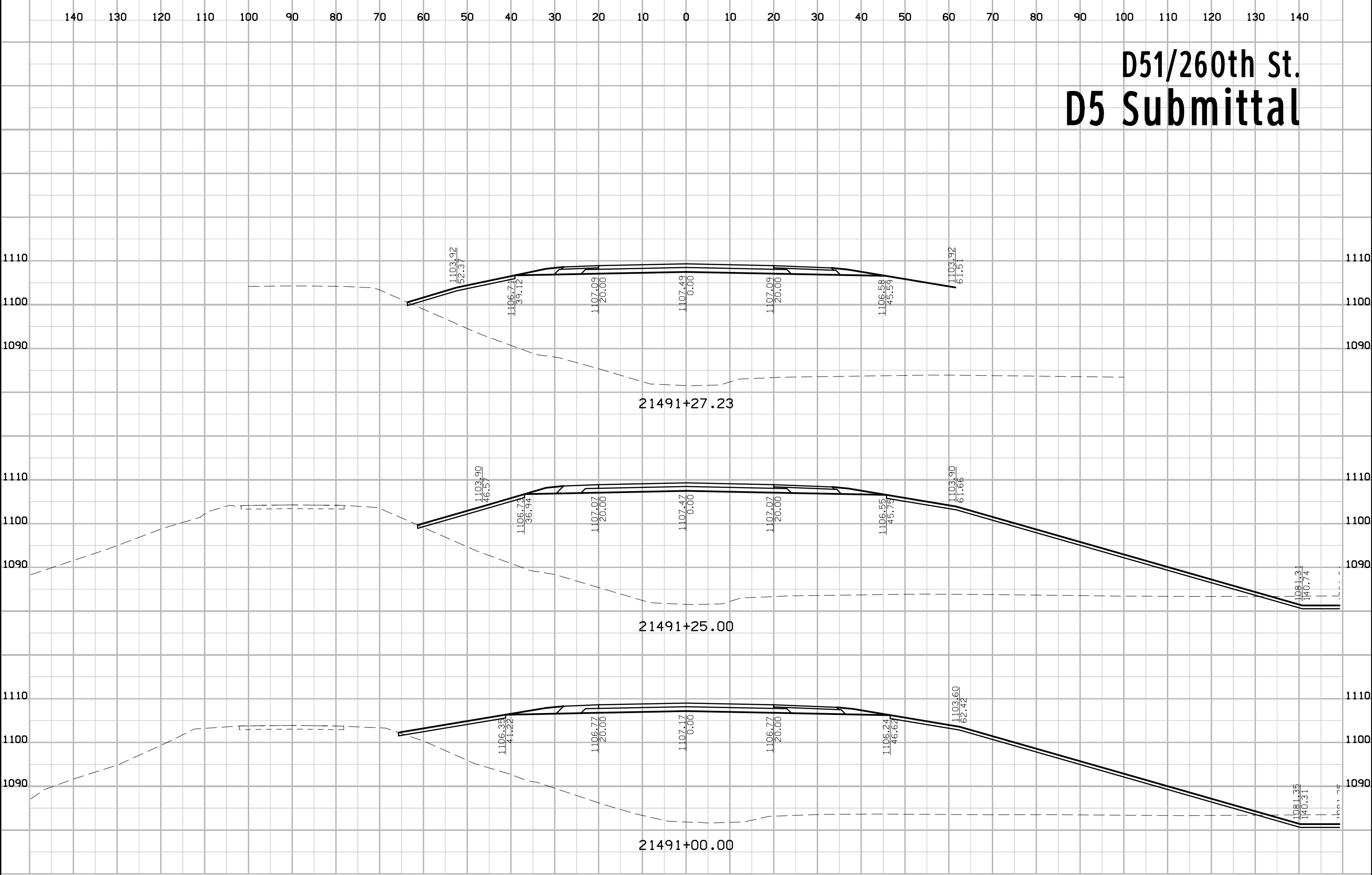

# D51/260th St. D5 Submittal

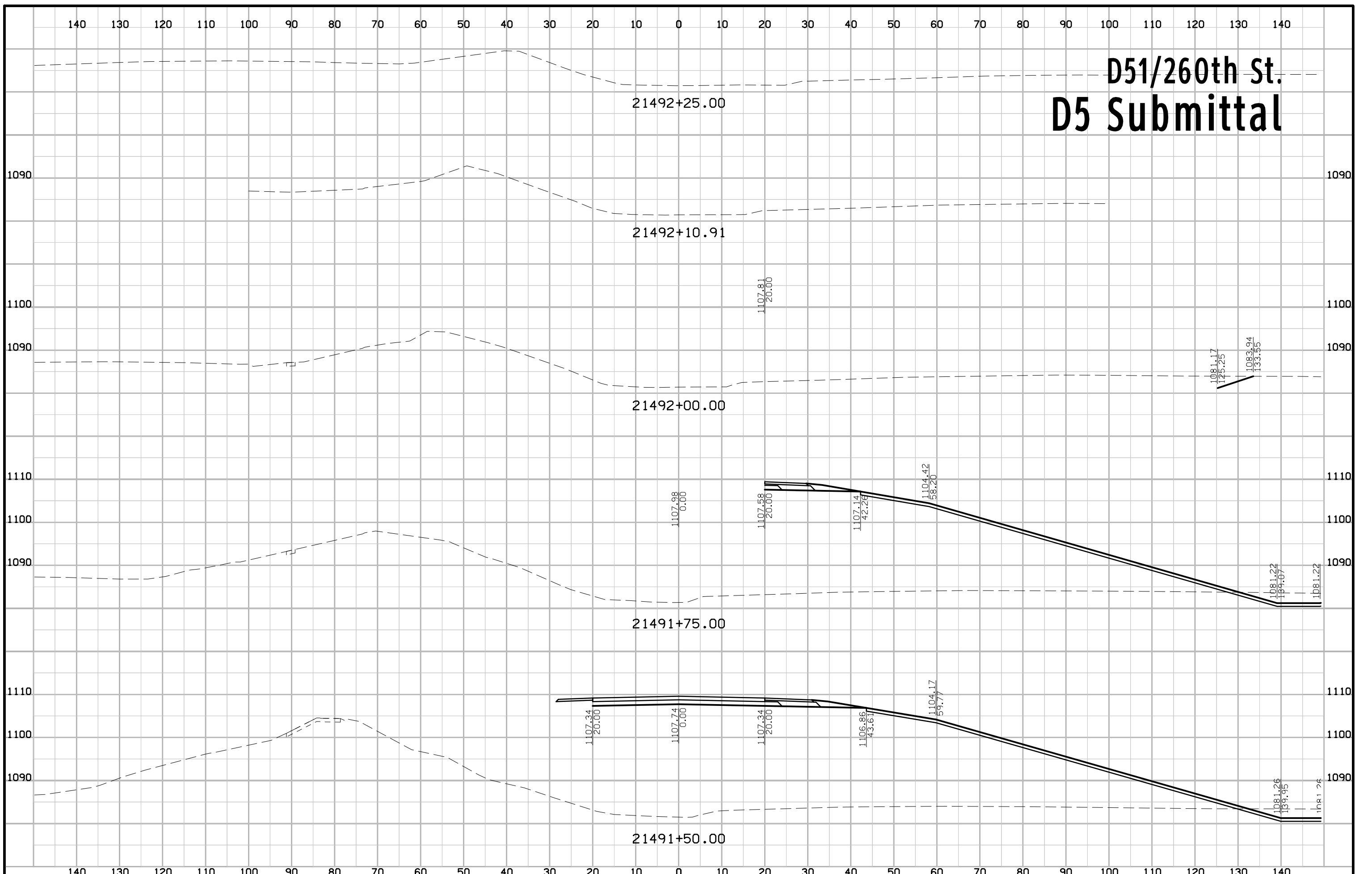

# D51/260th St. D5 Submittal

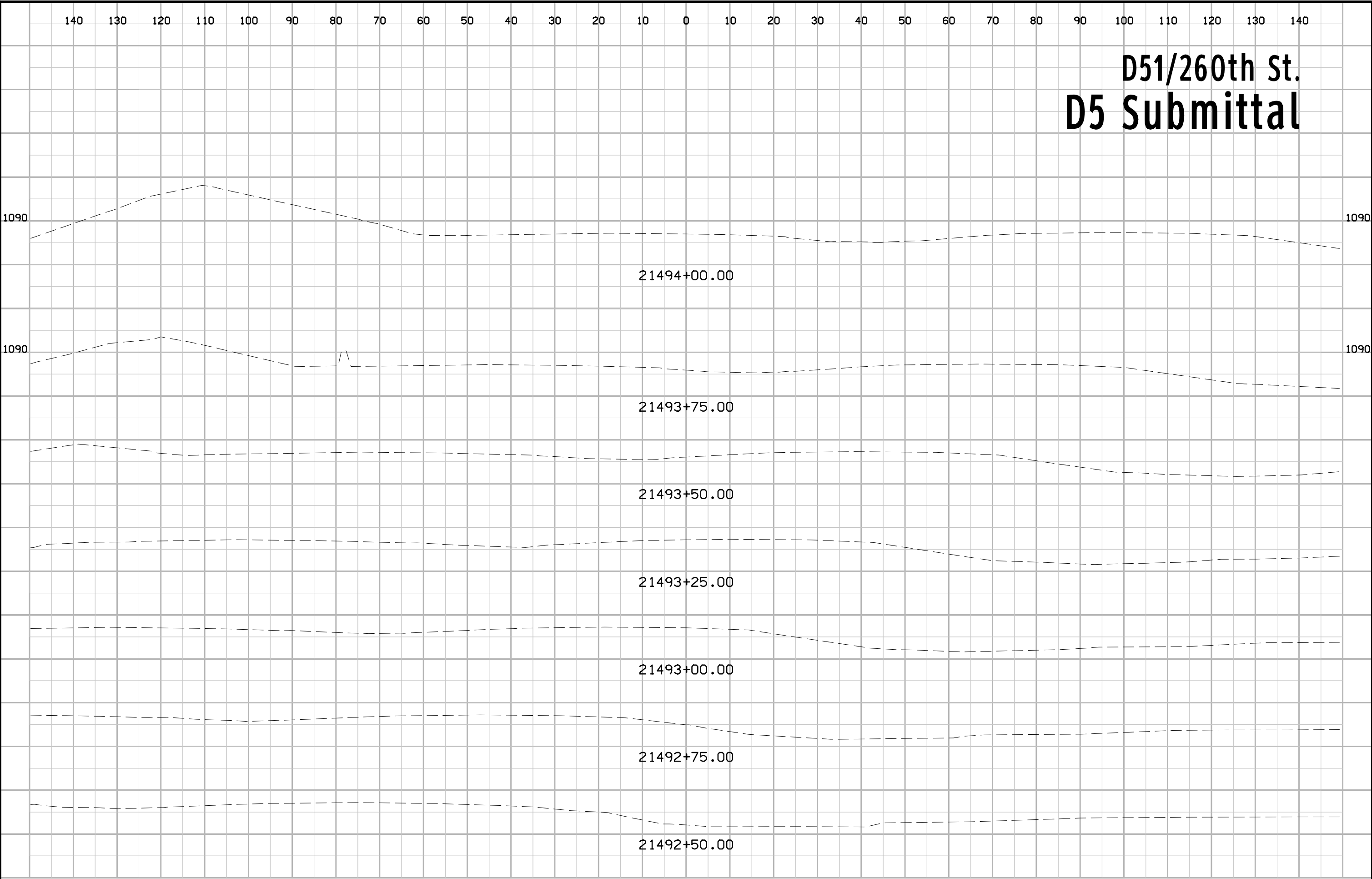

# D51/260th St. D5 Submittal

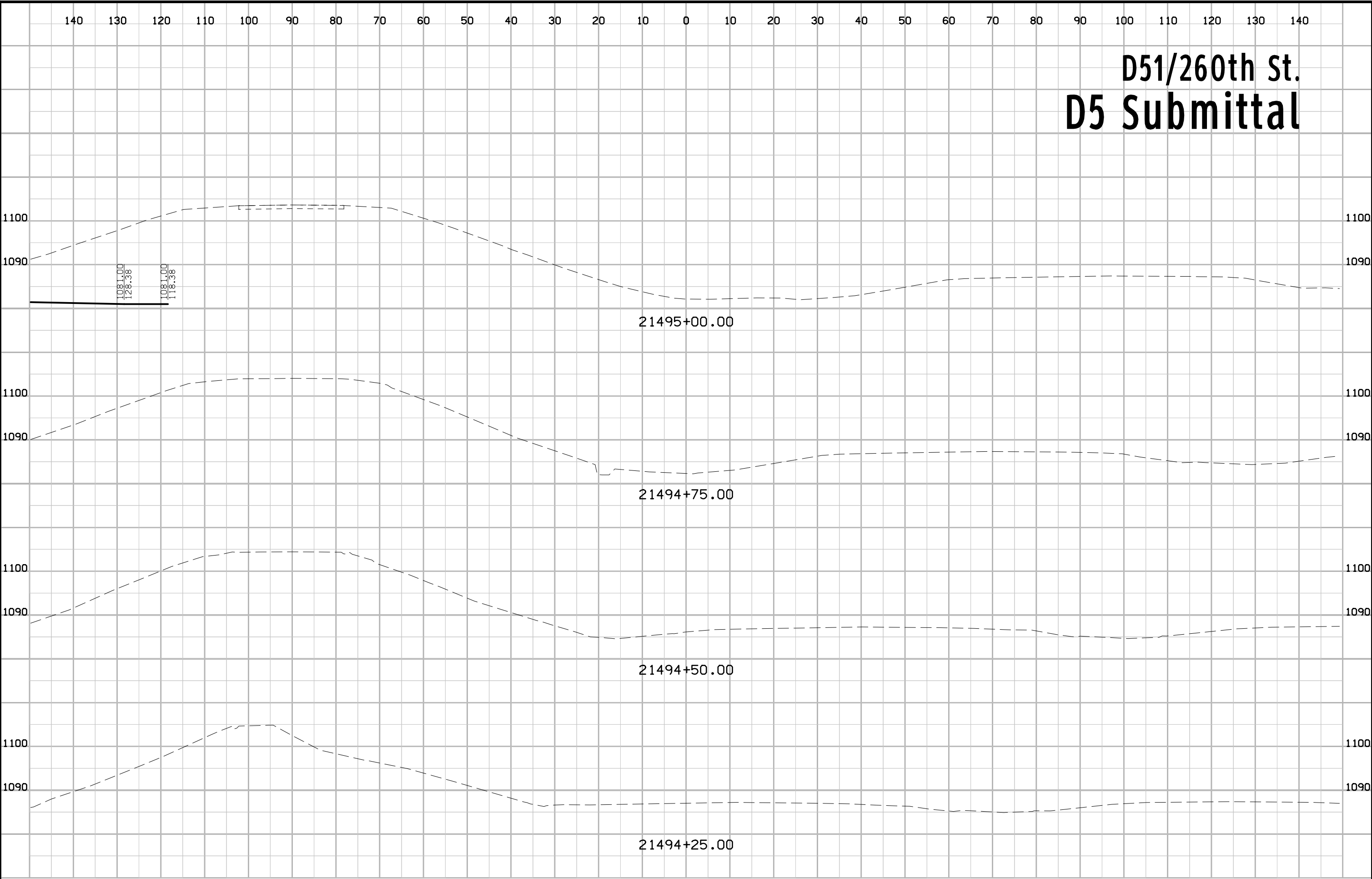

# D51/260th St. D5 Submittal

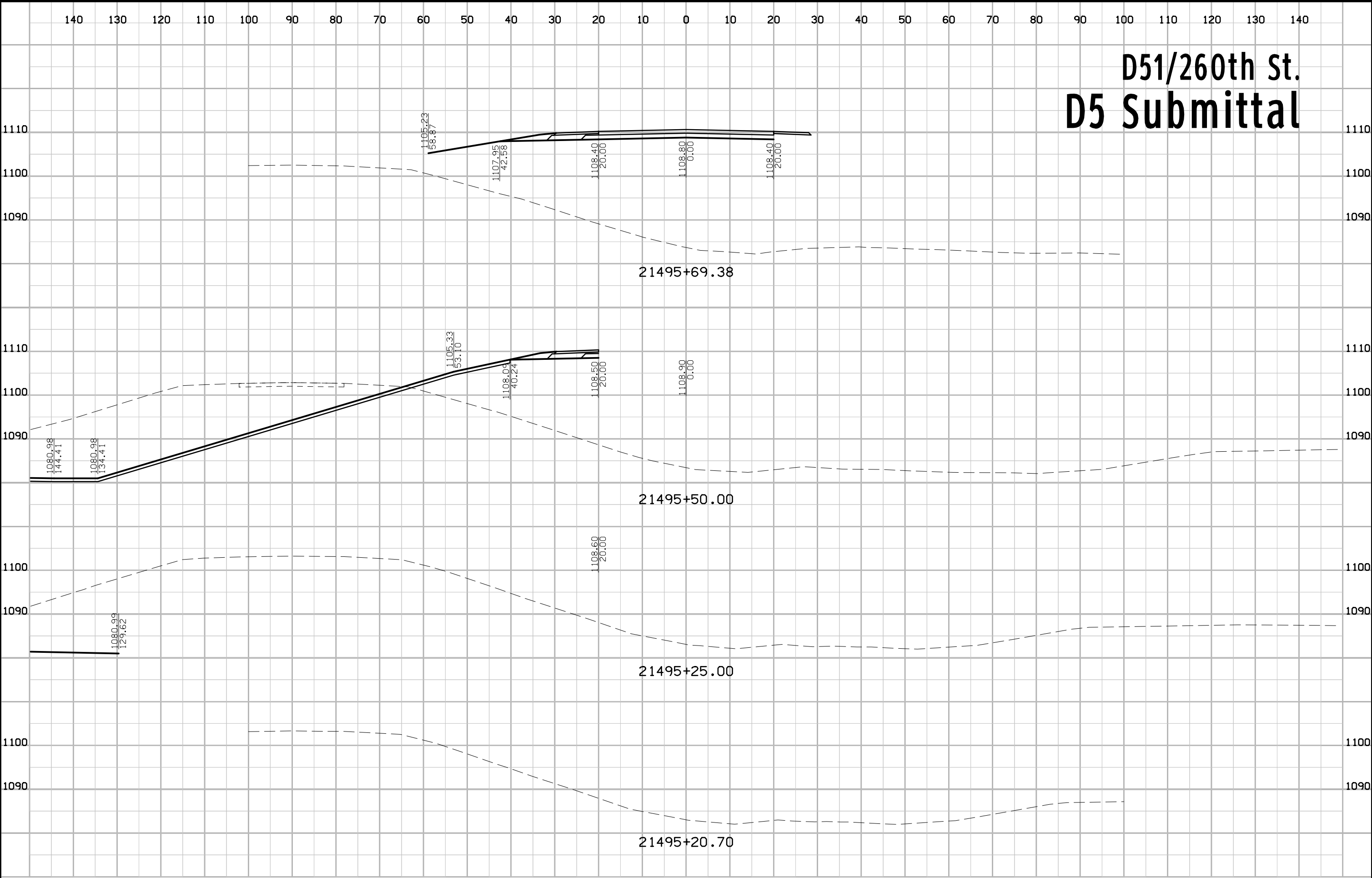



# D51/260th St. D5 Submittal

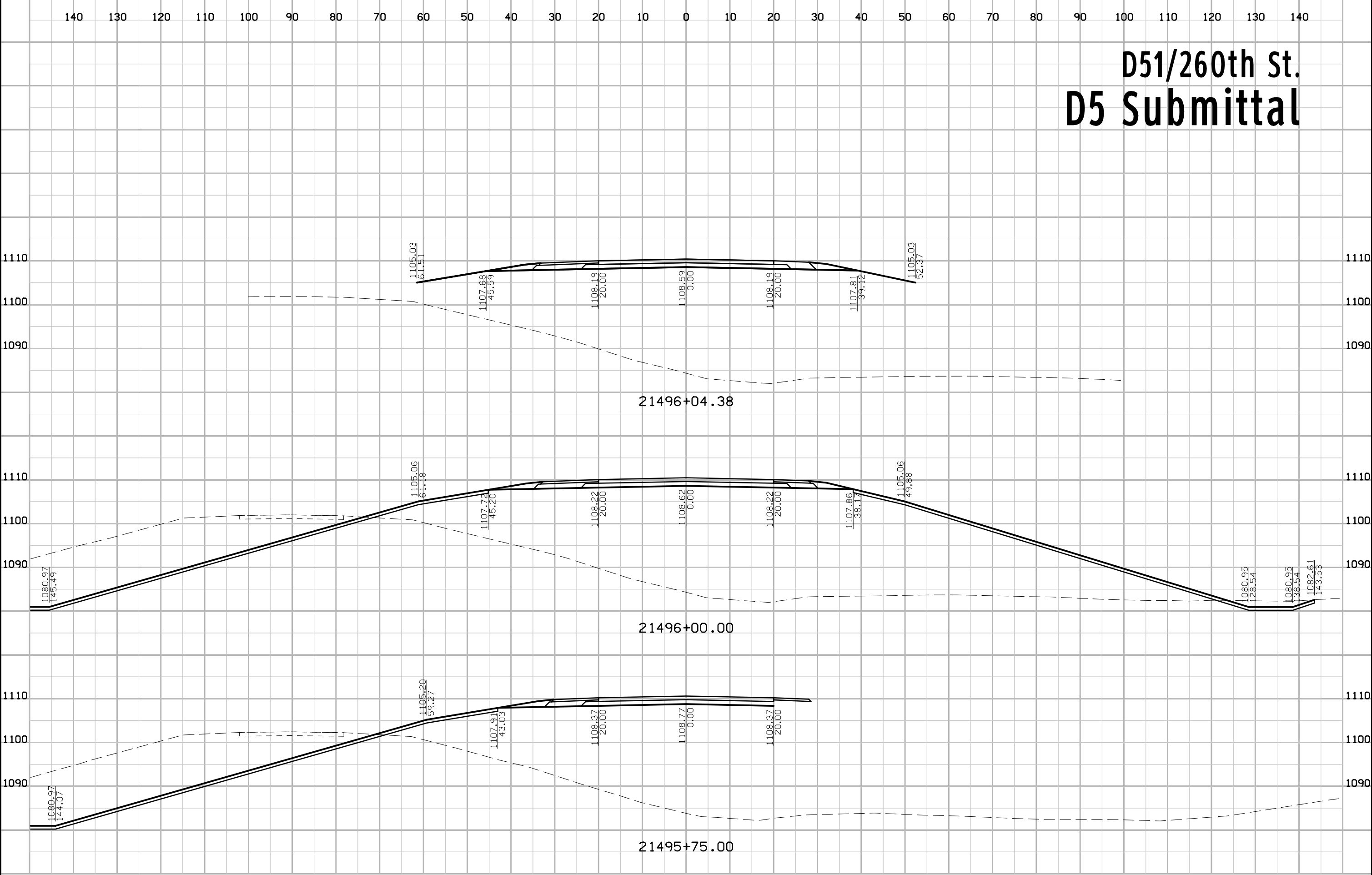

# D51/260th St. D5 Submittal

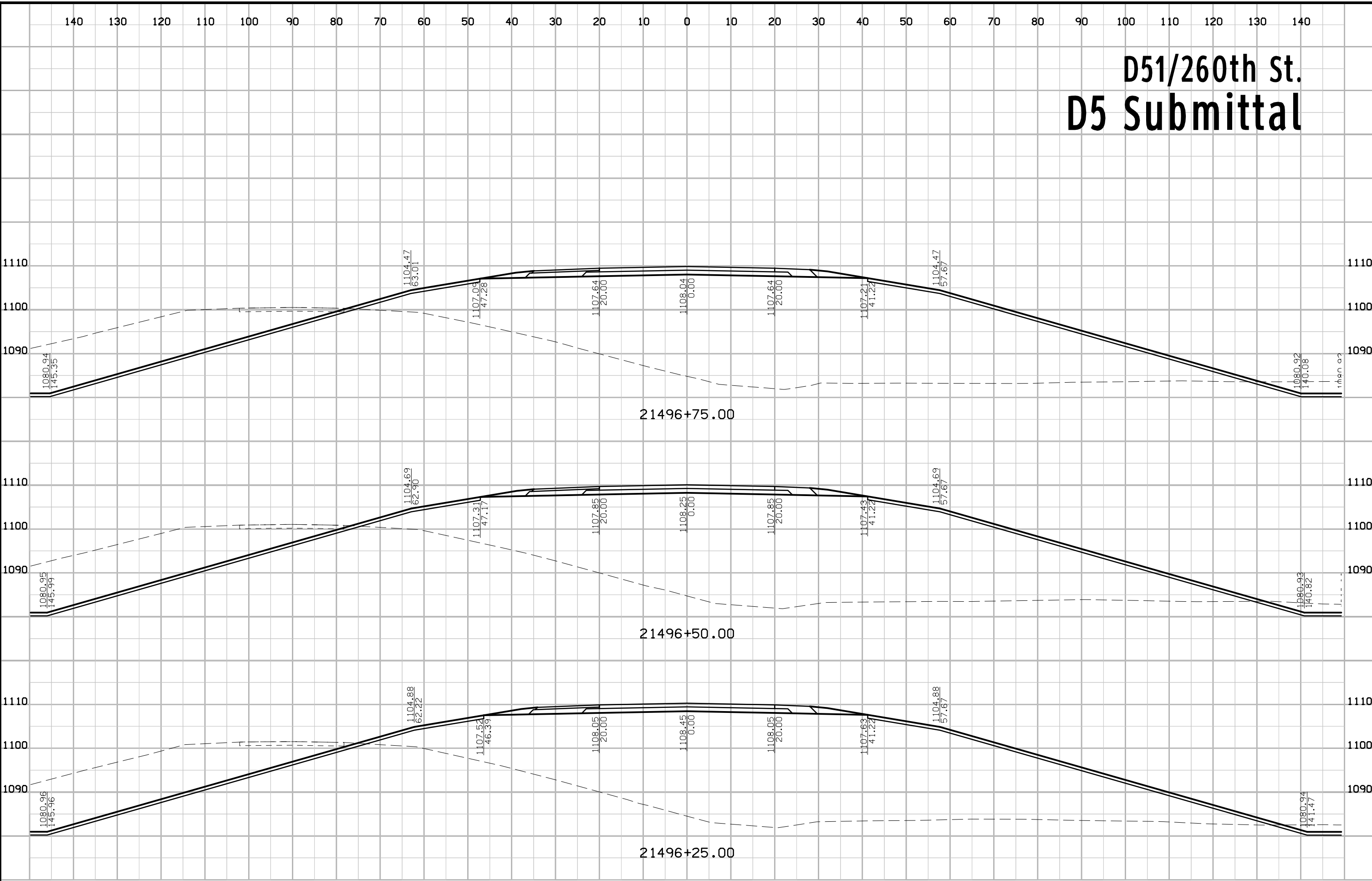

# D51/260th St. D5 Submittal

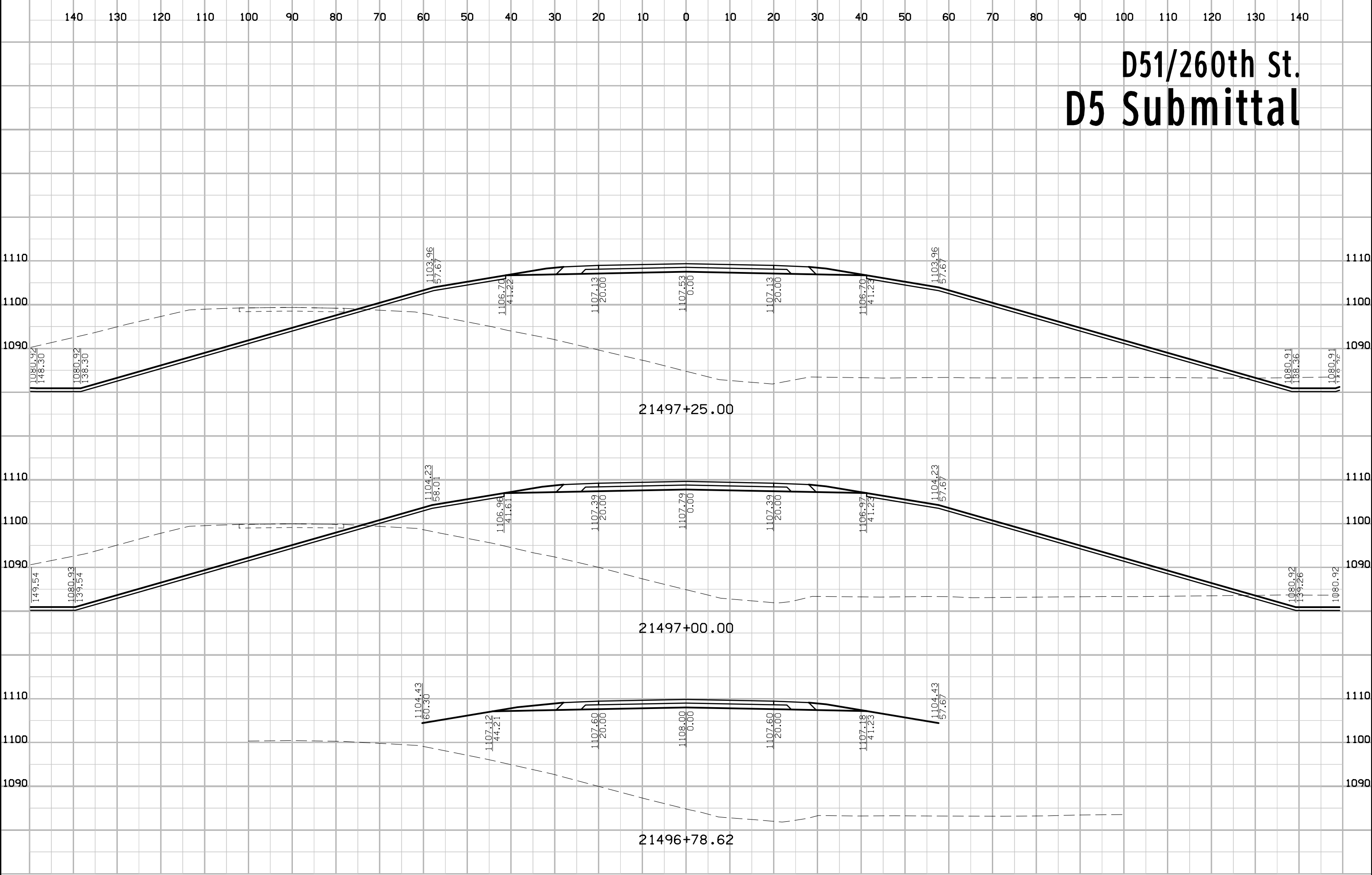

# D51/260th St. D5 Submittal

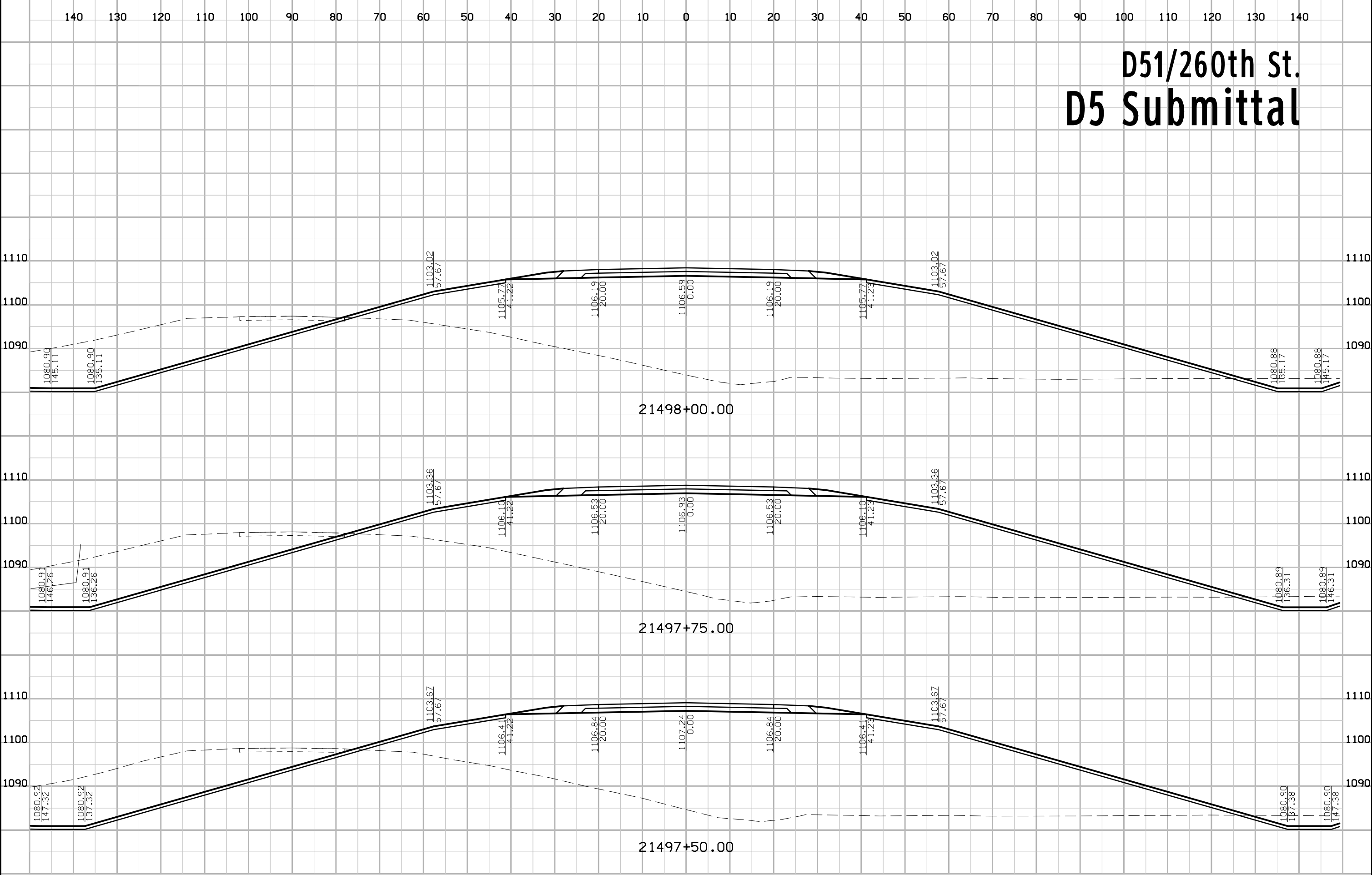

# D51/260th St. D5 Submittal

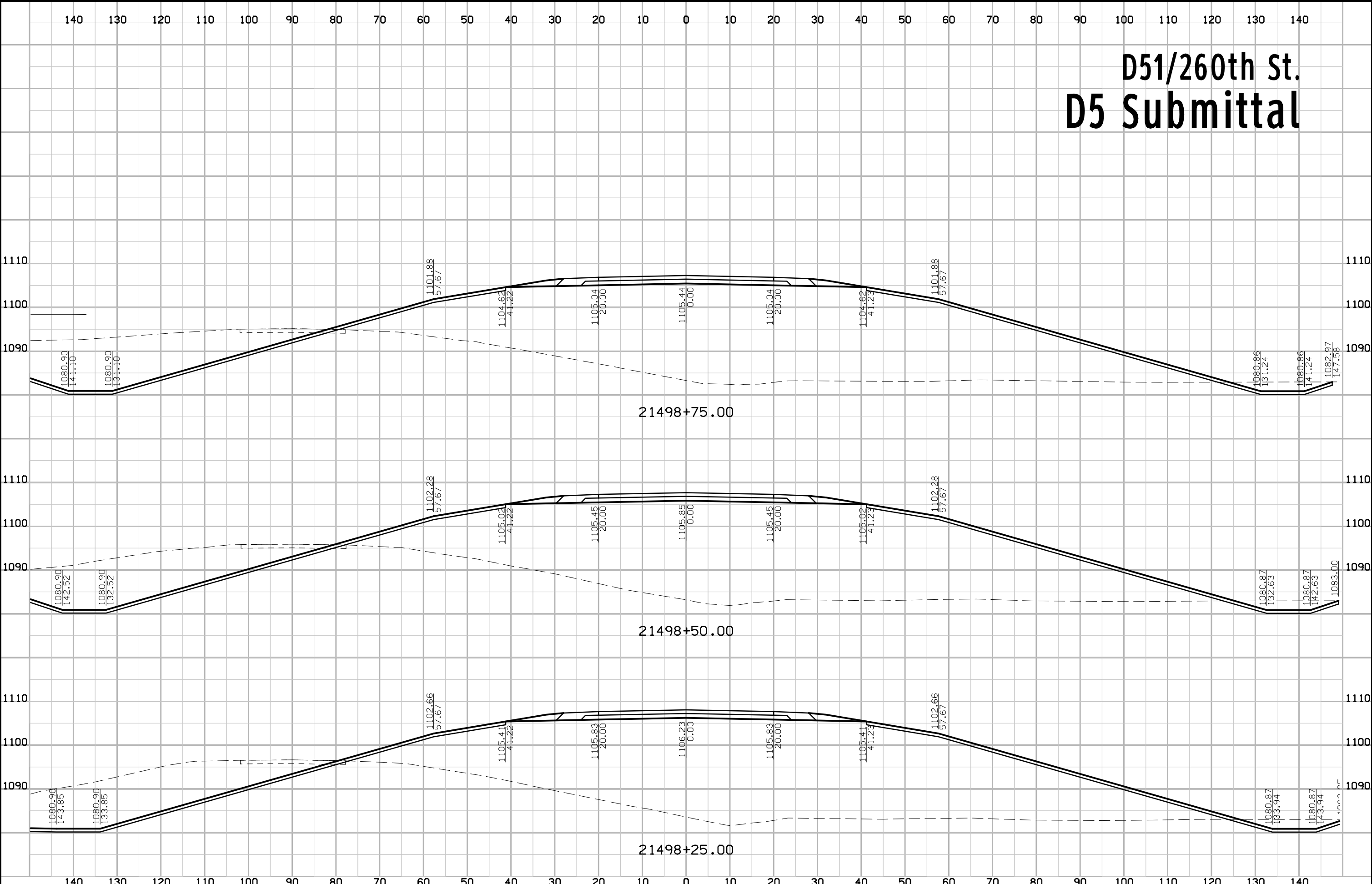

# D51/260th St. D5 Submittal

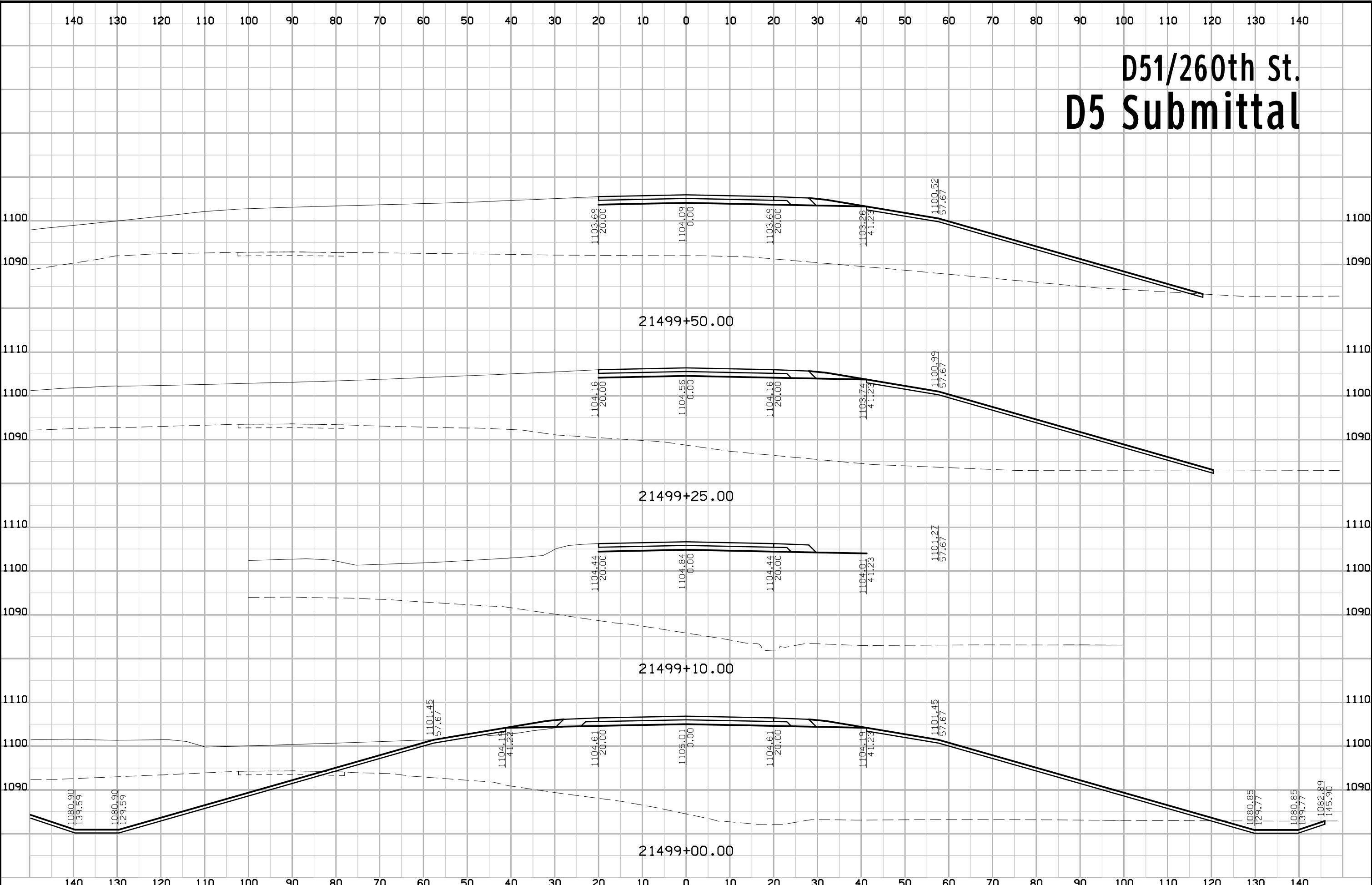

# D51/260th St. D5 Submittal

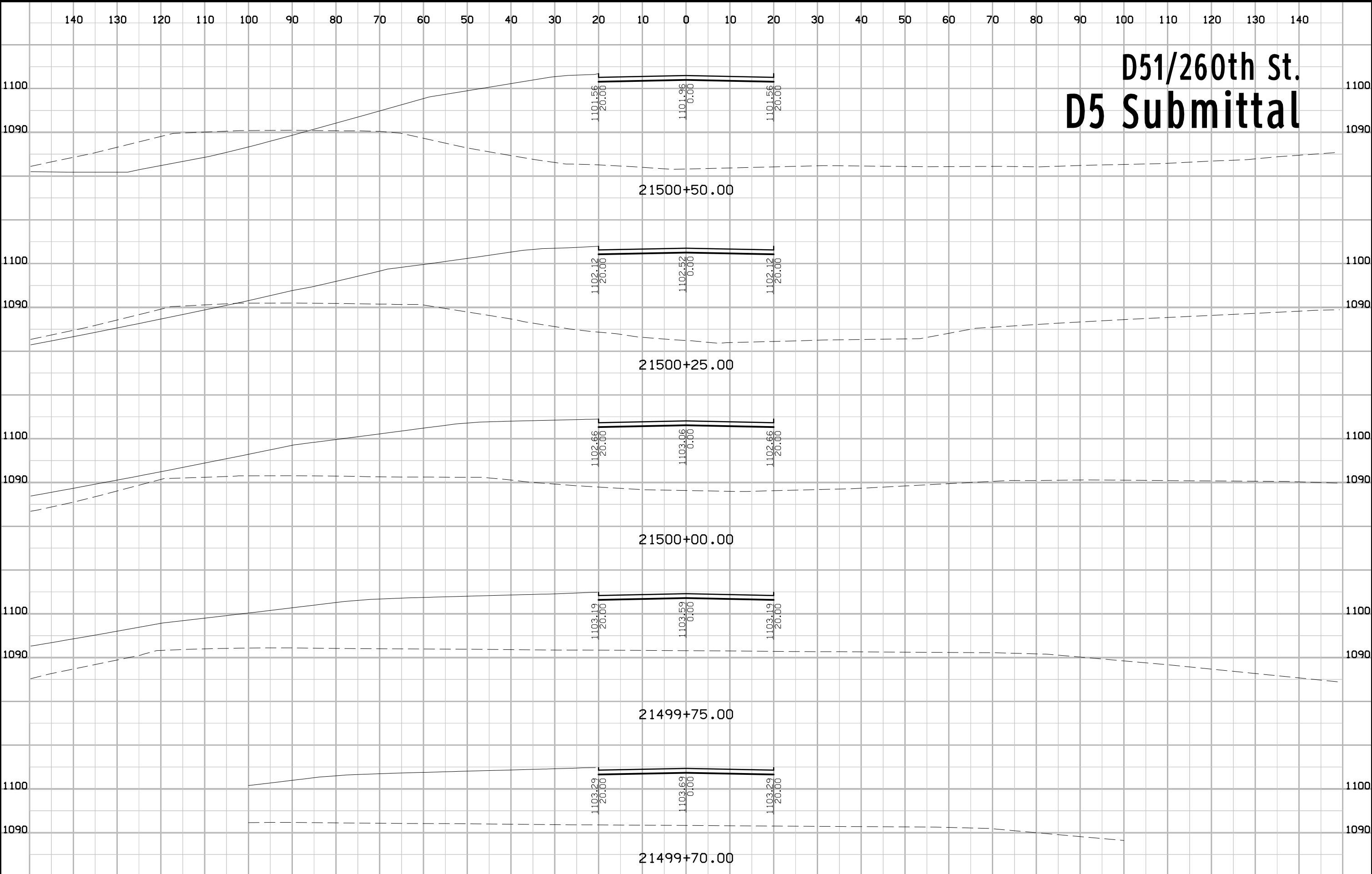

# D51/260th St. D5 Submittal

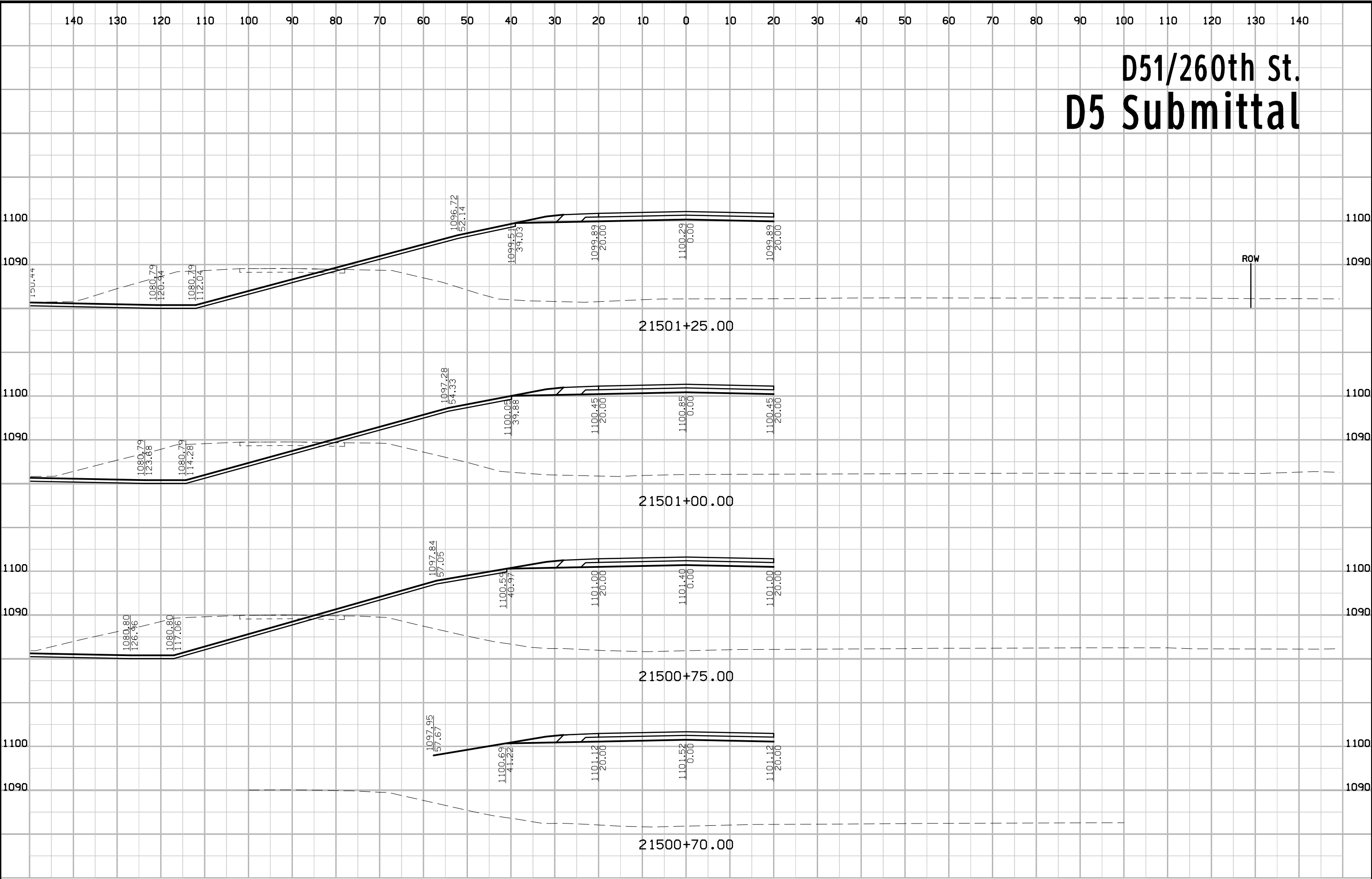



# D51/260th St. D5 Submittal

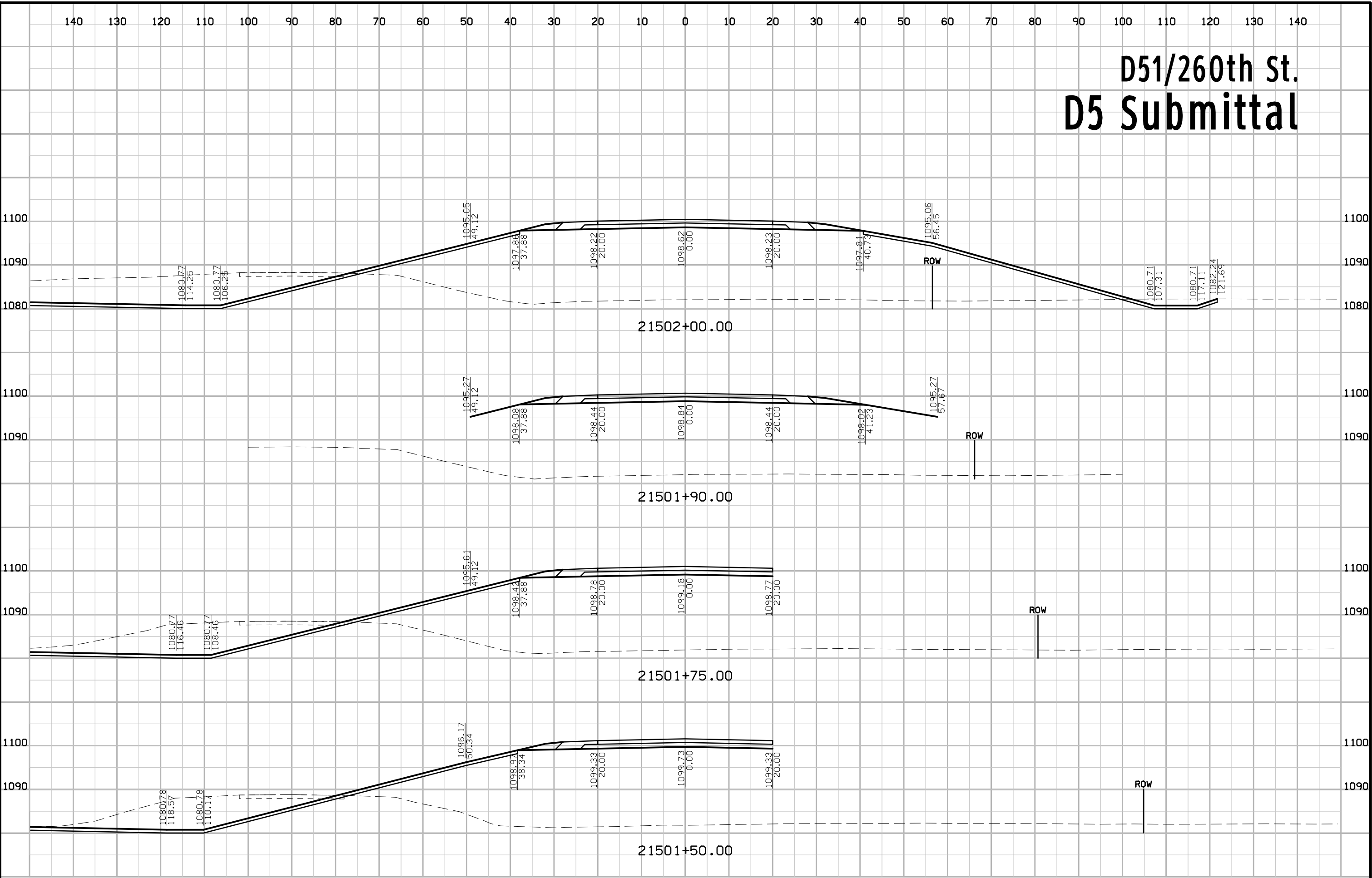

# D51/260th St. D5 Submittal

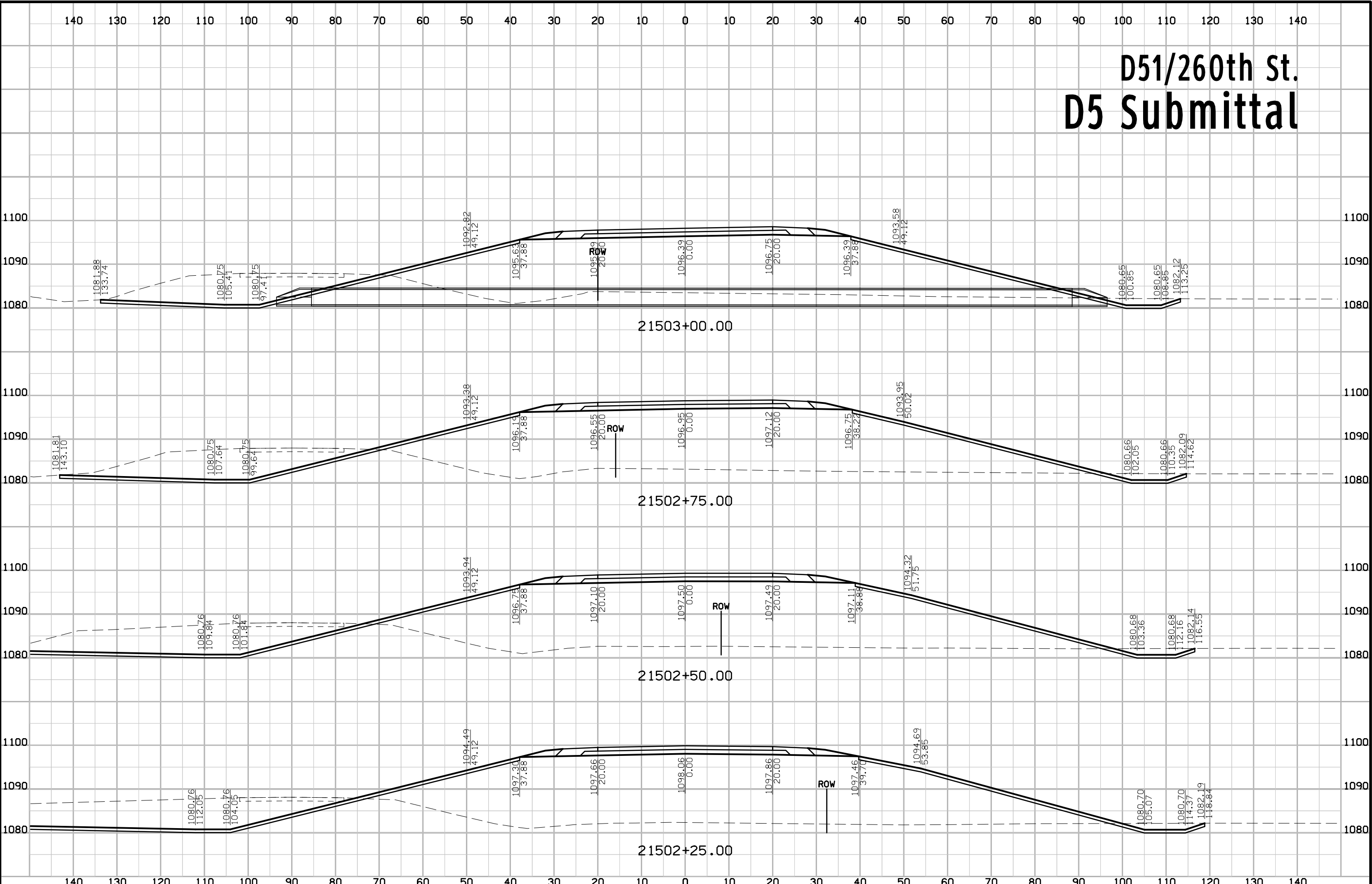

# D51/260th St. D5 Submittal

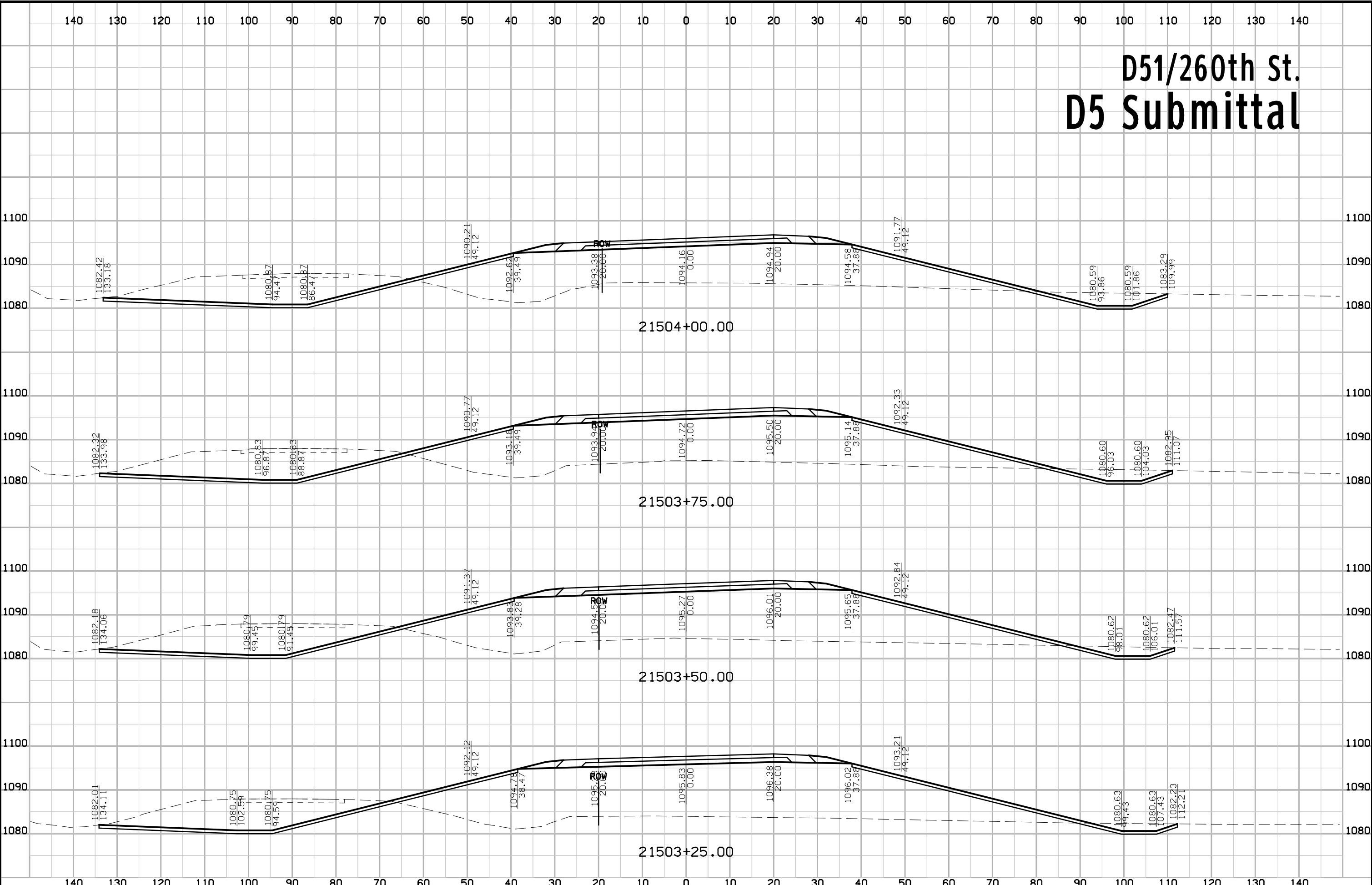

# D51/260th St. D5 Submittal

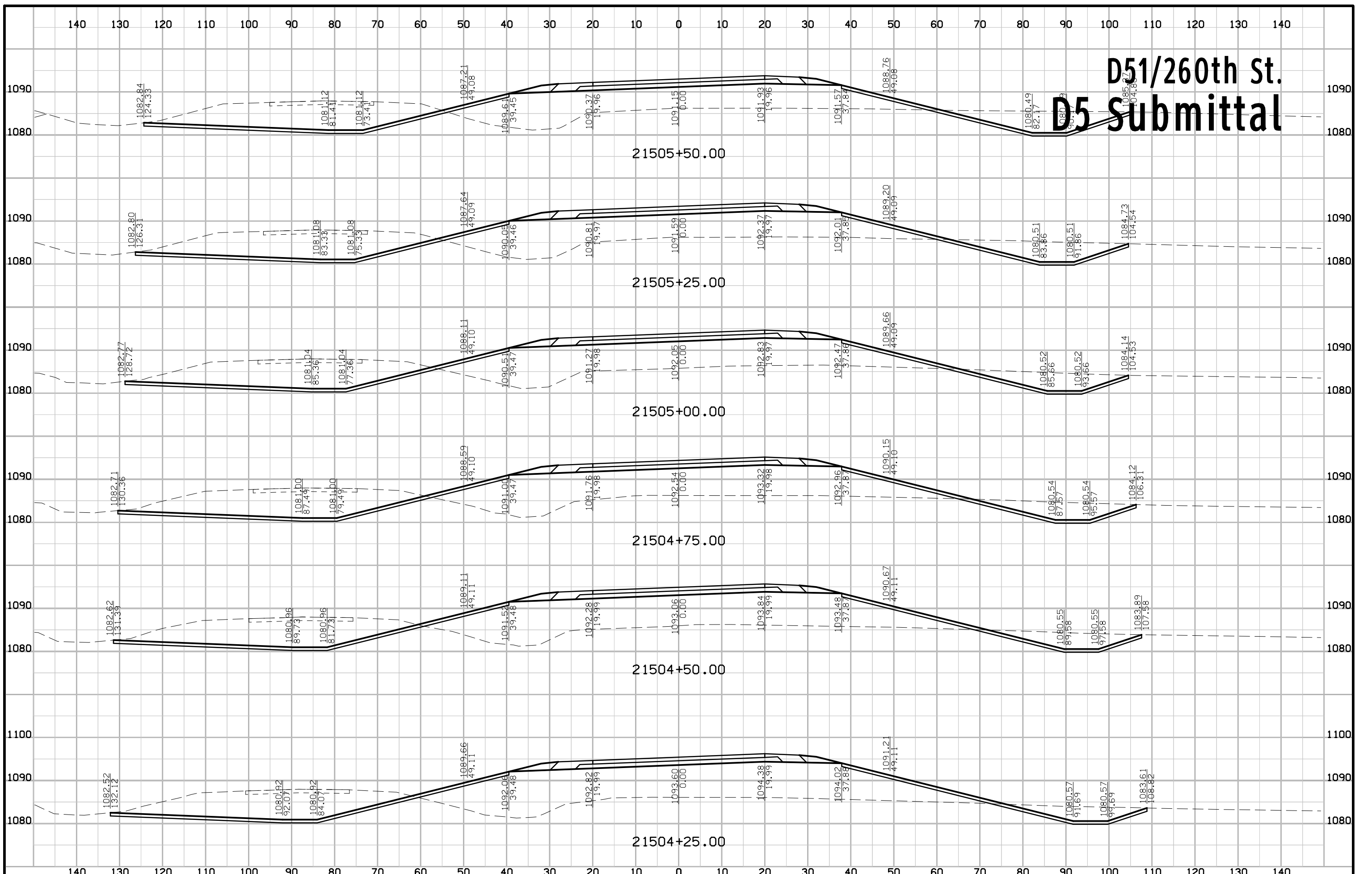

# D51/260th St. D5 Submittal

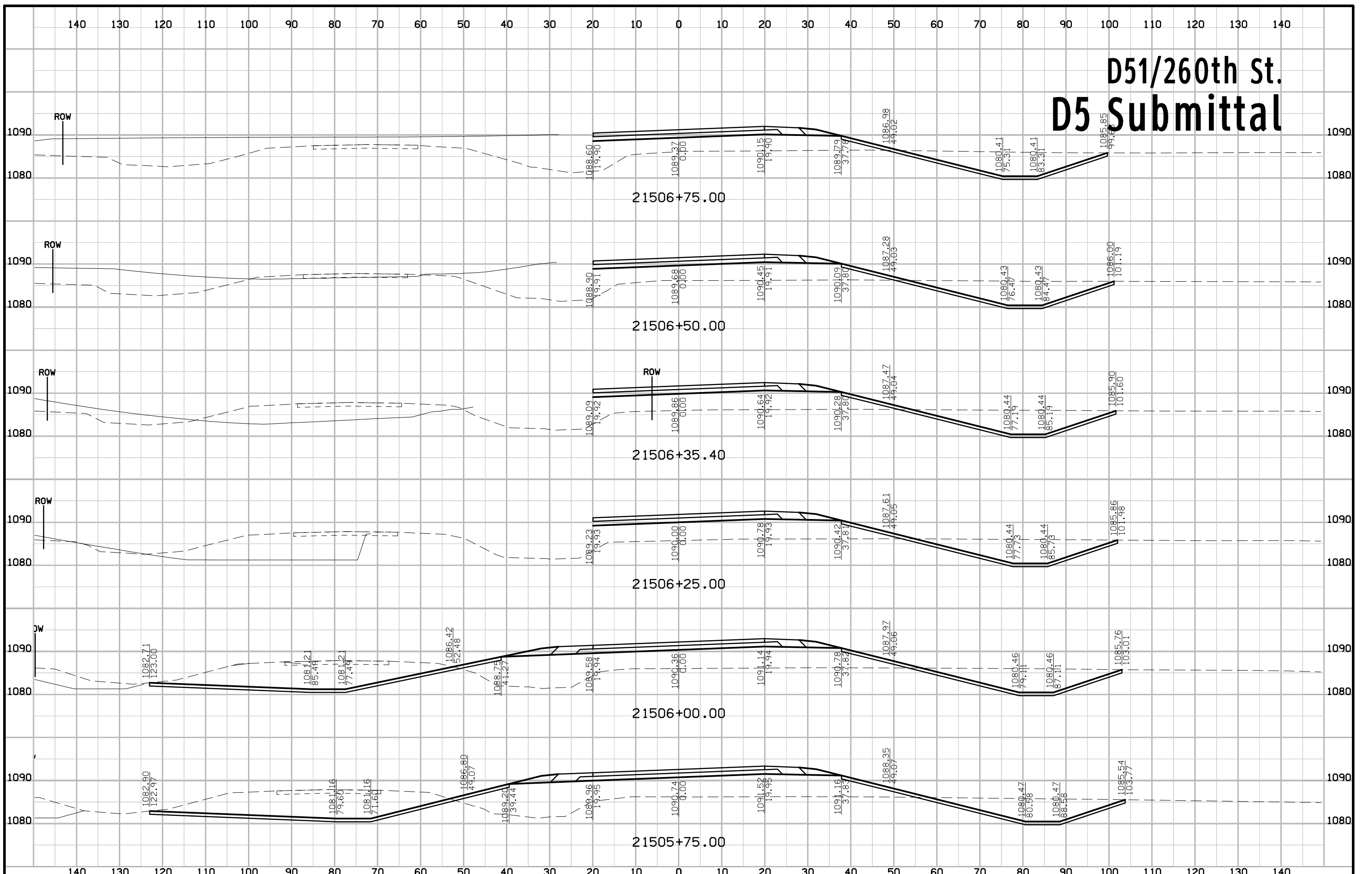

# D51/260th St. D5 Submittal

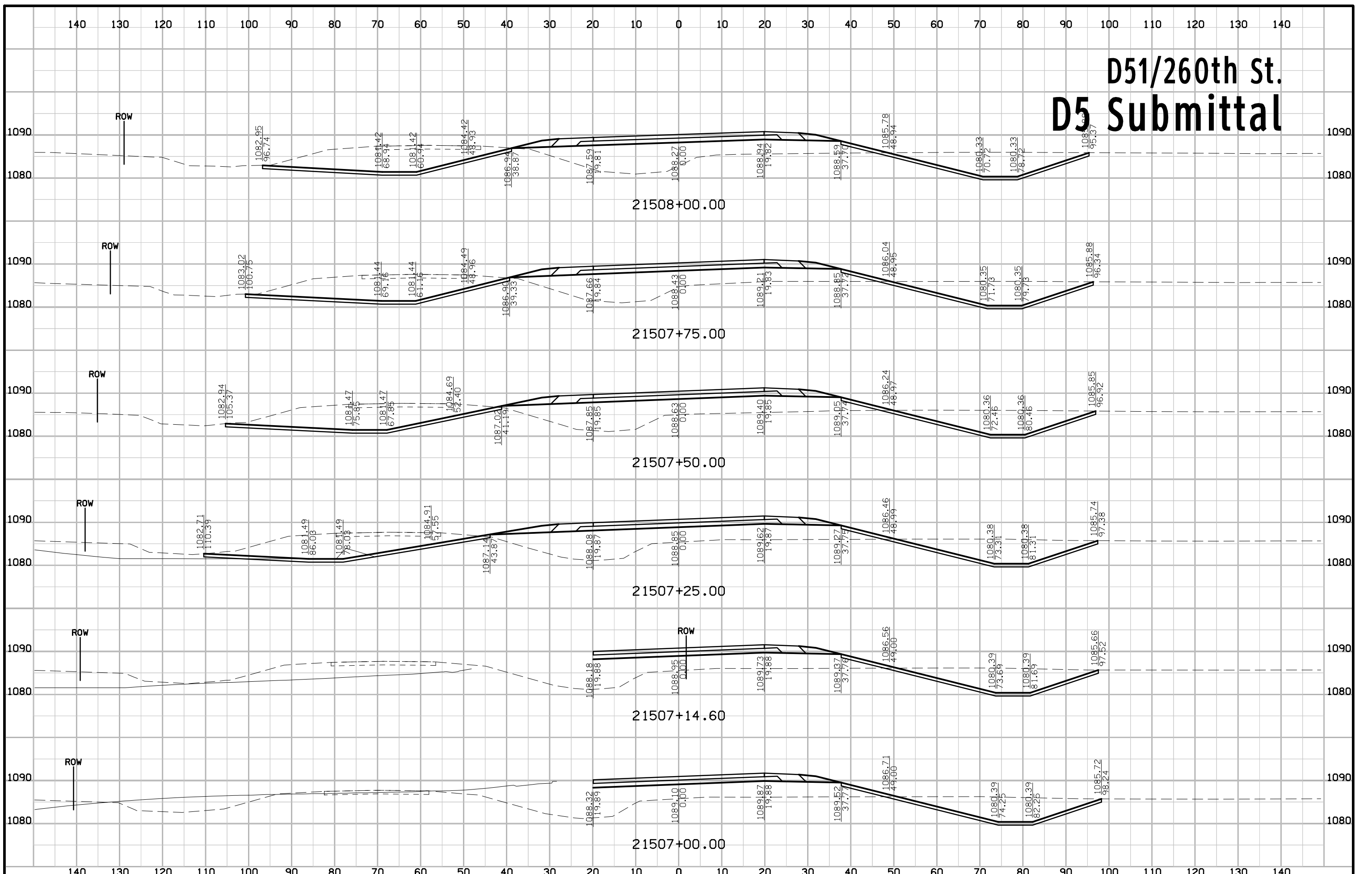

# D51/260th St. D5 Submittal

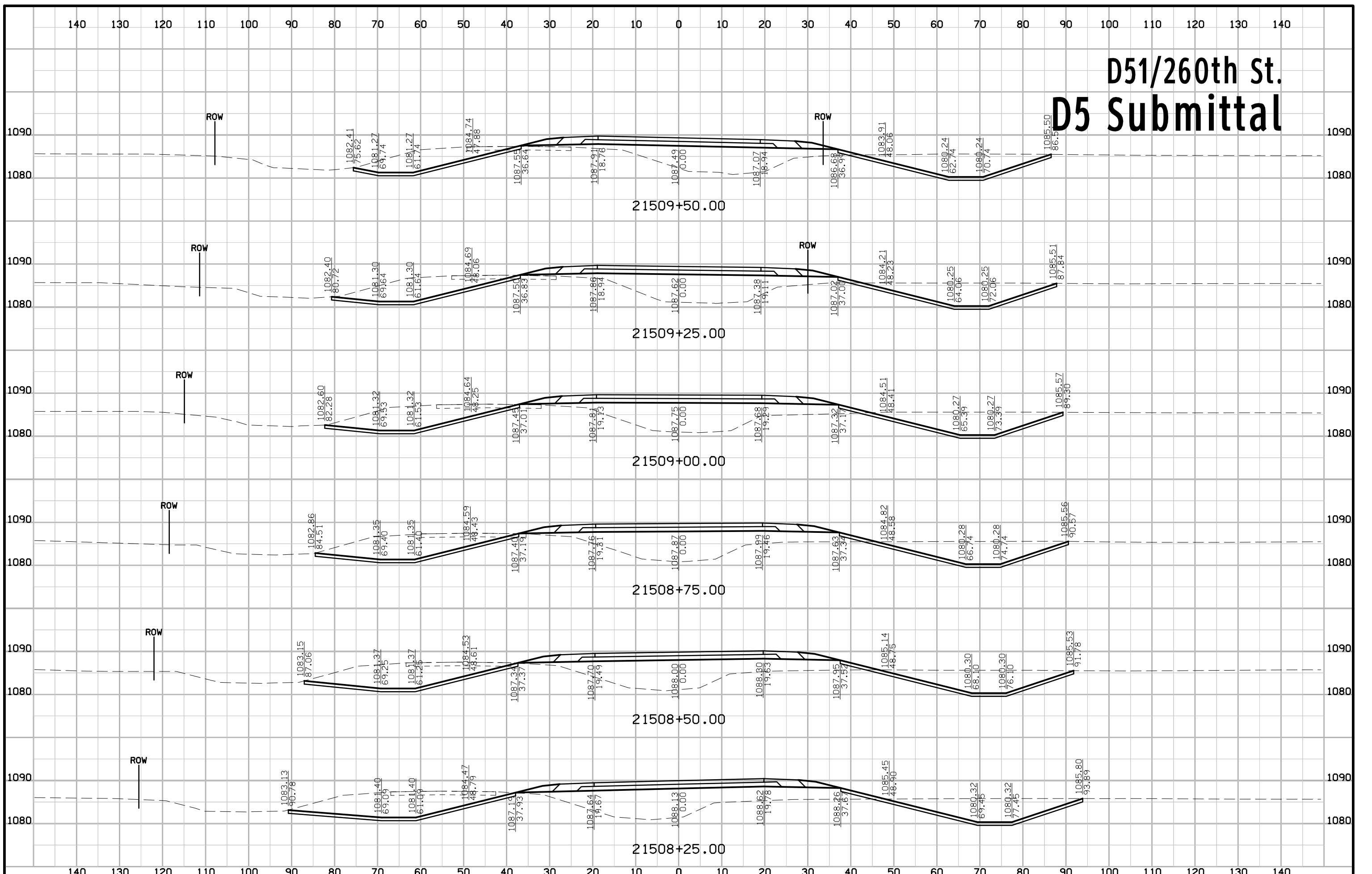

# D51/260th St. D5 Submittal

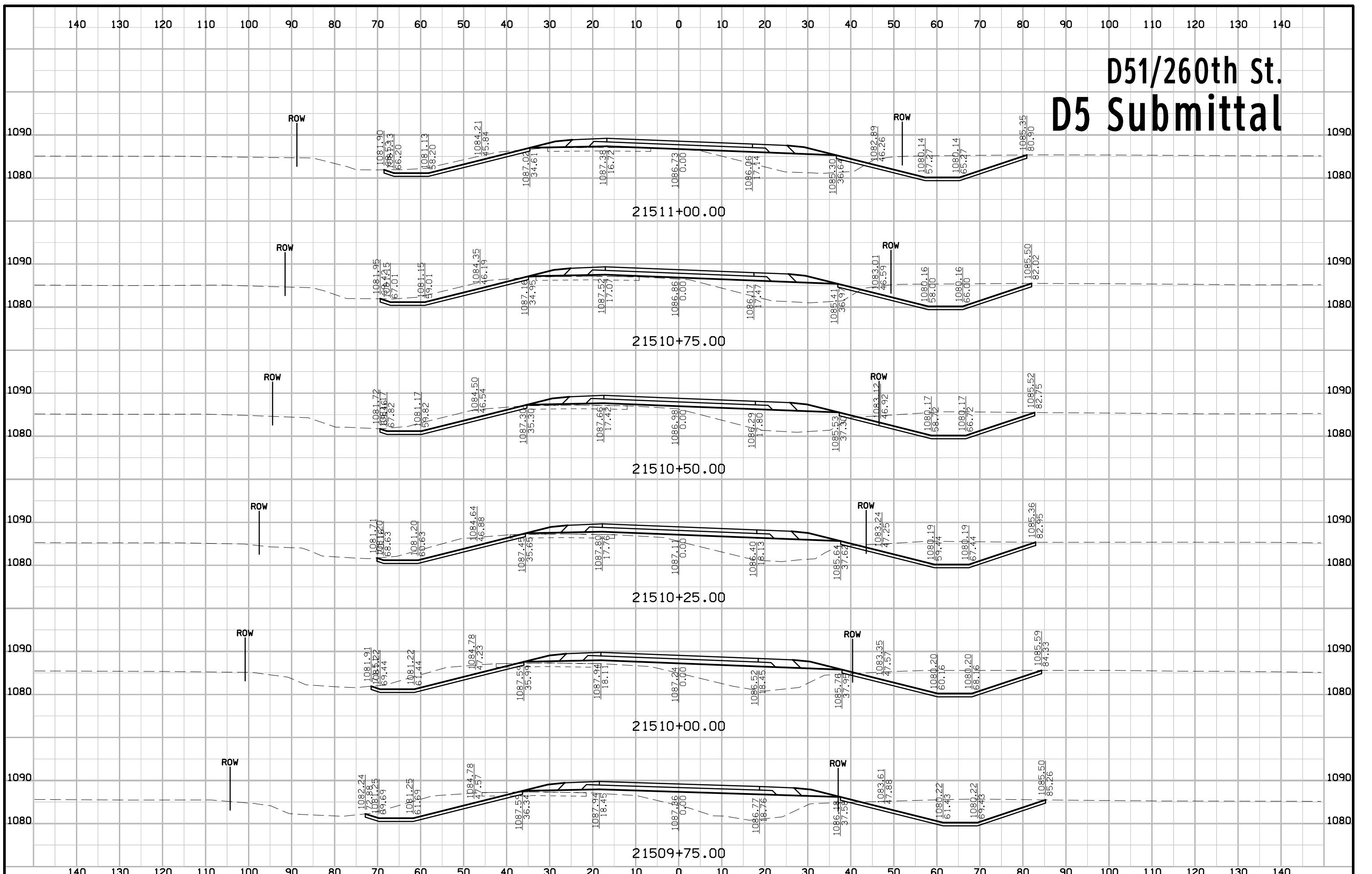



# D51/260th St. D5 Submittal

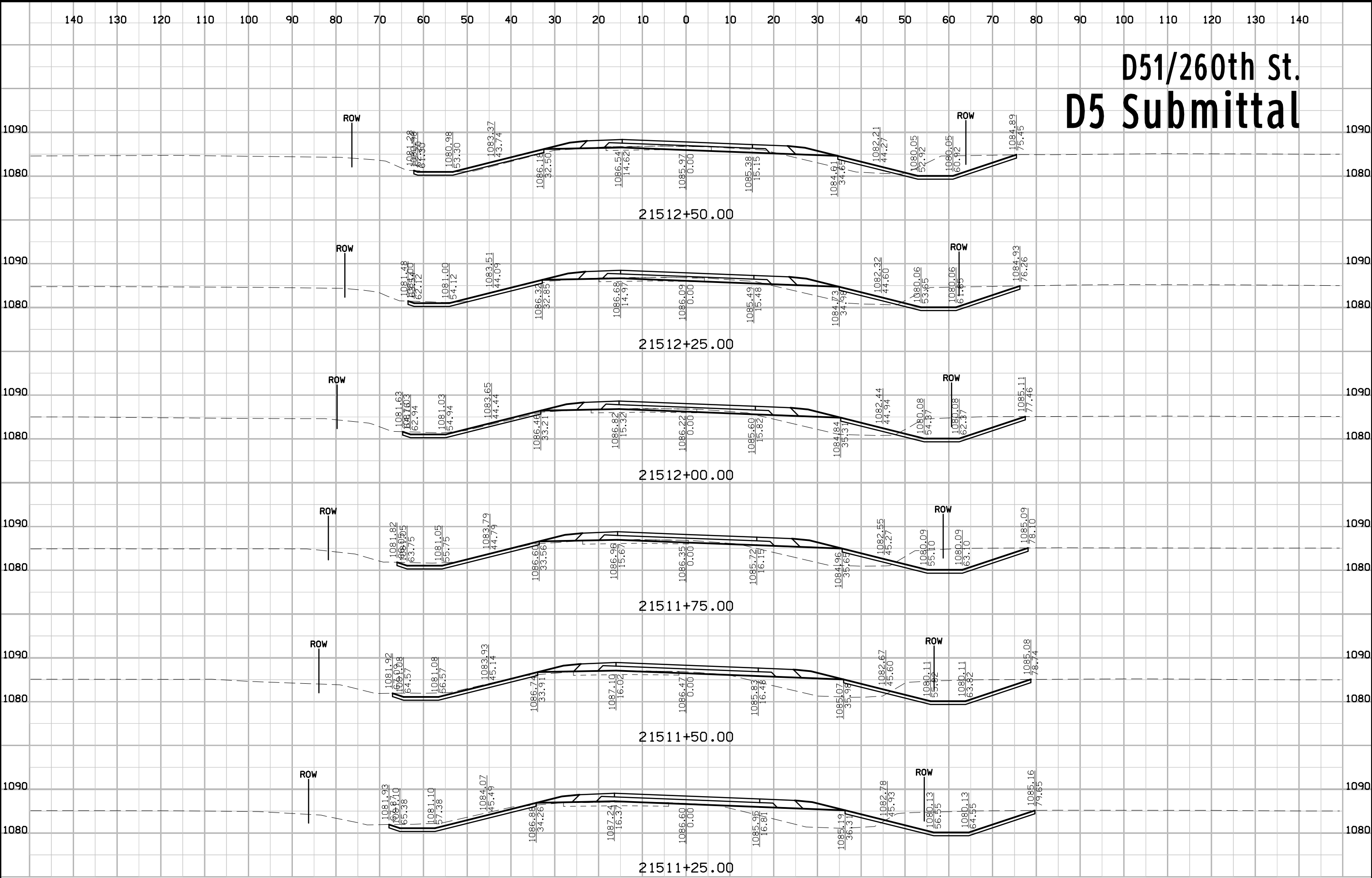

# D51/260th St. D5 Submittal

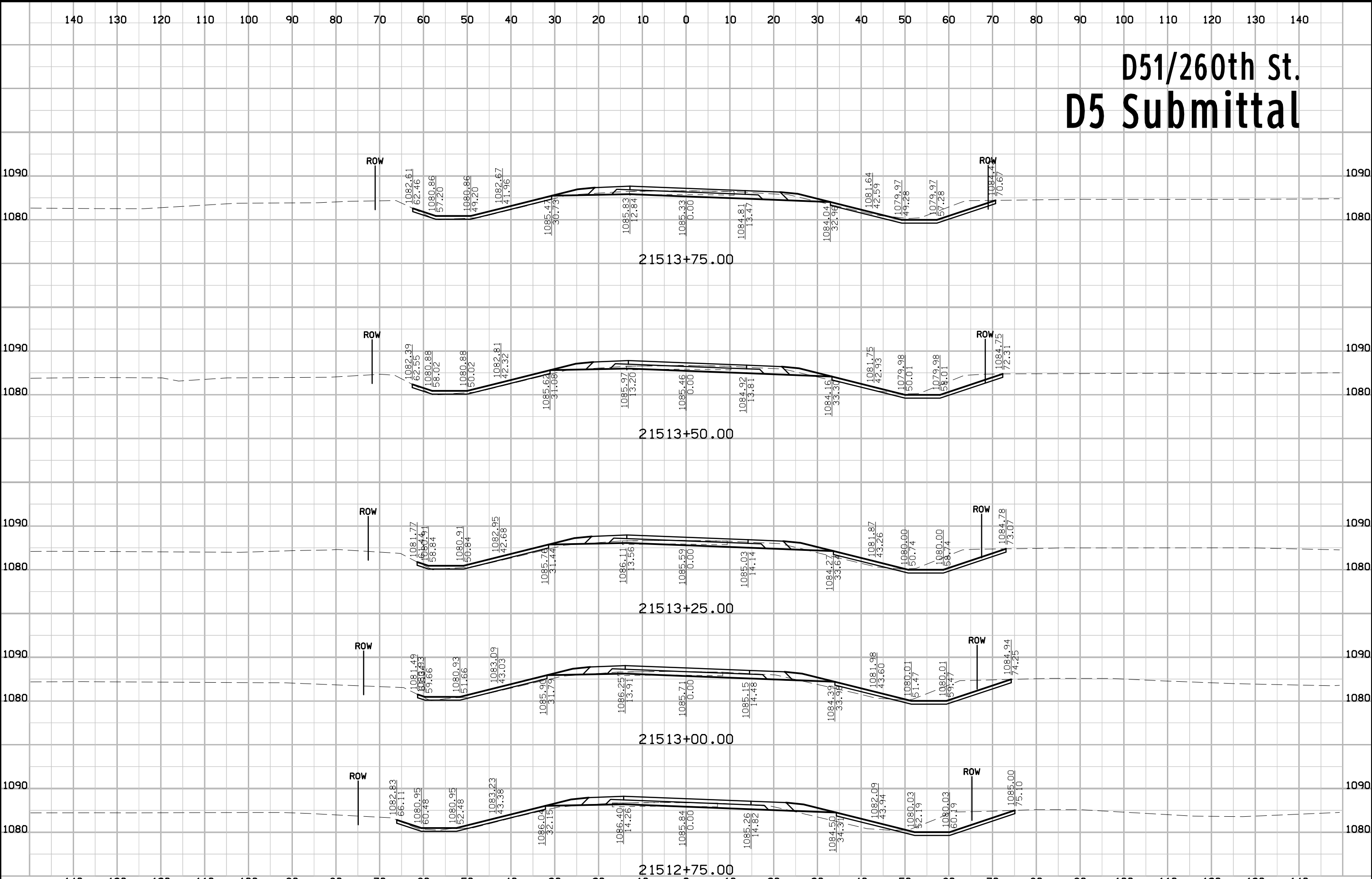

# D51/260th St. D5 Submittal

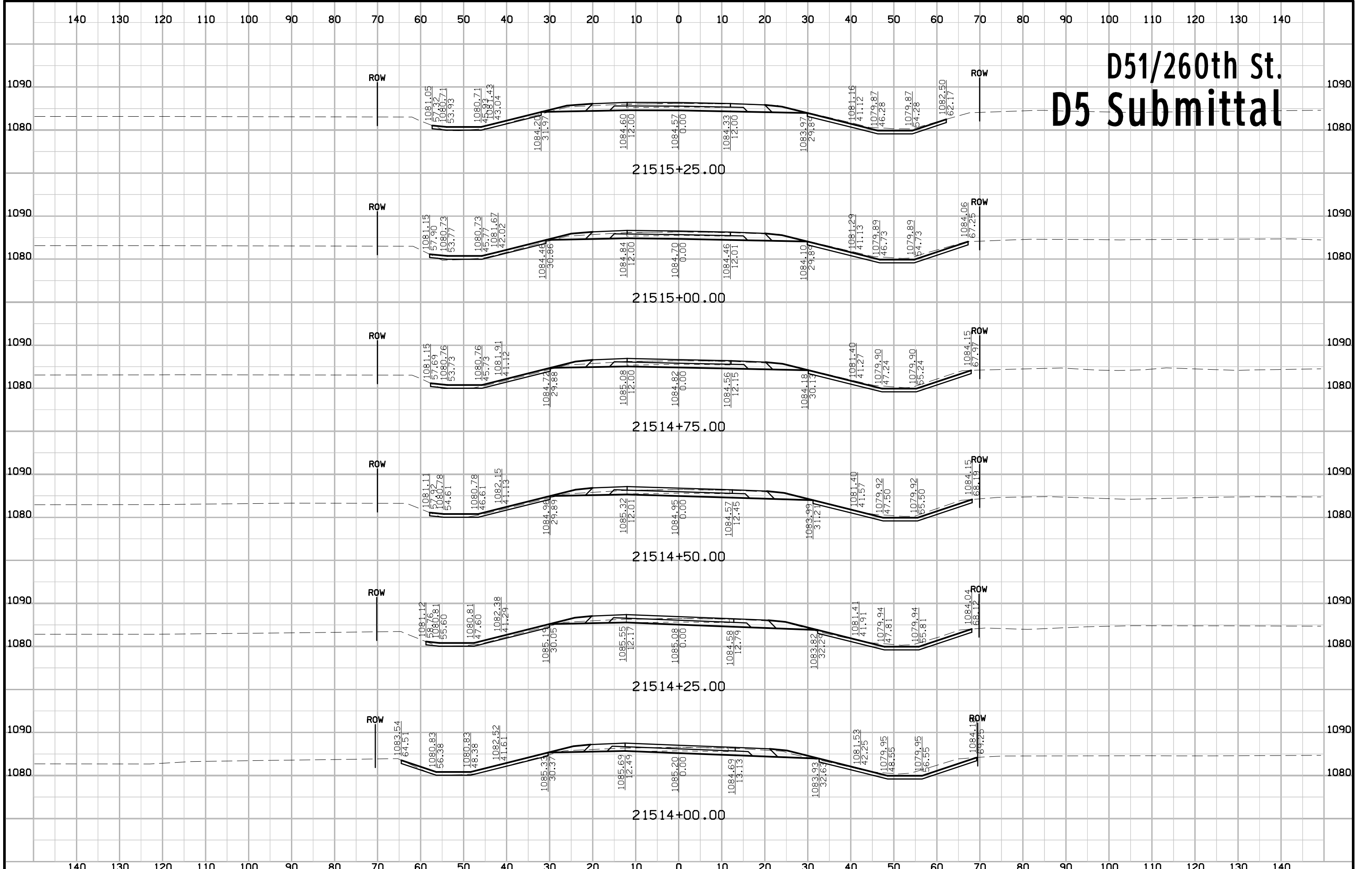

# D51/260th St. D5 Submittal

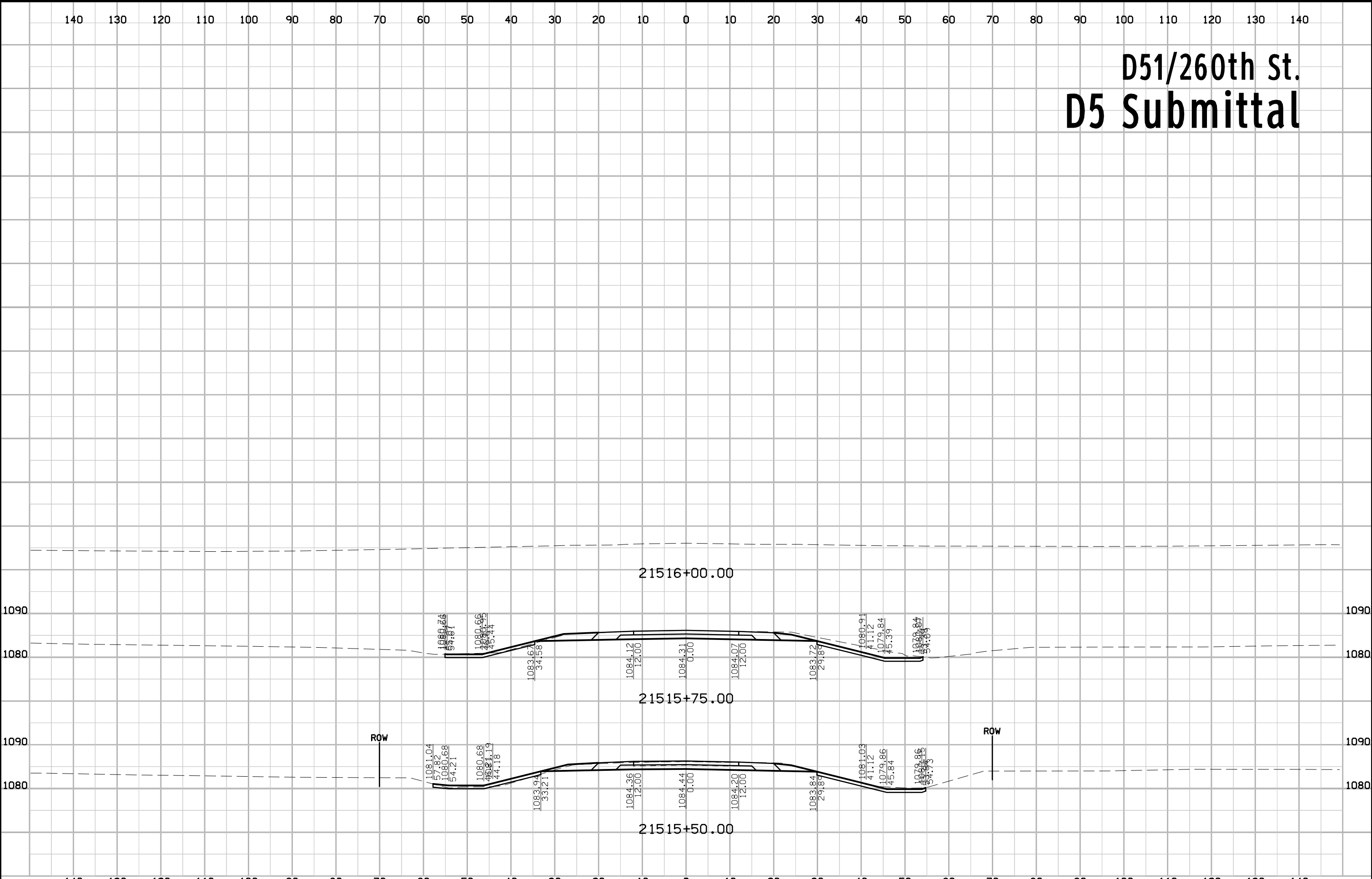

# Burnett Ave. D5 Submittal

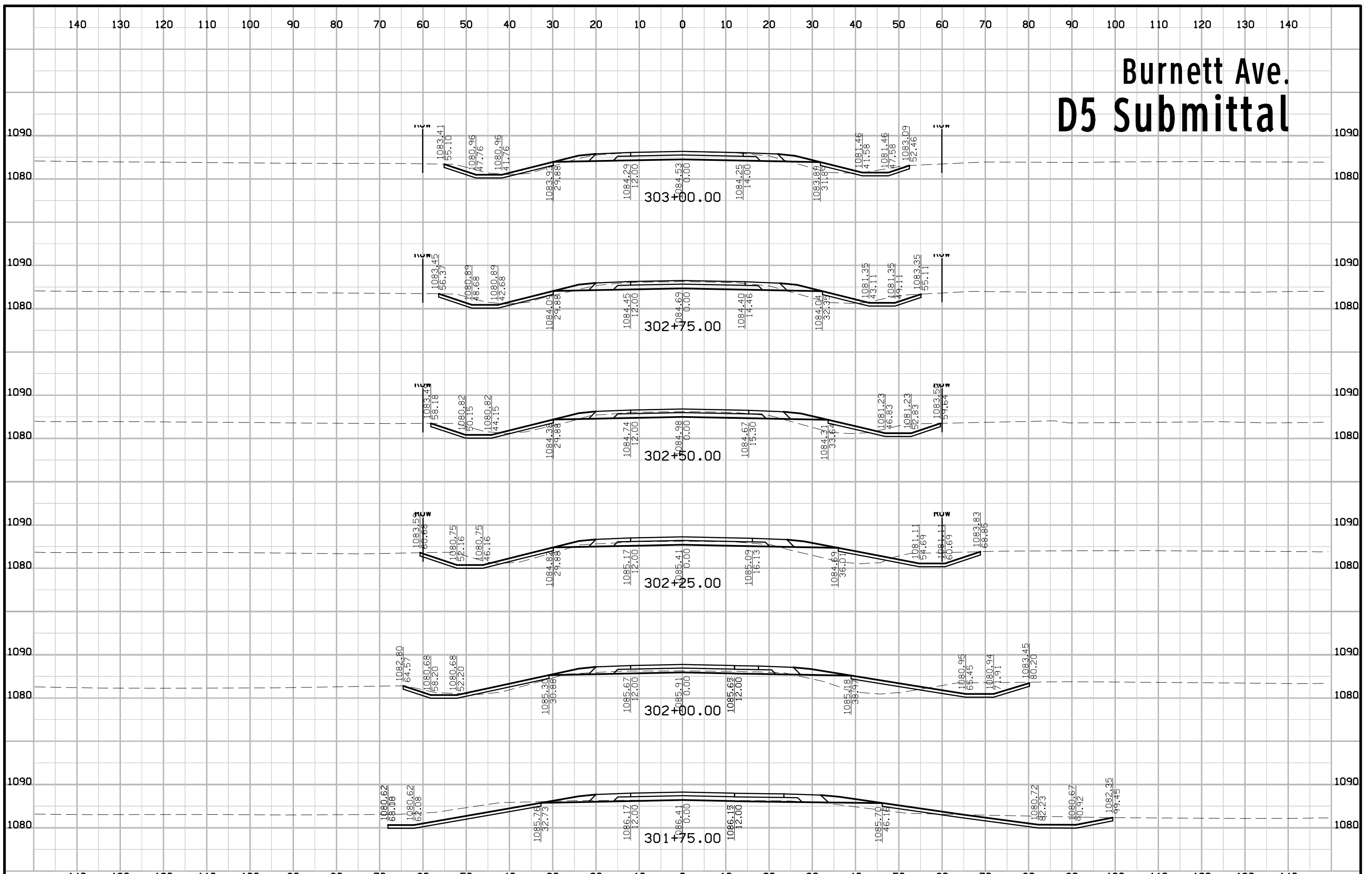

# Burnett Ave. D5 Submittal

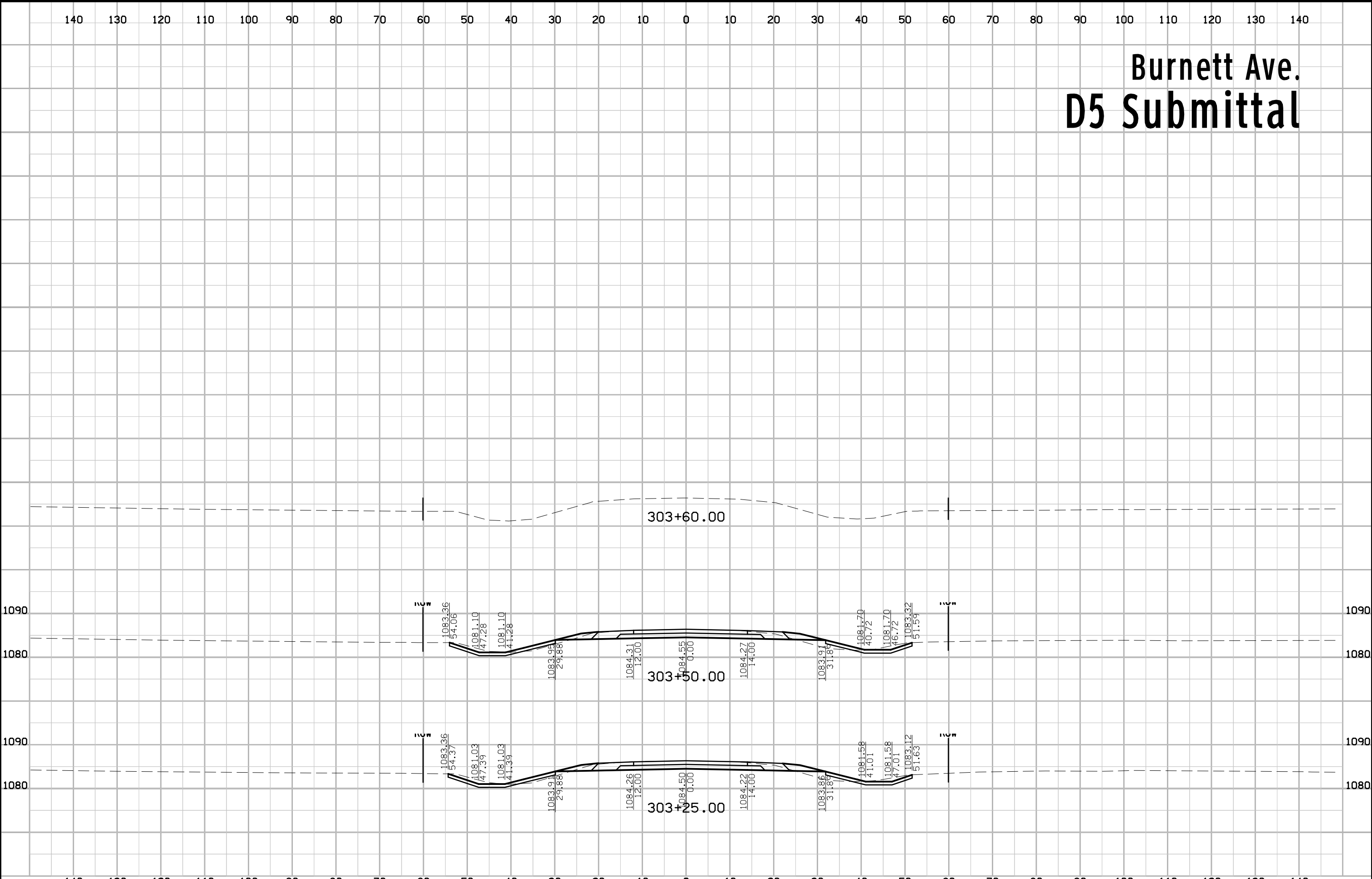

# Liberty Lane D5 Submittal

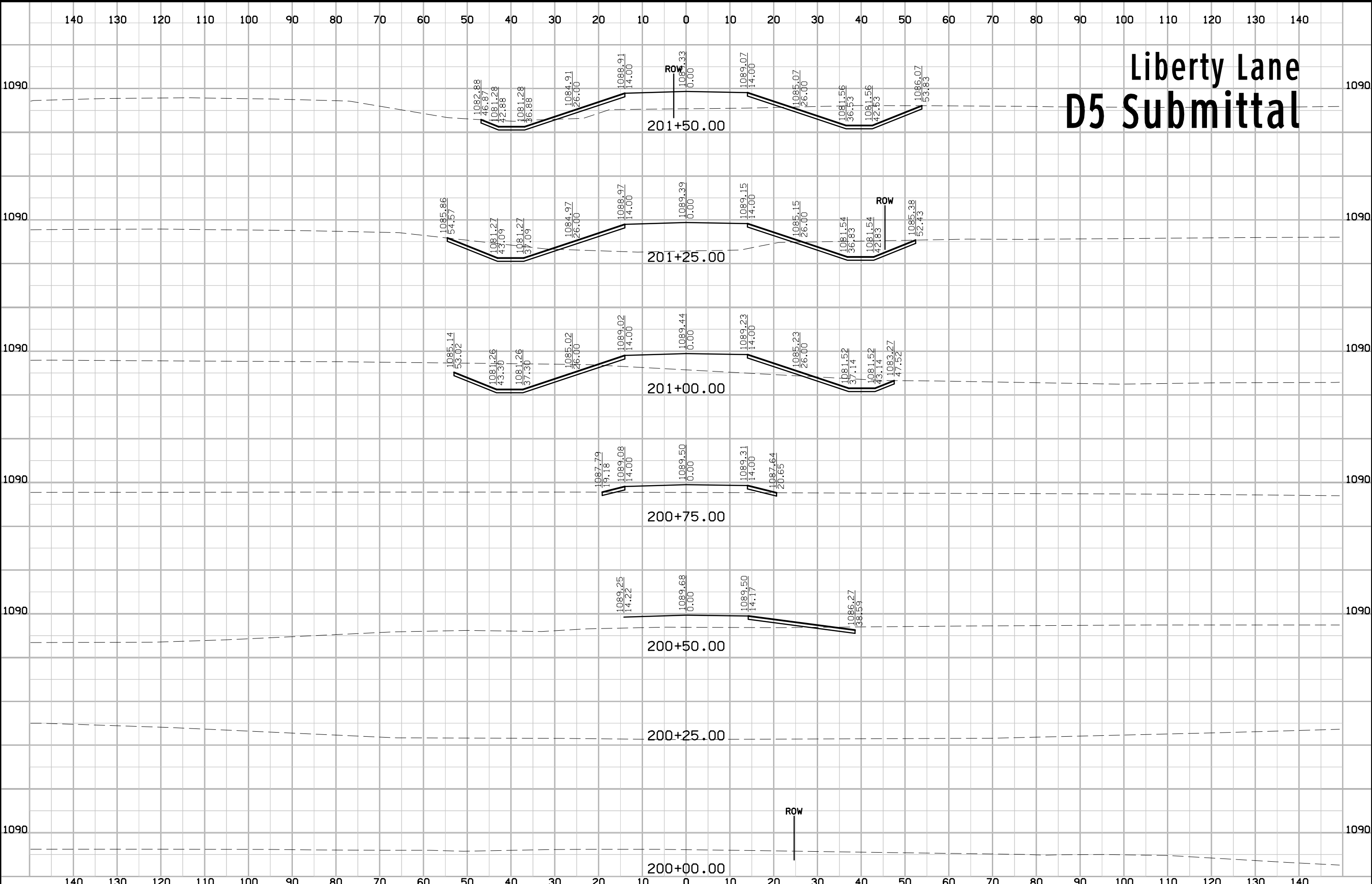

# Liberty Lane D5 Submittal

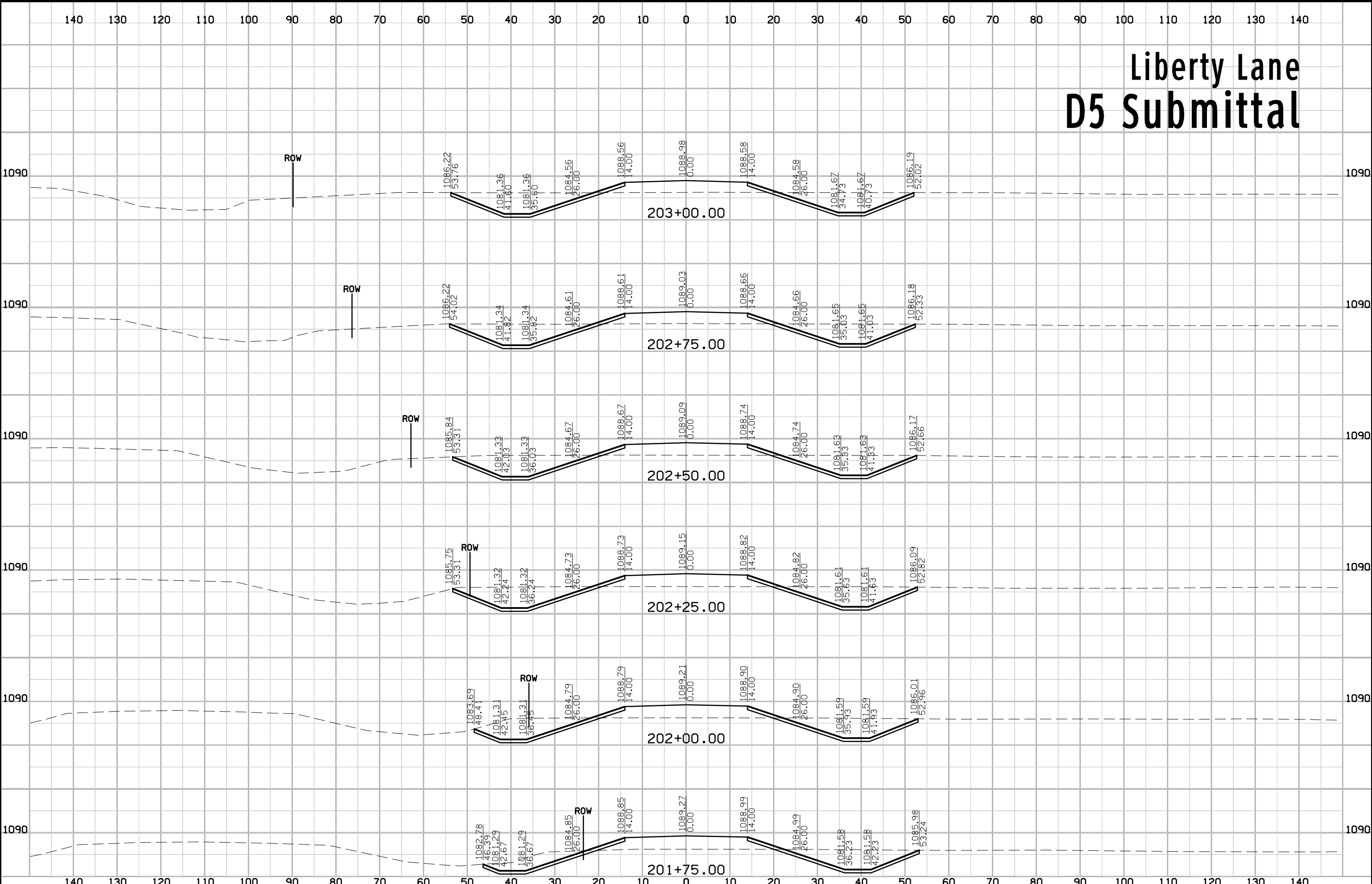



# Liberty Lane D5 Submittal

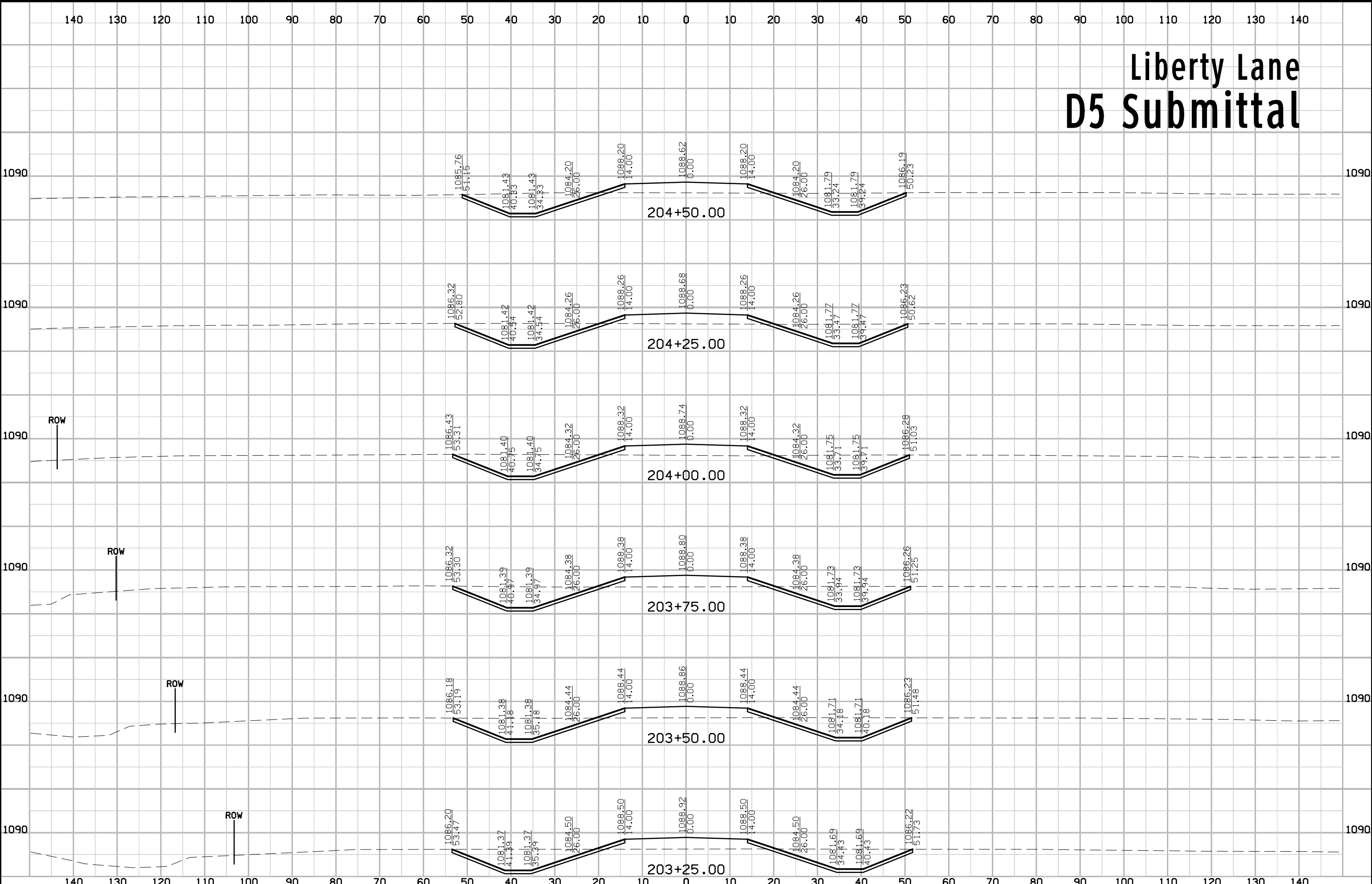

# Liberty Lane D5 Submittal

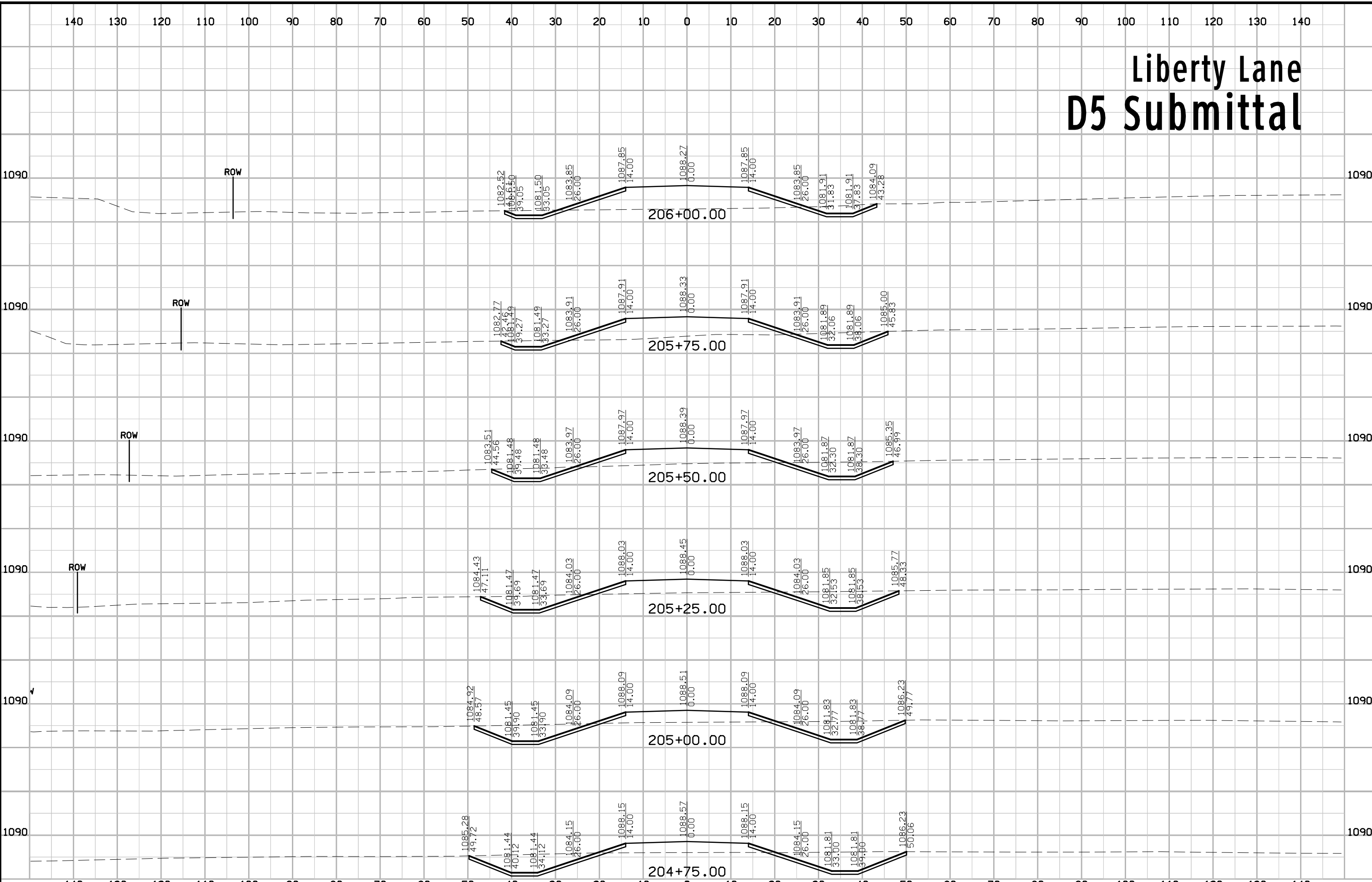

# Liberty Lane D5 Submittal

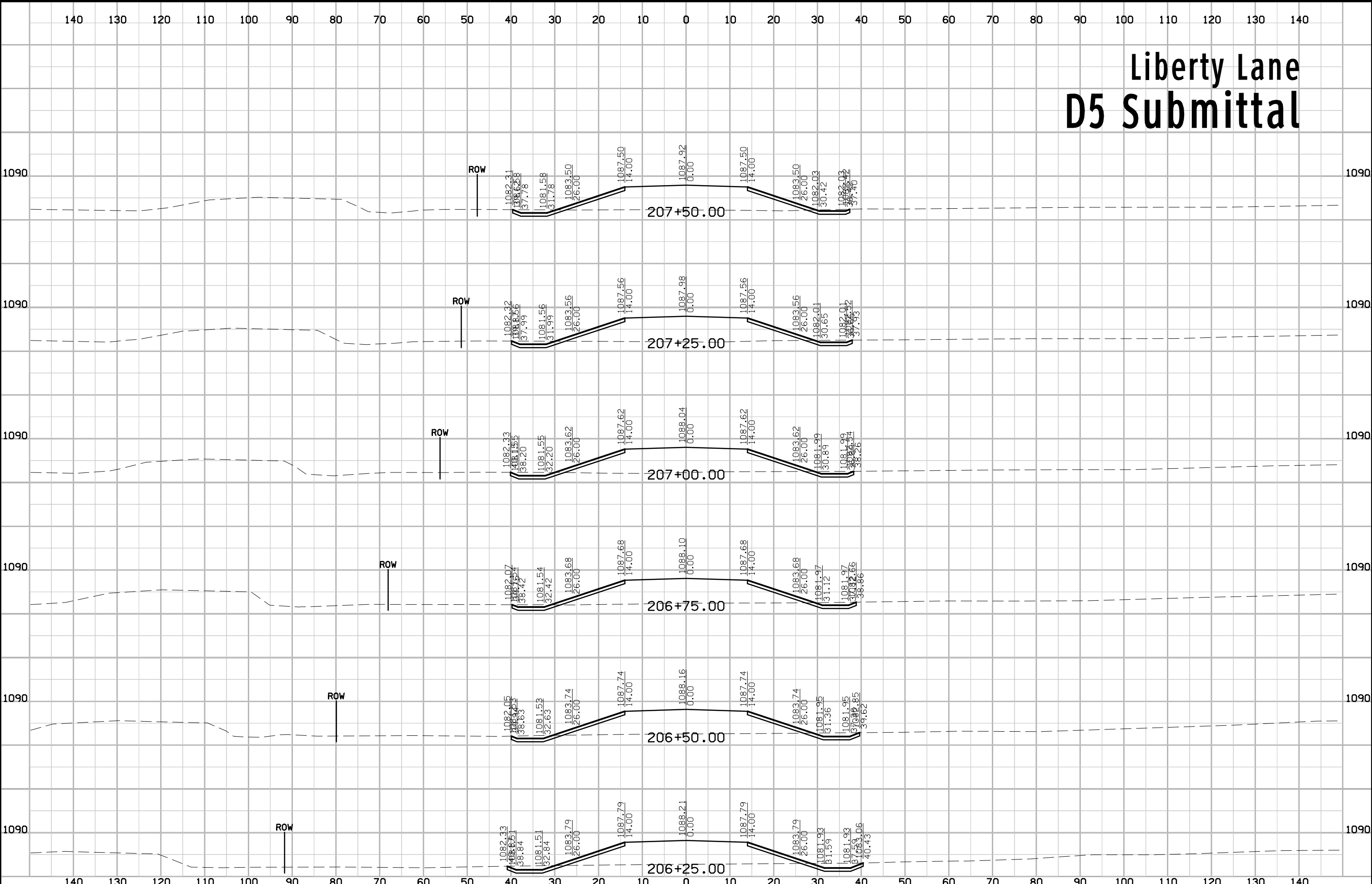

# Liberty Lane D5 Submittal

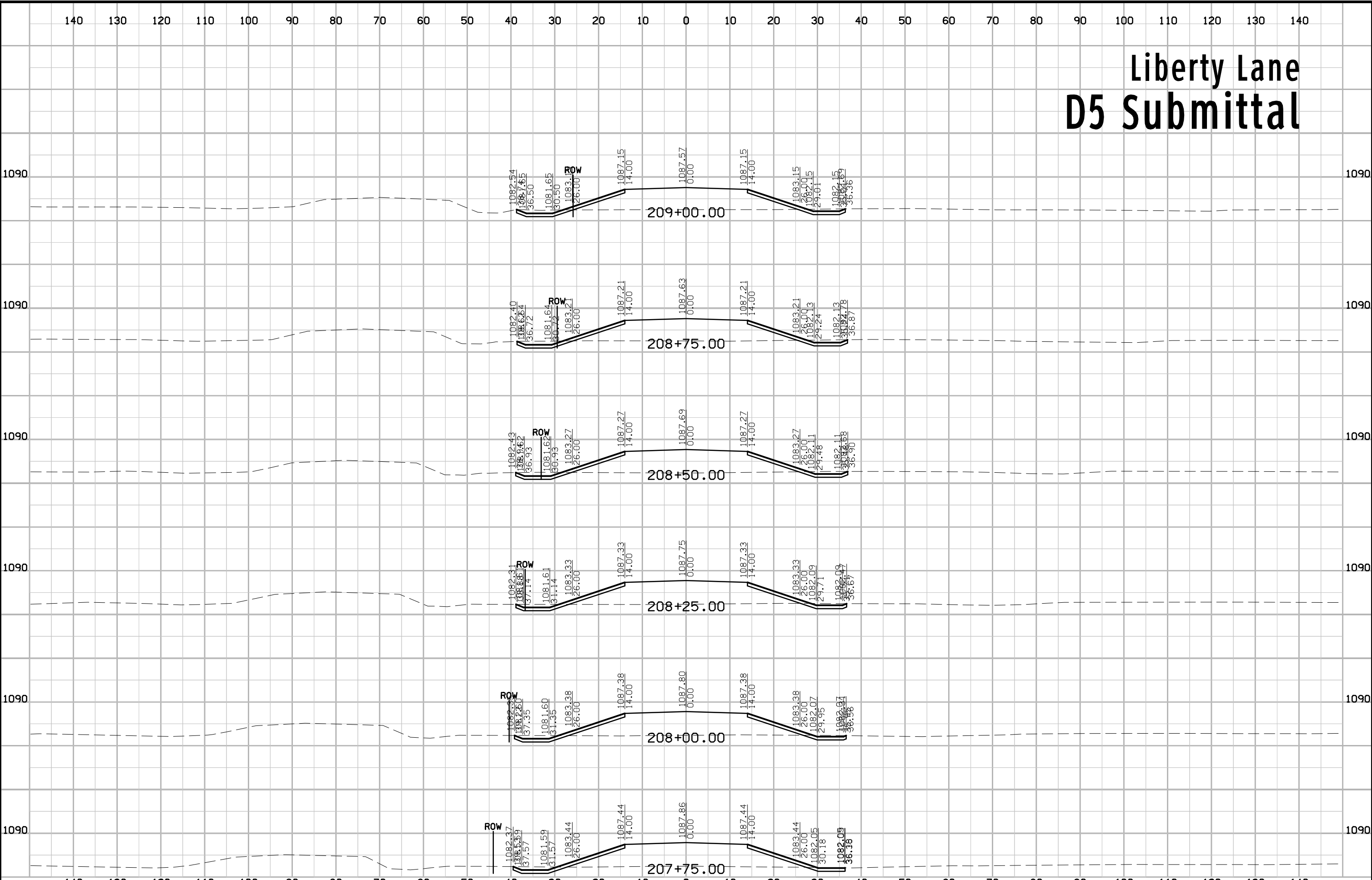

# Liberty Lane D5 Submittal

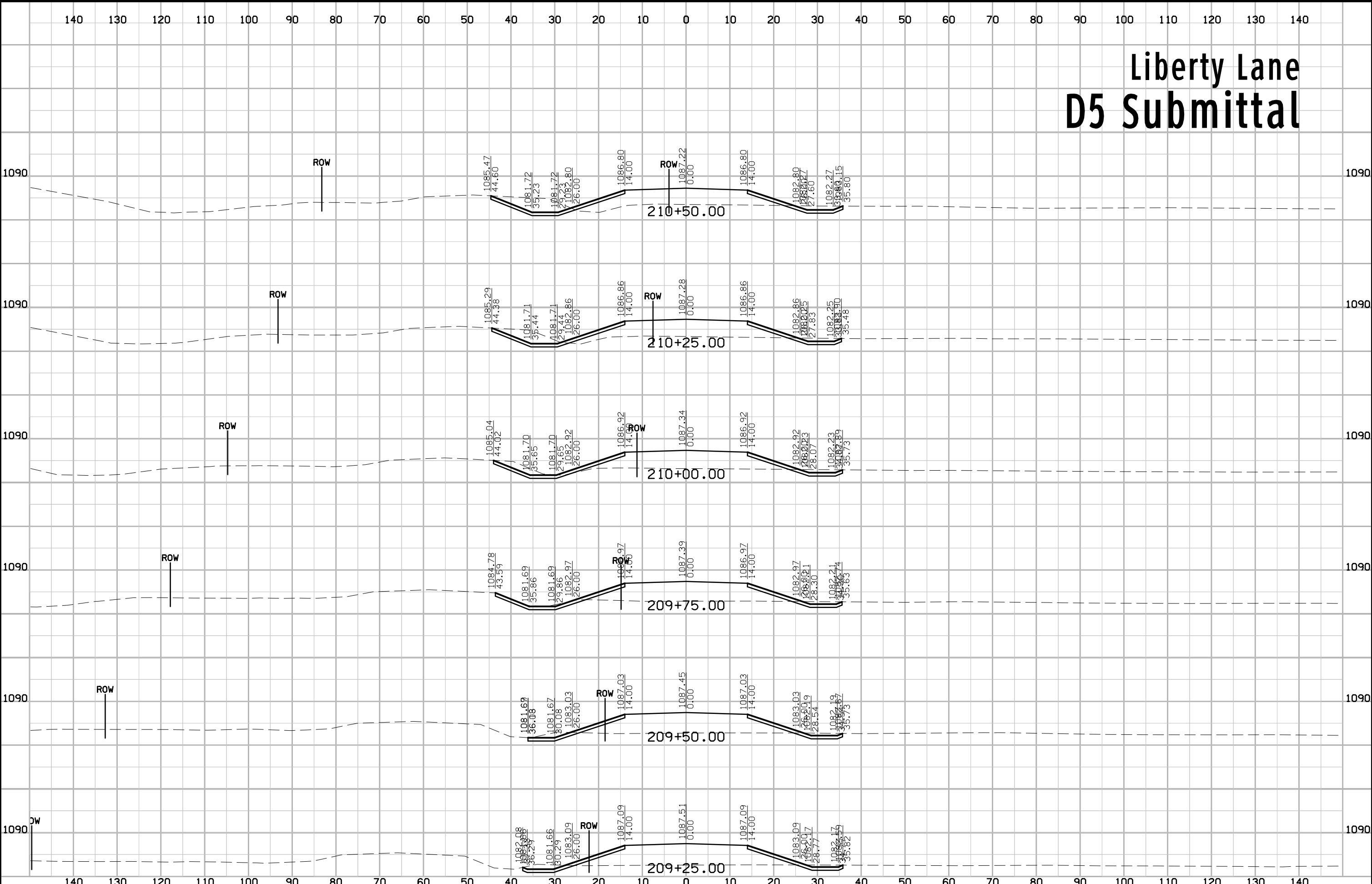

# Liberty Lane D5 Submittal

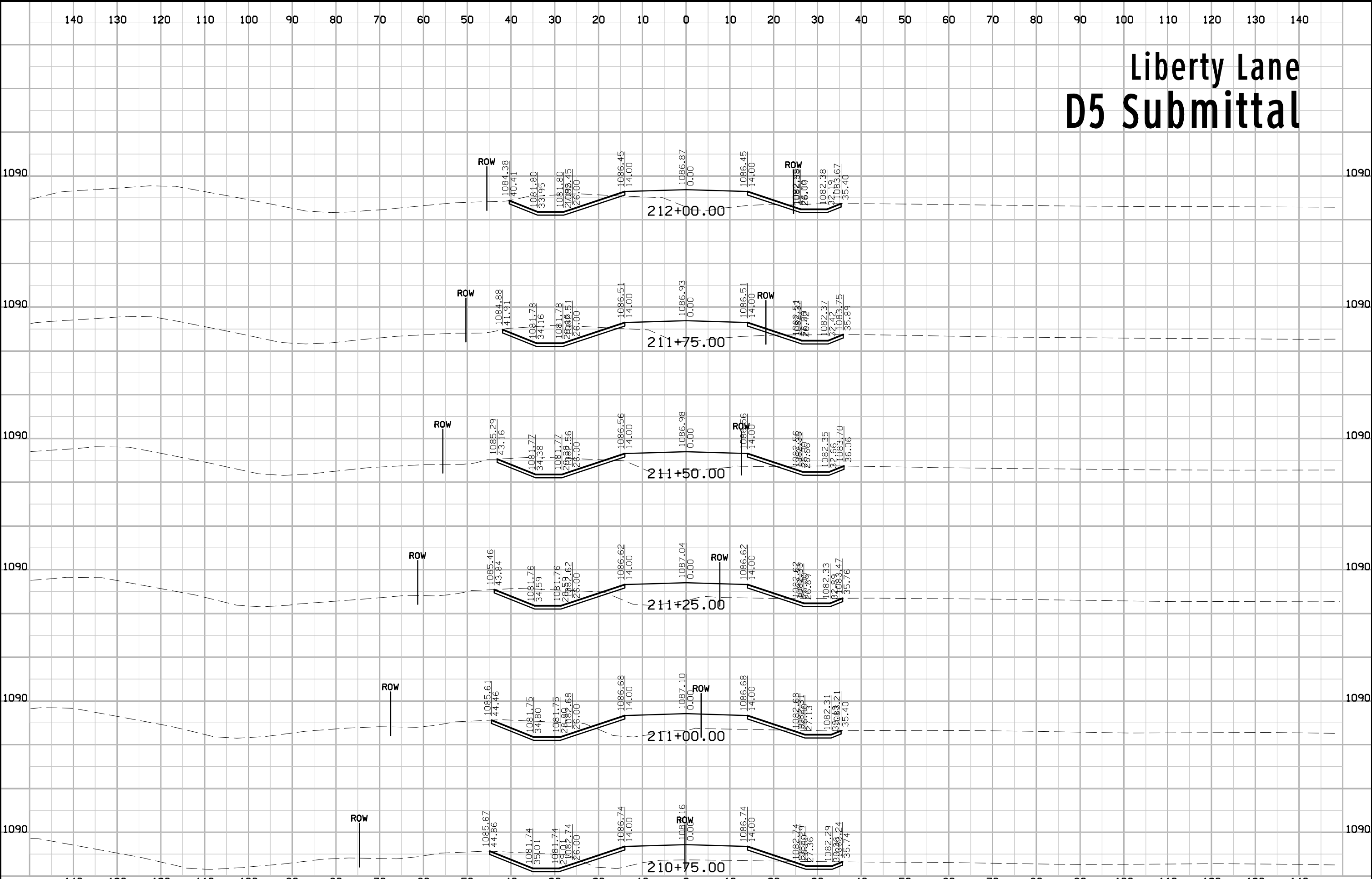

# Liberty Lane D5 Submittal

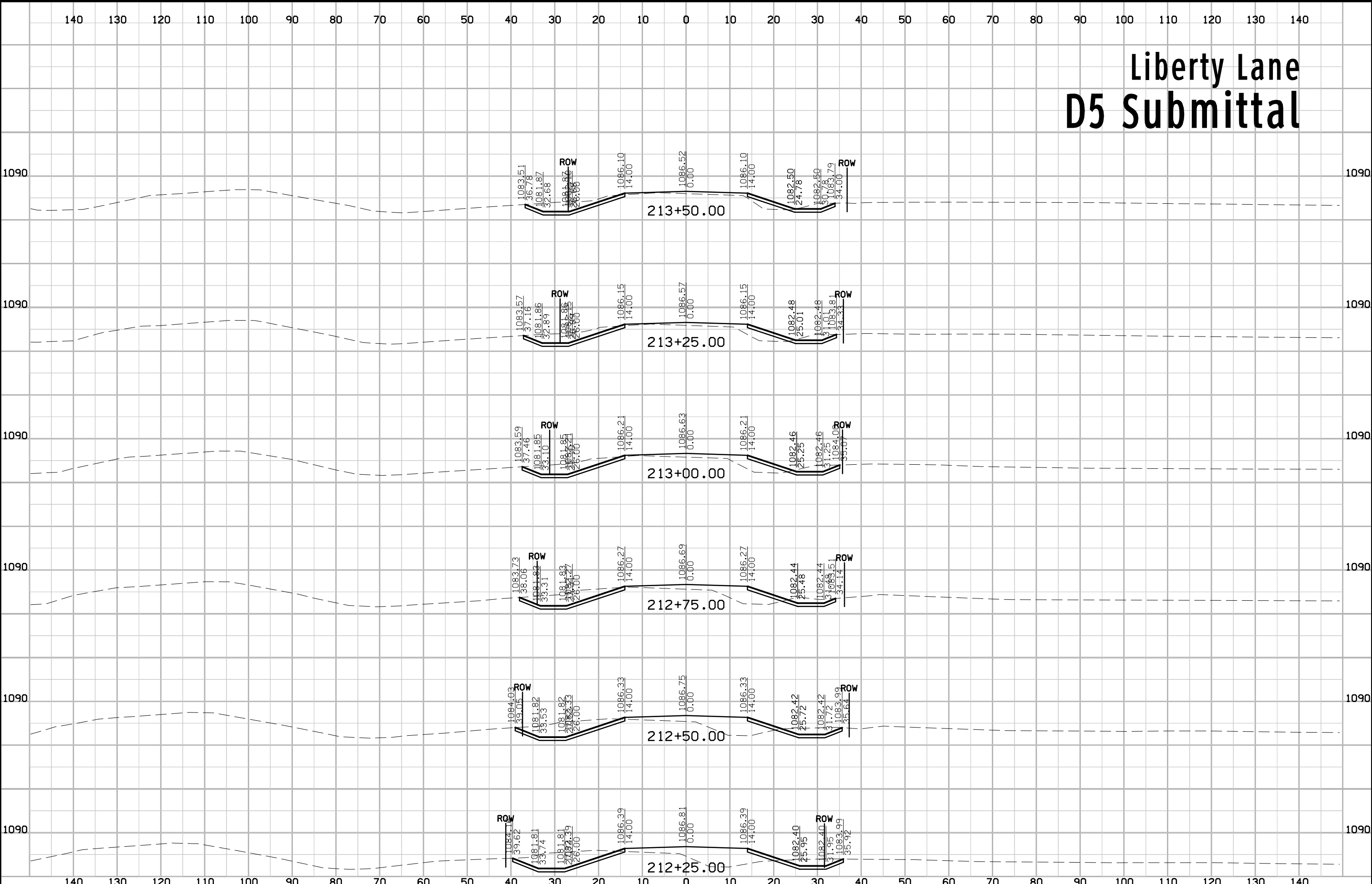

# Liberty Lane D5 Submittal

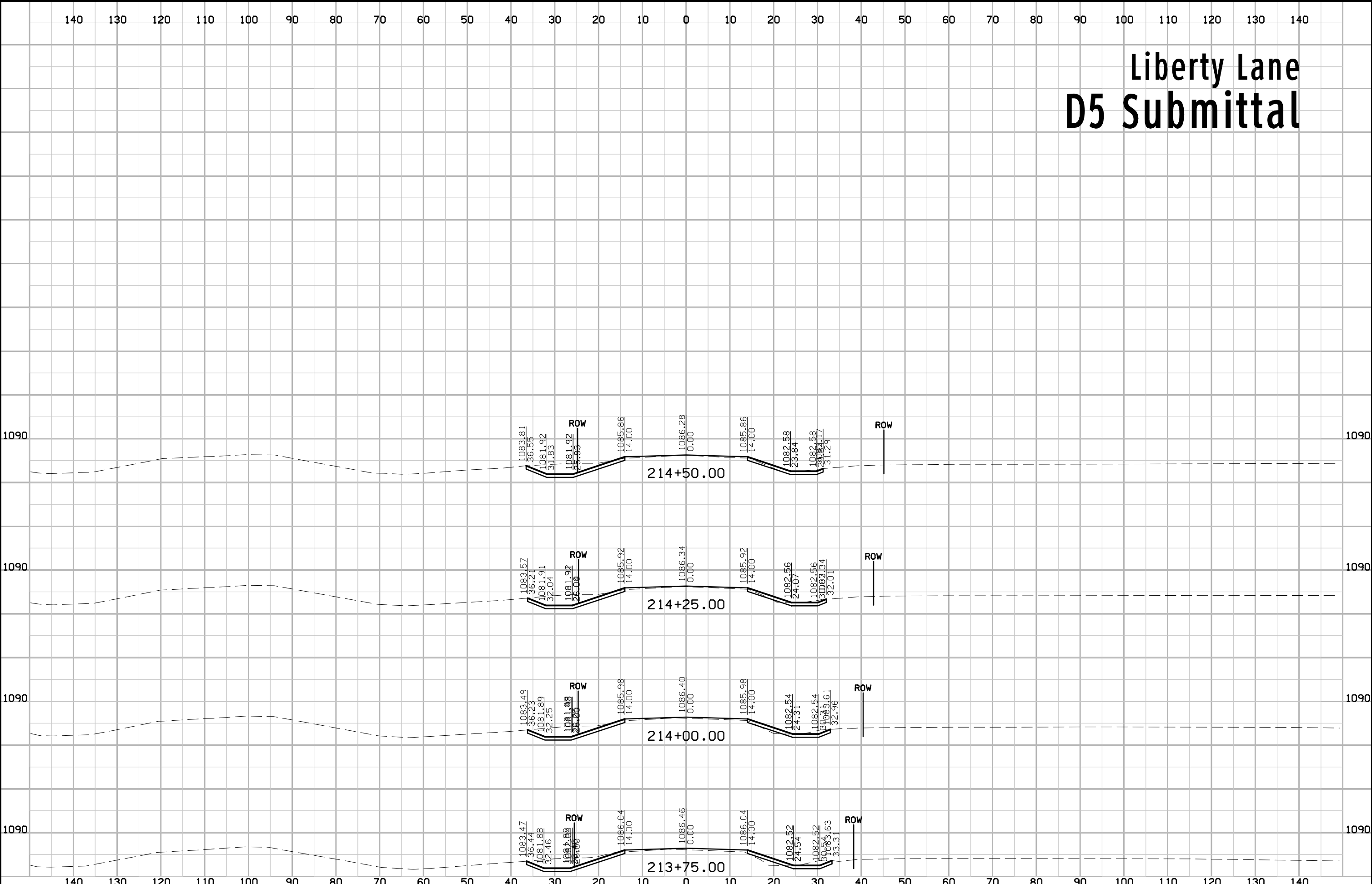



# Entrance Sta. 21476+37 D5 Submittal

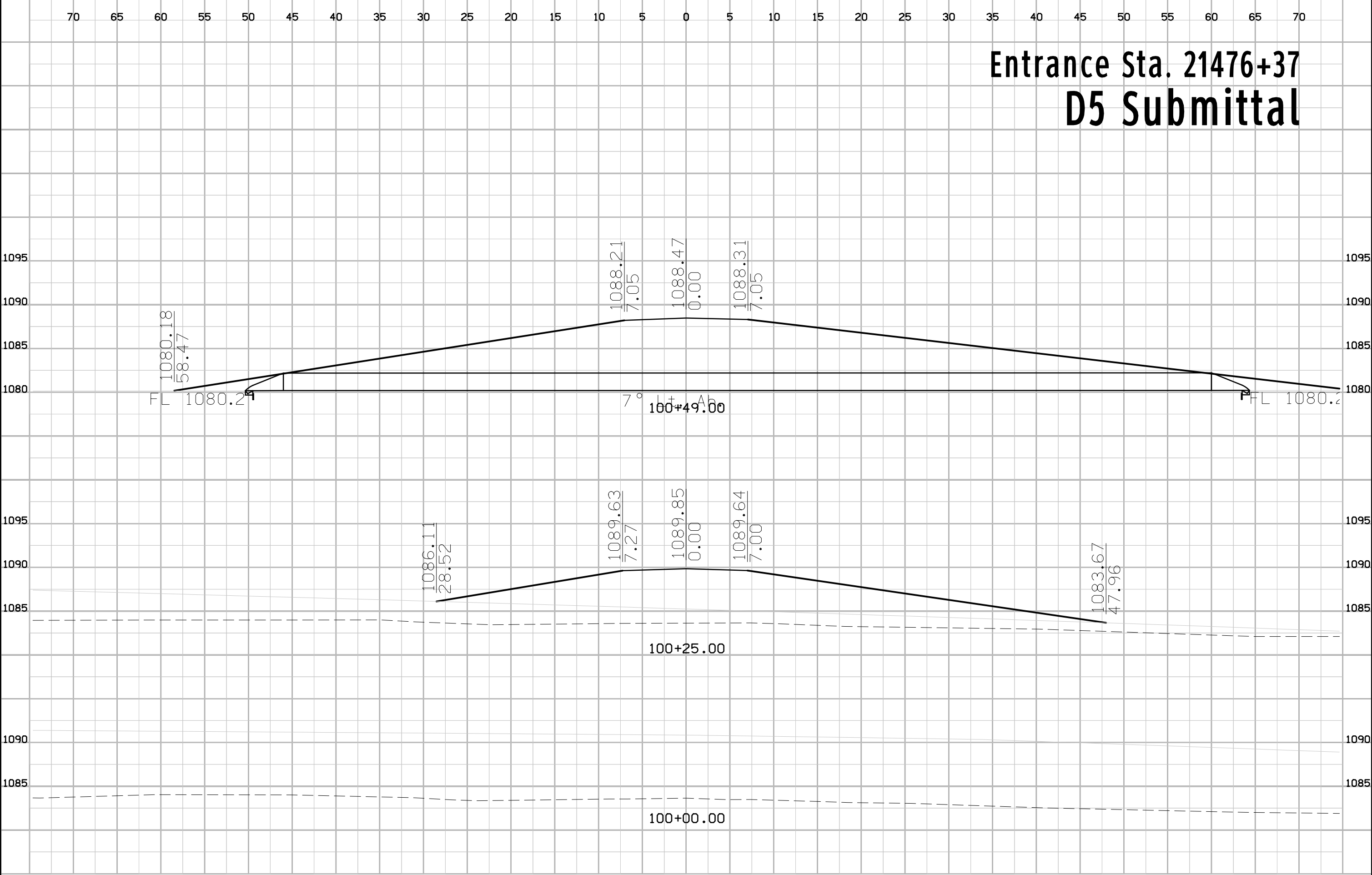

# Entrance Sta. 21476+37 D5 Submittal

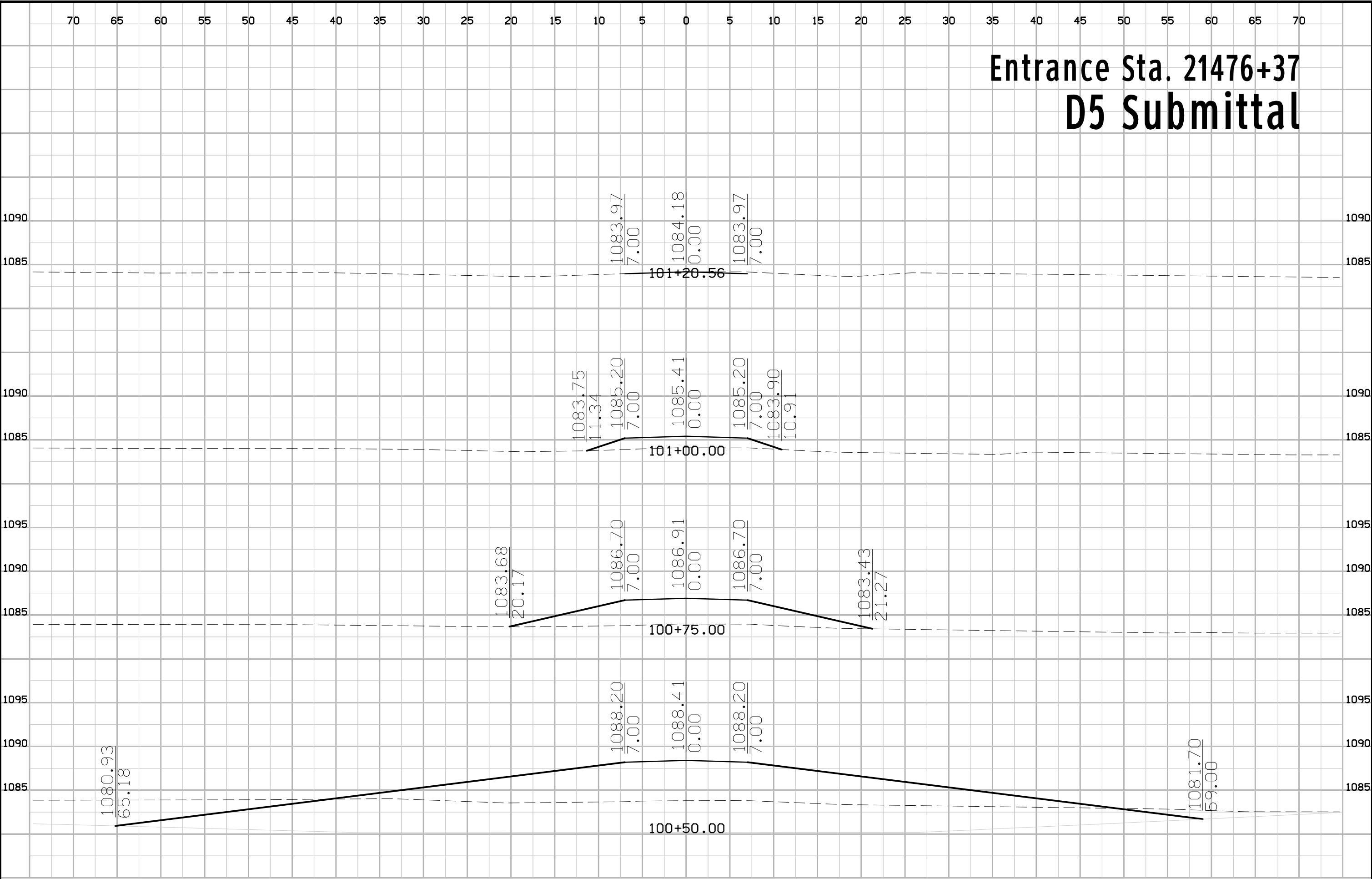

# Liberty Lane D5 Submittal

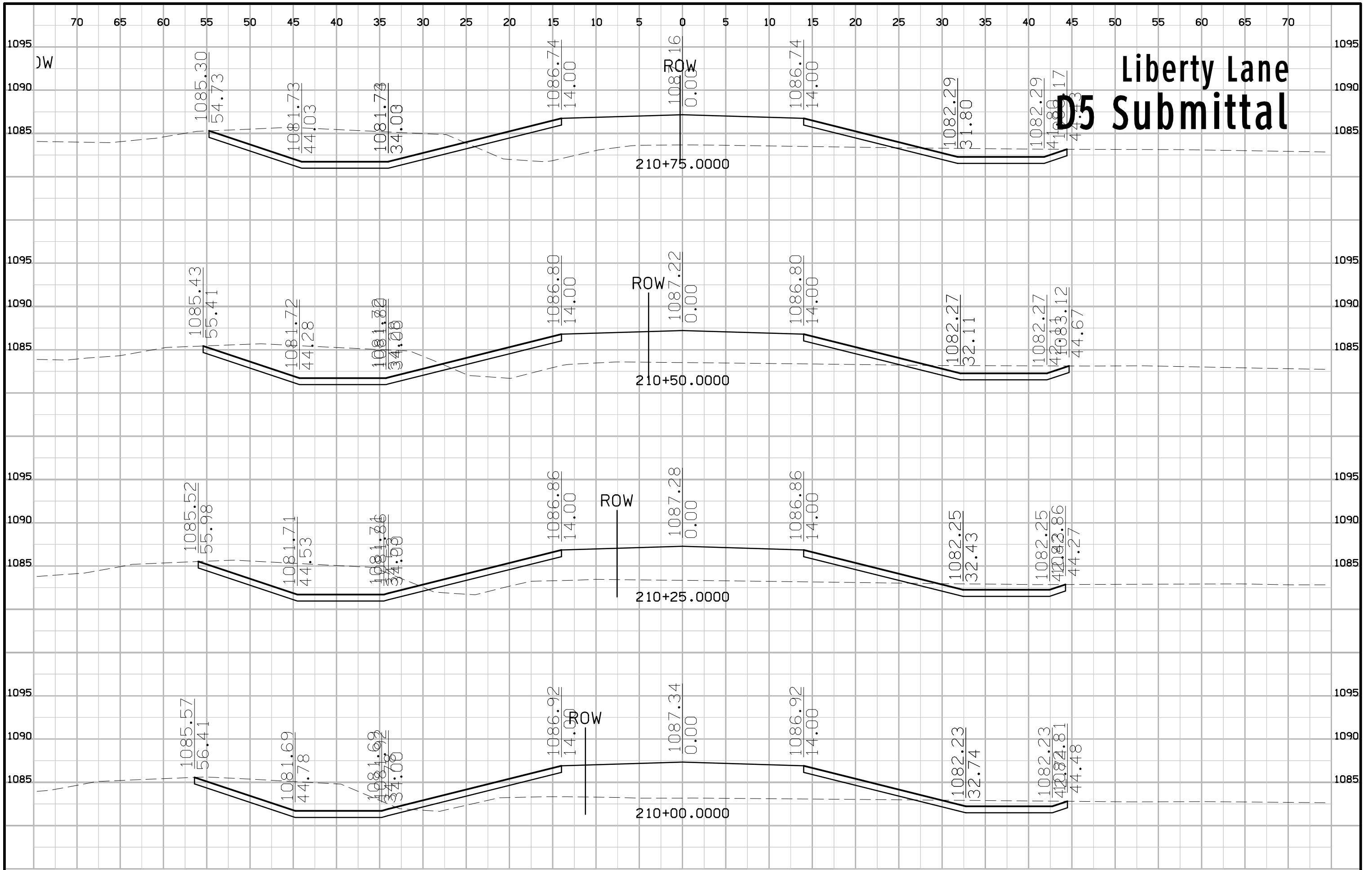

# Liberty Lane D5 Submittal

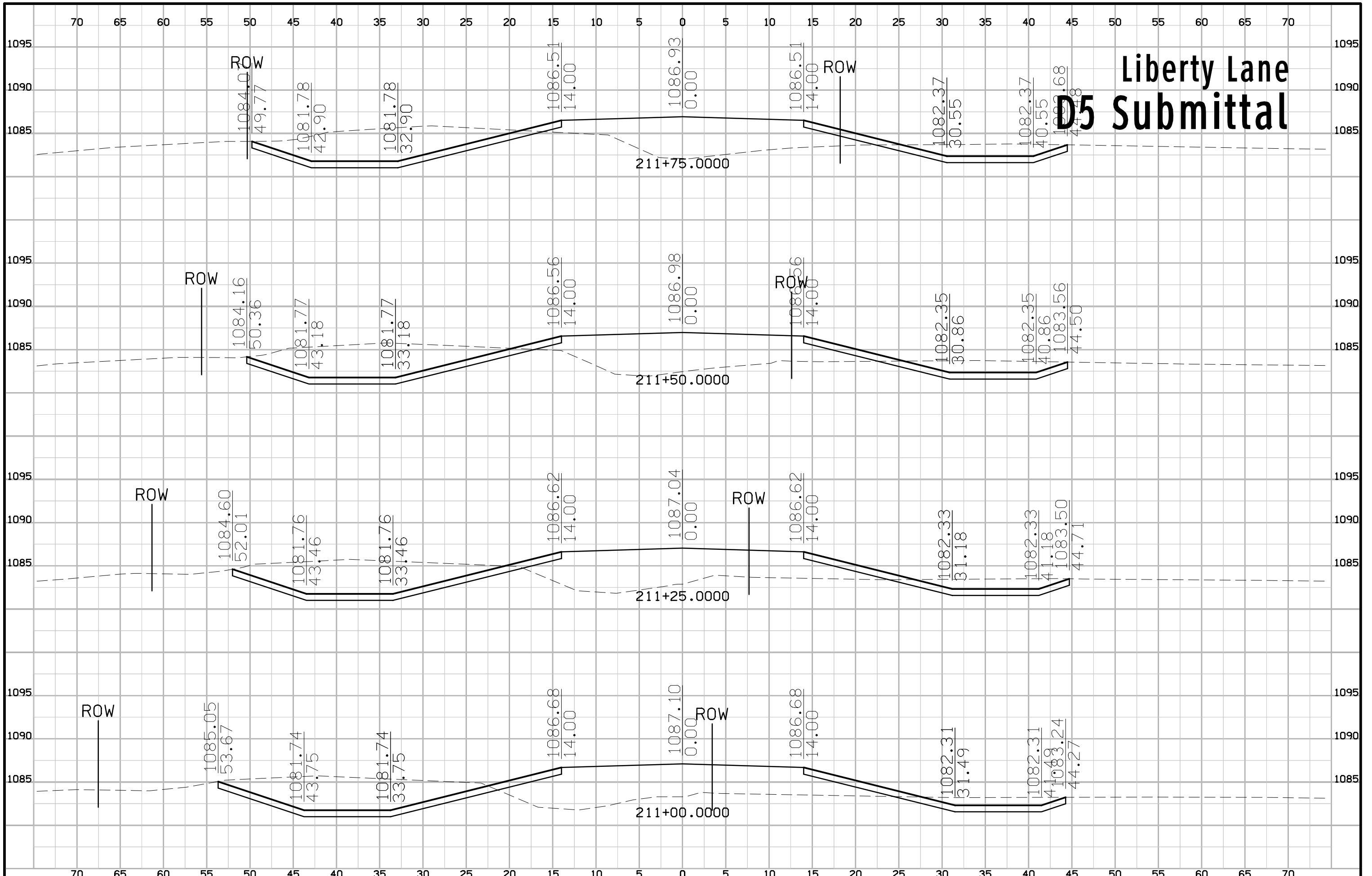

# Liberty Lane D5 Submittal

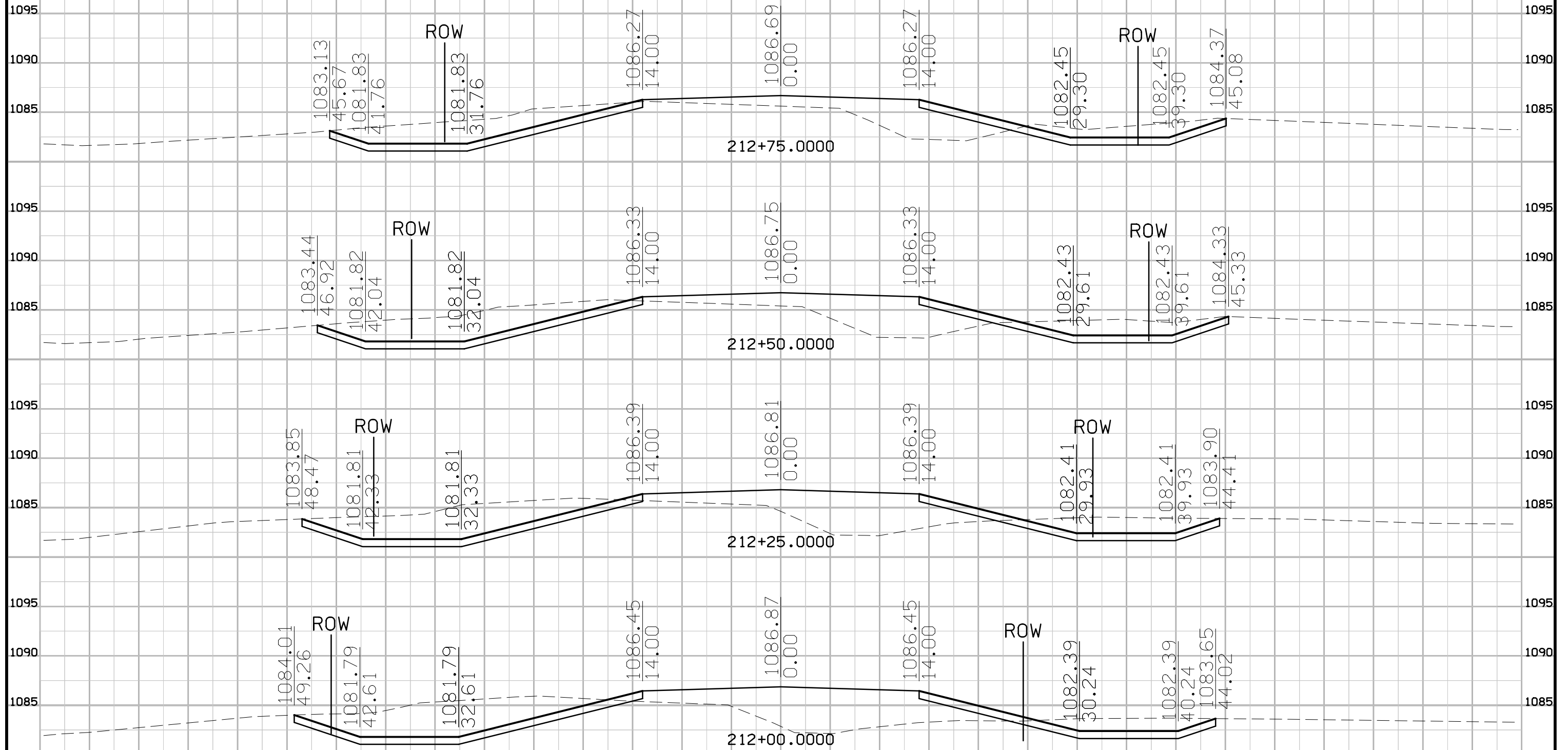

# Liberty Lane D5 Submittal

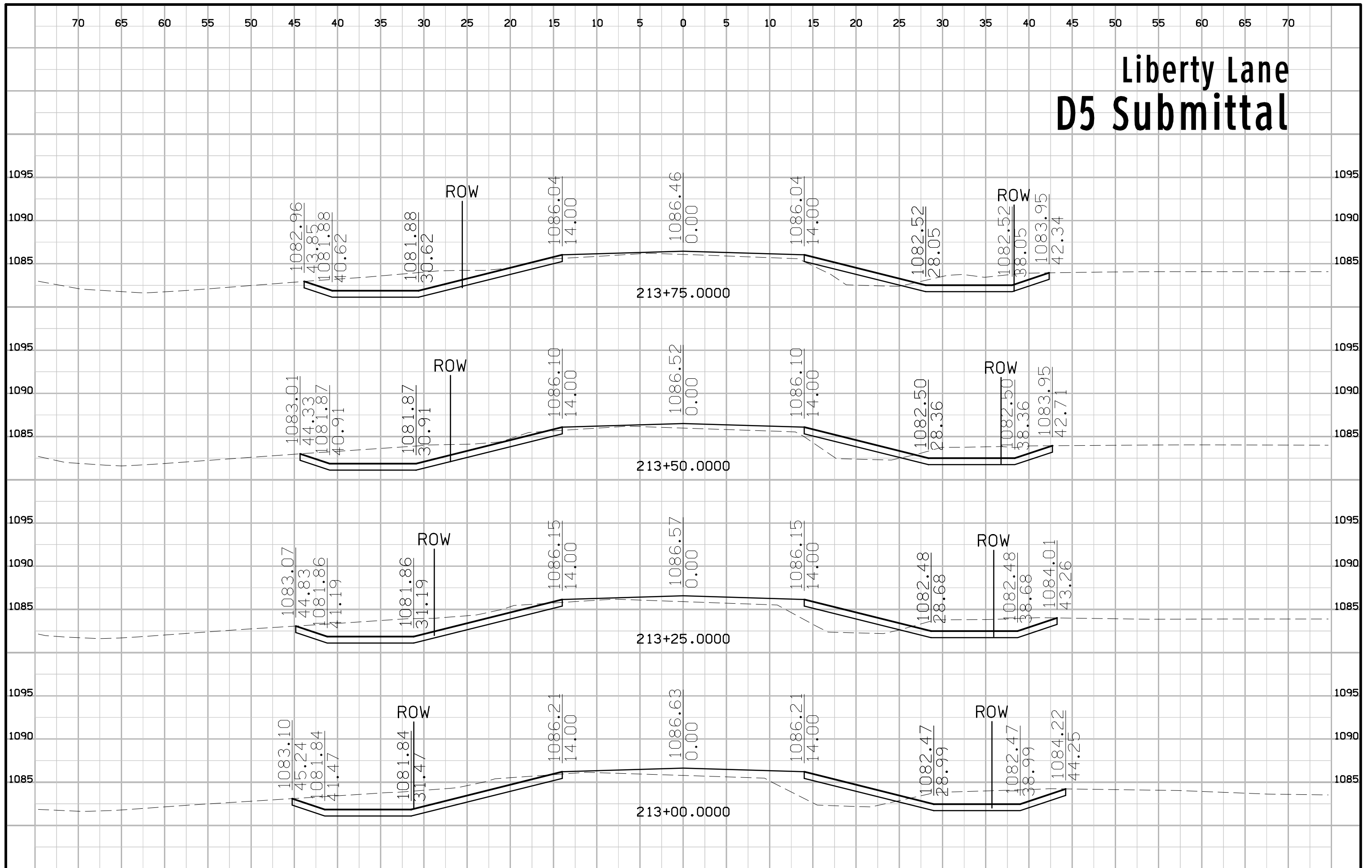

# Liberty Lane D5 Submittal

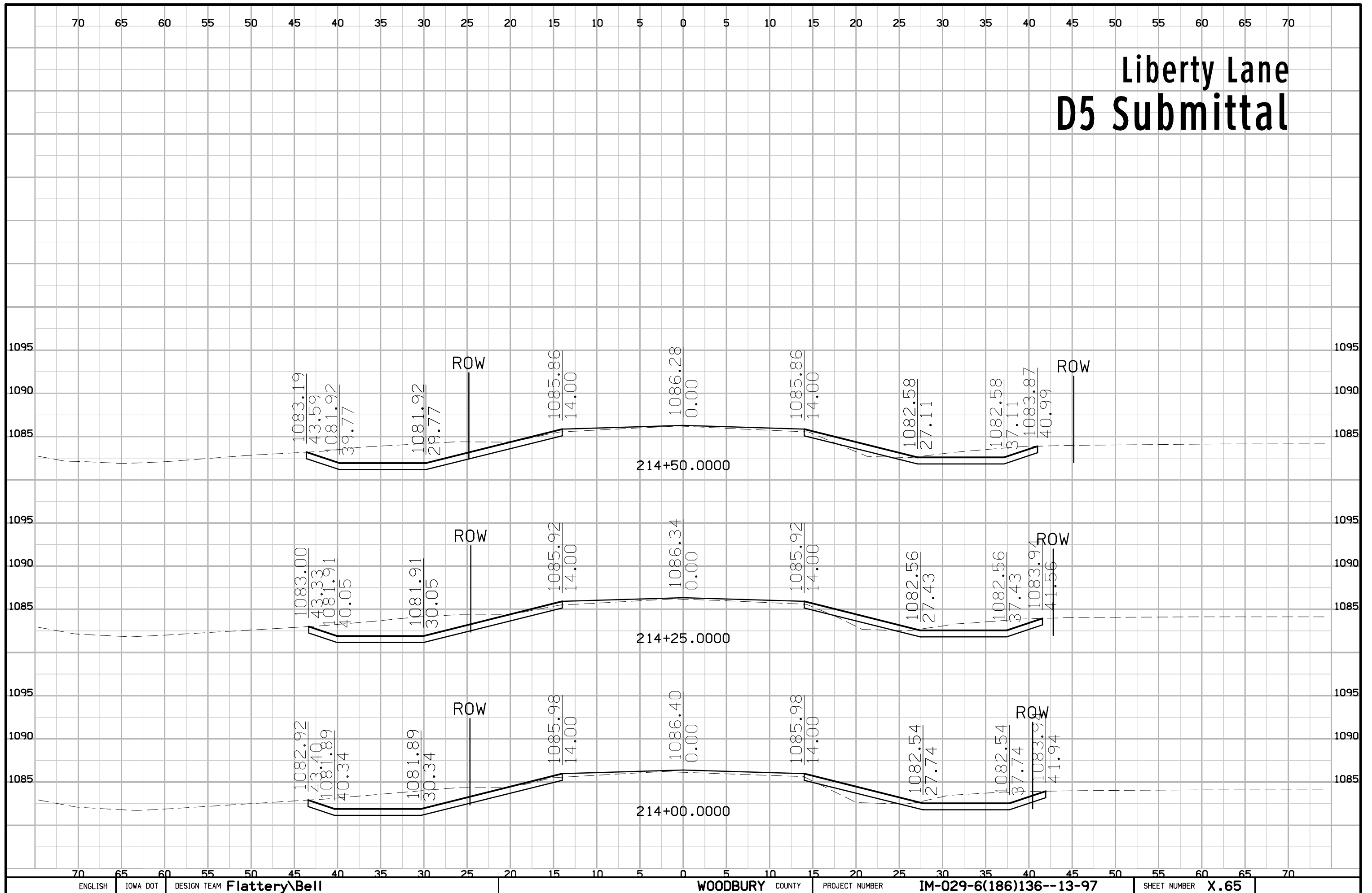

# Entrance Sta. 21476+37 D5 Submittal

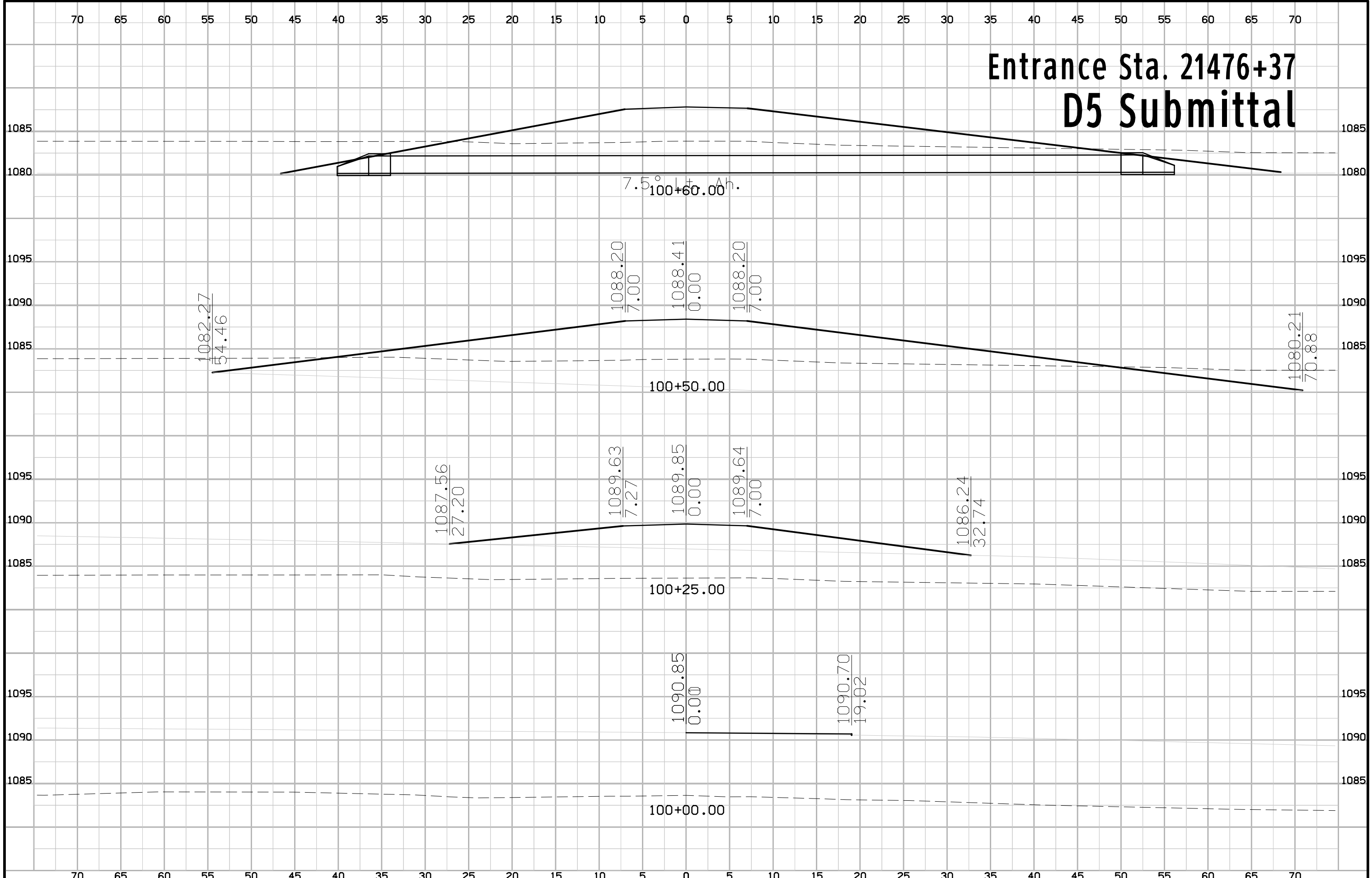



# Entrance Sta. 21476+37 D5 Submittal

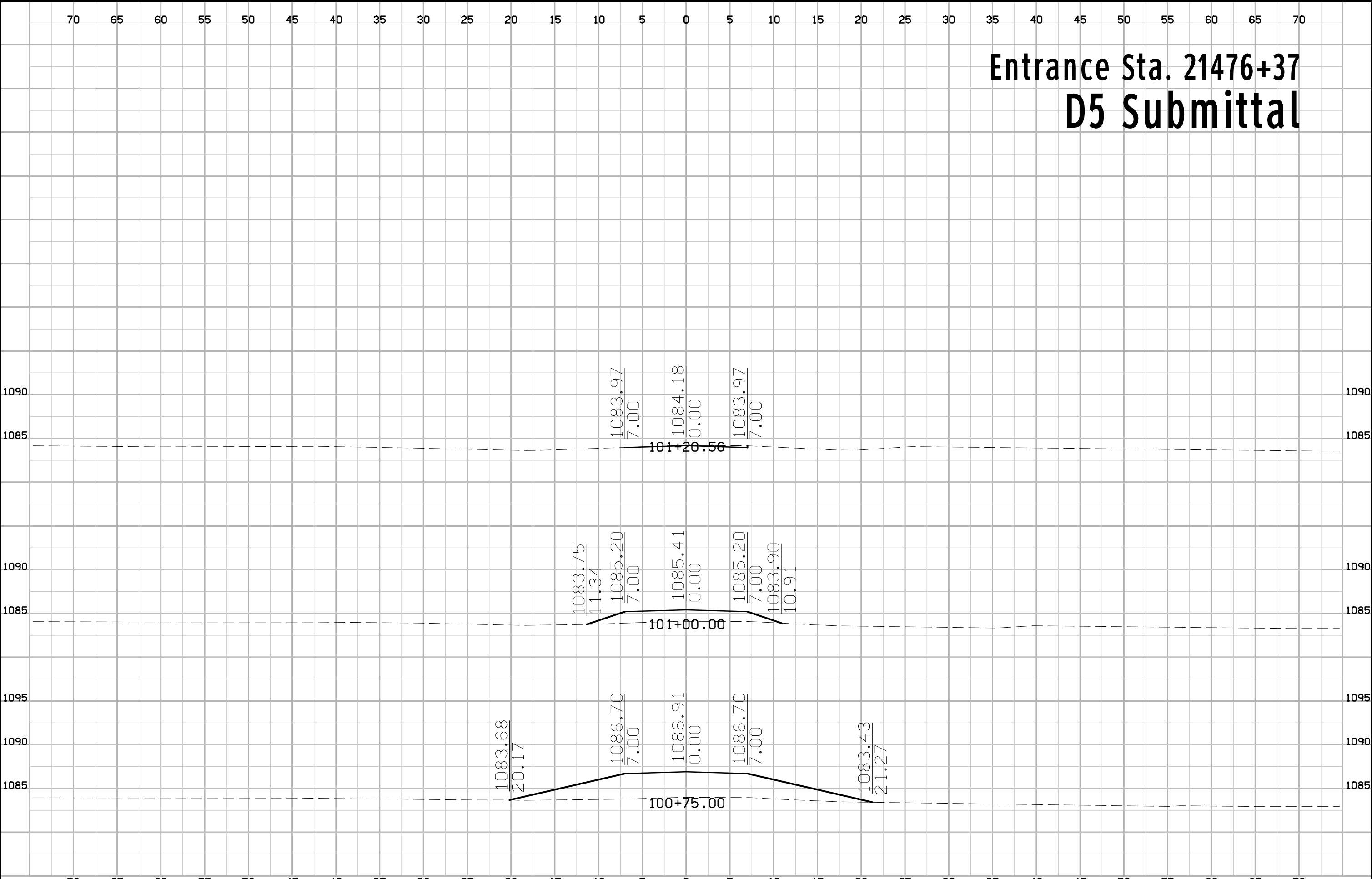

# D51 Ramp A D5 Submittal

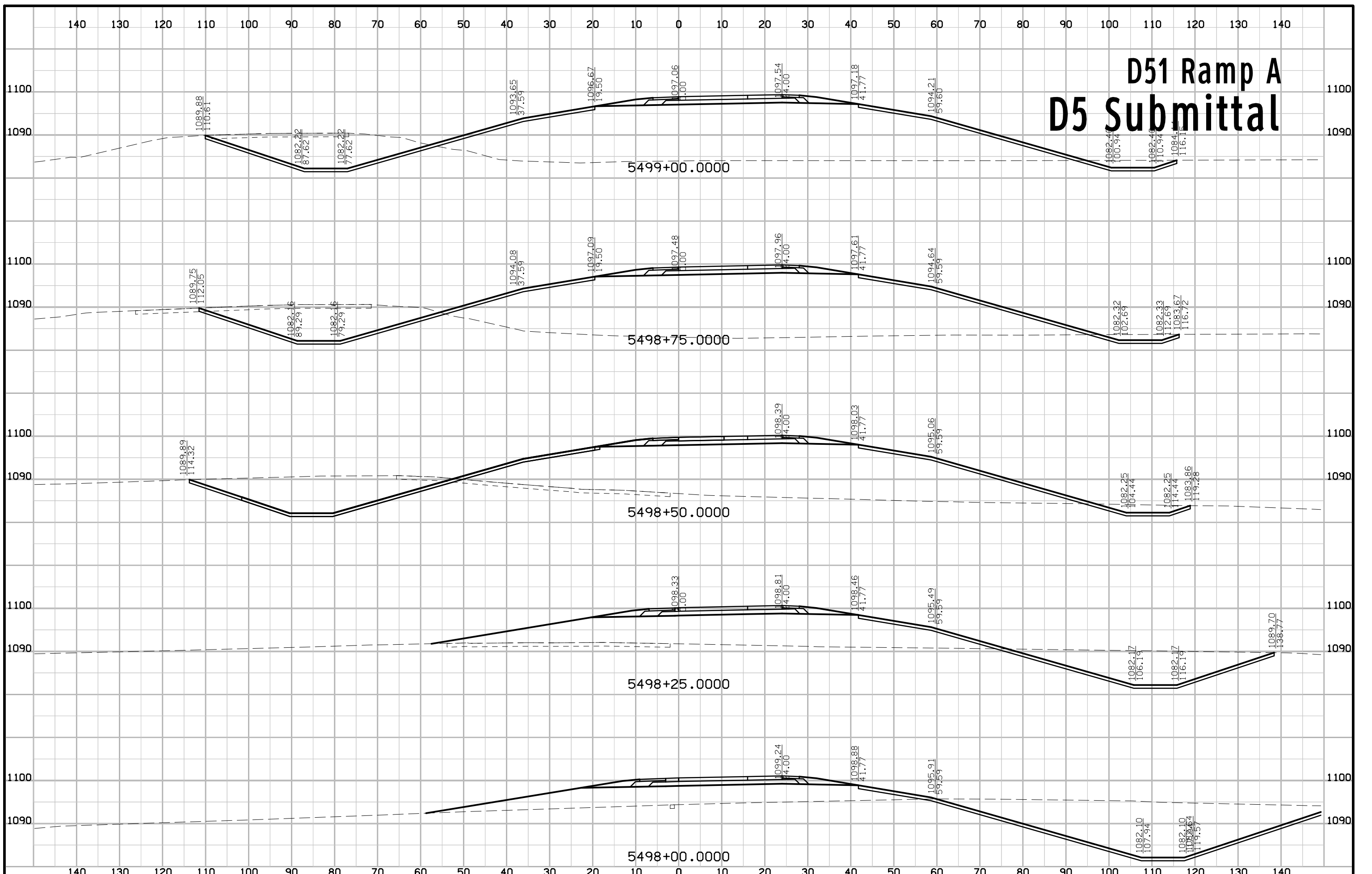

# D51 Ramp A D5 Submittal

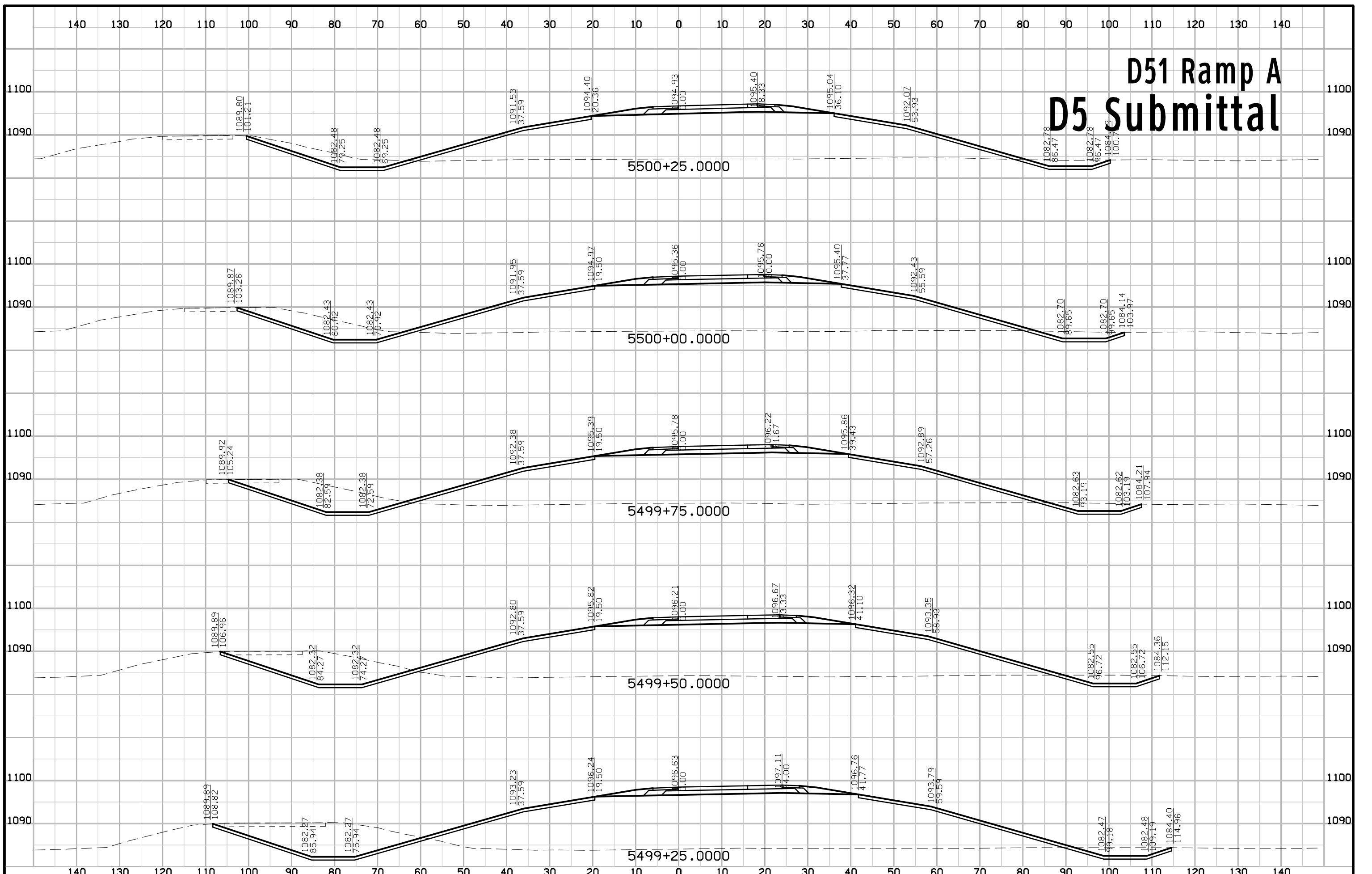

# D51 Ramp A D5 Submittal

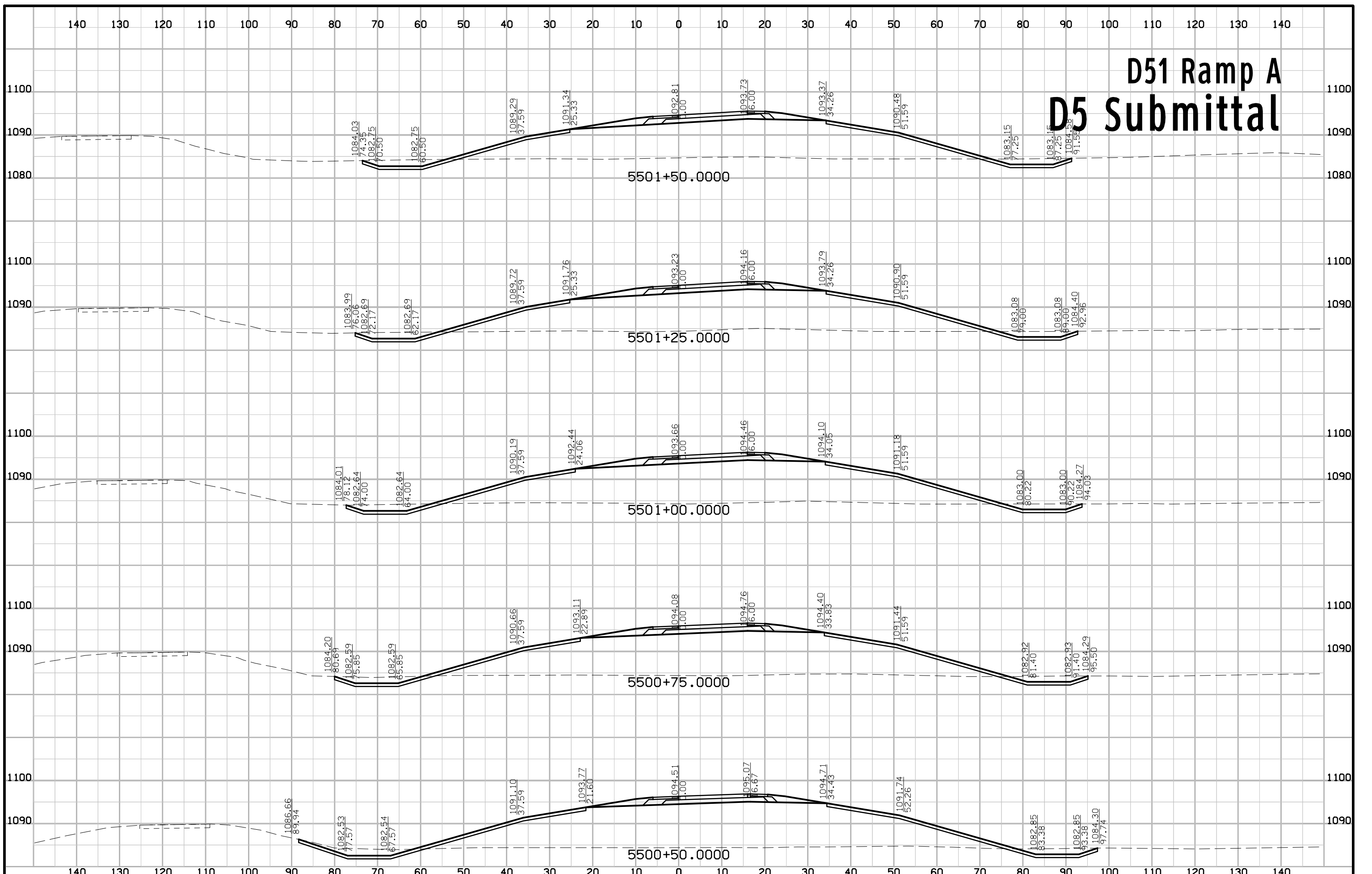

# D51 Ramp A D5 Submittal

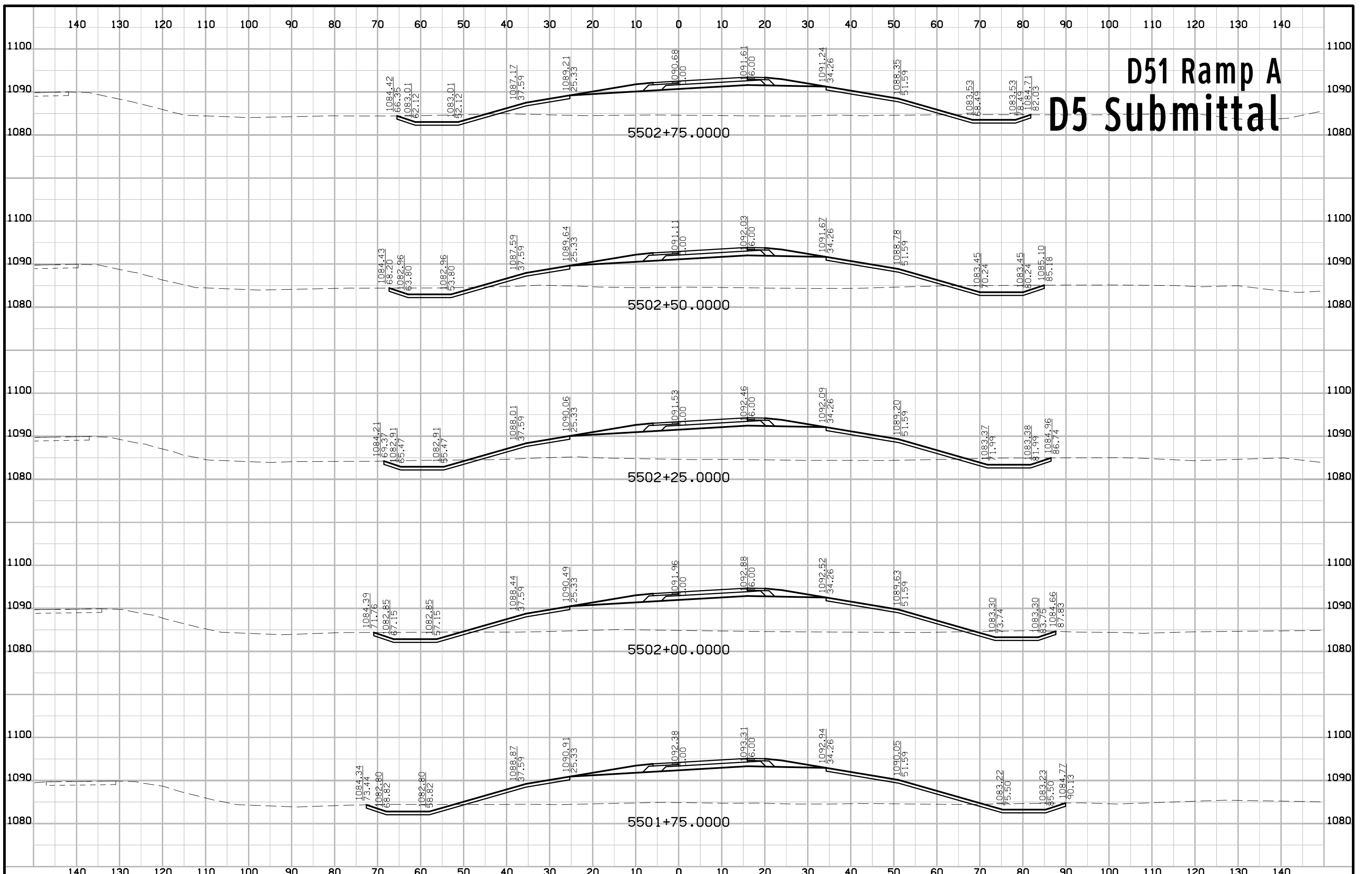

# D51 Ramp A D5 Submittal

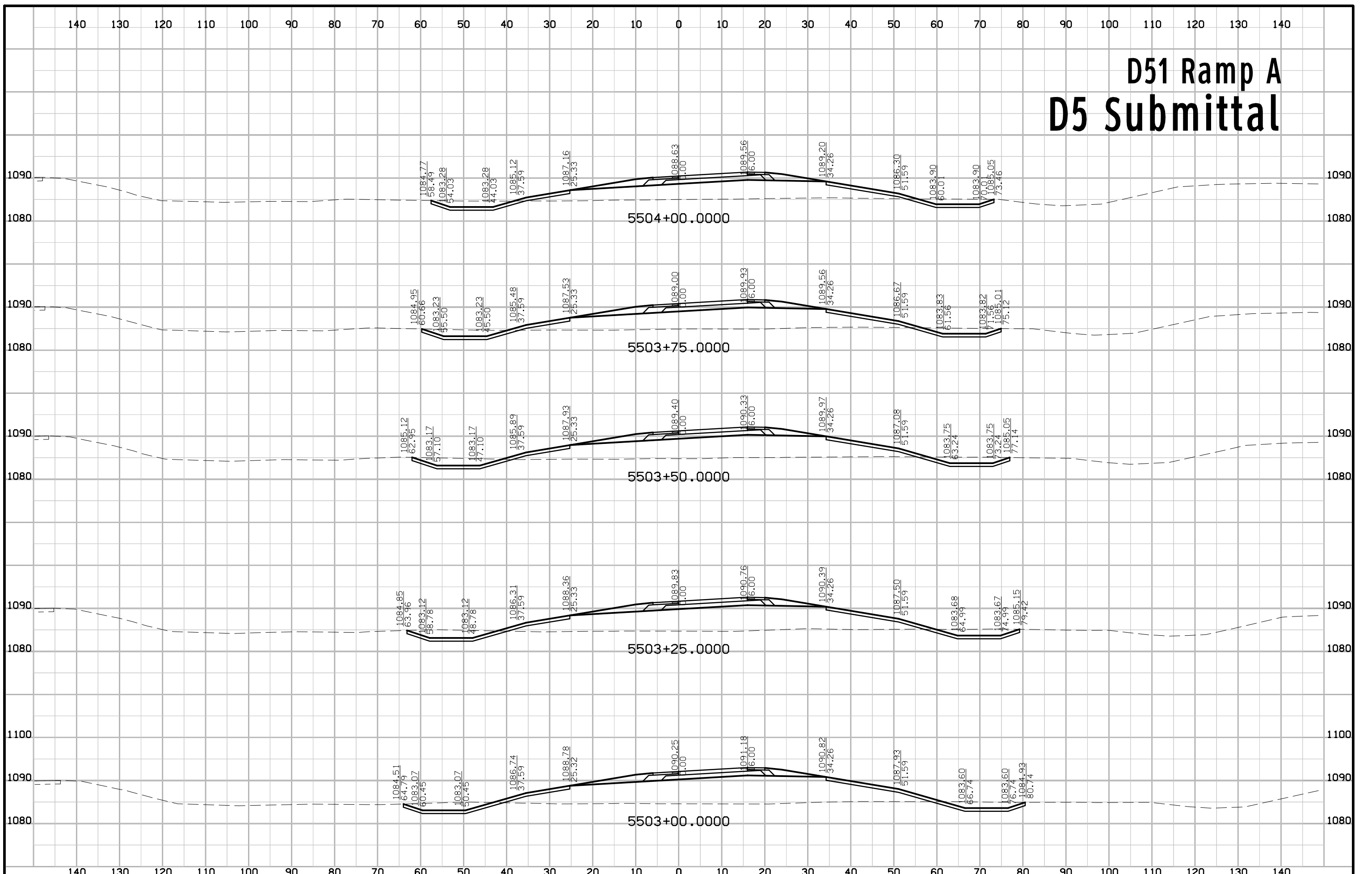

# D51 Ramp A D5 Submittal

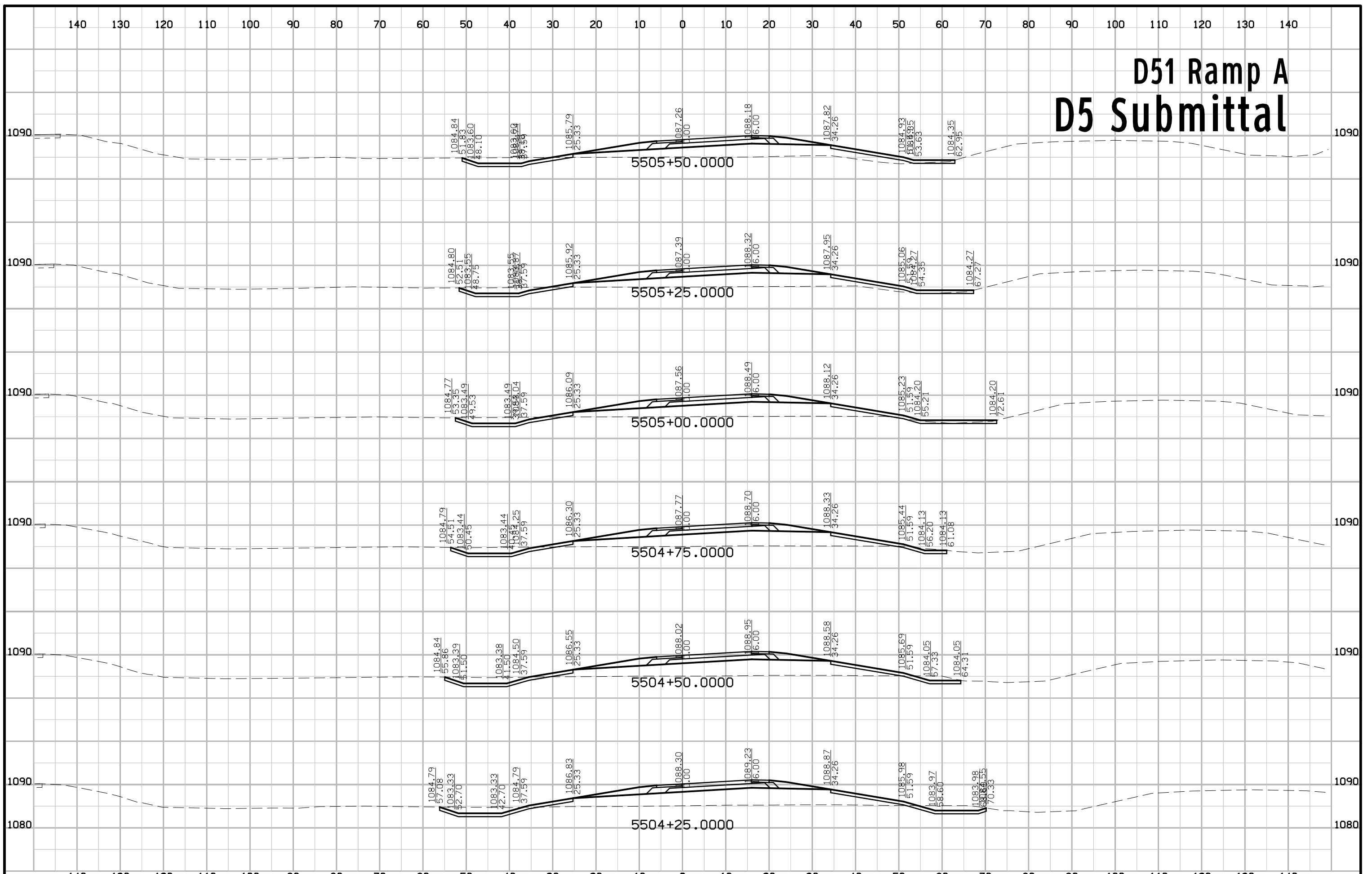

# D51 Ramp A D5 Submittal

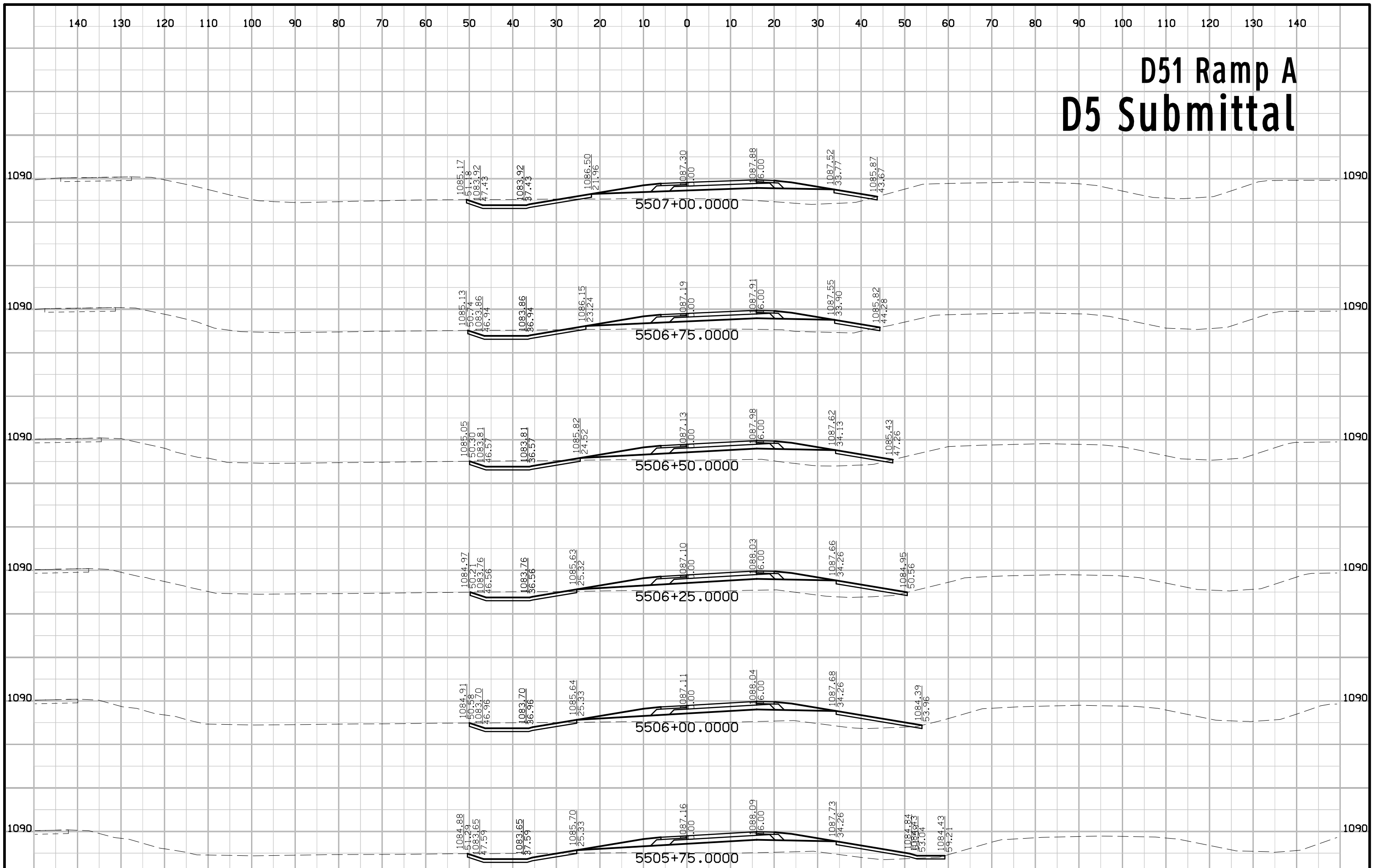



# D51 Ramp A D5 Submittal

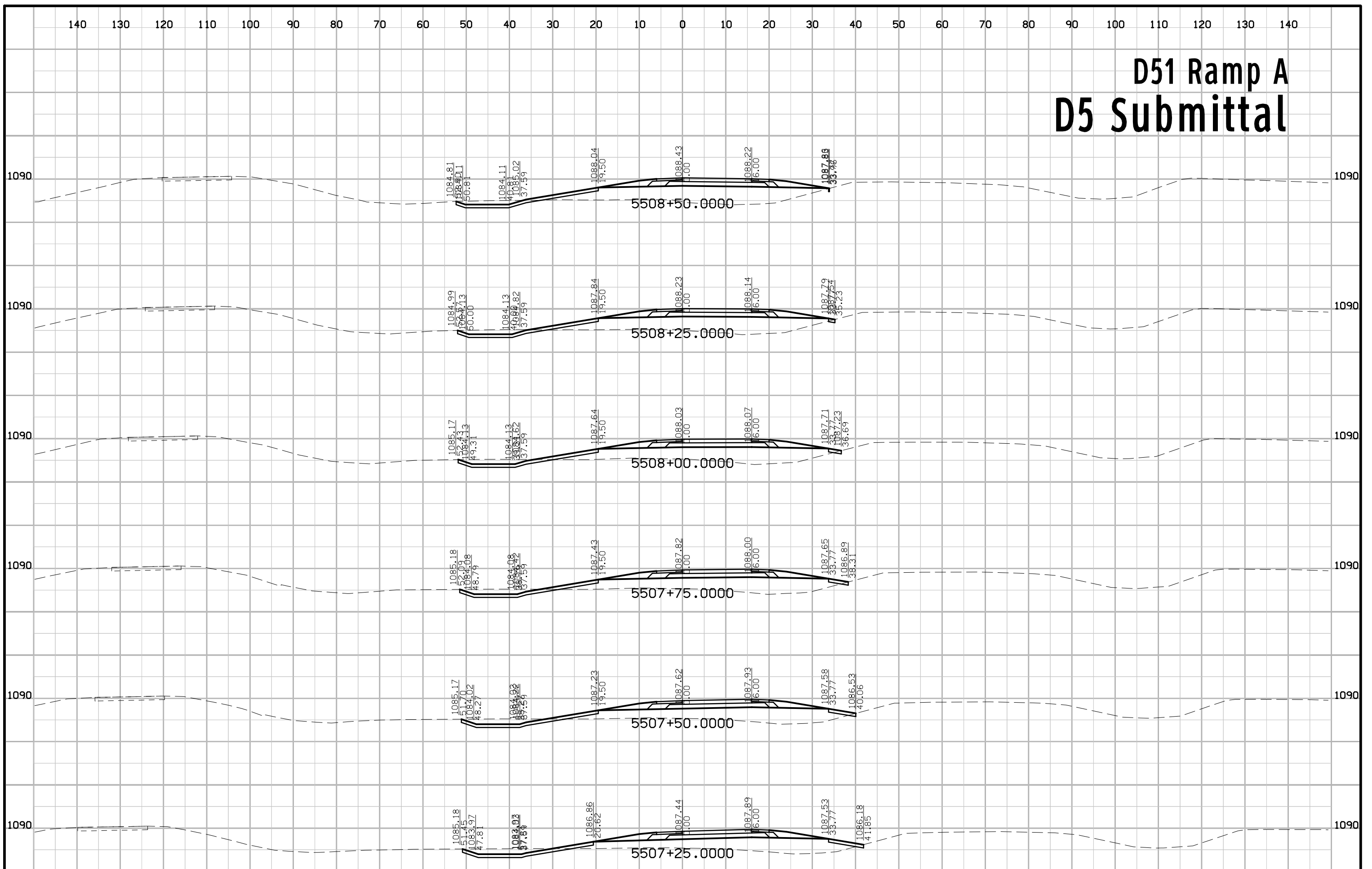

# D51 Ramp A D5 Submittal

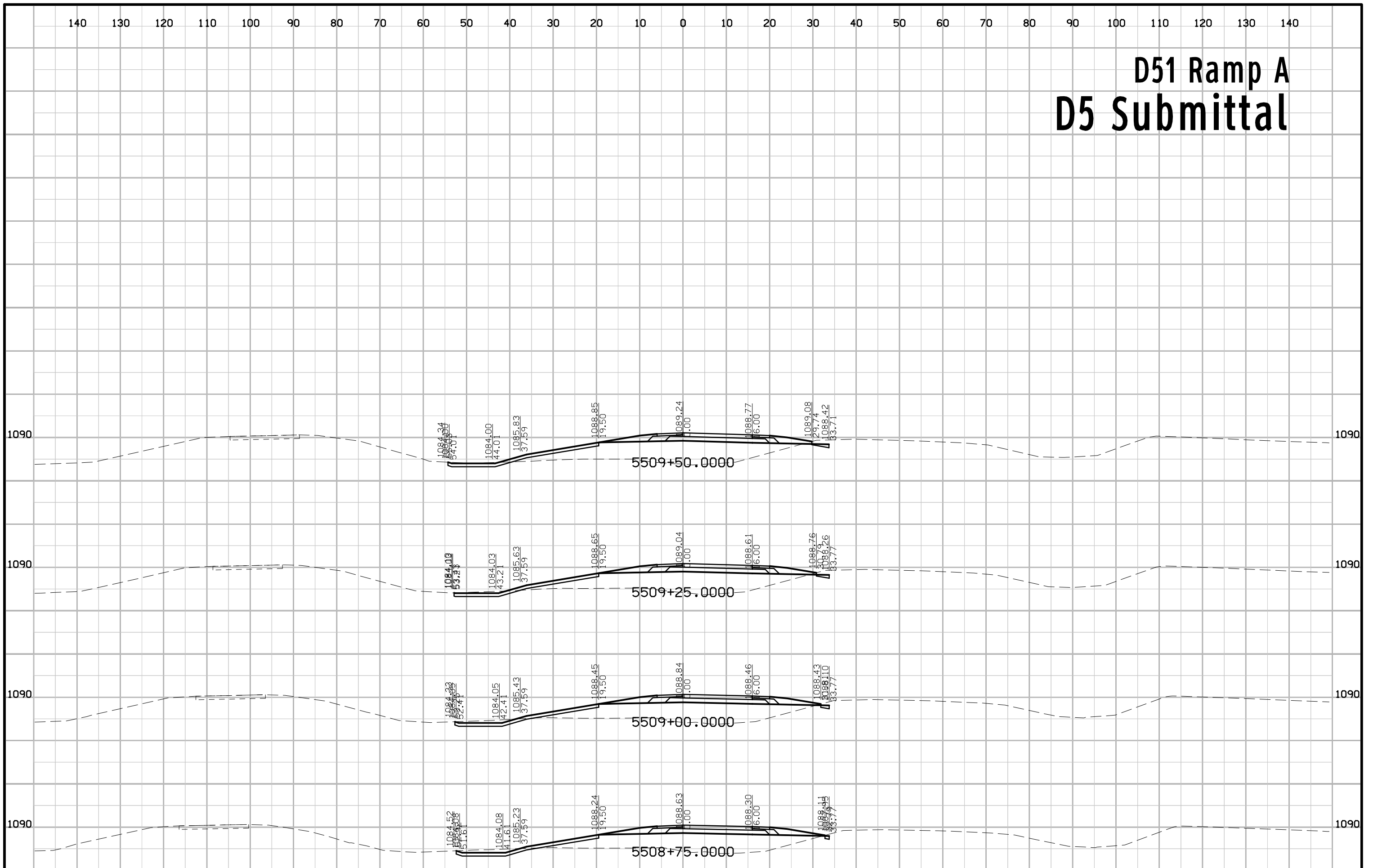

# D51 Ramp B D55 Submittal

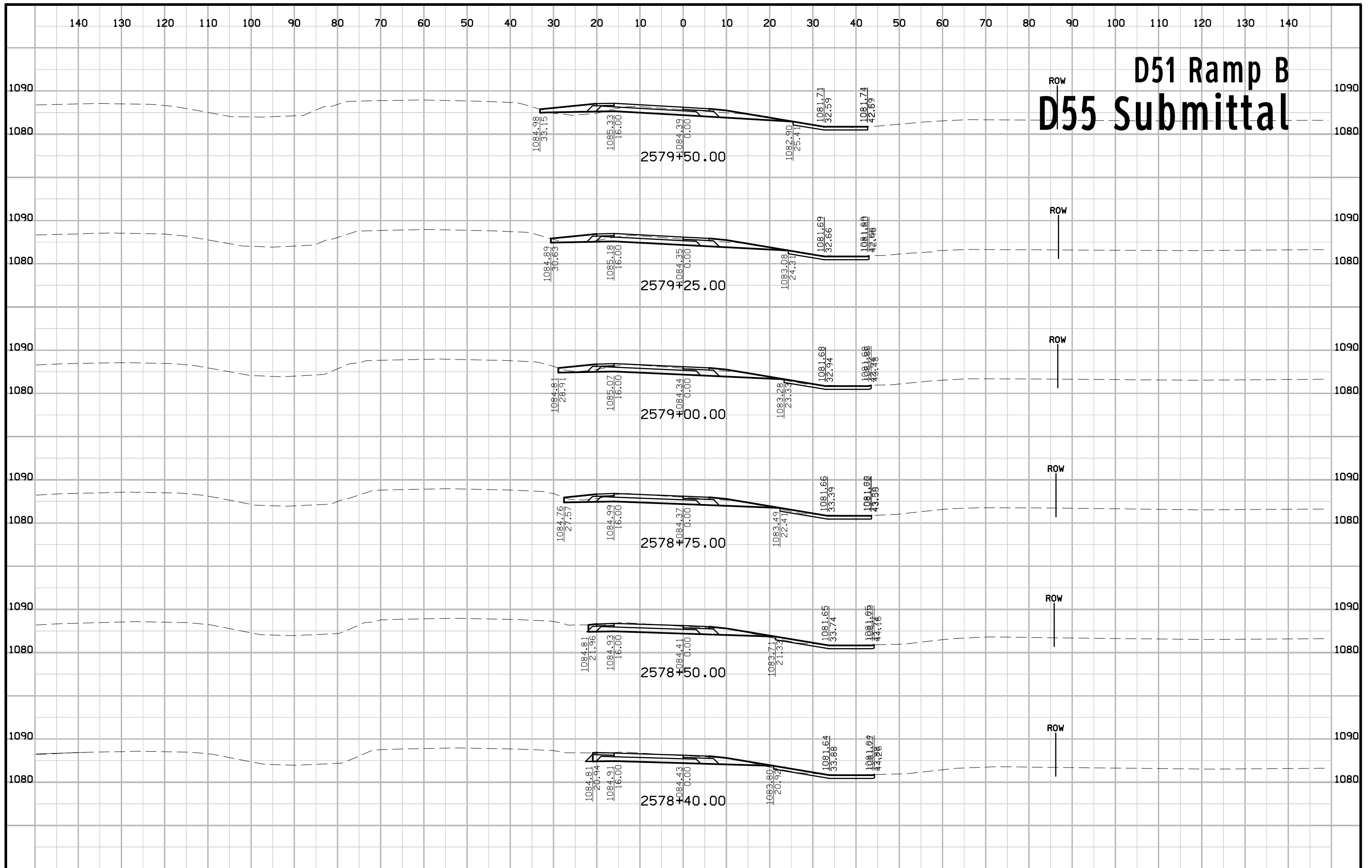

# D51 Ramp B D55 Submittal

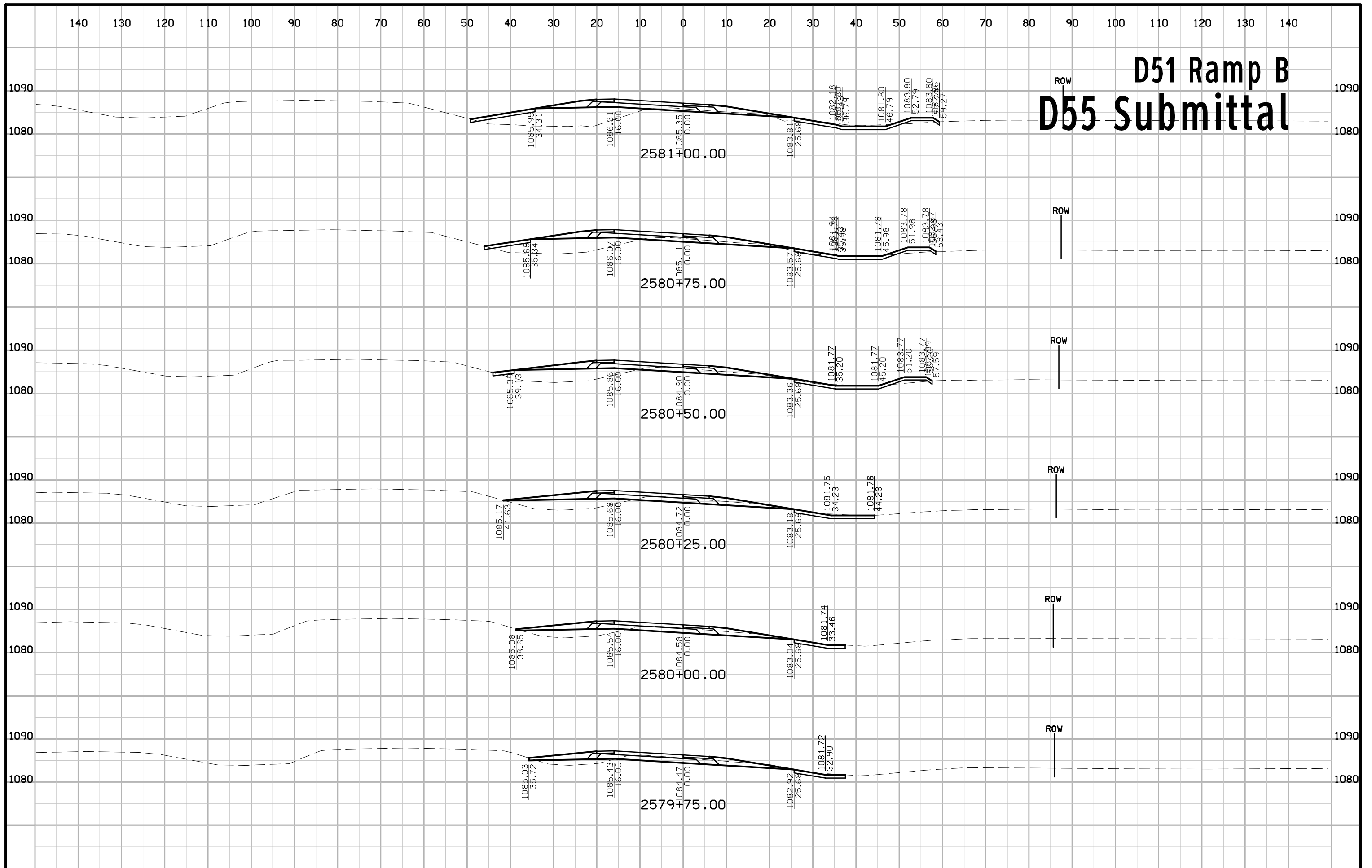

# D51 Ramp B D55 Submittal

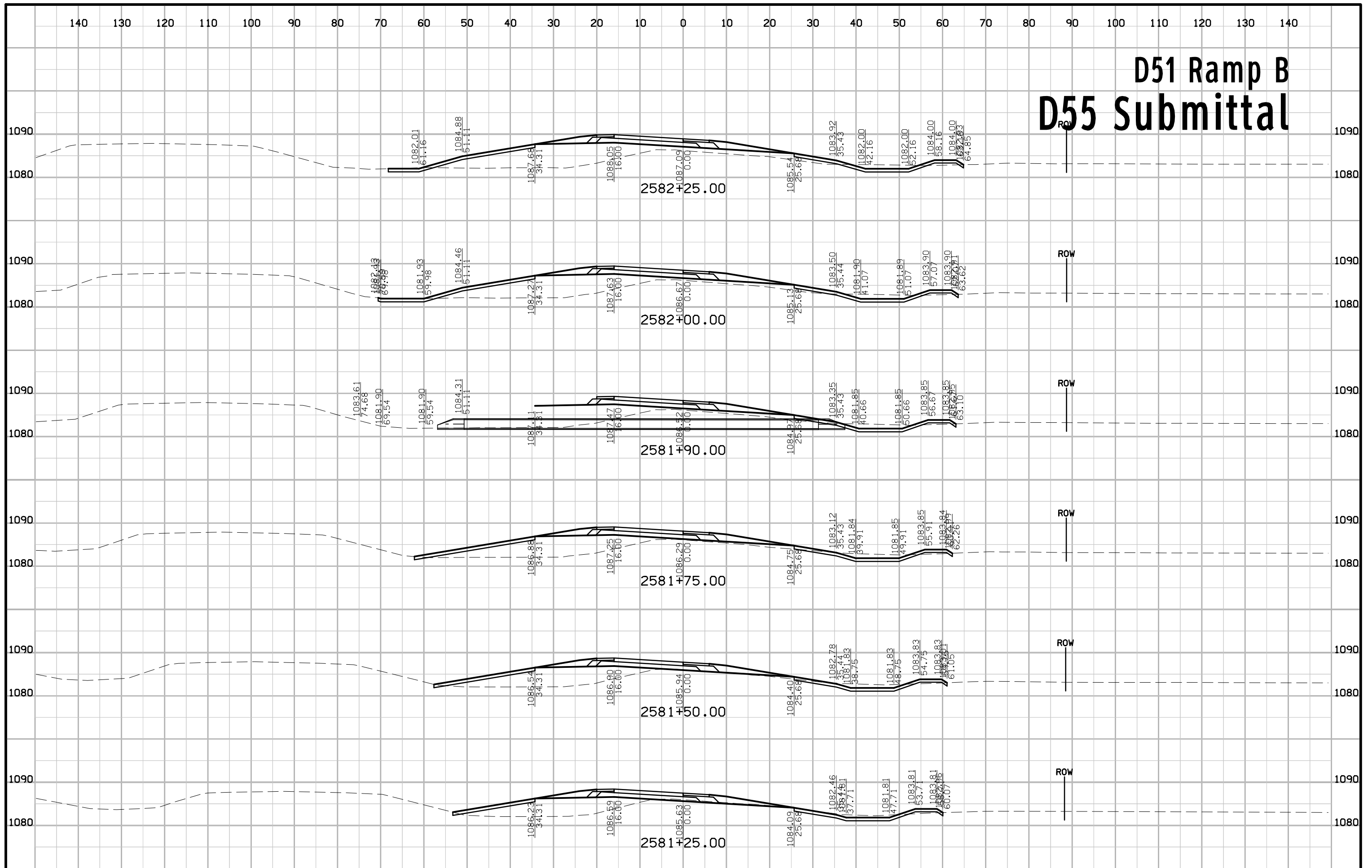

# D51 Ramp B D55 Submittal

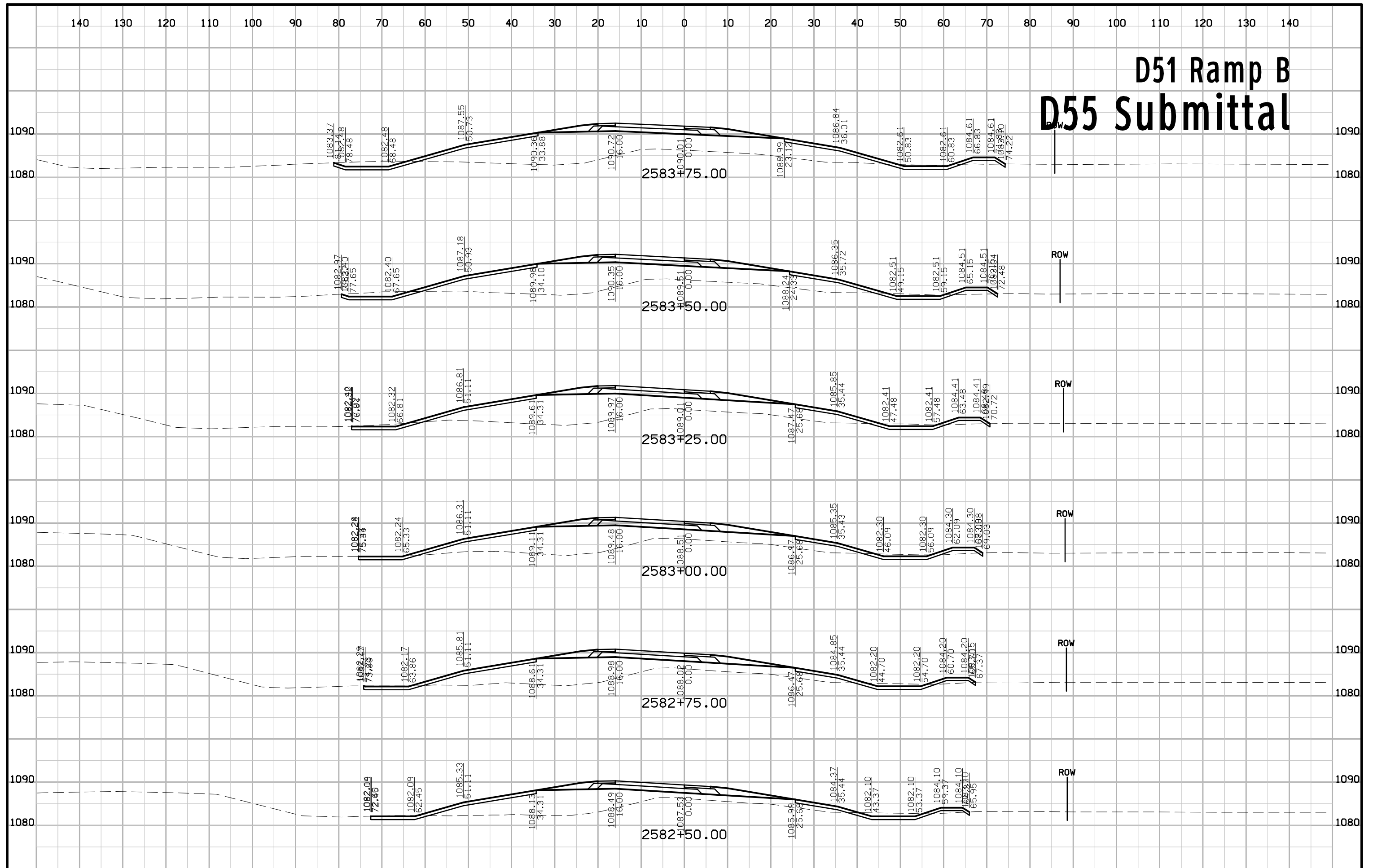

# D51 Ramp B D55 Submittal

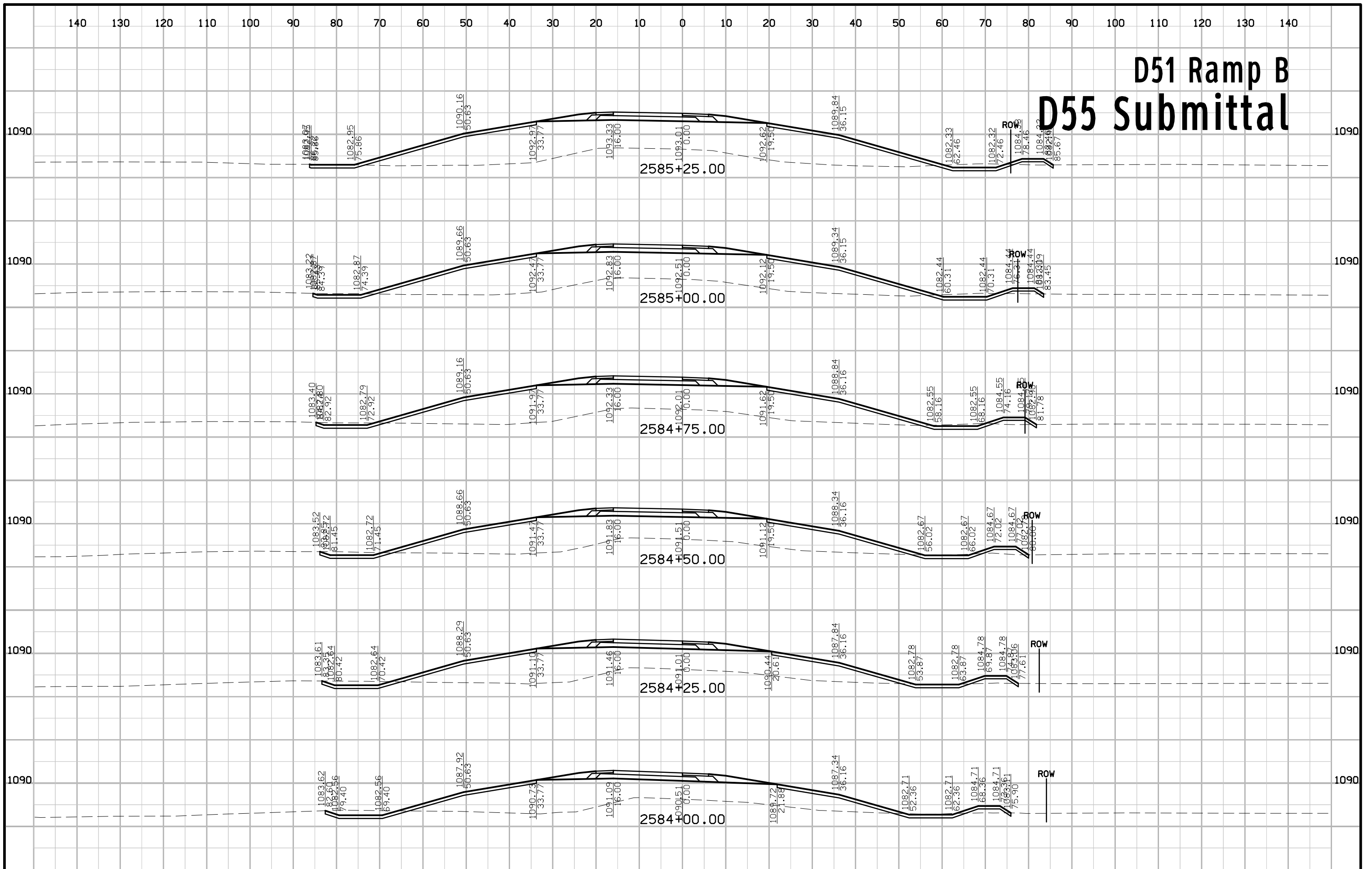

# D51 Ramp B D55 Submittal

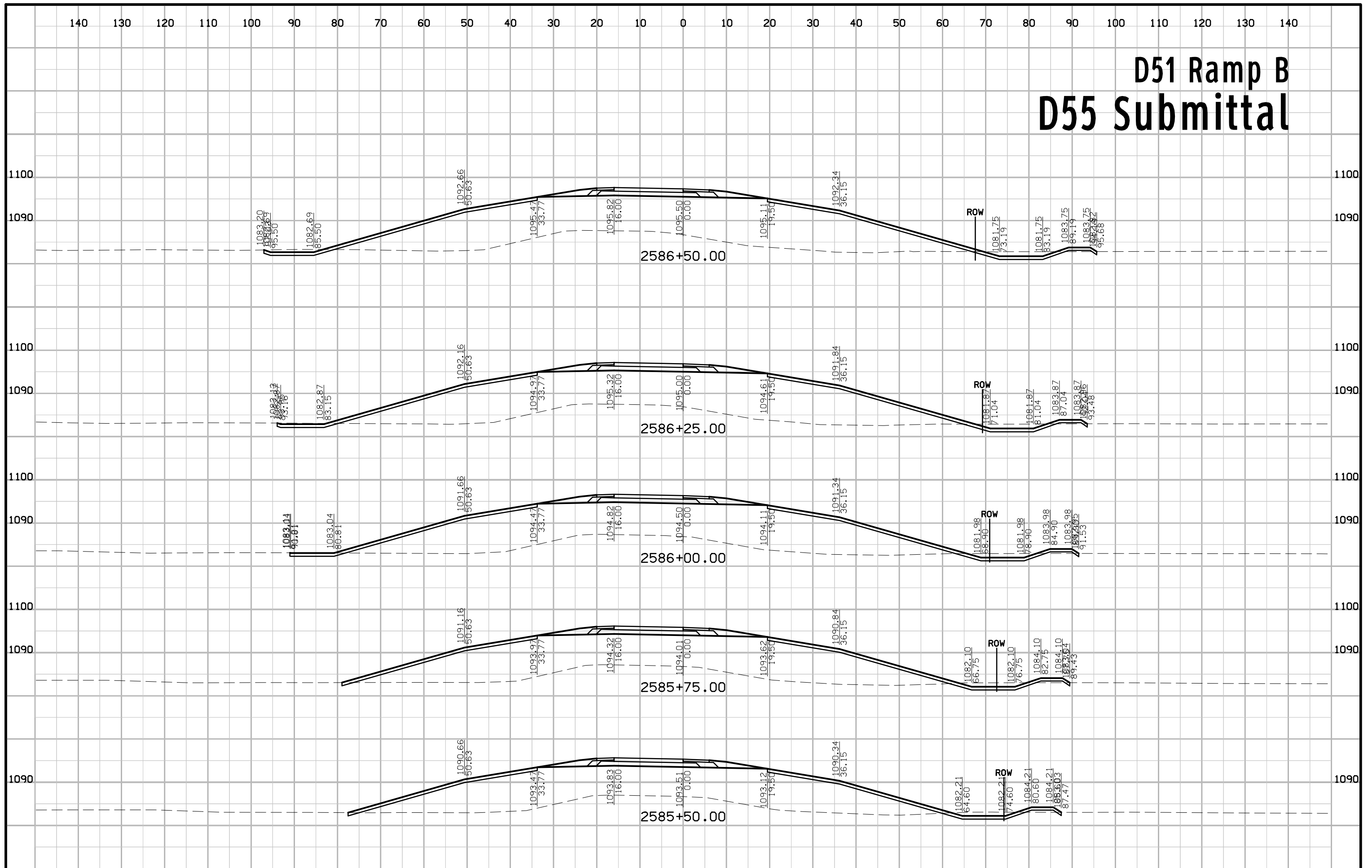



# D51 Ramp B D55 Submittal

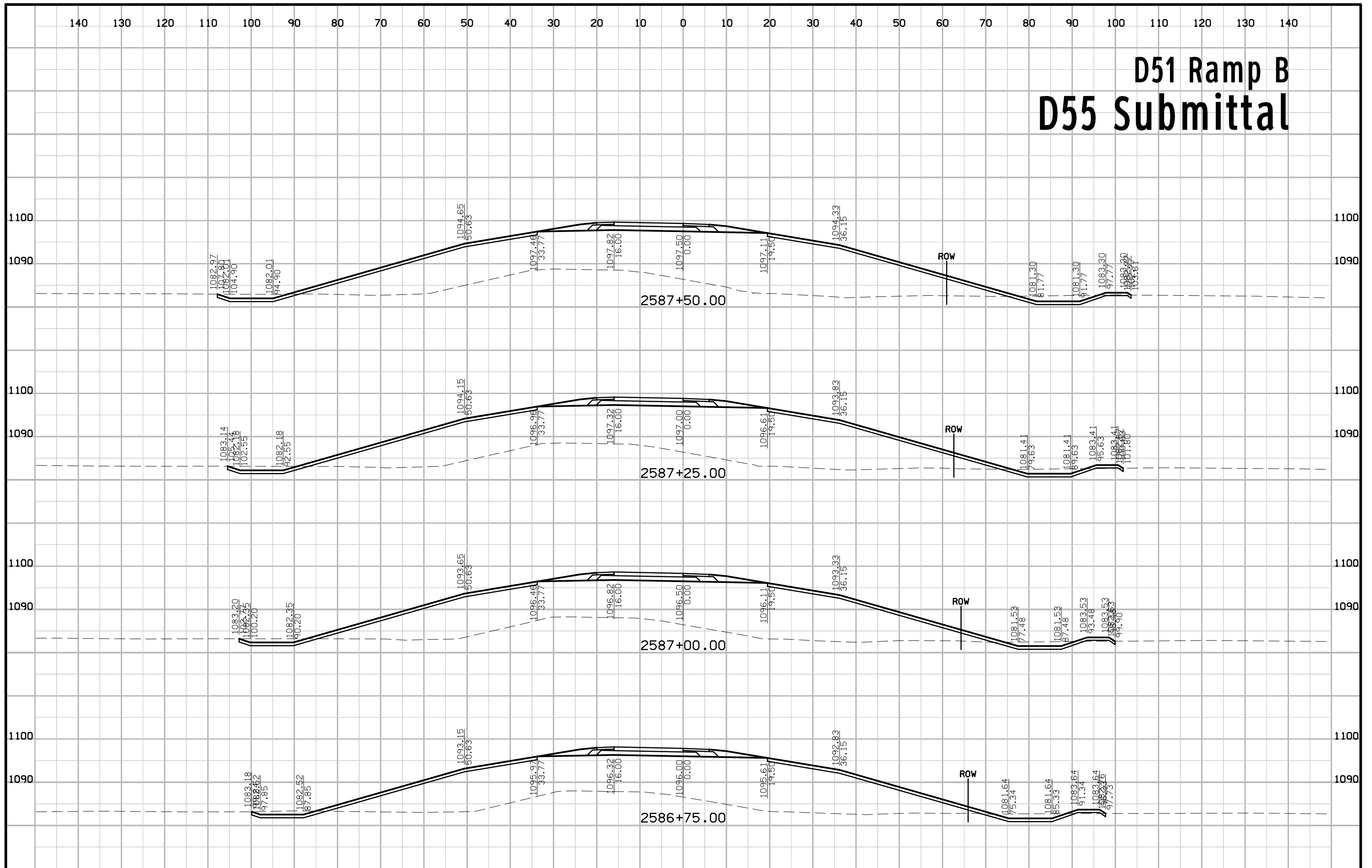

# D51 Ramp B D55 Submittal

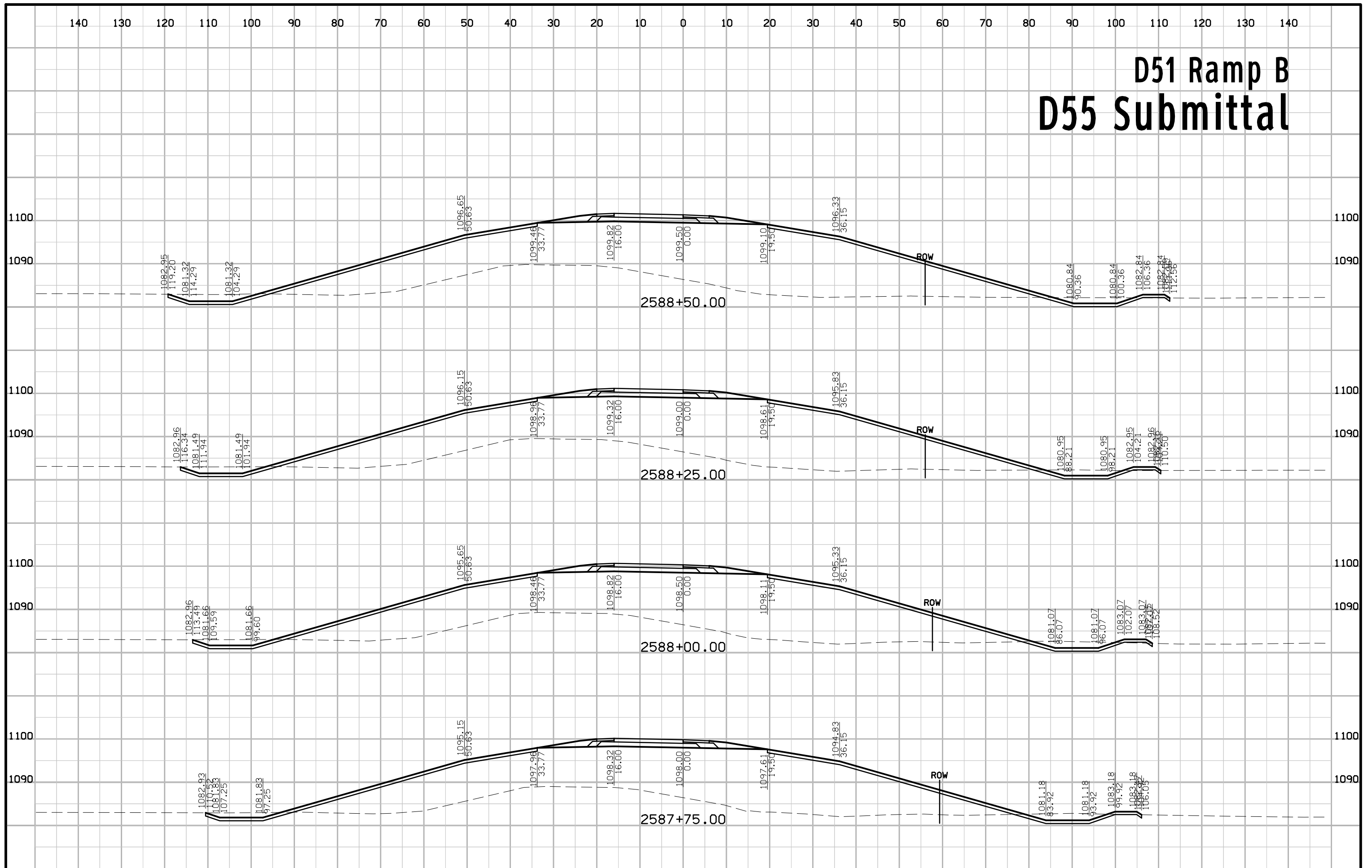

# D51 Ramp B D55 Submittal

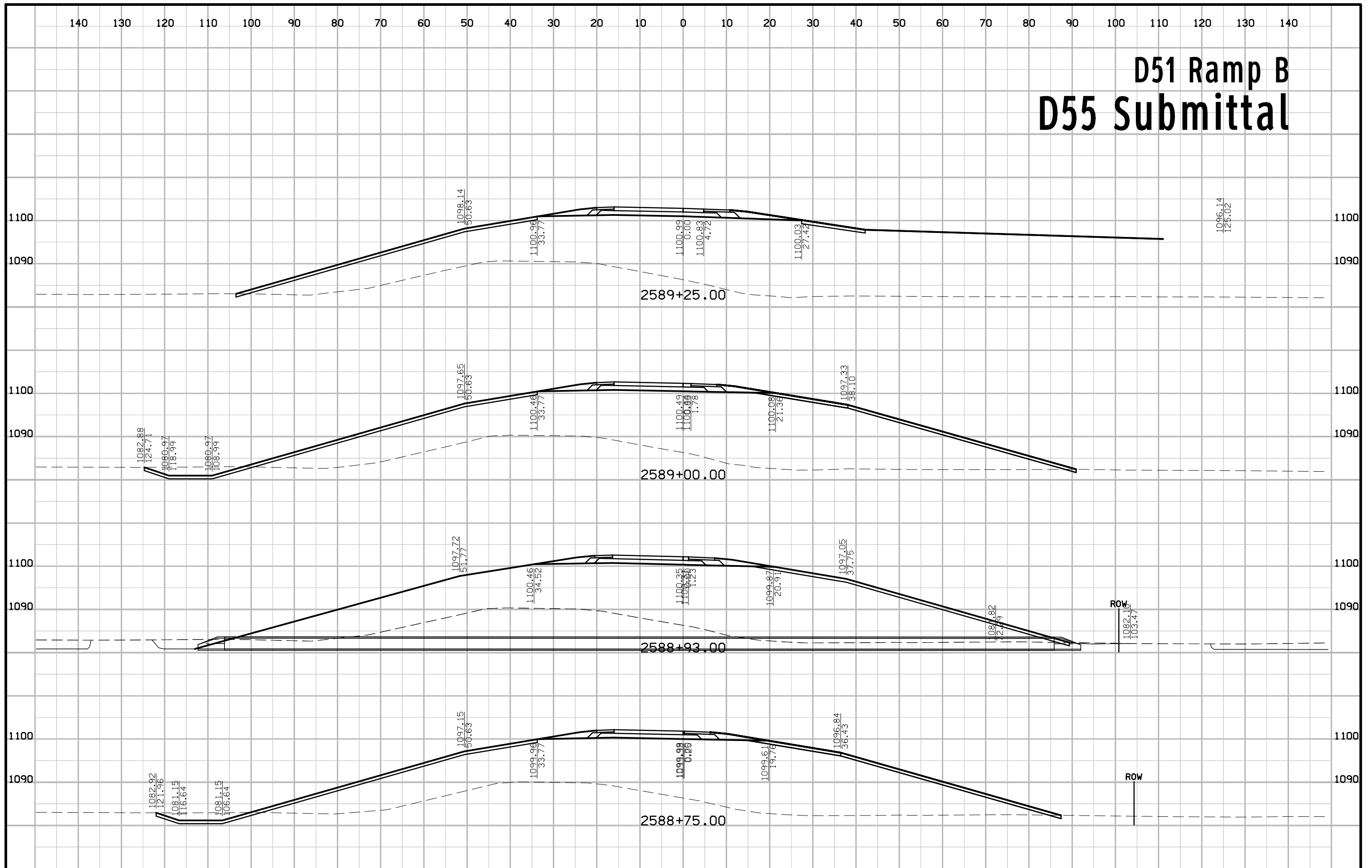

# D51 Ramp B D55 Submittal

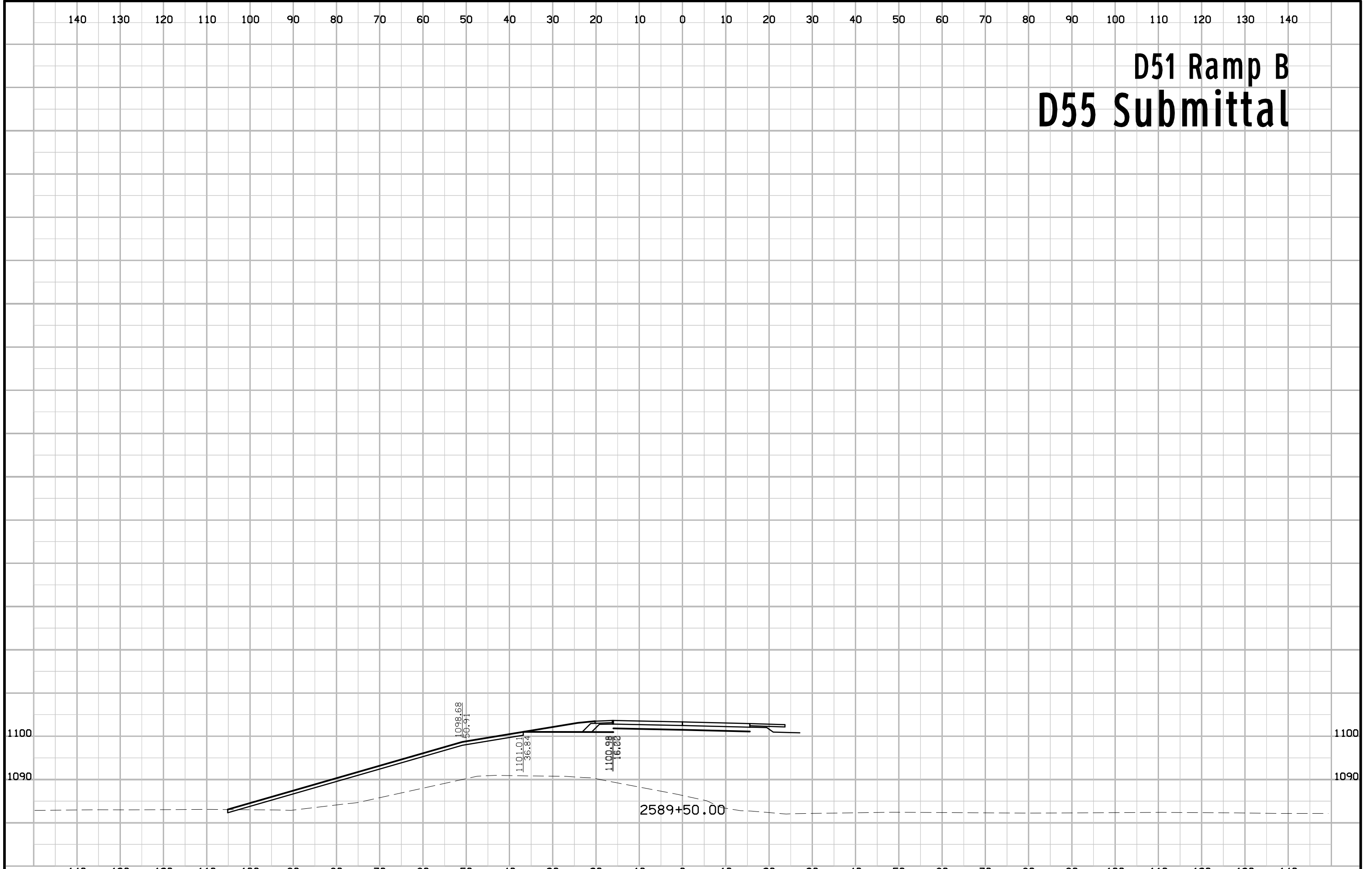

# D51 Ramp C D5 Submittal

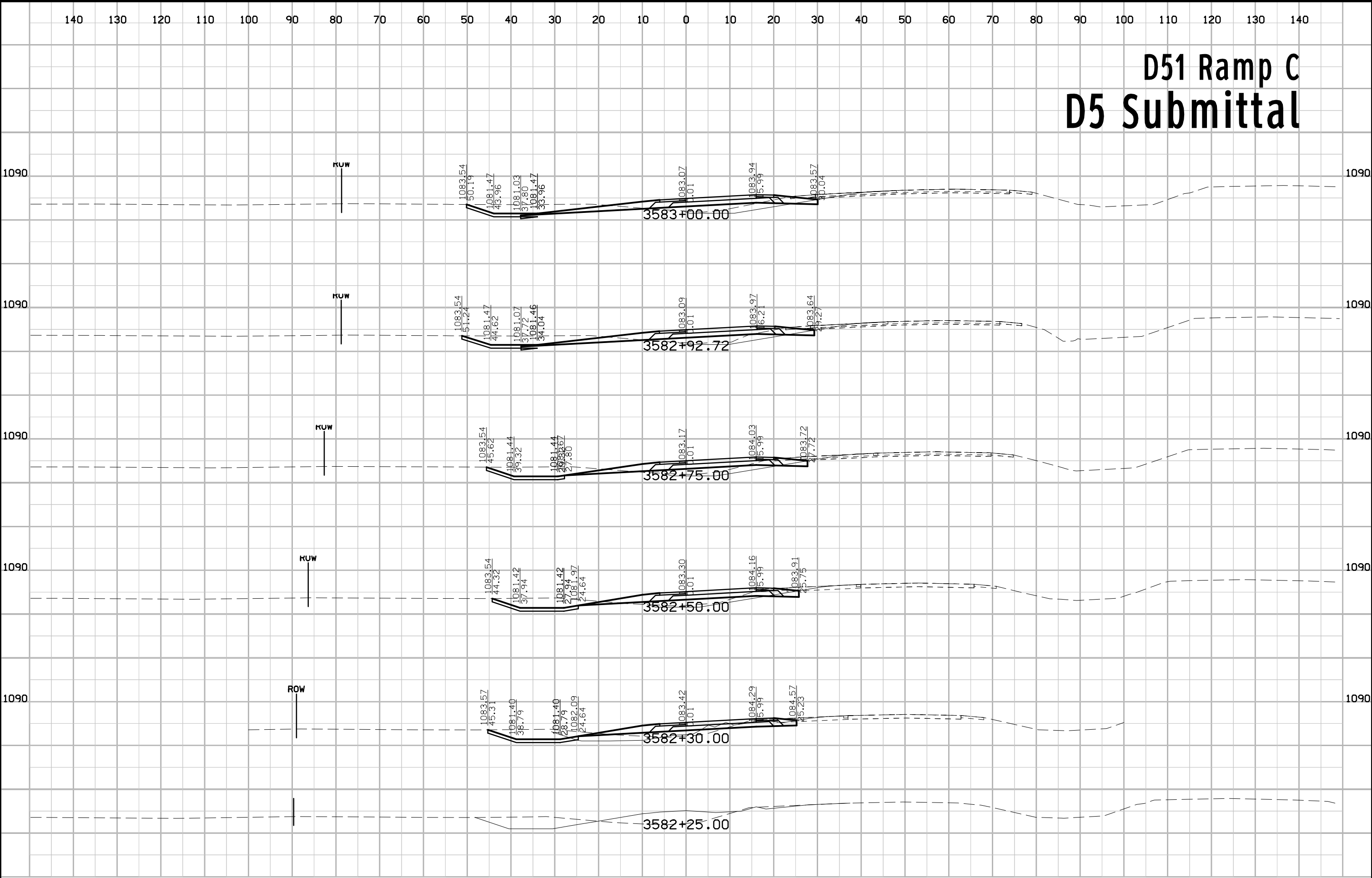

# D51 Ramp C D5 Submittal



# D51 Ramp C D5 Submittal

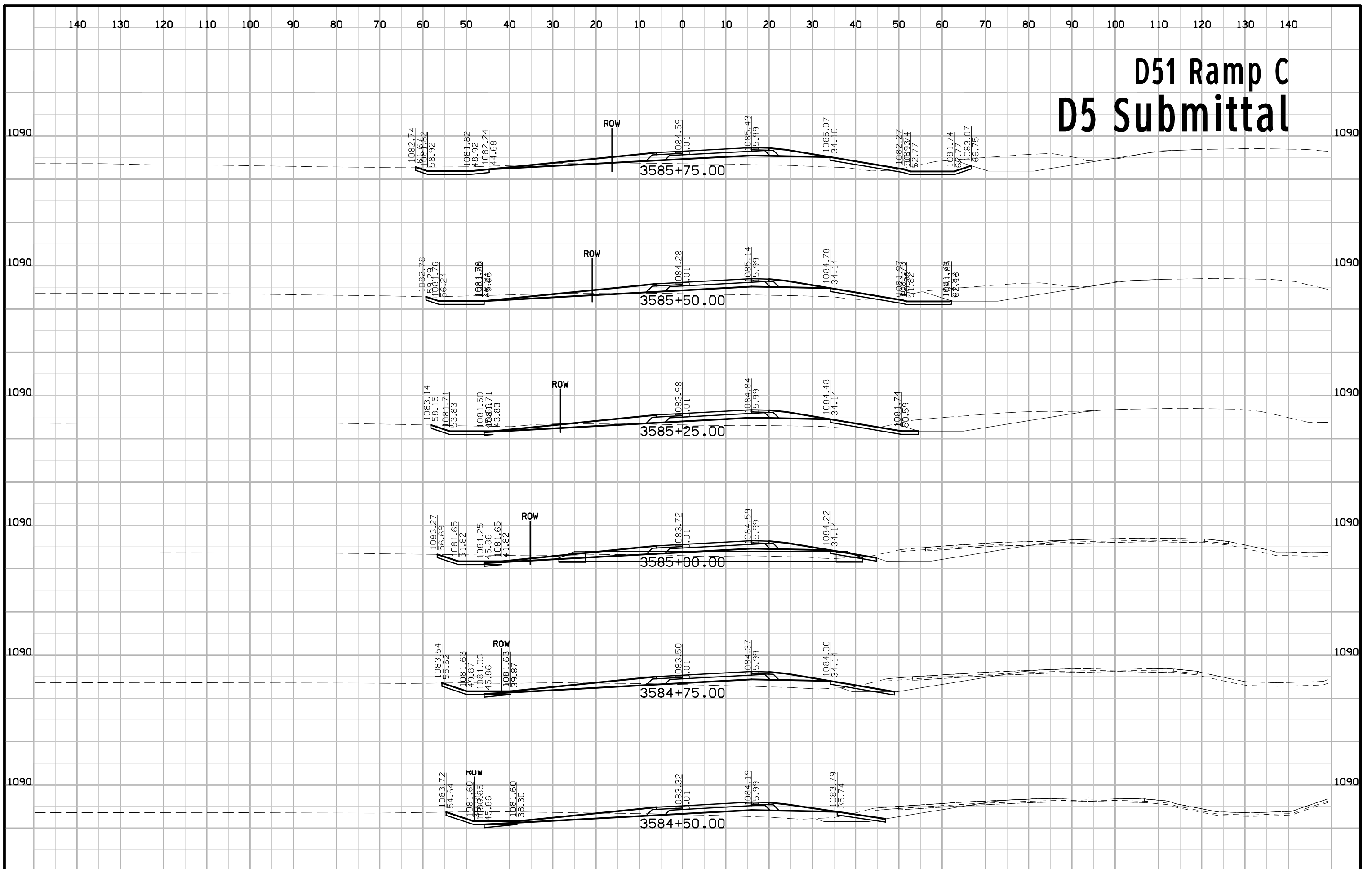

# D51 Ramp C D5 Submittal

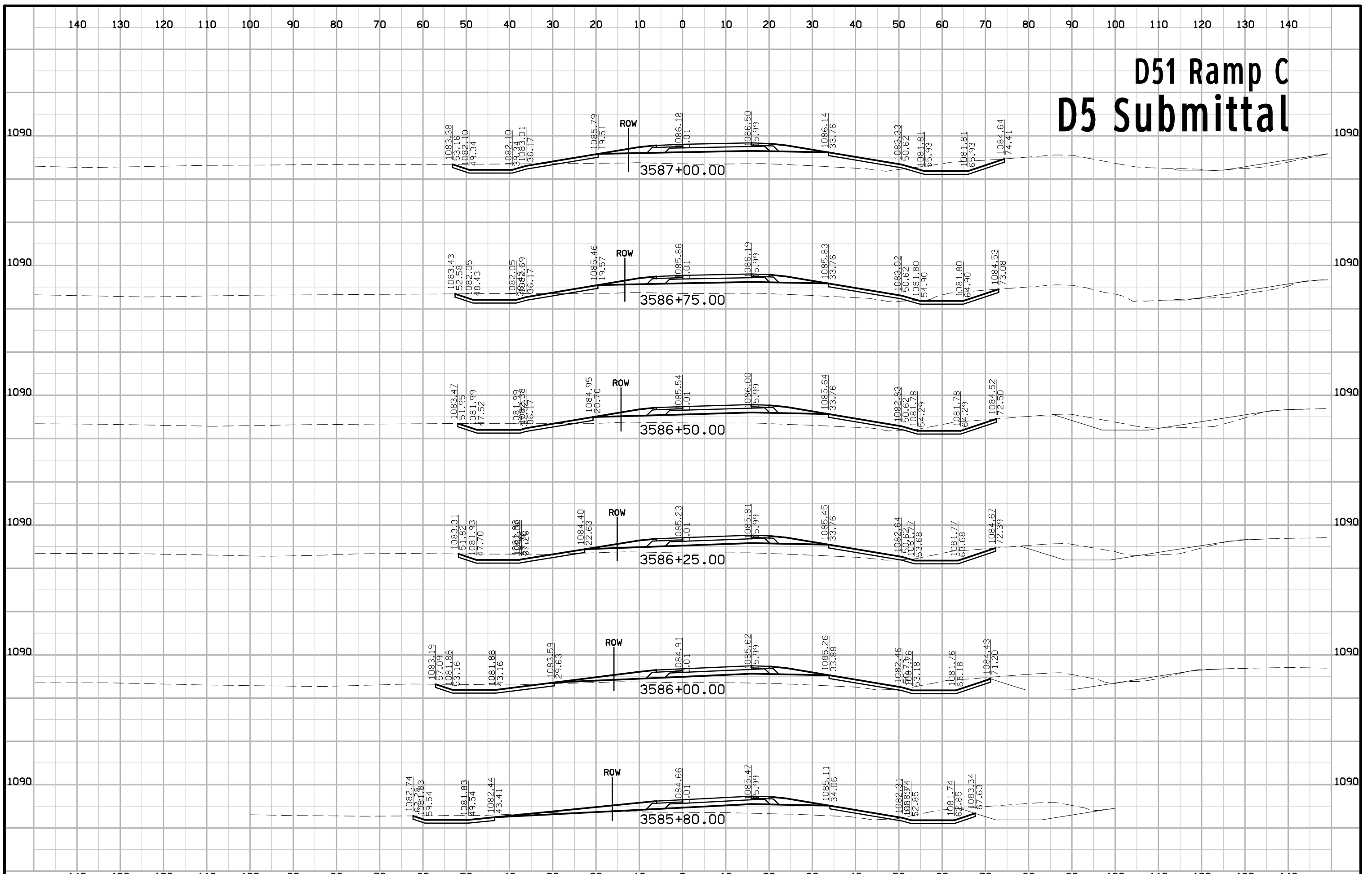



# D51 Ramp C D5 Submittal

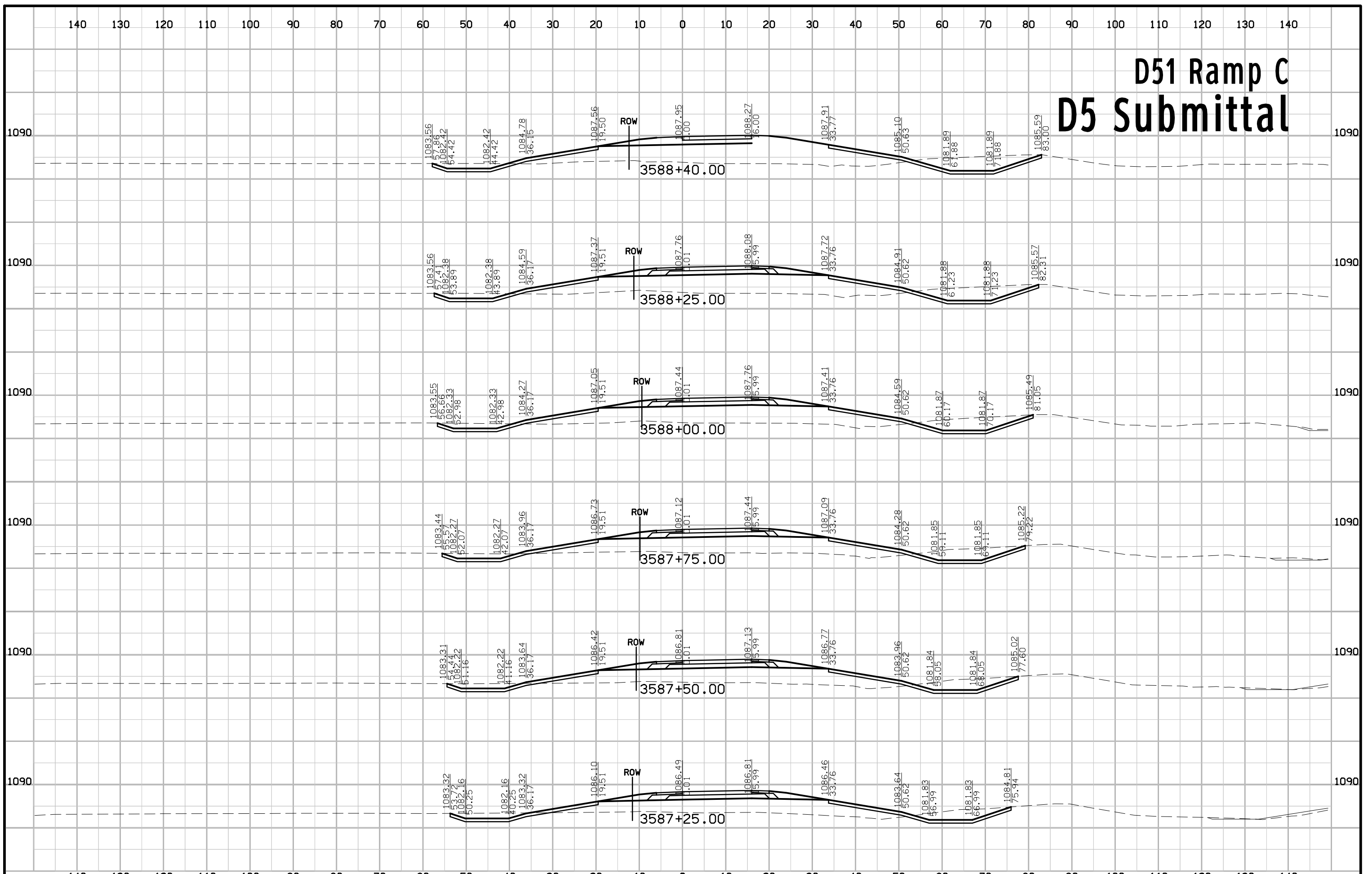

# D51 Ramp C D5 Submittal

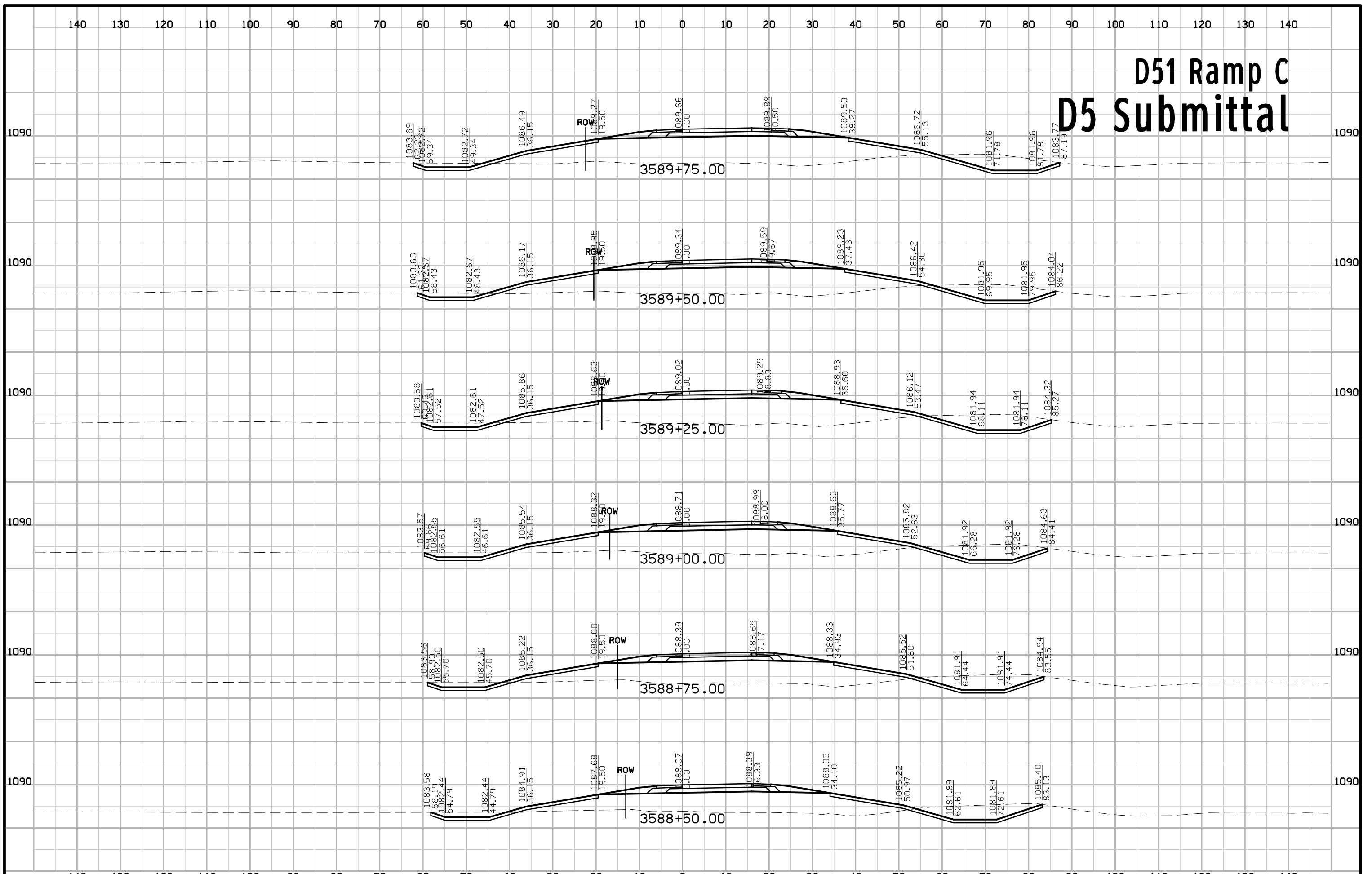

# D51 Ramp C D5 Submittal

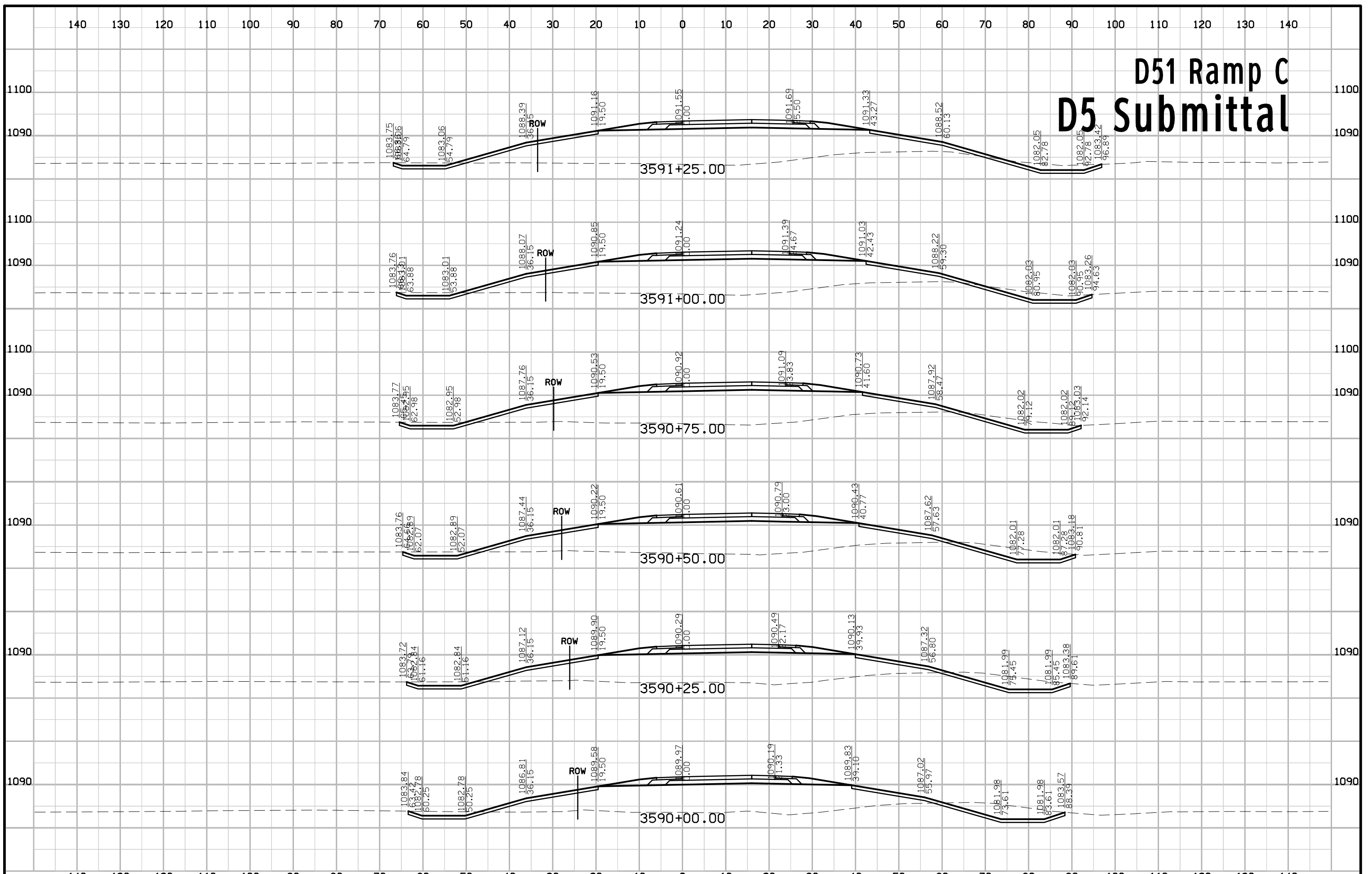

# D51 Ramp C D5 Submittal

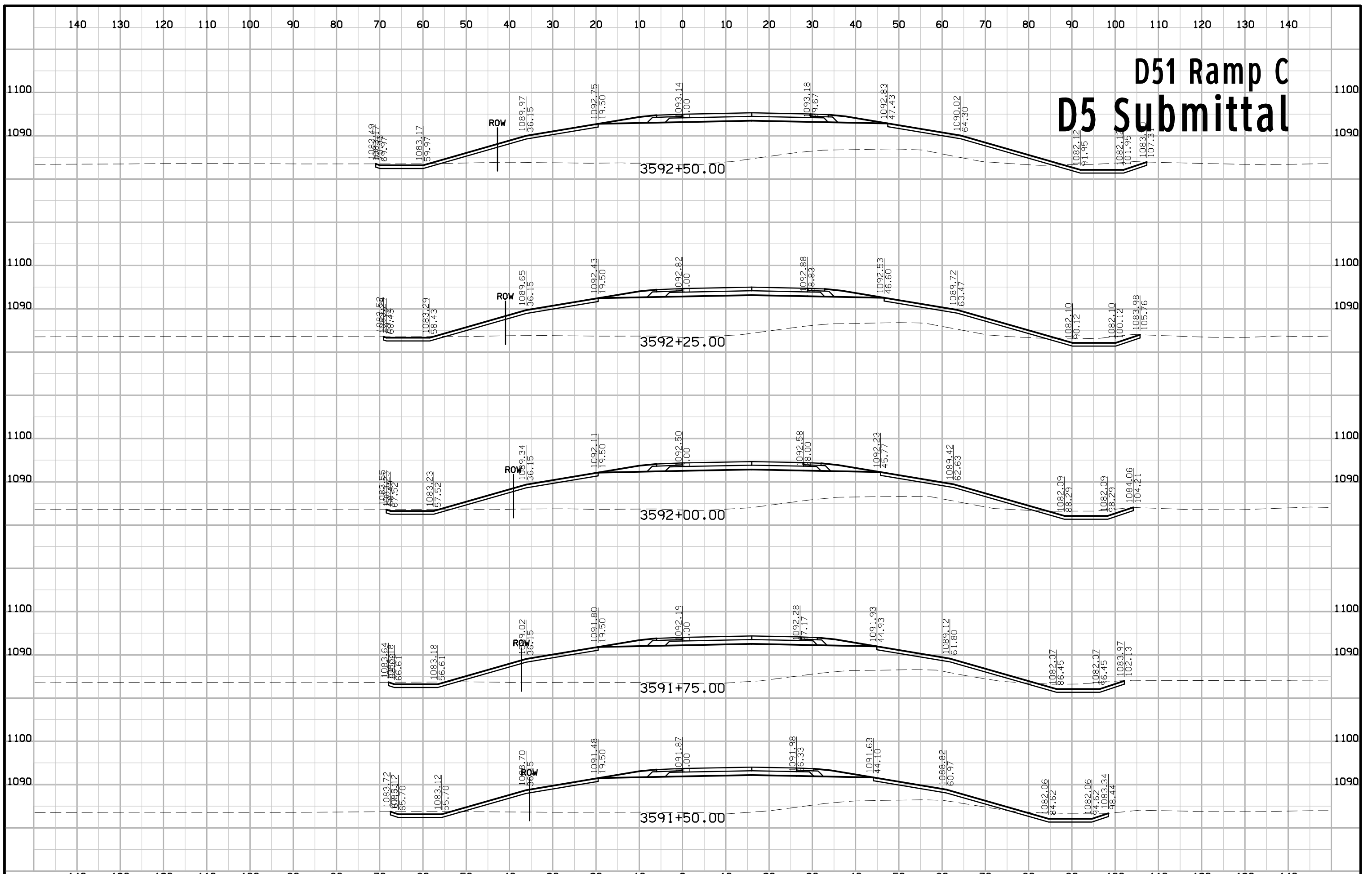

# D51 Ramp C D5 Submittal

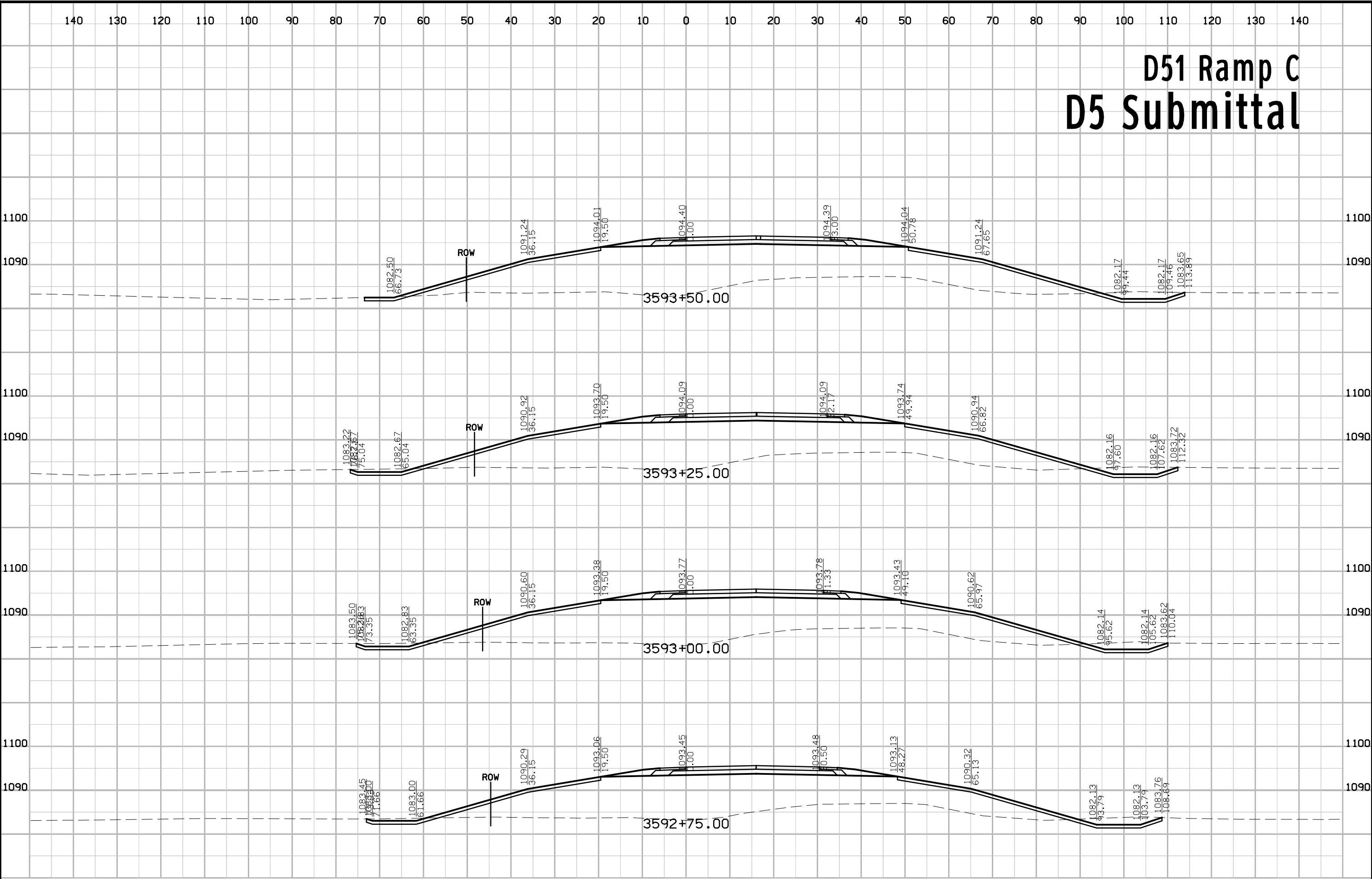

# D51 Ramp C D5 Submittal

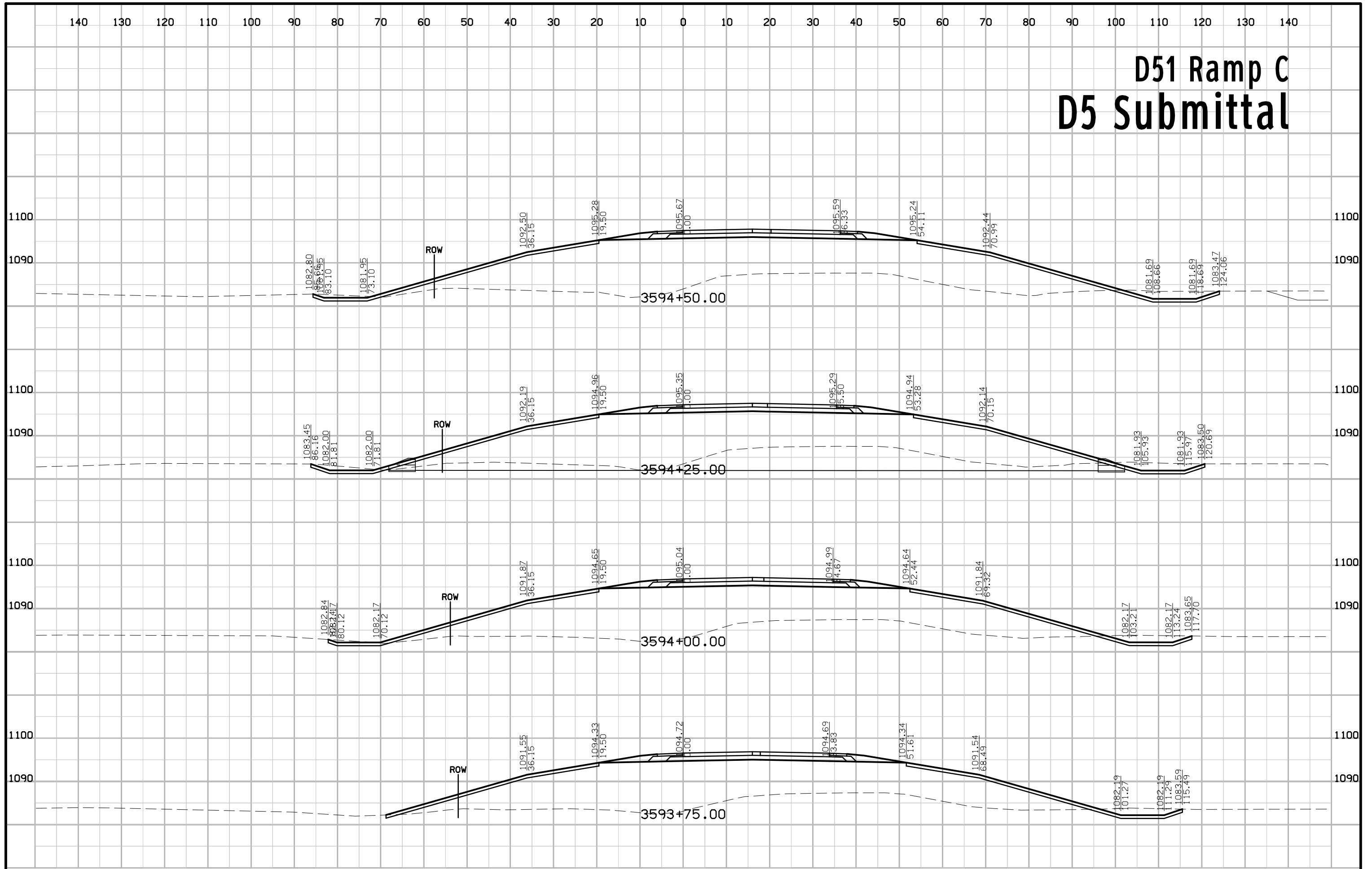

# D51 Ramp C D5 Submittal

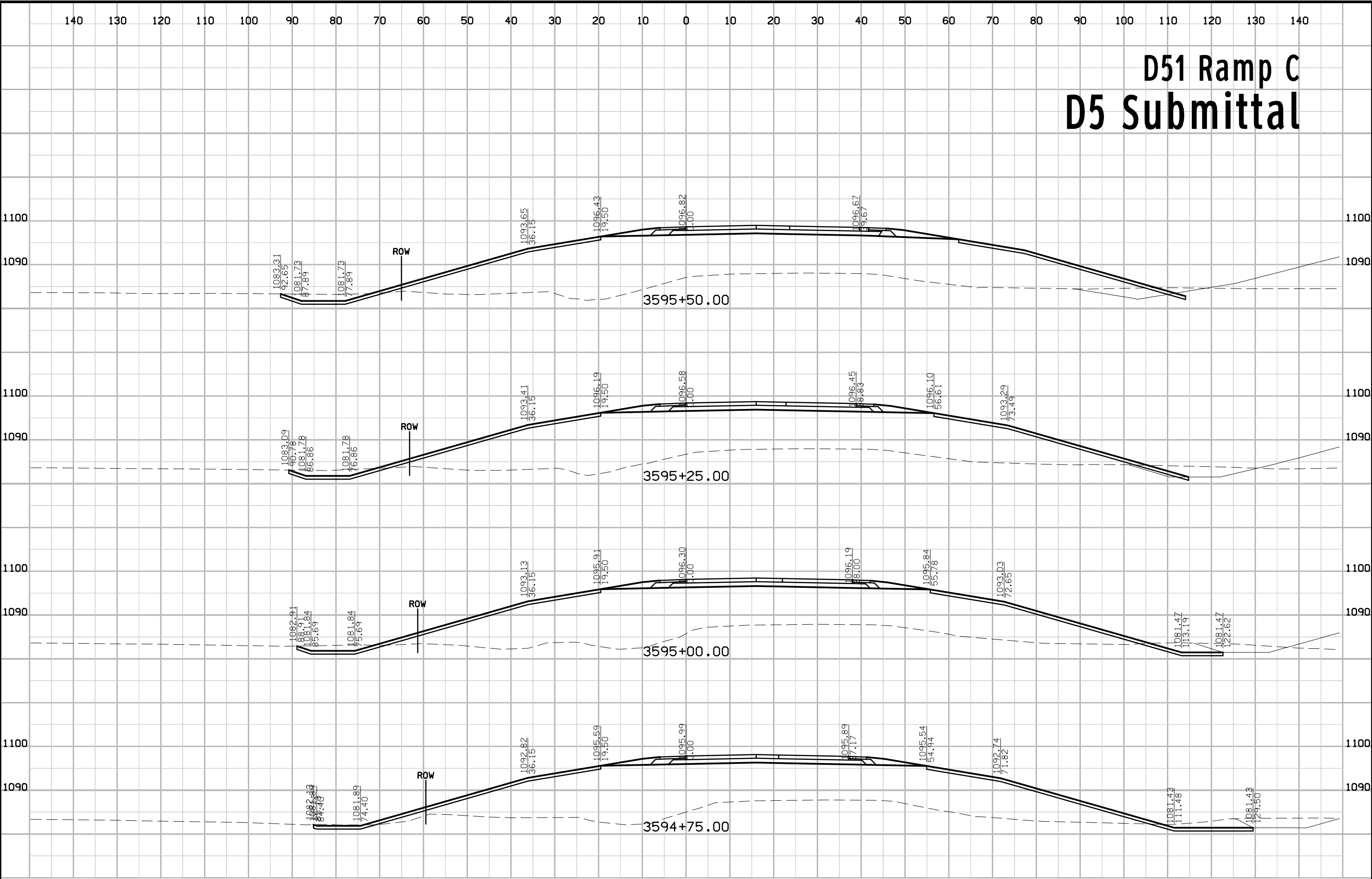

# D51 Ramp C D5 Submittal

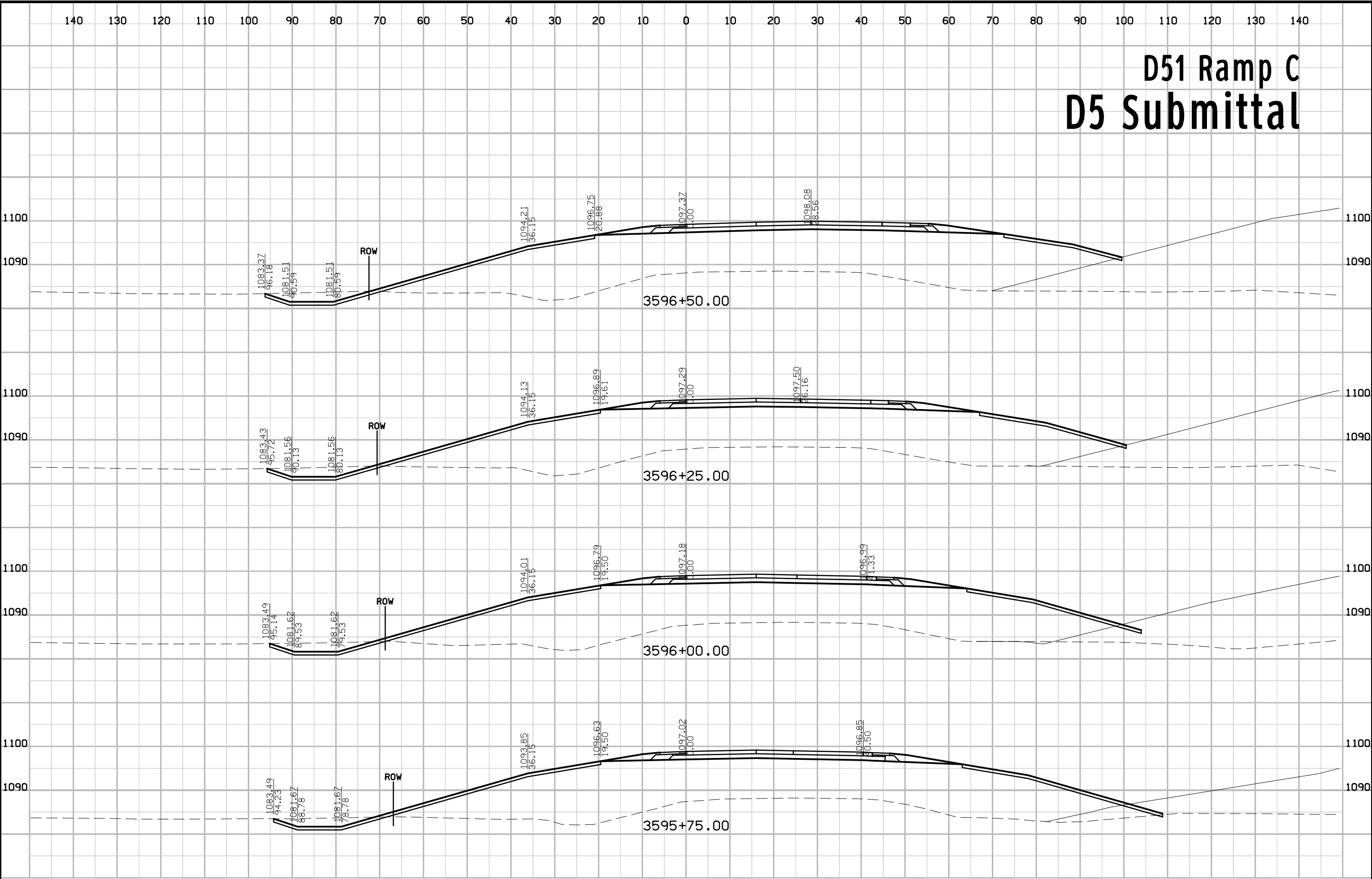



# D51 Ramp C D5 Submittal

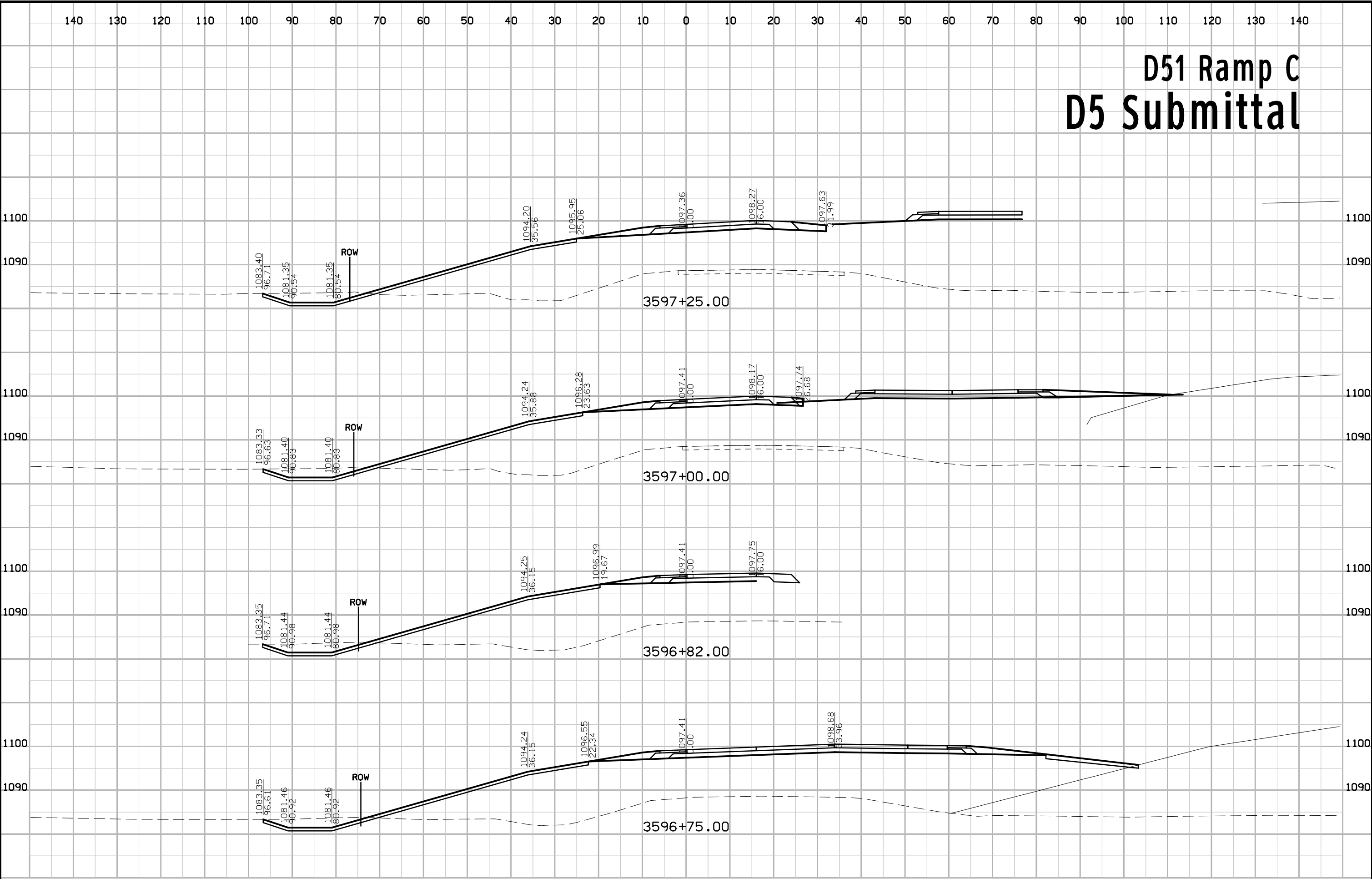

# D51 Ramp C D5 Submittal

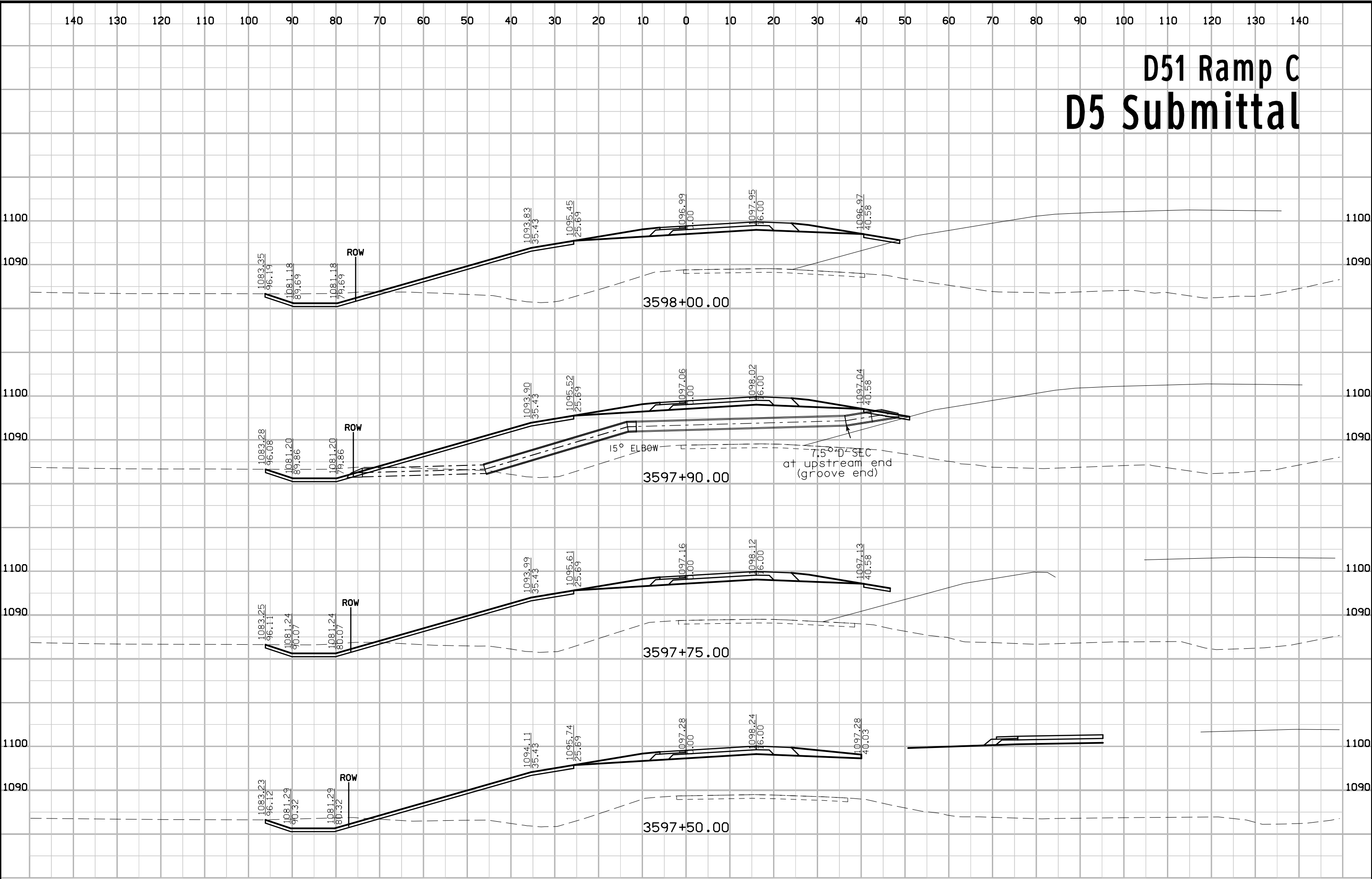

# D51 Ramp C D5 Submittal

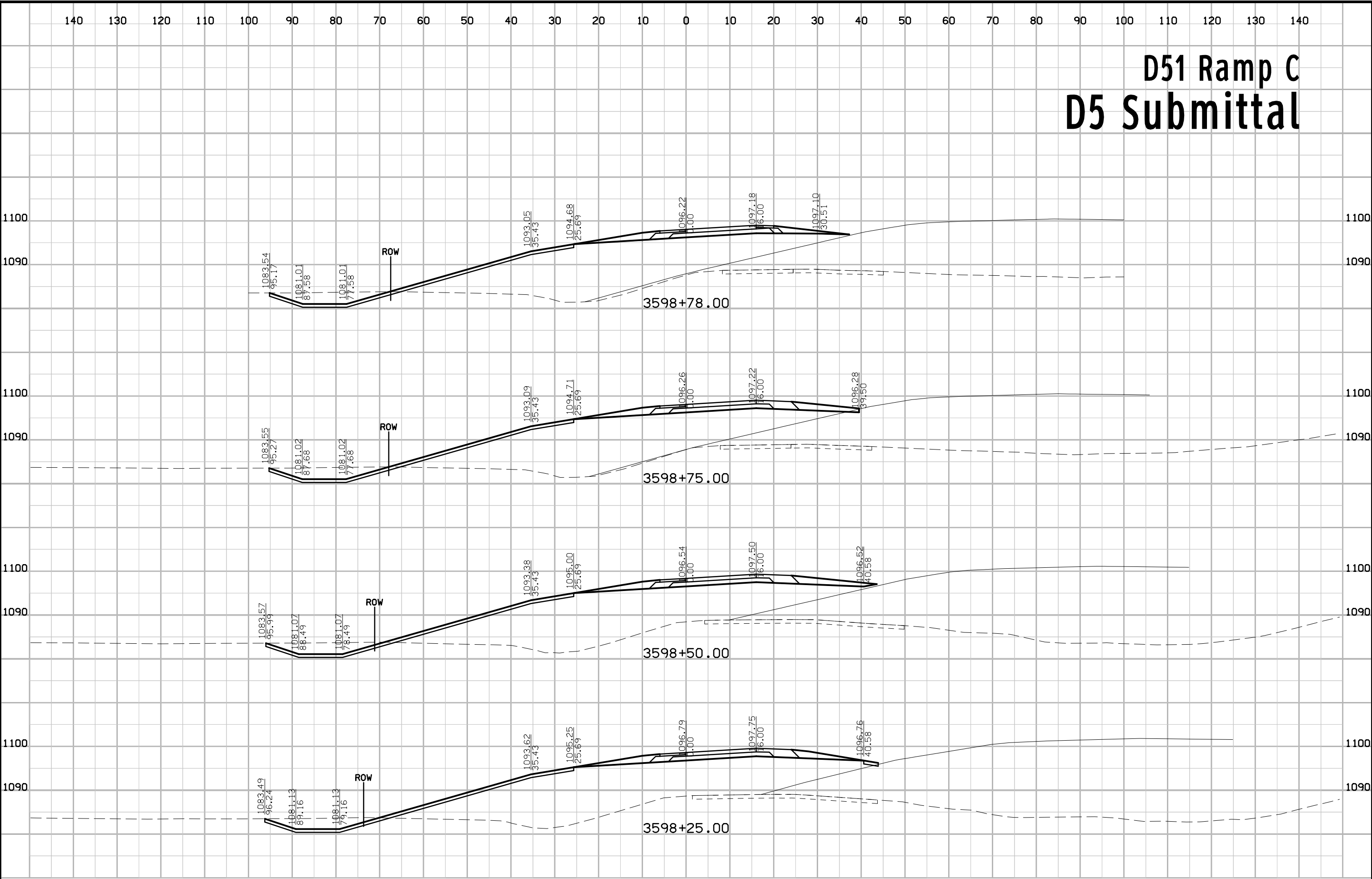

# D51 Ramp C D5 Submittal

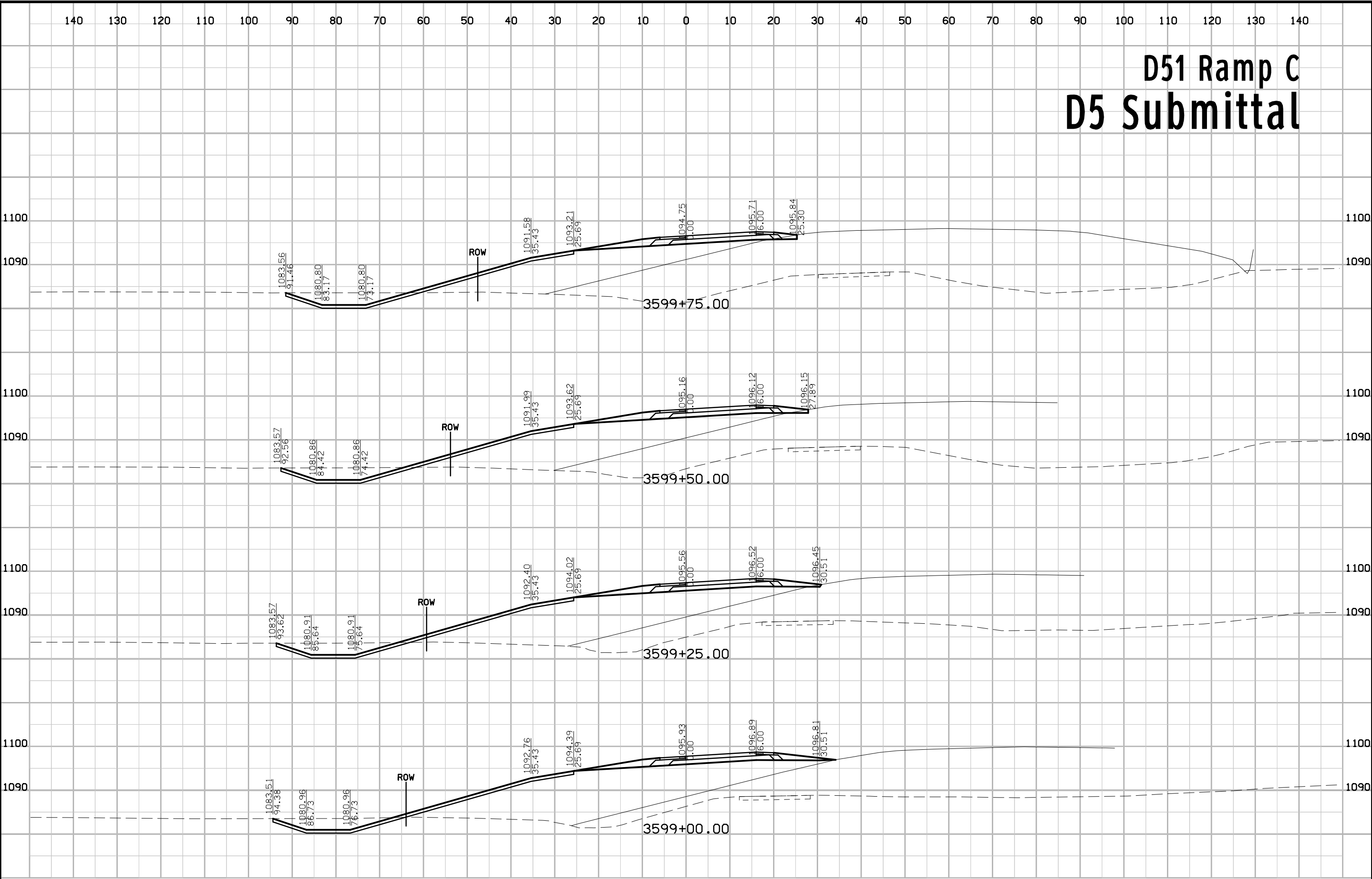

# D51 Ramp C D5 Submittal

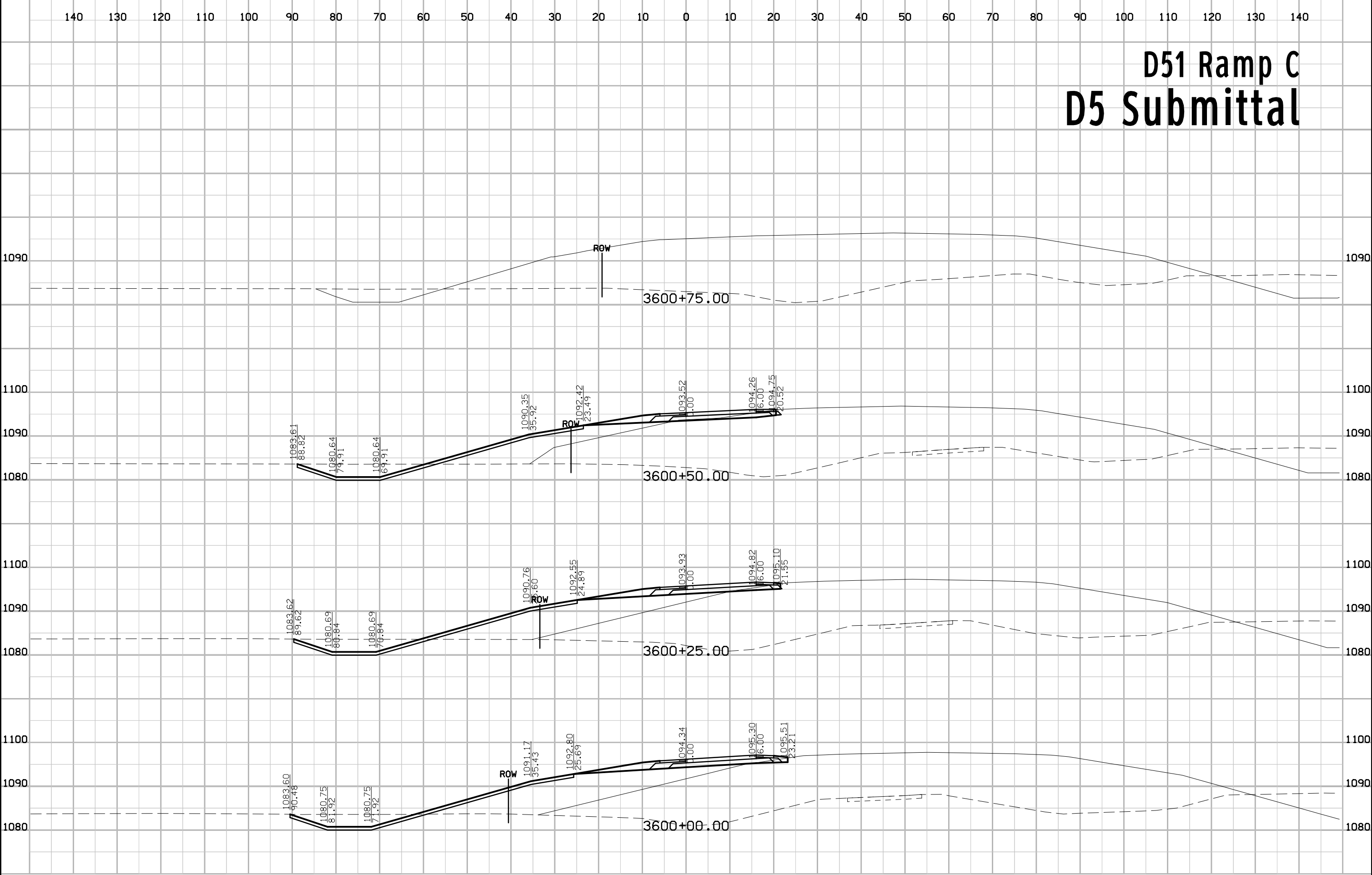

# D51 Ramp D D5 Submittal

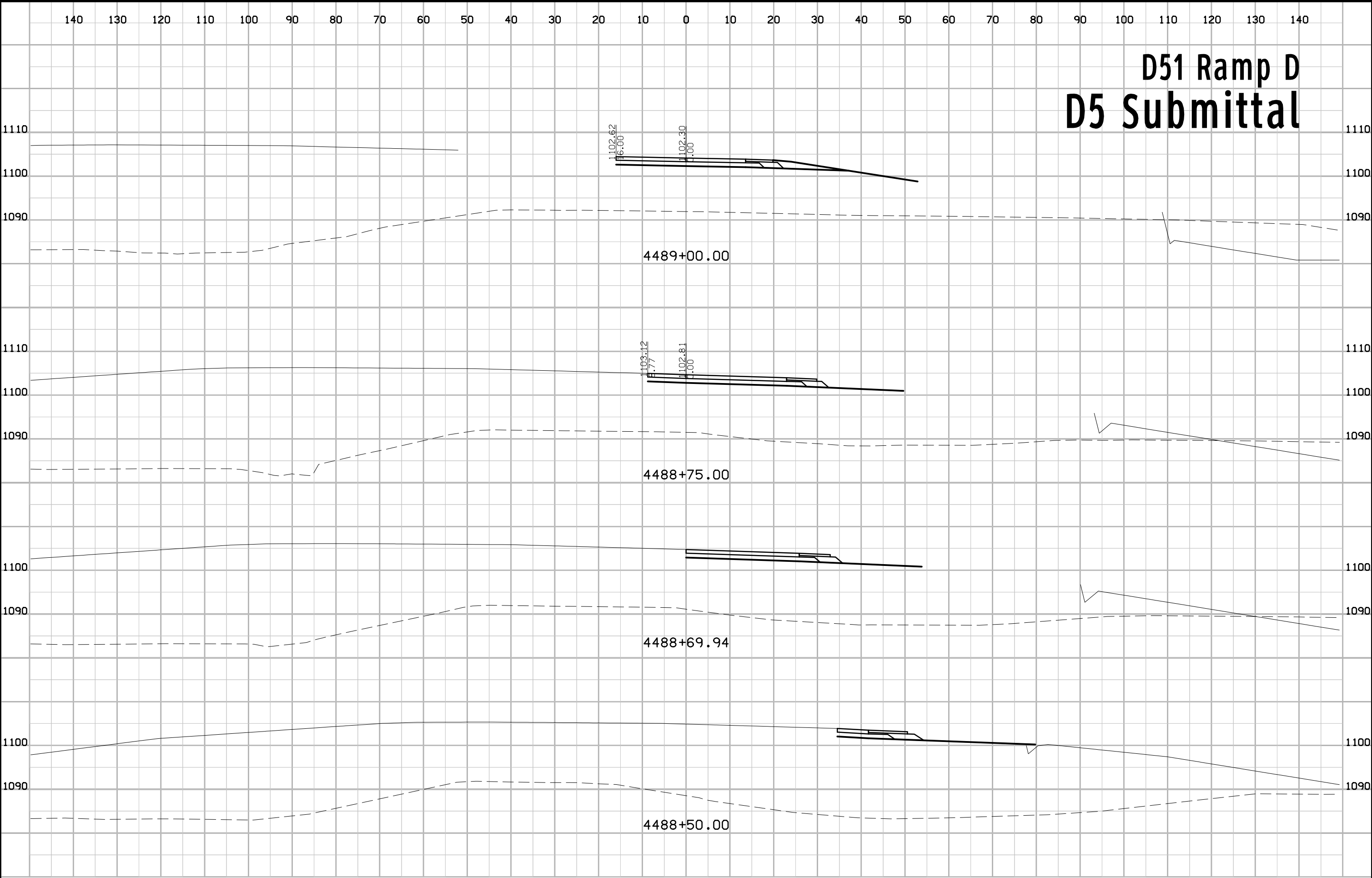

# D51 Ramp D D5 Submittal

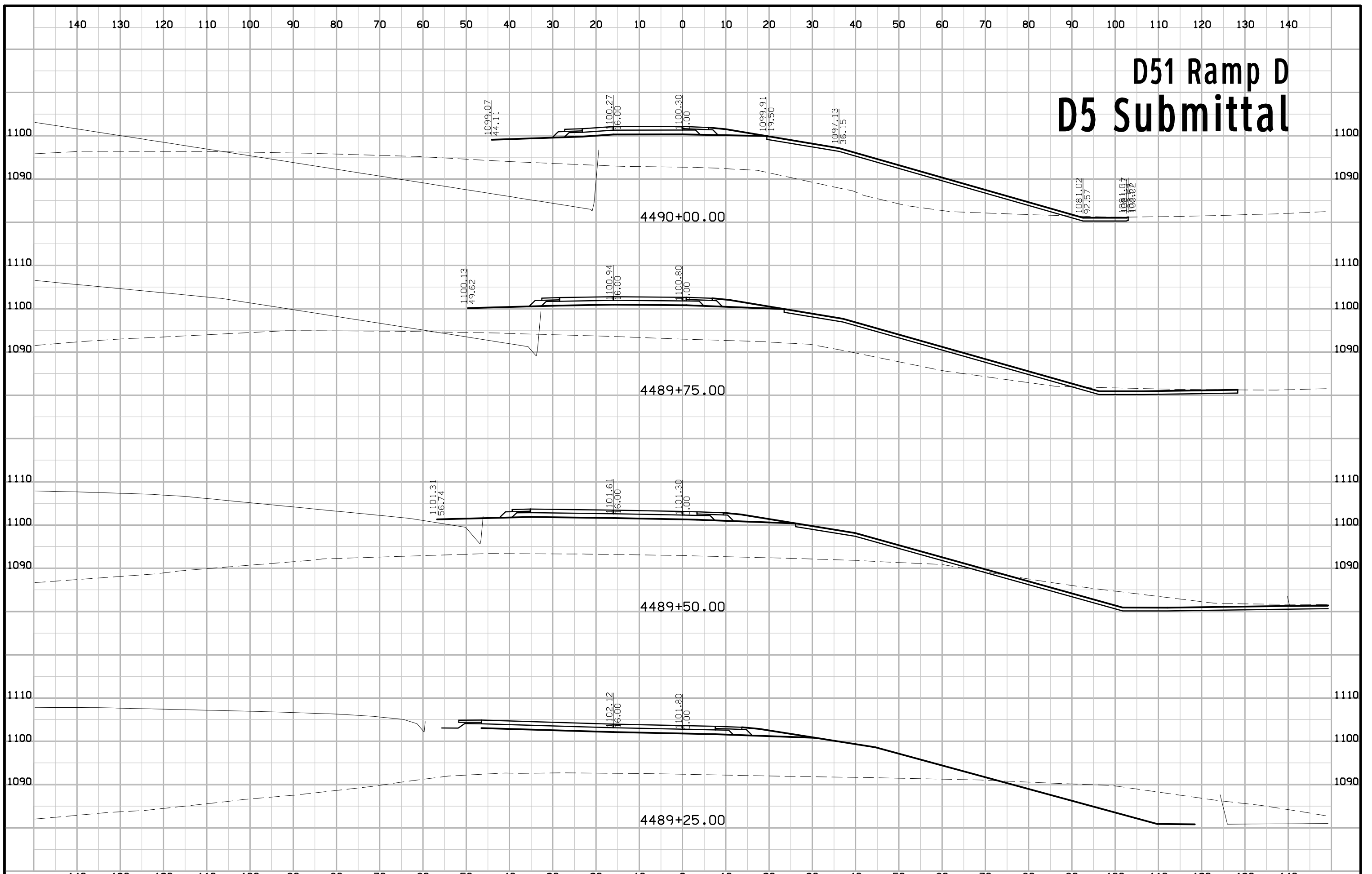

# D51 Ramp D D5 Submittal

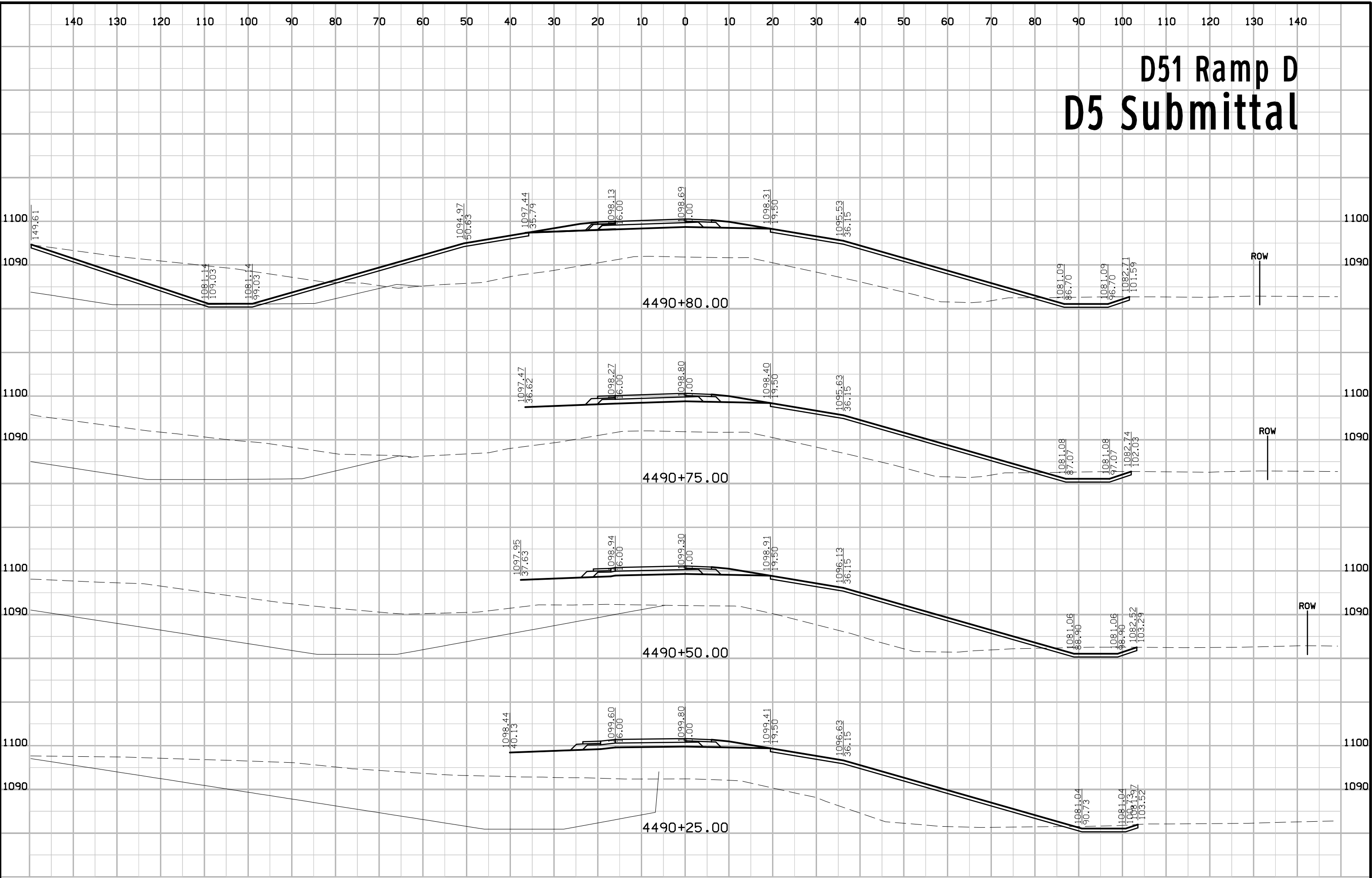



# D51 Ramp D D5 Submittal

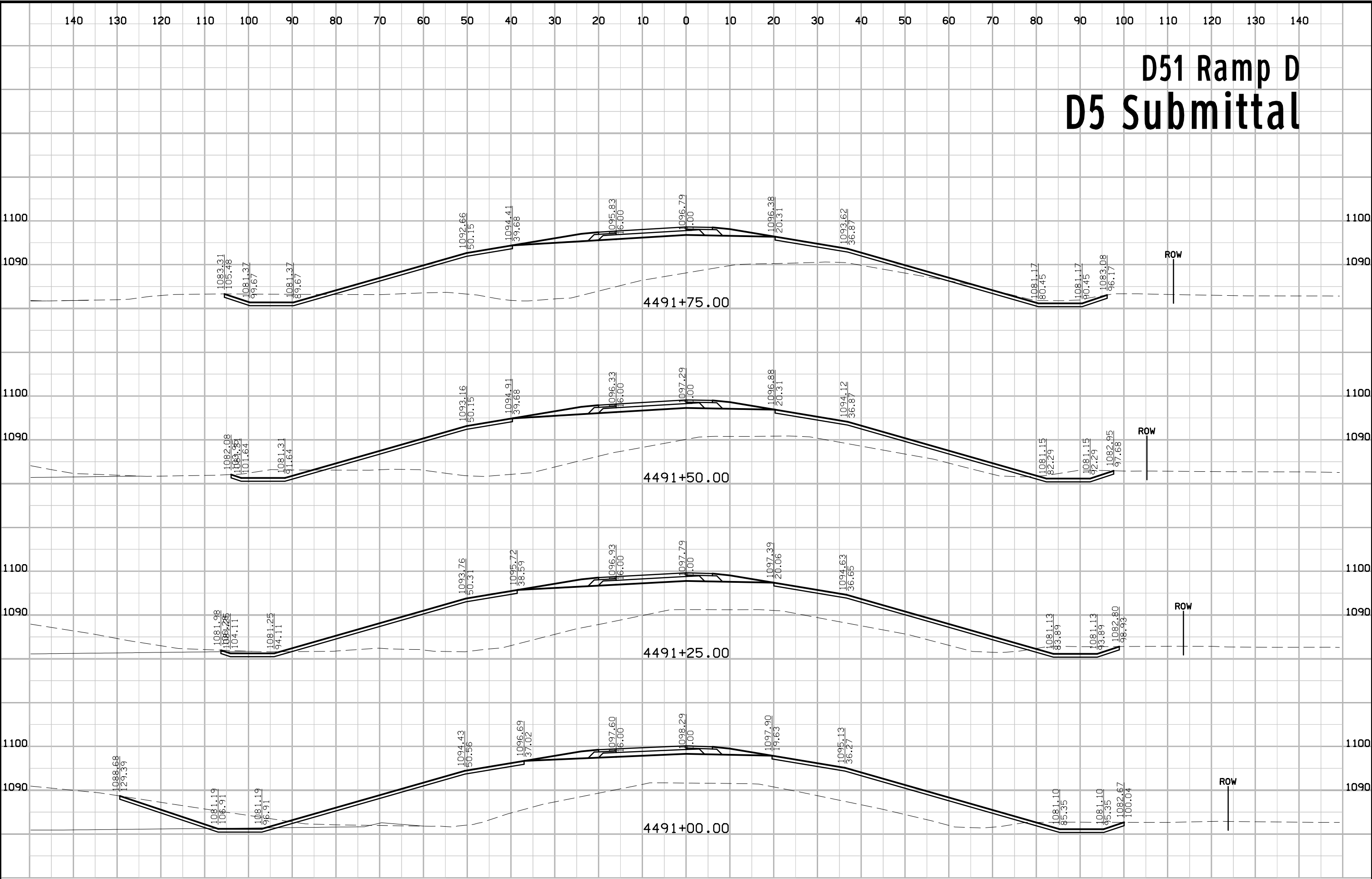

# D51 Ramp D D5 Submittal

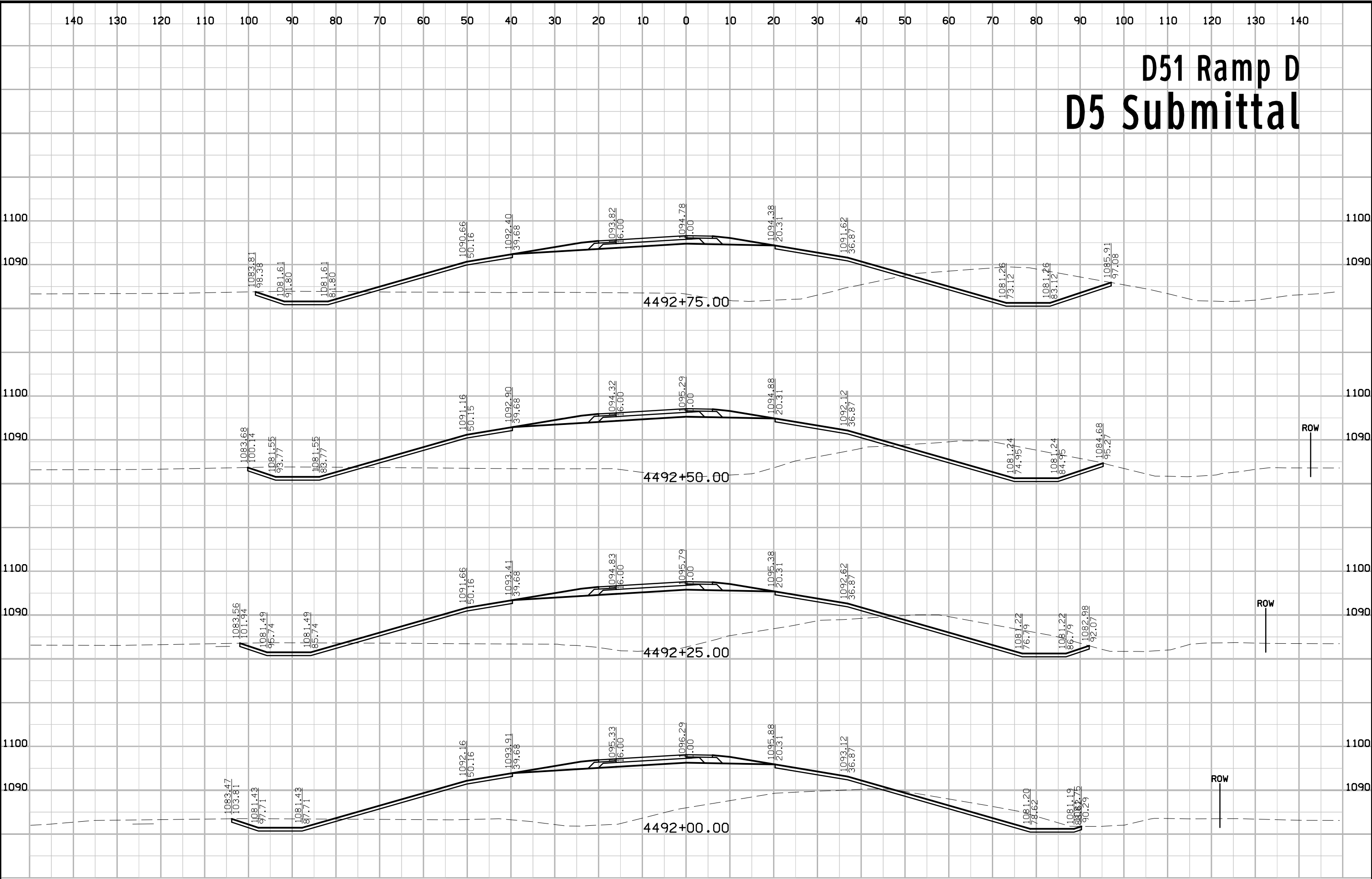

# D51 Ramp D D5 Submittal

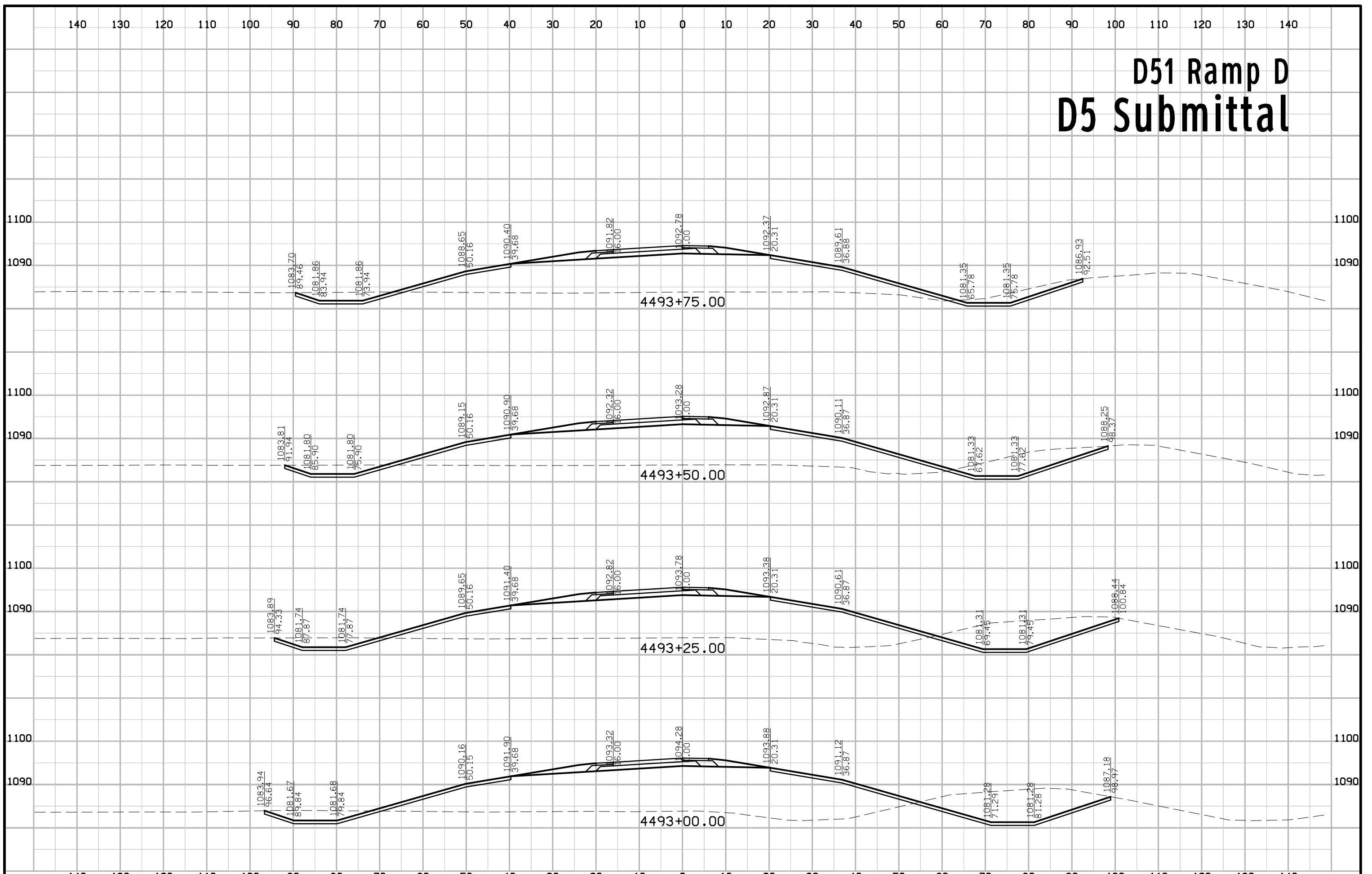

# D51 Ramp D D5 Submittal

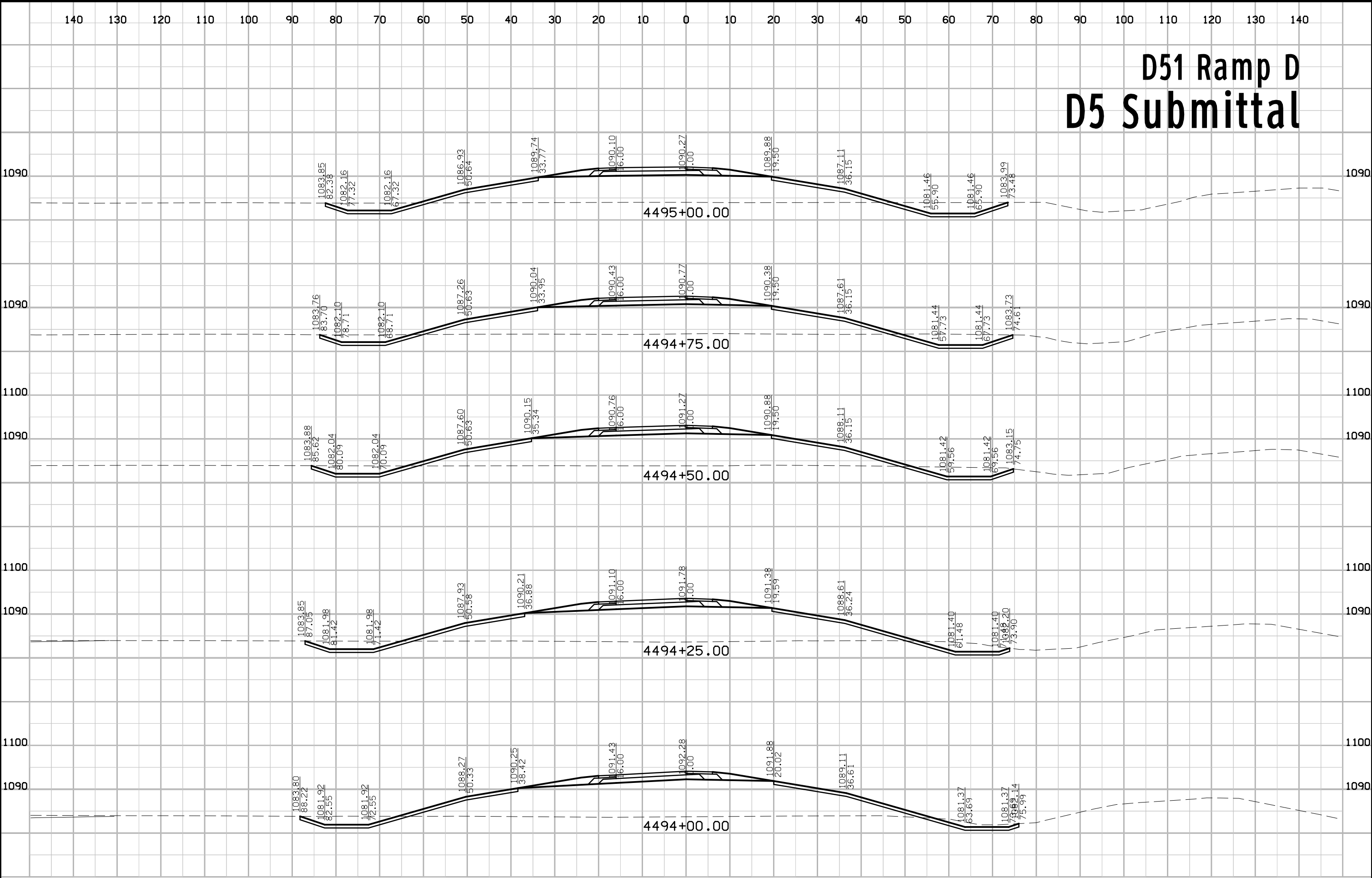

# D51 Ramp D D5 Submittal

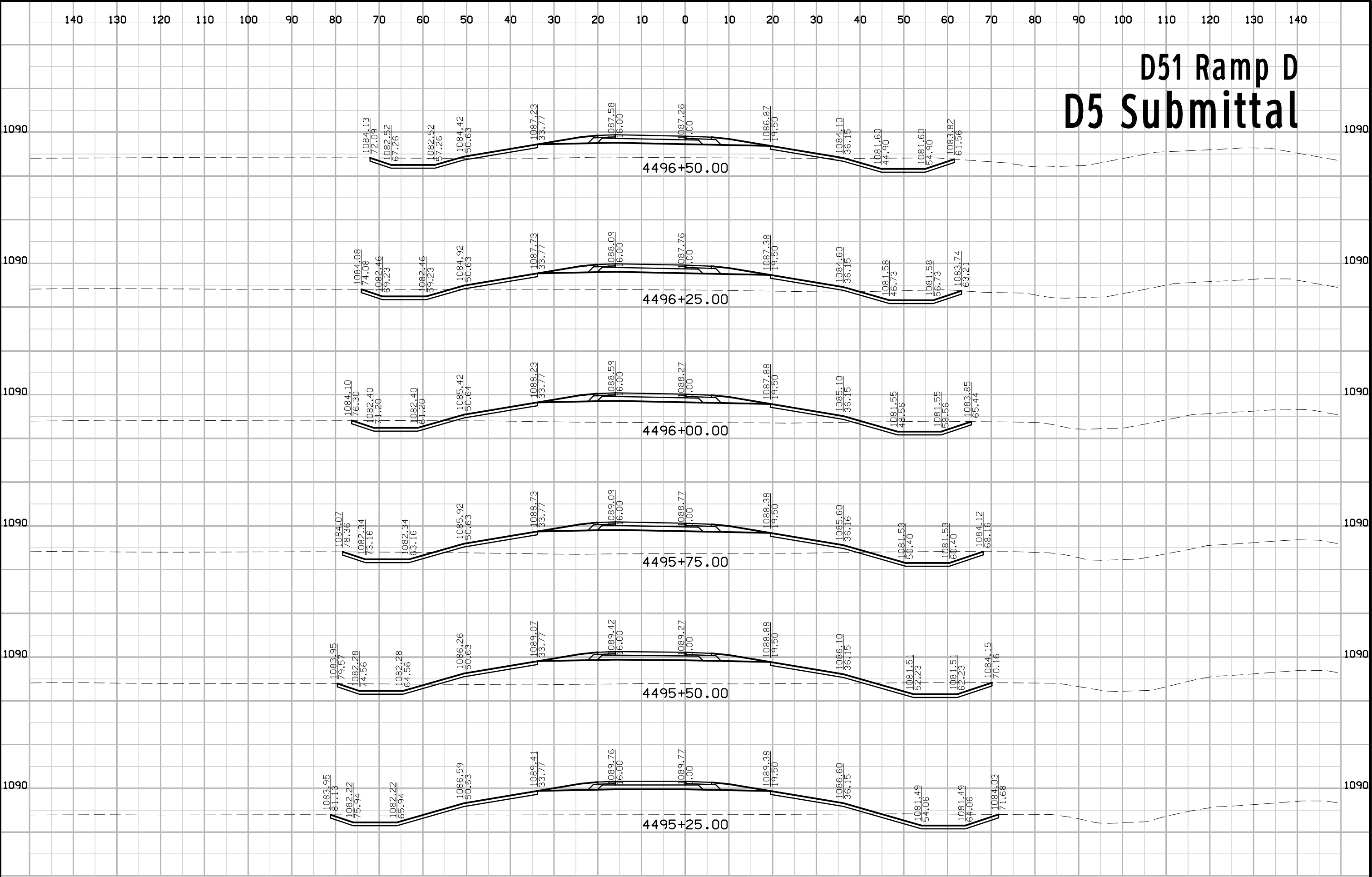

# D51 Ramp D D5 Submittal

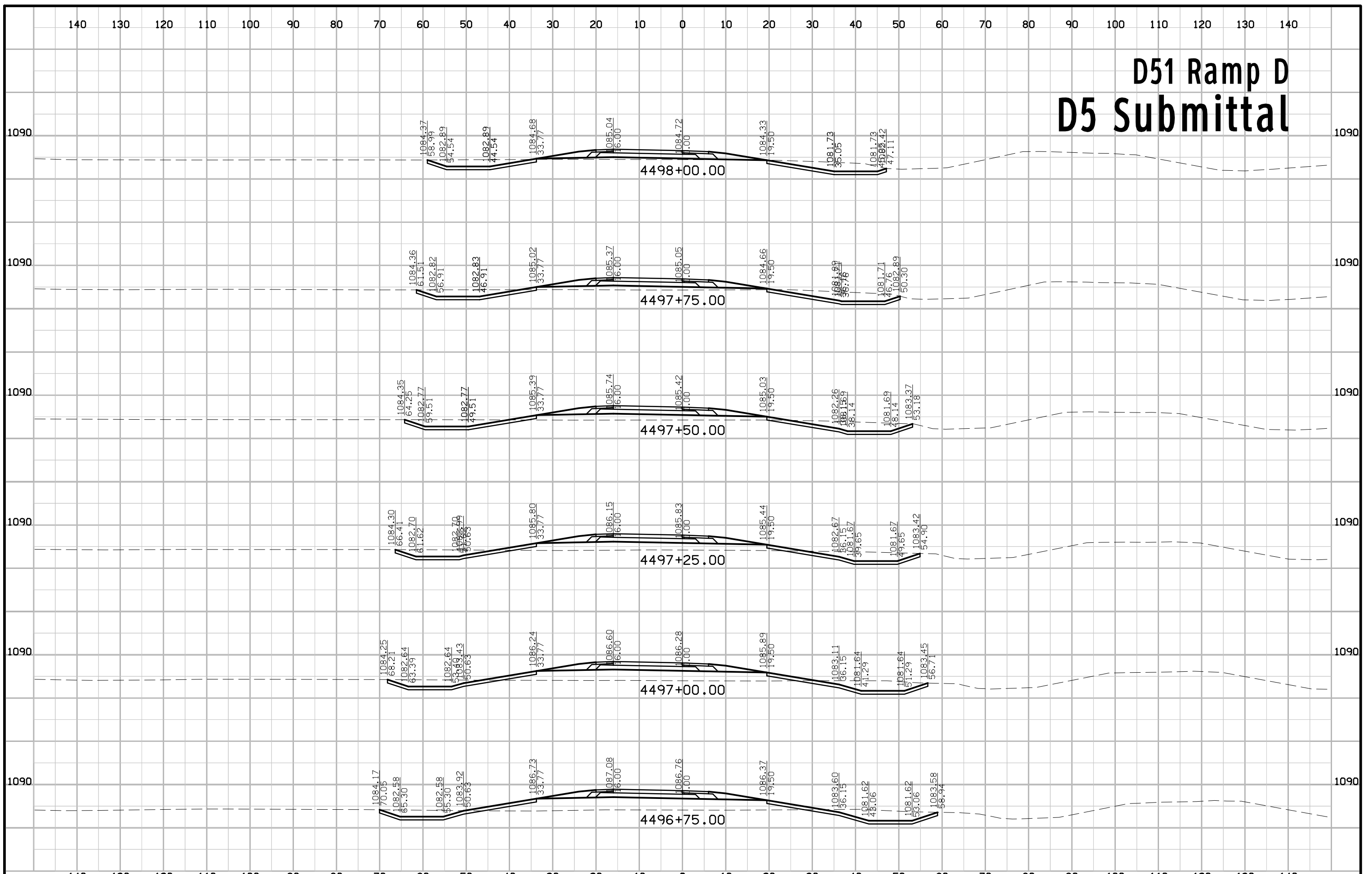

# D51 Ramp D D5 Submittal

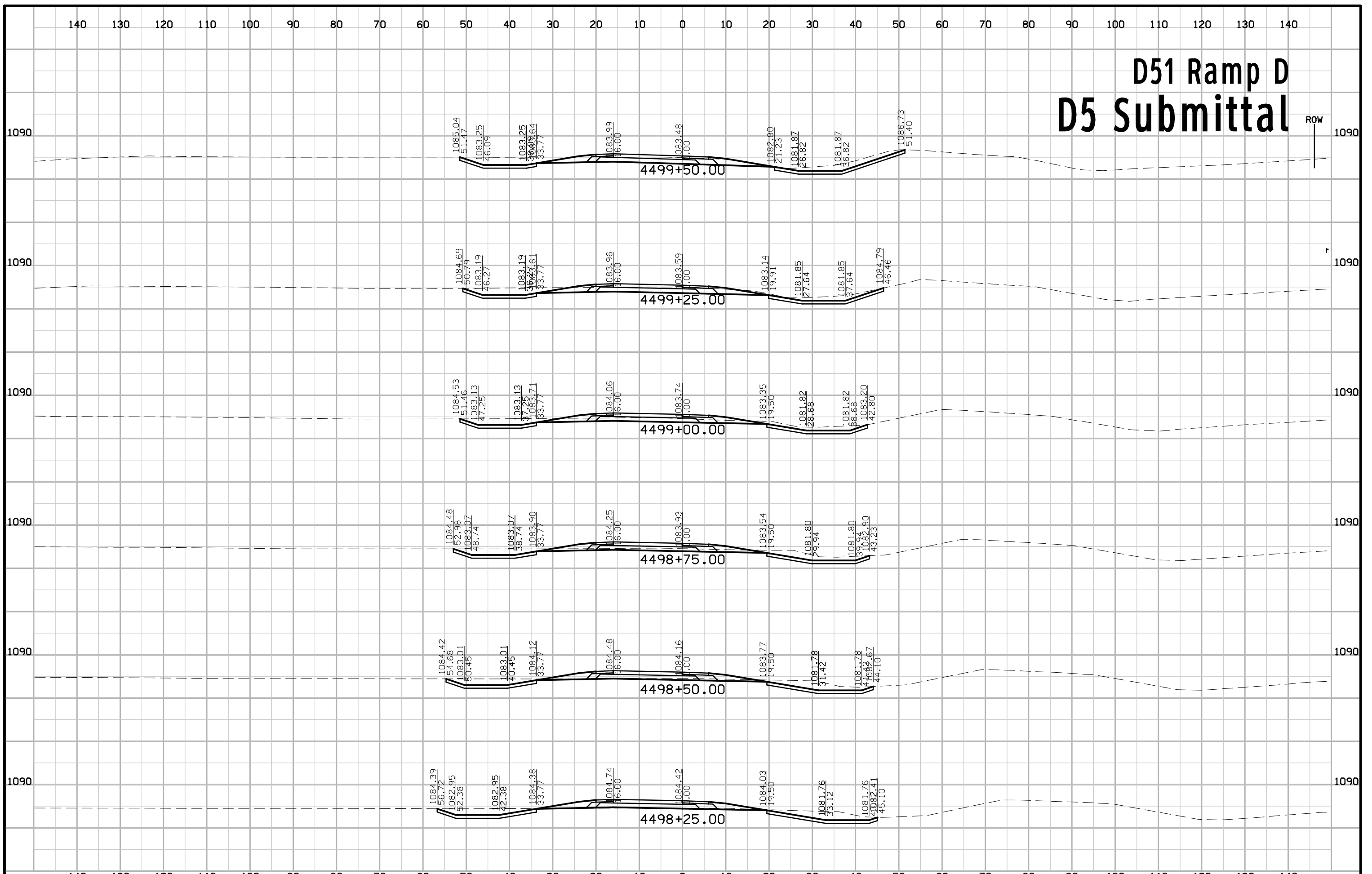

# D51 Ramp D D5 Submittal

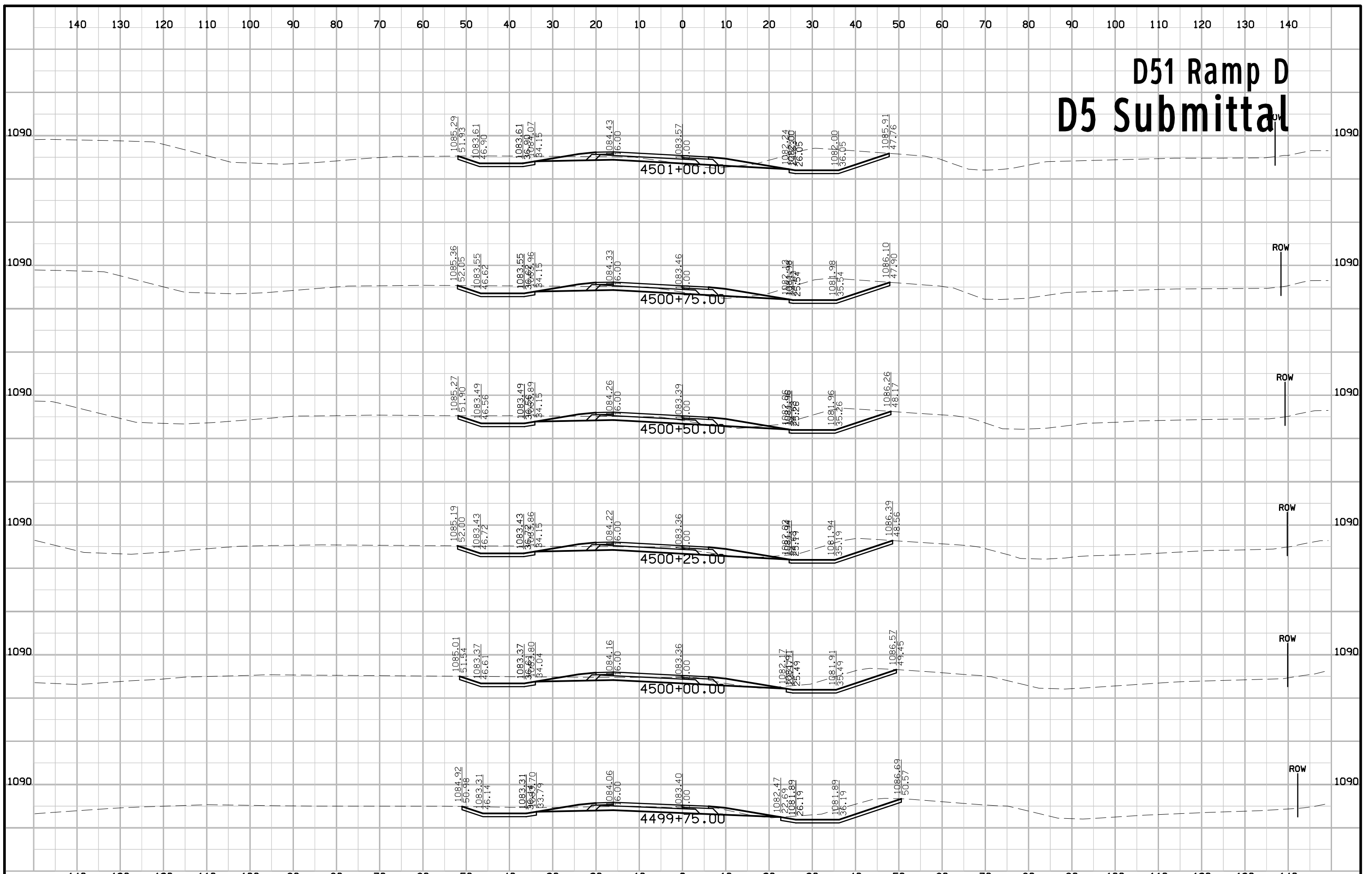



# D51 Ramp D D5 Submittal

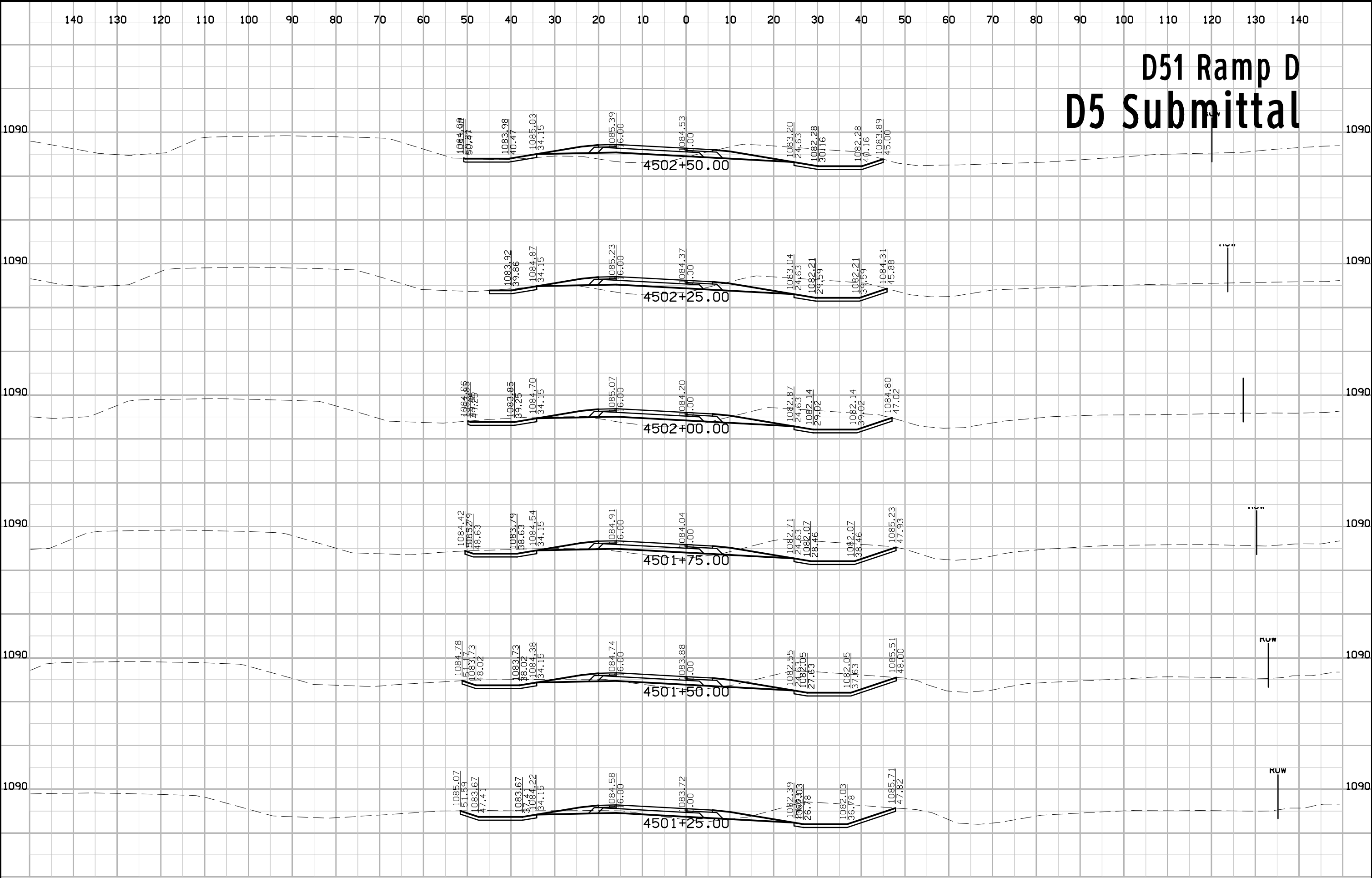

# D51 Ramp D D5 Submittal

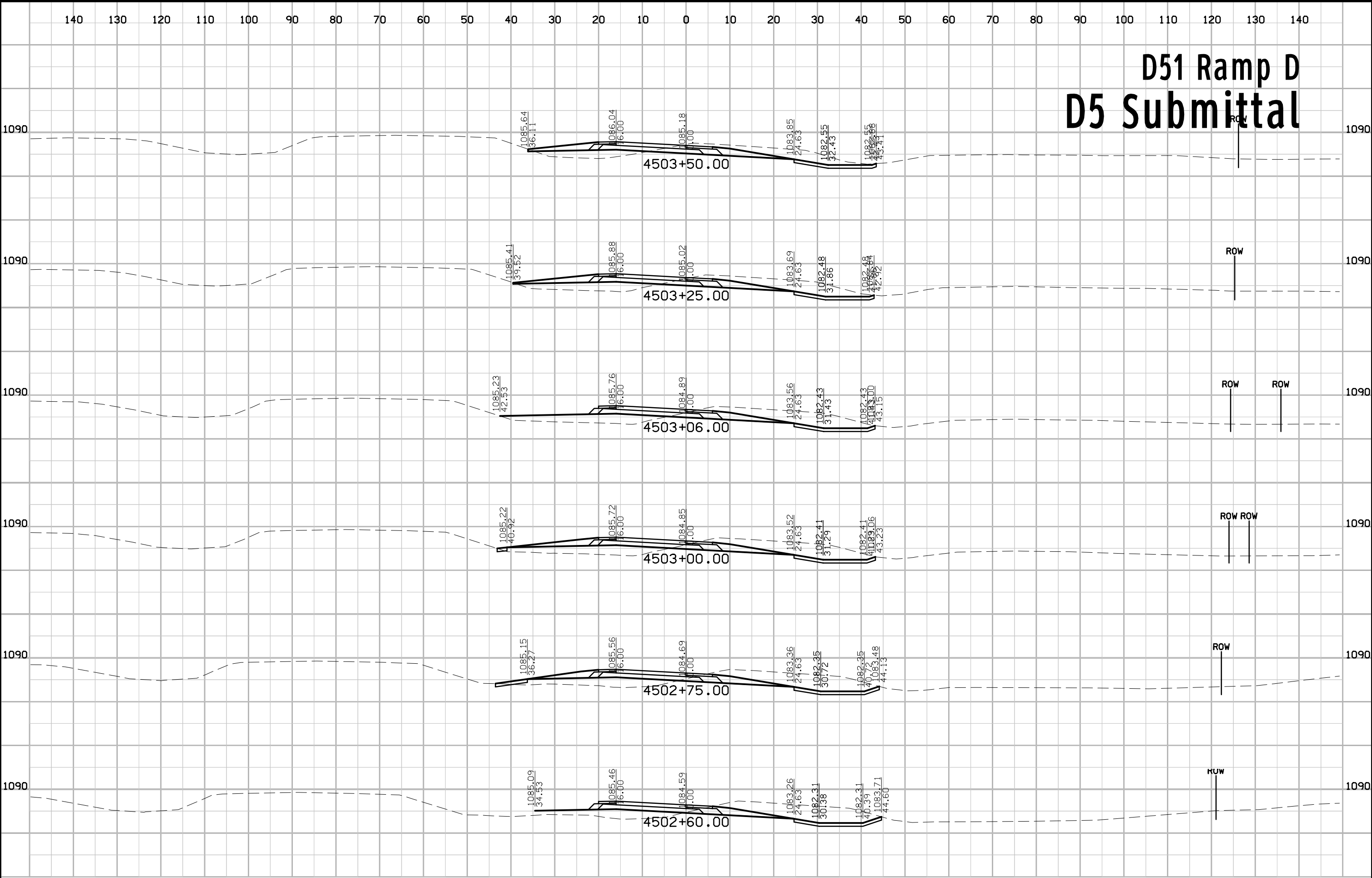

# D51 Ramp D D5 Submittal

