

WARREN COUNTY

**PCC PAVEMENT, GRADE AND REPLACE
IM-NHS-035-2(465)61--03-91**

LETTING DATE
DEC 16 2025

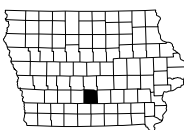

INDEX OF SHEETS	
No.	DESCRIPTION
A Sheets	Title Sheets
A.1	Title Sheet
A.2	Location Map Sheet
B Sheets	Typical Cross Sections and Details
B.1 - B.3	Typical Cross Sections and Details
C Sheets	Quantities and General Information
C.1	Tabulation Sheets
D Sheets	Mainline Plan and Profile Sheets
* D.1	Plan & Profile Legend & Symbol Information Sheet
* D.2 - D.6	Interstate 35 Plan & Profile
G Sheets	Survey Sheets
G.1	Reference Ties and Bench Marks
G.2 - G.3	Horizontal Control Tab. & Super for all Alignments
H Sheets	Right-of-Way Sheets
* H.1 - 9	Interstate 35
J Sheets	Traffic Control and Staging Sheets
* J.1	Traffic Control & Staging Legend & Symbol Info. Sheet
* J.2	Traffic Control Plan & Staging Notes Stage
* J.3-4	Traffic Control Typical Sections
* J.5 - J.11	Staging and Traffic Control Sheets
U Sheets	500 Series, Mod.Stds. and Detail Sheets
U.1 - U.5	500 Series, Modified Standards and Detail Sheets
* U.6	Temporary Median Crossover Detail Sheet
V Sheets	Bridge and Culvert Situation Plans
V.1 - V.7	Bridge and Culvert Situation Plans
W Sheets	Mainline Cross Sections
W.1	Cross Sections Legend & Symbol Information Sheet
W.2 - W.104	Mainline Cross Sections
	* Color Plan Sheets



PLANS OF PROPOSED IMPROVEMENT ON THE
**INTERSTATE ROAD SYSTEM
WARREN COUNTY**
PCC PAVEMENT, GRADE AND REPLACE
Northbound I-35 From
North of North River to South of Badger Creek

SCALES: As Noted

- Refer to the Proposal Form for list of applicable specifications.
- Value Engineering Saves. Refer to Article 1105.14 of the Specifications.
- For Project Location Map Refer to Sheet A.2



REVISIONS

TOTAL	154
PROJECT IDENTIFICATION NUMBER	00-91-035-030-06
PROJECT NUMBER	IM-NHS-035-2(465)61--03-91
R.O.W. PROJECT NUMBER	

EARTHWORK SUMMARY		
Cut	134,649	CY
Fill +30%	181,922	CY
Need	47,273	CY

I-35 101-4 04-30-02 DESIGN DATA RURAL			
2016 AADT	22,000	V.P.D.	
2035 AADT	--	V.P.D.	
20-- DHV	--	V.P.H.	
TRUCKS	26	%	
Total Design ESALs	--		

INDEX OF SEALS			
SHEET NO.	NAME	TYPE	BID QUANTITY SHEETS
A.1	Cindy A. Spencer	Primary Signature Block	X
X	X	X	X

LICENSED PROFESSIONAL ENGINEER

CINDY A. SPENCER

P17561

IOWA

D5 PLAN

I hereby certify that this engineering document was prepared by me or under my direct personal supervision and that I am a duly licensed Professional Engineer under the laws of the State of Iowa.

Cindy A. Spencer, P.E. Date

License Number P17561

My License Renewal Date is December 31, 2024

Pages or sheets covered by this seal:

Date: 05-26-23

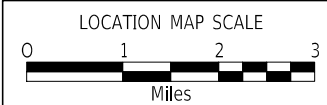
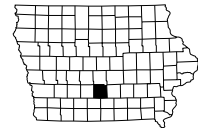
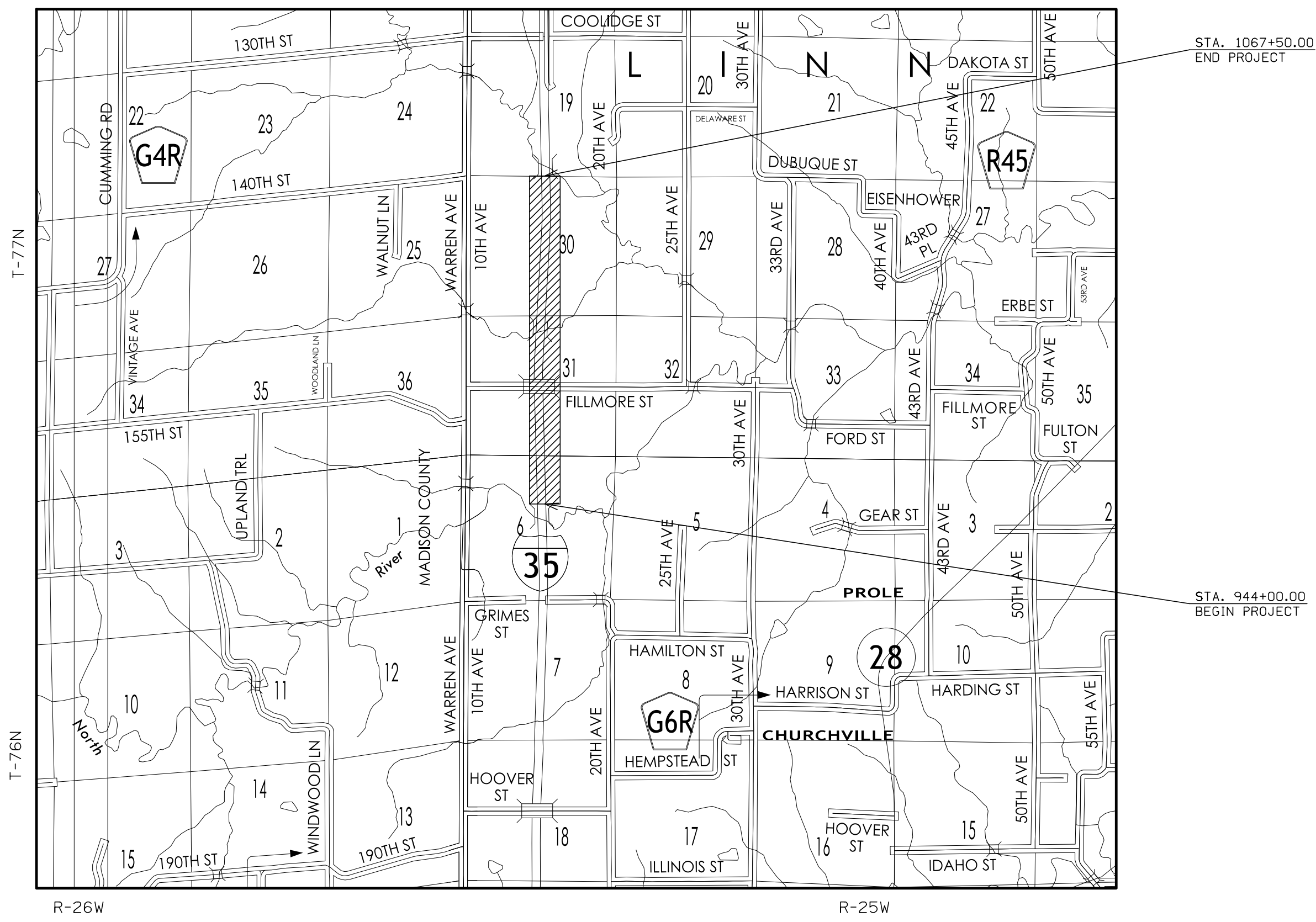

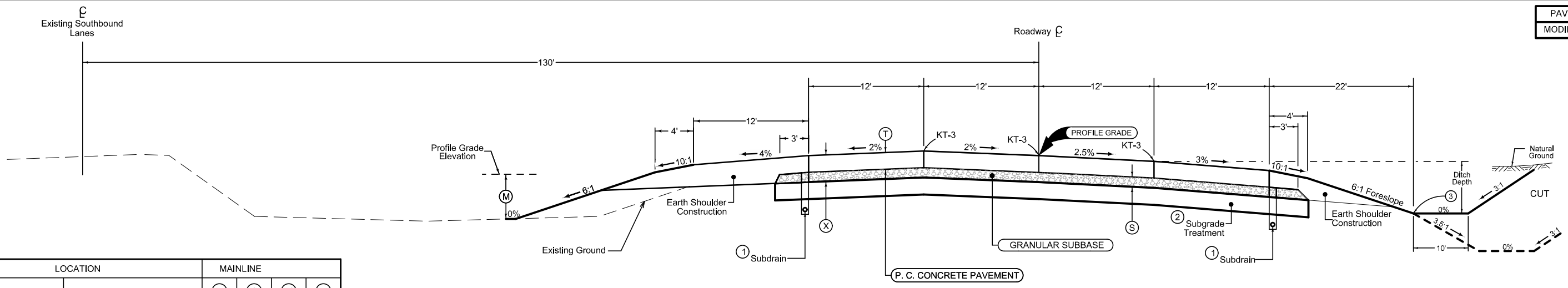

LOCATION		MAINLINE			
ROAD IDENTIFICATION	STATION TO STATION	T Inches	S Inches	FS Inches	X Inches
I-35 NB	944+00 1067+00	11.0	6	6	17.0

- Transverse joints: CD at 17' spacing
- ① Refer to Tab. 104-9.
 - ② Refer to Detail G_4D_Grade_Delay_S, Sheet B.3.
 - ③ Refer to project plan and cross sections for specific location of foreslope change.

Normal Section shown may be modified appropriately in areas of super-elevated curves or other locations specifically designated by the Engineer.

See Plan and Profile Sheets and Cross Sections for additional details of Ditches and Backslopes.

See Tab 100-24 for Pavement Quantities

**TYPICAL CROSS SECTION
NORTHBOUND LANES
GRADING AND PAVING**

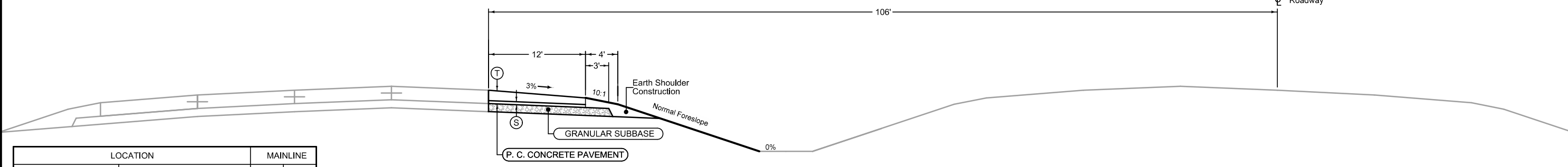

LOCATION		MAINLINE	
ROAD IDENTIFICATION	STATION TO STATION	T Inches	S Inches
I-35 SB	916+60.00 937+02.00	11.0	6
I-35 SB	941+87.86 1070+62.38	11.0	6

SOUTHBOUND SHOULDER CONSTRUCTION

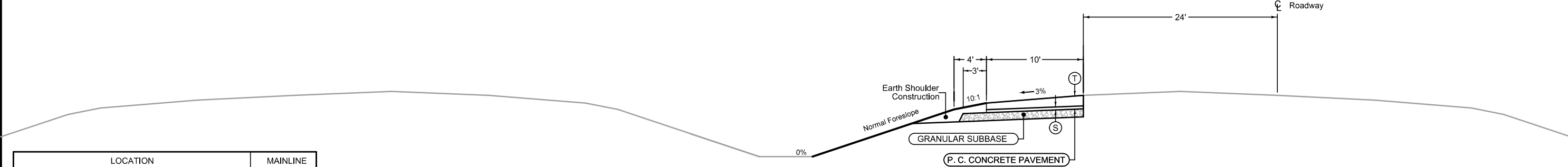

LOCATION		MAINLINE	
ROAD IDENTIFICATION	STATION TO STATION	T Inches	S Inches
I-35 NB	903+98.90 925+00.00	11.0	6

NORTHBOUND SHOULDER STRENGTHENING

8101
04-21-15

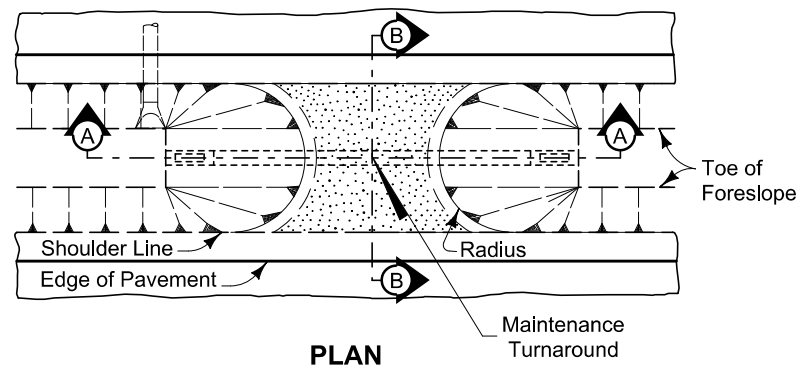

- ① Surfacing quantities based on a 6 inch layer of Macadam Stone base and a 4 inch layer of Class 'A' Road Stone. Apply surfacing as directed by the Engineer.
- ② Construct 8:1 foreslope when drainage pipe is incorporated into the maintenance turnaround.
- ③ Install Polymer Grid between Class 10 and stone material.
- ④ See Standard Road Plan DR-212.

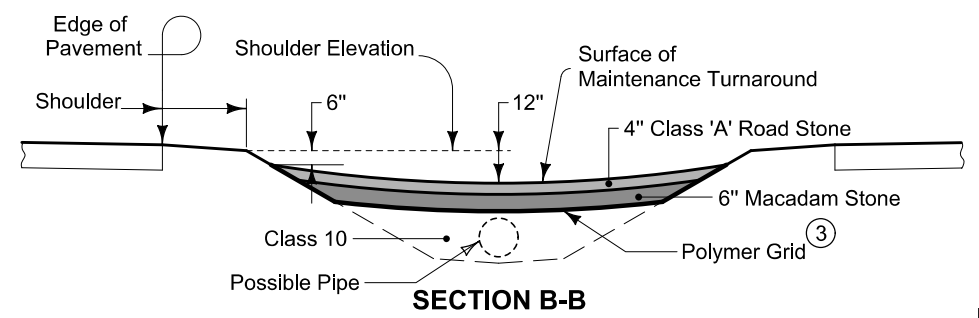
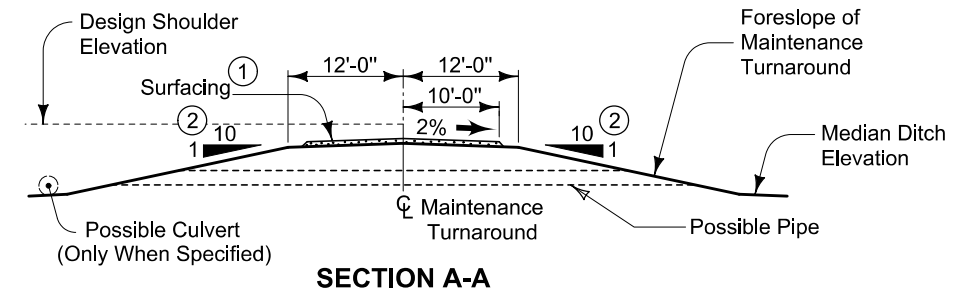

MAINTENANCE TURNAROUND

Location		Class 'A' Road Stone	Macadam Stone	Polymer Grid	Class 10	Pipe Length	Beveled Pipe & Guard ④	Radius	Remarks
Road Identification	Station	TONS	TONS	SY	CY	LF	EACH	FT	
I-35	--	--	--	--	-	-	-	--	

4104
04-21-15

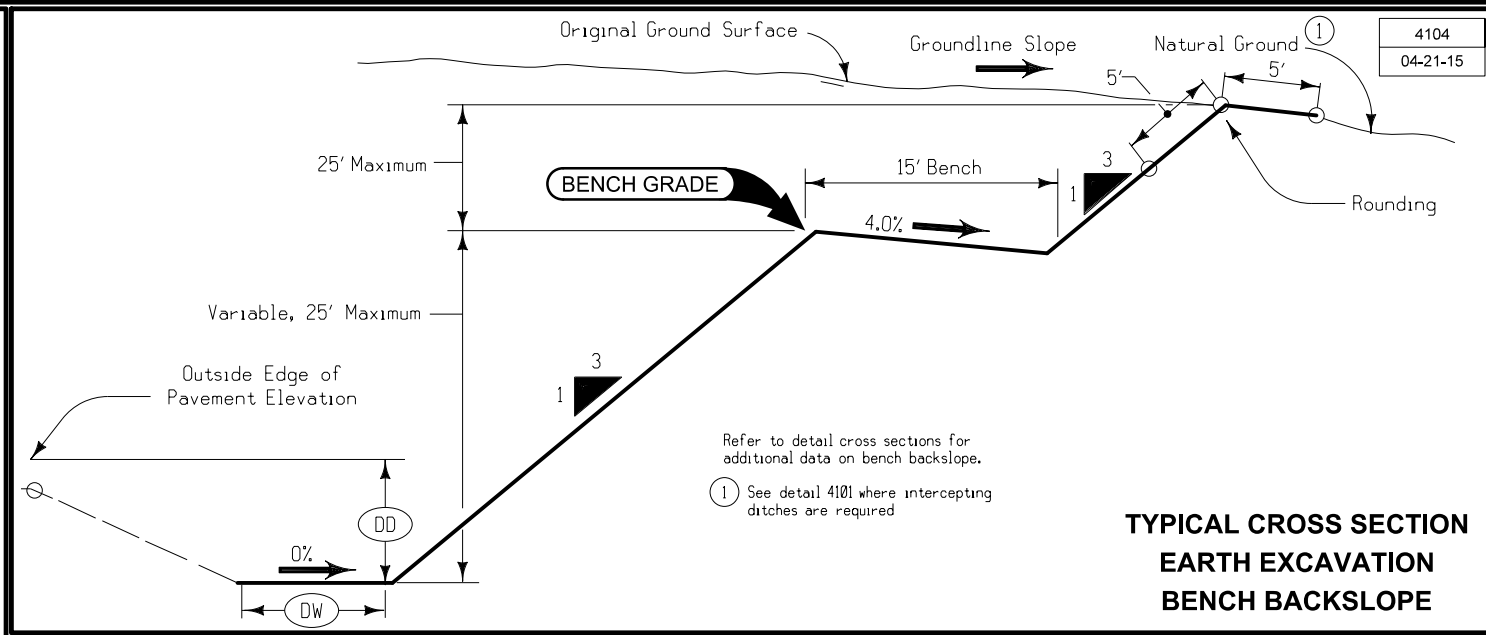

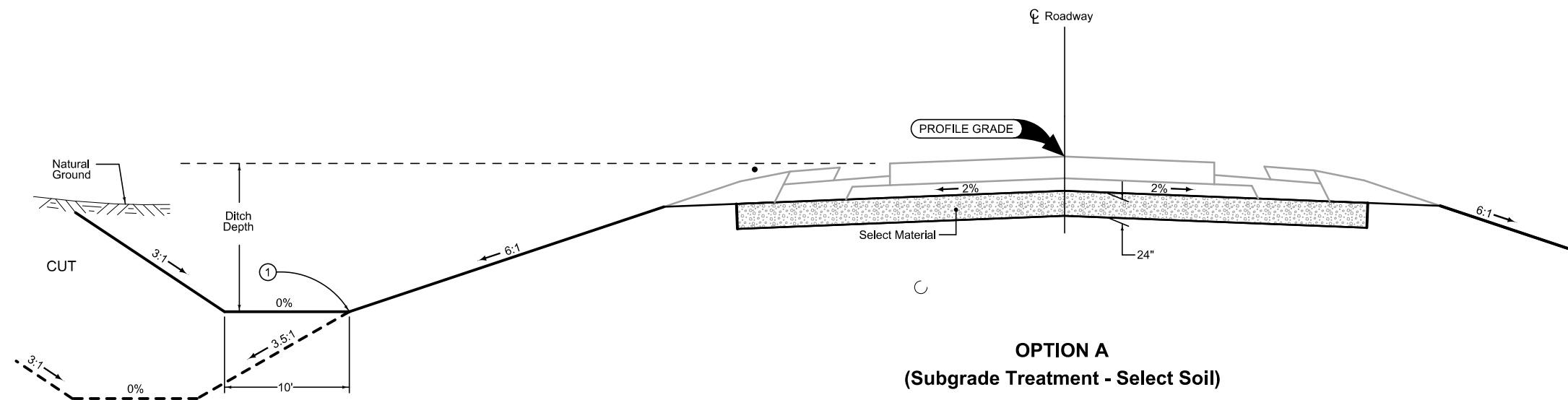

OPTION A
(Subgrade Treatment - Select Soil)

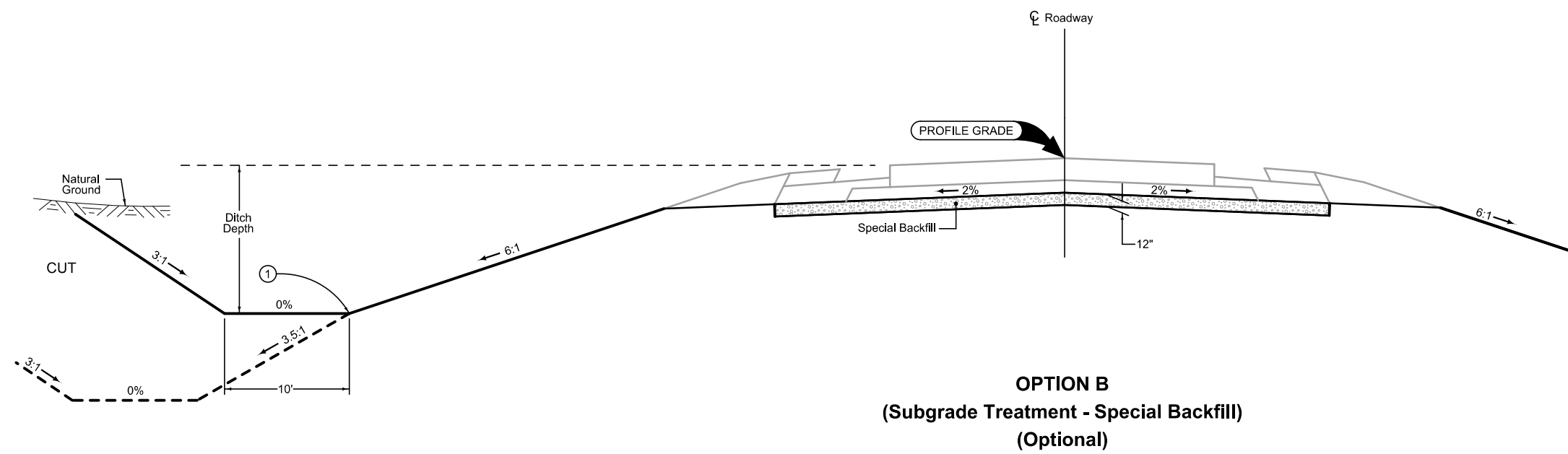

OPTION B
(Subgrade Treatment - Special Backfill)
(Optional)

Normal section shown may be modified appropriately in areas of superelevated curves or other locations specifically designated by the Engineer.

See Plan & Profiles sheets and cross sections for additional details of ditches and backslopes.

Quantity calculations based on Select Soil.

- ① Refer to project plan and cross sections for specific location of foreslope change.
- ② See Detail 'A'
- ③ Excavate a portion of subgrade as necessary to provide drainage for the treatment. The additional excavation and Special Backfill for outlets is incidental and will not be paid for separately.

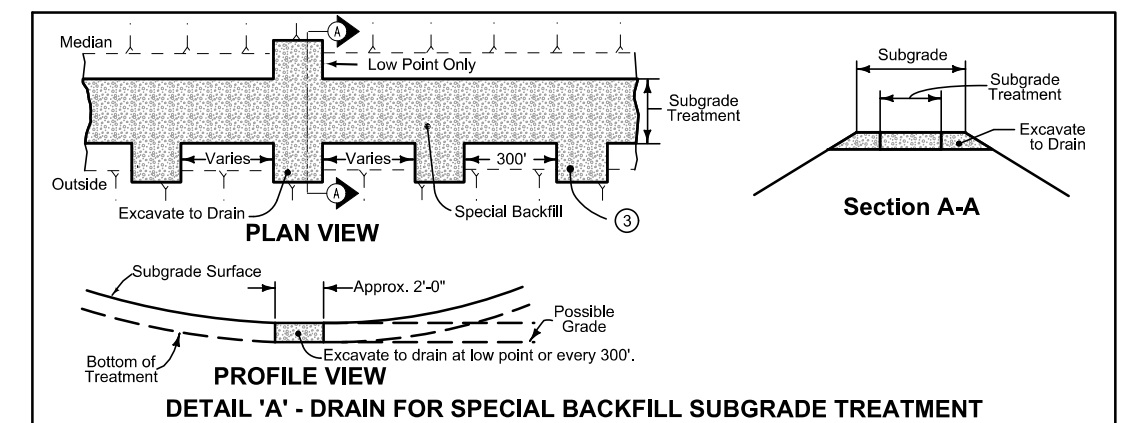

DRAINAGE STRUCTURE BY ROAD CONTRACTOR

Length of unclassified pipe calculated is based on using Reinforced Concrete Pipe.

- * Not a bid item
- ① Diameter or equivalent diameter
- ② UNCL = Unclassified Pipe CMP = Corrugated Metal Pipe RCP = Reinforced Concrete Pipe LCP = Arch or Elliptical Low Clearance Pipe SARC = Steel Arch Pipe
- ③ Backfill according to DR-101

Drainage Area	Location	Type	Size ①	Kind Of Pipe ②	Length New Const. LF	Bedding Class	Design Cover (H) FT	Camber* (DR-102) FT	Apron No.	Apron Guard* (DR-213) No.	Elbow* (DR-141) No.	Diaphragm* (DR-501) No.	Tee Section* (DR-142) No.	"D" Section* (DR-141) No.	Reducer*	Type 'C' Connections* (DR-122) Type No.	Connected Pipe Joint* (DR-121) Type	4" Perforated Subdrain*	Flow Line Elevations				Dimensions Lin. Ft.				Skew Ahead Degrees		Dike			Class 20 CY	Flowable Mortar CY	Floodable* Backfill CY	Porous* Backfill CY	Flooded Backfill ③ CY	Remarks					
																			Lt.	Rt.	Other	Other	Lt.	Rt.	Lt.	Rt.	Lt.	Rt.	Lt.	Rt.	Location Station							Top Elevation	Type	Rt. Location Station		
																			Total		Extensions		Total		Extensions		Total		Extensions		Total							Extensions		Total		Extensions
	970+59.65	DR-621	36	RCP	14	B										C-1	1	Type 3		UAC	859.00	859.54			UAC	74.7	14.0	30										R&R FES RT.				
	983+32.15	DR-621	48	RCP	32	B				1						C-1	1	Type 3		UAC	888.50	889.08			UAC	104.8	32.0	37										Clean out				
	1020+86.53	DR-621	54	RCP	42	B				1						C-2	1	Type 3		UAC	861.70	863.83			UAC	153.6	42.0	45														
	1038+95.38	DR-621	24	RCP	26	B				1						C-1	1	Type 3		UAC	893.60	894.12			UAC	110.6	26.0															
	1057+14.73	DR-621	42	RCP	14	B										C-1	1	Type 3		UAC	882.00	882.48			UAC	91.6	14.0	15											R&R FES RT.			

ROADWAY ITEMS FOR DRAINAGE STRUCTURES INSTALLED BY CULVERT CONTRACTOR

- * Not a Bid Item
- ① Backfill according to DR-111

Location	Design Number	Size	Kind	By Road Contractor			Floodable* Backfill ① CY	Porous* Backfill CY	Flooded Backfill CY	Excavation		Revetment		Engineering Fabric SY	Remarks		
				Dike						Compaction w/Moisture Control CY	Compaction w/Moisture and Density CY	Type	Quantity CY			Type	Quantity TONS
				Rt. Location Station	Top. Elev.	Type											
1010+17.81		Twin 12' x 12'	RCB						Class 10, Channel		Class E						
1042+75.15		5' x 6'	RCB														
		5' x 6'	Flume														

REMOVAL OF EXISTING STRUCTURES

Location	Description	Remarks
1010+17.81	Twin 12' x 12' RCB	Remove 173' barrel and headwalls RT.
1020+86.53	4' x 4' RCB	Remove Headwalls RT.
1042+75.15	5' x 6' RCB	Remove Headwalls RT.

MEDIAN CROSSOVERS

Refer to PV-500 Series.

* Not a bid item

Road Ident.	Location Station	Standard Road Plan No.	Detour Pavement SY	Special Backfill TON	Granular Shoulder TON	Embankment in Place CY	Class 10 Excavation CY	Class 13 Excavation CY	Removal of Pavement SY	Saw Cut* LF	18" Unclassified Roadway Pipe LF	36" CMP Slotted Drain/ 6" Grate LF	Beveled Pipe and Guard No.	Remarks
I-35	923+50.00		5252.3	2000.9	409.7									Refer to Sheet U.6. Refer to 112-9 for shoulders.

TEMPORARY BARRIER RAIL

Possible Standard: BA-401 Possible Detail: 560-7

* Not a bid item. Anchorage requirements are based on TBR locations shown in the plans. TBR alignments that vary from what is shown in the plans may result in additional TBR sections requiring anchorage.

No.	Station to Station	Length LF	(Select One)		Anchored* (Y/N)	Modular Glare Screen System (Y/N)	Remarks
			Concrete BA-401	Steel 560-7			
1	916+10.98	1072+42.84	15637.5	X	No	No	Stage 2
2	907+22.10	921+94.44	1475.0	X	No	No	Stage 2
3	922+72.01	1072+42.84	14975.0	X	No	No	Stage 3
4	934+00.94	938+10.48	412.5	X	No	No	Stage 3
5	1067+13.17	1071+35.61	425.0	X	No	No	Stage 3
6	907+22.10	921+94.44	1475.0	X	No	No	Stage 4

SURVEY SYMBOLS

- Interstate Highway Symbol
- U.S. Highway Symbol
- Iowa Highway Symbol
- County Road Highway Symbol
- Evergreen Tree
- Deciduous Tree
- Fruit Tree
- Shrub (Bushes)
- Timber
- Hedge
- Stump
- Swamp
- Rock Outcrop
- Broken Concrete
- Revetment (Rip Rap)
- Cemetery
- Grave
- Cave
- Sink Hole
- Board Fence
- Chain Link or Security Fence
- Wire Fence
- Terrace
- Earth Dam or Dike (Existing)
- Tile Outlet
- Edge of Water
- Existing Drainage
- Right of Way Rail or Lot Corner
- Concrete Monument
- Well
- Windmill
- Beehive Intake
- Existing Intake
- Existing Utility Access (Manhole)
- Fire Hydrant
- Water Hydrant (Rural)
- Septic Tank
- Cistern
- L.P. Gas Tank (No Footing)
- Underground Storage Tank
- Latrine
- Satellite TV Dish
- Water Hook Up
- Radio Tower
- Tower Anchor
- Guardrail (Beam or Cable)
- Guard Post (one or two)
- Guard Post (over two)
- Filler Pipe
- Gas Valve
- Water Valve
- Speed Limit Sign
- Mile Marker Post
- Sign
- Traffic Signal Control Box
- Rail Road Signal Control Box
- Telephone Switch Box
- Electric Box

UTILITY LEGEND

- MidAmerican Energy Company
Eric Heikes
10510 Douglas Avenue
Urbandale, IA 50322
515-252-6497
echeikes@midamerican.com
- CenturyLink
Phil Williams
2103 E University
Des Moines, IA 50317
515-263-7272
Phil.Williams@CenturyLink.com
- Warren Water District
Peggy Crabbs
1204 East 2nd Avenue
Indianola, IA 50125
515-962-1200
Peggy@warrenwaterdistrict.com

PLAN VIEW COLOR LEGEND OF PLAN AND PROFILE SHEETS

LINEWORK		Design Color No.
Green	(2)	Existing Topographic Features and Labels
Blue	(1)	Proposed Alignment, Stationing, Tic Marks, and Alignment Annotation
Magenta	(5)	Existing Utilities
SHADING		Design Color No.
Lavender	(9)	Temporary Pavement Shading
Yellow	(4)	Proposed Pavement Shading
Orange	(6)	Proposed Granular Shading
Orange	(70)	Proposed Shoulder Granular Shading
Yellow	(68)	Proposed Shoulder Paved Full Depth Shading
Yellow	(132)	Proposed Shoulder Paved Partial Depth Shading
Gray, Dark	(112)	Proposed Grade and Pave Shading "In conjunction with a paving project"
Brown, Light	(236)	Grading Shading
Orange, Light	(134)	Proposed Granular Entrance Shading
Yellow	(220)	Proposed Paved Entrance Shading
Tan	(8)	Proposed Sidewalk Shading
Blue, Light	(230)	Proposed Sidewalk Landing Shading
Pink	(11)	Proposed Sidewalk Ramp Shading
Green, Light	(225)	Existing Pavement Shading
Red	(3)	Proposed Structure Shading
Red	(3)	Delineates Restricted Areas

PROFILE VIEW COLOR LEGEND OF PLAN AND PROFILE SHEETS

LINEWORK		Design Color No.
Green	(10)	Existing Ground Line Profile
Blue	(1)	Proposed Profile and Annotation
Magenta	(5)	Existing Utilities
Blue, Light	(230)	Proposed Ditch Grades, Left
Black	(0)	Proposed Ditch Grades, Median
Rust	(14)	Proposed Ditch Grades, Right

- Reference Point
- Station
- Section Corner
- Ground Line Intercept
- Saw Cut
- Guardrail
- Trench Drain
- HighTension Cable Guardrail
- Sheet Pile
- Pavement Removal
- Clearing & Grubbing Area

RIGHT-OF-WAY LEGEND

- Proposed Right-of-Way
- Existing Right of Way
- Existing and Proposed Right-of-Way
- Easement and Existing Right-of-Way
- Easement (Temporary)
- Easement
- Access Control
- Property Line

PLAN AND PROFILE LEGEND AND SYMBOL INFORMATION SHEET

(COVERS SHEET SERIES D, E, F, & K)

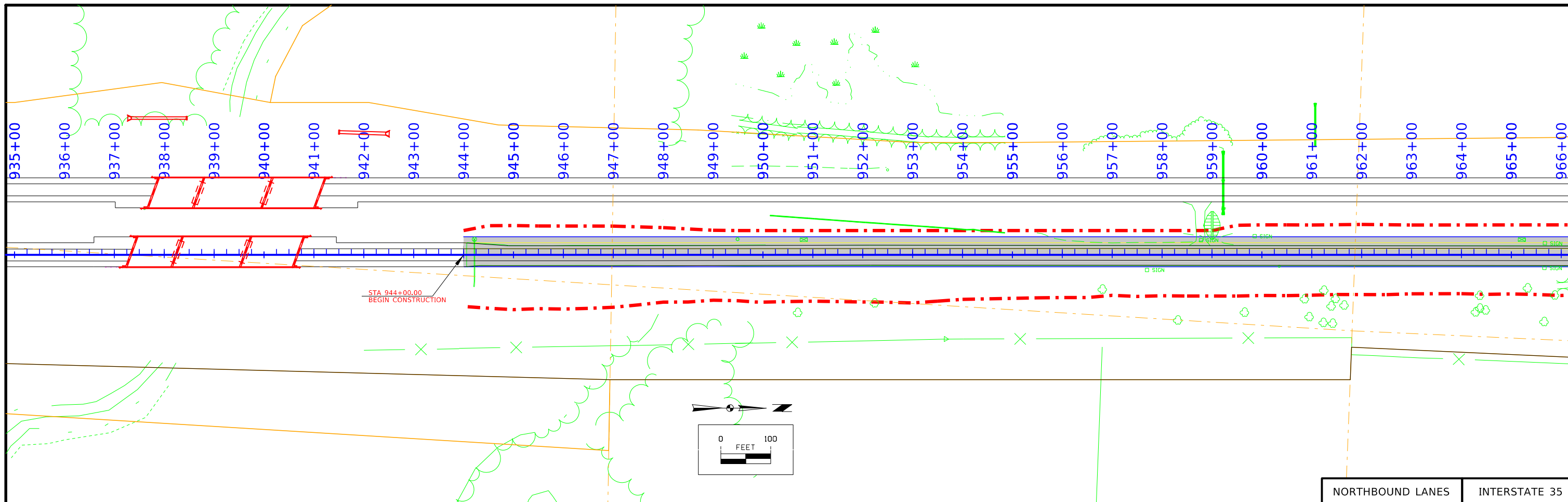

NORTHBOUND LANES INTERSTATE 35

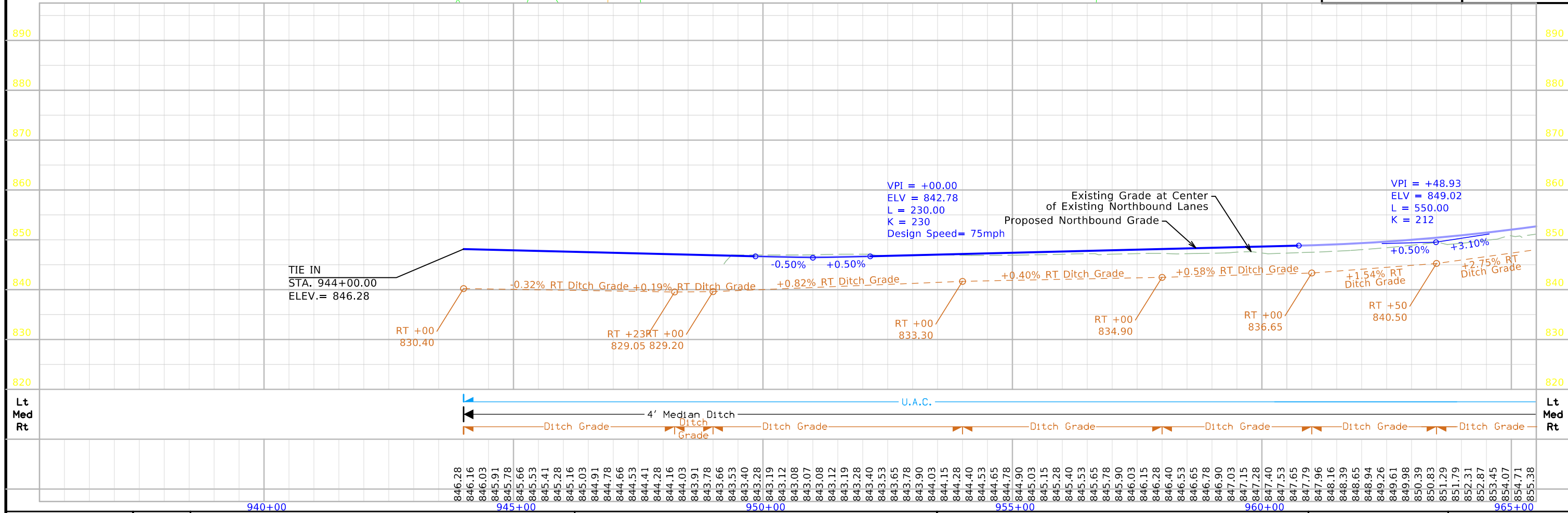

FILE NO. -- ENGLISH DESIGN TEAM Snyder & Associates, Inc. WARREN COUNTY PROJECT NUMBER IM-NHS-035-2(465)61--03-91 SHEET NUMBER D.2

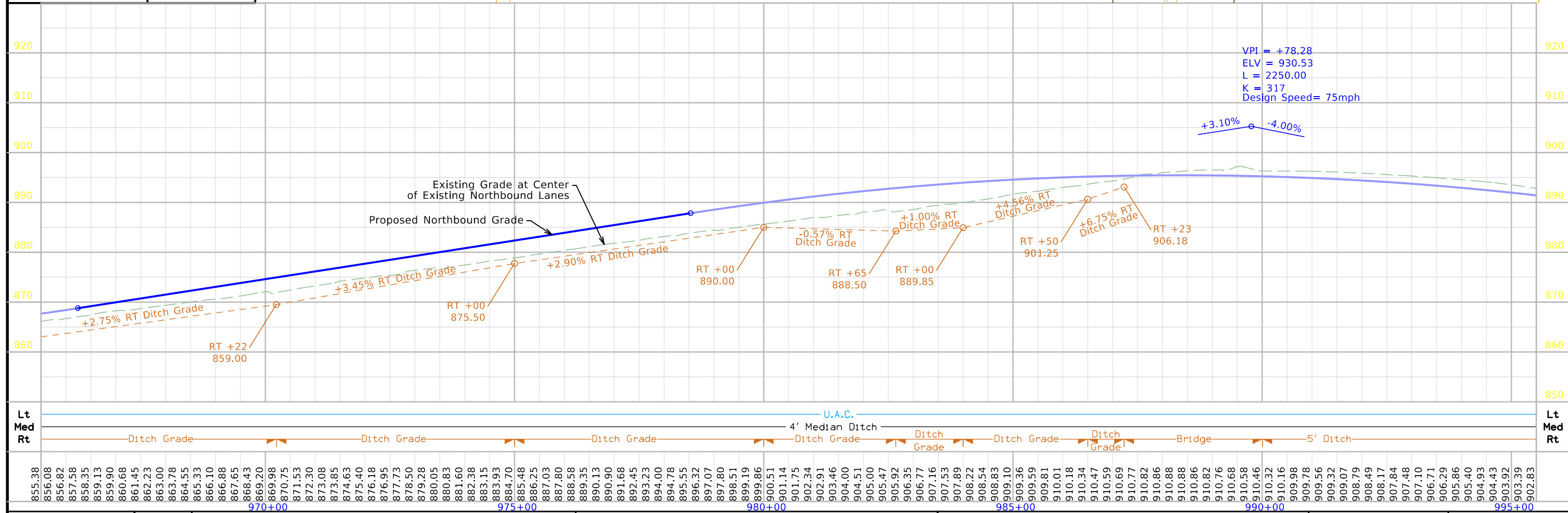
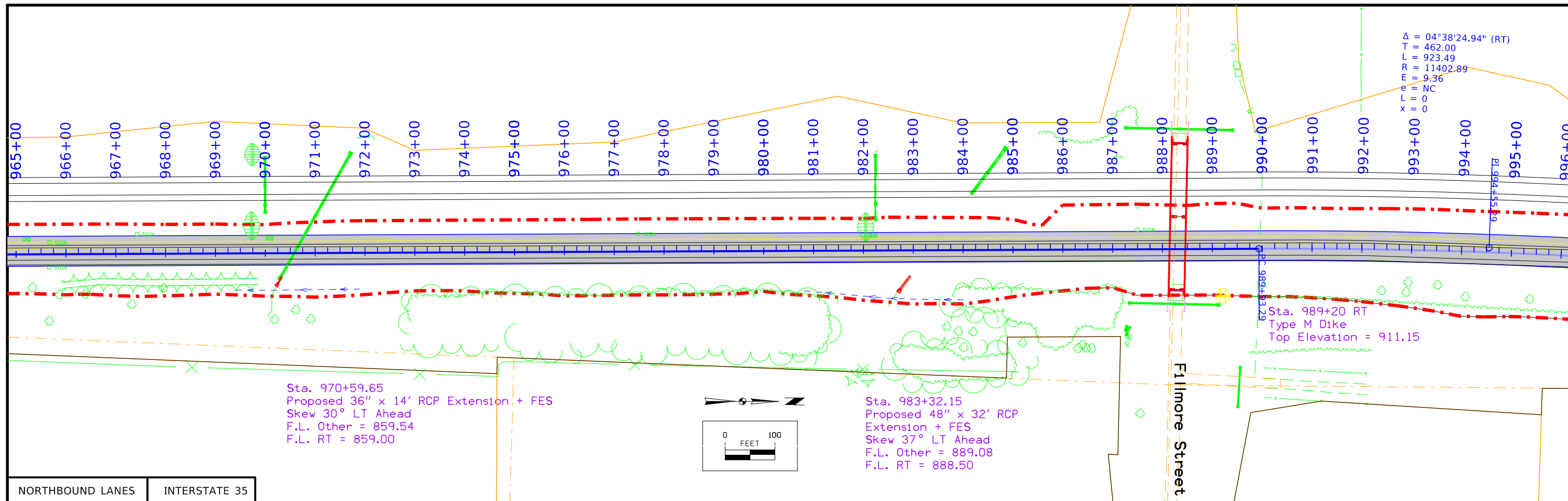

FILE NO. --	ENGLISH	DESIGN TEAM Snyder & Associates, Inc.	WARREN COUNTY	PROJECT NUMBER IM-NHS-035-2(465)61--03-91	SHEET NUMBER D.3
-------------	---------	---------------------------------------	---------------	---	------------------

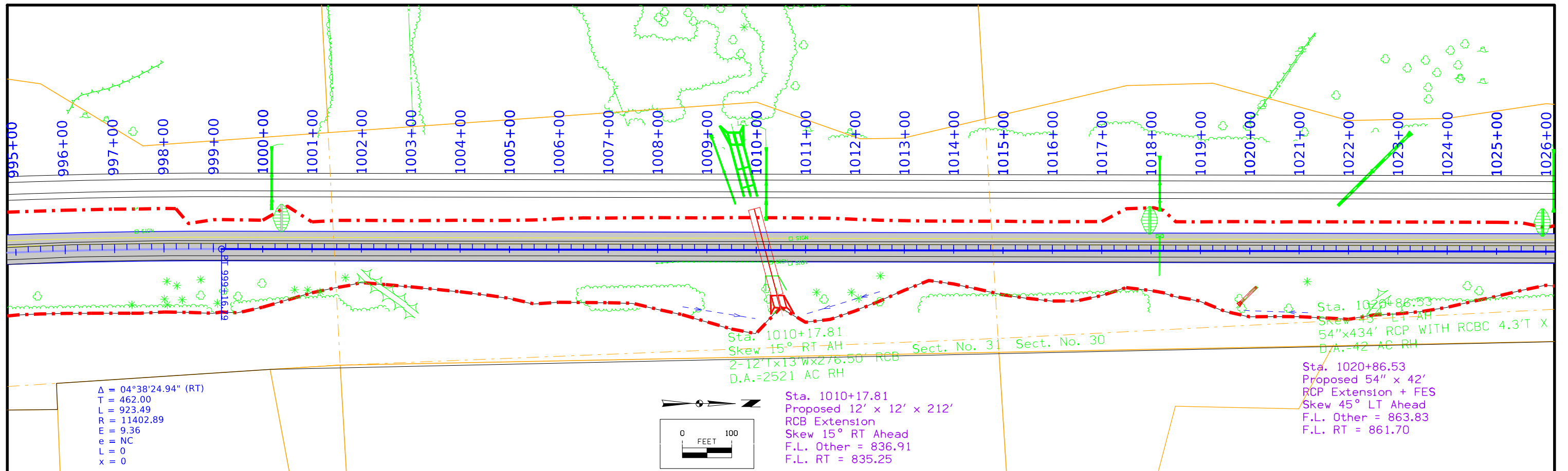

NORTHBOUND LANES INTERSTATE 35

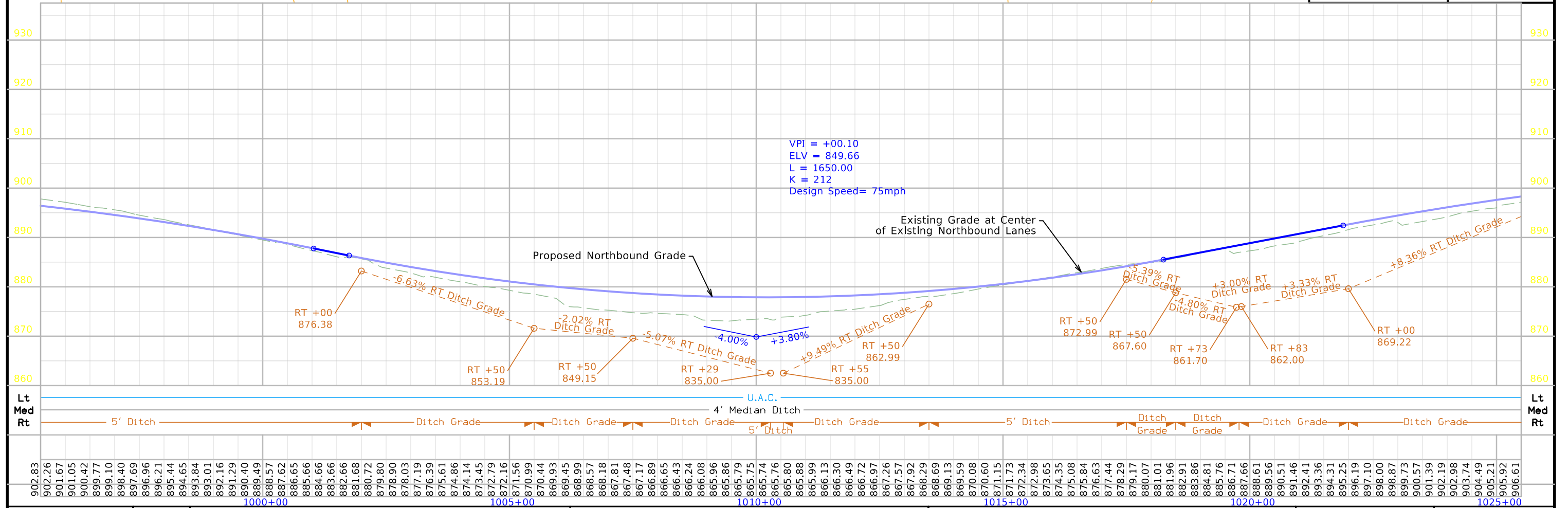

902.83	901.67	901.05	899.77	899.10	898.40	897.69	896.96	896.21	895.44	894.65	893.84	893.01	892.16	891.29	890.40	889.49	888.57	887.62	886.65	885.66	884.66	883.66	882.66	881.68	880.72	879.80	878.90	878.03	877.19	876.39	875.61	874.86	874.14	873.45	872.79	872.16	871.56	870.99	870.44	869.93	869.45	868.99	868.57	868.18	867.81	867.48	867.17	866.89	866.65	866.43	866.24	866.08	865.96	865.86	865.79	865.75	865.74	865.76	865.76	865.80	865.88	865.99	866.13	866.30	866.49	866.72	866.97	867.26	867.57	867.92	868.29	868.69	869.13	869.59	870.08	870.60	871.15	871.73	872.34	872.98	873.65	874.35	875.08	875.84	876.63	877.44	878.29	879.17	880.07	881.01	881.96	882.91	883.86	884.81	885.76	886.71	887.66	888.61	889.56	890.51	891.46	892.41	893.36	894.31	895.25	896.19	897.10	898.00	898.87	899.73	900.57	901.39	902.19	902.98	903.74	904.49	905.21	905.92	906.61
--------	--------	--------	--------	--------	--------	--------	--------	--------	--------	--------	--------	--------	--------	--------	--------	--------	--------	--------	--------	--------	--------	--------	--------	--------	--------	--------	--------	--------	--------	--------	--------	--------	--------	--------	--------	--------	--------	--------	--------	--------	--------	--------	--------	--------	--------	--------	--------	--------	--------	--------	--------	--------	--------	--------	--------	--------	--------	--------	--------	--------	--------	--------	--------	--------	--------	--------	--------	--------	--------	--------	--------	--------	--------	--------	--------	--------	--------	--------	--------	--------	--------	--------	--------	--------	--------	--------	--------	--------	--------	--------	--------	--------	--------	--------	--------	--------	--------	--------	--------	--------	--------	--------	--------	--------	--------	--------	--------	--------	--------	--------	--------	--------	--------	--------	--------	--------	--------	--------	--------

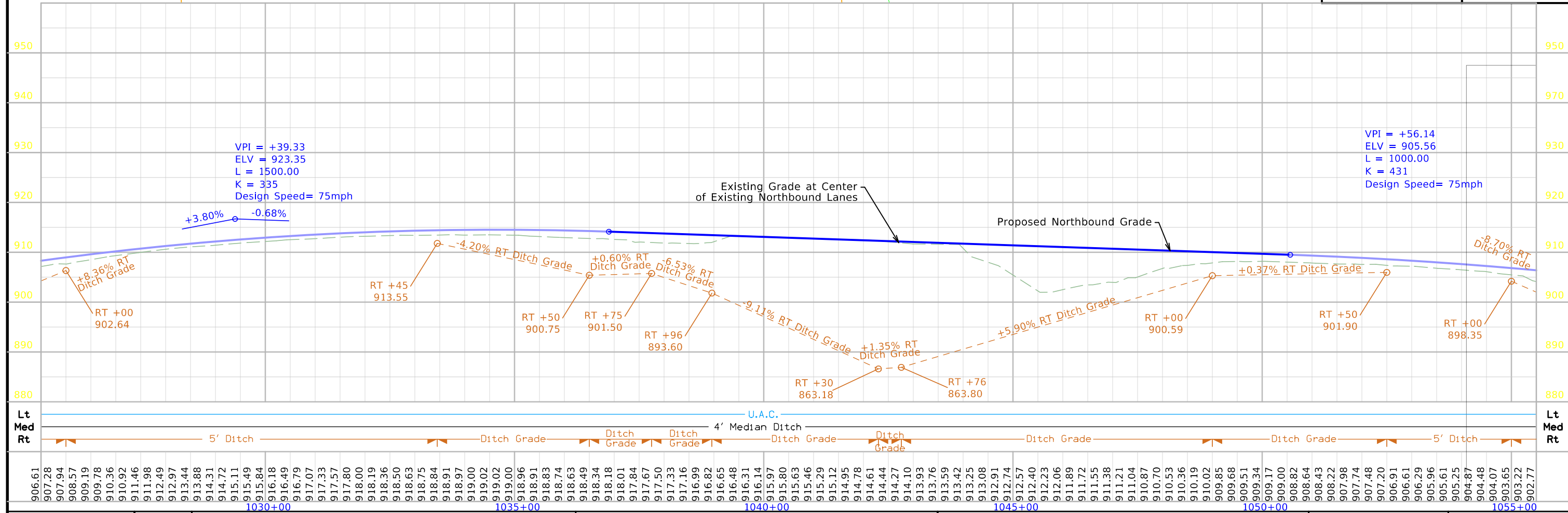
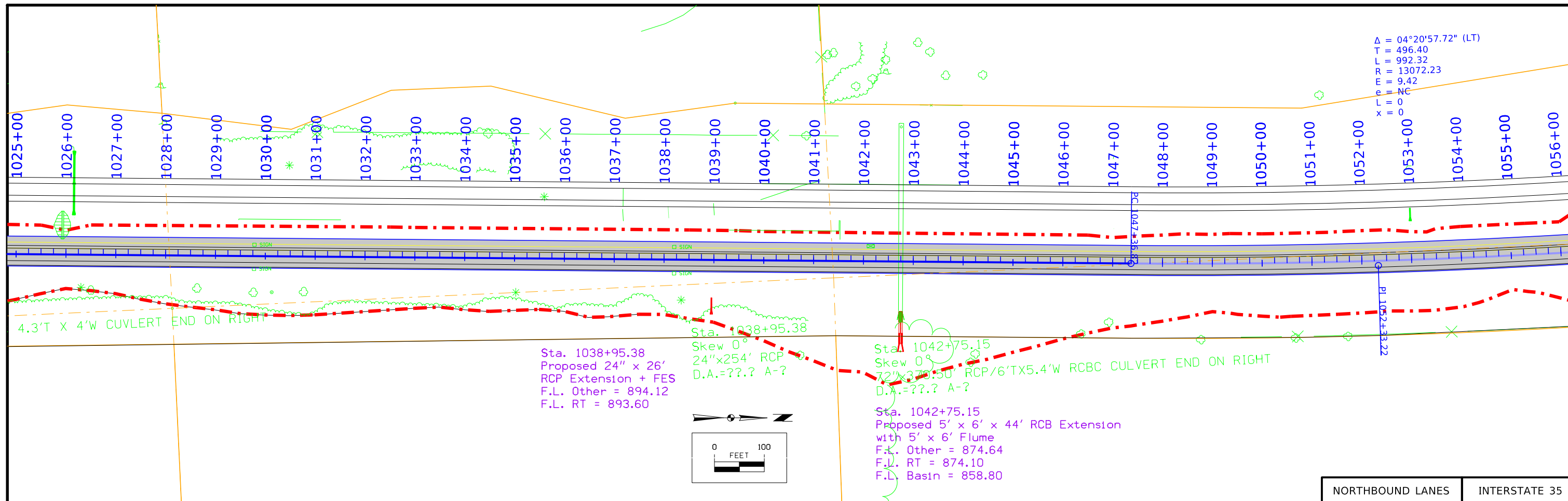

FILE NO. --	ENGLISH	DESIGN TEAM Snyder & Associates, Inc.	WARREN COUNTY	PROJECT NUMBER IM-NHS-035-2(465)61--03-91	SHEET NUMBER D.5
-------------	---------	---------------------------------------	---------------	---	------------------

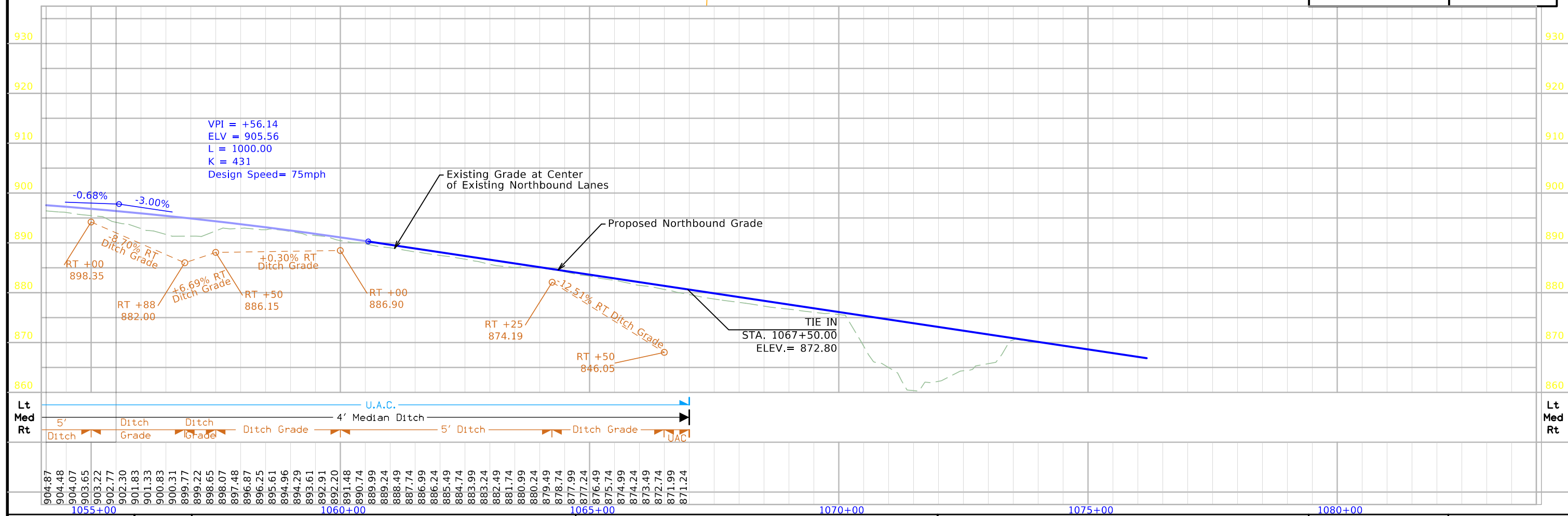
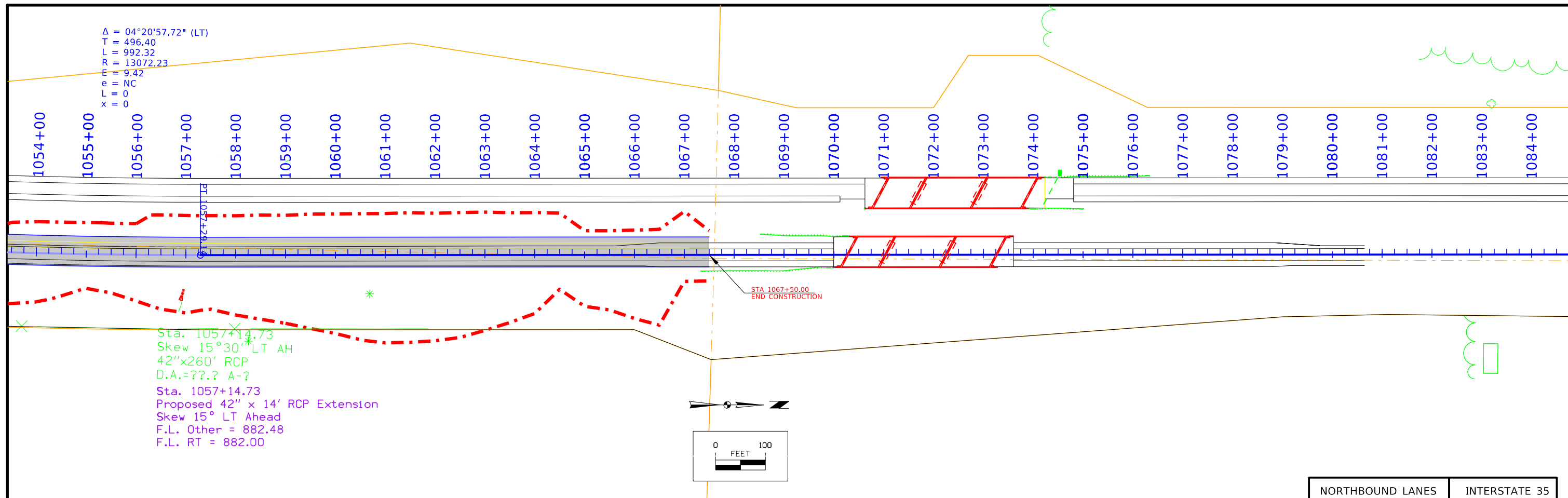

Survey Information

Warren County
242AB SA1: IM-NHS-035-2(465)61--03-91
I-35 NB from North River to Badger Creek
Project Directory: 9103503000
SAP-635.61

Party Personnel

Eric Miller - Survey Project Manager/PLS
Adam Catrenich - Survey Party Chief
Alex Moltalvo-Medina - Field Technician
Sam Blaisdell - Office Technician

Date(s) of Survey

Begin Date 05/19/2022
End Date 06/27/2022

General Information

Measurement units for this survey are US survey feet. This survey is for the reconstruction of NB I-35 from just north of the North River to just south of Badger Creek in Warren County.

Vertical Control

Vertical datum for this survey is relative to NAVD88, Geoid 12a. Control matches existing control from multiple projects along the I-35 corridor. See SAP #635 for additional information.

This survey control is relative to laRTN reference stations. Verified multiple control points along I-35 corridor from project IM-NHS-035-2(408)61--13-91, Project IM-NHS-035-2(429)61—03-91 and Project IM-NHS-035-2(467)63—03-91. laRTN check observations were within acceptable tolerance. Base station was set on existing control points and additional control points were established for this survey. Coordinate values were averaged from multiple observations with appropriate time spans between.

Horizontal Control

The following control information was provided by the Iowa Department of Transportation. The project coordinate system is Modified Iowa State Plane South Zone (U.S. Survey Feet) scaled around Pt. G070 at 513358.35 N, 1563703.57 E, 945.42 (H)eight.

1/Combined Scale Factor of project (State plane grid modified to ground) = 1.000086224.

This survey control is relative to laRTN reference stations. Verified multiple control points along I-35 corridor from project IM-NHS-035-2(408)61--13-91, Project IM-NHS-035-2(429)61—03-91 and Project IM-NHS-035-2(467)63—03-91. laRTN check observations were within acceptable tolerance. Base station was set on existing control points and additional control points were established for this survey. Coordinate values were averaged from multiple observations with appropriate time spans between.

Alignment Information

The I-35 alignment for this survey was provided by the State. Information on alignment can be found here: <pw:\\ntPwlnt1.dot.int.lan:PWMain\Documents\Projects\9103503000\PrelimSurvey\0635\I-35 alignment description.docx>.

The Filmore alignment for this survey was provided by the State and originated from project IM-NHS-035-2(429)61—03-91.

CONTROL POINT VICINITY MAP

This map is a guide to the vicinity of the primary project control points. Primary control is for use with RTK base stations and for RTN validation. Future surveys will use primary project control to establish temporary control as needed for construction or other surveying applications.

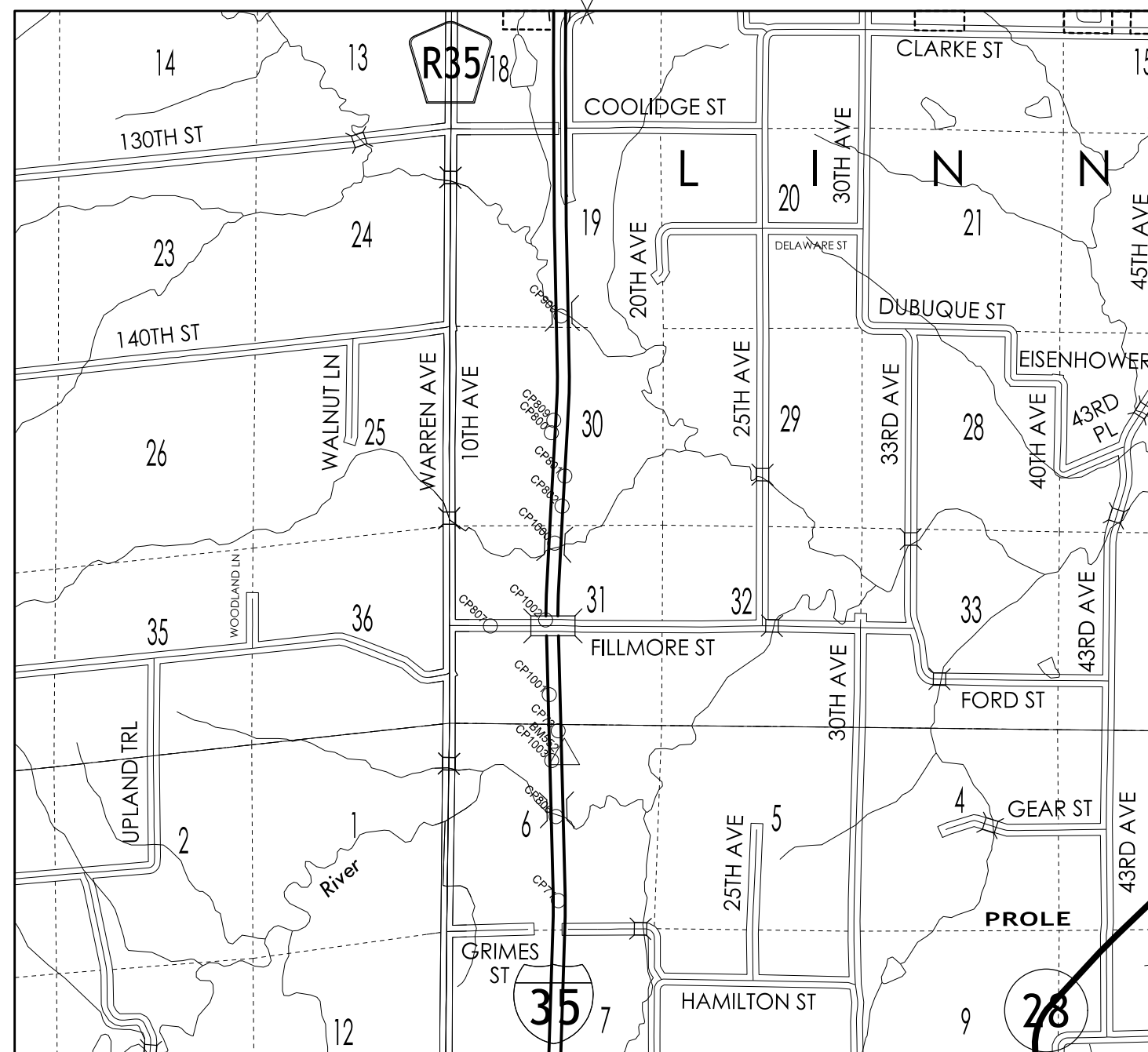

HORIZ. DATUM: NAD83(2011) EPOCH 2010.00

VERT. DATUM: NAVD88 - Geoid Model 12a

Coordinate listing from next sheet will be used with laRTN for monument recovery. No other reference ties are given.

HORIZONTAL AND VERTICAL PROJECT CONTROL COORDINATE LISTING

HORIZ. DATUM: NAD83(2011) EPOCH 2010.00

VERT. DATUM: NAVD88

Geoid Model 12a

Project Control Marks are Bench Marks

Point Name	Northing	Easting	Elevation	Feature Definition - Description
552	518547.27	1563747.47	840.73	BM FOUND RAILROAD SPIKE IN FENCE POST// +/-150FT EAST OF I-35
71	514702.63	1563589.57	903.01	CP FOUND 1/2IN REBAR +/-1FT WEST OF I-35// +/-2300FT SOUTH OF NORTH RIVER
73	519211.52	1563584.63	845.28	CP FOUND 1/2IN REBAR +/-1FT EAST OF I-35// +/-2200FT NORTH OF NORTH RIVER
800	527126.20	1563403.92	916.72	CP FOUND 5/8IN REBAR WITH ALUMINUM CAP// +/-1FT WEST OF FENCE// +/-200FT WEST OF I-35
801	525978.96	1563762.81	920.08	CP FOUND 5/8IN REBAR WITH RED PLASTIC CAP// +/-100FT EAST OF I-35// +/-1FT WEST OF SURVER MARKER SIGN
802	525180.41	1563686.07	869.38	CP FOUND CUT X ON TOP OF HEADWALL BOX CULVERT// +/-50FT EAST OF I-35
806	516934.98	1563527.83	852.04	CP FOUND CUT X ON TOP OF SOUTHEAST CORNER OF WINGWALL OF SOUTHBOUND LANE// +/-150FT SOUTH OF NORTH RIVER
807	521991.18	1561789.55	946.06	CP FOUND 1/2IN REBAR WITH RED PLASTIC CAP// +/-1FT SOUTH OF FILLMORE// +/-1500FT WEST OF I-35
809	527456.94	1563467.09	886.35	CP FOUND CUT X ON TOP OF 72IN RCP FES// +/-150FT WEST OF I-35
900	530227.79	1563658.47	859.88	CP FOUND CUT X ON SOUTHEAST WINGWALL OF SOUTHBOUND LANE// +/-100FT SOUTH OF BADGER CREEK
1000	524195.13	1563492.43	860.43	CP SET CUT X ON TOP OF 24IN RCP FES IN MEDIAN// +/-2200FT NORTH OF FILLMORE STREET BRIDGE
1001	520170.98	1563347.02	866.18	CP SET CUT X ON TOP OF 24IN RCP FES// +/-25FT WEST OF I-35// +/-75FT EAST OF FENCE
1002	522156.48	1563249.56	916.61	CP FOUND 1/2IN REBAR WITH ORANGE PLASTIC CAP// +/-1FT NORTHWEST OF FENCE CORNER// +/-75FT WEST OF I-35// +/-150FT NORTH OF FILLMORE STREET
1003	518421.84	1563411.98	841.39	CP FOUND 1/2IN REBAR WITH BLUE PLASTIC CAP// +/-5FT WEST OF I-35// +/-1300FT NORTH OF NORTH RIVER

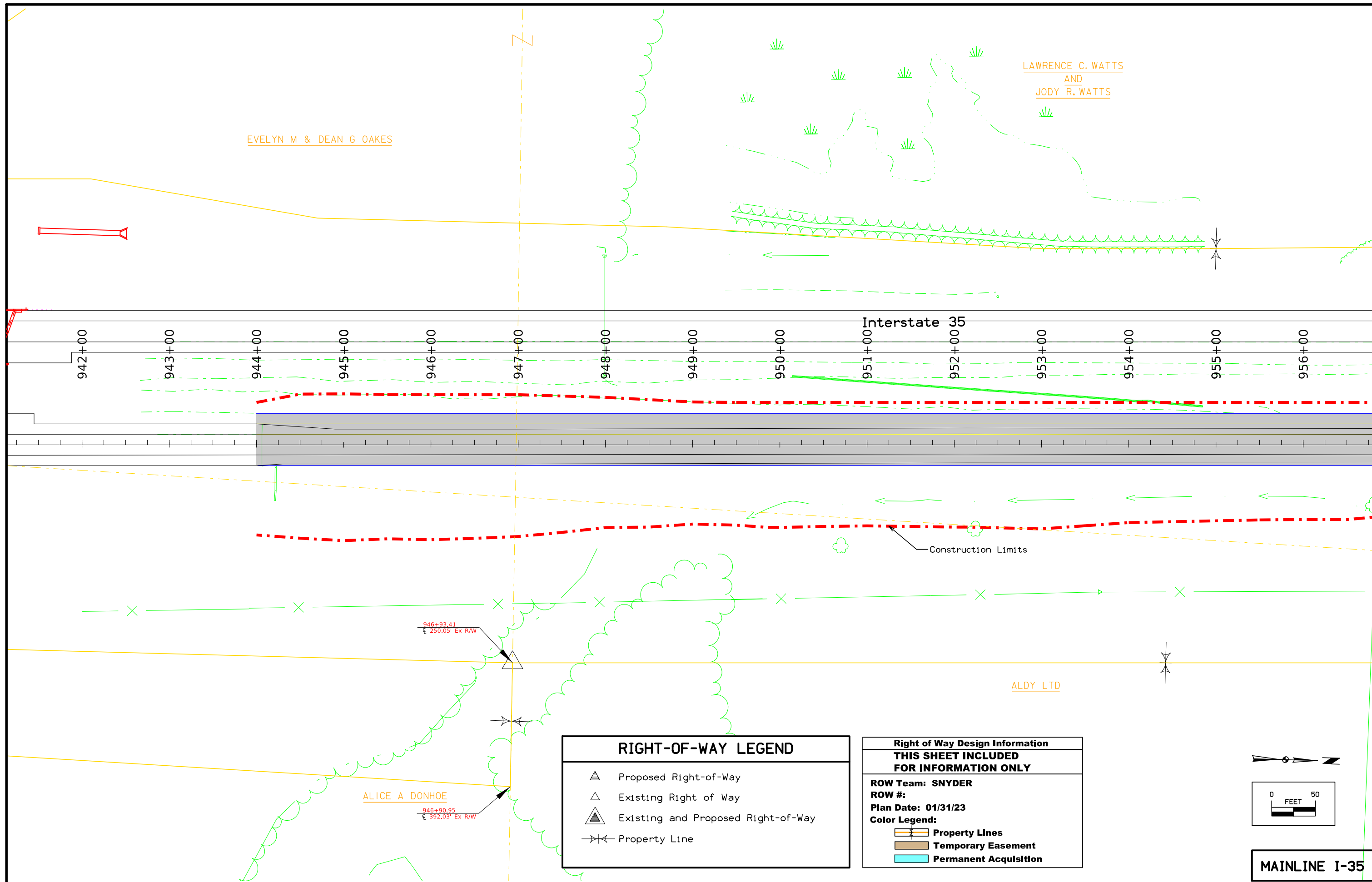

RIGHT-OF-WAY LEGEND	
	Proposed Right-of-Way
	Existing Right of Way
	Existing and Proposed Right-of-Way
	Property Line

Right of Way Design Information THIS SHEET INCLUDED FOR INFORMATION ONLY	
ROW Team: SNYDER	
ROW #:	
Plan Date: 01/31/23	
Color Legend:	
	Property Lines
	Temporary Easement
	Permanent Acquisition

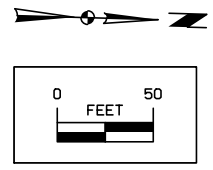

MAINLINE I-35

LAWRENCE C. WATTS
AND
JAMRS J. WATTS

LAWRENCE C. WATTS
AND
JODY R. WATTS

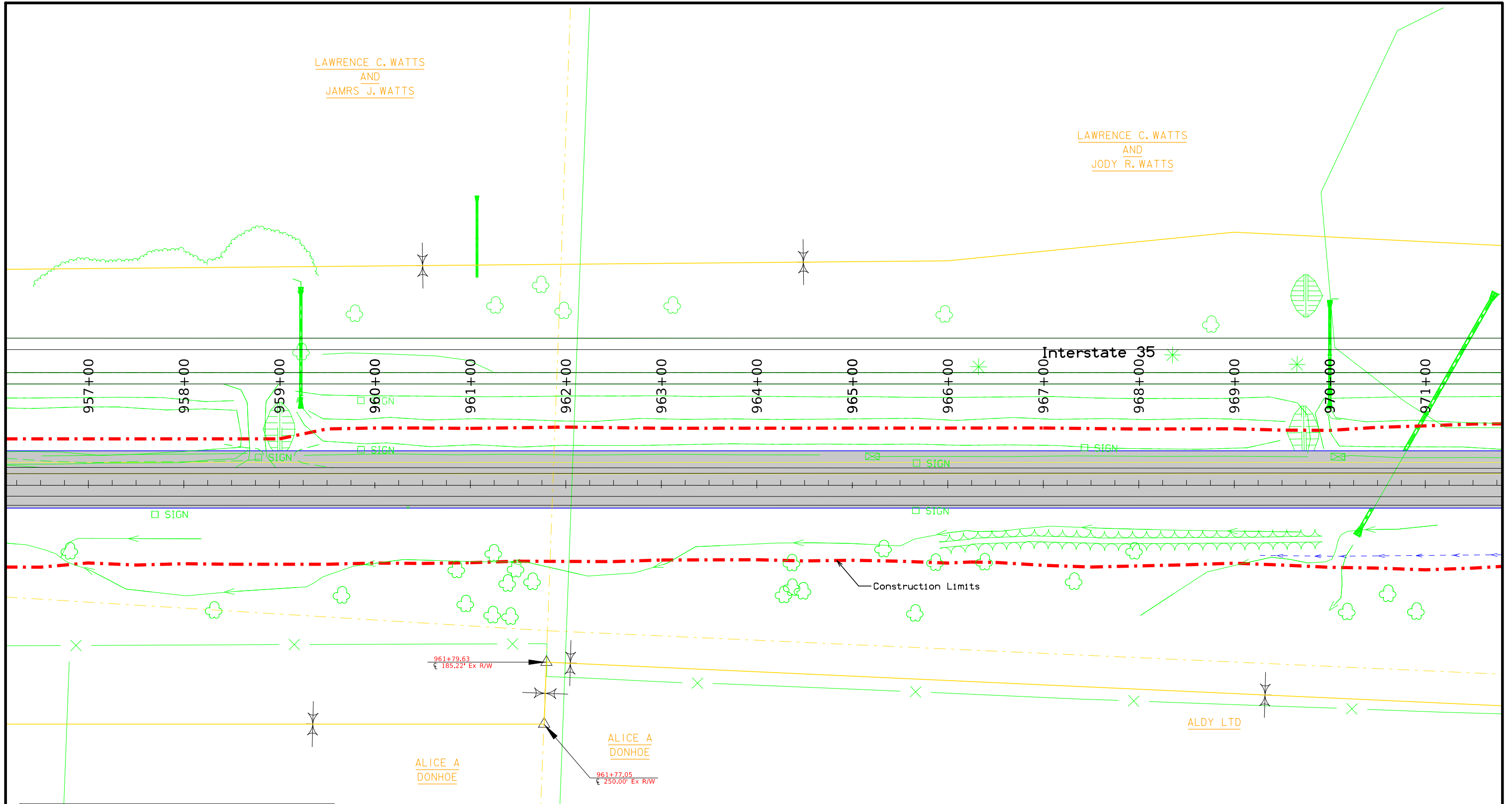

RIGHT-OF-WAY LEGEND	
	Proposed Right-of-Way
	Existing Right of Way
	Existing and Proposed Right-of-Way
	Property Line

Right of Way Design Information THIS SHEET INCLUDED FOR INFORMATION ONLY	
ROW Team: SNYDER	
ROW #:	
Plan Date: 01/31/23	
Color Legend:	
	Property Lines
	Temporary Easement
	Permanent Acquisition

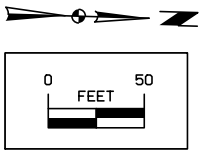

MAINLINE I-35

LAWRENCE C. WATTS
AND
JODY R. WATTS

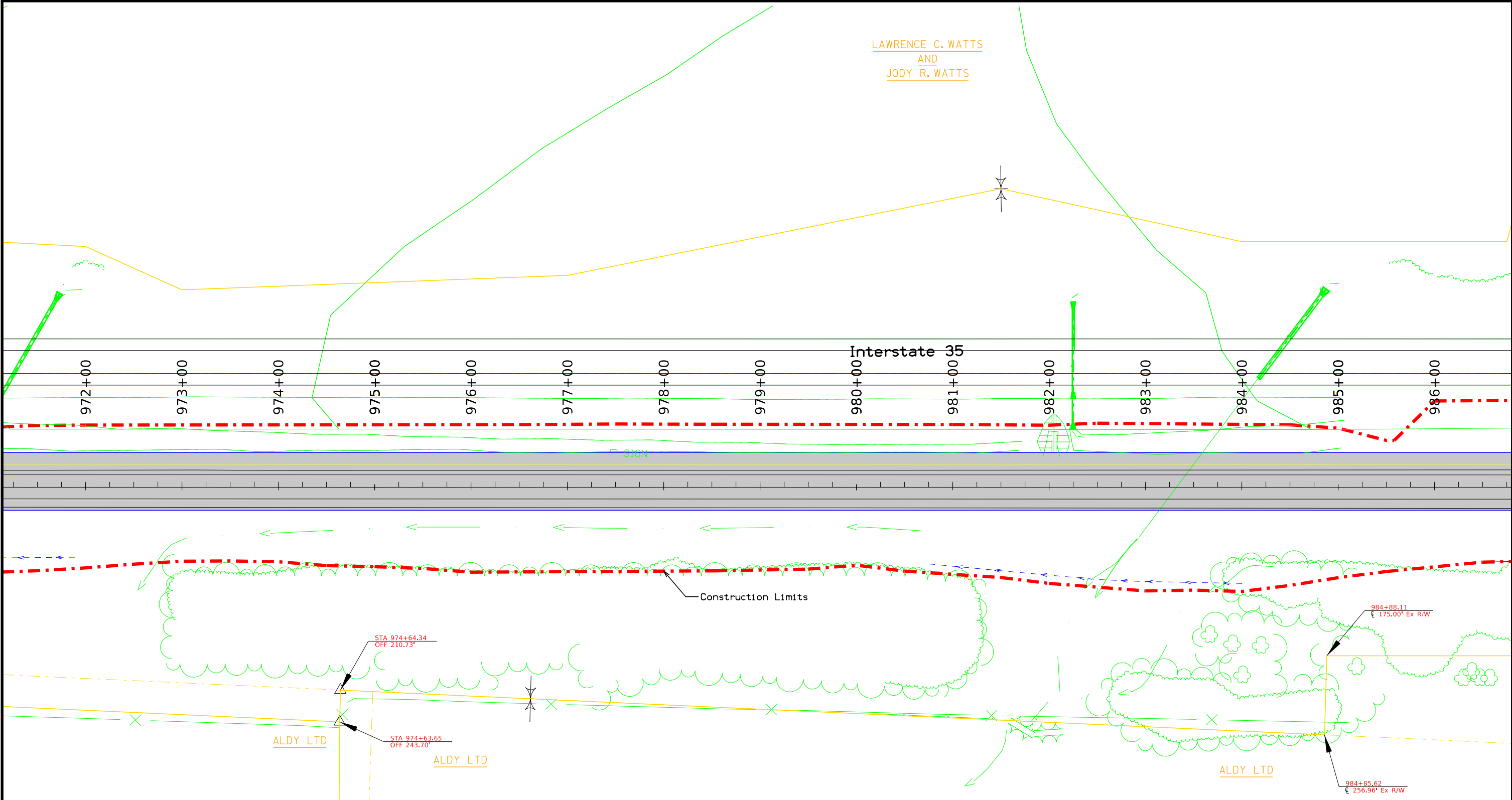

RIGHT-OF-WAY LEGEND	
	Proposed Right-of-Way
	Existing Right of Way
	Existing and Proposed Right-of-Way
	Property Line

Right of Way Design Information THIS SHEET INCLUDED FOR INFORMATION ONLY	
ROW Team: SNYDER	
ROW #:	
Plan Date: 01/31/23	
Color Legend:	
	Property Lines
	Temporary Easement
	Permanent Acquisition

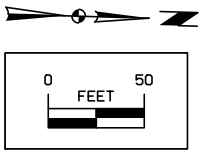

MAINLINE I-35

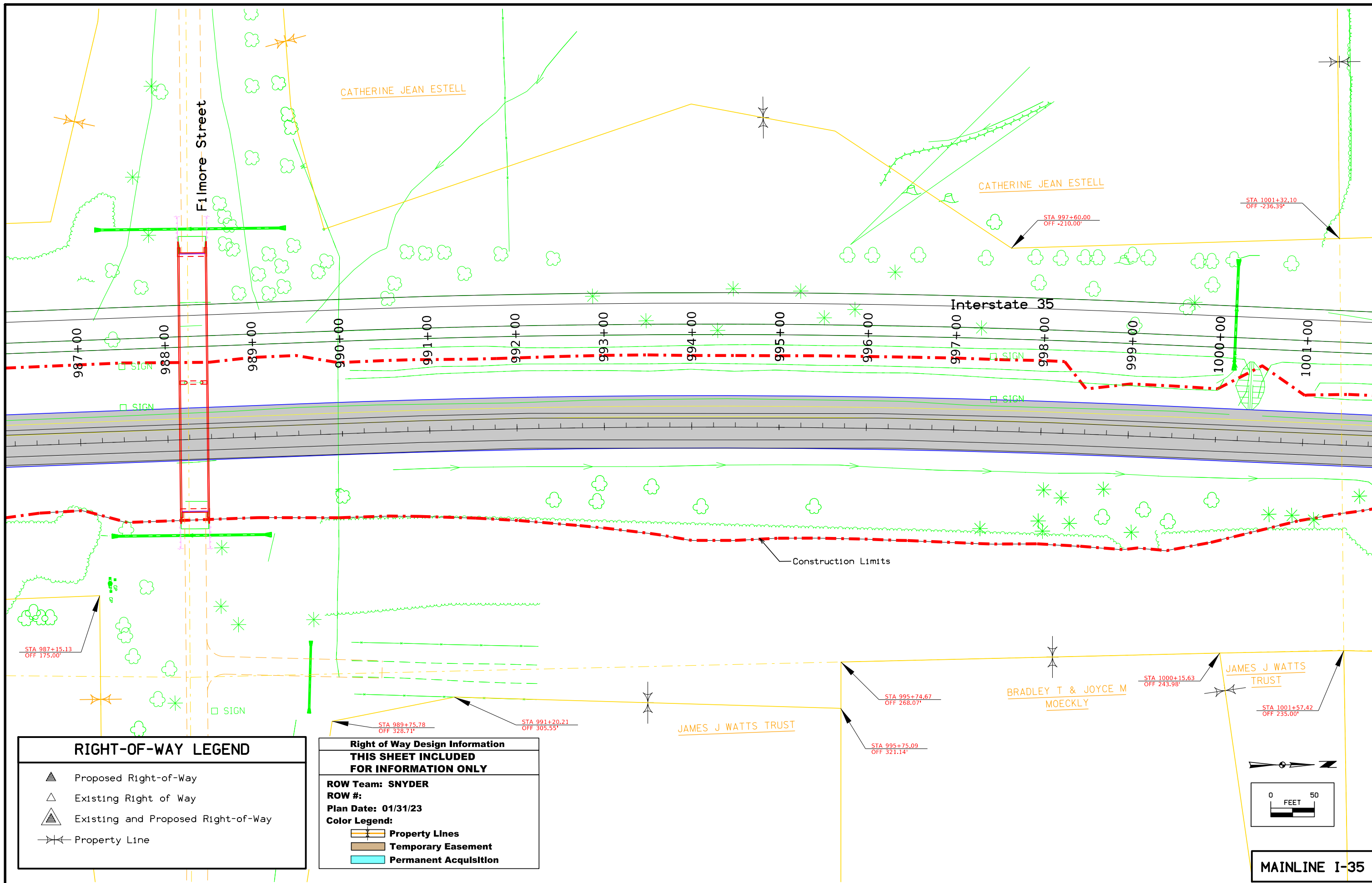

RIGHT-OF-WAY LEGEND	
	Proposed Right-of-Way
	Existing Right of Way
	Existing and Proposed Right-of-Way
	Property Line

Right of Way Design Information THIS SHEET INCLUDED FOR INFORMATION ONLY	
ROW Team: SNYDER	
ROW #:	
Plan Date: 01/31/23	
Color Legend:	
	Property Lines
	Temporary Easement
	Permanent Acquisition

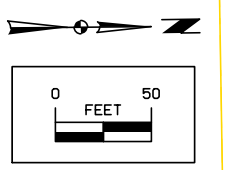

MAINLINE I-35

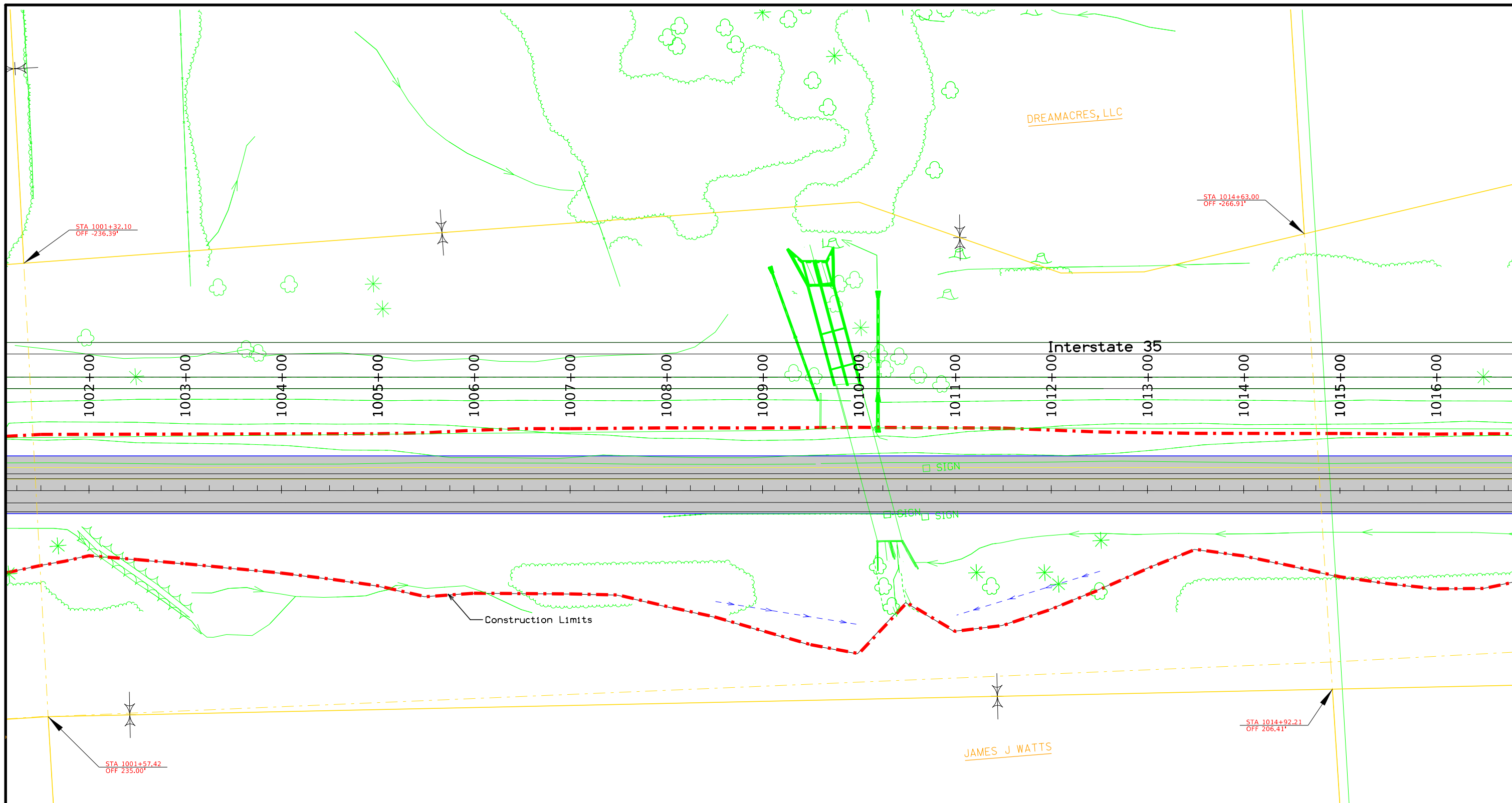

RIGHT-OF-WAY LEGEND	
	Proposed Right-of-Way
	Existing Right of Way
	Existing and Proposed Right-of-Way
	Property Line

Right of Way Design Information THIS SHEET INCLUDED FOR INFORMATION ONLY	
ROW Team: SNYDER	
ROW #:	
Plan Date: 01/31/23	
Color Legend:	
	Property Lines
	Temporary Easement
	Permanent Acquisition

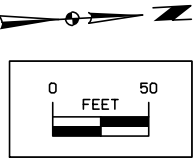

MAINLINE I-35

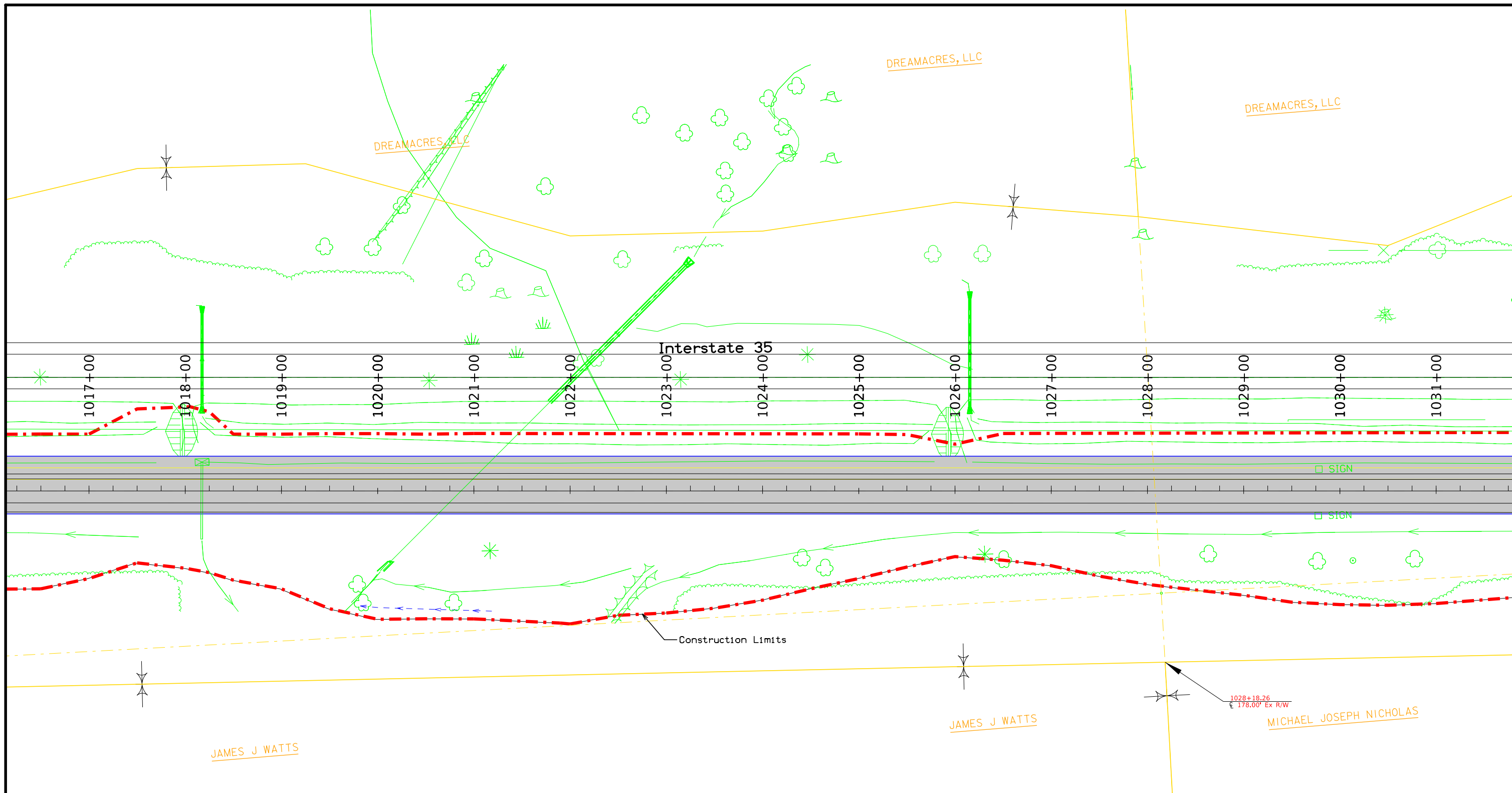

RIGHT-OF-WAY LEGEND	
	Proposed Right-of-Way
	Existing Right of Way
	Existing and Proposed Right-of-Way
	Property Line

Right of Way Design Information THIS SHEET INCLUDED FOR INFORMATION ONLY	
ROW Team: SNYDER	
ROW #:	
Plan Date: 01/31/23	
Color Legend:	
	Property Lines
	Temporary Easement
	Permanent Acquisition

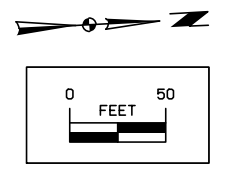

MAINLINE I-35

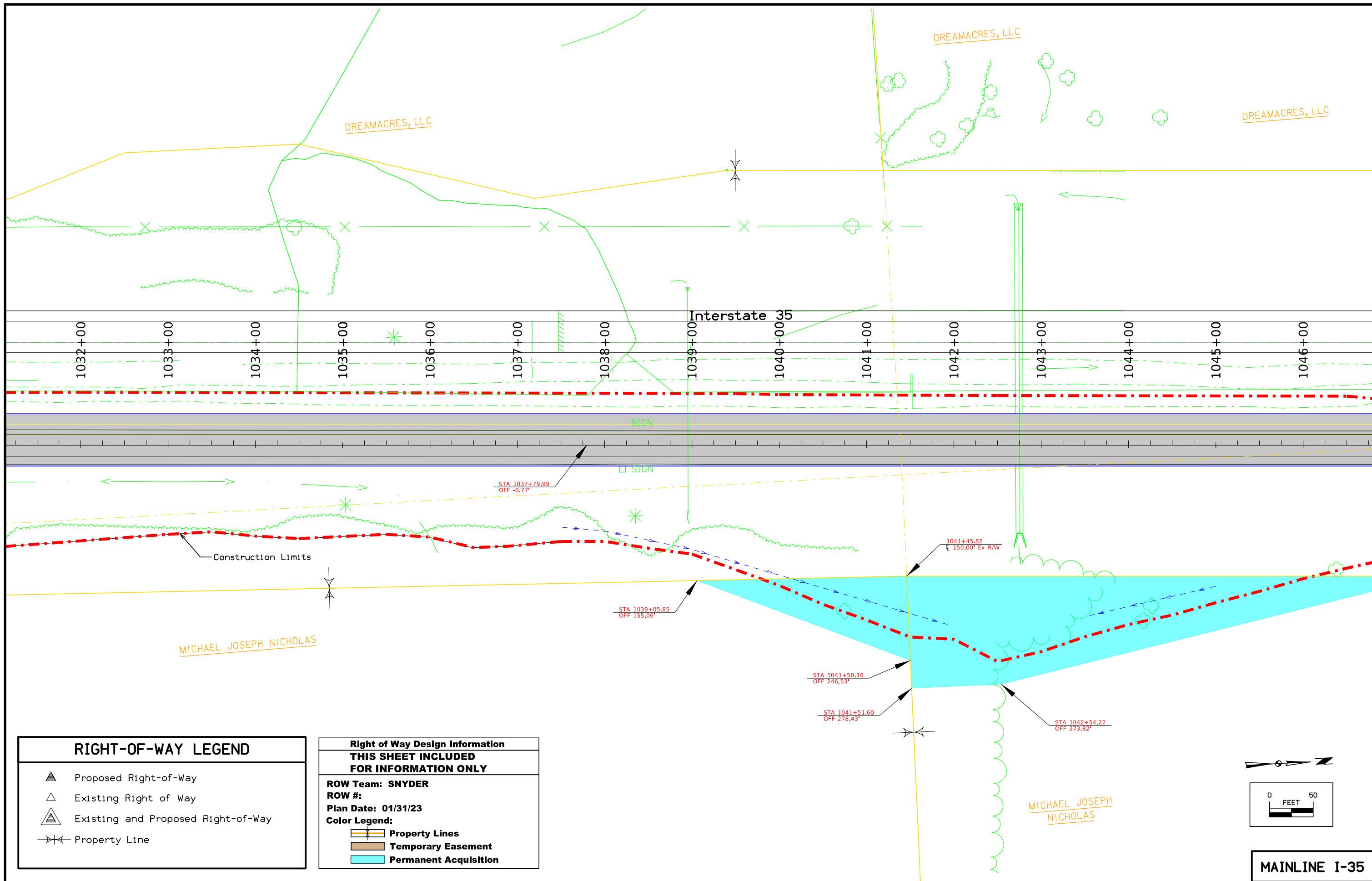

RIGHT-OF-WAY LEGEND	
	Proposed Right-of-Way
	Existing Right of Way
	Existing and Proposed Right-of-Way
	Property Line

Right of Way Design Information THIS SHEET INCLUDED FOR INFORMATION ONLY	
ROW Team: SNYDER	
ROW #:	
Plan Date: 01/31/23	
Color Legend:	
	Property Lines
	Temporary Easement
	Permanent Acquisition

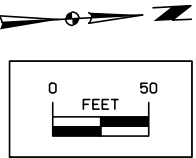

MAINLINE I-35

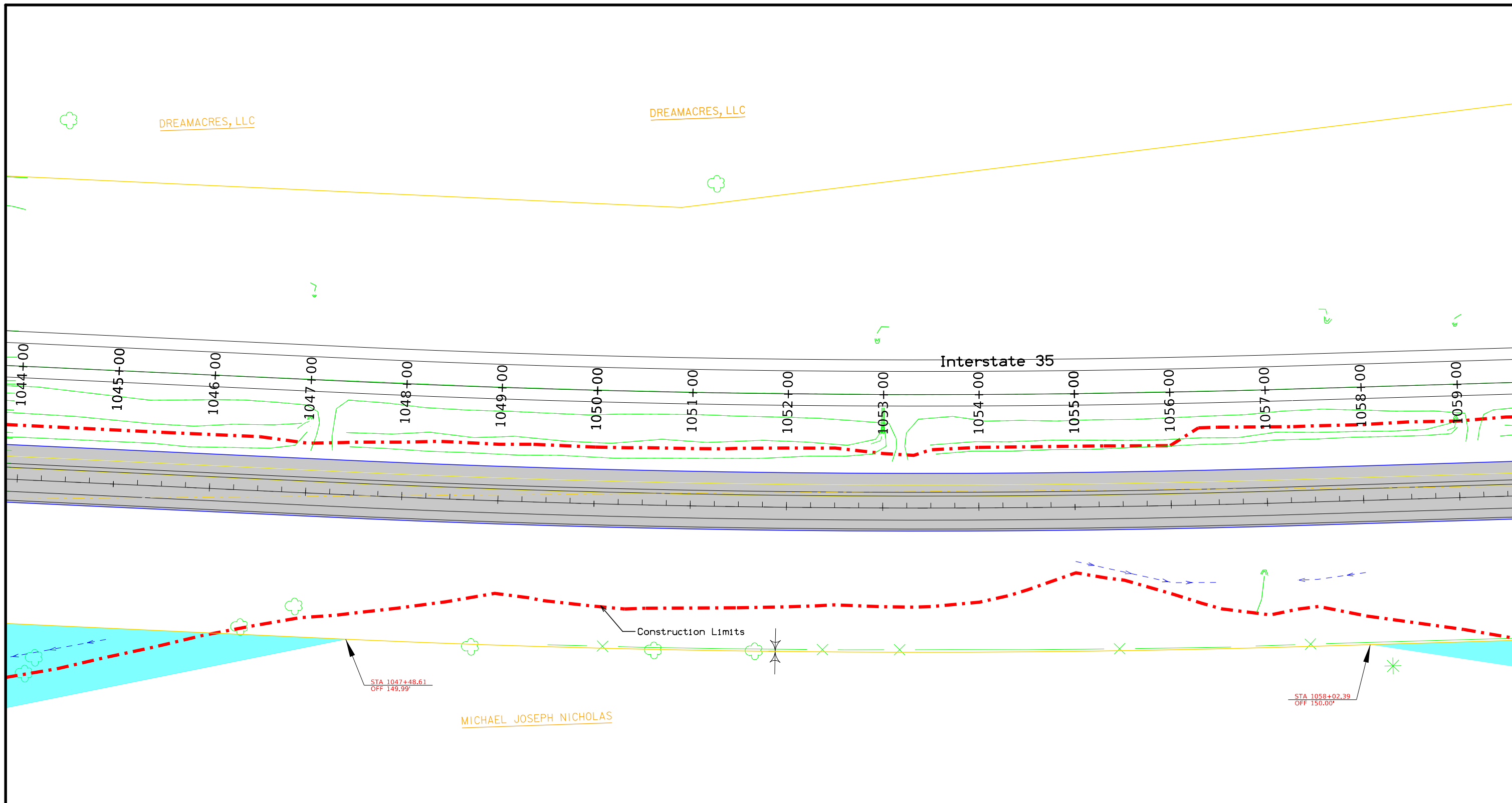

RIGHT-OF-WAY LEGEND	
	Proposed Right-of-Way
	Existing Right of Way
	Existing and Proposed Right-of-Way
	Property Line

Right of Way Design Information THIS SHEET INCLUDED FOR INFORMATION ONLY	
ROW Team: SNYDER	
ROW #:	
Plan Date: 01/31/23	
Color Legend:	
	Property Lines
	Temporary Easement
	Permanent Acquisition

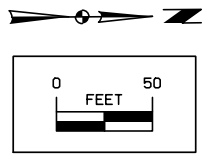

MAINLINE I-35

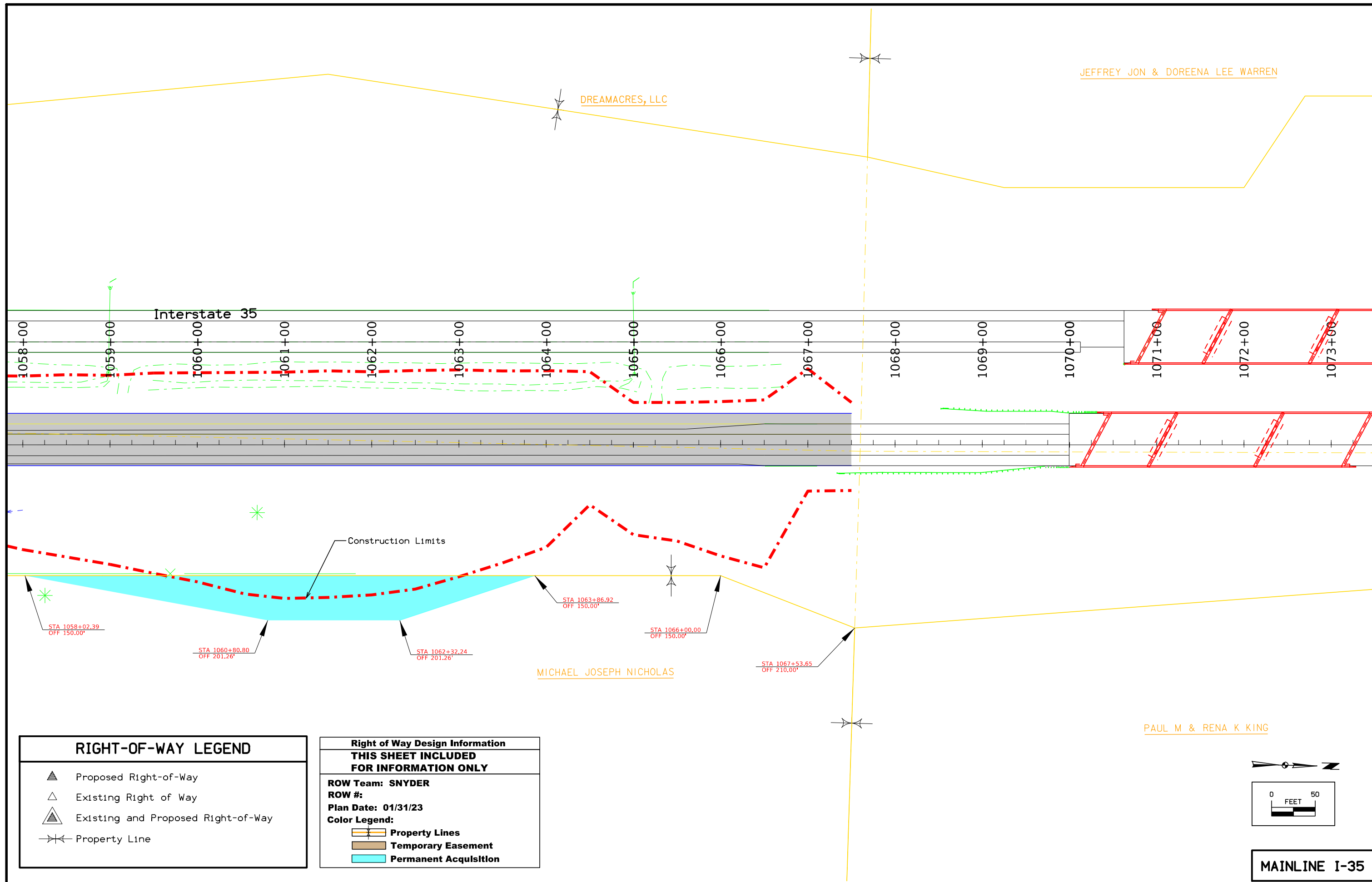

RIGHT-OF-WAY LEGEND	
	Proposed Right-of-Way
	Existing Right of Way
	Existing and Proposed Right-of-Way
	Property Line

Right of Way Design Information THIS SHEET INCLUDED FOR INFORMATION ONLY	
ROW Team: SNYDER	
ROW #:	
Plan Date: 01/31/23	
Color Legend:	
	Property Lines
	Temporary Easement
	Permanent Acquisition

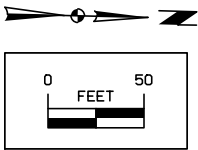









MAINLINE I-35

This Sheet For Information Only

**CROSS SECTION VIEW COLOR LEGEND
OF TRAFFIC CONTROL AND STAGING SHEETS**

SHADING	Design Color No.	
Green, Light	(225)	Existing Pavement Shading
Gray, Light	(48)	Previously Constructed Pavement Shading
Gray, Med	(80)	Previously Constructed Granular Surface Shading
Blue, Light	(230)	Proposed Pavement Shading
Lavender	(9)	Temporary Pavement Shading
Brown, Med	(237)	Future Proposed Pavement Shading

**CROSS SECTION VIEW PATTERN AND SYMBOL LEGEND
OF TRAFFIC CONTROL AND STAGING SHEETS**





















	Pavement Removal		Proposed Granular Shoulder
	Proposed Granular Subbase		Temporary Shoulder
	Proposed Special Backfill		Existing Shoulder Strengthening
	Temporary Barrier Rail		Permanent Barrier Rail
			Channelizing Device

PLAN VIEW COLOR LEGEND OF TRAFFIC CONTROL AND STAGING SHEETS

LINWORK	Design Color No.	
Green	(2)	Existing Topographic Features and Labels
Magenta	(5)	Pavement Marking Call Outs
Blue	(1)	Proposed Alignment, Stationing, Tic Marks, and Alignment Annotation
Yellow	(4)	Pavement Markings, Yellow
Off White	(254)	Pavement Markings, White
Violet	(15)	Temporary barrier rail, Unpinned
Flush Orange	(228)	Temporary barrier rail, Pinned

SHADING	Design Color No.	
Green, Light	(225)	Existing Pavement Shading
Gray, Light	(48)	Previously Constructed Pavement Shading
Gray, Med	(80)	Proposed Granular Surface Shading
Gray, Med	(80)	Previously Constructed Granular Surface Shading
Blue, Light	(230)	Proposed Pavement Shading
Lavender	(9)	Temporary Pavement Shading
Brown, Light	(236)	Proposed Grading Limits Shading
Pink, Dark	(13)	Proposed MSE or CIP Wall Shading
Red	(3)	Proposed Bridge Shading and Sign Trusses
Black w/Gray, Light Fill	(0,48)	Previously Constructed Structure

**PLAN VIEW PATTERN AND SYMBOL LEGEND
OF TRAFFIC CONTROL AND STAGING SHEETS**

	Channelizing Device		Crash Cushion (Temp or Perm)
	Drum		Traffic Signal
	Temporary Lane Separator		Flagger
	Tubular Marker		Temporary Floodlighting
	Channelizer Marker		Traffic Sign
	Concrete Barrier Marker		Type III Barricade
	Delineator		Type A Warning Light
	Temporary Barrier Rail		Direction of Traffic
	Pavement Removal		Safety Closure
	Sand Barrel Layout		Lane Identification

NOTE: Device spacing according to Standard Road Plans unless specifically dimensioned.

**TRAFFIC CONTROL
AND
STAGING
LEGEND AND SYMBOL
INFORMATION SHEET**

(COVERS SHEET SERIES J)



- Notes:
- ① Northbound Right Lane Closed from STA. 887+89.00 to STA. 926+13.23
 - ② 42" Channelizer

STAGE 1 CONSTRUCTION
 STA. 903+98.90 to STA. 925+00.00
 Northbound I-35 Outside 10' Shoulder Strengthening

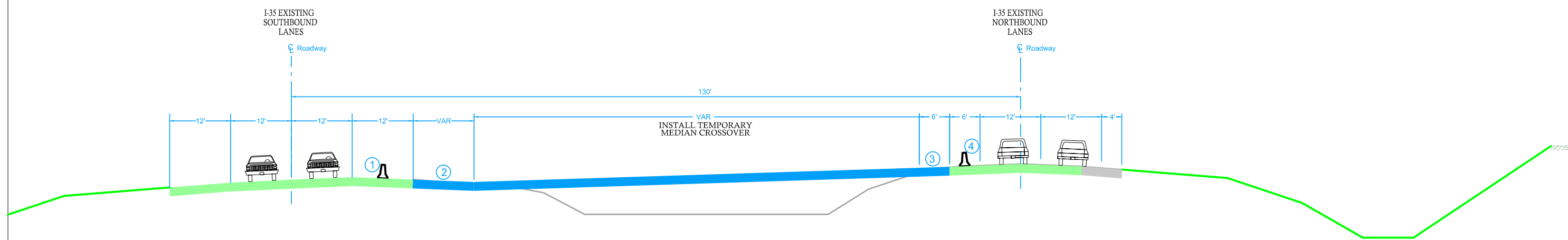

- Notes:
- ① Temporary Barrier Rail Placed 5' From Edge of Through Lane
 - ② Interior Southbound 12' Lane Construction. STA. 916+60.00 to STA. 937+02.00 and STA. 941+87.86 to STA. 1070+62.38
 - ③ Northbound Interior 6' Shoulder Reconstructed With Temporary Median Crossover
 - ④ Temporary Barrier Rail Placed 2' From Edge of Through Lane

STAGE 2 CONSTRUCTION
 STA. 908+18.86 to STA. 935+25.00
 Northbound Traffic Lanes Shift 6' To The East
 Temporary Median Crossover Pavement Construction

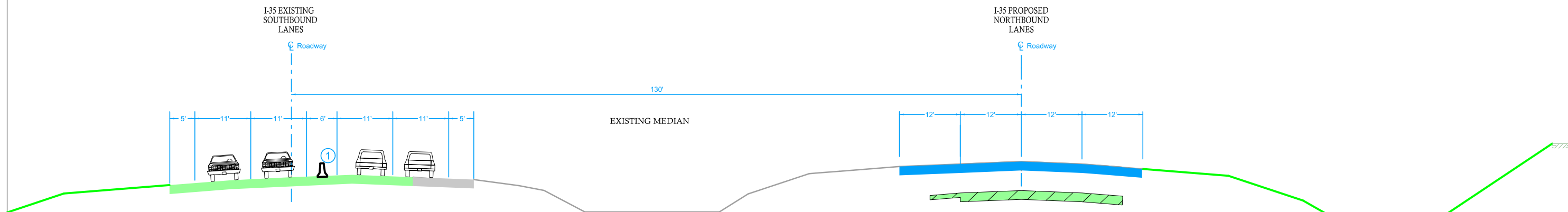

STAGE 3 CONSTRUCTION
STA. 944+00.00 to STA. 1066+60.00
Northbound Lane Paving

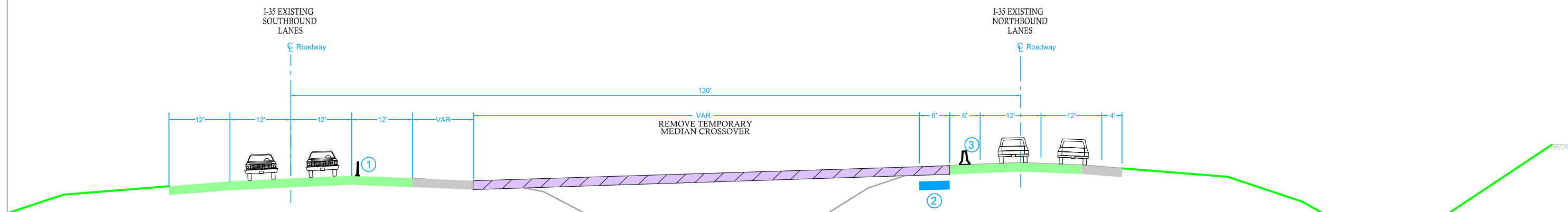

STAGE 4 CONSTRUCTION
STA. 908+18.86 to STA. 935+25.00
Northbound Traffic Lanes Shift 6' To The East
Temporary Median Crossover Pavement Removal

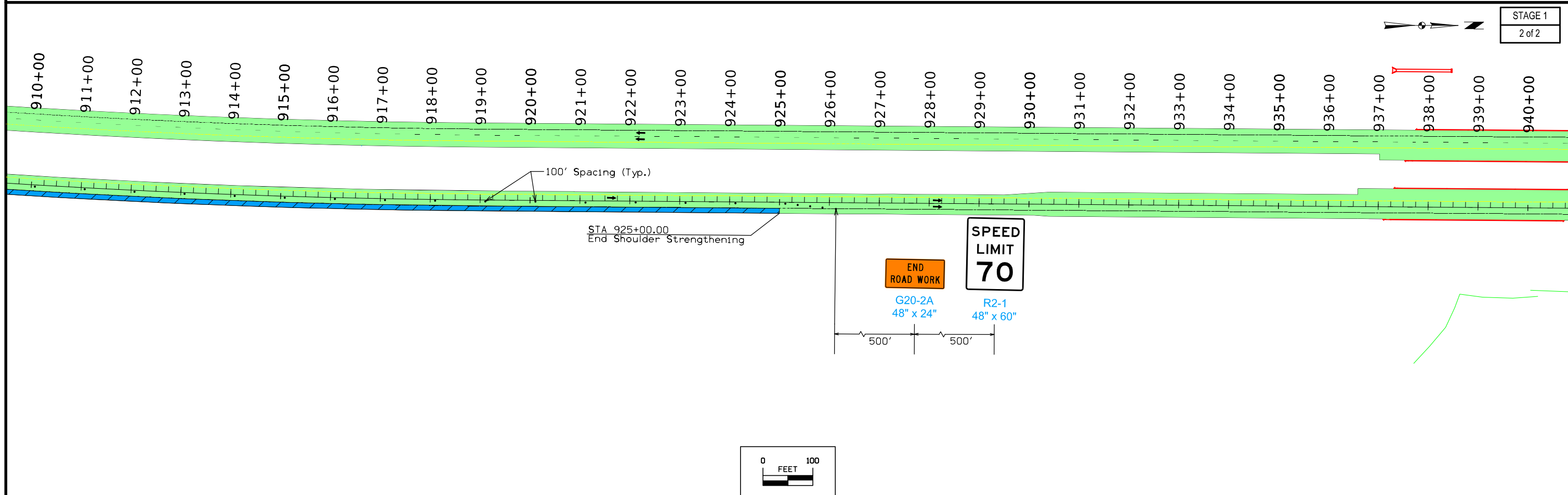
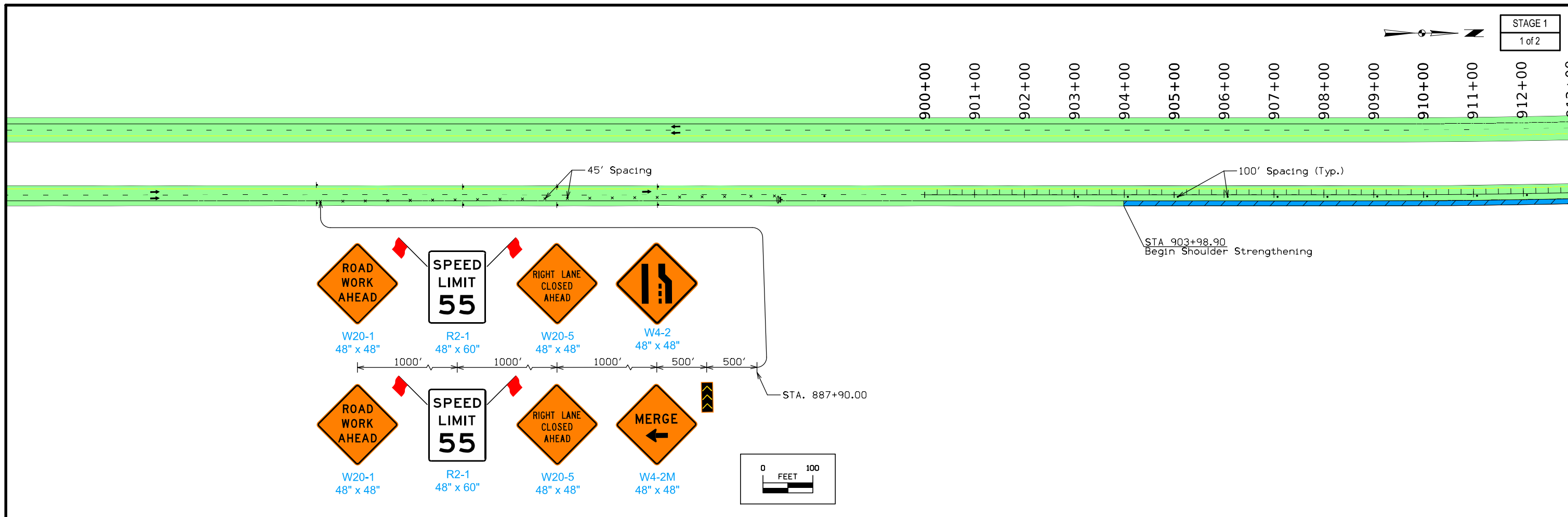

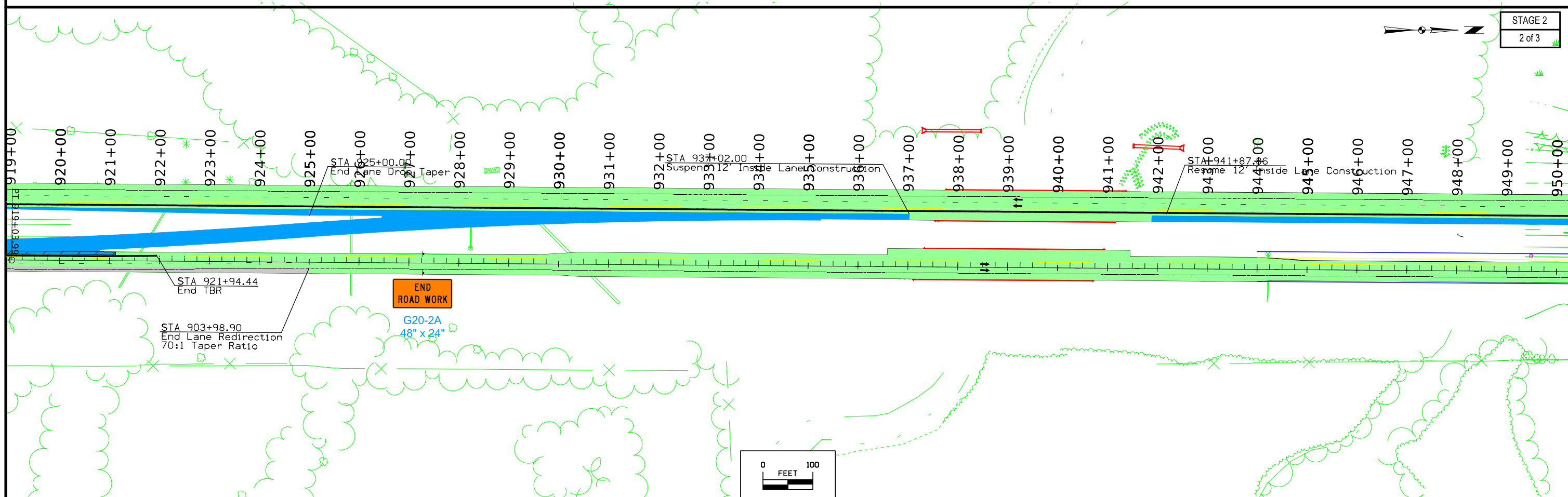
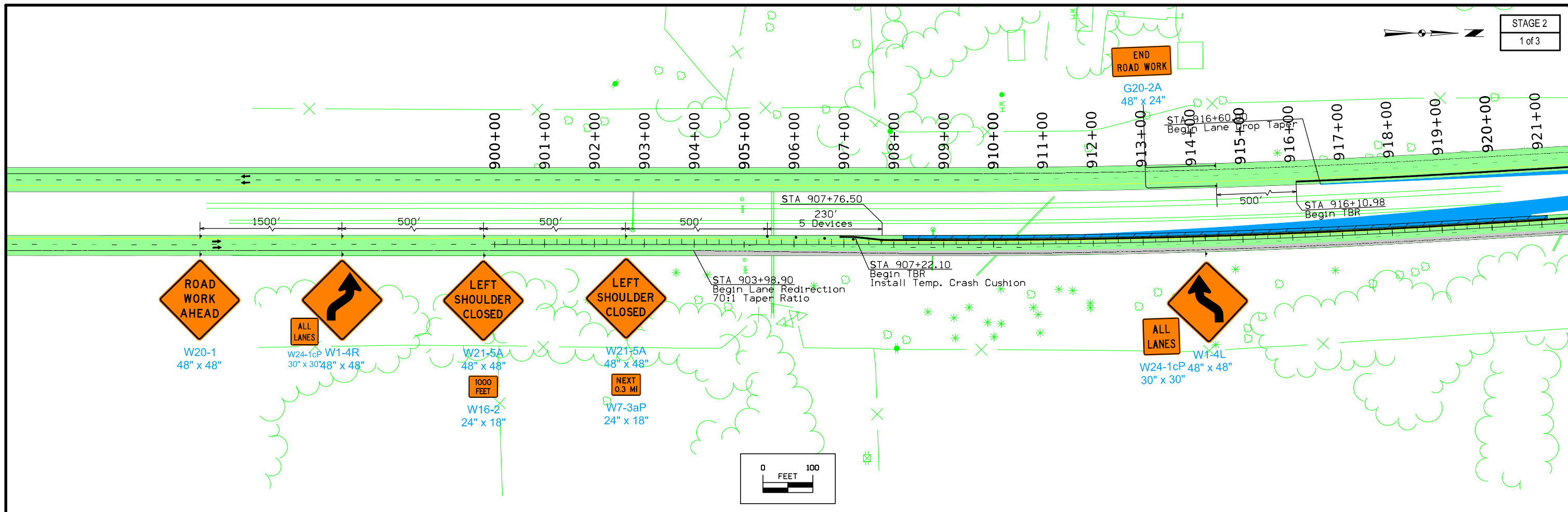



Refer to IM-NHS-2(467)63--03-91 for continuation
of TBR, pavement markings, and traffic control

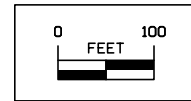
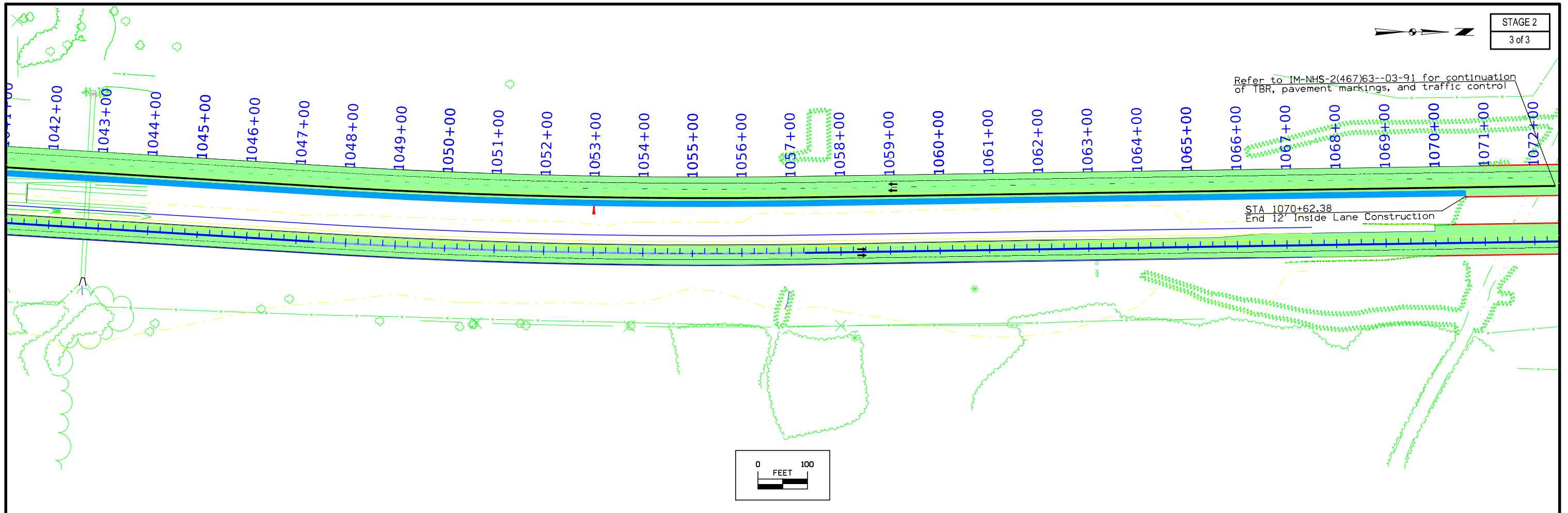

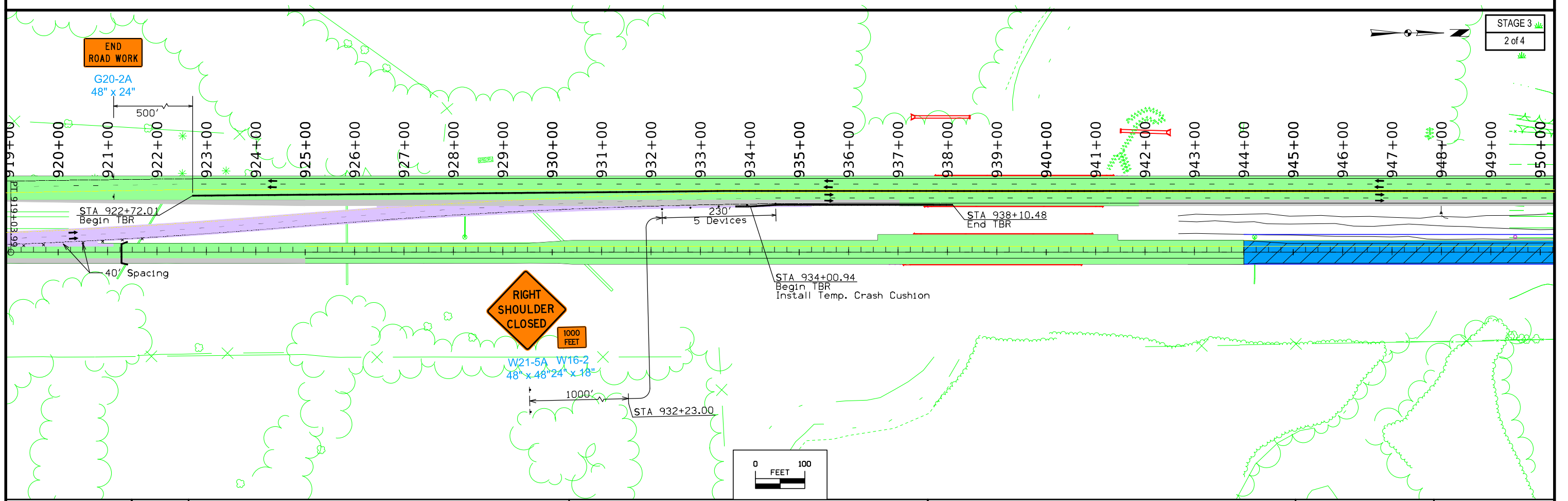
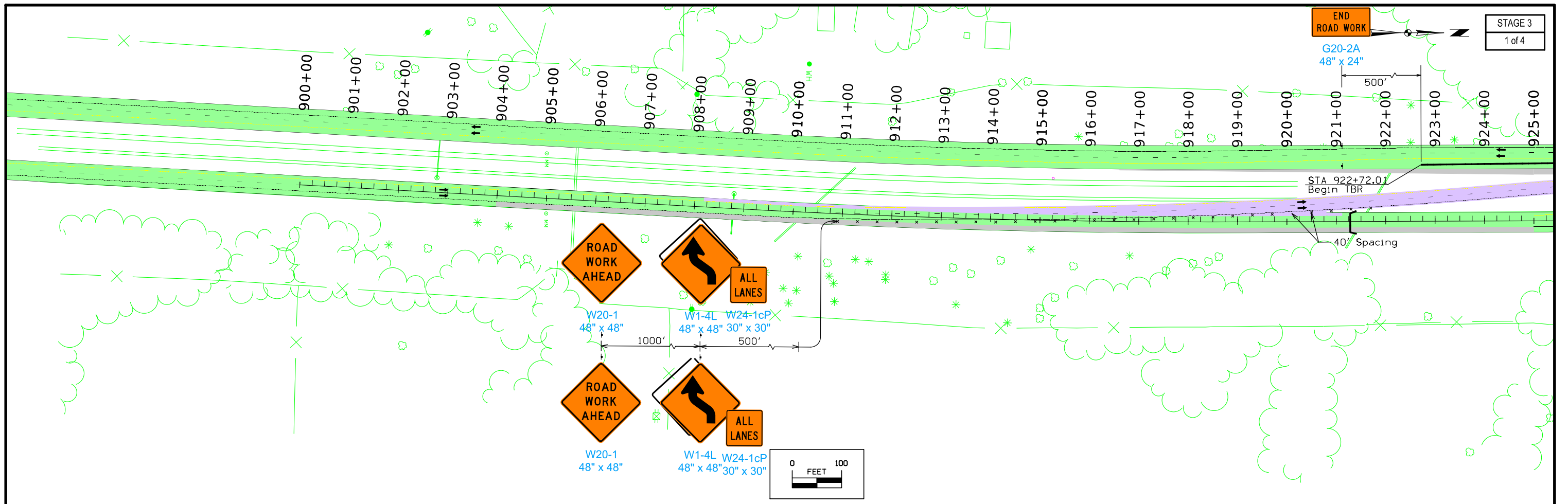

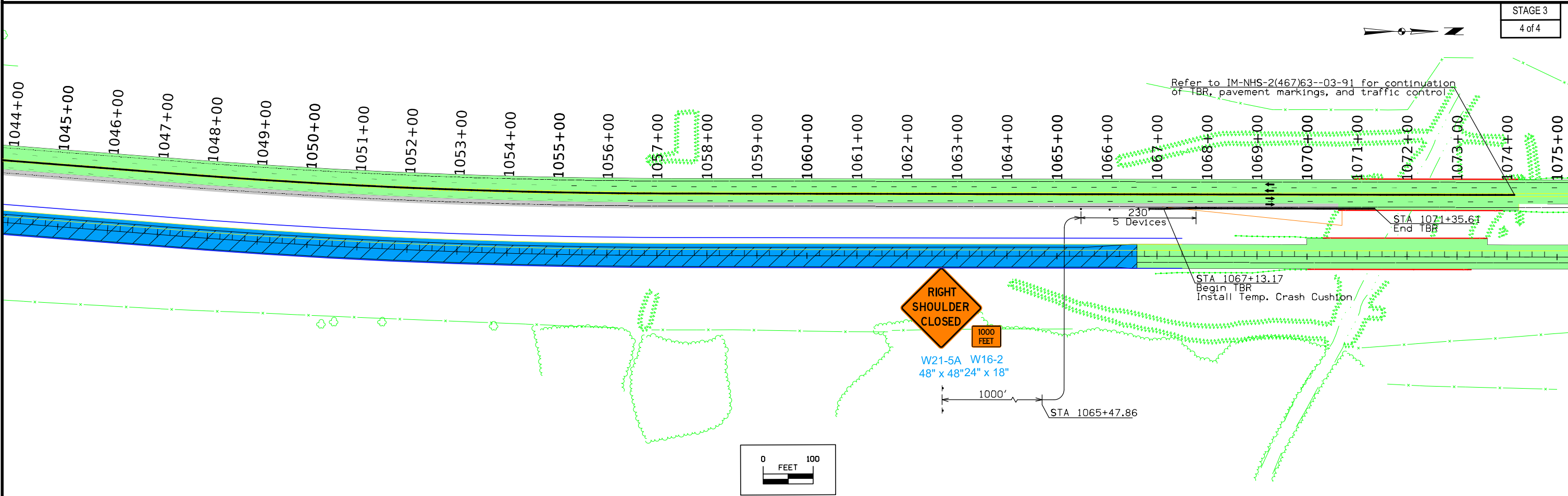
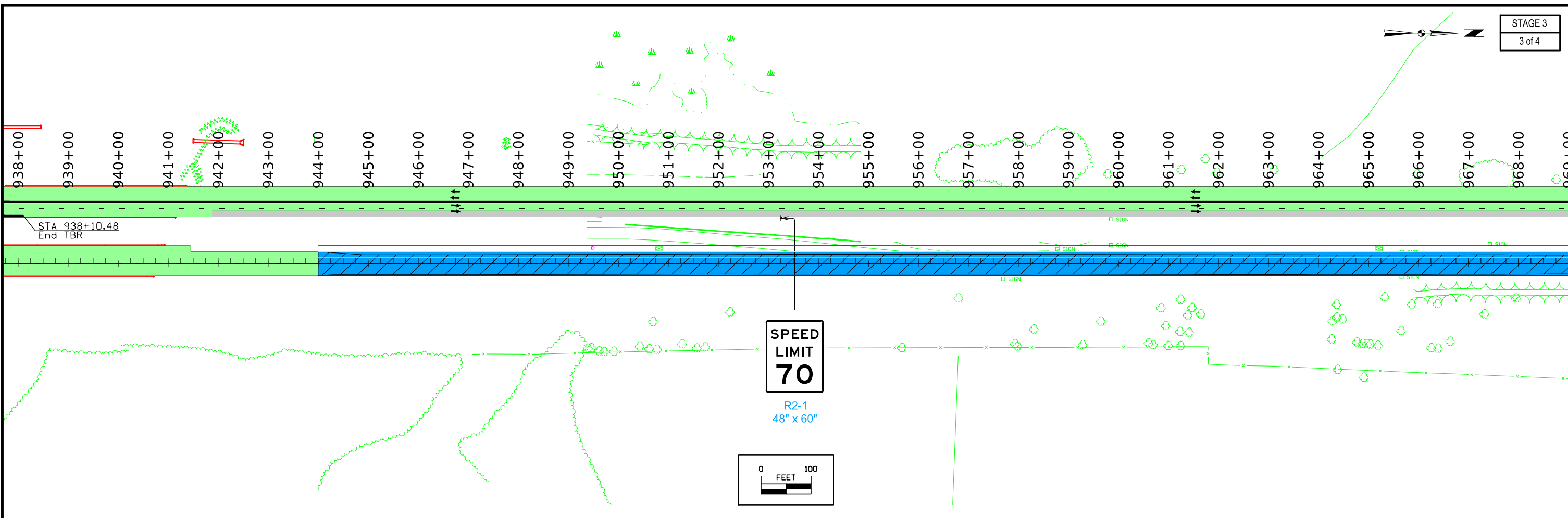

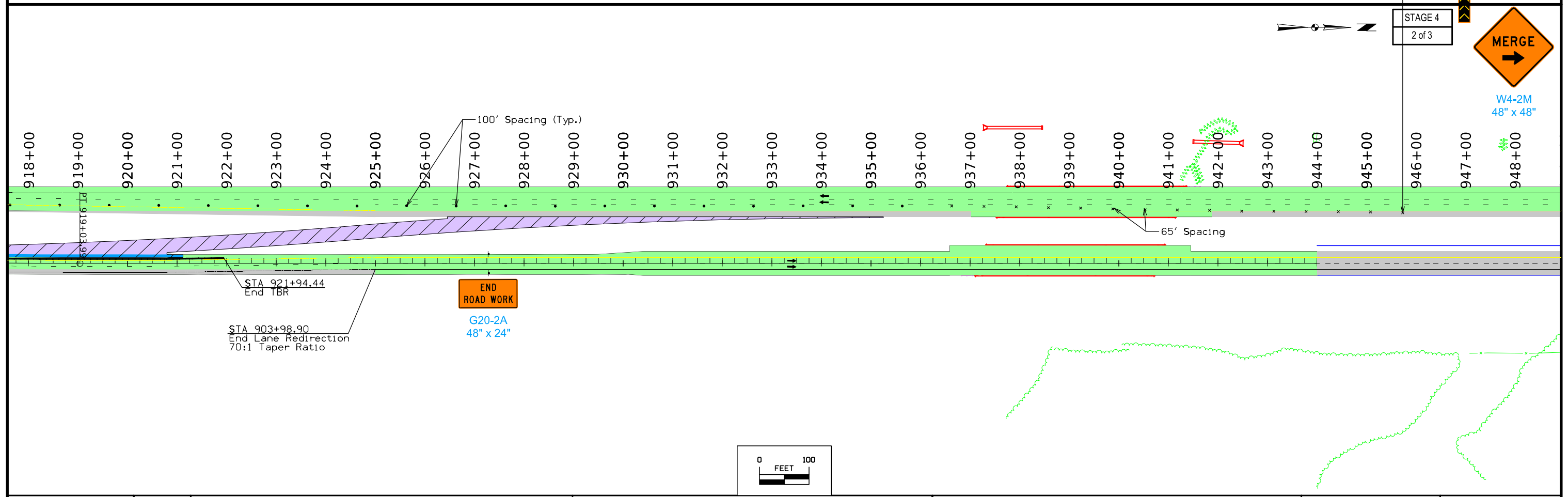
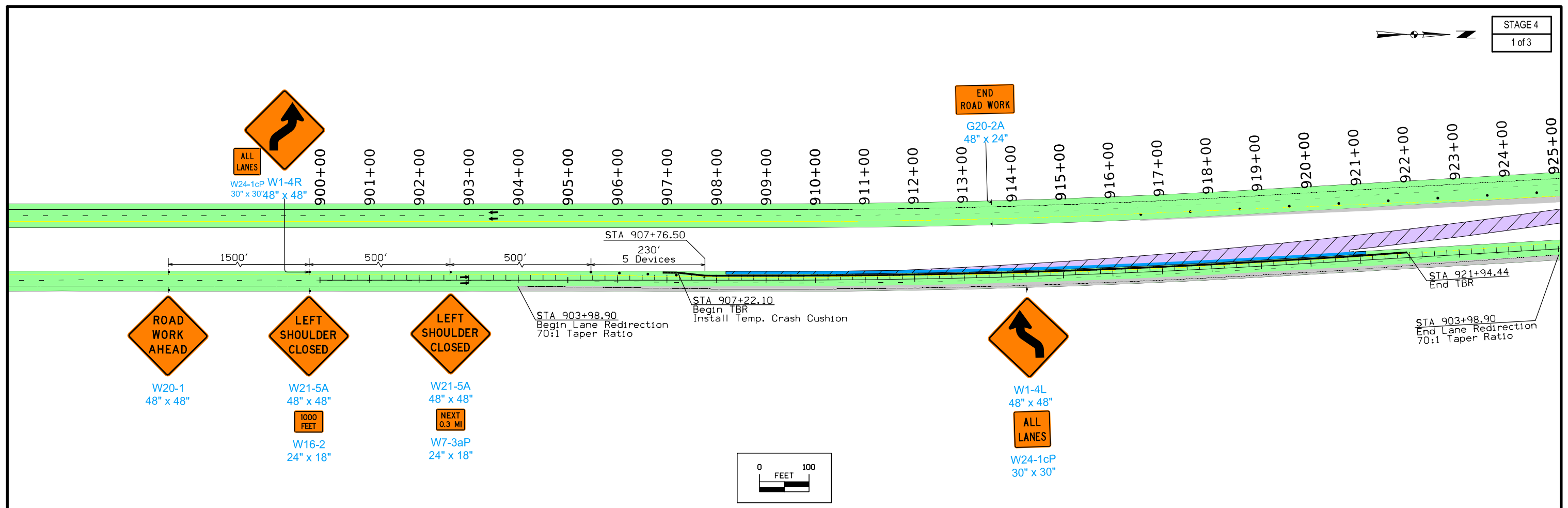

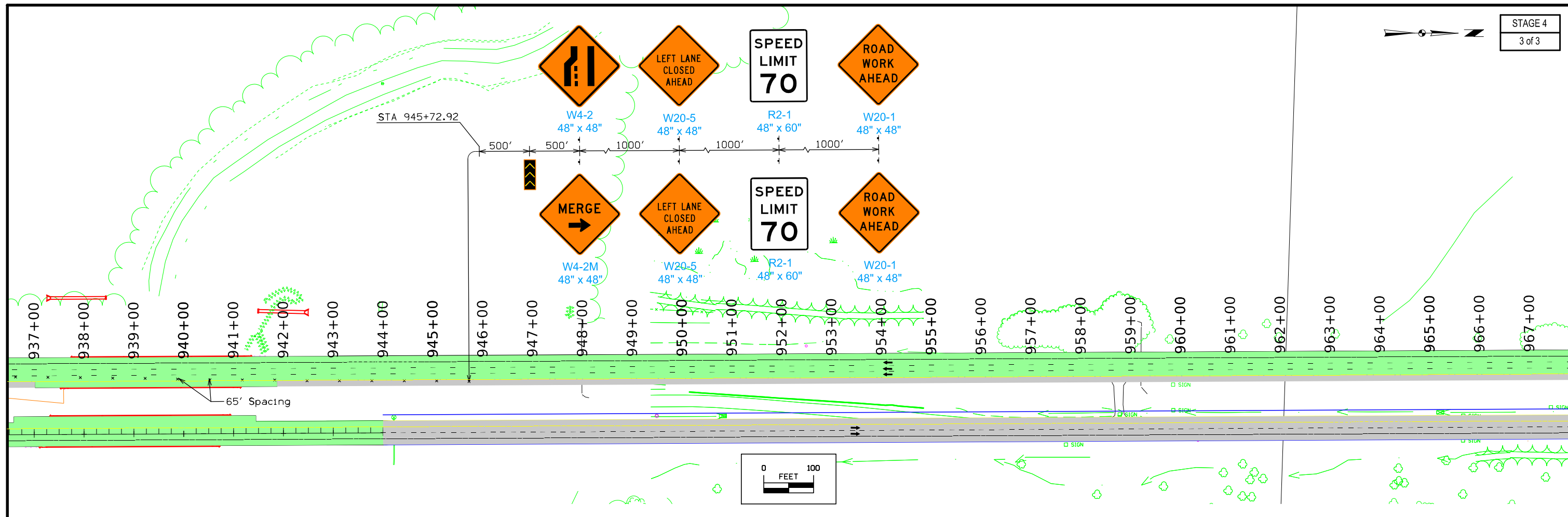

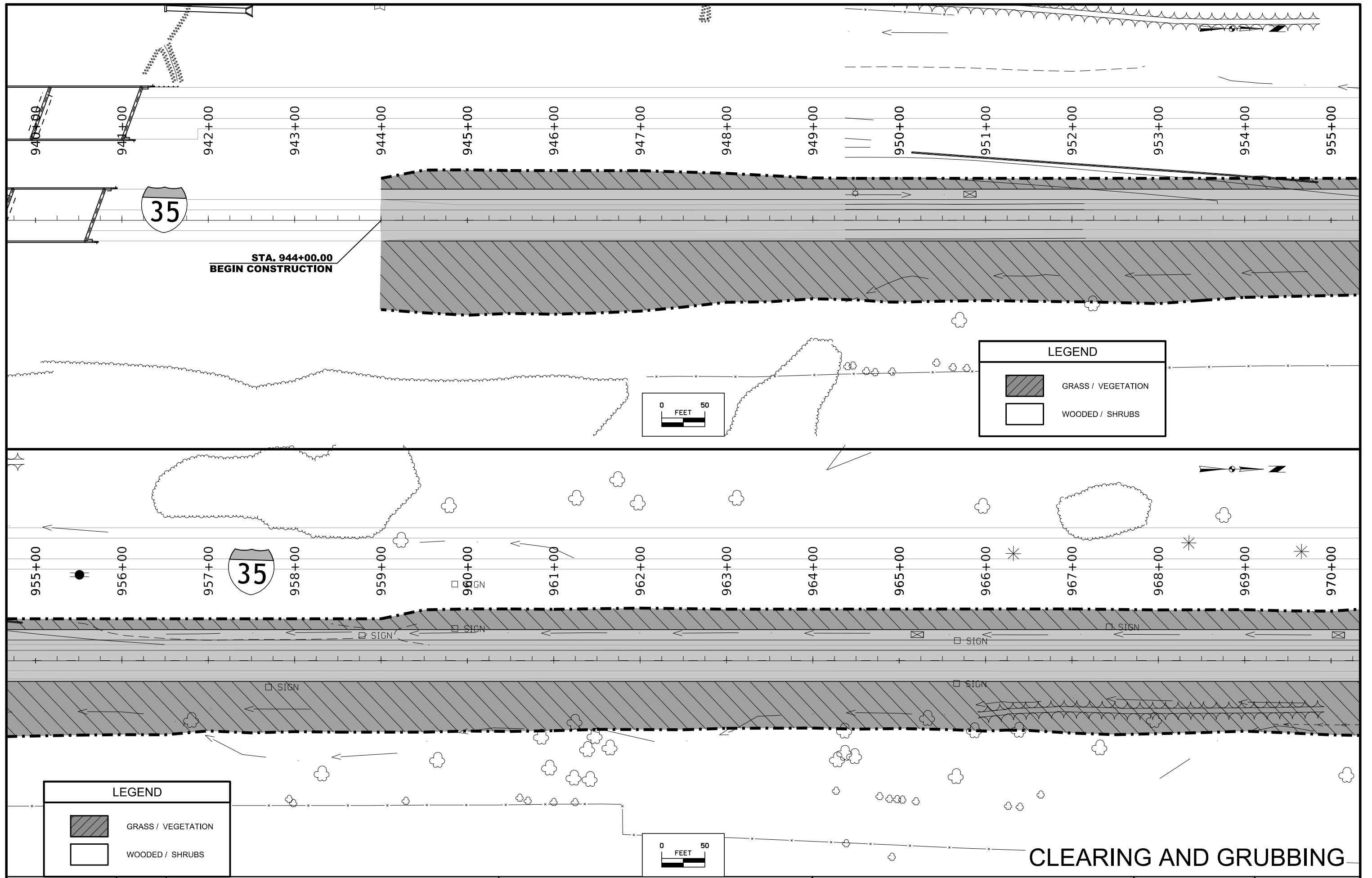

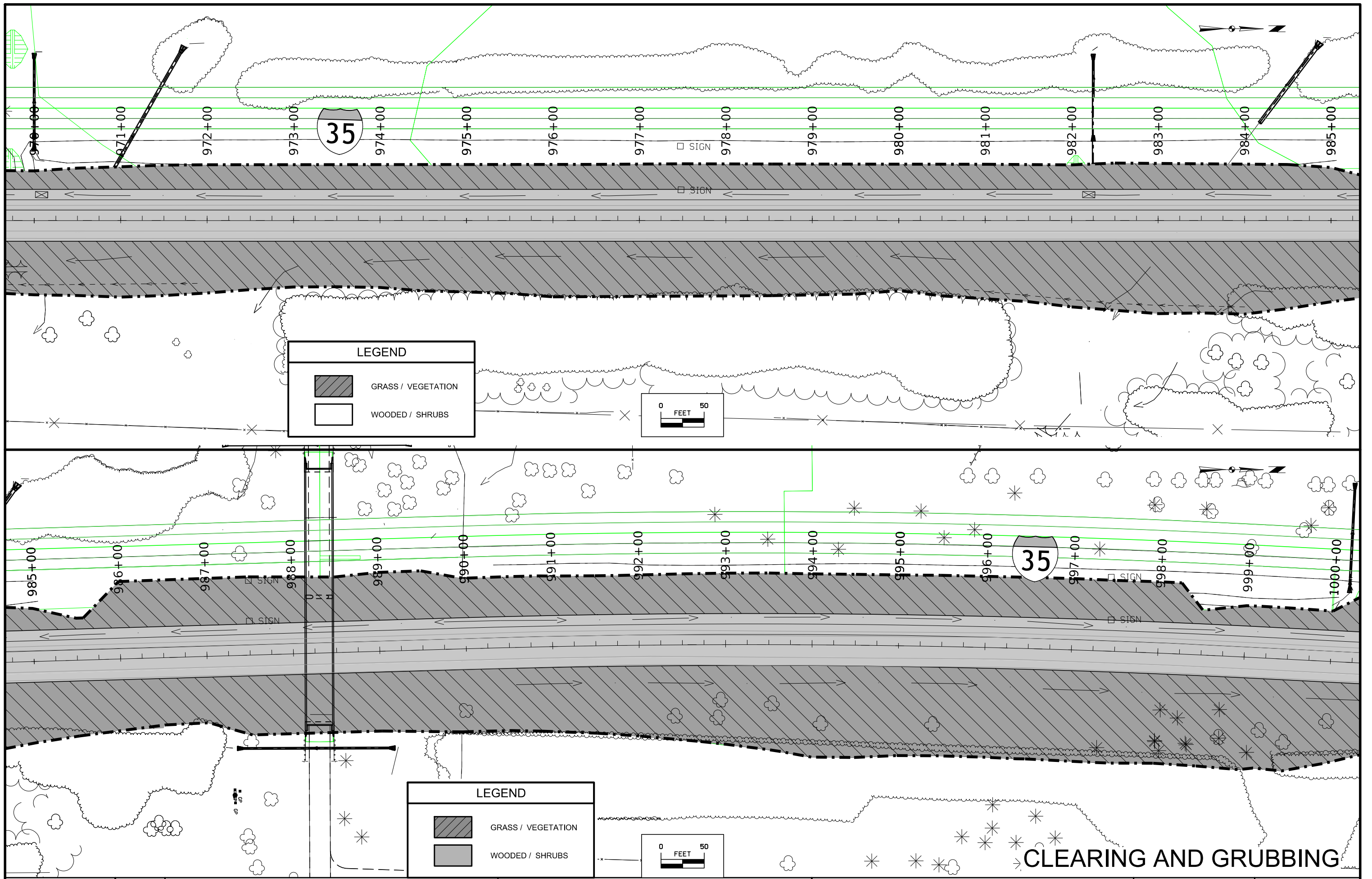



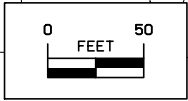

LEGEND

	GRASS / VEGETATION
	WOODED / SHRUBS



LEGEND

	GRASS / VEGETATION
	WOODED / SHRUBS

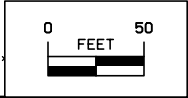

CLEARING AND GRUBBING

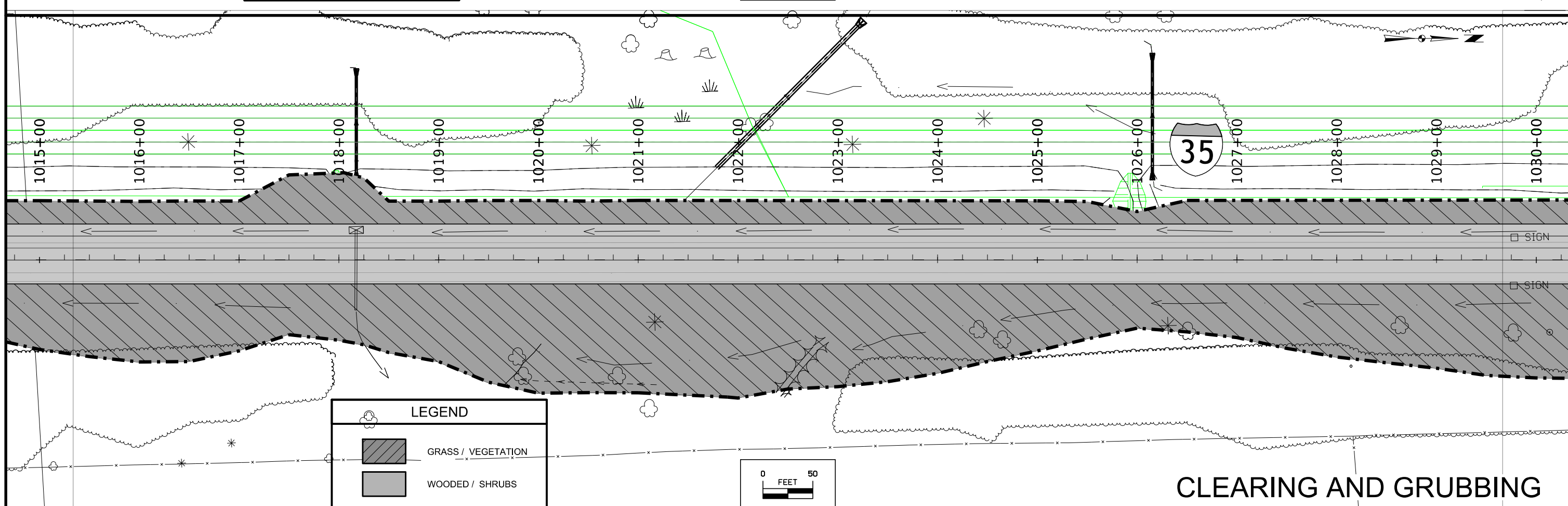
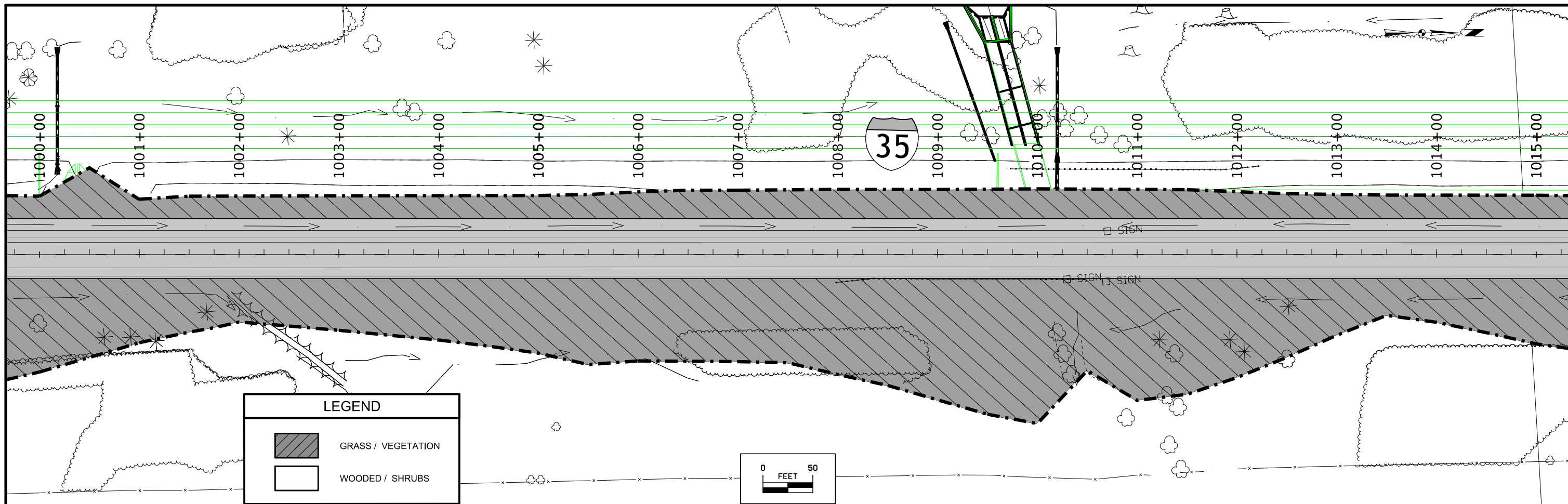

CLEARING AND GRUBBING

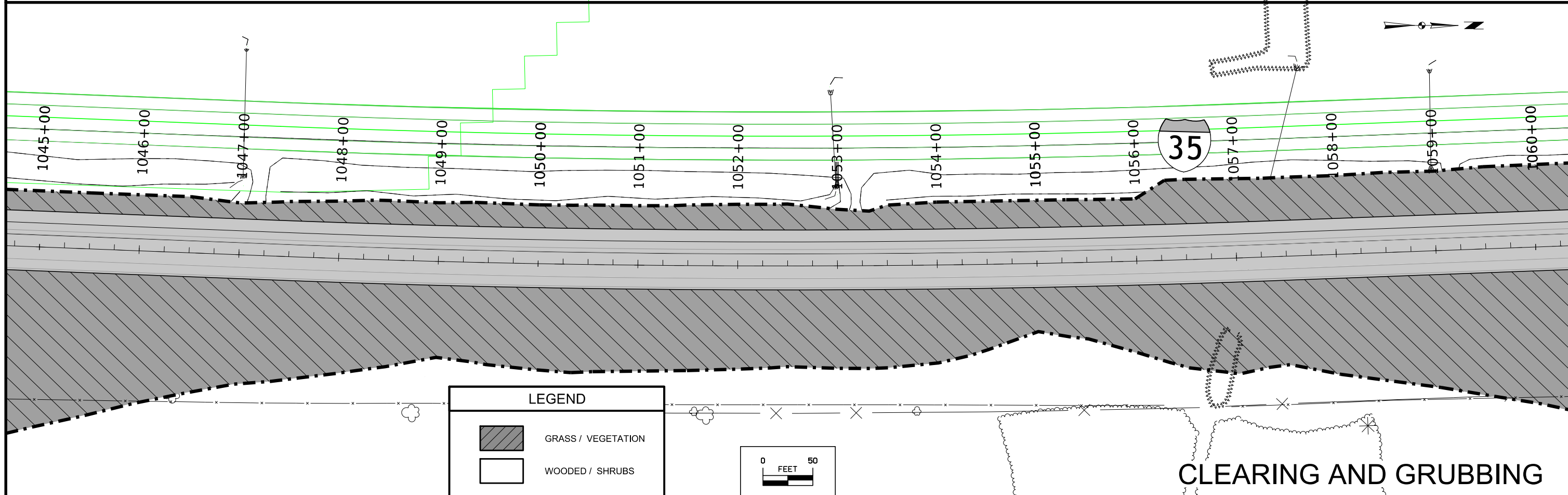
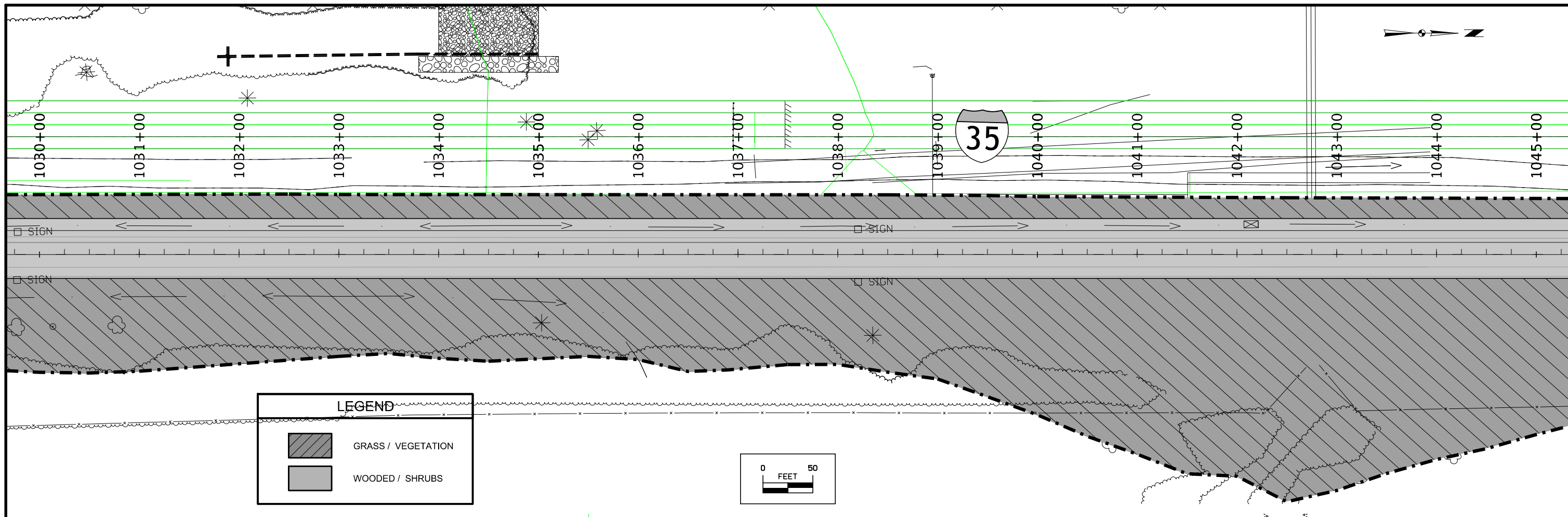

CLEARING AND GRUBBING

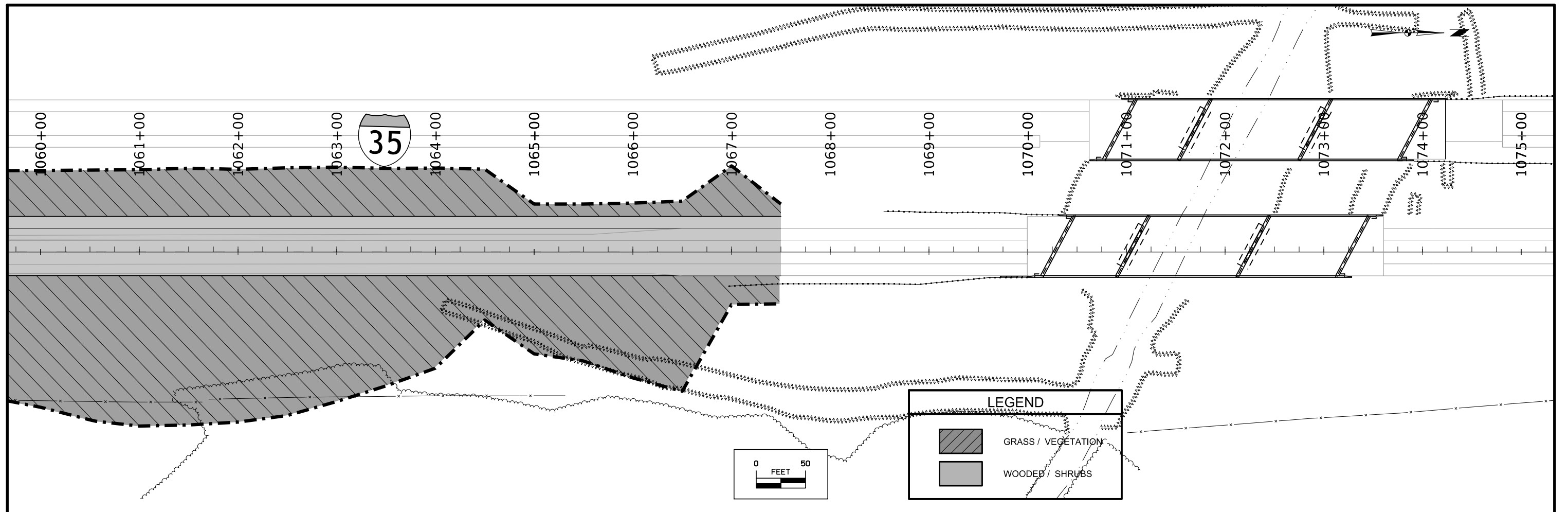

Horizontal Curve Data for Curve #1
 P.I. STA. 918+12.31, 22.17' LT.
 $\Delta = 05^\circ 44' 47.20''$ (LT)
 T = 647.44
 L = 1,293.80
 R = 12,900
 E = 16.24

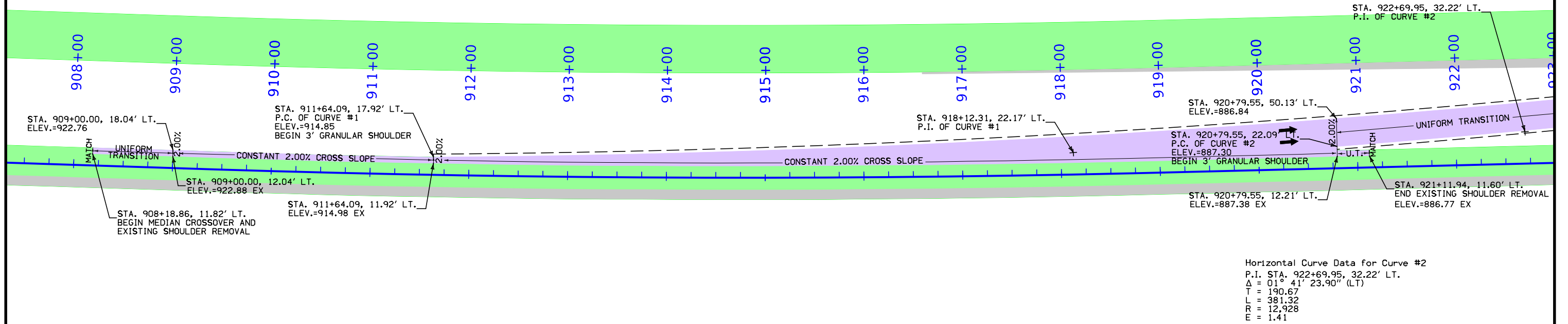

GEOMETRIC & STAKING DETAILS
 TEMPORARY MEDIAN CROSSOVER SOUTH OF NORTH RIVER
 106' MEDIAN, 28' WIDE 2 LANE

Horizontal Curve Data for Curve #3
 P.I. STA. 925+51.38, 83.63' LT.
 $\Delta = 01^\circ 40' 01.40''$ (RT)
 T = 94.04
 L = 188.08
 R = 12,928
 E = 0.34

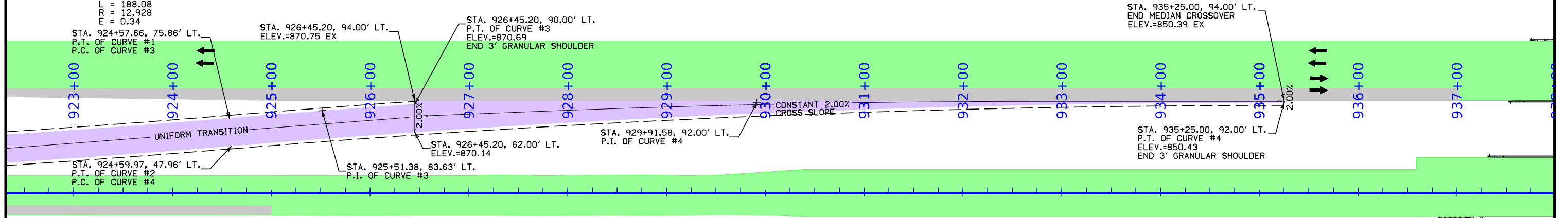

Horizontal Curve Data for Curve #4
 P.I. STA. 929+91.58, 92.00' LT.
 $\Delta = 04^\circ 44' 08.60''$ (RT)
 T = 533.42
 L = 1066.24
 R = 12,900
 E = 11.02

GEOMETRIC & STAKING DETAILS
 TEMPORARY MEDIAN CROSSOVER SOUTH OF NORTH RIVER
 106' MEDIAN, 28' WIDE 2 LANE

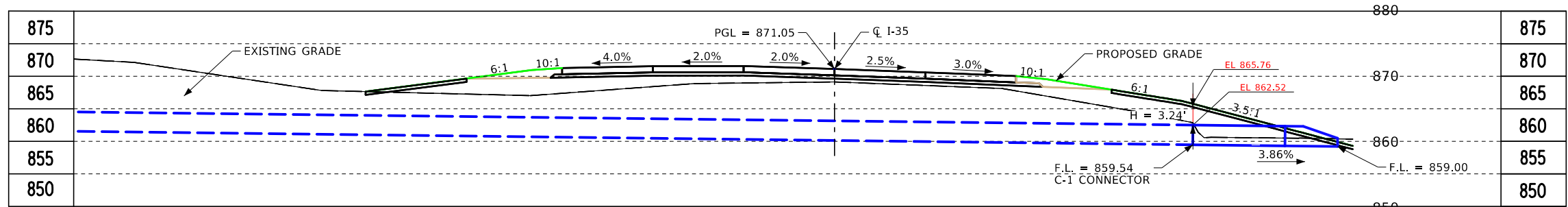

LONGITUDINAL SECTION ALONG CULVERT

BM552 NORTHING=518547.27, EASTING=1563747.47,
ELEVATION=840.73
FND RR SPIKE IN FENCE POST, +/-150' E OF I-35

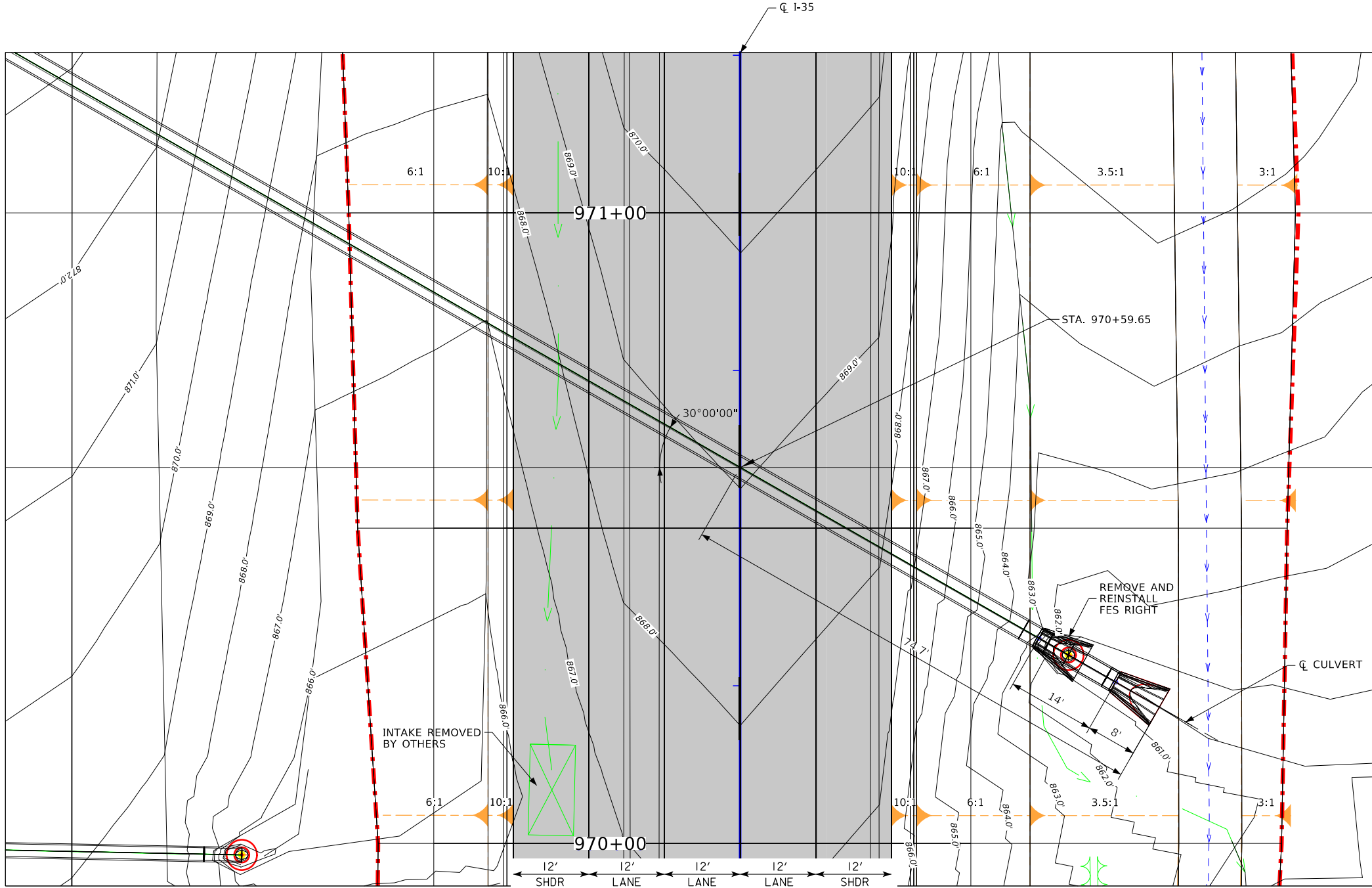

PLAT PLAN

UTILITIES LEGEND:
REFER TO D.I

HYDRAULIC DATA
DRAINAGE AREA = 17.9 ACRES ROLLING
DESIGN DISCHARGE, Q₅₀ = X.X CFS
DESIGN HIGH WATER = X.X

LOCATION
I-35
T-77N R-25W
SECTIONS 31
LINN TOWNSHIP
WARREN COUNTY

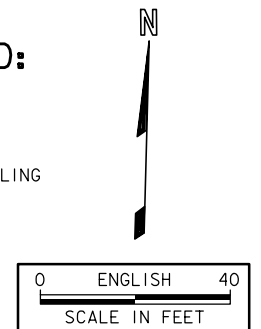

DESIGN FOR 30° SKEW LT. AHEAD
36" X 14'
REINFORCED CONCRETE PIPE
EXTENSION
PLAT PLAN
STA. 970+59.65 C-1-35 AUGUST 2022
WARREN COUNTY
IOWA DEPARTMENT OF TRANSPORTATION - HIGHWAY DIVISION
DESIGN SHEET NO. 1 OF 1 FILE NO. XXXXX DESIGN NO.

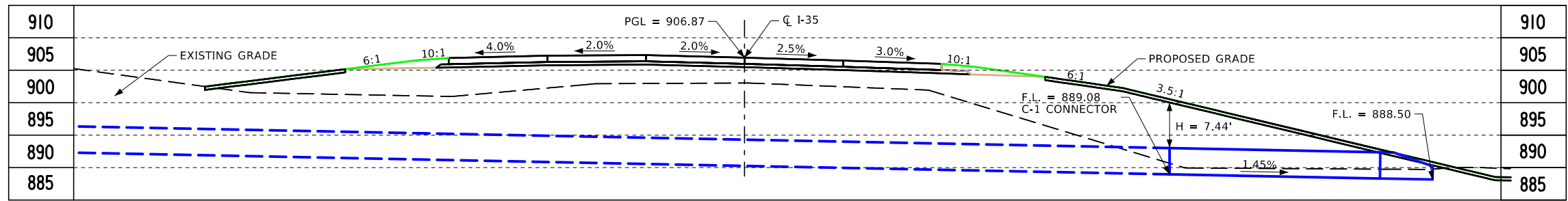

LONGITUDINAL SECTION ALONG CULVERT

BM552 NORTHING=518547.27, EASTING=1563747.47,
 ELEVATION=840.73
 FND RR SPIKE IN FENCE POST, +/-150' E OF I-35

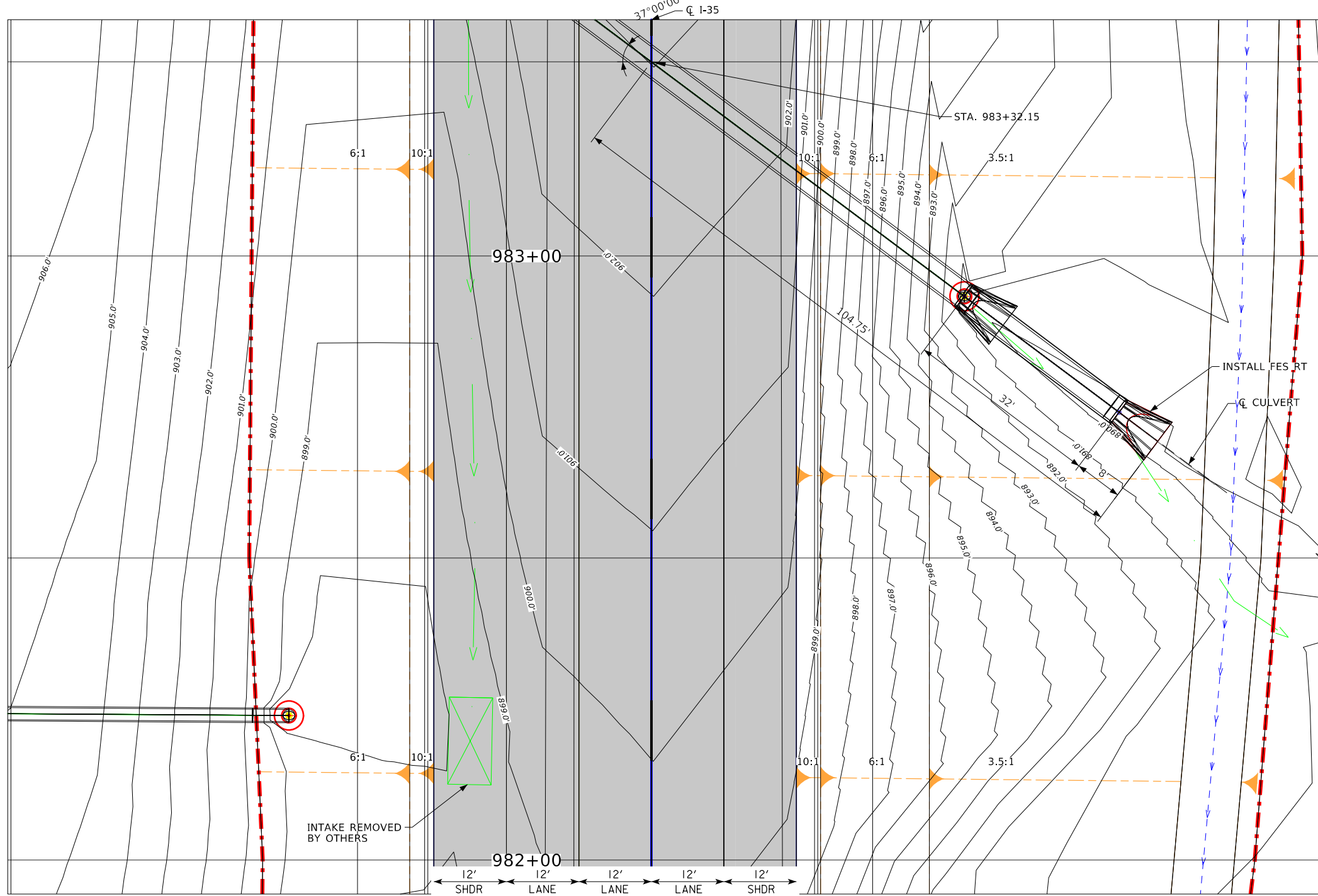

PLAT PLAN

UTILITIES LEGEND:

REFER TO D.I

HYDRAULIC DATA

DRAINAGE AREA = 21 ACRES HILLY
 DESIGN DISCHARGE, Q_{50} = X.X CFS
 DESIGN HIGH WATER = X.X

LOCATION

I-35
 T-77N R-25W
 SECTIONS 31
 LINN TOWNSHIP
 WARREN COUNTY

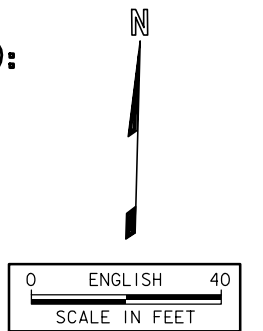

DESIGN FOR 37° SKEW LT. AHEAD
48" X 32'
REINFORCED CONCRETE PIPE
EXTENSION
PLAT PLAN
 STA. 983+32.15 C-1-35 AUGUST 2022
WARREN COUNTY
 IOWA DEPARTMENT OF TRANSPORTATION - HIGHWAY DIVISION
 DESIGN SHEET NO. 1 OF 1 FILE NO. XXXXX DESIGN NO.

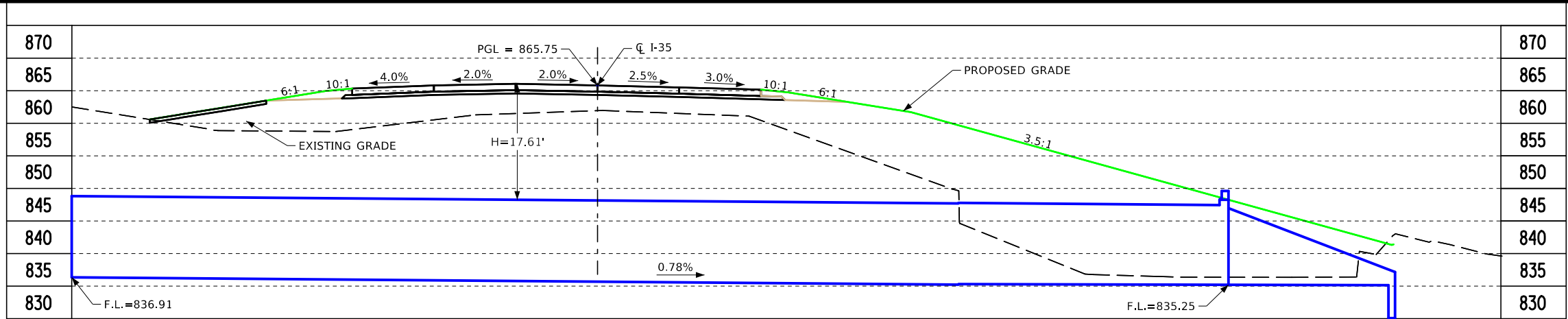

LONGITUDINAL SECTION ALONG CL CULVERT

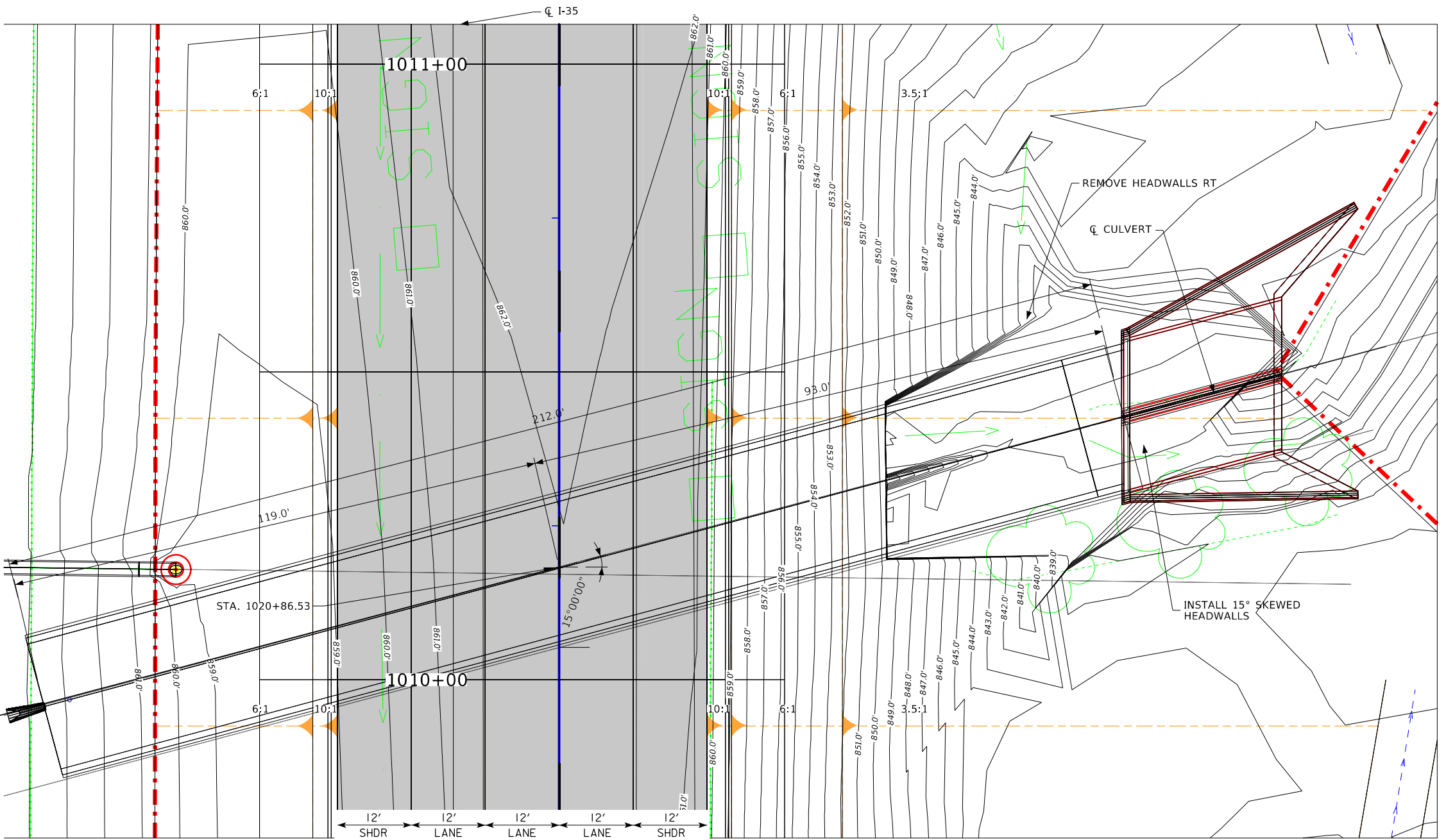

SITUATION PLAN

BM552 NORTHING=518547.27, EASTING=1563747.47,
ELEVATION=840.73
FND RR SPIKE IN FENCE POST, +/-150' E OF I-35

UTILITIES LEGEND:
REFER TO D.I

HYDRAULIC DATA
DRAINAGE AREA = 2580 ACRES HILLY
DESIGN DISCHARGE, Q₅₀ = X.X CFS
DESIGN HIGH WATER = X.X

LOCATION
I-35
T-77N R-25W
SECTIONS 31
LINN TOWNSHIP
WARREN COUNTY

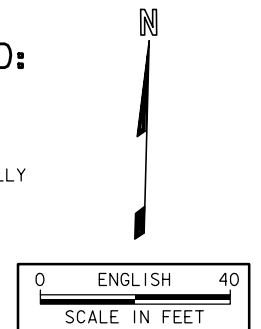

DESIGN FOR 15° SKEW RT. AHEAD
12' X 12' X 212'
TWIN REINFORCED CONCRETE BOX
EXTENSION
SITUATION PLAN
STA. 1010+17.81 CL I-35 AUGUST 2022
WARREN COUNTY
IOWA DEPARTMENT OF TRANSPORTATION - HIGHWAY DIVISION
DESIGN SHEET NO. 1 OF 1 FILE NO. XXXXX DESIGN NO.

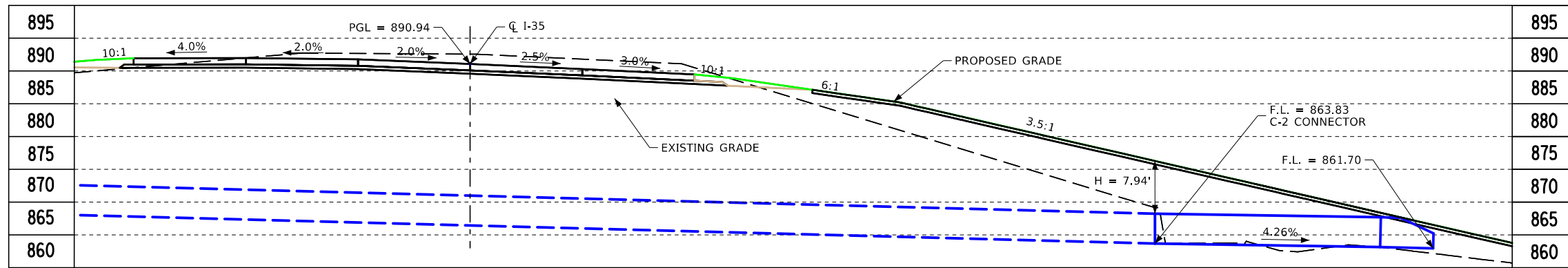

LONGITUDINAL SECTION ALONG CL CULVERT

BM552 NORTHING=518547.27, EASTING=1563747.47,
 ELEVATION=840.73
 FND RR SPIKE IN FENCE POST, +/-150' E OF I-35

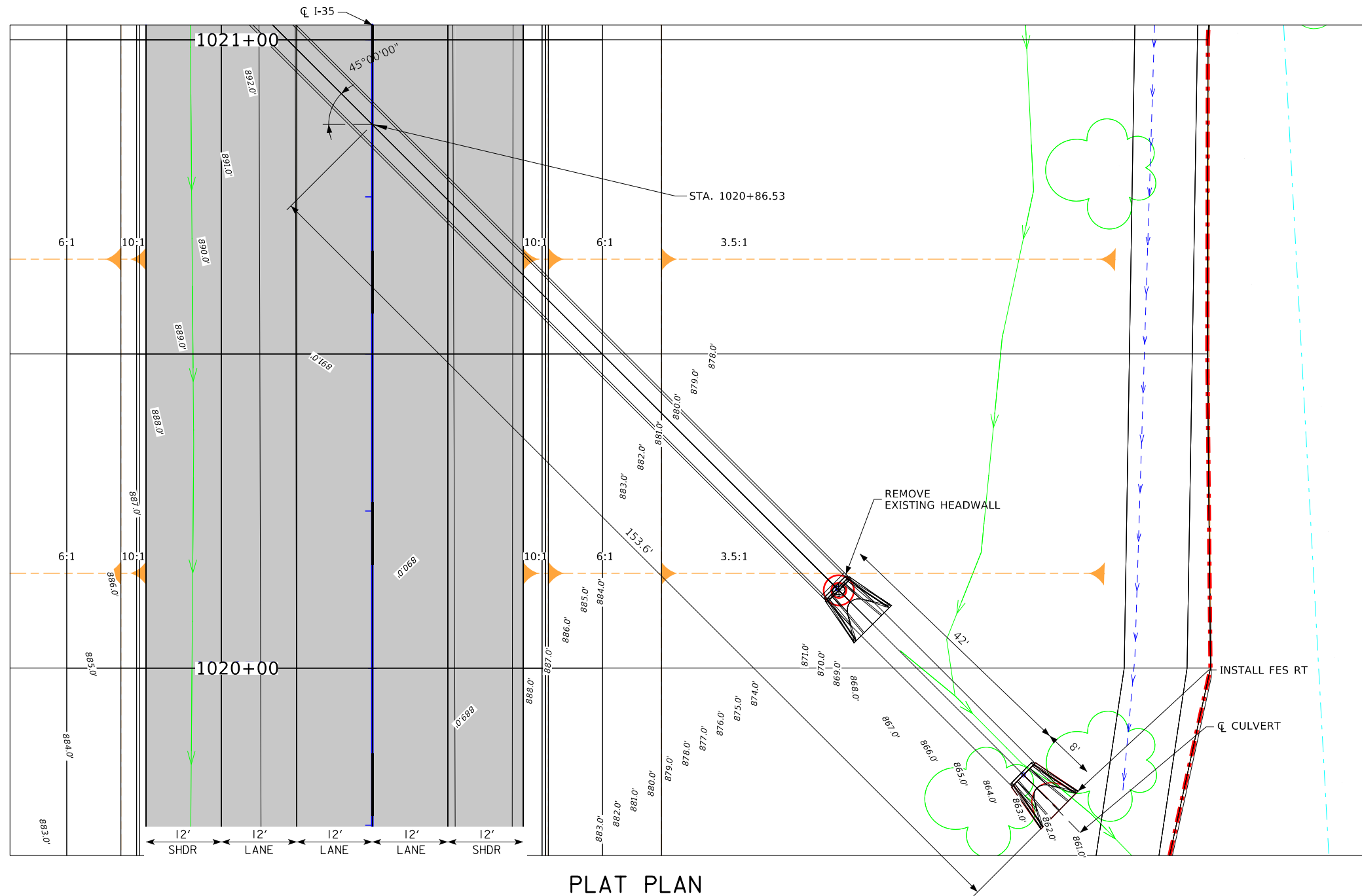

PLAT PLAN

UTILITIES LEGEND:

REFER TO D.I

HYDRAULIC DATA

DRAINAGE AREA = 49 ACRES HILLY
 DESIGN DISCHARGE, Q₅₀ = X.X CFS
 DESIGN HIGH WATER = X.X

LOCATION

I-35
 T-77N R-25W
 SECTIONS 30
 LINN TOWNSHIP
 WARREN COUNTY

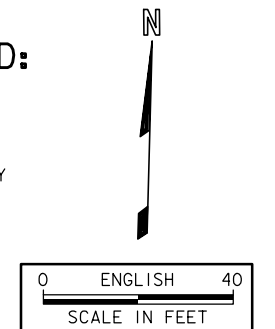

DESIGN FOR 45° SKEW LT. AHEAD
54" X 42'
REINFORCED CONCRETE PIPE
EXTENSION
PLAT PLAN
 STA. 1020+86.53 CL I-35 AUGUST 2022
WARREN COUNTY
 IOWA DEPARTMENT OF TRANSPORTATION - HIGHWAY DIVISION
 DESIGN SHEET NO. 1 OF 1 FILE NO. XXXXX DESIGN NO.

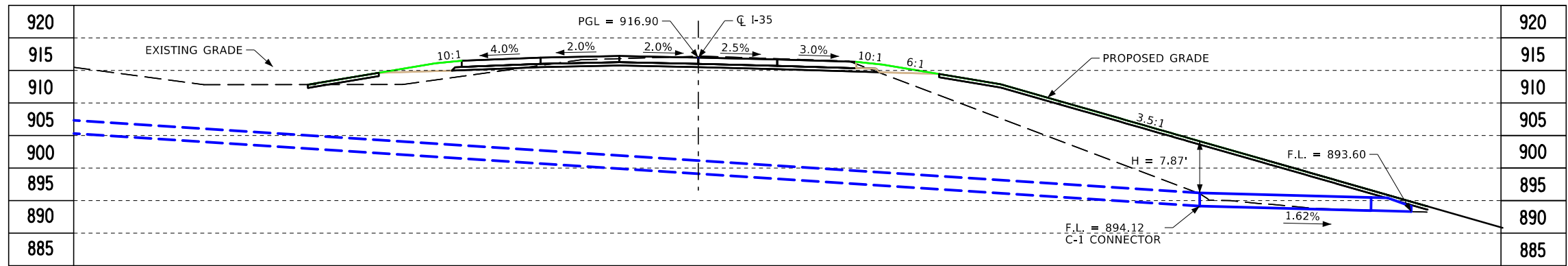

LONGITUDINAL SECTION ALONG CULVERT

BM552 NORTHING=518547.27, EASTING=1563747.47,
ELEVATION=840.73
FND RR SPIKE IN FENCE POST, +/-150' E OF I-35

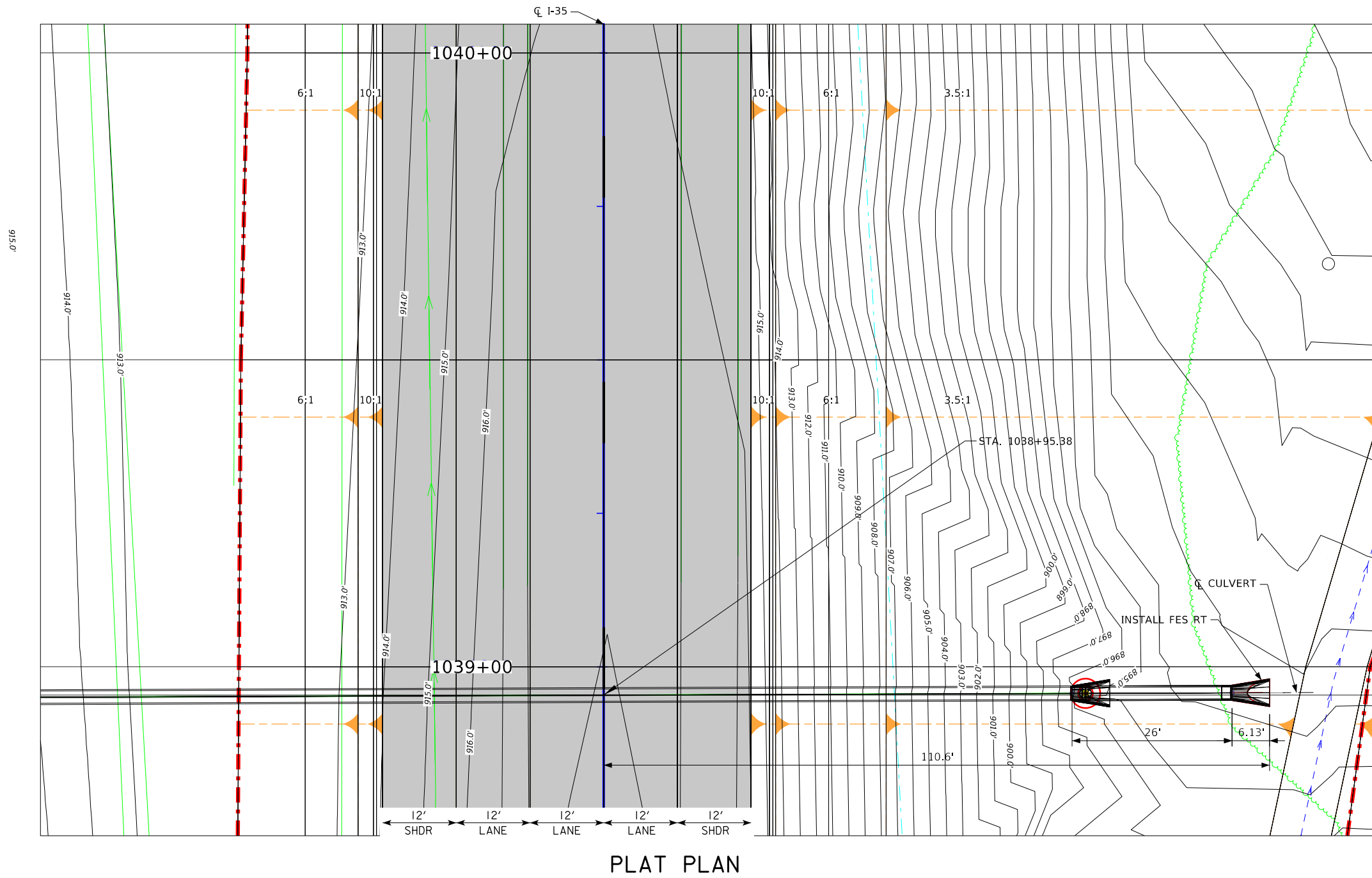

PLAT PLAN

UTILITIES LEGEND:
REFER TO D.I

HYDRAULIC DATA

DRAINAGE AREA = 13 ACRES HILLY
DESIGN DISCHARGE, $Q_{50} = X.X$ CFS
DESIGN HIGH WATER = X.X

LOCATION

I-35
T-77N R-25W
SECTIONS 30
LINN TOWNSHIP
WARREN COUNTY

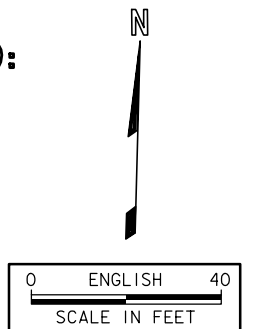

DESIGN FOR 0° SKEW
24" X 26'
REINFORCED CONCRETE PIPE
EXTENSION
PLAT PLAN
STA. 1038+95.38 C-1 I-35 AUGUST 2022
WARREN COUNTY
IOWA DEPARTMENT OF TRANSPORTATION - HIGHWAY DIVISION
DESIGN SHEET NO. 1 OF 1 FILE NO. XXXXX DESIGN NO.

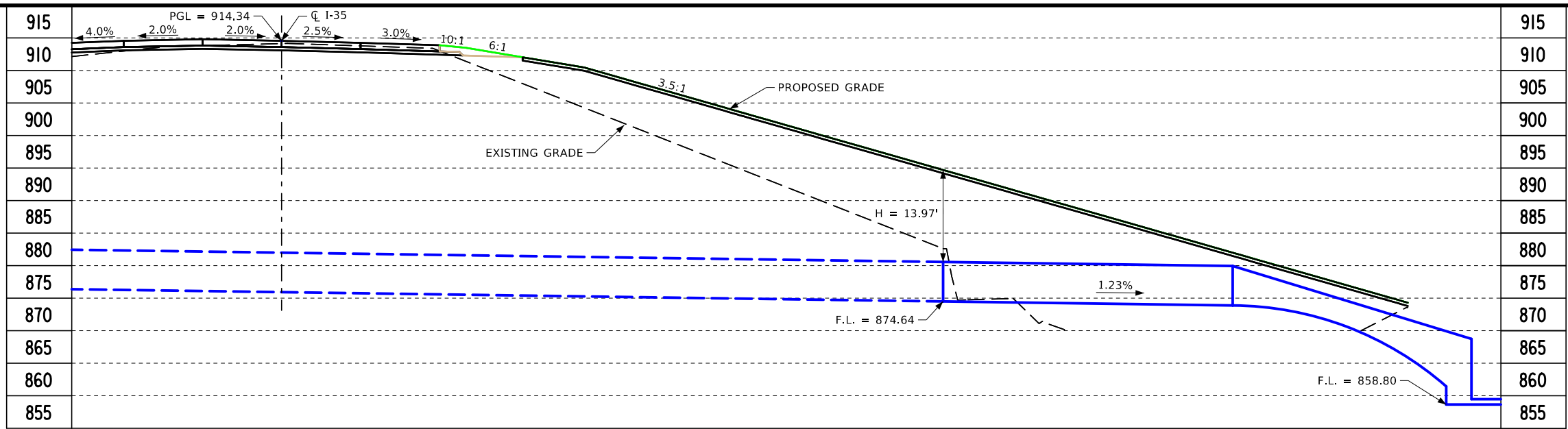

BM552 NORTHING=518547.27, EASTING=1563747.47,
 ELEVATION=840.73
 FND RR SPIKE IN FENCE POST, +/-150' E OF I-35

LONGITUDINAL SECTION ALONG \varnothing CULVERT

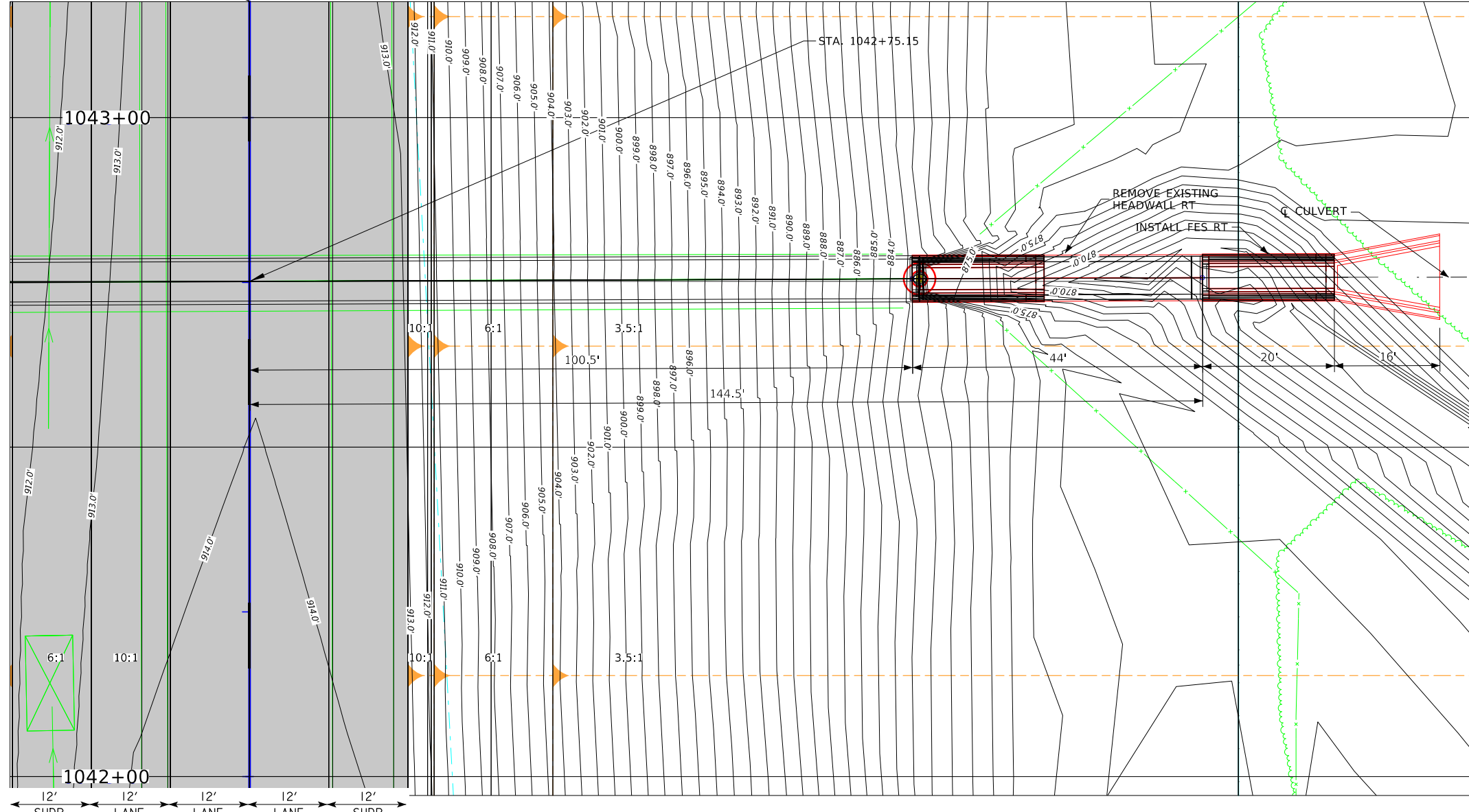

SITUATION PLAN

UTILITIES LEGEND:

REFER TO D.1
 HYDRAULIC DATA
 DRAINAGE AREA = 106 ACRES HILLY
 DESIGN DISCHARGE, Q_{50} = X.X CFS
 DESIGN HIGH WATER = X.X

LOCATION

I-35
 T-77N R-25W
 SECTIONS 30
 LINN TOWNSHIP
 WARREN COUNTY

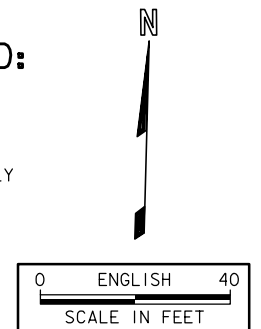

DESIGN FOR 0° SKEW
5' X 6' X 44'
REINFORCED CONCRETE BOX CULVERT
EXTENSION WITH 5' X 6' FLUME
SITUATION PLAN
 STA. 1042+75.15 \varnothing I-35 AUGUST 2022
WARREN COUNTY
 IOWA DEPARTMENT OF TRANSPORTATION - HIGHWAY DIVISION
 DESIGN SHEET NO. 1 OF 1 FILE NO. XXXXX DESIGN NO.

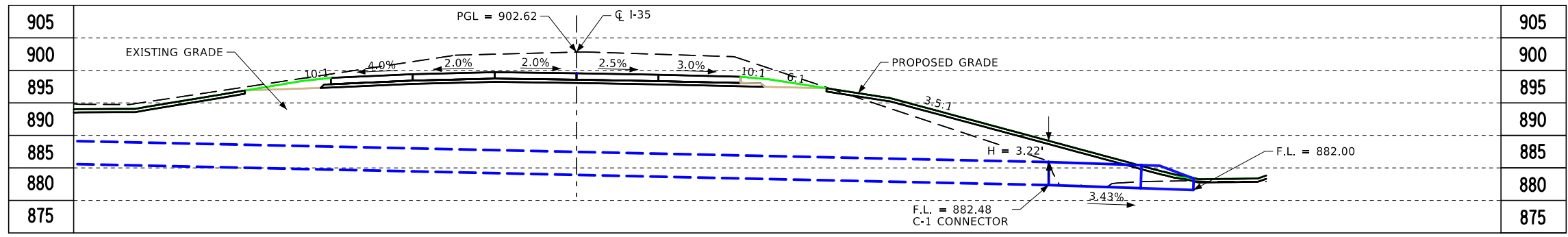

LONGITUDINAL SECTION ALONG \varnothing CULVERT

BM552 NORTHING=518547.27, EASTING=1563747.47,
ELEVATION=840.73
FND RR SPIKE IN FENCE POST, +/-150' E OF I-35

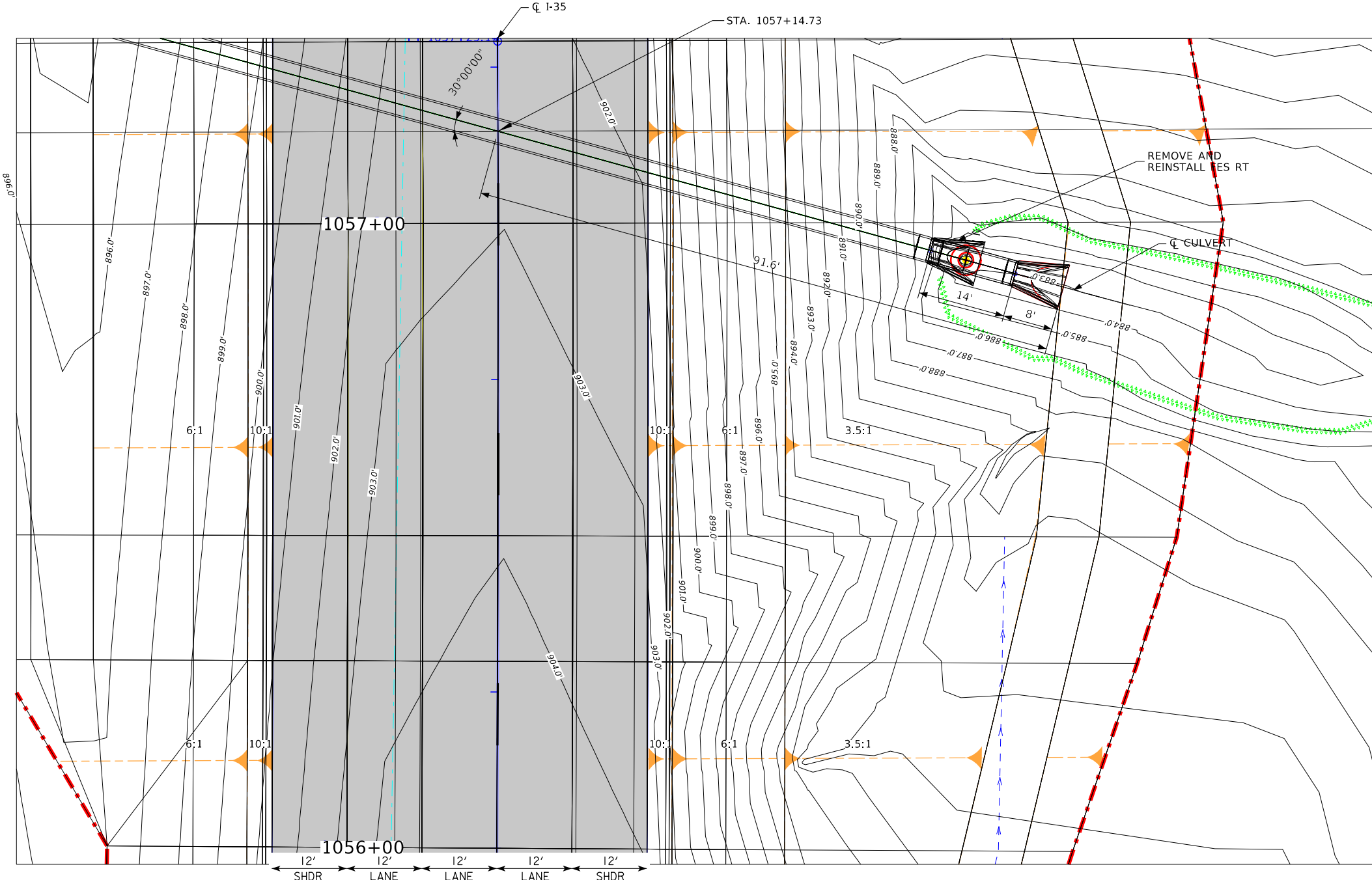

PLAT PLAN

UTILITIES LEGEND:
REFER TO D.I

HYDRAULIC DATA
DRAINAGE AREA = 22 ACRES HILLY
DESIGN DISCHARGE, Q_{50} = X.X CFS
DESIGN HIGH WATER = X.X

LOCATION
I-35
T-77N R-25W
SECTIONS 30
LINN TOWNSHIP
WARREN COUNTY

DESIGN FOR 30° SKEW LT. AHEAD
42" X 14'
REINFORCED CONCRETE PIPE
EXTENSION
PLAT PLAN
STA. 1057+14.73 \varnothing I-35 AUGUST 2022
WARREN COUNTY
IOWA DEPARTMENT OF TRANSPORTATION - HIGHWAY DIVISION
DESIGN SHEET NO. 1 OF 1 FILE NO. XXXXX DESIGN NO. _____

CROSS SECTION VIEW COLOR LEGEND

Design Color No.	Feature	Design Color No.	Feature
Aggregate			
(64)	Choke Stone	(112)	Noise Wall
(42)	Engineering Fabric	(112)	Noise Wall Footing
(8)	Flooded Backfill	(112)	Retaining Wall Back
(92)	Macadam Stone	(112)	Retaining Wall Back Excavate
(20)	Modified	(112)	Retaining Wall Face
(12)	Plowing Shaping	(112)	Retaining Wall Front Excavate
(14)	Porous Backfill	(112)	Retaining Wall Front Footing
(8)	Revetment Class A	(112)	Retaining Wall MSE Gutter
(6)	Revetment Class B	(112)	Retaining Wall Reinforced Earth
(62)	Revetment Class C		
(188)	Revetment Class D	Grading	
(28)	Revetment Class E	(8)	Behind Curb Cut
(12)	Shoulder Special Backfill	(6)	Granular
(12)	Special Backfill	(13)	Granular Back Fill
(20)	Subbase	(48)	Rock Undercut
(20)	Subbase Lower	(8)	Shoulder Earth Fill
(20)	Subbase Upper	(2)	Side Slopes
(118)	Subgrade Treatment	(226)	Side Slopes Dressing
Asphalt			
(207)	HMA Base Course	Substrata	
(207)	HMA Interim Course	(128)	Boulder Substrata
(207)	HMA Surface Course	(48)	Broken Weathered Substrata
Concrete			
(0)	Barrier Concrete	(3)	Core Out Substrata
(0)	Barrier Concrete Footing	(203)	Existing Pavement Substrata
(0)	Curb Gutter	(6)	Loam Substrata
(48)	Flowable Mortar	(80)	Rock Substrata
(0)	Median Concrete	(4)	Select Sand Substrata
(0)	PCC Pavement	(3)	Shale Substrata
(0)	Sidewalk	(10)	Topsoil Substrata
Shoulder			
(209)	Shoulder HMA	Unsuitable / Waste	
(0)	Shoulder PCC	(3)	Unsuitable Type A
(6)	Shoulder Granular	(13)	Unsuitable Type B
		(11)	Unsuitable Type C
		(3)	Waste
Existing			
(0)	Existing Pavement		

NOTES:

Text

NOTES:

Text

CROSS SECTIONS LEGEND AND INFORMATION SHEET

(COVERS SHEET SERIES W, X, Y, & Z)

ML - I35 NB

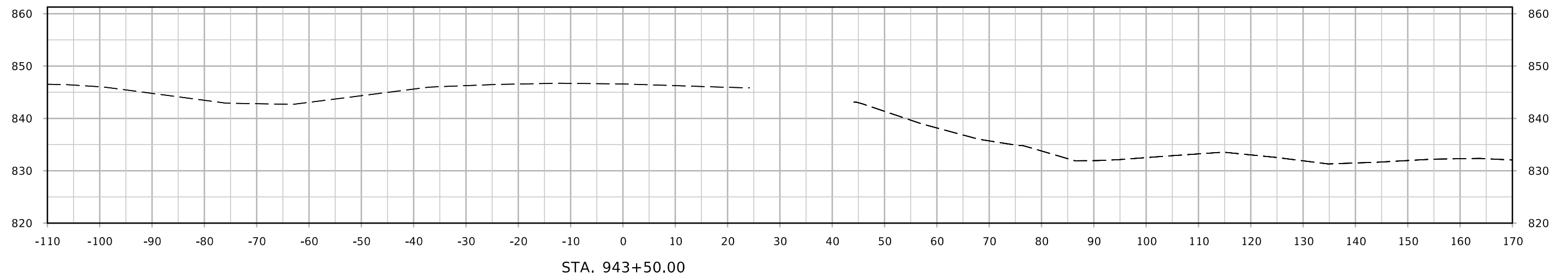
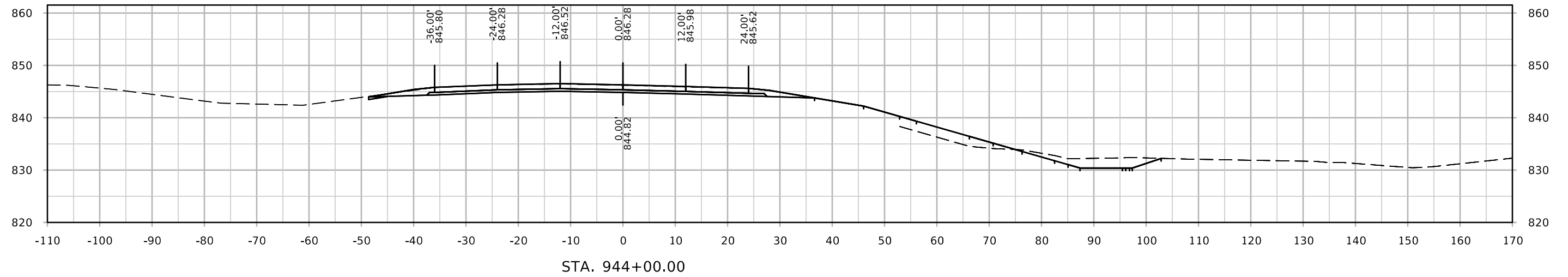
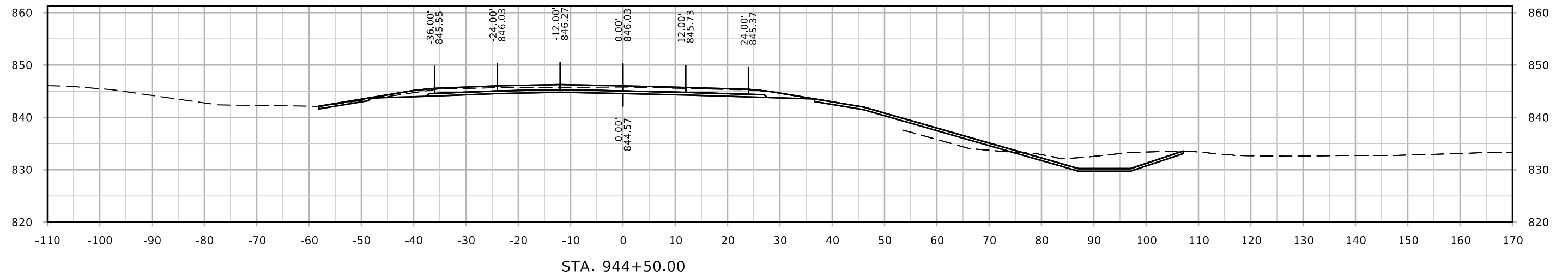

ML - I35 NB

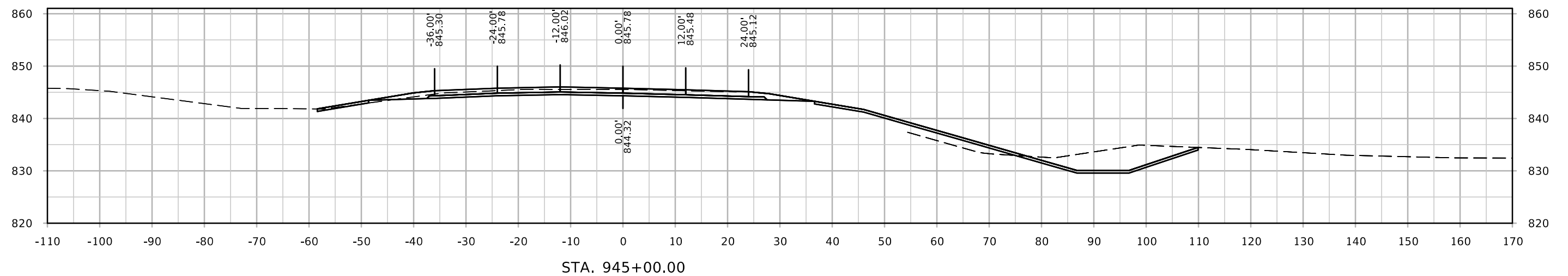
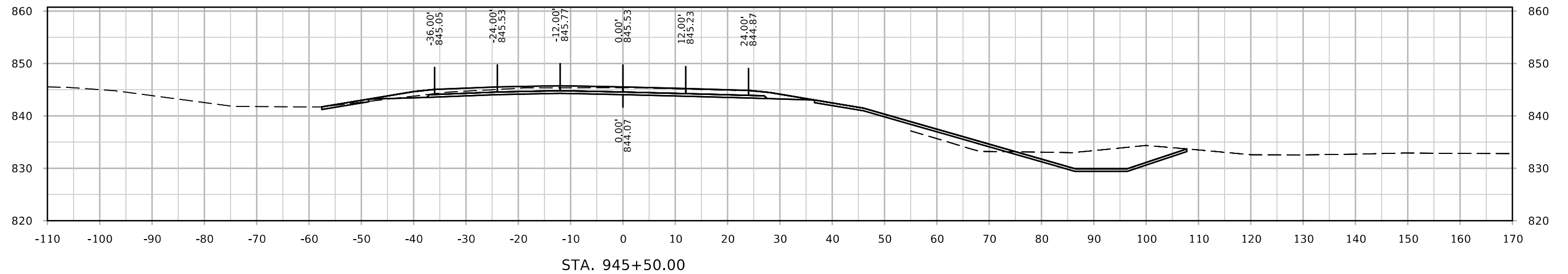
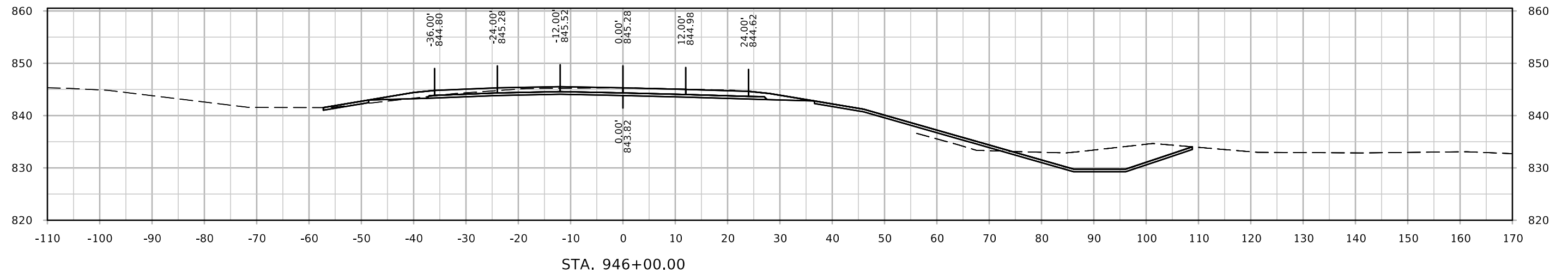

ML - I35 NB

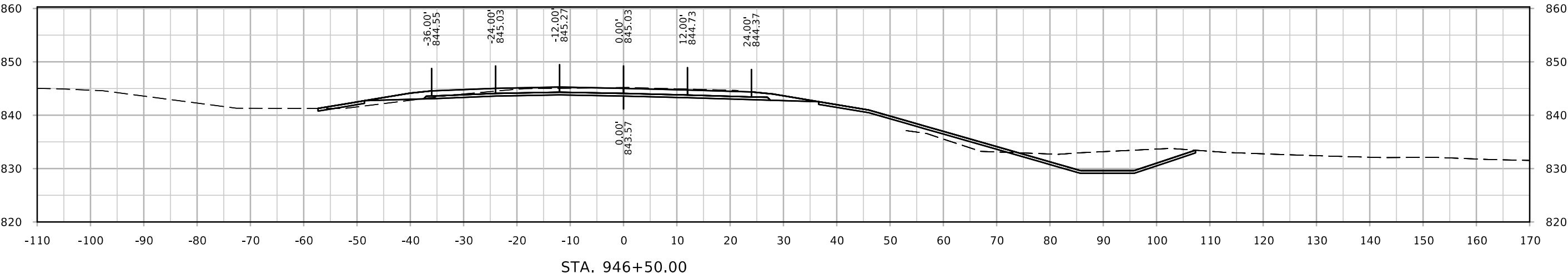
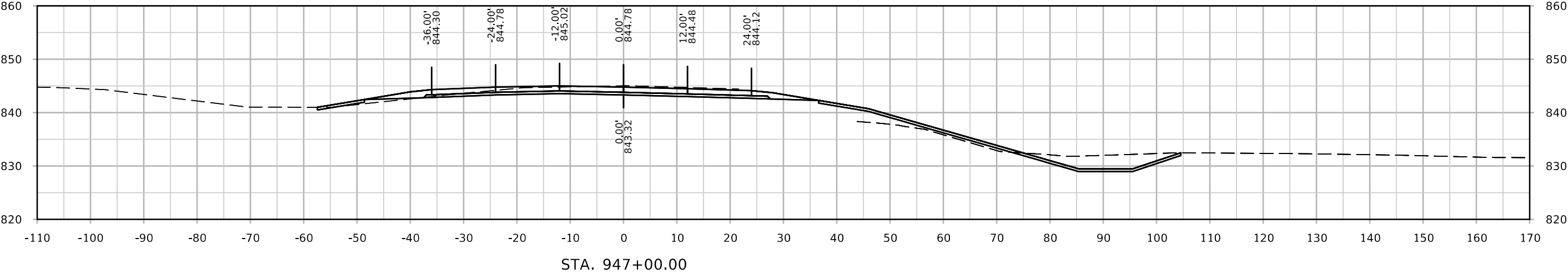
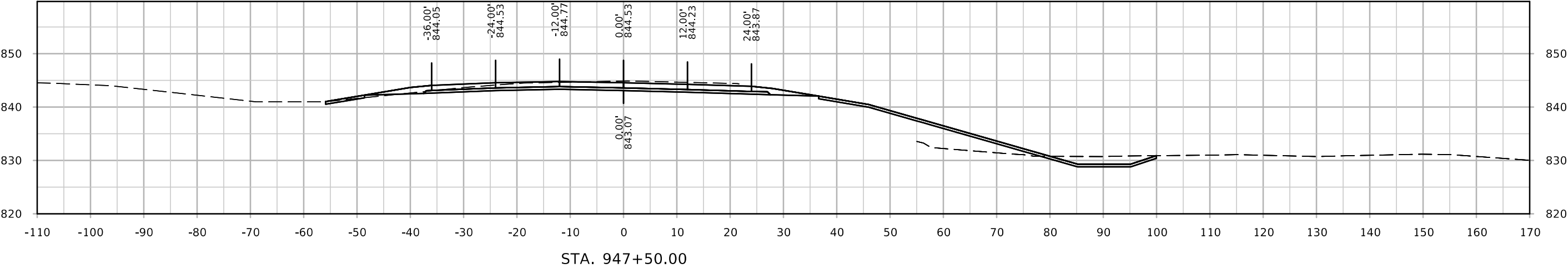

ML - I35 NB

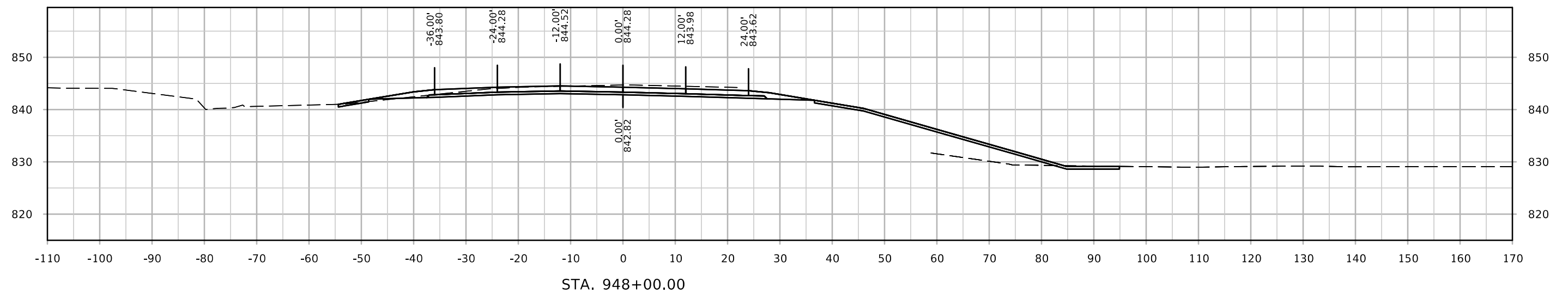
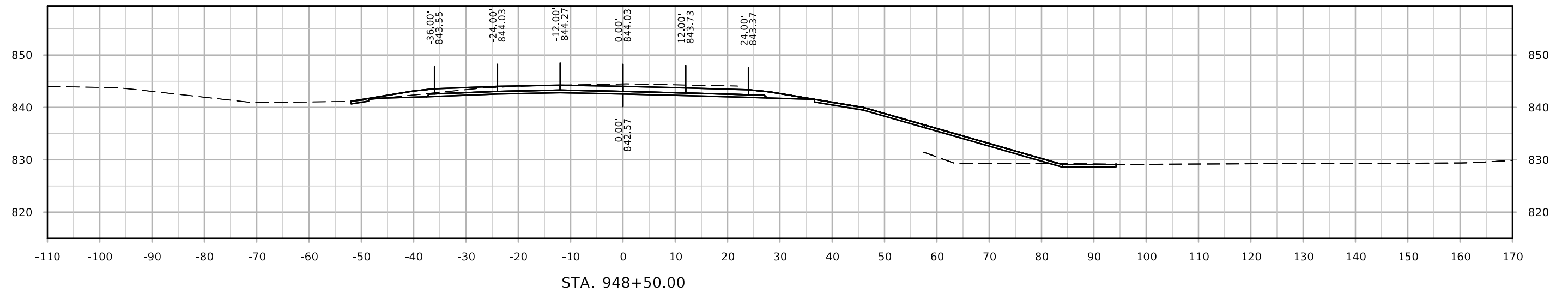
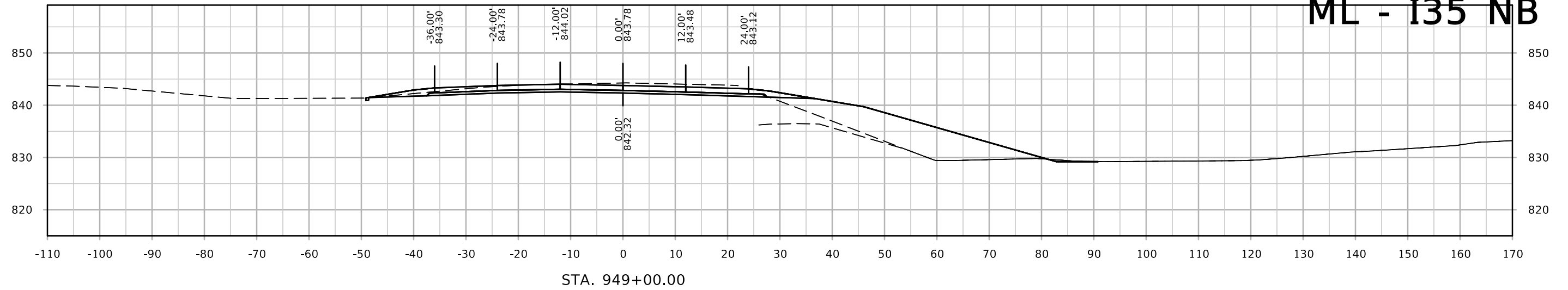

ML - I35 NB

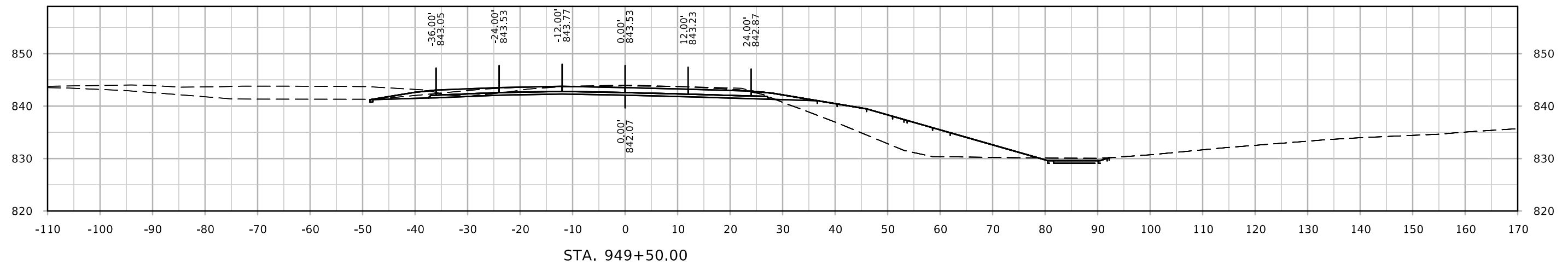
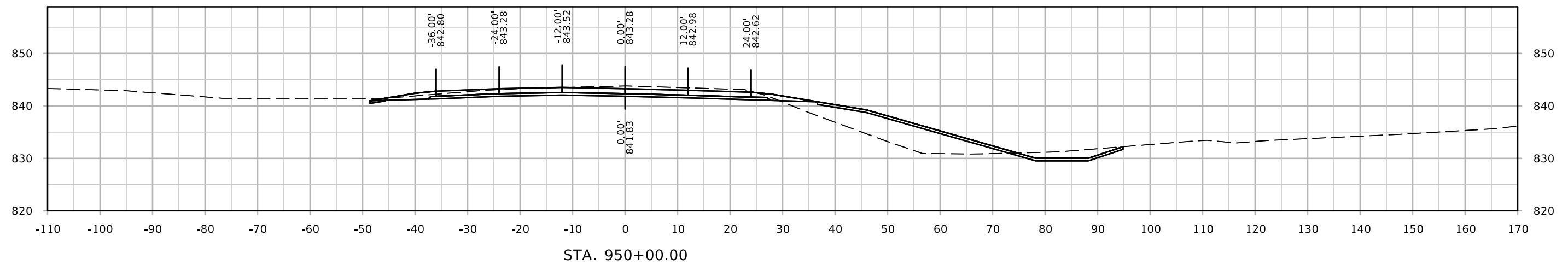
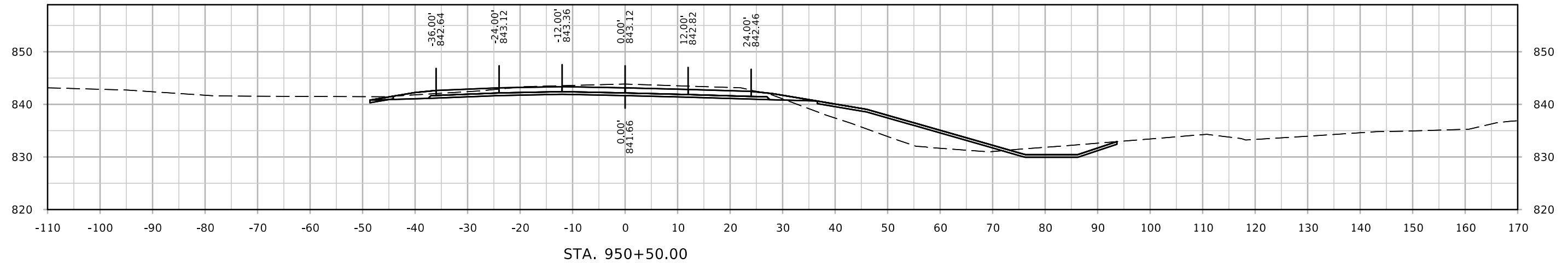

ML - I35 NB

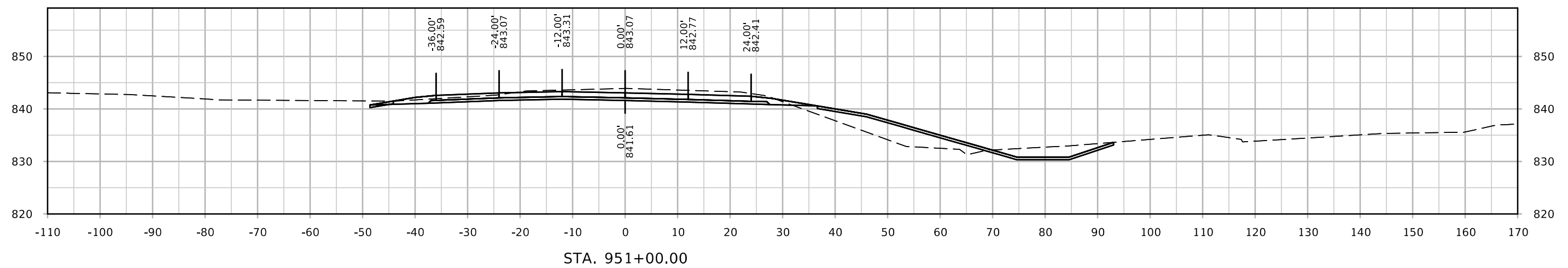
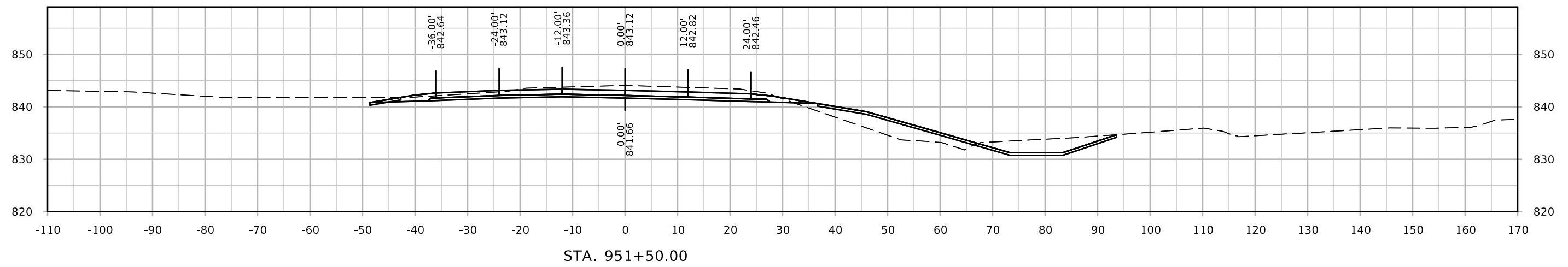
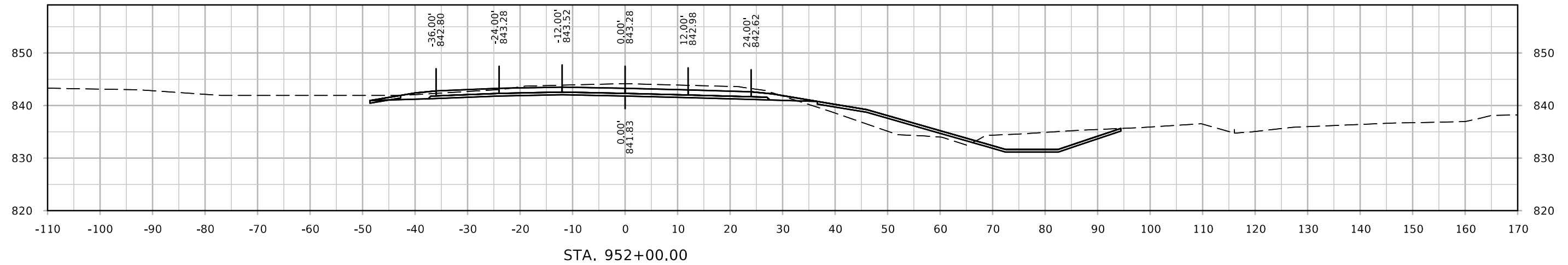

ML - I35 NB

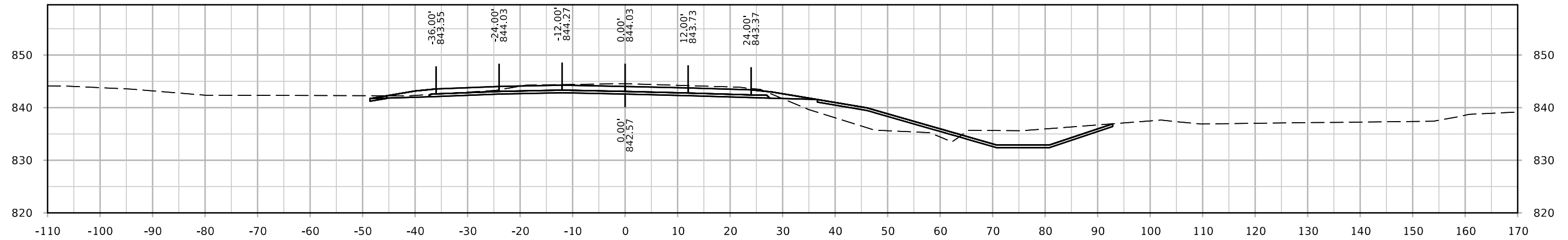

STA. 953+50.00

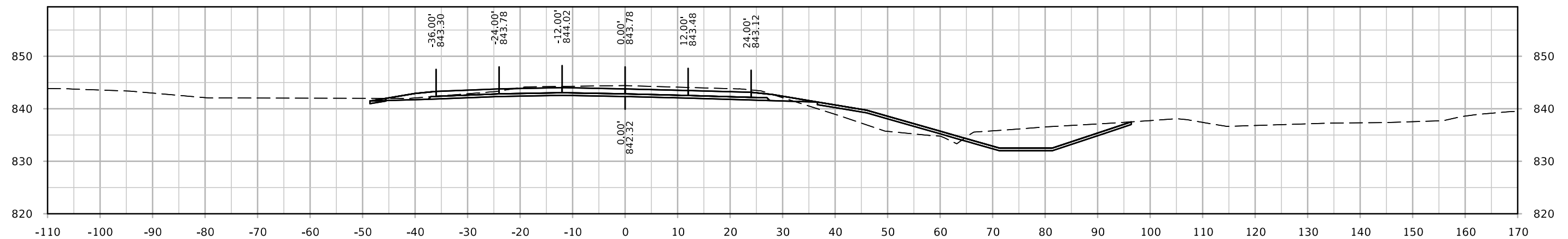

STA. 953+00.00

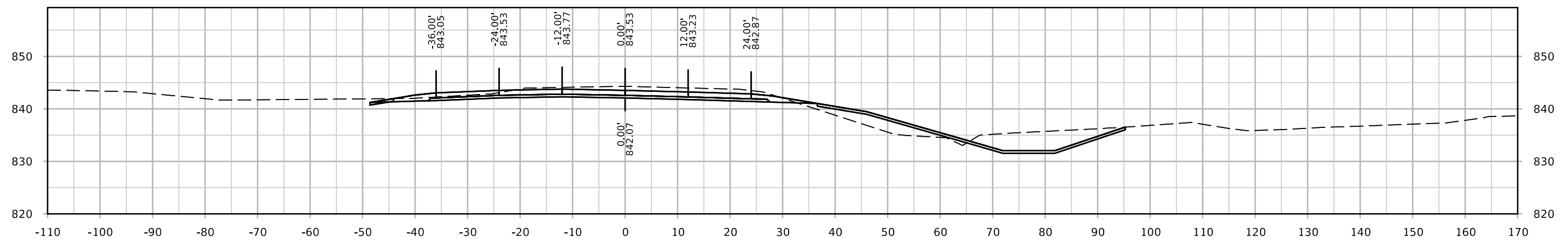

STA. 952+50.00

ML - I35 NB

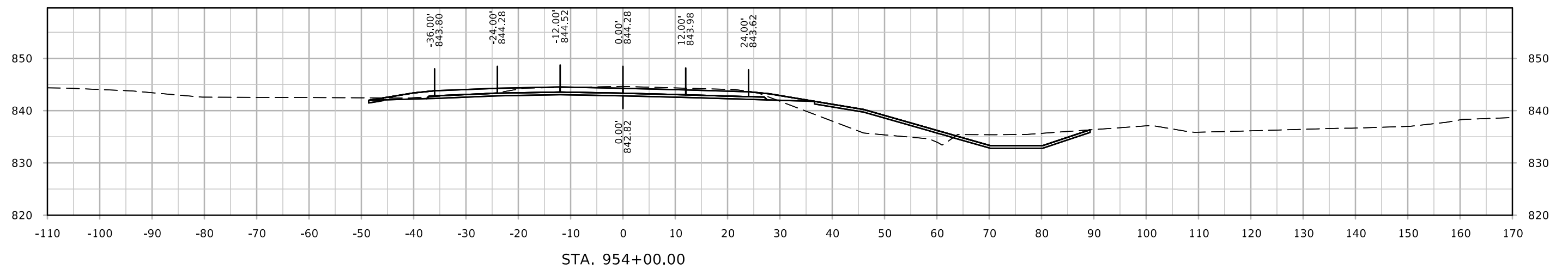
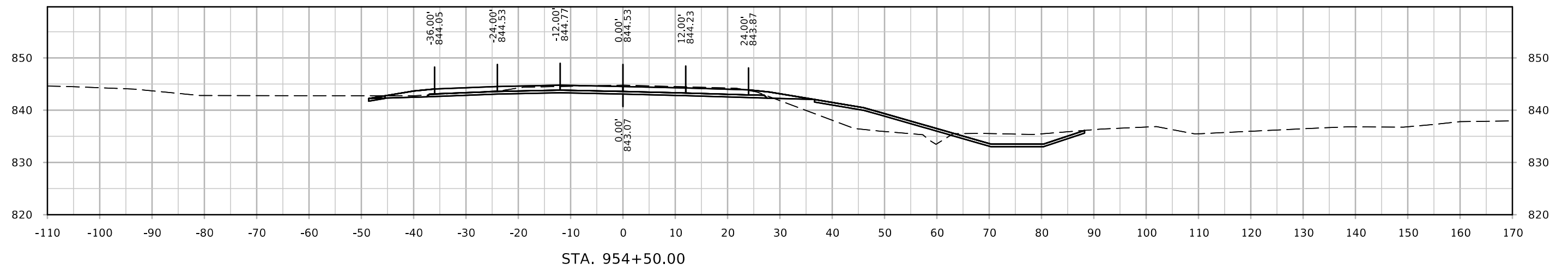
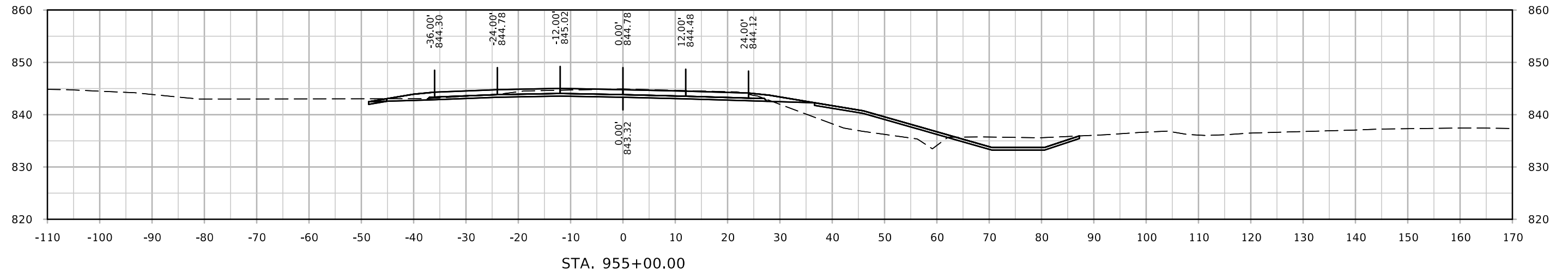

ML - I35 NB

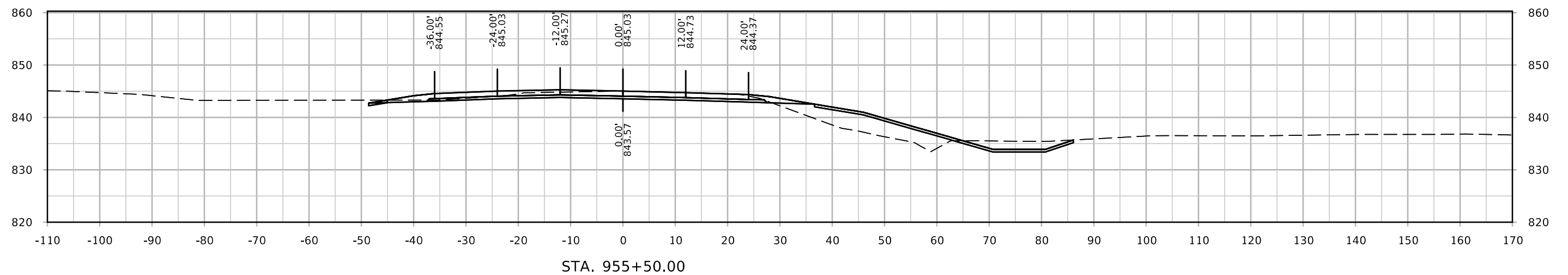
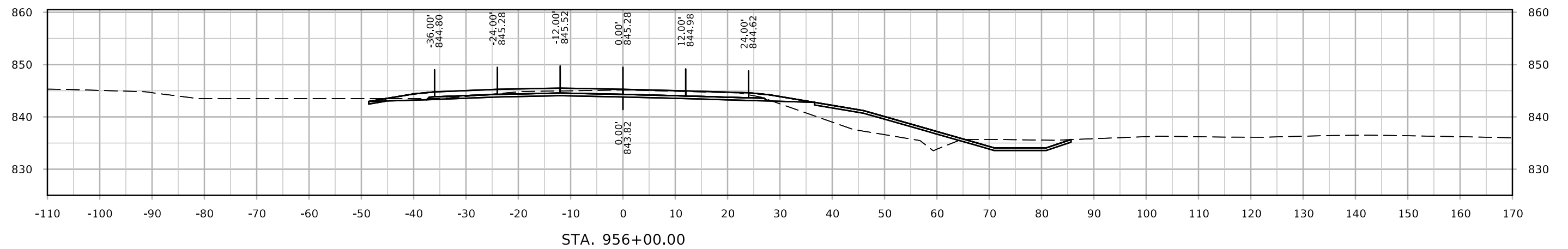
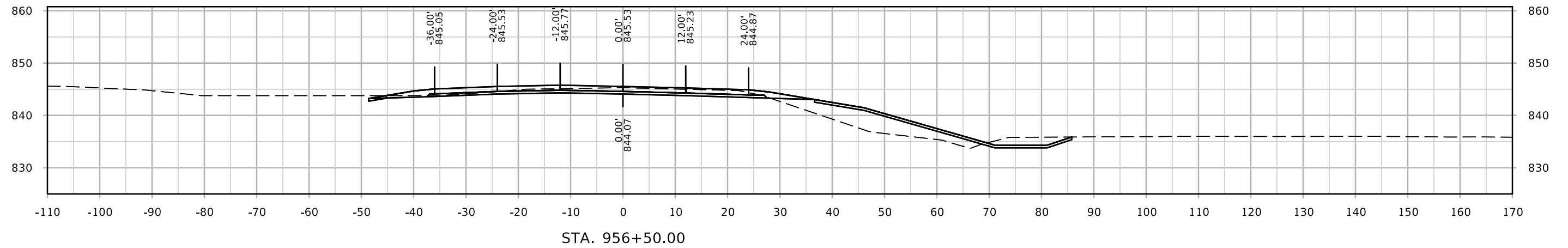

ML - I35 NB

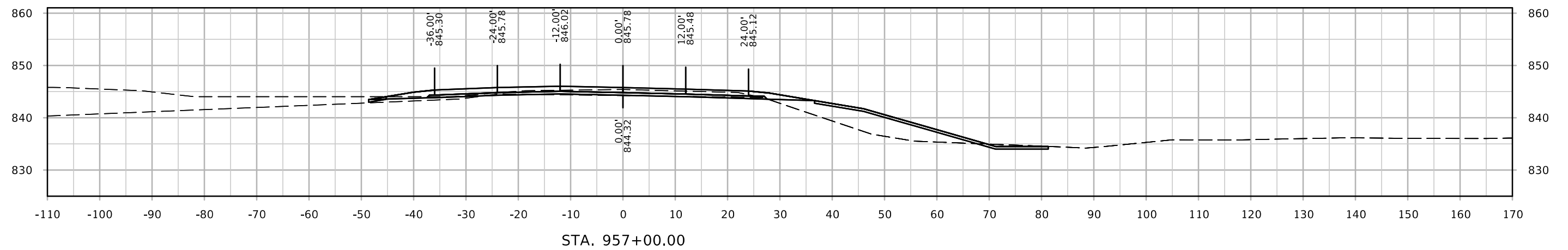
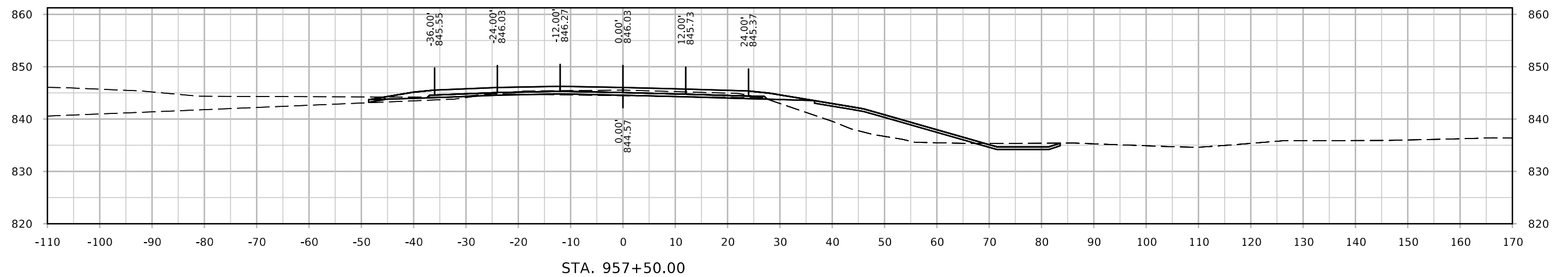
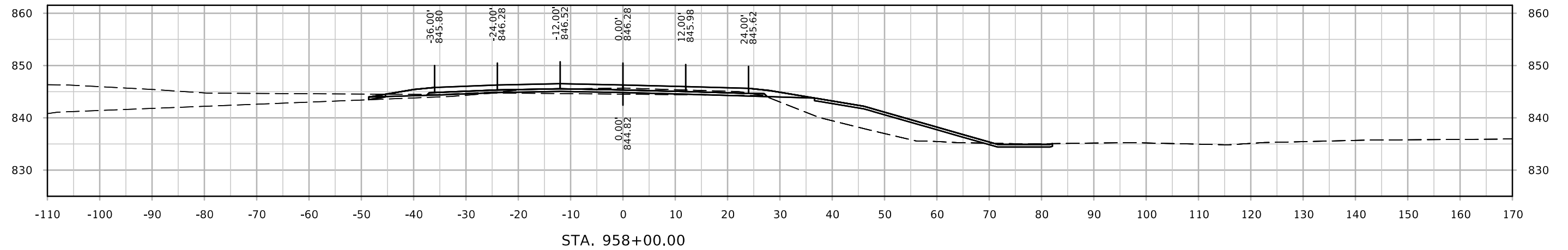

ML - I35 NB

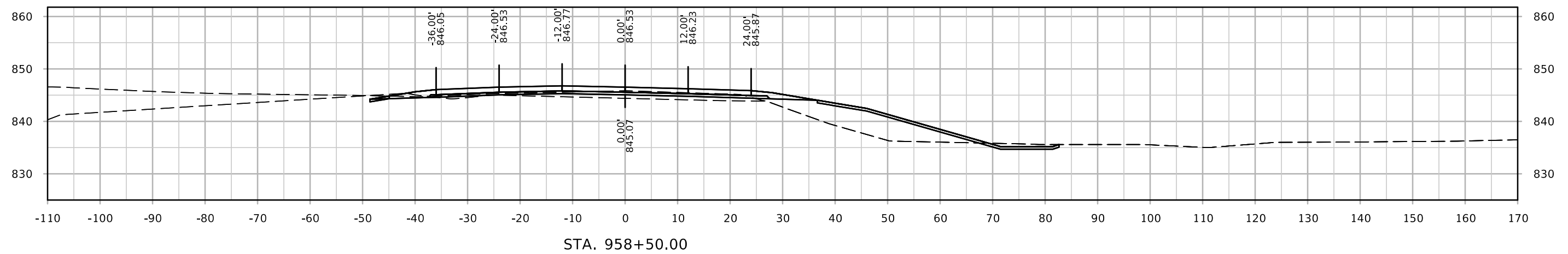
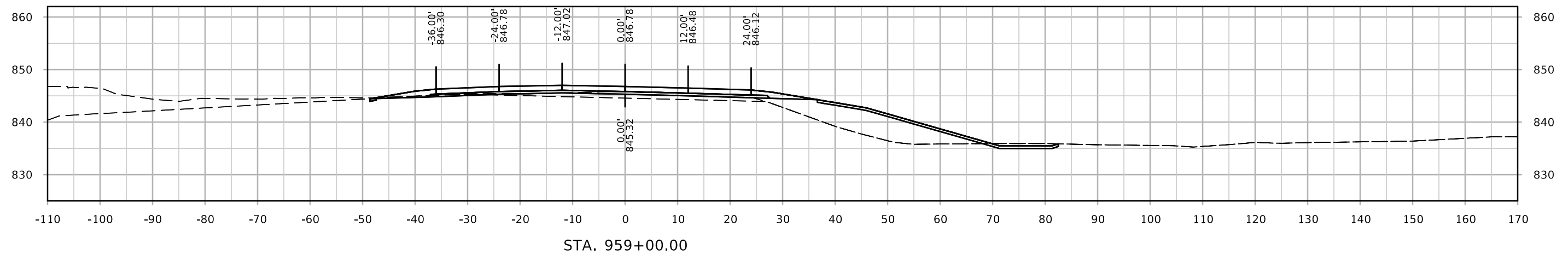
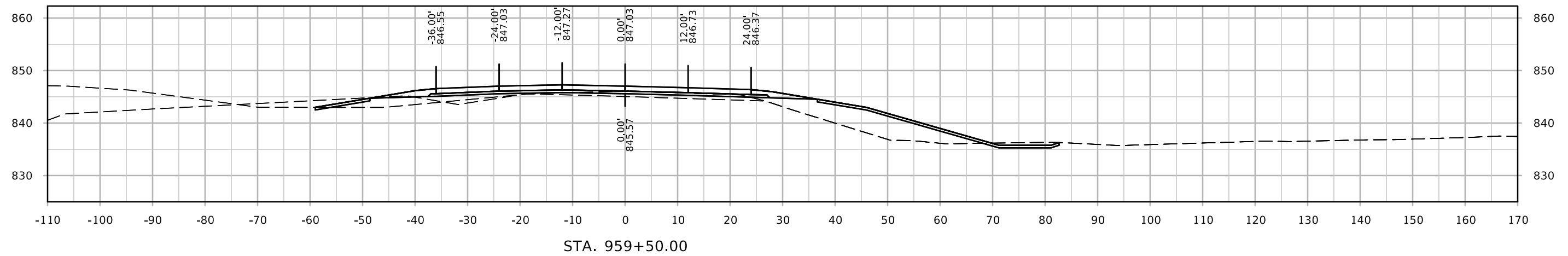

ML - I35 NB

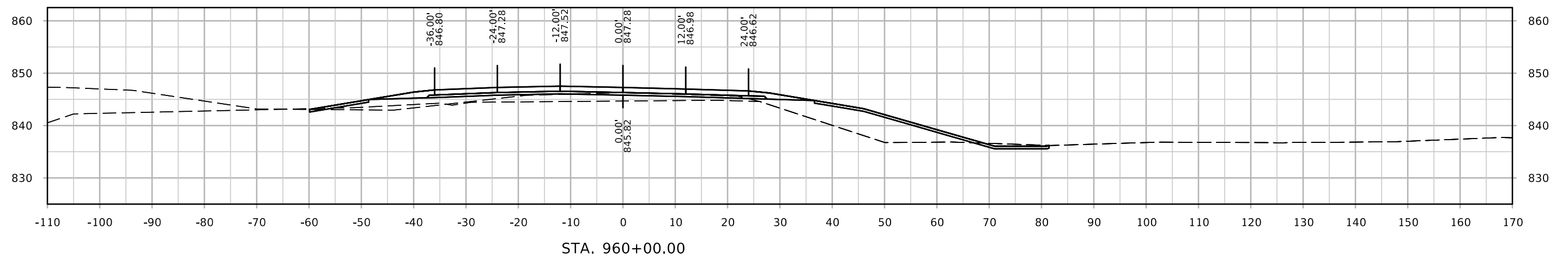
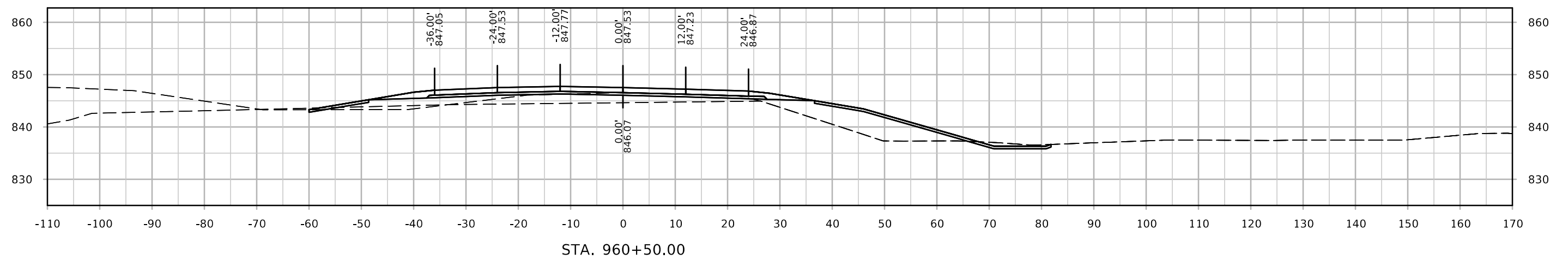
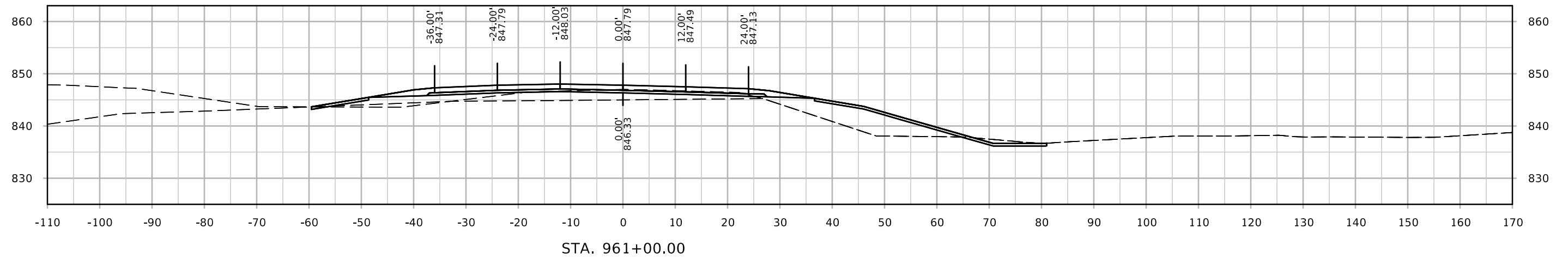

ML - I35 NB

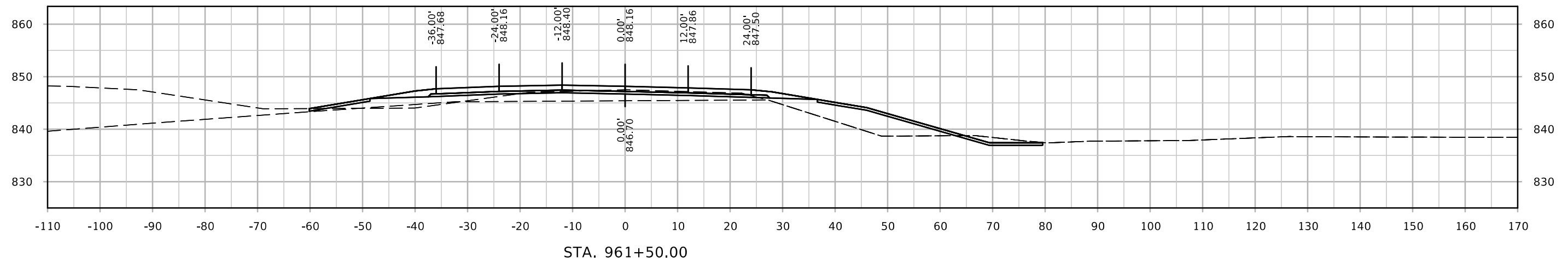
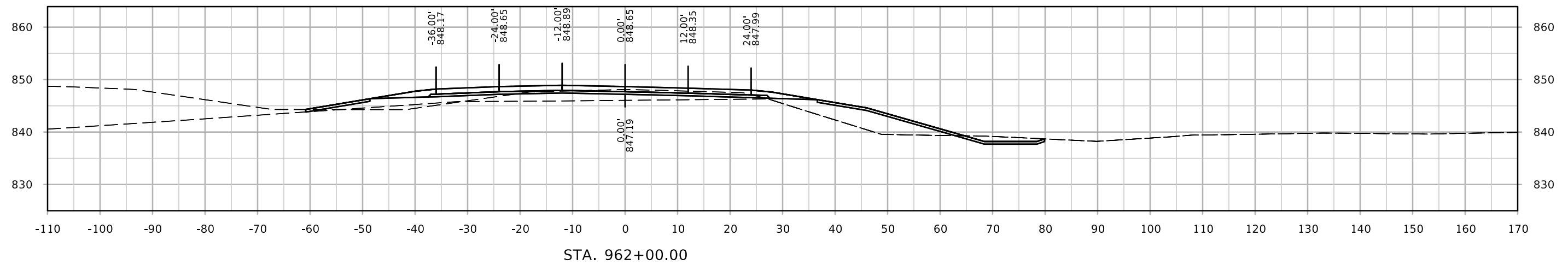
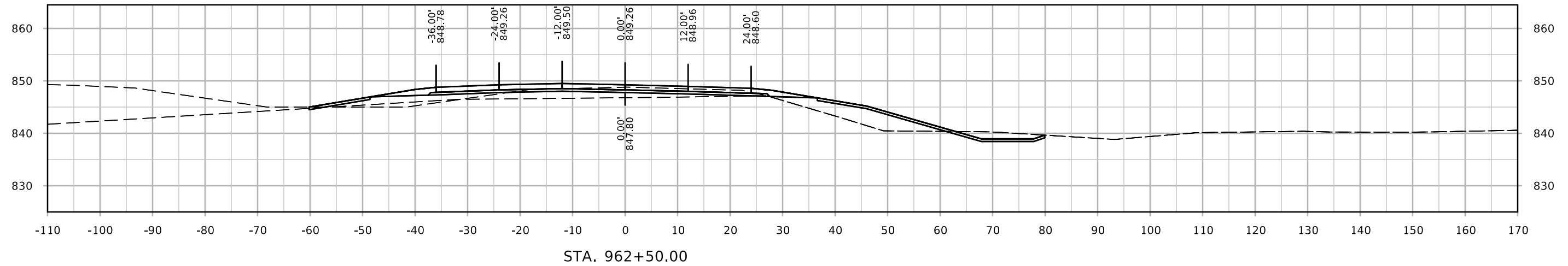

ML - I35 NB

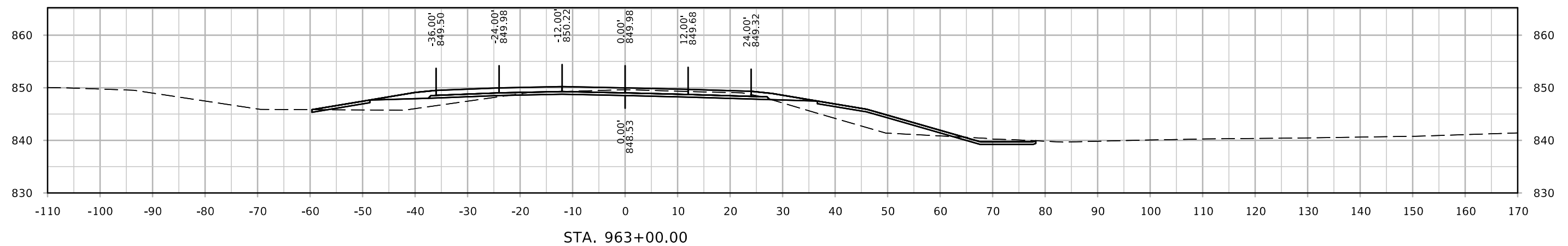
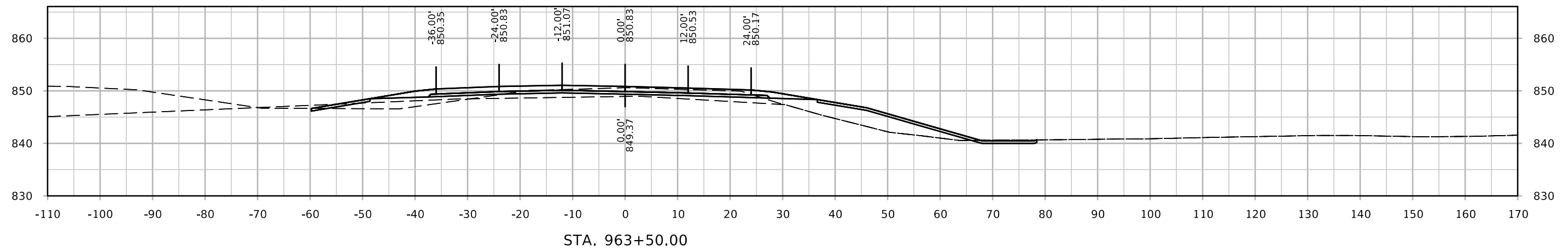
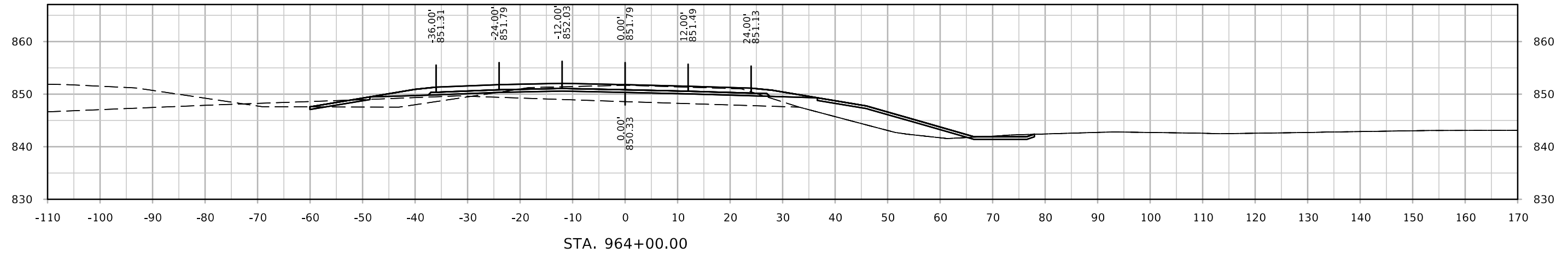

ML - I35 NB

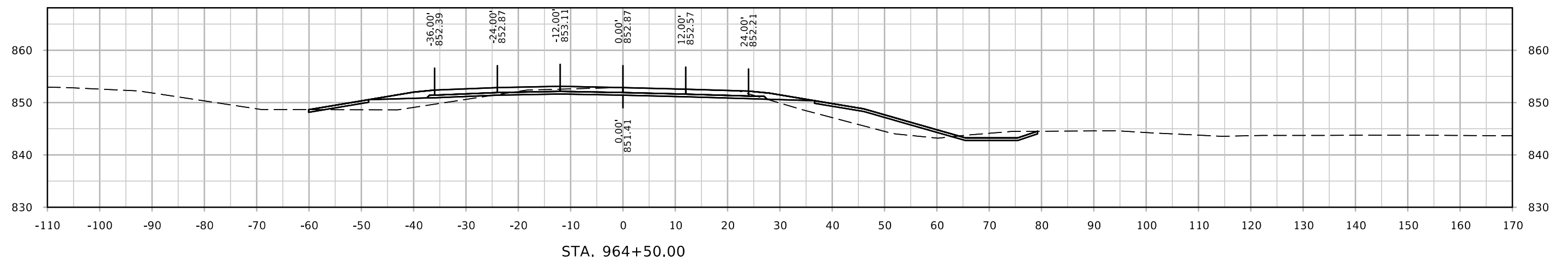
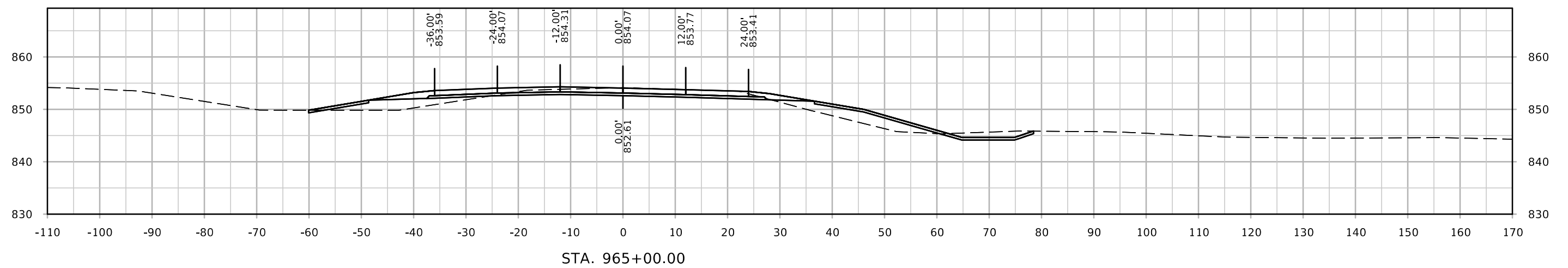
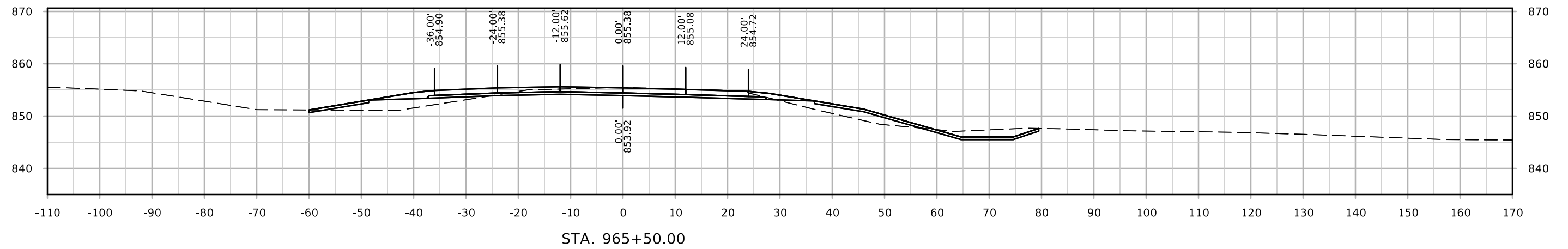

ML - I35 NB

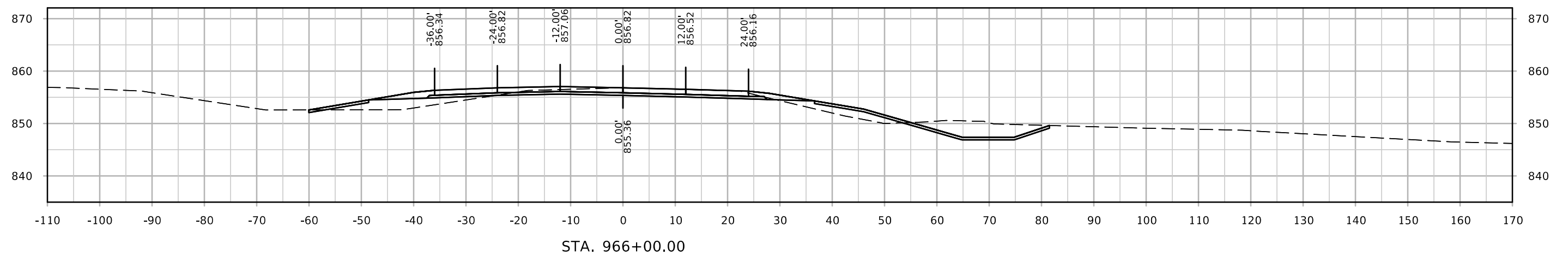
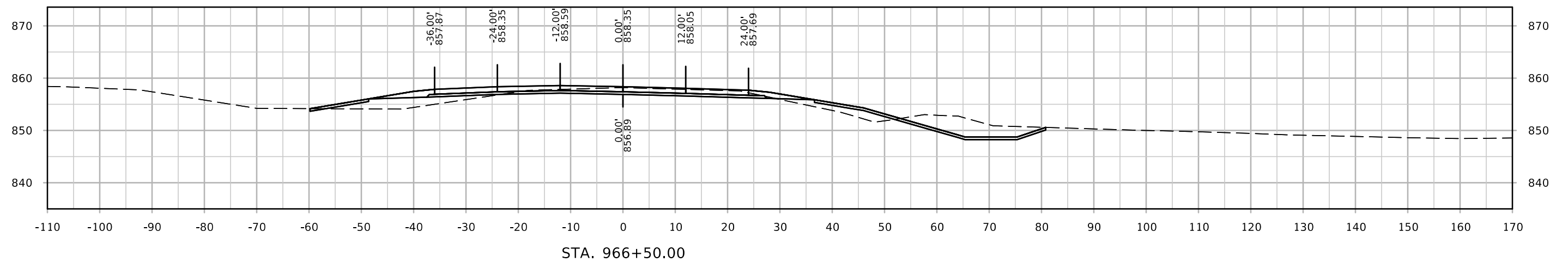
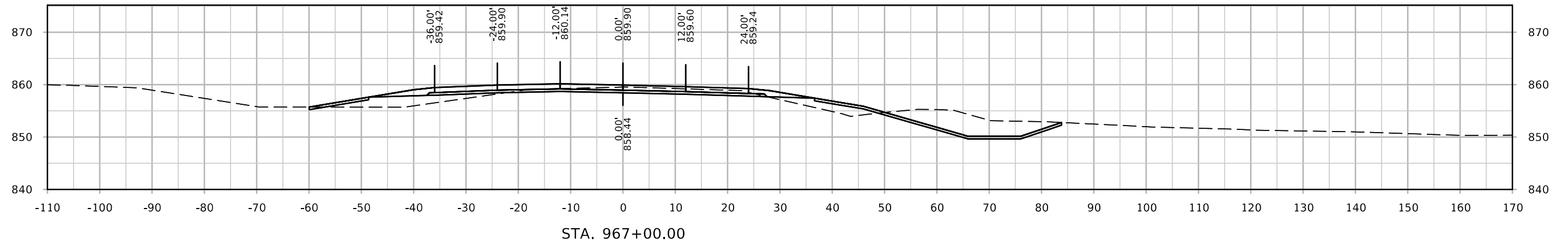

ML - I35 NB

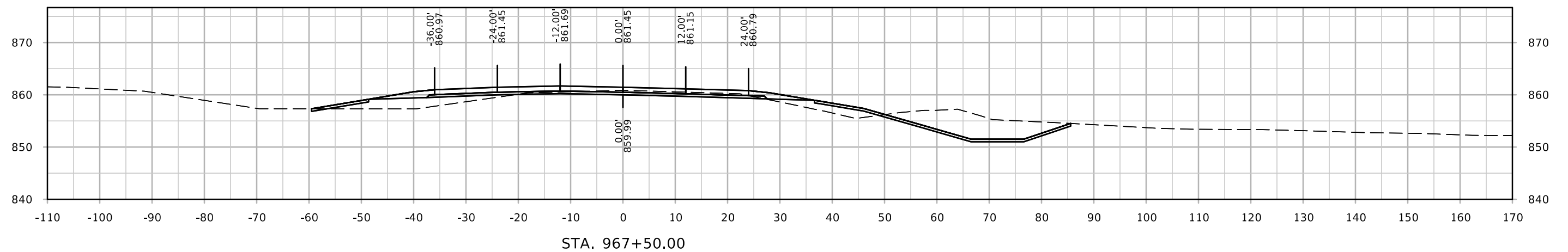
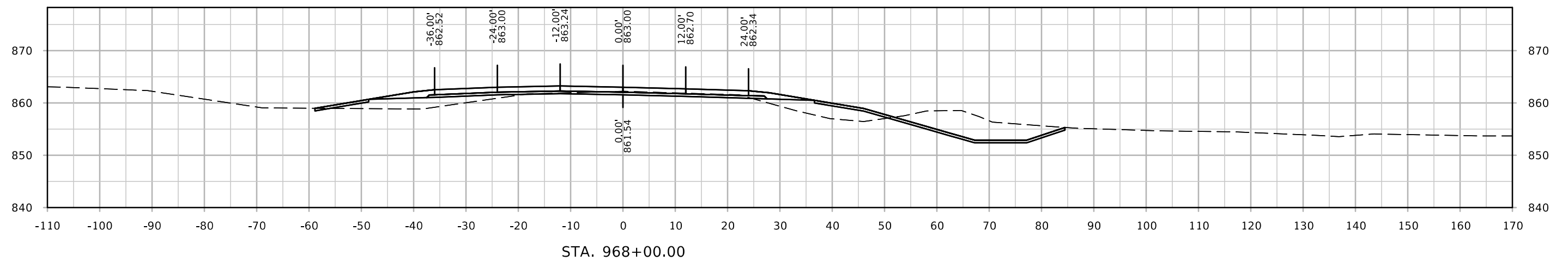
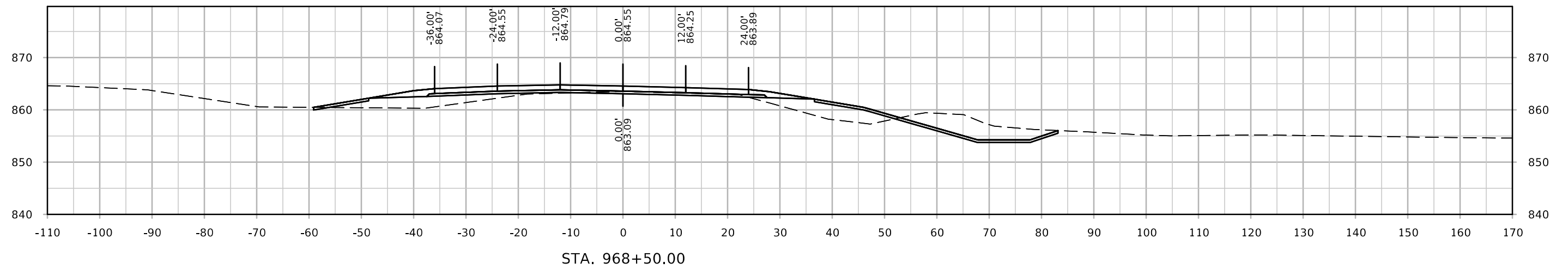

ML - I35 NB

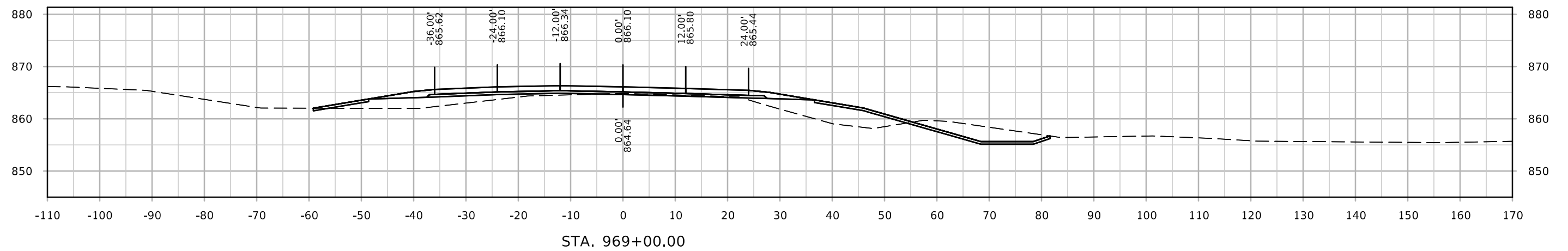
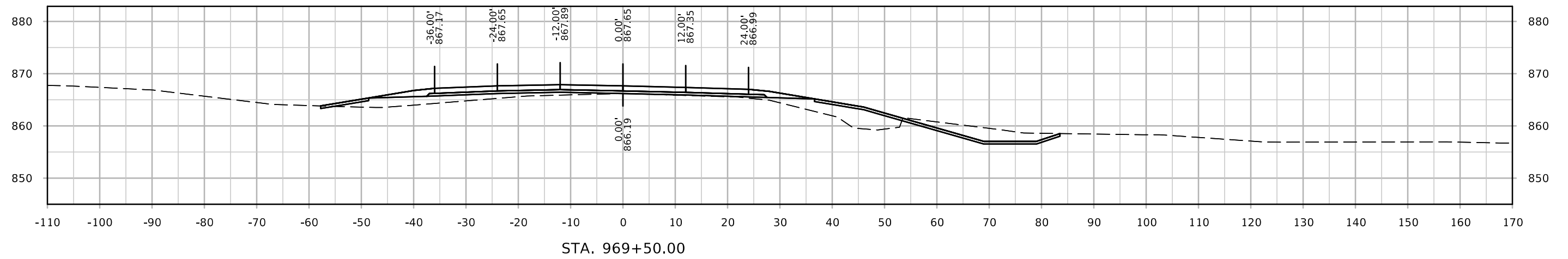
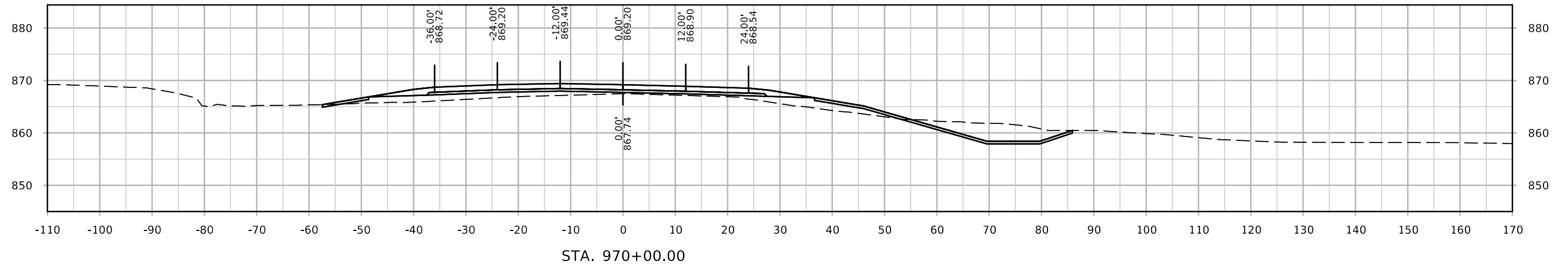

ML - I35 NB

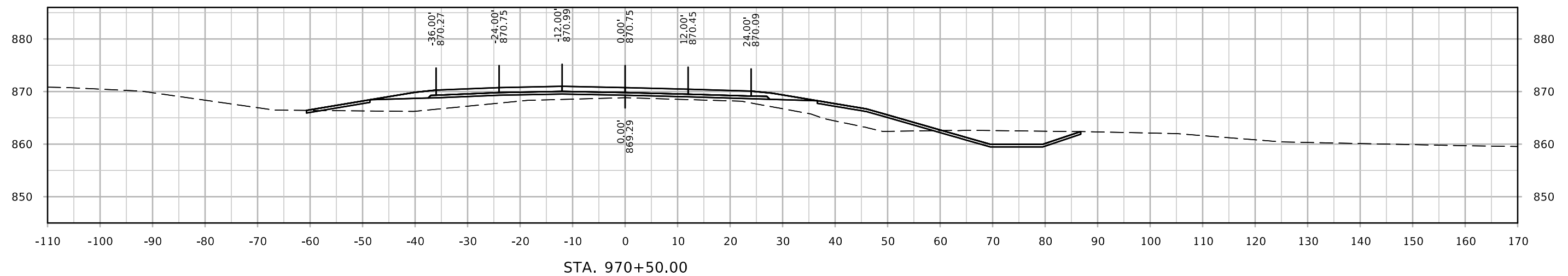
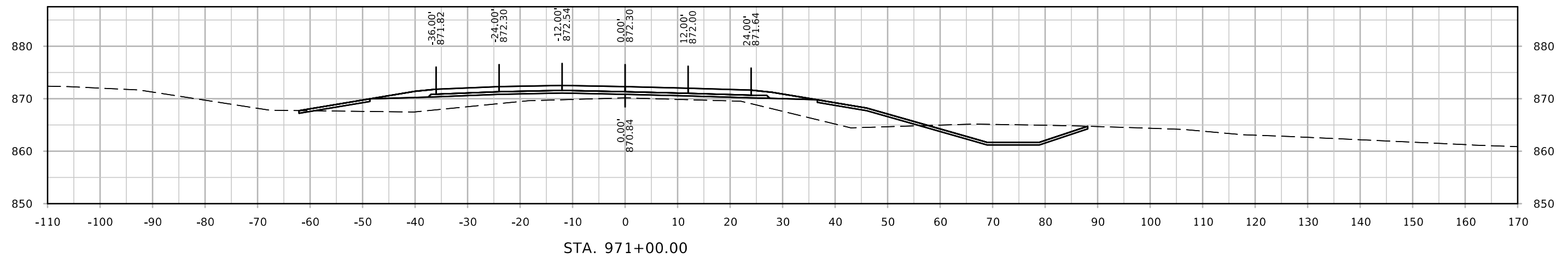
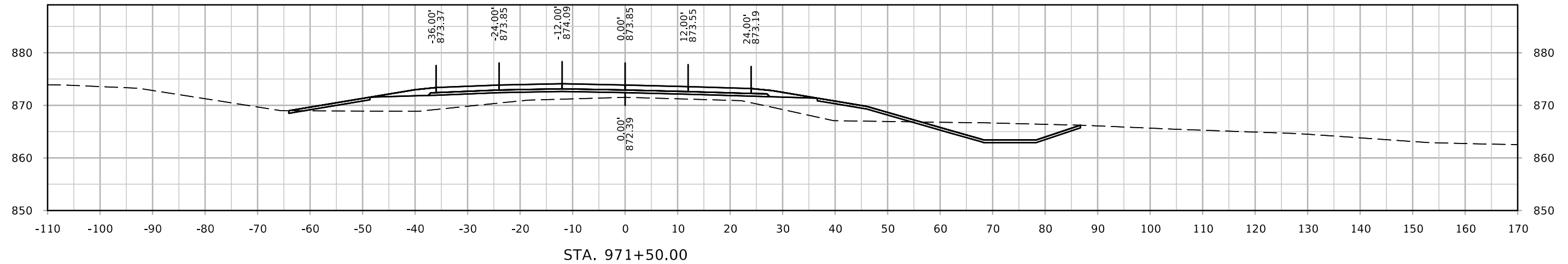

ML - I35 NB

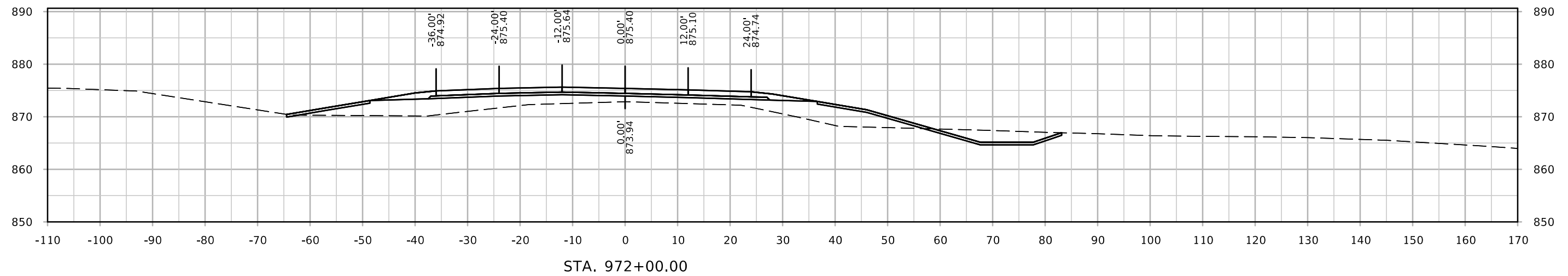
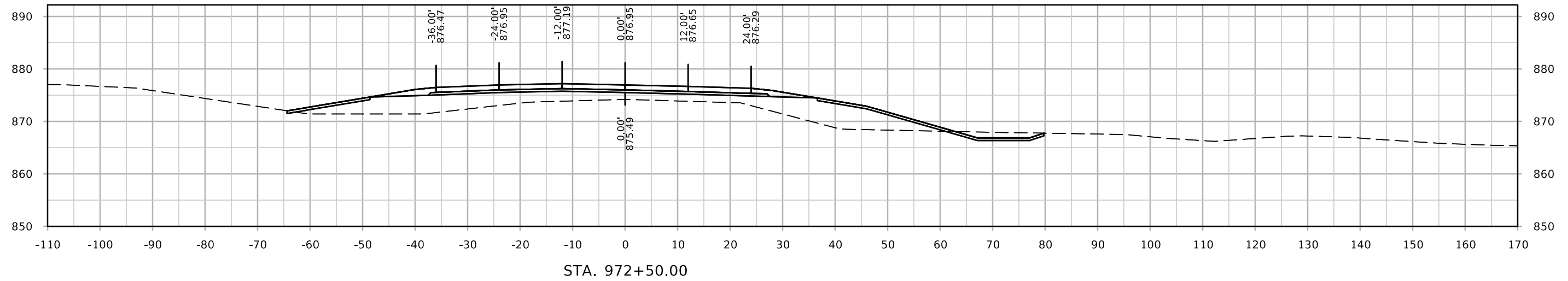
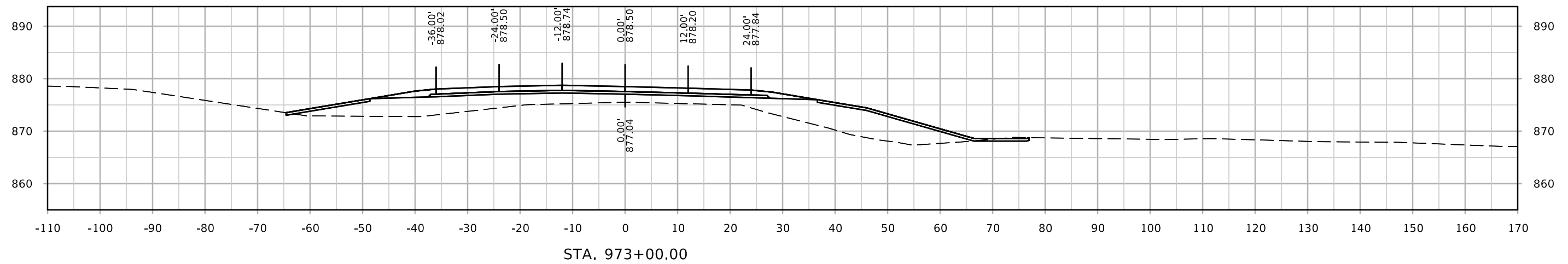

ML - I35 NB

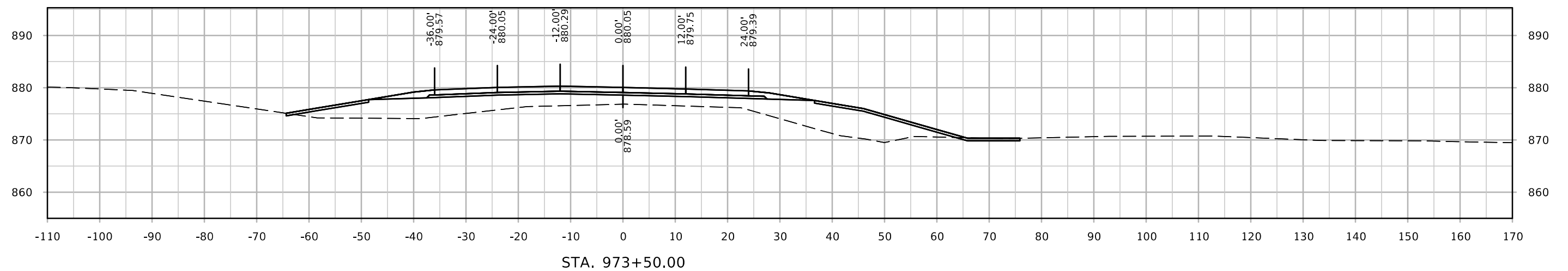
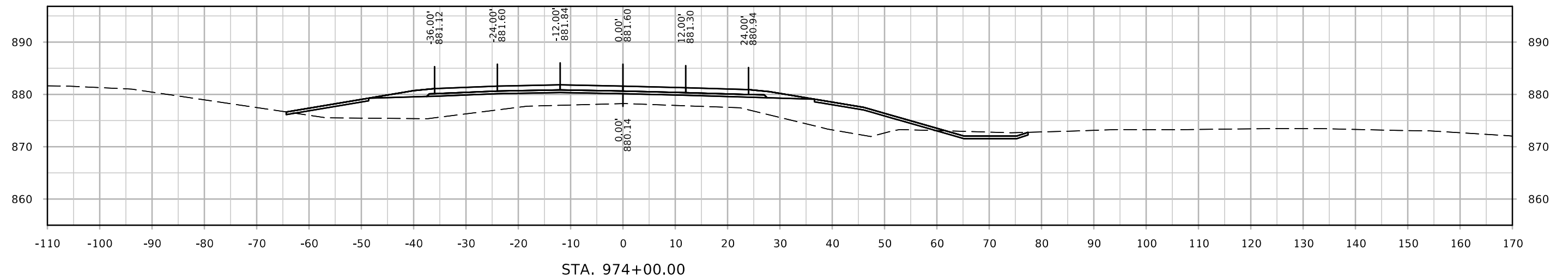
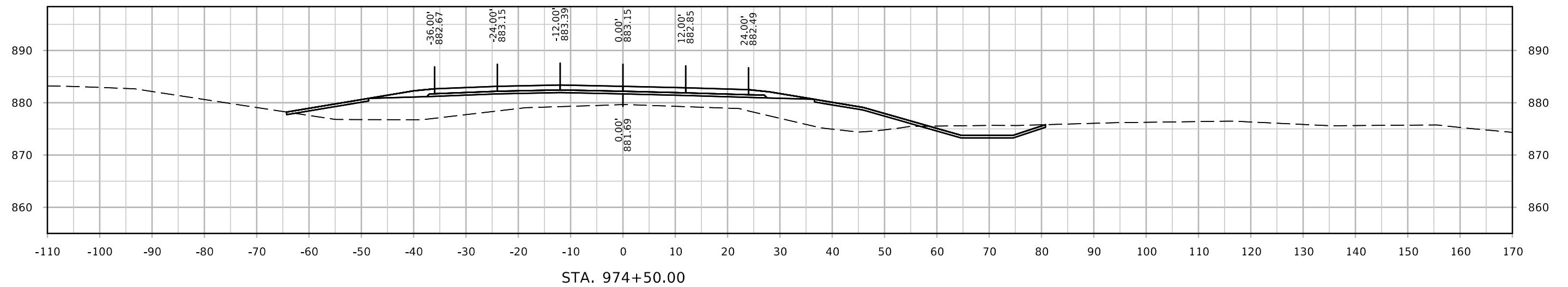

ML - I35 NB

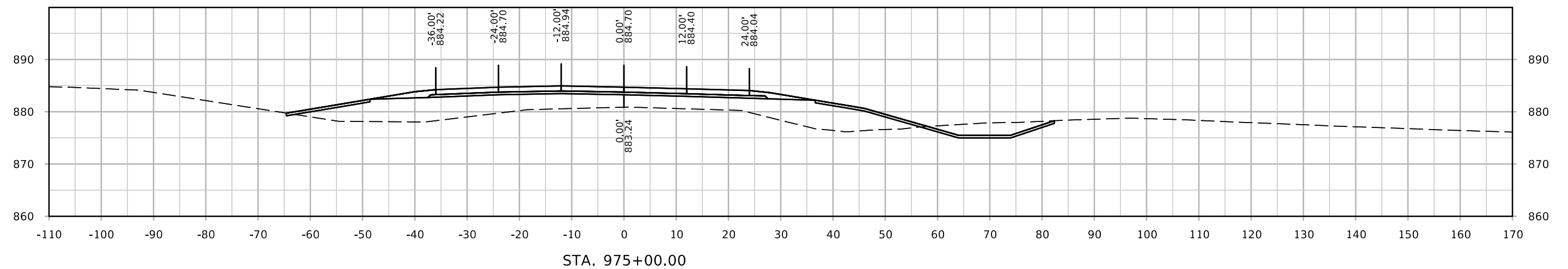
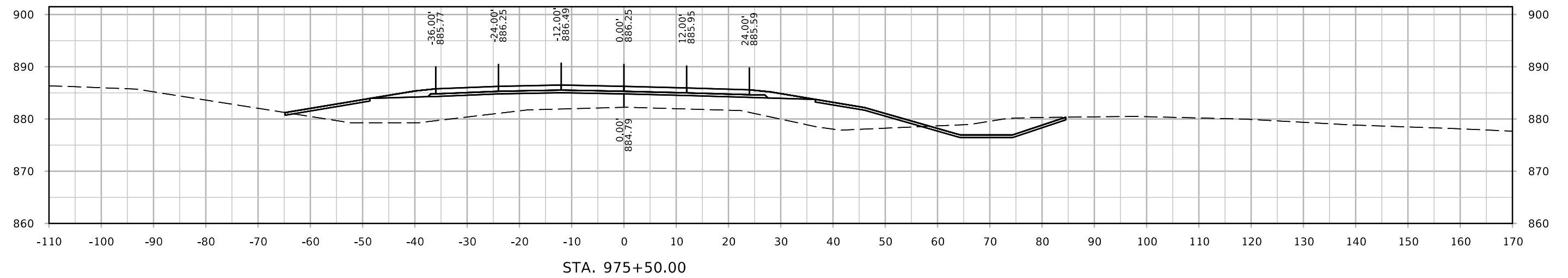
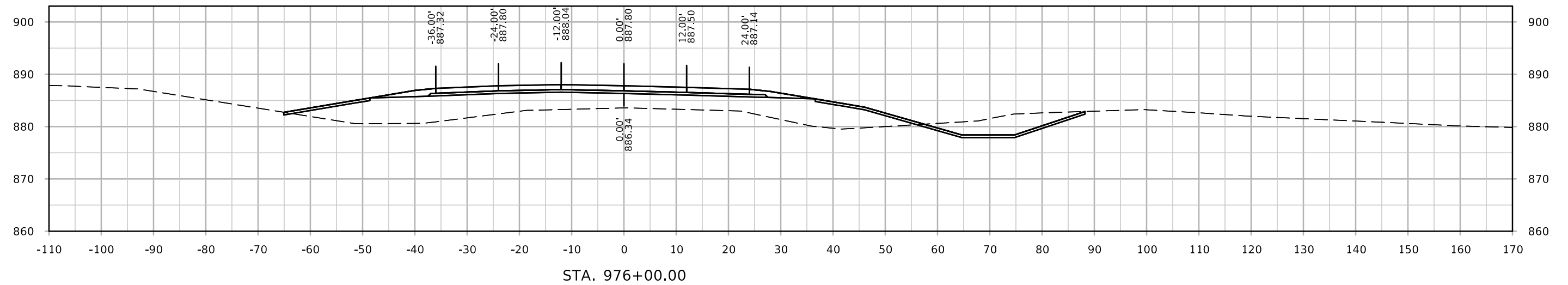

ML - I35 NB

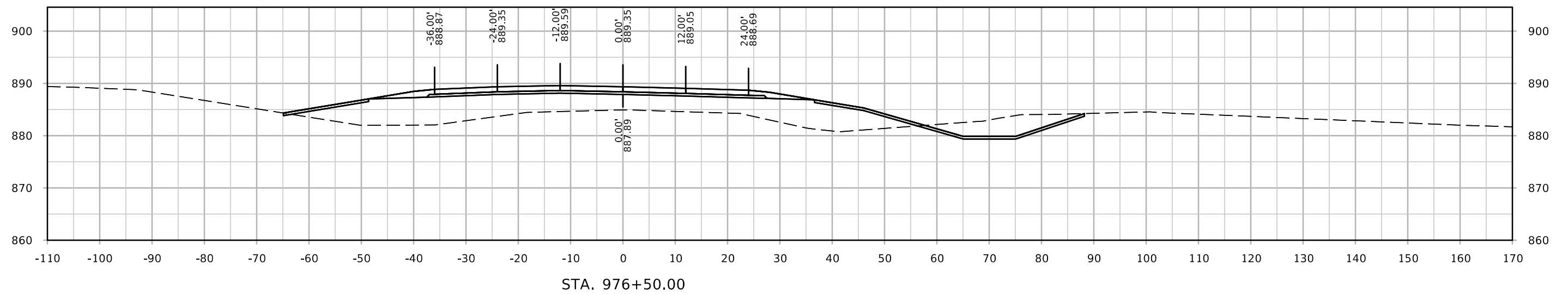
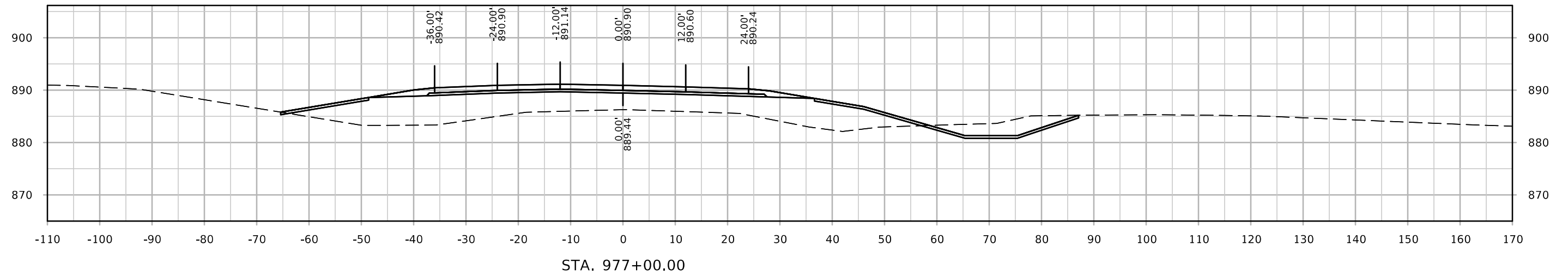
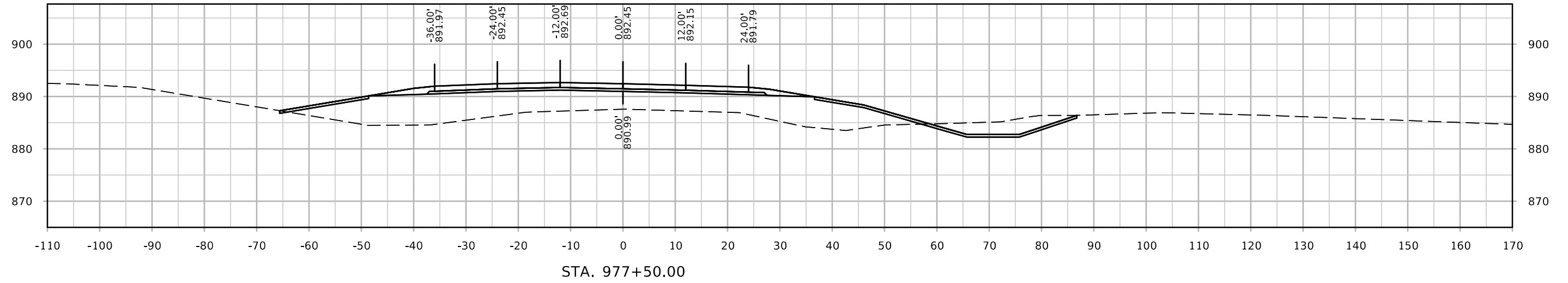

ML - I35 NB

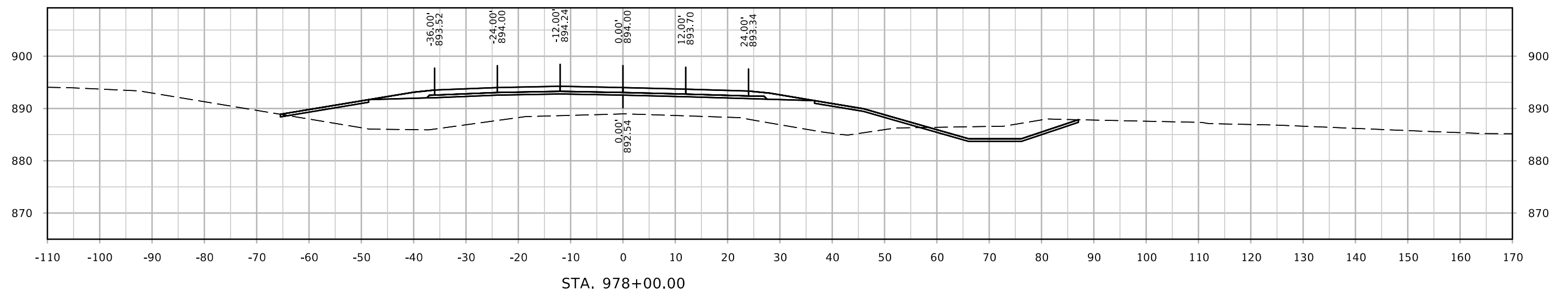
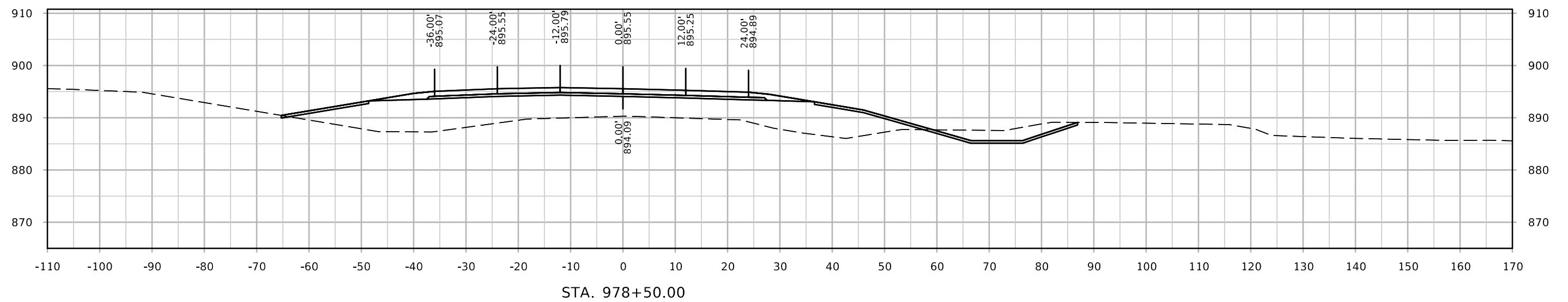

ML - I35 NB

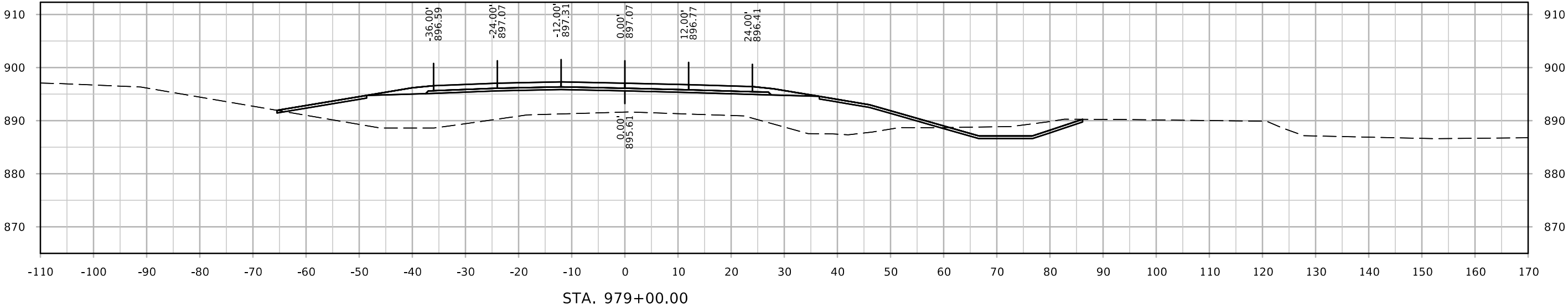
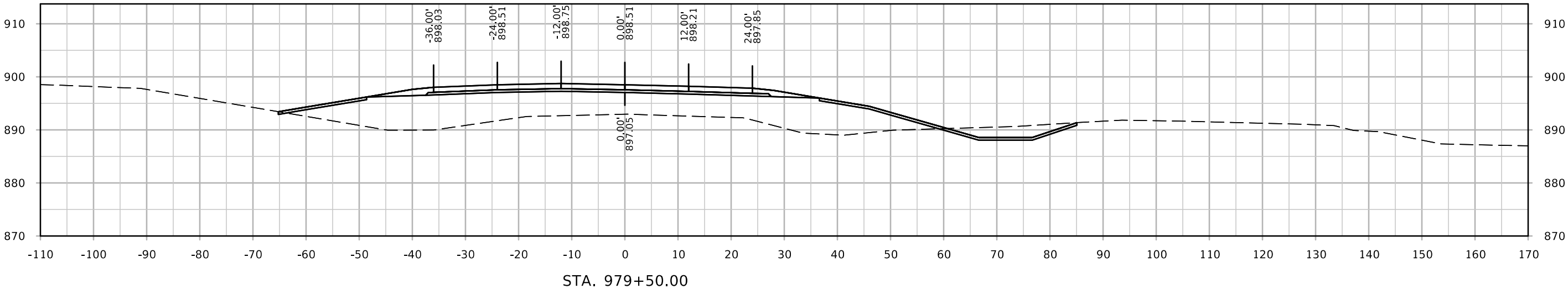

ML - I35 NB

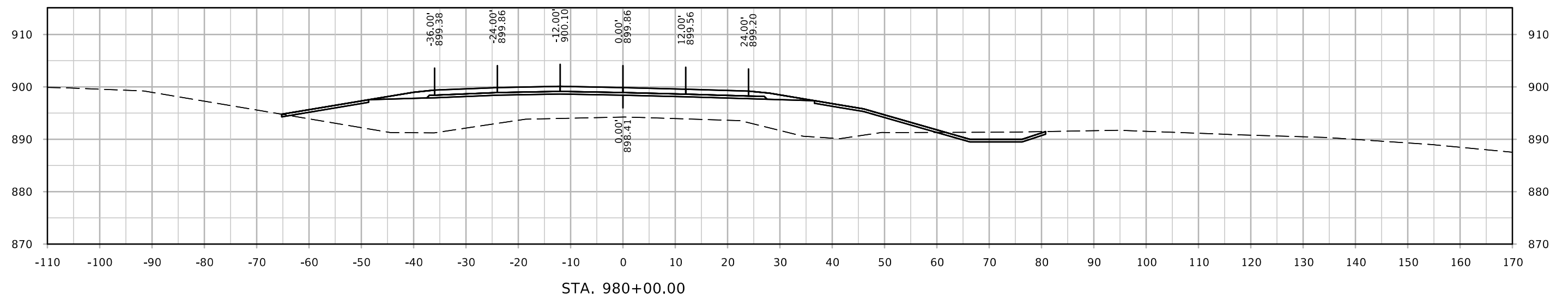
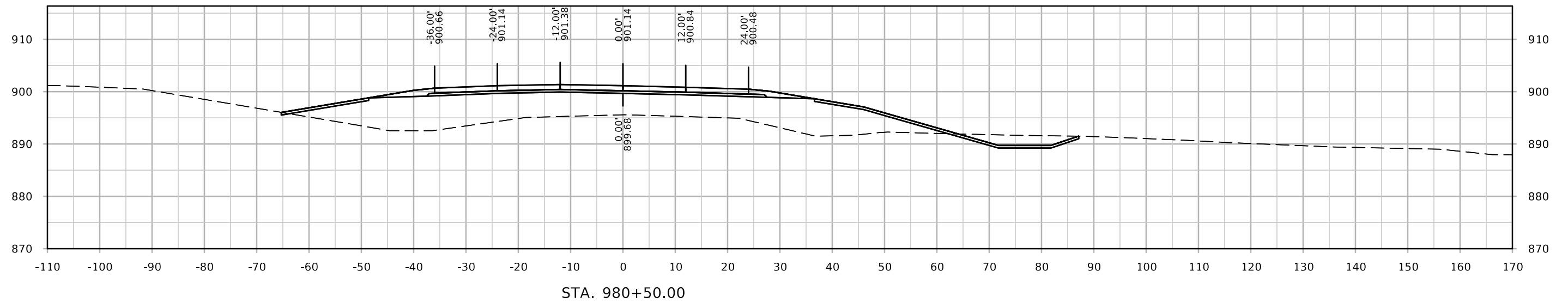

ML - I35 NB

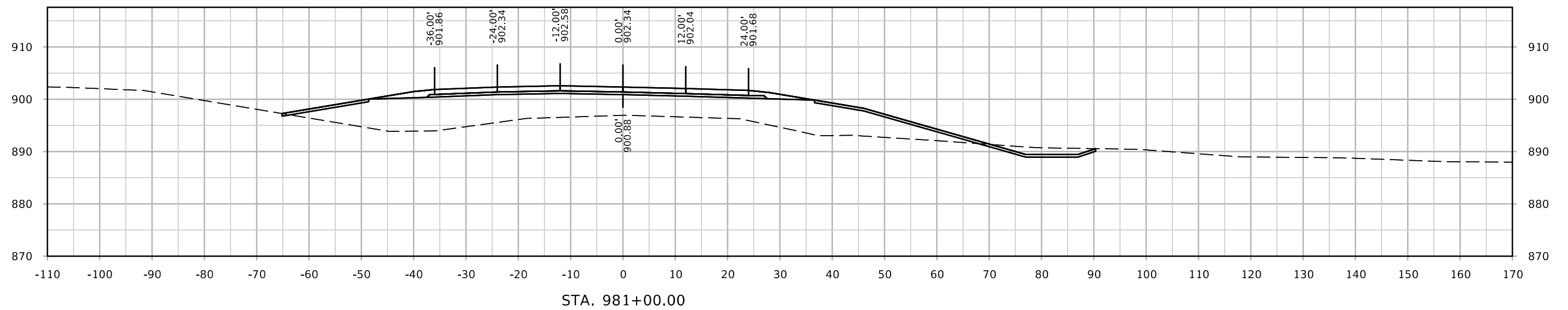
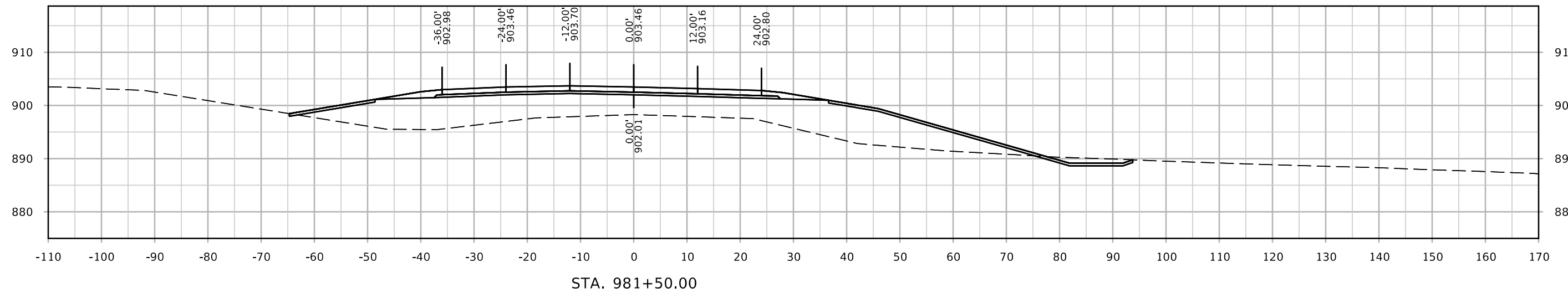

ML - I35 NB

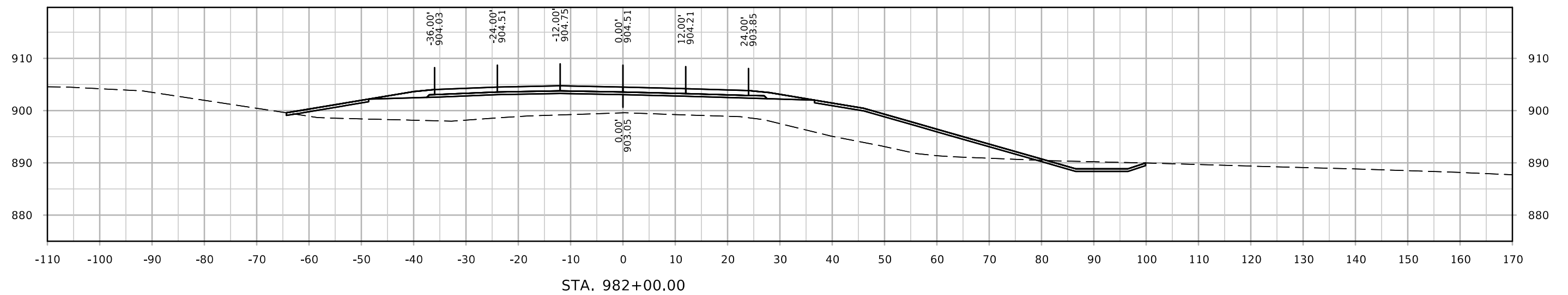
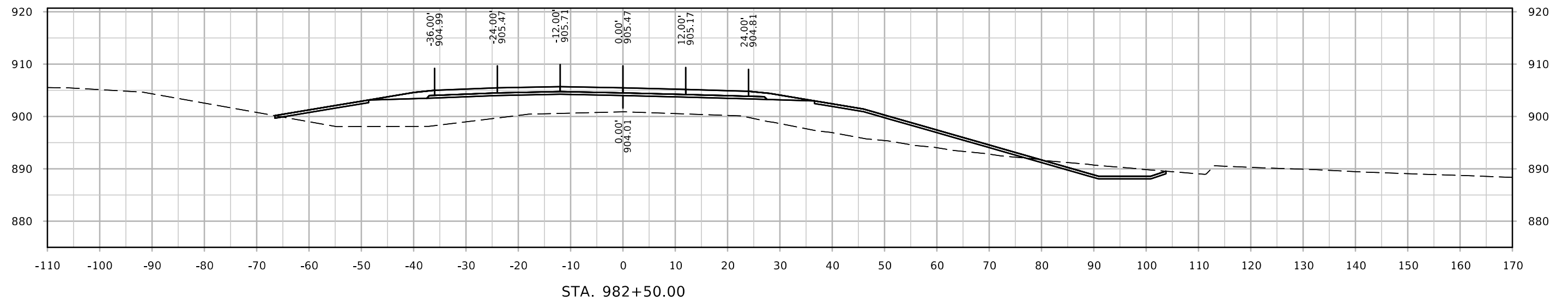

ML - I35 NB

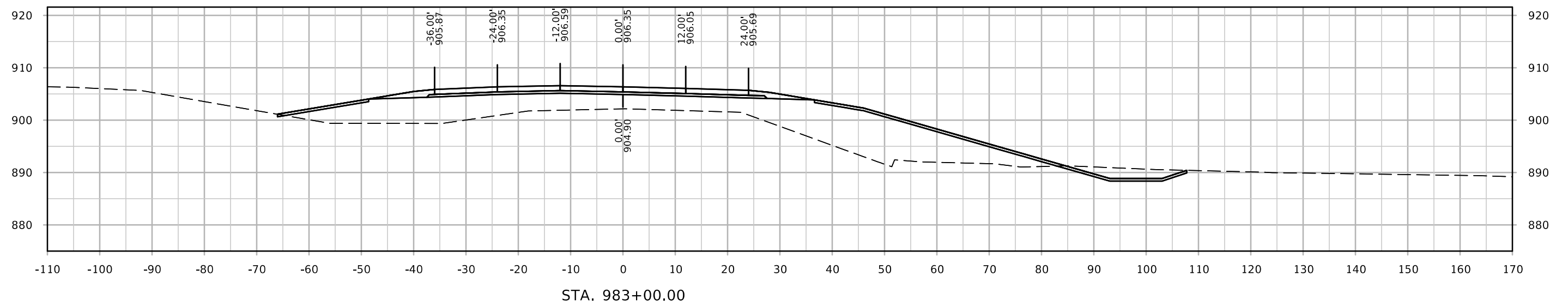
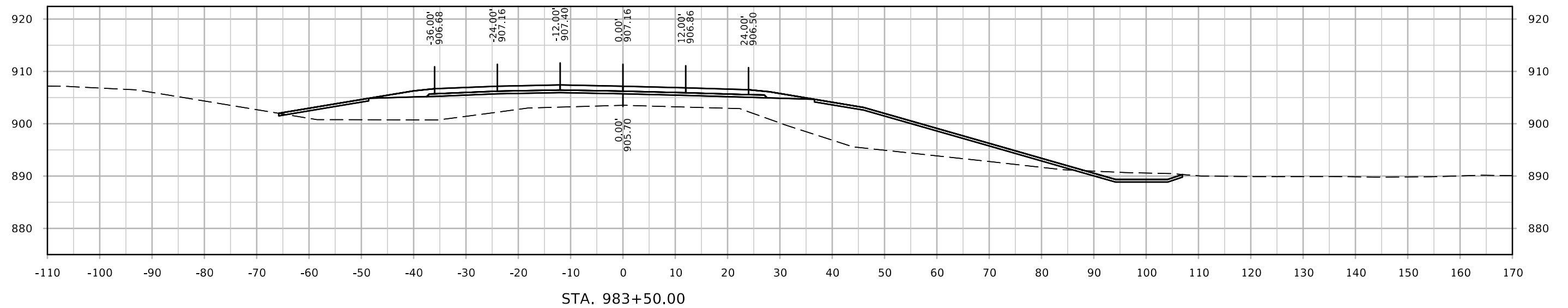

ML - I35 NB

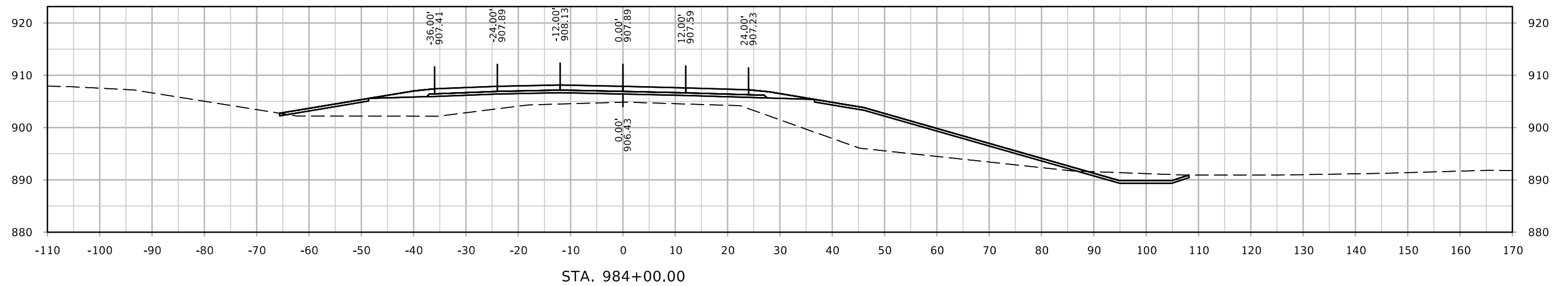
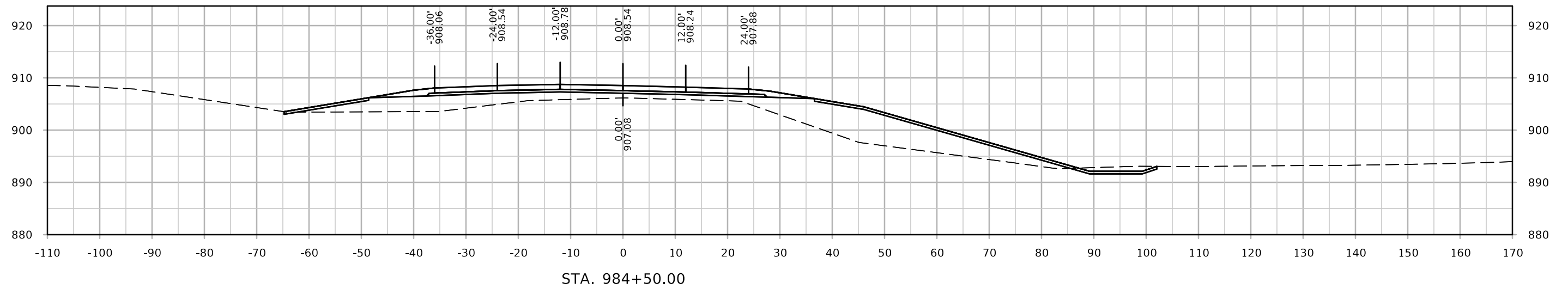
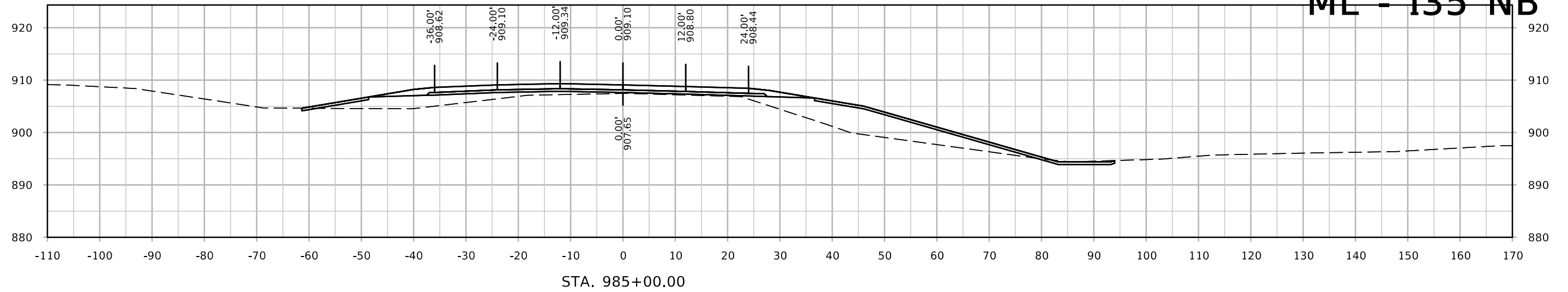

ML - I35 NB

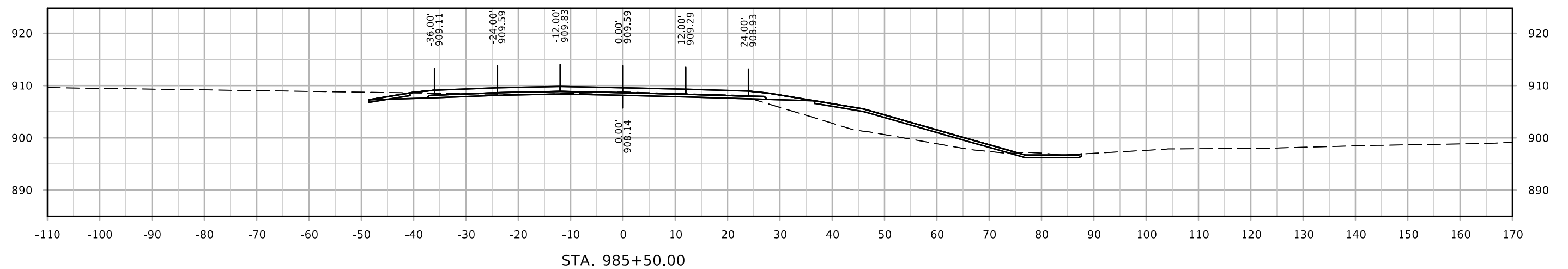
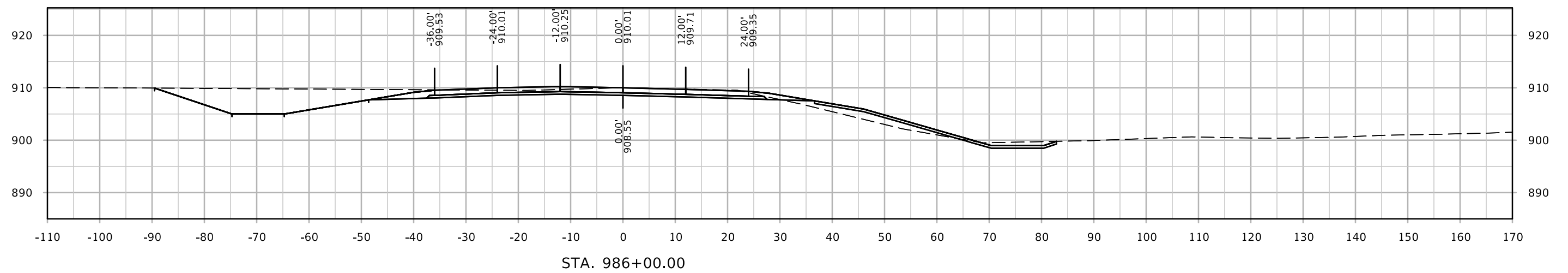
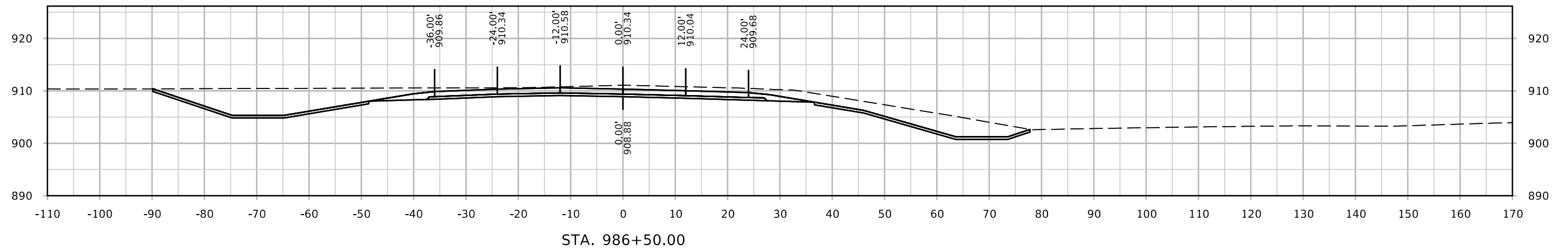

ML - I35 NB

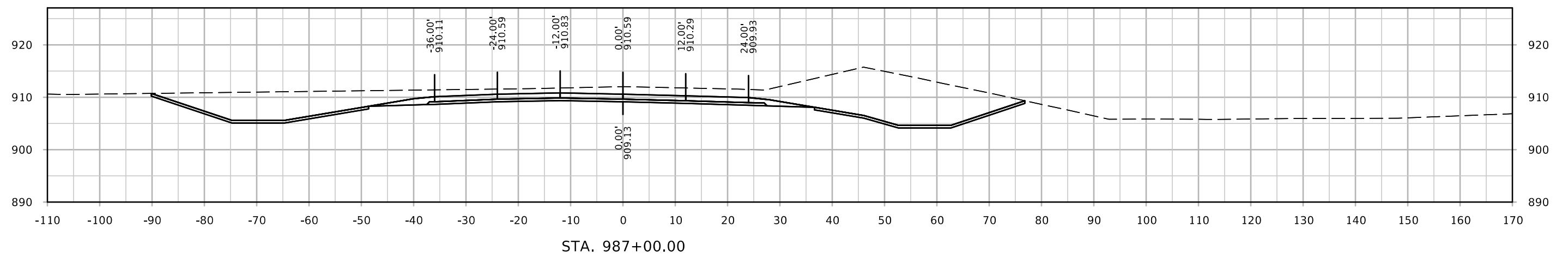
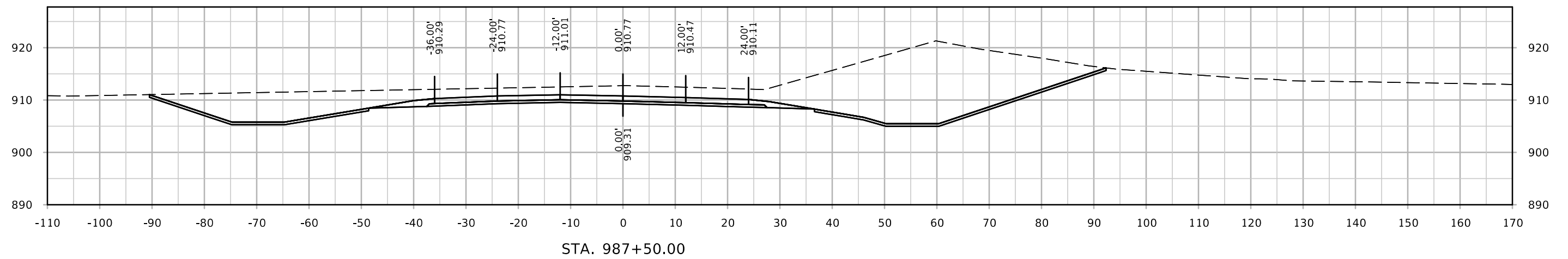
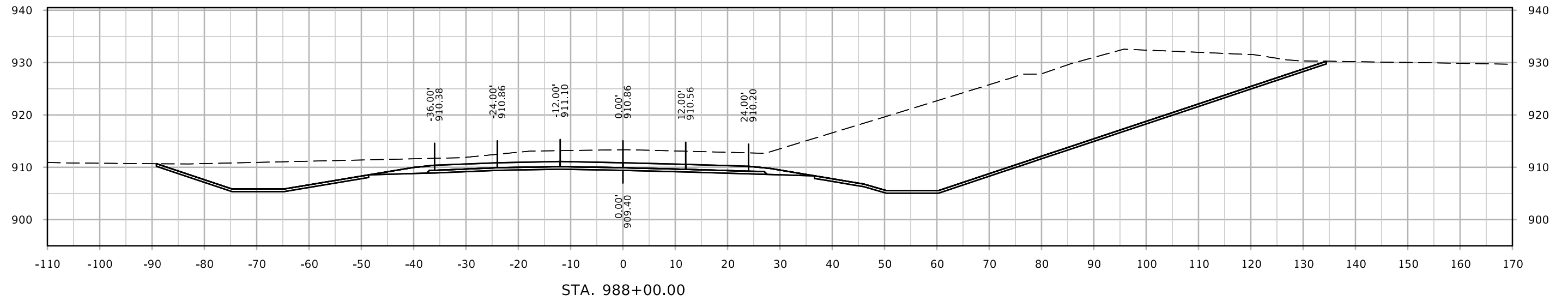

ML - I35 NB

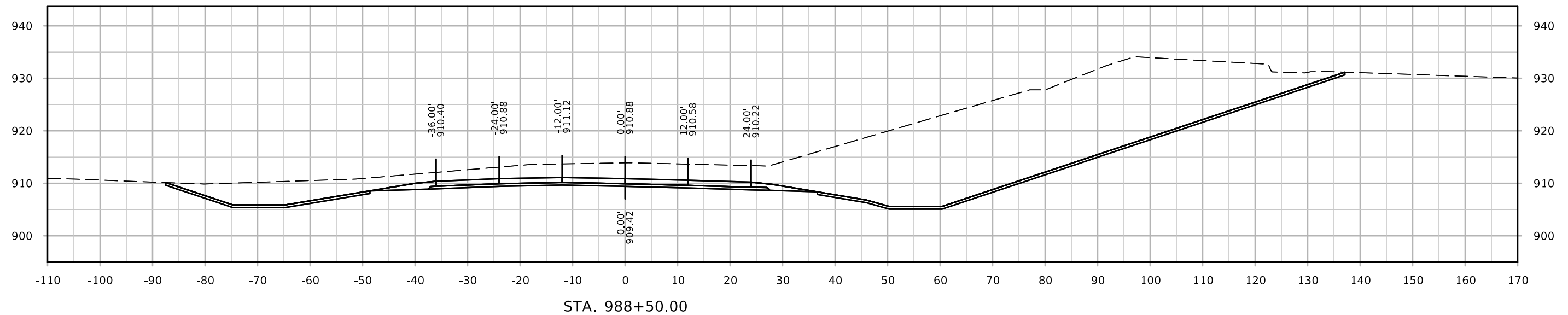
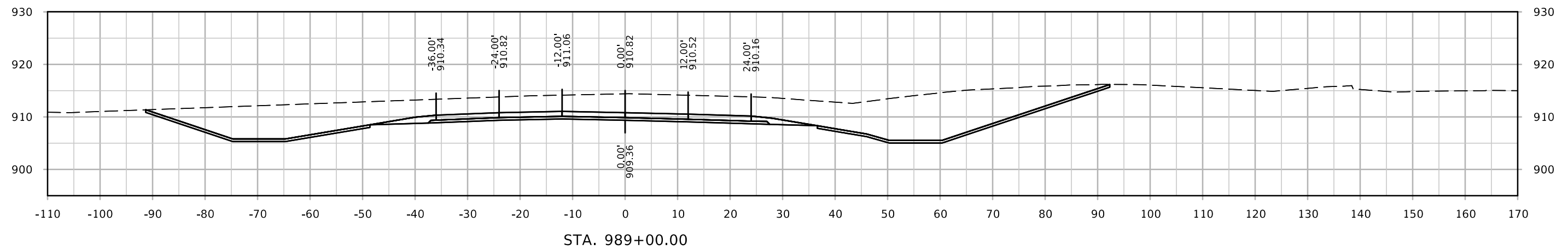
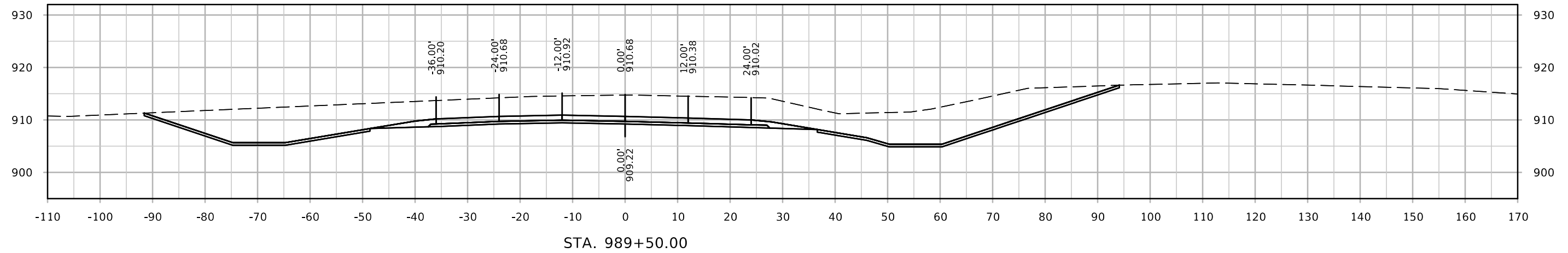

ML - I35 NB

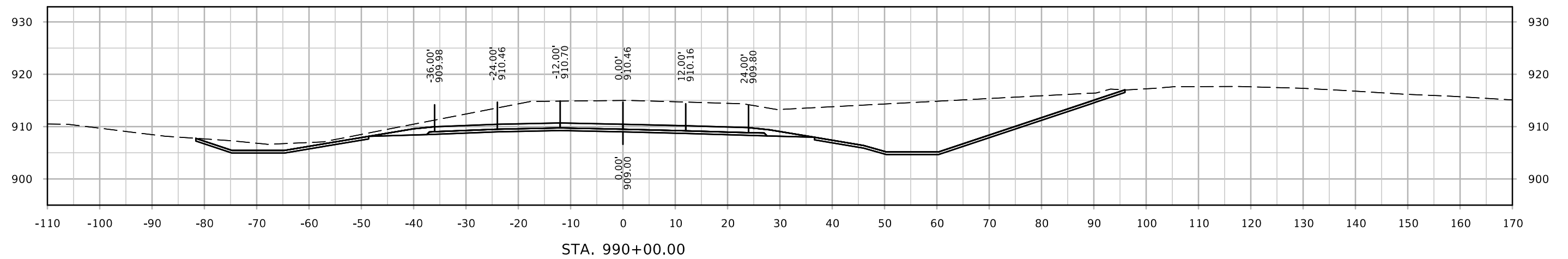
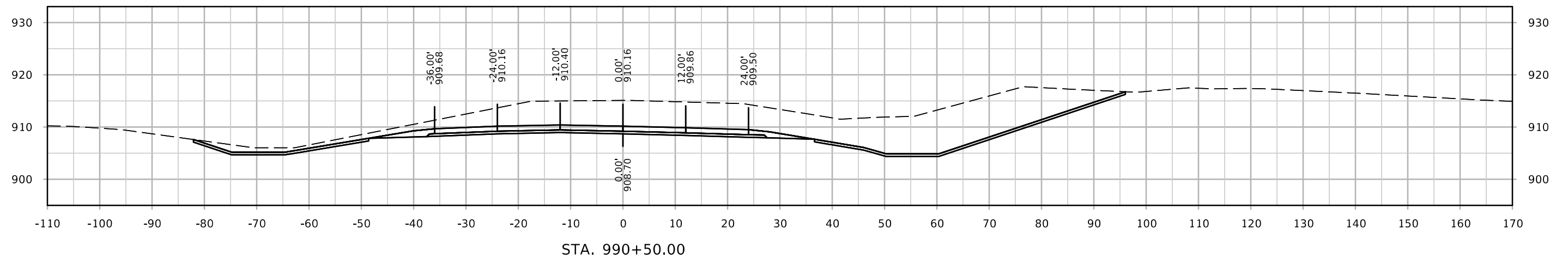
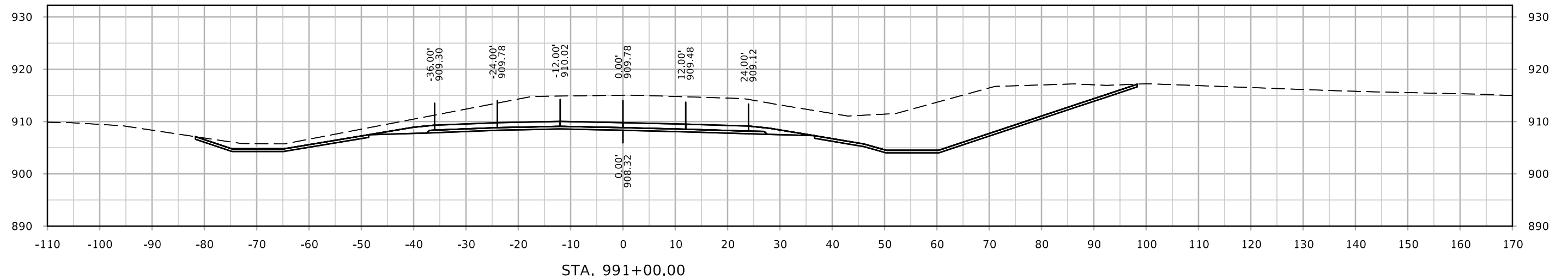

ML - I35 NB

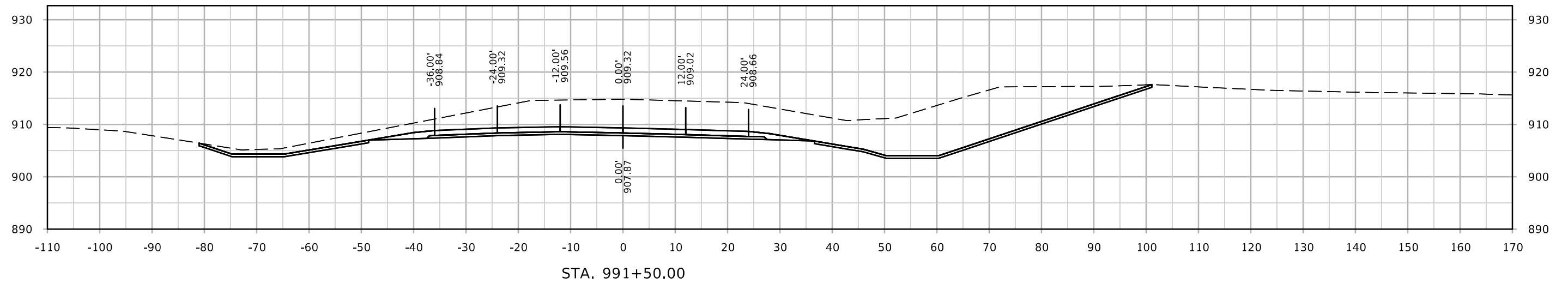
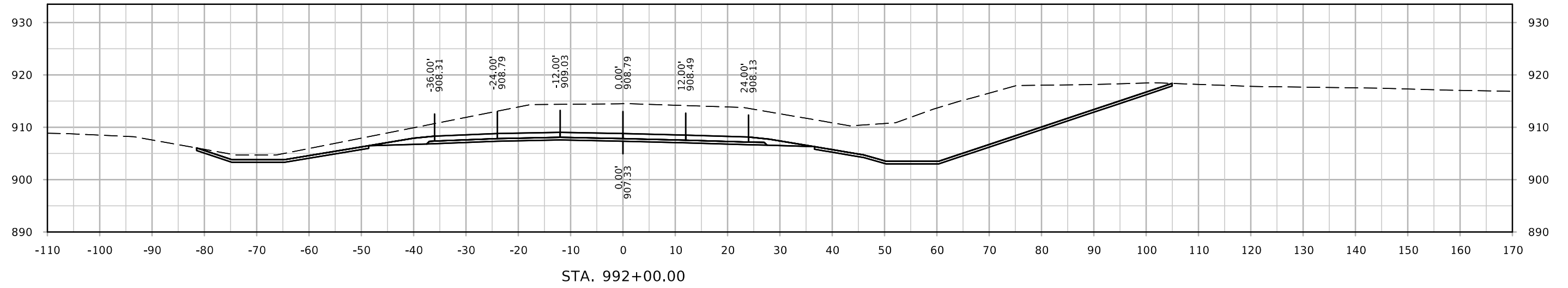
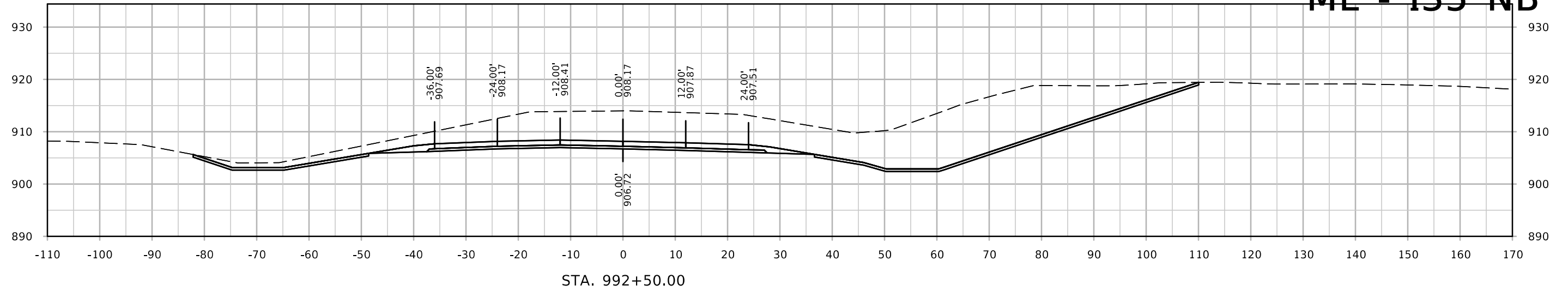

ML - I35 NB

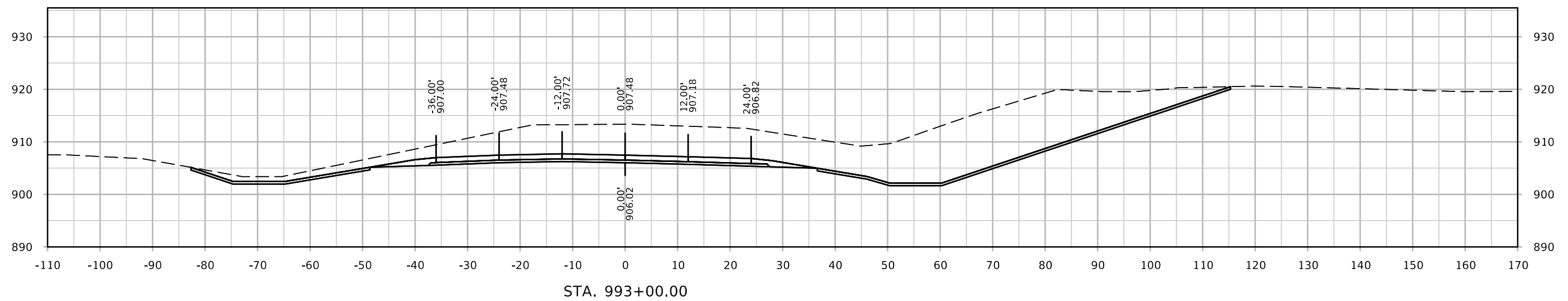
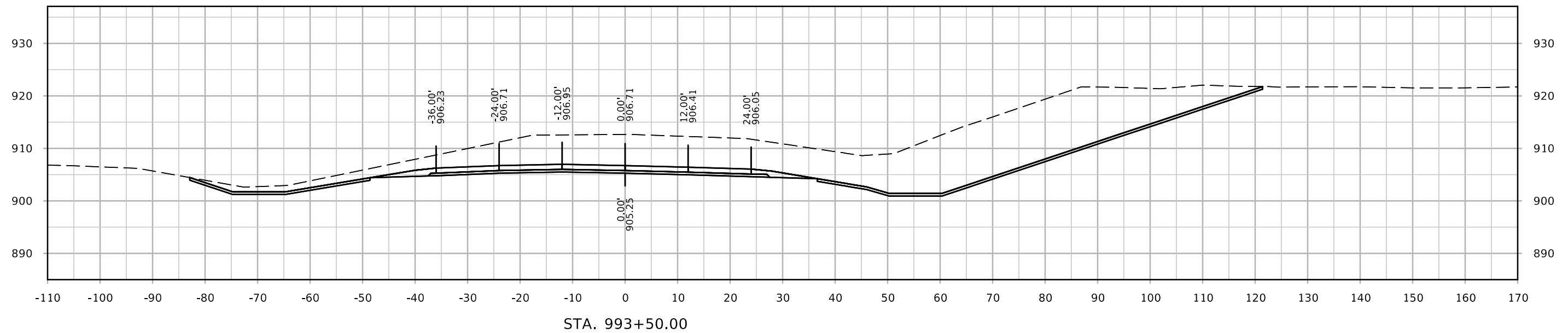

ML - I35 NB

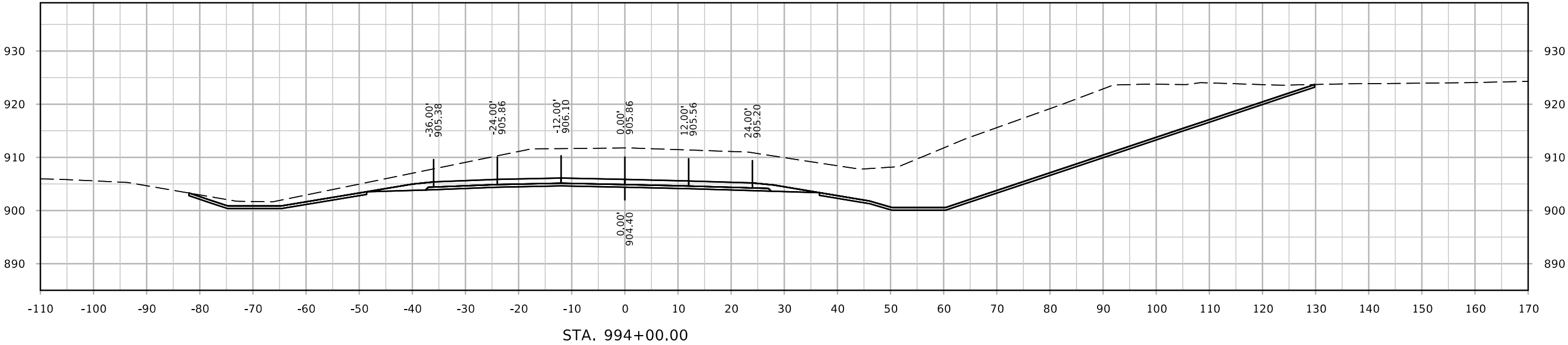
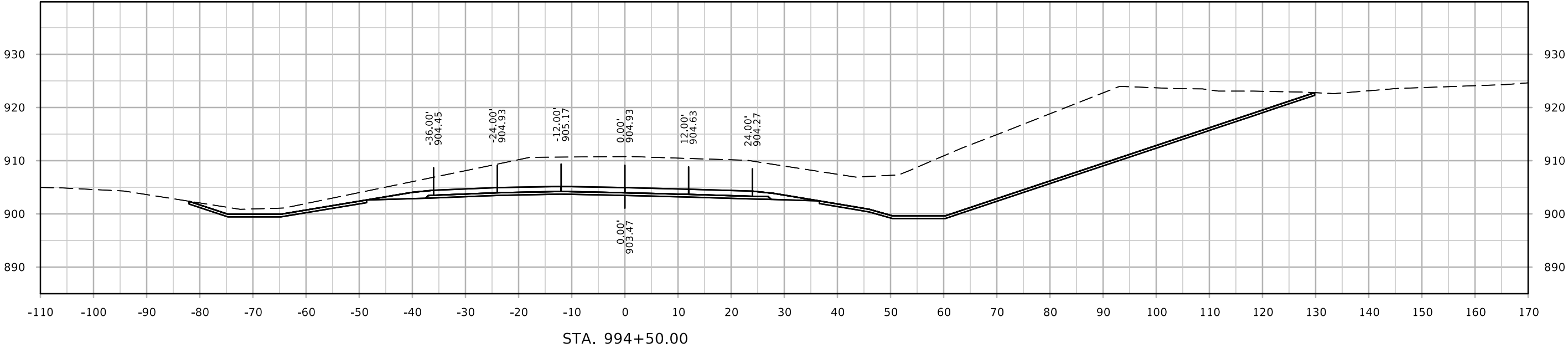

ML - I35 NB

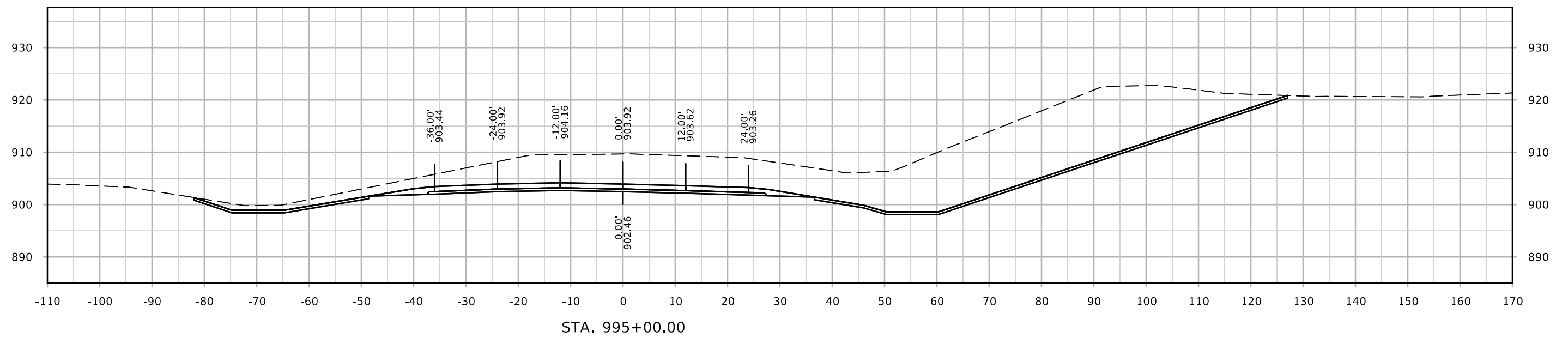
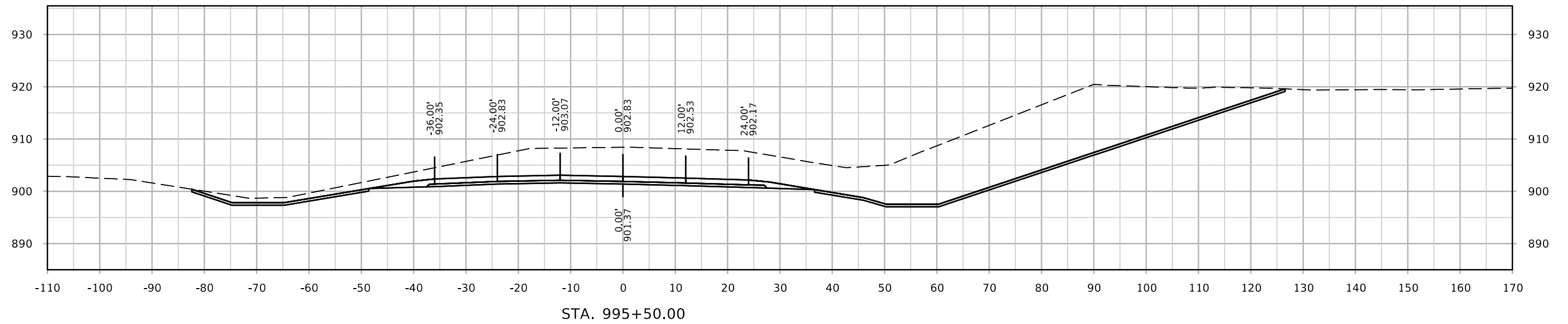

ML - I35 NB

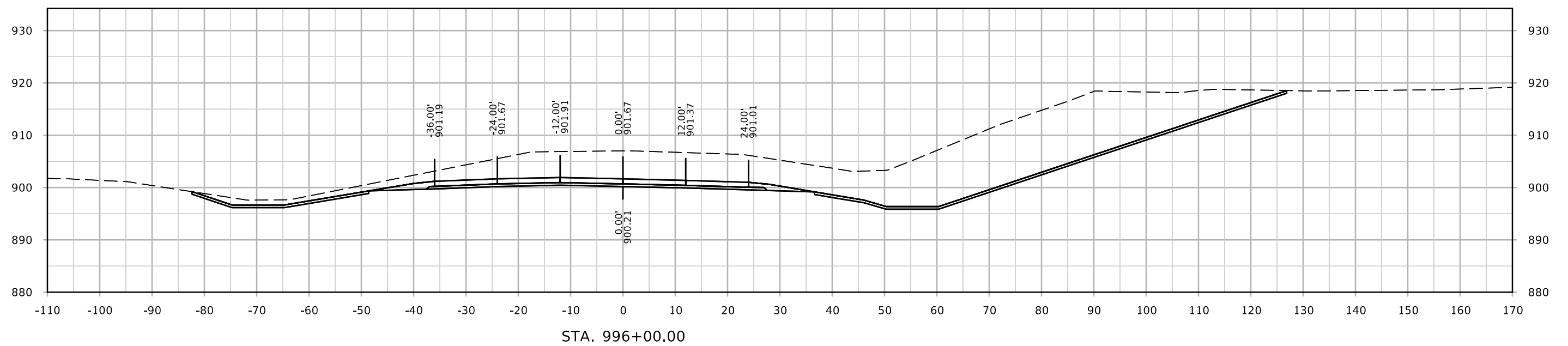
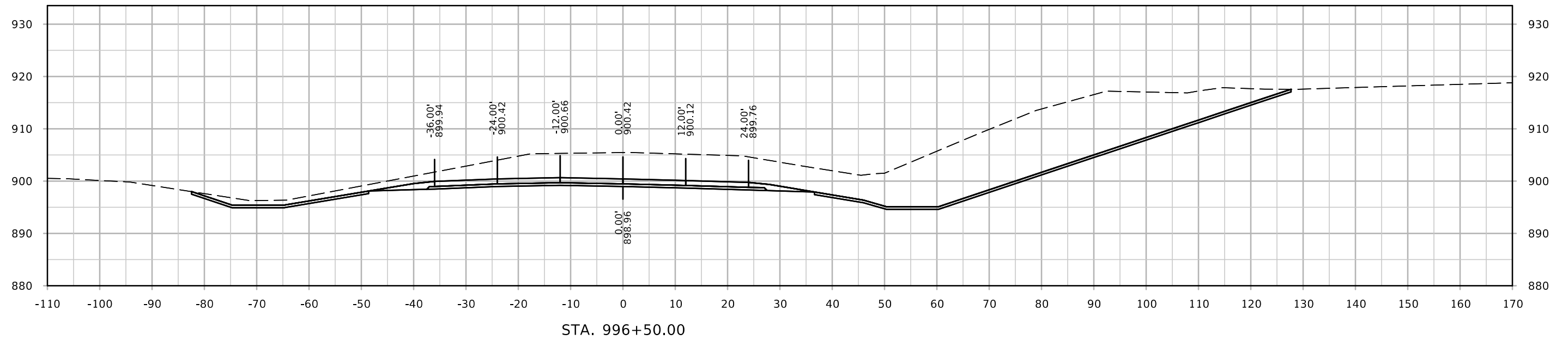

ML - I35 NB

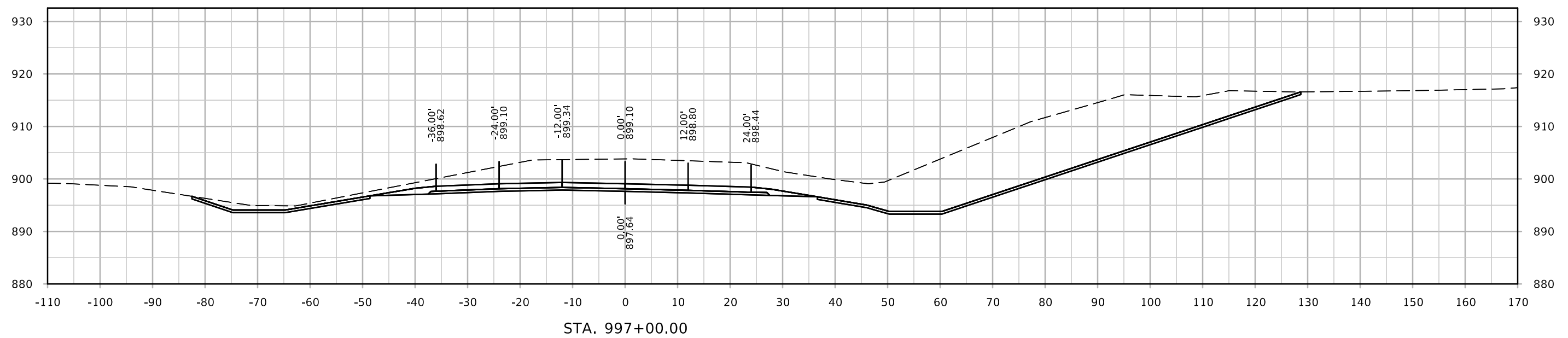
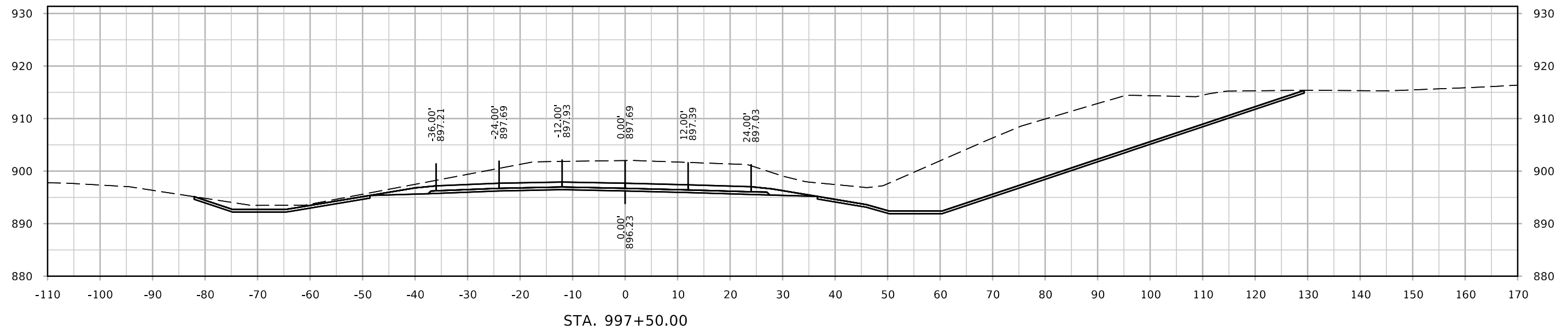

ML - I35 NB

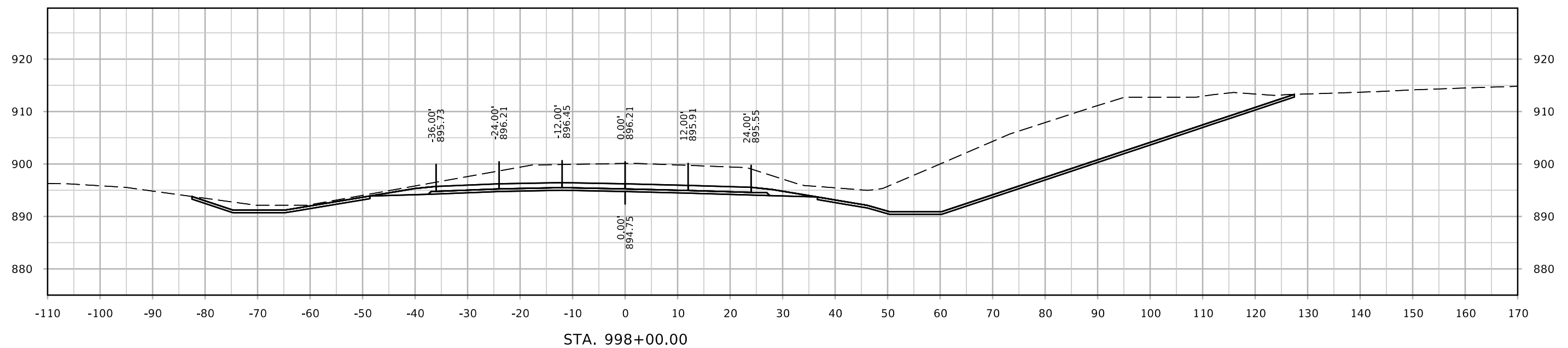
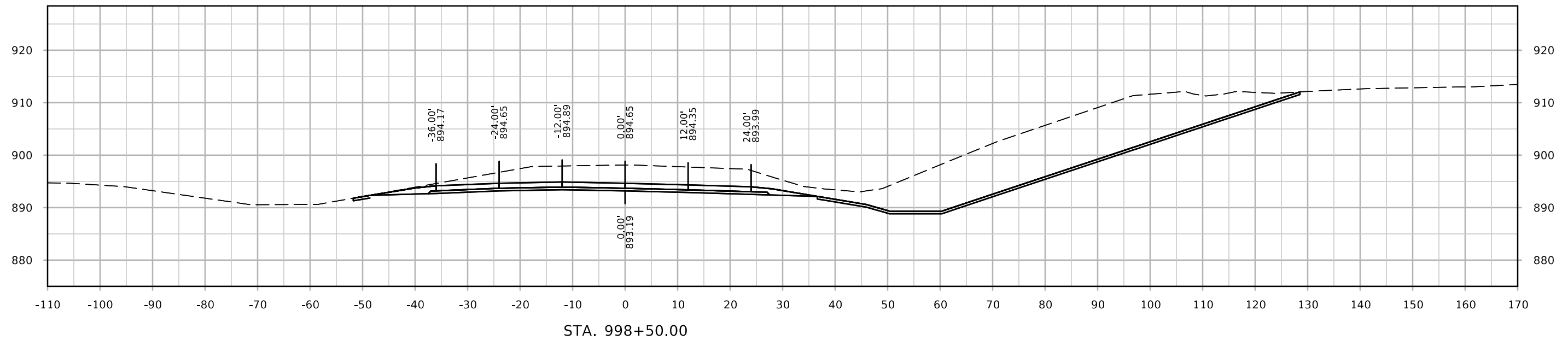

ML - I35 NB

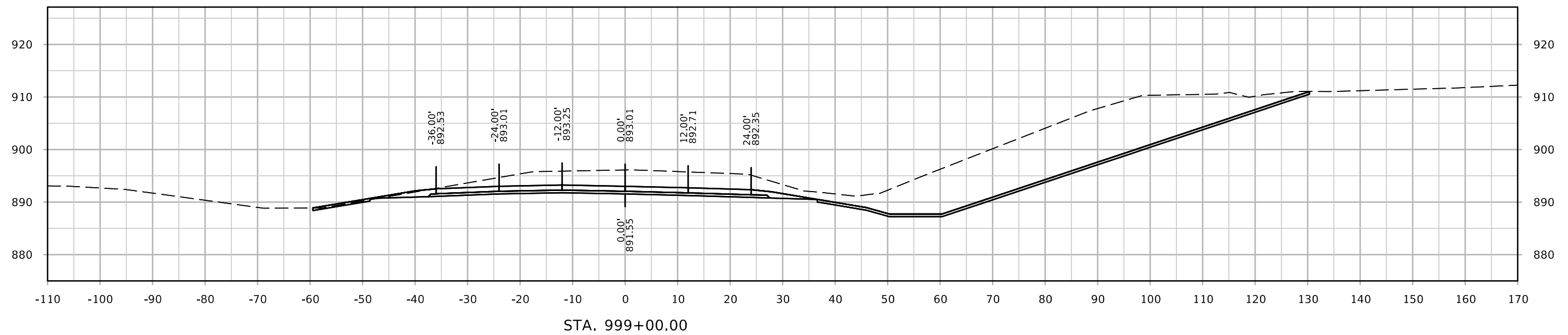
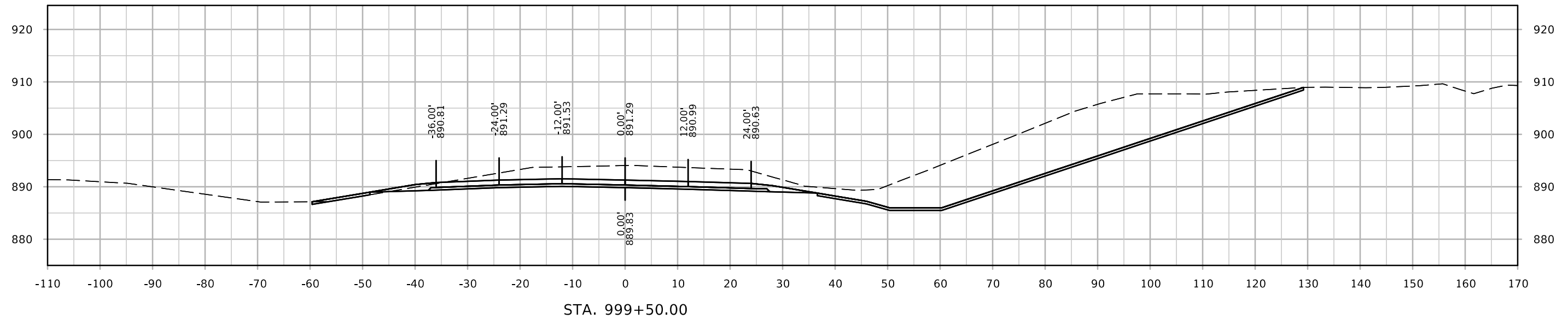

ML - I35 NB

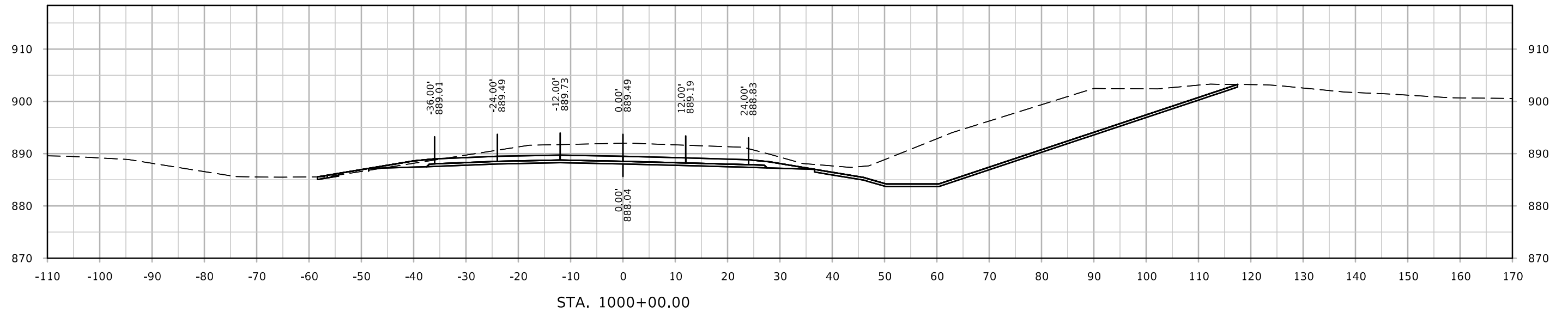
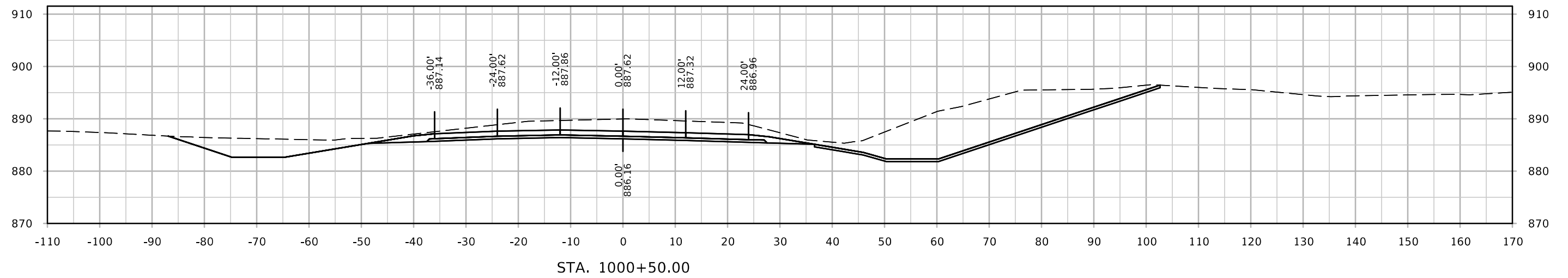
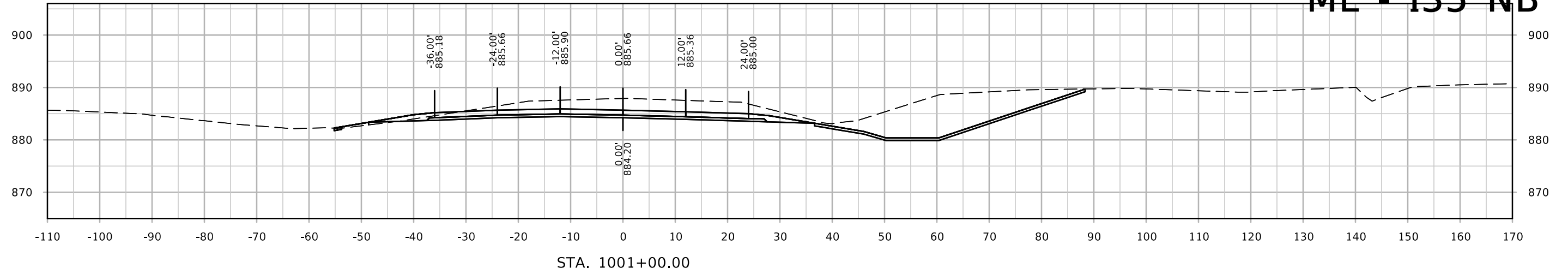

ML - I35 NB

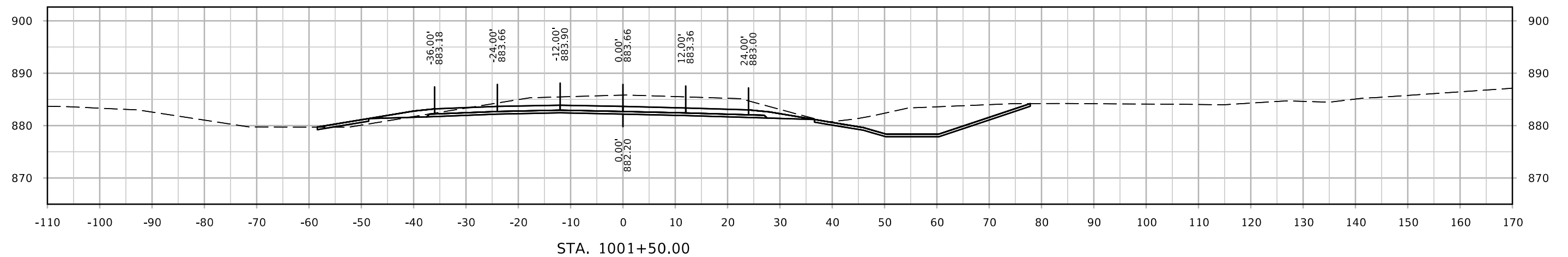
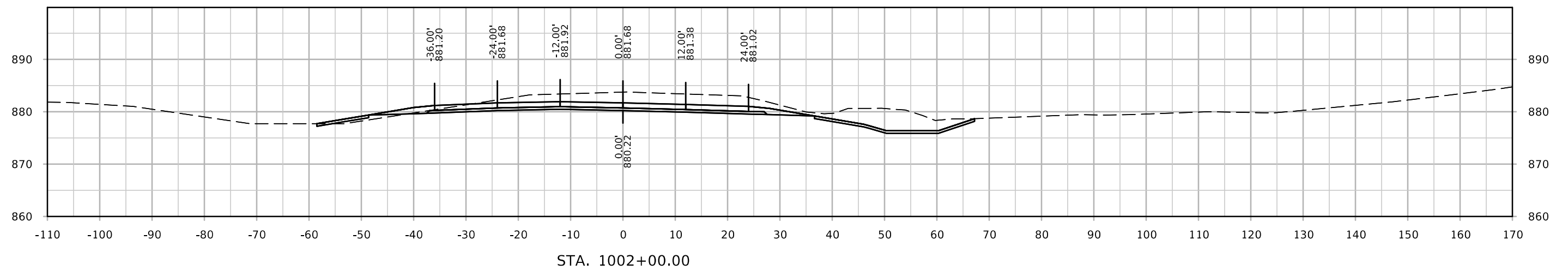
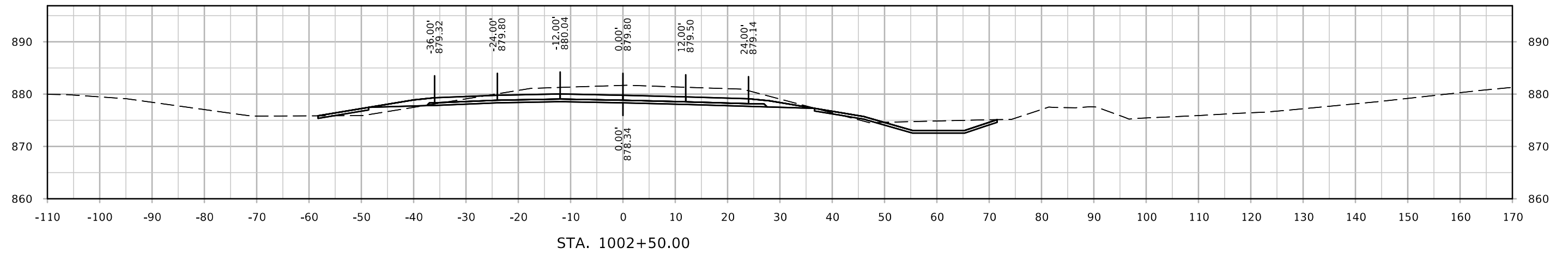

ML - I35 NB

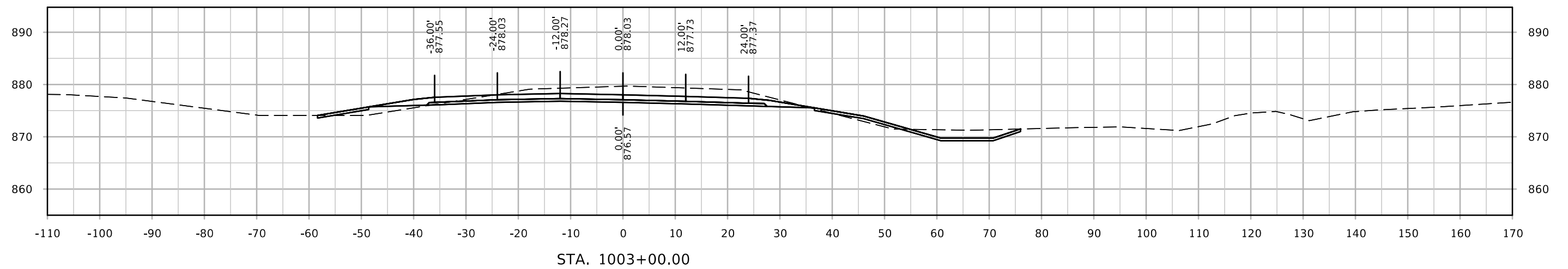
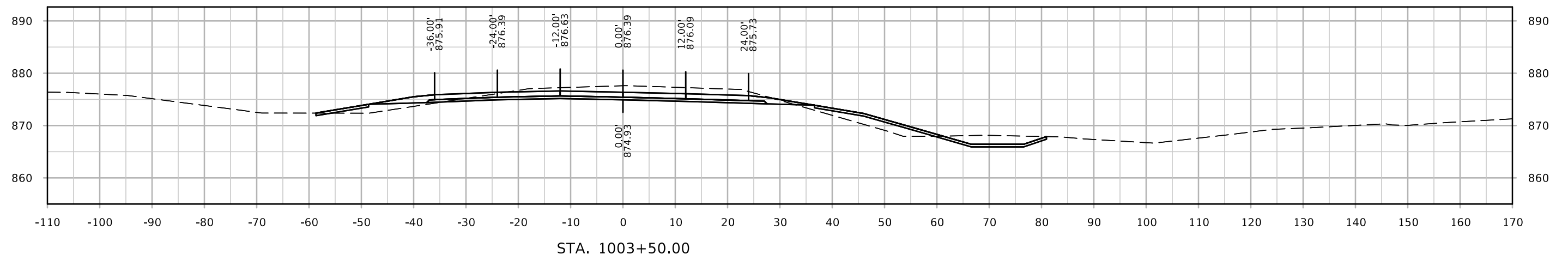
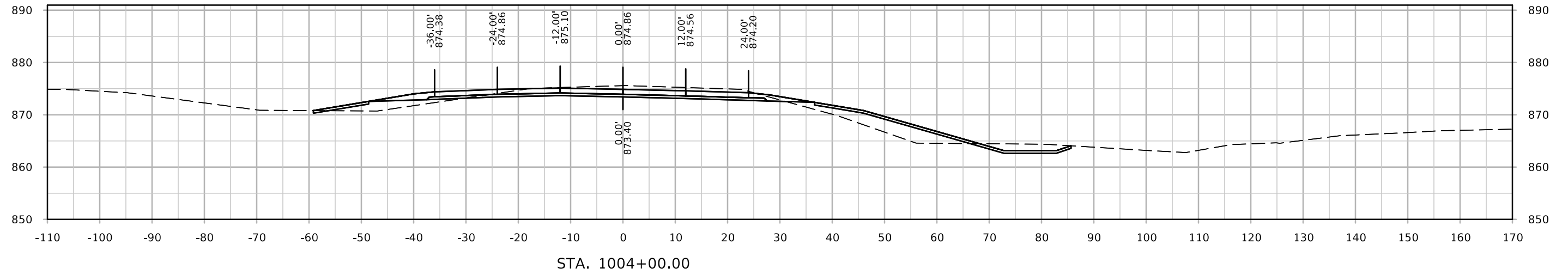

ML - I35 NB

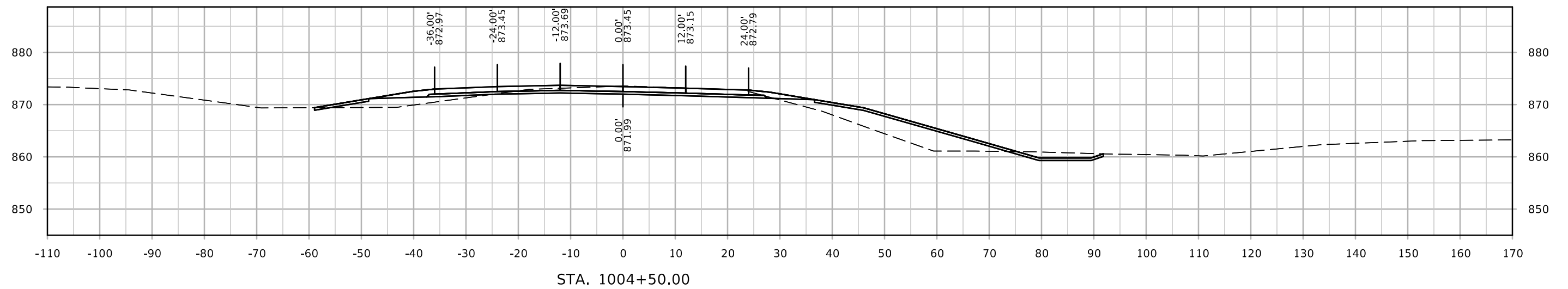
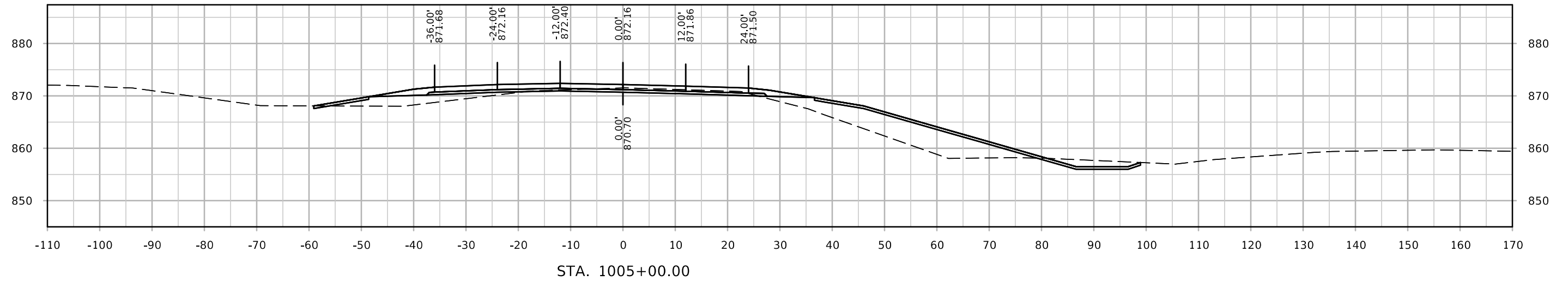
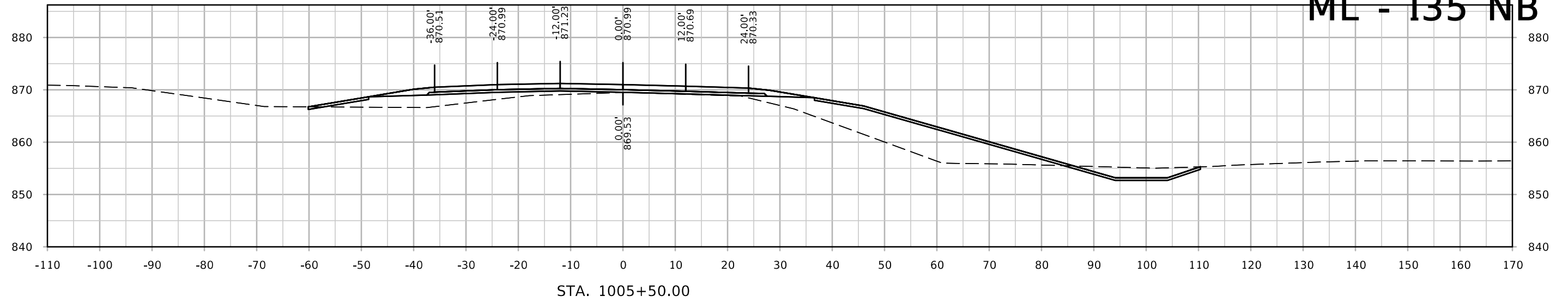

ML - I35 NB

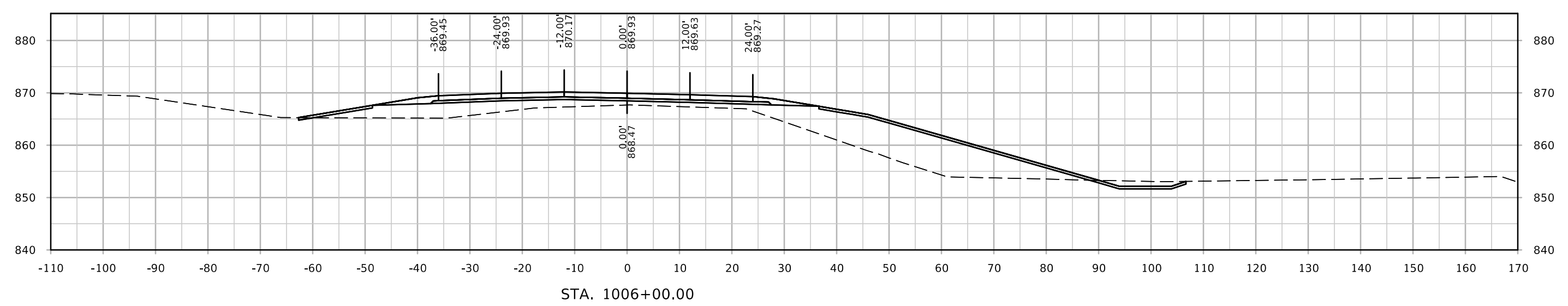
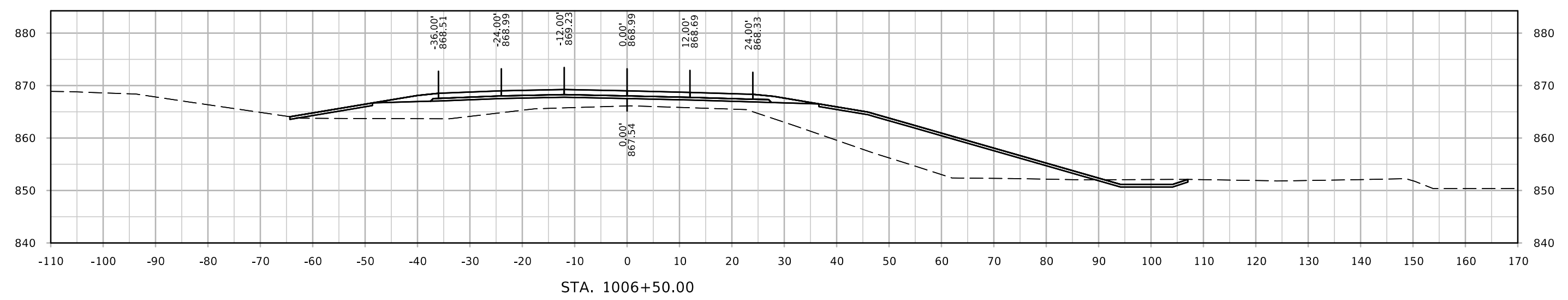
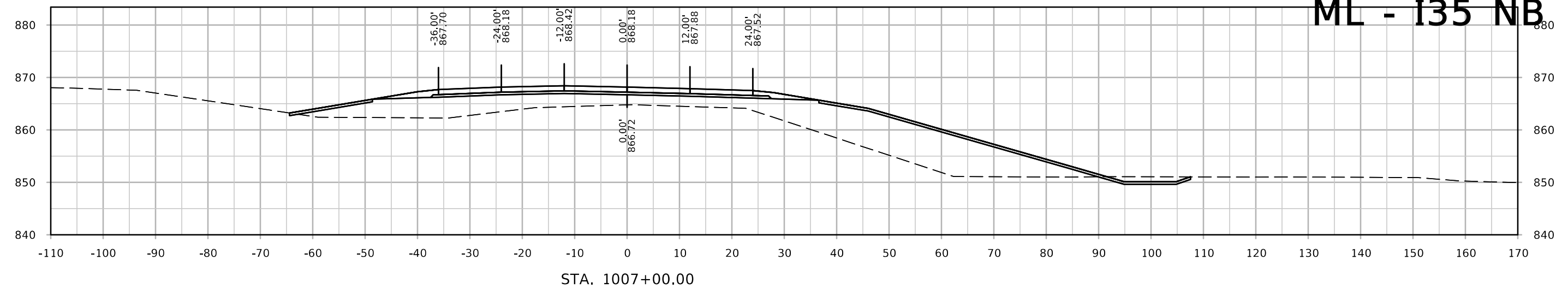

ML - I35 NB

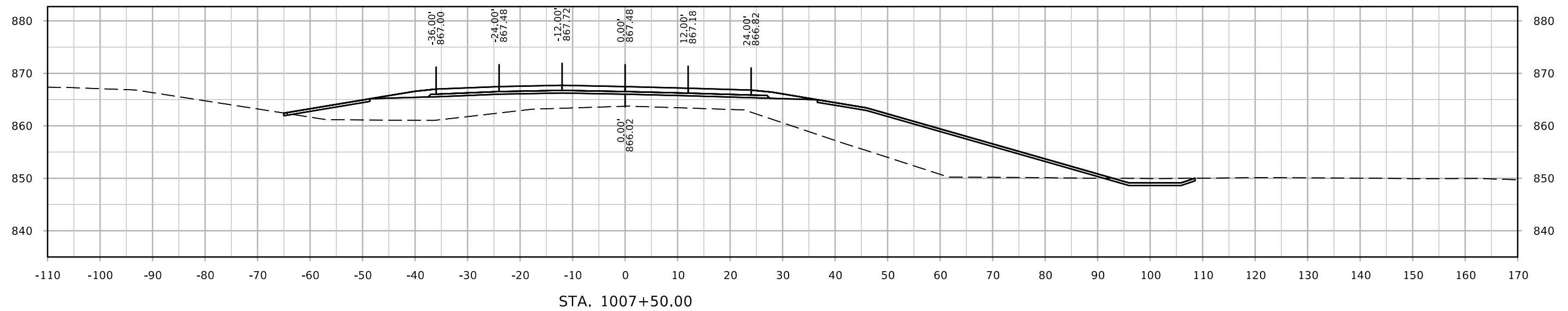
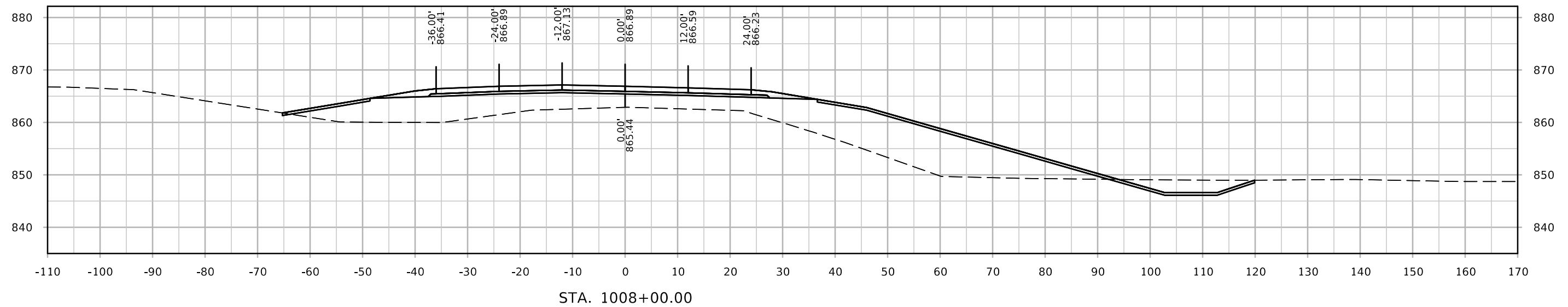

ML - I35 NB

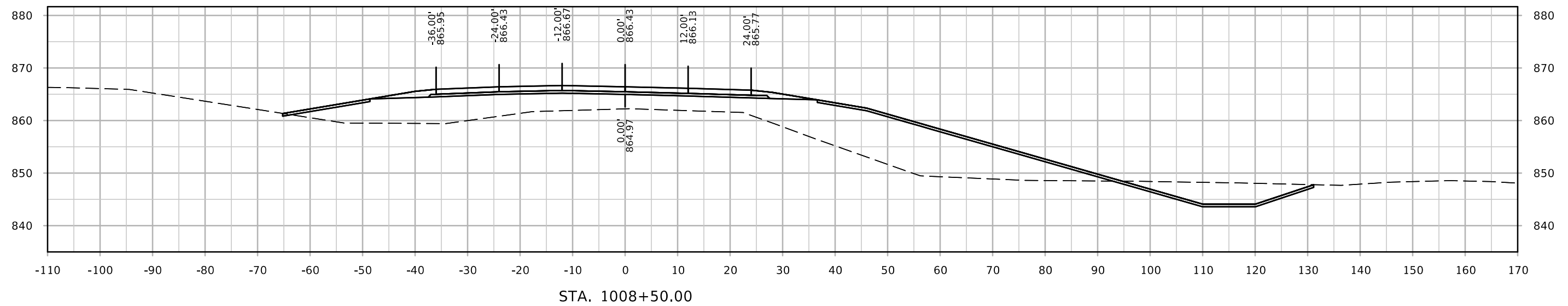
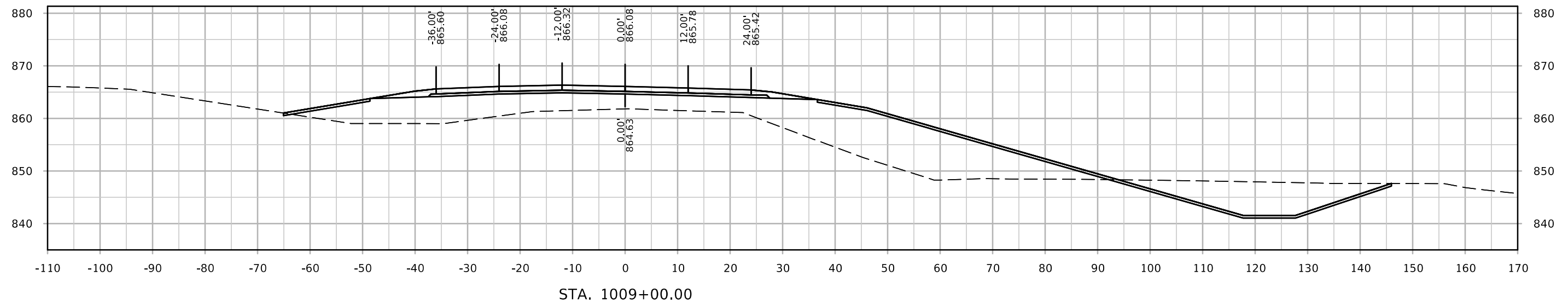

ML - I35 NB

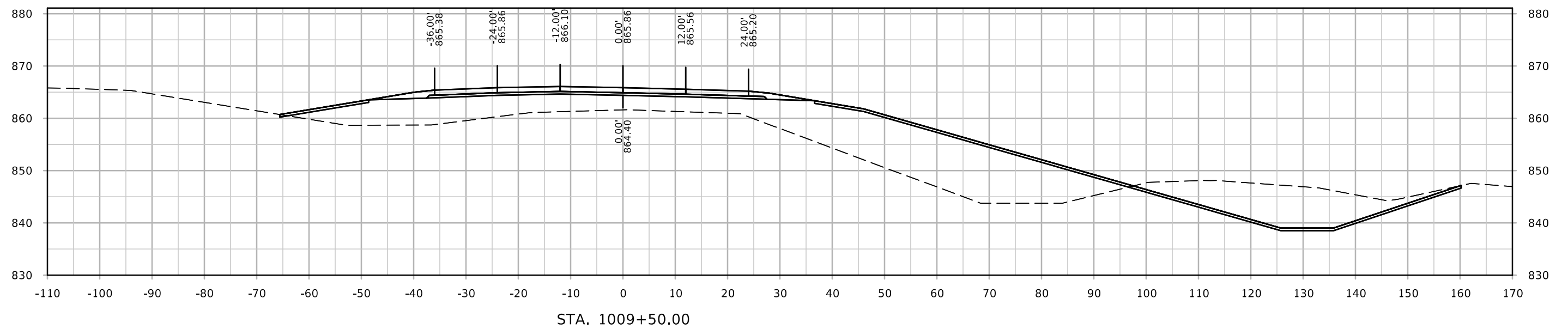
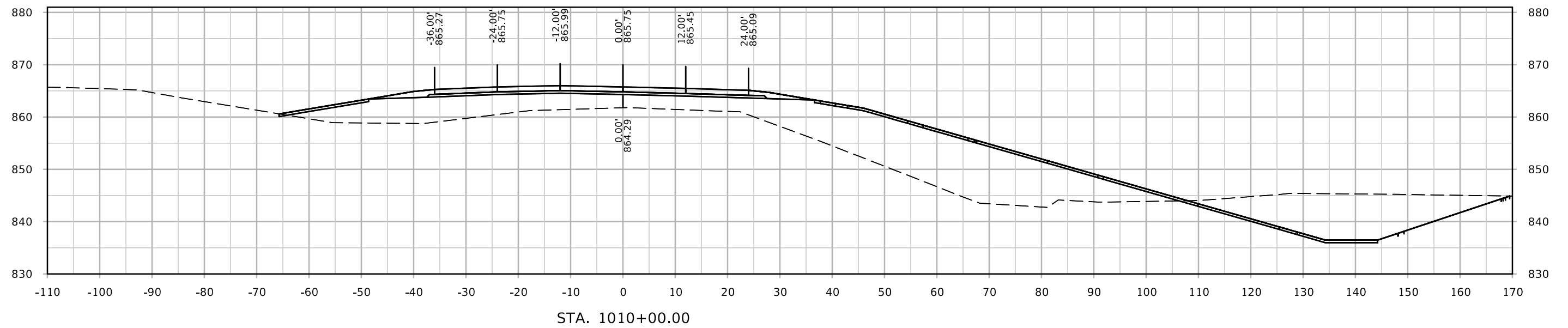

ML - I35 NB

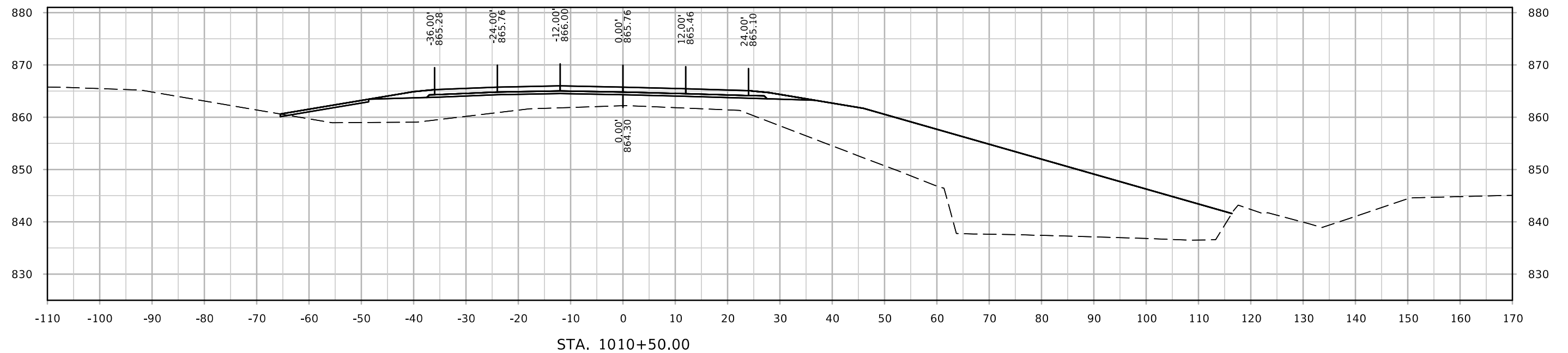
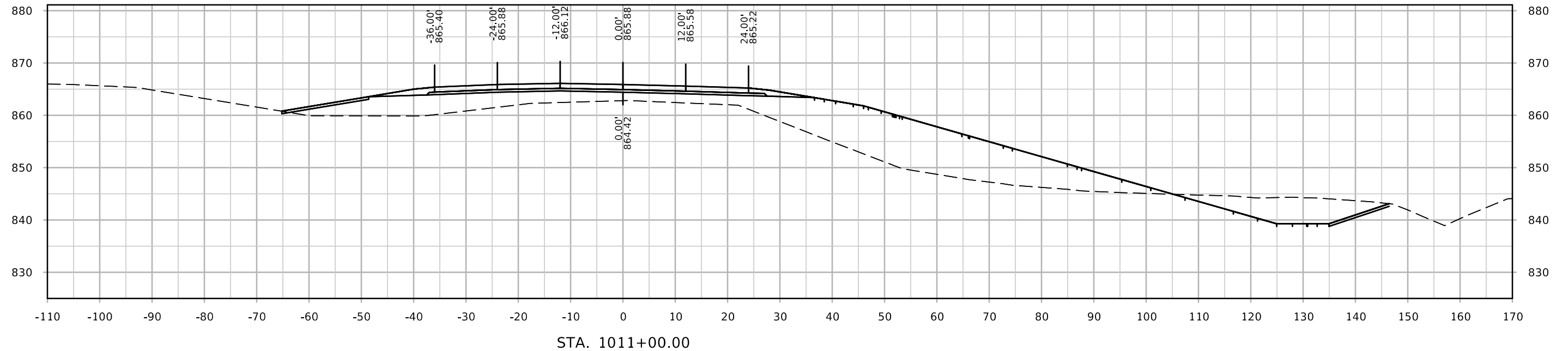

ML - I35 NB

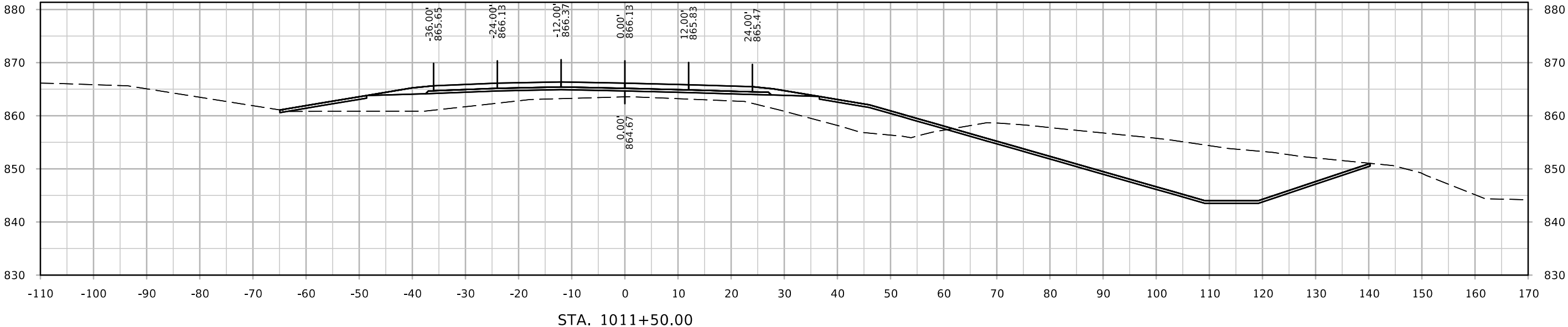
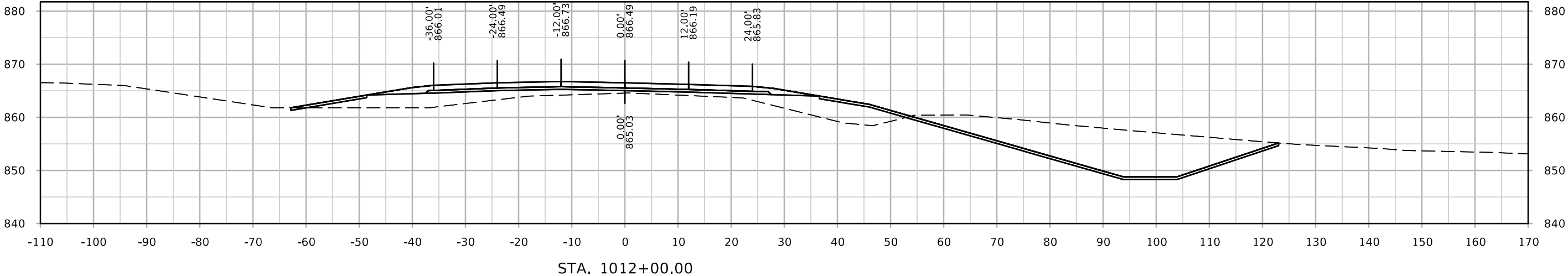

ML - I35 NB

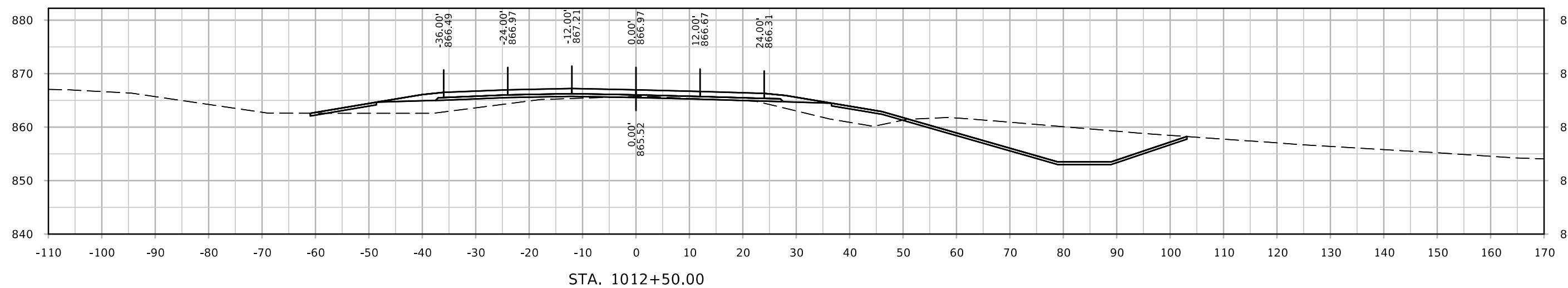
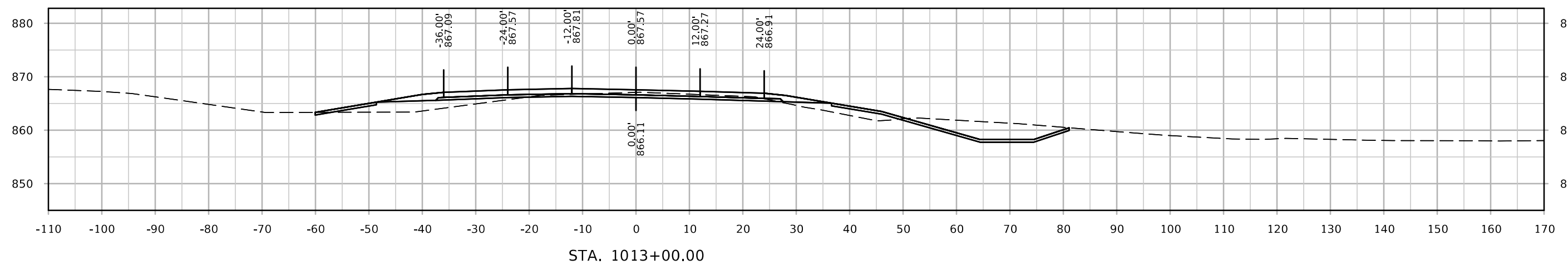
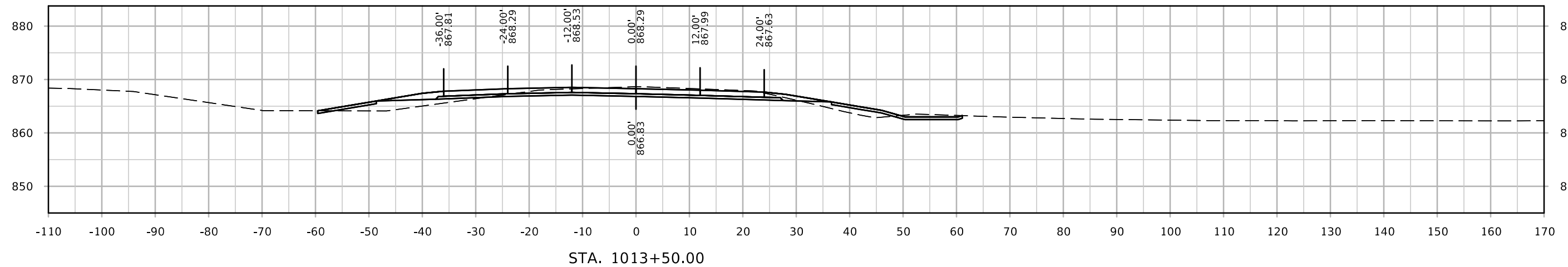

ML - I35 NB

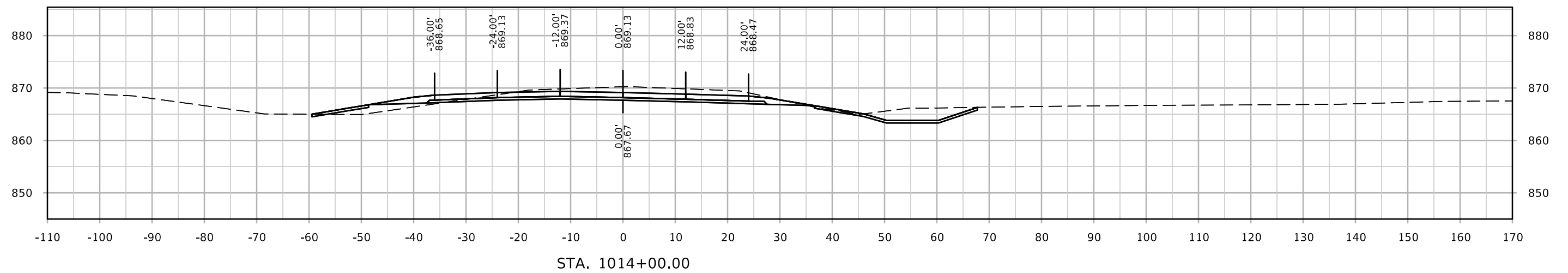
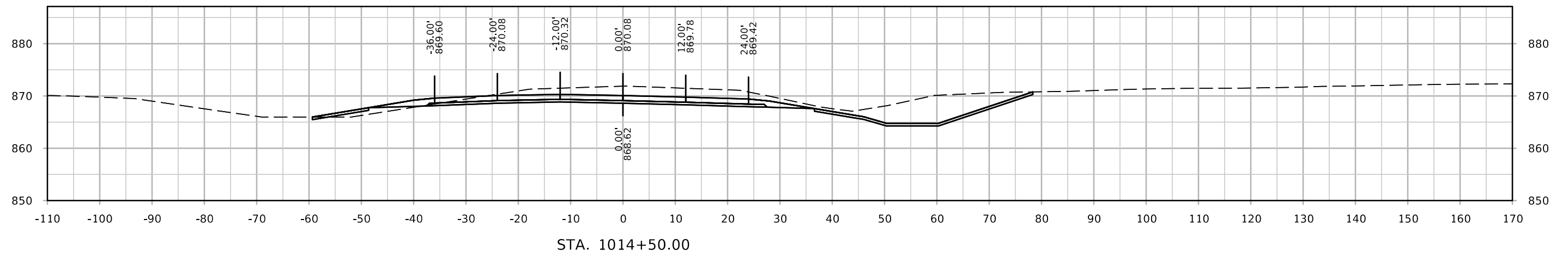
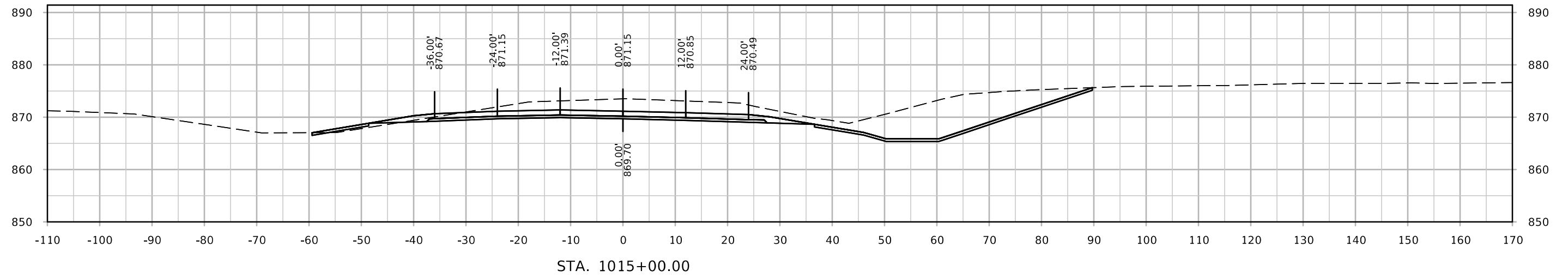

ML - I35 NB

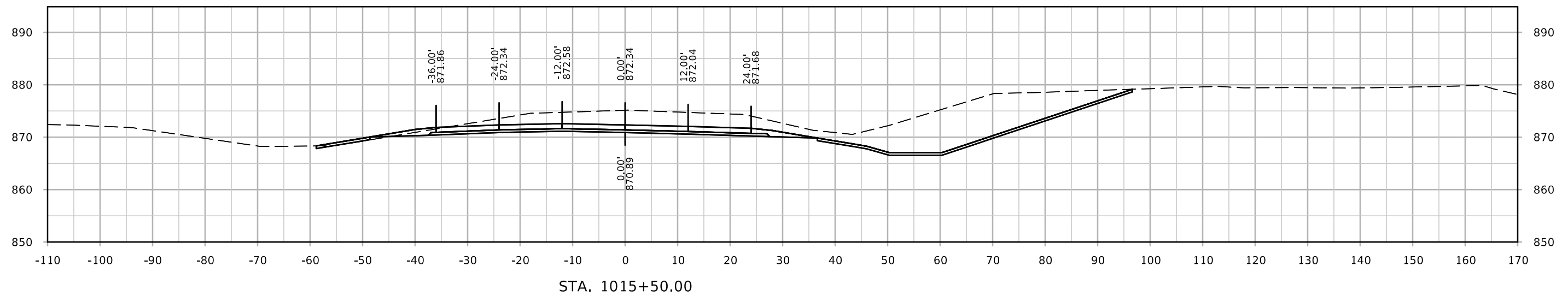
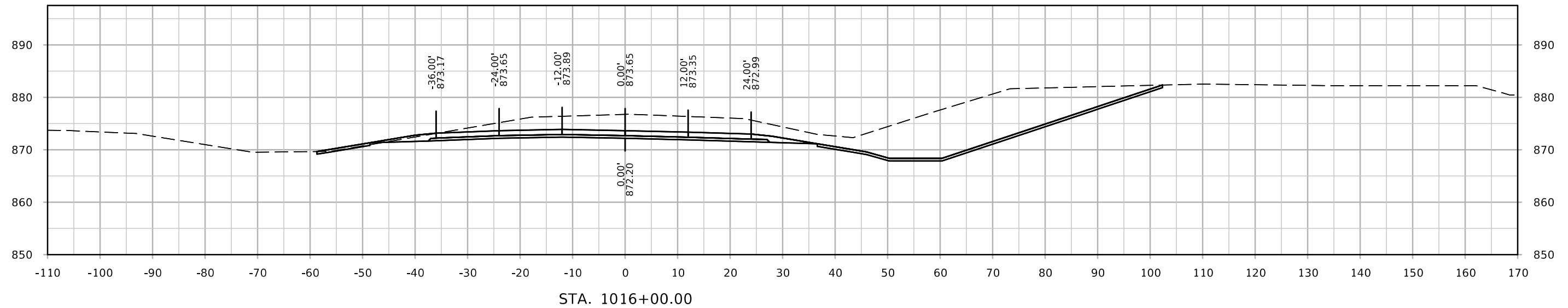

ML - I35 NB

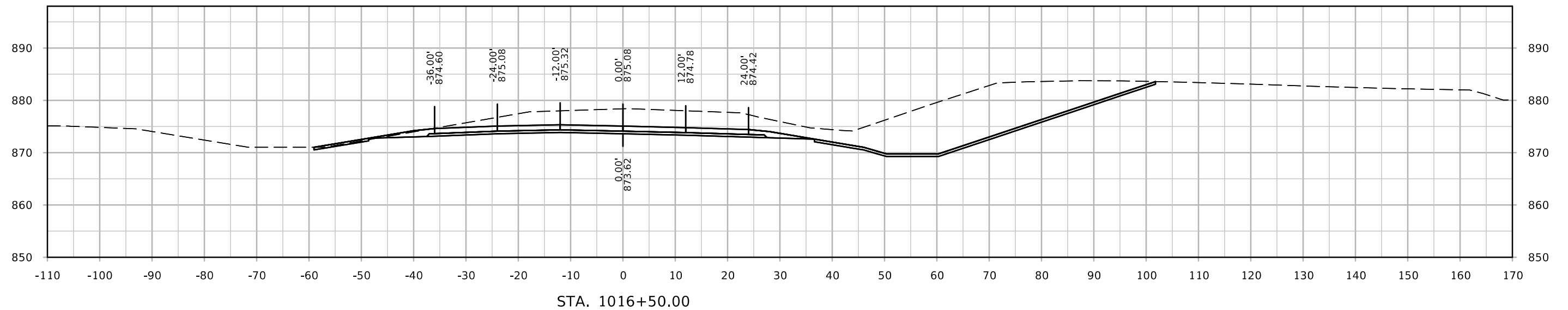
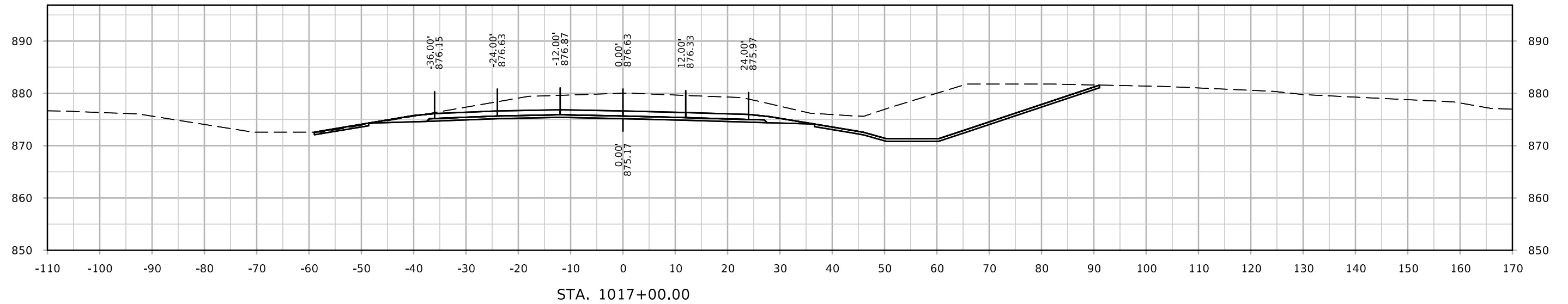

ML - I35 NB

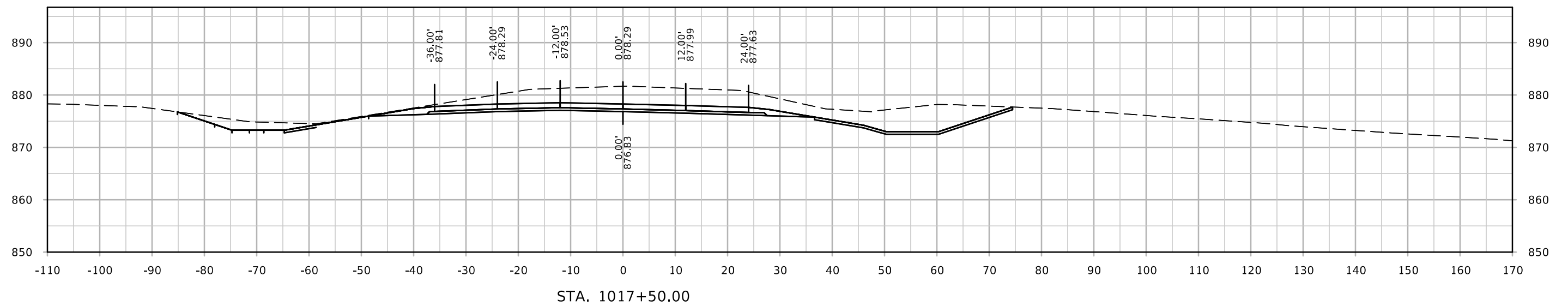
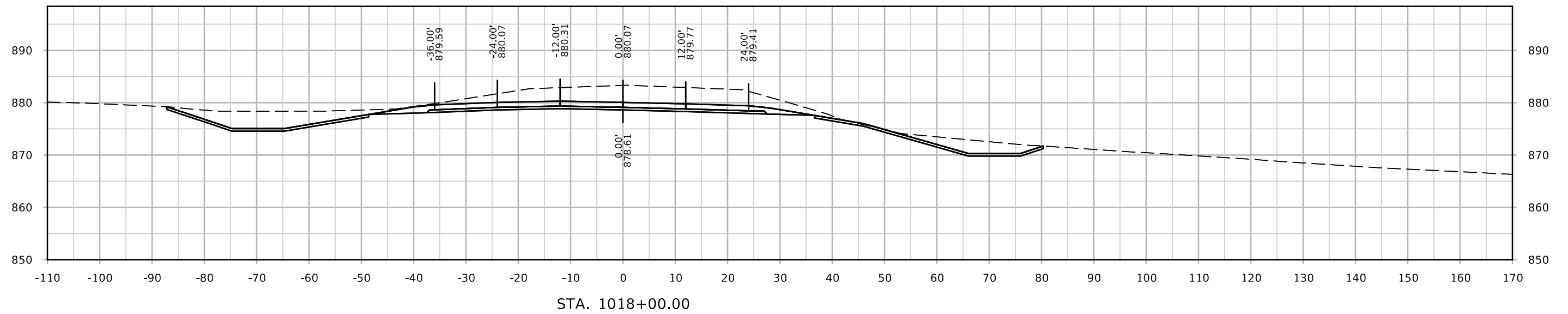

ML - I35 NB

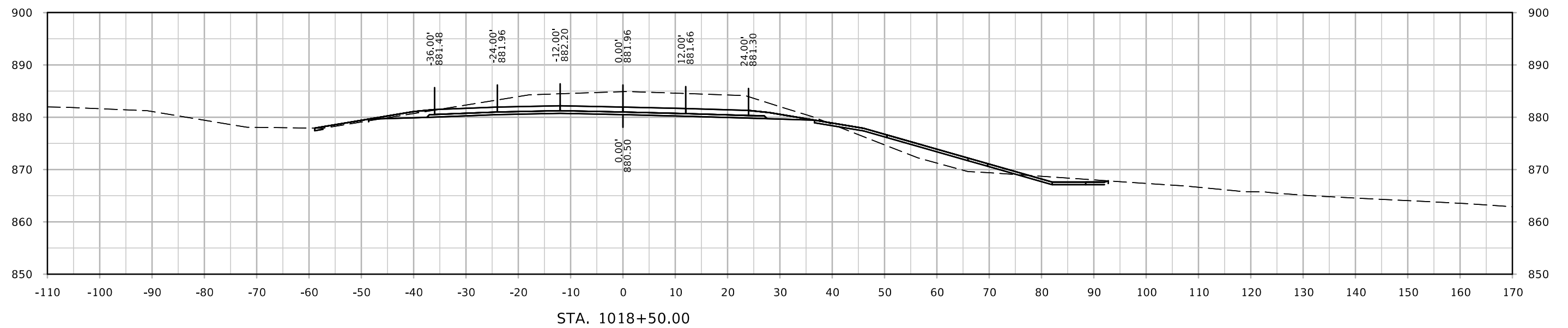
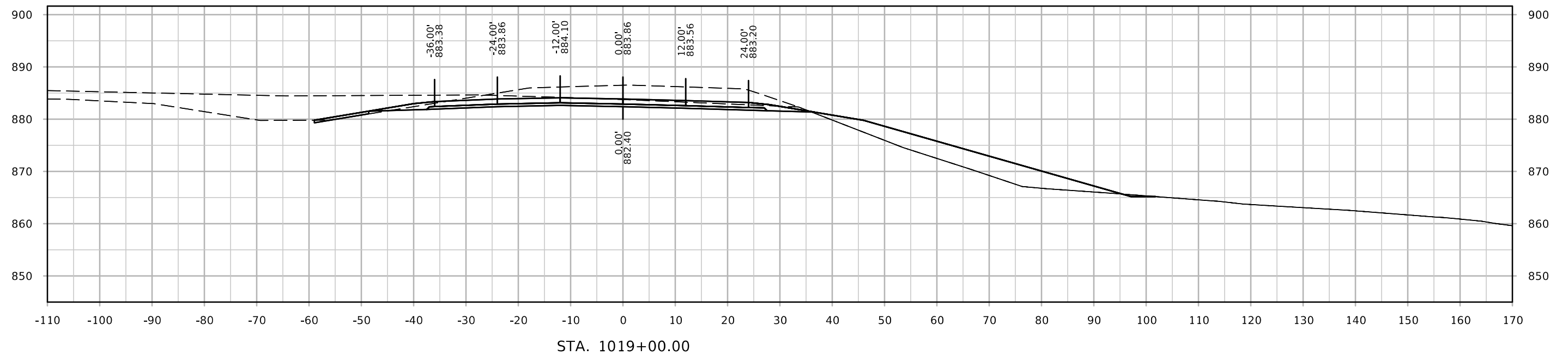

ML - I35 NB

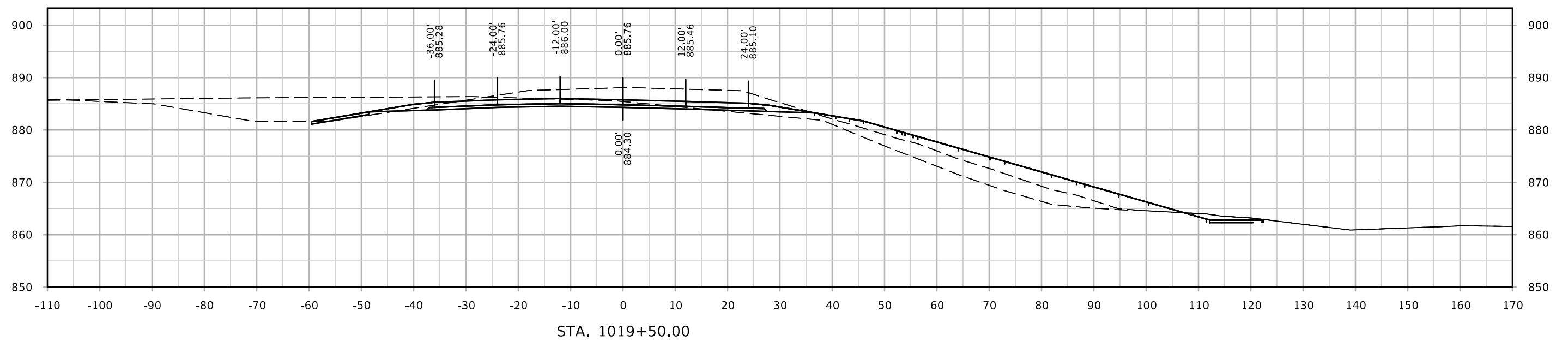
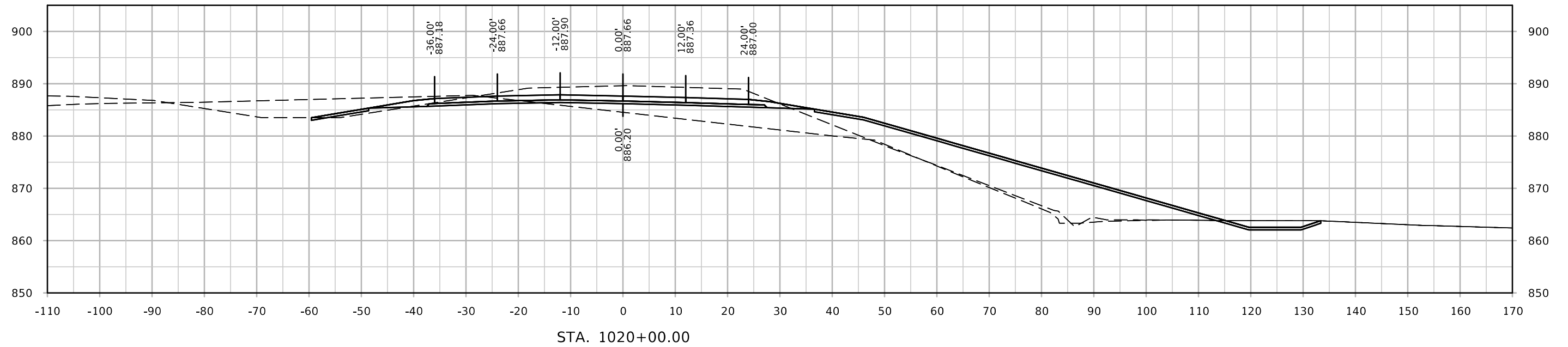

ML - I35 NB

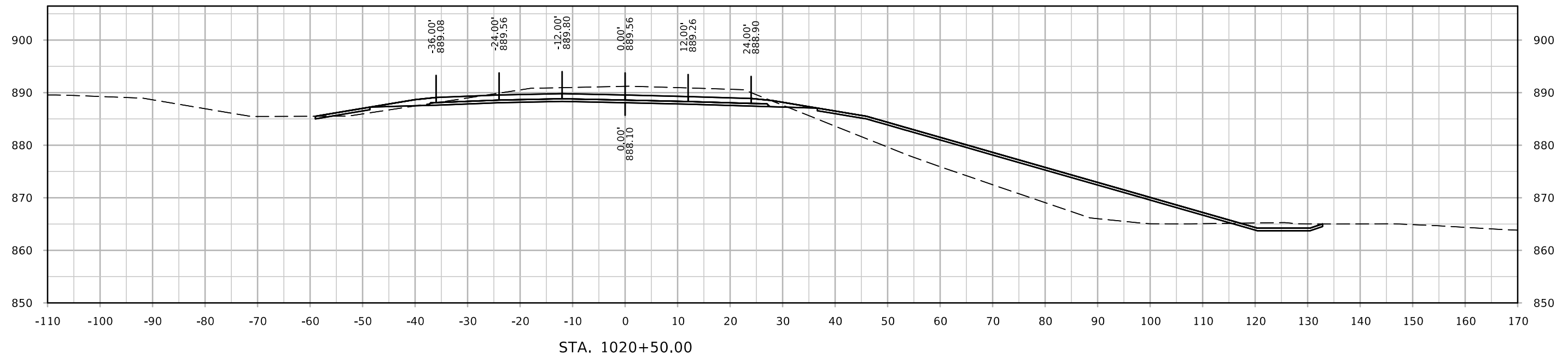
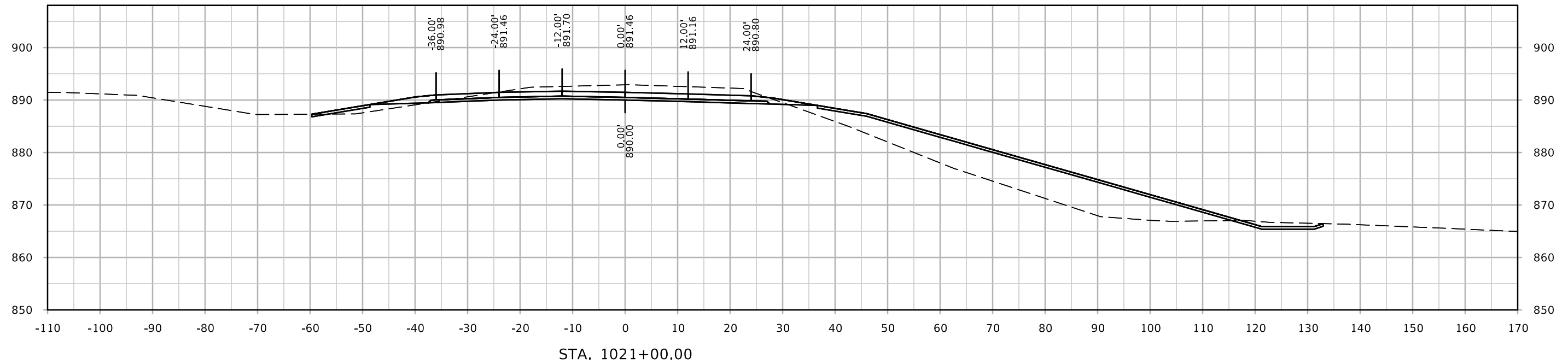

ML - I35 NB

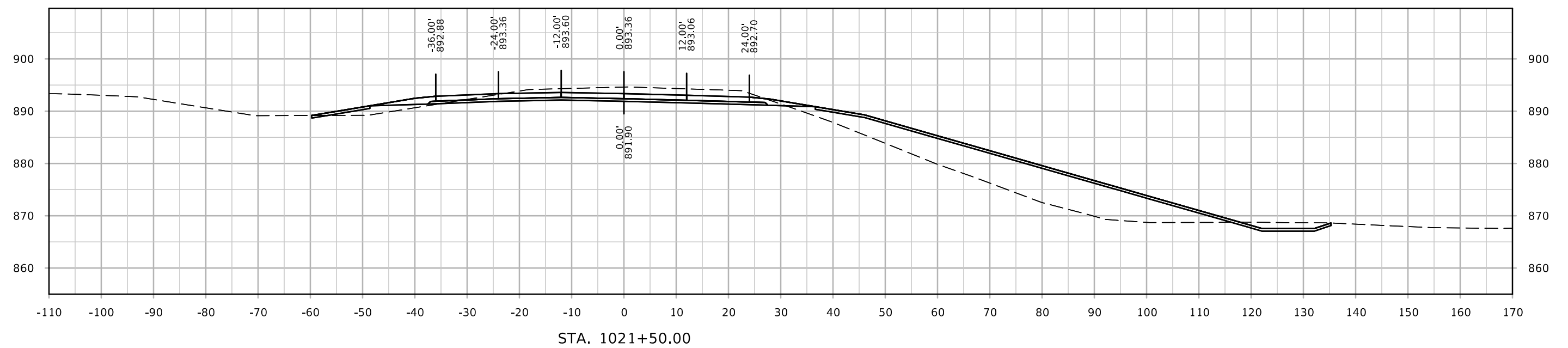
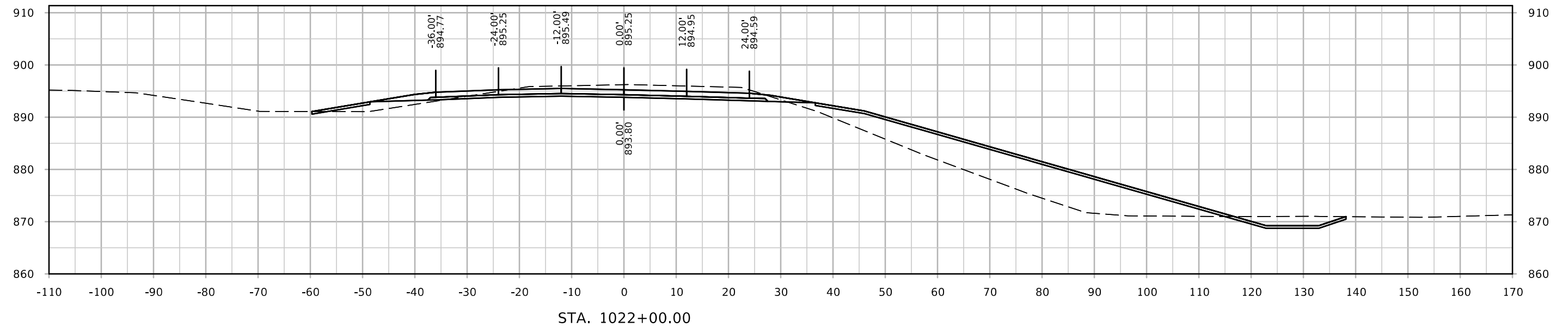

ML - I35 NB

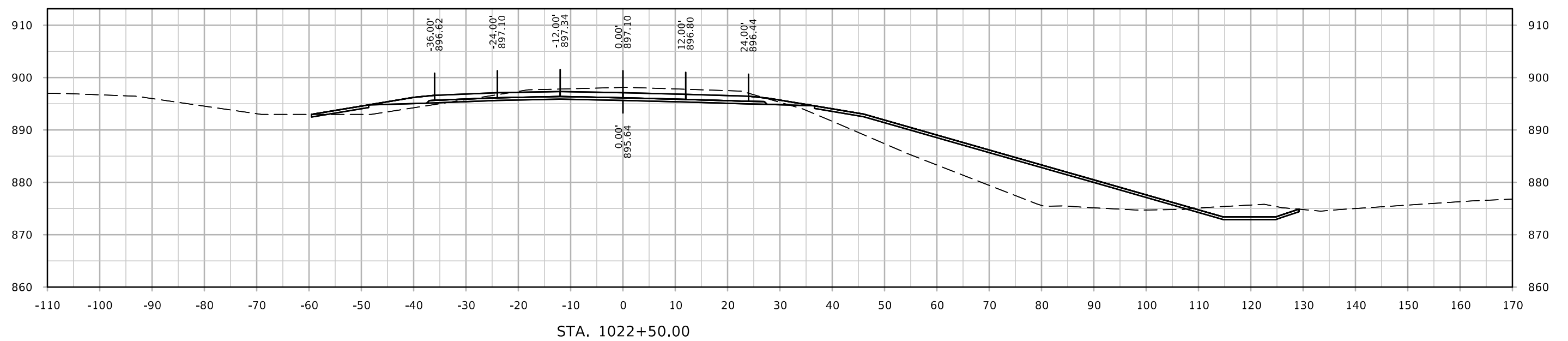
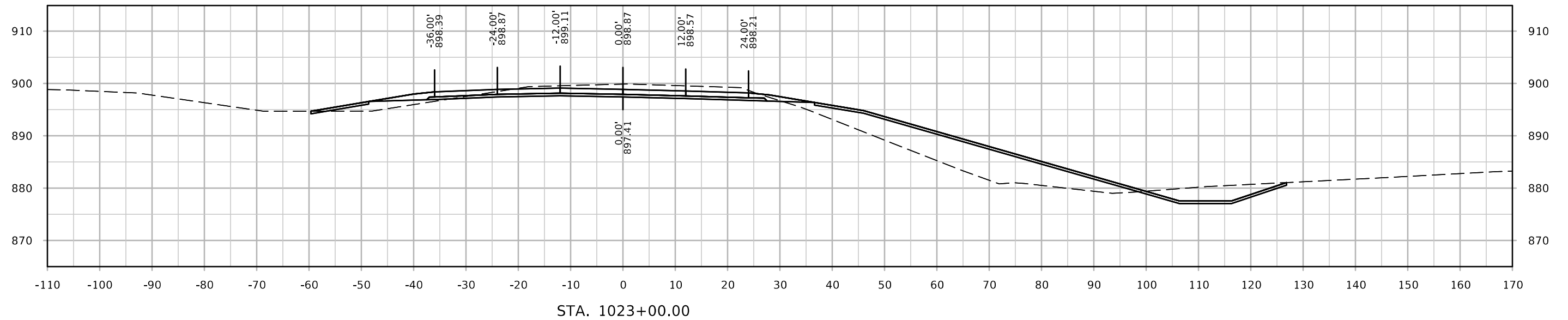

ML - I35 NB

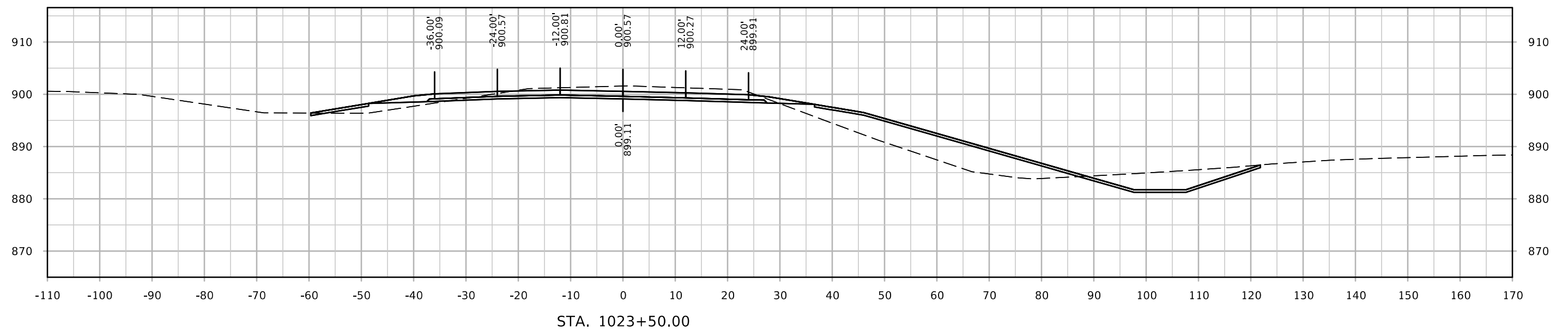
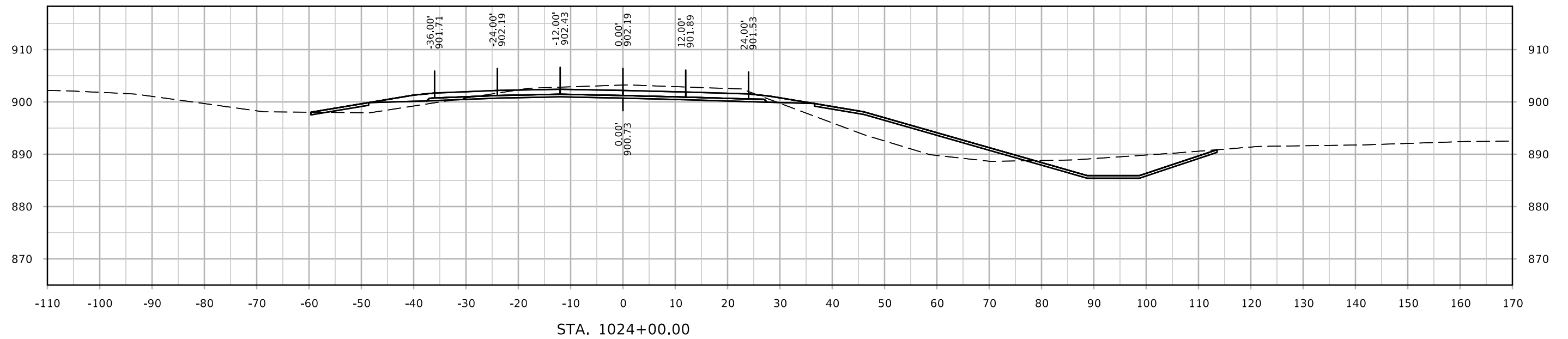

ML - I35 NB

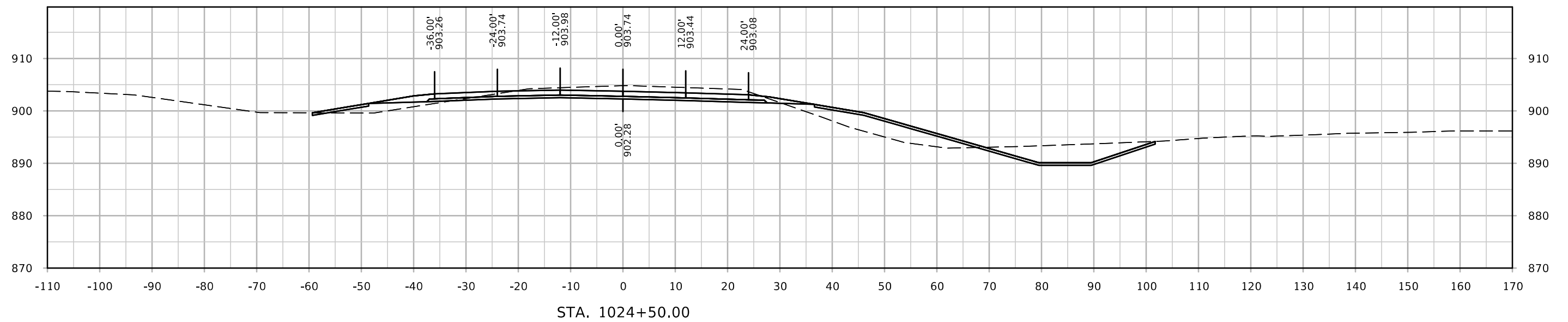
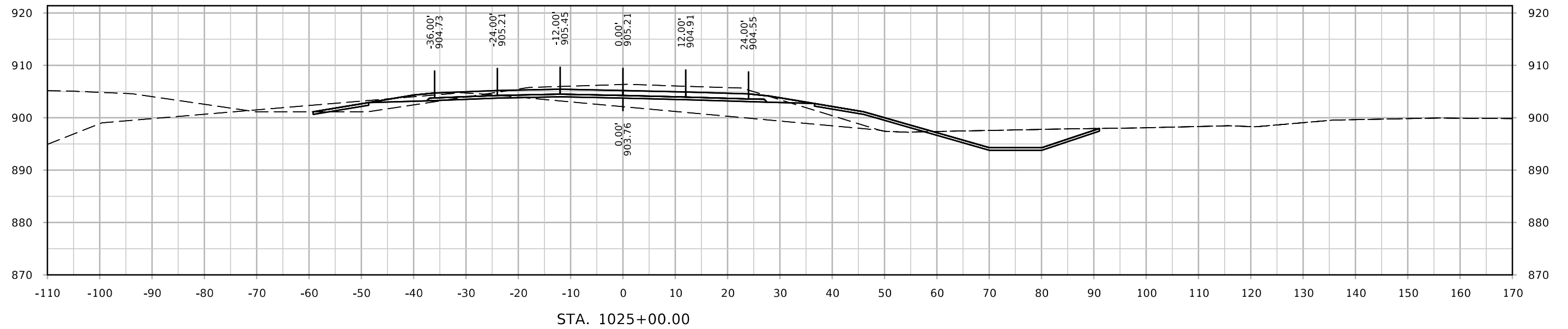

ML - I35 NB

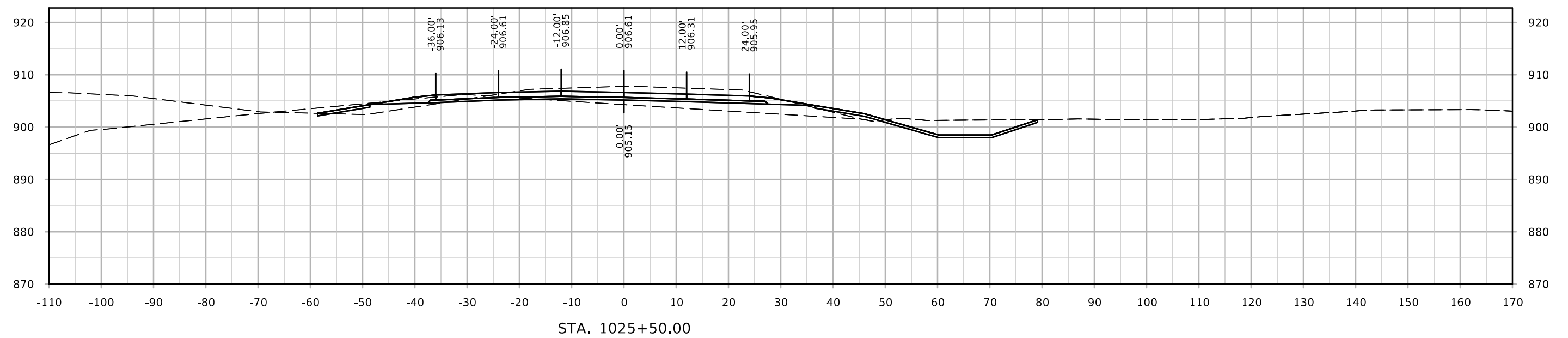
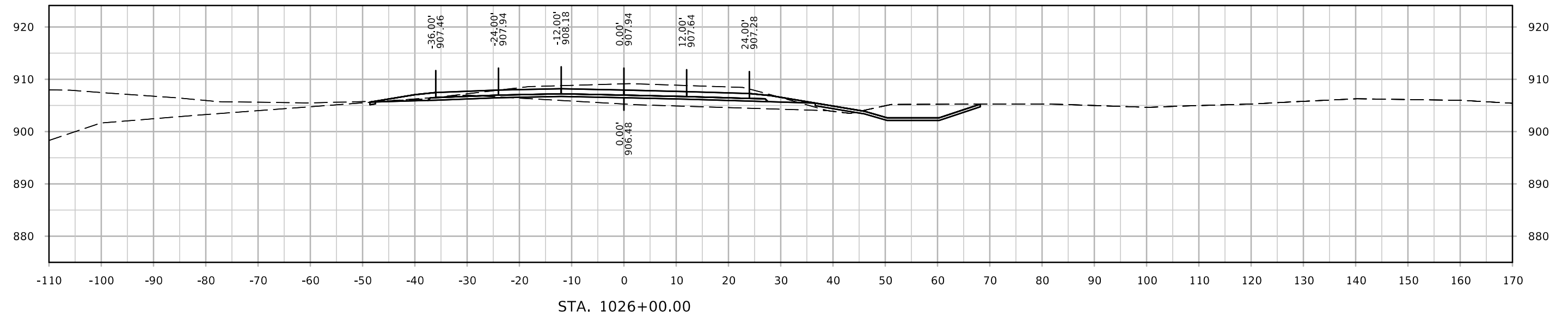

ML - I35 NB

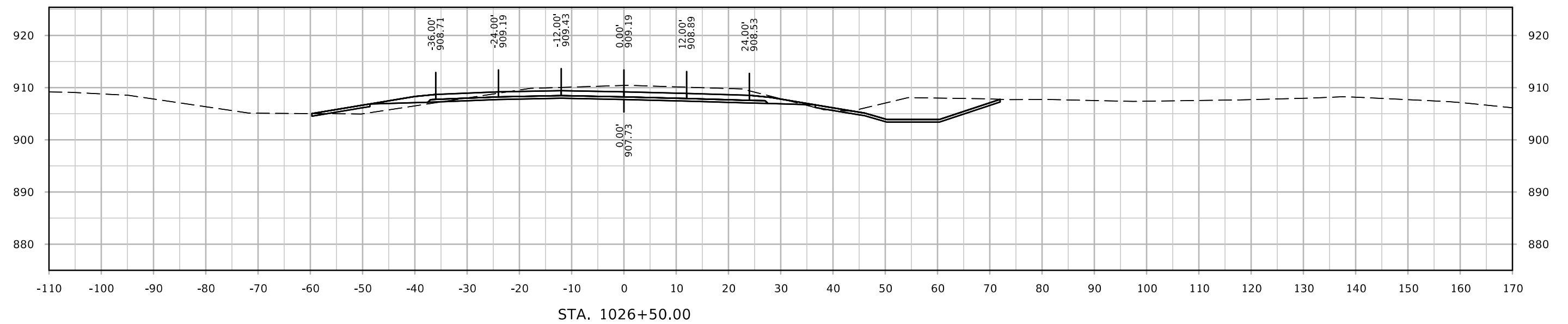
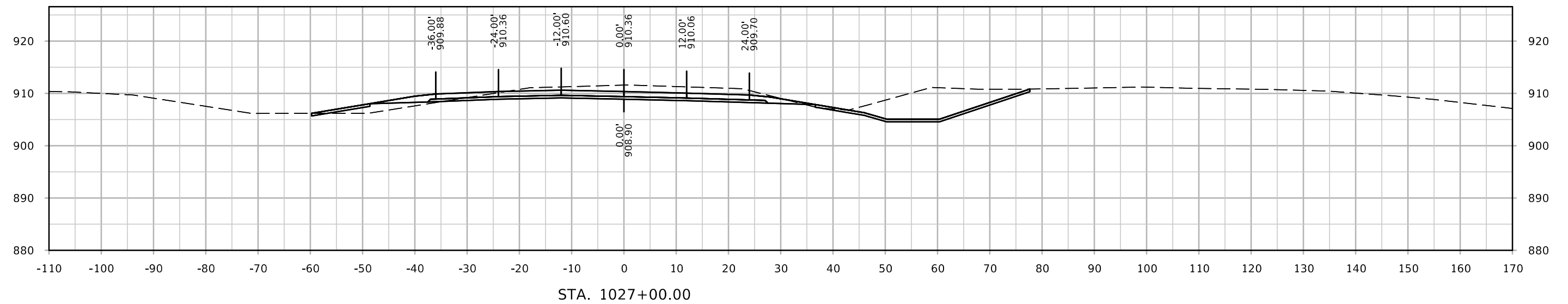

ML - I35 NB

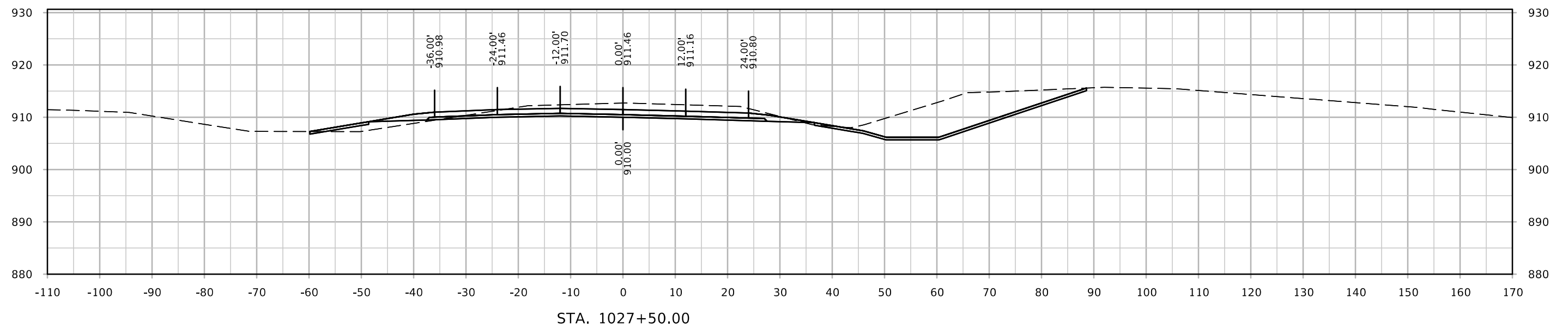
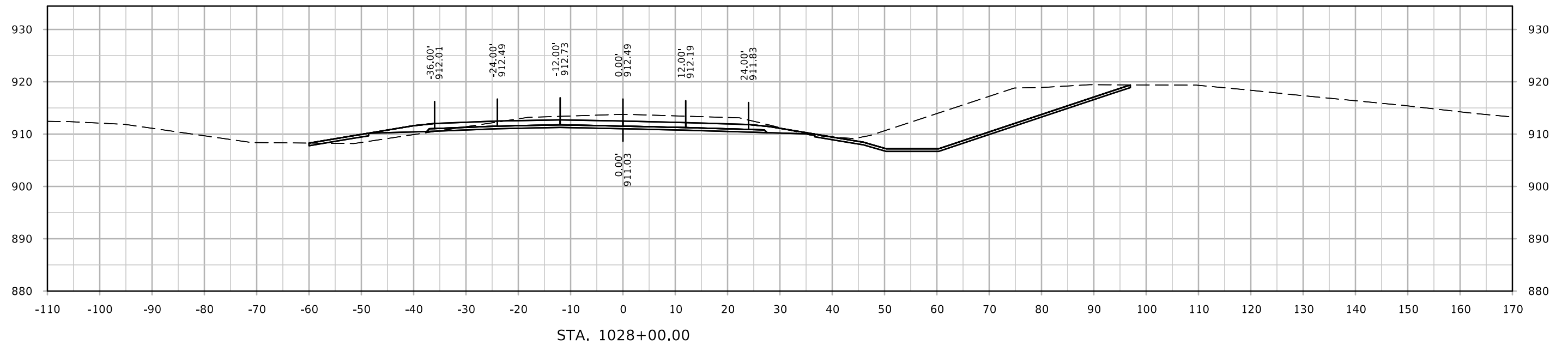

ML - I35 NB

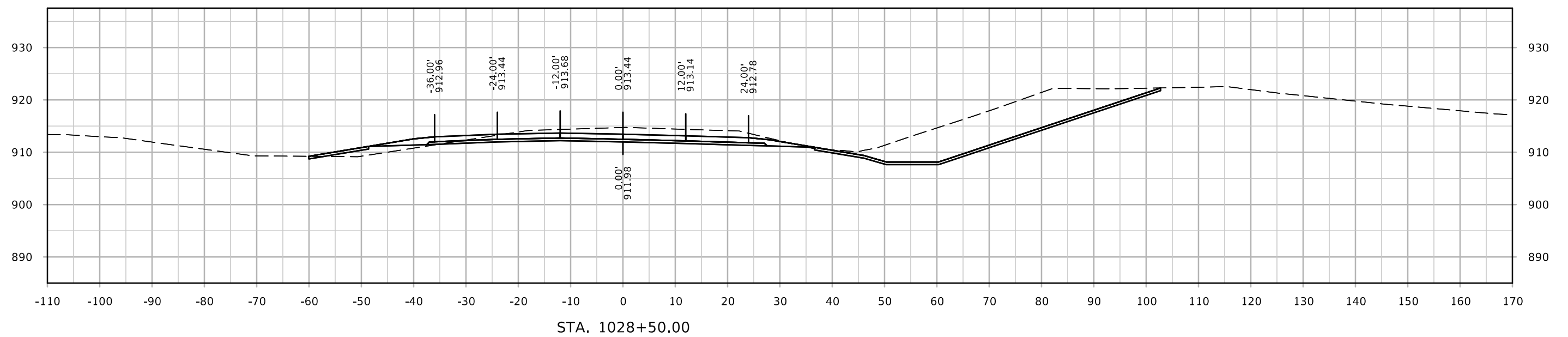
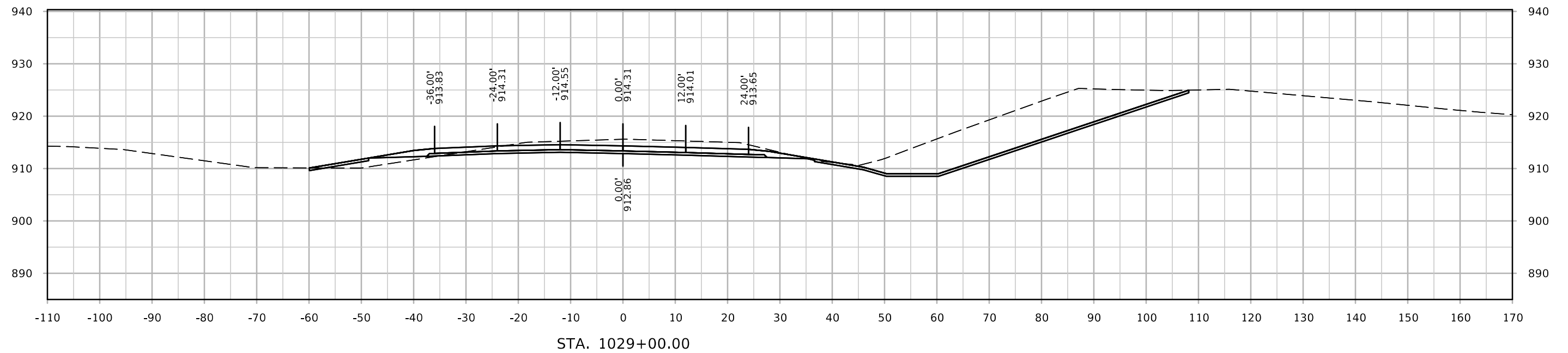

ML - I35 NB

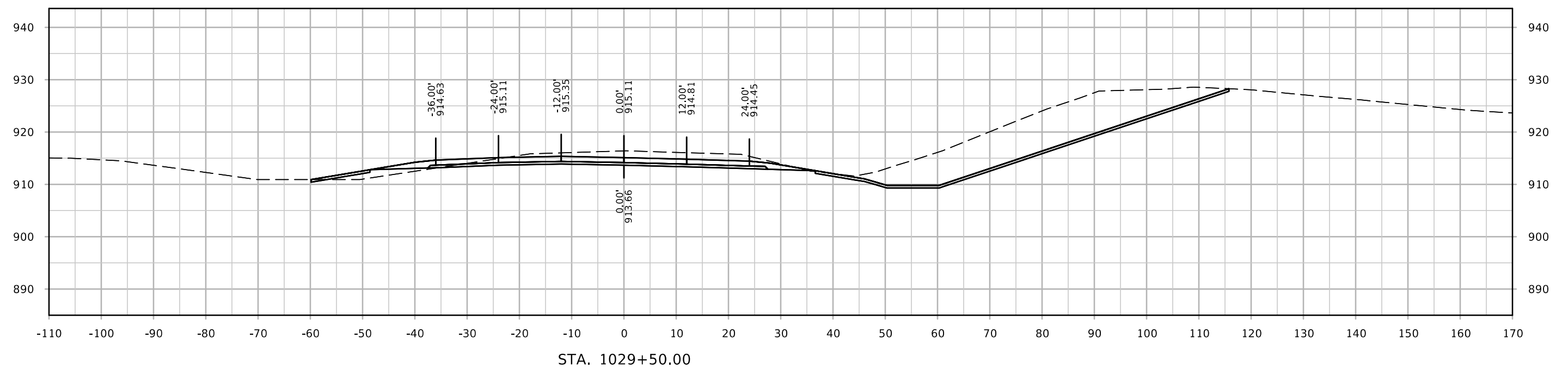
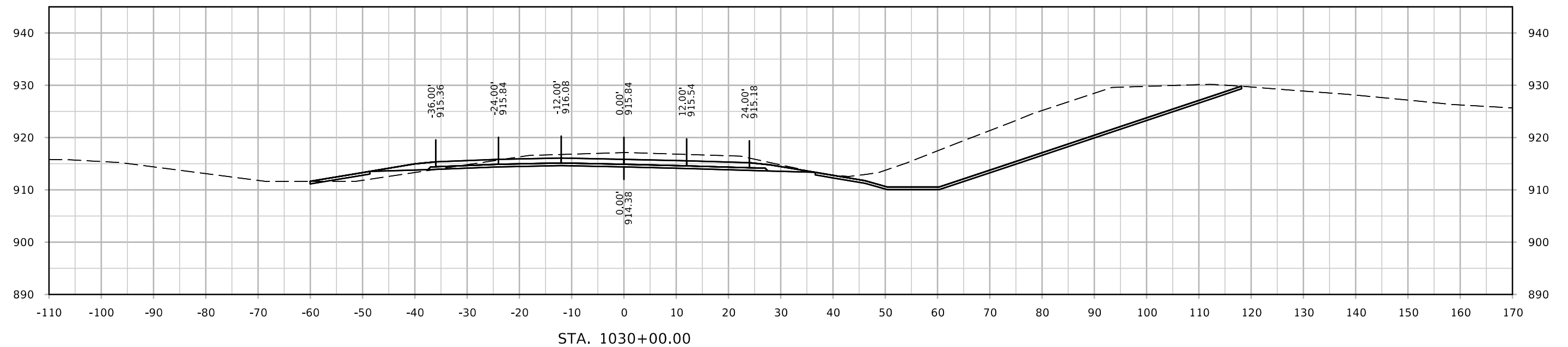

ML - I35 NB

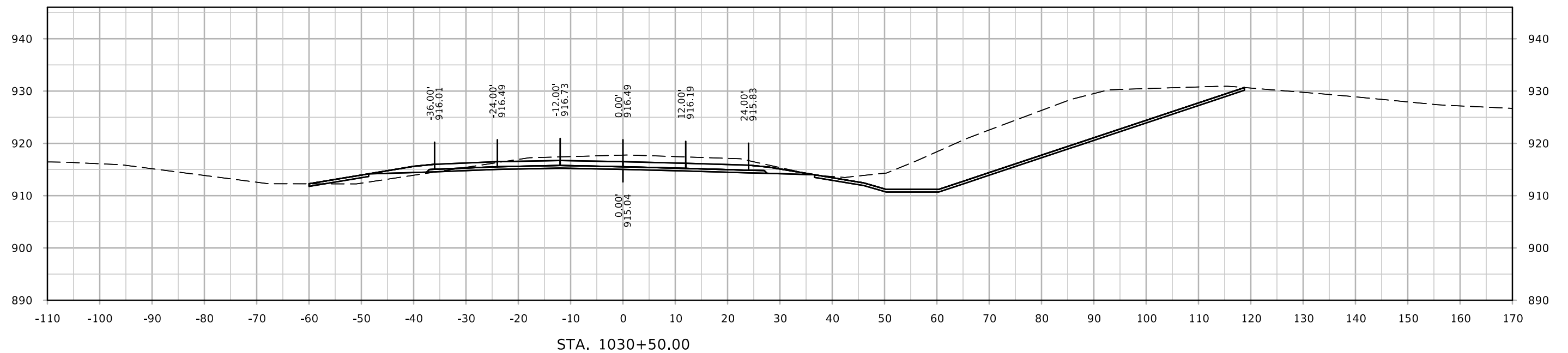
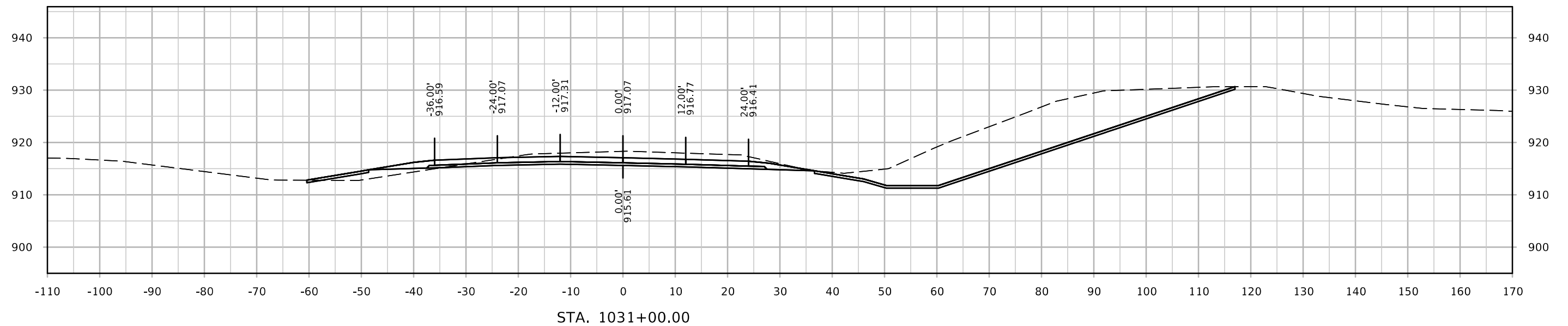

ML - I35 NB

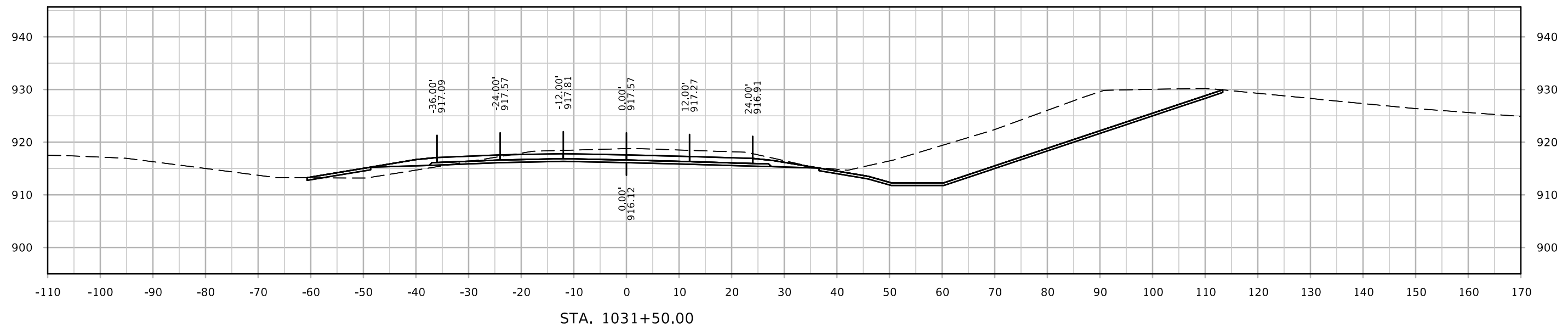
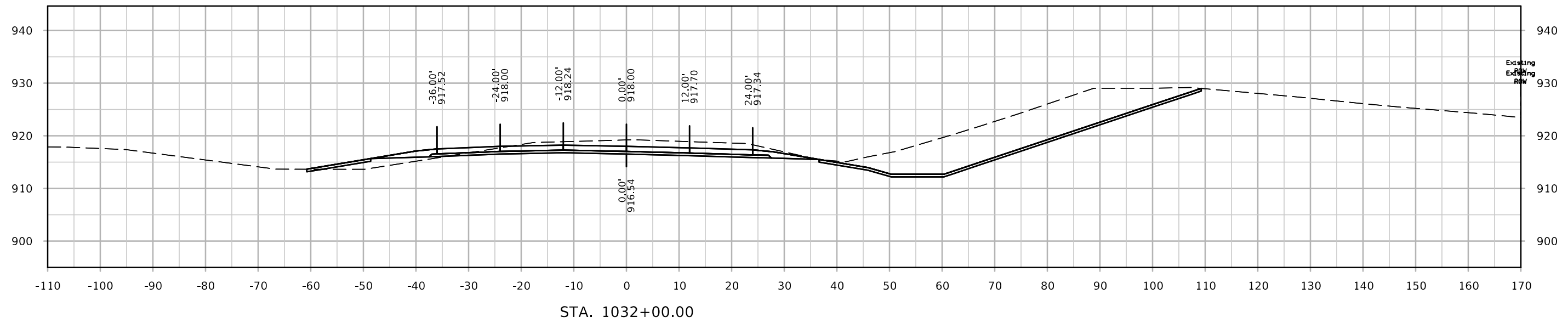

ML - I35 NB

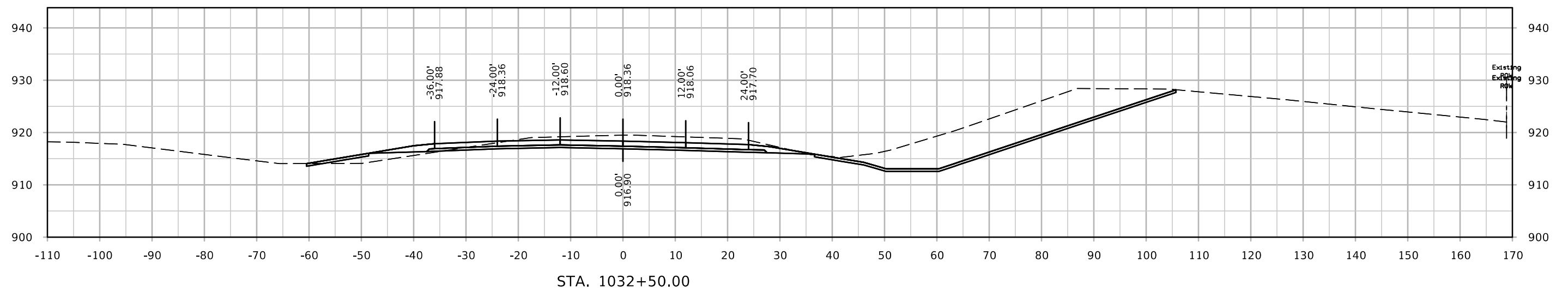
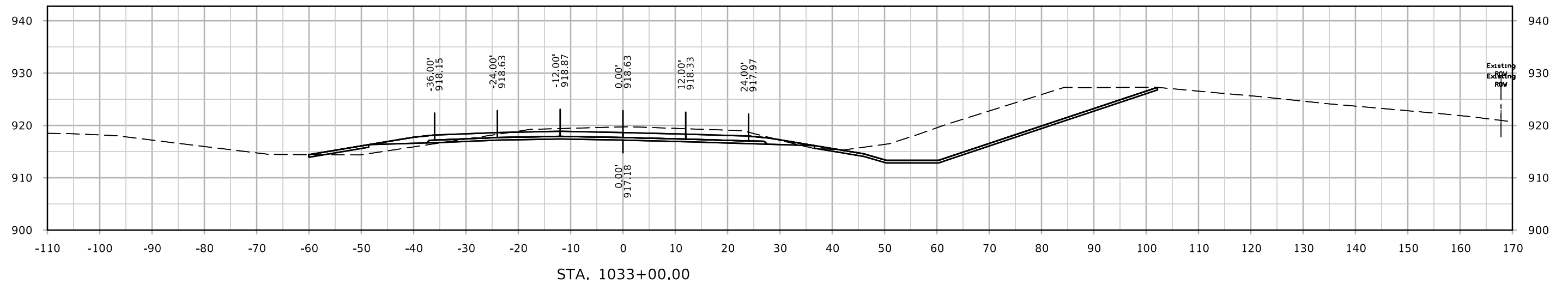
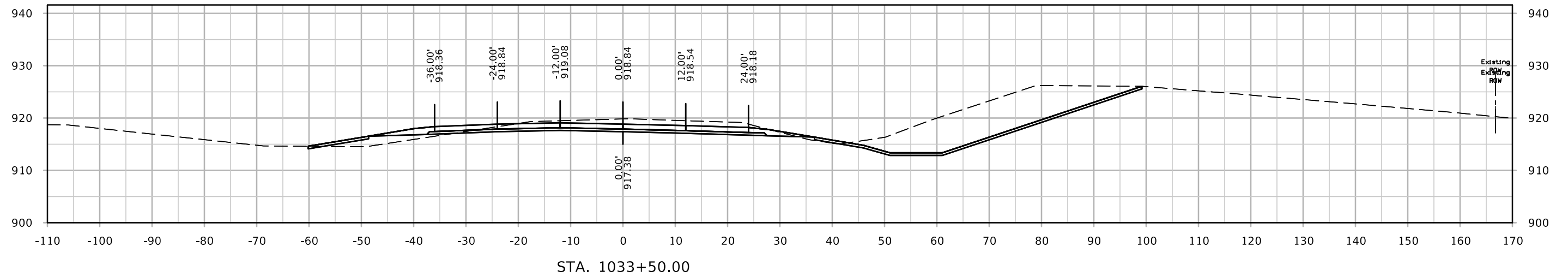

ML - I35 NB

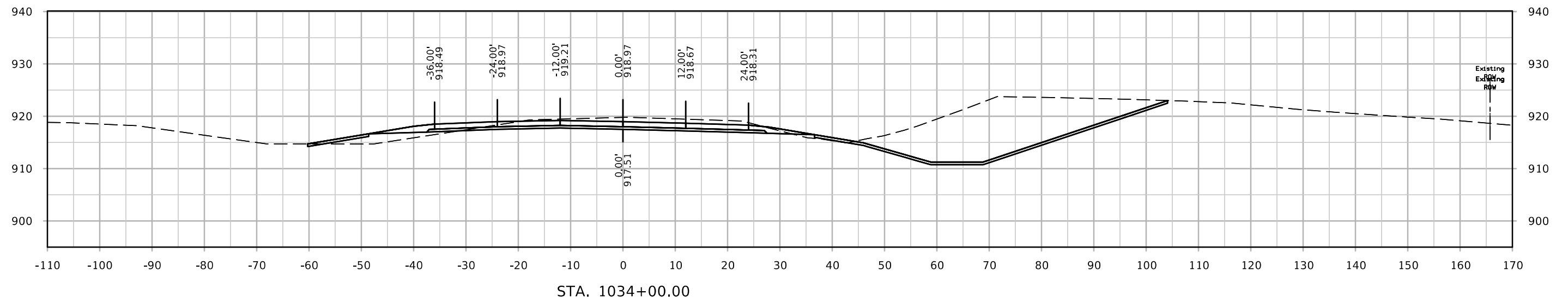
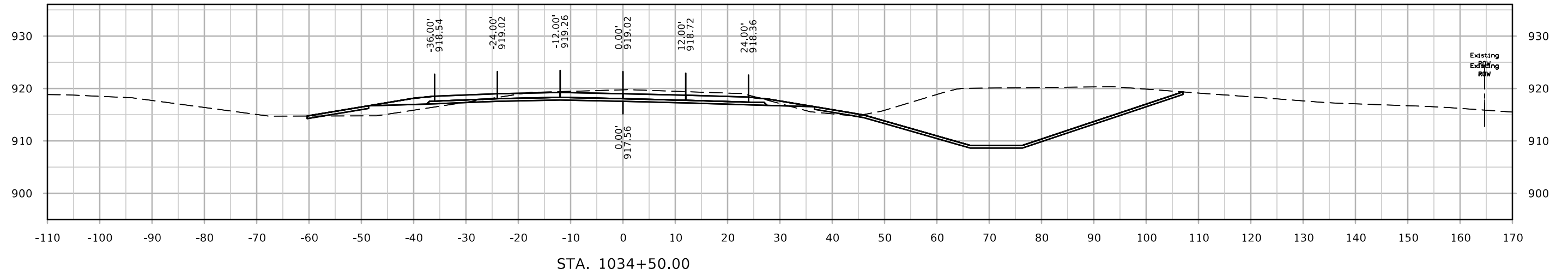
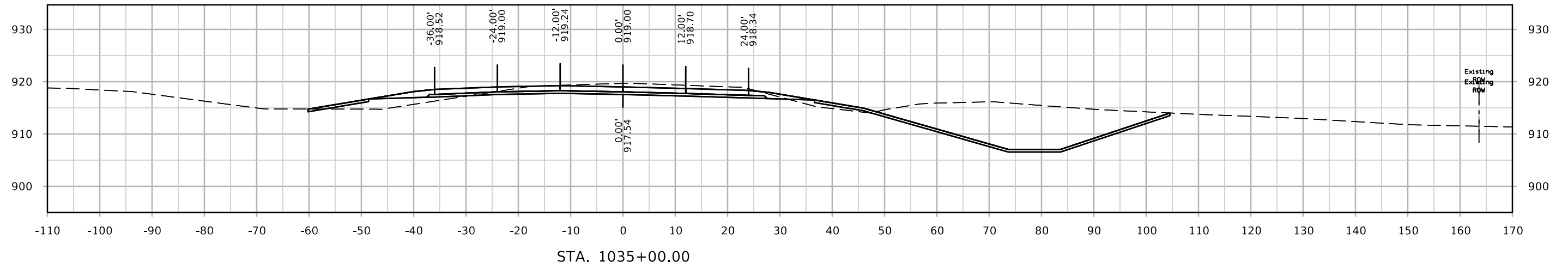

ML - I35 NB

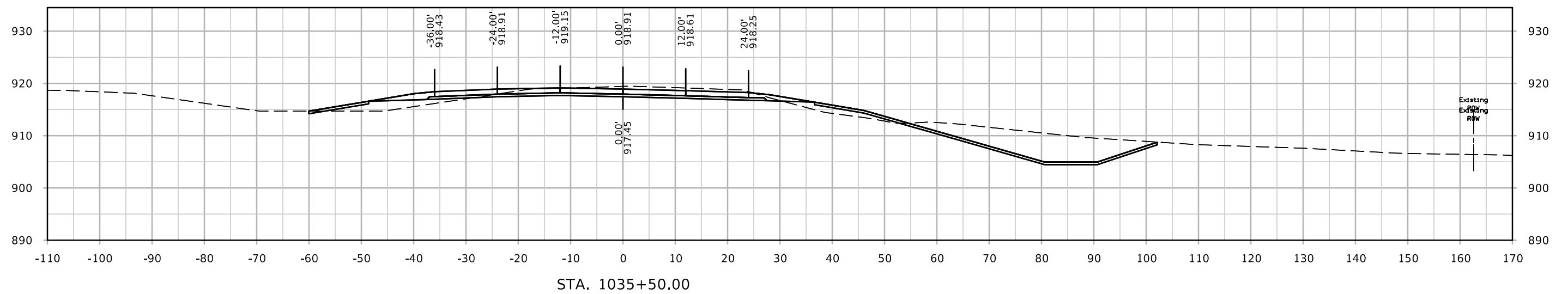
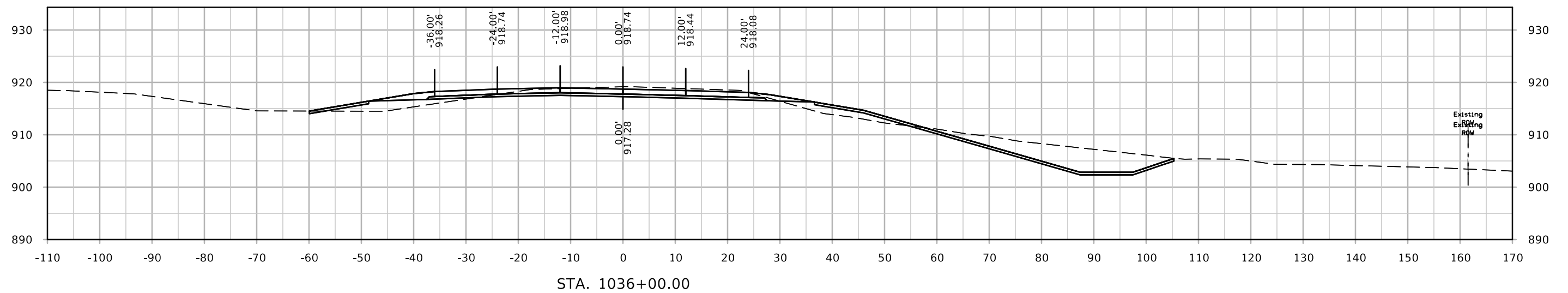

ML - I35 NB

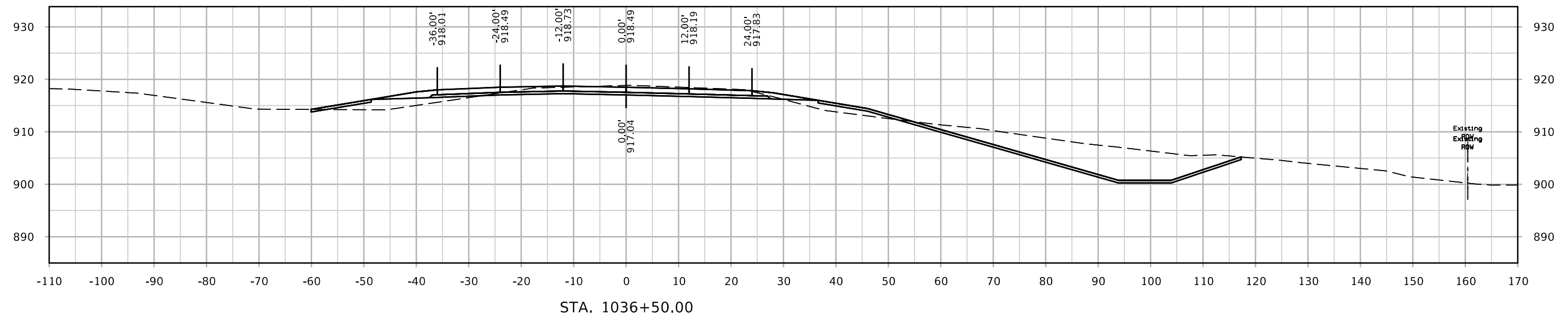
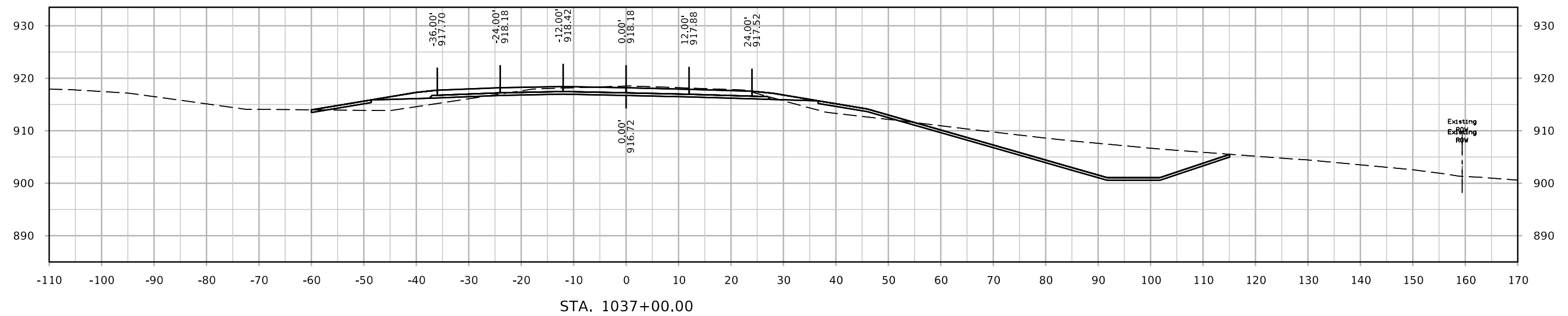

ML - I35 NB

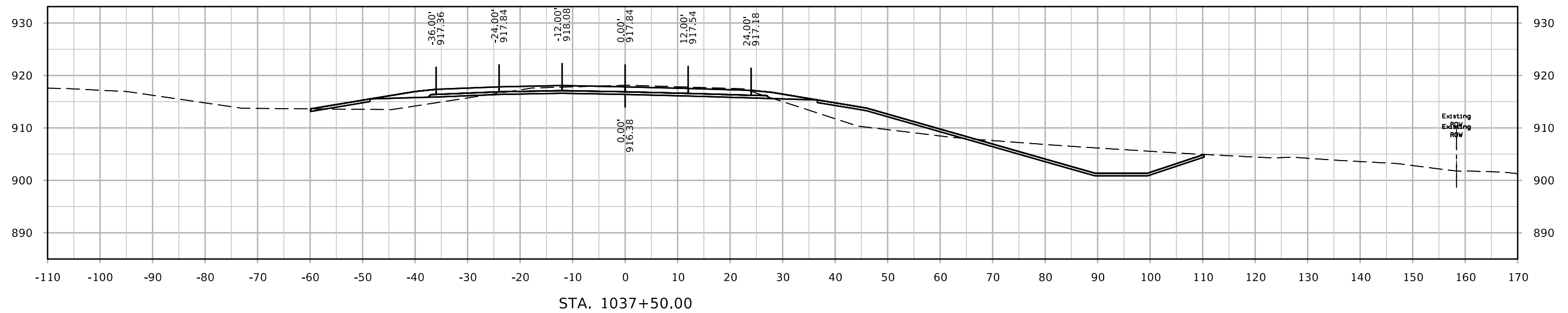
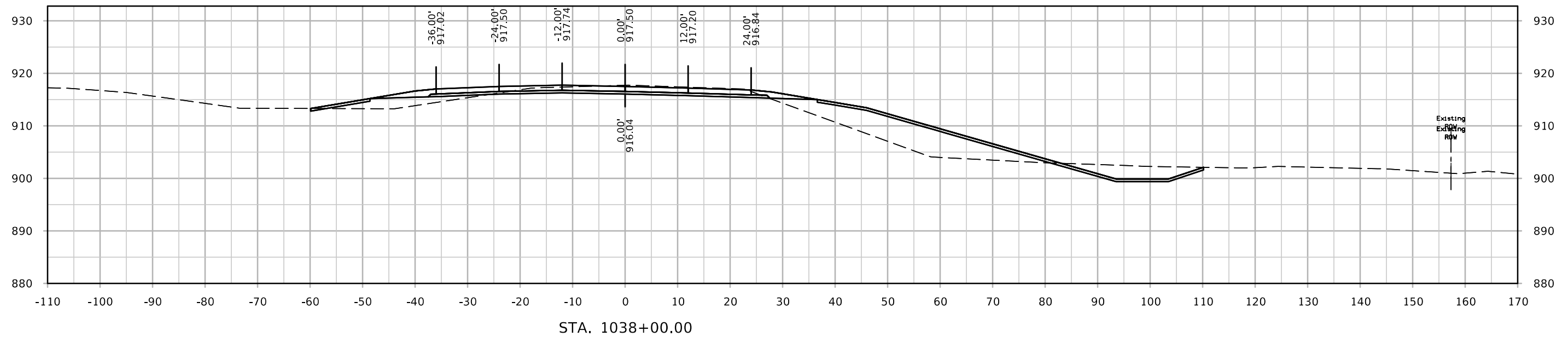

ML - I35 NB

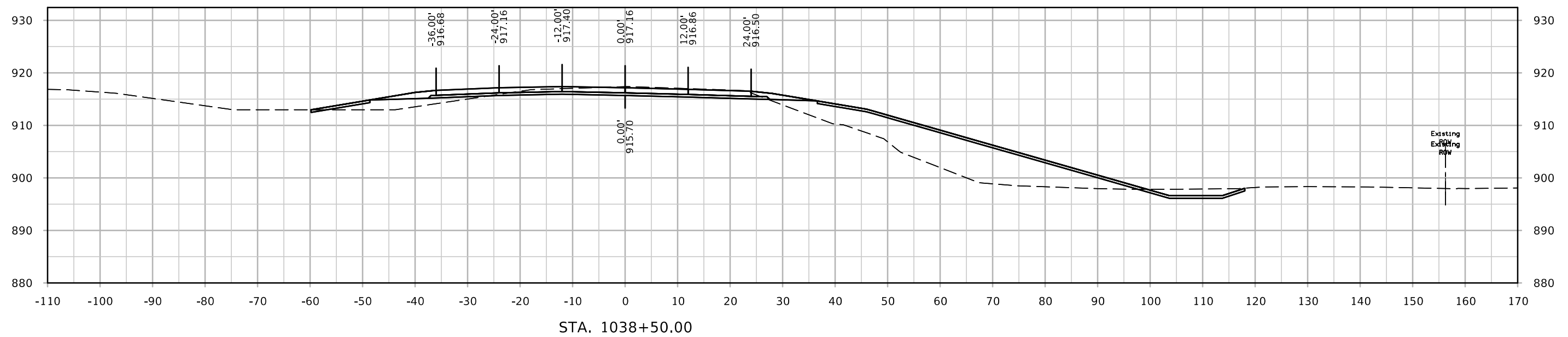
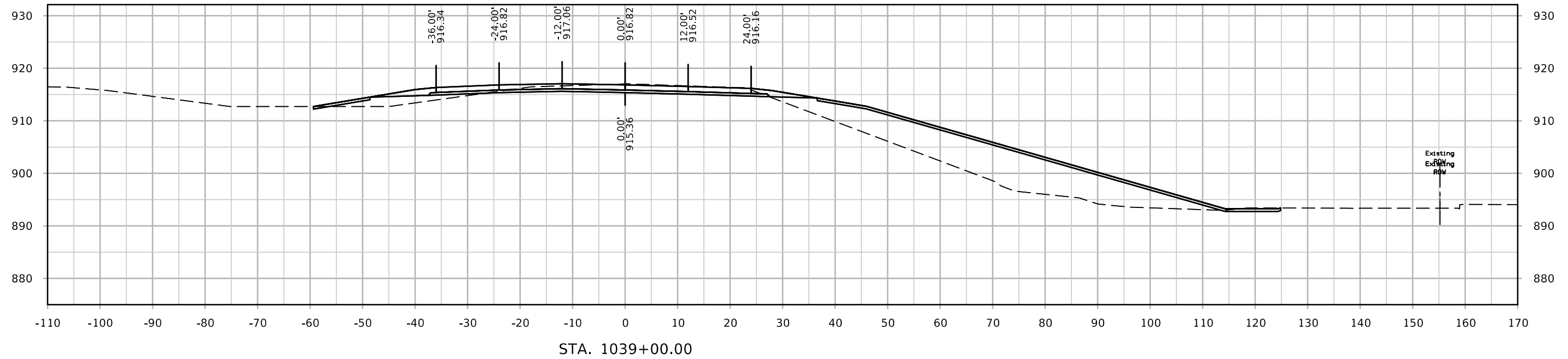

ML - I35 NB

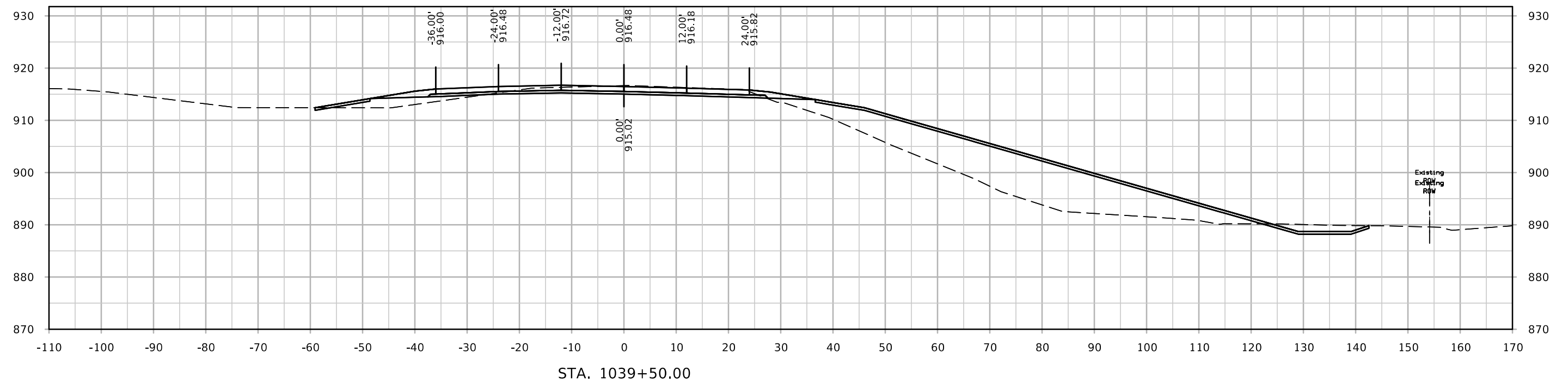
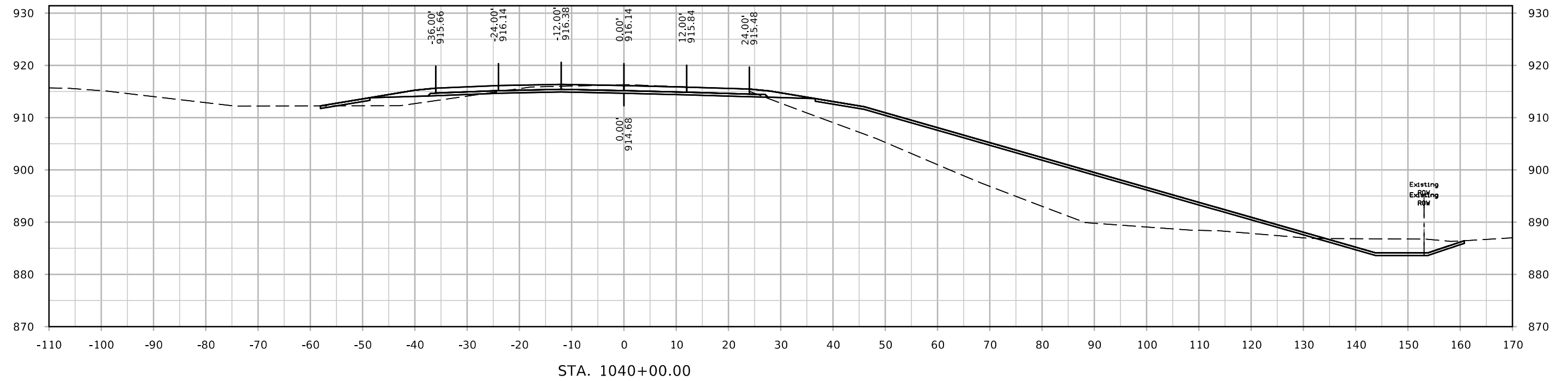

ML - I35 NB

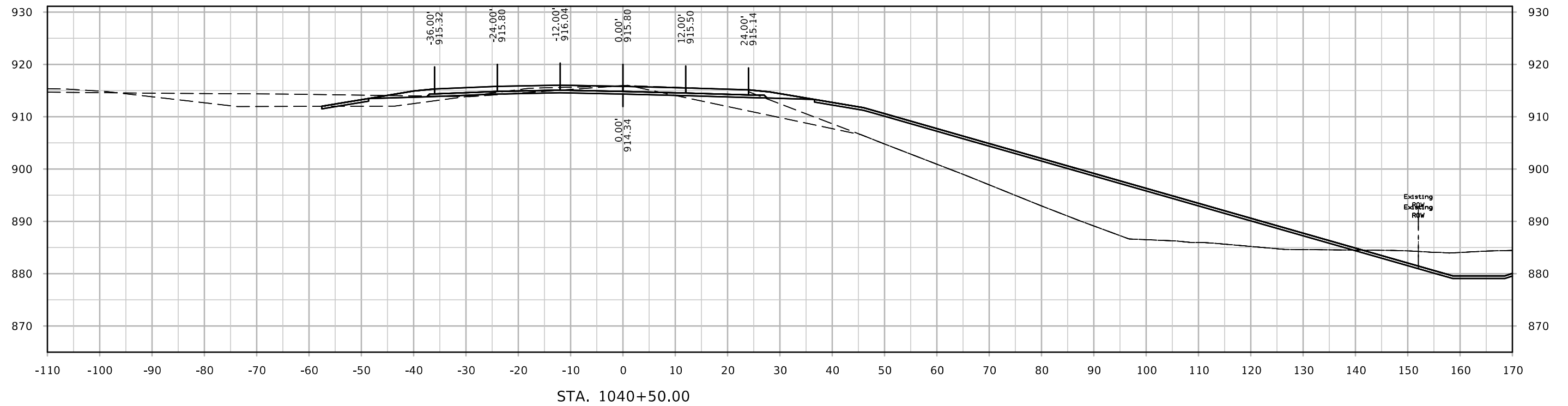
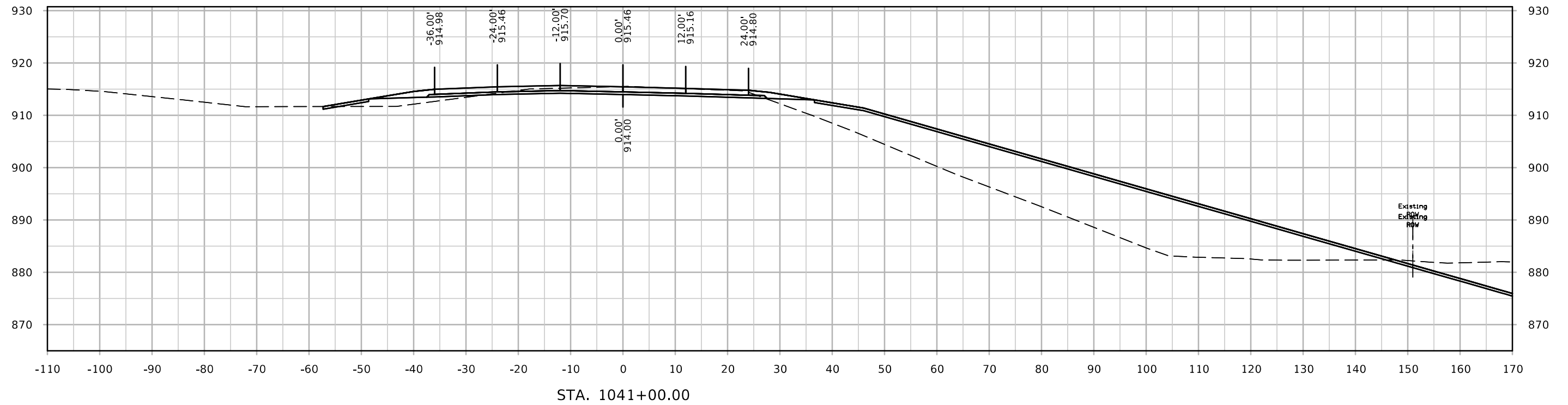

ML - I35 NB

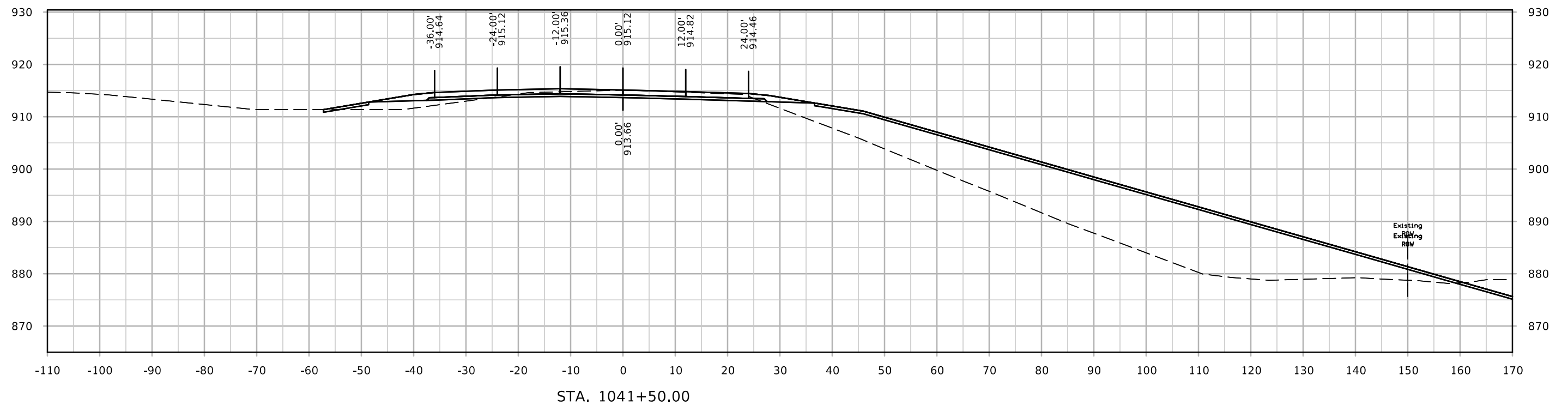
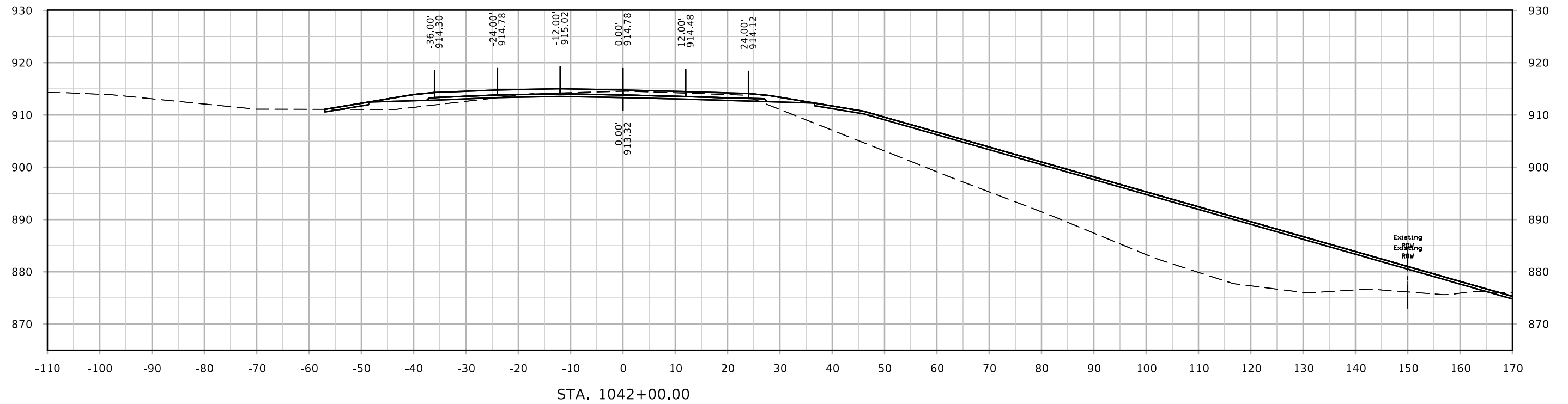

ML - I35 NB

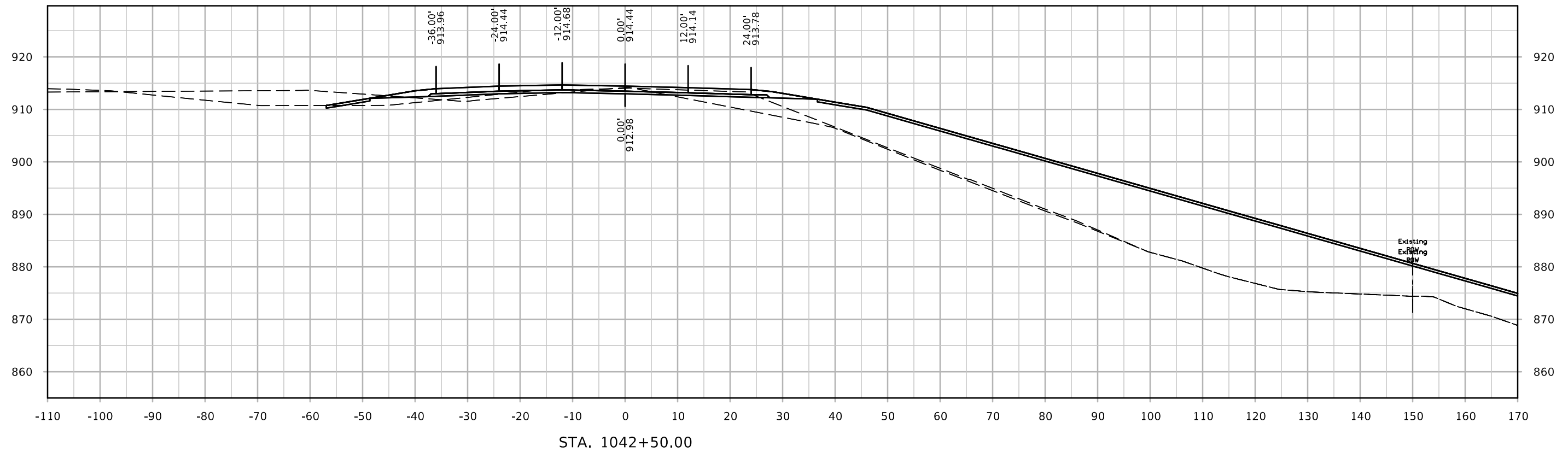
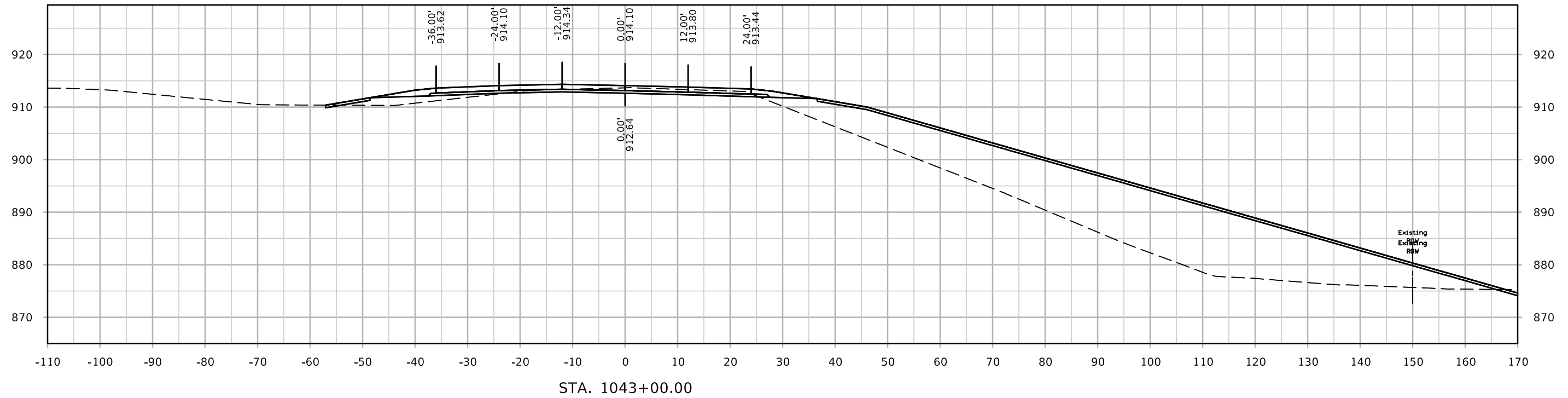

ML - I35 NB

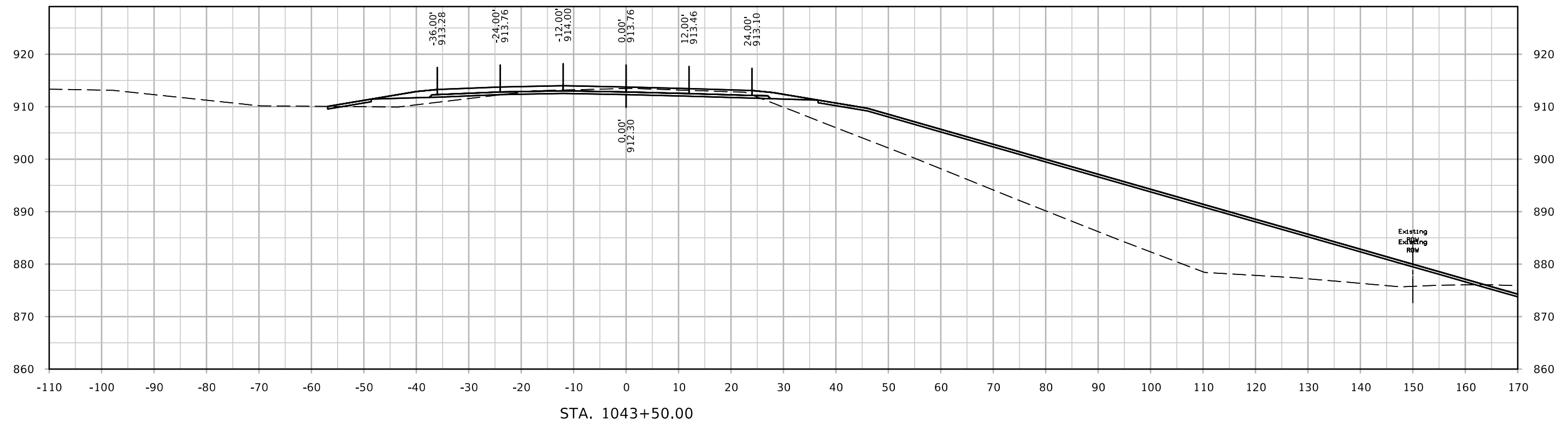
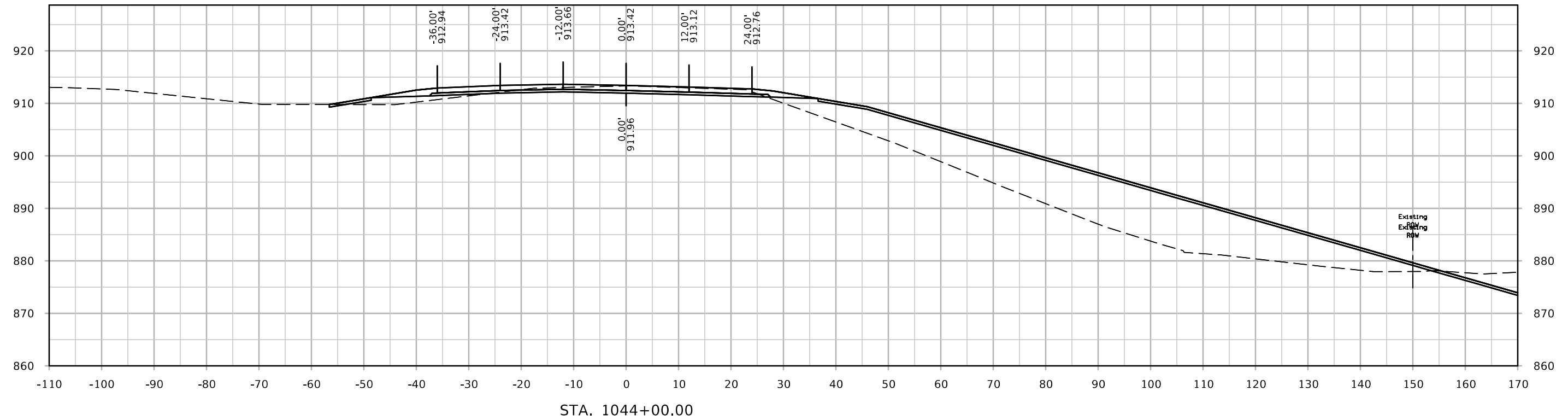

ML - I35 NB

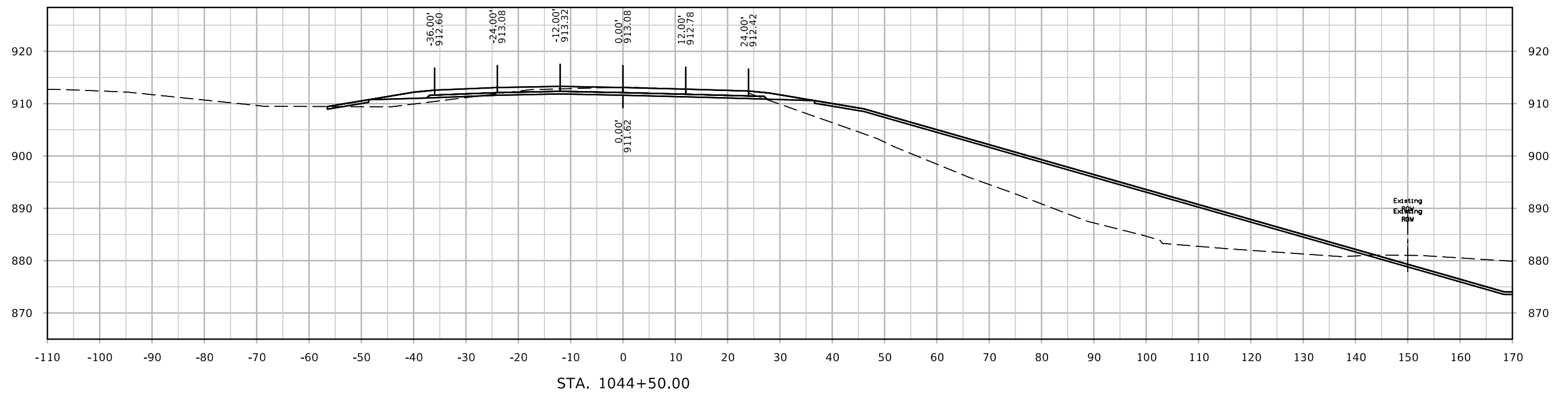
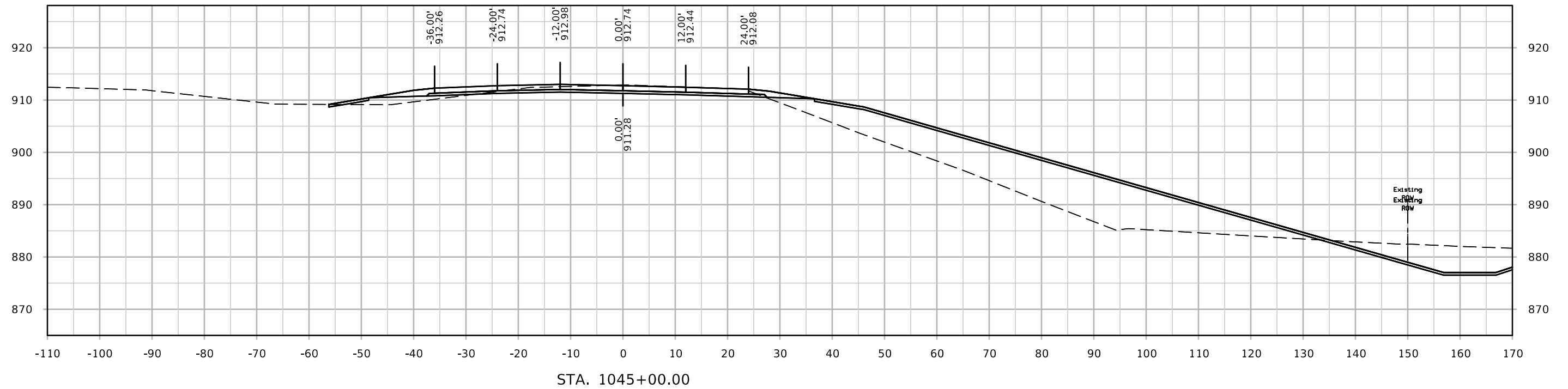

ML - I35 NB

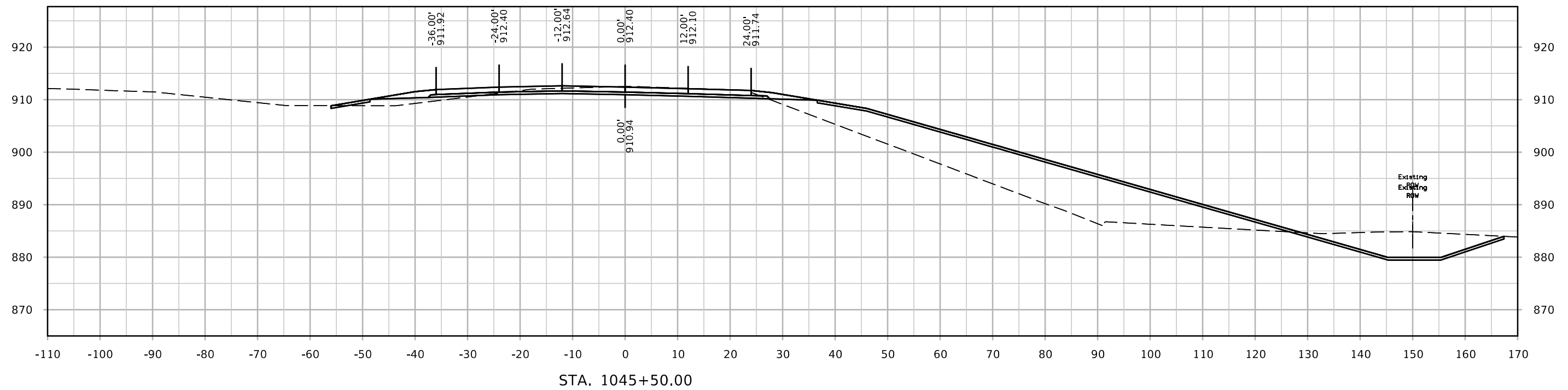
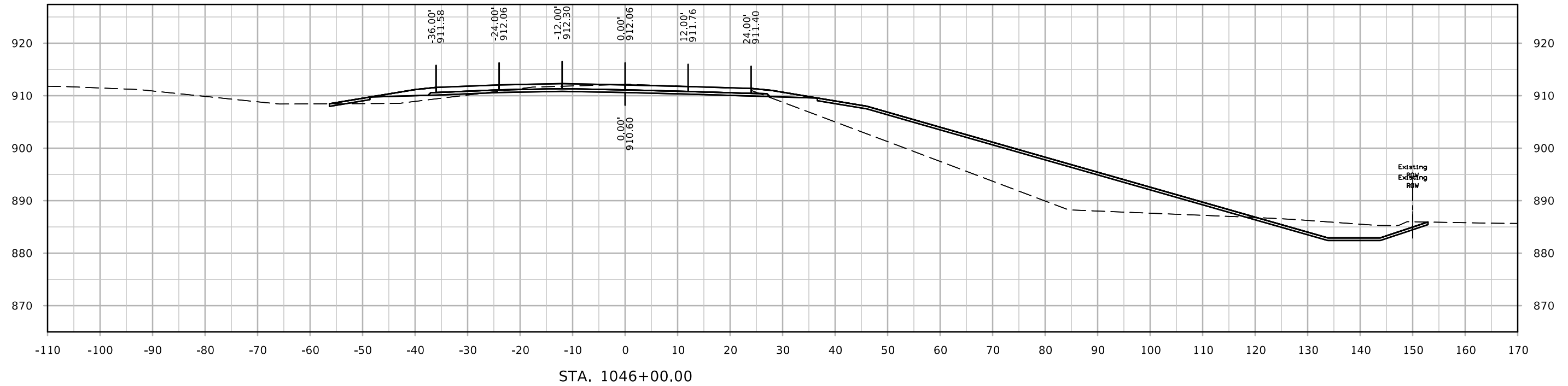

ML - I35 NB

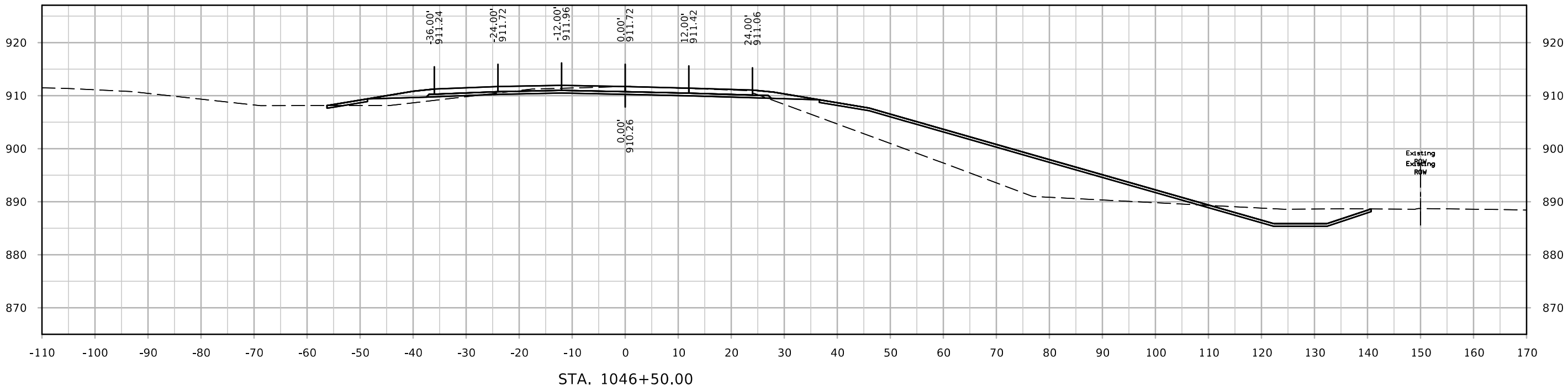
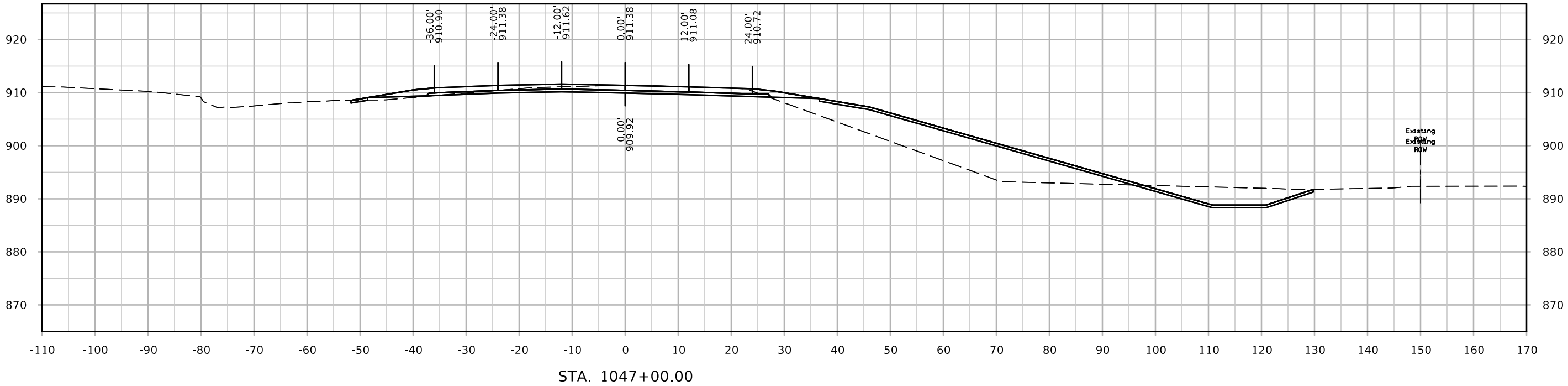

ML - I35 NB

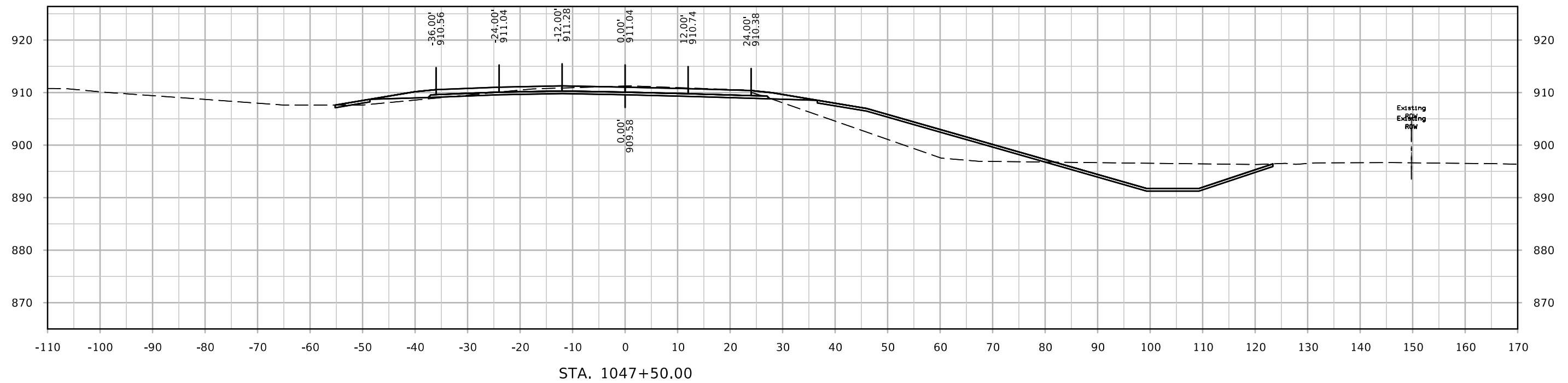
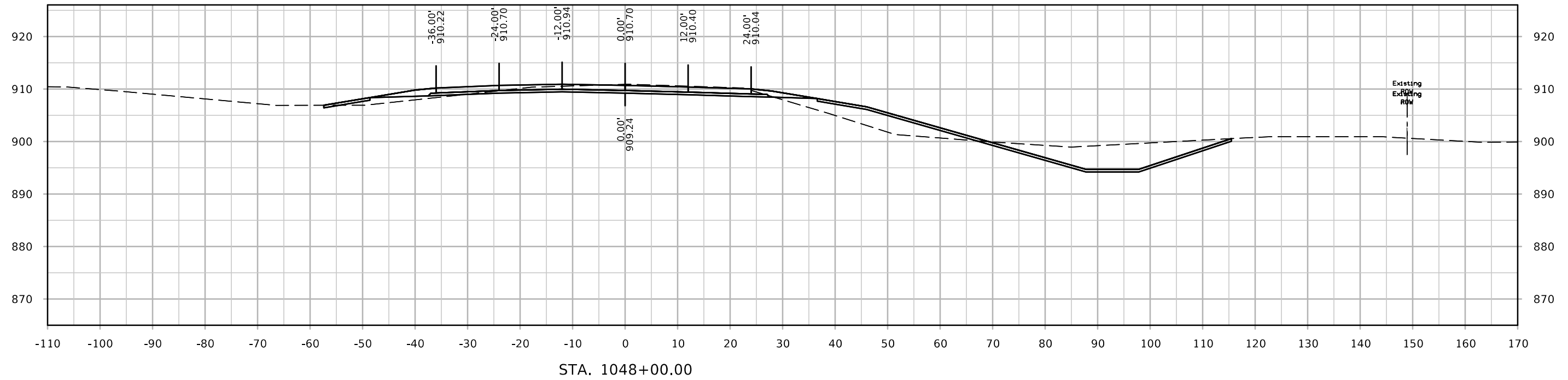

ML - I35 NB

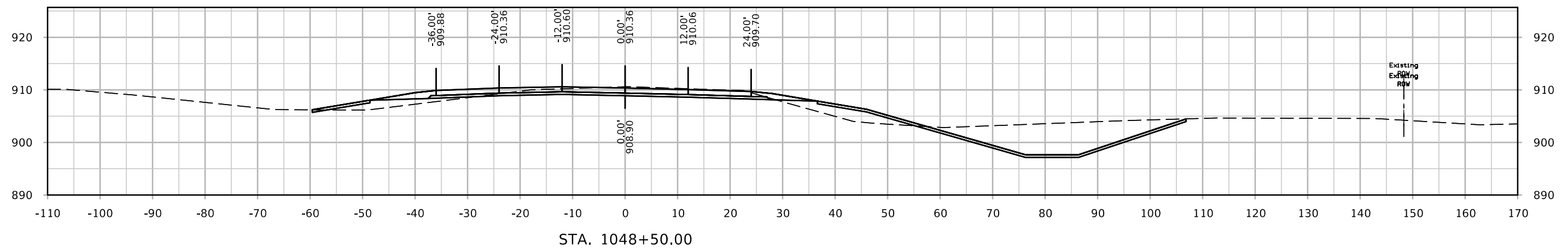
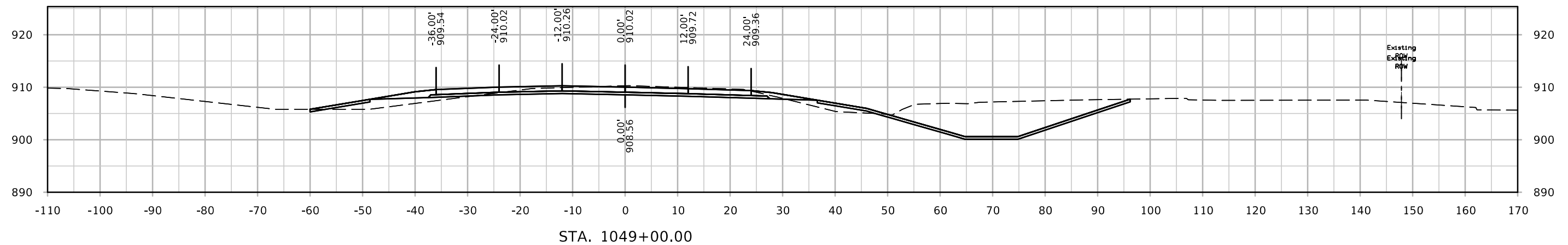
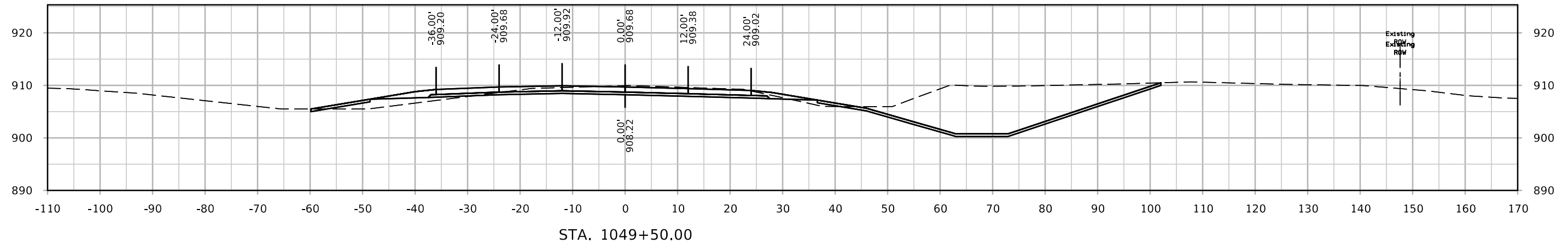

ML - I35 NB

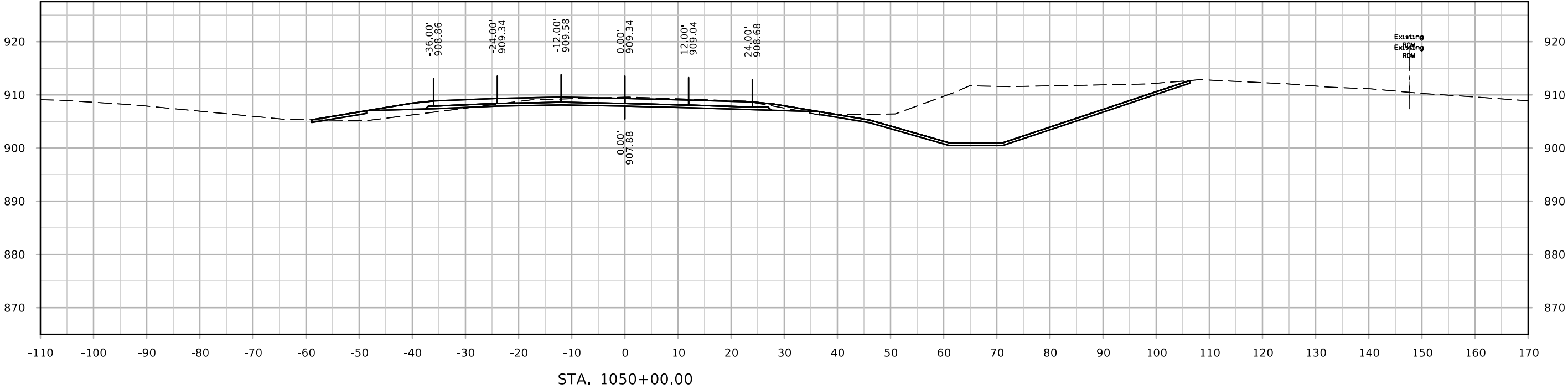
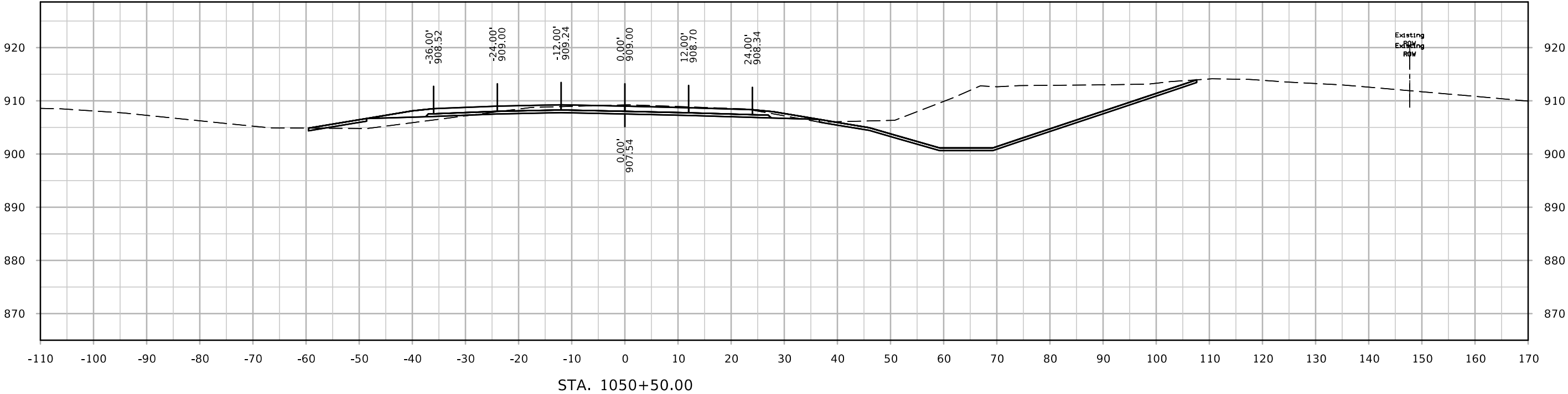

ML - I35 NB

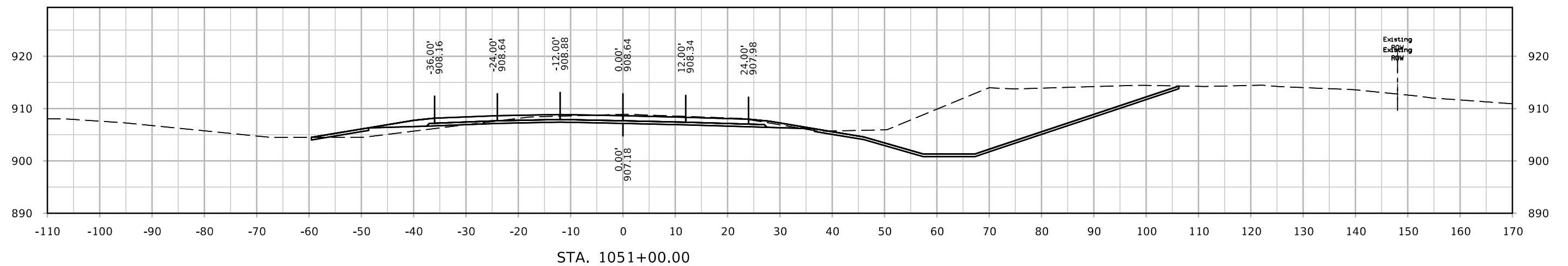
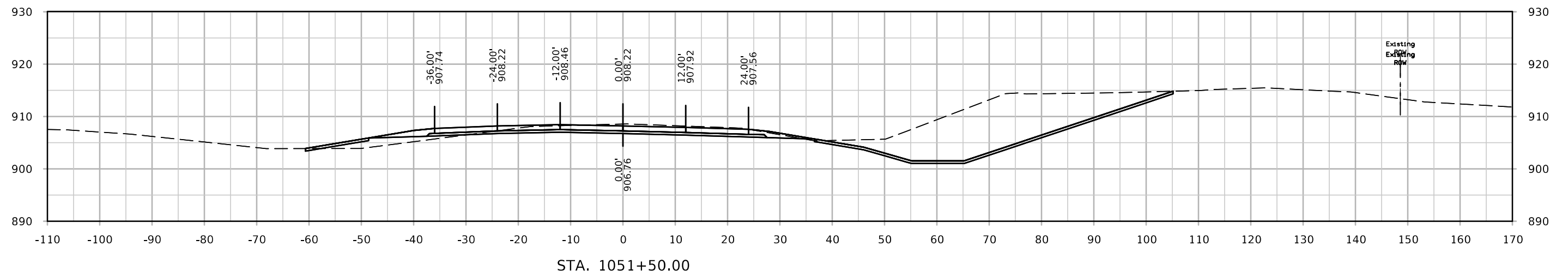
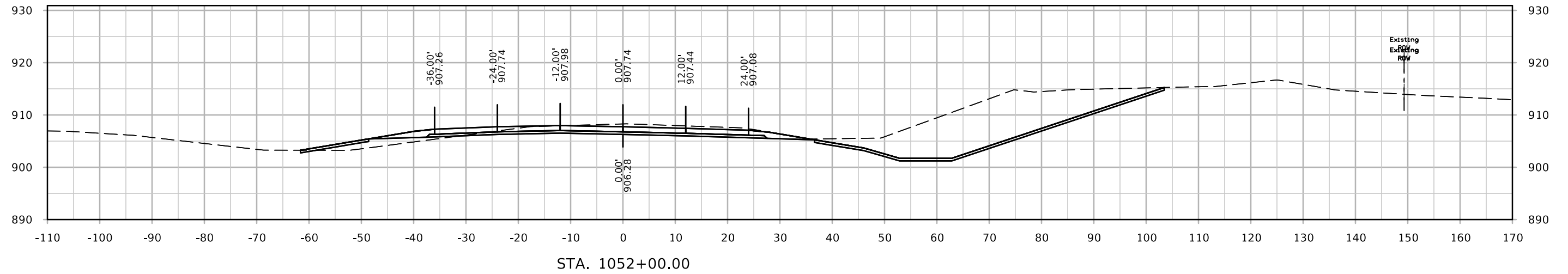

ML - I35 NB

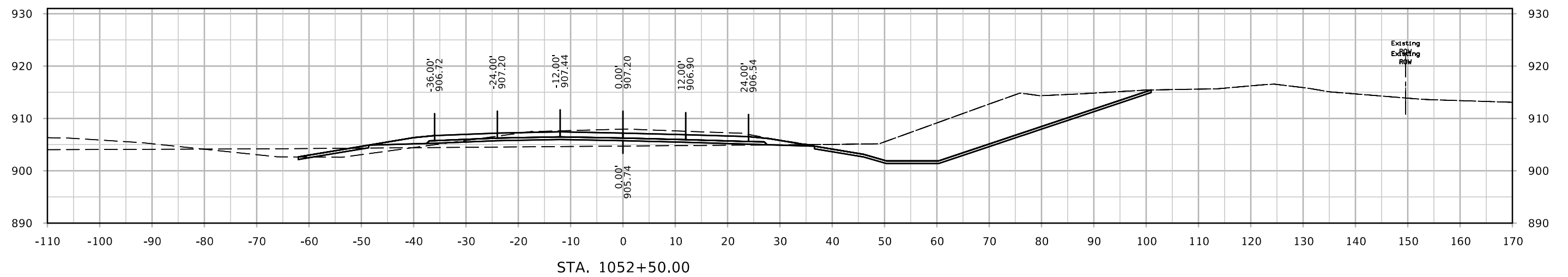
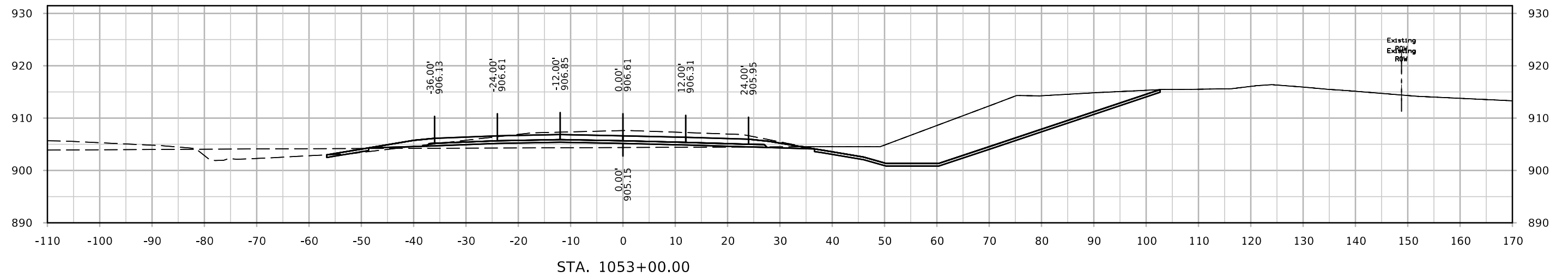
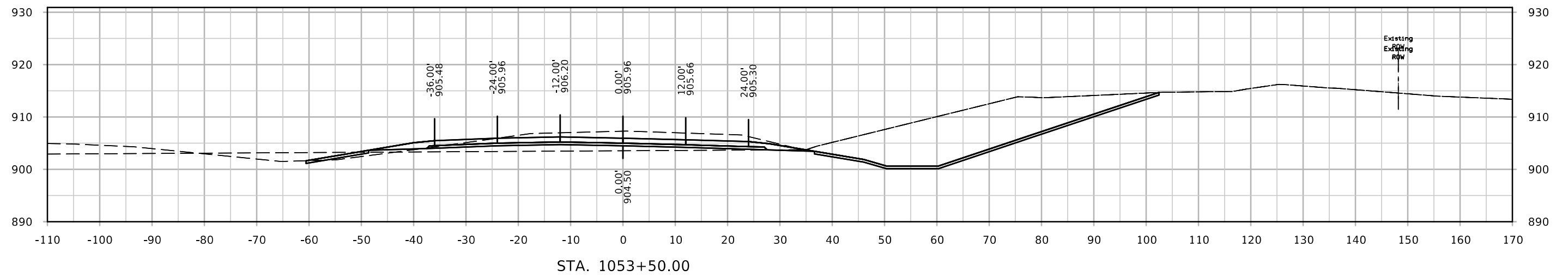

ML - I35 NB

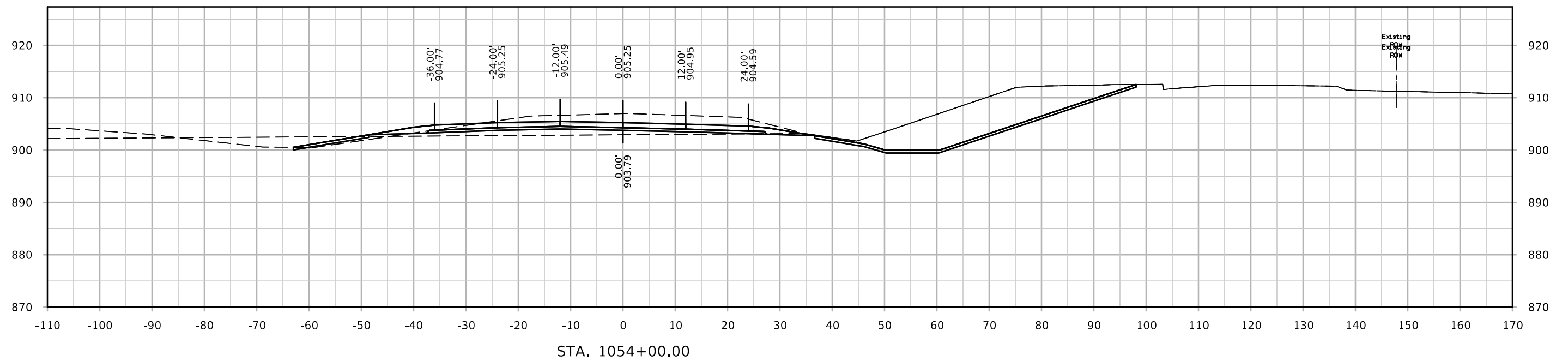
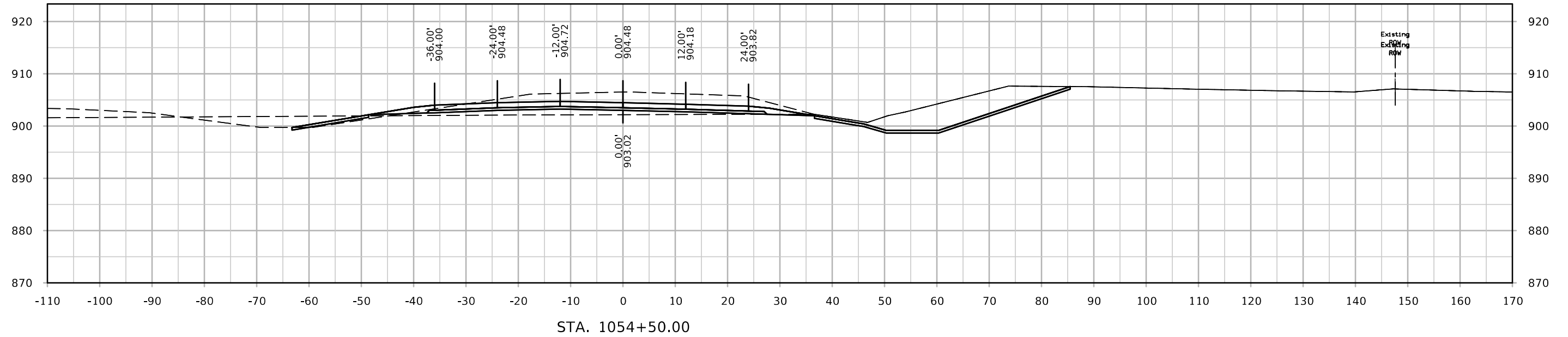

ML - I35 NB

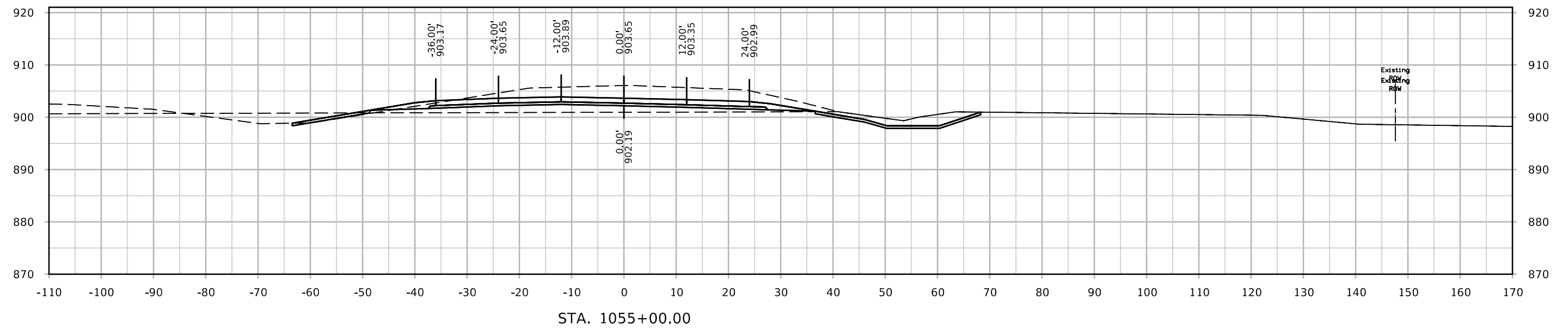
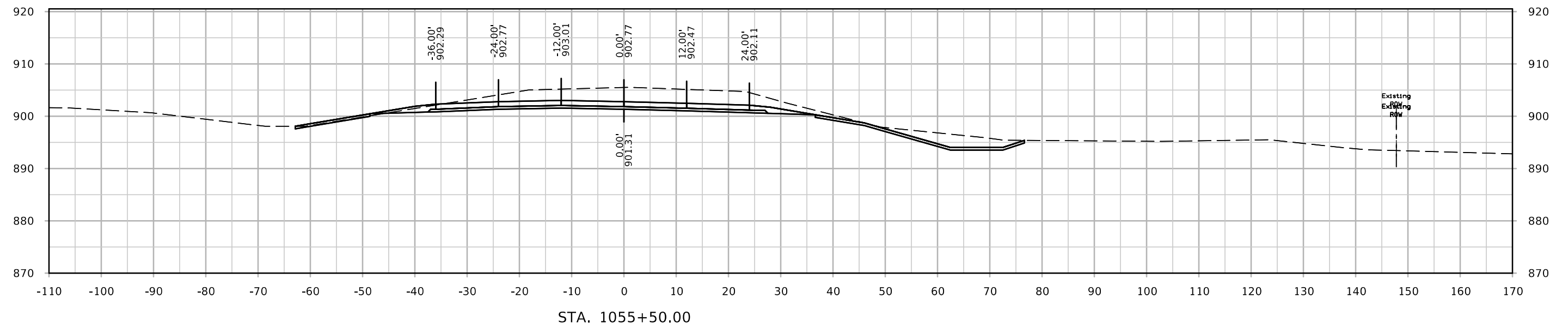

ML - I35 NB

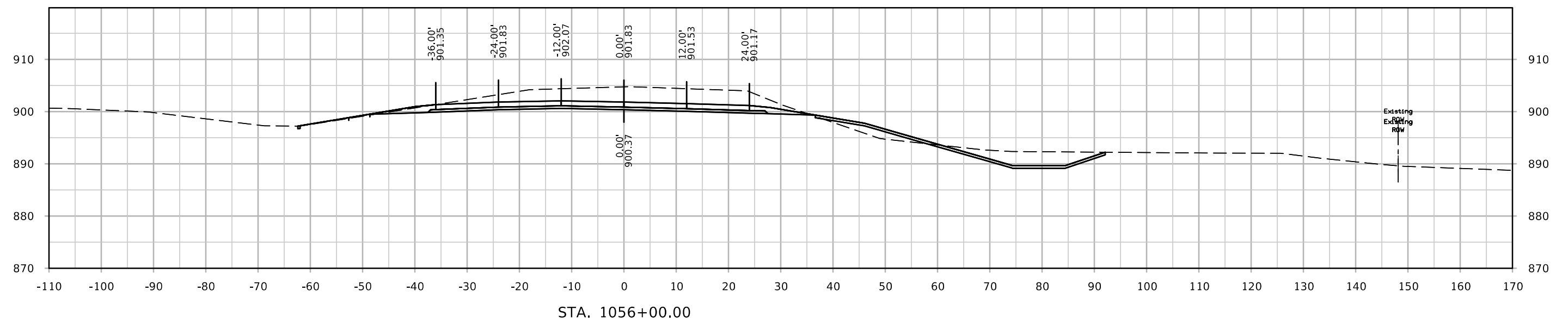
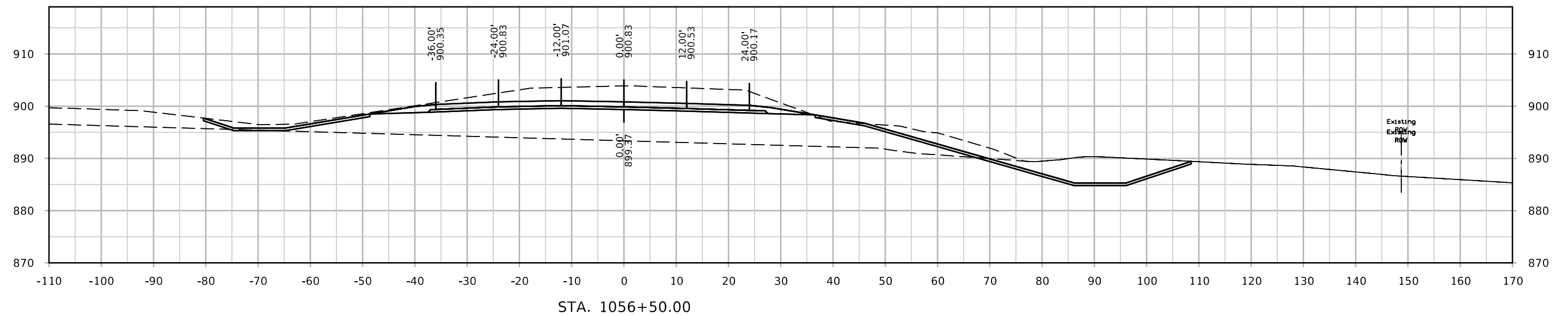

ML - I35 NB

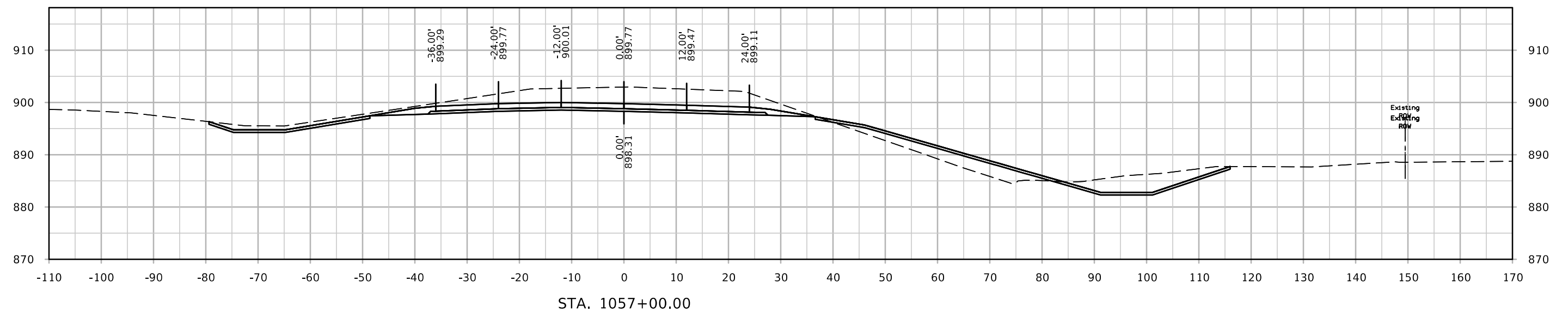
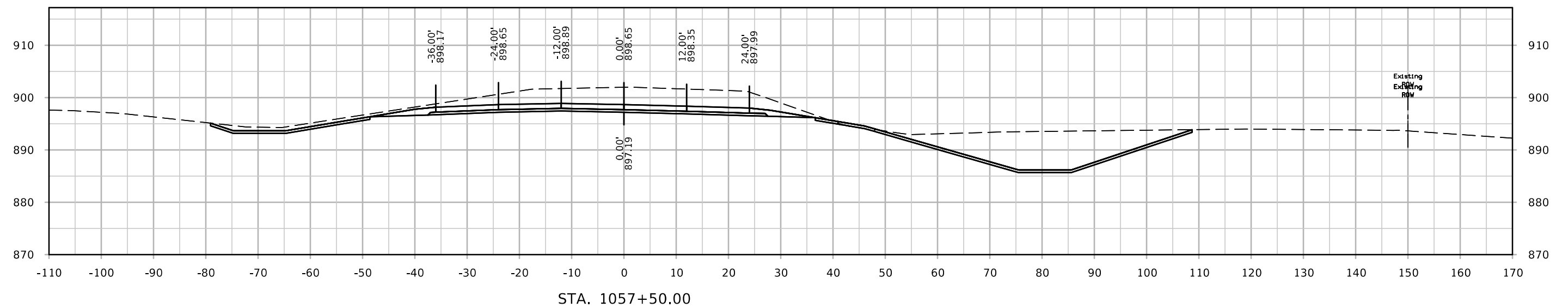

ML - I35 NB

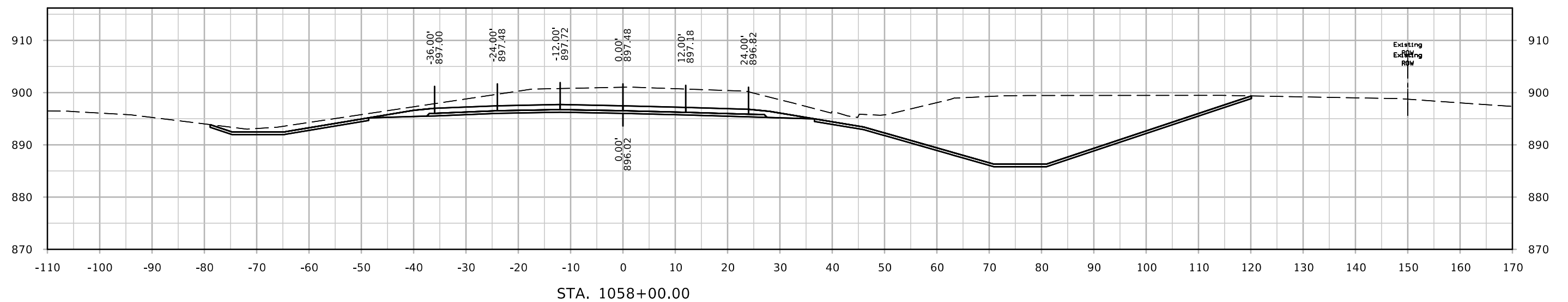
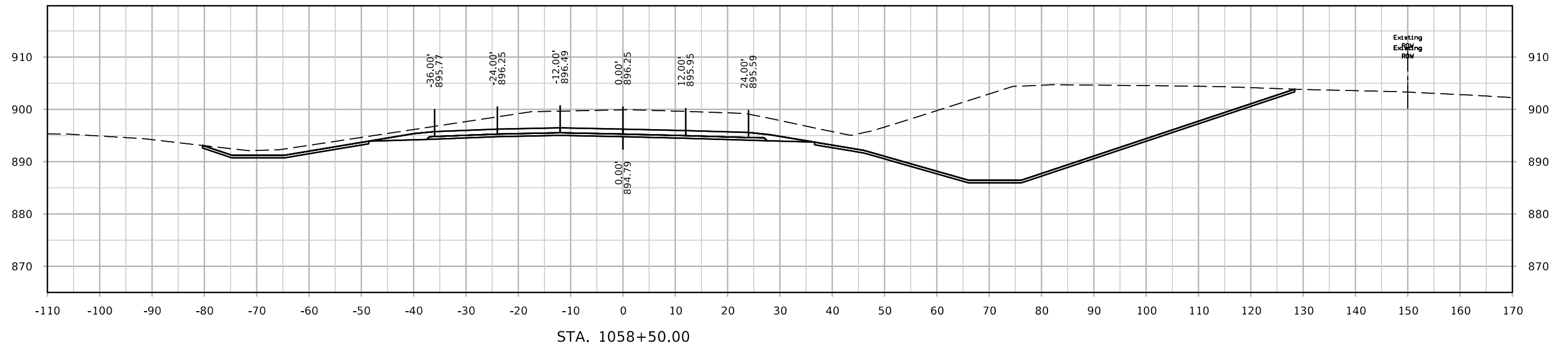

ML - I35 NB

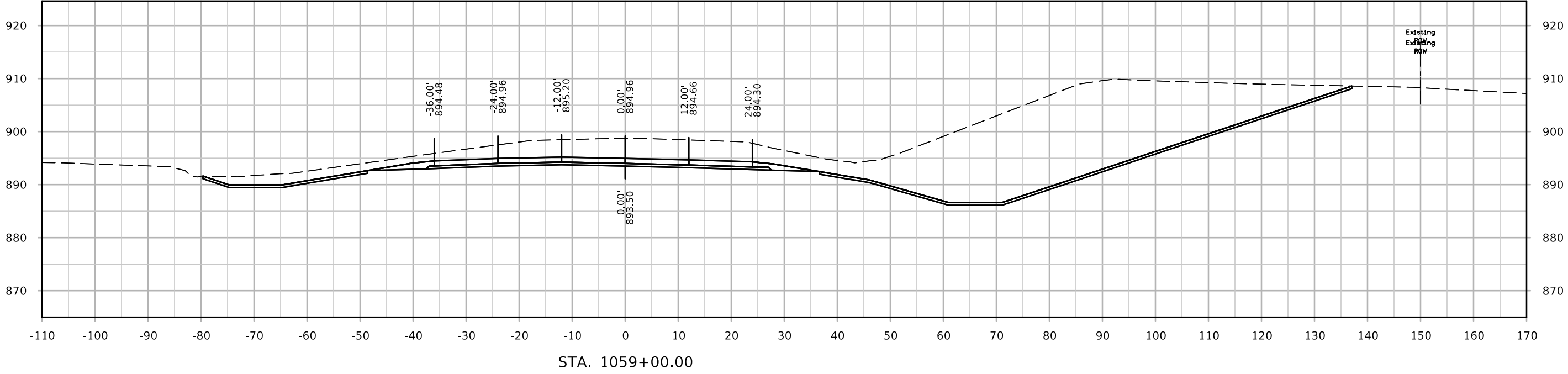
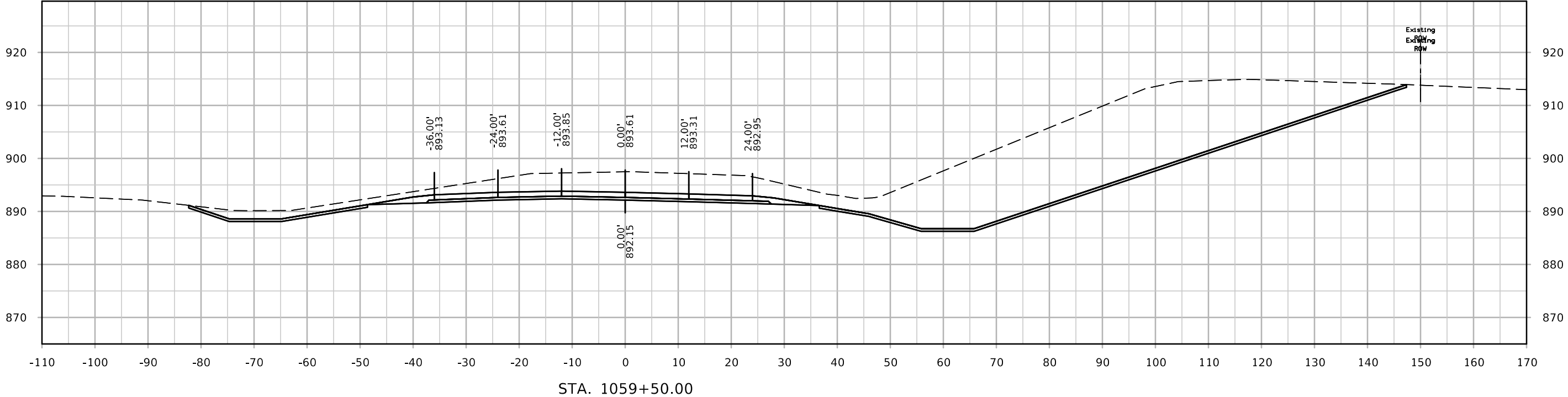

ML - I35 NB

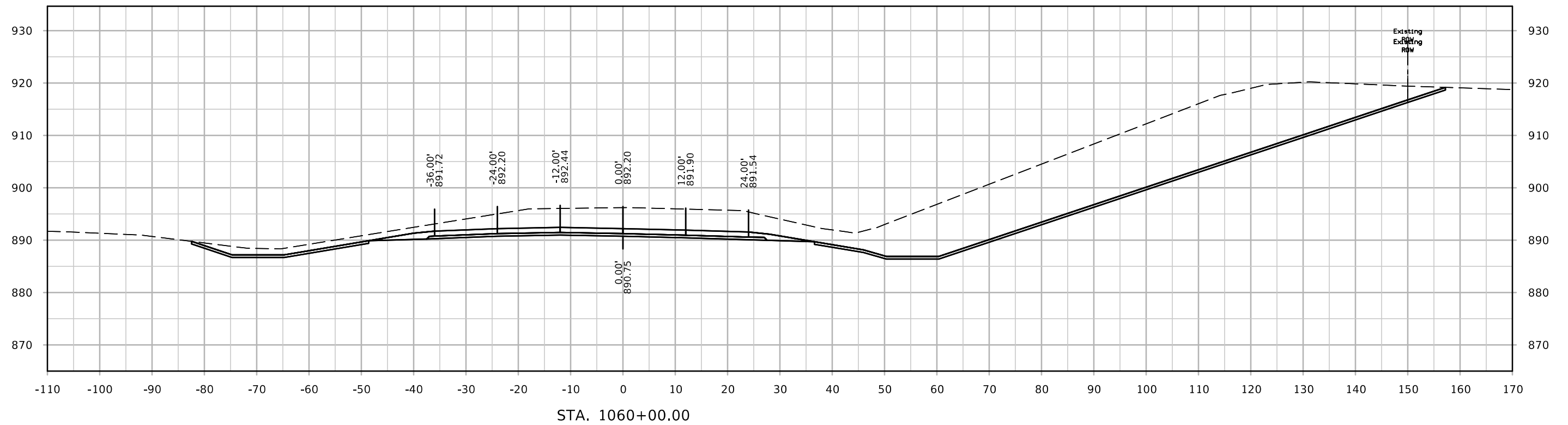
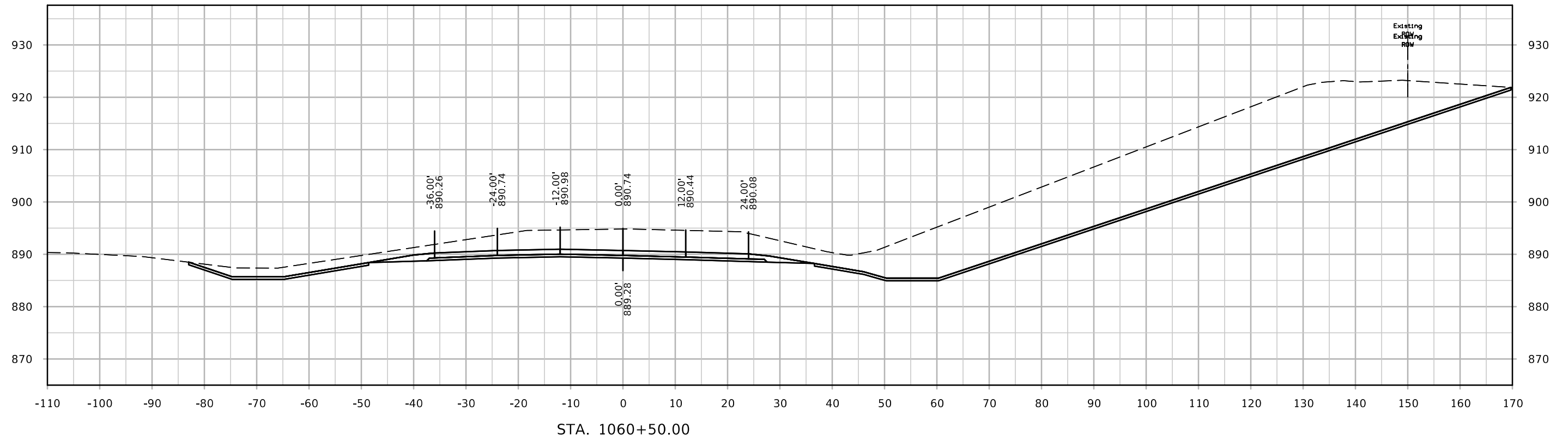

ML - I35 NB

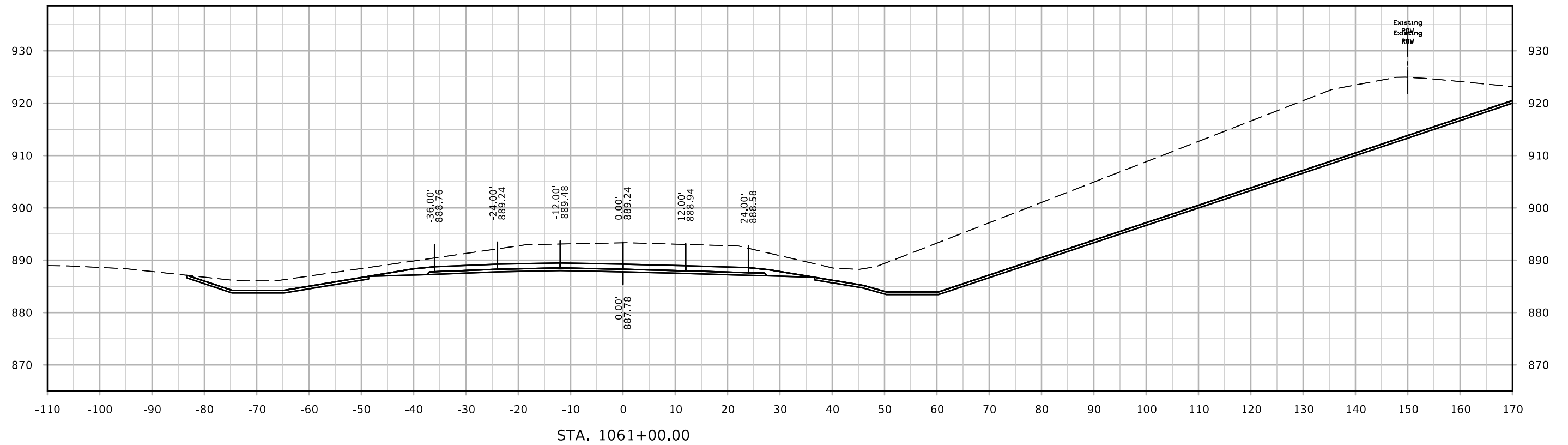
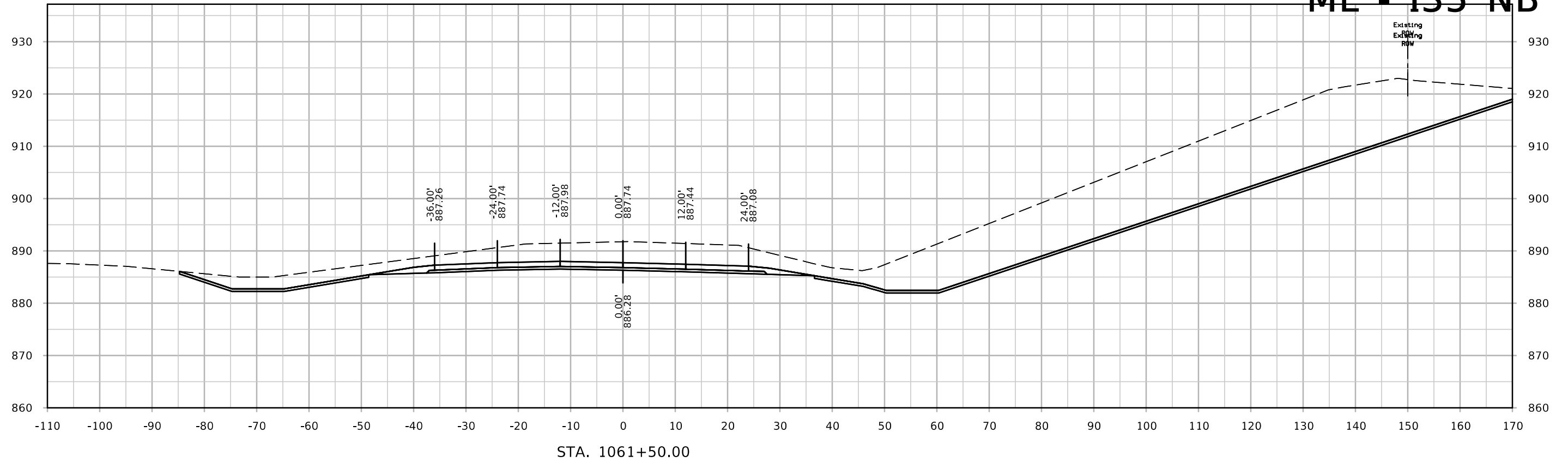

ML - I35 NB

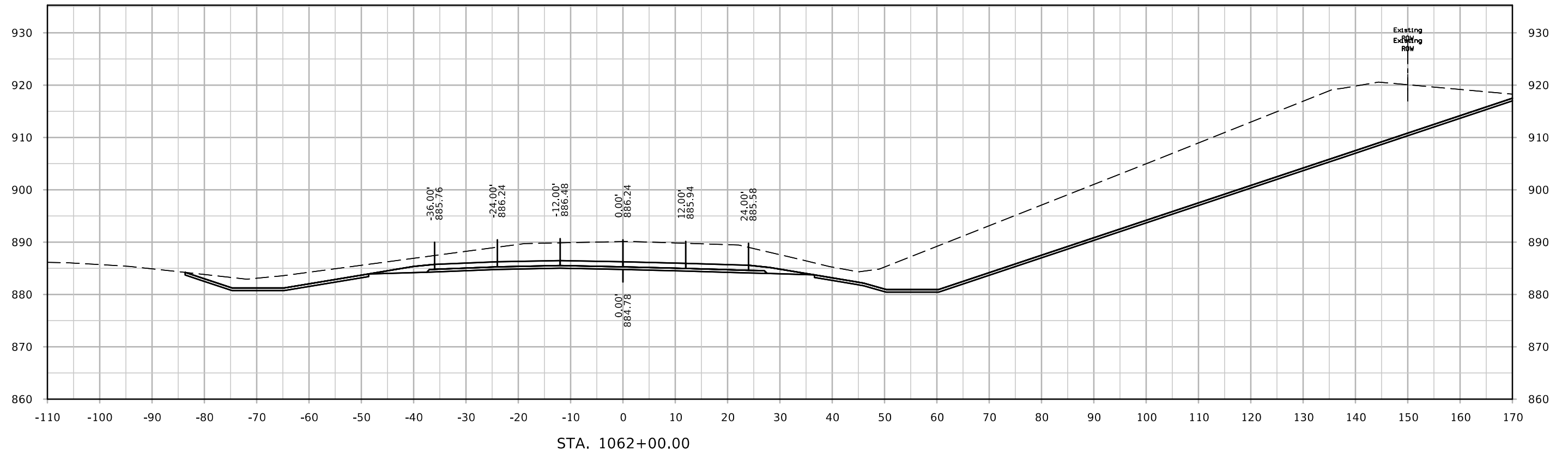
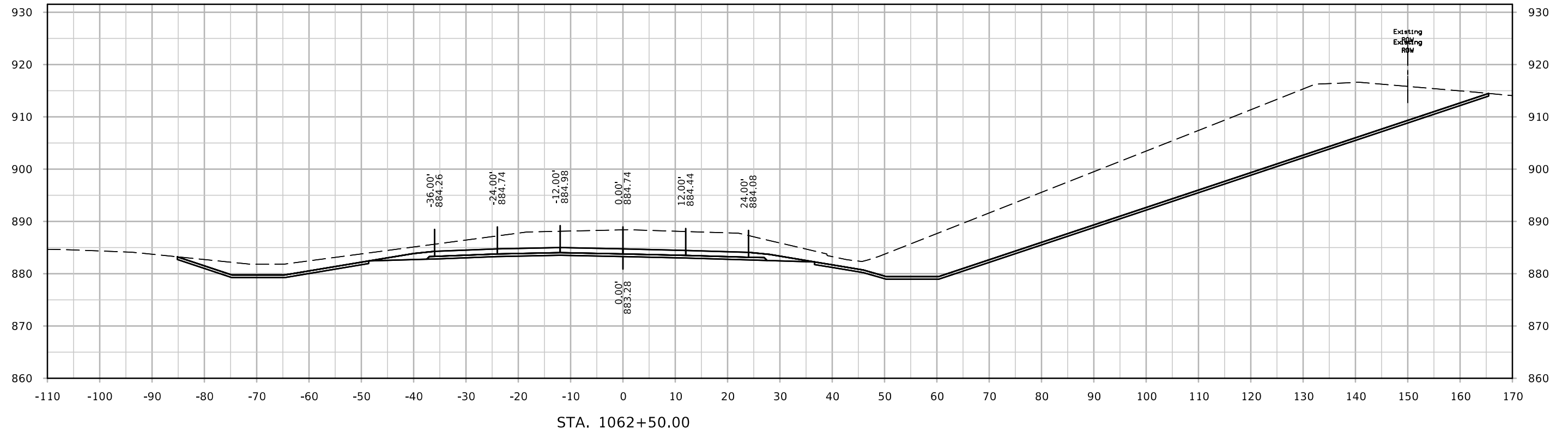

ML - I35 NB

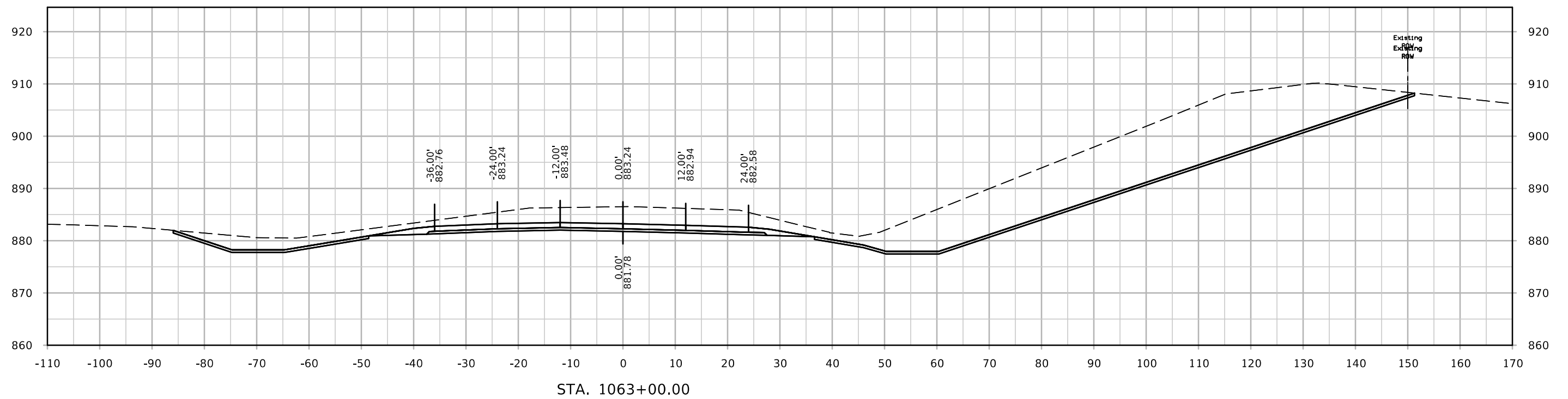
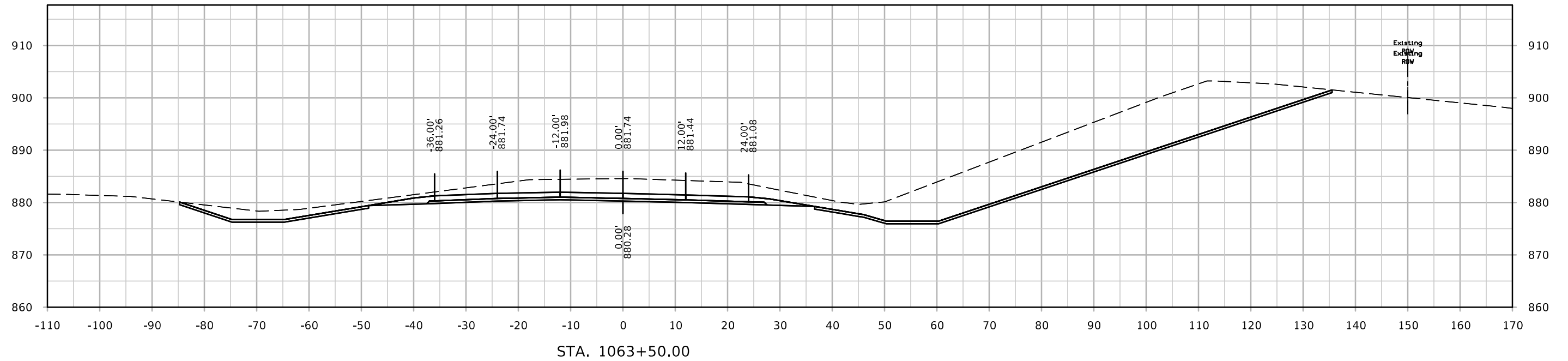

ML - I35 NB

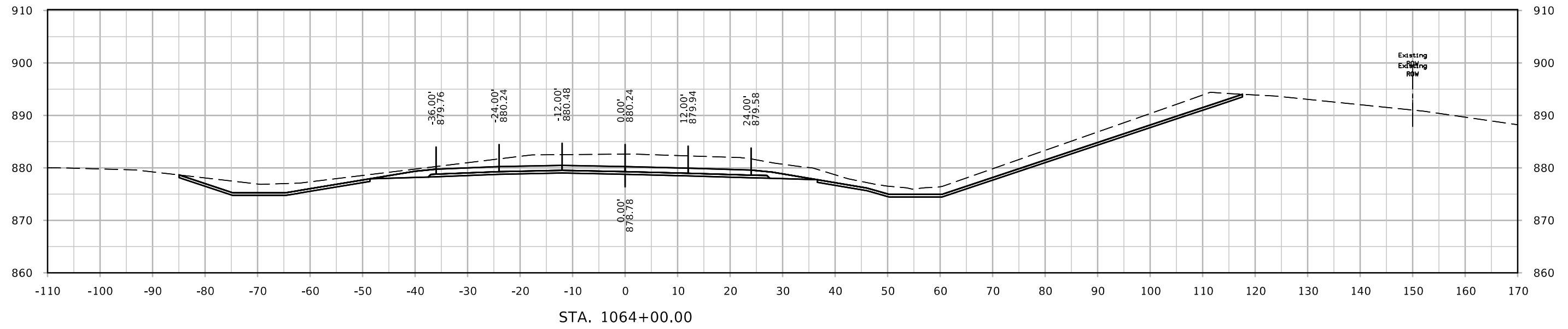
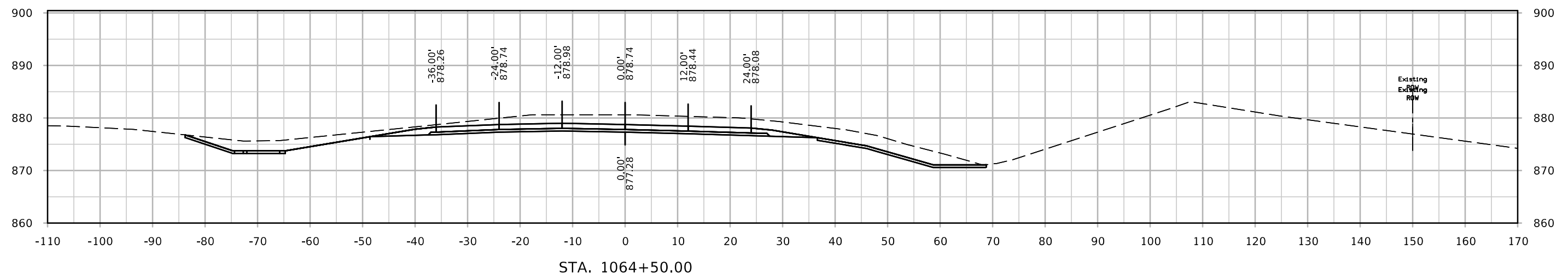
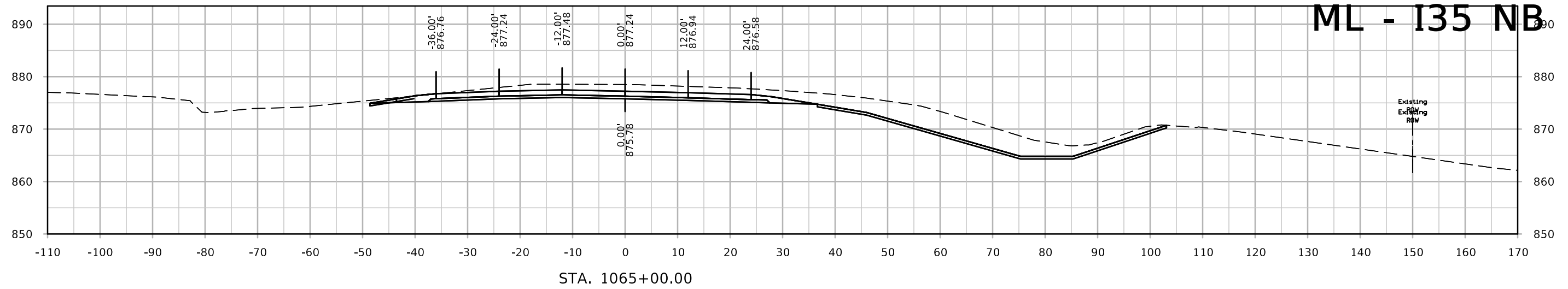

ML - I35 NB

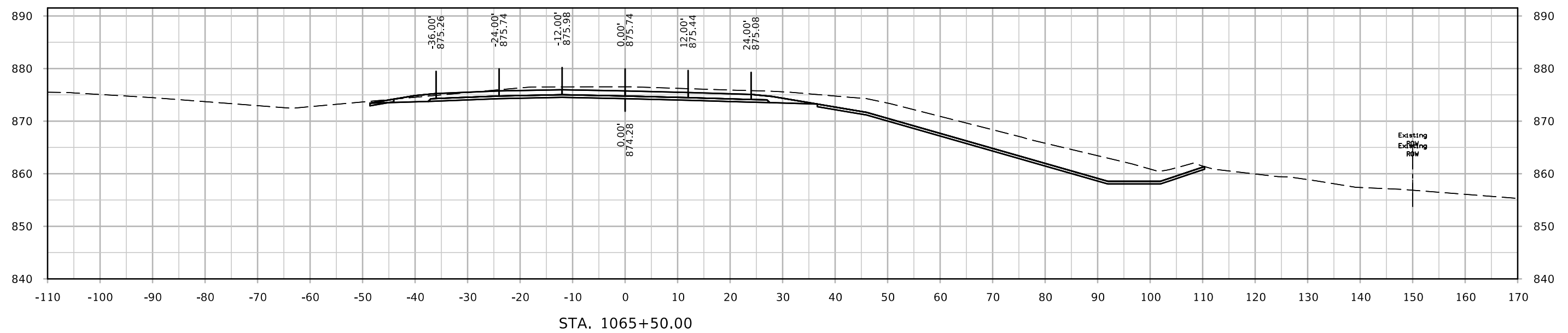
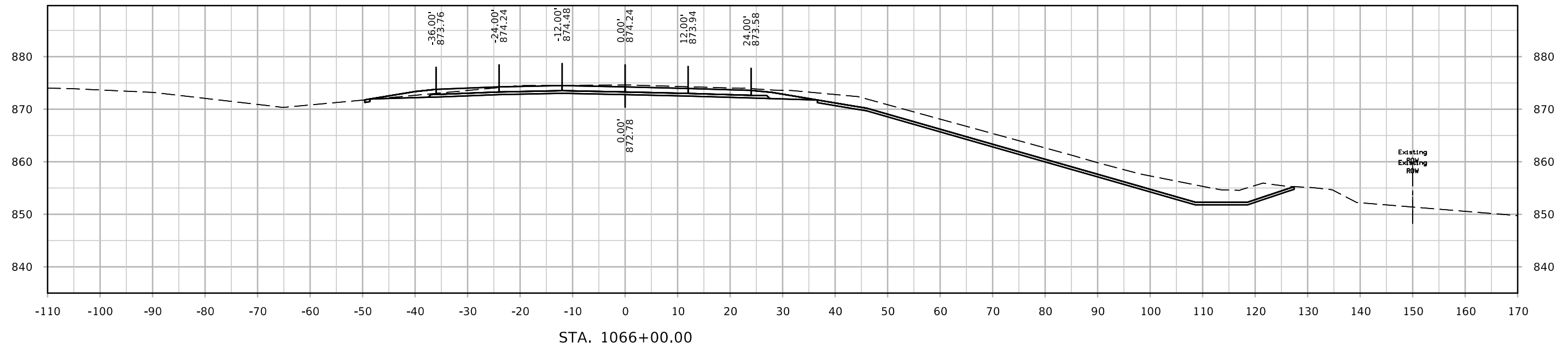

ML - I35 NB

