

**CEDAR CO.**  
 UNKNOWN PAVEMENT - GRADE AND NEW  
 IM-NHS-080-8(341)269--03-16  
 LETTING DATE  
 10-18-2022

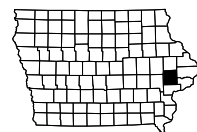

**INDEX OF SHEETS**

No.	DESCRIPTION
<b>A Sheets</b>	<b>Title Sheets</b>
* A.1	Title Sheet
* A.2	Location Map Sheet
<b>B Sheets</b>	<b>Typical Cross Sections and Details</b>
B.1 - 7	Typical Cross Sections
B.8 - 10	Design Details
<b>D Sheets</b>	<b>Mainline Plan and Profile Sheets</b>
* D.1	Plan & Profile Legend & Symbol Information Sheet
* D.2 - 4	I-80 Westbound
* D.5 - 7	I-80 Eastbound
<b>F Sheets</b>	<b>Detour or Temporary Pavement Sheets</b>
* F.1	Detour Plan and Profile Sheets
<b>G Sheets</b>	<b>Survey Sheets</b>
G.1	Survey Information
G.2	Control Point Vicinity Map
G.3	Horizontal Control Tab.
G.4 - 5	Alignment Information and Superelevation Data
<b>J Sheets</b>	<b>Traffic Control and Staging Sheets</b>
J.1 - 2	Staging Notes
* J.3	Traffic Control & Staging Legend & Symbol Info. Sheet
* J.4 - 7	Staging and Traffic Control Typical Section Sheets
* J.8 - 21	Staging and Traffic Control Plan Sheets, Stage 1
* J.22 - 35	Staging and Traffic Control Plan Sheets, Stage 2
* J.36 - 49	Staging and Traffic Control Plan Sheets, Stage 3
* J.50 - 63	Staging and Traffic Control Plan Sheets, Stage 4
<b>K Sheets</b>	<b>Interchange Sheets</b>
* K.1	Rest Area Interchange Layout
* K.2	Rest Area Ramp B
* K.3	Rest Area Ramp C
<b>M Sheets</b>	<b>Storm Sewer Sheets</b>
M.1	Storm Sewer Tabulation Sheet
* M.2	Storm Sewer Legend & Symbol Information Sheet
* M.3 - 6	Storm Sewer Plan & Profile Sheets
<b>W Sheets</b>	<b>Mainline Cross Sections</b>
W.1	Cross Sections Legend & Symbol Information Sheet
W.2 - 49	I-80 Westbound
W.50 - 93	I-80 Eastbound
<b>Y Sheets</b>	<b>Ramp Cross Sections</b>
Y.1 - 4	Rest Area Ramp C
	* Color Plan Sheets

H Sheets



PLANS OF PROPOSED IMPROVEMENT ON THE  
**INTERSTATE ROAD SYSTEM**  
**CEDAR COUNTY**  
**UNKNOWN PAVEMENT - GRADE AND NEW**

0.2 mi E of Co Rd X52 (Pine Ave) to 0.7 mi W of US 6 at Sugar Creek (EB/WB)

SCALES: As Noted

Refer to the Proposal Form for list of applicable specifications.



For Project Location Map  
 Refer to Sheet A.2

DESIGN DATA RURAL			
2020	AADT	41,185	V.P.D.
2040	AADT	75,580	V.P.D.
20--	DHV	--	V.P.H.
	TRUCKS	37	%
	Total Design ESALs	--	

INDEX OF SEALS		
SHEET NO.	NAME	TYPE
A.1	XXX	Primary Signature Block
CS.X	Zach Bonzer	Geotechnical Design
H.X	XXX	Right of Way Design
N.X	XXX	Traffic Signs Design
P.X	Steve Junod	Lighting Design

PRELIMINARY PLANS

Subject to change by final design.

U4 PLAN - Date: 02-15-22

REVISIONS	TOTAL
	194
PROJECT IDENTIFICATION NUMBER	
14-16-080-020-01	
PROJECT NUMBER	
IM-NHS-080-8(341)269--03-16	
R.O.W. PROJECT NUMBER	
IMN-080-8(340)270--0E-16	

I-80 WB BRIDGE OVER SUGAR CREEK  
 FHWA BRIDGE No.: 18661  
 BRIDGE DESIGN No.: 222

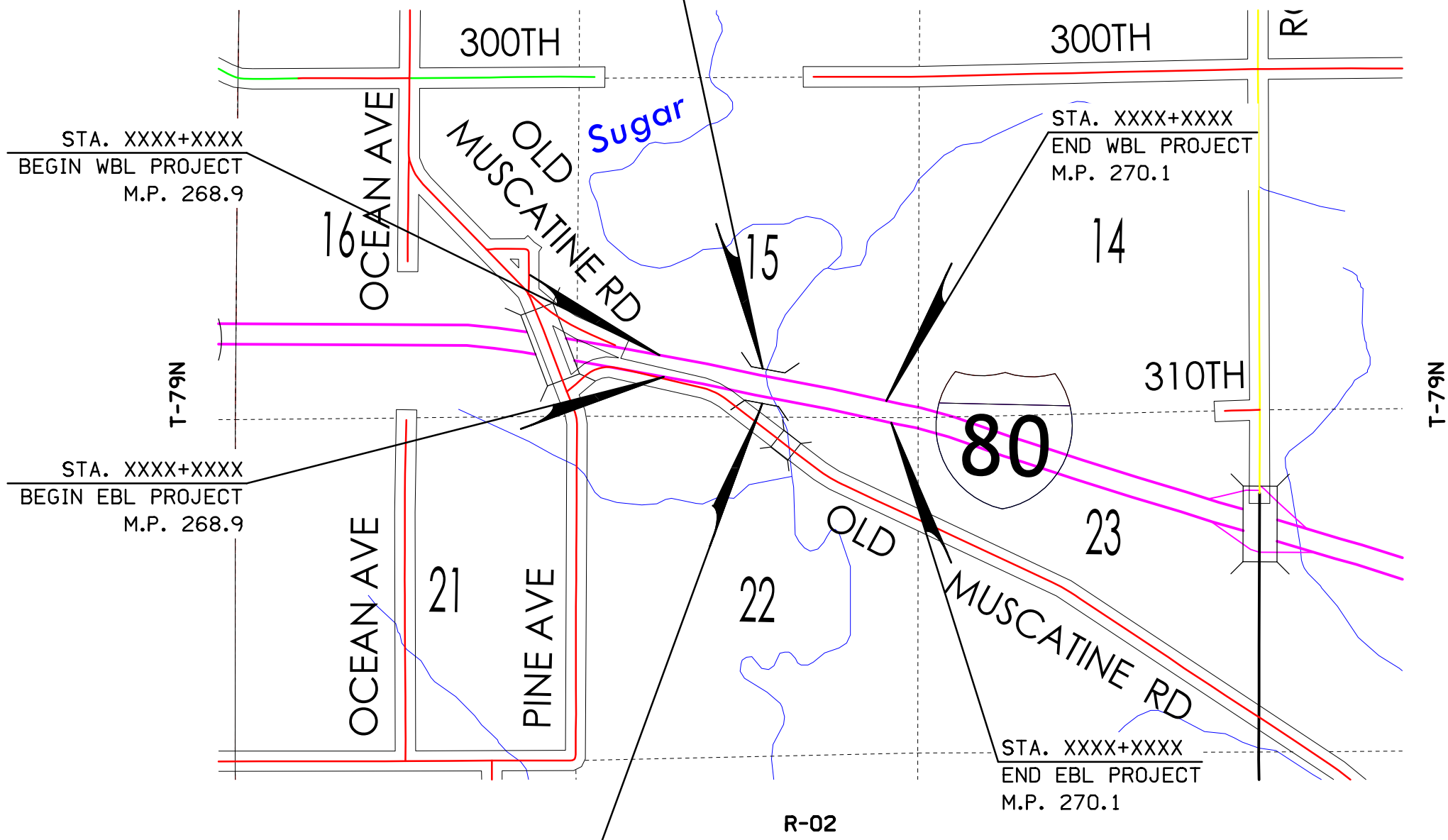

I-80 EB BRIDGE OVER SUGAR CREEK  
 FHWA BRIDGE No.: 18651  
 BRIDGE DESIGN No.: 322

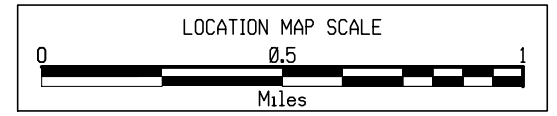
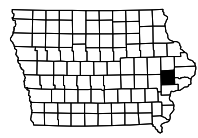

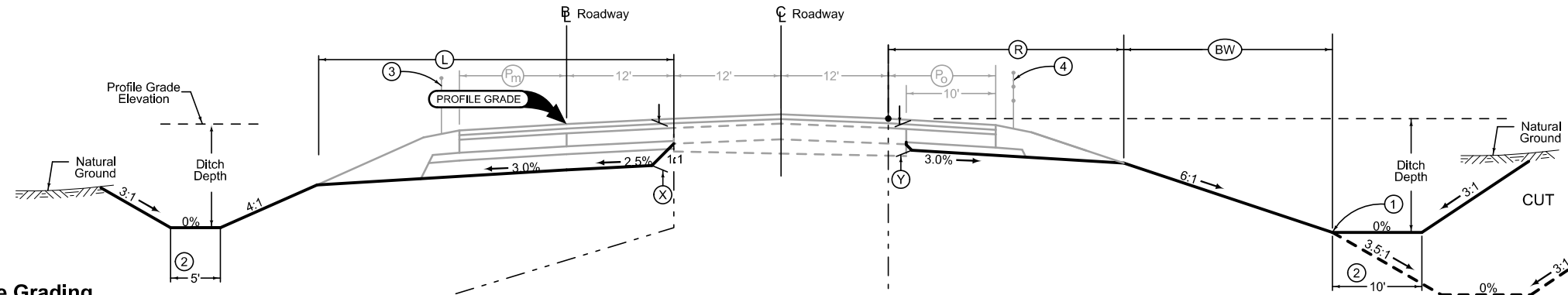

**Mainline Grading**

LOCATION		DIMENSIONS	
ROAD IDENTIFICATION	STATION TO STATION	(L) Feet	(X) Inches
I-80 WESTBOUND	4926+40.09 - 4938+75.00	38.9	32
I-80 WESTBOUND	4951+75.00 - 4970+00.00	36.1	32
I-80 WESTBOUND	4970+00.00 - 4972+00.00	38.9	32
I-80 EASTBOUND	5920+50.00 - 5939+00.00	38.9	32
I-80 EASTBOUND	5953+00.00 - 5973+00.00	38.9	32

**6 LANE GRADING - INTERIOR WIDENING  
(Depressed Variable Width Median)**

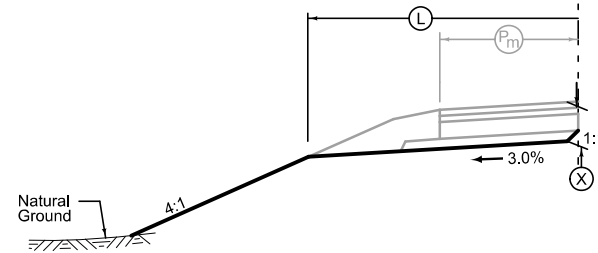

**Shoulder Grading**

LOCATION		DIMENSIONS	
ROAD IDENTIFICATION	STATION TO STATION	(L) Feet	(X) Inches
I-80 WESTBOUND	4919+34.40 - 4926+40.09	16.3	19.5
I-80 EASTBOUND	5919+57.45 - 5920+50.00	16.3	19.5

**Shoulder Grading**

LOCATION		DIMENSIONS		
ROAD IDENTIFICATION	STATION TO STATION	(R) Feet	(Y) Inches	(BW) Feet
I-80 WESTBOUND	4914+07.41 - 4926+40.09	20.1	19.5	-
I-80 WESTBOUND	4926+40.09 - 4933+50.00	25.8	19.5	8.2
I-80 WESTBOUND	4957+55.61 - 4972+00.00	25.8	19.5	8.2
I-80 WESTBOUND	4972+00.00 - 4976+86.46	25.8	19.5	-
I-80 EASTBOUND	5914+31.05 - 5920+50.00	20.1	19.5	-
I-80 EASTBOUND	5920+50.00 - 5939+00.00	25.8	19.5	8.2
I-80 EASTBOUND	5960+60.59 - 5973+00.00	25.8	19.5	8.2
I-80 EASTBOUND	5973+00.00 - 5979+00.00	25.8	19.5	-

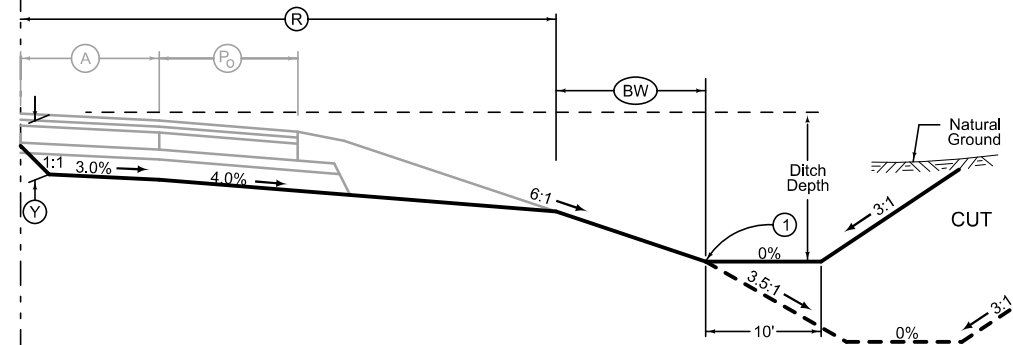

**Auxillary Lane Grading**

LOCATION		DIMENSIONS		
ROAD IDENTIFICATION	STATION TO STATION	(R) Feet	(Y) Inches	(BW) Feet
I-80 WESTBOUND	4933+50.00 - 4938+75.00	33.5-35.3	32	5-0
I-80 WESTBOUND	4951+75.00 - 4957+55.61	38.7-63.4	32	0
I-80 EASTBOUND	5953+00.00 - 5960+60.59	38.7	32	0

- ① Refer to project plan and cross sections for variable foreslopes and specific location of foreslope change.
- ② Refer to project plan and cross sections for specific location of ditching.
- ③ Cable guardrail present EB from 5963+50.00 to 5969+50.00, with variable slopes beyond 4' 10:1 area. Refer to cross-sections.
- ④ Cable guardrail present EB from 5964+50.00 to 5971+50.00, with 3:1 foreslope beyond 4' 10:1 area. Refer to cross sections.

Section shown in direction of travel.

Normal section shown may be modified appropriately in areas of superelevated curves or other locations specifically designated by the Engineer.

See Plan & Profiles sheets and cross sections for additional details of ditches and backslopes.

See Typical EW-302 for grading at guardrail.

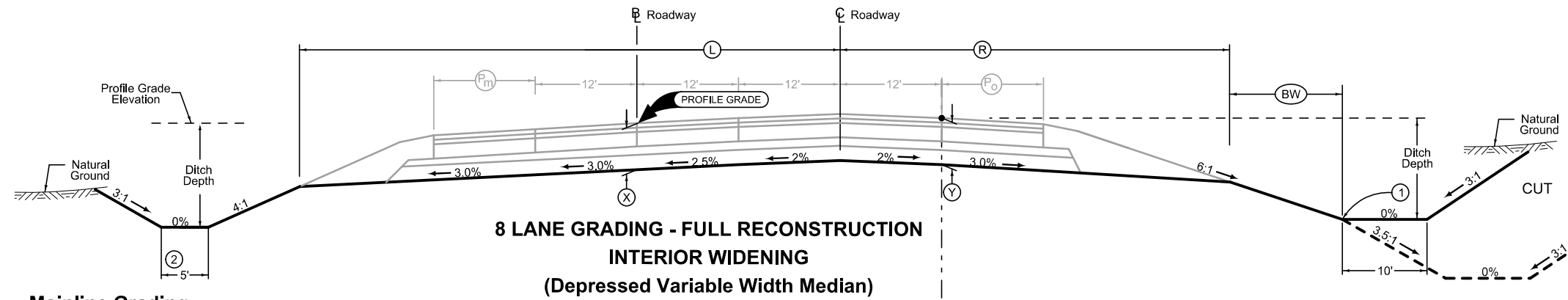

Mainline Grading

LOCATION		DIMENSIONS	
ROAD IDENTIFICATION	STATION TO STATION	(L) Feet	(X) Inches
I-80 WESTBOUND	4938+75.00 4939+43.76	63.6	32
I-80 WESTBOUND	4943+61.77 4944+43.89	65.2-66.7	32
I-80 WESTBOUND	4944+43.89 4951+75.00	63.6	32
I-80 EASTBOUND	5939+00.00 5939+82.28	63.6	32
I-80 EASTBOUND	5939+82.28 5940+64.22	66.7-65.2	32
I-80 EASTBOUND	5945+03.25 5953+00.00	63.6	32

Shoulder Grading

LOCATION		DIMENSIONS		
ROAD IDENTIFICATION	STATION TO STATION	(R) Feet	(Y) Inches	(BW) Feet
I-80 EASTBOUND	5939+00.00 5939+23.97	45.6	32	0
I-80 EASTBOUND	5939+23.97 5940+64.22	48.7-47.2	32	0

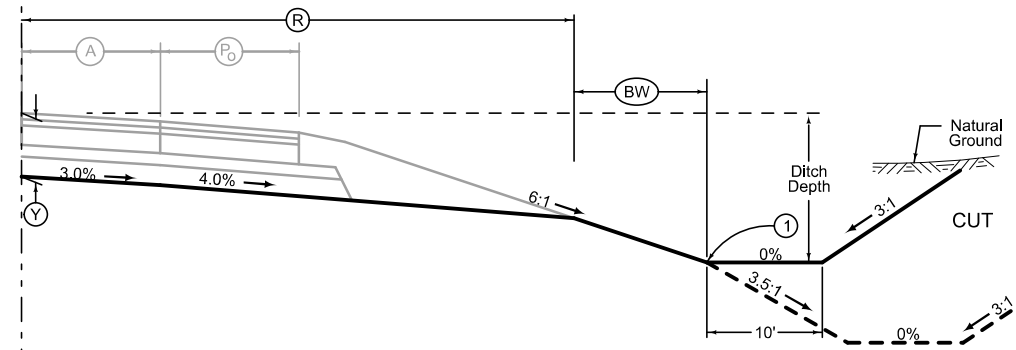

Auxillary Lane Grading

LOCATION		DIMENSIONS		
ROAD IDENTIFICATION	STATION TO STATION	(R) Feet	(Y) Inches	(BW) Feet
I-80 WESTBOUND	4938+75.00 4939+43.76	35.3-38.7	32	0
I-80 WESTBOUND	4943+61.77 4944+60.36	42.4-44.3	32	0
I-80 WESTBOUND	4944+60.36 4951+75.00	38.7	32	0
I-80 EASTBOUND	5945+03.25 5946+24.63	38.7	32	0
I-80 EASTBOUND	5946+24.63 5953+00.00	38.7	32	0

Section shown in direction of travel.

Normal section shown may be modified appropriately in areas of superelevated curves or other locations specifically designated by the Engineer.

See Plan & Profiles sheets and cross sections for additional details of ditches and backslopes.

See Typical EW-301 for grading at guardrail.

① Refer to project plan and cross sections for variable foreslopes and specific location of foreslope change.

② Refer to project plan and cross sections for specific location of ditching.



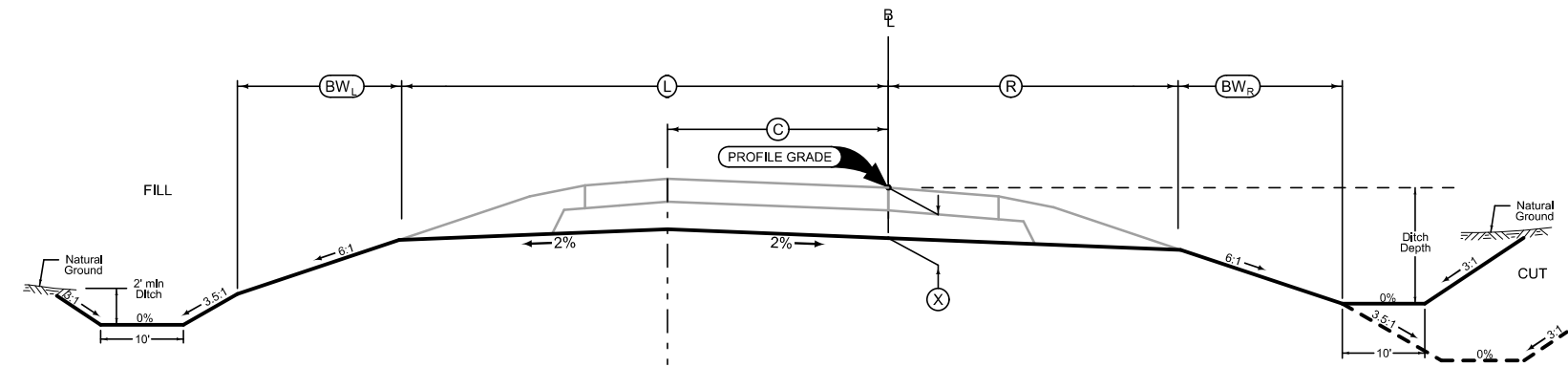

**RAMP GRADING**

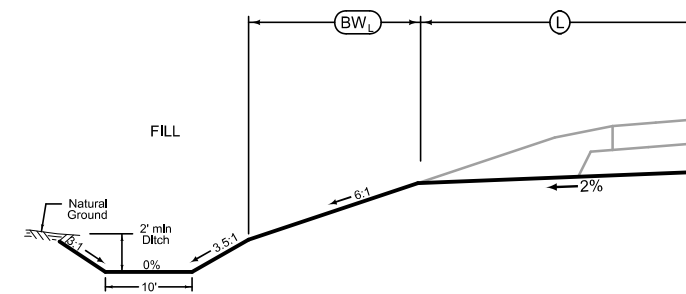

Section shown in direction of travel.  
Normal sections shown may be appropriately modified for areas specifically designated by the Engineer such as intersections or superelevated curves.

LOCATION			DIMENSIONS						
INTERCHANGE	RAMP	STATION TO STATION	(L) Feet	(R) Feet	(C) Feet	(X) Inches	(BW <sub>L</sub> ) Feet	(BW <sub>R</sub> ) Feet	
I-80 W.C. Rest Area	C	3557+54.38 3559+49.63	33.8	19.5	16	22	6.2	4.5	
I-80 W.C. Rest Area	C	3559+49.63 3560+25.00	33.8-38.8	19.5	16-19.7	22	6.2-1.2	4.5	

**Ramp Shoulder Grading**

LOCATION			DIMENSIONS	
INTERCHANGE	RAMP	STATION TO STATION	(L) Feet	(BW <sub>L</sub> ) Feet
I-80 W.C. Rest Area	C	3560+25.00 3561+85.52	19.1	1.2

### Full Depth PCC Shoulder

6D_Closed_P_FullPCC_ Modified				
Direction of Travel	BEGIN STATION	END STATION	(P) Feet	(S) Feet
WB	4926+40.09	4938+75.00	12	4
WB	4951+75.00	4970+00.00	12	0
WB	4970+00.00	4972+00.00	12	4
EB	5920+50.00	5939+00.00	12	4
EB	5953+00.00	5973+00.00	12	4

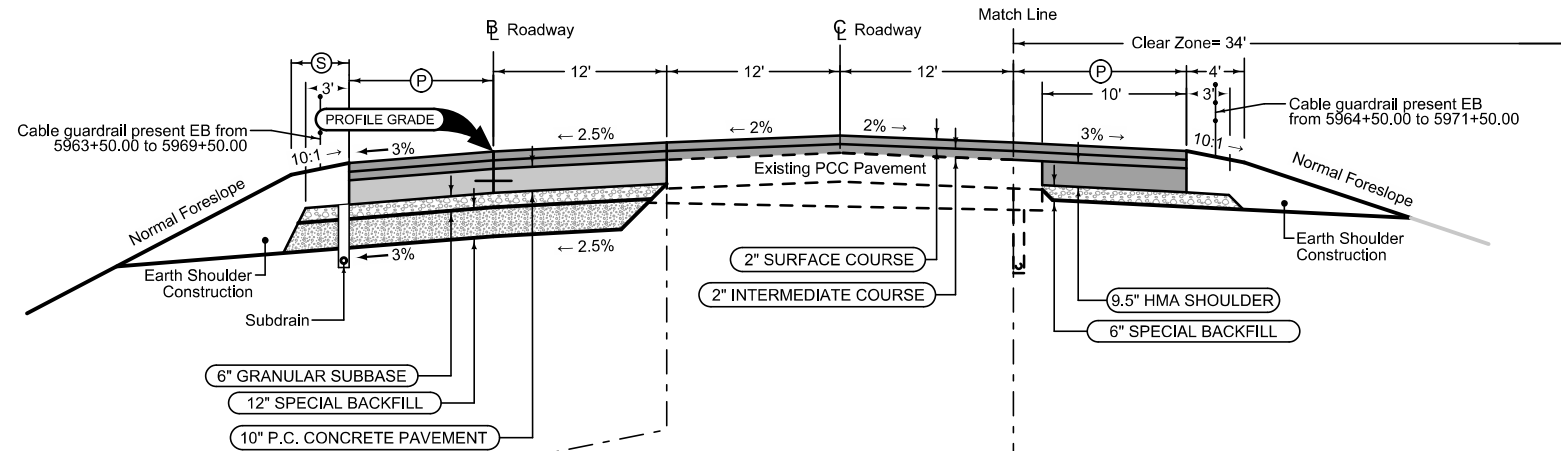

### Full Depth HMA Shoulder

Shoulder Jointing:  
 Longitudinal joint: L-2 or KT-2  
 Transverse joints: Match Existing. Refer to PV-121.

6D_P_FullPCC_ Modified			
Direction of Travel	BEGIN STATION	END STATION	(P) Feet
WB	4911+00.00	4933+50.00	12
WB	4957+55.61	4976+86.46	12
EB	5914+31.05	5939+00.00	12
EB	5960+60.59	5979+00.00	12

### 6 LANE PAVING - INTERIOR WIDENING (Depressed Variable Width Median)

Section shown in the direction of traffic.  
 Mainline Jointing:  
 Transverse joints: Match Existing. Refer to PV-121.

6DP_Dprs_ Modified		
Direction of Travel	BEGIN STATION	END STATION
WB	4926+40.09	4938+75.00
WB	4951+75.00	4972+00.00
EB	5920+50.00	5939+00.00
EB	5953+00.00	5973+00.00

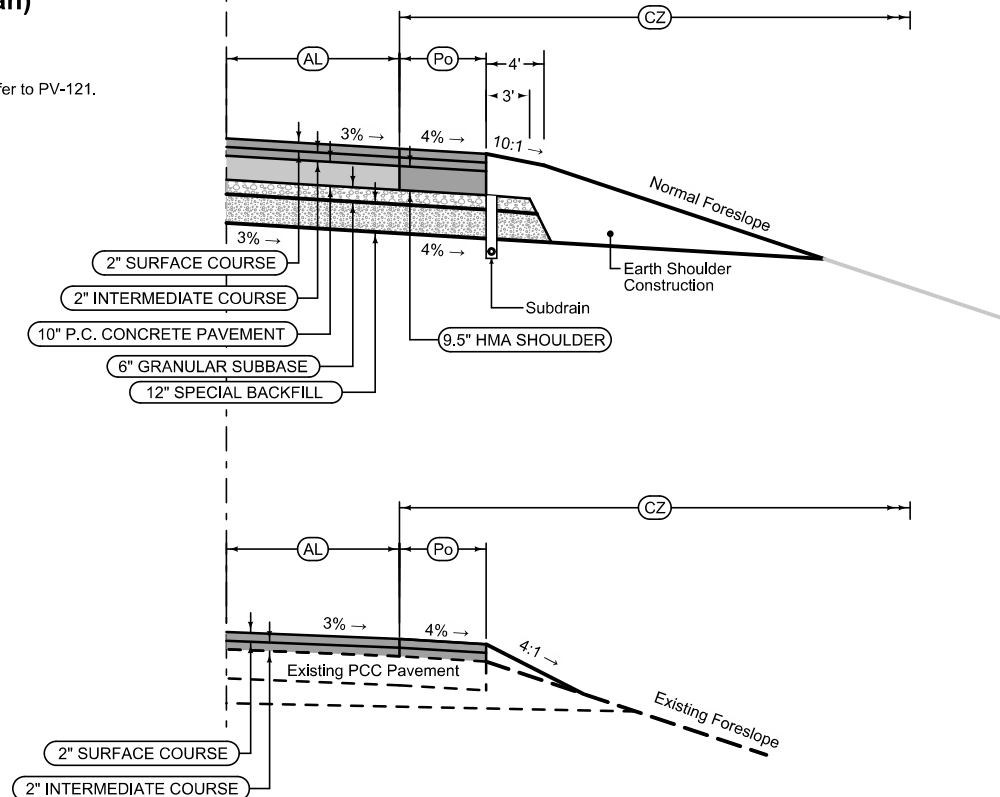

### Auxiliary Lane

2_AL_HMA_ Modified					
Direction of Travel	STATION TO STATION	(AL) Feet	(Po) Feet	(CZ) Feet	
WB	4933+50.00	4938+75.00	2-10.5	10-6	34-24
WB	4951+75.00	4954+45.46	12	6	24
WB	4954+45.46	4957+55.61	12-36.2	6	24
EB	5953+00.00	5956+24.63	12	6	24

### Full Depth HMA Shoulder

6D_Closed_P_FullPCC_ Modified				
Direction of Travel	BEGIN STATION	END STATION	(P) Feet	(S) Feet
WB	4919+34.40	4926+40.09	6	4
EB	5919+57.45	5920+50.00	6	4

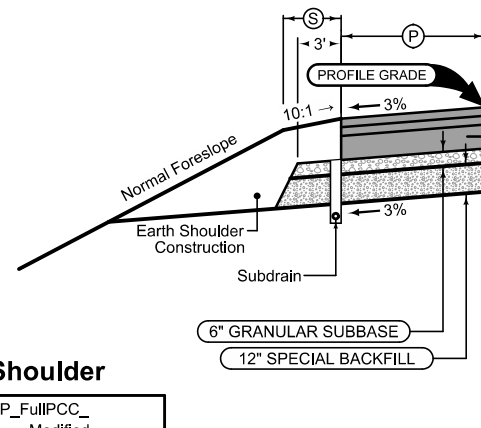

### Auxiliary Lane Resurfacing

_AuxLane_Overlay_ New					
Direction of Travel	STATION TO STATION	(AL) Feet	(Po) Feet	(CZ) Feet	
EB	5956+24.63	5960+60.59	12-41.6	6	24

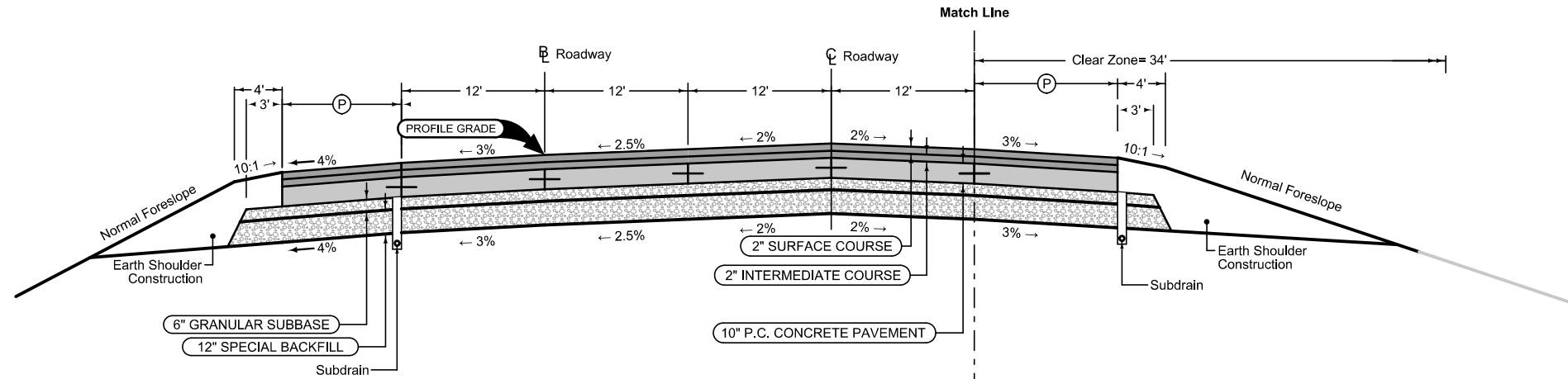

**8 LANE PAVING - FULL RECONSTRUCTION - INTERIOR WIDENING  
(Depressed Variable Width Median)**

Section shown in the direction of traffic.  
Mainline Jointing:  
Transverse joints: CD at 17' spacing

**Full Depth PCC Shoulder**

Shoulder Jointing:  
Longitudinal joint: L-2 or KT-2  
Transverse joints: C at 17' spacing

6D_Closed_P_FullPCC_04-19-11			
Direction of Travel	BEGIN STATION	END STATION	(P) Feet
WB	4938+75.00	4939+43.76	12
WB	4943+61.77	4944+43.89	13.6-15.1
WB	4944+43.89	4951+75.00	12
EB	5939+00.00	5939+82.28	12
EB	5939+82.28	5940+64.22	15.1-13.6
EB	5945+03.25	5953+00.00	12

8DP_Dprs_Modified		
Direction of Travel	BEGIN STATION	END STATION
WB	4938+75.00	4939+43.76
WB	4943+61.77	4951+75.00
EB	5939+00.00	5940+64.22
EB	5945+03.25	5953+00.00

**Full Depth PCC Shoulder**

Shoulder Jointing:  
Longitudinal joint: L-2 or KT-2  
Transverse joints: C at 17' spacing

6D_Closed_P_FullPCC_04-19-11			
Direction of Travel	BEGIN STATION	END STATION	(P) Feet
EB	5939+00.00	5939+23.97	12
EB	5939+23.97	5940+64.22	15.1-13.6

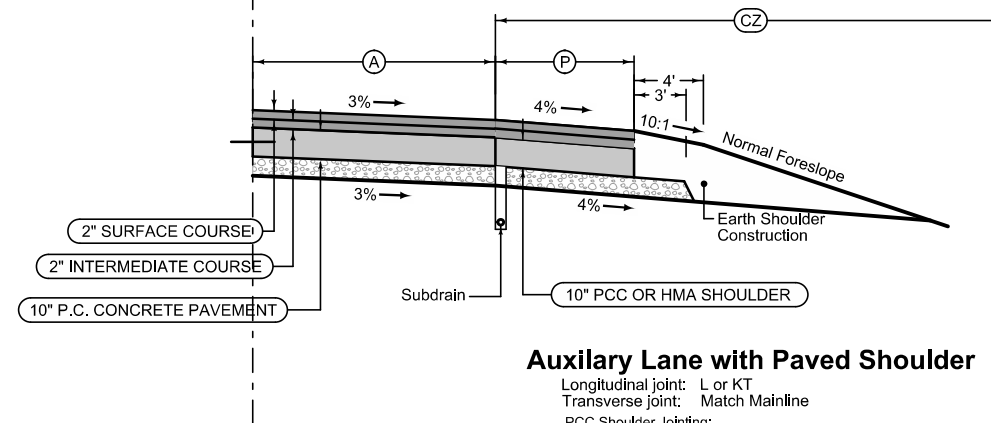

**Auxiliary Lane with Paved Shoulder**

Longitudinal joint: L or KT  
Transverse joint: Match Mainline  
PCC Shoulder Jointing:  
Longitudinal joint: L-2 or KT-2  
Transverse joints: C at 17' spacing  
HMA Shoulder Jointing:  
Longitudinal joint: B

2_AuxLane_PCC_Modified					
ROAD IDENTIFICATION	STATION TO STATION	(A) Feet	(P) Feet	(CZ) Feet	
WB	4938+75.00	4939+50.00	10.5-12	6	24
WB	4939+50.00	4939+43.76	12	6	24
WB	4943+61.77	4944+60.36	12	9.7-11.6	24
WB	4944+60.36	4951+75.00	12	6	24
EB	5945+03.25	5946+24.63	3.4-12	8.6-6	30.6-24
EB	5946+24.63	5953+00.00	12	6	24

**Ramp Shoulder**

PCC Shoulder Jointing:  
 Longitudinal joint: BT-1 or BT-5  
 Transverse joints: C at 15' spacing  
 HMA Shoulder Jointing:  
 Longitudinal joint: B

1RP_1R_P_ALT_ Modified				
ROAD IDENTIFICATION	BEGIN STATION	END STATION	(L) Feet	
I-80 W.C. Rest Area Ramp C	3557+54.38	3559+29.26	4	
I-80 W.C. Rest Area Ramp C	3559+29.26	3559+49.63	4-5	
I-80 W.C. Rest Area Ramp C	3559+49.63	3560+25.00	5	

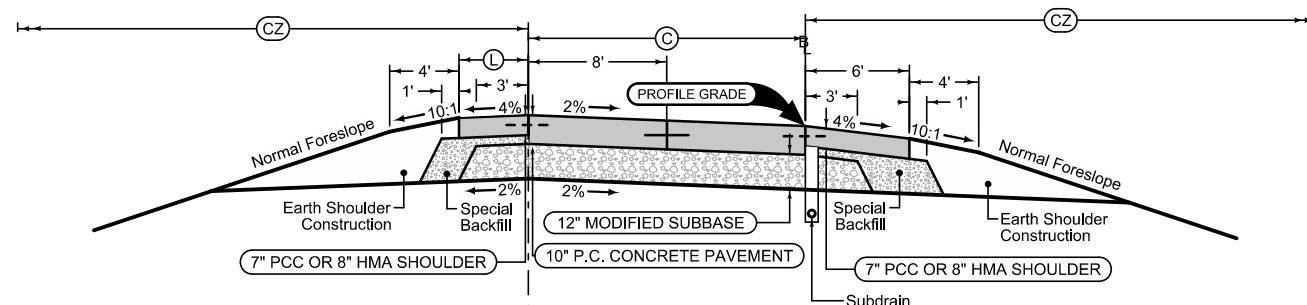

Section shown in the direction of traffic.

Ramp Jointing:  
 Transverse joints: CD at 15' spacing.  
 Longitudinal joints: L-2  
 PCC Shoulder Jointing:  
 Longitudinal joint: BT-1 or BT-5  
 Transverse joints: C at 15' spacing  
 HMA Shoulder Jointing:  
 Longitudinal joint: B

1RP_1R_P_ALT_ Modified					
ROAD IDENTIFICATION	BEGIN STATION	END STATION	(CZ) Feet	(C) Feet	
I-80 W.C. Rest Area Ramp C	3557+54.38	3559+49.63	24	16	
I-80 W.C. Rest Area Ramp C	3559+49.63	3560+25.00	24	16-19.7	

**Ramp Shoulder**

PCC Shoulder Jointing:  
 Longitudinal joint: BT-1 or BT-5  
 Transverse joints: C at 15' spacing  
 HMA Shoulder Jointing:  
 Longitudinal joint: B

1RP_1R_P_ALT_ Modified					
ROAD IDENTIFICATION	BEGIN STATION	END STATION	(CZ) Feet	(L) Feet	
I-80 W.C. Rest Area Ramp C	3560+25.00	3561+85.52	24	5	

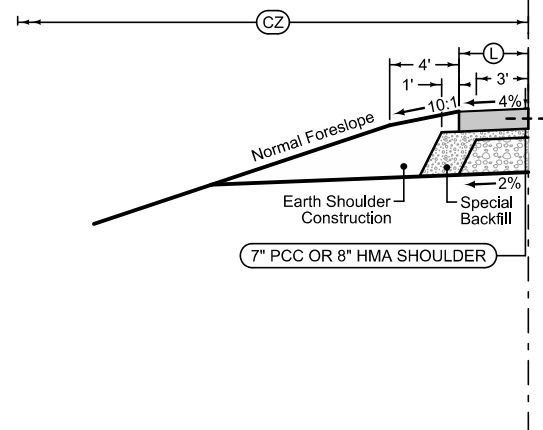

**Welcome Center Rest Area  
Interchange Ramps**

D\_Detour  
10-21-14

DESIGNER  
INFO

ROAD IDENTIFICATION	LOCATION STATION TO STATION		DIMENSIONS						6" Special Backfill Tons/Station	Earth Shoulder Construction Station
			HMA			PCC				
			(PW) Feet	(T) Inches	(SGW) Feet	(PW) Feet	(T) Inches	(SGW) Feet		
Temporary Rest Area Ramp C	34959+07.09	34961+12.72	20			20				

Quantity calculations based on vertical pavement edges.  
 Normal section shown may be modified appropriately in areas of super-elevated curves or other locations specifically designated by the Engineer.

① Possible HMA 1:1 slope

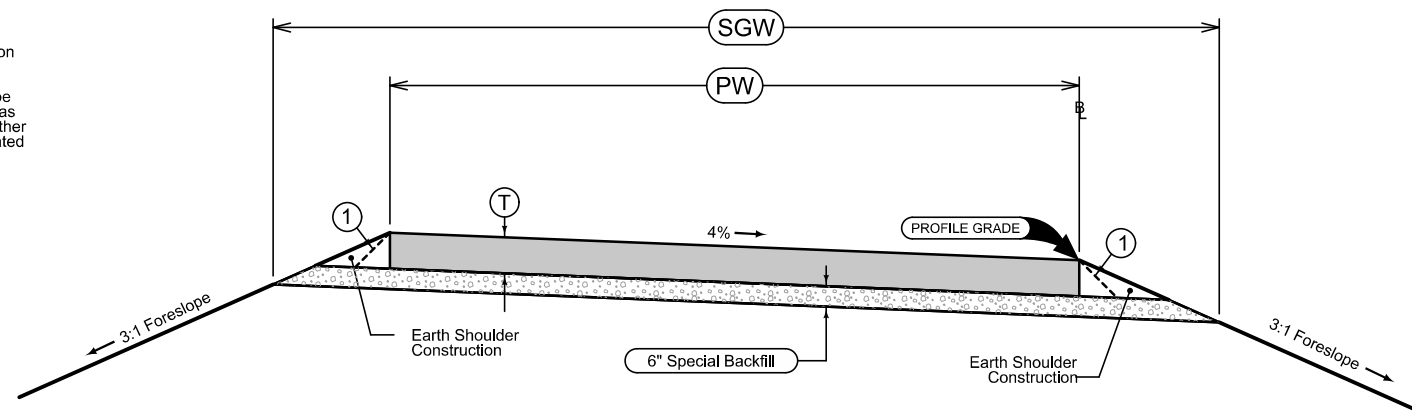

**DETOUR PAVING**

**Temporary Rest Area Ramp C**

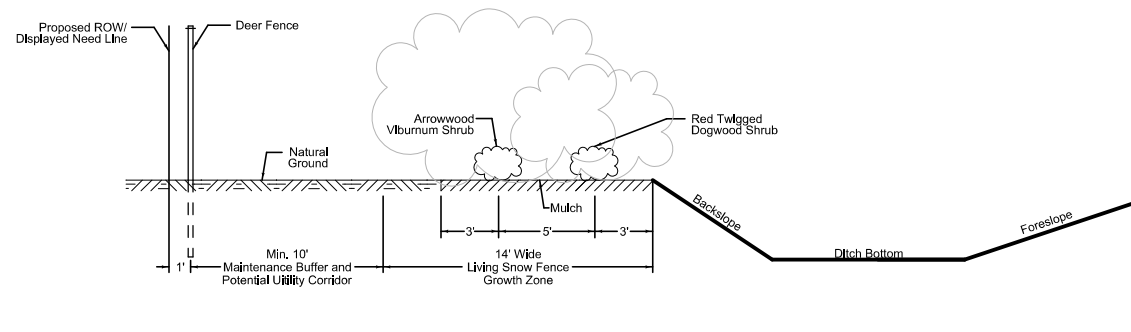

**TYP. WB MAINLINE  
& WB RAMPS  
(NORTH/LT)**

**APPLICABLE MAINLINE/RAMP  
ROADWAY SECTION**

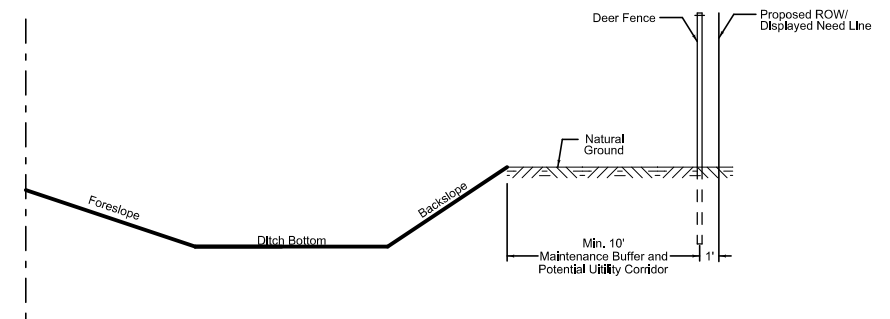

**TYP. EB MAINLINE  
& EB RAMPS  
(SOUTH/RT)**

**Living Snow Fence and  
Deer Fence Placement**

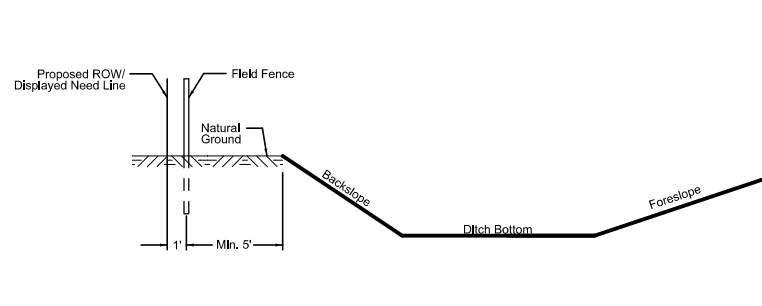

**APPLICABLE SIDE ROAD  
ROADWAY SECTION**

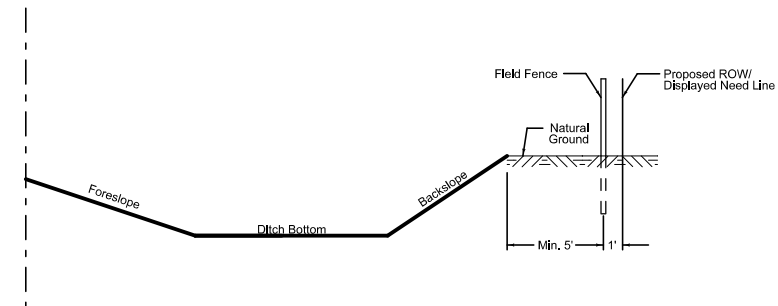

**Field Fence Placement**

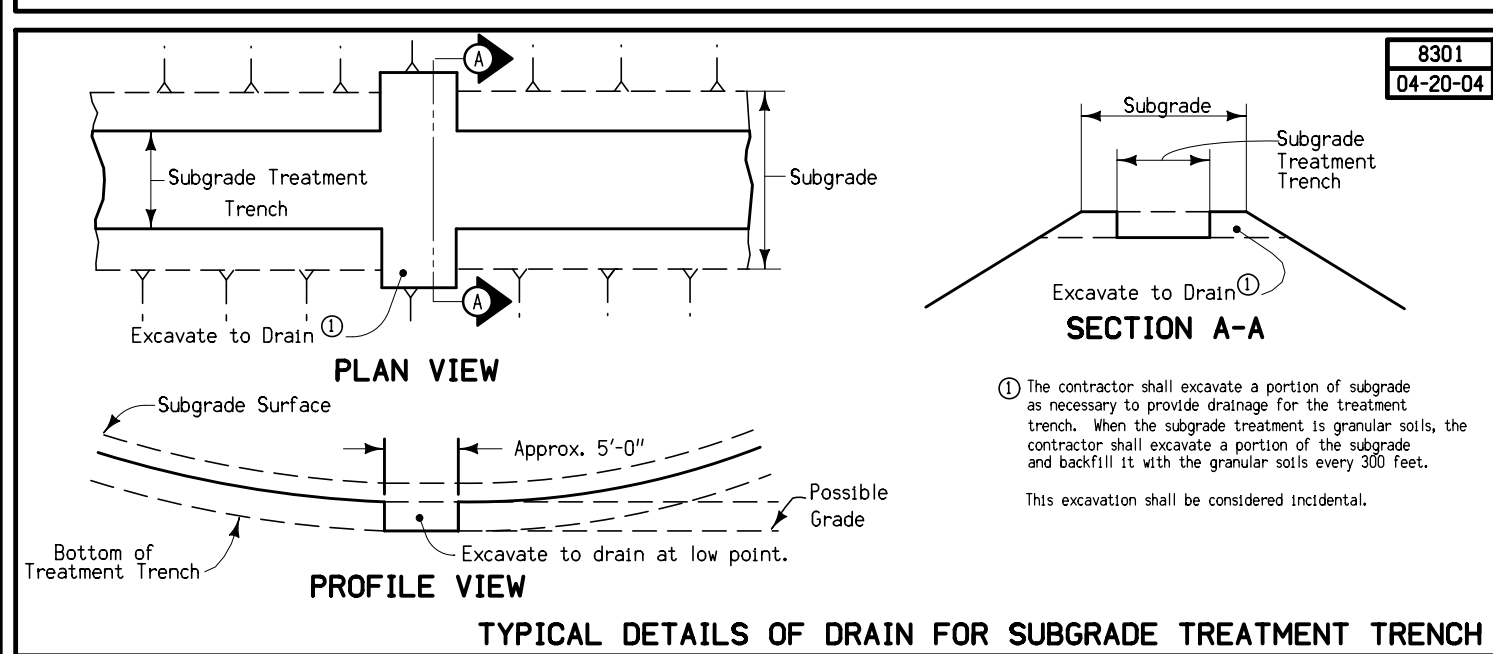
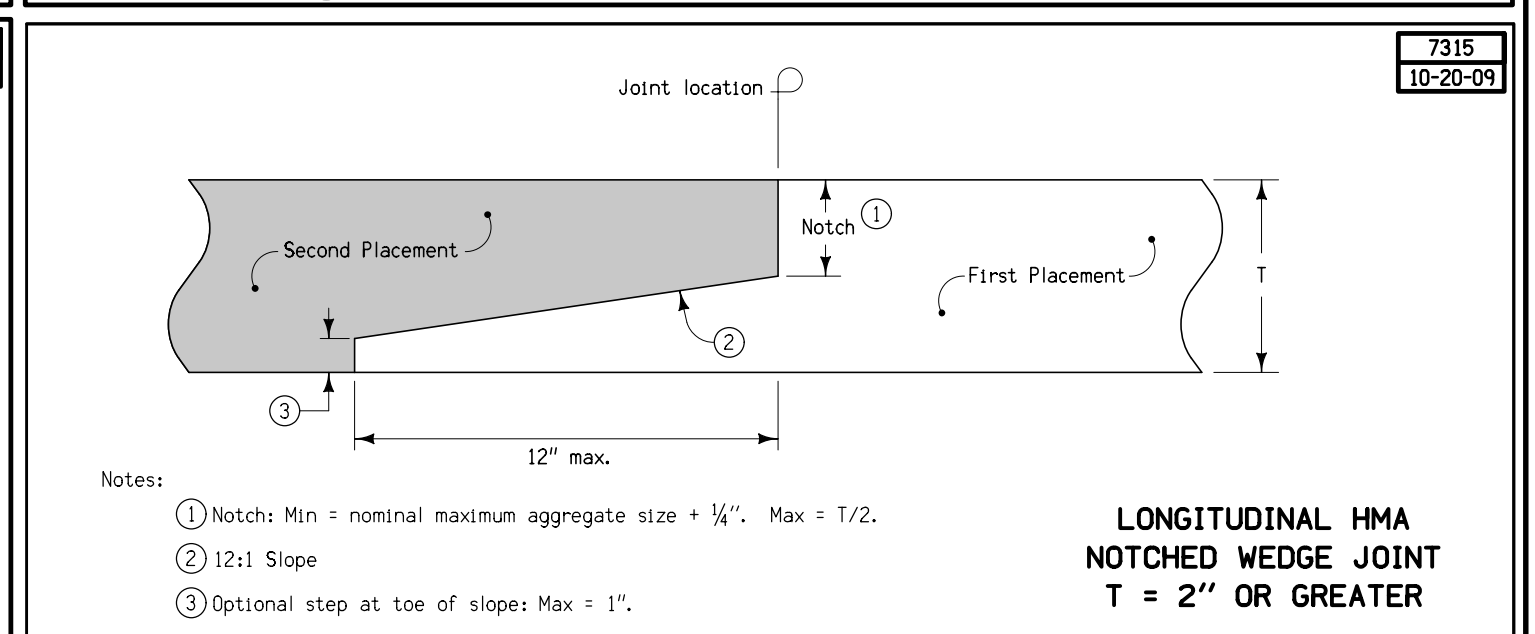
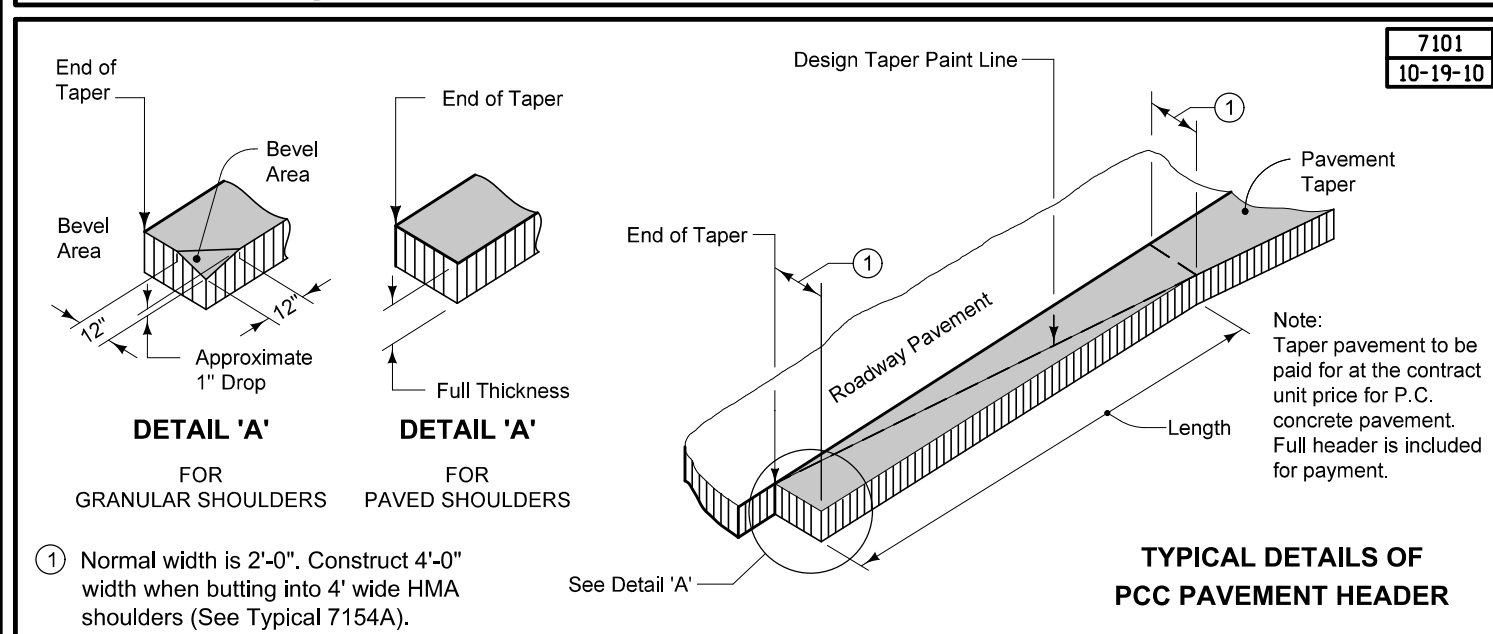
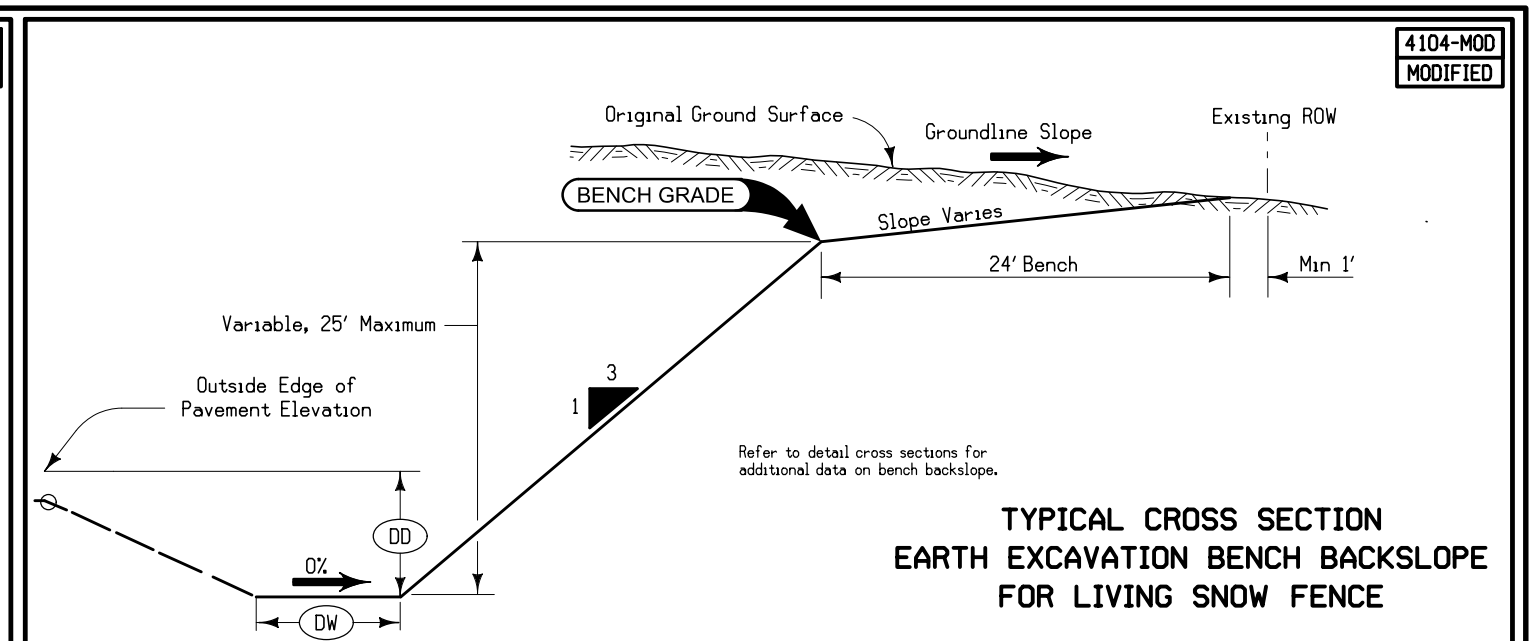
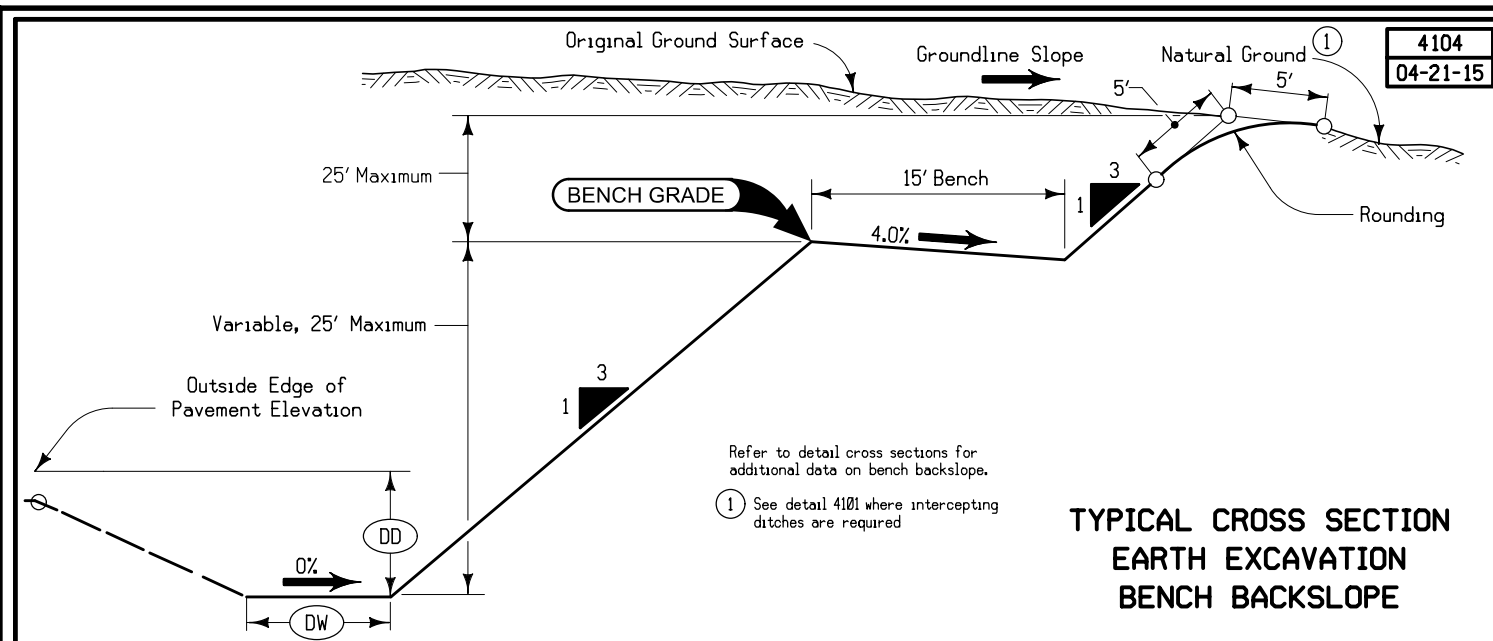

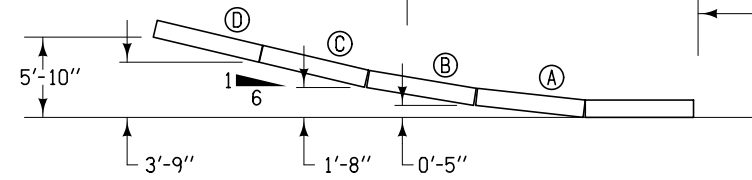
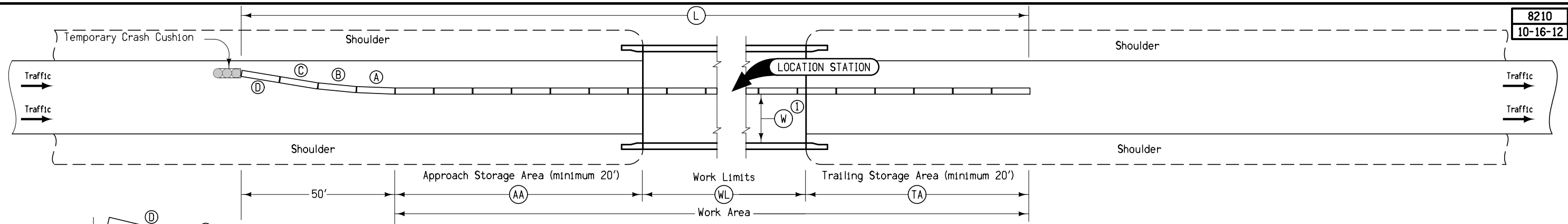

**BARRIER OFFSETS FOR FLARE SECTIONS**

Station	Side	AA	WL	TA	L	Anchored	W <sup>①</sup>	Remarks
		Feet	Feet	Feet	Feet	X	Ft-Inches	

① Where W is less than 14'-6", install restricted width signing as per Standard Road Plan TC-81.

**TEMPORARY CONCRETE BARRIER LAYOUT  
for One-Way Traffic**

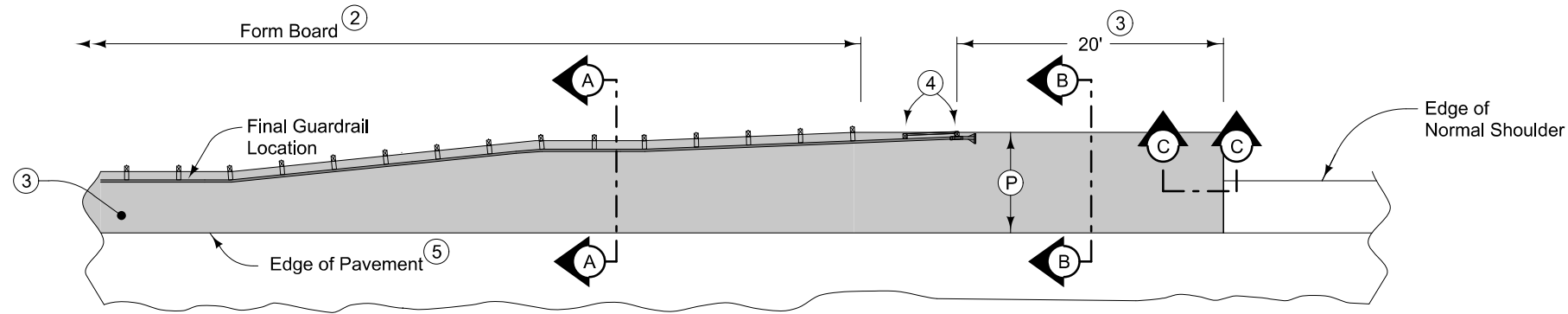

PLAN VIEW

Refer to Full Depth PCC Shoulder typical sections for pavement material and thicknesses. For PCC, use the following jointing layout:

Match mainline pavement joint spacing. When mainline pavement is 8" or greater in thickness, place additional transverse 'C' joints in shoulder at mid-panel of the mainline pavement. Place longitudinal 'C' joint at P/2 from edge of mainline pavement when P is greater than 10' wide. Terminate longitudinal joint at transverse joint less than 10' in length.

Compaction of HMA is required to face of guardrail post. Hand compaction will be allowed under guardrail. Removal and reinstallation of guardrail will be allowed with no additional payment.

Refer to Tabulation 112-9 for shoulder quantities.

- ① For subgrade treatment, refer to other details in the plan.
- ② PCC option only: When guardrail posts are installed prior to construction of PCC paved shoulder, fasten form board to the face of guardrail posts for the length shown. Refer to note 4 for final 2 posts.
- ③ Continue paved shoulder to existing paved shoulder or 20 feet beyond the center of the first post.
- ④ Shoulder may be notched for final 2 posts or post sleeves may be installed through pavement. Do not drive posts through pavement.
- ⑤ 'KT-1 joint for PCC shoulder. 'B' joint for HMA shoulder.

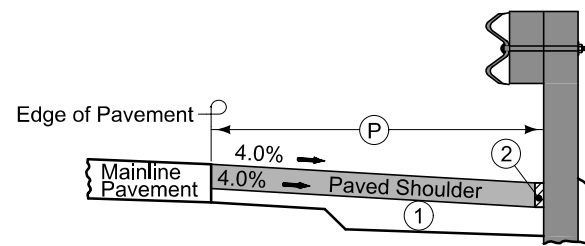

Section A-A

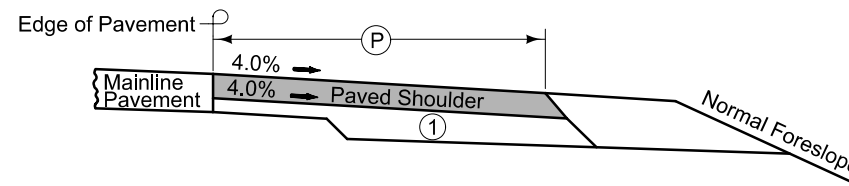

Section B-B

NEW CONSTRUCTION

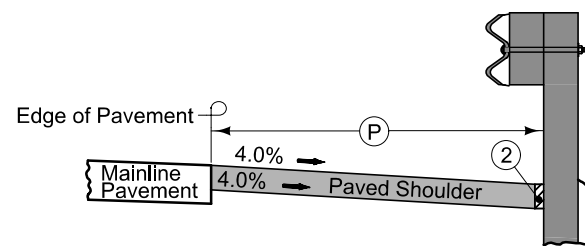

Section A-A

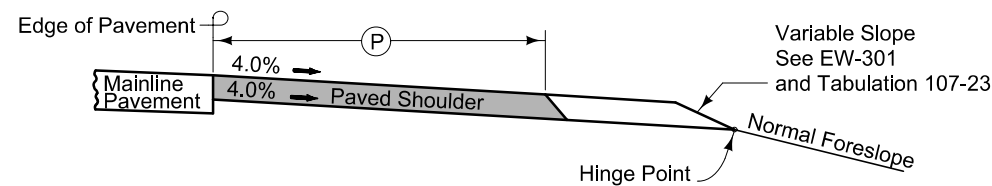

Section B-B

EXISTING SHOULDER

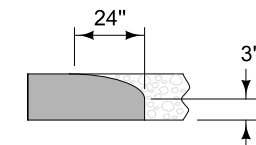

Section C-C  
Roll down at granular shoulder or earth.

PAVED SHOULDER AT GUARDRAIL



### SURVEY SYMBOLS

- FENO Control Monument
- TOP Top of Bridge Piers
- REF reference tie points
- SOP Size of pipe
- SBR size of bridge
- CP Control Point Generic
- UV Misc utility vault
- PIP pipes (cast iron, steel, tile, etc)
- ST stop sign
- PRO profile-r.r. rail, swk, abut
- BM bench mark
- D cl of draw or stream
- TLNR tree line right
- FW fence wire
- TDC tree deciduous
- GDL guard rails
- SI sign
- PPC power pole, Owner C
- PPB power pole, Owner B
- TEV evergreen tree
- ROW right of way rails
- PPA power pole, Owner A
- DU cl of draw upstream
- RIP rip-rap
- LUM luminaire
- GR Ground Field Survey
- BNK stream bank
- TLNL tree line left
- WC Wildcard
- TW Top of Water
- SP Stream Profile
- EG edge of gravel road
- CON concrete or a/c slab
- BD Bridge Deck
- BLS Bridge Low Steel
- BCL bridge centerline
- BRG bridge
- C center of roadway
- EB electrical box
- PL Photo Location
- CUL culvert
- INB intake-beehive
- OUT tile outlet
- STP stump
- GDC Cable Guardrail
- BB billboard or sign
- SL speed limit sign
- MM mile marker post
- TPD telephone pedestal
- LC lot corner
- MH Misc manhole
- UE utility elevation
- IN intake-grate, curb, umbrella
- LIN miscellaneous line
- CMP corrugated metal pipes
- WHD water hydrant
- BLD foundation or building
- SEP septic tank
- SHR shrub
- MIS miscellaneous
- LP L.P. tank
- TR Telephone Riser Pole
- ENU edge of unpaved entrance&parking
- CU curb or center island
- GU gutter
- UB Misc utility box
- CS concrete slab
- RET retaining walls
- FWD wood fence
- ROC rock outcropping
- TV tv dish
- WV water valve
- EW edge of water
- FCL security & chain link
- GP guard post / Bollard
- S Soil sampling site

- PPA power pole, Owner A
- E1(B) EL1B UG electric, Eastern Iowa Light & Power - Quality B
- E1(C) EL1C UG electric, Eastern Iowa Light & Power - Quality C
- F0(B) FO1B fiber optics, Iowa Communications Network - Quality B
- F0(C) FO1C fiber optics, Iowa Communications Network - Quality C

### UTILITY LEGEND

- Eastern Iowa Light and Power Cooperative  
600 East 5th Street  
Wilton, IA 52778  
563-732-2211: Ext 7330  
dennis.hill@easterniowa.com
- ICN (Iowa Communications Network)  
Mike Broderick  
400 East 1st Street / Grimes Office Building  
Des Moines, IA 50319  
515-725-4741  
mike.broderick@iowa.gov

### PLAN VIEW COLOR LEGEND OF PLAN AND PROFILE SHEETS

LINEWORK	Design Color No.	
Green	(2)	Existing Topographic Features and Labels
Blue	(1)	Proposed Alignment, Stationing, Tic Marks, and Alignment Annotation
Magenta	(5)	Existing Utilities
SHADING		
Design Color No.		
Yellow	(4)	Highlight for Critical Notes or Features
Red	(3)	Delineates Restricted Areas
Lavender	(9)	Temporary Pavement Shading
Gray, Light	(48)	Proposed PCC Pavement with HMA Surfacing Shading
Gray, Med	(80)	Proposed Granular Shading
Gray, Dark	(112)	Proposed HMA Resurfacing Shading
Brown, Light	(236)	Grading Shading
Tan	(8)	Proposed Sidewalk Shading
Blue, Light	(230)	Proposed Sidewalk Landing Shading
Pink	(11)	Proposed Sidewalk Ramp Shading

### PROFILE VIEW COLOR LEGEND OF PLAN AND PROFILE SHEETS

LINEWORK	Design Color No.	
Green	(2)	Existing Ground Line Profile
Blue	(1)	Proposed Profile and Annotation
Magenta	(5)	Existing Utilities
Blue, Light	(230)	Proposed Ditch Grades, Left
Black	(0)	Proposed Ditch Grades, Median
Rust	(14)	Proposed Ditch Grades, Right

- Reference Point
- Station
- Survey Line
- Section Corner
- Need Line
- Saw Cut
- Guardrail
- Trench Drain
- HighTension Cable Guardrail
- Sheet Pile
- Pavement Removal
- Clearing & Grubbing Area

- ### RIGHT-OF-WAY LEGEND
- Proposed Right-of-Way
  - Existing Right of Way
  - Existing and Proposed Right-of-Way
  - Easement and Existing Right-of-Way
  - Easement (Temporary)
  - Easement
  - Access Control
  - Property Line

- Existing Ditch Dike (U.A.C.)

## PLAN AND PROFILE LEGEND AND SYMBOL INFORMATION SHEET

(COVERS SHEET SERIES D, E, F, & K)

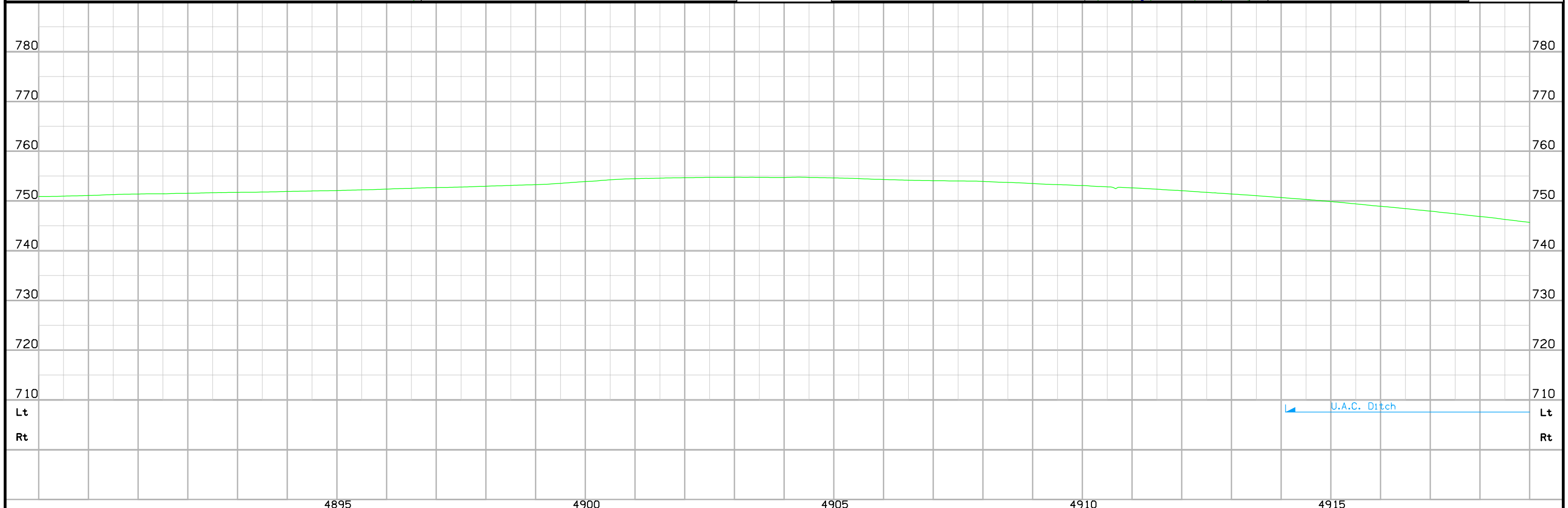
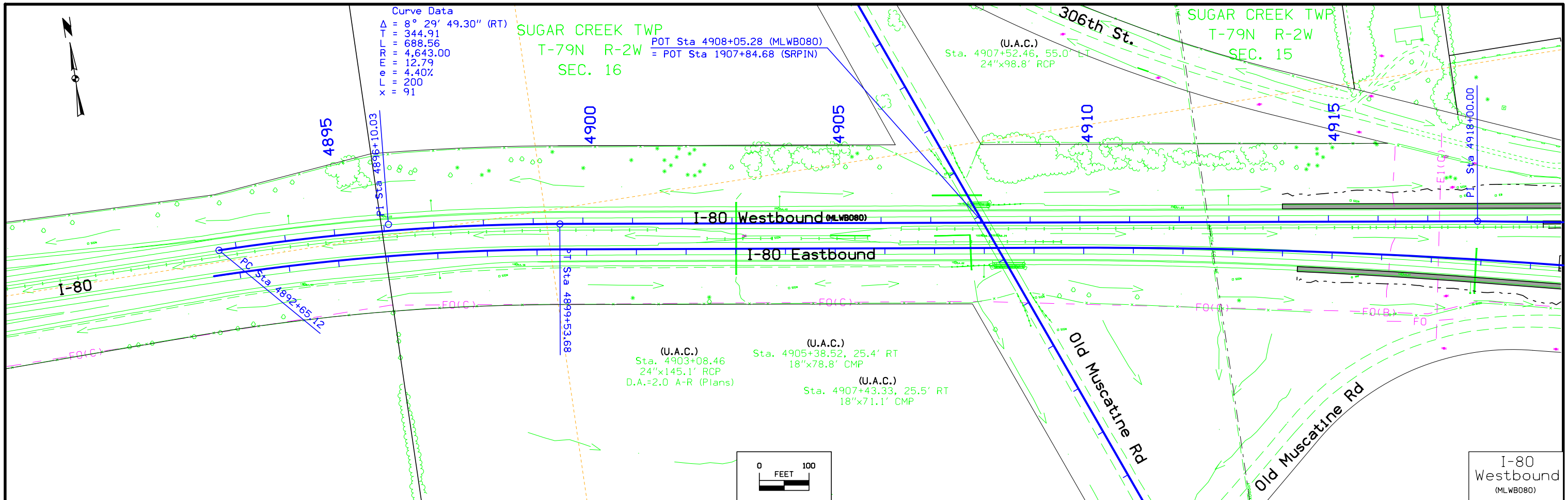

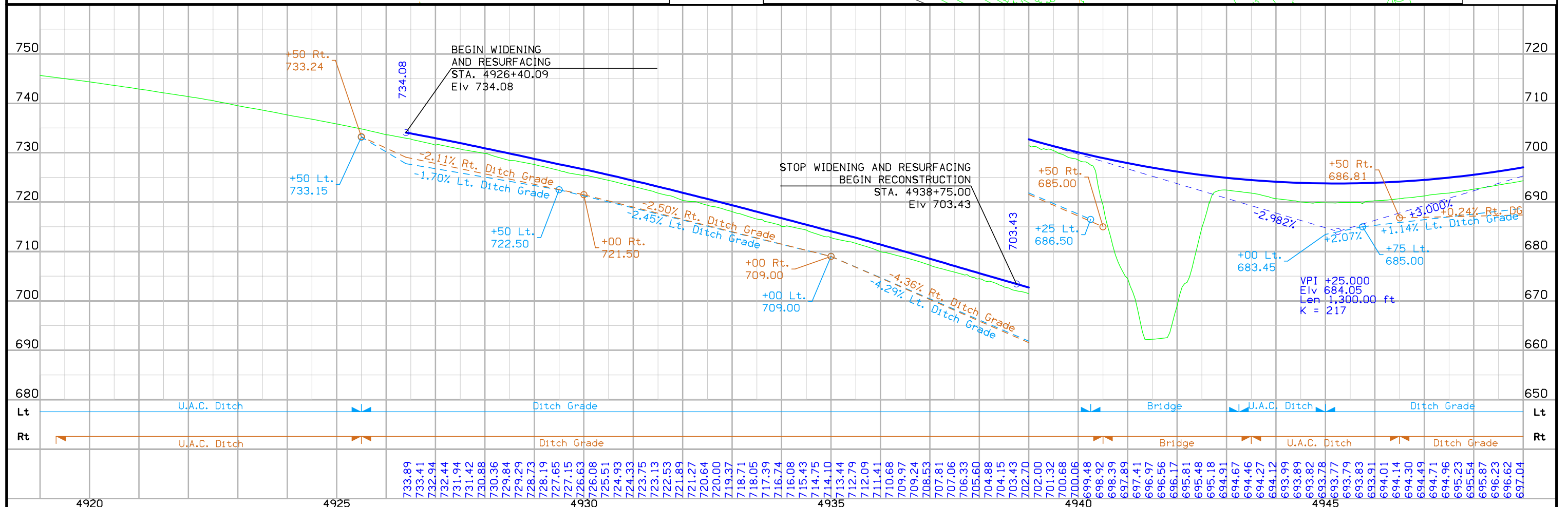
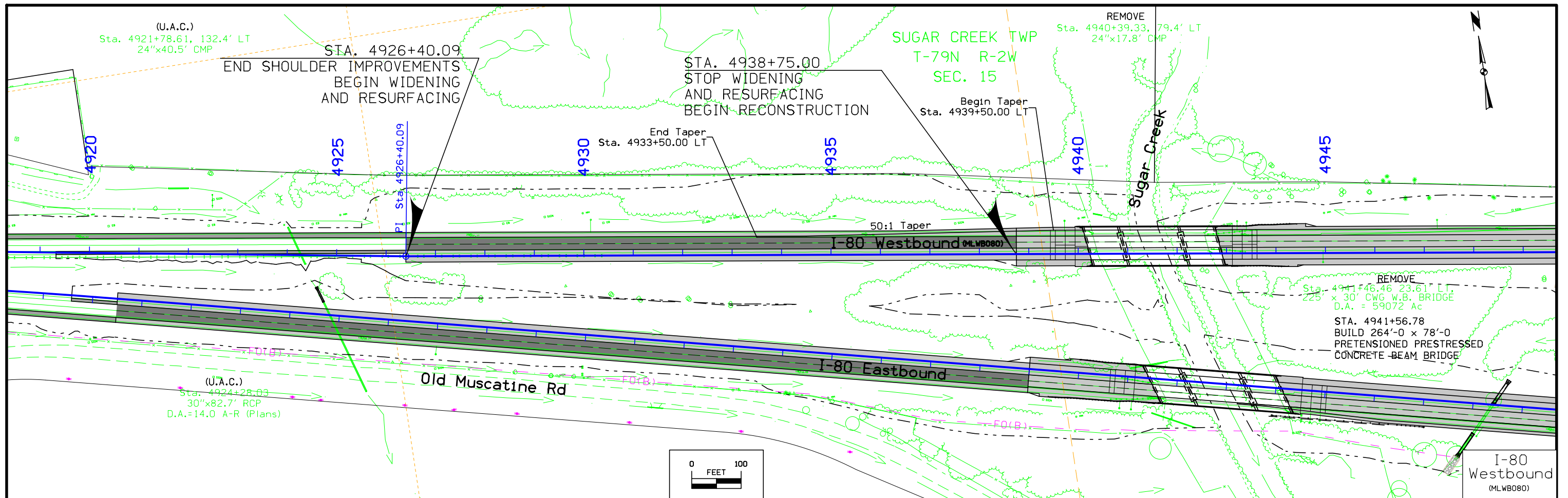

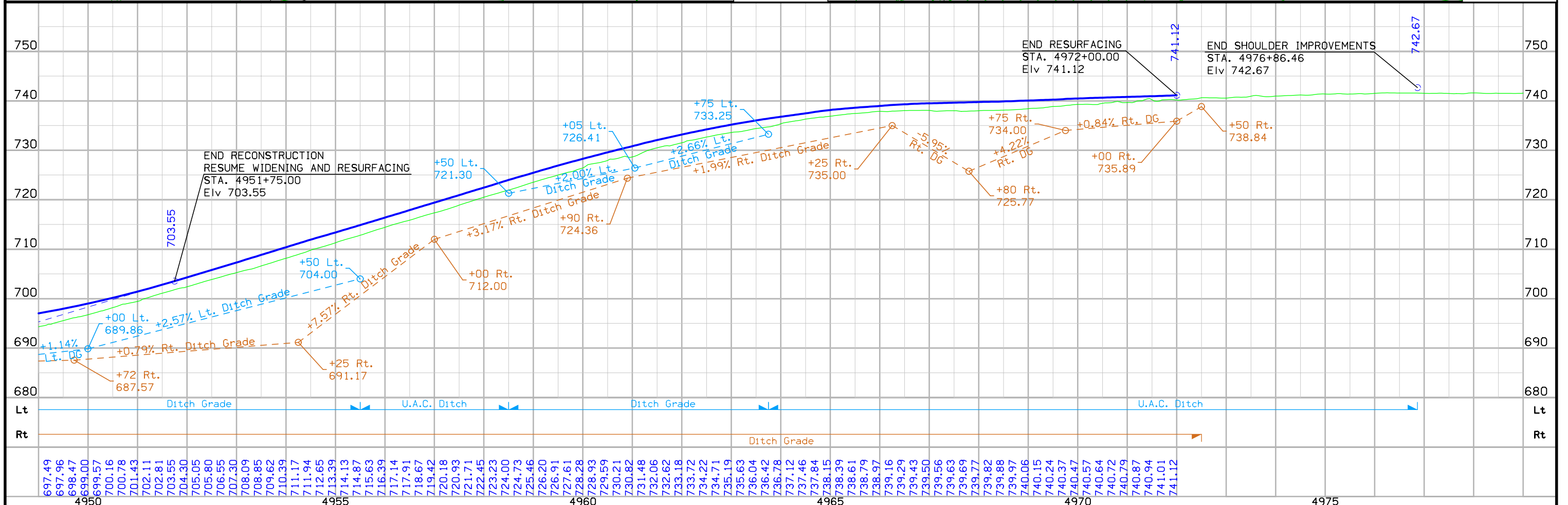
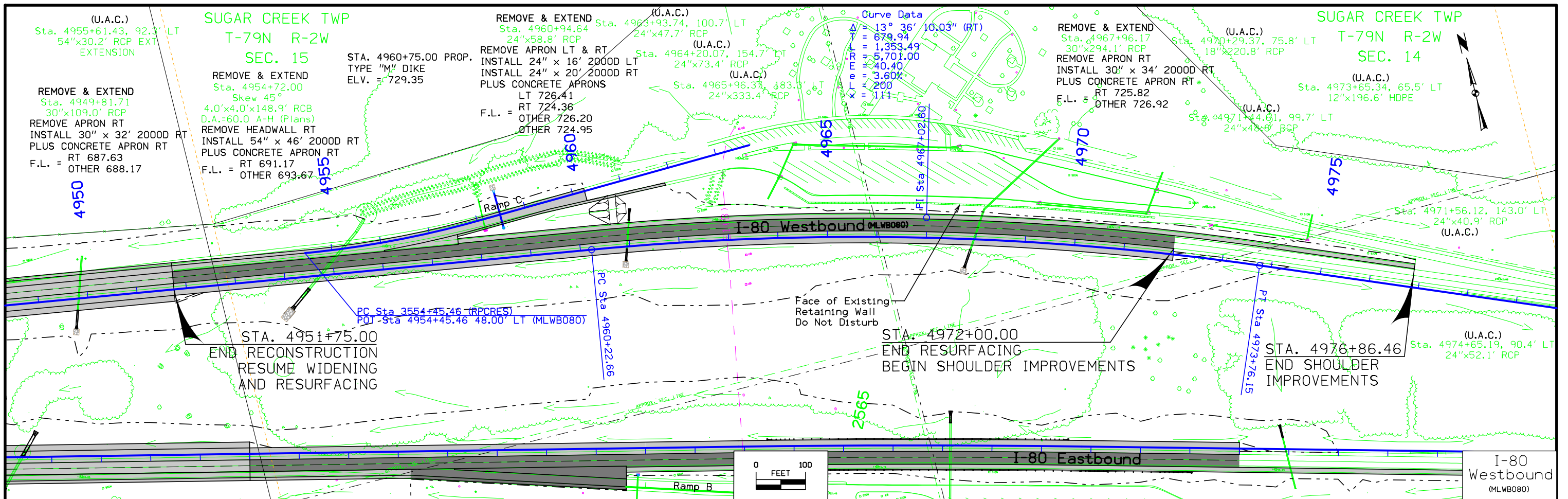



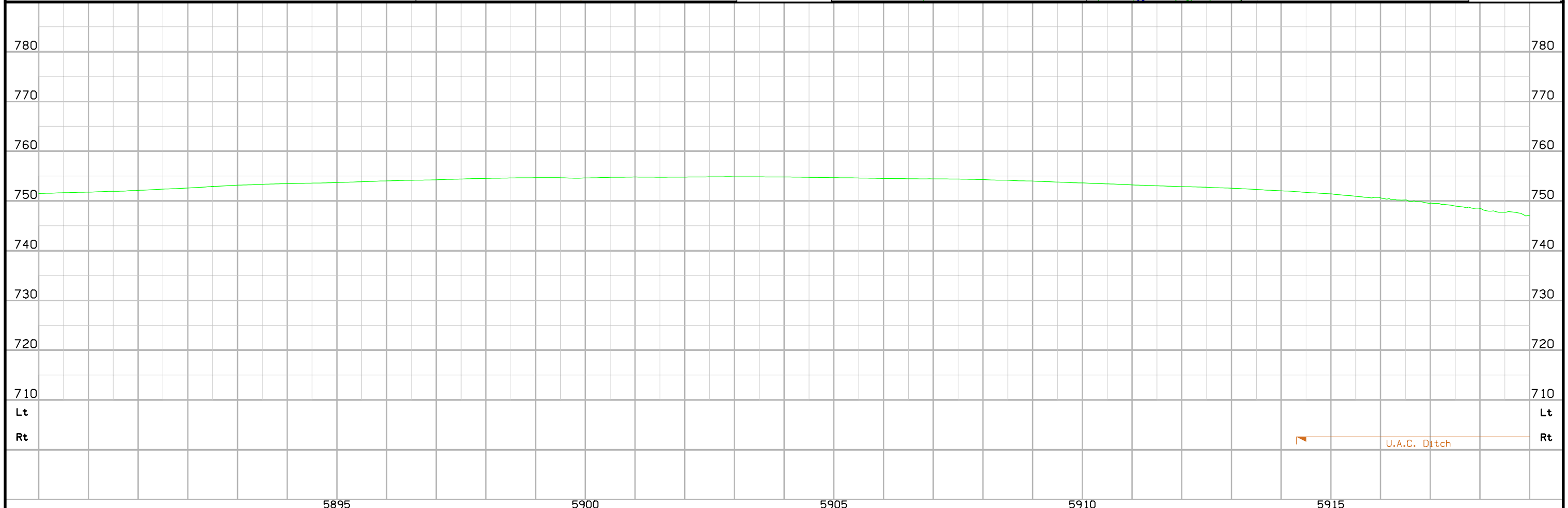
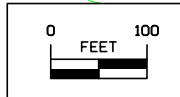
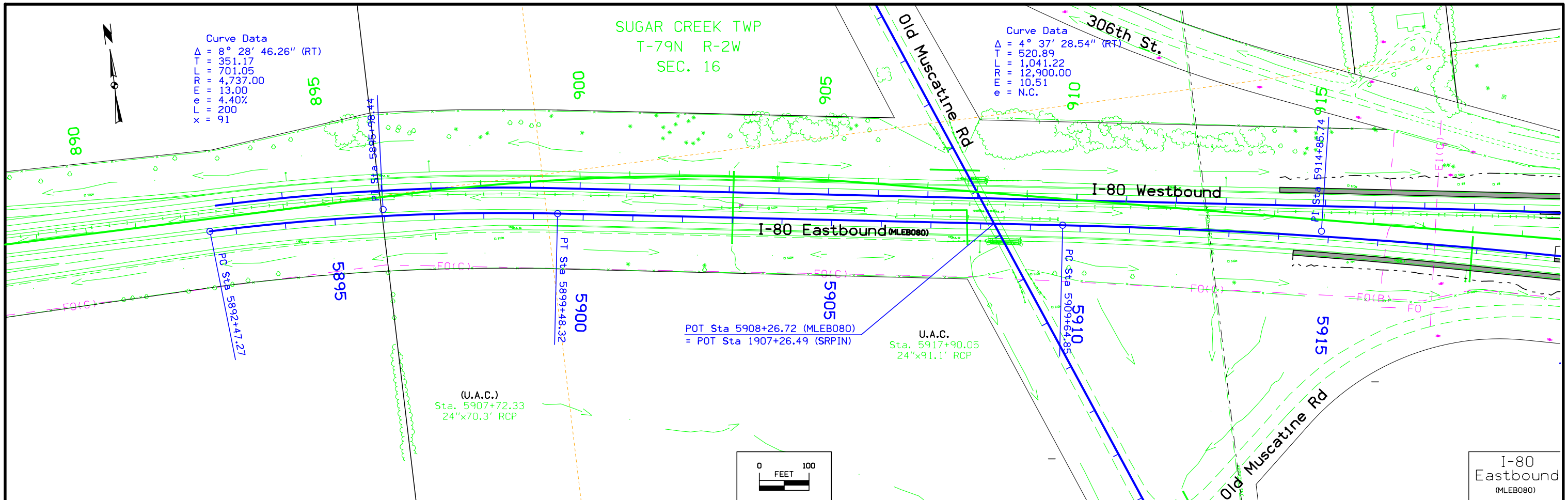

FILE NO.	ENGLISH	DESIGN TEAM	Iowa DOT \ HR Green	CEDAR COUNTY	PROJECT NUMBER	IM-NHS-080-8(341)269--03-16	SHEET NUMBER	D.5
----------	---------	-------------	---------------------	--------------	----------------	-----------------------------	--------------	-----

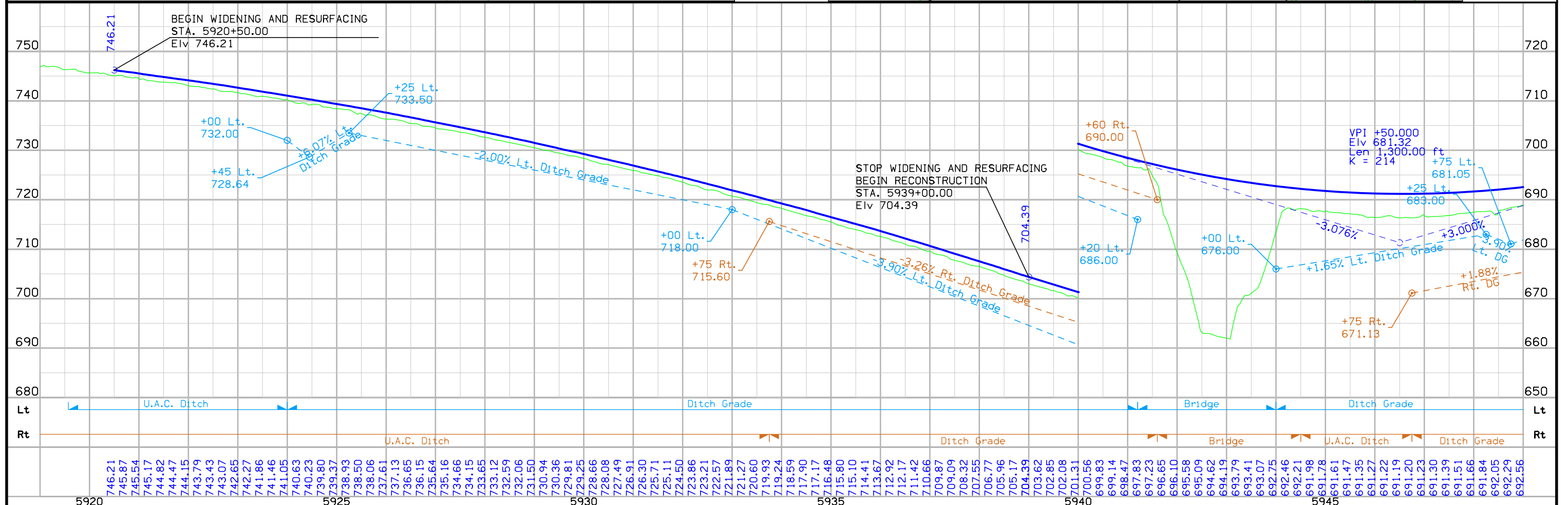
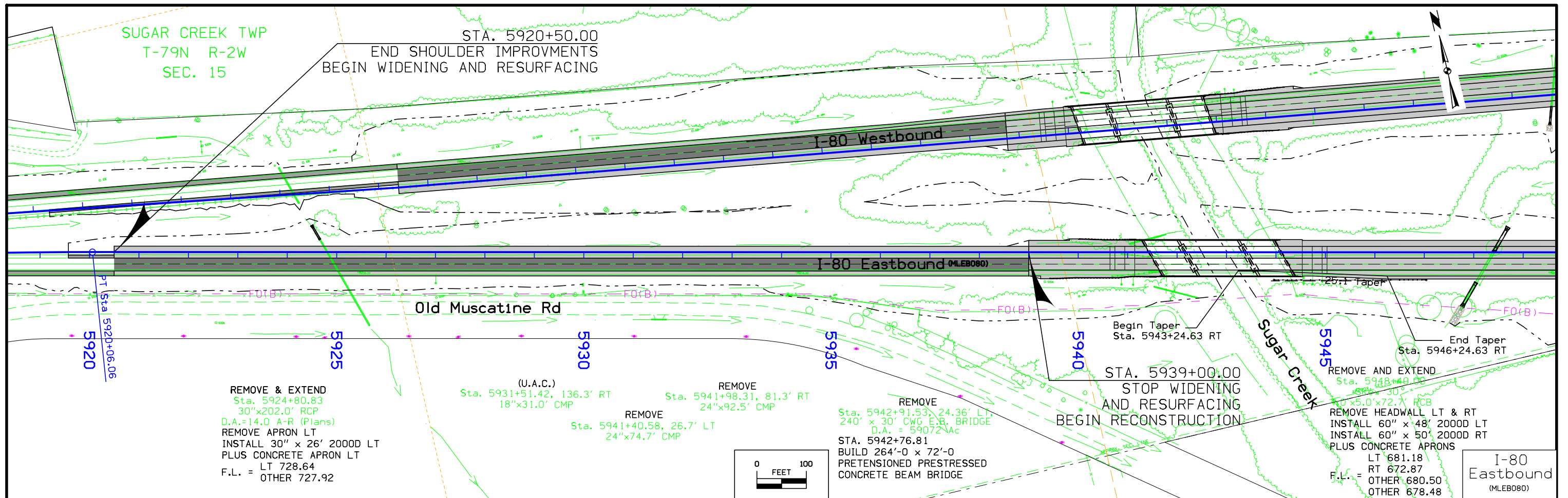

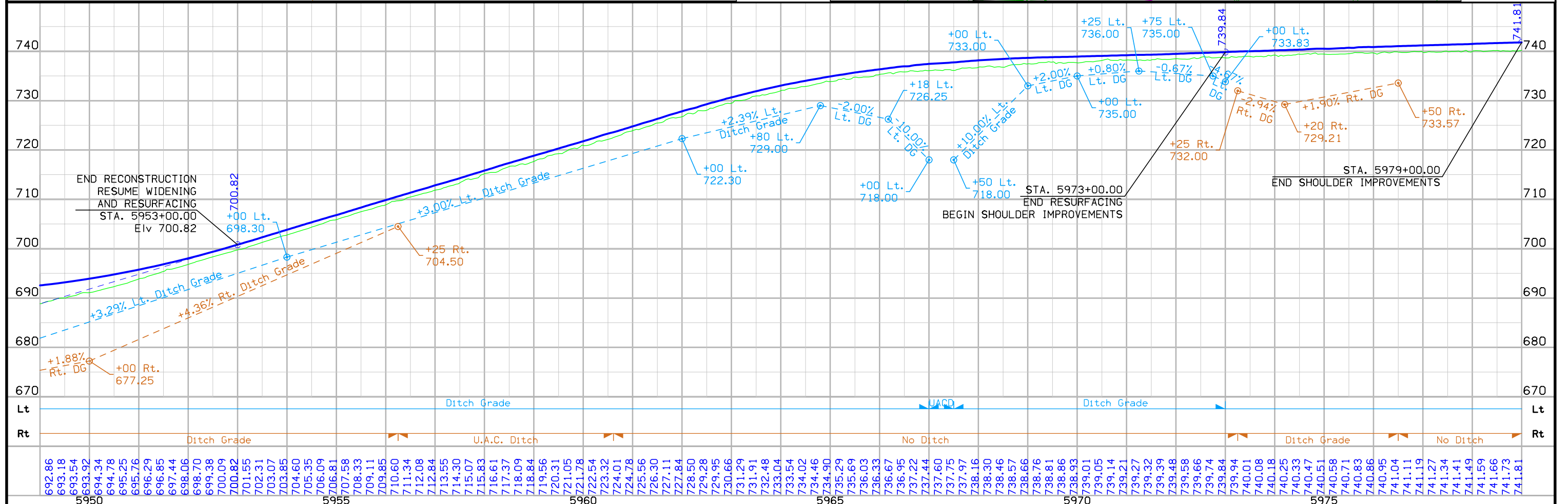
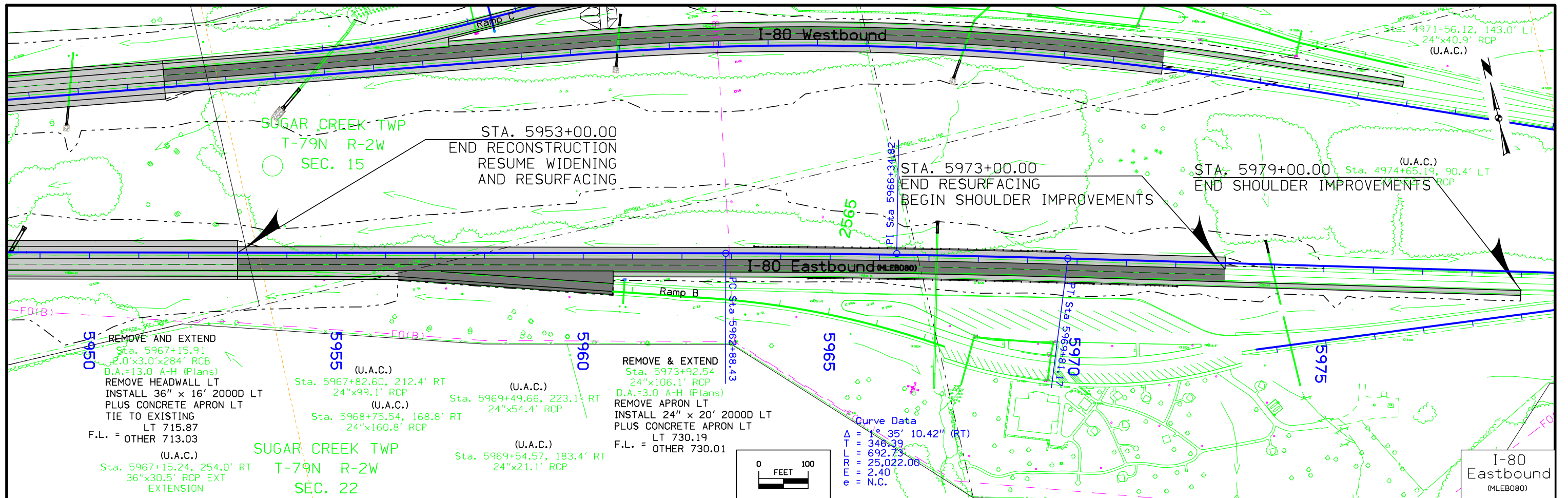

FILE NO.	ENGLISH	DESIGN TEAM	Iowa DOT \ HR Green	CEDAR COUNTY	PROJECT NUMBER	IM-NHS-080-8(341)269--03-16	SHEET NUMBER	D.7
----------	---------	-------------	---------------------	--------------	----------------	-----------------------------	--------------	-----

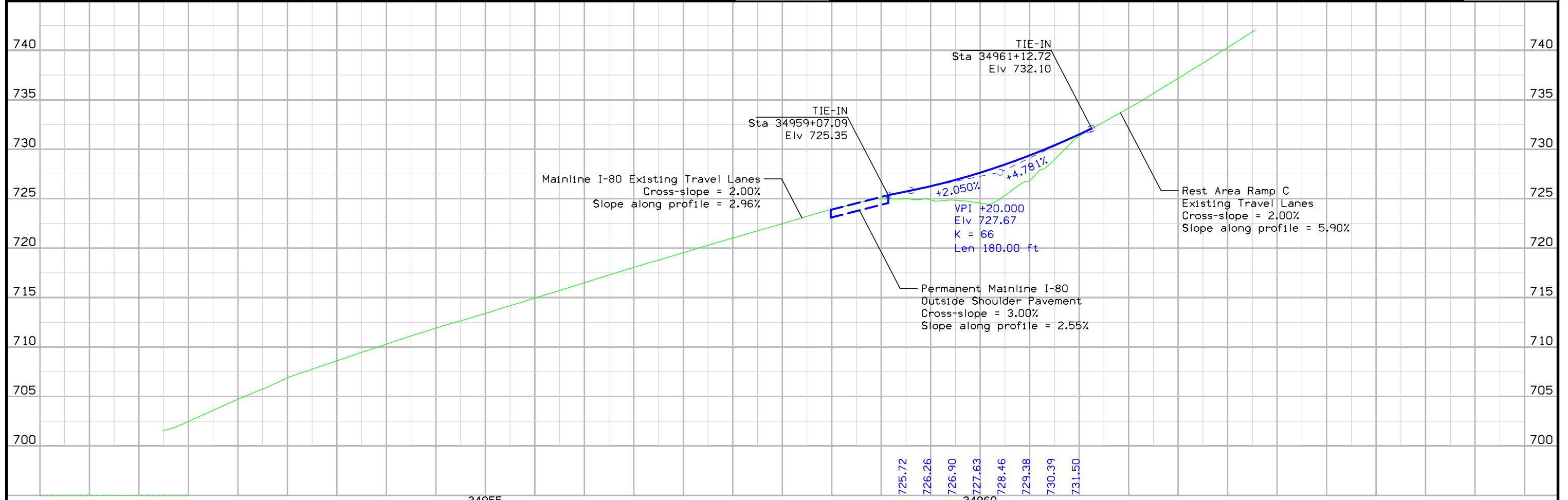
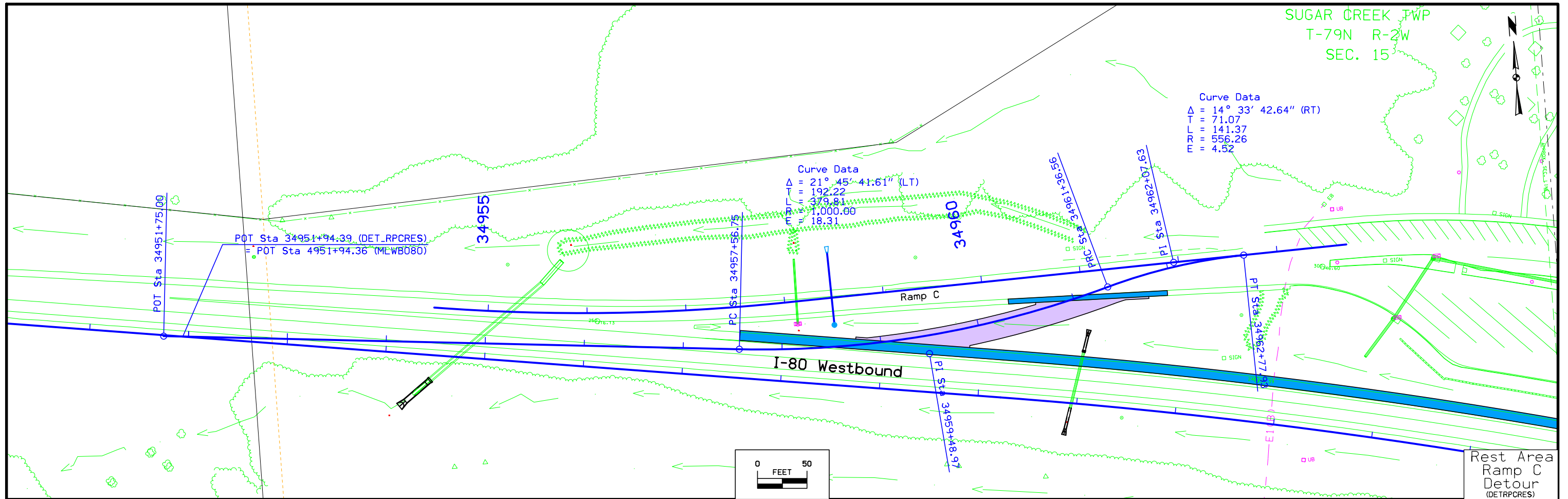



## Survey Information

Cedar County  
IM-080-7(132)266—13-16  
E of Cedar River to approx  
0.5 mi W of Co Rd Y26  
PIN 04-16-080-020

### General Information

Measurement units for this survey are US survey feet. This survey is for the preliminary design for the section of I-80 from Cedar River to the Cedar/Scott County line in Cedar County, Iowa. Project datum and control information is provided by Design Survey Office. This project is a Partial DTM with Photo control. This survey request was for the I-80 corridor only. Project horizontal datum is NAD83(2011), Iowa RCS Zone 10 (Cedar Rapids).

### Vertical Control

Vertical datum for this survey is relative to NAVD88 (computed using Geoid12B for the derived orthometric elevations listed). This survey consisted of observing 13 new FENO 1-meter rod monuments using minimum 2hr initial static observations along with data from 5 Iowa RTN CORS sites: Coralville (IACI), Muscatine (IAMU), Maquoketa (IAMQ), Davenport (IADA) and Tipton (IATI).

Additionally, 5 local existing county GPS monuments with published NAVD88 elevations were observed and used that are located in proximity to the I-80 corridor area: Scott County GPS 2005-624 along with Cedar County GPS points 2007-28, 2007-35, 2007-42 and 2007-48.

Scott County GPS Pt 2005-624 has a published Elv of: 726.41 usft  
Survey Elv = 726.4 usft

Cedar County GPS Pt 2007-28 has a published Elv of 718.04 usft  
Survey Elv = 718.03 usft

Cedar County GPS Pt 2007-35 has a published Elv of 737.79 usft  
Survey Elv = 737.80 usft

Cedar County GPS Pt 2007-42 has a published Elv of 731.74 usft  
Survey Elv = 731.74 usft

Cedar County GPS Pt 2007-48 has a published Elv of 748.57 usft  
Survey Elv = 748.57 usft

The final vertical adjustment results show standard deviations were less than 0.04 ft. at 95% confidence level (2 sigma) for the new FENO monuments.

### Horizontal Control

The project coordinate system for this survey is NAD83(2011) Iowa RCS Zone 10 (Cedar Rapids) us survey feet. This survey control is relative to IARTN reference stations. IARTN Reference Station coordinates are relative to the National Reference Station network datum: NAD83 (2011) for Epoch 2010.00. Coordinates were determined by averaging a minimum of two IARTN observations of 120 minutes minimum session length for the first observation, and 120 minutes minimum for the second observation with appropriate time spans between each session. The horizontal standard deviation of these adjusted observations was less than 0.02 ft. at 95% confidence level (2 sigma).

### Alignment Information

The horizontal alignment for this survey is a retrace of As-built Plans No. IR-80-7(57)256—12-16. Survey stationing was equated to the plan PI at STA 770+79.75 and run back and ahead with two station equations throughout the survey.

Survey stationing relates to as built plan stationing as follows:

PI STA 852+32.6 As-built Plans Project No. IR-80-7(57)256—12-16  
Survey PI STA 852+32.91

PI STA 901+28.40 As-built Plans Project No. IR-80-7(57)256—12-16  
Survey PI STA 901+25.46

PI STA 964+80.8 As-built Plans Project No. IR-80-7(57)256—12-16  
Survey PI STA 964+82.07

PI STA 1056+26.06 As-built Plans Project No. IR-80-7(57)256—12-16  
Survey PI STA 1056+23.36

PI STA 1097+36.09 As-built Plans Project No. IR-80-7(57)256—12-16  
Survey PI STA 1097+35.96

### Equation

PC STA 1155+72.21 (Back) =  
PC STA 1200+00.00 (Ahead)

PI STA 1204+62.50 As-built Plans Project No. IR-80-7(57)256—12-16  
Survey PI STA 1204+62.54

PI STA 1296+83.1 As-built Plans Project No. IR-80-7(57)256—12-16  
Survey PI STA 1296+83.17

PI STA 1359+99.7 As-built Plans Project No. IR-80-7(57)256—12-16  
Survey PI STA 1360+02.29

PI STA 1432+18.5 As-built Plans Project No. IR-80-7(57)256—12-16  
Survey PI STA 1432+16.38

### Equation

STA 1439+81.54 (Back) =  
STA 0+00.00 (Ahead)

### CONTROL POINT VICINITY MAP

This map is a guide to the vicinity of the primary project control points  
 Primary control is for use with RTK base stations and for RTN validation.  
 Future surveys will use primary project control to establish temporary control as needed for construction or other surveying applications.

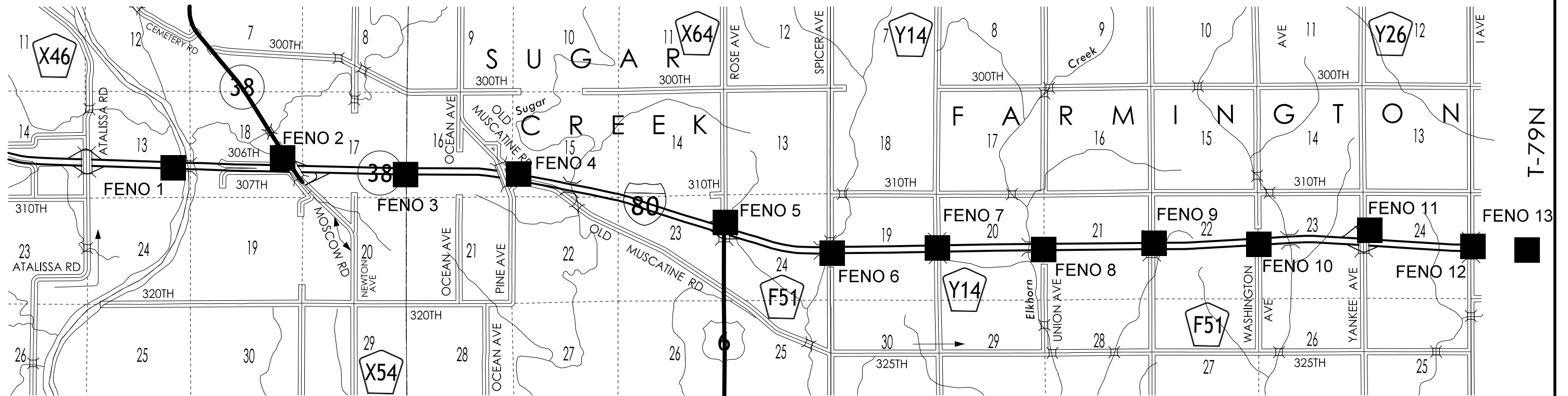

HORIZ. DATUM: NAD83(2011) EPOCH 2010.00

VERT. DATUM: NAVD88

1a. Regional Coordinate System Zone 10

Coordinate listing from next sheet will be used with 1aRTN for monument recovery. No other reference ties are given.

HORIZONTAL AND VERTICAL PROJECT CONTROL COORDINATE LISTING

HORIZ. DATUM: NAD83(2011) EPOCH 2010.00

VERT. DATUM: NAVD88

Ia. Regional Coordinate System Zone 10

Point Name	Northing	Easting	Elevation	Feature
FENO1	7931903.988	20645032.90	660.792	FENO
FENO2	7932401.155	20650487.31	675.723	FENO
FENO3	7931576.605	20656608.15	750.540	FENO
FENO4	7931615.375	20662241.43	745.228	FENO
FENO5	7929177.084	20672559.46	755.379	FENO
FENO6	7927658.057	20677873.71	707.123	FENO
FENO7	7928042.512	20683236.53	764.044	FENO
FENO8	7927833.998	20688433.39	696.149	FENO
FENO9	7928143.386	20693929.25	723.017	FENO
FENO10	7928103.960	20699161.29	736.667	FENO
FENO11	7928788.784	20704684.46	735.398	FENO
FENO12	7927995.048	20709822.03	721.353	FENO
FENO13	7927804.629	20712523.29	702.864	FENO

**ALIGNMENT COORDINATES**

Name	Location	Point on Tangent		Begin Spiral		Begin Curve		Simple Curve PI or Master PI of SCS		End Curve		End Spiral		
		Station	Coordinates	Station	Coordinates	Station	Coordinates	Station	Coordinates	Station	Coordinates	Station	Coordinates	
I-80														
1	MLEB080					5892+47.27 R1	7931707.95	20659941.52	5895+98.44 R1	7931707.40	20660292.69	5899+48.32 R1	7931655.07	20660639.94
3	MLEB080					5909+64.85 R1	7931503.61	20661645.11	5914+85.74 R1	7931426.00	20662160.19	5920+06.06 R1	7931307.11	20662667.33
5	MLEB080					5962+88.43 R1	7930329.69	20666836.66	5966+34.82 R1	7930250.62	20667173.91	5969+81.17 R1	7930162.26	20667508.84
7	MLEB080					5992+44.74 R1	7929584.81	20669697.52	5996+23.29 R1	7929488.23	20670063.54	6000+01.77 R1	7929379.41	20670426.12
8	MLEB080	6004+76.96 R1	7929242.79	20670881.24										
1	MLWB080					4892+65.12 R1	7931757.92	20659959.45	4896+10.03 R1	7931757.38	20660304.37	4899+53.68 R1	7931705.88	20660645.41
3	MLWB080	4918+00.00 R1	7931430.22	20662471.04										
4	MLWB080	4926+40.09 R1	7931292.94	20663299.83										
5	MLWB080					4960+22.66 R1	7930787.91	20666644.49	4967+02.60 R1	7930686.39	20667316.81	4973+76.15 R1	7930429.60	20667946.40
7	MLWB080					4993+02.00 R1	7929702.26	20669729.62	4999+19.57 R1	7929469.03	20670301.45	5005+36.19 R1	7929291.49	20670892.95
8	MLWB080	5005+92.76 R1	7929275.22	20670947.13										
Rest Area Ramp C														
1	RPCRES					3554+45.46 R1	7930921.55	20666080.93	3556+23.19 R1	7930895.01	20666256.67	3557+99.99 R1	7930899.88	20666434.33
2	RPCRES	3563+70.49 R1	7930915.51	20667004.62										
Rest Area Ramp C Detour														
1	DET RPCRES	4951+75.00 R1	7930913.48	20665806.18										
2	DET RPCRES					4957+56.75 R1	7930856.41	20666385.12	4959+48.97 R1	7930837.55	20666576.42	4961+36.56 R1	7930890.96	20666761.07
3	DET RPCRES					4961+36.56 R1	7930890.96	20666761.07	4962+07.63 R1	7930910.71	20666829.34	4962+77.93 R1	7930912.66	20666900.39
Existing Rest Area Ramp B														
1	EX RPBRES	2560+60.59 R1	7930306.36	20666596.06										
2	EX RPBRES					2562+59.29 R1	7930247.97	20666785.98	2565+03.01 R1	7930176.34	20667018.94	2567+43.82 R1	7930045.64	20667224.65

**SPIRAL OR CIRCULAR CURVE DATA**

Name	Location	ΔSCS	Horizontal Alignment Data											Remarks			
			Spiral Data						Curve Data								
			θS	Ls	Ts	Es	Xc	Yc	L.T.	S.T.	ΔC	T	L		R	E	
I-80																	
C1	MLEB080										8°28'46.3"	351.17	701.05	4737.00		13.00	
C2	MLEB080										4°37'28.5"	520.89	1041.22	12900.00		10.51	
C3	MLEB080										1°35'10.4"	346.39	692.73	25022.00		2.40	
C4	MLEB080										1°55'40.0"	378.55	757.03	22500.00		3.18	
C1	MLWB080										8°29'49.3"	344.91	688.56	4643.00		12.79	
C2	MLWB080										13°36'10.0"	679.94	1353.49	5701.00		40.40	
C3	MLWB080										5°28'54.1"	617.57	1234.19	12900.00		14.77	
Rest Area Ramp C																	
C1	RPCRES										10°09'23.9"	177.73	354.53	2000.00		7.88	
Rest Area Ramp C Detour																	
C1	DET RPCRES										21°45'41.6"	192.22	379.81	1000.00		18.31	
C2	DET RPCRES										14°33'42.6"	71.07	141.38	556.26		4.52	
Existing Rest Area Ramp B																	
C1	EX RPBRES										15°20'15.9"	243.72	484.53	1810.00		16.34	

**SUPERELEVATION DATA**

See PV-300 Series

Road Identification	Circular Curve or Spiral Curve Name	Radius	Superelevation Data			Standard Road Plan	Section A-A	Section B-B	Section C-C	Section D-D	Section E-E	Section F-F	Section G-G	Section H-H	Case A	Case B	Case C	Case S	Case T	Remarks
			e	L	x															
			FT	%	FT															
MLWB080	MLWB080_1	4643	4.4	200	91	PV-307Ma	4889+88.62	4890+11.37	4890+34.12	4891+25.12	4892+16.12	4892+38.87	4892+61.62	4893+25.12	4892+65.12			4893+06.92		
							4902+30.18	4902+07.43	4901+84.68	4900+93.68	4900+02.68	4899+79.93	4899+57.18	4898+93.68	4899+53.68			4899+11.88		
MLEB080	MLEB080_1	4737	4.4	200	91	PV-307Ma	5889+70.77	5889+93.52	5890+16.27	5891+07.27	5891+98.27	5892+21.02	5892+43.77	5893+07.27	5892+47.27			5892+43.77	5892+89.07	
							5902+24.82	5902+02.07	5901+79.32	5900+88.32	5899+97.32	5899+74.57	5899+51.82	5898+88.32	5899+48.32			5899+51.82	5899+06.52	
MLWB080	MLWB080_8	5701	3.6	200	111	PV-307Mb	4957+16.16	4957+43.91	4957+71.66	4958+82.66	4959+93.66	4960+21.41	4960+49.16	4960+82.66		4960+22.66				
							4976+82.65	4976+54.90	4976+27.15	4975+16.15	4974+05.15	4973+77.40	4973+49.65	4973+16.15		4973+76.15				
RPCRES	RPCRES	2000	5.4	168	62	PV-303	3552+65.86	3553+27.86	3554+45.46	3554+95.86								3554+52.30	3554+52.30	
							3559+79.59	3559+17.59	3557+99.99	3557+49.59								3557+93.15	3557+93.15	

NO ACCESS RIGHTS ARE TO BE ACQUIRED ON THIS PROJECT.

ACCESS CONTROL PREVIOUSLY ACQUIRED.



SUGAR CREEK TWP  
 T-79N R-2W  
 SEC. 15

②

CHARLES H FRYMOYER TRUST

4946+58 (MLWB080)  
 ±140'±EX R/W

4947+51  
 ±143'

4953+59  
 ±142'±EX R/W

N

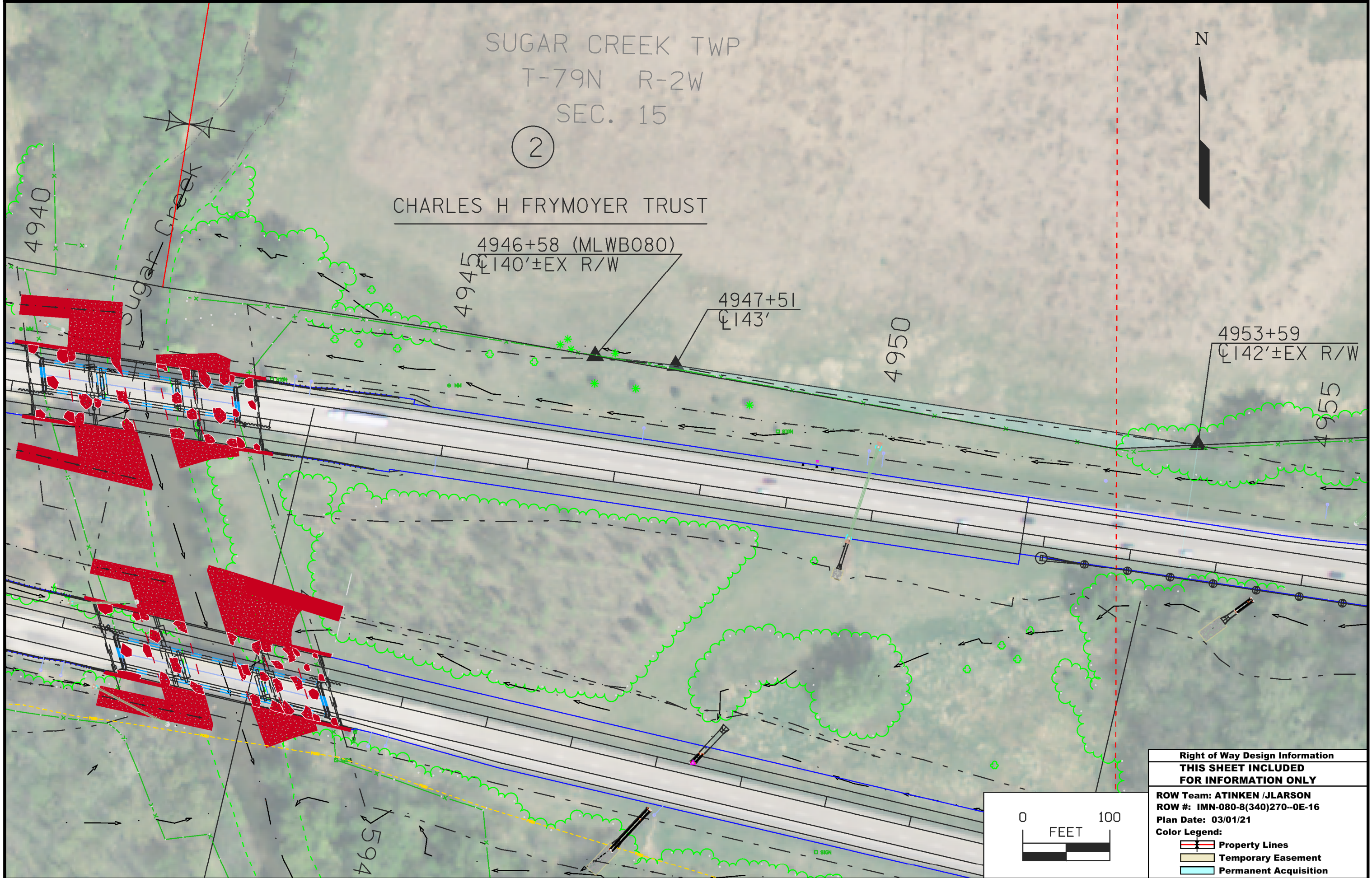
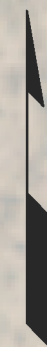

<b>Right of Way Design Information</b>	
<b>THIS SHEET INCLUDED FOR INFORMATION ONLY</b>	
ROW Team: ATINKEN /JLARSON	
ROW #: IMN-080-8(340)270-0E-16	
Plan Date: 03/01/21	
Color Legend:	
	Property Lines
	Temporary Easement
	Permanent Acquisition

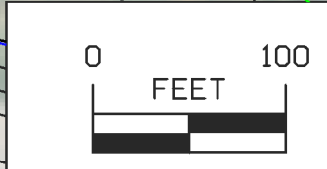

**TRAFFIC CONTROL PLAN**

Traffic control on this project shall be in accordance with the standard road plans shown in Tabulation 105-4 and the specific layouts shown in the plans. For additional complementary information, refer to Part 6 of the Manual on Uniform Traffic Control Devices (MUTCD) and the current standard specifications and supplemental specifications.

Maintain two lanes of traffic in each direction on I-80 during daylight hours. Night time single-lane closures will be allowed as shown on Tabulation 108-23B. Night work will be required.

The Engineer may modify lane closure hours as necessary to accommodate specific traffic conditions and events.

Maintain ingress and egress traffic and full parking capacity at both the eastbound and westbound rest area/welcome centers at all times. Short duration ramp closures may be allowed with prior coordination and approval by the Engineer. Construction activities shall not impact the availability and capacity of the rest areas to the west of the project site. Traffic on adjacent local roadways shall be maintained at all times.

**STAGING NOTES**

GENERAL NOTES:

It is not the intent of the sequence of construction to confine the Contractor's activity to the areas of suggested stages alone. It is understood that some of the various steps may occur simultaneously. Therefore, the Contractor may conduct several operations concurrently on the project, provided that traffic is maintained and that these operations do not conflict with the staging operations indicated herein.

STAGE 1

Summary:

This stage is primarily pre-work in preparation for Stage 2 maintenance of traffic needs. Temporary Rest Area Ramp C is constructed in this stage due to its proximity to the I-80 westbound mainline outside shoulder reconstruction work, but will not be utilized for maintenance of traffic until Stage 3.

Traffic:

I-80 (both directions):

- Maintain traffic on existing lanes
- Shift eastbound and westbound traffic towards the median and reduce travel lane widths to 11' from east of Old Muscatine Road to east of the existing Rest Area and Welcome Center.
- Close outside travel lanes in each direction of travel, as needed, for outside shoulder construction activities. Lane closure shall occur during night hours.

Rest Area Ramp B:

- Maintain traffic through the exit ramp taper and the existing ramp travel way.

Rest Area Ramp C:

- Maintain traffic on existing lanes. Partially close Ramp C with temporary traffic control, as needed, near the proposed temporary roadway for Rest Area Ramp C.

Construction:

I-80 Mainlines:

- Construct sections of eastbound and westbound outside shoulder improvements and shoulder reconstruction between Old Muscatine Road and Sugar Creek.
- Reconstruct eastbound and westbound outside shoulders between eastbound and westbound Rest Area/Welcome Center ingress and egress ramps.
- Reconstruct a portion of the eastbound outside shoulder just west of the Rest Area exit ramp (Ramp B).

Rest Area Ramp B:

- No construction.

Rest Area Ramp C:

- Grade and pave Temporary Rest Area Ramp C.

(All roadways):

- Conduct work associated with and necessary for said construction. This will include, but is not limited to, grading, paving, pavement removal, drainage, striping, signing, barrier, clearing and grubbing, and temporary erosion control.

STAGE 2

Summary:

This stage is the first major construction stage of the project and is for construction of I-80 widening towards the median and the first stage of construction for the new bridges at Sugar Creek.

Traffic:

**STAGING NOTES**

I-80 Mainlines:

- Shift eastbound and westbound traffic towards the outside and onto newly constructed shoulder pavements; reduce travel lane widths to 11' from east of Old Muscatine Road to east of the existing Rest Area and Welcome Center. Maintain traffic on existing bridges over Sugar Creek.
- Close inside lane for construction of short portions of interior widening construction near Sugar Creek Full Reconstruction area. Lane closure shall occur during night hours.

Rest Area Ramp B:

- Maintain traffic through the exit ramp taper and the existing ramp travel way.

Rest Area Ramp C:

- Maintain traffic on existing lanes.

Construction:

I-80 (both directions):

- Construct eastbound and westbound median widening from west of Sugar Creek to the Rest Area and Welcome Center.
- Begin eastbound and westbound staged bridge and approach pavement construction at Sugar Creek. Construct temporary asphalt runoff connections to new bridge approach pavements.
- Construct median shoulder improvements and temporary shoulder pavements between Old Muscatine Road and Sugar Creek.

Rest Area Ramp B:

- No construction.

Rest Area Ramp C:

- No construction.

(All roadways):

- Conduct work associated with and necessary for said construction. This will include, but is not limited to, grading, paving, pavement removal, drainage, striping, signing, barrier, guardrail, clearing and grubbing, and temporary erosion control.

STAGE 3

Summary:

This is the second major stage of construction that will complete construction of the Sugar Creek bridges and reconstruction of the mainline outside travel lanes and shoulders. Reconstruction of Rest Area Ramp C is included in this Stage of construction.

Traffic:

I-80 Mainlines:

- Shift mainline eastbound and westbound traffic towards the median and onto newly constructed roadway travel and shoulder pavements. Utilize the partially constructed new bridges over Sugar Creek. Lane widths remain at 11' from east of Old Muscatine Road to the Rest Area and Welcome Center.

Rest Area Ramp B:

- Maintain traffic through the exit ramp taper and the existing ramp travel way.

Rest Area Ramp C:

- Maintain traffic on Temporary Rest Area Ramp C.

Construction:

I-80 Mainlines:

- Construct eastbound and westbound outer travel lanes and shoulders from west of Sugar Creek to just west of the Rest Area and Welcome Center.
- Complete eastbound and westbound staged bridge and approach pavement construction at Sugar Creek. Construct temporary asphalt runoff connections to new bridge approach pavements.
- Construct proposed Rest Area Ramp C.

Rest Area Ramp B:

- No construction.

Rest Area Ramp C:

- Grade and pave proposed Rest Area Ramp C.

(All roadways):

- Conduct work associated with and necessary for said construction. This will include, but is not limited to, grading, paving, pavement removal, drainage, striping, signing, barrier, guardrail, clearing and grubbing, and temporary erosion control.

STAGE 4

Summary:

This last stage is primarily for removal of remaining temporary pavements and construction of the proposed HMA Overlay.

Traffic:

I-80 Mainlines:

- Maintain two lanes of eastbound and westbound traffic on newly constructed and existing roadway pavements during daytime periods and overnight to the extent possible.
- Close one travel lane each direction as needed to complete pavement overlay construction. Coordinate closure needs with the Engineer.



108-26A  
08-01-08

**STAGING NOTES**

Rest Area Ramp B:  
- Maintain ramp traffic to the extent possible; shift traffic through taper and gore areas as needed to accommodate pavement overlay operations.

Rest Area Ramp C:  
- Open newly constructed ramp pavement to traffic.

Construction:  
I-80 Mainlines:  
- Remove HMA Surface Runouts previously constructed adjacent to the eastbound and westbound Sugar Creek bridge approach pavement sections.  
- Remove temporary eastbound and westbound shoulder pavements.  
- Construct eastbound and westbound HMA overlays with nighttime construction for overlay operations requiring closure of one travel lane. HMA overlays are not to be constructed at bridge approach pavements, the Sugar Creek bridges, or areas where shoulders were previously constructed to final grade.

Rest Area Ramp B:  
- Construct HMA overlay through the Ramp B taper and gore areas adjacent to I-80 eastbound.

Rest Area Ramp C:  
- Remove Temporary Rest Area Ramp C and complete inside shoulder construction, as needed.

(All roadways):  
- Conduct work associated with and necessary for said construction. This will include, but is not limited to paving, finish grading, earth shoulder construction, pavement removal, striping, signing, barrier, and temporary erosion control.

111-01  
04-17-12

**COORDINATED OPERATIONS**

Other work in progress during the same period of time will include the construction of the projects listed. Coordinate operations with those of other contractors working within the same area.

Project	Type of Work
IM-NHS-080-7(164)270--03-16	Bridge Replacement - PPCB
BRFIMX-080-7(108)270--14-16	Bridge Replacement - PPCB

108-23B  
10-17-17

**TRAFFIC CONTROL CLOSURE TABLE(S)**

\* This is to only be used in conjunction with Tabulation 108-23A  
Shaded area indicates times that lane closures are not allowed











	AM												Noon	PM																																					
	12:00	12:30	1:00	1:30	2:00	2:30	3:00	3:30	4:00	4:30	5:00	5:30	6:00	6:30	7:00	7:30	8:00	8:30	9:00	9:30	10:00	10:30	11:00	11:30	12:00	12:30	1:00	1:30	2:00	2:30	3:00	3:30	4:00	4:30	5:00	5:30	6:00	6:30	7:00	7:30	8:00	8:30	9:00	9:30	10:00	10:30	11:00	11:30			
SUN																																																			
MON																																																			
TUE																																																			
WED																																																			
THU																																																			
FRI																																																			
SAT																																																			

108-25  
10-21-14







**511 TRAVEL RESTRICTIONS**

Route	Direction	County	Location Description	Feature Crossed	Object Type	Maint. Bridge No., Structure ID, or FHWA No.	Type of Restriction	Existing Measurement	Construction Measurement	Construction Measurement as Signed	Projected As Built Measurement	Remarks
I-80			No restrictions anticipated									













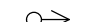





### CROSS SECTION VIEW COLOR LEGEND OF TRAFFIC CONTROL AND STAGING SHEETS

SHADING	Design Color No.	
Green, Light	(225)	 Existing Pavement Shading
Gray, Light	(48)	 Previously Constructed Pavement Shading
Gray, Med	(80)	 Previously Constructed Granular Surface Shading
Blue, Light	(230)	 Proposed Pavement Shading
Lavender	(9)	 Temporary Pavement Shading
Red	(3)	 Proposed Bridge Shading
Brown, Med	(237)	 Proposed Grading
Green, Dashed	(10)	 Existing Grading
Green, Solid	(237)	 Previously Constructed Grading
Violet	(15)	 Temporary Barrier Rail, Unpinned
Flush Orange	(228)	 Temporary Barrier Rail, Pinned

### PLAN VIEW COLOR LEGEND OF TRAFFIC CONTROL AND STAGING SHEETS

LINEWORK	Design Color No.	
Green	(2)	 Existing Topographic Features and Labels
Magenta	(5)	 Pavement Marking Call Outs
Blue	(1)	 Proposed Alignment, Stationing, Tic Marks, and Alignment Annotation
Yellow	(4)	 Pavement Markings, Yellow
Off White	(254)	 Pavement Markings, White
Violet	(15)	 Temporary barrier rail, Unpinned
Flush Orange	(228)	 Temporary barrier rail, Pinned
SHADING	Design Color No.	
Green, Light	(225)	 Existing Pavement Shading
Gray, Light	(48)	 Proposed PCC Pavement with HMA Surfacing Shading
Gray, Med	(80)	 Proposed Granular Shading
Gray, Dark	(112)	 Proposed HMA Resurfacing Shading
Blue, Light	(230)	 Proposed Pavement Shading
Lavender	(9)	 Temporary Pavement Shading
Brown, Light	(236)	 Proposed Grading Limits Shading
Pink, Dark	(13)	 Proposed MSE or CIP Wall Shading
Red	(3)	 Proposed Bridge Shading
Black w/Gray, Light Fill	(0,48)	 Previously Constructed Structure

### PLAN VIEW PATTERN AND SYMBOL LEGEND OF TRAFFIC CONTROL AND STAGING SHEETS

	Channelizing Device		Crash Cushion (Temp or Perm)
	Drum		Traffic Signal
	Temporary Lane Separator		Flagger
	Tubular Marker		Temporary Floodlighting
	Channelizer Marker		Traffic Sign
	Concrete Barrier Marker		Type III Barricade
	Delineator		Type A Warning Light
	Temporary Barrier Rail		Direction of Traffic
	Pavement Removal		Safety Closure
	Sand Barrel Layout		Lane Identification

NOTE: Device spacing according to Standard Road Plans unless specifically dimensioned.

## TRAFFIC CONTROL AND STAGING LEGEND AND SYMBOL INFORMATION SHEET

(COVERS SHEET SERIES J)

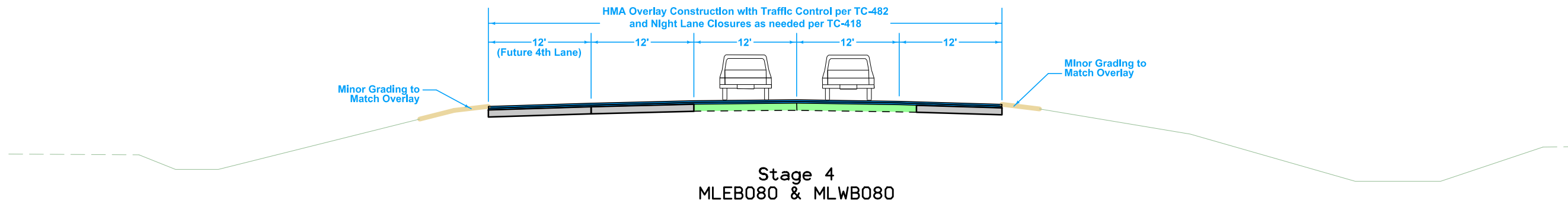
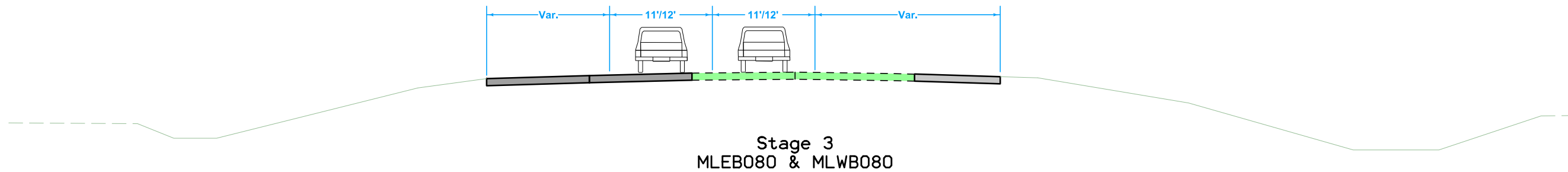
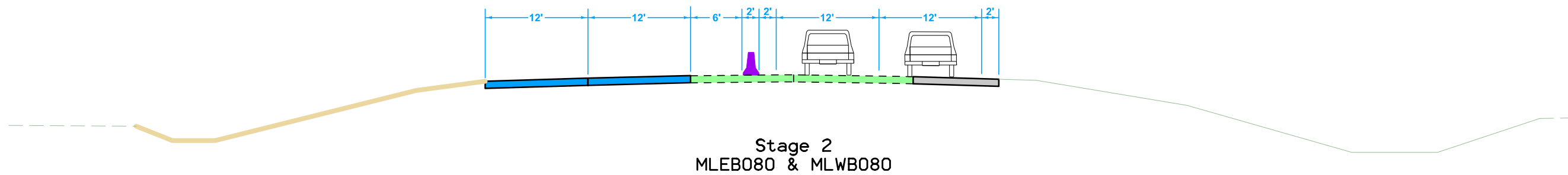
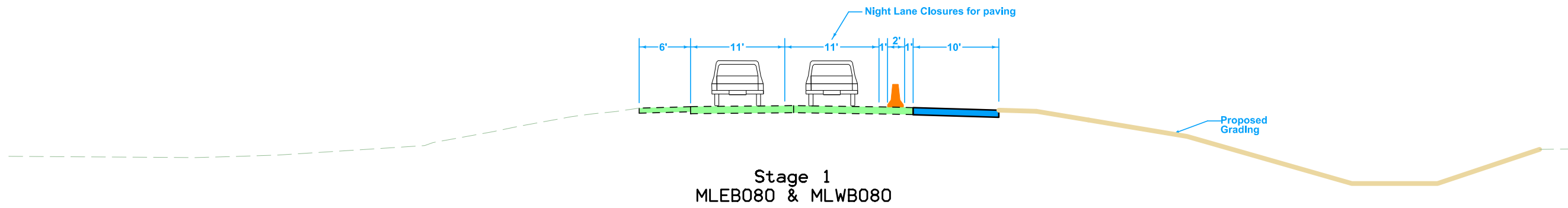

Section drawn in direction of travel

Typical Construction Sequence  
Interior Widening Areas

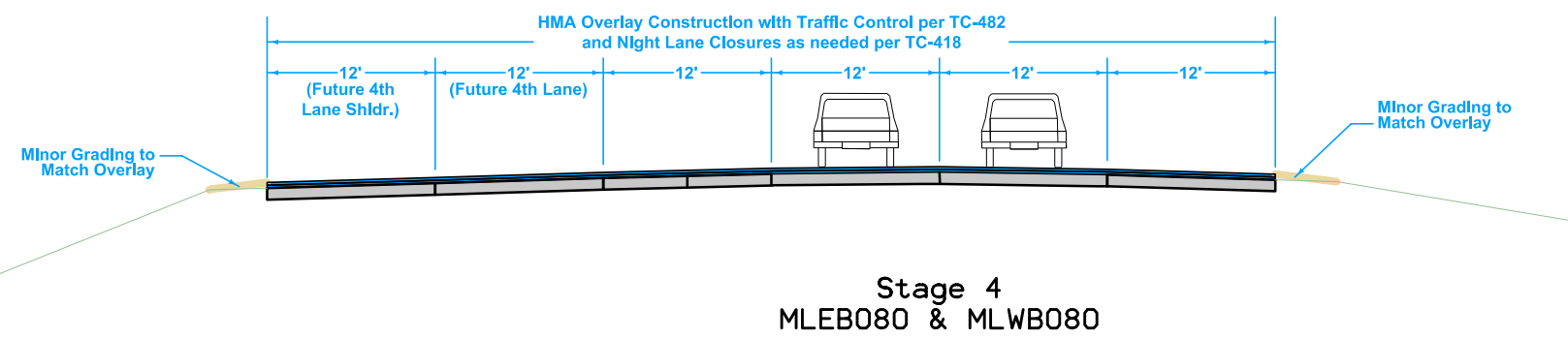
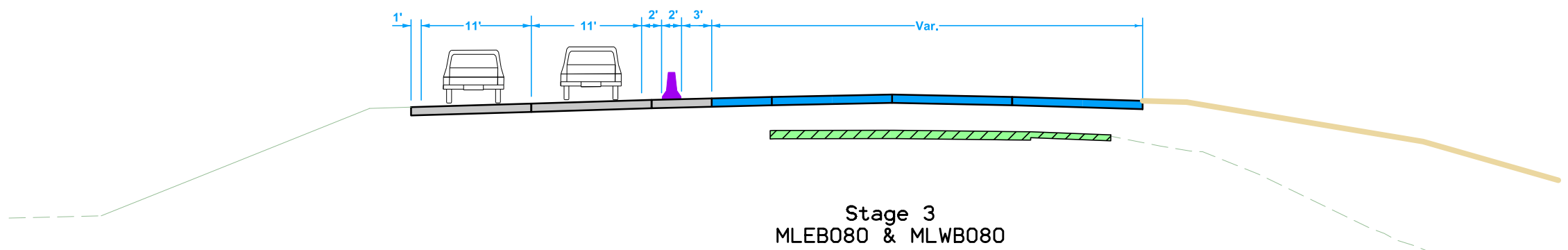
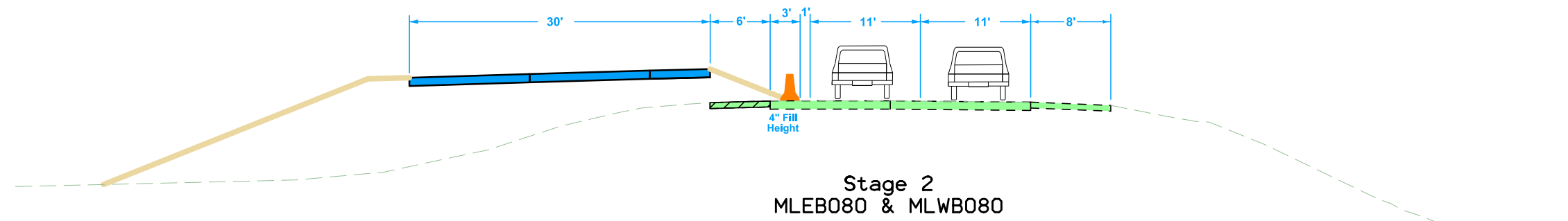
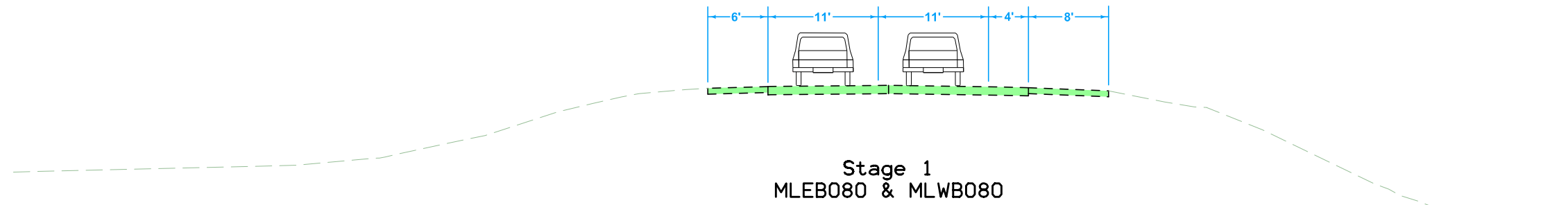

Section drawn in direction of travel

Typical Construction Sequence  
Sugar Creek Full Reconstruction Areas

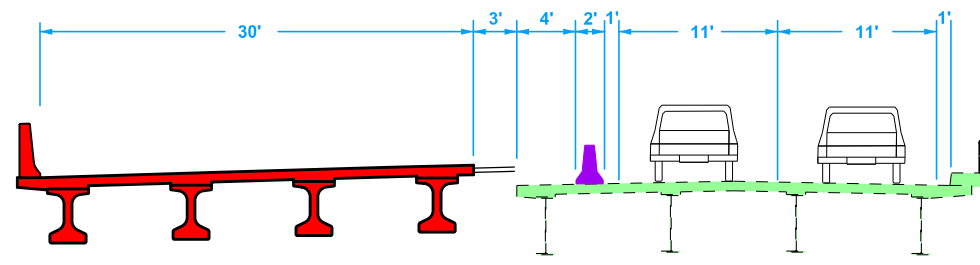

Stage 2  
MLEB080 & MLWB080

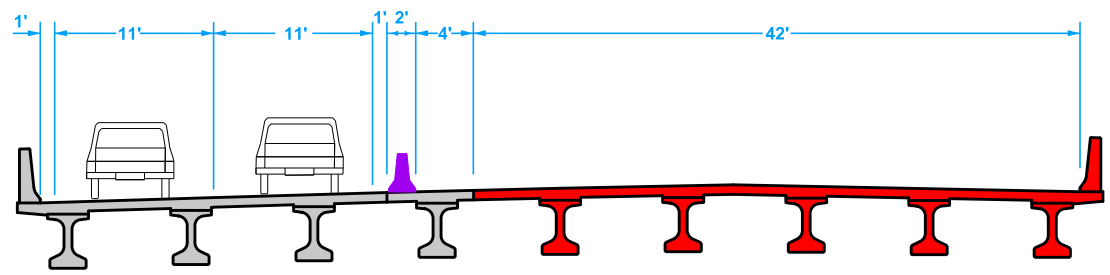

Stage 3  
MLEB080 & MLWB080  
(EB SHOWN)

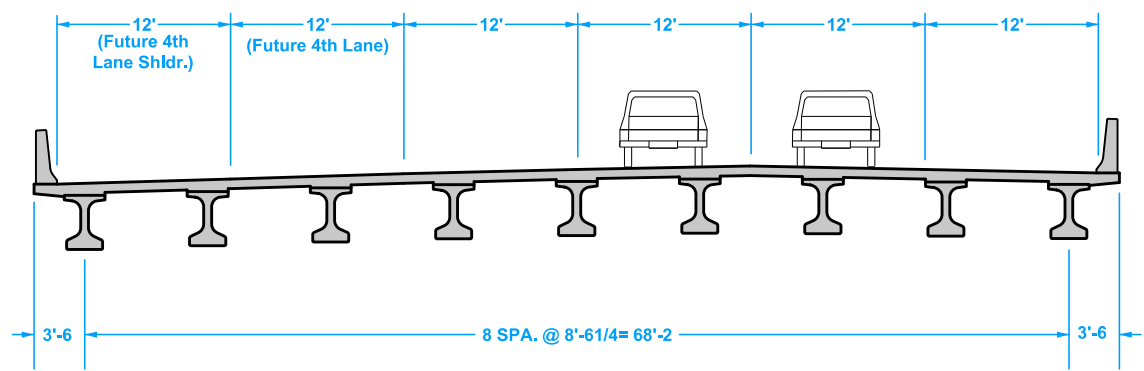

Stage 4  
MLEB080 & MLWB080  
(EB SHOWN)

Section drawn in direction of travel

Typical Construction Sequence  
I-80 over Sugar Creek  
Bridge Reconstruction

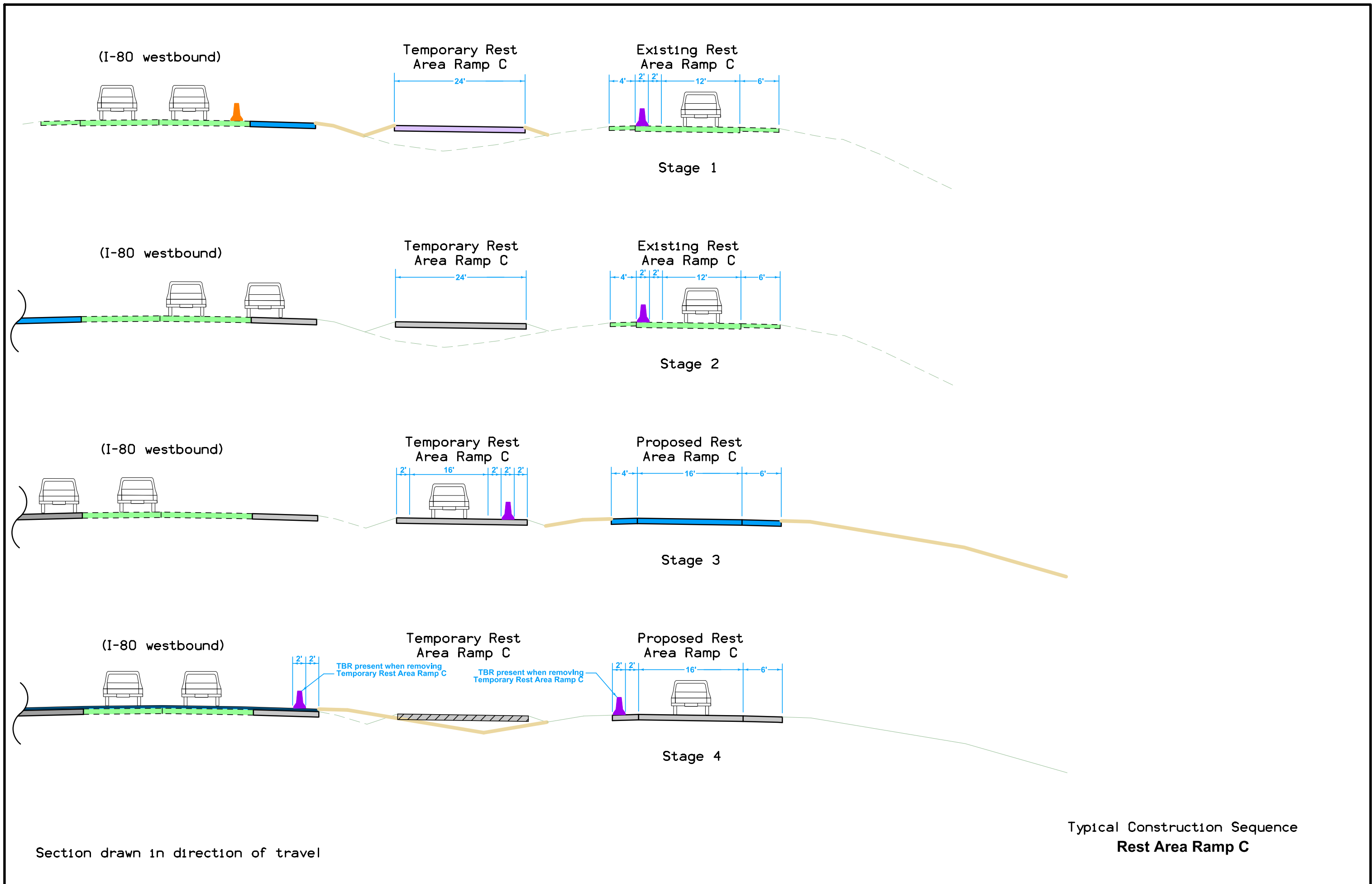

SUGAR CREEK TWP.  
T-79N R-2W  
SEC. 17

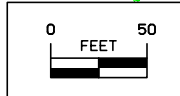
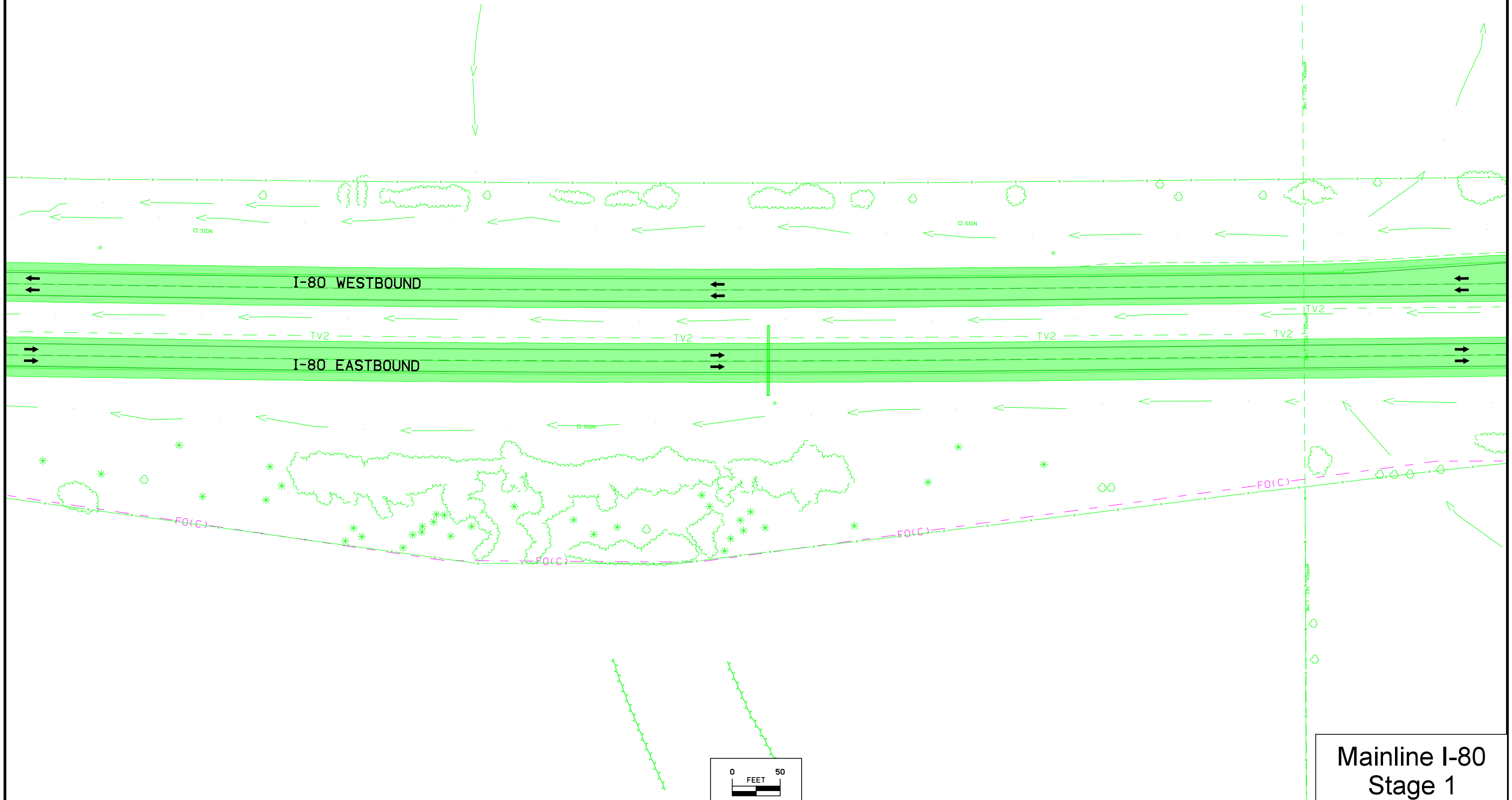

Mainline I-80  
Stage 1

SUGAR CREEK TWP.  
T-79N R-2W  
SEC. 16

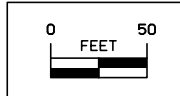
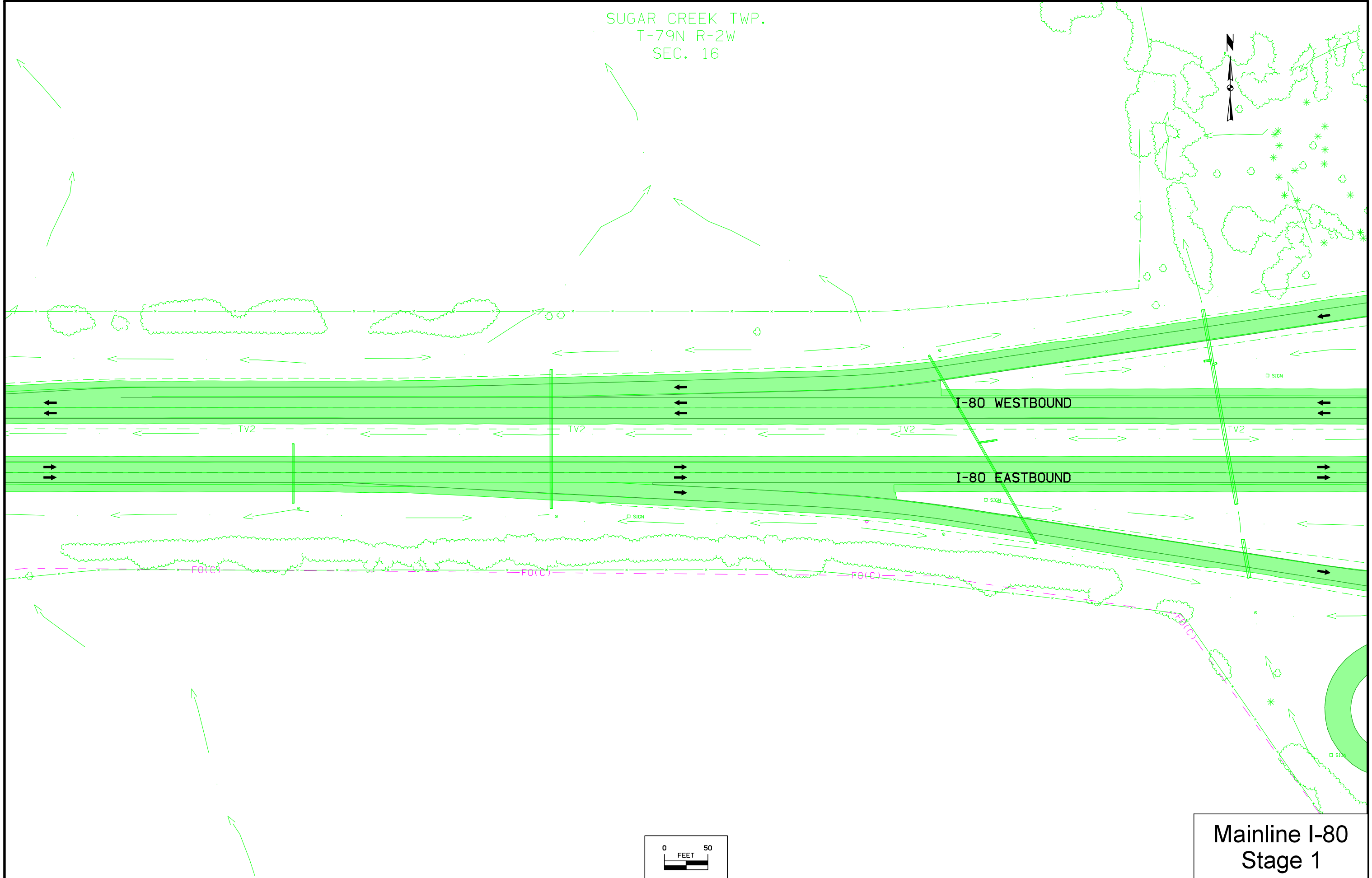

Mainline I-80  
Stage 1



SUGAR CREEK TWP.  
T-79N R-2W  
SEC. 16

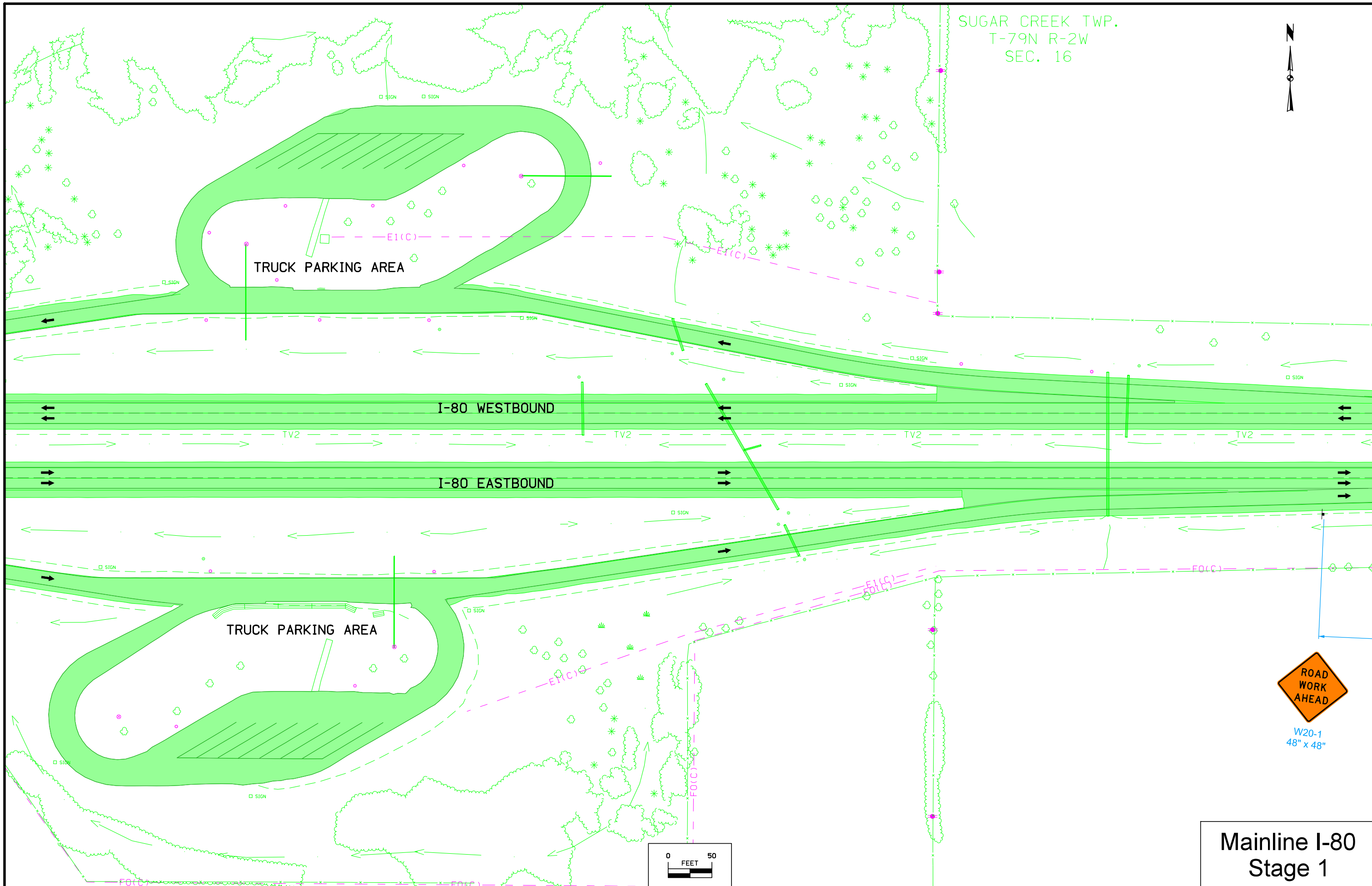

W20-1  
48" x 48"

# Mainline I-80 Stage 1

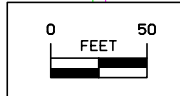

SUGAR CREEK TWP.  
T-79N R-2W  
SEC. 16

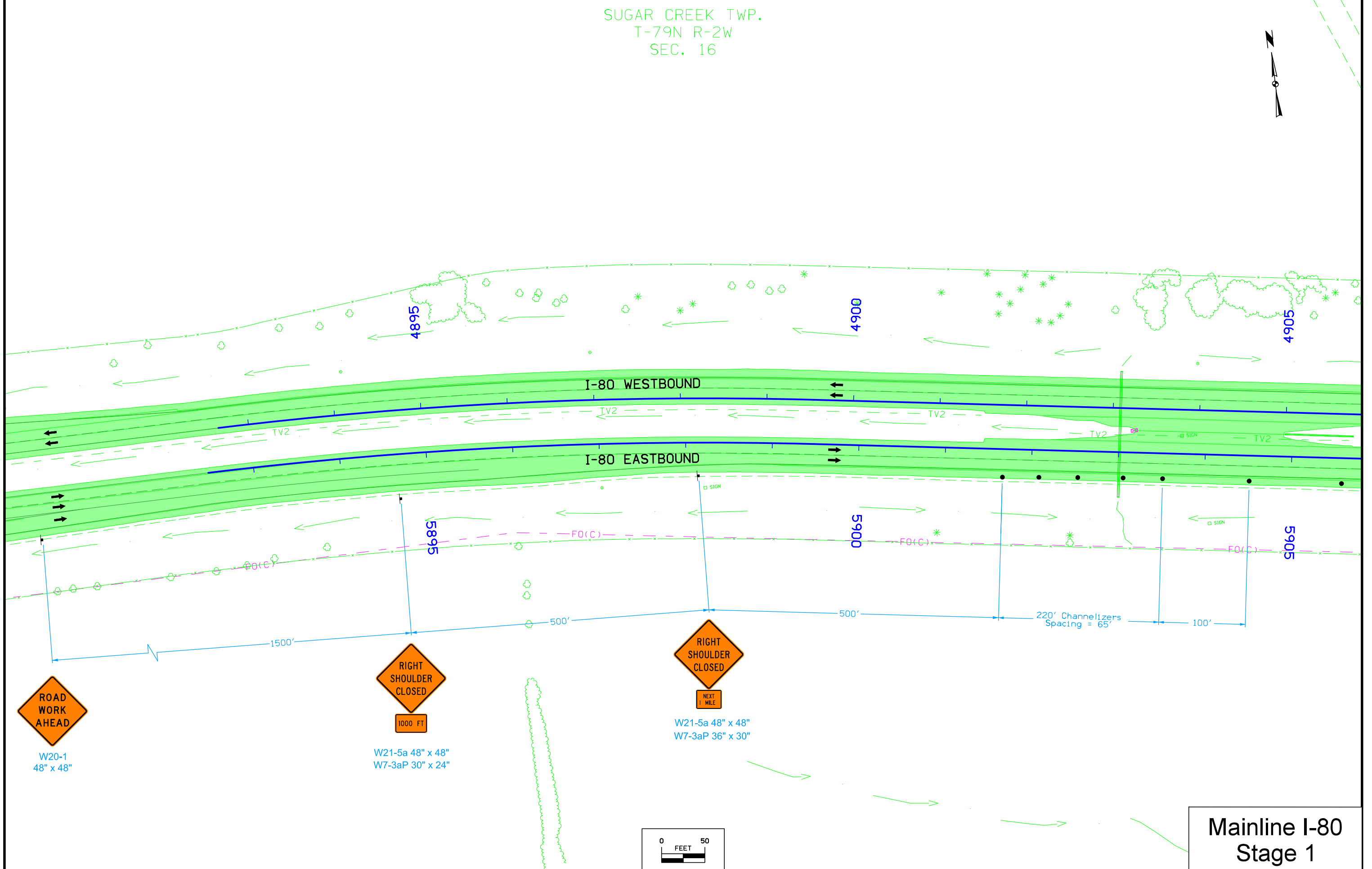

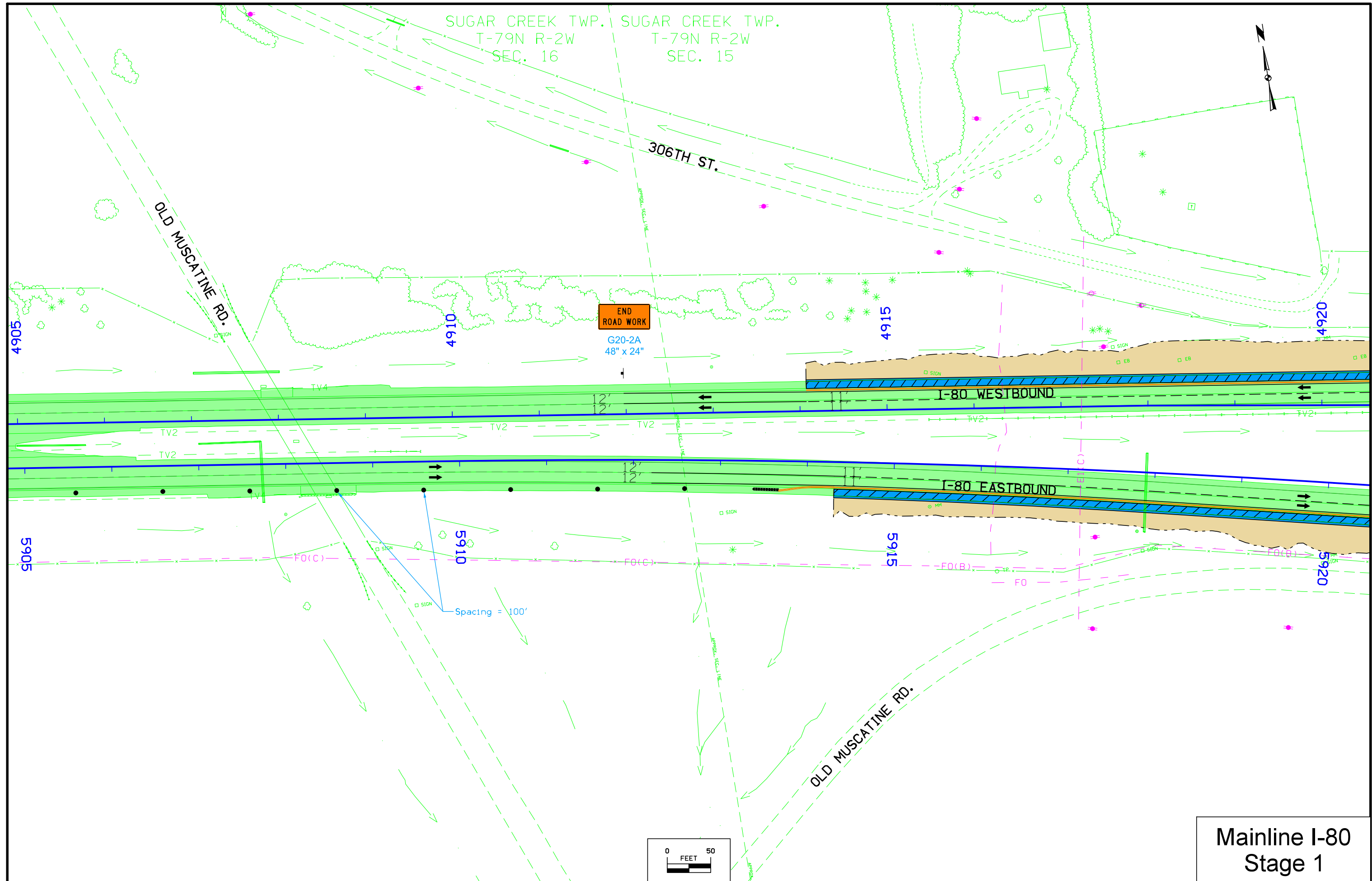

SUGAR CREEK TWP.  
T-79N R-2W  
SEC. 15

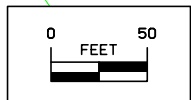
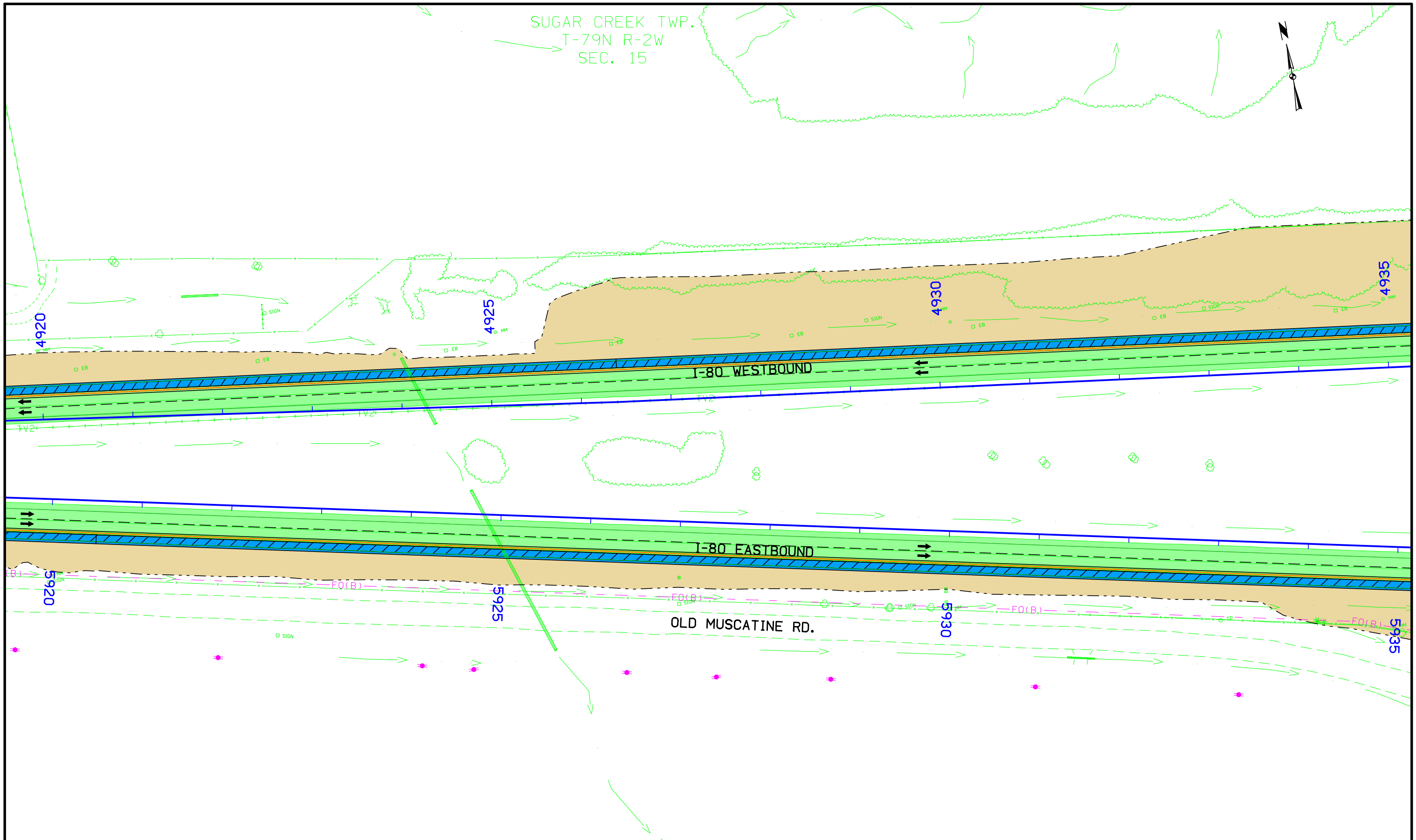

Mainline I-80  
Stage 1

FILE NO.	ENGLISH	DESIGN TEAM Iowa DOT \ HR Green	CEDAR COUNTY	PROJECT NUMBER IM-NHS-080-8(341)269--03-16	SHEET NUMBER J.13
----------	---------	---------------------------------	--------------	--	-------------------

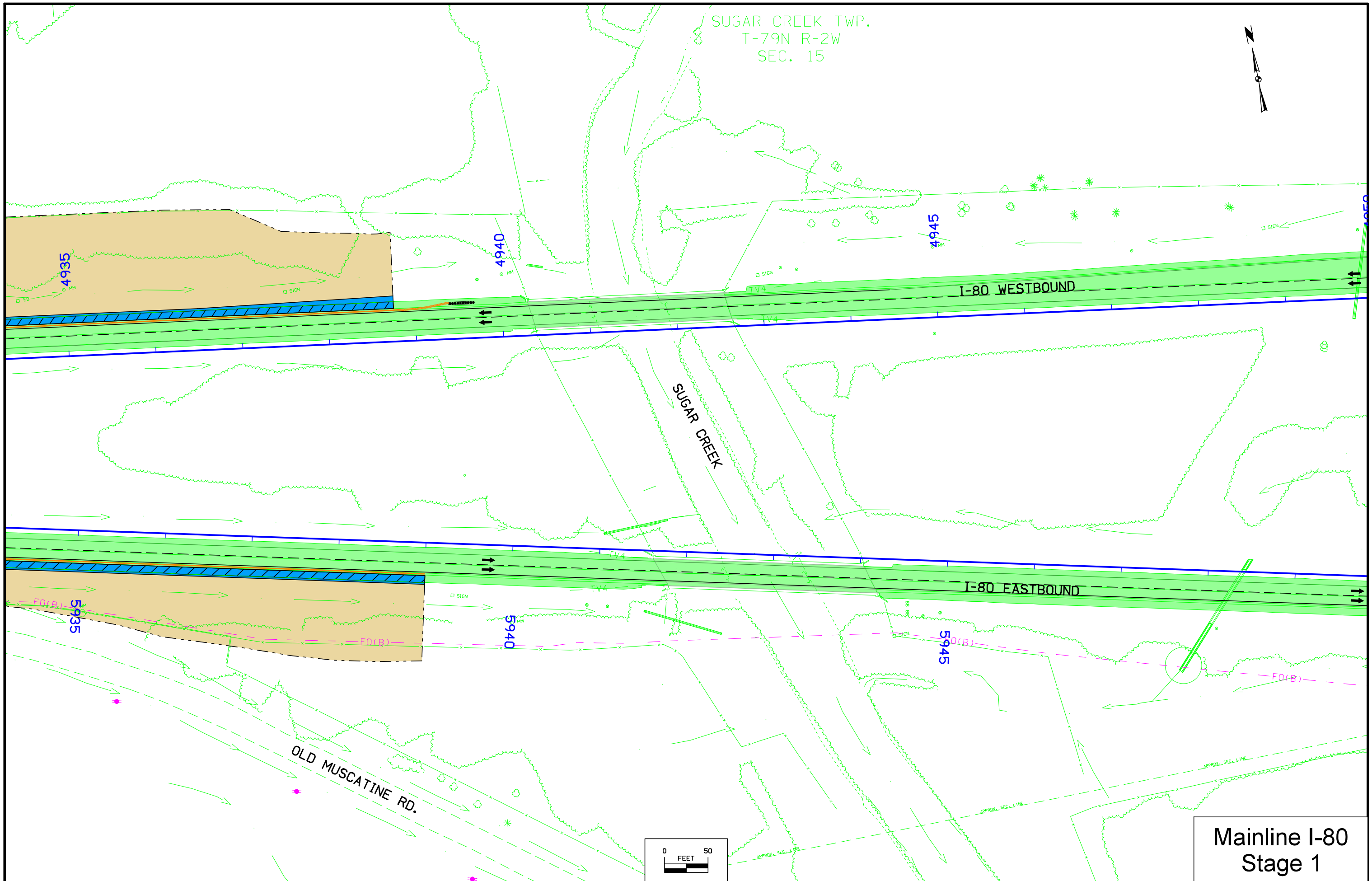

SUGAR CREEK TWP.  
T-79N R-2W  
SEC. 15

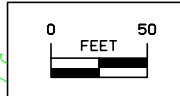

**Mainline I-80  
Stage 1**



SUGAR CREEK TWP.  
T-79N R-2W  
SEC. 15

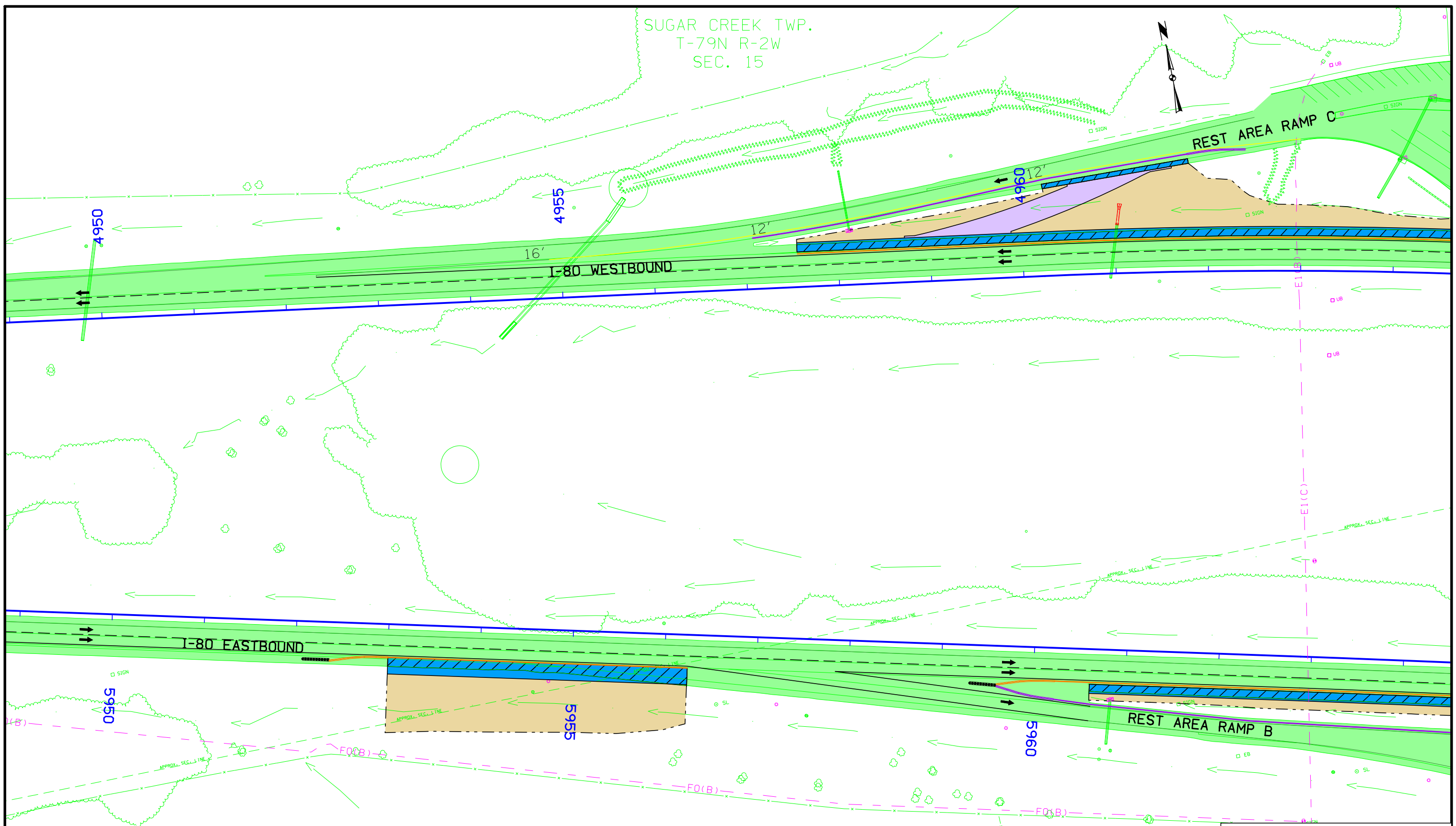

Mainline I-80  
Rest Area Ramp B  
Rest Area Ramp C  
Stage 1

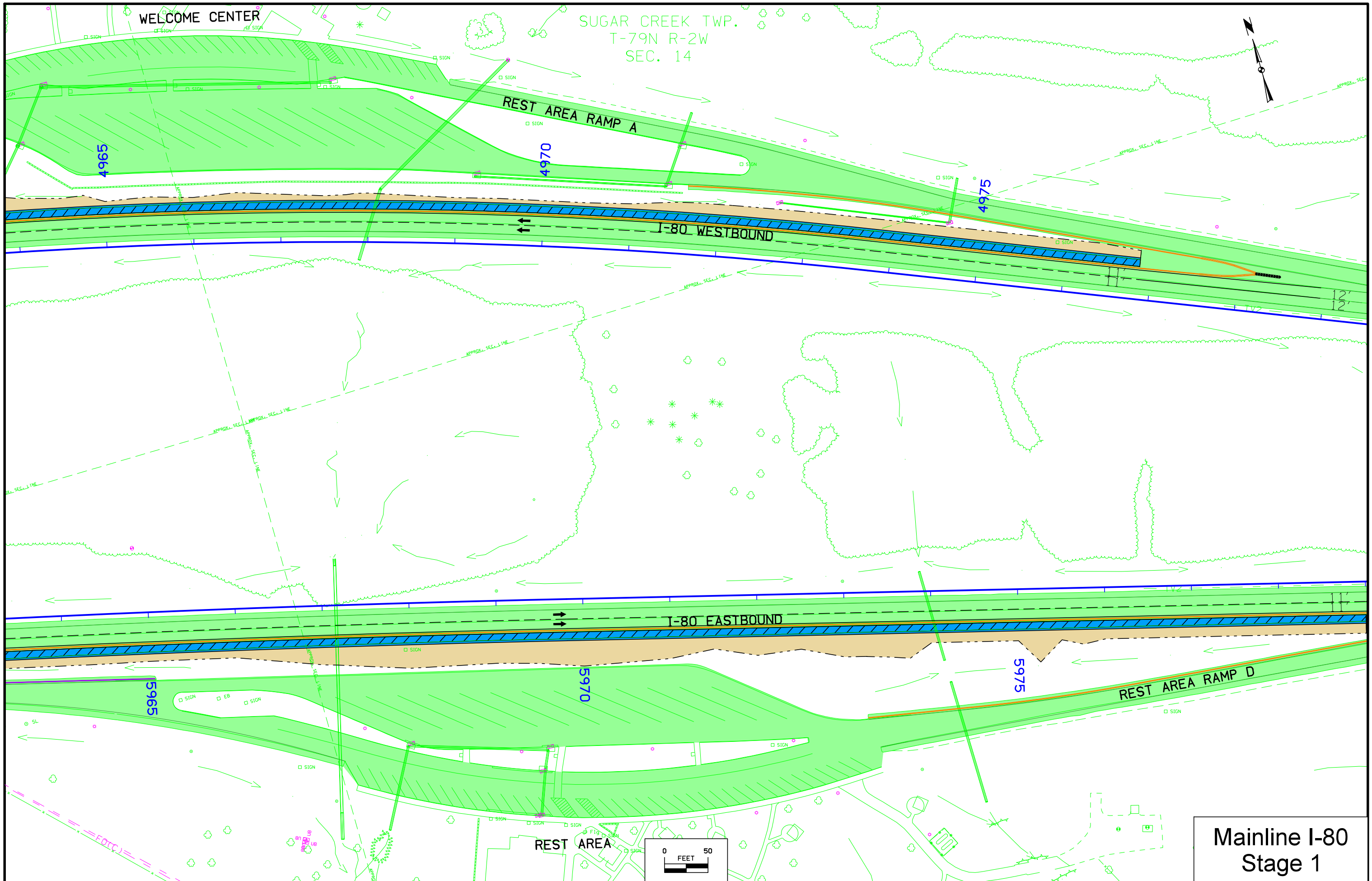

WELCOME CENTER

SUGAR CREEK TWP.  
T-79N R-2W  
SEC. 14

REST AREA RAMP A

I-80 WESTBOUND

I-80 EASTBOUND

REST AREA RAMP D

REST AREA

Mainline I-80  
Stage 1

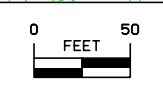

SUGAR CREEK TWP.  
T-79N R-2W  
SEC. 23

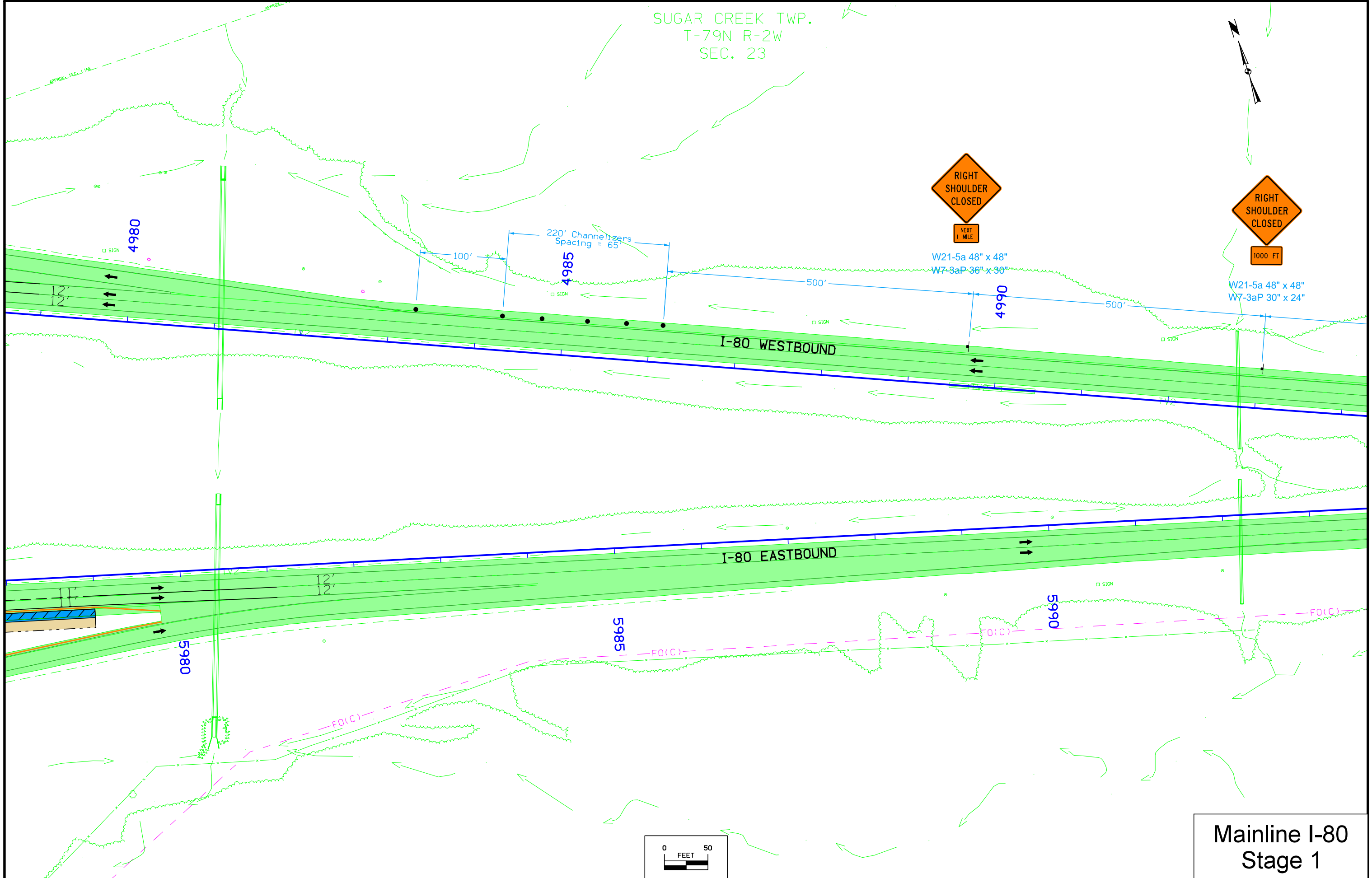

Mainline I-80  
Stage 1



SUGAR CREEK TWP.  
T-79N R-2W  
SEC. 23



W20-1  
48" x 48"

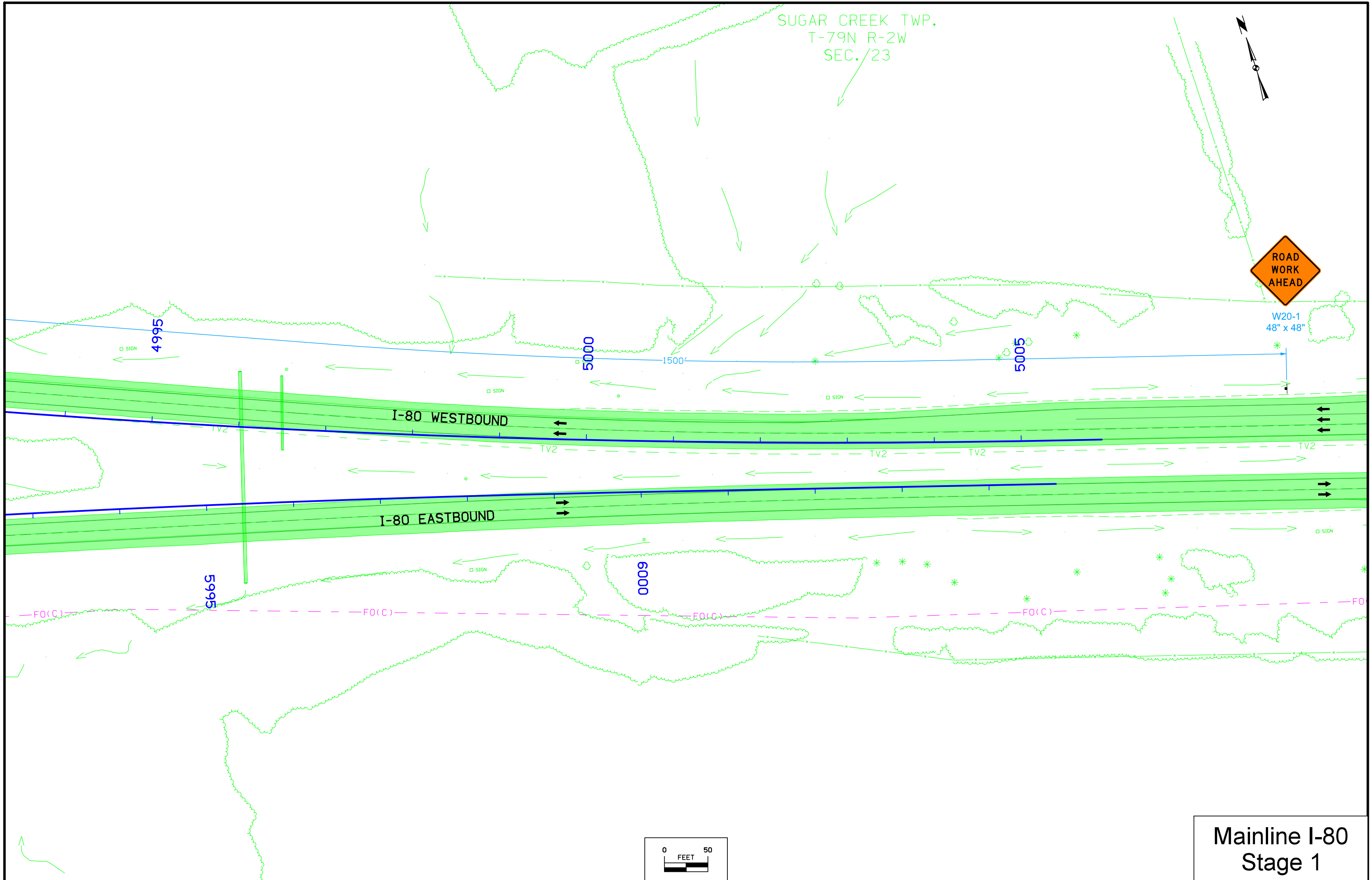

Mainline I-80  
Stage 1

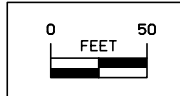

SUGAR CREEK TWP.  
T-79N R-2W  
SEC. 23



20-1  
x 48"

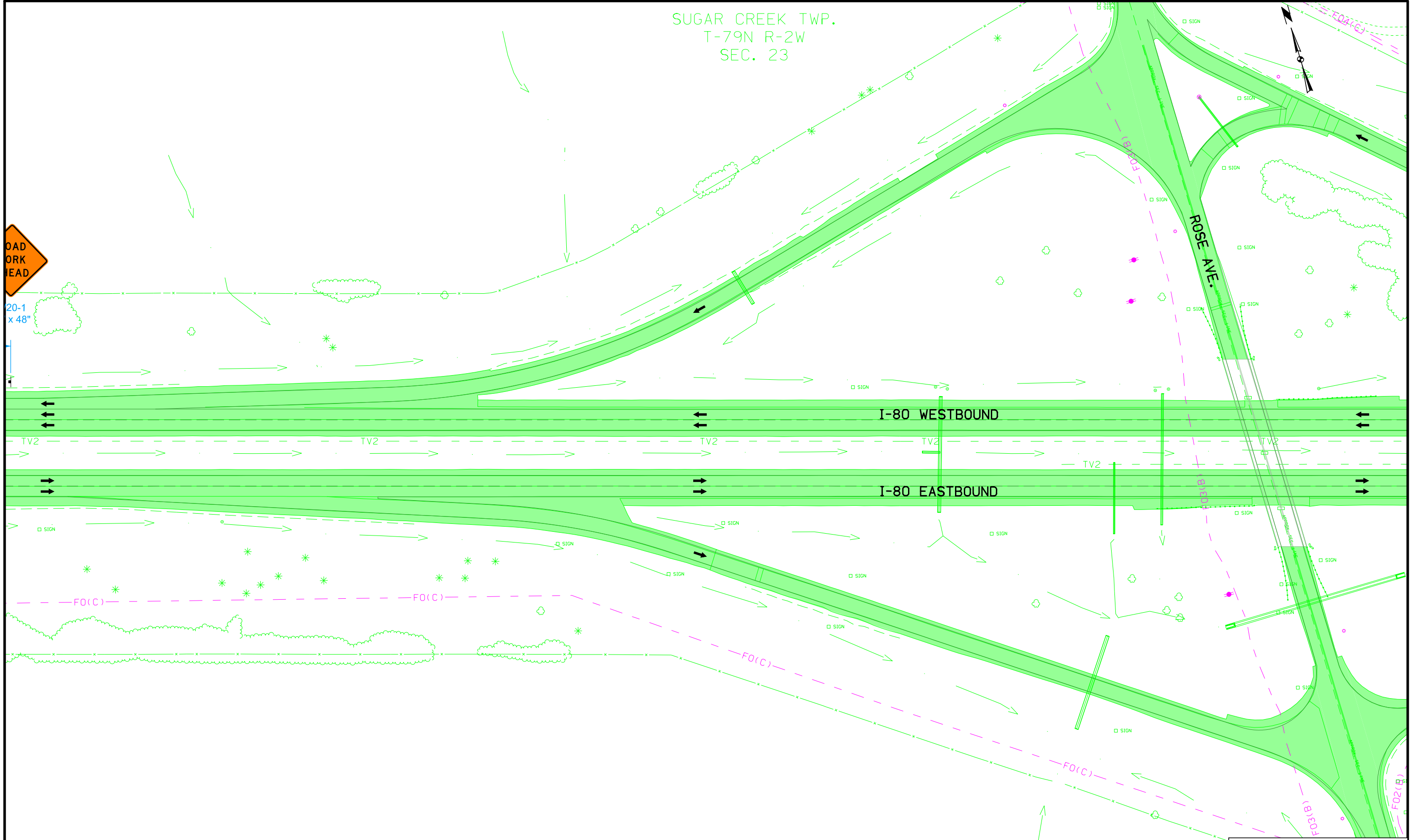

Mainline I-80  
Stage 1

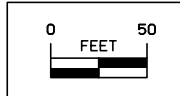

SUGAR CREEK TWP.  
T-79N R-2W  
SEC. 24

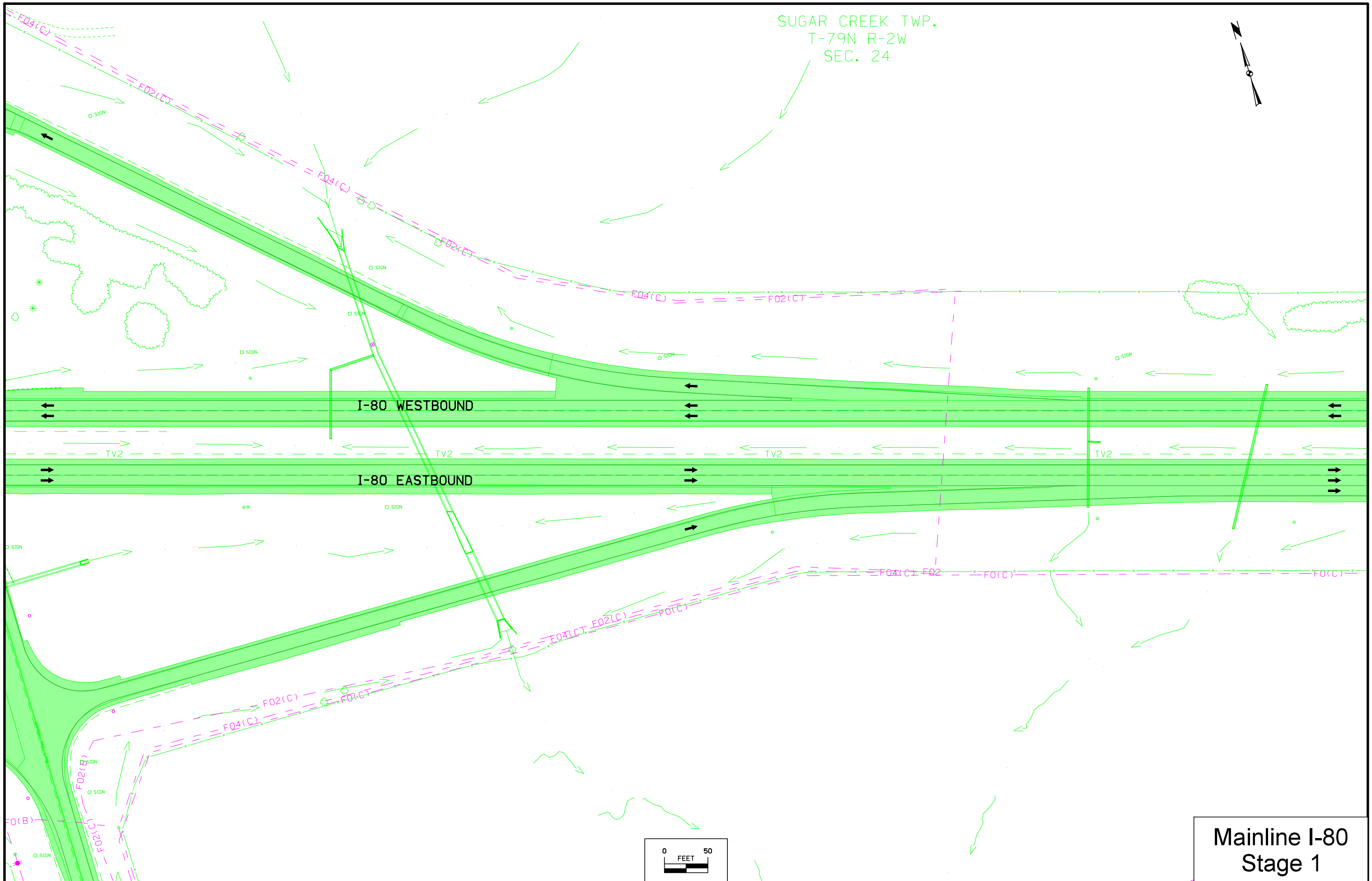

I-80 WESTBOUND

I-80 EASTBOUND

TV2

TV2

TV2

TV2

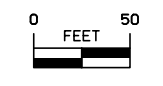

Mainline I-80  
Stage 1

SUGAR CREEK TWP.  
T-79N R-2W  
SEC. 24

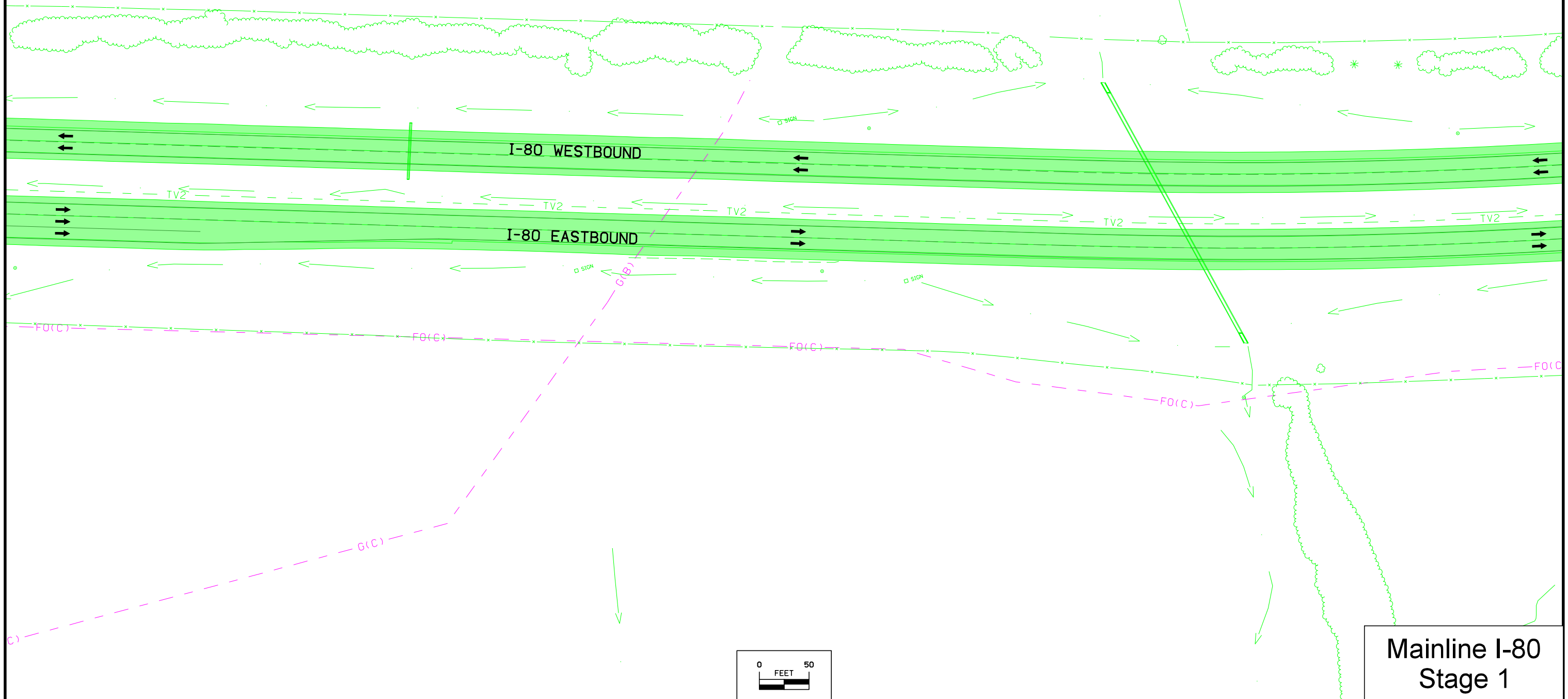

SUGAR CREEK TWP.  
T-79N R-2W  
SEC. 17

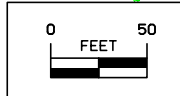
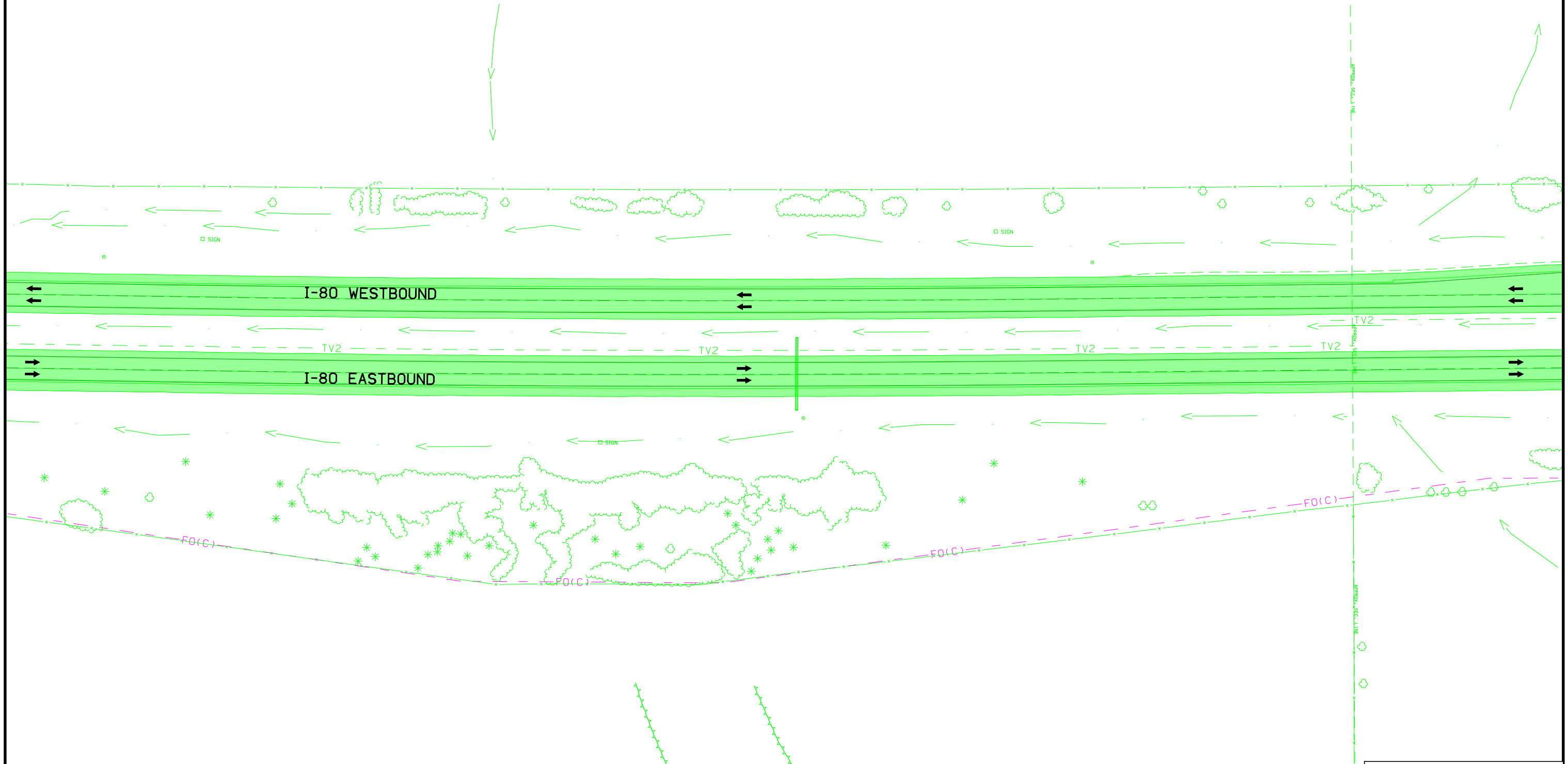

Mainline I-80  
Stage 2

SUGAR CREEK TWP.  
T-79N R-2W  
SEC. 16

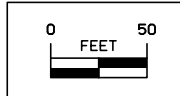
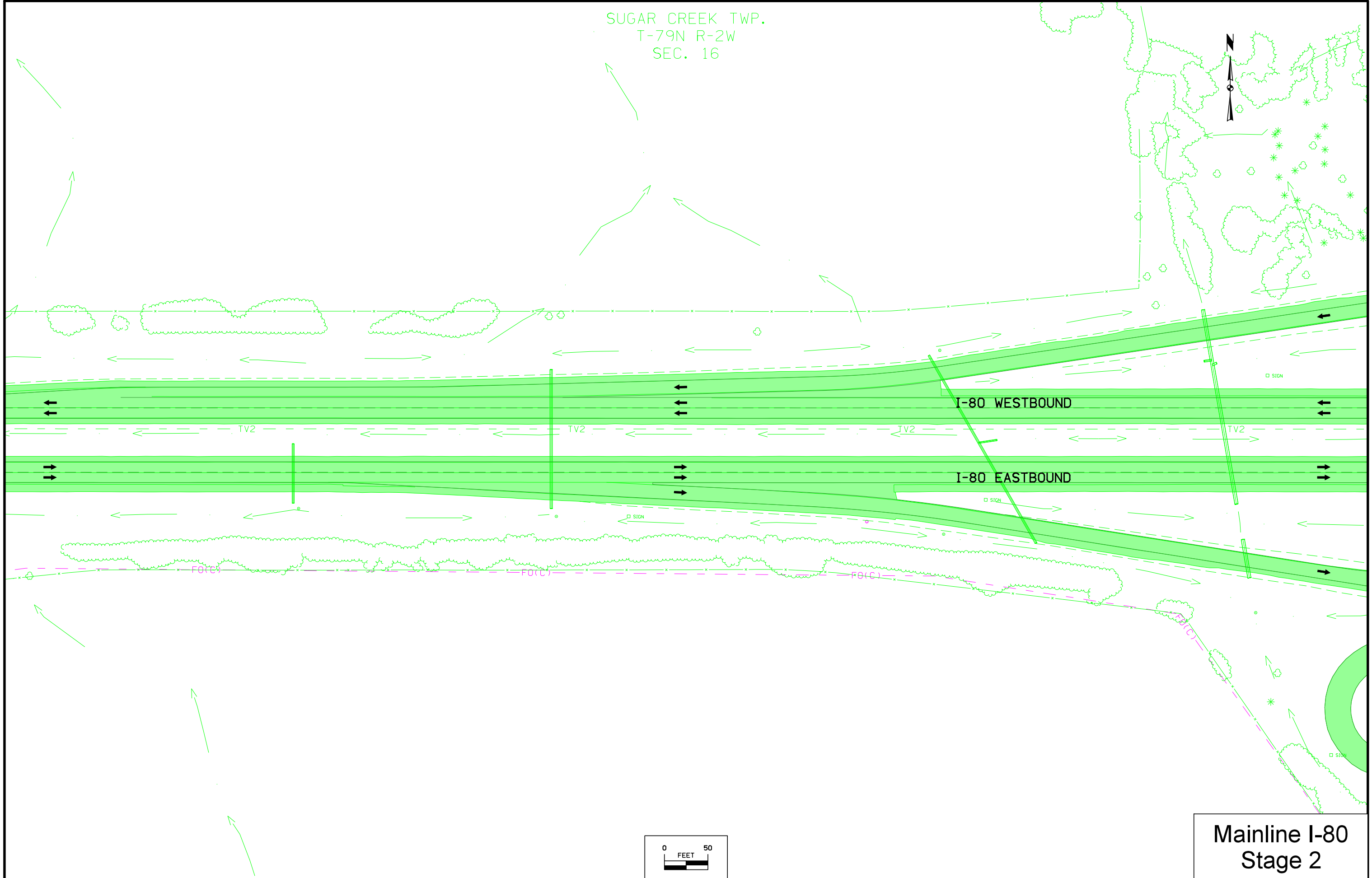

Mainline I-80  
Stage 2

SUGAR CREEK TWP.  
T-79N R-2W  
SEC. 16

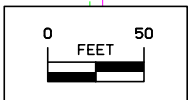
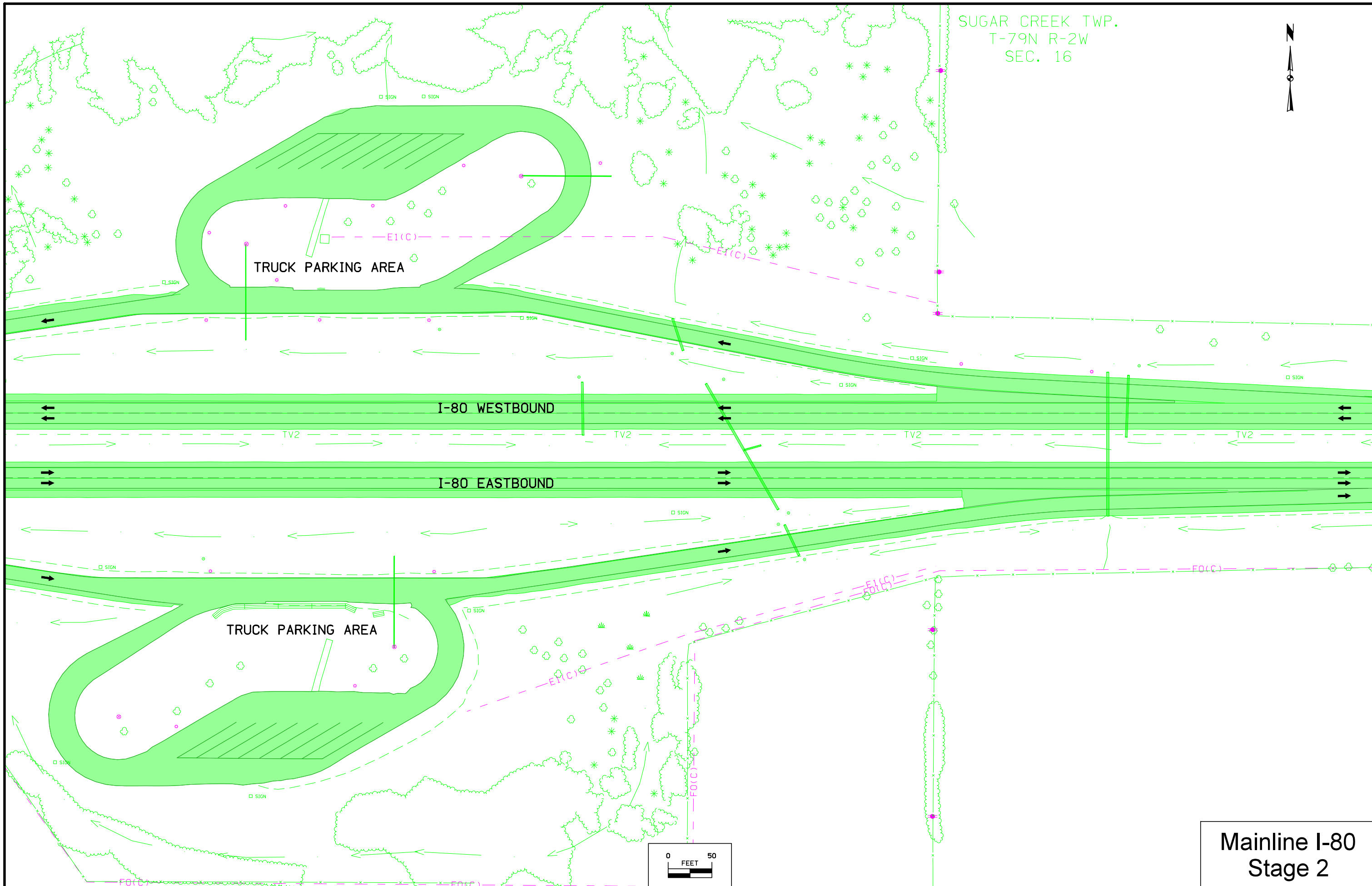

Mainline I-80  
Stage 2

SUGAR CREEK TWP.  
T-79N R-2W  
SEC. 16

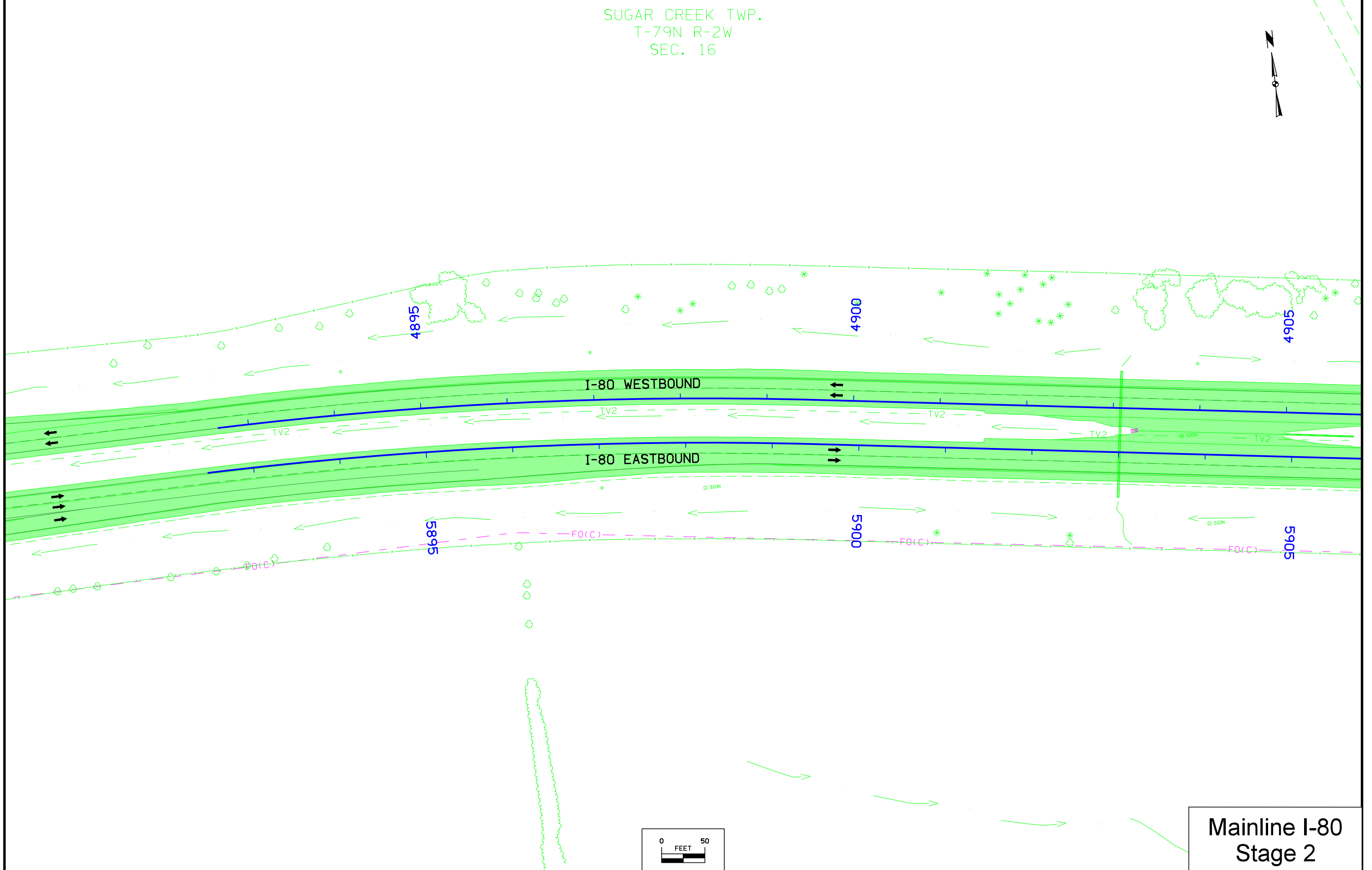

Mainline I-80  
Stage 2

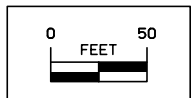



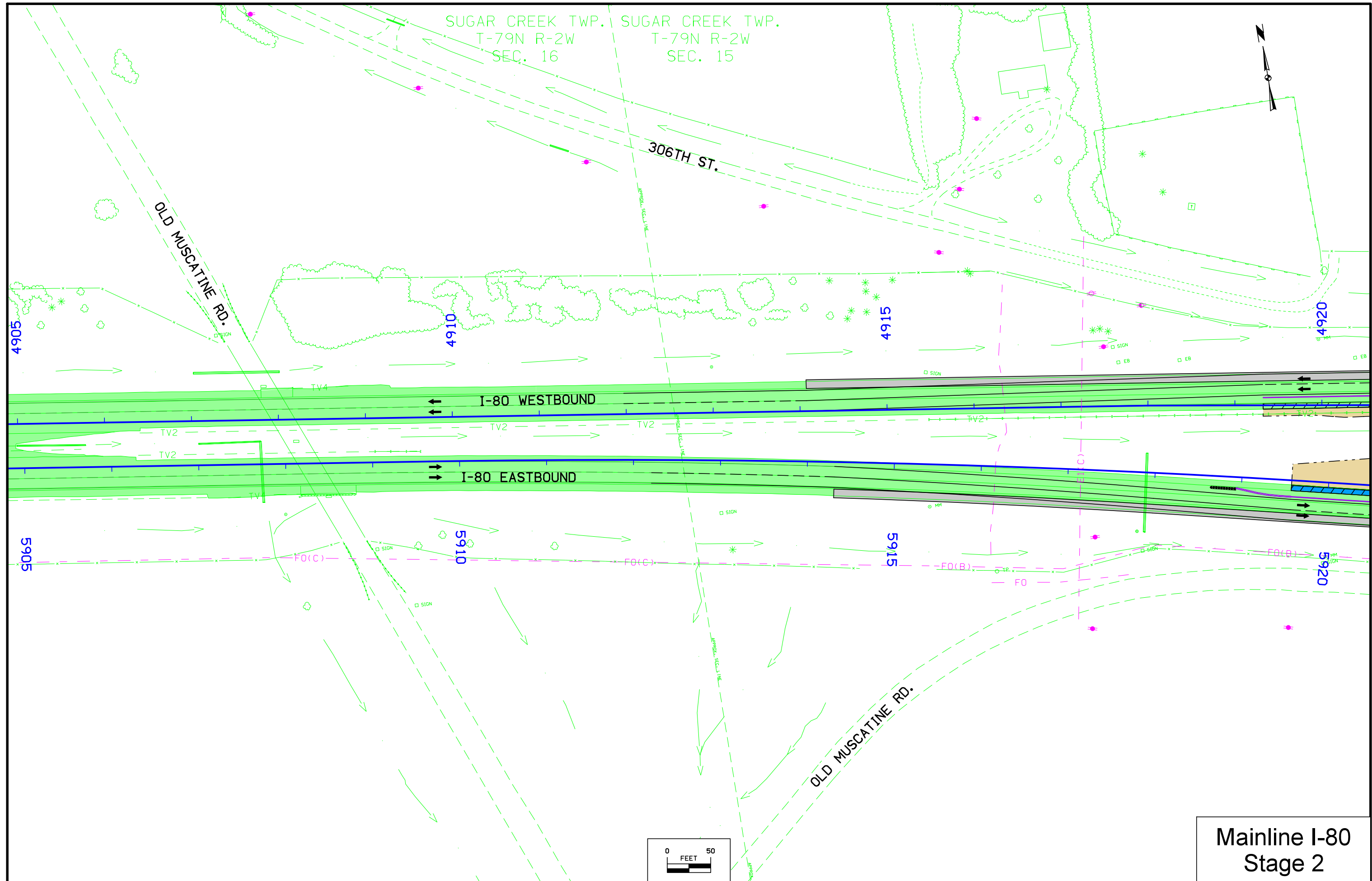

SUGAR CREEK TWP. T-79N R-2W SEC. 16  
 SUGAR CREEK TWP. T-79N R-2W SEC. 15

306TH ST.

OLD MUSCATINE RD.

I-80 WESTBOUND

I-80 EASTBOUND

OLD MUSCATINE RD.

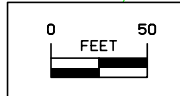

Mainline I-80  
 Stage 2

SUGAR CREEK TWP.  
T-79N R-2W  
SEC. 15

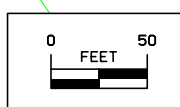
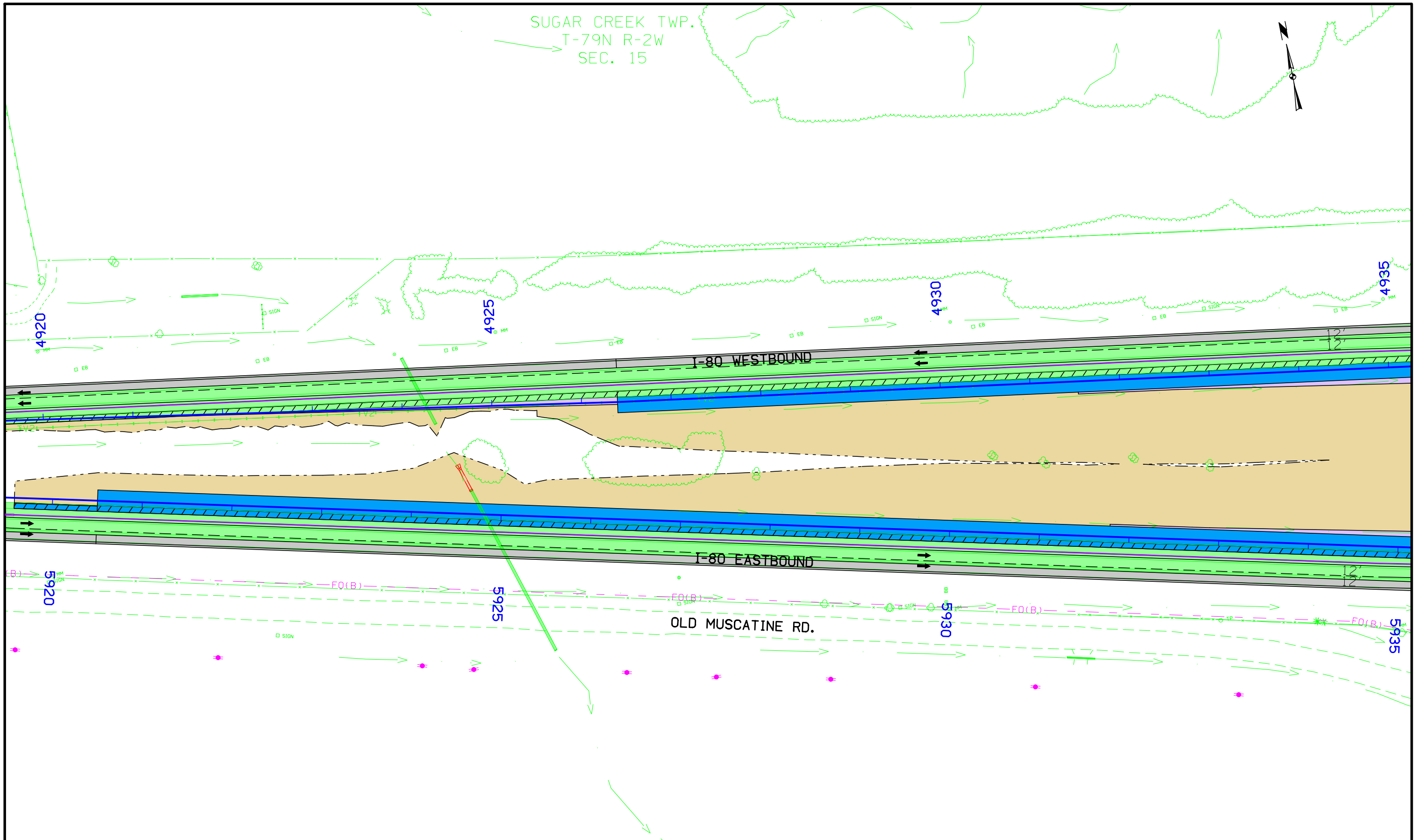

Mainline I-80  
Stage 2

SUGAR CREEK TWP.  
T-79N R-2W  
SEC. 15

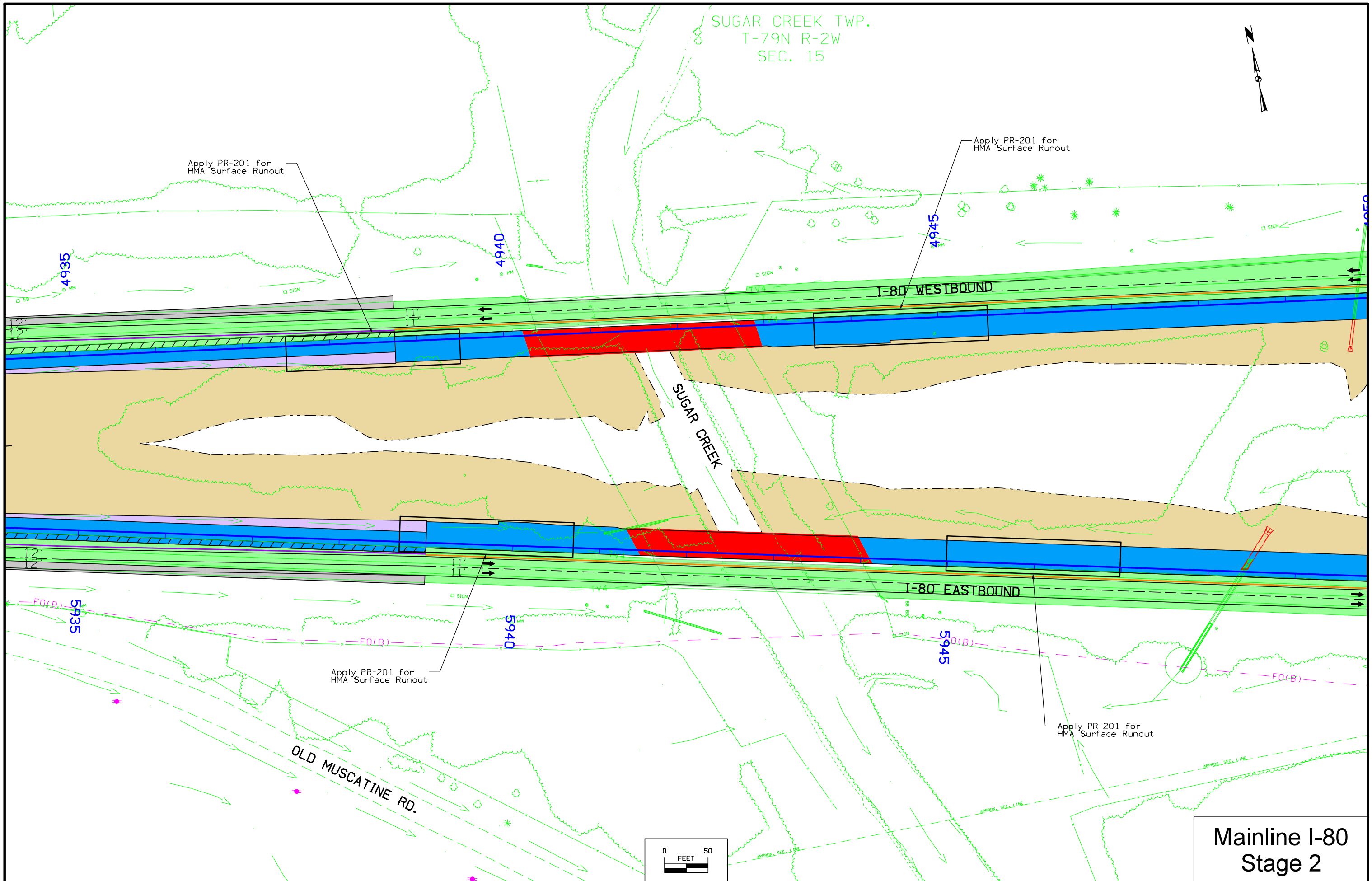

Apply PR-201 for  
HMA Surface Runout

Apply PR-201 for  
HMA Surface Runout

Apply PR-201 for  
HMA Surface Runout

Apply PR-201 for  
HMA Surface Runout

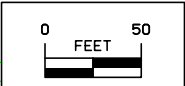

Mainline I-80  
Stage 2

SUGAR CREEK TWP.  
T-79N R-2W  
SEC. 15

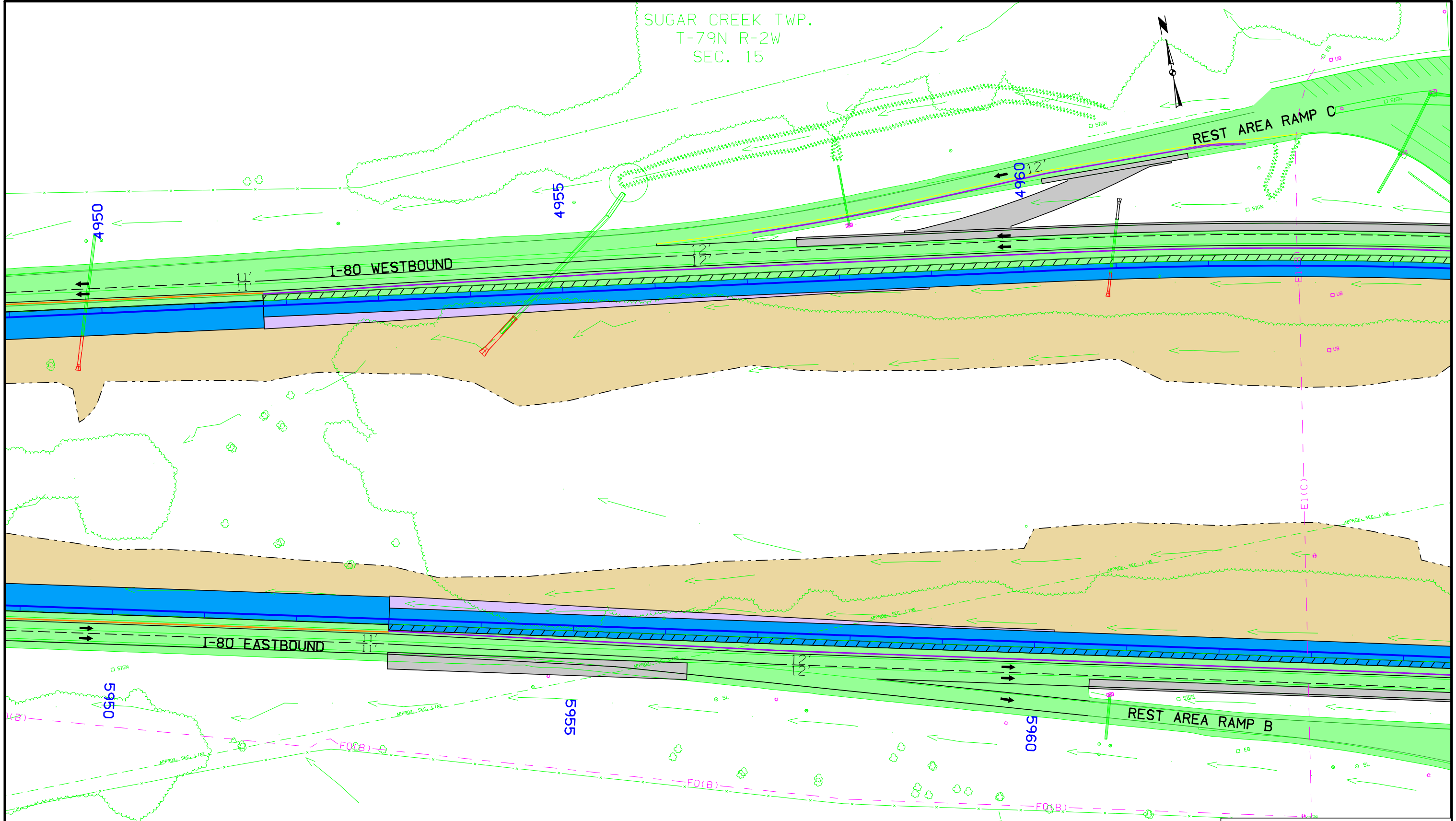

Mainline I-80  
Rest Area Ramp B  
Rest Area Ramp C  
Stage 2

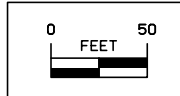



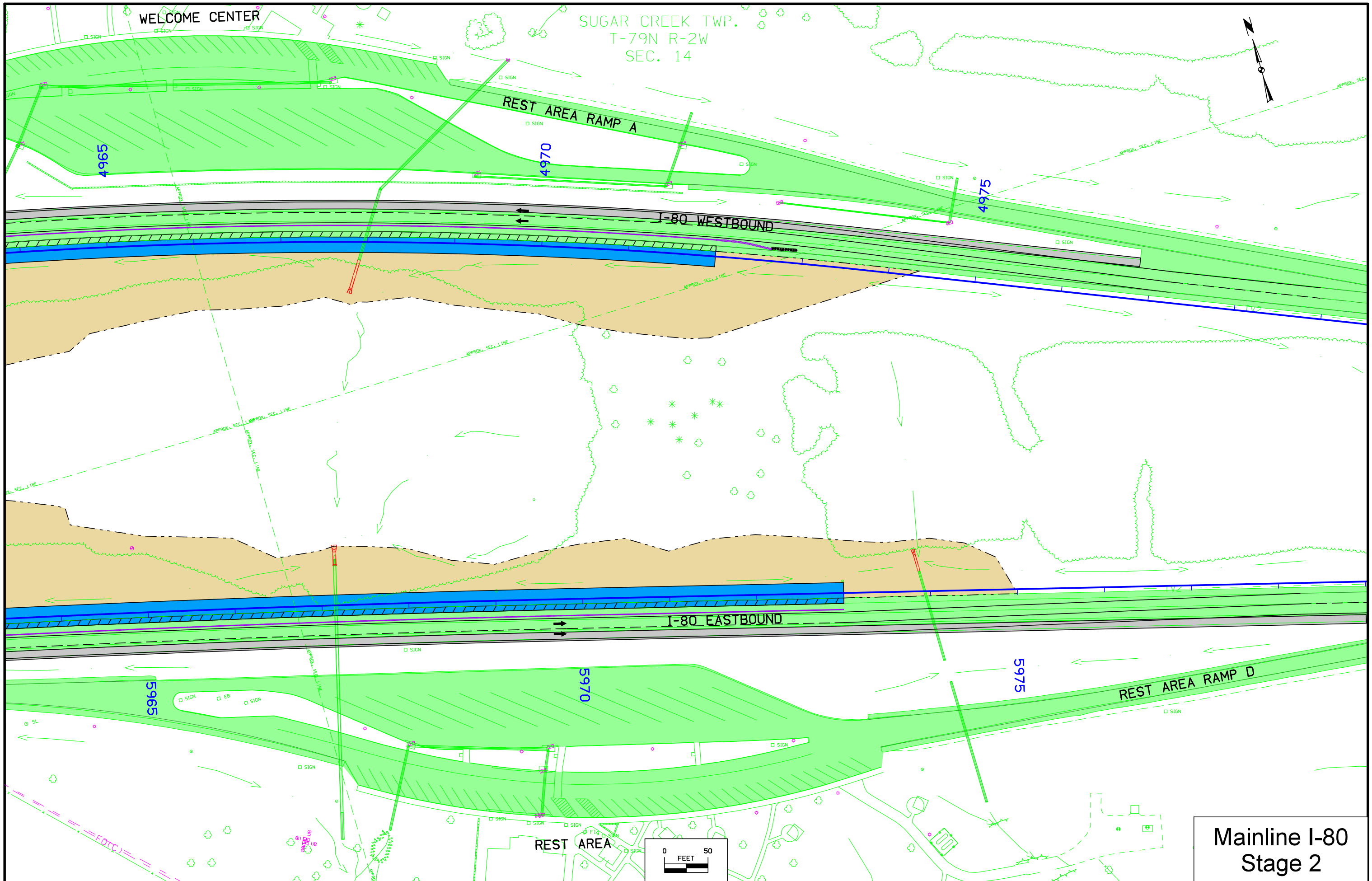

WELCOME CENTER

SUGAR CREEK TWP.  
T-79N R-2W  
SEC. 14

REST AREA RAMP A

I-80 WESTBOUND

I-80 EASTBOUND

REST AREA RAMP D

REST AREA

Mainline I-80  
Stage 2



SUGAR CREEK TWP.  
T-79N R-2W  
SEC. 23

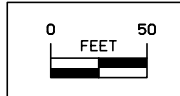
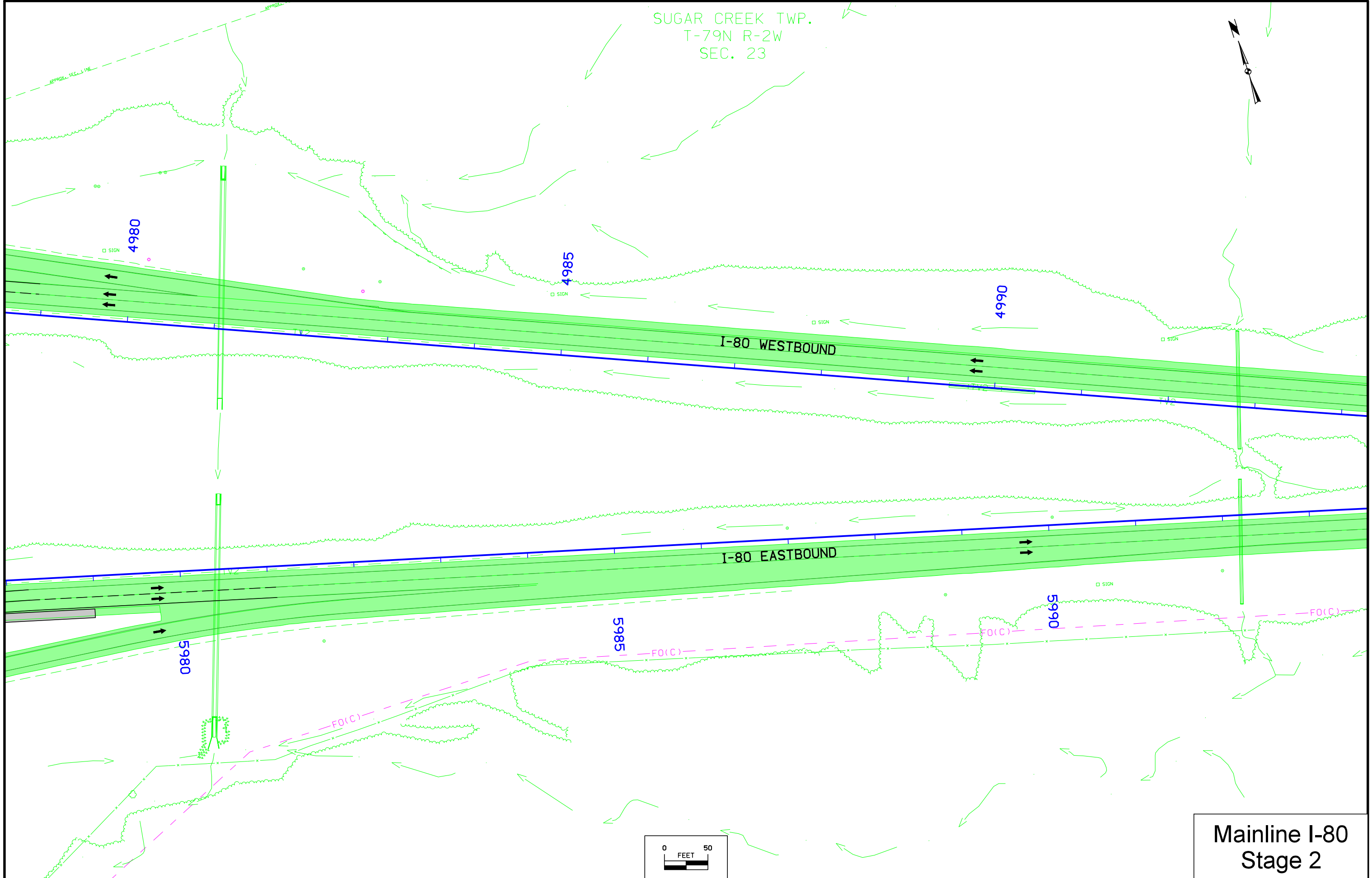

Mainline I-80  
Stage 2

SUGAR CREEK TWP.  
T-79N R-2W  
SEC. 23

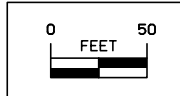
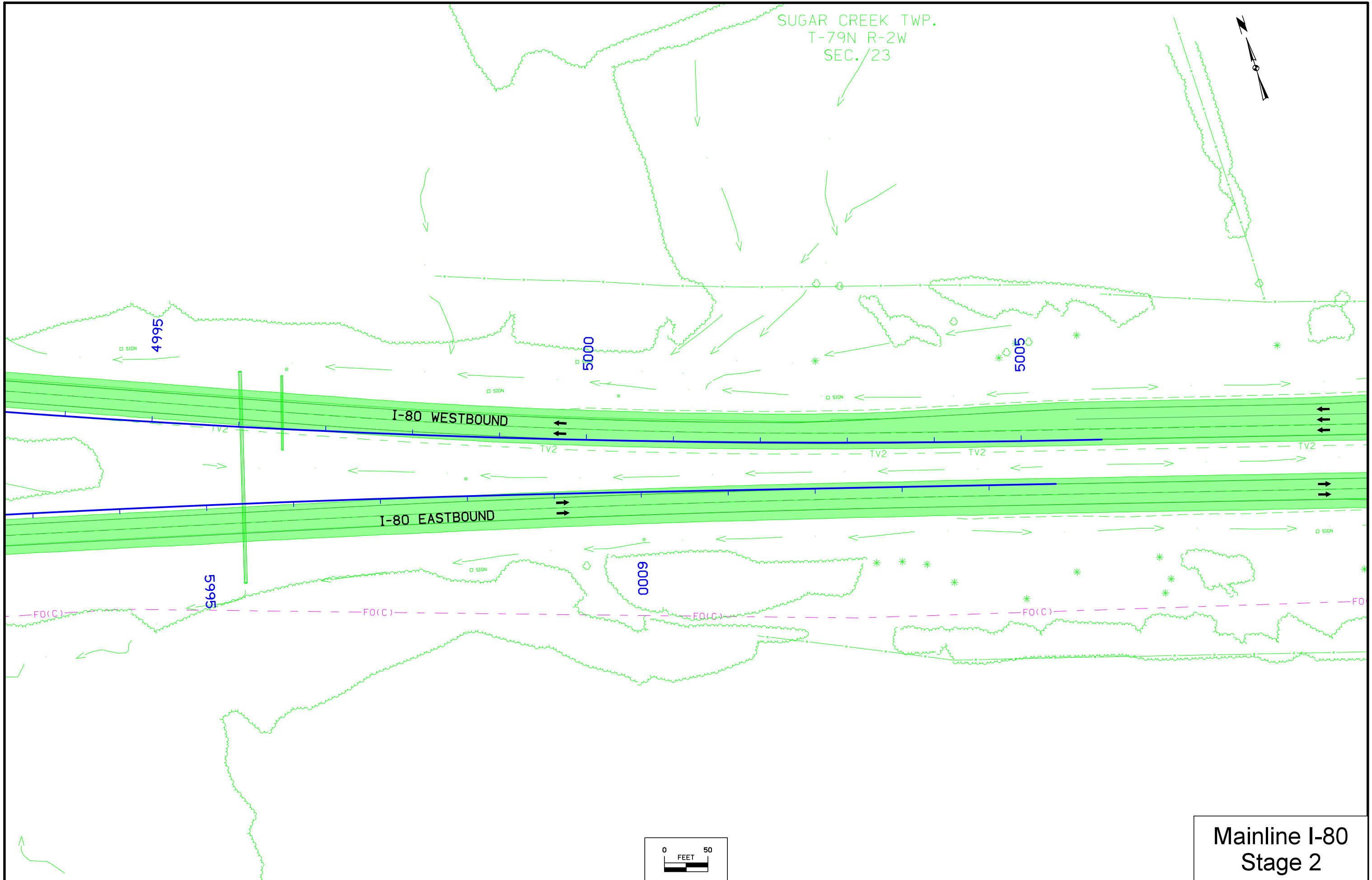

Mainline I-80  
Stage 2



SUGAR CREEK TWP.  
T-79N R-2W  
SEC. 23

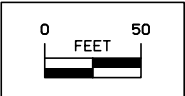
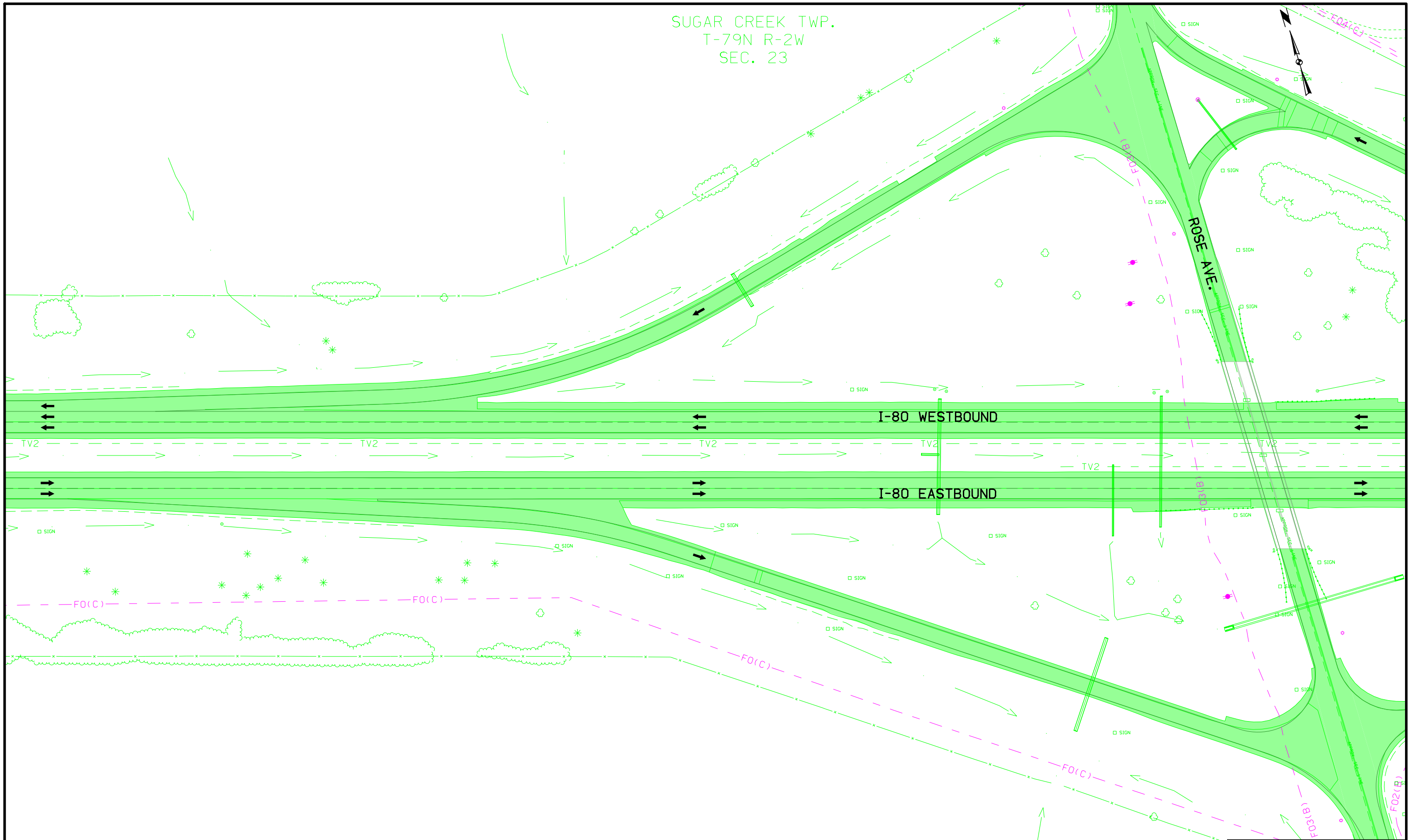

Mainline I-80  
Stage 2

SUGAR CREEK TWP.  
T-79N R-2W  
SEC. 24

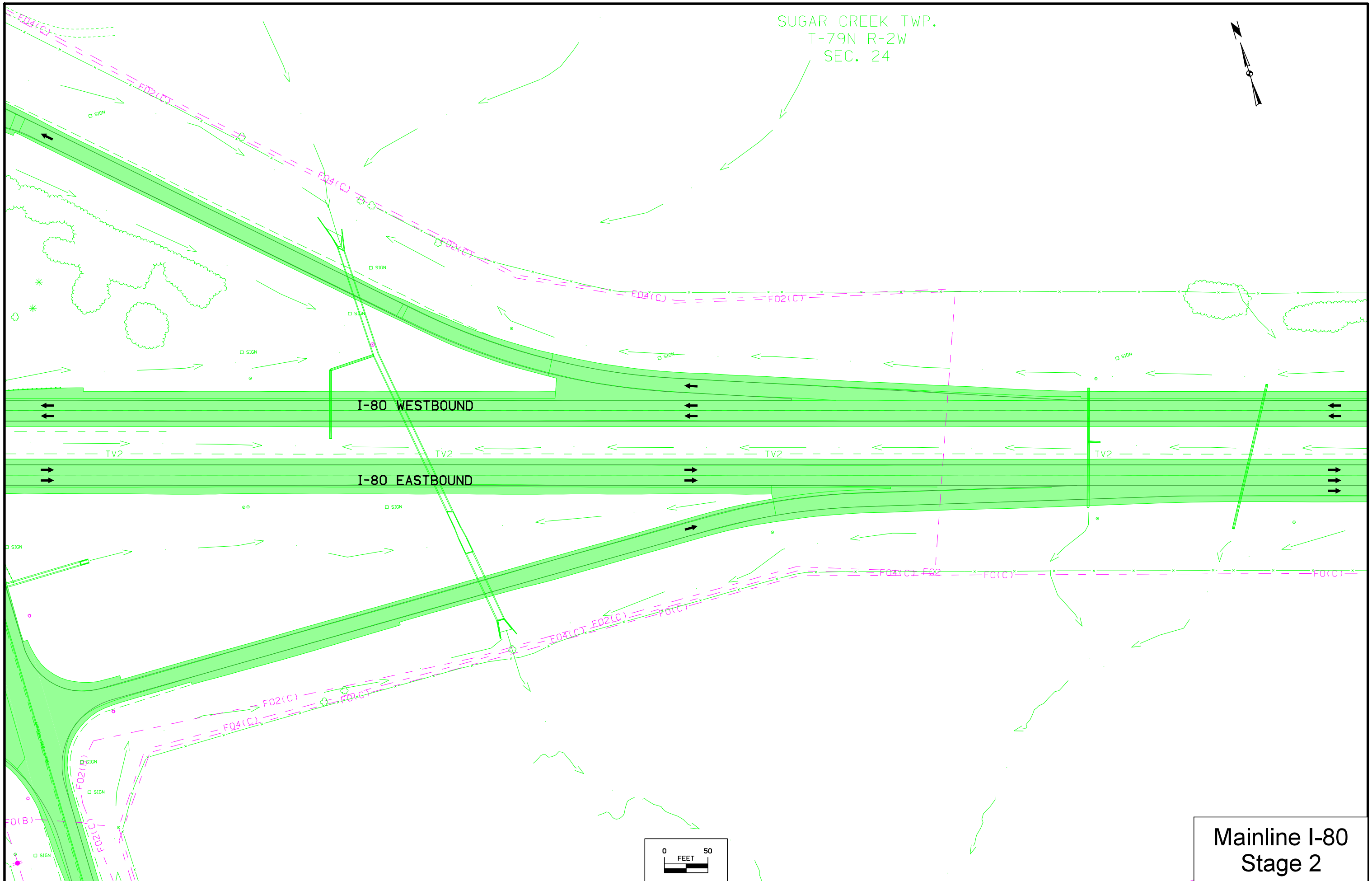

I-80 WESTBOUND

I-80 EASTBOUND

Mainline I-80  
Stage 2

SUGAR CREEK TWP.  
T-79N R-2W  
SEC. 24

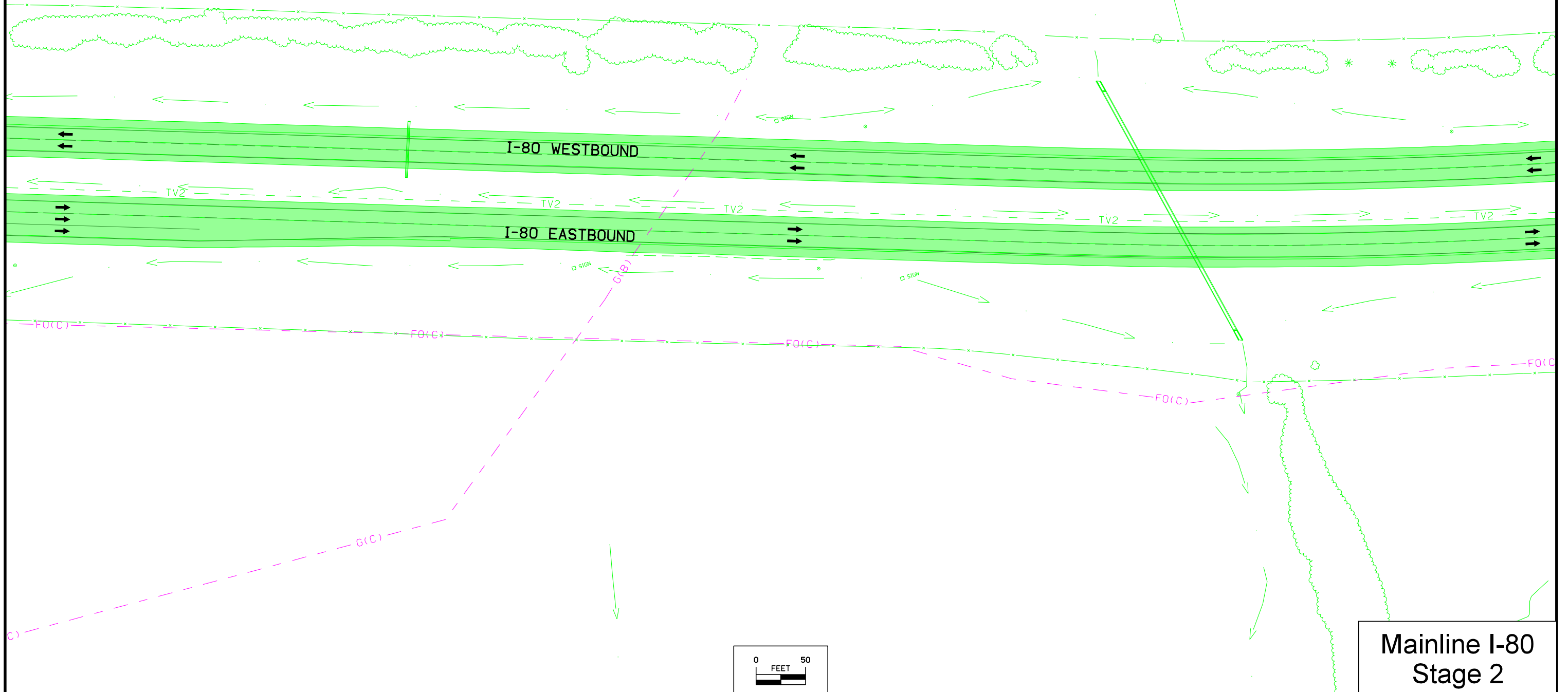

Mainline I-80  
Stage 2

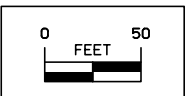

SUGAR CREEK TWP.  
T-79N R-2W  
SEC. 17

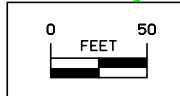
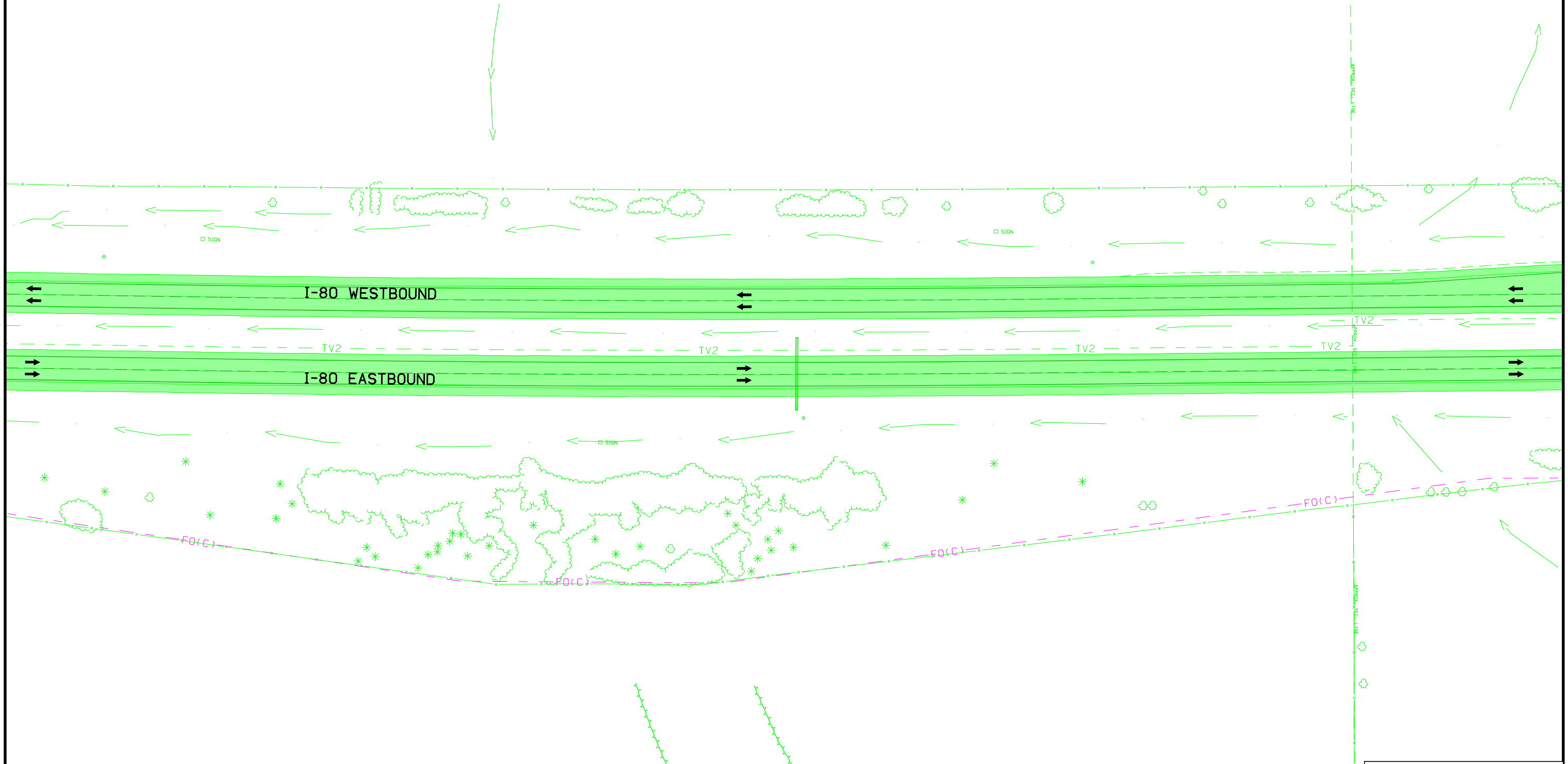

Mainline I-80  
Stage 3

SUGAR CREEK TWP.  
T-79N R-2W  
SEC. 16

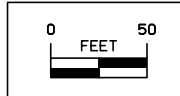
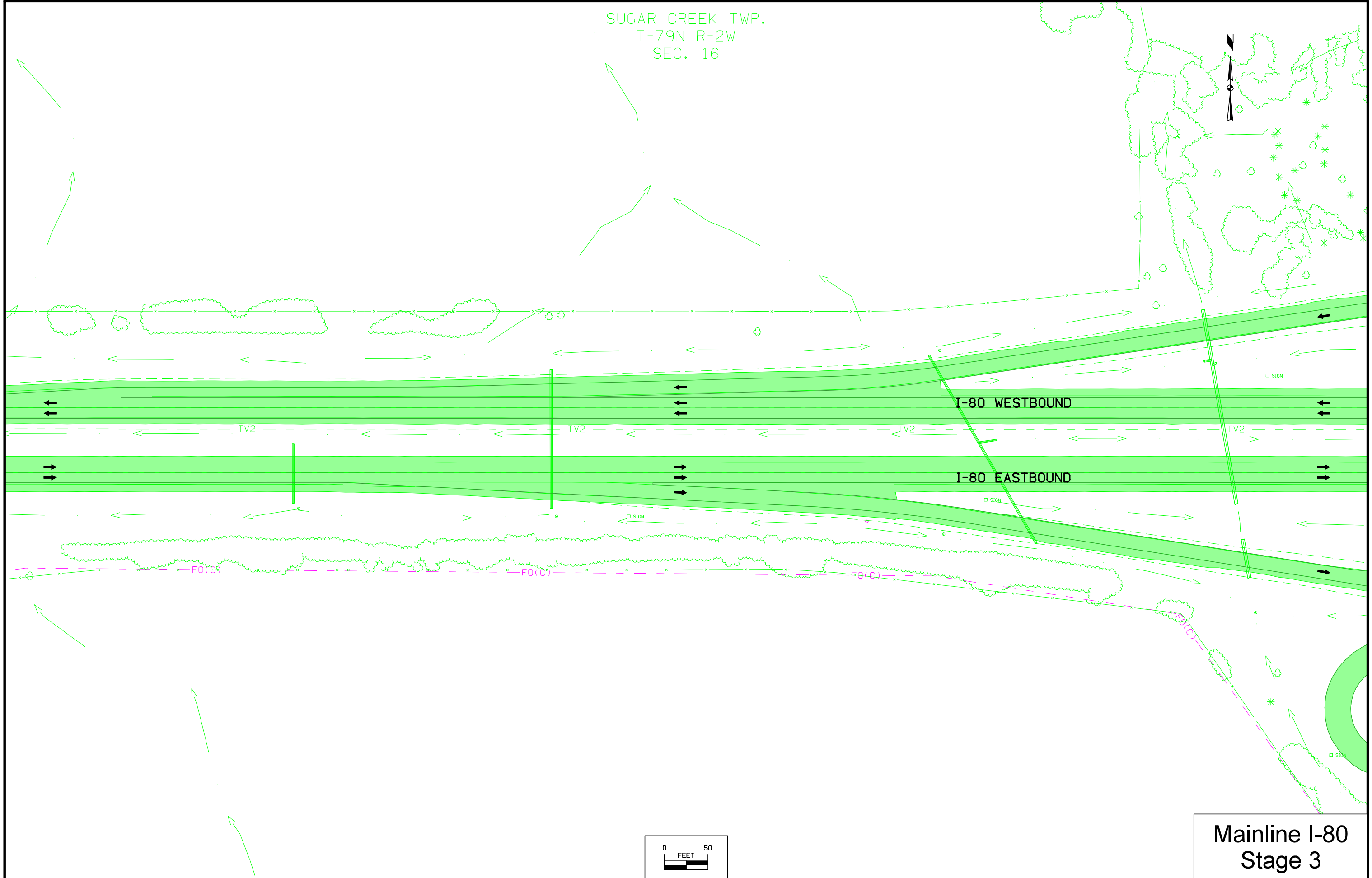

Mainline I-80  
Stage 3

SUGAR CREEK TWP.  
T-79N R-2W  
SEC. 16

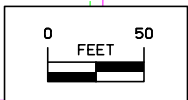
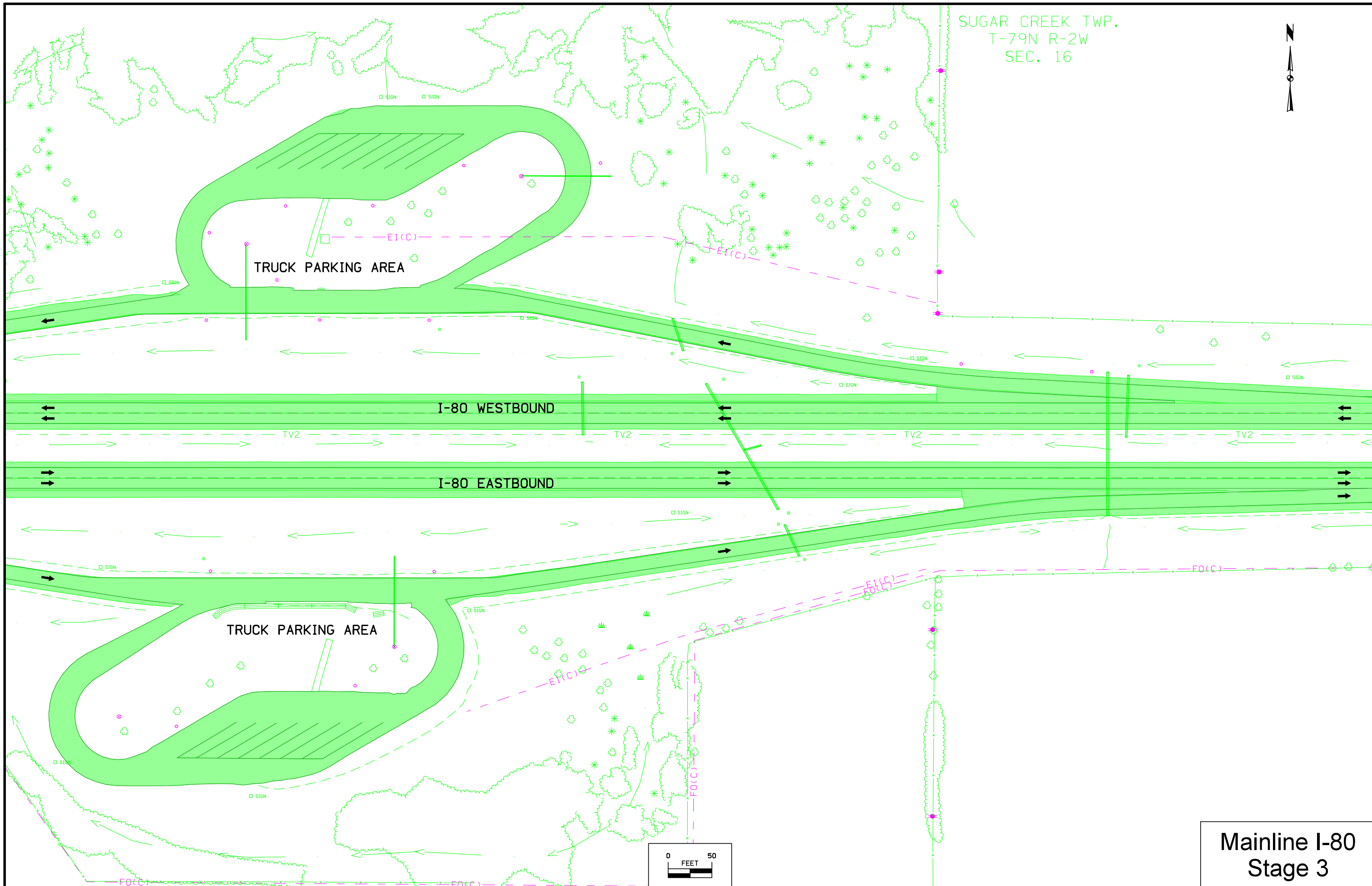

Mainline I-80  
Stage 3

SUGAR CREEK TWP.  
T-79N R-2W  
SEC. 16

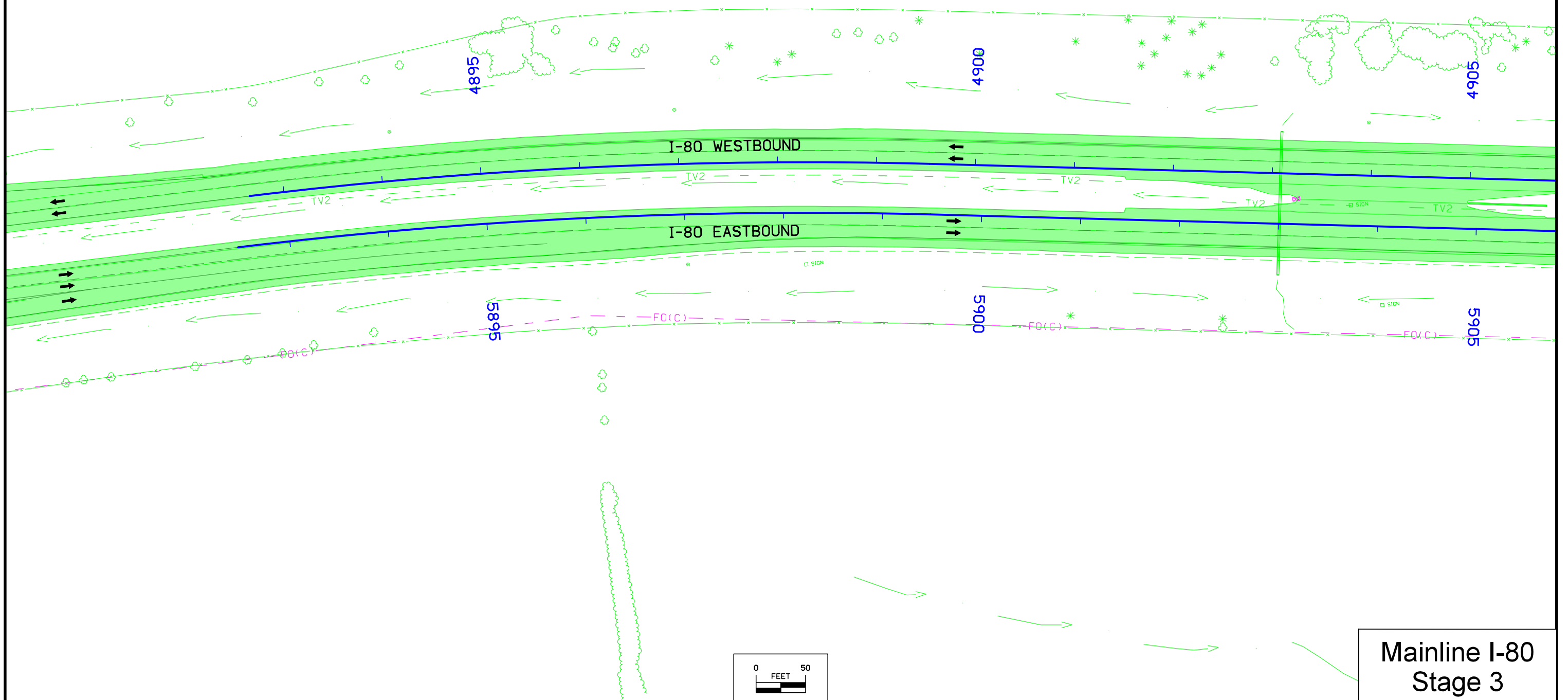

Mainline I-80  
Stage 3



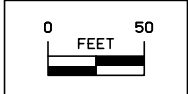
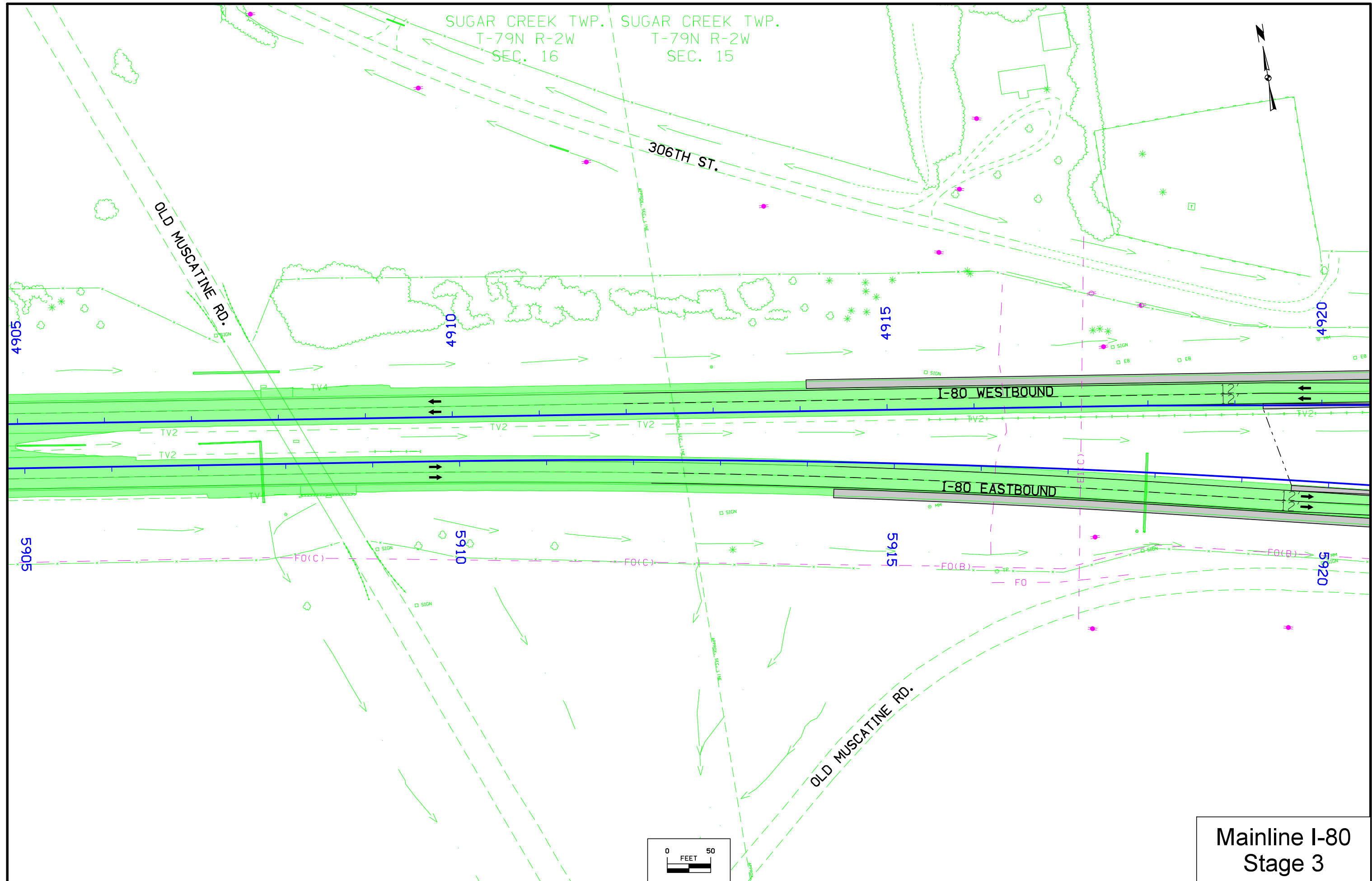

Mainline I-80  
Stage 3

SUGAR CREEK TWP.  
T-79N R-2W  
SEC. 15

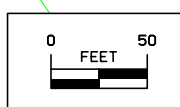
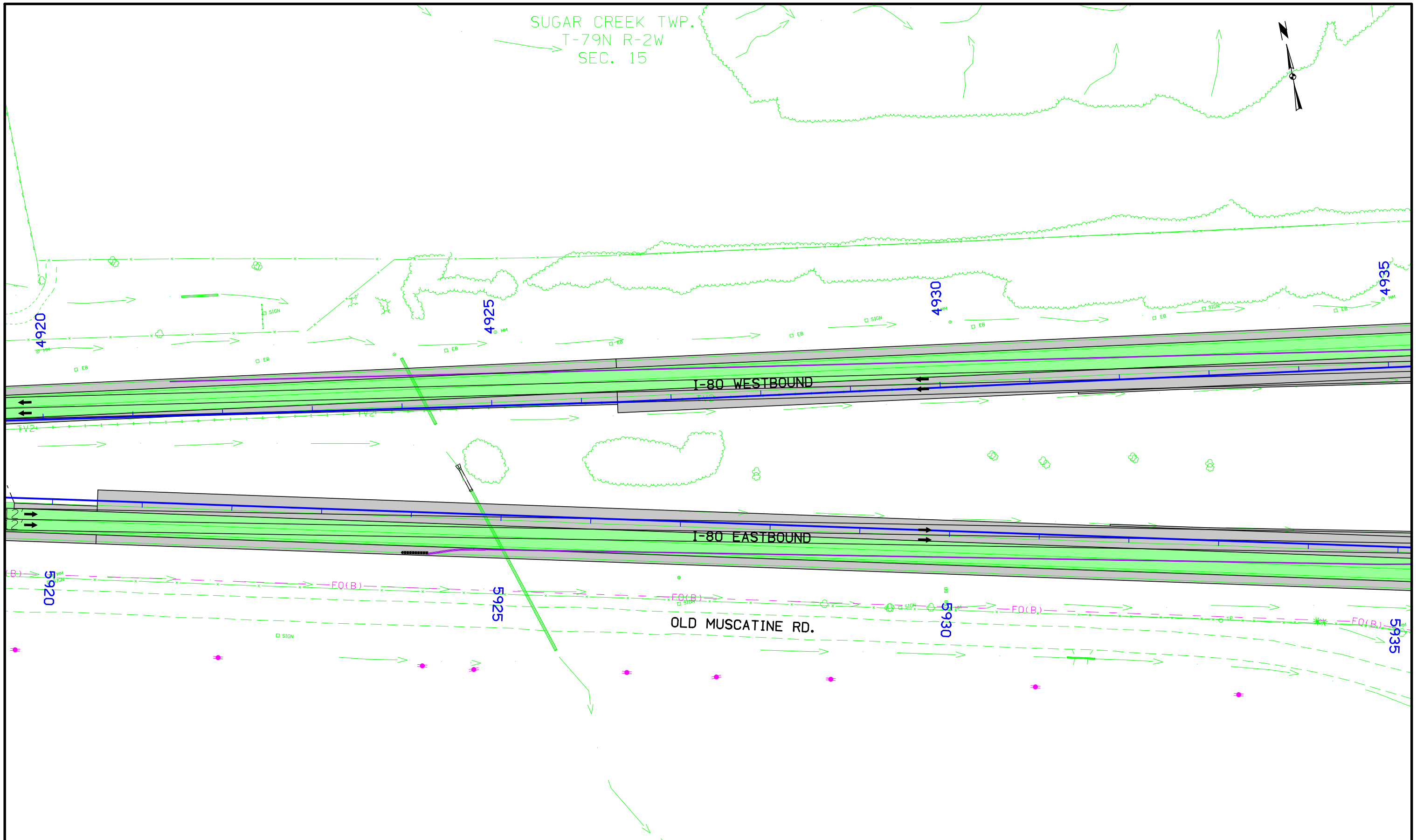

Mainline I-80  
Stage 3

SUGAR CREEK TWP.  
T-79N R-2W  
SEC. 15

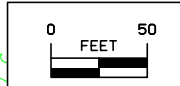
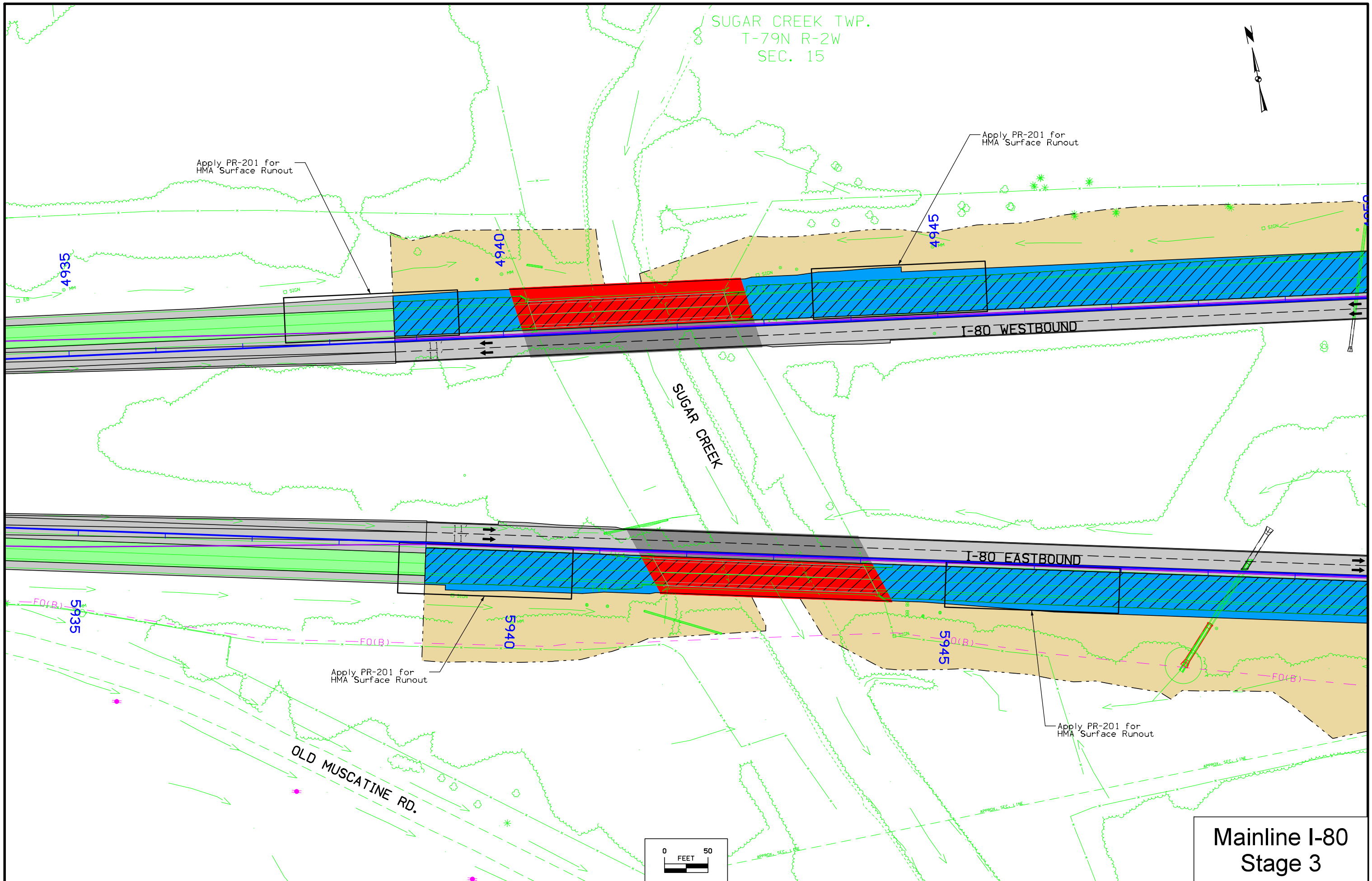

Mainline I-80  
Stage 3

SUGAR CREEK TWP.  
T-79N R-2W  
SEC. 15

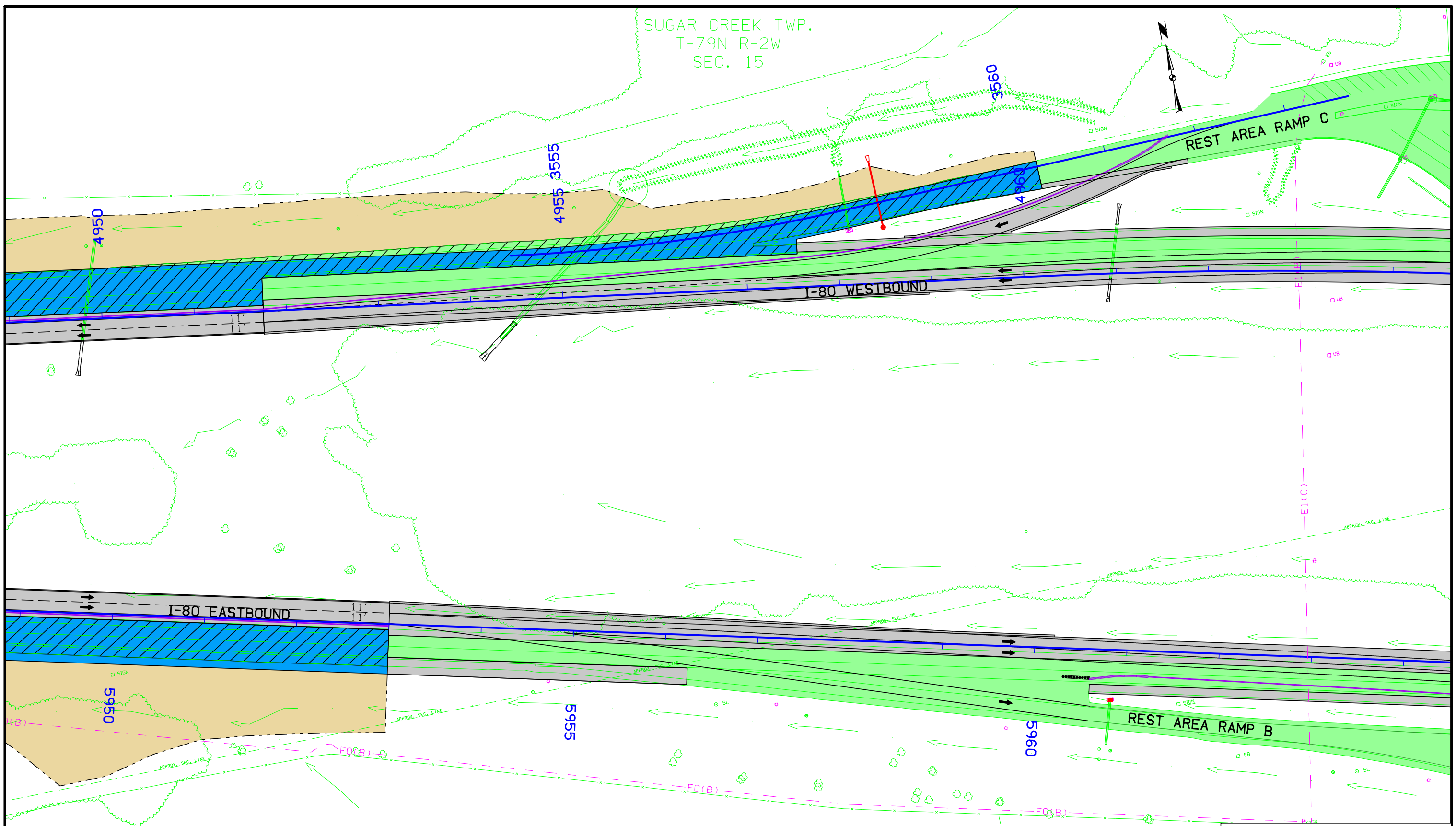

Mainline I-80  
Rest Area Ramp B  
Rest Area Ramp C  
Stage 3

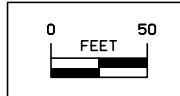



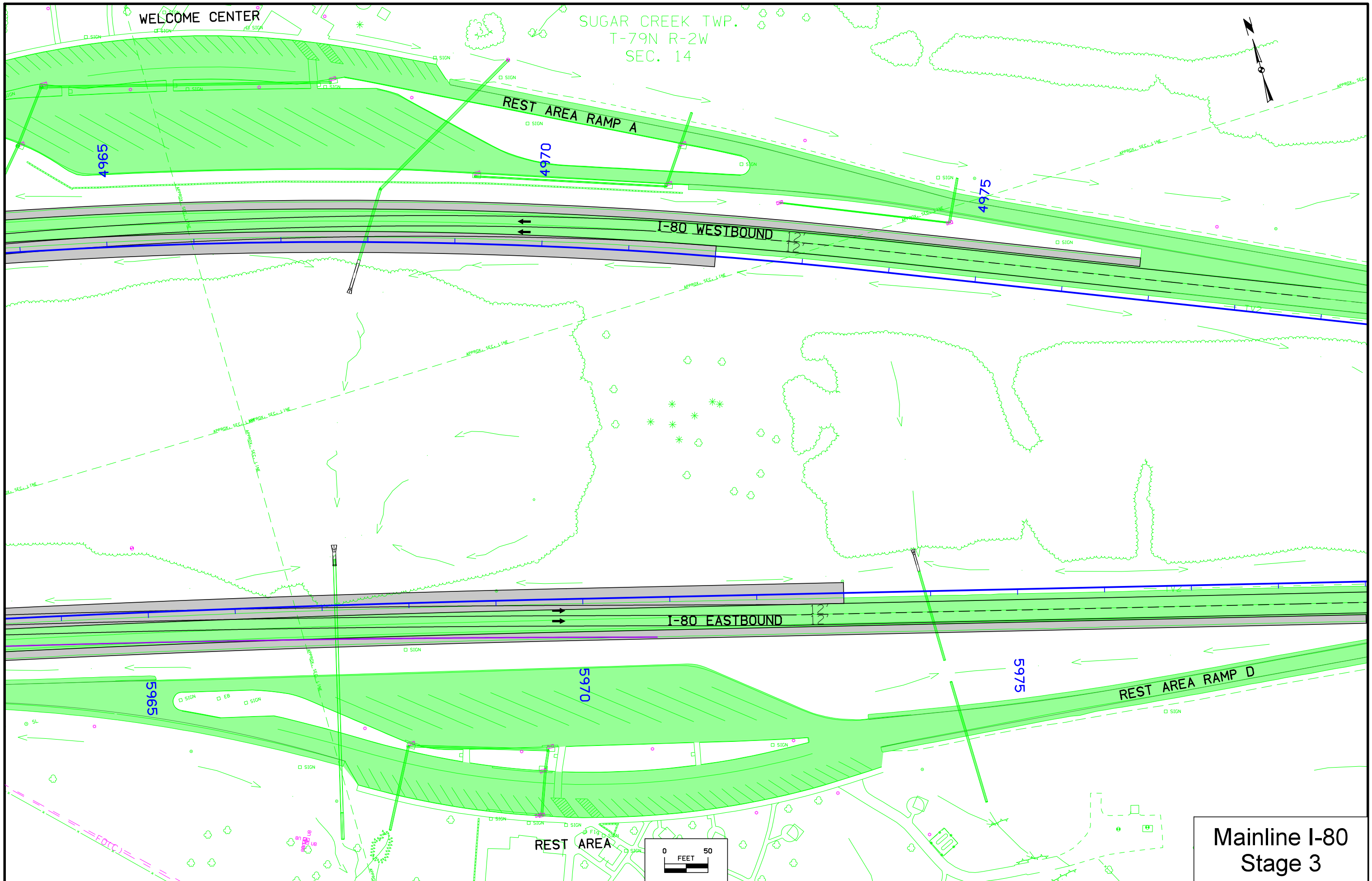

**Mainline I-80  
Stage 3**

SUGAR CREEK TWP.  
T-79N R-2W  
SEC. 23

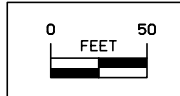
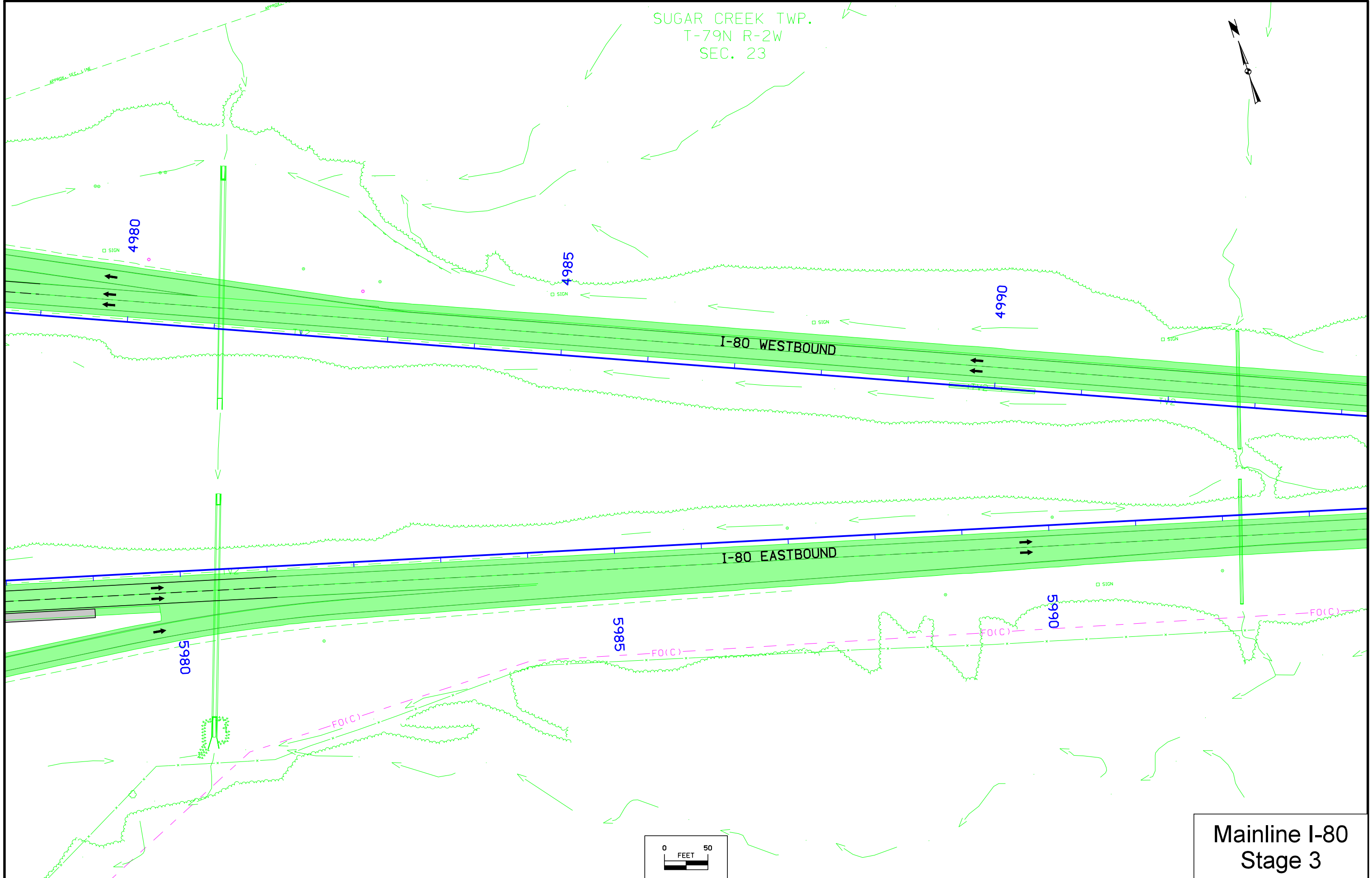

Mainline I-80  
Stage 3

FILE NO.	ENGLISH	DESIGN TEAM	Iowa DOT \ HR Green	CEDAR COUNTY	PROJECT NUMBER	IM-NHS-080-8(341)269--03-16	SHEET NUMBER	J.45
----------	---------	-------------	---------------------	--------------	----------------	-----------------------------	--------------	------

SUGAR CREEK TWP.  
T-79N R-2W  
SEC. 23

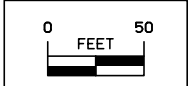
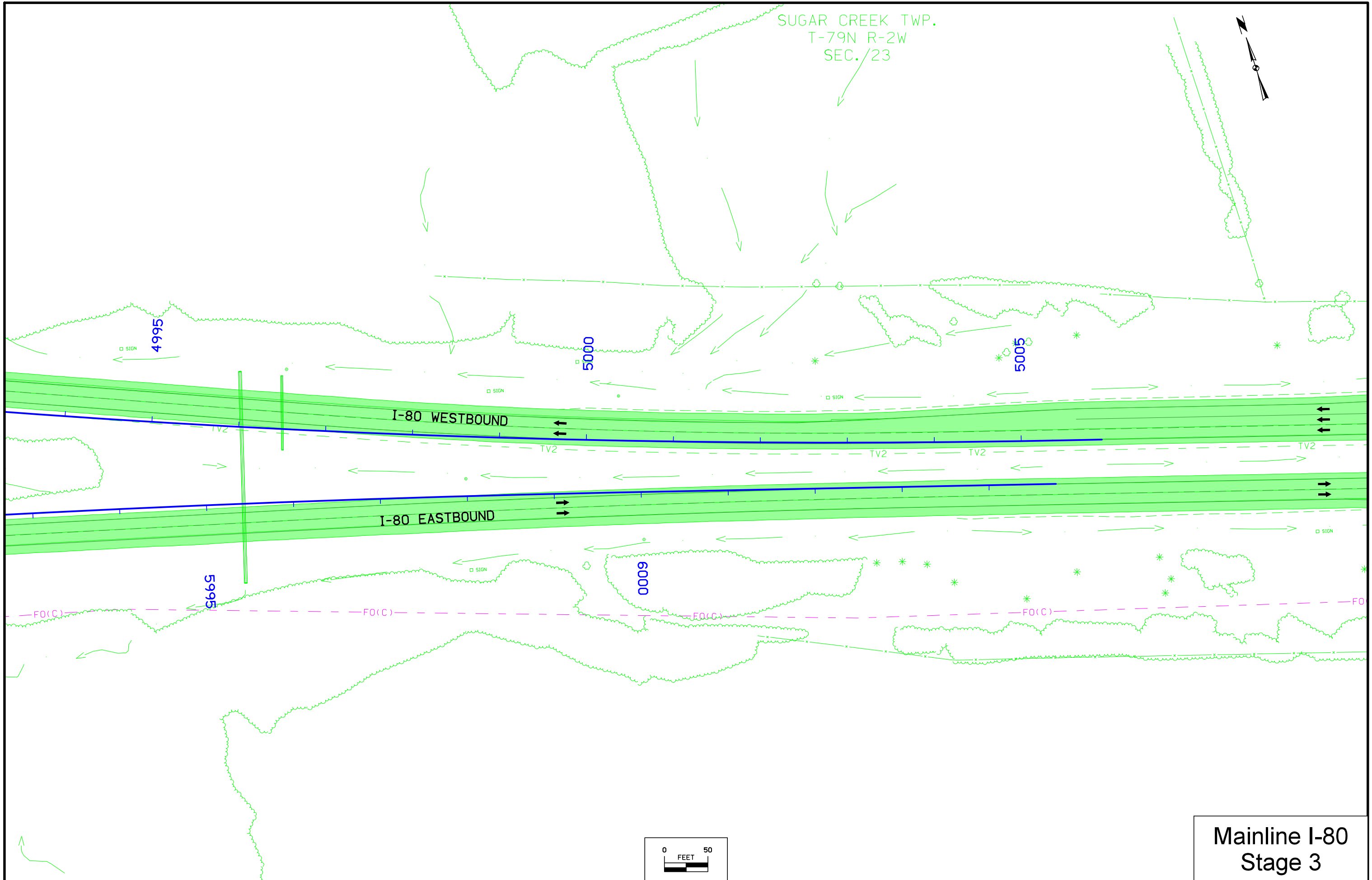

Mainline I-80  
Stage 3



SUGAR CREEK TWP.  
T-79N R-2W  
SEC. 23

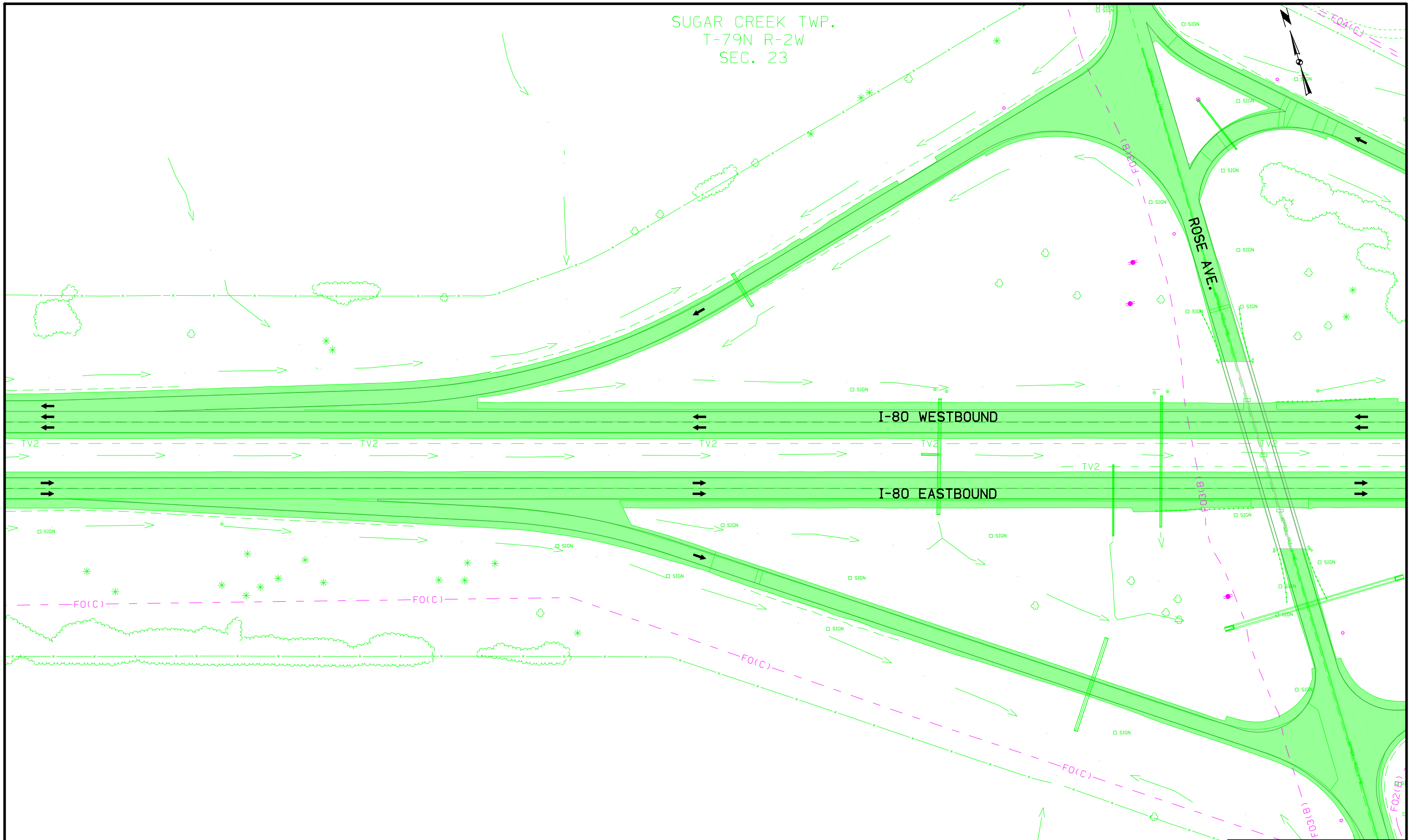

Mainline I-80  
Stage 3

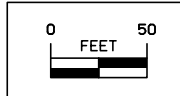

SUGAR CREEK TWP.  
T-79N R-2W  
SEC. 24

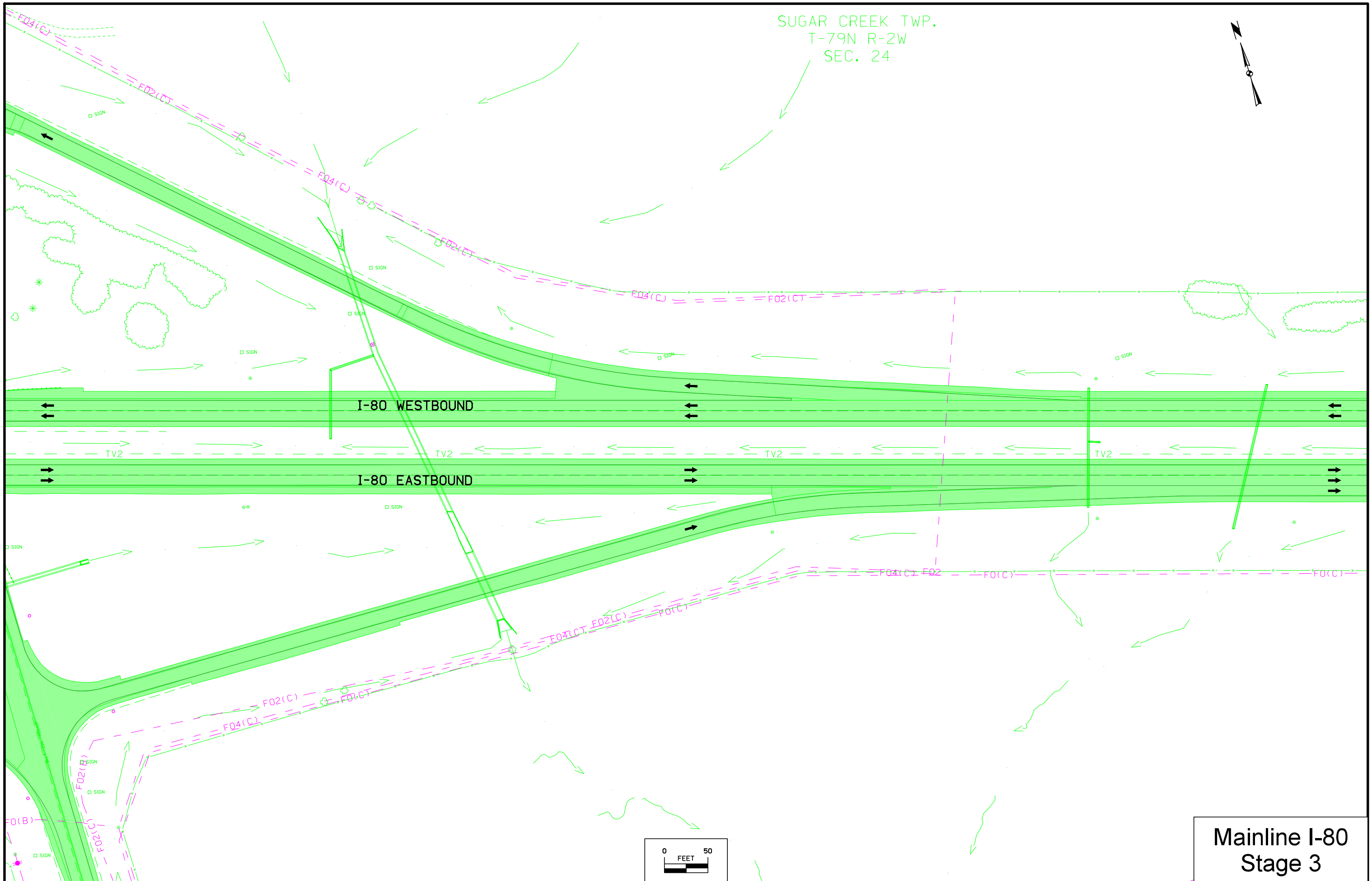

I-80 WESTBOUND

I-80 EASTBOUND

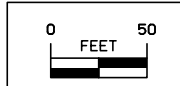

Mainline I-80  
Stage 3

SUGAR CREEK TWP.  
T-79N R-2W  
SEC. 24

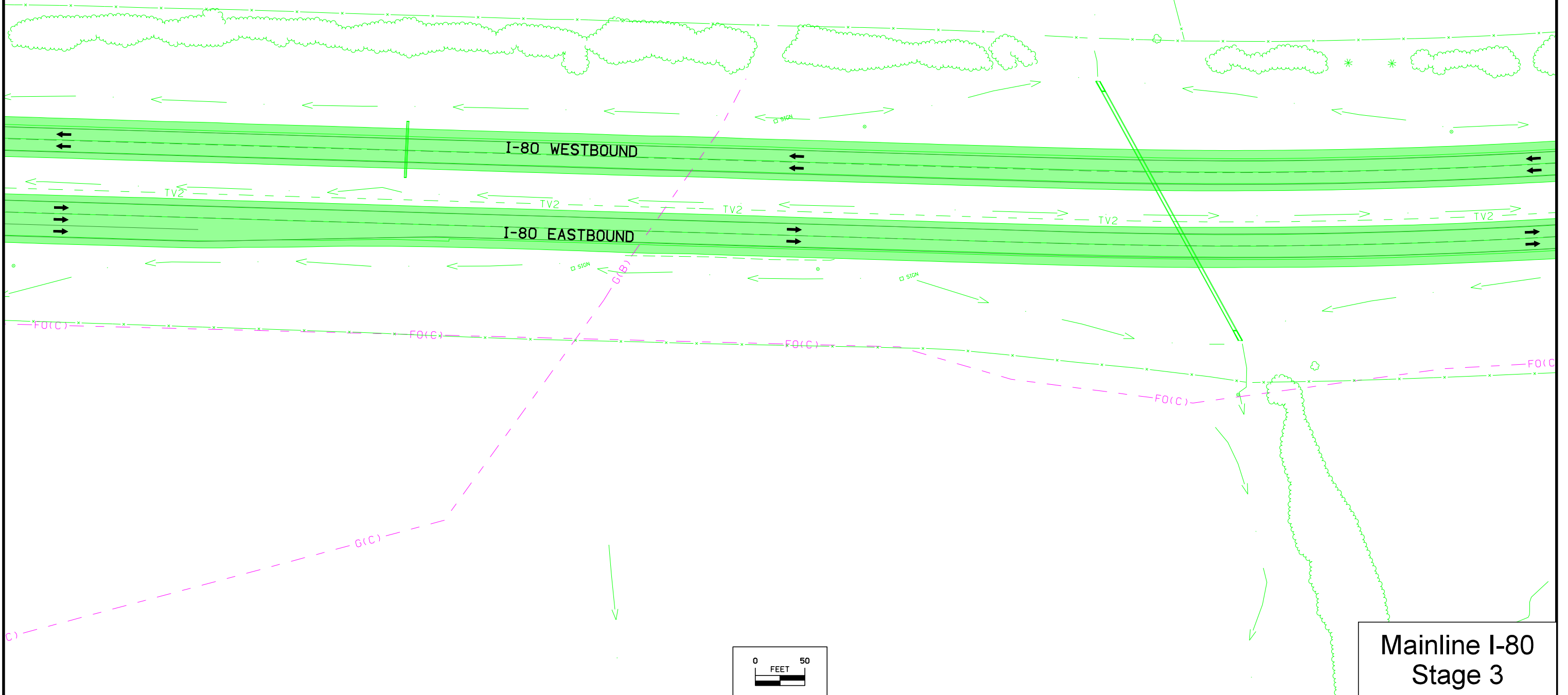

Mainline I-80  
Stage 3

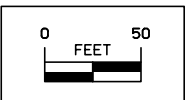

SUGAR CREEK TWP.  
T-79N R-2W  
SEC. 17

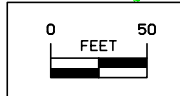
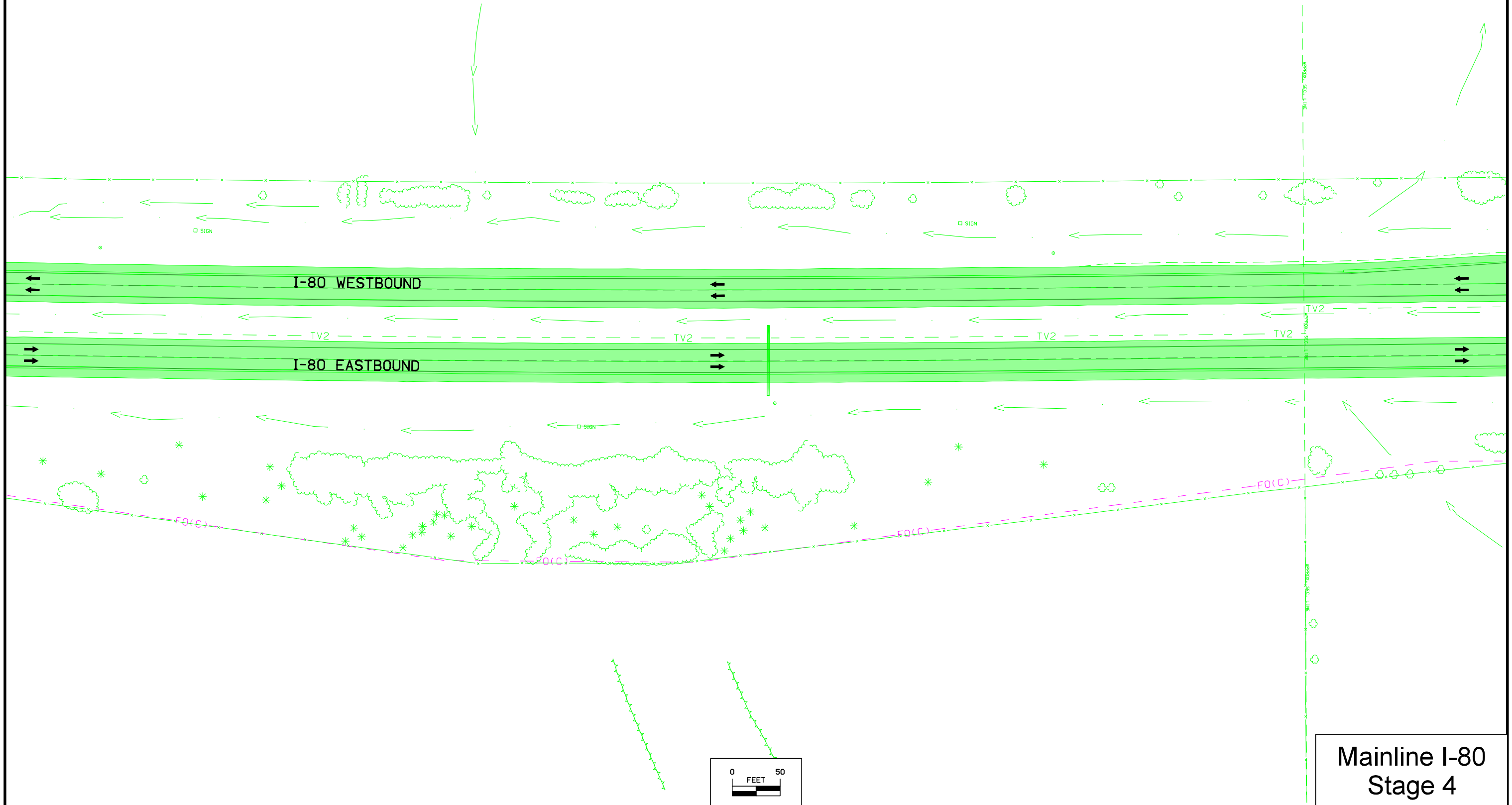

Mainline I-80  
Stage 4

SUGAR CREEK TWP.  
T-79N R-2W  
SEC. 16

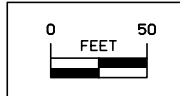
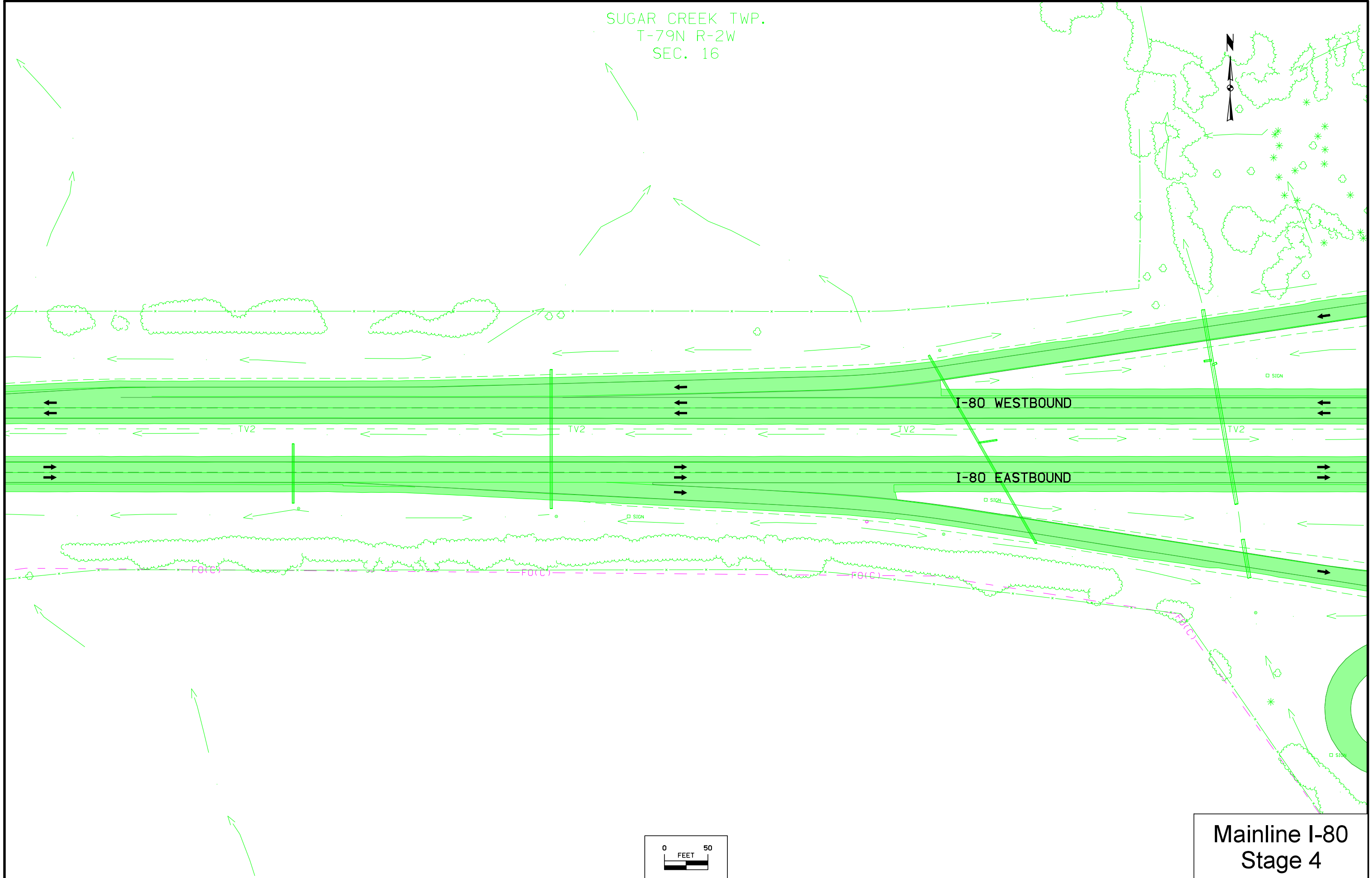

Mainline I-80  
Stage 4

SUGAR CREEK TWP.  
T-79N R-2W  
SEC. 16

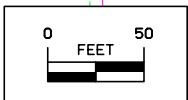
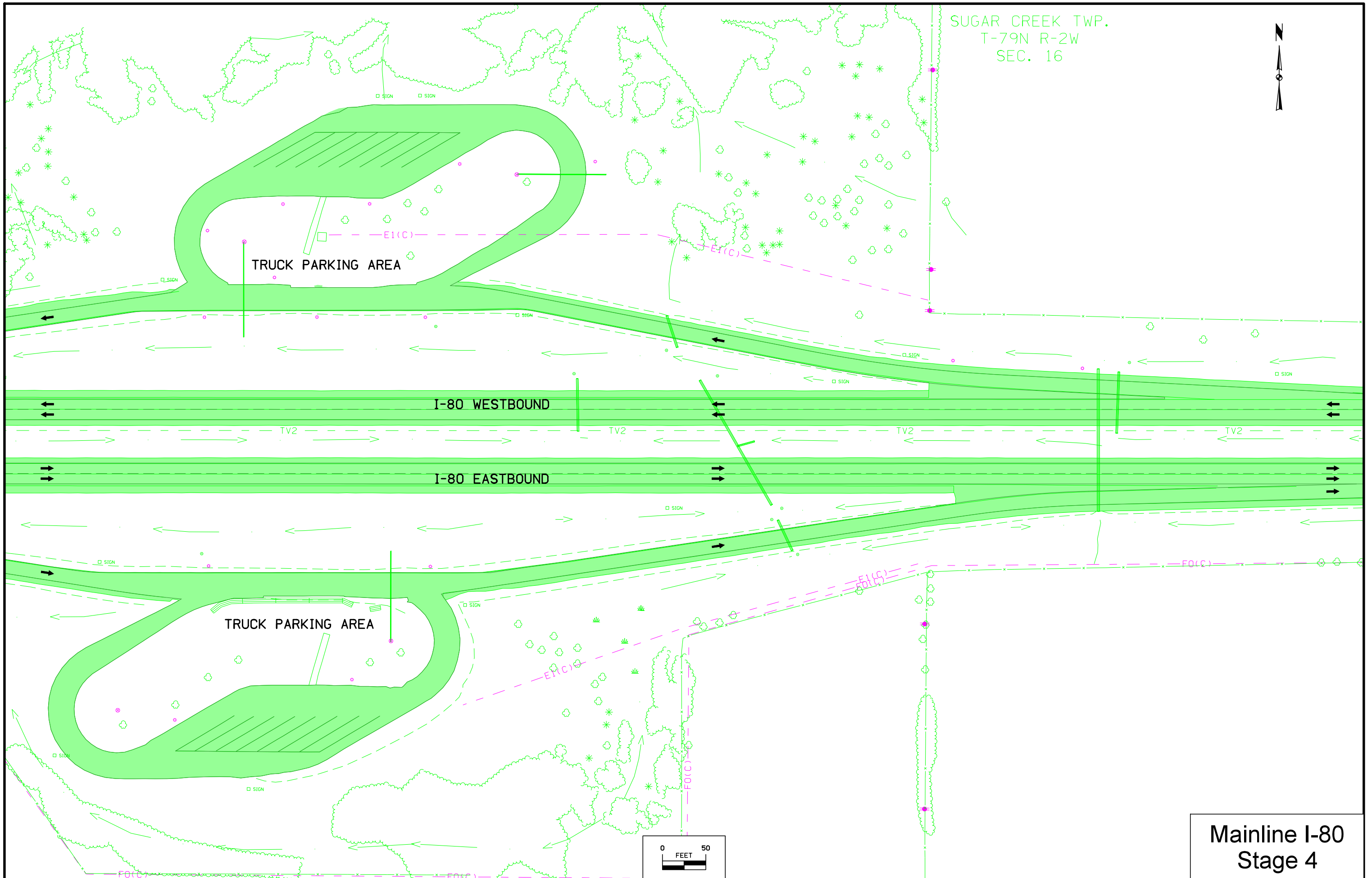

### Mainline I-80 Stage 4

SUGAR CREEK TWP.  
T-79N R-2W  
SEC. 16

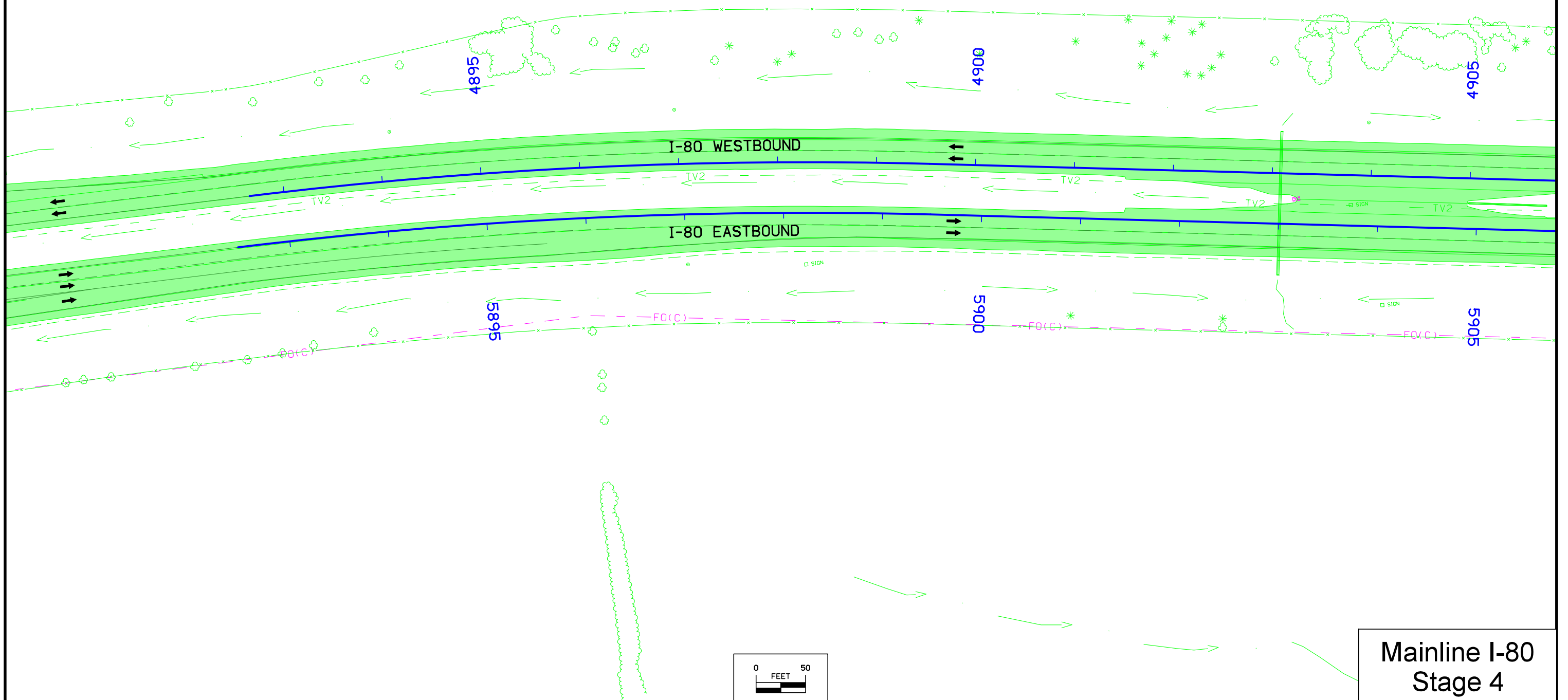

Mainline I-80  
Stage 4



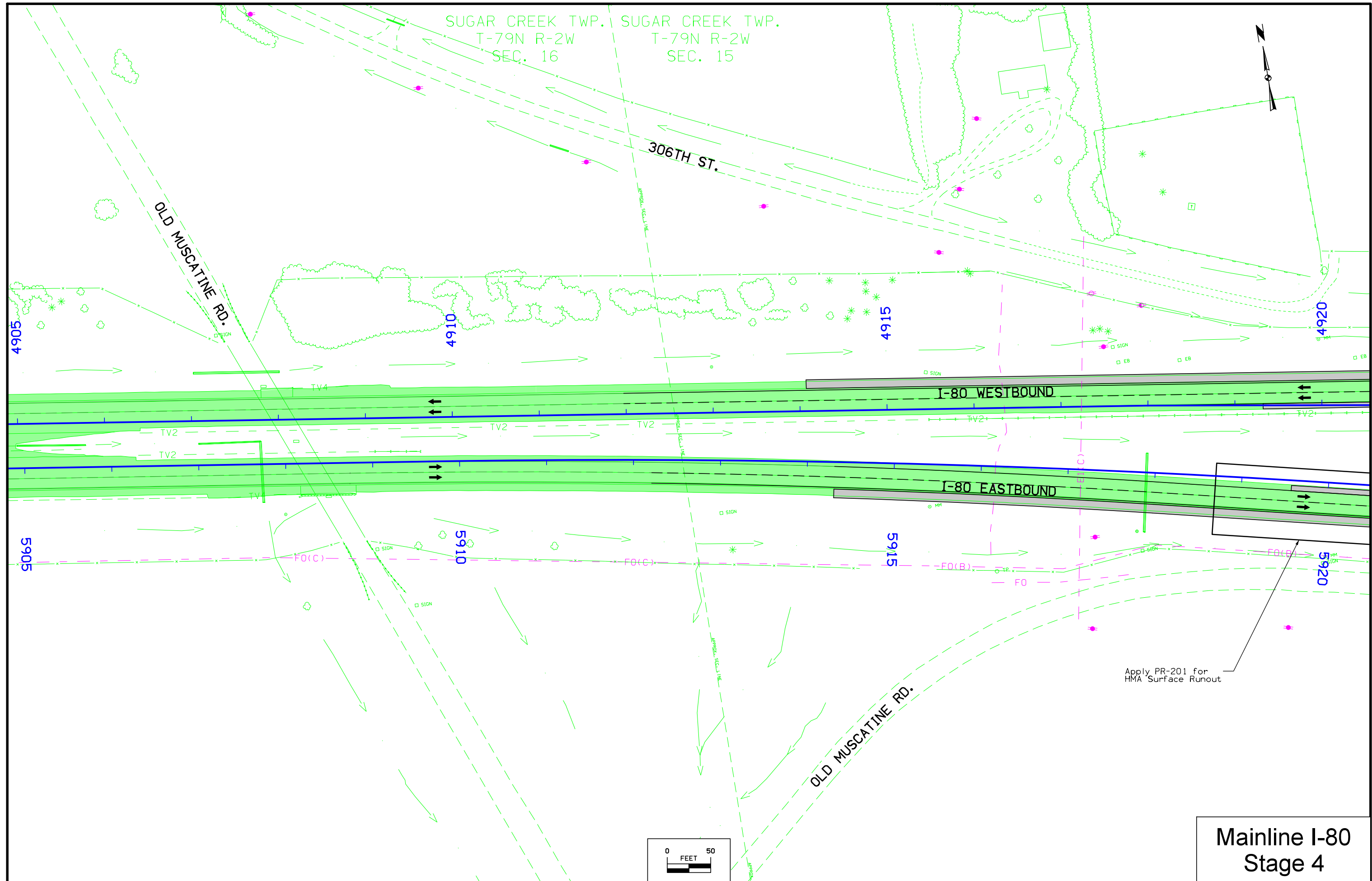

**Mainline I-80  
Stage 4**

SUGAR CREEK TWP.  
T-79N R-2W  
SEC. 15



HMA Overlay Construction with Traffic Control per TC-482  
and Night Lane Closures as needed per TC-418

Apply PR-201 for  
HMA Surface Runout

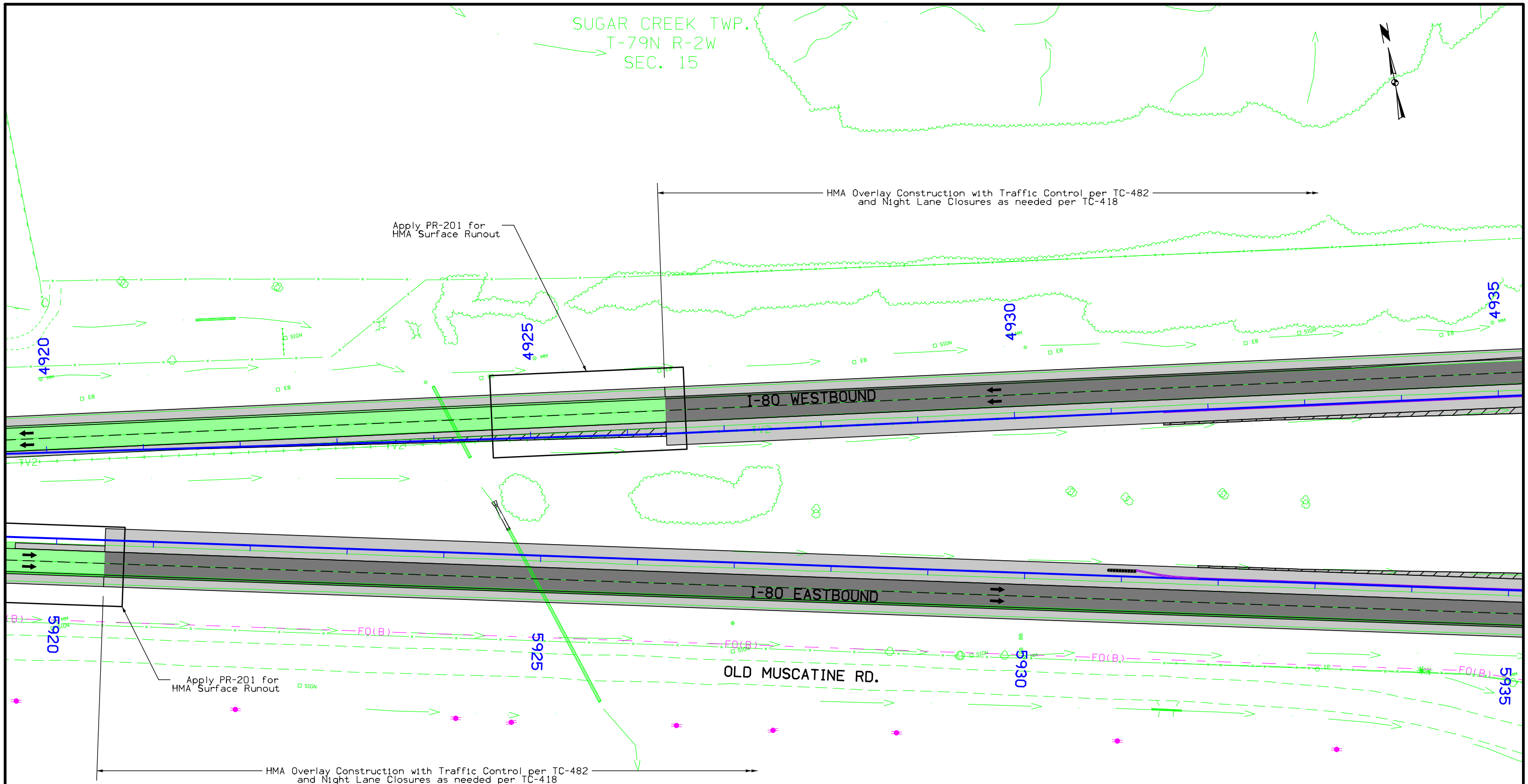

Apply PR-201 for  
HMA Surface Runout

HMA Overlay Construction with Traffic Control per TC-482  
and Night Lane Closures as needed per TC-418

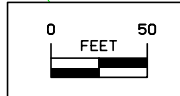

Mainline I-80  
Stage 4

SUGAR CREEK TWP.  
T-79N R-2W  
SEC. 15



HMA Overlay Construction with Traffic Control per TC-482 and Night Lane Closures as needed per TC-418

HMA Overlay Construction with Traffic Control per TC-482 and Night Lane Closures as needed per TC-418

Remove HMA Surface Runout before paving HMA Overlay

Remove HMA Surface Runout before paving HMA Overlay

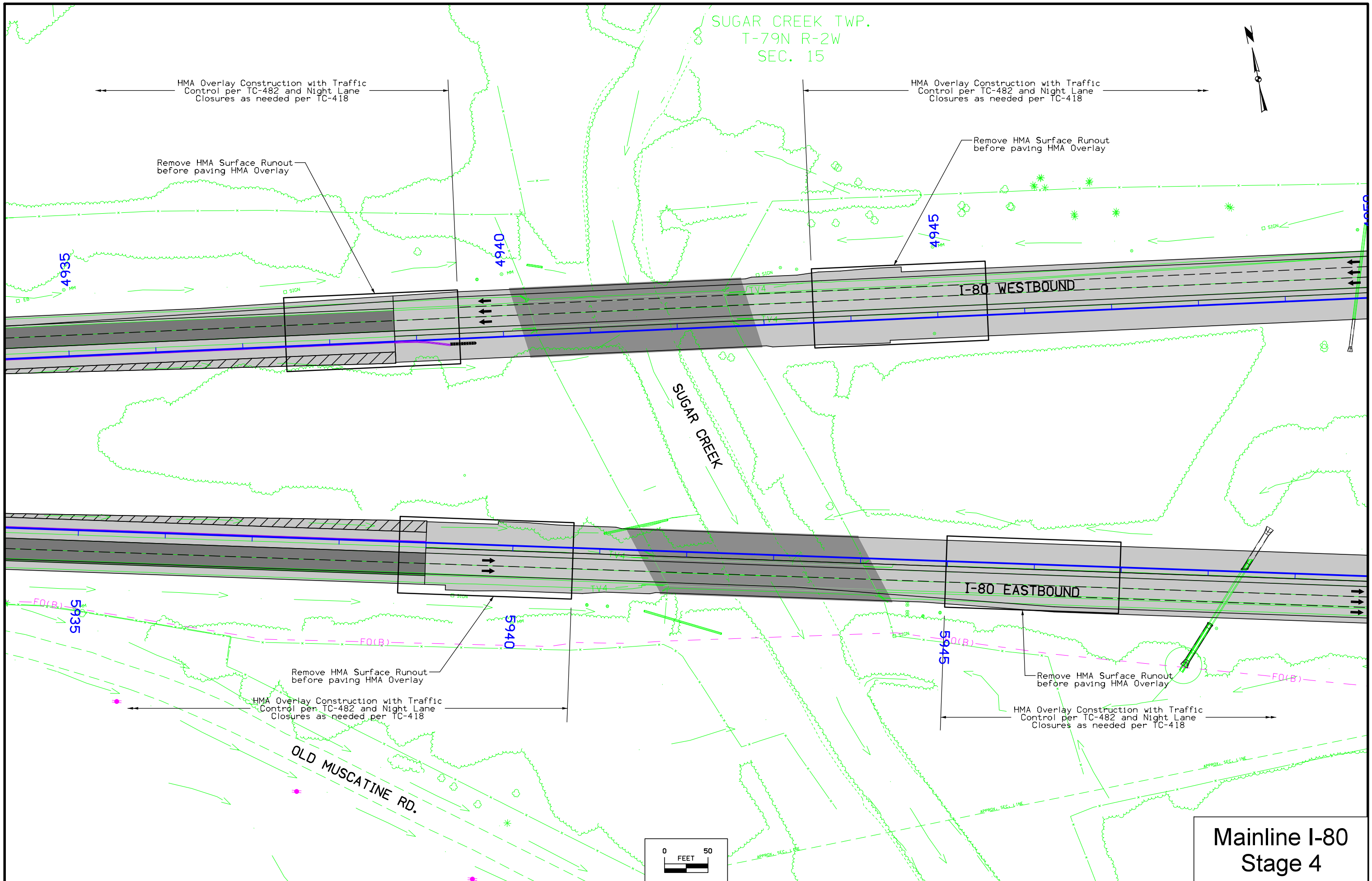

HMA Overlay Construction with Traffic Control per TC-482 and Night Lane Closures as needed per TC-418

HMA Overlay Construction with Traffic Control per TC-482 and Night Lane Closures as needed per TC-418

OLD MUSCATINE RD.

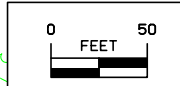

Mainline I-80  
Stage 4

SUGAR CREEK TWP.  
T-79N R-2W  
SEC. 15

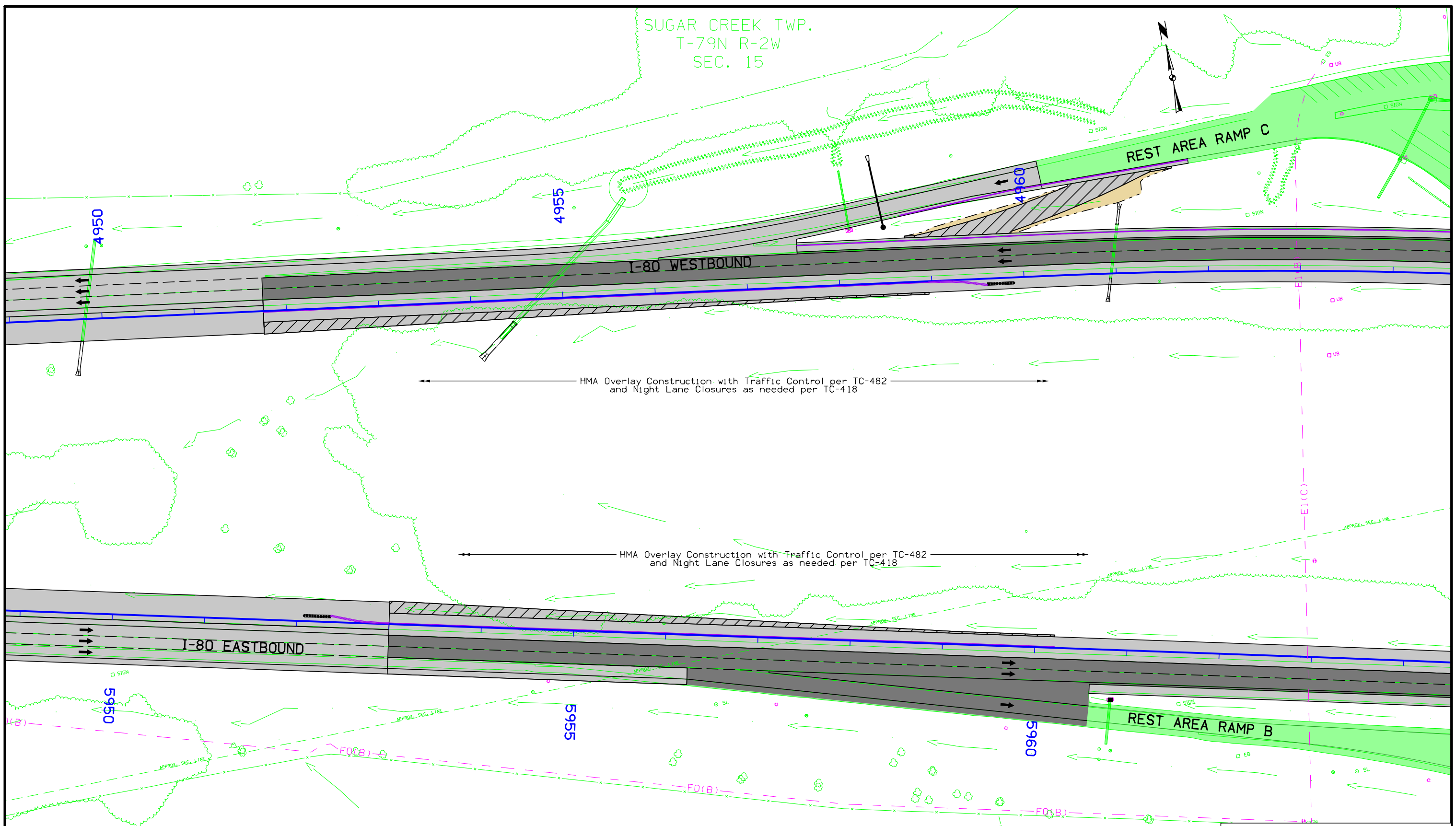

Mainline I-80  
Rest Area Ramp B  
Rest Area Ramp C  
Stage 4

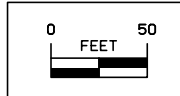

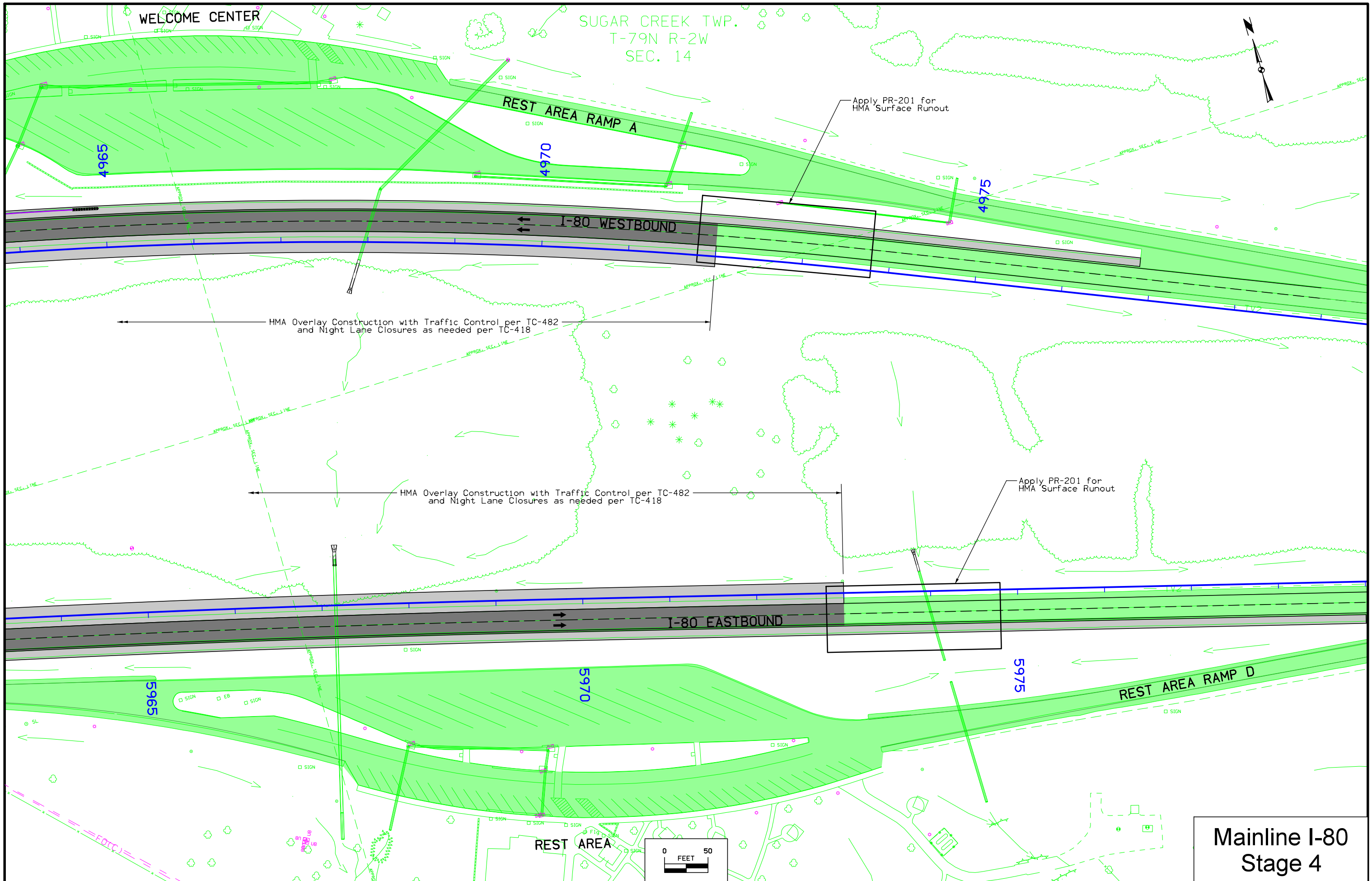

**Mainline I-80  
Stage 4**



SUGAR CREEK TWP.  
T-79N R-2W  
SEC. 23

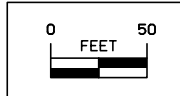
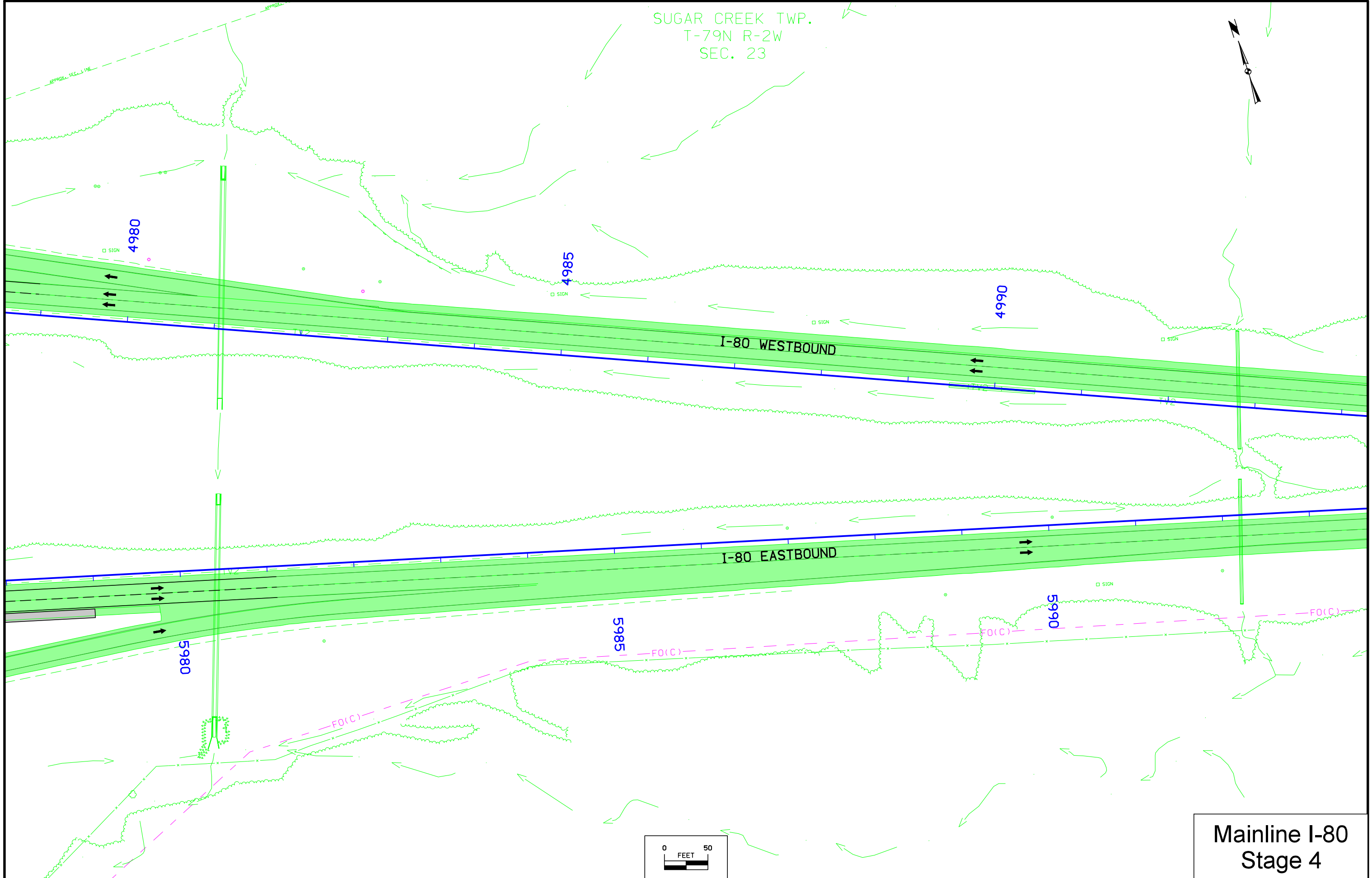

Mainline I-80  
Stage 4

SUGAR CREEK TWP.  
T-79N R-2W  
SEC. 23

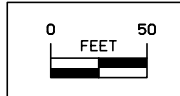
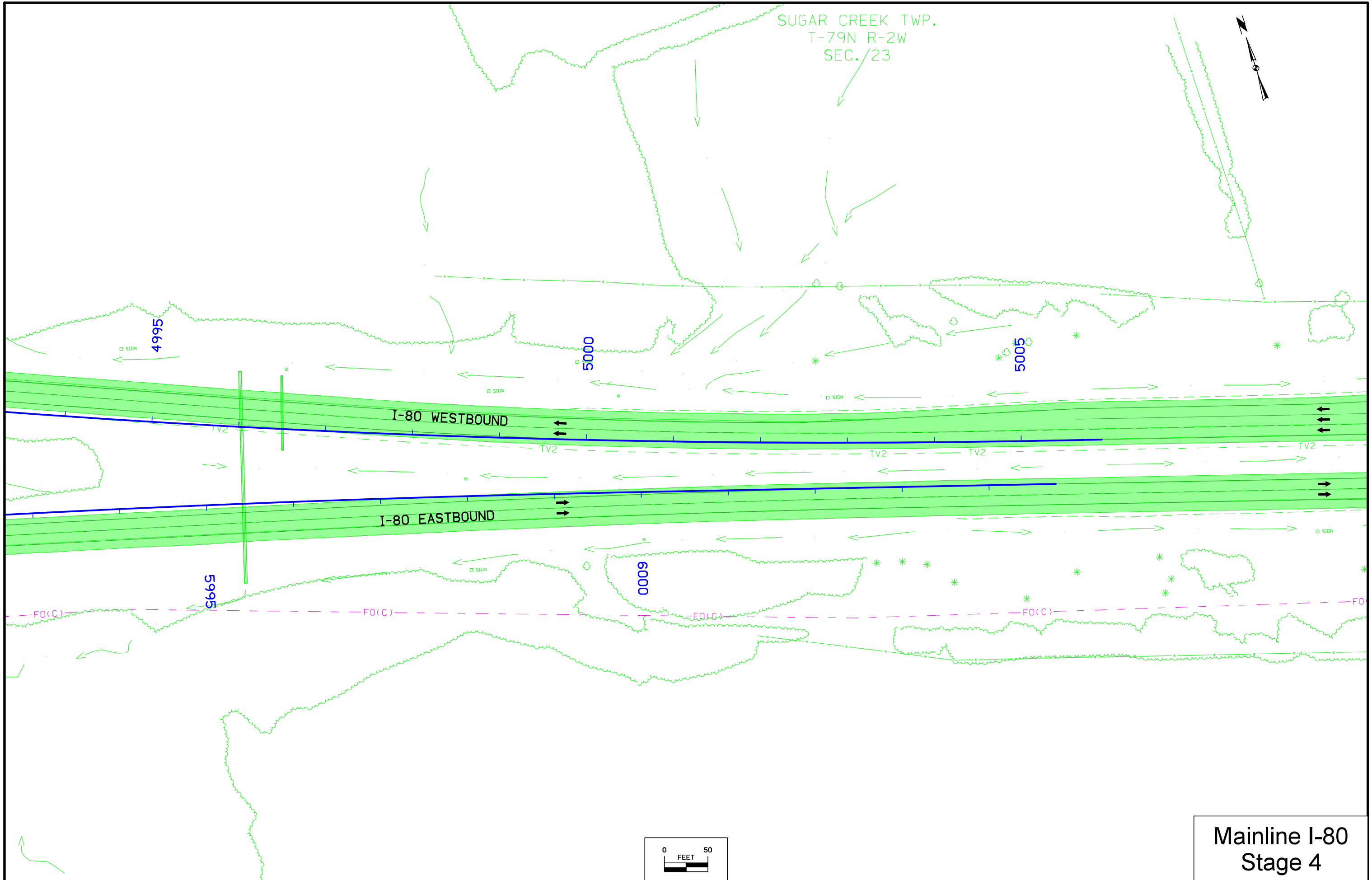

Mainline I-80  
Stage 4



SUGAR CREEK TWP.  
T-79N R-2W  
SEC. 23

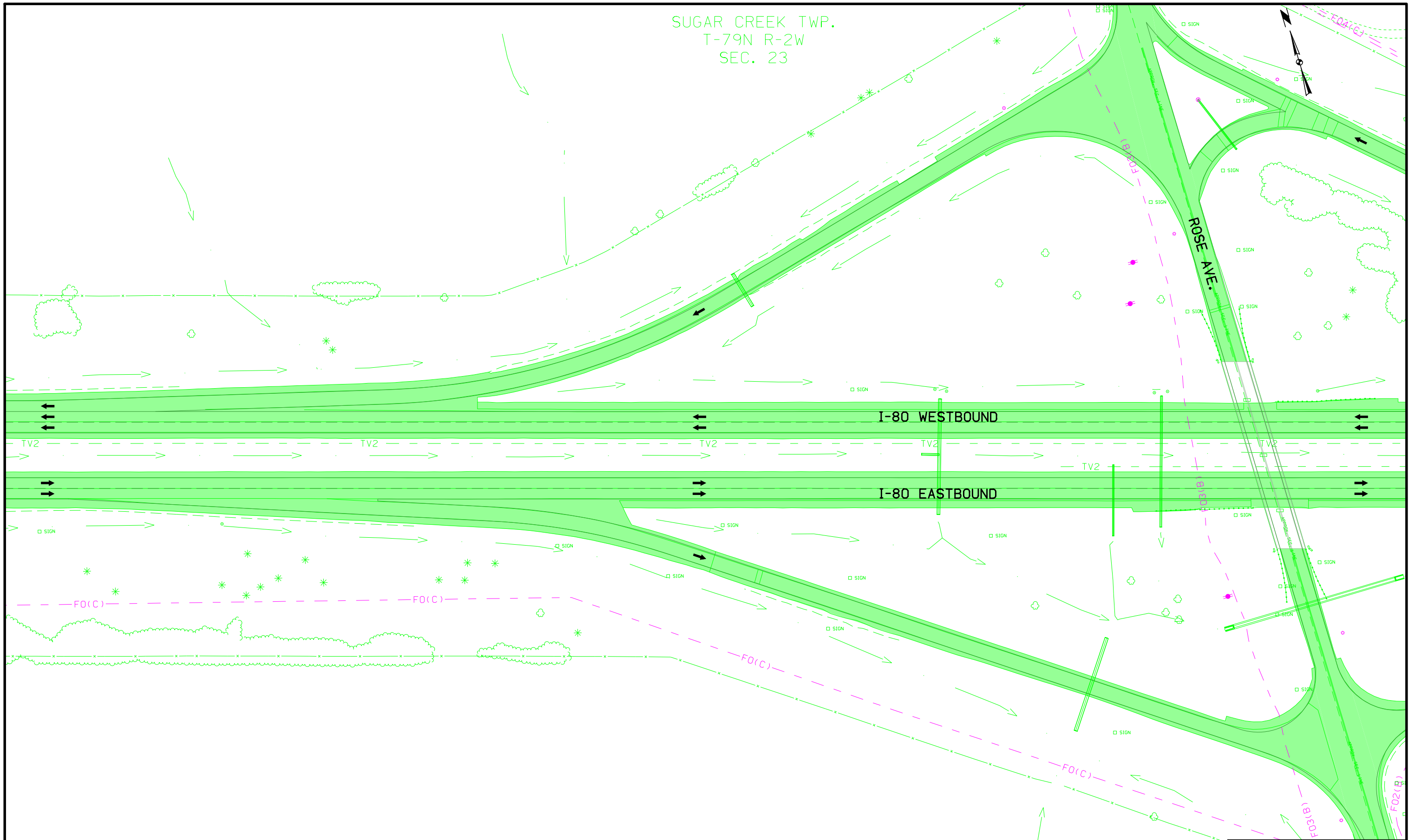

Mainline I-80  
Stage 4

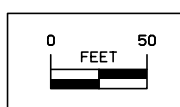

SUGAR CREEK TWP.  
T-79N R-2W  
SEC. 24

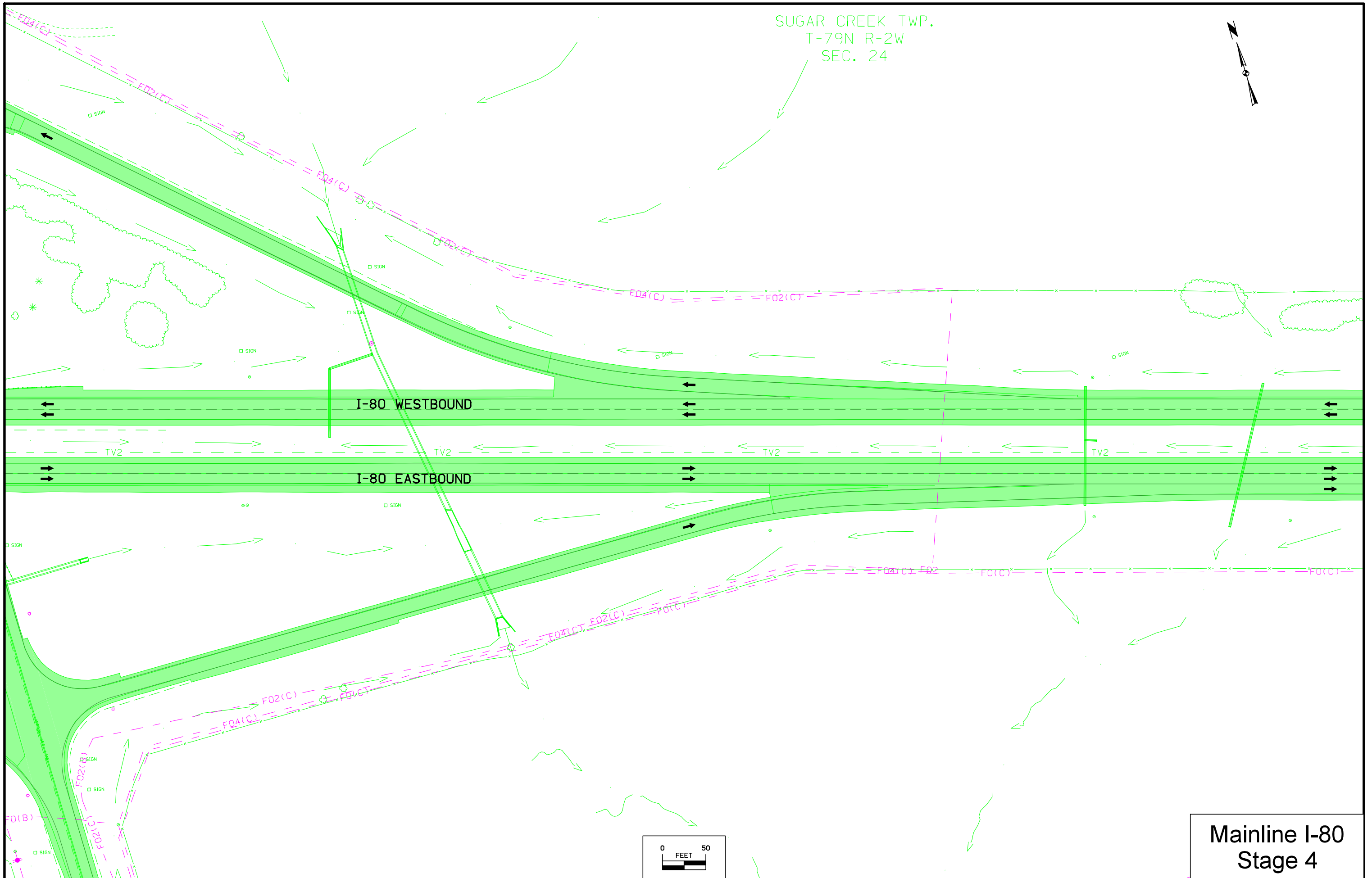

I-80 WESTBOUND

I-80 EASTBOUND

TV2

TV2

TV2

TV2

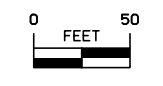

Mainline I-80  
Stage 4

SUGAR CREEK TWP.  
T-79N R-2W  
SEC. 24

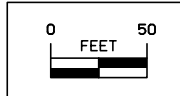
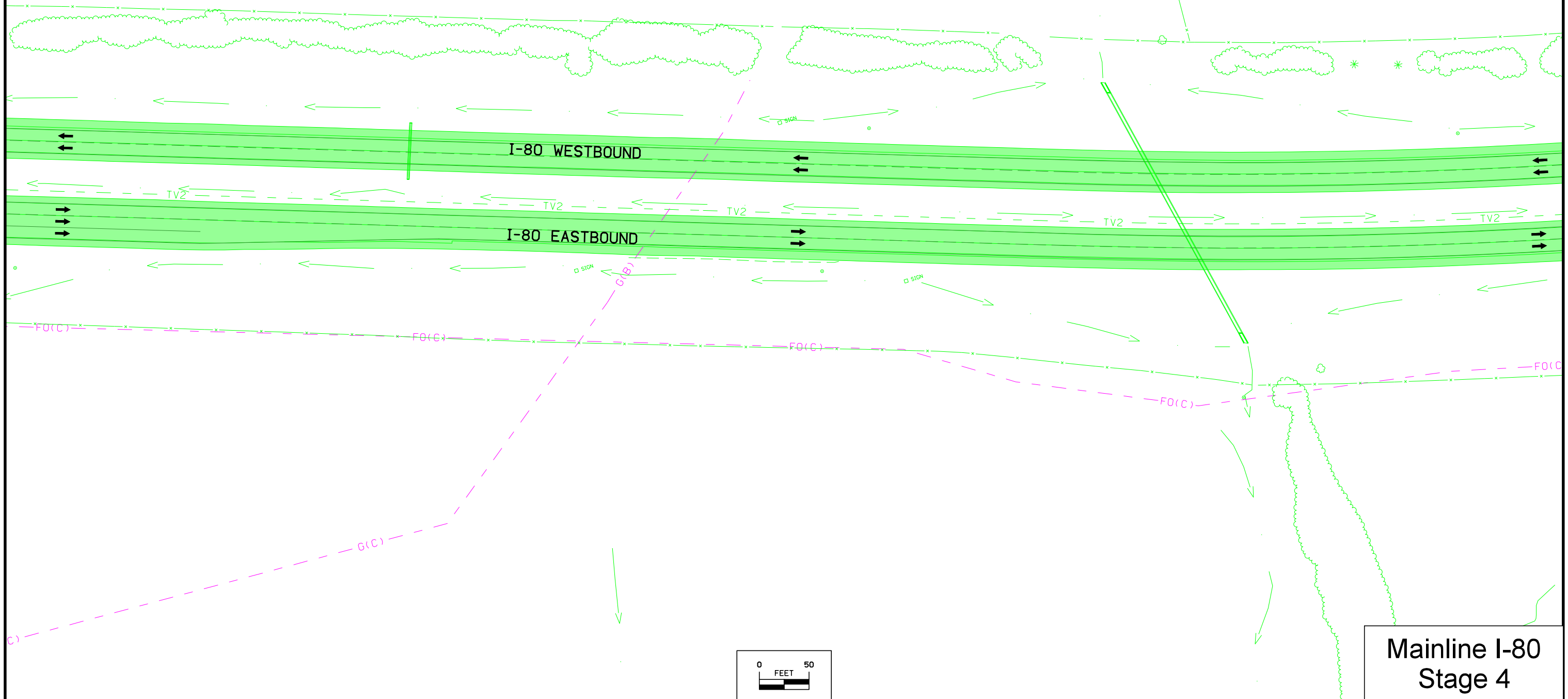

**Mainline I-80  
Stage 4**

SUGAR CREEK TWP  
T-79N R-2W  
SEC. 15

Curve Data  
 $\Delta = 10^{\circ} 09' 23.89''$  (LT)  
 T = 177.73  
 L = 354.53  
 ER = 2,000.00  
 E = 7.88  
 e = 5.40%  
 LL = 168  
 x = 62  
 DS = 60mph

Curve Data  
 $\Delta = 4^{\circ} 48' 54.08''$  (RT)  
 T = 481.82  
 L = 963.08  
 ER = 11,460.00  
 E = 10.12

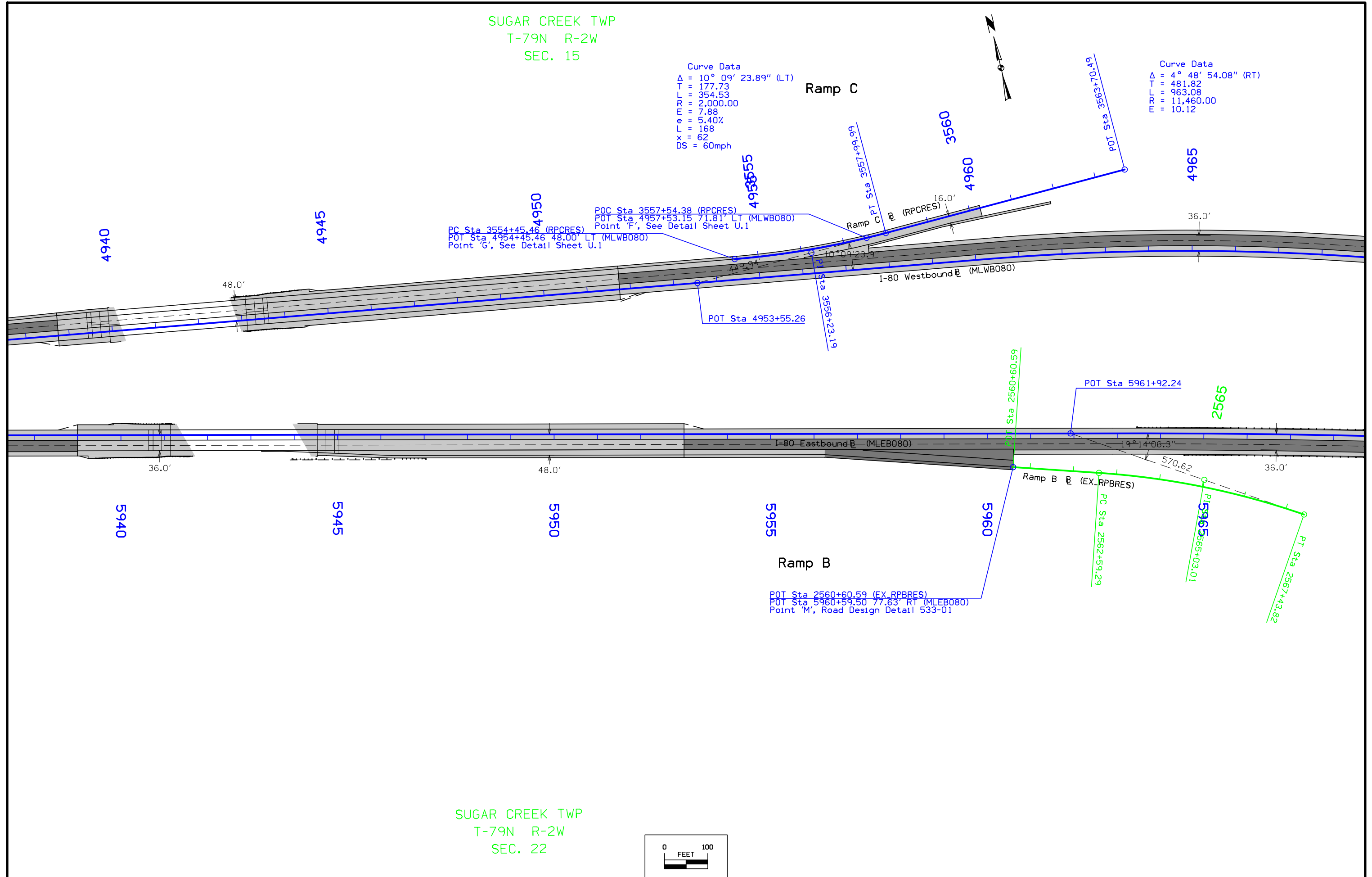

SUGAR CREEK TWP  
T-79N R-2W  
SEC. 22

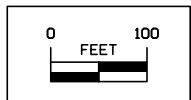

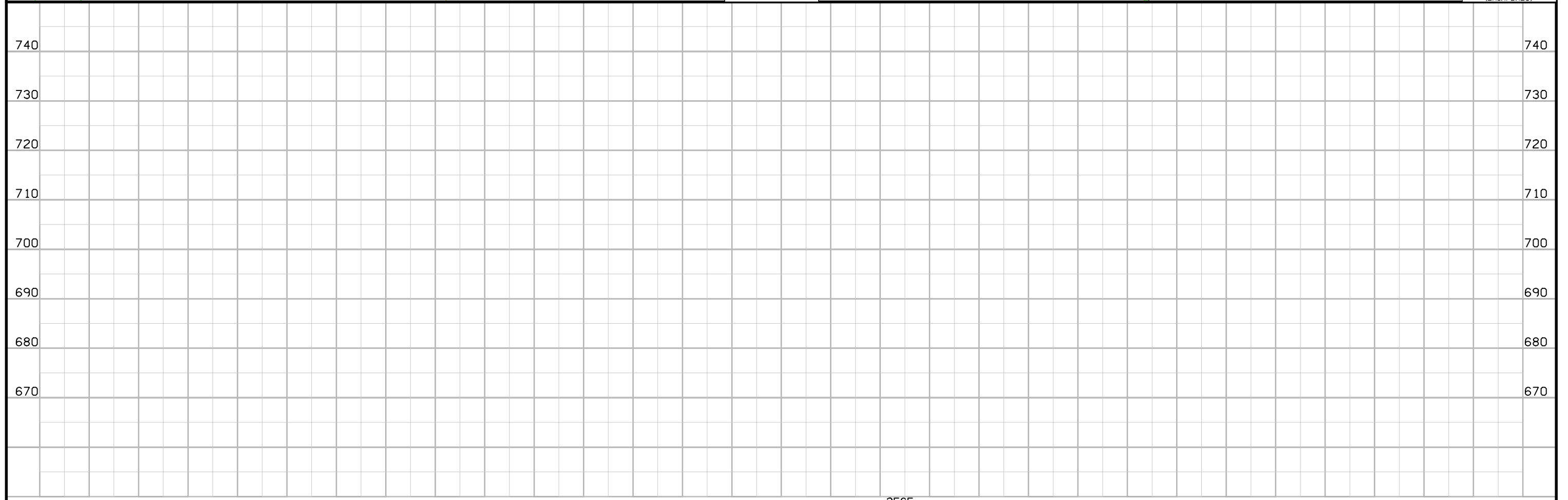
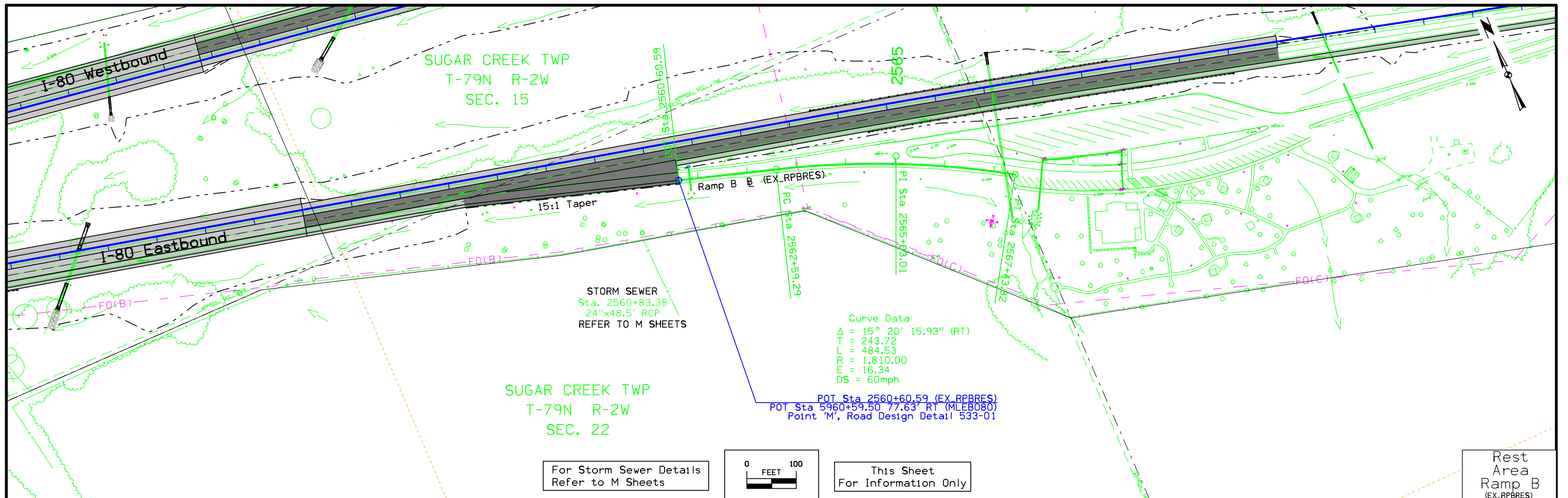

For Storm Sewer Details  
Refer to M Sheets

SUGAR CREEK TWP  
T-79N R-2W  
SEC. 15

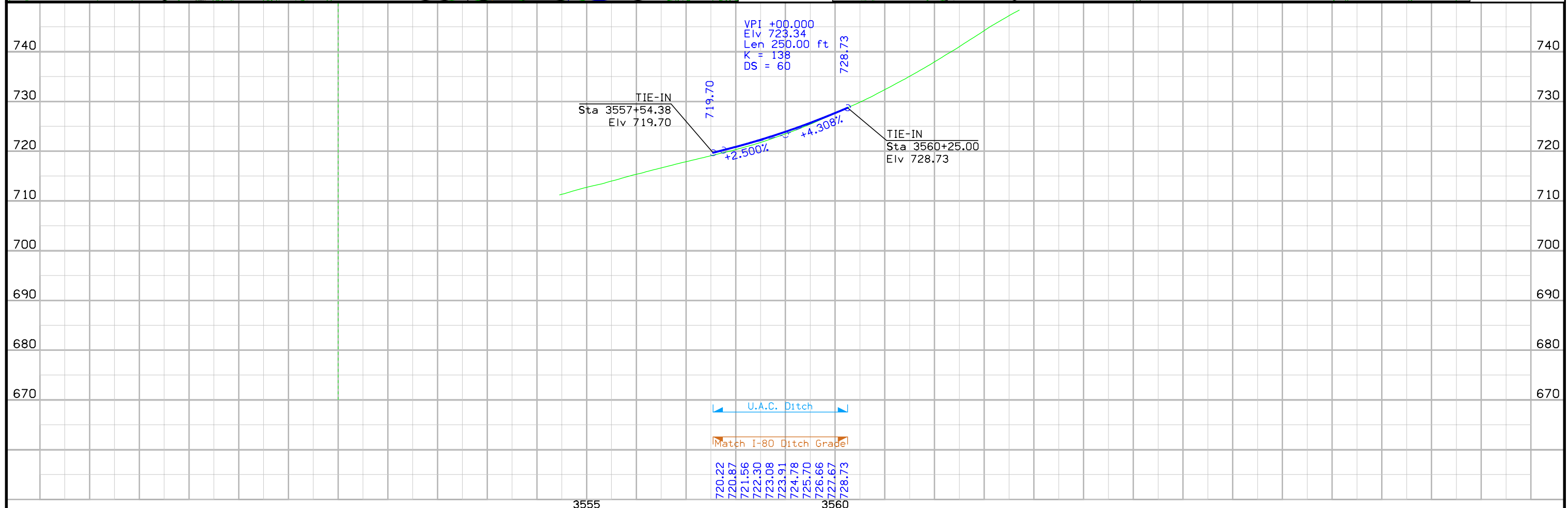
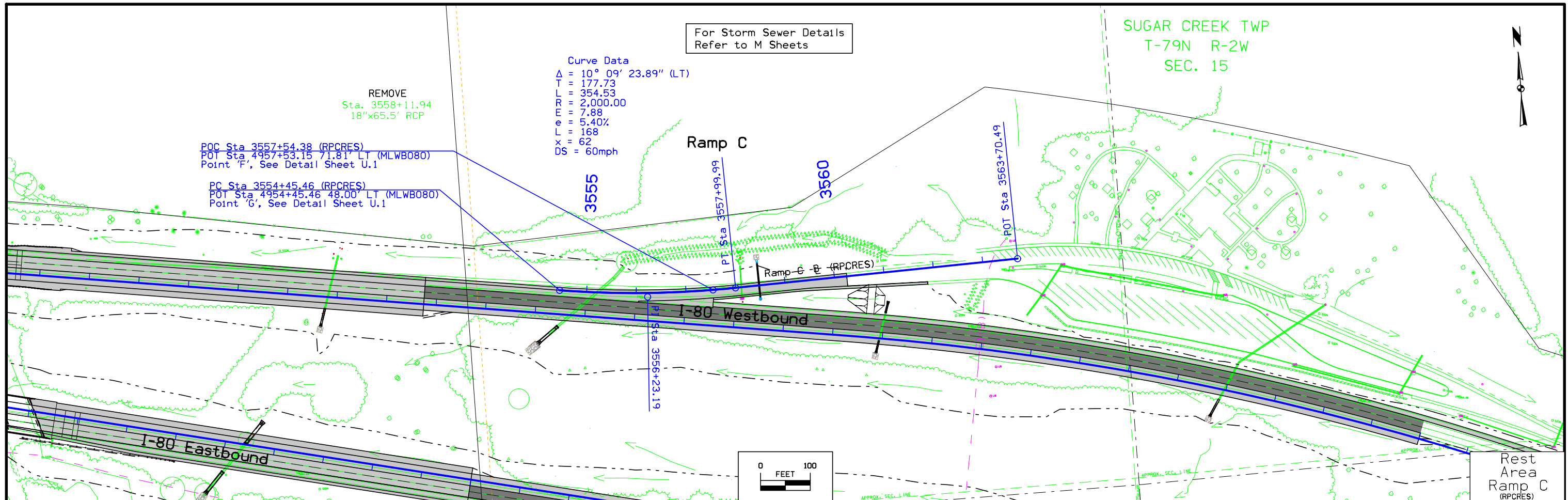

### STORM SEWER

- ① Diameter or equivalent diameter
- ② XSTS = Existing Structure    XSTP = Existing Pipe
- \* Bid Item

#### INTAKES AND UTILITY ACCESSES

#### PIPES

Design Length, Slope, and Flowlines are calculated from inside wall to inside wall along CL of pipe. An additional 2 ft length is added to each side of the Design Length to account for estimated length to center of structures.

No.	Location Station and Offset	*Type or Standard Road Plan	Form	Bottom	Other	Notes	Line Number	Intake/Utility Access No.		Class 'D'	Pipe	Bid* Length	Design Length	Slope %	Connected Pipe Joint (DR-121) Type	Flow Lines			Pipe Profile Sheet No.	Notes
			Grade	Well				From	To		Size					Inlet Elevation	Outlet Elevation	Other Elevation		
			Elev.	Elev.				FT			IN					FT	FT			
040	2560+83.50, 25.00' LT (MLEB080)	INTAKE ADJUSTMENT, MAJOR	743.05	N/A			XSTP-040	040	XSTS041	-	24	Incid'l	N/A	0.50+/-		718.42+/-	718.18+/-		M.6	
XSTS041	2560+83.36, 29.39' RT (MLEB080)	EXISTING OUTLET	FL=718.10	N/A																
030	3558+47.70, 27.60' RT (SURMLA080)	SW-401 MOD (48")	721.3	711.79			P-030	030	031	2000	24	73	70.8	2.00		712.29	711.17		M.4	
031	3558+47.70, 51.85' LT (SURMLA080)	DR-201 (24")	FL=710.78	N/A																



### SURVEY SYMBOLS

- FENO Control Monument
- TOP Top of Bridge Piers
- REF reference tie points
- SOP Size of pipe
- SBR size of bridge
- CP Control Point Generic
- UV Misc utility vault
- PIP pipes(cast iron,steel,tile,etc)
- ST stop sign
- PRO profile-r.r. rail,swk,abut
- BM bench mark
- D cl of draw or stream
- TLNR tree line right
- FW fence wire
- TDC tree deciduous
- GDL guard rails
- SI sign
- PPC power pole, Owner C
- PPB power pole, Owner B
- TEV evergreen tree
- ROW right of way rails
- PPA power pole, Owner A
- DU cl of draw upstream
- RIP rip-rap
- LUM luminaire
- GR Ground Field Survey
- BNK stream bank
- TLNL tree line left
- WC Wildcard
- TW Top of Water
- SP Stream Profile
- EG edge of gravel road
- CON concrete or a/c slab
- BD Bridge Deck
- BLS Bridge Low Steel
- BCL bridge centerline
- BRG bridge
- C center of roadway
- EB electrical box
- PL Photo Location
- CUL culvert
- INB intake-beehive
- OUT tile outlet
- STP stump
- GDC Cable Guardrail
- BB billboard or sign
- SL speed limit sign
- MM mile marker post
- TPD telephone pedestal
- LC lot corner
- MH Misc manhole
- UE utility elevation
- IN intake-grate,curb,umbrella
- LIN miscellaneous line
- CMP corrugated metal pipes
- WHD water hydrant
- BLD foundation or building
- SEP septic tank
- SHR shrub
- MIS miscellaneous
- LP L.P. tank
- TR Telephone Riser Pole
- ENU edge of unpaved entrance&parking
- CU curb or center island
- GU gutter
- UB Misc utility box
- CS concrete slab
- RET retaining walls
- FWD wood fence
- ROC rock outcropping
- TV tv dish
- WV water valve
- EW edge of water
- FCL security & chain link
- GP guard post / Bollard
- S Soil sampling site

- PPA power pole, Owner A
- EL1(B) EL1B UG electric, Eastern Iowa Light & Power - Quality B
- EL1(C) EL1C UG electric, Eastern Iowa Light & Power - Quality C
- FO1(B) FO1B fiber optics, Iowa Communications Network - Quality B
- FO1(C) FO1C fiber optics, Iowa Communications Network - Quality C

### UTILITY LEGEND

- Eastern Iowa Light and Power Cooperative  
600 East 5th Street  
Wilton, IA 52778  
563-732-2211: Ext 7330  
dennis.hill@easterniowa.com
- ICN (Iowa Communications Network)  
Mike Broderick  
400 East 1st Street / Grimes Office Building  
Des Moines, IA 50319  
515-725-4741  
mike.broderick@iowa.gov

### PLAN VIEW COLOR LEGEND OF STORM SEWER SHEETS

LINEWORK	Design	Color No.	
Black	(17)		Proposed Storm Sewer Details
Blue	(1)		Alignment, Stationing, Tic Marks, and Alignment Annotation
SHADING		Design	Color No.
Gray, Light	(48)		Proposed PCC Pavement with HMA Surfacing Shading
Gray, Med	(80)		Proposed Granular Shading
Gray, Dark	(112)		Proposed HMA Resurfacing Shading

### PROFILE VIEW COLOR LEGEND OF STORM SEWER SHEETS

LINEWORK	Design	Color No.	
Green	(18)		Existing Ground Line Profile
Black	(17)		Proposed Ground Line Profile
Gray, Dark	(112)		Existing Storm Sewer Pipe
Blue	(1)		Proposed Storm Sewer Pipe
Blue, Light	(230)		Proposed Storm Sewer Structure

### PLAN VIEW LINE STYLE LEGEND OF STORM SEWER SHEETS

- Proposed Storm Sewer Pipe
- Proposed Storm Sewer Structure
- Existing Culvert
- Proposed Culvert

### PROFILE VIEW LINE STYLE LEGEND OF STORM SEWER SHEETS

- Existing Ground
- Proposed Ground
- Existing Storm Sewer Pipe or Structure
- Proposed Storm Sewer Pipe
- Proposed Storm Sewer Structure

- Reference Point
- Station
- Survey Line
- Section Corner
- Need Line
- Saw Cut
- Guardrail

### RIGHT-OF-WAY LEGEND

- Proposed Right-of-Way
- Existing and Proposed Right-of-Way
- Easement and Existing Right-of-Way
- Borrow
- Easement (Temporary)
- Easement
- Excess
- Access Control

# STORM SEWER LEGEND AND SYMBOL INFORMATION SHEET

(COVERS SHEET SERIES M)

SUGAR CREEK TWP.  
T-79N R-2W  
SEC. 15



I-80 Westbound



3557

3558

3559

3560

030

031

P-030

Ramp C (RPCRES)

TILE

726

726

724

724

722

722

720

720

718

718

716

716

714

714

712

712

710

710

708

708

706

706

030  
 SW-401 MOD (48")  
 3558+47.70, 27.60'  
 FG 721.30  
 BW 711.79

031  
 DR-201 (24")  
 3558+47.70, -51.85'  
 FG 710.78

P-030  
 70.8 LF  
 24' 20000  
 2.00%

FL 712.29

FL 710.88

SUGAR CREEK TWP.  
T-79N R-2W  
SEC. 15

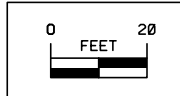
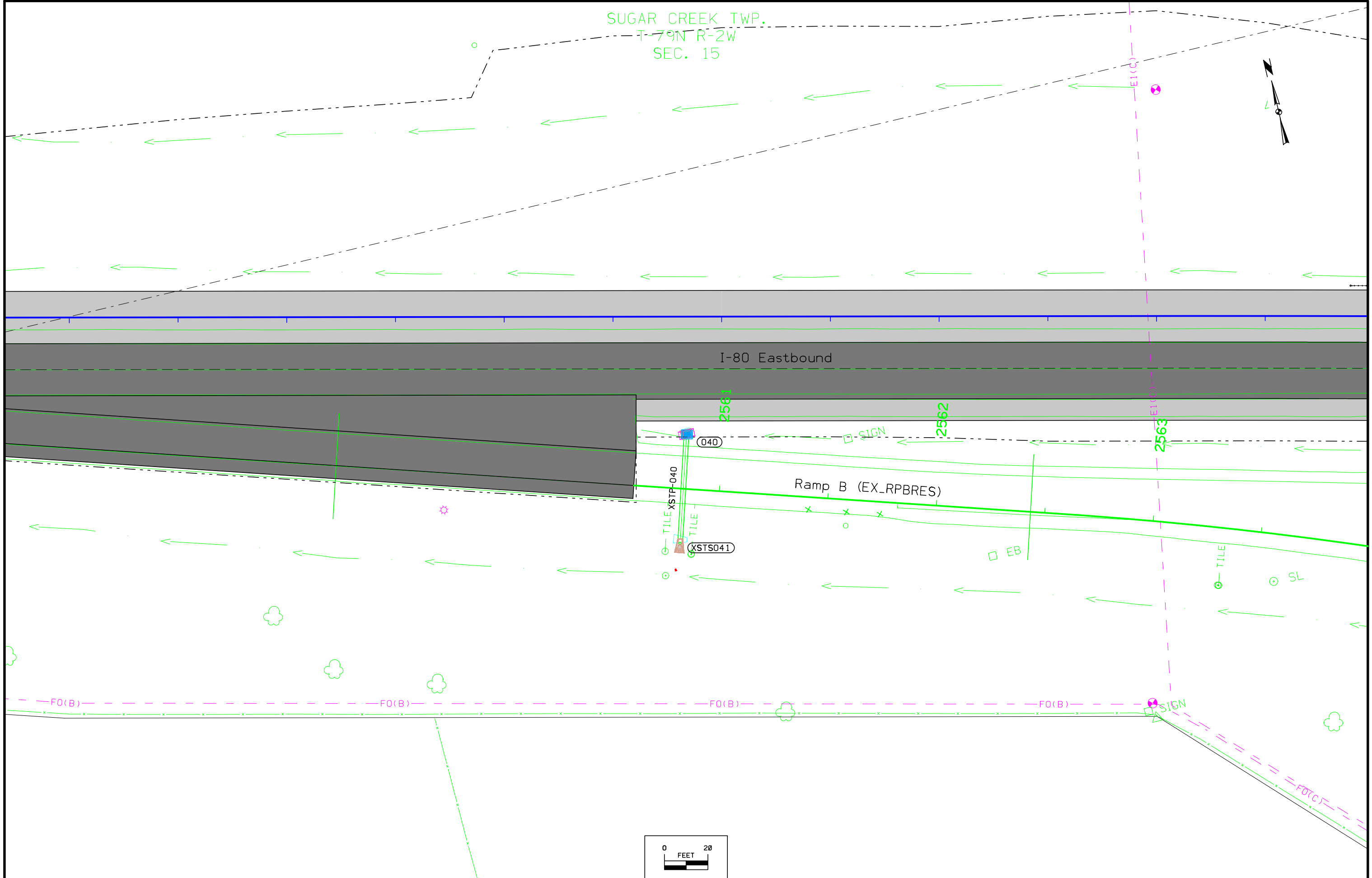
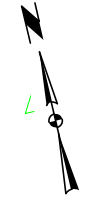

728

728

726

726

724

724

722

722

720

720

718

718

716

716

714

714

XSTS041  
 EXISTING OUTLET  
 2560+83.36, 29.39'  
 FL 718.10+/-

040  
 INTAKE ADJUSTMENT, MAJOR  
 2560+83.50, -25.00'  
 FG 723.05  
 BW N/A

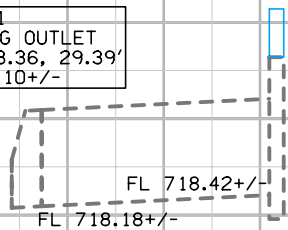

XSTS-040

**LINE STYLE LEGEND OF CROSS SECTION SHEETS (ROAD)**

- Existing Ground Line
- Proposed Template
- Proposed Topsoil Placement
- - - - - Additional Topsoil Removal
- Subgrade Treatment
- - - - - Granular Shoulder
- Pavement
- - - - - Existing Pipe\RCB
- Proposed Pipe\RCB
- Proposed Dike
- All Elements Associated with Proposed Entrances

**LINE STYLE LEGEND OF CROSS SECTION SHEETS (SOILS)**

- TOPSOIL — Topsoil (Class 10)
- Slope Dressing Only
- CL 10 — Class 10 Materials
- SEL LO — Select Loams And Clay-Loams
- SEL SA — Select Sand
- UNS A — Unsuitable Type A Disposal
- UNS B — Unsuitable Type B Disposal
- UNS C — Unsuitable Type C Disposal
- SHALE — Shale
- WASTE — Waste
- B&W LS — Broken and Weathered Rock
- ROCK — Solid Rock
- BLDRS — Boulders

Note: All layer lines and descriptions identify layers above the line.

Note: Vertical or near vertical lines connecting soil layers at edges of cross sections are only for the purpose of calculating template quantities and do not depict soil stratification.

**SYMBOL LEGEND OF CROSS SECTION SHEETS**

- Existing ROW  
| Existing Right-of-Way Limit
- Proposed ROW  
| Proposed Right-of-Way Limit
- Temporary ROW  
| Temporary Right-of-Way Limit

**CROSS SECTION  
LEGEND AND SYMBOL  
INFORMATION SHEET**

(COVERS SHEET SERIES W, X, Y, & Z)

# I-80 WB (MLWB080) Preliminary

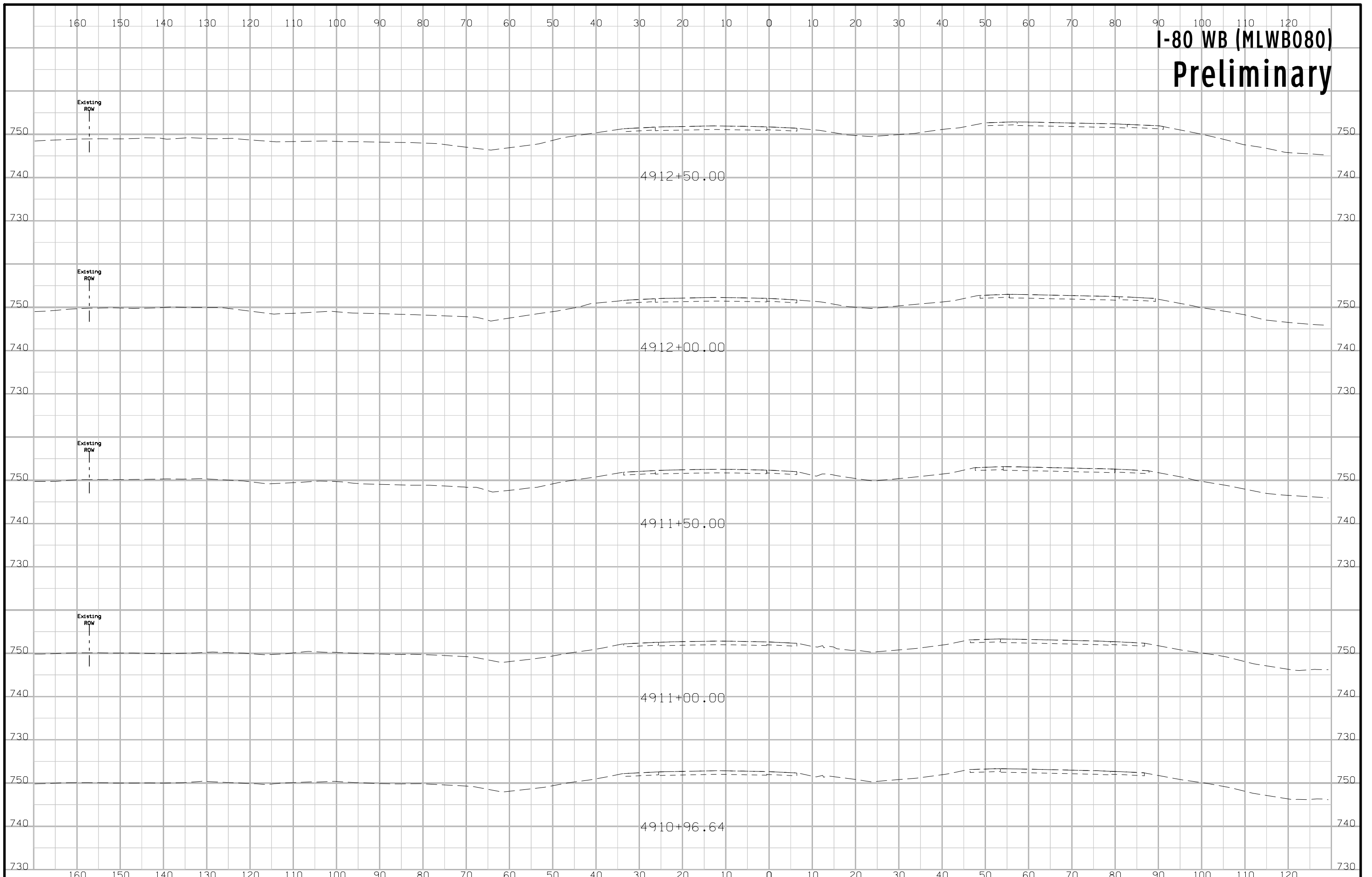



# I-80 WB (MLWB080) Preliminary

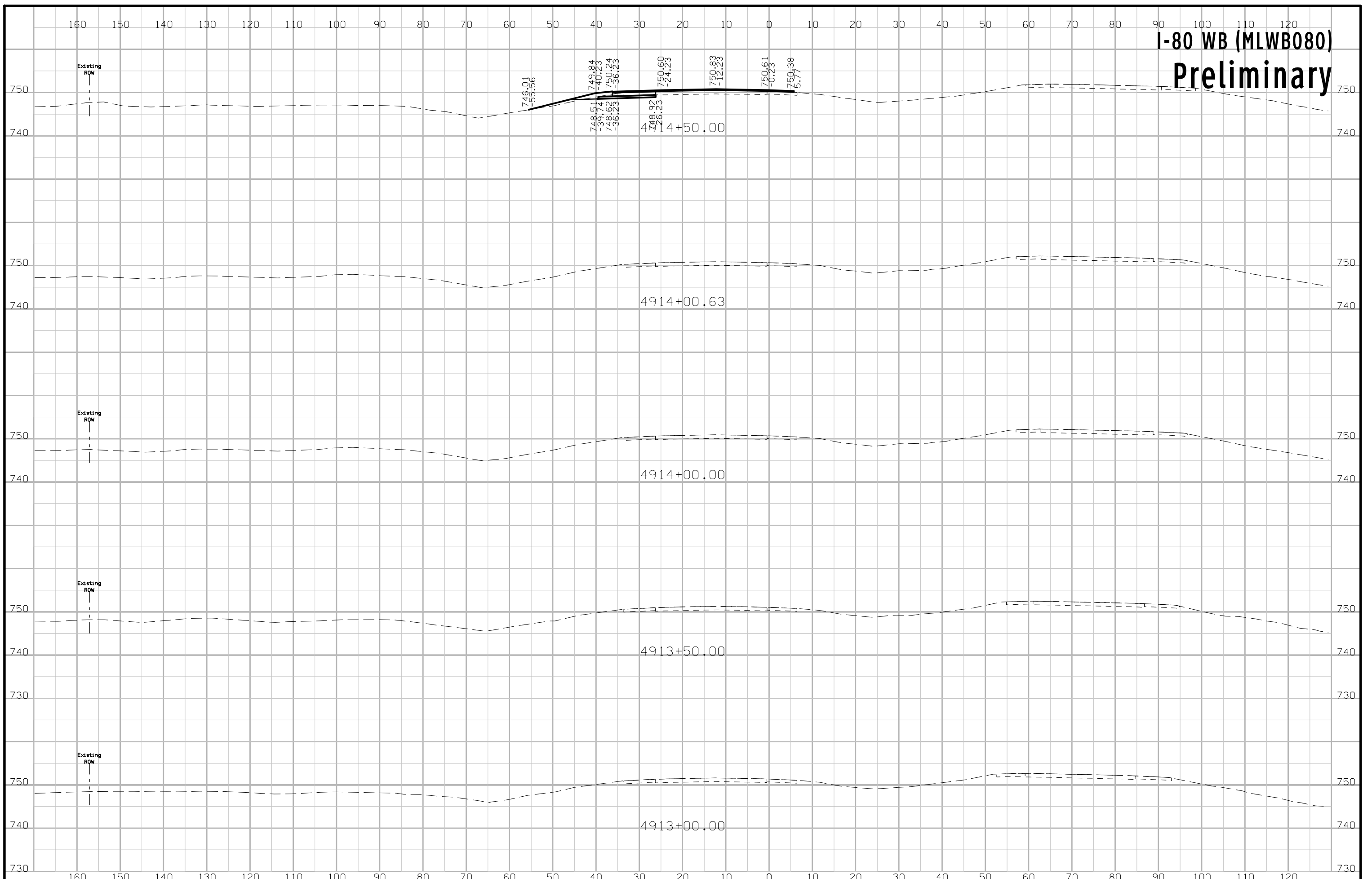

# I-80 WB (MLWB080) Preliminary

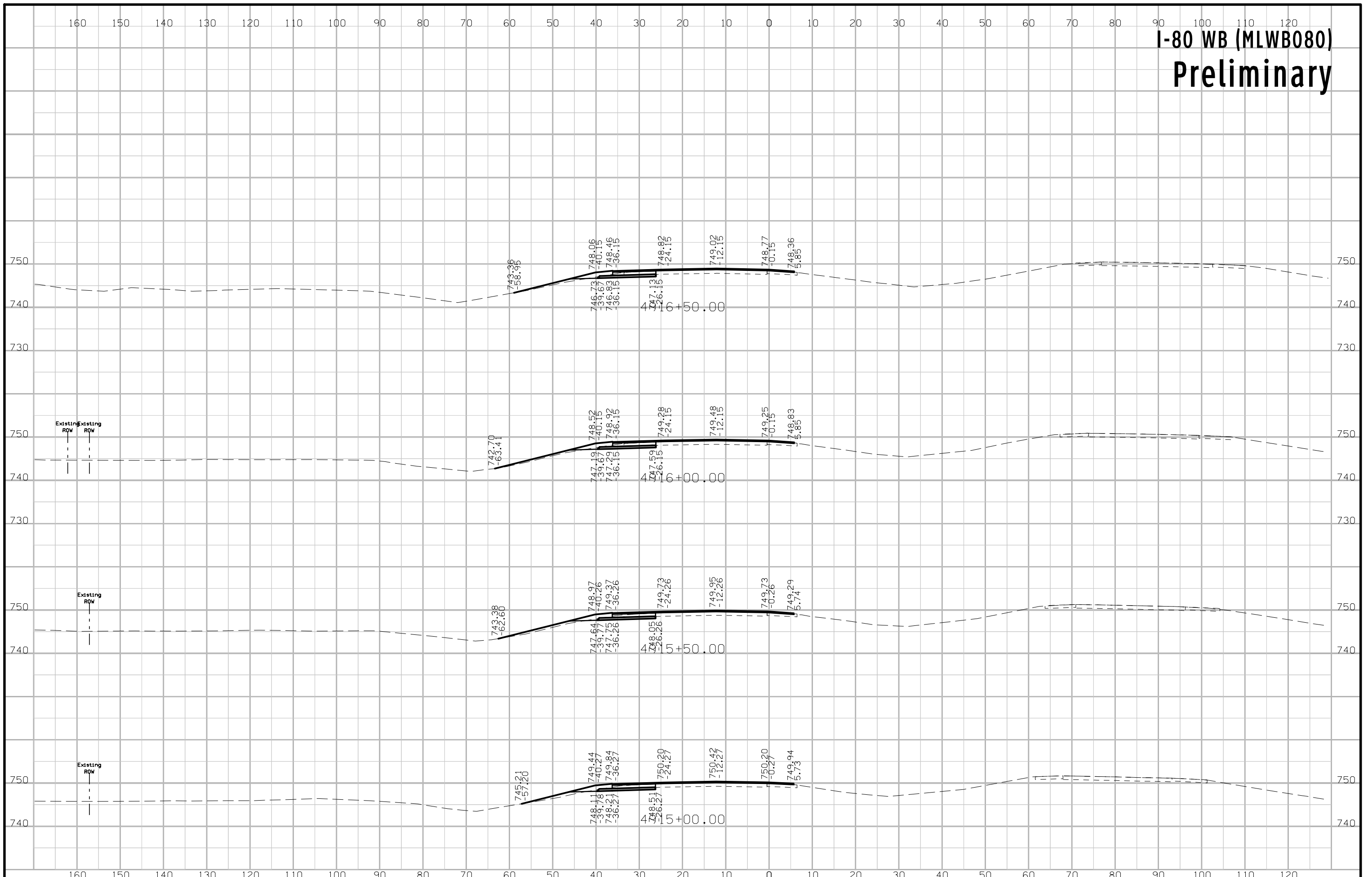

# I-80 WB (MLWB080) Preliminary

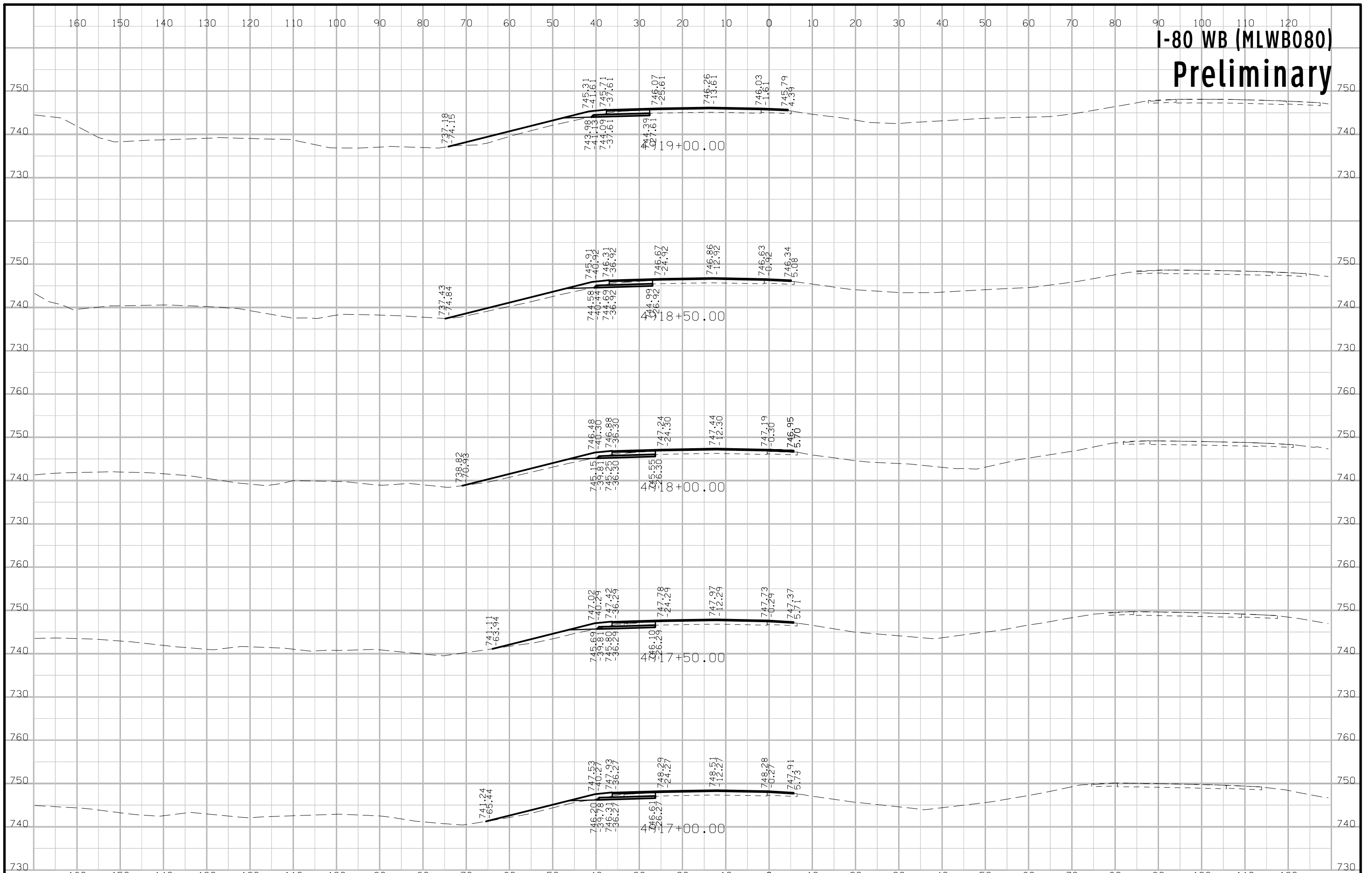

# I-80 WB (MLWB080) Preliminary

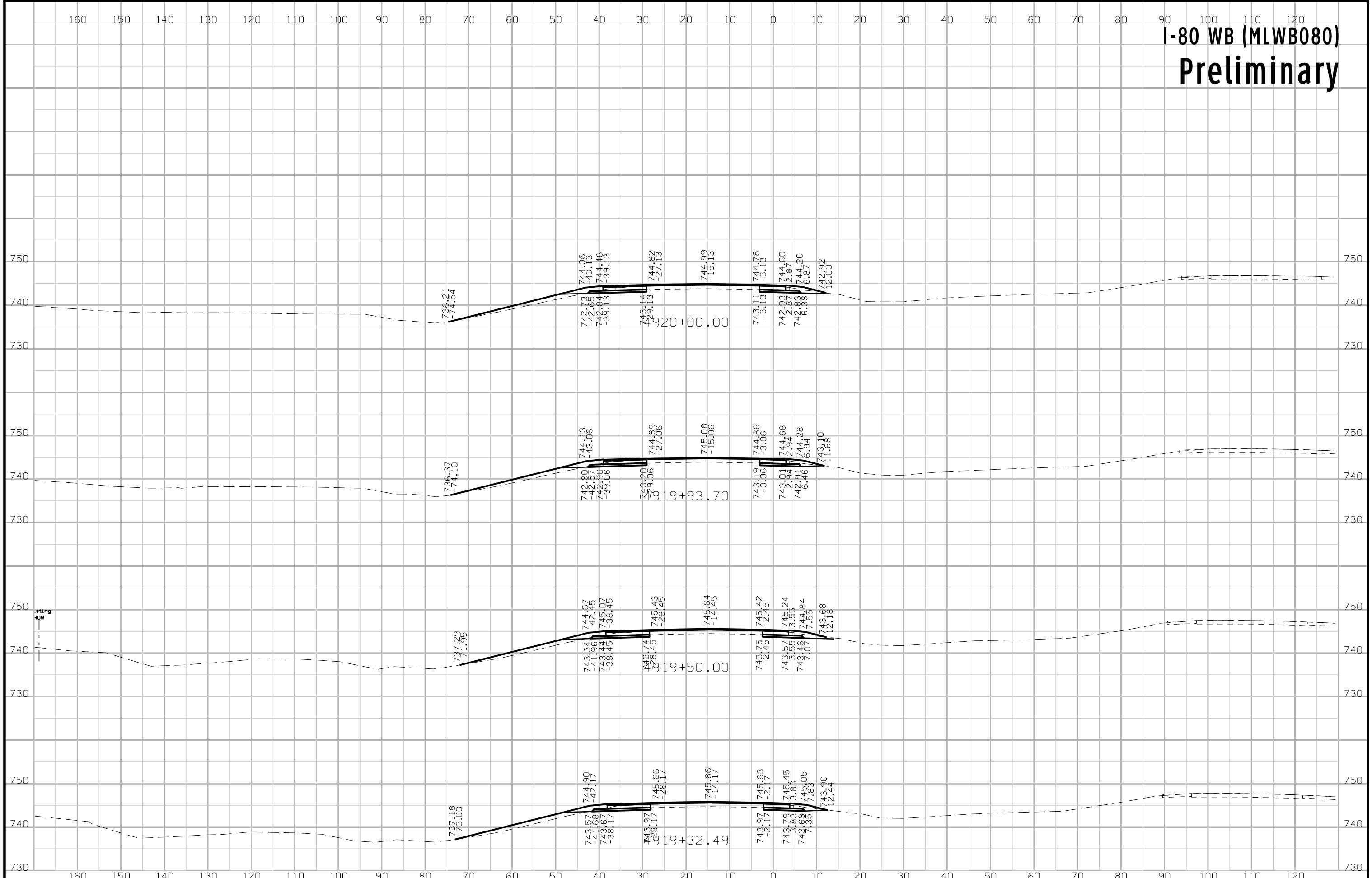

# I-80 WB (MLWB080) Preliminary

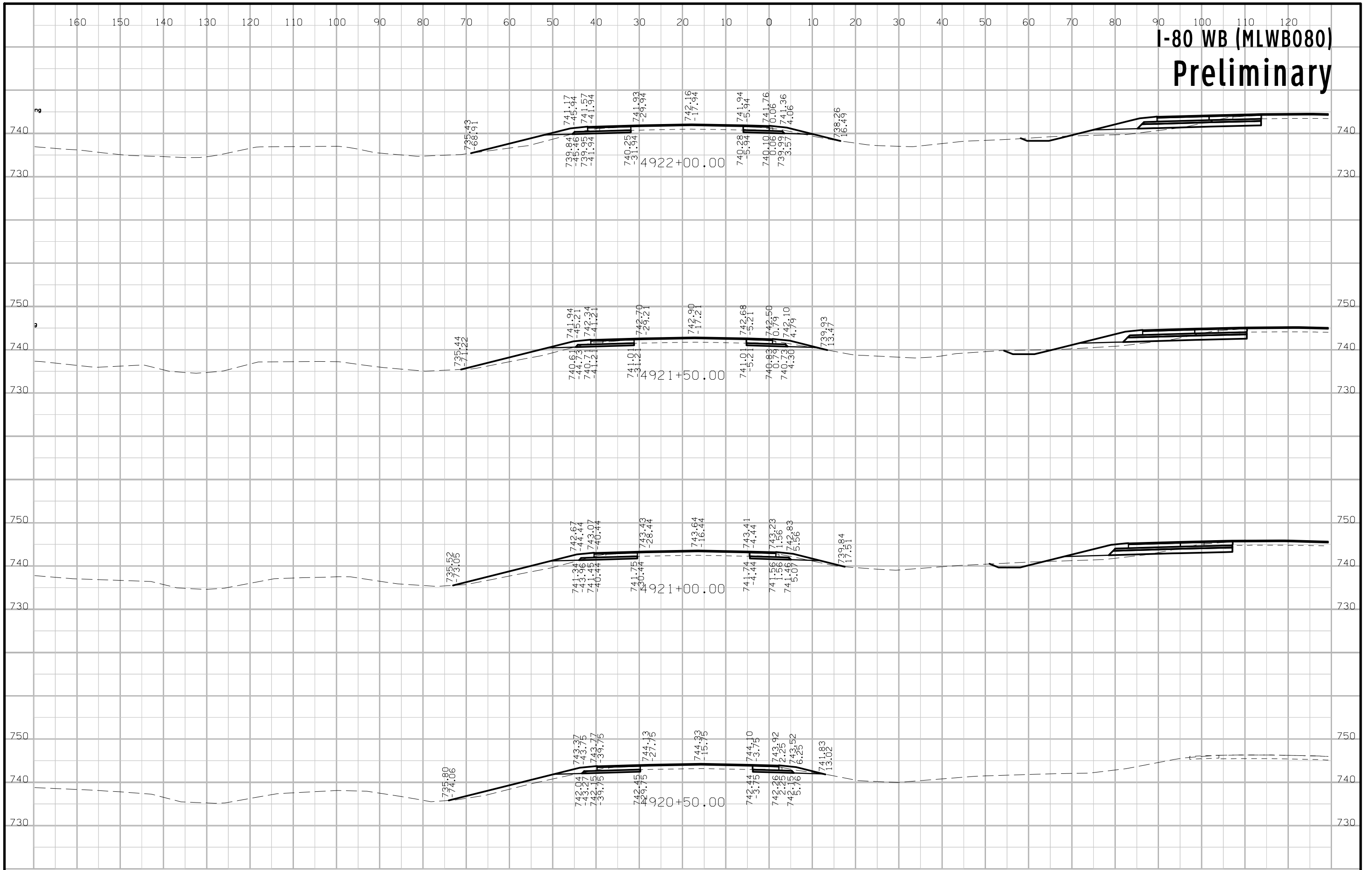

# I-80 WB (MLWB080) Preliminary

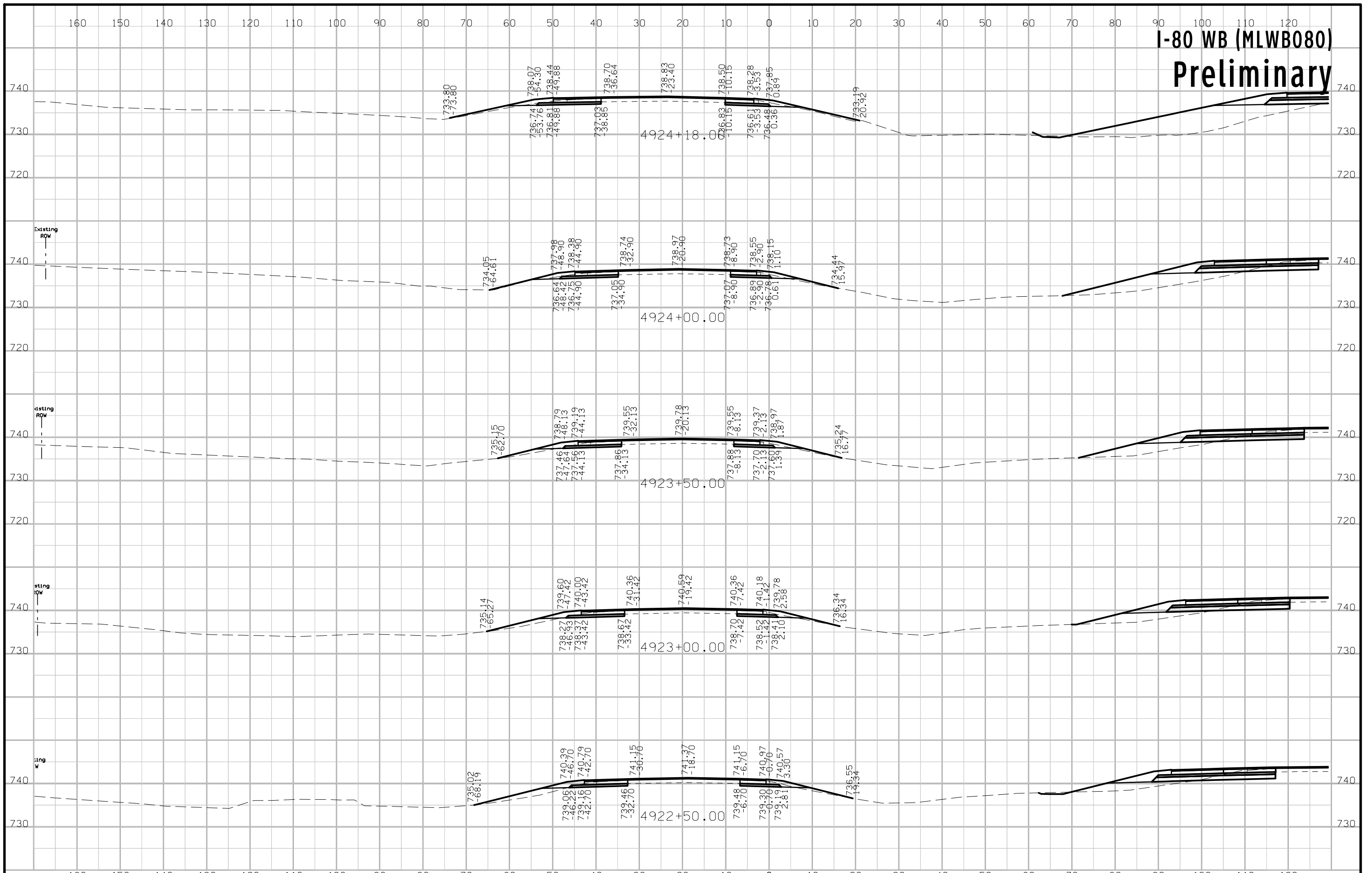

# I-80 WB (MLWB080) Preliminary

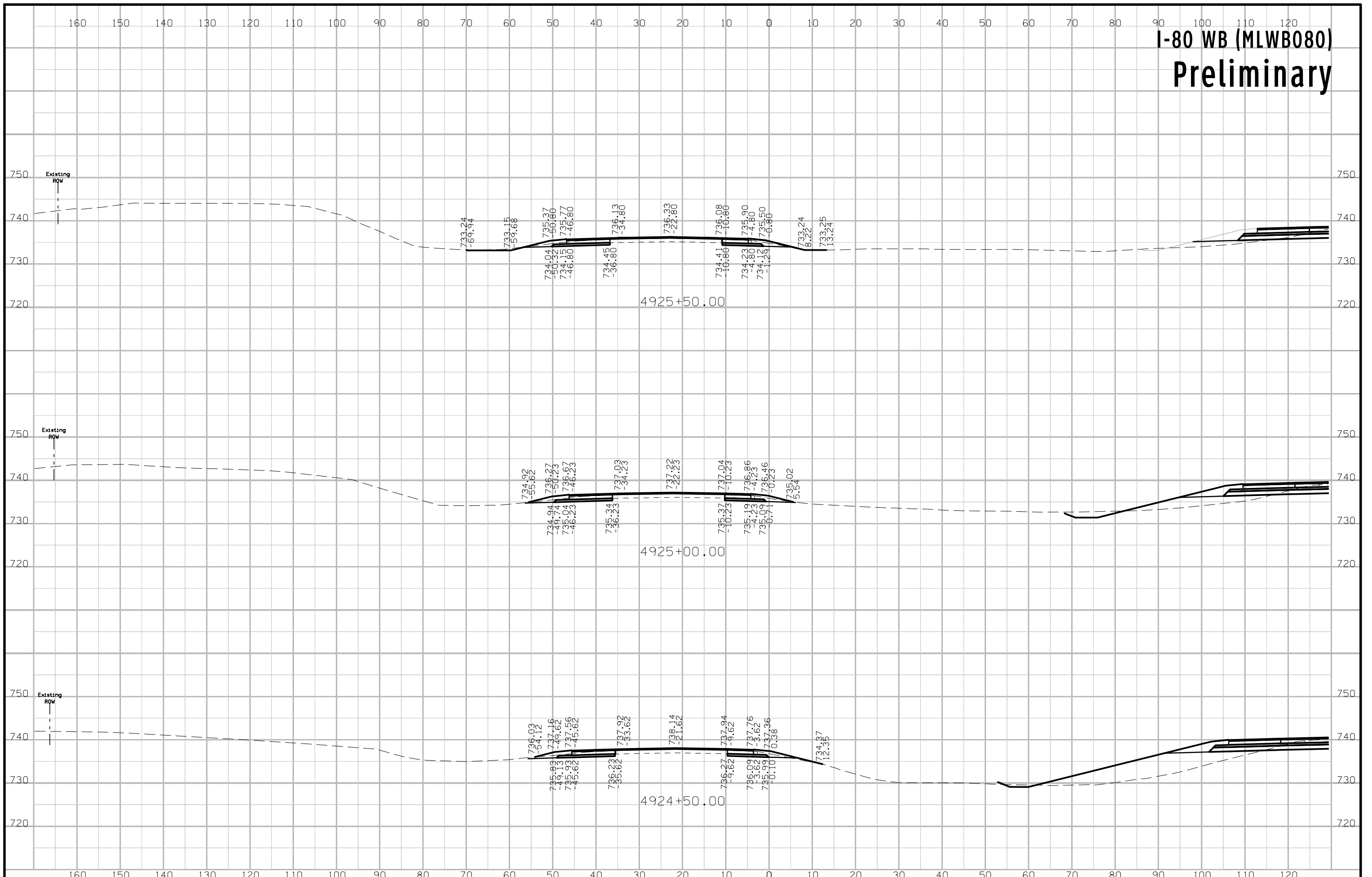



# I-80 WB (MLWB080) Preliminary

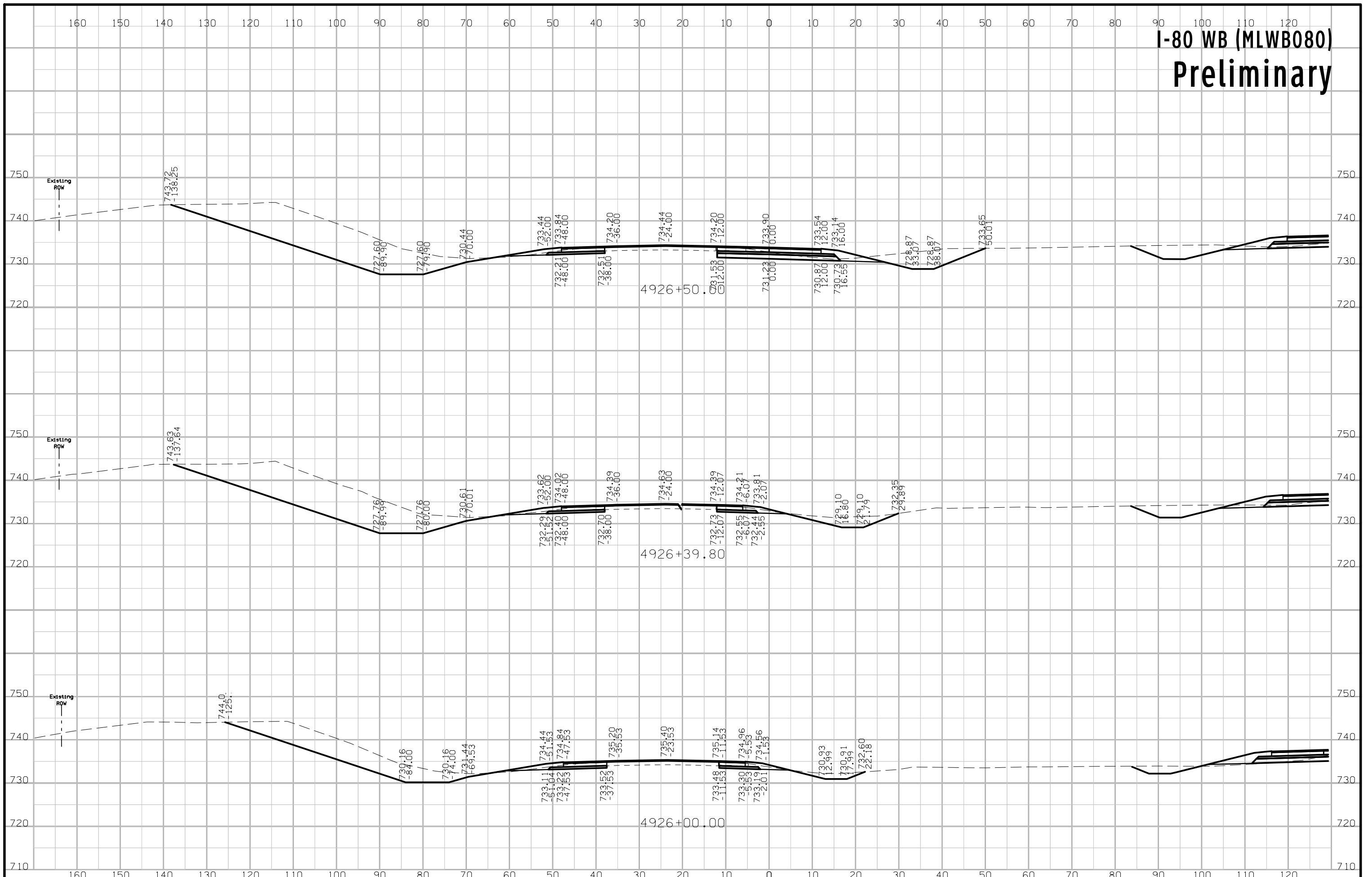

# I-80 WB (MLWB080) Preliminary

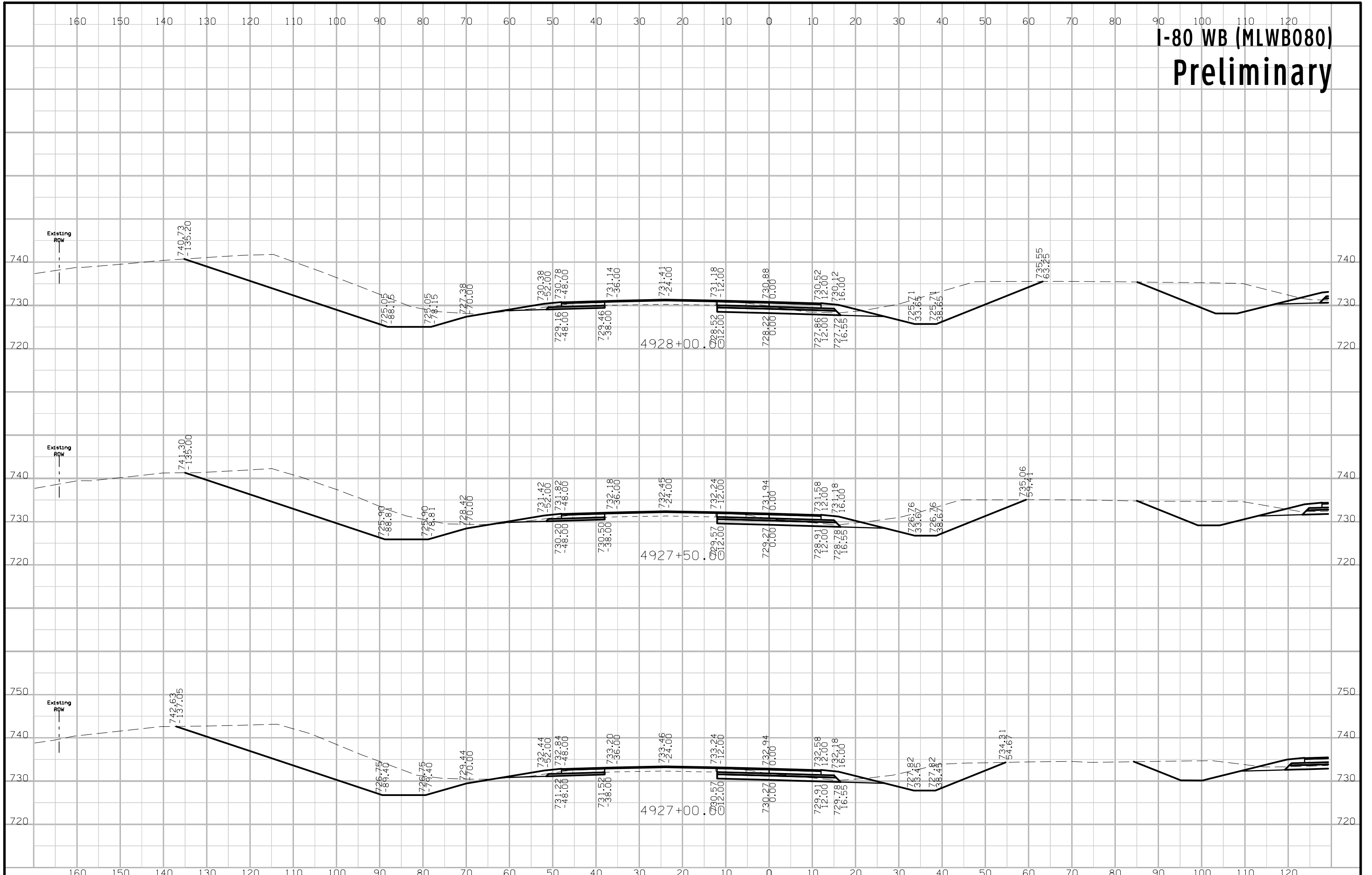

# I-80 WB (MLWB080) Preliminary

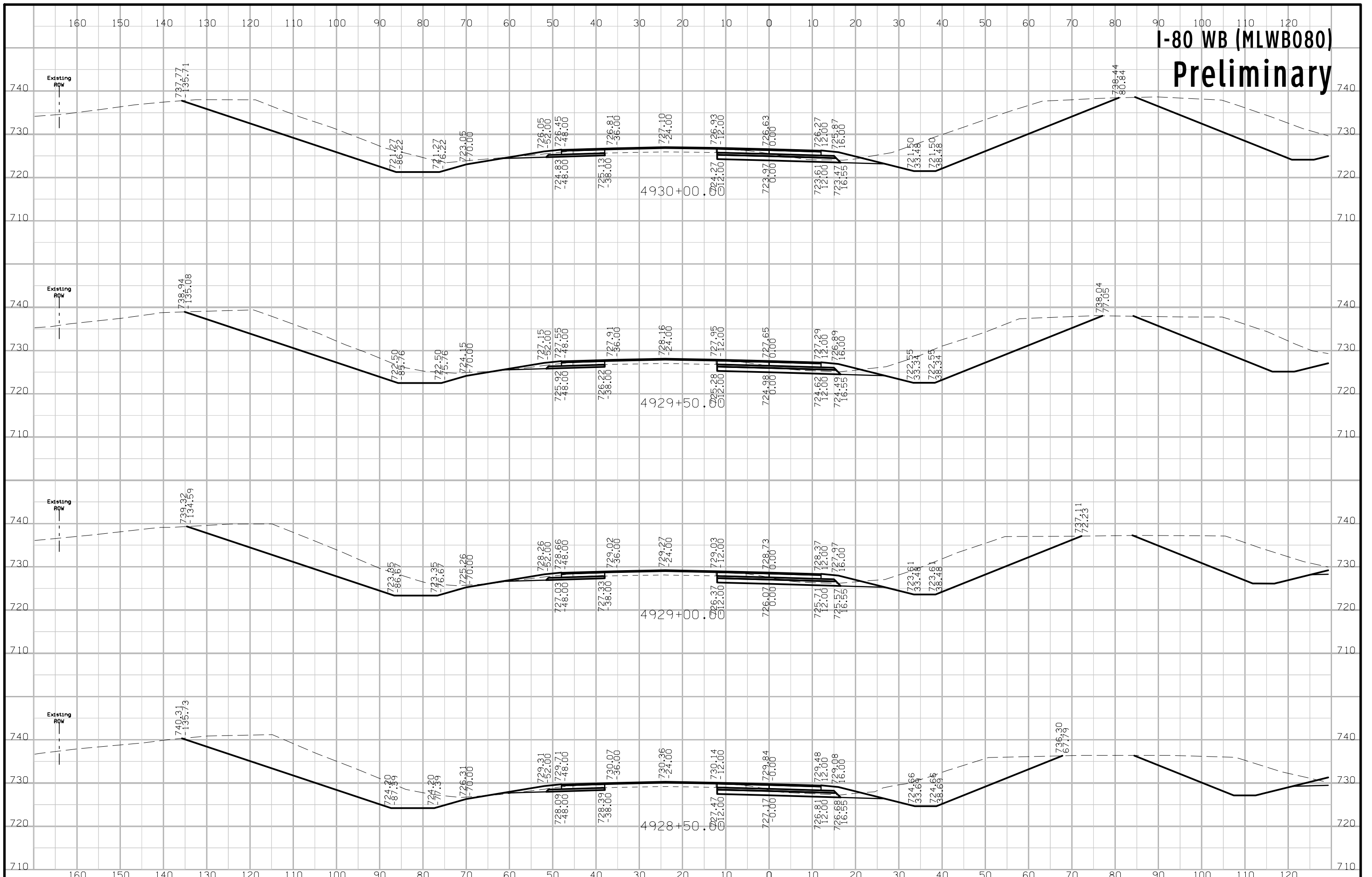

# I-80 WB (MLWB080) Preliminary

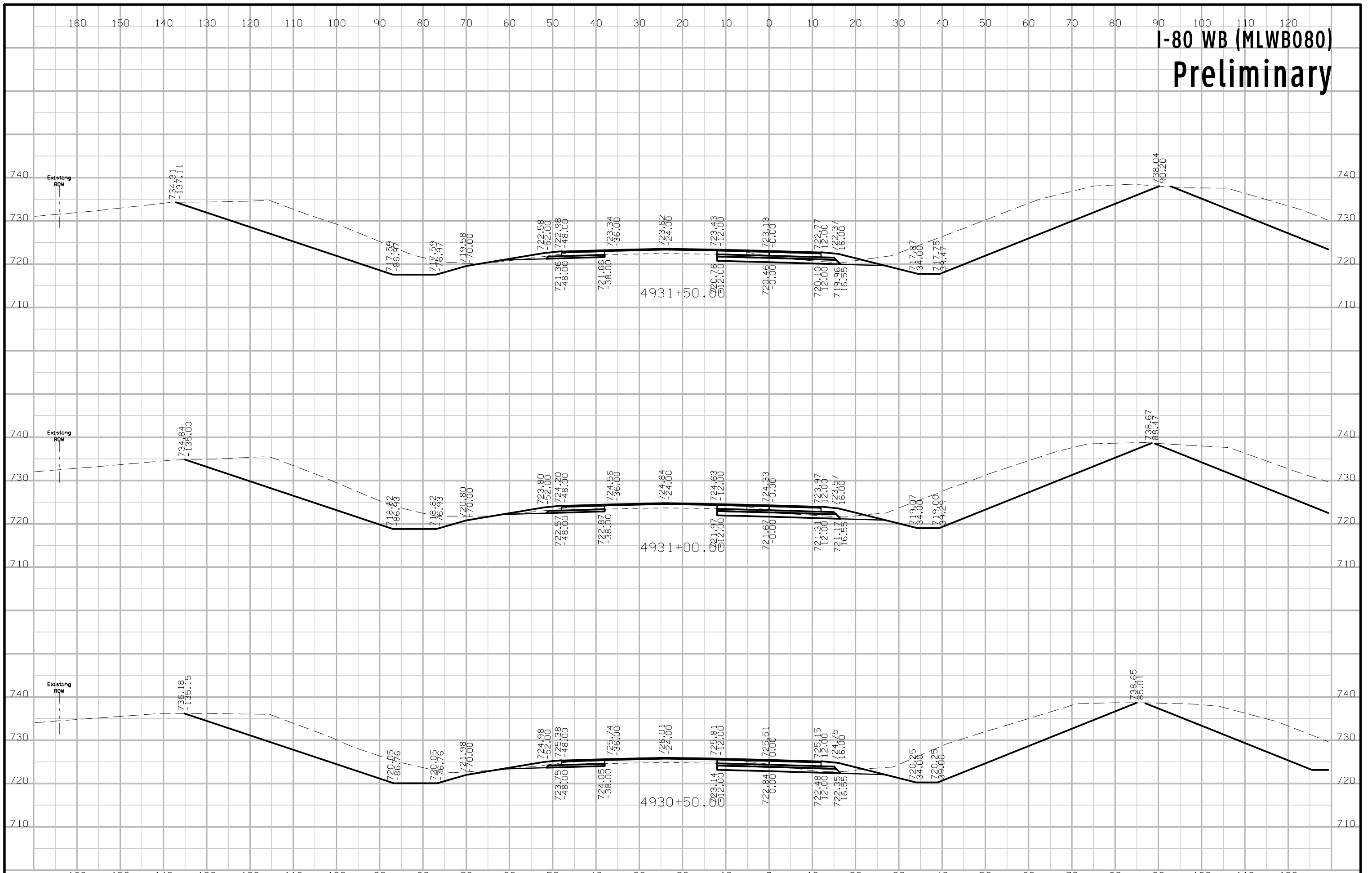

# I-80 WB (MLWB080) Preliminary

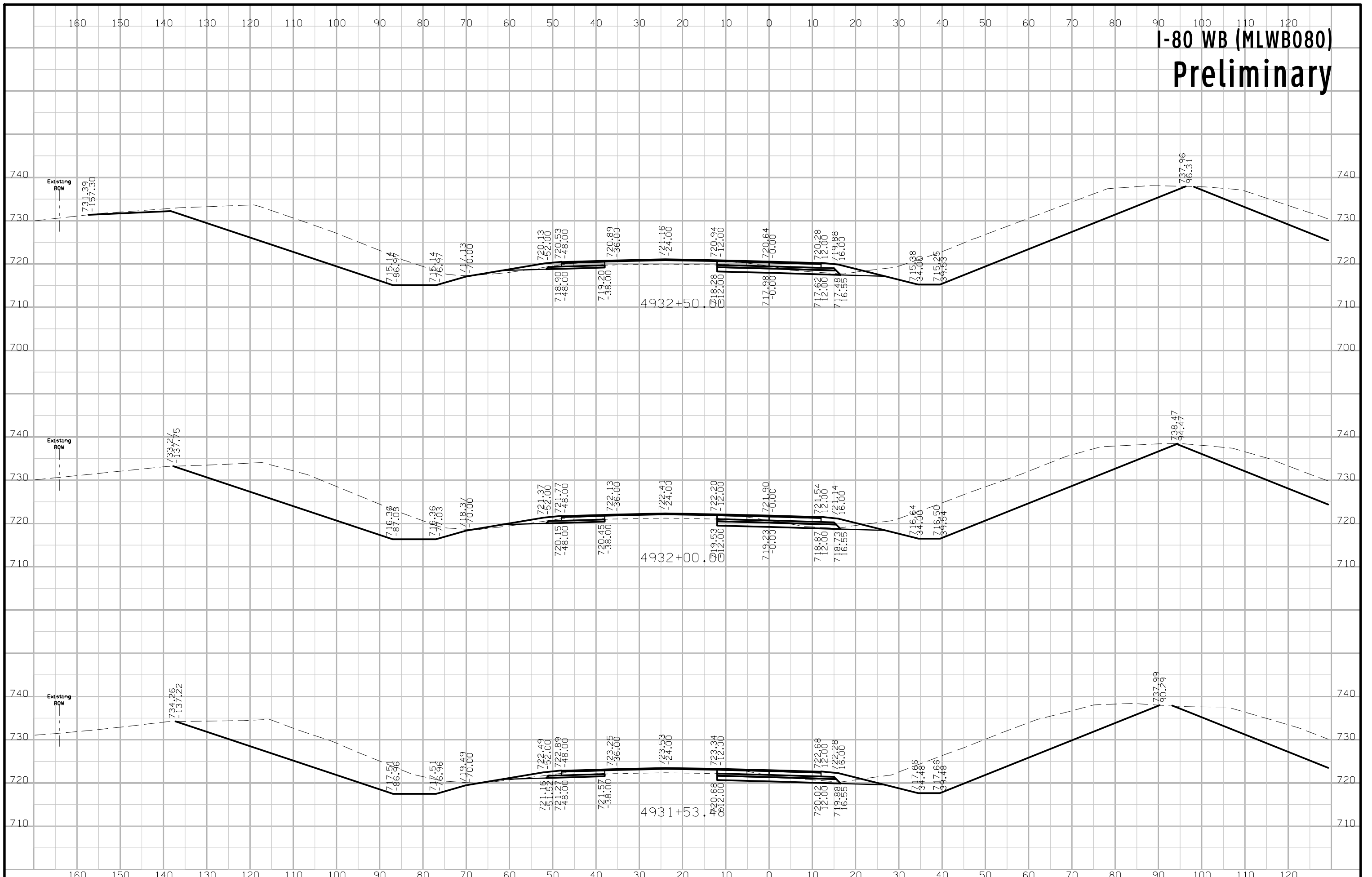

# I-80 WB (MLWB080) Preliminary

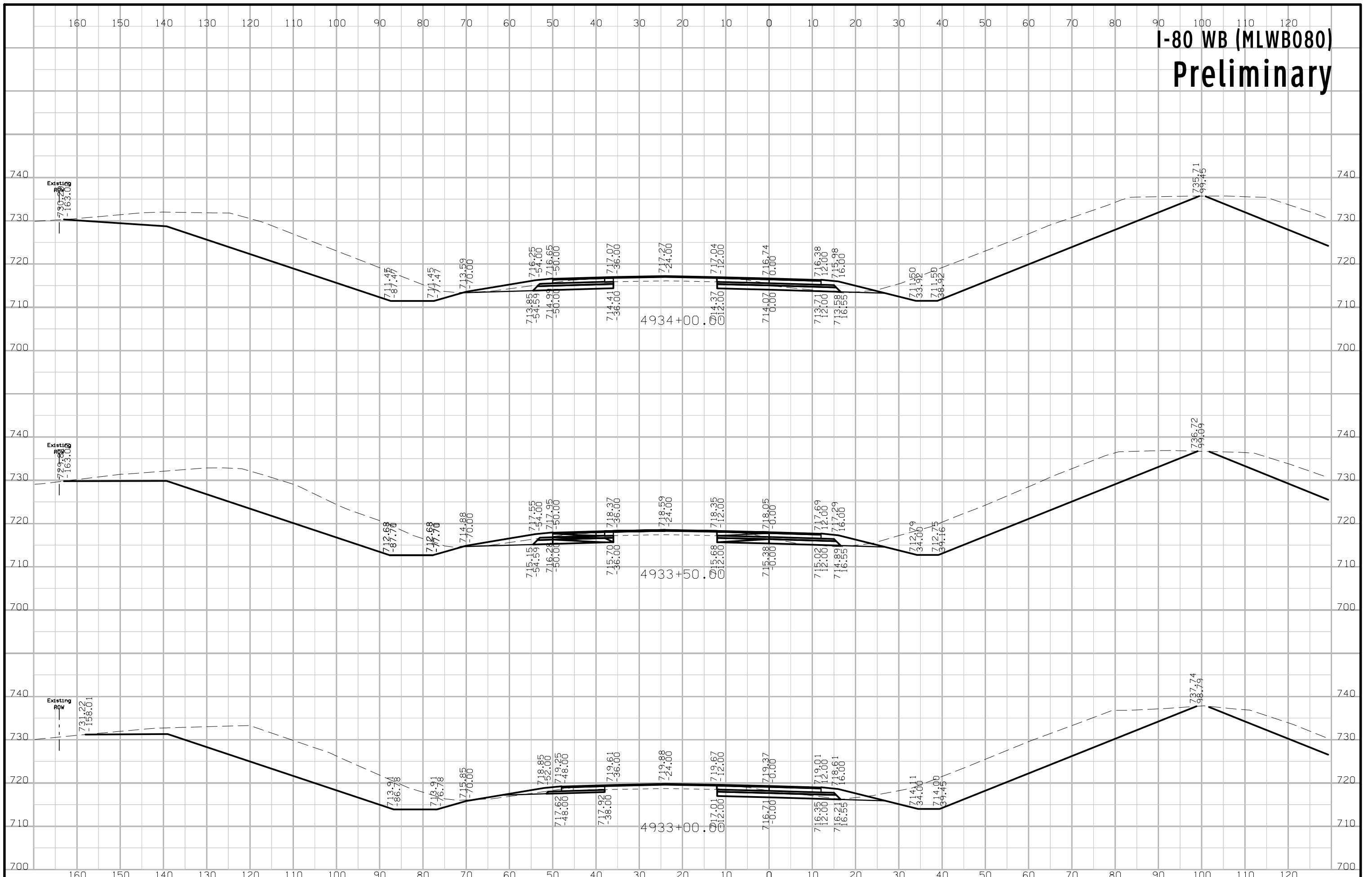

# I-80 WB (MLWB080) Preliminary

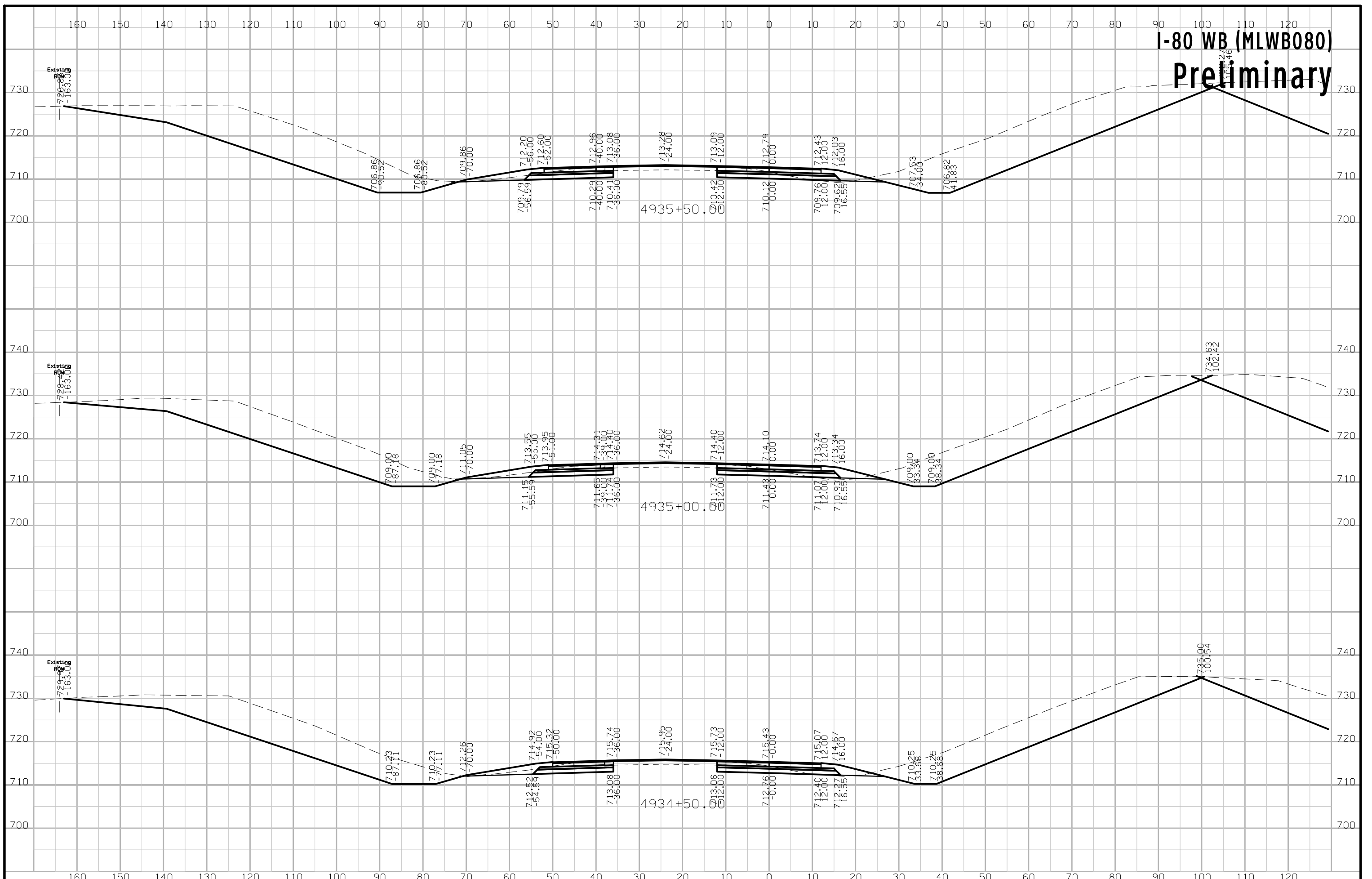



# I-80 WB (MLWB080) Preliminary

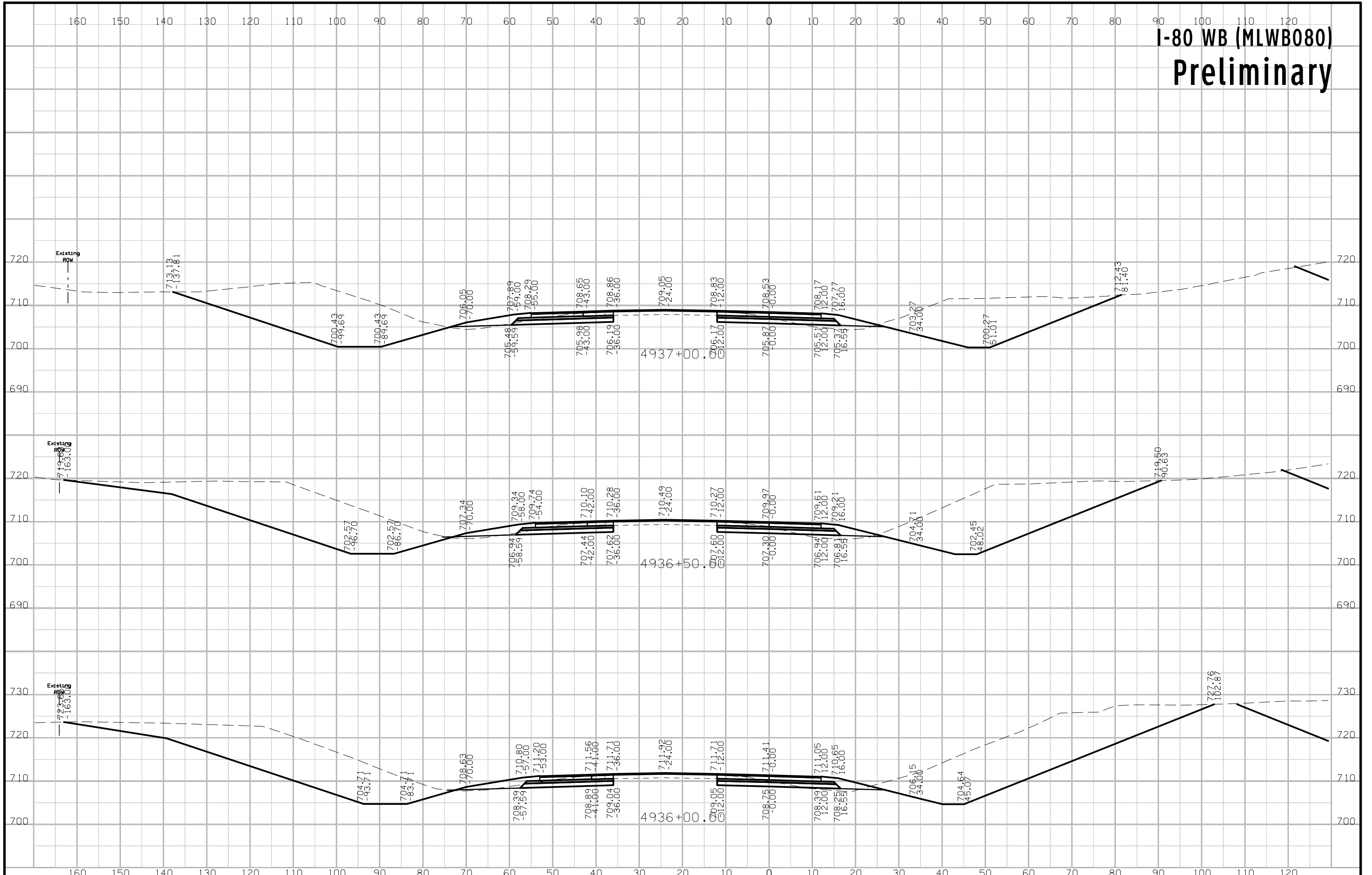

# I-80 WB (MLWB080) Preliminary

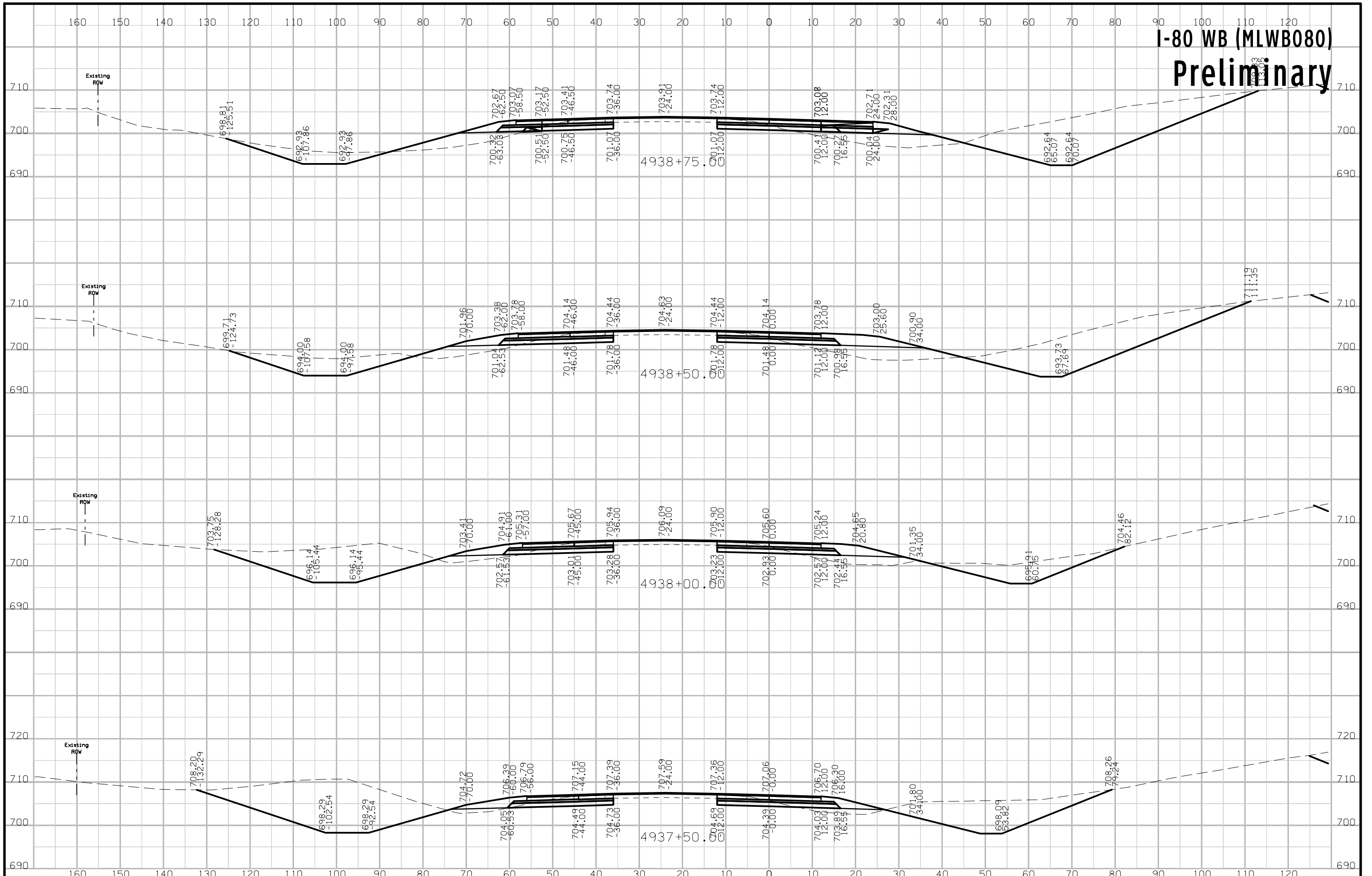

# I-80 WB (MLWB080) Preliminary

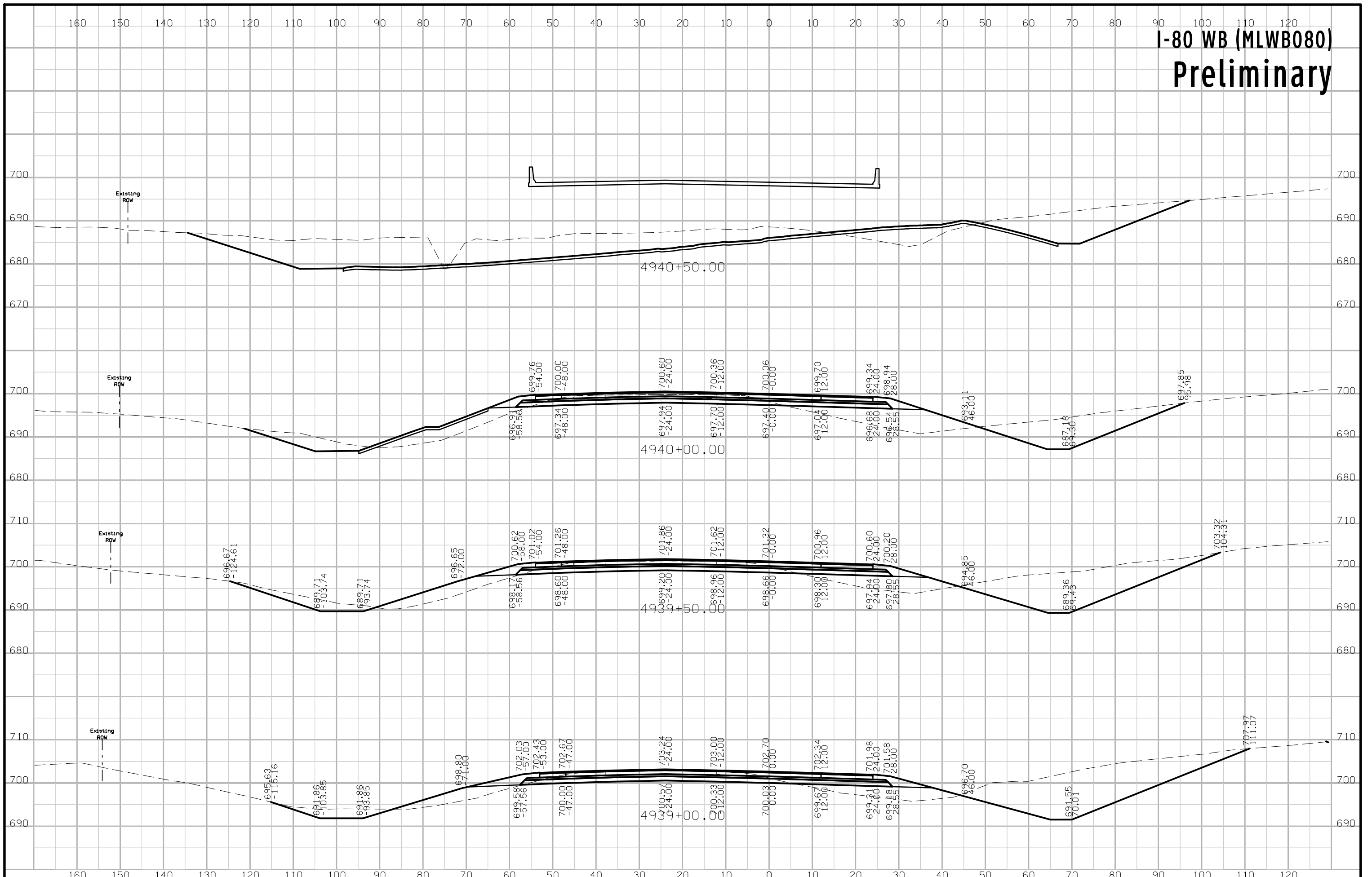

# I-80 WB (MLWB080) Preliminary

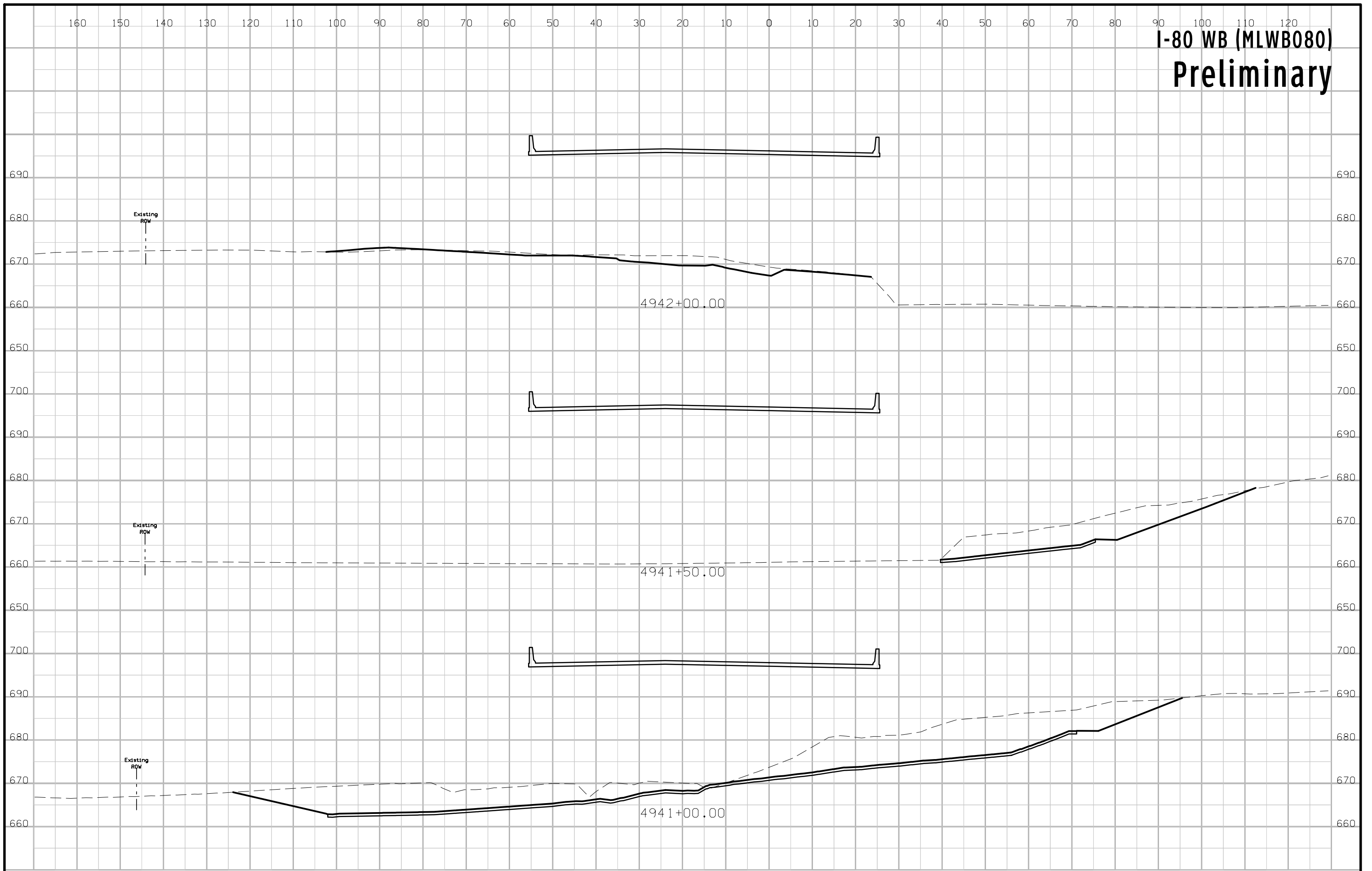

# I-80 WB (MLWB080) Preliminary

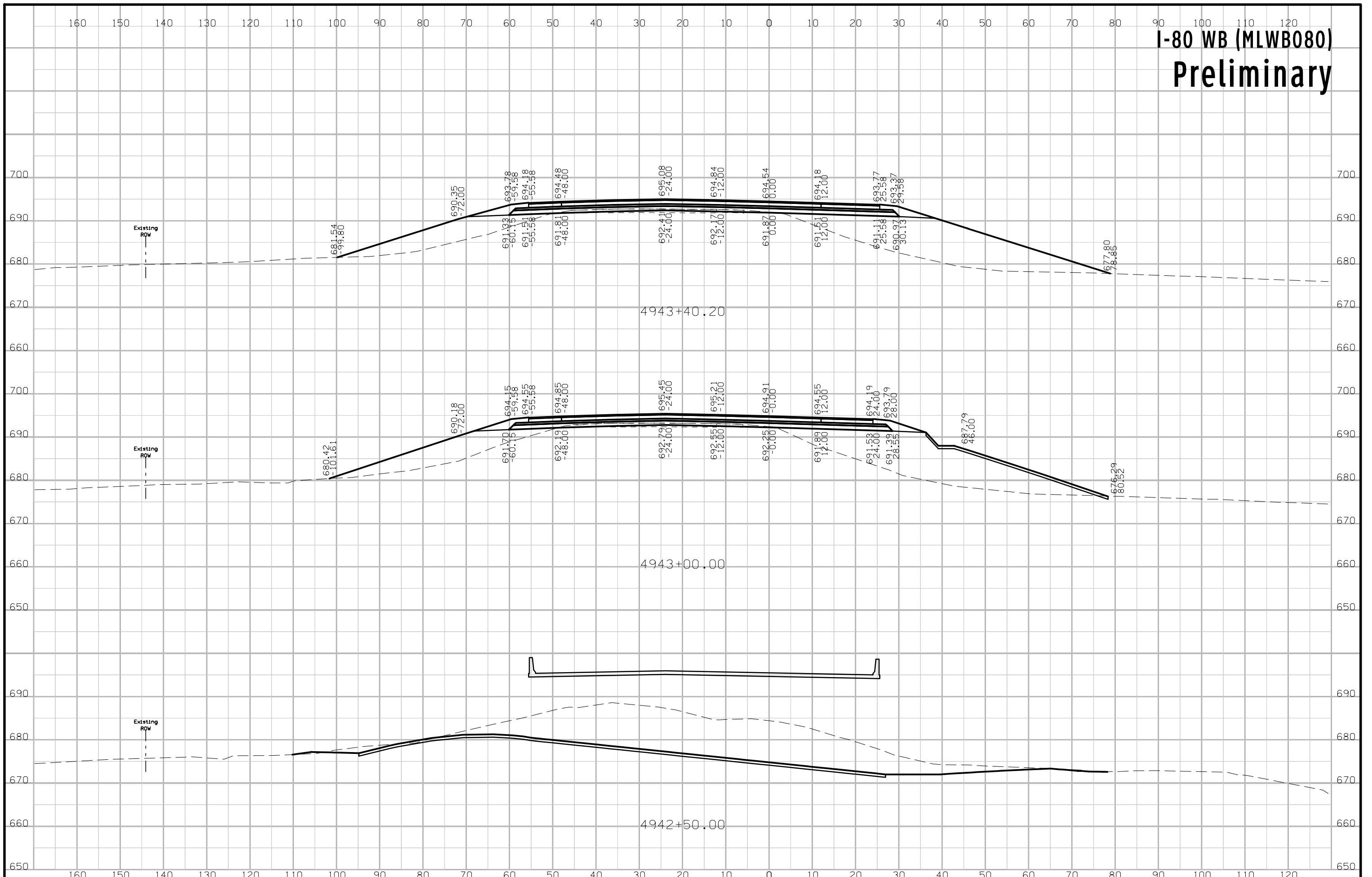

# I-80 WB (MLWB080) Preliminary

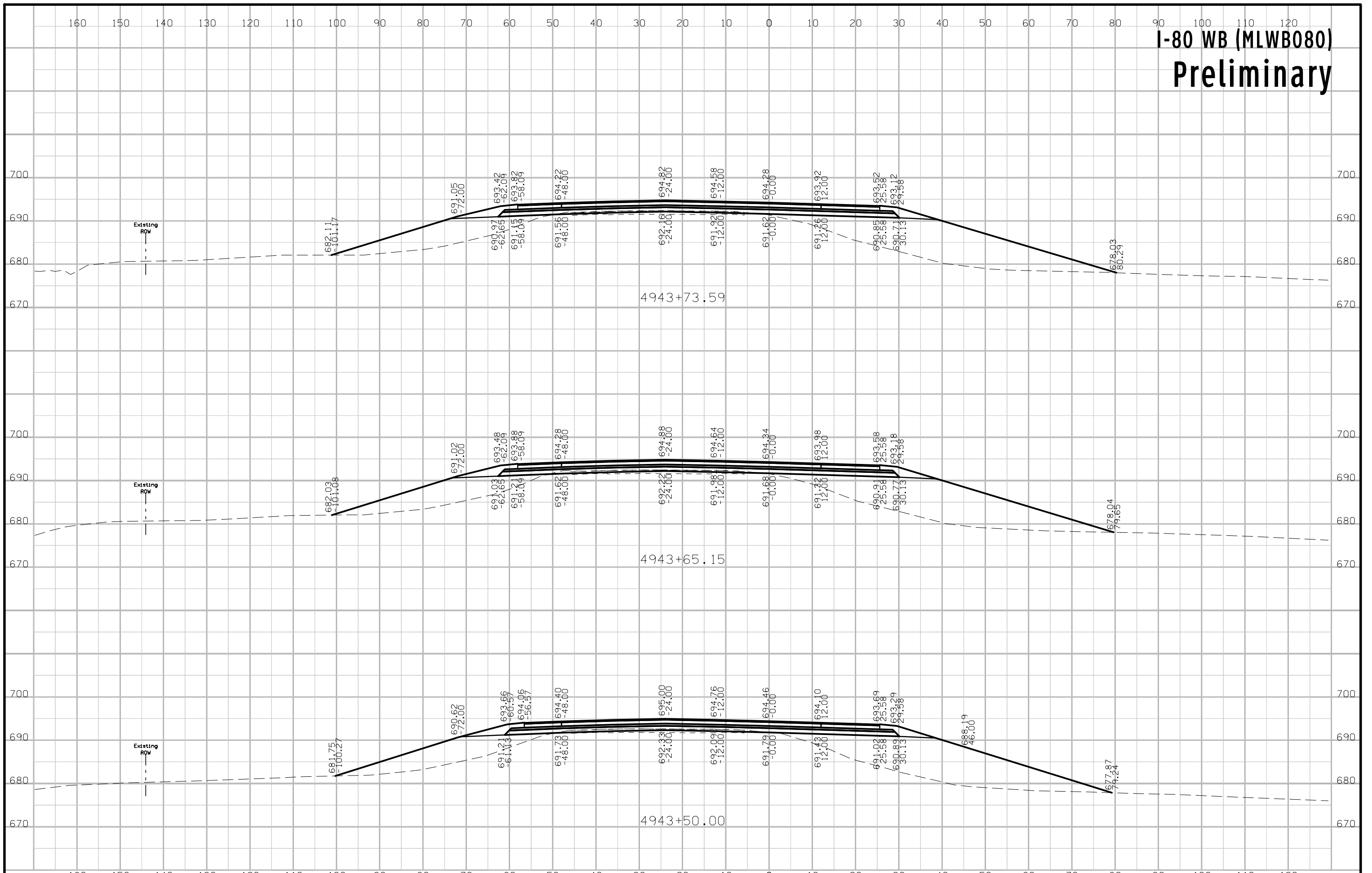

# I-80 WB (MLWB080) Preliminary

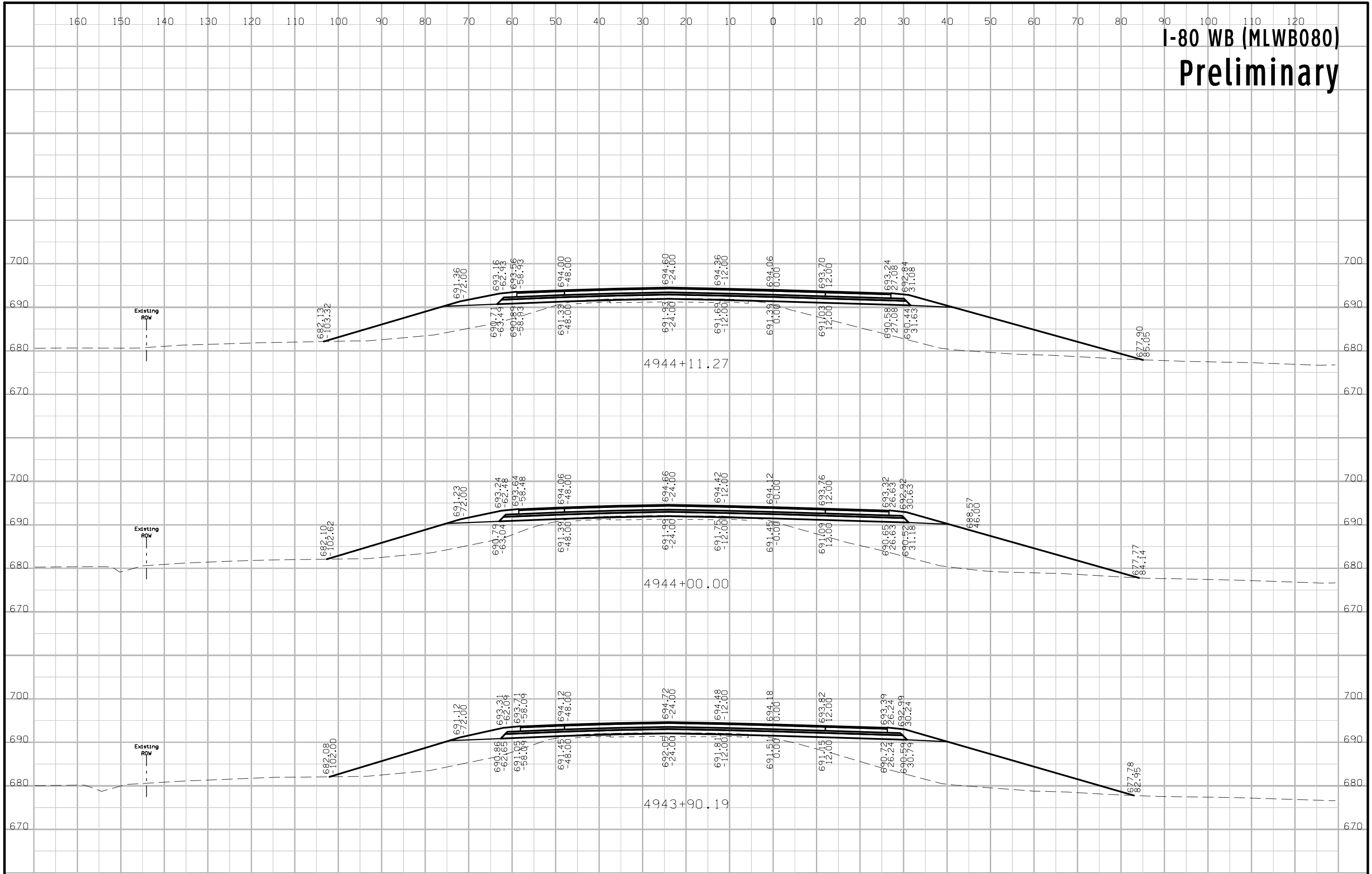



# I-80 WB (MLWB080) Preliminary

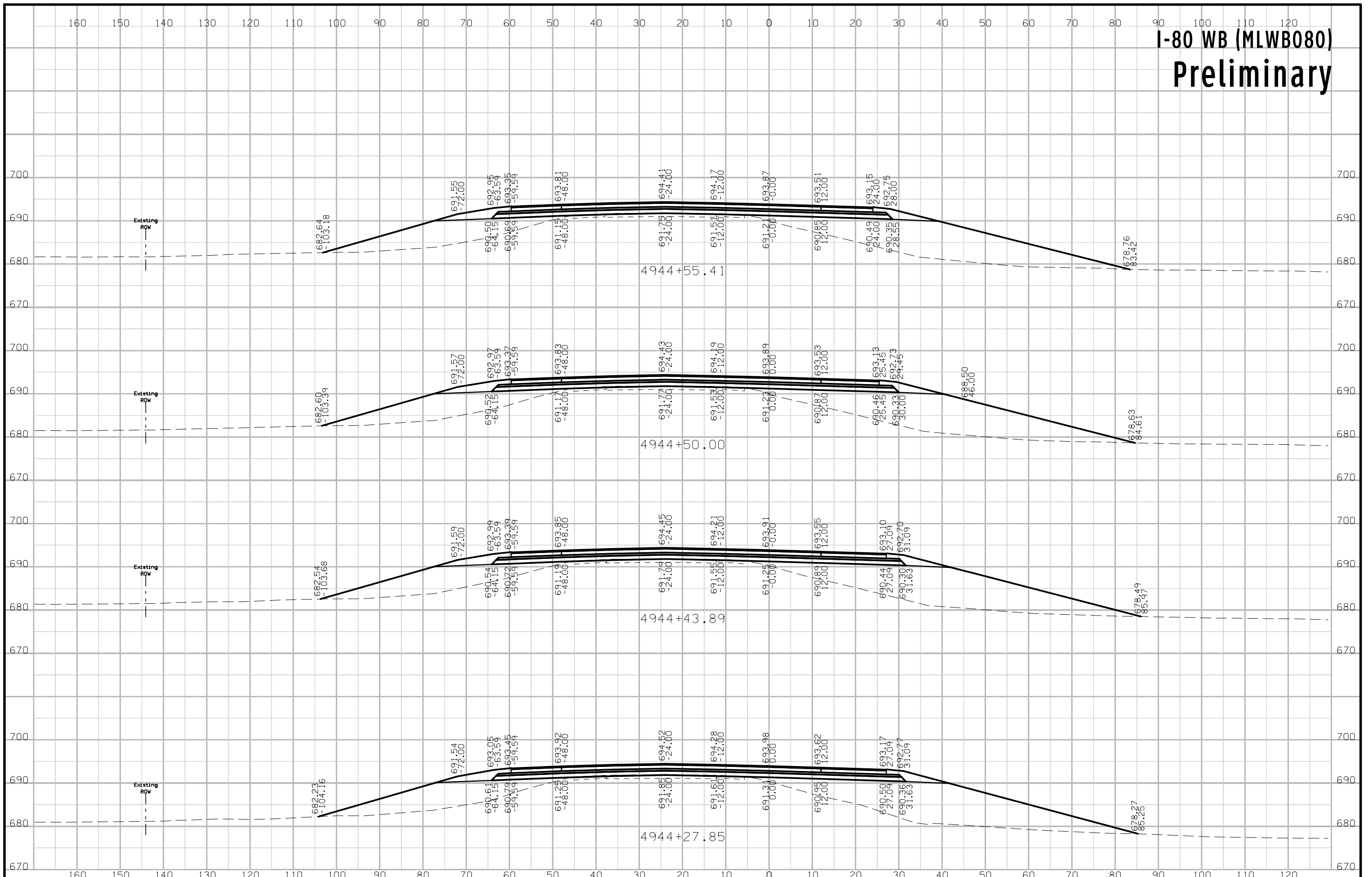

# I-80 WB (MLWB080) Preliminary

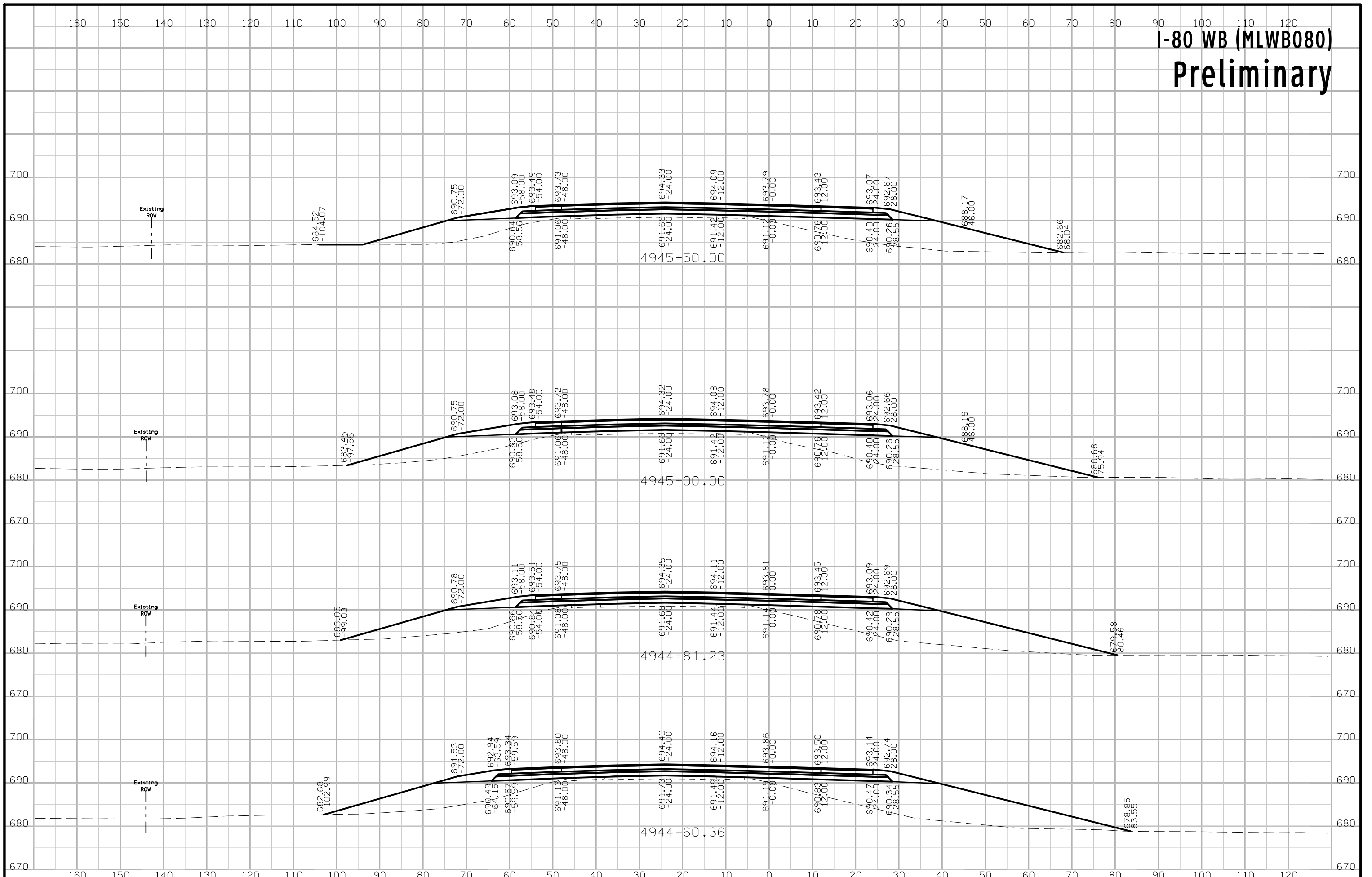

# I-80 WB (MLWB080) Preliminary

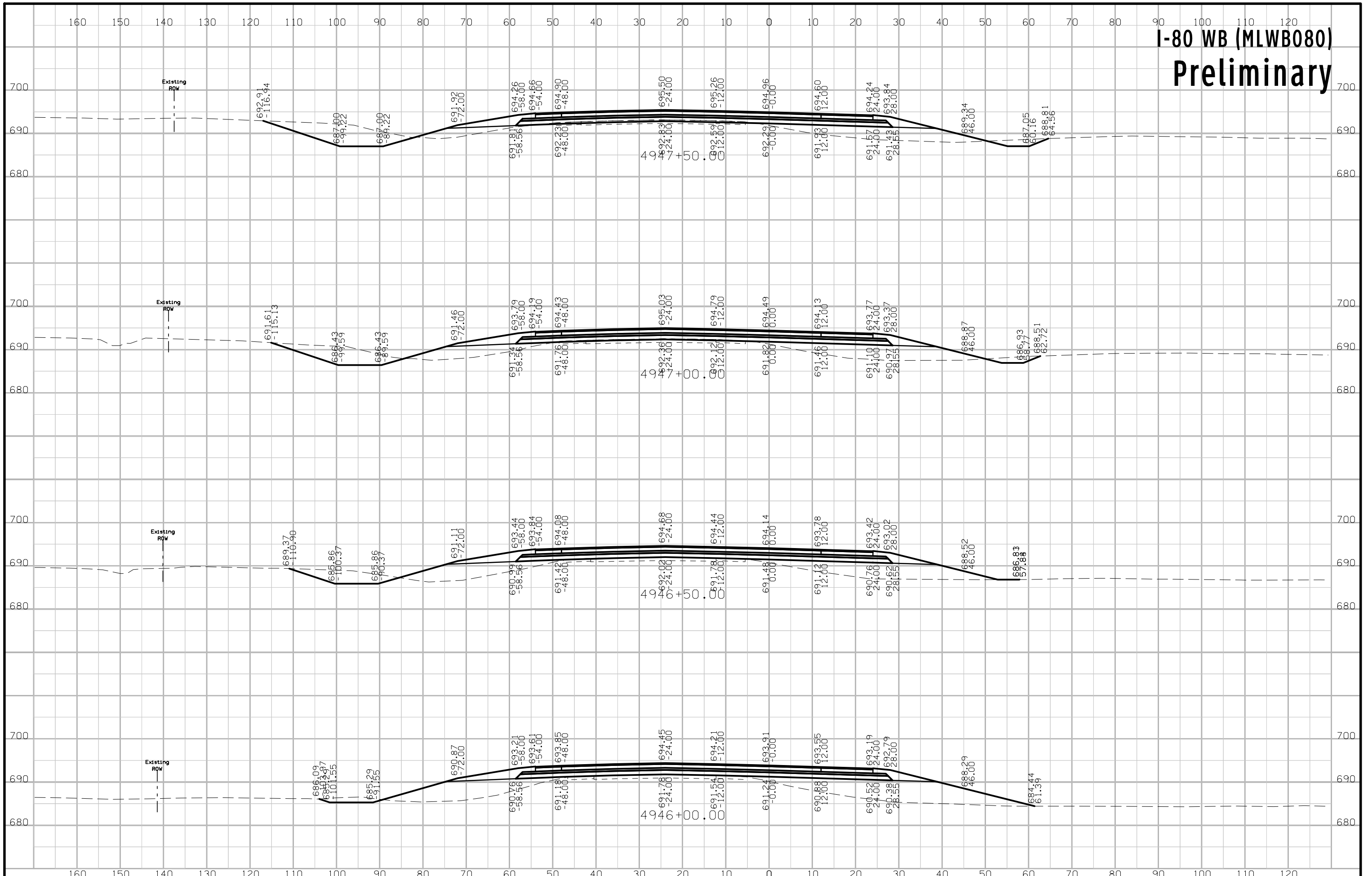

# I-80 WB (MLWB080) Preliminary

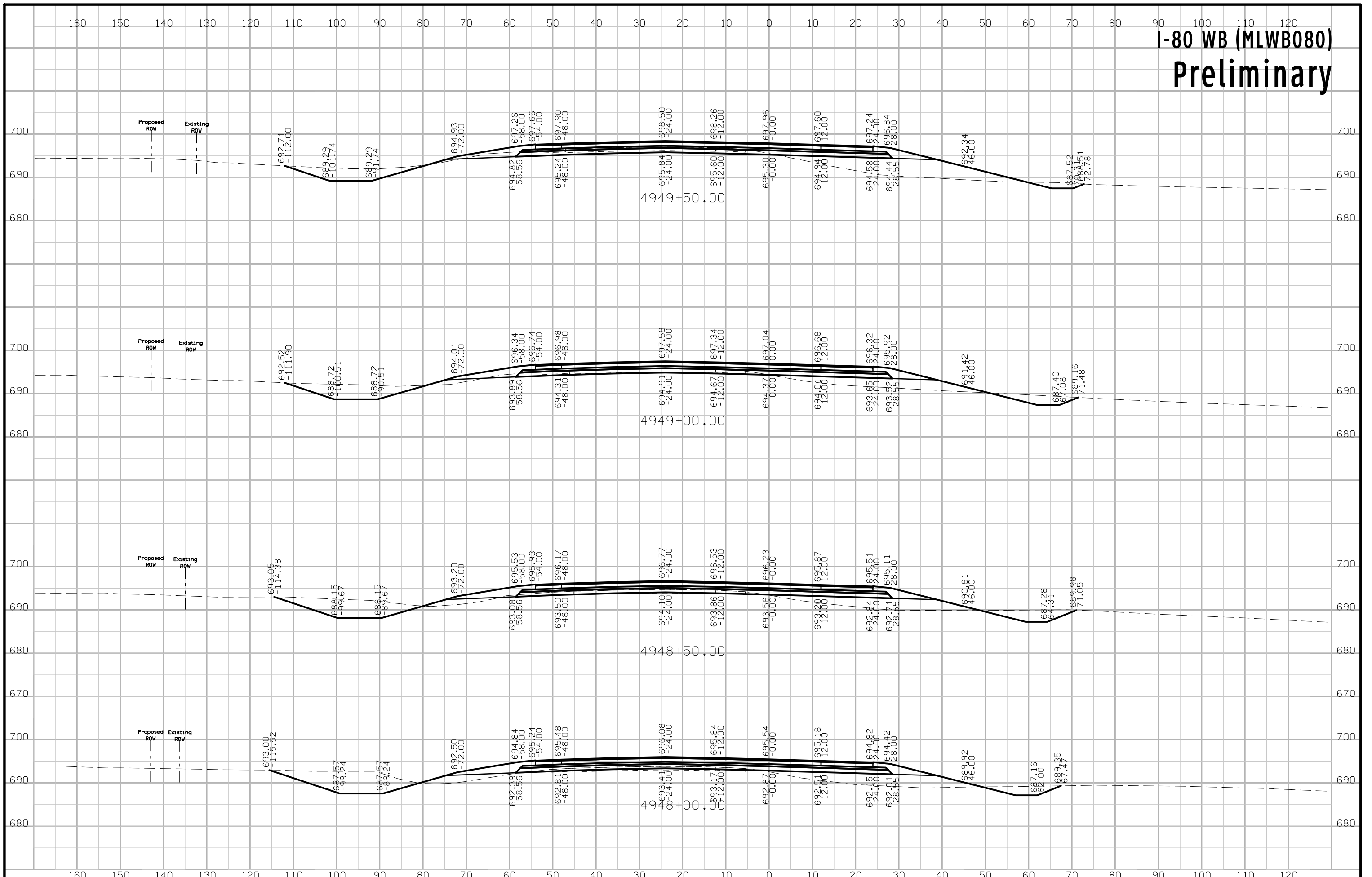

# I-80 WB (MLWB080) Preliminary

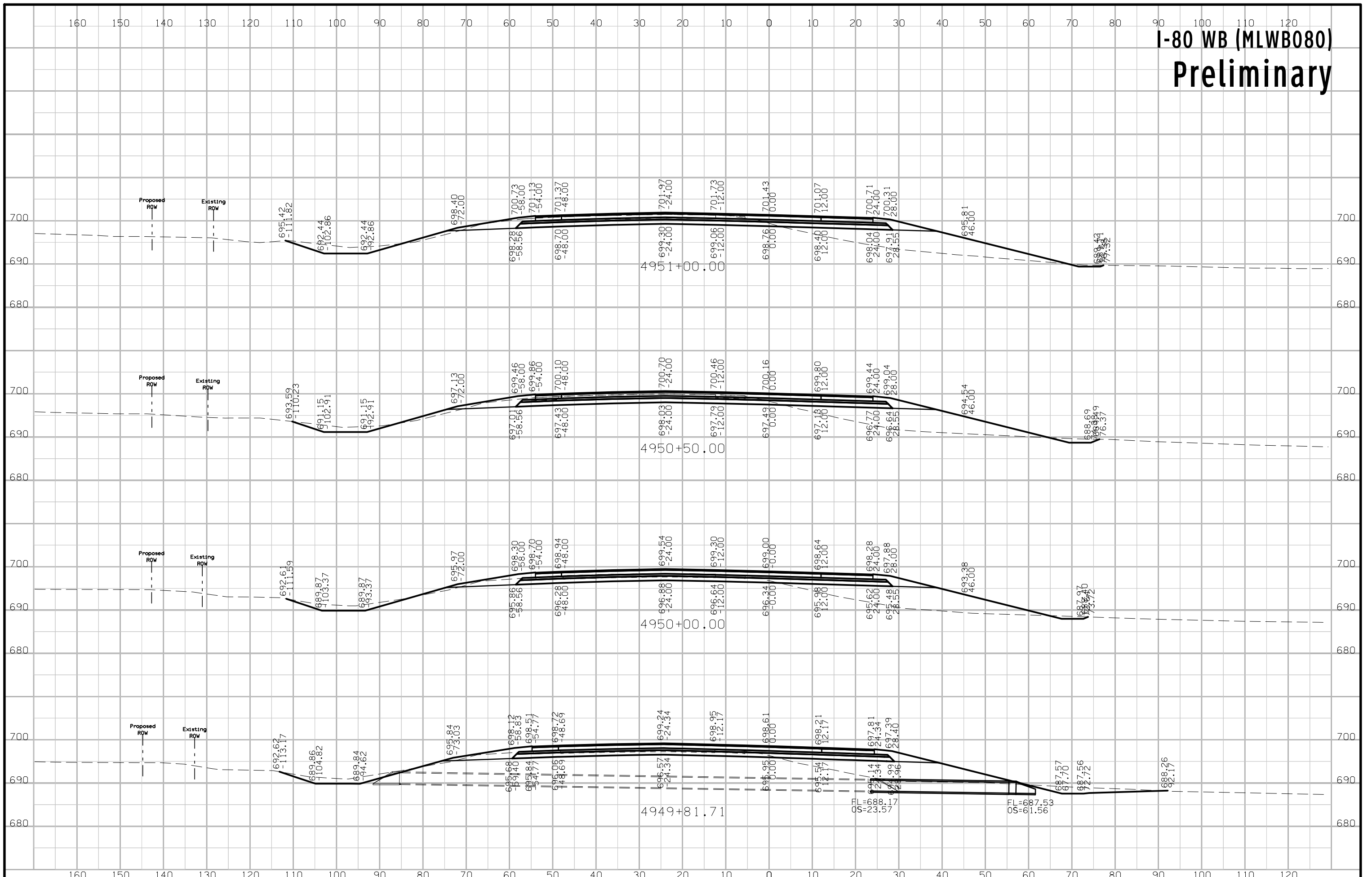

# I-80 WB (MLWB080) Preliminary

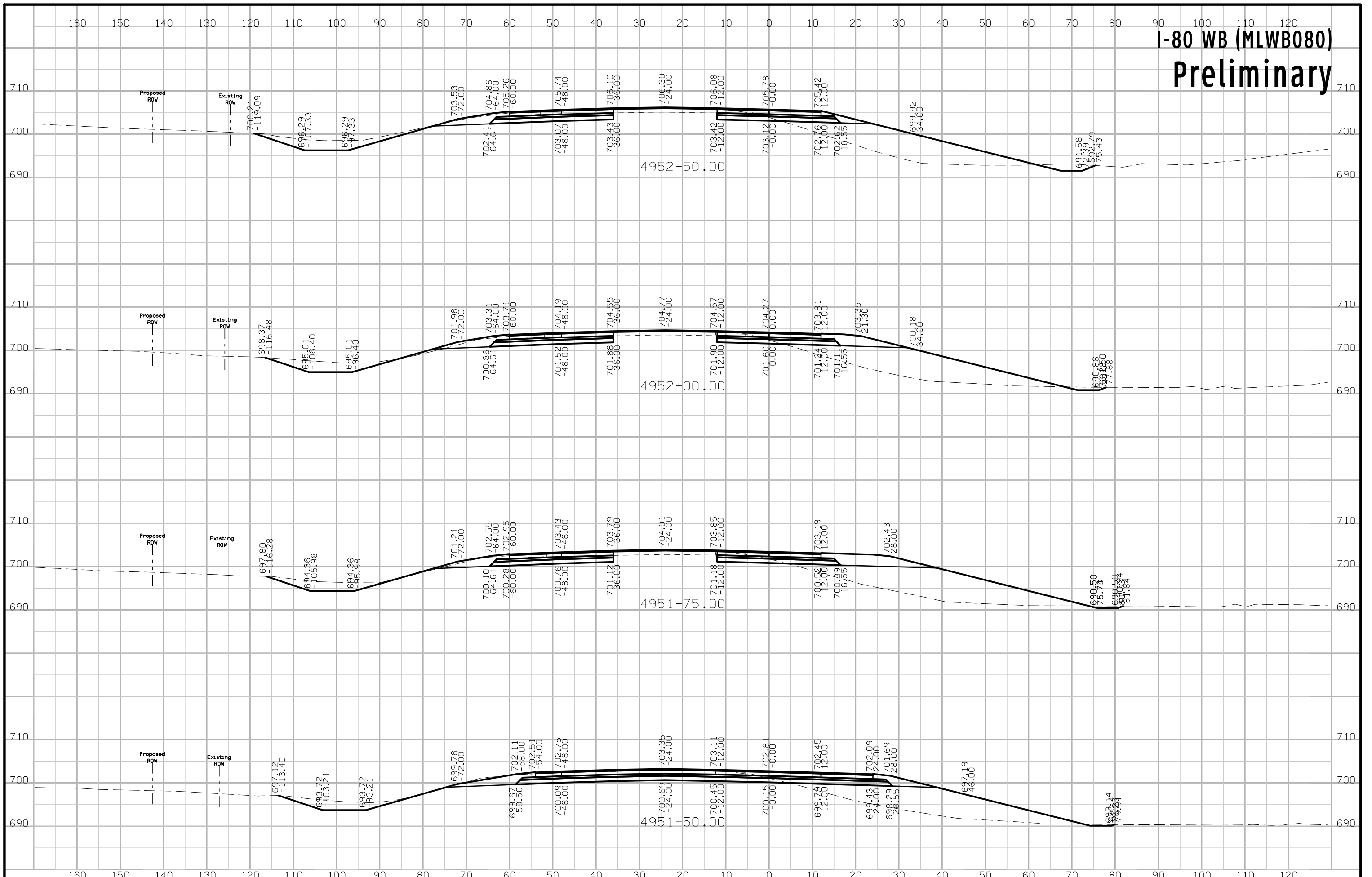

# I-80 WB (MLWB080) Preliminary

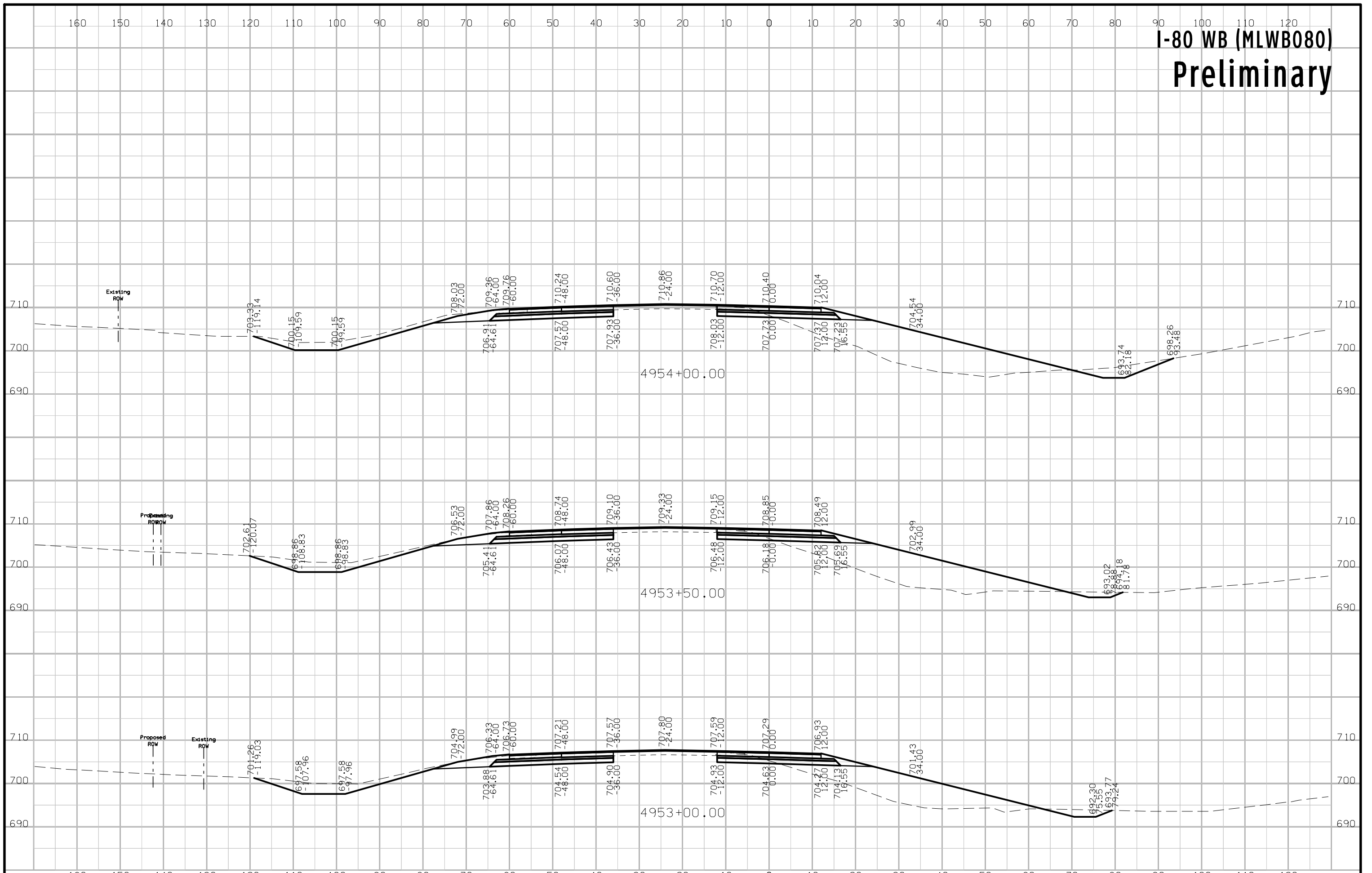

# I-80 WB (MLWB080) Preliminary

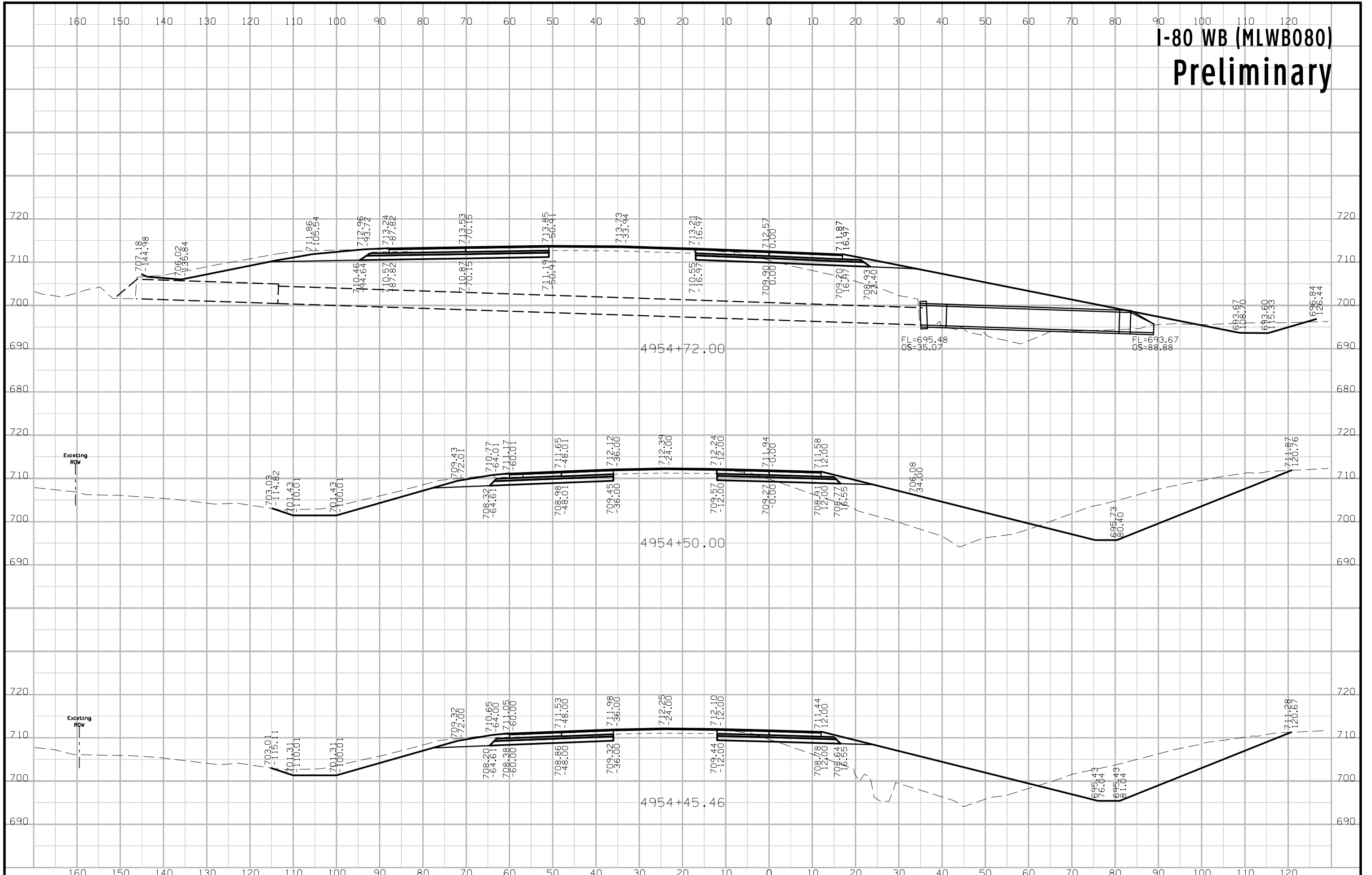



# I-80 WB (MLWB080) Preliminary

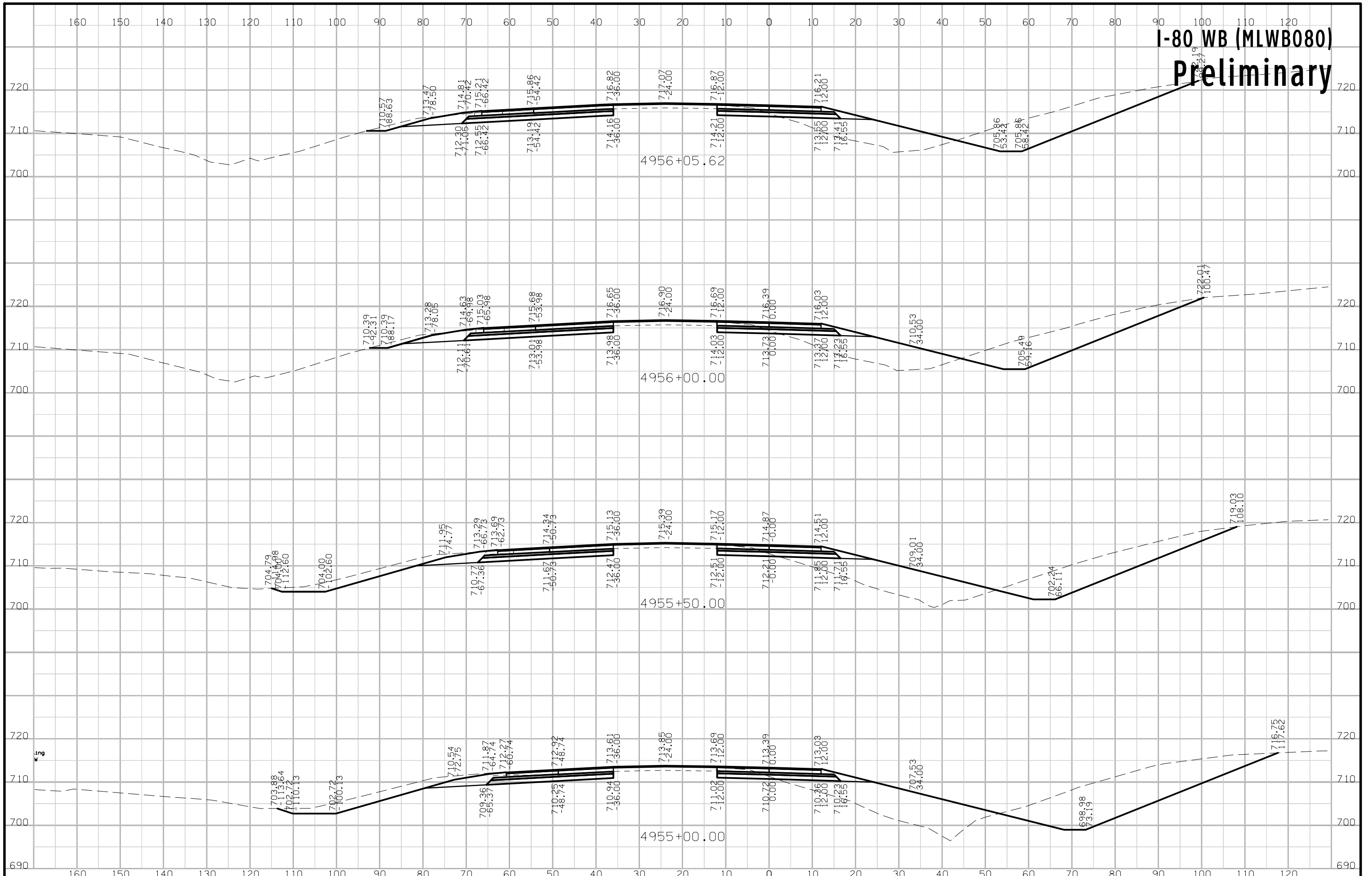

# I-80 WB (MLWB080) Preliminary

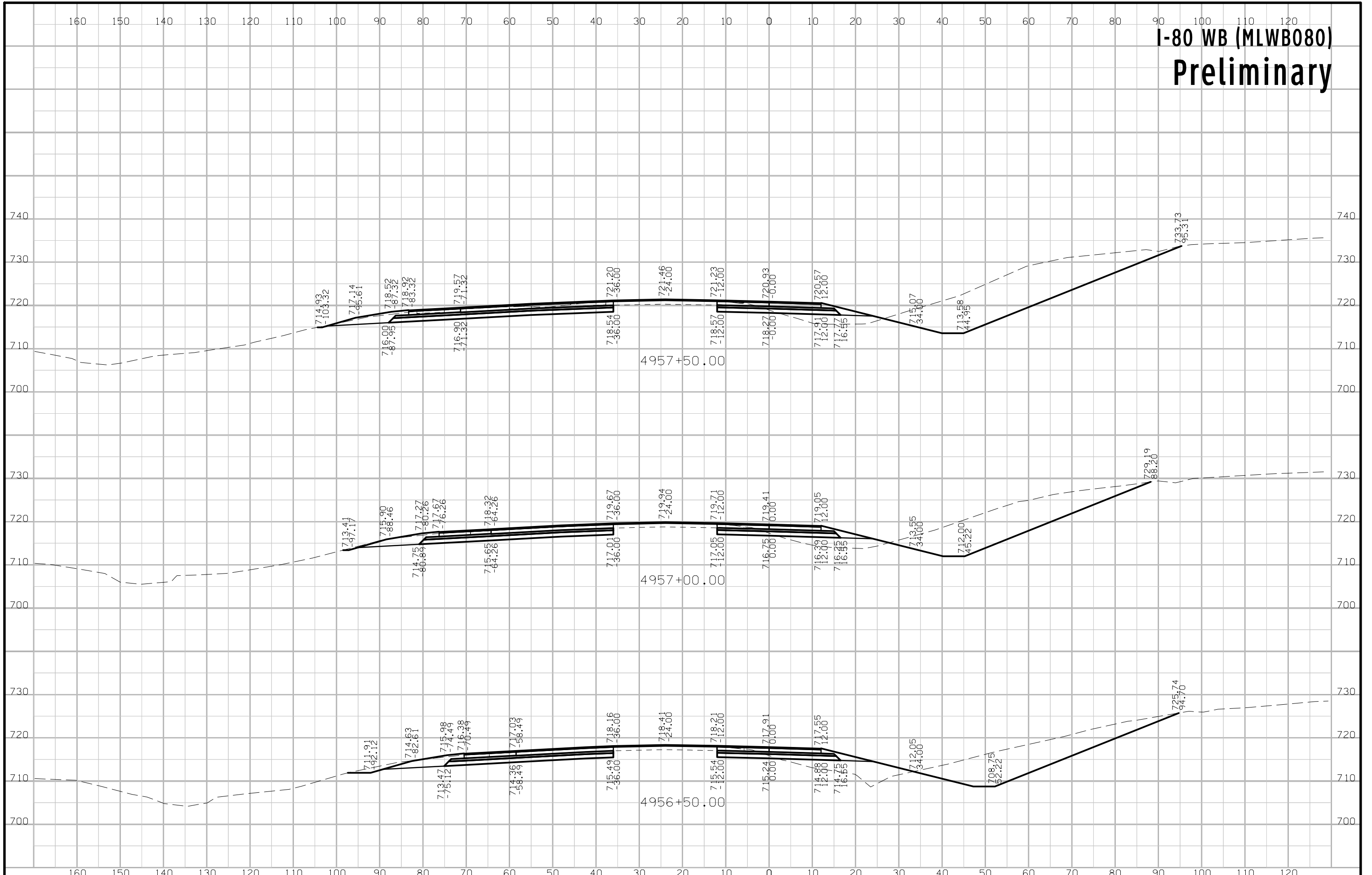

# I-80 WB (MLWB080) Preliminary

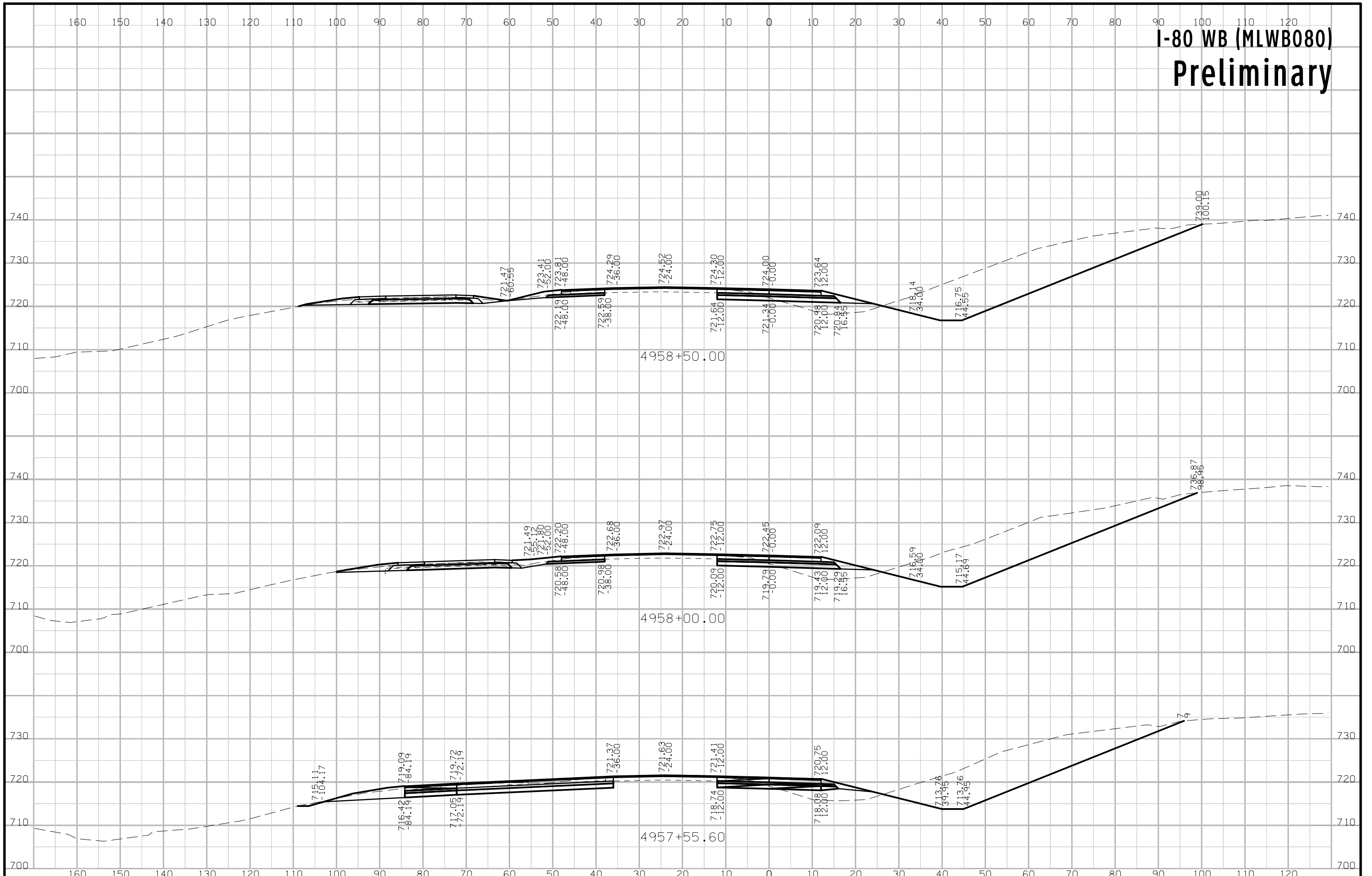

# I-80 WB (MLWB080) Preliminary

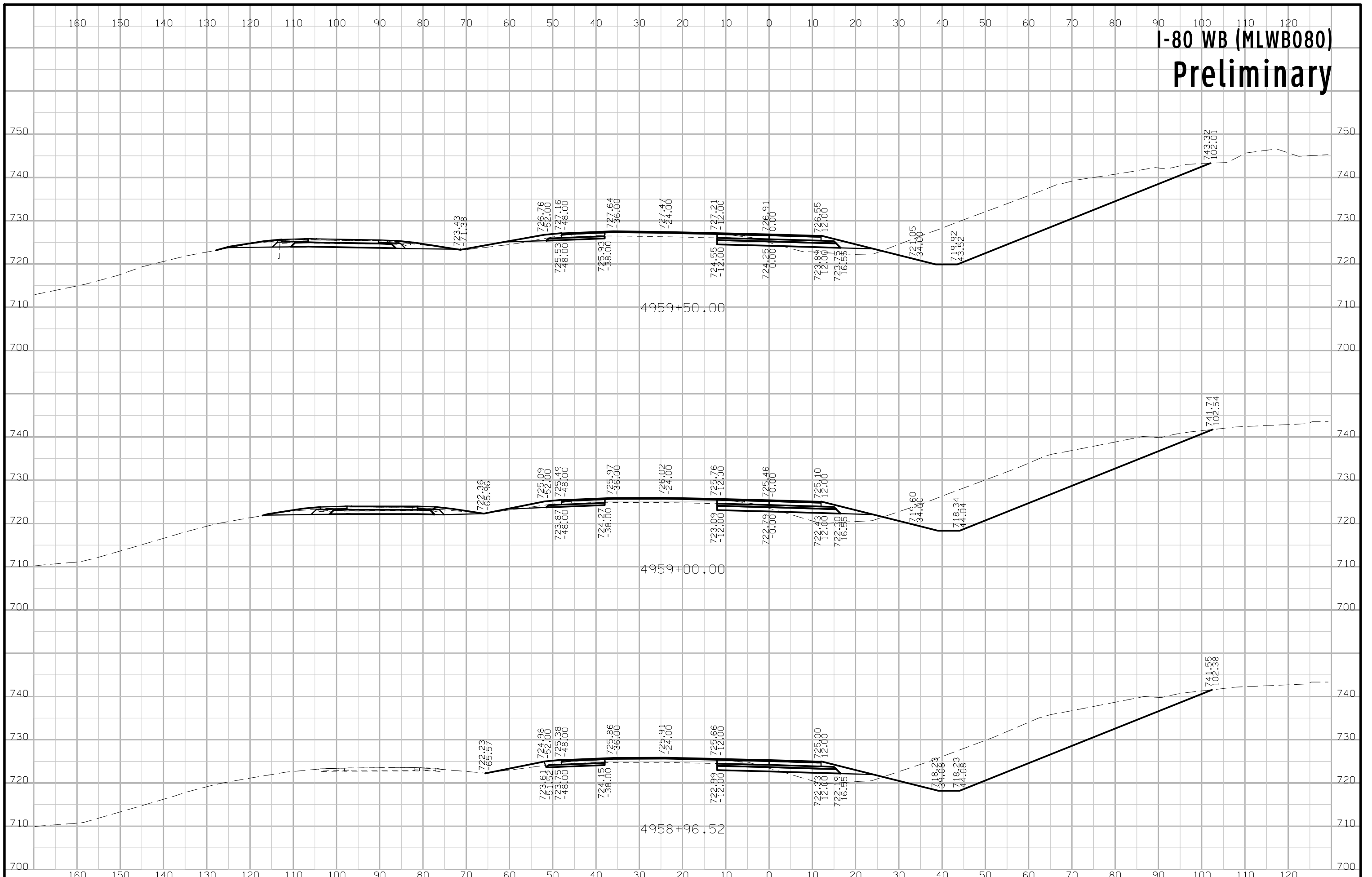

# I-80 WB (MLWB080) Preliminary

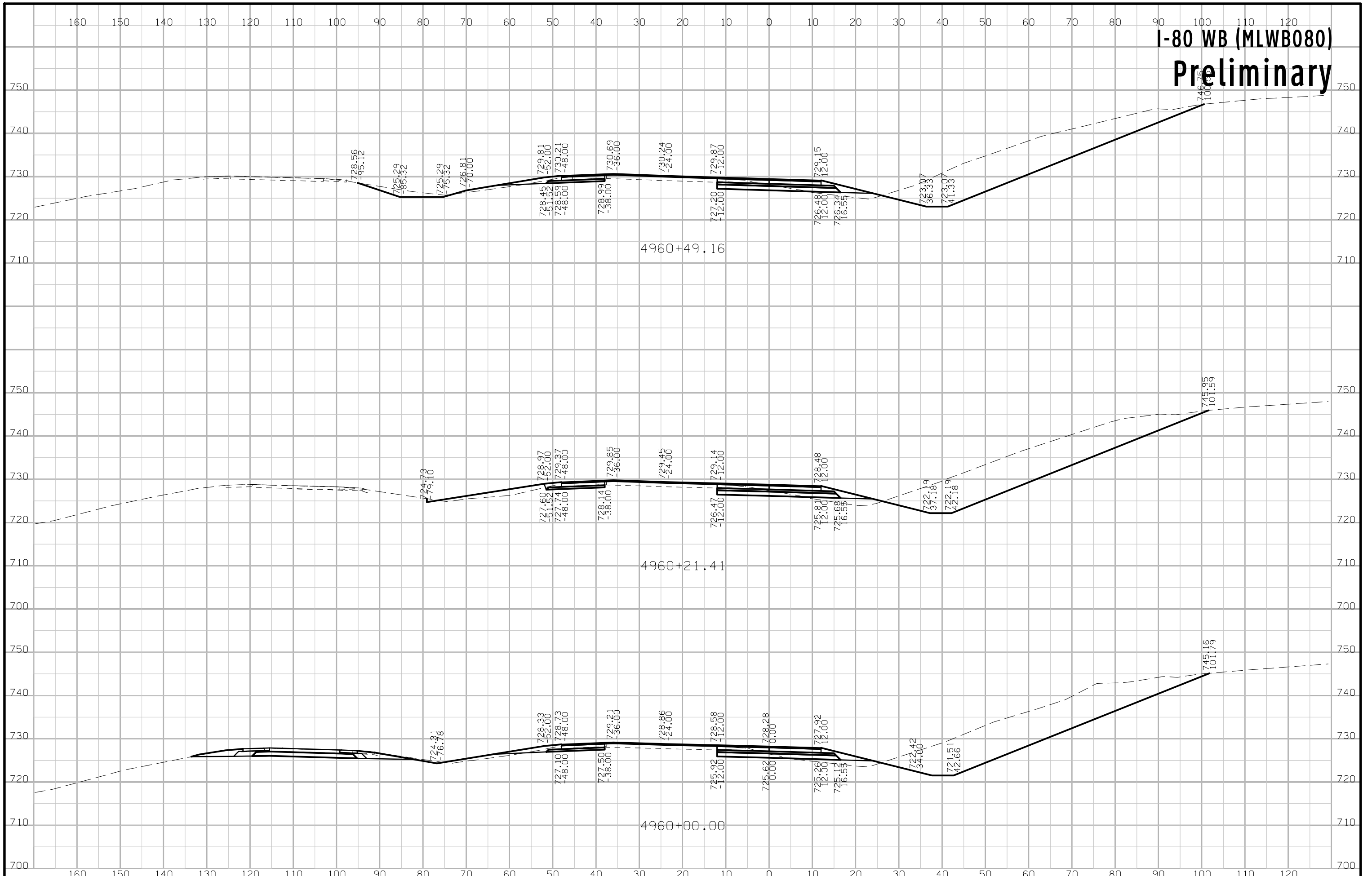

# I-80 WB (MLWB080) Preliminary

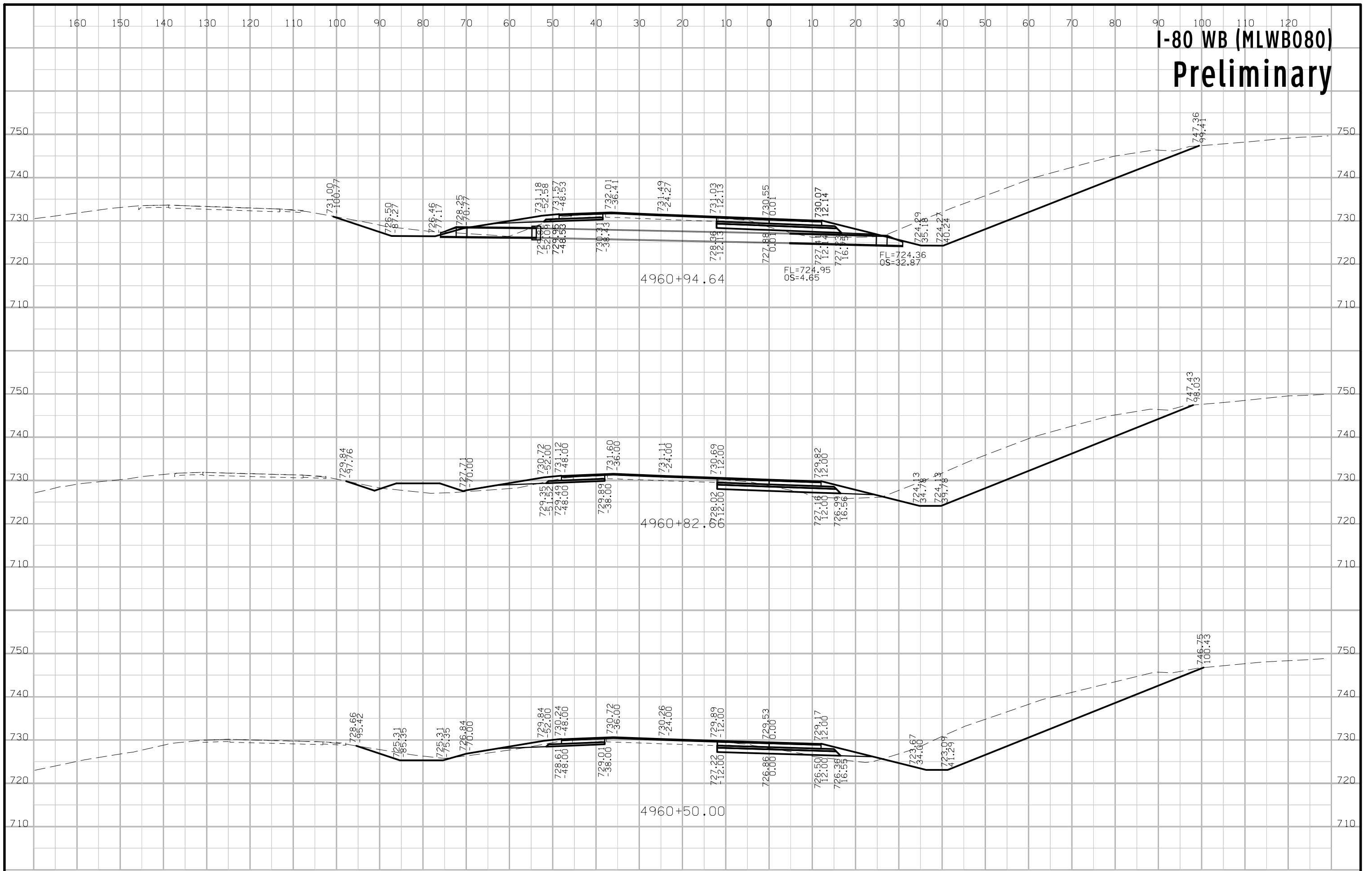

# I-80 WB (MLWB080) Preliminary

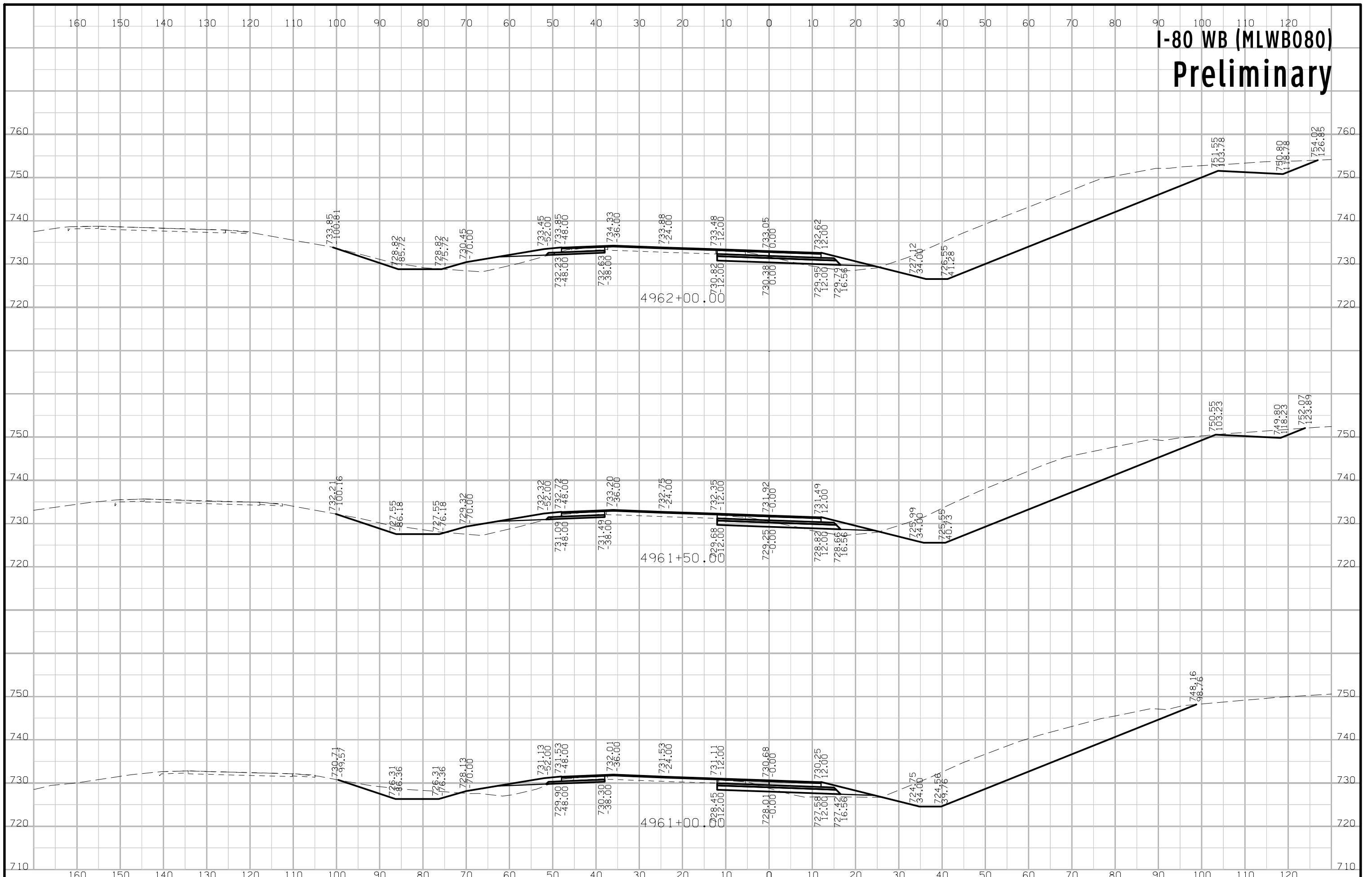

# I-80 WB (MLWB080) Preliminary

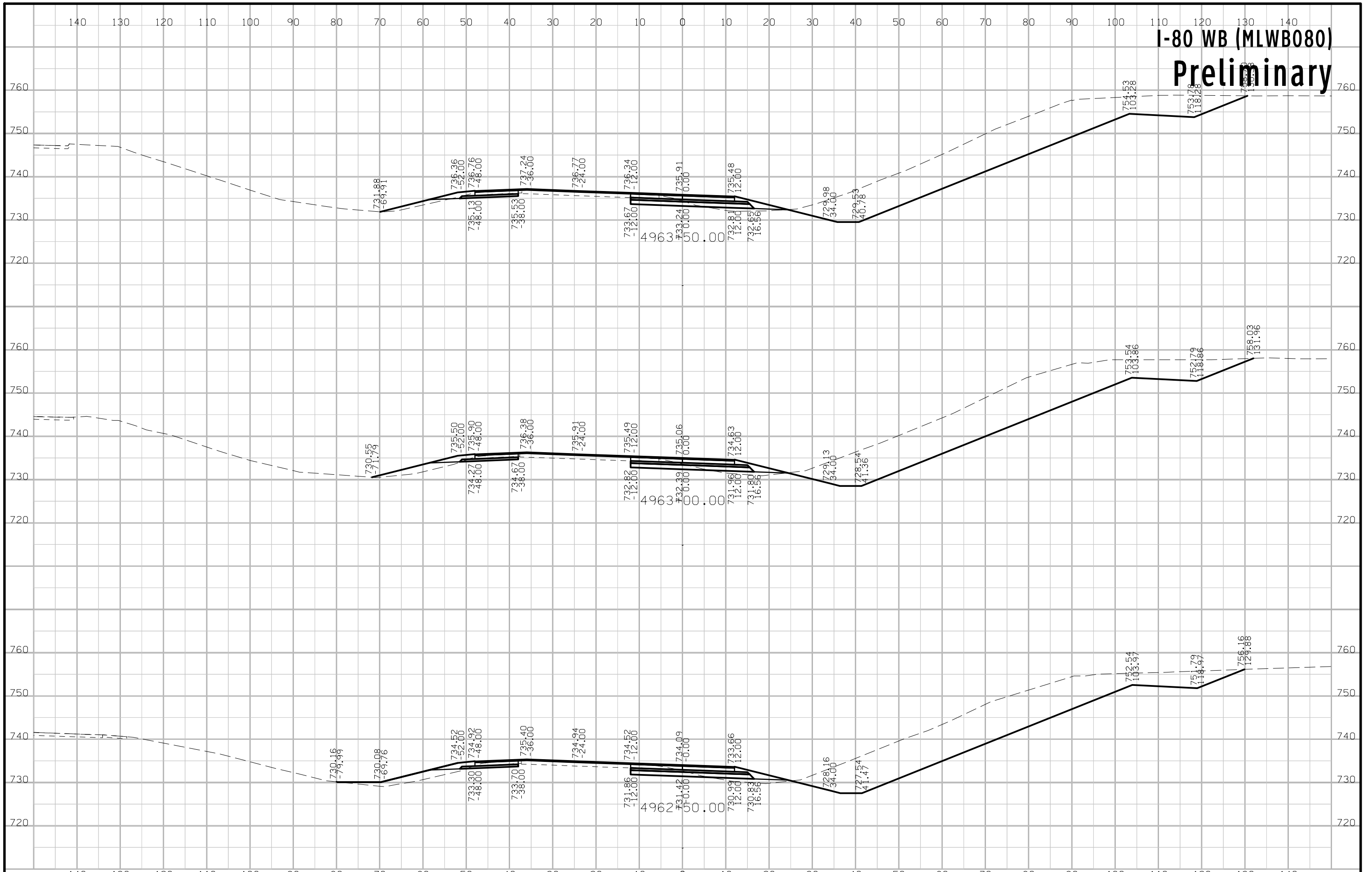



# I-80 WB (MLWB080) Preliminary

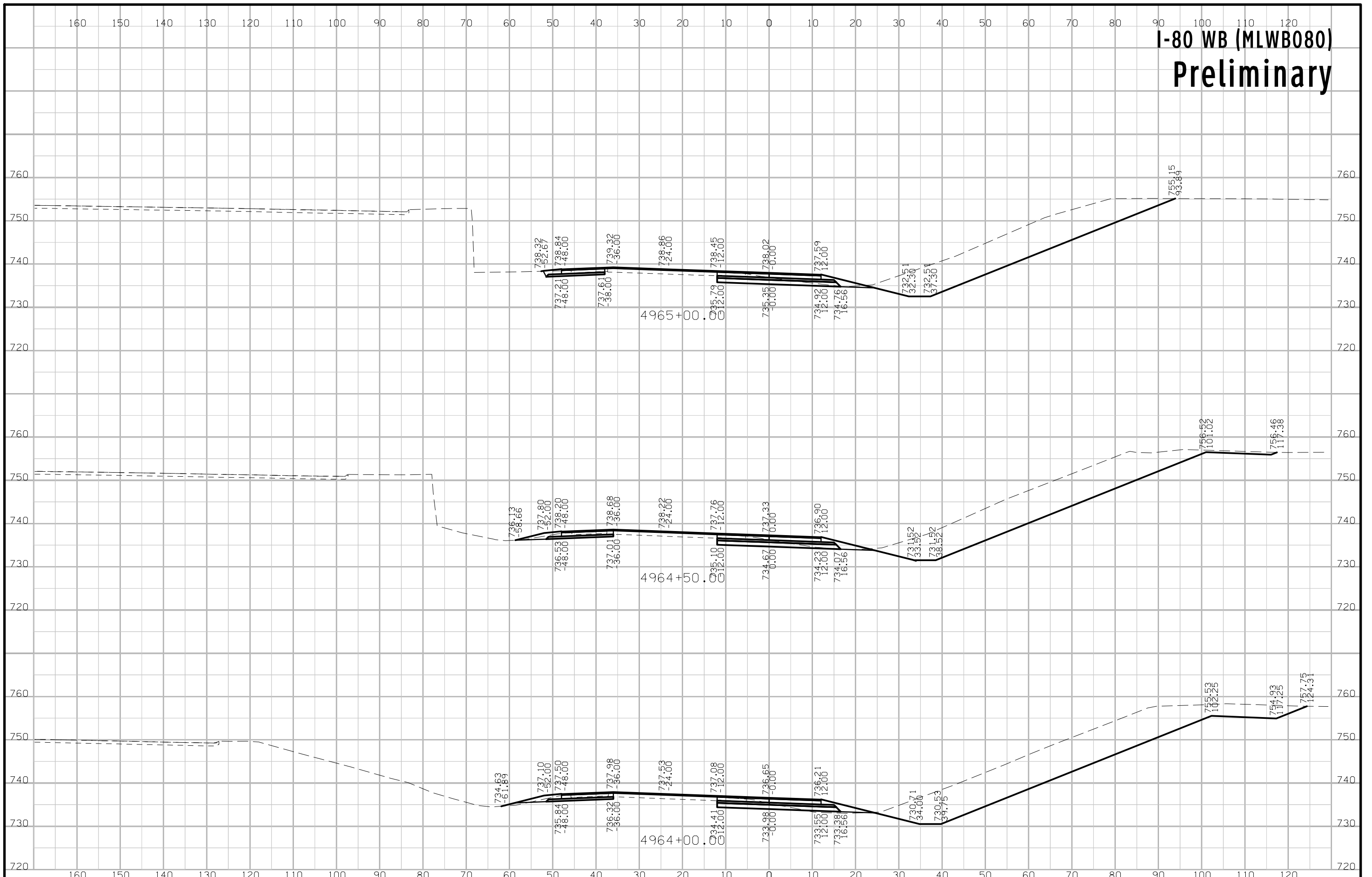

# I-80 WB (MLWB080) Preliminary

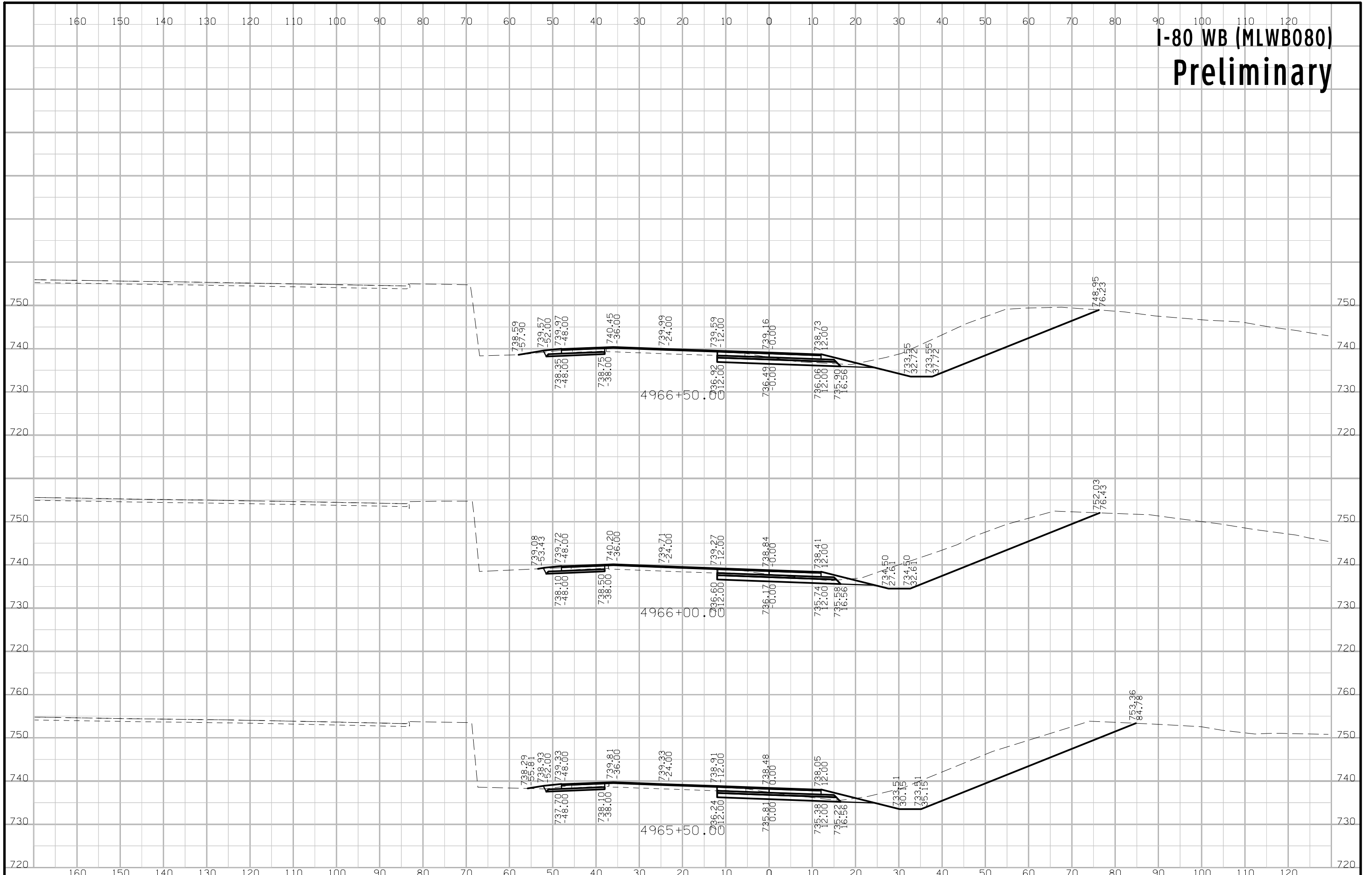

# I-80 WB (MLWB080) Preliminary

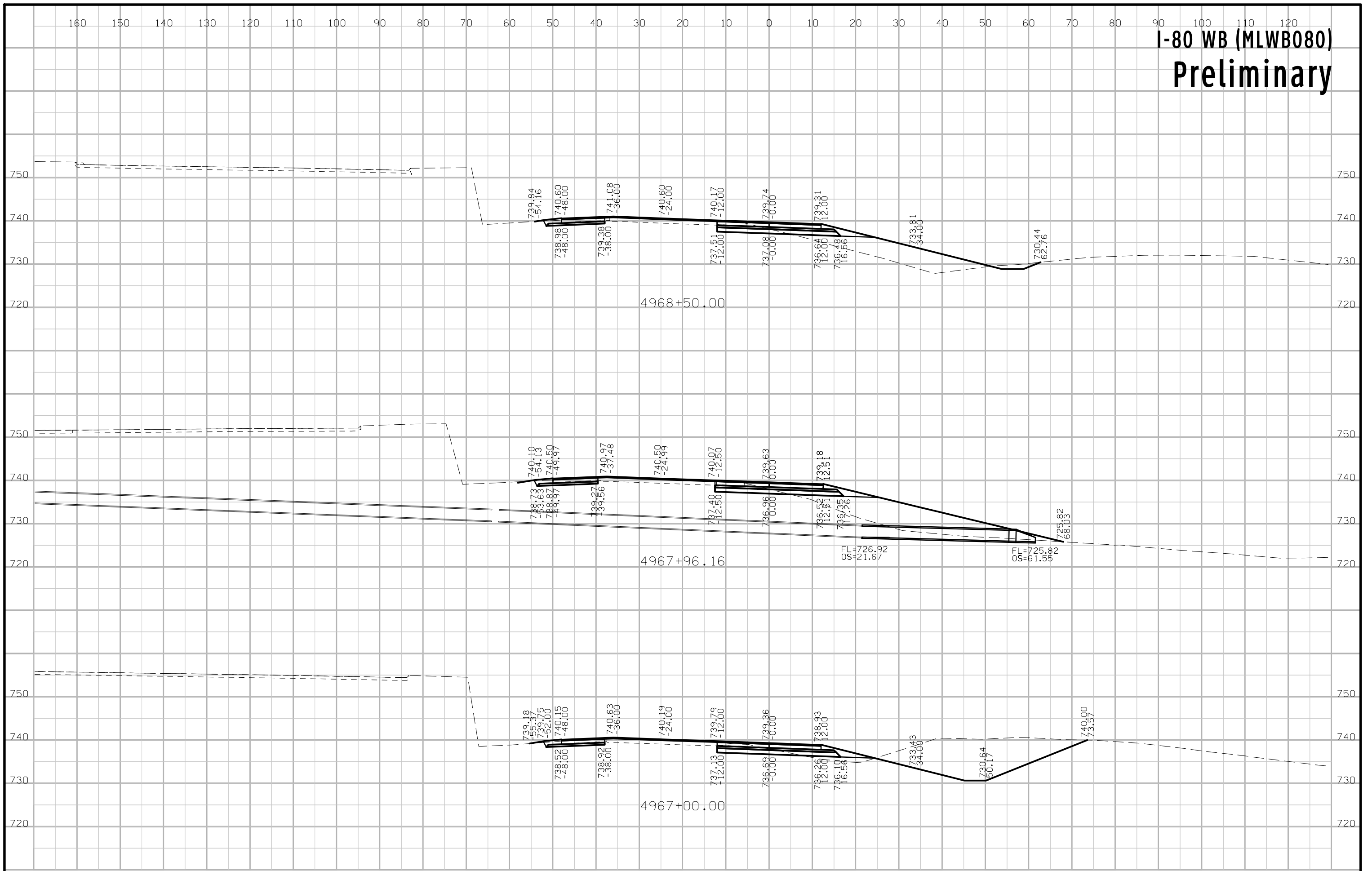

# I-80 WB (MLWB080) Preliminary

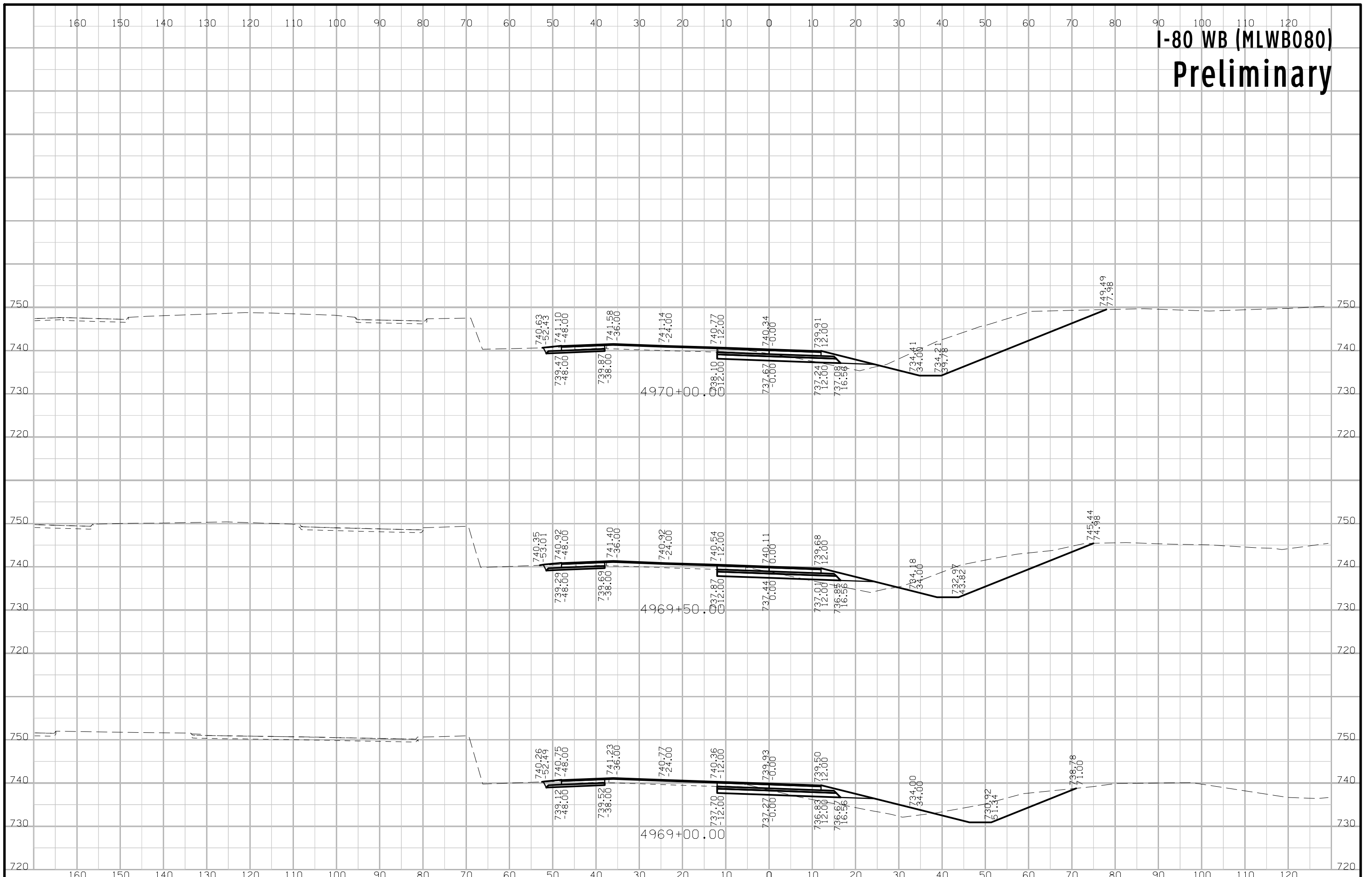

# I-80 WB (MLWB080) Preliminary

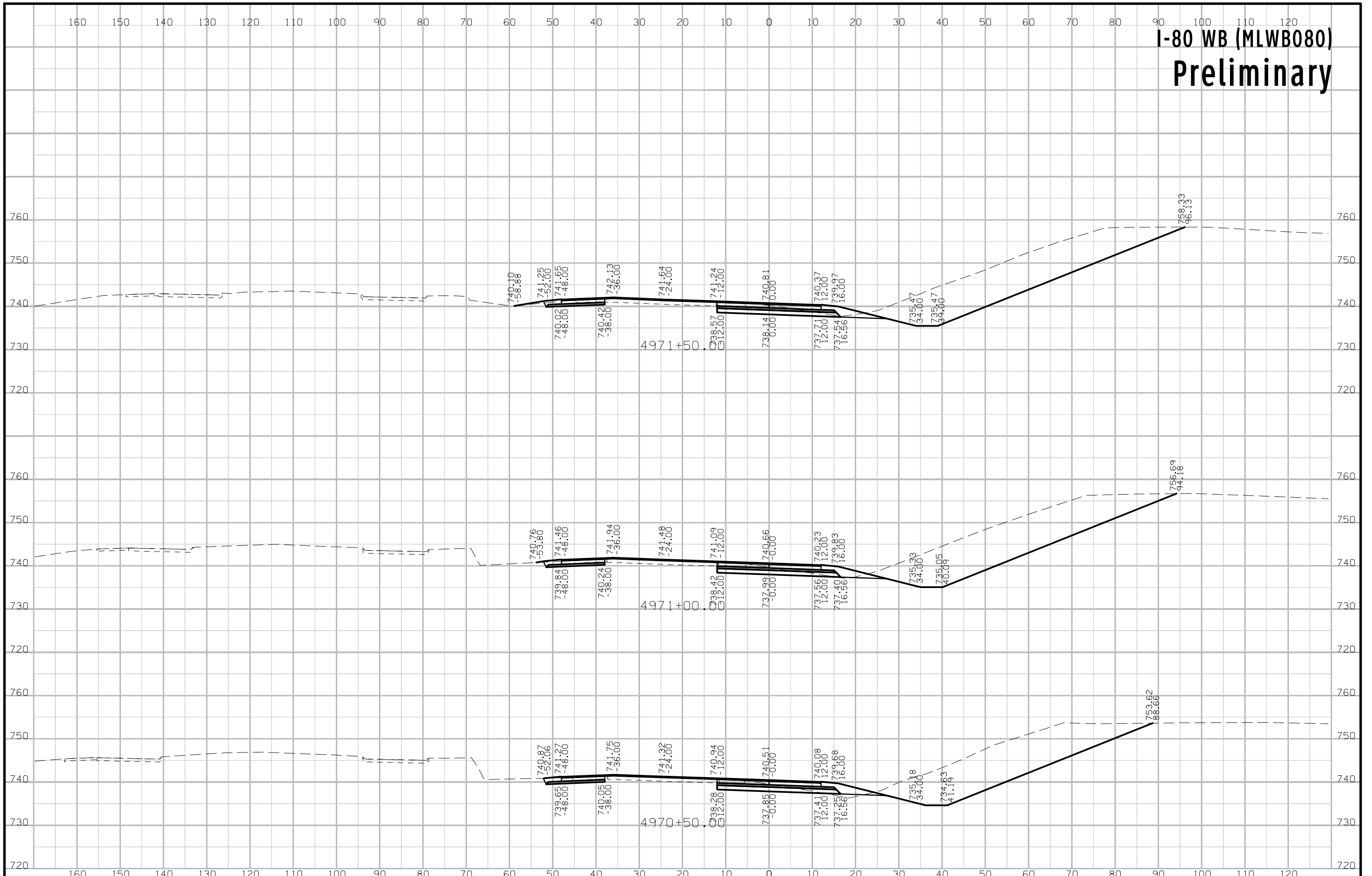

# I-80 WB (MLWB080) Preliminary

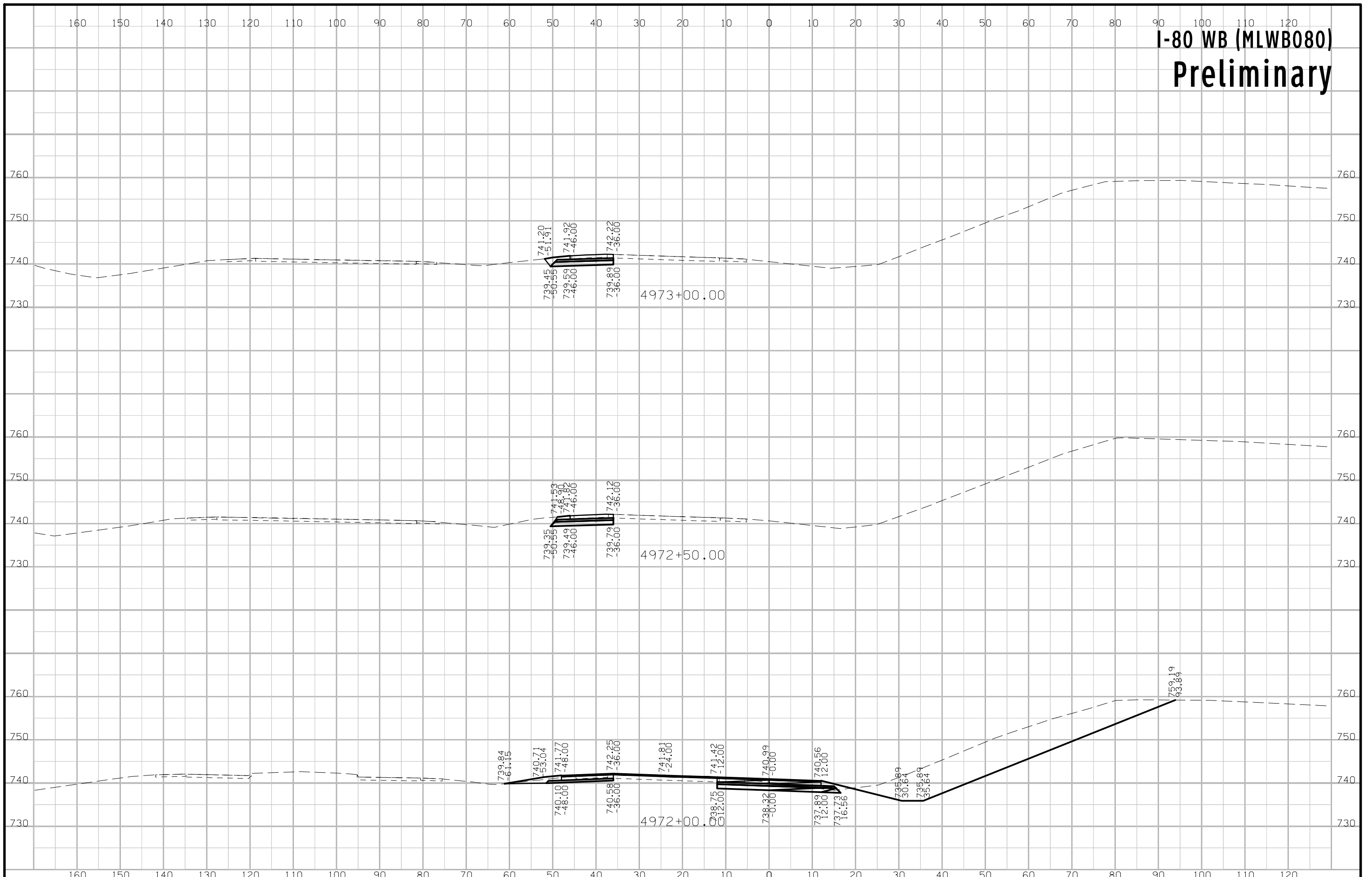

# I-80 WB (MLWB080) Preliminary

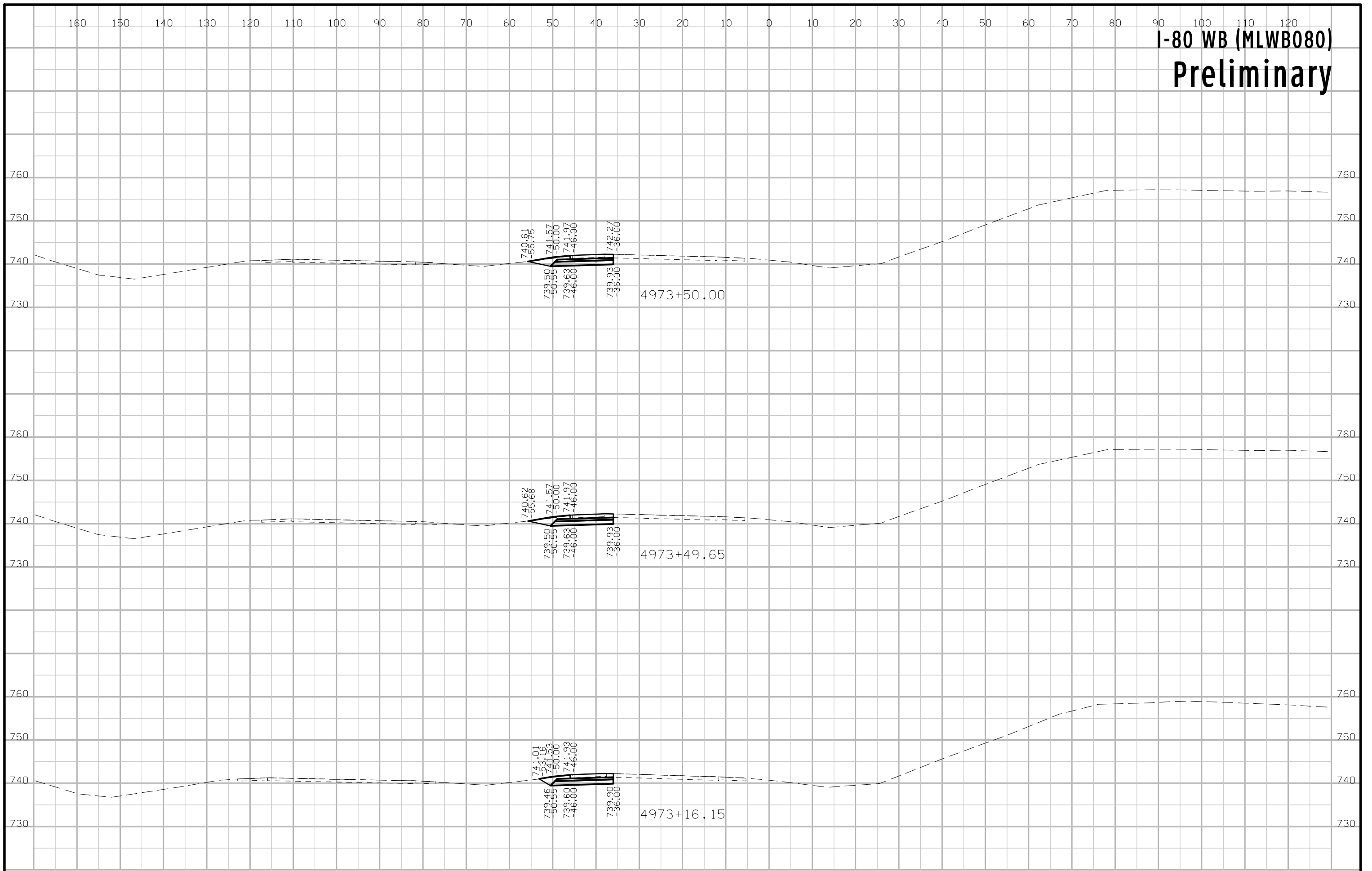

# I-80 WB (MLWB080) Preliminary

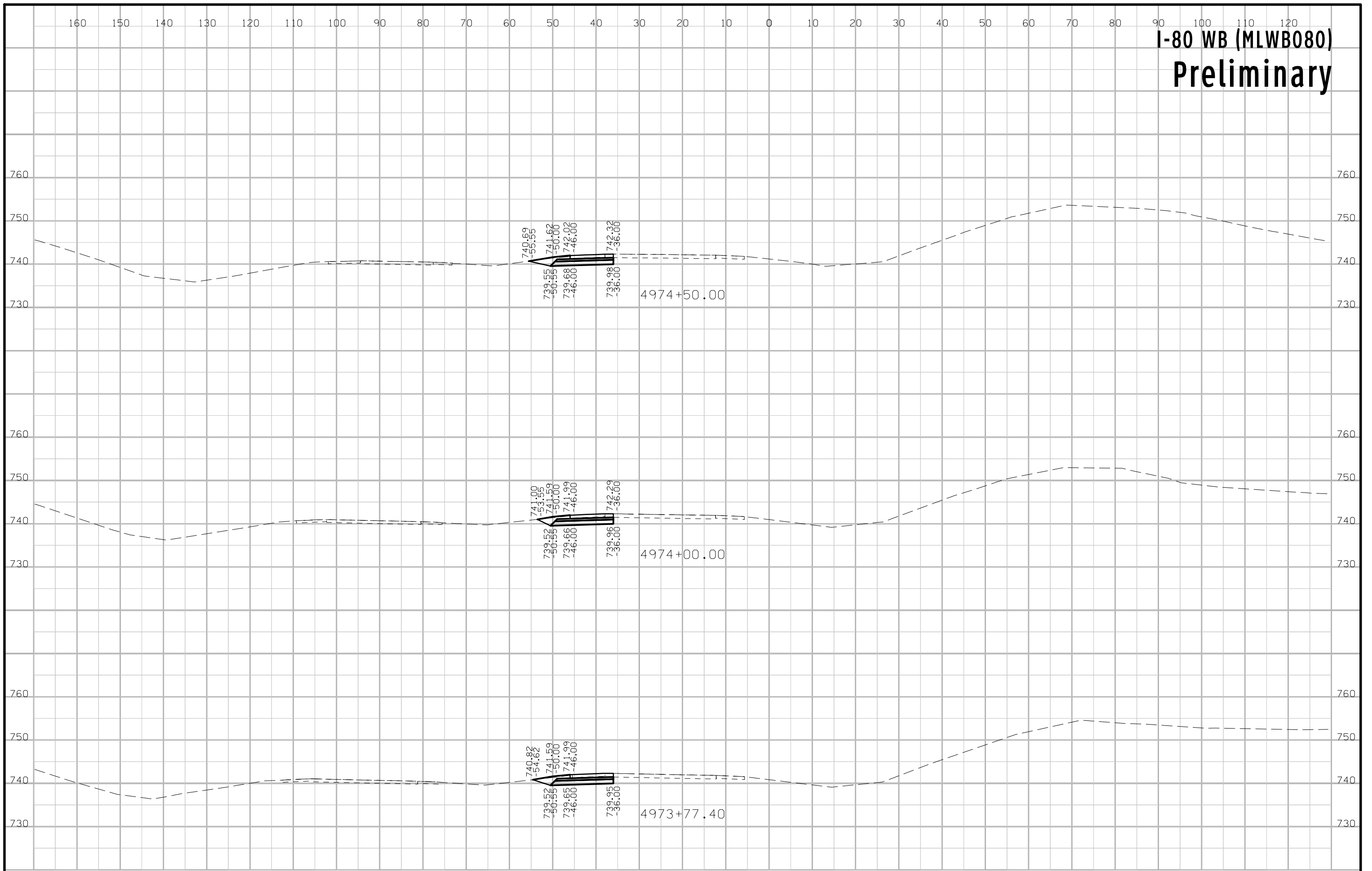



**I-80 WB (MLWB080)  
Preliminary**

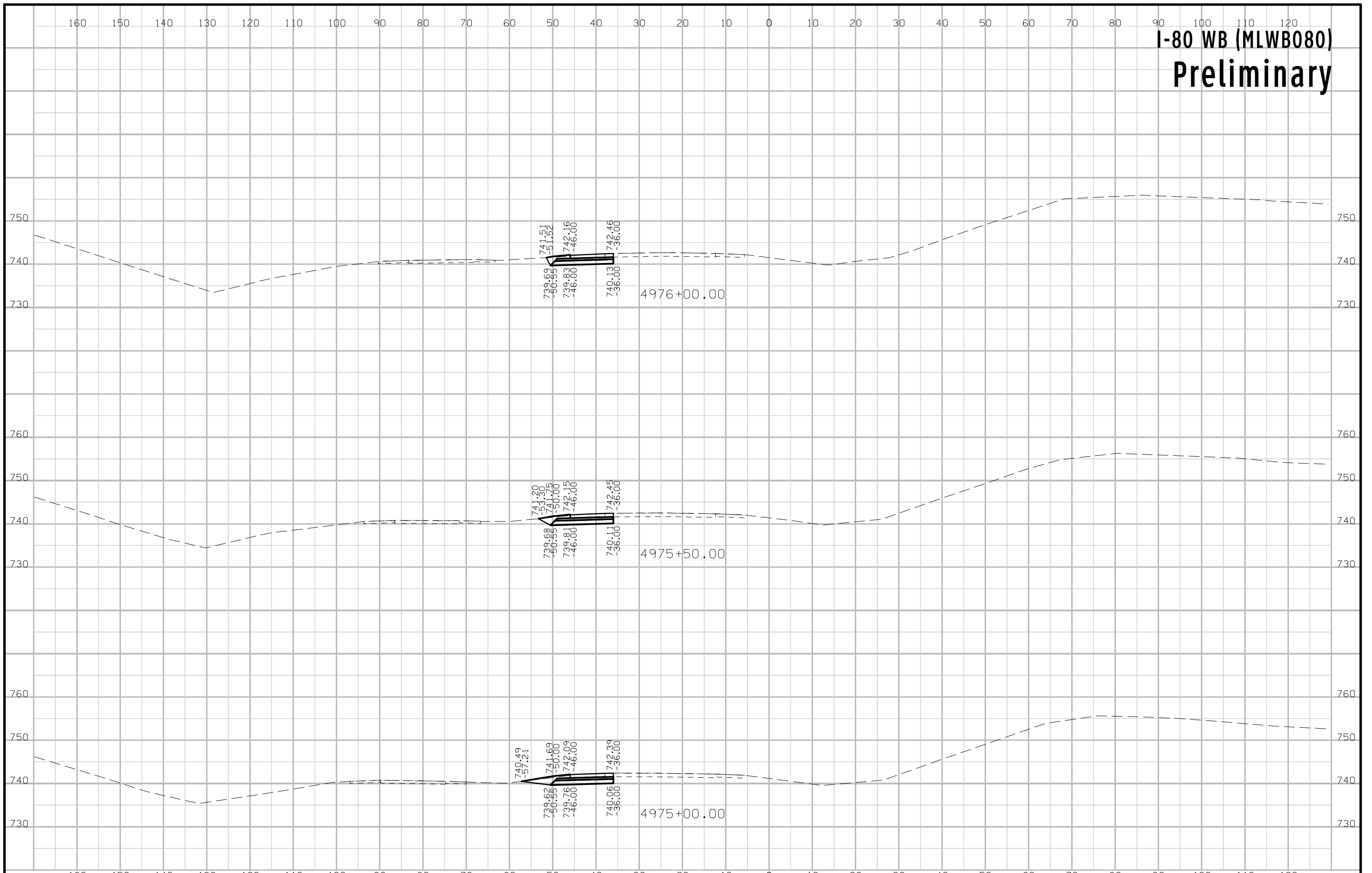

**I-80 WB (MLWB080)**  
**Preliminary**

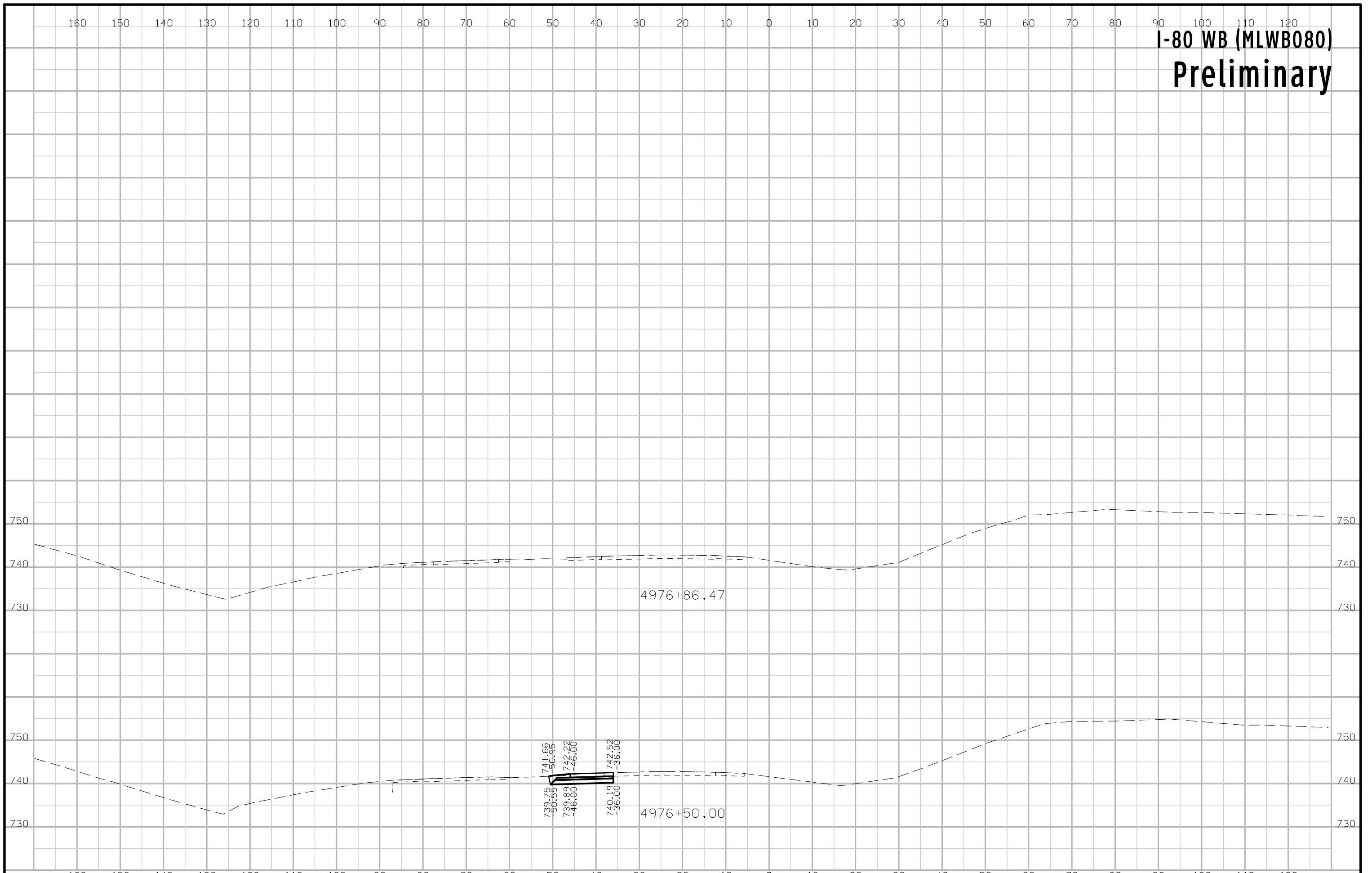

# I-80 EB (MLEB080) Preliminary

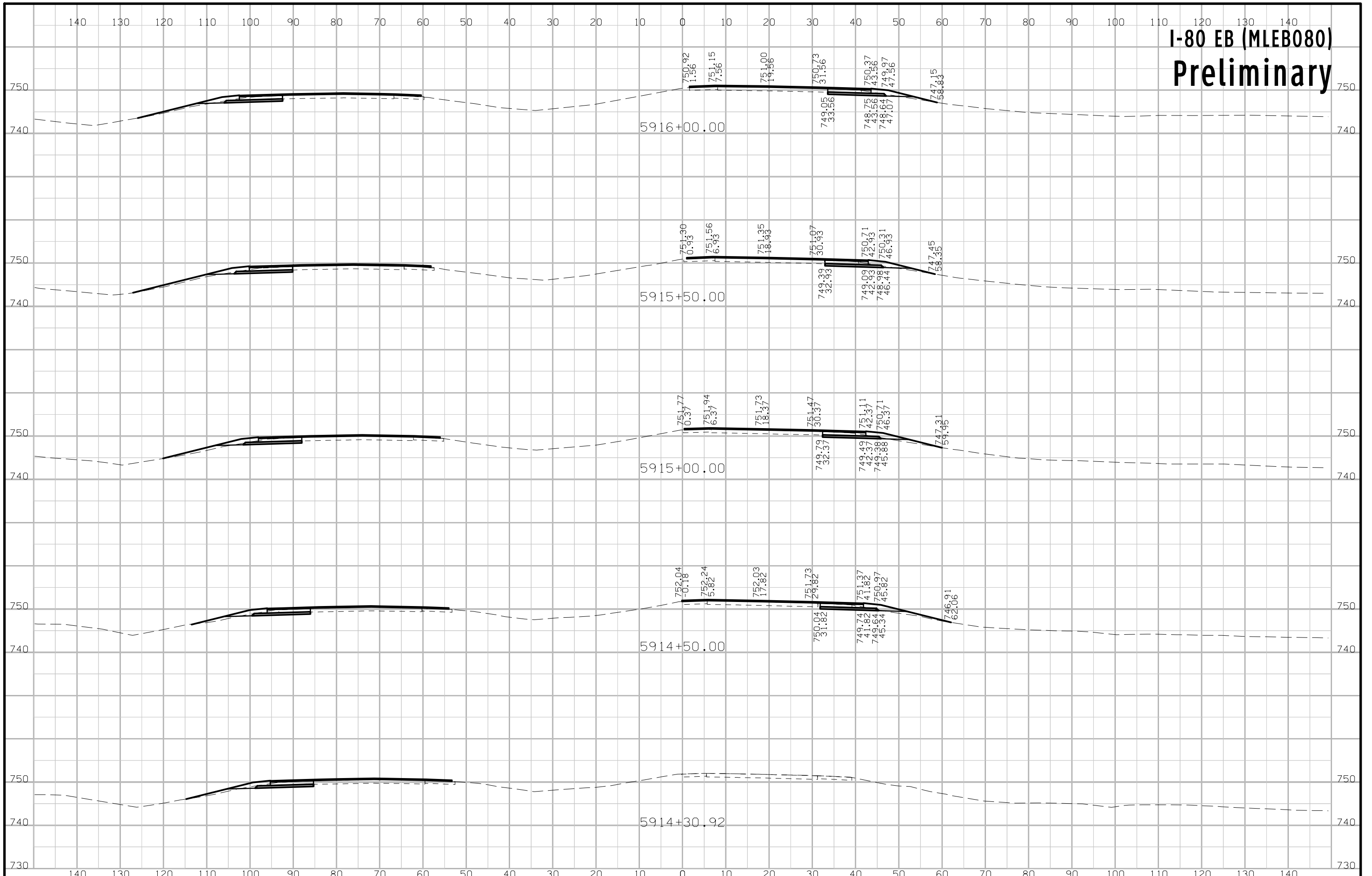

# I-80 EB (MLEB080) Preliminary

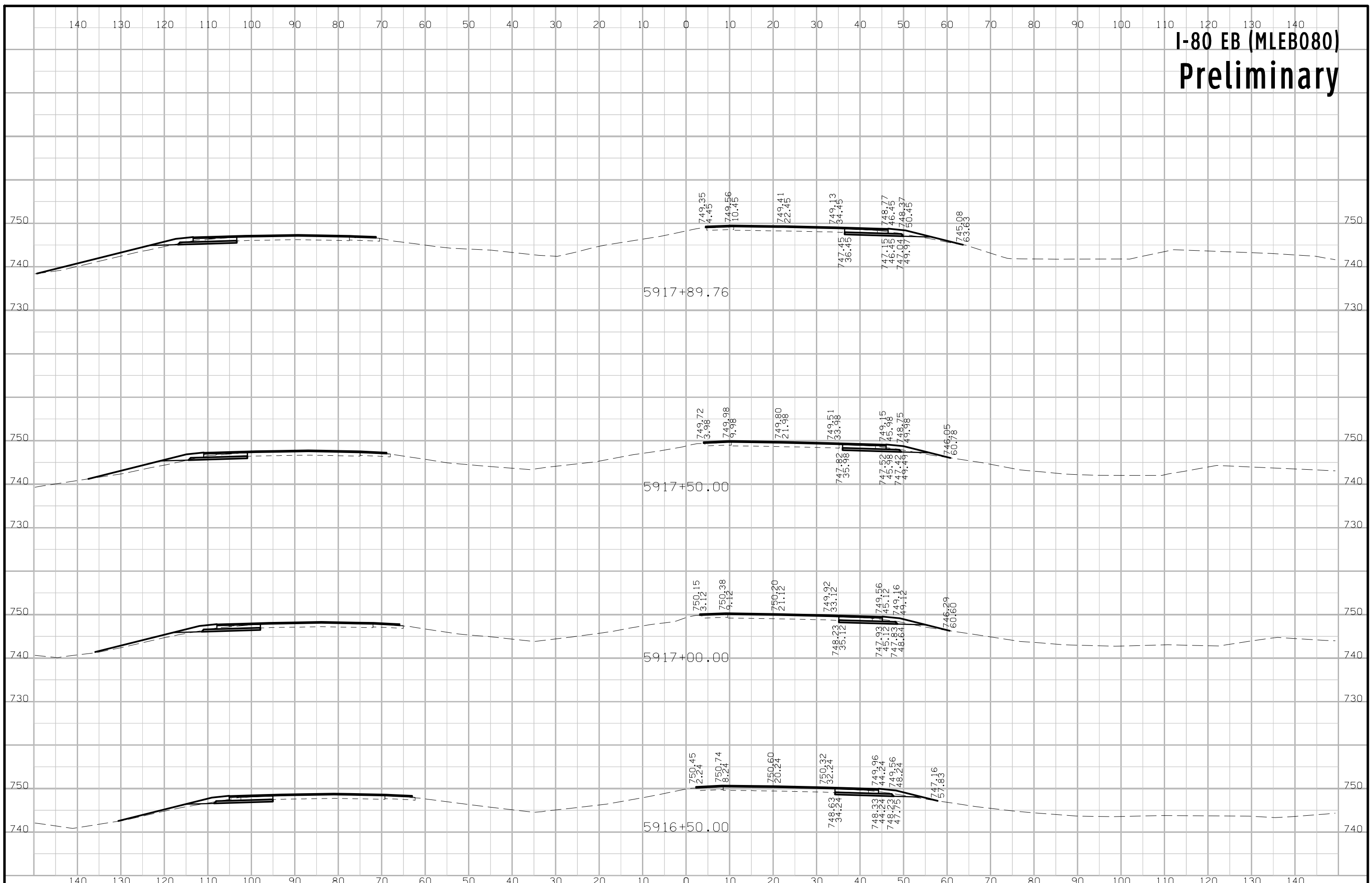

# I-80 EB (MLEB080) Preliminary

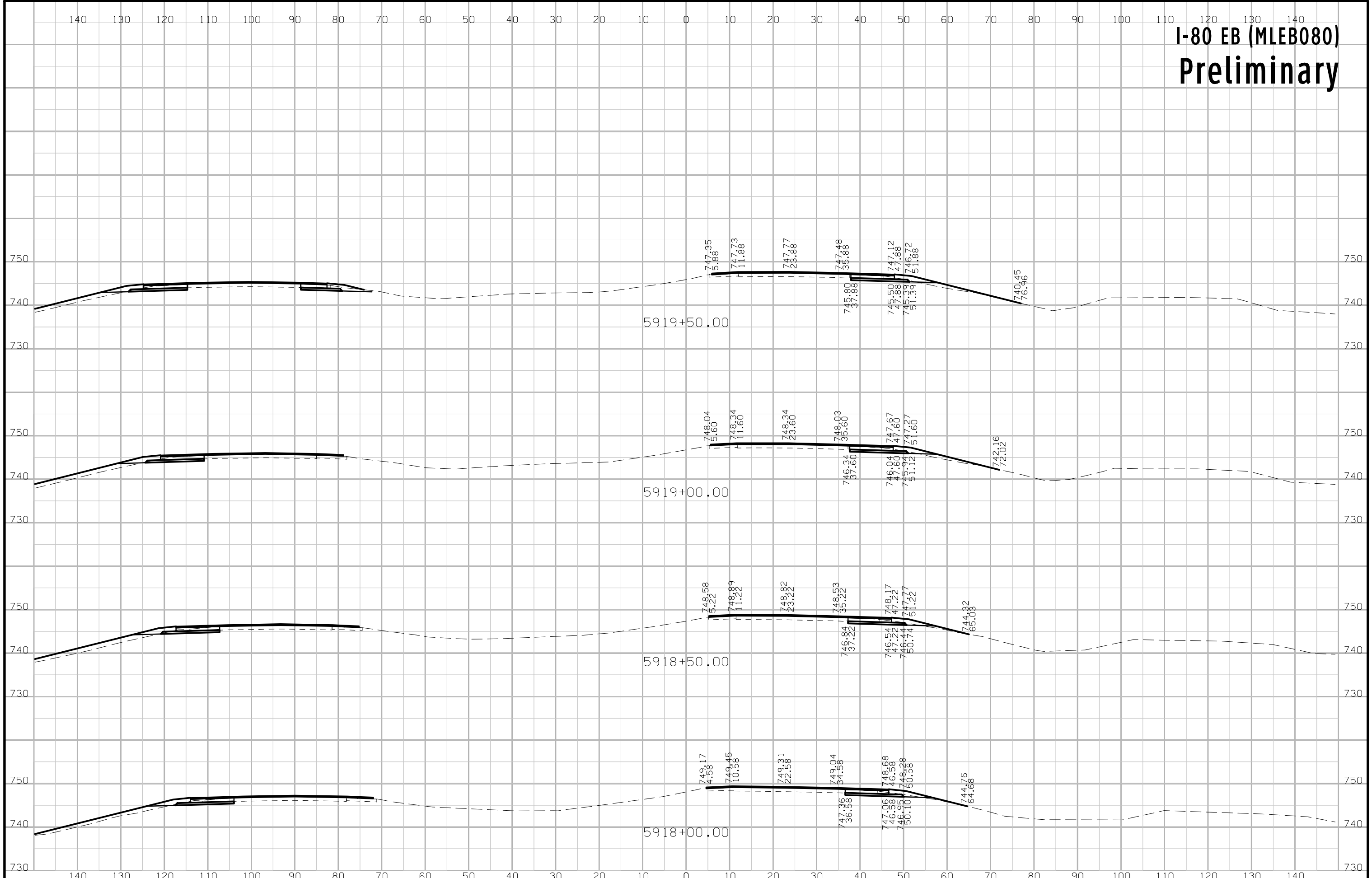

# I-80 EB (MLEB080) Preliminary

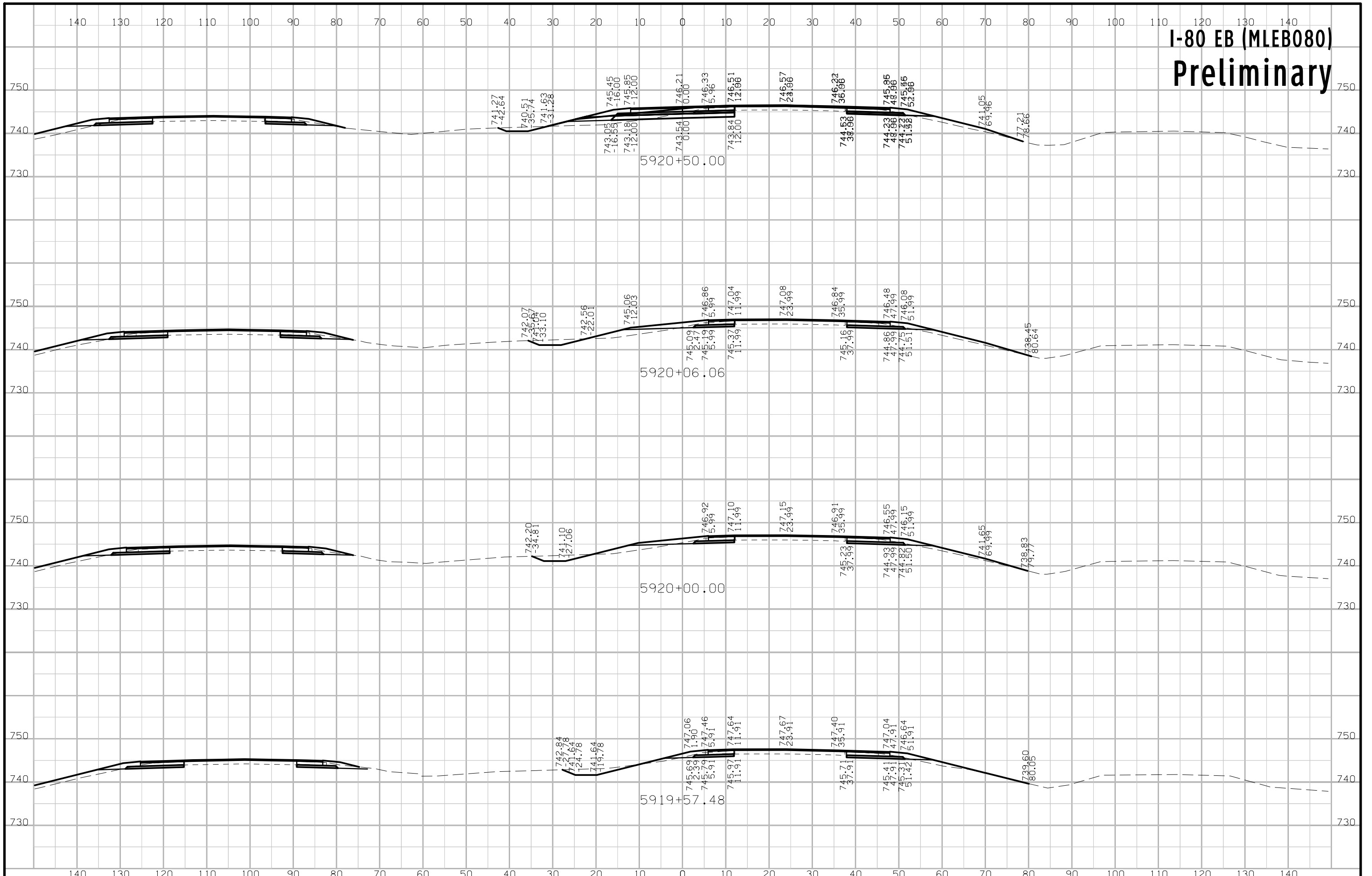

# I-80 EB (MLEB080) Preliminary

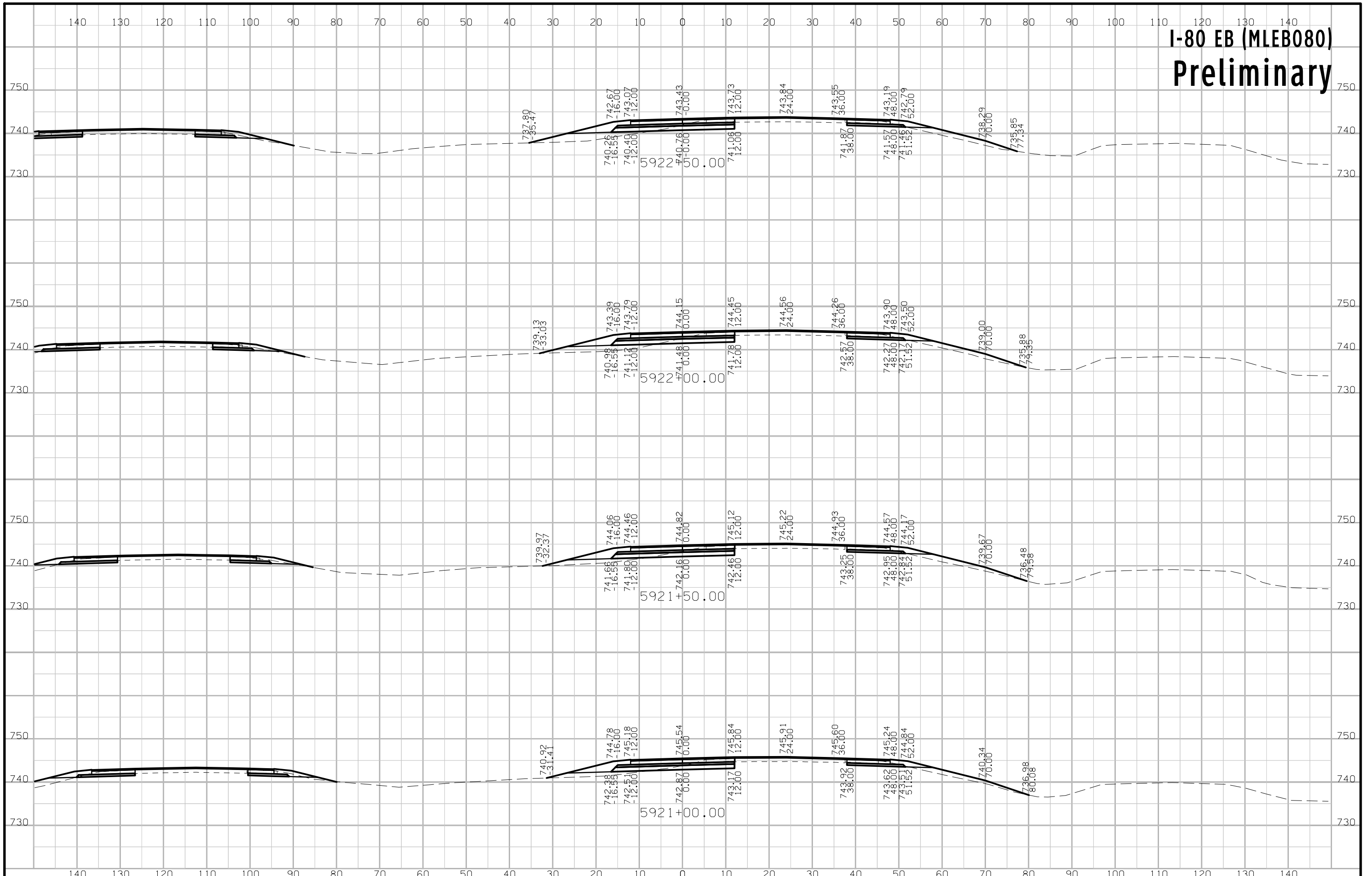

# I-80 EB (MLEB080) Preliminary

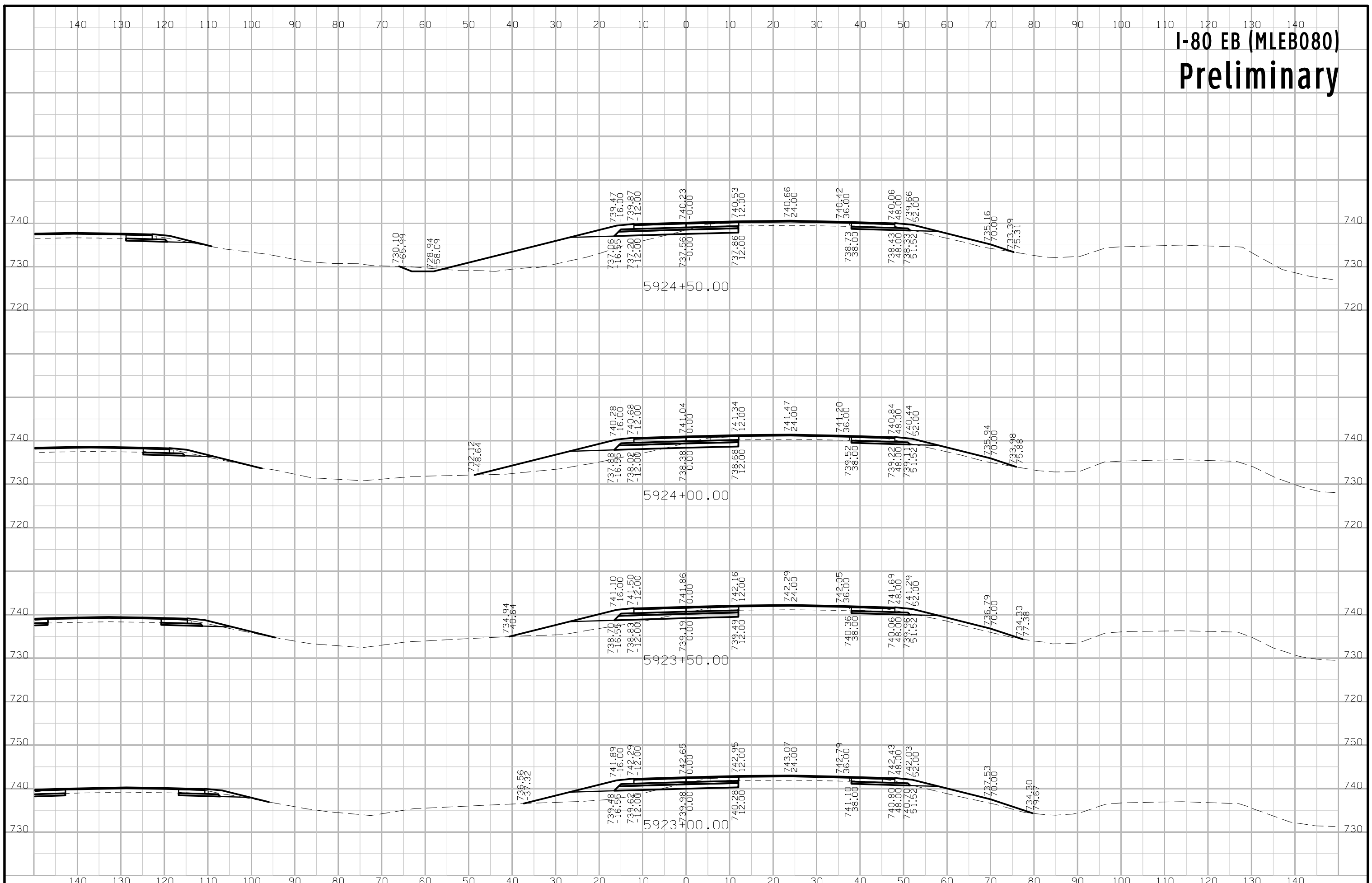



# I-80 EB (MLEB080) Preliminary

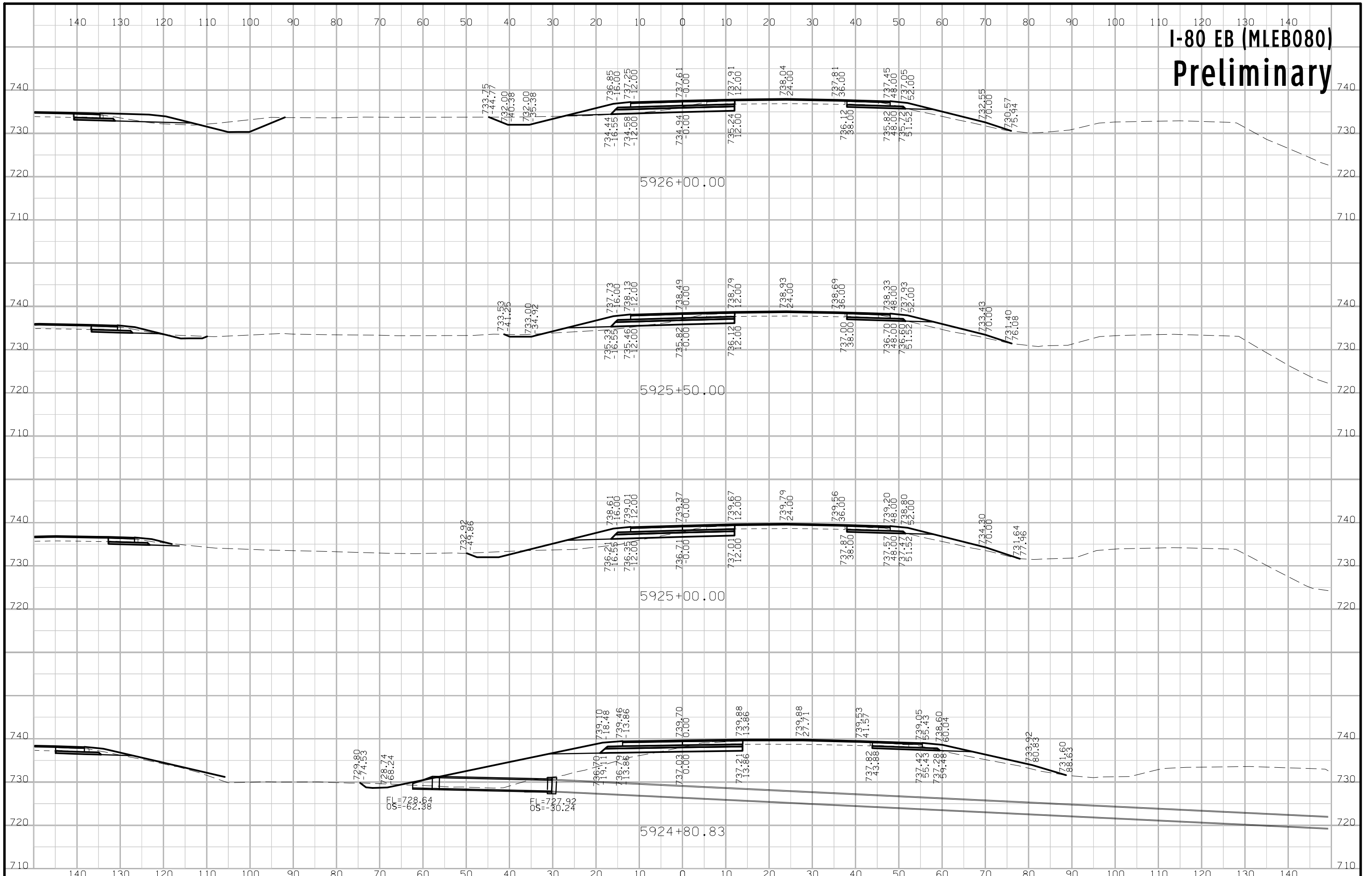

# I-80 EB (MLEB080) Preliminary

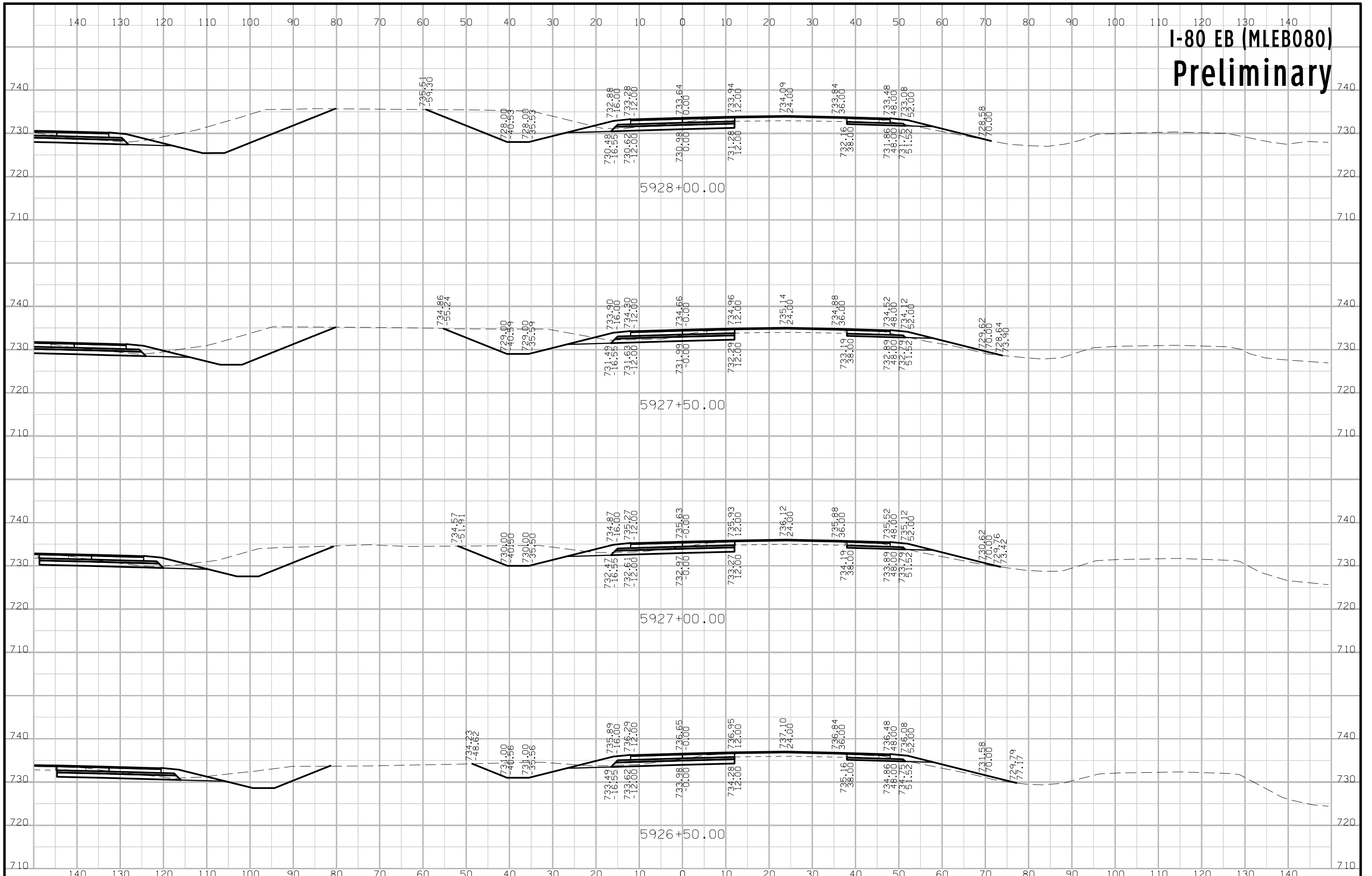

# I-80 EB (MLEB080) Preliminary

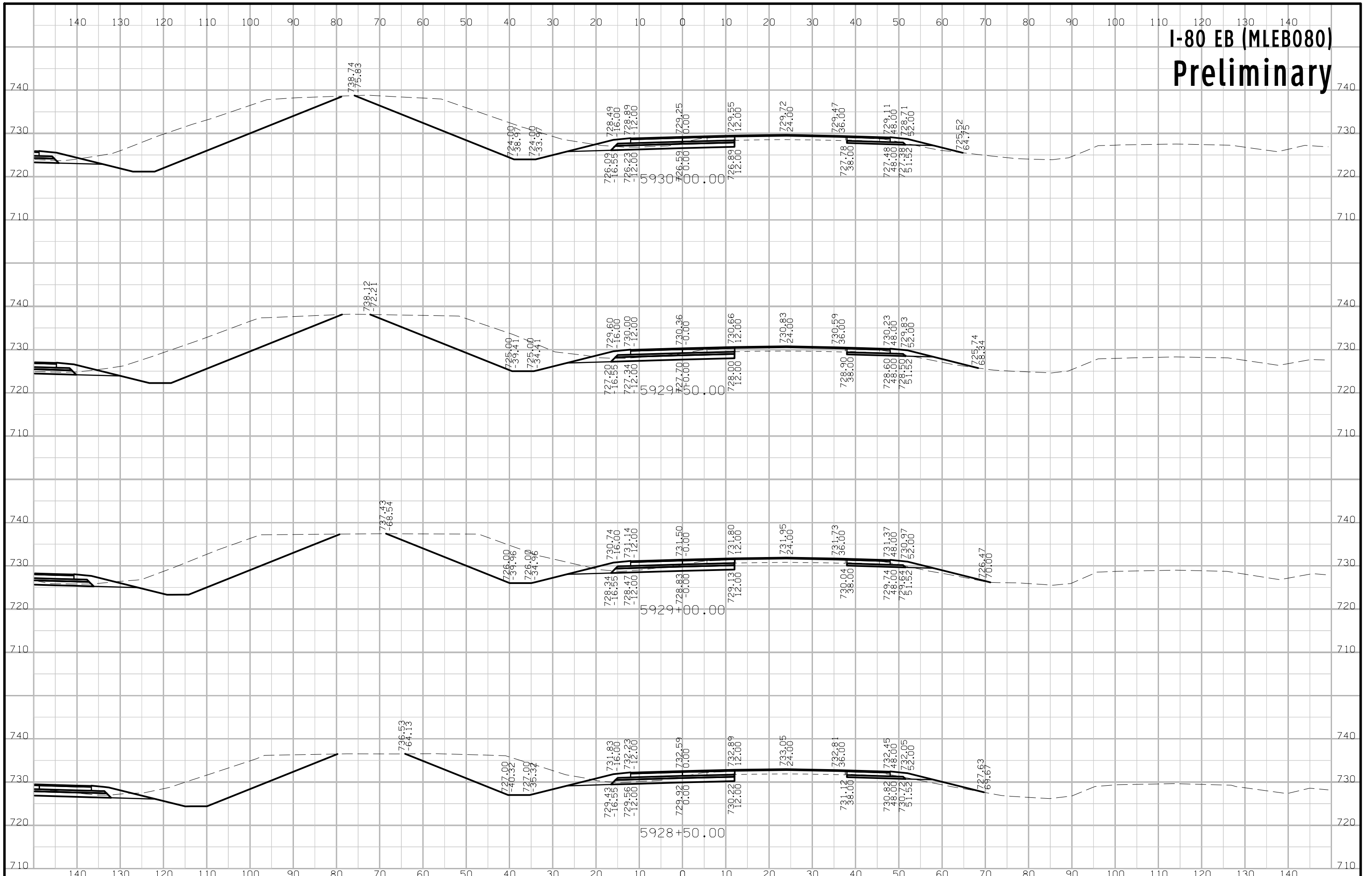

# I-80 EB (MLEB080) Preliminary

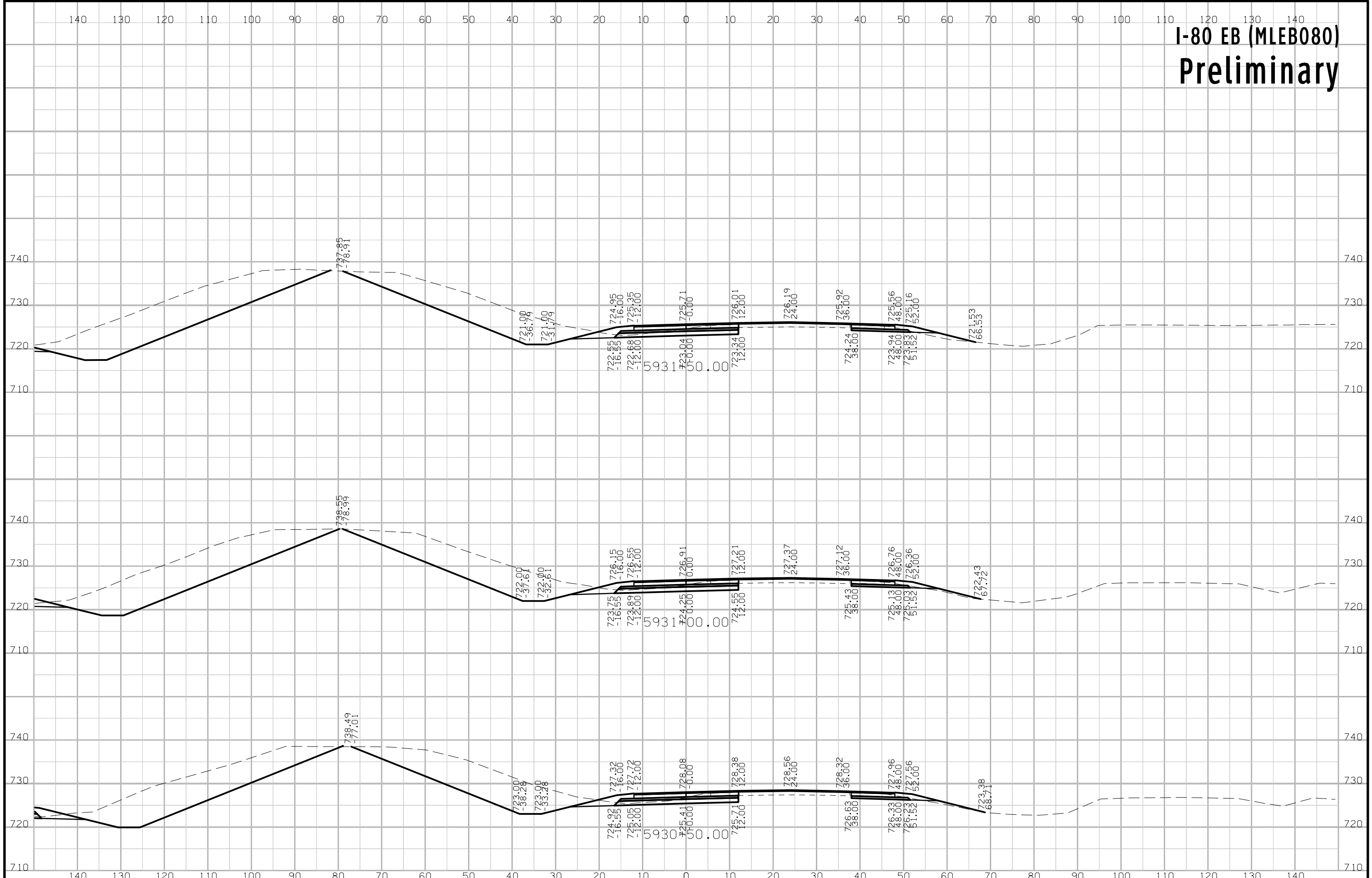

# I-80 EB (MLEB080) Preliminary

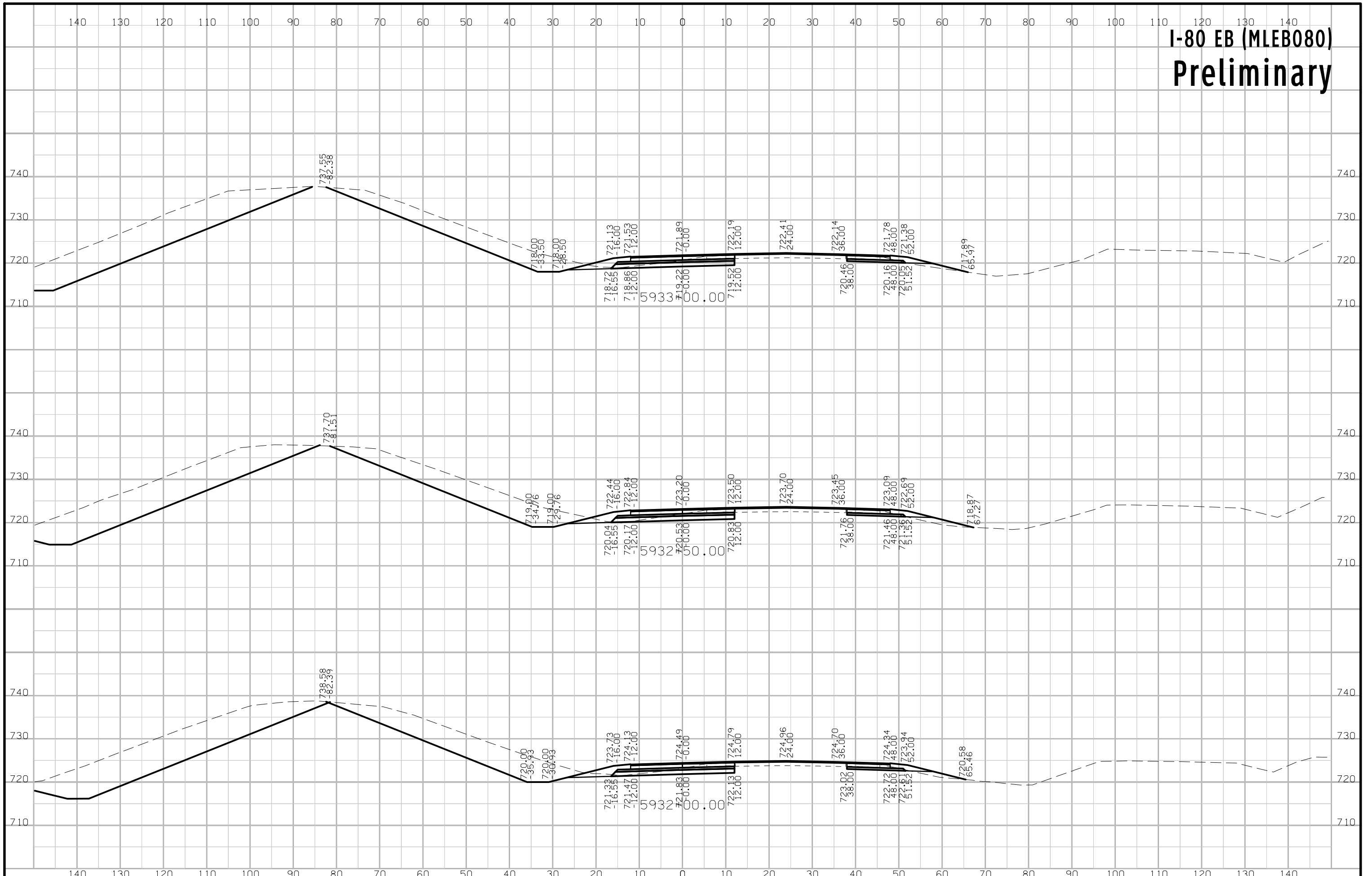

# I-80 EB (MLEB080) Preliminary

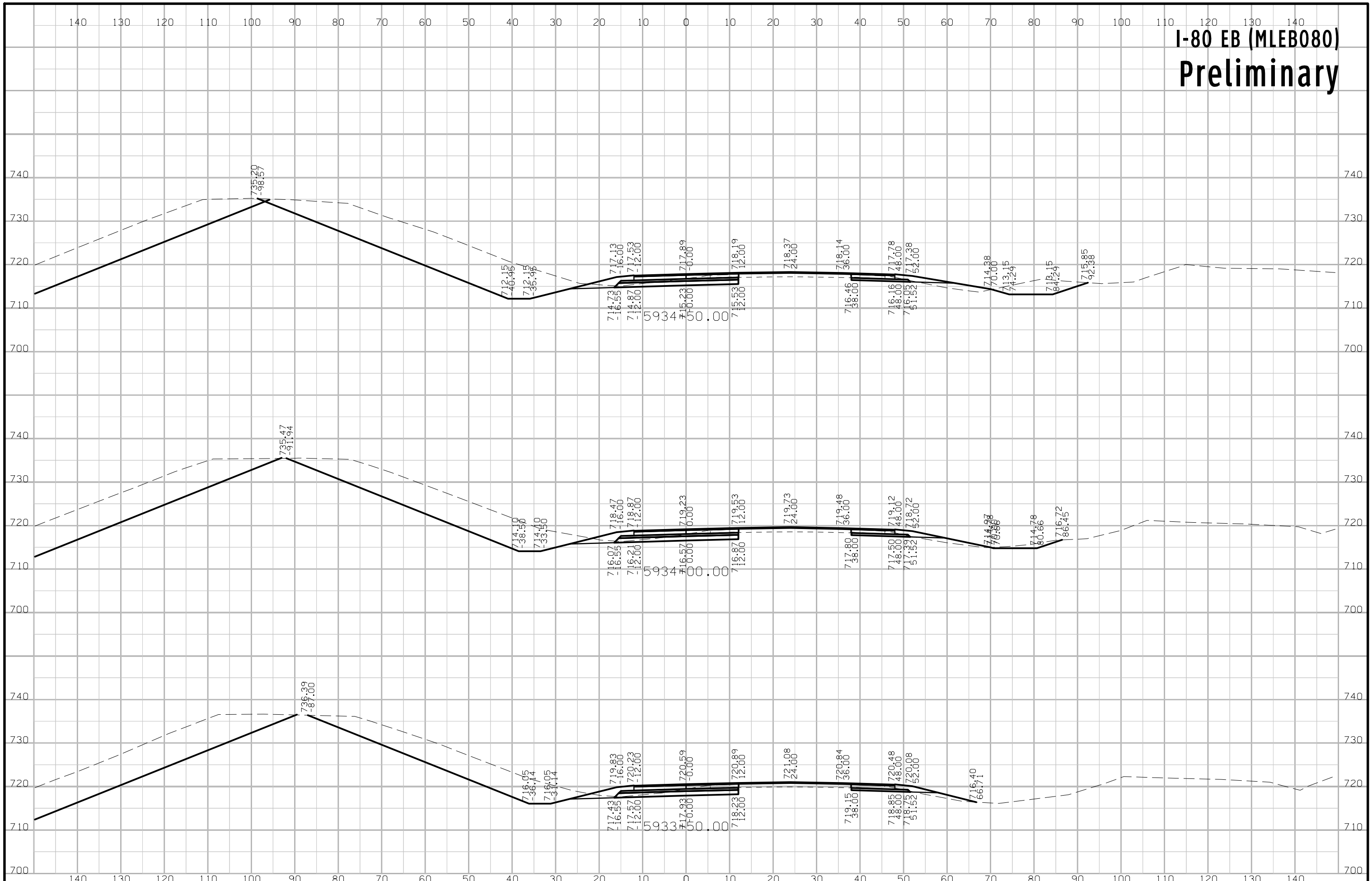

# I-80 EB (MLEB080) Preliminary

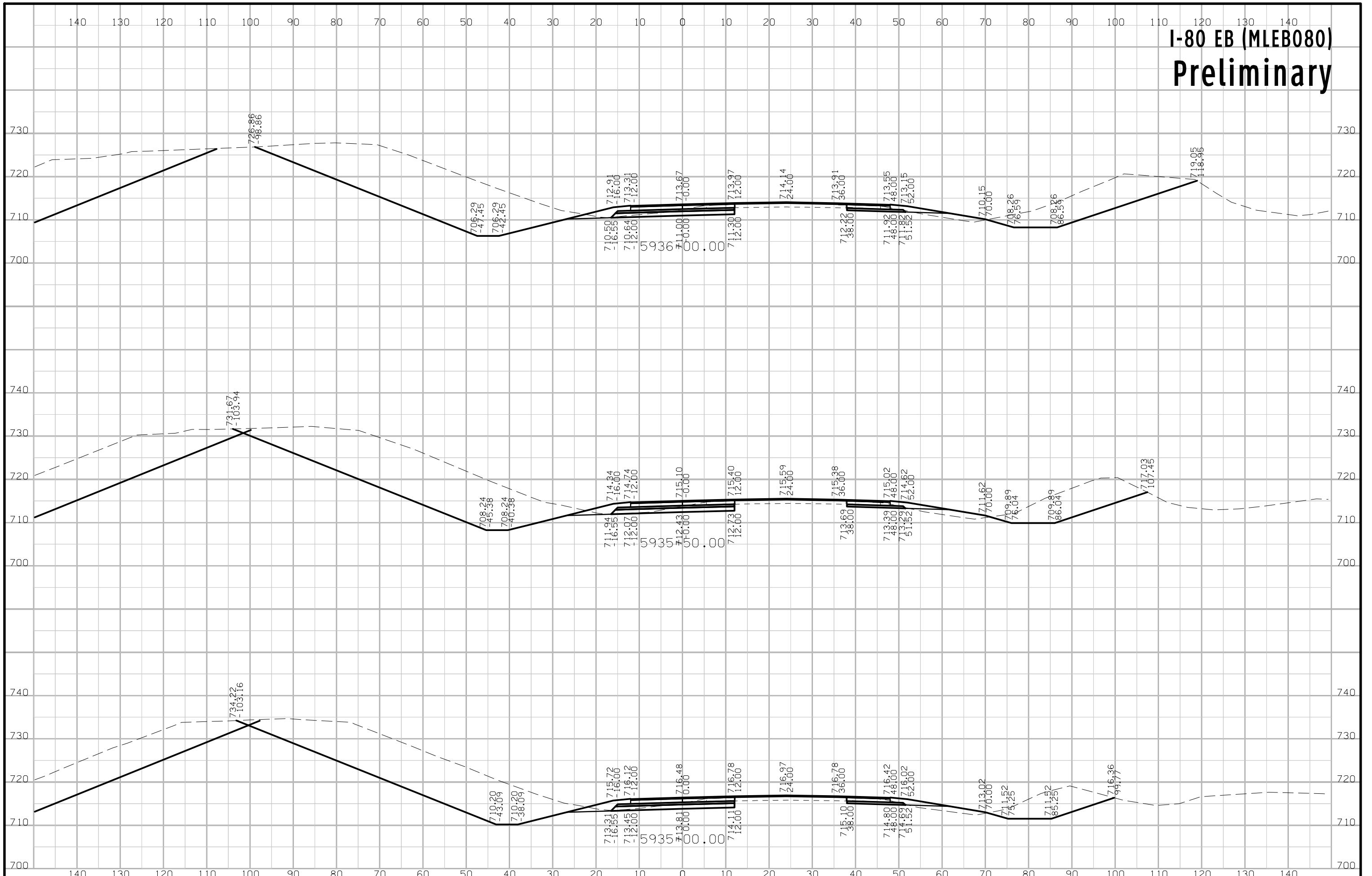

# I-80 EB (MLEB080) Preliminary

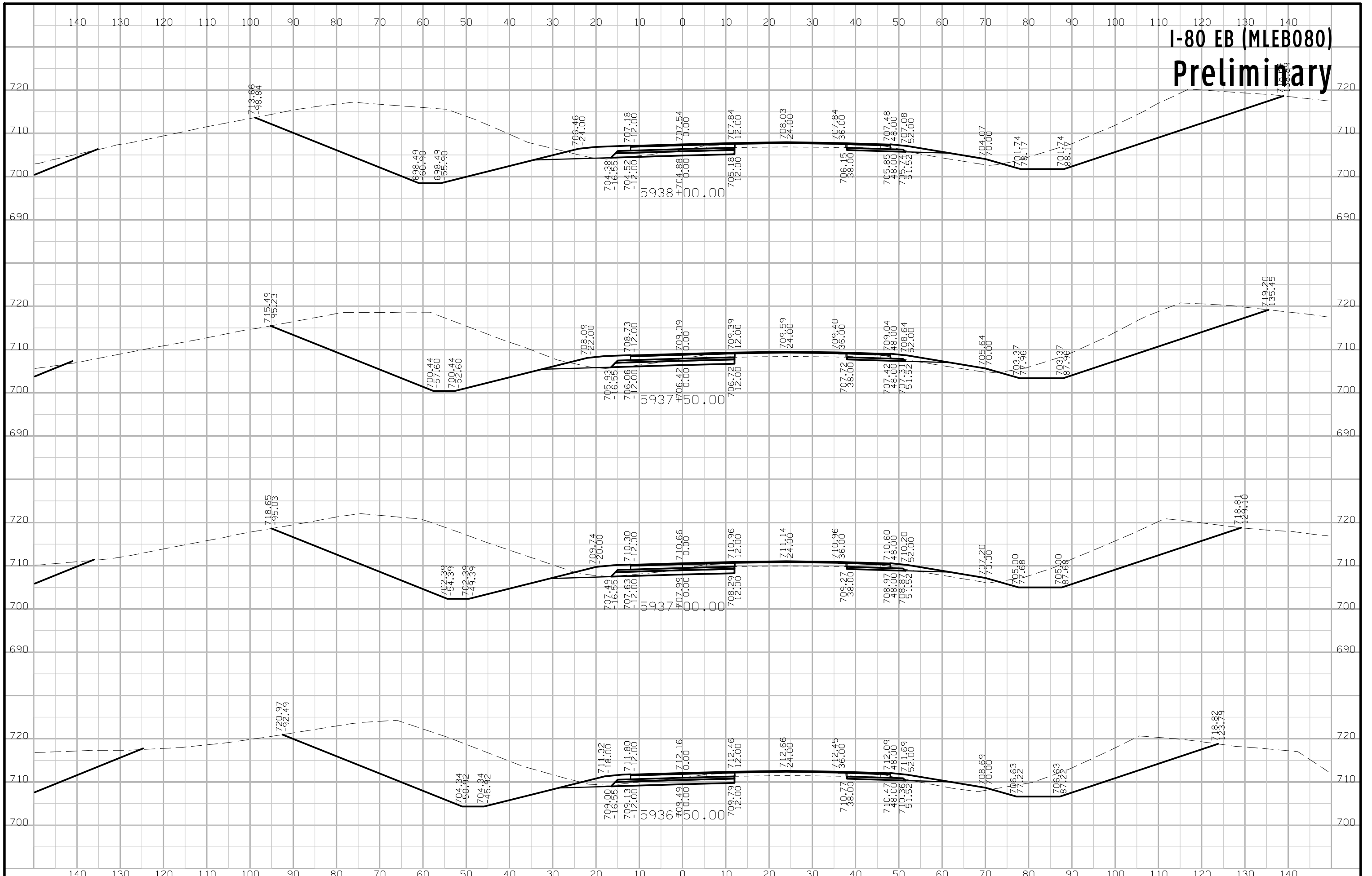



# I-80 EB (MLEB080) Preliminary

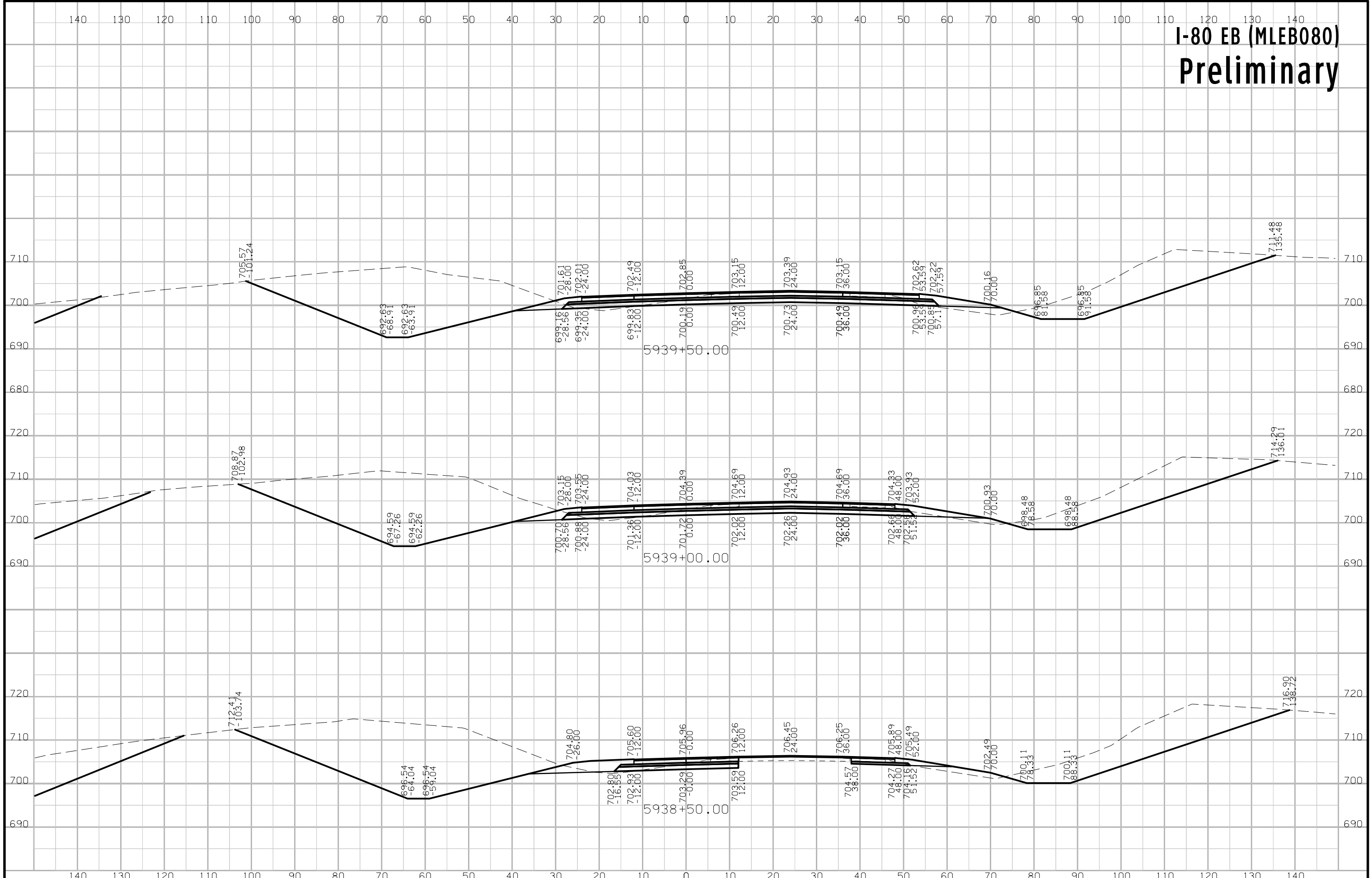

# I-80 EB (MLEB080) Preliminary

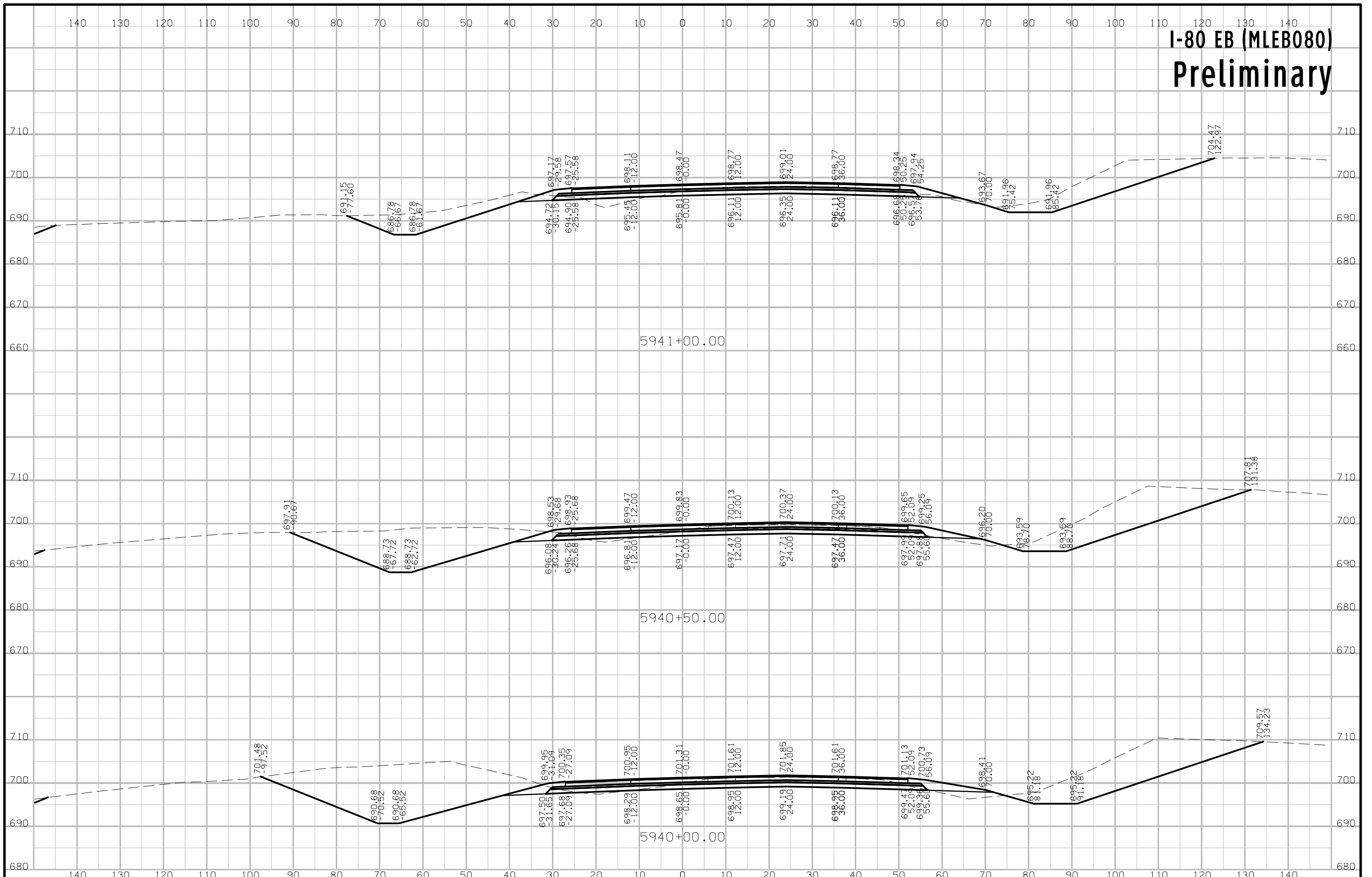

# I-80 EB (MLEB080) Preliminary

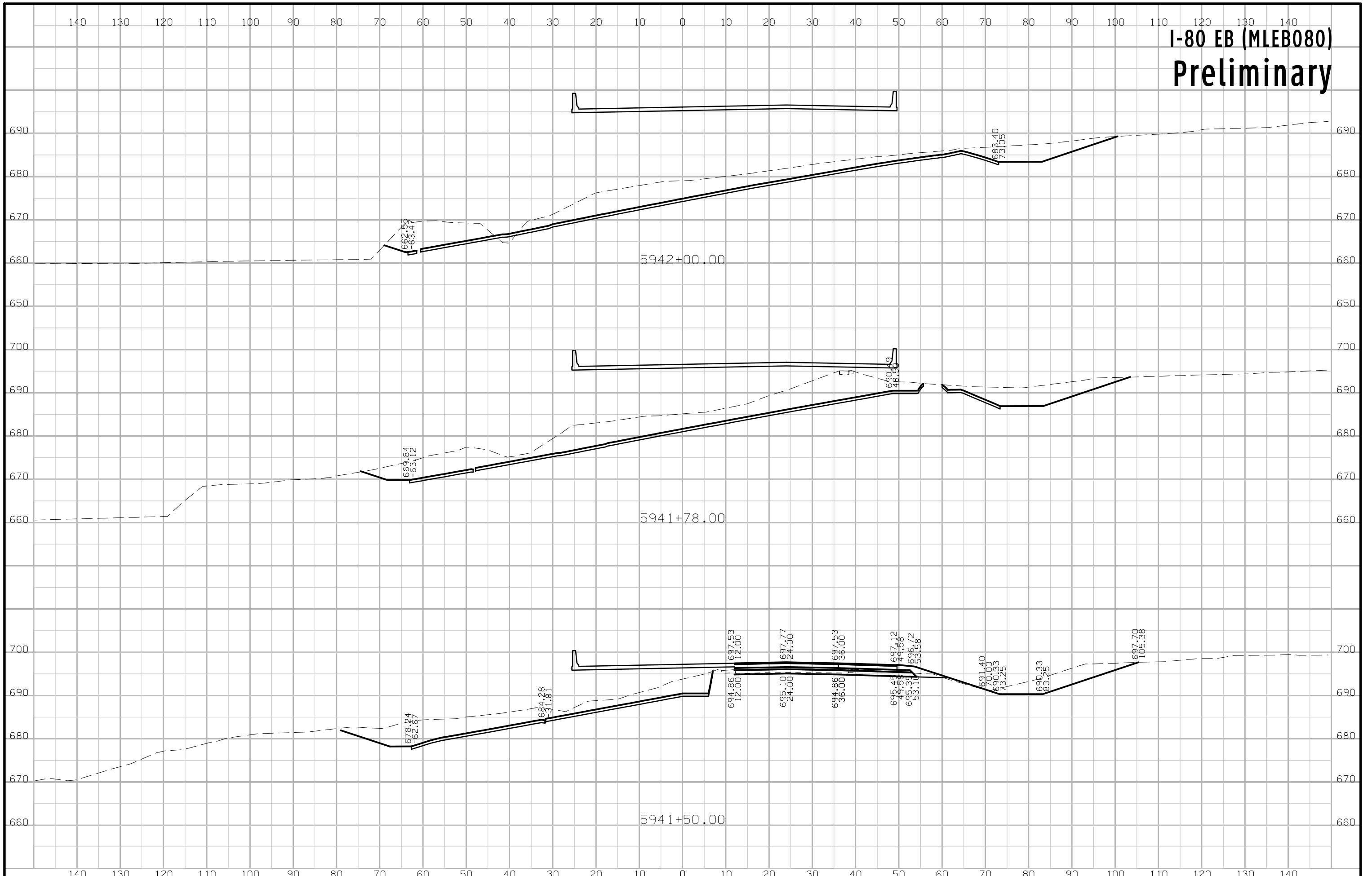

# I-80 EB (MLEB080) Preliminary

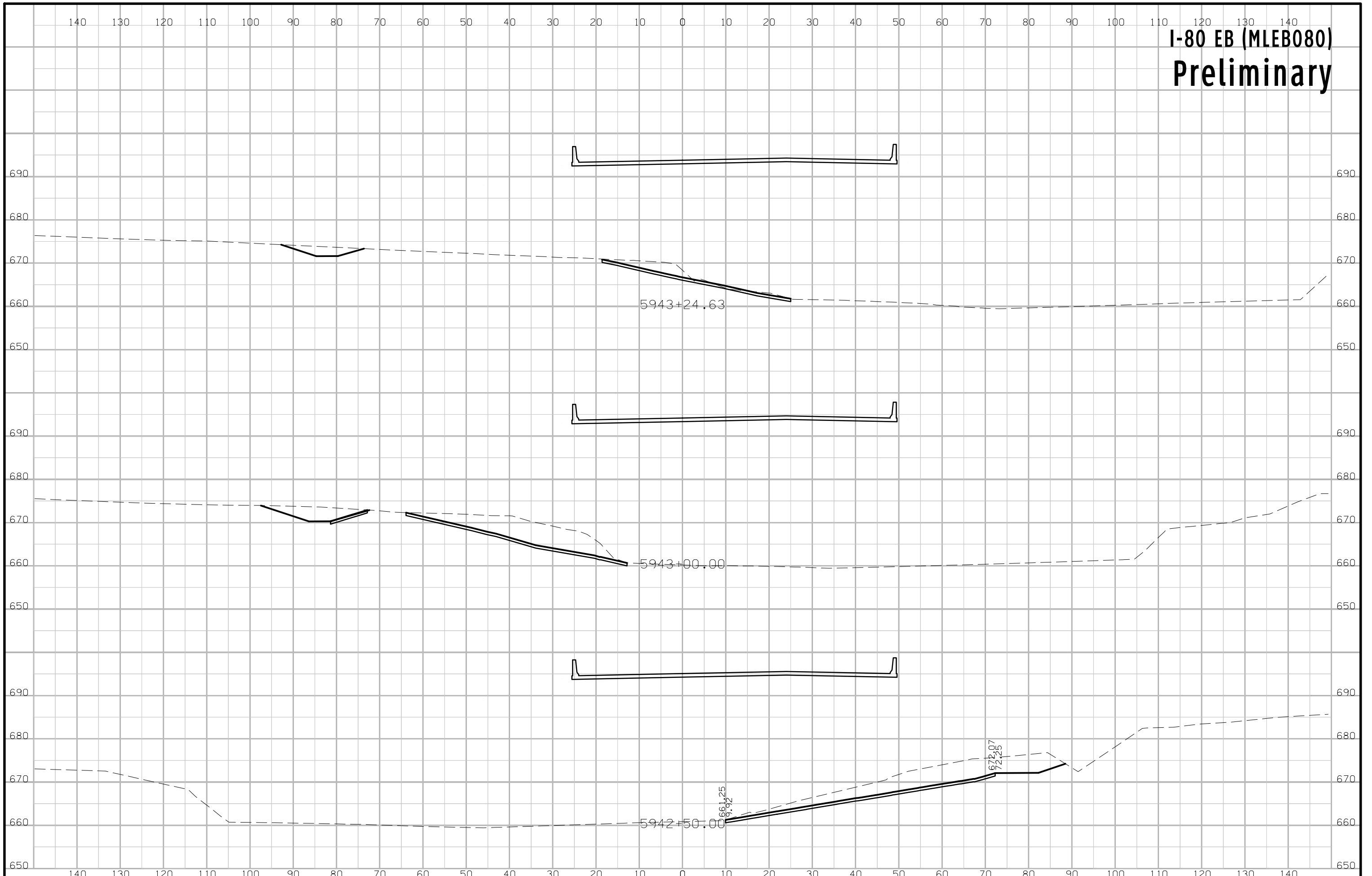

# I-80 EB (MLEB080) Preliminary

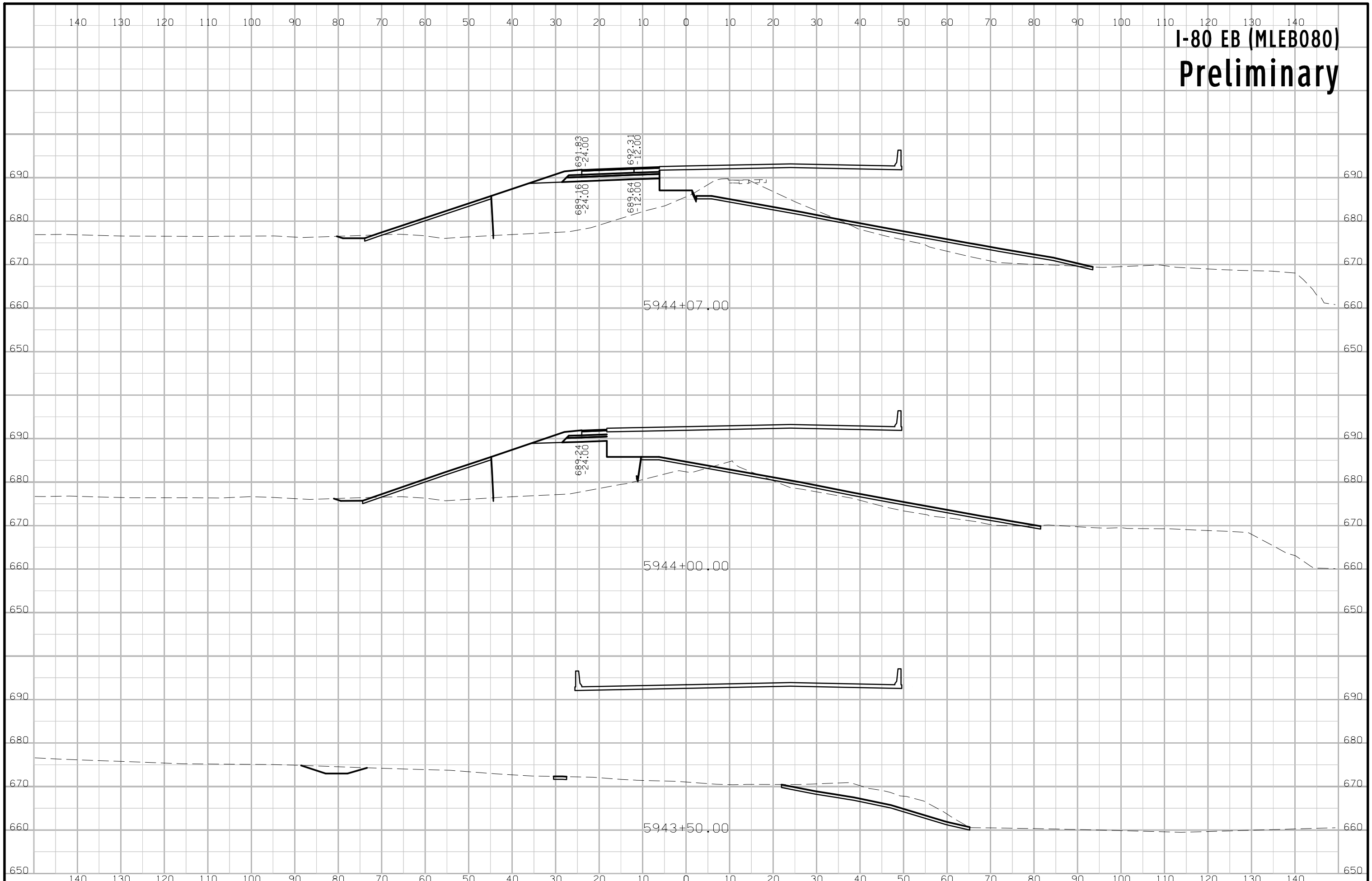

# I-80 EB (MLEB080) Preliminary

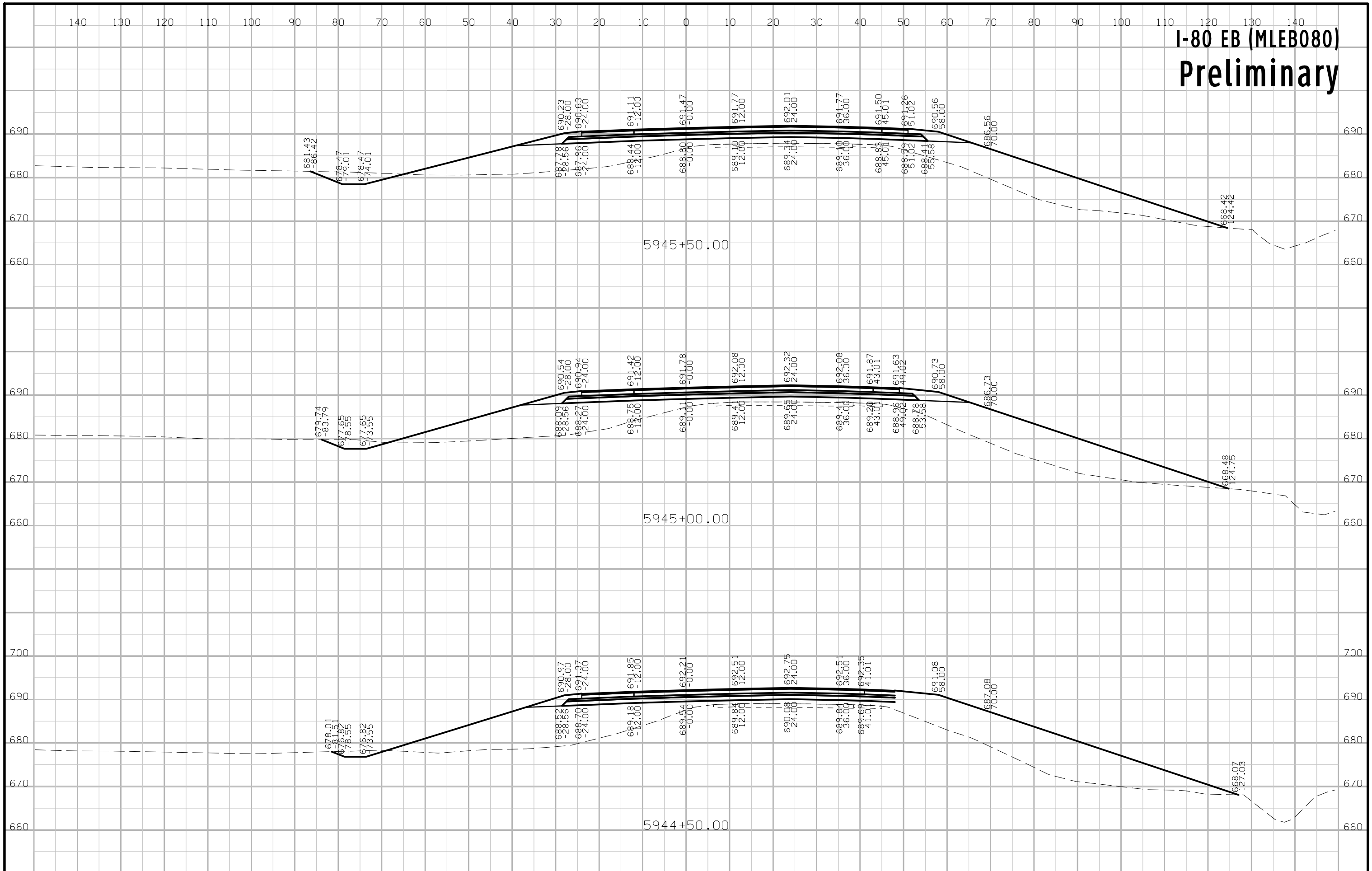

# I-80 EB (MLEB080) Preliminary

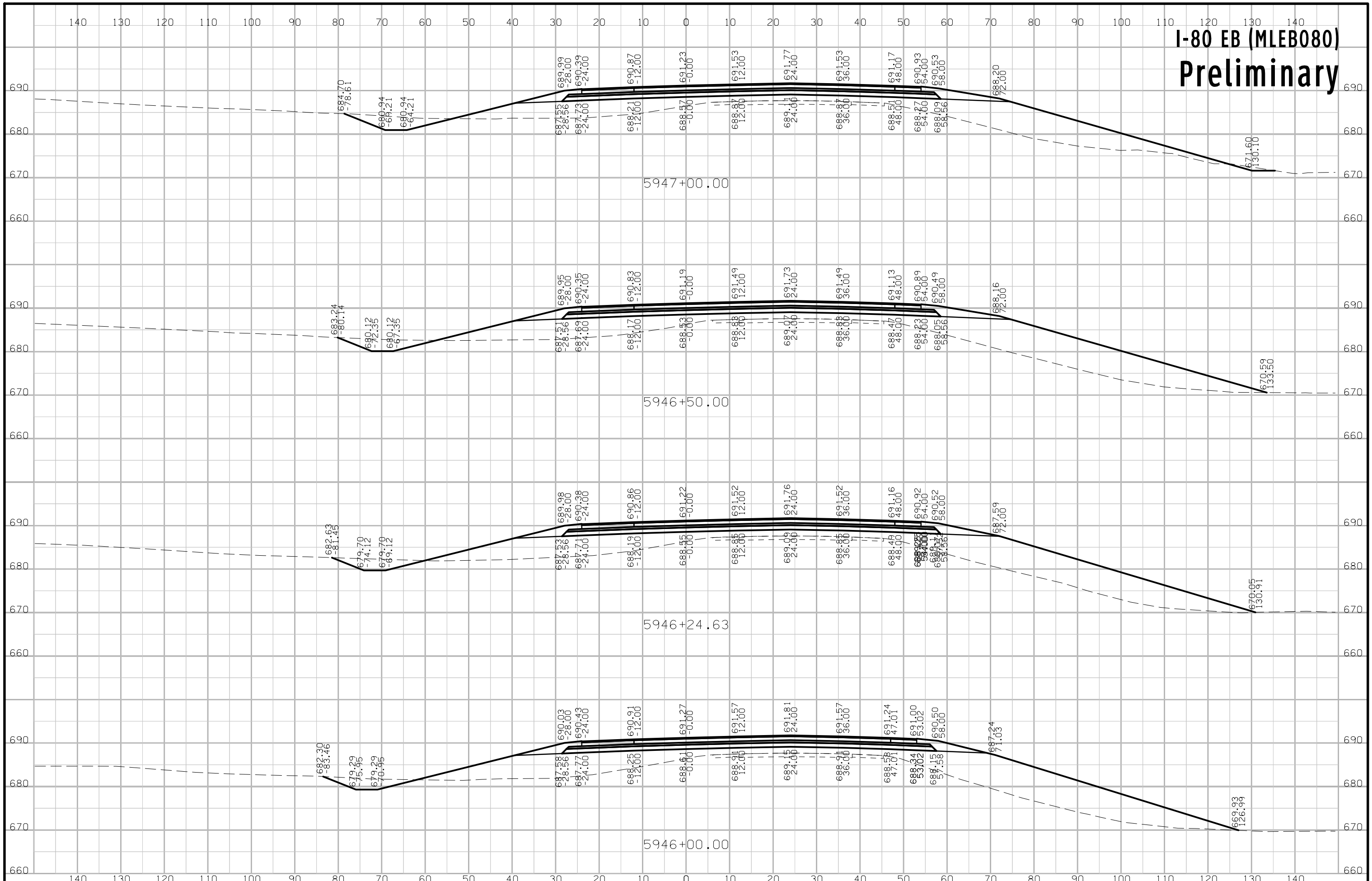

# I-80 EB (MLEB080) Preliminary

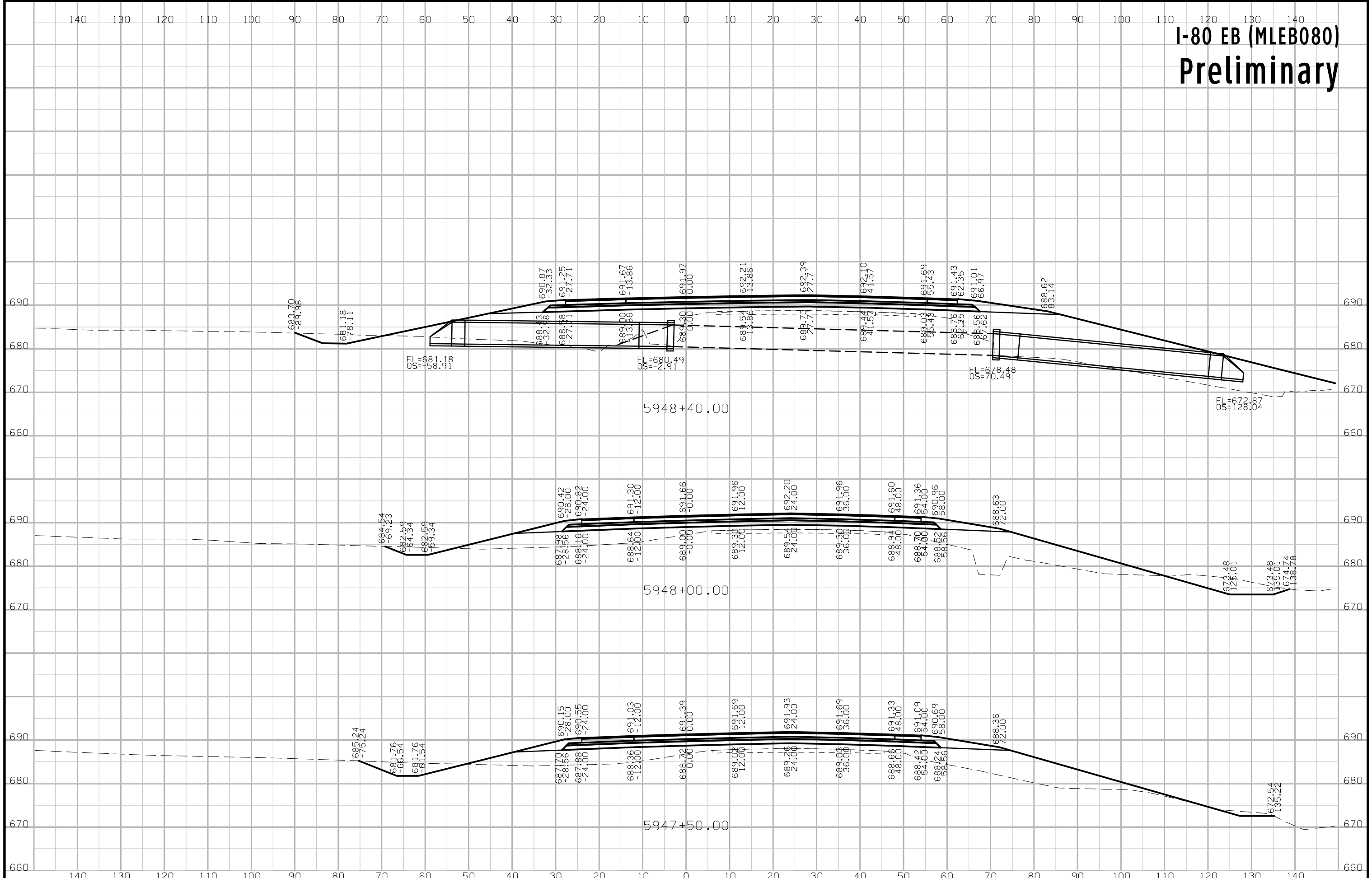



# I-80 EB (MLEB080) Preliminary

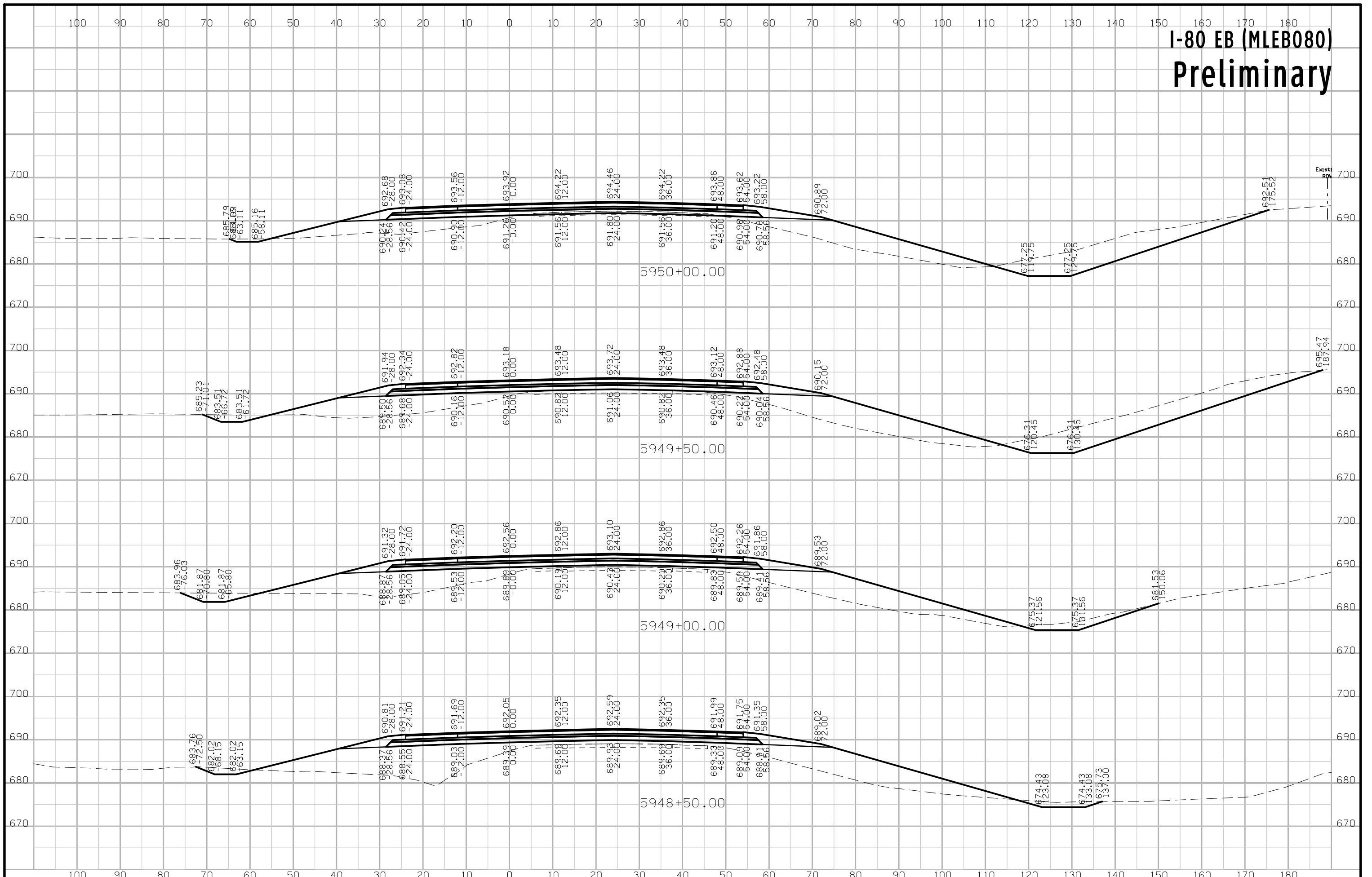

# I-80 EB (MLEB080) Preliminary

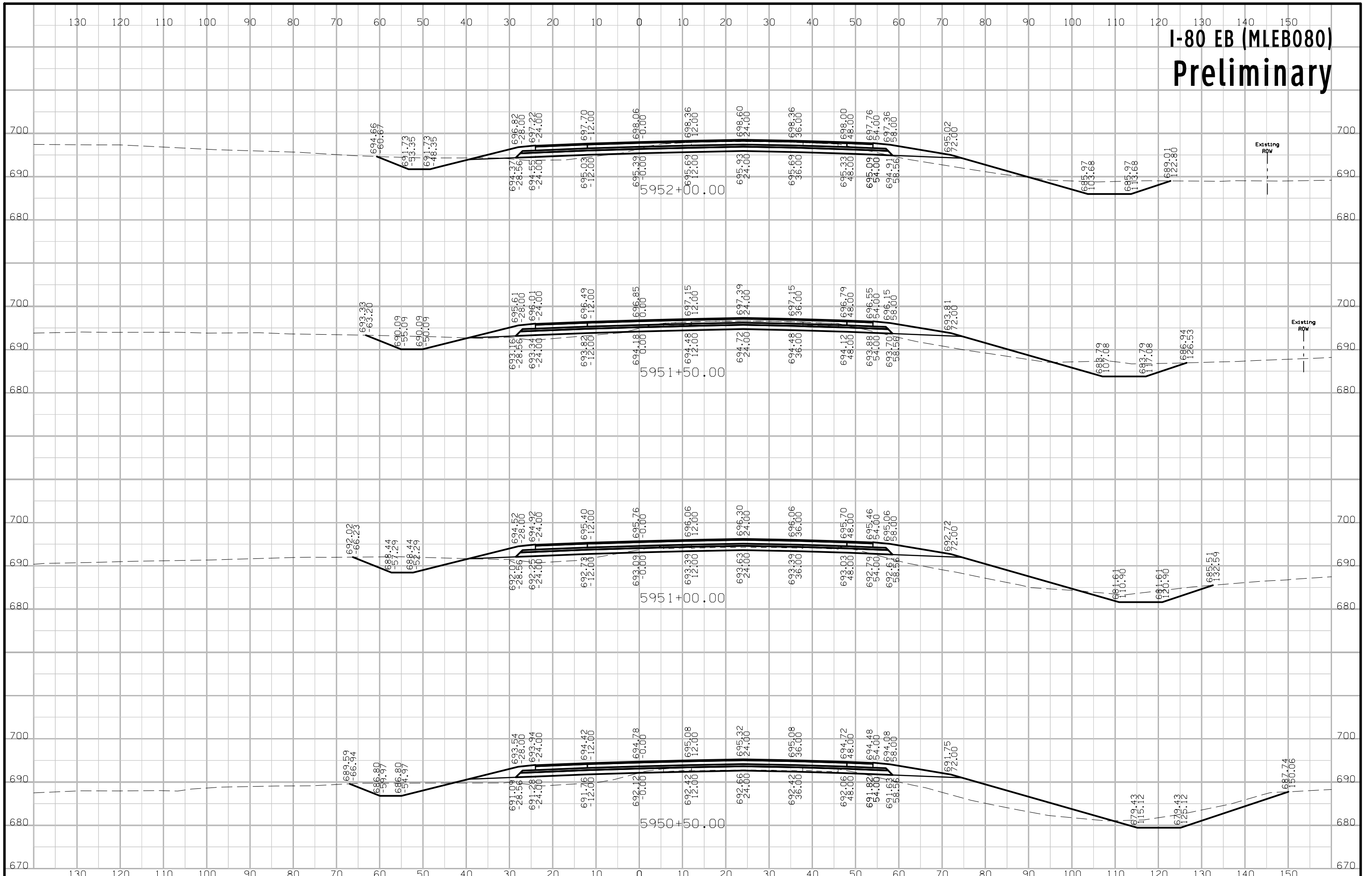

# I-80 EB (MLEB080) Preliminary

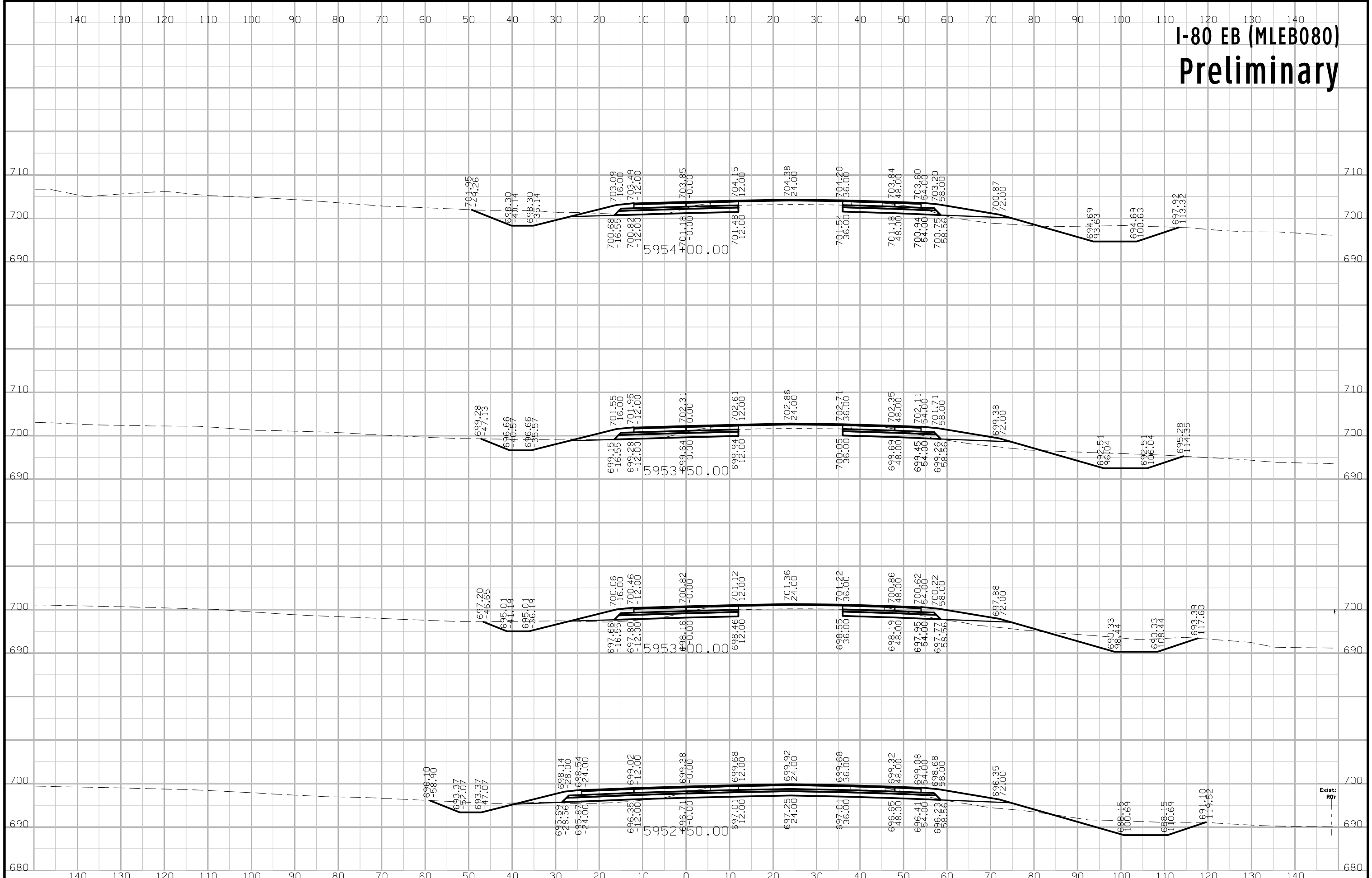

# I-80 EB (MLEB080) Preliminary

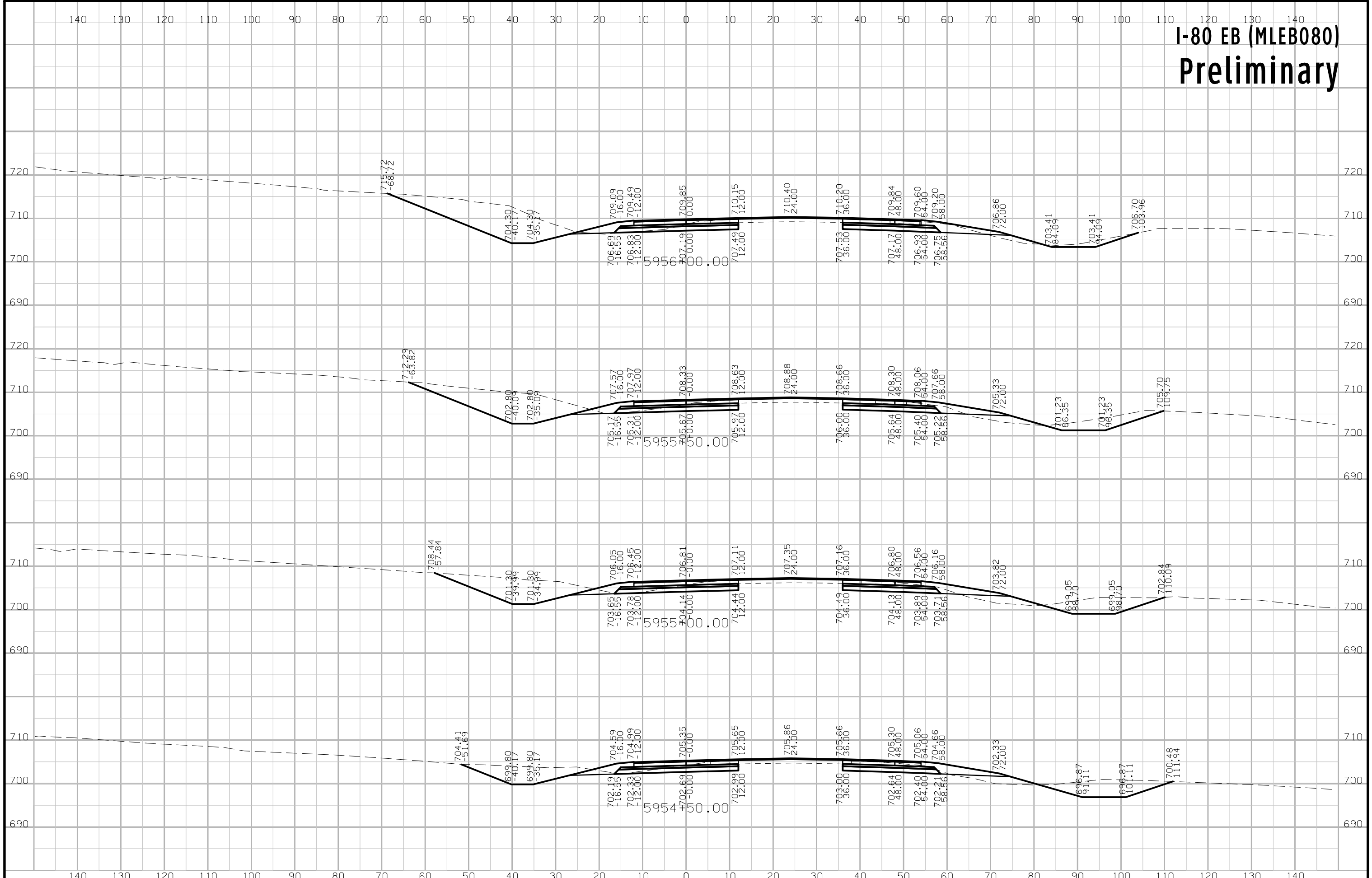

# I-80 EB (MLEB080) Preliminary

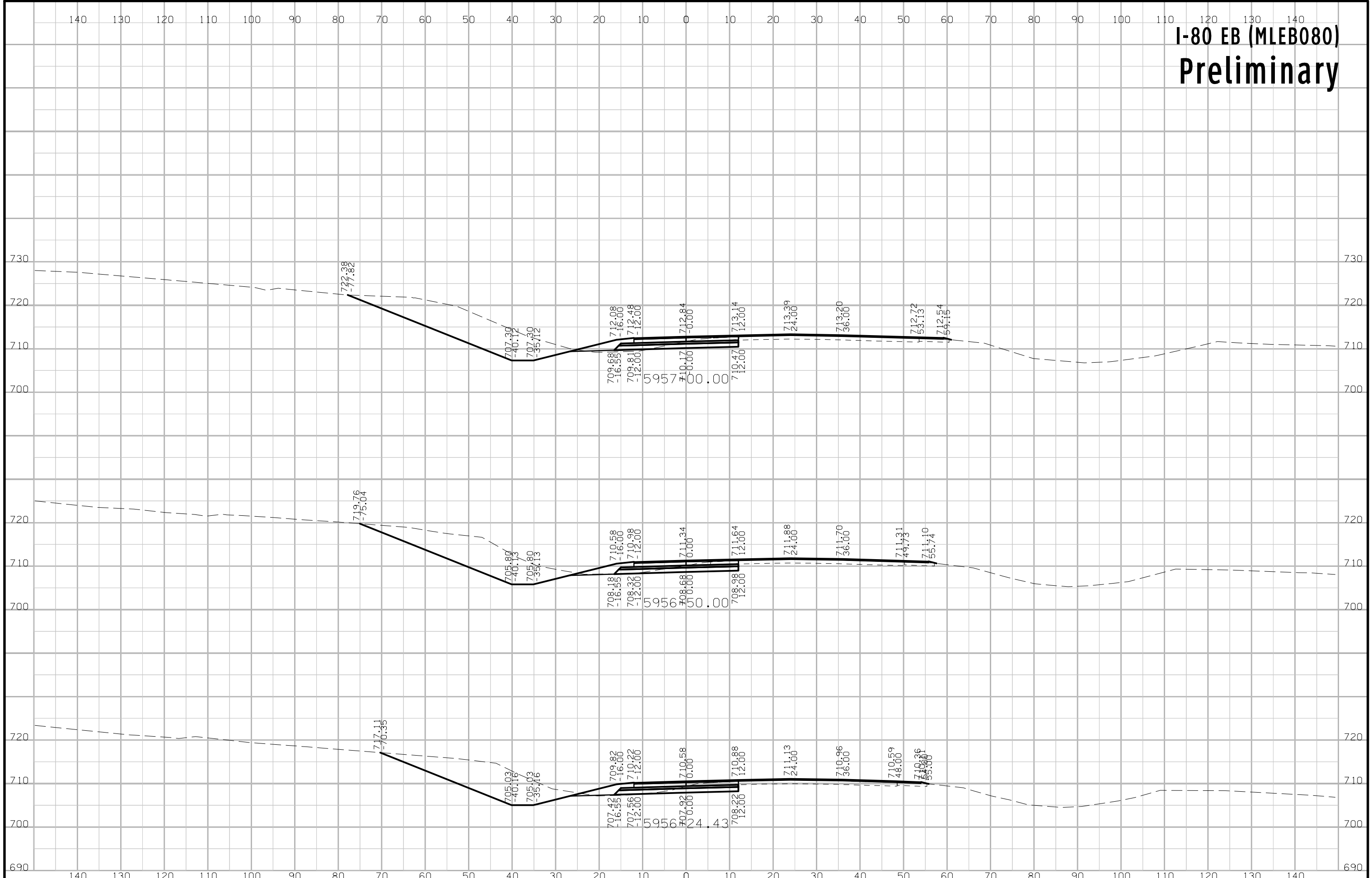

# I-80 EB (MLEB080) Preliminary

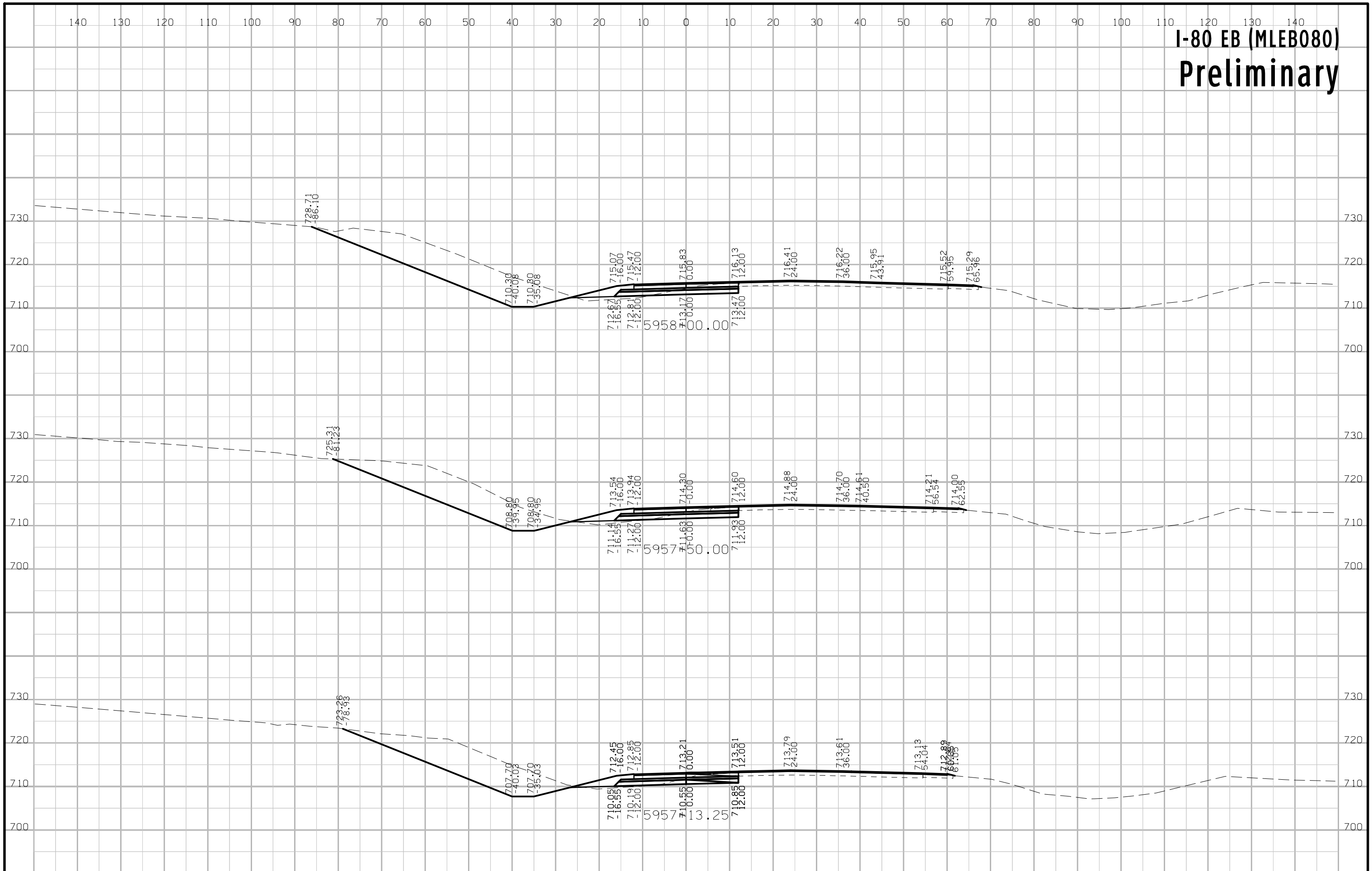

# I-80 EB (MLEB080) Preliminary

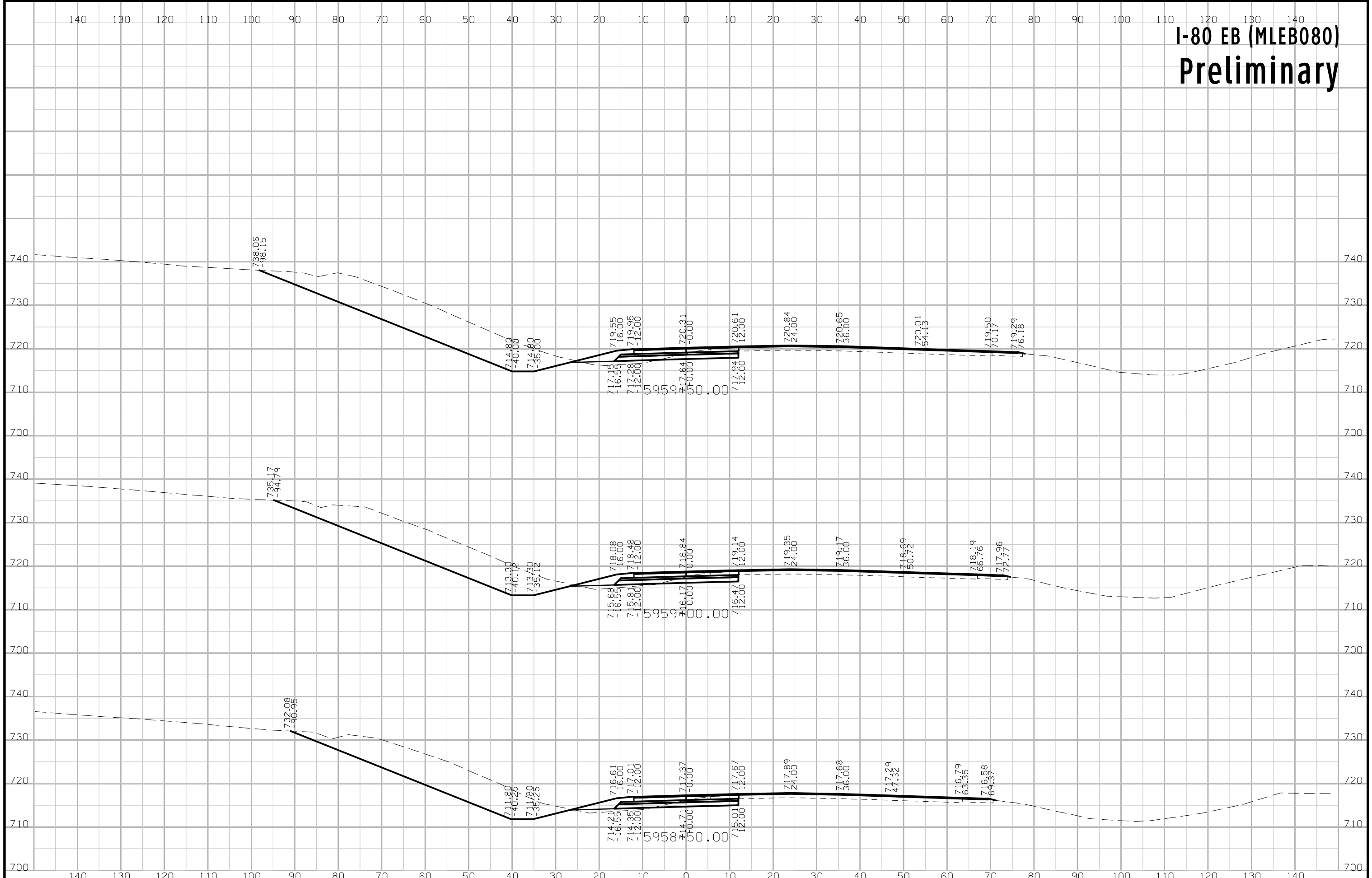

# I-80 EB (MLEB080) Preliminary

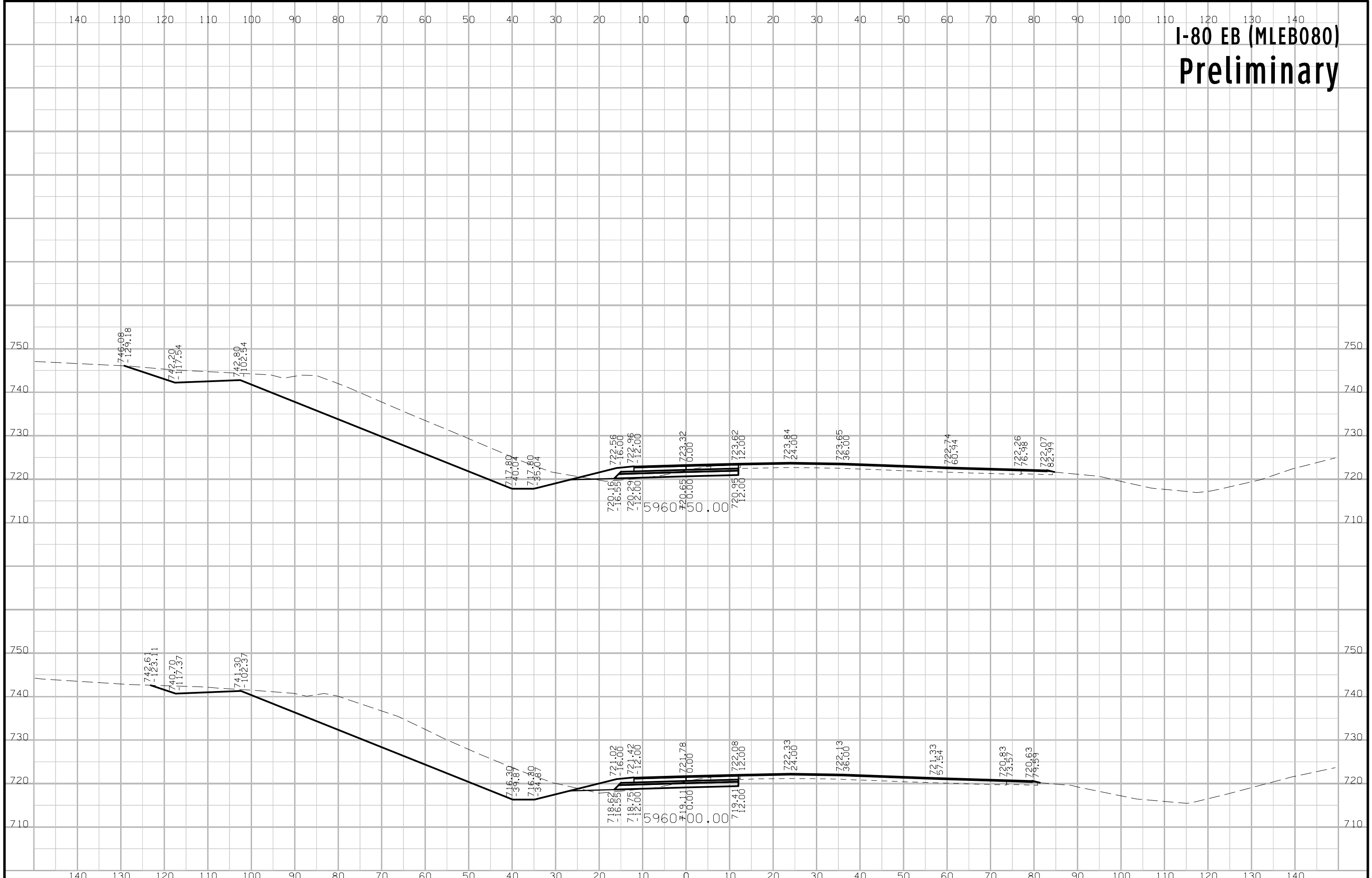



# I-80 EB (MLEB080) Preliminary

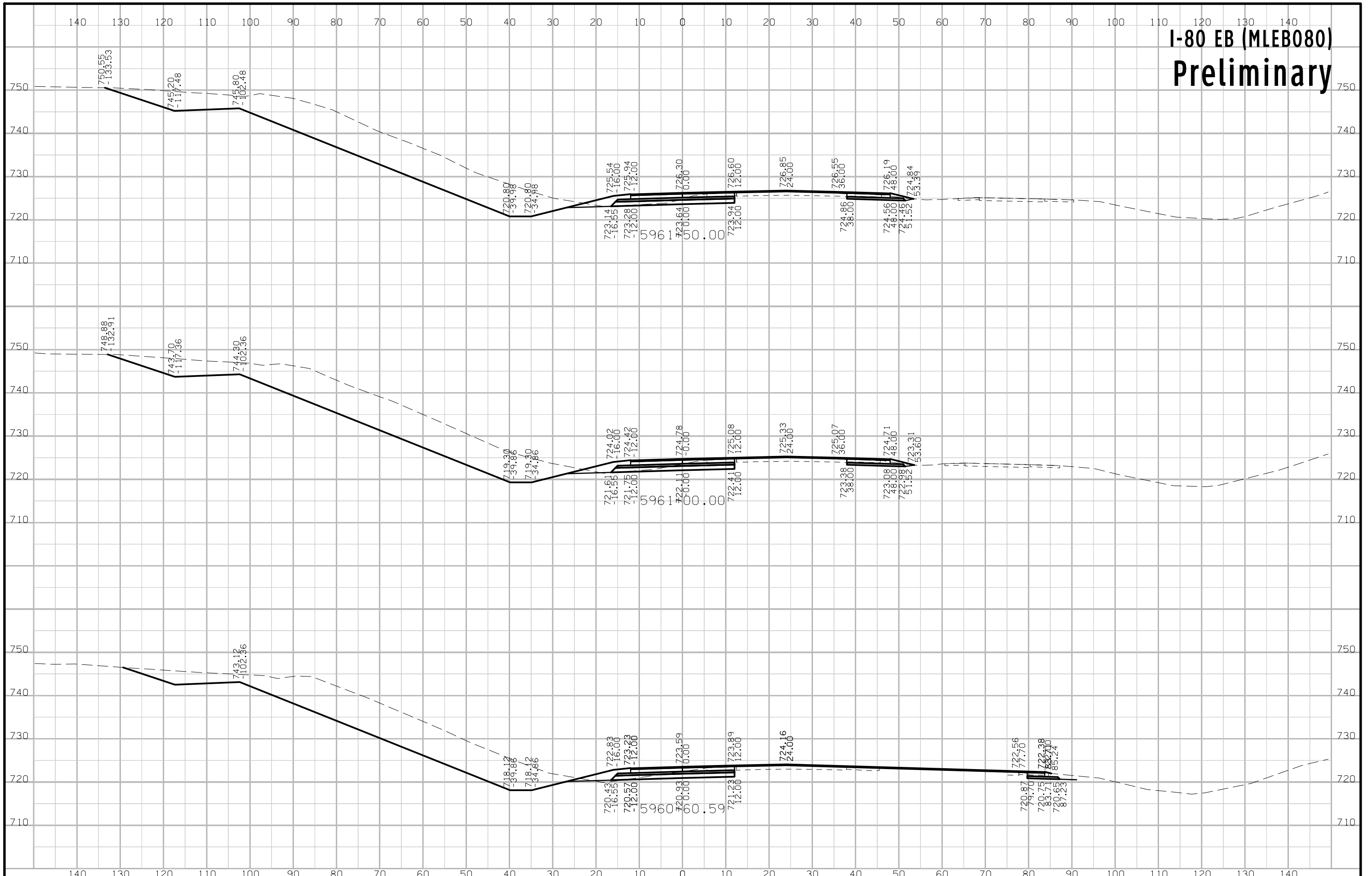

# I-80 EB (MLEB080) Preliminary

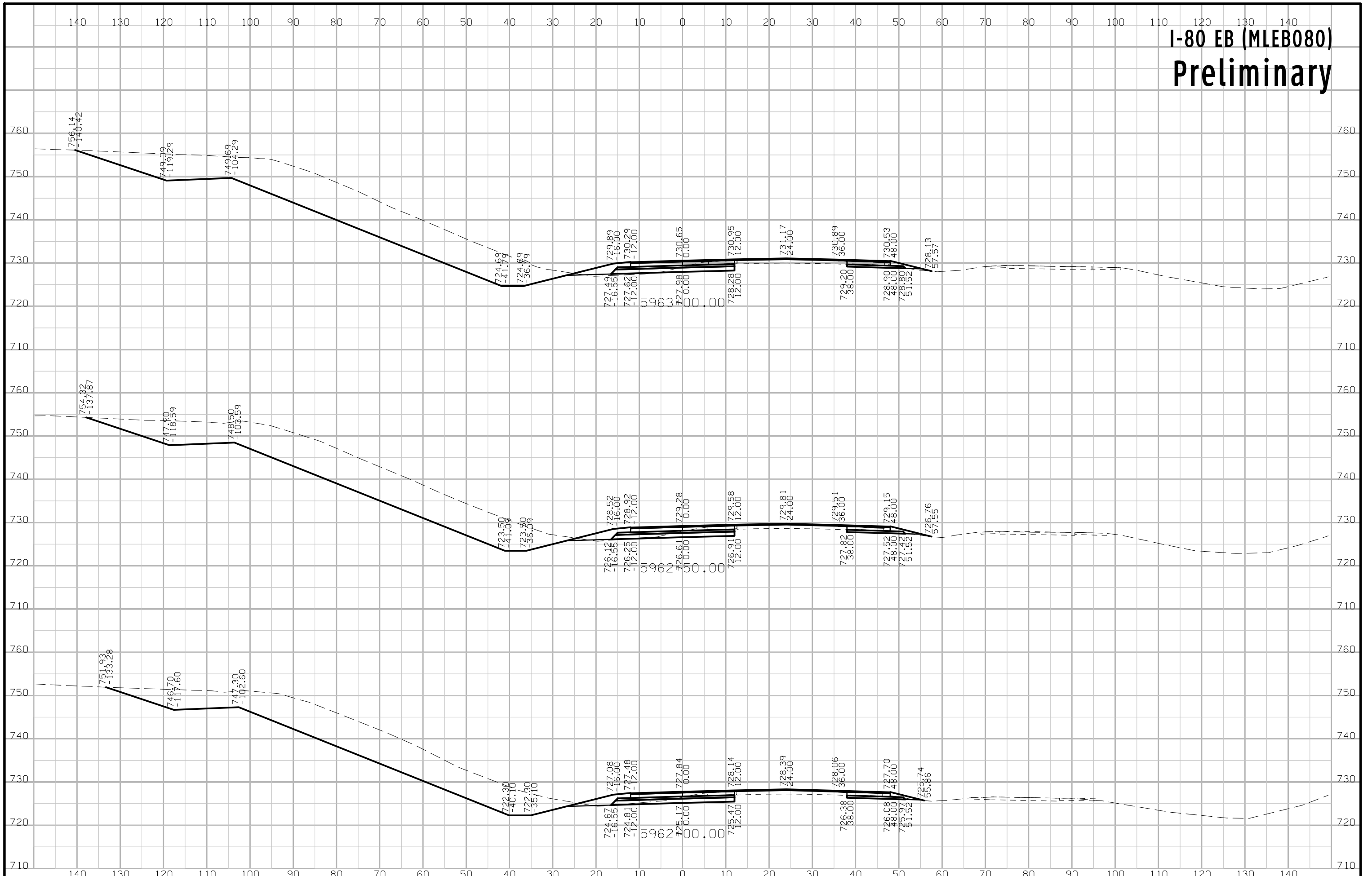

# I-80 EB (MLEB080) Preliminary

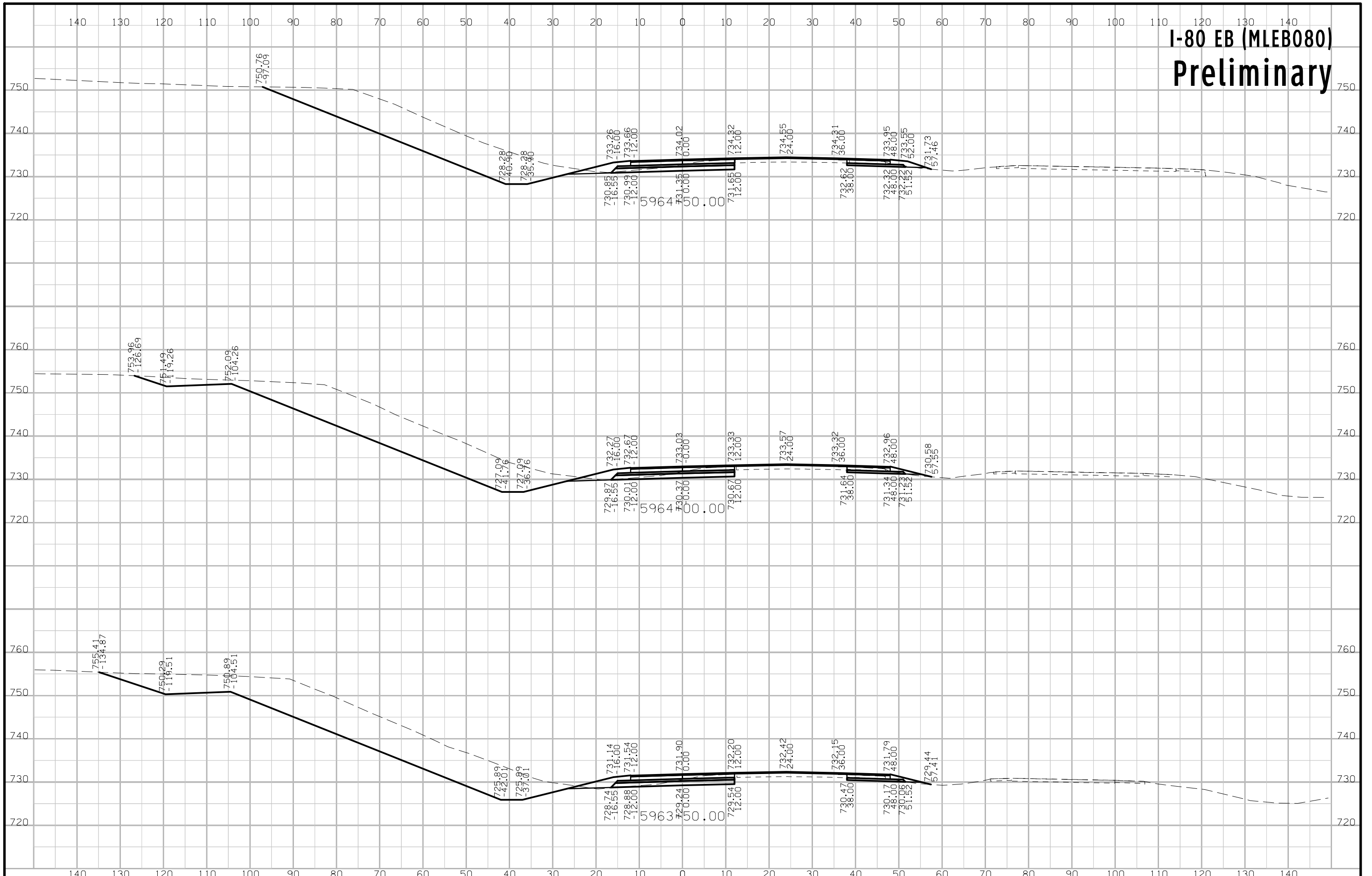

# I-80 EB (MLEB080) Preliminary

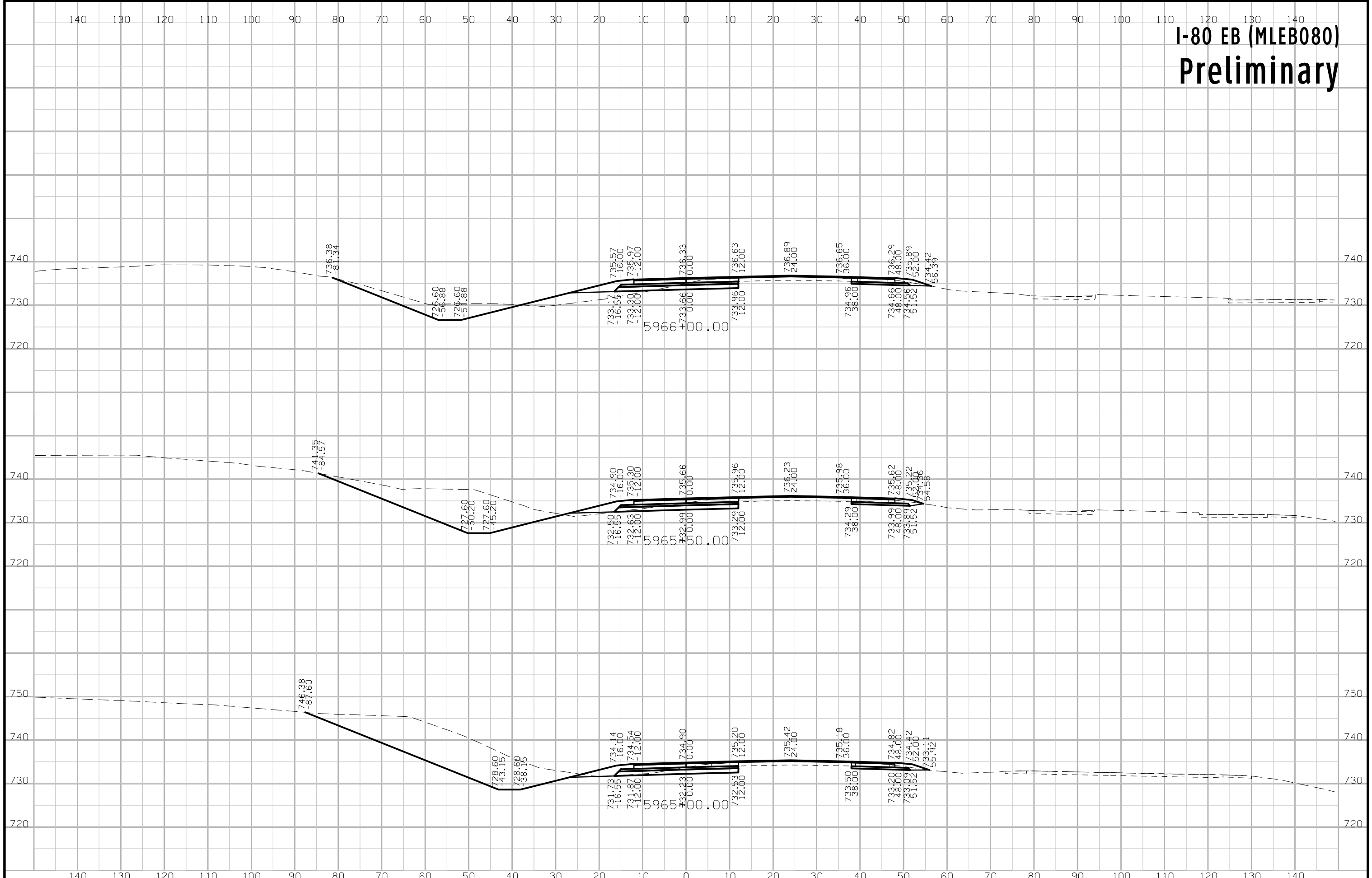

# I-80 EB (MLEB080) Preliminary

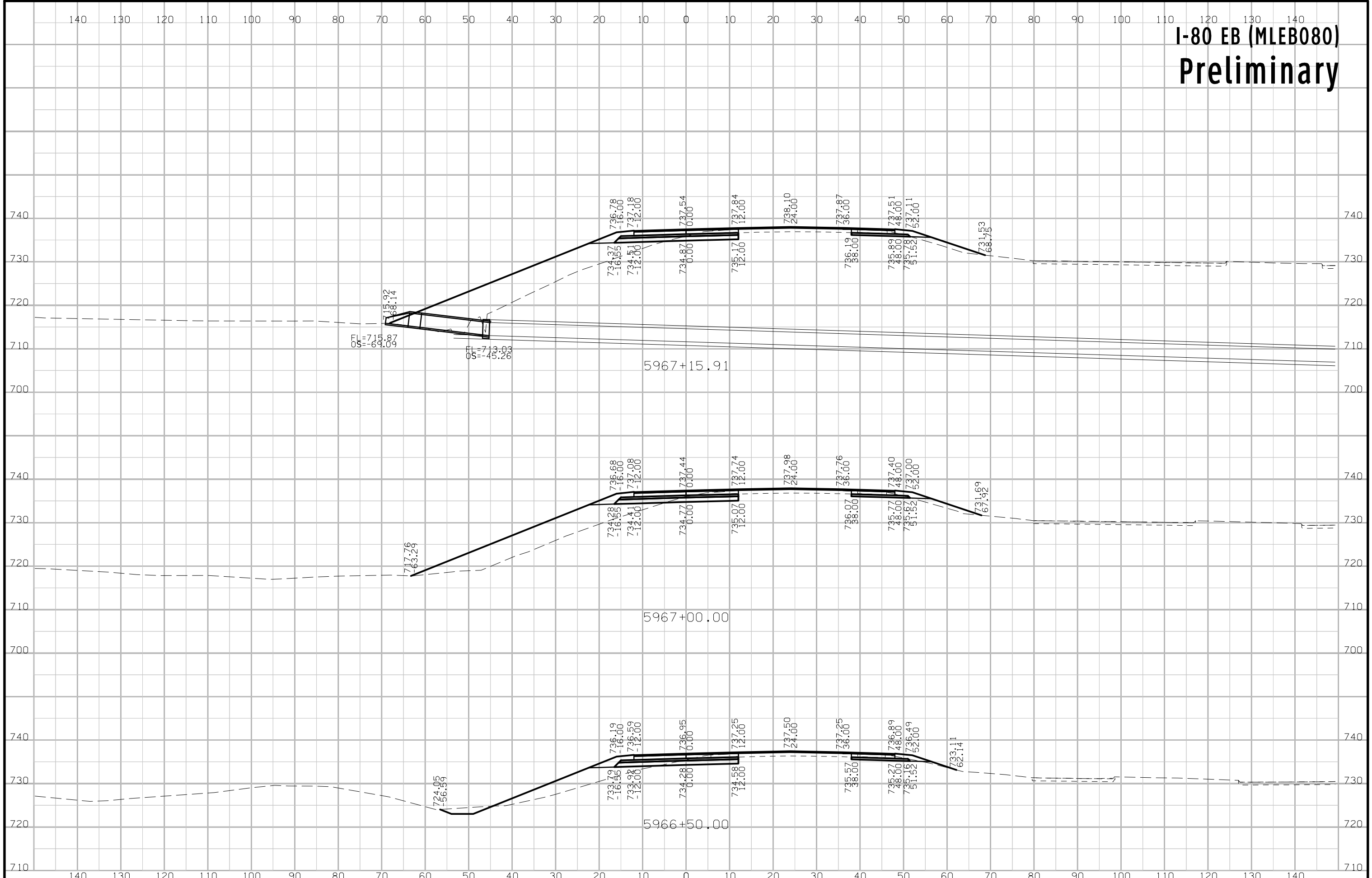

# I-80 EB (MLEB080) Preliminary

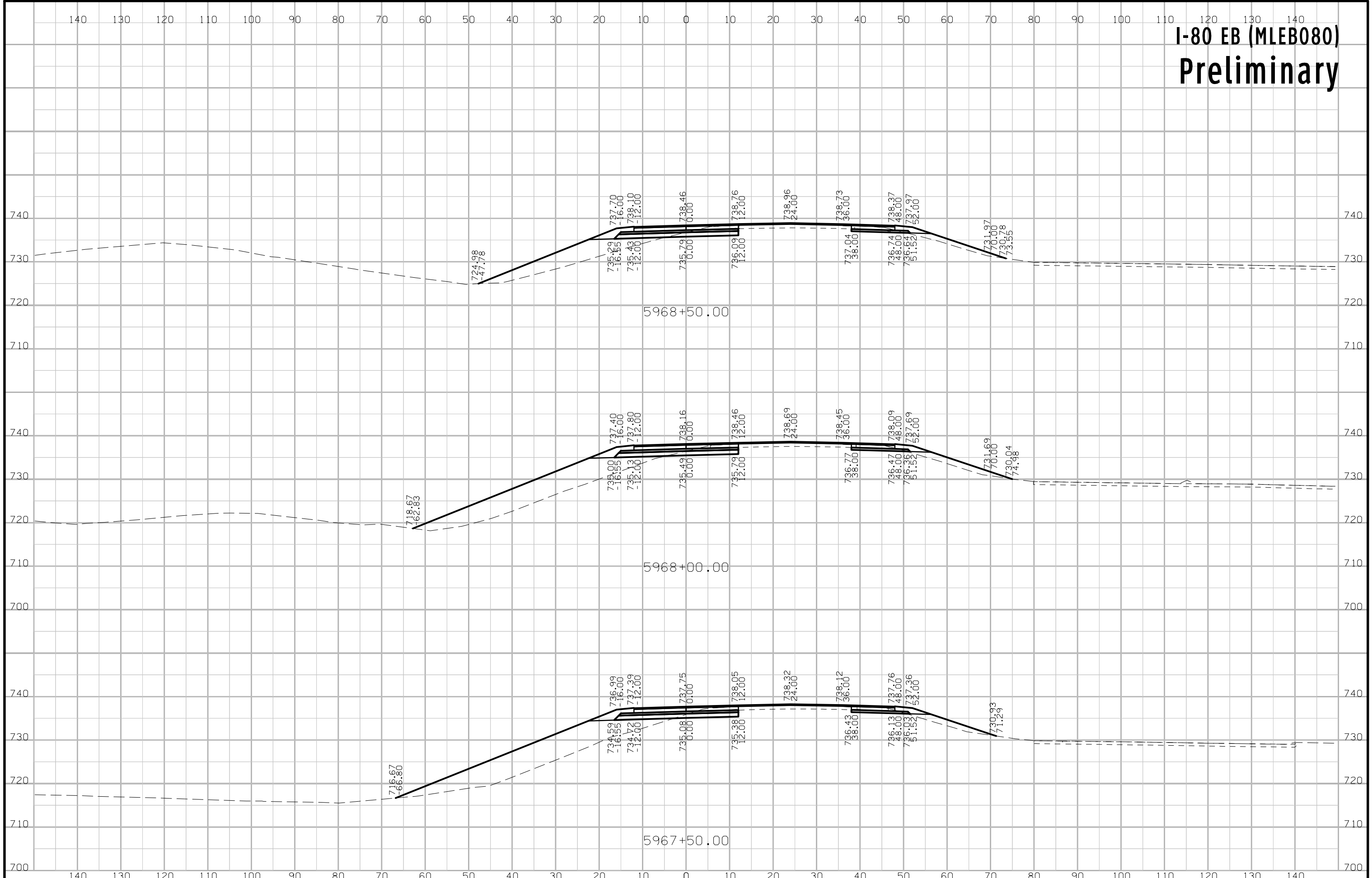

# I-80 EB (MLEB080) Preliminary

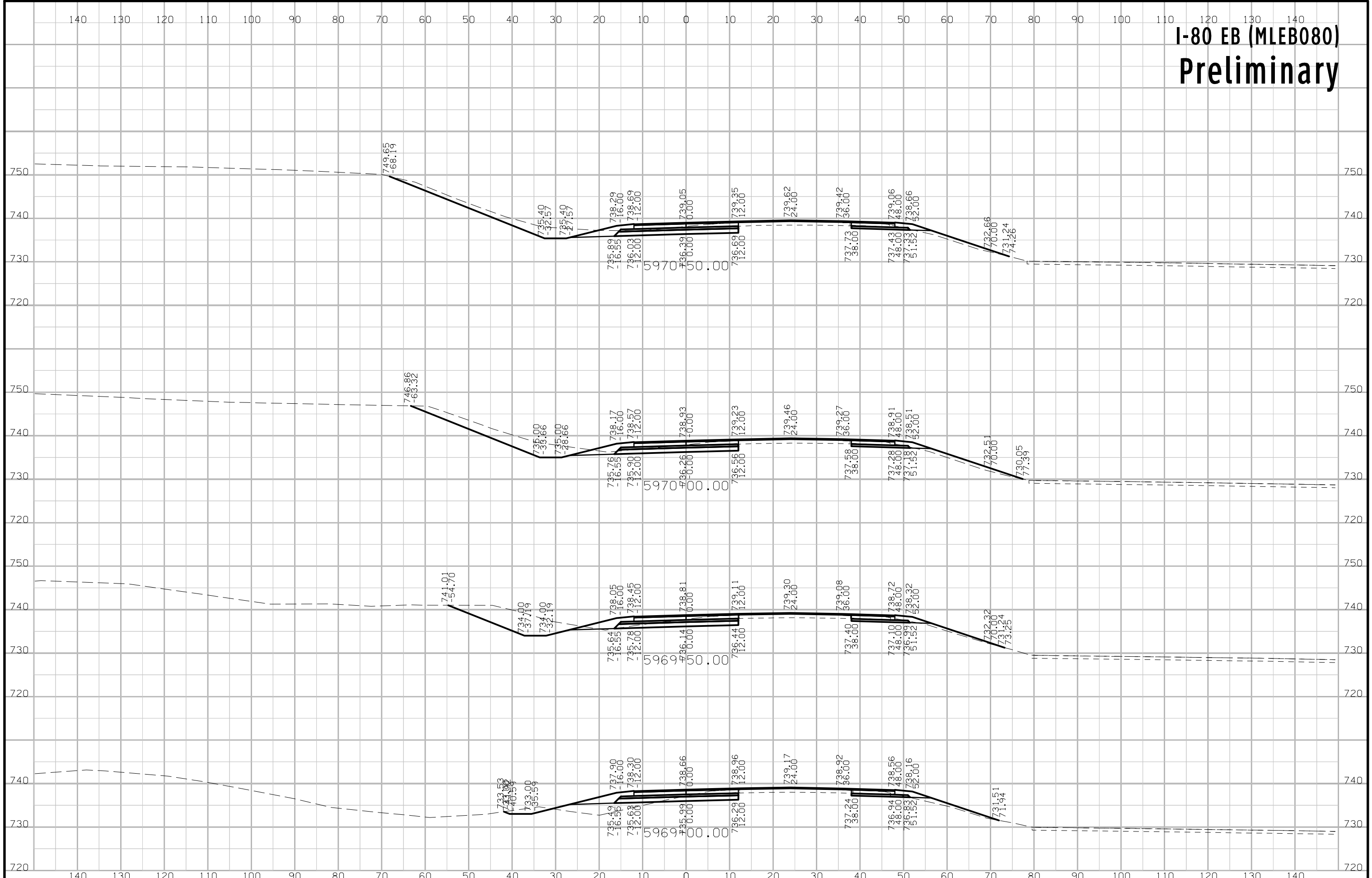

# I-80 EB (MLEB080) Preliminary

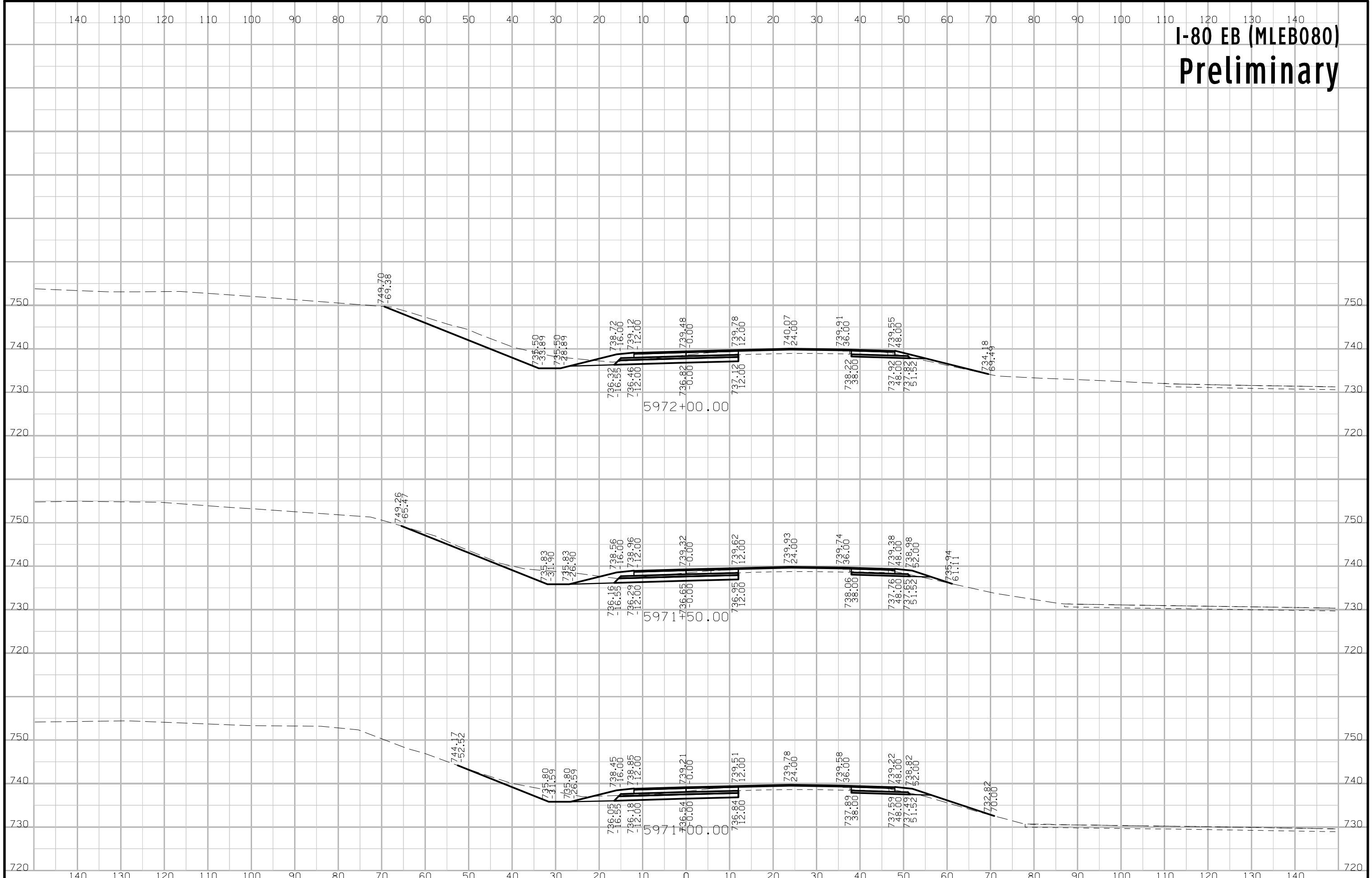



# I-80 EB (MLEB080) Preliminary

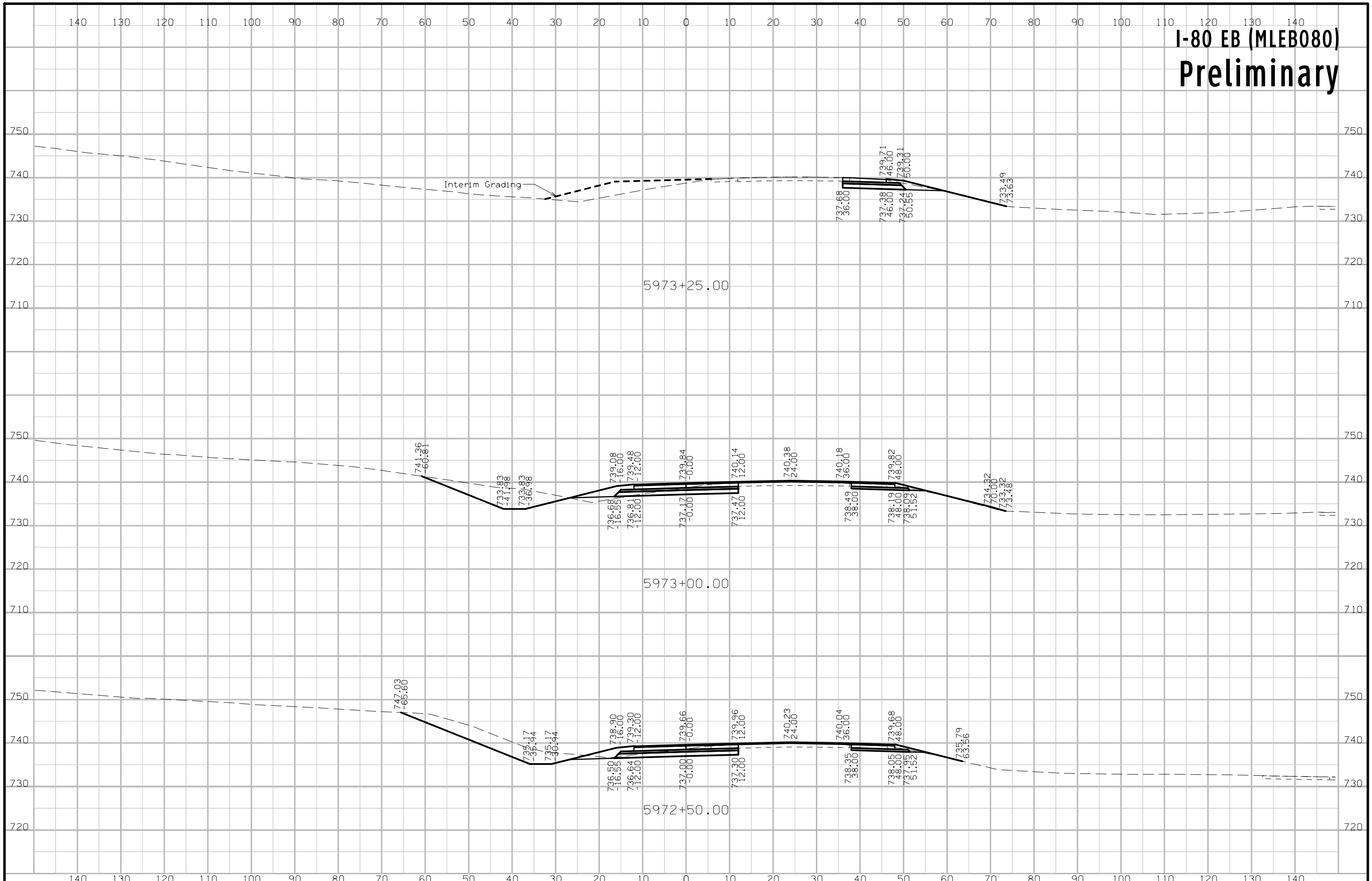

# I-80 EB (MLEB080) Preliminary

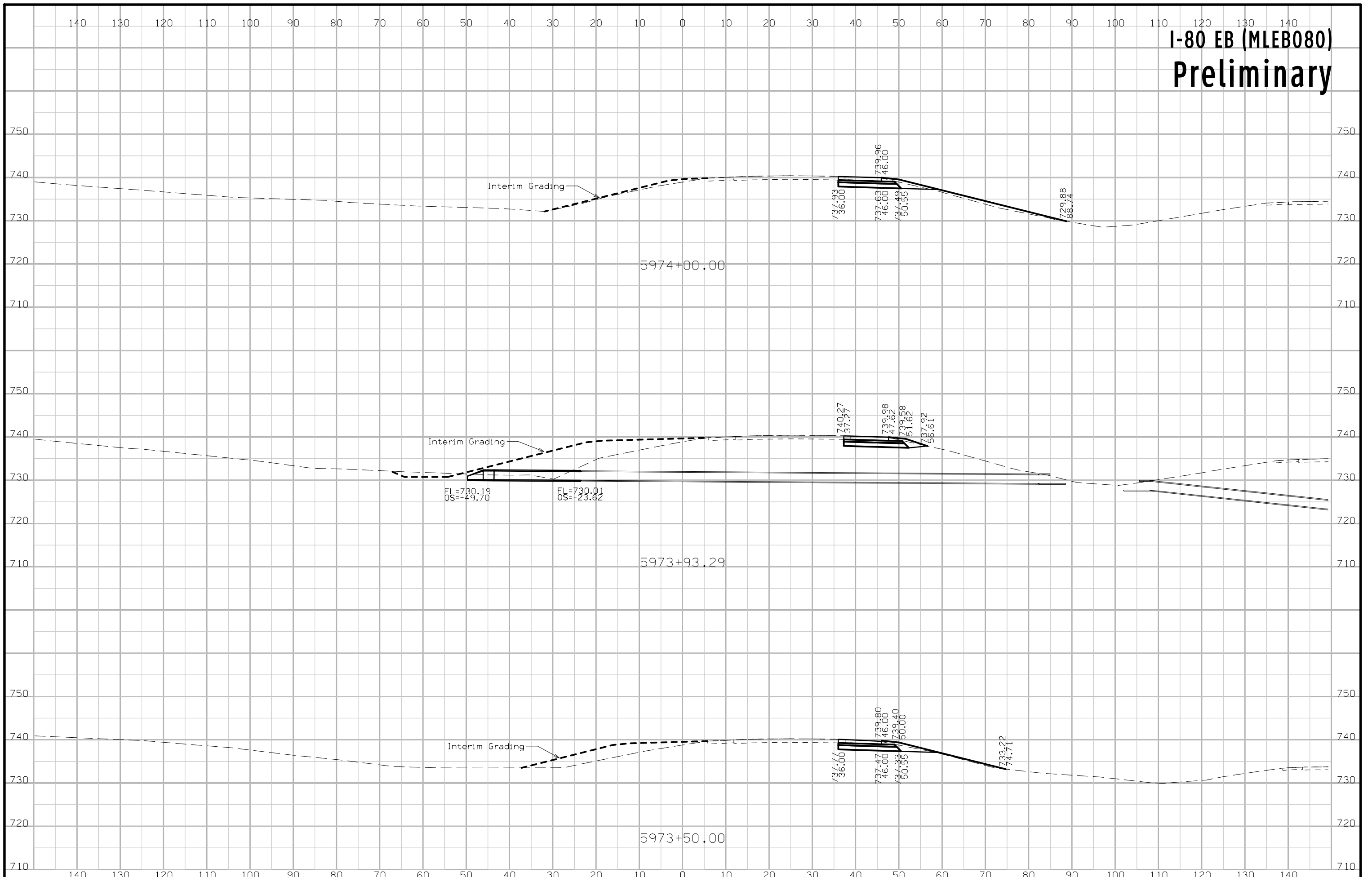

# I-80 EB (MLEB080) Preliminary

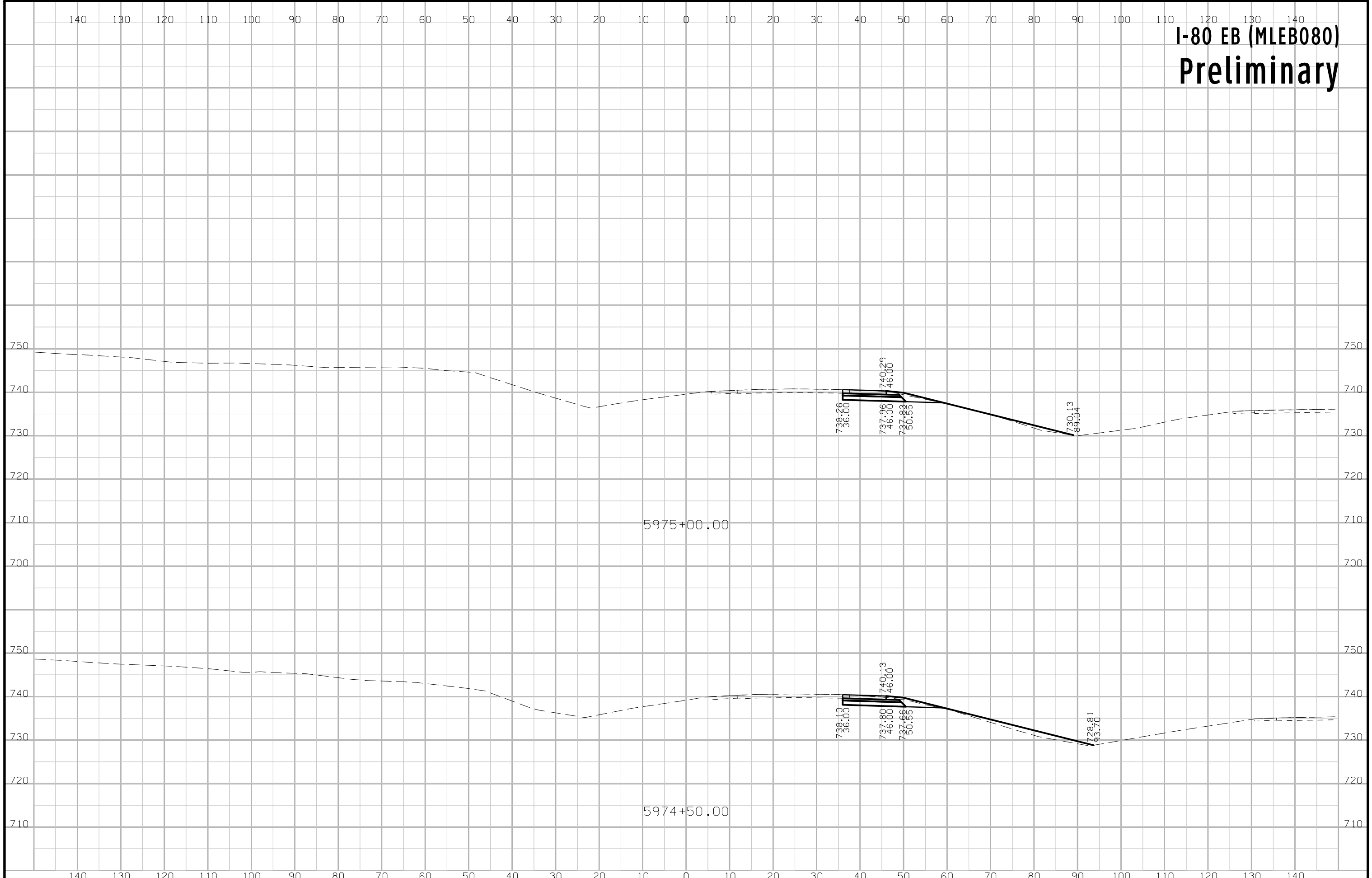

# I-80 EB (MLEB080) Preliminary

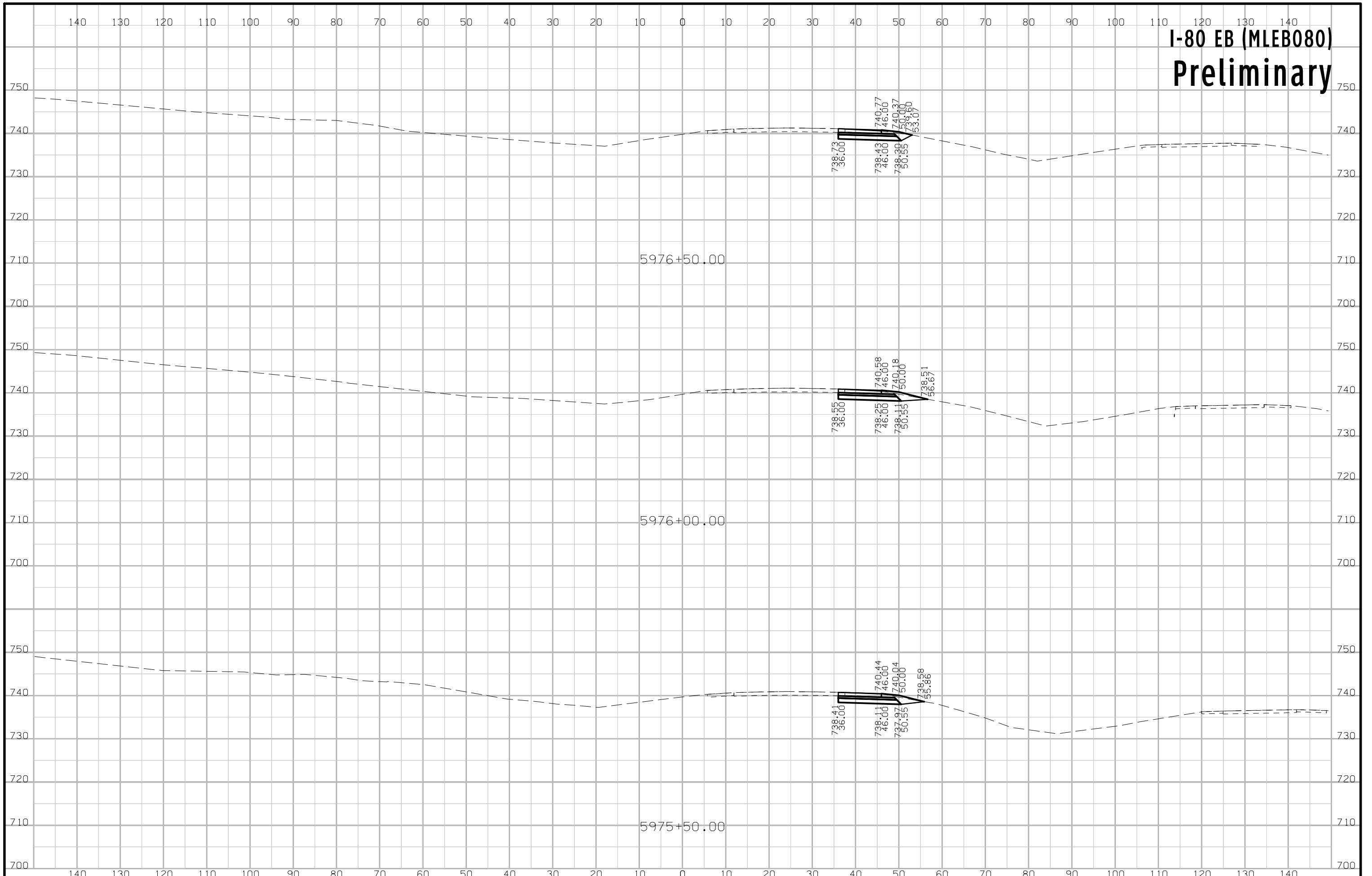

# I-80 EB (MLEB080) Preliminary

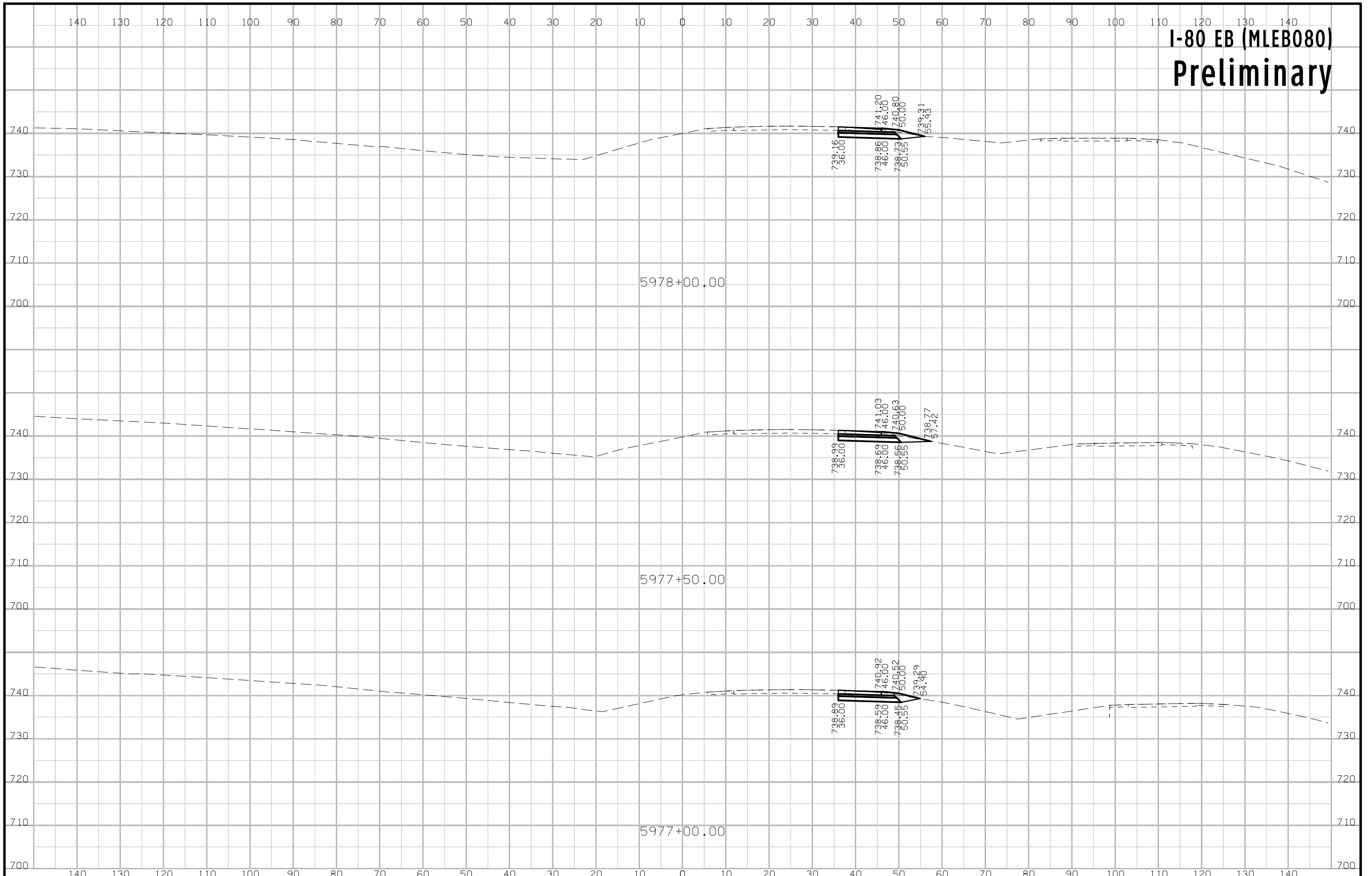

**I-80 EB (MLEB080)  
Preliminary**

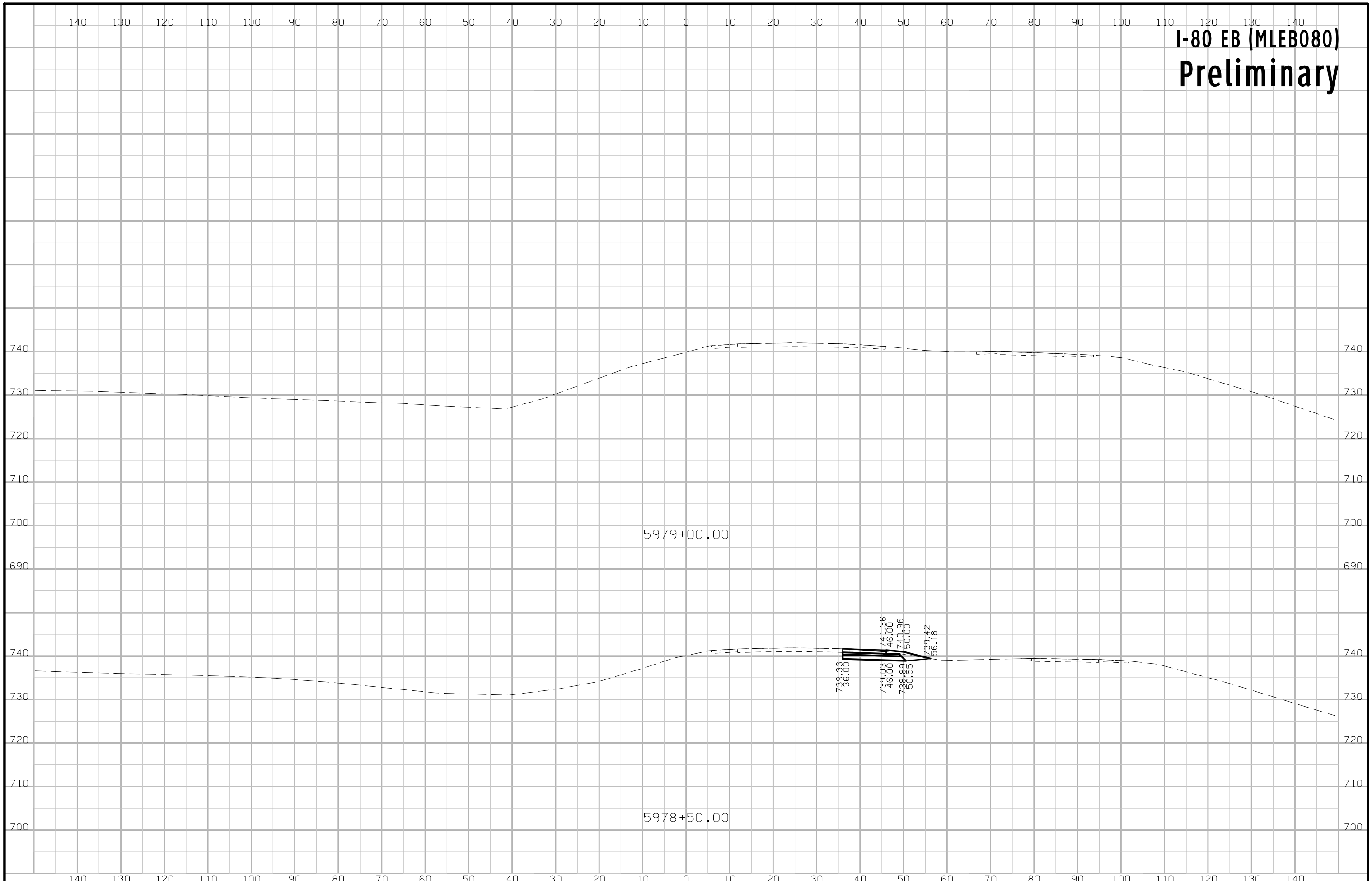

# Rest Area Ramp C Preliminary

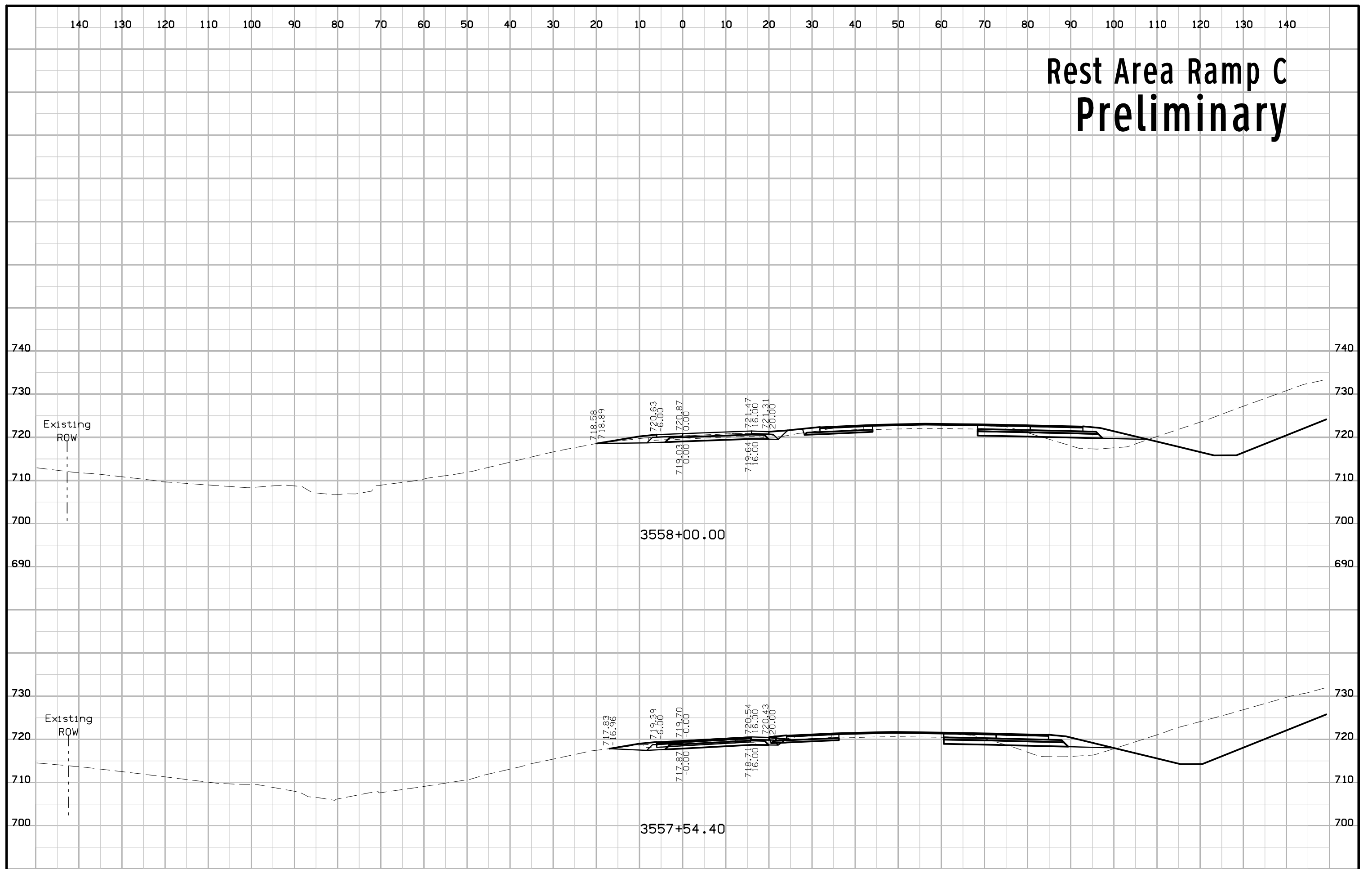

# Rest Area Ramp C Preliminary

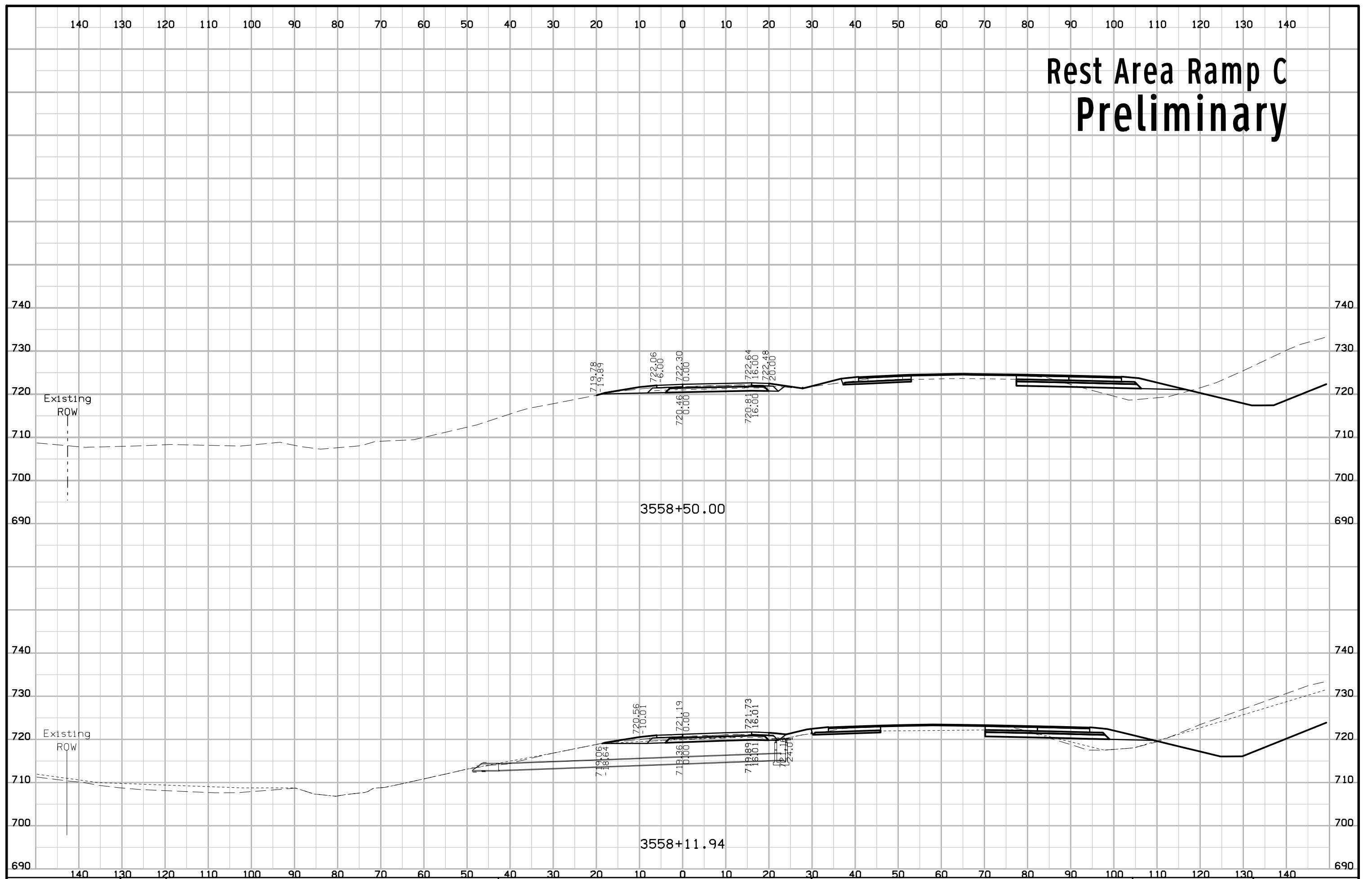



# Rest Area Ramp C Preliminary

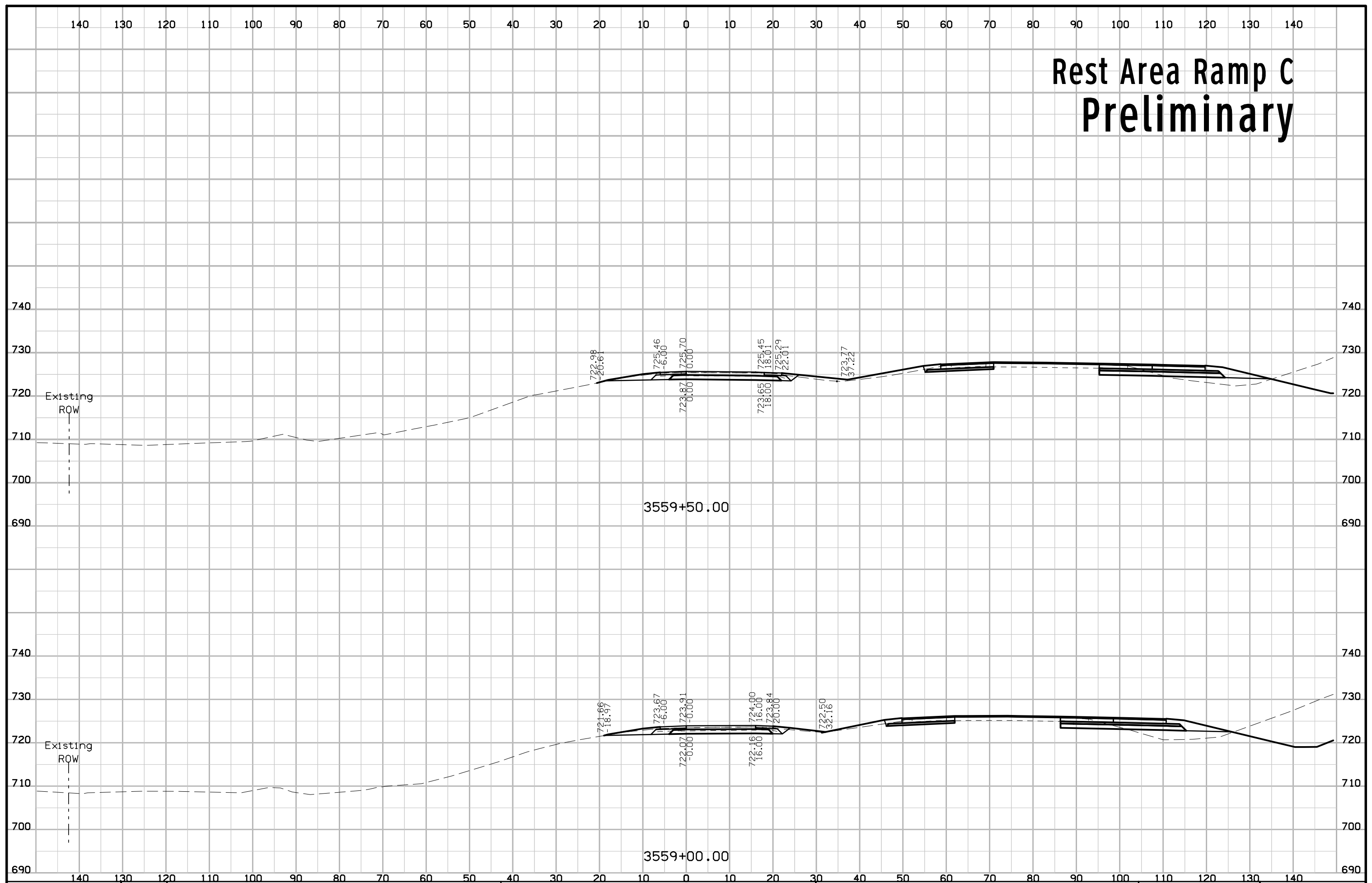

# Rest Area Ramp C Preliminary

