

PCC PAVEMENT - GRADE AND NEW
IMN-029-6(170)139--0E-97

WOODBURY

LETTING DATE
Jan 21 2026

INDEX OF SHEETS	
No.	DESCRIPTION
A Sheets	Title Sheets
* A.1	Title Sheet
* A.2	Location Map Sheet
B Sheets	Typical Cross Sections and Details
B.1 - B.9	Typical Cross Sections and Details
D Sheets	Mainline Plan and Profile Sheets
* D.1	Plan & Profile Legend & Symbol Information Sheet
* D.2 - D.6	I-29 Plan and Profile Sheets
E Sheets	Sideroad Plan and Profile Sheets
* E.1 - E.4	235th Street
* E.5	Old U.S. 75
* E.6 - E.7	Banner Avenue
* E.8	Barker Avenue
G Sheets	Survey Sheets
* G.1 - G.3	Reference Ties and Bench Marks
G.4 - G.5	Horizontal Control Tab. and Super
J Sheets	Traffic Control and Staging Sheets
J.1	Traffic Control Plan, Staging Notes and Tabulations
* J.2	Traffic Control & Staging Legend & Symbol Info. Sheet
* J.3	Staging Typical
* J.4 - J.19	Staging and Traffic Control Sheets
K Sheets	Interchange Sheets
*K.1 - K.3	Interchange Layout Sheets
*K.4	Ramp A Plan and Profile Sheets
*K.5 - K.6	Ramp B Plan and Profile Sheets
*K.7 - K.8	Ramp C Plan and Profile Sheets
*K.9 - K.10	Ramp D Plan and Profile Sheets
U Sheets	Modified Standards and Detail Sheets
* U.1 - U.4	UPRR Crossing Details
V Sheets	Bridge Situation Plans
* V.1 - V.2	Bridge Situation Plans
VW/VX/VY Sheets	Culvert Situation Plans
* VW.1	ML029 Culverts
* VX.1 - VX.4	Side Road Culverts
* VY.1 - VY.4	Ramp Culverts
W Sheets	Mainline Cross Sections
* W.1	Cross Sections Legend and Information Sheet
* W.2 - W.46	ML029 Cross Sections
X Sheets	Side Road Cross Sections
* X.1 - X.43	235th Street Cross Sections
* X.44 - X.51	Old U.S. 75 Cross Sections
* X.52 - X.55	Banner Avenue Cross Sections
* X.56	Barker Avenue Cross Sections
Y Sheets	Ramp Cross Sections
* Y.1 - Y.11	Ramp A Cross Sections
* Y.12 - Y.23	Ramp B Cross Sections
* Y.24 - Y.35	Ramp C Cross Sections
* Y.36 - Y.45	Ramp D Cross Sections
	* Color Plan Sheets

H Sheets



PLANS OF PROPOSED IMPROVEMENT ON THE
INTERSTATE ROAD SYSTEM
WOODBURY
PCC PAVEMENT - GRADE AND NEW
I-29 / 235TH STREET (SOUTHBRIDGE) INTERCHANGE
 Approx. 2.5 mi S of the Co Rd D38 Interchange at Sergeant Bluff
SCALES: As Noted

Refer to the Proposal Form for list of applicable specifications.

Value Engineering Saves. Refer to Article 1105.14 of the Specifications.



I-29 SOUTHBRIDGE	
DESIGN DATA RURAL	
2022 AADT	20600 V.P.D.
2050 AADT	31400 V.P.D.
20 -- DHV	-- V.P.H.
TRUCKS	26.1 %
Total Design ESALS	--

235th St.	
DESIGN DATA RURAL	
2019 AADT	100 V.P.D.
2050 AADT	4490 V.P.D.
20 -- DHV	-- V.P.H.
TRUCKS	-- %
Total Design ESALS	--

Preliminary Earthwork

Cut	58,000	CY
Fill	295,000	CY
Total	237,000	CY Balance

For Project Location Map Refer to Sheet No. A.2

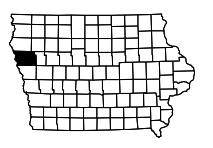

INDEX OF SEALS			
SHEET NO.	NAME	TYPE	BID QUANTITY SHEETS
A.1	X	Primary Signature Block	X
X	X	X	X

PRELIMINARY PLANS

Subject to change by final design.

D5 Rev. - Date: 12/21/2023

REVISIONS

TOTAL
221
PROJECT IDENTIFICATION NUMBER
06-97-029-010
PROJECT NUMBER
IMN-029-6(170)139--0E-97
R.O.W. PROJECT NUMBER
IMN-029-6(170)139--0E-97

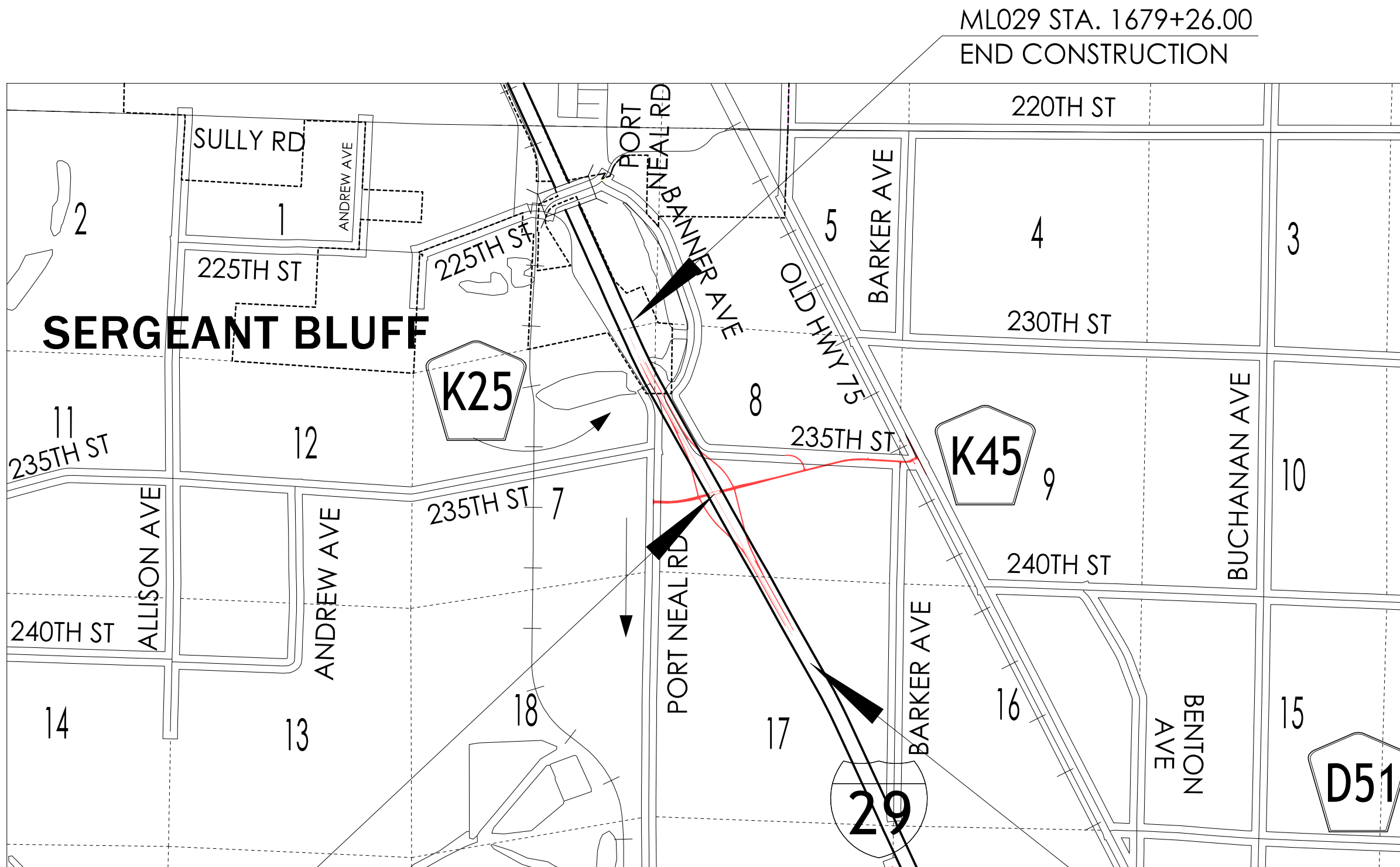

BRIDGE
235th St
Sta. 5013+74.10
FHWA #701220 (NEW)

ML029 STA. 1596+32.00
BEGIN CONSTRUCTION

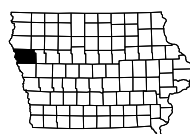
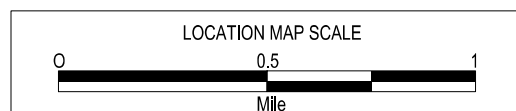

LOCATION				DIMENSIONS		
INTERCHANGE	RAMP	STATION TO STATION		(L) Feet	(R) Feet	(X) Inches
235th Street	A	1000+20.00	1014+61.31	33	18	23
235th Street	B	2000+00.00	2015+31.10	33	18	23
235th Street	C	3000+00.00	3017+83.21	33	18	23
235th Street	D	4000+20.71	4016+72.70	33	18	23

Section view is in direction of traffic.

Normal section shown may be modified appropriately in areas of superelevated curves or other locations specifically designated by the Engineer.

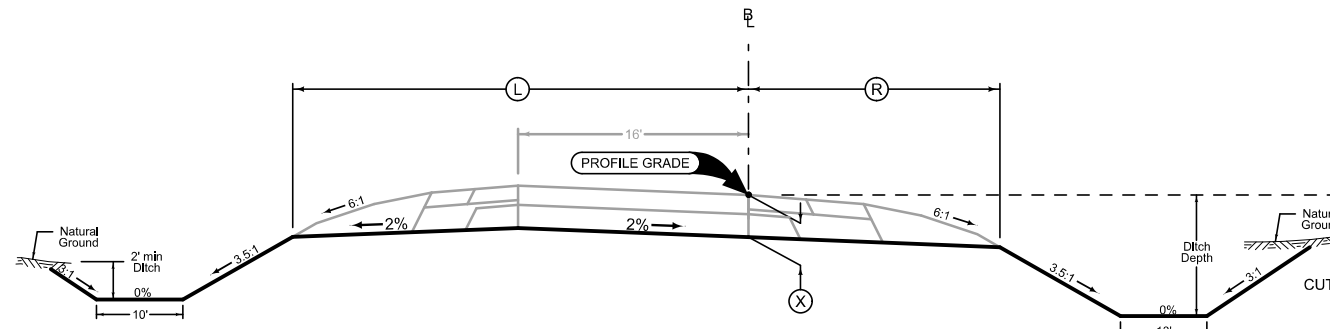

RAMP GRADING

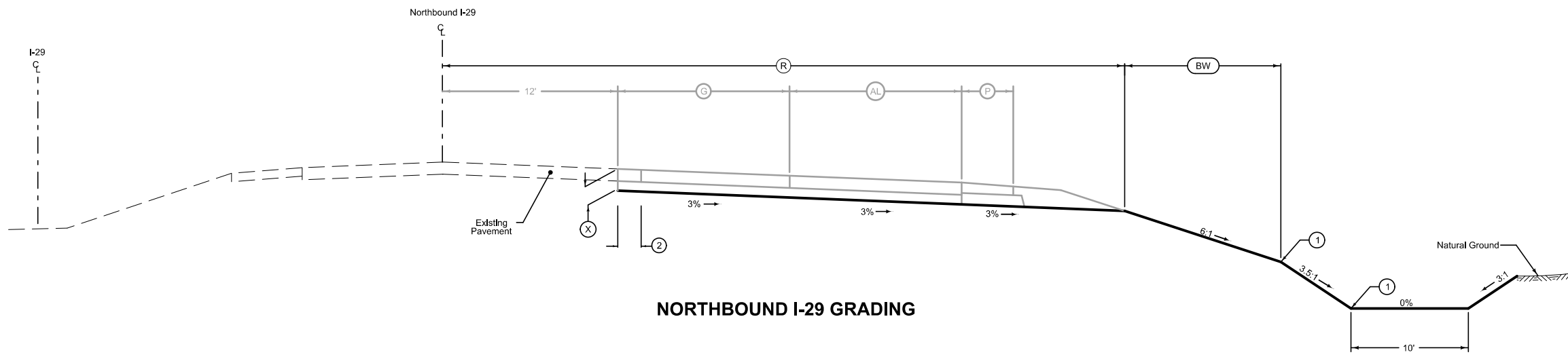

NORTHBOUND I-29 GRADING

Gore, Acceleration and Deceleration Lane

Section view is in the direction of traffic.

Direction of Travel	BEGIN STATION	END STATION	(X) Inches	(R) Feet	(BW) Feet
NB	1604+30.00	1607+30.00	25	28.5-41	4.5
NB	1607+30.00	1617+30.00	25	41	4.5
NB	1617+30.00	1618+20.00	25	41-47	4.5
NB	1618+20.00	1621+50.00	25	47-69	4.5
NB	1650+58.50	1652+08.50	25	65-47	4.5
NB	1652+08.50	1653+68.65	25	47-41	4.5
NB	1653+68.65	1665+00.00	25	41	4.5
NB	1665+00.00	1671+00.00	25	41-37	4.5

Normal section shown may be modified appropriately in areas of superelevated curves or other locations specifically designated by the Engineer.

- ① Refer to project plan and cross sections for specific location of foreslope change and ditch details.
- ② Remove 2'-0" existing slab.

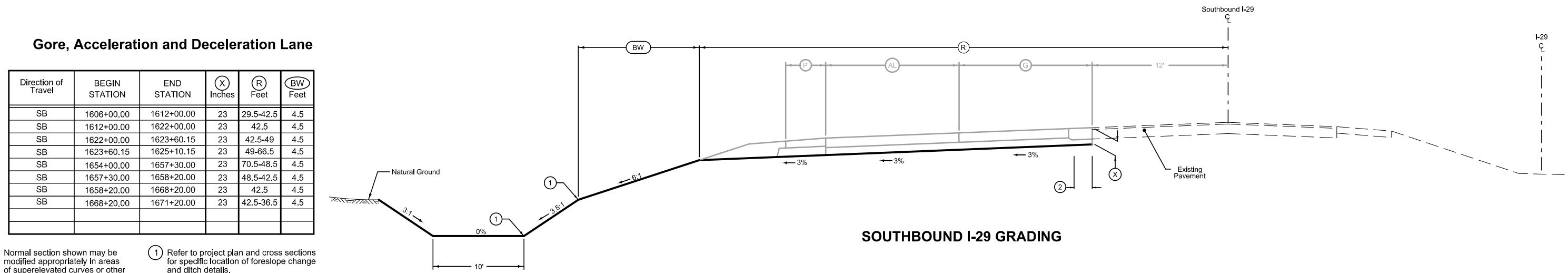

SOUTHBOUND I-29 GRADING

Gore, Acceleration and Deceleration Lane

Direction of Travel	BEGIN STATION	END STATION	(X) Inches	(R) Feet	(BW) Feet
SB	1606+00.00	1612+00.00	23	29.5-42.5	4.5
SB	1612+00.00	1622+00.00	23	42.5	4.5
SB	1622+00.00	1623+60.15	23	42.5-49	4.5
SB	1623+60.15	1625+10.15	23	49-66.5	4.5
SB	1654+00.00	1657+30.00	23	70.5-48.5	4.5
SB	1657+30.00	1658+20.00	23	48.5-42.5	4.5
SB	1658+20.00	1668+20.00	23	42.5	4.5
SB	1668+20.00	1671+20.00	23	42.5-36.5	4.5

Normal section shown may be modified appropriately in areas of superelevated curves or other locations specifically designated by the Engineer.

- ① Refer to project plan and cross sections for specific location of foreslope change and ditch details.
- ② Remove 2'-0" existing slab.

MAINLINE AND RAMP GRADING

LOCATION			DIMENSIONS			
ROAD IDENTIFICATION	STATION TO STATION		Ⓐ Feet	Ⓑ Feet	Ⓐ Inches	Ⓓ Feet
235th Street	5000+62.00	5001+77.00	41	37	15.5	4
235th Street	5001+77.00	5002+72.41	41-37	37	15.5	4
235th Street	5002+72.41	5006+28.05	37	37	15.5	4-10
235th Street	5006+28.05	5008+08.11	37	37-49	15.5	10
235th Street	5008+08.11	5010+10.83	37	49	15.5	10
235th Street	5010+10.83	5012+54.99	37-42	42	21.5	0
235th Street	5014+93.20	5018+23.83	42	42	21.5	0
235th Street	5018+23.83	5020+18.40	49	37	15.5	10
235th Street	5020+18.40	5021+98.40	49-37	37	15.5	10
235th Street	5021+98.40	5027+38.40	37-29	37-29	15.5	10-4
235th Street	5027+38.40	5056+20.15	29	29	15.5	4
235th Street	5056+20.15	5057+26.58	29-38	29-39	15.5	4
235th Street	5057+26.58	5058+36.00	29	40	15.5	4-0
235th Street	5058+36.00	5058+41.59	29	40	15.0	0

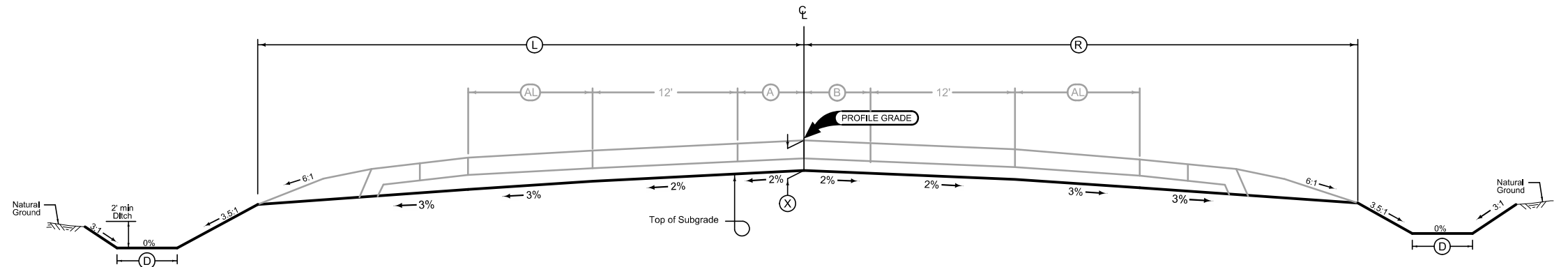

235TH STREET

Normal section shown may be modified appropriately in areas of superelevated curves or other locations specifically designated by the Engineer.

See plan & profile sheets and cross sections for additional details of ditches and backslopes.

LOCATION			DIMENSIONS		
ROAD IDENTIFICATION	STATION TO STATION		Ⓐ Feet	Ⓑ Feet	Ⓐ Inches
Old US 75	335+25.00	339+27.97	18	18	15
Old US 75	339+27.97	343+50.00	30	18	15
Old US 75	343+50.00	344+97.97	30	0	15
Old US 75	344+97.97	346+17.97	30-18	0	15

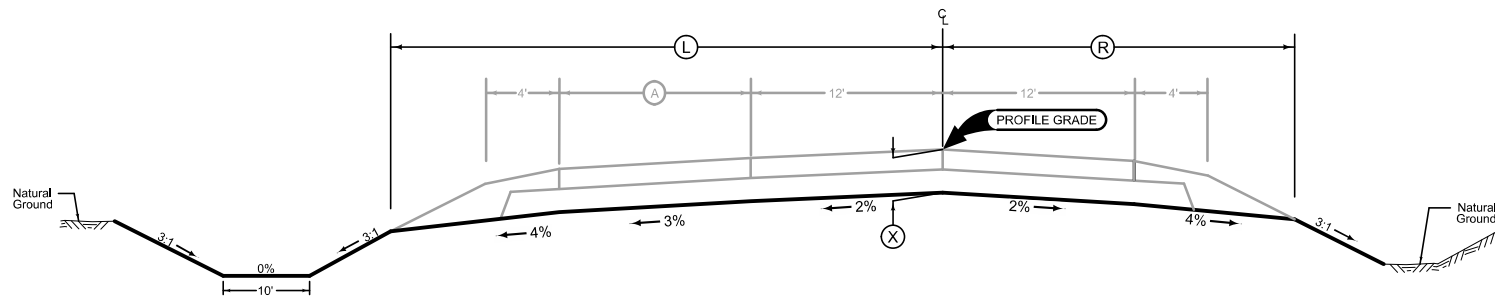

OLD US 75

LOCATION			DIMENSIONS		
ROAD IDENTIFICATION	STATION TO STATION		Ⓐ Feet	Ⓑ Feet	Ⓐ Inches
Banner Avenue	8000+75.03	8006+62.00	16	16	6
Barker Avenue	9001+85.00	9002+41.69	19	19	6

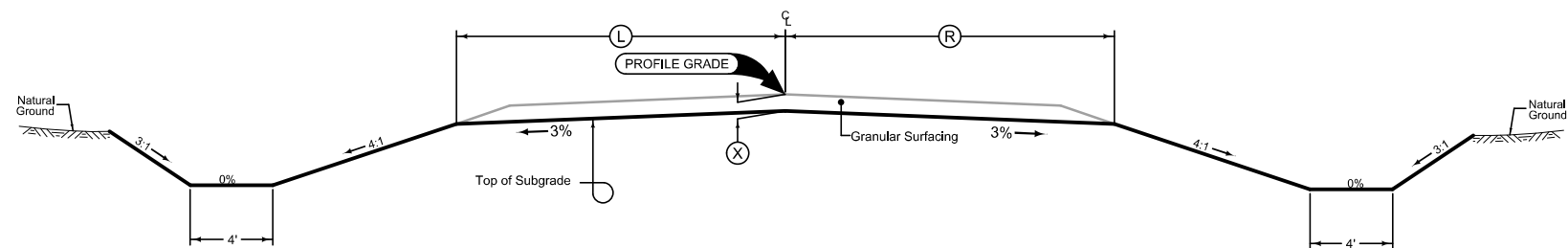

**BANNER AVENUE
BARKER AVENUE**

SIDEROAD GRADING

Normal section shown may be modified appropriately in areas of superelevated curves or other locations specifically designated by the Engineer.

See plan & profile sheets and cross sections for additional details of ditches and backslopes.

PCC Shoulder

Shoulder Jointing:
 Longitudinal joint: L-2
 Transverse joints: CD, Match Ramp

ROAD IDENTIFICATION	BEGIN STATION	END STATION	(P) Feet
Ramp A	1000+20.00	1014+61.31	4
Ramp B	2000+00.00	2016+31.10	4
Ramp C	3003+08.92	3017+83.21	4
Ramp D	4000+20.71	4013+63.78	4

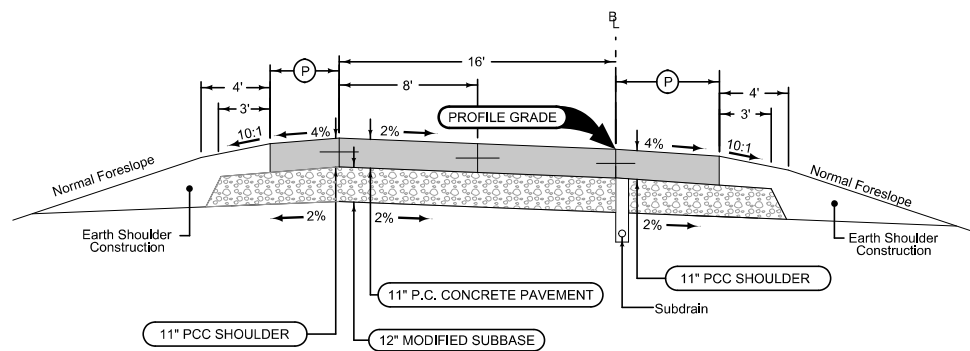

Section shown in the direction of traffic.

Ramp Jointing:
 Transverse joints: CD at 17' spacing.
 Longitudinal joints: L-2

ROAD IDENTIFICATION	BEGIN STATION	END STATION
Ramp A	1000+20.00	1014+61.31
Ramp B	2000+00.00	2016+31.10
Ramp C	3000+00.00	3017+83.21
Ramp D	4000+20.71	4016+72.70

PCC Shoulder

Shoulder Jointing:
 Longitudinal joint: L-2
 Transverse joints: CD, Match Ramp

ROAD IDENTIFICATION	BEGIN STATION	END STATION	(P) Feet
Ramp A	1000+20.00	1014+61.31	6
Ramp B	2000+00.00	2015+31.10	6
Ramp C	3000+00.00	3017+83.21	6
Ramp D	4000+20.71	4016+72.70	6

RAMP PAVING

PCC Auxiliary Lane And Shoulder

Shoulder Jointing:
 Longitudinal joint: L-2
 Transverse joints: CD, Match Ramp

ROAD IDENTIFICATION	BEGIN STATION	END STATION	(AL) Feet
235th Street	5000+12.00	5001+77.00	12
235th Street	5001+77.00	5002+72.41	12-0
235th Street	5002+72.41	5009+60.00	0
235th Street	5018+75.00	5020+18.40	12
235th Street	5020+18.40	5021+98.40	12-0
235th Street	5021+98.40	5058+91.57	0

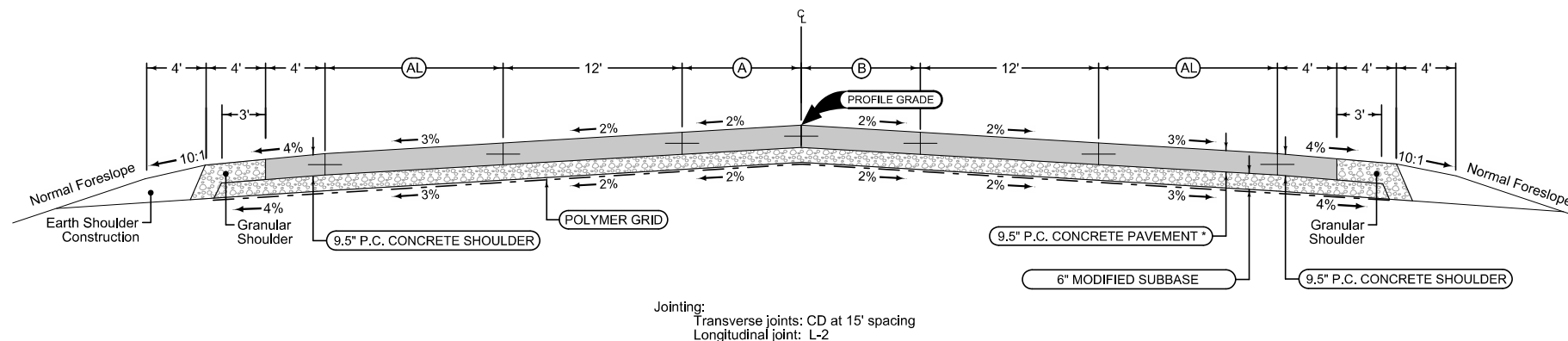

STATION TO STATION		(A) Feet	(B) Feet
5000+12.00	5001+77.00	12	8
5001+77.00	5002+72.41	12-8	8
5002+72.41	5009+60.00	8	8
5018+75.00	5022+98.40	8	8
5022+98.40	5027+38.40	8-0	8-0
5027+38.40	5056+05.46	0	0
5056+05.46	5057+26.60	0-4	0
5057+26.60	5058+91.57	4	0

*Note: The area east of the UPRR (Sta. 5058+36.00 to 5058+41.59), use 9" P.C. CONCRETE PAVEMENT to match the Old US 75 pavement section.

PCC Auxiliary Lane And Shoulder

PCC Shoulder Jointing:
 Longitudinal joint: L-2
 Transverse joints: CD, Match Ramp

ROAD IDENTIFICATION	BEGIN STATION	END STATION	(AL) Feet
235th Street	5000+12.00	5006+28.05	0
235th Street	5006+28.05	5008+08.11	0-12
235th Street	5008+08.11	5009+60.00	12
235th Street	5018+75.00	5056+00.00	0
235th Street	5056+00.00	5057+20.00	0-12
235th Street	5057+20.00	5058+91.57	12

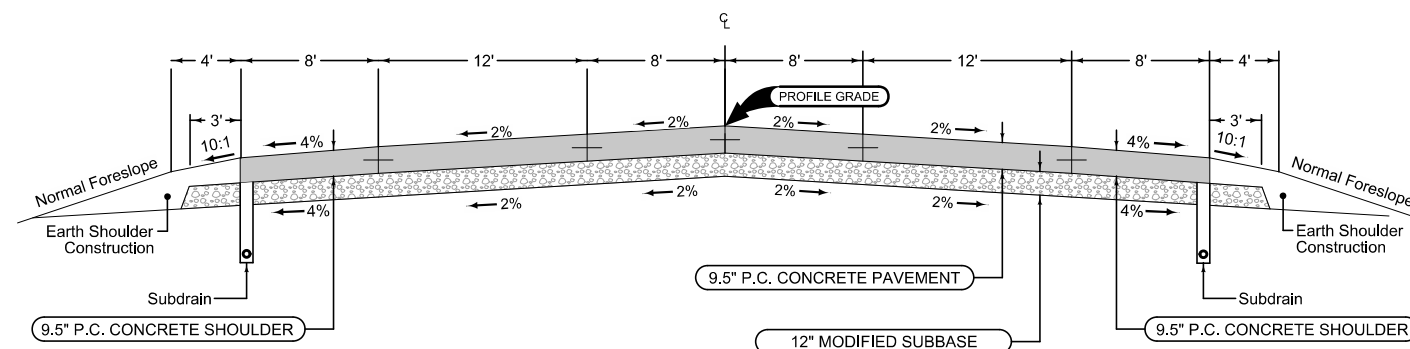

STATION TO STATION	
5009+60.00	5012+54.99
5014+93.20	5018+75.00

SIDEROAD PAVING 235TH STREET

Auxiliary Lane

Jointing:
 Transverse joints: CD, Match Mainline
 Longitudinal joints: L-2 or KT-2

STATION TO STATION		(AL) Feet
339+93.99	343+50.00	12

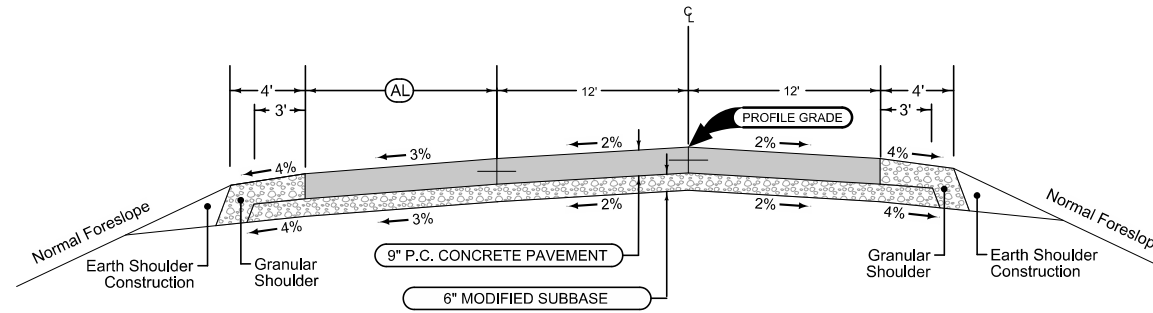

Section shown in the direction of stationing.

Jointing:
 Transverse joints: CD at 15' spacing.
 Longitudinal joints: L-2

ROAD IDENTIFICATION	BEGIN STATION	END STATION
Old US 75	335+25.00	343+50.00

Auxiliary Lane

Jointing:
 Transverse joints: CD, Match Mainline
 Longitudinal joints: KT-2

STATION TO STATION		(AL) Feet
343+50.00	345+60.00	12
345+60.00	347+40.00	12-0

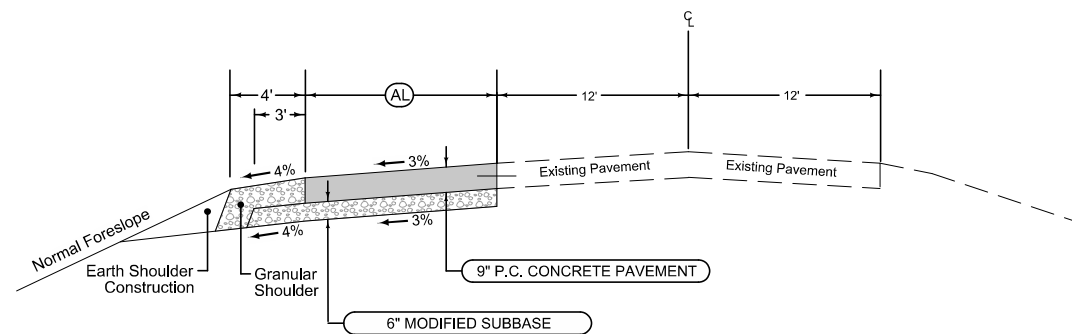

Section shown in the direction of stationing.

SIDEROAD PAVING OLD US 75

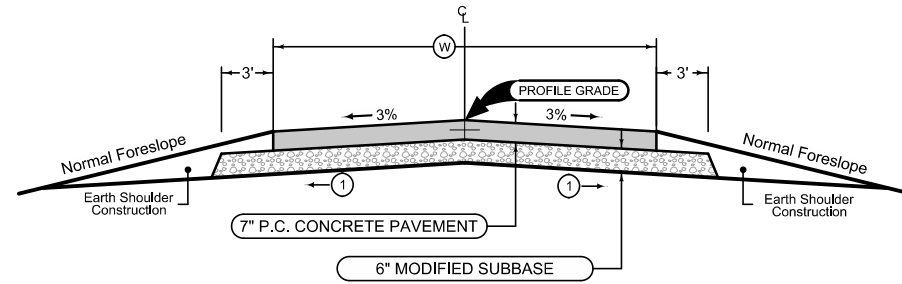

① Subgrade parallels pavement slope.
See L sheets for details.

Jointing:
Transverse joints: CD at 15' spacing
Longitudinal joint: L-2

LOCATION		DIMENSIONS
ROAD IDENTIFICATION	STATION TO STATION	Ⓜ Feet
Banner Avenue	8000+12.00 8000+74.03	26
Barker Avenue	9002+41.69 9003+01.84	32

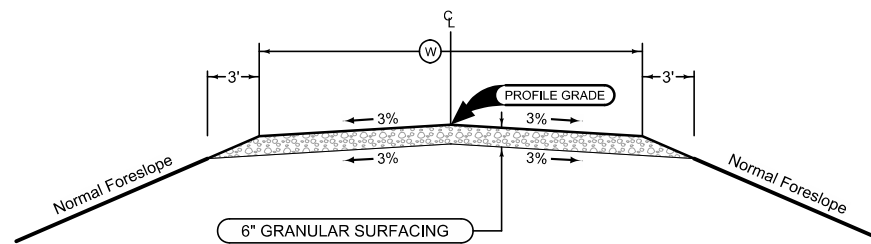

LOCATION		DIMENSIONS
ROAD IDENTIFICATION	STATION TO STATION	Ⓜ Feet
Banner Avenue	8000+74.03 8006+62.00	26
Barker Avenue	9001+85.00 9002+41.69	32
ENTR5026	0+22.51 1+45.00	40
ENTL5048	0+20.00 0+95.00	40
ENTR5048	0+20.00 0+75.00	40
ENTL5055	0+20.00 0+70.00	40
ENTR5057	0+32.00 0+78.00	12
ENTR5057	0+78.00 1+05.00	12-31
ENTL8006	0+13.00 0+78.00	40
ENTL8016	0+12.50 0+35.00	40

**SIDEROAD PAVING
BANNER AVENUE
BARKER AVENUE
FIELD ENTRANCES**

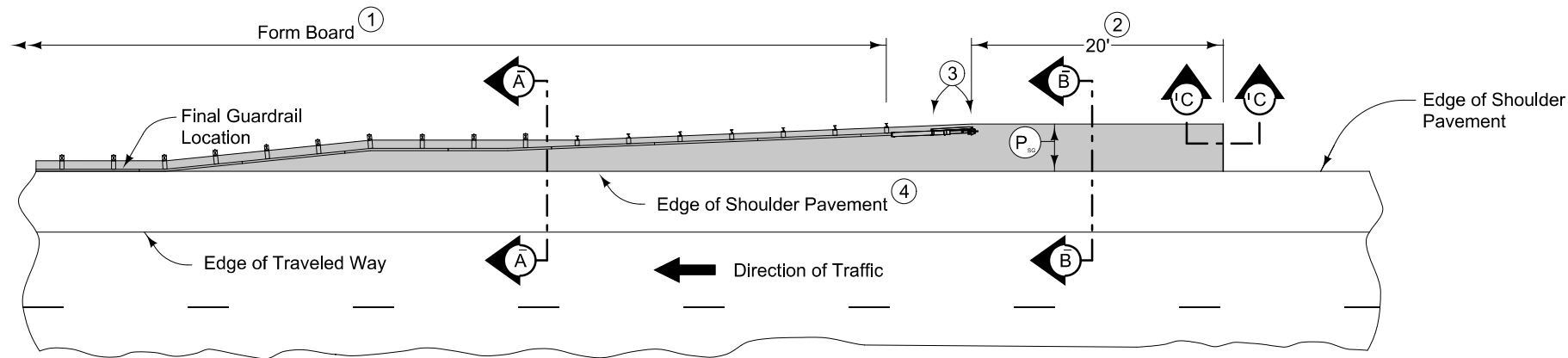

PLAN VIEW

9" HMA Paved Shoulder at guardrail. 8" PCC may be substituted with the following jointing layout:

Match mainline pavement joint spacing. When mainline pavement is 8" or greater in thickness, place additional transverse 'C' joints in shoulder at mid-panel of the mainline pavement. Place longitudinal 'C' joint at P/2 from edge of mainline pavement when P is greater than 10' wide. Terminate longitudinal joint at transverse joint less than 10' in length.

Compaction of HMA is required to face of guardrail post. Hand compaction will be allowed under guardrail. Removal and reinstallation of guardrail will be allowed with no additional payment.

Refer to Tabulation 112-9 for shoulder quantities.

- ① PCC option only: When guardrail posts are installed prior to construction of PCC paved shoulder, fasten form board to the face of guardrail posts for the length shown.
- ② Continue paved shoulder 20 feet beyond the center of the first post.
- ③ Shoulder may be notched for first 2 posts or post sleeves may be installed through pavement. Do not drive posts through pavement.
- ④ 'KT' (per PV-101) joint for PCC shoulder. 'B' (per PV-101) joint for HMA shoulder.
- ⑤ Match shoulder slope.
- ⑥ The Contractor has the option to pave the paved shoulder at guardrail and the full width paved shoulder as one operation.
- ⑦ Refer to other details in the plan.

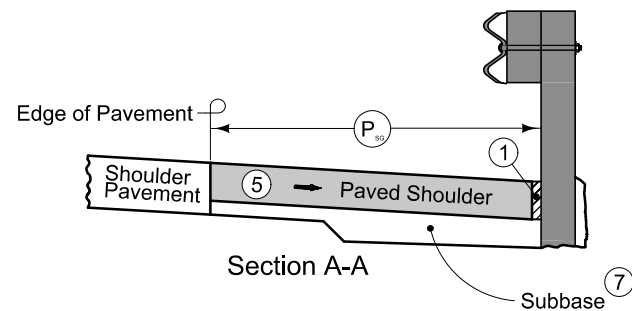

Section A-A

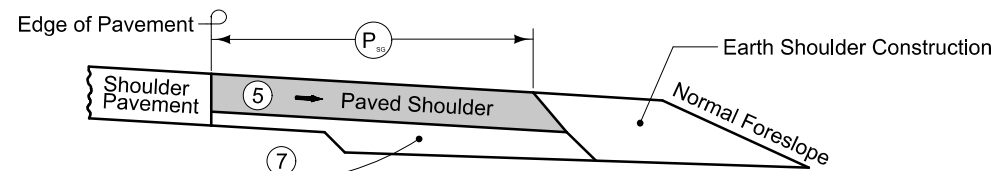

Section B-B

NEW CONSTRUCTION

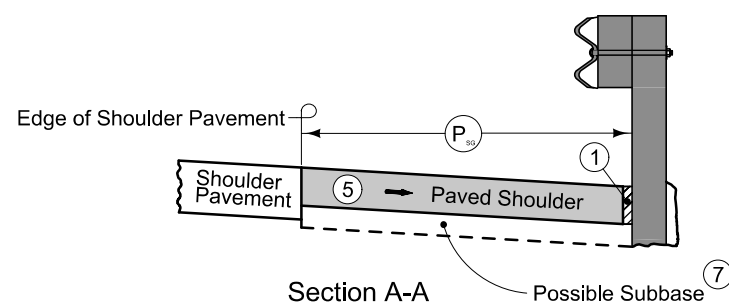

Section A-A

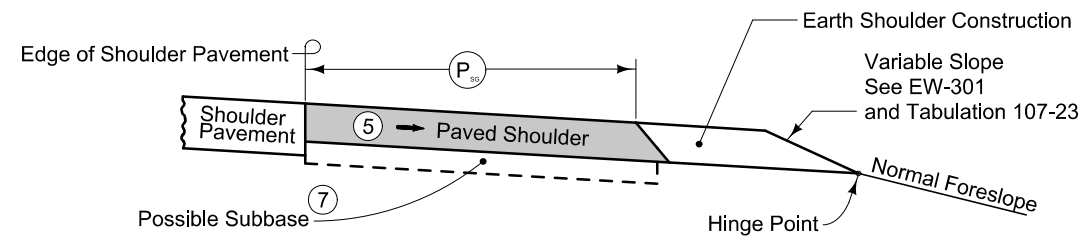

Section B-B

EXISTING SHOULDER

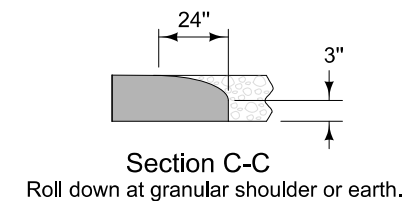

PAVED SHOULDER AT GUARDRAIL
(ADJACENT TO FULL WIDTH PAVED SHOULDER)

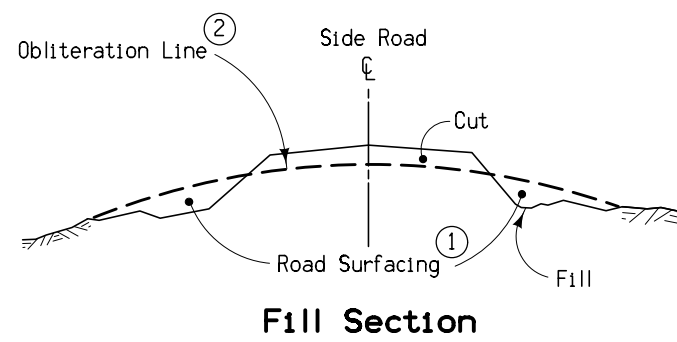

Fill Section

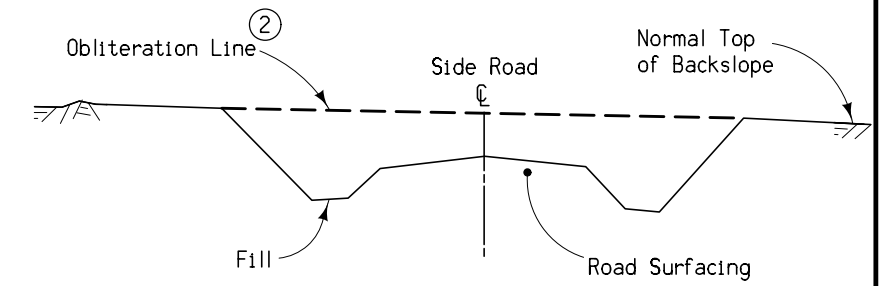

Cut Section

① Existing road surfacing (granular material) shall be placed as shown unless otherwise directed by the Engineer or provided for in the detail project plans.

② When specified, the upper 1' to be suitable for vegetation (grass or crops).

Note:
The work of obliterating or reshaping old roadbeds shall be done at the direction of the Engineer.
Refer to cross sections for project grading.

TYPICAL DETAILS FOR OBLITERATION EXISTING ROADBED

SURVEY SYMBOLS

- Interstate Highway Symbol
- U.S. Highway Symbol
- Iowa Highway Symbol
- County Road Highway Symbol
- Evergreen Tree
- Deciduous Tree
- Fruit Tree
- Shrub (Bushes)
- Timber
- Hedge
- Stump
- Swamp
- Rock Outcrop
- Broken Concrete
- Revetment (Rip Rap)
- Cemetery
- Grave
- Cave
- Sink Hole
- Board Fence
- Chain Link or Security Fence
- Wire Fence
- Terrace
- Earth Dam or Dike (Existing)
- Tile Outlet
- Edge of Water
- Existing Drainage
- Right of Way Rail or Lot Corner
- Concrete Monument
- Well
- Windmill
- Beehive Intake
- Existing Intake
- Existing Utility Access (Manhole)
- Fire Hydrant
- Water Hydrant (Rural)
- Septic Tank
- Cistern
- L.P. Gas Tank (No Footing)
- Underground Storage Tank
- Latrine
- Satellite TV Dish
- Water Hook Up
- Radio Tower
- Tower Anchor
- Guardrail (Beam or Cable)
- Guard Post (one or two)
- Guard Post (over two)
- Filler Pipe
- Gas Valve
- Water Valve
- Speed Limit Sign
- Mile Marker Post
- Sign
- Traffic Signal Control Box
- Rail Road Signal Control Box
- Telephone Switch Box
- Electric Box

UTILITY LEGEND

- FO2 -** LONG LINES LTD. (Telephone)
TOM CONNORS
712-333-1352
tom.connors@longlines.biz
- FO -** MIDWEST FIBER NETWORKS LCC
Contact Name
Contact Email
- G -** NORTHERN NATURAL GAS COMPANY (Gas Transmission)
JEFF LARSON
402-398-7618
Jeff.Larson@nngco.com
- SAN -** SIOUX CITY (Sanitary Sewer, Water)
JON O'BRIEN
712-279-6135
jobrien@sioux-city.org
- E1 -** WOODBURY COUNTY REC (Electric Distribution)
Nate Bauer
712-873-3125
nbauer@woodburyrec.com
- AT&T (Fiber Transmission)
LENNY VOHS
816-275-4014
lv2121@att.com
- BLACK HILLS ENERGY (Gas)
BRAD FLEMING
402-221-2714
brad.fleming@blackhillscorp.com
- FIBERCOMM (Fiber Distribution)
RICK WELCH
712-224-2054
rwelch@fibercomm.net
- LUMEN CENTURYLINK (Fiber Distribution)
SEAN HOSTETTER
515-233-6404
sean.hostetter@lumen.com
- MIDAMERICAN ENERGY COMPANY (Electric Distribution)
CASEY MEINEN
712-233-4831
Casey.meinen@midamerican.com
- MIDAMERICAN ENERGY COMPANY (Electric Distribution)
WILLIAM SCHIERBROCK
563-333-8155
William.Schierbrock@midamerican.com
- MIDAMERICAN ENERGY COMPANY (Gas)
TYLER AHLQUIST
712-277-7832
tjalquist@midamerican.com
- MIDAMERICAN ENERGY COMPANY (Fiber)
BRIAN RECKER
515-242-4377
Brian.Recker@midamerican.com
- FO3 -** SPRINT-TMOBILE (Fiber Transmission)
MIKE CHEBUL
402-522-2607
michael.j.chebul@t-mobile.com

PLAN VIEW COLOR LEGEND OF PLAN AND PROFILE SHEETS

LINEWORK		Design Color No.	
Green	(2)		Existing Topographic Features and Labels
Blue	(1)		Proposed Alignment, Stationing, Tic Marks, and Alignment Annotation
Magenta	(5)		Existing Utilities
SHADING		Design Color No.	
Lavender	(9)		Temporary Pavement Shading
Yellow	(4)		Proposed Pavement Shading
Orange	(6)		Proposed Granular Shading
Orange	(70)		Proposed Shoulder Granular Shading
Yellow	(68)		Proposed Shoulder Paved Full Depth Shading
Yellow	(132)		Proposed Shoulder Paved Partial Depth Shading
Gray, Dark	(112)		Proposed Grade and Pave Shading "In conjunction with a paving project"
Brown, Light	(236)		Grading Shading
Orange, Light	(134)		Proposed Granular Entrance Shading
Yellow	(220)		Proposed Paved Entrance Shading
Tan	(8)		Proposed Sidewalk Shading
Blue, Light	(230)		Proposed Sidewalk Landing Shading
Pink	(11)		Proposed Sidewalk Ramp Shading
Green, Light	(225)		Existing Pavement Shading
Red	(3)		Proposed Structure Shading
Red	(3)		Delineates Restricted Areas

PROFILE VIEW COLOR LEGEND OF PLAN AND PROFILE SHEETS

LINEWORK		Design Color No.	
Green	(10)		Existing Ground Line Profile
Blue	(1)		Proposed Profile and Annotation
Magenta	(5)		Existing Utilities
Blue, Light	(230)		Proposed Ditch Grades, Left
Black	(0)		Proposed Ditch Grades, Median
Rust	(14)		Proposed Ditch Grades, Right

- Reference Point
- Station
- Survey Line
- Section Corner
- Ground Line Intercept
- Saw Cut
- Guardrail
- Trench Drain
- High Tension Cable Guardrail
- Sheet Pile
- Pavement Removal
- Clearing & Grubbing Area

RIGHT-OF-WAY LEGEND

- Proposed Right-of-Way
- Existing Right of Way
- Existing and Proposed Right-of-Way
- Easement and Existing Right-of-Way
- Easement (Temporary)
- Easement
- Access Control
- Property Line

PLAN AND PROFILE LEGEND AND SYMBOL INFORMATION SHEET

(COVERS SHEET SERIES D, E, K, & U)

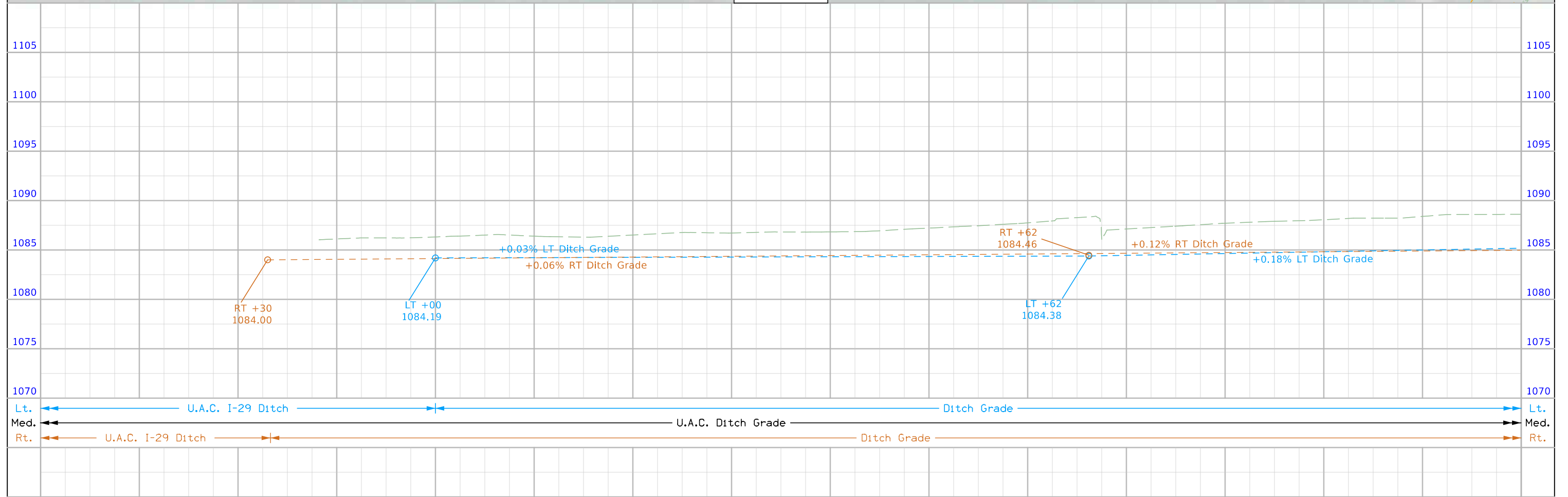
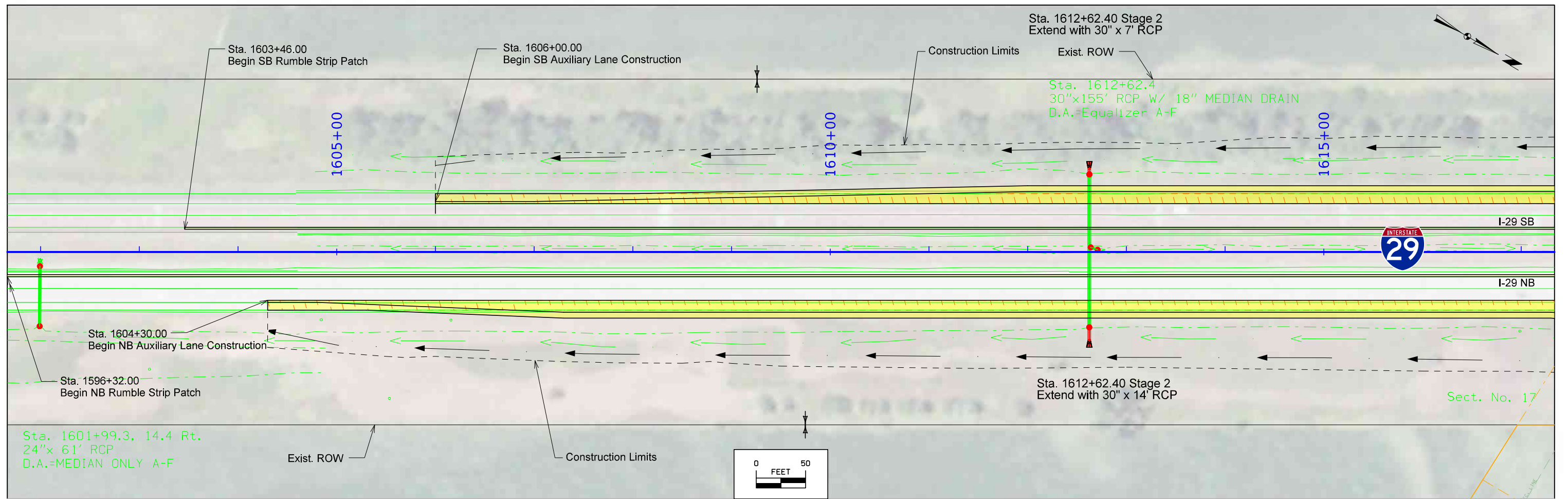

1602+00	1603+00	1604+00	1605+00	1606+00	1607+00	1608+00	1609+00	1610+00	1611+00	1612+00	1613+00	1614+00	1615+00	1616+00	1617+00
FILE NO.	ENGLISH	DESIGN TEAM Iowa DOT / HNTB				WOODBURY COUNTY				PROJECT NUMBER IMN-029-6(170)139--0E-97				SHEET NUMBER D.2	

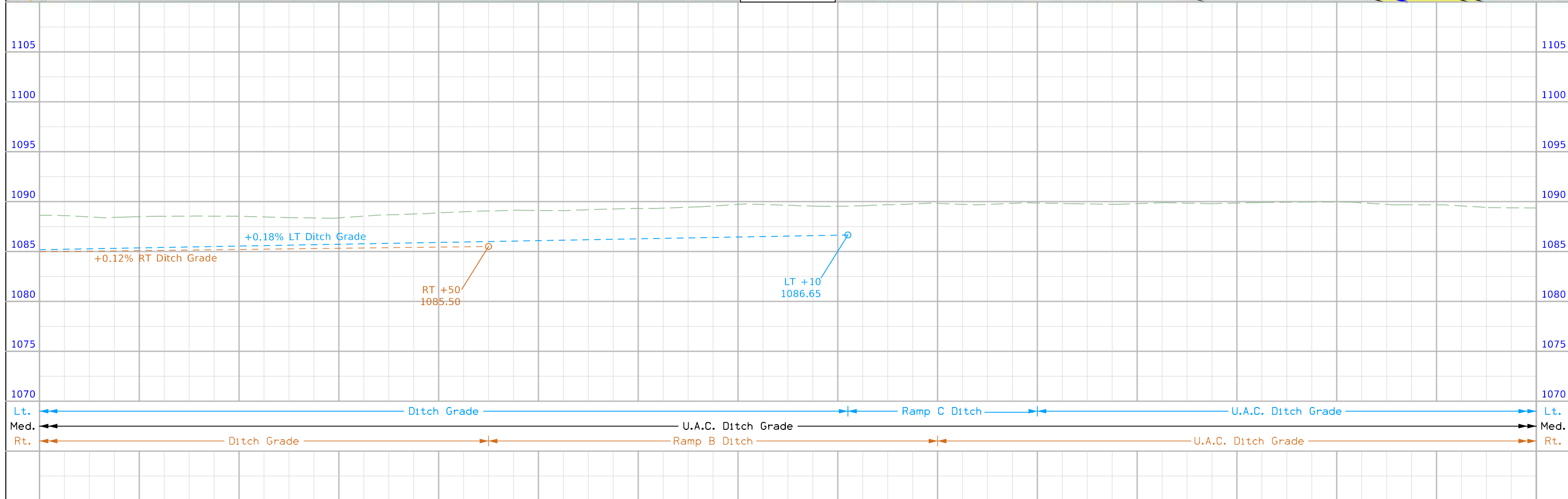
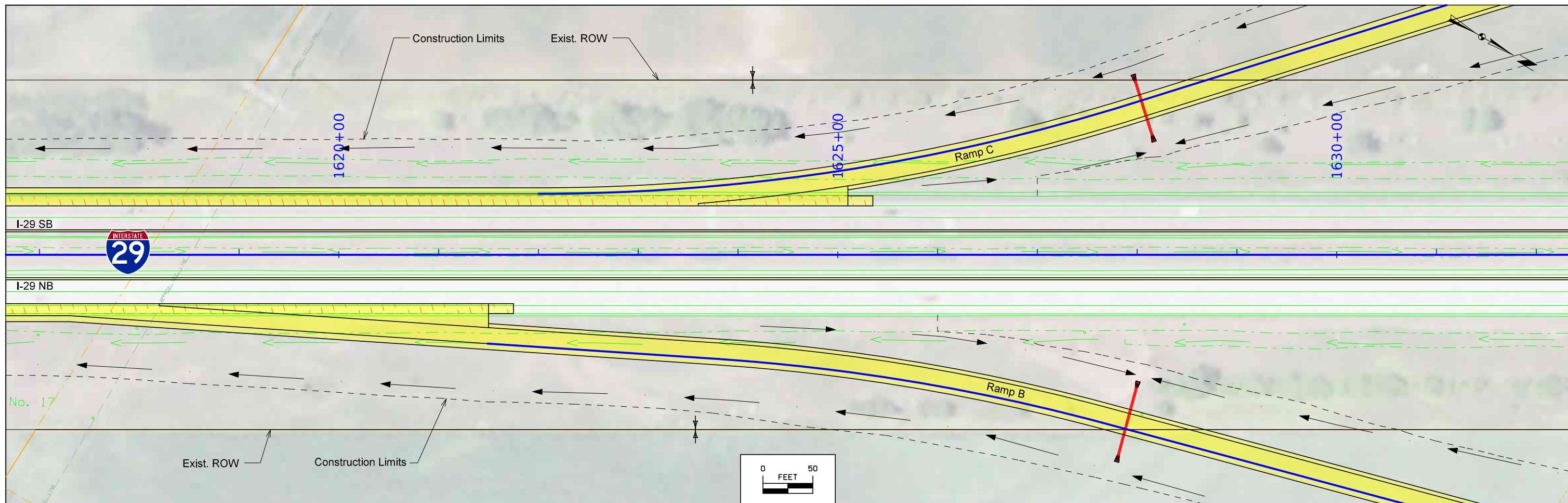

1617+00	1618+00	1619+00	1620+00	1621+00	1622+00	1623+00	1624+00	1625+00	1626+00	1627+00	1628+00	1629+00	1630+00	1631+00	1632+00
FILE NO.	ENGLISH	DESIGN TEAM Iowa DOT / HNTB				WOODBURY COUNTY			PROJECT NUMBER IMN-029-6(170)139--0E-97				SHEET NUMBER D.3		

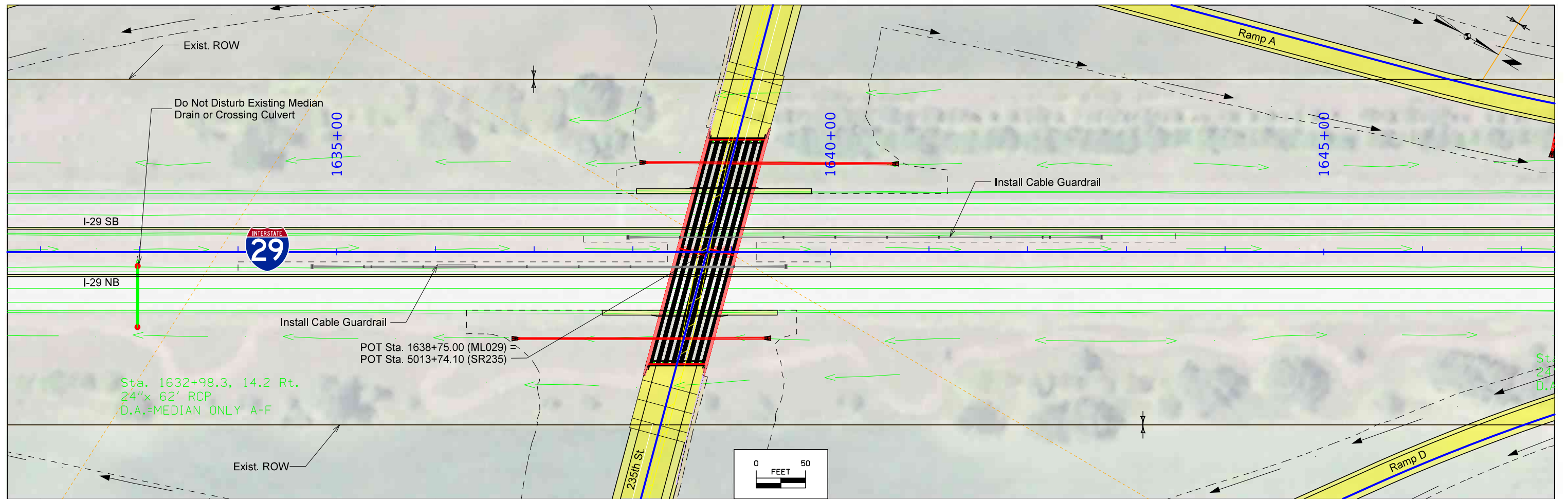

1632+00	1633+00	1634+00	1635+00	1636+00	1637+00	1638+00	1639+00	1640+00	1641+00	1642+00	1643+00	1644+00	1645+00	1646+00	1647+00
FILE NO.	ENGLISH	DESIGN TEAM Iowa DOT / HNTB				WOODBURY COUNTY				PROJECT NUMBER IMN-029-6(170)139--0E-97				SHEET NUMBER D.4	

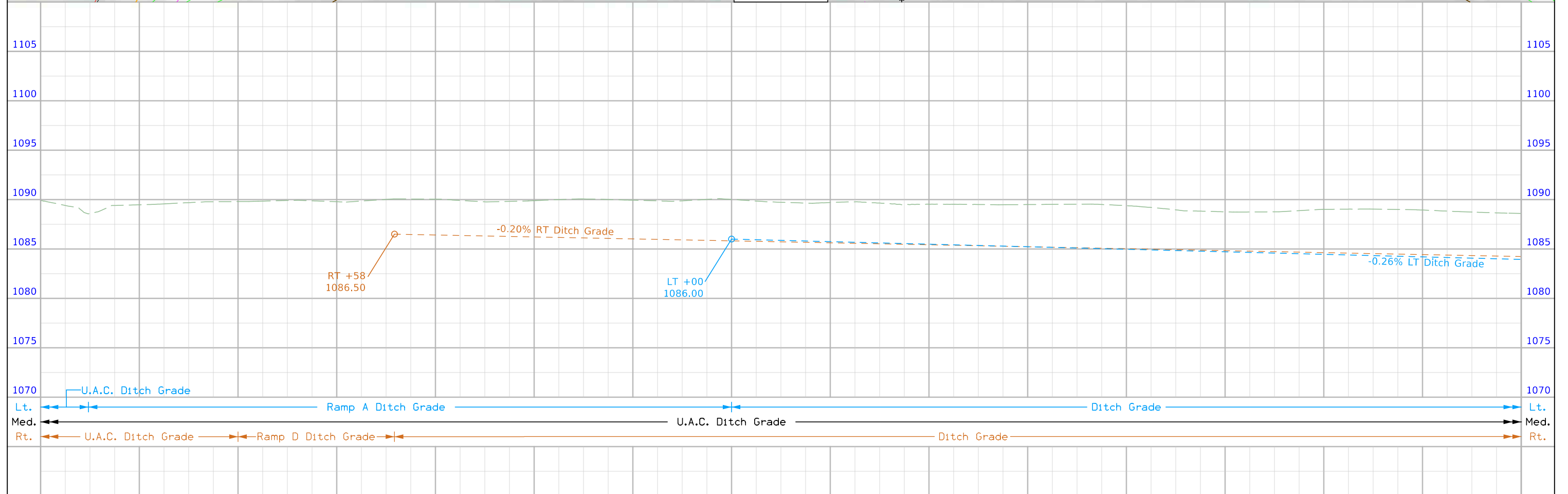
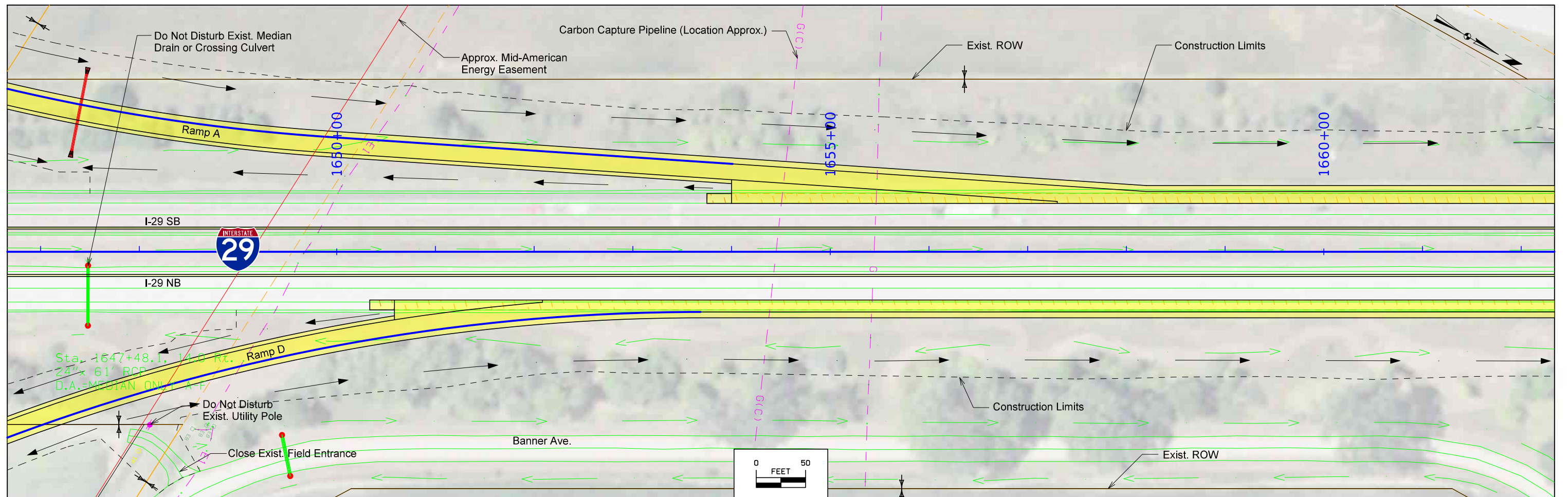

1647+00	1648+00	1649+00	1650+00	1651+00	1652+00	1653+00	1654+00	1655+00	1656+00	1657+00	1658+00	1659+00	1660+00	1661+00	1662+00		
FILE NO.	ENGLISH	DESIGN TEAM	Iowa DOT / HNTB			WOODBURY COUNTY			PROJECT NUMBER			IMN-029-6(170)139--0E-97			SHEET NUMBER		D.5

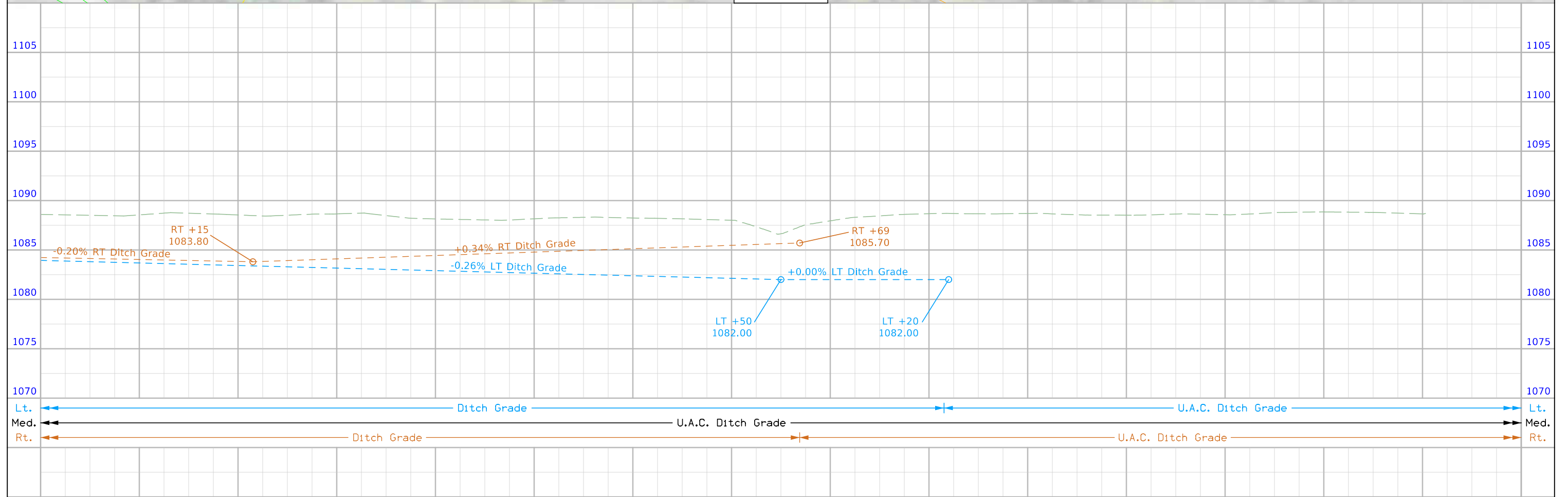
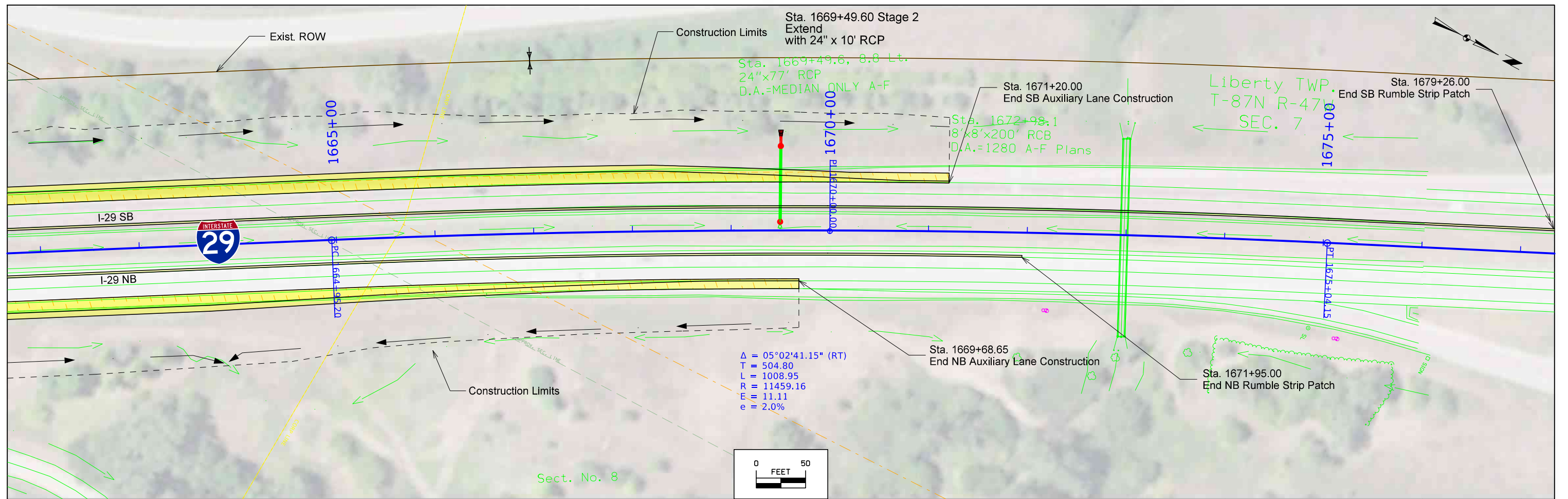

1662+00	1663+00	1664+00	1665+00	1666+00	1667+00	1668+00	1669+00	1670+00	1671+00	1672+00	1673+00	1674+00	1675+00	1676+00	1677+00
FILE NO.	ENGLISH	DESIGN TEAM Iowa DOT / HNTB	WOODBURY COUNTY				PROJECT NUMBER	IMN-029-6(170)139--0E-97				SHEET NUMBER D.6			

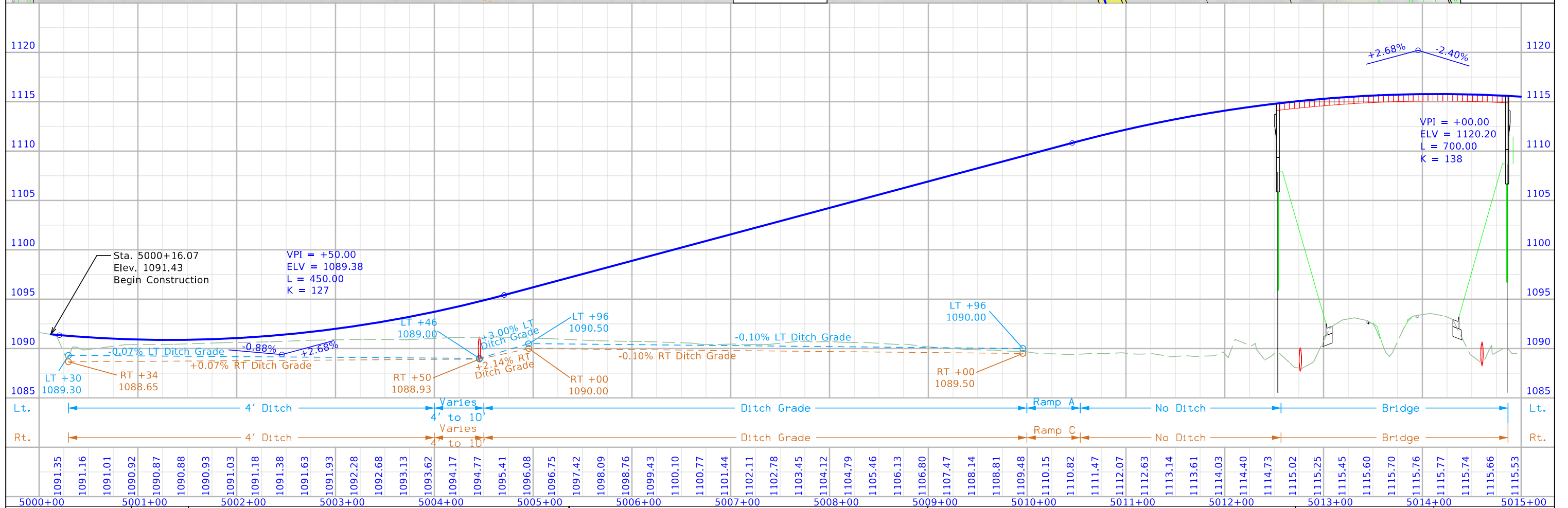
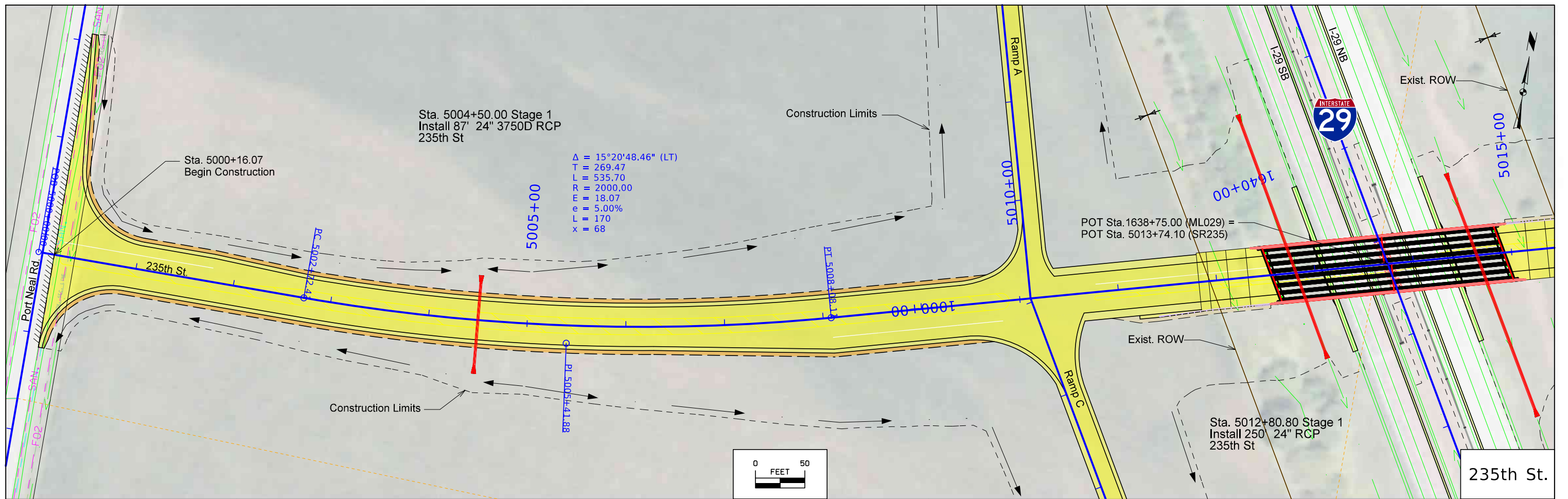

FILE NO.	ENGLISH	DESIGN TEAM IOWA DOT / HNTB	WOODBURY COUNTY	PROJECT NUMBER	IMN-029-6(170)139--0E-97	SHEET NUMBER	E.1
----------	---------	-----------------------------	-----------------	----------------	--------------------------	--------------	-----

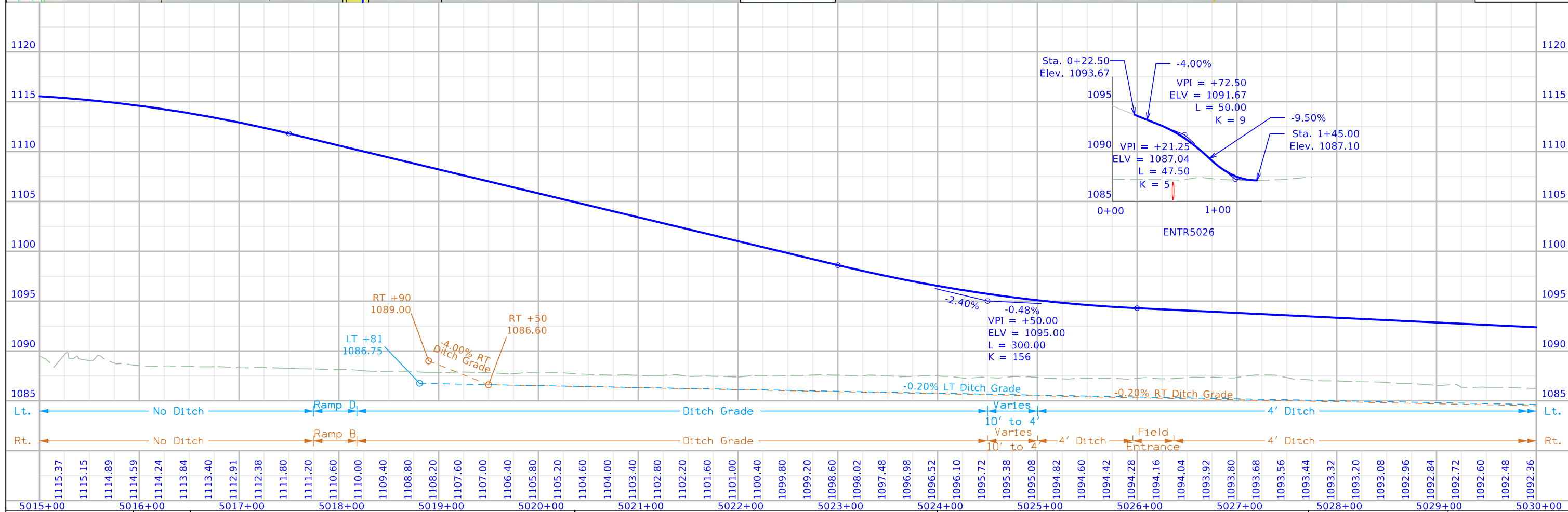
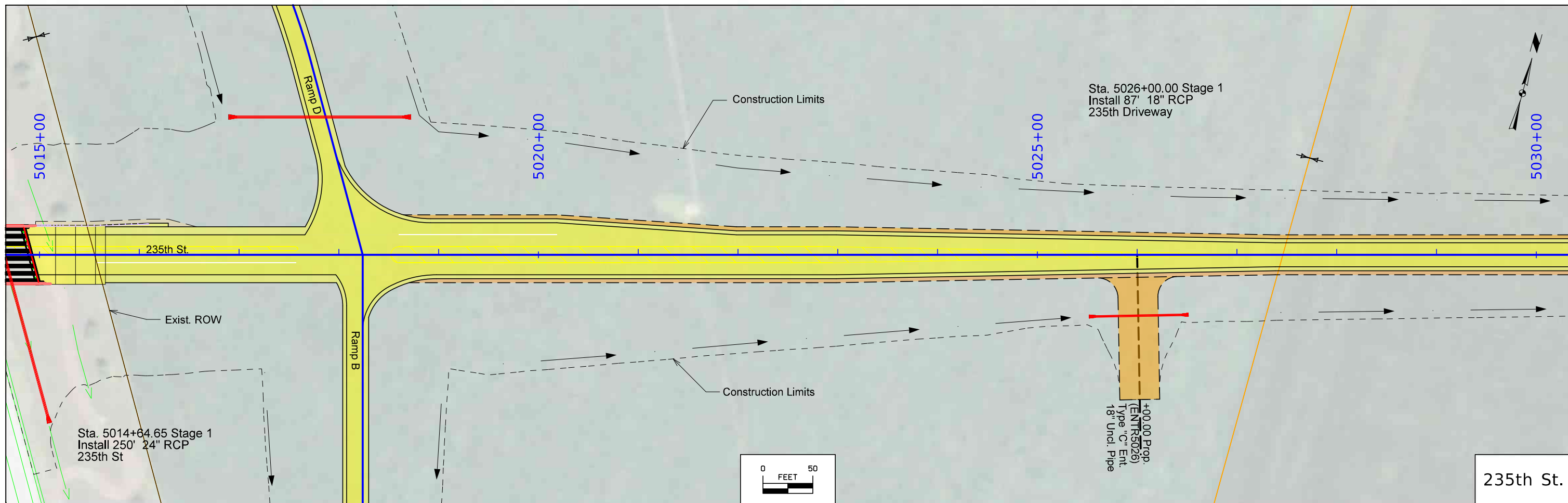

FILE NO.	ENGLISH	DESIGN TEAM Iowa DOT / HNTB	WOODBURY COUNTY	PROJECT NUMBER IMN-029-6(170)139--0E-97	SHEET NUMBER E.2
----------	---------	-----------------------------	-----------------	---	------------------

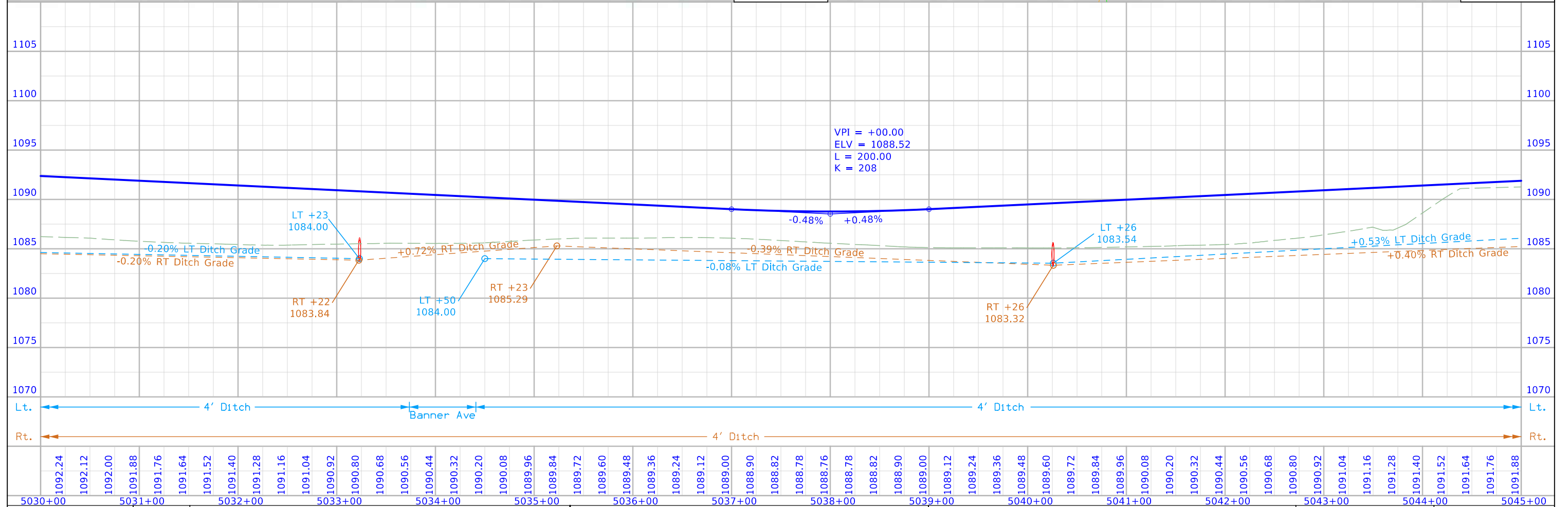
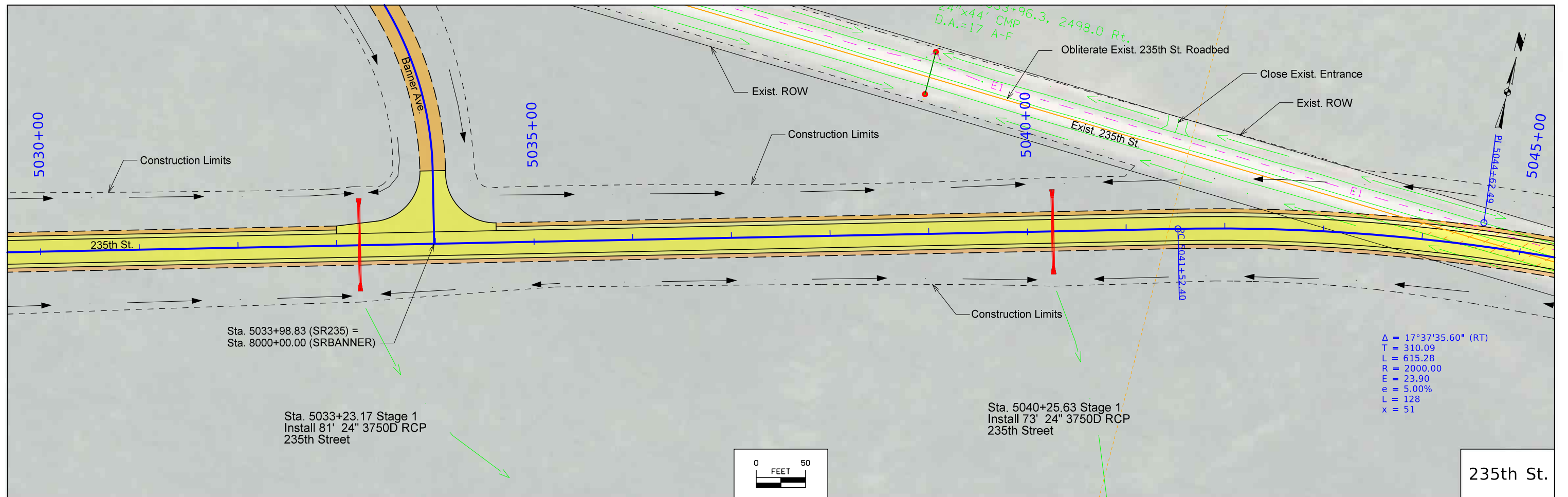

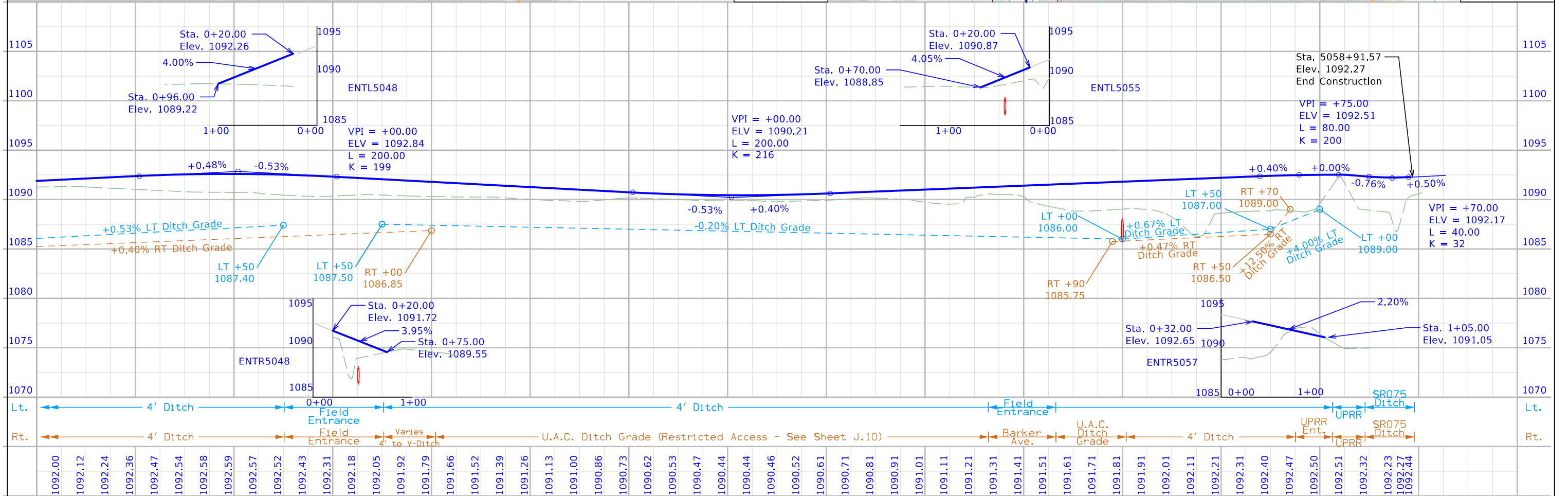
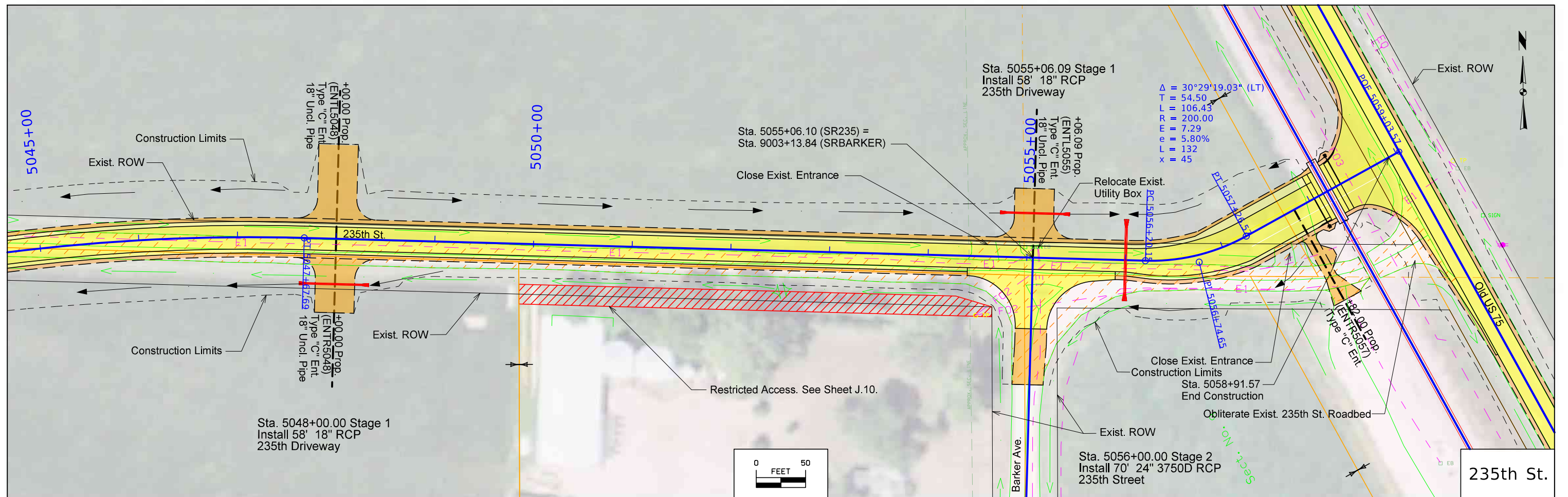

5045+00	5046+00	5047+00	5048+00	5049+00	5050+00	5051+00	5052+00	5053+00	5054+00	5055+00	5056+00	5057+00	5058+00	5059+00	5060+00																																									
1092.00	1092.12	1092.24	1092.36	1092.47	1092.54	1092.58	1092.59	1092.57	1092.52	1092.43	1092.31	1092.18	1092.05	1091.92	1091.79	1091.66	1091.52	1091.39	1091.26	1091.13	1091.00	1090.86	1090.73	1090.62	1090.53	1090.47	1090.44	1090.44	1090.46	1090.52	1090.61	1090.71	1090.81	1090.91	1091.01	1091.11	1091.21	1091.31	1091.41	1091.51	1091.61	1091.71	1091.81	1091.91	1092.01	1092.11	1092.21	1092.31	1092.40	1092.47	1092.50	1092.51	1092.32	1092.23	1092.27	1092.44

Sect. No. 9

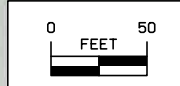
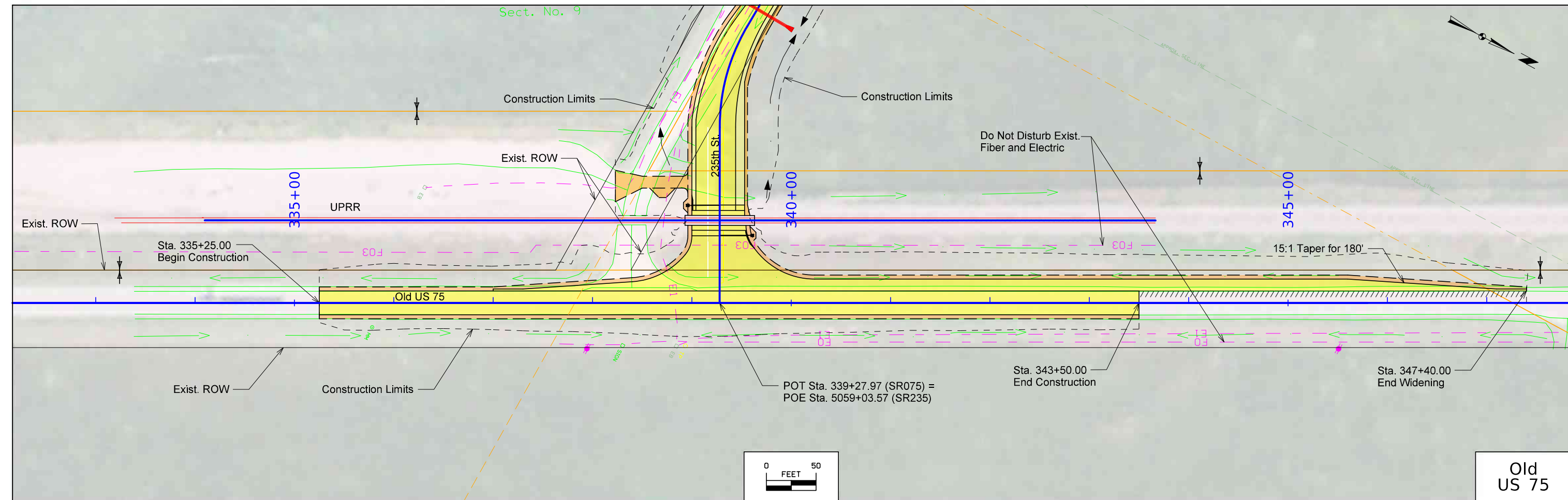

Old US 75

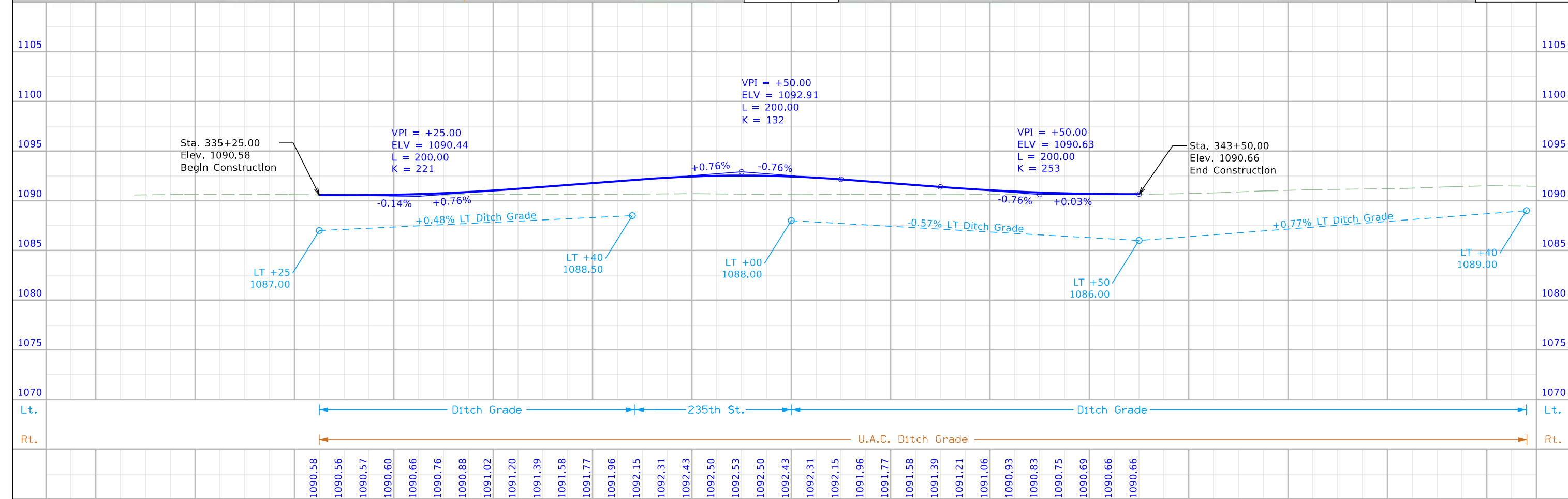

FILE NO.	ENGLISH	DESIGN TEAM Iowa DOT / HNTB	WOODBURY COUNTY	PROJECT NUMBER IMN-029-6(170)139--0E-97	SHEET NUMBER E.5
----------	---------	-----------------------------	-----------------	---	------------------

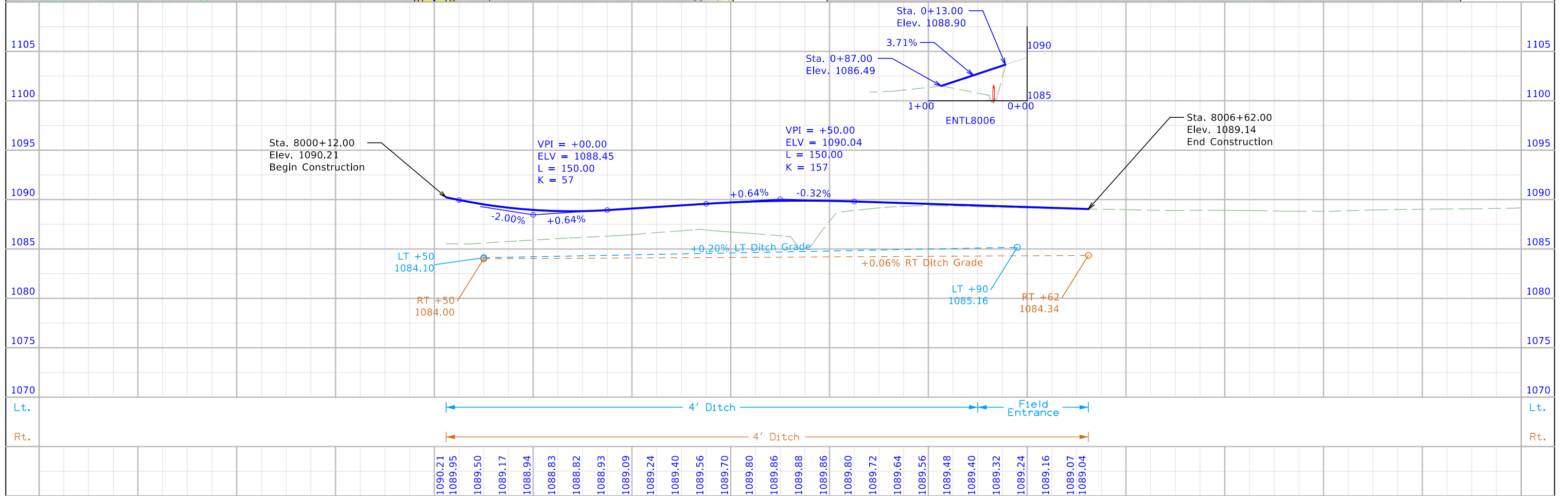
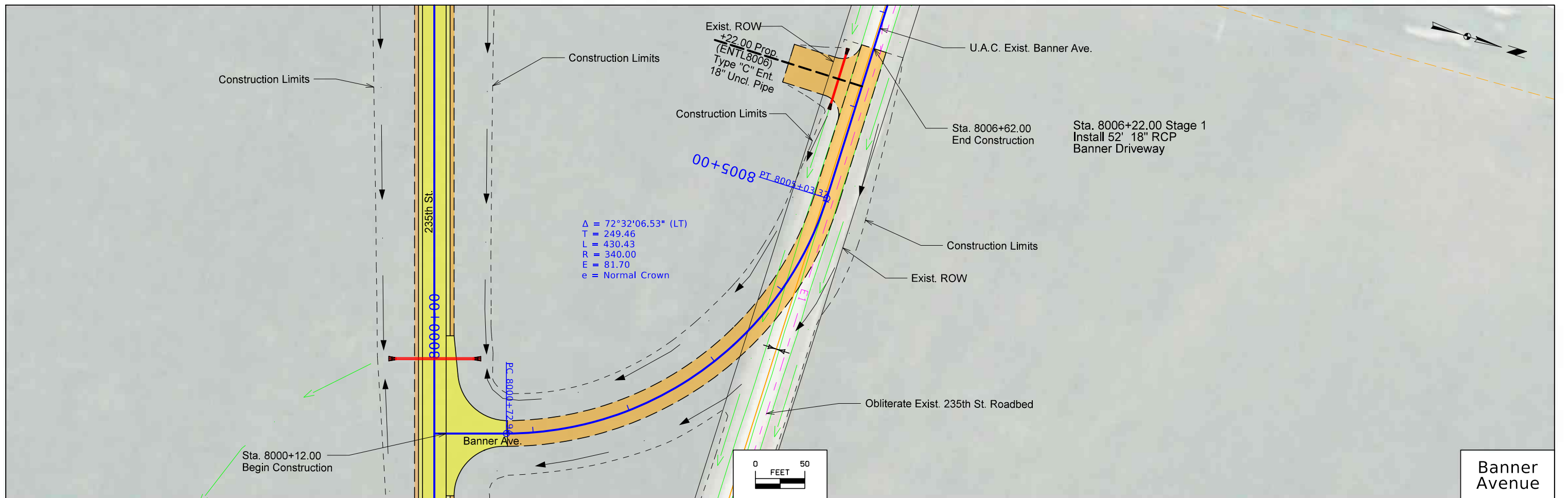

FILE NO.	ENGLISH	DESIGN TEAM Iowa DOT / HNTB	WOODBURY COUNTY	PROJECT NUMBER IMN-029-6(170)139--0E-97	SHEET NUMBER E.6
----------	---------	-----------------------------	-----------------	---	------------------

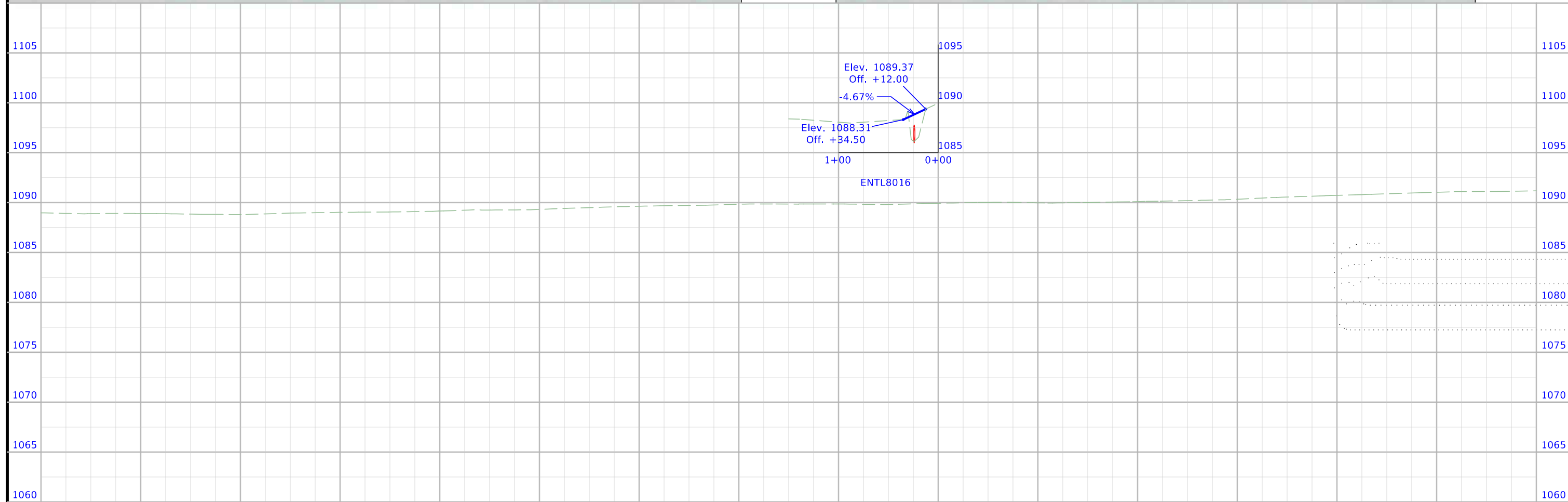
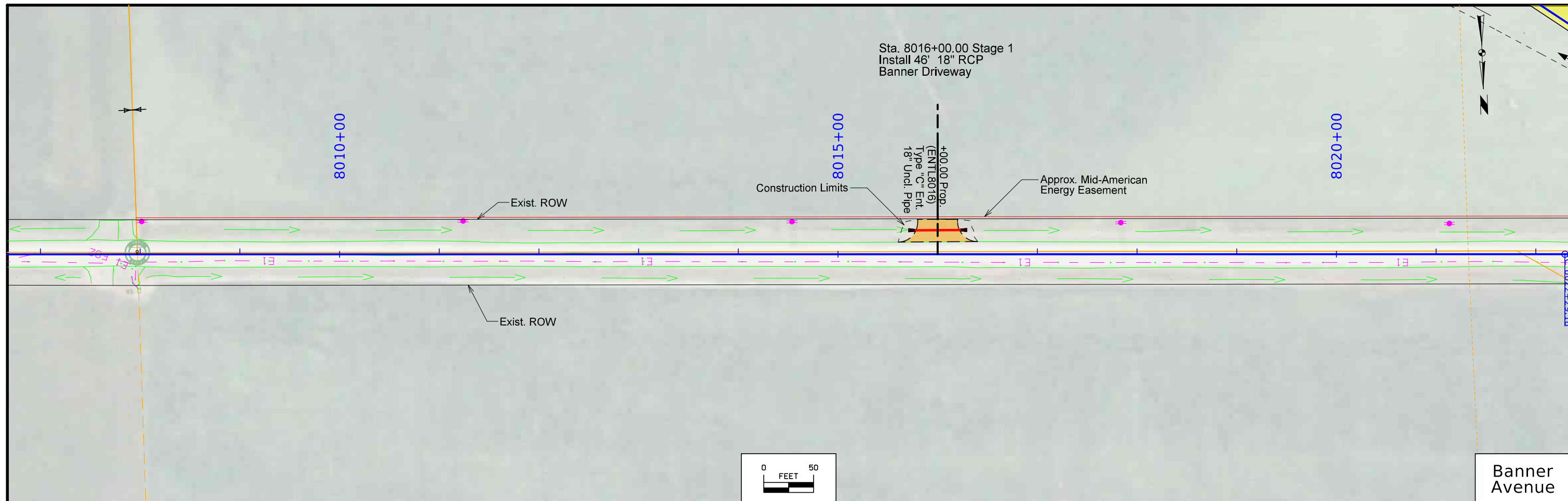

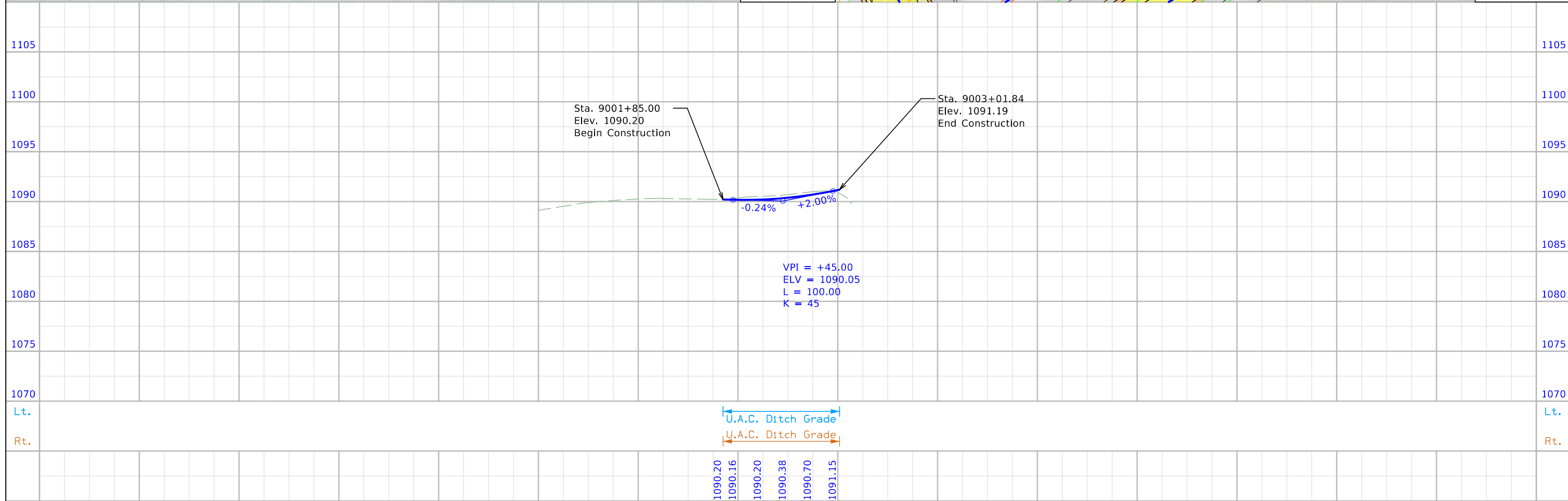
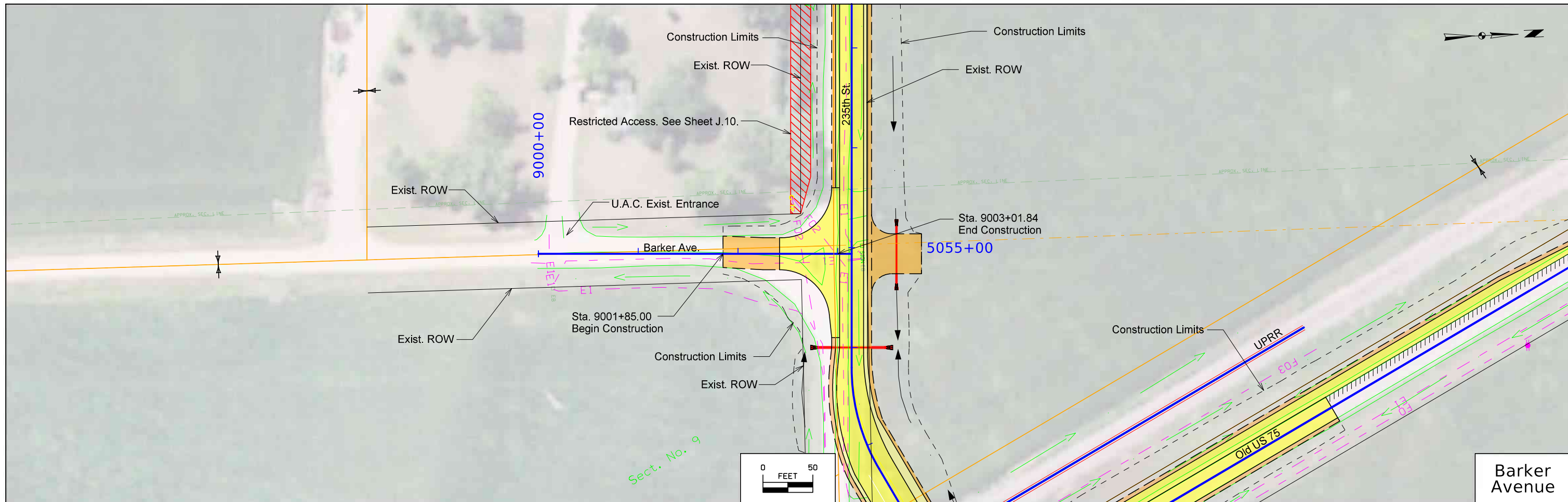

FILE NO.	ENGLISH	DESIGN TEAM Iowa DOT / HNTB	WOODBURY COUNTY	PROJECT NUMBER IMN-029-6(170)139--0E-97	SHEET NUMBER E.8
----------	---------	-----------------------------	-----------------	---	------------------

Survey Information

SURVEY INDEX

**County: Woodbury
PIN: 06-97-029-010**

Project Number: IM-029-6(278)139--13-97

Location: New I-29 Interchange approx. 2.5 mi S of the Co Rd D38

Interchange at Sergeant Bluff

Work Code: 9040-Preliminary Engineering

Project Directory: 9702901006

**PROJECT DATUM: NAD83(2011) for EPOCH 2010.00 (IaRTN 2019 ADJUSTMENT)
COORDINATE SYSTEM: IOWA REGIONAL COORDINATE SYSTEM ZONE 4
(U.S. SURVEY FOOT)
VERTICAL DATUM: NAVD88
GEOID MODEL: 2018u2**

Alignment Information

SURMLA29

The horizontal alignment for I-29 this survey is a retrace of P.C.C. Paving Plans No. I-29-6(10)136. Survey stationing was equated to the plan PI at Sta. 1670+00 and run back and ahead without equation throughout the survey.

Survey stationing relates to as built plan stationing as follows:

PT Sta. 1591+06.81 P.C.C. Paving Plans No. I-29-6(10)136
Survey PT Sta. 1591+07.27

PI Sta. 1670+00 P.C.C. Paving Plans No. I-29-6(10)136
Survey PI Sta. 1670+00

TS Sta. 1754+64.76 P.C.C. Paving Plans No. I-29-6(10)136
Survey TS Sta. 1754+64.64

SURMLB75

The horizontal alignment for county road K45 (old hwy 75) has been provided by the district 3 survey office.

Survey Personnel

Clayton Henningsen – Survey Party Chief
Jason Arn – Survey Party Chief
Robert Fredrickson – Assistant Survey Party Chief

Date(s) of Survey

Begin Date 12/04/2023
End Date 05/30/2023

General Information

This survey is for New I-29 Interchange approx. 2.5 mi S of the Co Rd D38 Interchange at Sergeant Bluff. This survey request was for the I-29 corridor only. Partial Field DTM with Photo Control. Full Field DTM Survey was completed for survey area's not covered by Photo imagery.

Utility Information

For logging data and other utility details see Utility Survey and Ownership Report in the Utility folder of the PrelimSurvey project directory.

Project Control

Coordinates were determined for primary project control points by conducting concurrent six-hour static observations. Post processing is constrained to nearby Iowa Real Time Network reference stations. For additional details of the control survey, contact the Preliminary Survey department.

CONTROL POINT VICINITY MAP

This map is a guide to the vicinity of the primary project control points. Primary control is for use with RTK base stations and for RTN validation. Future surveys will use primary project control to establish temporary control as needed for construction or other surveying applications.

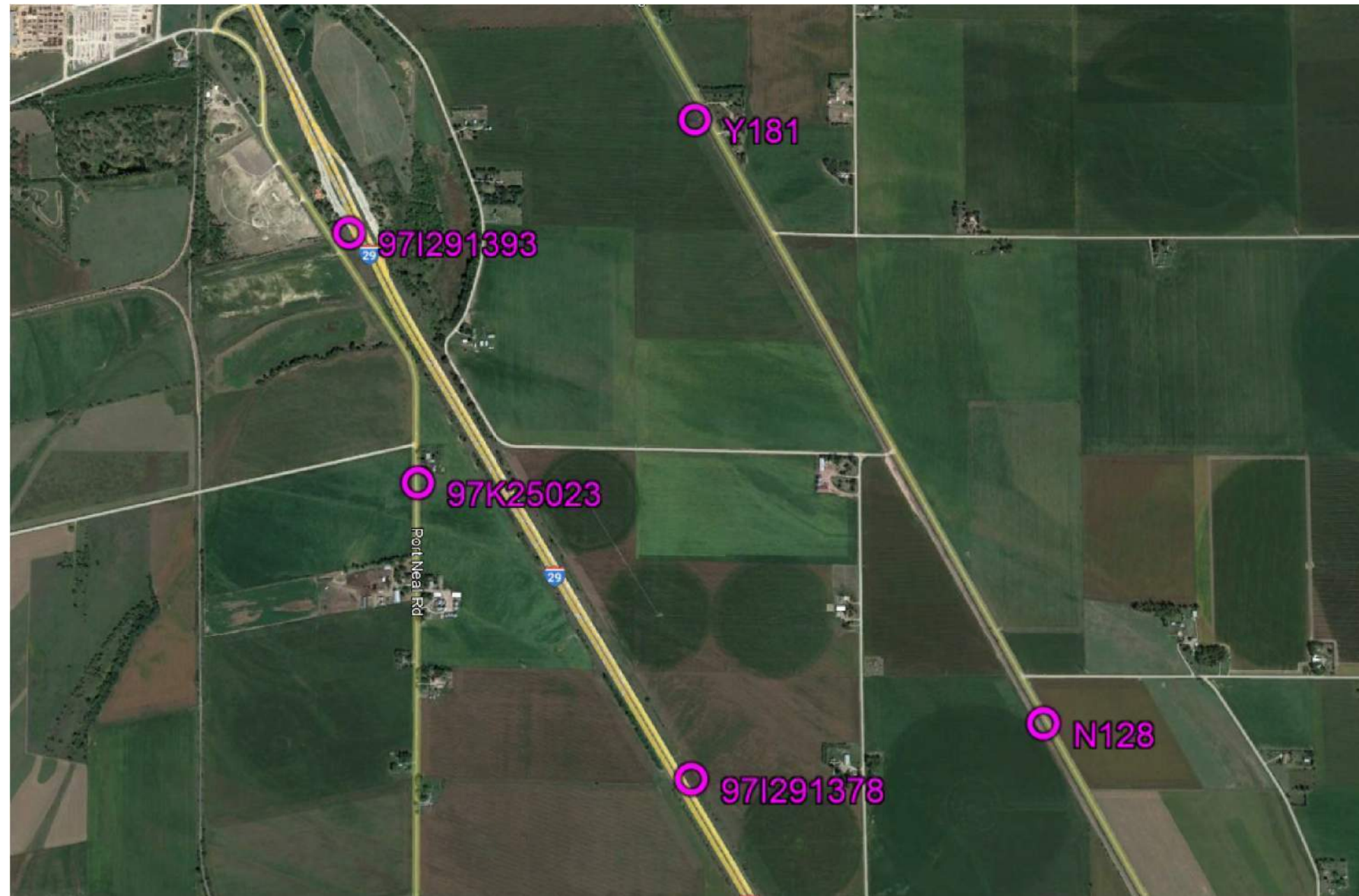

HORIZ. DATUM: NAD83(2011) for EPOCH 2010.00 (IaRTN 2019 Adjustment) - Iowa RCS Zone 04 (U.S. Survey Foot)

VERT. DATUM: NAVD88 - Geoid Model: 2018u2

Coordinate listing from next sheet will be used with IaRTN for monument recovery. No other reference ties are given.

HORIZONTAL AND VERTICAL PROJECT CONTROL COORDINATE LISTING

HORIZ. DATUM: NAD83(2011) for EPOCH 2010.00 (IaRTN 2019 Adjustment)

Ia. Regional Coordinate System Zone 04 (U.S. Survey Foot)

VERT. DATUM: NAVD88

Geoid Model: 2018u2

<u>Point Name</u>	<u>Northing</u>	<u>Easting</u>	<u>Elevation</u>	<u>Feature Definition-Description</u>
97I291378	8538986.96	14093201.77	1084.33	CP FENO MONUMENT SET IN EAST ROW I-29
97I291393	8545559.95	14089126.55	1090.71	CP FENO MONUMENT SET IN TOP OF BACKSLOPE AT SOUTHBOUND I29 REST AREA APPROX 600 FT S OF BUILDING
97K25023	8542503.05	14089982.04	1091.12	CP FENO MONUMENT SET IN N EDGE OF FIELD ENT ON EAST SIDE K25 APPROX 450 FT S INTERSECTION K25 & 235TH ST
N128	8539694.98	14097356.05	1085.94	CP NGS MONUMENT AS DESCRIBED IN GOOD CONDITION
Y181	8546901.00	14093405.44	1090.94	CP NGS PIN AS DESCRIBED IN GOOD CONDITION

ALIGNMENT COORDINATES

Name	Location	Point on Tangent			Begin Spiral			Begin Curve			Simple Curve PI or Master PI of SCS			End Curve			End Spiral		
		Station	Coordinates		Station	Coordinates		Station	Coordinates		Station	Coordinates		Station	Coordinates		Station	Coordinates	
			Y (Northing)	X (Easting)		Y (Northing)	X (Easting)		Y (Northing)	X (Easting)		Y (Northing)	X (Easting)		Y (Northing)	X (Easting)		Y (Northing)	X (Easting)
ML I-29	Point ML029_1	1591+07.27	8537887.85	14093705.11															
	Curve ML029_2						1664+95.20	8544270.35	14089984.19	1670+00.00	8544706.45	14089729.95	1675+04.15	8545163.22	14089515.04				
	Point ML029_3	1754+64.31	8552365.97	14086126.16															
Ramp A	Point RPA 1	1000+00.00	8541911.23	14090953.36															
	Curve RPA 2						1006+60.12	8542548.14	14090779.82	1008+55.89	8542737.02	14090728.35	1010+50.42	8542912.34	14090641.24				
	Point RPA 3	1014+61.31	8543280.31	14090458.39															
Ramp B	Point RPB 1	2000+00.00	8540560.38	14092250.04															
	Curve RPB 2						2002+31.96	8540768.11	14092146.82	2004+27.73	8540943.42	14092059.70	2006+22.25	8541132.30	14092008.24				
	Point RPB 3	2016+51.10	8542124.96	14091737.76															
Ramp C	Curve RPC 1						3000+00.00	8540528.97	14092094.77	3003+05.19	8540792.63	14091941.06	3006+05.71	8540998.44	14091715.71				
	Curve RPC 2						3009+67.32	8541242.30	14091448.70	3012+72.51	8541448.11	14091223.35	3015+73.03	8541711.77	14091069.64				
	Point RPC 3	3018+03.91	8541911.23	14090953.36															
Ramp D	Point RPD 1	4000+00.00	8542124.96	14091737.76															
	Curve RPD 2						4001+98.68	8542296.60	14091637.70	4003+48.00	8542425.60	14091562.50	4004+92.90	8542512.68	14091441.20				
	Curve RPD 3						4008+32.05	8542710.47	14091165.70	4012+58.67	8542959.27	14090819.14	4016+72.70	8543327.84	14090604.27				
SR075	Point SR075_1	277+68.26	8537444.32	14098606.83															
	Point SR075_2	386+74.10	8547063.05	14093467.04															
SR235	Point SR235_1	5000+00.00	8541788.09	14089955.99															
	Curve SR235_2						5002+72.41	8541787.60	14090228.33	5005+41.87	8541787.10	14090497.79	5008+08.11	8541857.94	14090757.78				
	Curve SR235_3						5041+52.40	8542737.13	14093984.43	5044+62.49	8542818.65	14094283.62	5047+67.69	8542805.74	14094593.44				
	Curve SR235_4						5056+20.15	8542770.27	14095445.17	5056+74.65	8542768.00	14095499.62	5057+26.58	8542793.68	14095547.70				
	Point SR235_5	5059+03.57	8542877.06	14095703.83															
SRBANNER	Point SRBANNER 1	8000+00.00	8542539.02	14093257.36															
	Curve SRBANNER 2						8000+72.94	8542609.39	14093238.19	8003+22.40	8542850.09	14093172.63	8005+03.37	8542859.75	14092923.34				
	Curve SRBANNER 3						8022+29.18	8542926.70	14091198.83	8024+35.15	8542934.69	14090993.02	8026+06.10	8543112.33	14091213.43				
	Point SRBANNER 4	8036+22.52	8543988.95	14090374.34															
SRBARKER	Point SRBARKER 1	9000+00.00	8542461.45	14095318.15															
	Point SRBARKER 2	9003+13.84	8542775.02	14095331.21															
SRPORTNEAL	Point SRPORTNEAL	6000+00.00	8540306.80	14089958.08															
	Point SRPORTNEAL	6026+63.10	8542969.90	14089961.51															
ENTR5026	Point ENTR5026	0+00.00	8542329.01	14092486.63															
	Point ENTR5026	2+00.00	8542137.04	14092542.71															
ENTR5048	Point ENTR5048	0+00.00	8542804.40	14094625.73															
	Point ENTR5048	1+50.00	8542654.53	14094619.48															
ENTL5048	Point ENTL5048	0+00.00	8542804.40	14094625.73															
	Point ENTL5048	1+50.00	8542954.27	14094631.97															
ENTL5055	Point ENTL5055	0+00.00	8542775.02	14095331.21															
	Point ENTL5055	1+50.00	8542924.89	14095337.45															
ENTR5057	Point ENTR5057	0+00.00	8542819.79	14095596.59															
	Point ENTR5057	1+50.00	8542687.47	14095667.25															
ENTL8006	Point ENTL8006	0+00.00	8542864.36	14092804.80															
	Point ENTL8006	1+50.00	8542714.47	14092789.98															
ENTL8016	Point ENTL8016	0+00.00	8542902.29	14091827.53															
	Point ENTL8016	1+50.00	8542752.41	14091821.72															

SPIRAL OR CIRCULAR CURVE DATA

Name	Location	ΔSCS	Horizontal Alignment Data											Remarks			
			Spiral Data						Curve Data								
			OS	Ls	Ts	Es	Xc	Yc	L.T.	S.T.	ΔC	T	L		R	E	
ML I-29	Curve ML029_2											5.045°	504.803	1008.953	11459.160	11.113	
Ramp A	Curve RPA_2											11.181°	195.768	390.294	2000.00	9.558	
Ramp B	Curve RPB_2											11.181°	195.768	390.284	2000.00	9.558	
Ramp C	Curve RPC_1											17.352°	305.194	605.715	2000.00	23.152	
Ramp C	Curve RPC_2											17.352°	305.194	605.715	2000.00	23.152	
Ramp D	Curve RPD_1											24.083°	149.319	294.227	700.00	15.749	
Ramp D	Curve RPD_2											24.083°	426.625	840.650	2000.00	44.996	
SR235	Curve SR235_2											15.347°	269.465	535.704	2000.00	18.071	
SR235	Curve SR235_3											17.627°	310.091	615.283	2000.00	23.896	
SR235	Curve SR235_4											30.489°	54.505	106.425	200.00	7.294	
SRBANNER	Curve SRBANNER_2											72.535°	249.46	430.43	340.00	81.70	
SRBANNER	Curve SRBANNER_3											57.221°	205.964	376.921	376.43	52.663	

SUPERELEVATION DATA

See PV-300 Series

Road Identification	Circular Curve or Spiral Curve Name	Radius FT	Superelevation Data			Standard Road Plan	Section A-A	Section B-B	Section C-C	Section D-D	Section E-E	Section F-F	Case A	Case B	Case C	Case S	Case T	Case U	Remarks	
			e %	L FT	X FT															
RPA	RPA_1	2000	5.4	168	62	PV-303	1006+04.52 1011+06.02		1006+60.12 1010+50.42	1007+10.52 1010+00.02						1006+66.96 1010+43.58	1006+66.96 1010+43.58			
RPB	RPB_1	2000	5.4	168	62	PV-303	2001+76.36 2006+77.85		2002+31.96 2006+22.25	2002+82.36 2005+71.85						2002+38.80 2006+15.41	2002+38.80 2006+15.41			
RPC	RPC_1	2000	5.4	168	62	PV-303	2999+44.40 3006+61.31		3000+00.00 3006+05.71	3000+50.40 3005+55.31						3000+06.84 3005+98.87	3000+06.84 3005+98.87			
RPC	RPC_2	2000	3.4	82	48	PV-303	3008+61.92 3016+78.43	3009+09.92 3016+30.43	3009+67.32 3015+73.03	3009+91.92 3015+48.43										
RPD	RPD_1	700	5.6	135	48	PV-303	4000+61.58 4006+35.40	4001+09.58 4005+87.40	4001+98.68 4004+92.90	4002+44.58 4004+52.40										
RPD	RPD_2	2000	5.4	168	62	PV-303	4007+76.45 4017+28.30		4008+32.05 4016+72.70	4008+82.45 4016+22.30						4004+90.97 4008+38.89	4004+90.97 4008+38.89			
SR235	SR235_1	2000	5.0	170	68	PV-301	5000+85.41 5009+95.11	5001+53.41 5009+27.11	5002+21.41 5008+59.11	5003+23.41 5007+57.11		5002+72.41 5008+08.11			5002+89.41 5007+91.11	5002+89.41 5007+91.11				
SR235	SR235_2	2000	5.0	128	51	PV-301	5040+11.80 5049+08.29	5040+62.80 5048+57.29	5041+13.80 5048+06.29	5041+90.80 5047+29.29		5041+52.40 5047+67.69			5041+65.20 5047+54.89	5041+65.20 5047+54.89				
SR235	SR235_3	200	5.8	132	45	PV-301	5054+82.75	5055+27.75 5058+15.50	5055+72.75 5057+70.50	5056+59.75 5056+83.50		5056+20.15 5057+26.58			5056+18.78 5057+24.55	5056+18.78 5057+24.55				



To: Nikki Cuva/Amelia Fredrickson
Right of Way Design

Final Draft Revised: February 26th, 2024

District 3: Jessica Felix
Shane Tymkowicz

Project Details:
PIN: 06-97-029-010
Project #: IM-029-6(278)139--13-97
ROW #: IMN-029-6(318)139--0E-97

TAS: Jan Laaser-Webb
Traffic & Safety Bureau

From: Leilah Armstrong
Traffic & Safety Bureau

WOODBURY COUNTY
New I-29 interchange 2.5 mi S of D38

SUBJECT: Access Review

PROJECT LOCATION AND DESCRIPTION:

This project is the construction of a new interchange on I-29 between the existing interchanges at Sergeant Bluff to the north and Port Neal Landing in Salix to the south. The new interchange will add access to I-29 from 235th Street.

ACCESS CATEGORY CLASSIFICATION:

I-29

I-29 is classified as an Interstate/Freeway and access is only allowed at interchanges.

ACCESS RIGHTS ACQUISITION:

Access rights are to be acquired from Sta. 5004+000 to Sta. 5024+25 with access only being allowed at the ramp terminals located at Sta. 5010+00 and Sta. 5018+25.

ADMINISTRATIVE RULES:

In accordance with Chapter 112.5(5)(f) *Interchange and intersection access control*, "For any new interchange or interchange reconstruction, access rights should be acquired and extend a minimum of 600 feet away from the ramp bifurcation point. If the AADT will exceed 10,000 within 20 years, a minimum of 1,000 feet of access rights should be acquired."

e. "When the interchange crossroad AADT will not exceed 3,000 within 20 years, access public intersections and private access types A and B should be at least 600 feet away from the ramp bifurcation point. Types C and D should be at least 300 feet from the bifurcation point and may be subject to operational restrictions."

ACCESS CONTROL LIMITS:

235th Street

The access control line will extend from Sta. 5004+000 to Sta. 5024+25.

ACCESS LOCATION DETAILS:

Location	Access	Comments
5000+16	SR 235th	Begin Project Construction
5026+00 RT	Type D Entrance	Proposed
5034+00 LT	Banner Avenue	Proposed
5041+52 LT	Type C Entrance	Close – on existing 235th
5048+00 RT	Type D Entrance	Proposed
5048+00 LT	Type D Entrance	Proposed
5054+71 LT	Type D Entrance	Close
5055+06 RT	Barker Ave	Proposed
5055+06 LT	Type D Entrance	Proposed
5057+60 LT	Type C Entrance	Close – on existing 235th
5057+82 RT	Type D Entrance	Proposed – UP Railroad relocated from 5057+90
5057+90 RT	Type C Entrance	Close – on existing 235 th relocated to 5057+82
5058+92	SR 235th	End Project Construction
8000+12	SRBANNER	Begin Project Construction
8006+22 LT	Type D Entrance	Proposed
8007+78	Type C Entrance	Close – both sides
8016+00 LT	Type D Entrance	Proposed
8024+13 LT	Type C Entrance	Close
8006+62	SRBANNER	End Project Construction

ACCESS CONTROL DIAGRAM:

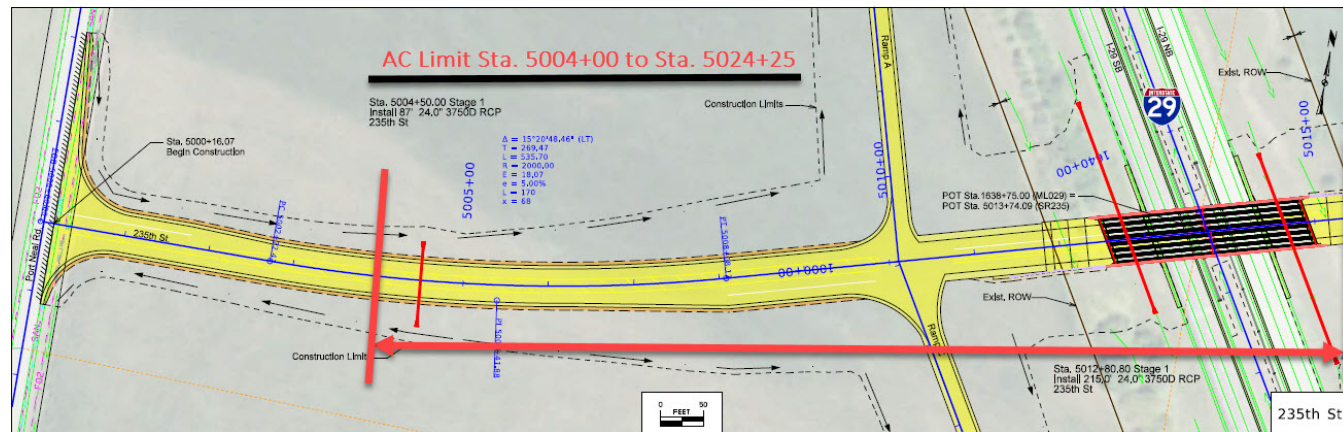

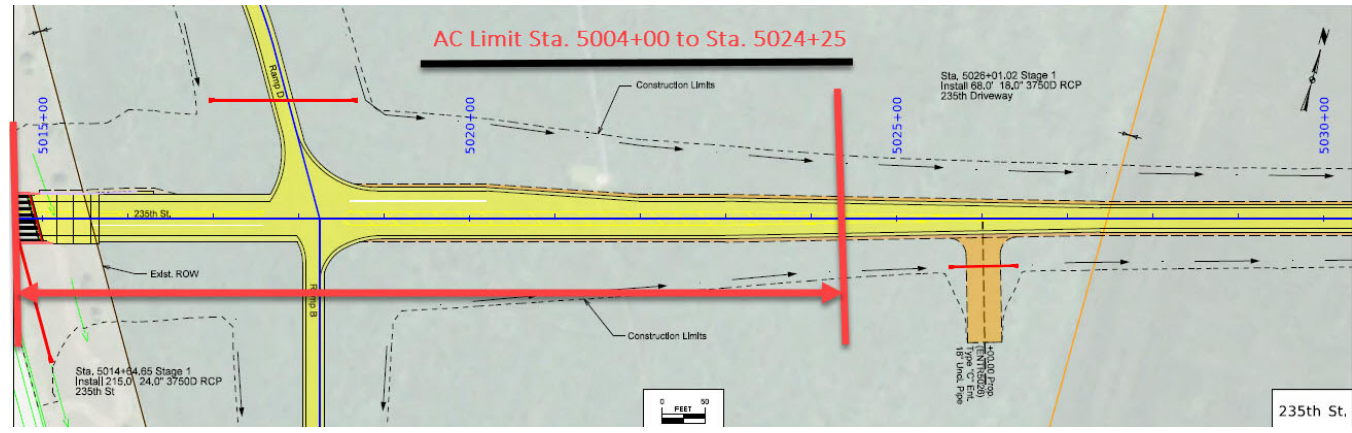

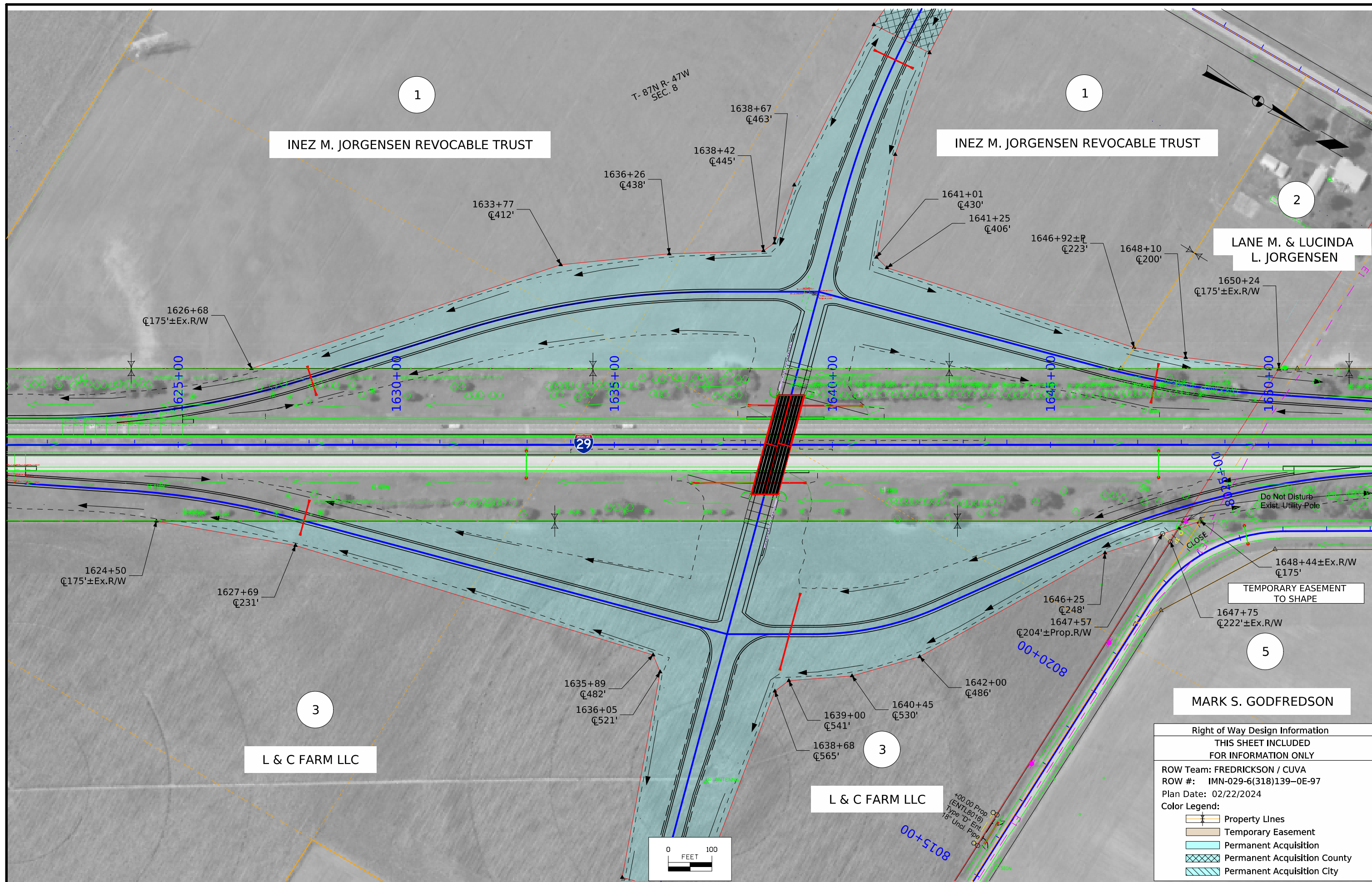

INEZ M. JORGENSEN REVOCABLE TRUST

INEZ M. JORGENSEN REVOCABLE TRUST

LANE M. & LUCINDA L. JORGENSEN

L & C FARM LLC

L & C FARM LLC

MARK S. GODFREDSON

Right of Way Design Information	
THIS SHEET INCLUDED FOR INFORMATION ONLY	
ROW Team: FREDRICKSON / CUVA	
ROW #: IMN-029-6(318)139--0E-97	
Plan Date: 02/22/2024	
Color Legend:	
	Property Lines
	Temporary Easement
	Permanent Acquisition
	Permanent Acquisition County
	Permanent Acquisition City

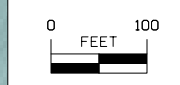

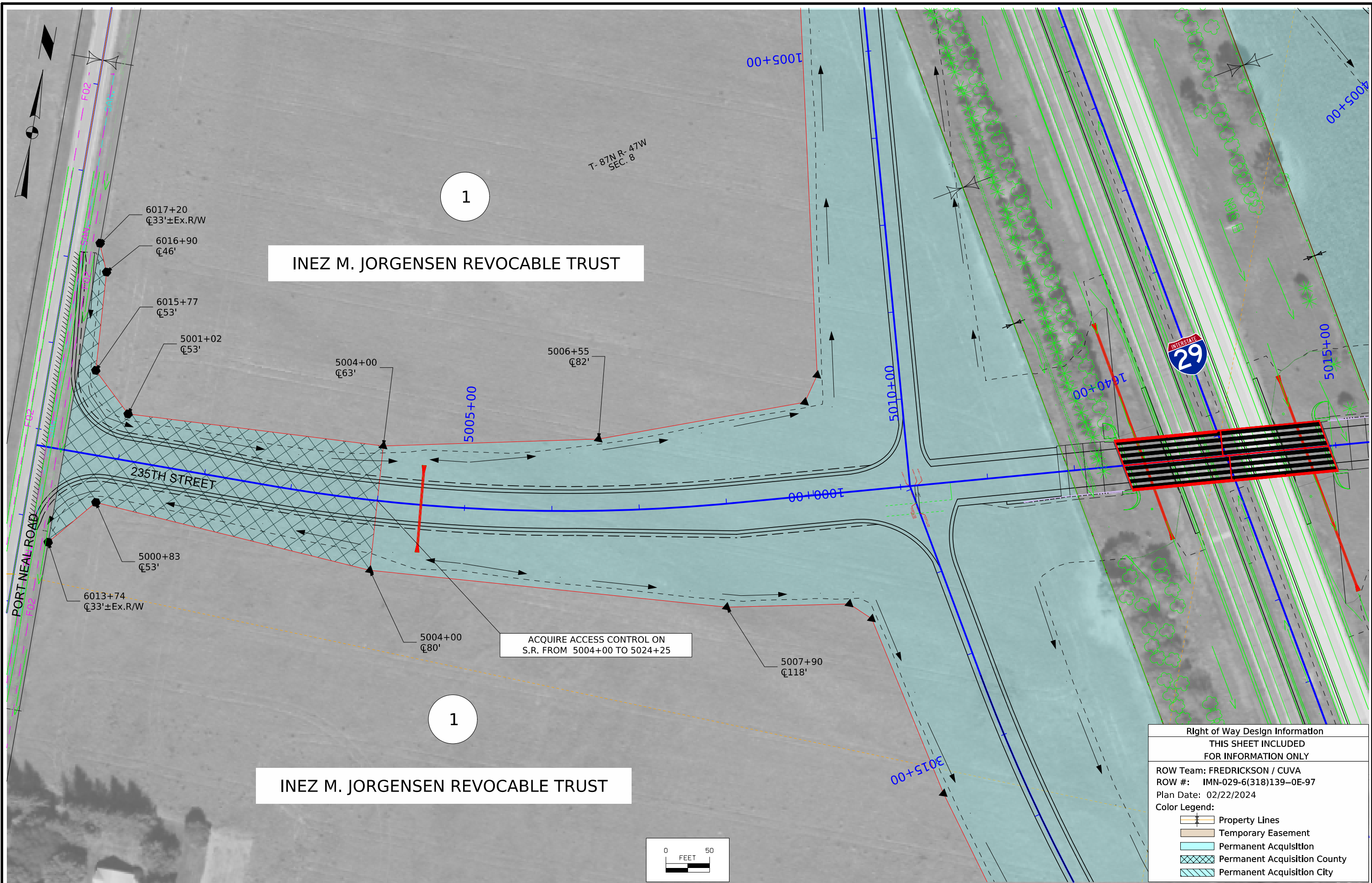

Right of Way Design Information	
THIS SHEET INCLUDED FOR INFORMATION ONLY	
ROW Team:	FREDRICKSON / CUVA
ROW #:	IMN-029-6(318)139-0E-97
Plan Date:	02/22/2024
Color Legend:	
	Property Lines
	Temporary Easement
	Permanent Acquisition
	Permanent Acquisition County
	Permanent Acquisition City

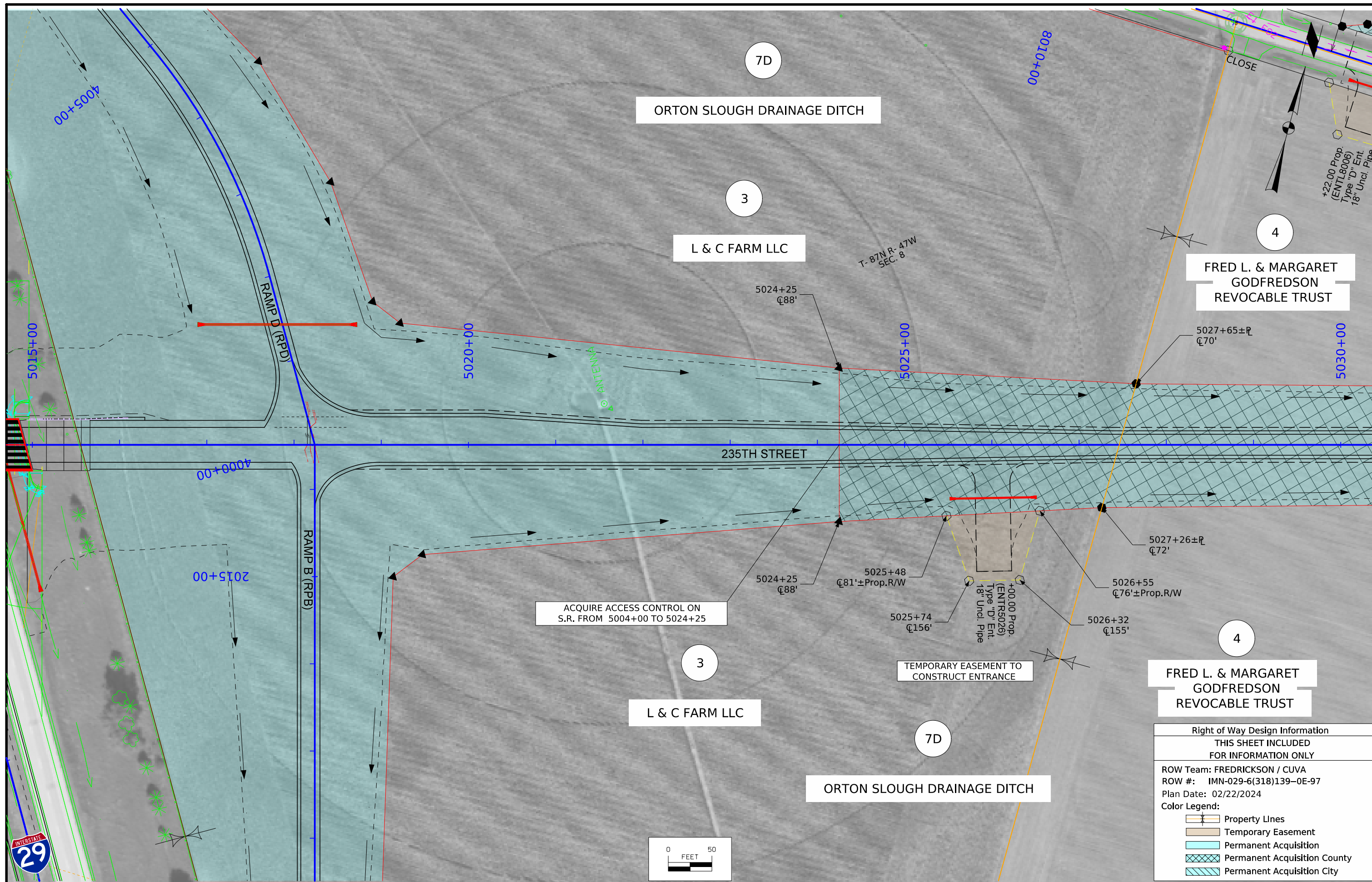

ACQUIRE ACCESS CONTROL ON
S.R. FROM 5004+00 TO 5024+25

TEMPORARY EASEMENT TO
CONSTRUCT ENTRANCE

Right of Way Design Information
THIS SHEET INCLUDED
FOR INFORMATION ONLY

ROW Team: FREDRICKSON / CUVA
ROW #: IMN-029-6(318)139-0E-97
Plan Date: 02/22/2024

Color Legend:

- Property Lines
- Temporary Easement
- Permanent Acquisition
- Permanent Acquisition County
- Permanent Acquisition City

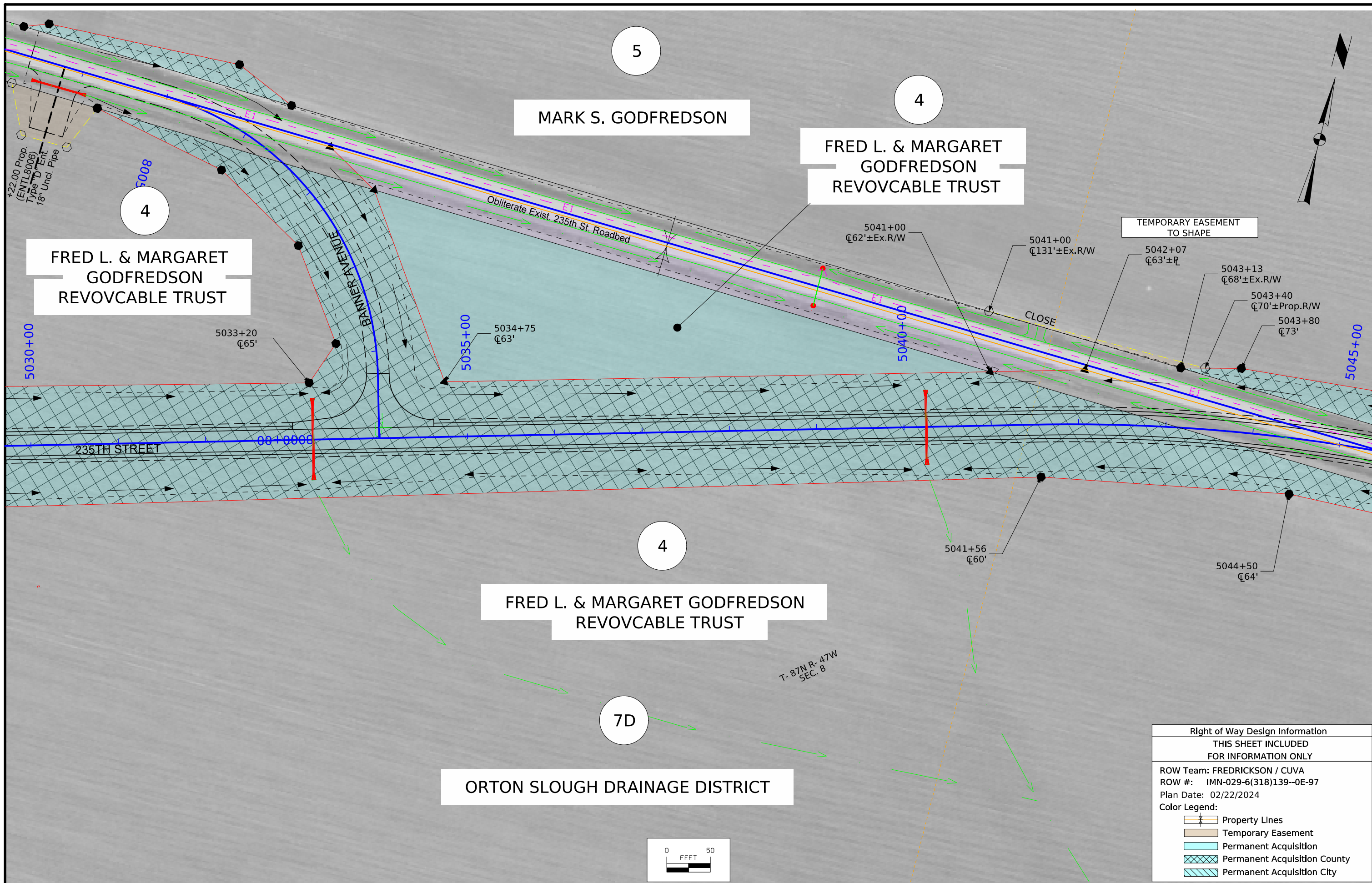

Right of Way Design Information	
THIS SHEET INCLUDED FOR INFORMATION ONLY	
ROW Team: FREDRICKSON / CUVA	
ROW #: IMN-029-6(318)139--0E-97	
Plan Date: 02/22/2024	
Color Legend:	
	Property Lines
	Temporary Easement
	Permanent Acquisition
	Permanent Acquisition County
	Permanent Acquisition City

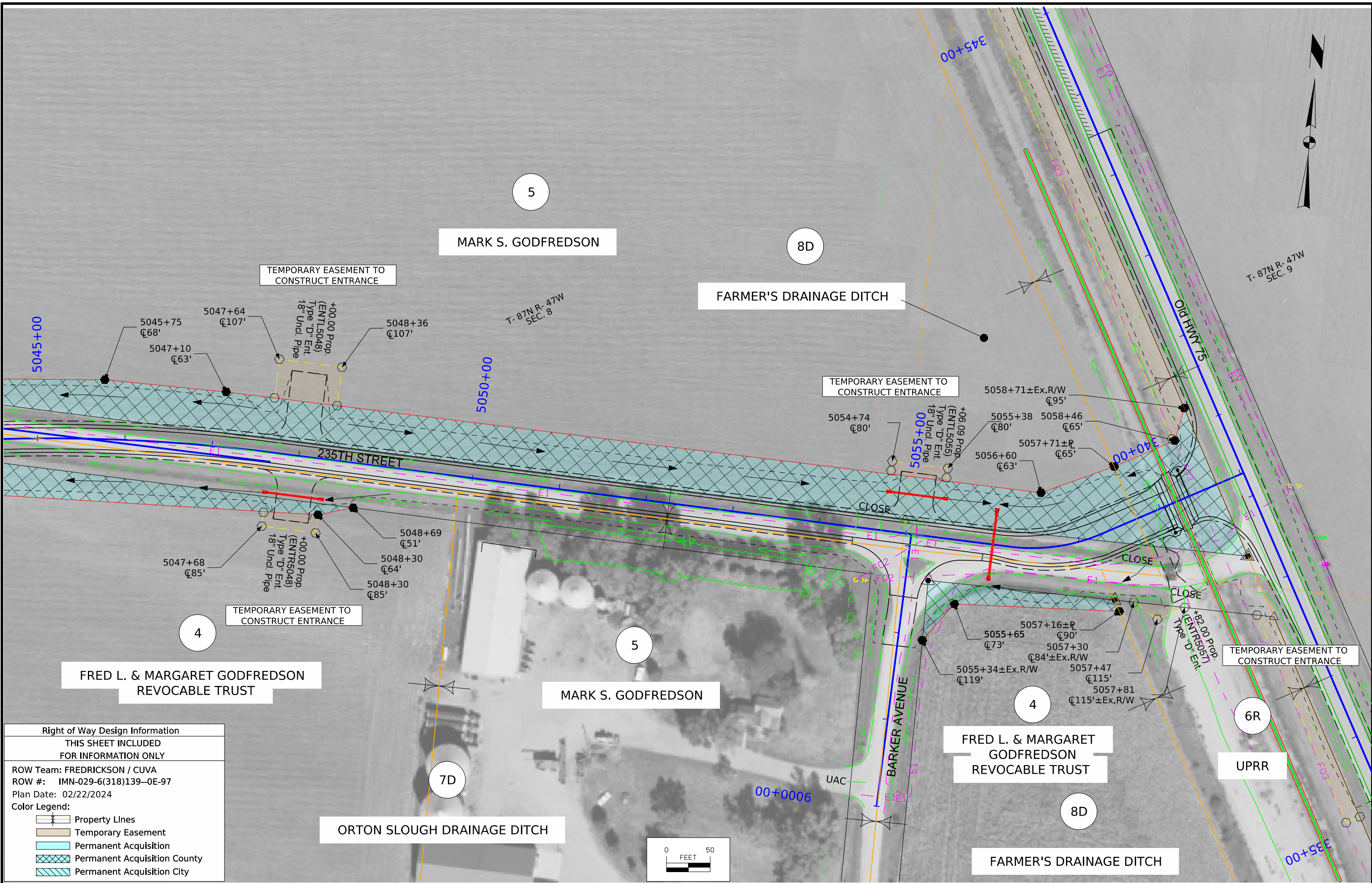

Right of Way Design Information	
THIS SHEET INCLUDED FOR INFORMATION ONLY	
ROW Team: FREDRICKSON / CUVA	
ROW #: IMN-029-6(318)139--0E-97	
Plan Date: 02/22/2024	
Color Legend:	
	Property Lines
	Temporary Easement
	Permanent Acquisition
	Permanent Acquisition County
	Permanent Acquisition City

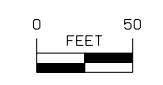

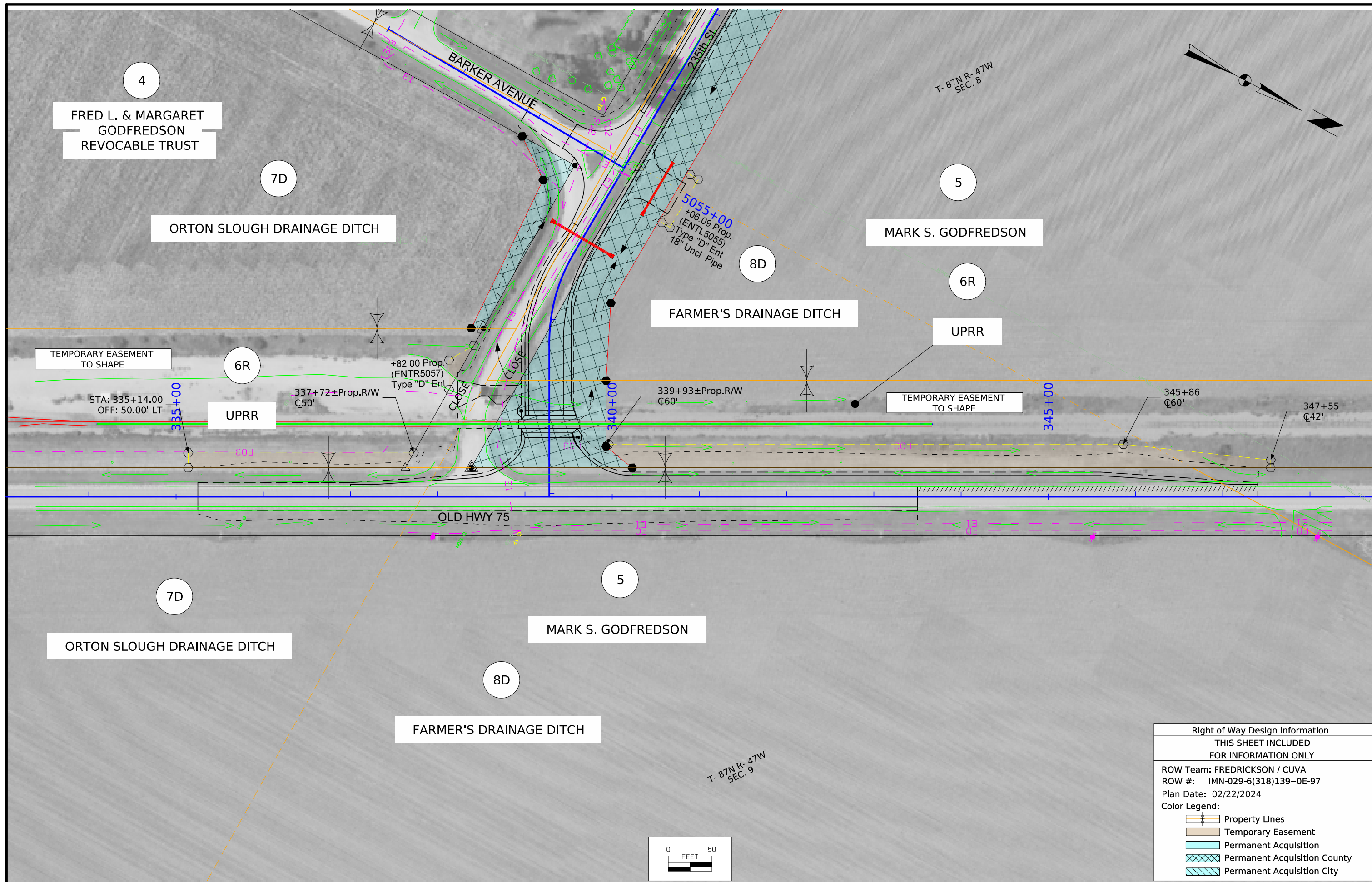

Right of Way Design Information	
THIS SHEET INCLUDED FOR INFORMATION ONLY	
ROW Team: FREDRICKSON / CUVA	
ROW #: IMN-029-6(318)139-0E-97	
Plan Date: 02/22/2024	
Color Legend:	
	Property Lines
	Temporary Easement
	Permanent Acquisition
	Permanent Acquisition County
	Permanent Acquisition City



5

MARK S. GODFREDSON

BANNER AVENUE

3

L & C FARM LLC

7D

ORTON SLOUGH DRAINAGE DITCH

4

FRED L. & MARGARET GODFREDSON REVOCABLE TRUST

+00.00 Prop. (ENTL8016) Type "D" Ent. 18" Uncl. Pipe
8016+42 \varnothing 46'
8015+59 \varnothing 46'

TEMPORARY EASEMENT TO CONSTRUCT ENTRANCE

8015+00

8010+00

8006+53 \varnothing 42'
8006+80 \varnothing 31'±Ex.R/W
CLOSE
8004+42 \varnothing 65'
8003+78 \varnothing 57'±Ex.R/W
8003+22 \varnothing 51'±R
8002+62 \varnothing 61'±Ex.R/W

8006+75 \varnothing 65'±Ex.R/W
8006+48 \varnothing 89'
+22.00 Prop. (ENTL8006) Type "D" Ent. 18" Uncl. Pipe
8005+73 \varnothing 35'±Ex.R/W
8005+94 \varnothing 88'
8005+00
8004+00 \varnothing 50'
8002+55 \varnothing 47'
8001+15 \varnothing 45'

TEMPORARY EASEMENT TO CONSTRUCT ENTRANCE

8000+00E05

235TH STREET

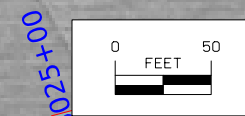

Right of Way Design Information	
THIS SHEET INCLUDED FOR INFORMATION ONLY	
ROW Team: FREDRICKSON / CUVA	
ROW #: IMN-029-6(318)139--0E-97	
Plan Date: 02/22/2024	
Color Legend:	
	Property Lines
	Temporary Easement
	Permanent Acquisition
	Permanent Acquisition County
	Permanent Acquisition City

TRAFFIC CONTROL PLAN

Interstate 29: Maintain traffic on NB and SB Interstate 29 at all times in accordance with J Sheets. Single lane closures will be permitted as necessary to remove rumble strips and set TBR.

Sideroads: Portions of 235th Street, Old US 75, Banner Avenue and Barker Avenue will have closures at varying times. Access to Barker Avenue will be provided at all times.

Refer to Tab. 108-26A for Staging Notes.

No lane closure restrictions for I-29 construction.

For additional information, refer to Part 6 of the Manual on Uniform Traffic Control Devices, Iowa DOT Standard Road Plan TC Series and the current Standard Specifications.

STAGING NOTES

Stage 1:

Traffic:
Interstate 29: Maintain traffic on Interstate 29 at all times in accordance with J Sheets. Single lane closures will be permitted as necessary to complete inside shoulder rumble strip patching and set TBR in accordance with Standard Road Plan TC-418 and the allowable closure time frames shown on Sheet J.2.

Sideroads: Maintain traffic along existing 235th Street from Old US 75 to Barker Avenue in accordance with J Sheets. Close 235th Street to all traffic between Barker Avenue and Banner Avenue. Partial road closure at intersection of Banner Avenue and Port Neal Road per Standard Road Plan TC-252. Full road closure at last driveway before the work area on Banner Avenue per Standard Road Plan TC-252.

Construction:
Interstate 29: Construct I-29 median shoulder rumble strip patching in order to shift traffic in Stage 2. Construct Ramps A, B, C, and D except for within 30 feet of I-29.

Sideroads: Construct 235th Street between Port Neal Road and Barker Avenue, including new 235th Street bridge substructure.

Stage 2:

Traffic:
Interstate 29: Shift northbound and southbound traffic to the median as shown in the J Sheets. Traffic will shift back to existing after the 235th Street bridge construction. During girder setting over I-29, utilize rolling road blocks between the hours of 2:00AM and 5:00AM with DMS warning messages set in advance of the anticipated queue.

Sideroads: Fully close Old US 75 to all traffic south of 230th Street and north of 240th Street. Open new 235th Street between Banner Avenue and Barker Avenue. Close 235th Street east of Barker Avenue.

Construction:
Interstate 29: Construct remaining acceleration and deceleration lanes for Ramps A, B, C, and D.

Sideroads: Construct new thru lanes on Old US 75 along with the new southbound right turn lane to 235th Street. Construct 235th Street between Old US 75 and Barker Avenue. Complete new 235th Street bridge at I-29 and approach pavement.

Final:

Traffic:
Interstate 29: Open new ramps to all traffic. Place traffic back on existing lanes.

Sideroads: Open all roads to all traffic.

Set up pavement marking operations utilizing Standard Road Plan TC-433.
Set up rumble strip operations in accordance with Standard Road Plan TC-432.

Construction: Complete final pavement markings and mill rumble strips.

COORDINATED OPERATIONS

Other work in progress during the same period of time will include the construction of the projects listed. Coordinate operations with those of other contractors working within the same area.

Project	Type of Work

511 TRAVEL RESTRICTIONS

Route	Direction	County	Location Description	Feature Crossed	Object Type	Maint. Bridge No., Structure ID, or FHWA No.	Type of Restriction	Existing Measurement	Construction Measurement	Construction Measurement as Signed	Projected As Built Measurement	Remarks

CROSS SECTION VIEW COLOR LEGEND OF TRAFFIC CONTROL AND STAGING SHEETS

SHADING	Design Color No.	
Green, Light	(225)	Existing Pavement Shading
Gray, Light	(48)	Previously Constructed Pavement Shading
Gray, Med	(80)	Previously Constructed Granular Surface Shading
Blue, Light	(230)	Proposed Pavement Shading
Lavender	(9)	Temporary Pavement Shading
Brown, Med	(237)	Future Proposed Pavement Shading

CROSS SECTION VIEW PATTERN AND SYMBOL LEGEND OF TRAFFIC CONTROL AND STAGING SHEETS

	Pavement Removal		Proposed Granular Shoulder
	Proposed Granular Subbase		Temporary Shoulder
	Proposed Special Backfill		Existing Shoulder Strengthening
	Temporary Barrier Rail		Permanent Barrier Rail
	Lane Open To Traffic		Channelizing Device

PLAN VIEW COLOR LEGEND OF TRAFFIC CONTROL AND STAGING SHEETS

LINEWORK	Design Color No.	
Green	(2)	Existing Topographic Features and Labels
Magenta	(5)	Pavement Marking Call Outs
Blue	(1)	Proposed Alignment, Stationing, Tic Marks, and Alignment Annotation
Yellow	(4)	Pavement Markings, Yellow
Off White	(254)	Pavement Markings, White
Violet	(15)	Temporary barrier rail, Unpinned
Flush Orange	(228)	Temporary barrier rail, Pinned

SHADING	Design Color No.	
Green, Light	(225)	Existing Pavement Shading
Gray, Light	(48)	Previously Constructed Pavement Shading
Gray, Med	(80)	Proposed Granular Surface Shading
Gray, Med	(80)	Previously Constructed Granular Surface Shading
Blue, Light	(230)	Proposed Pavement Shading
Lavender	(9)	Temporary Pavement Shading
Brown, Light	(236)	Proposed Grading Limits Shading
Pink, Dark	(13)	Proposed MSE or CIP Wall Shading
Red	(3)	Proposed Bridge Shading and Sign Trusses
Black w/Gray, Light Fill	(0,48)	Previously Constructed Structure

PLAN VIEW PATTERN AND SYMBOL LEGEND OF TRAFFIC CONTROL AND STAGING SHEETS

	Channelizing Device		Crash Cushion (Temp or Perm)
	Drum		Traffic Signal
	Temporary Lane Separator		Flagger
	Tubular Marker		Temporary Floodlighting
	Channelizer Marker		Traffic Sign
	Concrete Barrier Marker		Type III Barricade
	Delineator		Type A Warning Light
	Temporary Barrier Rail		Direction of Traffic
	Pavement Removal		Safety Closure
	Sand Barrel Layout		Lane Identification
	Sawcut		

NOTE: Device spacing according to Standard Road Plans unless specifically dimensioned.

TRAFFIC CONTROL AND STAGING LEGEND AND SYMBOL INFORMATION SHEET

(COVERS SHEET SERIES J)

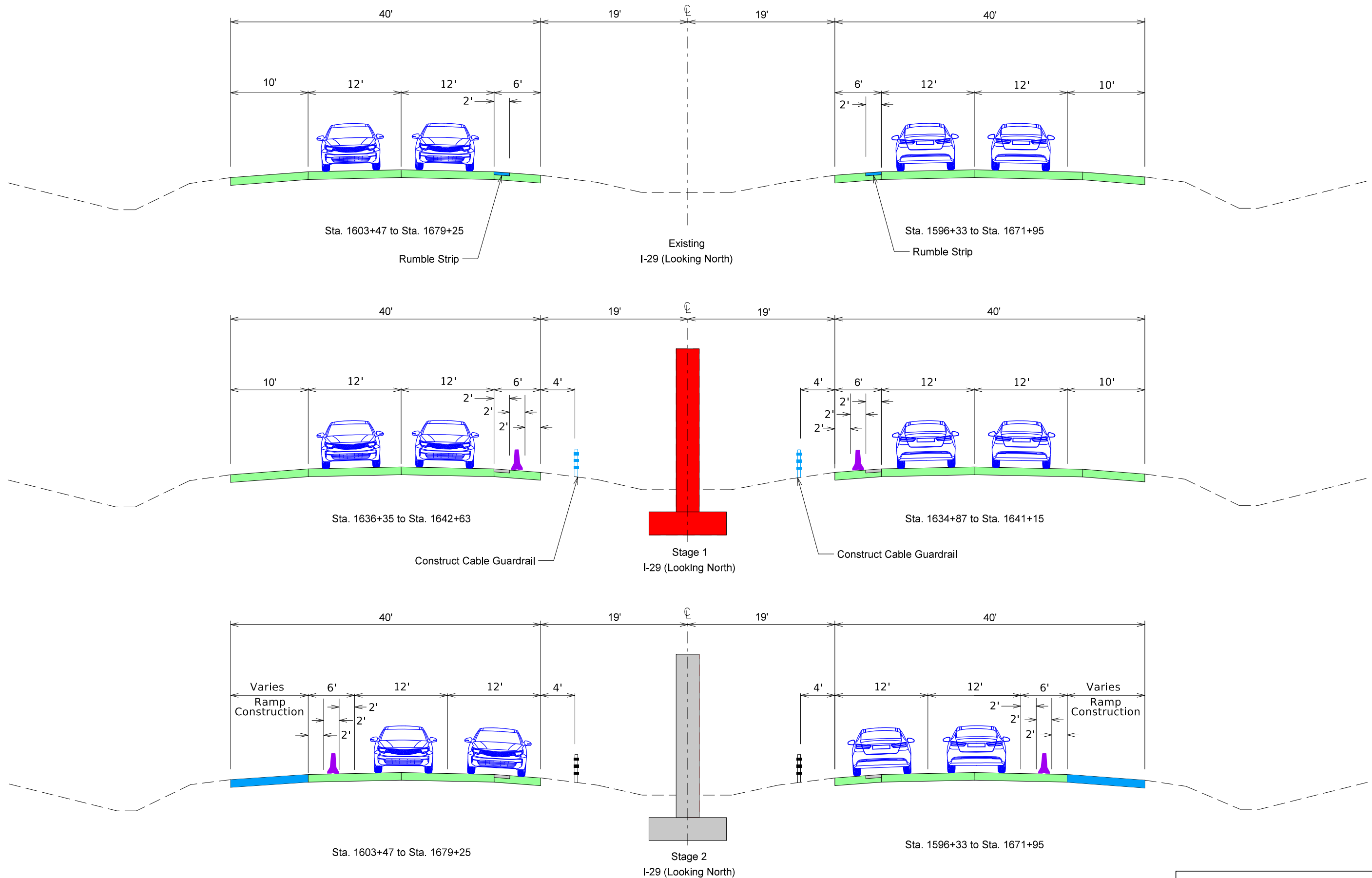

STAGING TYPICALS

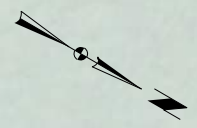

POB 1591407.27

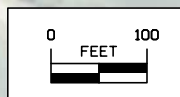

Stage 1
Traffic Control Layout

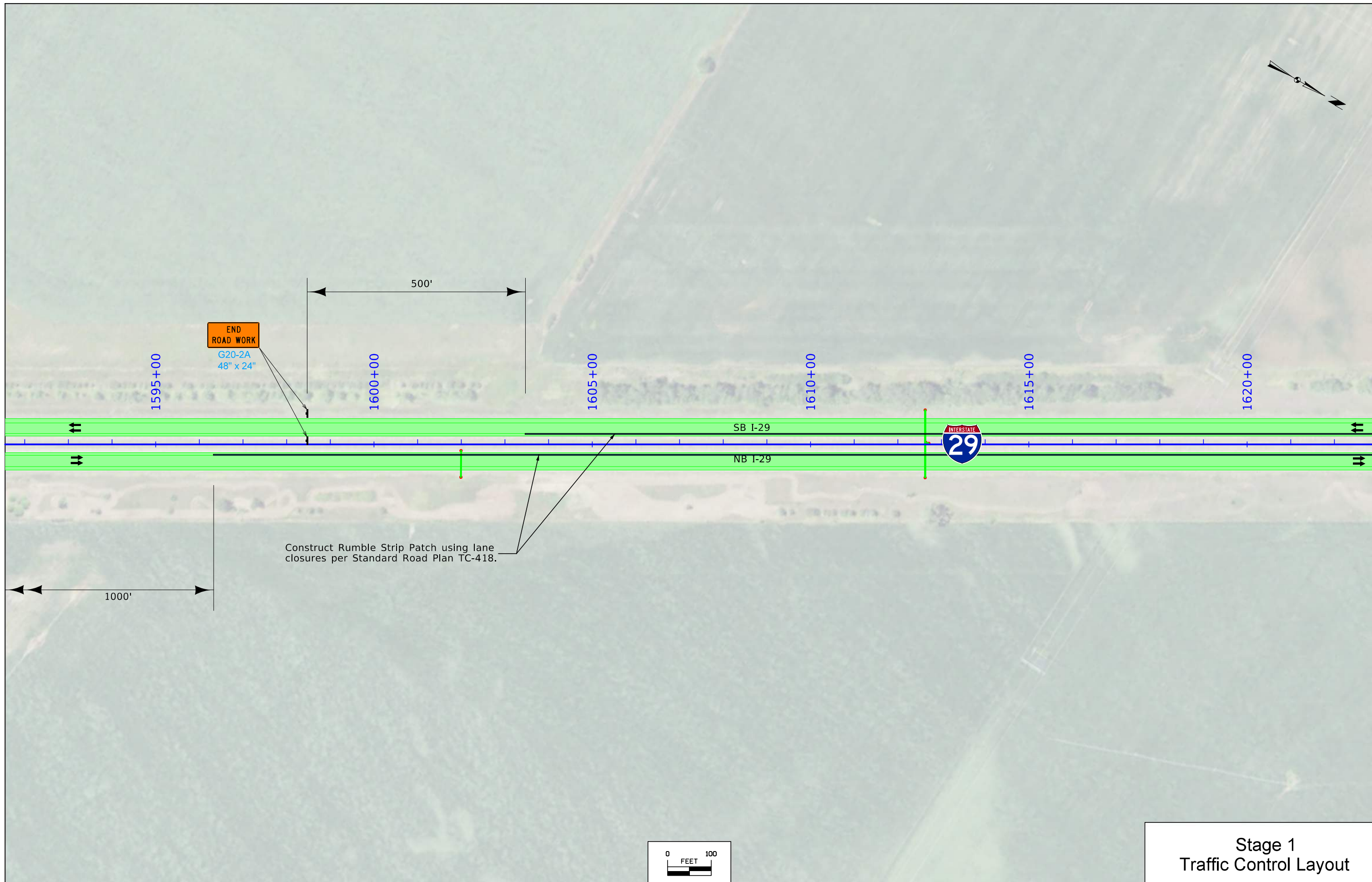

Construct Rumble Strip Patch using lane closures per Standard Road Plan TC-418.

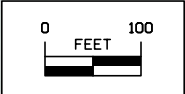

Stage 1
Traffic Control Layout

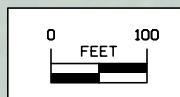
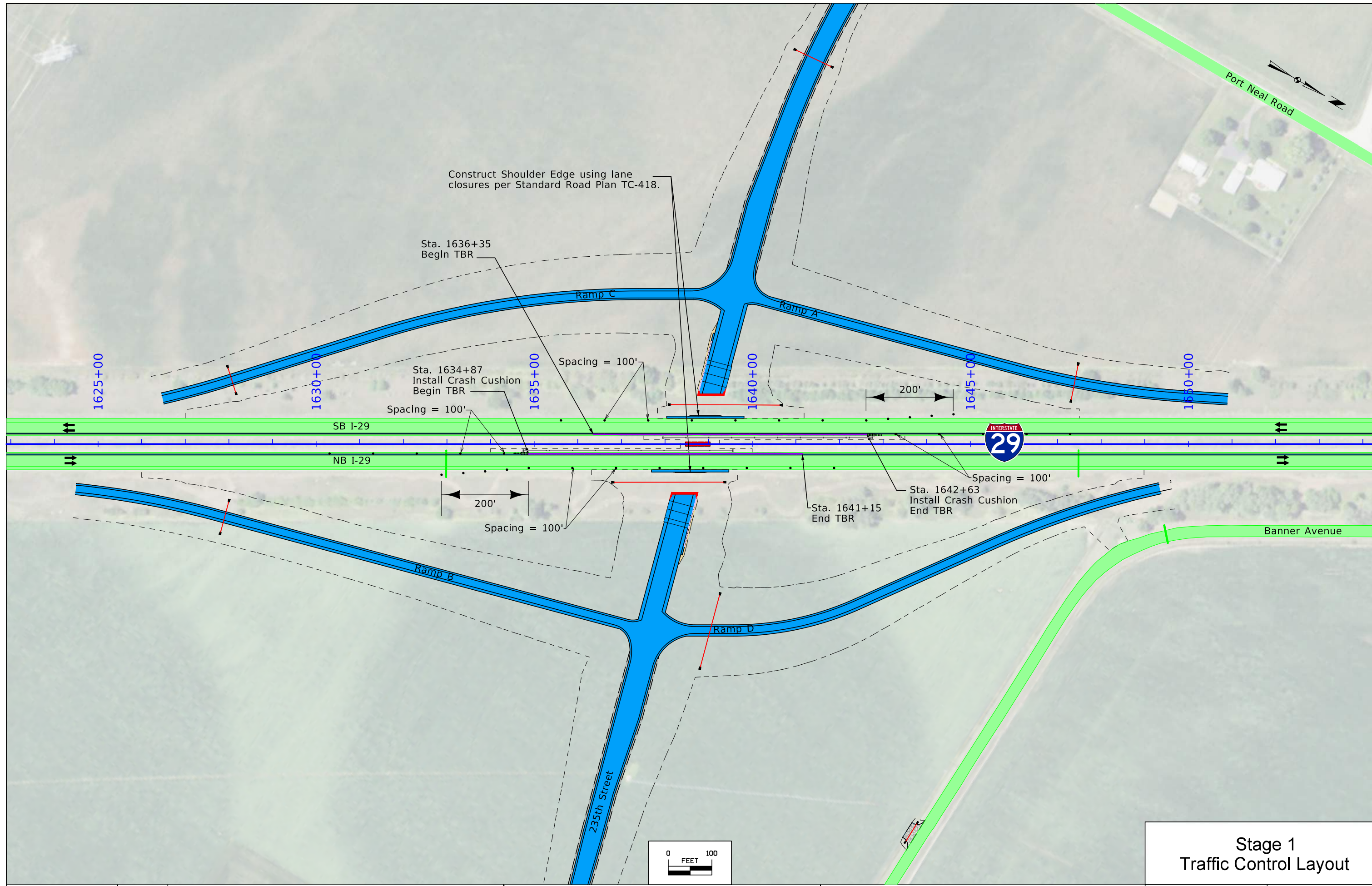

**Stage 1
Traffic Control Layout**

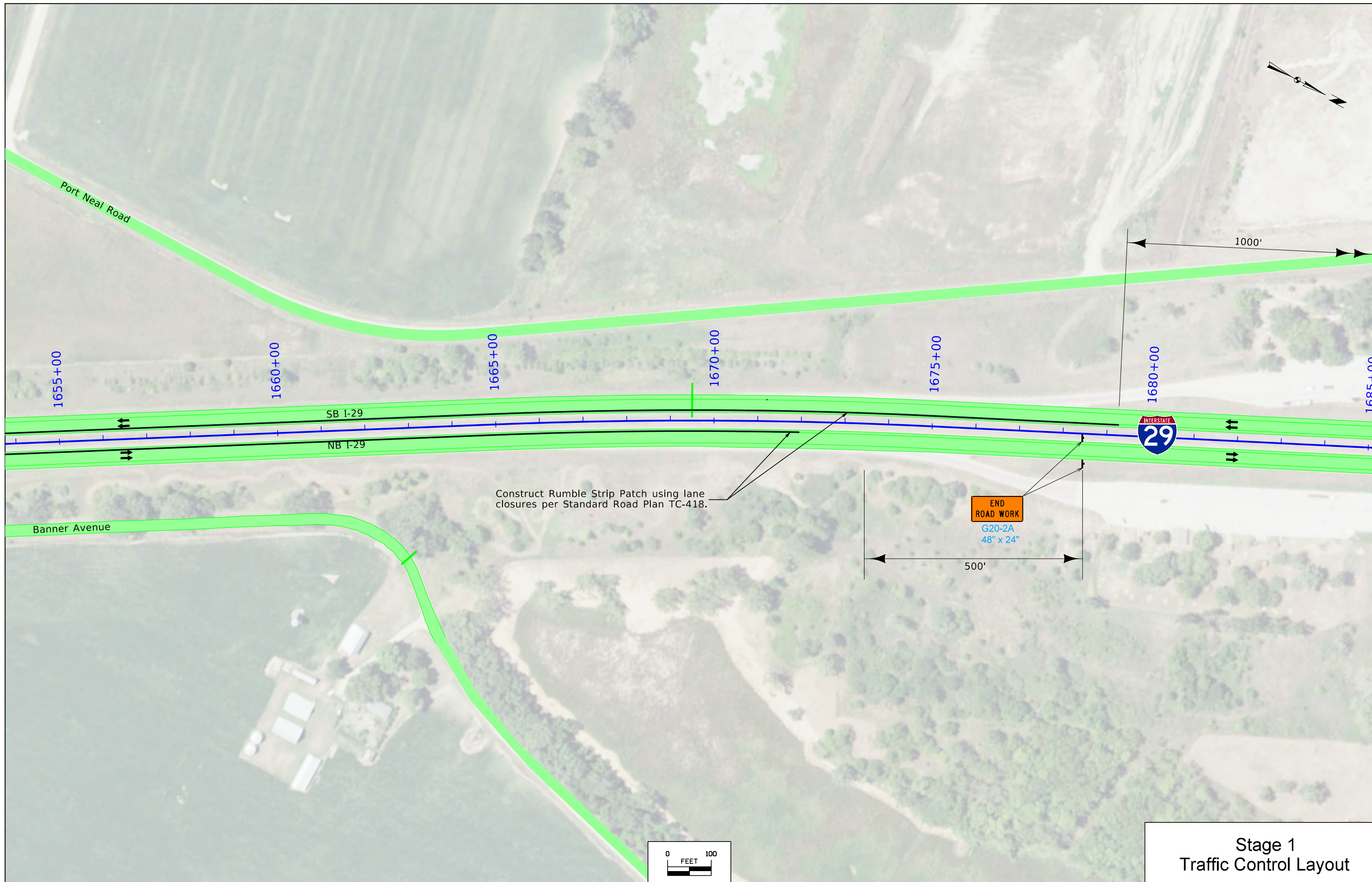

Stage 1
Traffic Control Layout

FILE NO.	ENGLISH	DESIGN TEAM Iowa DOT / HNTB	WOODBURY COUNTY	PROJECT NUMBER IMN-029-6(170)139--0E-97	SHEET NUMBER J.7
----------	---------	-----------------------------	-----------------	---	------------------

3:00:00 PM 12/21/2023 bcharipar pw:\projectwise.dot.int.lan:PWMMain\Documents\Projects\9702901006\Design\CADD_Files\Sheet_Files\SHT_J_97029278Z04.dgn

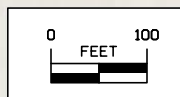
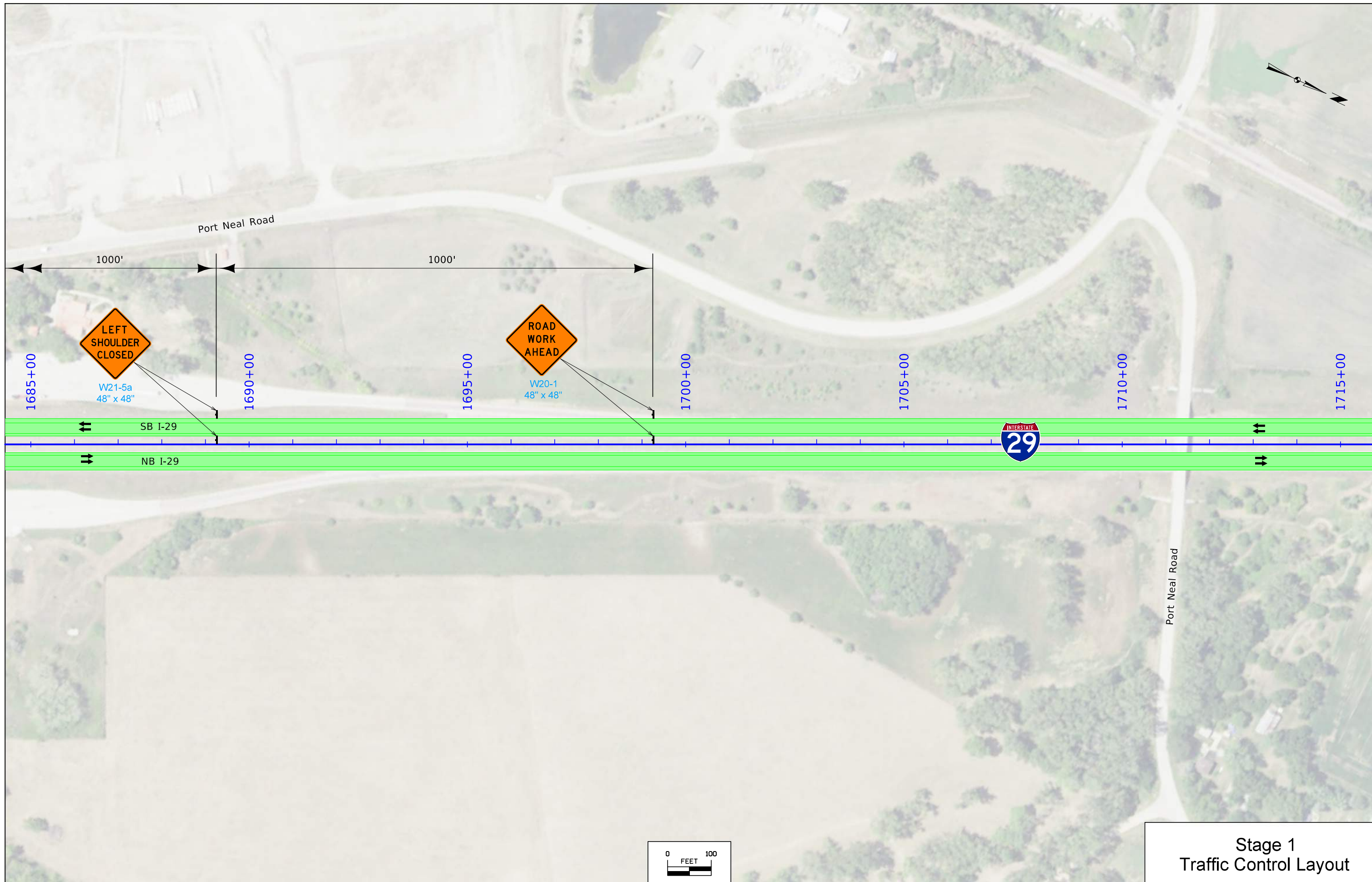

**Stage 1
Traffic Control Layout**

FILE NO.	ENGLISH	DESIGN TEAM Iowa DOT / HNTB	WOODBURY COUNTY	PROJECT NUMBER IMN-029-6(170)139--0E-97	SHEET NUMBER J.8
----------	---------	-----------------------------	-----------------	---	------------------

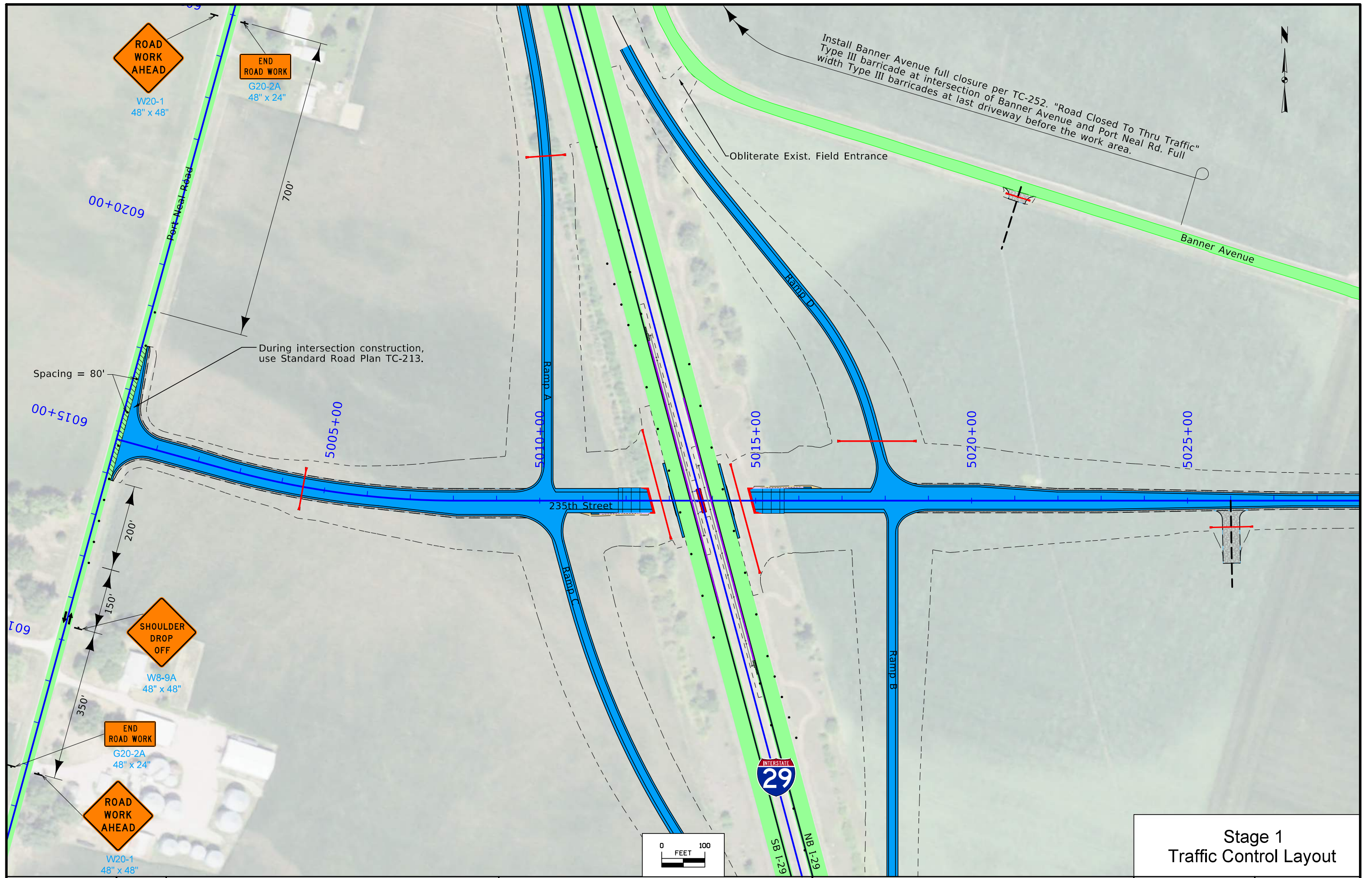

Stage 1
Traffic Control Layout

Restricted Access:

1. The Contractor will note the "Restricted Access - No Access" located on Sheet E.4. The Contractor shall furnish and install orange safety fence according to Article 4188.03 of the Standard Specifications.
2. The Contractor shall contact Janee Becker (515-233-7820) with the Location and Environment Bureau with questions regarding the Restricted Access location.



**Stage 1
Traffic Control Layout**

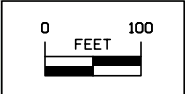

**Stage 1
Traffic Control Layout**



W20-1
48" x 48"

800'



W3-5
48" x 48"

800'



R2-1
48" x 60"

1000'



W1-4L
48" x 48"



W24-1cP
30" x 24"

1000'

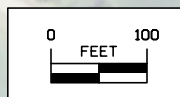

Stage 2
Traffic Control Layout

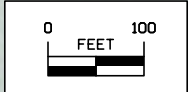
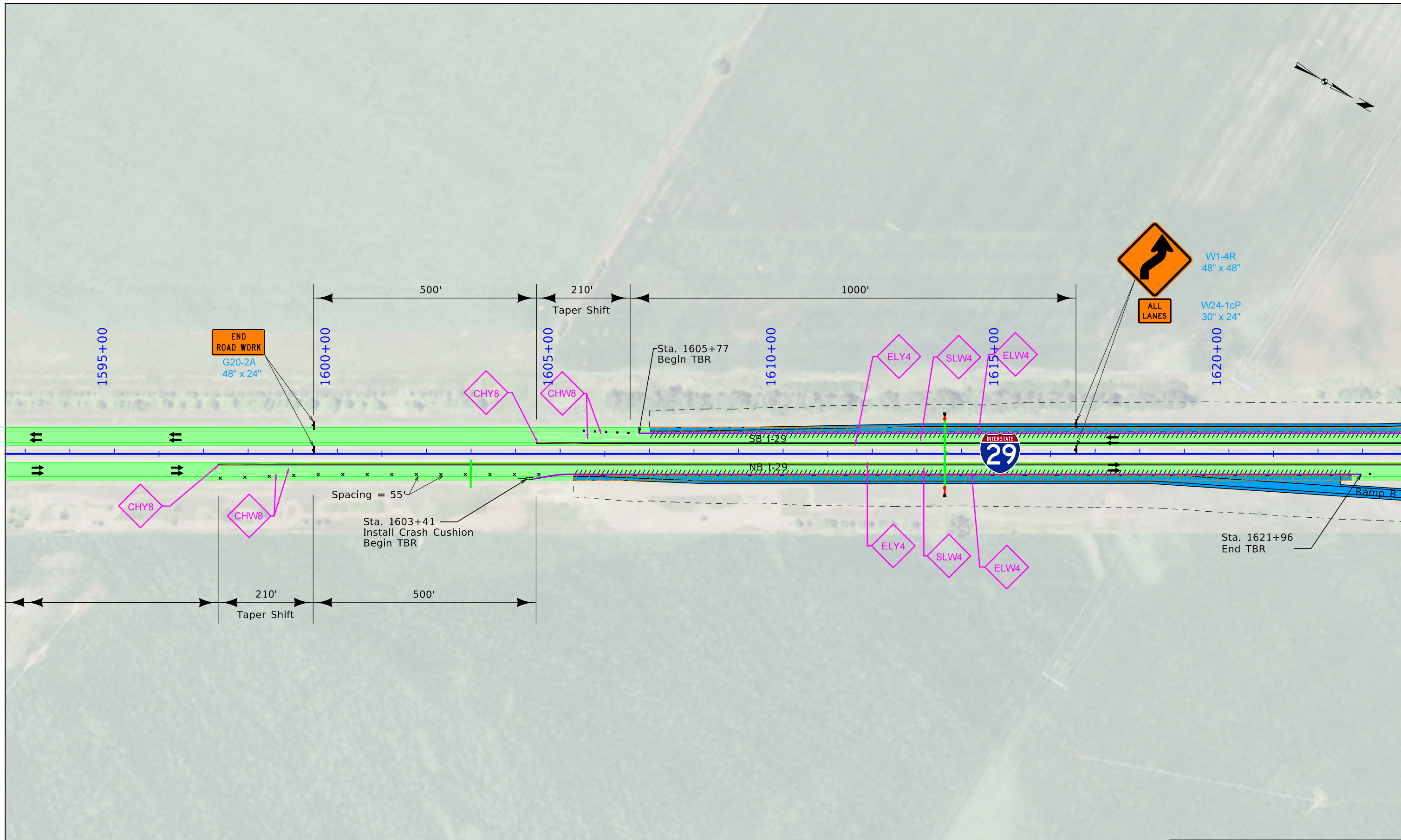

**Stage 2
Traffic Control Layout**

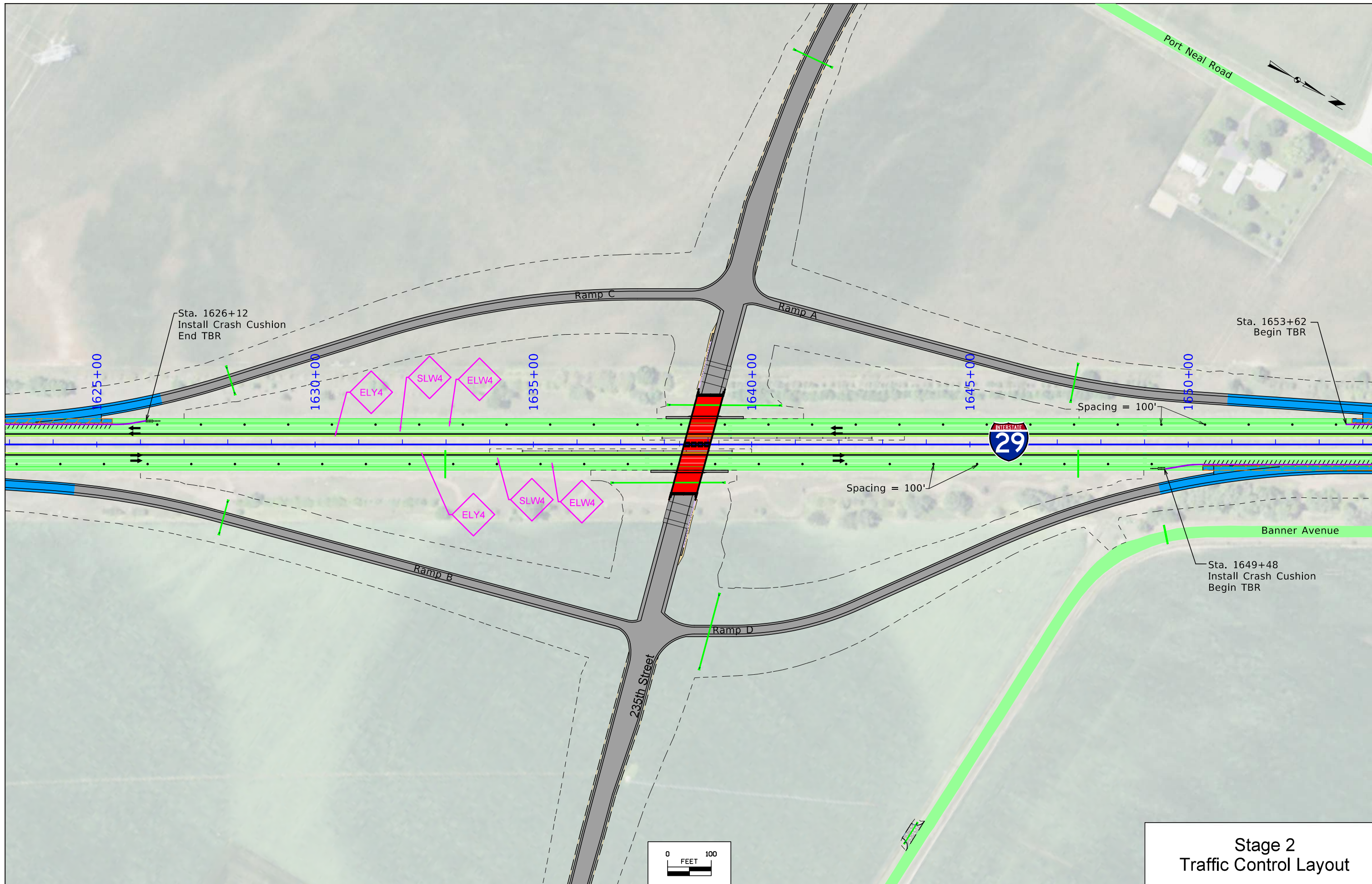

**Stage 2
Traffic Control Layout**

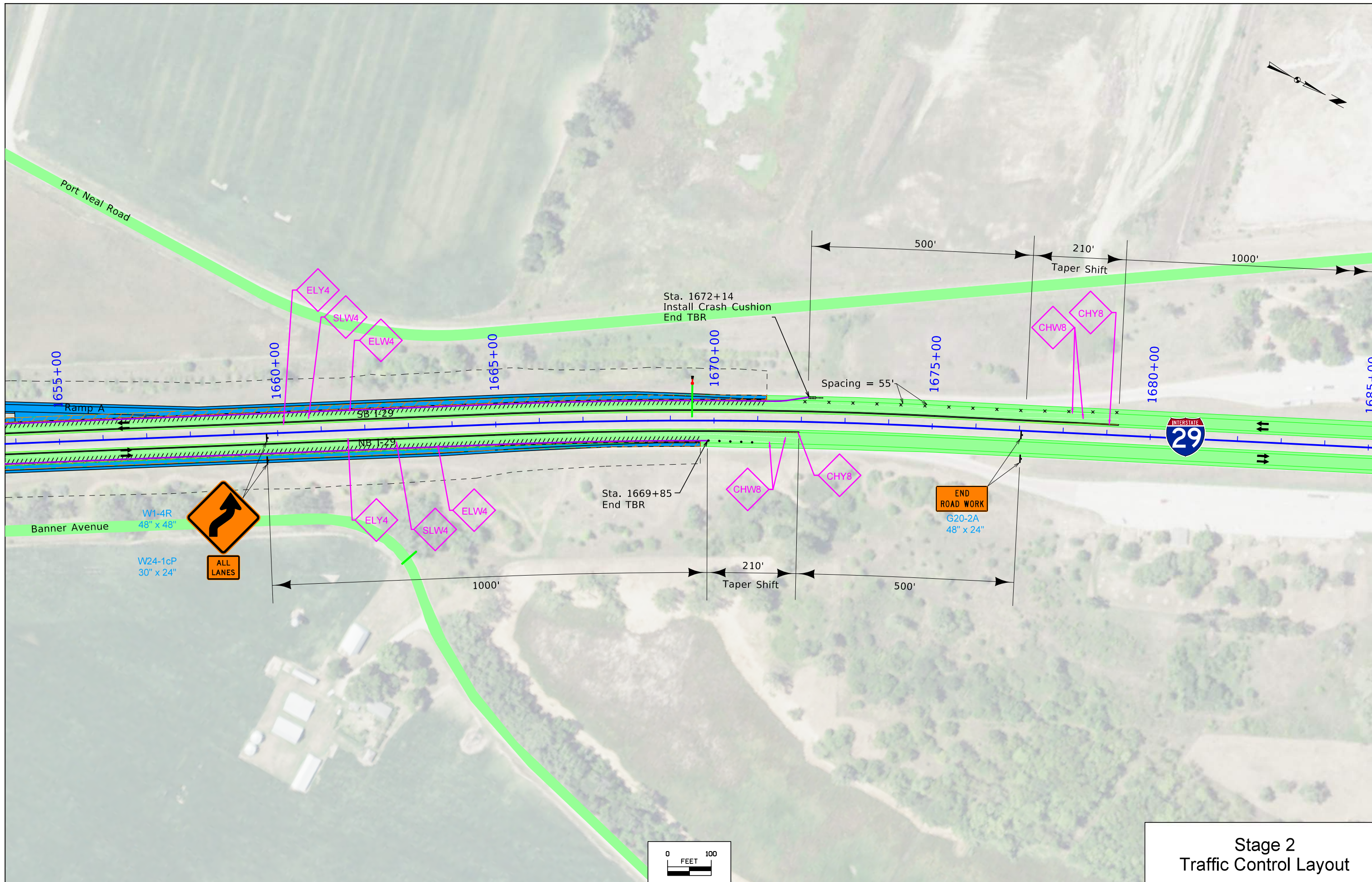

Stage 2
Traffic Control Layout

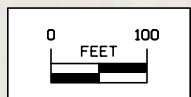
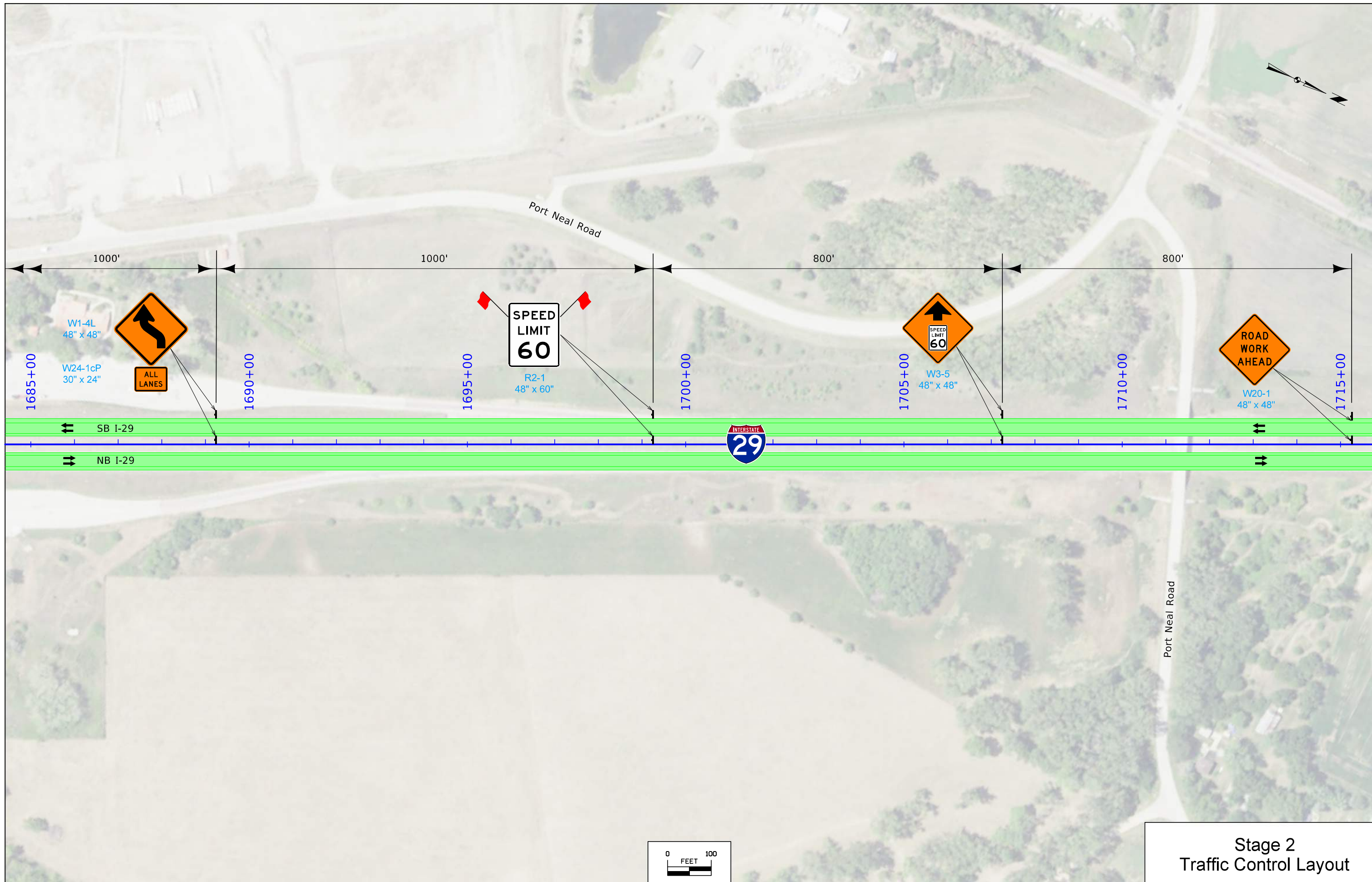

Stage 2
Traffic Control Layout

FILE NO.	ENGLISH	DESIGN TEAM Iowa DOT / HNTB	WOODBURY COUNTY	PROJECT NUMBER IMN-029-6(170)139--0E-97	SHEET NUMBER J.16
----------	---------	-----------------------------	-----------------	---	-------------------

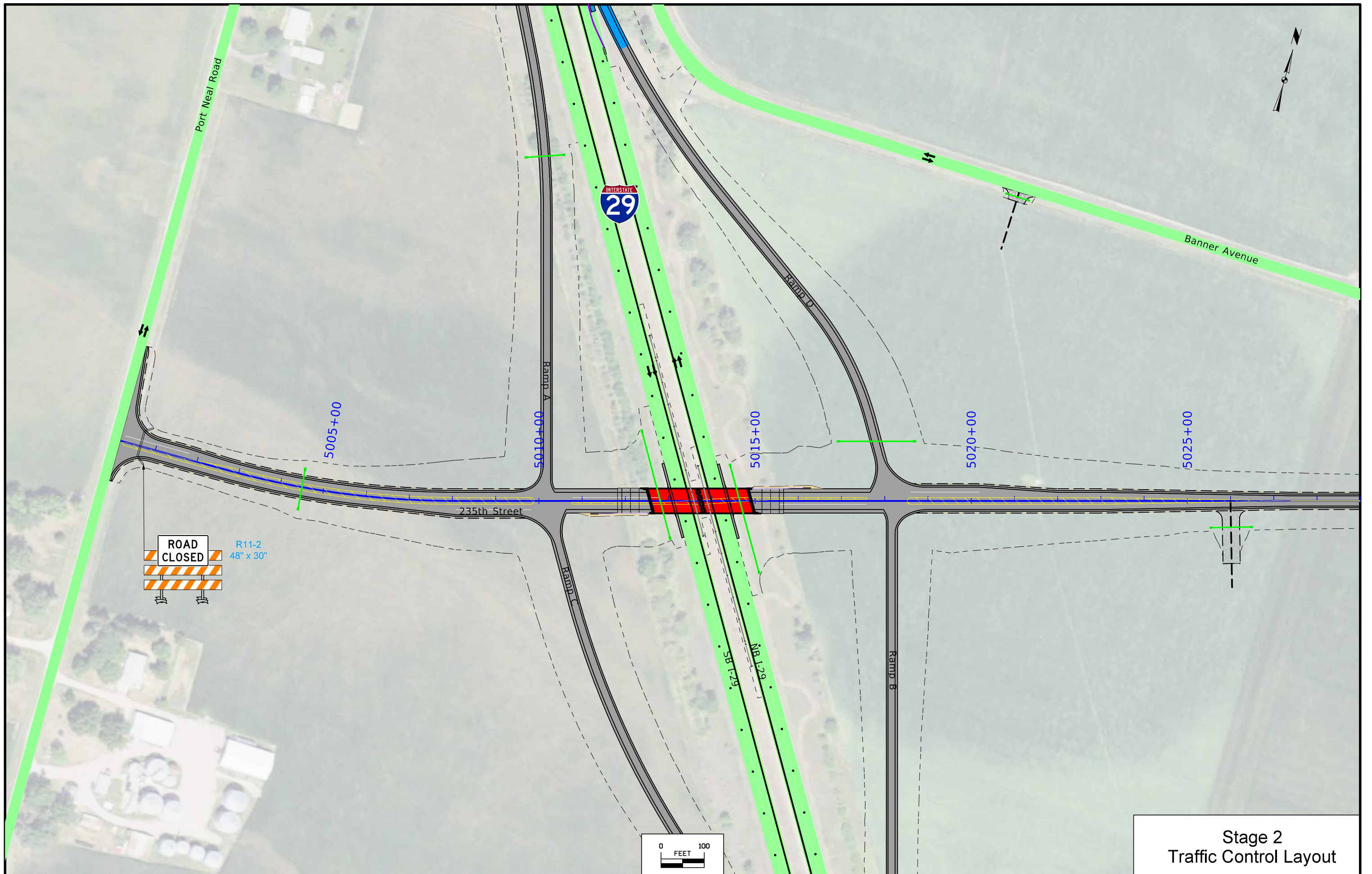

Stage 2
Traffic Control Layout

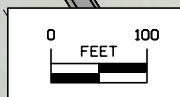

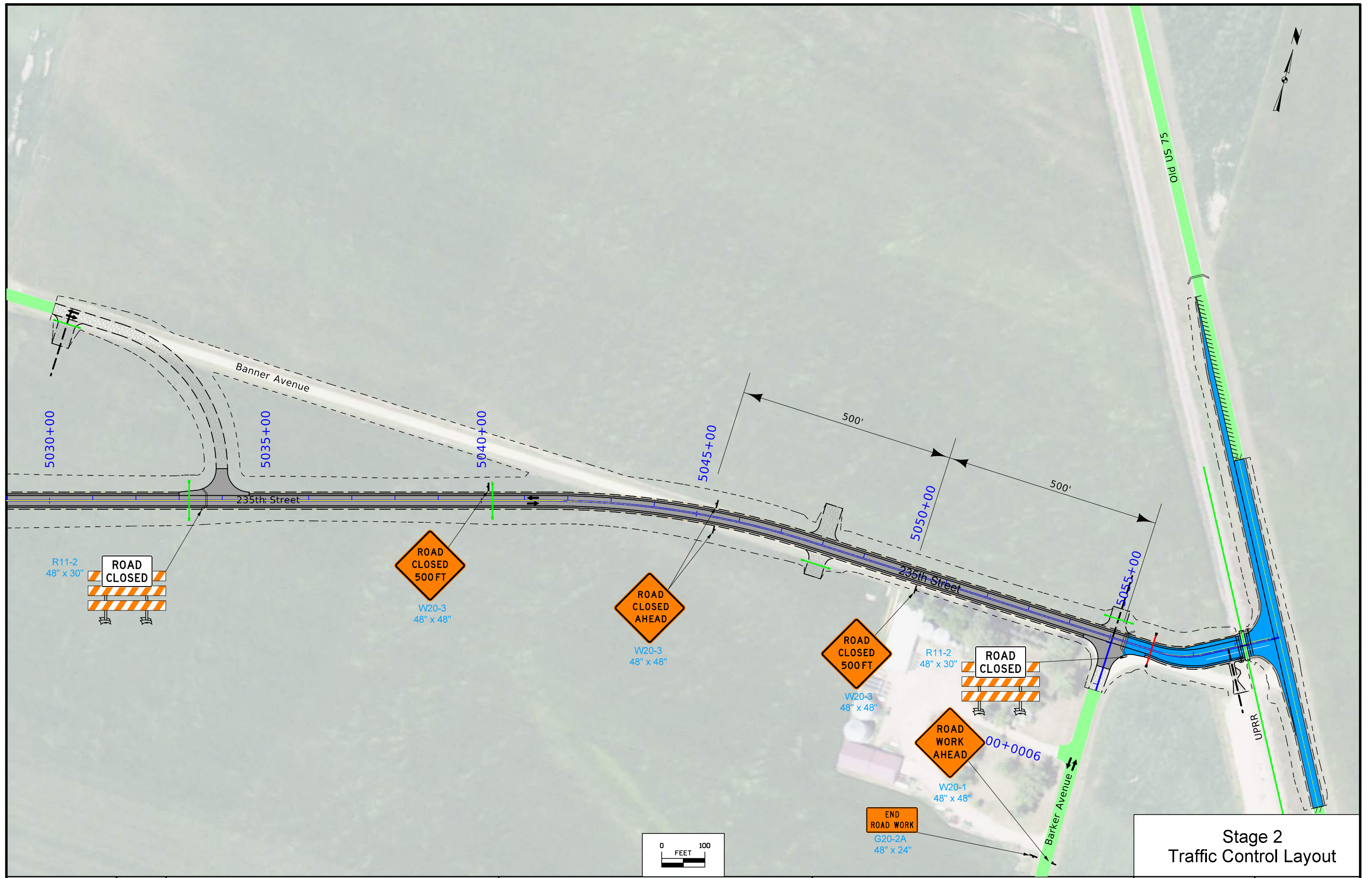

**Stage 2
Traffic Control Layout**

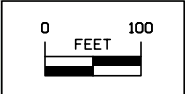

**Stage 2
Traffic Control Layout**

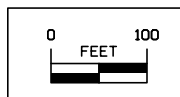
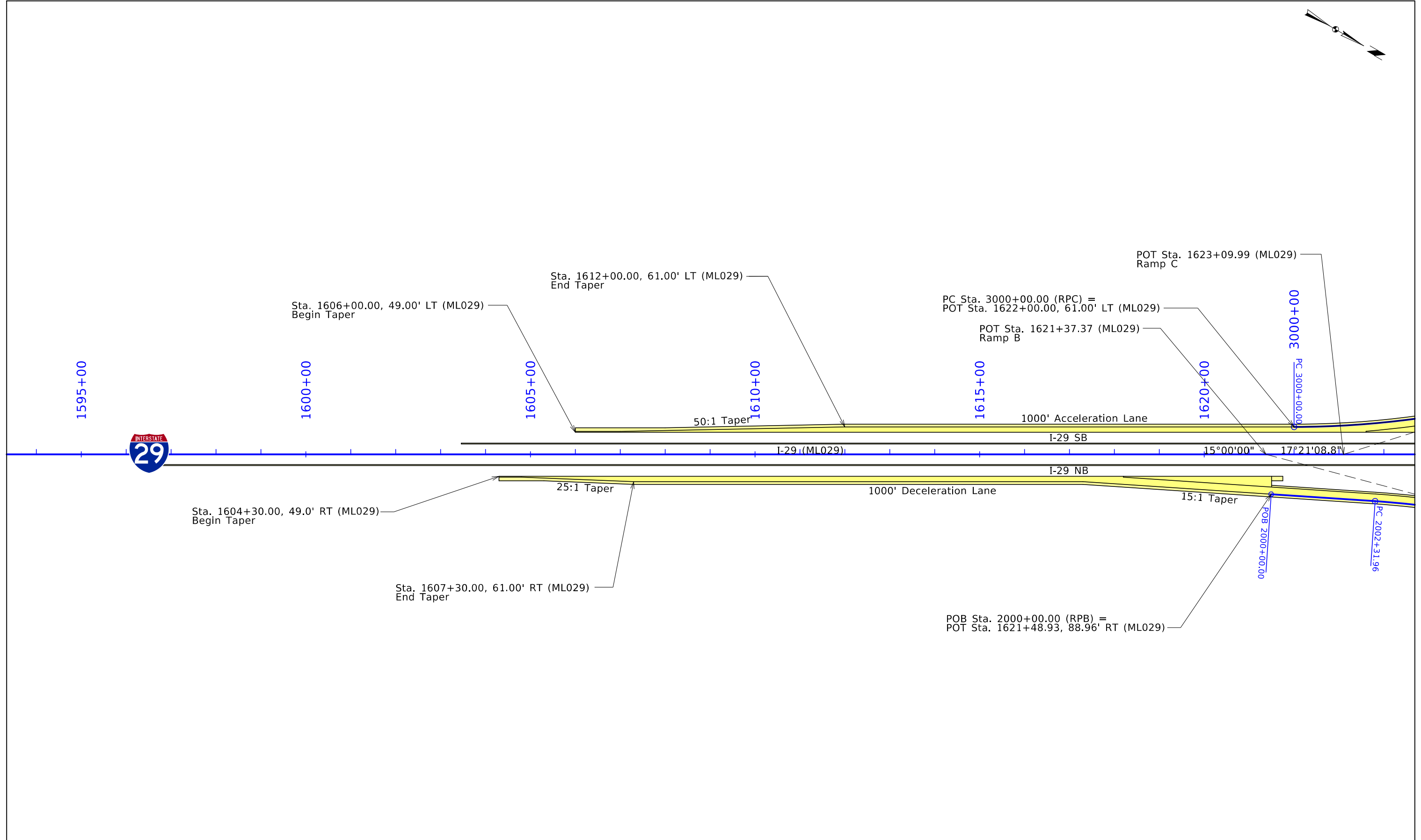
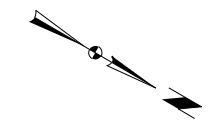

Geometric Plan

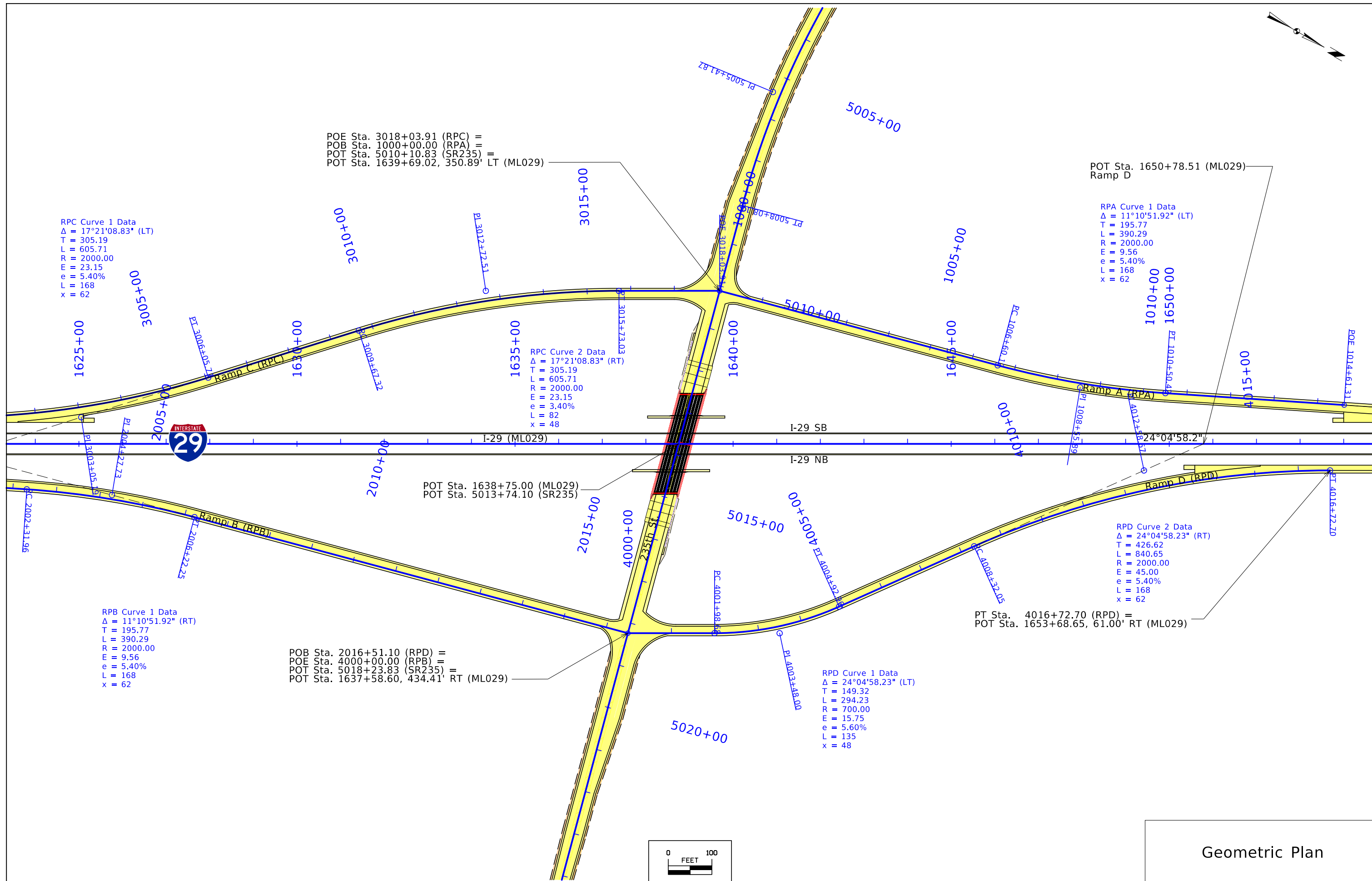

Geometric Plan

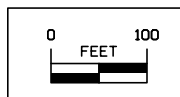
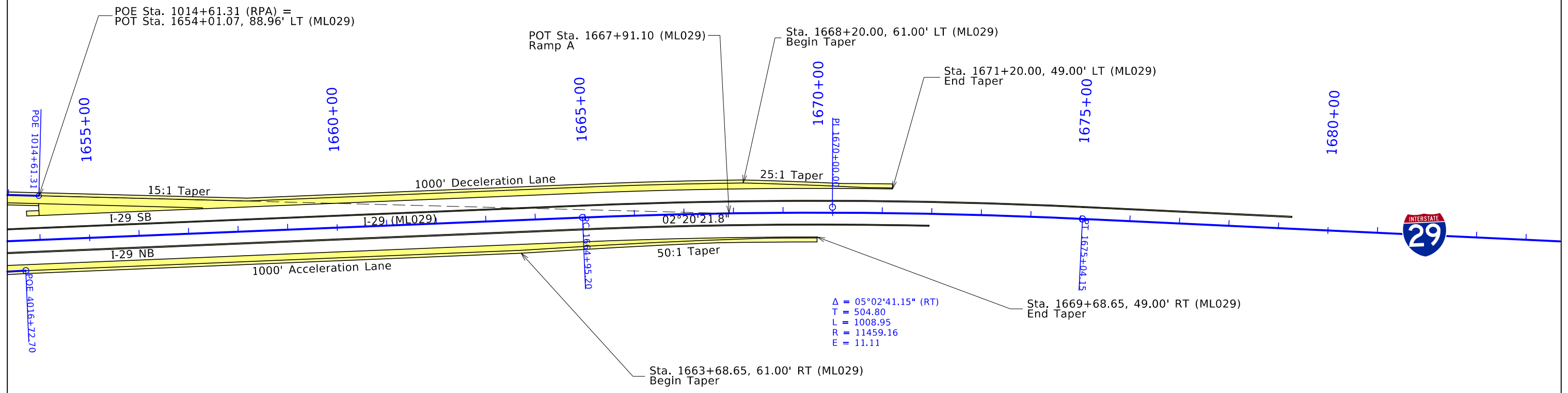
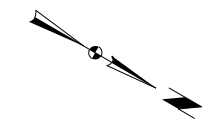

Geometric Plan

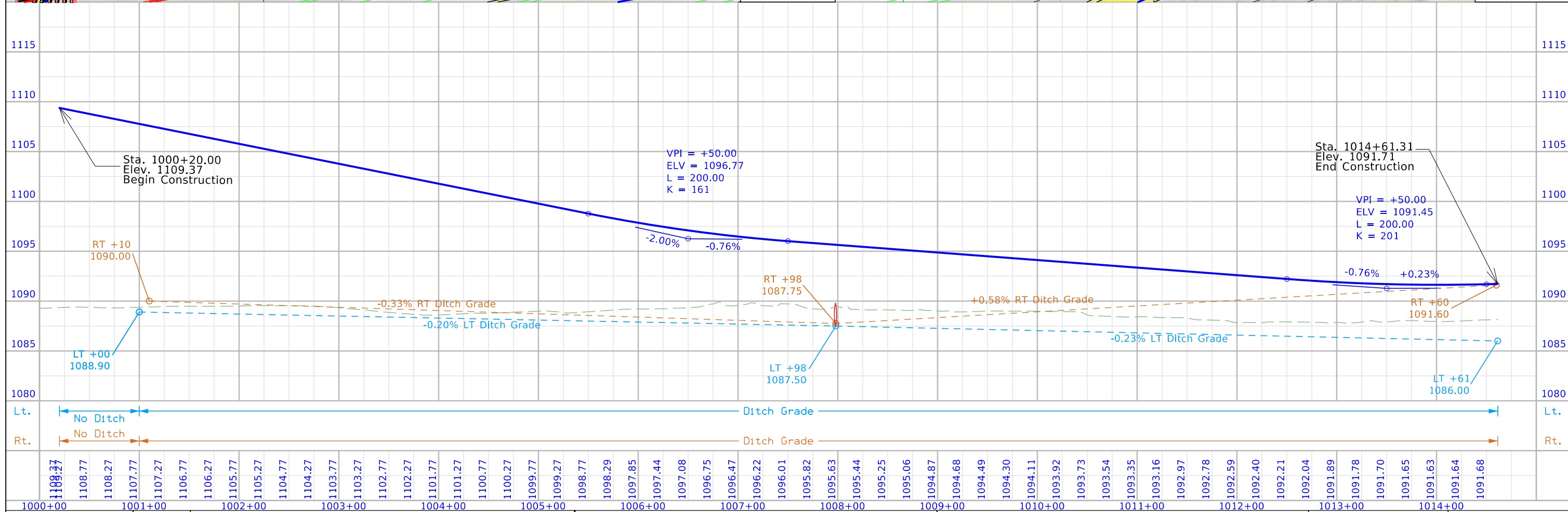
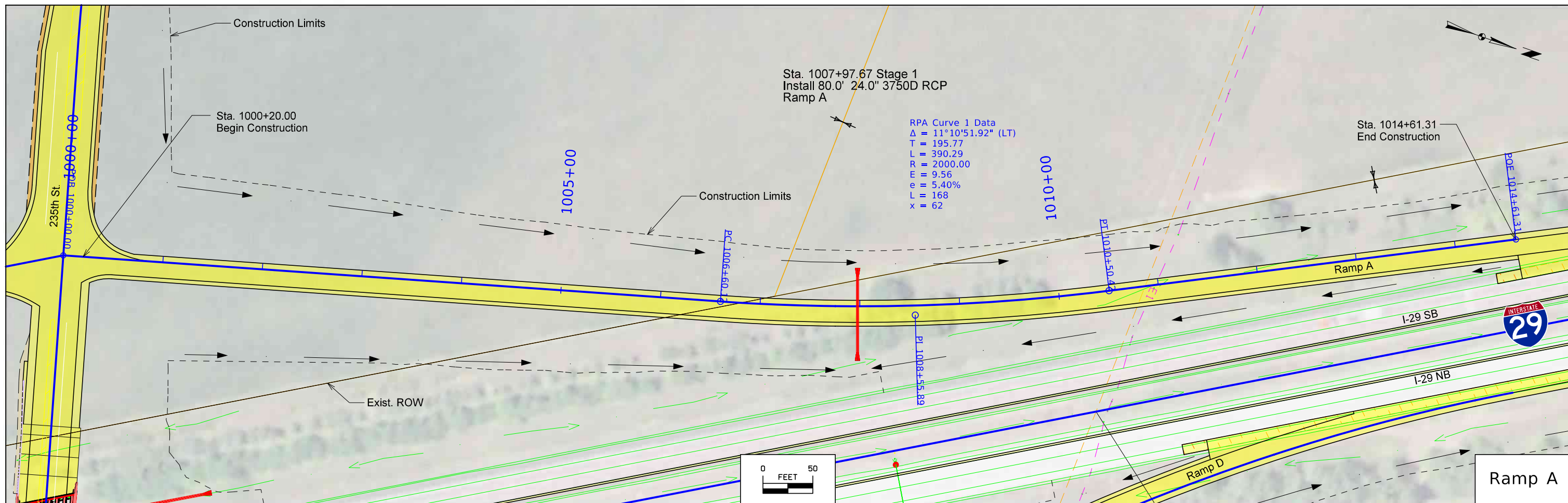

FILE NO.	ENGLISH	DESIGN TEAM	Iowa DOT / HNTB	WOODBURY COUNTY	PROJECT NUMBER	IMN-029-6(170)139--0E-97	SHEET NUMBER	K.4
----------	---------	-------------	-----------------	-----------------	----------------	--------------------------	--------------	-----

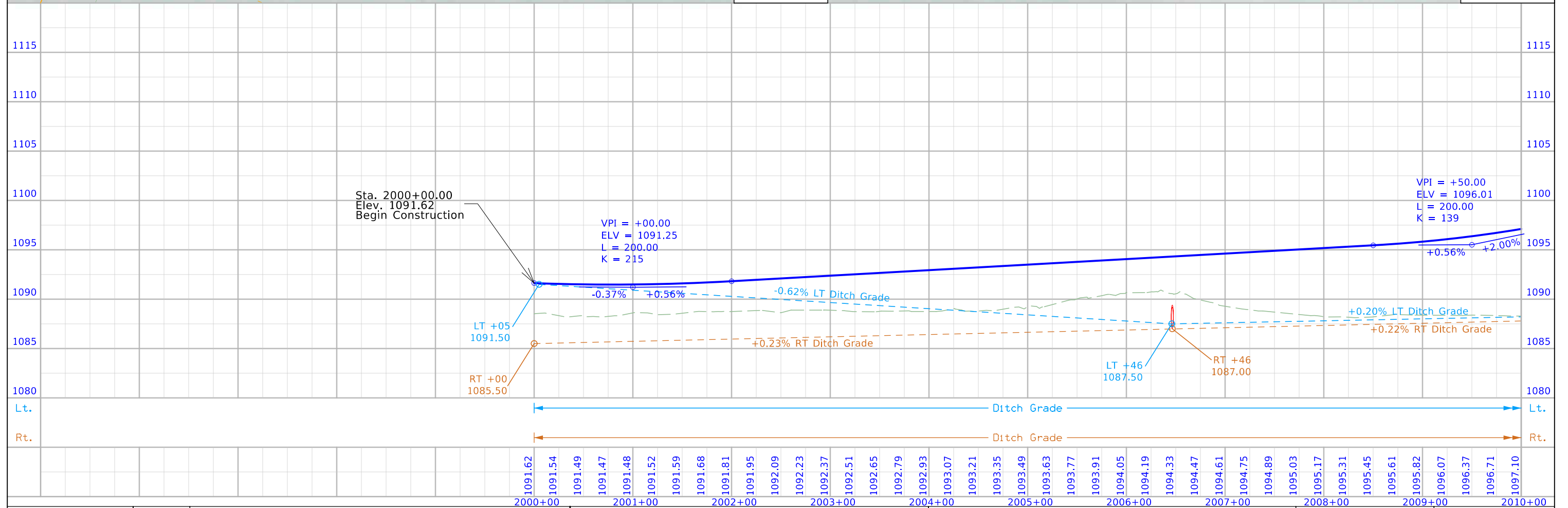
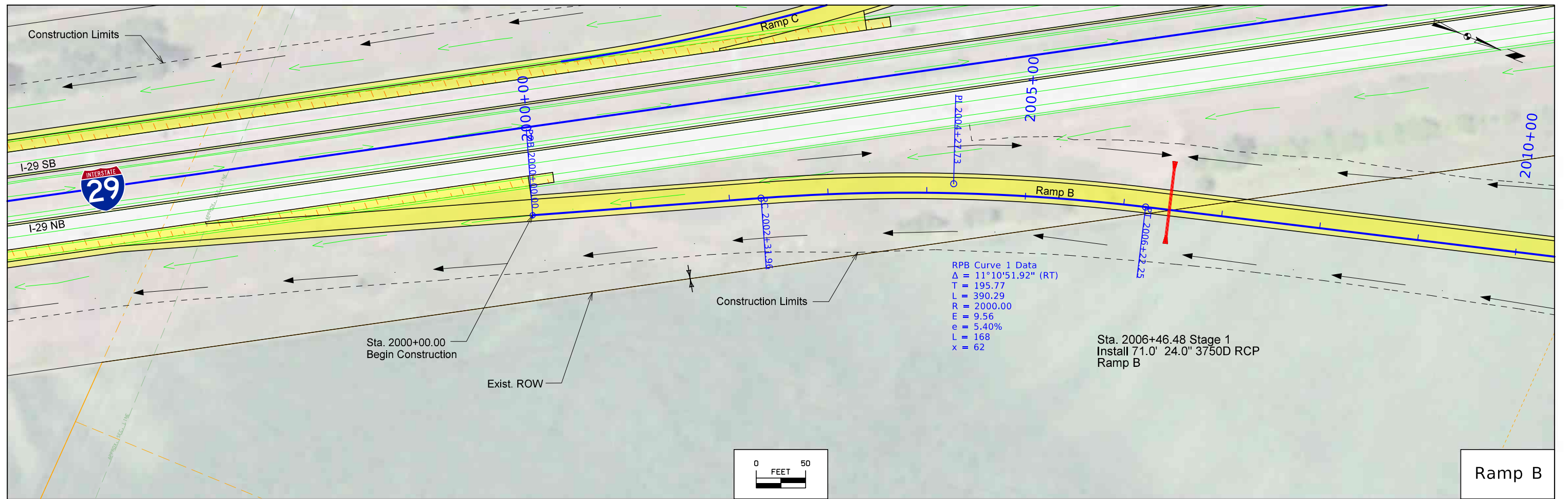

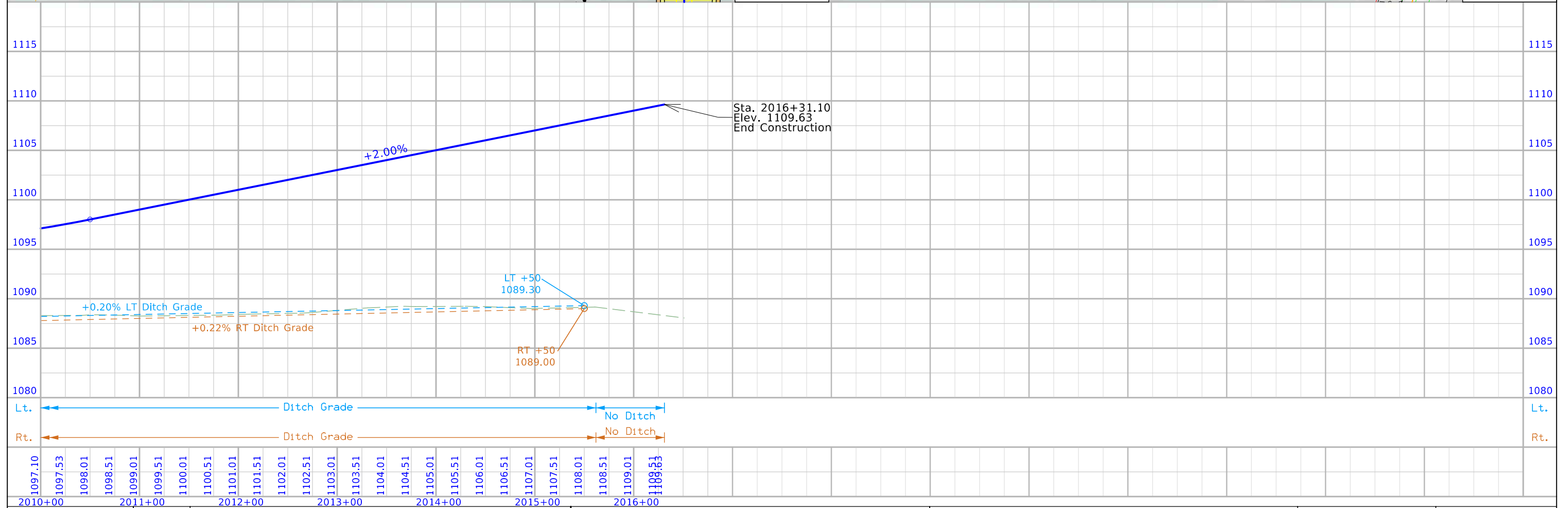
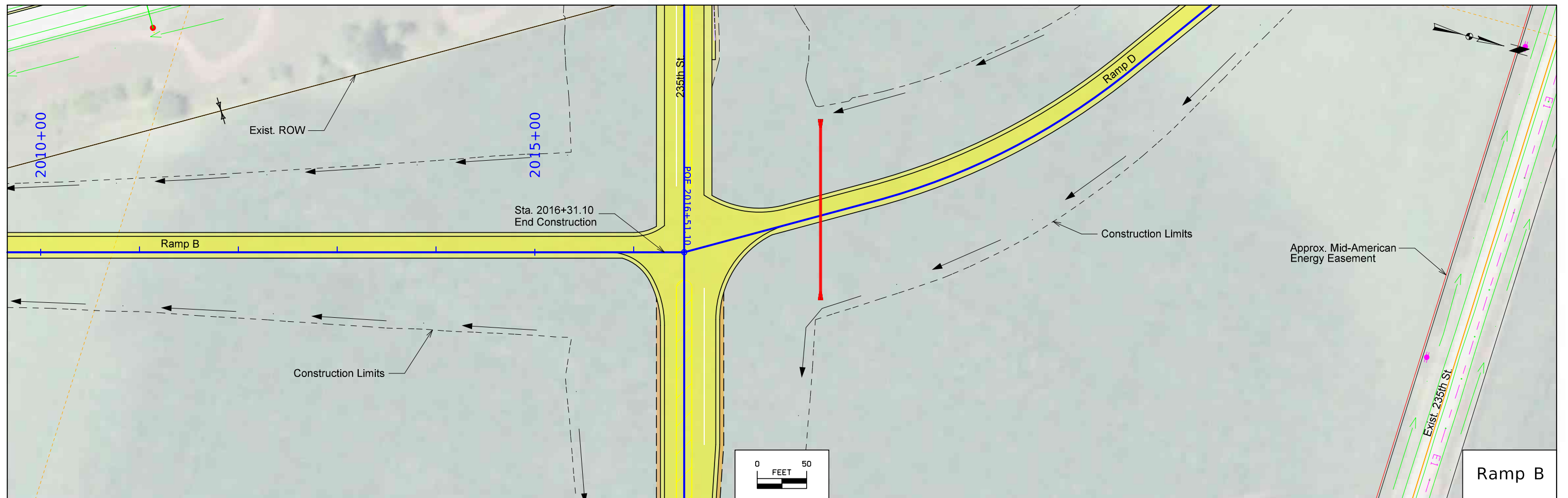

1097.10	1097.53	1098.01	1098.51	1099.01	1099.51	1100.01	1100.51	1101.01	1101.51	1102.01	1102.51	1103.01	1103.51	1104.01	1104.51	1105.01	1105.51	1106.01	1106.51	1107.01	1107.51	1108.01	1108.51	1109.01	1109.51	1110.01	1110.51	1111.01	1111.51	1112.01	1112.51	1113.01	1113.51	1114.01	1114.51	1115.01	1115.51
2010+00	2011+00	2012+00	2013+00	2014+00	2015+00	2016+00																															

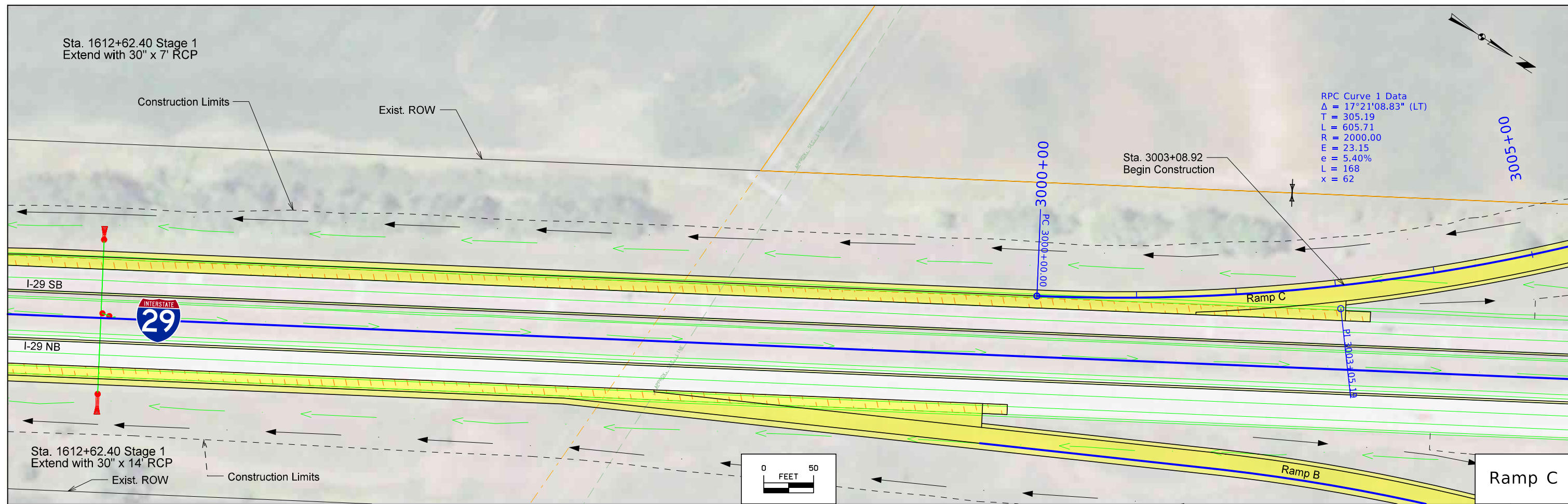

FILE NO.	ENGLISH	DESIGN TEAM Iowa DOT / HNTB	WOODBURY COUNTY	PROJECT NUMBER IMN-029-6(170)139--0E-97	SHEET NUMBER K.7
----------	---------	-----------------------------	-----------------	---	------------------

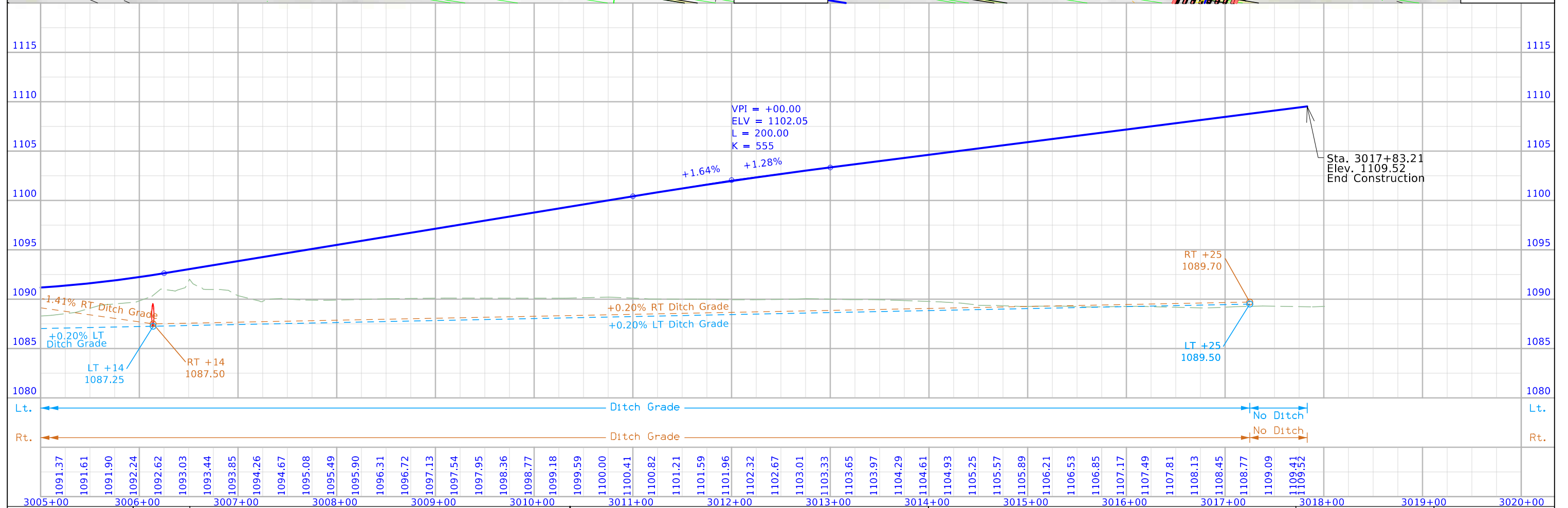
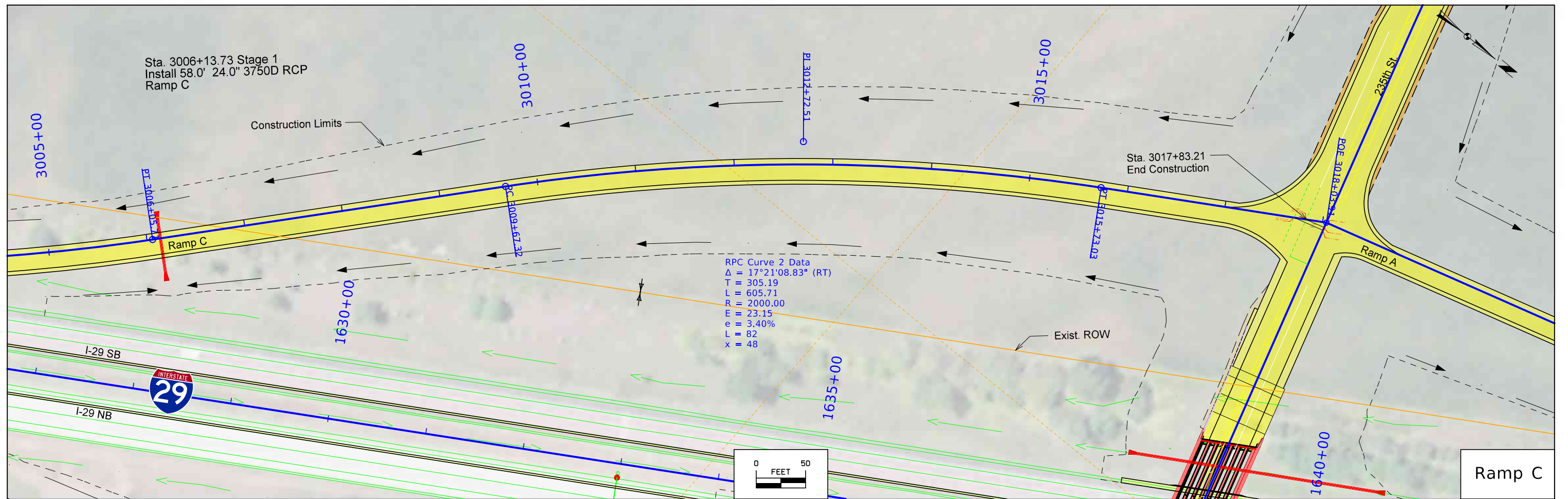

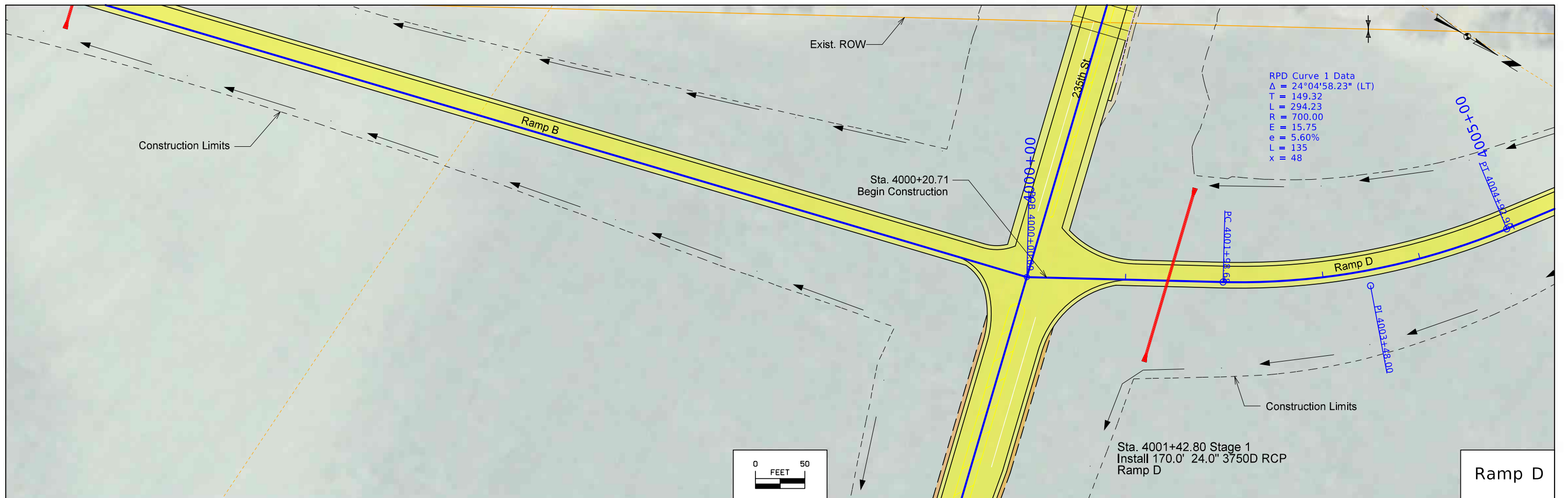

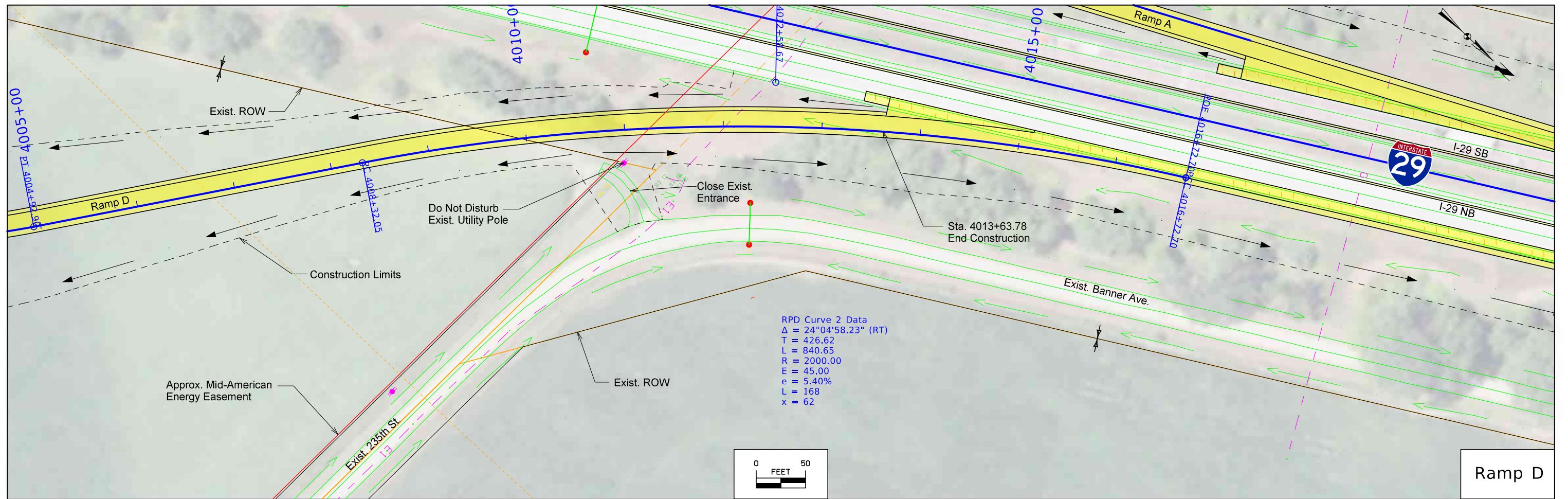

RPD Curve 2 Data
 $\Delta = 24^{\circ}04'58.23"$ (RT)
 T = 426.62
 L = 840.65
 R = 2000.00
 E = 45.00
 e = 5.40%
 L = 168
 x = 62

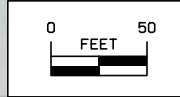

Ramp D

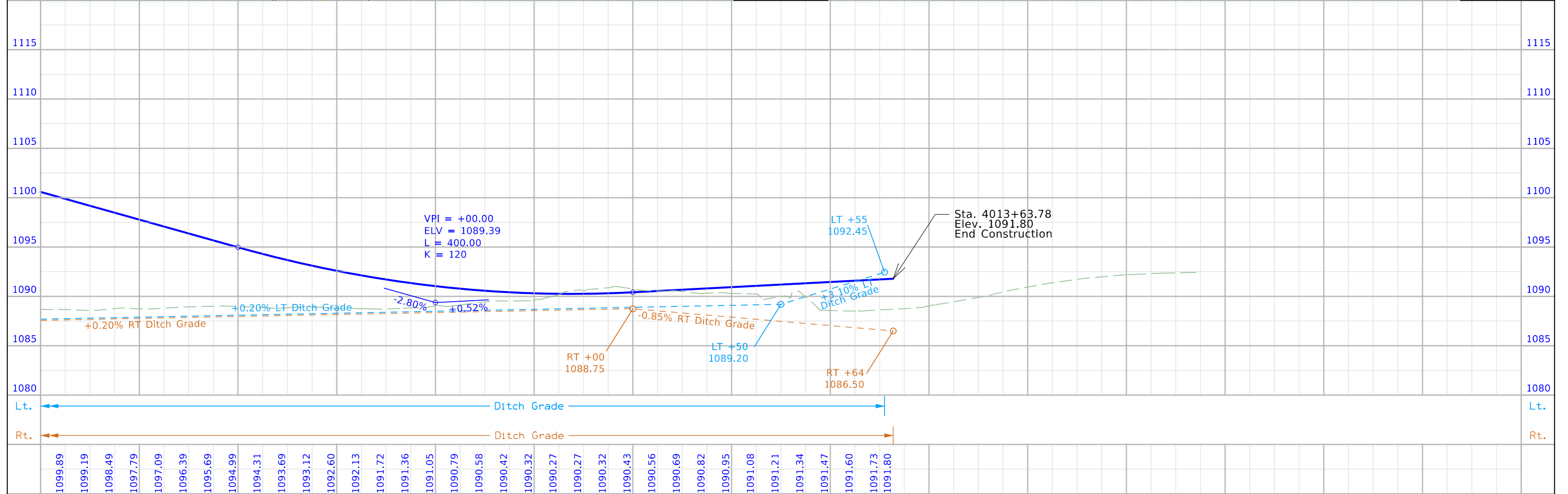

1099.89	1099.19	1098.49	1097.79	1097.09	1096.39	1095.69	1094.99	1094.31	1093.69	1093.12	1092.60	1092.13	1091.72	1091.36	1091.05	1090.79	1090.58	1090.42	1090.32	1090.27	1090.27	1090.32	1090.43	1090.56	1090.69	1090.82	1090.95	1091.08	1091.21	1091.34	1091.47	1091.60	1091.73	1091.80									
4006+00				4007+00				4008+00				4009+00				4010+00				4011+00				4012+00				4013+00				4014+00				4015+00				4016+00			

SURVEY SYMBOLS

- | | | | |
|--|-----------------------------------|--|------------------------------|
| | Interstate Highway Symbol | | Septic Tank |
| | U.S. Highway Symbol | | Cistern |
| | Iowa Highway Symbol | | L.P. Gas Tank (No Footing) |
| | County Road Highway Symbol | | Underground Storage Tank |
| | Evergreen Tree | | Latrine |
| | Deciduous Tree | | Satellite TV Dish |
| | Fruit Tree | | Water Hook Up |
| | Shrub (Bushes) | | Radio Tower |
| | Timber | | Tower Anchor |
| | Hedge | | Guardrail (Beam or Cable) |
| | Stump | | Guard Post (one or two) |
| | Swamp | | Guard Post (over two) |
| | Rock Outcrop | | Filler Pipe |
| | Broken Concrete | | Gas Valve |
| | Revetment (Rip Rap) | | Water Valve |
| | Cemetery | | Speed Limit Sign |
| | Grave | | Mile Marker Post |
| | Cave | | Sign |
| | Sink Hole | | Traffic Signal Control Box |
| | Board Fence | | Rail Road Signal Control Box |
| | Chain Link or Security Fence | | Telephone Switch Box |
| | Wire Fence | | Electric Box |
| | Terrace | | |
| | Earth Dam or Dike (Existing) | | |
| | Tile Outlet | | |
| | Edge of Water | | |
| | Existing Drainage | | |
| | Right of Way Rail or Lot Corner | | |
| | Concrete Monument | | |
| | Well | | |
| | Windmill | | |
| | Beehive Intake | | |
| | Existing Intake | | |
| | Existing Utility Access (Manhole) | | |
| | Fire Hydrant | | |
| | Water Hydrant (Rural) | | |

UTILITY LEGEND

- F02 - LONG LINES LTD. (Telephone)
TOM CONNORS
712-333-1352
tom.connors@longlines.biz
- FO - MIDWEST FIBER NETWORKS LCC
Contact Name
Contact Email
- G - NORTHERN NATURAL GAS COMPANY
(Gas Transmission)
JEFF LARSON
402-398-7618
Jeff.Larson@nngco.com
- SAN - SIOUX CITY (Sanitary Sewer, Water)
JON O'BRIEN
712-279-6135
jobrien@sioux-city.org
- E1 - WOODBURY COUNTY REC
(Electric Distribution)
Nate Bauer
712-873-3125
nbauer@woodburyrec.com
- AT&T (Fiber Transmission)
LENNY VOHS
816-275-4014
lv2121@att.com
- BLACK HILLS ENERGY (Gas)
BRAD FLEMING
402-221-2714
brad.fleming@blackhillscorp.com
- FIBERCOMM (Fiber Distribution)
RICK WELCH
712-224-2054
rwelch@fibercomm.net
- LUMEN CENTURYLINK (Fiber Distribution)
SEAN HOSTETTER
515-233-6404
sean.hostetter@lumen.com
- MIDAMERICAN ENERGY COMPANY
(Electric Distribution)
CASEY MEINEN
712-233-4831
Casey.meinen@midamerican.com
- MIDAMERICAN ENERGY COMPANY
(Electric Distribution)
WILLIAM SCHIERBROCK
563-333-8155
William.Schierbrock@midamerican.com
- MIDAMERICAN ENERGY COMPANY (Gas)
TYLER AHLQUIST
712-277-7832
tjalquist@midamerican.com
- MIDAMERICAN ENERGY COMPANY (Fiber)
BRIAN RECKER
515-242-4377
Brian.Recker@midamerican.com
- F03 - SPRINT-TMOBILE (Fiber Transmission)
MIKE CHEBUL
402-522-2607
michael.j.chebul@t-mobile.com

PLAN VIEW COLOR LEGEND OF PLAN AND PROFILE SHEETS

LINEWORK		Design Color No.	
Green	(2)		Existing Topographic Features and Labels
Blue	(1)		Proposed Alignment, Stationing, Tic Marks, and Alignment Annotation
Magenta	(5)		Existing Utilities
SHADING		Design Color No.	
Lavender	(9)		Temporary Pavement Shading
Yellow	(4)		Proposed Pavement Shading
Orange	(6)		Proposed Granular Shading
Orange	(70)		Proposed Shoulder Granular Shading
Yellow	(68)		Proposed Shoulder Paved Full Depth Shading
Yellow	(132)		Proposed Shoulder Paved Partial Depth Shading
Gray, Dark	(112)		Proposed Grade and Pave Shading "In conjunction with a paving project"
Brown, Light	(236)		Grading Shading
Orange, Light	(134)		Proposed Granular Entrance Shading
Yellow	(220)		Proposed Paved Entrance Shading
Tan	(8)		Proposed Sidewalk Shading
Blue, Light	(230)		Proposed Sidewalk Landing Shading
Pink	(11)		Proposed Sidewalk Ramp Shading
Green, Light	(225)		Existing Pavement Shading
Red	(3)		Proposed Structure Shading
Red	(3)		Delineates Restricted Areas

PROFILE VIEW COLOR LEGEND OF PLAN AND PROFILE SHEETS

LINEWORK		Design Color No.	
Green	(10)		Existing Ground Line Profile
Blue	(1)		Proposed Profile and Annotation
Magenta	(5)		Existing Utilities
Blue, Light	(230)		Proposed Ditch Grades, Left
Black	(0)		Proposed Ditch Grades, Median
Rust	(14)		Proposed Ditch Grades, Right

- | | | | |
|--|-----------------------------|--|--------------------------|
| | Reference Point | | Survey Line |
| | Station | | Section Corner |
| | Ground Line Intercept | | Saw Cut |
| | Guardrail | | Trench Drain |
| | HighTension Cable Guardrail | | Sheet Pile |
| | Pavement Removal | | Clearing & Grubbing Area |

RIGHT-OF-WAY LEGEND

-
-
-
-
-
-
-
-

PLAN AND PROFILE LEGEND AND SYMBOL INFORMATION SHEET

(COVERS SHEET SERIES U)

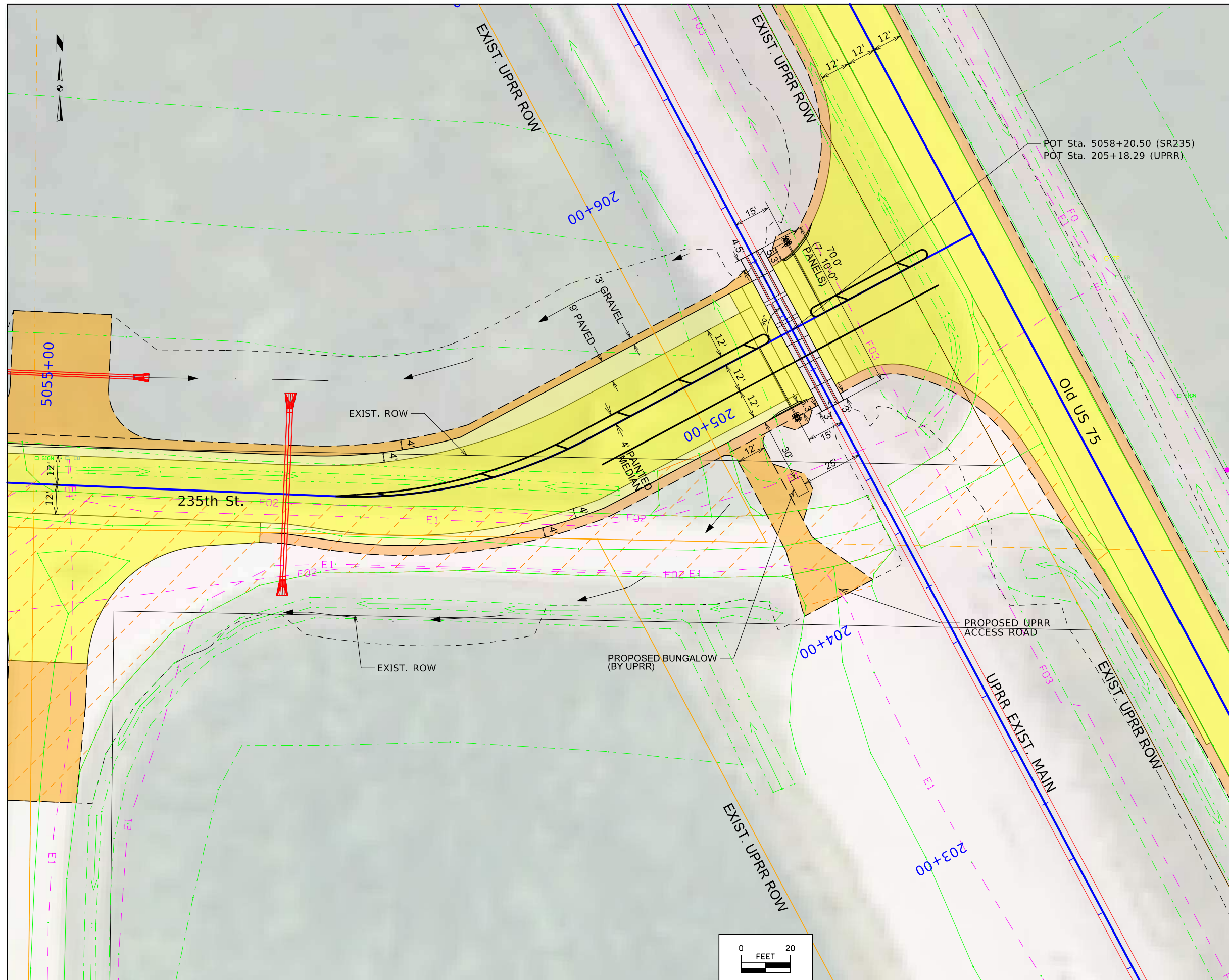

CONSTRUCTION NOTES

1. ALL SIGNING, PAVEMENT MARKINGS, AND WARNING DEVICES SHALL BE CONSTRUCTED / INSTALLED IN ACCORDANCE WITH THE LATEST EDITION OF THE MANUAL OF UNIFORM TRAFFIC CONTROL DEVICES (MUTCD) AND STATE HIGHWAY STANDARDS.
2. FULL ROAD CLOSURE WITH DETOUR IS PLANNED TO COMPLETE ROADWAY WORK.

UPRR

1. EXISTING AT-GRADE CROSSING TO REMAIN IN SERVICE DURING CONSTRUCTION.
2. UPRR TO PERFORM TRACK WORK AND INSTALL NEW CONCRETE PANELS, WARNING DEVICES AND BUNGALOW.
3. AFTER PROPOSED ROADWAY CONSTRUCTION AND CUT OVER, UPRR SHALL REMOVE EXISTING CROSSING PANELS, ROADWAY SURFACE AND PASSIVE WARNING DEVICES TO BE DISPOSED BY IOWA DOT CONTRACTOR.

CONTRACTOR

1. CONSTRUCT PROPOSED ROADWAY ADJACENT TO PROPOSED UPRR WORK LIMITS.
2. CONSTRUCT PROPOSED ACCESS ROAD AND BUNGALOW PAD.
3. AFTER PROPOSED ROADWAY CONSTRUCTION AND CUT OVER, REMOVE EXISTING ROADWAY APPROACHES AND PERFORM NECESSARY GRADING ALONG UPRR ROW.

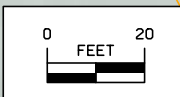

MP 65.38 SIOUX CITY SUBDIVISION
 SERGEANT BLUFF, IA (WOODBURY COUNTY)
 I-29 / 235TH ST. INTERCHANGE
PROPOSED UPRR CROSSING DETAIL
 235TH STREET PLAN

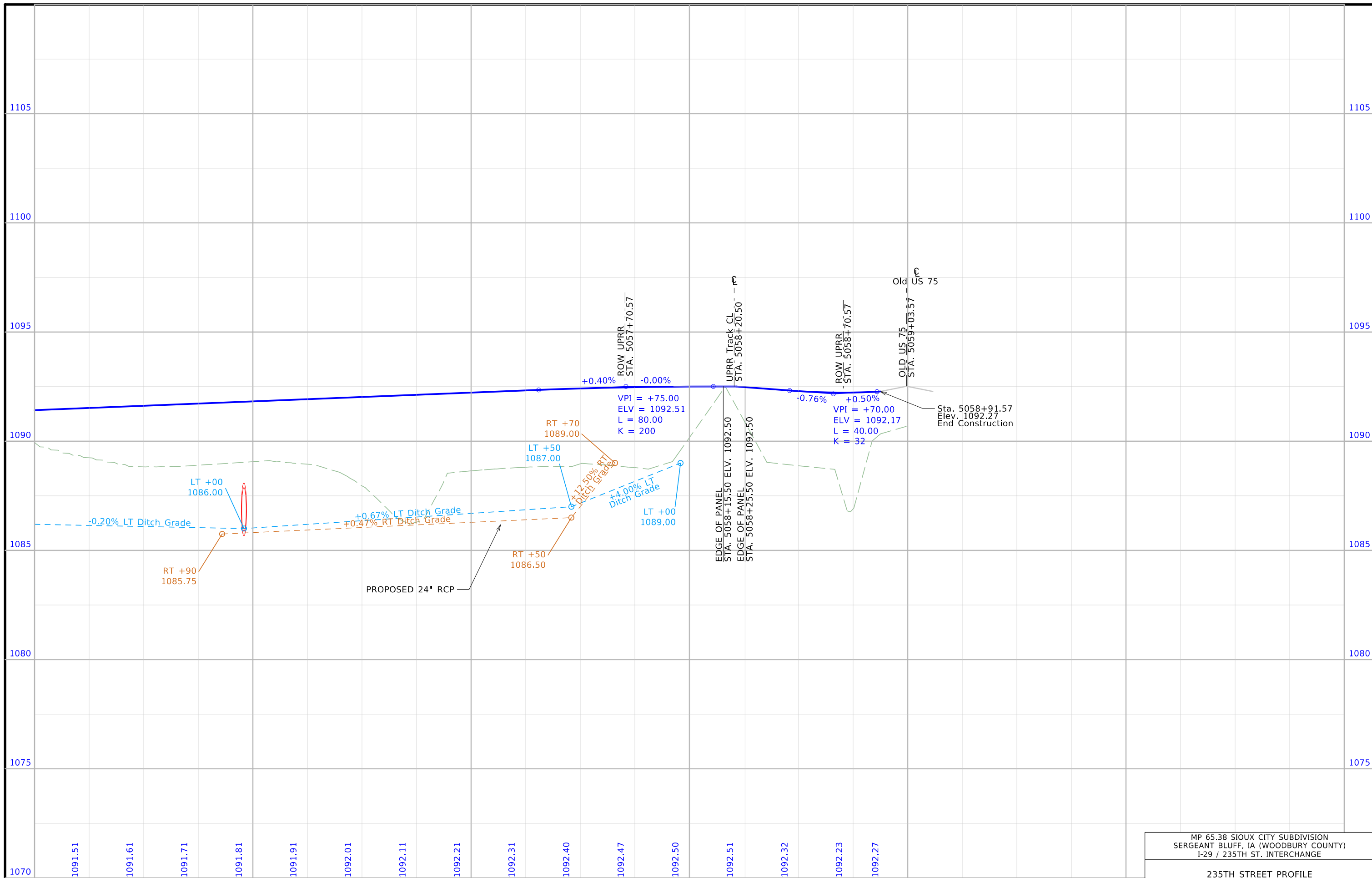

MP 65.38 SIOUX CITY SUBDIVISION SERGEANT BLUFF, IA (WOODBURY COUNTY) I-29 / 235TH ST. INTERCHANGE	
235TH STREET PROFILE	
FILE NO.	SHEET NUMBER U.3

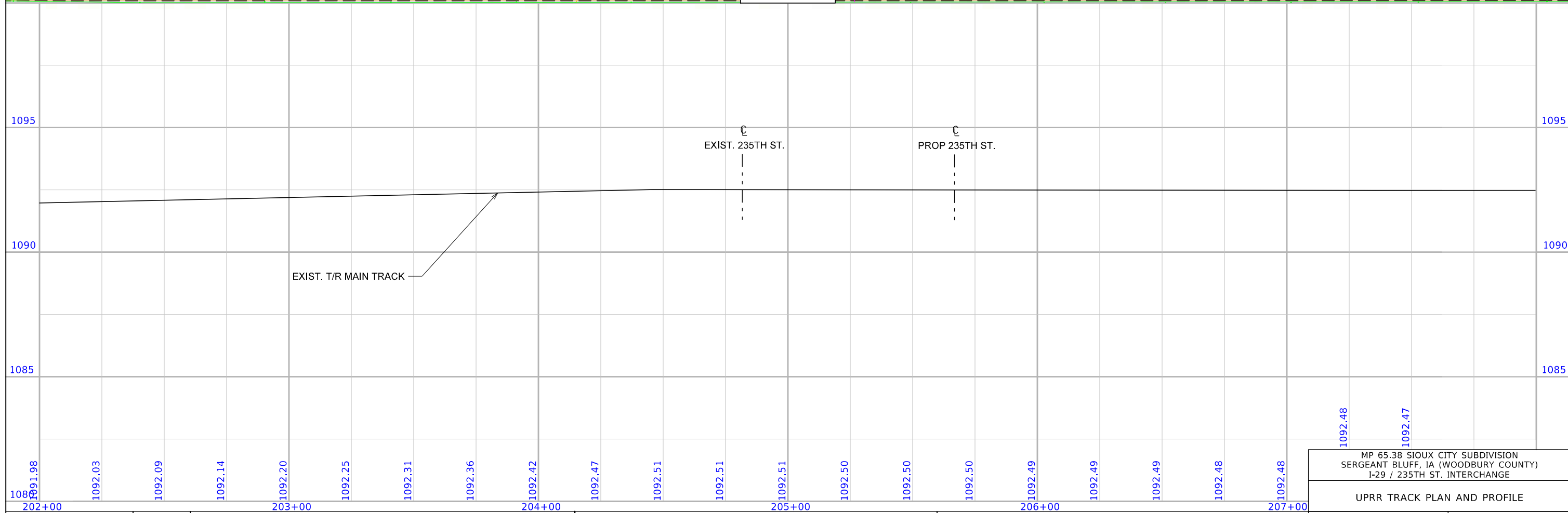
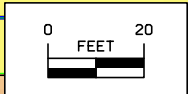
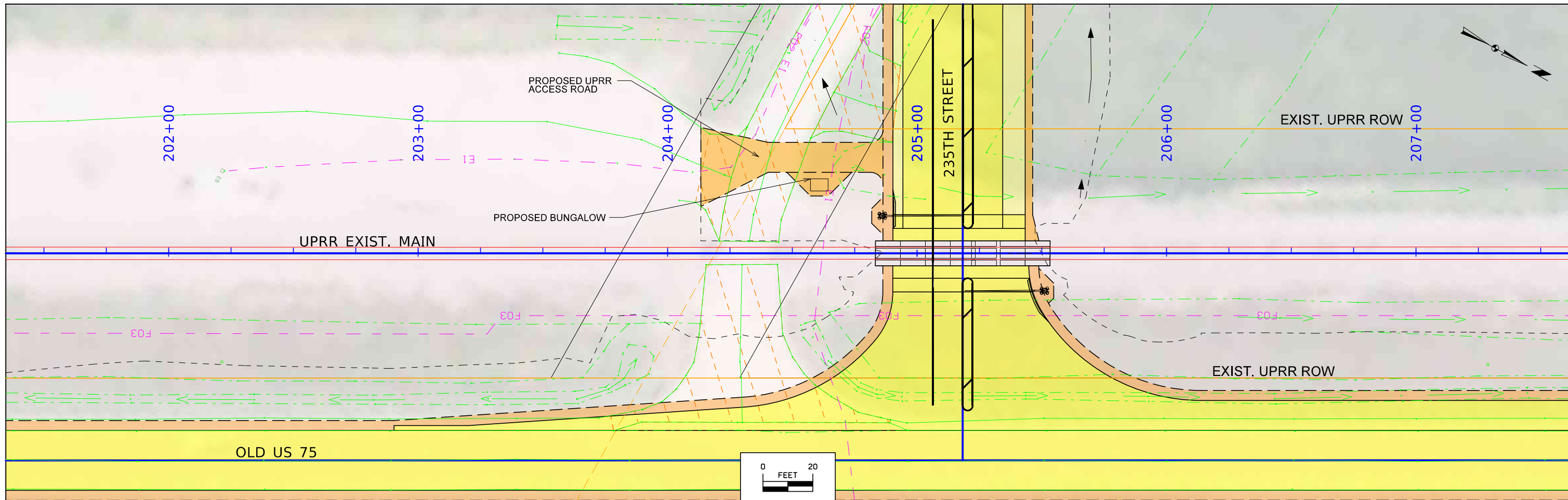

MP 65.38 SIOUX CITY SUBDIVISION
 SERGEANT BLUFF, IA (WOODBURY COUNTY)
 I-29 / 235TH ST. INTERCHANGE

UPRR TRACK PLAN AND PROFILE

SHEET NUMBER U.4

1091.92

Control Point 97K25023: N 8542503.05, E 14089982.04; CP FENO Monument set in N edge of field entrance on east side K25 approx. 450 ft. S. Intersection K25 and 235th St. Elev. 1091.12

- ① EW-204 Grading
- ② Minimum vertical clearance = 17.20'
- ③ Minimum vertical clearance = 17.07'
- ④ Grading Surface
- ⑤ Frame Pier
- ⑥ Proposed 24 in. RCP Culvert
- ⑦ Macadam Stone Slope Protection (Embedded)

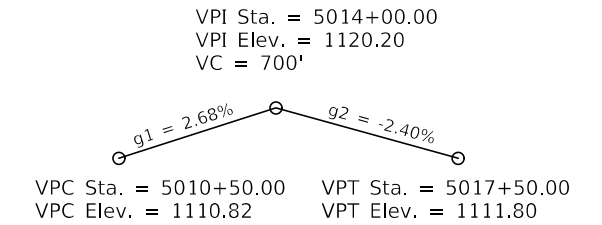
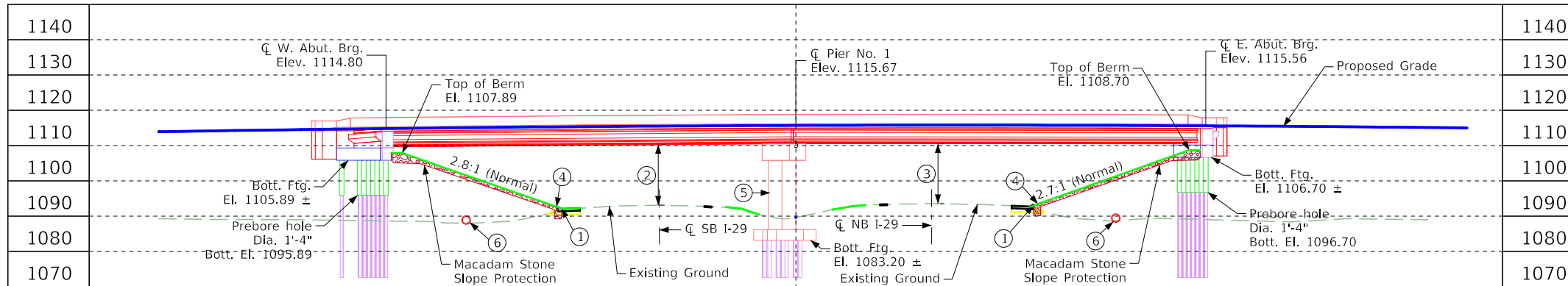

Longitudinal Section Along Centerline of 235th Street

Minimum Vertical Clearance

Proposed Profile Grade 235th St.

Note:
Top of bridge deck at centerline roadway is 0.03' below the profile grade to account for parabolic crown. Profile grade line (PGL) is at centerline.

- Design Notes**
1. TSS TL-5 Bridge Railing Proposed
 2. Frame Type Pier Proposed assumed 4'-0" column width, pier type may change in final design
 3. BTC Beams Proposed
 4. Pier 1 is located within the acceptable clear zone of 30 feet. Collision requirement shall be evaluated during final design.
 5. 2-Span Grading Shown (see EW 204 - 5' offset)
 6. Superstructure and substructure shall be designed to accommodate future freight loads.
 7. Review need for temporary shoring in median during final design.

SB I-29

NB I-29

Traffic Estimate

Overhead Station = 5013+28.81, 26.08' LT.
Overhead Elevation = 1114.95
Depth of Superstructure = 4.63'
Underpass Station = 1639+11.92, 37' LT.
Underpass Elevation = 1093.12
Minimum Vertical Clearance = 17.20'

Overhead Station = 5014+05.42, 26.08' LT.
Overhead Elevation = 1115.24
Depth of Superstructure = 4.63'
Underpass Station = 1638+92.09, 37' RT.
Underpass Elevation = 1093.54
Minimum Vertical Clearance = 17.07'

I-29	
2022 AADT	20600 V.P.D.
2050 AADT	31,400 V.P.D.
20-- DHV	- V.P.H.
TRUCKS	26.1 %
Total Design ESALS	-

Utilities Note:

Utilities shown on this sheet are for information only. See Road Design sheets for utility information.

General Utility Symbols:

- E - Electric Line
- G - Gas Line
- SAN. - Sanitary Sewer
- T - Telephone Line
- W - Water Line
- FO - Fiber Optic Line
- GHP - Gas High Pressure
- ST S - Storm Sewer
- TV - TV
- Power Poles

Traffic Estimate

235th Street	
2019 AADT	100 V.P.D.
2050 AADT	4490 V.P.D.
20-- DHV	- V.P.H.
TRUCKS	- %
Total Design ESALS	-

Location

235th Street over I-29
T-87N R-47W
Section 8
Liberty Township
Woodbury County
FHWA No. 701220
Latitude 42.364207°
Longitude -96.345550°

PRELIMINARY

Design For 15° Skew (R.A.)
232'-0" x 56'-0" Pretensioned Prestressed Conc. Beam Bridge
116'-0" End Spans BTC Beams

Situation Plan
STA. 5013+74.10 (235th St.) Turn-in Date: Nov 2023

Woodbury County
IOWA DEPARTMENT OF TRANSPORTATION
Design No. 626 Design Sheet No. 1 of 2 FHWA No. 701220

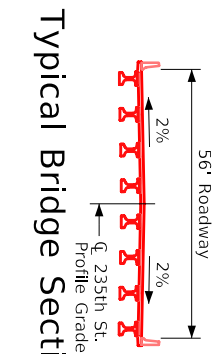
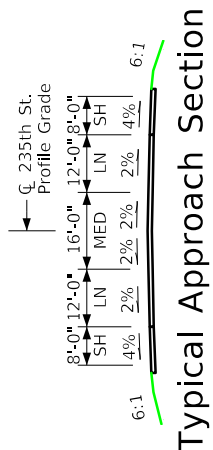
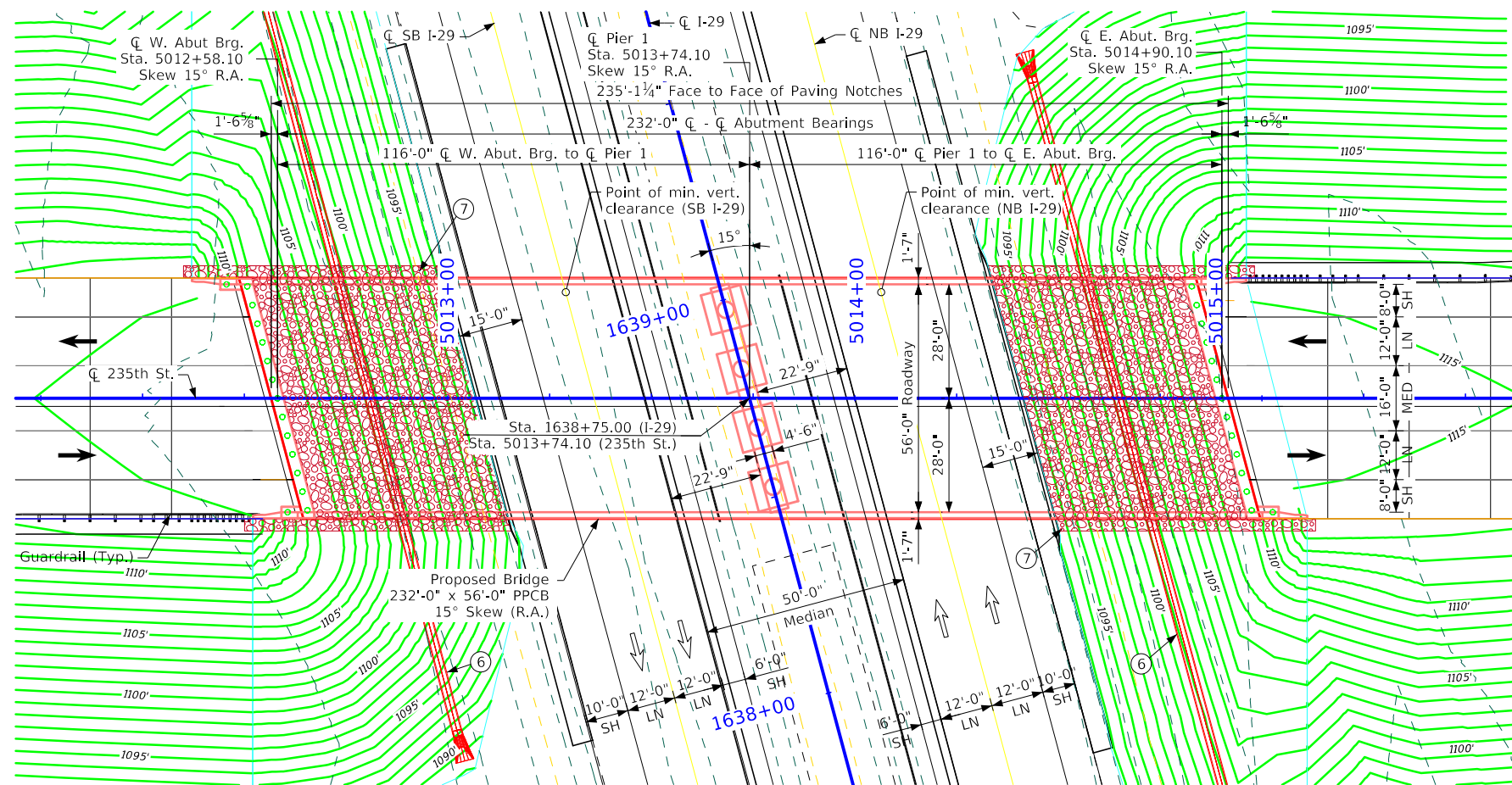

Situation Plan

Control Point 97K25023: N 8542503.05, E 14089982.04; CP FENO Monument set in N edge of field entrance on east side K25 approx. 450 ft. S. Intersection K25 and 235th St. Elev. 1091.12

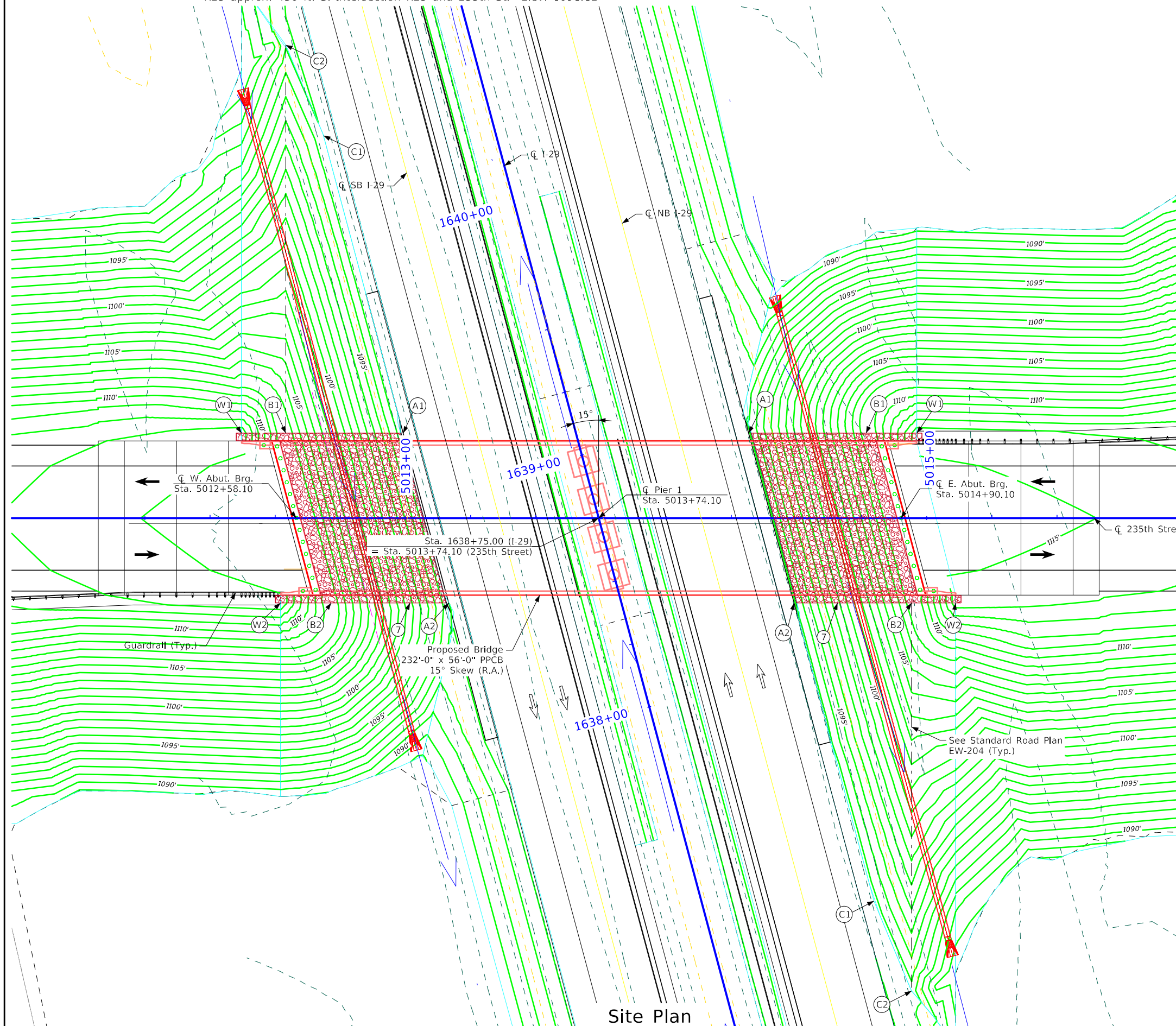

⑦ Macadam Stone Slope Protection

Berm Slope Location Table

Points	West Abutment			East Abutment		
	Station	Offset	Elev.	Station	Offset	Elev.
A1	5012+99.11	32.58' Lt.	1092.08	5014+31.62	32.58' Lt.	1092.71
A2	5013+16.57	32.58' Rt.	1092.05	5014+49.08	32.58' Rt.	1092.77
B1	5012+54.02	32.58' Lt.	1107.89	5014+76.71	32.58' Lt.	1108.70
B2	5012+71.49	32.58' Rt.	1107.89	5014+94.17	32.58' Rt.	1108.70
W1	5012+37.10	32.58' Lt.	1113.85	5014+96.10	32.58' Lt.	1114.84
W2	5012+52.10	32.58' Rt.	1114.04	5015+11.10	32.58' Rt.	1114.75

Berm slope elevations reflect the grading surface.

Recoverable Berm Location Table

Points	West Abutment			East Abutment		
	Station	Offset	Elev.	Station	Offset	Elev.
C1	5012+68.51	146.76' Lt.	1092.03	5014+79.76	147.06' Rt.	1092.75
C2	5012+54.02	181.52' Lt.	1091.87	5014+94.16	181.51' Rt.	1092.61
C3	5012+54.02	220.16' Lt.	1092.29	5014+94.16	219.95' Rt.	1093.02

Points C3 for the abutments are beyond the limits of this sheet. See the "Recoverable Berm Location Table" for their locations, offsets and elevations.

Design Notes

1. TL-5 Bridge Railing Proposed
2. Frame Type Pier Proposed
3. BTC Beams Proposed
4. Pier 1 is located within the acceptable clear zone of 30 feet.
5. 2-Span Grading Shown (see EW 204 - 5' offset)
6. Superstructure and substructure shall be designed to accommodate future freight loads.
7. Review need for temporary shoring in median during final design.

PRELIMINARY

Design For 15° Skew (R.A.)
**232'-0" x 56'-0" Prestressed
 Conc. Beam Bridge**
 116'-0" End Spans BTC Beams
Situation Plan - Site
 STA. 5013+74.10 (235th St.) Turn-in Date: Nov 2023
Woodbury County
 IOWA DEPARTMENT OF TRANSPORTATION
 Design No. 626 Design Sheet No. 2 of 2 FHWA No. 701220

Site Plan

Remove existing apron and lay 10ft of 24" RCP and place DR-201 outlet apron and a DR-122 pipe connection. Install culvert extension and apron during Stage 2.

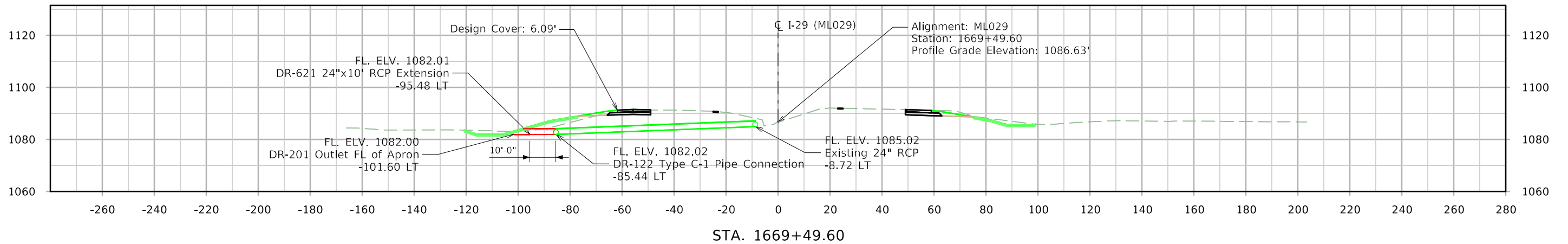

Remove existing apron both ends. Left end lay 7ft of 30" RCP, place DR-201 outlet apron. Right end lay 14ft of 30" RCP, place DR-201 inlet apron. Install both culvert extensions and aprons during Stage 2.

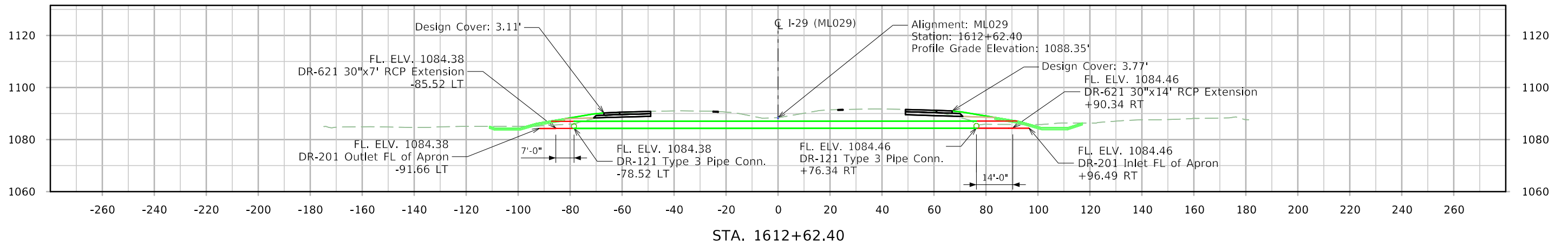

235th Street

Lay 250ft 24" RCP with DR-201 apron on Inlet and DR-201 on outlet. Skew RT ahead 15 degrees. Install culvert and aprons during Stage 1.

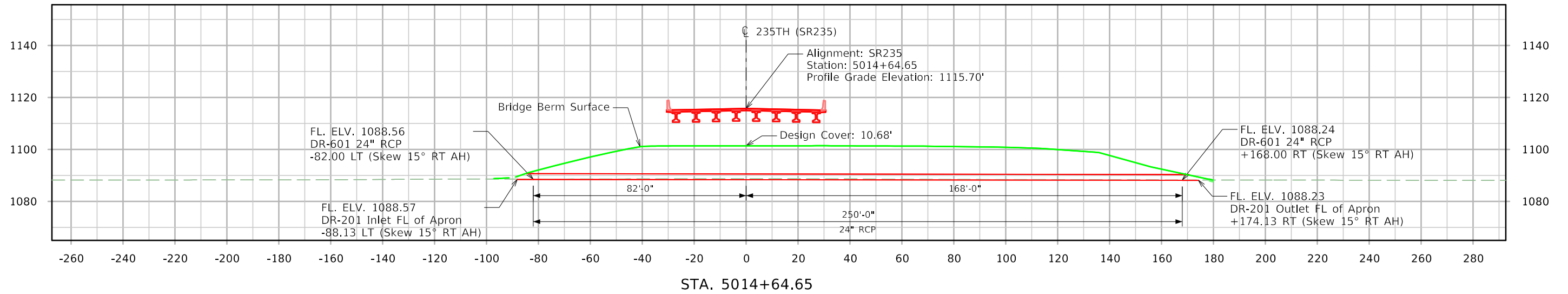

Lay 250ft 24" RCP with DR-201 apron on Inlet and DR-201 on outlet. Skew RT ahead 15 degrees. Install culvert and aprons during Stage 1.

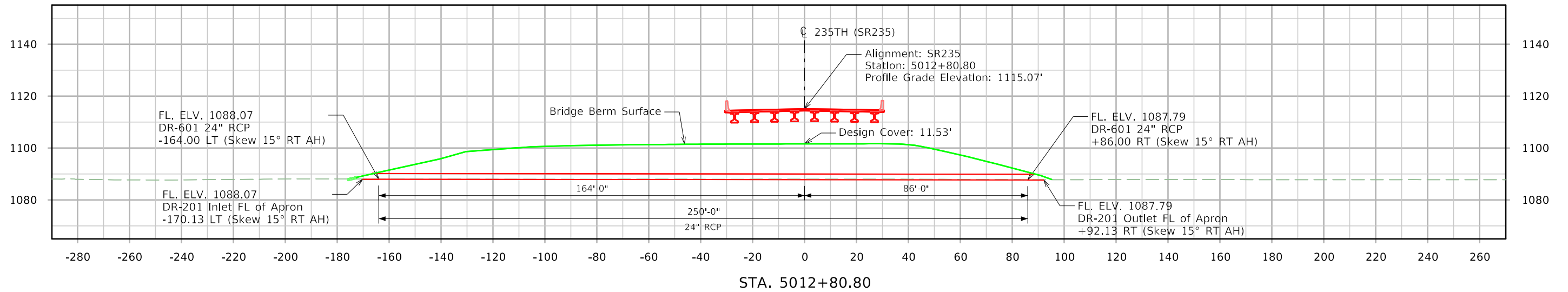

Lay 87ft 24" 3750D RCP with DR-201 apron on Inlet and DR-201 on outlet. Install culvert and aprons during Stage 1.

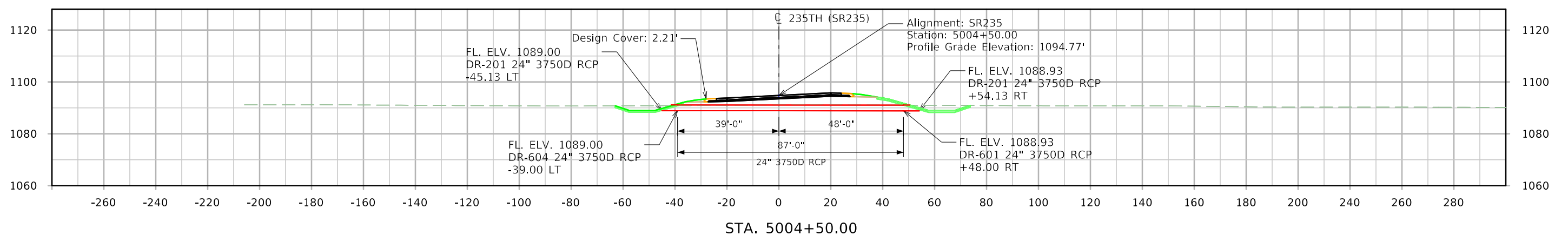

235th Street

Lay 70ft 24" 3750D RCP with DR-201 apron on Inlet and DR-201 on outlet. Install culvert and aprons during Stage 2.

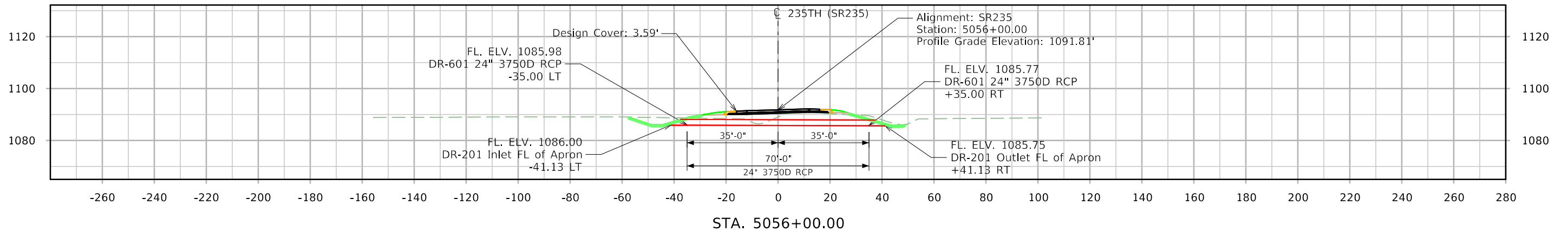

Lay 73ft 24" 3750D RCP with DR-201 apron on Inlet and DR-201 on outlet. Install culvert and aprons during Stage 1.

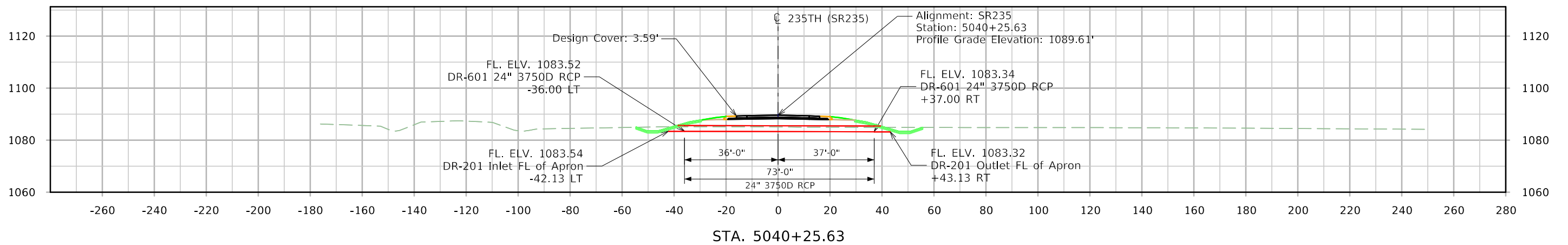

Lay 81ft 24" 3750D RCP with DR-201 apron on Inlet and DR-201 on outlet. Install culvert and aprons during Stage 1.

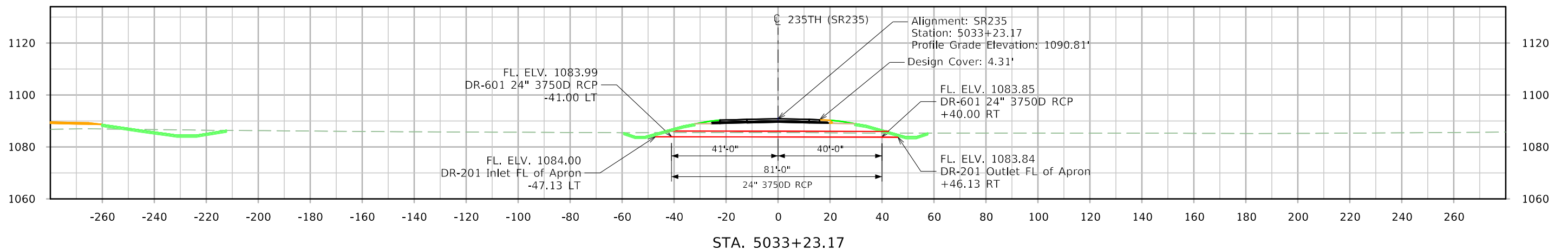

235th Street Field Entrances

Lay 58ft 18" RCP with DR-201 apron on Inlet and DR-201 apron on Outlet. Install culvert and aprons during Stage 1. Offsets labeled in cross section are measured from CL of field entrance along culvert alignment.

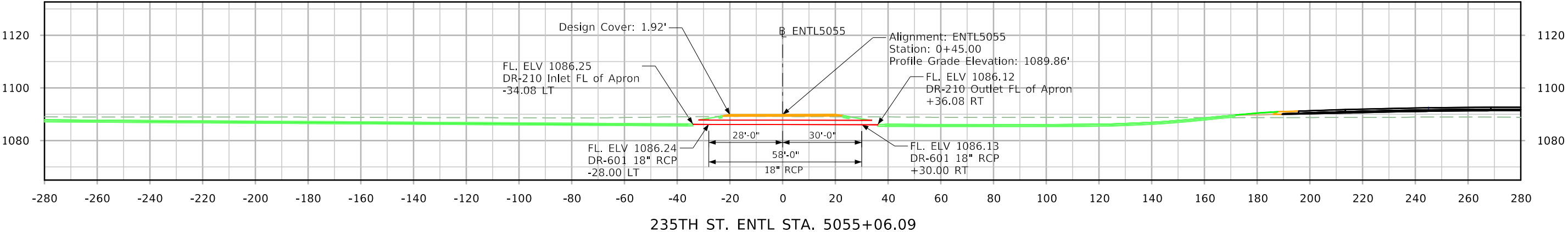

Lay 58ft 18" RCP with DR-201 apron on Inlet and DR-201 apron on Outlet. Install culvert and aprons during Stage 1. Offsets labeled in cross section are measured from CL of field entrance along culvert alignment.

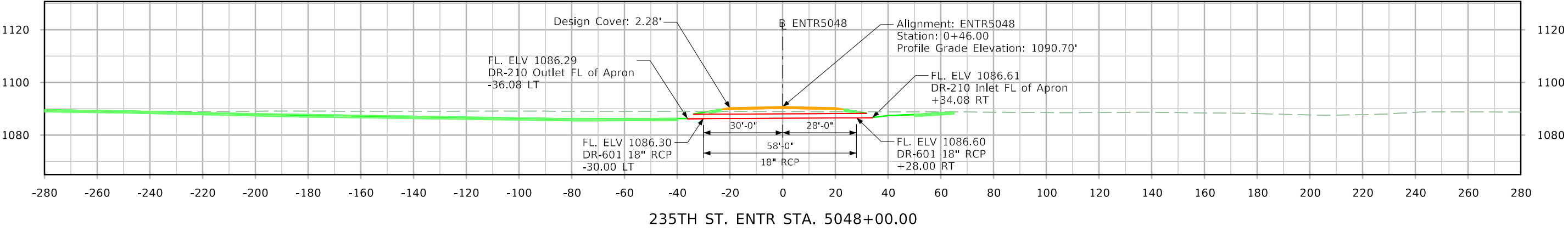

Lay 87ft 18" RCP with DR-201 apron on Inlet and DR-201 apron on Outlet. Install culvert and aprons during Stage 1. Offsets labeled in cross section are measured from CL of field entrance along culvert alignment.

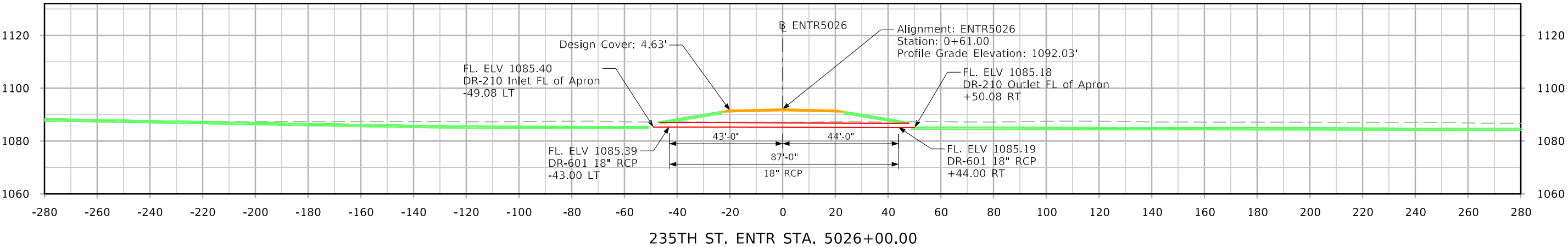

Banner Avenue Field Entrances

Lay 46ft 18" RCP with DR-201 apron on Inlet and DR-201 apron on Outlet. Install culvert and aprons during Stage 1. Offsets labeled in cross section are measured from CL of field entrance along culvert alignment.

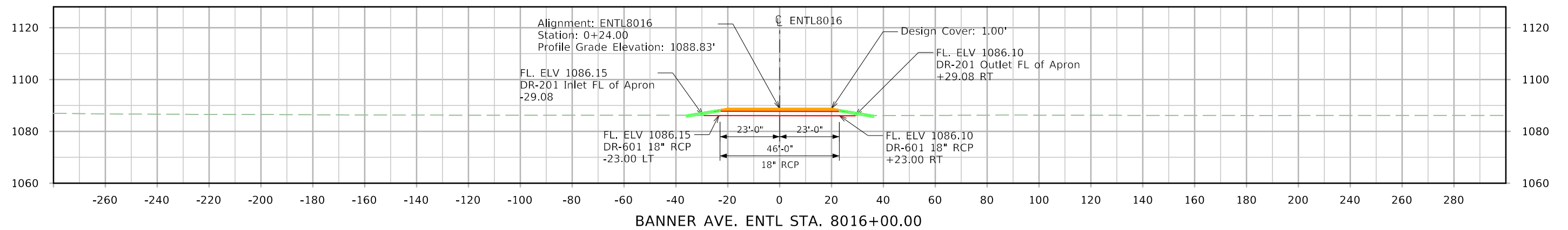

Lay 52ft 18" RCP with DR-201 apron on Inlet and DR-201 apron on Outlet. Install culvert and aprons during Stage 1. Offsets labeled in cross section are measured from CL of field entrance along culvert alignment.

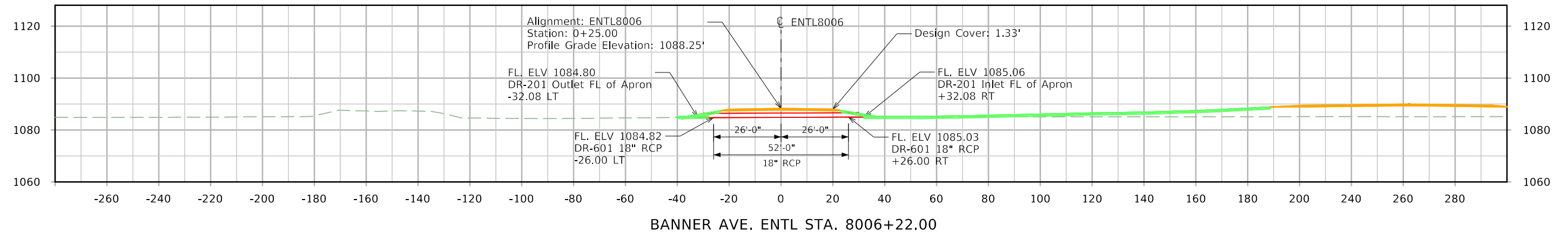

I-29 Ramp A

Lay 80ft 24" 3750 RCP with DR-201 apron on Inlet and DR-201 on outlet. Install culvert and aprons during Stage 1.

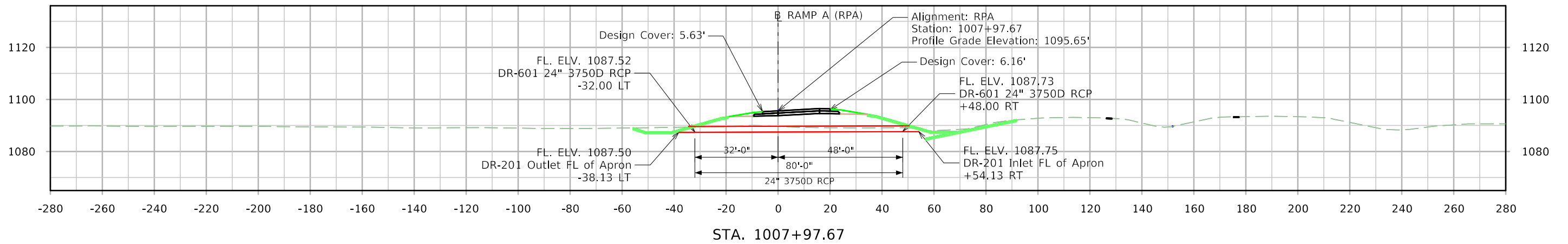

I-29 Ramp B

Lay 71ft 24" 3750 RCP with DR-201 apron on Inlet and DR-201 on outlet. Install culvert and aprons during Stage 1.

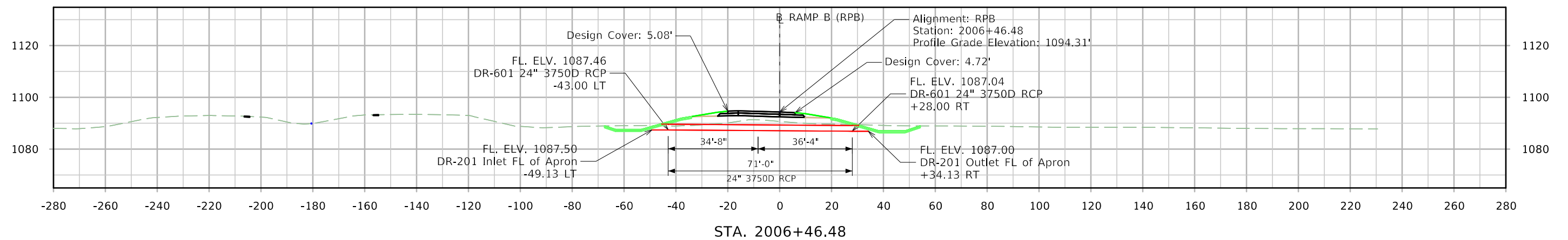

I-29 Ramp C

Lay 58ft 24" 3750 RCP with DR-201 apron on Inlet and DR-201 on outlet. Install culvert and aprons during Stage 1.

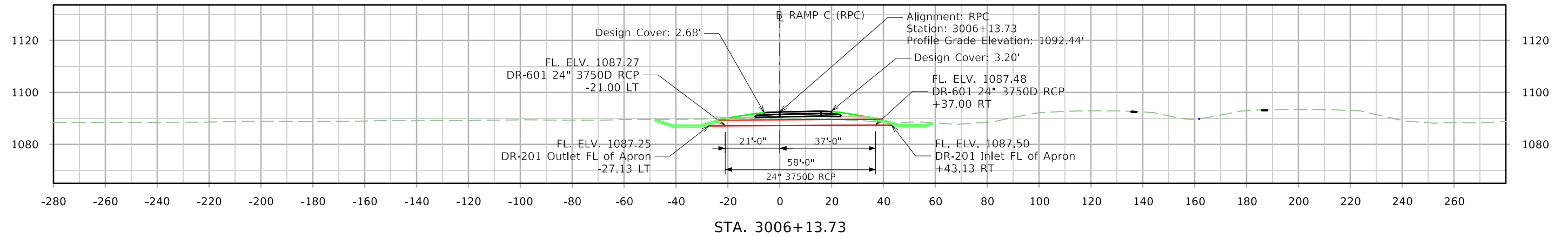

I-29 Ramp D

Lay 170ft 24" 3750 RCP with DR-201 apron on Inlet and DR-201 on outlet. Skew LT ahead 15 degrees. Install culvert and aprons during Stage 1.

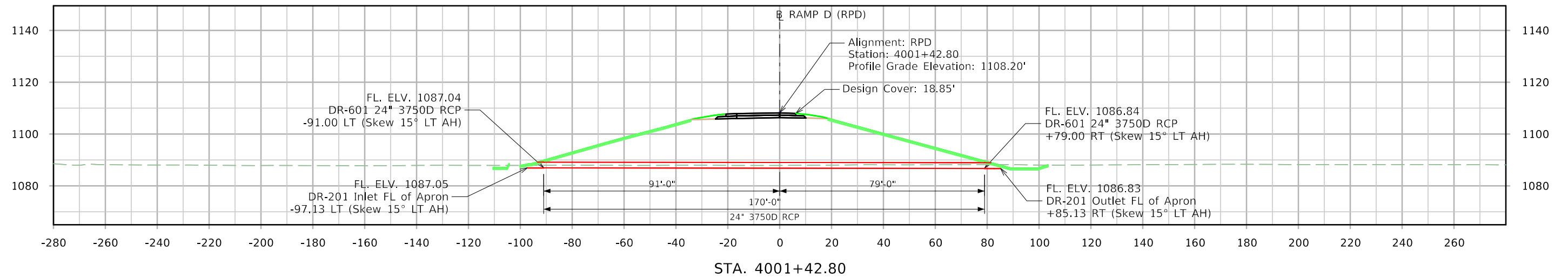

CROSS SECTION VIEW COLOR LEGEND

Design Color No.	Feature	Design Color No.	Feature
Aggregate			
(64)	Choke Stone	(112)	Noise Wall
(42)	Engineering Fabric	(112)	Noise Wall Footing
(8)	Flooded Backfill	(112)	Retaining Wall Back
(92)	Macadam Stone	(112)	Retaining Wall Back Excavate
(20)	Modified	(112)	Retaining Wall Face
(12)	Plowing Shaping	(112)	Retaining Wall Front Excavate
(14)	Porous Backfill	(112)	Retaining Wall Front Footing
(8)	Revetment Class A	(112)	Retaining Wall MSE Gutter
(6)	Revetment Class B	(112)	Retaining Wall Reinforced Earth
(62)	Revetment Class C	Grading	
(188)	Revetment Class D	(8)	Behind Curb Cut
(28)	Revetment Class E	(6)	Granular
(12)	Shoulder Special Backfill	(13)	Granular Back Fill
(12)	Special Backfill	(48)	Rock Undercut
(20)	Subbase	(8)	Shoulder Earth Fill
(20)	Subbase Lower	(2)	Side Slopes
(20)	Subbase Upper	(226)	Side Slopes Dressing
(118)	Subgrade Treatment	Substrata	
Asphalt			
(207)	HMA Base Course	(128)	Boulder Substrata
(207)	HMA Interim Course	(48)	Broken Weathered Substrata
(207)	HMA Surface Course	(3)	Core Out Substrata
Concrete			
(0)	Barrier Concrete	(203)	Existing Pavement Substrata
(0)	Barrier Concrete Footing	(6)	Loam Substrata
(0)	Curb Gutter	(80)	Rock Substrata
(48)	Flowable Mortar	(4)	Select Sand Substrata
(0)	Median Concrete	(3)	Shale Substrata
(0)	PCC Pavement	(10)	Topsoil Substrata
(0)	Sidewalk	Unsuitable / Waste	
Shoulder			
(209)	Shoulder HMA	(3)	Unsuitable Type A
(0)	Shoulder PCC	(13)	Unsuitable Type B
(6)	Shoulder Granular	(11)	Unsuitable Type C
(3)		(3)	Waste
Existing			
(0)	Existing Pavement		

NOTES:

Text

NOTES:

Text

CROSS SECTIONS LEGEND AND INFORMATION SHEET

(COVERS SHEET SERIES W, X, & Y)

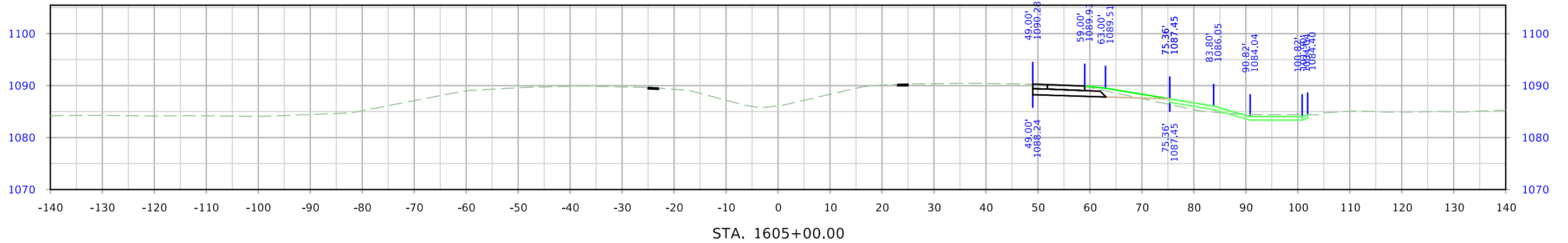
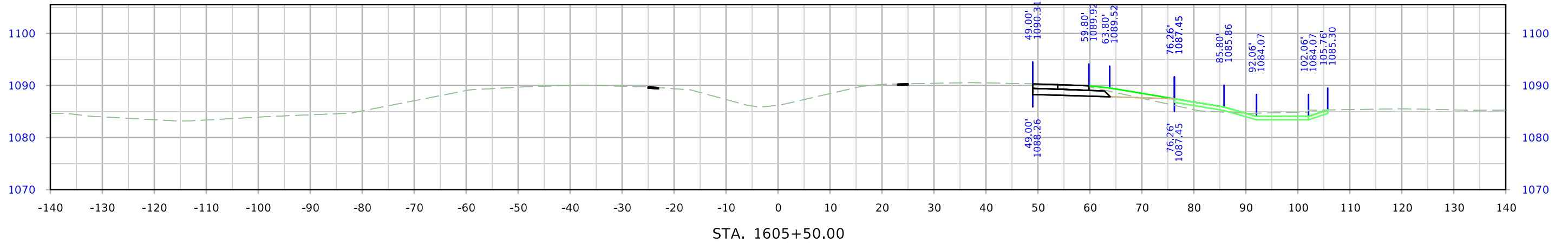
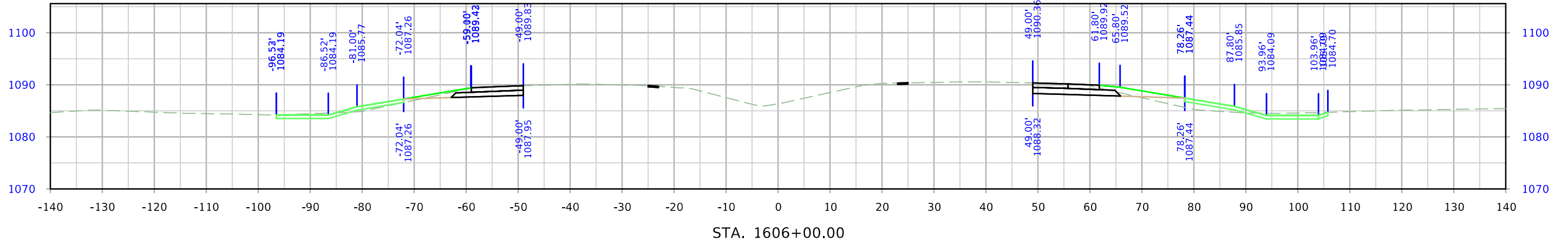

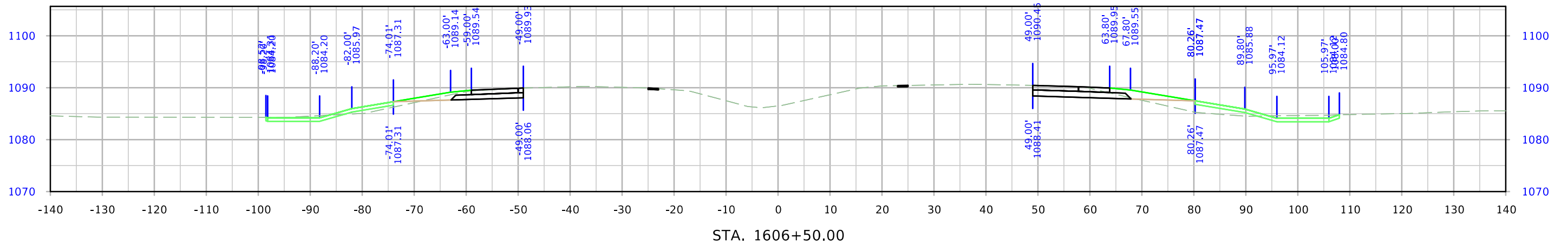
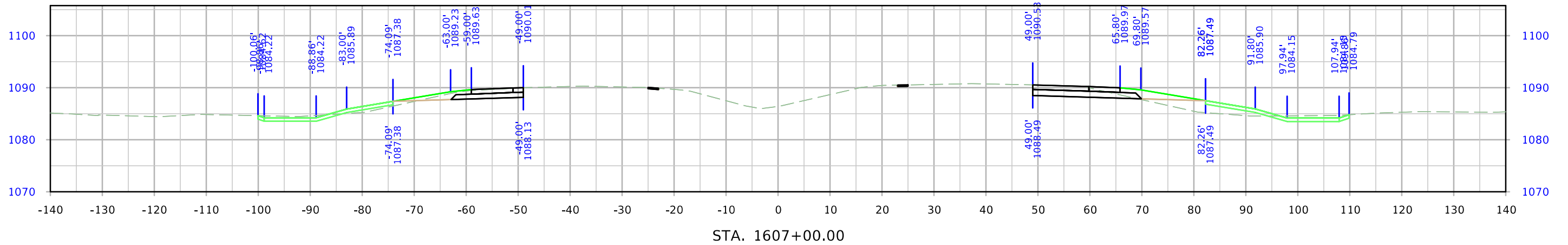
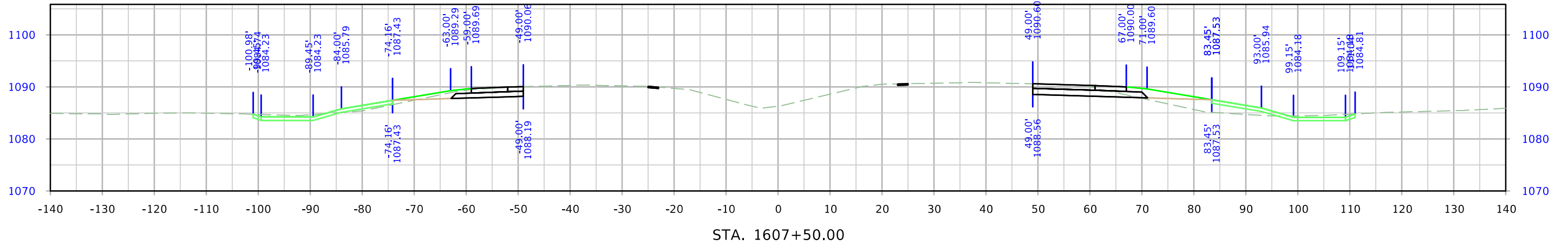

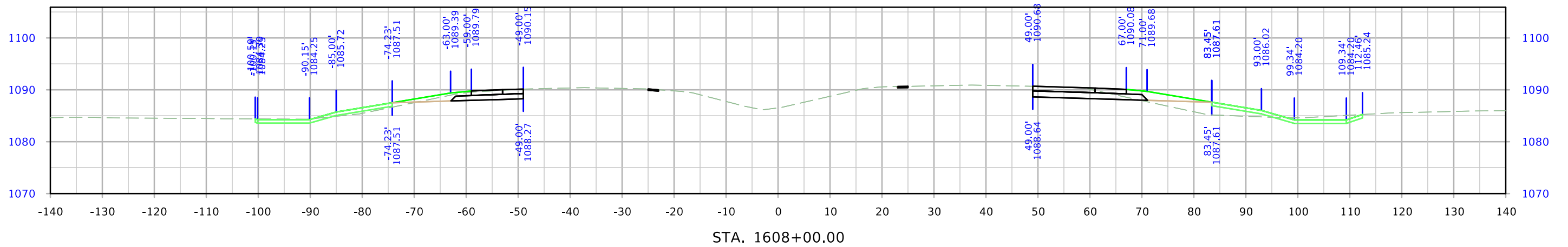
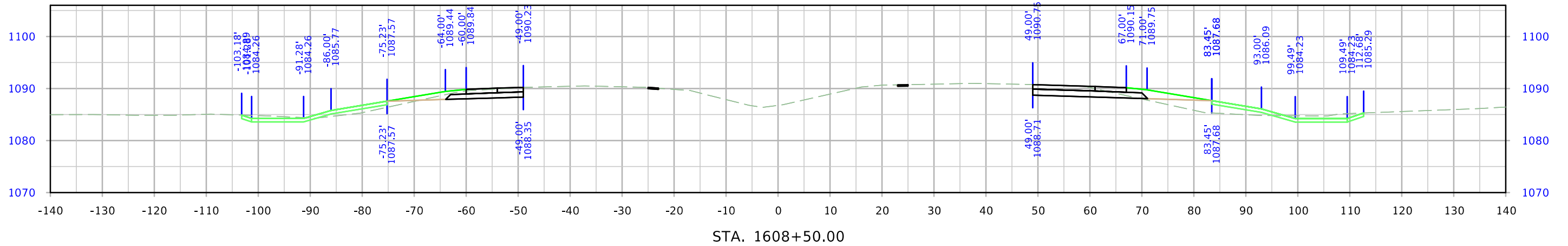
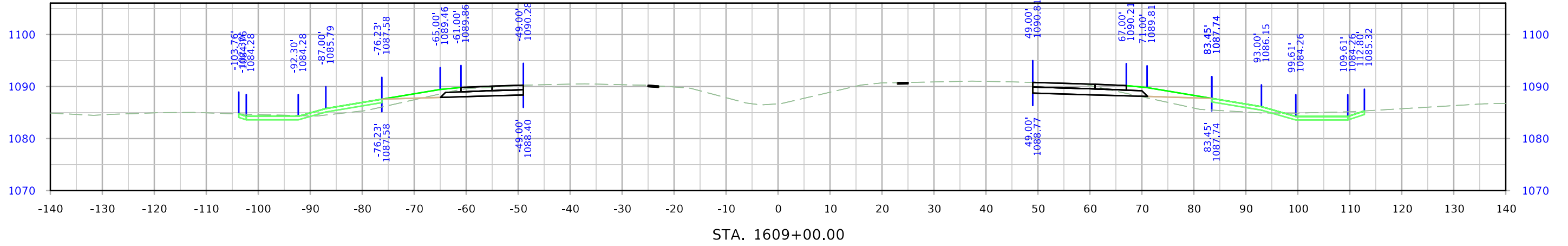

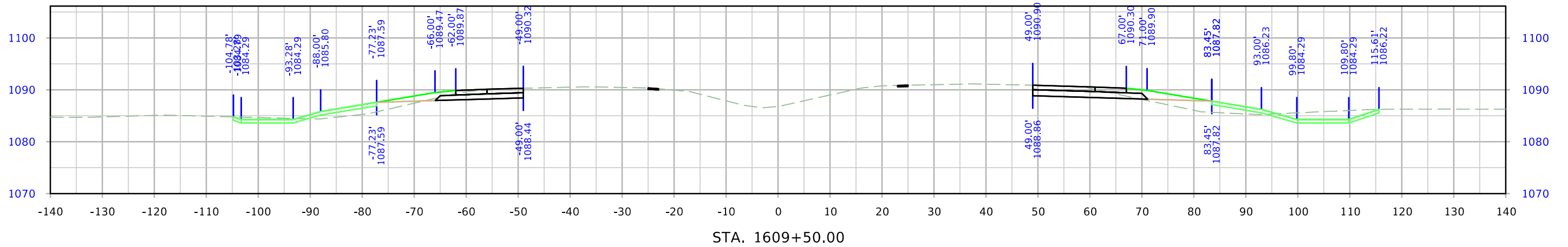
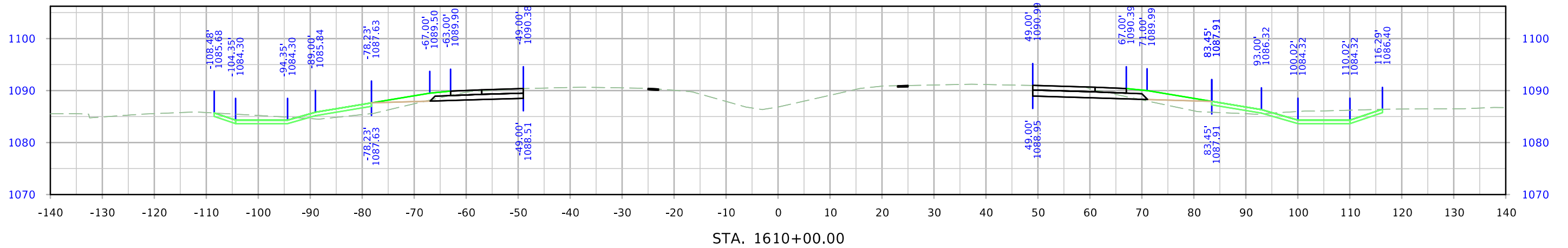
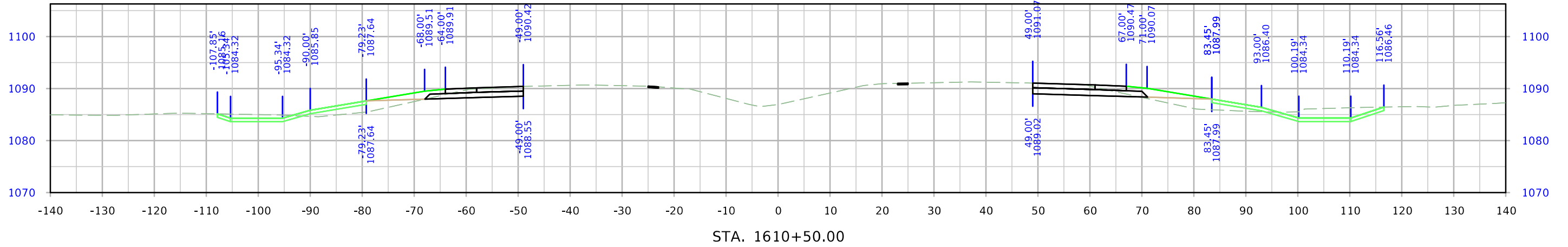

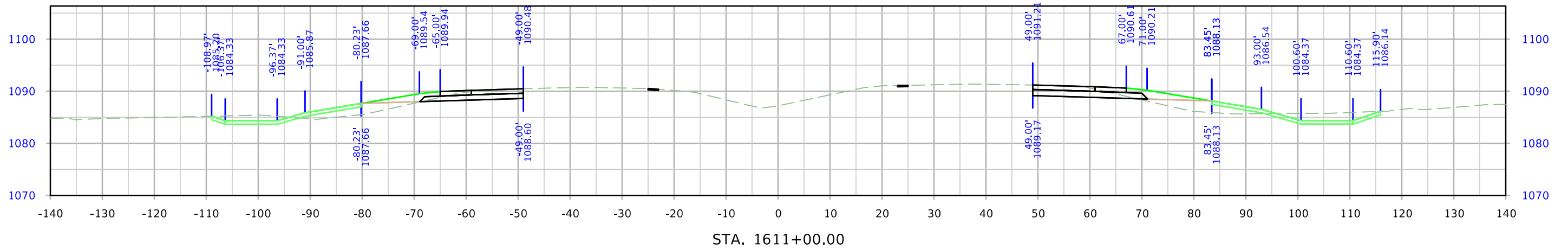
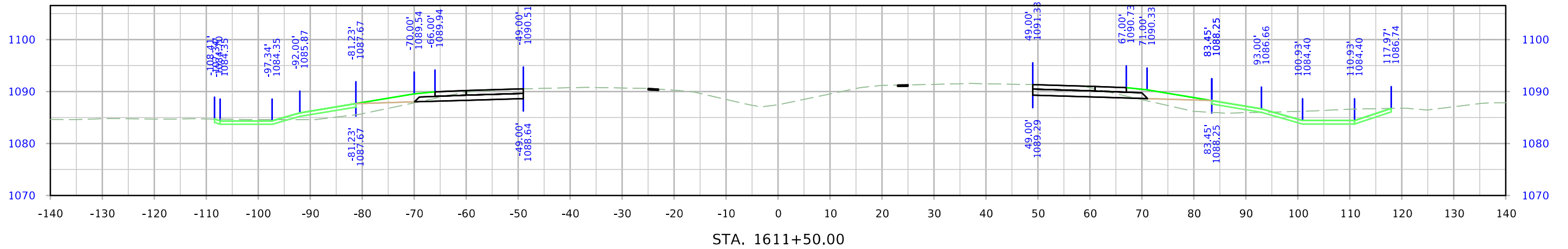
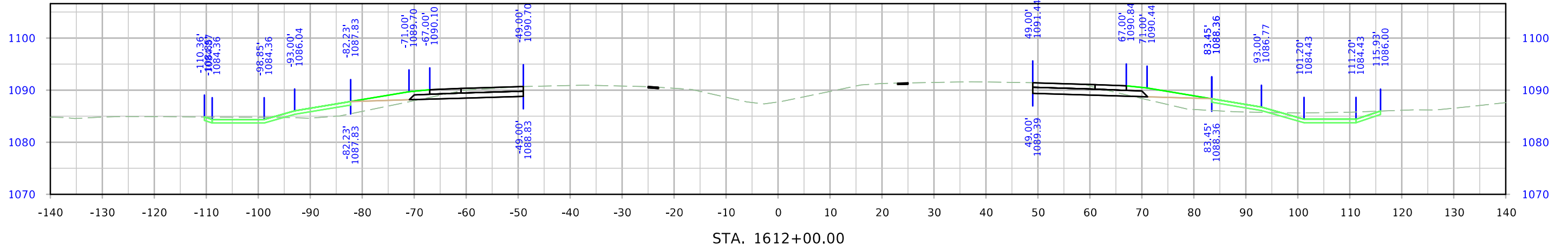

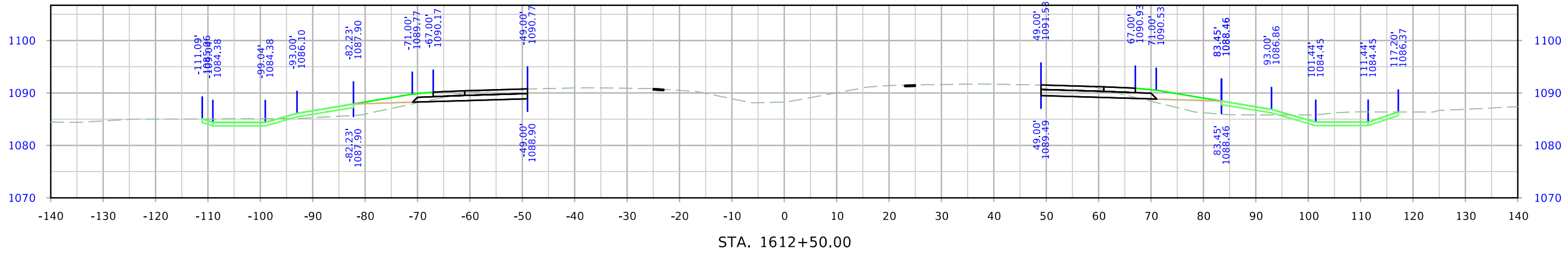
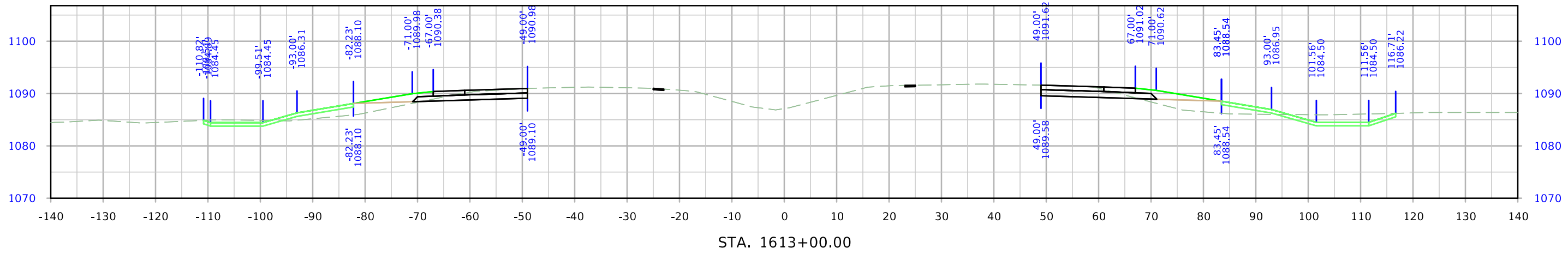
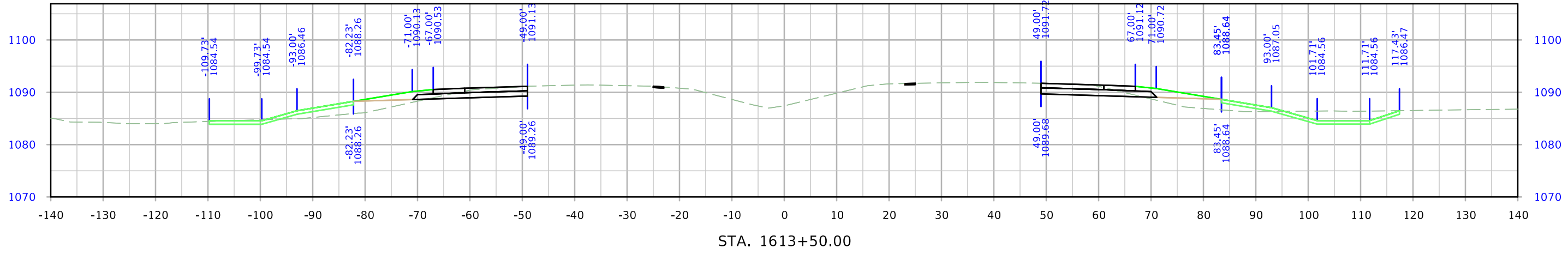

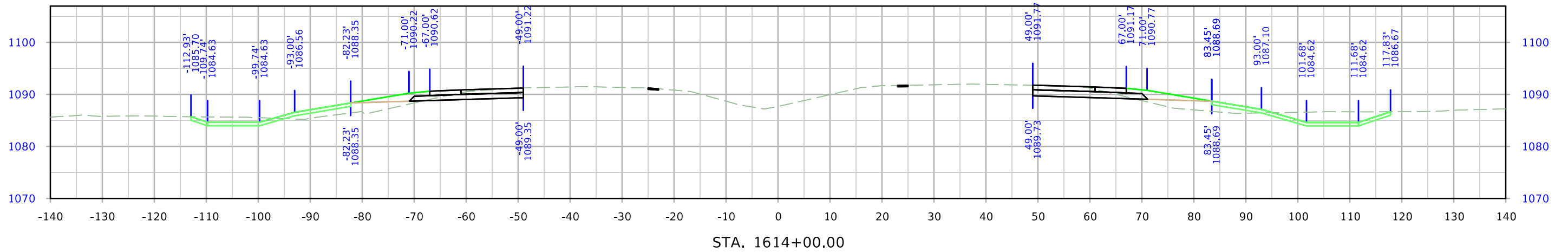
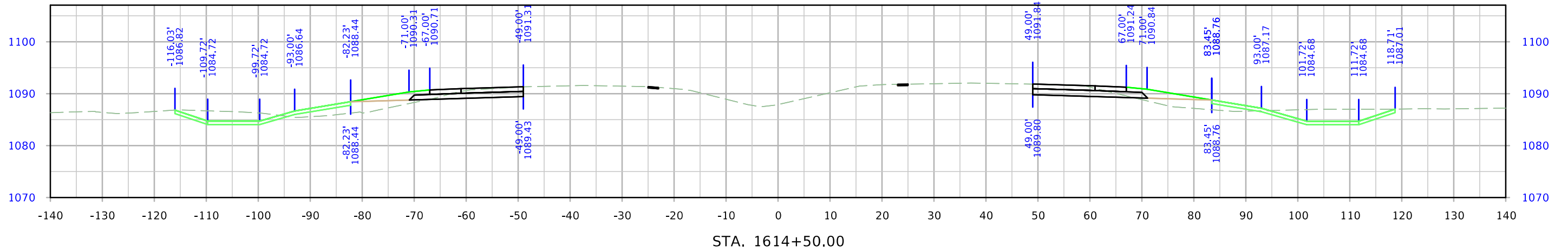
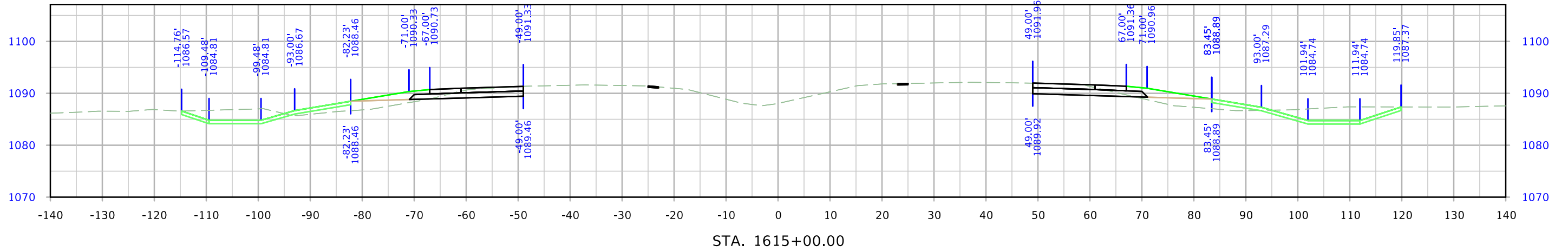

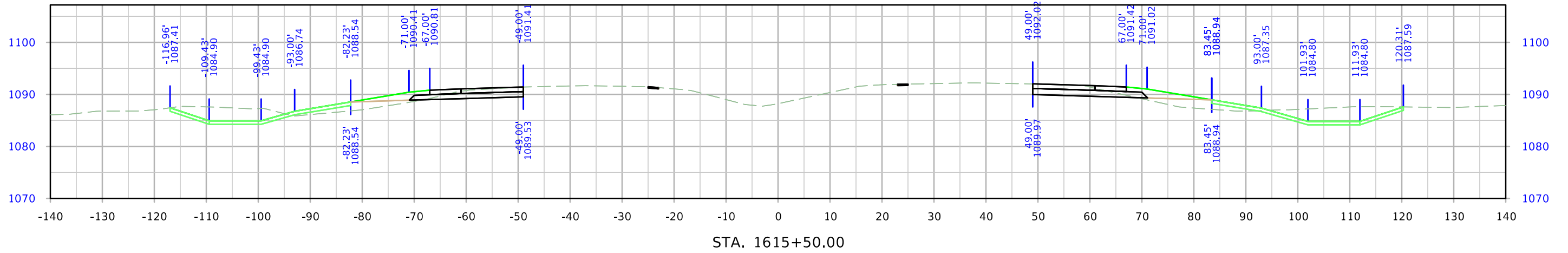
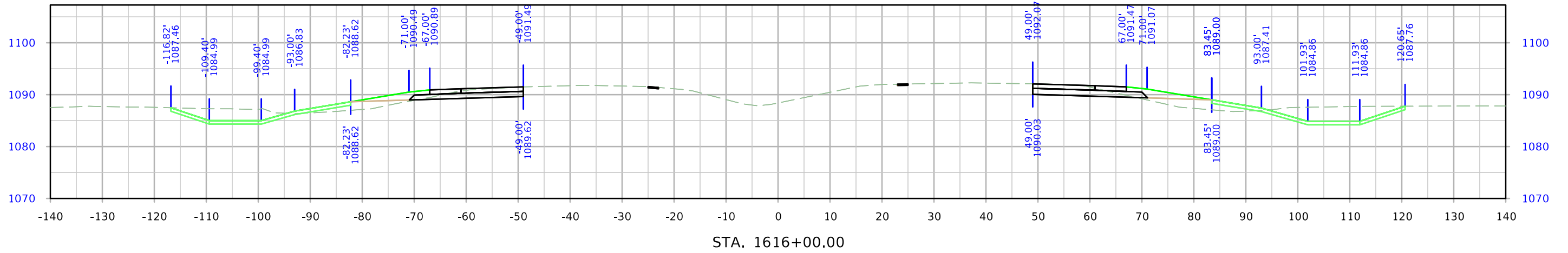
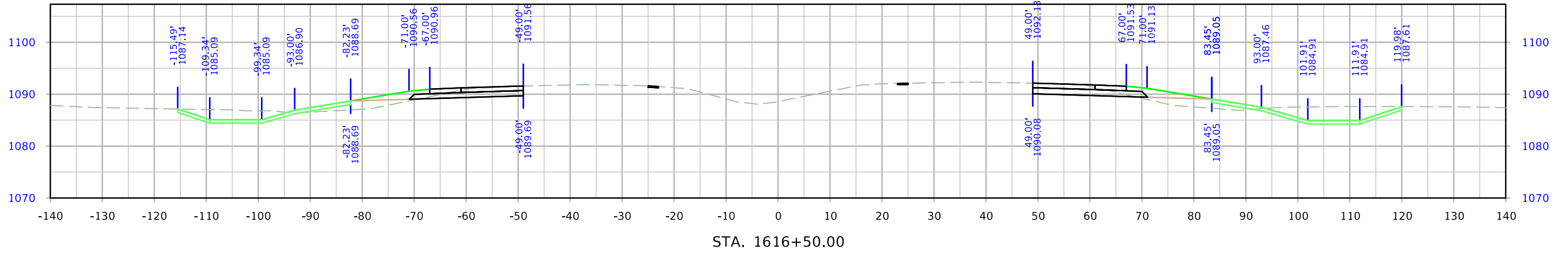

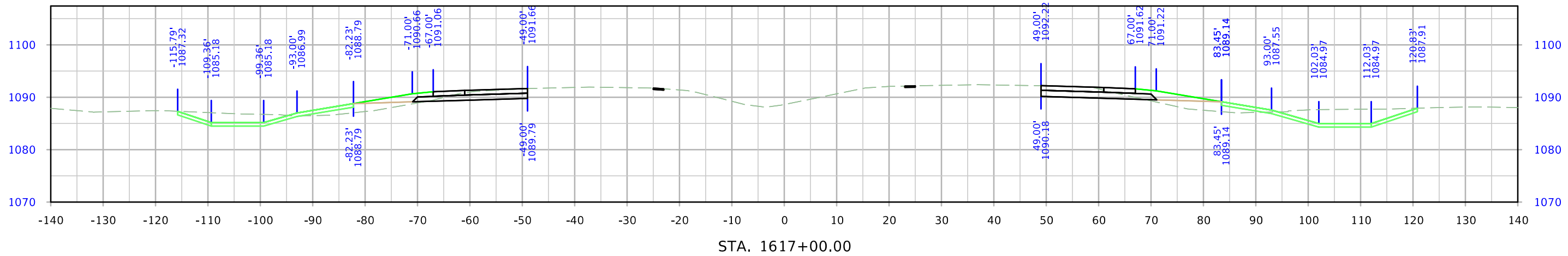
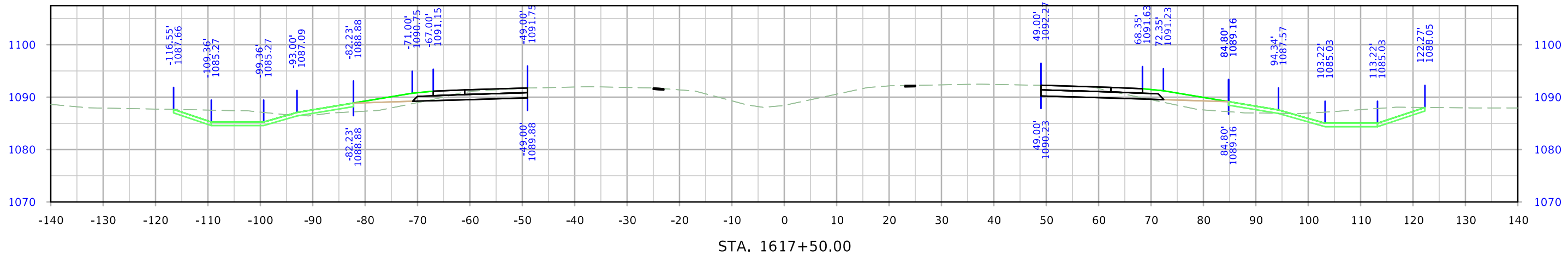
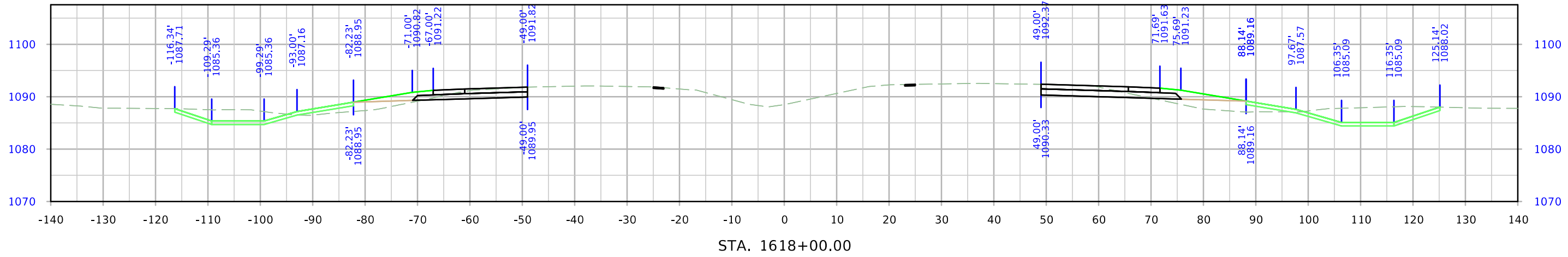

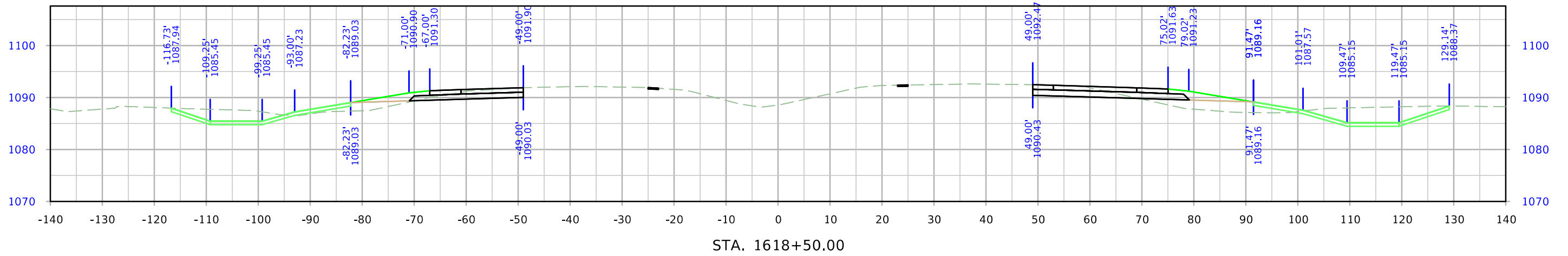
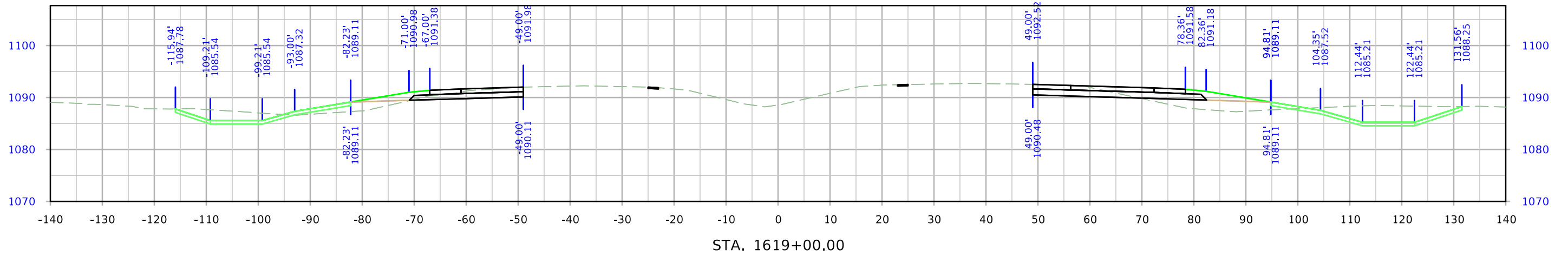
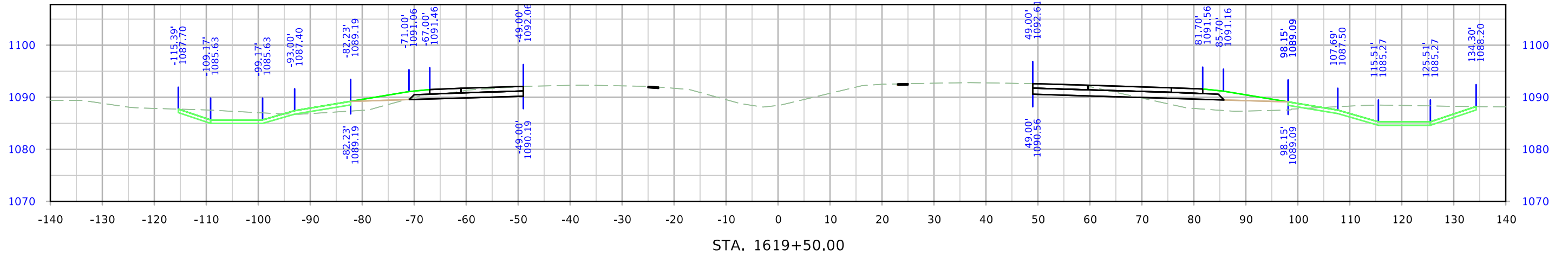

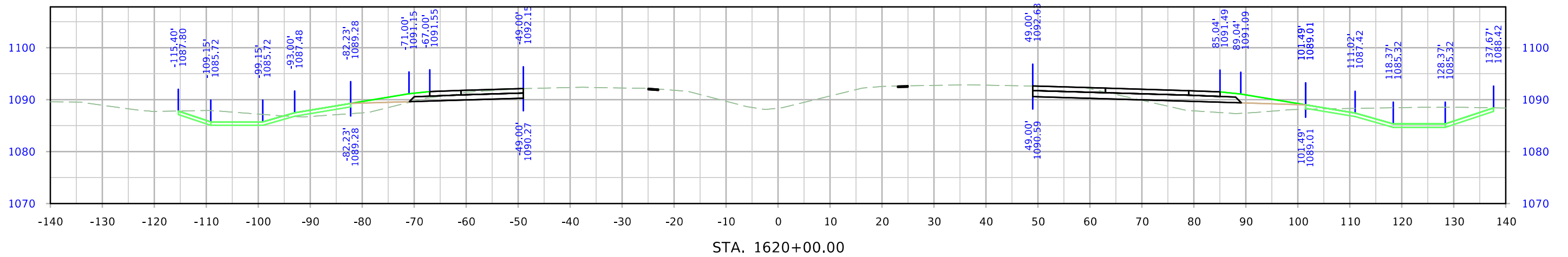
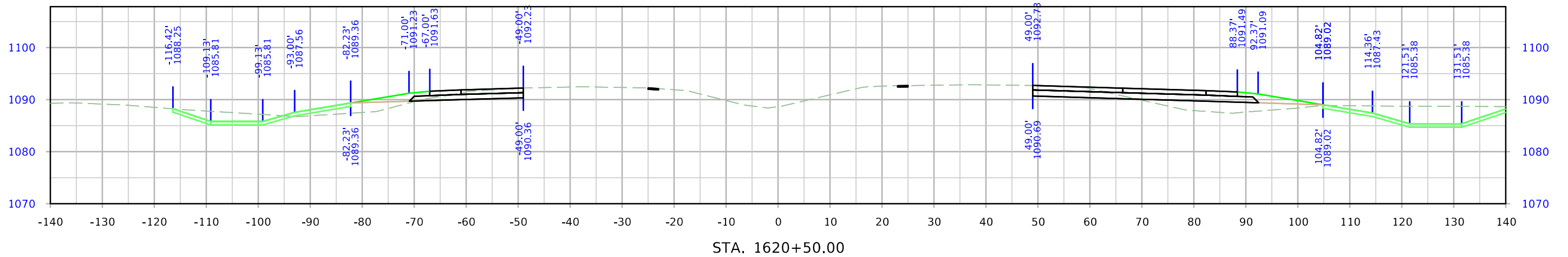
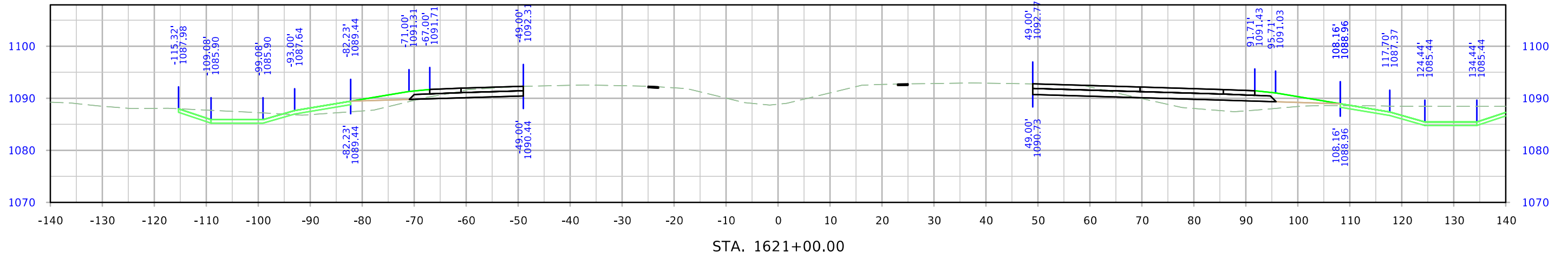

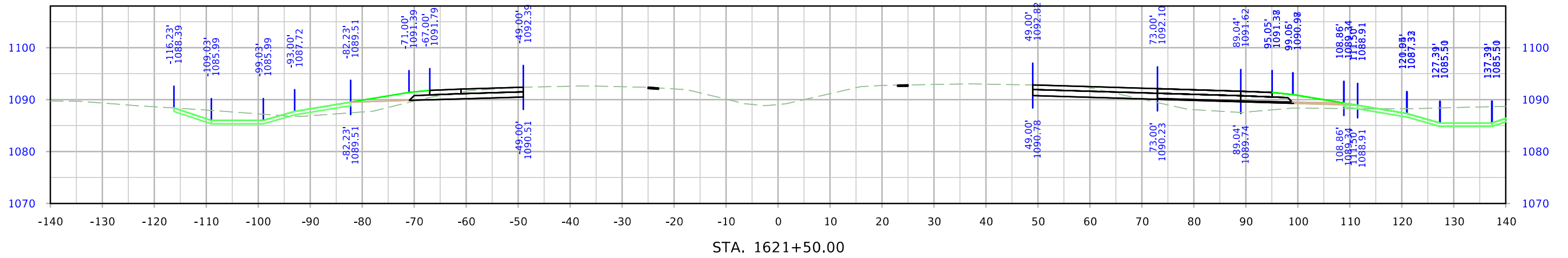
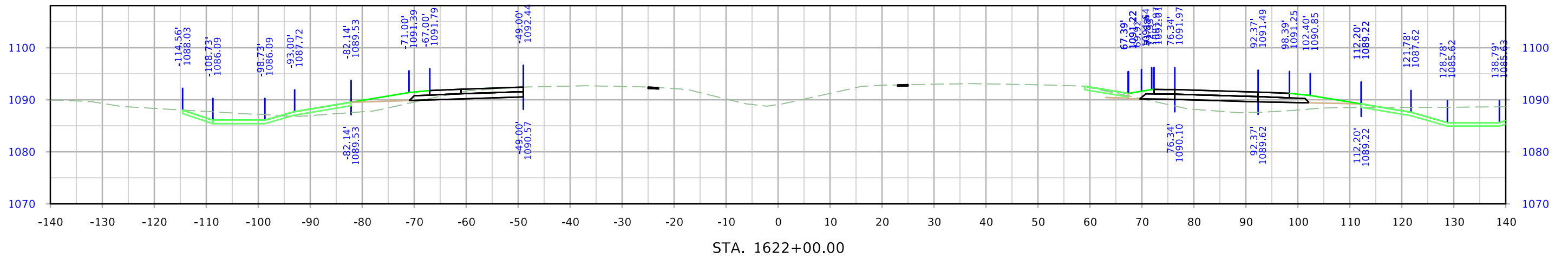
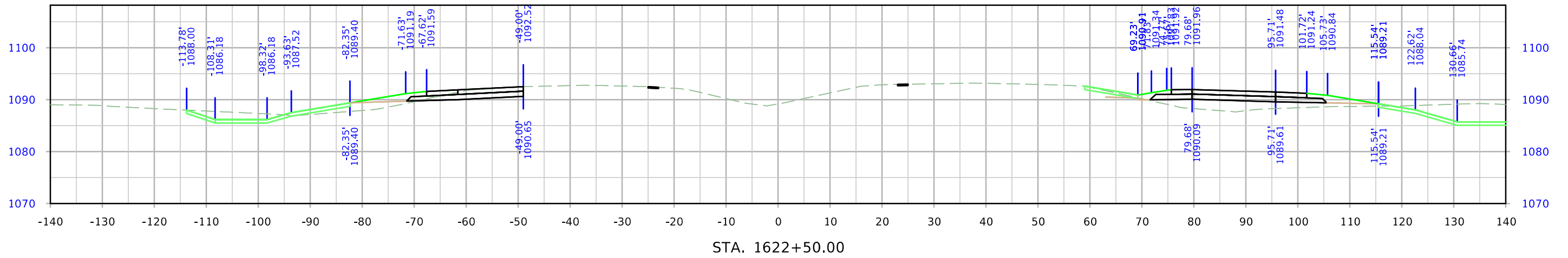

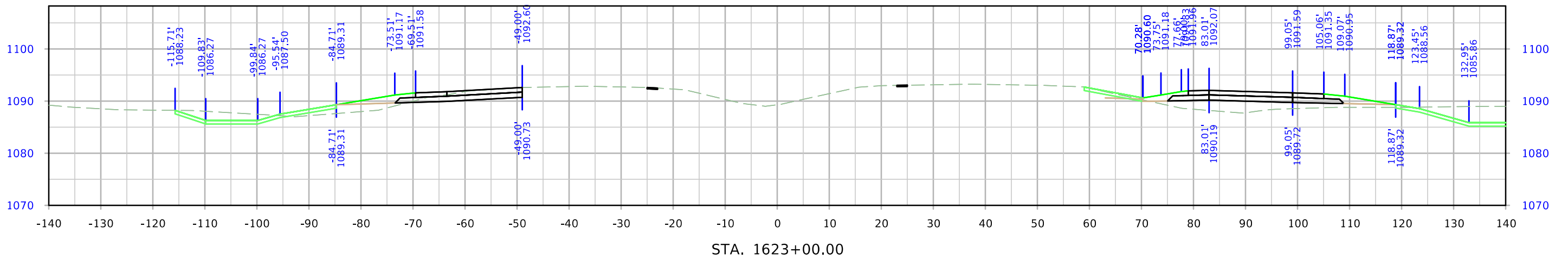
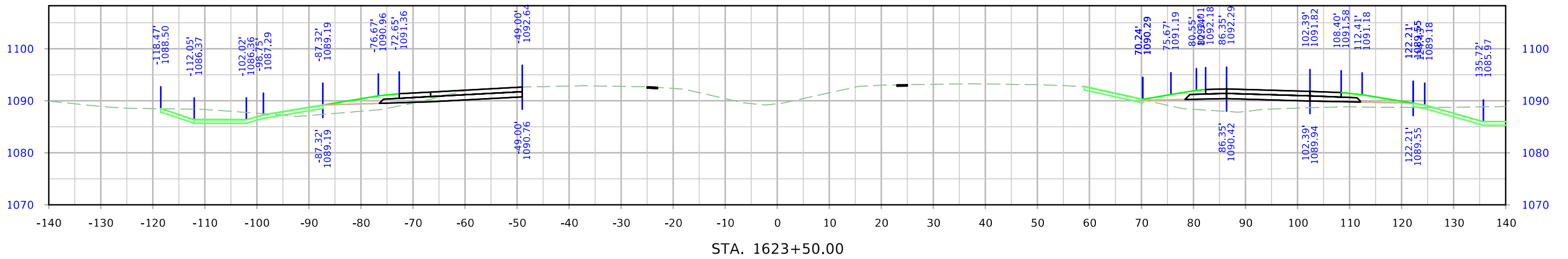
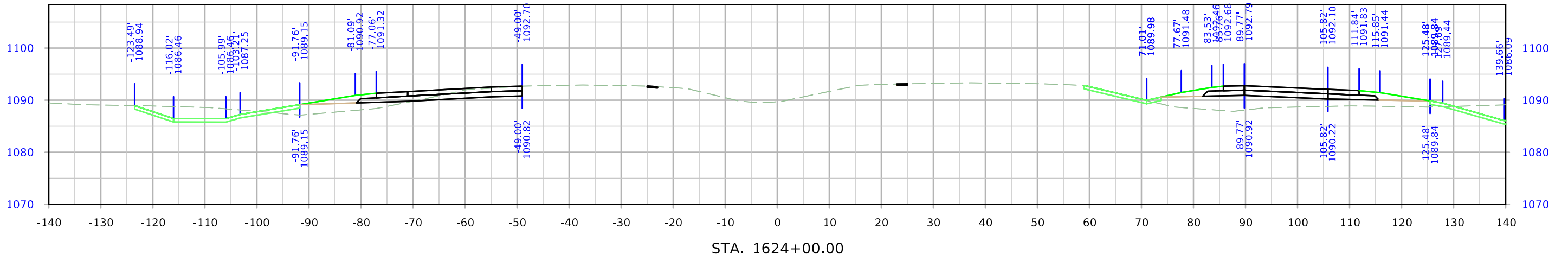

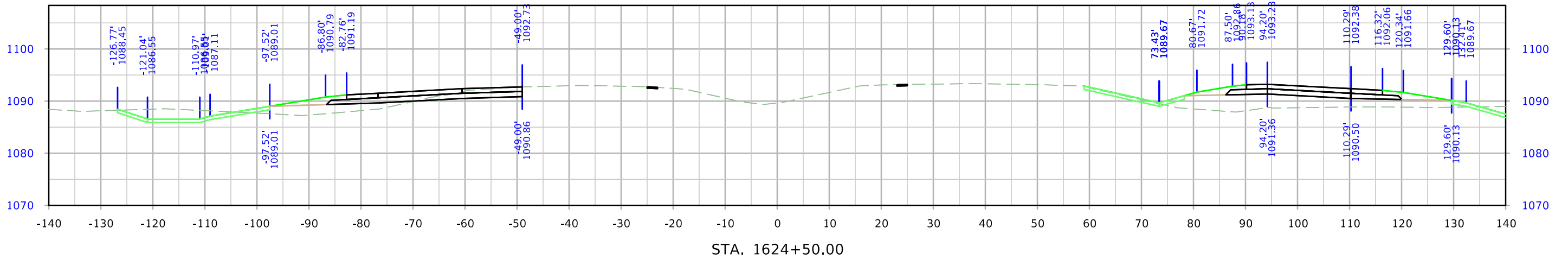
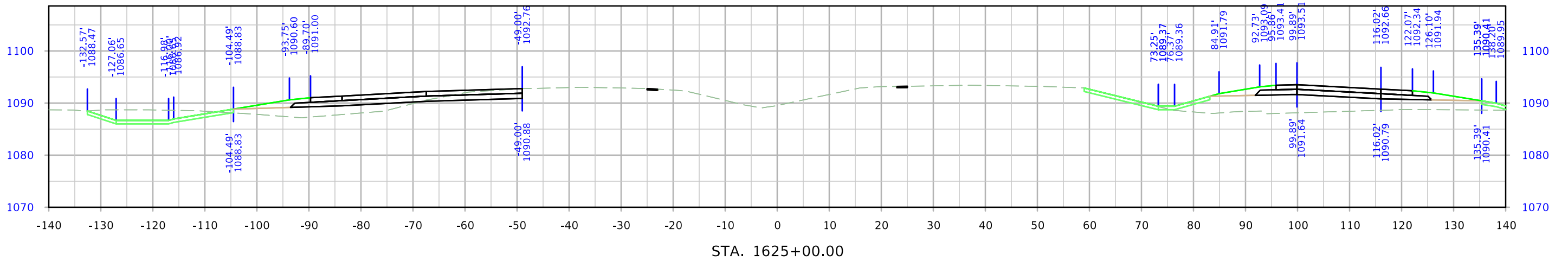
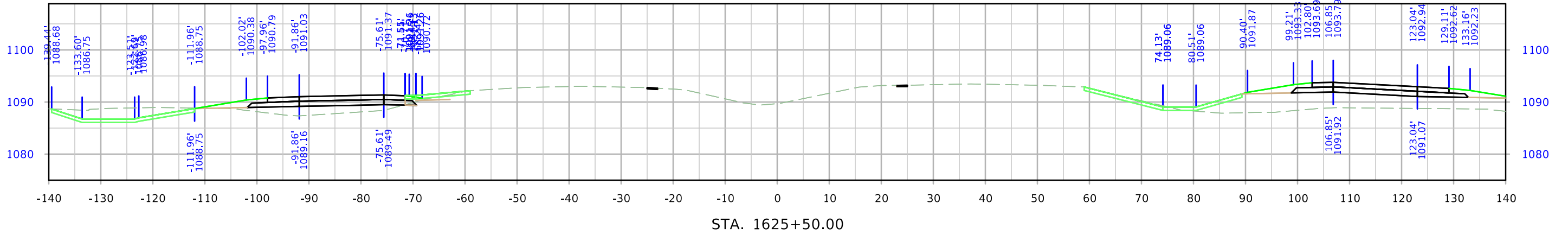

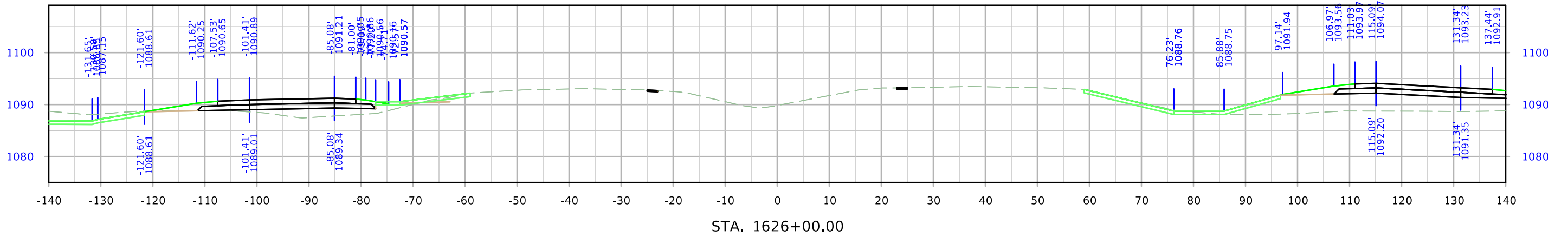
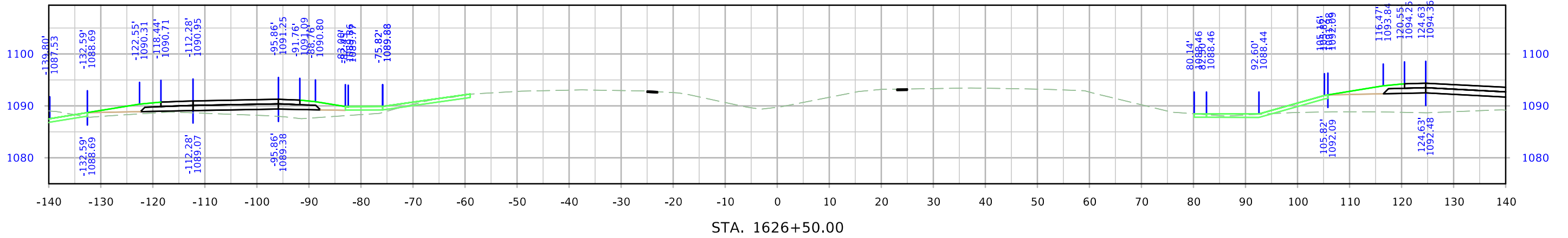
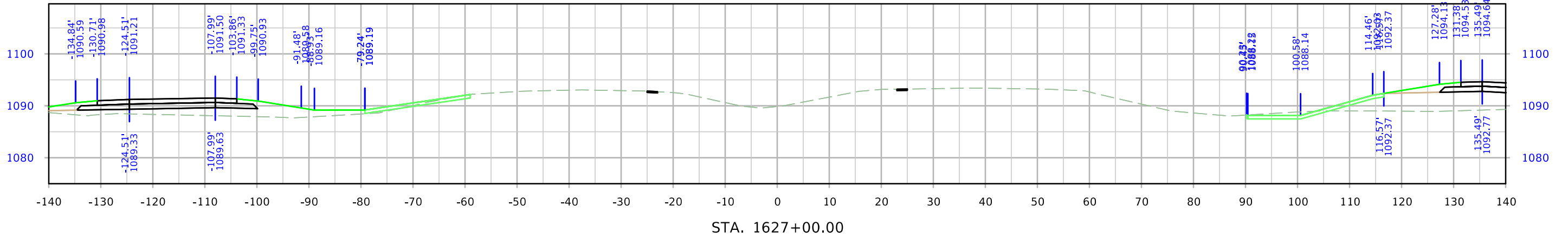

I-29

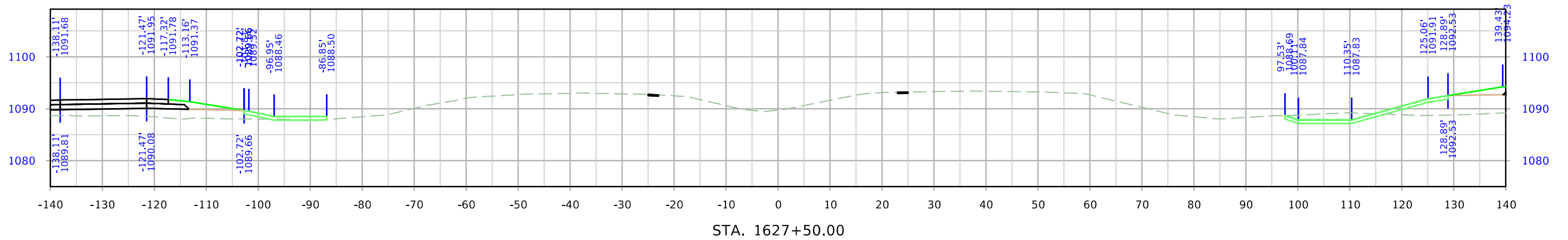
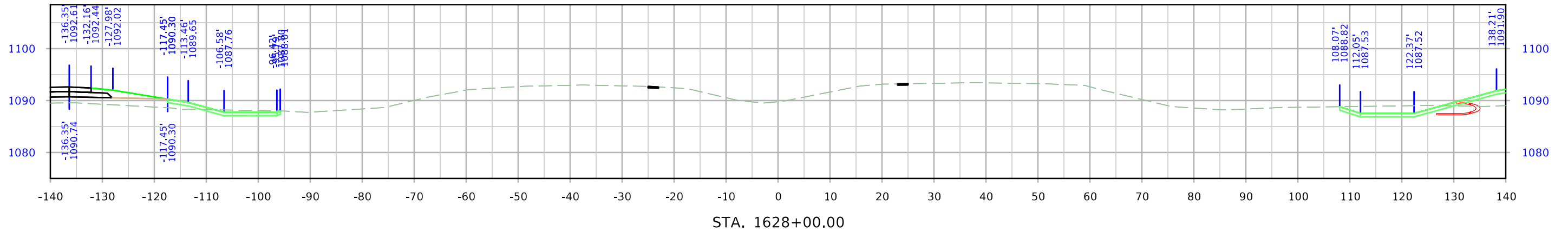
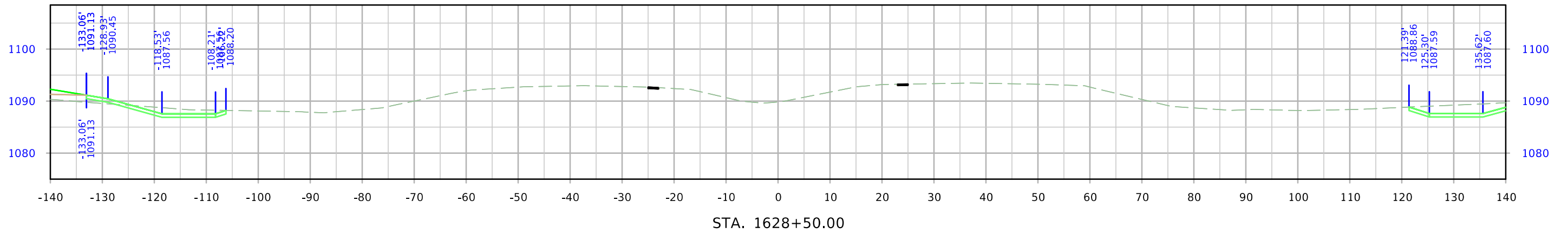

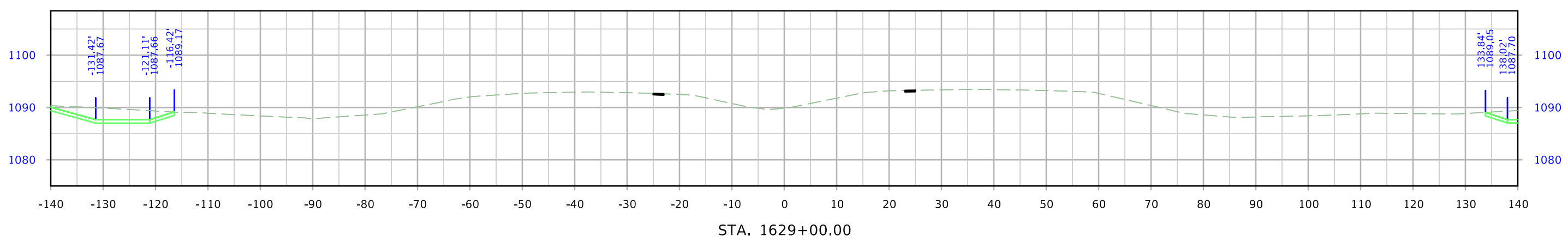
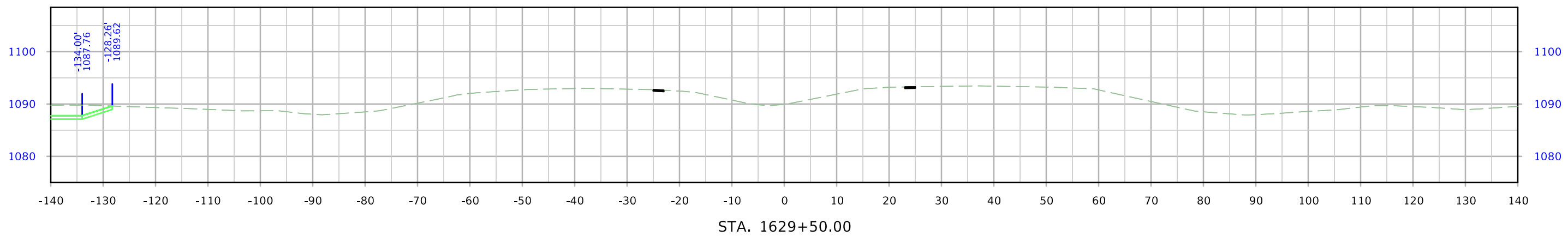
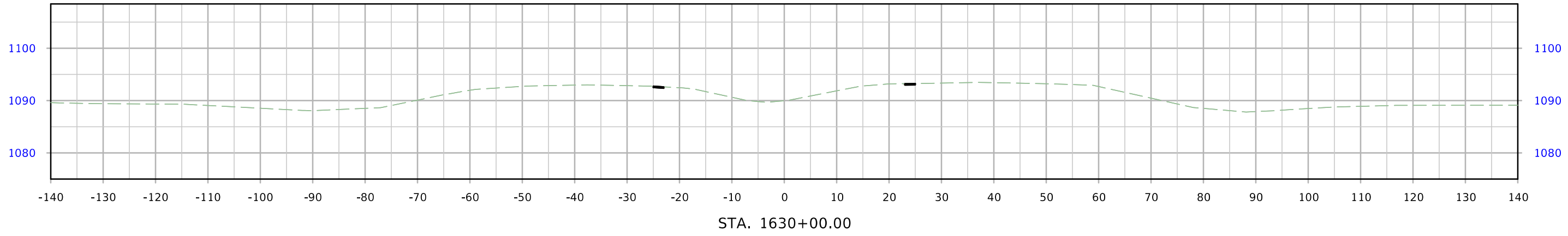

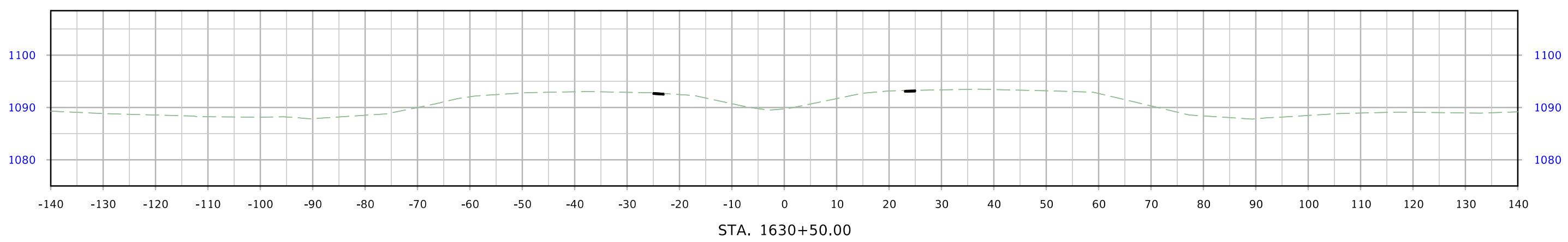
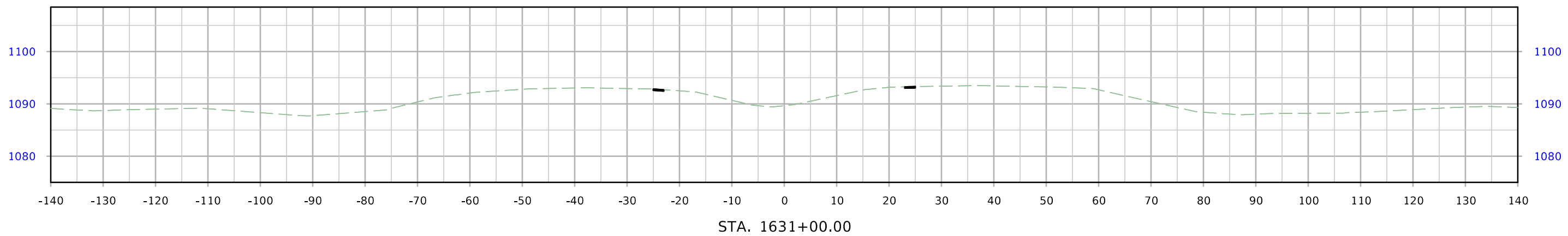
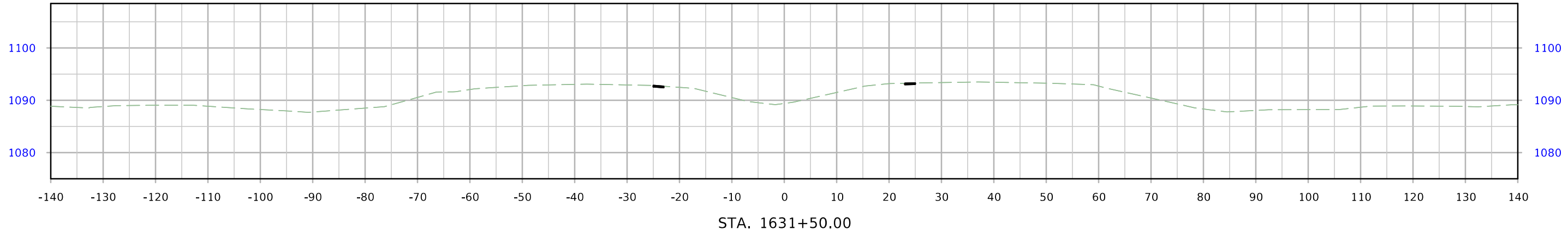

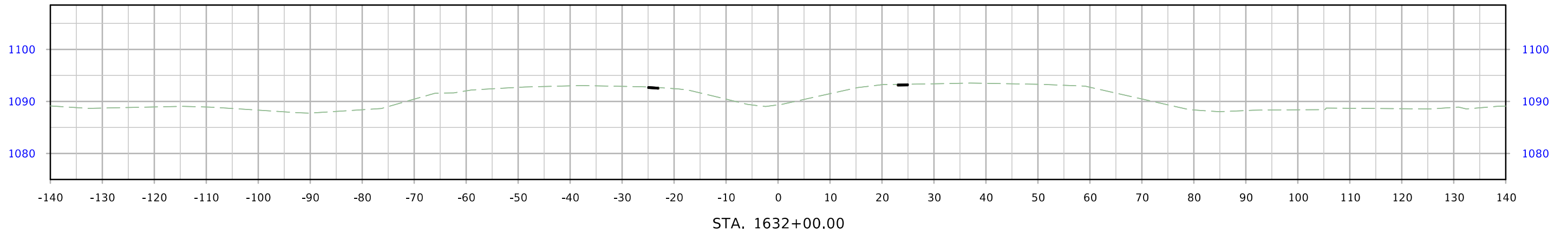
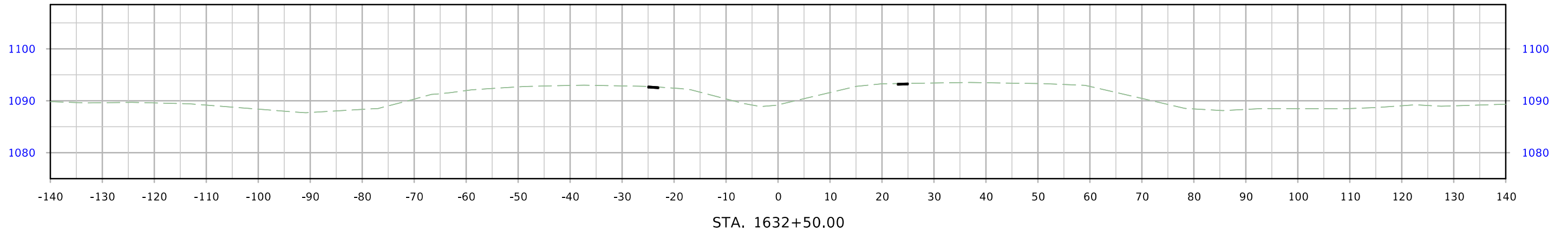
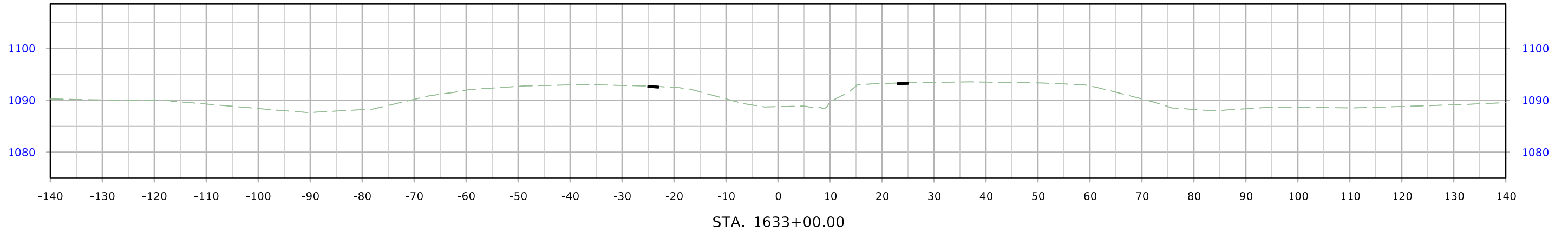

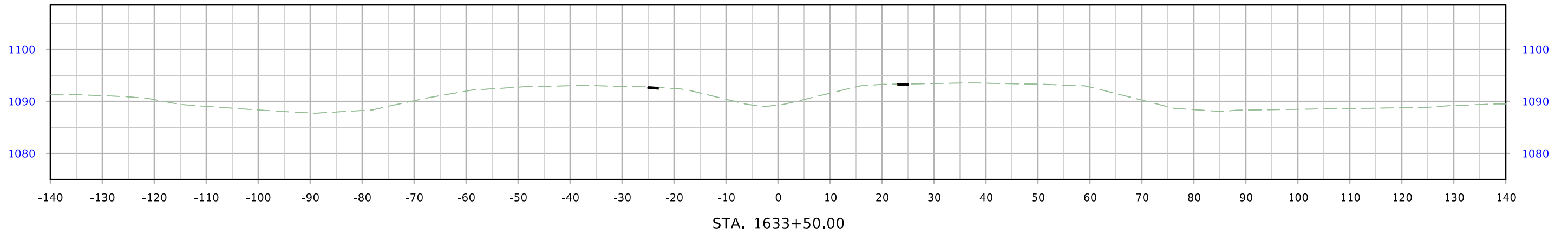
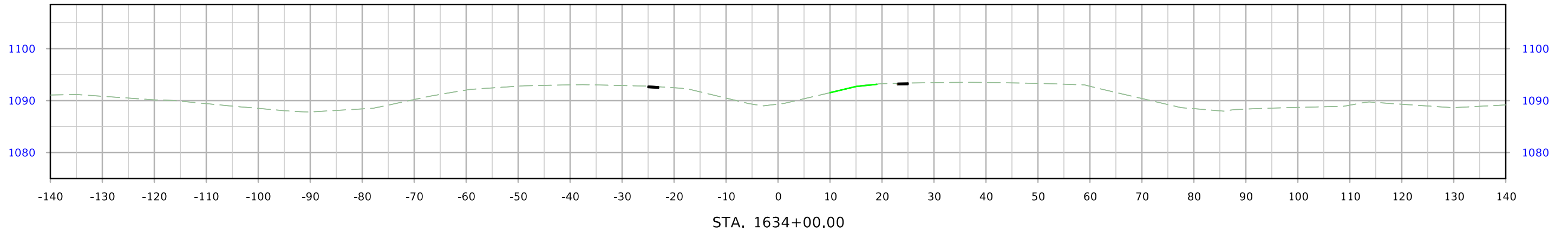
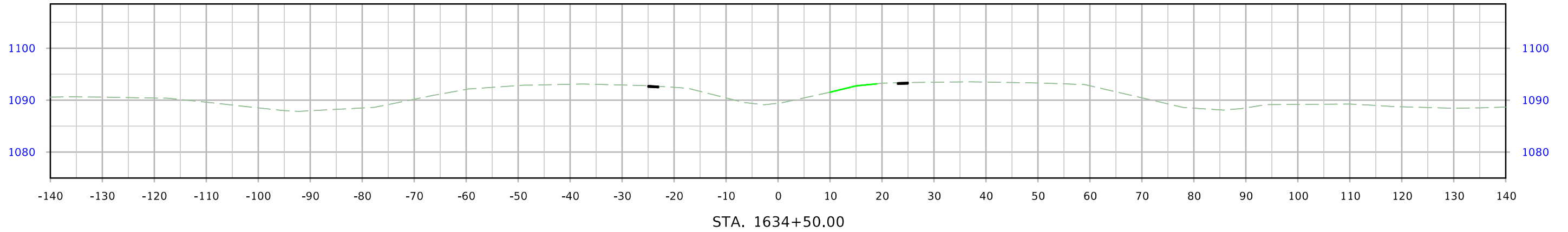

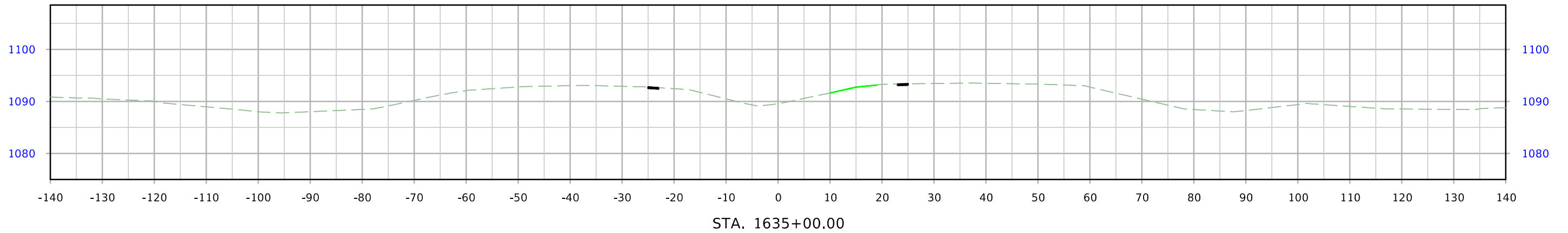
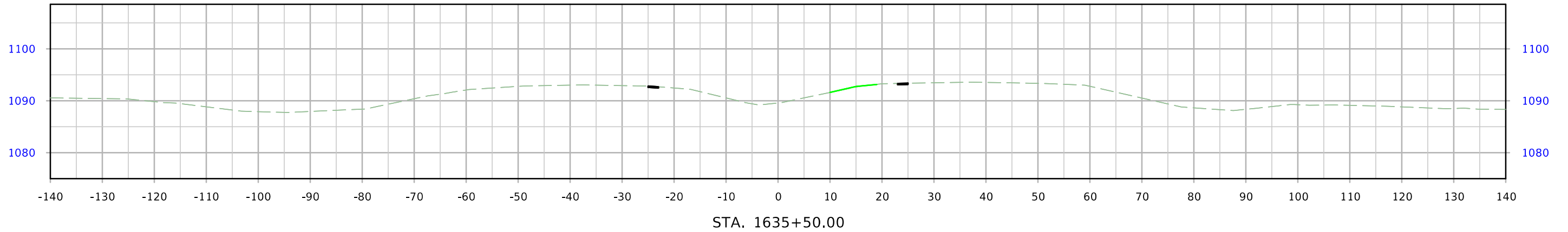
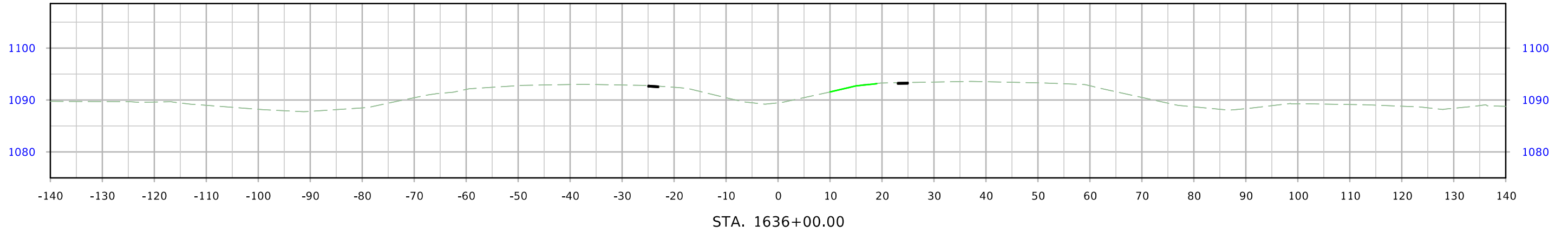

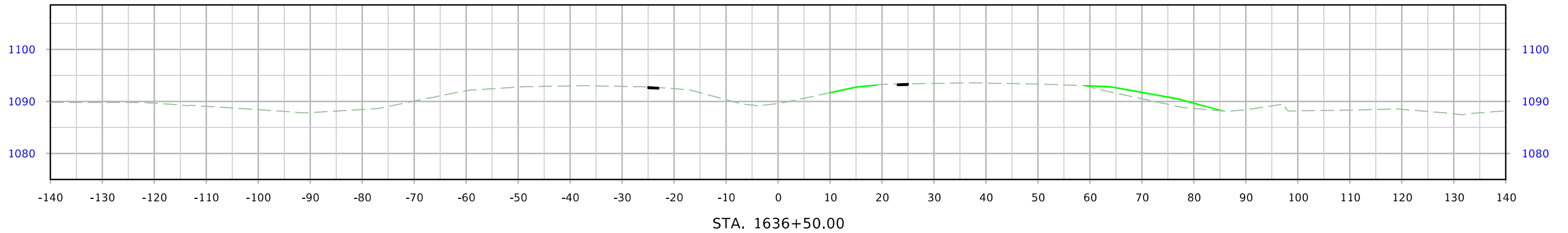
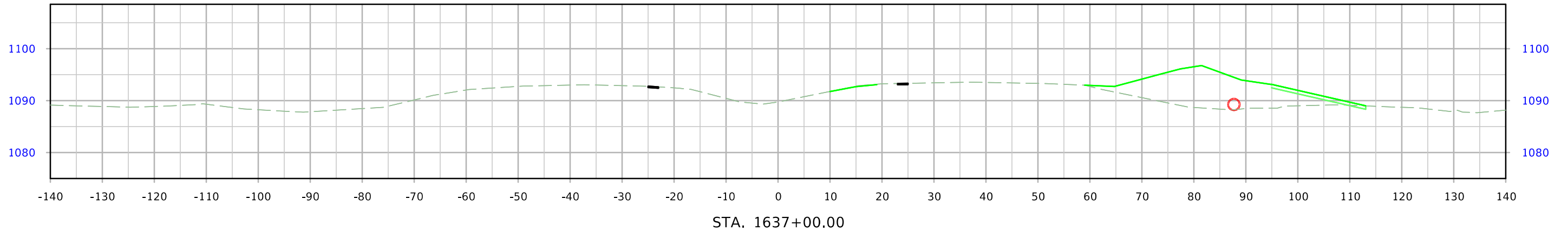
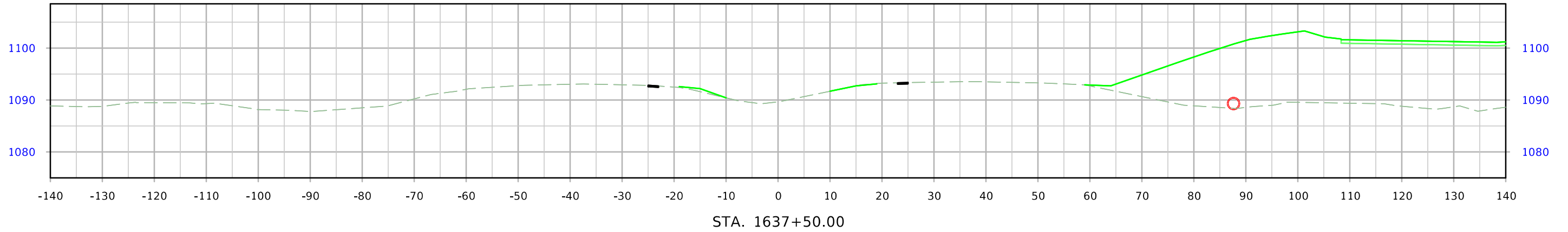

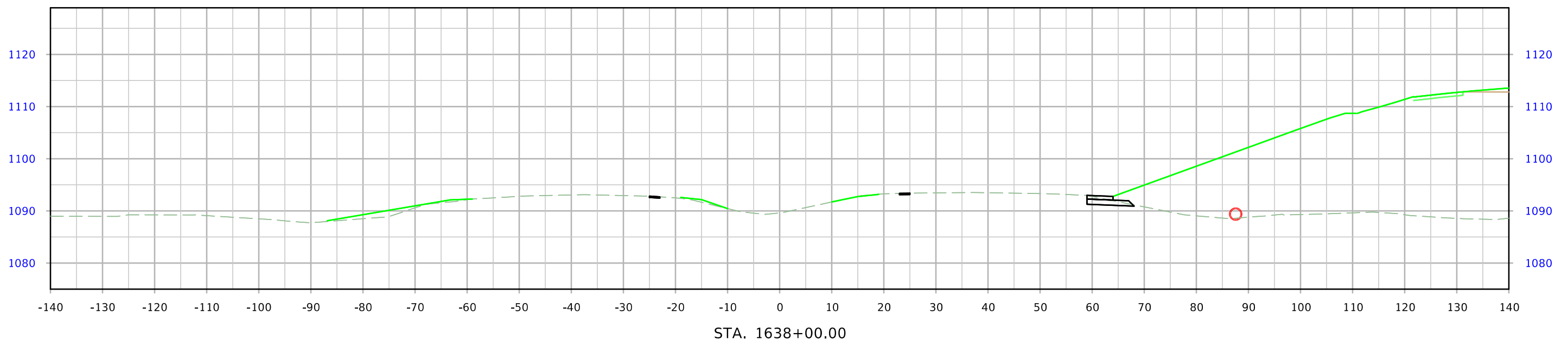
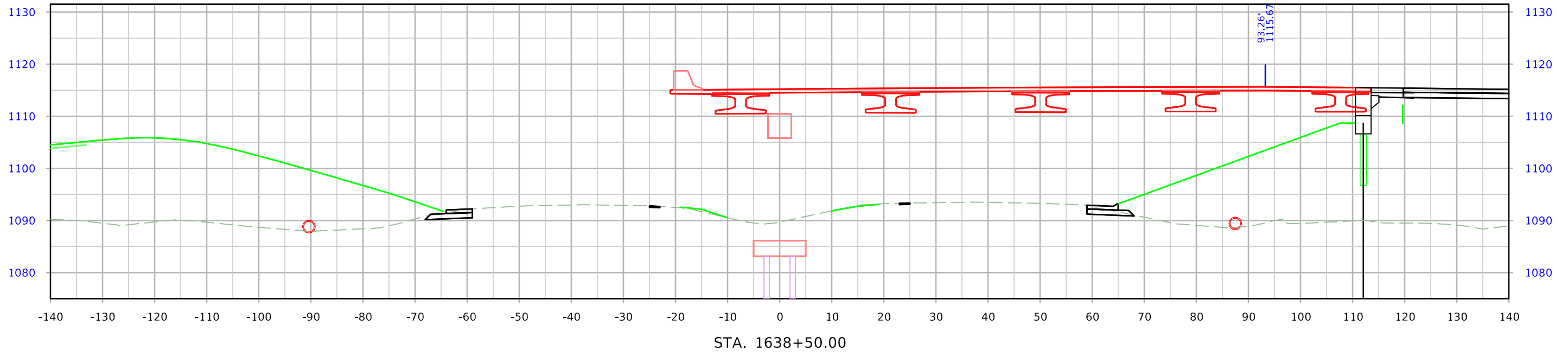

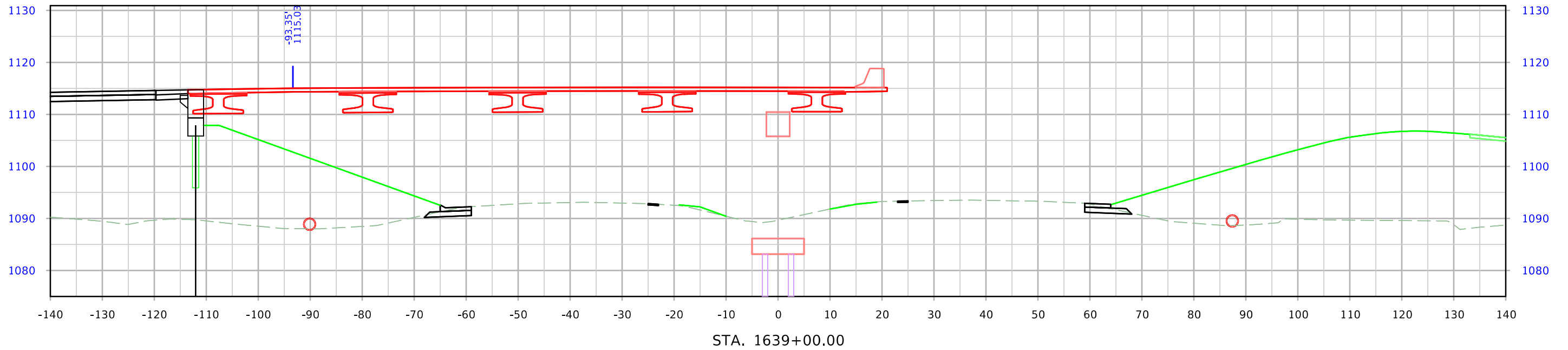
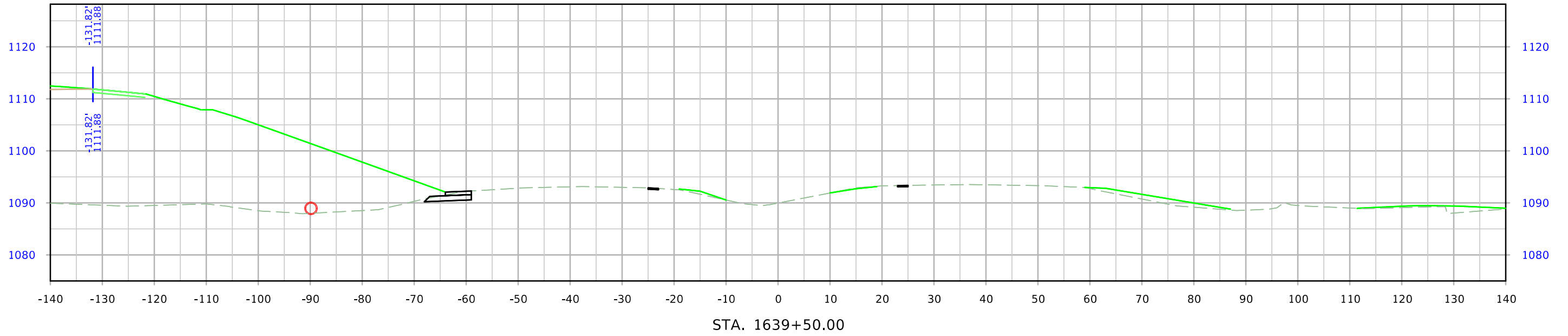

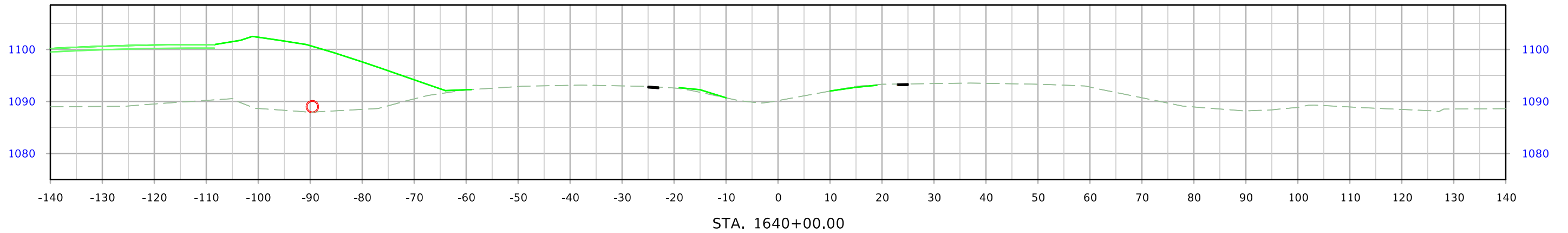
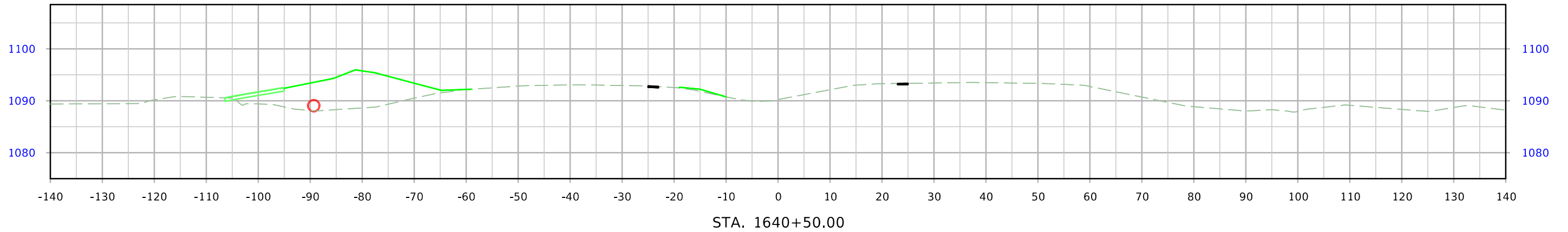
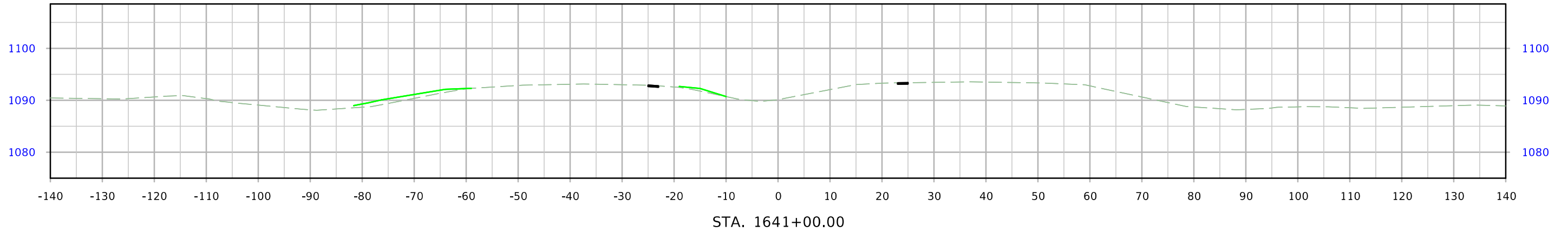

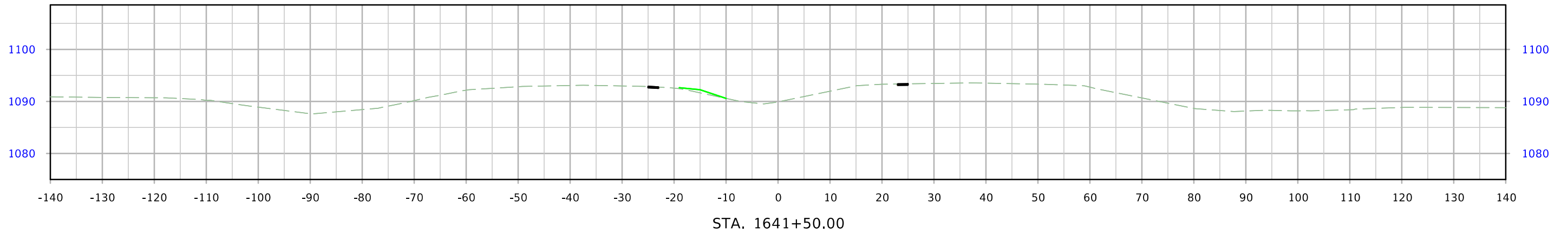
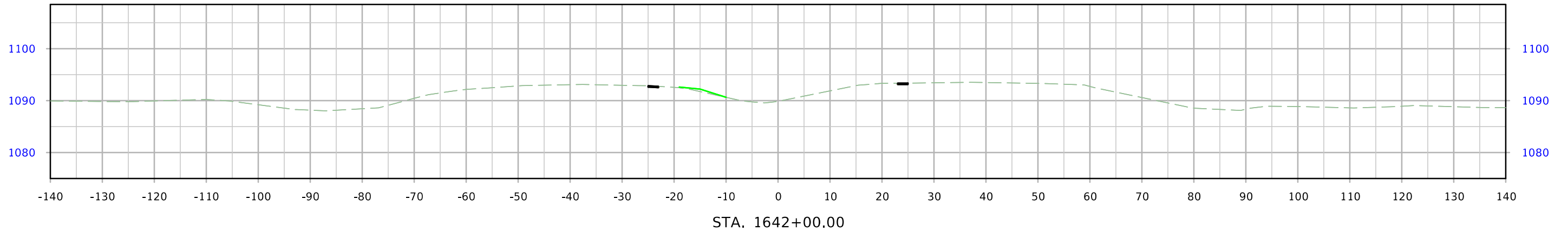
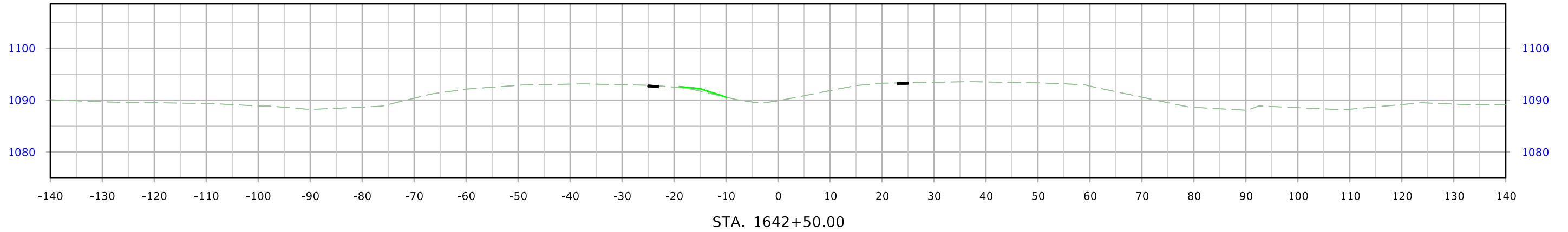

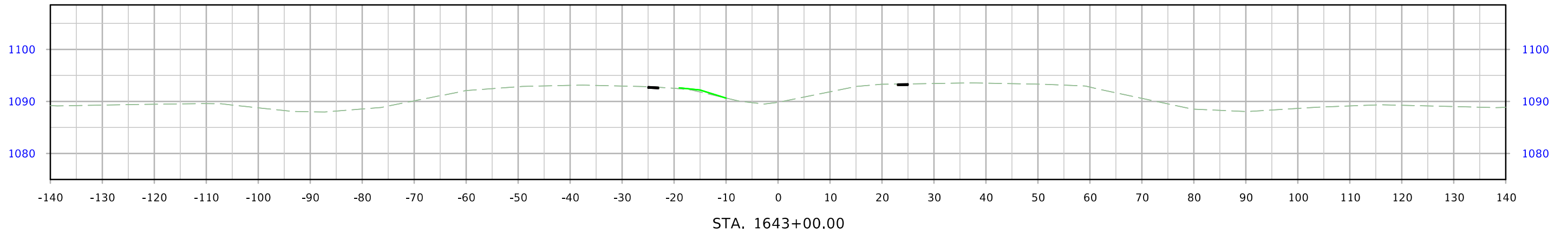
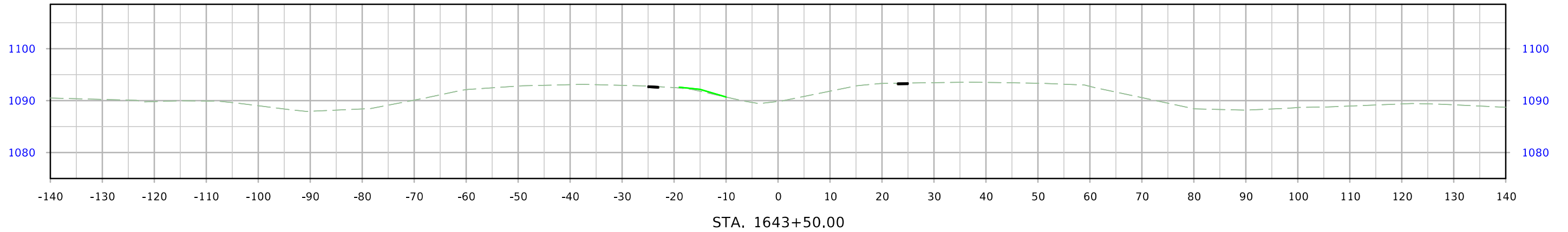
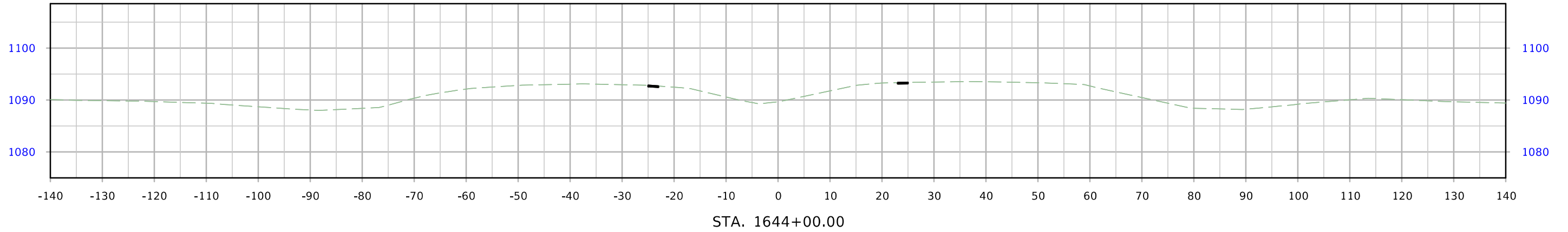

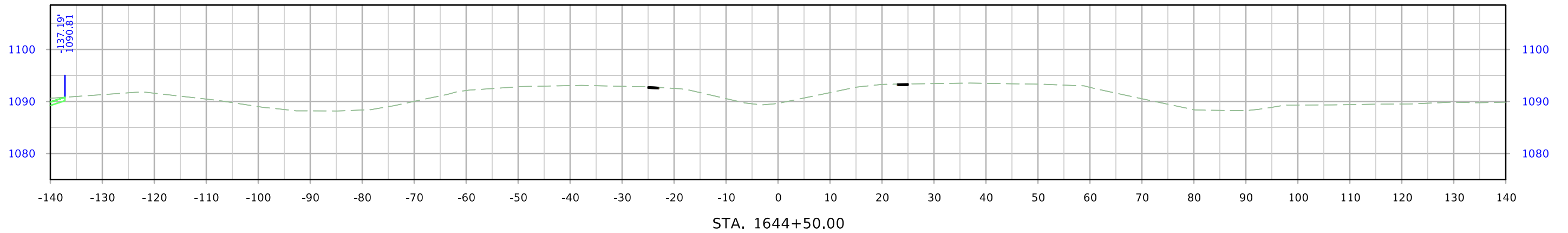
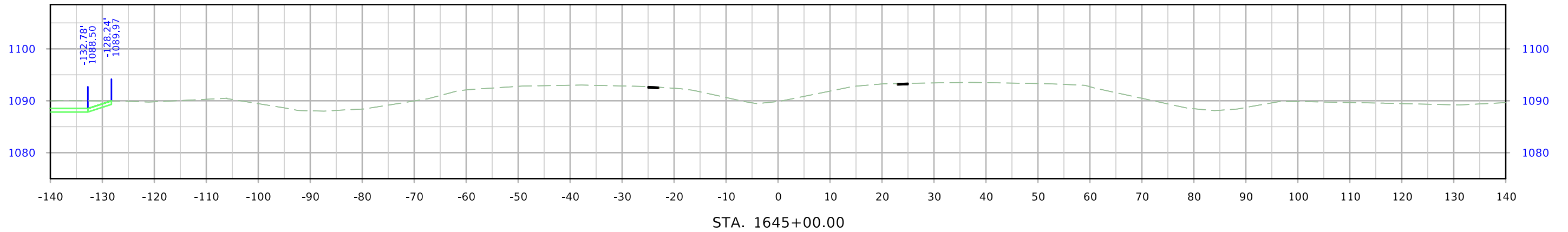
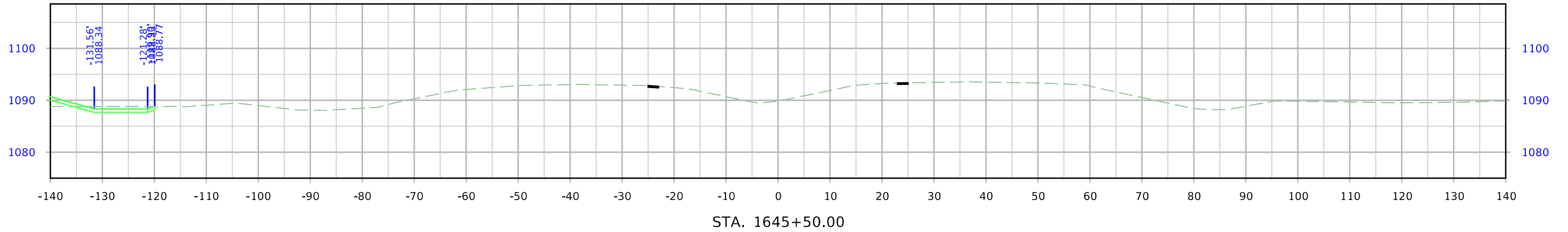

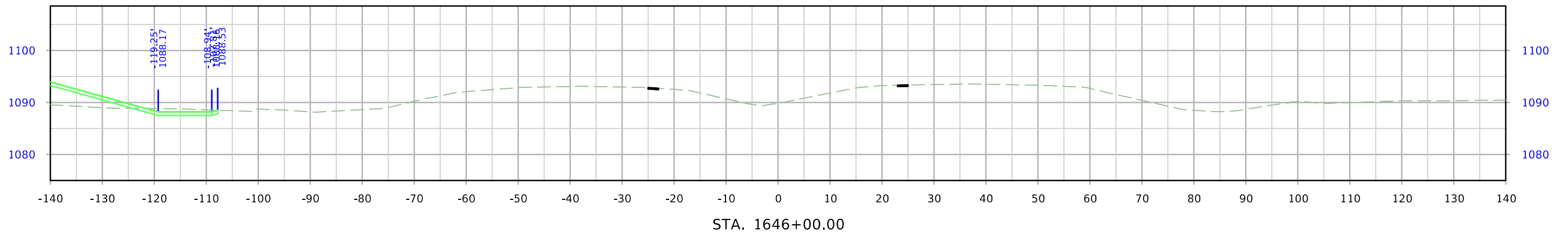
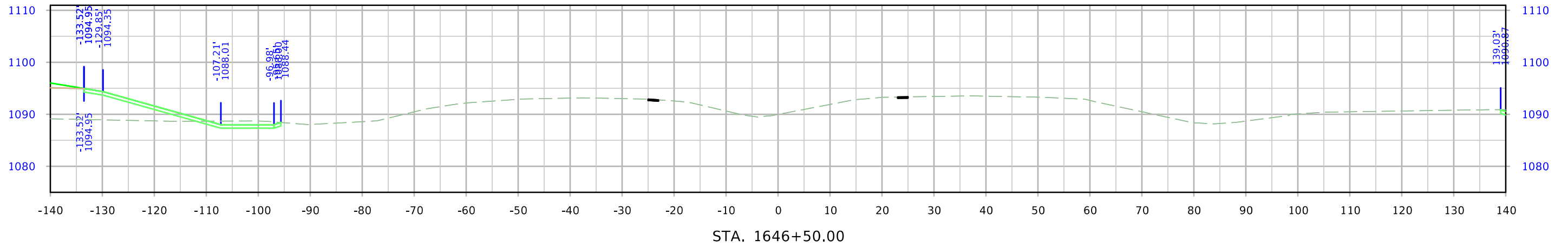
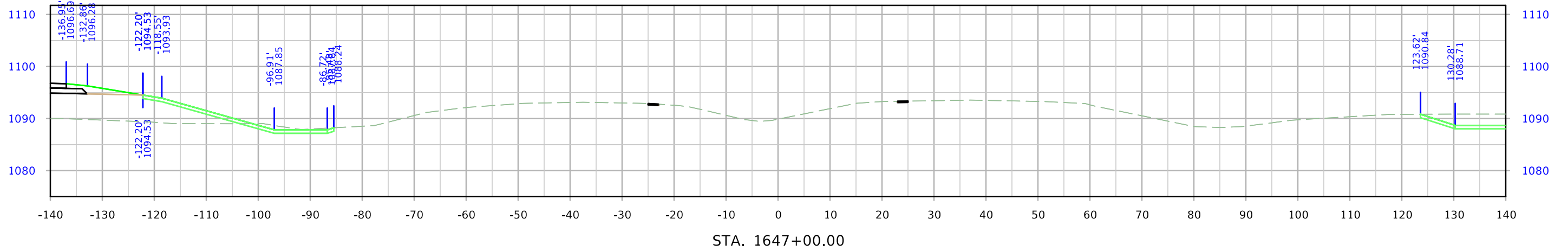

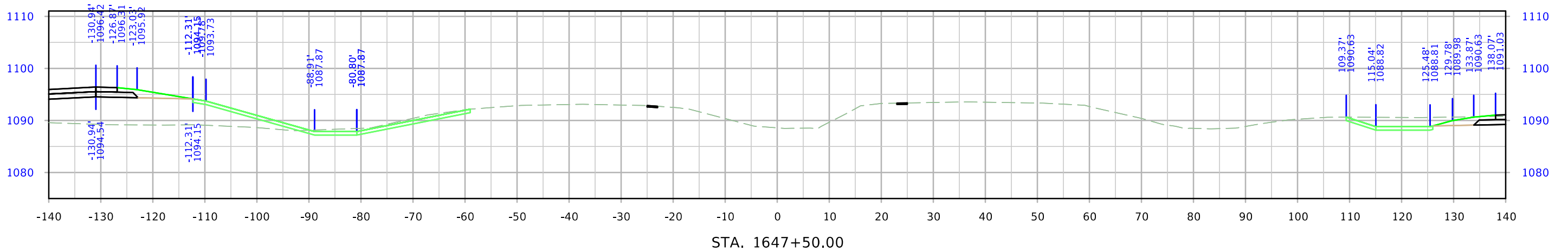
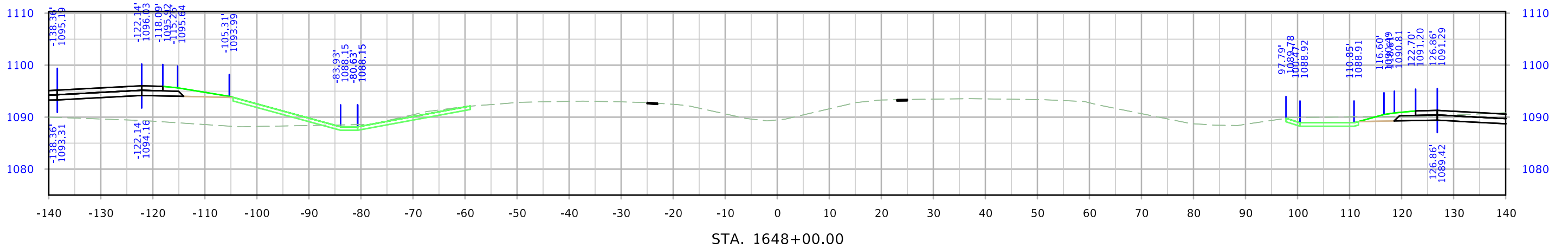
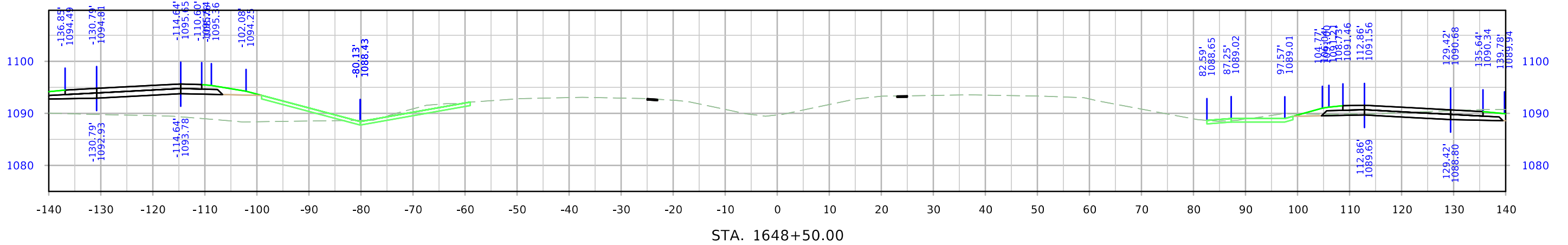

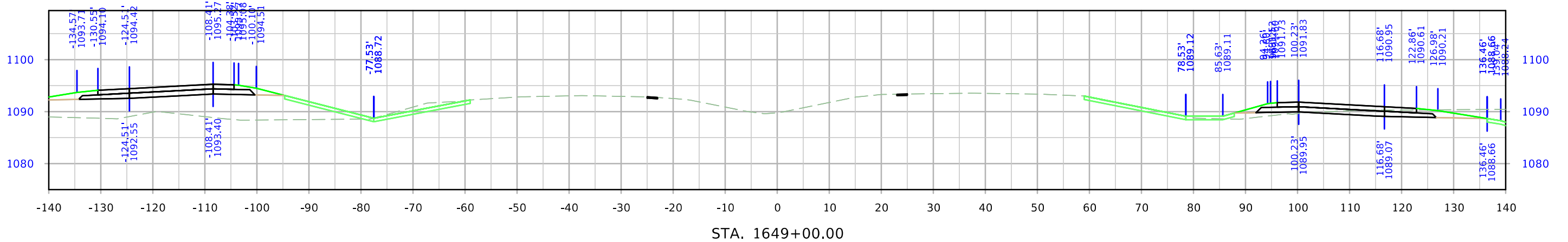
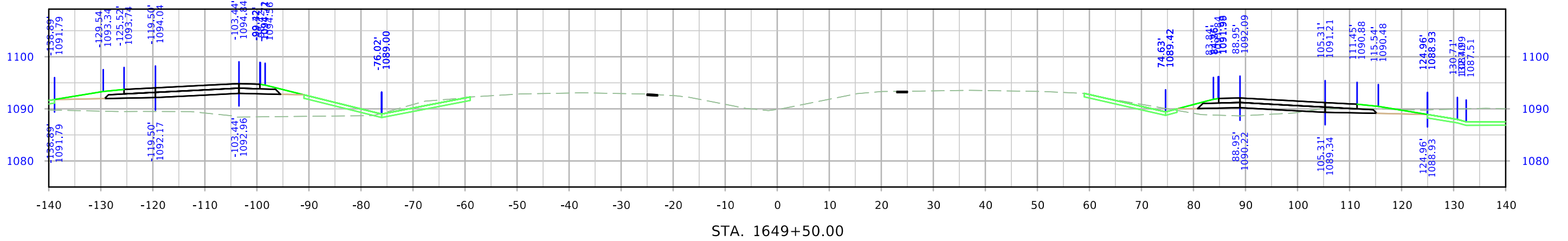
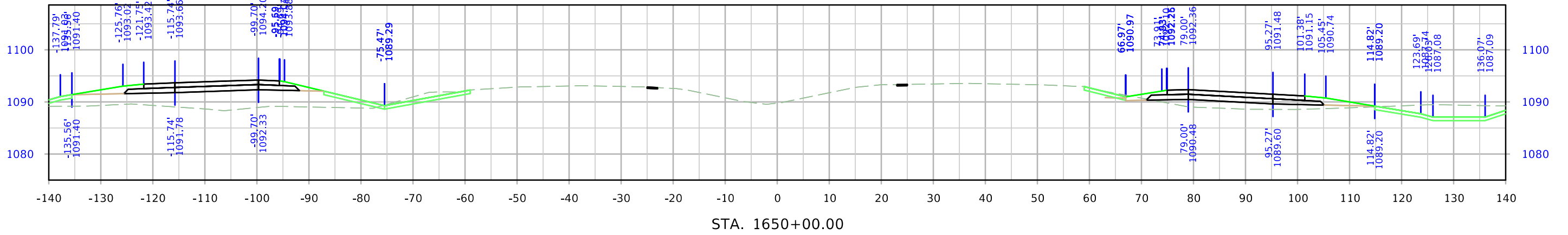

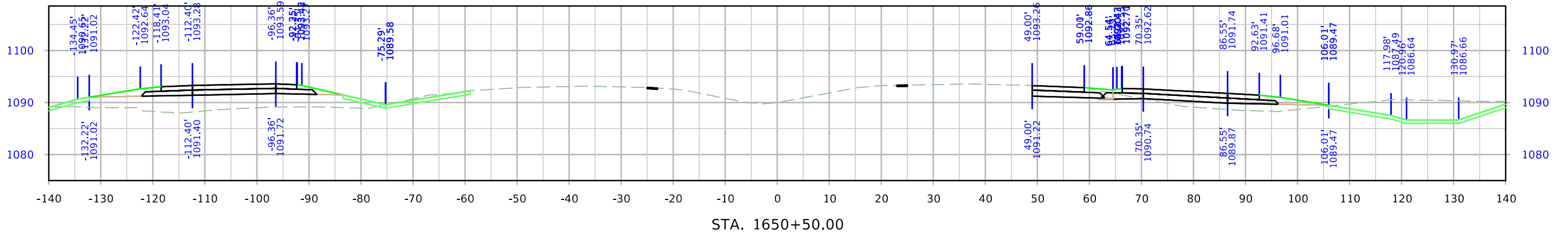
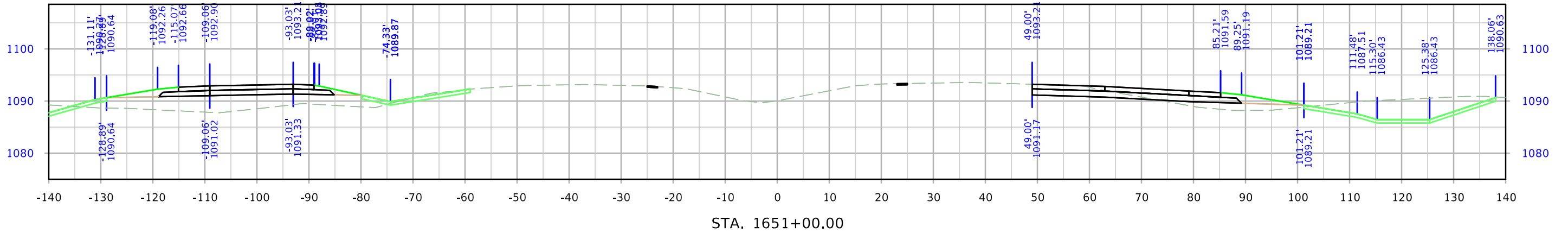
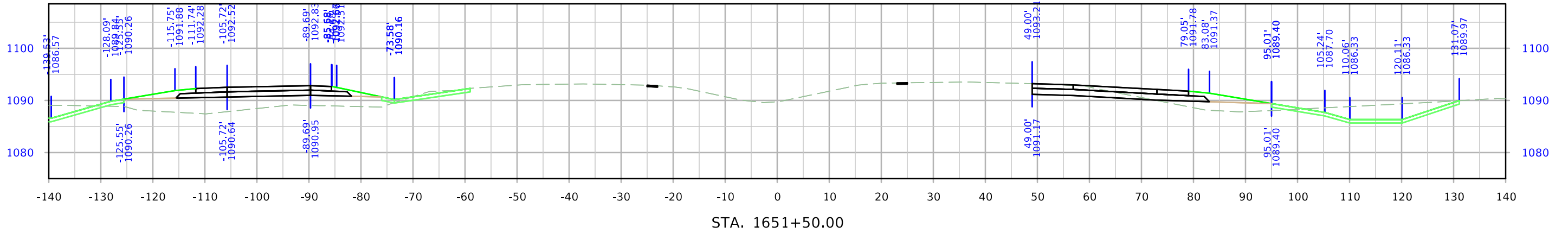

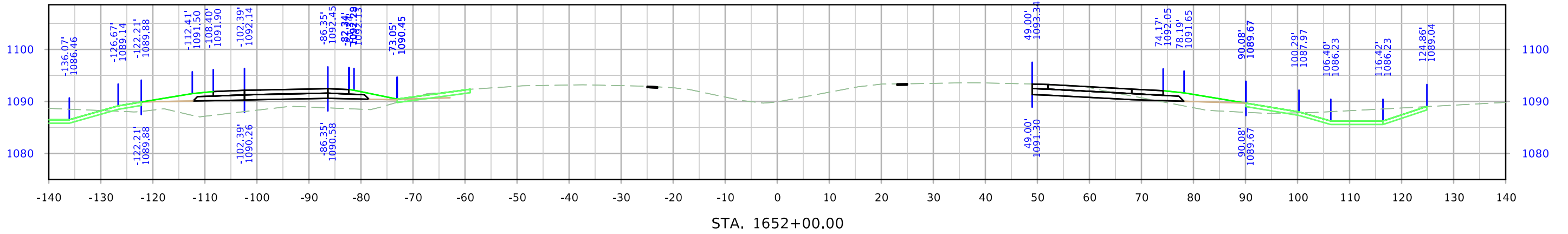
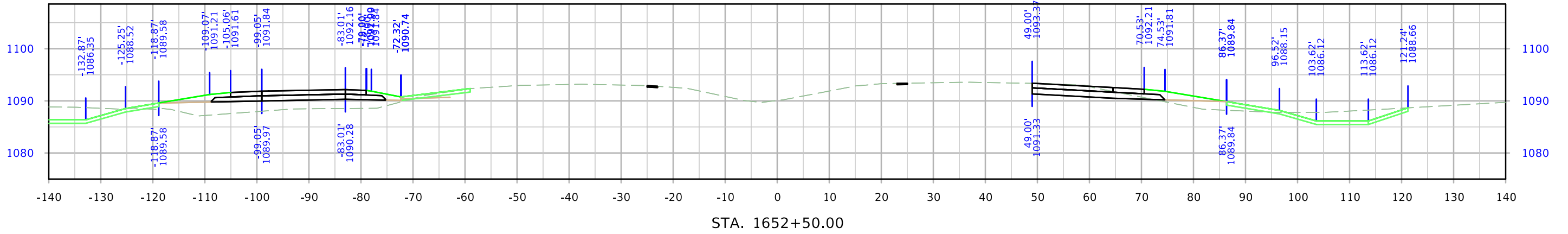
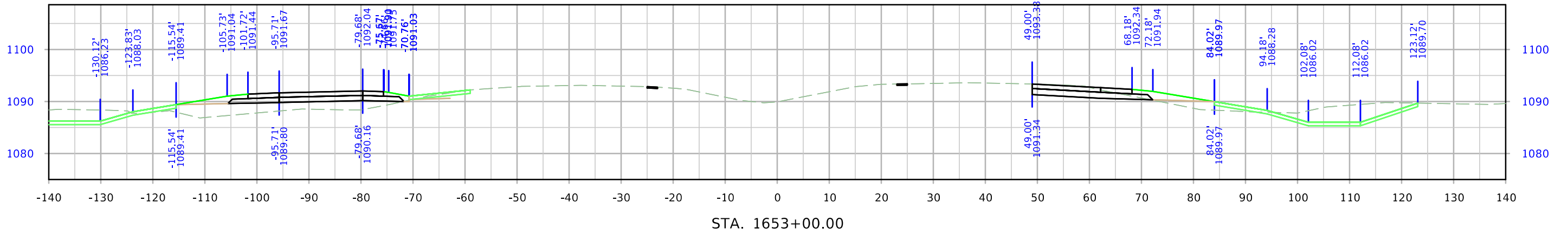

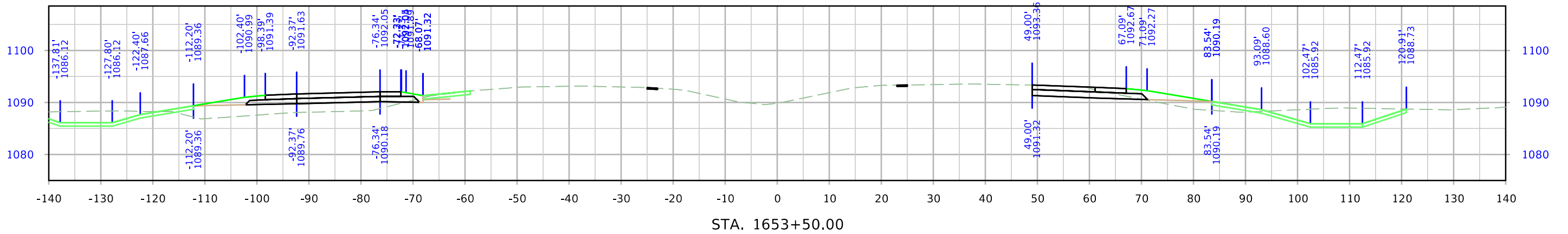
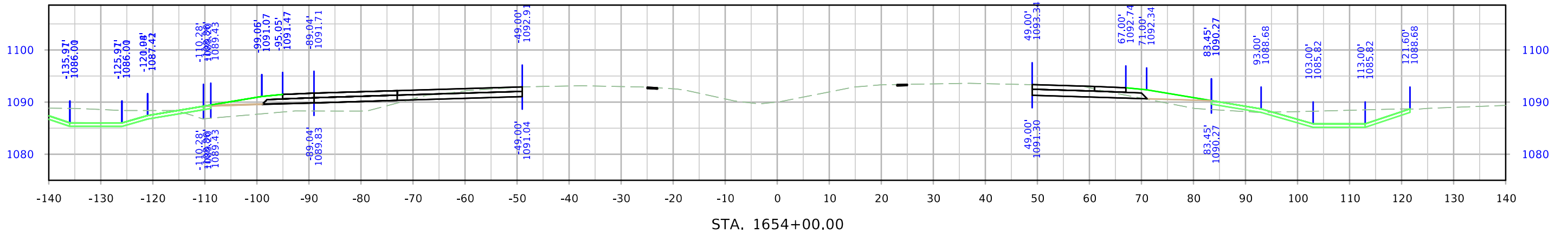
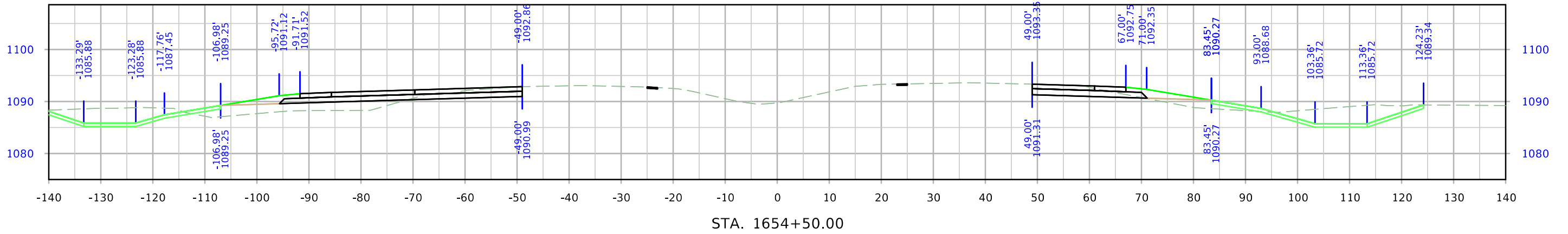

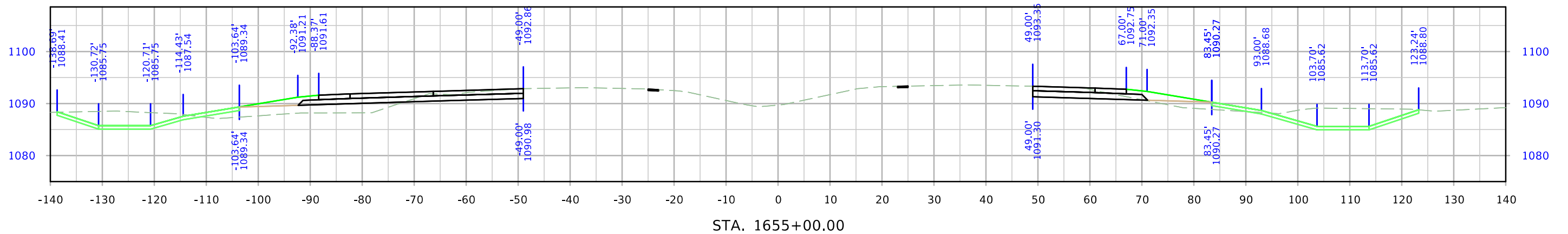
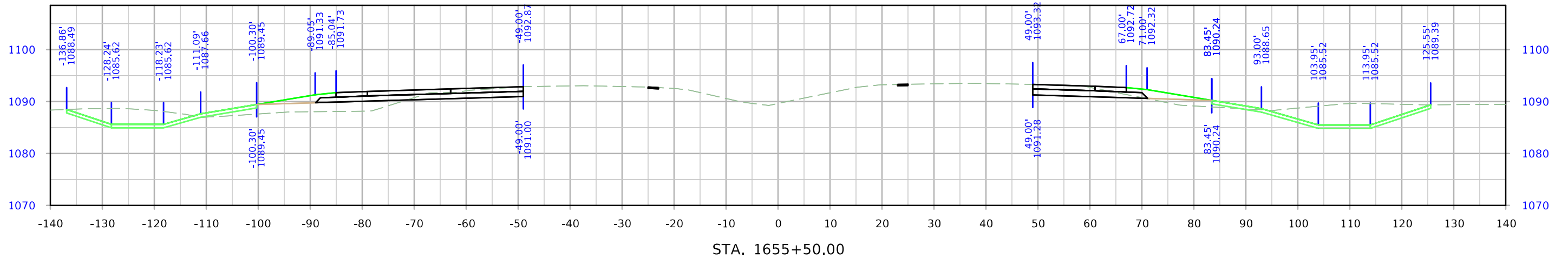
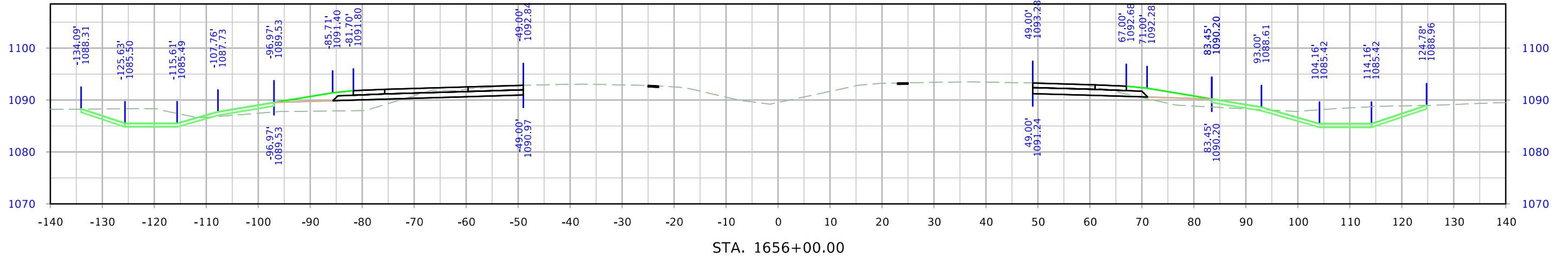

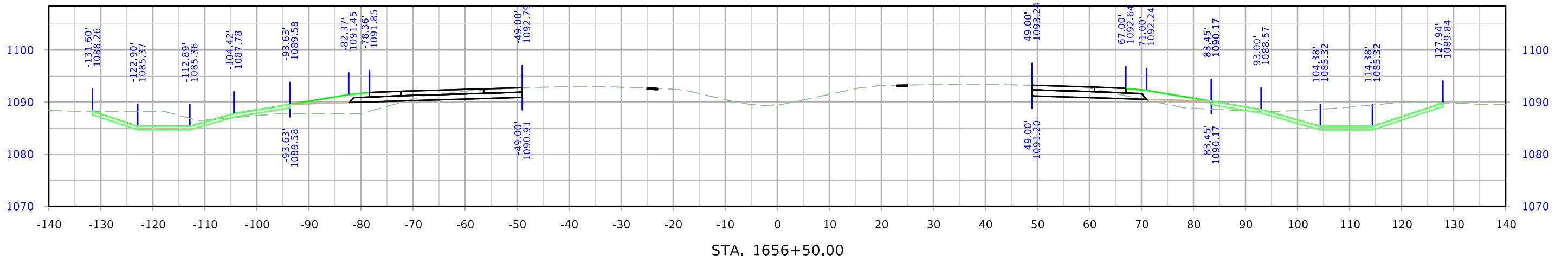
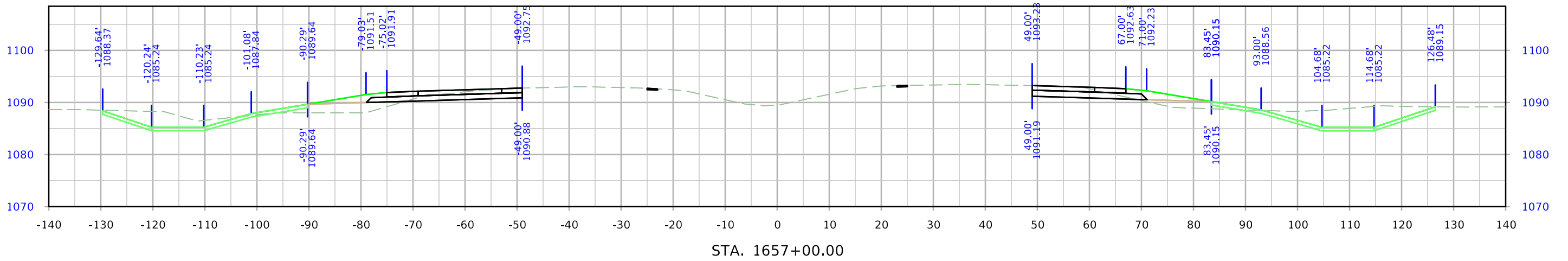
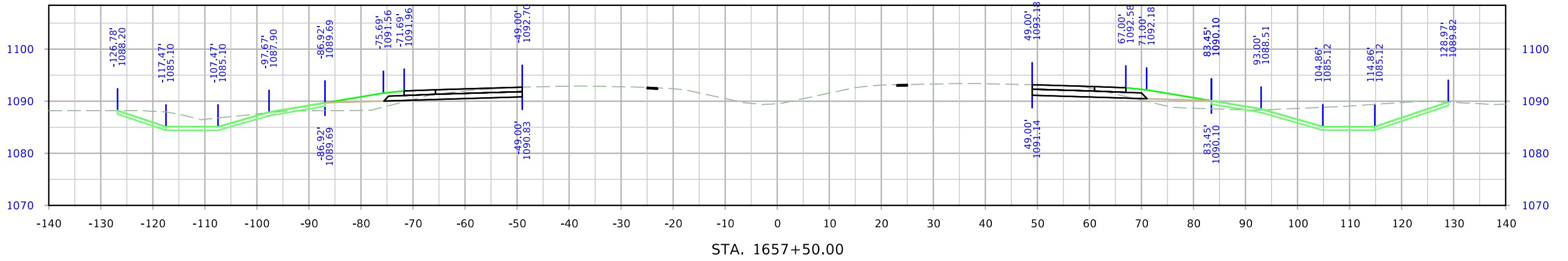

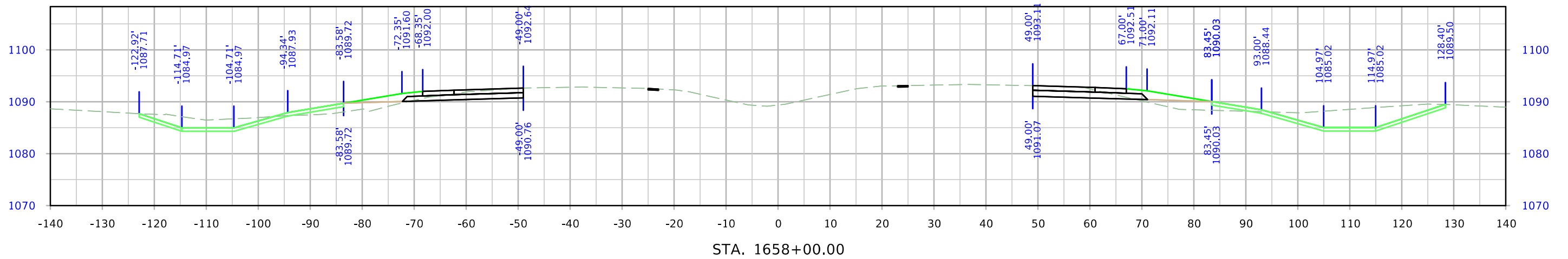
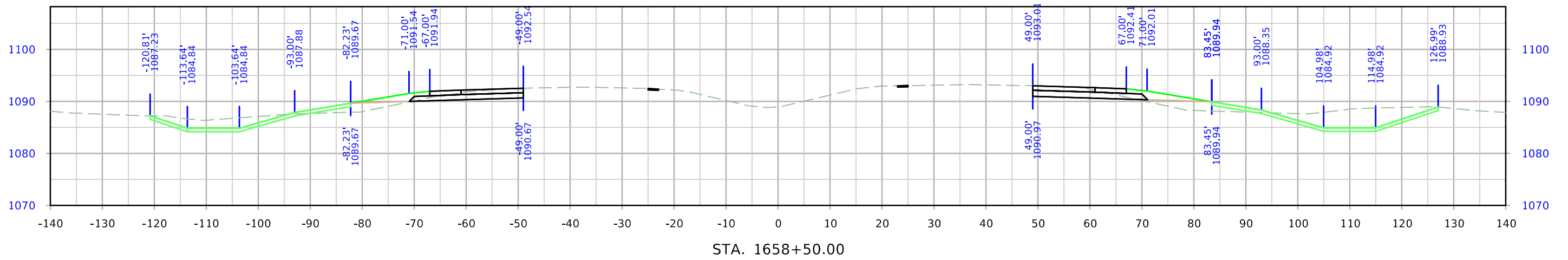
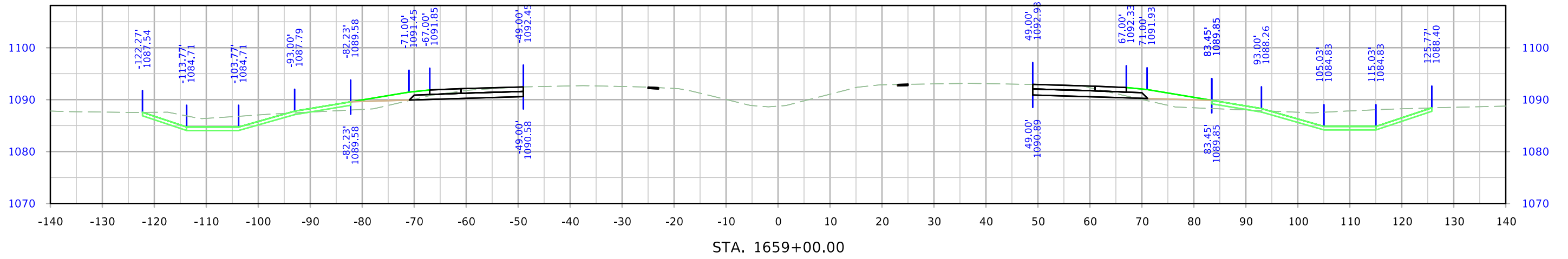

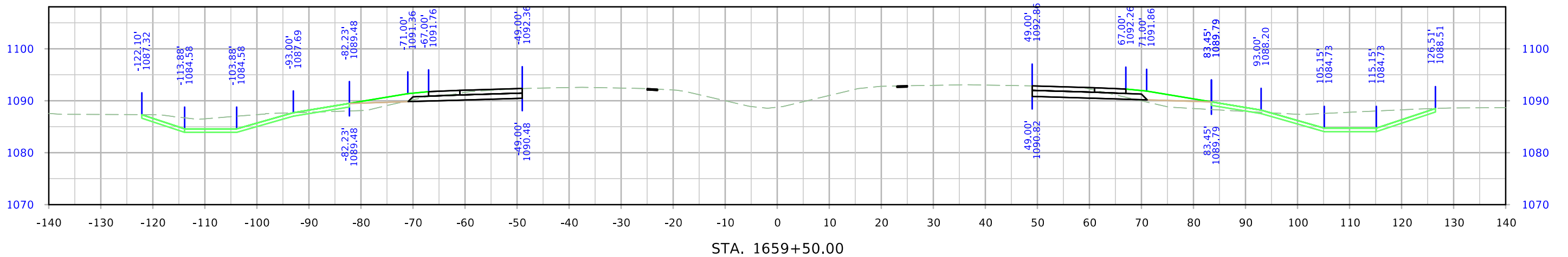
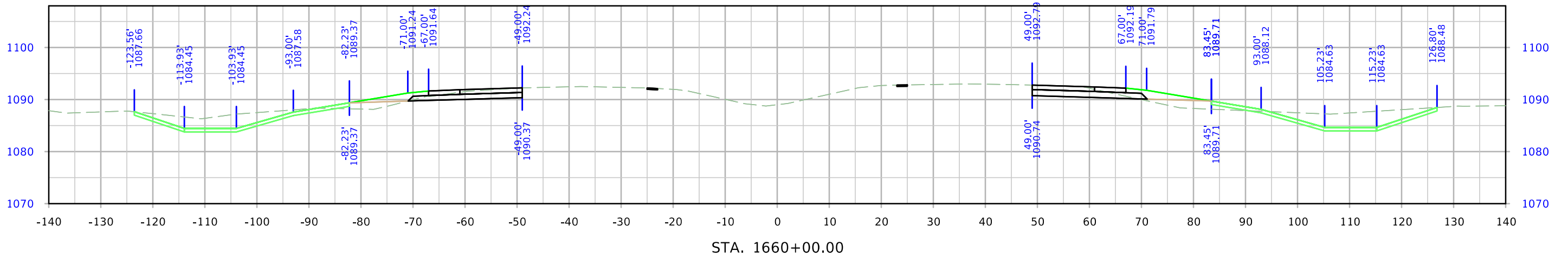
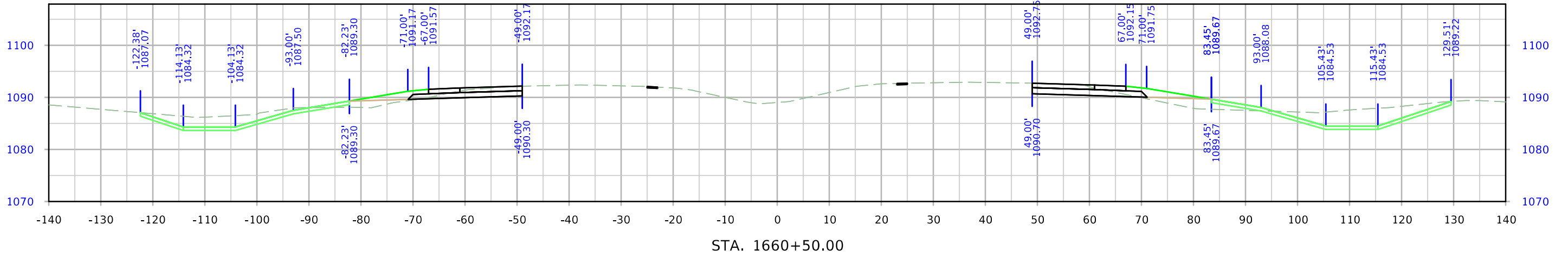

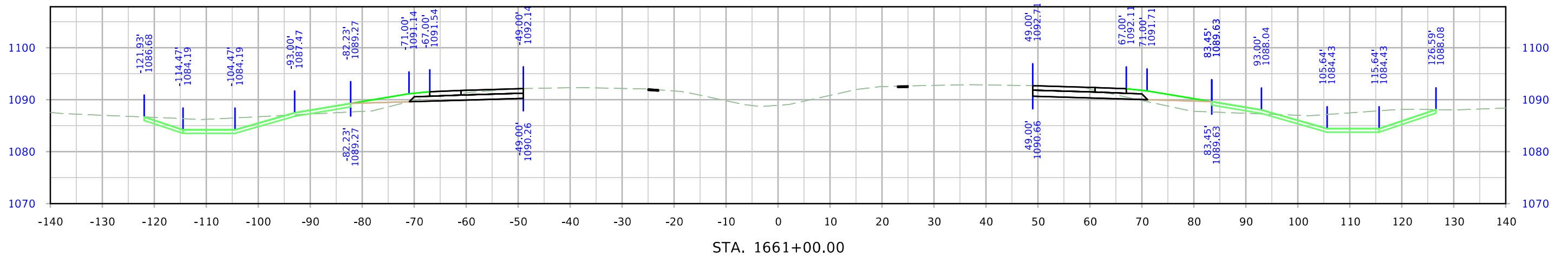
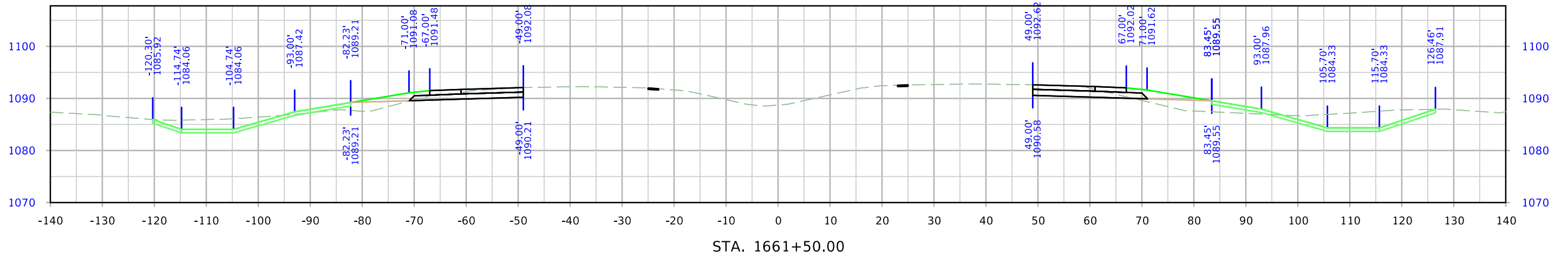
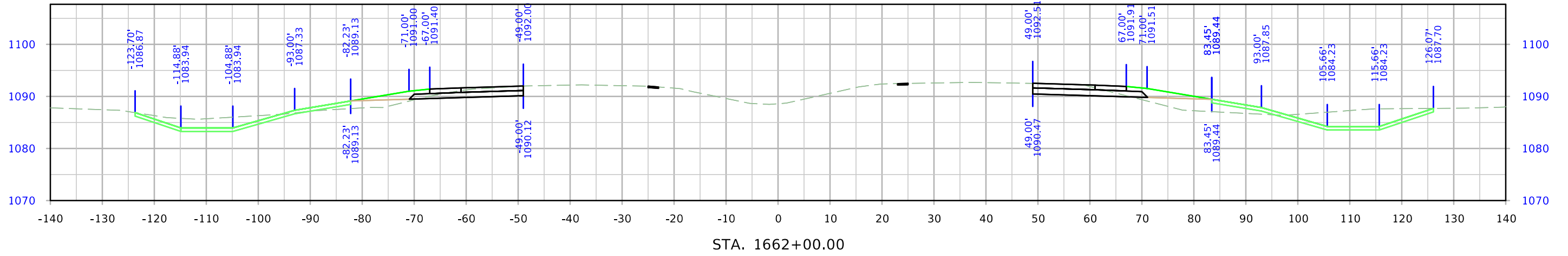

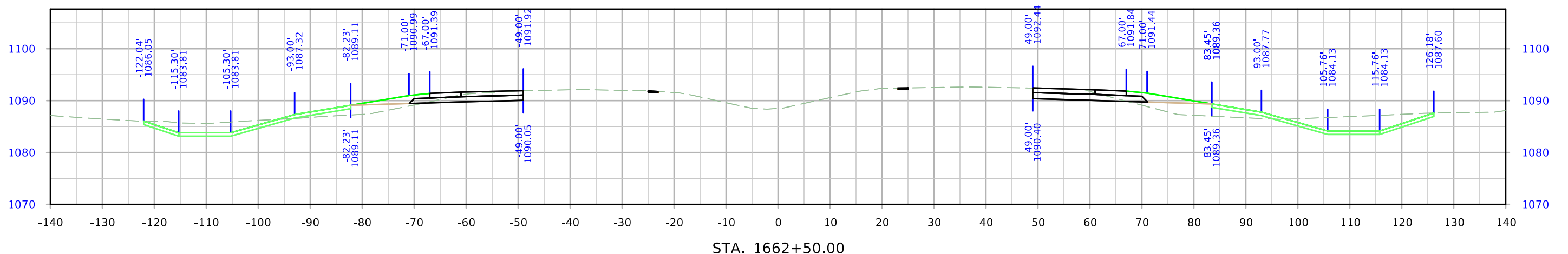
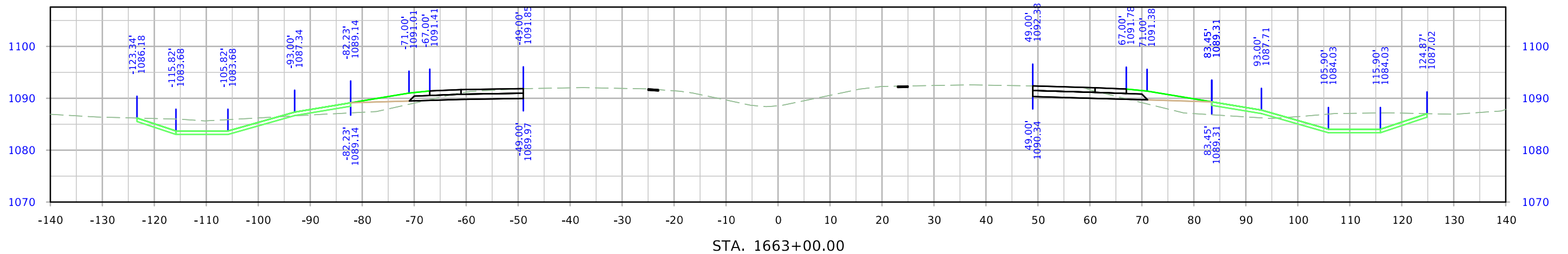
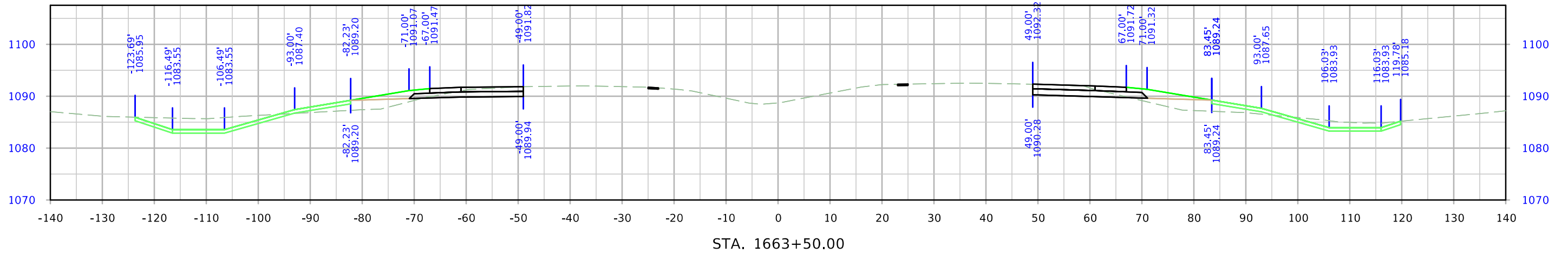

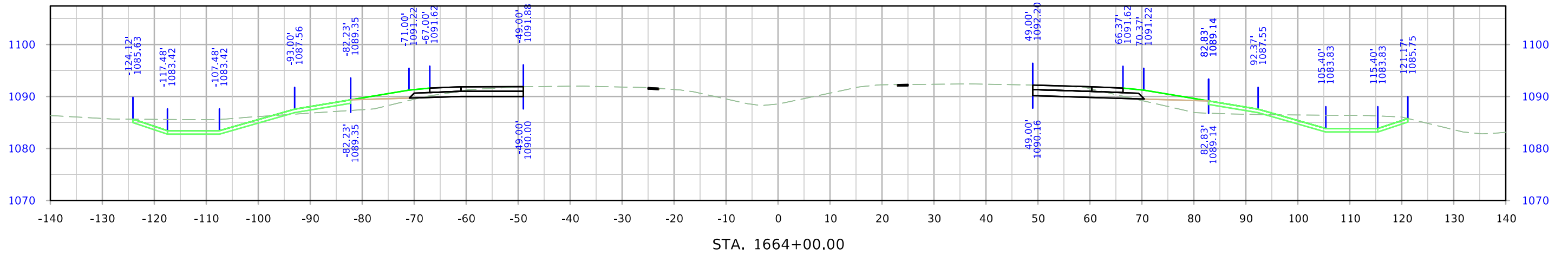
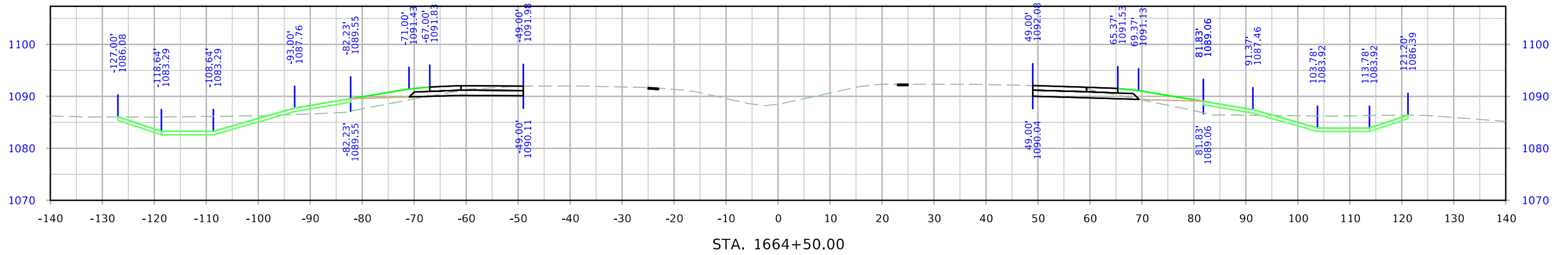
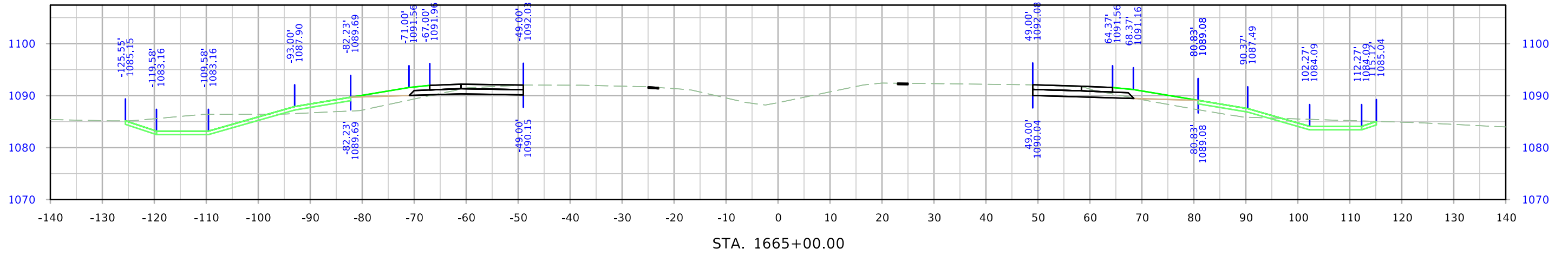

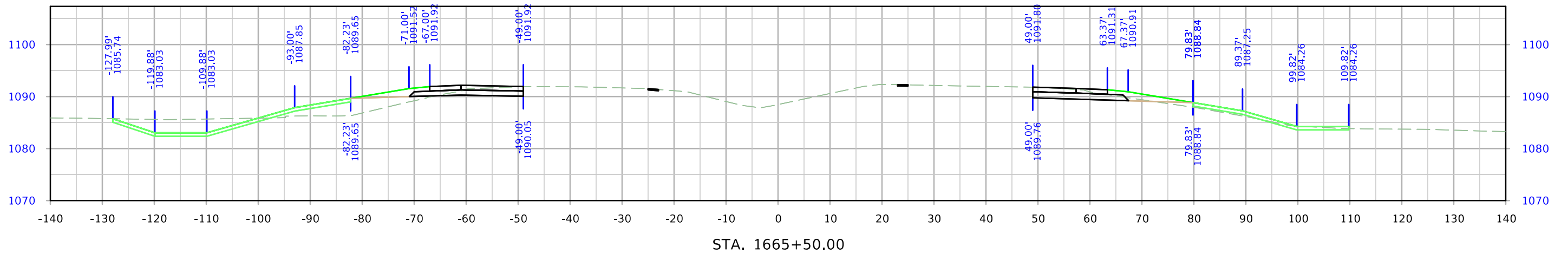
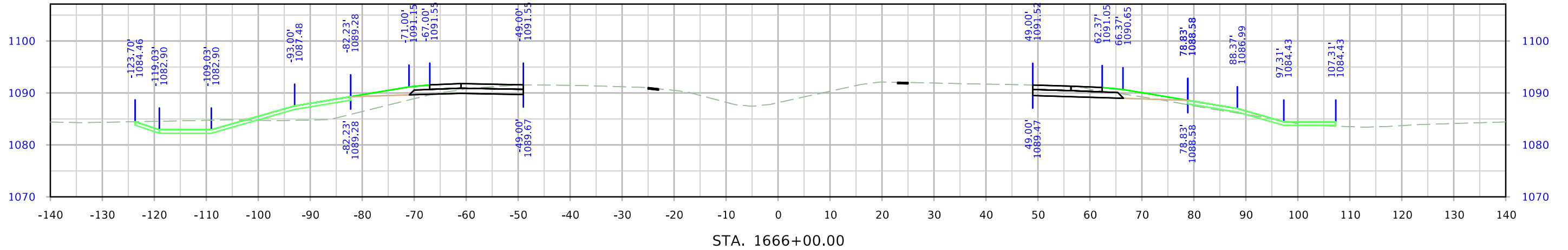
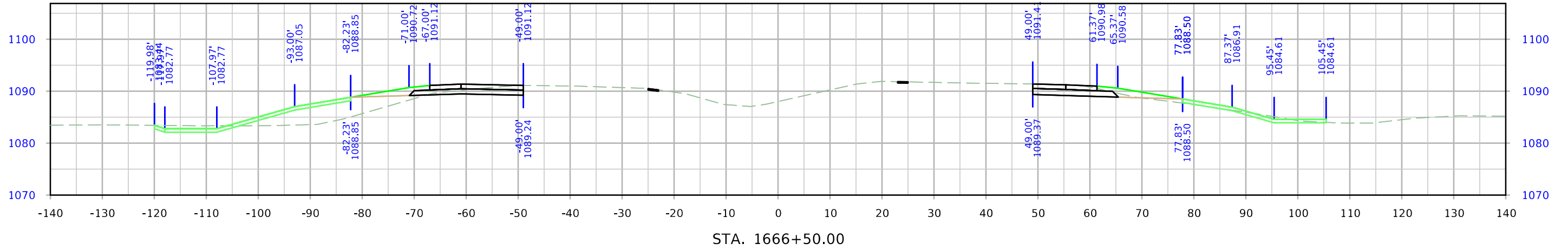

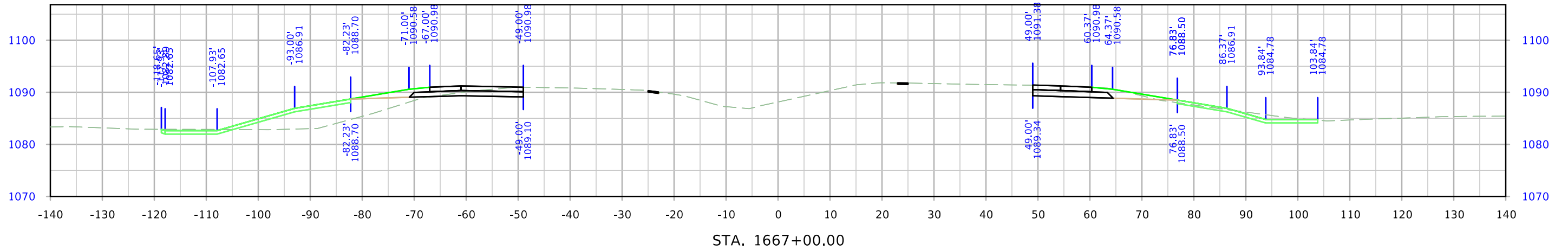
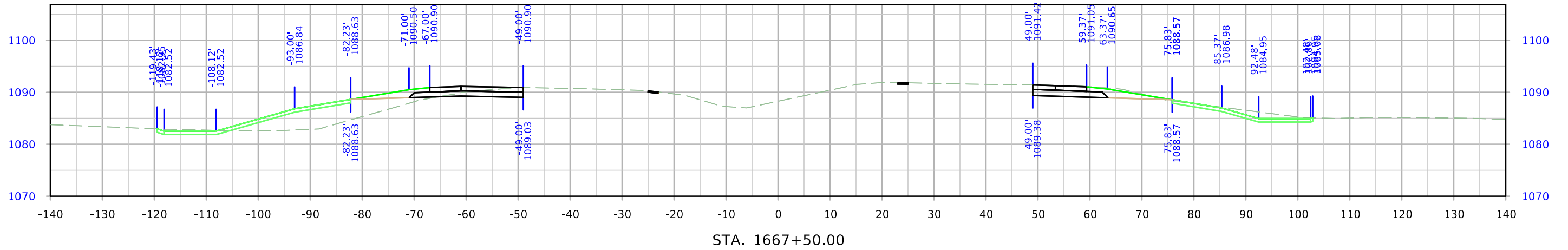
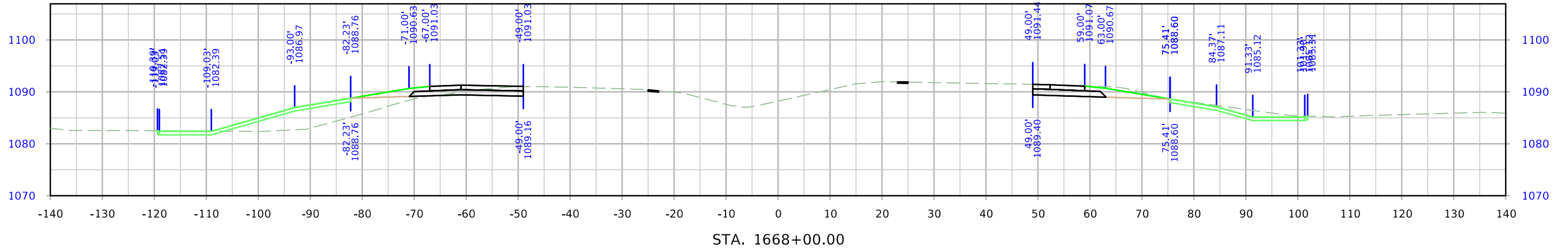

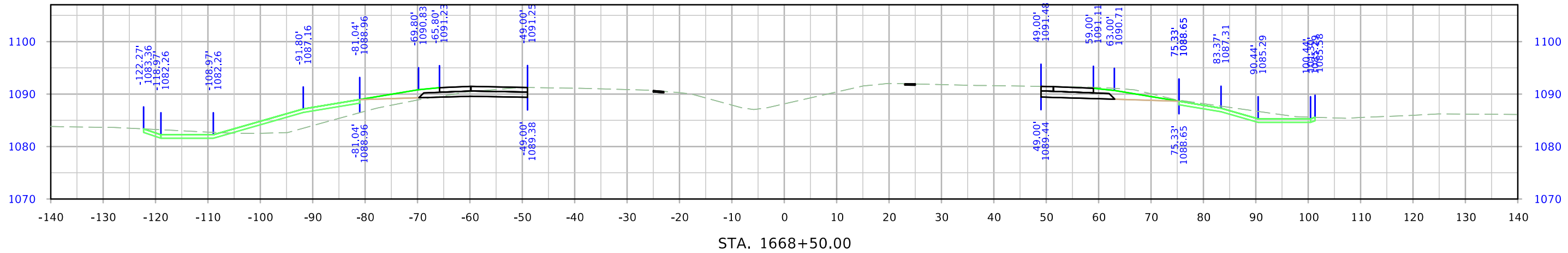
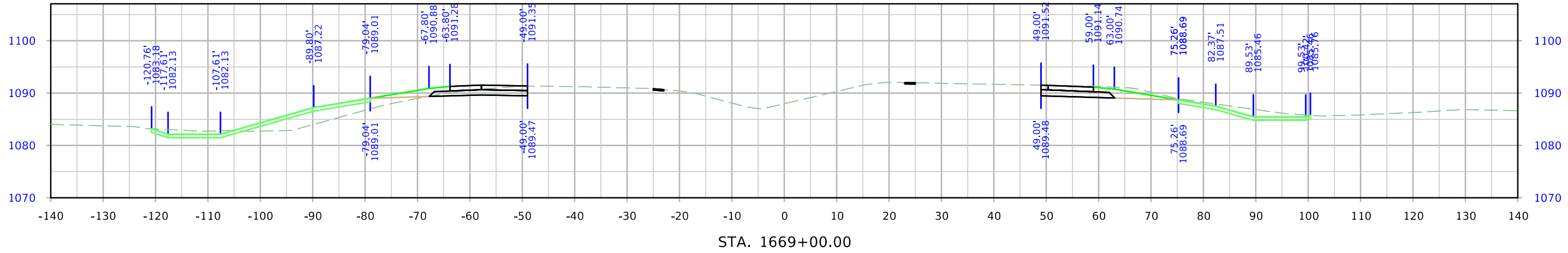
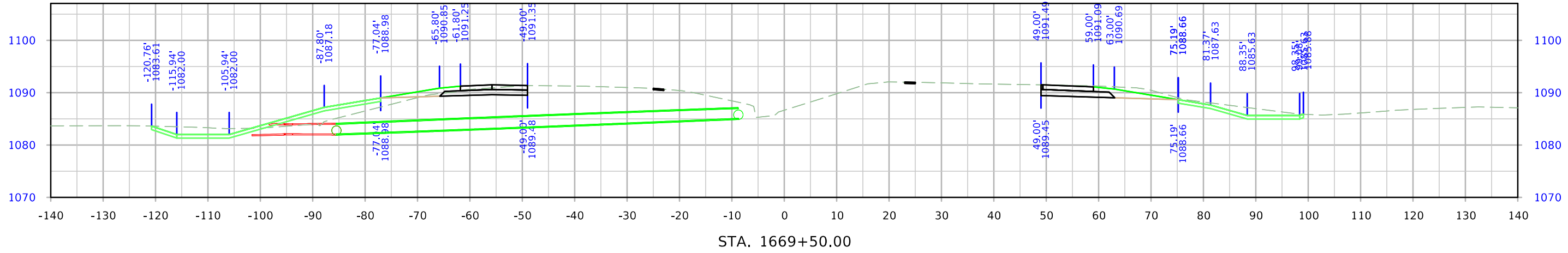

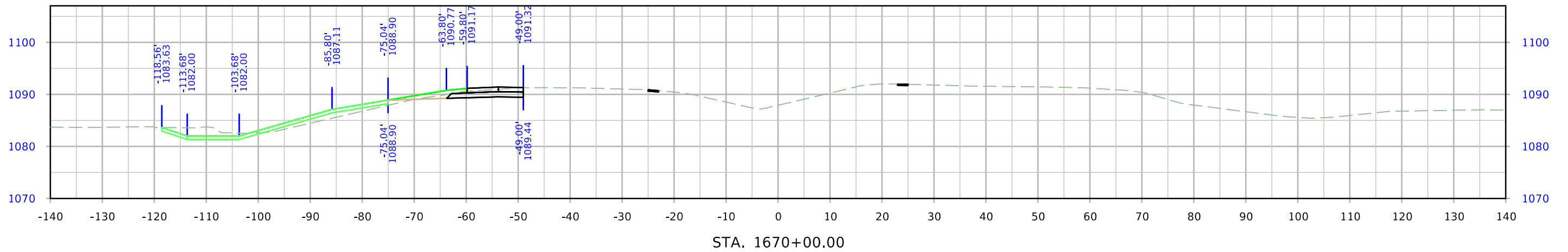
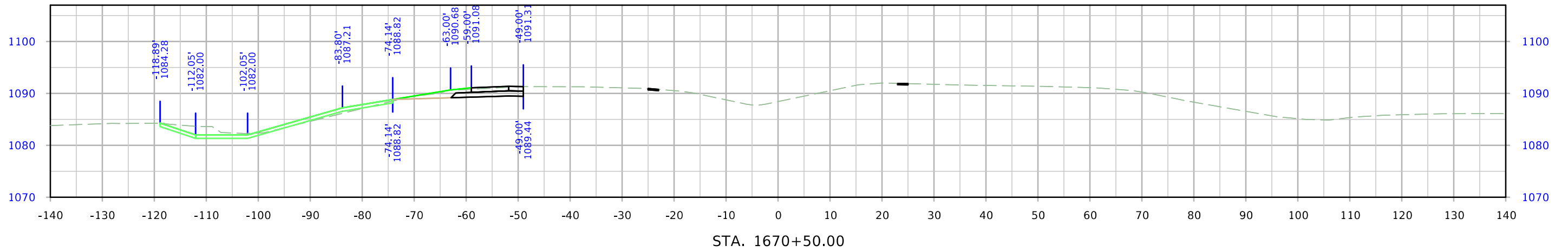
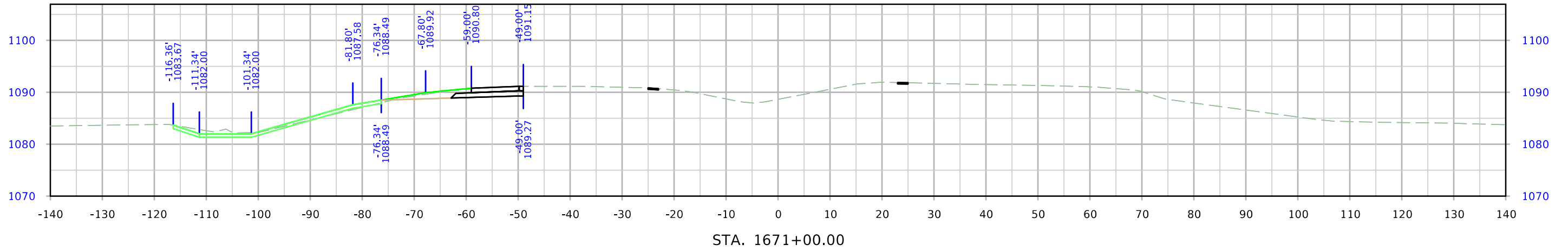

235th Street

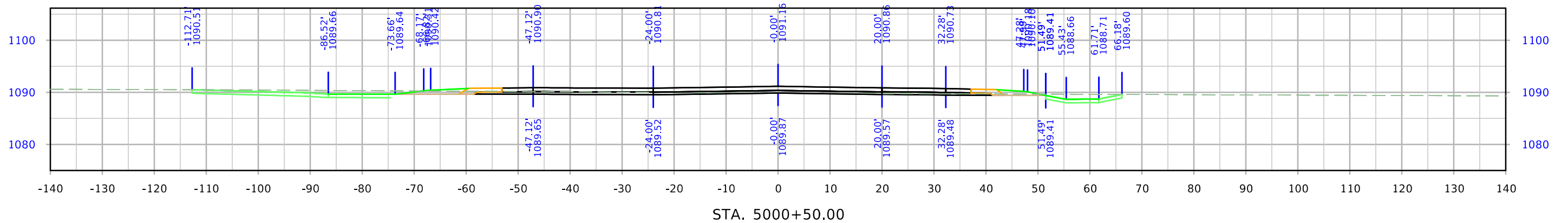
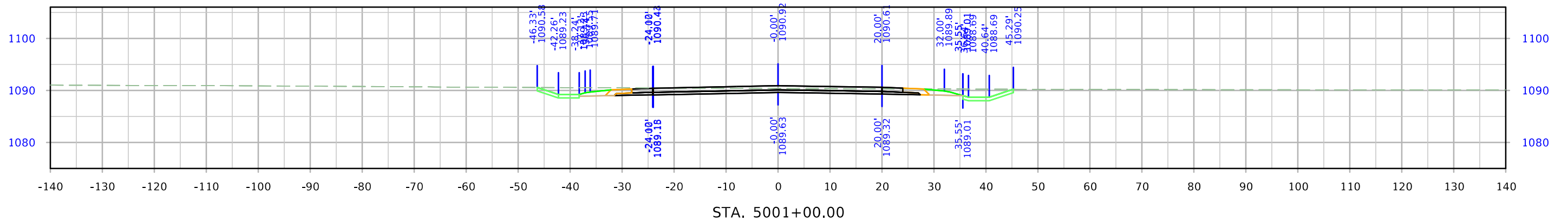
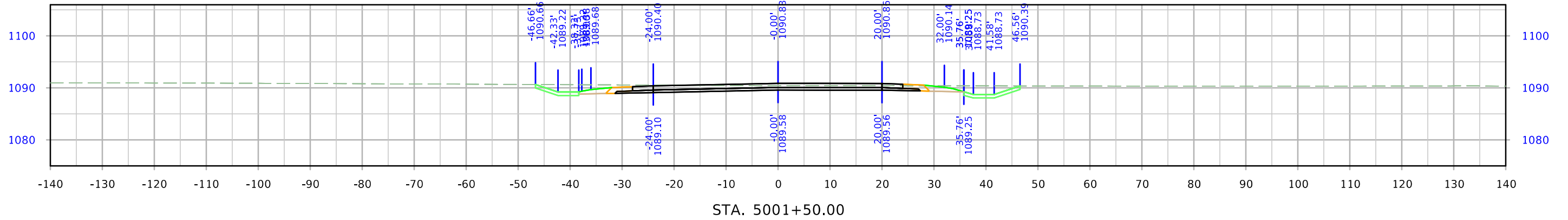

235th Street

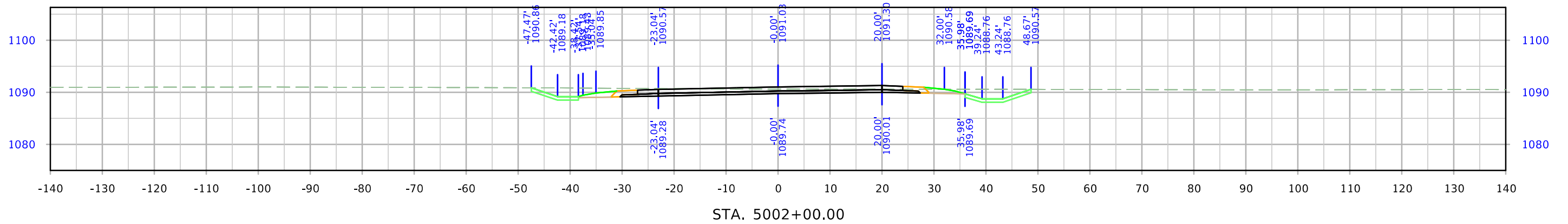
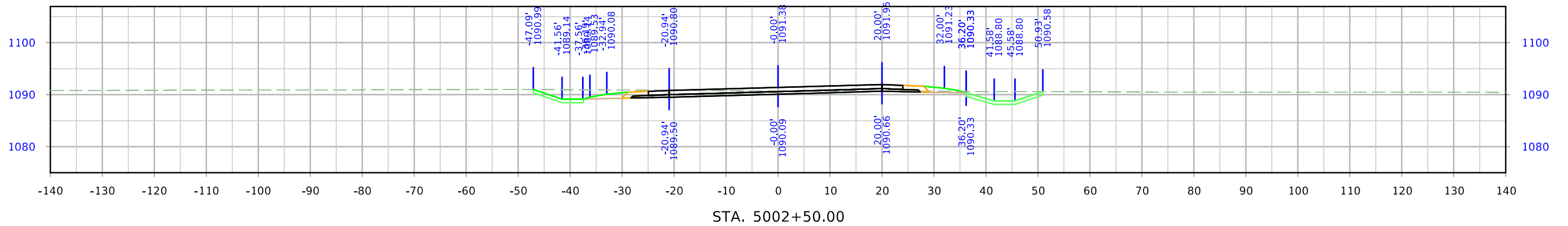
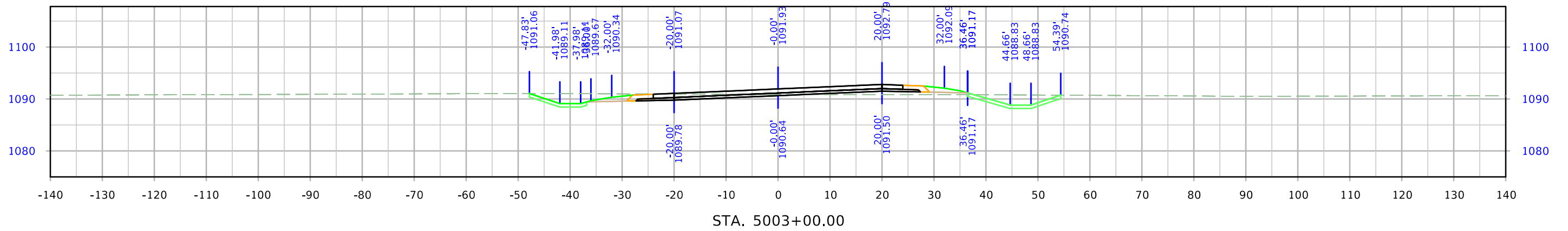

235th Street

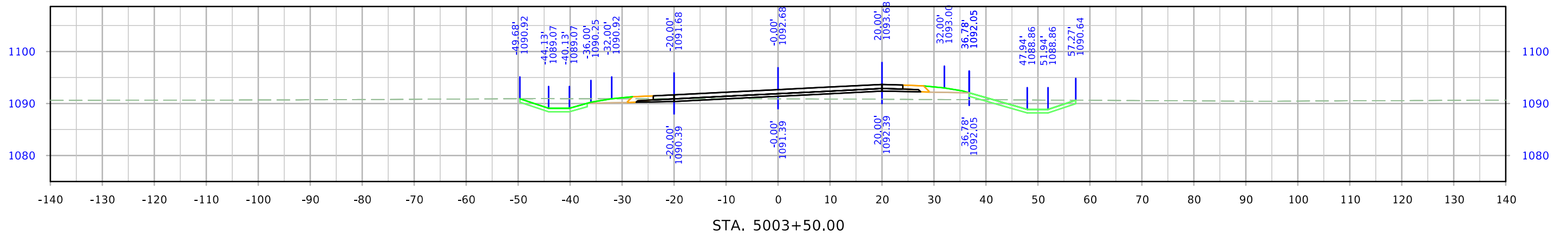
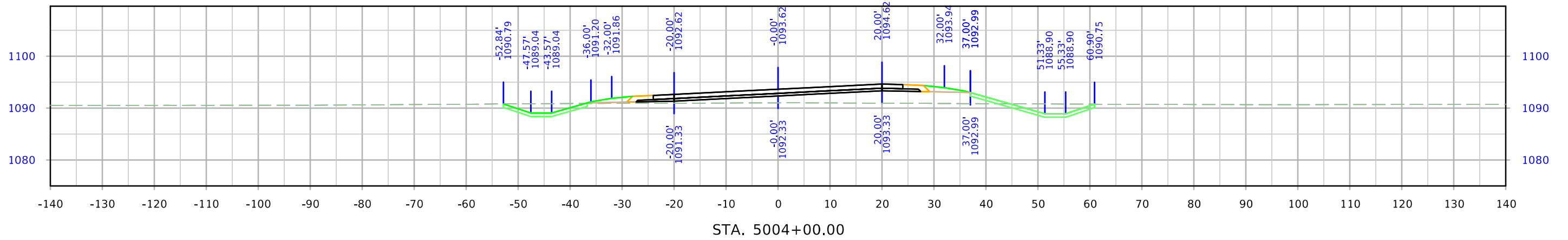
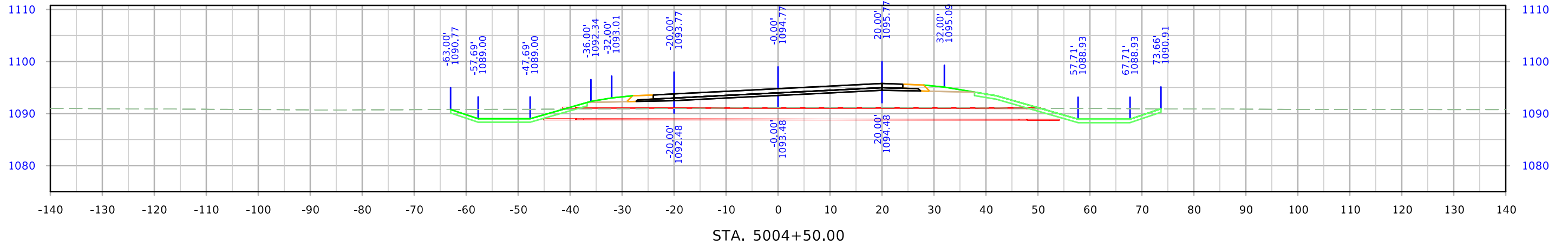

235th Street

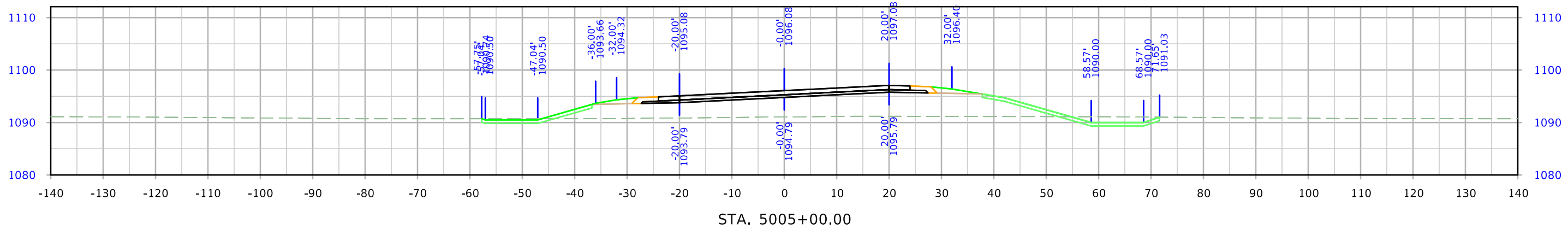
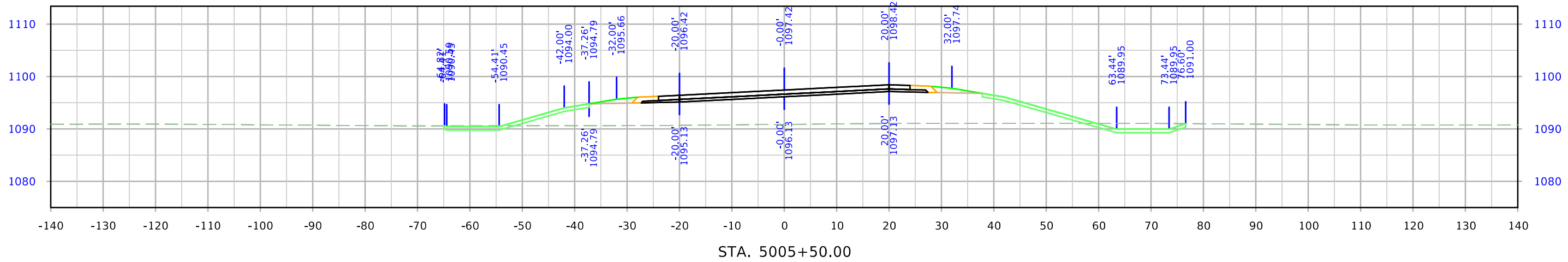
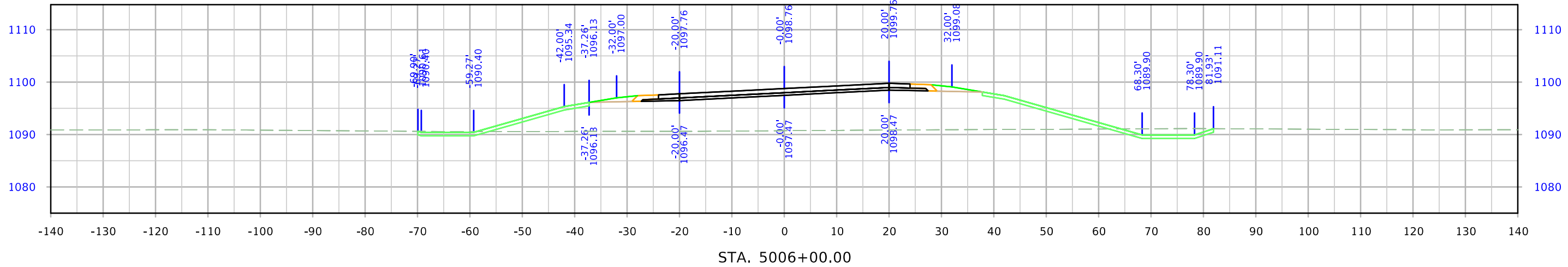

235th Street

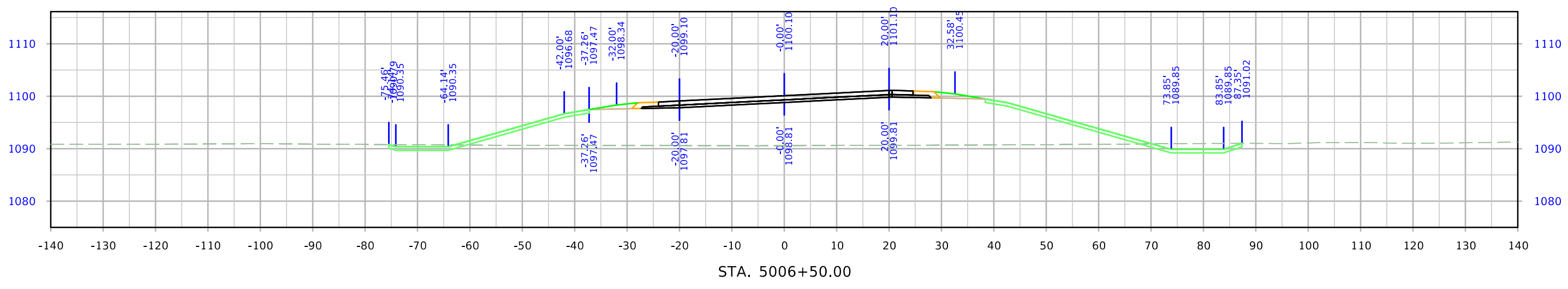
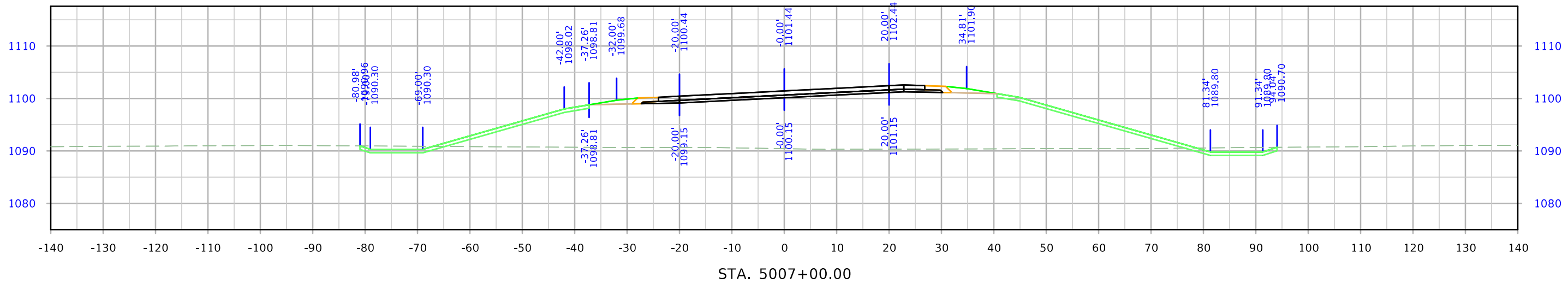
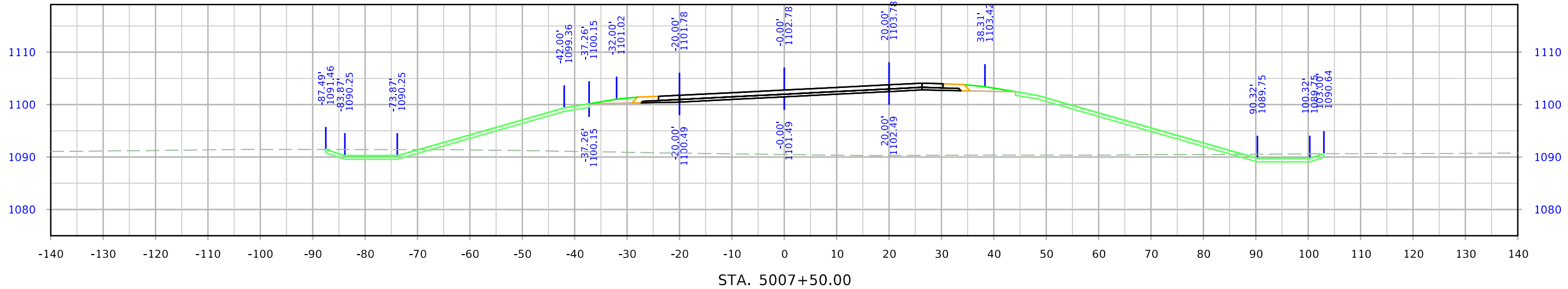

235th Street

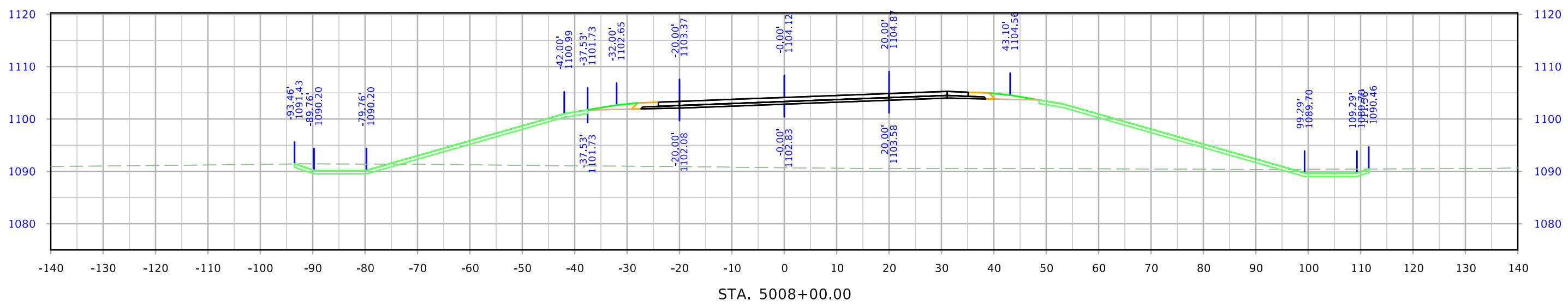
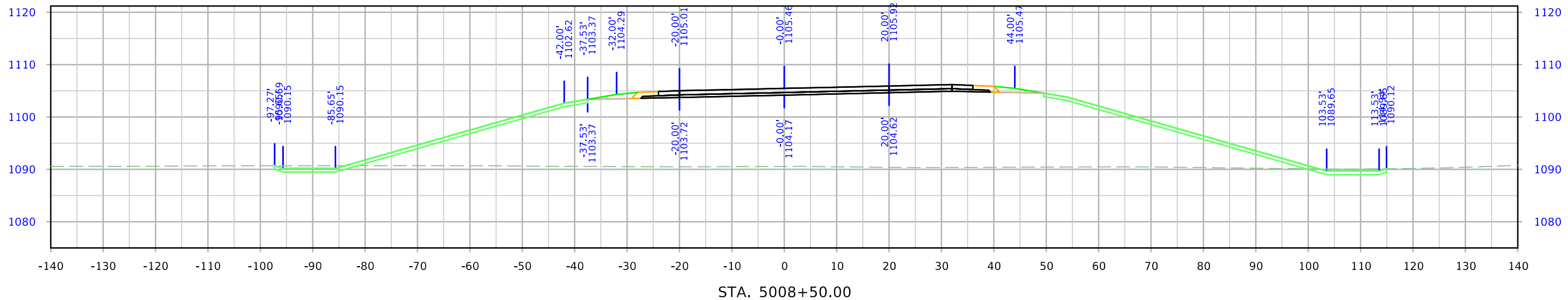

235th Street

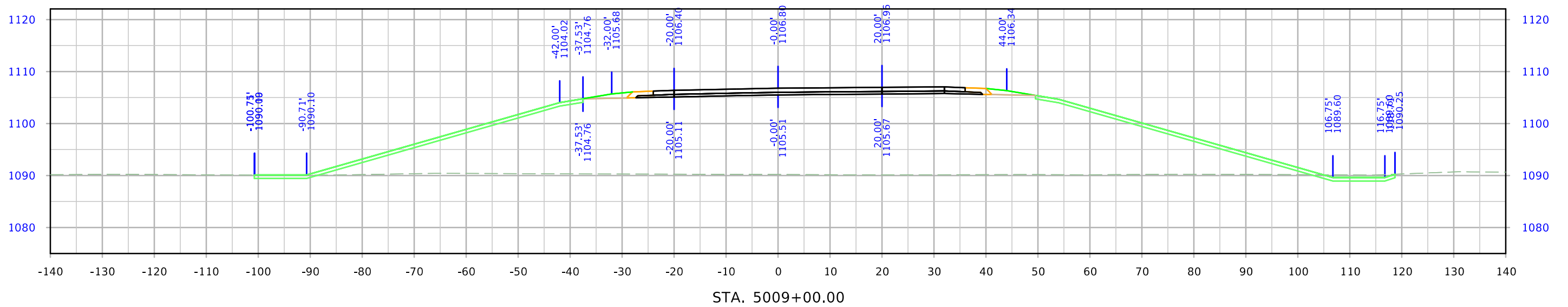
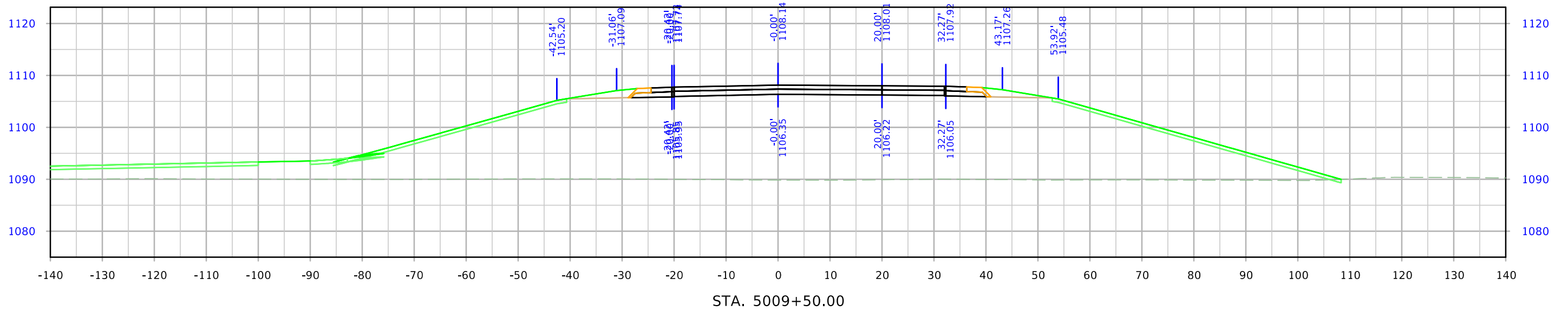

235th Street

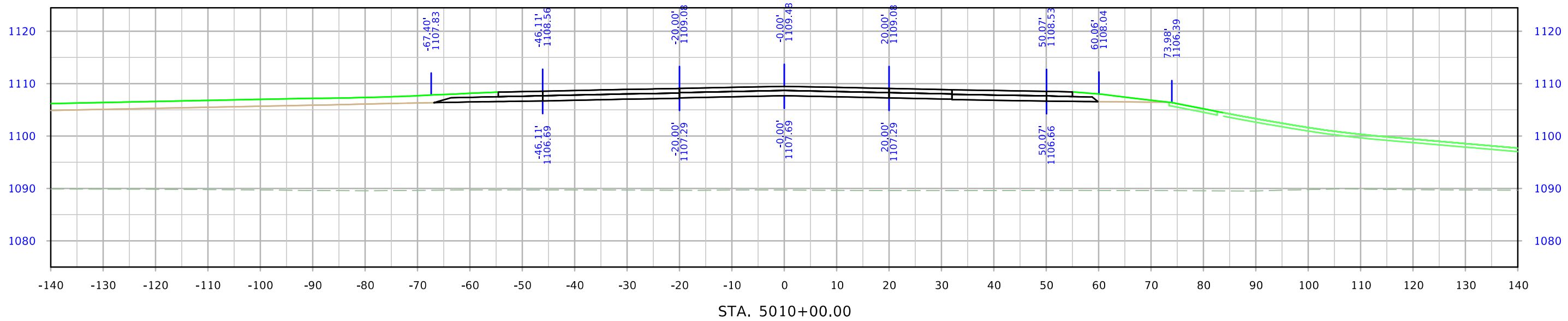
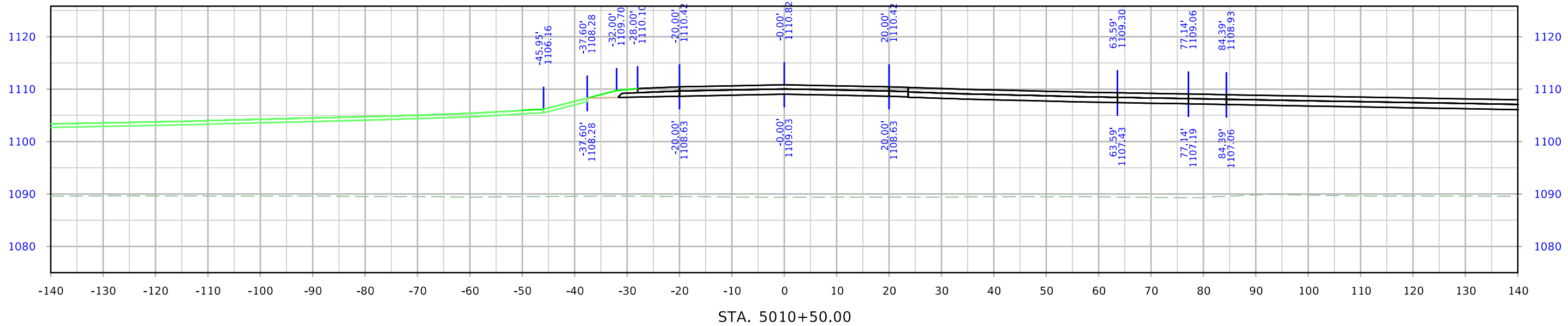

235th Street

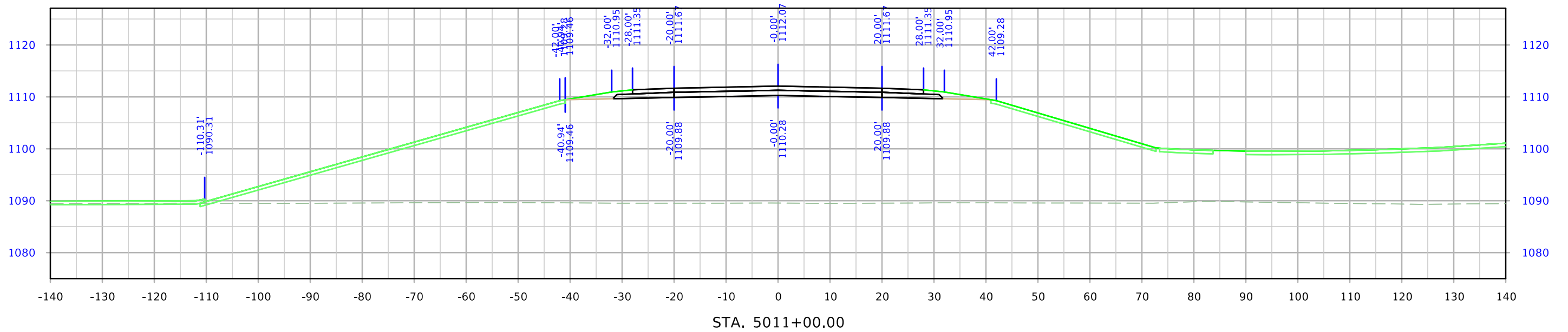
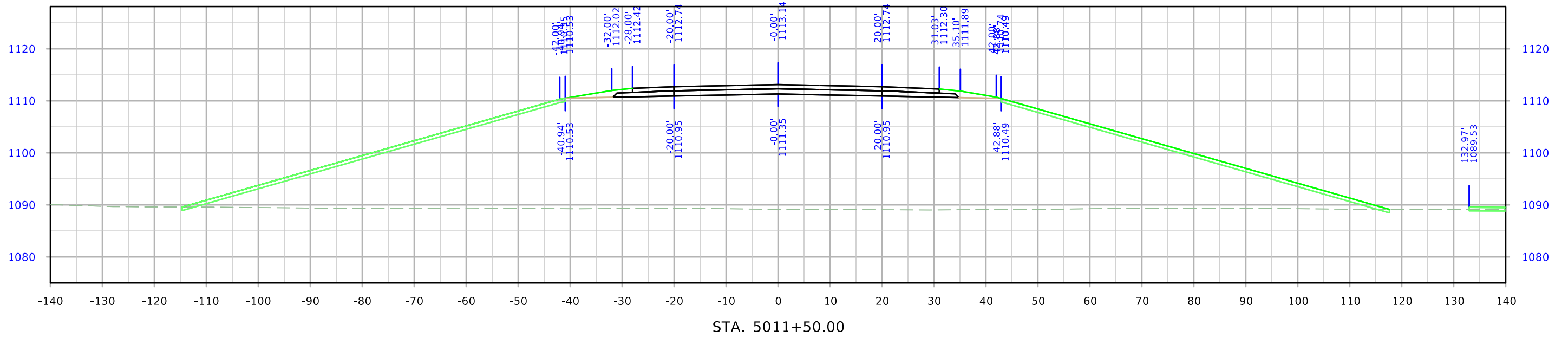

235th Street

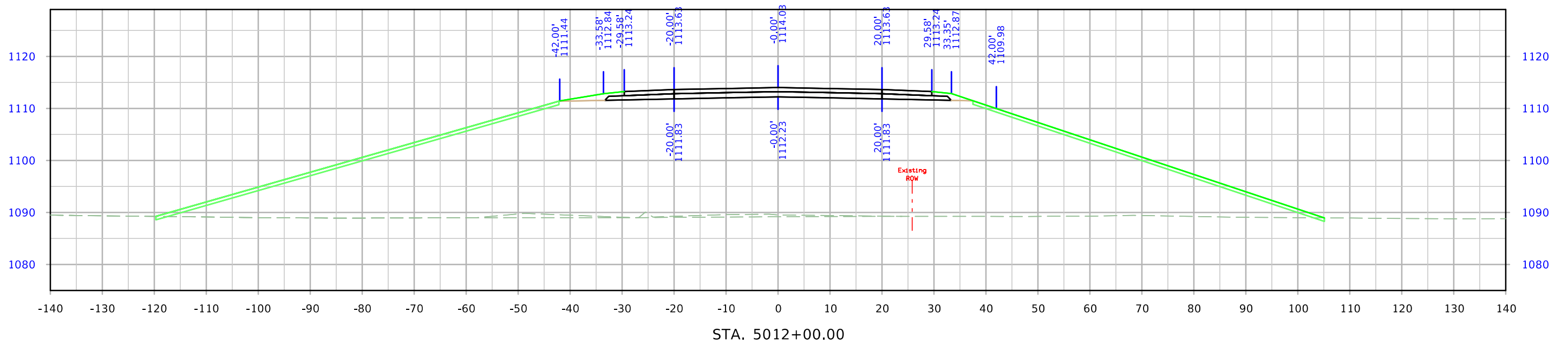
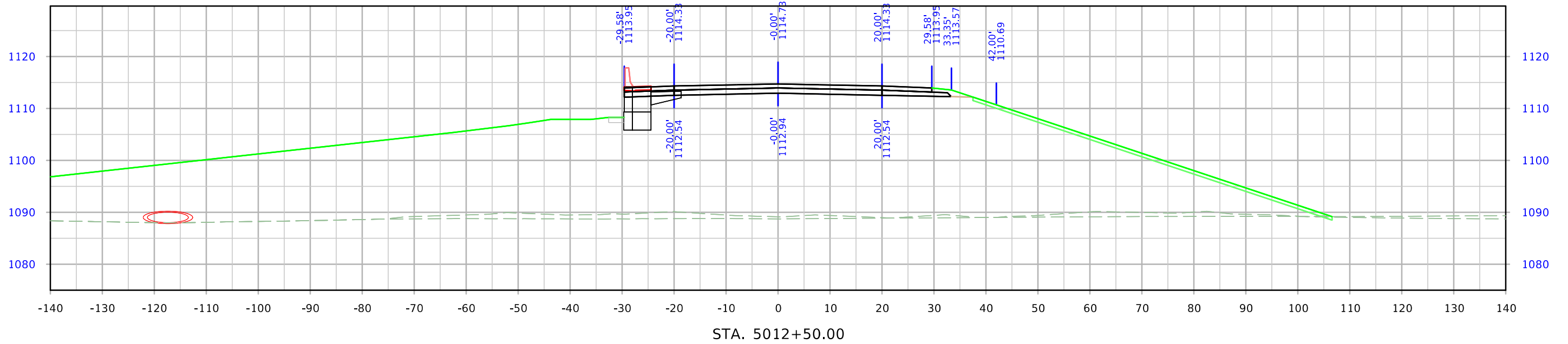

235th Street

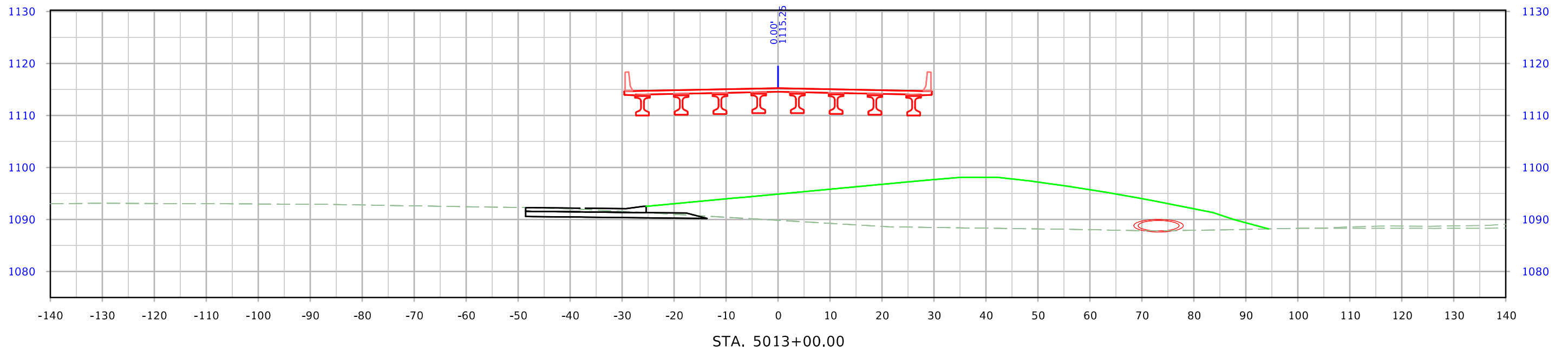
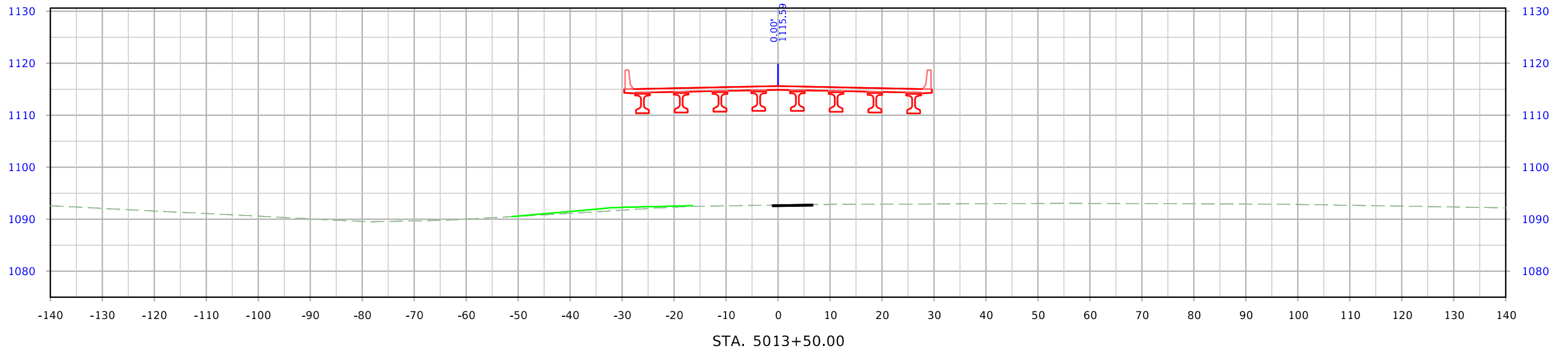

235th Street

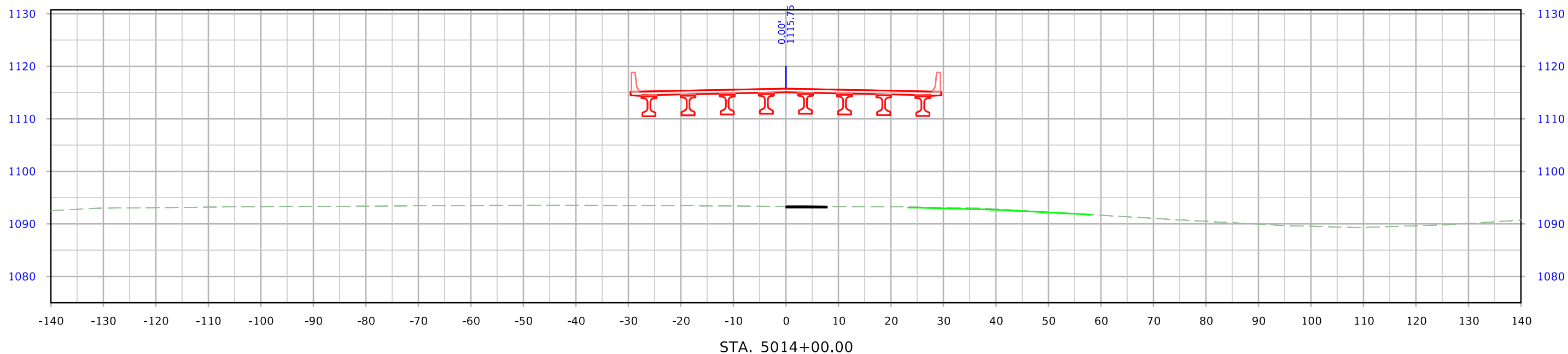
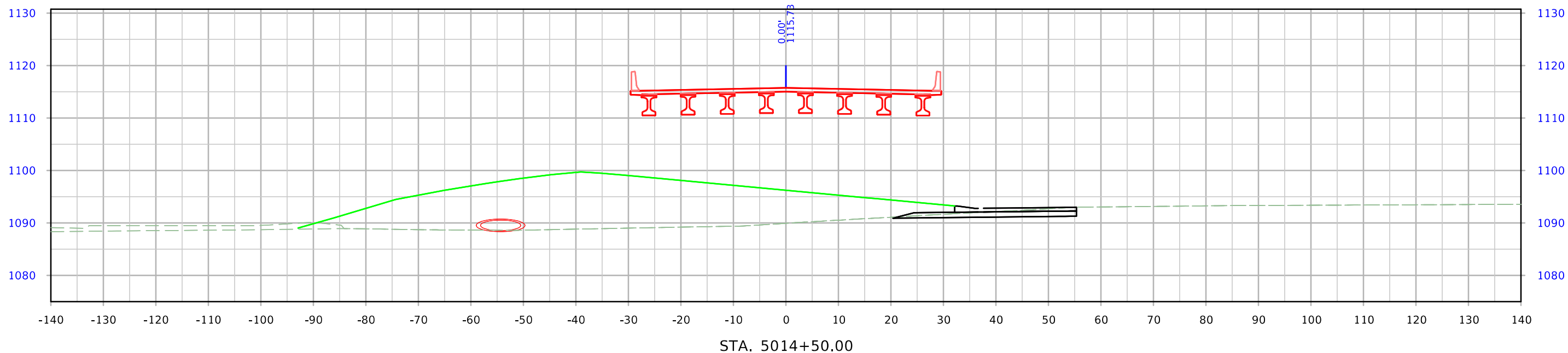

235th Street

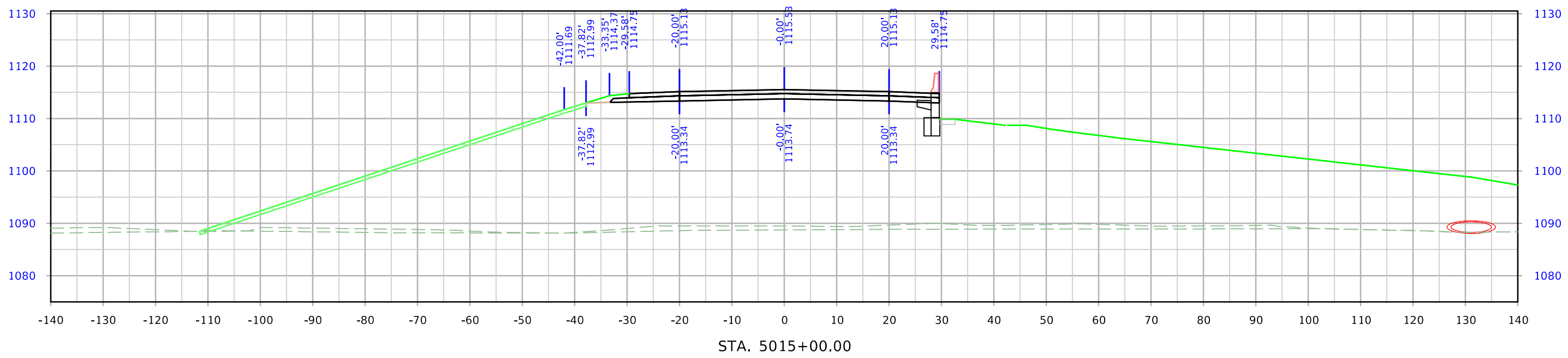
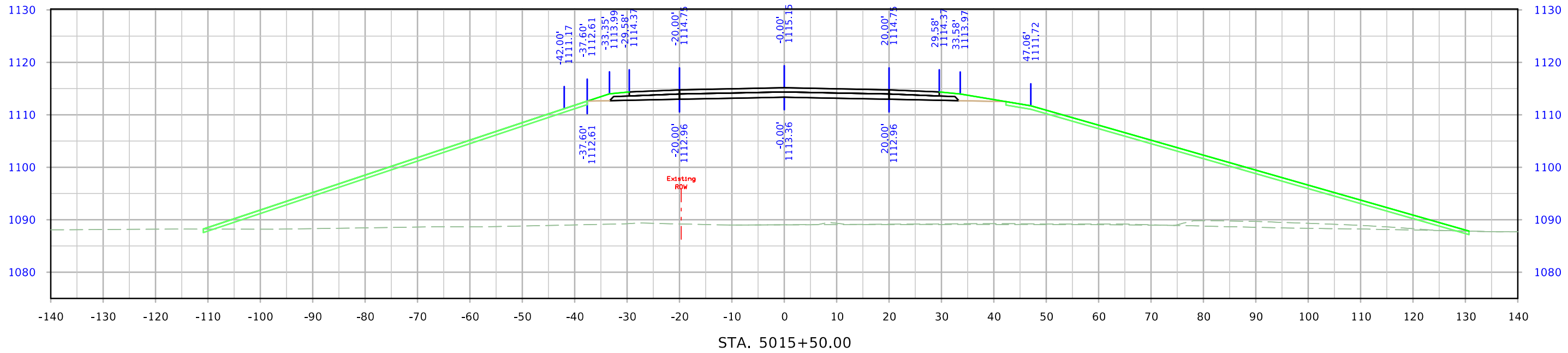

235th Street

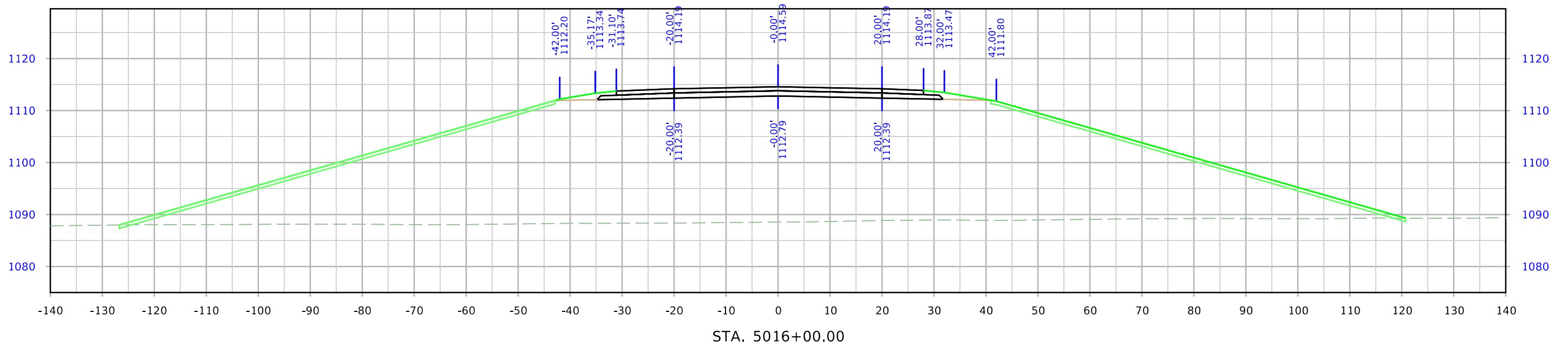
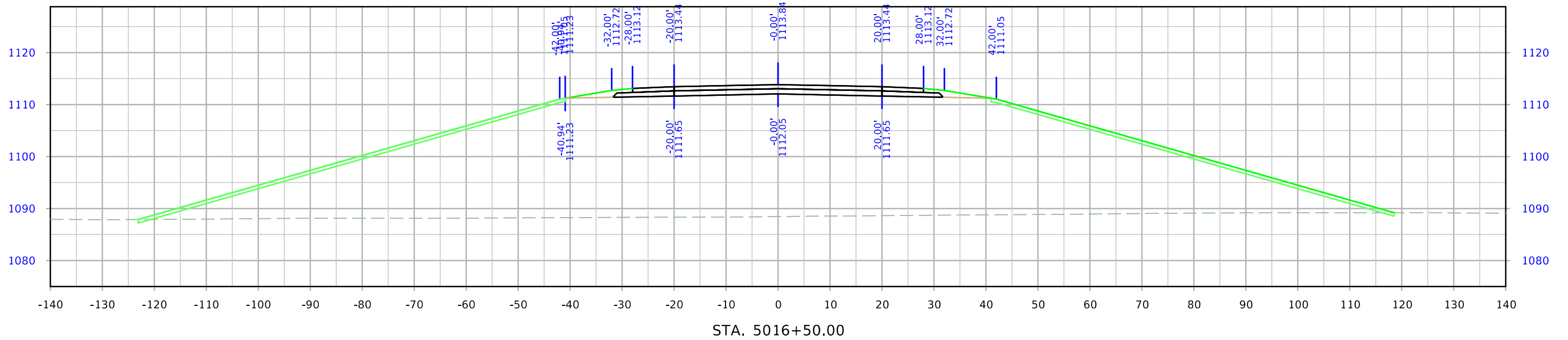

235th Street

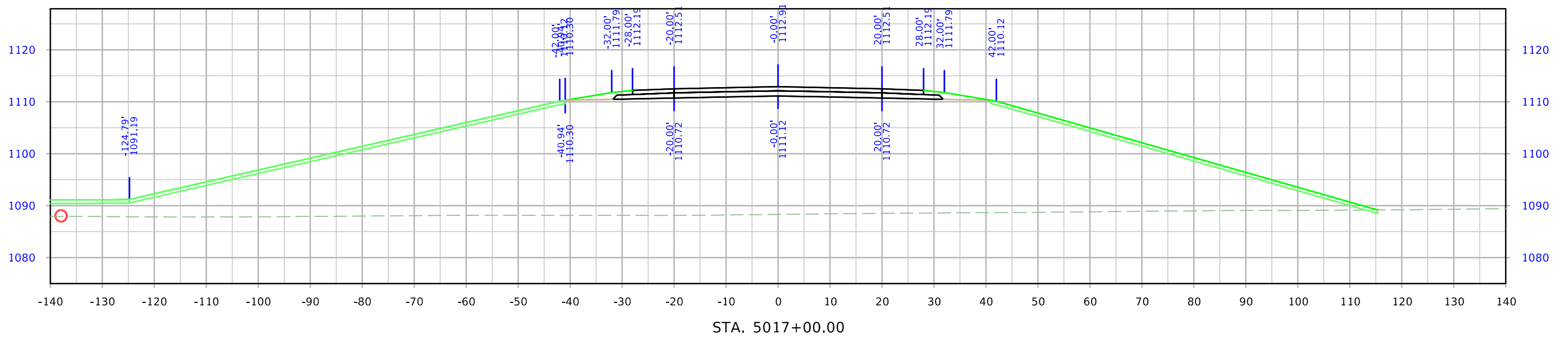
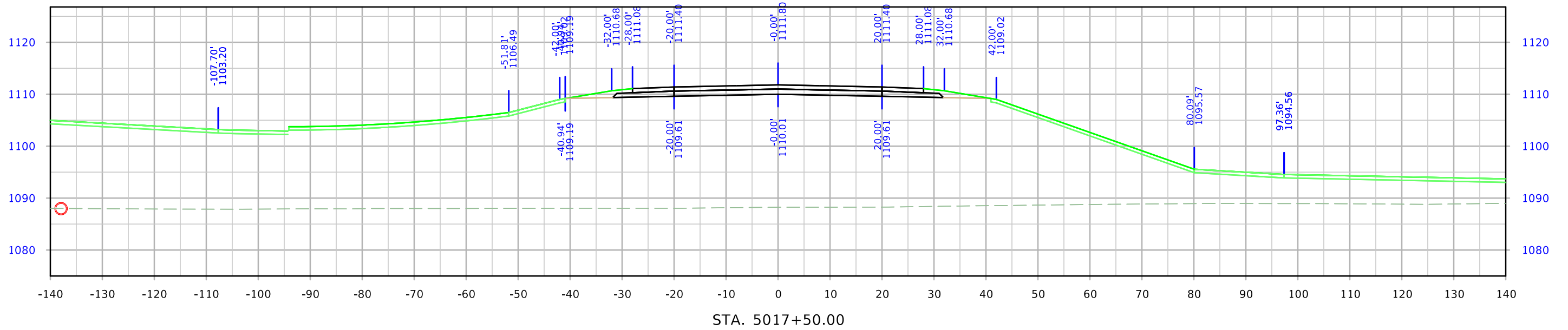

235th Street

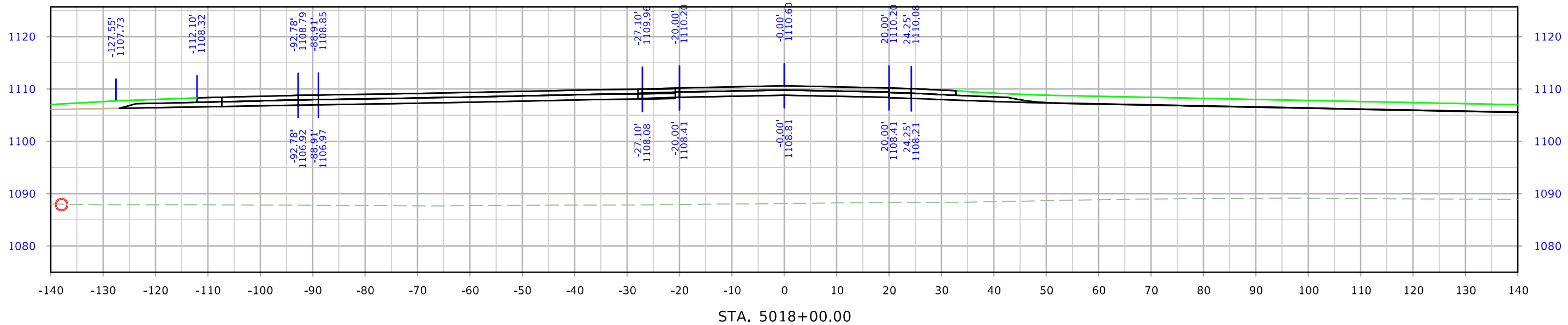
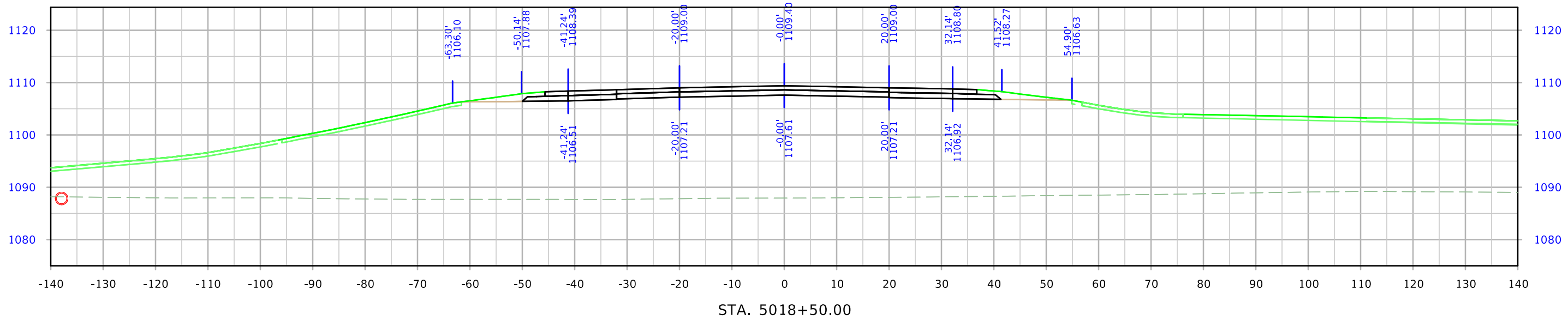

235th Street

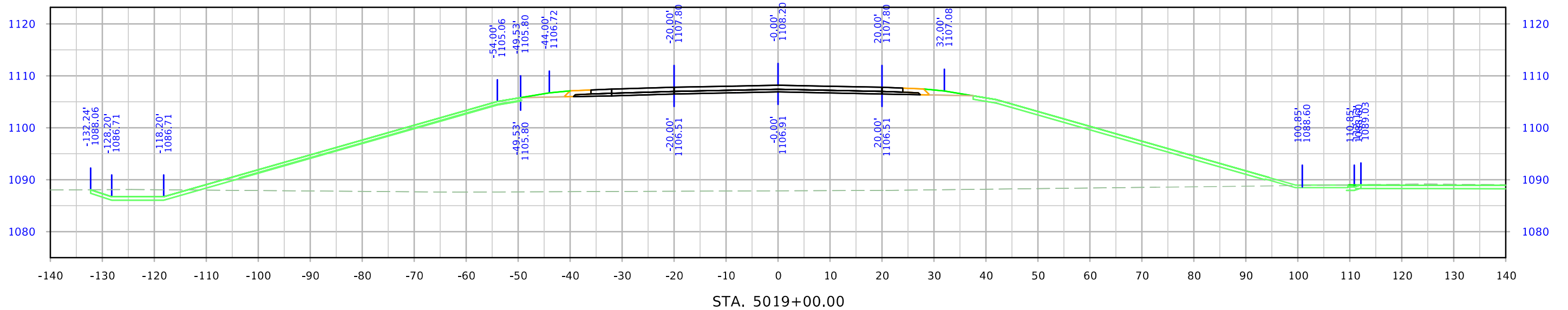
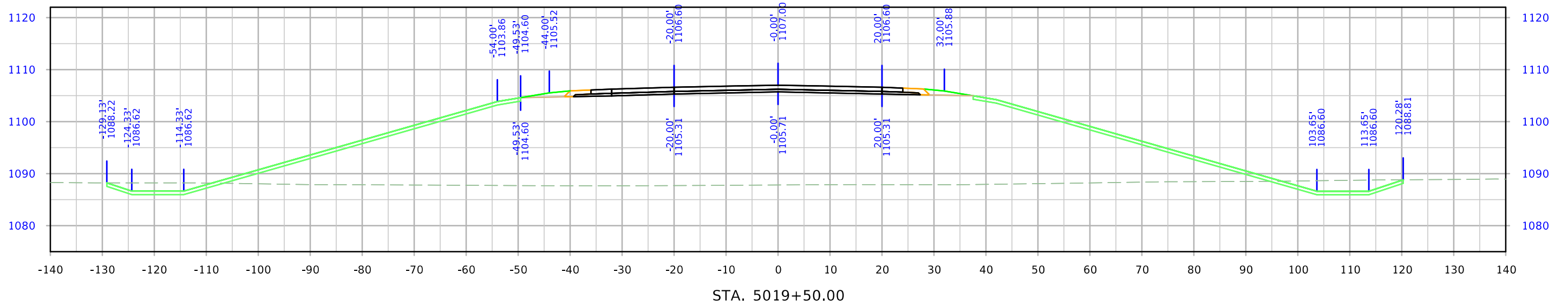

235th Street

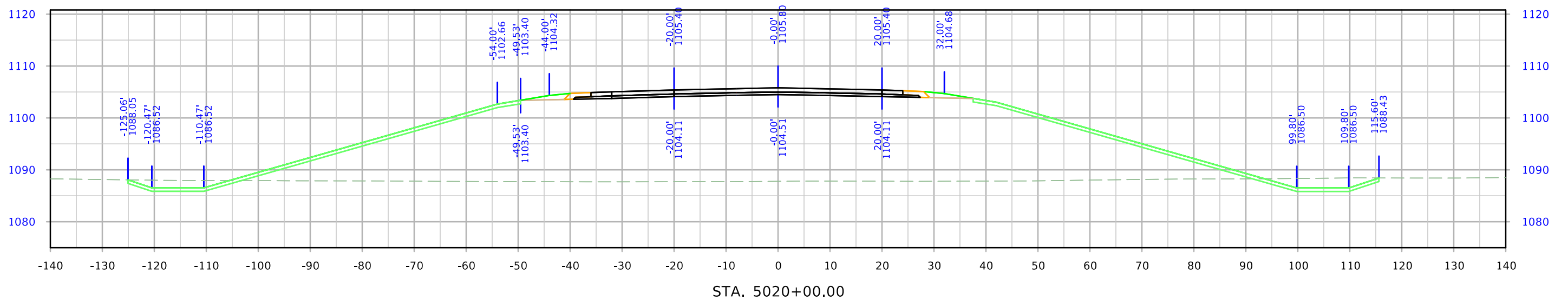
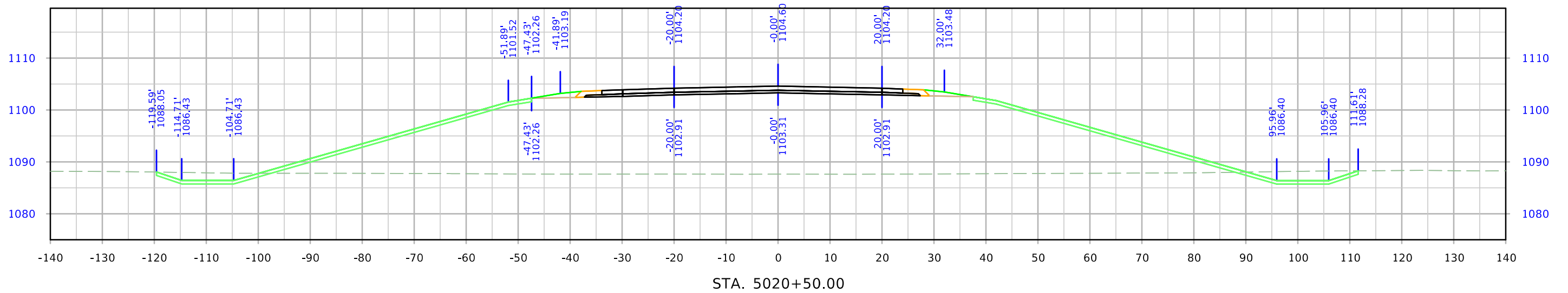
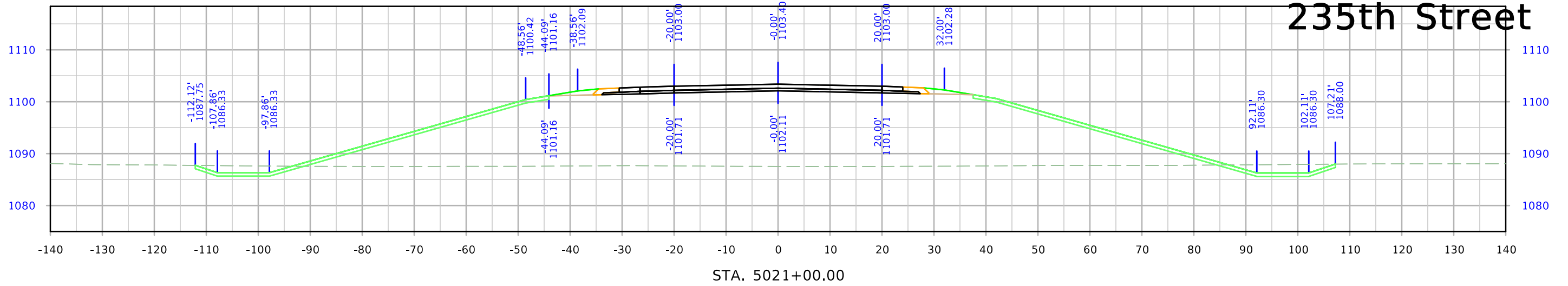

235th Street

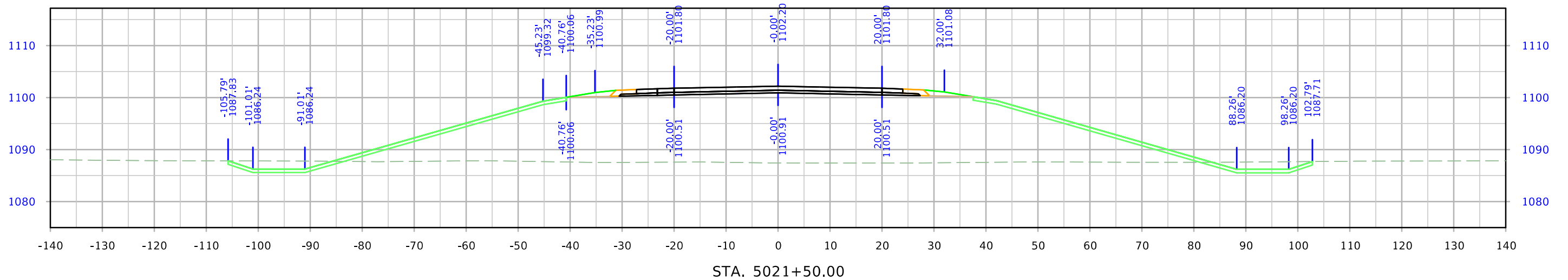
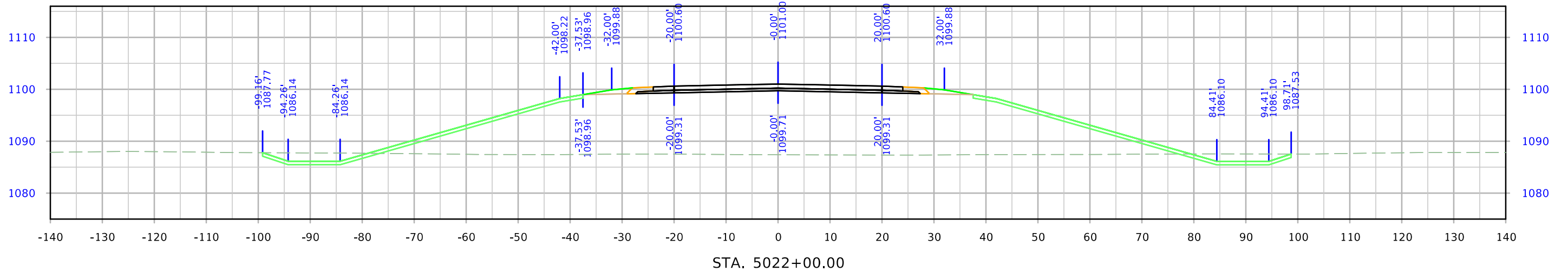
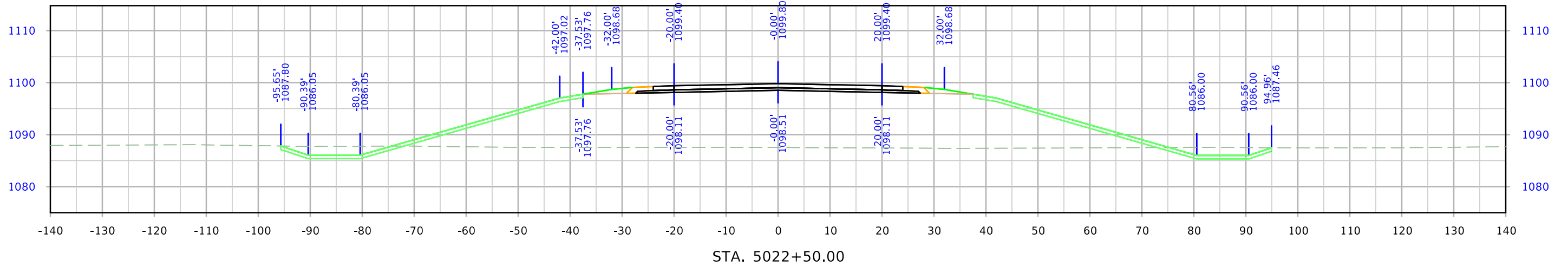

235th Street

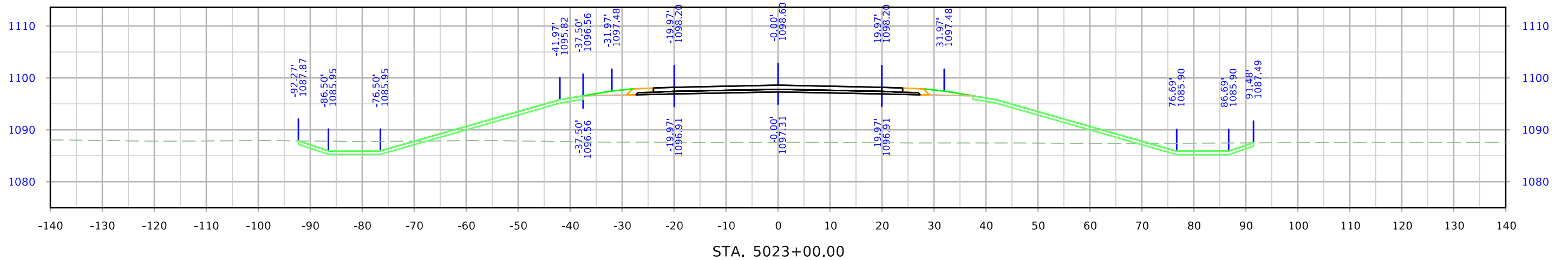
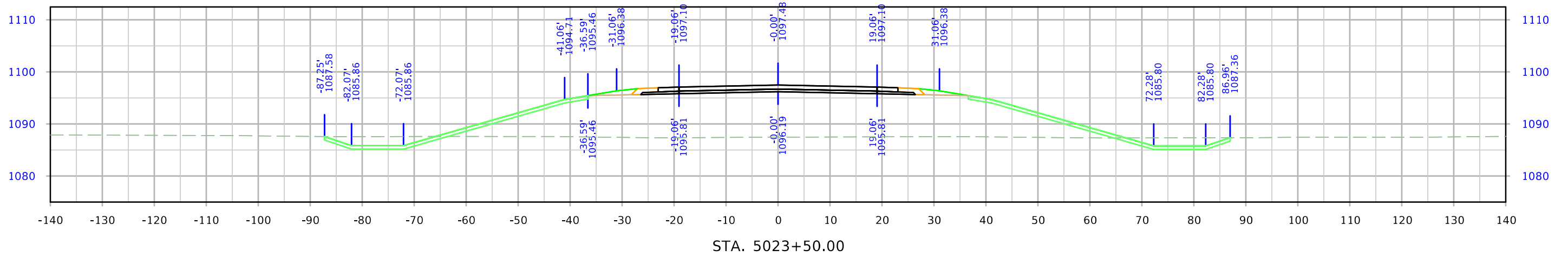
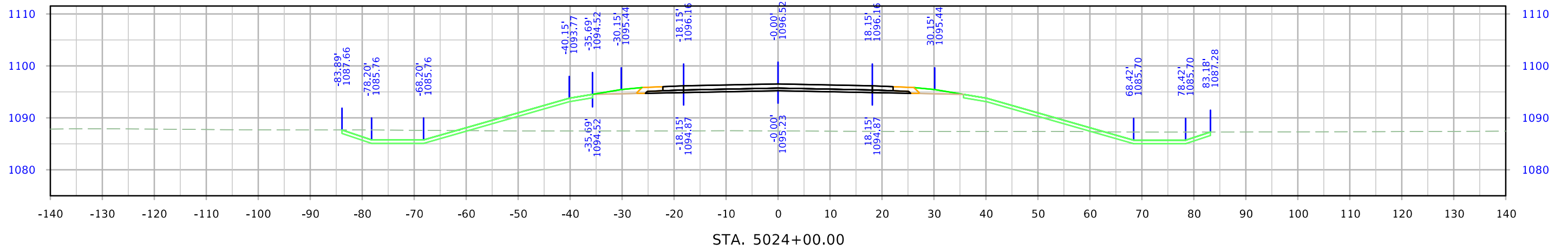

235th Street

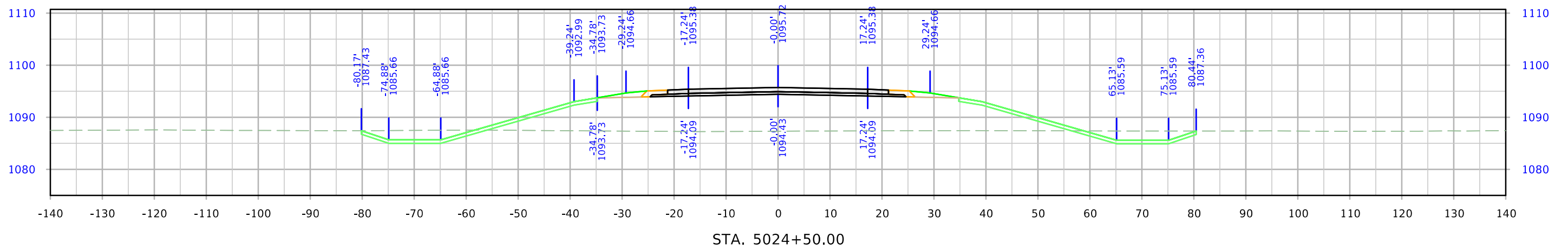
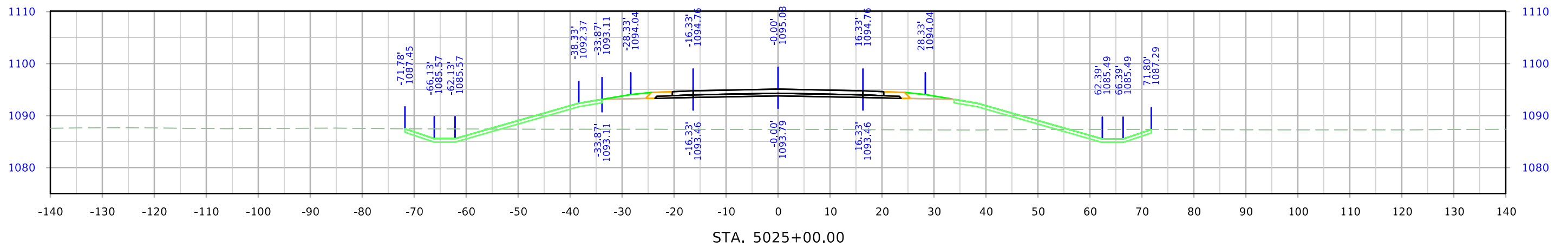
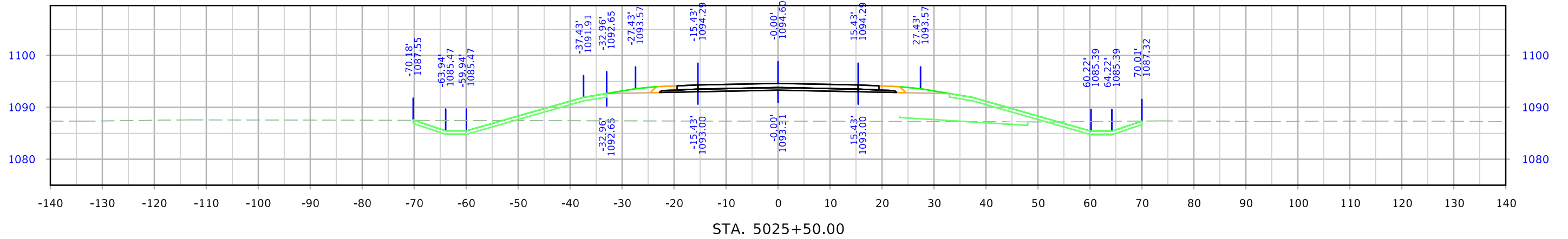

235th Street

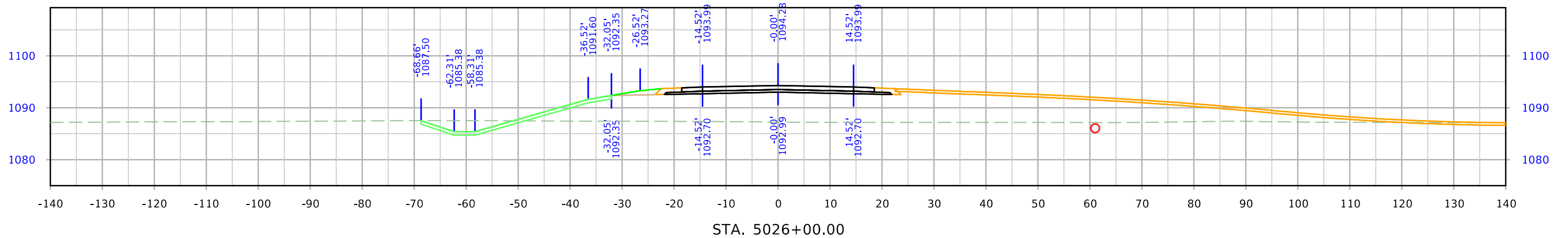
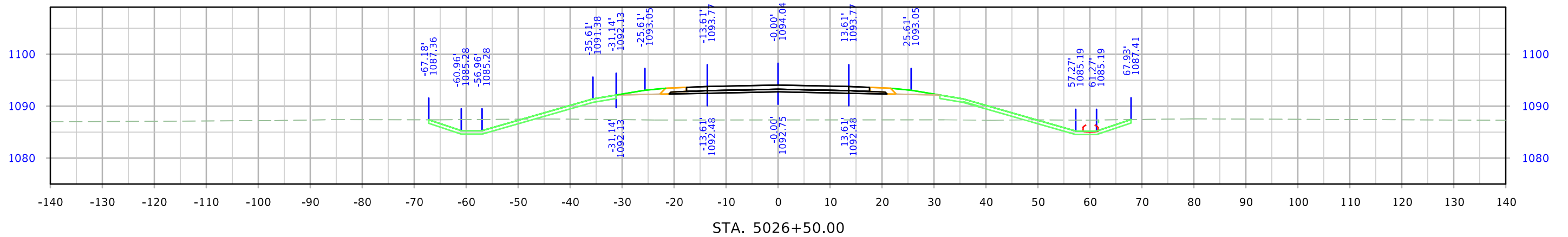
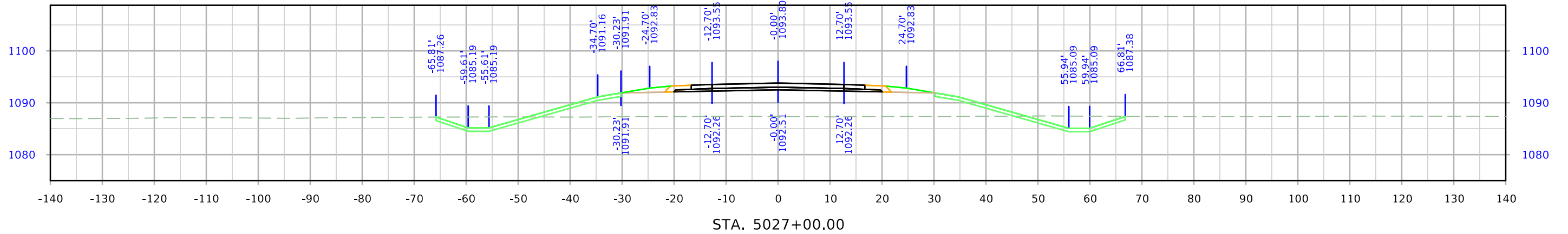

235th Street

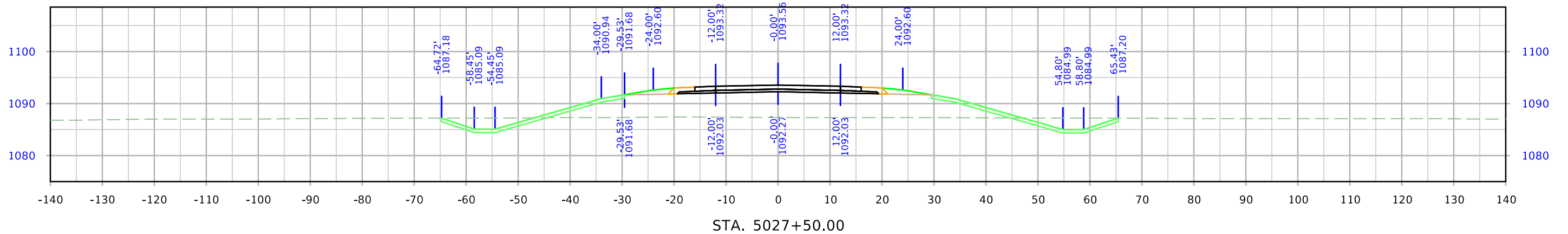
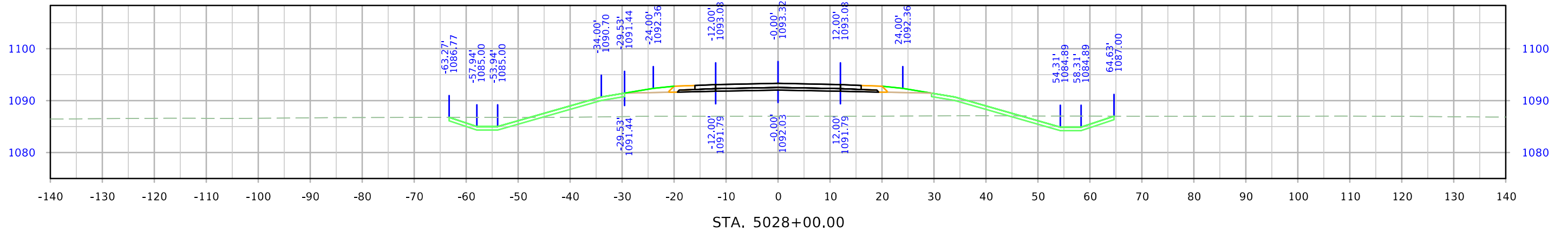
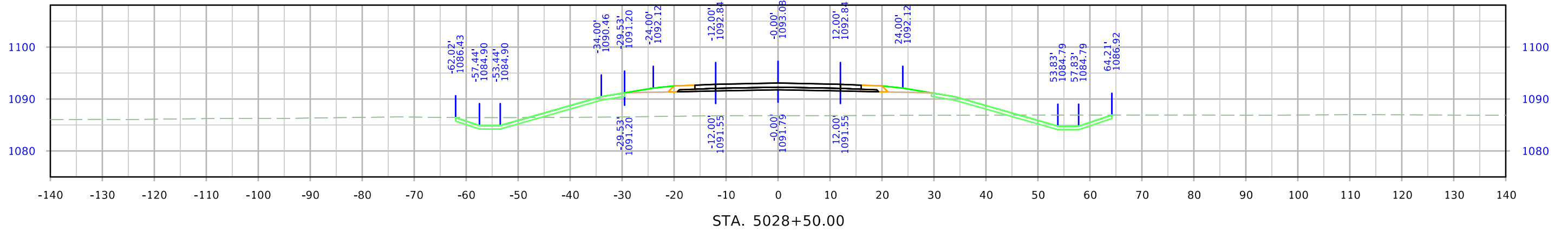

235th Street

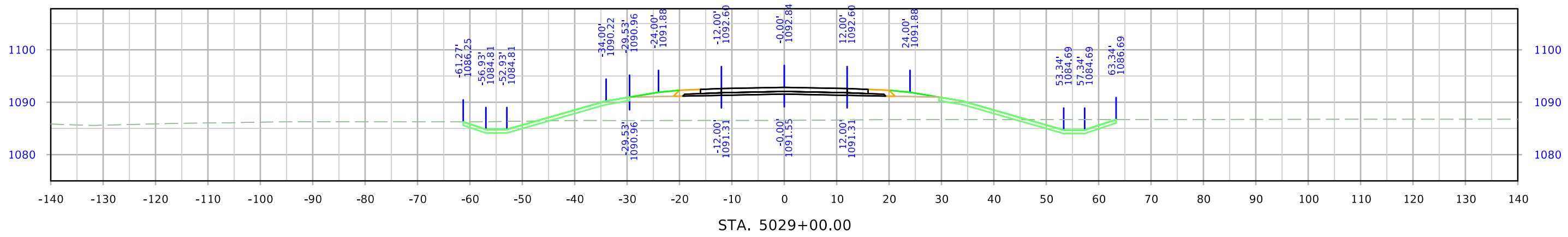
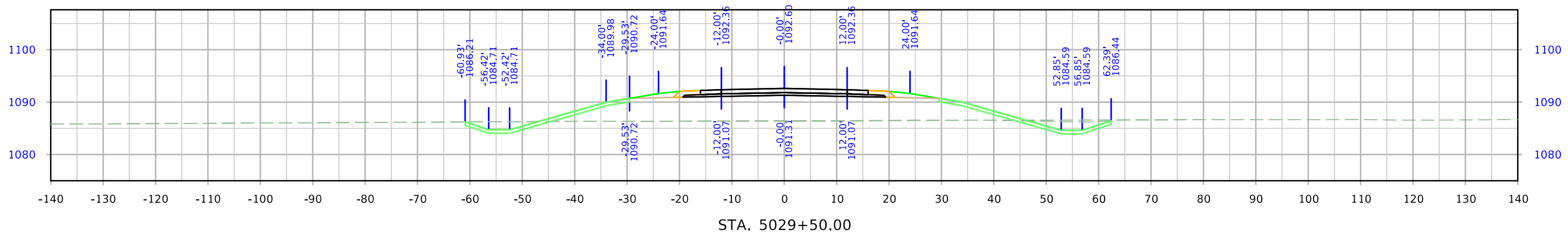
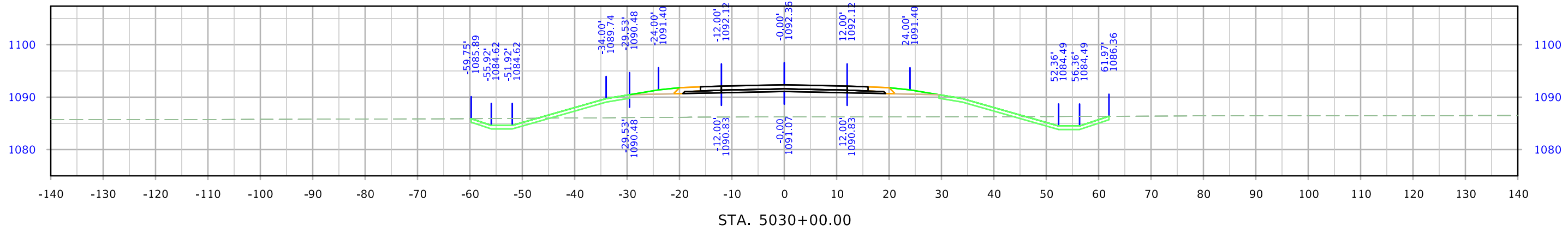

235th Street

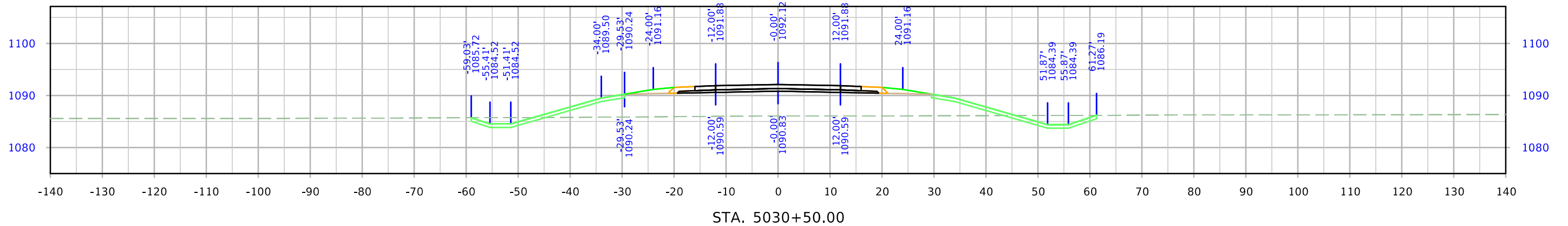
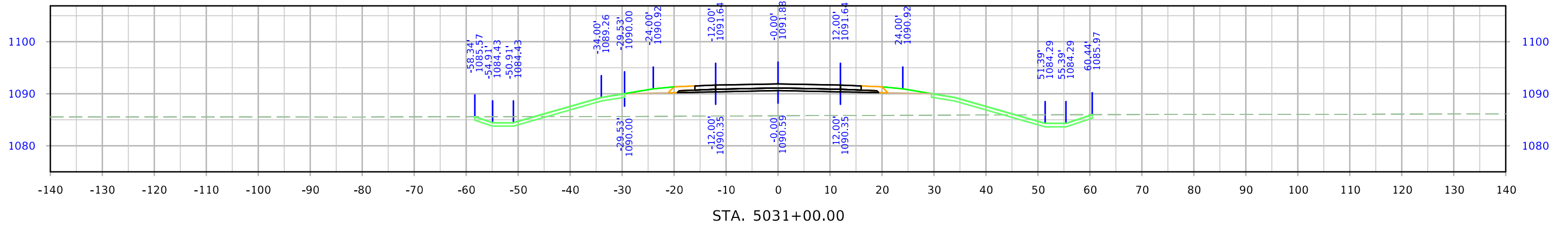
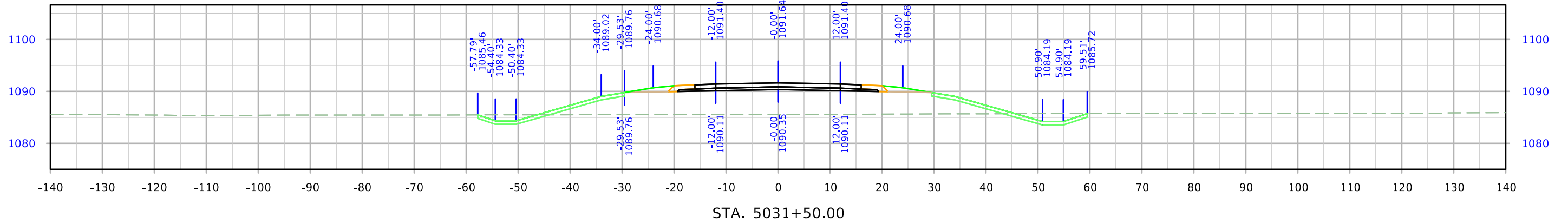

235th Street

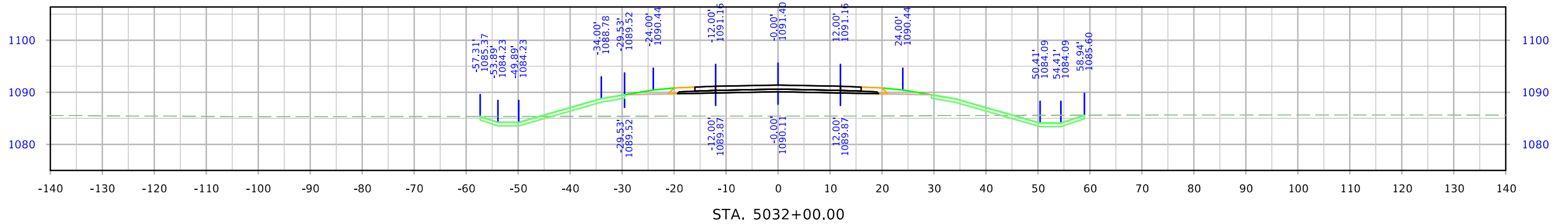
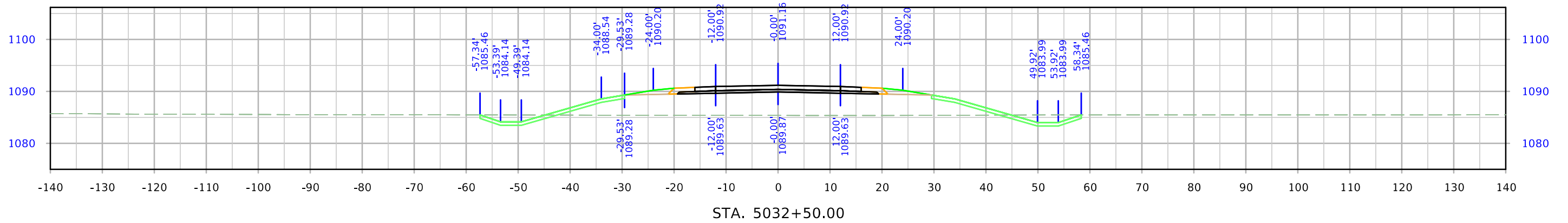
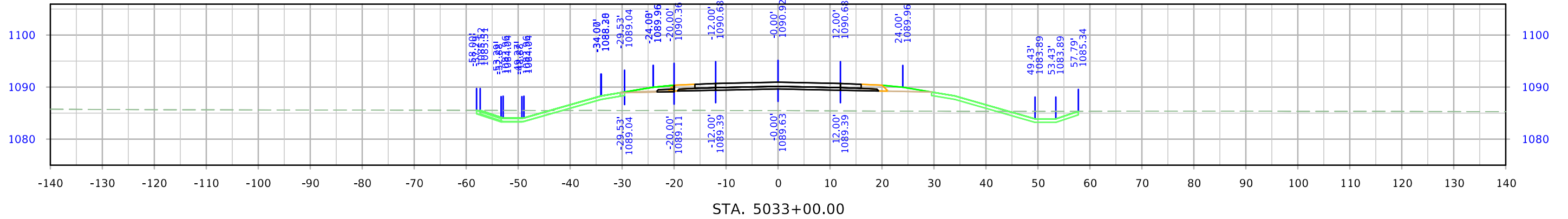

235th Street

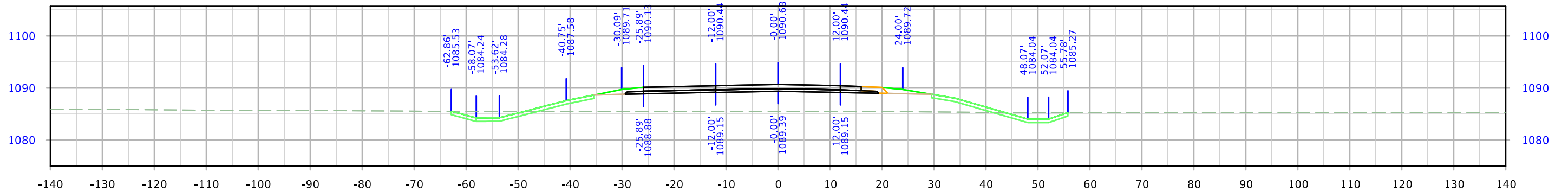
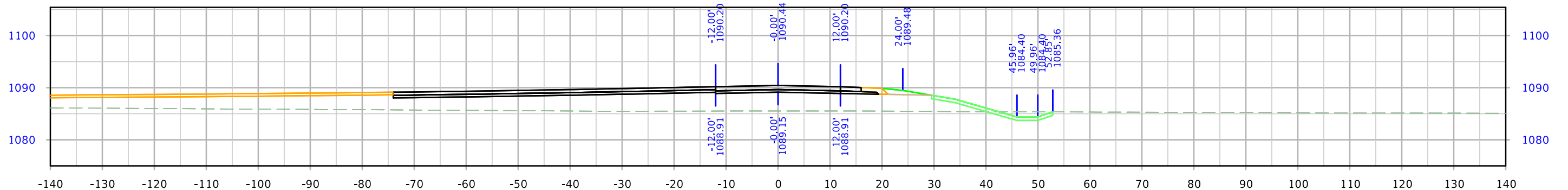
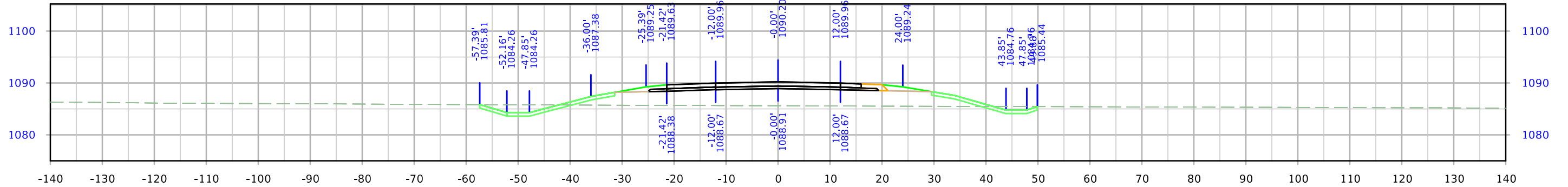

235th Street

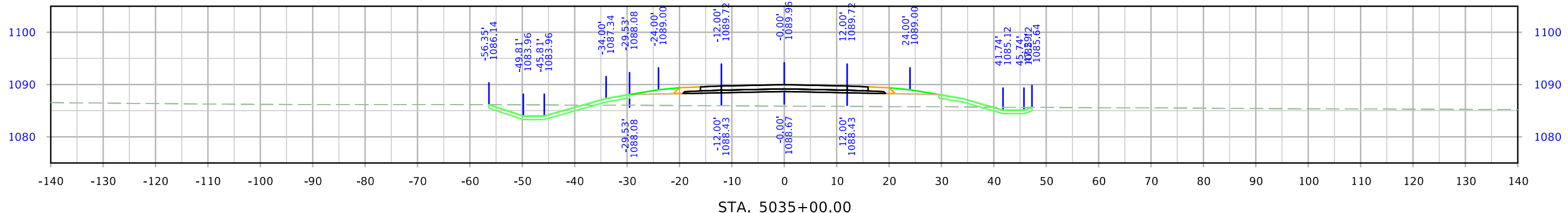
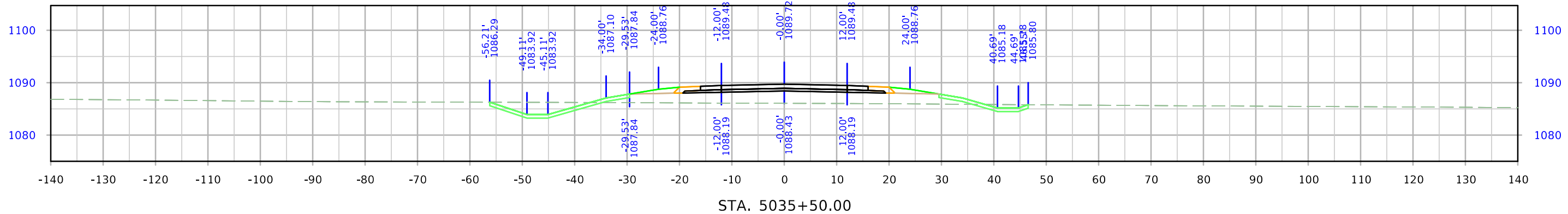
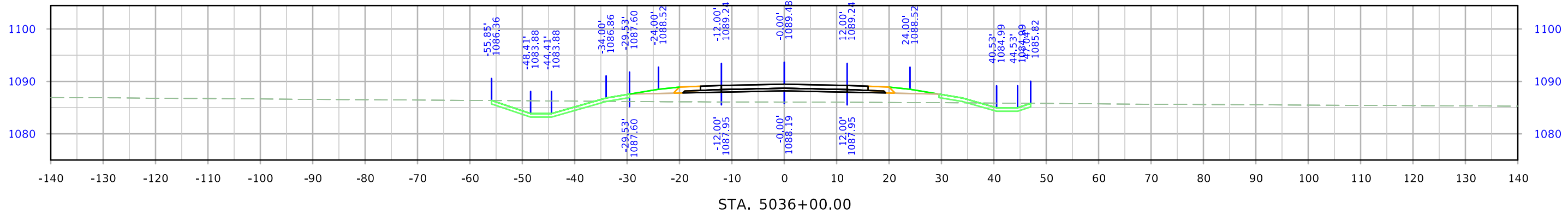

235th Street

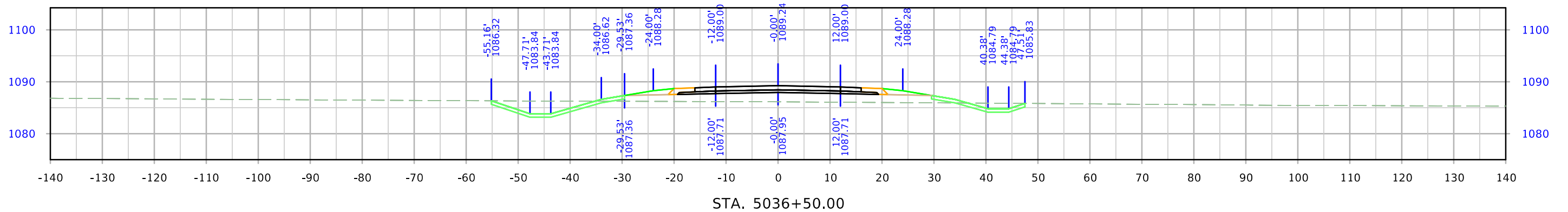
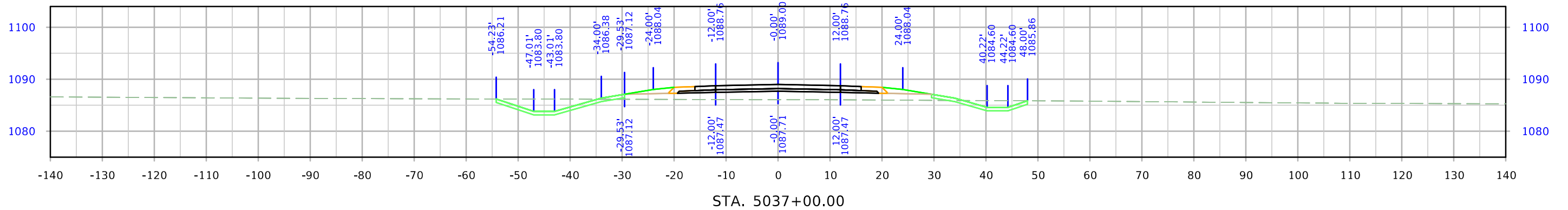
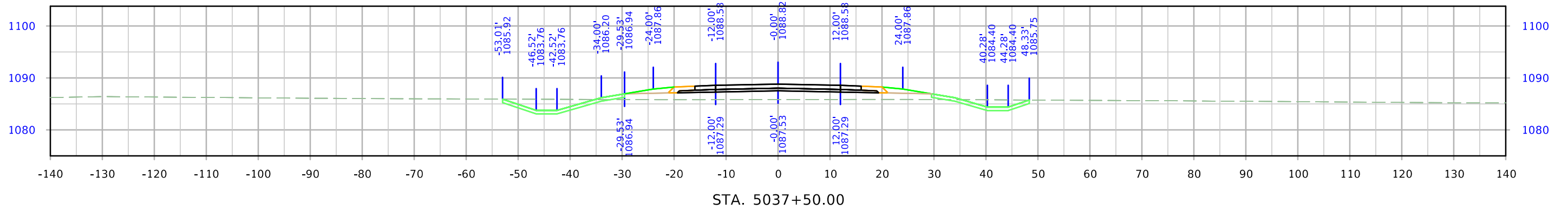

235th Street

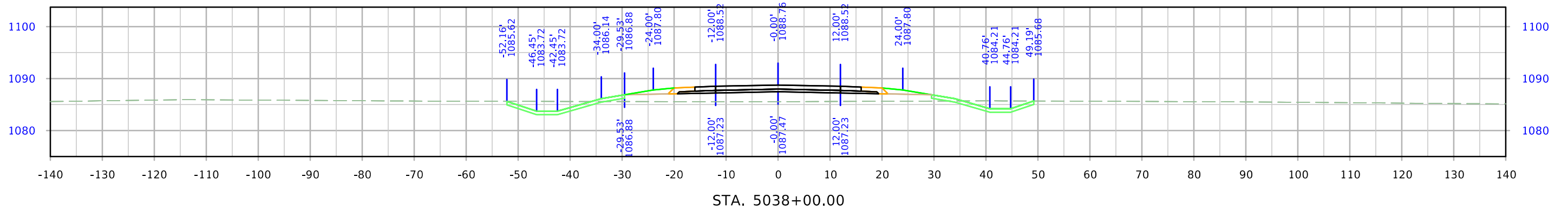
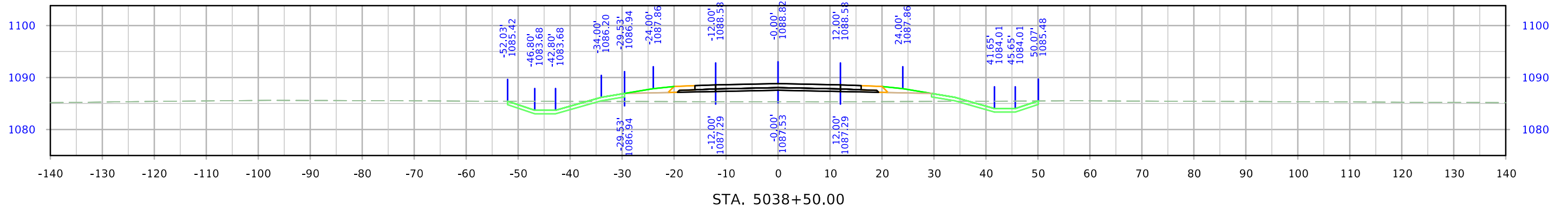
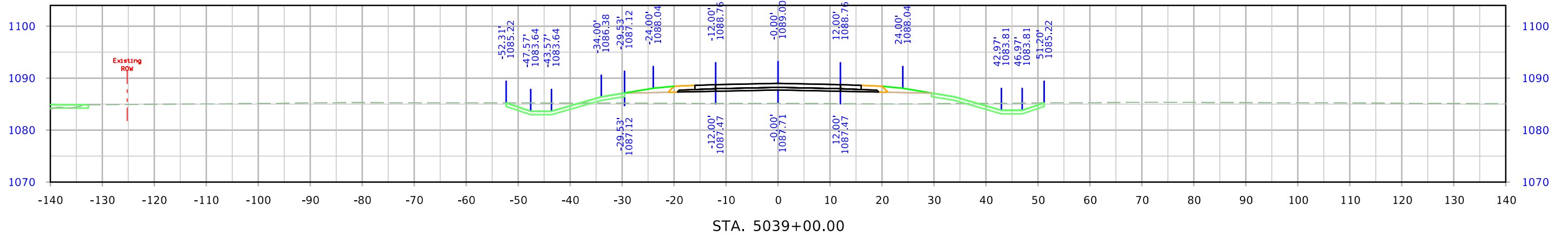

235th Street

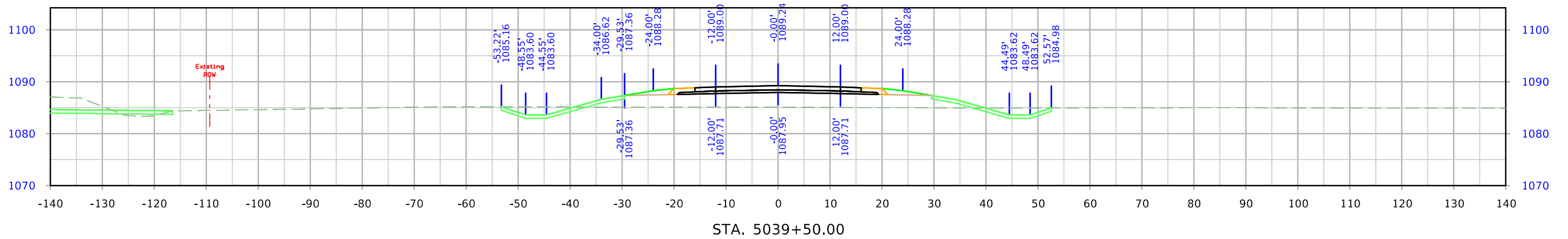
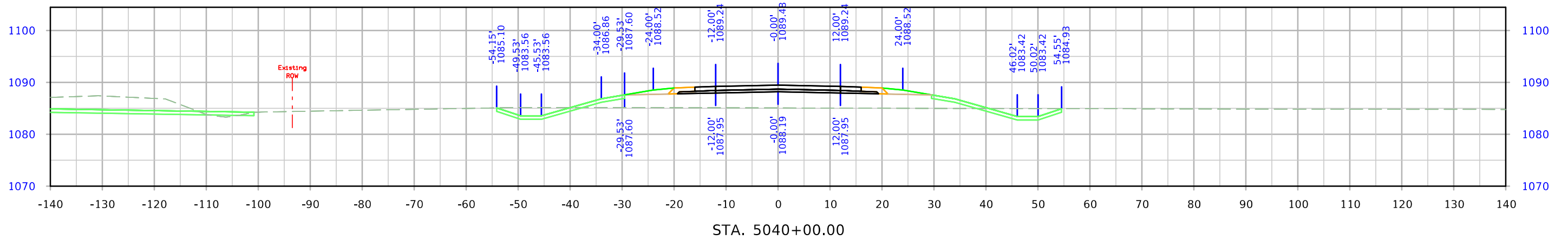
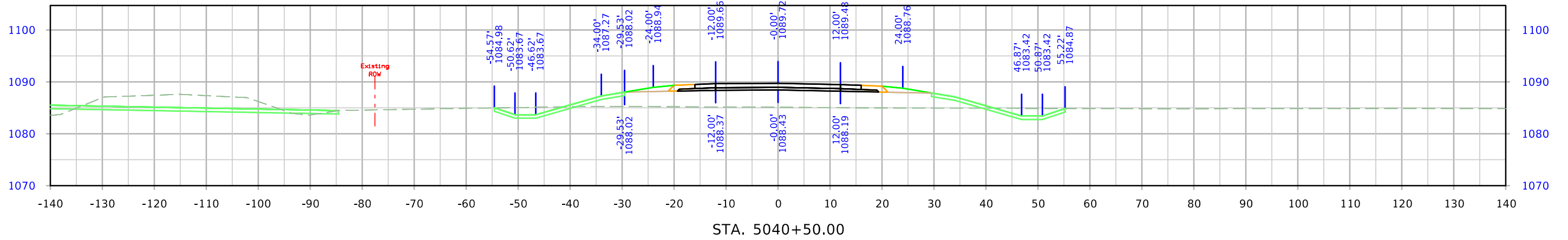

235th Street

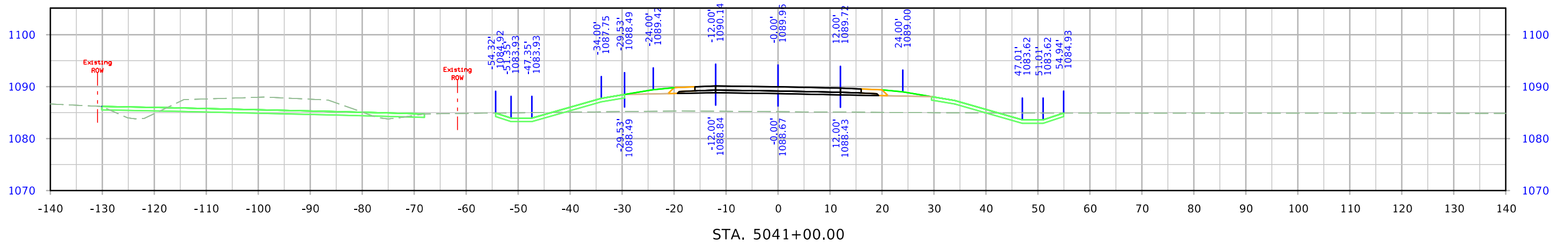
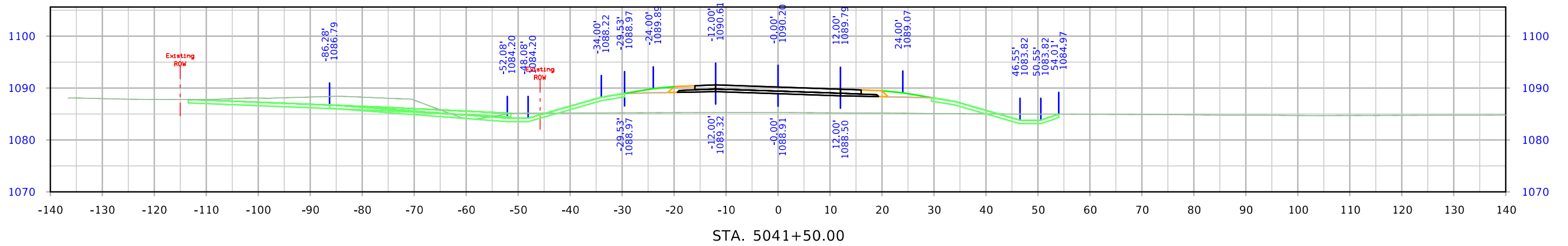
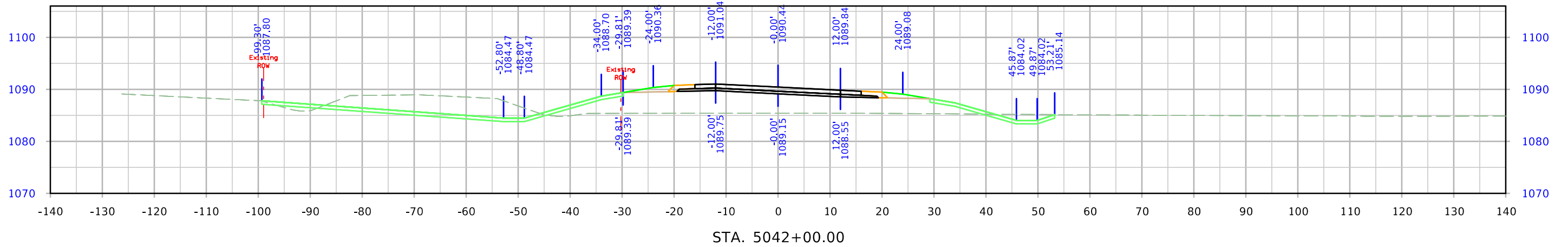

235th Street

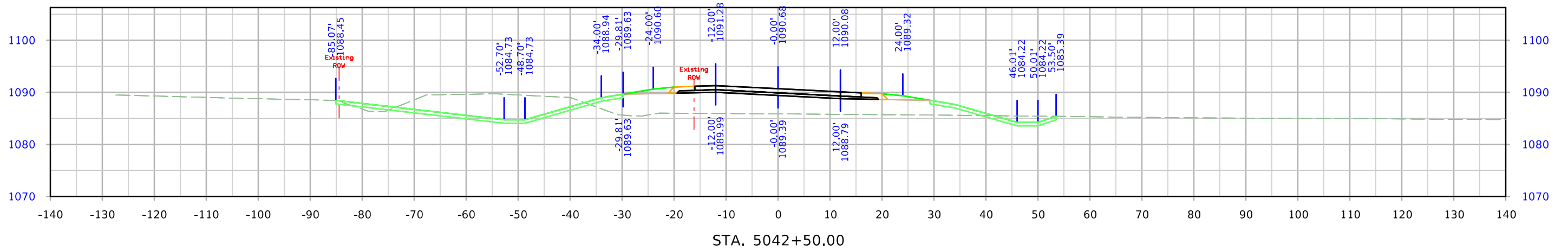
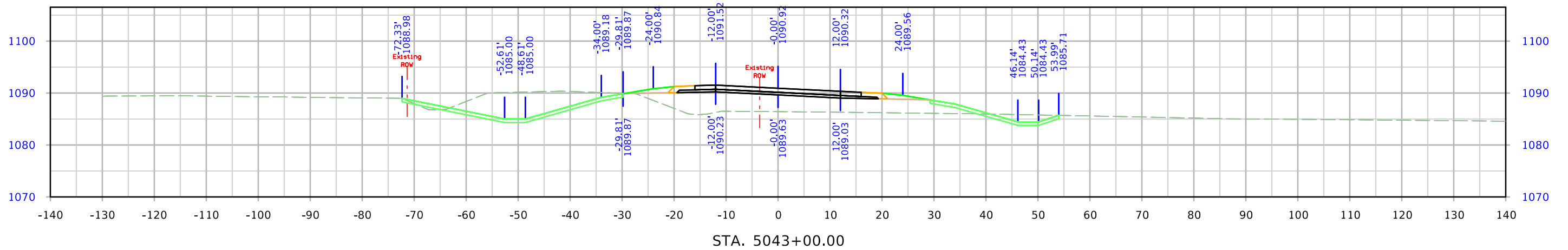
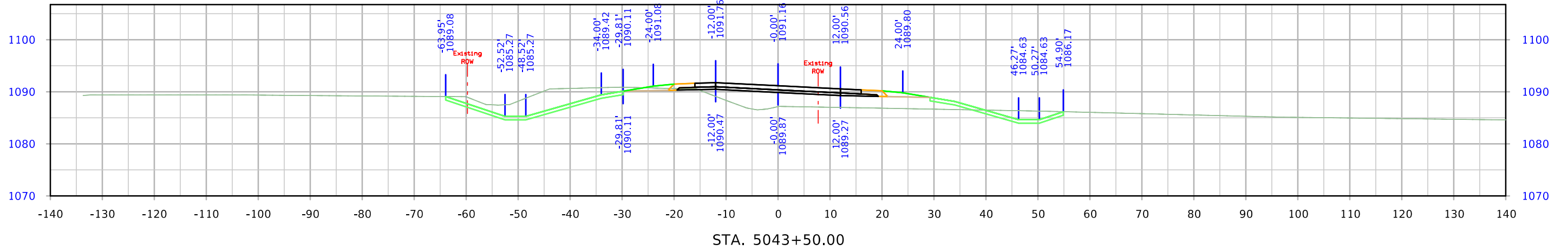

235th Street

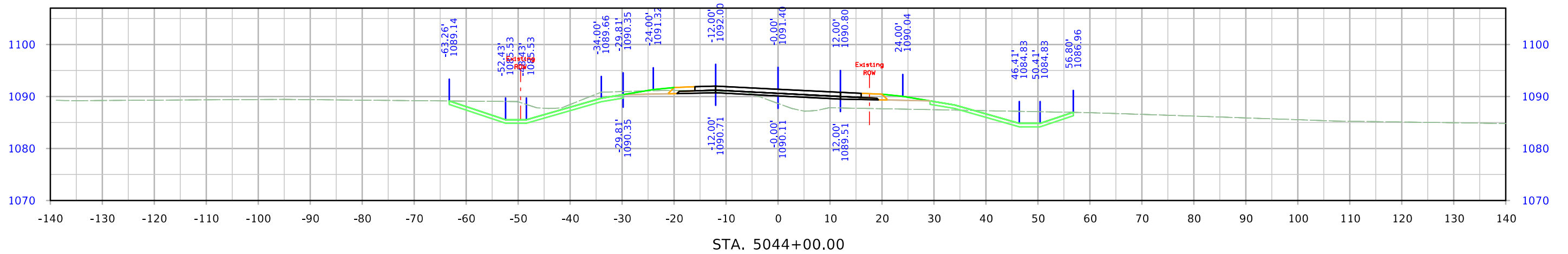
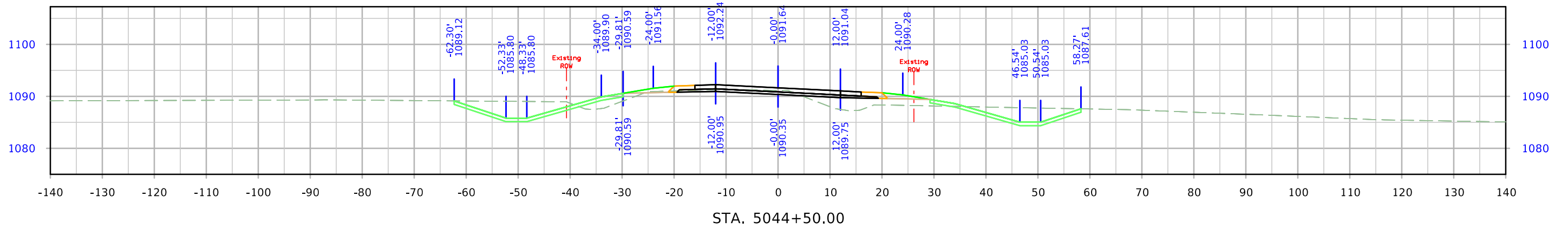
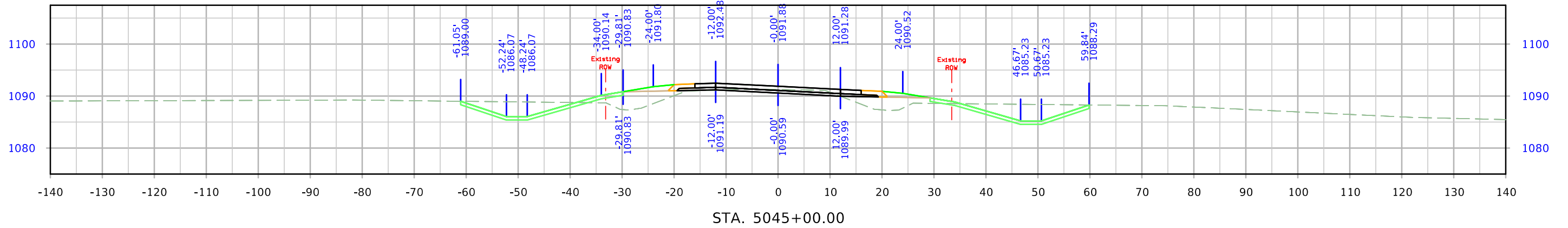

235th Street

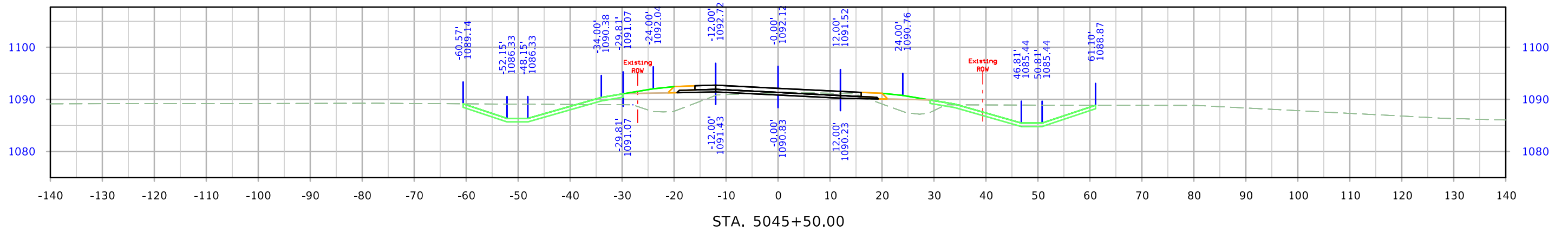
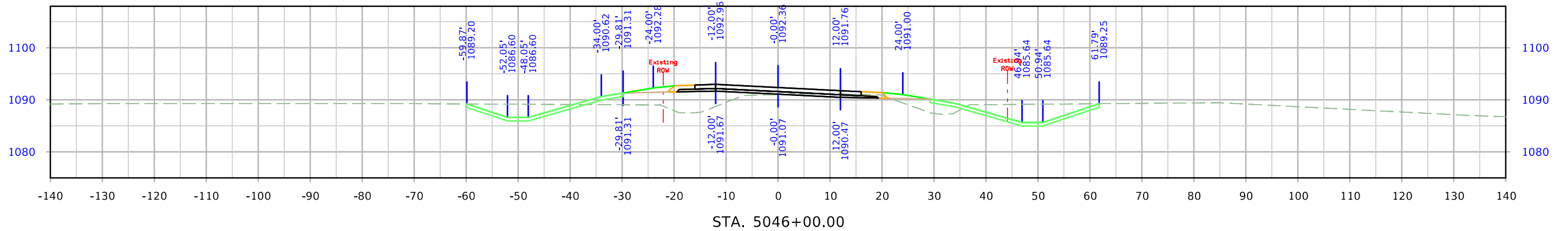
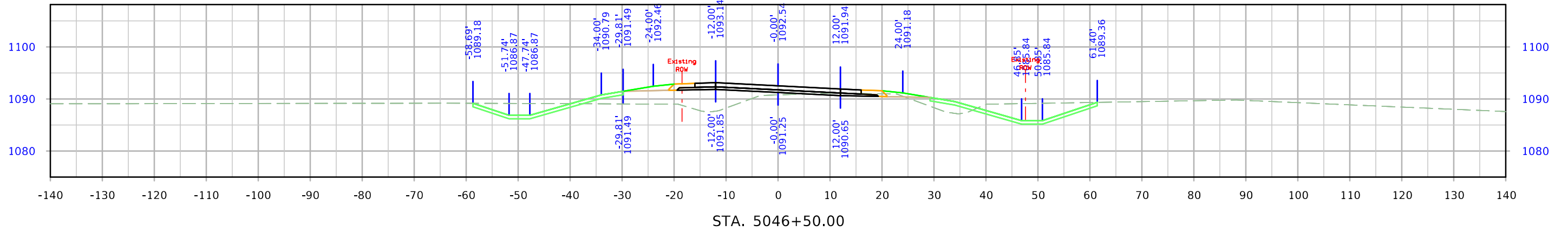

235th Street

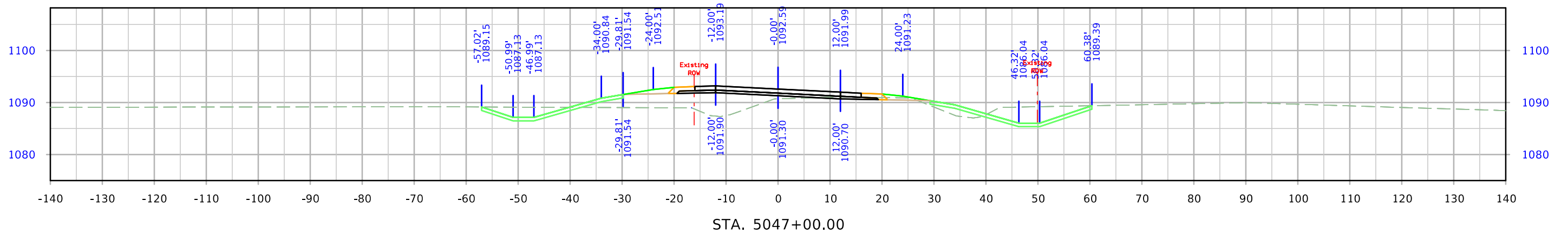
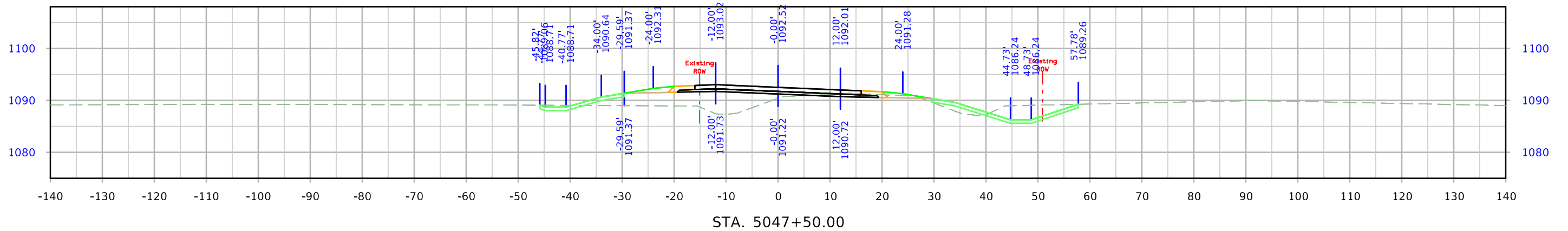
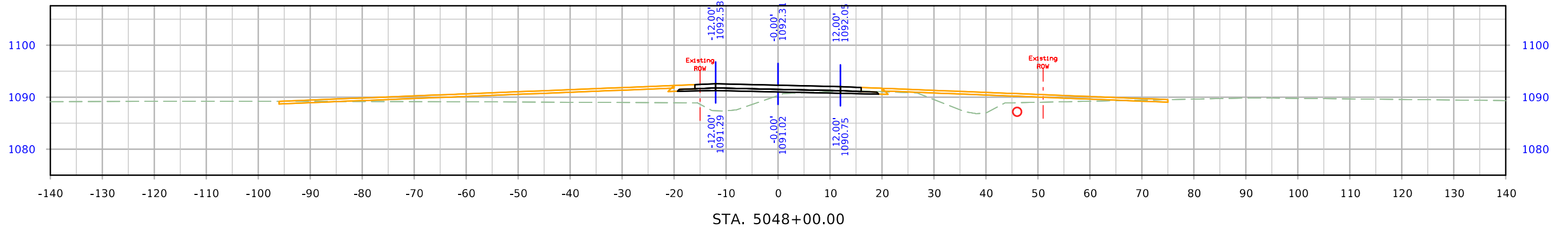

235th Street

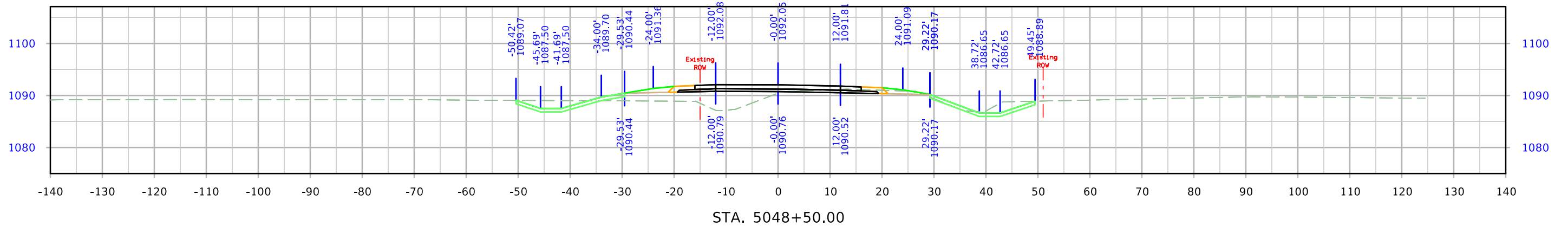
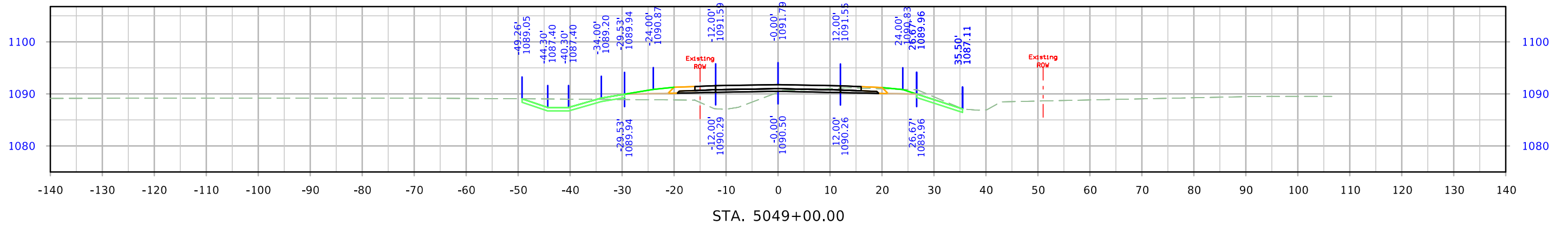
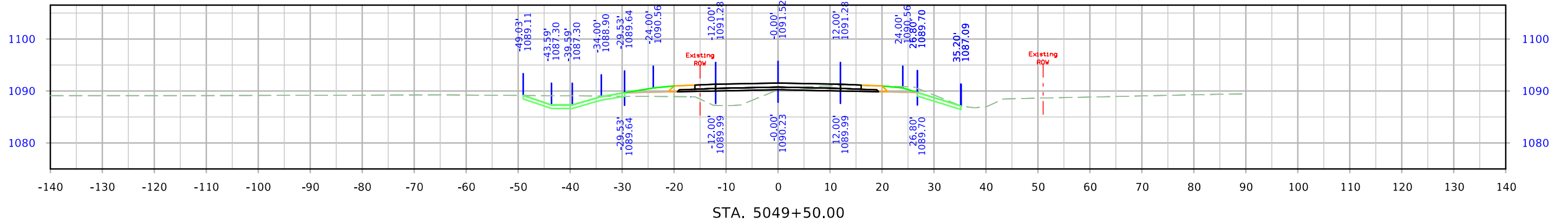

235th Street

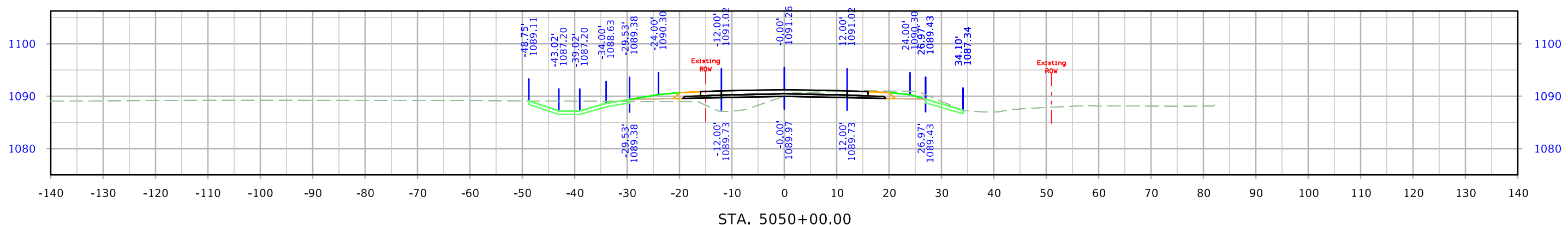
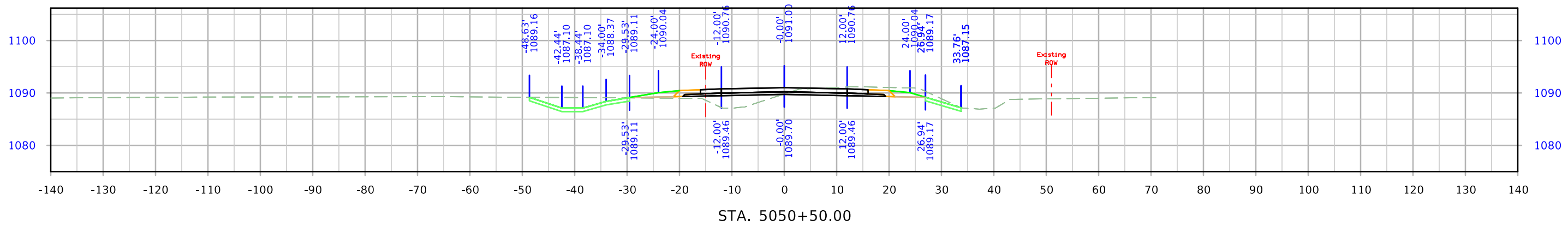
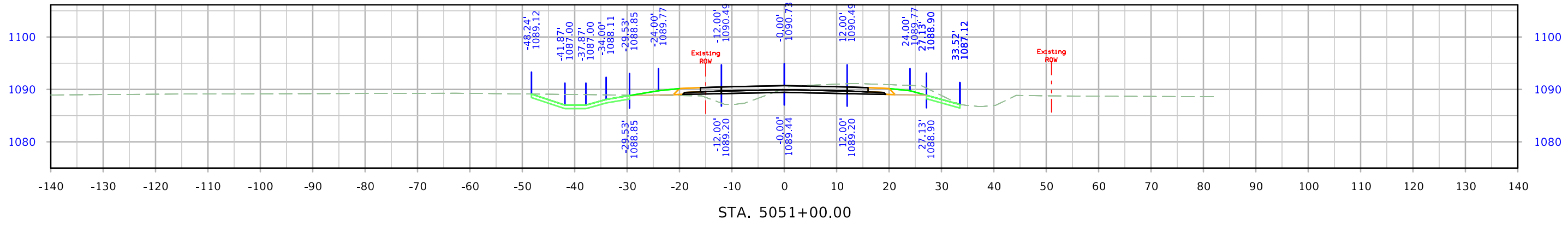

235th Street

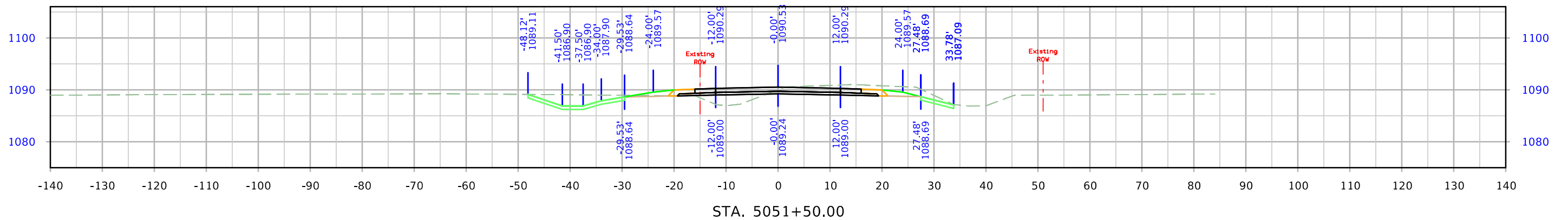
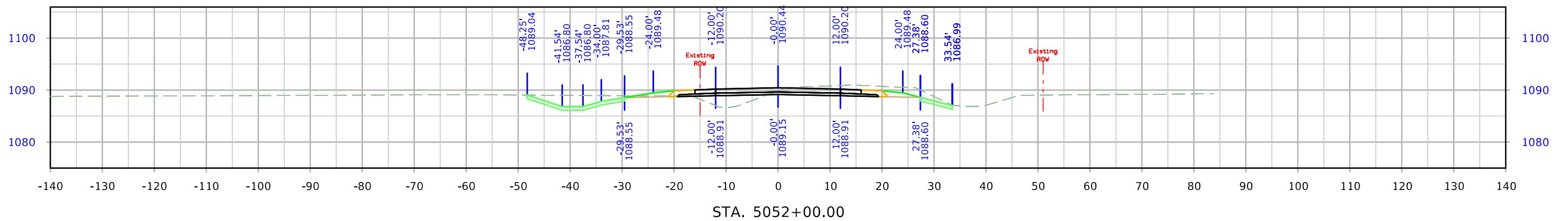
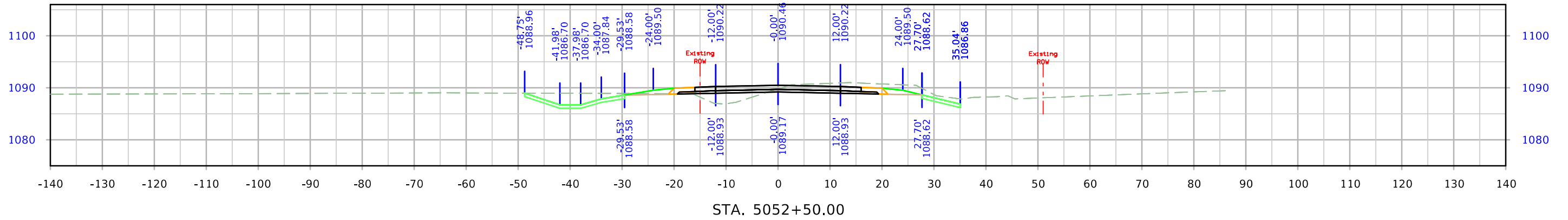

235th Street

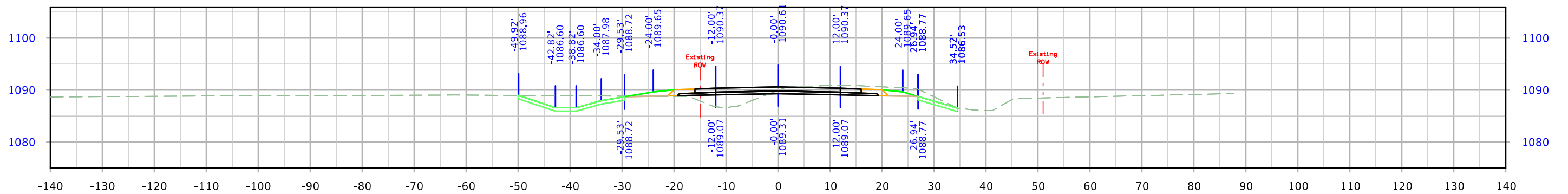
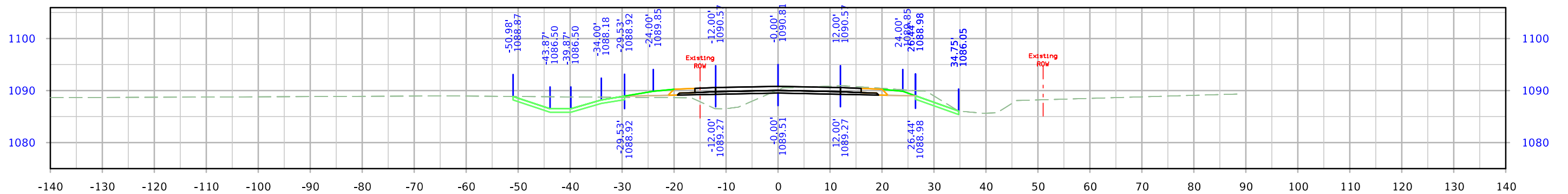
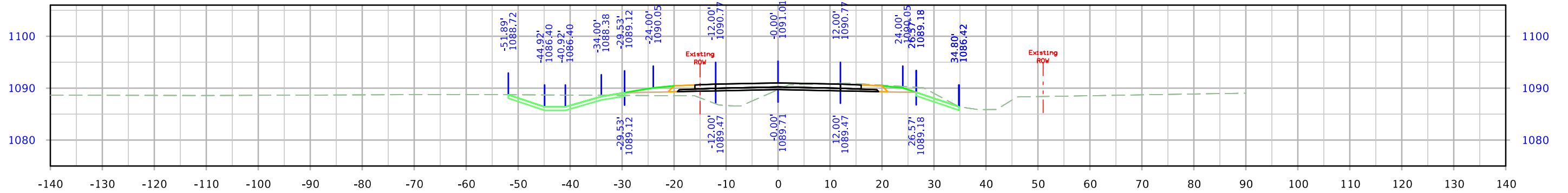

235th Street

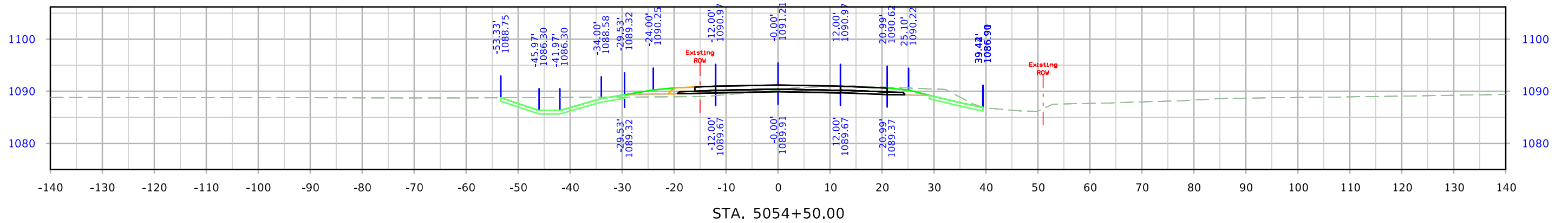
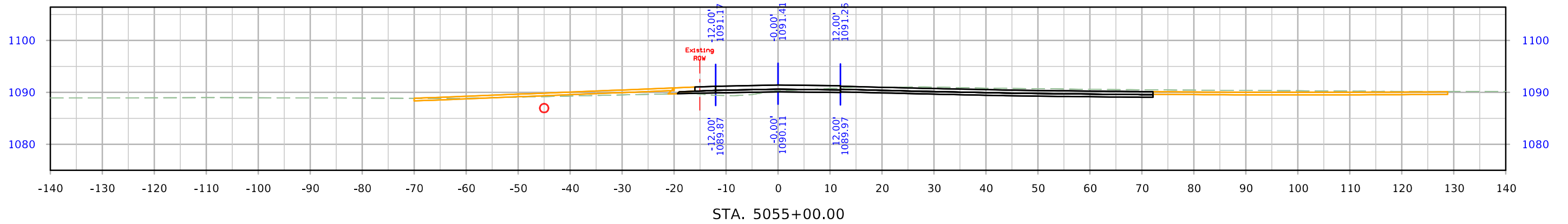
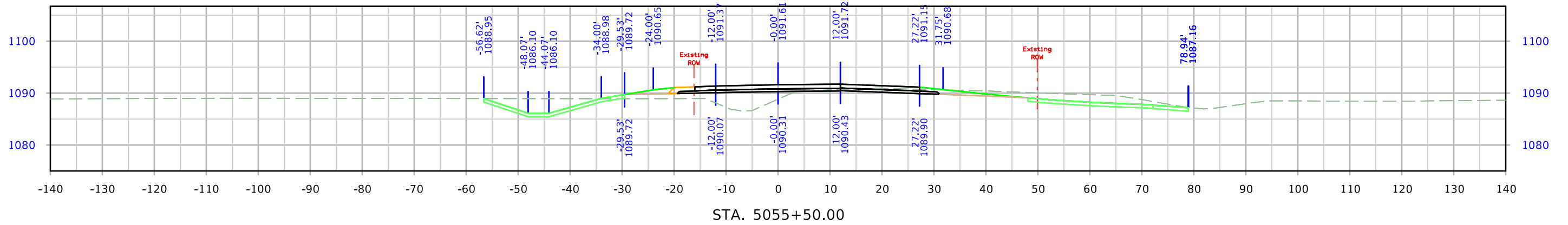

235th Street

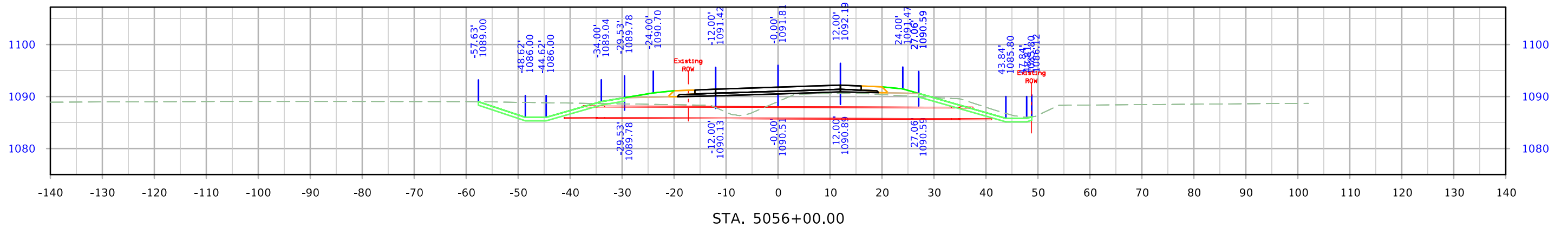
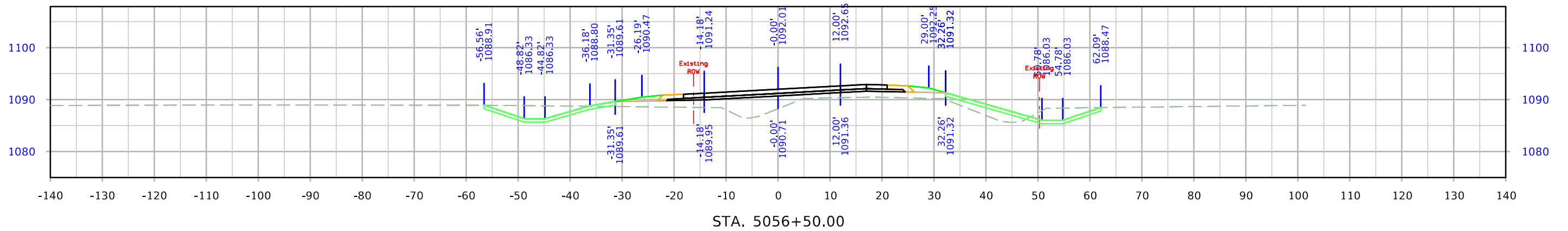
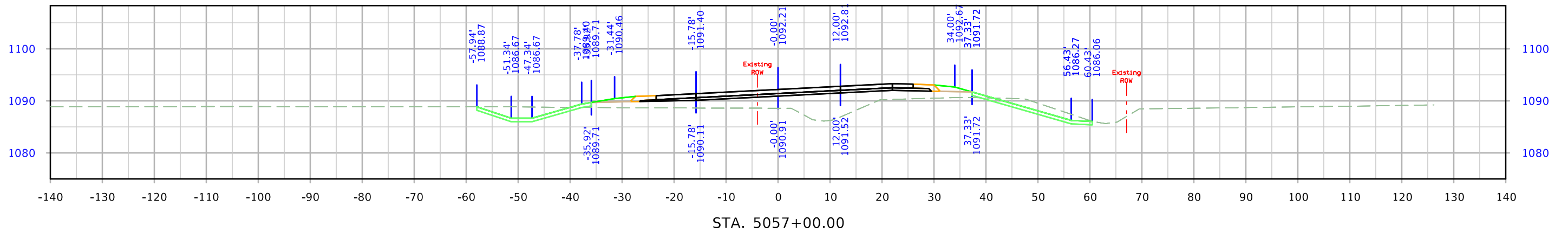

235th Street

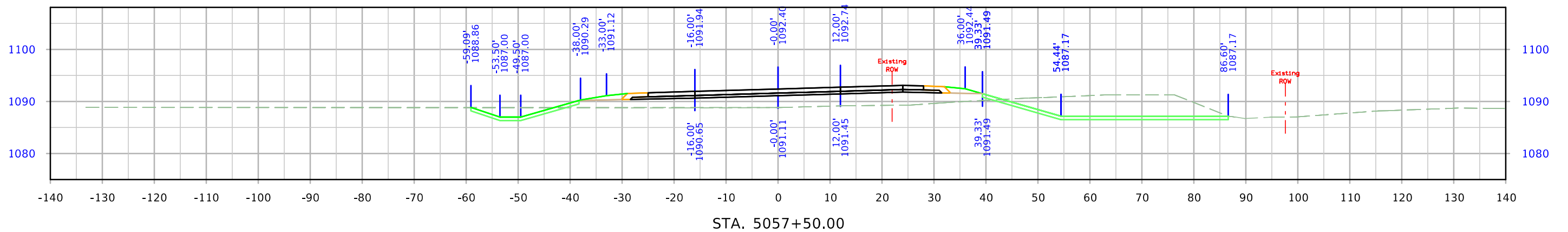
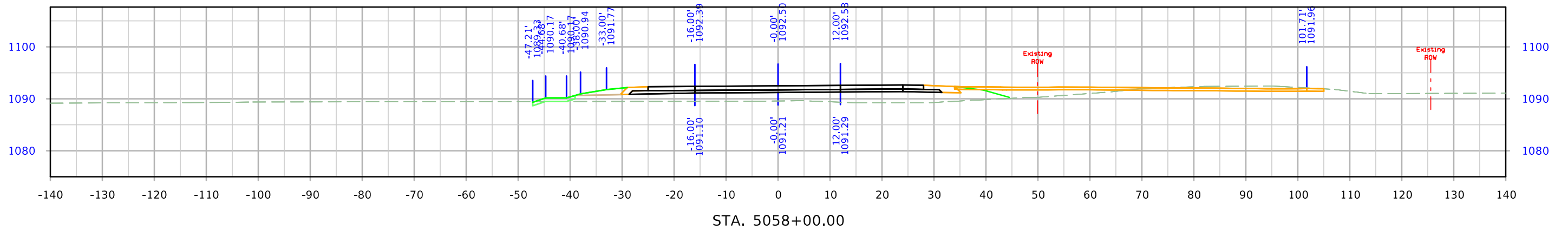
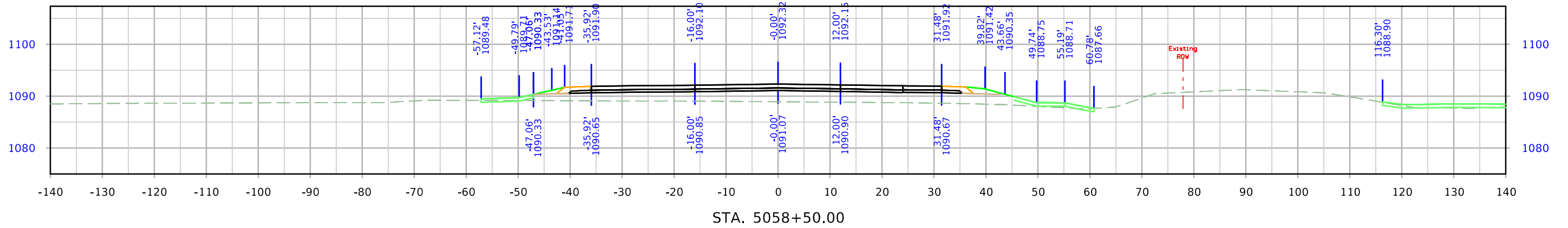

Old US 75

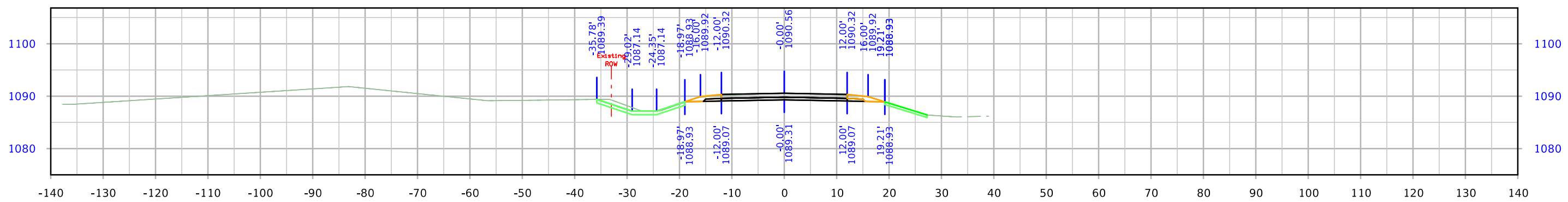
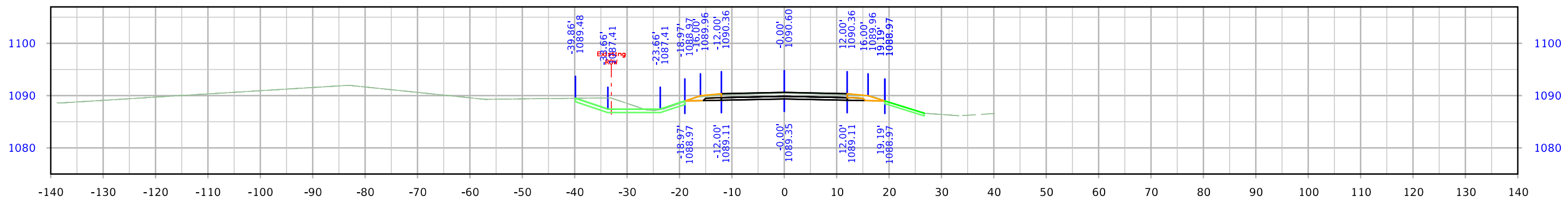
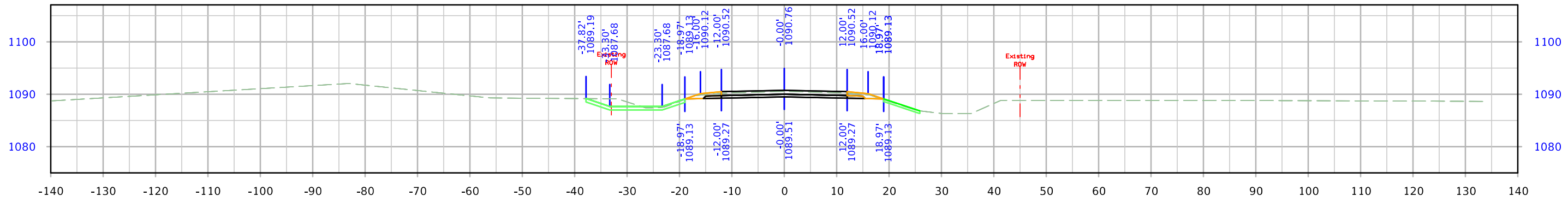

Old US 75

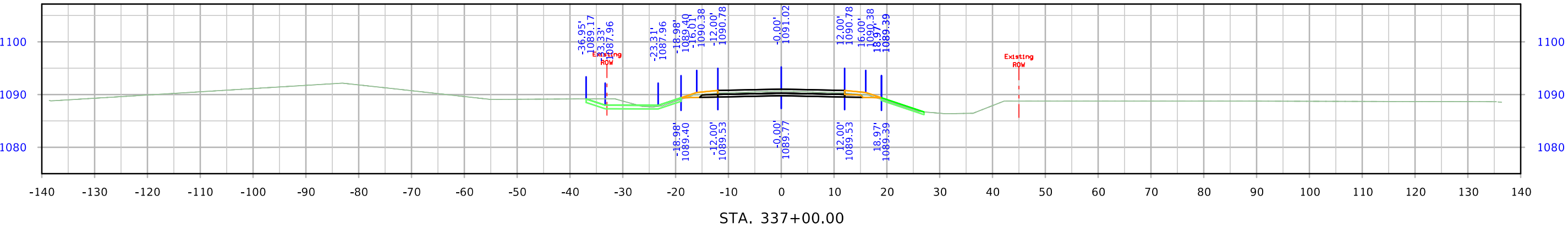
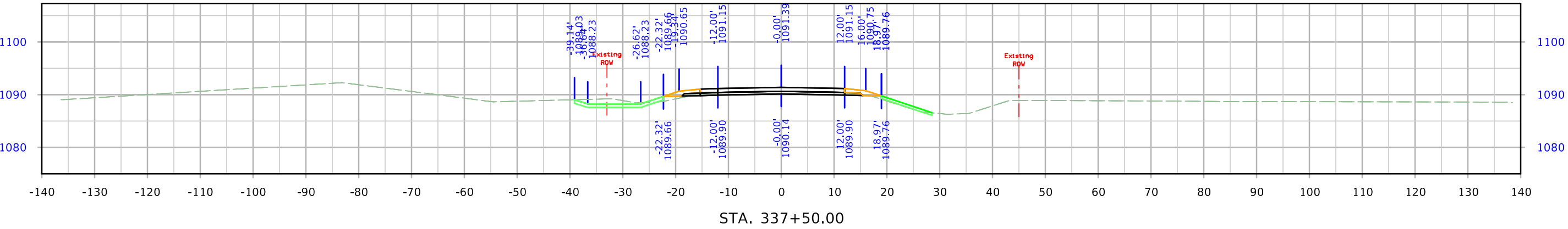
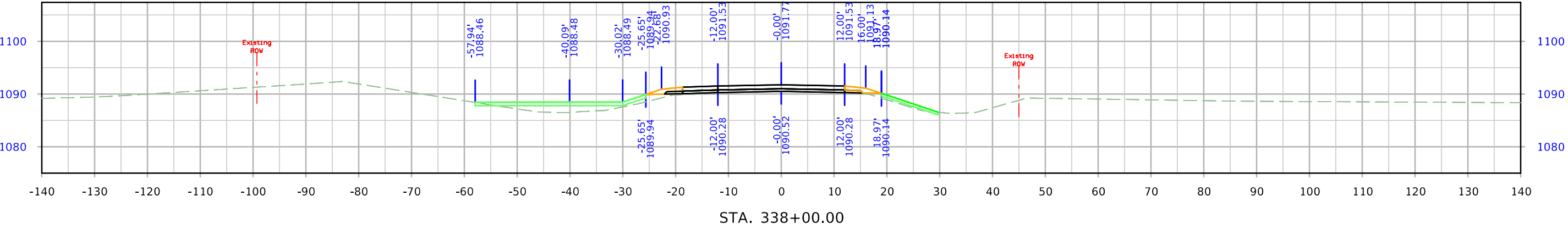

Old US 75

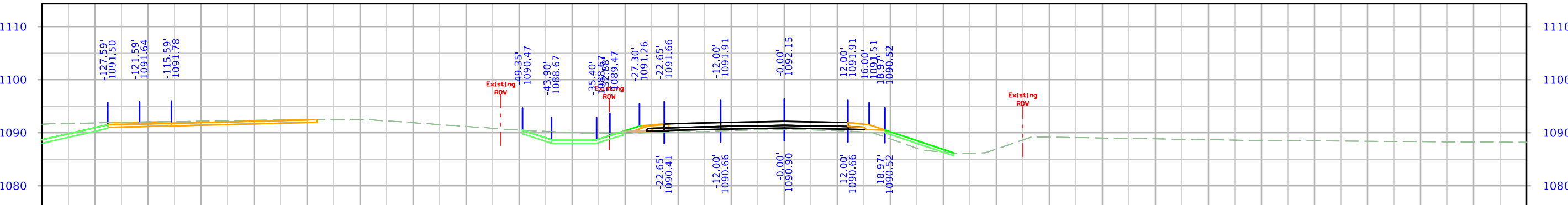
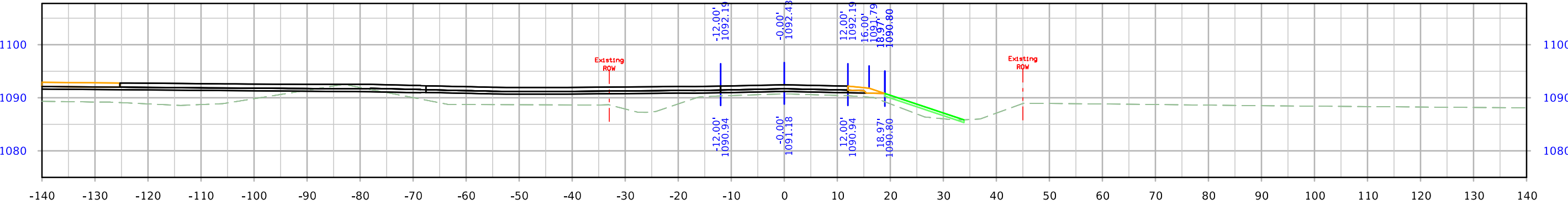
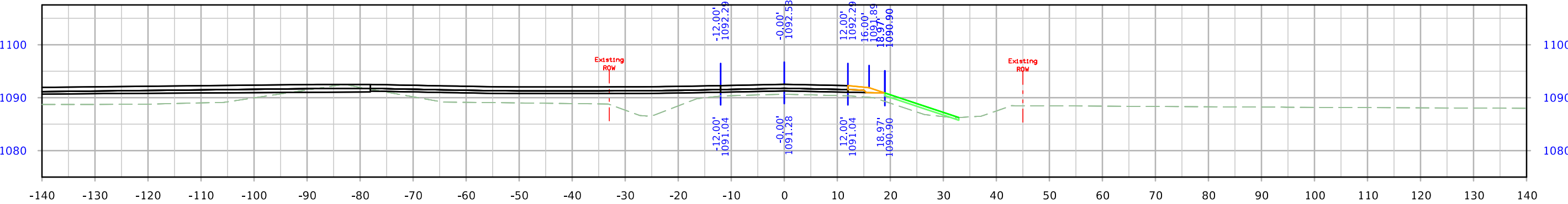

Old US 75

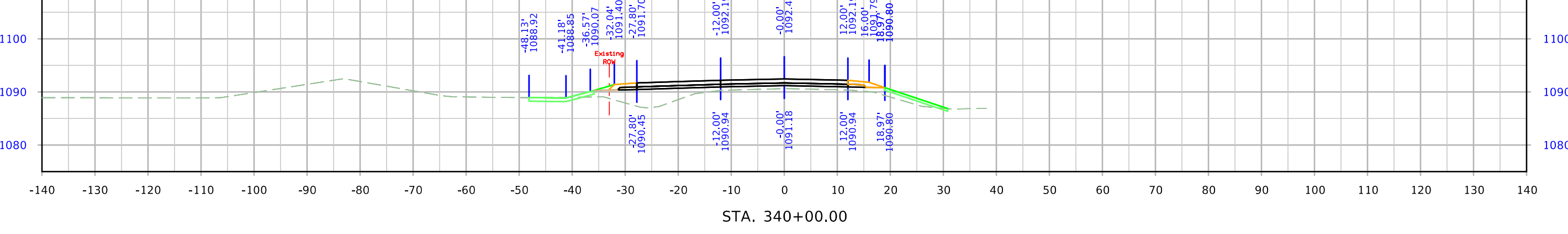
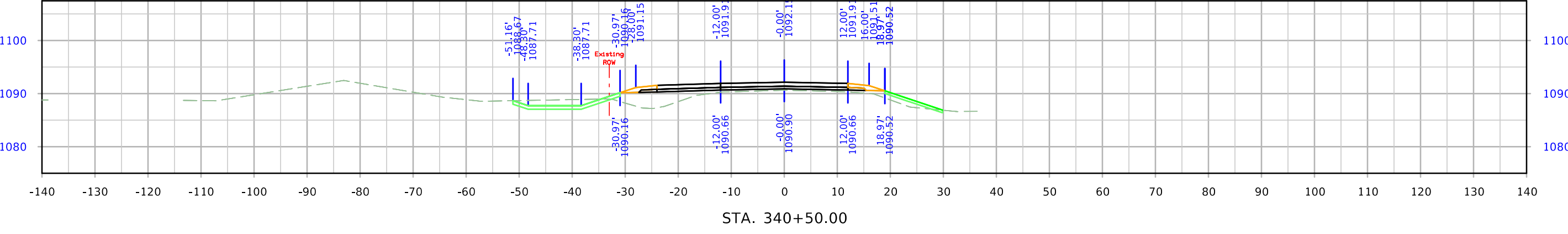
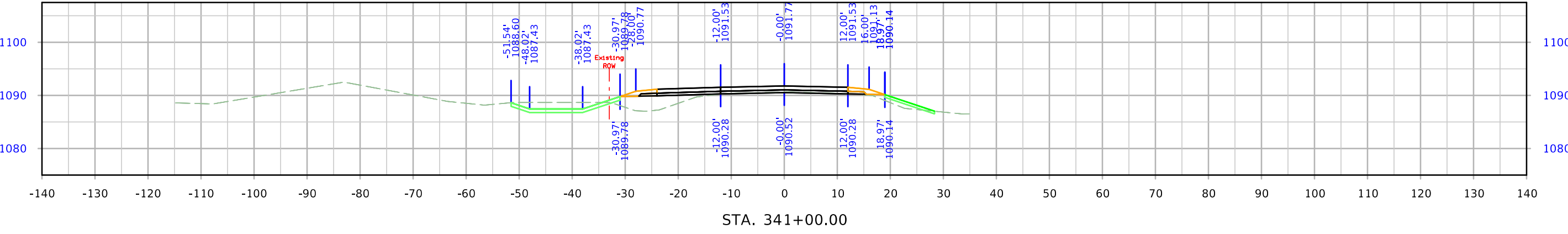

Old US 75

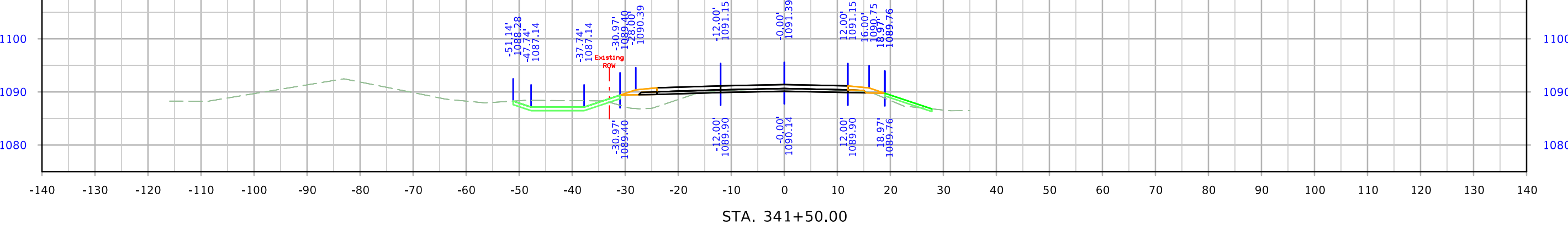
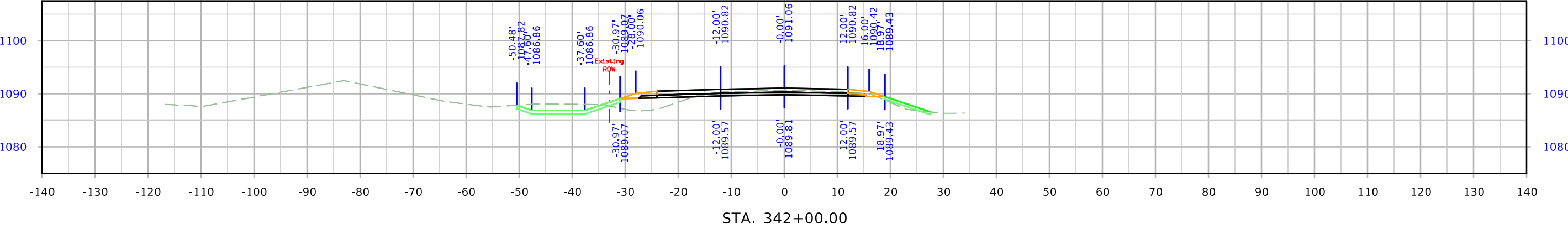
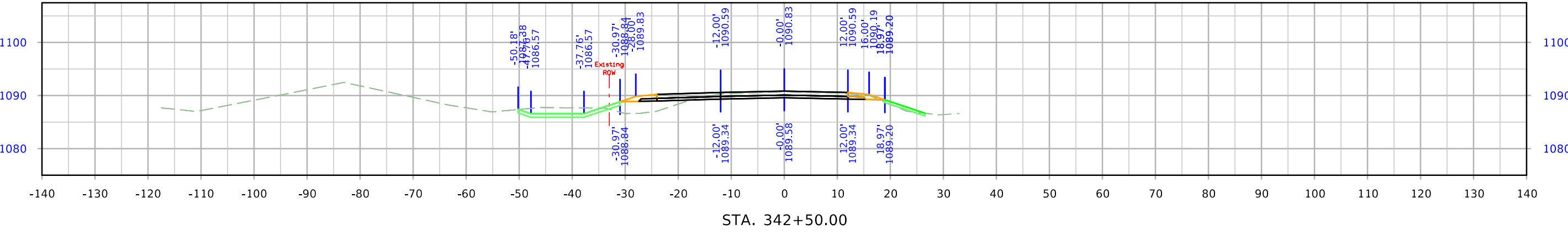

Old US 75

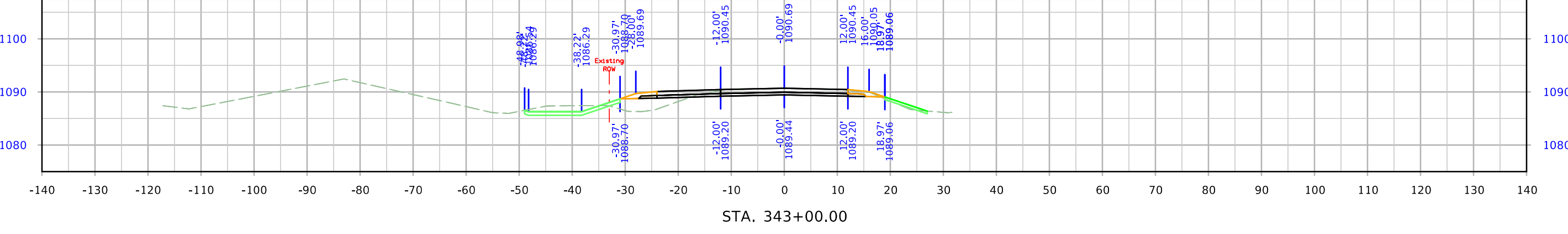
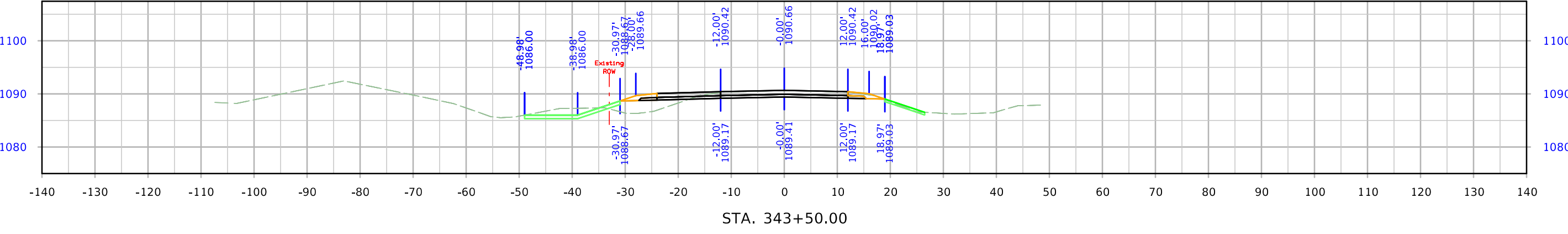
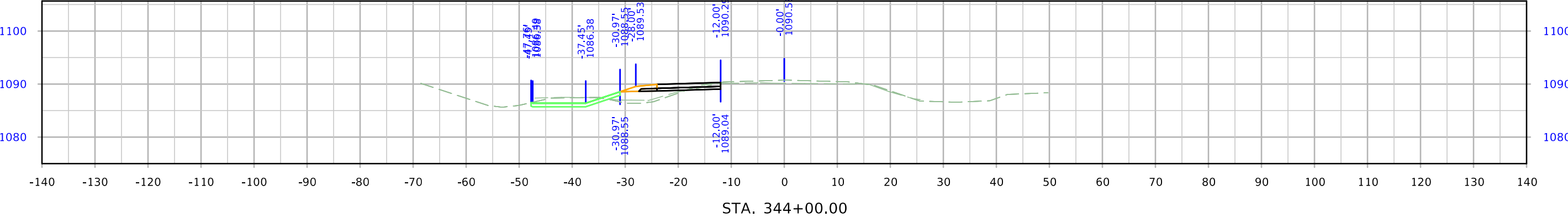

Old US 75

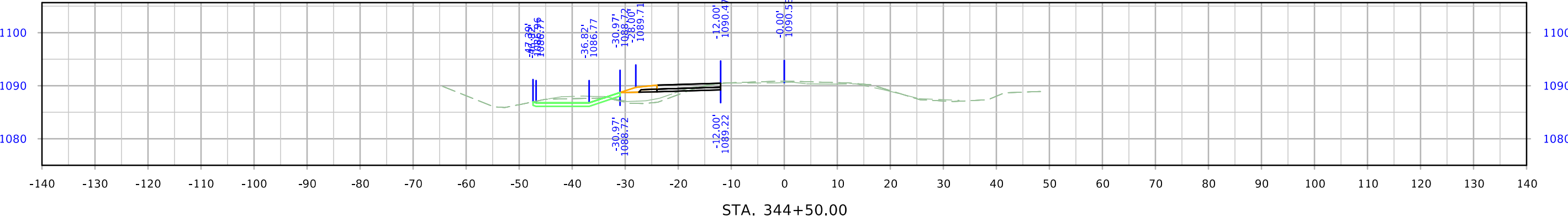
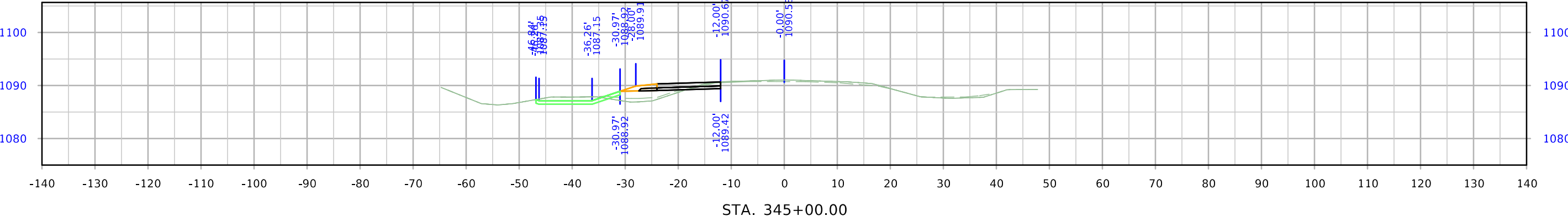
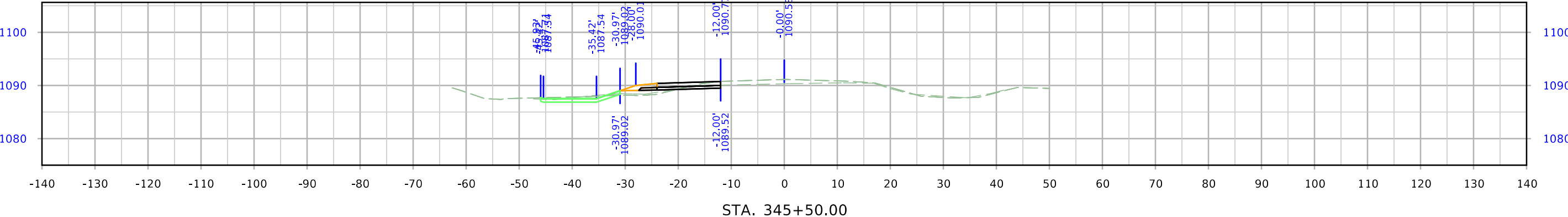

Old US 75

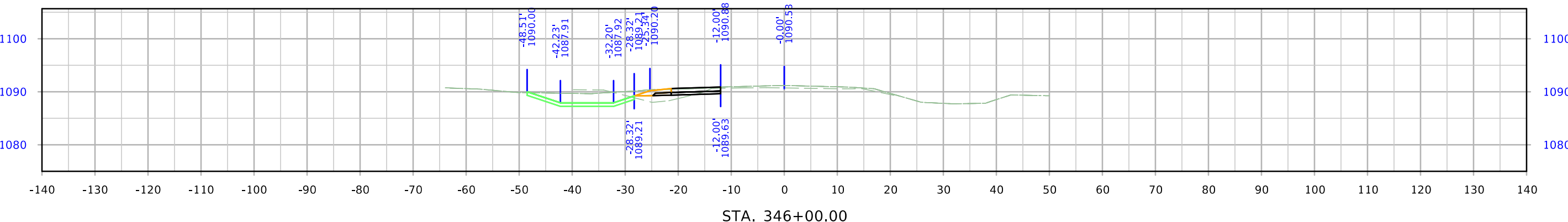

Banner Avenue

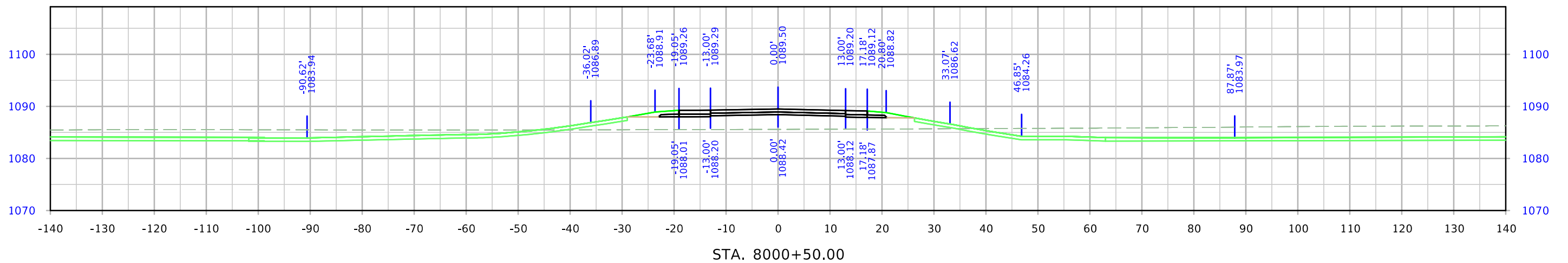
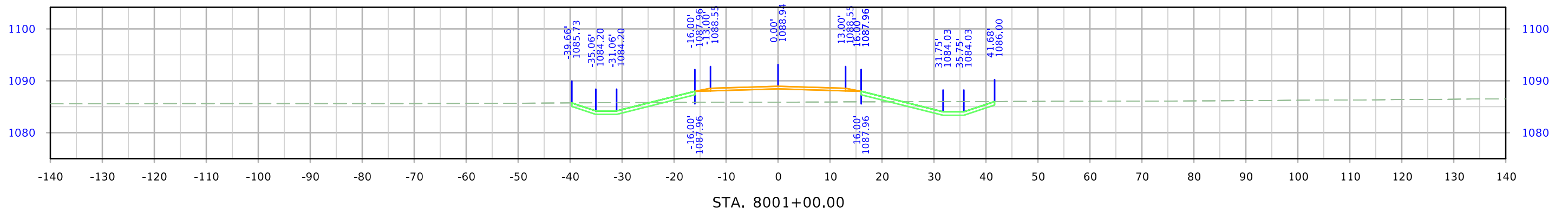
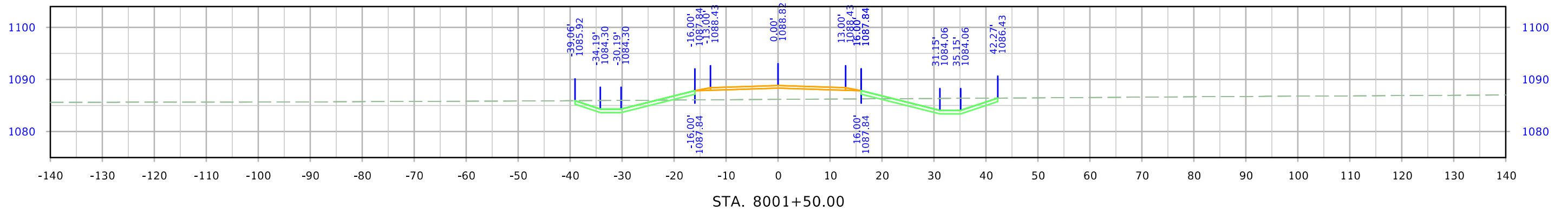

Banner Avenue

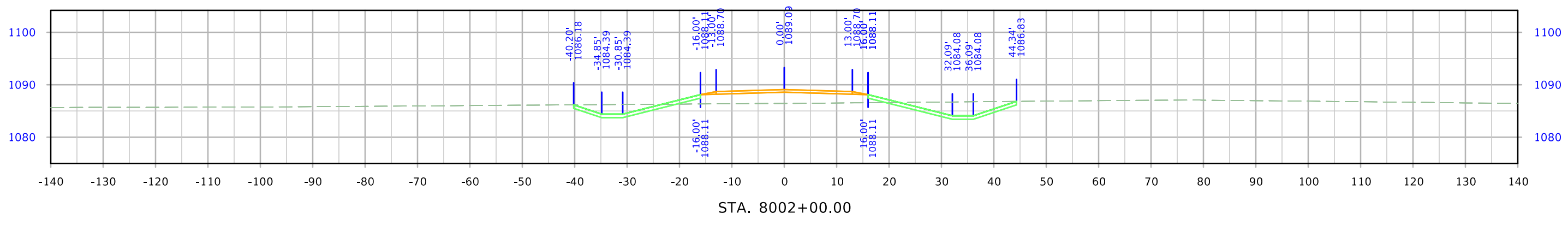
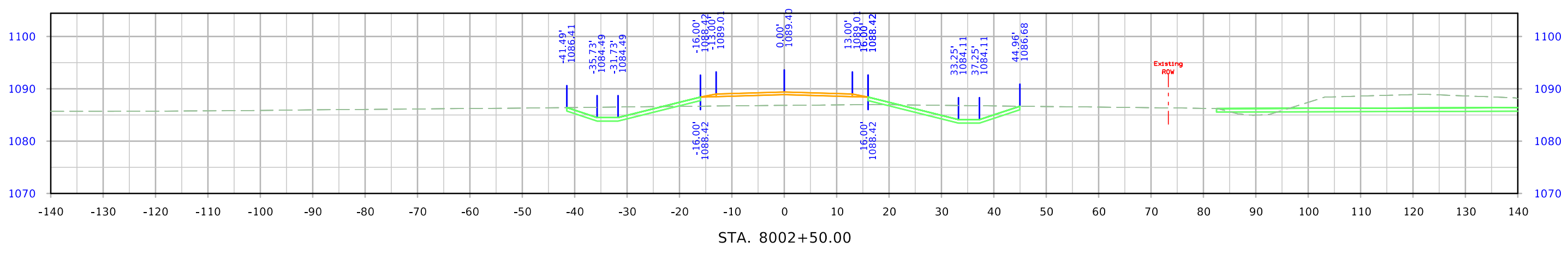
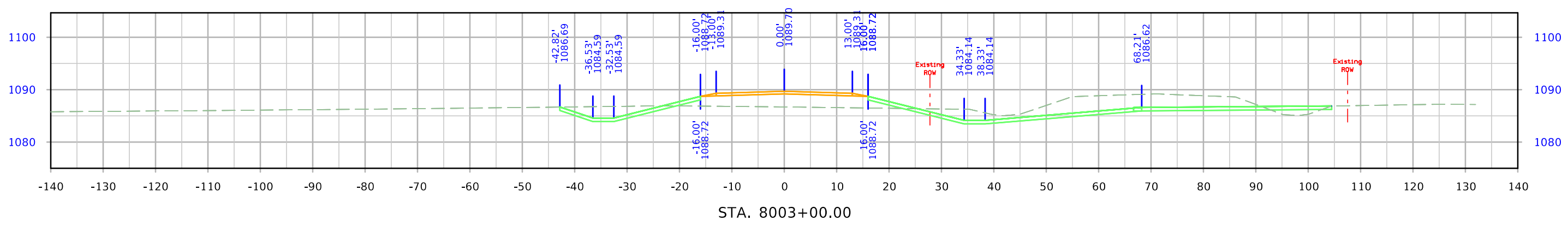

Banner Avenue

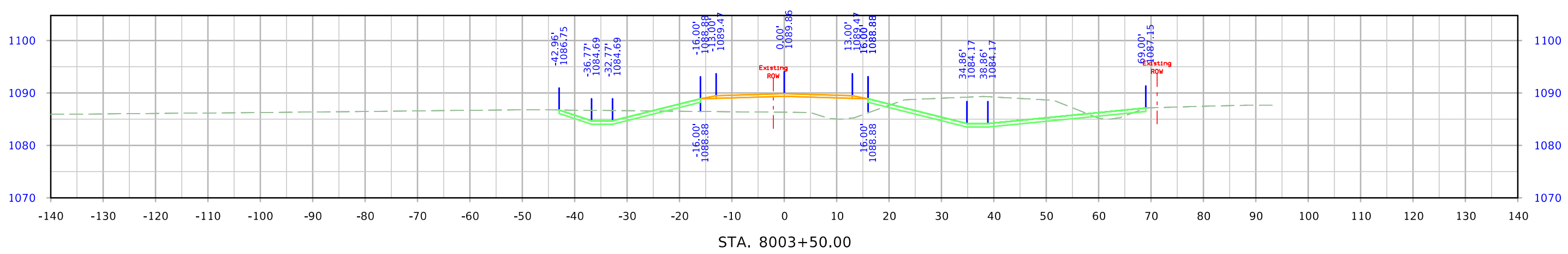
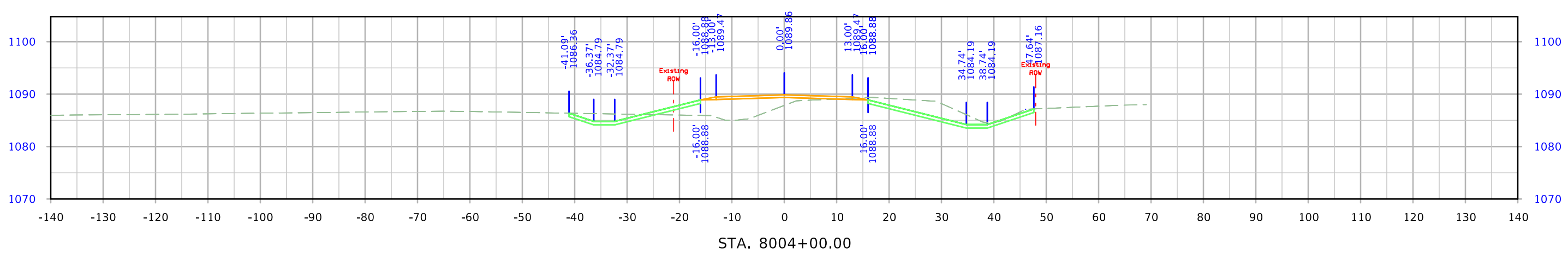
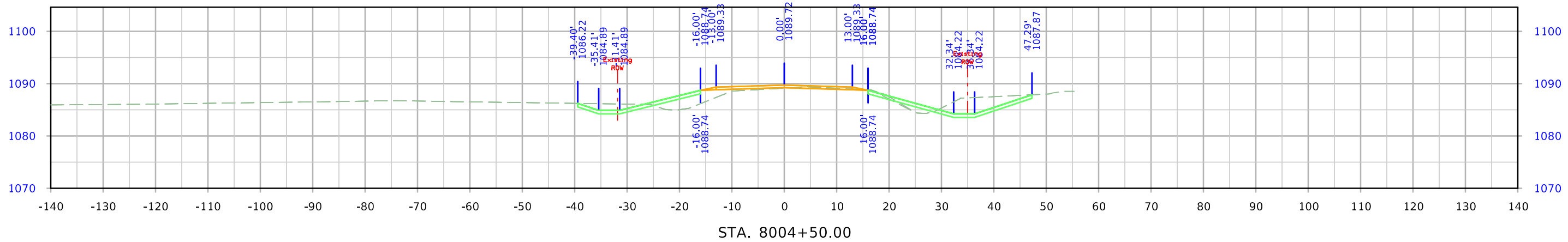

Banner Avenue

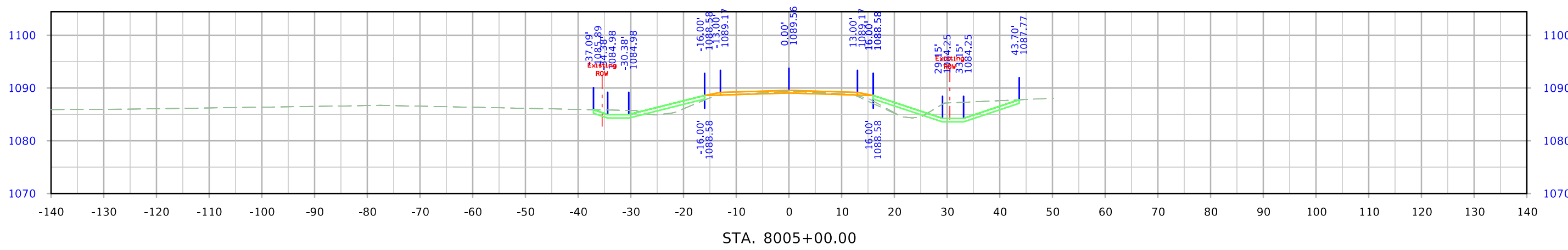
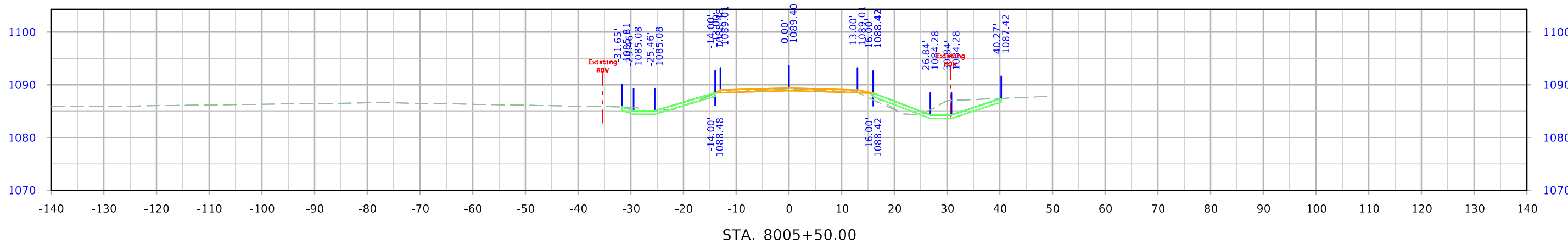
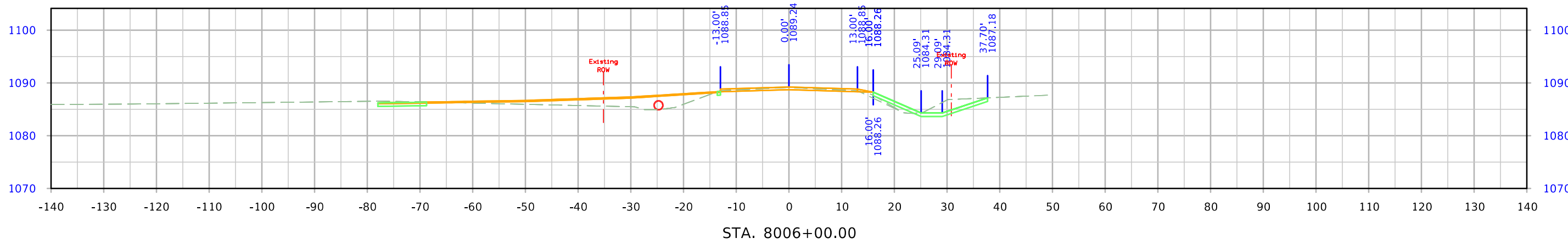

Barker Avenue

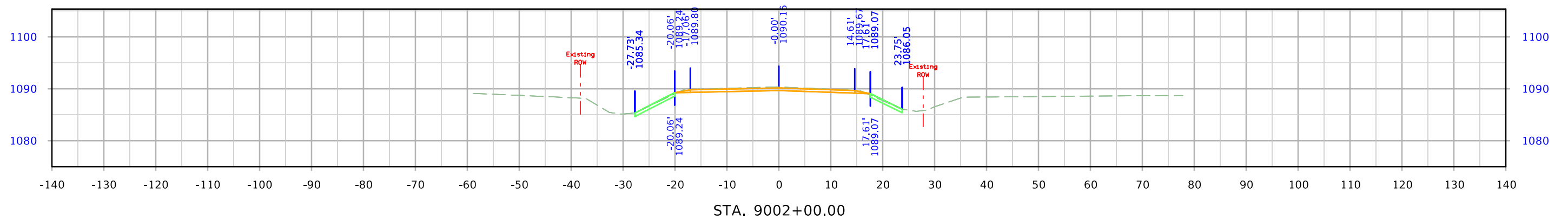
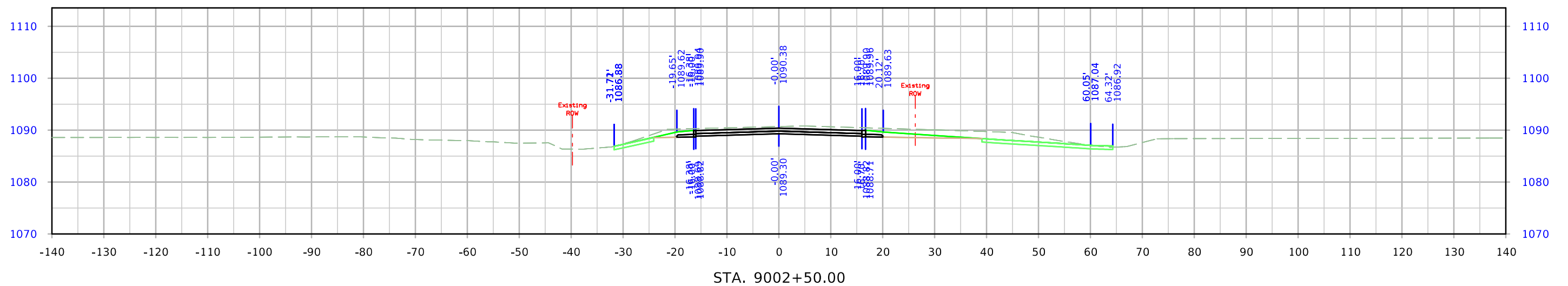

I-29 Ramp A

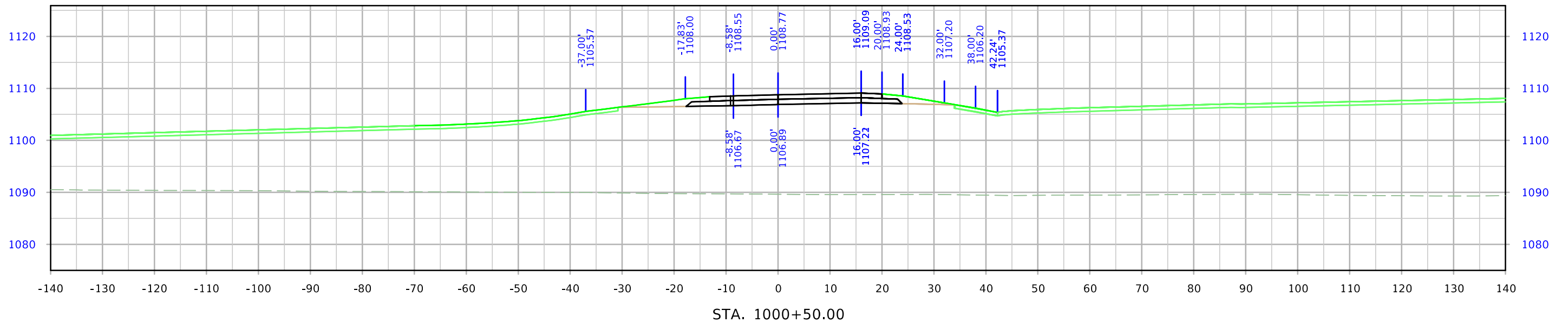
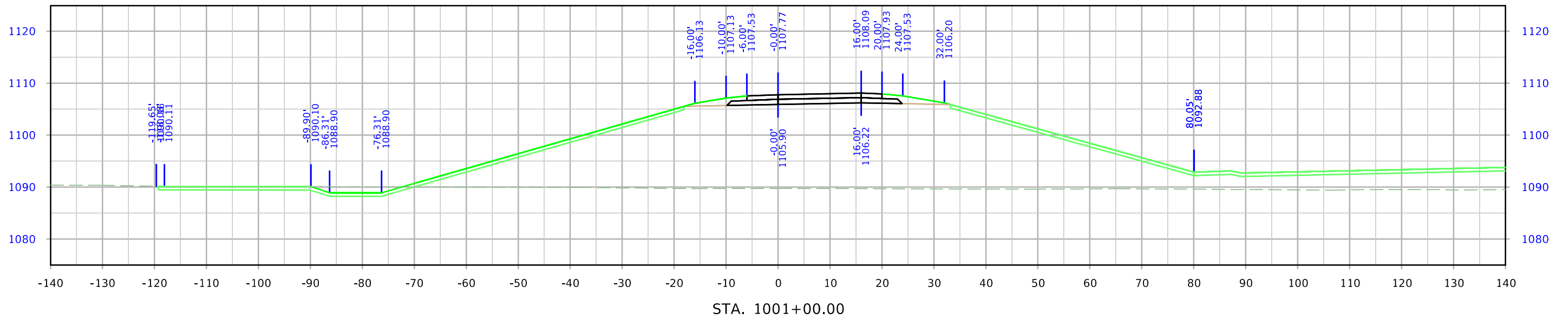

I-29 Ramp A

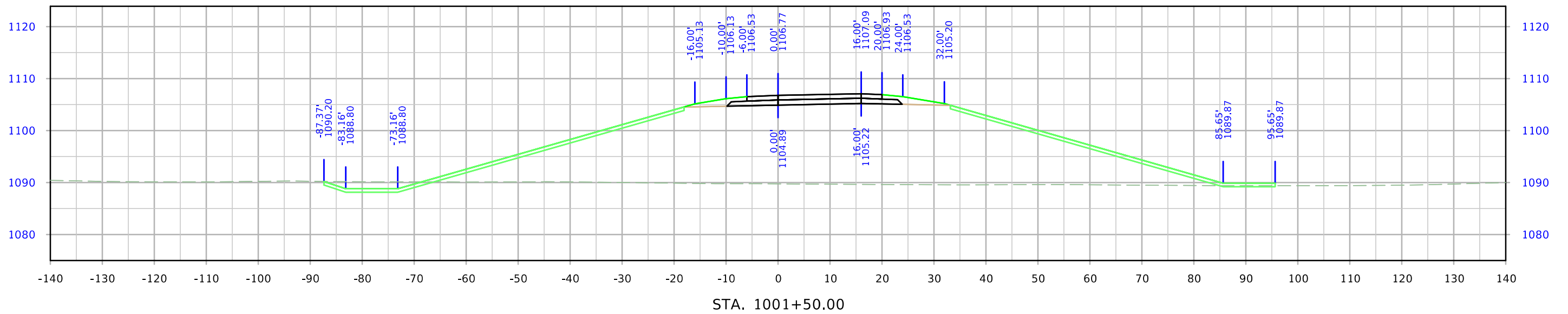
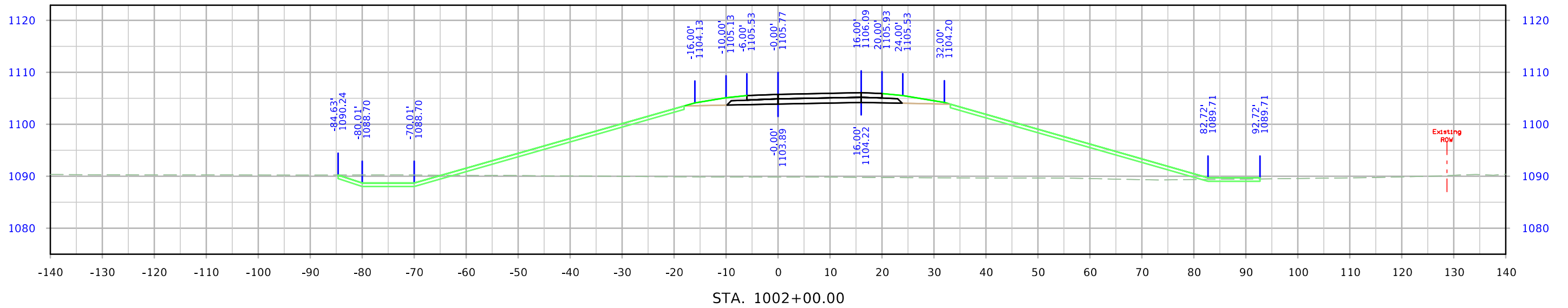

I-29 Ramp A

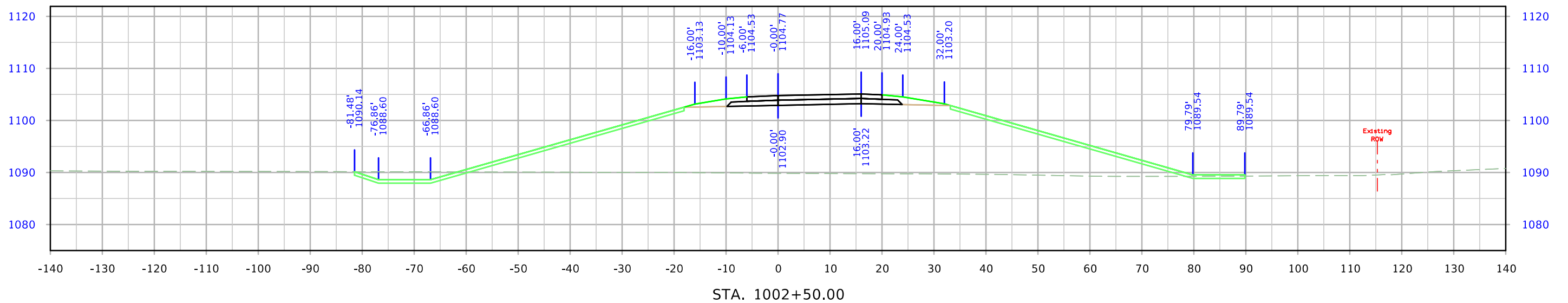
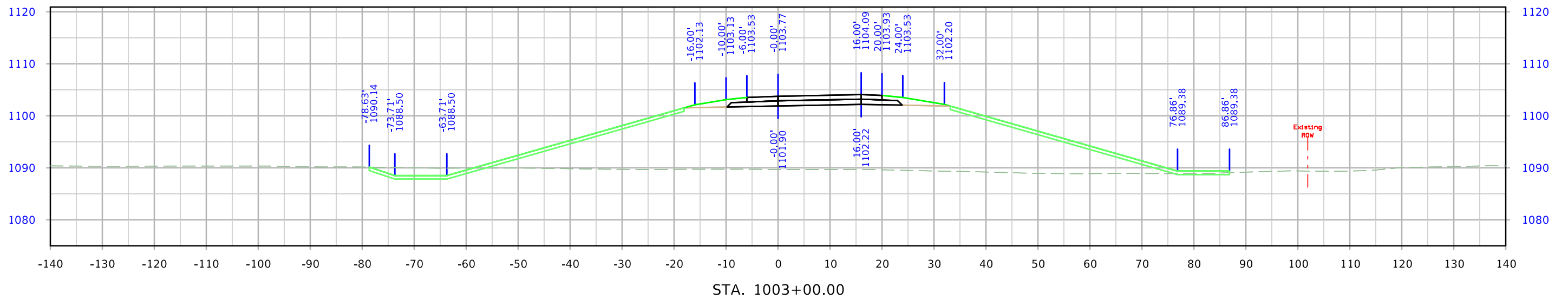

I-29 Ramp A

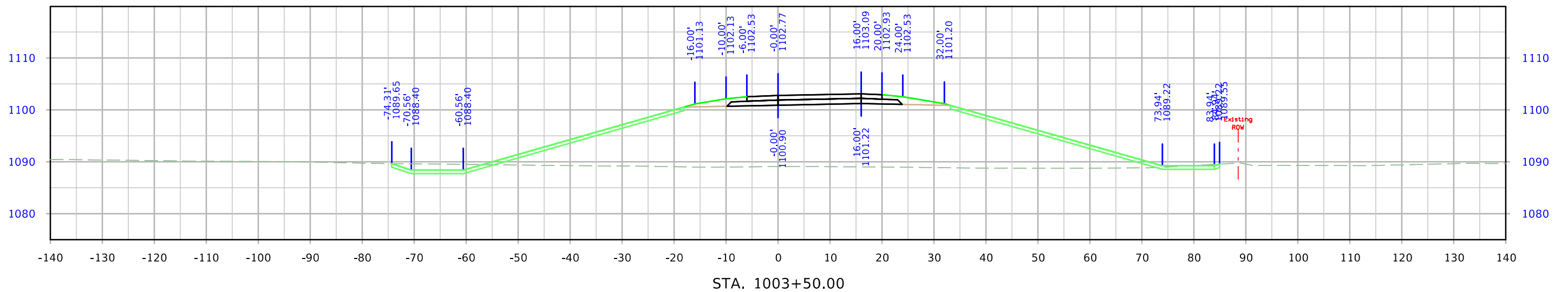
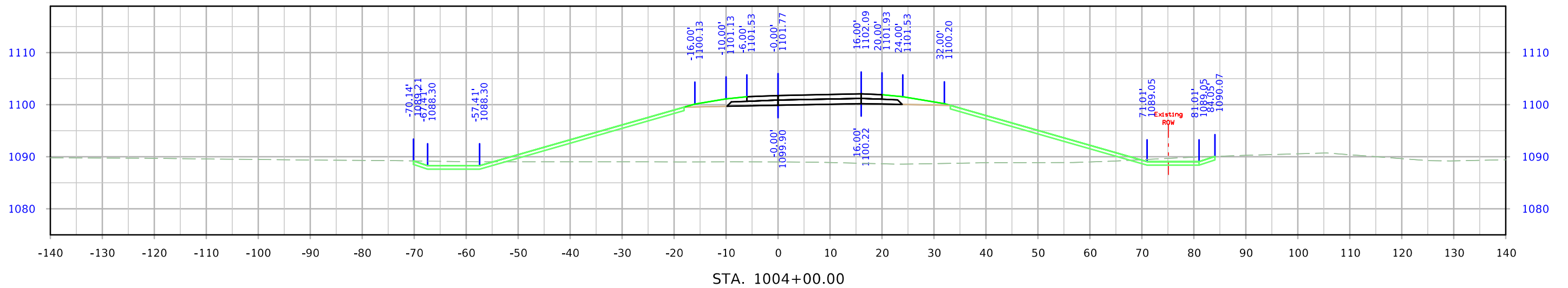
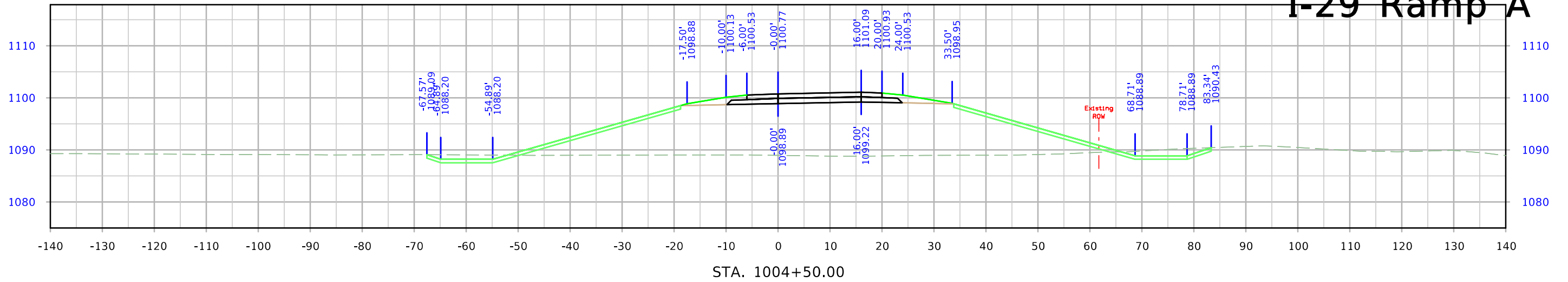

I-29 Ramp A

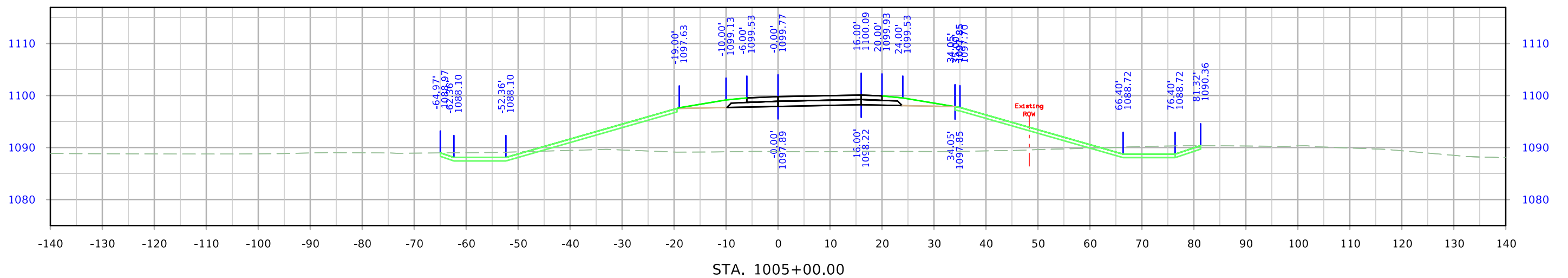
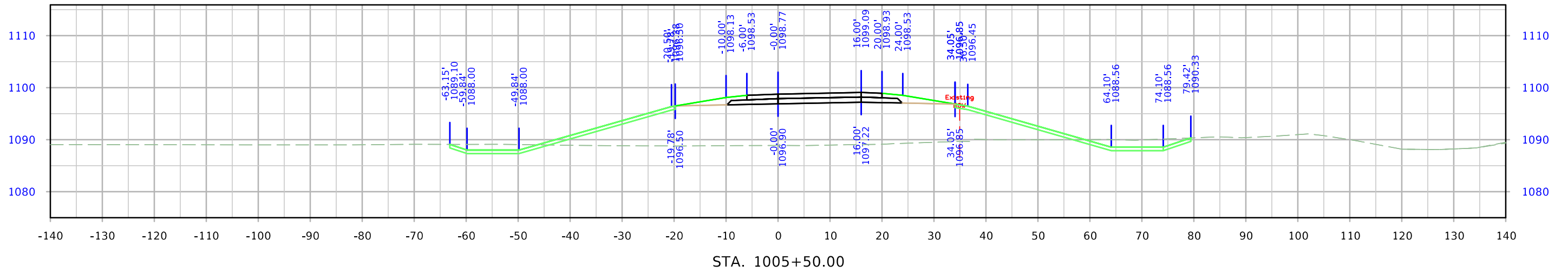
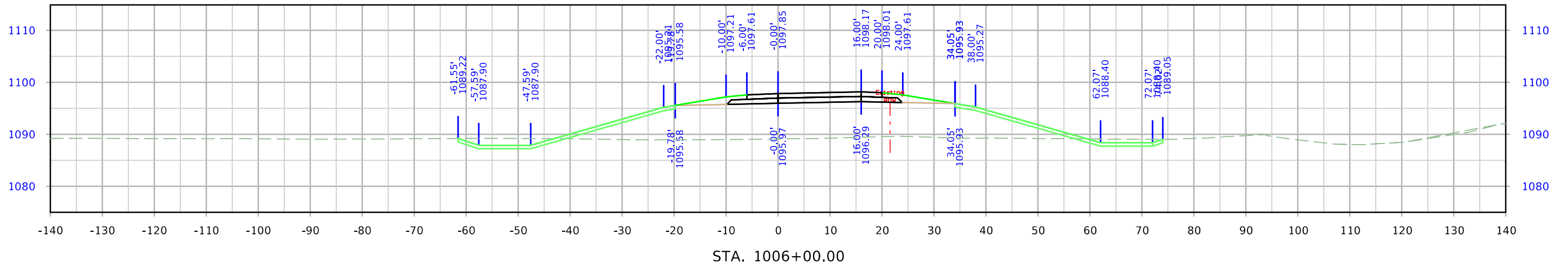

I-29 Ramp A

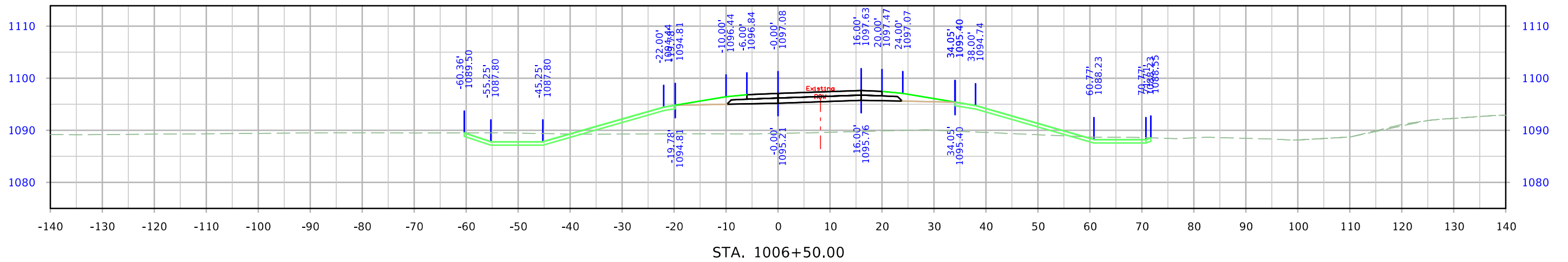
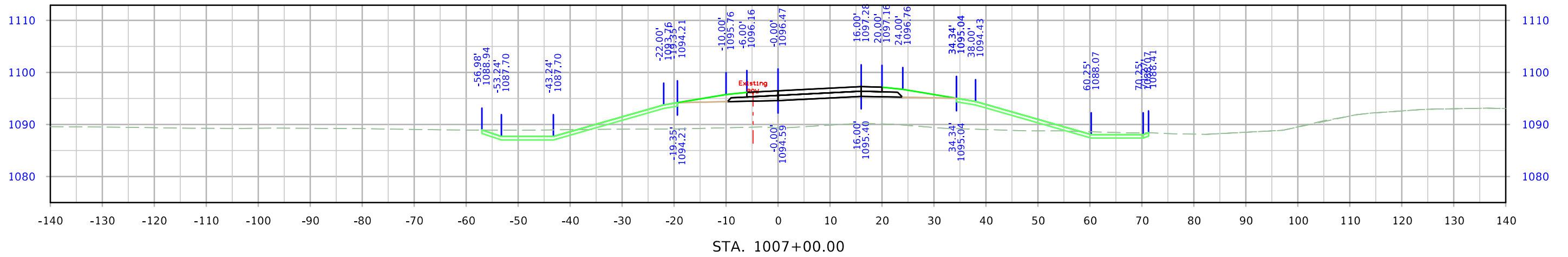
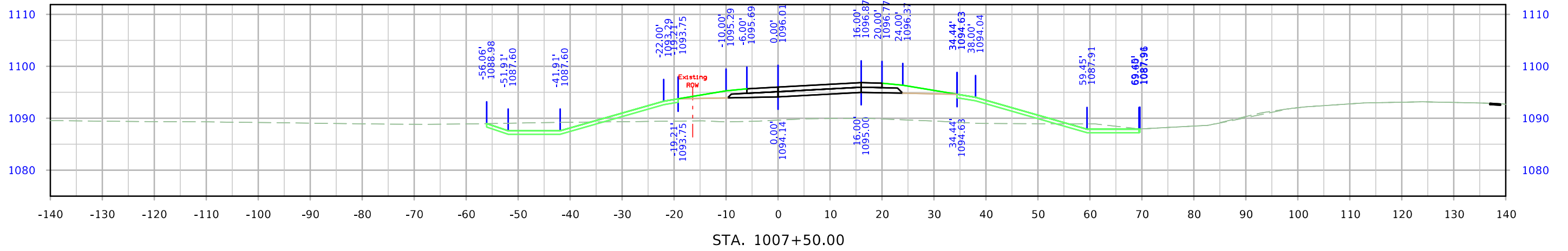

I-29 Ramp A

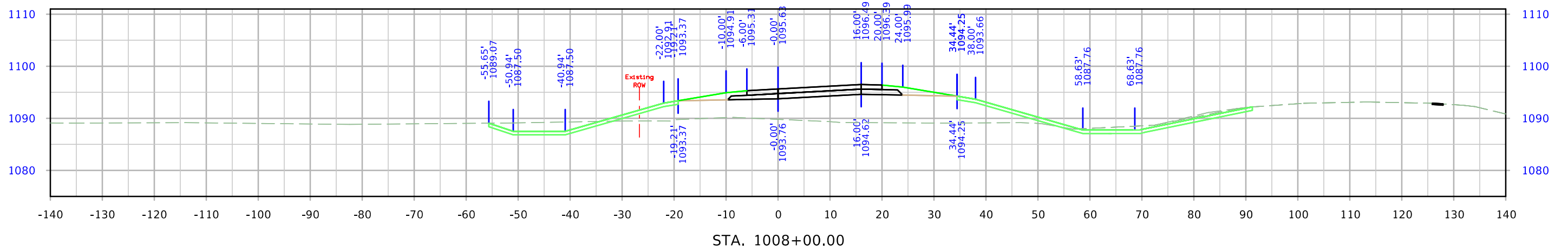
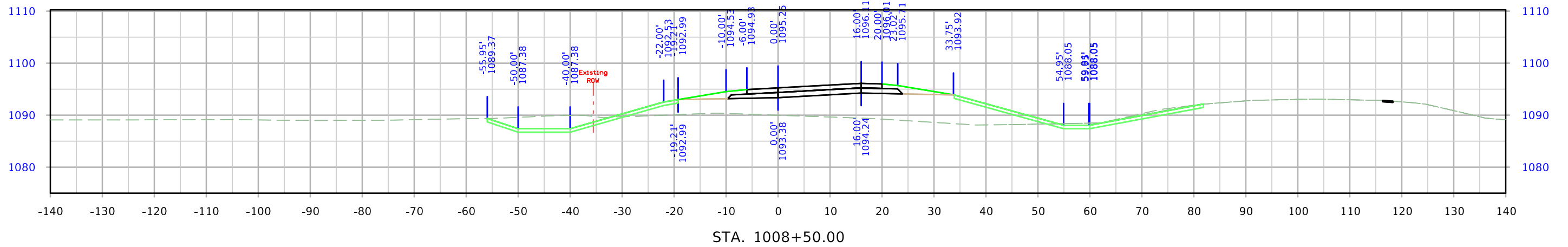
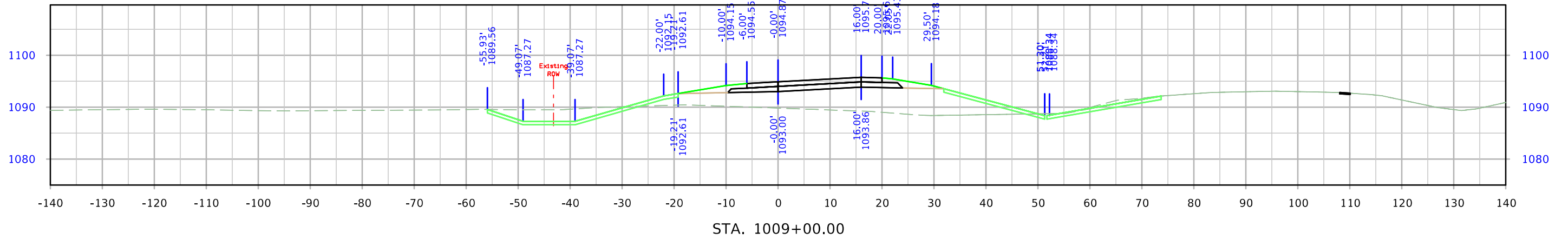

I-29 Ramp A

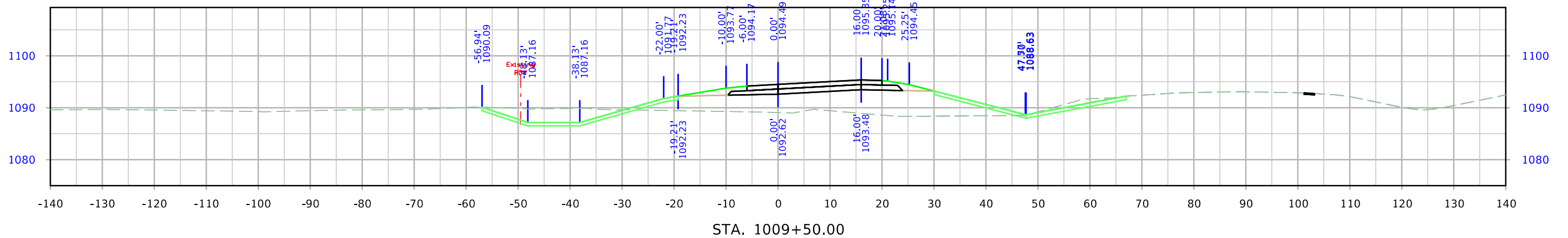
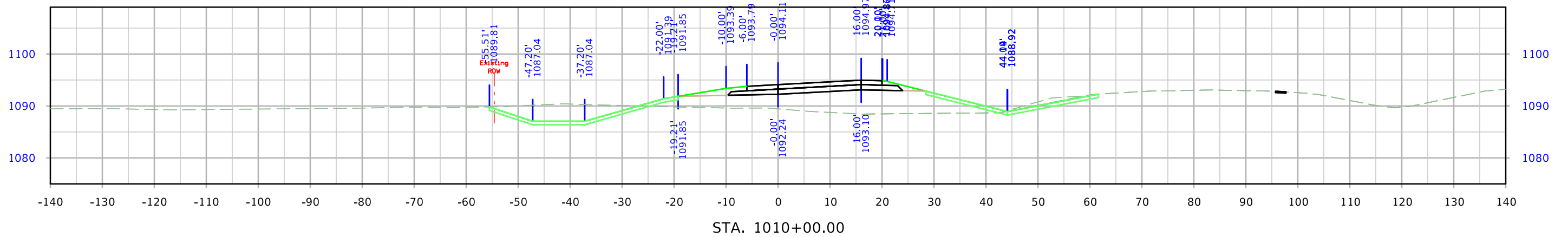
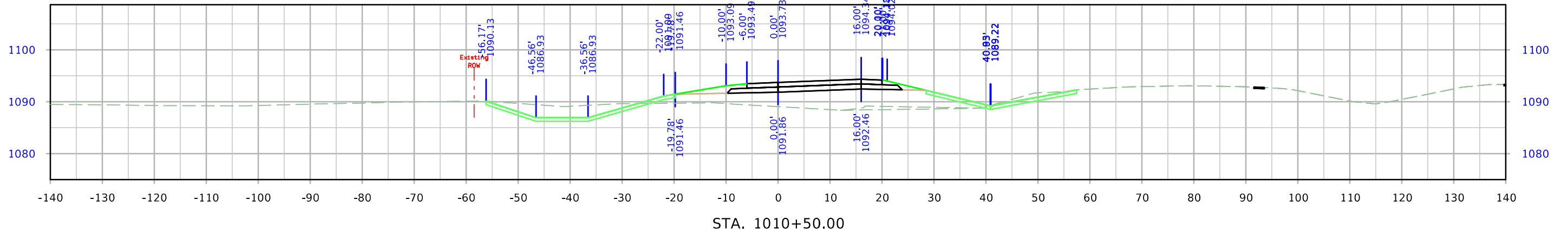

I-29 Ramp A

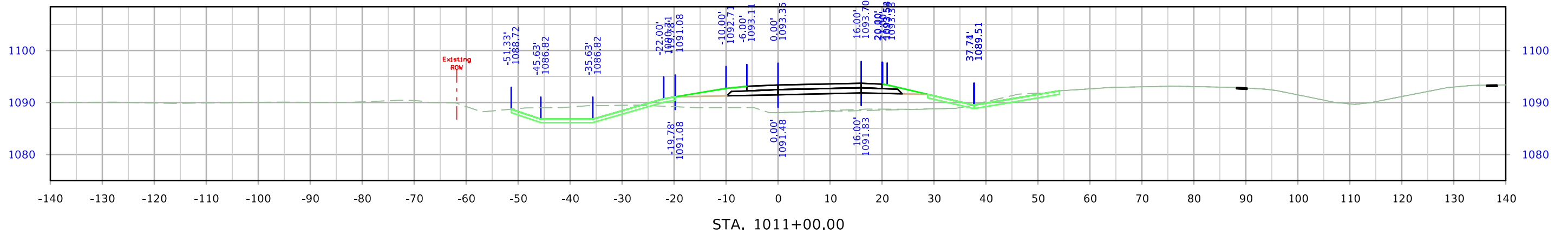
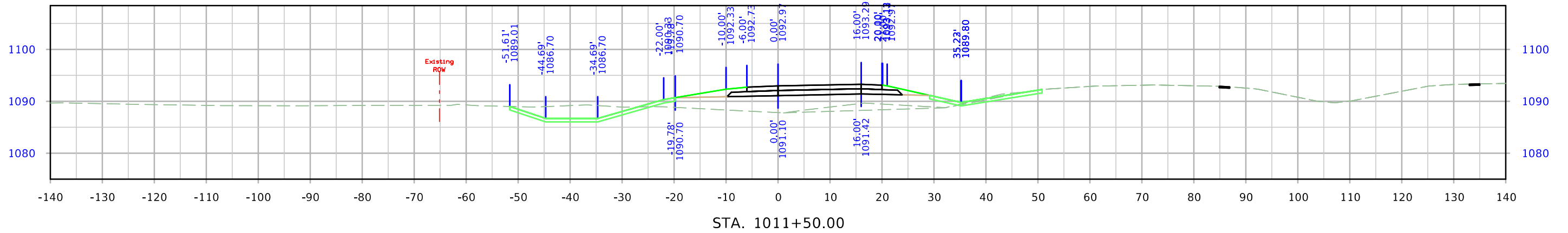
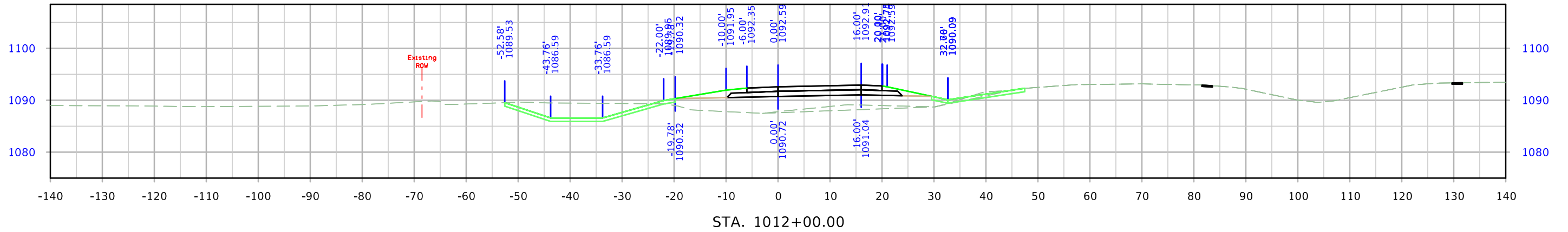

I-29 Ramp A

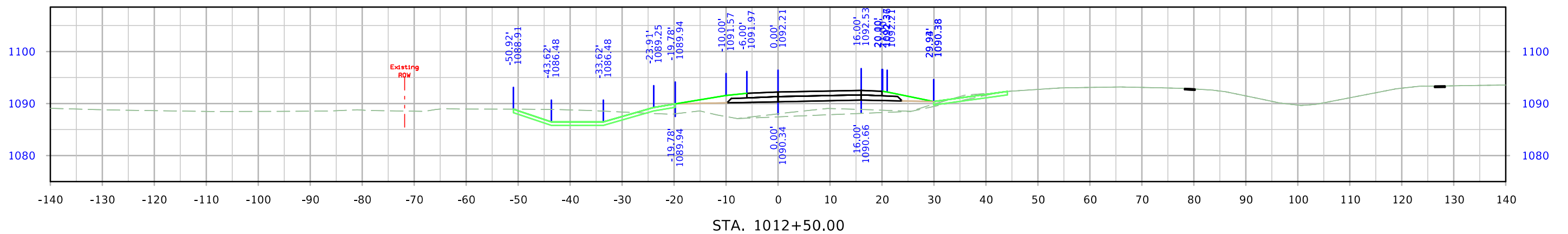
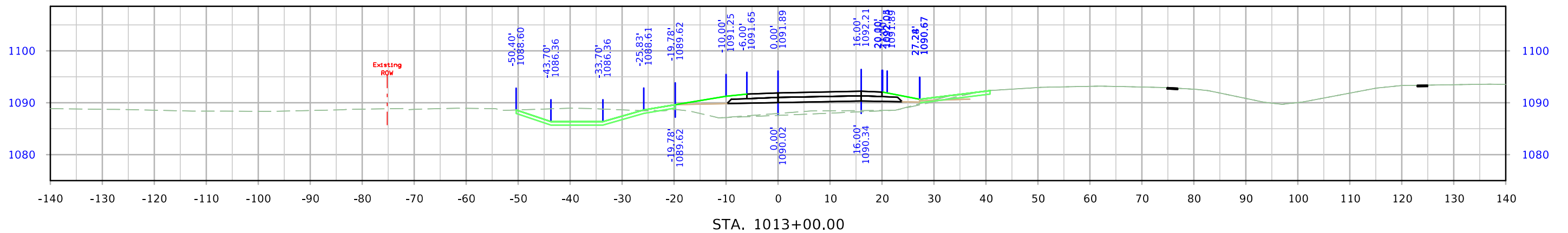
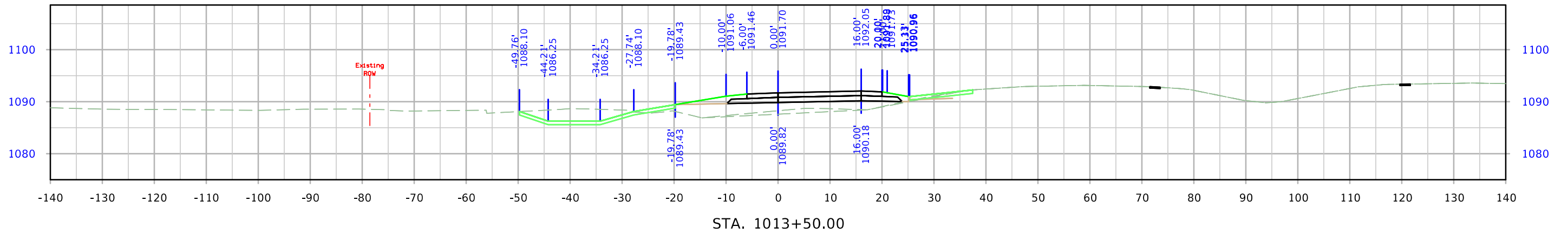

I-29 Ramp A

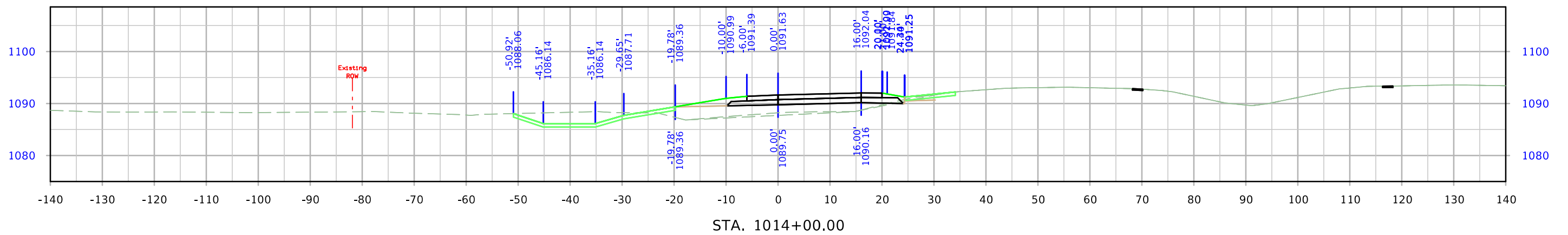
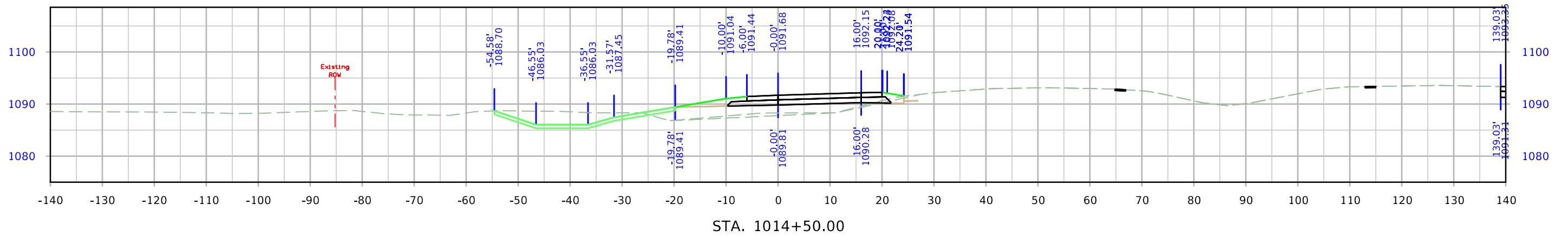

I-29 Ramp B

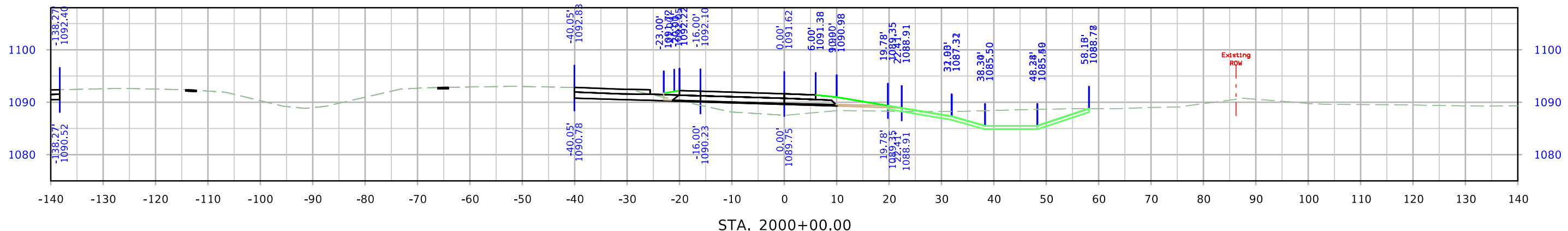
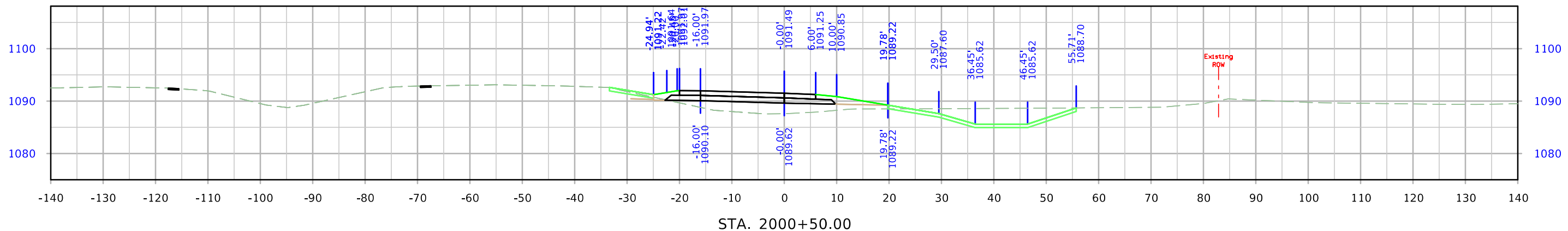
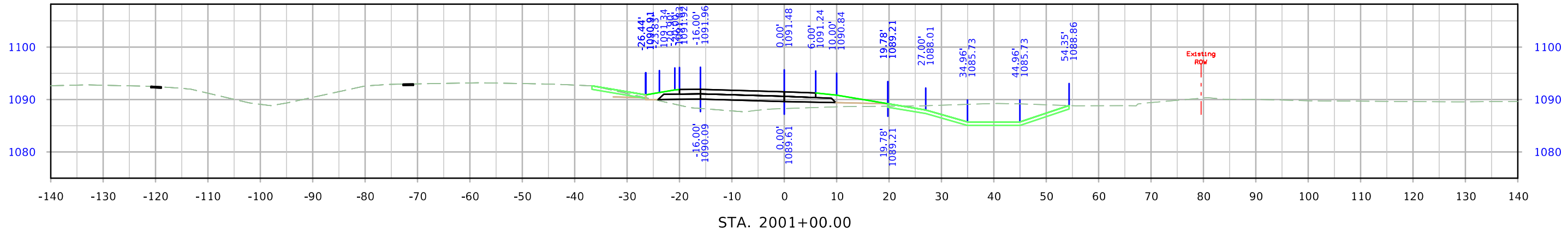

I-29 Ramp B

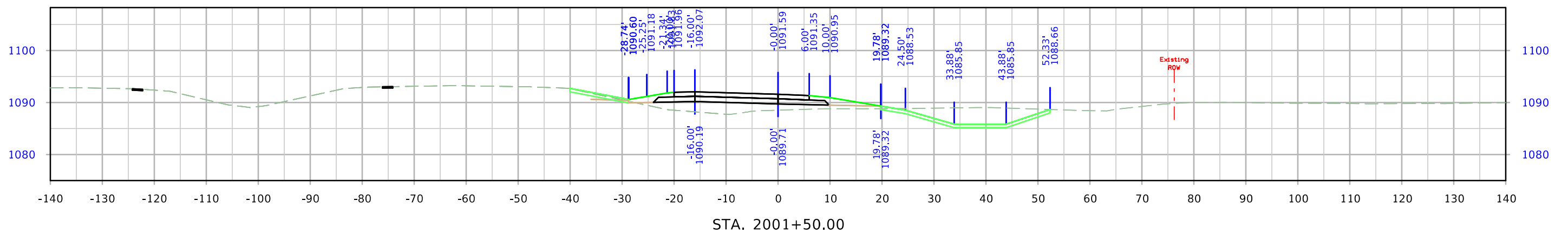
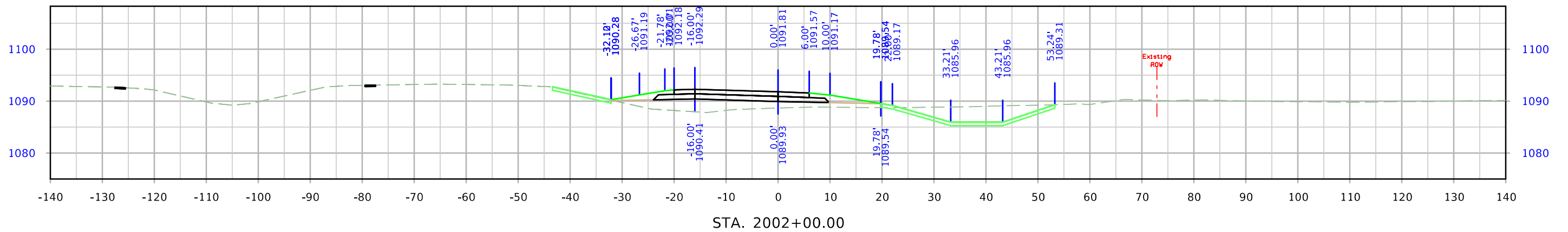
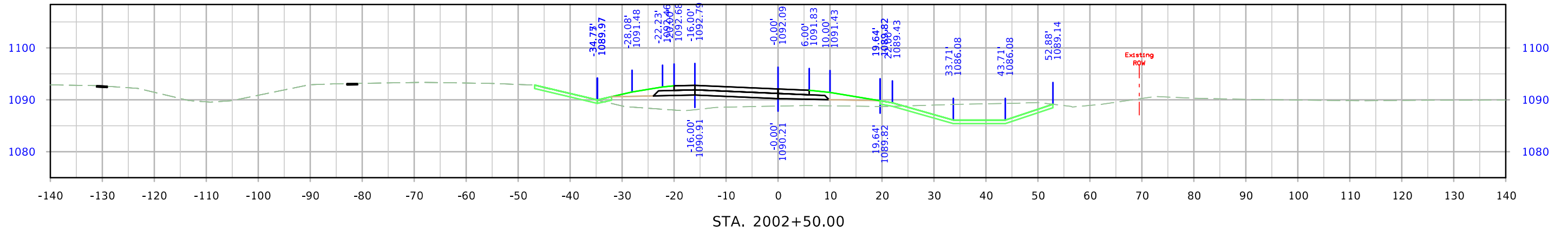

I-29 Ramp B

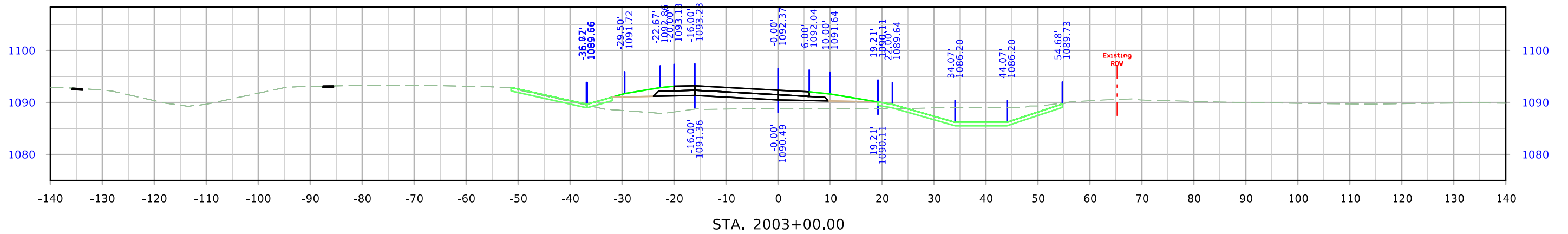
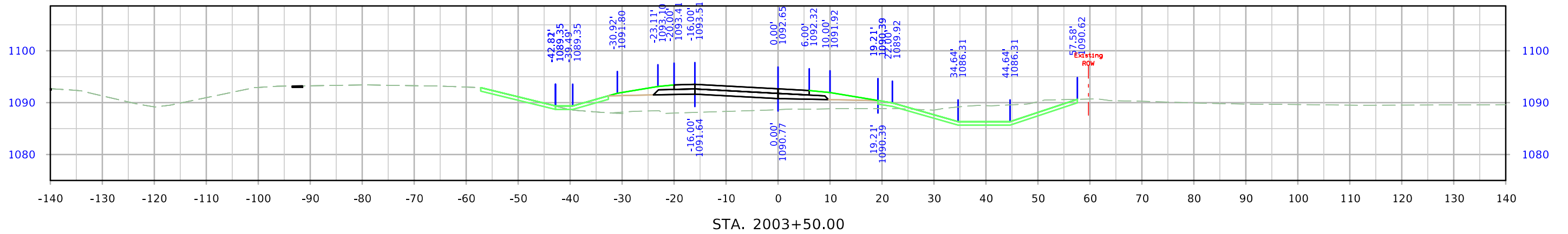
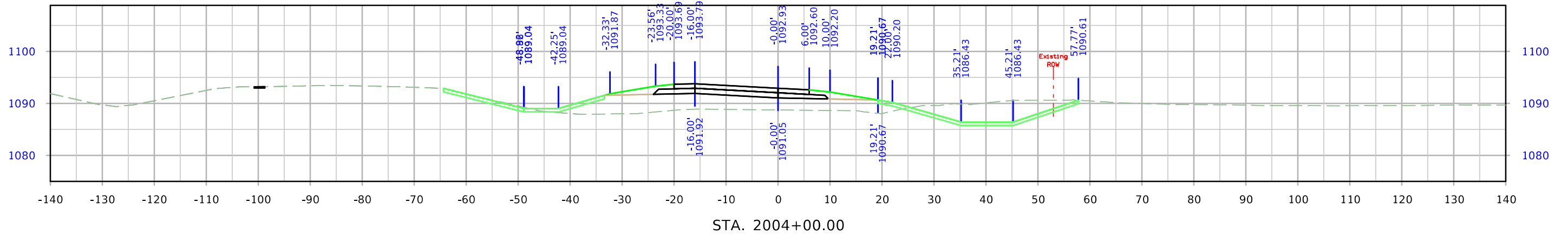

I-29 Ramp B

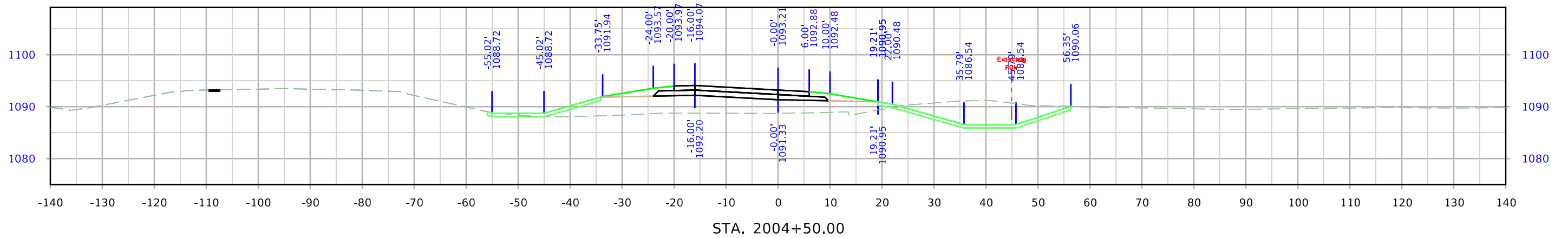
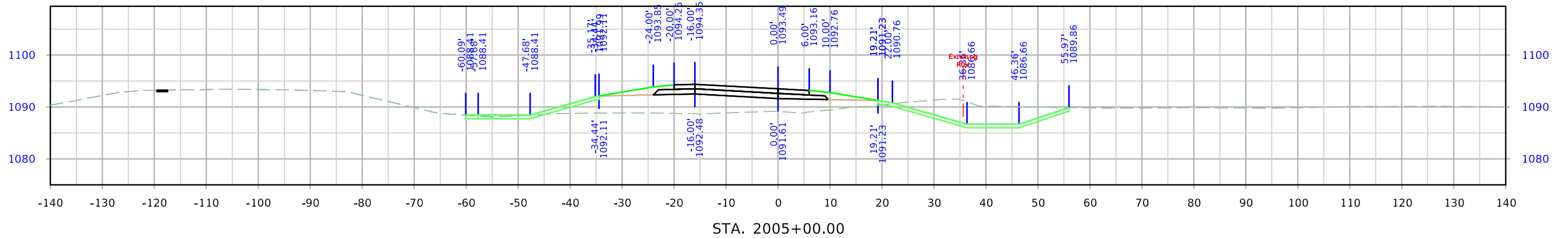
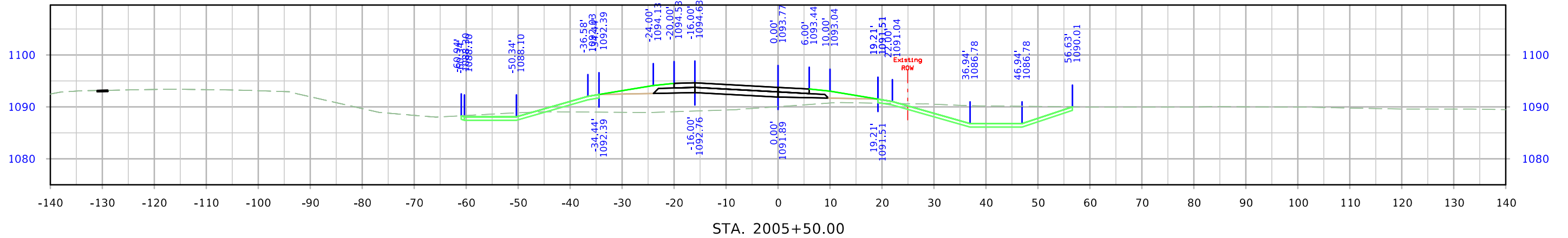

I-29 Ramp B

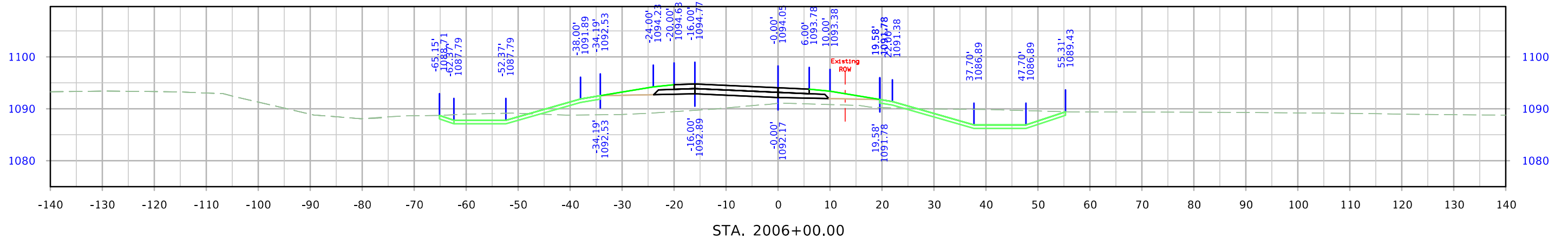
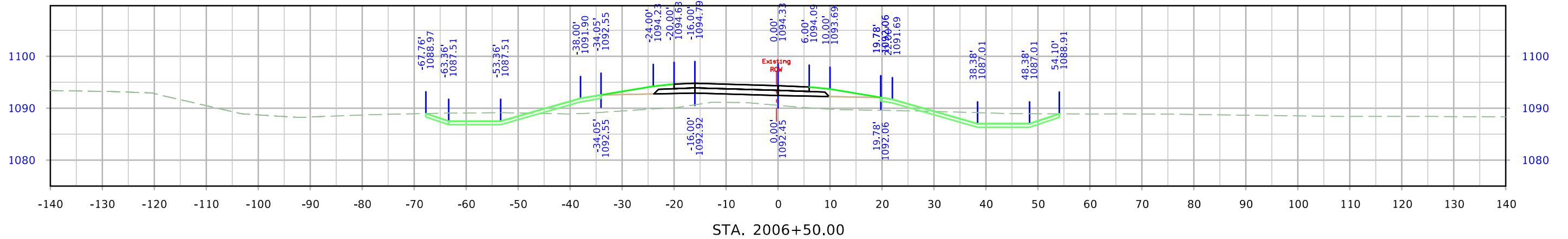
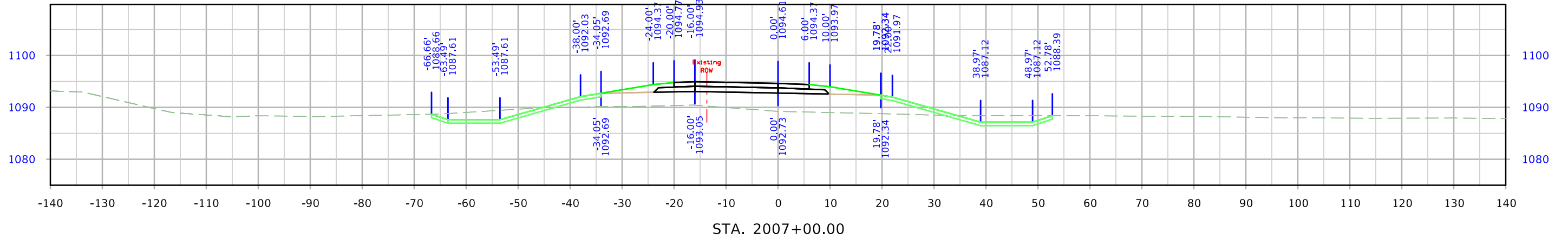

I-29 Ramp B

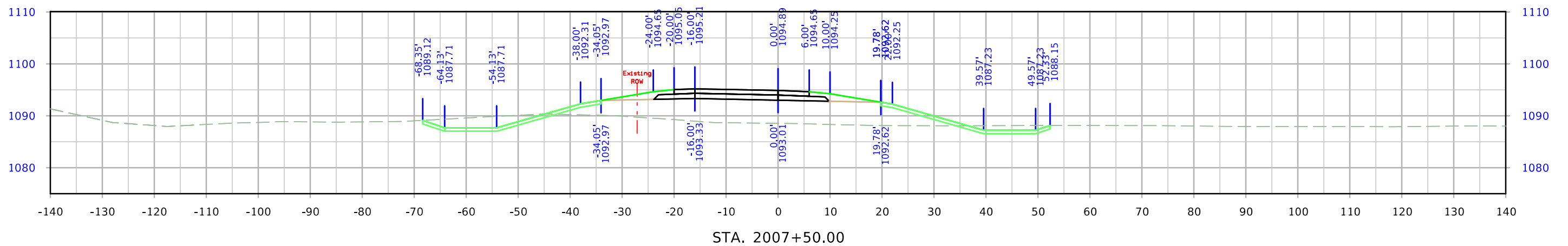
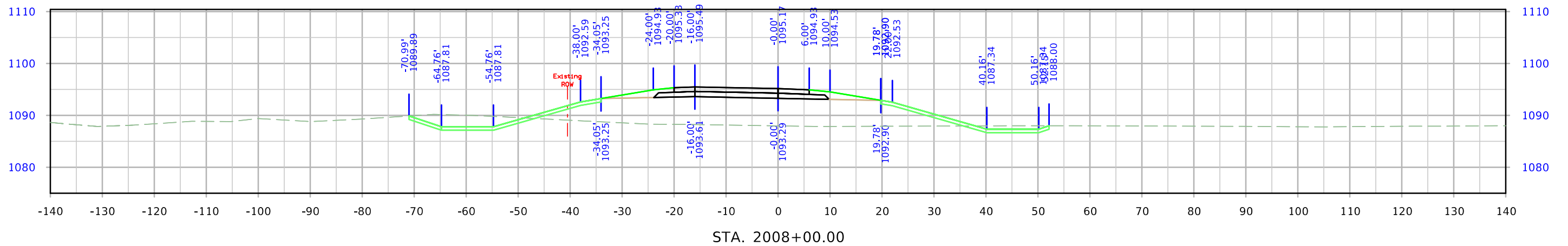
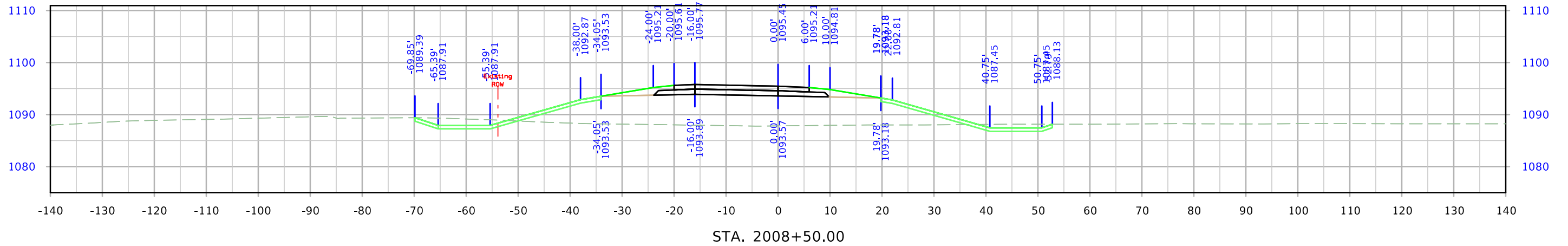

I-29 Ramp B

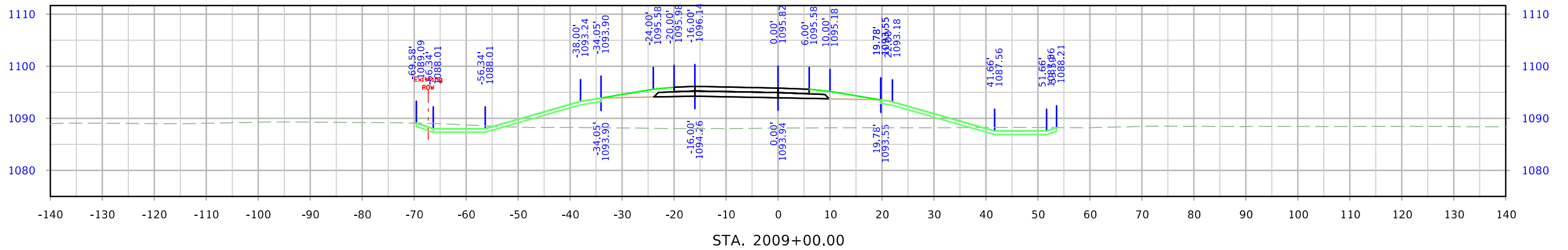
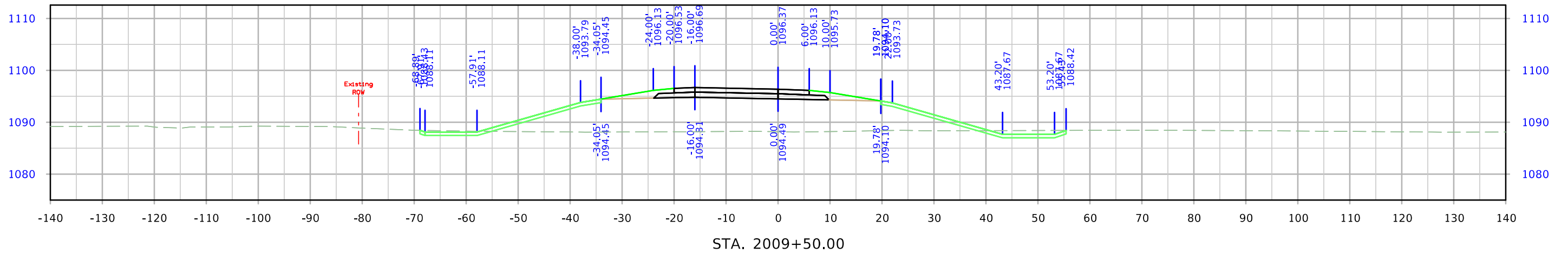
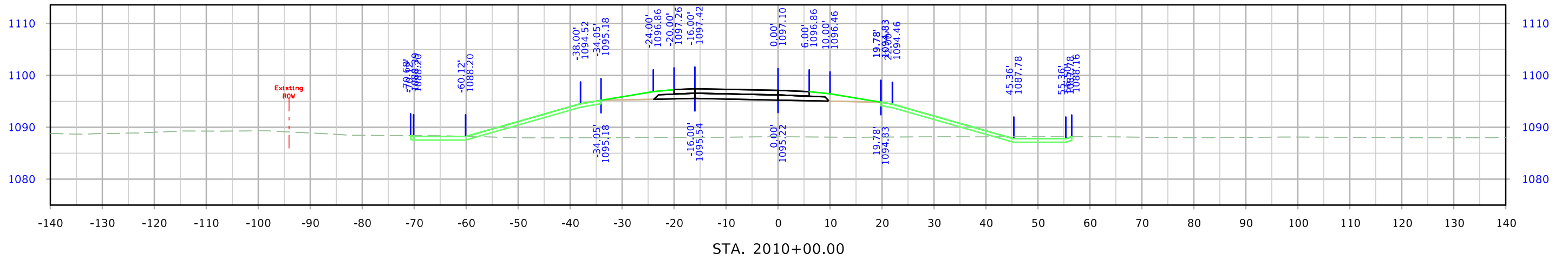

I-29 Ramp B

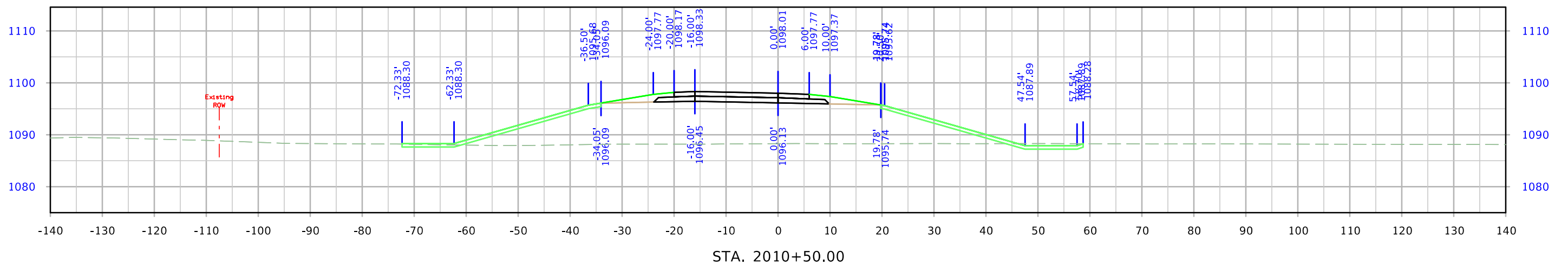
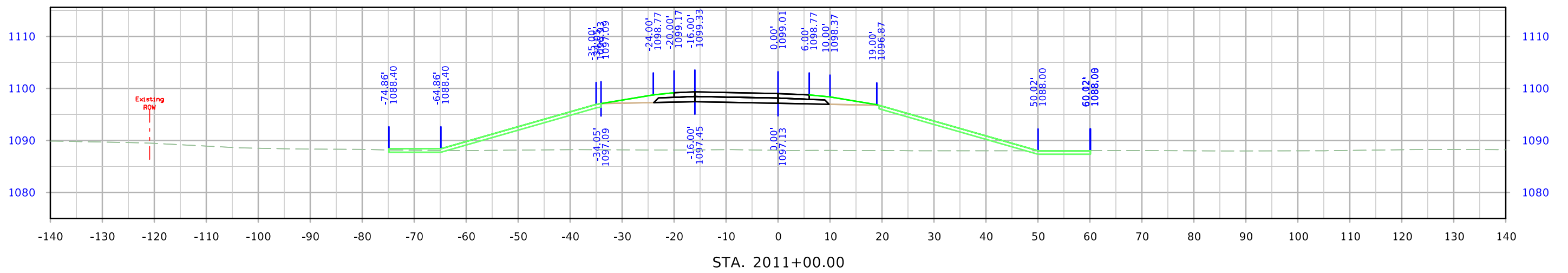
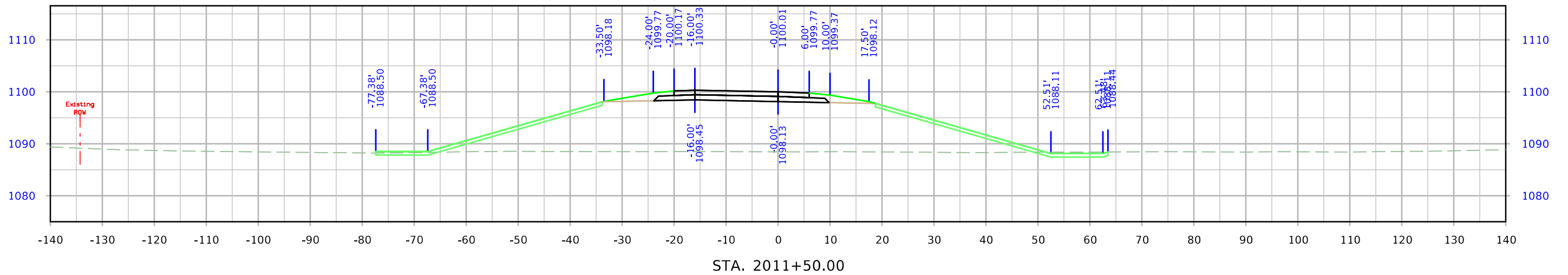

I-29 Ramp B

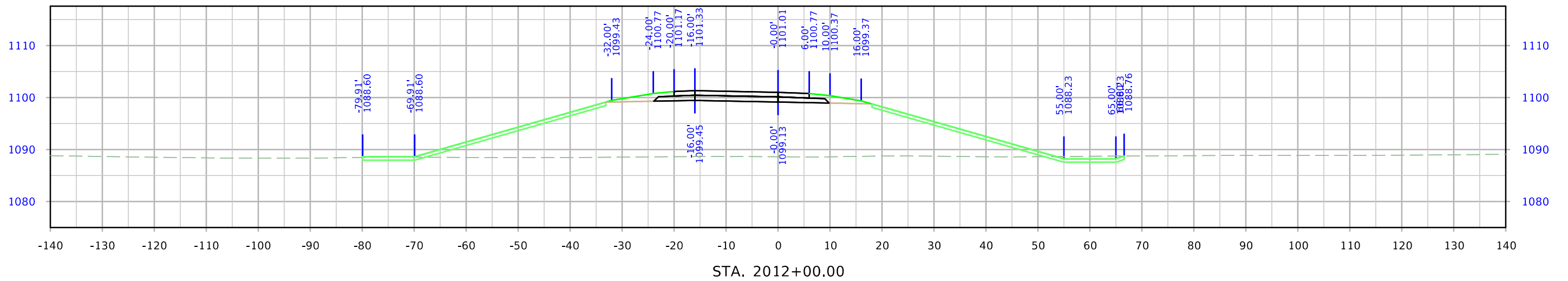
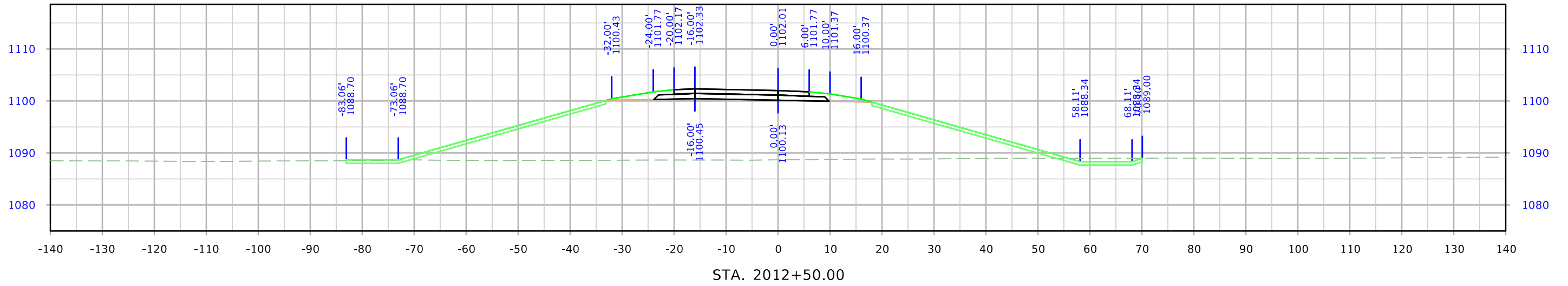
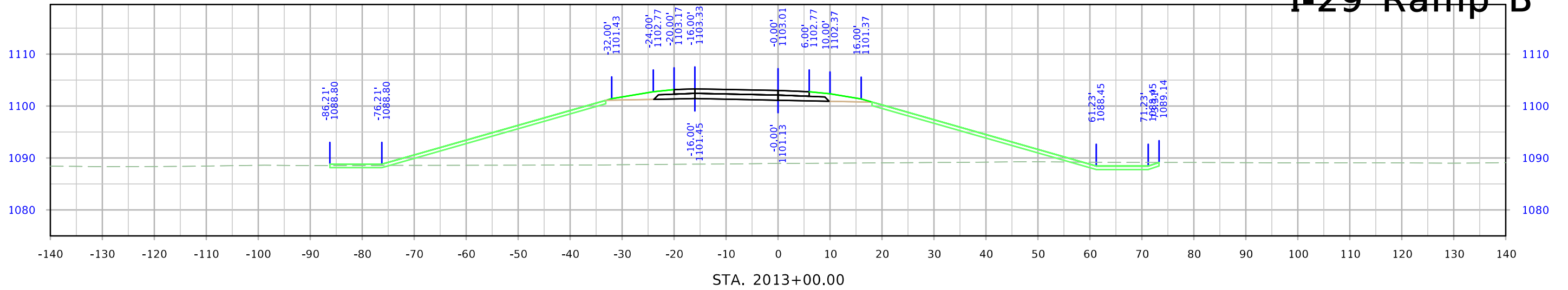

I-29 Ramp B

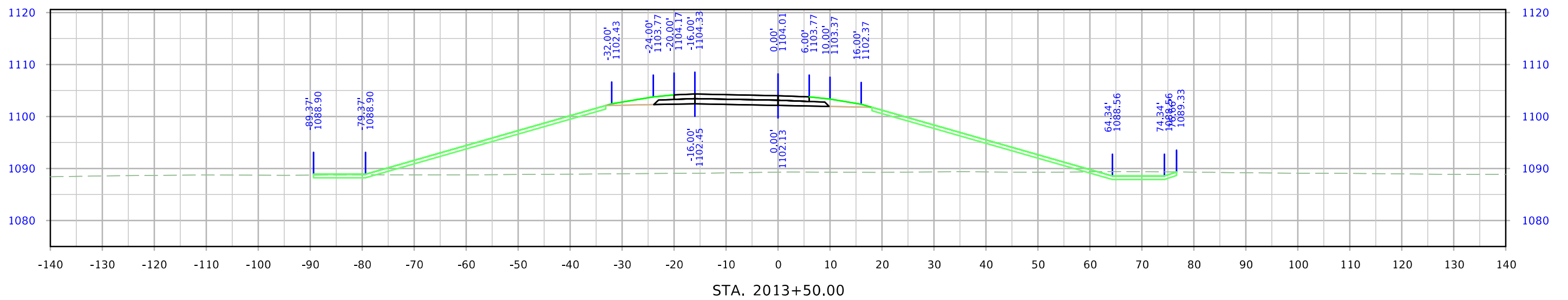
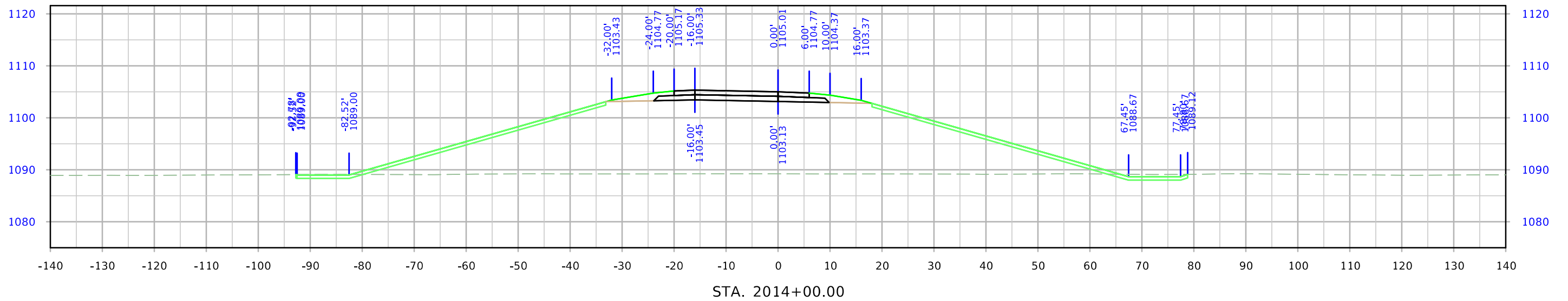

I-29 Ramp B

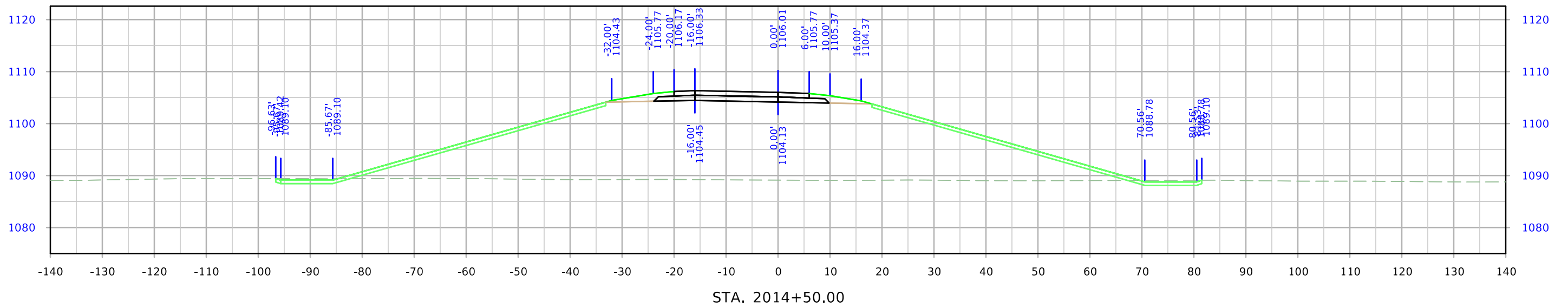
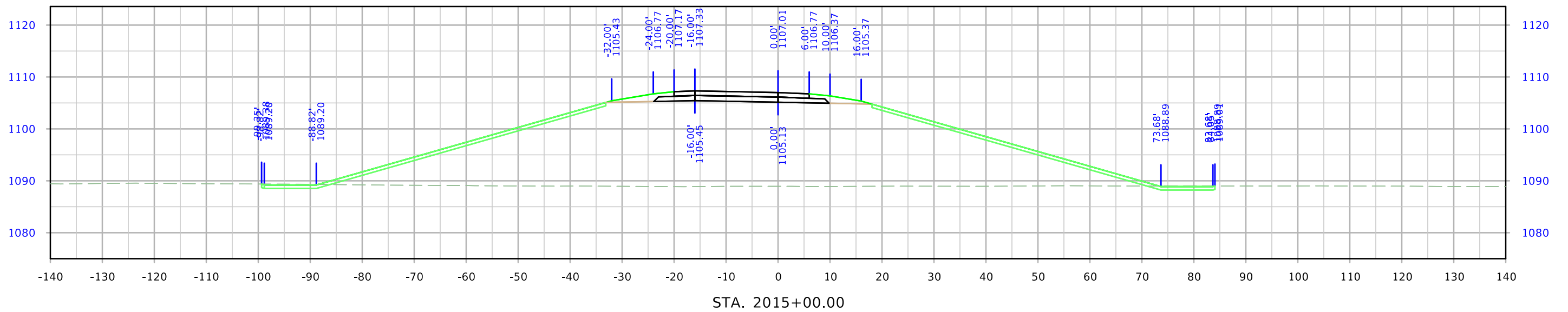

I-29 Ramp B

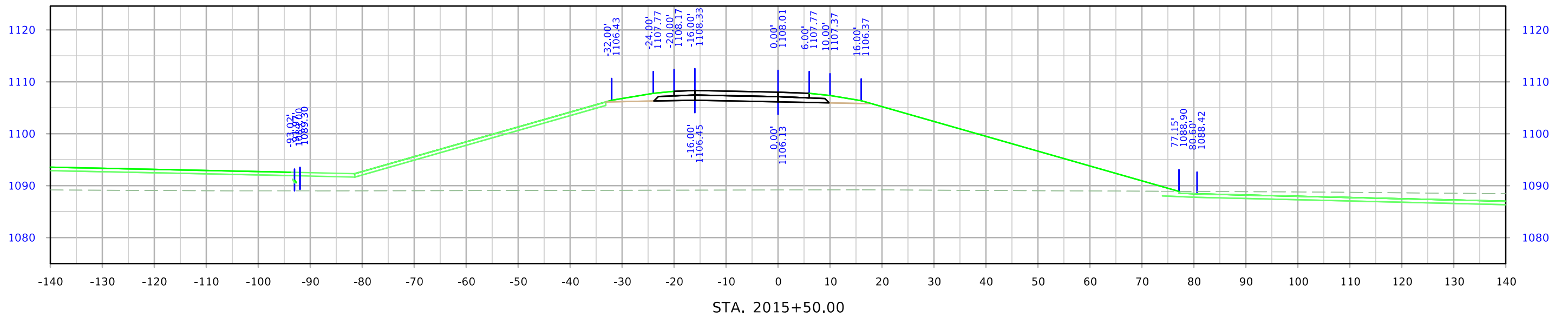
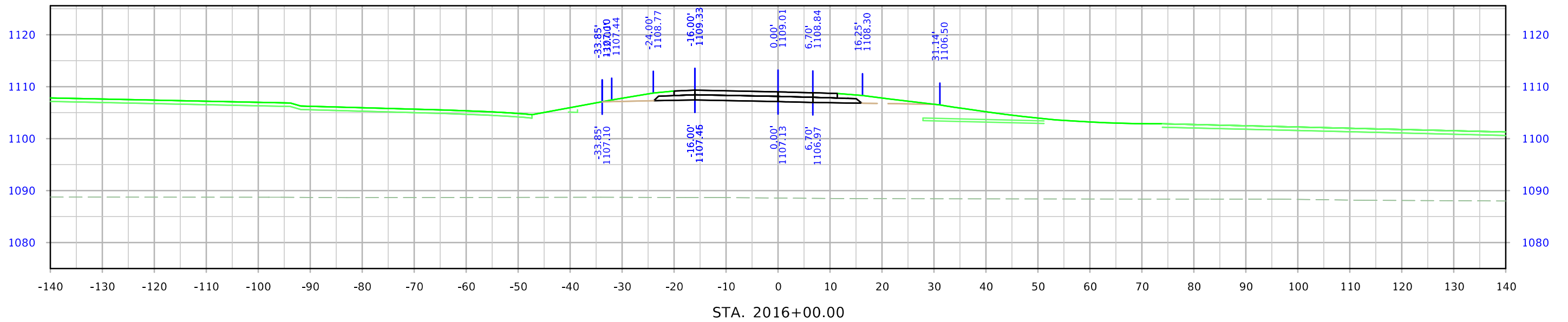

I-29 Ramp C

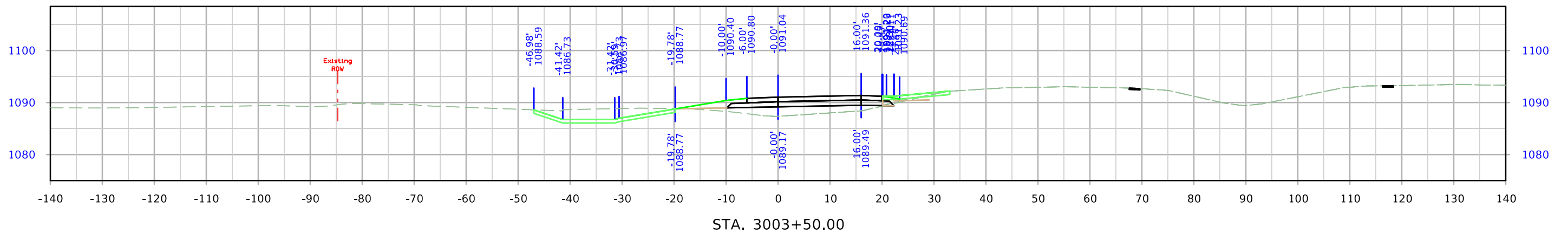
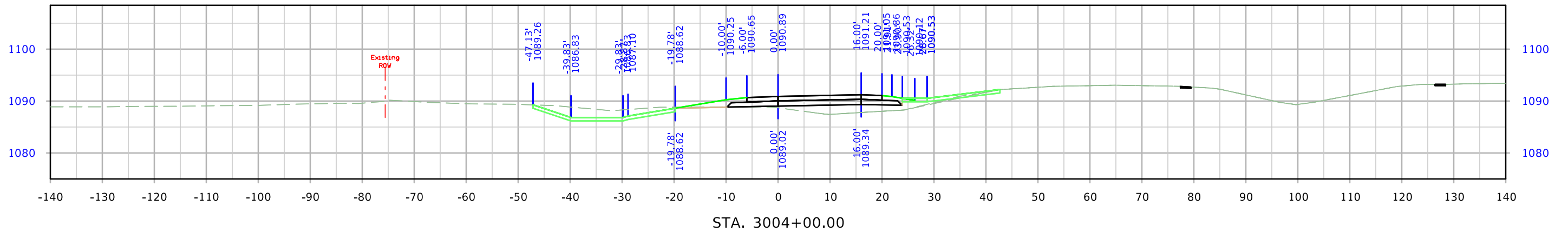
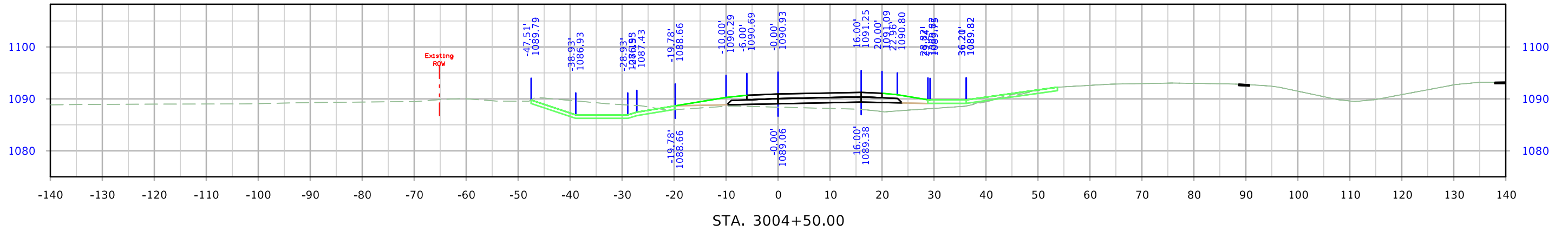

I-29 Ramp C

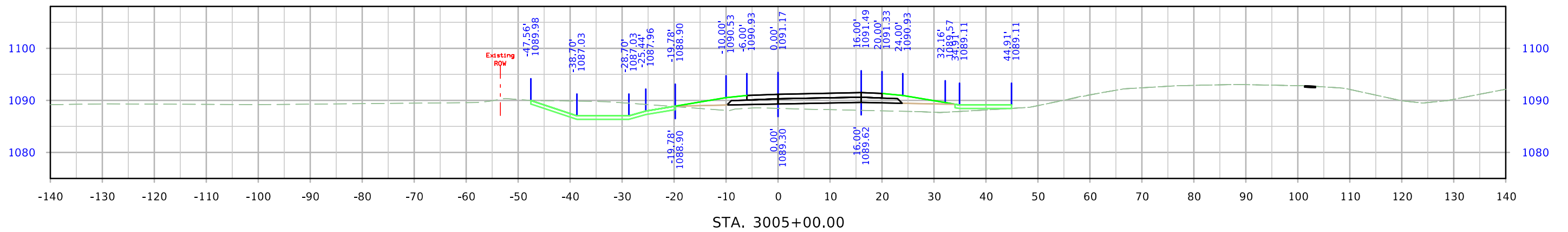
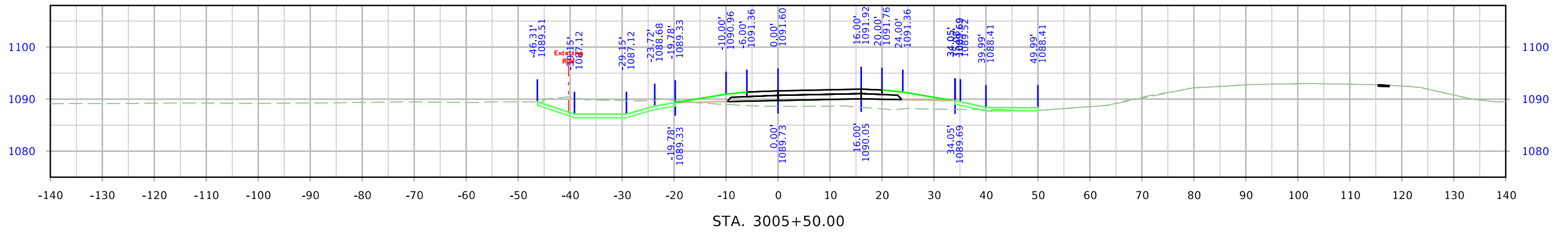
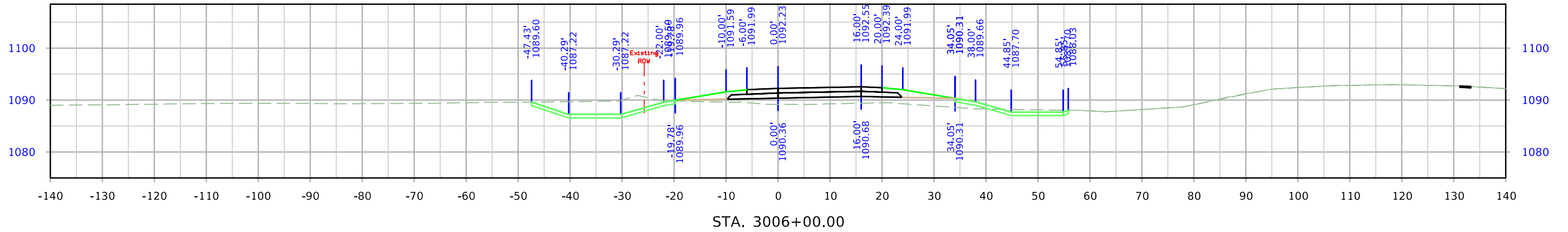

I-29 Ramp C

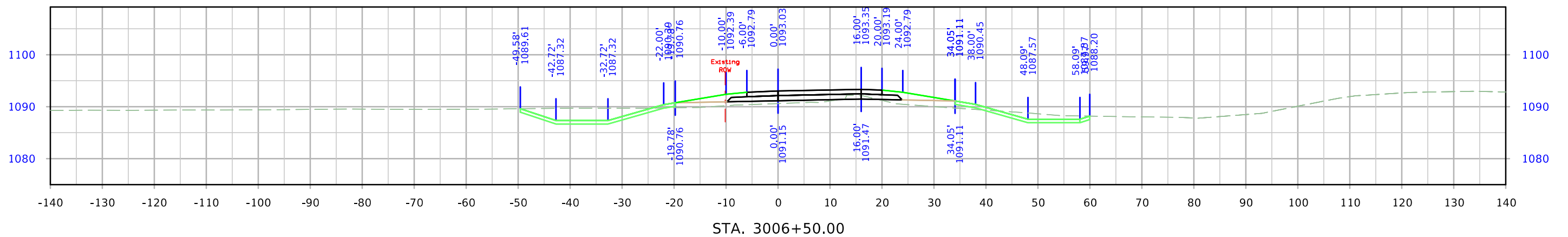
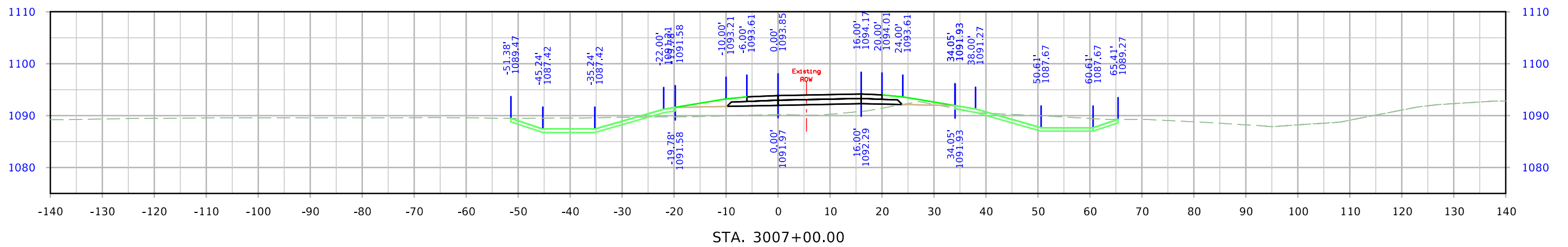
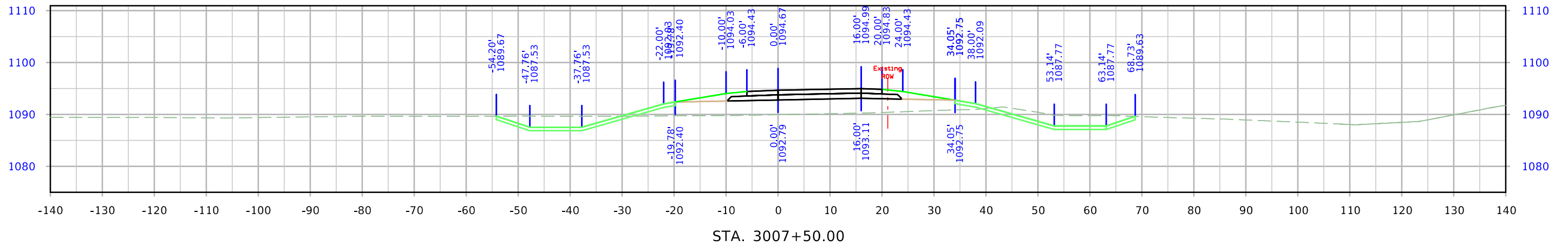

I-29 Ramp C

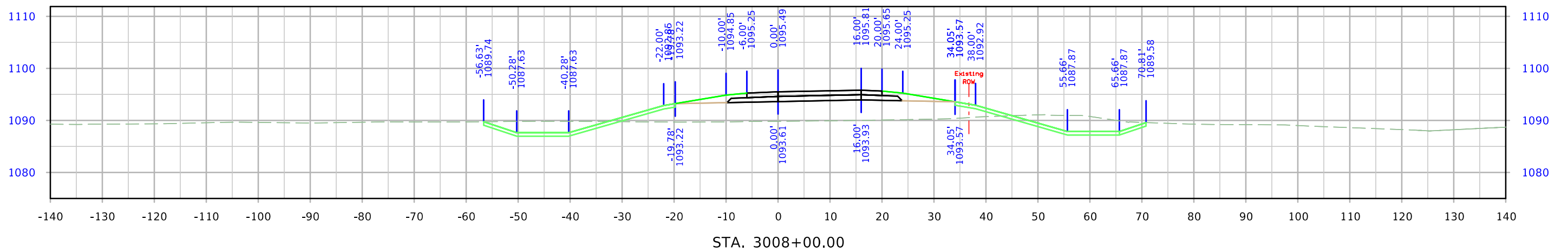
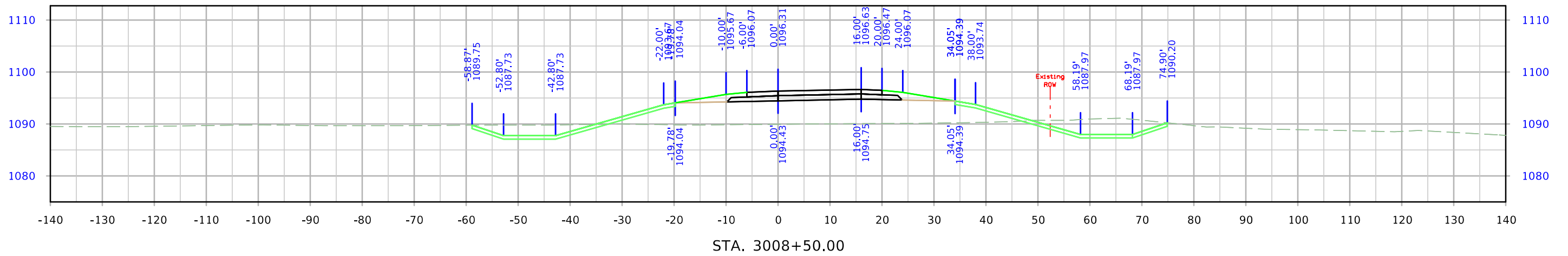
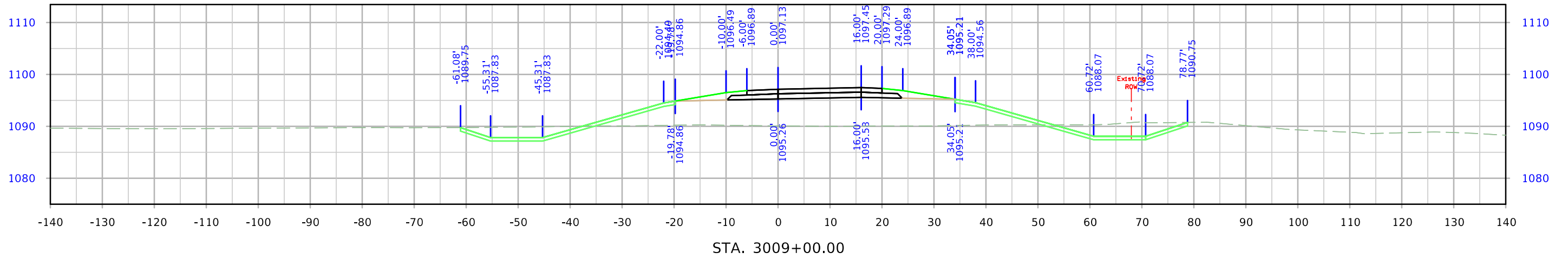

I-29 Ramp C

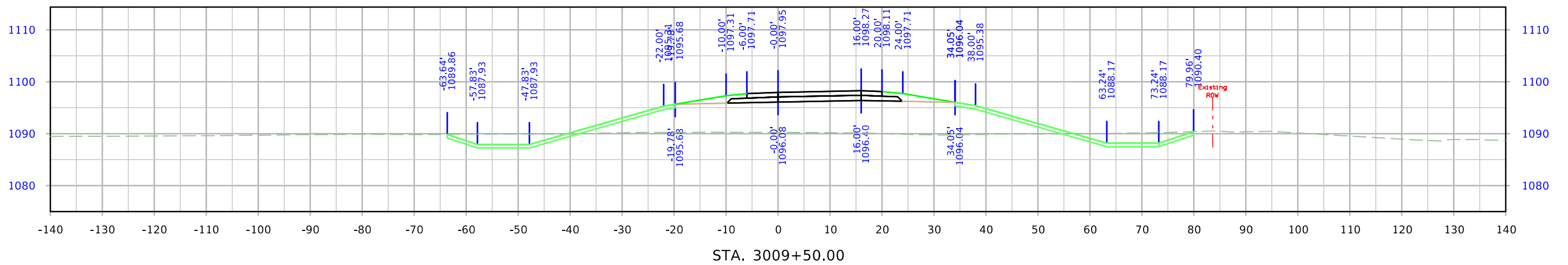
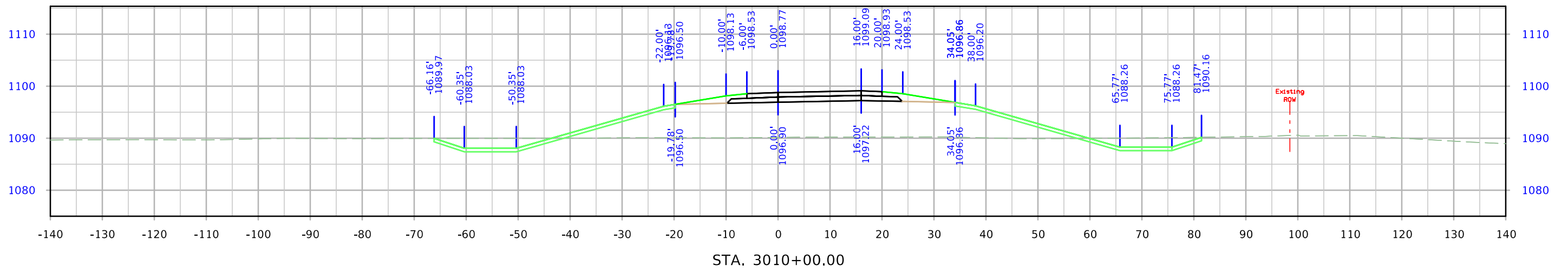
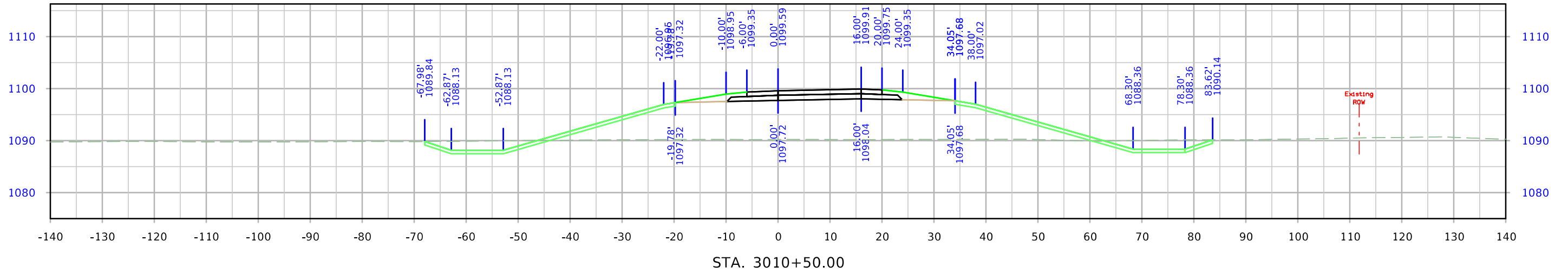

I-29 Ramp C

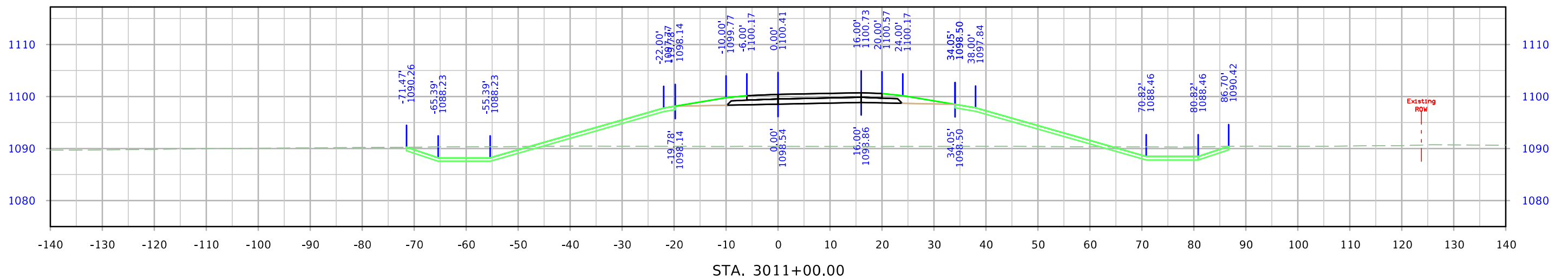
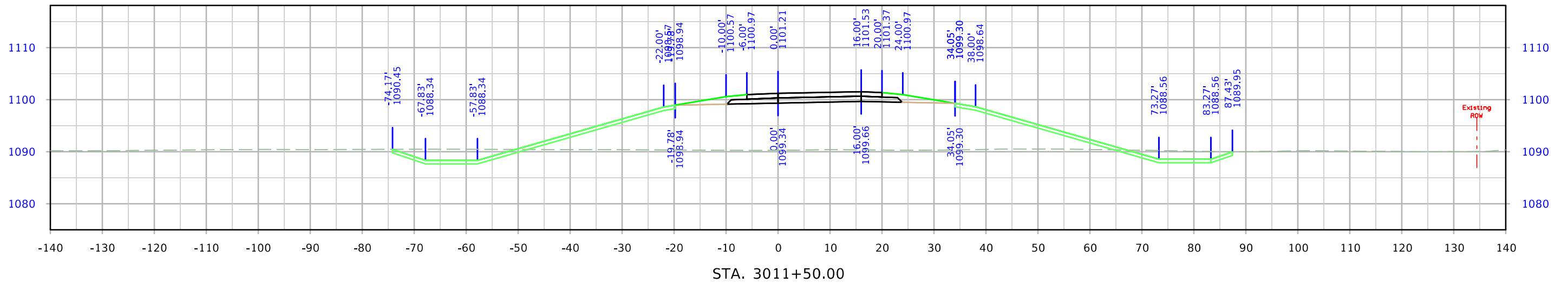
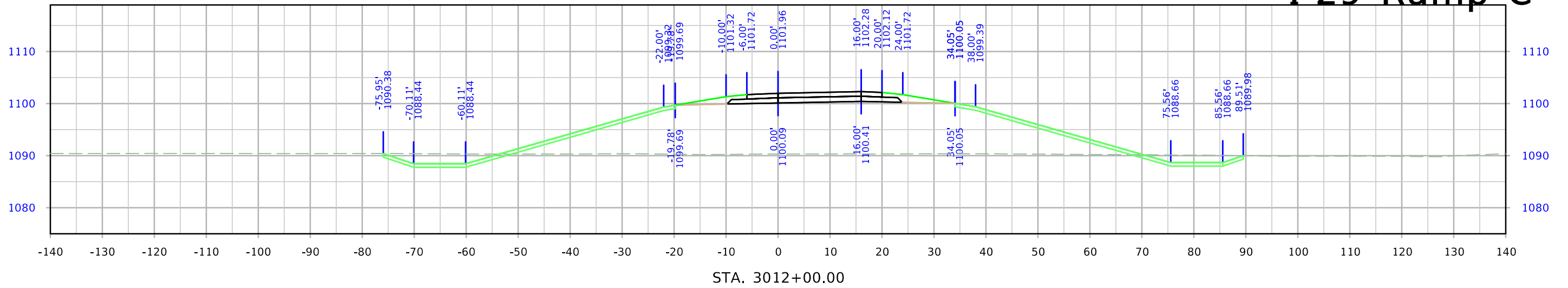

I-29 Ramp C

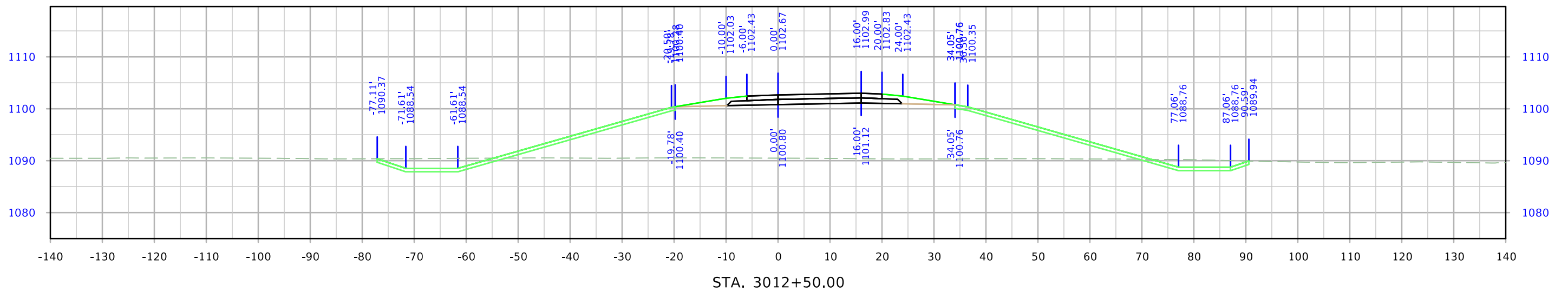
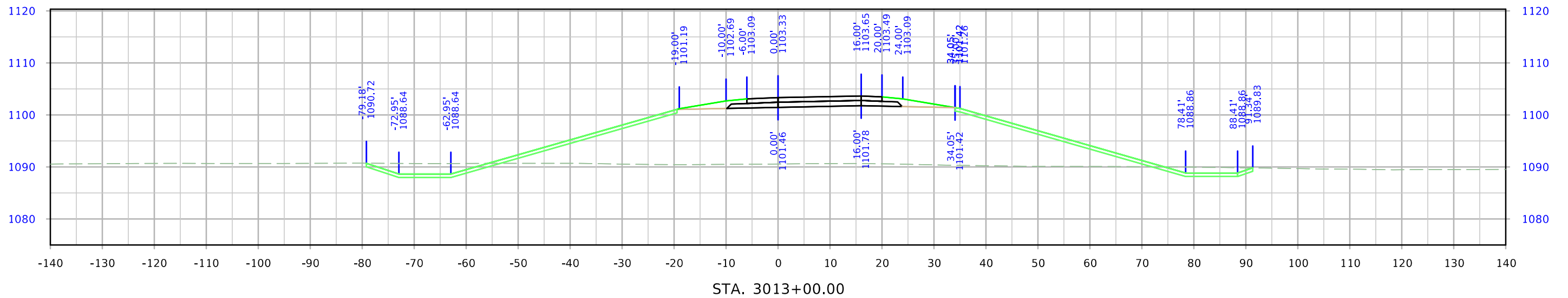

I-29 Ramp C

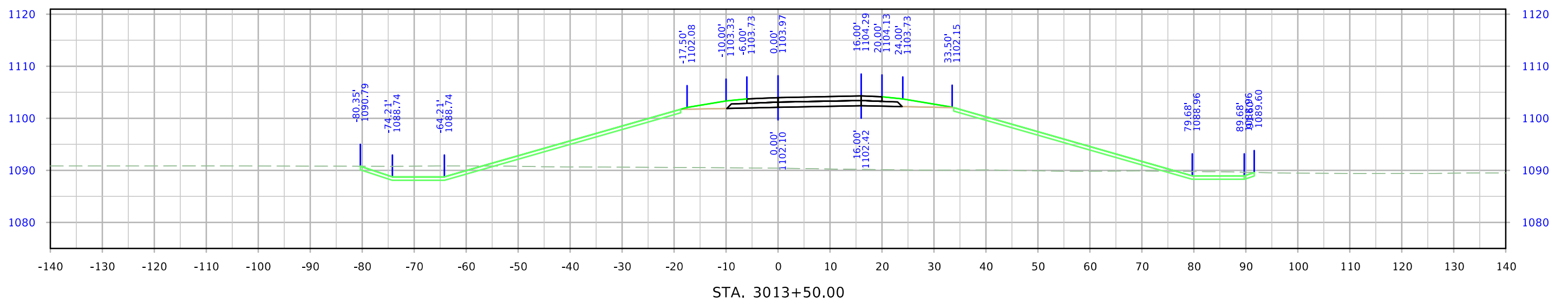
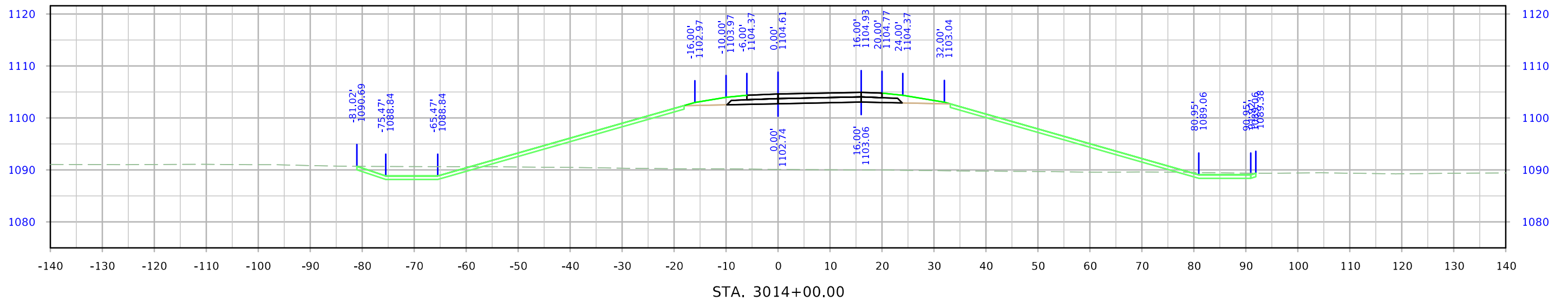

I-29 Ramp C

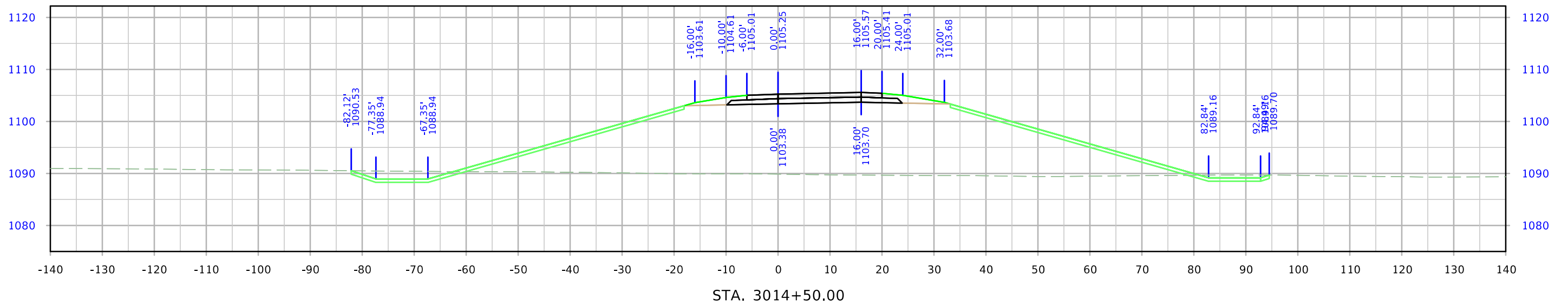
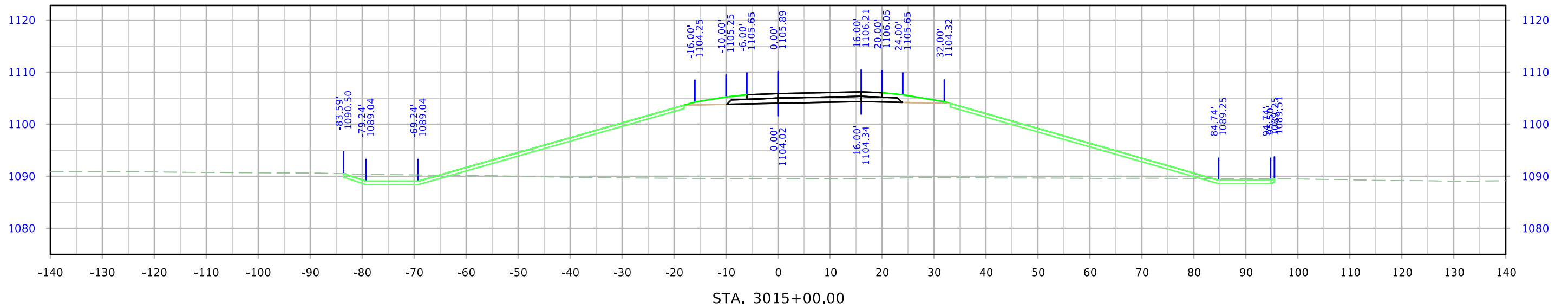

I-29 Ramp C

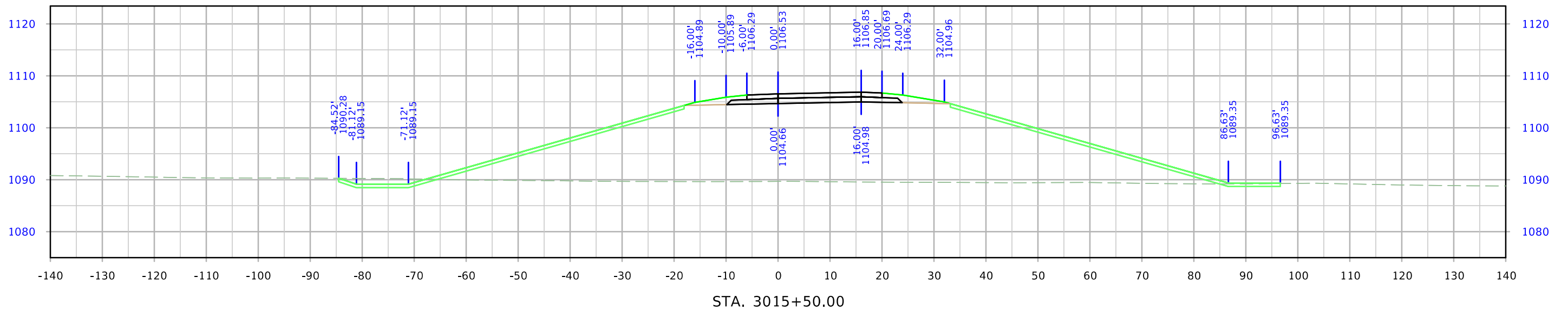
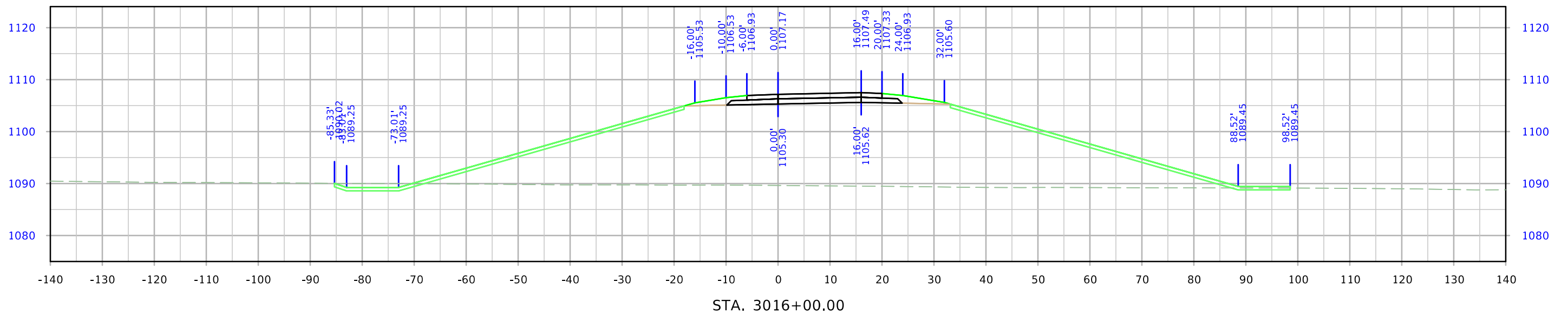

I-29 Ramp C

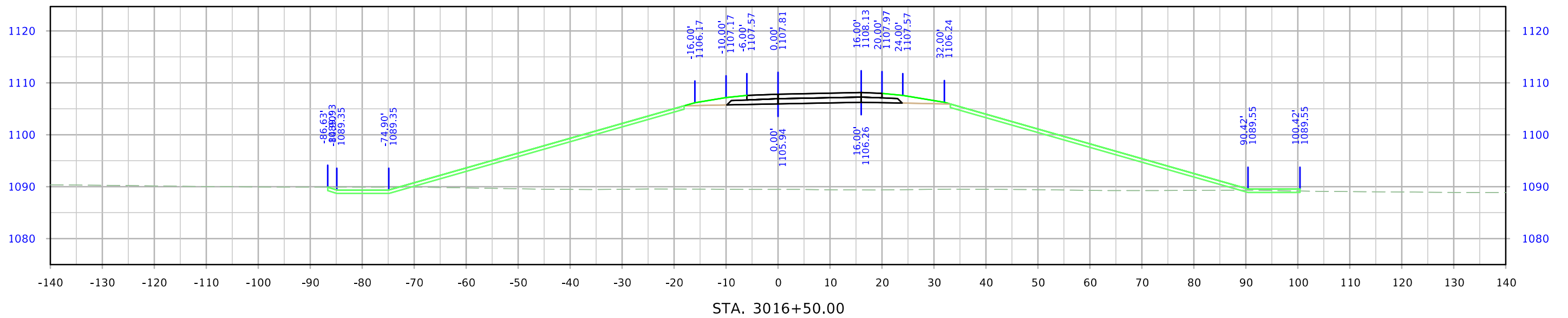
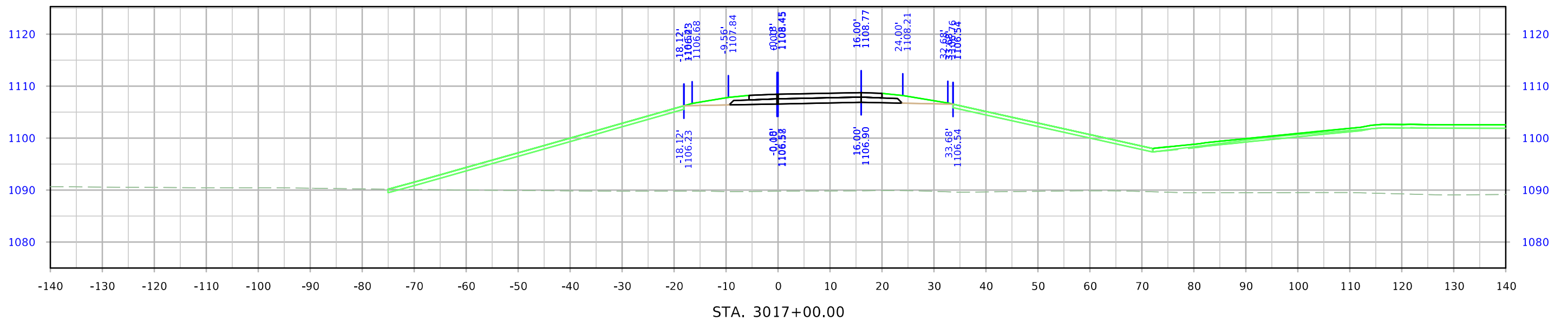

I-29 Ramp C

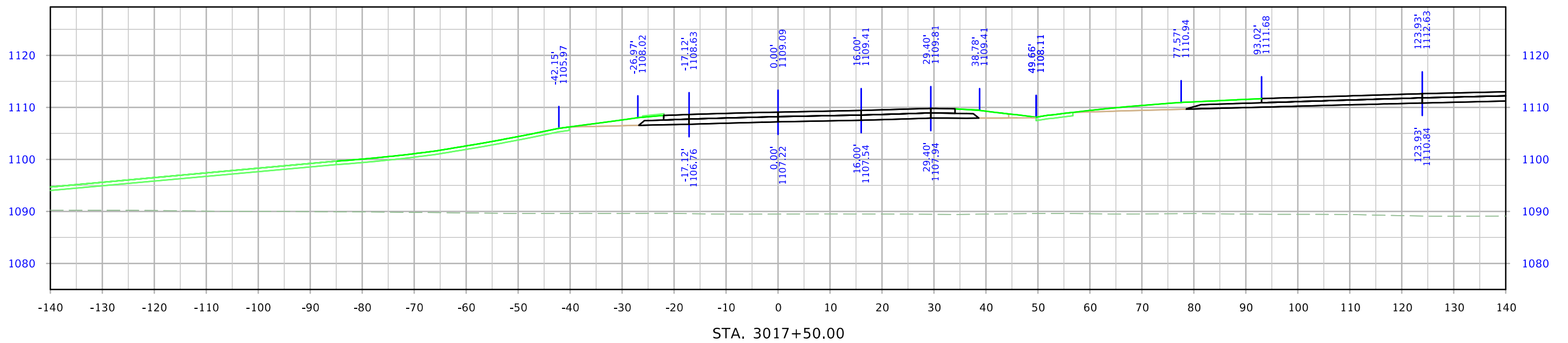

I-29 Ramp D

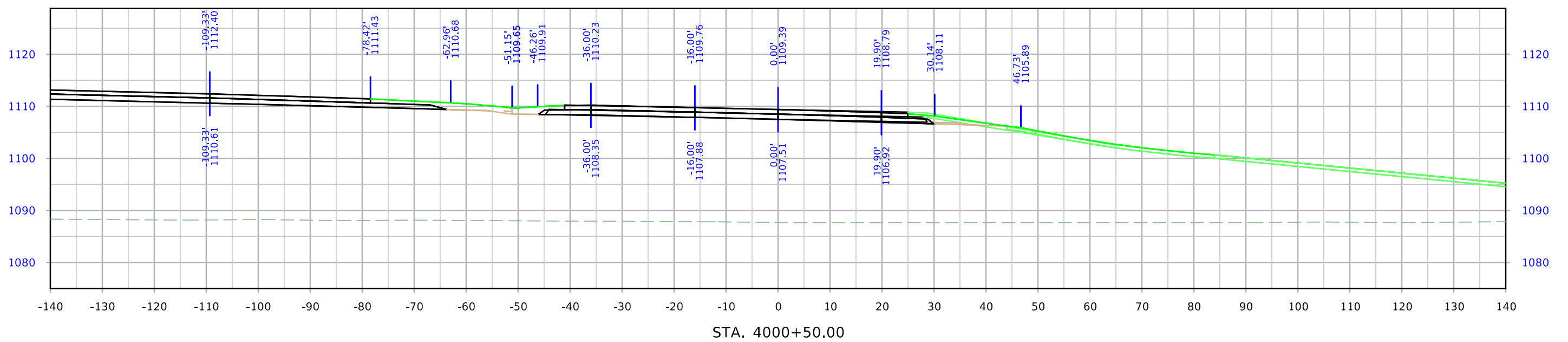
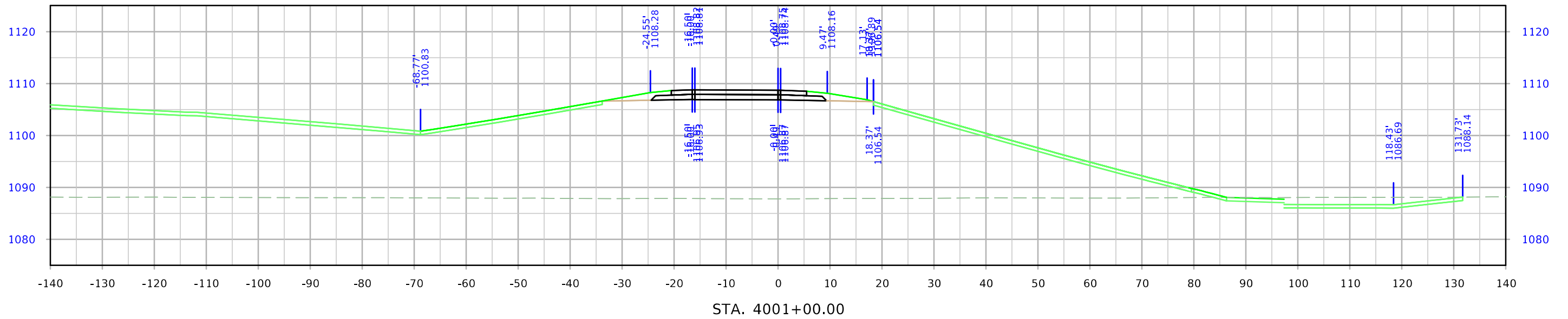

I-29 Ramp D

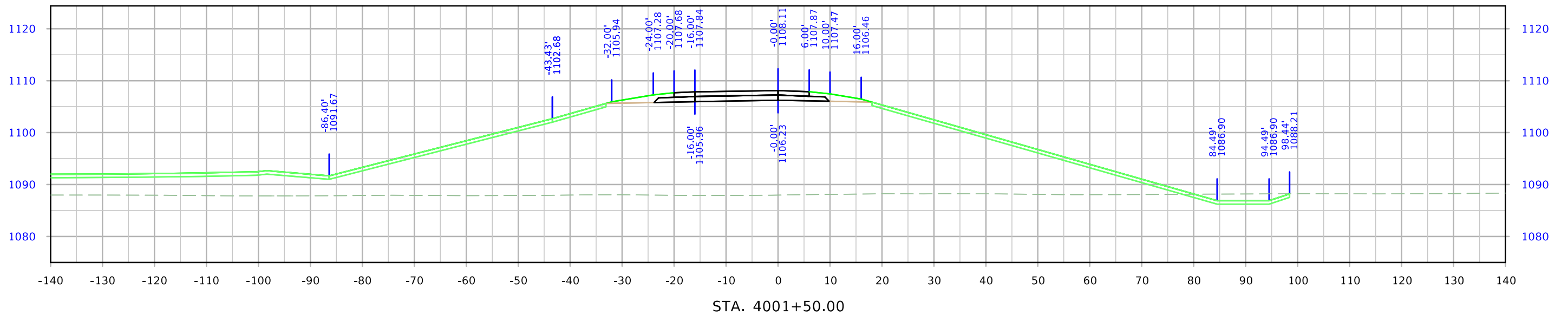
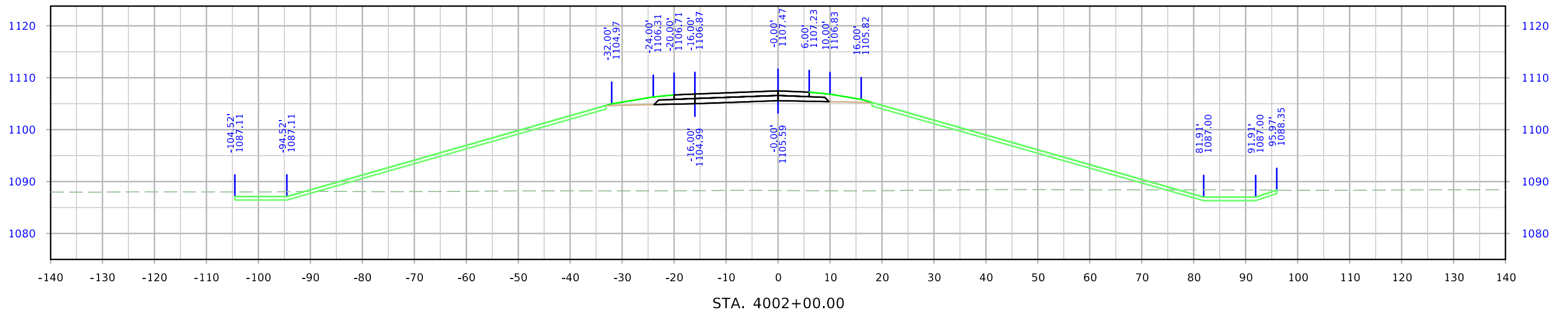

I-29 Ramp D

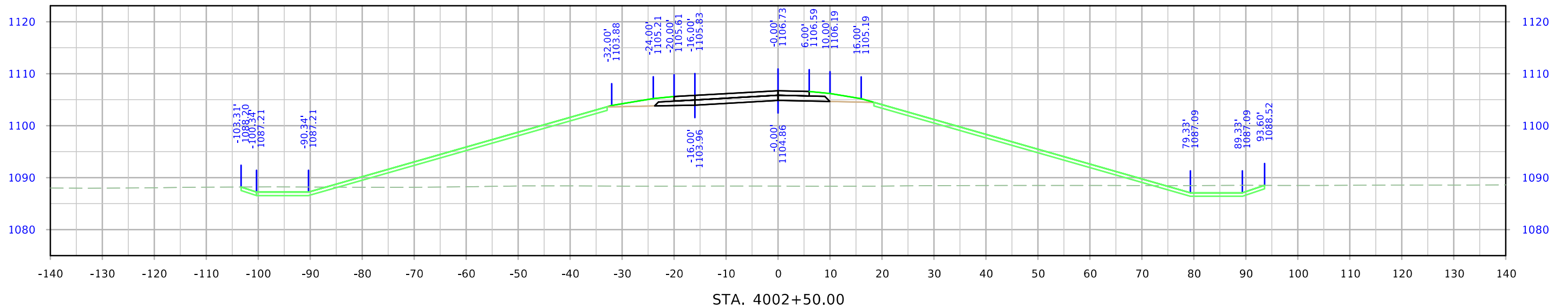
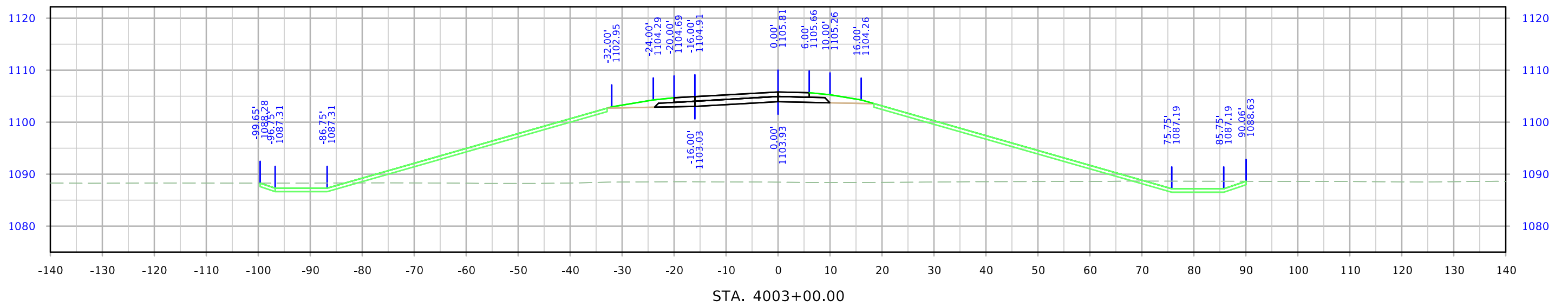

I-29 Ramp D

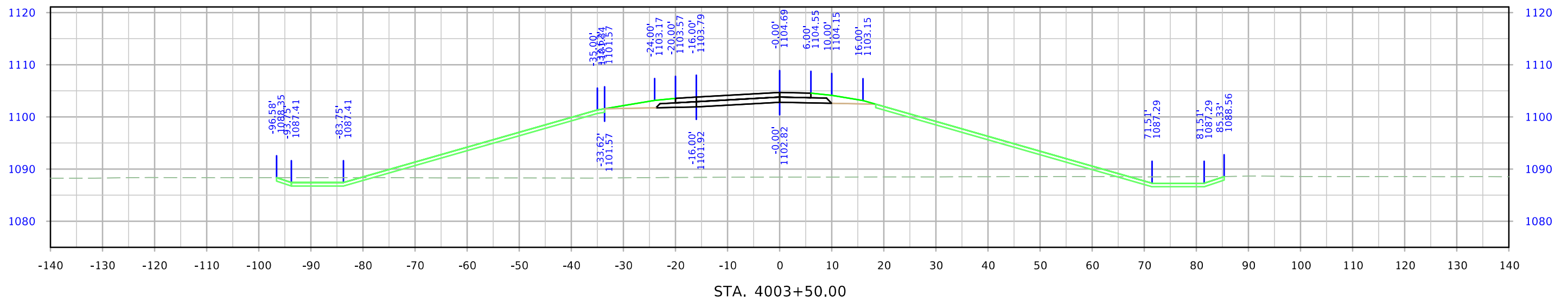
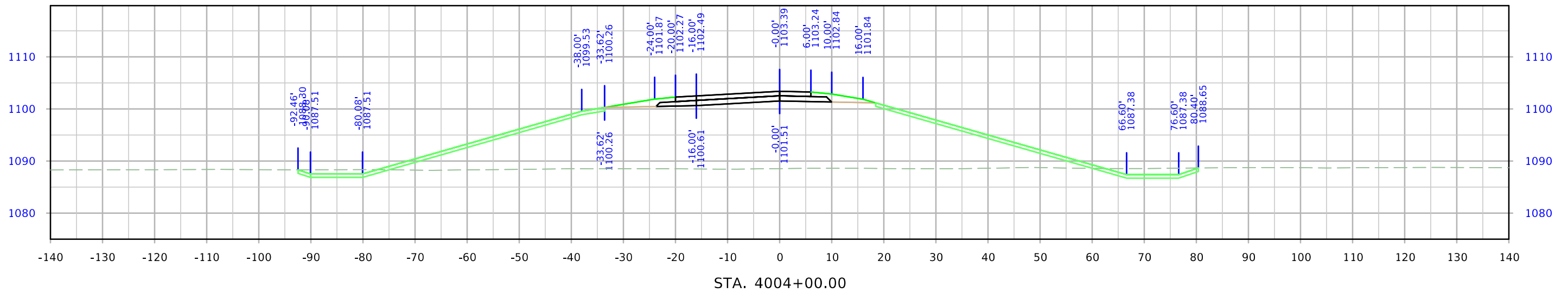
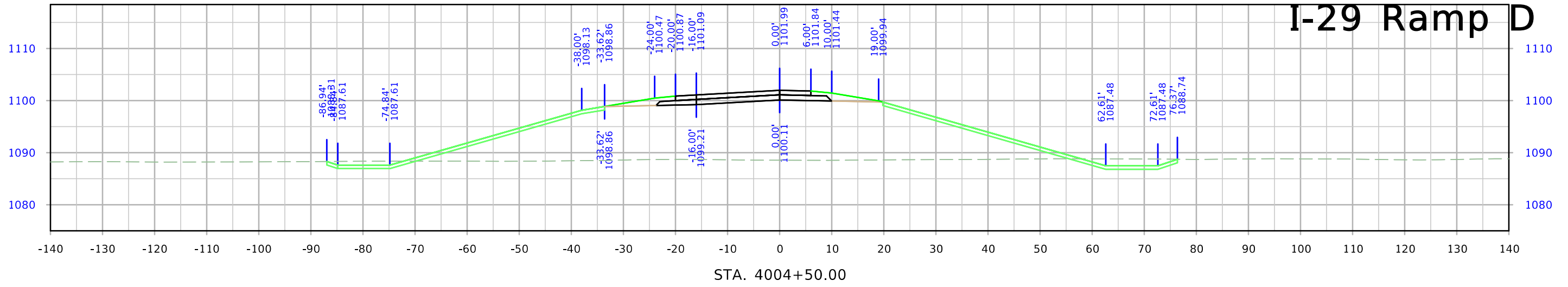

I-29 Ramp D

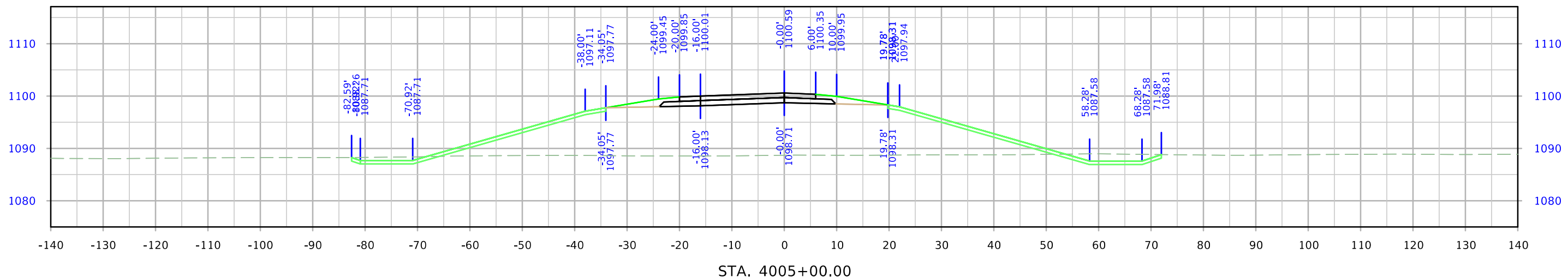
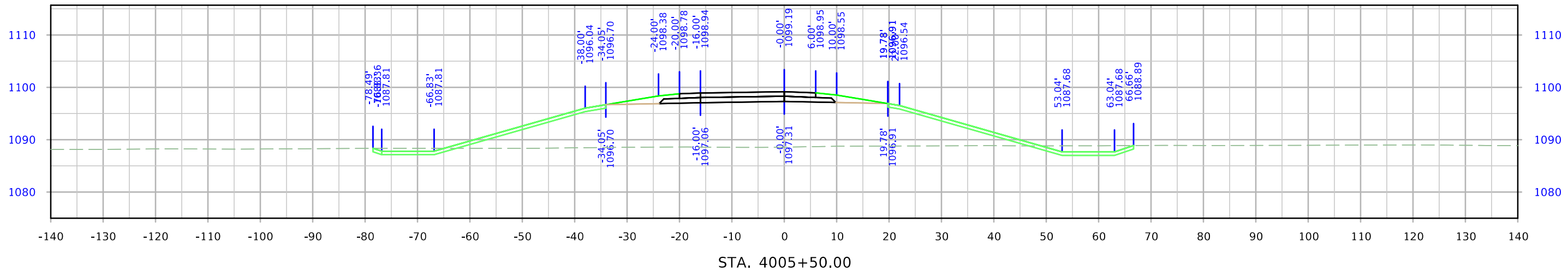
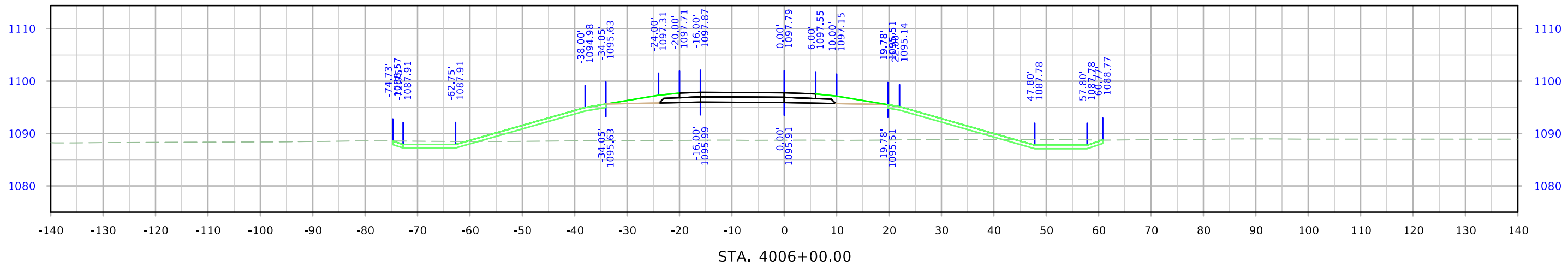

I-29 Ramp D

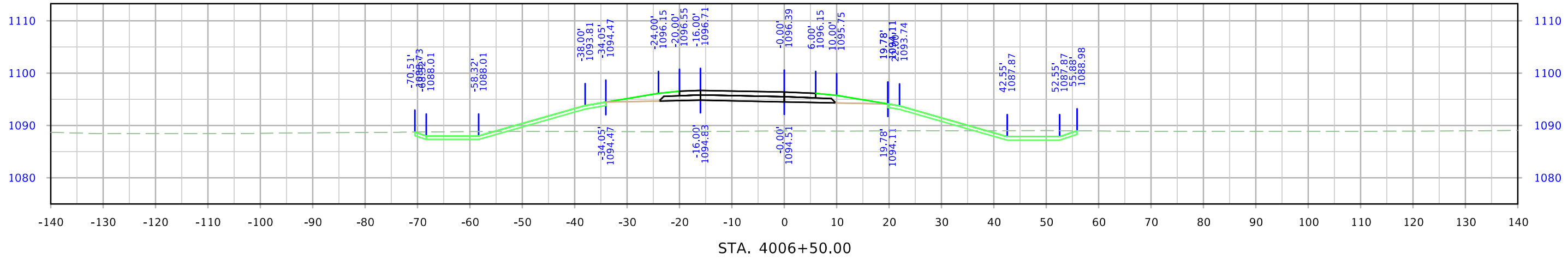
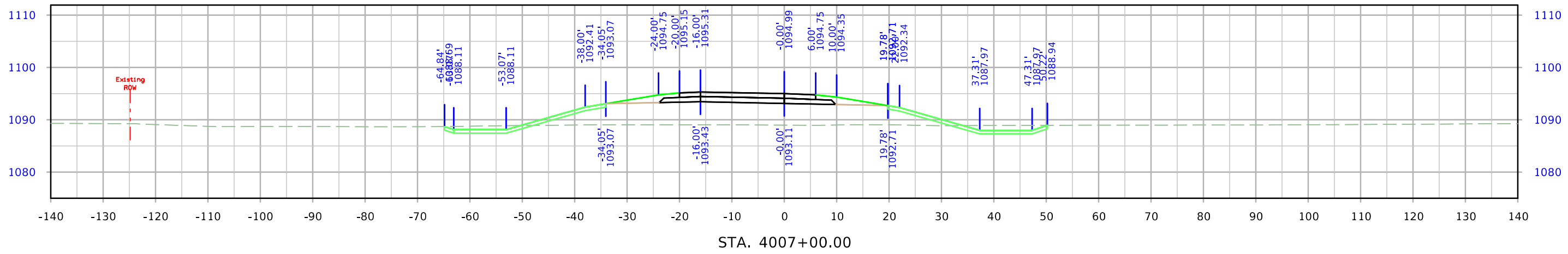
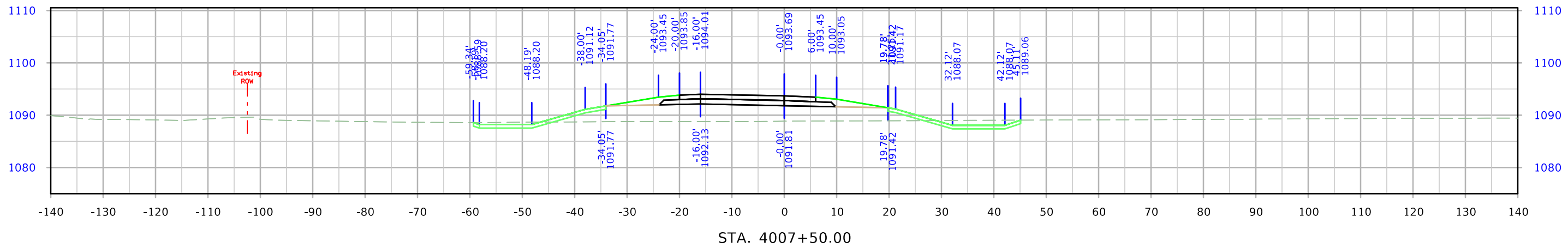

I-29 Ramp D

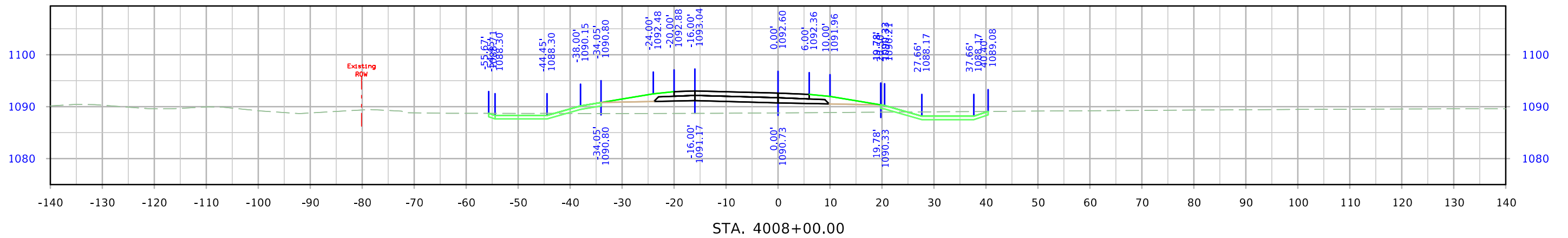
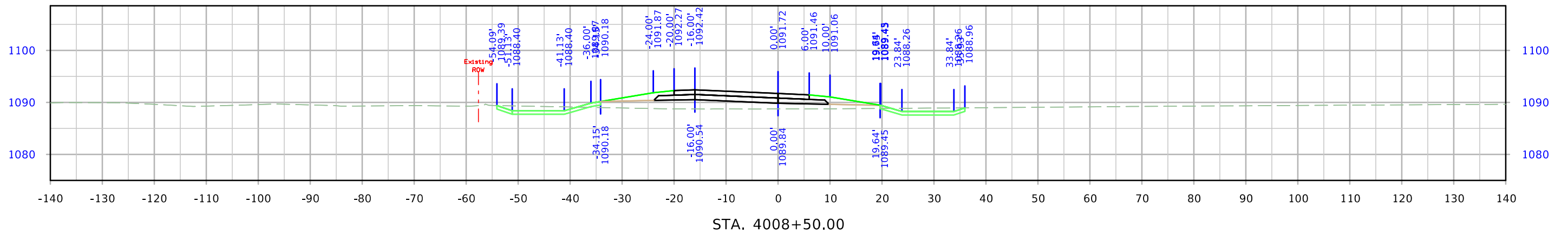
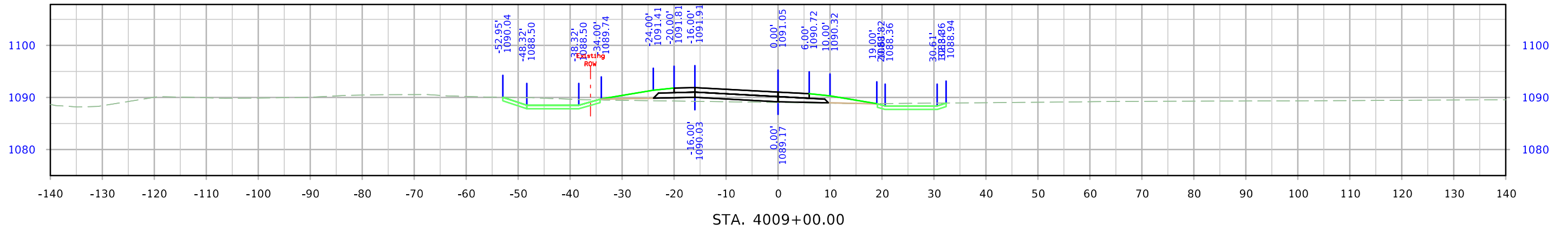

I-29 Ramp D

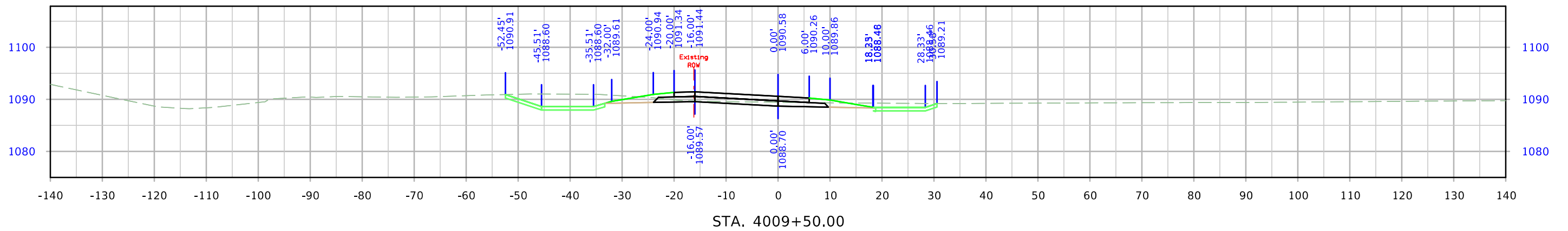
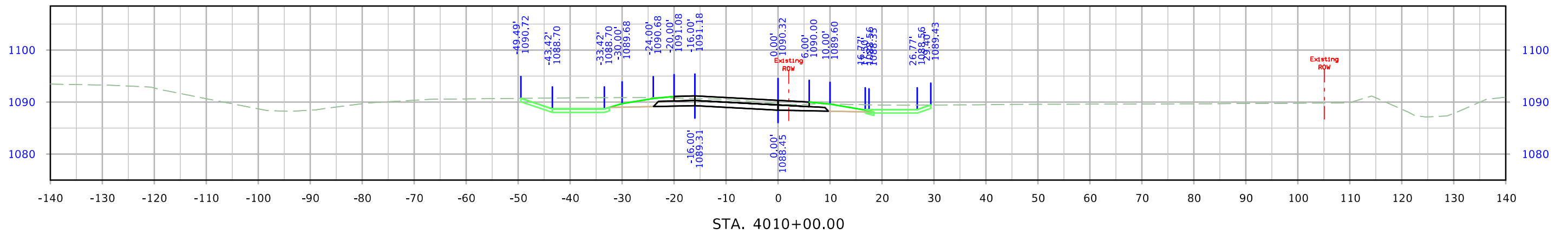
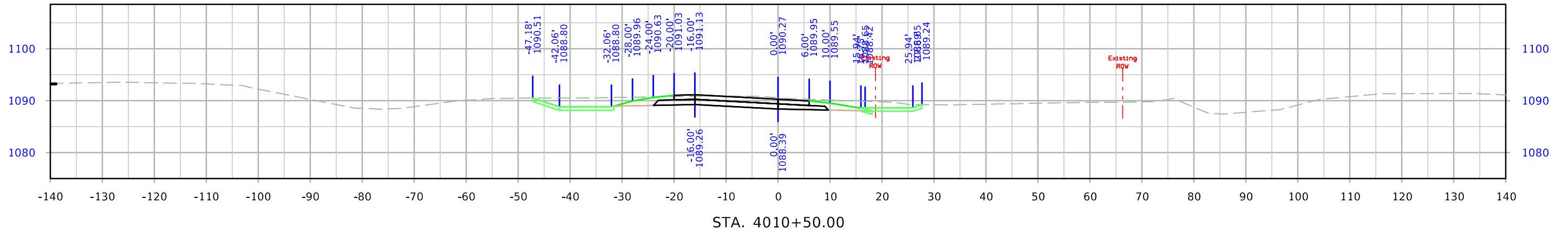

I-29 Ramp D

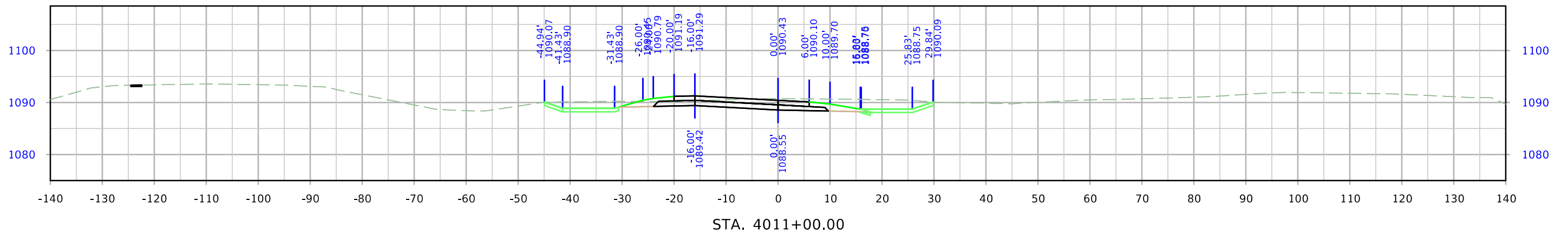
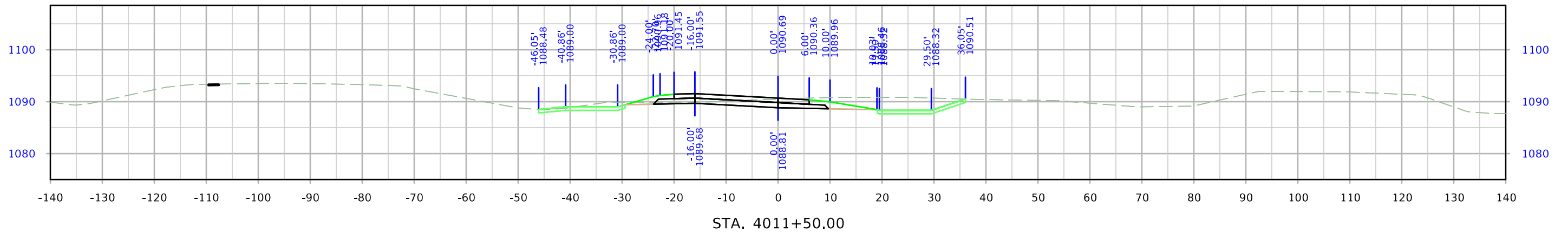
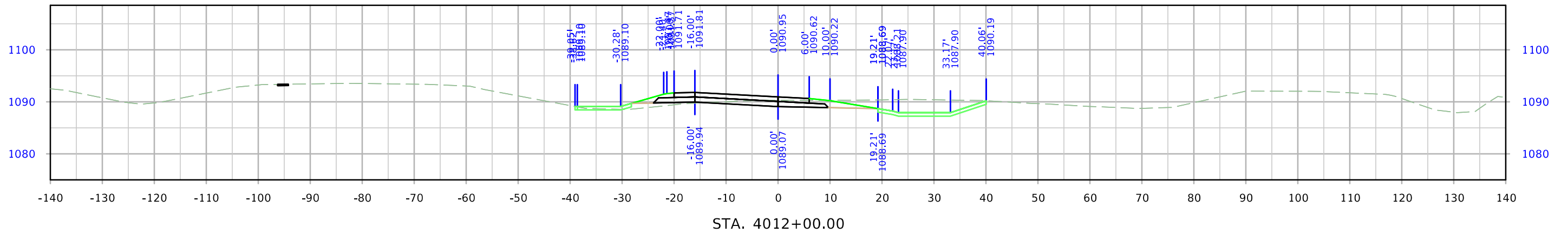

I-29 Ramp D

