

PCC PAVEMENT - GRADE AND REPLACE
IMX-029-5(282)109--02-67

MONONA COUNTY

LETTING DATE
April 21, 2026



PLANS OF PROPOSED IMPROVEMENT ON THE
**INTERSTATE ROAD SYSTEM
MONONA COUNTY**
PCC PAVEMENT - GRADE AND REPLACE

Onawa Rest Area 2.6 mi S of IA 175 (NB)

SCALES: As Noted

Refer to the Proposal Form for list of applicable specifications.

Value Engineering Saves. Refer to Article 1105.14 of the Specifications.



REVISIONS

TOTAL	..
PROJECT IDENTIFICATION NUMBER	24-67-029-050
PROJECT NUMBER	IMX-029-5(282)109--02-67
R.O.W. PROJECT NUMBER	IMN-029-5(285)109--0E-67

No.	DESCRIPTION
A Sheets	Title Sheets
* A.1	Title Sheet
* A.2	Location Map
B Sheets	Typical Cross Sections and Details
B.1 - 7	Typical Cross Sections and Details
C Sheets	Quantities and General Information
CD.1 - 2	Drainage Structure Tabulations
D Sheets	Mainline Plan and Profile Sheets
* D.1	Plan & Profile Legend & Symbol Information Sheet
* D.2 - 5	I-29 NB Mainline Plan & Profile Sheets
G Sheets	Survey Sheets
G.1 - 3	Reference Ties & Bench Marks
G.4	Horizontal Control Tab. & Super for all Alignments
J Sheets	Traffic Control and Staging Sheets
J.1	Traffic Control Plan
J.2	Staging Notes
J.3	Coordinated Operations
J.4	Incident Management
* J.5	Traffic Control & Staging Legend & Symbol Info. Sheet
* J.6	Staging Typical Sections
* J.7 - 8	Staging & Traffic Control Sheets Stage 1
* J.9 - 10	Staging & Traffic Control Sheets Stage 2
K Sheets	Interchange Sheets
* K.1 - 2	Rest Area Geometric Plan
* K.3 - 7	Rest Area Ramp & Parking Area Plan & Profile Sheets
M Sheets	Storm Sewer Sheets
* M.1	Storm Sewer & Utilities Legend & Symbol Information Sheet
* M.2	Sewer Plan and Profile Sheets
MSA Sheets	Sanitary Sewer Sheets
* MSA.1 - 2	Sanitary Sewer Plan & Profile Sheets
MWM Sheets	Water Main Sheets
* MWM.1 - 2	Water Main Plan & Profile Sheets
U Sheets	500 Series, Mod.Stds. and Detail Sheets
* U.1 - 3	Ramp H Truck Parking Lot Turning Movement Details
W Sheets	Mainline Cross Sections
* W.1	Cross Sections Legend & Symbol Information Sheet
* W.2 - 20	I-29 NB Mainline Cross Sections
* W.21	I-29 NB Mainline Culvert Cross Sections
Y Sheets	Ramp Cross Sections
* Y.1 - 41	Rest Area Ramp & Parking Area Cross Sections
* Y.42	Rest Area Ramp & Parking Area Culvert Cross Sections
	* Color Plan Sheets

**For Project Location Map
Refer to Sheet No. A.2**

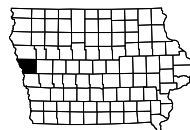

I-29 NB	
DESIGN DATA RURAL	
2027 AADT	8,000 V.P.D.
2047 AADT	10,000 V.P.D.
20 -- DHV	-- V.P.H.
TRUCKS	24 %
Total Design ESALs	--

INDEX OF SEALS			
SHEET NO.	NAME	TYPE	BID QUANTITY SHEETS
A.1	X	Primary Signature Block	X
X	X	X	X

PRELIMINARY PLANS

Subject to change by final design.

D5 Plans to Right-Of-Way
Date: November 15, 2024

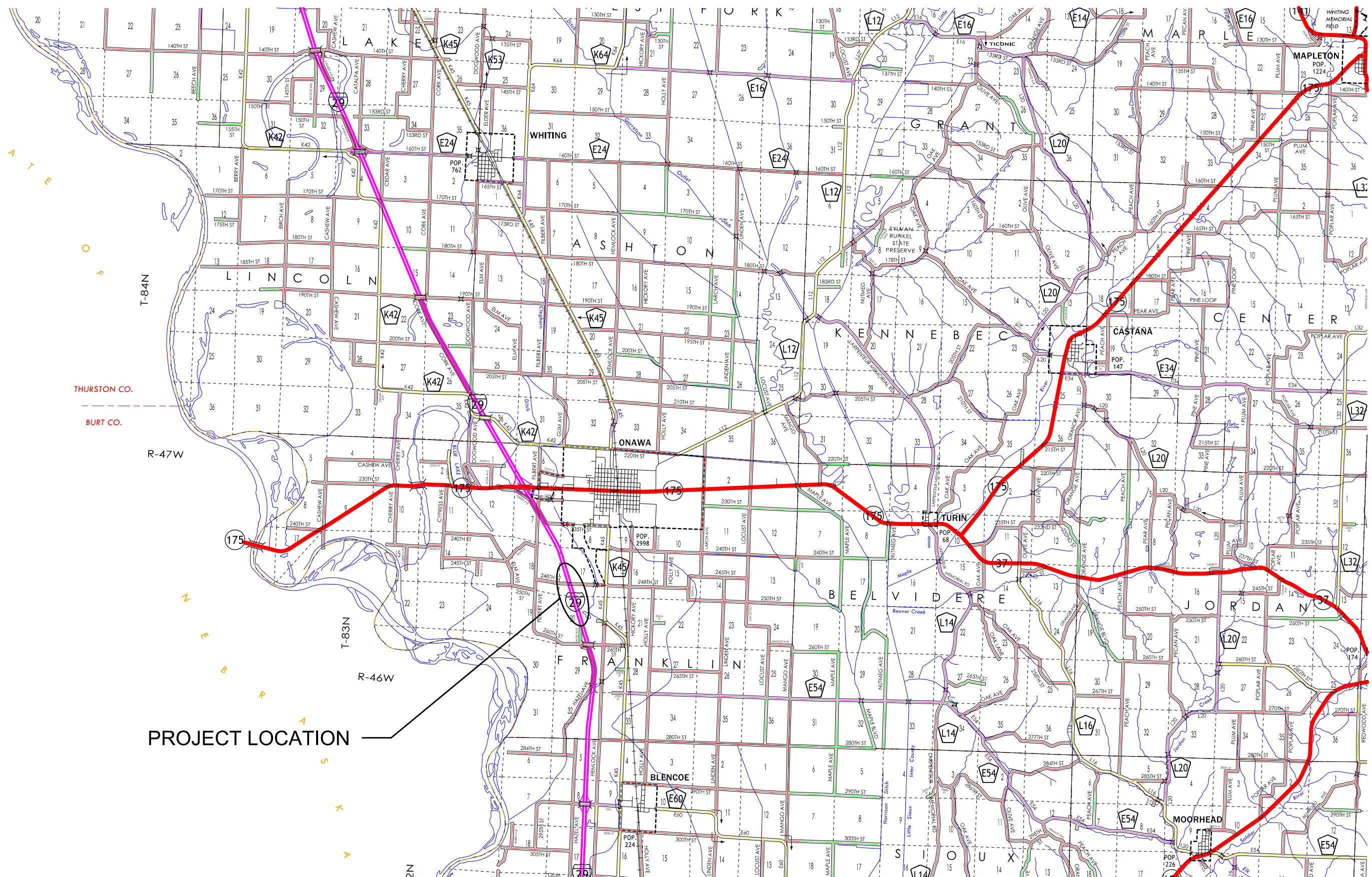

PROJECT LOCATION

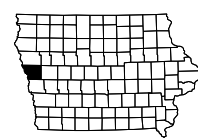

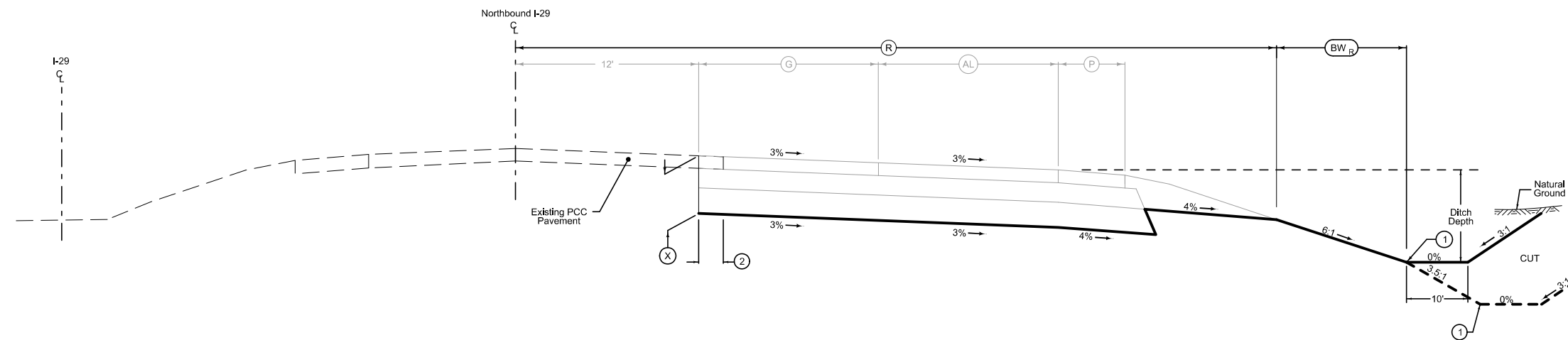

I-29 Northbound

Section view is in the direction of traffic.

Direction of Travel	BEGIN STATION	END STATION	(X) Inches	(R) Feet	(BWR) Feet
NB	2889+00.00	2895+89.54	32	39.2	6.8
NB	2895+89.54	2897+39.85	32	70.4 - 51.0	2.1-3.5
NB	2897+39.85	2899+00.00	32	51.0 - 45.2	3.5-2.8
NB	2899+00.00	2909+00.00	32	45.2	2.8
NB	2909+00.00	2910+00.00	32	45.2 - 43.2	2.8
NB	2910+00.00	2912+00.00	32	43.2 - 39.2	2.8-6.8
NB	2912+00.00	2915+00.00	32	39.2	6.8

Normal section shown may be modified appropriately in areas of superelevated curves or other locations specifically designated by the Engineer.

- ① Refer to project plan and cross sections for specific location of foreslope change and ditch details.
- ② Saw cut and remove the outside 2' of existing 14' lane.

I-29 NORTHBOUND GRADING

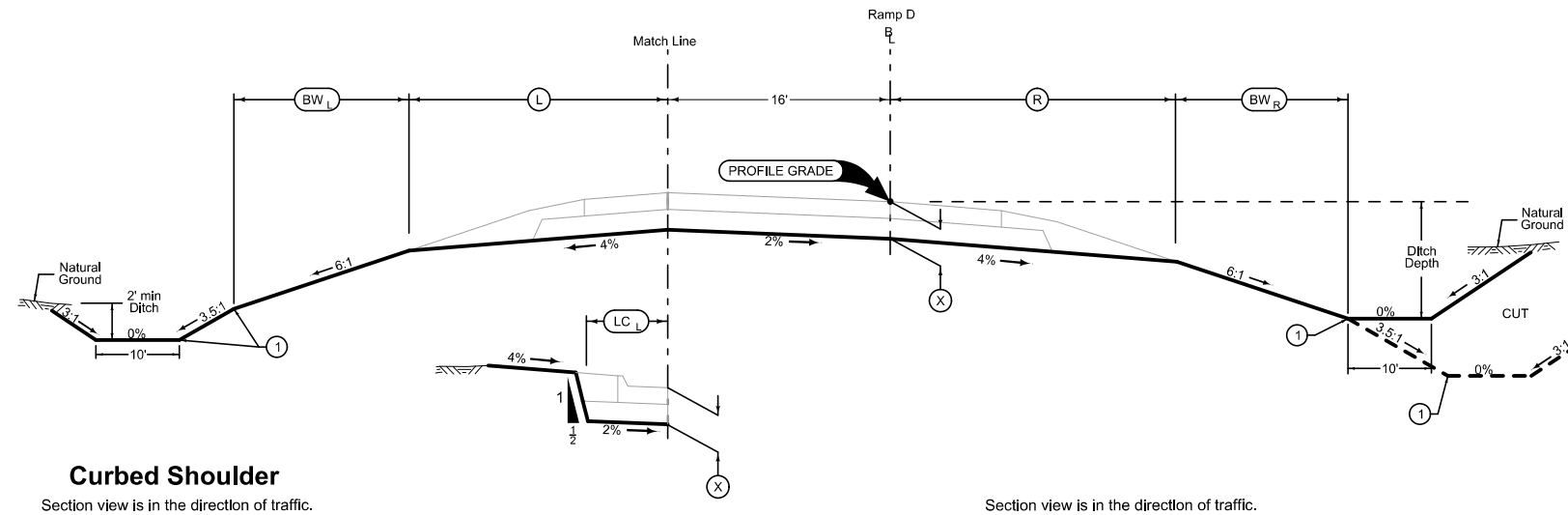

Curbed Shoulder

Section view is in the direction of traffic.

Section view is in the direction of traffic.

1 Refer to project plan and cross sections for specific location of foreslope change and ditch details.

Normal sections shown may be appropriately modified for areas specifically designated by the Engineer such as intersections or super-elevated curves.

LOCATION			DIMENSIONS	
INTERCHANGE	RAMP	STATION TO STATION	(X) Inches	(LC _L) Feet
NB REST AREA	D	4086+44.59 - 4087+49.71	22	18.5-8.0
NB REST AREA	D	4087+49.71 - 4091+83.56	22	8.0

LOCATION				DIMENSIONS				
INTERCHANGE	RAMP	STATION TO STATION		(L) Feet	(R) Feet	(X) Inches	(BW _L) Feet	(BW _R) Feet
NB REST AREA	D	4086+44.59	4091+83.56	N/A	22.6	22	N/A	1.4
NB REST AREA	D	4091+83.56	4093+77.87	N/A	22.6	22	N/A	1.4
NB REST AREA	D	4093+77.87	4095+90.87	VARIES	22.6	22	VARIES	1.4-2.1

RAMP D GRADING

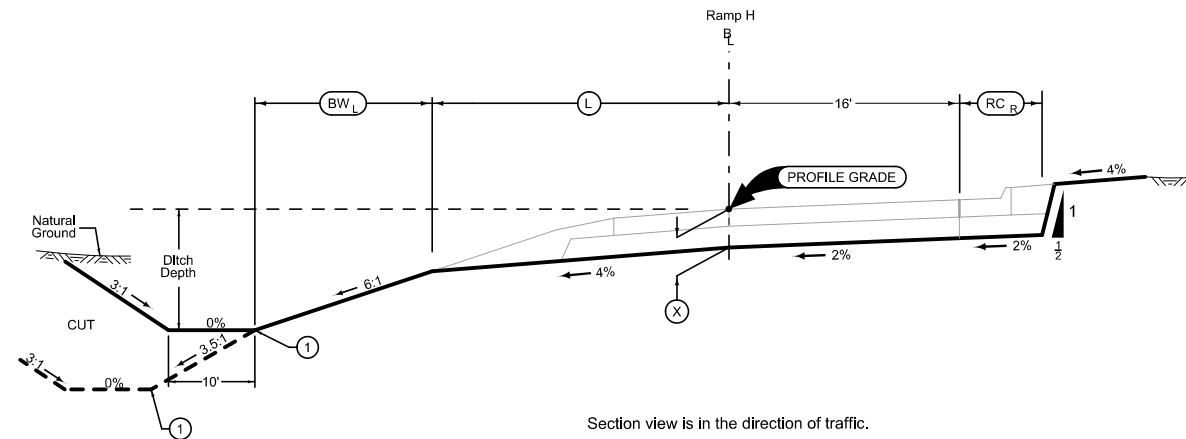

Section view is in the direction of traffic.

1 Refer to project plan and cross sections for specific location of foreslope change and ditch details.

Normal sections shown may be appropriately modified for areas specifically designated by the Engineer such as intersections or super-elevated curves.

LOCATION			DIMENSIONS			
INTERCHANGE	RAMP	STATION TO STATION	(L) Feet	(X) Inches	(BW _L) Feet	(RC _R) Feet
NB REST AREA	H	8091+01.15 - 8092+40.82	20.6	22	0	10.0
NB REST AREA	H	8092+40.82 - 8093+77.87	20.6	22	0	N/A

RAMP H GRADING

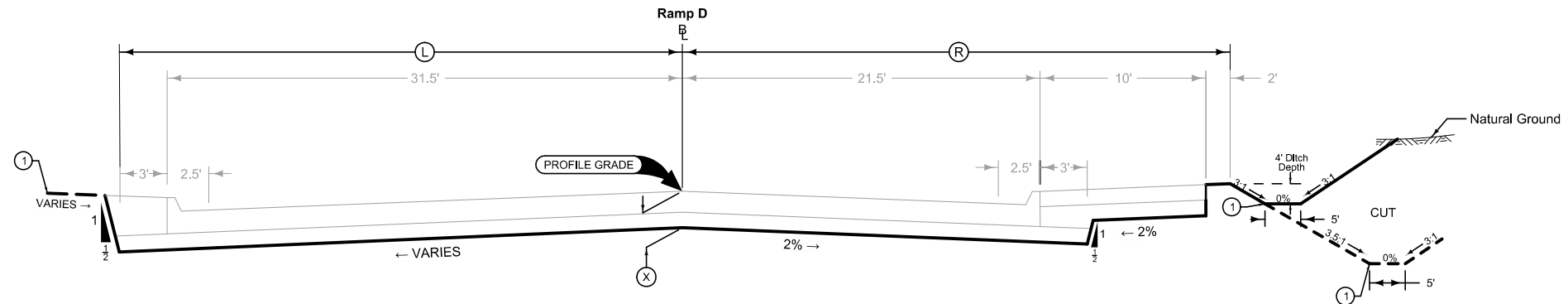

Section view is in the direction of traffic.

LOCATION		DIMENSIONS		
PARK. LOT	STATION TO STATION	(L) Feet	(R) Feet	(X) Inches
RAMP D	4082+10.11 4086+44.59	34.5	33.5	22

**RAMP D VEHICLE
PARKING LOTS GRADING**

① Refer to project plan and cross sections for specific location of foreslope change and ditch details.

Normal sections shown may be appropriately modified for areas specifically designated by the Engineer such as intersections or superelevated curves.

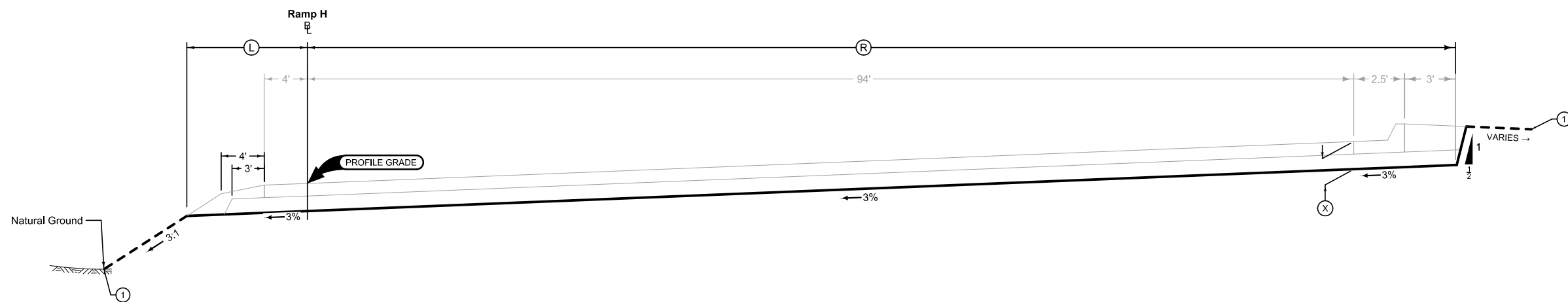

Section view is in the direction of traffic.

LOCATION		DIMENSIONS		
PARK. LOT	STATION TO STATION	(L) Feet	(R) Feet	(X) Inches
RAMP H	8081+95.98 8088+95.36	13.4	99.5	22

**RAMP H TRUCK
PARKING LOTS GRADING**

① Refer to project plan and cross sections for specific location of foreslope change and ditch details.

Normal sections shown may be appropriately modified for areas specifically designated by the Engineer such as intersections or superelevated curves.

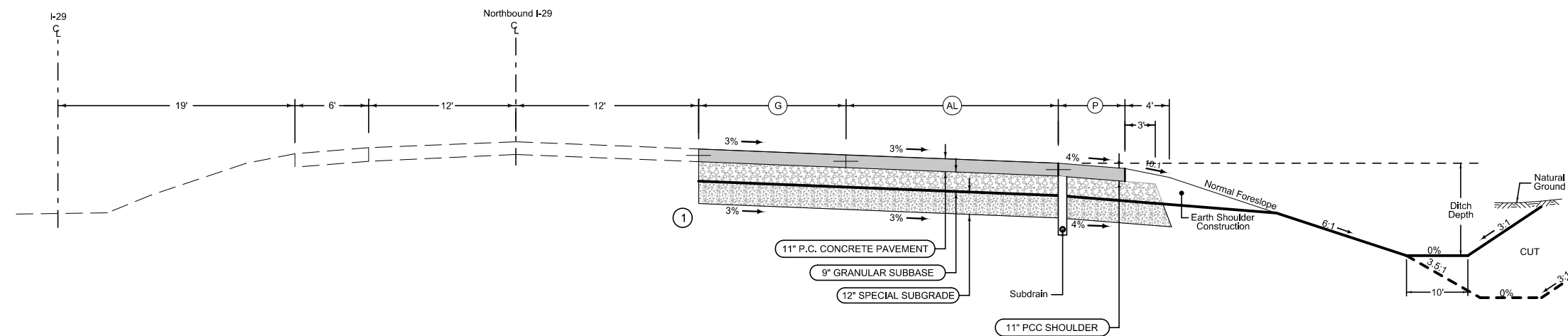

I-29 Northbound

Longitudinal joint: L-2 or KT-2
 Transverse joint: Match Mainline

Direction of Travel	BEGIN STATION	END STATION	ⓐ Feet	ⓑ Feet
NB	2889+00.00	2895+89.54	0	0
NB	2895+89.54	2897+39.85	20 - 2	16
NB	2897+39.85	2899+00.00	0	18-12
NB	2899+00.00	2909+00.00	0	12
NB	2909+00.00	2915+00.00	0	12-0

Full Depth PCC Shoulder

PCC Shoulder Jointing:
 Longitudinal joint: BT-1 or BT-5
 Transverse joints: C at 17' spacing

Direction of Travel	BEGIN STATION	END STATION	ⓐ Feet
NB	2889+00.00	2895+89.54	12
NB	2895+89.54	2913+00.00	6
NB	2913+00.00	2915+00.00	6-12

I-29 NORTHBOUND PAVING

① Saw cut and remove the outside 2' of existing 14' lane.

Full Depth PCC Shoulder

PCC Shoulder Jointing:
 Longitudinal joint: BT-1 or BT-5
 Transverse joints: C at 17' spacing

BEGIN STATION	END STATION	(P) Feet
4093+77.87	4095+90.87	4

Curbed Shoulder

PCC Shoulder Jointing:
 Longitudinal joint not required when distance from back of curb to nearest joint is less than 16':
 Single Pour: L-2
 Staged: KT-2

BEGIN STATION	END STATION	(P) Feet	(M) Feet	(MS) Percent
4086+44.84	4087+49.71	15.5-5	VARIES	VARIES
4087+49.71	4089+58.71	5	VARIES	VARIES
4089+58.71	4091+36.08	5	10	10
4091+36.08	4091+83.56	5	VARIES	VARIES

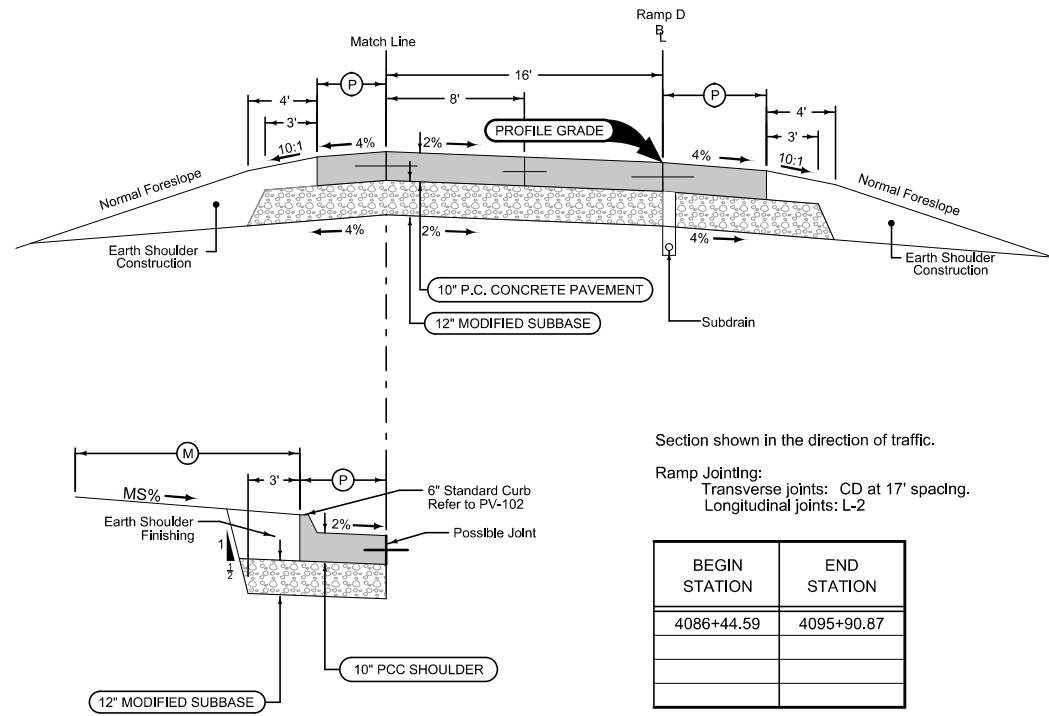

BEGIN STATION	END STATION
4086+44.59	4095+90.87

RAMP D PAVING

Full Depth PCC Shoulder

PCC Shoulder Jointing:
 Longitudinal joint: BT-1 or BT-5
 Transverse joints: C at 17' spacing

BEGIN STATION	END STATION	(P) Feet
8091+01.15	8093+77.87	4

Curbed Shoulder

PCC Shoulder Jointing:
 Longitudinal joint not required when distance from back of curb to nearest joint is less than 16':
 Single Pour: L-2
 Staged: KT-2

BEGIN STATION	END STATION	(P) Feet	(M) Feet	(MS) Percent
8091+01.15	8091+42.71	7	10	10
8091+42.71	8091+88.03	7	VARIES	VARIES
8091+88.03	8093+77.87	0	0	N/A

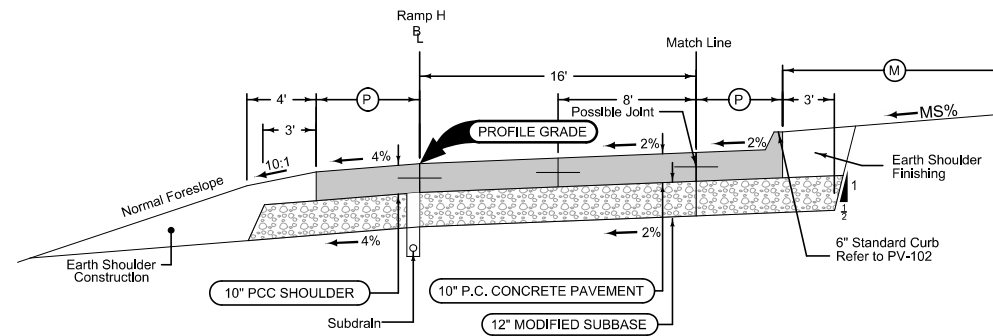

BEGIN STATION	END STATION
8091+01.15	8093+77.87

RAMP H PAVING

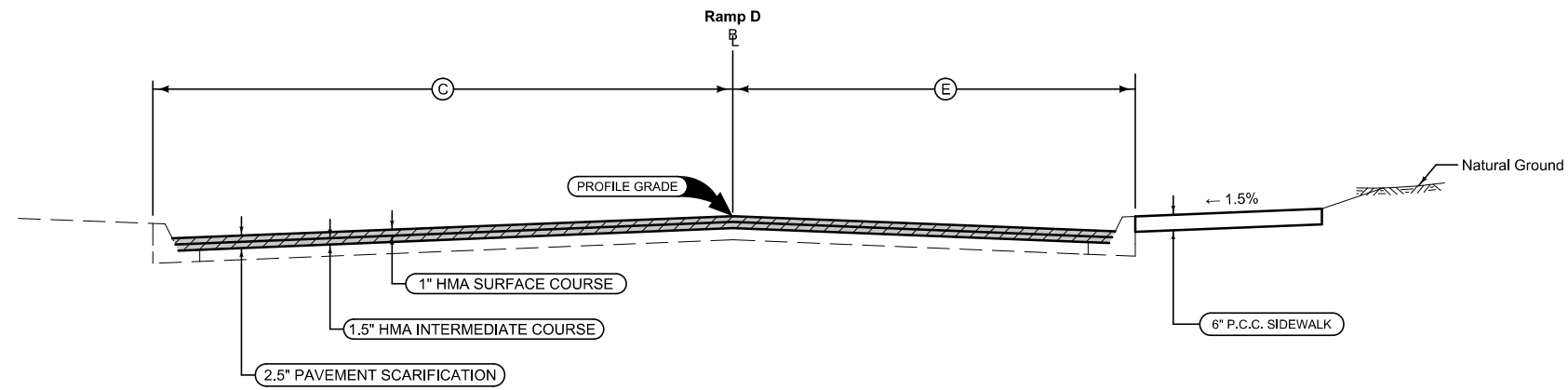

BEGIN STATION	END STATION	(C) Feet	(E) Feet
4078+27.18	4082+10.11	31.5	21.5

Section view is in direction of traffic.

RAMP D VEHICLE PARKING LOTS MILLING AND OVERLAY

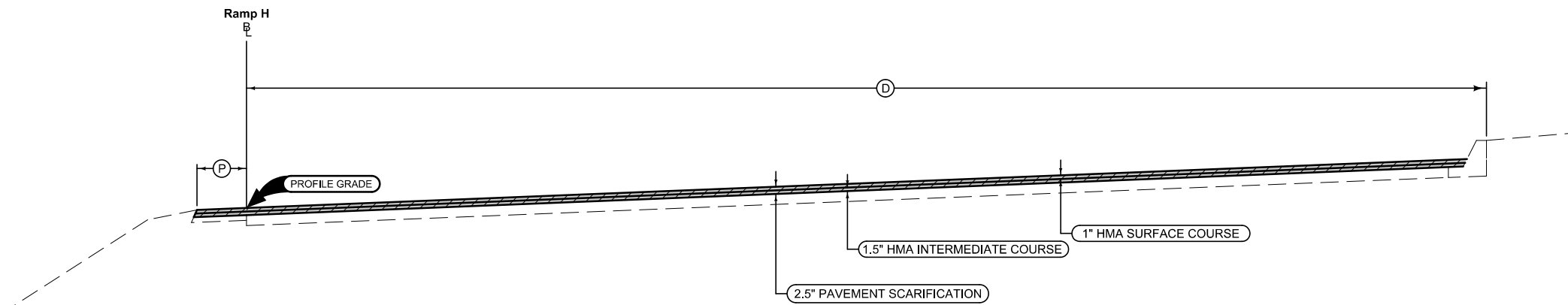

BEGIN STATION	END STATION	(P) Feet	(D) Feet
8078+41.47	8081+95.98	4	96.5

Section view is in direction of traffic.

RAMP H TRUCK PARKING LOTS MILLING AND OVERLAY

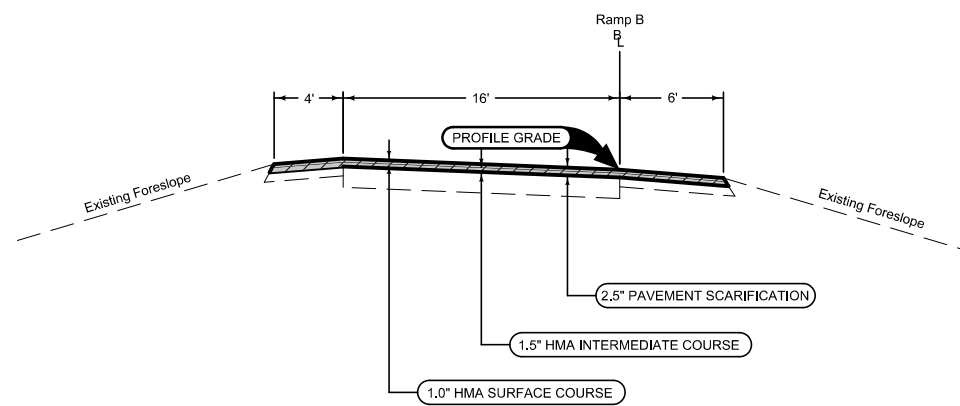

STATION TO STATION	
2072+21.13	2075+40.80

Section shown in the direction of traffic.

RAMP B PAVING MILLING AND OVERLAY

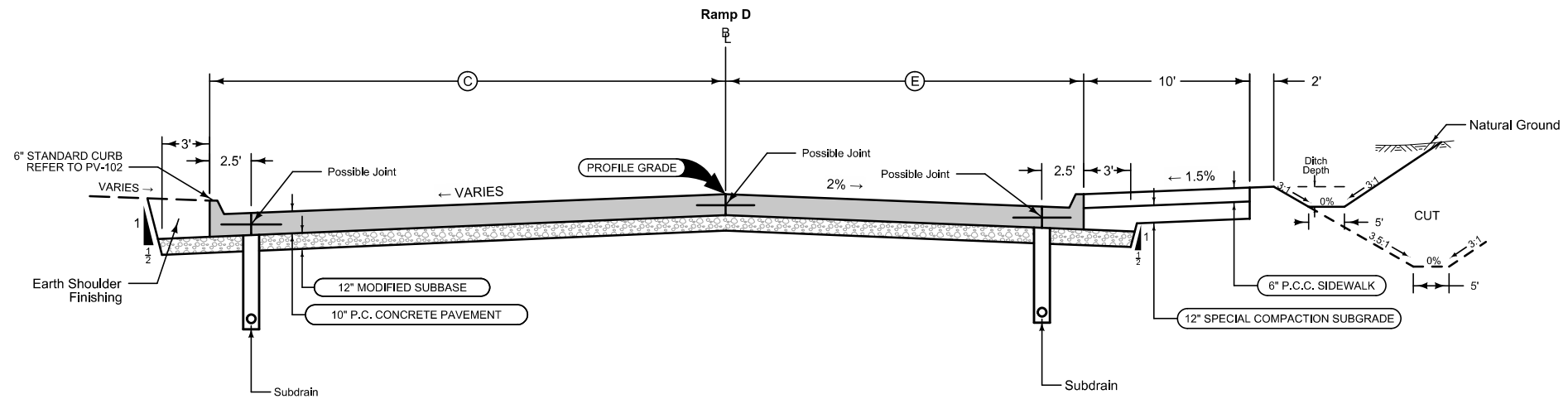

PARK. LOT	BEGIN STATION	END STATION	ⓐ Feet	ⓔ Feet
Ramp D	4082+10.11	4086+44.59	31.5	21.5

Section view is in direction of traffic.

RAMP D VEHICLE PARKING LOTS

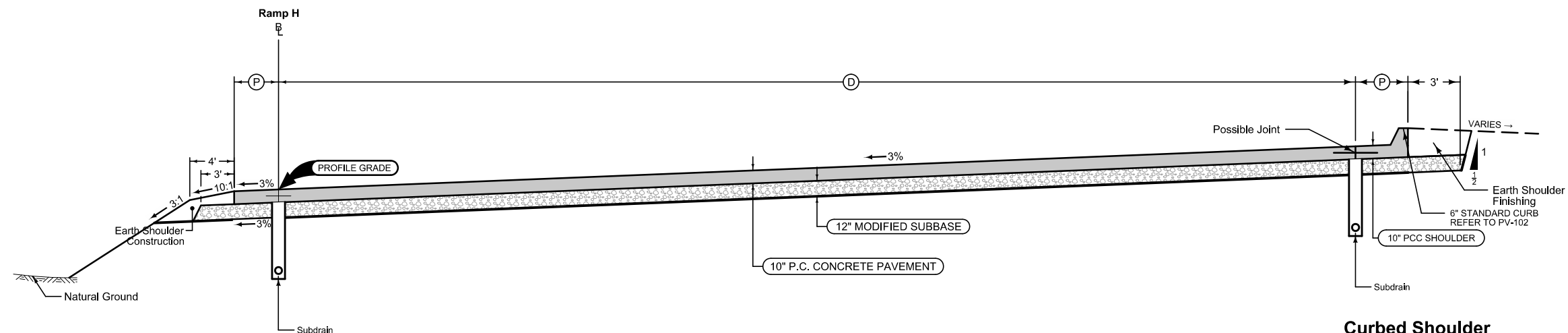

Full Depth PCC Shoulder

PCC Shoulder Jointing:
 Longitudinal joint: BT-1 or BT-5
 Transverse joints: C at 17' spacing

BEGIN STATION	END STATION	Ⓟ Feet
8081+95.98	8091+02.05	4

PARK. LOT	BEGIN STATION	END STATION	ⓓ Feet
Ramp H	8081+95.98	8088+95.36	94
Ramp H	8088+95.36	8091+02.05	94-16

Section view is in direction of traffic.

Curbed Shoulder

PCC Shoulder Jointing:
 Longitudinal joint not required when distance from back of curb to nearest joint is less than 16':
 Single Pour: L-2
 Staged: KT-2

BEGIN STATION	END STATION	Ⓟ Feet
8081+95.98	8090+46.07	2.5
8091+46.07	8091+02.05	2.5-7

RAMP H TRUCK PARKING LOTS

DRAINAGE STRUCTURE BY ROAD CONTRACTOR

Length of unclassified pipe calculated is based on using Reinforced Concrete Pipe.

* Not a bid item

(1) Diameter or equivalent diameter

(2) UNCL = Unclassified Pipe CMP = Corrugated Metal Pipe RCP = Reinforced Concrete Pipe LCP = Arch or Elliptical Low Clearance Pipe SARC = Steel Arch Pipe

(3) Backfill according to DR-101

Drainage Area (ACRE)	Location	Type	Size (IN) (1)	Pipe Classification	Kind of Pipe (2)	Length New Const. (LF)	Length of total that is Trenchless Bedding Class	Design Cover (H) (FT)	Camber* (DR-102) (FT)	Apron No. (IN)	Apron No. (OUT)	Apron Guard* (DR-213) (No.)	Elbow* (DR-141) (No.)	Diaphragm* (DR-501) (No.)	Tee Section* (DR-142) (No.)	"D" Section* (DR-141) (No.)	Reducer* (No.)	Type 'C' Conn.* (DR-122)	Type 'C' Conn.* (No.)	Connected Pipe Joint* (DR-121)	4" Perforated Subdrain* (FT)	Flow Line Elevation LT.	Flow Line Elevation RT.	Flow Line Elevation Other	Flow Line Elevation Other	Dimensions Lineal Feet Total (Left)	Dimensions Lineal Feet Total (Right)	Dimensions Lineal Feet Extensions	Dimensions Lineal Feet Extensions	Skew Ahead Degrees (Left)	Skew Ahead Degrees (Right)	Dike Location	Dike Station	Dike Elevation	Dike Type	Class 20 (CY)	Flowable Mortar	Floodable Backfill* (A)	Porous Backfill* (B)	Flooded Backfill (A+B)	Remarks				
312.2	2899+34.31	DR-621	60.0	2000D	LCP	30.0	B	2.47	0.08		1							C-2	1	Type 3		1042.73	1042.81					30.00																	
323.5	4087+97.16	DR-601	30.0	2000D	LCP	183.0	B	4.75	0.08	1	1											1041.57	1041.98		153.08	29.92																			[1]
1.1	4092+75.00	DR-601	24.0	2000D	RCP	70.0	B	2.85	0.08	1	1											1044.20	1042.30		44.00	26.00																			

[1] 80' of 30" LCP placed in Stage 1, 103' of 30" LCP placed in Stage 2.

110_02
8/15/22

REMOVAL OF EXISTING STRUCTURES

Line No.	Location	Description	Remarks
1.0	2899+34.31	One 72 IN CMP Apron	
2.0	2899+34.31	72 IN x 16 FT CMP	
3.0	2899+34.31	6 FT x 5 FT x 8 FT RCB	
4.0	8084+98.00	24 IN RCP Aprons	
5.0	8084+98.00	24 IN x 37 FT RCP	
6.0	8087+82.90	24 IN RCP Aprons	
7.0	8087+82.90	24 IN x 55 FT RCP	

SURVEY SYMBOLS

- Interstate Highway Symbol
- U.S. Highway Symbol
- Iowa Highway Symbol
- County Road Highway Symbol
- Evergreen Tree
- Deciduous Tree
- Fruit Tree
- Shrub (Bushes)
- Timber
- Hedge
- Stump
- Swamp
- Rock Outcrop
- Broken Concrete
- Revetment (Rip Rap)
- Cemetery
- Grave
- Cave
- Sink Hole
- Board Fence
- Chain Link or Security Fence
- Wire Fence
- Terrace
- Earth Dam or Dike (Existing)
- Tile Outlet
- Edge of Water
- Existing Drainage
- Right of Way Rail or Lot Corner
- Concrete Monument
- Well
- Windmill
- Beehive Intake
- Existing Intake
- Existing Utility Access (Manhole)
- Fire Hydrant
- Water Hydrant (Rural)
- Septic Tank
- Cistern
- L.P. Gas Tank (No Footing)
- Underground Storage Tank
- Latrine
- Satellite TV Dish
- Water Hook Up
- Radio Tower
- Tower Anchor
- Guardrail (Beam or Cable)
- Guard Post (one or two)
- Guard Post (over two)
- Filler Pipe
- Gas Valve
- Water Valve
- Speed Limit Sign
- Mile Marker Post
- Sign
- Traffic Signal Control Box
- Rail Road Signal Control Box
- Telephone Switch Box
- Electric Box

UTILITY LEGEND

- CITY OF ONAWA
Contact Name: Elaine Miller
Contact Phone: (712)433-1181
Contact Email: emiller@onawa.com
- Contact Name: John Casady
Contact Phone: (712)433-1511
Contact Email: jcasady@onawa.com
- IOWA DEPARTMENT OF TRANSPORTATION
Contact Name: Ron Gleiser
Contact Phone: (712)261-0196
Contact Email: Ron.Gleiser@iowadot.us
- Contact Name: Jason Dale
Contact Phone: (515)239-1995
Contact Email: Jason.Dale@iowadot.us
- WESTERN IOWA POWER COOPERATIVE
Contact Name: Jason Lee
Contact Phone: (712)263-2943
Contact Email: jason.lee@wipco.com
- Contact Name: Jeremy Kreger
Contact Phone: (712)263-2943
Contact Email: jeremy.kreger@wipco.com
- CENTURYLINK
Contact Name: Sadie Hull
Contact Phone: (918)547-0147
Contact Email: sadie.hull@lumen.com

PLAN VIEW COLOR LEGEND OF PLAN AND PROFILE SHEETS

LINEWORK		Design Color No.	
Green	(2)		Existing Topographic Features and Labels
Blue	(1)		Proposed Alignment, Stationing, Tic Marks, and Alignment Annotation
Magenta	(5)		Existing Utilities
SHADING		Design Color No.	
Lavender	(9)		Temporary Pavement Shading
Yellow	(4)		Proposed Pavement Shading
Yellow	(132)		Proposed Pavement Scarification and Overlay
Orange	(6)		Proposed Granular Shading
Orange	(70)		Proposed Shoulder Granular Shading
Yellow	(68)		Proposed Shoulder Paved Full Depth Shading
Yellow	(132)		Proposed Shoulder Paved Partial Depth Shading
Gray, Dark	(112)		Proposed Grade and Pave Shading "In conjunction with a paving project"
Brown, Light	(236)		Grading Shading
Orange, Light	(134)		Proposed Granular Entrance Shading
Yellow	(220)		Proposed Paved Entrance Shading
Tan	(8)		Proposed Sidewalk Shading
Blue, Light	(230)		Proposed Sidewalk Landing Shading
Pink	(11)		Proposed Sidewalk Ramp Shading
Green, Light	(225)		Existing Pavement Shading
Red	(3)		Proposed Structure Shading
Red	(3)		Delineates Restricted Areas

PROFILE VIEW COLOR LEGEND OF PLAN AND PROFILE SHEETS

LINEWORK		Design Color No.	
Green	(10)		Existing Ground Line Profile
Blue	(1)		Proposed Profile and Annotation
Magenta	(5)		Existing Utilities
Blue, Light	(230)		Proposed Ditch Grades, Left
Black	(0)		Proposed Ditch Grades, Median
Rust	(14)		Proposed Ditch Grades, Right

- Reference Point
- Station
- Survey Line
- Section Corner
- Ground Line Intercept
- Utilities Trench Limits
- Saw Cut
- Guardrail
- Trench Drain
- HighTension Cable Guardrail
- Sheet Pile
- Pavement Removal
- Clearing & Grubbing Area

- #### RIGHT-OF-WAY LEGEND
- Proposed Right-of-Way
 - Existing Right of Way
 - Existing and Proposed Right-of-Way
 - Easement and Existing Right-of-Way
 - Easement (Temporary)
 - Easement
 - Access Control
 - Property Line

PLAN AND PROFILE LEGEND AND SYMBOL INFORMATION SHEET

(COVERS SHEET SERIES D & K)

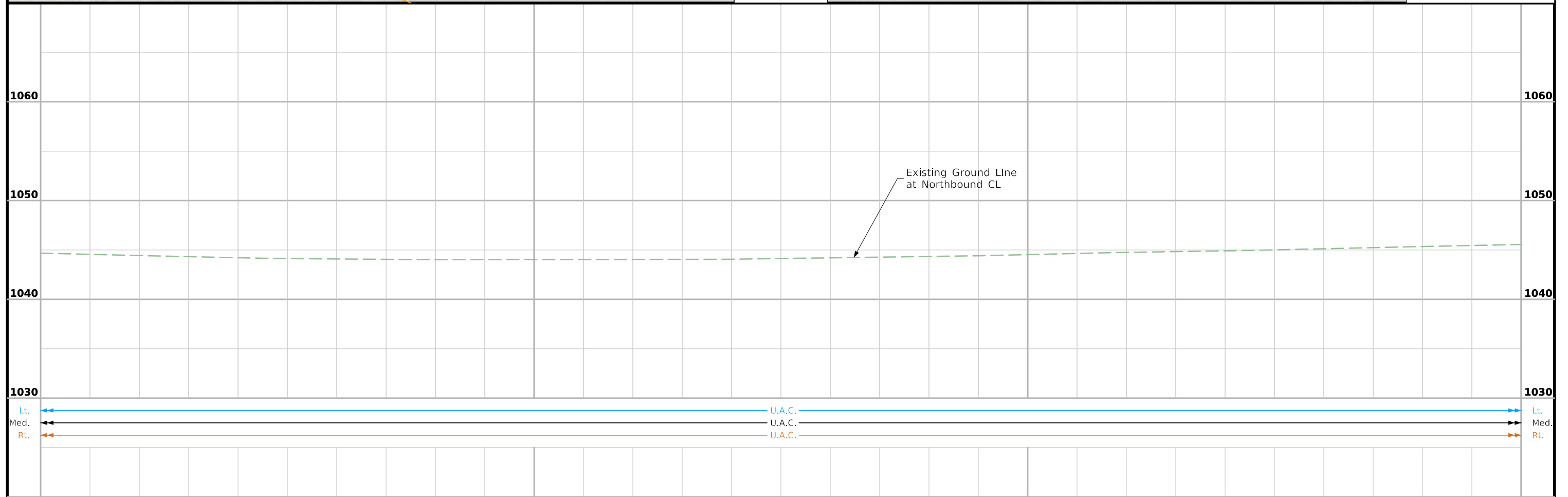
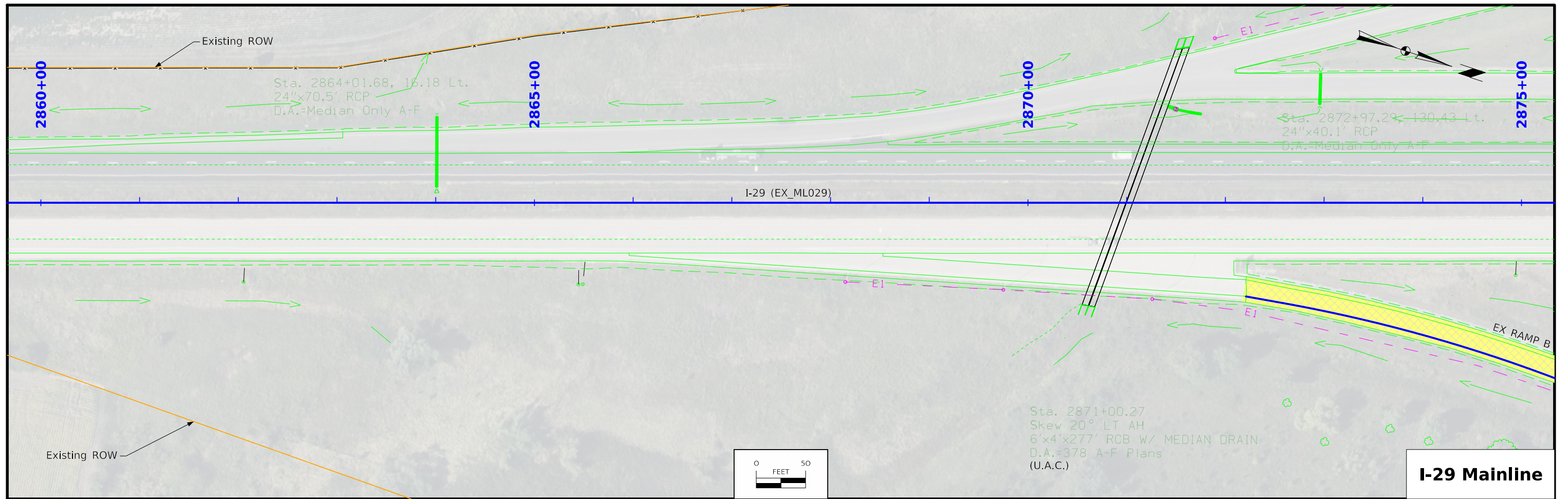

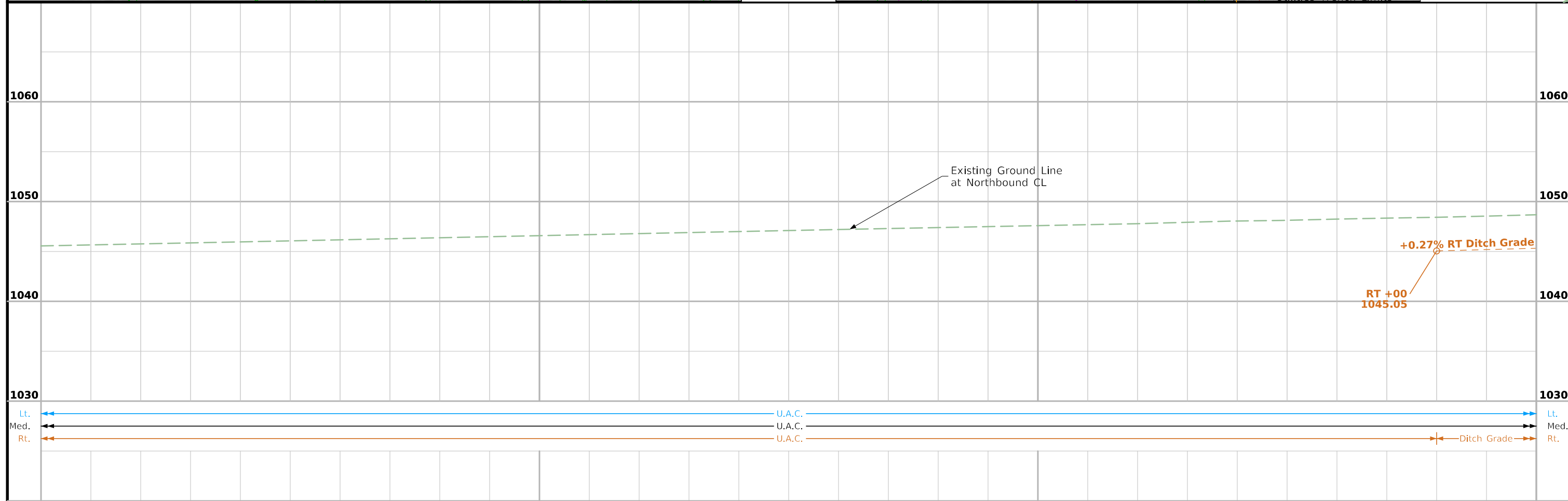
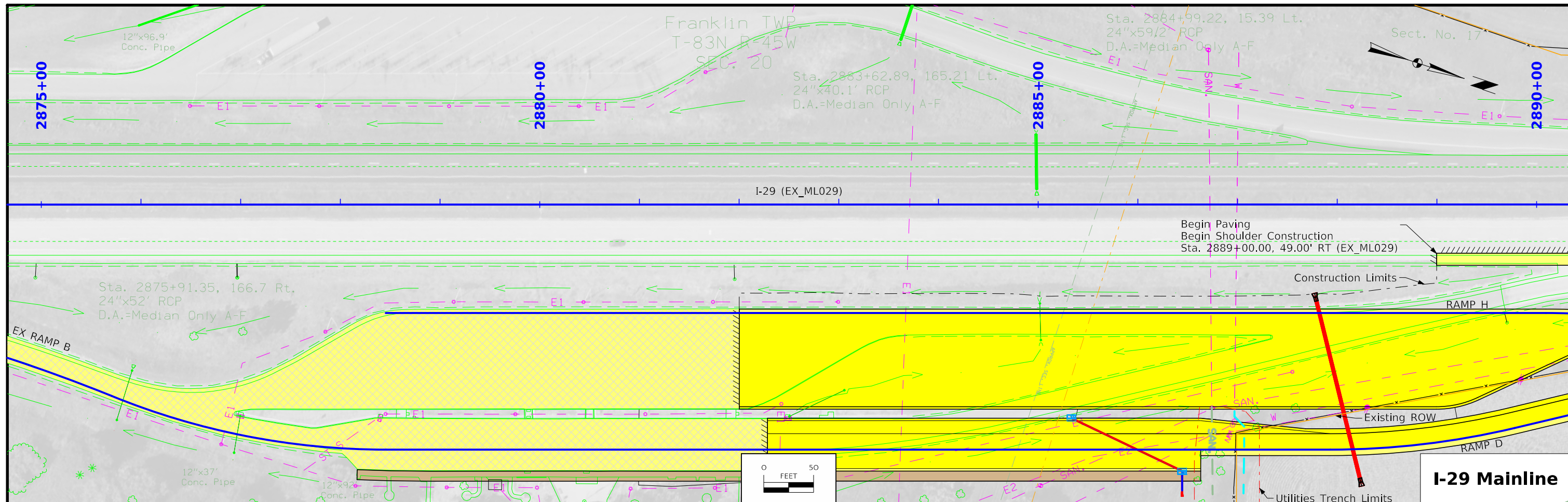

FILE NO.	ENGLISH	DESIGN TEAM Iowa DOT \ HR Green, Inc.	MONONA COUNTY	PROJECT NUMBER IMX-029-5(282)109--02-67	SHEET NUMBER D.3
----------	---------	---------------------------------------	---------------	-----------------------------------------	------------------

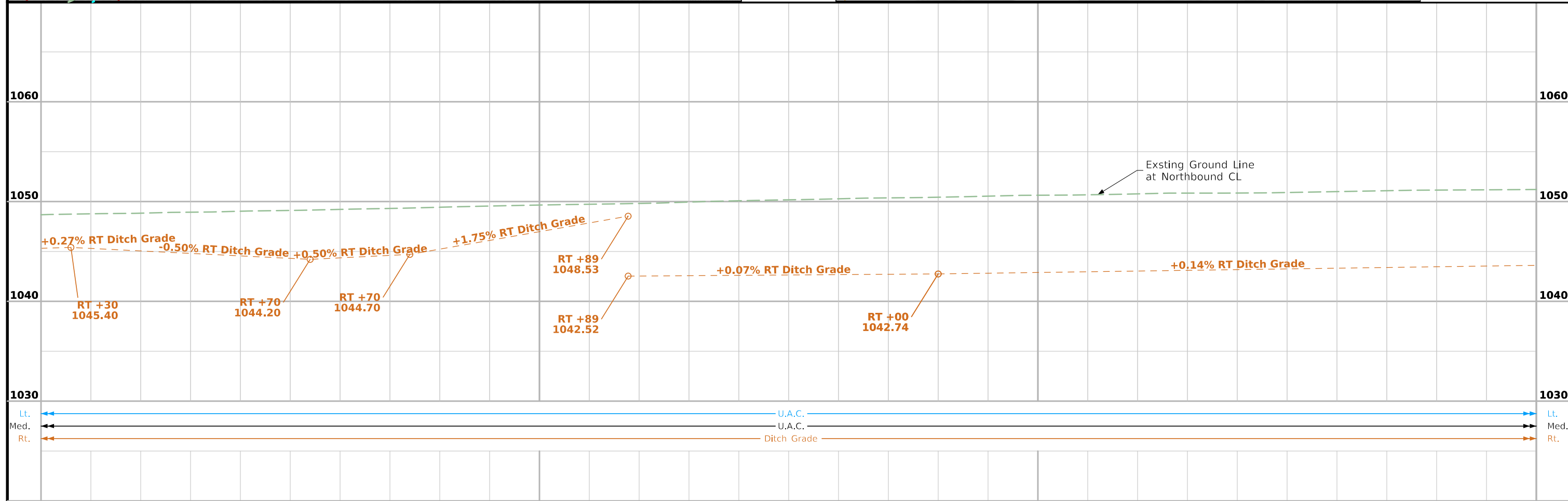
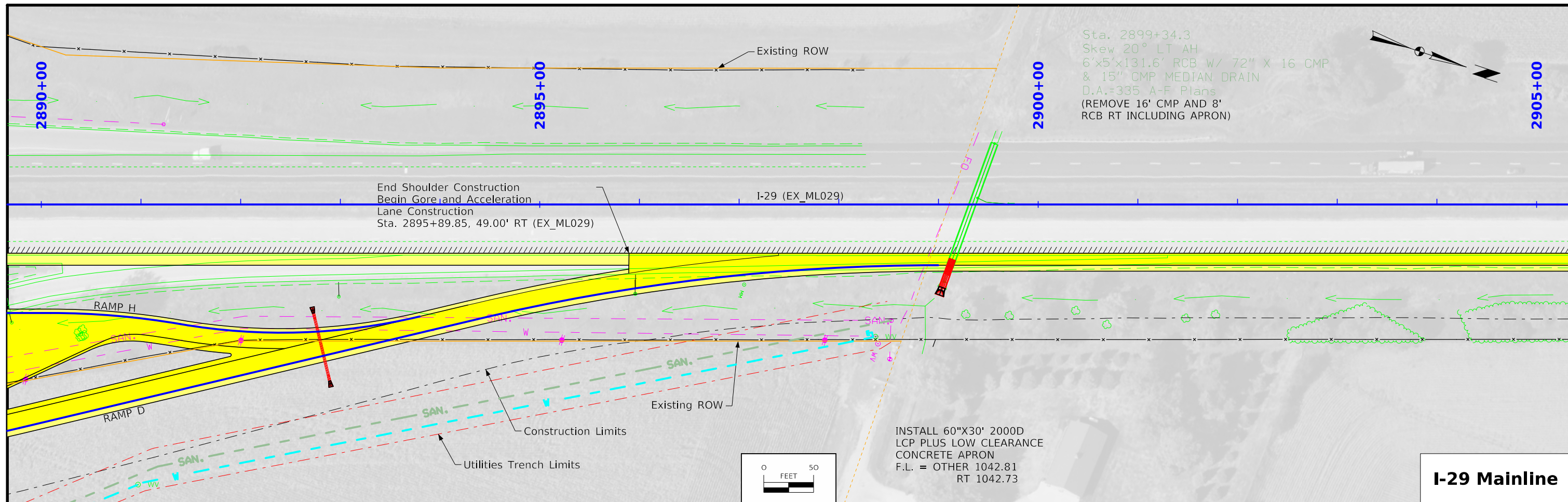

FILE NO.	ENGLISH	DESIGN TEAM Iowa DOT \ HR Green, Inc.	MONONA COUNTY	PROJECT NUMBER IMX-029-5(282)109--02-67	SHEET NUMBER D.4
----------	---------	---------------------------------------	---------------	-----------------------------------------	------------------

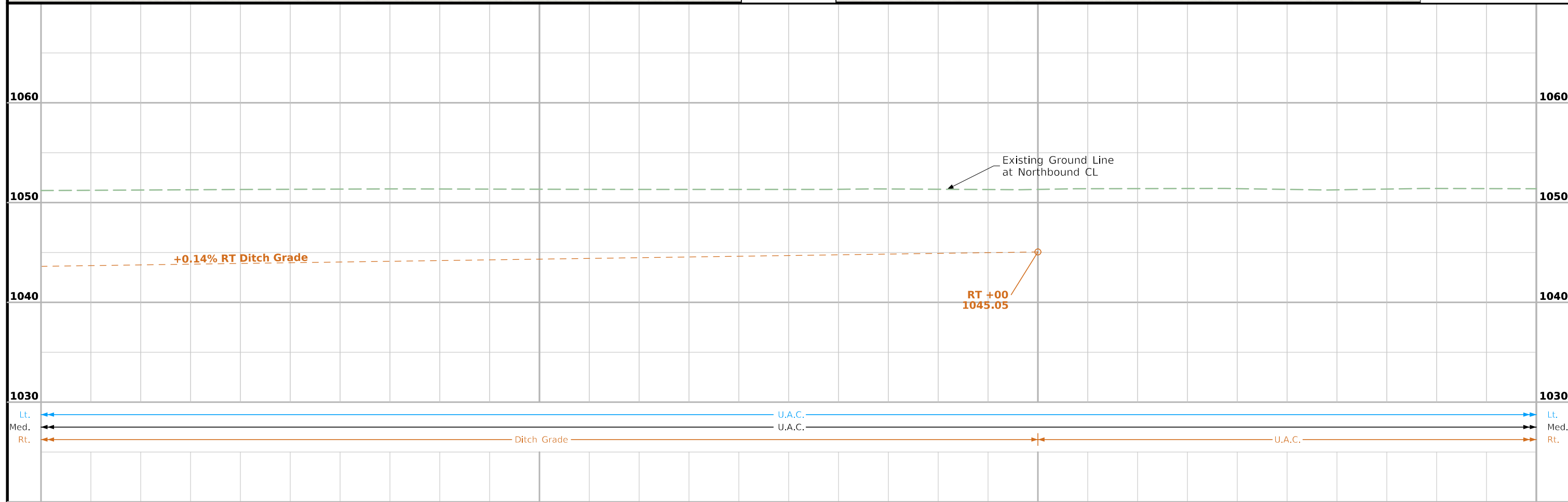
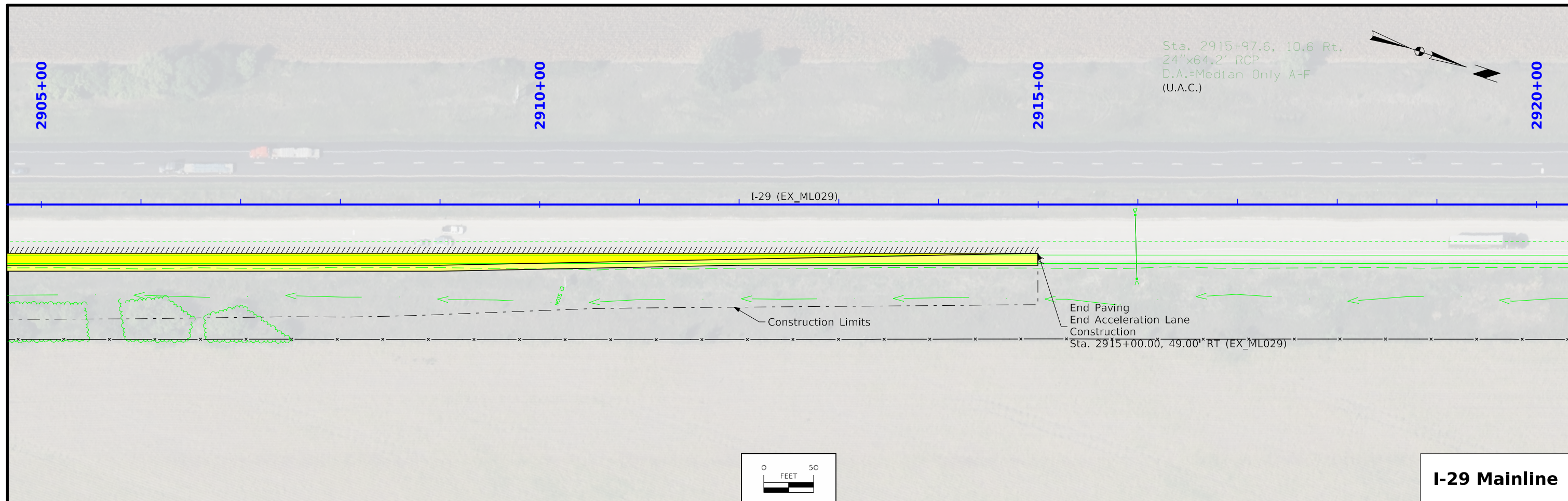

FILE NO.	ENGLISH	DESIGN TEAM Iowa DOT \ HR Green, Inc.	MONONA COUNTY	PROJECT NUMBER IMX-029-5(282)109--02-67	SHEET NUMBER D.5
----------	---------	---------------------------------------	---------------	-----------------------------------------	------------------

Survey Information

SURVEY INDEX

County: Monona
PIN: 24-67-029-050
Project Number: IMX-029-5(282)109--02-67
Location: Onawa Rest Area 2.6 mi S of IA 175 (NB)
Work Code: 1014-PCC Pavement - Grade and Replace Project
Directory: 6702905024

Survey Personnel

Clayton Henningsen – Survey Party Chief
Jason Arn – Survey Party Chief
Paul Harry – Survey Party Chief

Date(s) of Survey

Begin Date 02/04/2024
End Date 02/22/2024

General Information

This survey is for I-29 northbound rest area 2.6 miles south of IA 175. This survey request was for the I-29 corridor only. This project is a Full Field DTM survey.

Utility Information

For logging data and other utility details see Utility Survey and Ownership Report in the Utility folder of the PrelimSurvey project directory.

Project Control

Coordinates were determined for primary project control points by conducting concurrent six-hour static observations. Post processing is constrained to nearby Iowa Real Time Network reference stations. For additional details of the control survey, contact the Preliminary Survey department.

PROJECT DATUM: NAD83(2011) for EPOCH 2010.00 (IaRTN 2019 ADJUSTMENT)
COORDINATE SYSTEM: IOWA REGIONAL COORDINATE SYSTEM ZONE 06
(U.S. SURVEY FOOT)
VERTICAL DATUM: NAVD88
GEOID MODEL: 2018u2

Alignment Information

The horizontal alignment for I-29 this survey is a retrace of As-built Plans No. I-29-5(14)108—01-67. Survey stationing was equated to the plan POT at Sta. 2857+02.1 and carried ahead without equation throughout the survey.

Survey stationing relates to as built plan stationing as follows:

POT Sta. 2857+02.1 As-built Plans Project No. I-29-5(14)108—01-67
Survey POT Sta. 2857+02.1

PC Sta. 2935+29.0 As-built Plans Project No. I-29-5(14)108—01-67
Survey PC Sta. 2935+26.71

CONTROL POINT VICINITY MAP

This map is a guide to the vicinity of the primary project control points. Primary control is for use with RTK base stations and for RTN validation. Future surveys will use primary project control to establish temporary control as needed for construction or other surveying applications.



HORIZ. DATUM: NAD83(2011) for EPOCH 2010.00 (IaRTN 2019 Adjustment) - Iowa RCS Zone 06 (U.S. Survey Foot)

VERT. DATUM: NAVD88 - Geoid Model: 2018u2

Coordinate listing from next sheet will be used with IaRTN for monument recovery. No other reference ties are given.

HORIZONTAL AND VERTICAL PROJECT CONTROL COORDINATE LISTING
 HORIZ. DATUM: NAD83(2011) for EPOCH 2010.00 (IaRTN 2019 Adjustment)
 Ia. Regional Coordinate System Zone 06 (U.S. Survey Foot)
 VERT. DATUM: NAVD88
 Geoid Model: 2018u2

<u>Point Name</u>	<u>Northing</u>	<u>Easting</u>	<u>Elevation</u>	<u>Feature Definition-Description</u>
67I29110	7236976.95	16396999.78	1044.05	CP SET FENO MONUMENT IN EAST DITCH OF I-29 NEAR MILE MARKER 110 APPROX 20 FT WEST OF ROW FENCE
67I291092	7233146.74	16398299.11	1043.36	CP FOUND CONC MONUMENT ON EAST TOP OF BACKSLOPE 3 FEET WEST OF ROW FENCE APPROX 65 FT NORTH CL OF 256TH ST
67I291096	7234825.35	16397293.93	1045.76	CP SET REBAR AT SOUTHBOUND REST AREA APPROX 100 FT SOUTH OF END OF SIDEWALK
V145	7230407.47	16398091.50	1048.97	CP NGS MONUMENT AS DESCRIBED IN GOOD CONDITION

108_23A
8/15/22

TRAFFIC CONTROL PLAN

1. Traffic control on this project shall be in accordance with the Standard Road Plans listed in tabulation 105-4 and the specific layouts shown in the plans. For additional information, refer to Part 6 of the Manual on Uniform Traffic Control Devices (MUTCD).
2. The rest area will be closed to traffic during Stage 2 of construction. Contractor shall notify the Engineer in writing two weeks prior to the planned closure date of the rest area.
3. Traffic on I-29 shall be maintained in accordance with the J sheets. A northbound right lane closure will be permitted as necessary to complete Ramp D gore and acceleration lane paving. Contractor shall notify the Engineer in writing two weeks prior to the planned closure date of the northbound right lane of I-29.
4. Traffic control devices shown in the J sheets are part of the Traffic Control bid item and will not be paid for individually.
5. The Contractor shall coordinate traffic control with all other projects in the area including, but not limited to, those in Coordinated Operations tabulation 111-01 and the NB rest area building replacement project.

108_26A
8/15/22

STAGING NOTES

STAGE 1

Traffic:

- *Close the northbound right travel lane of I-29 north of the rest area exit gore to the north paving limits.
- * Maintain all access and keep the rest area open during Stage 1.

Construction:

- * Construct proposed Ramp D, Ramp H, and the I-29 acceleration lane and shoulder to the extent practical.

STAGE 2

Traffic:

- * Close the northbound right travel lane of I-29 south of the rest area exit to the north paving limits.
- * Close the rest area to the public. Maintain access for Iowa DOT maintenance personnel.

Construction:

- * Remove existing on-ramp, construct parking areas, and construct new shoulder through the existing on-ramp.

111_01
10/14/22

COORDINATED OPERATIONS

Other work in progress during the same period of time will include the construction of the projects listed. Coordinate operations with those of other contractors working within the same area.

Project	Type of Work
IMX-029-5(283)109--02-67	Tied Project - Traffic Signs
IMX-029-5(284)109--02-67	Tied Project - Lighting Rest Area Facilities Improvements
Sergeant Bluff NB Rest Area	Adjacent Project - Remove

254_01
9/28/22

INCIDENT MANAGEMENT

An incident management plan, provided by the District Office, will be discussed at the pre-construction conference.

**CROSS SECTION VIEW COLOR LEGEND
OF TRAFFIC CONTROL AND STAGING SHEETS**

SHADING	Design Color No.	
Green, Light	(225)	Existing Pavement Shading
Gray, Light	(48)	Previously Constructed Pavement Shading
Gray, Med	(80)	Previously Constructed Granular Surface Shading
Blue, Light	(230)	Proposed Pavement Shading
Lavender	(9)	Temporary Pavement Shading
Brown, Med	(237)	Future Proposed Pavement Shading

**CROSS SECTION VIEW PATTERN AND SYMBOL LEGEND
OF TRAFFIC CONTROL AND STAGING SHEETS**

	Pavement Removal		Proposed Granular Shoulder
	Proposed Granular Subbase		Temporary Shoulder
	Proposed Special Backfill		Existing Shoulder Strengthening
	Temporary Barrier Rail, Unpinned		Permanent Barrier Rail
	Temporary Barrier Rail, Pinned		Channelizing Device

PLAN VIEW COLOR LEGEND OF TRAFFIC CONTROL AND STAGING SHEETS

LINEWORK	Design Color No.	
Green	(2)	Existing Topographic Features and Labels
Magenta	(5)	Pavement Marking Call Outs
Blue	(1)	Proposed Alignment, Stationing, Tic Marks, and Alignment Annotation
Yellow	(4)	Pavement Markings, Yellow
Off White	(254)	Pavement Markings, White
Violet	(15)	Temporary barrier rail, Unpinned
Flush Orange	(228)	Temporary barrier rail, Pinned

SHADING	Design Color No.	
Green, Light	(225)	Existing Pavement Shading
Gray, Light	(48)	Previously Constructed Pavement Shading
Gray, Med	(80)	Proposed Granular Surface Shading
Gray, Med	(80)	Previously Constructed Granular Surface Shading
Blue, Light	(230)	Proposed Pavement Shading
Blue, Light	(230)	Proposed Pavement Scarification and Overlay
Lavender	(9)	Temporary Pavement Shading
Brown, Light	(236)	Proposed Grading Limits Shading
Pink, Dark	(13)	Proposed MSE or CIP Wall Shading
Red	(3)	Proposed Bridge Shading and Sign Trusses
Black w/Gray, Light Fill	(0,48)	Previously Constructed Structure

**PLAN VIEW PATTERN AND SYMBOL LEGEND
OF TRAFFIC CONTROL AND STAGING SHEETS**

	Channelizing Device		Crash Cushion (Temp)
	Drum		Traffic Signal
	Temporary Lane Separator		Flagger
	Tubular Marker		Temporary Floodlighting
	Channelizer Marker		Traffic Sign
	Concrete Barrier Marker		Type III Barricade
	Delineator		Type A Warning Light
	Temporary Barrier Rail		Direction of Traffic
	Pavement Removal		Safety Closure
	Sand Barrel Layout		Lane Identification
	Shoring		

NOTE: Device spacing according to Standard Road Plans unless specifically dimensioned.

**TRAFFIC CONTROL
AND
STAGING
LEGEND AND SYMBOL
INFORMATION SHEET**

(COVERS SHEET SERIES J)

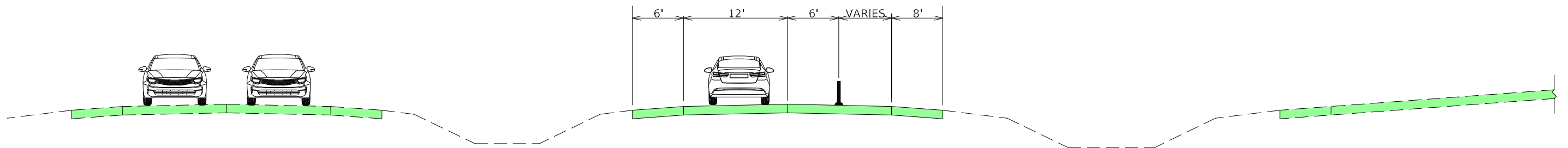

Stage 1
(Looking North)
South of Temporary barrier,
right lane closed

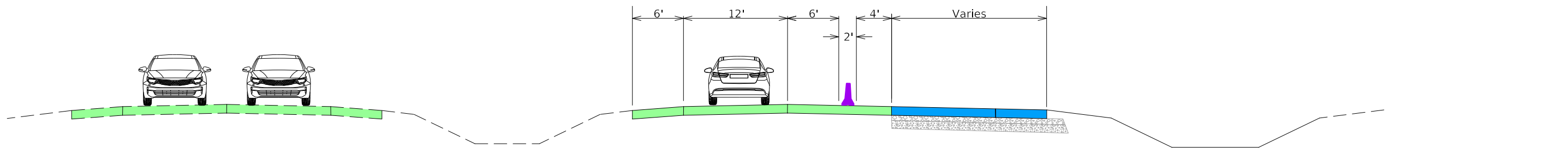

Stage 1
(Looking North)
Gore, Acceleration Lane,
and Shoulder Construction

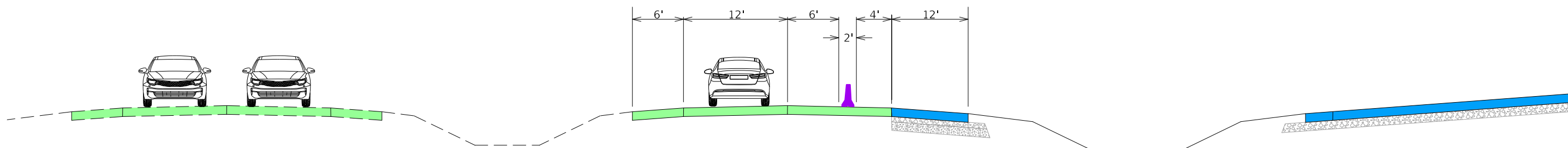

Stage 2
(Looking North)
I-29 Shoulder and Rest Area
Parking Lot Construction

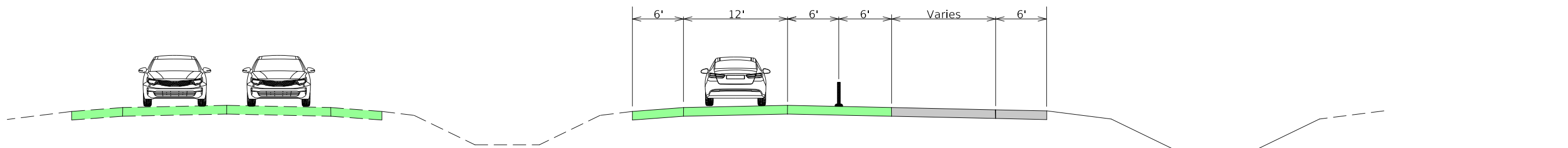

Stage 2
(Looking North)
Gore, Acceleration Lane,
and Shoulder Construction
Completed but Closed to Traffic

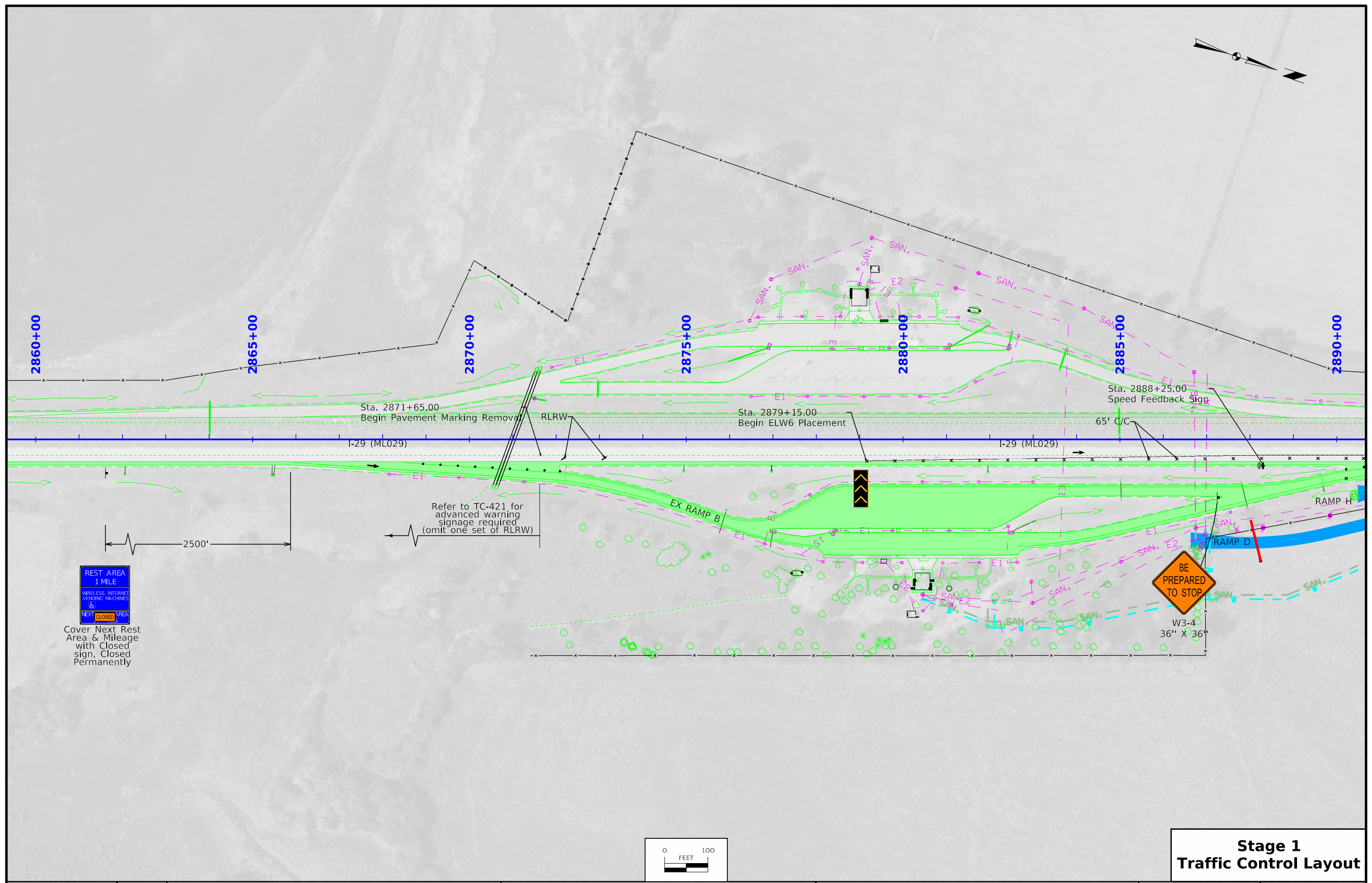
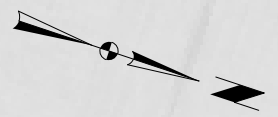

Cover Next Rest Area & Mileage with Closed sign, Closed Permanently

2500'

Refer to TC-421 for advanced warning signage required (omit one set of RLRW)



W3-4
36" X 36"

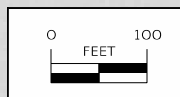

Stage 1 Traffic Control Layout

FILE NO.	ENGLISH	DESIGN TEAM Iowa DOT \ HR Green, Inc.	MONONA COUNTY	PROJECT NUMBER IMX-029-5(282)109--02-67	SHEET NUMBER J.7
----------	---------	---------------------------------------	---------------	-----------------------------------------	------------------

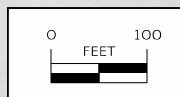
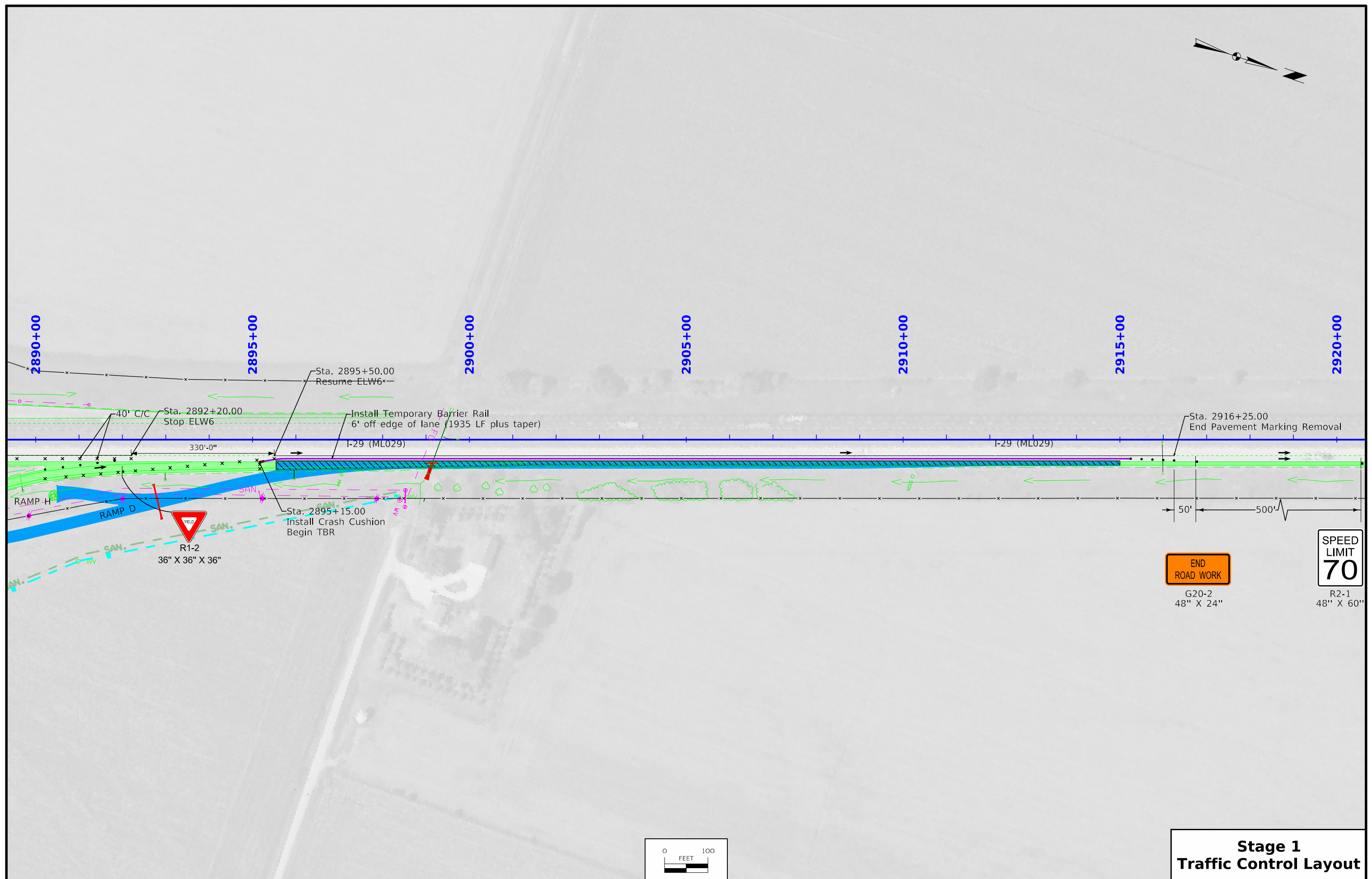

**Stage 1
Traffic Control Layout**

FILE NO.	ENGLISH	DESIGN TEAM Iowa DOT \ HR Green, Inc.	MONONA COUNTY	PROJECT NUMBER IMX-029-5(282)109--02-67	SHEET NUMBER J.8
----------	---------	---------------------------------------	---------------	-----------------------------------------	------------------

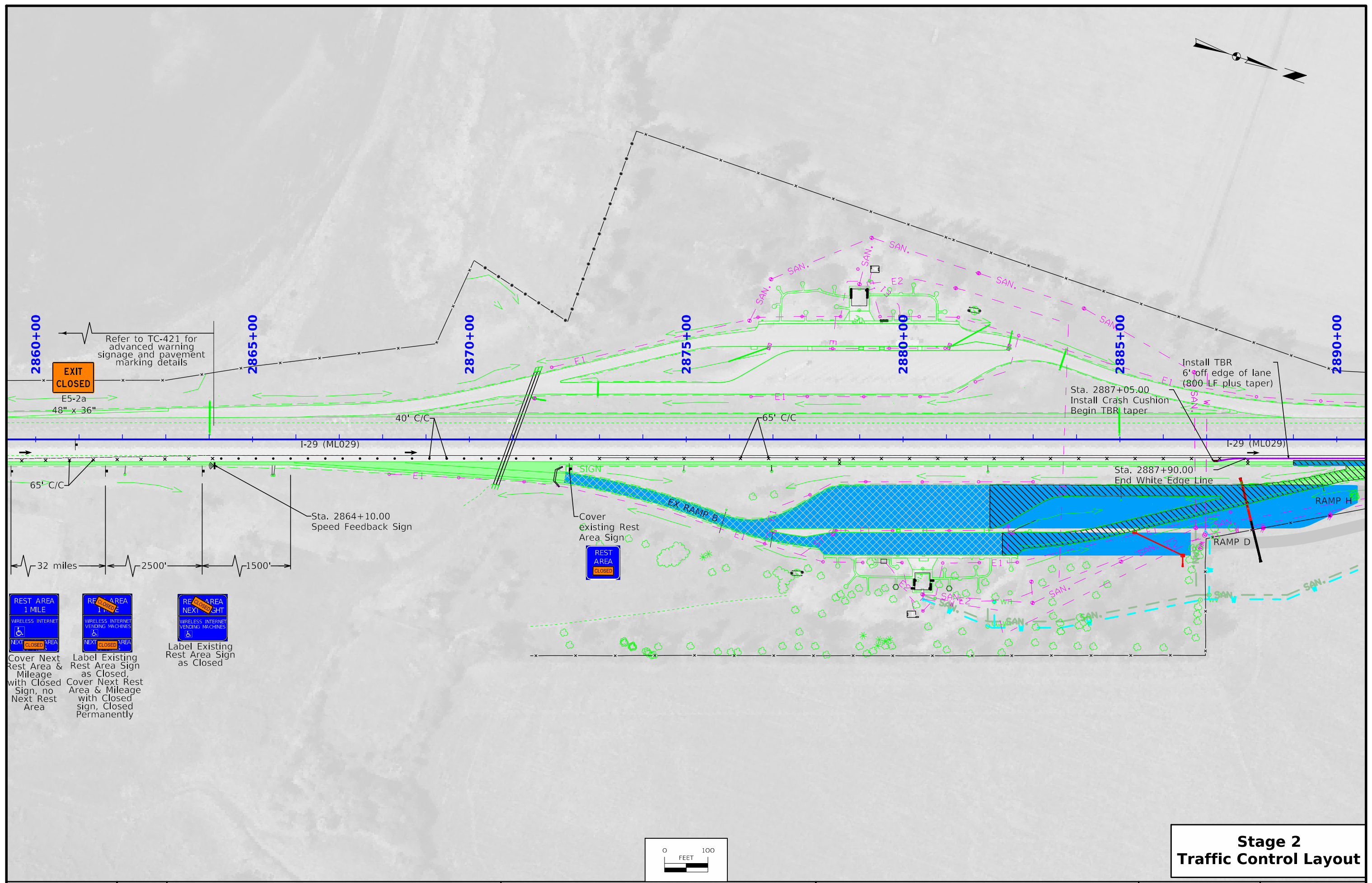
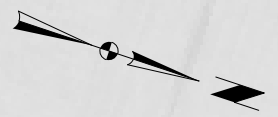

2860+00
EXIT CLOSED
E5-2a
48" x 36"

Refer to TC-421 for advanced warning signage and pavement marking details

2865+00

2870+00

2875+00

2880+00

2885+00

2890+00

I-29 (ML029)

I-29 (ML029)

Sta. 2887+05.00
Install Crash Cushion
Begin TBR taper

Install TBR
6' off edge of lane
(800 LF plus taper)

Sta. 2887+90.00
End White Edge Line

Sta. 2864+10.00
Speed Feedback Sign

Cover existing Rest Area Sign

REST AREA CLOSED

32 miles 2500' 1500'

REST AREA 1 MILE

WIRELESS INTERNET

WIRELESS INTERNET VENDING MACHINES

NEXT CLOSED AREA

REST AREA 1 MILE

WIRELESS INTERNET VENDING MACHINES

NEXT CLOSED AREA

REST AREA NEXT 1/2 MILE

WIRELESS INTERNET VENDING MACHINES

NEXT CLOSED AREA

Cover Next Rest Area & Mileage with Closed Sign, no Next Rest Area

Label Existing Rest Area Sign as Closed, Cover Next Rest Area & Mileage with Closed sign, Closed Permanently

Label Existing Rest Area Sign as Closed

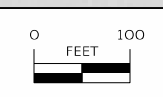

Stage 2 Traffic Control Layout

FILE NO.	ENGLISH	DESIGN TEAM Iowa DOT \ HR Green, Inc.	MONONA COUNTY	PROJECT NUMBER IMX-029-5(282)109--02-67	SHEET NUMBER J.9
----------	---------	---------------------------------------	---------------	-----------------------------------------	------------------

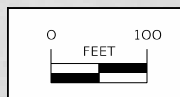
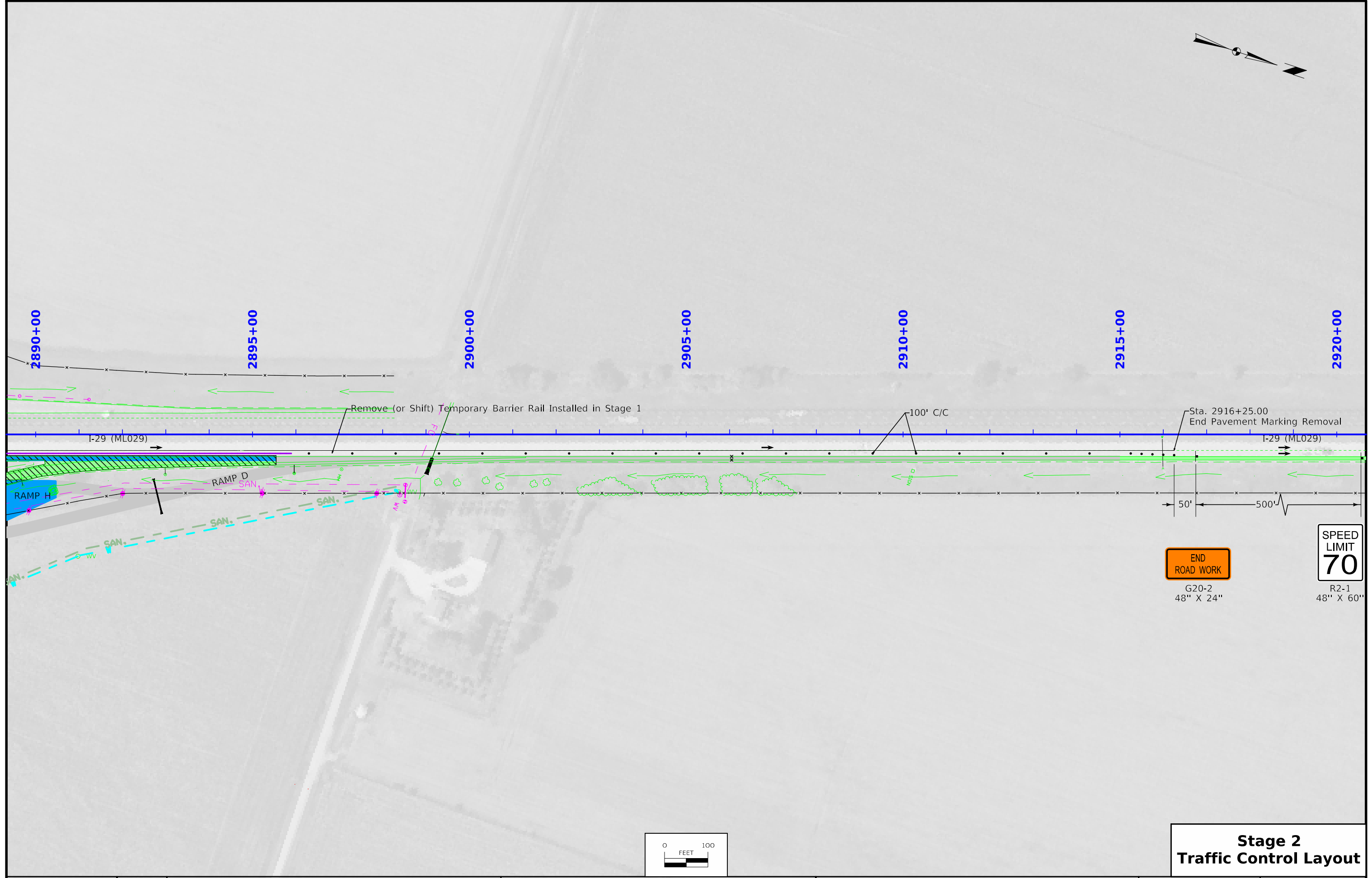

**Stage 2
Traffic Control Layout**

FILE NO.	ENGLISH	DESIGN TEAM Iowa DOT \ HR Green, Inc.	MONONA COUNTY	PROJECT NUMBER IMX-029-5(282)109--02-67	SHEET NUMBER J.10
----------	---------	---------------------------------------	---------------	-----------------------------------------	-------------------

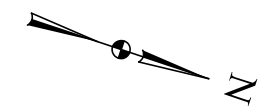

$\Delta = 22^\circ 08' 21.59''$ (LT)
 $T = 142.82'$
 $L = 282.08'$
 $R = 730.00'$
 $E = 13.84'$

2855+00

2860+00

2865+00

2870+00

2875+00

2880+00

2885+00

POT Sta. 2866+91.49 I-29 (EX_ML029)
Ramp B (EX_RPB)

POT Sta. 2872+21.13, 95.0' RT I-29 (EX_ML029) =
POB Sta. 2072+21.13 Ramp B (EX_RPB)

POT Sta. 2878+45.87, 109.0' RT I-29 (EX_ML029) =
POB Sta. 8078+41.47 Ramp H (RPH)

I-29 SB

I-29 NB

I-29 (EX_ML029)

$10^\circ 10' 8''$
 $538.10'$

2075+00

PRC 2075+84.80
 PRC 2075+84.80

POB 8078+41.47
 POE 2078+66.87
 POB 4078+27.18

PI 2074+22.43
 PC 2072+58.87
 POB 2072+21.13

Ramp B (EX_RPB)

PI 2077+27.61

Ramp H (RPH)

Ramp D (RPD)

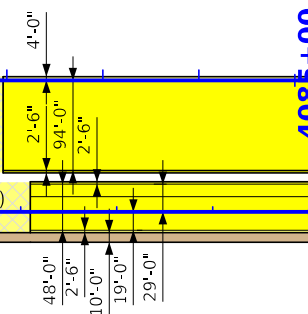

$\Delta = 11^\circ 58' 14.00''$ (RT)
 $T = 163.56'$
 $L = 325.92'$
 $R = 1560.00'$
 $E = 8.55'$

POT Sta. 2878+45.87, 246.0' RT I-29 (EX_ML029) =
POB Sta. 4078+27.18 Ramp D (RPD) =
POE Sta. 2078+66.87 Ramp B (EX_RPB)

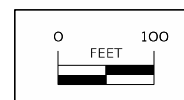

Geometric Plan
Proposed Interchange of
Interstate 29 with
Rest Area near Onawa (NB)

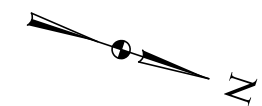

RPH CURVE 1
 $\Delta = 09^\circ 43' 42.86''$ (RT)
 T = 65.53'
 L = 130.74'
 R = 770.00'
 E = 2.78'
 e = -2.0%
 DS = 40 mph
 Method 2

RPH CURVE 2
 $\Delta = 23^\circ 05' 37.00''$ (RT)
 T = 122.58'
 L = 241.84'
 R = 600.00'
 E = 12.39'
 e = 2.0%
 DS = 40 mph
 Method 2

RPD CURVE 1
 $\Delta = 13^\circ 21' 54.14''$ (RT)
 T = 93.73'
 L = 186.61'
 R = 800.00'
 E = 5.47'
 e = -2.0%
 DS = 40 mph
 Method 2

RPD CURVE 2
 $\Delta = 13^\circ 21' 54.14''$ (RT)
 T = 234.33'
 L = 466.53'
 R = 2000.00'
 E = 13.68'
 e = 5.4%
 X = 62
 DS = 60 mph

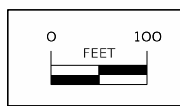
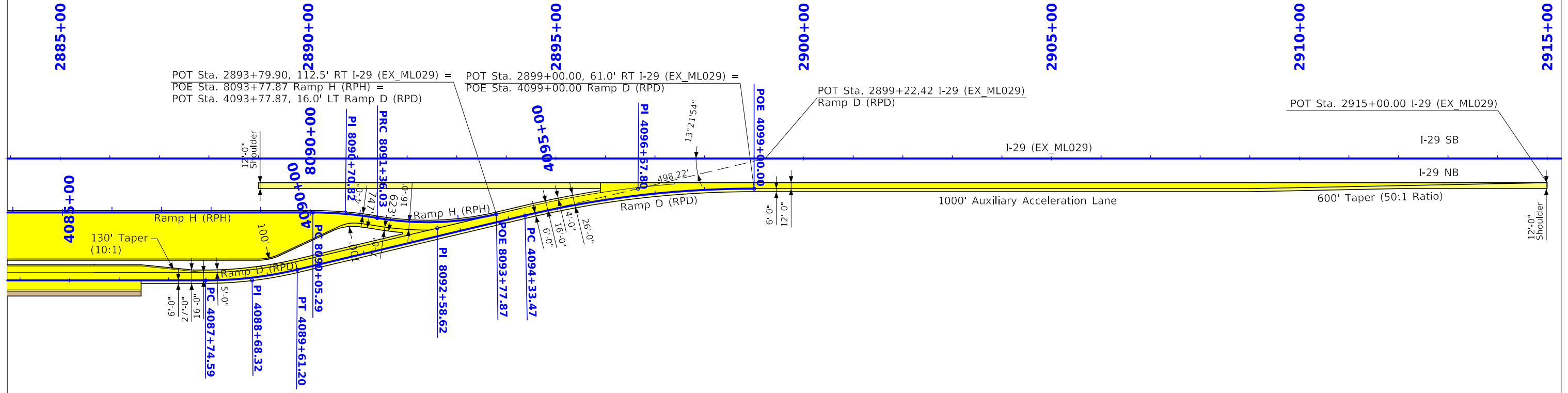

**Geometric Plan
 Proposed Interchange of
 Interstate 29 with
 Rest Area near Onawa (NB)**

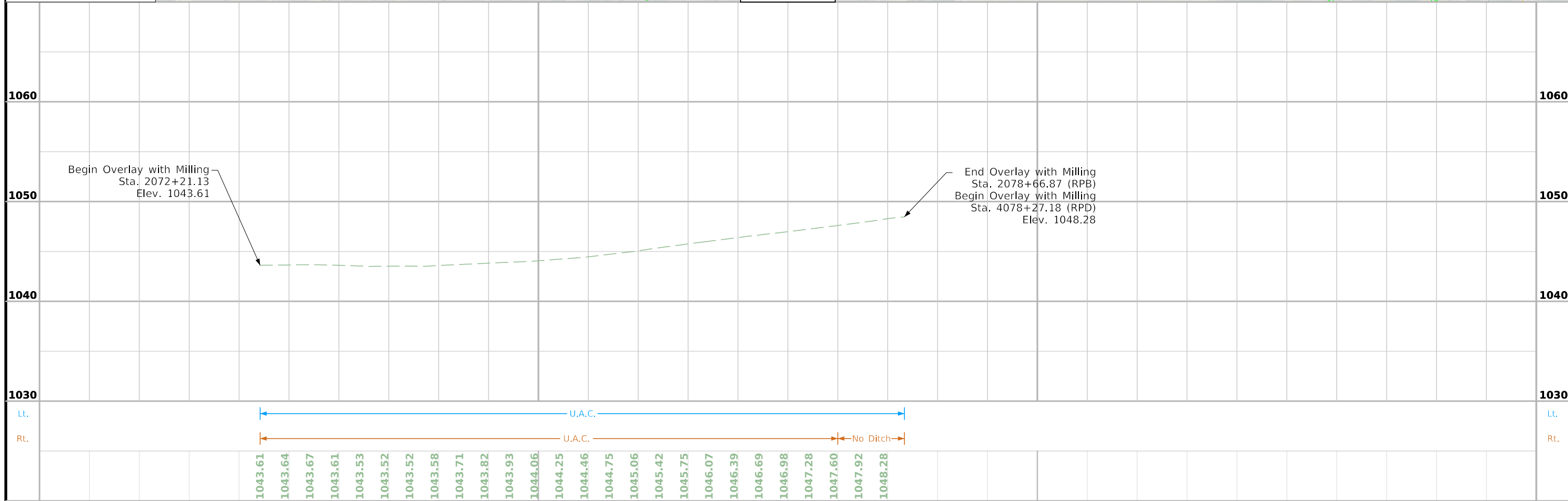
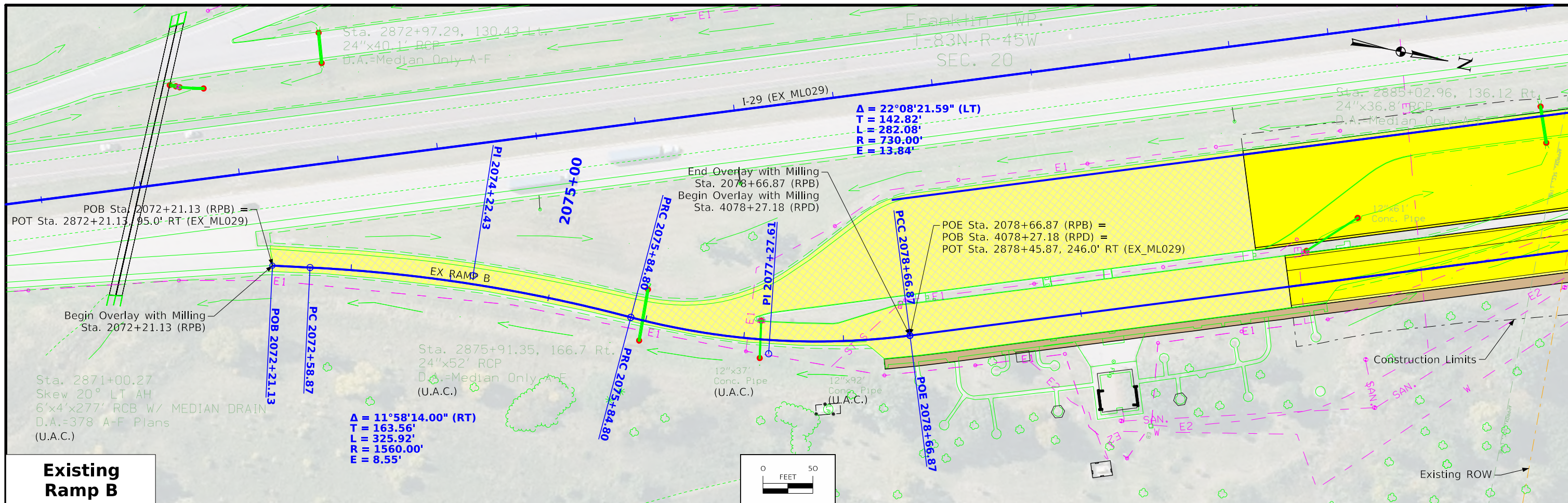

2070+00	1043.61	1043.64	1043.67	1043.61	1043.53	1043.52	1043.52	1043.58	1043.71	1043.82	1043.93	1044.06	1044.25	1044.46	1044.75	1045.06	1045.42	1045.75	1046.07	1046.39	1046.69	1046.98	1047.28	1047.60	1047.92	1048.28	2085+00
---------	---------	---------	---------	---------	---------	---------	---------	---------	---------	---------	---------	---------	---------	---------	---------	---------	---------	---------	---------	---------	---------	---------	---------	---------	---------	---------	---------

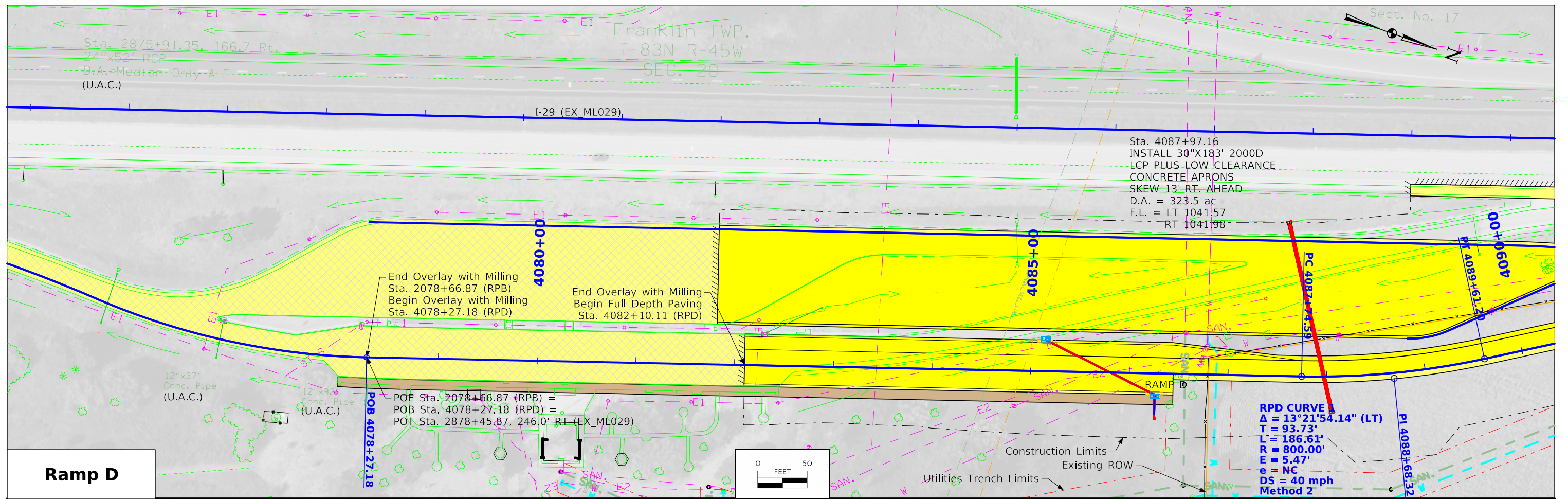

Ramp D

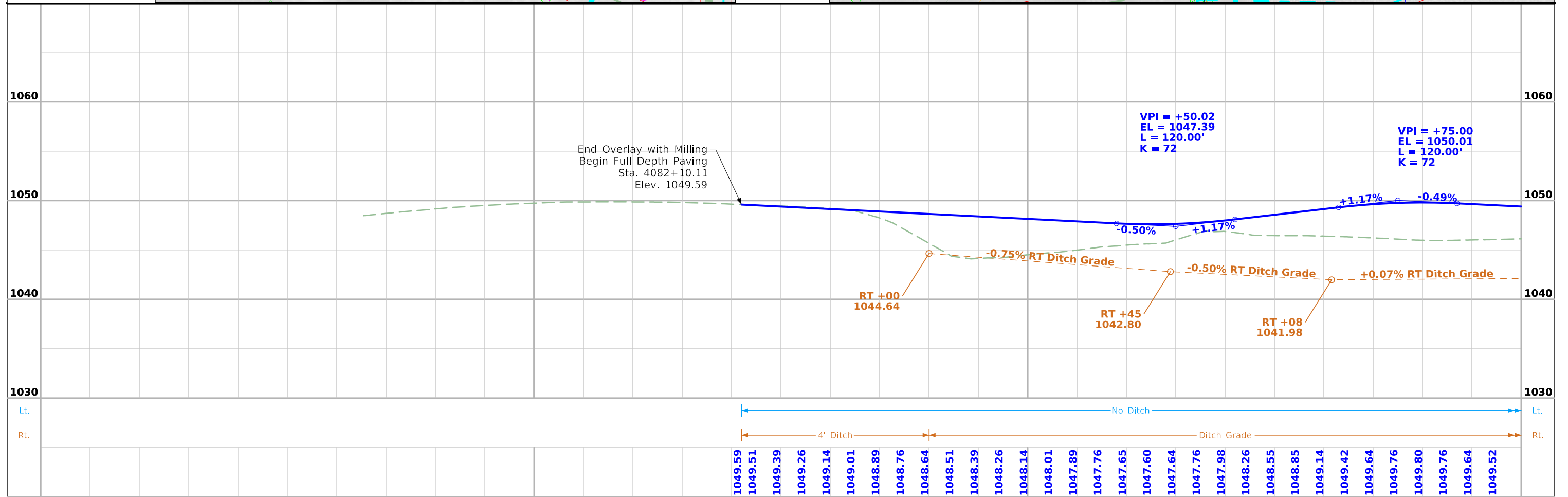

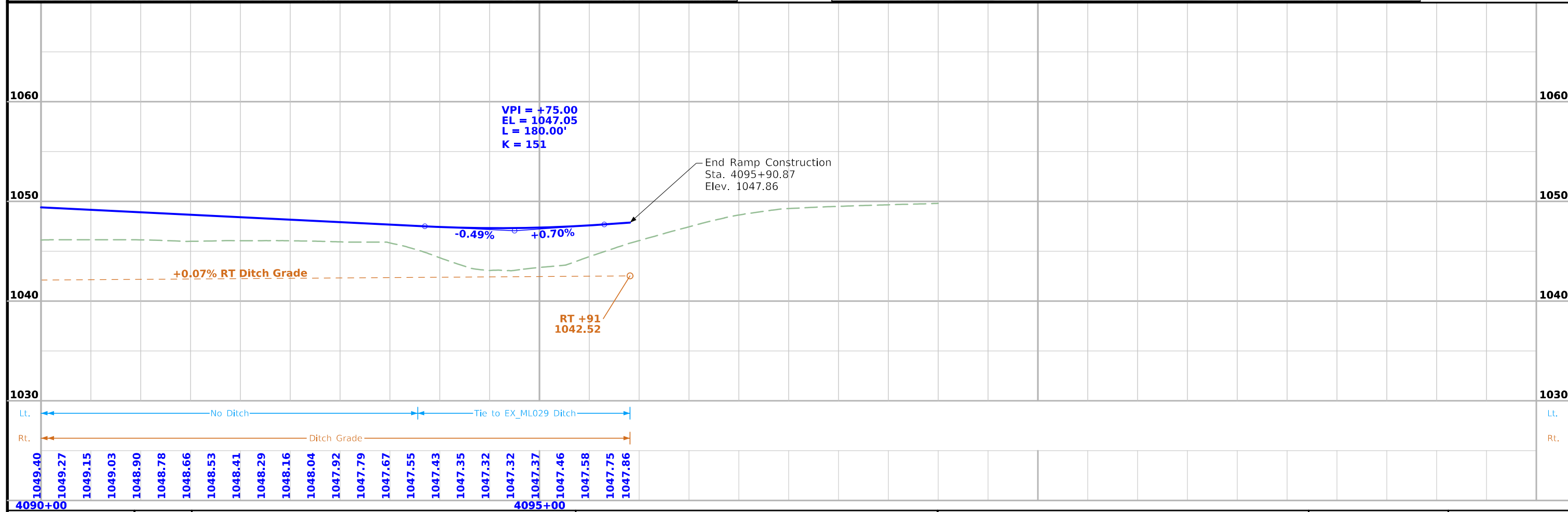
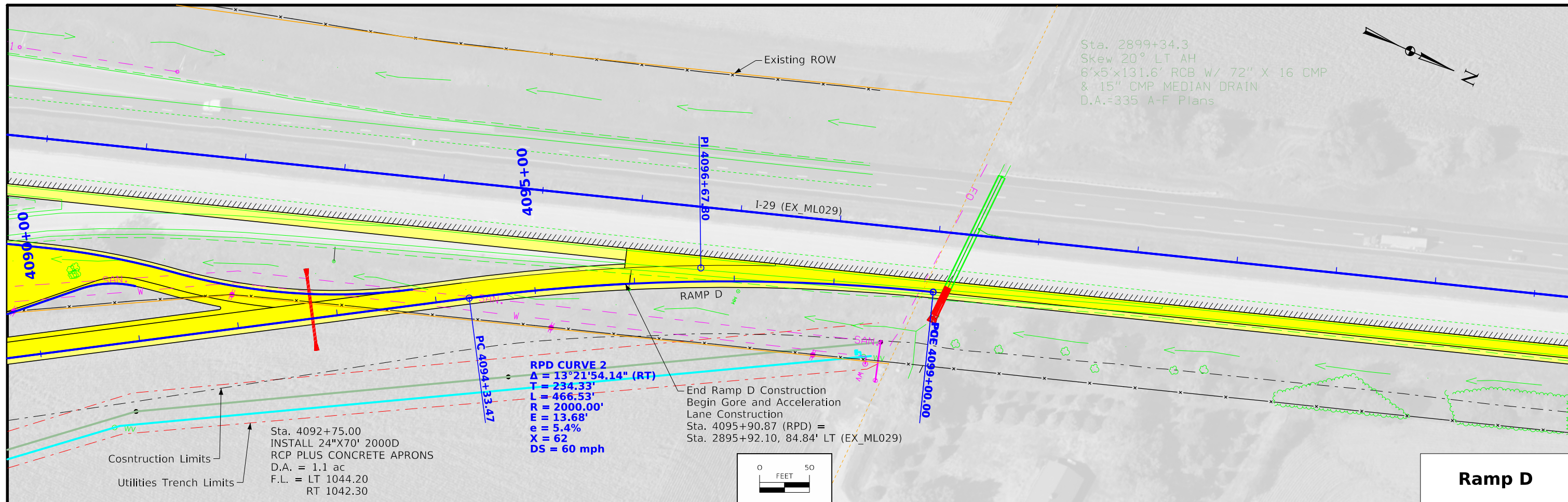

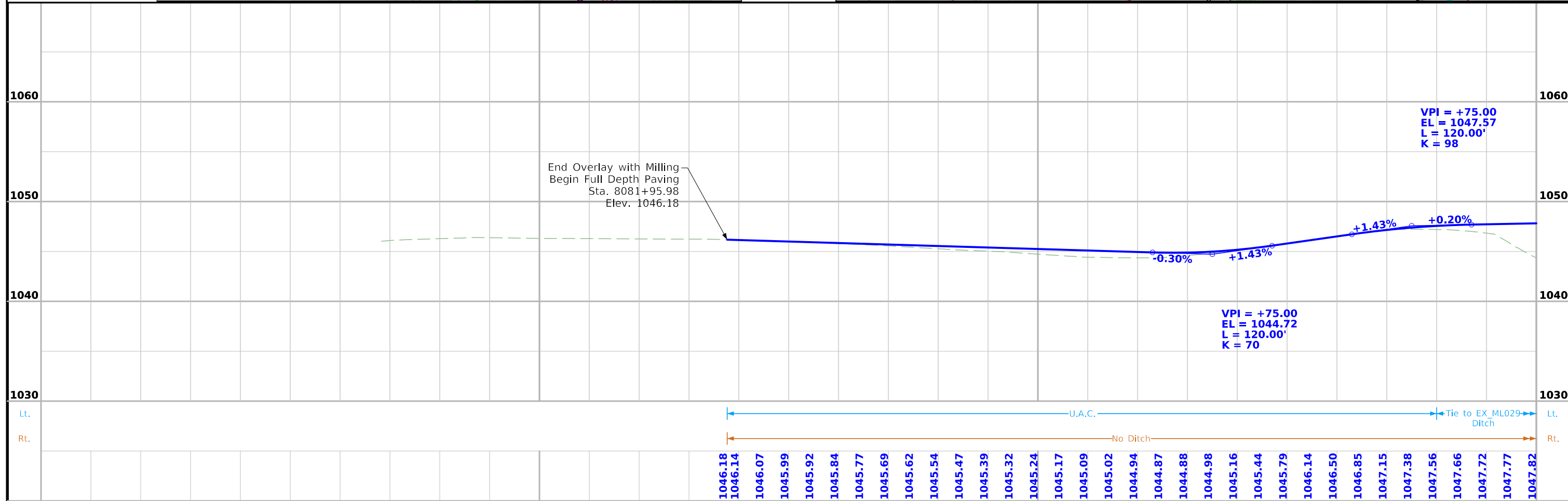
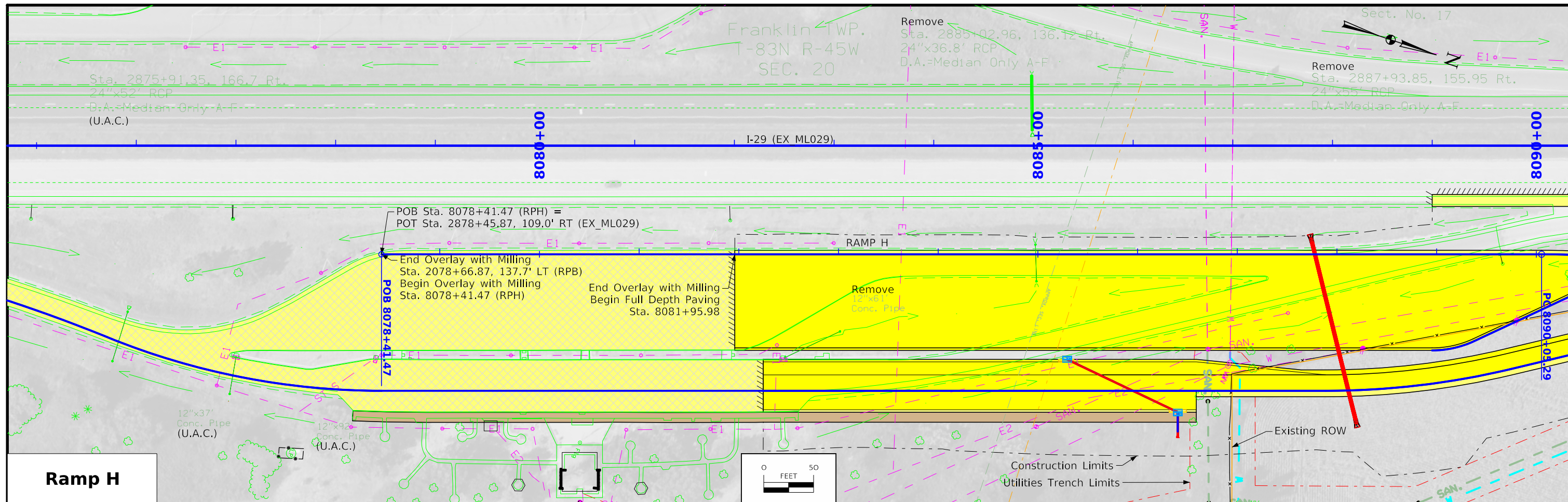

FILE NO.	ENGLISH	DESIGN TEAM Iowa DOT \ HR Green, Inc.	MONONA COUNTY	PROJECT NUMBER IMX-029-5(282)109--02-67	SHEET NUMBER K.6
----------	---------	---------------------------------------	---------------	-----------------------------------------	------------------

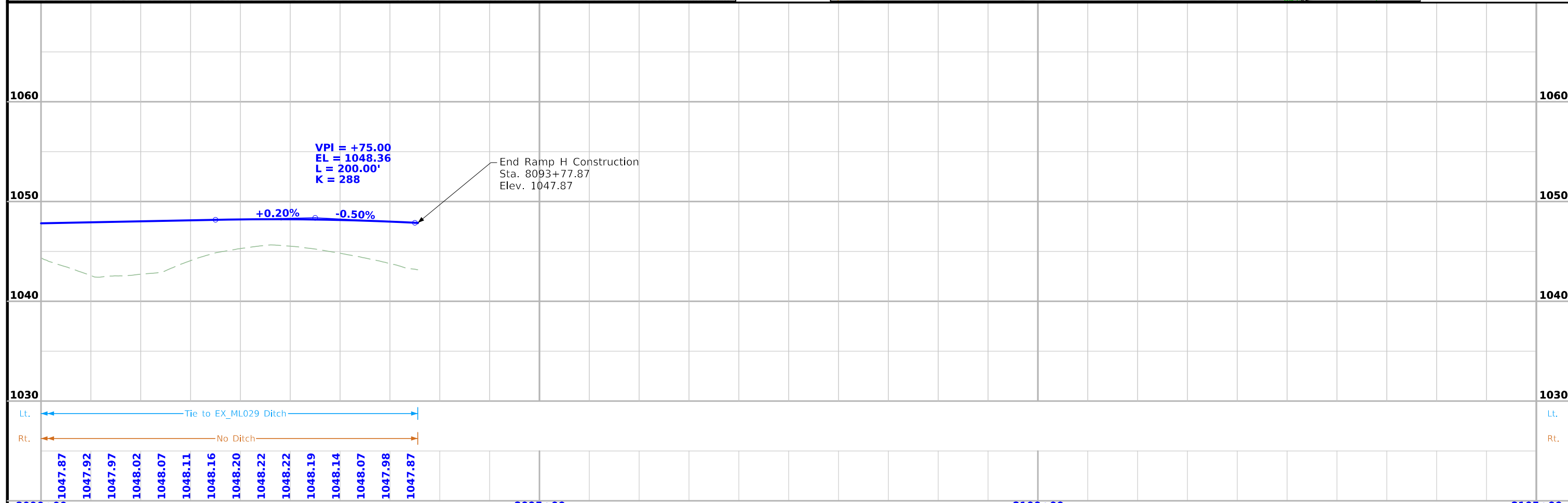
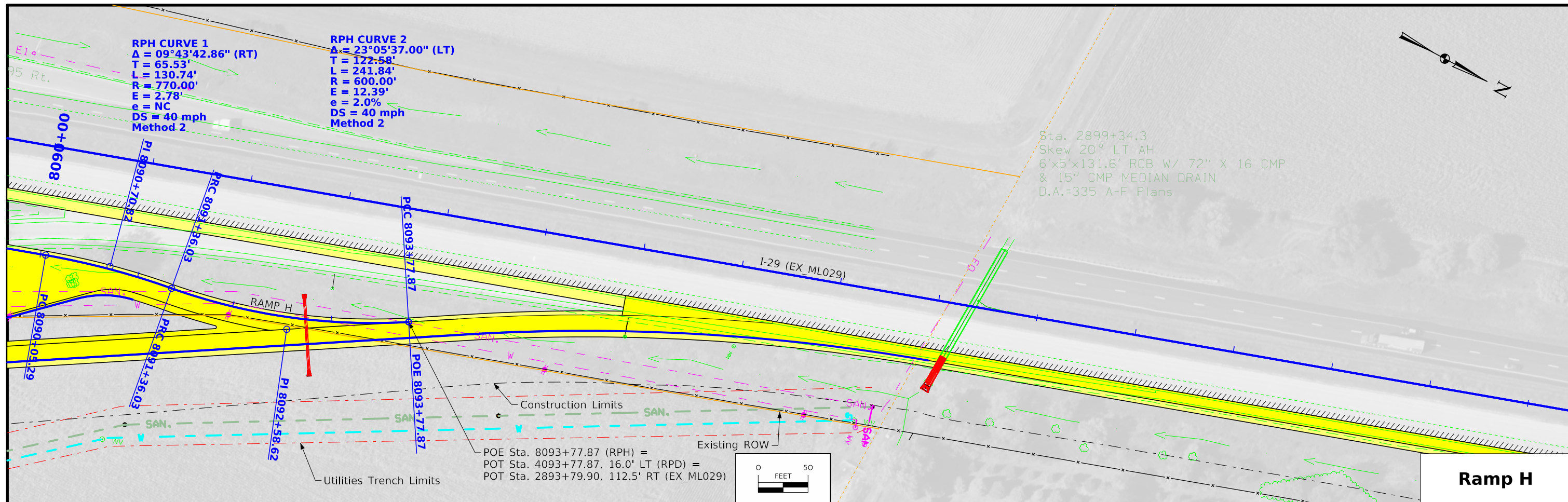

SURVEY SYMBOLS

- Interstate Highway Symbol
- U.S. Highway Symbol
- Iowa Highway Symbol
- County Road Highway Symbol
- Evergreen Tree
- Deciduous Tree
- Fruit Tree
- Shrub (Bushes)
- Timber
- Hedge
- Stump
- Swamp
- Rock Outcrop
- Broken Concrete
- Revetment (Rip Rap)
- Cemetery
- Grave
- Cave
- Sink Hole
- Board Fence
- Chain Link or Security Fence
- Wire Fence
- Terrace
- Earth Dam or Dike (Existing)
- Tile Outlet
- Edge of Water
- Existing Drainage
- Right of Way Rail or Lot Corner
- Concrete Monument
- Well
- Windmill
- Beehive Intake
- Existing Intake
- Existing Utility Access (Manhole)
- Fire Hydrant
- Water Hydrant (Rural)

- Septic Tank
- Cistern
- L.P. Gas Tank (No Footing)
- Underground Storage Tank
- Latrine
- Satellite TV Dish
- Water Hook Up
- Radio Tower
- Tower Anchor
- Guardrail (Beam or Cable)
- Guard Post (one or two)
- Guard Post (over two)
- Filler Pipe
- Gas Valve
- Water Valve
- Speed Limit Sign
- Mile Marker Post
- SIGN Sign
- TCB Traffic Signal Control Box
- RRB Rail Road Signal Control Box
- TSB Telephone Switch Box
- EB Electric Box

UTILITY LEGEND

- CITY OF ONAWA
Contact Name: Elaine Miller
Contact Phone: (712)433-1181
Contact Email: emiller@onawa.com
- Contact Name: John Casady
Contact Phone: (712)433-1511
Contact Email: jcasady@onawa.com
- IOWA DEPARTMENT OF TRANSPORTATION
Contact Name: Ron Gleiser
Contact Phone: (712)261-0196
Contact Email: Ron.Gleiser@iowadot.us
- Contact Name: Jason Dale
Contact Phone: (515)239-1995
Contact Email: Jason.Dale@iowadot.us
- WESTERN IOWA POWER COOPERATIVE
Contact Name: Jason Lee
Contact Phone: (712)263-2943
Contact Email: jason.lee@wipco.com
- Contact Name: Jeremy Kreger
Contact Phone: (712)263-2943
Contact Email: jeremy.kreger@wipco.com
- CENTURYLINK
Contact Name: Sadie Hull
Contact Phone: (918)547-0147
Contact Email: sadie.hull@lumen.com

PLAN VIEW COLOR LEGEND OF STORM SEWER SHEETS

LINEWORK		Design Color No.	
Green	(2)		Existing Topographic Features, Utilities, and Labels
Blue	(1)		Proposed Storm Sewer Details, Alignment, Stationing, Tic Marks, and Alignment Annotation
SHADING		Design Color No.	
Yellow	(4)		Proposed Pavement Shading
Yellow	(4)		Proposed Pavement Scarification and Overlay
Yellow	(68)		Proposed Shoulder Paved Full Depth Shading
Tan	(8)		Proposed Sidewalk Shading

PROFILE VIEW COLOR LEGEND OF STORM SEWER SHEETS

LINEWORK		Design Color No.	
Green	(2)		Existing Ground Line Profile and Existing Utilities Information
Blue	(1)		Proposed Pipes and Intakes

PLAN VIEW LINE STYLE LEGEND OF STORM SEWER SHEETS

- Plug and Abandon Existing Pipe or Structure
- Removal of Existing Pipe or Structure
- Previously Constructed Pipe or Structure
- Direction of Pipe Flow

PROFILE VIEW LINE STYLE LEGEND OF STORM SEWER SHEETS

- Existing Ground
- Proposed Ground
- Previously Constructed Pipe or Structure
- Proposed Storm Sewer Structure
- Proposed Storm Sewer Pipe
- Proposed Sanitary Sewer Pipe or Structure
- Proposed Water Main Pipe or Structure

- Reference Point
- Station
- Section Corner
- Ground Line Intercept
- Saw Cut
- Guardrail
- Trench Drain
- Sheet Pile
- Clearing & Grubbing Area
- Pavement Removal

RIGHT-OF-WAY LEGEND

- Proposed Right-of-Way
- Existing and Proposed Right-of-Way
- Easement and Existing Right-of-Way
- Borrow
- Easement (Temporary)
- Easement
- Excess
- A/C Access Control
- Property Line

STORM SEWER LEGEND AND SYMBOL INFORMATION SHEET

(COVERS SHEET SERIES M)

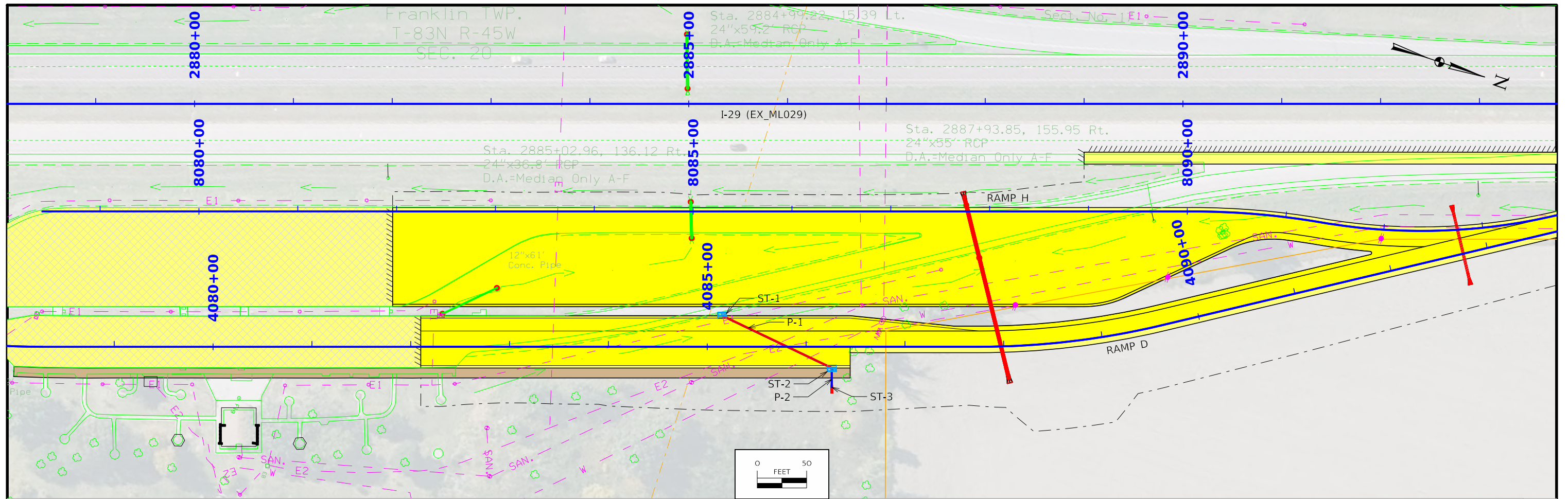

ST. SWR. ST-1 SW-509L STA. 4085+15.00 31.5' LT (RPD) FG = 1047.94 BW = 1043.11	ST. SWR. ST-2 SW-509S STA. 4086+26.00 21.5' RT (RPD) FG = 1047.17 BW = 1042.65
--------------------------------------------------------------------------------------------------	--------------------------------------------------------------------------------------------------

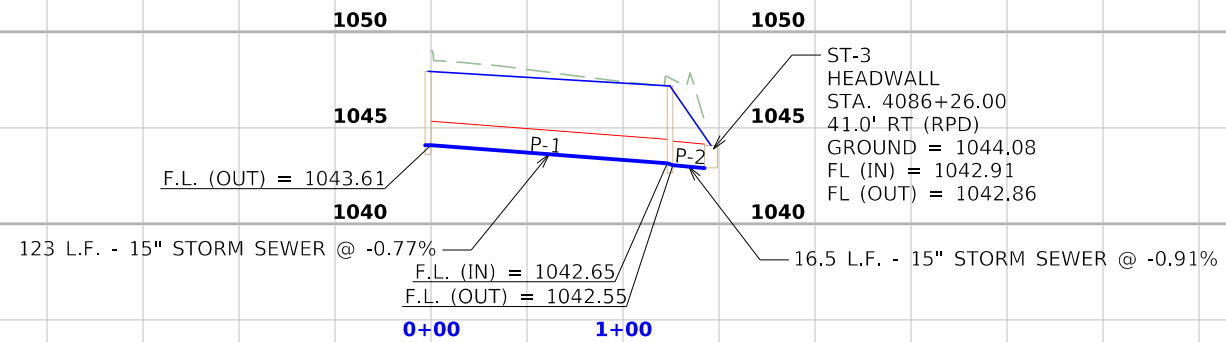

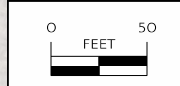
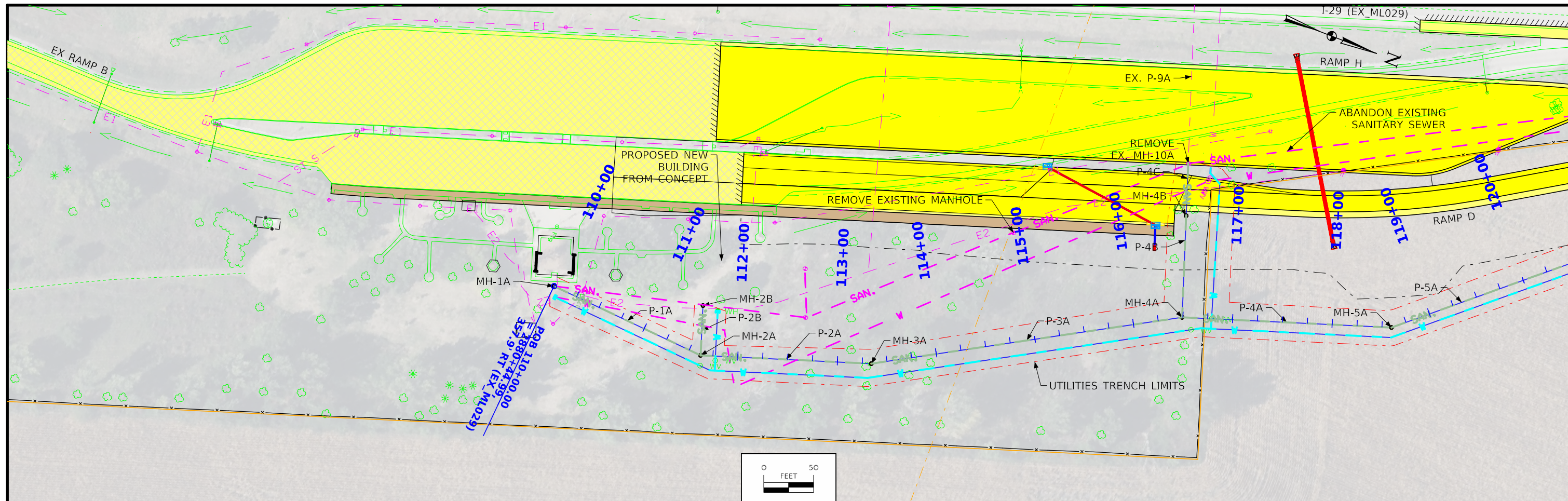

1050	SAN. SWR. MH-1A SW-301, 48" DIA. STA. 2880+44.99 357.90' RT (EX_ML029) FG (EXIST) = 1050.47 FG (PROP) = 1050.47 BW = 1043.71	SAN. SWR. MH-2A SW-301, 48" DIA. STA. 2881+95.21 420.12' RT (EX_ML029) FG (EXIST) = 1049.64 FG (PROP) = 1049.64 BW = 1040.89	SAN. SWR. MH-2B SW-301, 48" DIA. STA. 2881+95.21 370.12' RT (EX_ML029) FG (EXIST) = 1049.69 FG (PROP) = 1049.69 BW = 1043.63	SAN. SWR. MH-3A SW-301, 48" DIA. STA. 2883+66.73 420.12' RT (EX_ML029) FG (EXIST) = 1049.60 FG (PROP) = 1049.60 BW = 1037.60	SAN. SWR. MH-4A SW-301, 48" DIA. STA. 2886+75.92 358.59' RT (EX_ML029) FG (EXIST) = 1046.60 FG (PROP) = 1046.60 BW = 1031.47	SAN. SWR. MH-4B SW-301, 48" DIA. STA. 2886+74.96 257.00' RT (EX_ML029) FG (EXIST) = 1046.40 FG (PROP) = 1048.25 BW = 1032.92	SAN. SWR. MH-5A SW-301, 48" DIA. STA. 2889+24.98 264.21' RT (EX_ML029) FG (EXIST) = 1046.17 FG (PROP) = 1046.17 BW = 1030.85	1050
------	------------------------------------------------------------------------------------------------------------------------------------------------	------------------------------------------------------------------------------------------------------------------------------------------------	------------------------------------------------------------------------------------------------------------------------------------------------	------------------------------------------------------------------------------------------------------------------------------------------------	------------------------------------------------------------------------------------------------------------------------------------------------	------------------------------------------------------------------------------------------------------------------------------------------------	------------------------------------------------------------------------------------------------------------------------------------------------	------

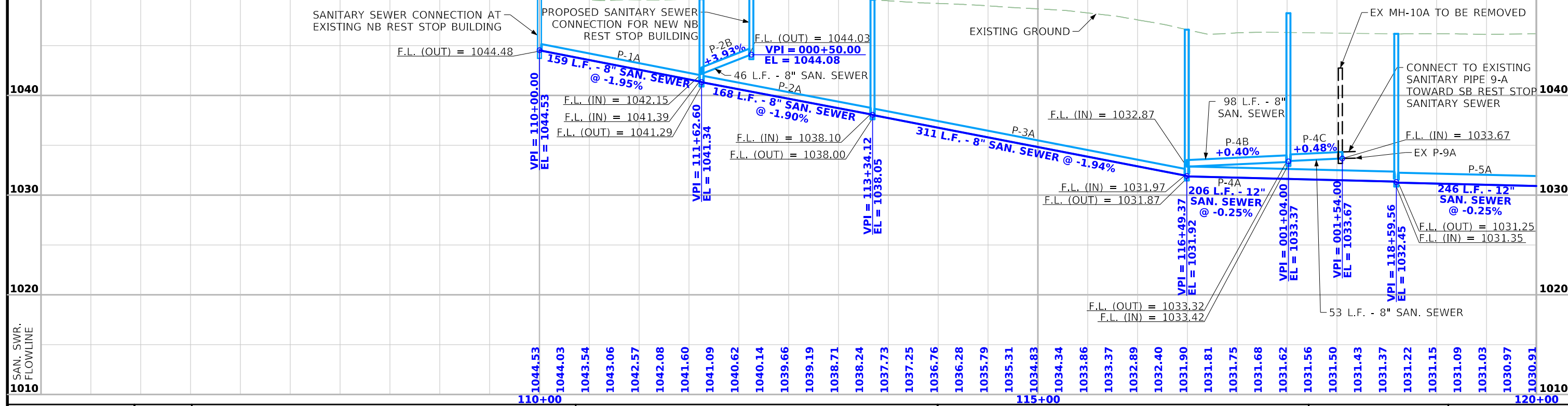

FILE NO.	ENGLISH	DESIGN TEAM Iowa DOT \ HR Green, Inc.	MONONA COUNTY	PROJECT NUMBER IMX-029-5(282)109--02-67	SHEET NUMBER MSA.1
----------	---------	---------------------------------------	---------------	-----------------------------------------	--------------------

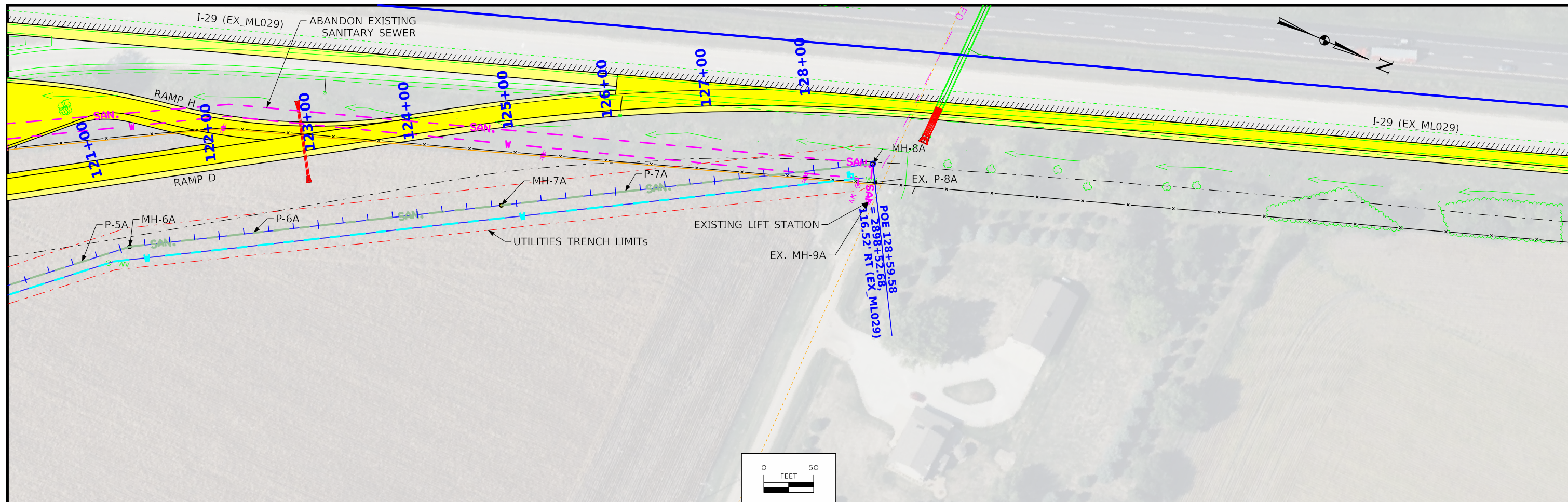

1050	SAN. SWR. MH-6A SW-301, 48" DIA. STA. 2891+17.08 262.92' RT (EX_ML029) FG (EXIST) = 1046.31 FG (PROP) = 1046.31 BW = 1030.14	SAN. SWR. MH-7A SW-301, 48" DIA. STA. 2894+84.88 189.72' RT (EX_ML029) FG (EXIST) = 1045.85 FG (PROP) = 1045.85 BW = 1029.11	SAN. SWR. MH-8A SW-301, 48" DIA. STA. 2898+52.68 116.52' RT (EX_ML029) FG (EXIST) = 1043.00 FG (PROP) = 1044.96 BW = 1027.99	1050
------	---------------------------------------------------------------------------------------------------------------------------------------------------	---------------------------------------------------------------------------------------------------------------------------------------------------	---------------------------------------------------------------------------------------------------------------------------------------------------	------

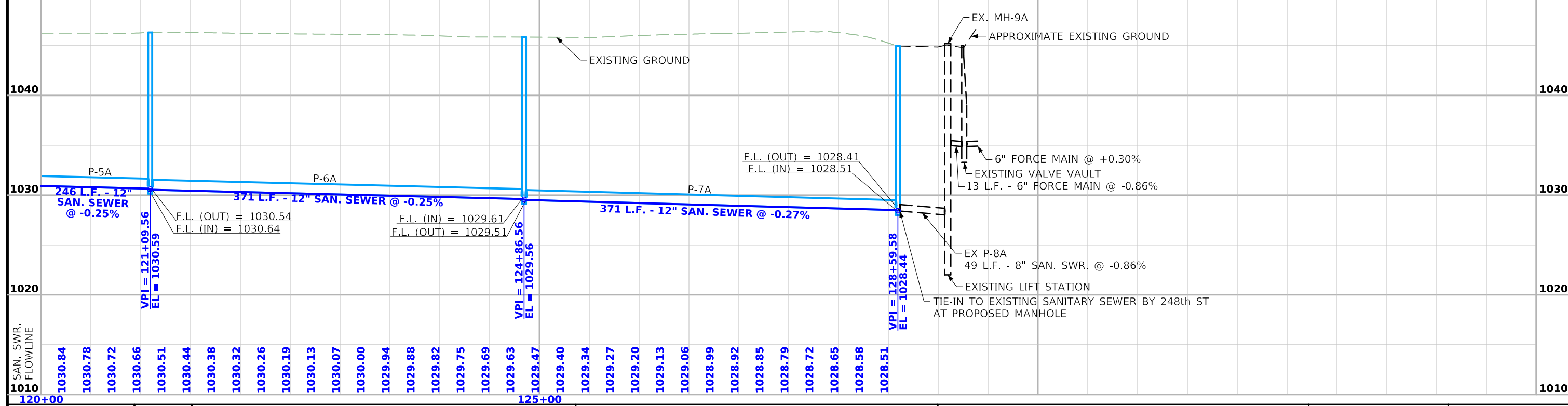

FILE NO.	ENGLISH	DESIGN TEAM	Iowa DOT \ HR Green, Inc.	MONONA COUNTY	PROJECT NUMBER	IMX-029-5(282)109--02-67	SHEET NUMBER	MSA.2
----------	---------	-------------	---------------------------	---------------	----------------	--------------------------	--------------	-------

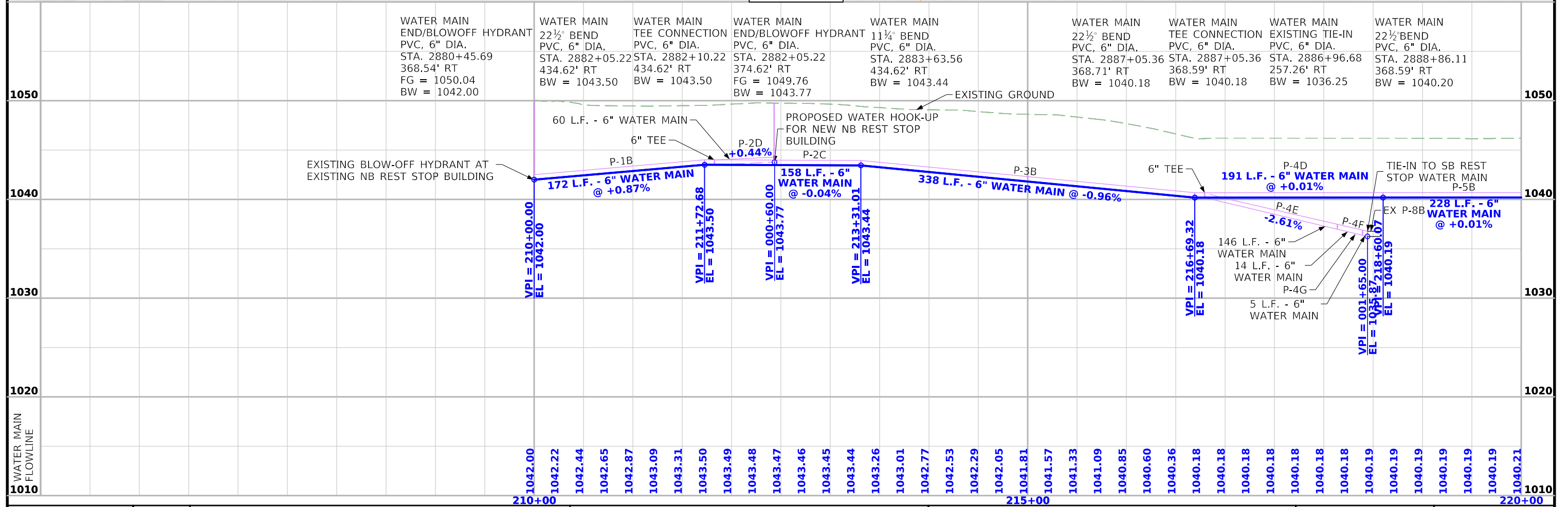
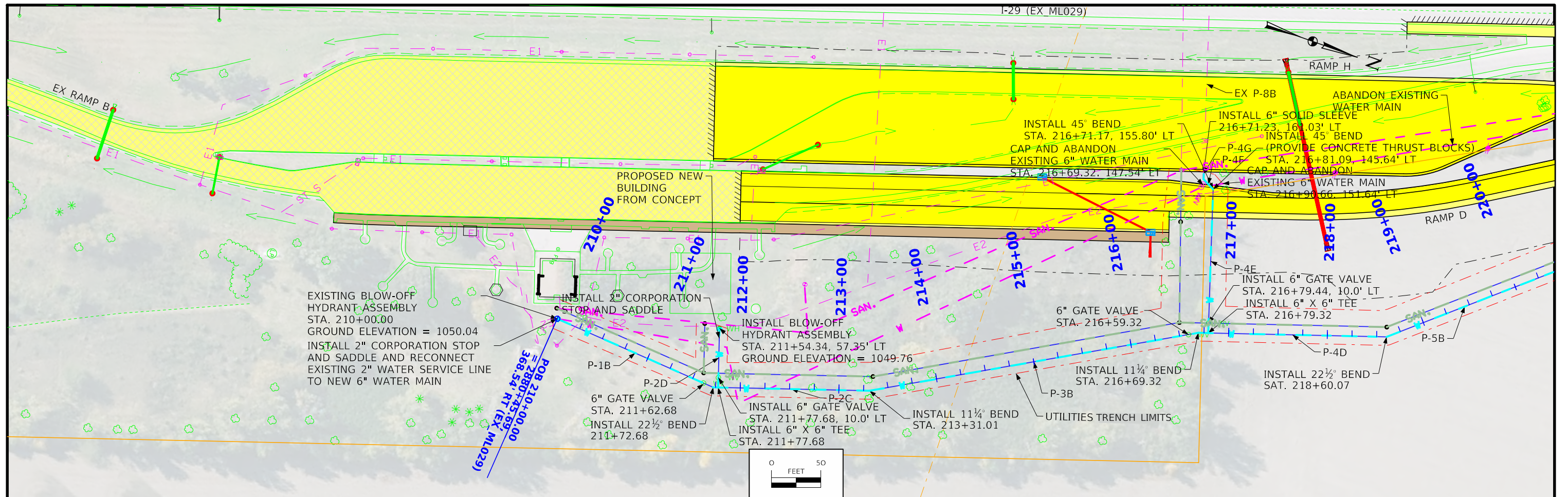

FILE NO.	ENGLISH	DESIGN TEAM Iowa DOT \ HR Green, Inc.	MONONA COUNTY	PROJECT NUMBER IMX-029-5(282)109--02-67	SHEET NUMBER MWM.1
----------	---------	---------------------------------------	---------------	-----------------------------------------	--------------------

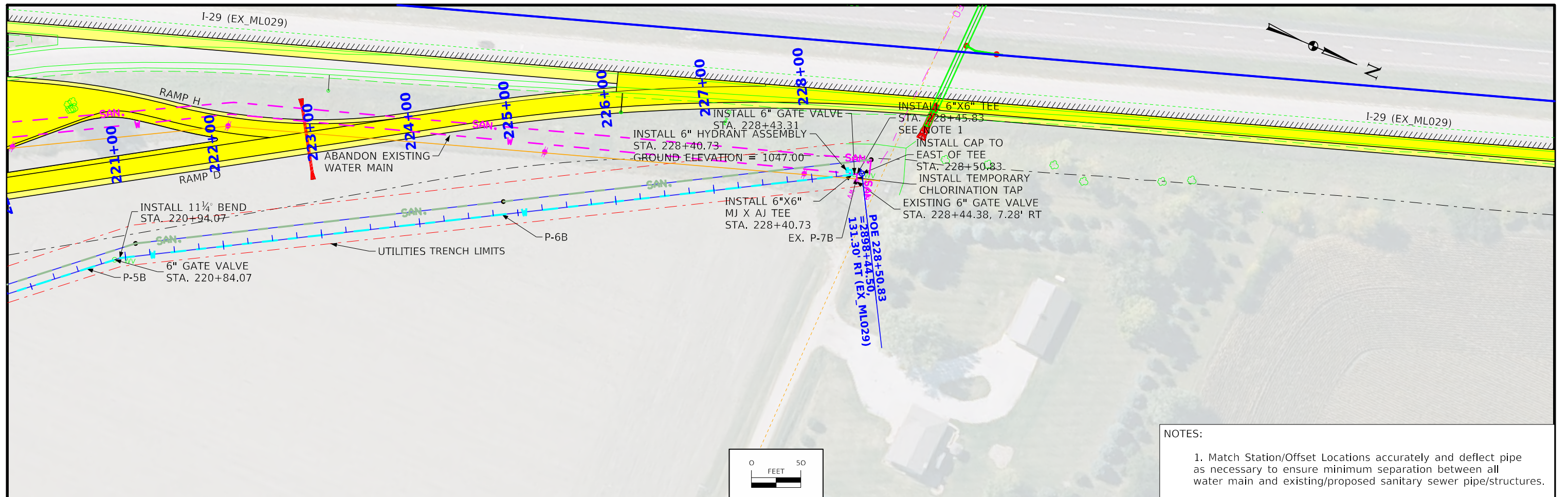

NOTES:
 1. Match Station/Offset Locations accurately and deflect pipe as necessary to ensure minimum separation between all water main and existing/proposed sanitary sewer pipe/structures.

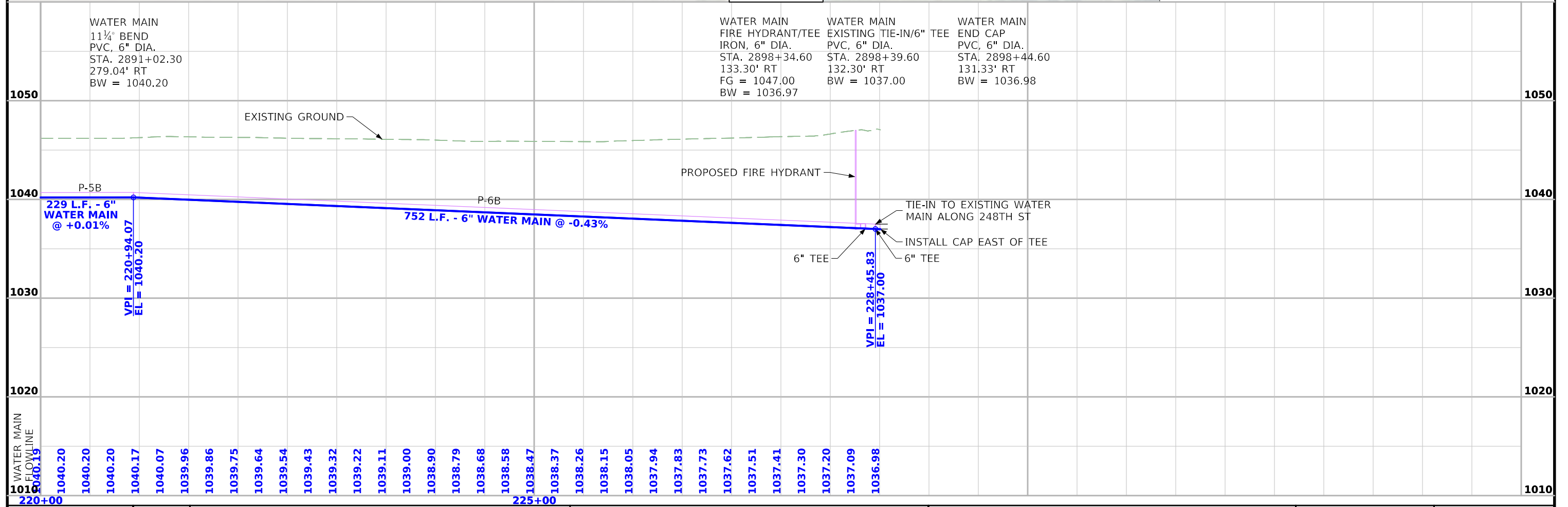

FILE NO.	ENGLISH	DESIGN TEAM	Iowa DOT \ HR Green, Inc.	MONONA COUNTY	PROJECT NUMBER	IMX-029-5(282)109--02-67	SHEET NUMBER	MWM.2
----------	---------	-------------	---------------------------	---------------	----------------	--------------------------	--------------	-------



I-29 (EX_ML029)

2890+00



8090+00

Ramp H (RPH)

R 770'

R 600'

R 75'

4090+00

Ramp D (RPD)

R 97.5'

RAMP H TRUCK PARKING LOT TURNING MOVEMENT



I-29 (EX_ML029)

2890+00

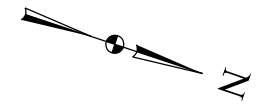

8090+00

Ramp H (RPH)

R 770'

R 600'

R 75'

4090+00

Ramp D (RPD)

R 97.5'

**40 MPH DRIVING SPEED
RAMP H TRUCK
PARKING LOT
TURNING MOVEMENT**



I-29 (EX_ML029)

2880+00

8080+00

4080+00

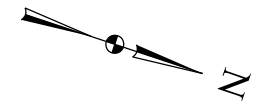

New Parking Lot Striping Layout

Ramp H (RPH)

26'-6"

155°

Ramp D (RPD)

RAMP H TRUCK PARKING LOT TURNING MOVEMENTS

CROSS SECTION VIEW COLOR LEGEND

Design Color No.	Feature	Design Color No.	Feature
Aggregate			
(64)	Choke Stone	(112)	Noise Wall
(42)	Engineering Fabric	(112)	Noise Wall Footing
(8)	Flooded Backfill	(112)	Retaining Wall Back
(92)	Macadam Stone	(112)	Retaining Wall Back Excavate
(20)	Modified	(112)	Retaining Wall Face
(12)	Plowing Shaping	(112)	Retaining Wall Front Excavate
(14)	Porous Backfill	(112)	Retaining Wall Front Footing
(8)	Revetment Class A	(112)	Retaining Wall MSE Gutter
(6)	Revetment Class B	(112)	Retaining Wall Reinforced Earth
(62)	Revetment Class C	Grading	
(188)	Revetment Class D	(8)	Behind Curb Cut
(28)	Revetment Class E	(6)	Granular
(12)	Shoulder Special Backfill	(13)	Granular Back Fill
(12)	Special Backfill	(48)	Rock Undercut
(20)	Subbase	(8)	Shoulder Earth Fill
(20)	Subbase Lower	(2)	Side Slopes
(20)	Subbase Upper	(226)	Side Slopes Dressing
(118)	Subgrade Treatment	Substrata	
Asphalt			
(207)	HMA Base Course	(128)	Boulder Substrata
(207)	HMA Interim Course	(48)	Broken Weathered Substrata
(207)	HMA Surface Course	(3)	Core Out Substrata
Concrete			
(0)	Barrier Concrete	(203)	Existing Pavement Substrata
(0)	Barrier Concrete Footing	(6)	Loam Substrata
(0)	Curb Gutter	(80)	Rock Substrata
(48)	Flowable Mortar	(4)	Select Sand Substrata
(0)	Median Concrete	(3)	Shale Substrata
(0)	PCC Pavement	(10)	Topsoil Substrata
(0)	Sidewalk	Unsuitable / Waste	
Shoulder			
(209)	Shoulder HMA	(3)	Unsuitable Type A
(0)	Shoulder PCC	(13)	Unsuitable Type B
(6)	Shoulder Granular	(11)	Unsuitable Type C
(3)		(3)	Waste
Existing			
(0)	Existing Pavement		

NOTES:

Text

NOTES:

Text

CROSS SECTIONS LEGEND AND INFORMATION SHEET

(COVERS SHEET SERIES W & Y)

I-29 Northbound

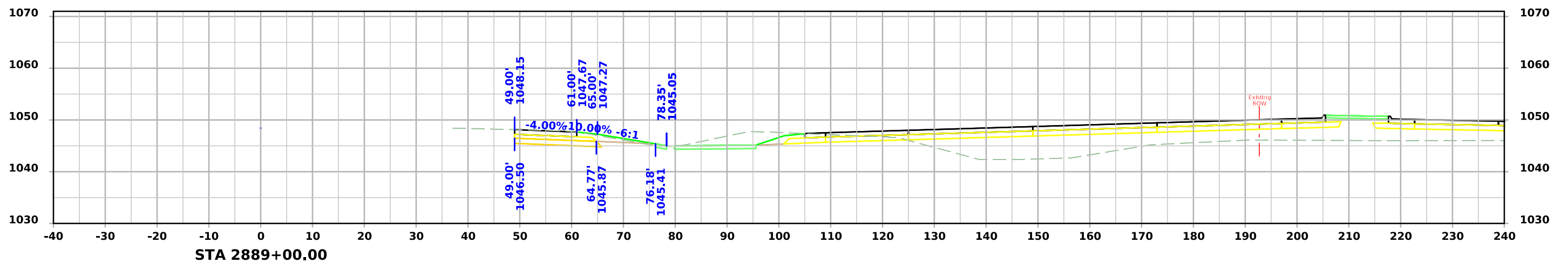
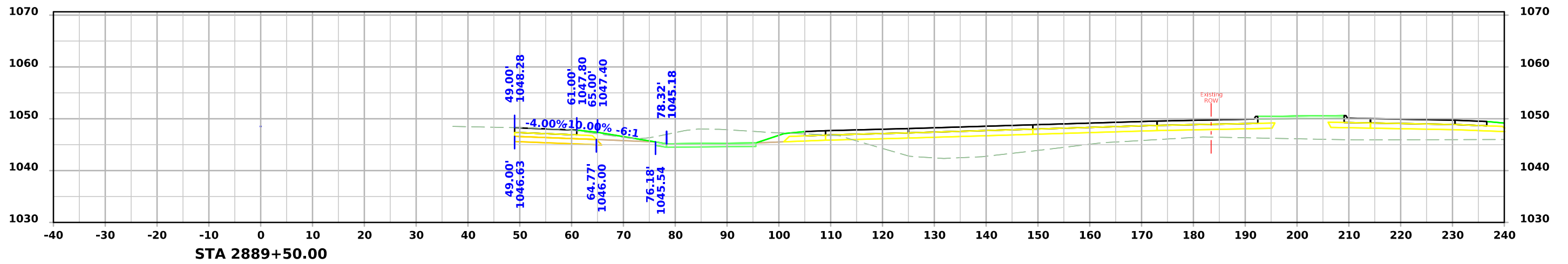
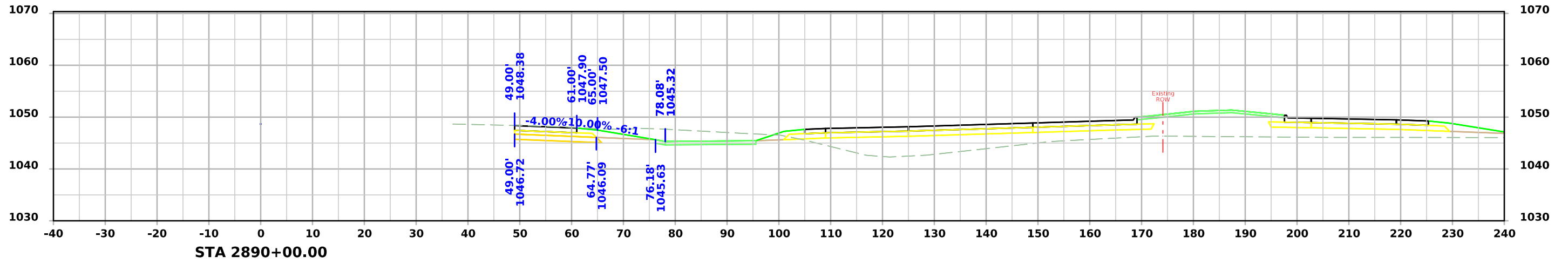

I-29 Northbound

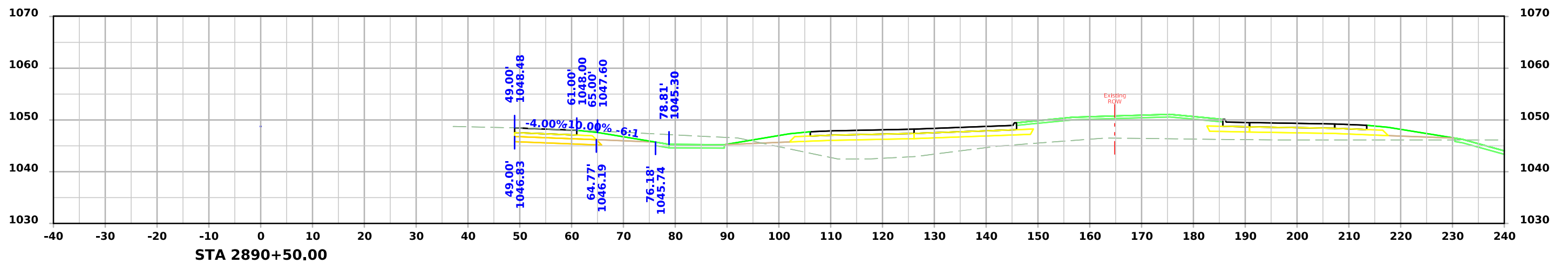
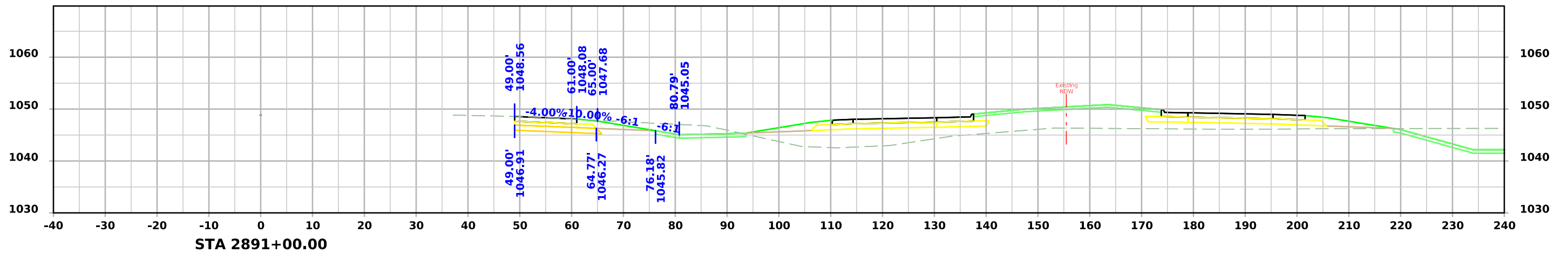
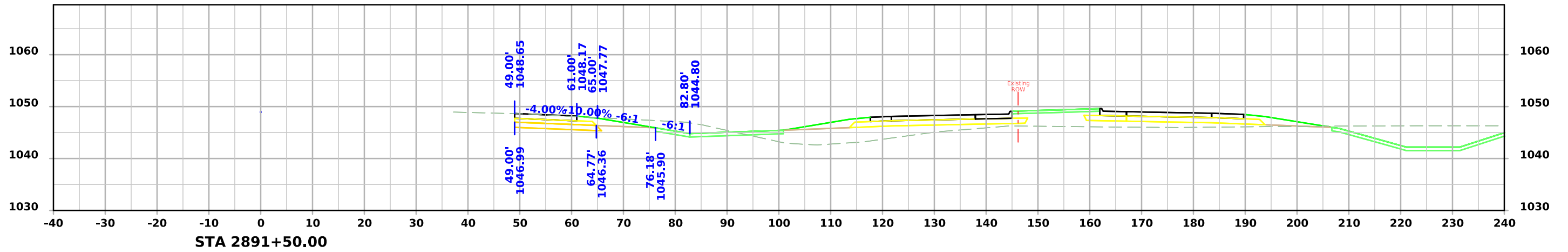

I-29 Northbound

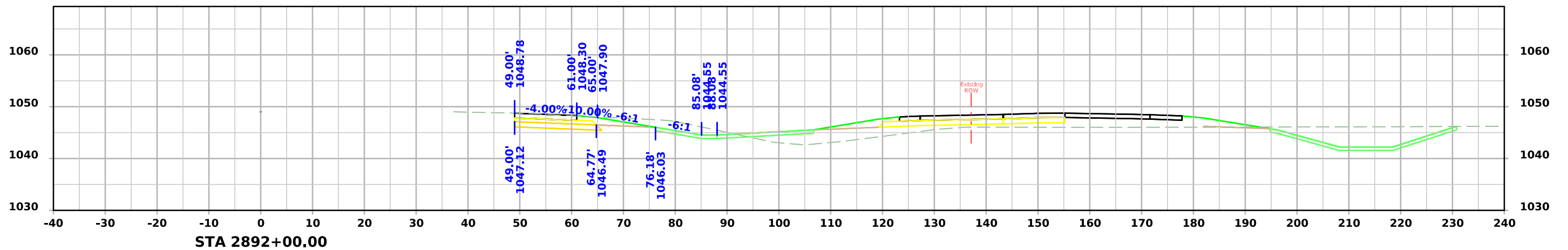
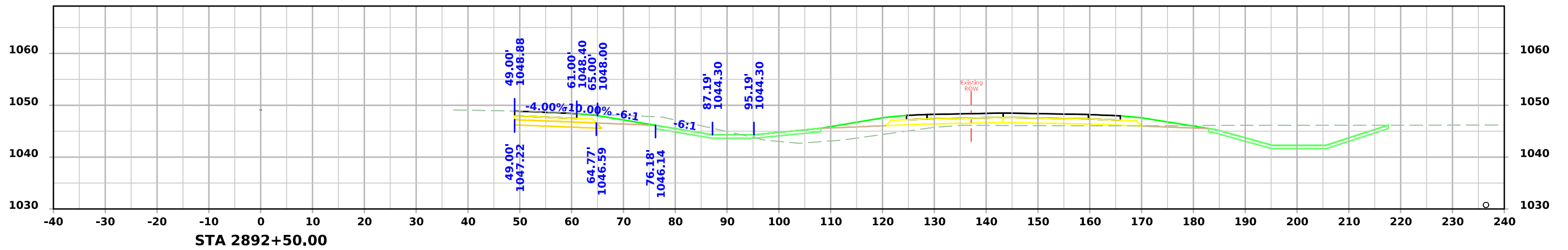
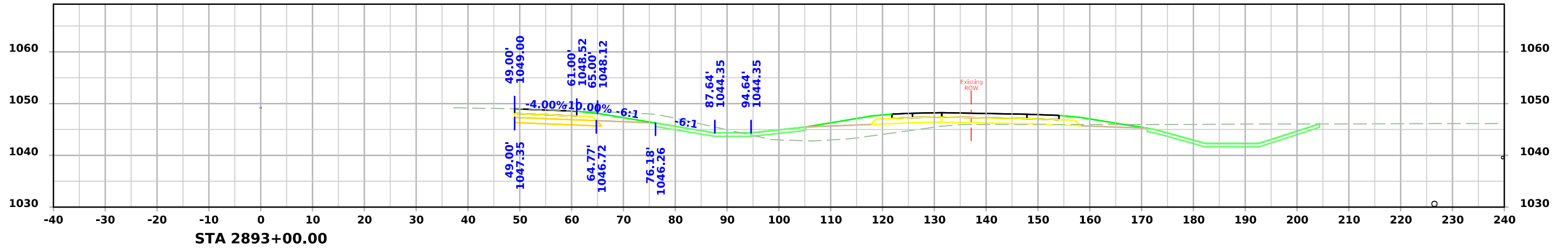

I-29 Northbound

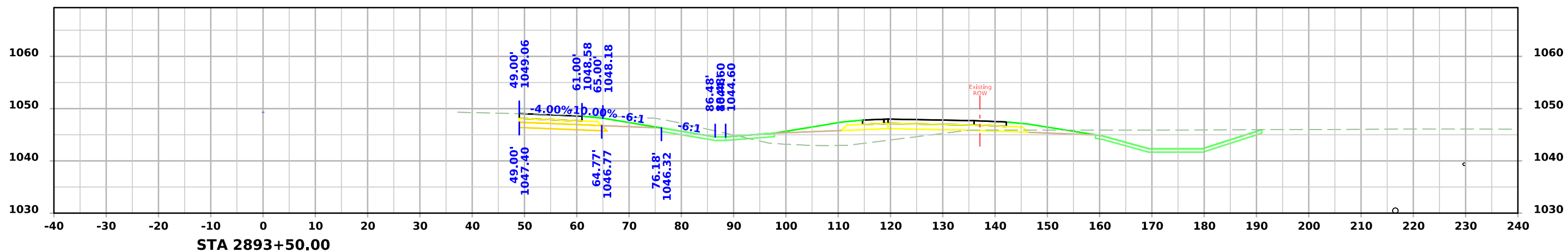
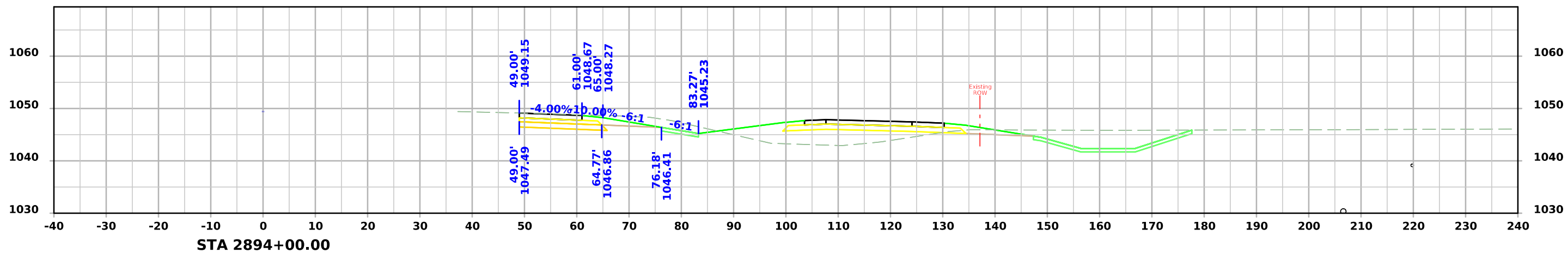
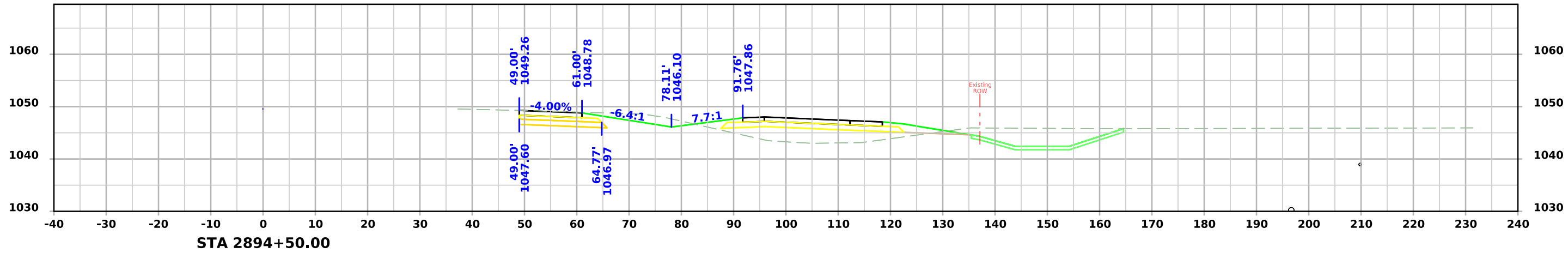

I-29 Northbound

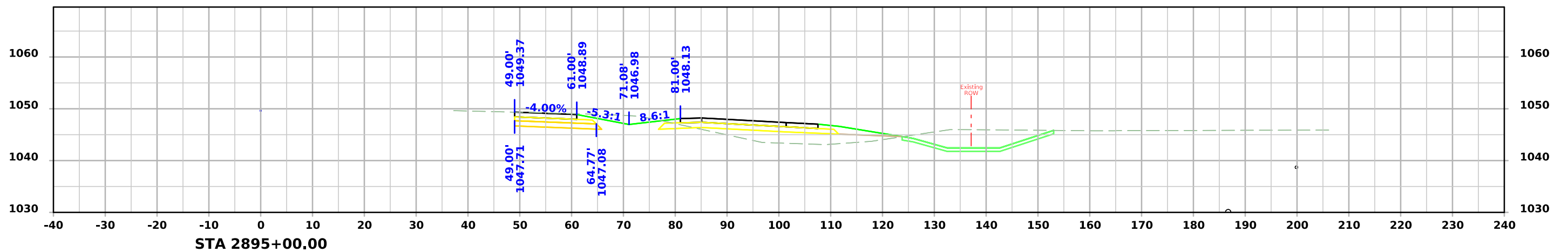
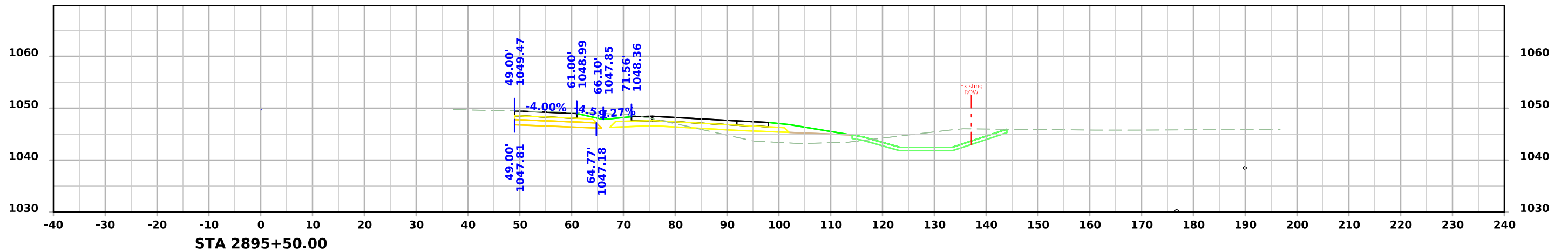
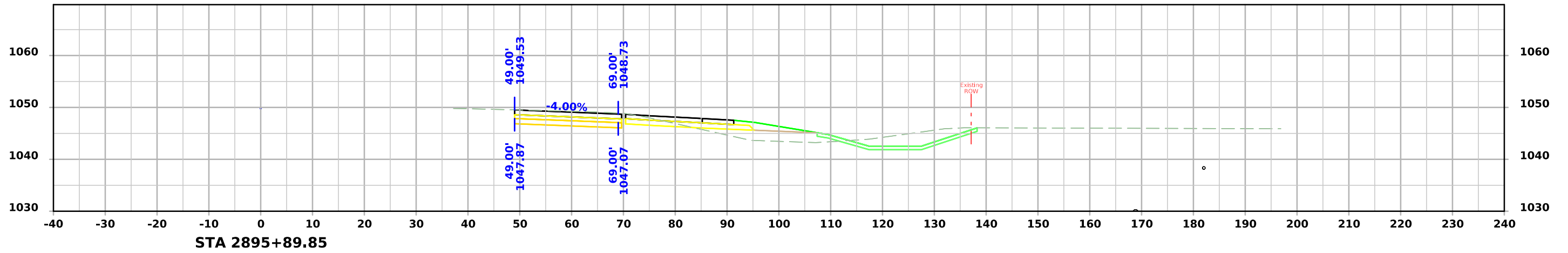

I-29 Northbound

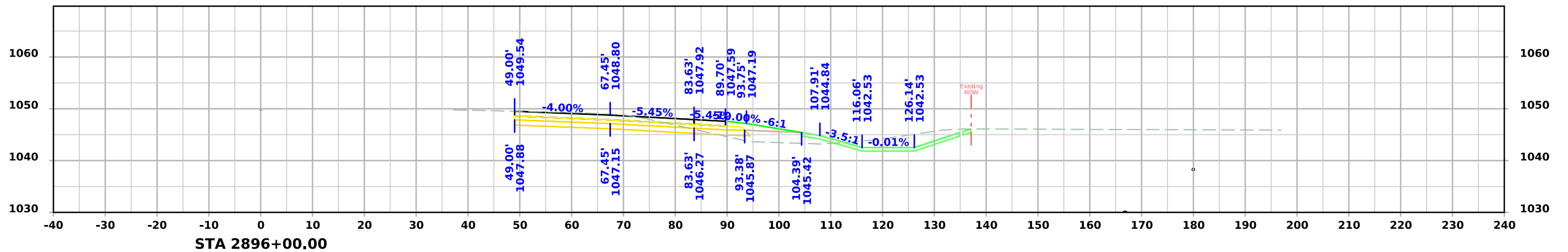
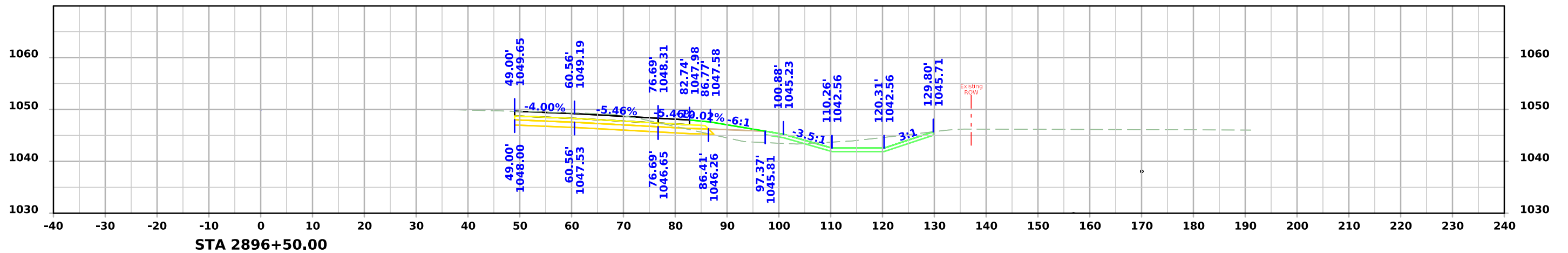
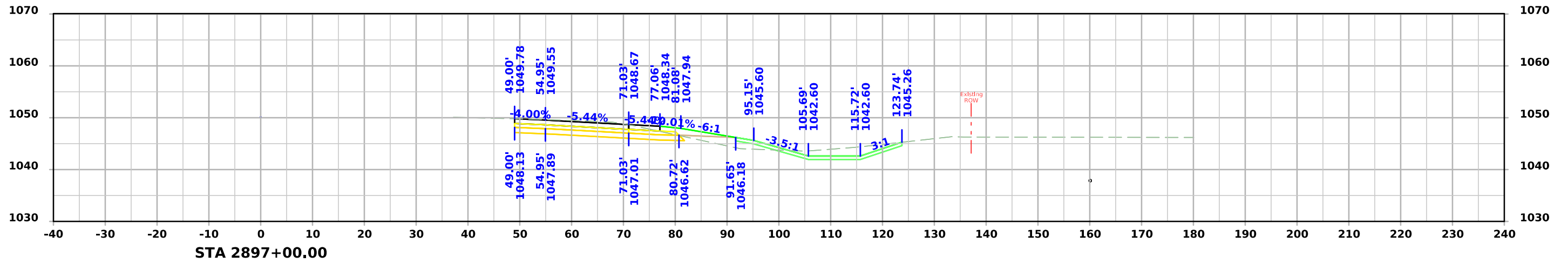

I-29 Northbound

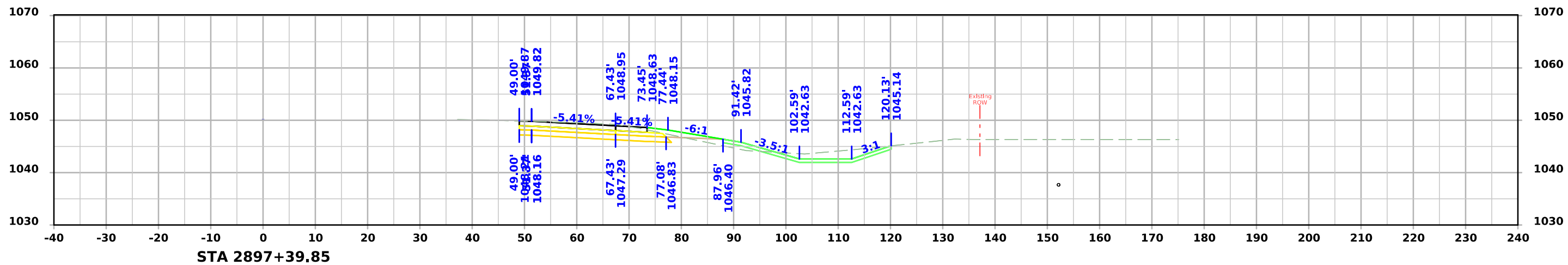
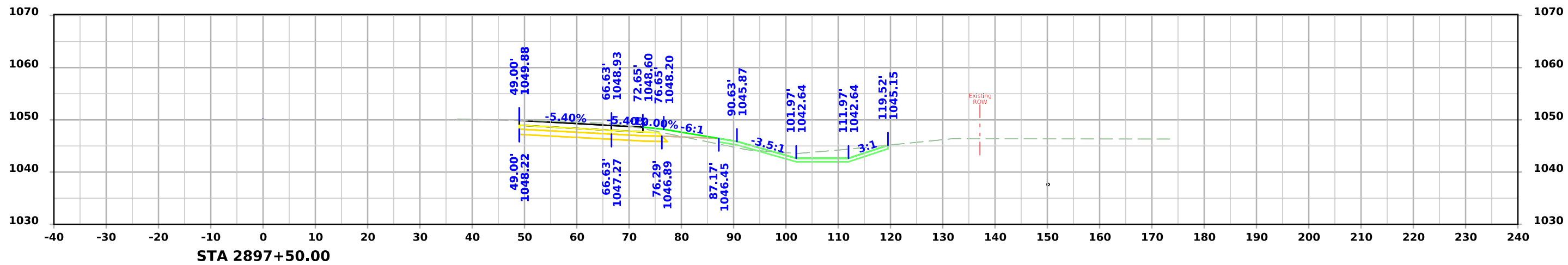
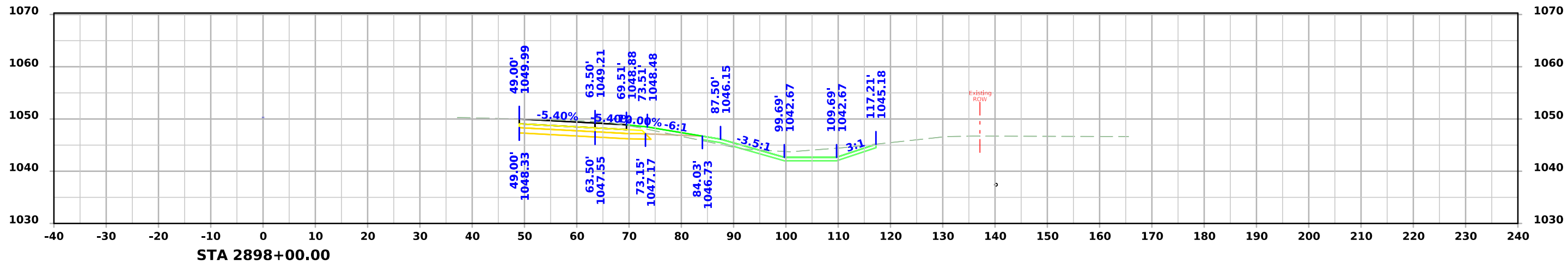

I-29 Northbound

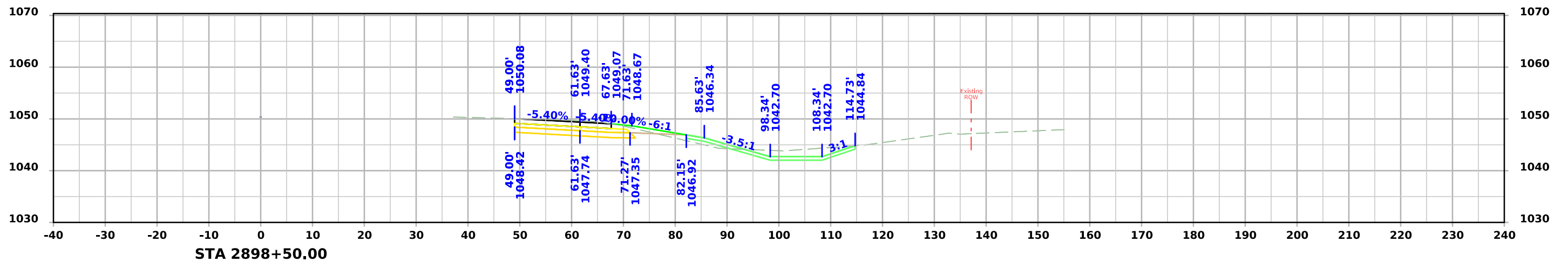
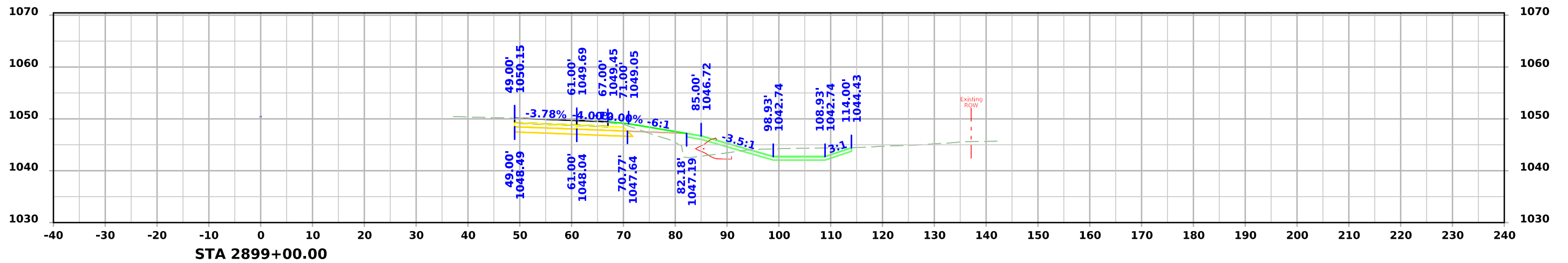
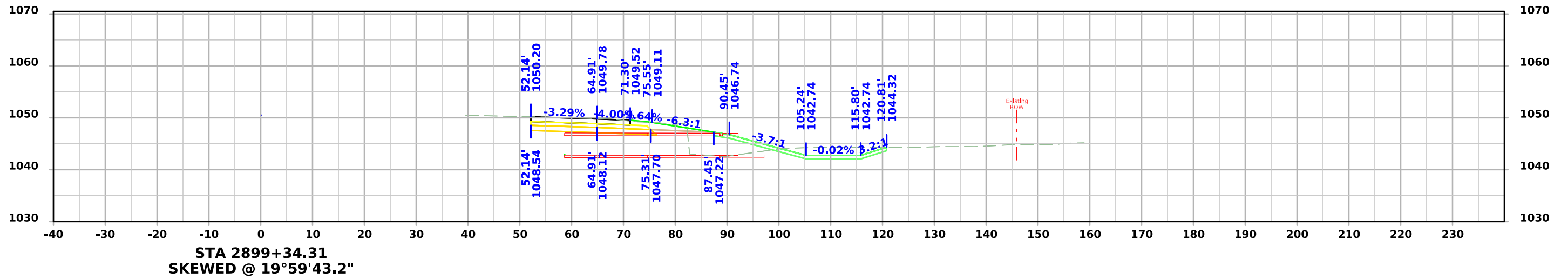

I-29 Northbound

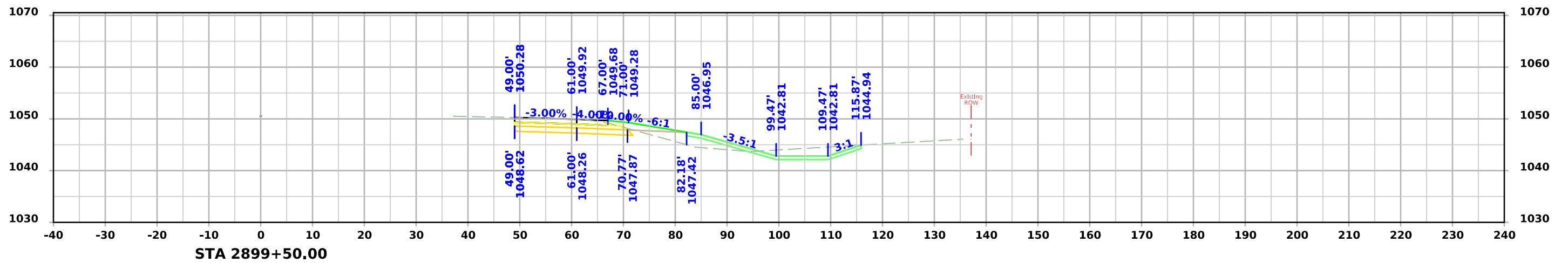
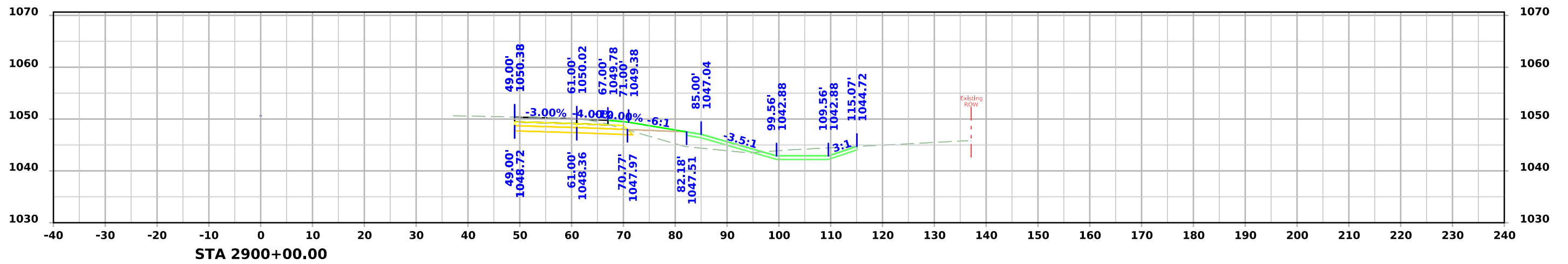
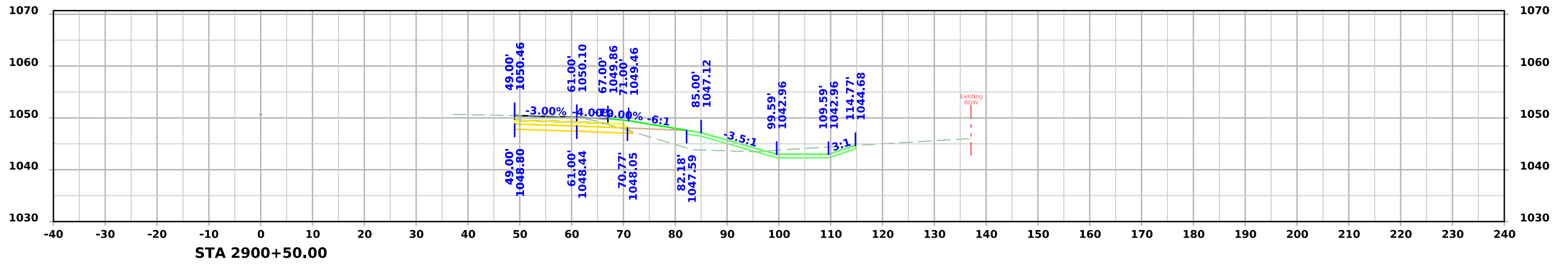

I-29 Northbound

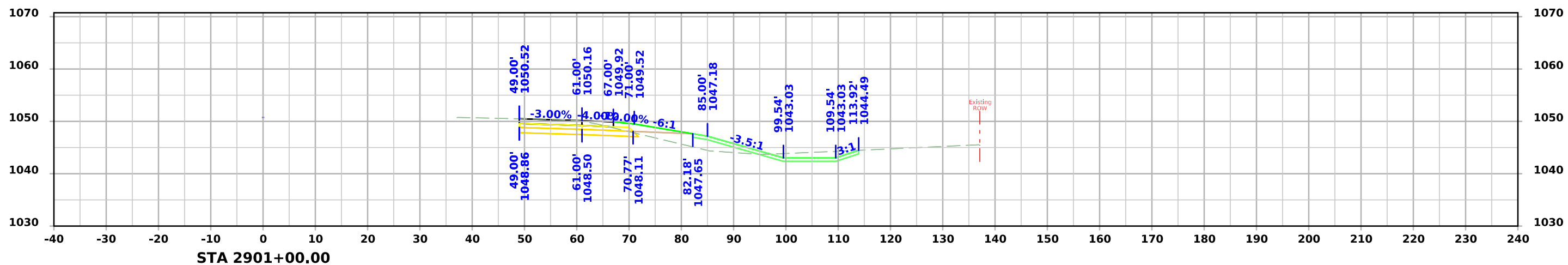
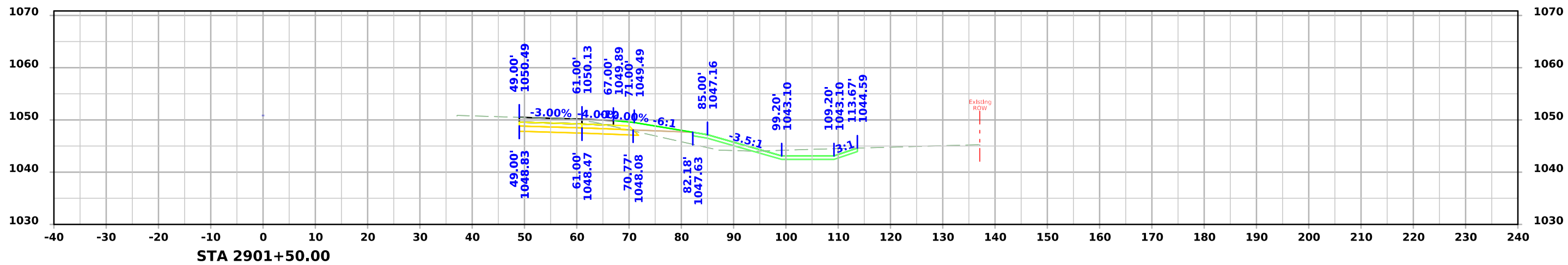
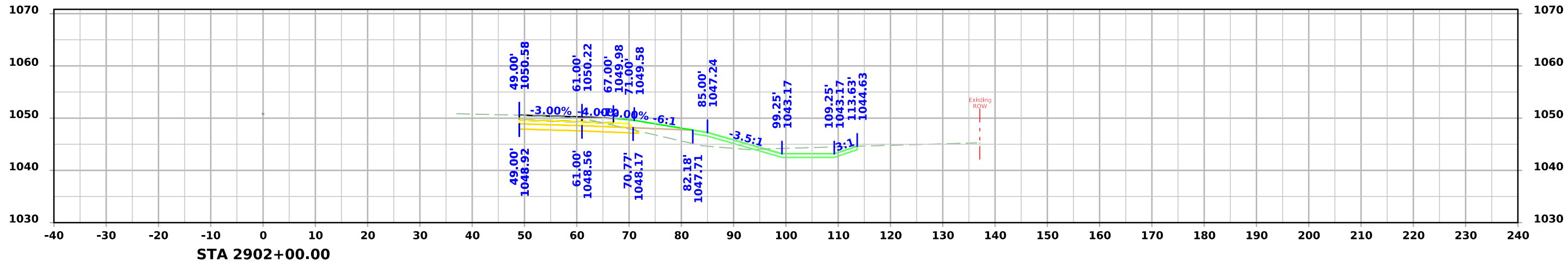

I-29 Northbound

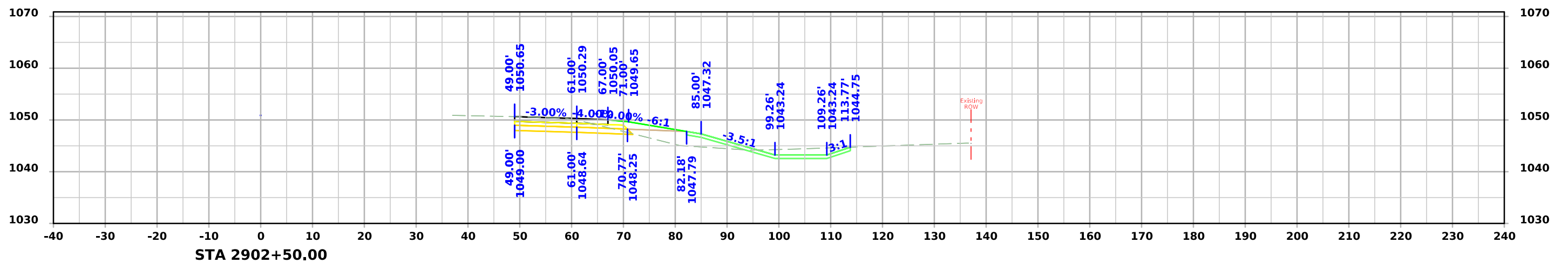
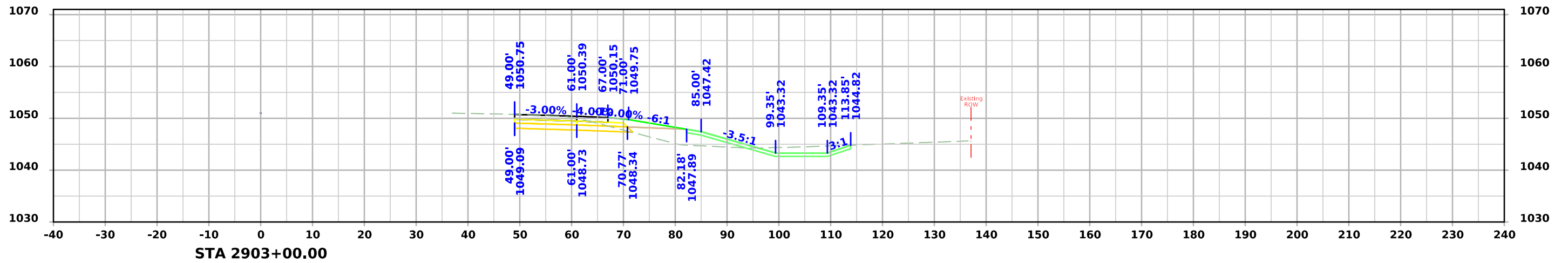
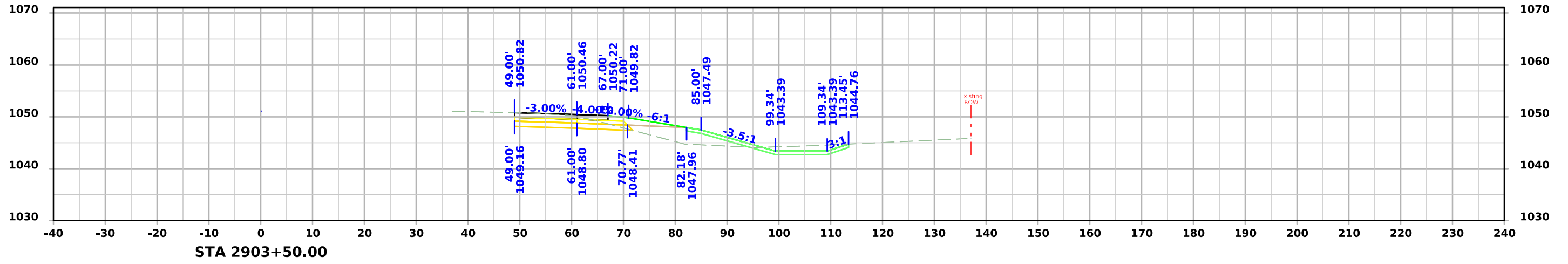

I-29 Northbound

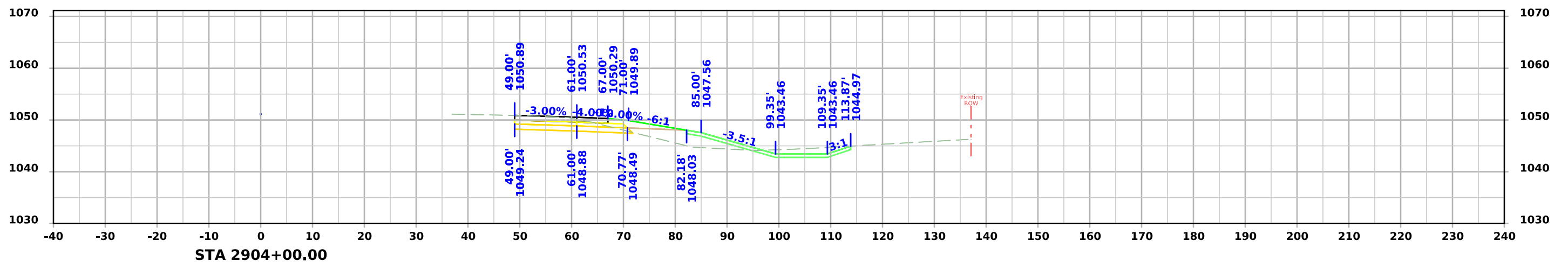
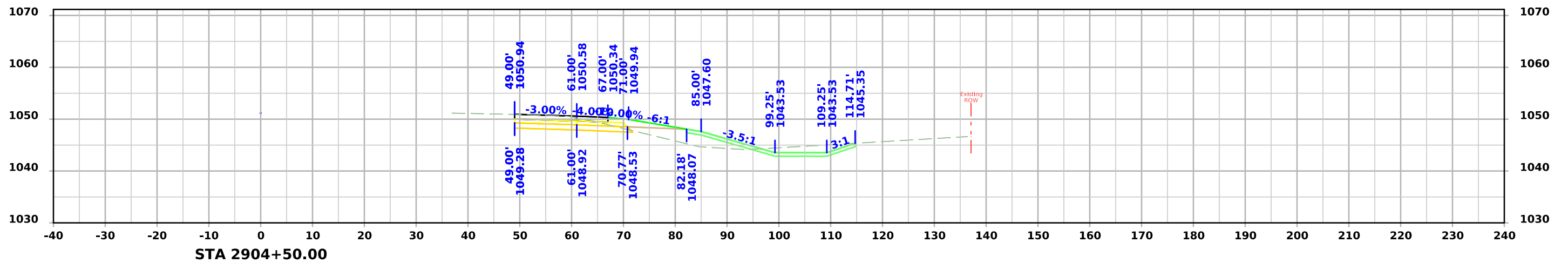
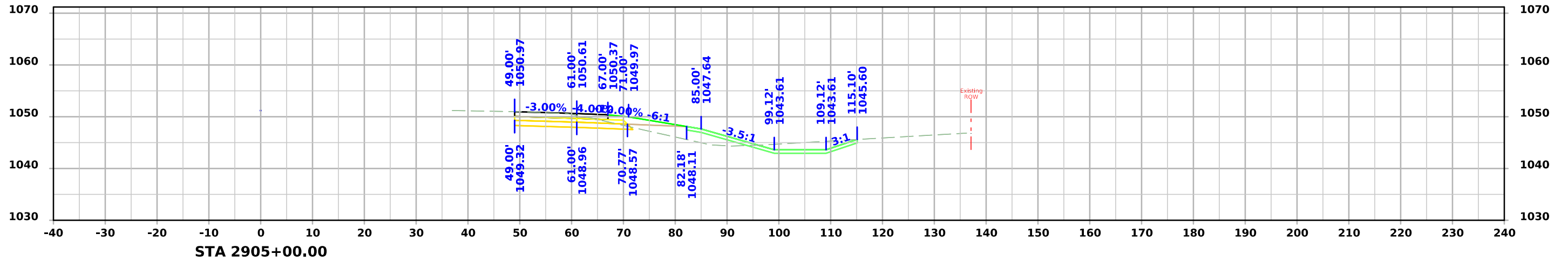

I-29 Northbound

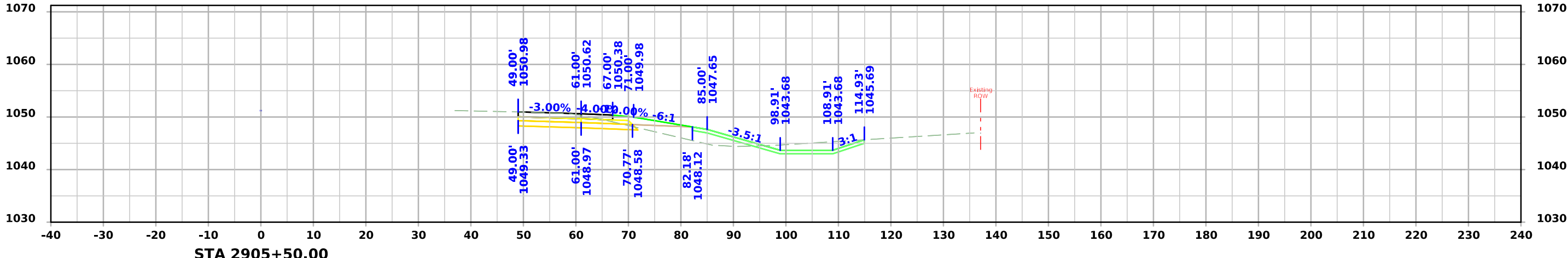
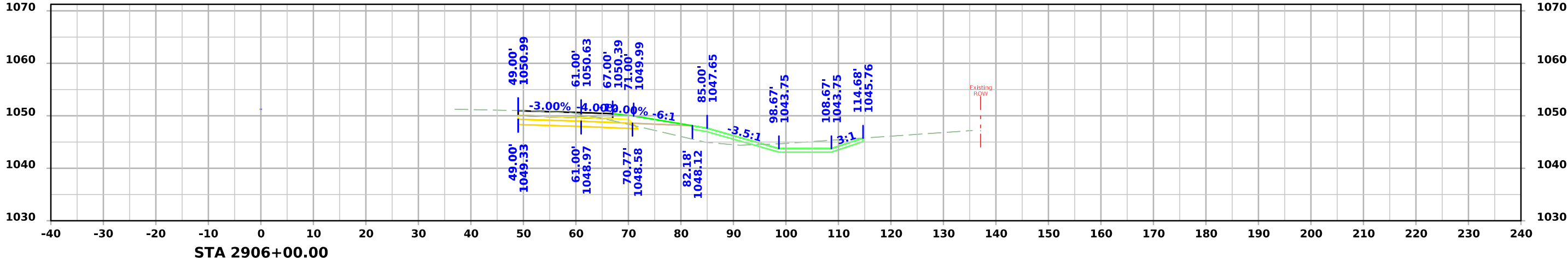
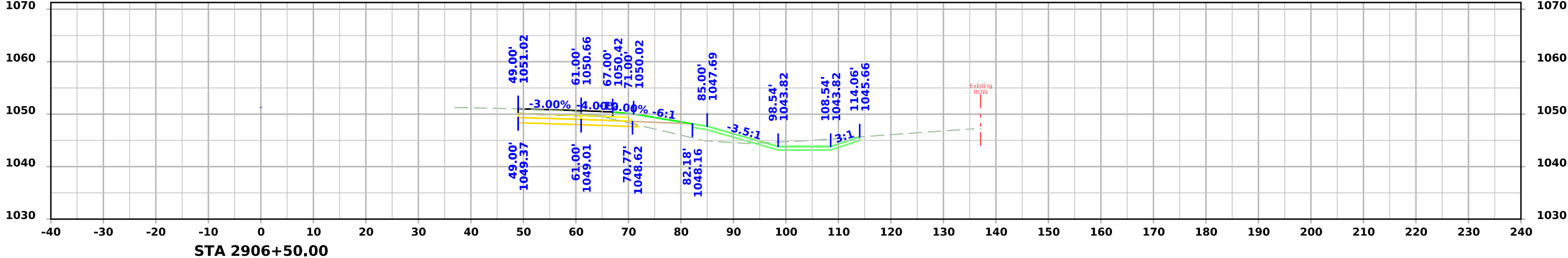

I-29 Northbound

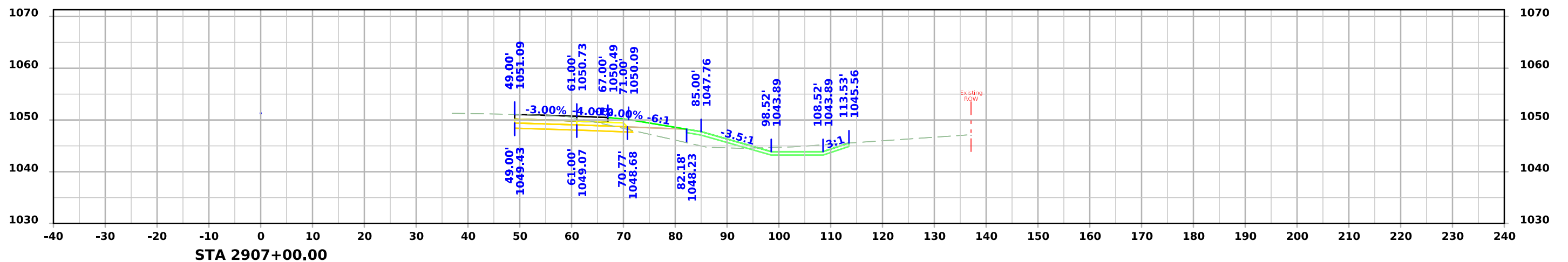
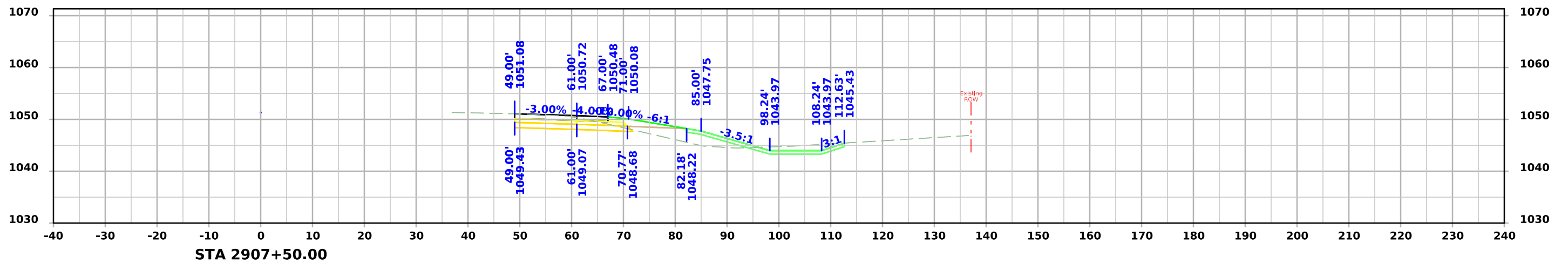
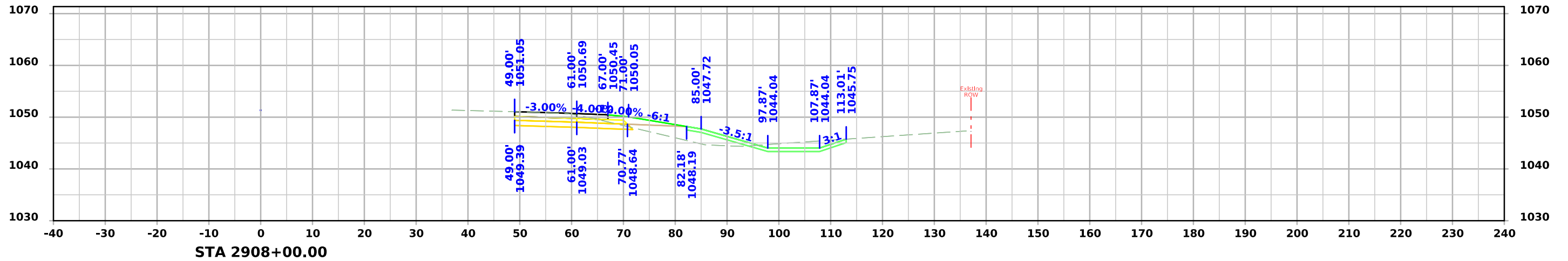

I-29 Northbound

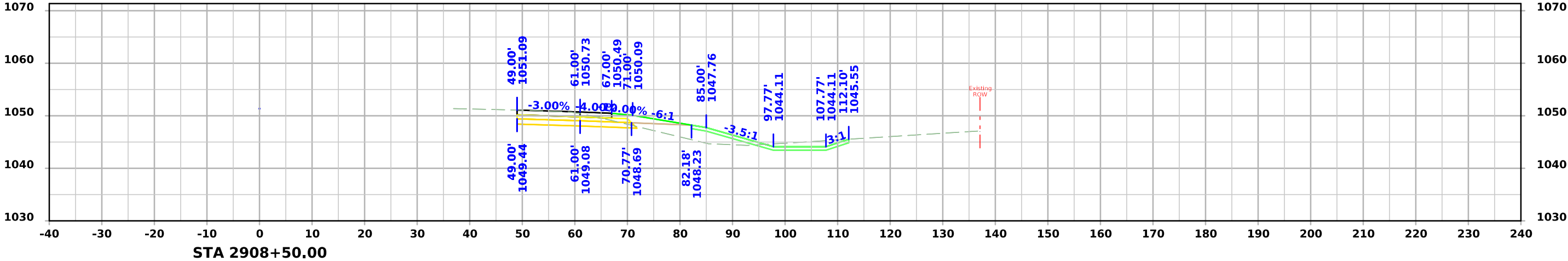
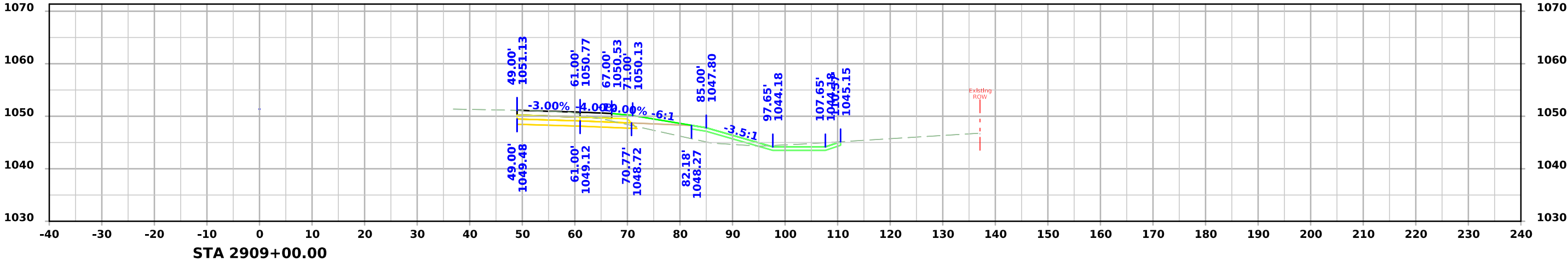
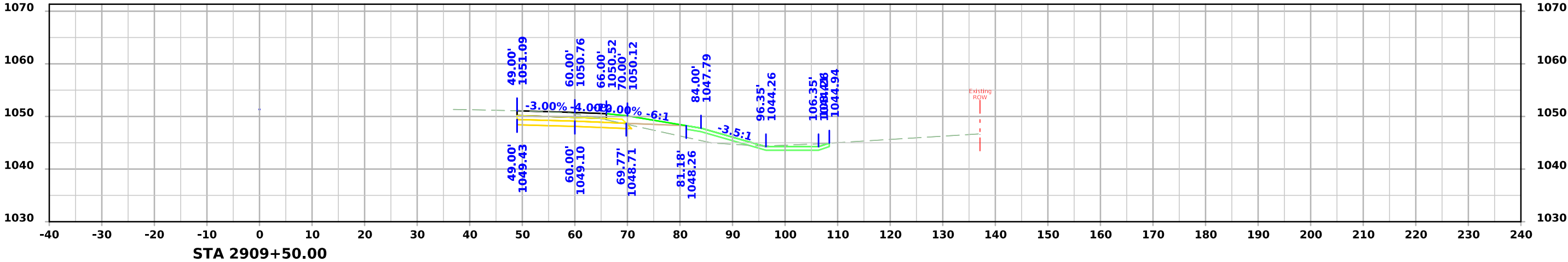

I-29 Northbound

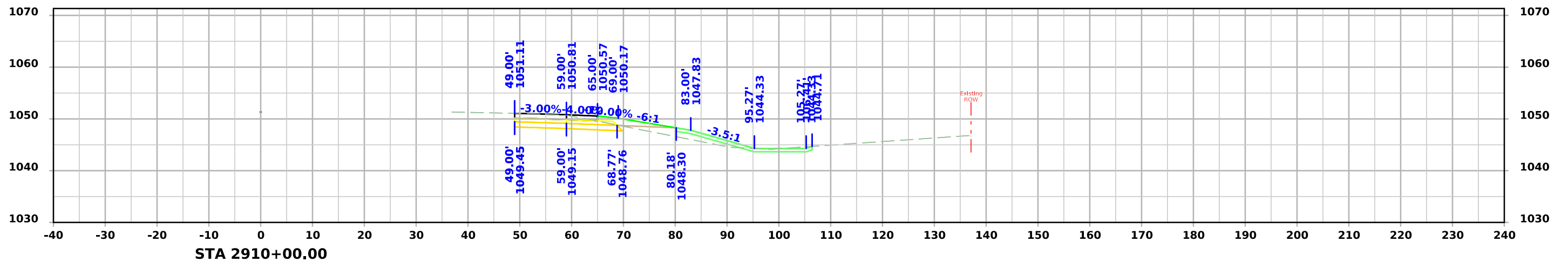
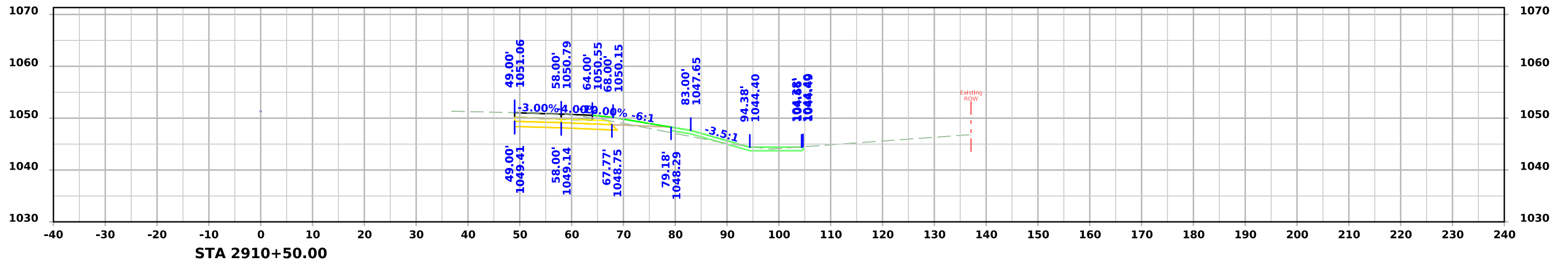
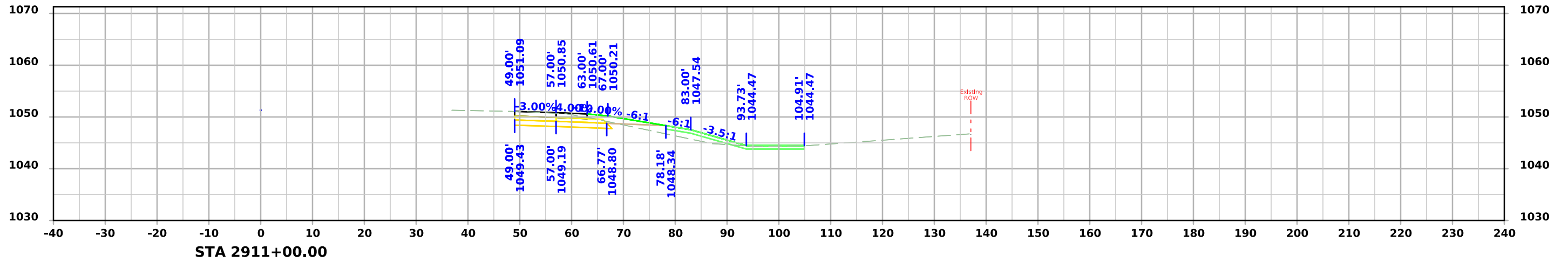

I-29 Northbound

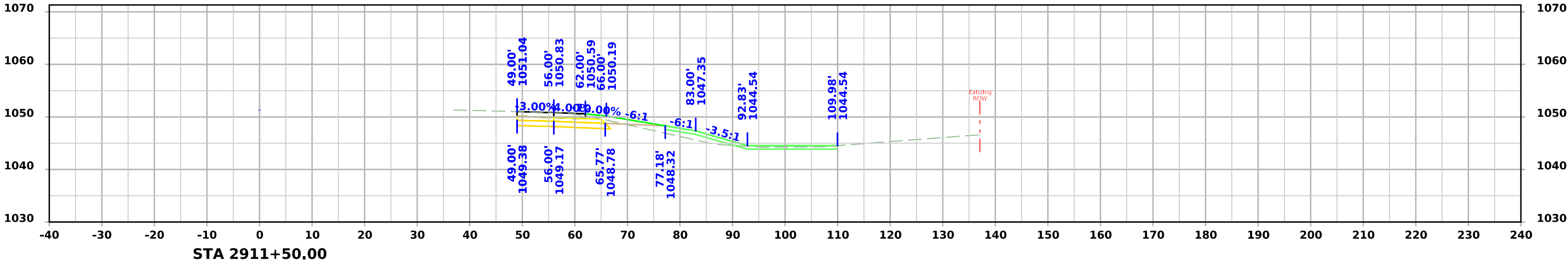
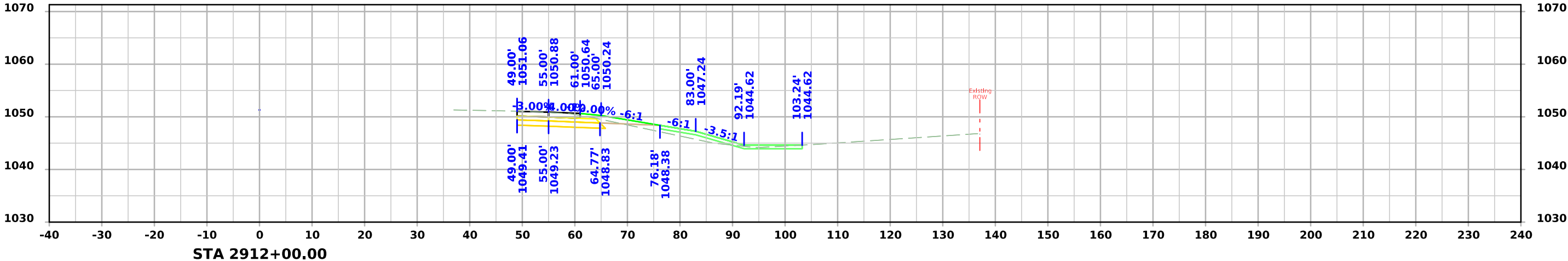
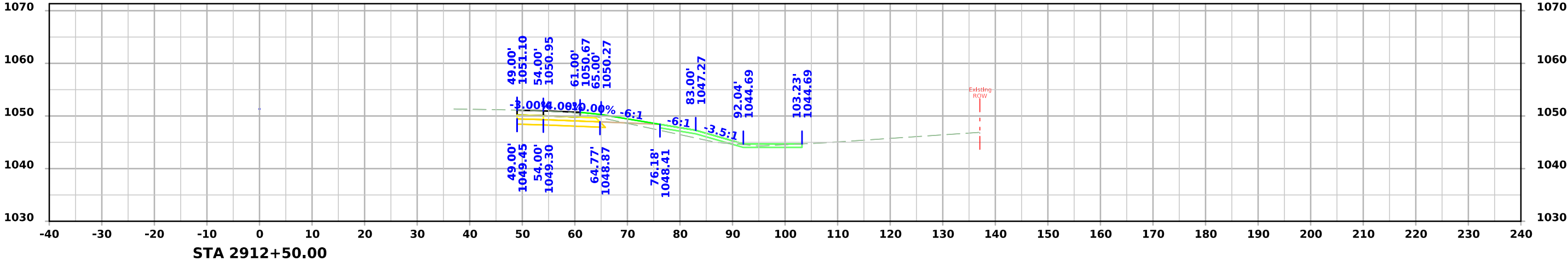

I-29 Northbound

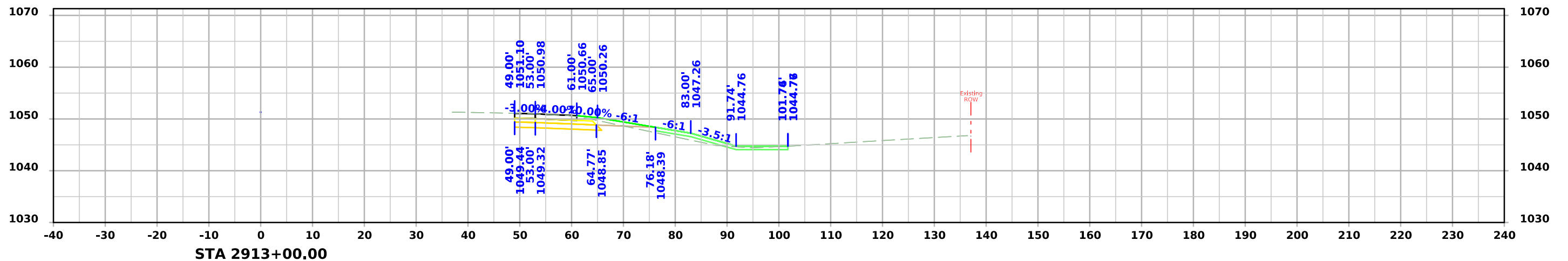
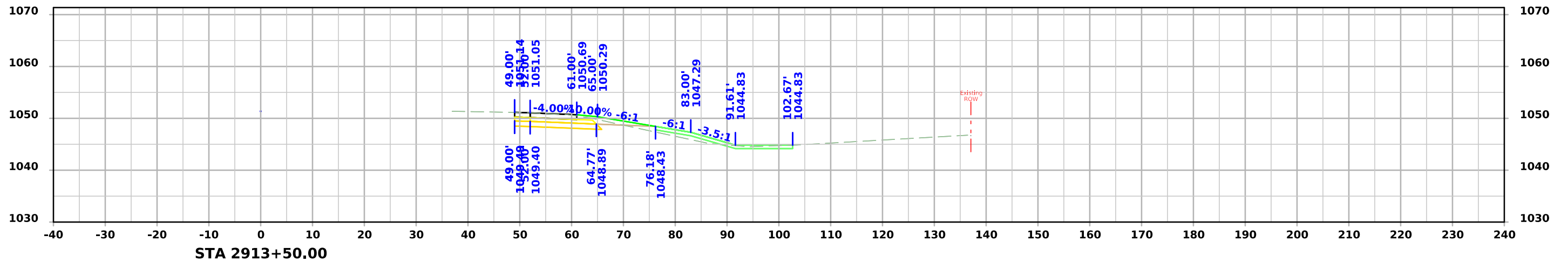
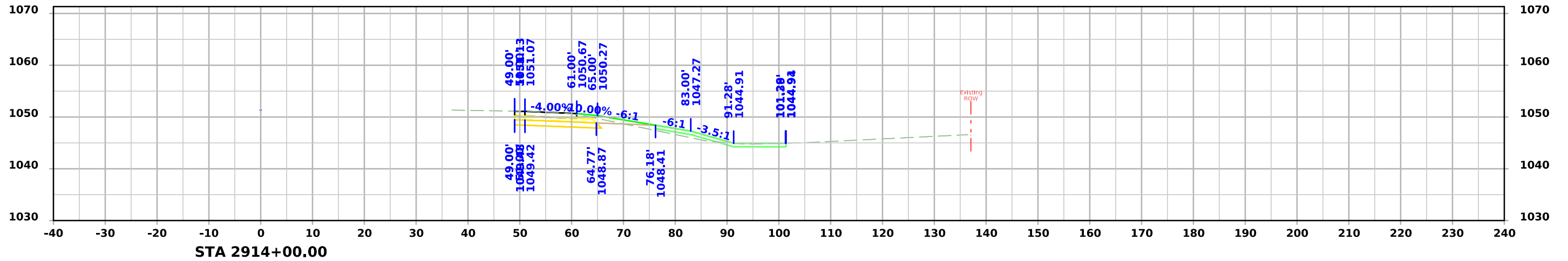

I-29 Northbound

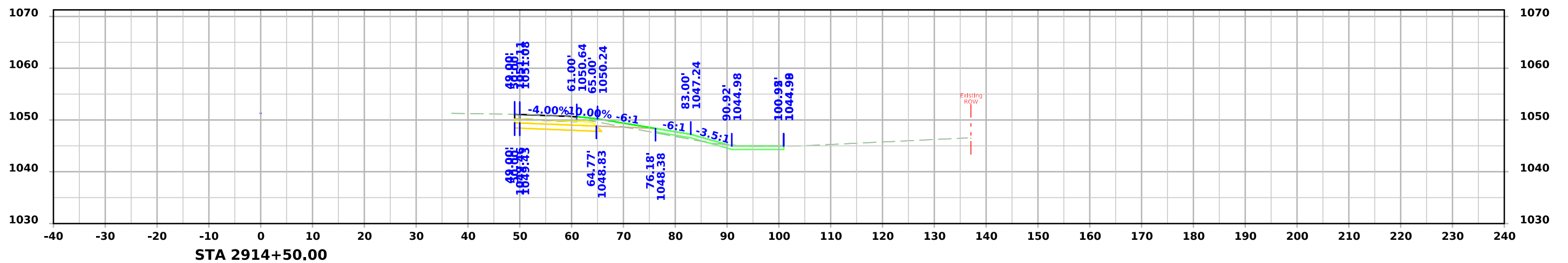
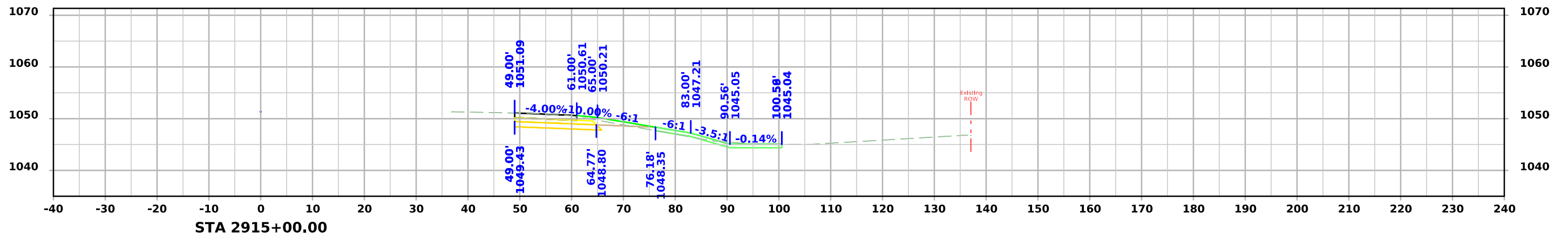

I-29 Northbound

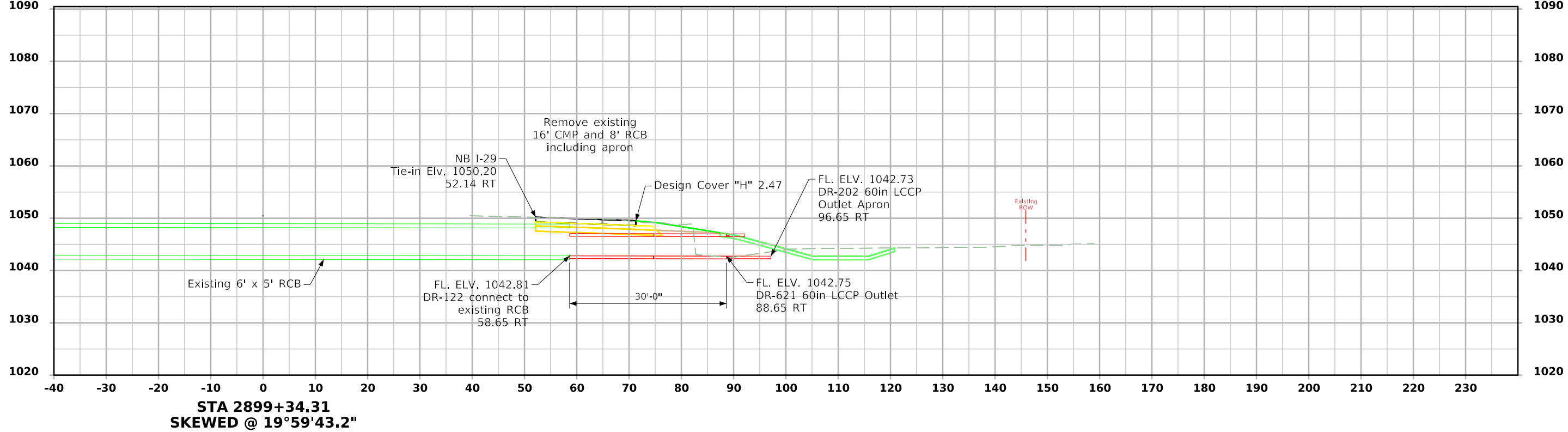

I-29 Ramp D

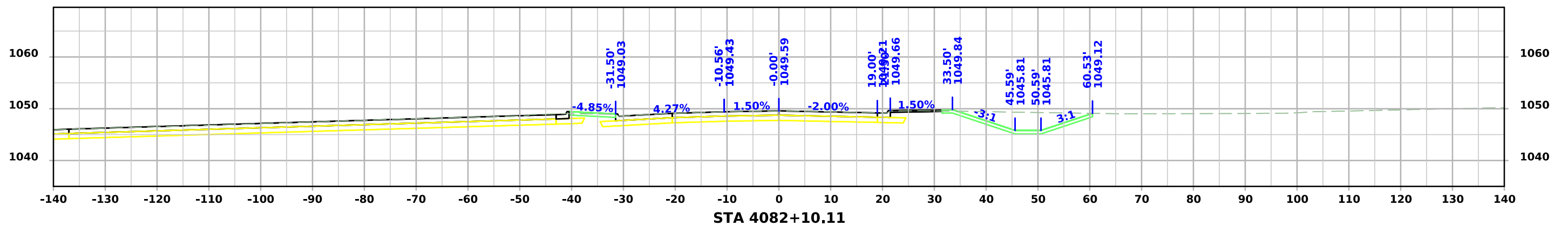
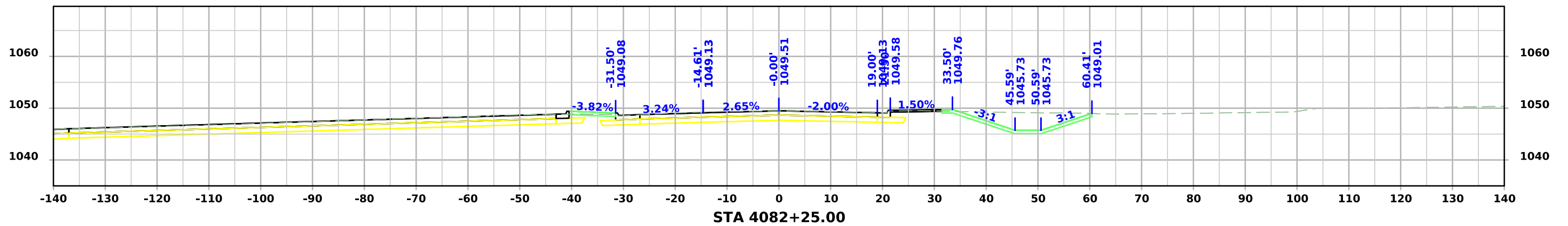
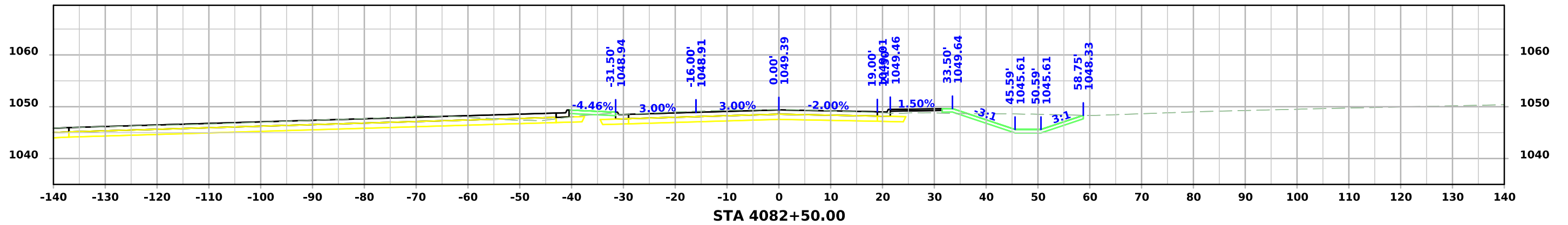

I-29 Ramp D

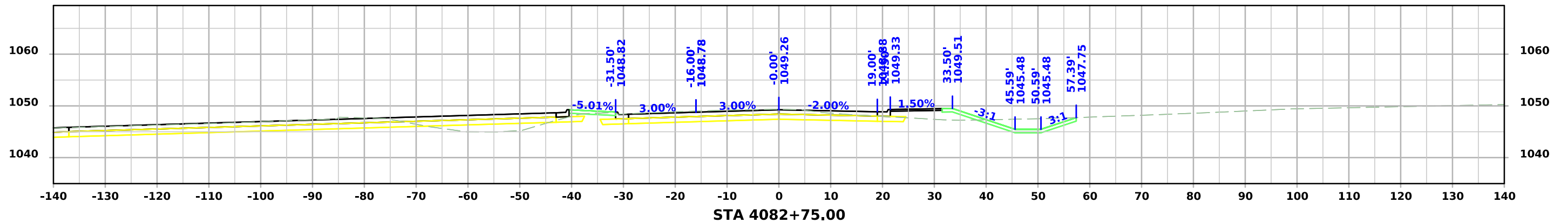
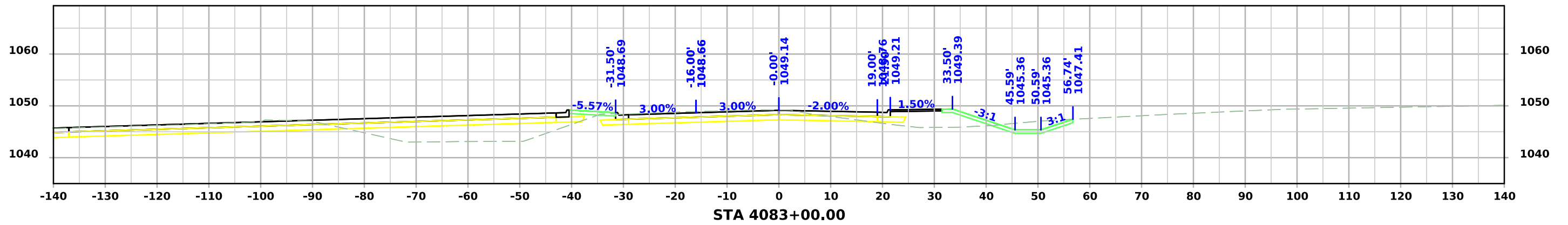
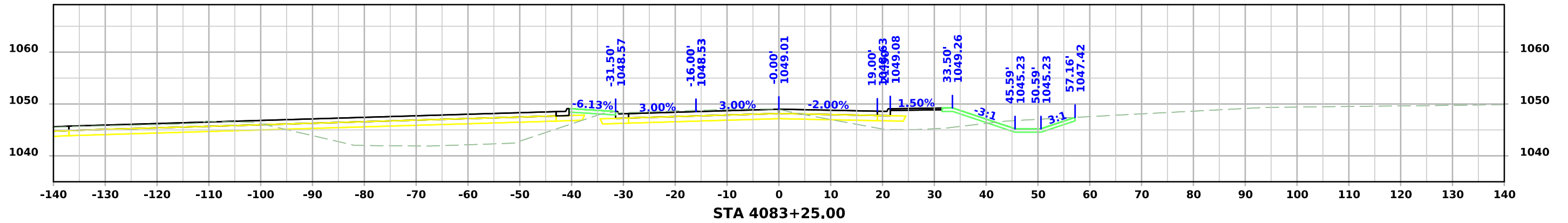

I-29 Ramp D

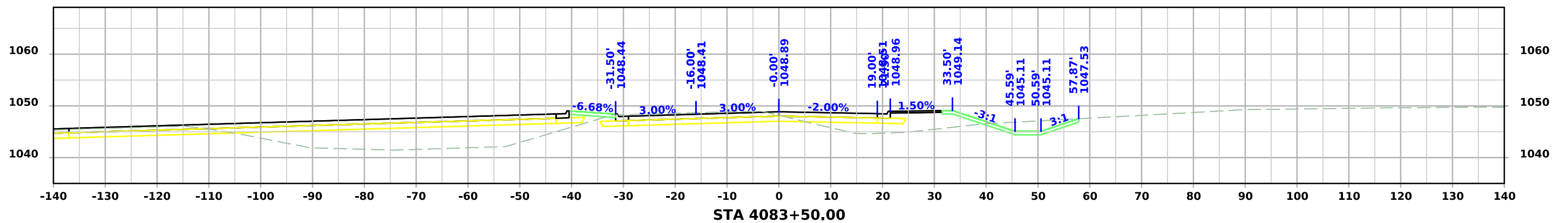
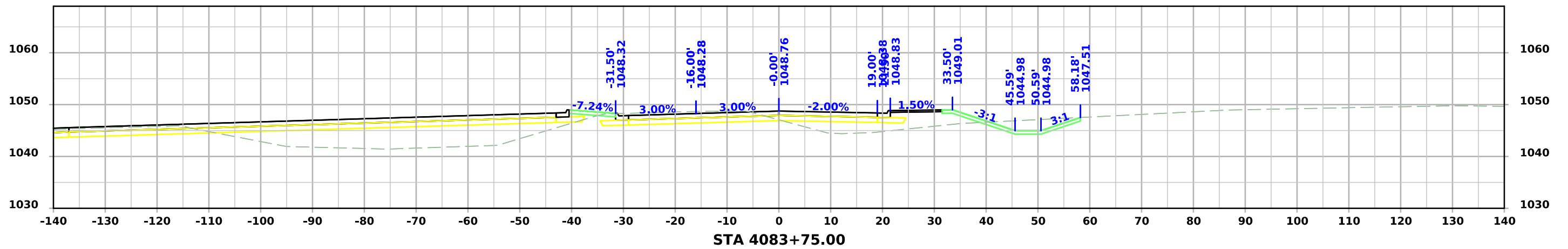
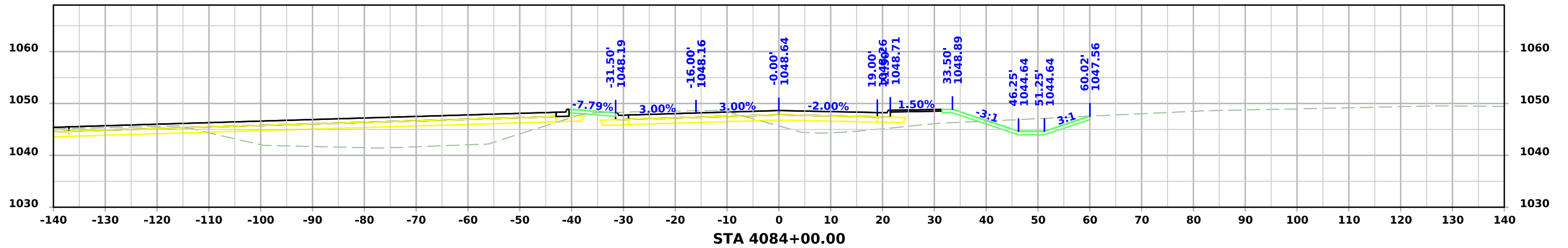

I-29 Ramp D

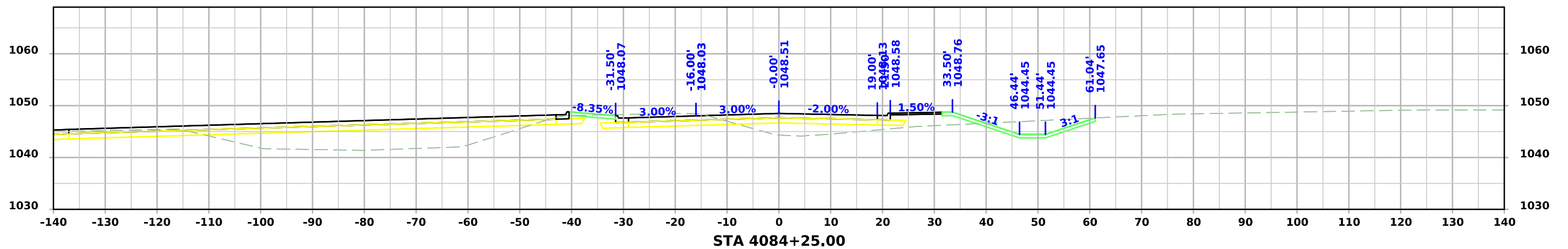
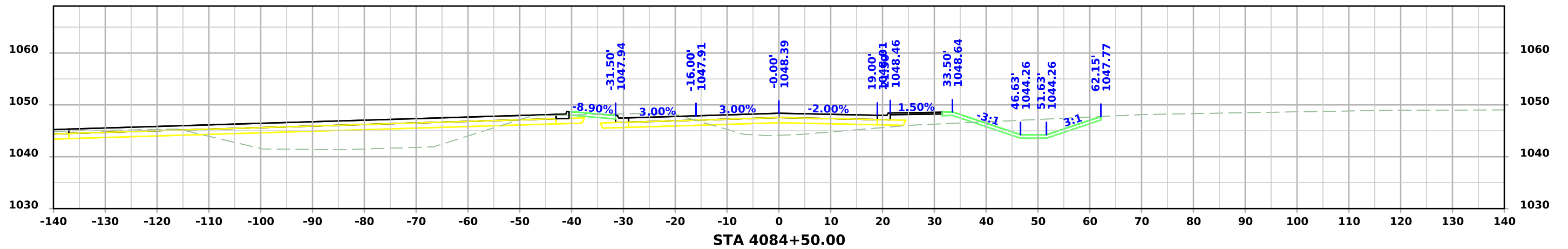
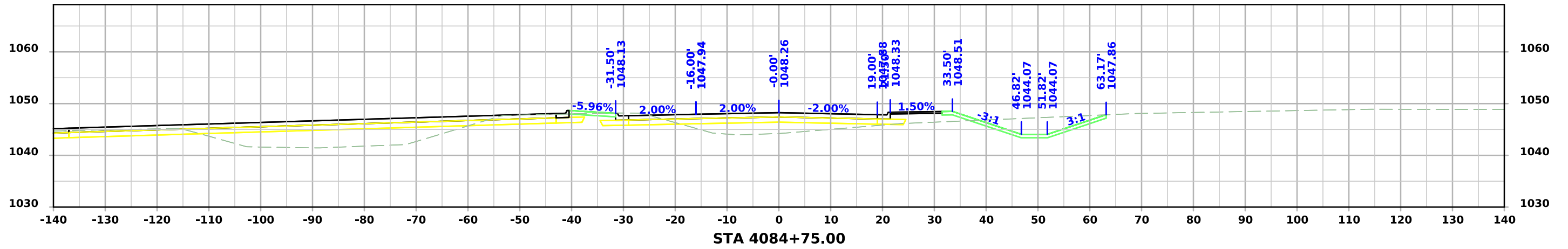

I-29 Ramp D

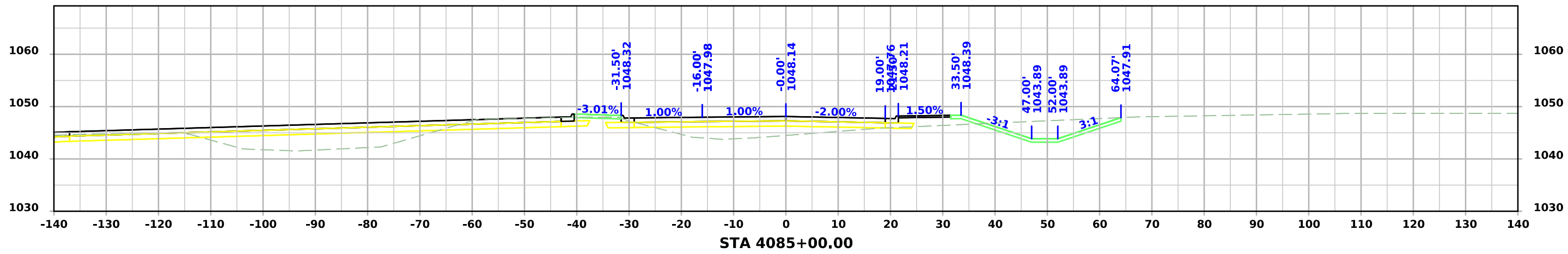
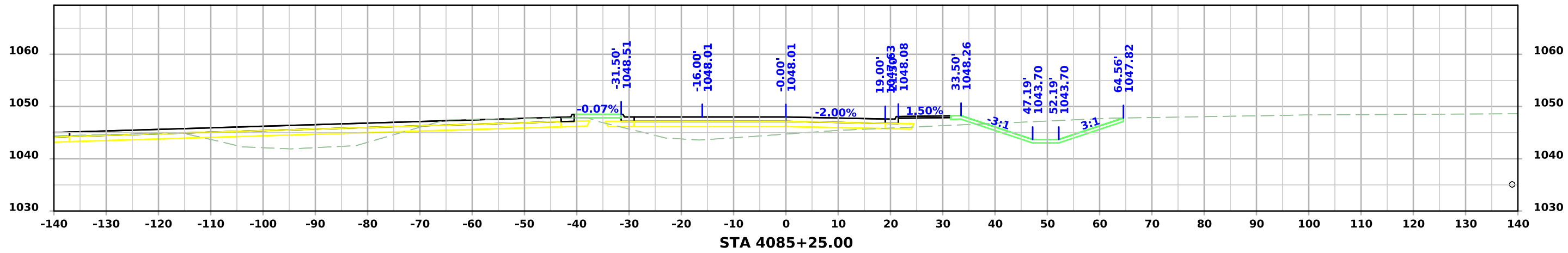
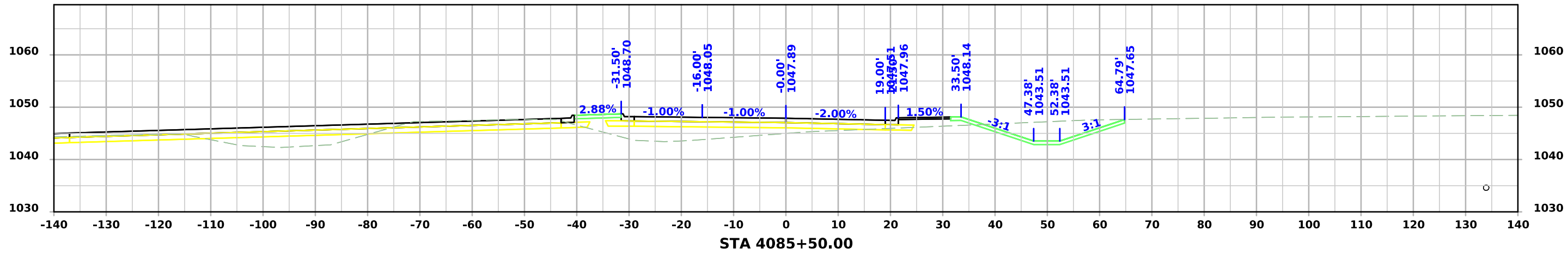

I-29 Ramp D

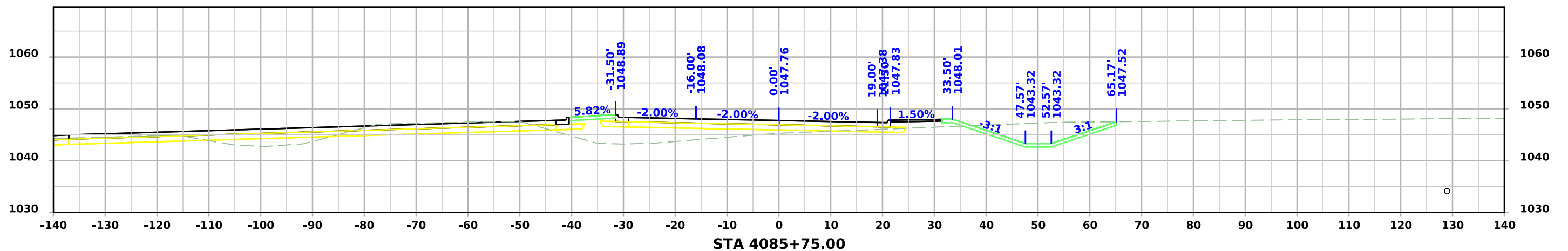
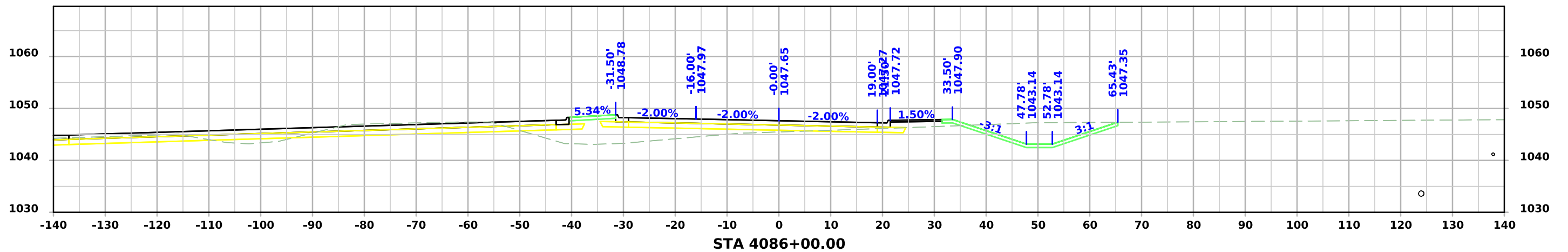
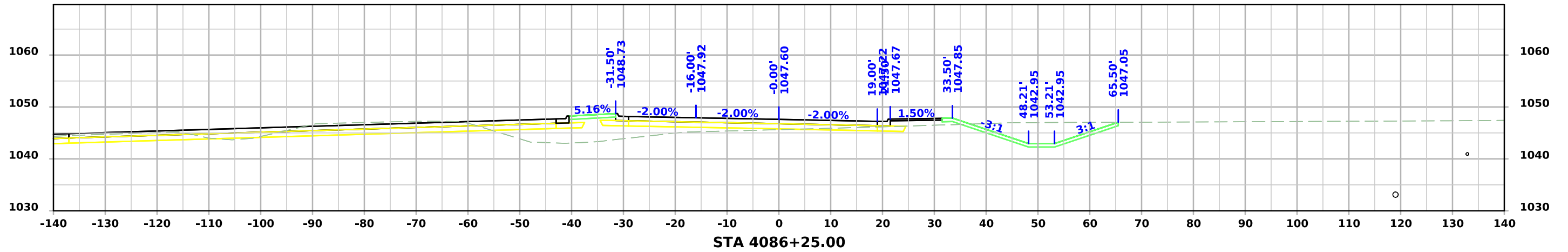

I-29 Ramp D

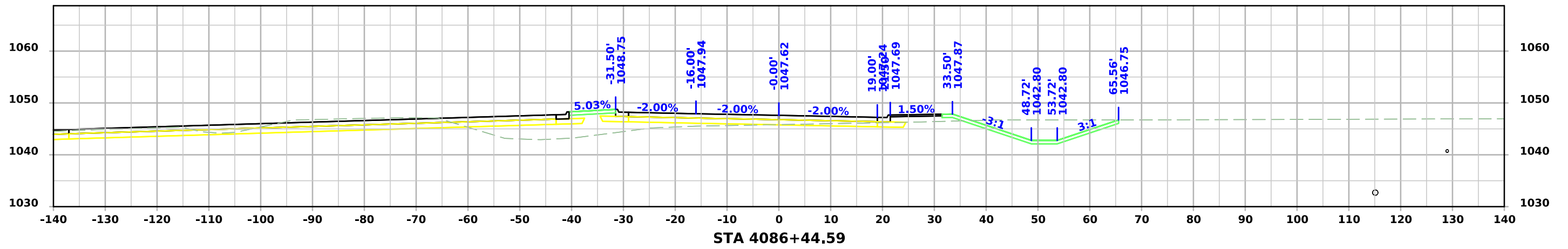
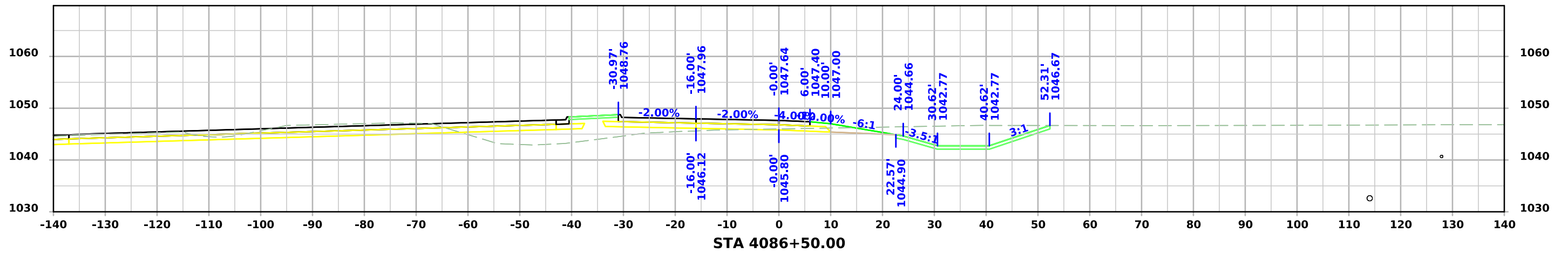
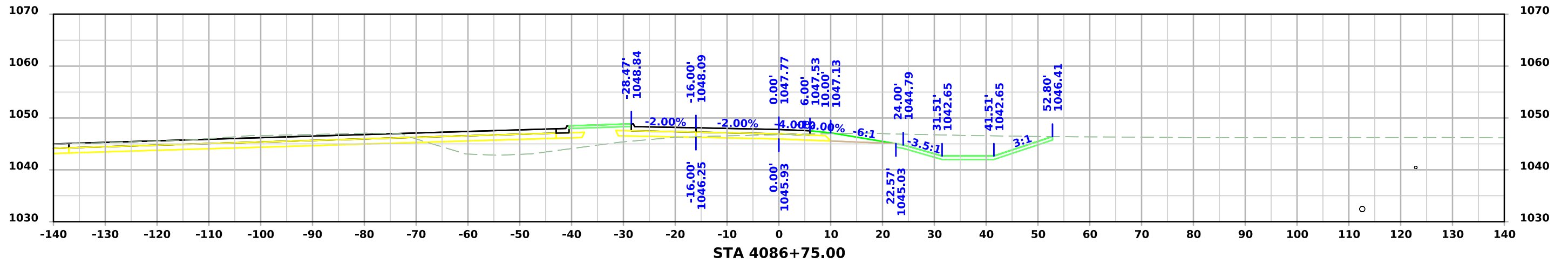

I-29 Ramp D

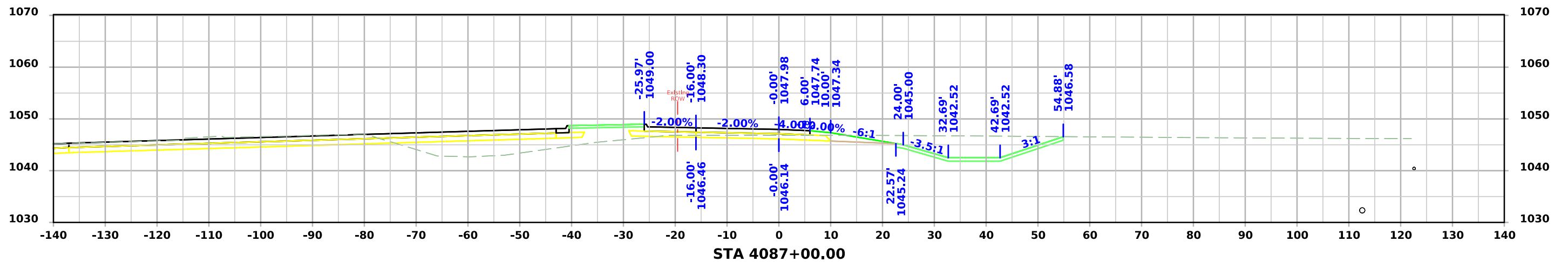
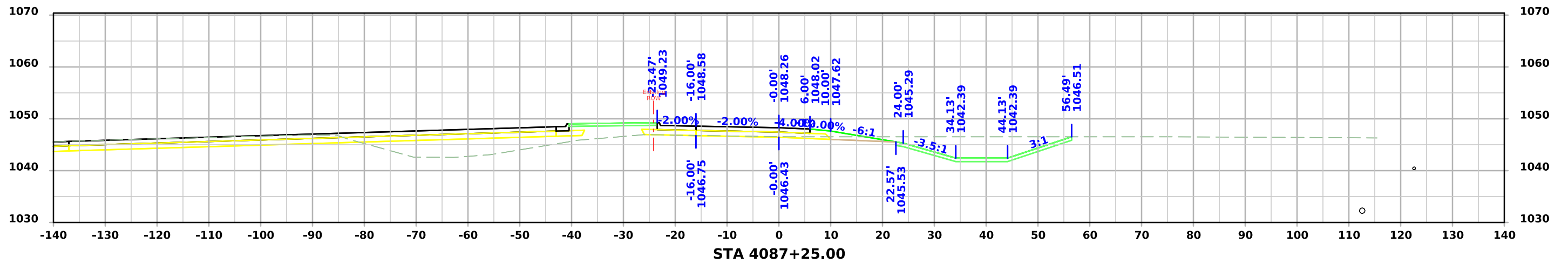
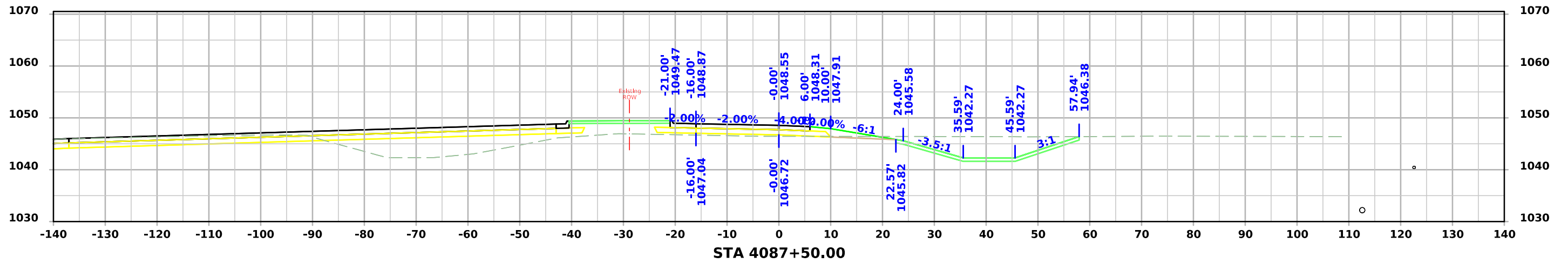

I-29 Ramp D

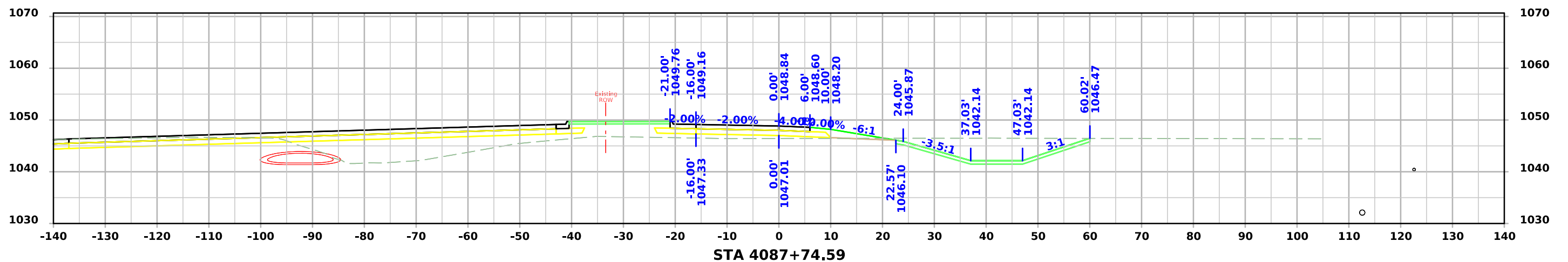
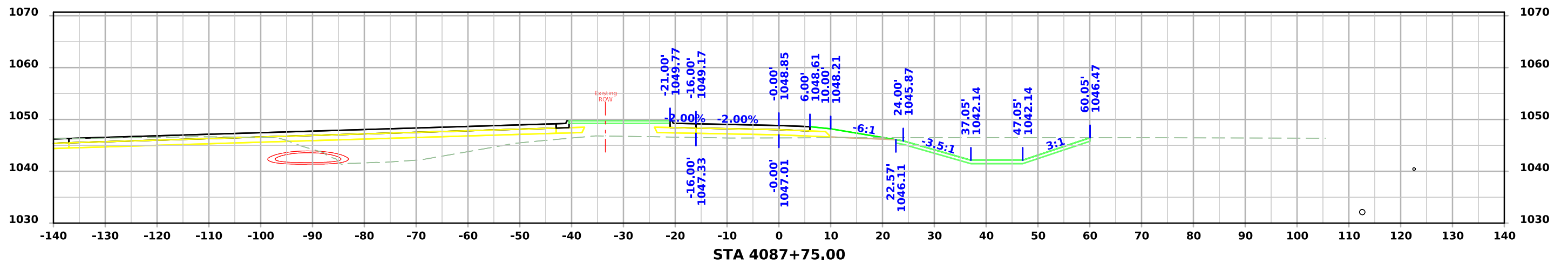
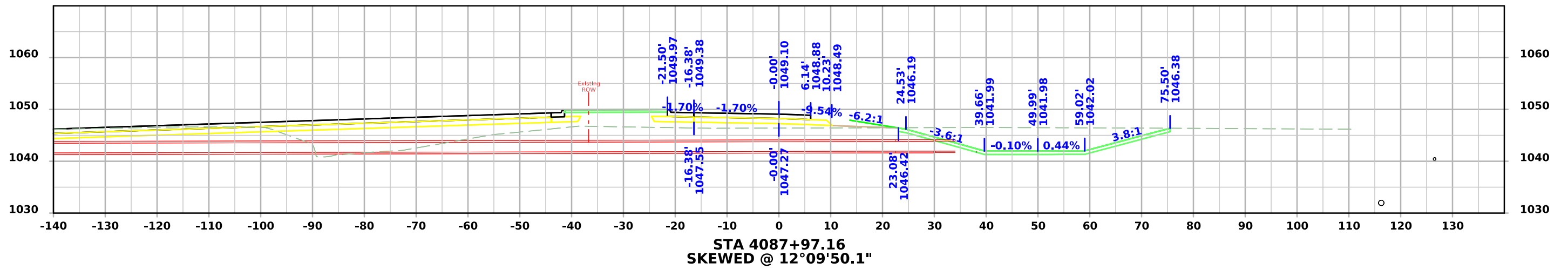

I-29 Ramp D

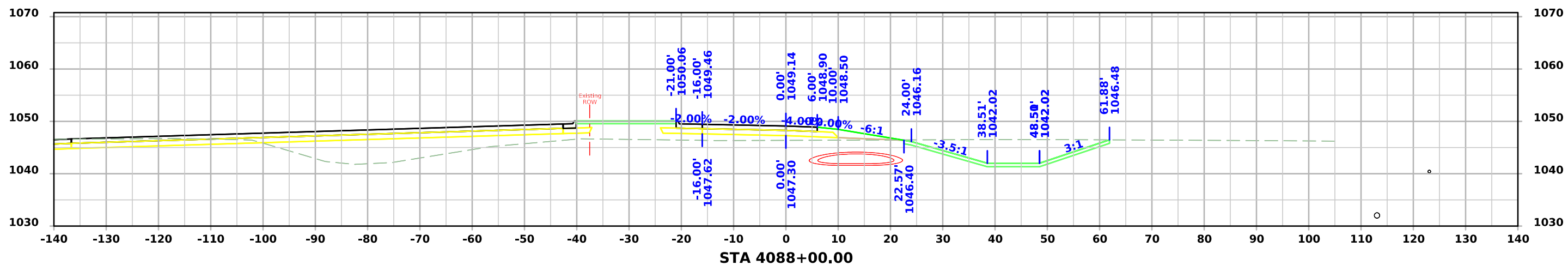
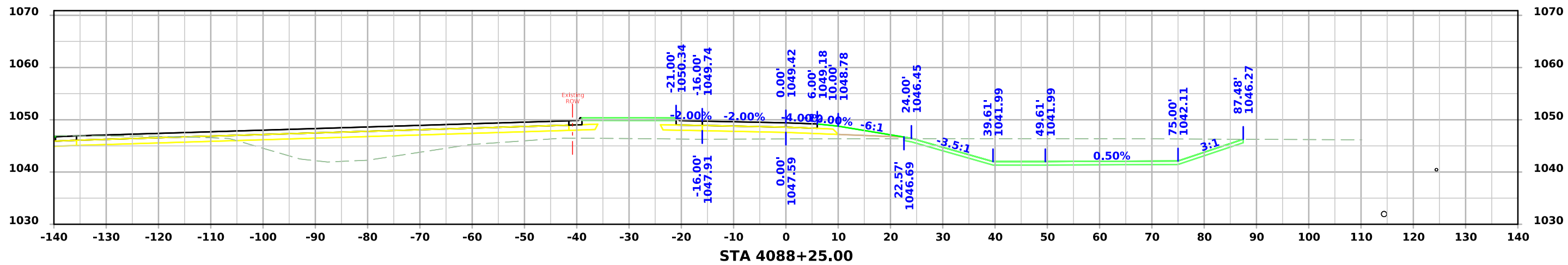
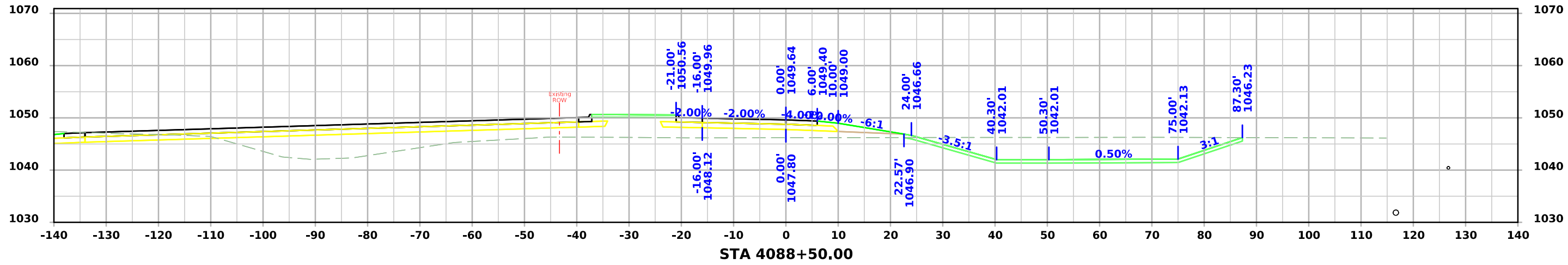

I-29 Ramp D

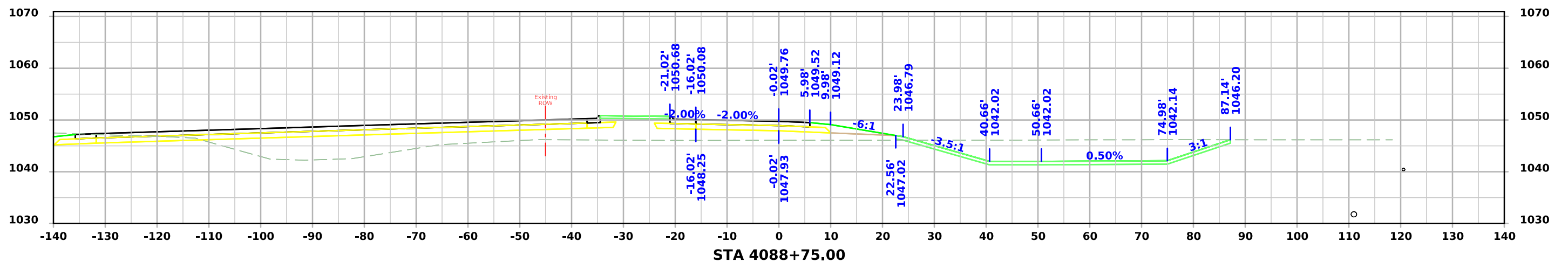
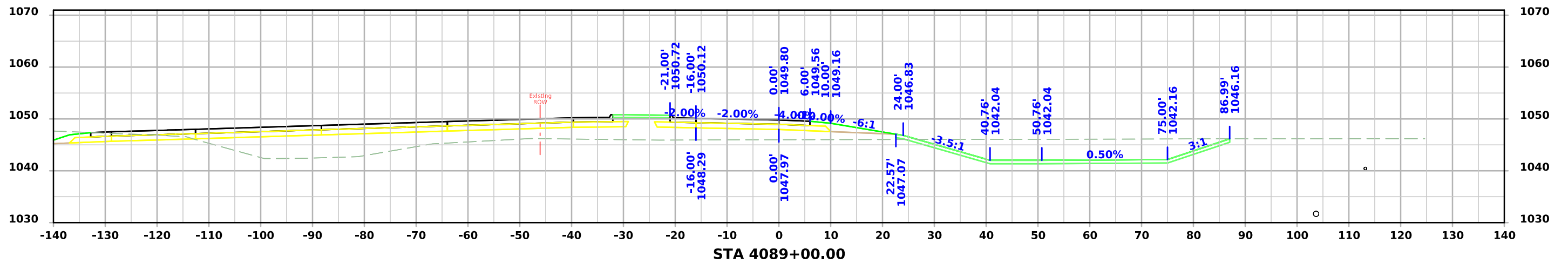
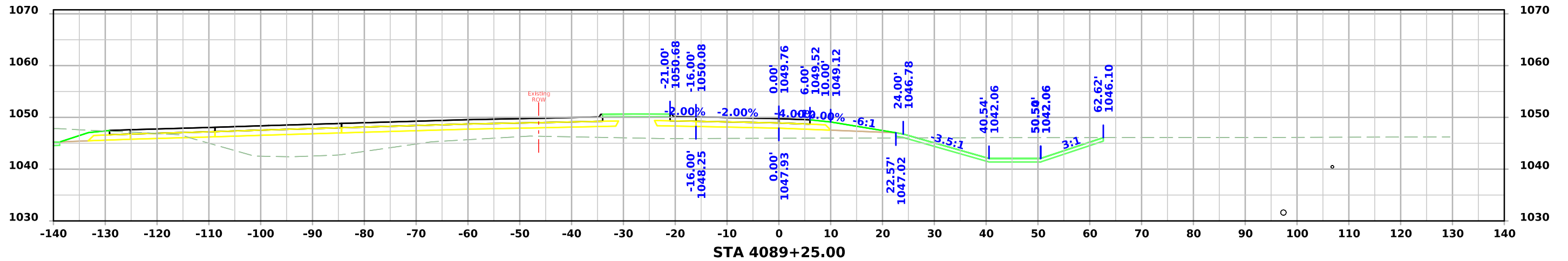

I-29 Ramp D

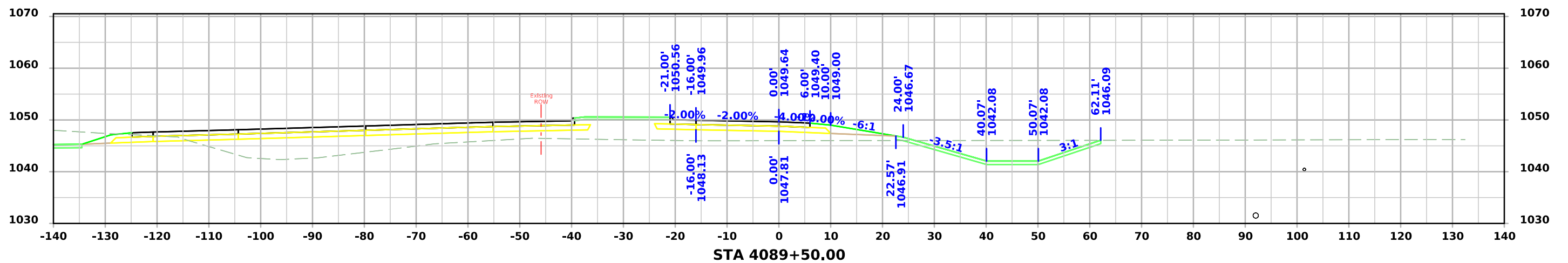
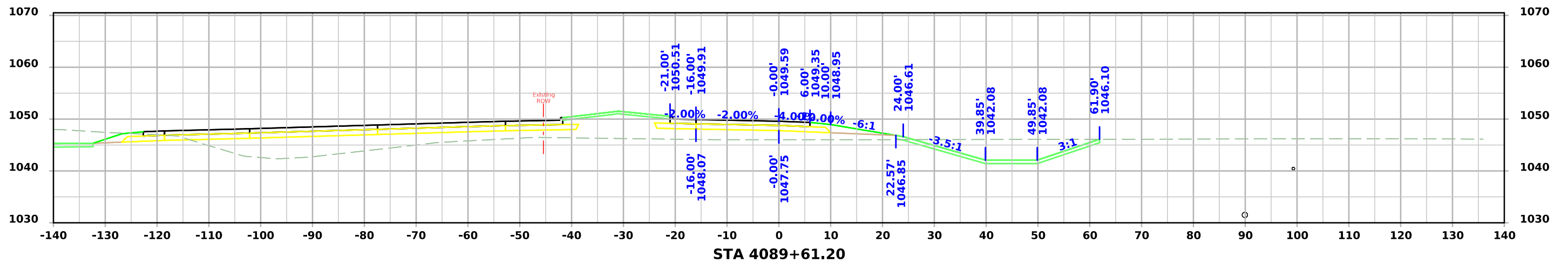
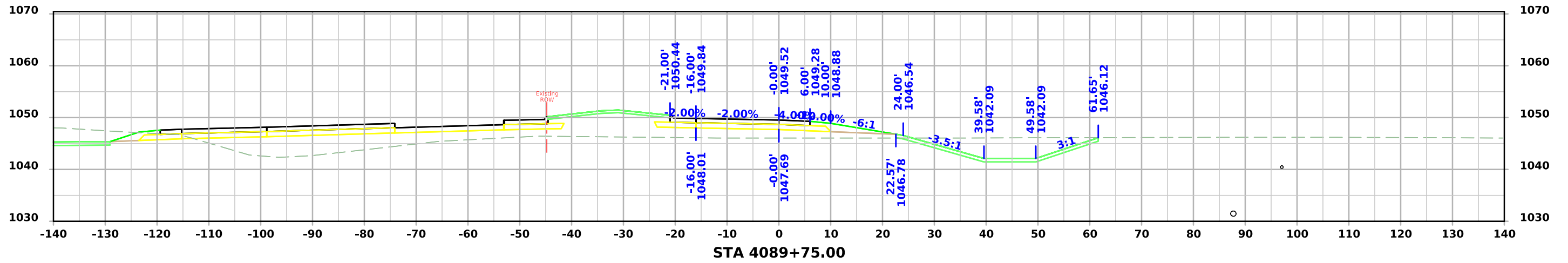

I-29 Ramp D

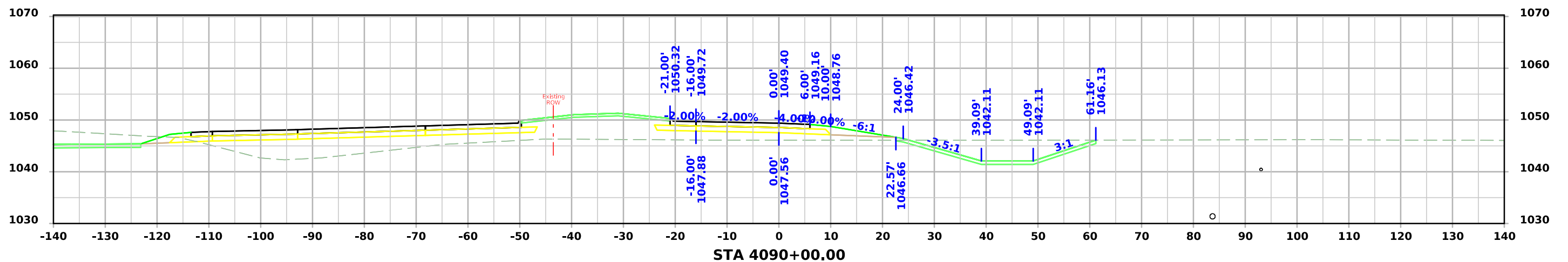
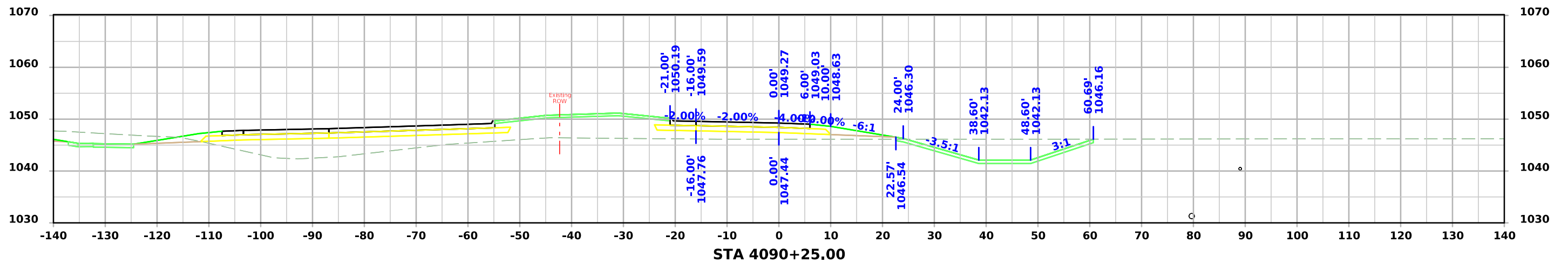
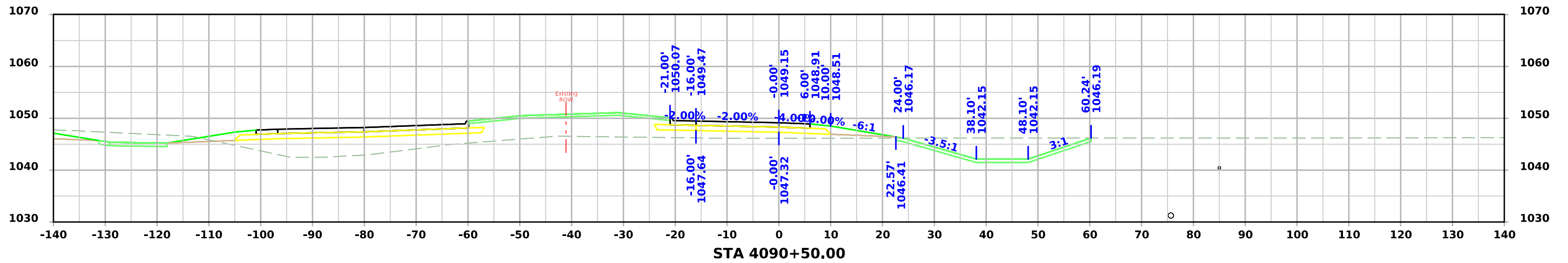

I-29 Ramp D

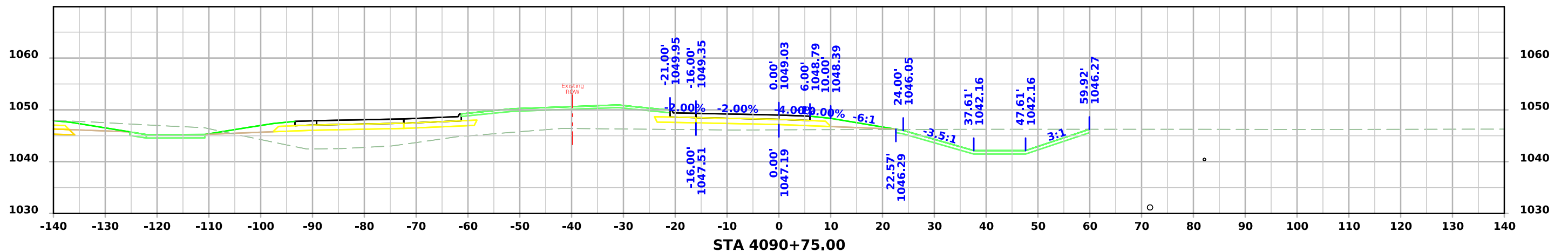
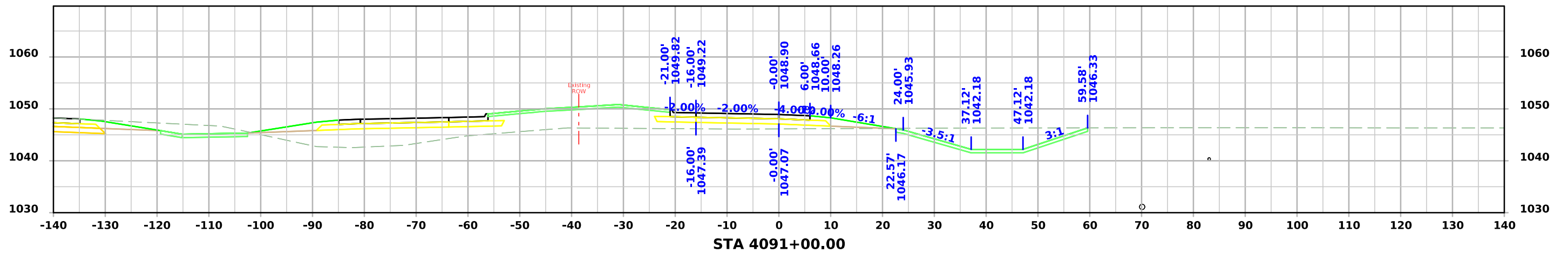
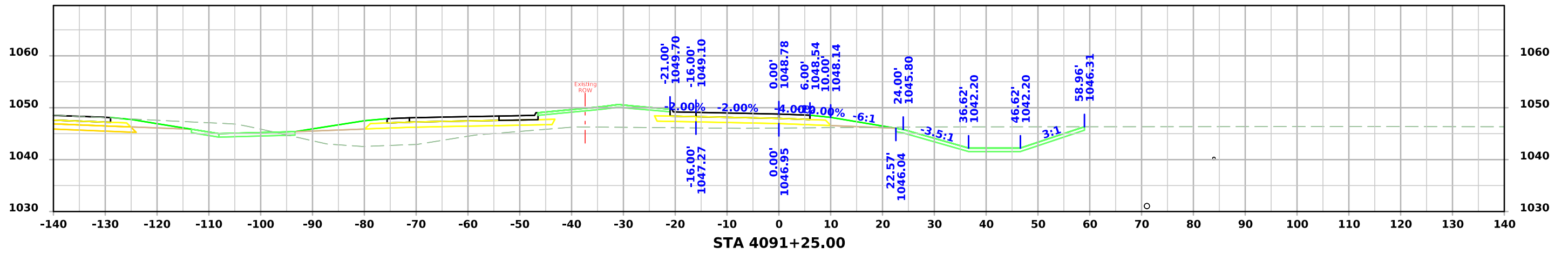

I-29 Ramp D

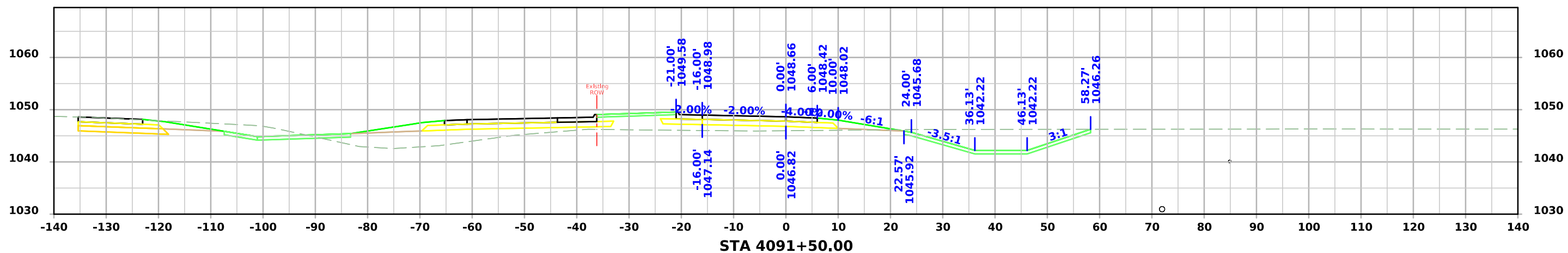
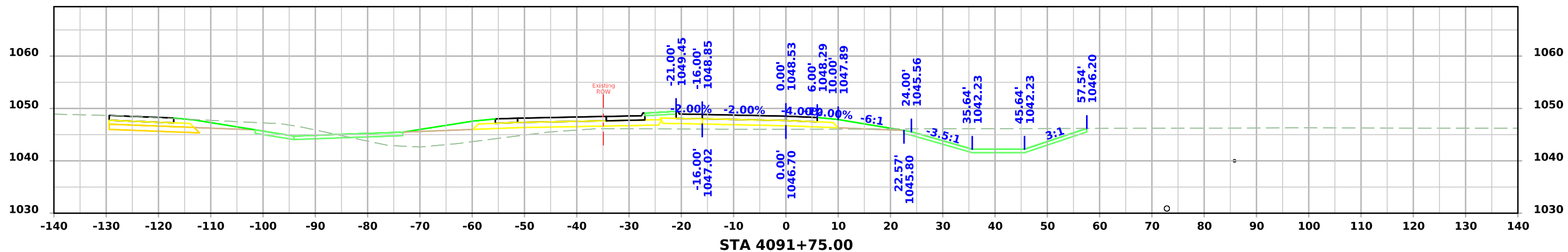
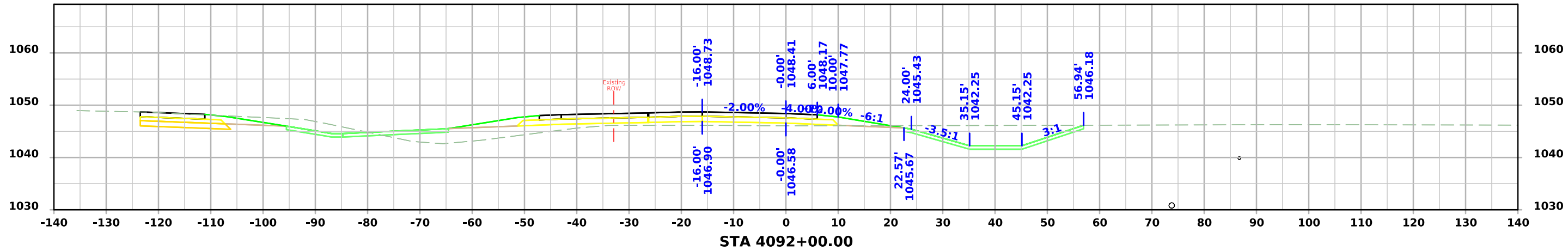

I-29 Ramp D

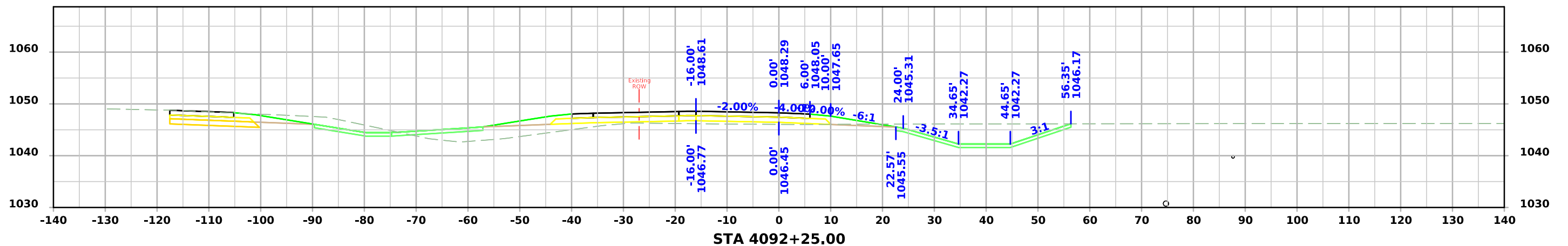
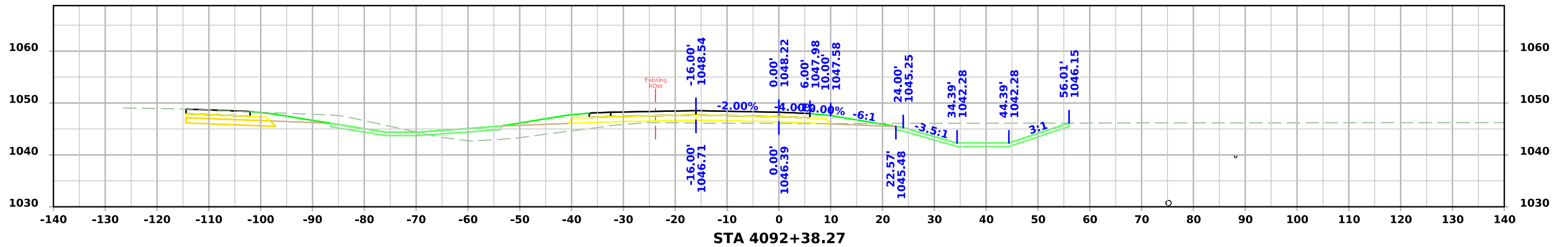
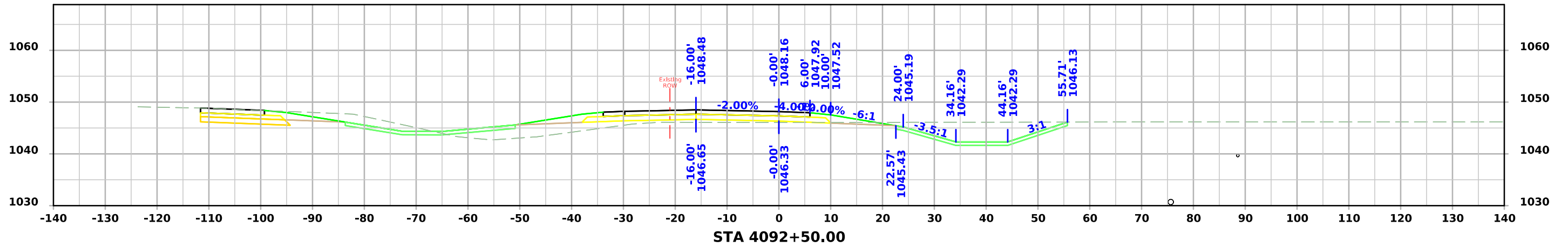

I-29 Ramp D

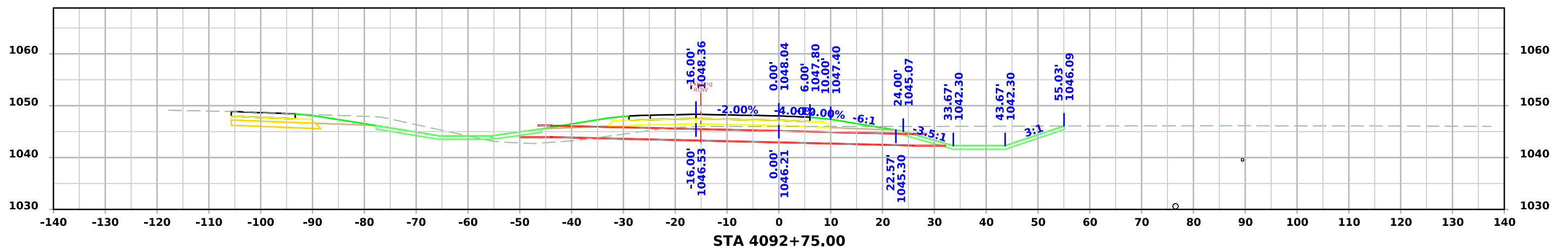
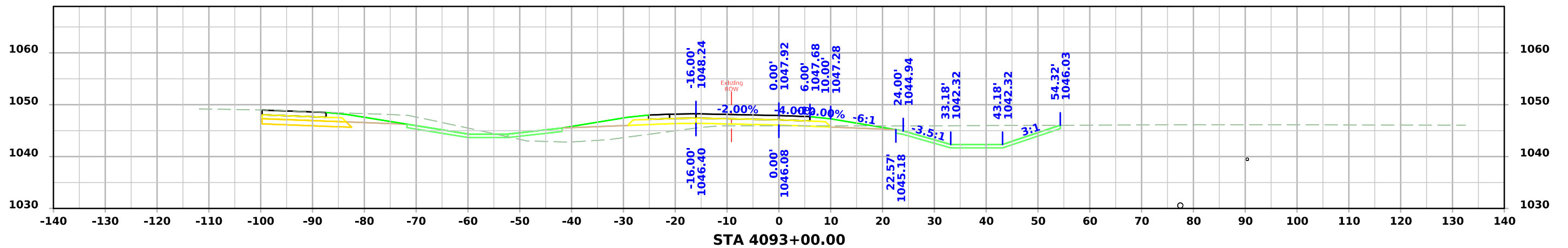
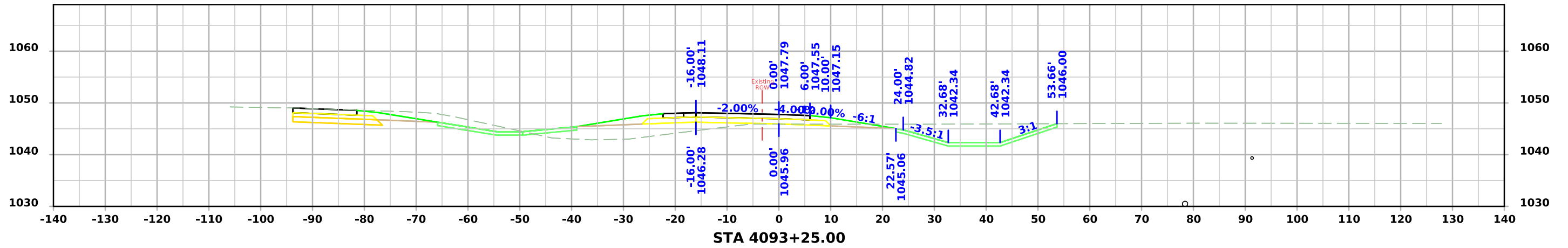

I-29 Ramp D

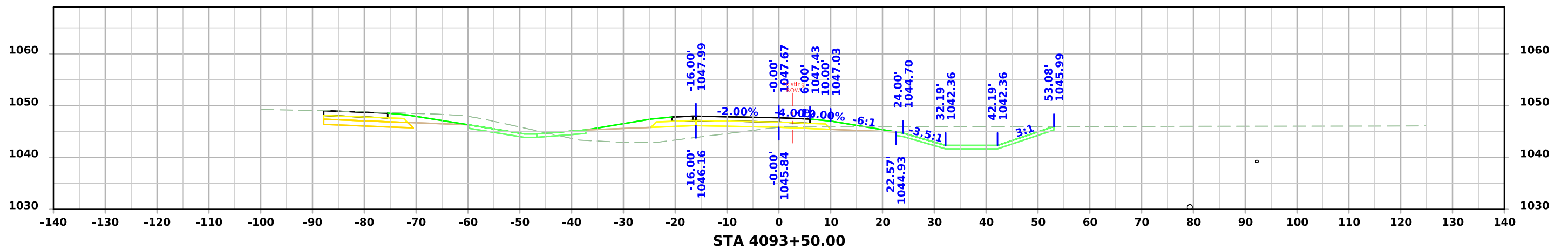
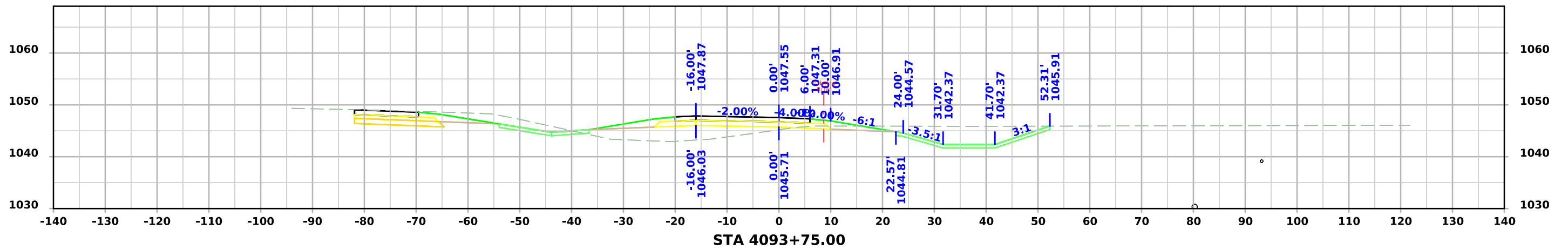
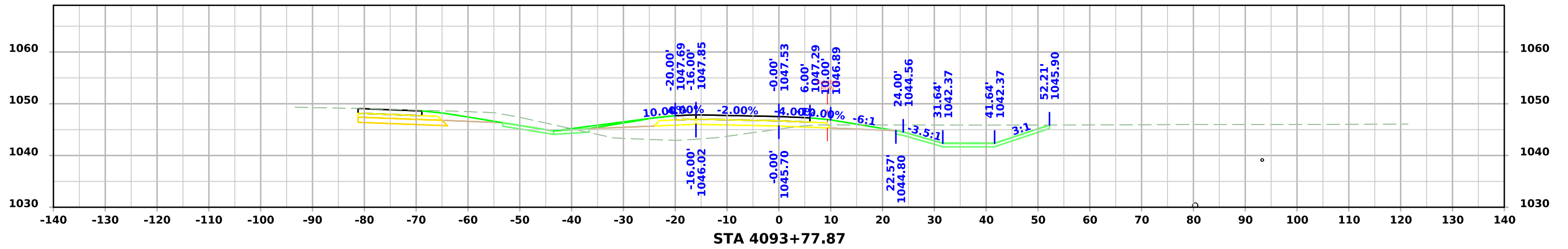

I-29 Ramp D

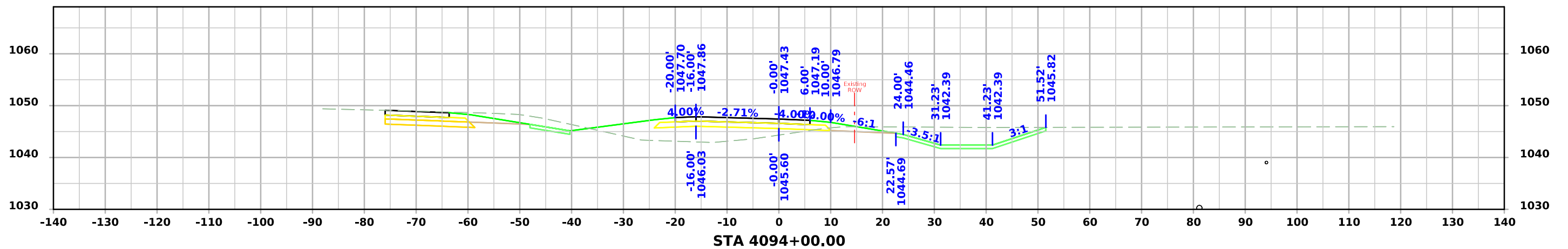
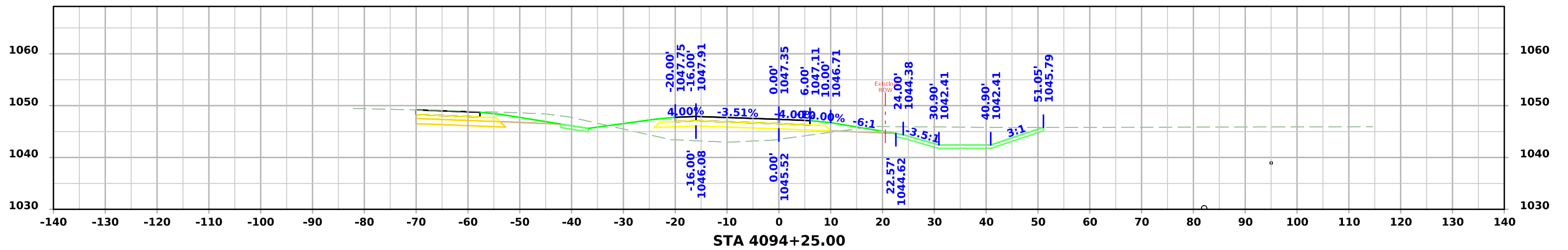
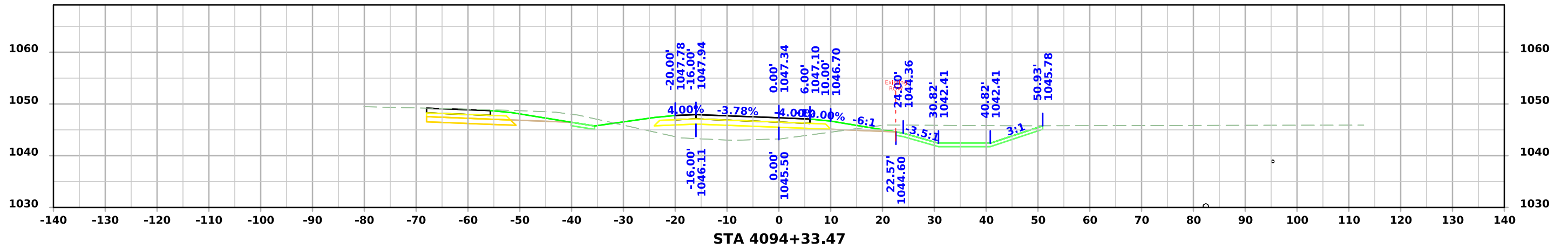

I-29 Ramp D

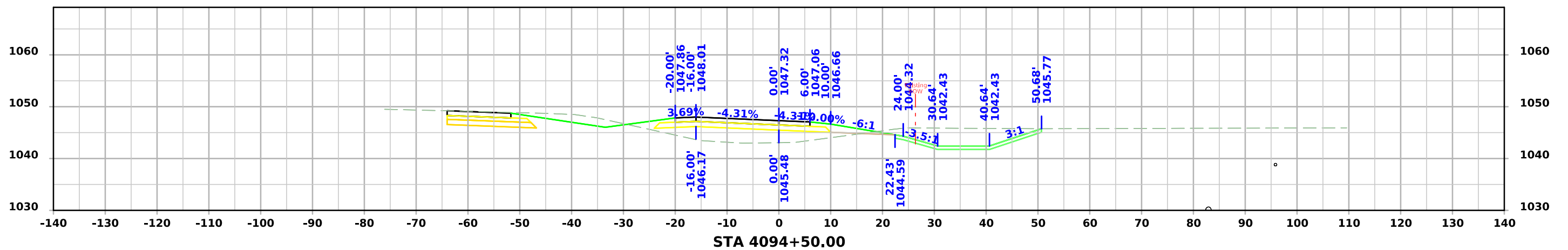
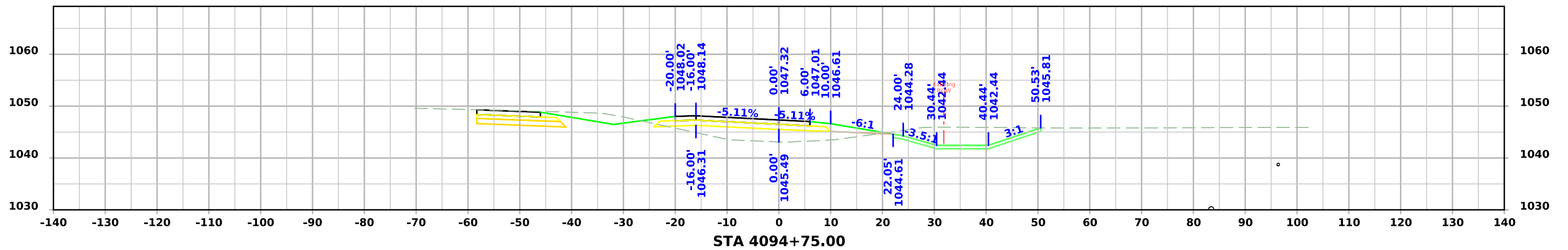
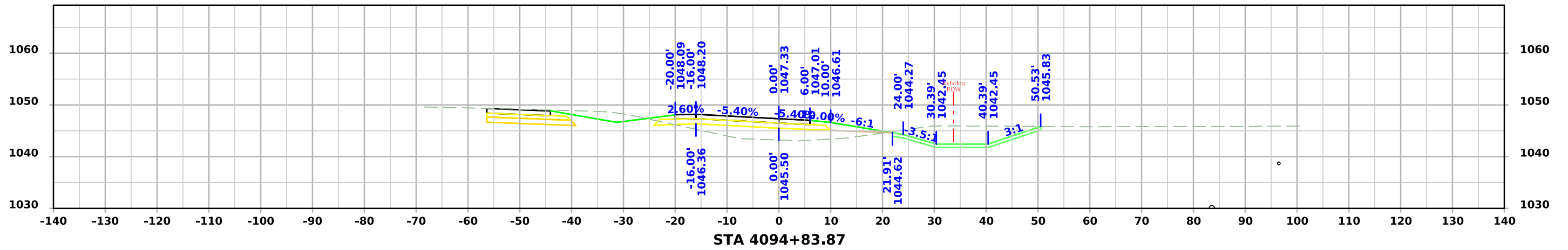

I-29 Ramp D

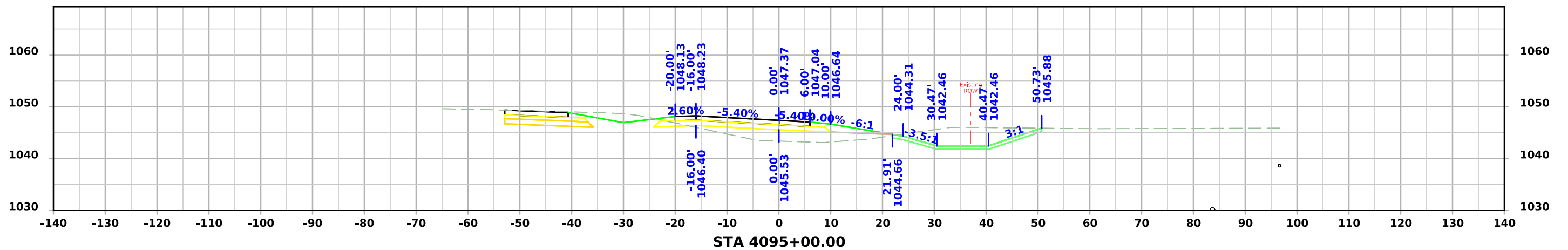
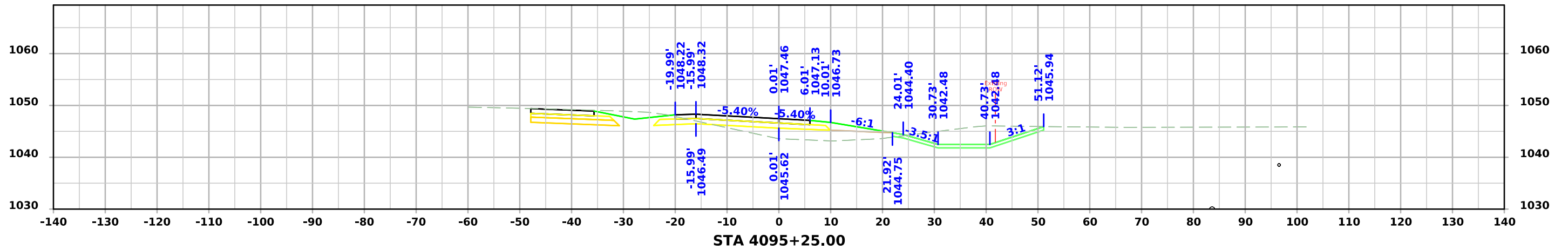
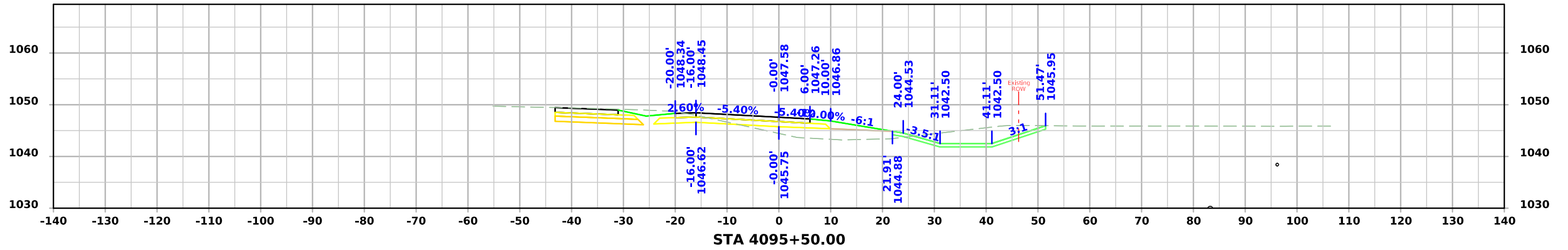

I-29 Ramp D

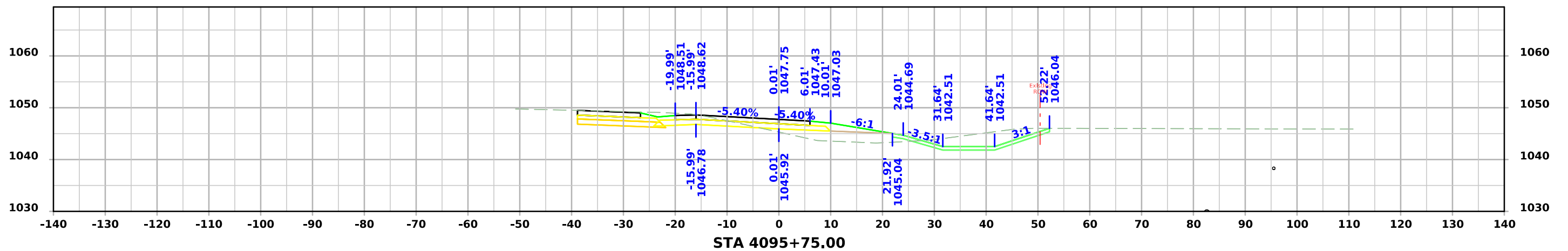
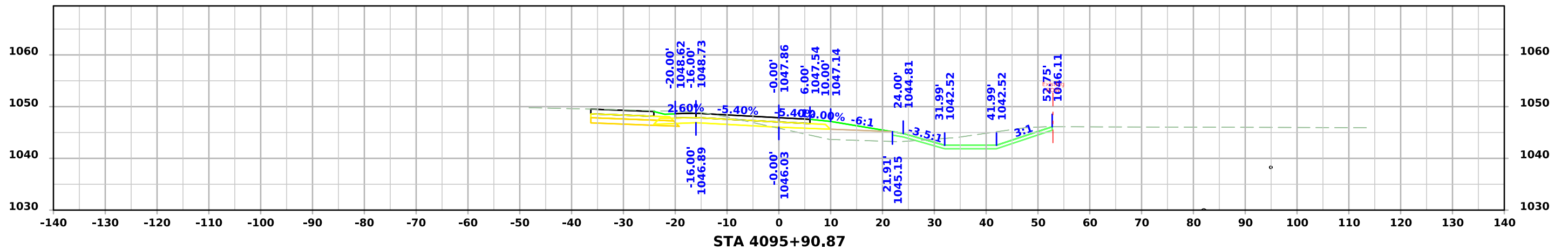

I-29 Ramp H

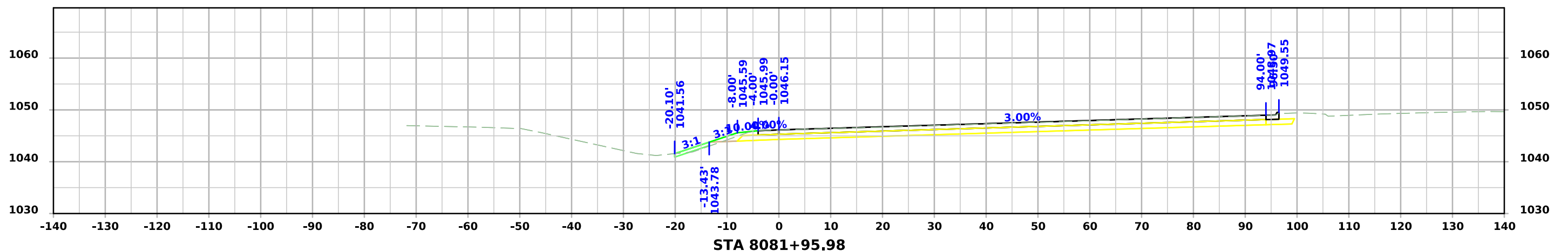
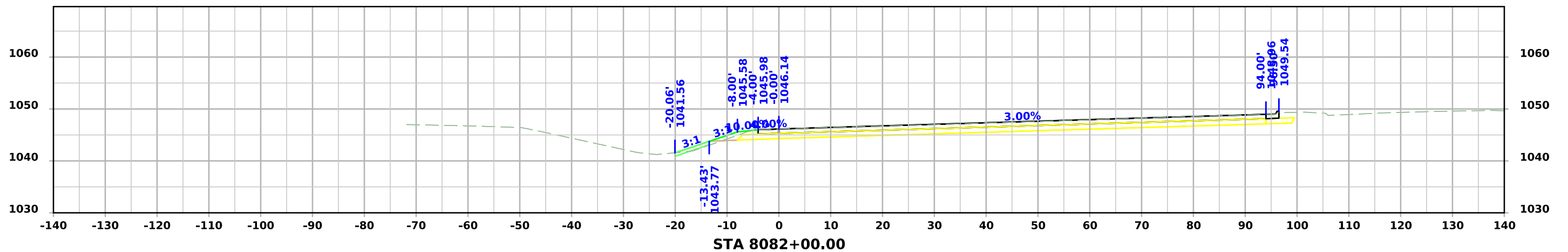
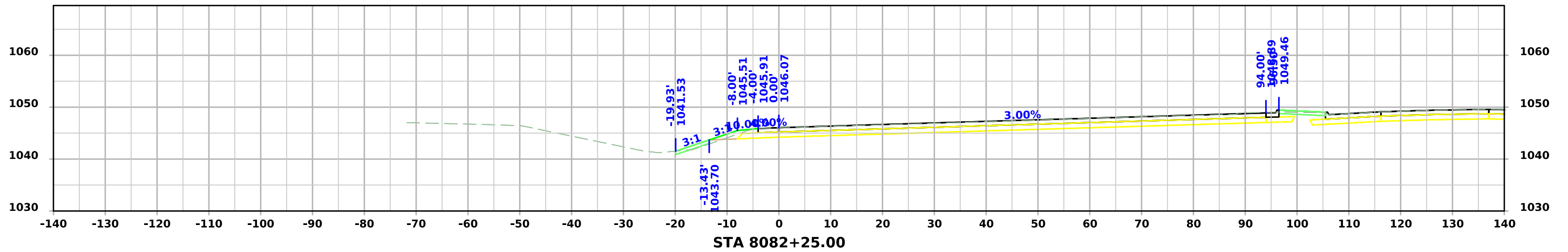

I-29 Ramp H

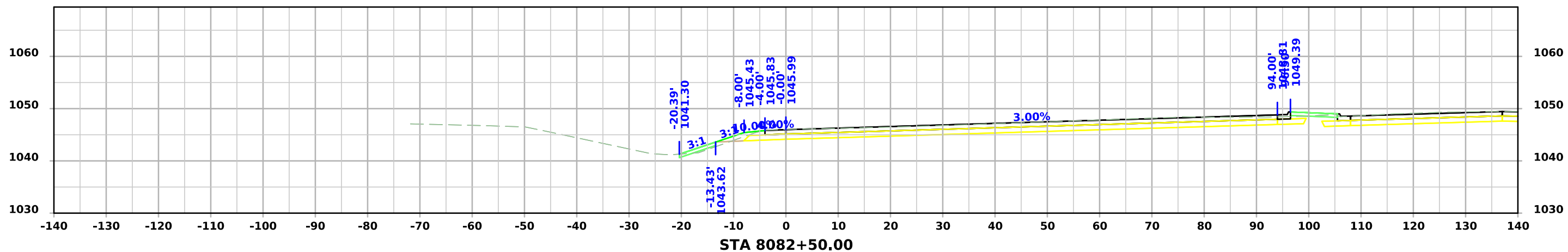
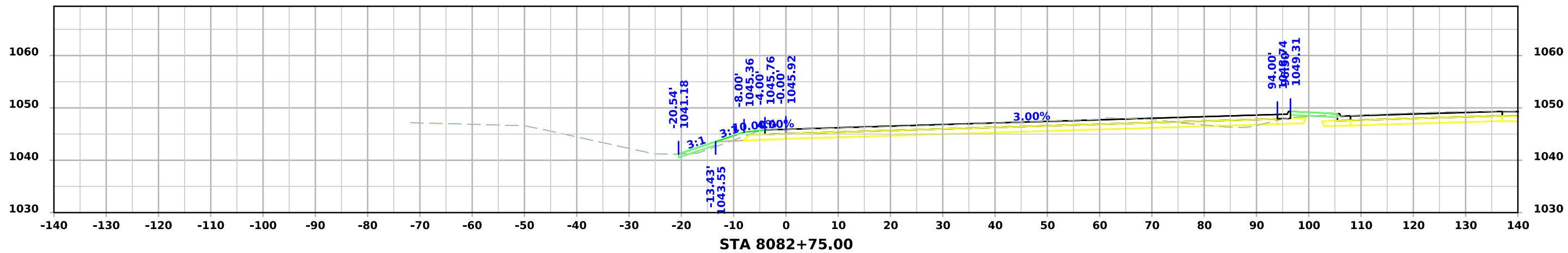
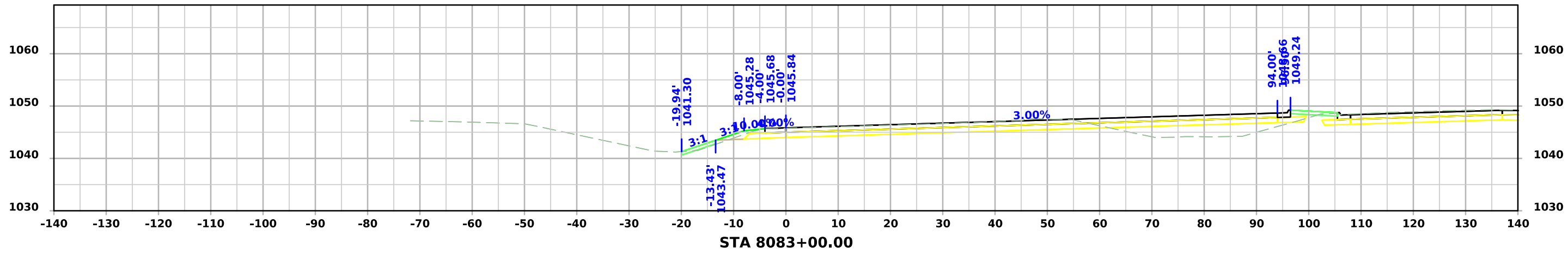

I-29 Ramp H

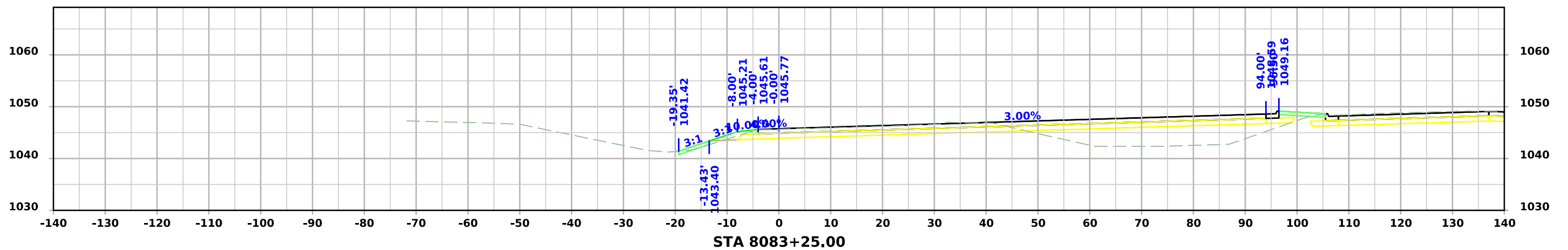
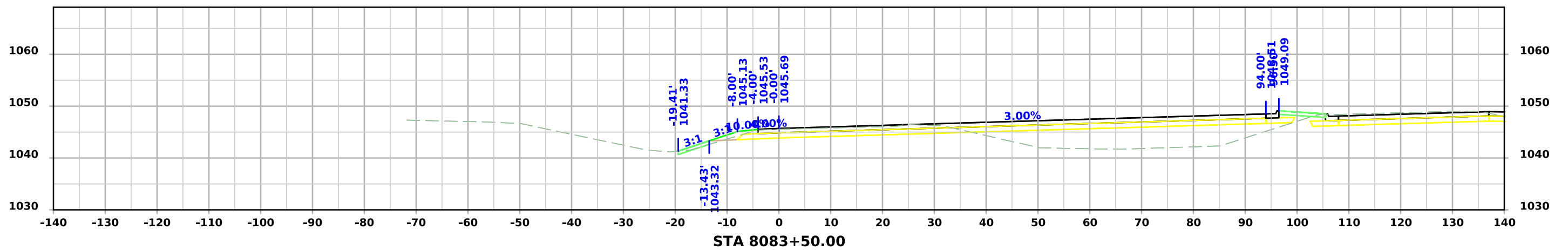
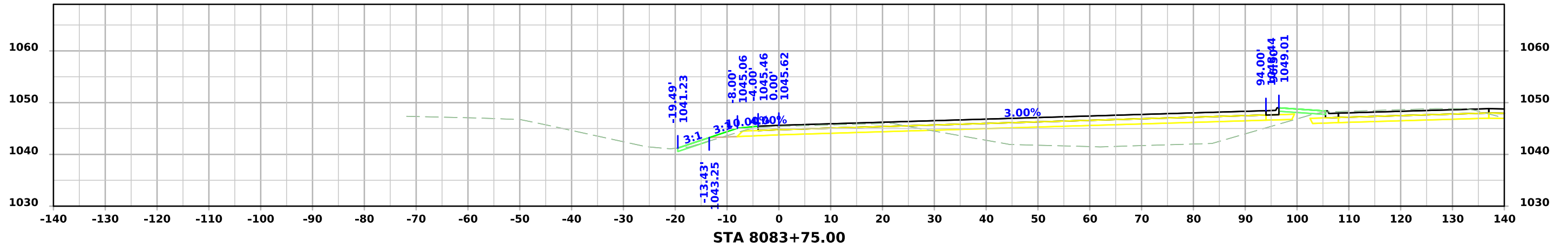

I-29 Ramp H

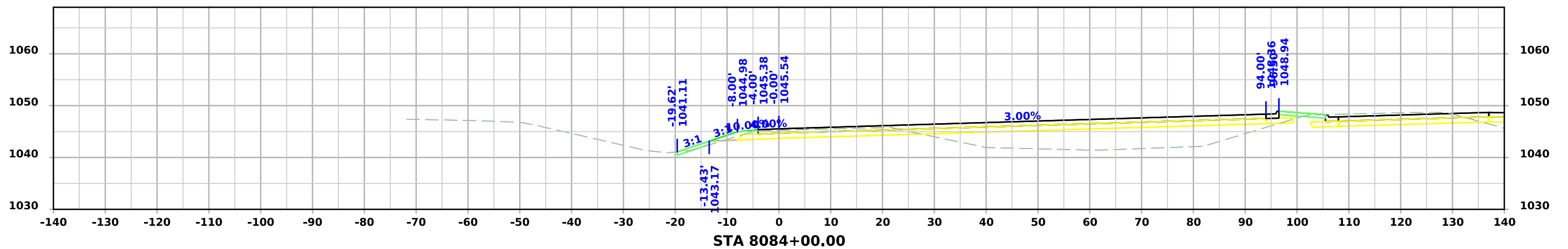
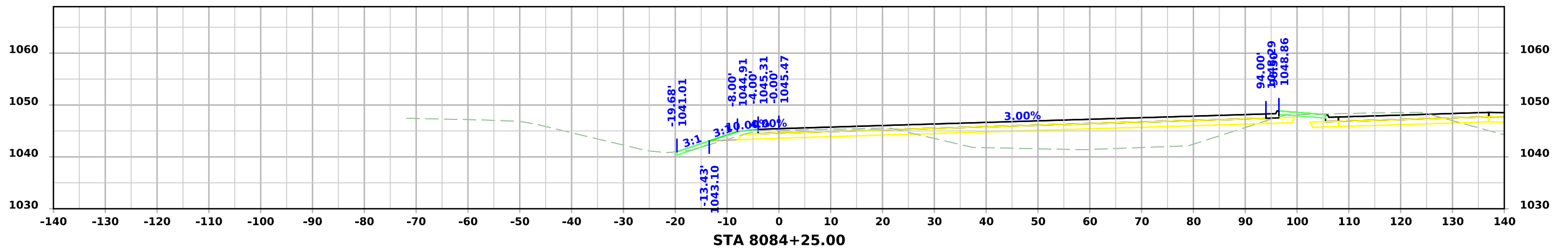
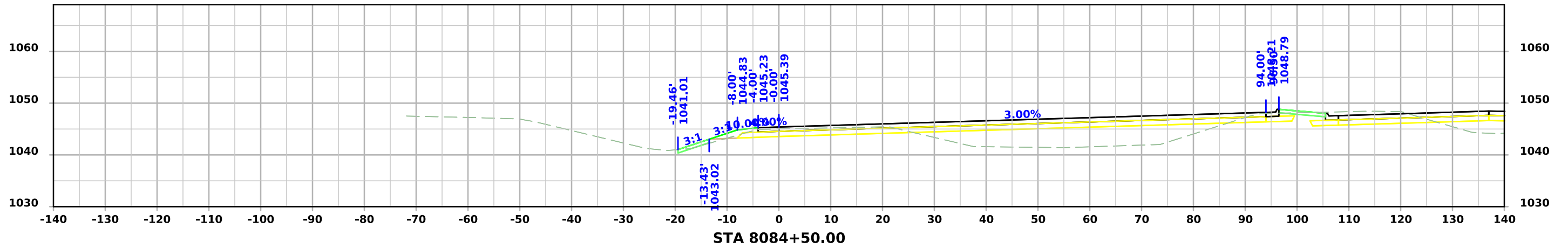

I-29 Ramp H

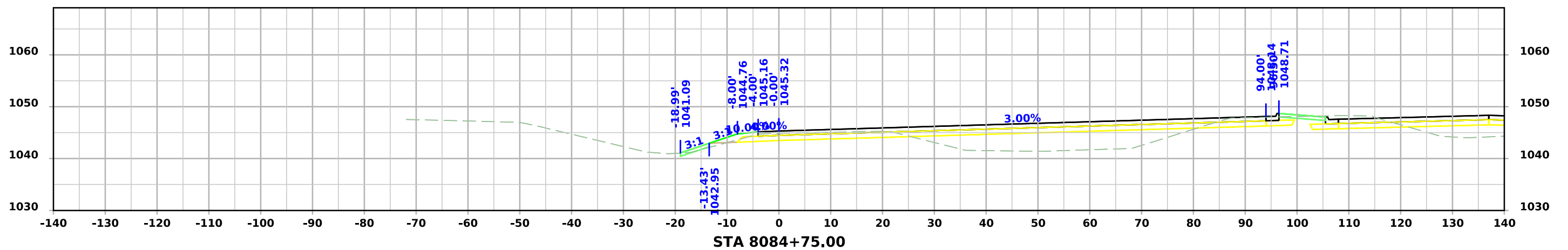
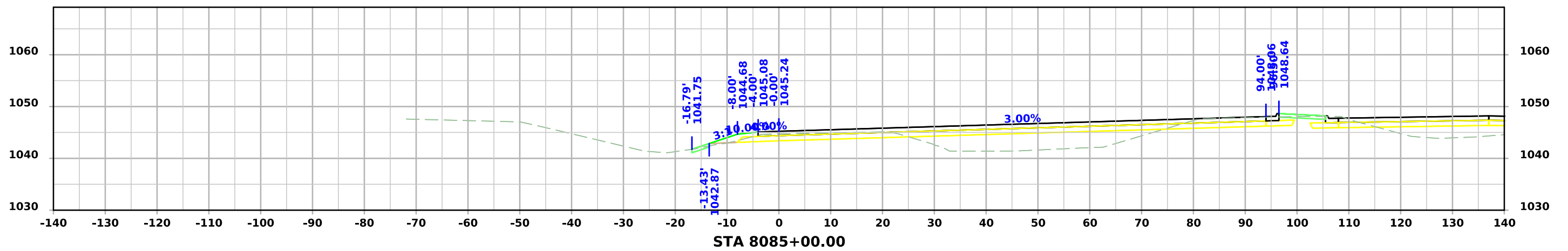
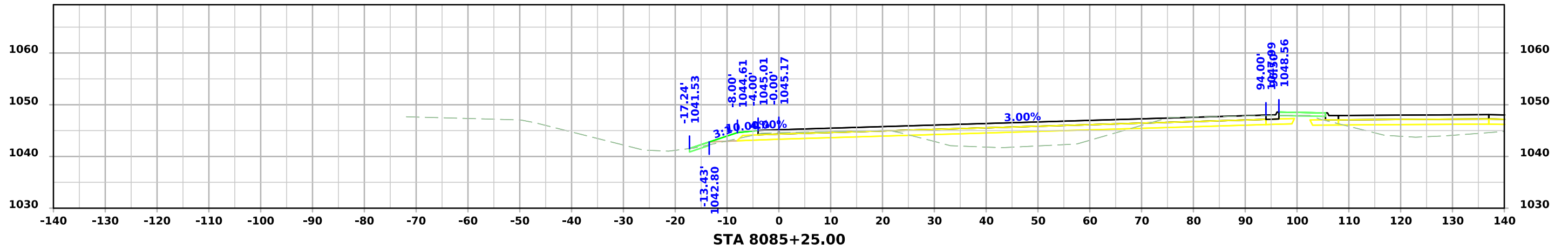

I-29 Ramp H

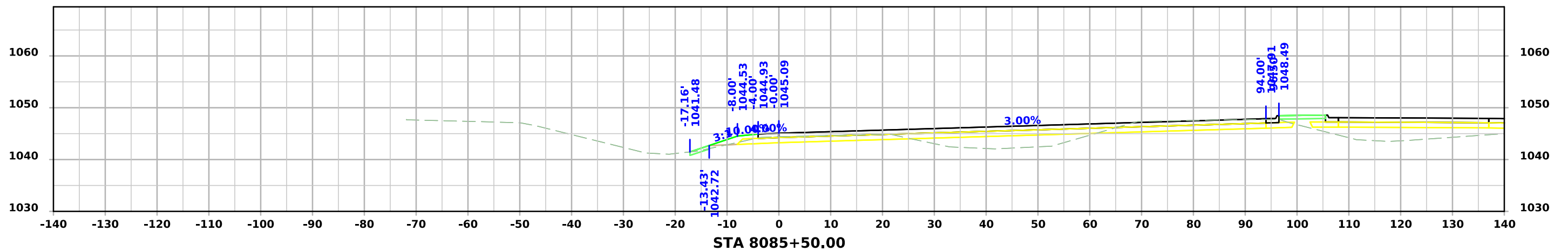
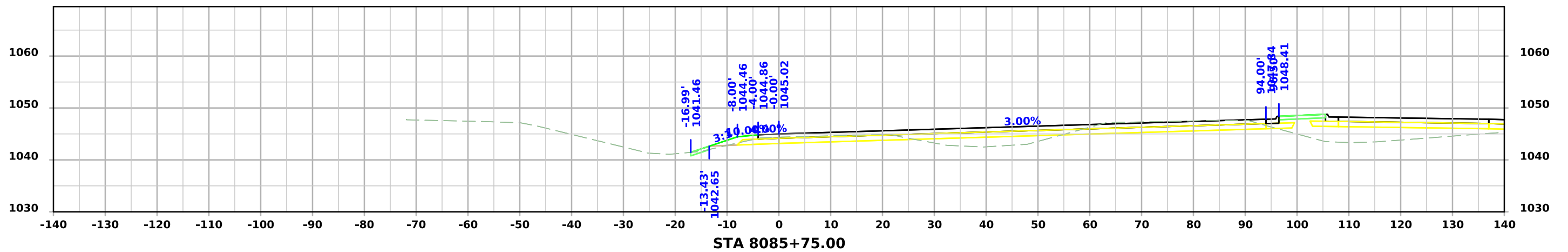
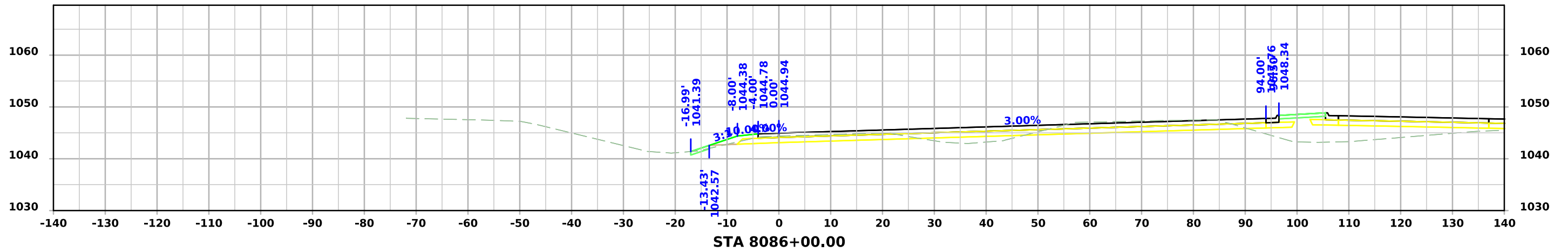

I-29 Ramp H

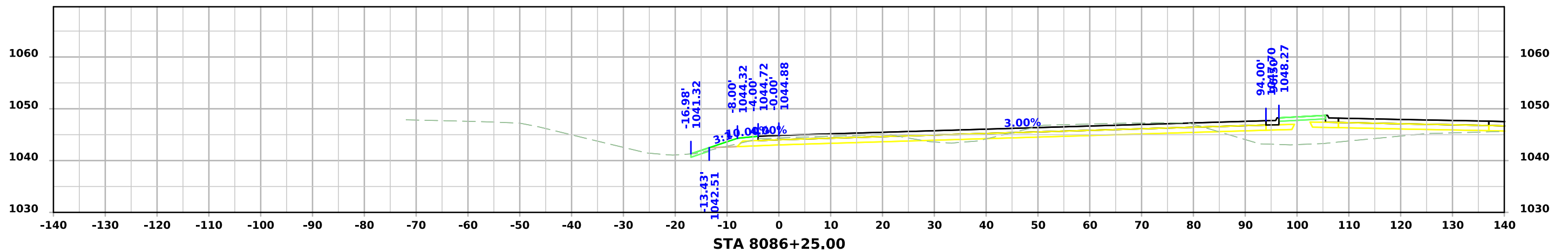
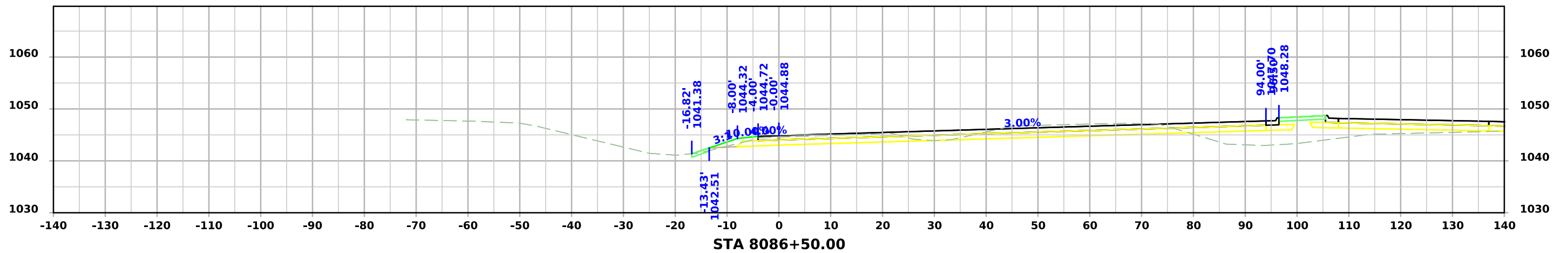
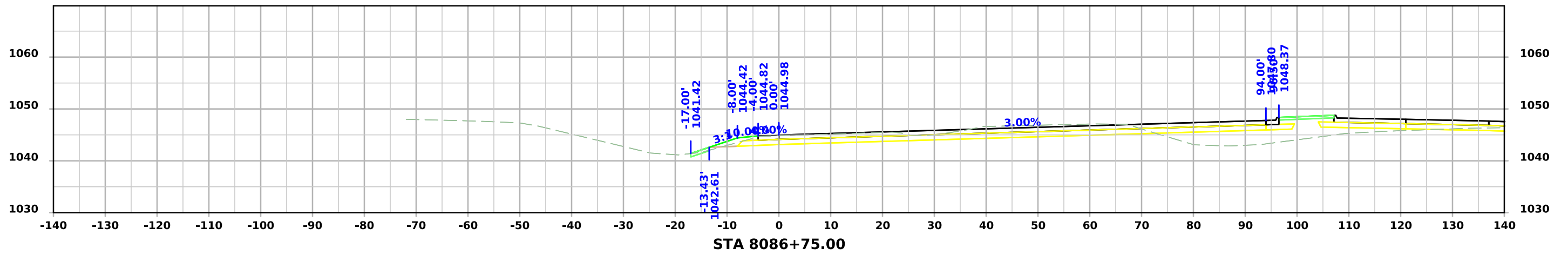

I-29 Ramp H

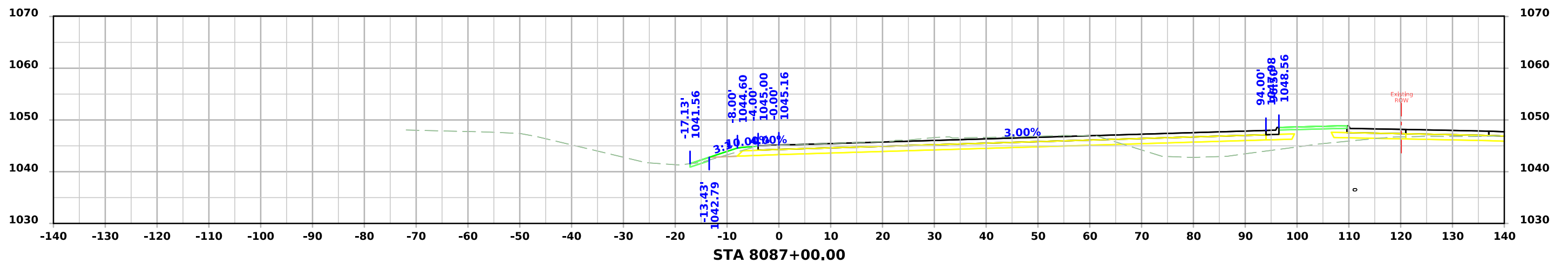
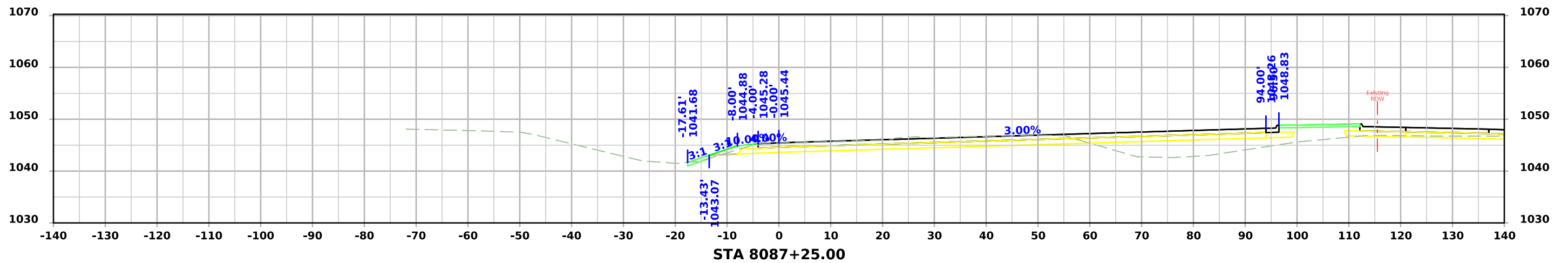
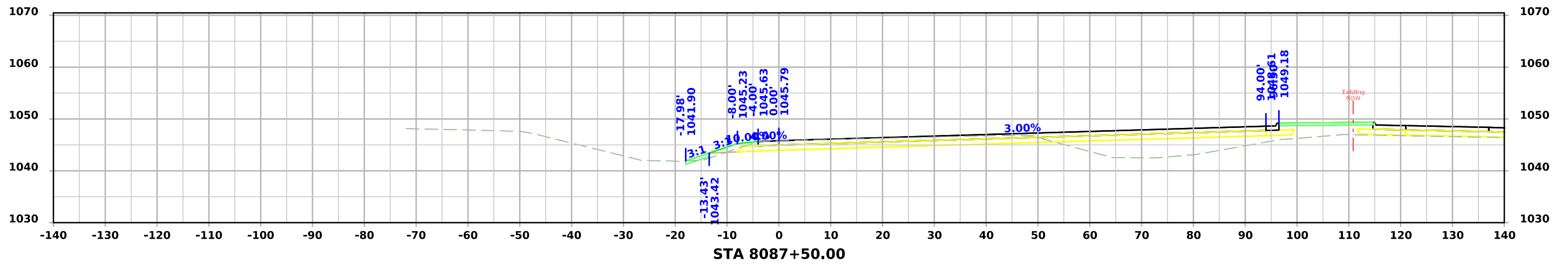

I-29 Ramp H

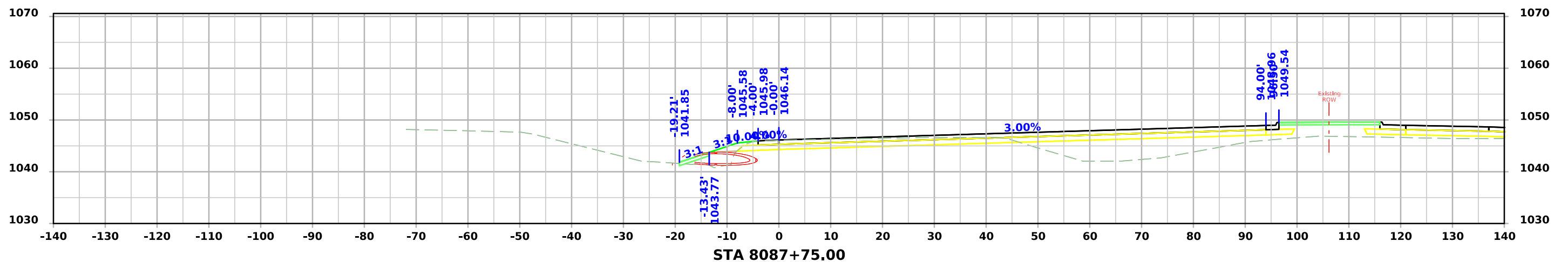
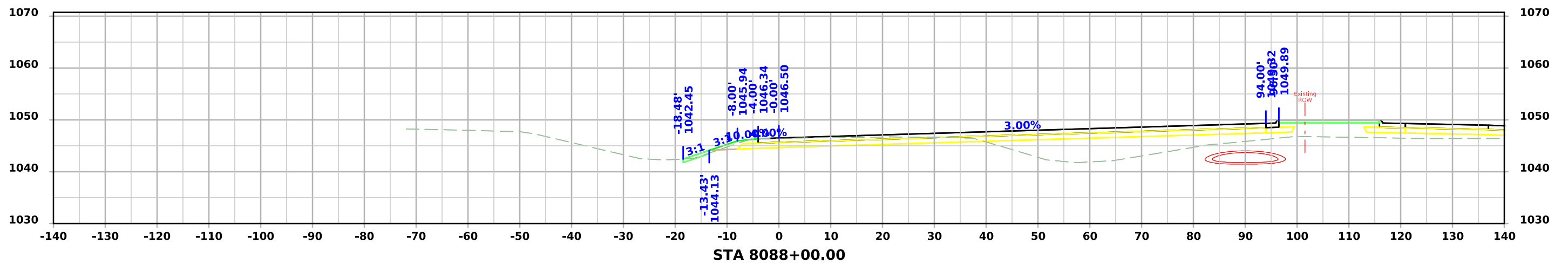
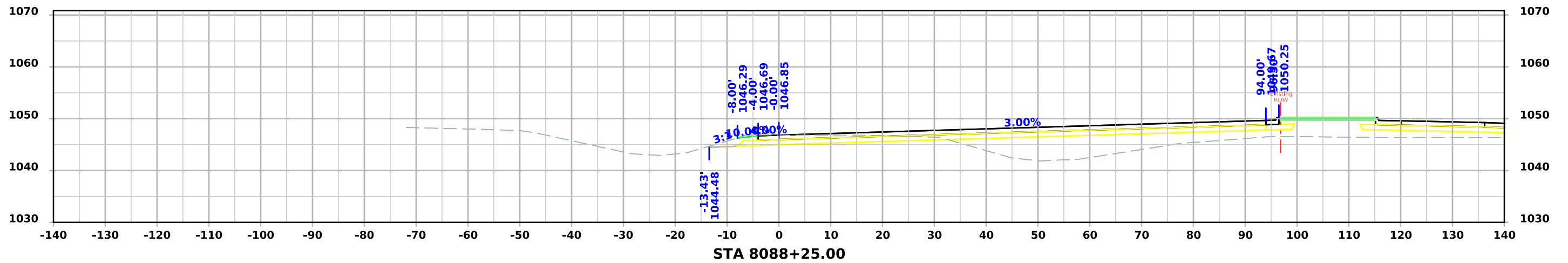

I-29 Ramp H

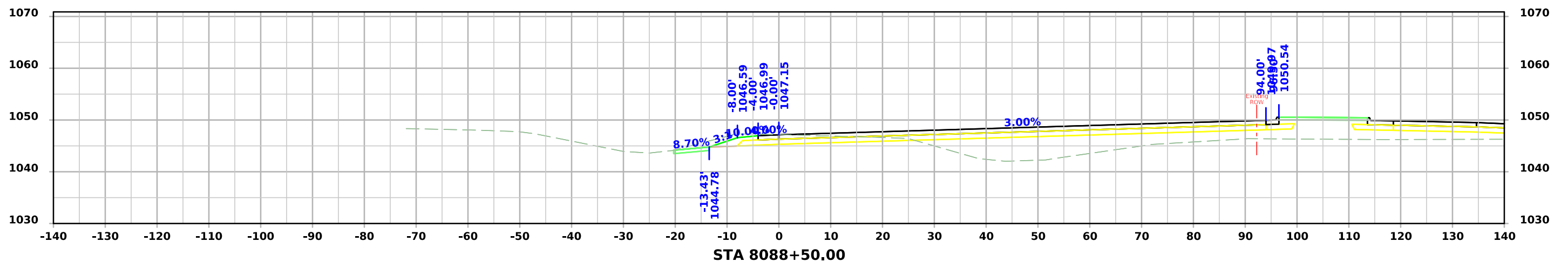
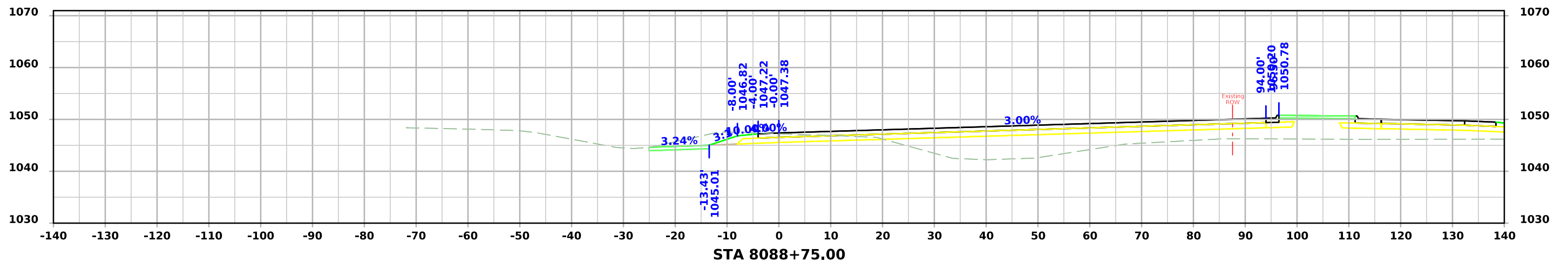
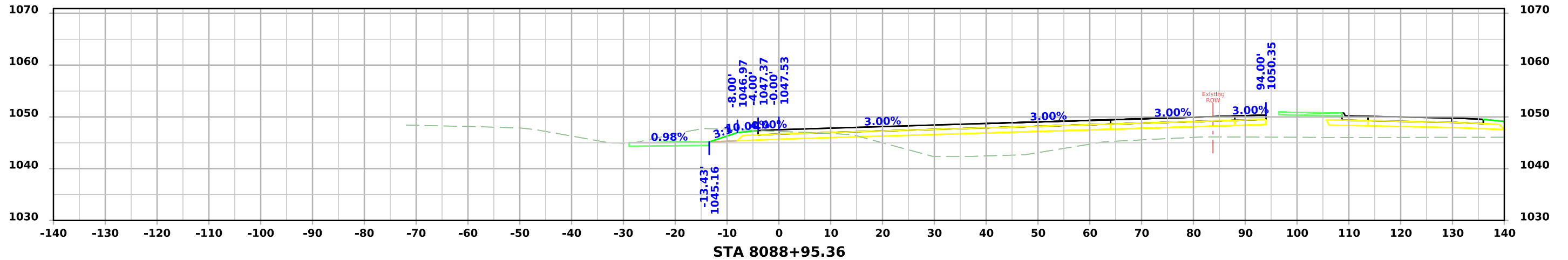

I-29 Ramp H

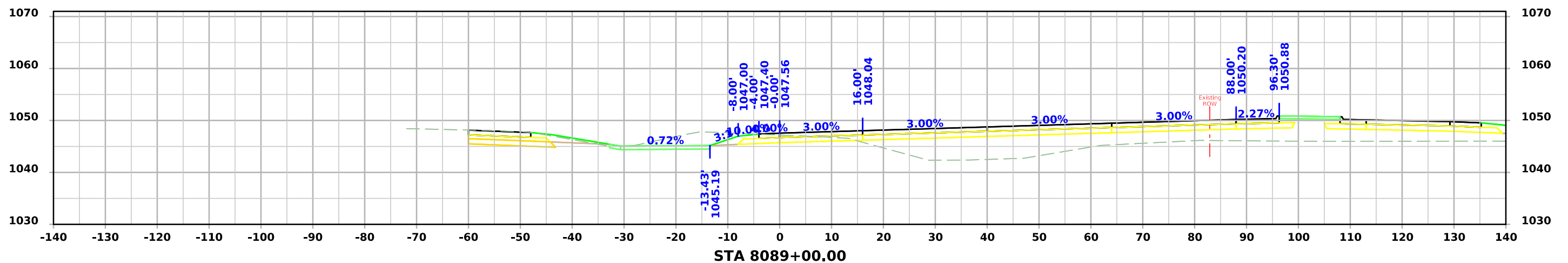
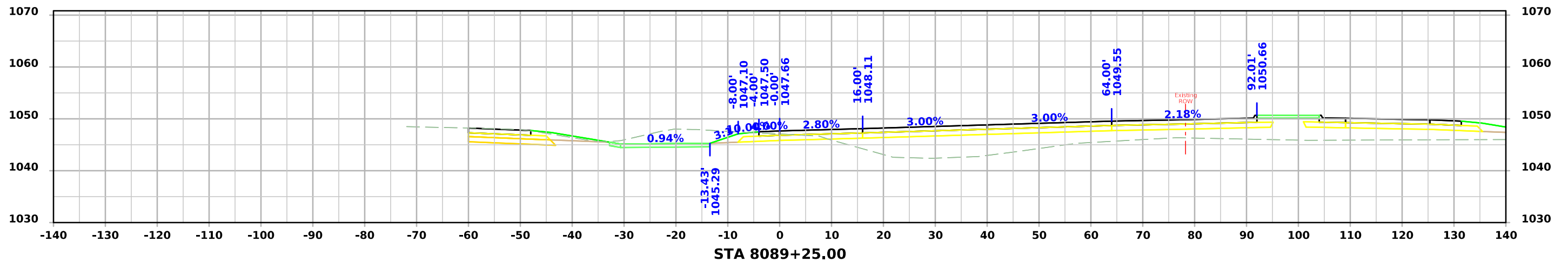
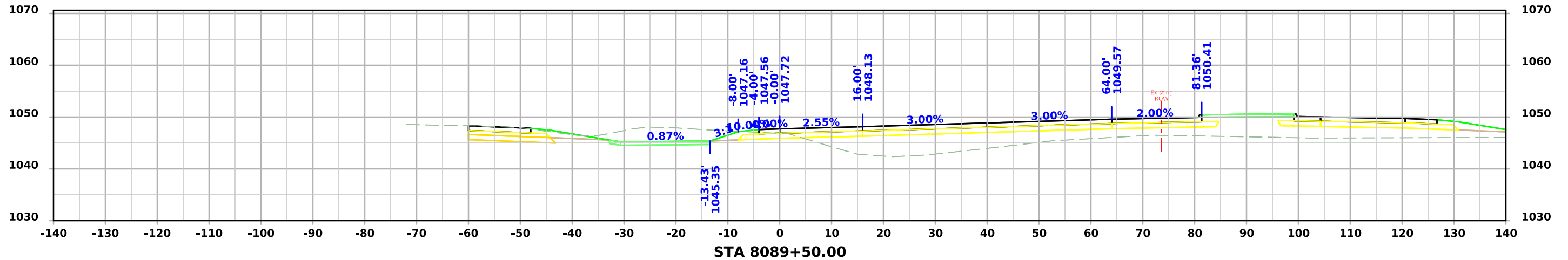

I-29 Ramp H

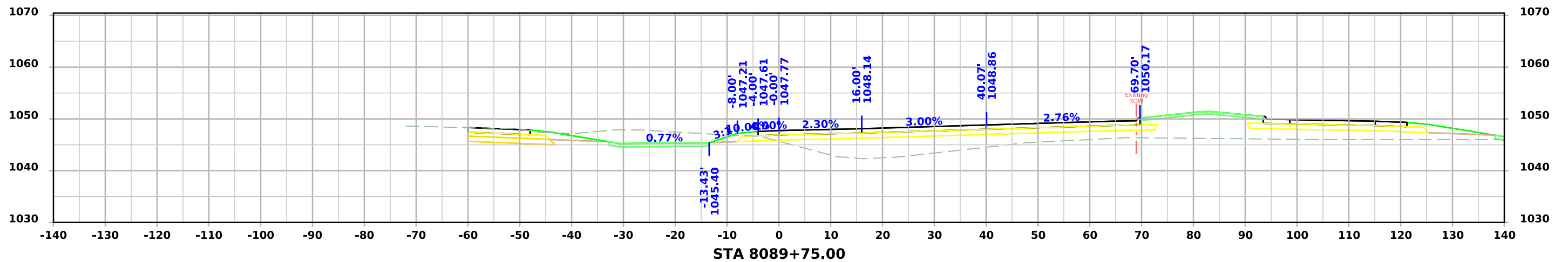
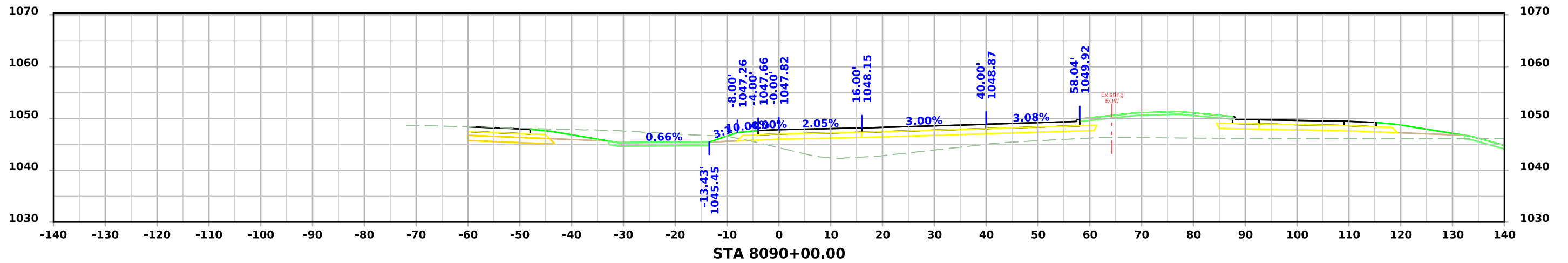
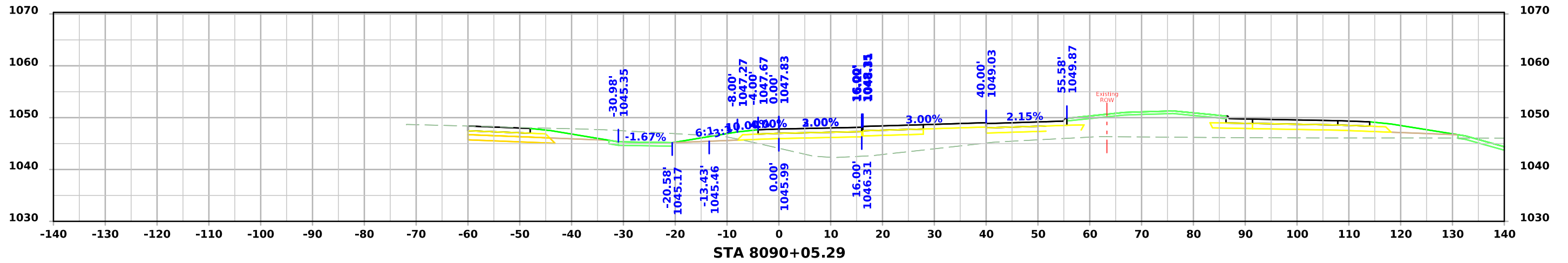

I-29 Ramp H

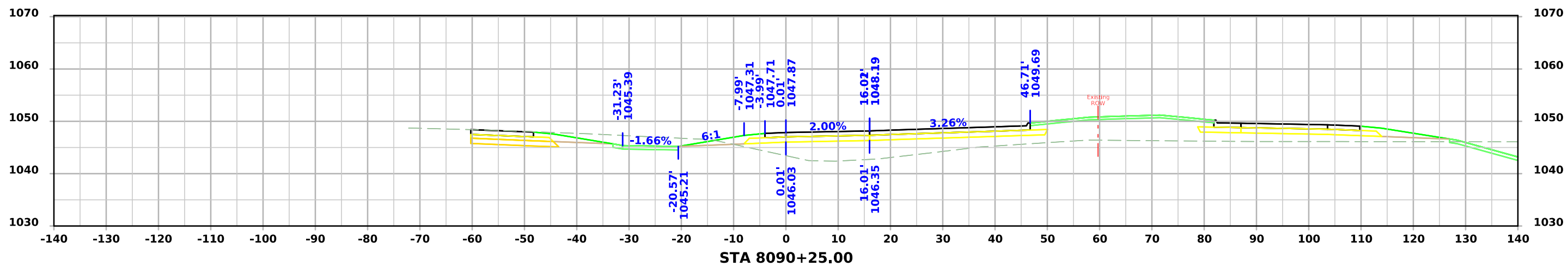
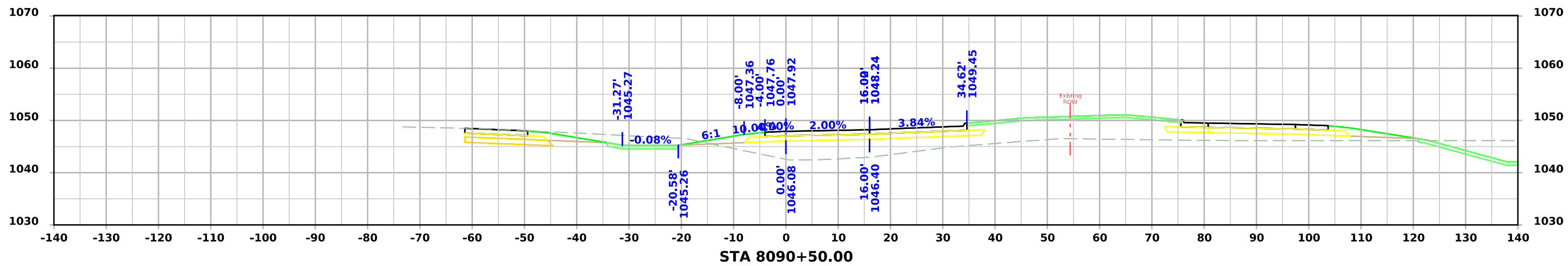
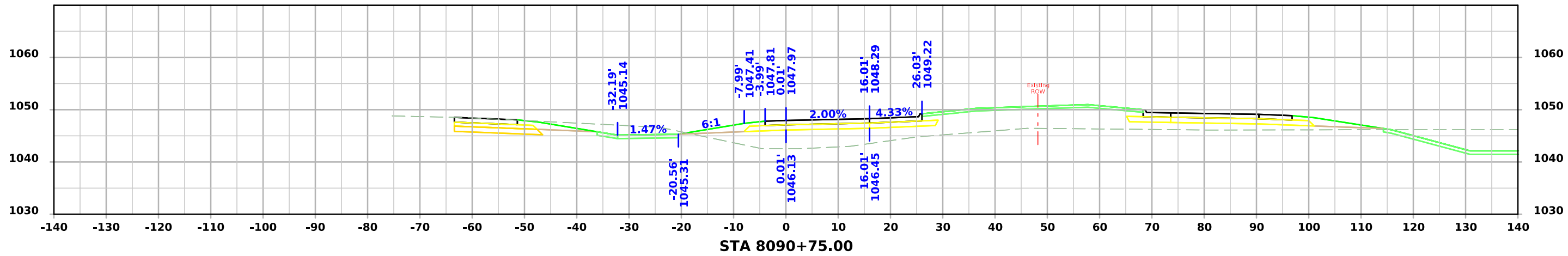

I-29 Ramp H

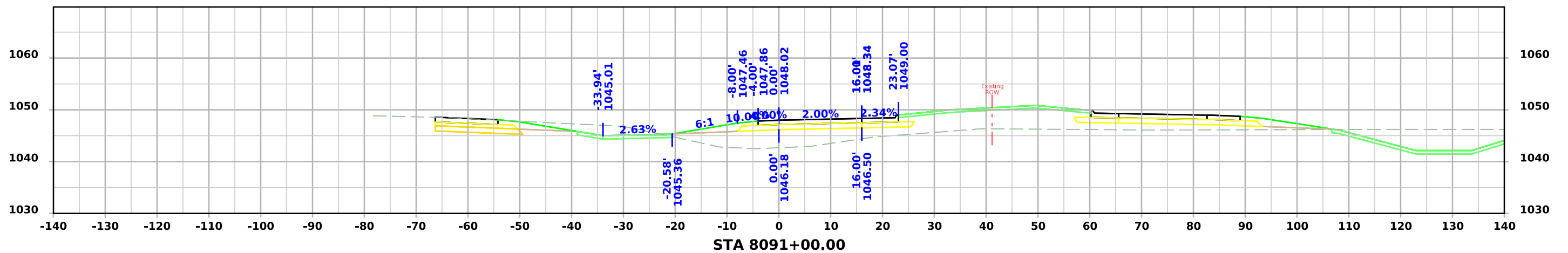
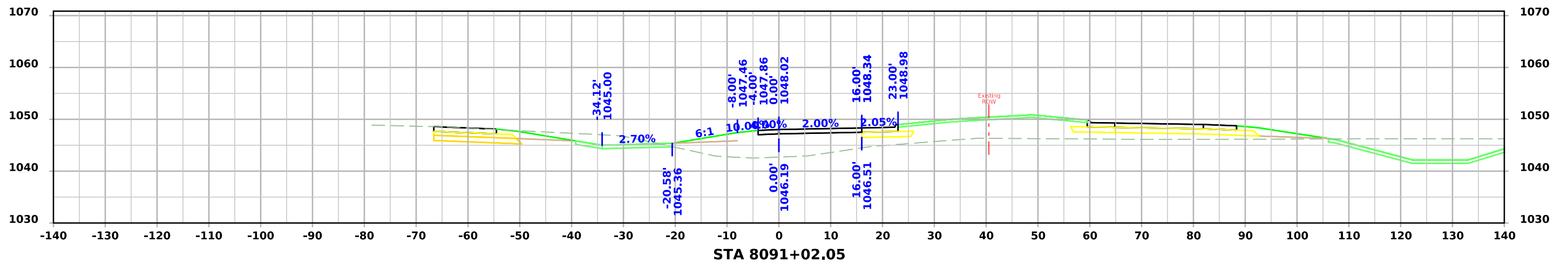
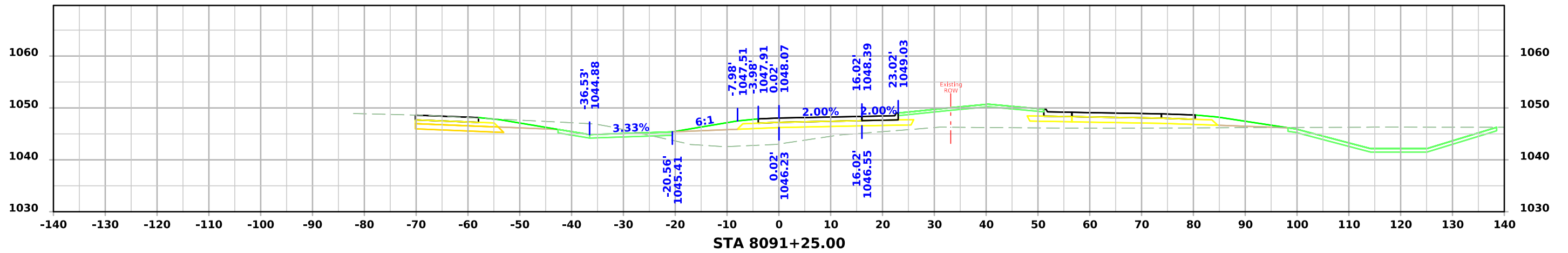

I-29 Ramp H

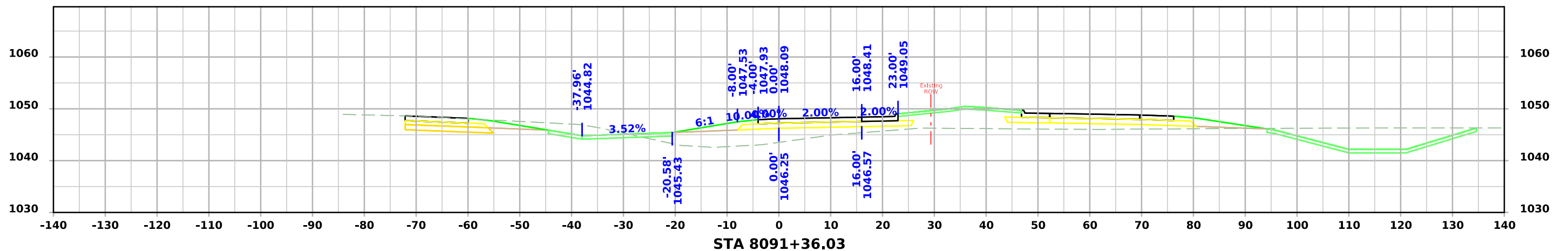
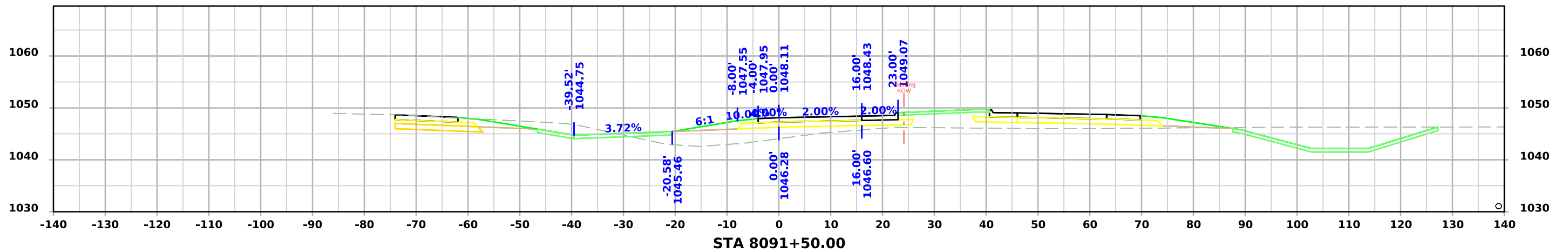
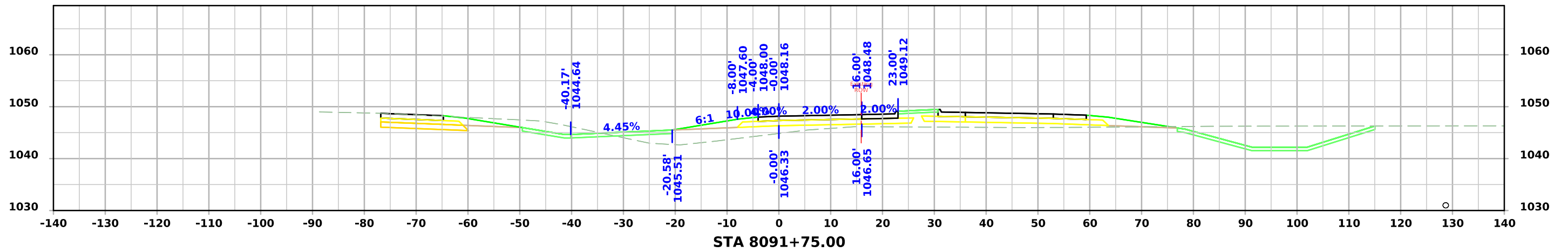

I-29 Ramp H

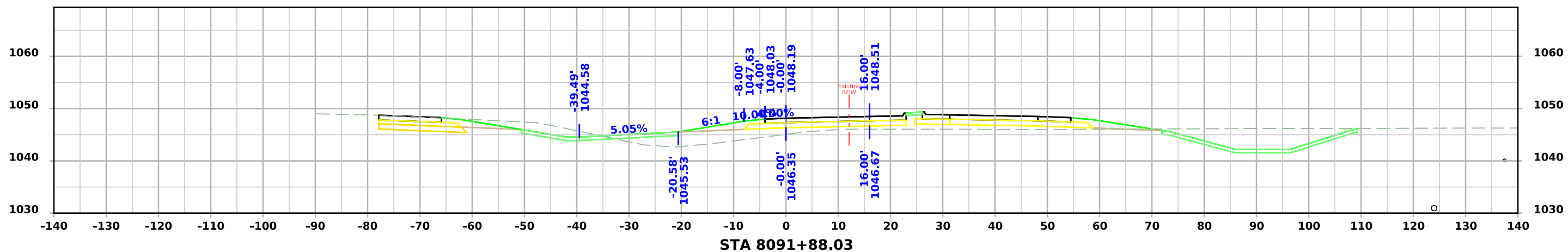
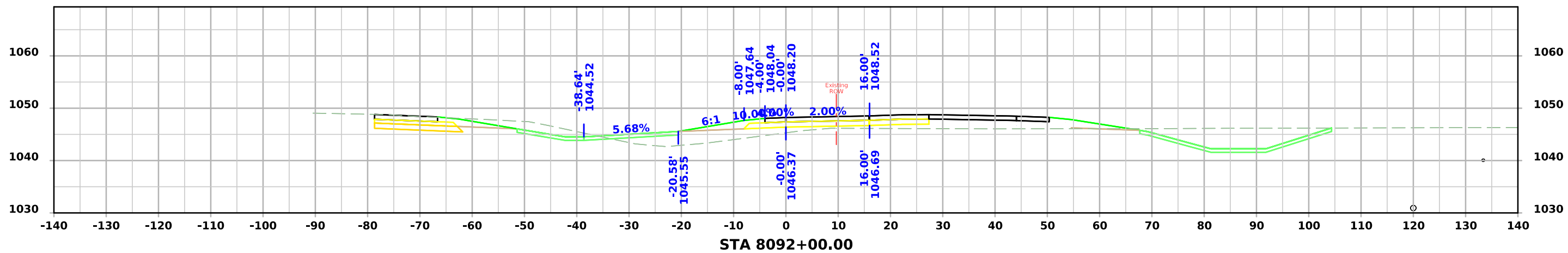
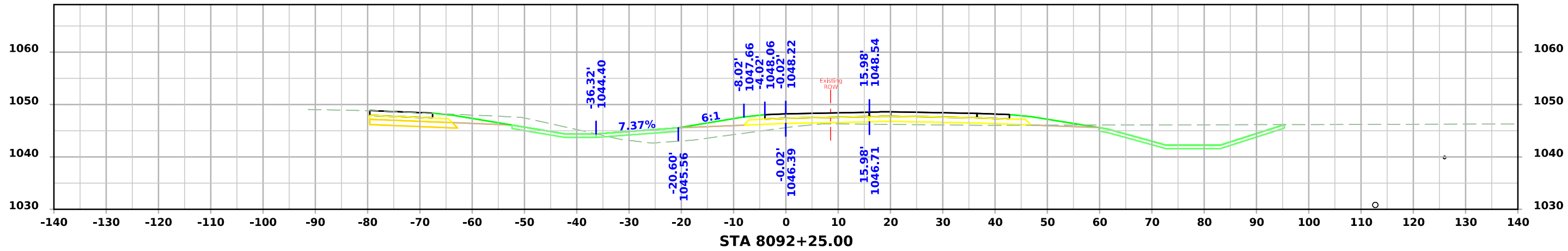

I-29 Ramp H

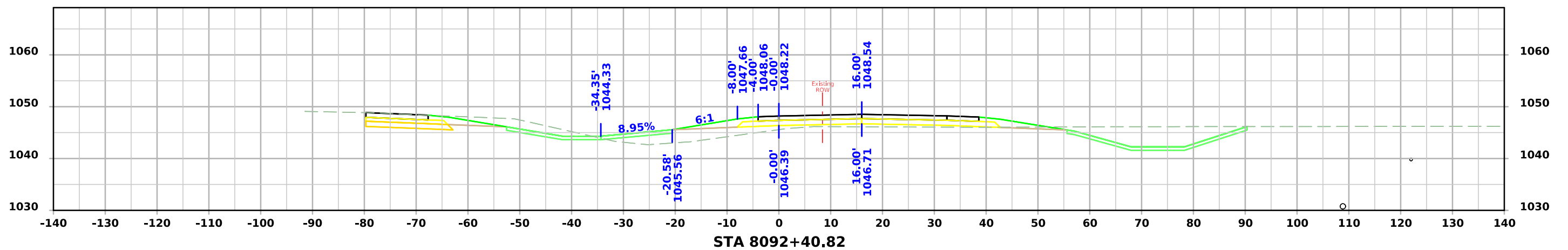
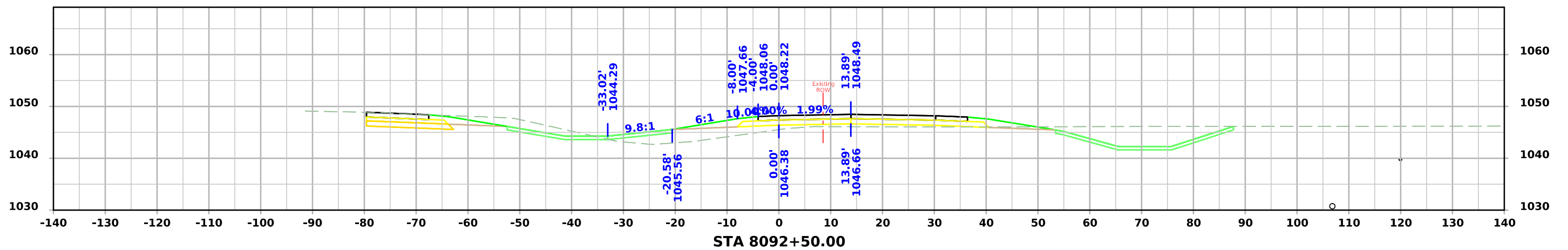
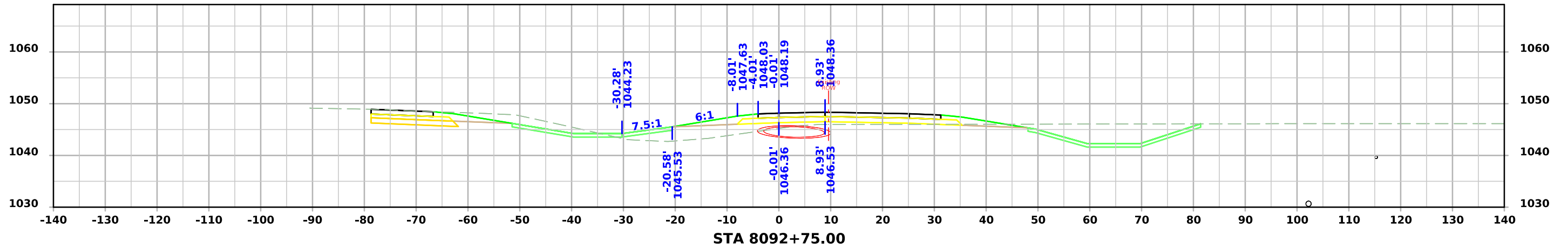

I-29 Ramp H

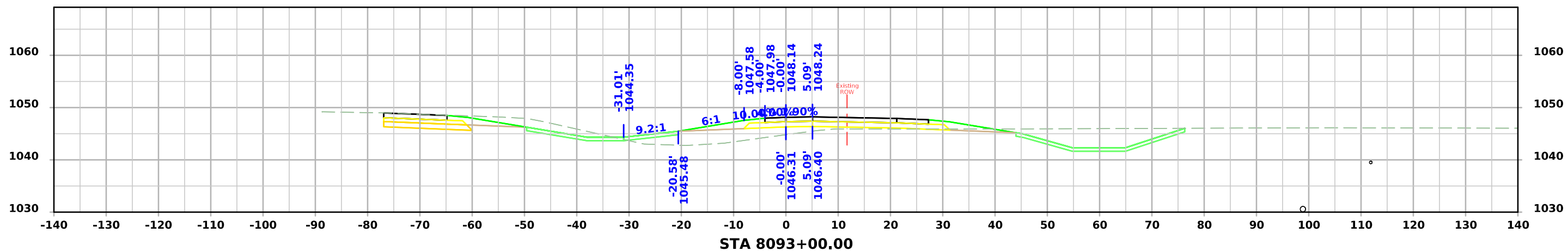
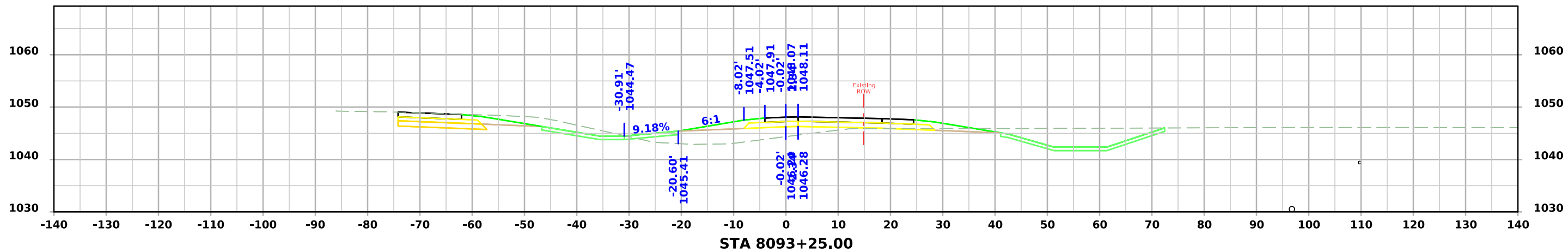
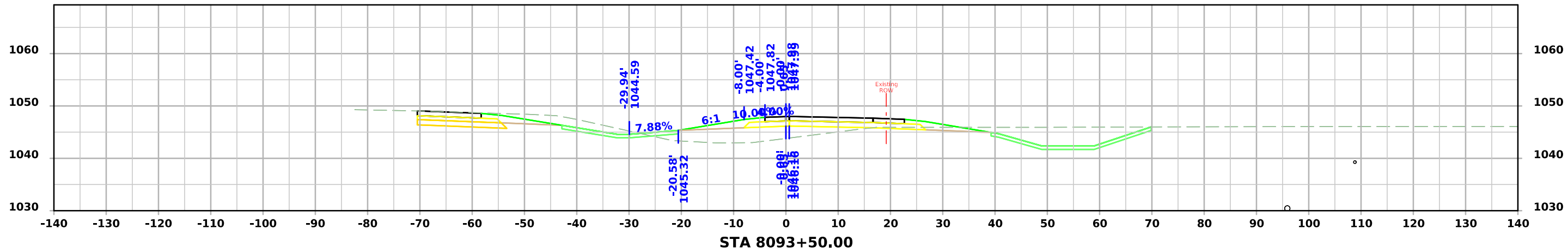

I-29 Ramp H

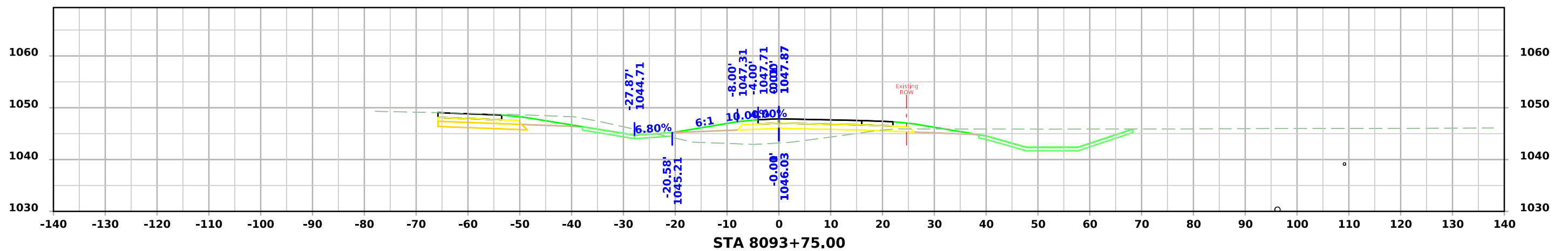
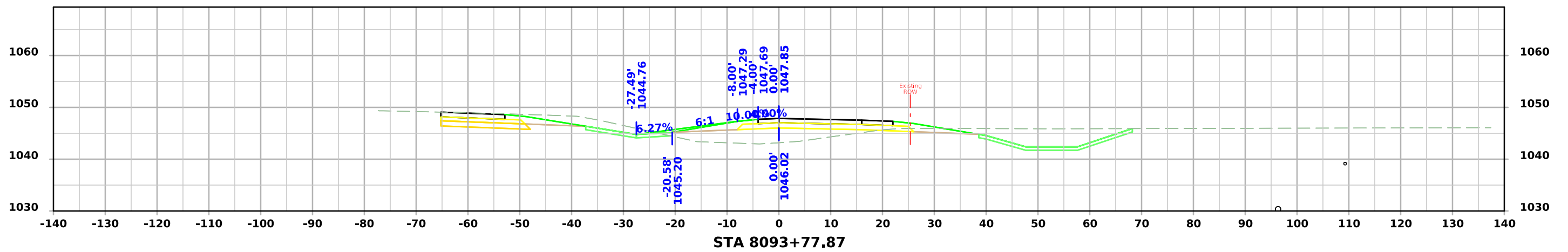

I-29 Ramp H

