

INDEX OF SHEETS	
No.	DESCRIPTION
A Sheets	Title Sheets
A.1	Title Sheet
A.2	Location Map Sheet
B Sheets	Typical Cross Sections and Details
B.1 - B.3	Typical Cross Sections and Details
C Sheets	Quantities and General Information
C.1 - C.3	Tabulation Sheets
D Sheets	Mainline Plan and Profile Sheets
* D.1	Plan & Profile Legend & Symbol Information Sheet
* D.2 - D.6	I-80
G Sheets	Survey Sheets
G.1	Horizontal Control Tab. & Super for all Alignments
G.2	Survey Information
G.3	Control Point Vicinity Map
G.4	Horizontal & Vertical Project Control Coordinate Listing
J Sheets	Traffic Control and Staging Sheets
J.1	Traffic Control Plan
J.2	Traffic Control & Staging Legend & Symbol Information Sheet
J.3	Traffic Control Typical
J.4 - J.8	Staging & Traffic Control Sheets
K Sheets	Interchange Sheets
* K.1	Plan and Profile Legend and Symbol Information Sheet
* K.2 - K.4	Interchange Layout Sheets
* K.5 - K.6	Ramp A Plan and Profile Sheets
* K.7 - K.8	Ramp C Plan and Profile Sheets
* K.9 - K.10	Ramp E Plan and Profile Sheets
* K.11 - K.13	Ramp G Plan and Profile Sheets
M Sheets	Storm Sewer Sheets
M.1	Storm Sewer Tabulations
R Sheets	Erosion Control Sheets
RC.1	Est. Quantities, PPP, General Notes and Tabulations
U Sheets	500 Series, Mod. Stds. and Detail Sheets
U.1 - U.2	500 Series, Modified Standards and Detail Sheets
V Sheets	Bridge and Culvert Situation Plans
* V.1 - V.14	Bridge and Culvert Plans
W Sheets	Mainline Cross Sections
W.1	Cross Sections Legend & Symbol Information Sheet
W.2 - W.45	Mainline Cross Sections
Y Sheets	Ramp Cross Sections
Y.1 - Y.102	Ramp Cross Sections
	* Color Plan Sheets



PLANS OF PROPOSED IMPROVEMENT ON THE
PRIMARY ROAD SYSTEM
Iowa COUNTY
PCC Pavement - Grade and New
Victor Rest Area 2.5 mi
E of Co RD V38 (WB)

SCALES: As Noted

Refer to the Proposal Form for list of applicable specifications.

Value Engineering Saves. Refer to Article 1105.14 of the Specifications.



REVISIONS

TOTAL	203
PROJECT IDENTIFICATION NUMBER	
PROJECT NUMBER	22-48-080-070
R.O.W. PROJECT NUMBER	IMX-080-6(536)208--02-48

INDEX OF SEALS			
SHEET NO.	NAME	TYPE	BID QUANTITY SHEETS
A.1	Cindy A. Spencer	Primary Signature Block	X
X	X	X	X

PRELIMINARY PLANS

Subject to change by final design.

D2 PLAN - Date: 6-30-23

PROJECT LOCATION

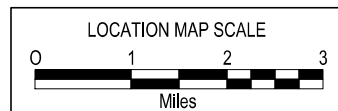
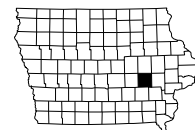
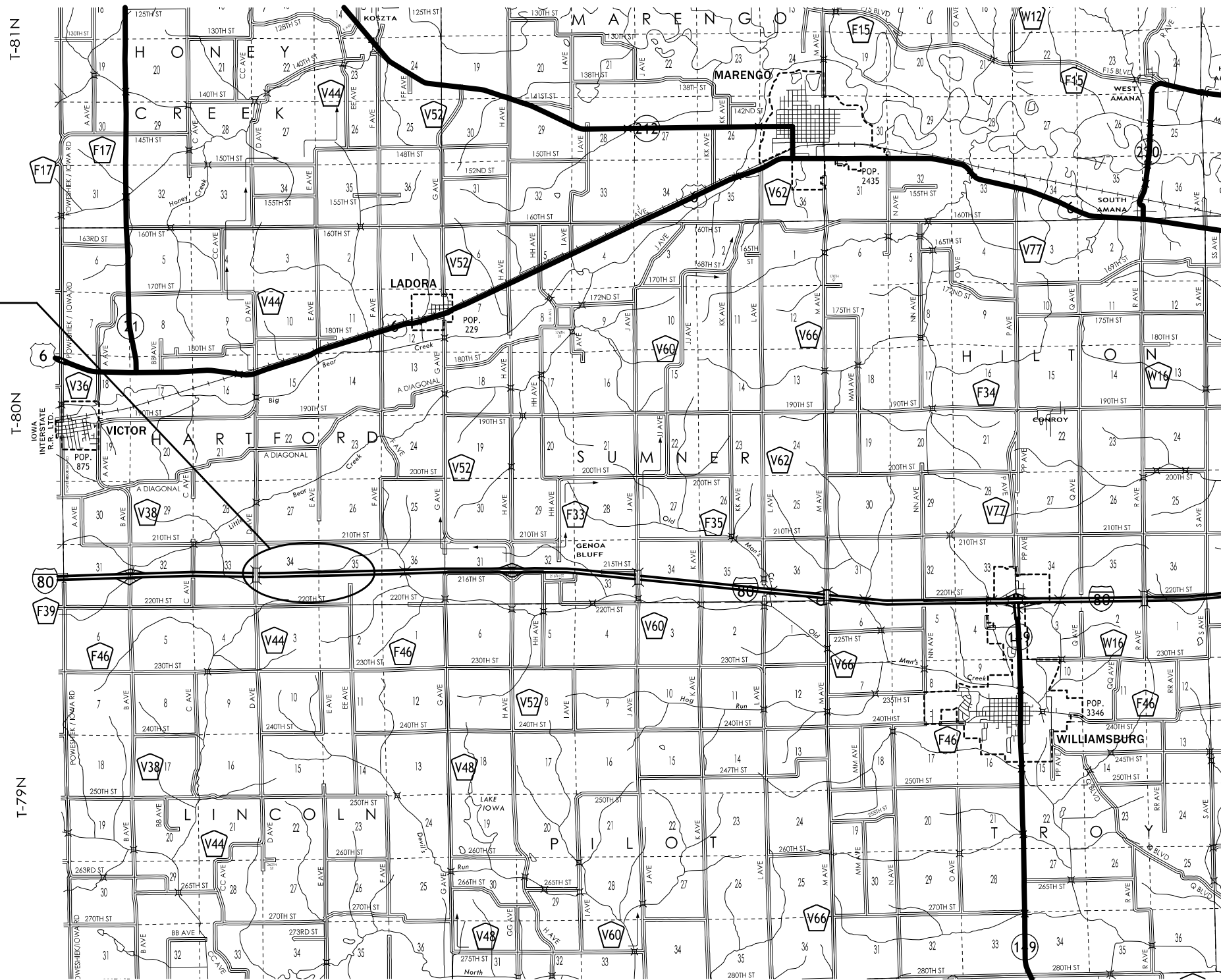

LOCATION			DIMENSIONS						
INTERCHANGE	RAMP	STATION TO STATION	(L) Feet	(R) Feet	(C) Feet	(X) Inches	(BW _L) Feet	(BW _R) Feet	(D) Feet
INTERSTATE 80	A	1000+00.00 1000+72.00	36.57	22.58	16	20.5	3.43	1.42	10.0
INTERSTATE 80	A	1006+27.11 1021+46.52	36.57	22.58	16	20.5	3.43	1.42	10.0
INTERSTATE 80	C	3023+61.56 3034+13.86	36.57	22.58	16	20.5	3.43	1.42	10.0
INTERSTATE 80	G	7003+08.92 7012+87.82	36.57	22.58	16	22	3.43	1.42	10.0
INTERSTATE 80	G	7030+85.54 7042+94.76	36.57	22.58	16	22	3.43	1.42	10.0

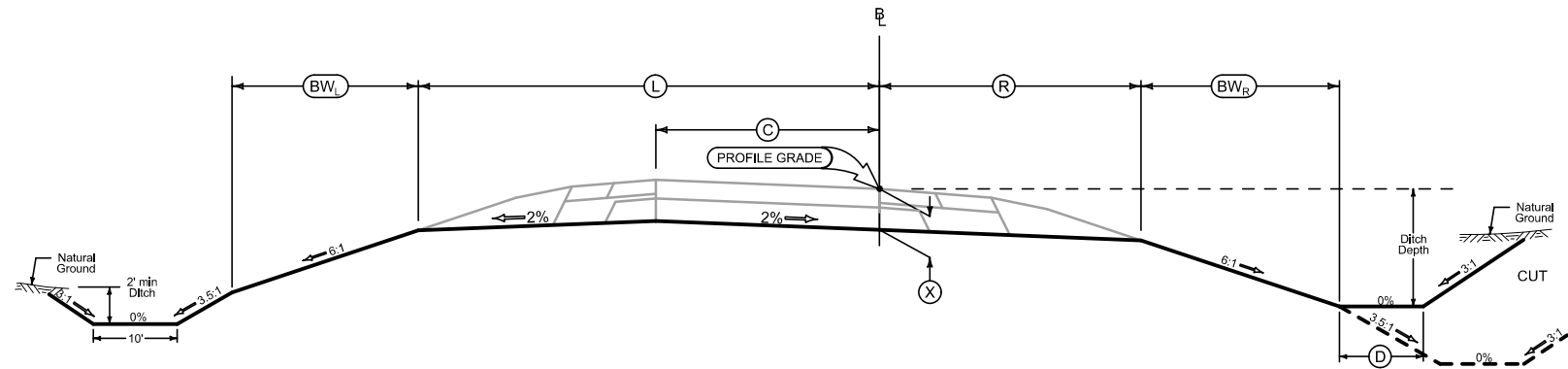

RAMP GRADING

Section shown in the direction of traffic.

Paved Shoulder Alternates

PCC Shoulder Jointing:
 Longitudinal joint: BT-1 or BT-5
 Transverse joints: C at 15' spacing
 HMA Shoulder Jointing:
 Longitudinal joint: B

1R_P_ALT_10-16-18			
RAMP	BEGIN STATION	END STATION	(P) Feet
A	1006+27.11	1021+46.52	4
C	3023+61.56	3034+13.86	4
G	7003+08.92	7012+87.82	4
G	7030+85.54	7042+94.76	4

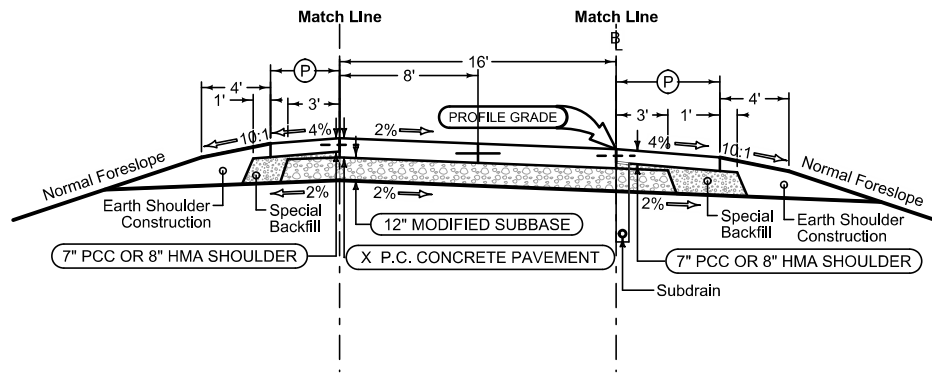

Section shown in the direction of traffic.

Ramp Jointing:
 Transverse joints: CD at 15' spacing.
 Longitudinal joints: L-2

1RP_10-17-17			
RAMP	BEGIN STATION	END STATION	(X) Inches
A	1000+00.00	1000+72.00	8.5
A	1006+27.11	1021+46.52	8.5
C	3023+61.56	3034+13.86	8.5
G	7003+08.92	7012+87.82	10
G	7030+85.54	7042+94.76	10

Paved Shoulder Alternates

PCC Shoulder Jointing:
 Longitudinal joint: BT-1 or BT-5
 Transverse joints: C at 15' spacing
 HMA Shoulder Jointing:
 Longitudinal joint: B

1R_P_ALT_10-16-18			
RAMP	BEGIN STATION	END STATION	(P) Feet
A	1006+27.11	1021+46.52	6
C	3023+61.56	3034+13.86	6
G	7003+08.92	7012+87.82	6
G	7030+85.54	7042+94.76	6

See Tab 100-24 or 100-25 for pavement quantities.

See Tab 112-9 for shoulder quantities.

**INTERSTATE 80 IOWA COUNTY REST AREA
 WESTBOUND RAMPS**

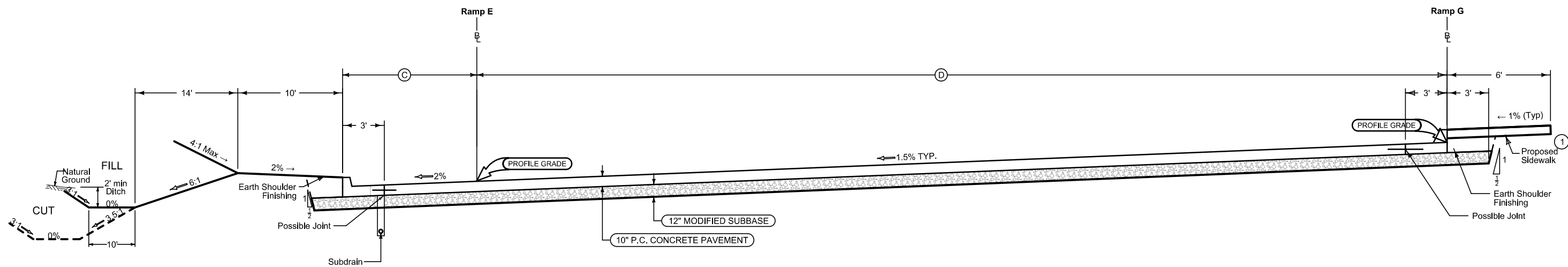

Integral Curb

Shoulder jointing:
 Longitudinal joint not required when distance from back of curb to nearest joint is less than 16':

Transverse: CD at 17' spacing
 Single pour: L-2
 Staged: KT-2

BEGIN STATION	END STATION	ⓐ Feet	Curb Type See PV-102
5001+00.00	5001+58.85	0-15.5	Standard
5001+58.85	5015+06.11	15.5	Standard
5015+06.11	5016+61.11	15.5-0	Standard

Integral Curb

Shoulder jointing:
 Longitudinal joint not required when distance from back of curb to nearest joint is less than 16':

Transverse: CD at 17' spacing
 Single pour: L-2
 Staged: KT-2

BEGIN STATION	END STATION	ⓓ Feet	Curb Type See PV-102
7012+89.22	7015+18.74	16-77.5	Standard
7015+18.74	7028+49.33	77.5	Standard
7028+49.33	7030+86.94	77.5-16	Standard

① Only install sidewalk adjacent to full-width pavement. Do not install in tapers.

**INTERSTATE 80 IOWA COUNTY REST AREA
 TRUCK PARKING LOTS**

Section shown in direction of traffic.

Refer to Plan and Profile sheets for Ditch Grade elevations

Direction of Travel	BEGIN STATION	END STATION
W.B.	184+76.73	196+88.19
W.B.	203+73.11	224+27.77

Full Depth HMA Shoulder

Shoulder Jointing:
Longitudinal joint: B

4_P_FullHMA_04-21-20			
Direction of Travel	BEGIN STATION	END STATION	(P) Feet
W.B.	196+88.19	203+73.11	8.0

Auxiliary Lane (1)

Direction of Travel	BEGIN STATION	END STATION	(W) Feet
W.B.	165+65.76	171+66.57	2'-12"
W.B.	171+66.57	181+66.58	12'
W.B.	224+27.77	230+27.77	39.9'-2"

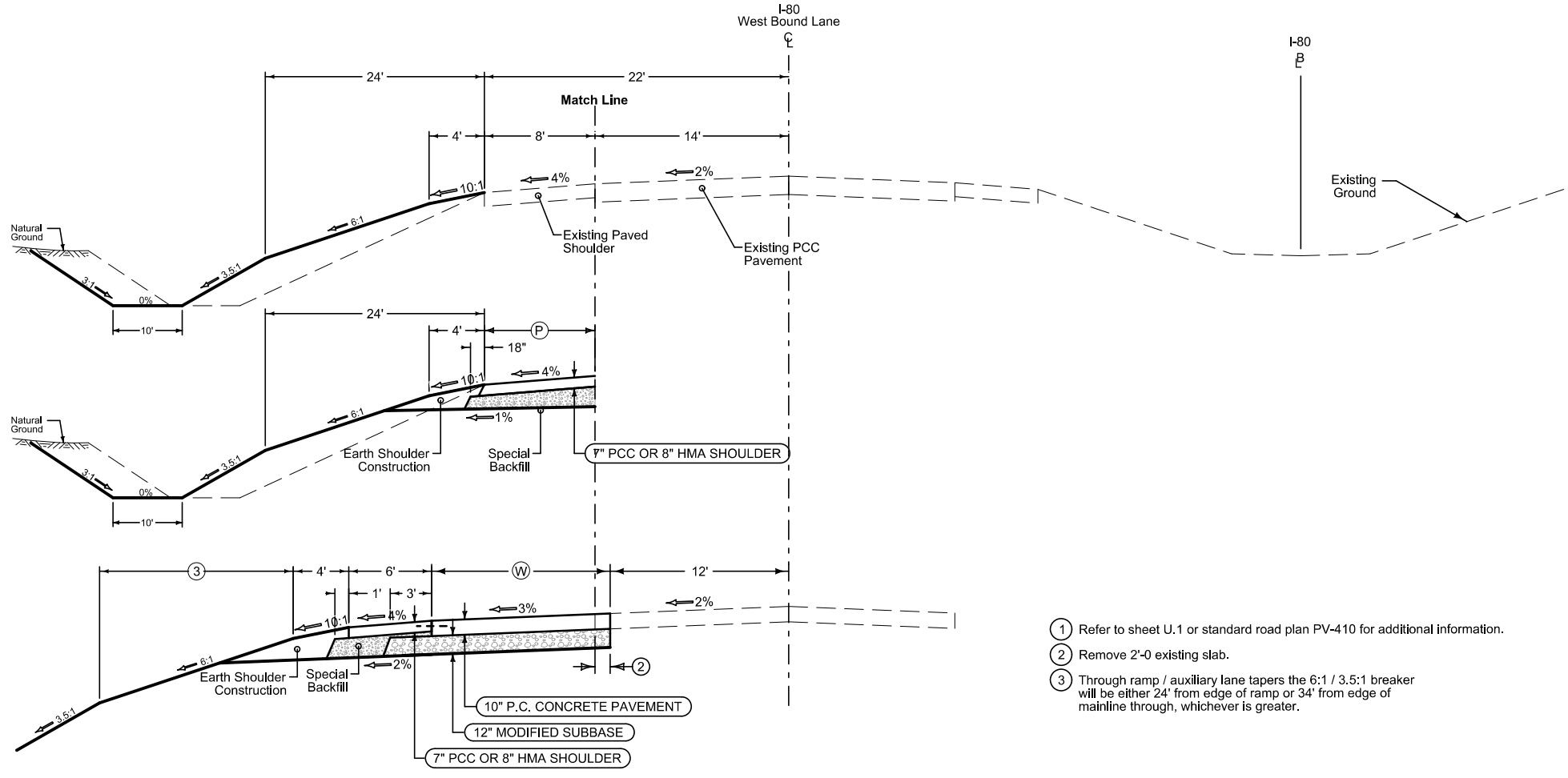

- (1) Refer to sheet U.1 or standard road plan PV-410 for additional information.
- (2) Remove 2'-0" existing slab.
- (3) Through ramp / auxiliary lane tapers the 6:1 / 3.5:1 breaker will be either 24' from edge of ramp or 34' from edge of mainline through, whichever is greater.

**INTERSTATE 80
FORESLOPE IMPROVEMENTS**

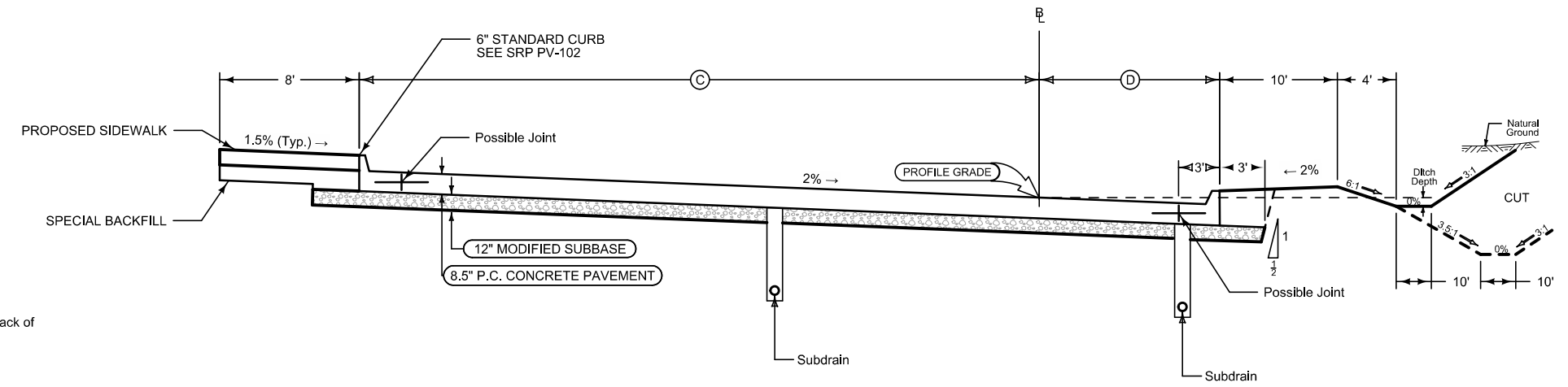

Integral Curb

Shoulder jointing:
Longitudinal joint not required when distance from back of curb to nearest joint is less than 16':

Transverse: C at 17' spacing
Single pour: L-2
Staged: KT-2

BEGIN STATION	END STATION	(D) Feet
1000+72.00	1000+77.77	0-10
1000+77.77	1006+21.34	10
1006+21.34	1006+27.11	10-0

Integral Curb
Shoulder jointing:
Longitudinal joint not required when distance from back of curb to nearest joint is less than 16':

Transverse: C at 17' spacing
Single pour: L-2
Staged: KT-2

BEGIN STATION	END STATION	(C) Feet
1000+72.00	1006+13.84	39
1006+13.84	1006+27.11	39-16

PARK. LOT	BEGIN STATION	END STATION
Ramp A	1000+72.00	1006+27.11

Section view is in direction of traffic.

**INTERSTATE 80 IOWA COUNTY REST AREA
AUTO PARKING LOTS**

DRAINAGE STRUCTURE BY ROAD CONTRACTOR

Length of unclassified pipe calculated is based on using Reinforced Concrete Pipe.

- * Not a bid item
- ① Diameter or equivalent diameter
- ② UNCL = Unclassified Pipe CMP = Corrugated Metal Pipe RCP = Reinforced Concrete Pipe LCP = Arch or Elliptical Low Clearance Pipe SARC = Steel Arch Pipe
- ③ Backfill according to DR-101

Drainage Area ACRE	Location	Type	Size ① IN	Kind Of Pipe ②	Length New Const. LF	Bedding Class	Design Cover (H) FT	Camber* (DR-102) FT	Apron No.		Apron Guard* (DR-213) No.	Elbow* (DR-141) No.	Diaphragm* (DR-501) No.	Tee Section* (DR-142) No.	"D" Section* (DR-141) No.	Reducer* No.	Type 'C' Connections* (DR-122)		Connected Pipe Joint* (DR-121) Type	4" Perforated Subdrain* FT	Flow Line Elevations				Dimensions Lin. Ft.				Skew Ahead Degrees		Dike			Class 20 CY	Flowable Mortar CY	Floodable* Backfill (A) CY	Porous* Backfill (B) CY	Flooded Backfill (A+B) CY	Remarks				
									IN	OUT							Type	No.			Lt.	Rt.	Other	Other	Lt.	Rt.	Lt.	Rt.	Lt.	Rt.	Lt.	Rt.	Lt.							Rt.	Location Station	Top Elevation	Type
									Total								Extensions				Total		Extensions		Total		Extensions		Total		Extensions												
	164+99.70	DR-621	30	RCP	14	B											C-1	1			914.00	UAC	913.90		87.6	UAC	14.0												Rmv&Reinst Apron				
	+00.70, 37' LT	DR-621	24	RCP	14	B											C-1	1			914.75	UAC	914.85		86.5	UAC	14.0												Rmv&Reinst Apron				
	7003+23.37	DR-621	42	RCP	-44	B											C-1	1			910.40	UAC			45.0	UAC	-44.0													Rmv&Reinst Apron			
	+19.23, 37' LT	DR-621	24	RCP	12	B											C-1	1			915.10	UAC	915.53		87.4	UAC	12.0													Rmv&Reinst Apron			
	194+38.90	DR-621	24	RCP	12	B											C-1	1			912.50	UAC	912.62		87.2	UAC	12.0													Rmv&Reinst Apron			
	199+92.20	DR-621	30	RCP	-10	B											C-1	1			906.91	UAC	917.02		99.6	UAC	-10.0			10										Rmv&Reinst Apron			
	+50.00, 37' LT	DR-621	24	RCP	14	B											C-1	1			907.22	UAC	907.46		88.0	UAC	14.0													Rmv&Reinst Apron			
	206+70.40	DR-621	24	RCP	16	B											C-1	1			907.30	UAC	907.56		86.5	UAC	16.0													Rmv&Reinst Apron			
	213+75.20	DR-621	36	RCP	10	B											C-1	1			885.70	UAC	885.82		133.0	UAC	10.0			45										Rmv&Reinst Apron			
21.5	1014+75.00	DR-601	36	RCP	98	B	8.6	0.17	1	1	1								Type 2		879.55	884.02		56.7	57.3																		
11.3	3030+19.00	DR-601	30	RCP	116	B	10.8	0.25	1	1	1								Type 2		902.00	905.94		62.9	65.4																		
1.0	7006+00.00	DR-601	24	RCP	78	B	4.9	0.08	1	1	1								Type 2		912.50	913.96		41.7	48.6																		
10.6	7013+50.90	DR-601	30	RCP	152	B	11.4	0.25	1	1	1								Type 2		906.26	910.50		84.5	79.8																		

ROADWAY ITEMS FOR DRAINAGE STRUCTURES INSTALLED BY CULVERT CONTRACTOR

- * Not a Bid Item
- ① Backfill according to DR-111

Location	Design Number	Size	Kind	By Road Contractor							Floodable* Backfill (A) CY	Porous* Backfill (B) CY	Flooded Backfill (A+B) CY	Excavation		Revetment		Engineering Fabric SY	Remarks	
				Dike				Compacting Backfill Adjacent CY	Compaction w/Moisture Control CY	Compaction w/Moisture and Density CY				Type	Type	Quantity CY	Type			Quantity TONS
				Rt.	Location Station	Top. Elev.	Type													
226+38.20		8' x 4'	RCB											Class 10, Channel		Class E				

SANITARY OR STORM SEWER ABANDONMENT OR REMOVAL

* Not a bid item

Location/Description	Sanitary or Storm Sewer	Abandonment, Plug Only or Abandonment, Plug and Fill or Removal	Length of Pipe		Fill Material* Flowable Mortar or CLSM CY	Remarks
			≤ 36 inch diameter LF	> 36 inch diameter LF		
			Sta. 2056+26 LT - 42" RCP	Storm Sewer		
Sta. 2056+26 under pavement - 42" RCP	Storm Sewer	Removal		34		
Sta. 2056+99 RT - 15" RCP	Storm Sewer	Removal	114			Also remove apron
Sta. 2058+44 RT - 15" RCP	Storm Sewer	Removal	122			Also remove apron
Sta. 2060+10 under pavement - 18" RCP	Storm Sewer	Removal	27			
Sta. 2060+10 LT - 18" RCP	Storm Sewer	Removal	12			Also remove apron
Sta. 166+00.70, 37' LT - 24" RCP	Storm Sewer	Removal				Remove apron LT
Sta. 185+29.00 - 42" RCP	Storm Sewer	Removal		44		Remove pipe LT side
Sta. 185+08 LT - 24" RCP	Storm Sewer	Removal	16			Also remove apron. Plug tee to 42" RCP
Sta. 194+19.23, 37' LT - 24" RCP	Storm Sewer	Removal				Remove apron LT
Sta. 194+38 LT under ramps - 24" RCP	Storm Sewer	Removal	91			Also remove aprons
Sta. 194+38.90 - 24" RCP	Storm Sewer	Removal				Remove apron LT
Sta. 199+92.20 - 30" RCP	Storm Sewer	Removal	10			Remove pipe LT. Also remove apron LT.
Sta. 206+18.90, 37' LT - 24" RCP	Storm Sewer	Removal				Remove apron LT
Sta. 206+70.40 - 24" RCP	Storm Sewer	Removal				Remove apron LT
Sta. 213+75.20 - 36" RCP	Storm Sewer	Removal				Remove apron LT
Sta. 219+18.40, 37' LT - 24" RCP	Storm Sewer	Removal				Remove apron LT
Sta. 219+44.50 - 24" RCP	Storm Sewer	Removal				Remove apron LT

REMOVAL OF EXISTING STRUCTURES

Location	Description	Remarks
226+38.20	8' x 4' RCB	Remove headwalls / wingwalls LT

PCC PAVEMENT

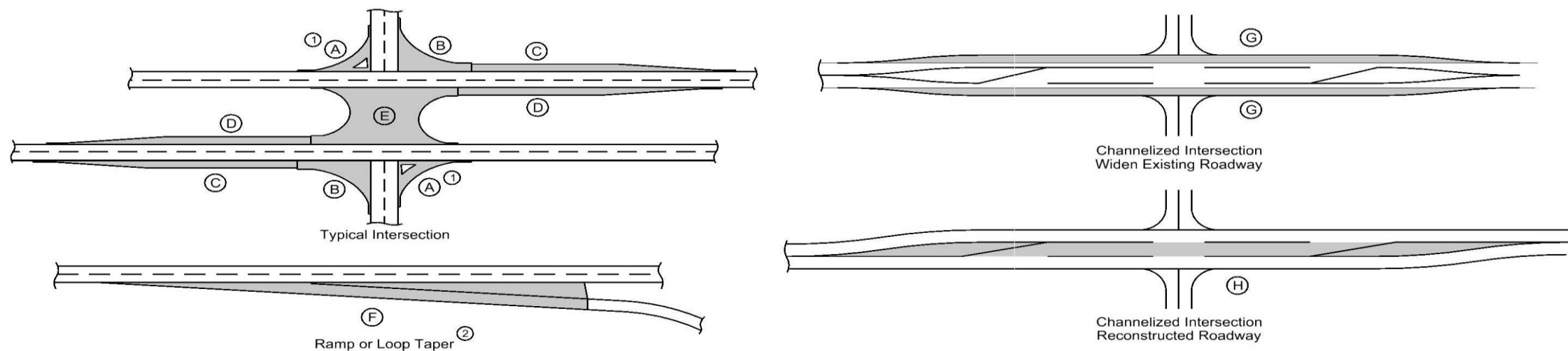

- ① Does not include raised island area or curb. Refer to tabulation 112-4 for quantities.
- ② Refer to PV-410, PV-411, PV-412, and PV-414.
- ③ Quantity includes Pavement Header.

Road Identification	Location		Mainline			Area ③								Total Area By Pavement Thickness		Special Backfill	Modified Subbase	Granular Subbase	Remarks	
	Direction of Travel	Station to Station		Width	Length	Area	A ①	B	C	D	E	F ②	G	H	SY					
		FT	FT												SY					10 IN
I-80	WB	165+65.76	184+76.73		1911.0							2234.7			2234.7		957.2			
		224+27.77	230+27.77		600.0							1332.0			1332.0		510.7			
Ramp G	WB	7003+08.92	7012+87.82	16.0	978.9	1740.3						213.8			1954.1		868.9			
		7012+87.82	7015+75.18	16-93	287.4	1740.1									1740.1		643.9			
		7015+75.18	7028+47.92	93.0	1272.7	13151.6									13151.6		4666.7			
Ramp E	WB	5014+30.58	5015+05.11	93-73	74.5	687.3									687.3		245.7			
		5015+05.11	5016+60.11	73-16	155.0	766.6									766.6		290.0			
		5016+60.11	5028+68.26	16.0	1208.2	2147.8						213.8			2361.6		1055.7			
Ramp C	WB	3023+61.56	3034+85.86	16.0	1124.3	1998.8									1998.8		916.1			
Ramp A	WB	1000+72.00	1000+77.77	39-49	5.8	28.2									28.2		10.7			
		1000+77.77	1006+13.84	49.0	536.1	2918.6									2918.6		1092.0			
		1006+13.84	1006+27.11	49-16	13.3	52.1									52.1		20.3			
		1006+27.11	1021+46.52	16.0	1519.4	2701.2									2701.2		1238.0			

REMOVAL OF PAVEMENT

Refer to Tabulation 102-5

* Not a Bid Item

Begin Station	End Station	Side	Pavement Type	Area	Saw Cut*	Remarks
				SY	LF	
162+94.50	238+38.00	RT	HMA	5029.0	12.0	Inside shoulder
224+27.77	230+27.77	LT	HMA	533.3	16.0	Outside shoulder
224+27.77	230+27.77	LT	PCC	133.3	604.0	Mainline slab
165+65.76	181+33.51	LT	HMA	1059.4	8.0	Outside shoulder
165+65.76	181+33.51	LT	PCC	2431.9	1569.8	Mainline slab and accel lane / taper
181+33.51	184+76.73	LT	HMA	305.1	8.0	Outside shoulder
181+33.51	184+76.73	LT	PCC	76.3	347.2	Mainline slab
181+33.51	196+89.38	LT	PCC	14762.9	0.0	Parking area
196+89.38	203+75.51	LT	HMA	481.6	8.0	Outside shoulder
196+89.38	203+75.51	LT	PCC	1885.8	686.1	Decel taper

110-1
04-16-13

SHOULDERS

- ① Lane(s) to which the shoulder is adjacent.
- ② See Typ. 7156, 7157, or 7158.
- ③ Bid Item.
- ④ Applies only for Paved Shoulders constructed on project with existing granular shoulders.
- ⑤ Bid Item. Typ. 7156, 7157, or 7158.
- ⑥ Does not include shrink.

Calculations assume a HMA unit weight (lbs/cf) of 150, a Special Backfill unit weight (lbs/cf) of 140, and a Granular Shoulder unit weight (lbs/cf) of 140.

Road Identification	Direction Of Traffic	Location				Quantities																	Remarks						
		Station to Station		Side	P Width FT	P _{SG} Width FT ②	G Width FT	L Length FT	Class 13 ^④ Excavation CY ③	Hot Mix Asphalt		Binder TONS	Paved Shoulder SY ③	" Paved Shoulder at Guardrail SY ⑤	Reinforced Paved Shoulder SY ③	Special Backfill				Subbase CY ③	Granular Shoulder			Earth Shoulder Construction Alternates					
		Start	End							TON	TON/STA					HMA Alternate		PCC Alternate			TON	TON/STA		STA ③	HMA CY ⑥	PCC CY ⑥			
I-80	WB	196+90.00	203+75.51	LT	10.0			685.5		342.926	50.025	20.576	761.7					360.565	52.598							6.9			Outs
		165+65.76	167+66.12	LT	10 to 6			200.4		80.169	40.013	4.810	178.1					90.925	45.381							2.0			
		167+66.12	184+76.73	LT	6.0			1710.6		513.183	30.000	30.791	1140.4					652.717	38.157							17.1			
Ramp G	WB	7003+08.92	7007+62.02	LT	6.0			453.1		135.930	30.000	8.156	302.1					172.889	38.157							4.5			
		7003+08.92	7012+87.82	RT	4.0			978.9		195.878	20.010	11.753	435.1					220.987	22.575							9.8			
		7007+62.02	7009+08.09	LT	0 to 6			146.1		21.910	15.000	1.315	48.7					27.873	19.082							1.5			
		7009+08.09	7012+87.82	LT	6.0			379.7		113.919	30.000	6.835	253.2					144.894	38.157							3.8			
		7012+87.82	7013+02.74	RT	4 to 0			14.9		1.493	10.005	0.090	3.3					2.642	17.710							0.1			
Ramp C	WB	3023+61.56	3034+85.86	LT	6.0			1124.3		337.290	30.000	20.237	749.5					344.120	30.608							11.2			
		3023+61.56	3025+07.80	RT	0 to 4			146.2		14.631	10.005	0.878	32.5					12.182	8.330							1.5			
		3025+07.80	3034+85.86	RT	4.0			978.1		195.710	20.010	11.743	434.7					162.945	16.660							9.8			
		3034+85.86	3034+89.32	LT	6 to 0			3.5		0.519	15.000	0.031	1.2					0.710	20.521							0.0			
Ramp A	WB	1006+23.65	1006+27.11	LT	0 to 6			3.5		0.519	15.000	0.031	1.2					0.710	20.521							0.0			
		1006+24.80	1006+27.11	RT	0 to 4			2.3		0.231	10.005	0.014	0.5					0.313	13.548							0.0			
		1006+27.11	1021+45.45	LT	6.0			1518.3		455.502	30.000	27.330	1012.2					464.726	30.608							15.2			
		1006+27.11	1020+03.23	RT	4.0			1376.1		275.362	20.010	16.522	611.6					229.262	16.660							13.8			
Ramp E	WB	5016+37.71	5016+60.11	LT	0 to 6			22.4		3.360	15.000	0.202	7.5					5.645	25.200							0.2			
		5016+20.11	5016+60.11	RT	0 to 4			40.0		4.002	10.005	0.240	8.9					7.084	17.710							0.4			
		5016+60.11	5023+12.27	LT	6.0			652.2		195.648	30.000	11.739	434.8					248.845	38.157							6.5			
		5016+60.11	5028+68.26	RT	4.0			1208.2		241.751	20.010	14.505	537.0					272.740	22.575							12.1			
I-80	WB	224+27.77	229+61.30	LT	6.0			533.5		160.059	30.000	9.604	355.7					203.579	38.157							5.3			
		229+61.30	230+27.77	LT	6 to 10			66.5		26.596	40.013	1.596	59.1					30.165	45.381							0.7			

108-33
10-15-19

TEMPORARY BARRIER RAIL

Possible Standard: BA-401 Possible Detail: 560-7

* Not a bid item. Anchorage requirements are based on TBR locations shown in the plans. TBR alignments that vary from what is shown in the plans may result in additional TBR sections requiring anchorage.

No.	Station to Station		Length LF	(Select One)		Anchored* (Y/N)	Modular Glare Screen System (Y/N)	Remarks
				Concrete BA-401	Steel 560-7			
1	223+98.00	230+98.00	700.0	X		Yes	No	Stage 2
2	196+58.50	204+46.00	787.5	X		Yes	No	Stage 3
3	165+34.50	185+47.00	2012.5	X		Yes	No	Stage 3

106-4
04-16-13

SHOULDERS FOR WIDENING & RESURFACING

*Not a Bid Item

Begin Station	End Station	Side	Length of Shoulder Type in Stations			
			A	B	C	D*
162+94.50	238+38.00	LT	75.44			

108-30
04-16-13

CRASH CUSHIONS

* Bid Item

① Lane(s) to which the installation is adjacent.

② Complete this section when using the Temporary Crash Cushion bid item and Earthwork is needed for Sand Barrel placement. Refer to BA-500

No.	Direction Of Traffic	Location Station	Side	Obstacle Width FT	Crash Cushion (Select One)*					Sand Barrel Details ②					Earthwork*		Spare Parts Kit (Select One)*		Obstacle Description	Remarks
					Temporary	Temporary Redirective	Temporary Severe Use	Permanent	Permanent Severe Use	V	W	X	Y	Z	Excavation Class 10 CY	Embankment In Place CY	Permanent EACH	Permanent Severe Use EACH		
1		230+98.00	LT	1.88															Temporary Barrier Rail	Stage 2
2		204+46.00	LT	1.88															Temporary Barrier Rail	Stage 3
3		185+47.00	LT	1.88															Temporary Barrier Rail	Stage 3

SURVEY SYMBOLS

- Interstate Highway Symbol
- U.S. Highway Symbol
- Iowa Highway Symbol
- County Road Highway Symbol
- Evergreen Tree
- Deciduous Tree
- Fruit Tree
- Shrub (Bushes)
- Timber
- Hedge
- Stump
- Swamp
- Rock Outcrop
- Broken Concrete
- Revetment (Rip Rap)
- Cemetery
- Grave
- Cave
- Sink Hole
- Board Fence
- Chain Link or Security Fence
- Wire Fence
- Terrace
- Earth Dam or Dike (Existing)
- Tile Outlet
- Edge of Water
- Existing Drainage
- Right of Way Rail or Lot Corner
- Concrete Monument
- Well
- Windmill
- Beehive Intake
- Existing Intake
- Existing Utility Access (Manhole)
- Fire Hydrant
- Water Hydrant (Rural)
- Septic Tank
- Cistern
- L.P. Gas Tank (No Footing)
- Underground Storage Tank
- Latrine
- Satellite TV Dish
- Water Hook Up
- Radio Tower
- Tower Anchor
- Guardrail (Beam or Cable)
- Guard Post (one or two)
- Guard Post (over two)
- Filler Pipe
- Gas Valve
- Water Valve
- Speed Limit Sign
- Mile Marker Post
- Sign
- Traffic Signal Control Box
- Rail Road Signal Control Box
- Telephone Switch Box
- Electric Box

UTILITY LEGEND

- E2 (WIL) Iowa Department of Transportation
Contact Name : Jim Hanson
Contact Phone: 3196682397
Contact Email: james.hanson@dot.iowa.gov
- G
- SAN.
- FO (COP) Cooperative Telephone Company
Contact Name : Scott Schabacker
Contact Phone: 3196473131
Contact Email: coopitel@netins.net
- F02 (ICNDOT) Iowa Communications Network
Contact Name : Shannon Marlow
Contact Phone: 8005723940
Contact Email: icnoutsideplantiowaonecall@iowa.gov
- W (PWA) Poweshiek Water Association
Contact Name : Rick Anderson
Contact Phone: 6415227416
Contact Email: rick@poweshiekwater.com
- E1 (TIP) Tip Rural Electric Cooperative
Contact Name : Scott Long
Contact Phone: 8009347976
Contact Email: slong@tiprec.com
- Clear (MAW) MidAmer-Wind
Contact Name : Wind Engineer
Contact Phone: 8006320999
Contact Email: mecdsmdesignlocates@midamerican.com

PLAN VIEW COLOR LEGEND OF PLAN AND PROFILE SHEETS

LINEWORK		Design Color No.
Green	(2)	Existing Topographic Features and Labels
Blue	(1)	Proposed Alignment, Stationing, Tic Marks, and Alignment Annotation
Magenta	(5)	Existing Utilities
SHADING		Design Color No.
Lavender	(9)	Temporary Pavement Shading
Yellow	(4)	Proposed Pavement Shading
Orange	(6)	Proposed Granular Shading
Orange	(70)	Proposed Shoulder Granular Shading
Yellow	(68)	Proposed Shoulder Paved Full Depth Shading
Yellow	(132)	Proposed Shoulder Paved Partial Depth Shading
Gray, Dark	(112)	Proposed Grade and Pave Shading "In conjunction with a paving project"
Brown, Light	(236)	Grading Shading
Orange, Light	(134)	Proposed Granular Entrance Shading
Yellow	(220)	Proposed Paved Entrance Shading
Tan	(8)	Proposed Sidewalk Shading
Blue, Light	(230)	Proposed Sidewalk Landing Shading
Pink	(11)	Proposed Sidewalk Ramp Shading
Green, Light	(225)	Existing Pavement Shading
Red	(3)	Proposed Structure Shading
Red	(3)	Delineates Restricted Areas

PROFILE VIEW COLOR LEGEND OF PLAN AND PROFILE SHEETS

LINEWORK		Design Color No.
Green	(10)	Existing Ground Line Profile
Blue	(1)	Proposed Profile and Annotation
Magenta	(5)	Existing Utilities
Blue, Light	(230)	Proposed Ditch Grades, Left
Black	(0)	Proposed Ditch Grades, Median
Rust	(14)	Proposed Ditch Grades, Right

- Reference Point
- Station
- Survey Line
- Section Corner
- Ground Line Intercept
- Saw Cut
- Guardrail
- Trench Drain
- HighTension Cable Guardrail
- Sheet Pile
- Pavement Removal
- Clearing & Grubbing Area

RIGHT-OF-WAY LEGEND

- Proposed Right-of-Way
- Existing Right of Way
- Existing and Proposed Right-of-Way
- Easement and Existing Right-of-Way
- Easement (Temporary)
- Easement
- Access Control
- Property Line

PLAN AND PROFILE LEGEND AND SYMBOL INFORMATION SHEET

(COVERS SHEET SERIES D, E, F, & K)

HARTFORD TWP.
T-80N R-12W
SEC. 35



Sta. 164+99.70
Install 30"x14' RCP Extension
FL LT=914.00
Other=913.90

Sta. 166+00.70, 37' LT
Install 24"x14' RCP Extension & FES
FL LT=914.75
Other=914.85

$\Delta = 02^{\circ}45'29.75''$ (LT)
551.80
1103.39
22920.00
6.64

APPROX. SEG. 1 LINE
PI 163+90.41
SEG. 2 LINE

Sta. 164+99.7
30"x135' RCP
D.A.=5.0 A-R (FROM PLANS)
(Extend, Remove & Reinstall FES LT)

Sta. 166+00.7 10.2' LT
24"x56' RCP
D.A.=MEDIAN
(Extend, Remove FES LT)

I-80 Existing W.B.

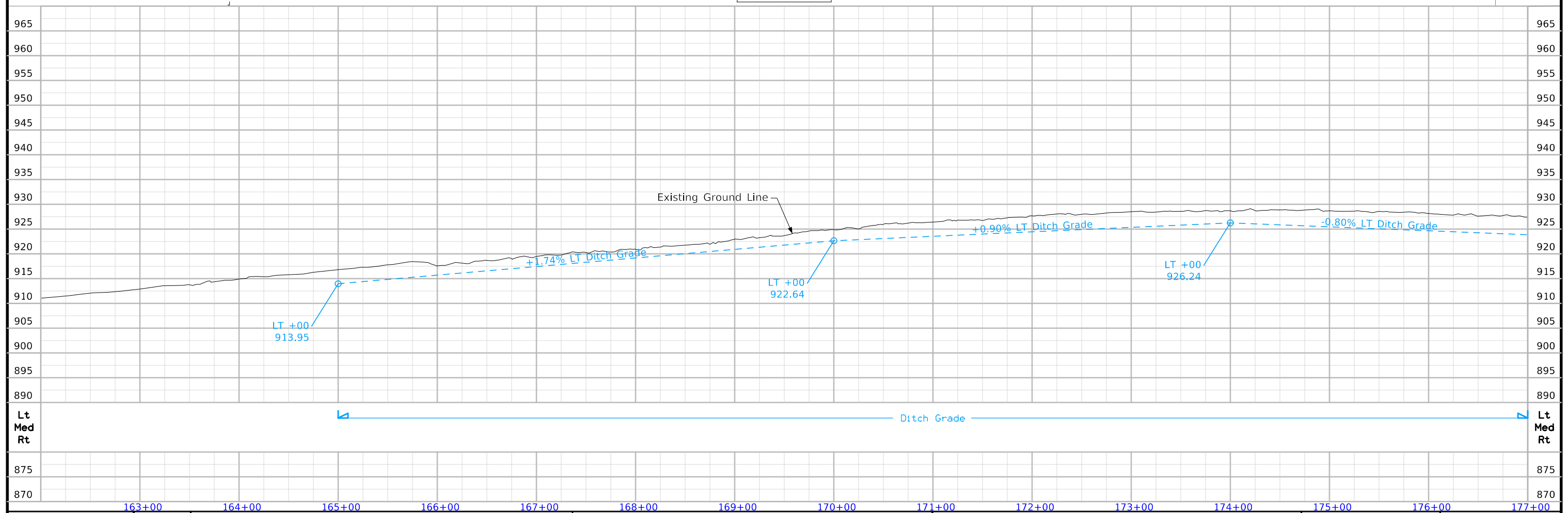
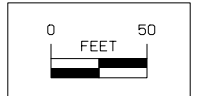

FILE NO.	ENGLISH	DESIGN TEAM Snyder & Associates	IOWA COUNTY	PROJECT NUMBER IMX-080-6(536)208--02-48	SHEET NUMBER D.2
----------	---------	---------------------------------	-------------	---	------------------

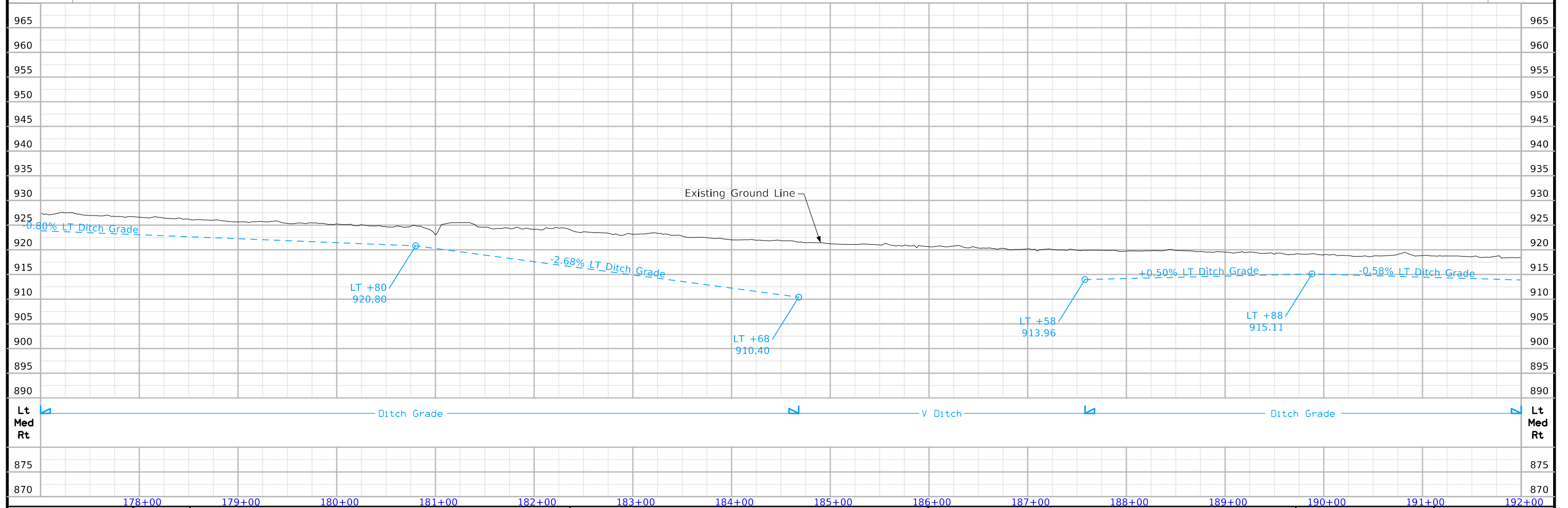
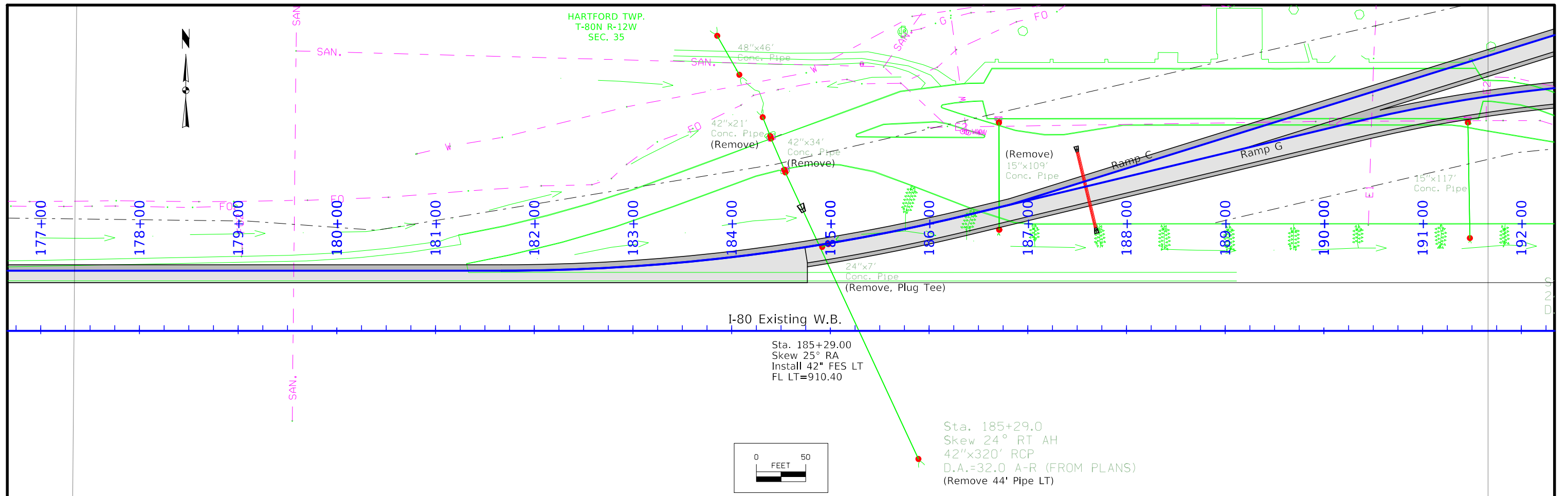

FILE NO.	ENGLISH	DESIGN TEAM Snyder & Associates	IOWA COUNTY	PROJECT NUMBER IMX-080-6(536)208--02-48	SHEET NUMBER D.3
----------	---------	---------------------------------	-------------	---	------------------

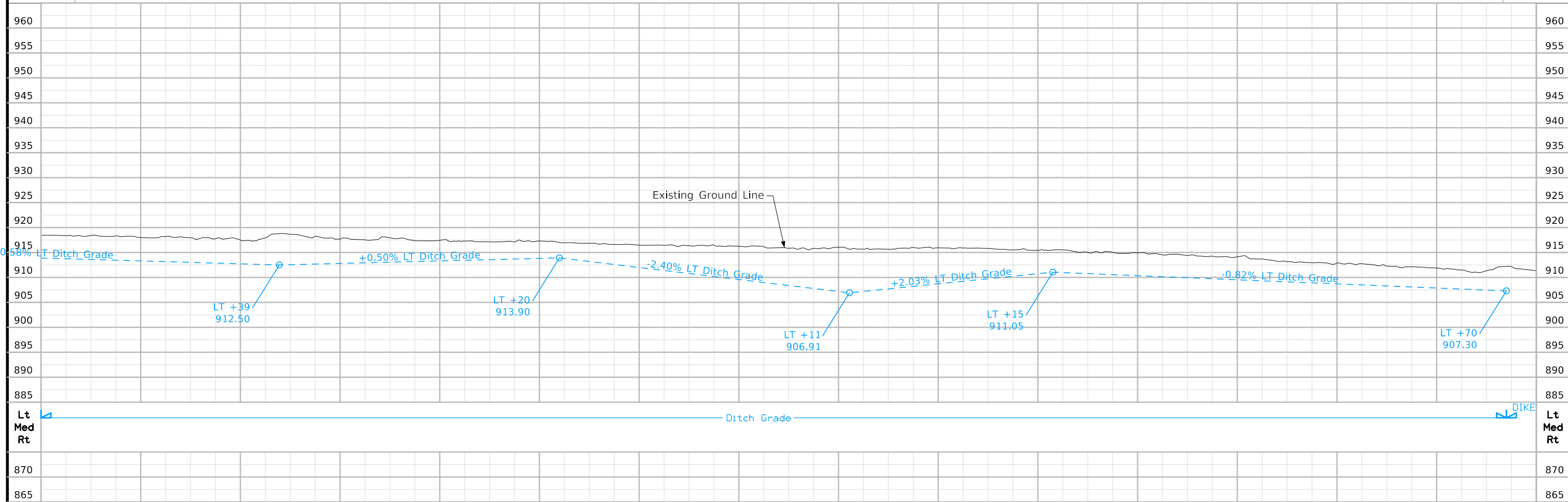
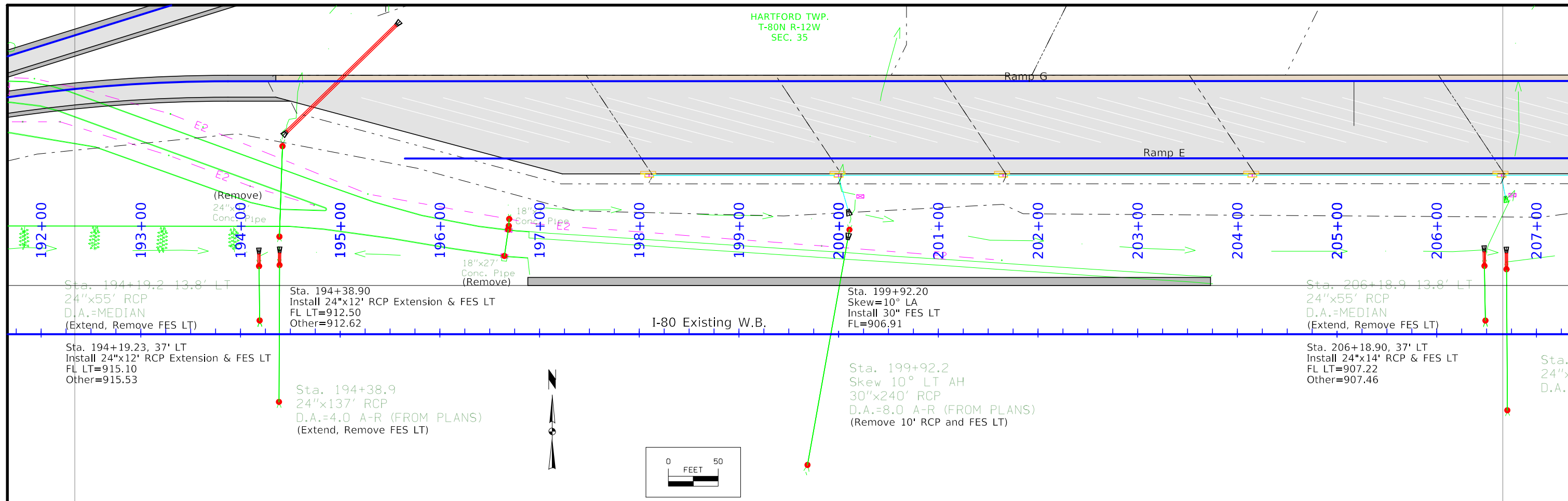

FILE NO.	ENGLISH	DESIGN TEAM Snyder & Associates	IOWA COUNTY	PROJECT NUMBER IMX-080-6(536)208--02-48	SHEET NUMBER D.4
----------	---------	---------------------------------	-------------	---	------------------

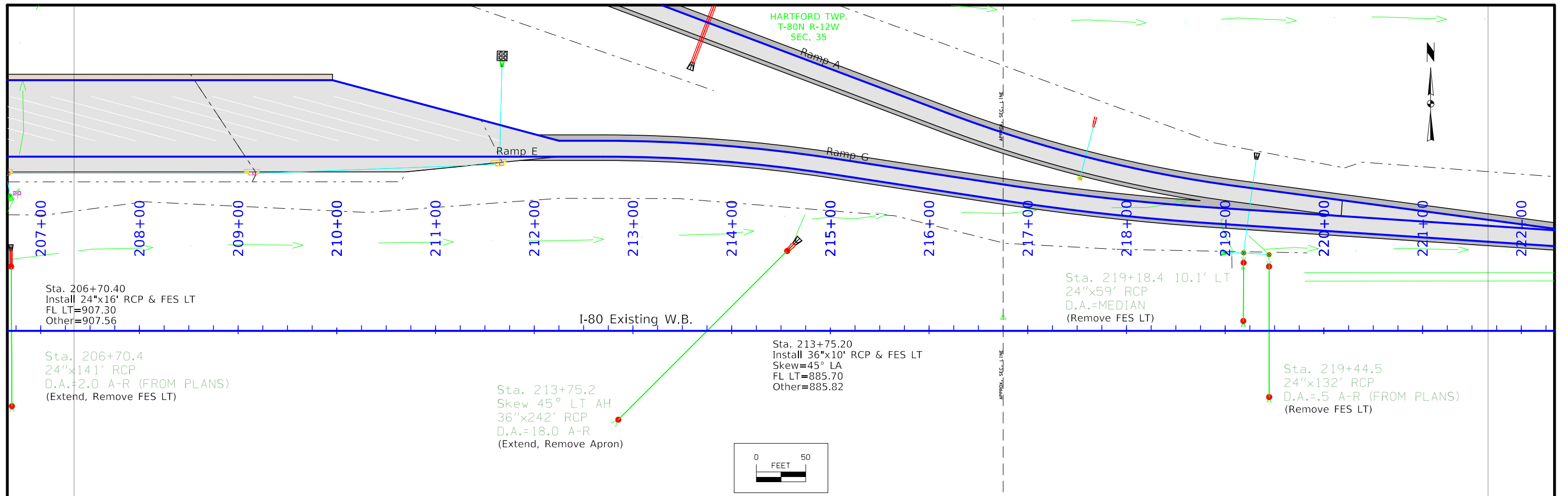

HARTFORD TWP.
T-80N R-12W
SEC. 35



Sta. 226+38.20
Install 8'x4'x40' RCB Extension
Skew=30° LT Ahead
FL LT=870.90
Other=871.27

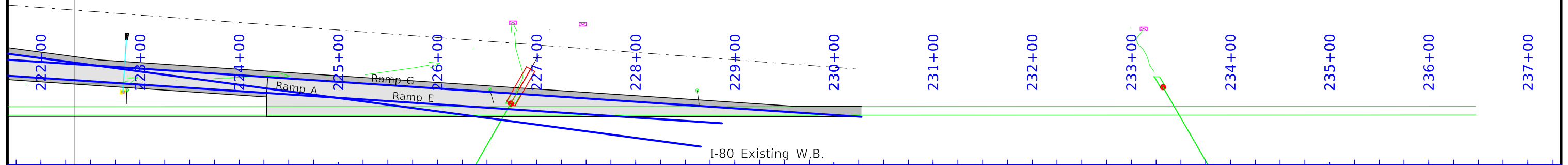

Sta. 226+38.2
SKEW 30° LT AH
8'X4'x144' RCB
D.A.=168.0 A-R (FROM PLANS)
(Extend, Remove Headwalls LT)

Sta. 233+77.6
Skew 30° RT AH
4'X4'x177' RCB
D.A.=60.0 A-R (FROM PLANS)
(UAC)

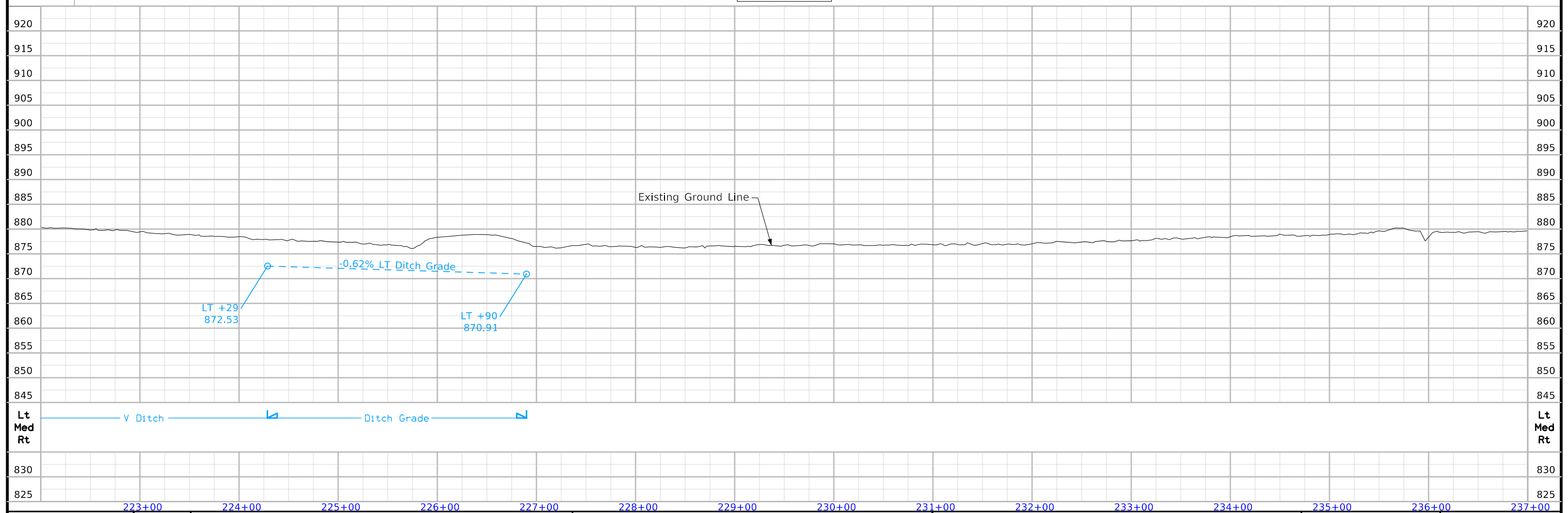
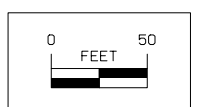

223+00 224+00 225+00 226+00 227+00 228+00 229+00 230+00 231+00 232+00 233+00 234+00 235+00 236+00 237+00

SPIRAL OR CIRCULAR CURVE DATA

Name	Location	ΔSCS	Horizontal Alignment Data												Remarks		
			Spiral Data						Curve Data								
			θS	Ls	Ts	Es	Xc	Yc	L.T.	S.T.	ΔC	T	L	R		E	
A-1	1010+38.20												20°41'23.71"	182.54	361.11	1000	16.52
A-2	1018+87.51												13°03'06.04"	152.14	302.97	1330	8.67
C-1	3032+64.06												17°17'52.32"	152.11	301.9	1000	11.5
G-1	7002+36.60												13°29'37.42"	236.6	471.02	2000	13.95
G-2	7010+60.62												13°29'01.09"	180.87	360.06	1530	10.65
G-3	7032+46.72												08°42'42.96"	116.54	232.64	1530	4.43
G-4	7036+47.19												04°53'15.97"	106.7	213.27	2500	2.28

SUPERELEVATION DATA

See PV-300 Series

Road Identification	Circular Curve or Spiral Curve Name	Radius FT	Superelevation Data			Standard Road Plan	Section A-A	Section B-B	Section C-C	Section D-D	Section E-E	Section F-F	Case A	Case B	Case C	Case S	Case T	Case U	Remarks
			e	L	x														
			%	FT	FT														
Ramp A	A-1	1000	5.0	120	48	PV-303	1007+23.65	1007+71.65	1008+55.65	1008+91.65					1008+67.65	1008+67.65			
Ramp A	A-2	1330	4.2	101	48	PV-303	1013+48.76	1013+00.76	1012+16.76	1011+80.76					1012+04.76	1012+04.76			
Ramp C	C-1	1000	5.0	120	48	PV-303	1017+12.67		1017+35.37	1017+65.67					1017+60.86	1017+60.86			
Ramp G	G-1	2000	5.4	168	62	PV-303	1020+61.04		1020+38.34	1020+08.04					1020+12.85	1020+12.85			
Ramp G	G-2	1530	4.0	96	48	PV-303	3029+79.95	3030+27.95	3031+11.95	3031+47.95					3031+23.95	3031+23.95			
Ramp G	G-3	1530	4.0	96	48	PV-303	3035+45.86	3034+97.86	3034+13.86	3033+77.86					3034+01.86	3034+01.86			
Ramp G	G-4	2500	2.8	67	48	PV-303	6999+44.40		7000+00.00	7000+50.40					7000+06.84	7000+06.84			
							7005+26.62		7004+71.02	7004+20.62					7004+64.18	7004+64.18			
							7007+64.55	7008+12.55	7008+79.75	7009+08.55					7009+08.55	7009+08.55			
							7013+55.02	7013+07.02	7012+39.82	7012+11.02					7012+11.02	7012+11.02			
							7030+14.98	7030+62.98	7031+30.18	7031+58.98					7031+58.98	7031+58.98			
							7034+78.02	7034+30.02	7033+62.82	7033+34.02					7033+34.02	7033+34.02			
							7035+41.60		7035+40.50	7035+60.60									
							7037+52.66		7037+53.76	7037+33.66									

Survey Information

SURVEY INDEX

County: Iowa
PIN: 22-48-080-070
Project Number: IMX-080-6(536)208--02-48
Location: Victor Rest Area 2.5 mi E of Co Rd V38 (WB)
Type of Work: PCC Pavement Grade and Replace
Project Directory: 4808007022

Alignment Information

The horizontal alignment for this U.S. Hwy 18 survey was provided by WHKS from the previous project IMN-080-6(483)208-0E-48, a similar survey involving the east-bound rest-stop of U.S. Hwy 18 immediately south of the current area of interest. Two PIs (4003 and 4022) used by WHKS to construct the alignment were field validated as part of this survey.

Survey Personnel

John Hahn – Survey Party Chief
Robert Fredrickson – Assistant Survey Party Chief

Date(s) of Survey

Begin Date 11/02/2022
End Date 01/12/2023

General Information

This survey is for the Victor rest area PCC pavement grading and replacement located 2.5 miles east of County Road V38 westbound. This project is a Partial Field DTM with Photo control.

Utility Information

For logging data and other utility details see Utility Survey and Ownership Report in the Utility folder of the PrelimSurvey project directory.

Project Control

Nearby Iowa Real Time Network reference stations were utilized to obtain horizontal and vertical control on primary project control points. Six five-minute observations were taken with a minimum two-hour time span between and used in a weighted average to obtain final coordinate values. For additional details of the control survey, contact the Preliminary Survey department.

PROJECT DATUM: NAD83(2011) for EPOCH 2010.00 (IaRTN 2019 ADJUSTMENT)
COORDINATE SYSTEM: IOWA REGIONAL COORDINATE SYSTEM ZONE 10.
(U.S. SURVEY FOOT)
VERTICAL DATUM: NAVD88
GEOID MODEL: 2018u3

CONTROL POINT VICINITY MAP

This map is a guide to the vicinity of the primary project control points. Primary control is for use with RTK base stations and for RTN validation. Future surveys will use primary project control to establish temporary control as needed for construction or other surveying applications.

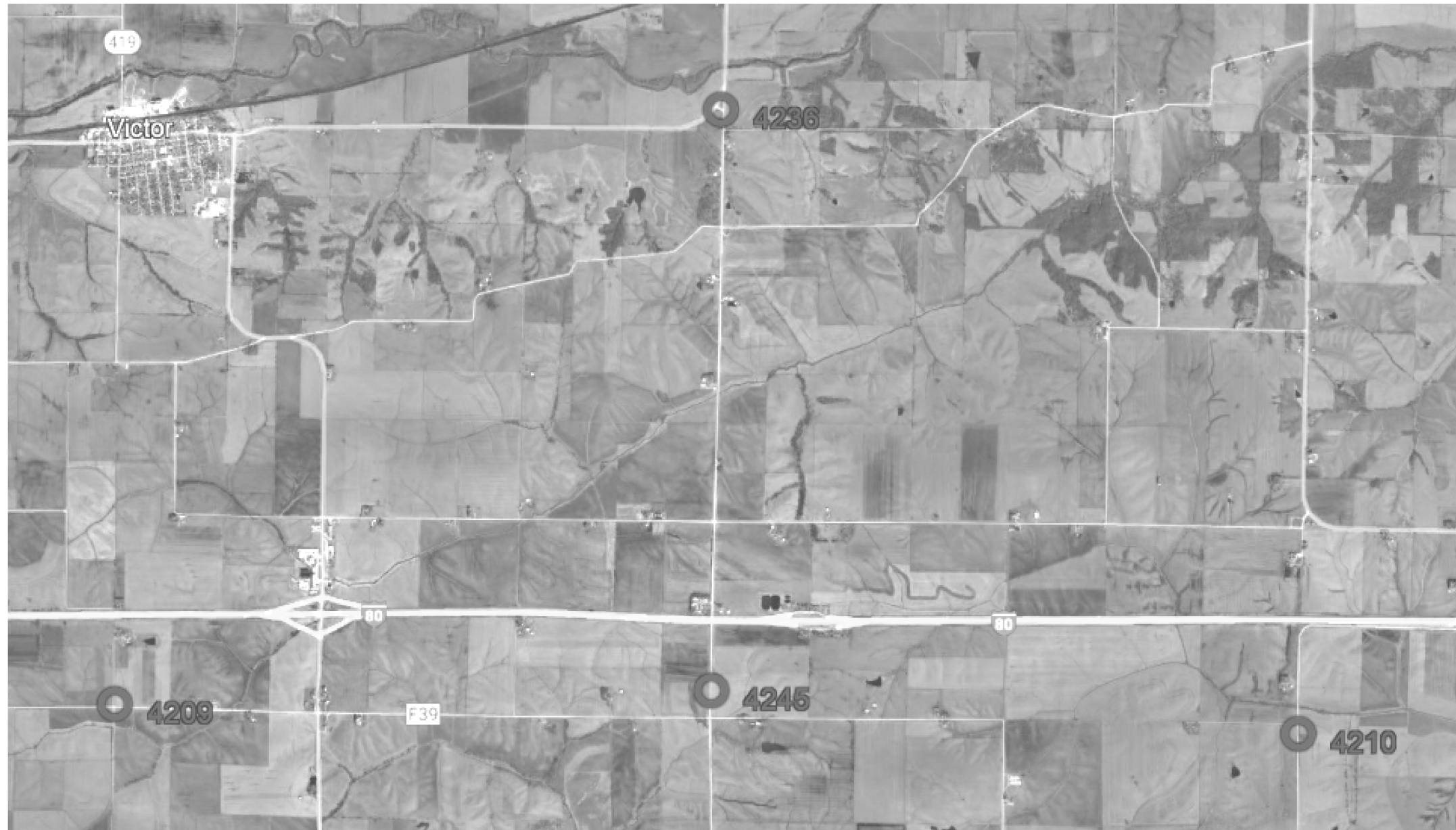

HORIZ. DATUM: NAD83(2011) for EPOCH 2010.00 (IaRTN 2019 Adjustment) - Iowa RCS Zone 10 (U.S. Survey Foot)

VERT. DATUM: NAVD88 - Geoid Model: 2018u3

Coordinate listing from next sheet will be used with IaRTN for monument recovery. No other reference ties are given.

HORIZONTAL AND VERTICAL PROJECT CONTROL COORDINATE LISTING
 HORIZ. DATUM: NAD83(2011) for EPOCH 2010.00 (IaRTN 2019 Adjustment)
 Ia. Regional Coordinate System Zone XX (U.S. Survey Foot)
 VERT. DATUM: NAVD88
 Geoid Model: 2018u3

Point Name	Northing	Easting	Elevation	Code/Description
4245	7948506.95	20343112.97	914.86	CP FND IOWA COUNTY GPS MONUMENT AS DESCRIBED IN GOOD CONDITION
4209	7948124.83	20327059.98	910.67	CP FND IOWA COUNTY GPS MONUMENT AS DESCRIBED IN GOOD CONDITION
4210	7947354.13	20358921.15	883.1	CP FND IOWA COUNTY GPS MONUMENT AS DESCRIBED IN GOOD CONDITION
4236	7964098.74	20343356.57	796.89	CP FND IOWA COUNTY GPS MONUMENT AS DESCRIBED IN GOOD CONDITION

TRAFFIC CONTROL PLAN

1. Two lanes of I-80 shall remain open to traffic at all times. Shoulder closures as necessary will be allowed during nighttime hours only, as follows:
 Sunday: 9 PM - 6 AM Monday
 Monday: 7 PM - 6 AM Tuesday
 Tuesday: 7 PM - 6 AM Wednesday
 Wednesday: 7 PM - 6 AM Thursday
 Thursday: 7 PM - 6 AM Friday
 Shoulder closures will not be allowed overnights on Fridays and Saturdays.
2. For construction in the outside shoulder area, shift traffic per details shown elsewhere in these plans.
3. Refer to staging plan for rest area closure information. The existing rest area is to remain open to traffic as much as possible. Notify DOT staff at least 2 weeks prior to expected closing date.









STAGING NOTES

- Stage 1: Traffic utilizes existing I-80 and existing rest area ramps. Rest area remains open to traffic.
 - Construct inside shoulder strengthening on I-80 from STA. 162+94.50 to STA. 238+38.00. Will require traffic shift to construct.
- Stage 2: Shift I-80 traffic onto inside shoulder. Existing rest area ramps and parking area to remain open to traffic. Construct car and truck parking areas and ramps outside of existing pavement. Includes:
 - Westbound outside shoulder removals from STA. 224+27.77 to STA 230+27.77
 - Deceleration taper and ramps.
 - Truck Parking
 - Car parking and Ramp C from STA. 3029+20.00 to STA. 3034+85.86
- Stage 3: I-80 traffic remains shifted to inside shoulder. Rest area is closed to all traffic.
 - Westbound outside shoulder removals from STA. 165+65.62 to STA. 184+76.73 and STA. 196+88.19 to STA. 203+73.11
 - Remove existing tapers and rest area pavement.
 - Construct acceleration taper and acceleration lane.
 - Construct remaining ramps.

**CROSS SECTION VIEW COLOR LEGEND
OF TRAFFIC CONTROL AND STAGING SHEETS**

SHADING	Design Color No.	
Green, Light	(225)	Existing Pavement Shading
Gray, Light	(48)	Previously Constructed Pavement Shading
Gray, Med	(80)	Previously Constructed Granular Surface Shading
Blue, Light	(230)	Proposed Pavement Shading
Lavender	(9)	Detour Pavement Shading
Brown, Med	(237)	Future Proposed Pavement Shading
Pink, Lavender(5)		Shoulder Strengthening Shading

**CROSS SECTION VIEW PATTERN AND SYMBOL LEGEND
OF TRAFFIC CONTROL AND STAGING SHEETS**





















	Pavement Removal		Proposed Granular Shoulder
	Proposed Granular Subbase		Temporary Shoulder
	Proposed Special Backfill		Existing Shoulder Strengthening
	Temporary Barrier Rail		Permanent Barrier Rail
			Channelizing Device

PLAN VIEW COLOR LEGEND OF TRAFFIC CONTROL AND STAGING SHEETS

LINEWORK	Design Color No.	
Green	(2)	Existing Topographic Features and Labels
Magenta	(5)	Pavement Marking Call Outs
Blue	(1)	Proposed Alignment, Stationing, Tic Marks, and Alignment Annotation
Yellow	(4)	Pavement Markings, Yellow
Off White	(254)	Pavement Markings, White

SHADING	Design Color No.	
Green, Light	(225)	Existing Pavement Shading
Gray, Light	(48)	Previously Constructed Pavement Shading
Gray, Med	(80)	Proposed Granular Surface Shading
Gray, Med	(80)	Previously Constructed Granular Surface Shading
Blue, Light	(230)	Proposed Pavement Shading
Lavender	(9)	Temporary Pavement Shading
Brown, Light	(236)	Proposed Grading Limits Shading
Pink, Dark	(13)	Proposed MSE or CIP Wall Shading
Pink, Lavender(5)		Shoulder Strengthening Shading
Black w/Gray, Light Fill	(0,48)	Previously Constructed Structure

**PLAN VIEW PATTERN AND SYMBOL LEGEND
OF TRAFFIC CONTROL AND STAGING SHEETS**

	Channelizing Device		Crash Cushion
	Drum		Traffic Signal
	Temporary Lane Separator		Flagger
	Tubular Marker		Temporary Floodlighting
	Channelizer Marker		Traffic Sign
	Concrete Barrier Marker		Type III Barricade
	Delineator		Type A Warning Light
	Temporary Barrier Rail		Direction of Traffic
	Pavement Removal		Safety Closure
	Arrow Board		Speed Feedback Sign

NOTE: Device spacing according to Standard Road Plans unless specifically dimensioned.

**TRAFFIC CONTROL
AND
STAGING
LEGEND AND SYMBOL
INFORMATION SHEET**

(COVERS SHEET SERIES J)

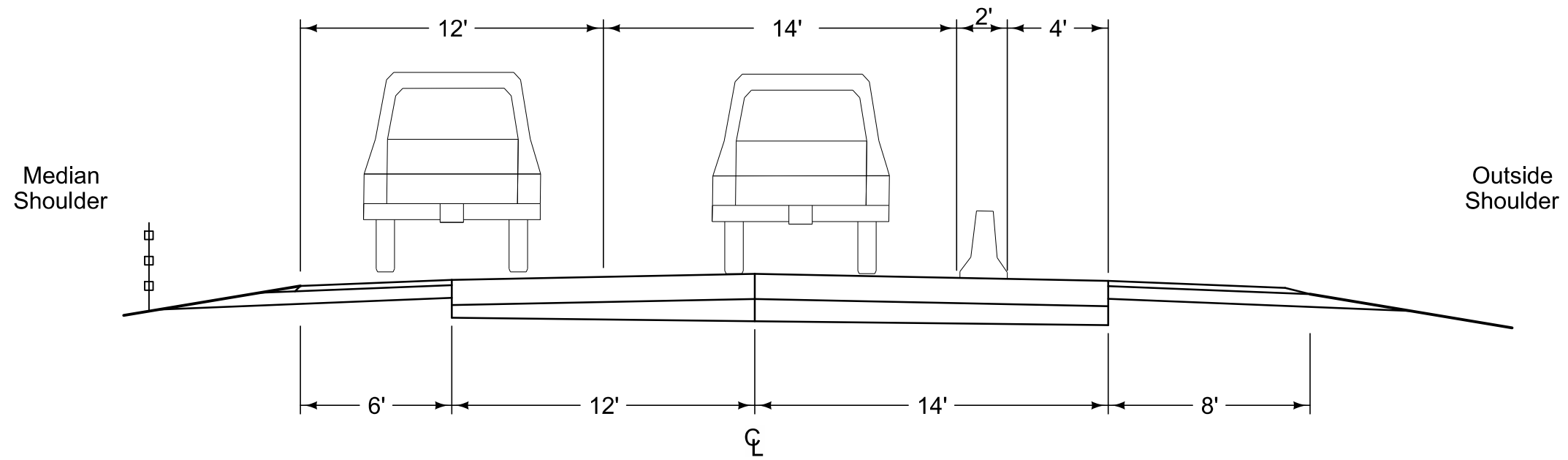

**INTERSTATE 80 W.B. IOWA COUNTY
Traffic Control Lane Shift
Section Shown in Direction of Traffic**



END ROAD WORK

G20-2A
48" x 24"

500'

STA. 162+94.50

I-80 W.B.



I-80 E.B.

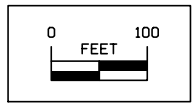

Stage 1
Shoulder Strengthening
Traffic Control Layout



Existing Westbound
Rest Area Parking

I-80 W.B.



I-80 E.B.

Existing Eastbound
Rest Area Parking

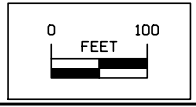

Stage 1
Shoulder Strengthening
Traffic Control Layout

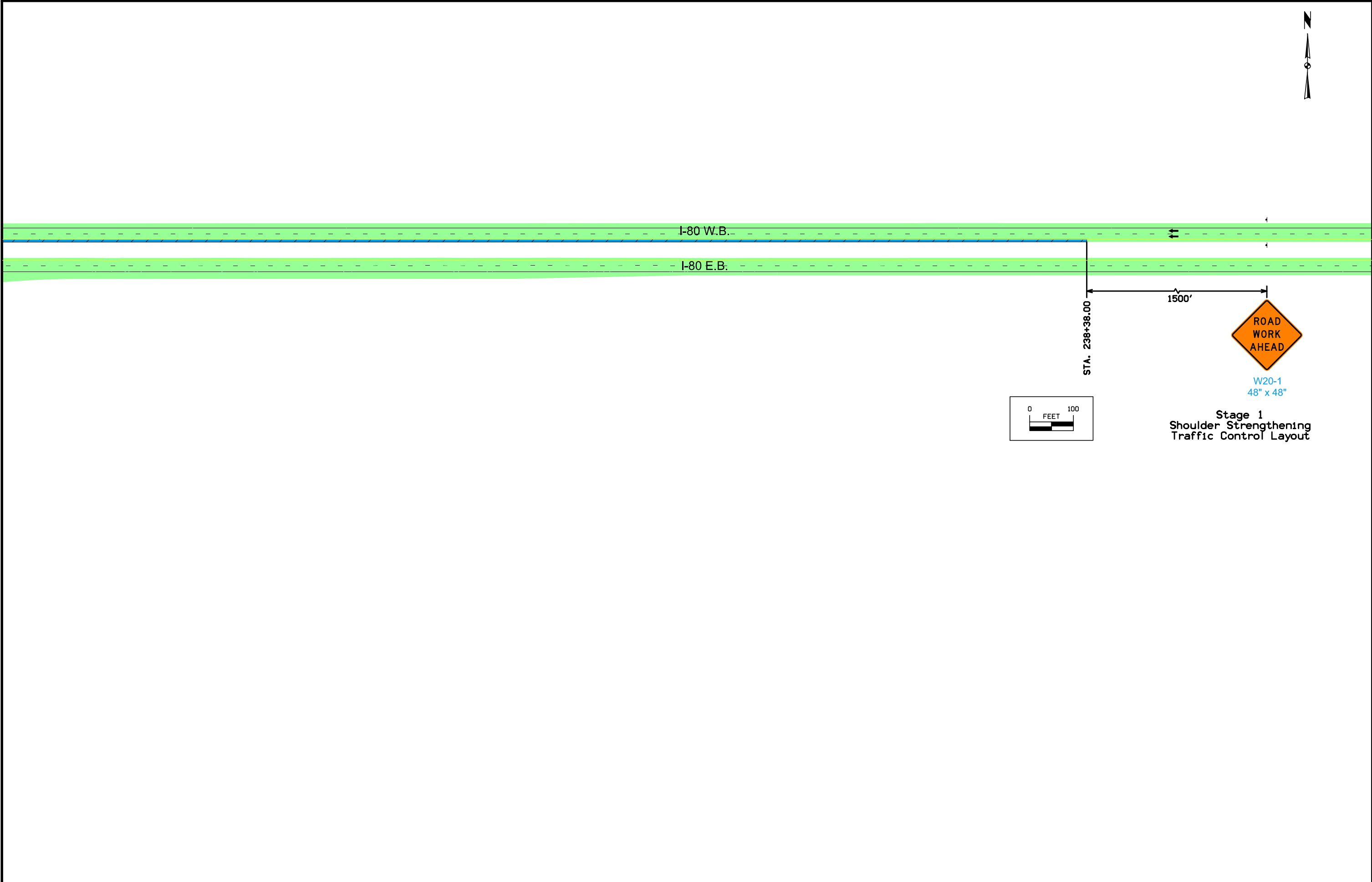

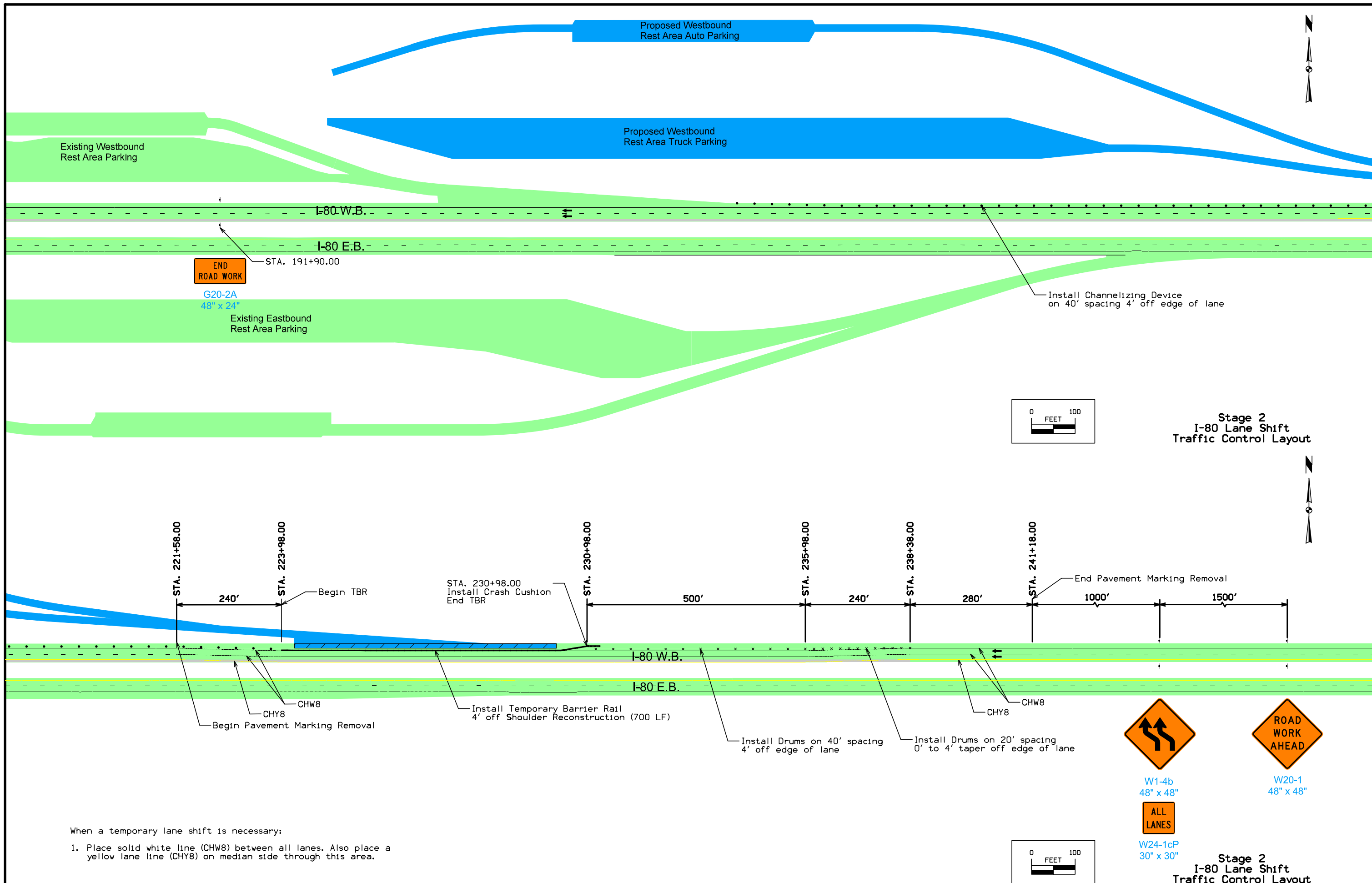

When a temporary lane shift is necessary:

- Place solid white line (CHW8) between all lanes. Also place a yellow lane line (CHY8) on median side through this area.

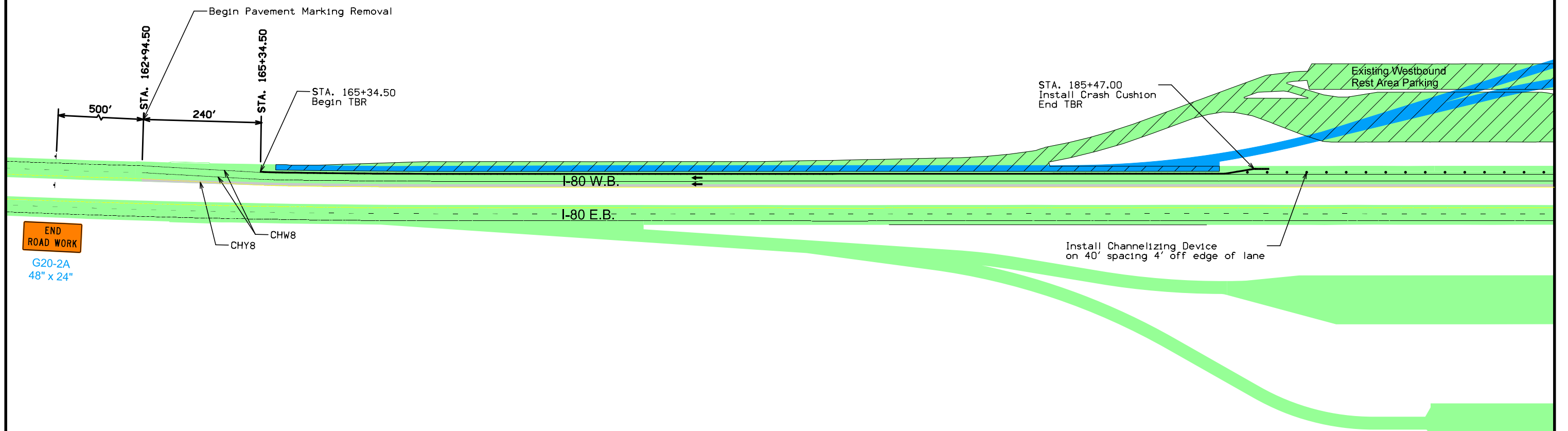

END
ROAD WORK
G20-2A
48" x 24"

When a temporary lane shift is necessary:

1. Place solid white line (CHW8) between all lanes. Also place a yellow lane line (CHY8) on median side through this area.

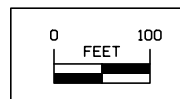

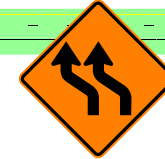
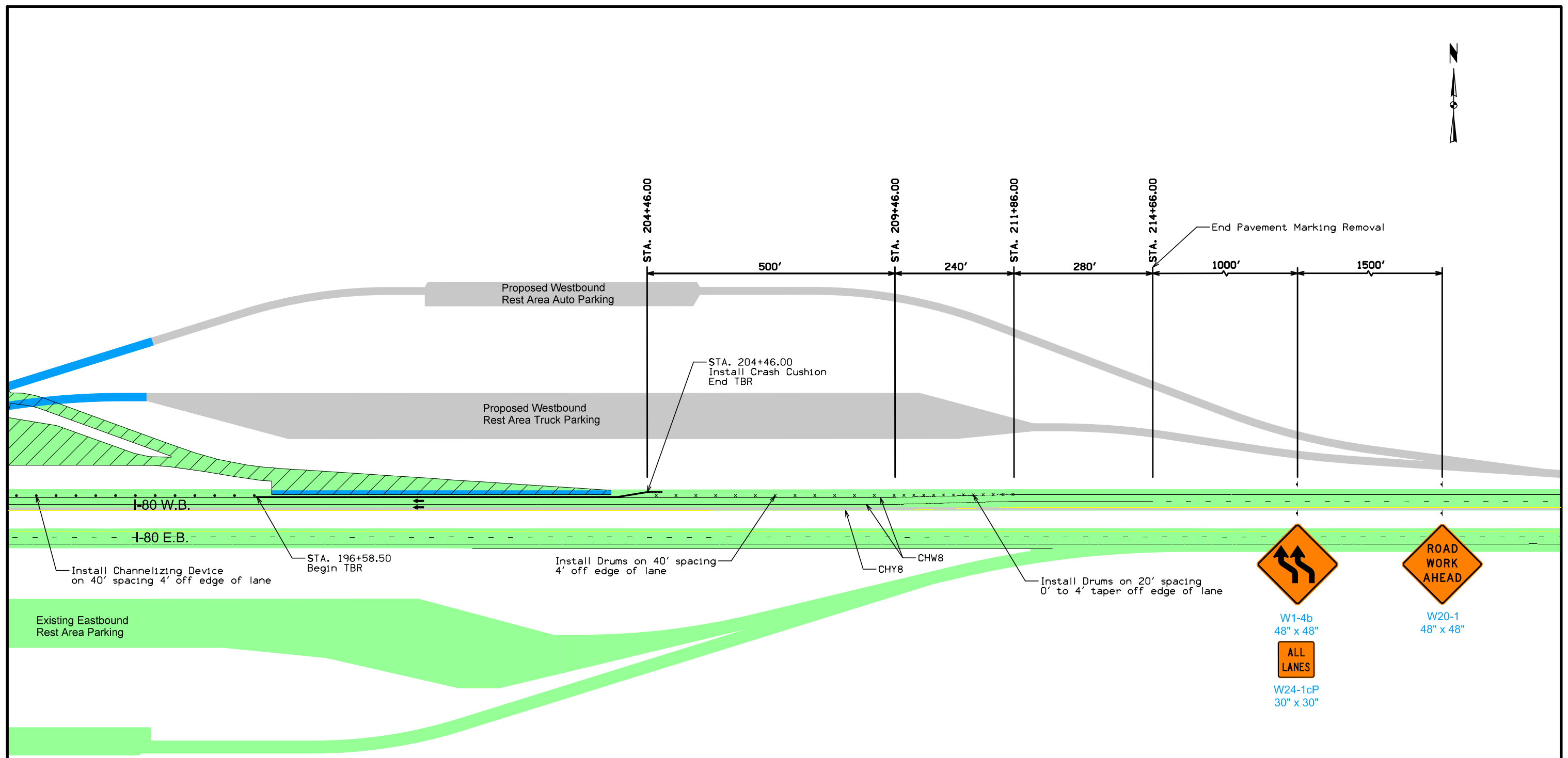

W1-4b
48" x 48"



W24-1cP
30" x 30"



W20-1
48" x 48"

When a temporary lane shift is necessary:

1. Place solid white line (CHW8) between all lanes. Also place a yellow lane line (CHY8) on median side through this area.

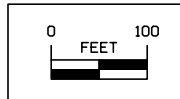

SURVEY SYMBOLS

- Interstate Highway Symbol
- U.S. Highway Symbol
- Iowa Highway Symbol
- County Road Highway Symbol
- Evergreen Tree
- Deciduous Tree
- Fruit Tree
- Shrub (Bushes)
- Timber
- Hedge
- Stump
- Swamp
- Rock Outcrop
- Broken Concrete
- Revetment (Rip Rap)
- Cemetery
- Grave
- Cave
- Sink Hole
- Board Fence
- Chain Link or Security Fence
- Wire Fence
- Terrace
- Earth Dam or Dike (Existing)
- Tile Outlet
- Edge of Water
- Existing Drainage
- Right of Way Rail or Lot Corner
- Concrete Monument
- Well
- Windmill
- Beehive Intake
- Existing Intake
- Existing Utility Access (Manhole)
- Fire Hydrant
- Water Hydrant (Rural)
- Septic Tank
- Cistern
- L.P. Gas Tank (No Footing)
- Underground Storage Tank
- Latrine
- Satellite TV Dish
- Water Hook Up
- Radio Tower
- Tower Anchor
- Guardrail (Beam or Cable)
- Guard Post (one or two)
- Guard Post (over two)
- Filler Pipe
- Gas Valve
- Water Valve
- Speed Limit Sign
- Mile Marker Post
- Sign
- Traffic Signal Control Box
- Rail Road Signal Control Box
- Telephone Switch Box
- Electric Box

UTILITY LEGEND

- E2 (WIL) Iowa Department of Transportation
Contact Name : Jim Hanson
Contact Phone: 3196682397
Contact Email: james.hanson@dot.iowa.gov
- G
- SAN.
- FO (COP) Cooperative Telephone Company
Contact Name : Scott Schabacker
Contact Phone: 3196473131
Contact Email: coopitel@netins.net
- F02 (ICNDOT) Iowa Communications Network
Contact Name : Shannon Marlow
Contact Phone: 8005723940
Contact Email: icnoutsideplantiowaonecall@iowa.gov
- W (PWA) Poweshiek Water Association
Contact Name : Rick Anderson
Contact Phone: 6415227416
Contact Email: rick@poweshiekwater.com
- E1 (TIP) Tip Rural Electric Cooperative
Contact Name : Scott Long
Contact Phone: 8009347976
Contact Email: slong@tiprec.com
- Clear (MAW) MidAmer-Wind
Contact Name : Wind Engineer
Contact Phone: 8006320999
Contact Email: mecdsmdesignlocates@midamerican.com

PLAN VIEW COLOR LEGEND OF PLAN AND PROFILE SHEETS

LINEWORK		Design Color No.
Green	(2)	Existing Topographic Features and Labels
Blue	(1)	Proposed Alignment, Stationing, Tic Marks, and Alignment Annotation
Magenta	(5)	Existing Utilities
SHADING		Design Color No.
Lavender	(9)	Temporary Pavement Shading
Yellow	(4)	Proposed Pavement Shading
Orange	(6)	Proposed Granular Shading
Orange	(70)	Proposed Shoulder Granular Shading
Yellow	(68)	Proposed Shoulder Paved Full Depth Shading
Yellow	(132)	Proposed Shoulder Paved Partial Depth Shading
Gray, Dark	(112)	Proposed Grade and Pave Shading "In conjunction with a paving project"
Brown, Light	(236)	Grading Shading
Orange, Light	(134)	Proposed Granular Entrance Shading
Yellow	(220)	Proposed Paved Entrance Shading
Tan	(8)	Proposed Sidewalk Shading
Blue, Light	(230)	Proposed Sidewalk Landing Shading
Pink	(11)	Proposed Sidewalk Ramp Shading
Green, Light	(225)	Existing Pavement Shading
Red	(3)	Proposed Structure Shading
Red	(3)	Delineates Restricted Areas

PROFILE VIEW COLOR LEGEND OF PLAN AND PROFILE SHEETS

LINEWORK		Design Color No.
Green	(10)	Existing Ground Line Profile
Blue	(1)	Proposed Profile and Annotation
Magenta	(5)	Existing Utilities
Blue, Light	(230)	Proposed Ditch Grades, Left
Black	(0)	Proposed Ditch Grades, Median
Rust	(14)	Proposed Ditch Grades, Right

- Reference Point
- Station
- Survey Line
- Section Corner
- Ground Line Intercept
- Saw Cut
- Guardrail
- Trench Drain
- HighTension Cable Guardrail
- Sheet Pile
- Pavement Removal
- Clearing & Grubbing Area

RIGHT-OF-WAY LEGEND

- Proposed Right-of-Way
- Existing Right of Way
- Existing and Proposed Right-of-Way
- Easement and Existing Right-of-Way
- Easement (Temporary)
- Easement
- Access Control
- Property Line

PLAN AND PROFILE LEGEND AND SYMBOL INFORMATION SHEET

(COVERS SHEET SERIES D, E, F, & K)

Curve RPC Data
 $\Delta = 13^\circ 29' 37.42''$ (LT)
 T = 236.60
 L = 471.02
 R = 2000.00
 E = 13.95
 e = 5.4%
 L = 168'
 x = 62'

Curve RPG Data
 $\Delta = 13^\circ 29' 37.42''$ (LT)
 T = 236.60
 L = 471.02
 R = 2000.00
 E = 13.95
 e = 5.4%
 L = 168'
 x = 62'

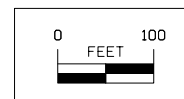
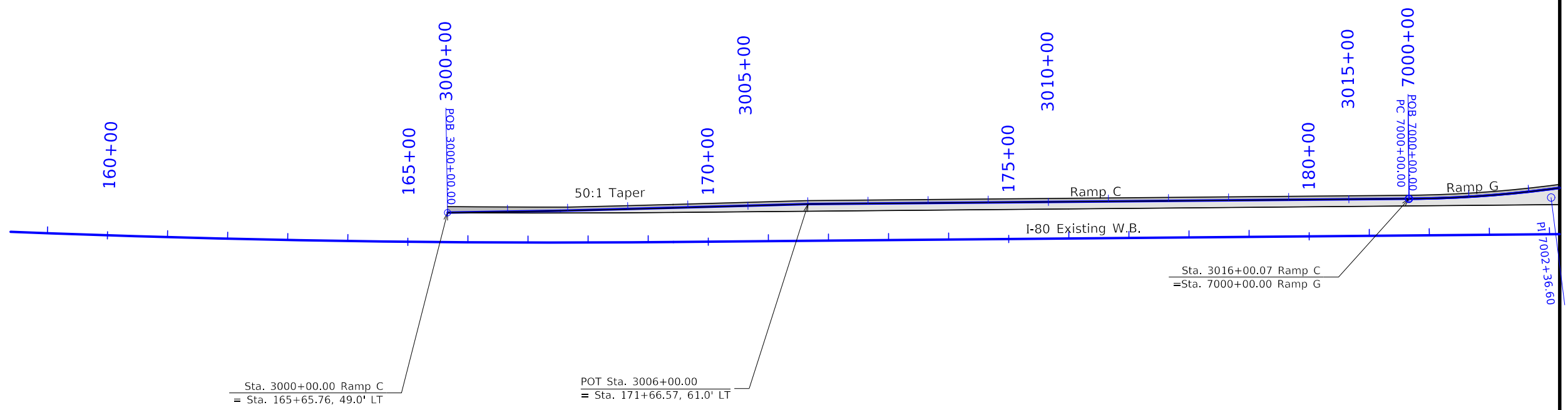

Geometric Plan
 Proposed Interchange of
 Interstate 80 with
 Rest Area (WB)
 Iowa County

Curve RPC Data
 $\Delta = 13^\circ 29' 37.42''$ (LT)
 T = 236.60
 L = 471.02
 R = 2000.00
 E = 13.95
 e = 5.4%
 L = 168'
 x = 62'

Curve RPG Data
 $\Delta = 13^\circ 29' 37.42''$ (LT)
 T = 236.60
 L = 471.02
 R = 2000.00
 E = 13.95
 e = 5.4%
 L = 168'
 x = 62'

Curve RPC Data
 $\Delta = 17^\circ 17' 52.32''$ (RT)
 T = 152.11
 L = 301.90
 R = 1000.00
 E = 11.50
 e = 5.0%
 L = 120'
 x = 48'

Curve RPA Data
 $\Delta = 20^\circ 41' 23.71''$ (RT)
 T = 182.54
 L = 361.11
 R = 1000.00
 E = 16.52
 e = 5.0%
 L = 120'
 x = 48'

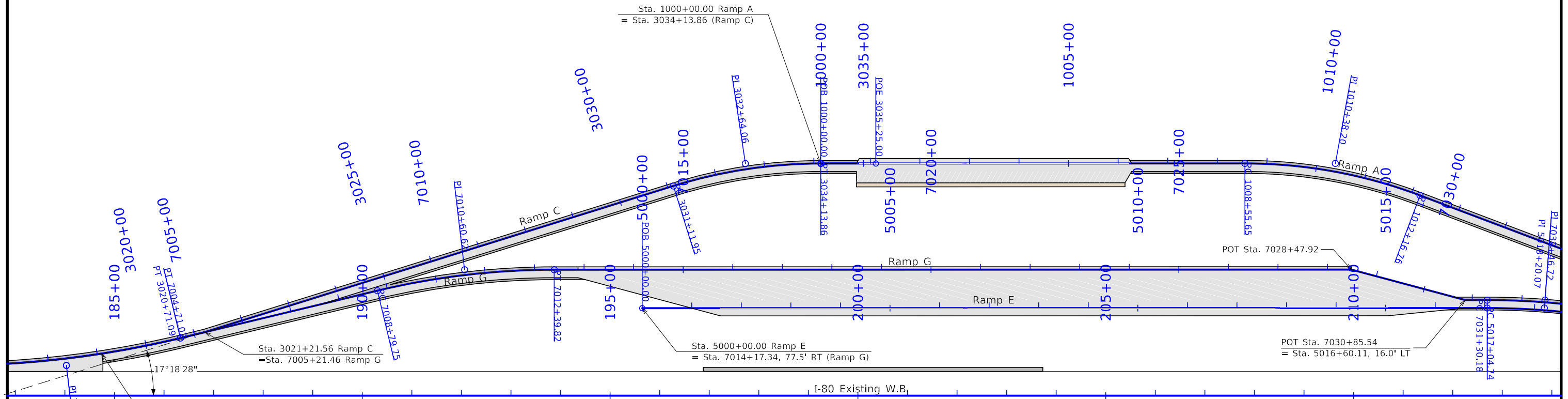

Sta. 7003+08.92, 0.0' LT (Ramp G)
 = Sta. 3019+08.99, 0.0' LT (Ramp C)
 = Sta. 184+74.26, 84.81' LT (I-80)
 Point F Standard Detail 533-02

Curve RPG Data
 $\Delta = 13^\circ 29' 01.09''$ (RT)
 T = 180.87
 L = 360.06
 R = 1530.00
 E = 10.65
 e = 4.0%
 L = 96'
 x = 48'

Curve RPG Data
 $\Delta = 08^\circ 42' 42.96''$ (RT)
 T = 116.54
 L = 232.64
 R = 1530.00
 E = 4.43
 e = 4.0%
 L = 96'
 x = 48'

Curve RPE Data
 $\Delta = 08^\circ 42' 42.96''$ (RT)
 T = 115.33
 L = 230.21
 R = 1514.00
 E = 4.39
 e = 4.0%
 L = 96'
 x = 48'

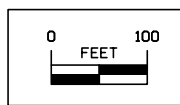

Geometric Plan
 Proposed Interchange of
 Interstate 80 with
 Rest Area (WB)
 Iowa County

Curve RPA Data
 $\Delta = 13^{\circ}03'06.04''$ (LT)
 T = 152.14
 L = 302.97
 R = 1330.00
 E = 8.67
 e = 4.2%
 L = 101'
 x = 48'

Curve RPG Data
 $\Delta = 04^{\circ}53'15.97''$ (LT)
 T = 106.70
 L = 213.27
 R = 2500.00
 E = 2.28
 e = 2.8%
 L = 67'
 x = 48'

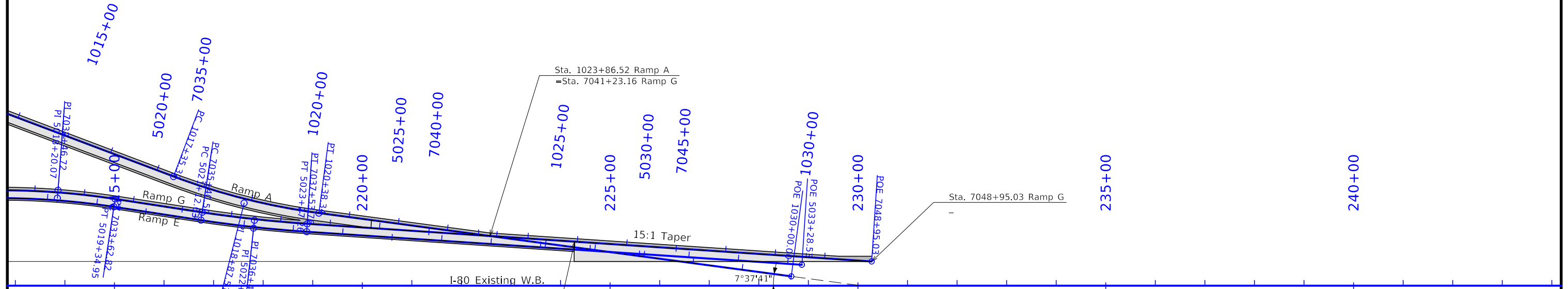

Sta. 7042+94.76 (Ramp G)
 = Sta. 224+28.83, 88.93' LT (I-80)
 Point M on Std. Road Plan PV-410

Curve RPG Data
 $\Delta = 08^{\circ}42'42.96''$ (RT)
 T = 116.54
 L = 232.64
 R = 1530.00
 E = 4.43
 e = 4.0%
 L = 96'
 x = 48'

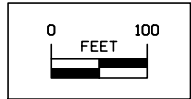

Geometric Plan
 Proposed Interchange of
 Interstate 80 with
 Rest Area (WB)
 Iowa County

HARTFORD TWP.
T-80N R-12W
SEC. 34



Begin Construction
Sta. 1000+00.00
=Sta. 3034+13.86 (Ramp C)

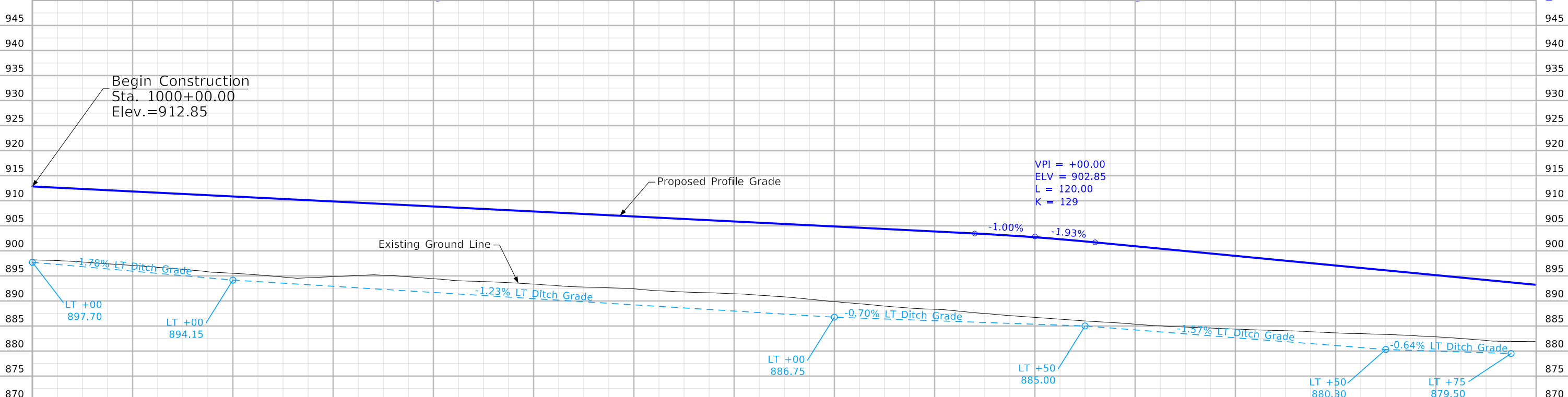
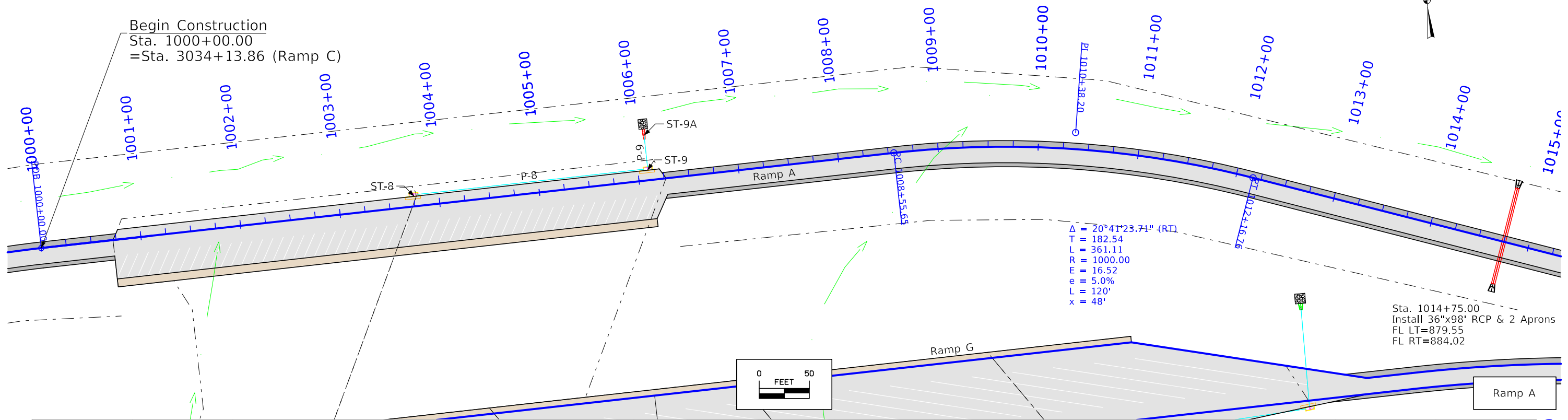

Station	1000+00	1001+00	1002+00	1003+00	1004+00	1005+00	1006+00	1007+00	1008+00	1009+00	1010+00	1011+00	1012+00	1013+00	1014+00	1015+00																																												
Lt	897.70	894.15							886.75		885.00			880.30	879.50																																													
Med																																																												
Rt																																																												
Proposed Profile	912.60	912.35	912.10	911.85	911.60	911.35	911.10	910.85	910.60	910.35	910.10	909.85	909.60	909.35	909.10	908.85	908.60	908.35	908.10	907.85	907.60	907.35	907.10	906.85	906.60	906.35	906.10	905.85	905.60	905.35	905.10	904.85	904.60	904.35	904.10	903.85	903.60	903.35	903.05	902.71	902.32	901.88	901.40	900.92	900.44	899.96	899.48	898.99	898.51	898.03	897.55	897.06	896.58	896.10	895.62	895.14	894.65	894.17	893.69	893.21

HARTFORD TWP.
T-80N R-12W
SEC. 34

HARTFORD TWP.
T-80N R-12W
SEC. 35

$\Delta = 13^{\circ}03'06.04"$ (LT)
T = 152.14
L = 302.97
R = 1330.00
e = 8.67
f = 4.2%
m = 101'
x = 48'

End Construction
Sta. 1023+86.52

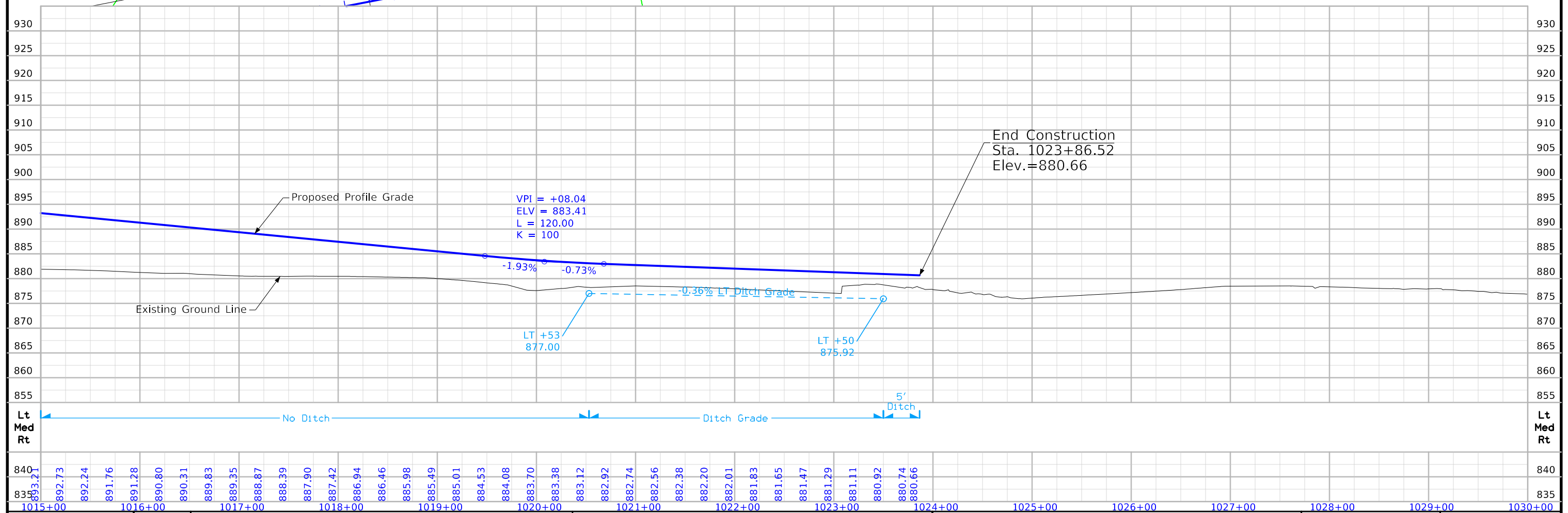
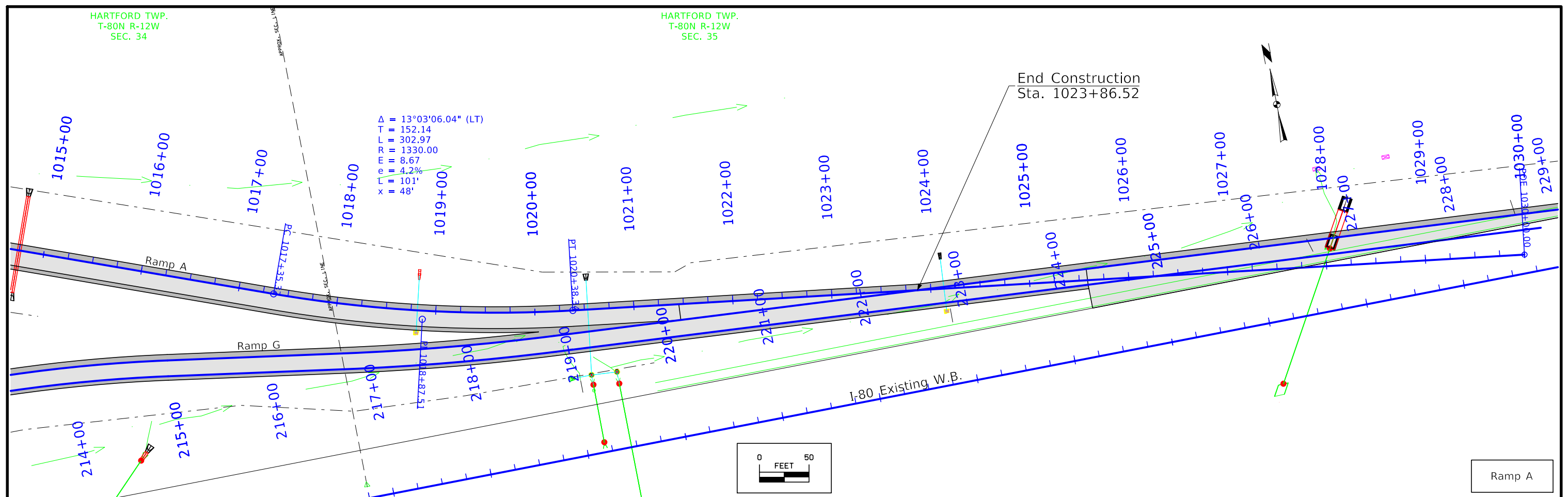

FILE NO.	ENGLISH	DESIGN TEAM	Snyder & Associates	Iowa COUNTY	PROJECT NUMBER	IMX-080-6(536)208--02-48	SHEET NUMBER	K.6
----------	---------	-------------	---------------------	-------------	----------------	--------------------------	--------------	-----

HARTFORD TWP.
T-80N R-12W
SEC. 34

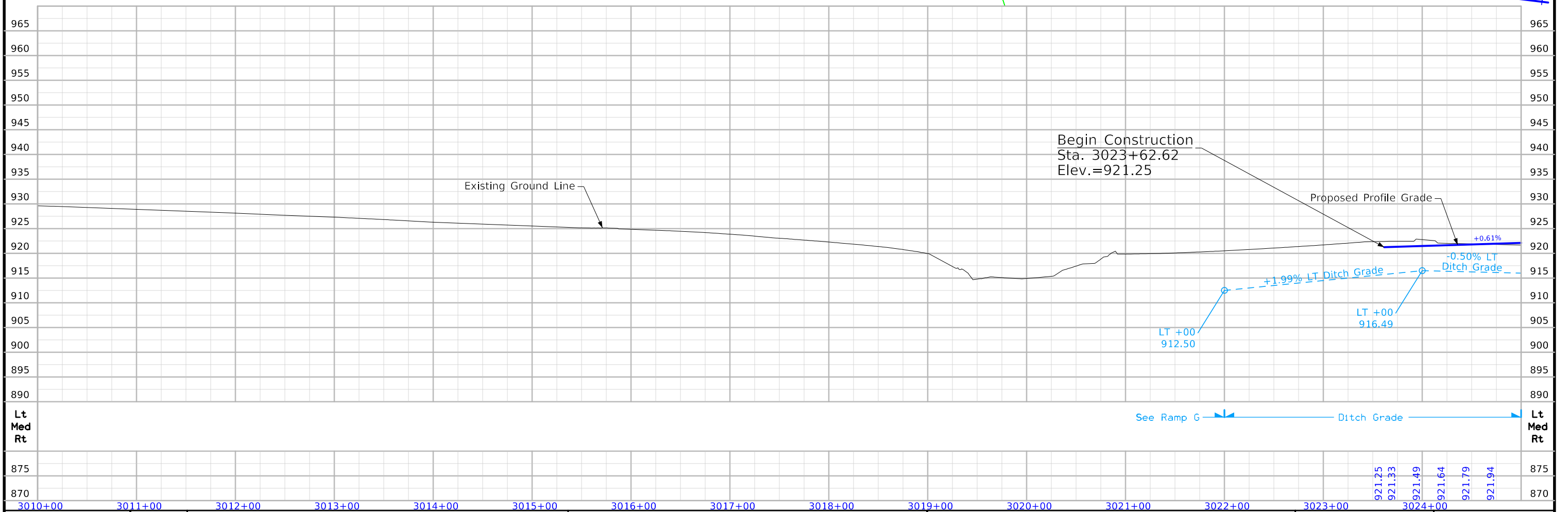
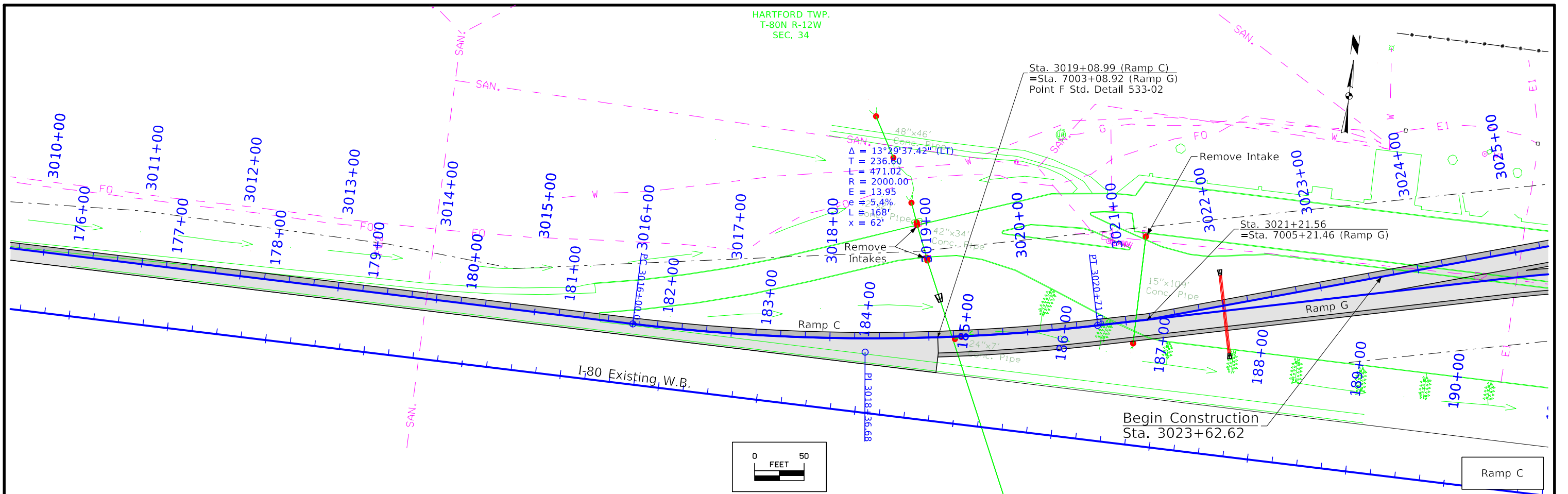

FILE NO.	ENGLISH	DESIGN TEAM Snyder & Associates	Iowa COUNTY	PROJECT NUMBER IMX-080-6(536)208--02-48	SHEET NUMBER K.7
----------	---------	---------------------------------	-------------	---	------------------

Sta. 3030+19.00
 Install 30"x116' RCP & 2 FES's
 FL LT=902.00
 FL RT=905.94

HARTFORD TWP.
 T-80N R-12W
 SEC. 34

End Construction
 Sta. 3034+13.86
 =Sta. 1000+00.00 (Ramp A)

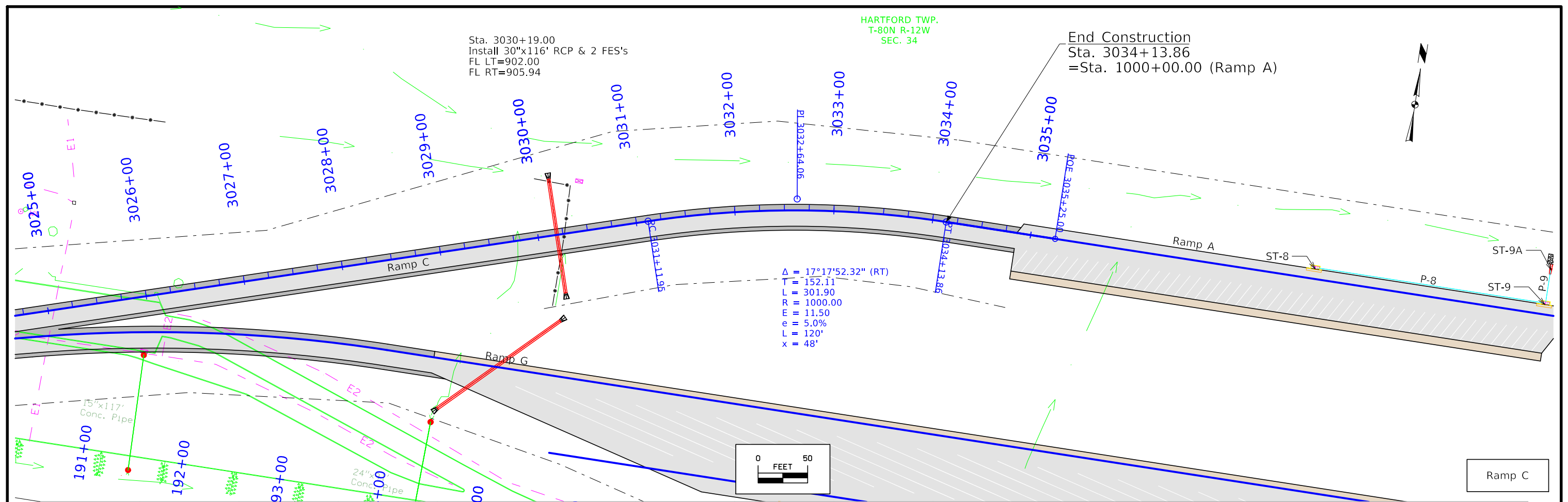

$\Delta = 17^{\circ}17'52.32"$ (RT)
 $T = 152.11$
 $L = 301.90$
 $R = 1000.00$
 $E = 11.50$
 $e = 5.0\%$
 $L = 120'$
 $x = 48'$

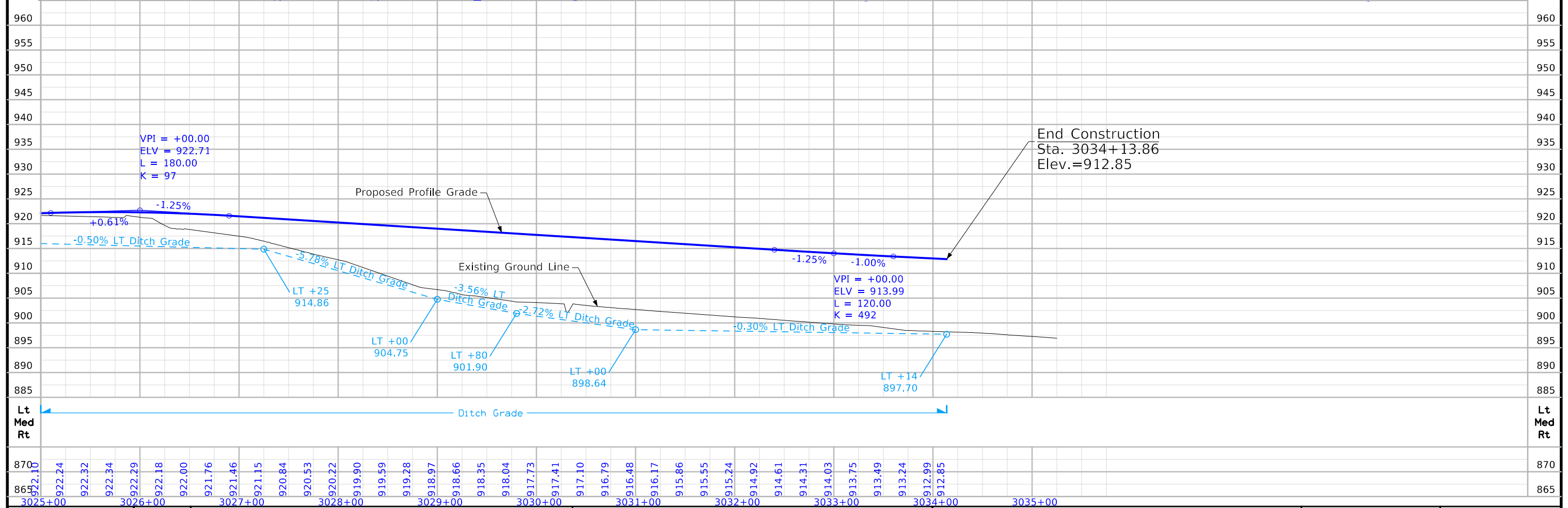

FILE NO.	ENGLISH	DESIGN TEAM	Snyder & Associates	Iowa COUNTY	PROJECT NUMBER	IMX-080-6(536)208--02-48	SHEET NUMBER	K.8
----------	---------	-------------	---------------------	-------------	----------------	--------------------------	--------------	-----

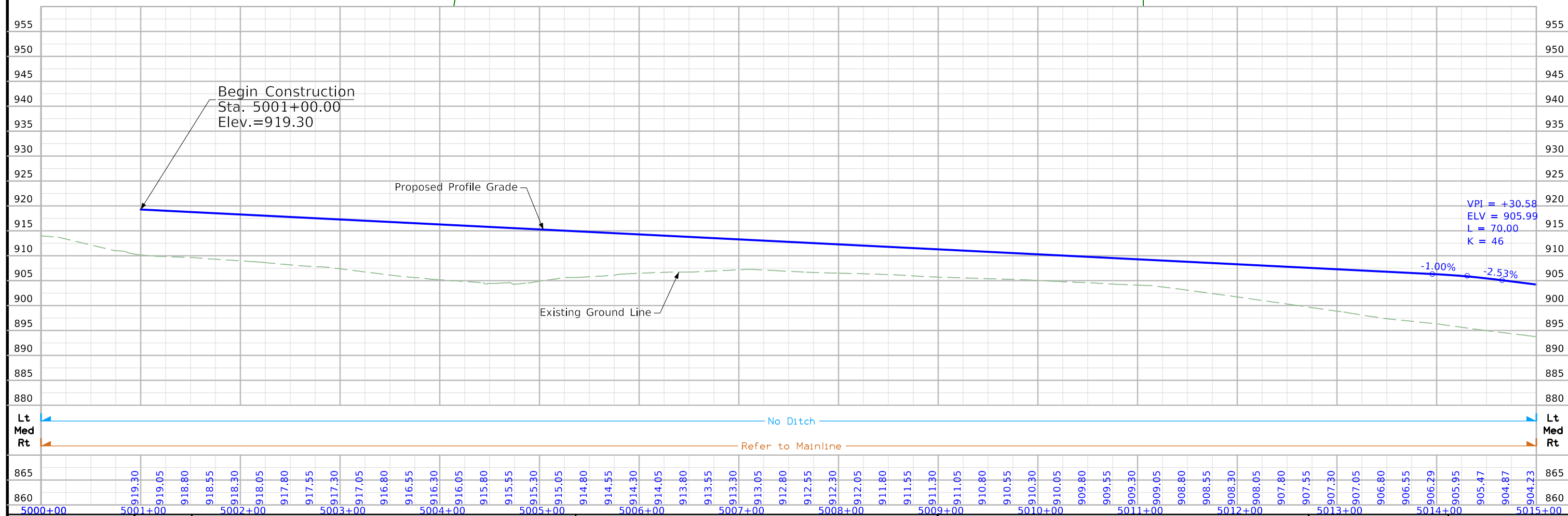
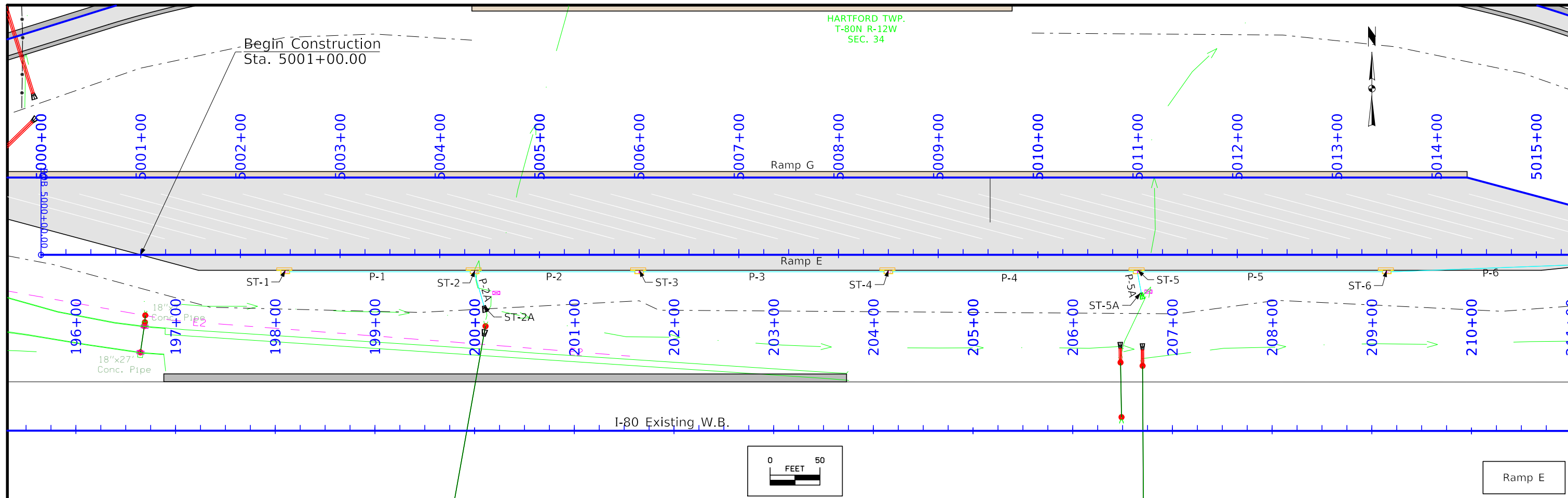

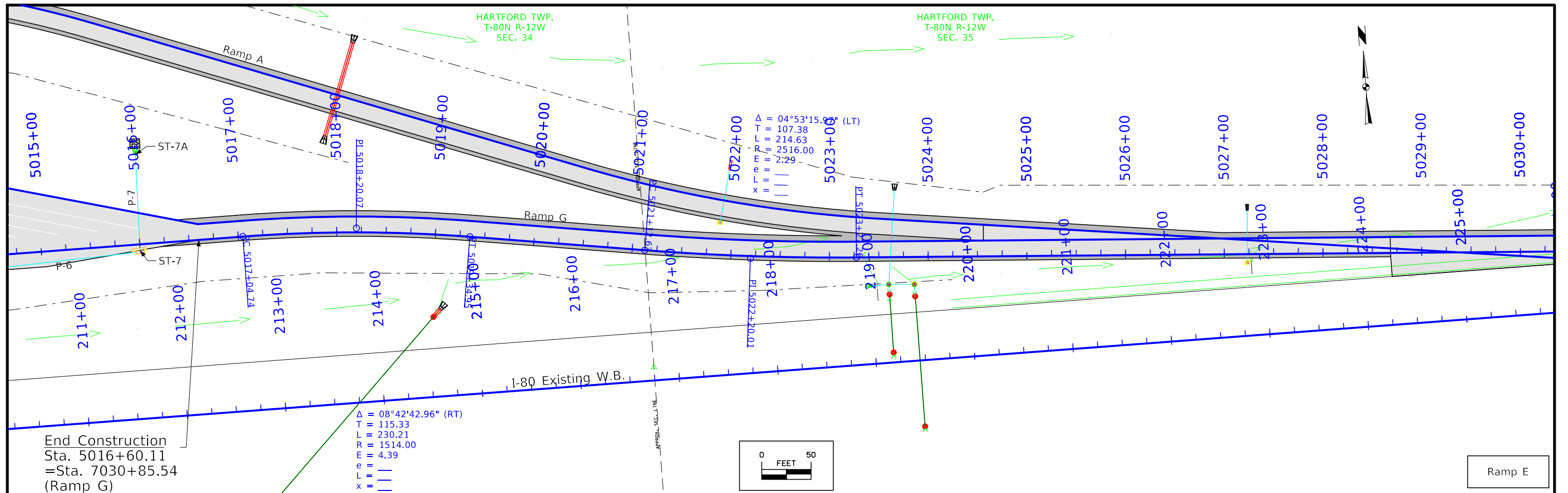

End Construction
 Sta. 5016+60.11
 =Sta. 7030+85.54
 (Ramp G)

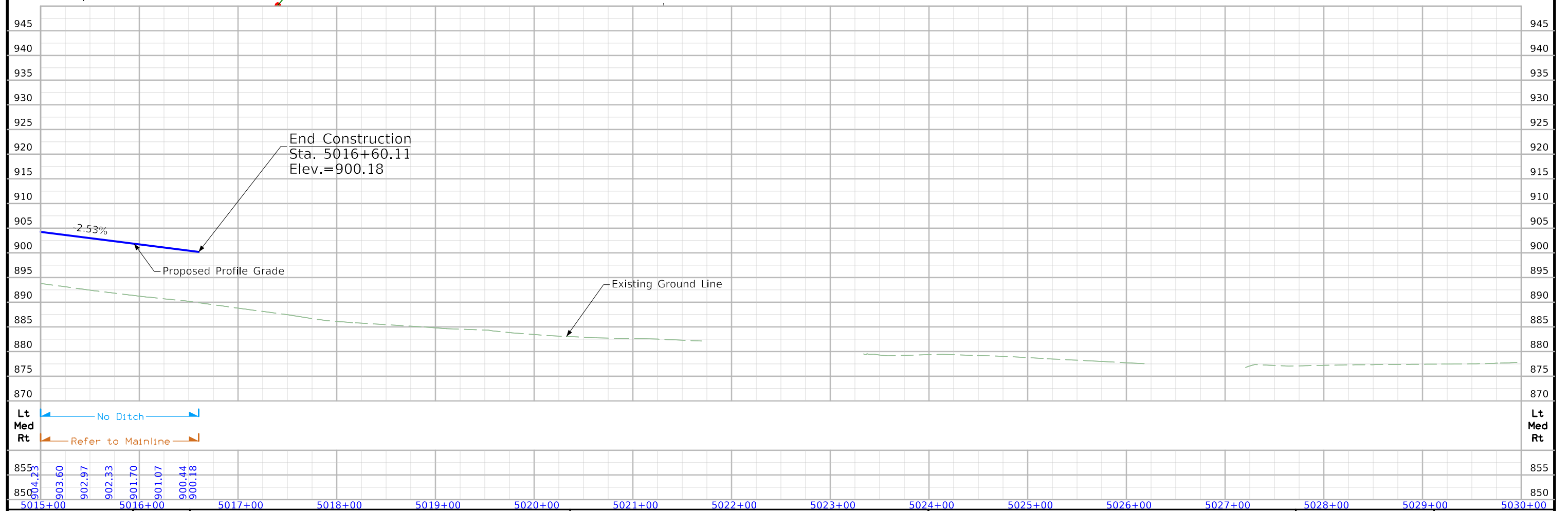
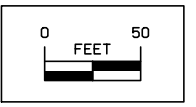

HARTFORD TWP.
T-80N R-12W
SEC. 34

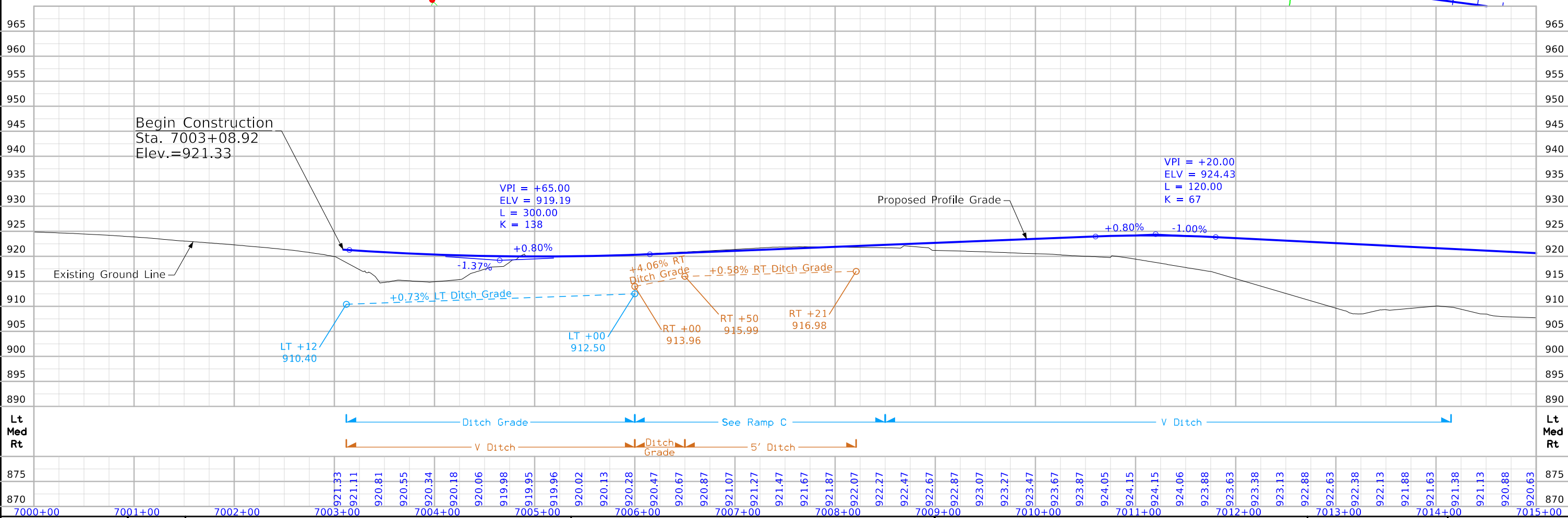
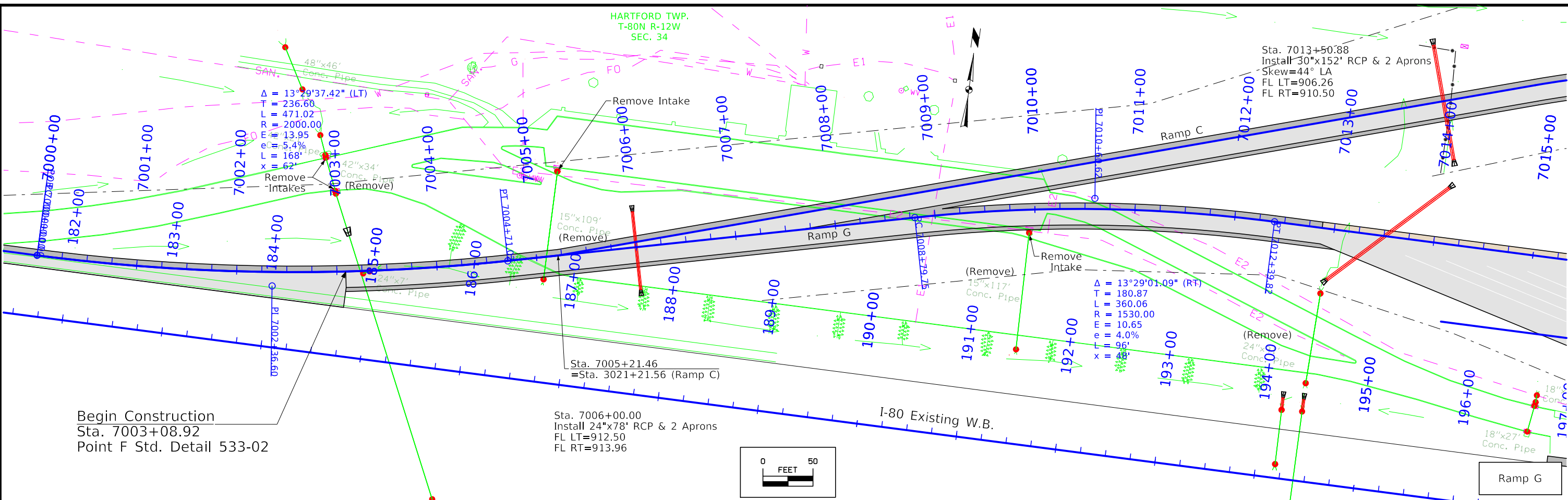

FILE NO.	ENGLISH	DESIGN TEAM Snyder & Associates	IOWA COUNTY	PROJECT NUMBER IMX-080-6(536)208--02-48	SHEET NUMBER K.11
----------	---------	---------------------------------	-------------	---	-------------------

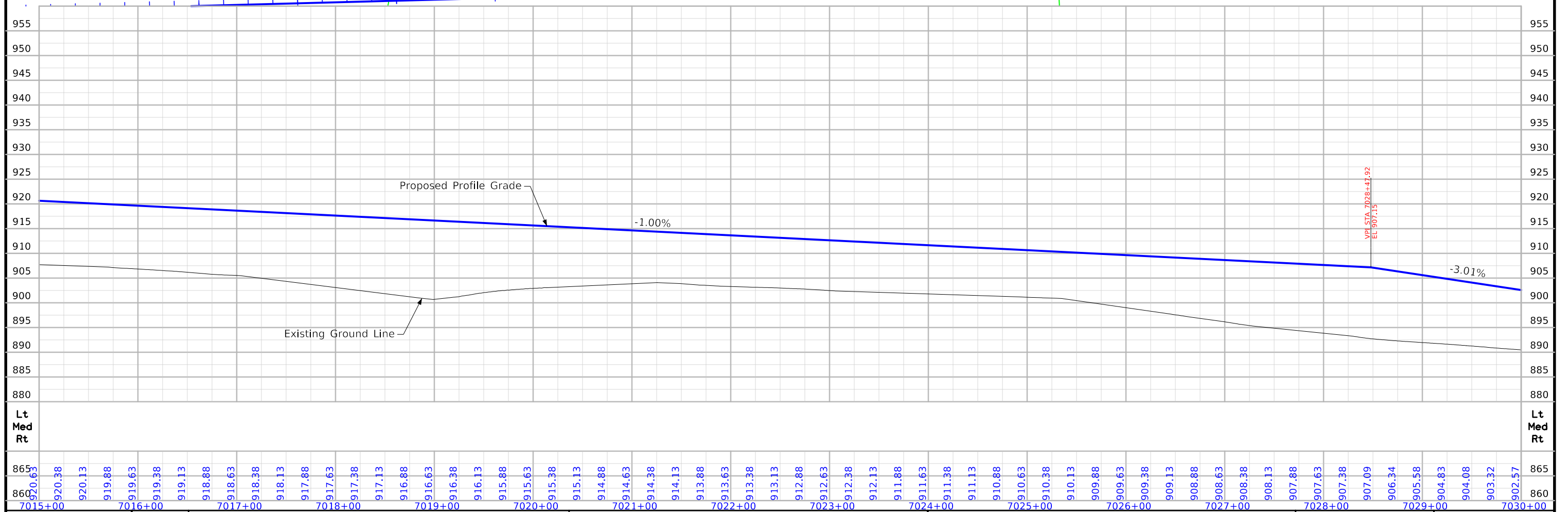
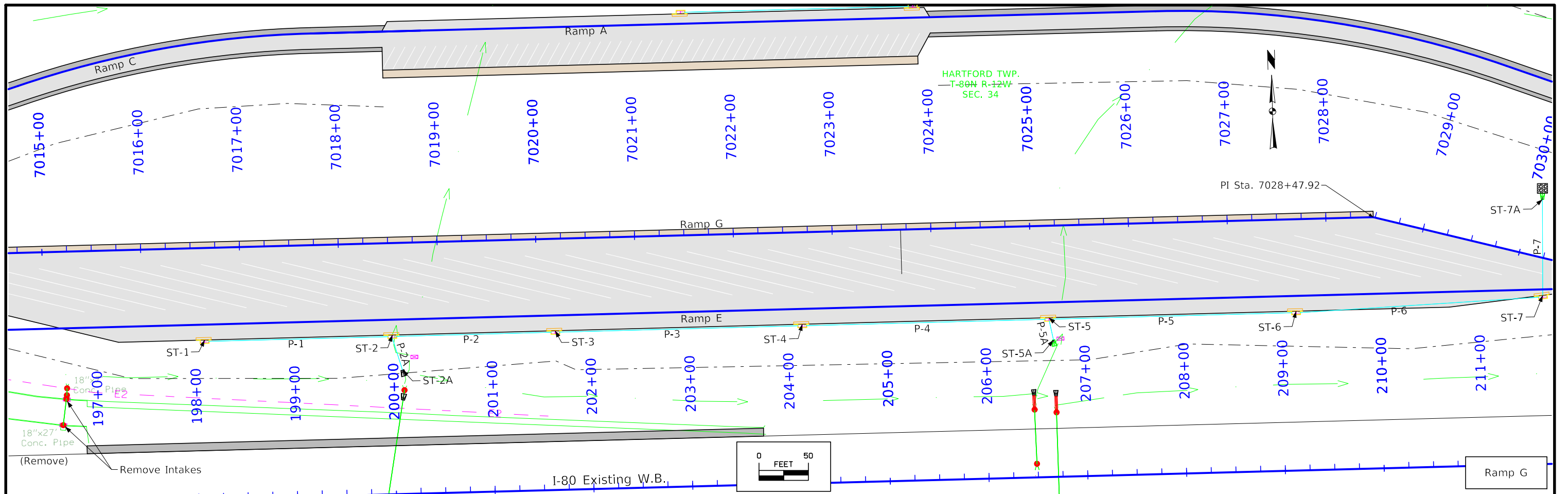

FILE NO.	ENGLISH	DESIGN TEAM Snyder & Associates	Iowa COUNTY	PROJECT NUMBER IMX-080-6(536)208--02-48	SHEET NUMBER K.12
----------	---------	---------------------------------	-------------	---	-------------------

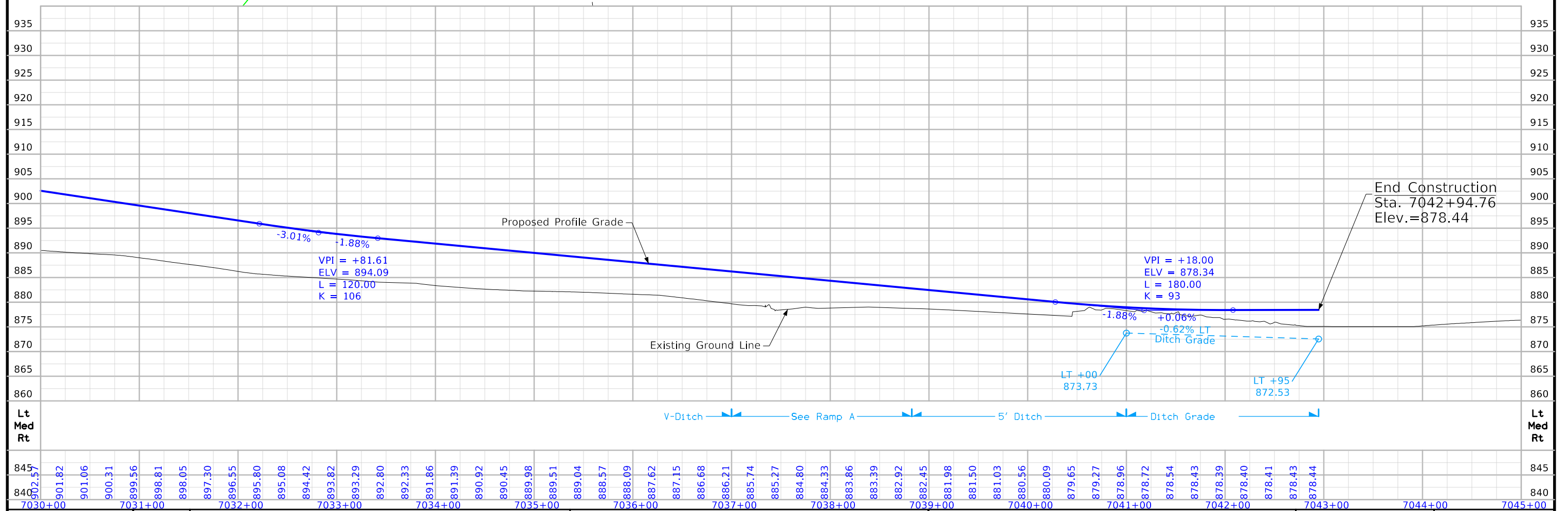
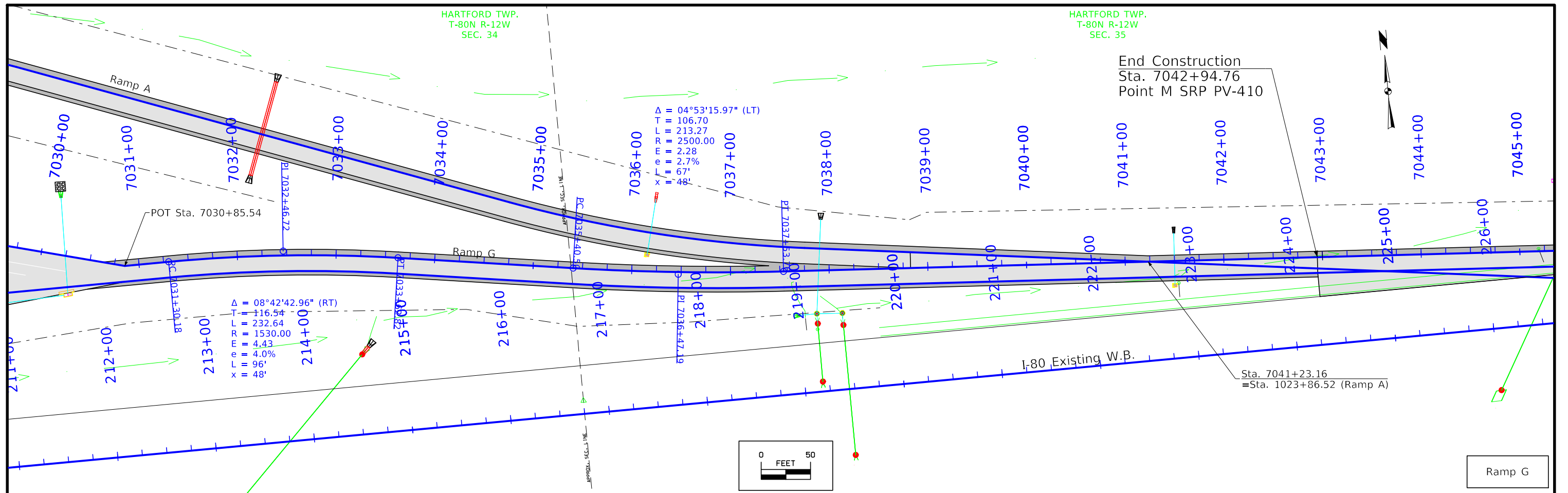

FILE NO.	ENGLISH	DESIGN TEAM	Snyder & Associates	IOWA COUNTY	PROJECT NUMBER	IMX-080-6(536)208--02-48	SHEET NUMBER	K.13
----------	---------	-------------	---------------------	-------------	----------------	--------------------------	--------------	------

① Diameter or equivalent diameter

* Bid Item
** For SW-545

STORM SEWER

INTAKES AND UTILITY ACCESSES

PIPES

Design Length, Slope, and Flowlines are calculated from center to center of structures.

No.	Location Station and Offset	*Type or Standard Road Plan	Form	Bottom	Ext.	Notes	Line Number	Intake/Utility Access No.		Class 'D'	Pipe	Bid* Length	Design Length	Slope %	Connected Pipe Joint (DR-121) Type	Flow Lines			Pipe Profile Sheet No.	Notes
			Grade	Well	Length**			From	To		Size					Inlet	Outlet	Other		
			Elev.	Elev.	FT			IN	FT		FT					Elevation	Elevation	Elevation		
ST-1	5002+45.00, 15.5' RT	SW-509	917.54	912.79			P-1	ST-1	ST-2	2000	15	190	190.0	2		913.29	909.65			
ST-2A	5004+44.33, 51.2' RT	DR-201 (30")					P-2A	ST-2A	ST-2	2000	30	34	40.2	0.4		907.20	907.06			
ST-2	5004+35.00, 15.5' RT	SW-509	915.64	906.36			P-2	ST-2	ST-3	2000	30	165	165.0	0.75		906.86	905.68			
ST-3	5006+00.00, 15.5' RT	SW-509	913.99	904.88			P-3	ST-3	ST-4	2000	30	250	250.0	0.75		905.38	903.57			
ST-4	5008+50.00, 15.5' RT	SW-509	911.49	902.77			P-4	ST-4	ST-5	2000	30	250	250.0	0.75		903.27	901.46			
ST-5A	5011+03.81, 38.1' RT	DR-201 (24")					P-5A	ST-5A	ST-5	2000	24	20	26.2	2		904.25	903.85			
ST-5	5011+00.00, 15.5' RT	SW-509	908.99	900.66			P-5	ST-5	ST-6	2000	30	250	250.0	1		901.16	898.74			
ST-6	5013+50.00, 15.5' RT	SW-509	906.49	897.74			P-6	ST-6	ST-7	2000	30	250	250.0	1		898.24	895.82			
ST-7	5016+00.00, 6.0' RT	SW-509	901.58	891.26			P-7	ST-7	ST-7A	2000	24	97	103.2	3.7		891.76	888.17			
ST-7A	5016+02.33, 91.0' LT	DR-201 (24")					P-8	ST-8	ST-9	2000	15	235	235.0	1		904.65	902.38			
ST-8	1003+75.00, 10.0' LT	SW-509	908.90	904.15			P-9	ST-9	ST-9A	2000	15	32	38.2	3		901.37	900.41			
ST-9	1006+10.00, 10.0' LT	SW-509	906.55	900.87			P-10	ST-10	ST-11	2000	24	11	17.1	15.8		882.31	879.60			
ST-9A	1006+10.00, 45.0' LT	DR-201 (15")					P-11	EX	ST-11	2000	24	10	10.0	3.39	C-1	879.44	879.10			
ST-10	7023+69.35, 44.9' RT	DR-201 (24")					P-11A	ST-12	ST-11	2000	24	26	26.0	1.5		879.49	879.10			
ST-11	7037+86.41, 43.7' RT	SW-401	884.18	878.20			P-12	EX	ST-12	2000	24	12	12.0	1.41	C-1	879.76	879.59			
ST-12	7038+12.22, 43.9' RT	SW-401	884.20	878.99			P-13	ST-11	ST-13	2000	30	90	95.7	1.78		878.70	877.00			
ST-13	1020+53.42, 29.7' LT	DR-201 (30")					P-14	ST-14	ST-15	2000	18	47	53.1	1		873.95	873.42			
ST-14	7041+50.00, 24.8' RT	SW-511	878.17	873.45			P-16	ST-16	ST-17	2000	15	52	58.1	3.89		881.17	878.91			
ST-15	7041+50.00, 28.3' LT	DR-201 (18")																		
ST-16	7036+15.00, 16.5' LT	SW-511	886.17	880.67																
ST-17	1018+81.44, 35.2' LT	DR-201 (15")																		

ROCK EROSION CONTROL

Refer to EC-301 and Detail 570-8

Location				Rock Erosion Control (REC)					Material Bid Quantities			Remarks		
Road Identification	Begin Station	End Station	Side	(L)	(W)	Type 1	Type 2	Type 3	Type 4	Type 5	Eng. Fabric		Class E Revetment	Erosion Stone
			Lt./Rt.	FT	FT	Rock Ditch Check	Rock Ditch	Rock Flume	Rock Splash Basin	Rock Slope Protection	SY		TON	TON
I-80 WB	166+00.70		LT	10.5	10				X		22.6		11.6	
Ramp G	7003+11.41		LT	13.3	10				X		26.9	14.6		
I-80 WB	194+19.23		LT	10.5	10				X		22.6	11.6		
	194+38.90		LT	10.5	10				X		22.6	11.6		
	200+09.44		LT	11.6	10				X		24.3	12.8		
	206+18.90		LT	10.5	10				X		22.6	11.6		
	206+70.40		LT	10.5	10				X		22.6	11.6		
	214+68.32		LT	12.7	10				X		26.0	13.9		
Ramp A	1014+75.00		LT	10.5	10				X		22.6	11.6		
	1018+81.44		LT	8.9	10				X		20.1	9.8		
	1020+53.42		LT	11.6	20				X		24.3	12.8		
Ramp C	3030+19.00		LT	11.6	10				X		24.3	12.8		
Ramp G	7006+00.00		LT	10.5	10				X		22.6	11.6		
	7014+15.00		LT	11.6	10				X		24.3	12.8		
	7041+50.00		LT	9.4	10				X		20.8	10.4		
Ramp A/Auto Parking	1006+10.00		LT	8.9	10				X		20.1	9.8		
Ramp E/Truck Parking	5016+02.47		LT	10.5	10				X		22.6	11.6		

1000' min. (12' wide)
Refer to plans for length
of acceleration lane

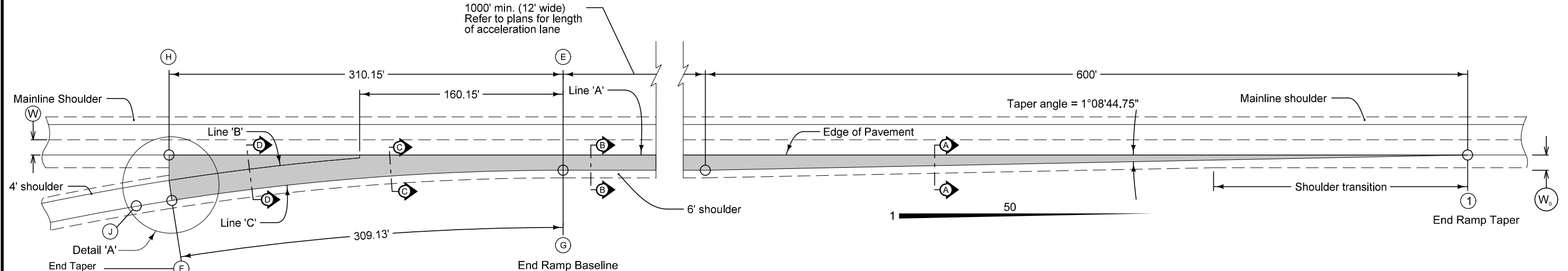

Pt. 'G' to Pt. 'J'
 $\Delta = 8^\circ 51' 20.88''$
 $T = 164.23'$
 $L = 327.73'$
 $E = 6.73'$
 $R = 2000.00'$

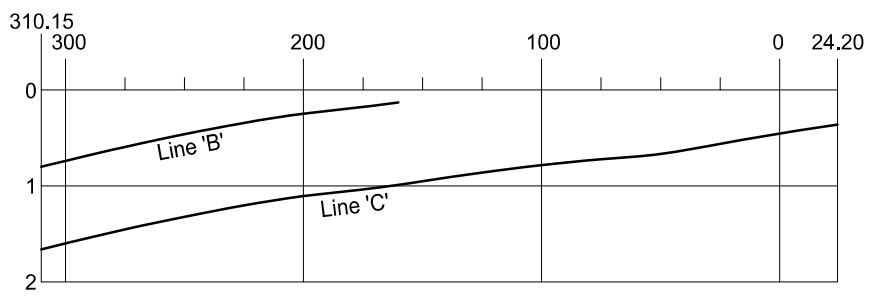

NOTE: The algebraic difference between ramp profile grade at point (F) and relative profile grade of mainline at point (H) is 0.62%

W _o	Shoulder Width beyond Edge of Mainline Pavement		
	8'	10'	12'
12'	NA	100'	150'

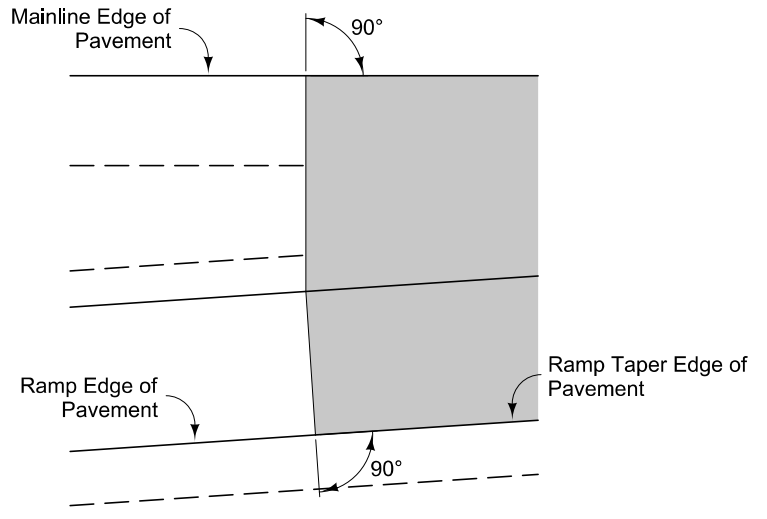

DETAIL A

Construct ramp exit pavement the same thickness as mainline pavement.

For joint detail, see PV-101.

① For header construction detail at the end of taper, see Typical 7101 or Typical 7102.

② Construct subbase for ramp exit pavement the same thickness as mainline subbase.

		(H)	310.15	300	275	250	225	204	200	175	160.15	150	125	100	75	50	25	0	24.2	(E)				
From Line 'A' To Line 'B'	OFFSET (Ft.)		20.00	18.45	14.84	11.56	8.60	6.30	5.95	3.61	2.37													
	SLOPE (%)		← Constant 4.0% Slope →								4.11	4.92	5.40											
	DROP (Ft.)		0.80	0.74	0.59	0.46	0.34	0.25	0.24	0.18	0.13													
From Line 'B' To Line 'C'	OFFSET (Ft.)		← Constant 16' Offset →																					
	SLOPE (%)		← Constant 5.4% Slope →																					
	DROP (Ft.)		0.86	0.86	0.86	0.86	0.86	0.86	0.86	0.86	0.86	0.86												
From Line 'A' To Line 'C'	OFFSET (Ft.)											17.63	15.91	14.50	13.41	12.63	12.16	12.00	12.00					
	SLOPE (%)											5.40	5.40	5.40	5.40	5.40	4.59	3.78	3.00					
	DROP (Ft.)		1.66	1.60	1.45	1.32	1.20	1.11	1.10	1.04	0.99	0.95	0.86	0.78	0.72	0.68	0.56	0.45	0.36					
DISTANCE FROM POINT (G) ALONG LINE 'C' (Ft.)			309.13	298.73	273.67	248.66	223.68	202.73	198.74	173.83	159.04	150.14	125.08	100.04	75.02	50.01	25.00	0.00						

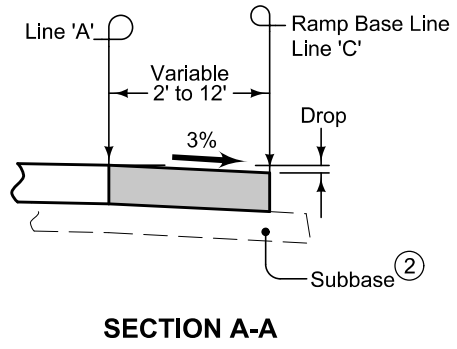

SECTION A-A

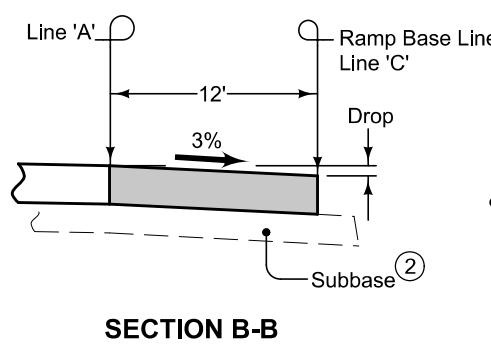

SECTION B-B

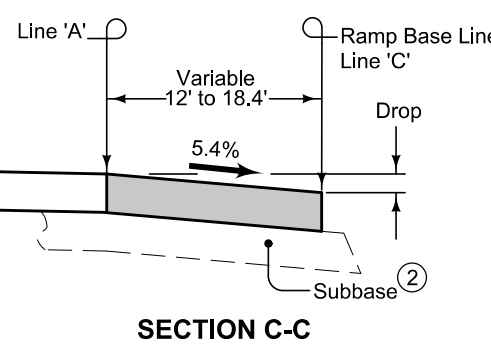

SECTION C-C

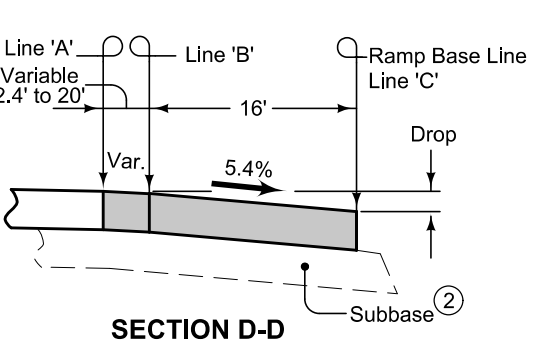

SECTION D-D

ROAD DESIGN DETAIL	REVISION	
	3	04-20-21
	533-02	
SHEET 1 of 2		
Added Point J and Ramp Profile note.		
PARALLEL ACCELERATION TAPER FOR 16' RAMP (60 MPH DESIGN SPEED)		

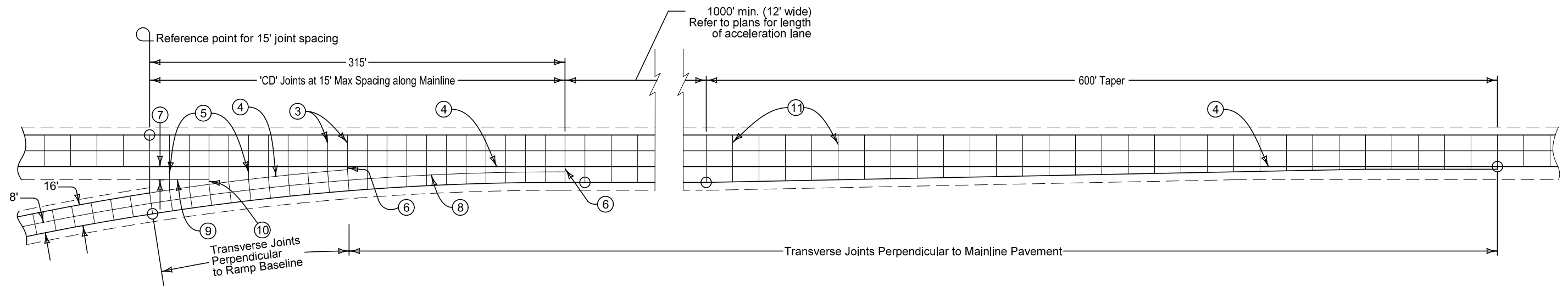

- ③ 'CD' Joints at 15' spacing.
- ④ 'BT-2' or 'KT-2' Joint.
- ⑤ 'C' Joint.
- ⑥ 'B' Joint. 2' minimum, 4' maximum.
- ⑦ 10' minimum or equal to mainline shoulder width.
- ⑧ 'L-2' Joint.
- ⑨ 'C' Joint parallel to mainline pavement.
- ⑩ 'B' or 'C' Joint. 2' minimum, 4' maximum.
- ⑪ 'CD' Joints at 17' spacing.

ROAD DESIGN DETAIL	REVISION	
	3	04-20-21
	533-02	
SHEET 2 of 2		
Added Point J and Ramp Profile note.		
PARALLEL ACCELERATION TAPER FOR 16' RAMP (60 MPH DESIGN SPEED)		

Control Point:

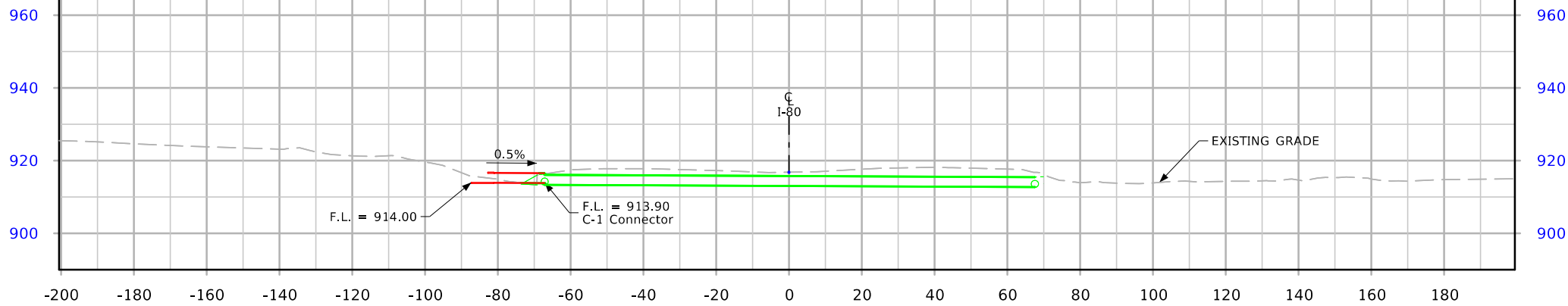

Longitudinal Section Along Q Culvert

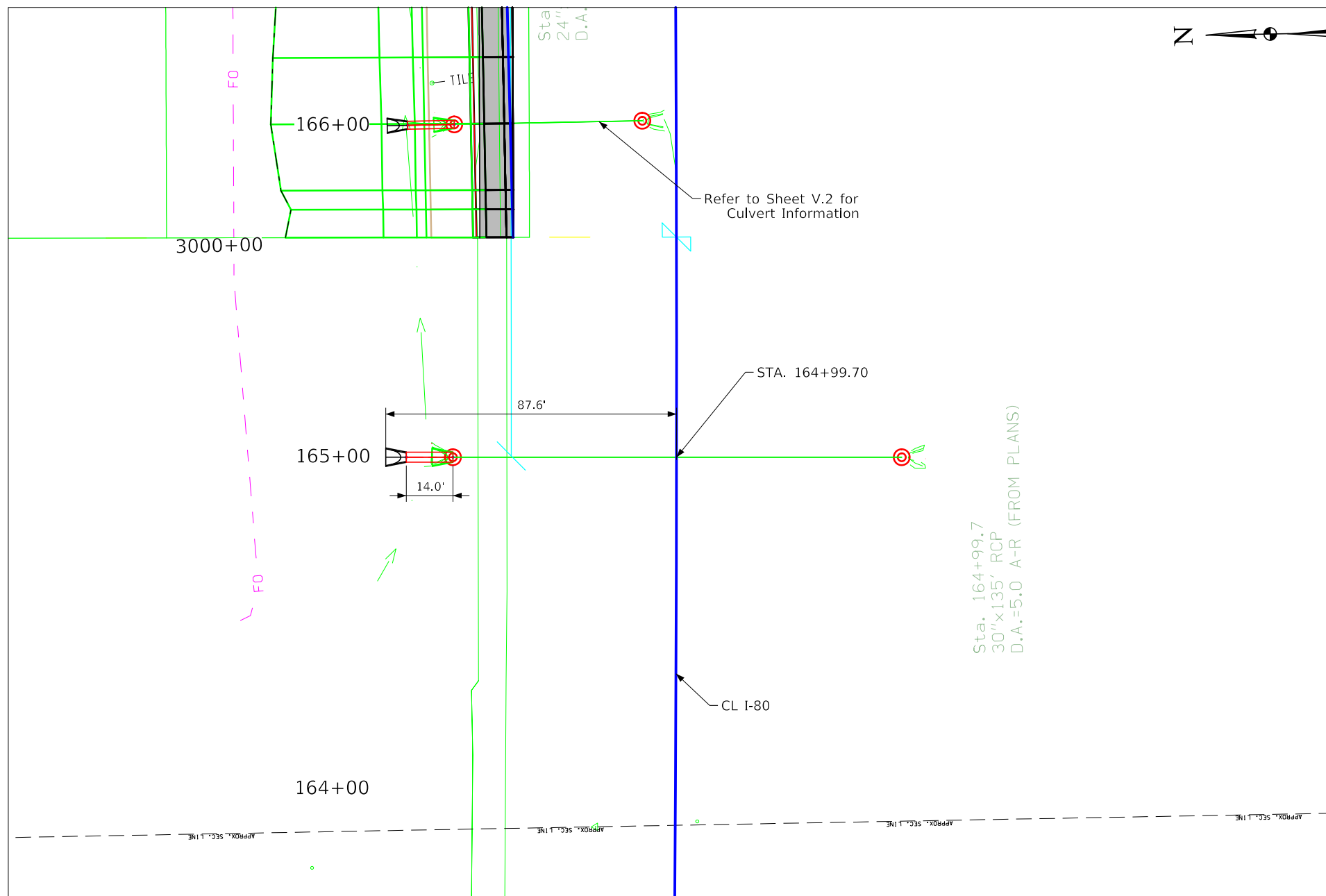

Plat Plan

UTILITIES LEGEND

REFER TO D.1

Hydraulic Data

Drainage Area = 5.0 Acres

Q₅₀ = X.X cfs

HW Elev. = X.X

Location

I-80
T-80N R-12W
Section 34
Hartford Township
Iowa County



Design For 0° Skew
30" x 14'
Reinforced Concrete
Pipe Culvert Extension
 STA. 164+99.70 I-80 Letting Date: Jan. 2026
Iowa County
 IOWA DEPARTMENT OF TRANSPORTATION
 Design No. _____ Design Sheet No. of _____ FHWA/Asset _____

Control Point:

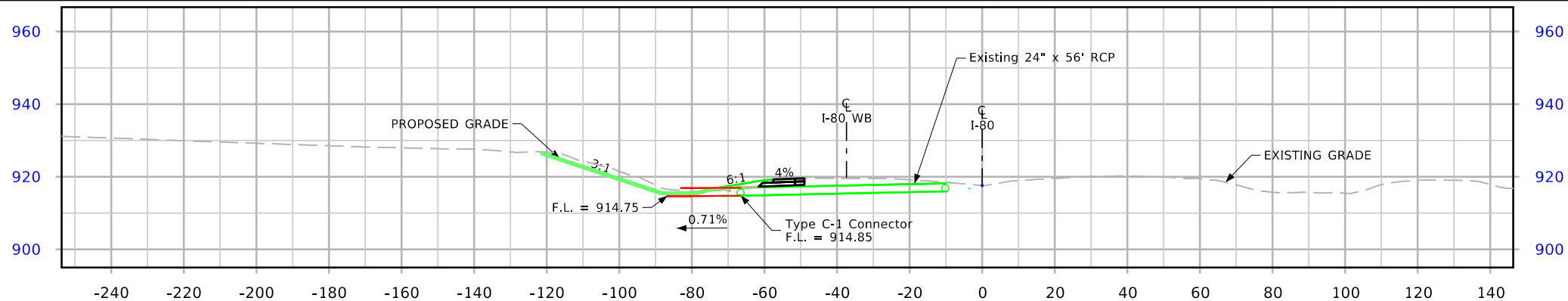

Longitudinal Section Along \mathcal{Q} Culvert

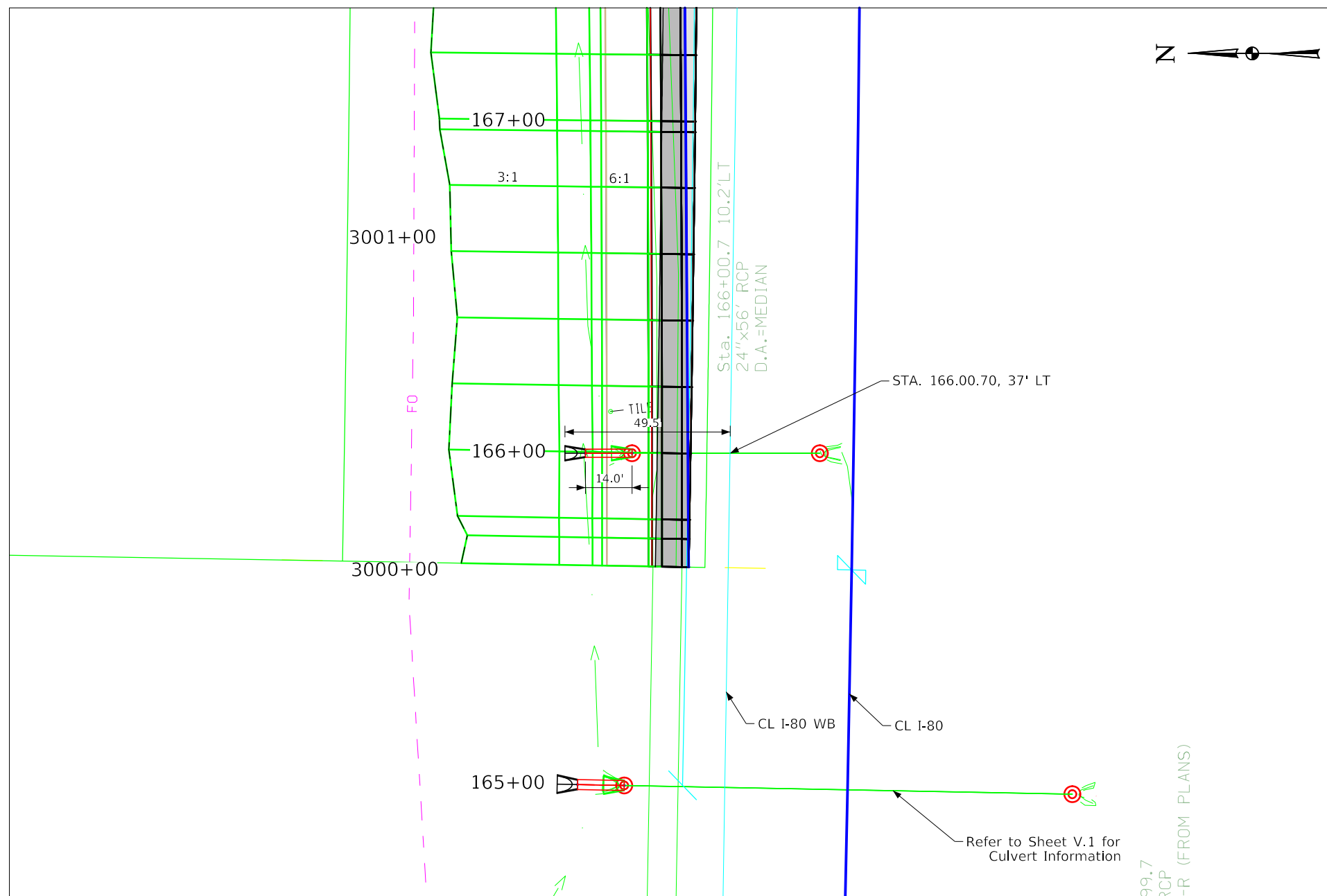

Plat Plan

UTILITIES LEGEND

REFER TO D.1

Hydraulic Data

Drainage Area = ? Acres
Q₅₀ = X.X cfs
HW Elev. = X.X

Location

I-80
T-80N R-12W
Section 34
Hartford Township
Iowa County

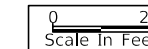

Design For 0° Skew
24" x 14'
Reinforced Concrete
Pipe Culvert Extension
STA. 166+00.70, 37.0' LT I-80 Letting Date: Jan. 2026
Iowa County
IOWA DEPARTMENT OF TRANSPORTATION
Design No. _____ Design Sheet No. of _____ FHWA/Asset _____

Control Point:

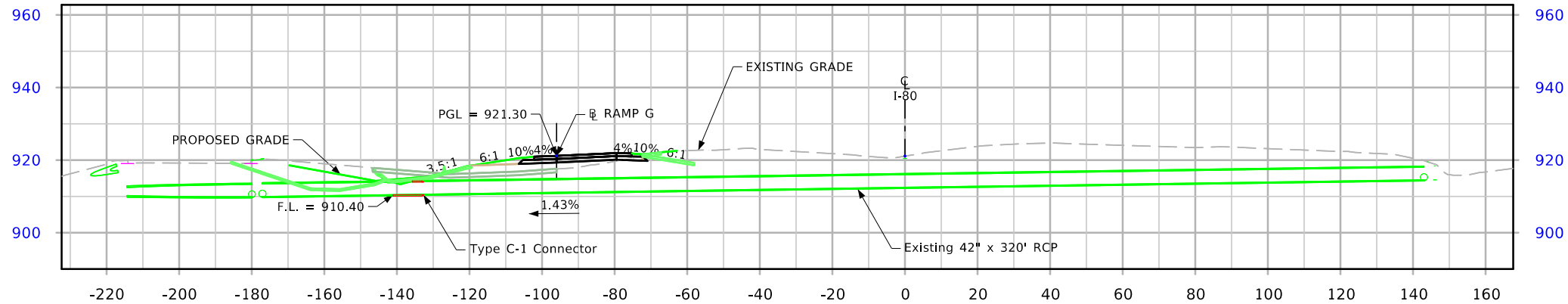

Longitudinal Section Along Q Culvert

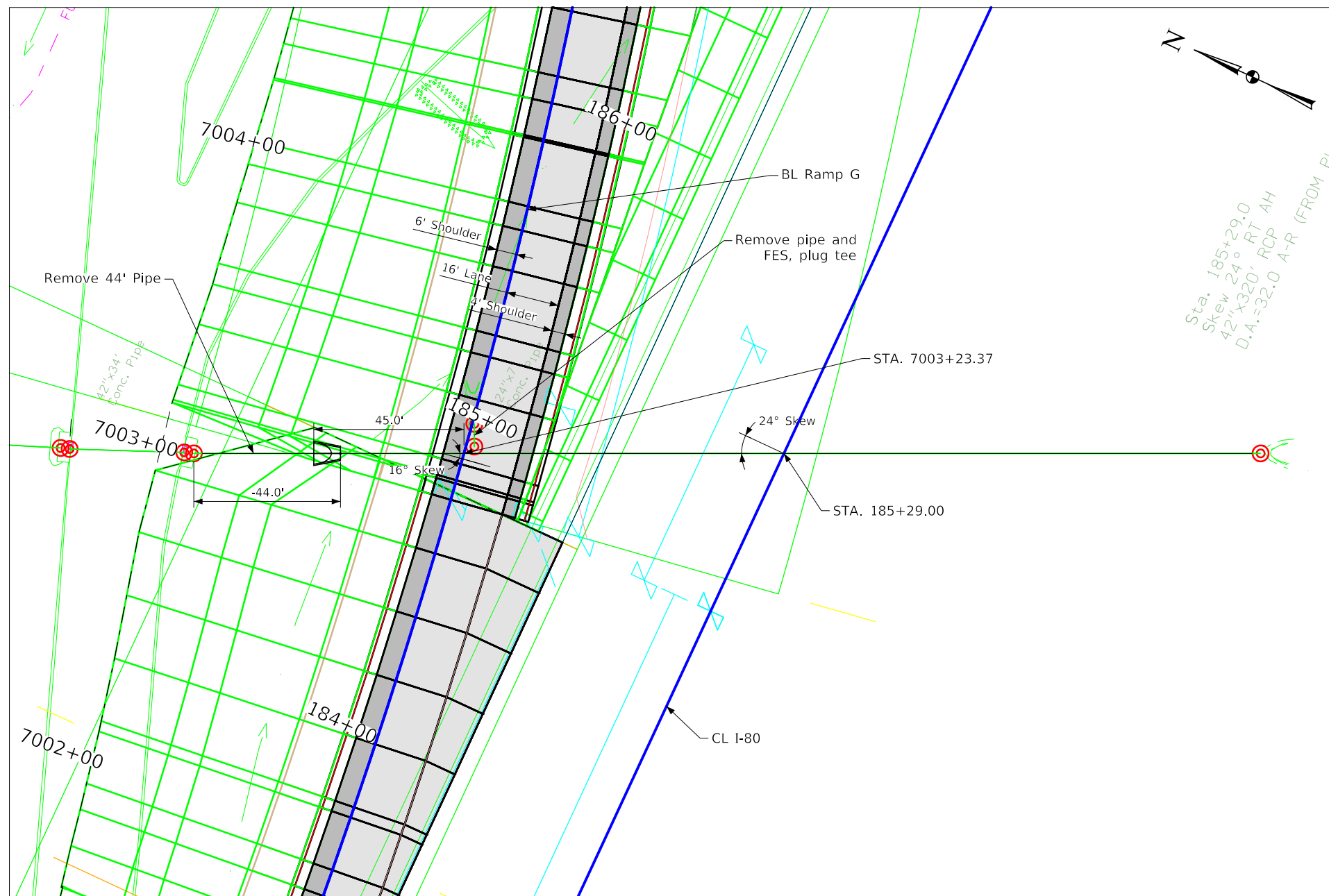

Plat Plan

UTILITIES LEGEND

REFER TO D.1

Hydraulic Data

Drainage Area = 320.0 Acres

Q₅₀ = X.X cfs

HW Elev. = X.X

Location

I-80
T-80N R-12W
Section 34
Hartford Township
Iowa County

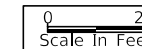

Design For 16° Skew
42" x -44'
Reinforced Concrete
Pipe Culvert Extension
 STA. 7003+23.37 Ramp G Letting Date: Jan. 2026
Iowa County
 IOWA DEPARTMENT OF TRANSPORTATION
 Design No. _____ Design Sheet No. of _____ FHWA/Asset _____
 SHEET NUMBER **V.3**

Control Point:

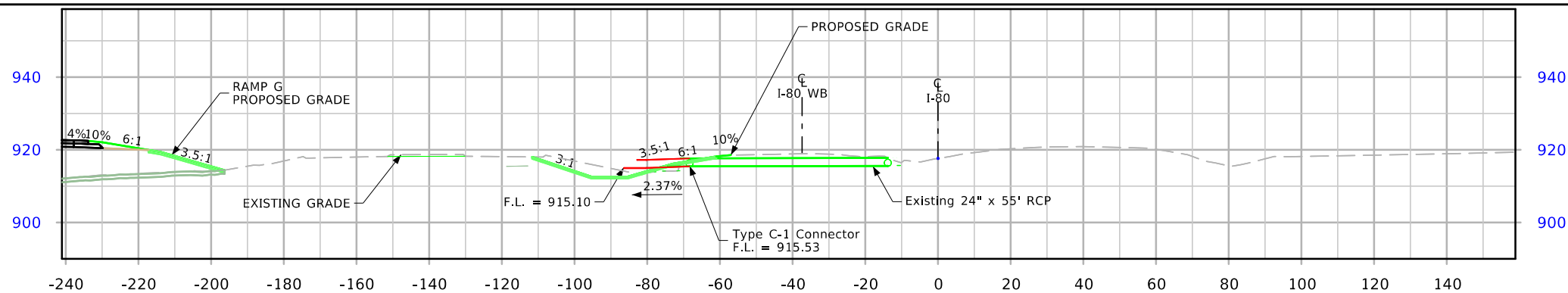

Longitudinal Section Along C Culvert

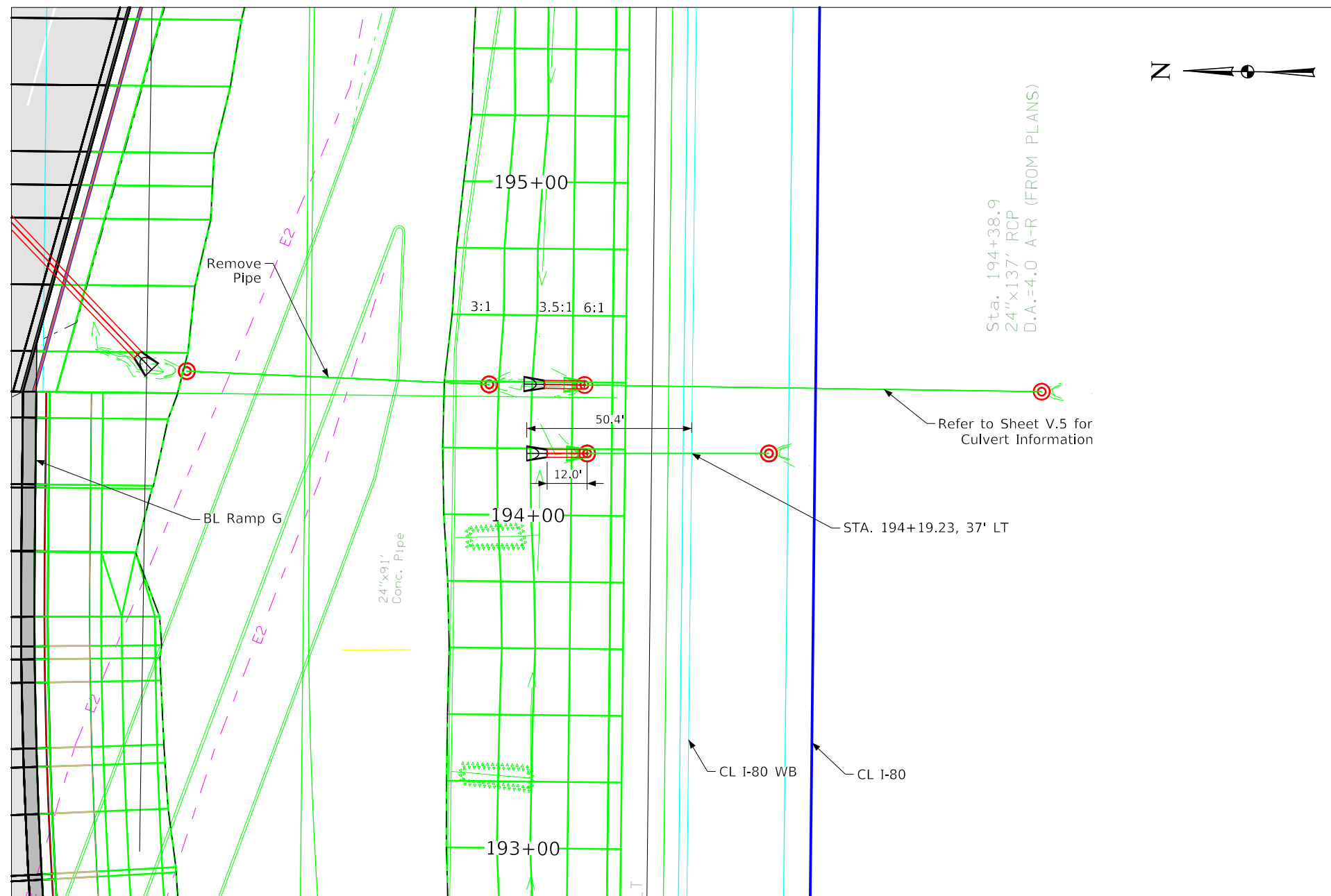

Plat Plan

UTILITIES LEGEND

REFER TO D.1

Hydraulic Data

Drainage Area = ? Acres

Q₅₀ = X.X cfs

HW Elev. = X.X

Location

I-80
T-80N R-12W
Section 34
Hartford Township
Iowa County



Design For 0° Skew
24" x 12'
Reinforced Concrete
Pipe Culvert Extension
 STA. 194+19.23, 37' LT I-80 Letting Date: Jan. 2026
Iowa County
 IOWA DEPARTMENT OF TRANSPORTATION
 Design No. _____ Design Sheet No. of _____ FHWA/Asset _____
 SHEET NUMBER **V.4**

Control Point:

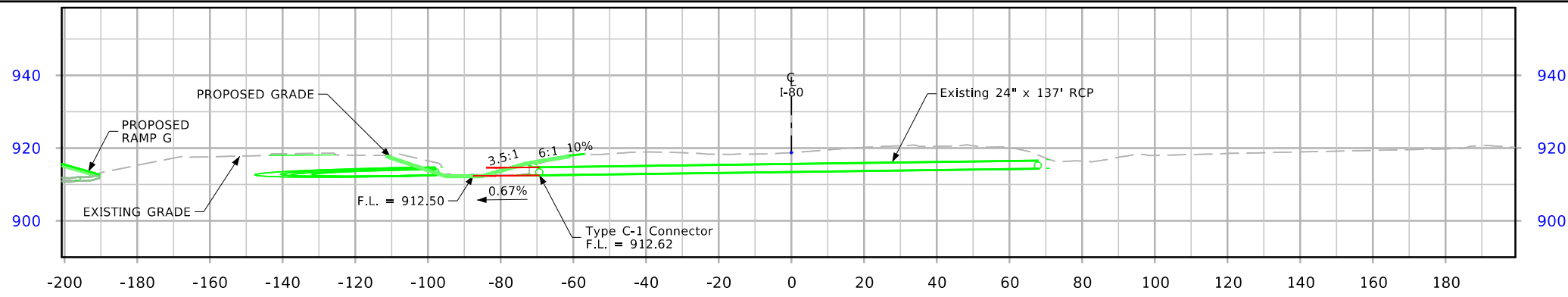

Longitudinal Section Along C Culvert

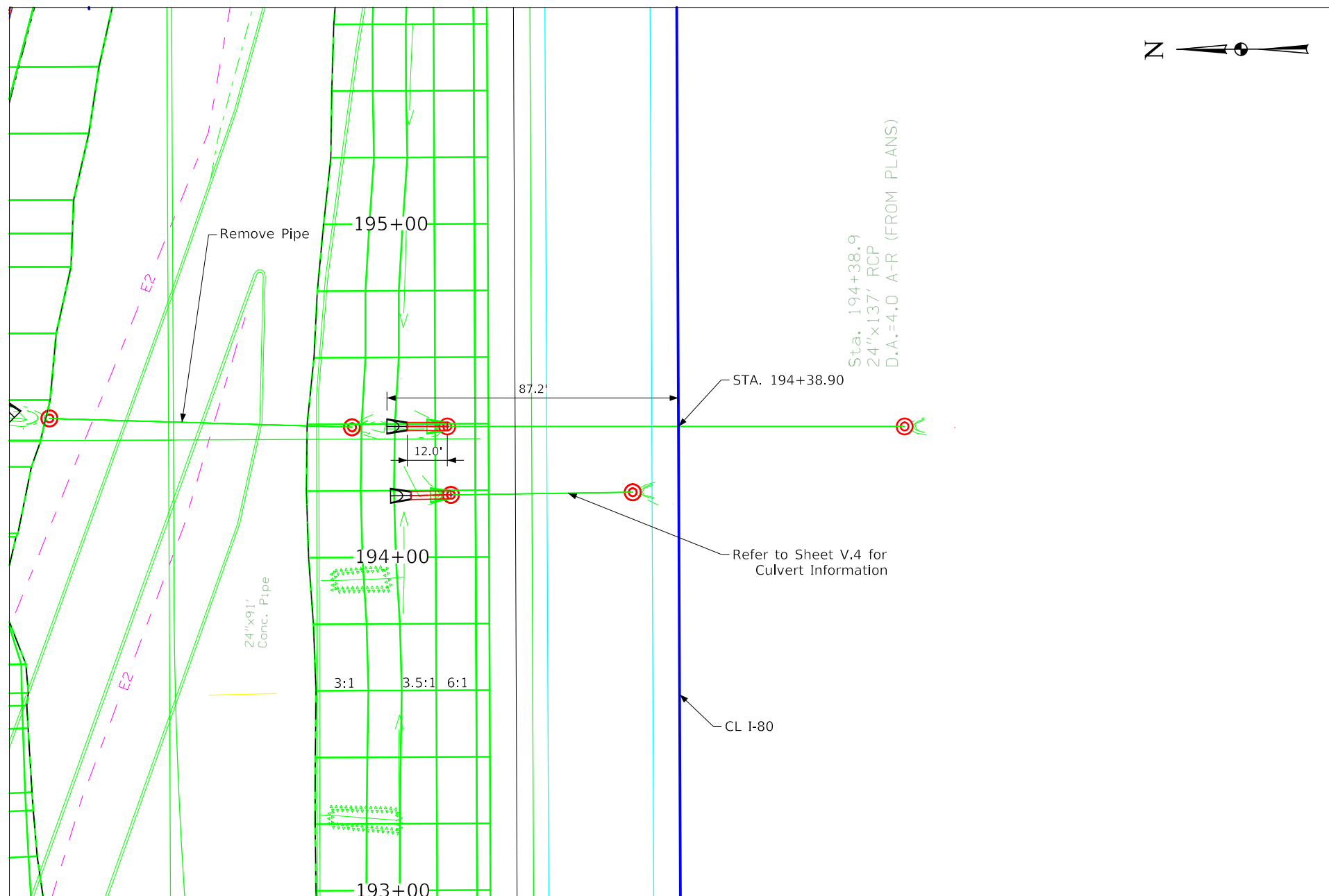

Plat Plan

UTILITIES LEGEND

REFER TO D.1

Hydraulic Data

Drainage Area = 4.0 Acres
Q₅₀ = X.X cfs
HW Elev. = X.X

Location

I-80
T-80N R-12W
Section 34
Hartford Township
Iowa County

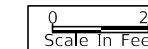

Design For 0° Skew
24" x 12'
Reinforced Concrete
Pipe Culvert Extension
 STA. 194+38.90 I-80 Letting Date: Jan. 2026
Iowa County
 IOWA DEPARTMENT OF TRANSPORTATION
 Design No. _____ Design Sheet No. of _____ FHWA/Asset _____

Control Point:

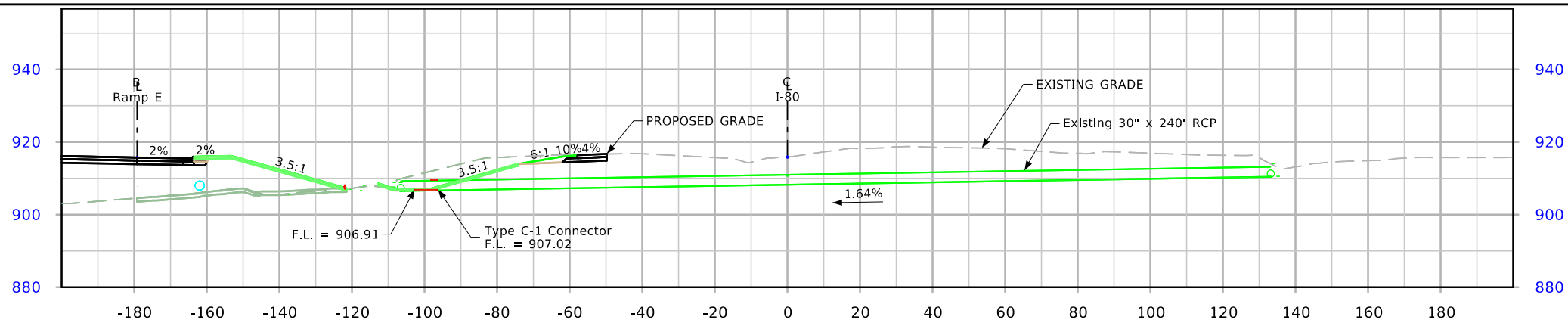

Longitudinal Section Along C Culvert

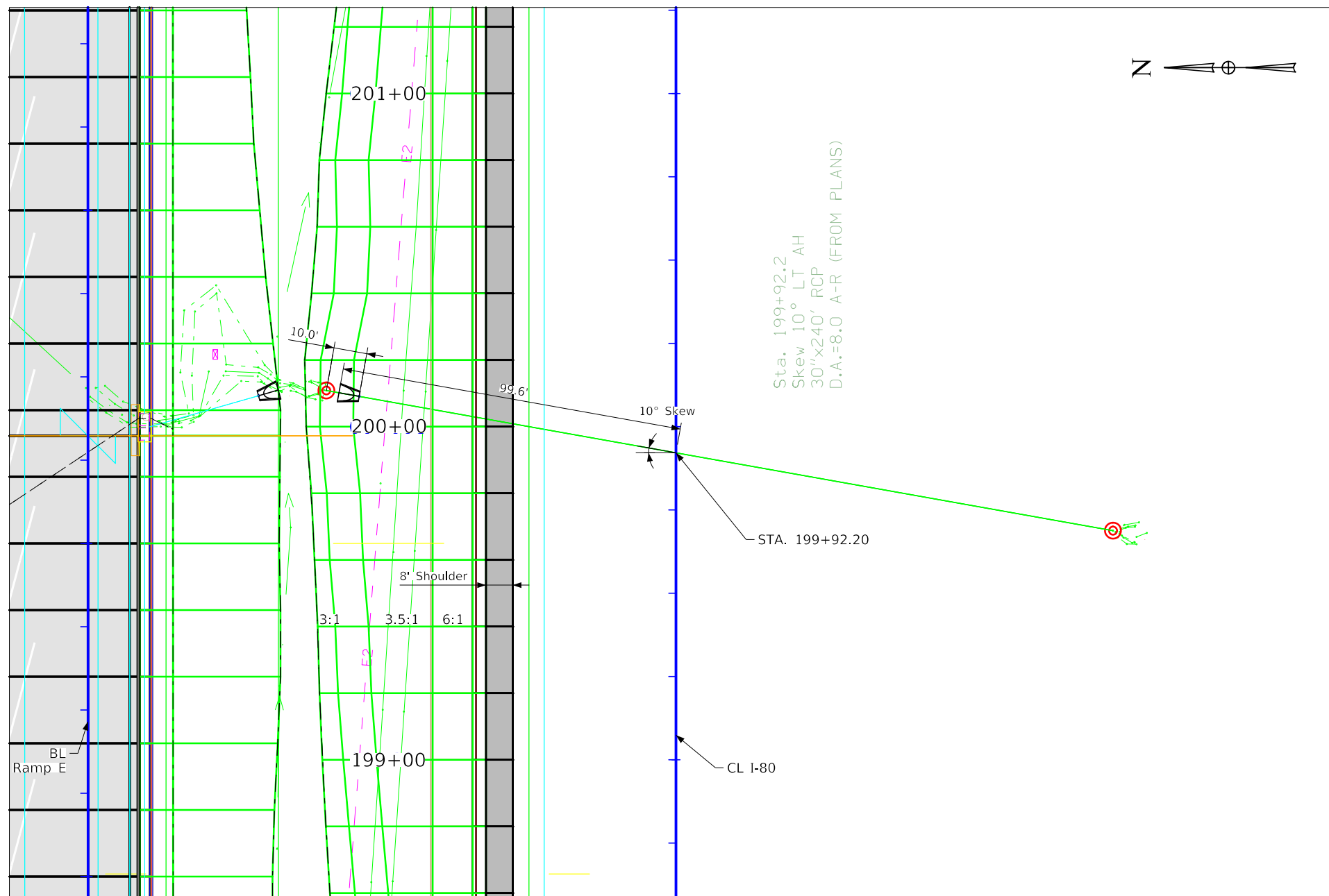

Situation Plan

UTILITIES LEGEND

REFER TO D.1

Hydraulic Data

Drainage Area = 8.0 Acres

Q₅₀ = X.X cfs

HW Elev. = X.X

Location

I-80
T-80N R-12W
Section 34
Hartford Township
Iowa County

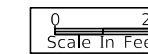

Design For 10° Lt. Ahead
30" x -10'
Reinforced Concrete
Pipe Culvert Extension
 STA. 199+92.20 I-80 Letting Date: Jan. 2026
Iowa County
 IOWA DEPARTMENT OF TRANSPORTATION
 Design No. Design Sheet No. of FHWA/Asset

Control Point:

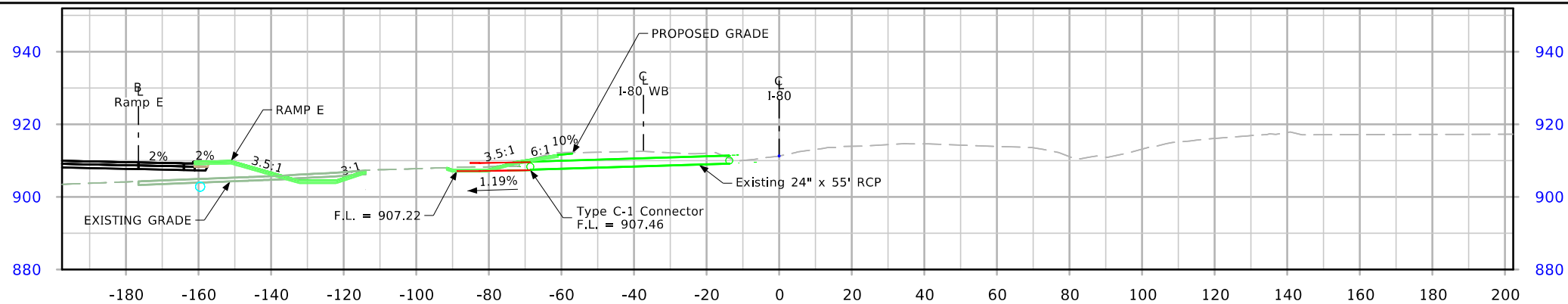

Longitudinal Section Along Q Culvert

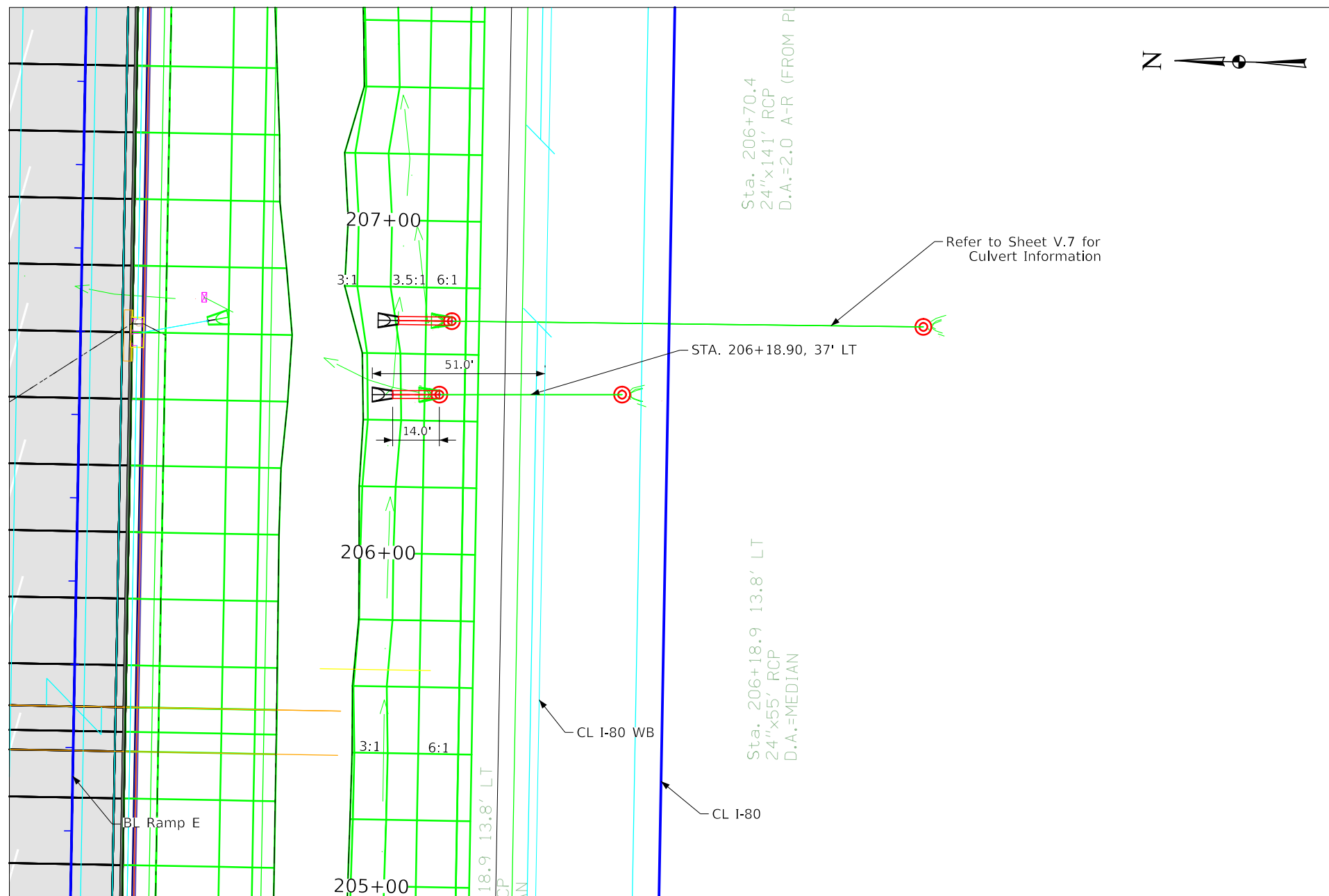

Plat Plan

UTILITIES LEGEND

REFER TO D.1

Hydraulic Data

Drainage Area = 8.0 Acres

Q₅₀ = X.X cfs

HW Elev. = X.X

Location

I-80
T-80N R-12W
Section 34
Hartford Township
Iowa County

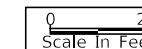

Design For 0° Skew
24" x 14'
Reinforced Concrete
Pipe Culvert Extension
 STA. 206+18.90, 37.0' LT I-80 Letting Date: Jan. 2026
Iowa County
 IOWA DEPARTMENT OF TRANSPORTATION
 Design No. _____ Design Sheet No. of _____ FHWA/Asset _____
 SHEET NUMBER **V.7**

Control Point:

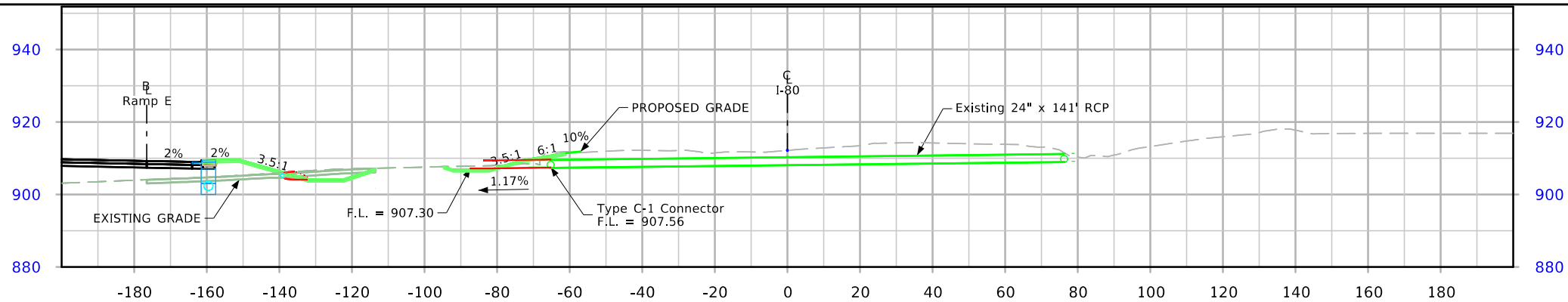

Longitudinal Section Along CL Culvert

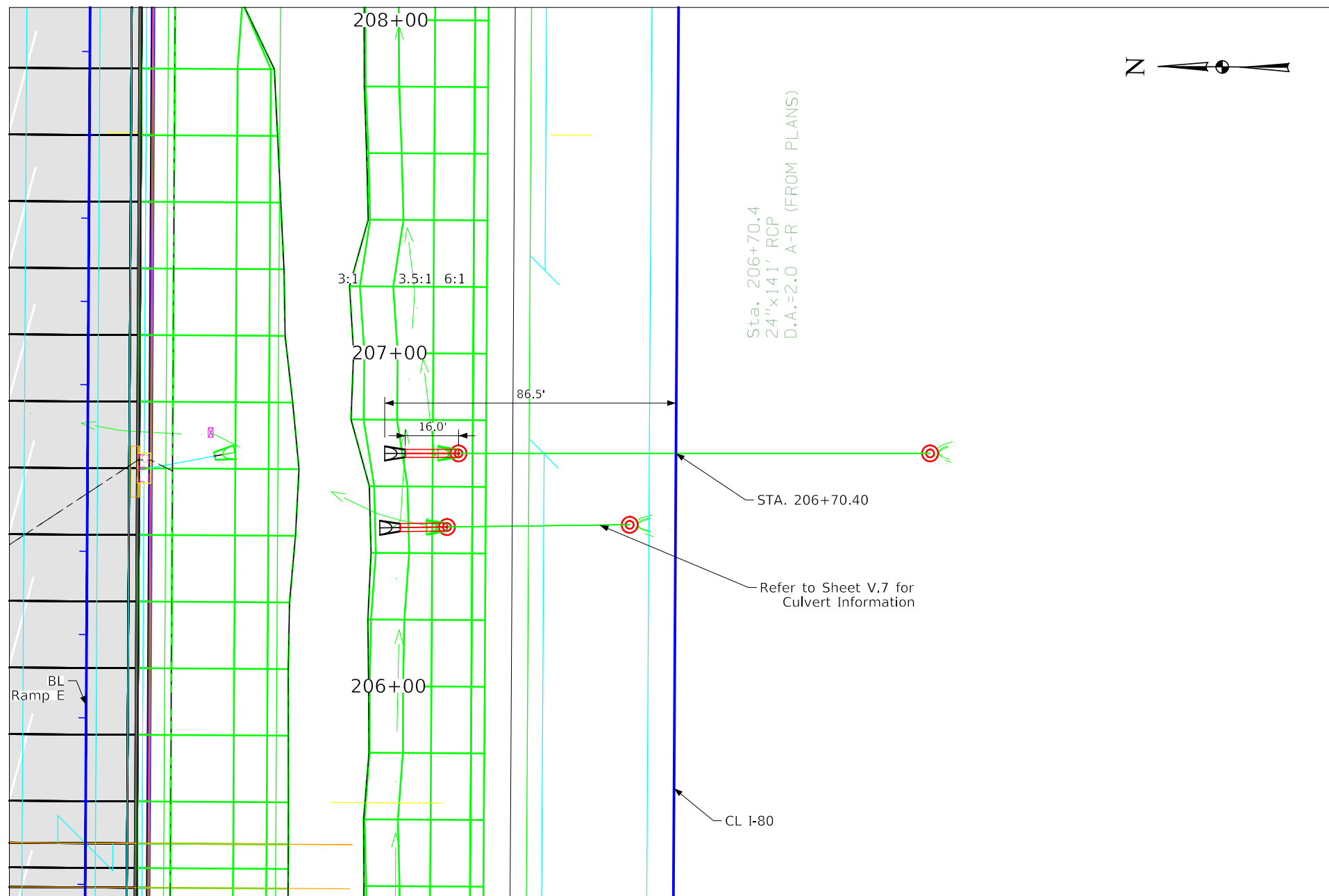

Plat Plan

UTILITIES LEGEND

REFER TO D.1

Hydraulic Data

Drainage Area = 2.0 Acres

Q₅₀ = X.X cfs

HW Elev. = X.X

Location

I-80

T-80N R-12W

Section 34

Hartford Township

Iowa County



Design For 0° Skew
24" x 16'
Reinforced Concrete
Pipe Culvert Extension
 STA. 206+70.40 I-80 Letting Date: Jan. 2026
Iowa County
 IOWA DEPARTMENT OF TRANSPORTATION
 Design No. _____ Design Sheet No. of _____ FHWA/Asset _____

Control Point:

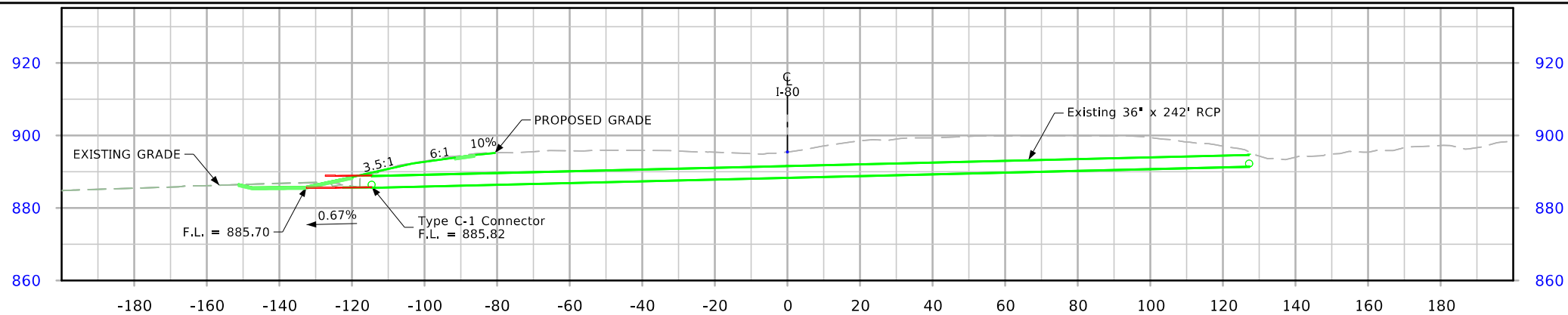

Longitudinal Section Along CL Culvert

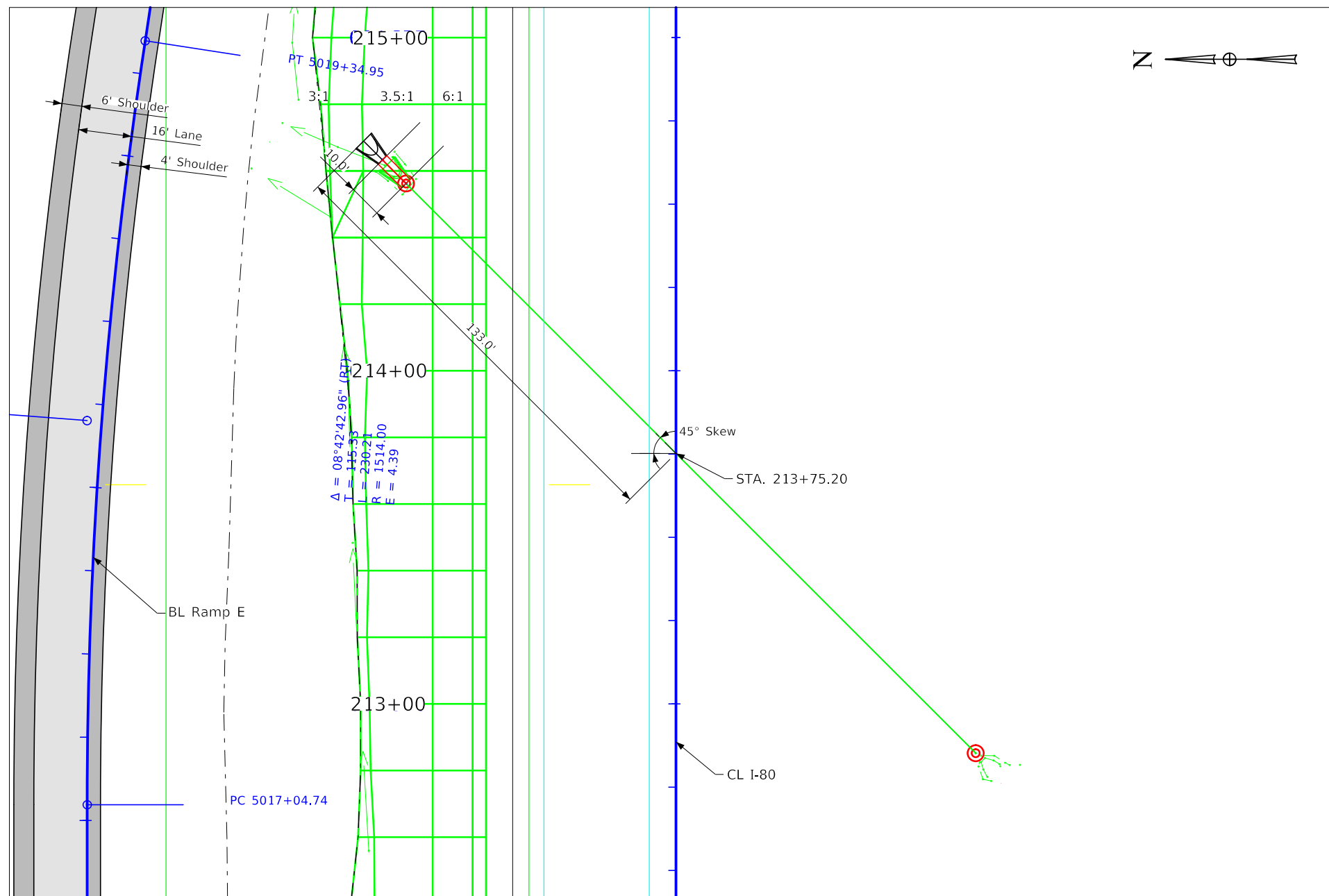

Situation Plan

UTILITIES LEGEND

REFER TO D.1

Hydraulic Data

Drainage Area = 18.0 Acres

Q₅₀ = X.X cfs

HW Elev. = X.X

Location

I-80
T-80N R-12W
Section 34
Hartford Township
Iowa County

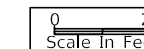

Design For 45° Lt. Ahead
36" x 10'
Reinforced Concrete
Pipe Culvert Extension
 STA. 213+75.20 I-80 Letting Date: Jan. 2026
Iowa County
 IOWA DEPARTMENT OF TRANSPORTATION
 Design No. Design Sheet No. of FHWA/Asset

Control Point:

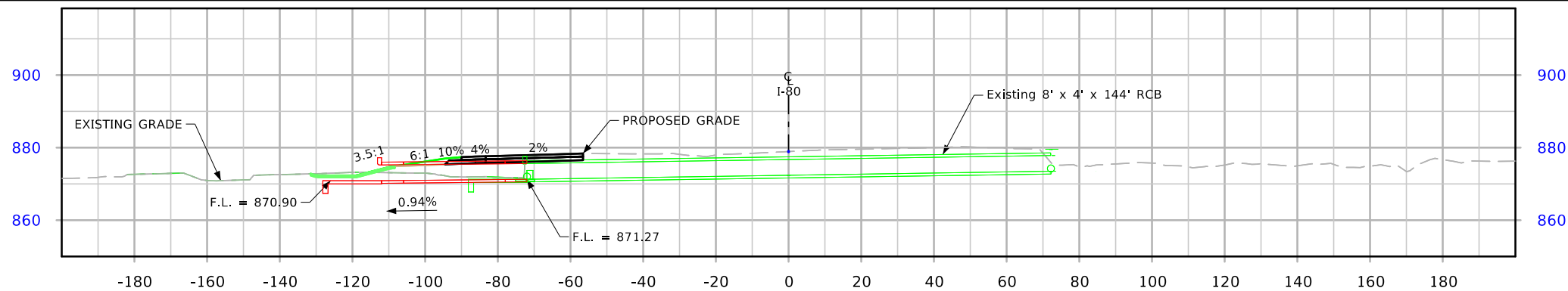

Longitudinal Section Along Q Culvert

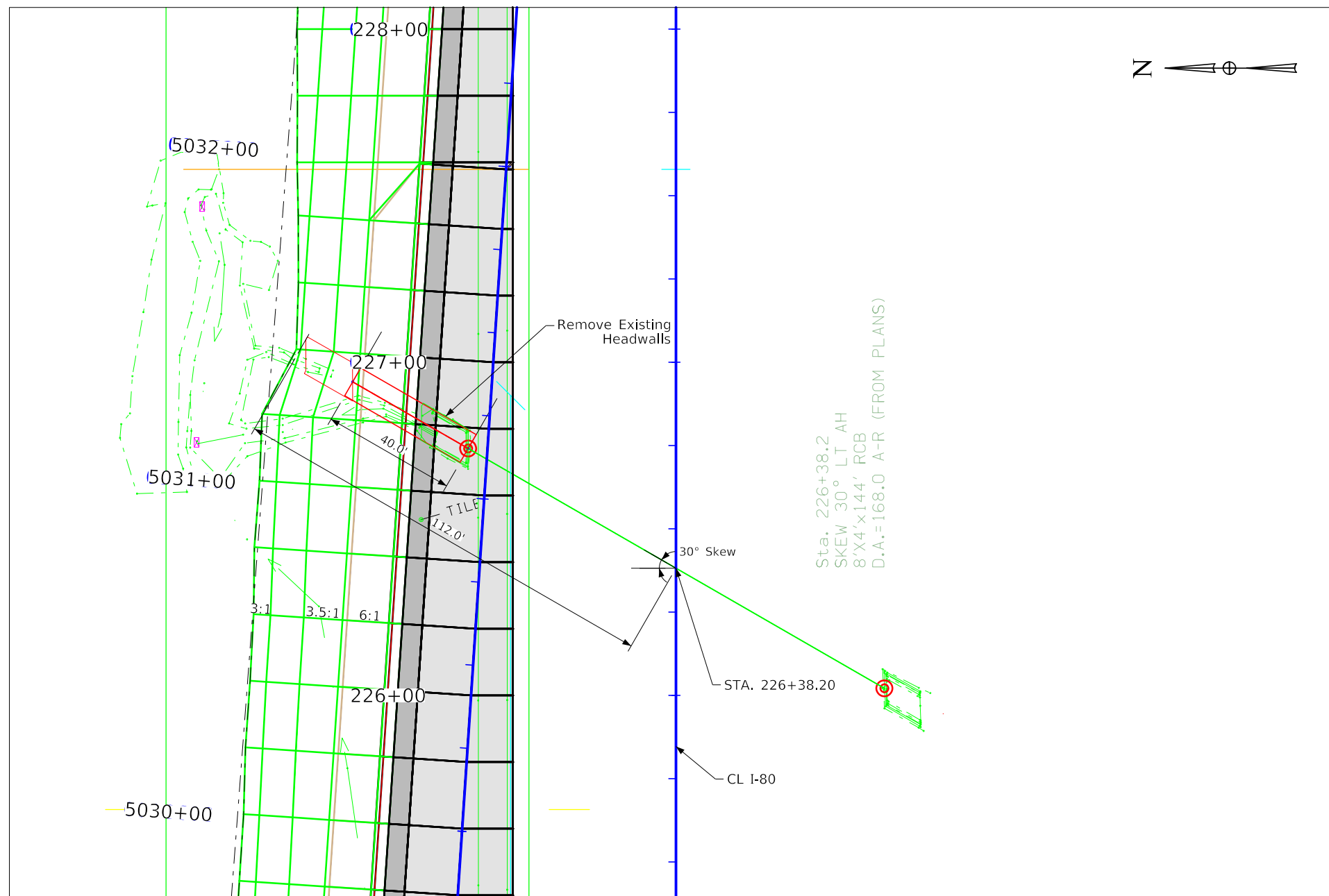

Situation Plan

UTILITIES LEGEND

REFER TO D.1

Hydraulic Data

Drainage Area = 168.0 Acres
 Q₅₀ = X.X cfs
 HW Elev. = X.X

Location

I-80
 T-80N R-12W
 Section 35
 Hartford Township
 Iowa County

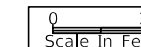

Design For 30° Lt. Ahead
8' x 4' x 40'
Reinforced Concrete
Box Extension
 STA. 226+38.20 I-80 Letting Date: Jan. 2026
Iowa County
 IOWA DEPARTMENT OF TRANSPORTATION
 Design No. _____ Design Sheet No. of _____ FHWA/Asset _____

Control Point:

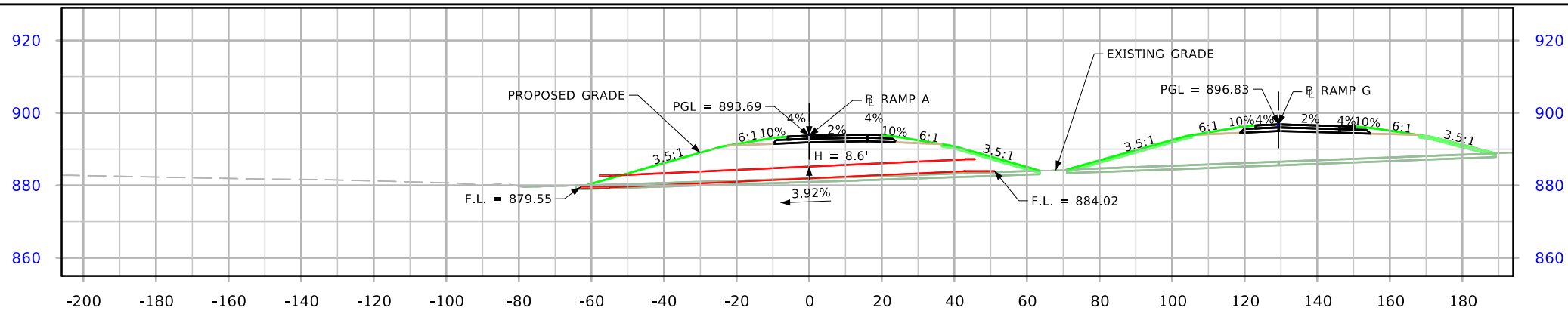

STA. 1014+75.01
Longitudinal Section Along \bar{C} Culvert

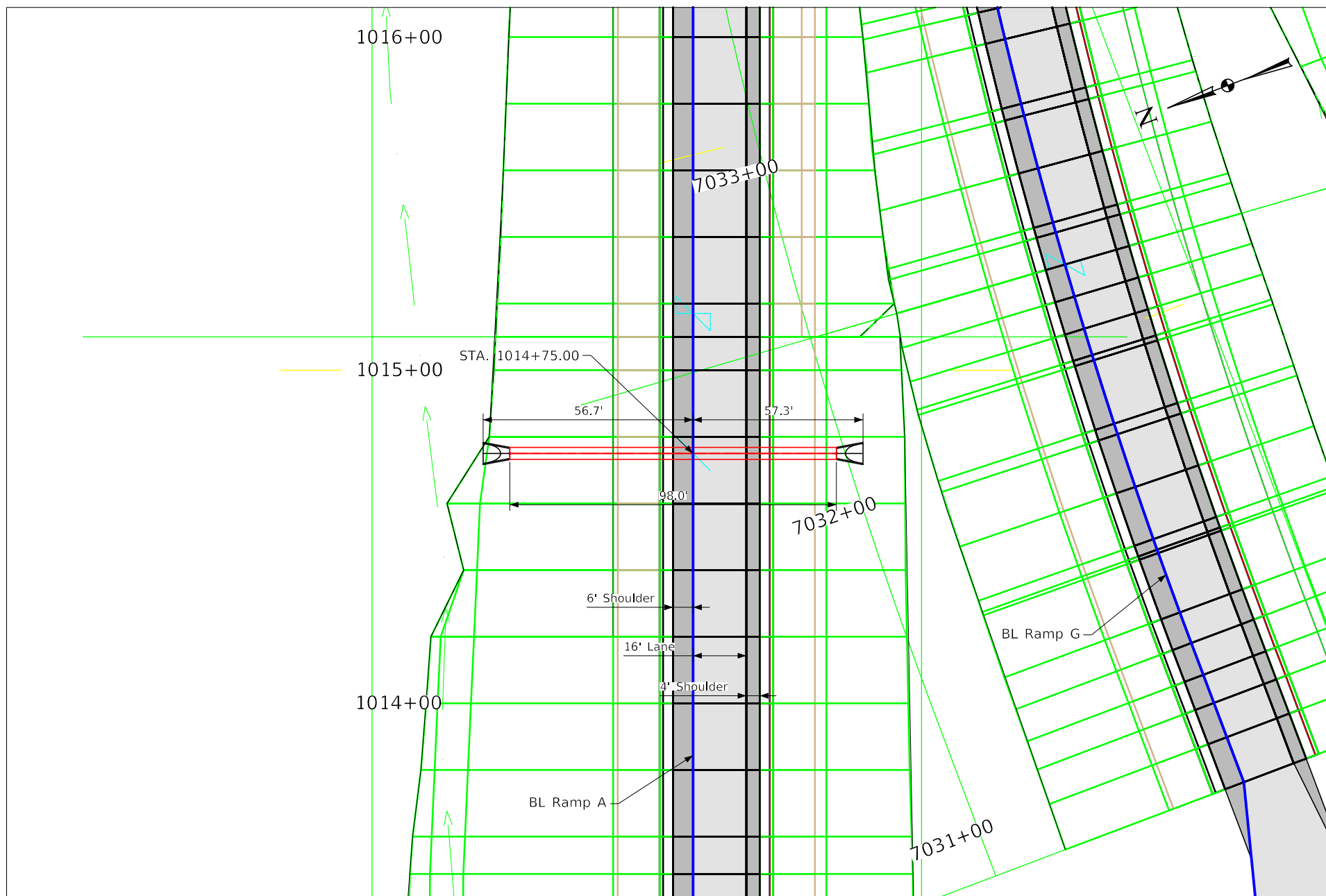

Plat Plan

UTILITIES LEGEND

REFER TO D.1

Hydraulic Data

Drainage Area = 21.53 Acres
 $Q_{50} = 47.1$ cfs
HW Elev. = 887.47

Location

I-80
T-80N R-12W
Section 34
Hartford Township
Iowa County

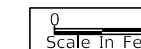

Design For 0° Skew
36" x 98'
Reinforced Concrete Pipe Culvert

STA. 1014+75.00 Ramp A Letting Date: Jan. 2026

Iowa County

IOWA DEPARTMENT OF TRANSPORTATION

Design No. Design Sheet No. of FHWA/Asset

Control Point:

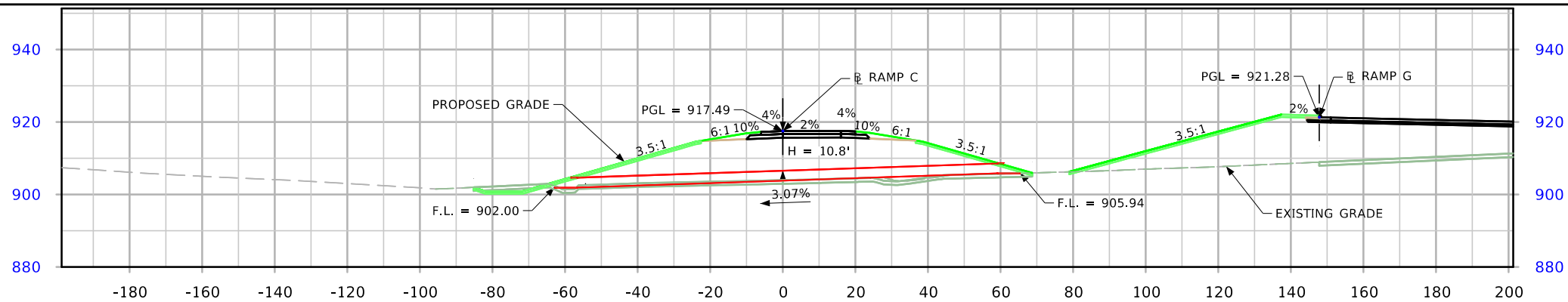

STA. 3030+19.00
Longitudinal Section Along \varnothing Culvert

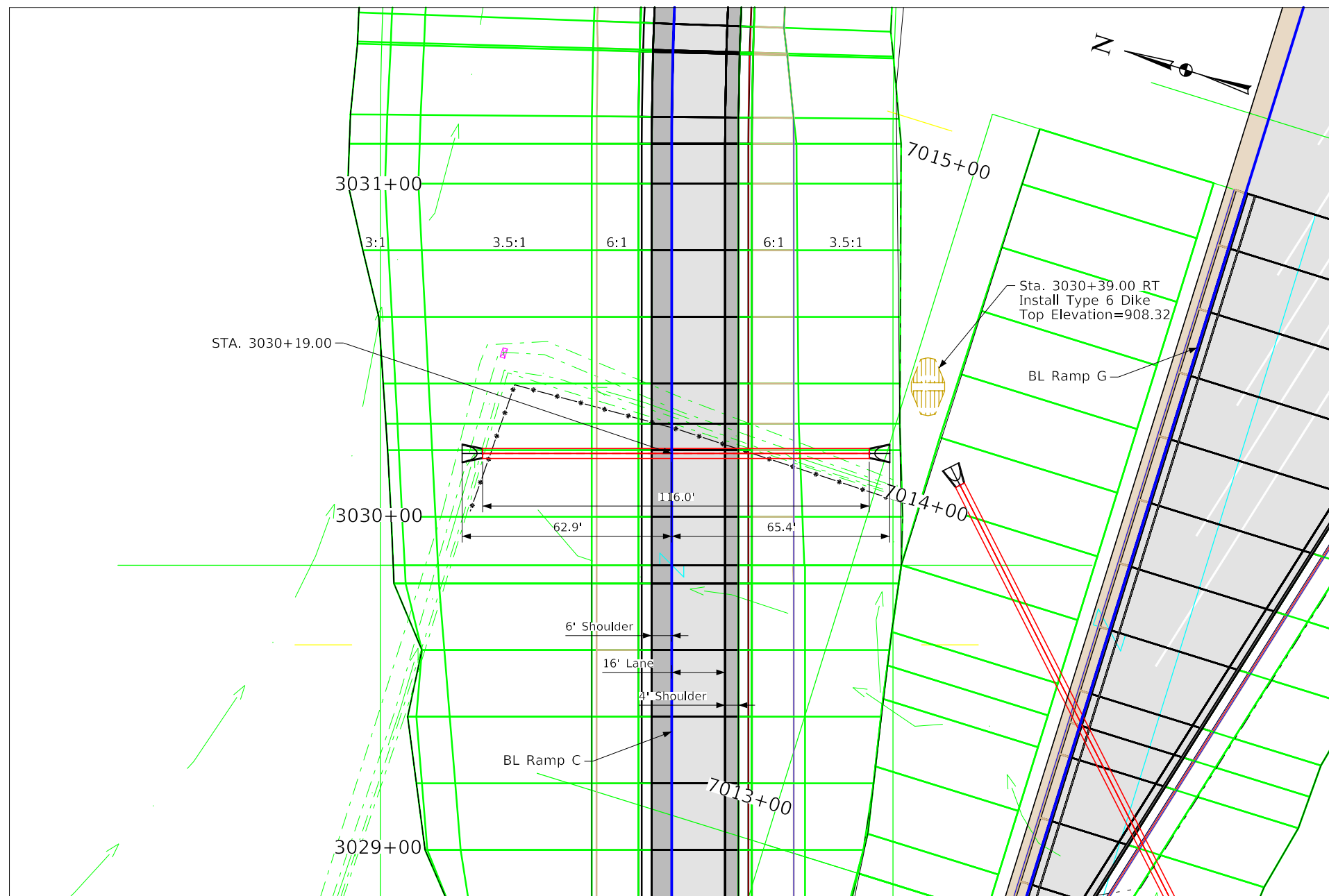

Plat Plan

UTILITIES LEGEND

REFER TO D.1

Hydraulic Data

Drainage Area = 11.28 Acres
 $Q_{50} = 22.95$ cfs
HW Elev. = 908.32

Location

I-80
T-80N R-12W
Section 34
Hartford Township
Iowa County

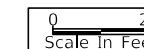

Design For 0° Skew
30" x 116'
Reinforced Concrete Pipe Culvert

STA. 3030+19.00 Ramp C Letting Date: Jan. 2026

Iowa County
IOWA DEPARTMENT OF TRANSPORTATION
Design No. Design Sheet No. of FHWA/Asset

Control Point:

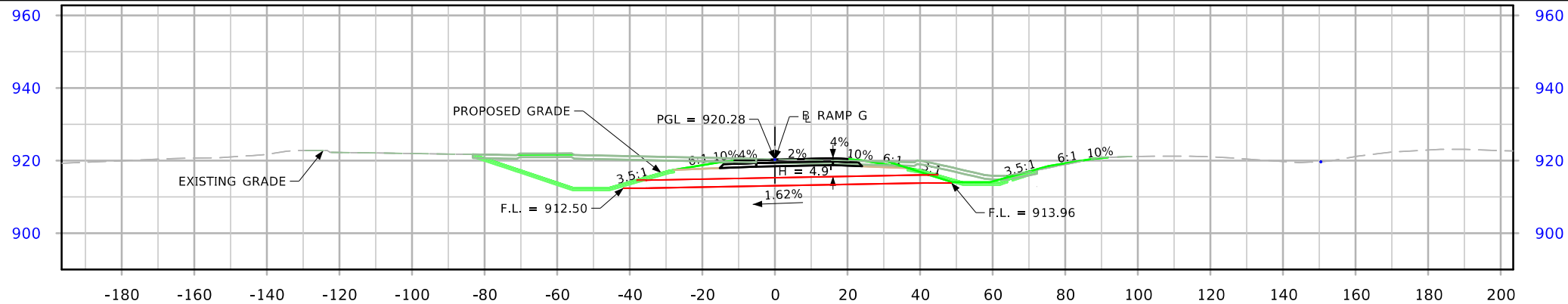

STA. 7006+00.00
Longitudinal Section Along \mathcal{Q} Culvert

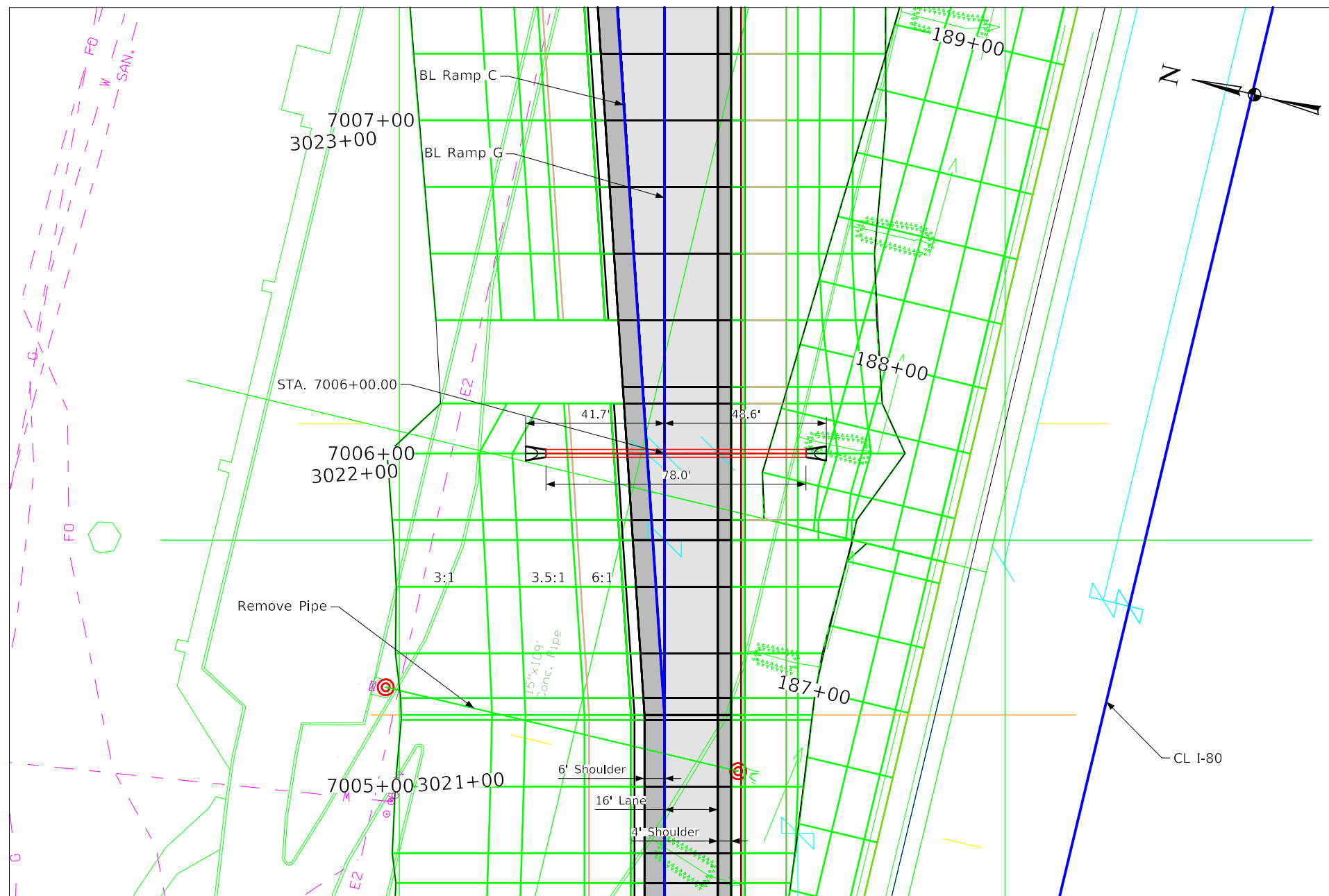

Plat Plan

UTILITIES LEGEND

REFER TO D.1

Hydraulic Data

Drainage Area = 1.03 Acres
Q₅₀ = 3.0 cfs
HW Elev. = 914.96

Location

I-80
T-80N R-12W
Section 34
Hartford Township
Iowa County

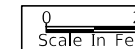

Design For 0° Skew
24" x 78'
Reinforced Concrete Pipe Culvert

STA. 7006+00.00 Ramp G Letting Date: Jan. 2026

Iowa County

IOWA DEPARTMENT OF TRANSPORTATION

Design No. Design Sheet No. of FHWA/Asset

Control Point:

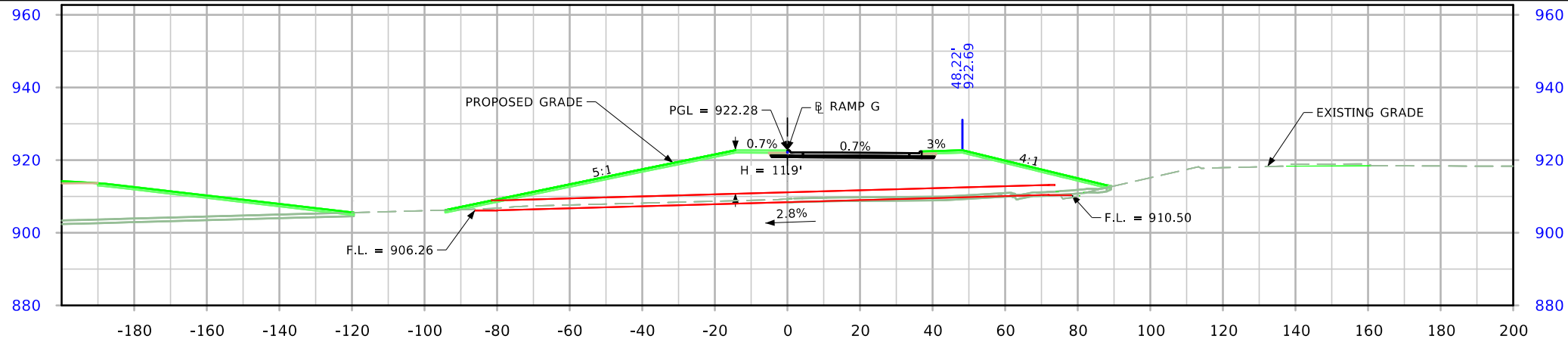

STA. 7013+50.88
Longitudinal Section Along ζ Culvert

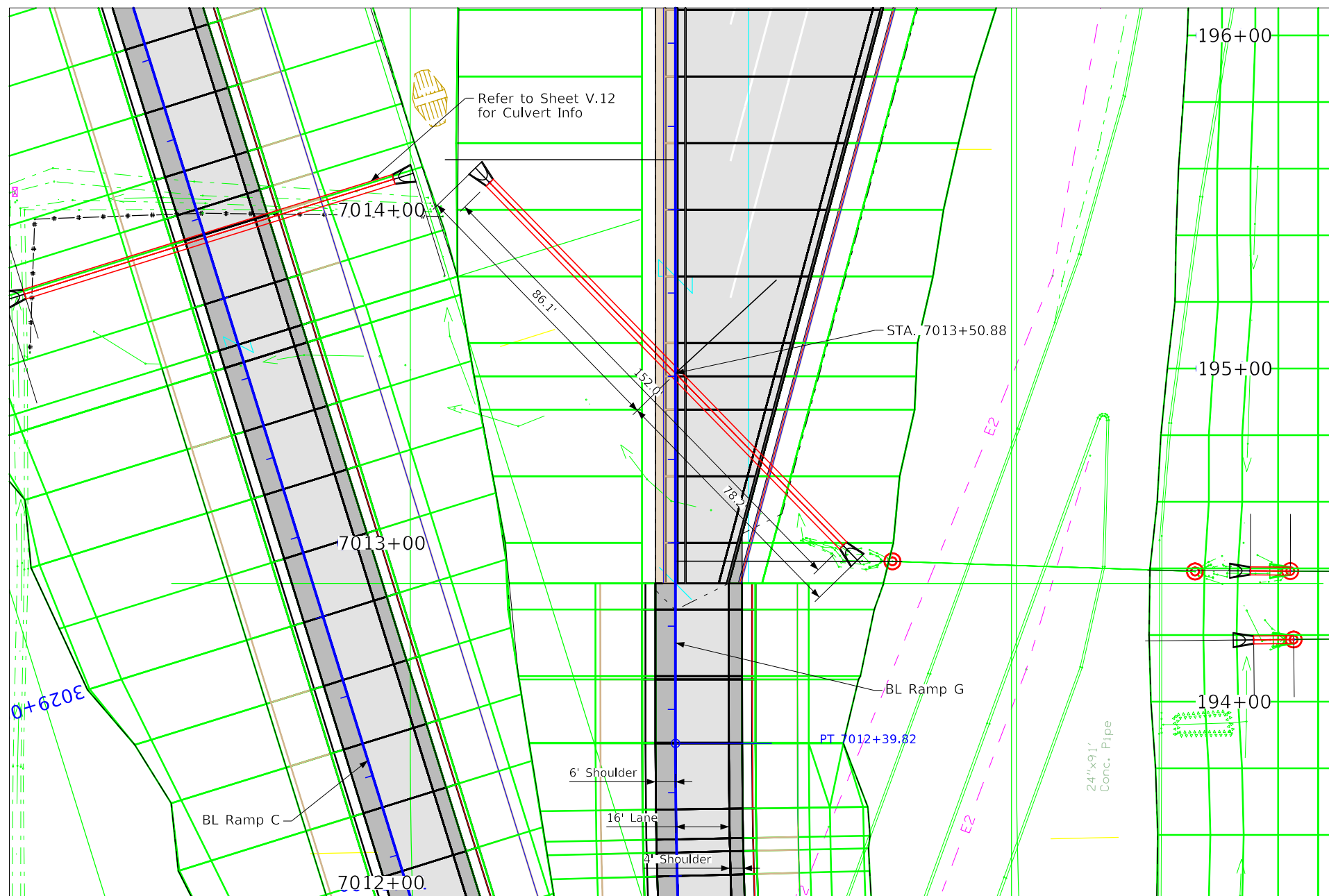

Situation Plan

UTILITIES LEGEND

REFER TO D.1

Hydraulic Data

Drainage Area = 10.56 Acres
Q₅₀ = 21.8 cfs
HW Elev. = 912.75

Location

I-80
T-80N R-12W
Section 34
Hartford Township
Iowa County

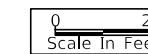

Design For 44° LT Ahead
30" x 152'
Reinforced Concrete Pipe Culvert

STA. 7013+50.88 Ramp G Letting Date: Jan. 2026

Iowa County
IOWA DEPARTMENT OF TRANSPORTATION

Design No. Design Sheet No. of FHWA/Asset

I-80

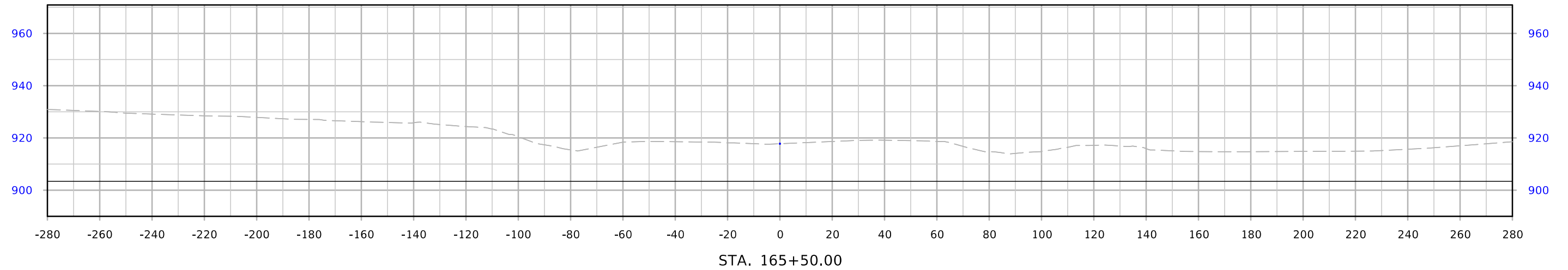
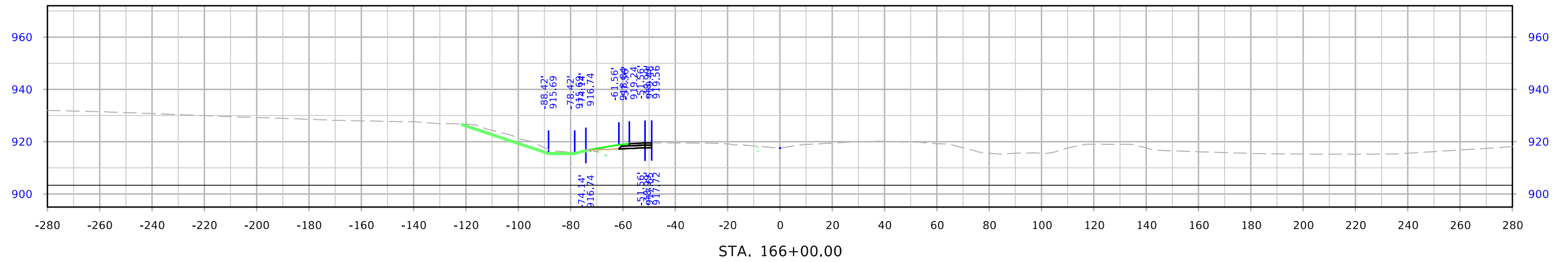
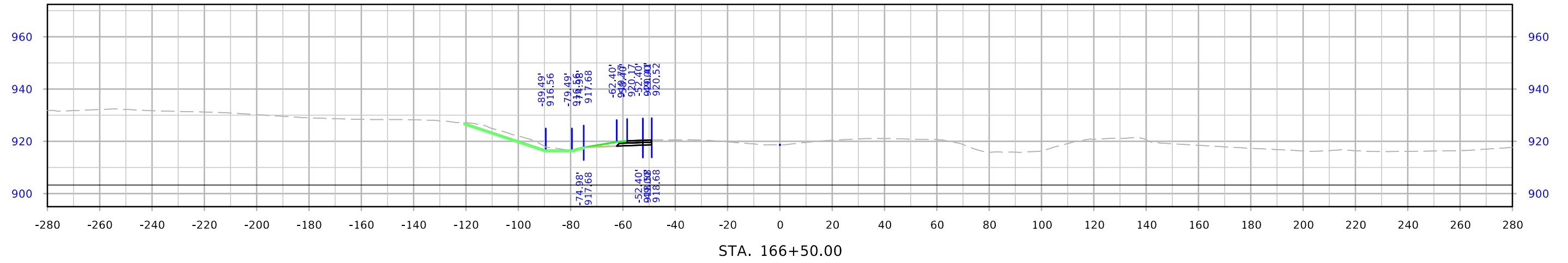

I-80

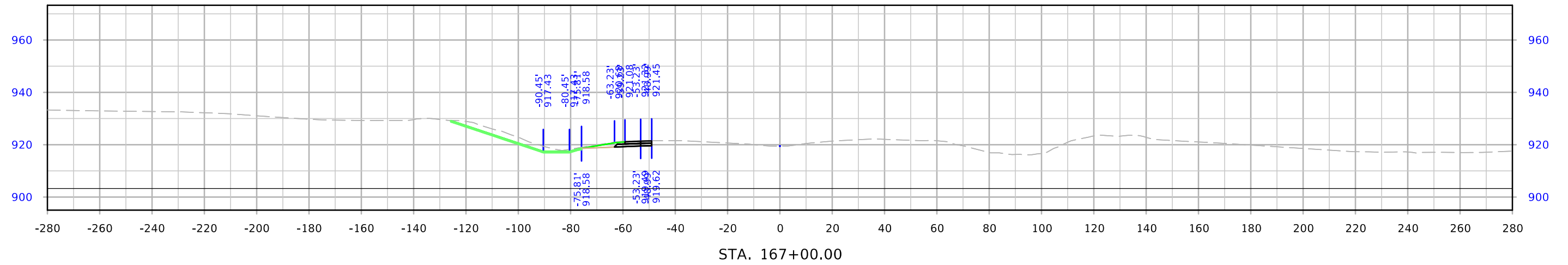
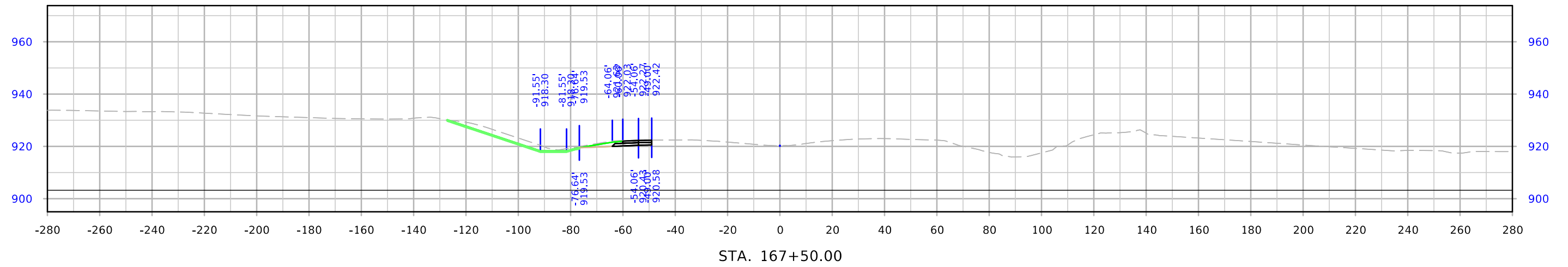
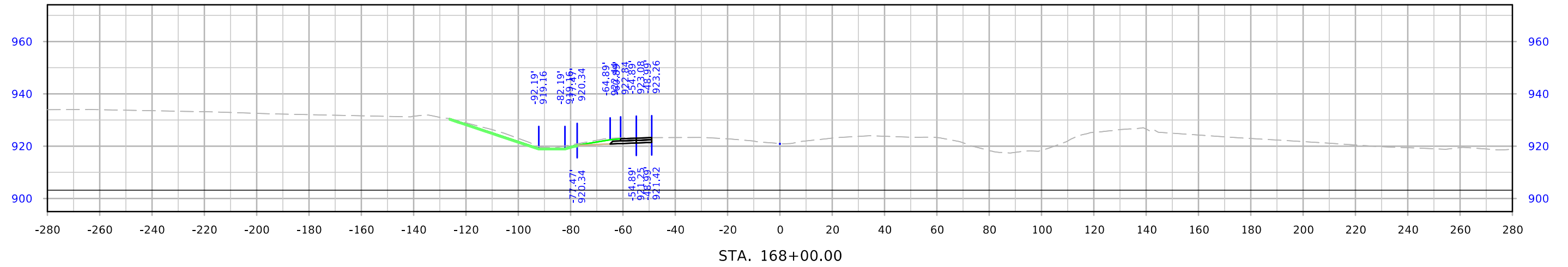

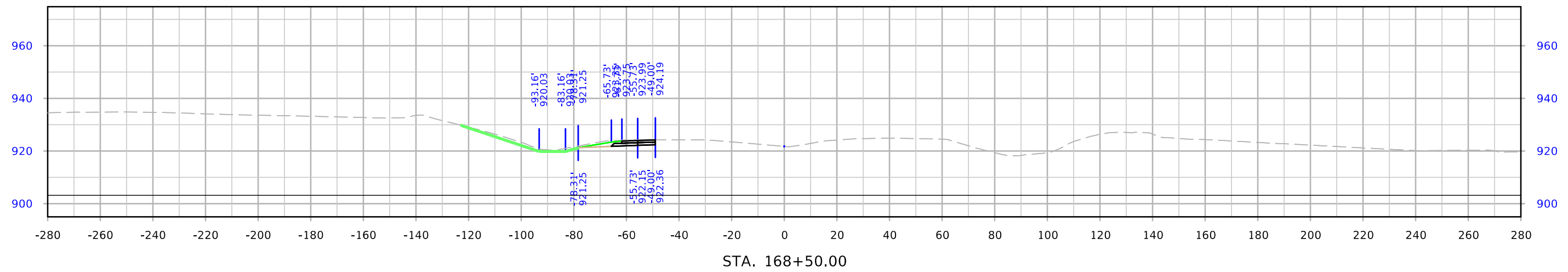
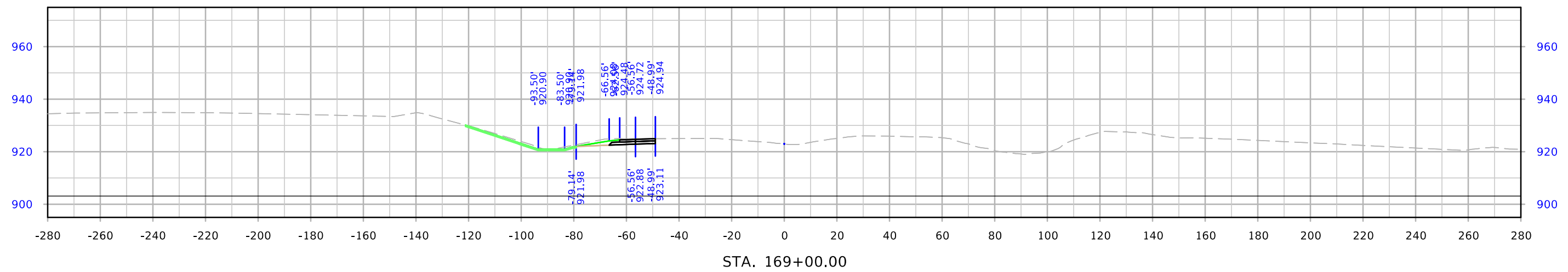
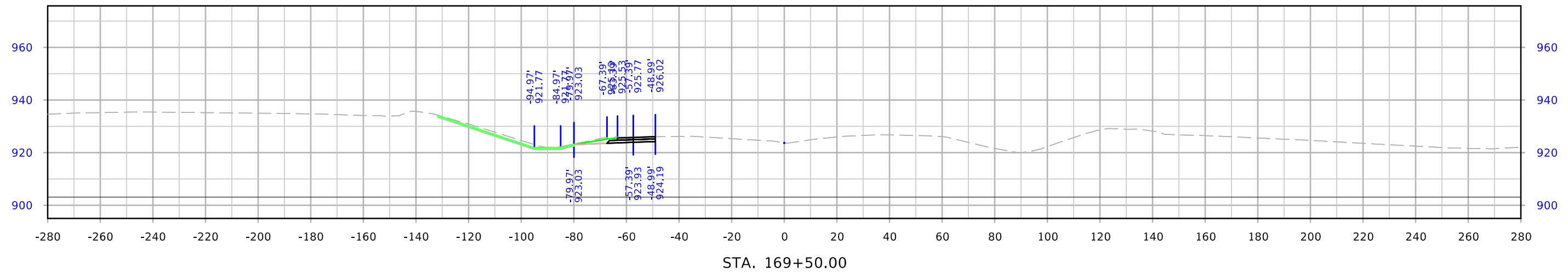

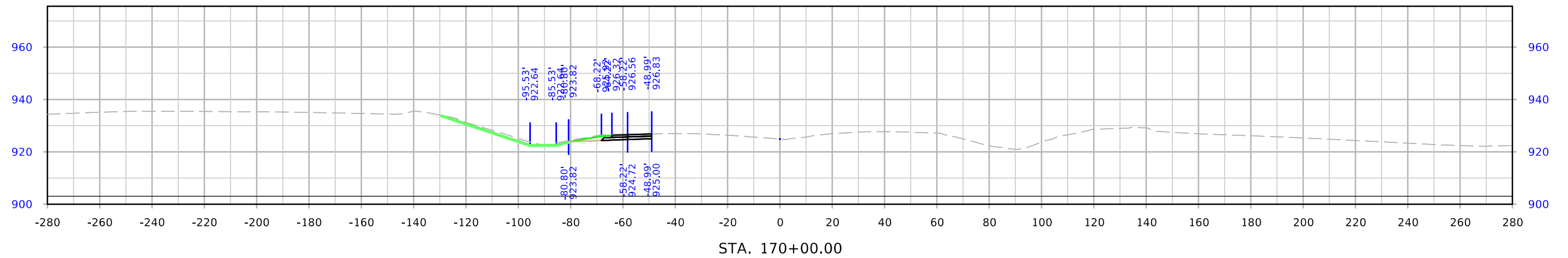
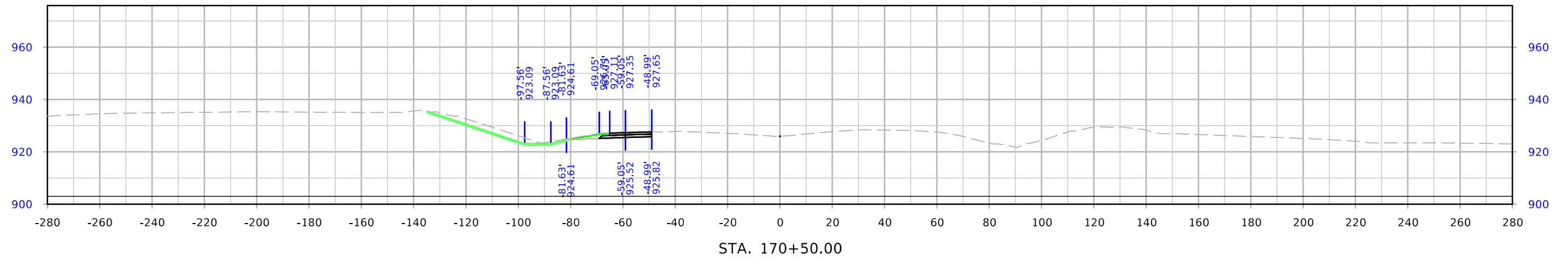
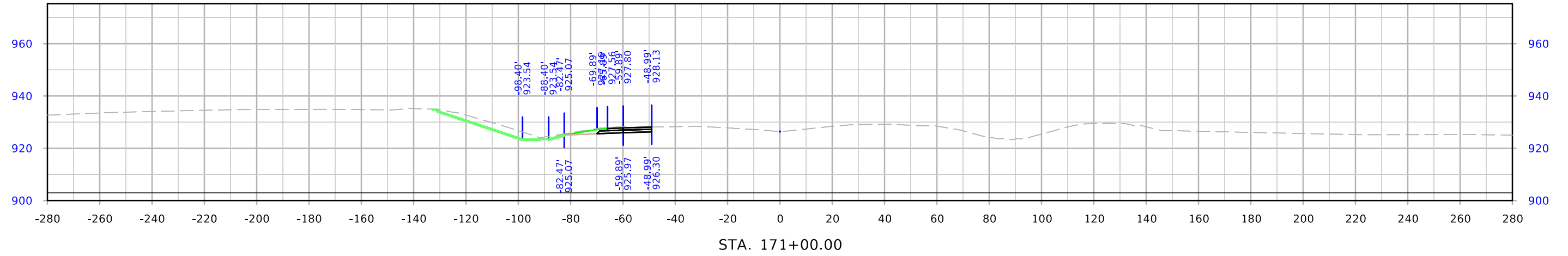

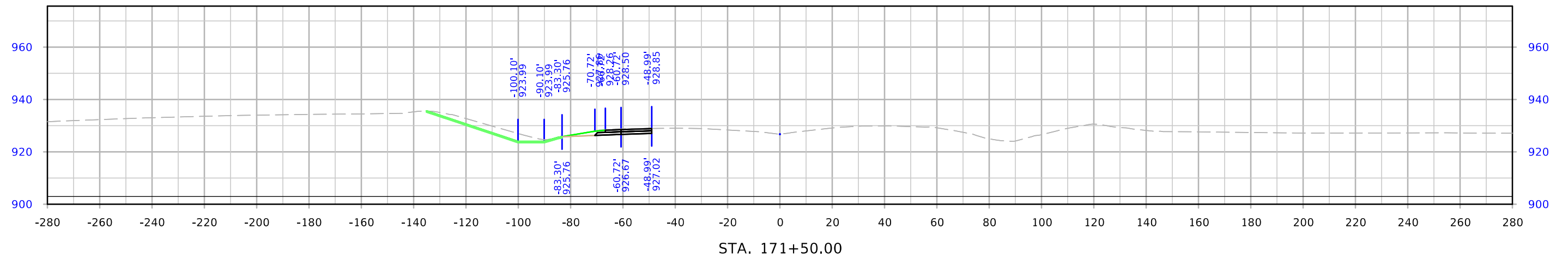
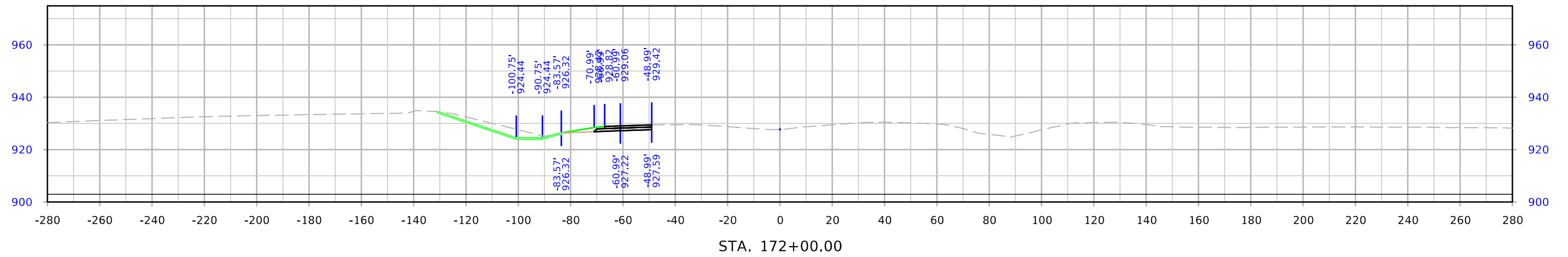
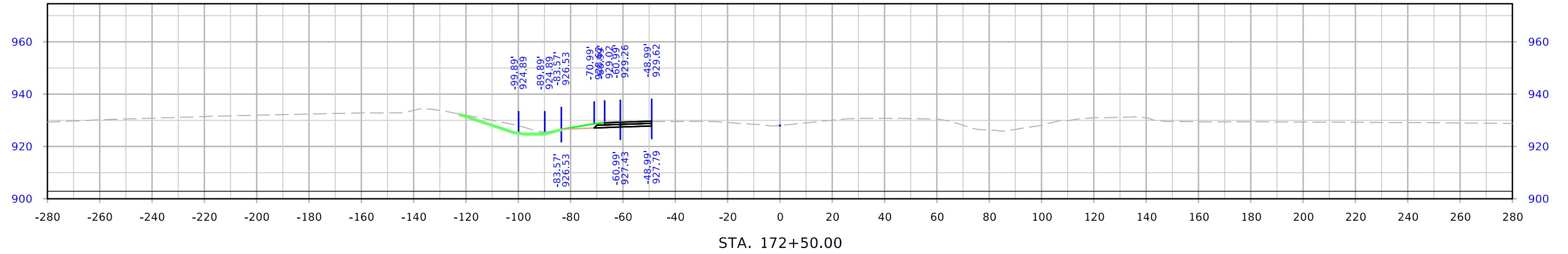

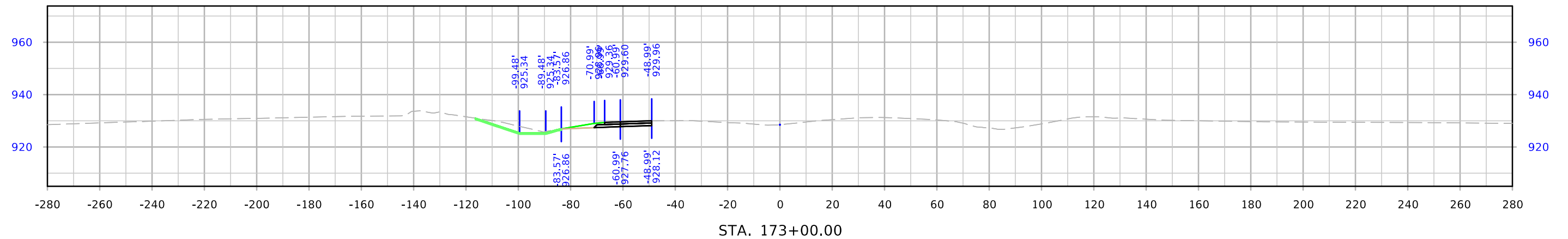
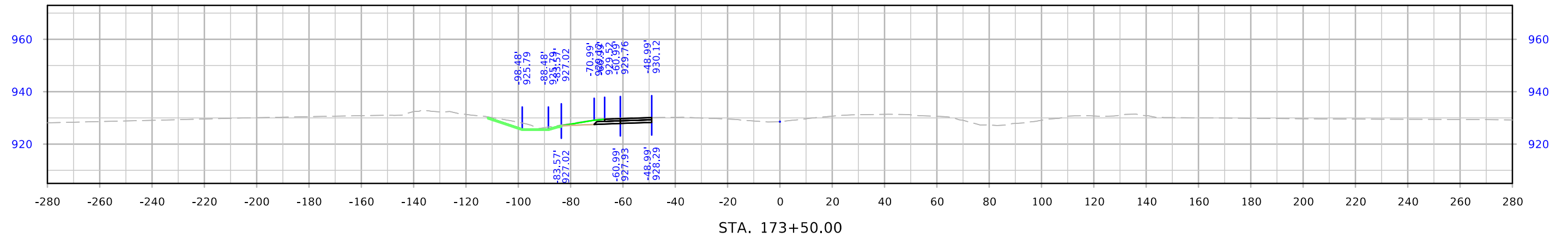
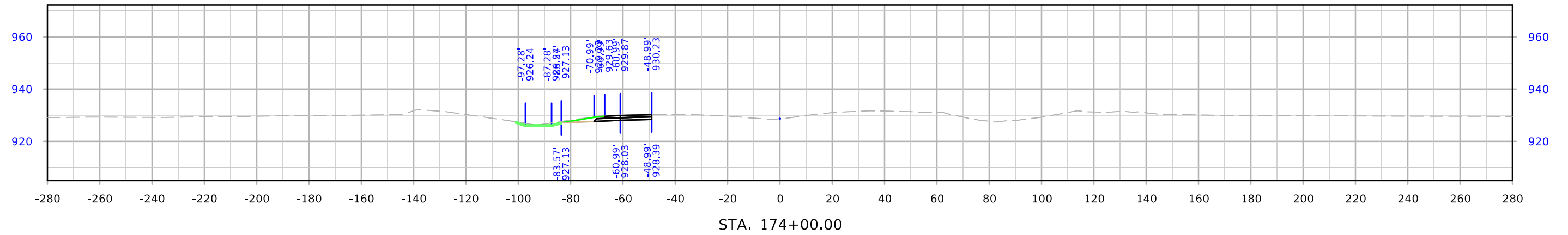

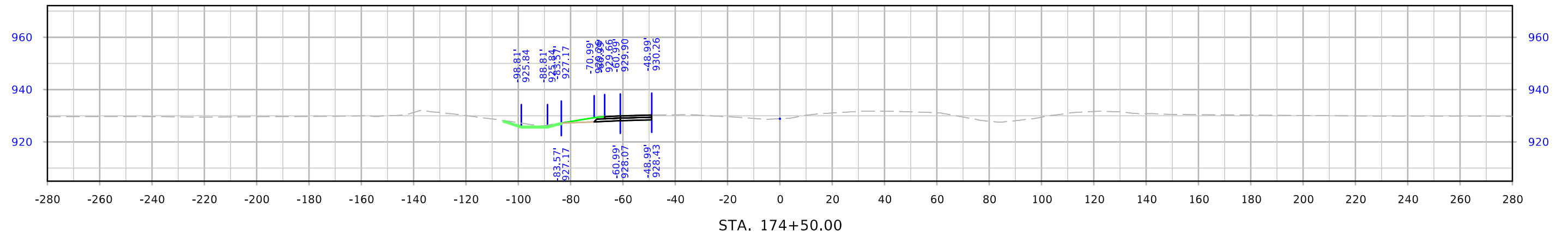
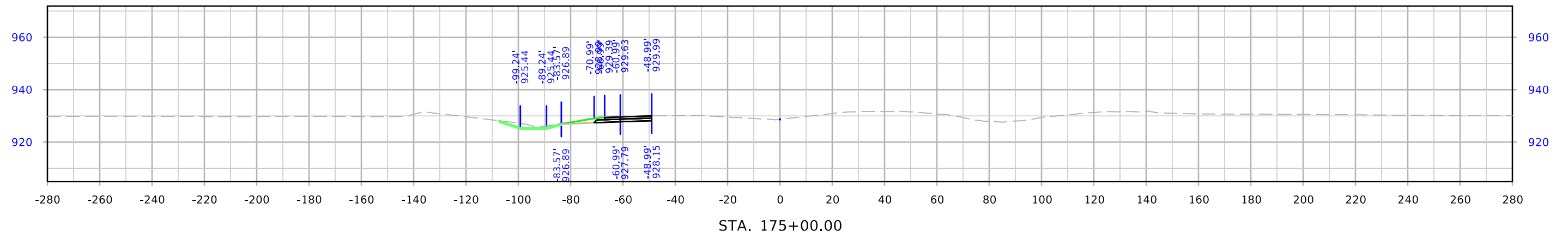
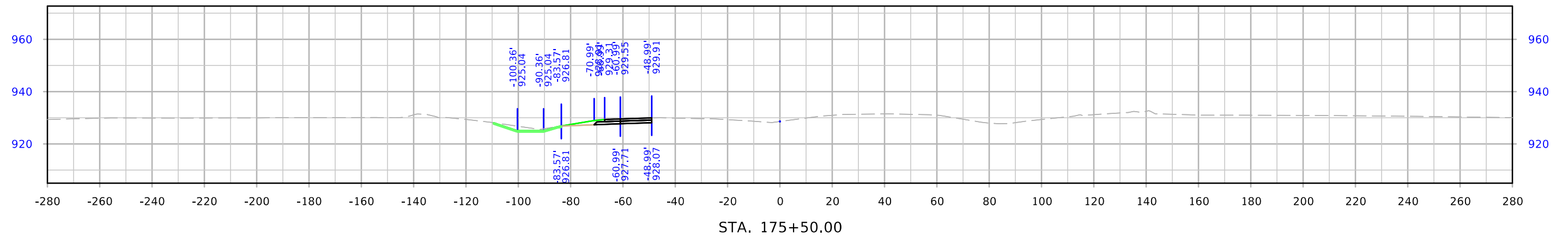

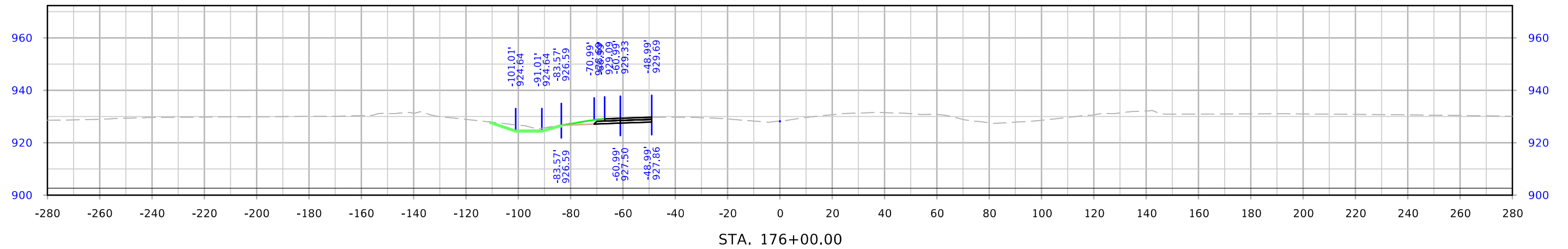
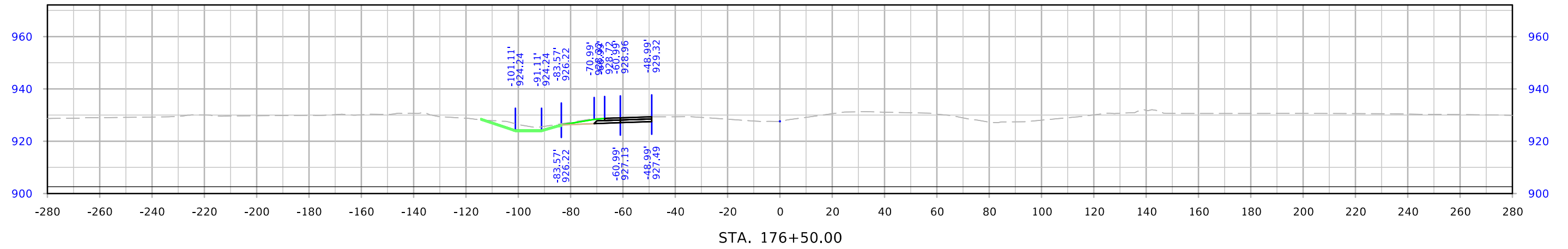
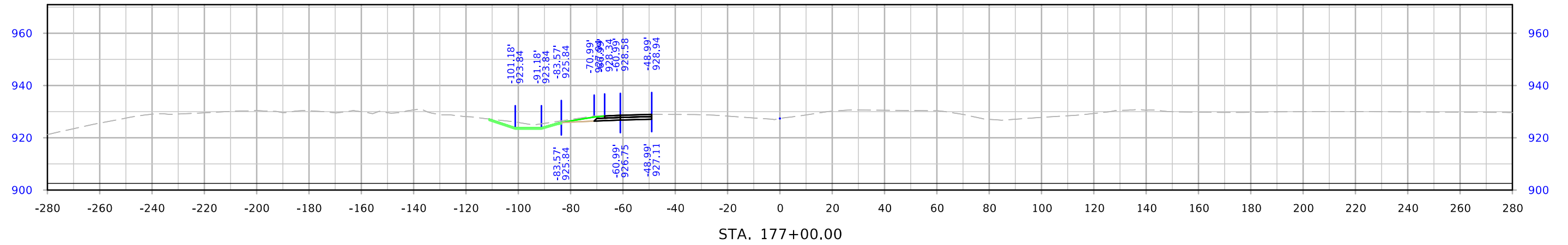

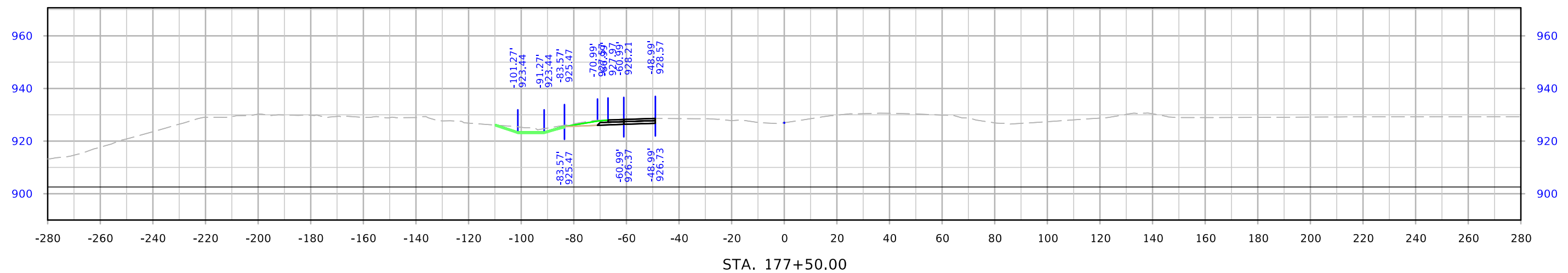
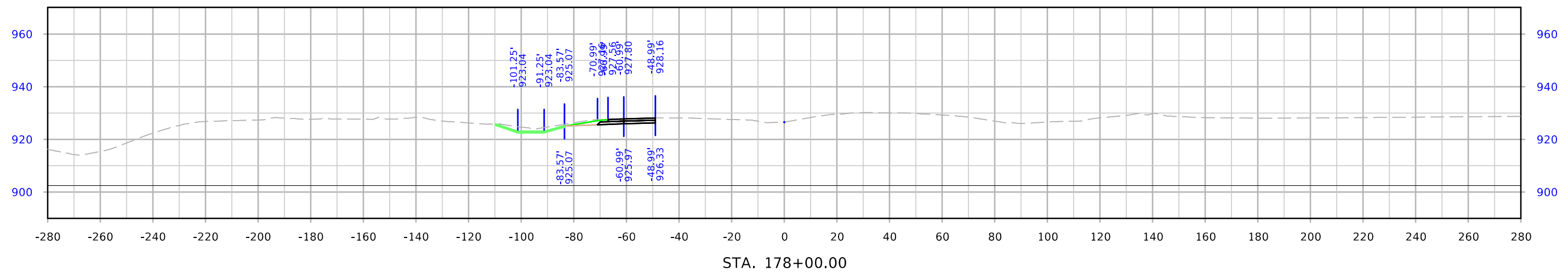
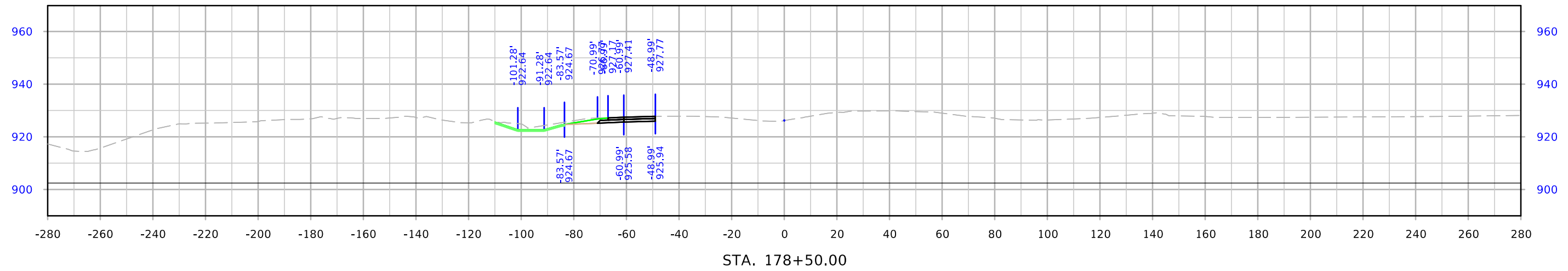

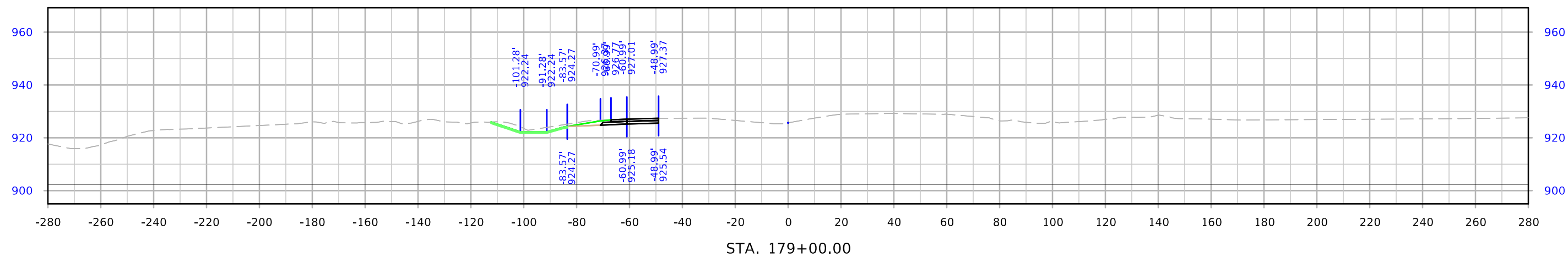
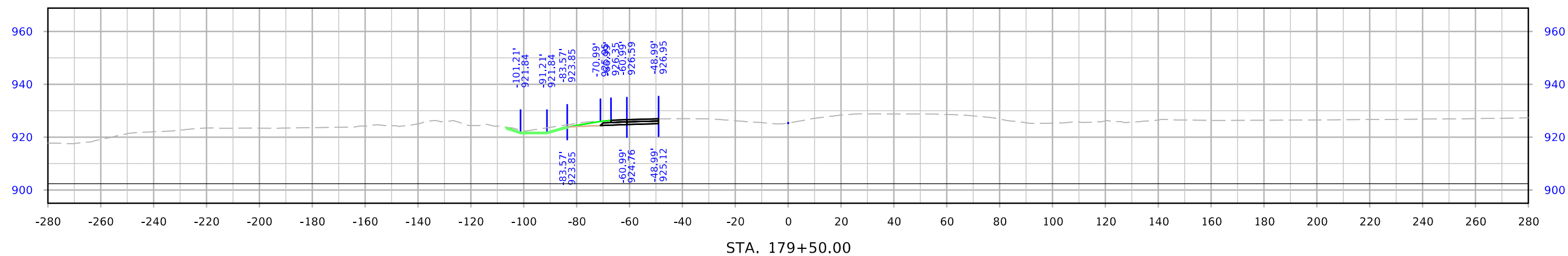
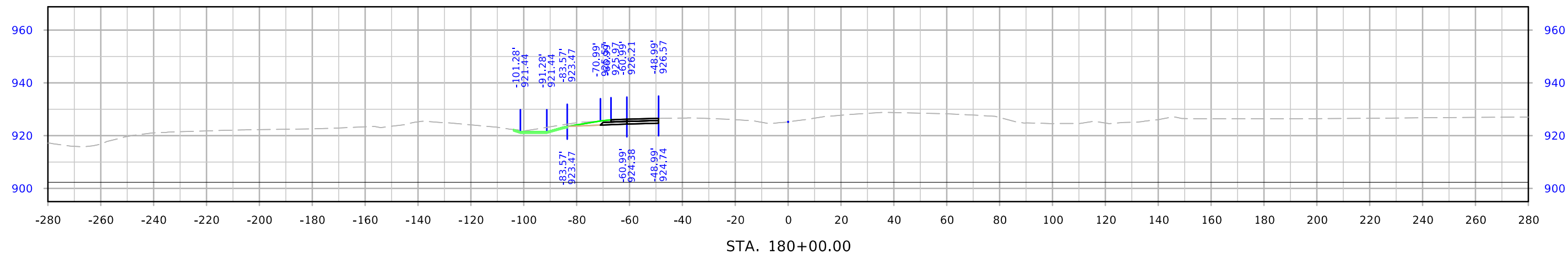

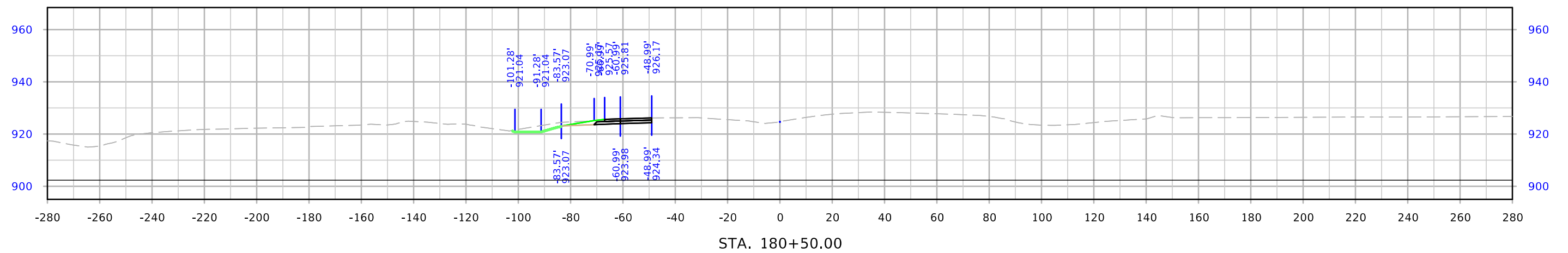
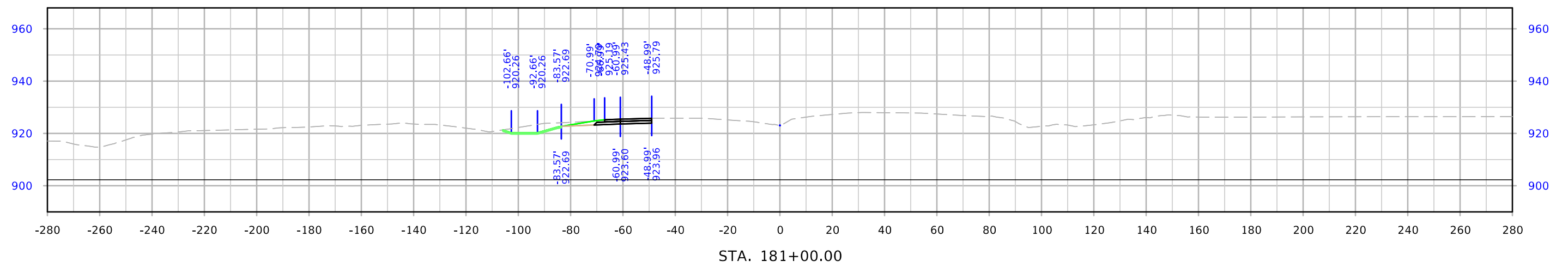
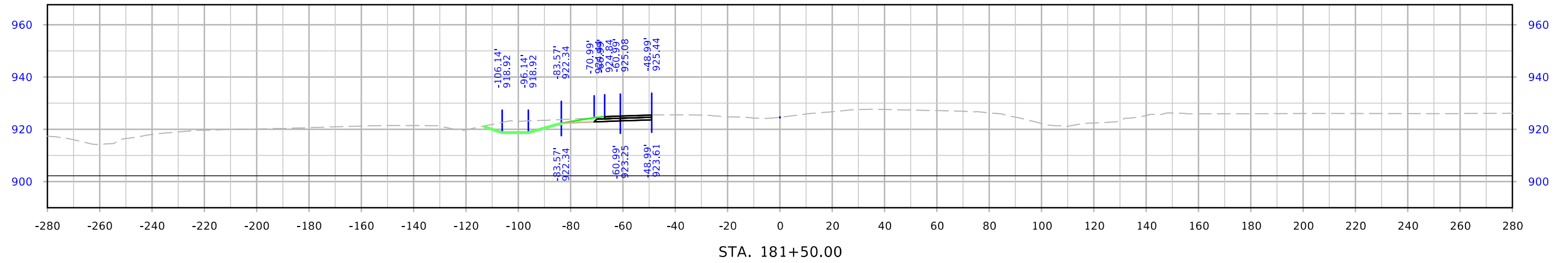

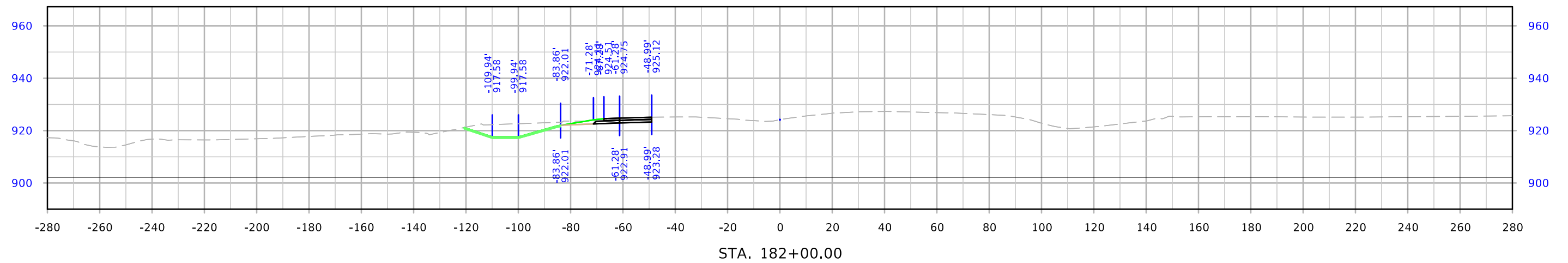
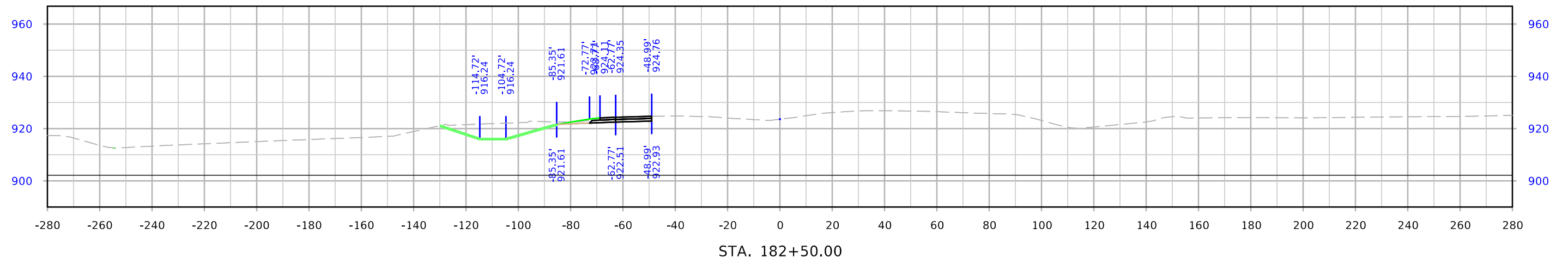
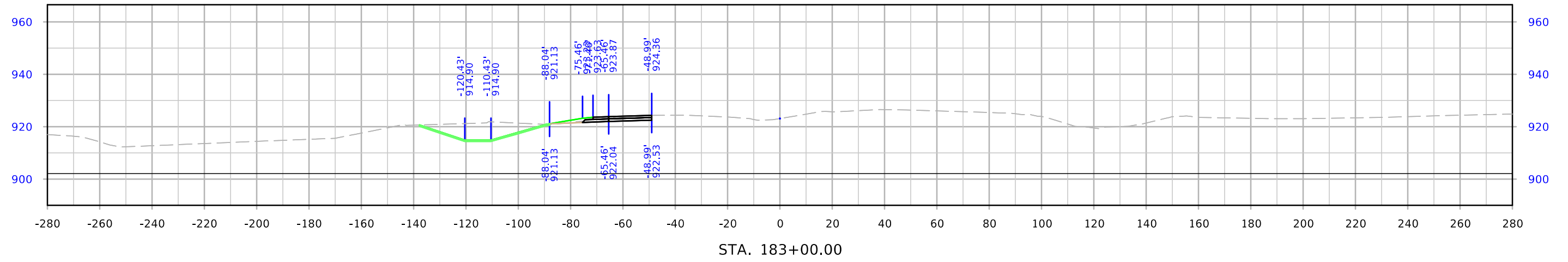

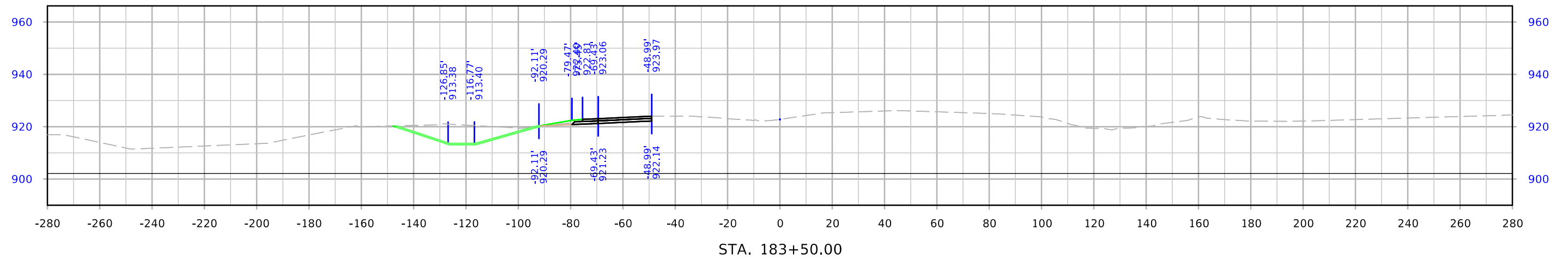
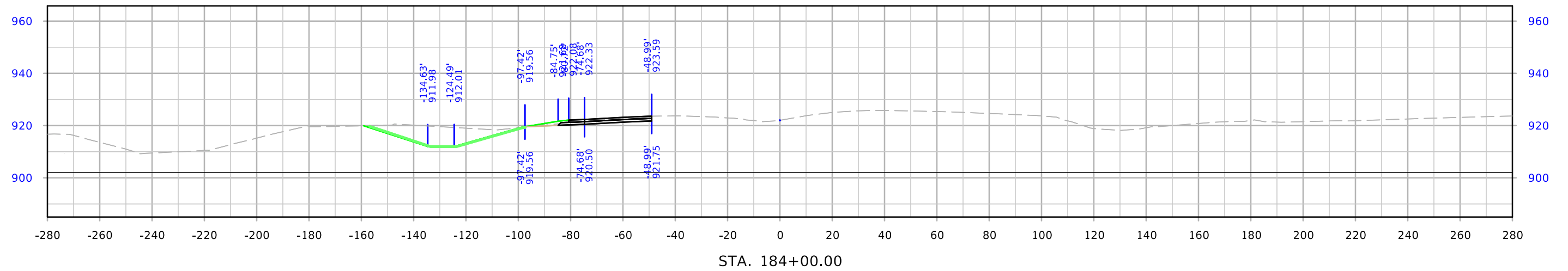
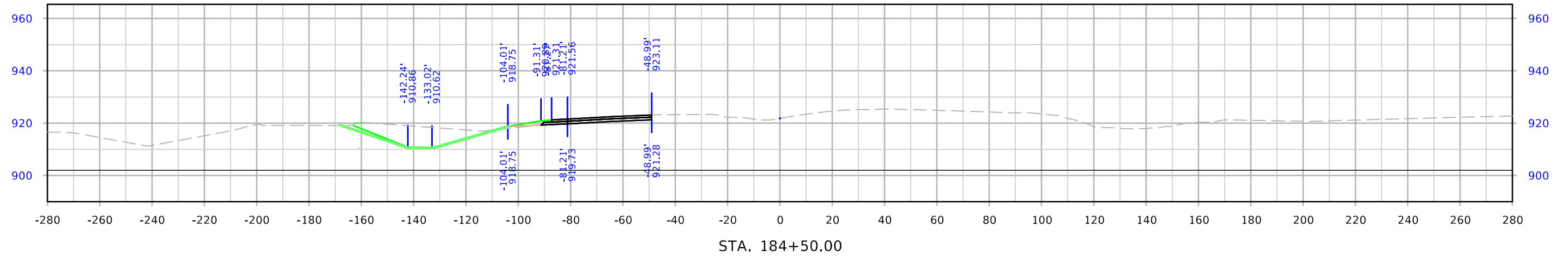

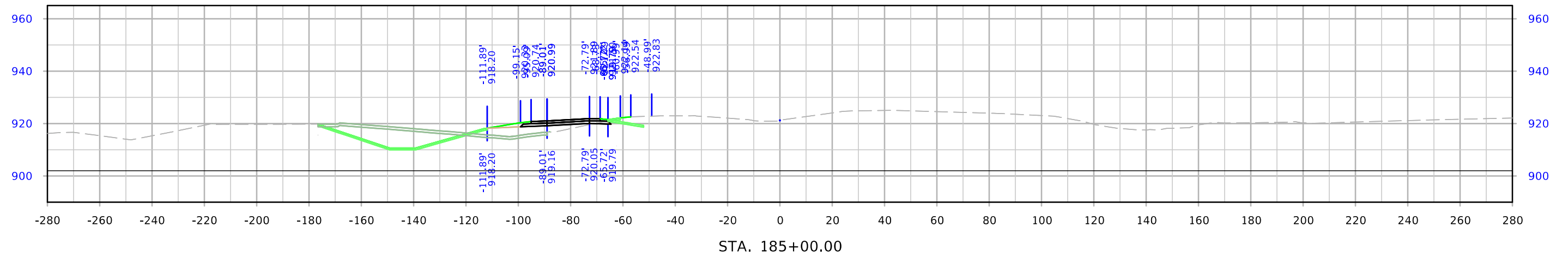
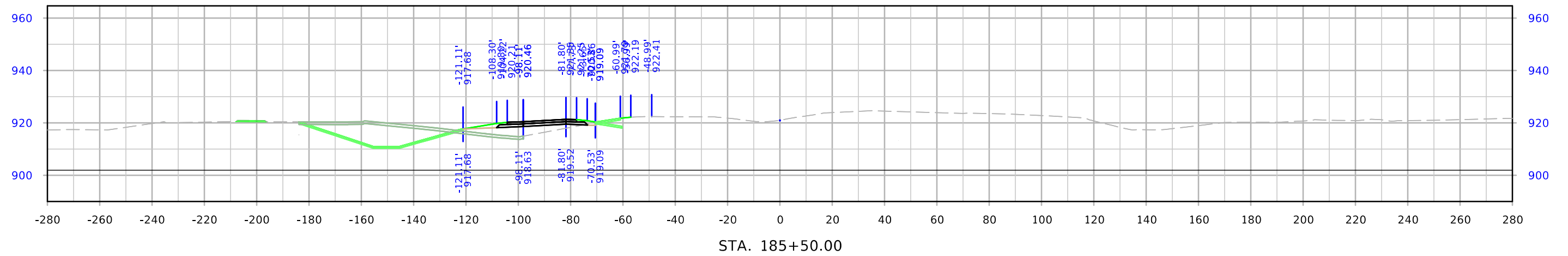
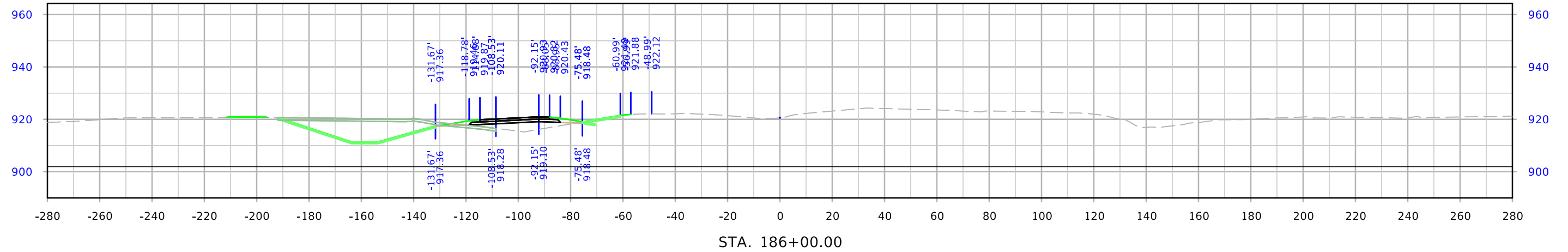

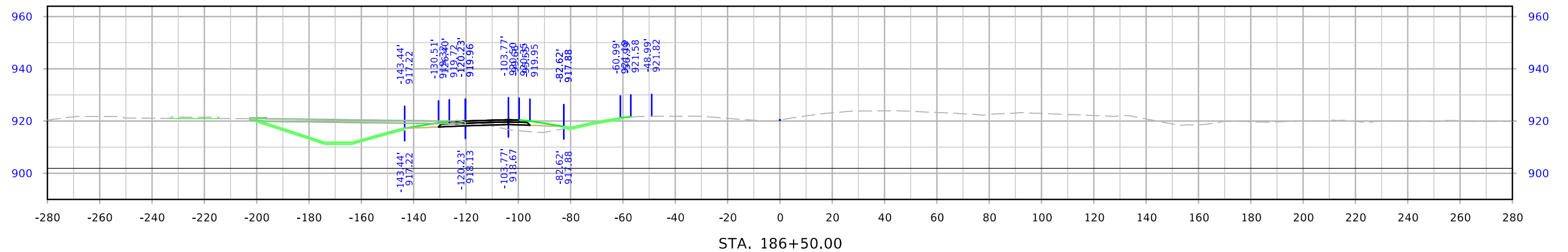
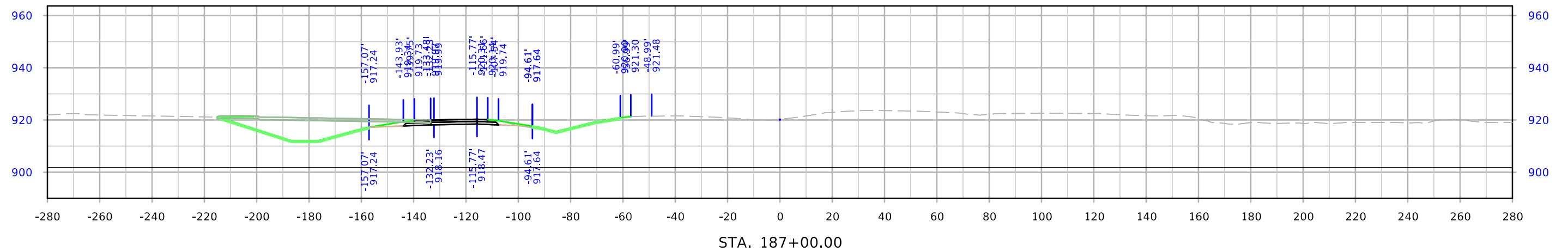
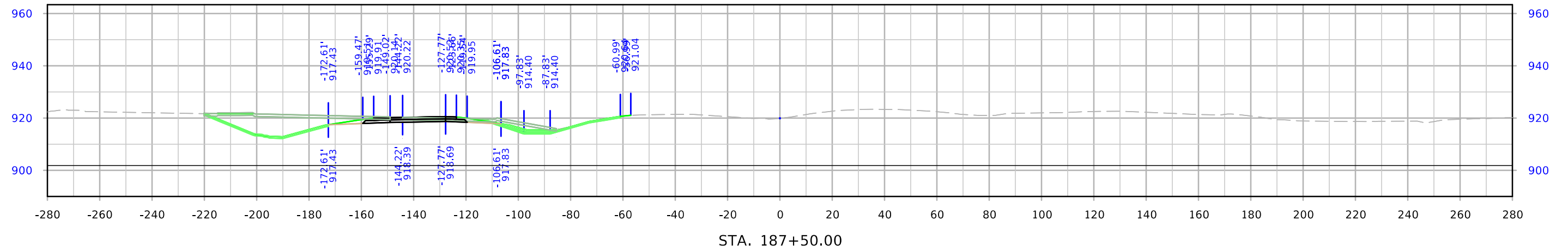

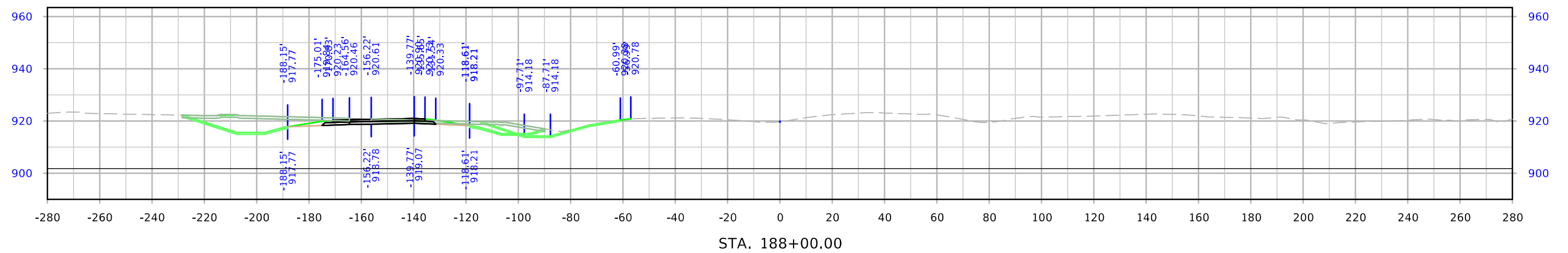
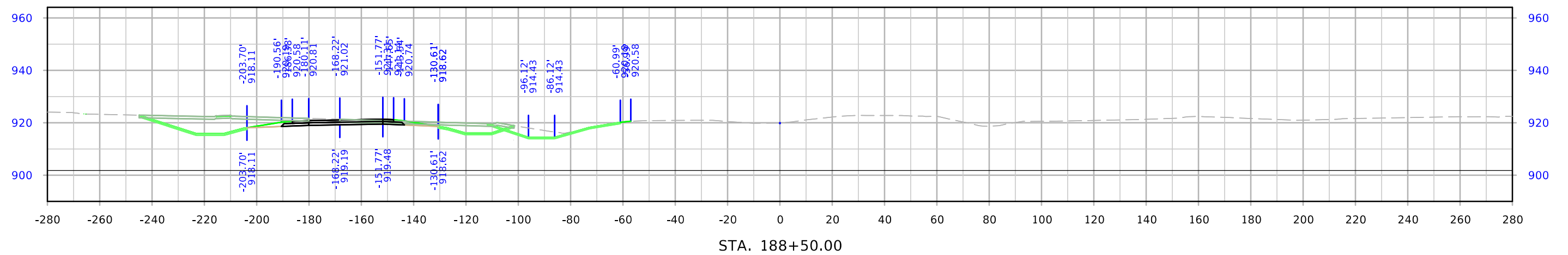
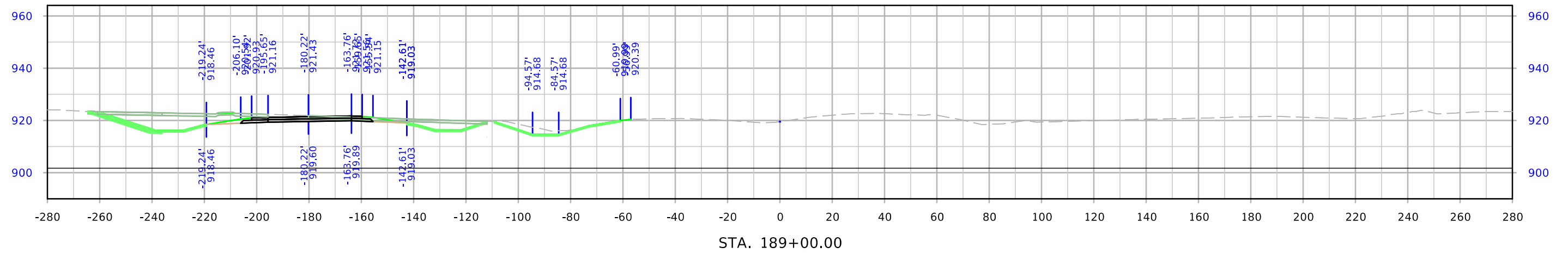

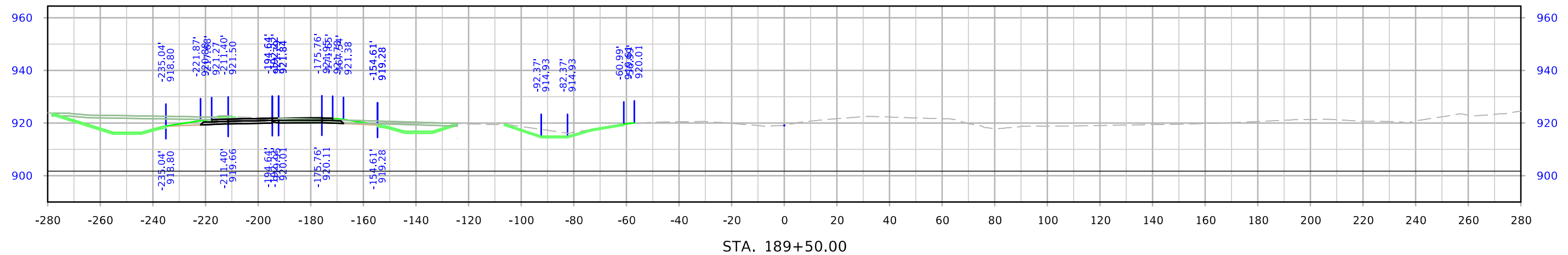
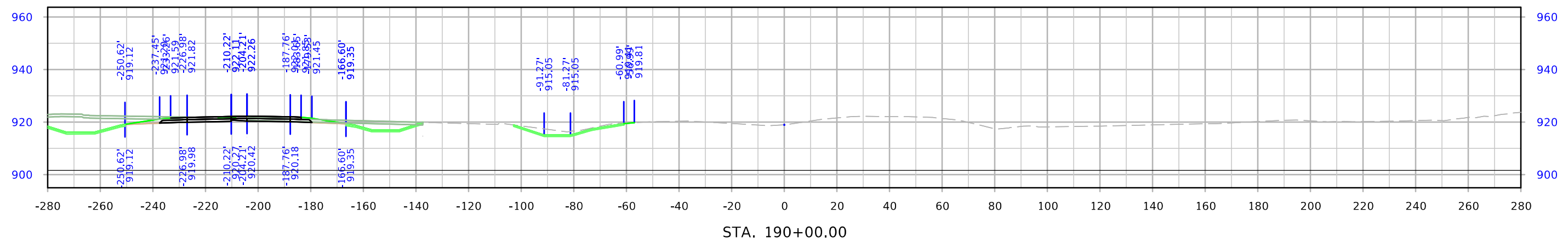
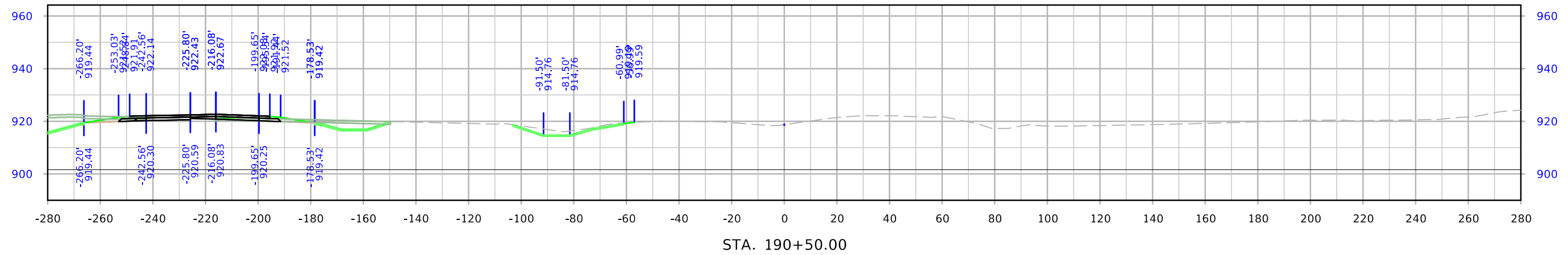

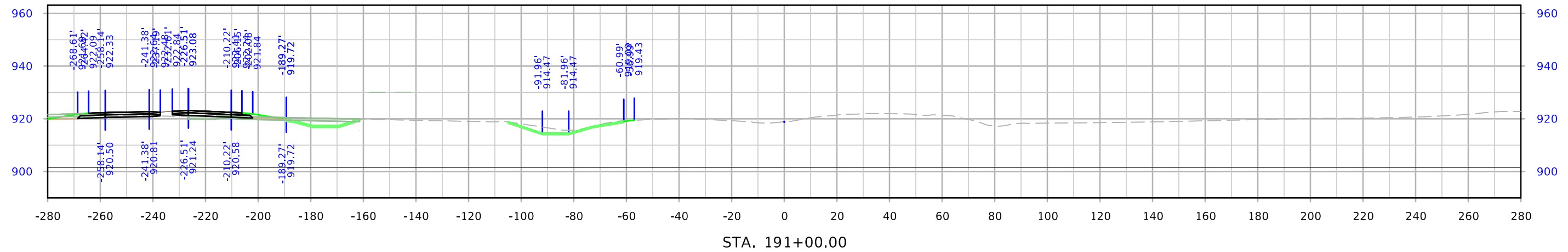
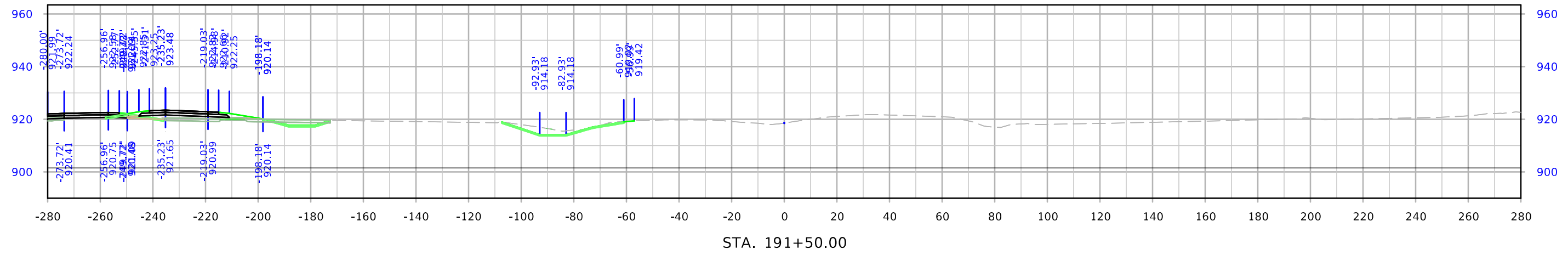
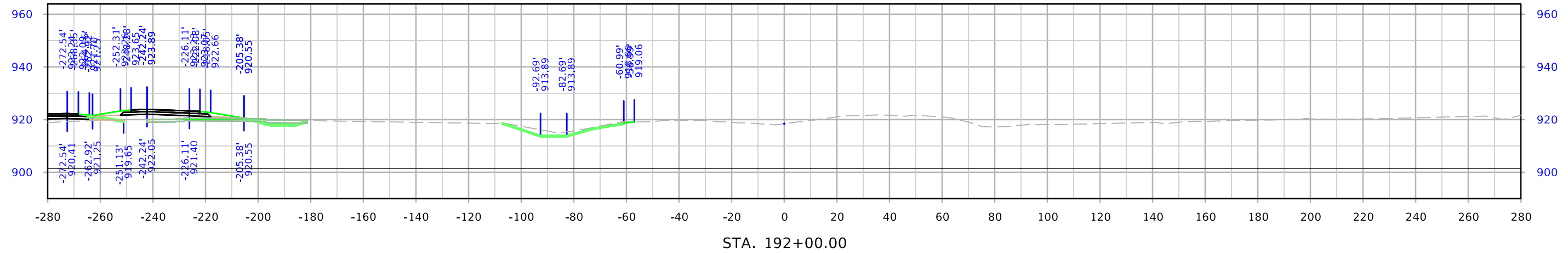

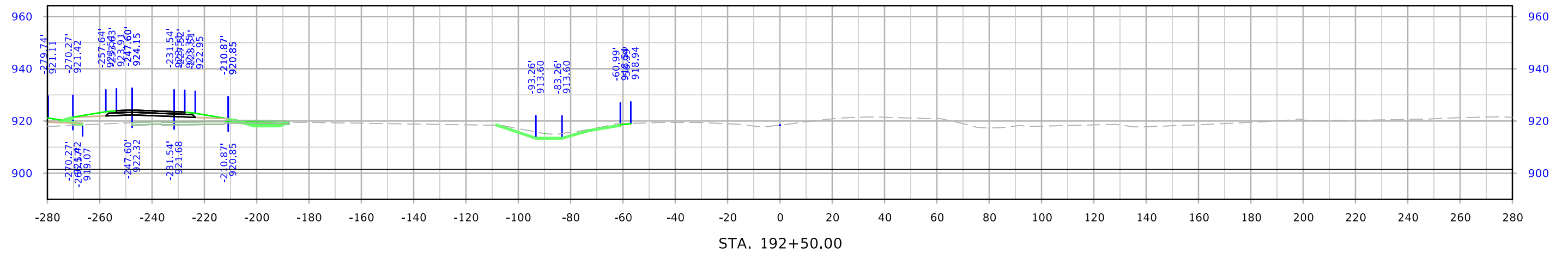
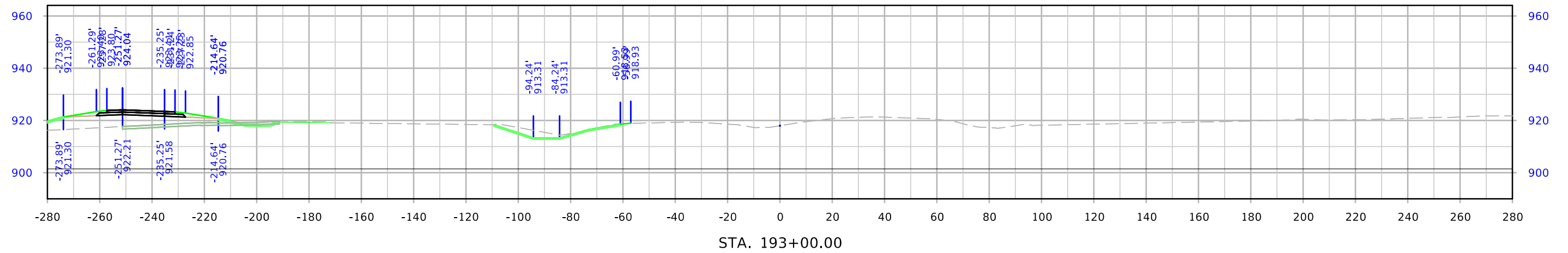
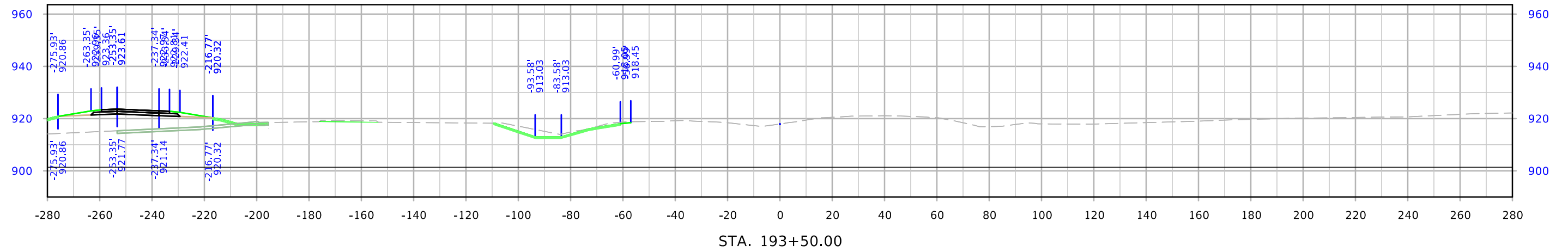

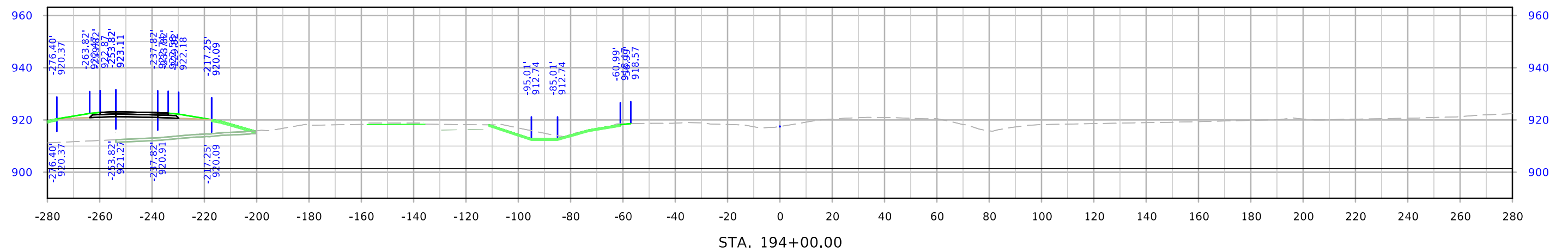
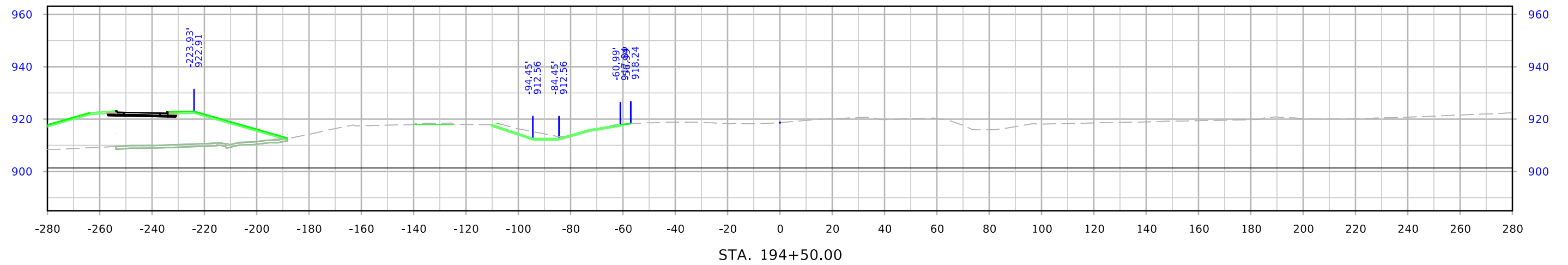
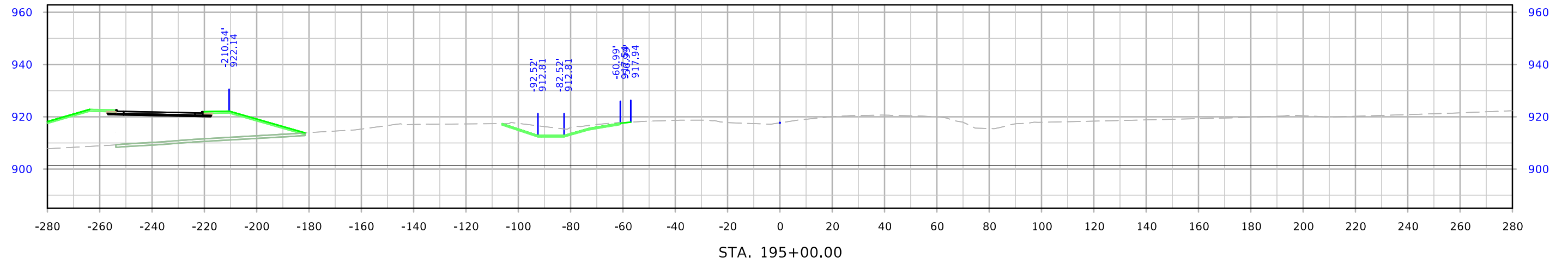

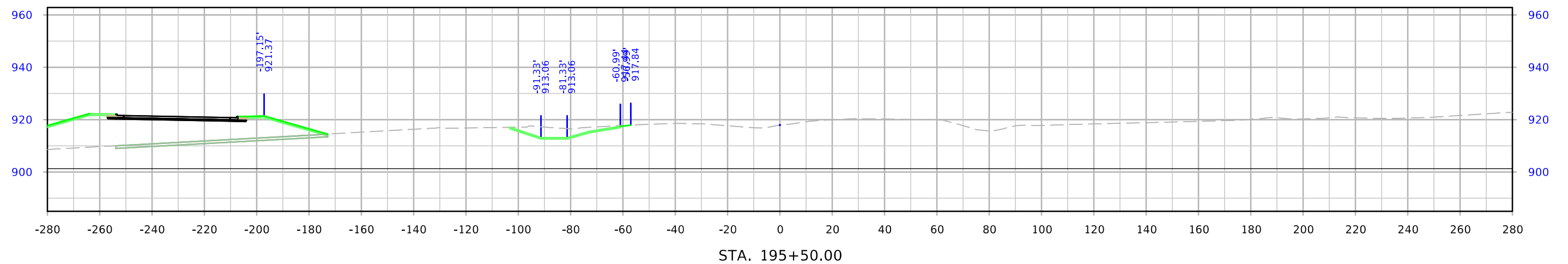
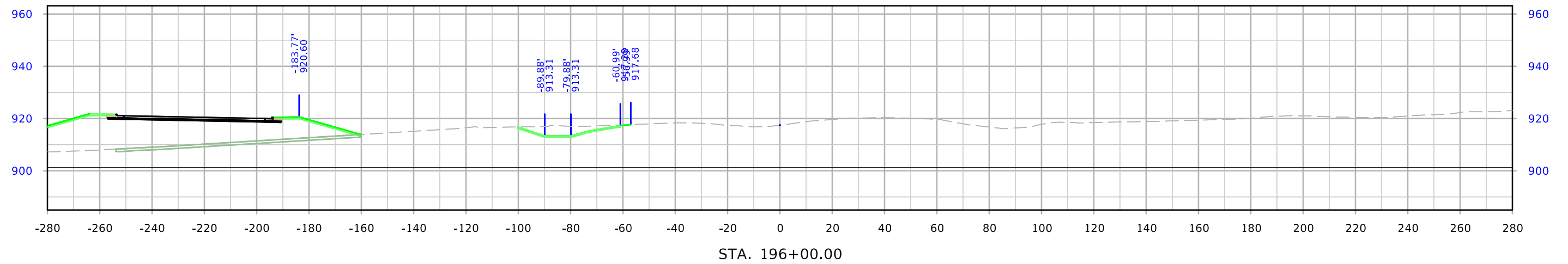
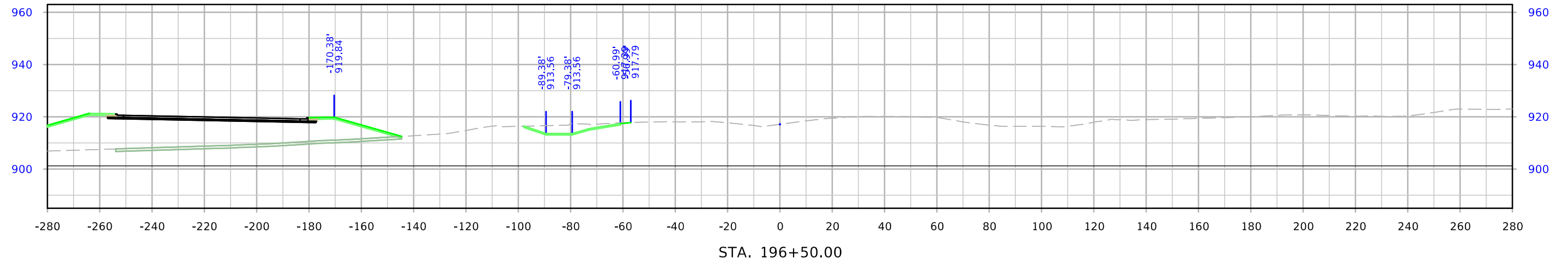

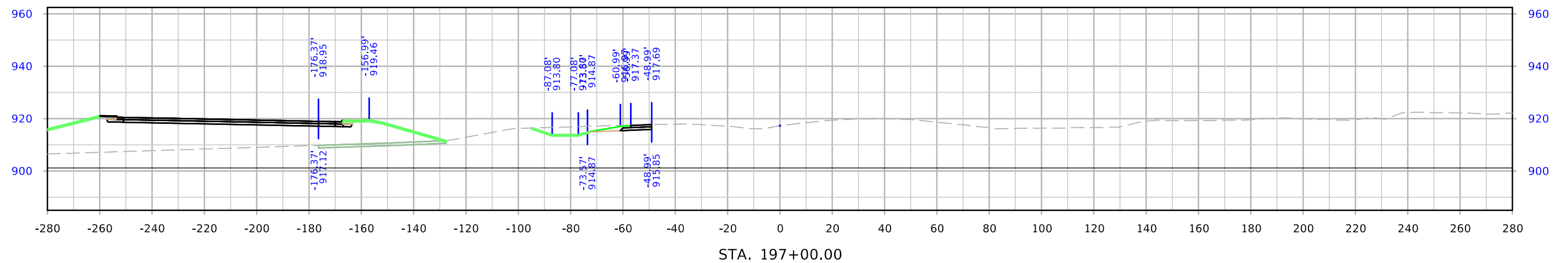
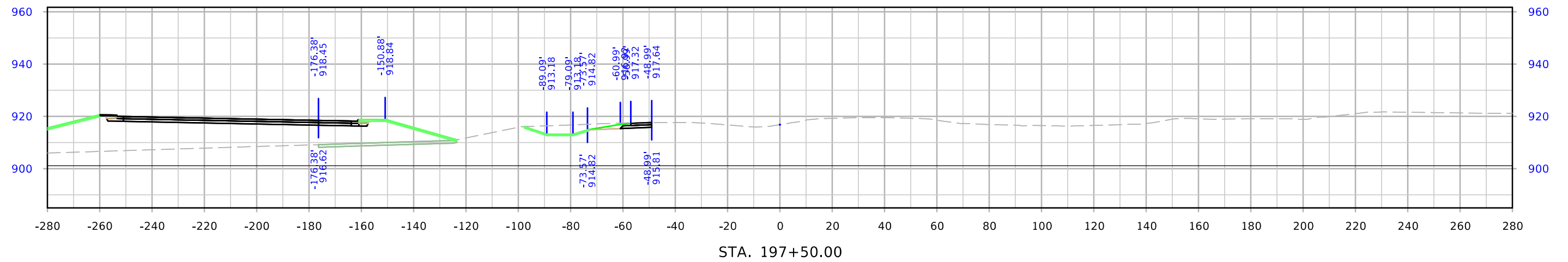
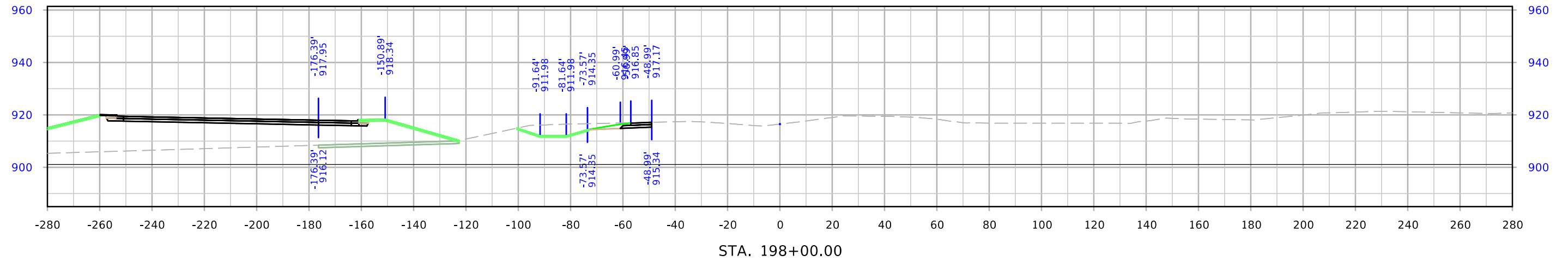

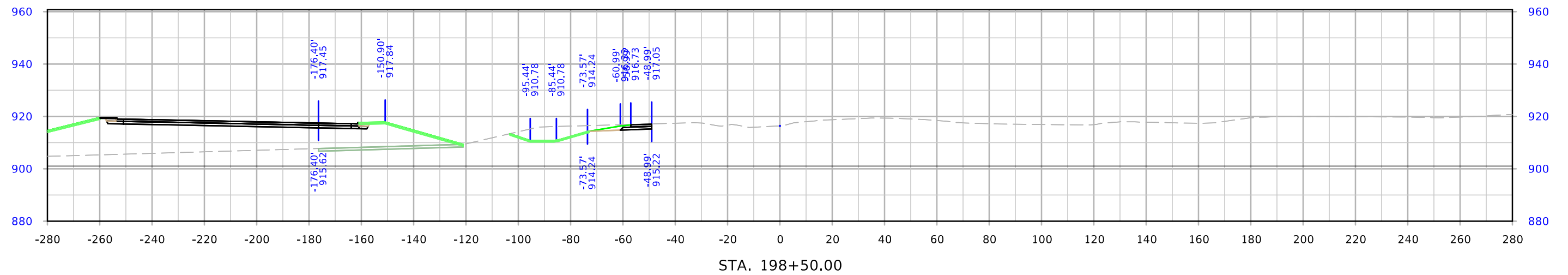
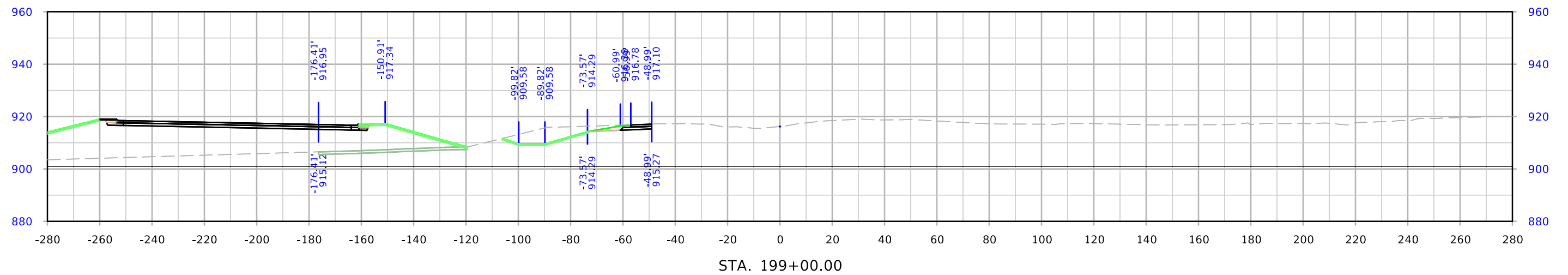
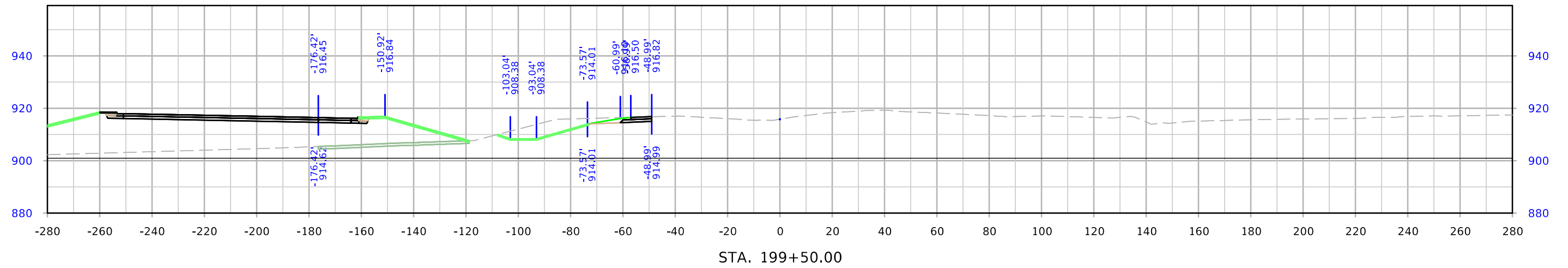

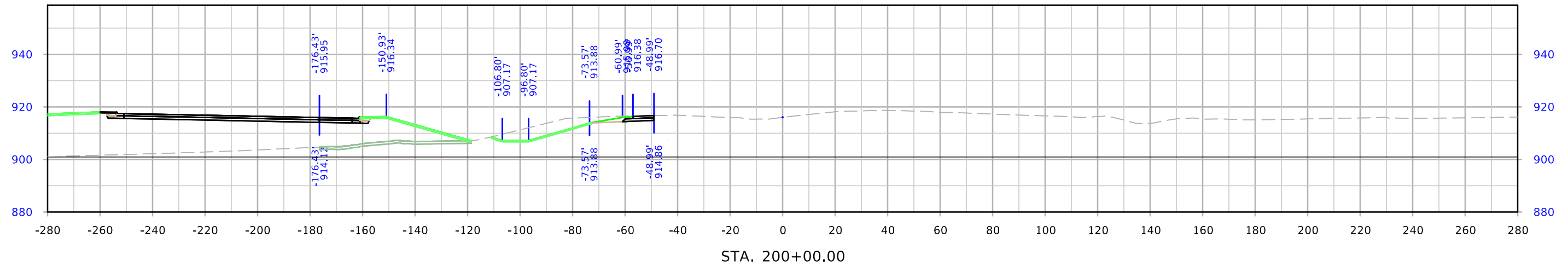
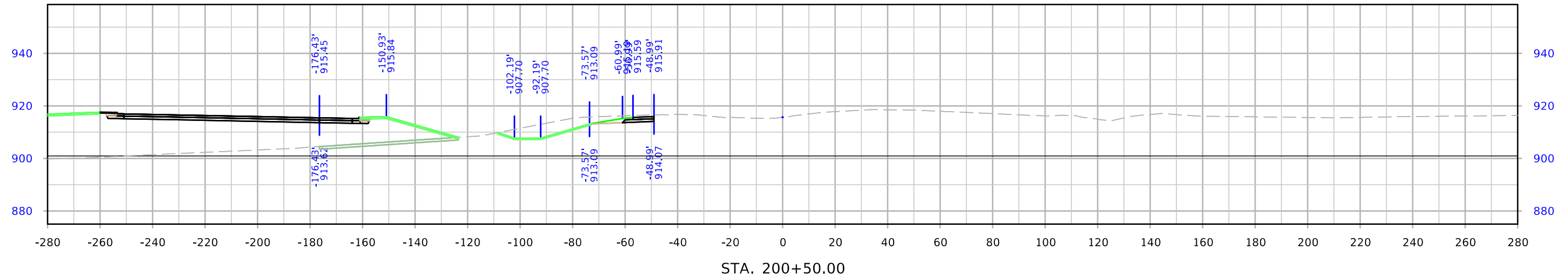
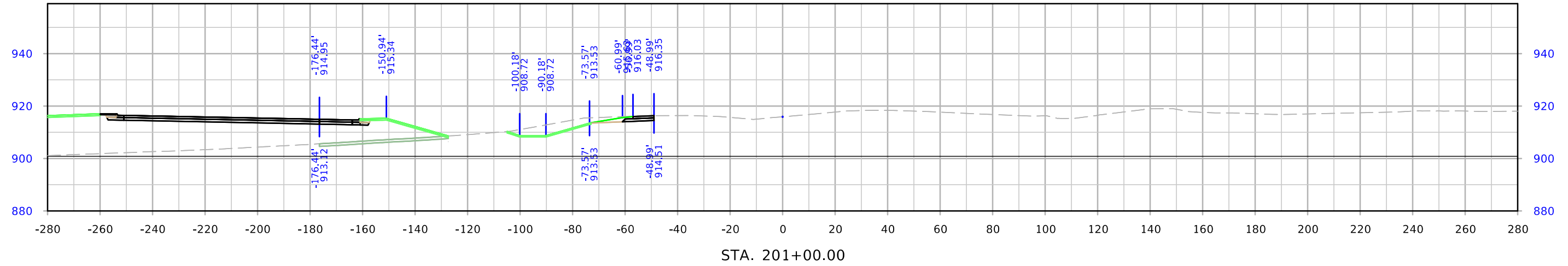

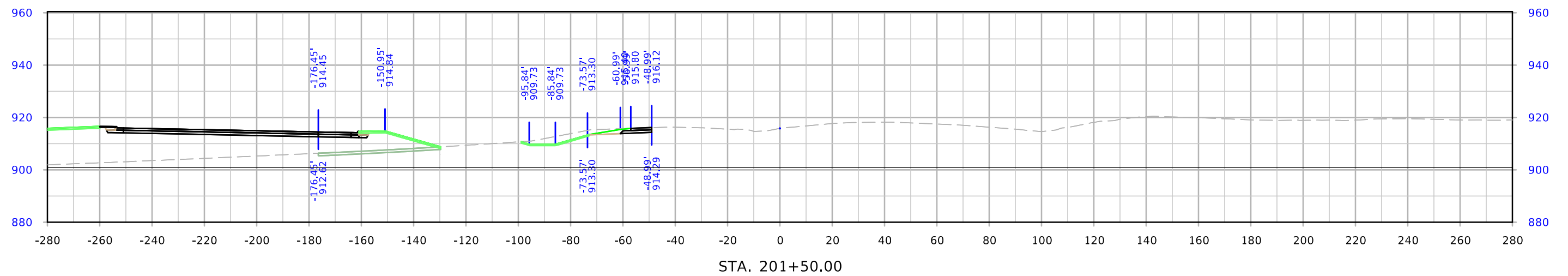
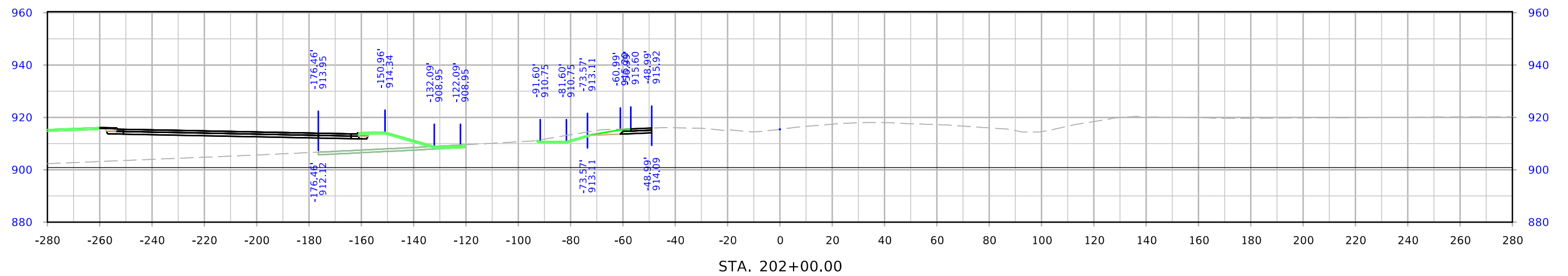
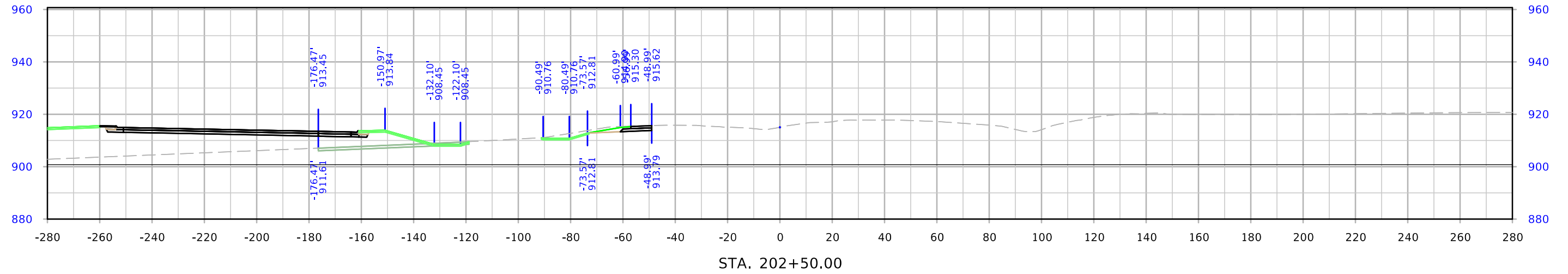

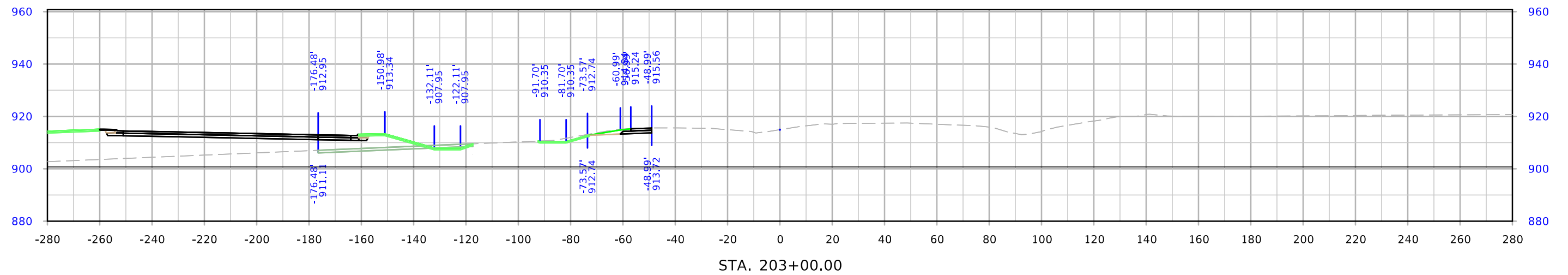
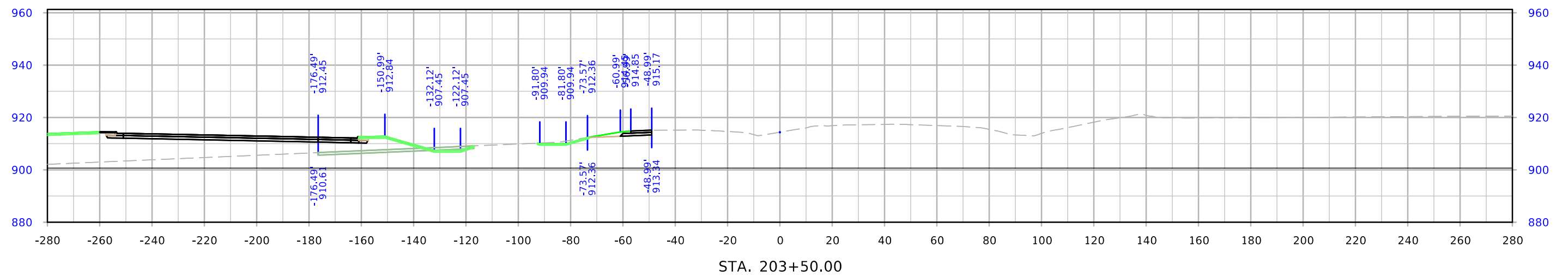
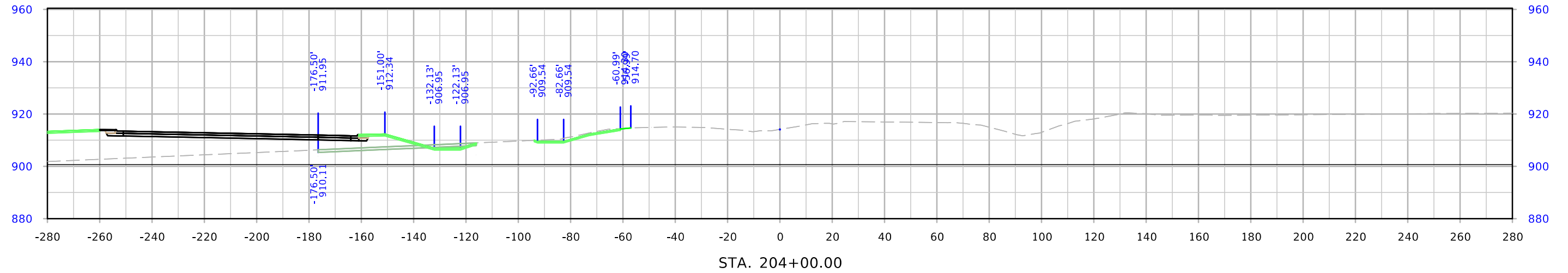

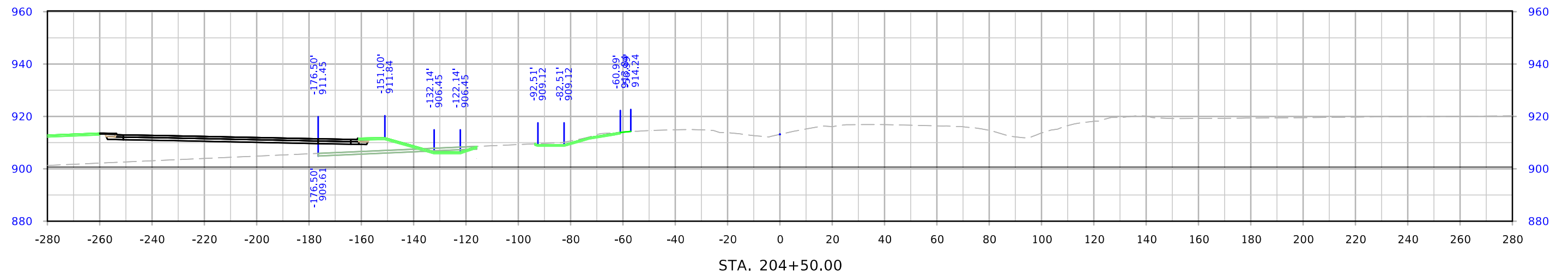
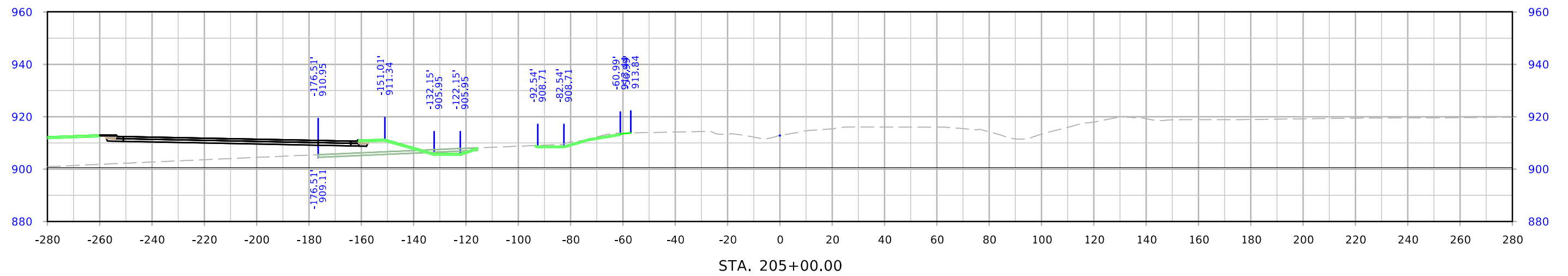
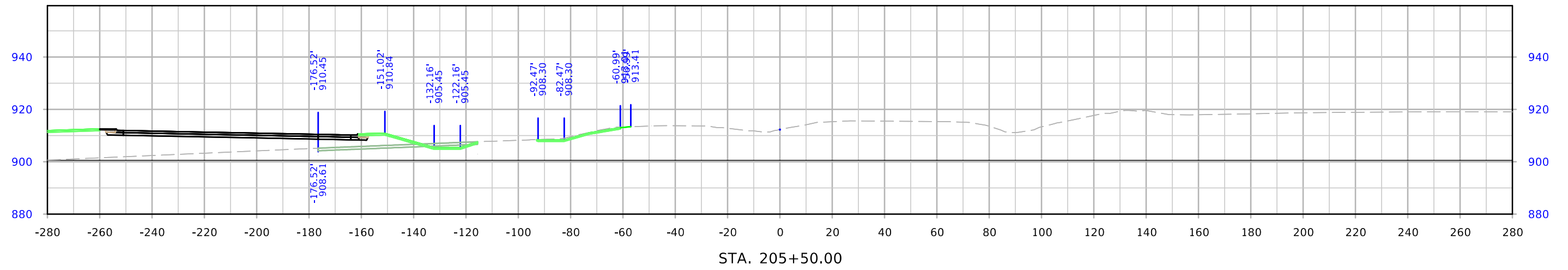

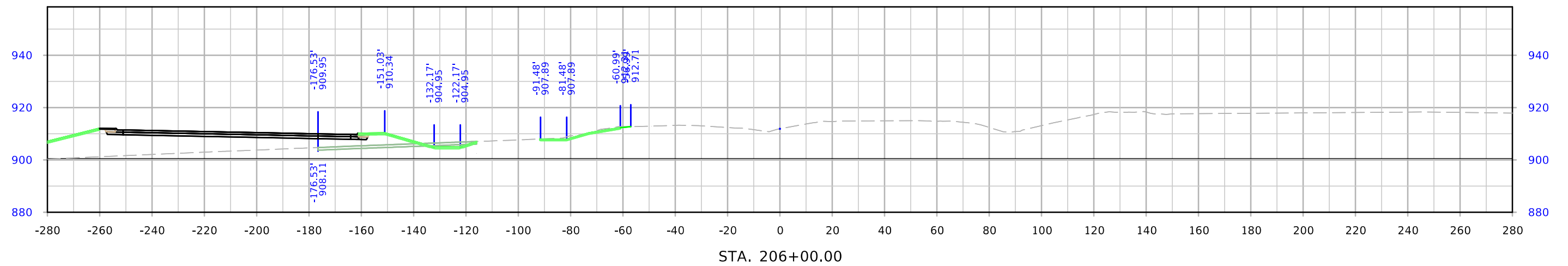
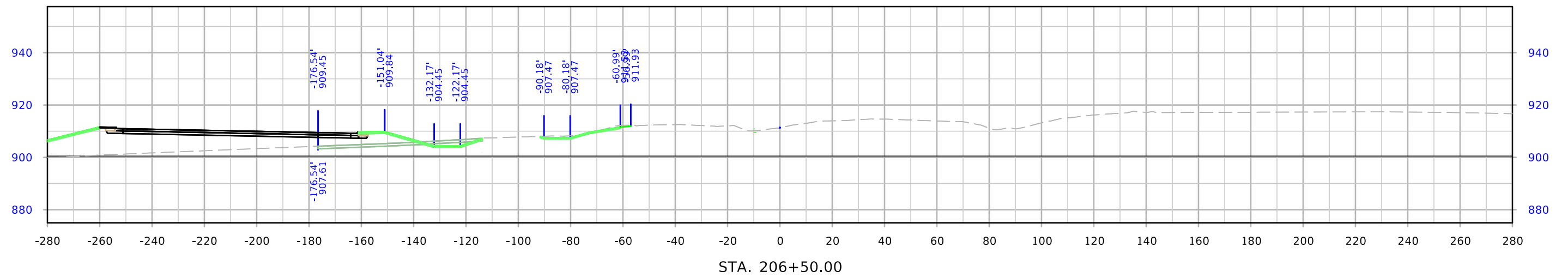
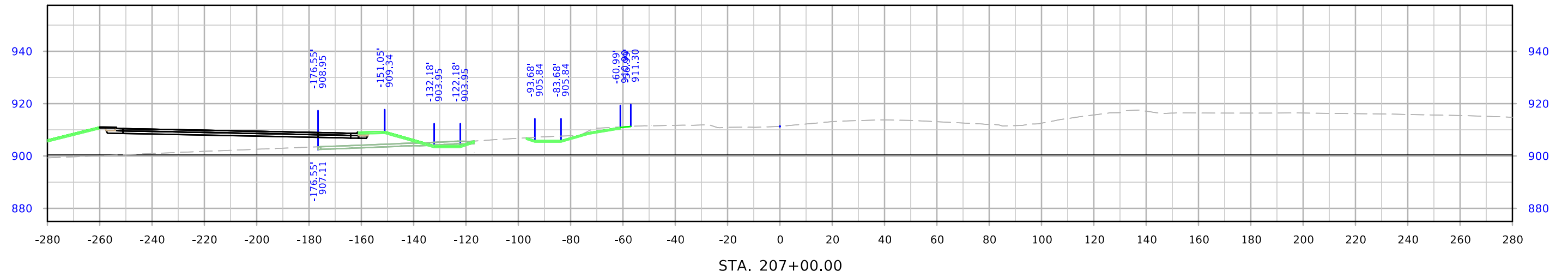

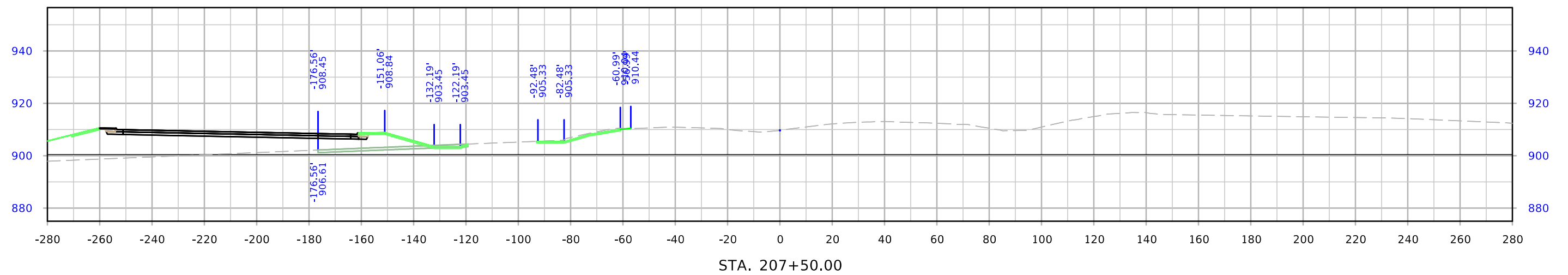
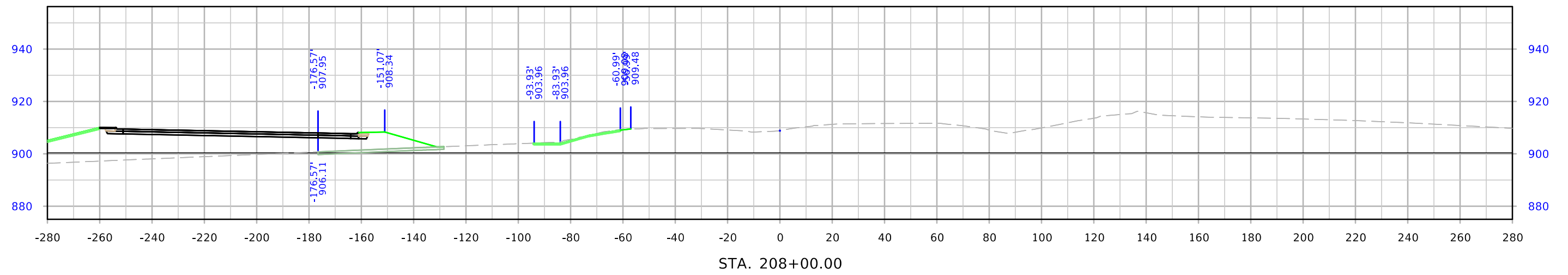
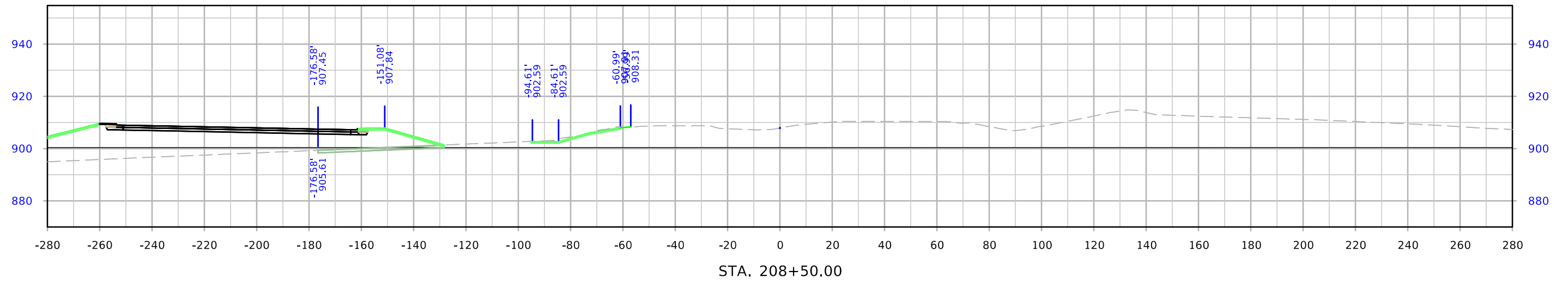

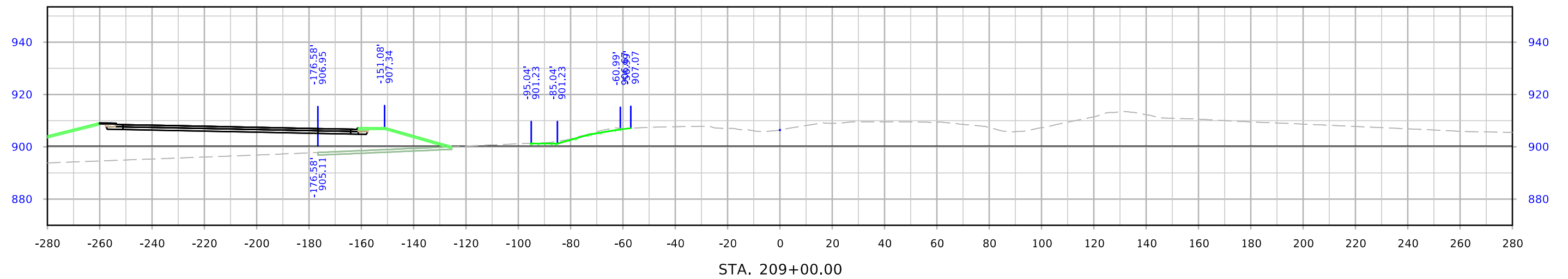
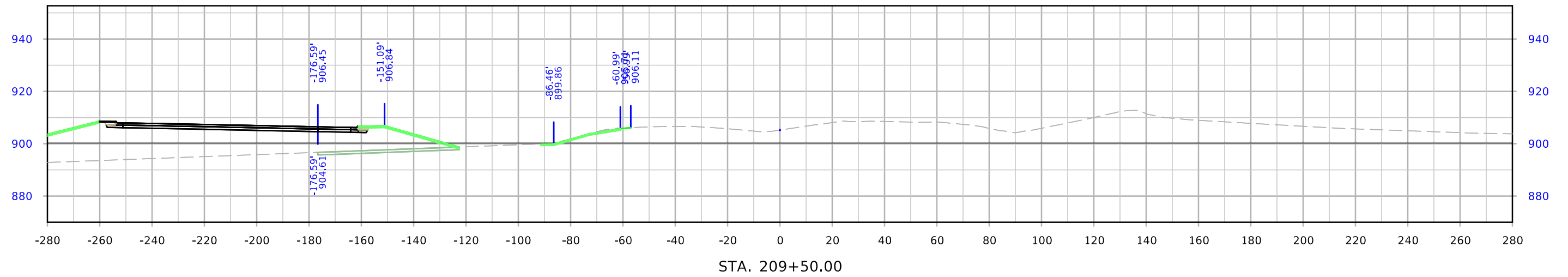
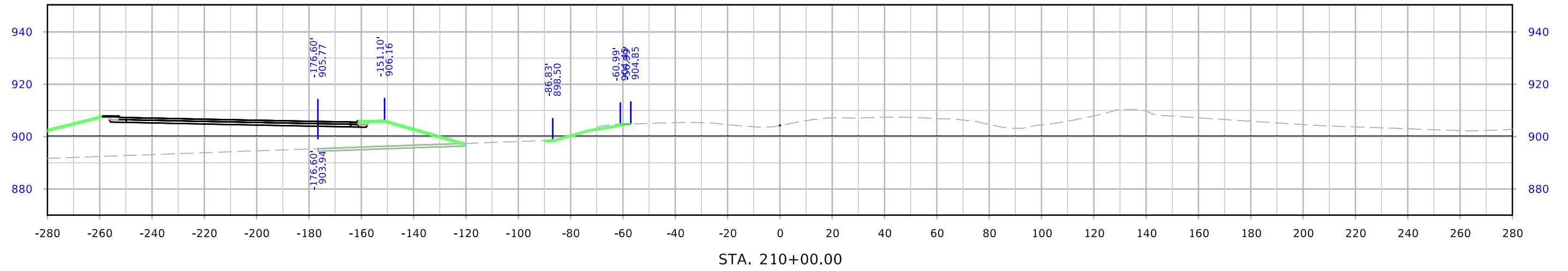

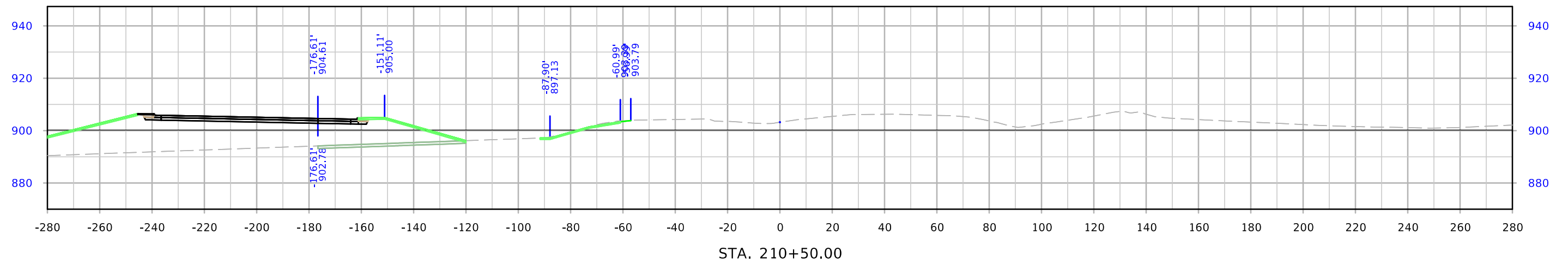
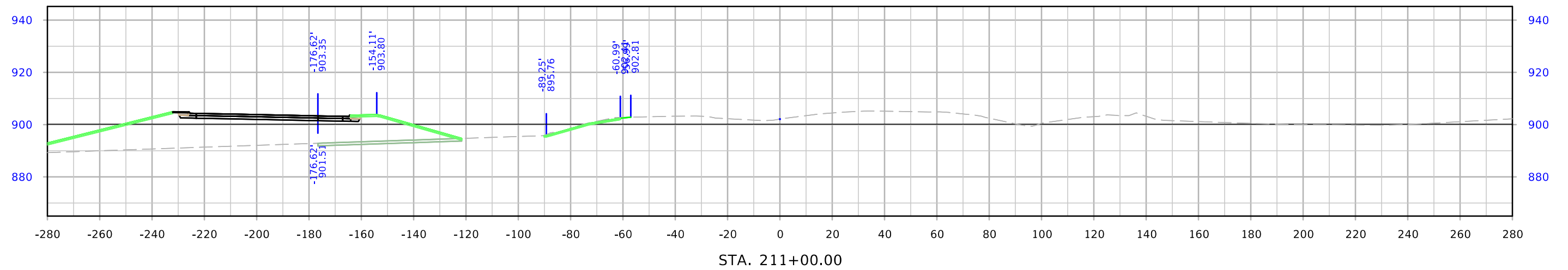
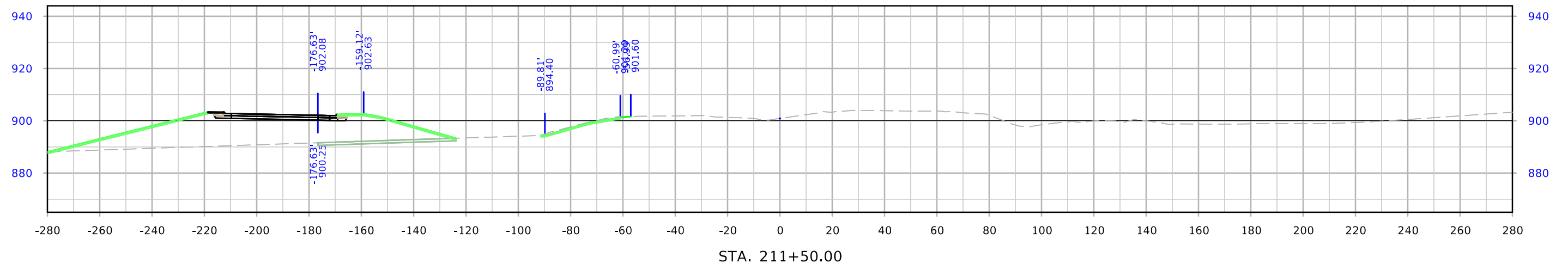

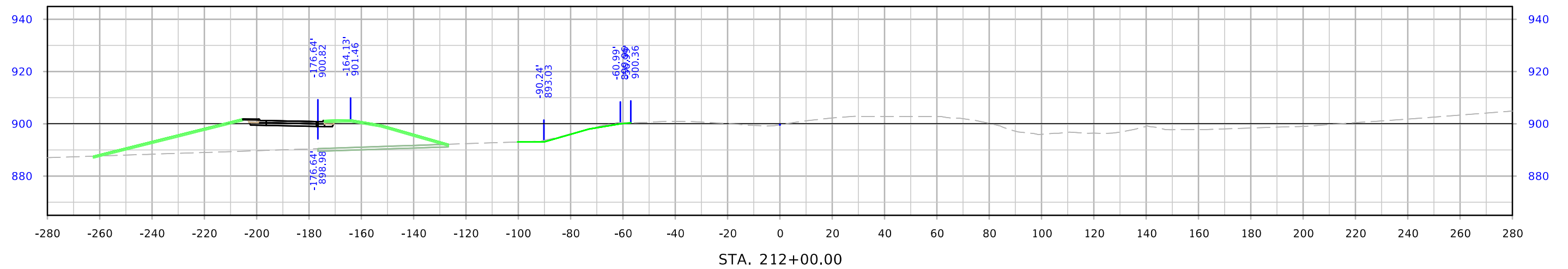
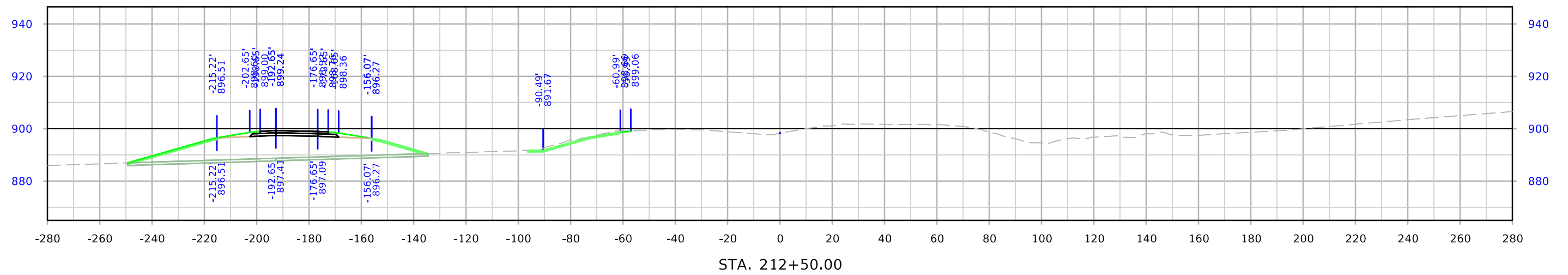
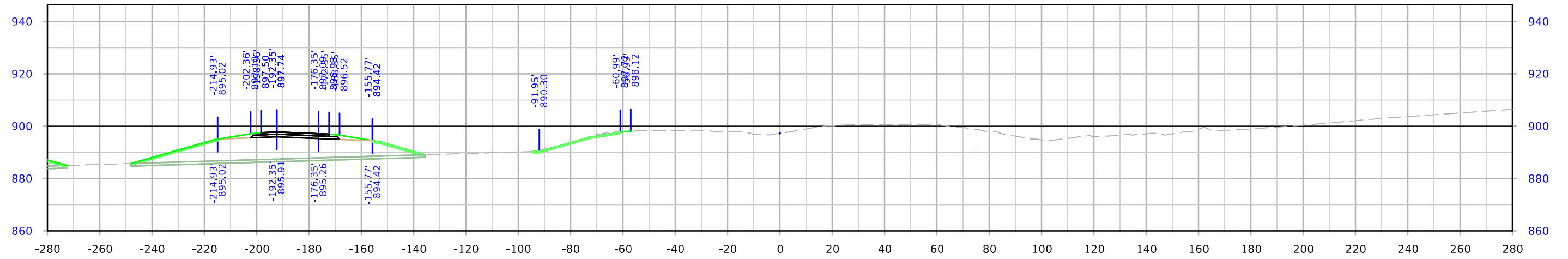

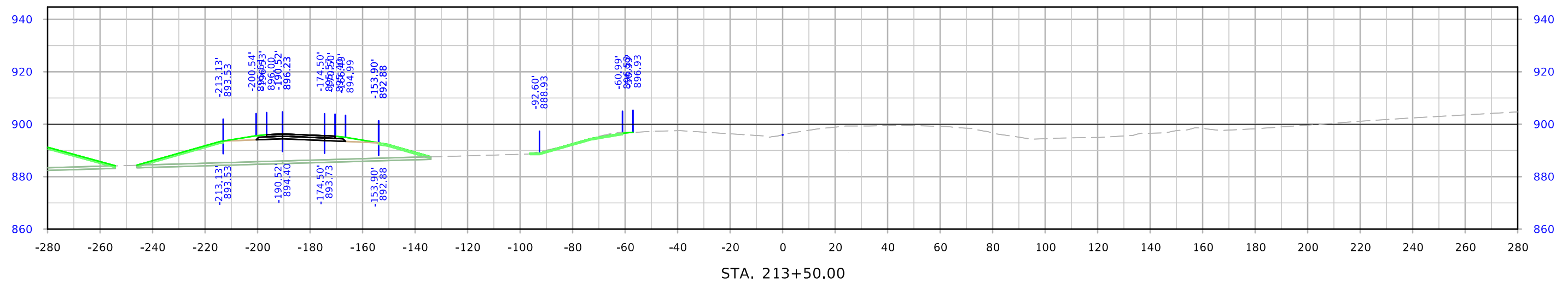
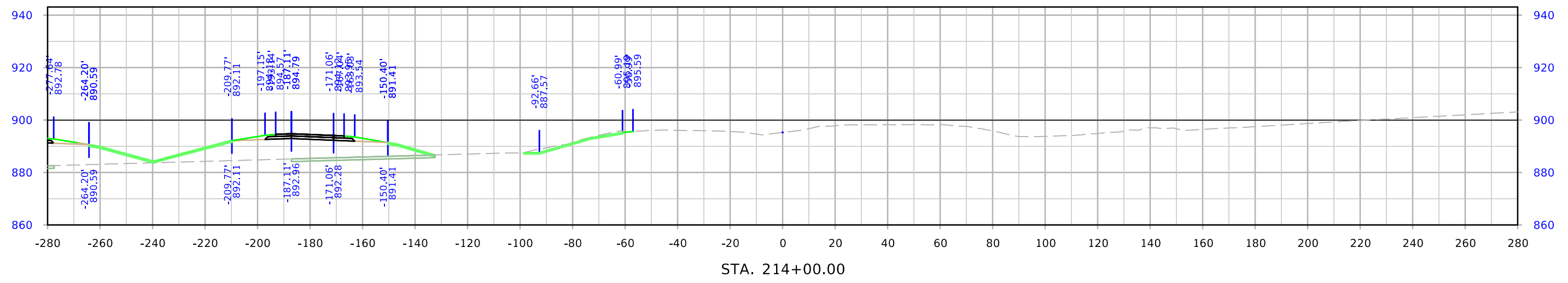
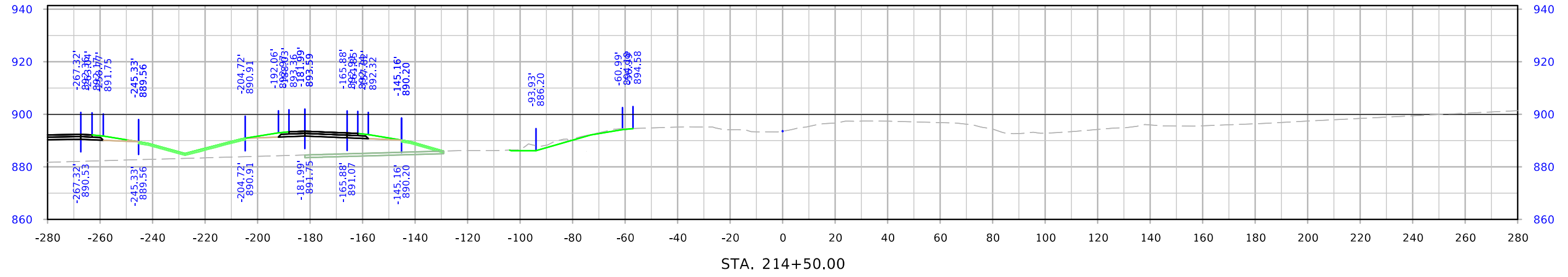

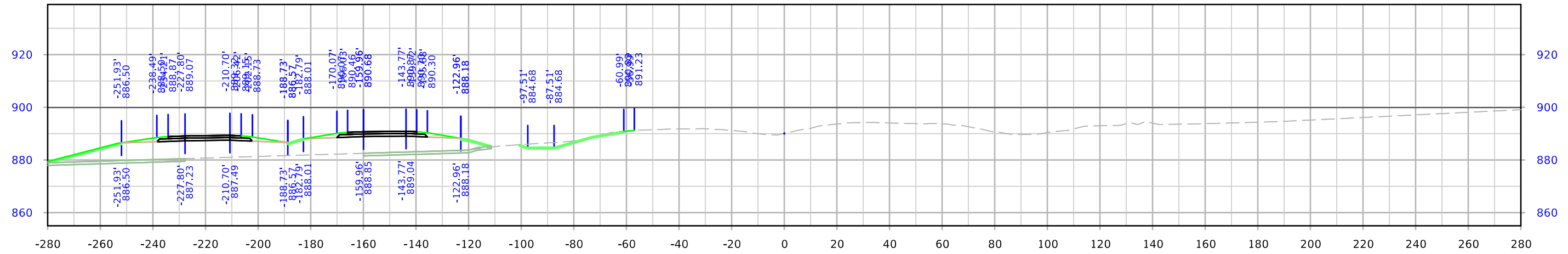

STA. 216+00.00

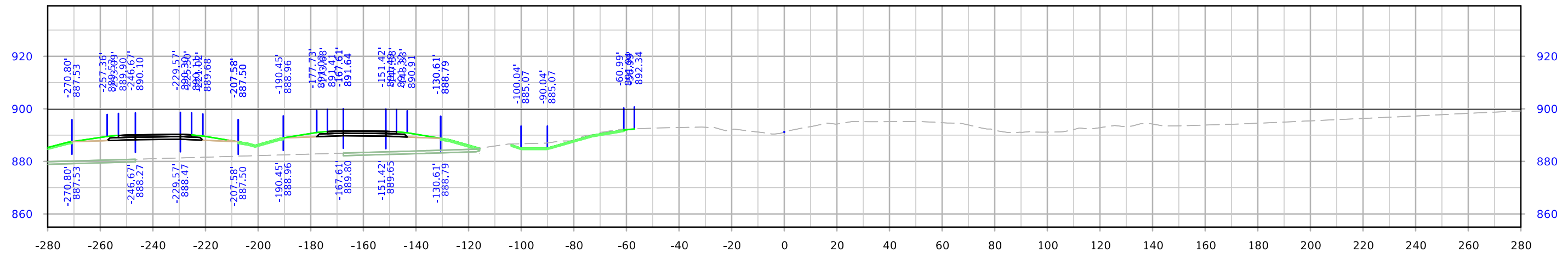

STA. 215+50.00

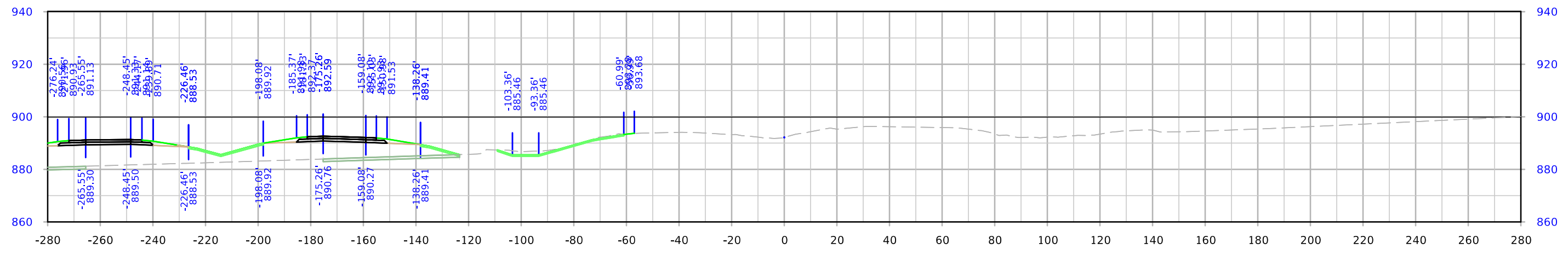

STA. 215+00.00

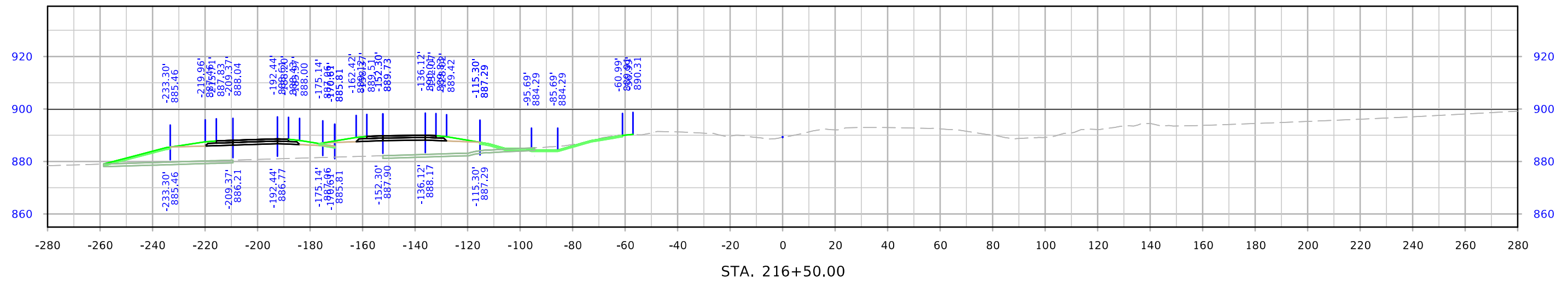
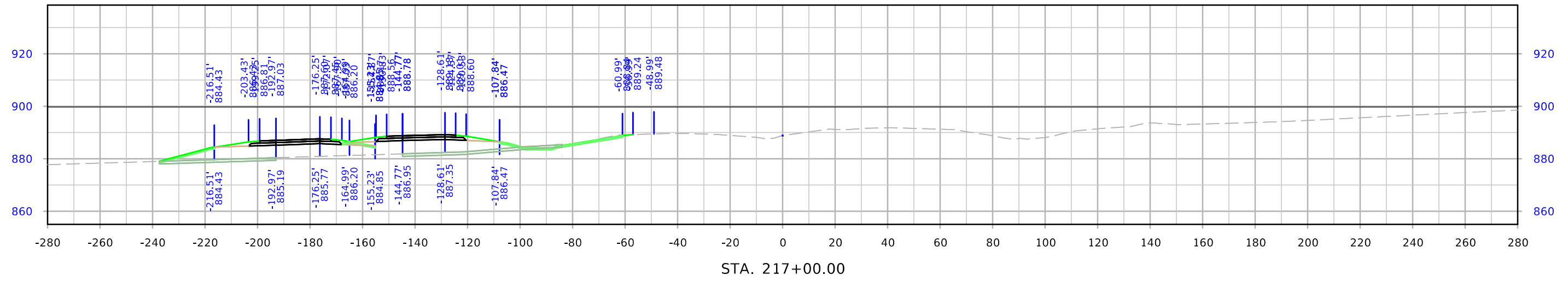
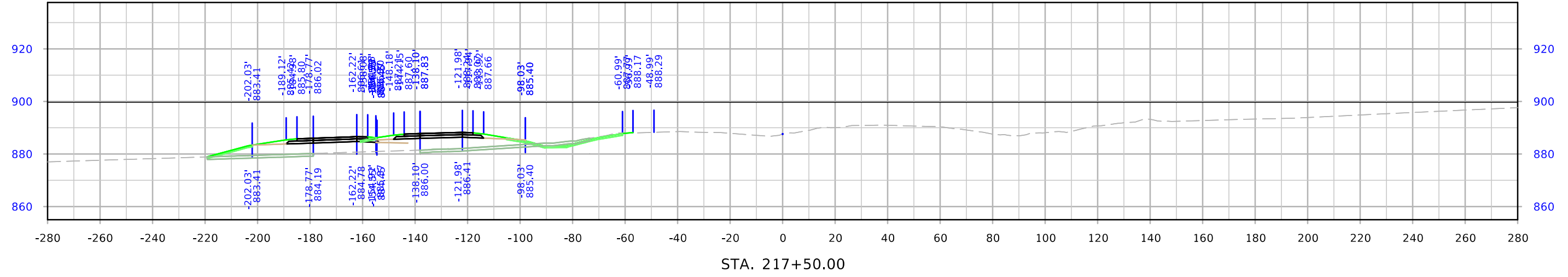

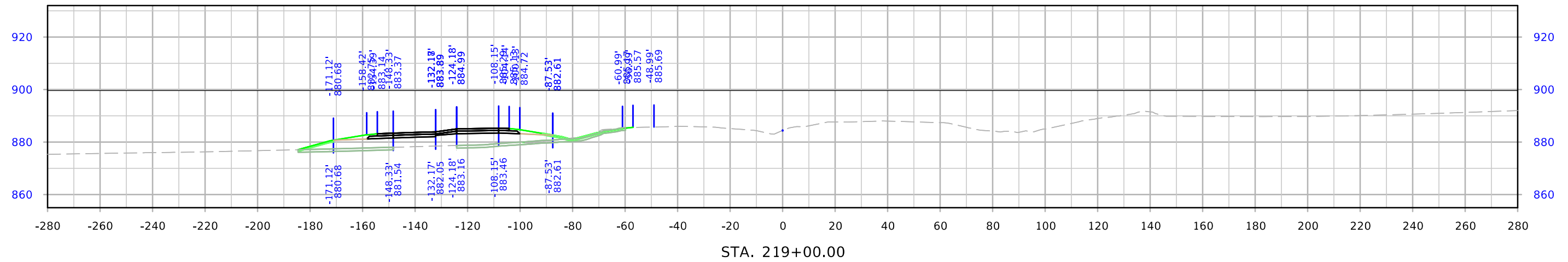

STA. 219+00.00

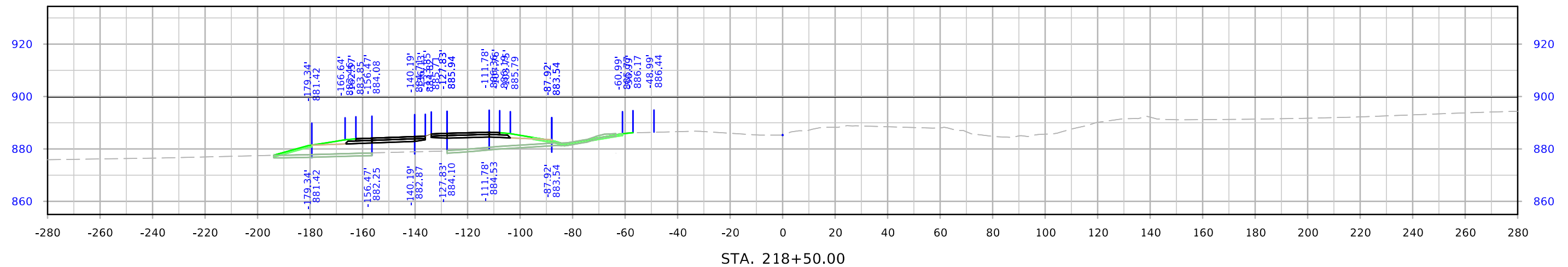

STA. 218+50.00

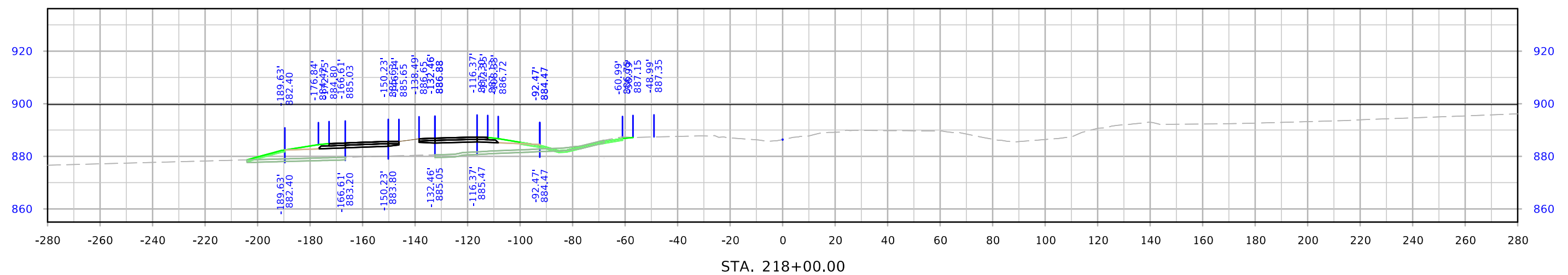

STA. 218+00.00

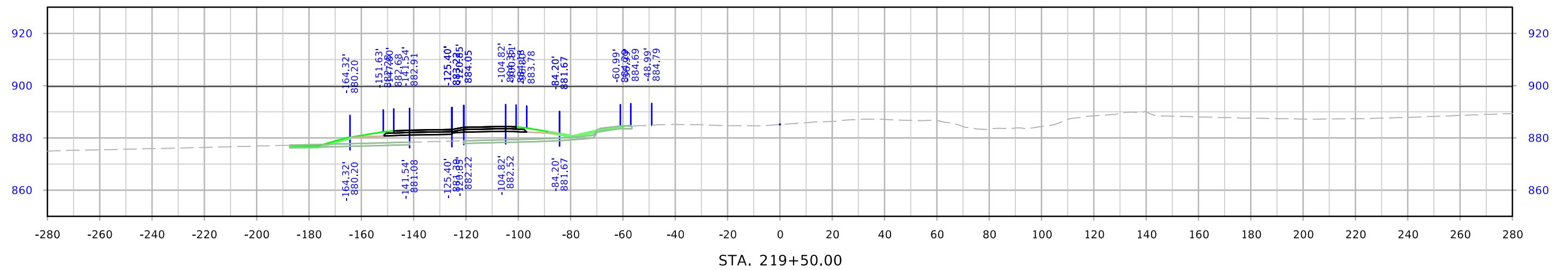
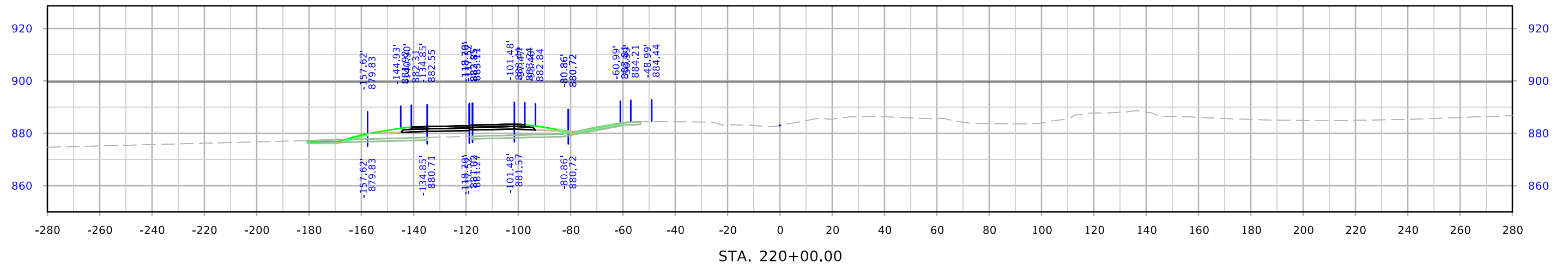
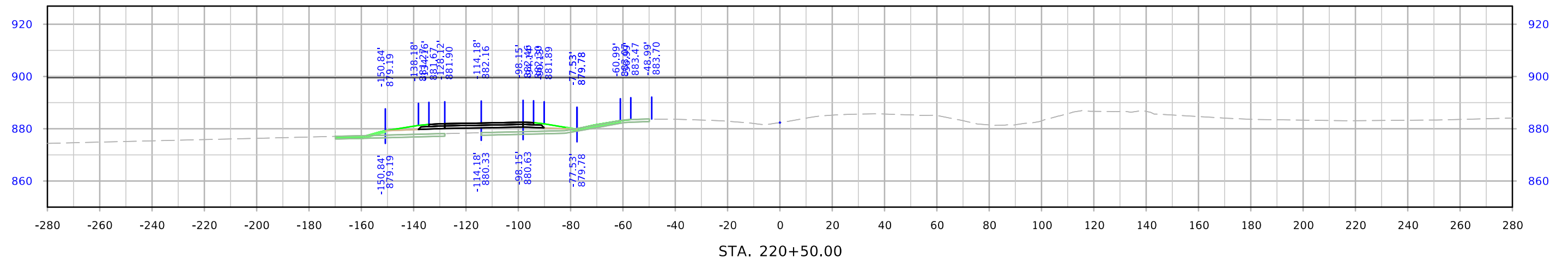

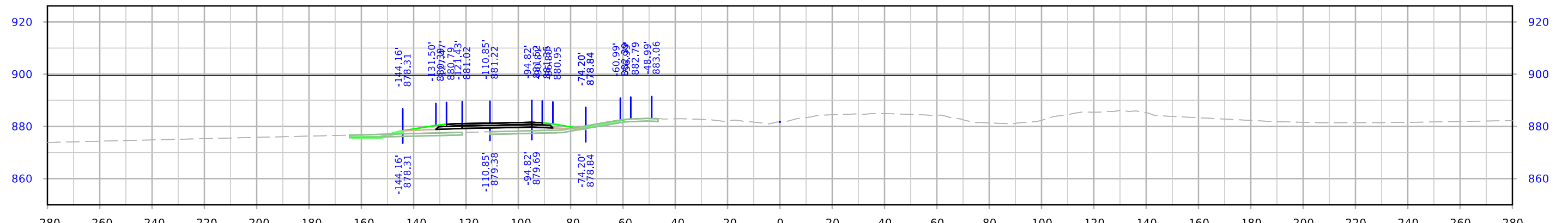
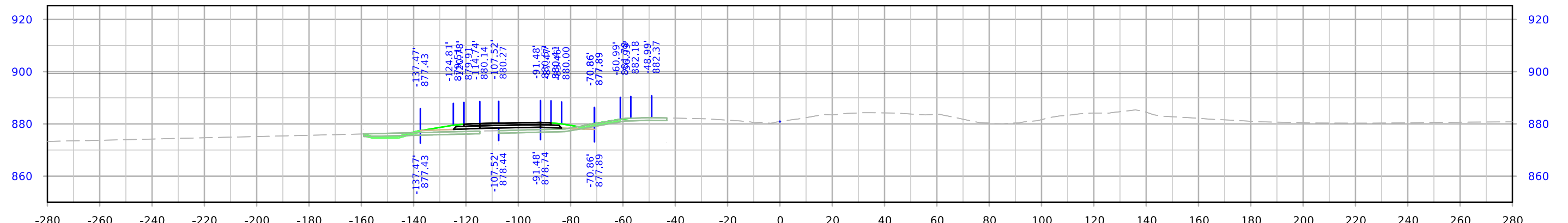
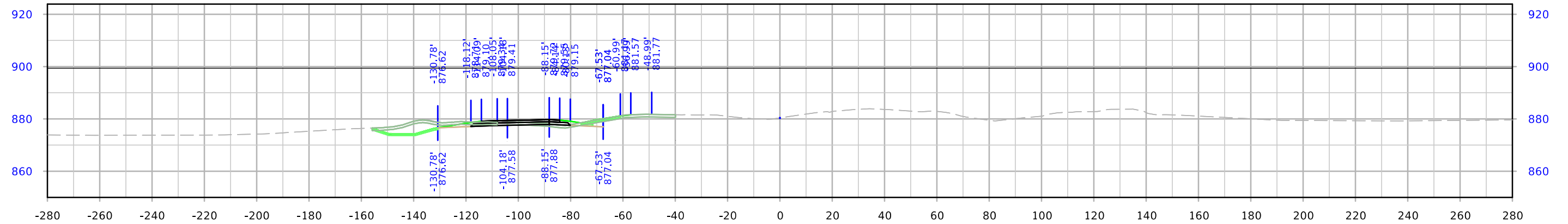

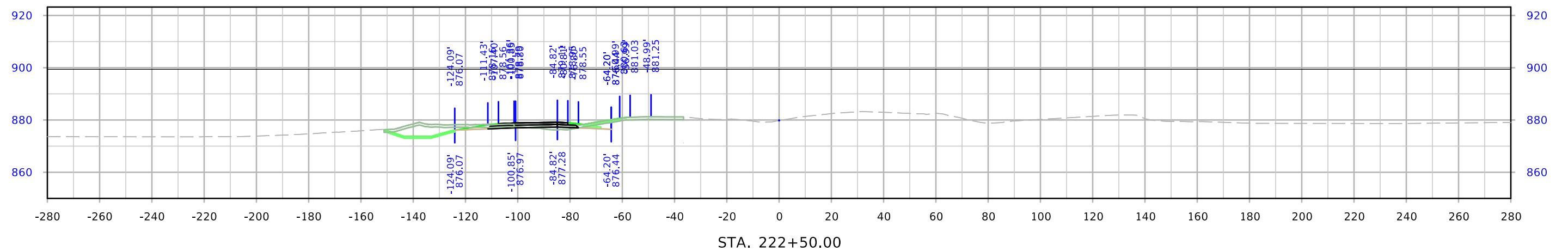
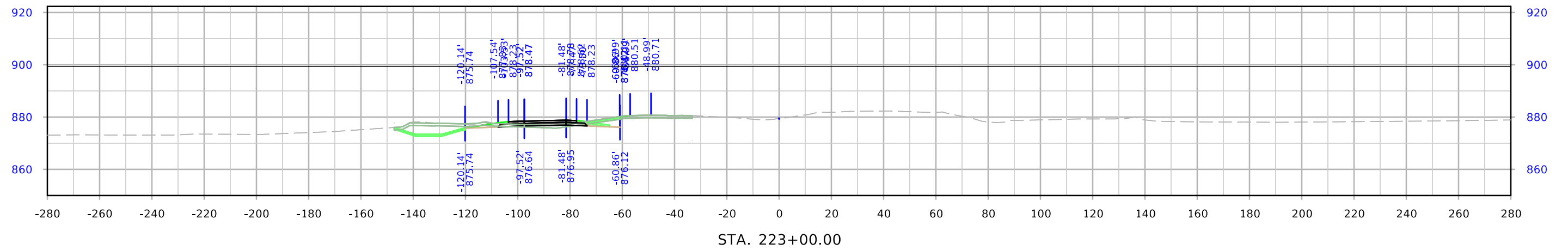
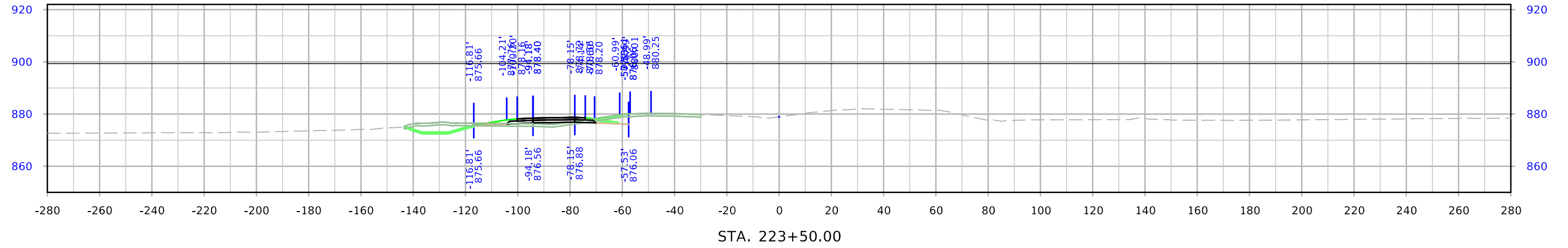

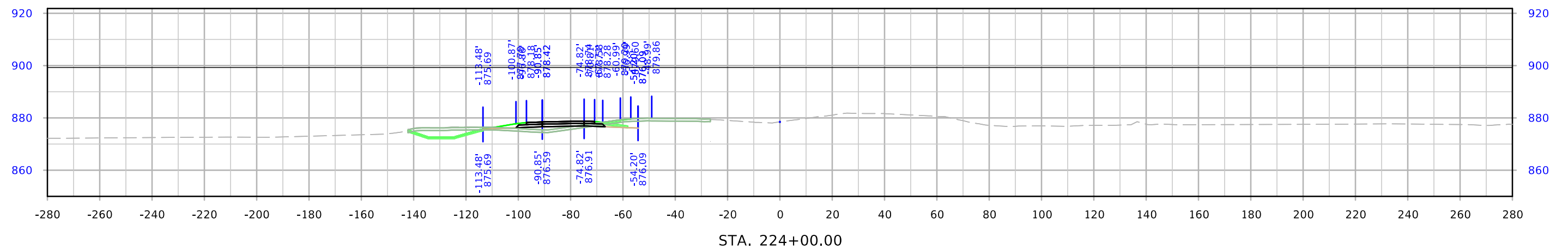
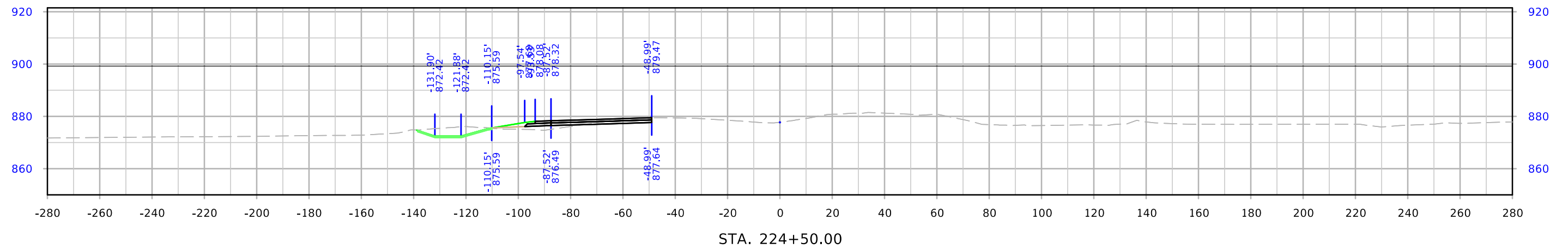
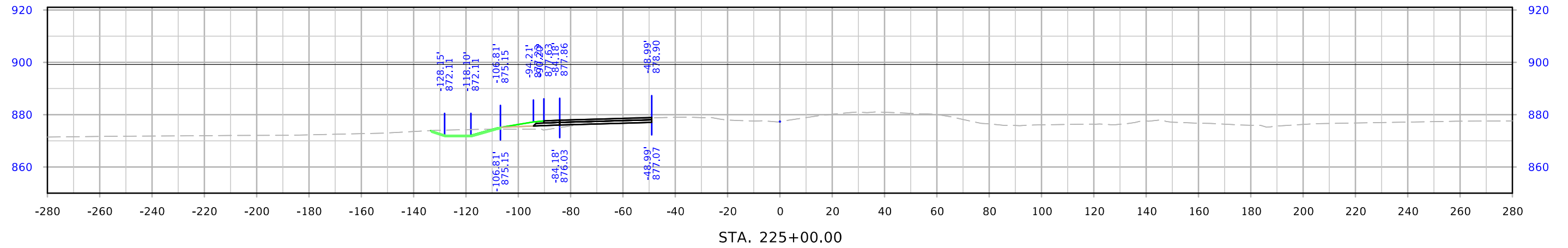

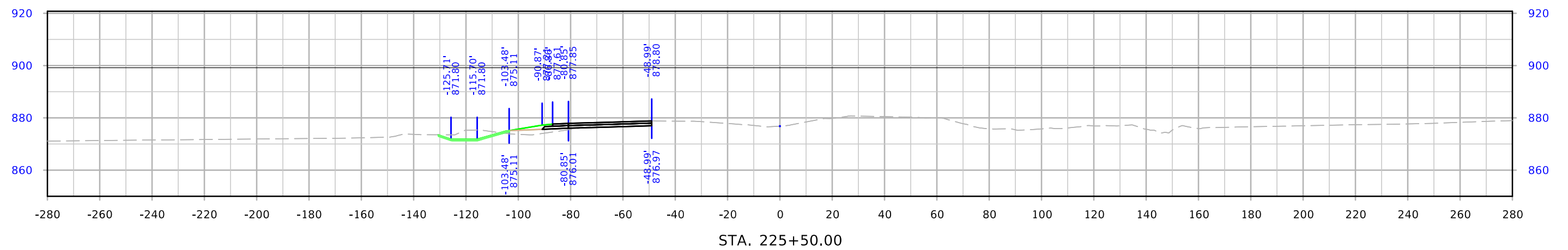
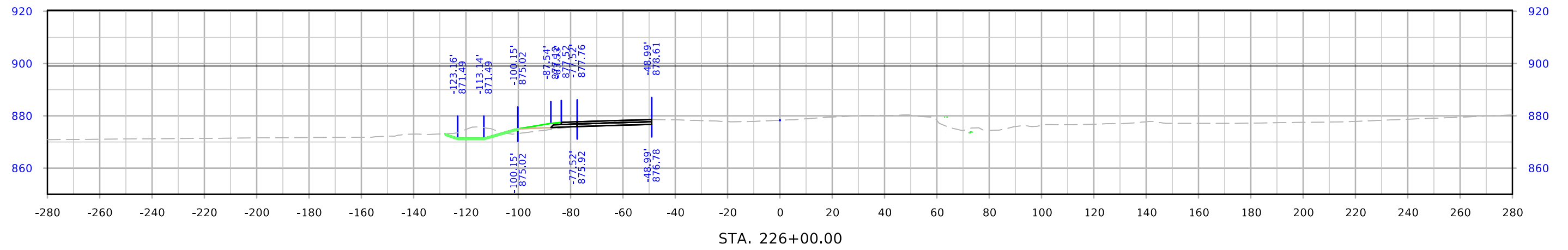
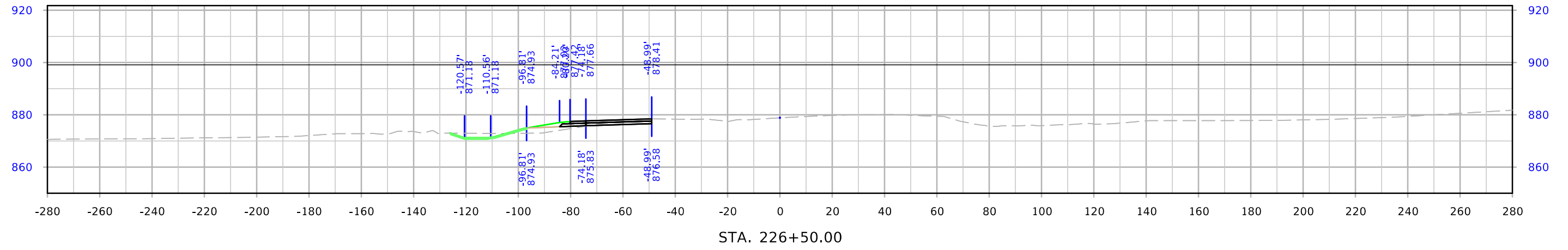

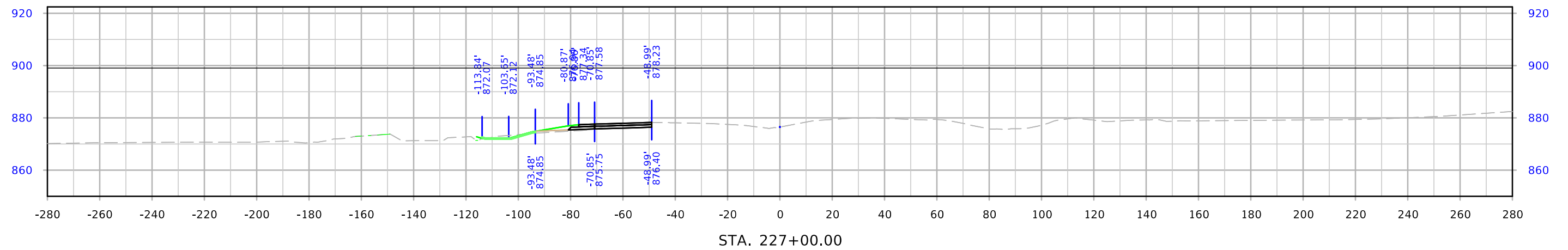
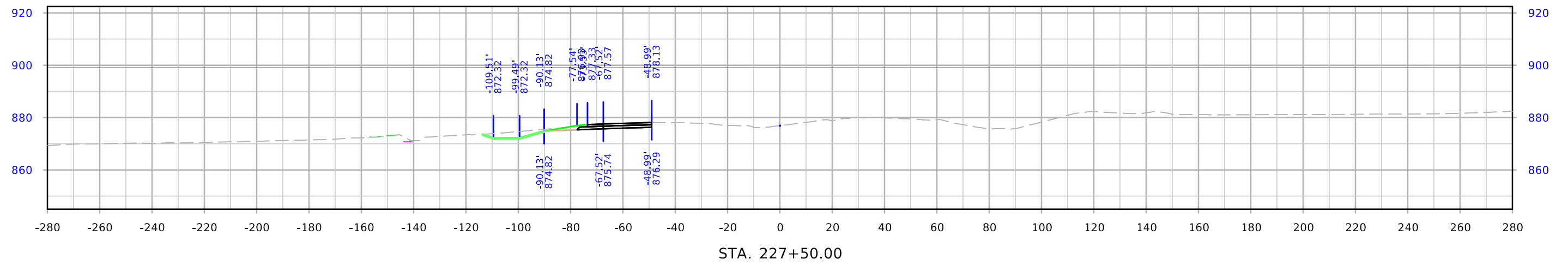
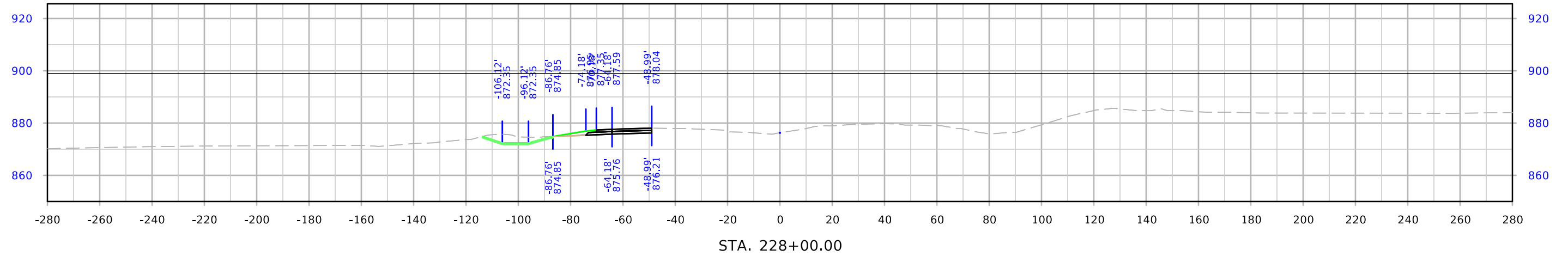

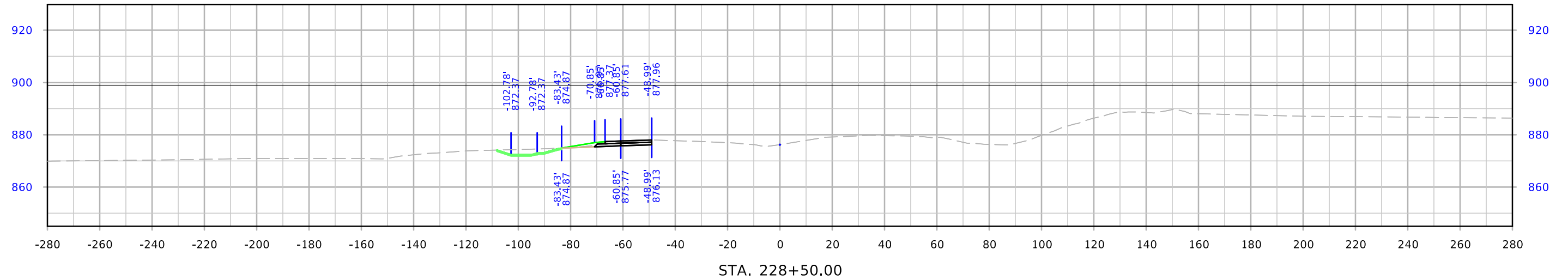
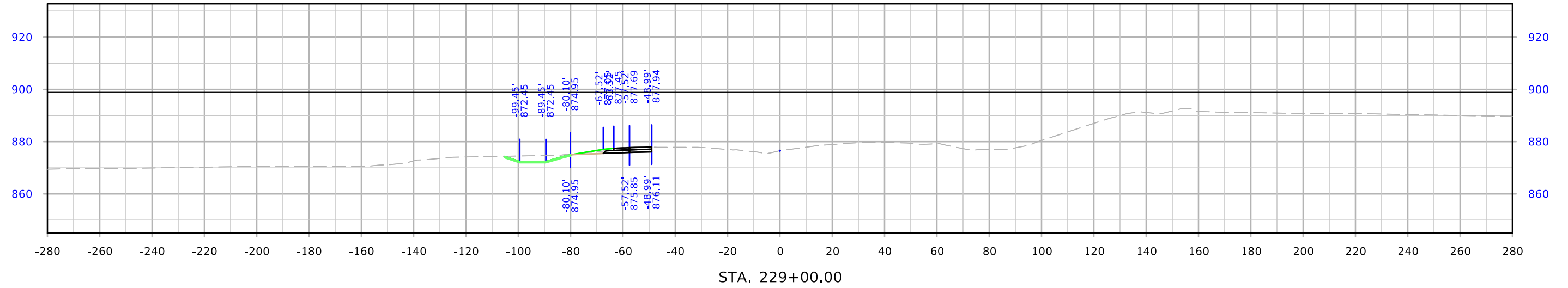
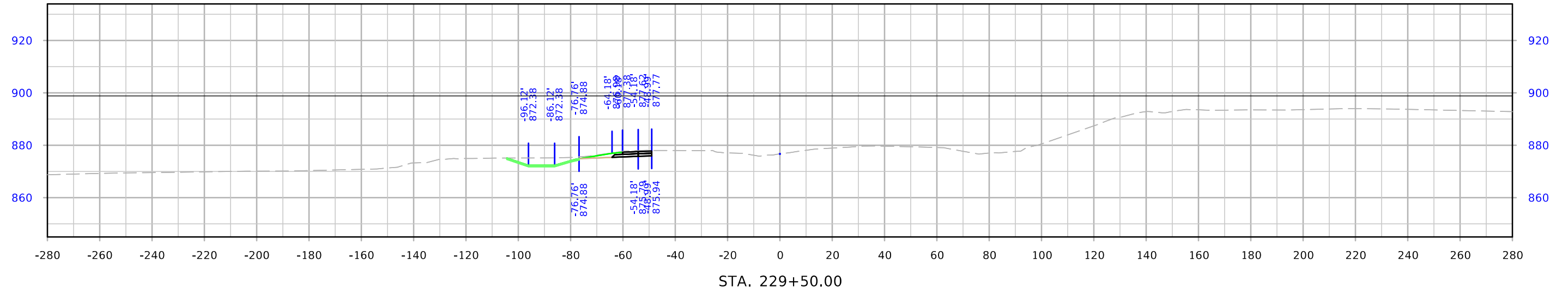

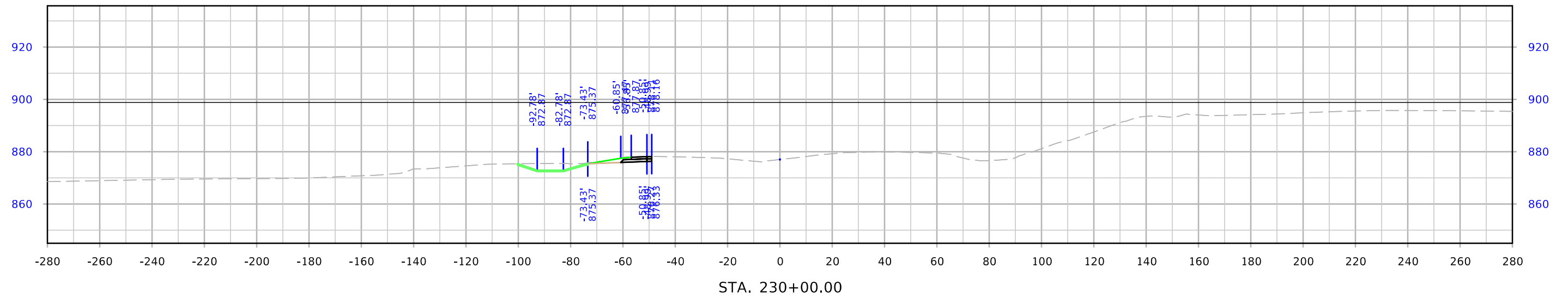
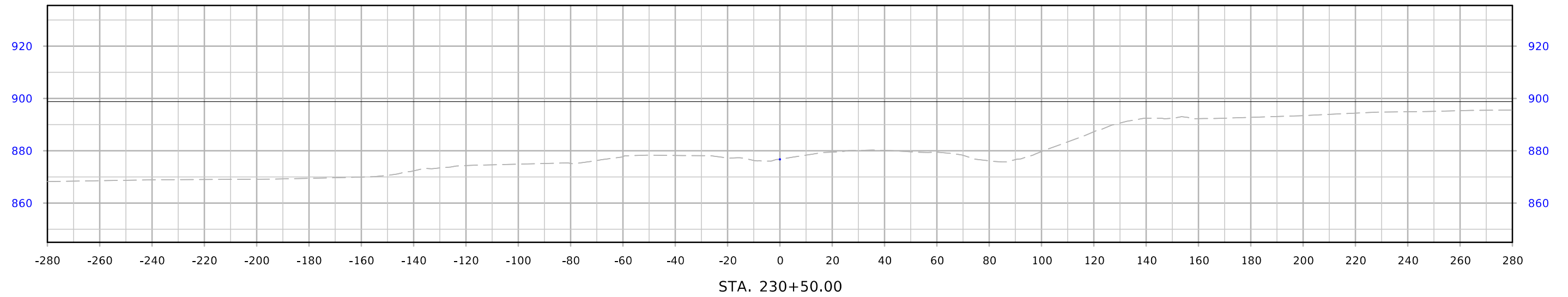

I-80 Ramp A Preliminary

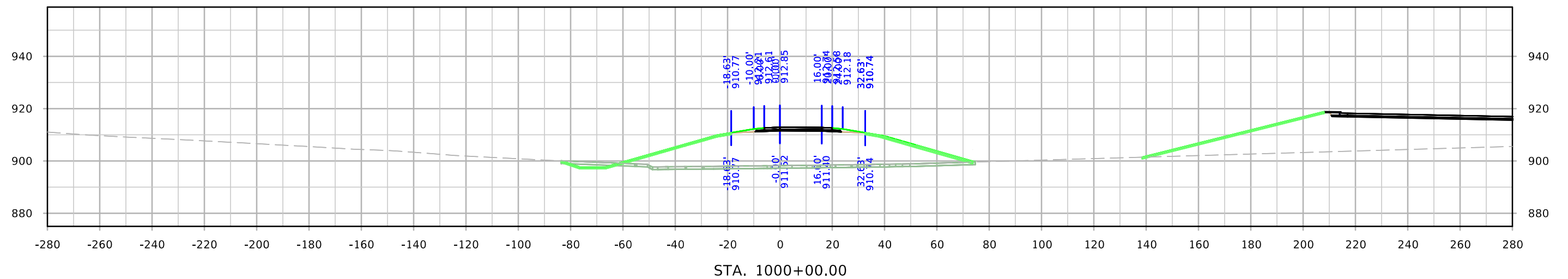
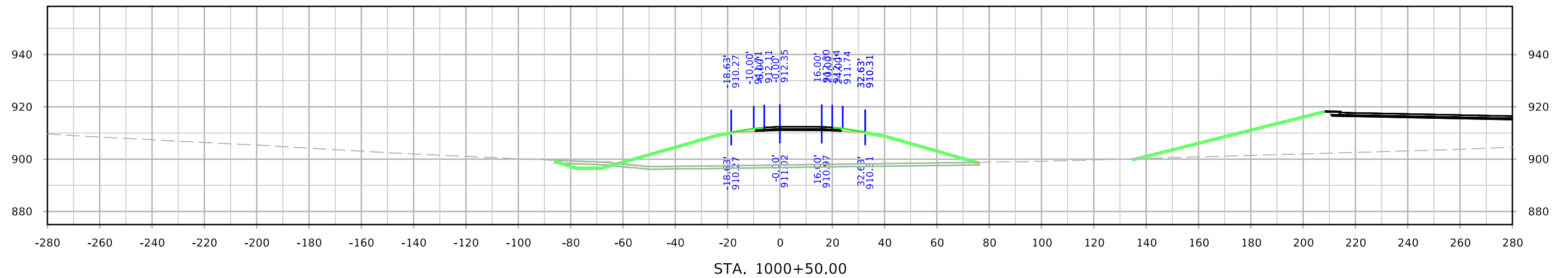
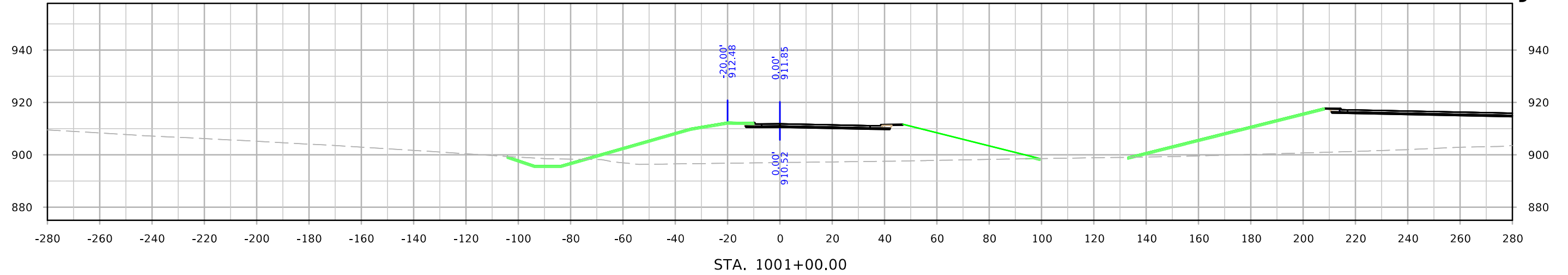

I-80 Ramp A Preliminary

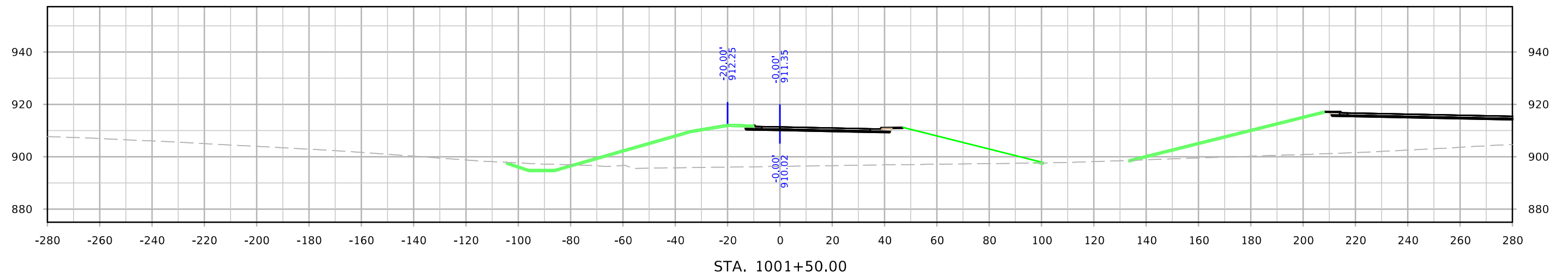
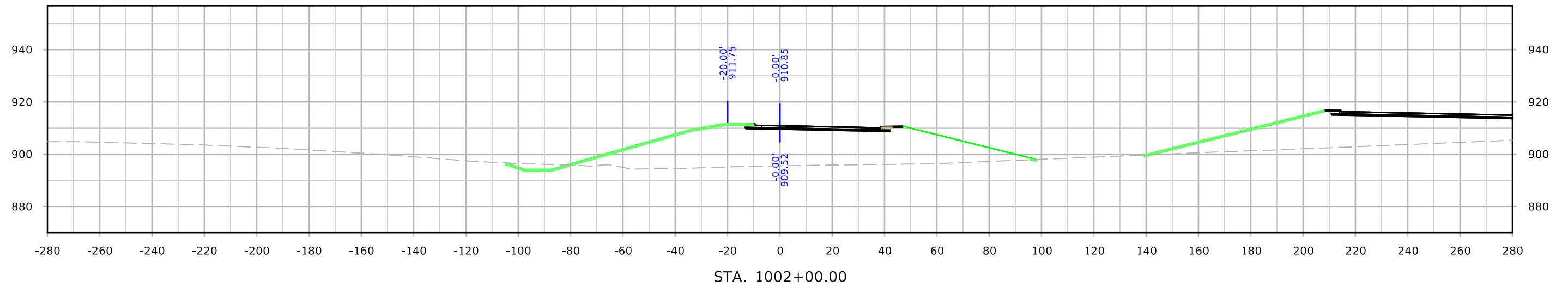
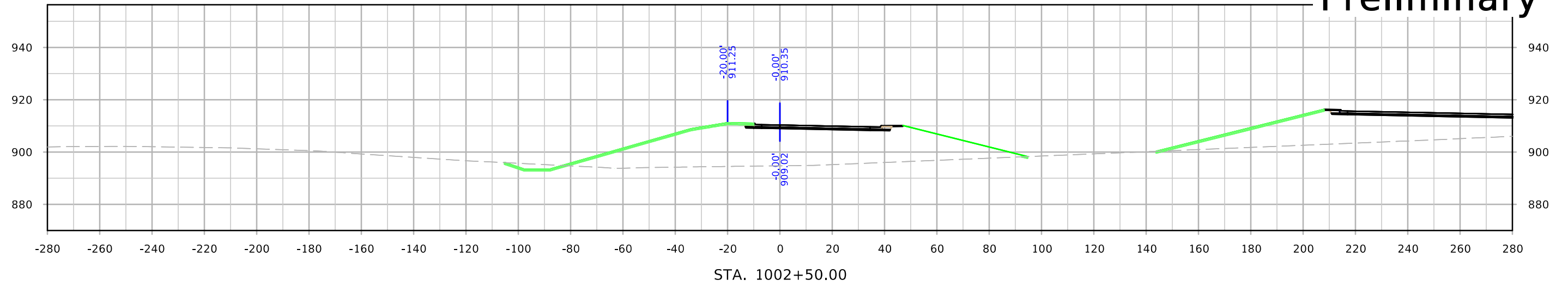

I-80 Ramp A Preliminary

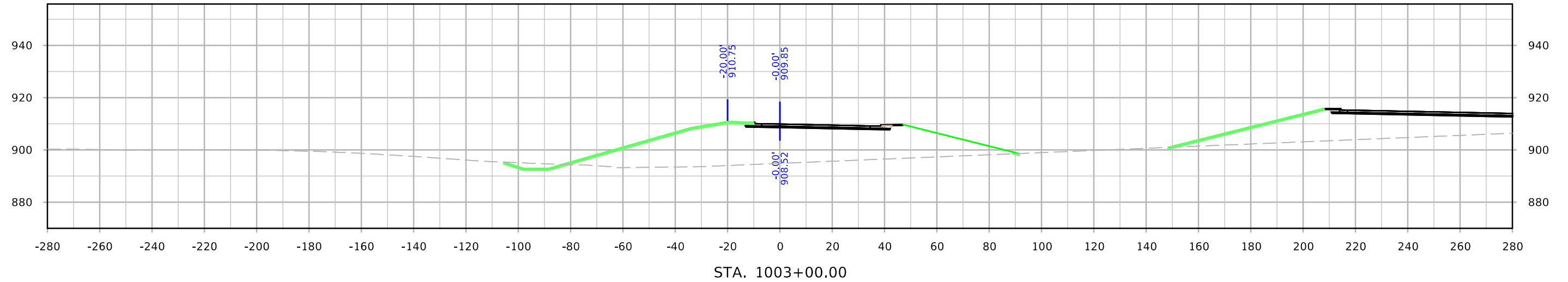
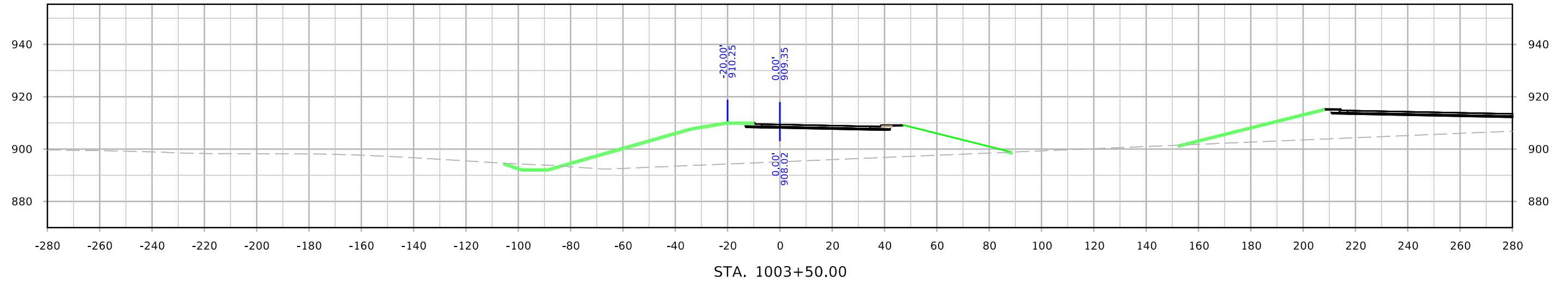
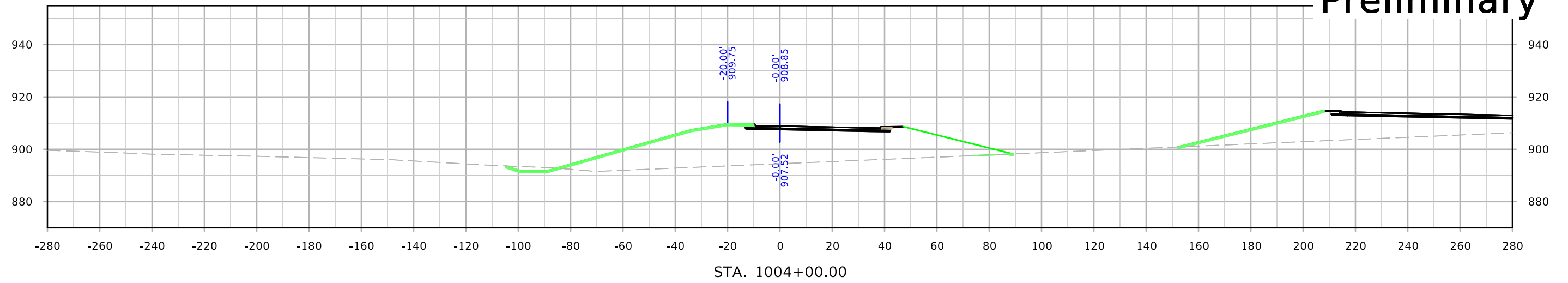

I-80 Ramp A Preliminary

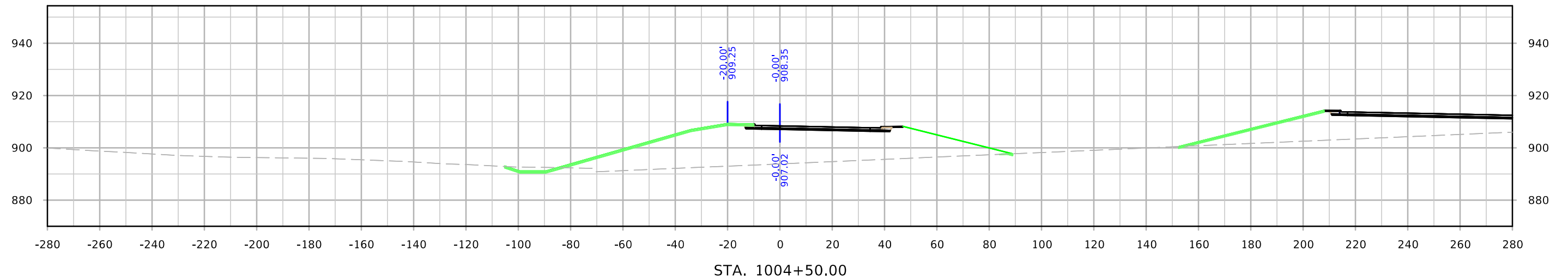
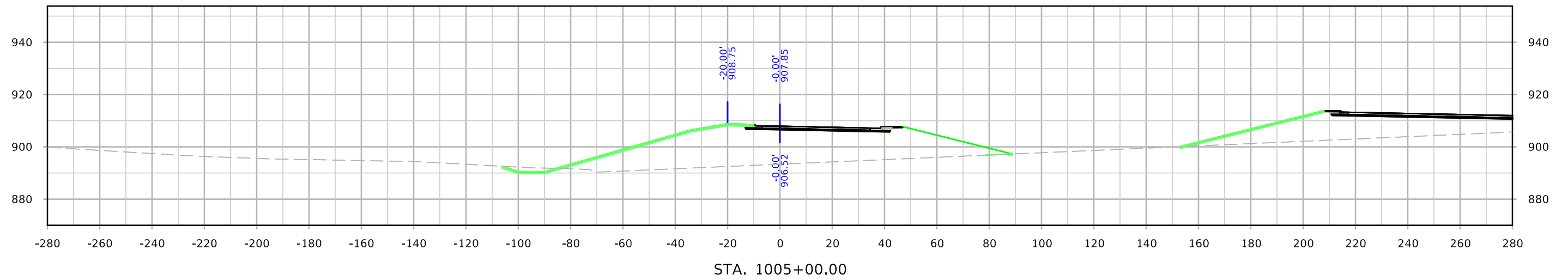
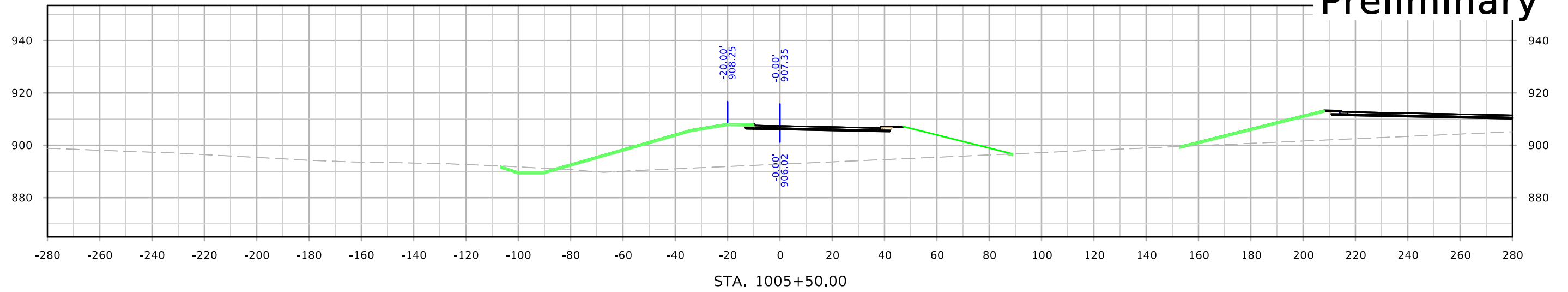

I-80 Ramp A Preliminary

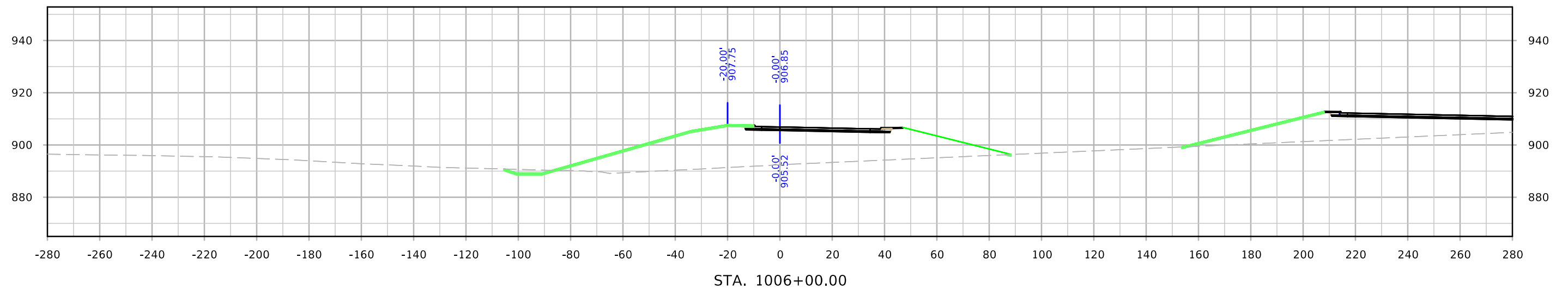
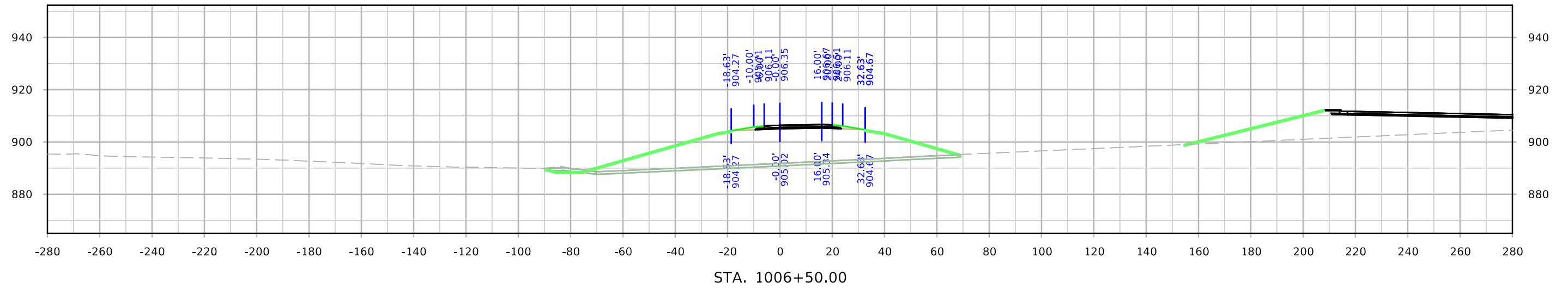
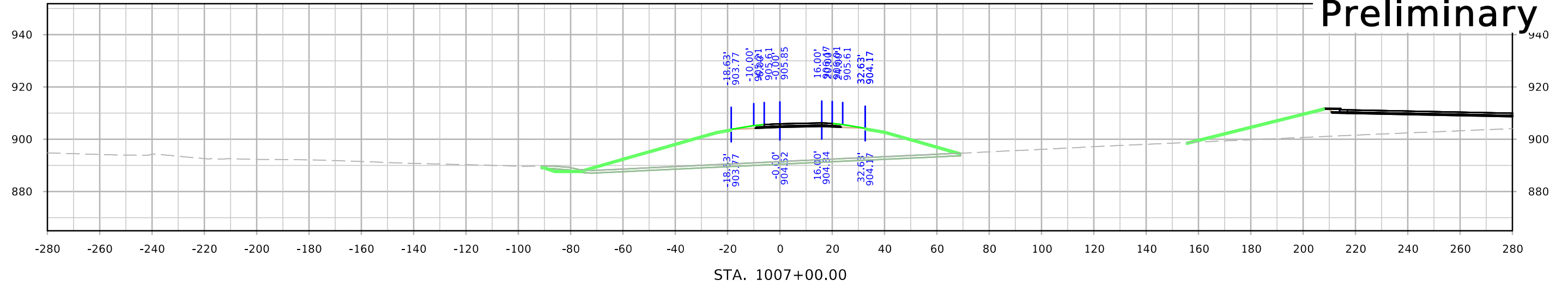

I-80 Ramp A Preliminary

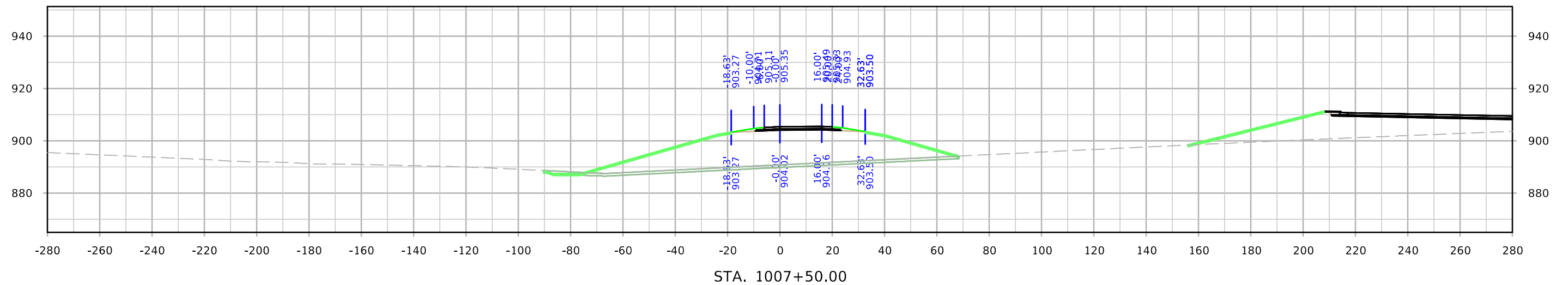
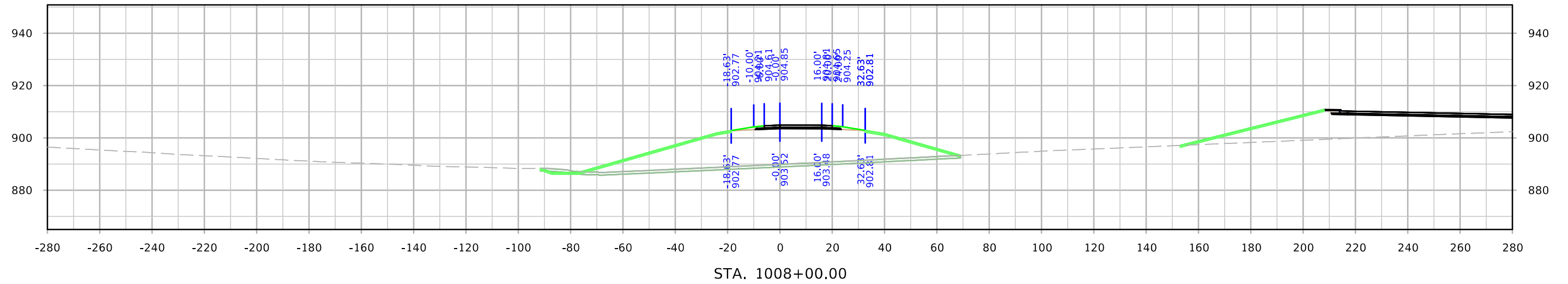
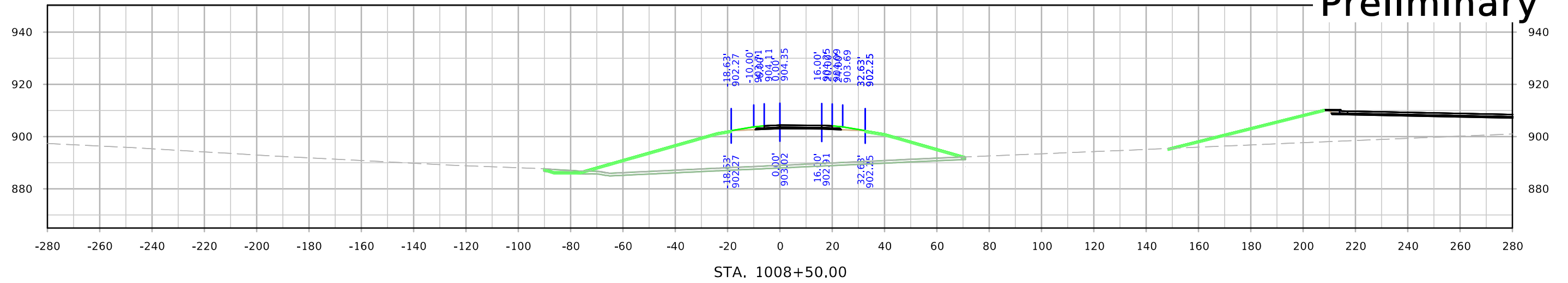

I-80 Ramp A Preliminary

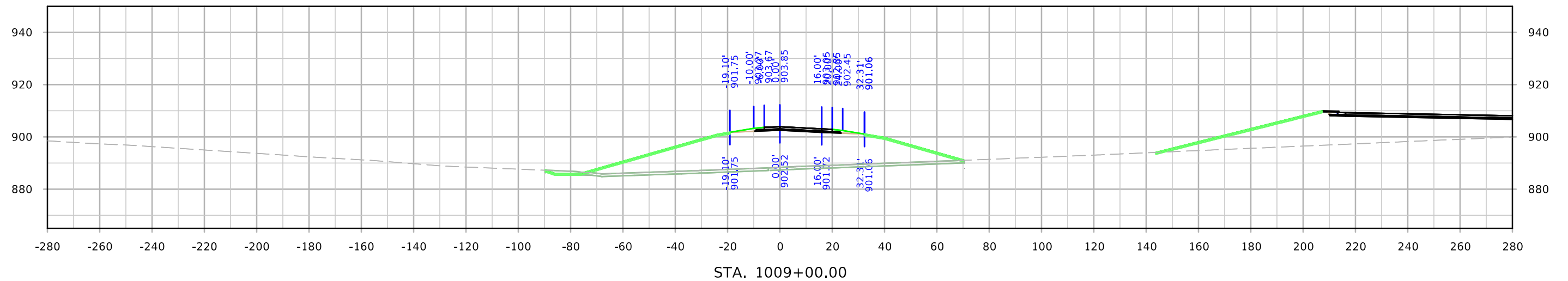
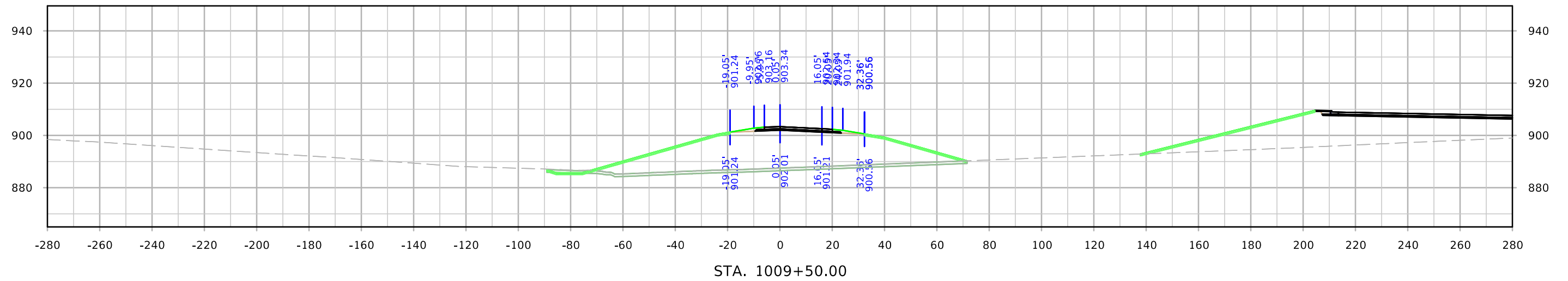
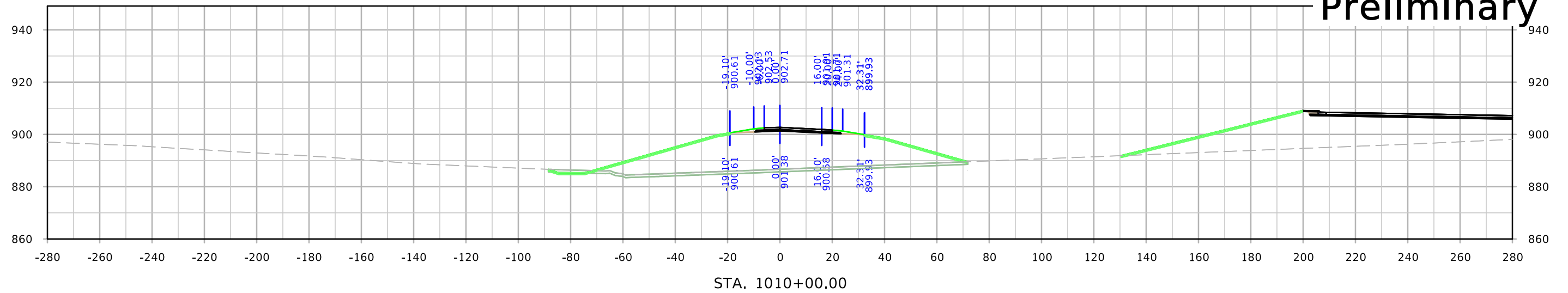

I-80 Ramp A Preliminary

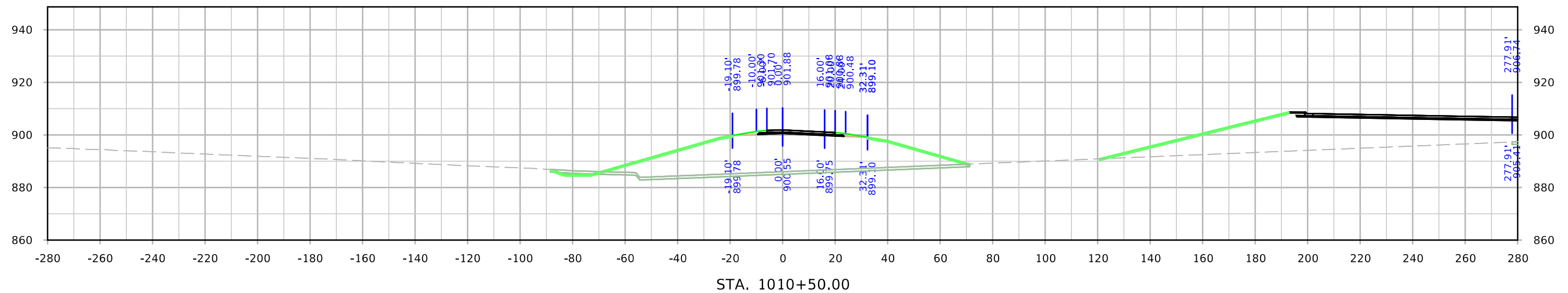
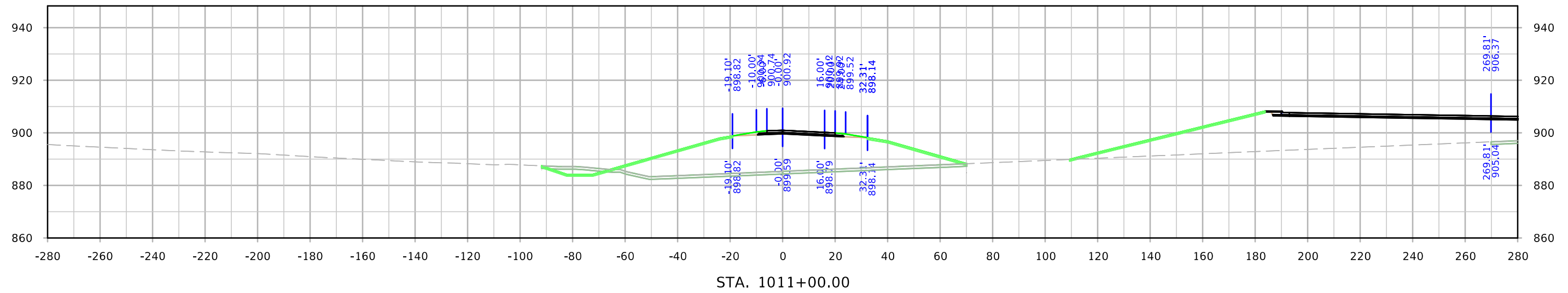
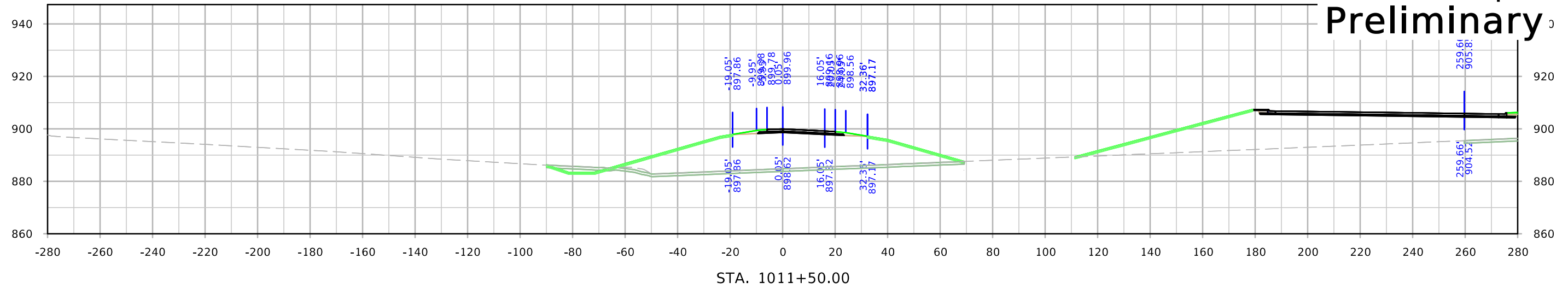

I-80 Ramp A Preliminary

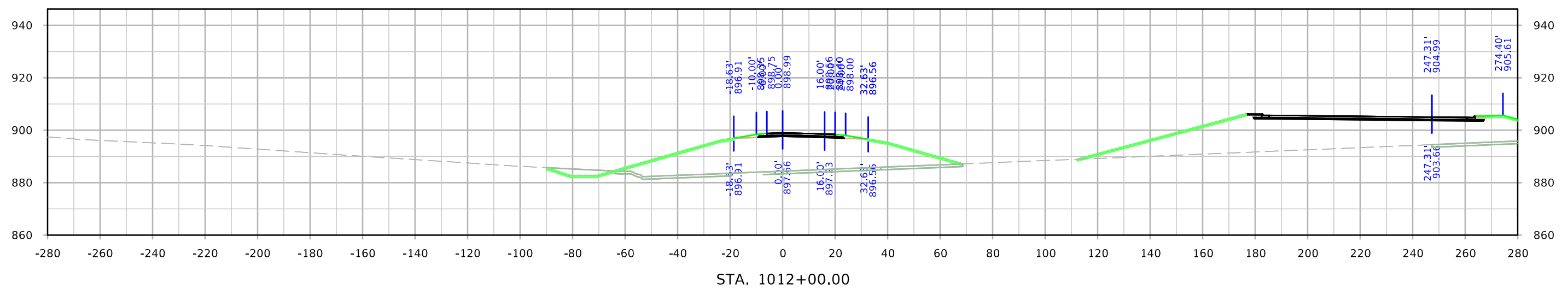
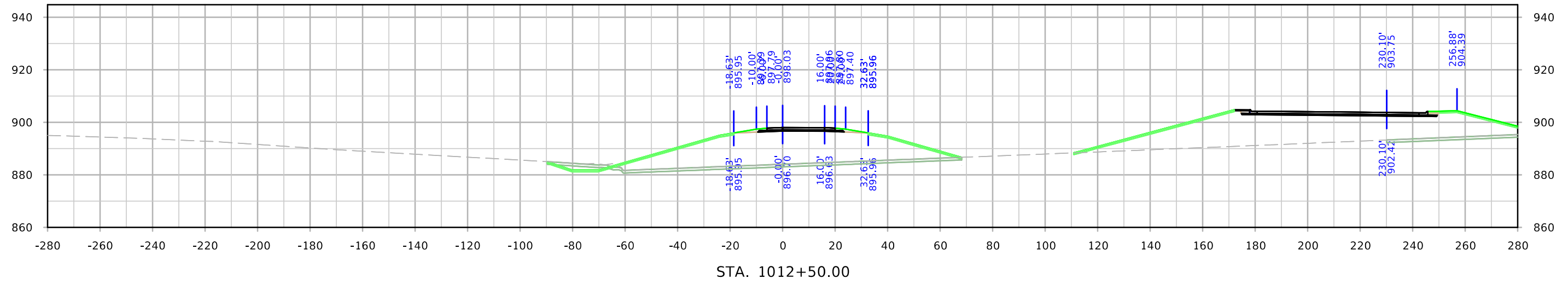
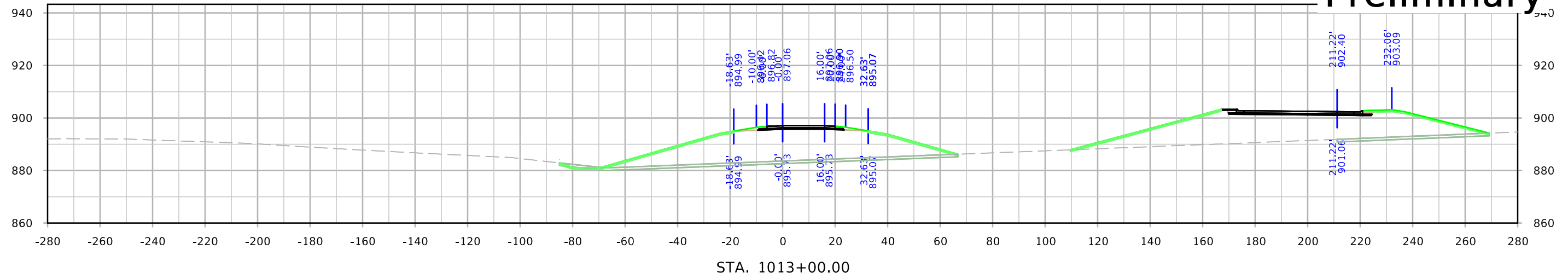

I-80 Ramp A Preliminary

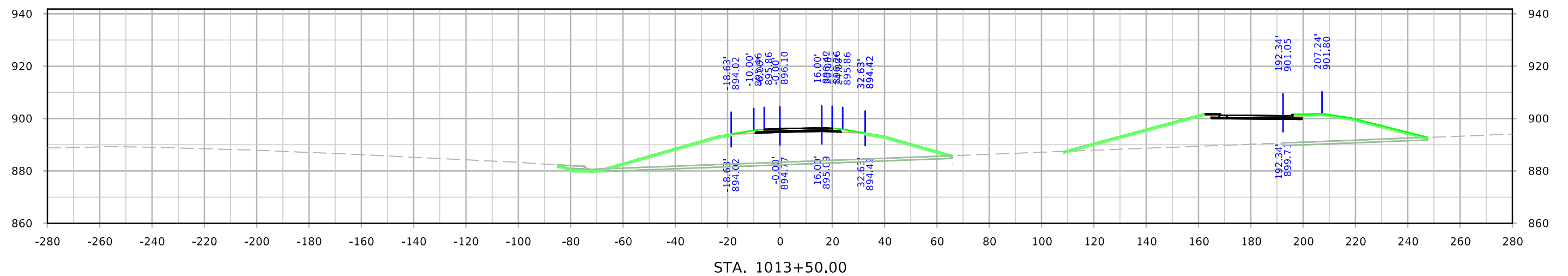
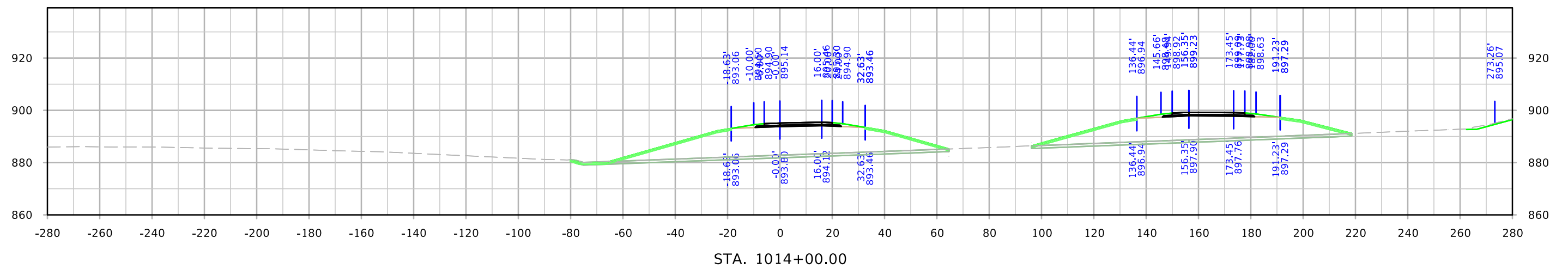
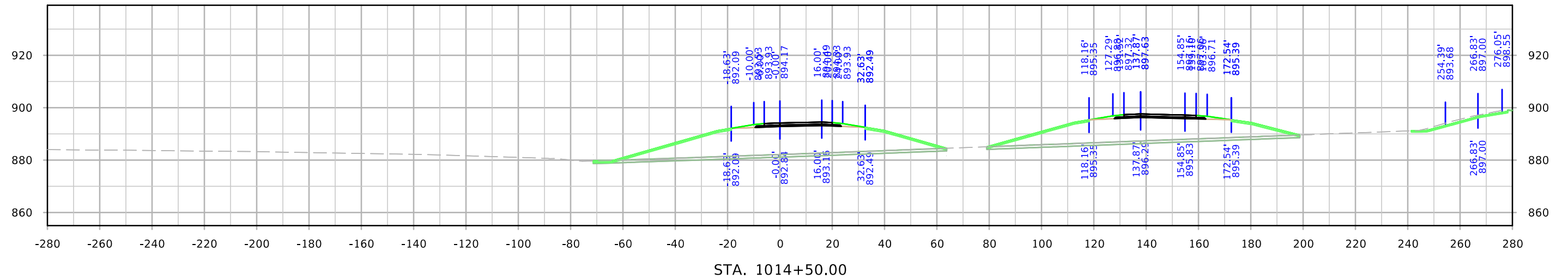

I-80 Ramp A Preliminary

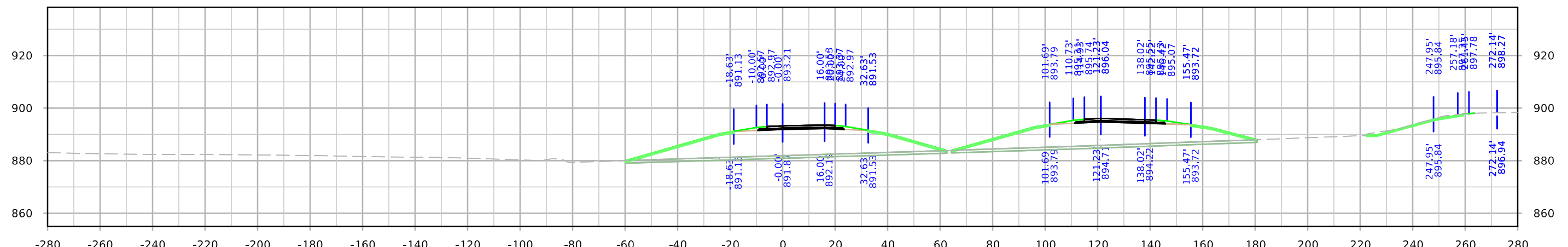
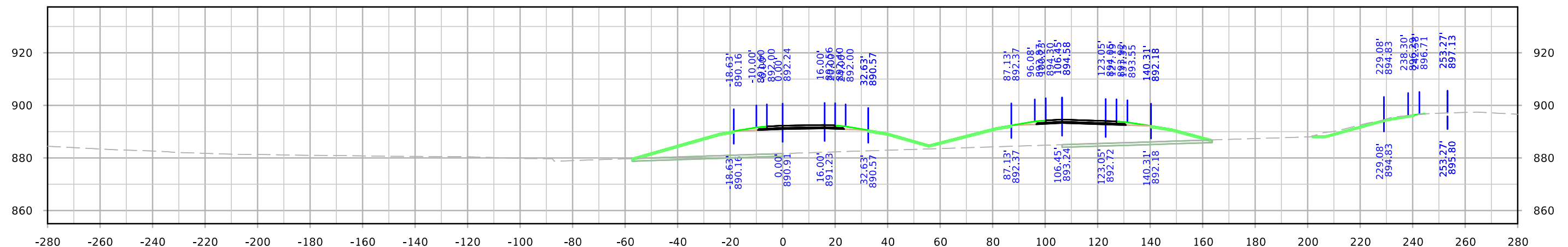
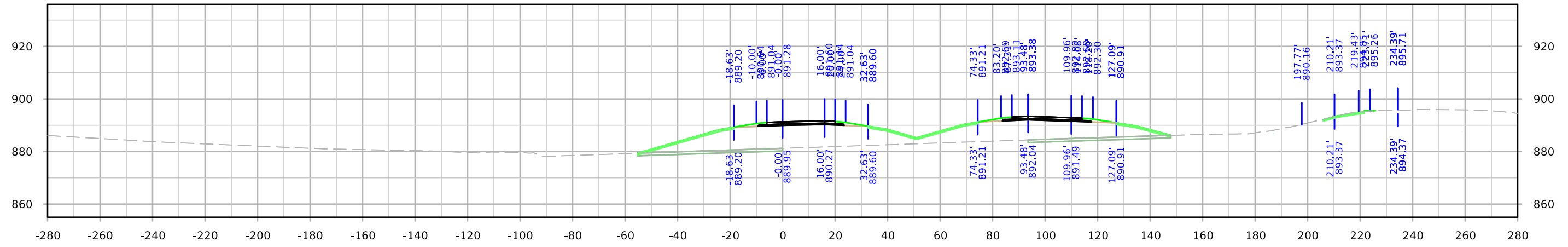

I-80 Ramp A Preliminary

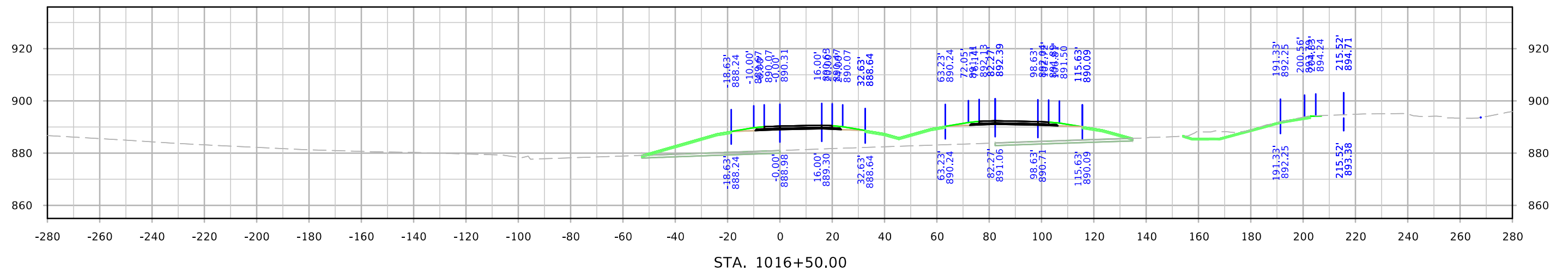
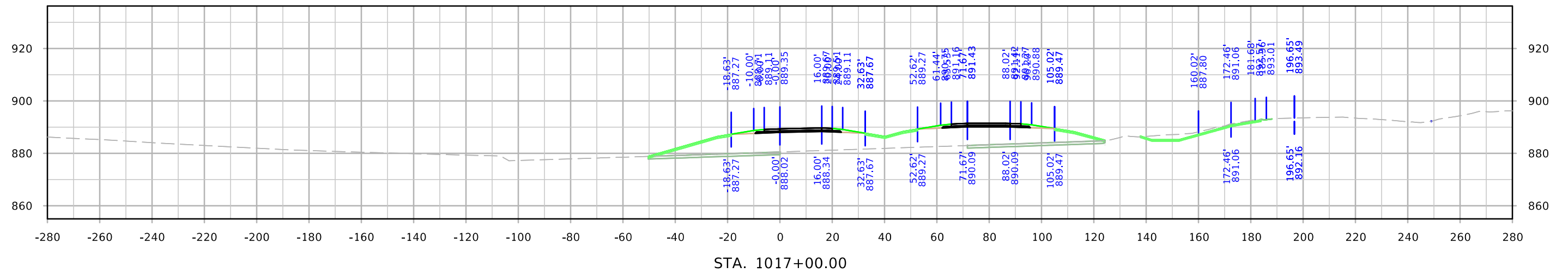
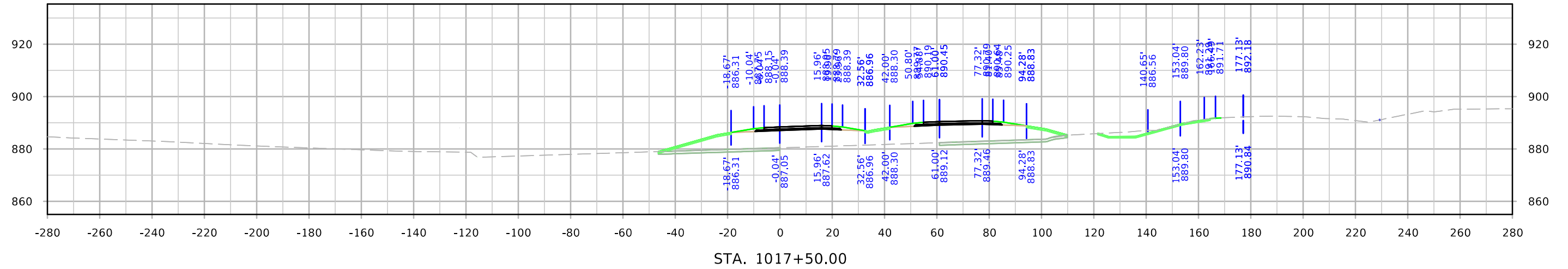

I-80 Ramp A Preliminary

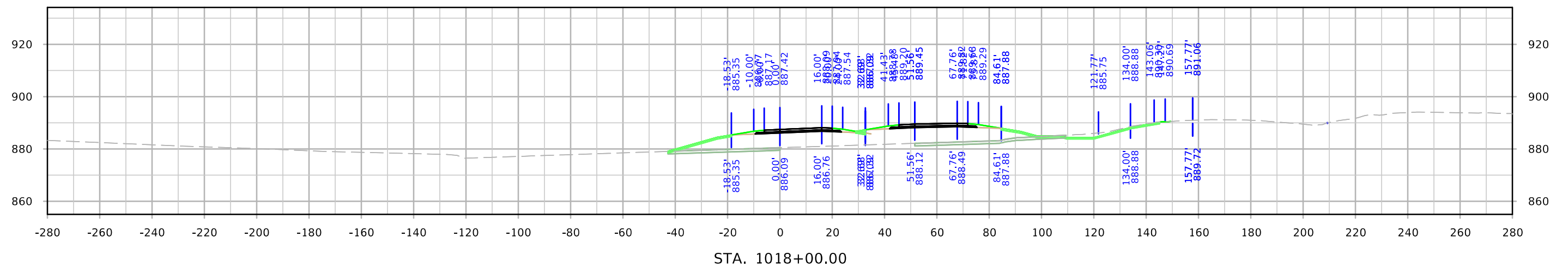
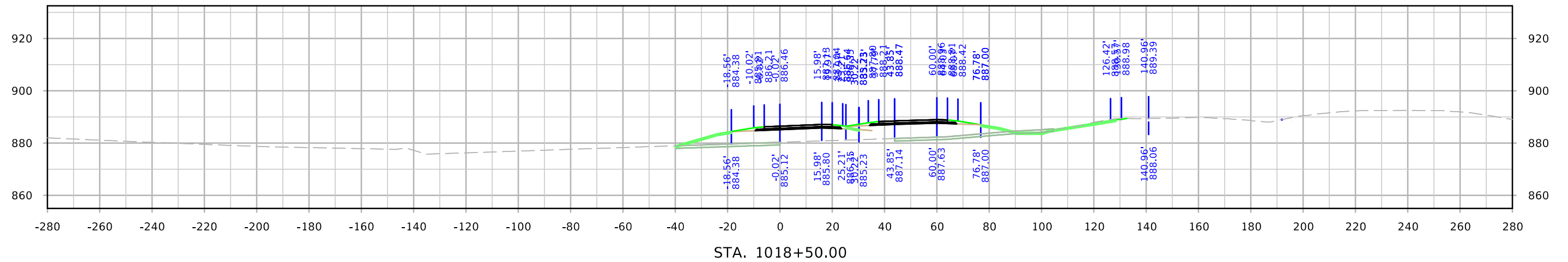
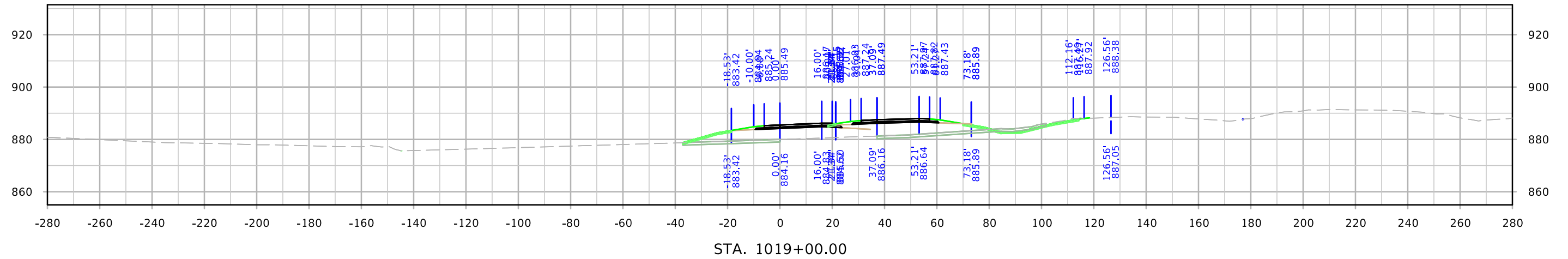

I-80 Ramp A Preliminary

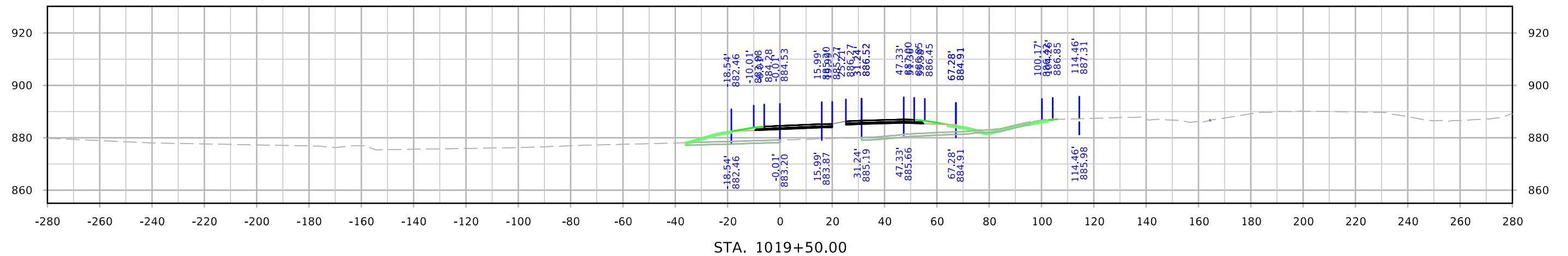
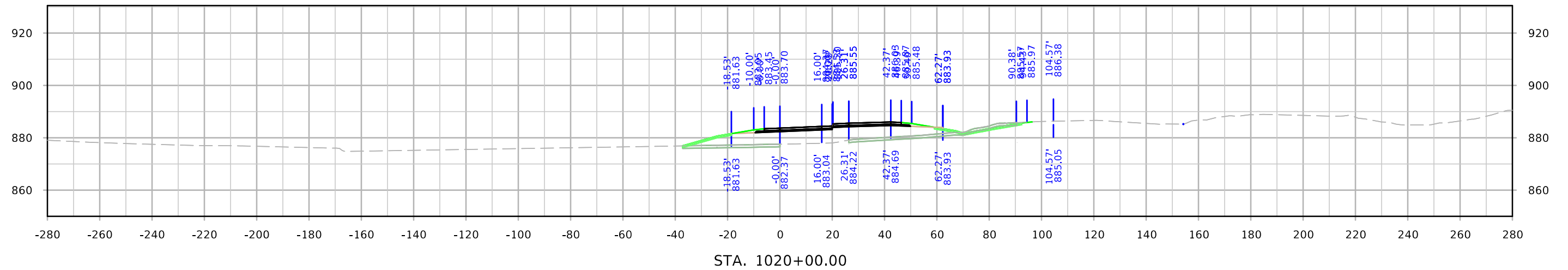
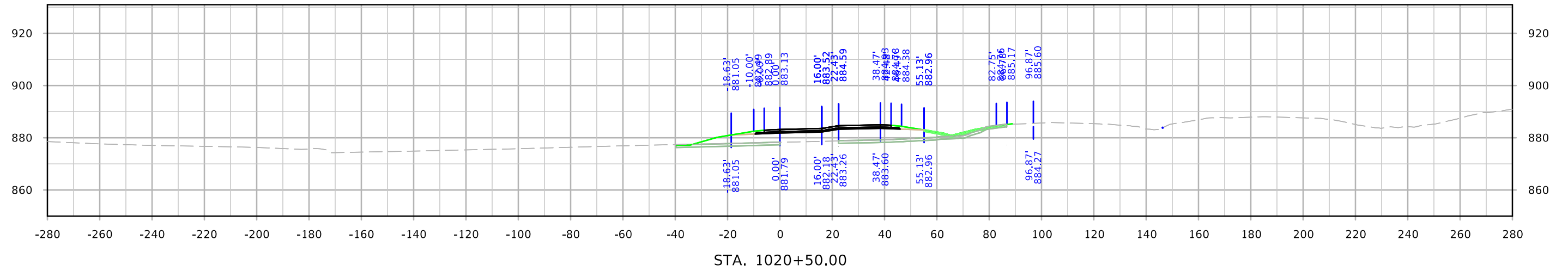

I-80 Ramp A Preliminary

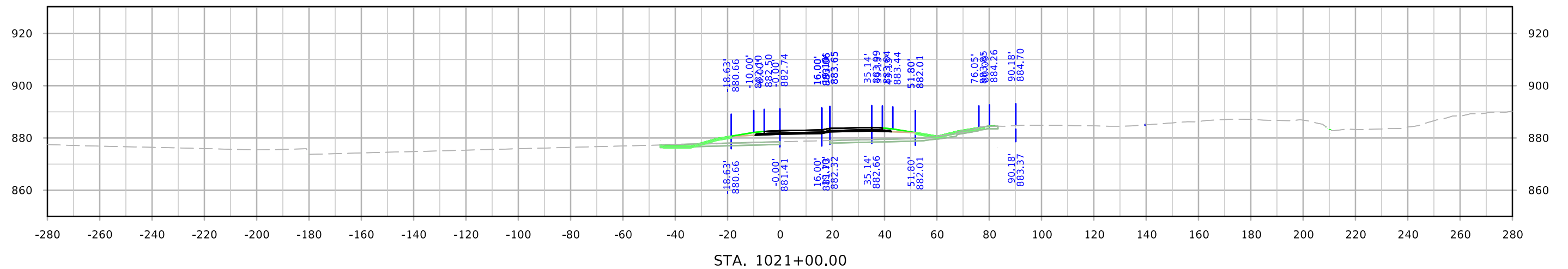
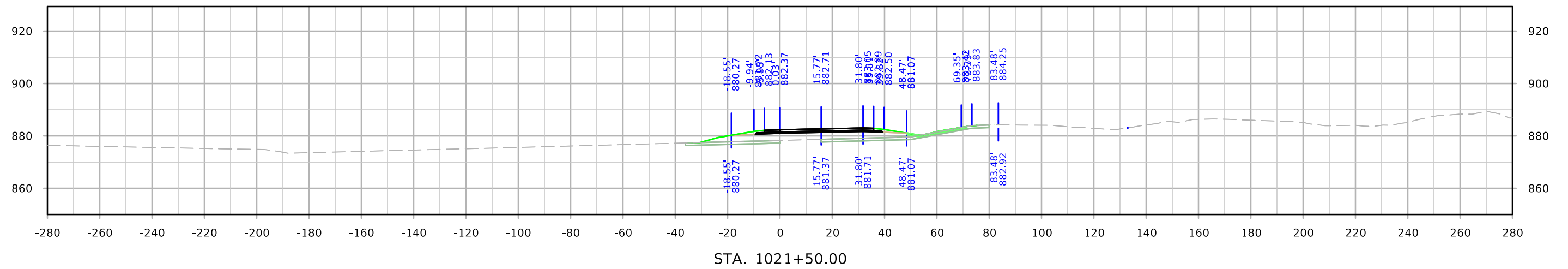
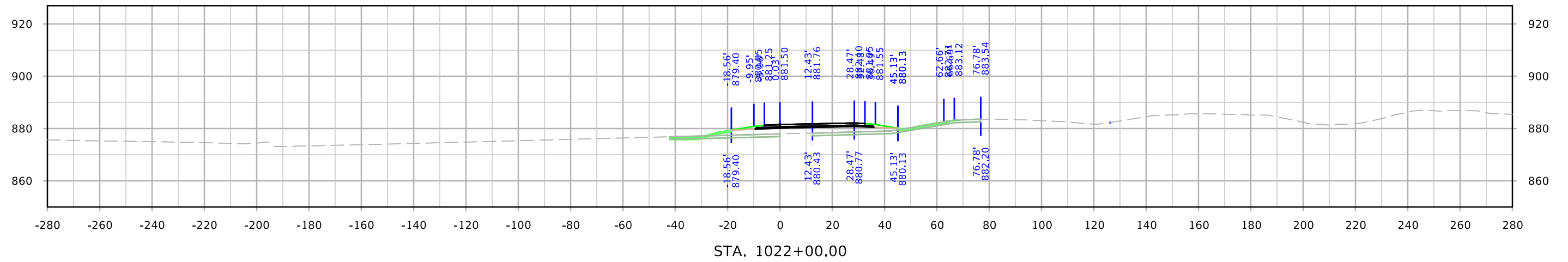

I-80 Ramp A Preliminary

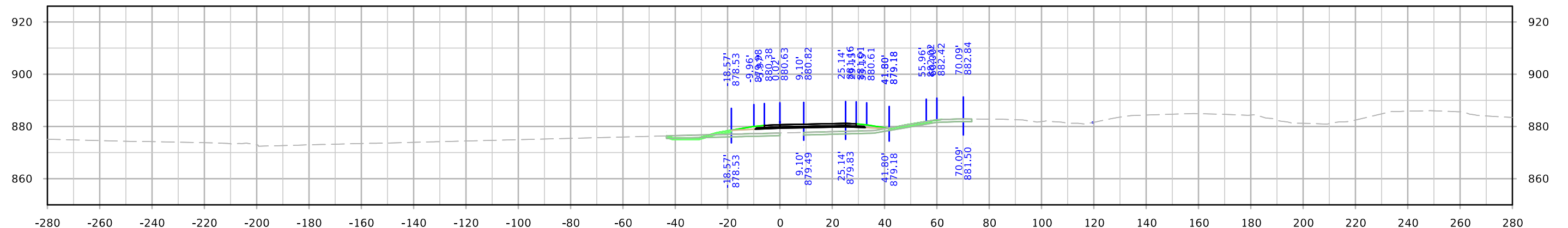
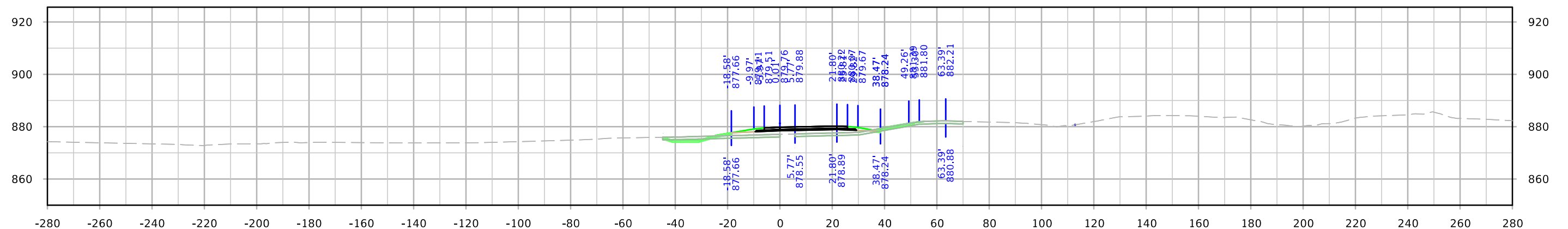
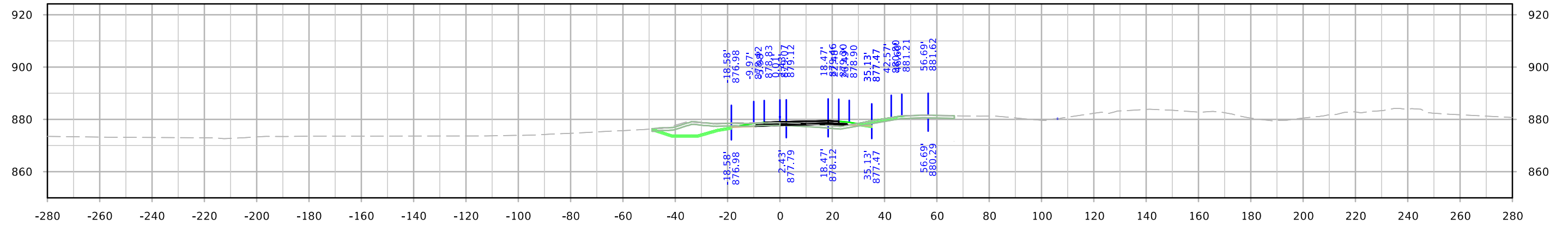

I-80 Ramp A Preliminary

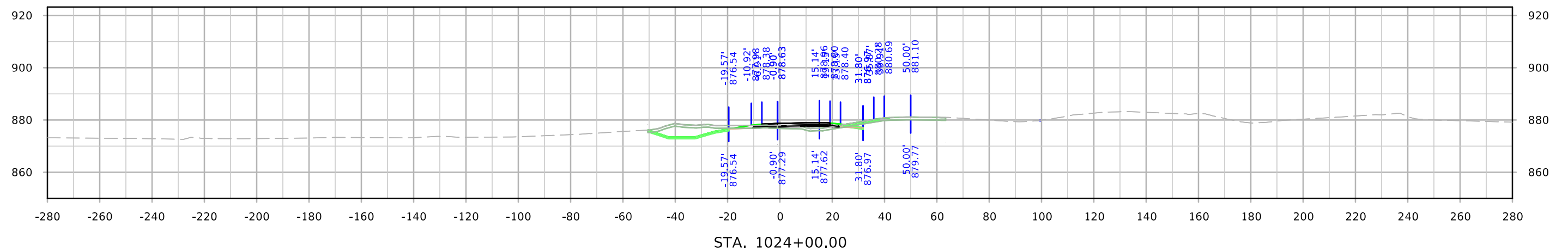
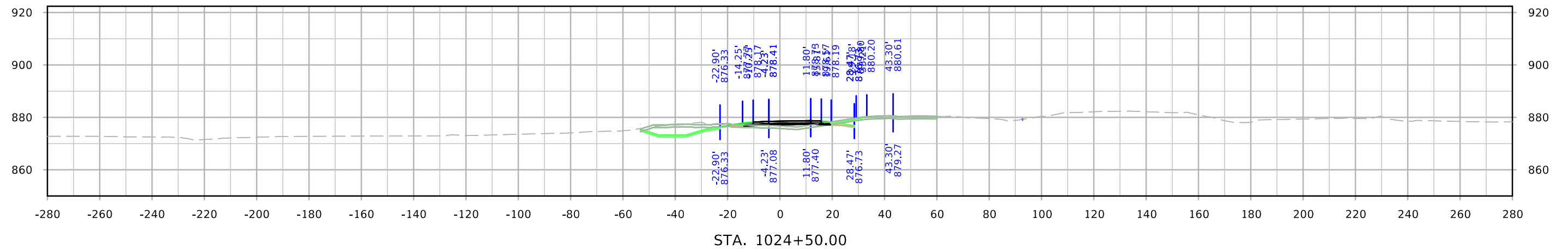
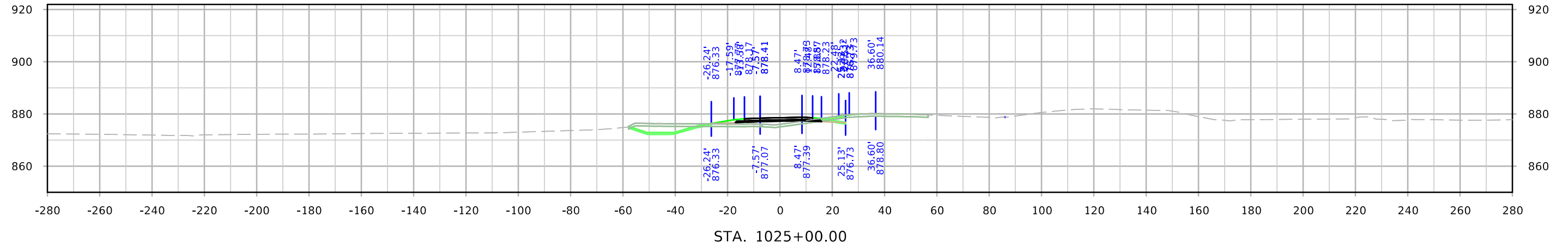

I-80 Ramp A Preliminary

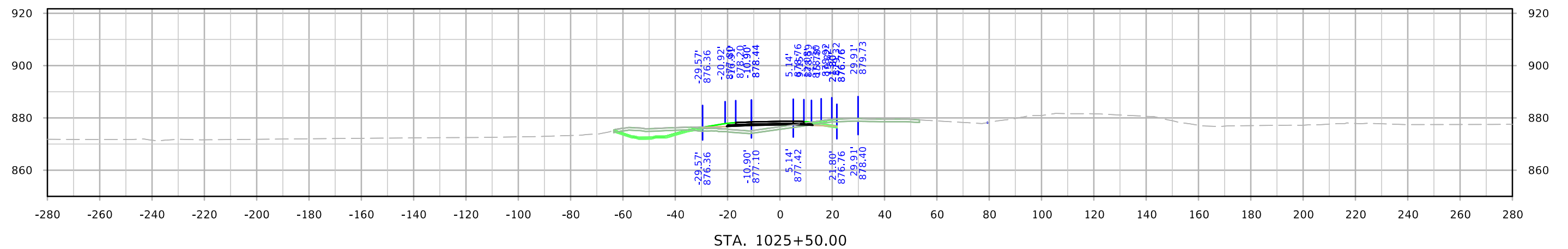
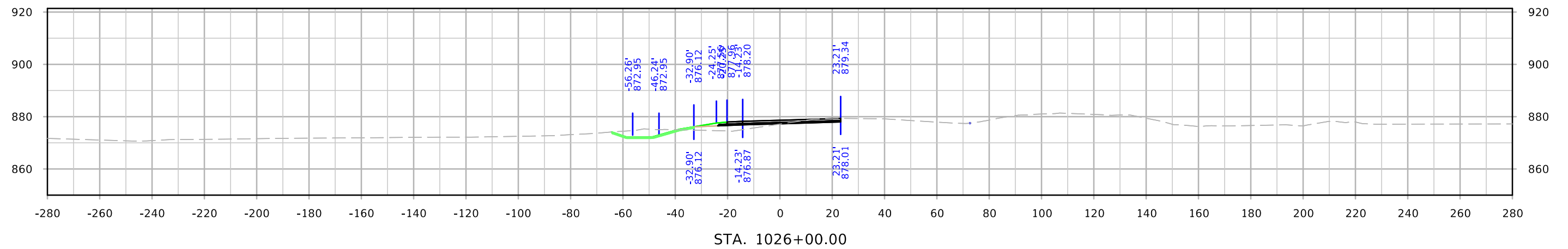
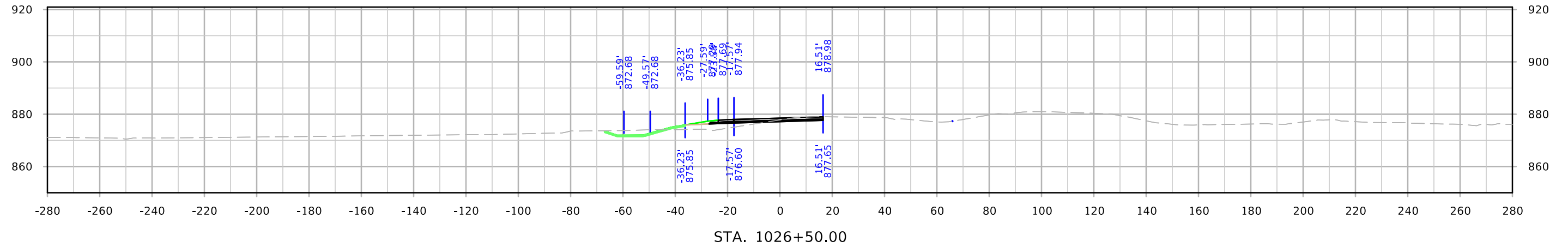

I-80 Ramp A Preliminary

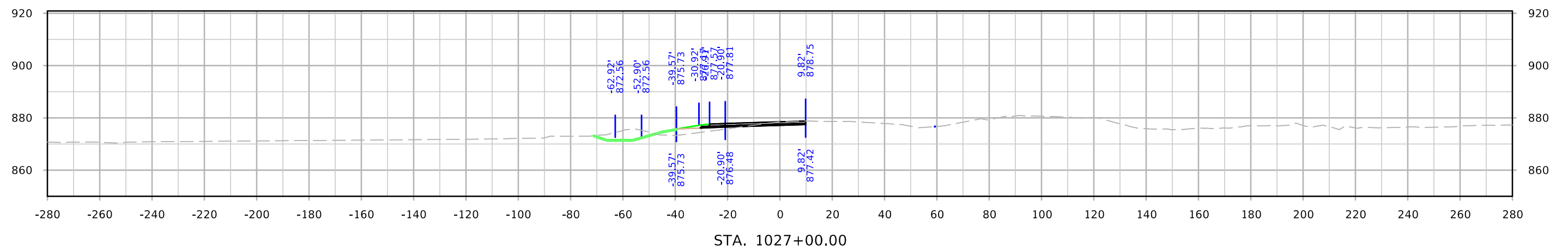
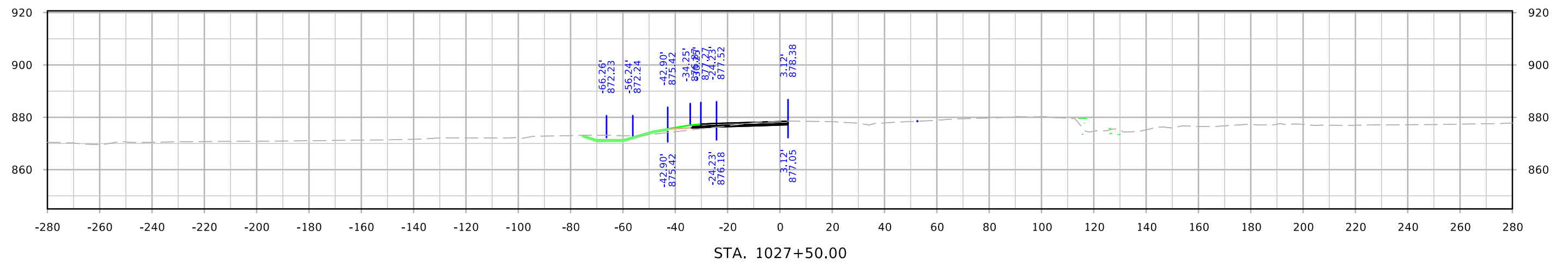
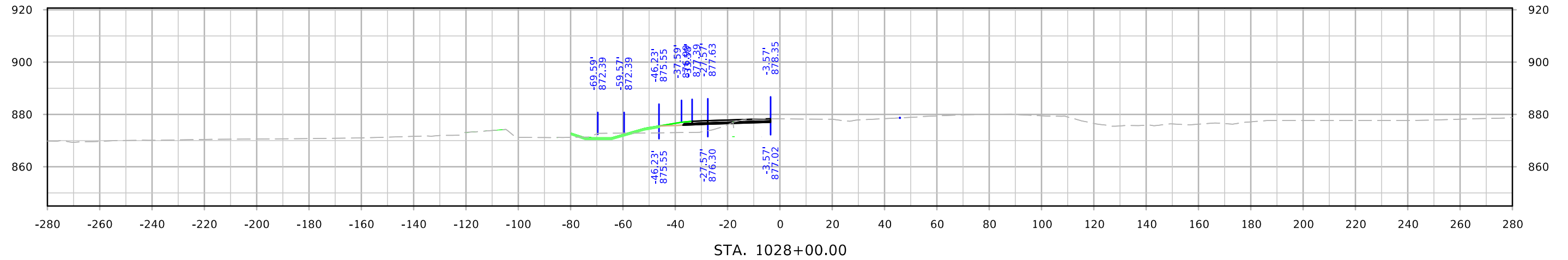

I-80 Ramp A Preliminary

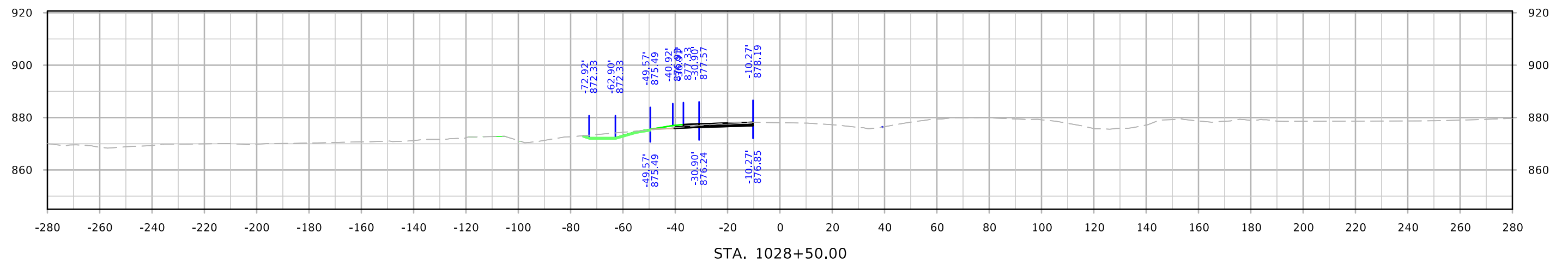
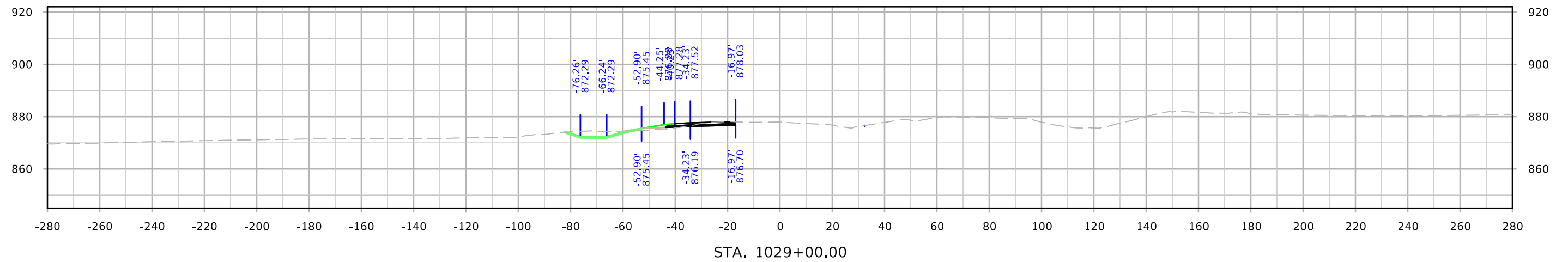
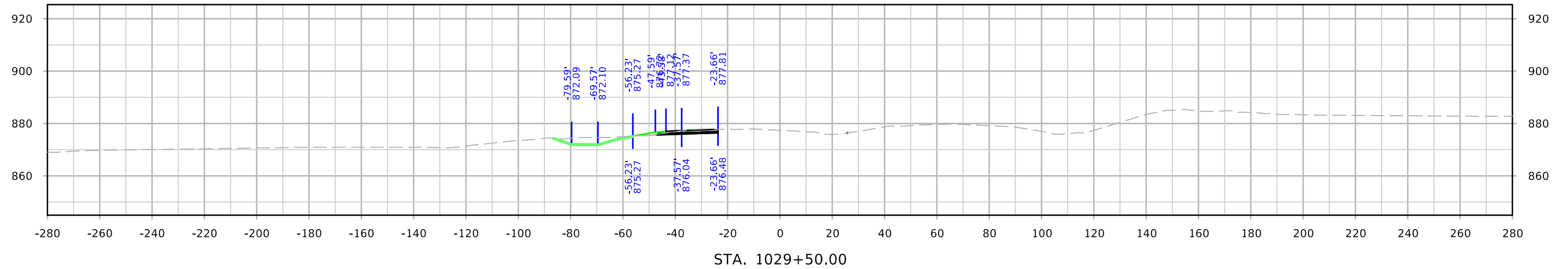

I-80 Ramp A Preliminary

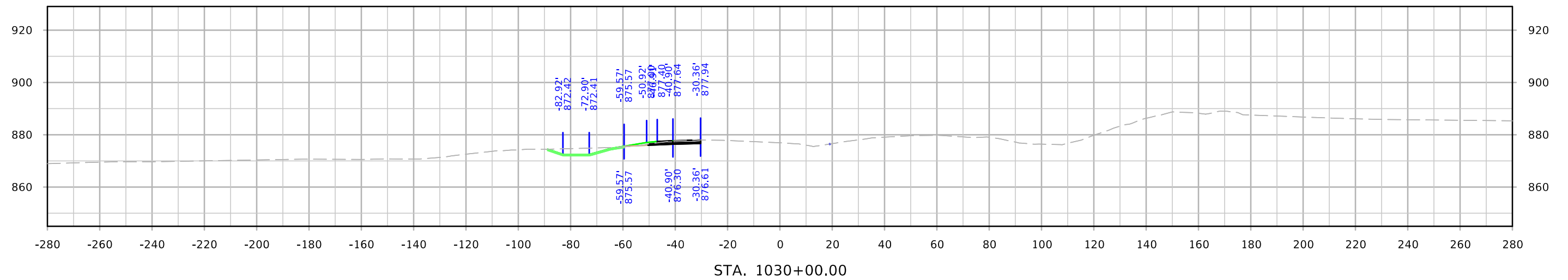

I-80 Ramp C Preliminary

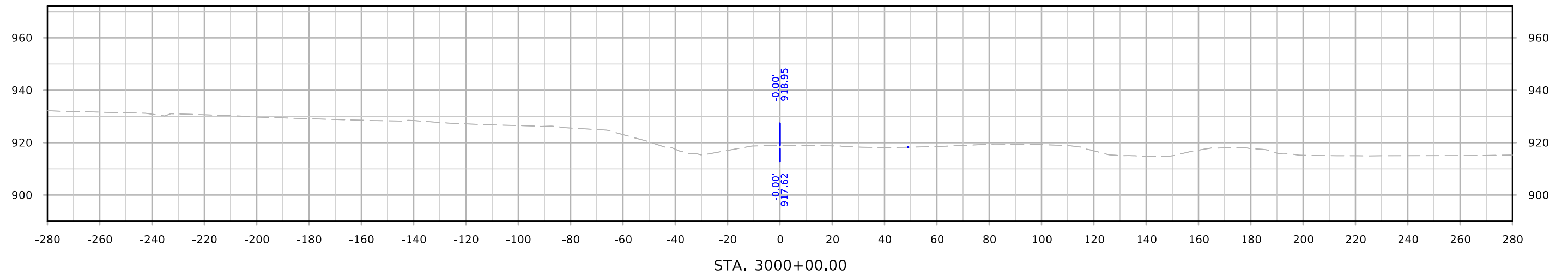
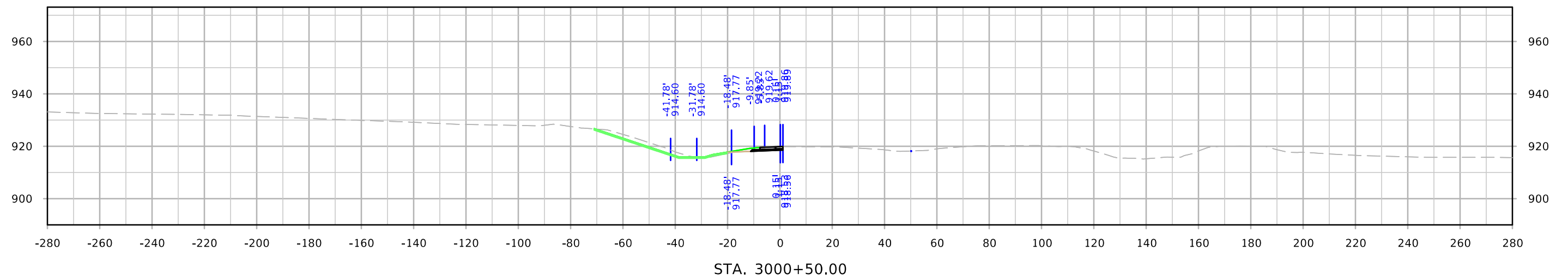
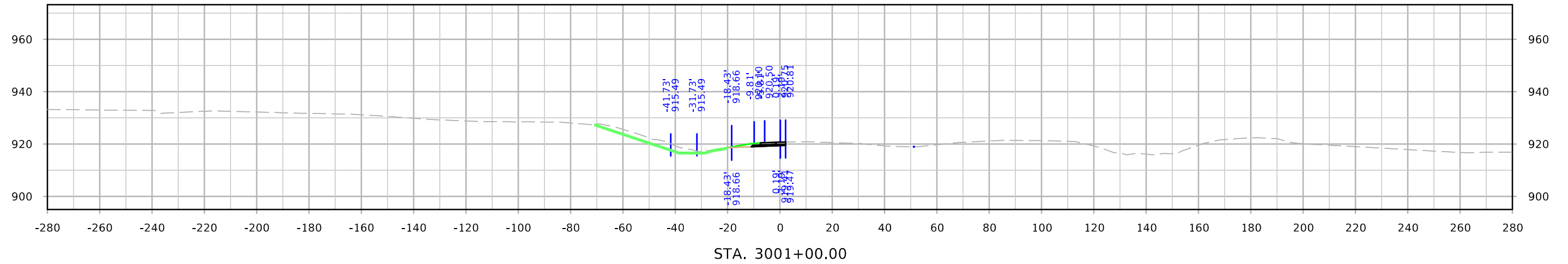

I-80 Ramp C Preliminary

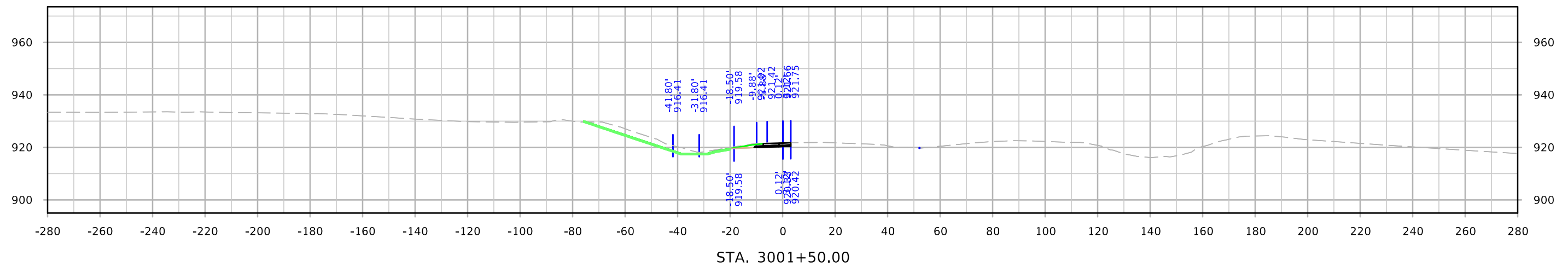
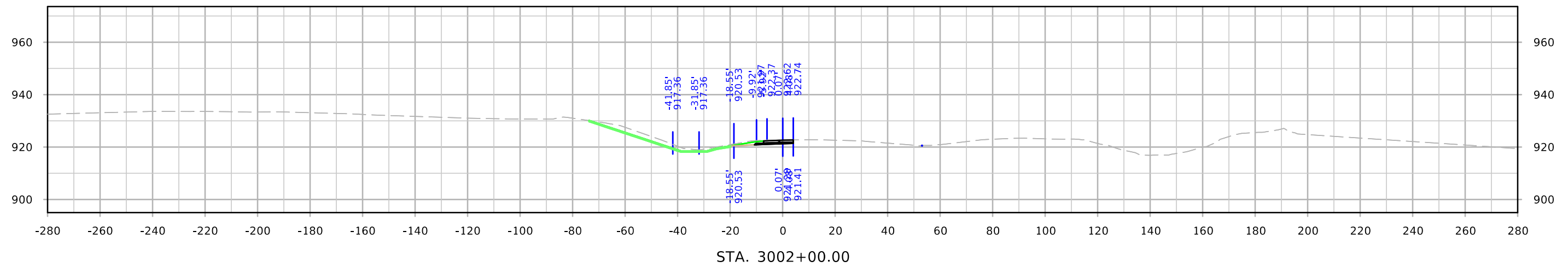
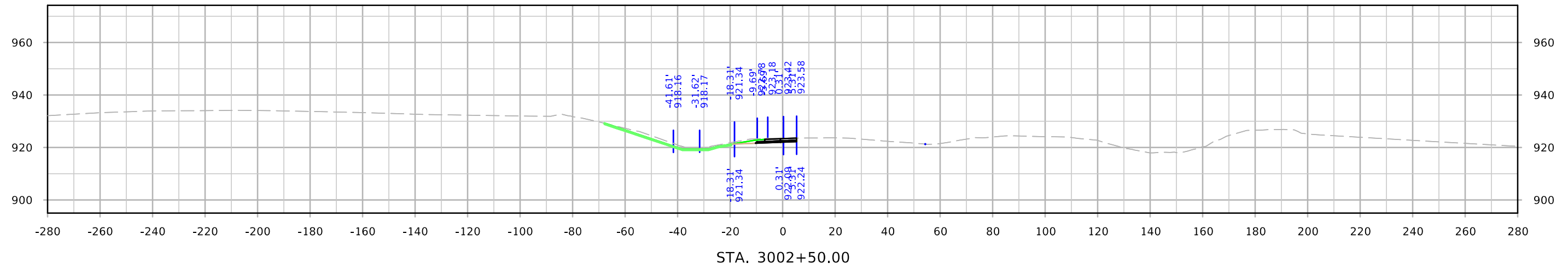

I-80 Ramp C Preliminary

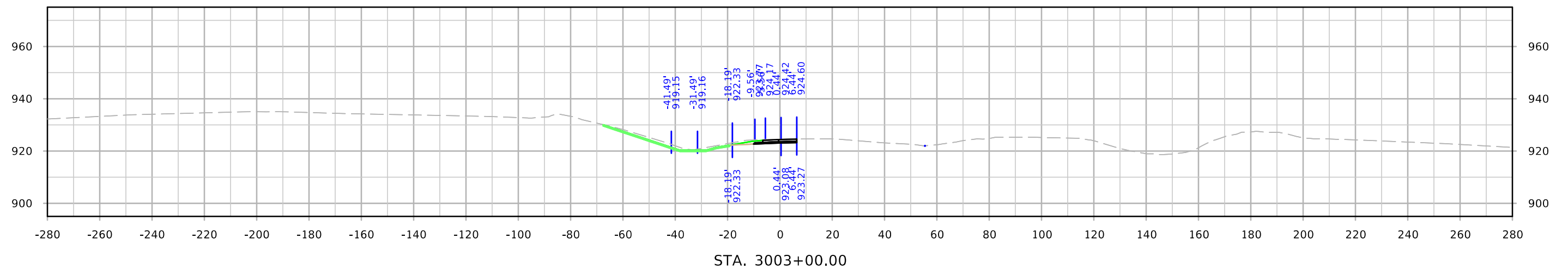
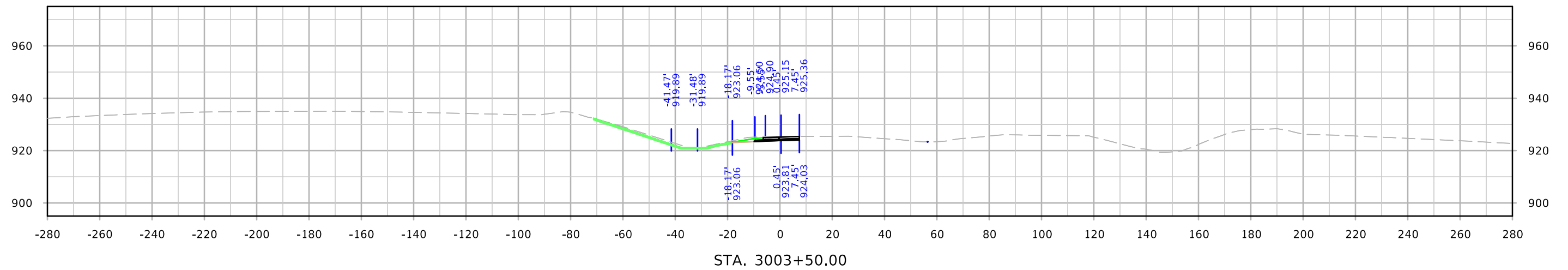
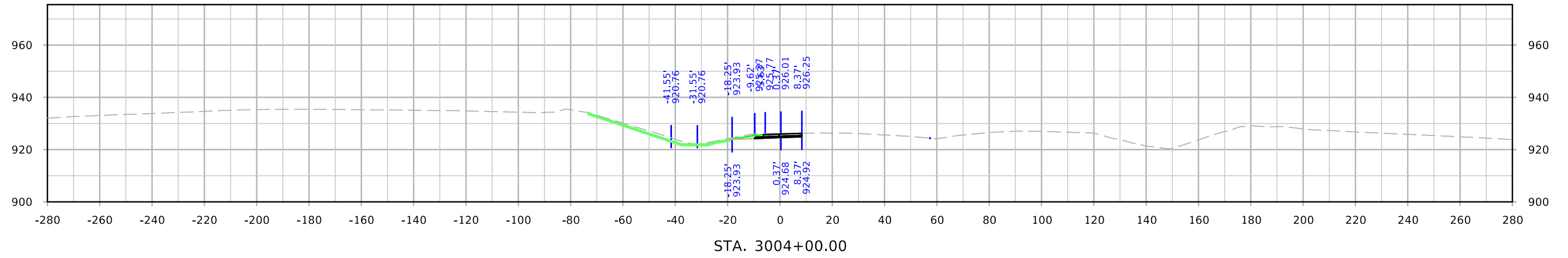

I-80 Ramp C Preliminary

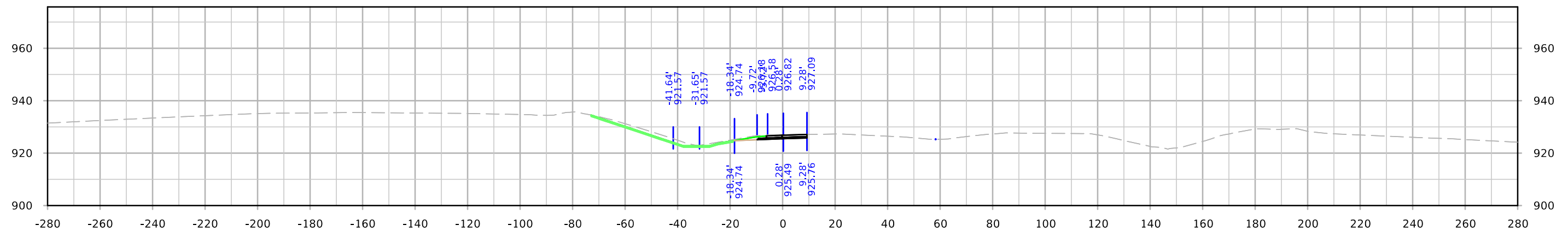
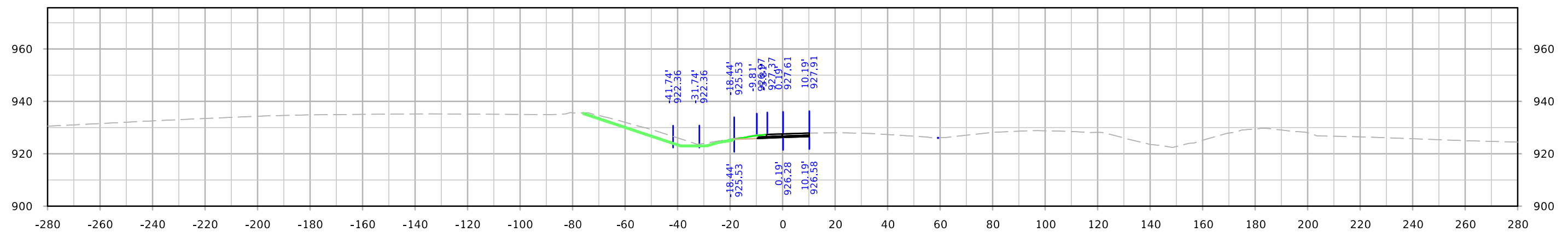
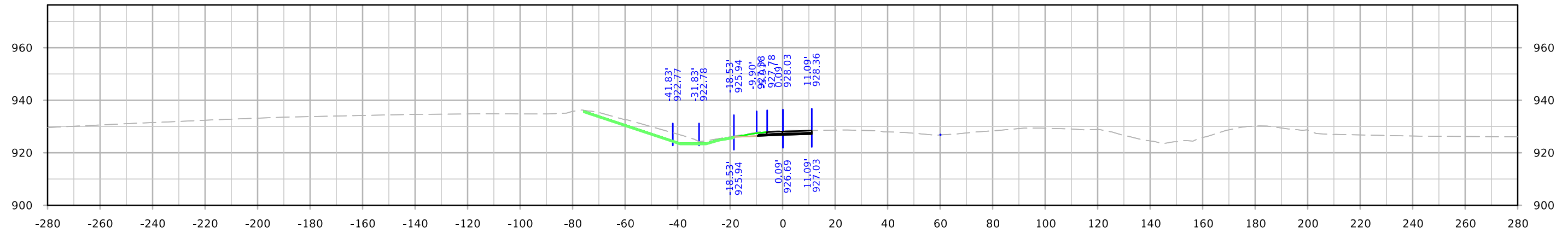

I-80 Ramp C Preliminary

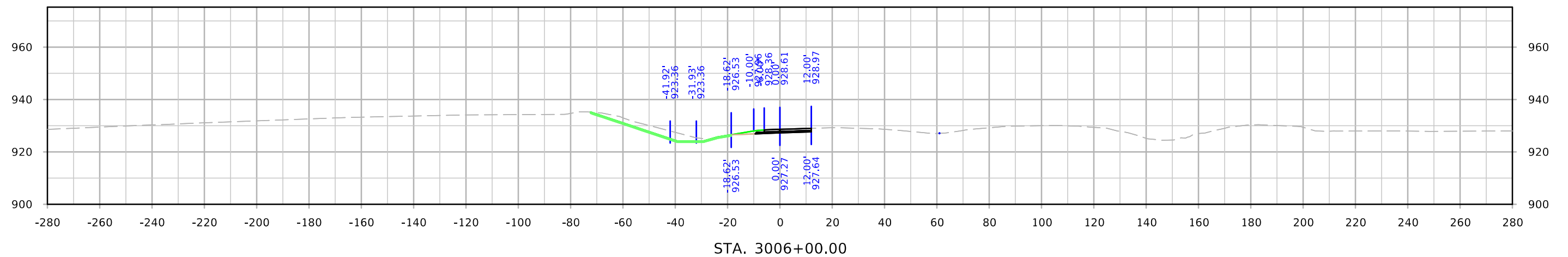
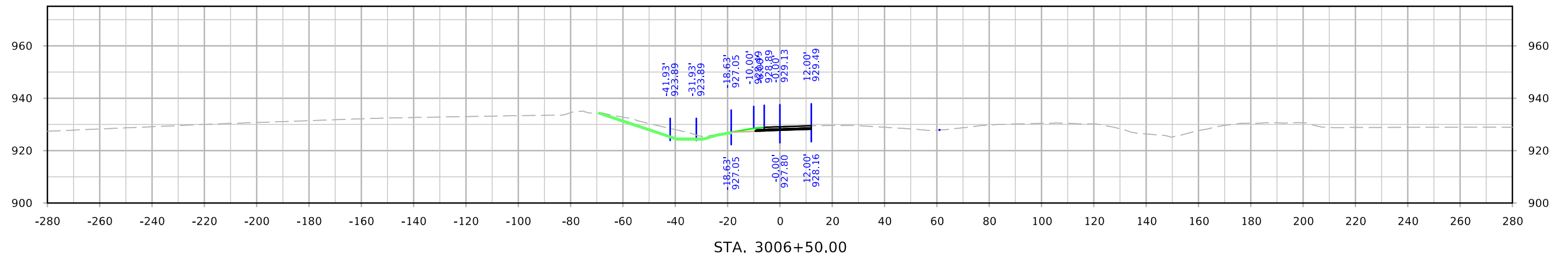
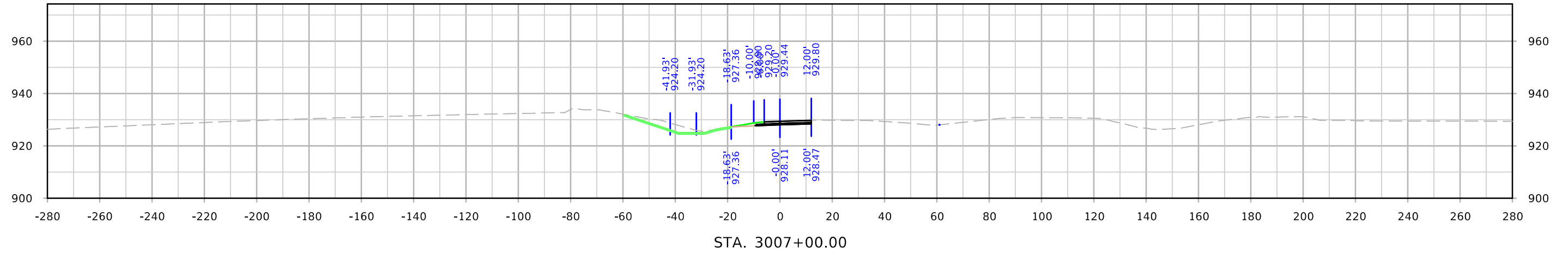

I-80 Ramp C Preliminary

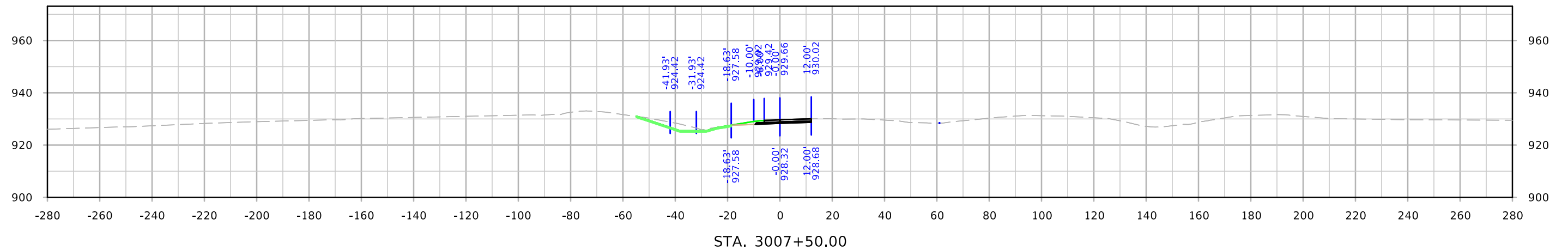
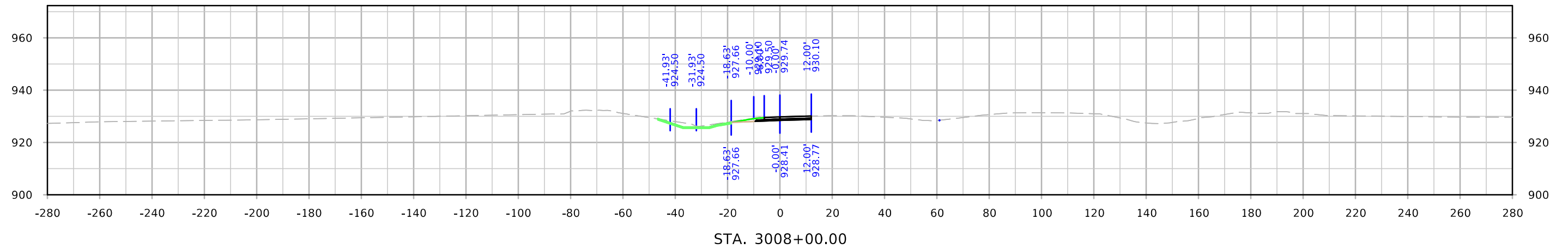
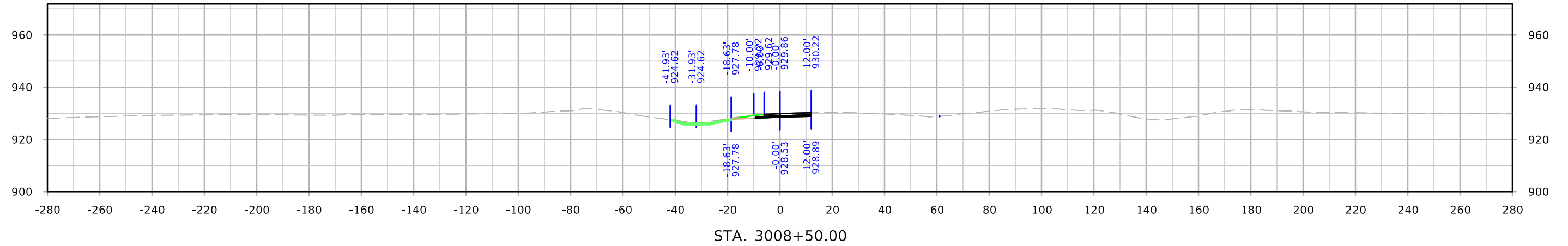

I-80 Ramp C Preliminary

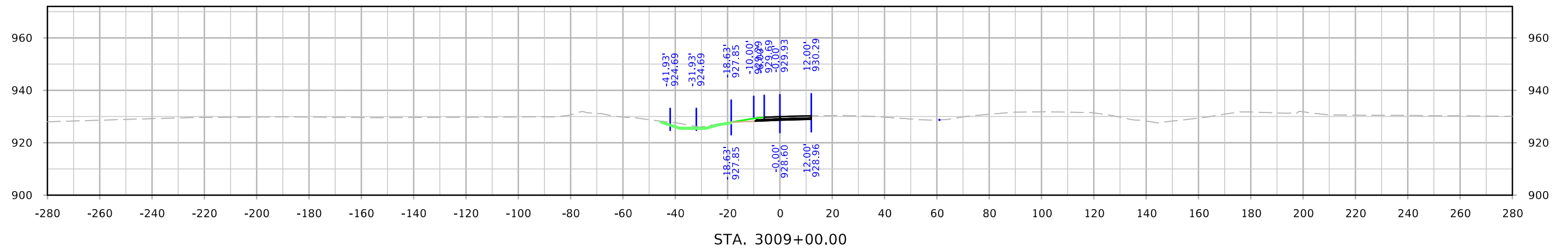
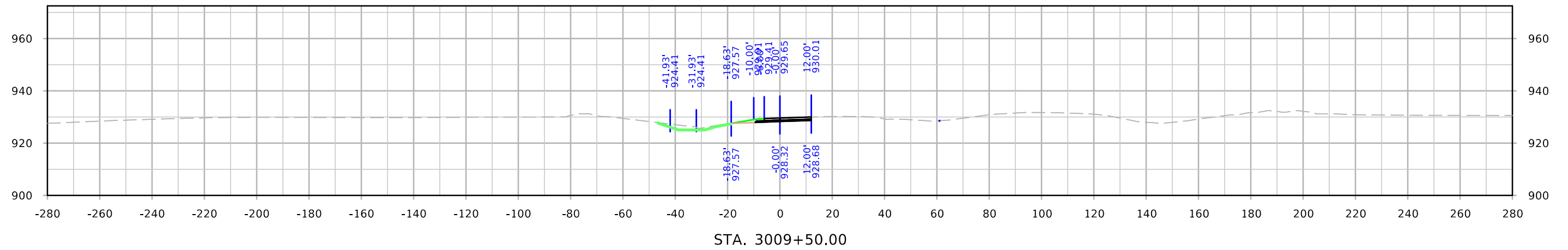
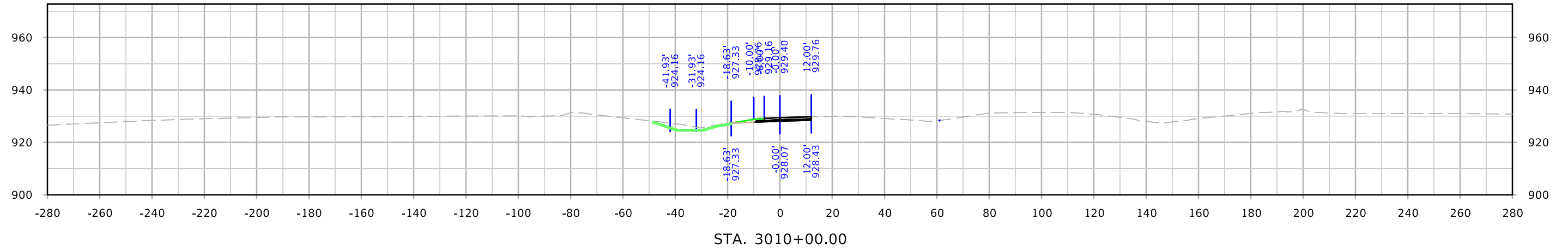

I-80 Ramp C Preliminary

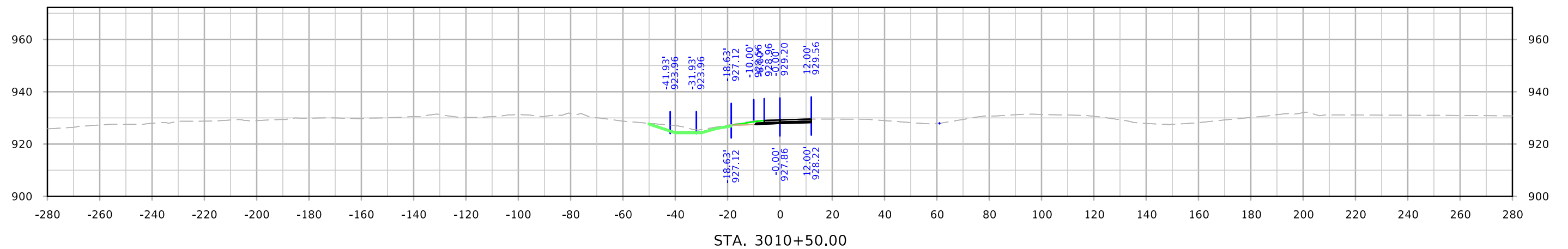
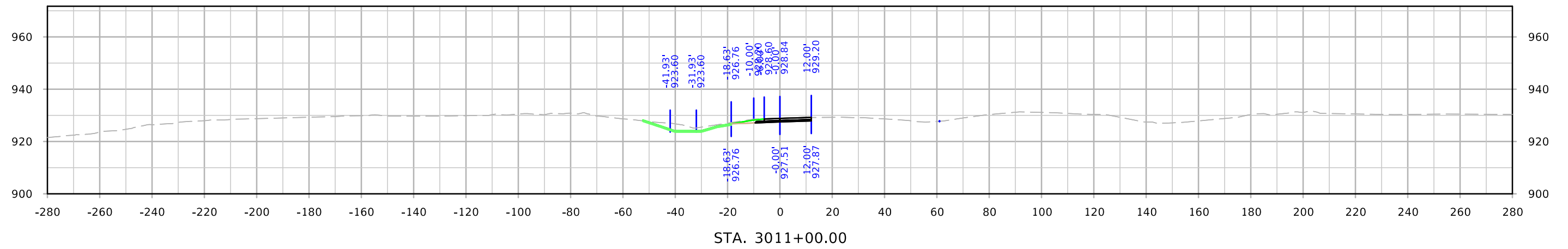
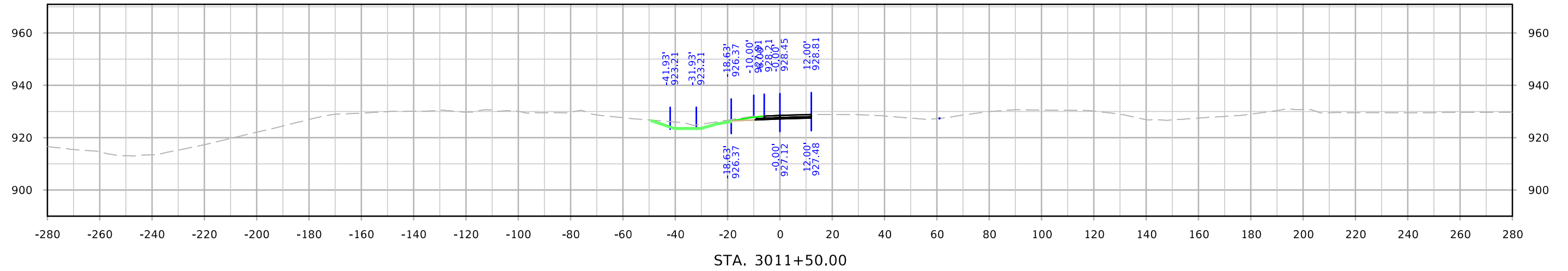

I-80 Ramp C Preliminary

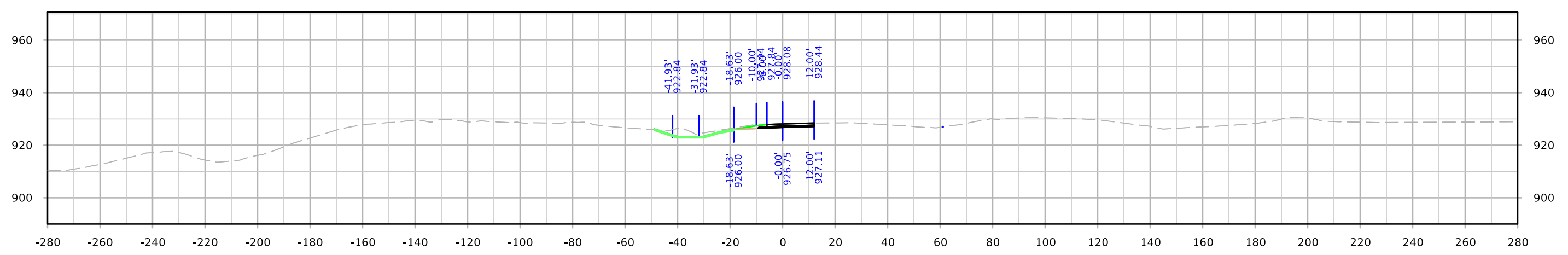
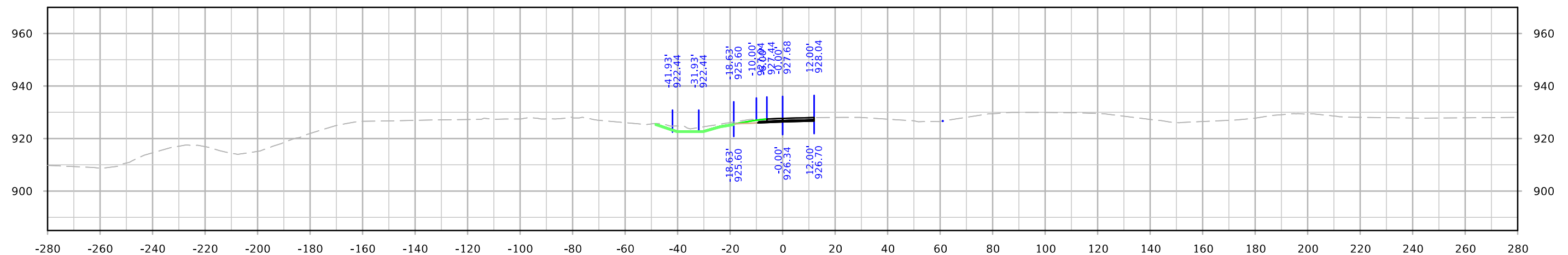
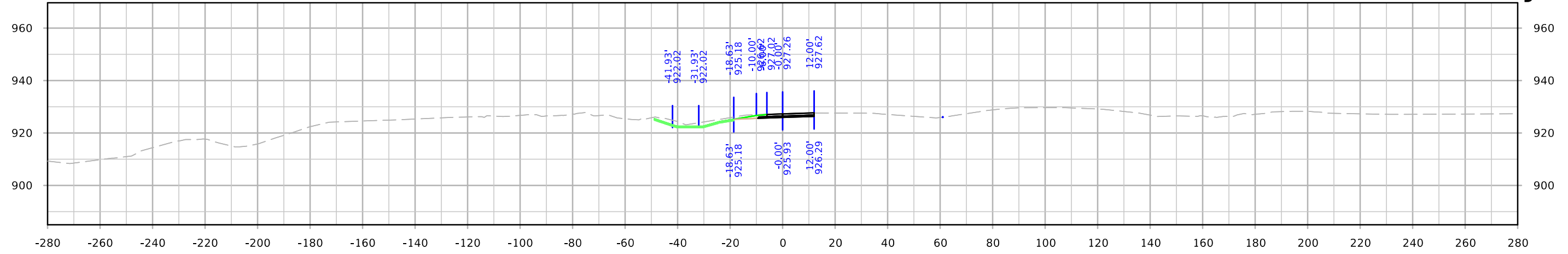

I-80 Ramp C Preliminary

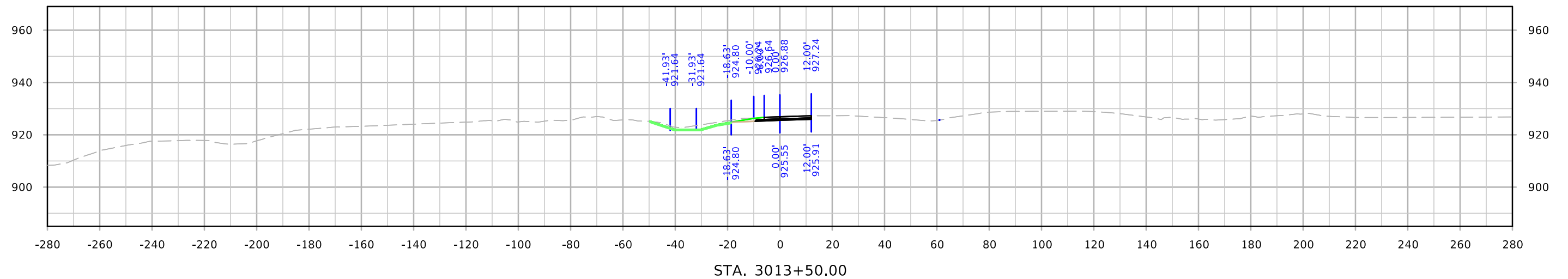
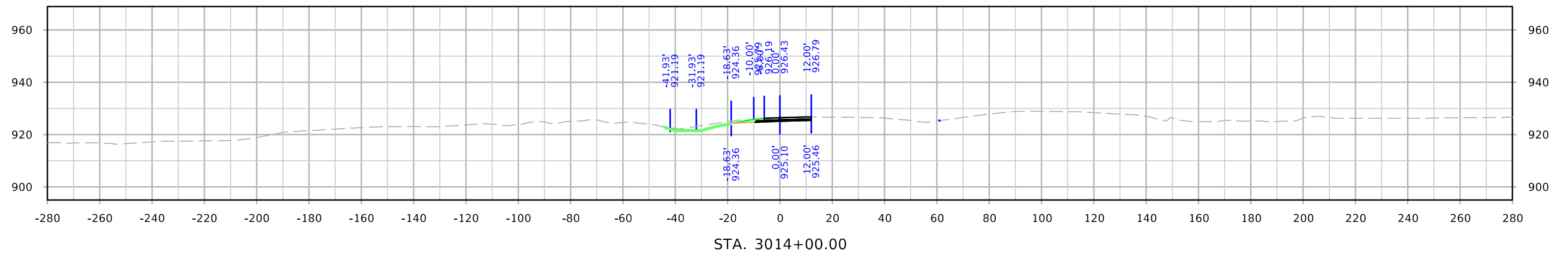
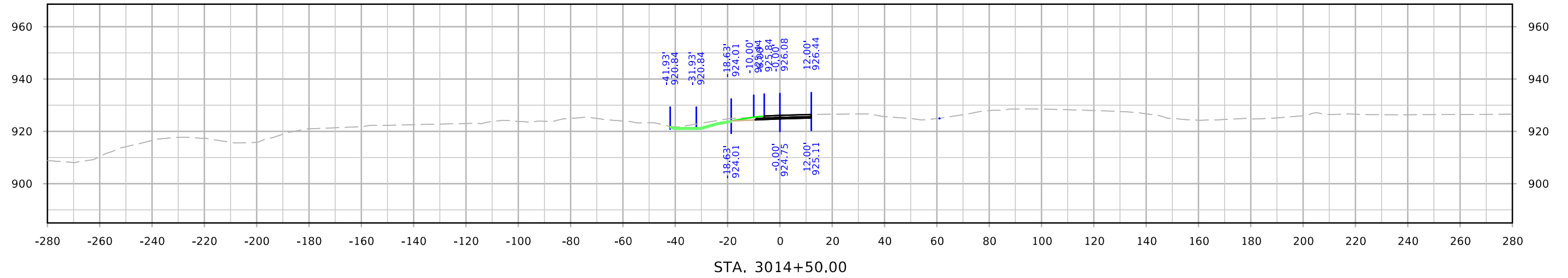

I-80 Ramp C Preliminary

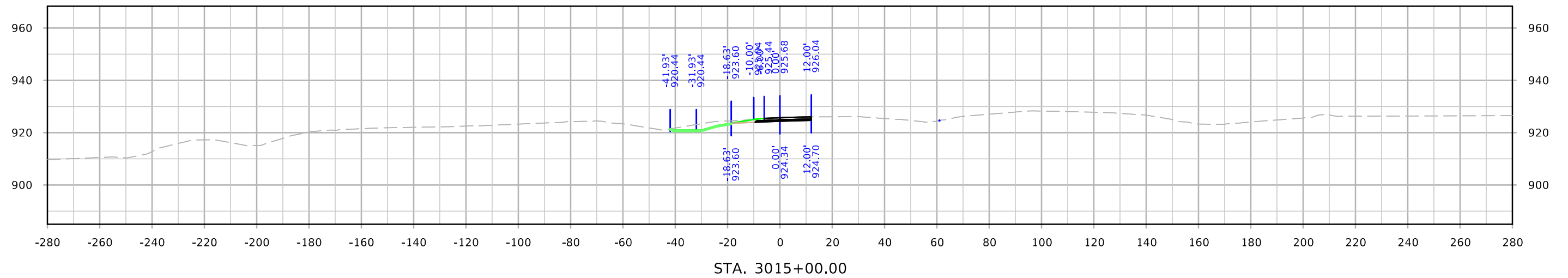
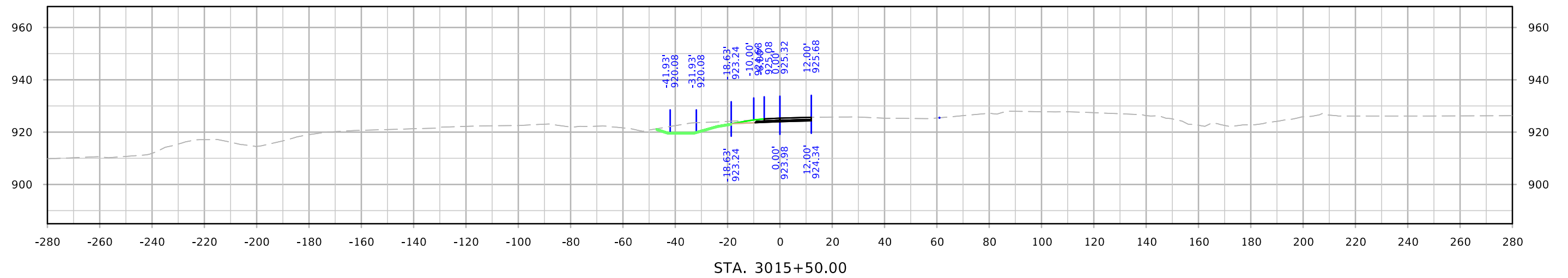
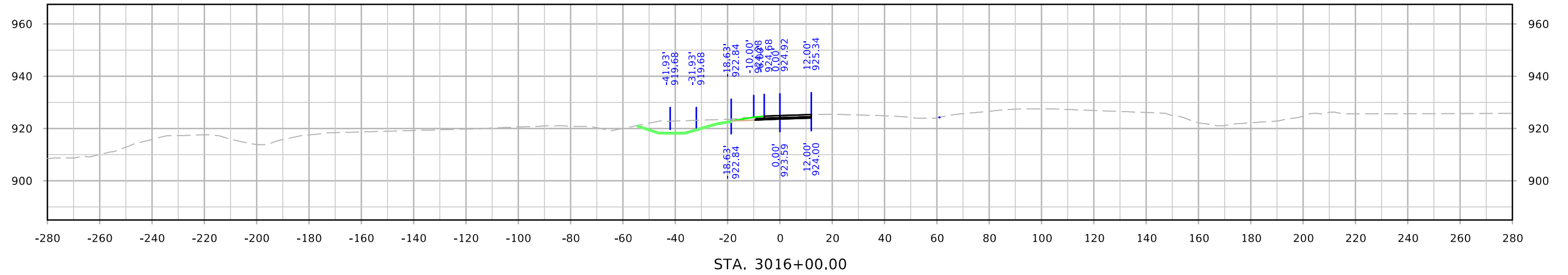

I-80 Ramp C Preliminary

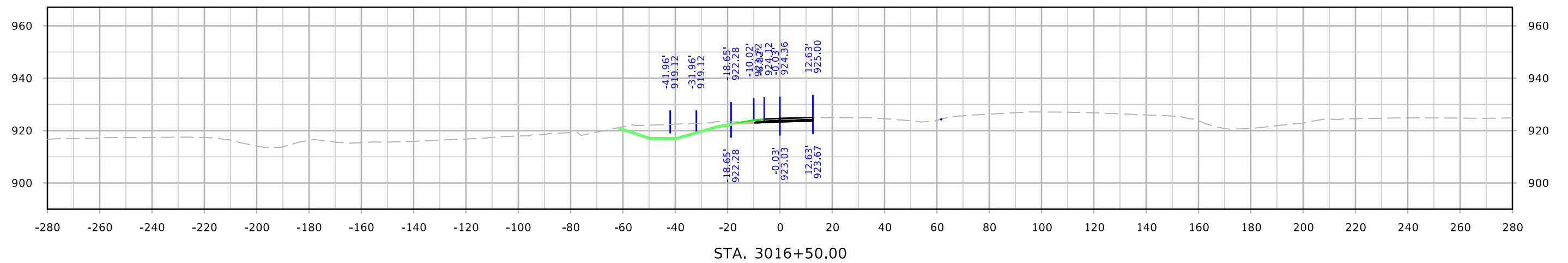
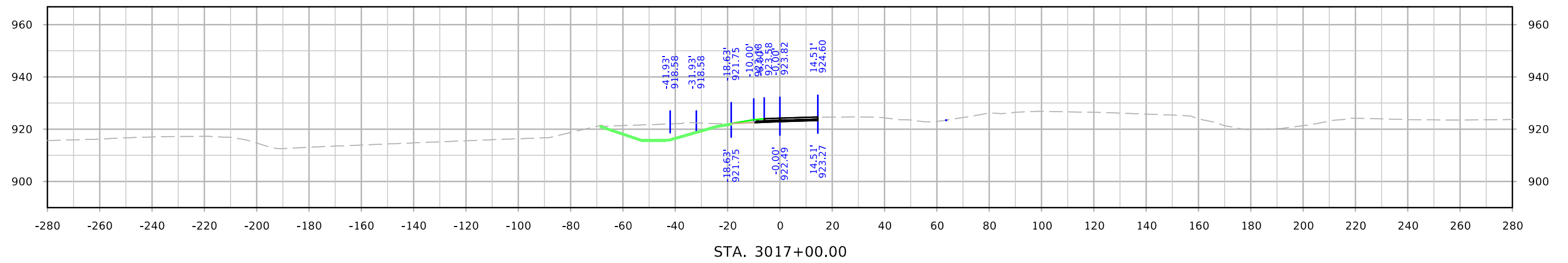
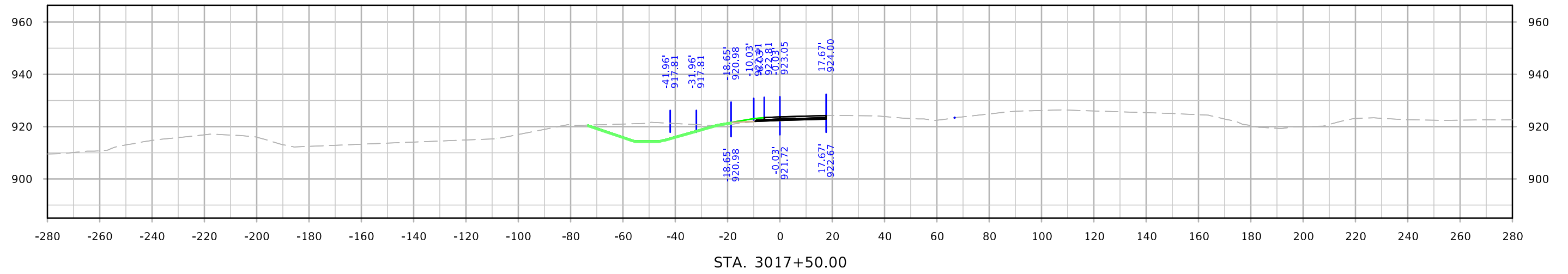

I-80 Ramp C Preliminary

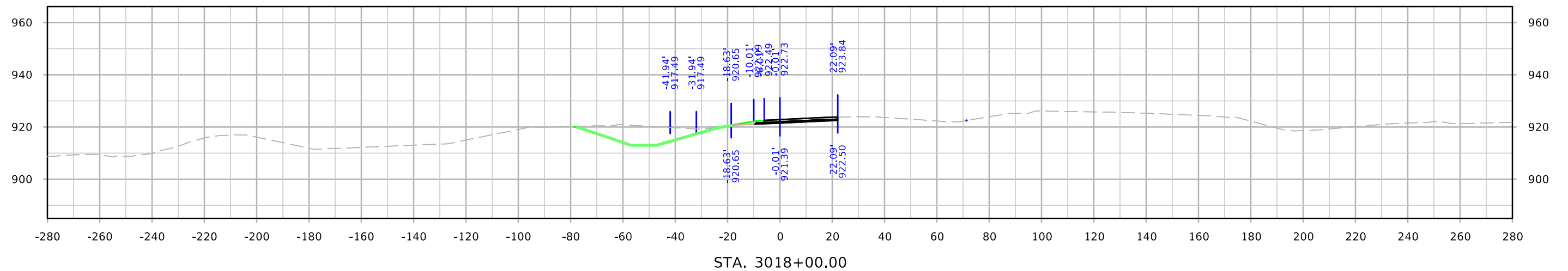
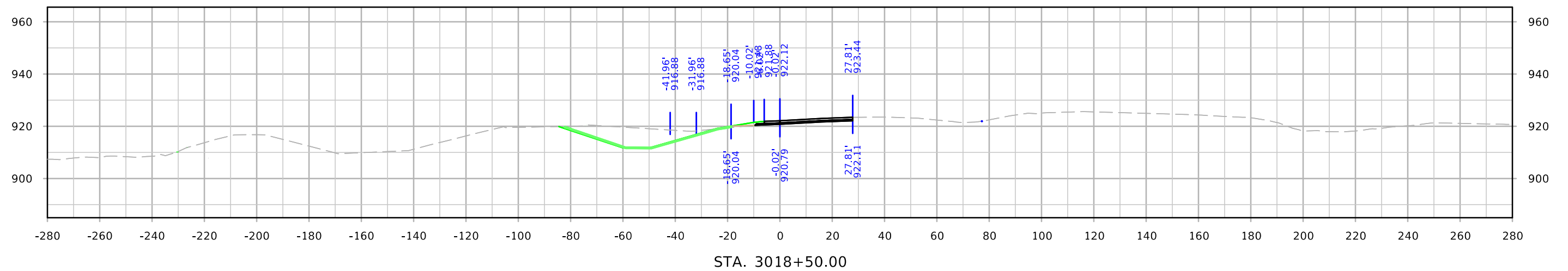
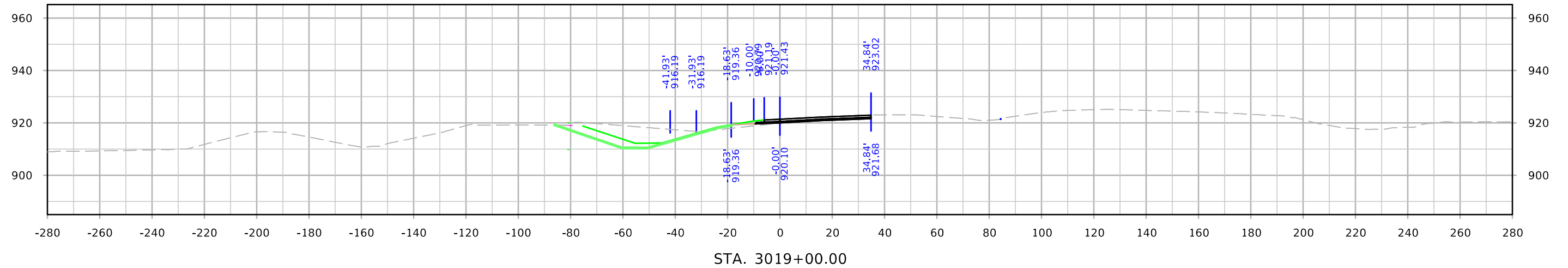

I-80 Ramp C Preliminary

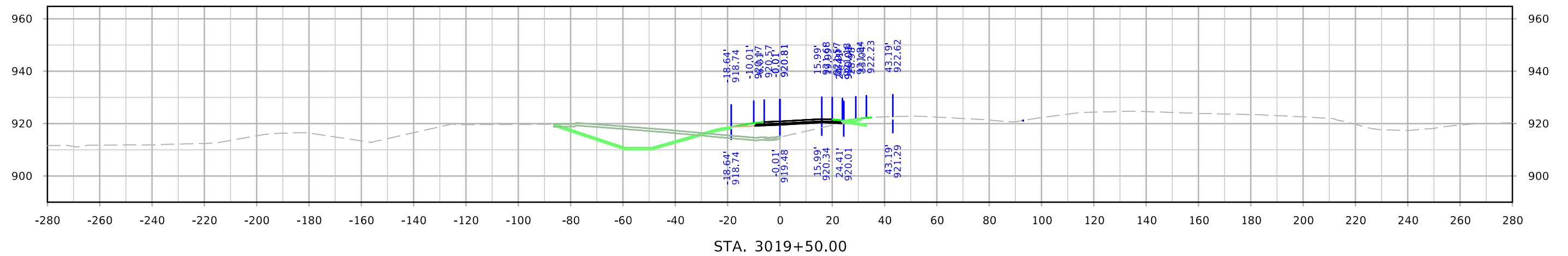
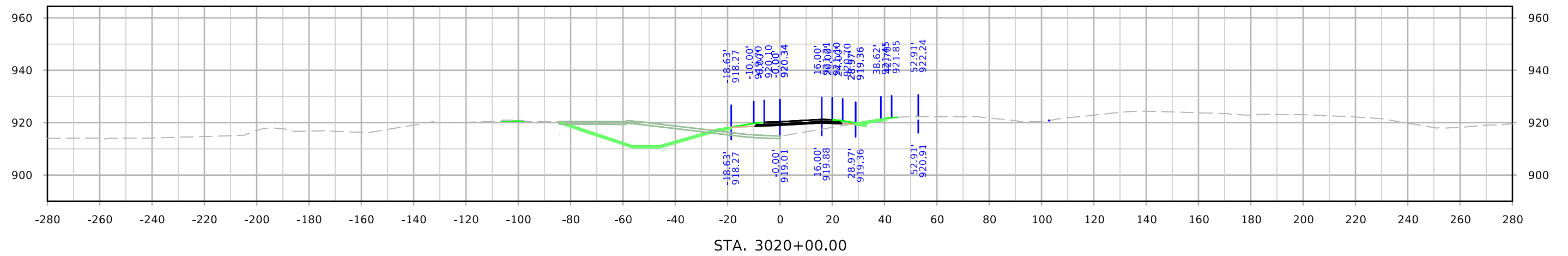
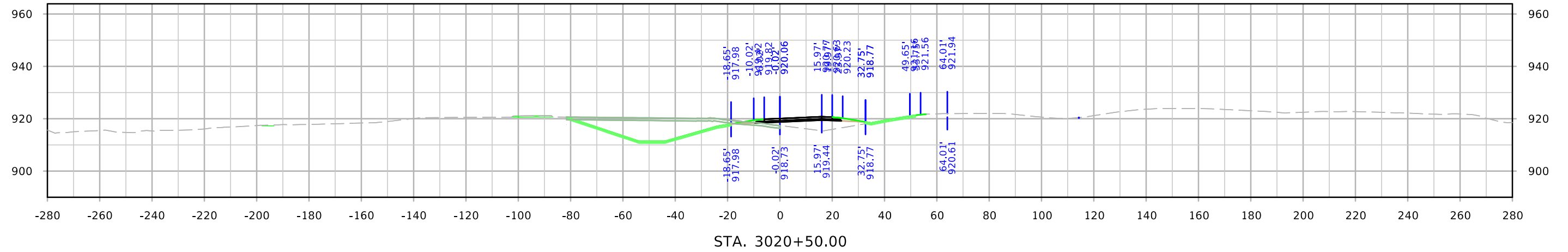

I-80 Ramp C Preliminary

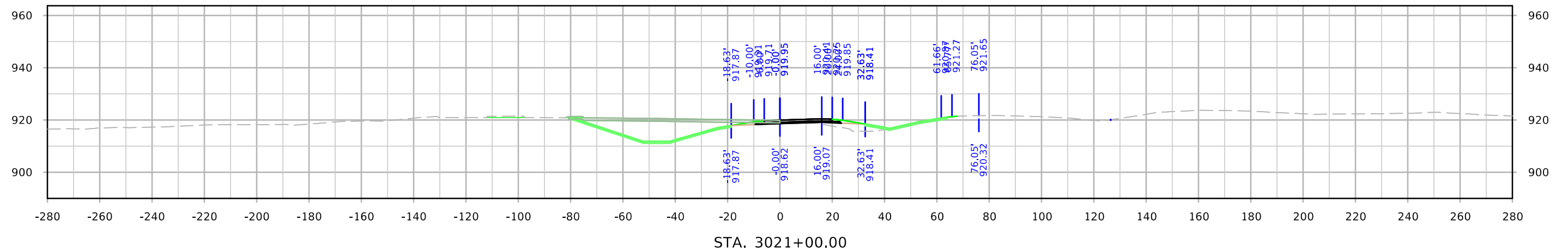
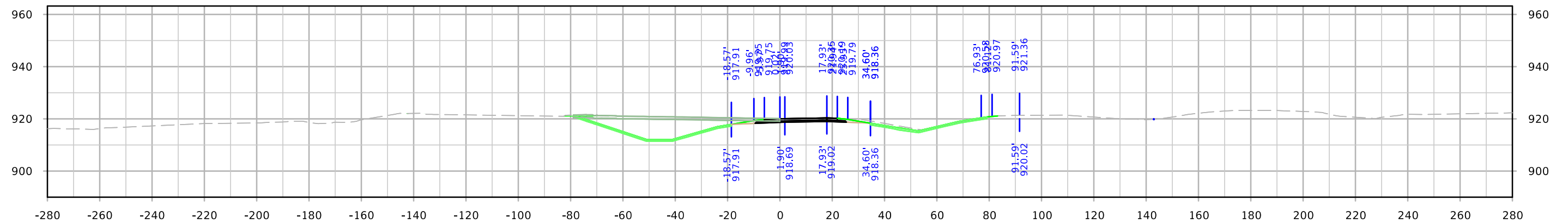
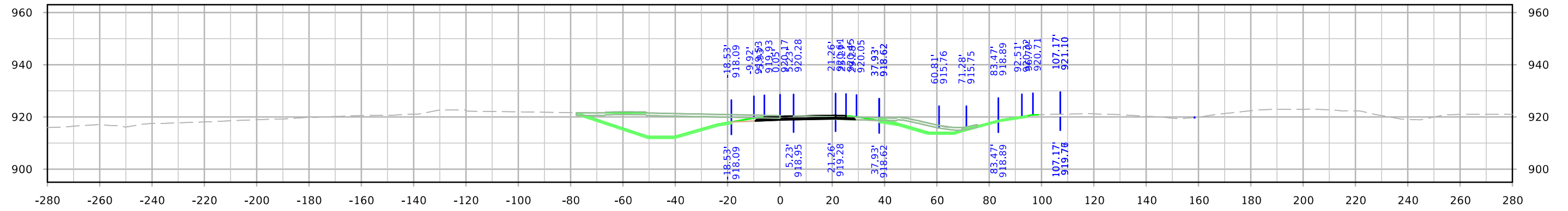

I-80 Ramp C Preliminary

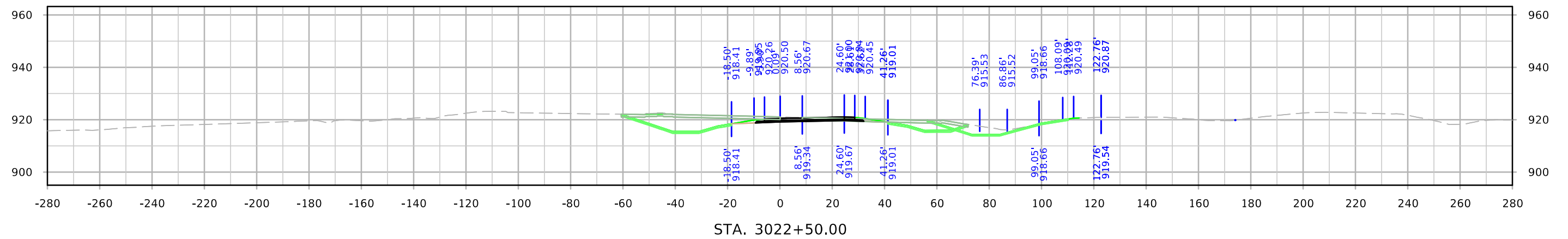
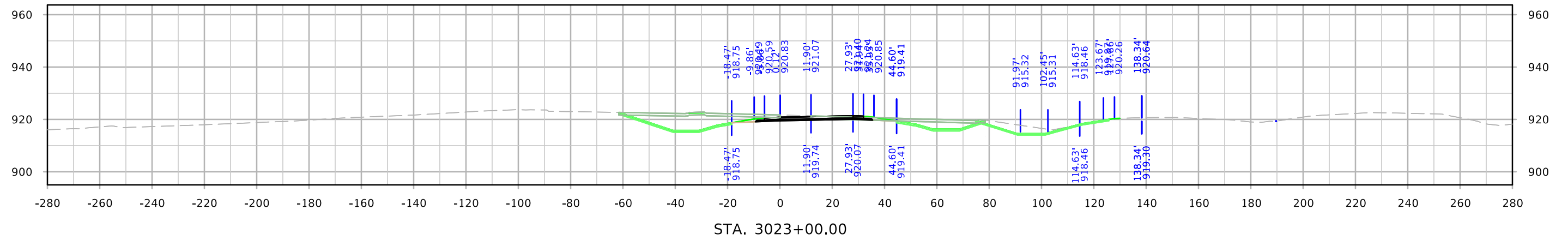
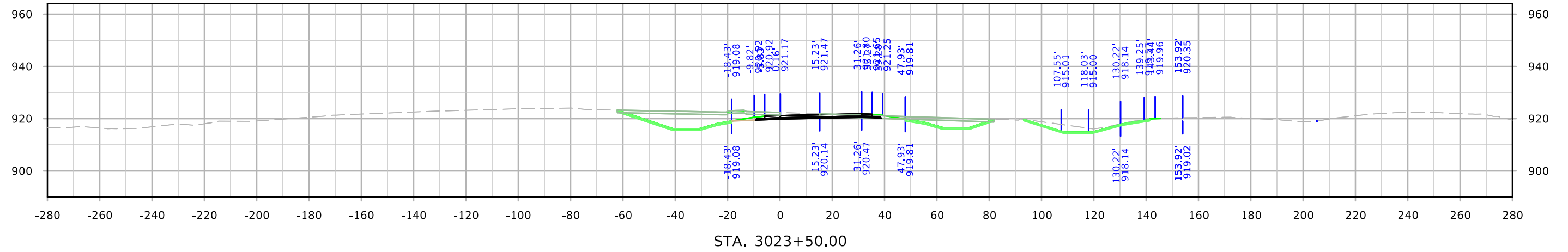

I-80 Ramp C Preliminary

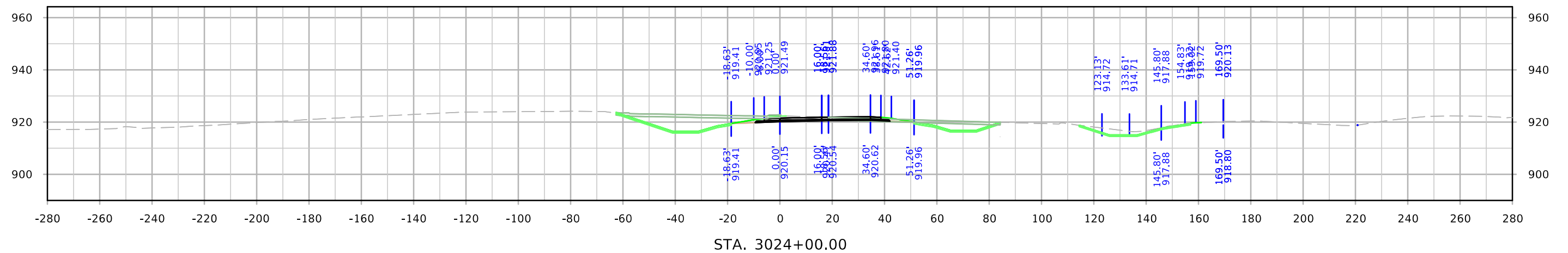
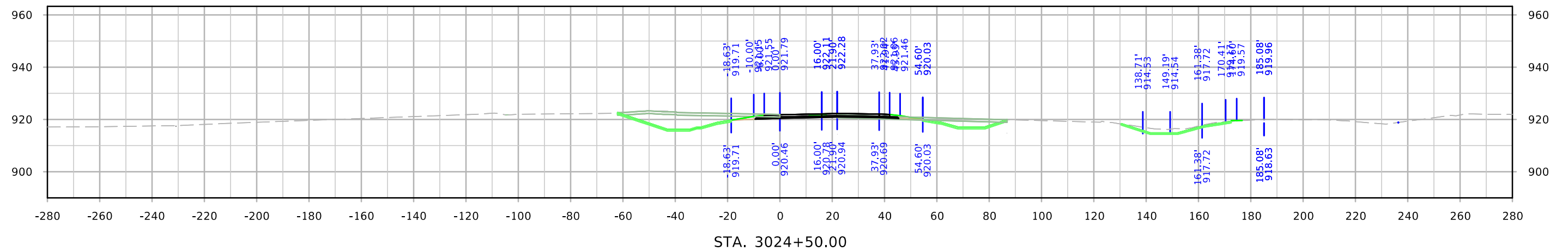
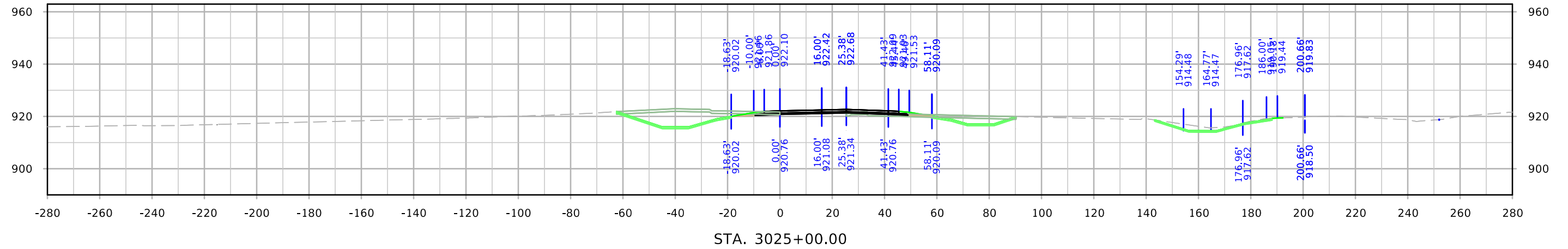

I-80 Ramp C Preliminary

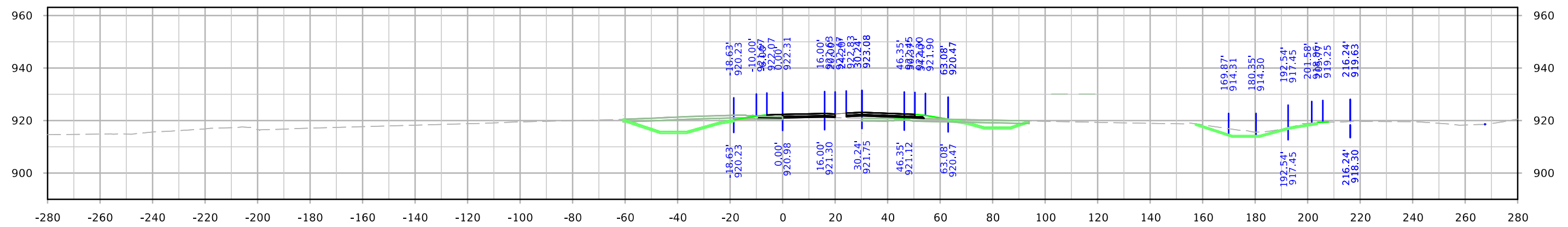
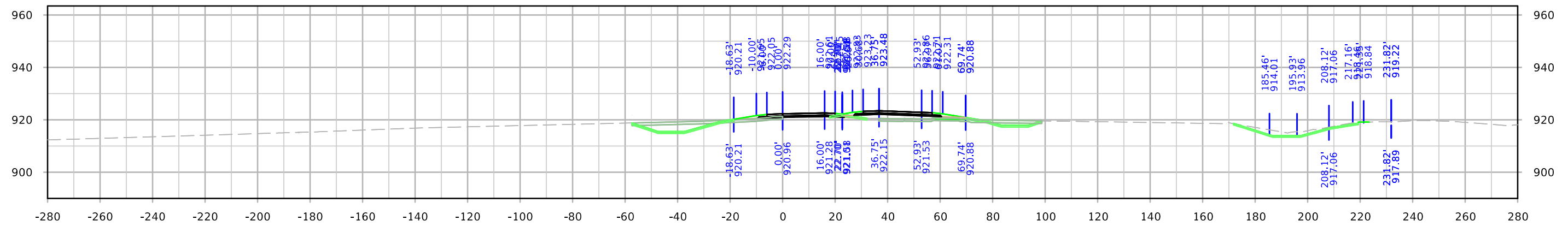
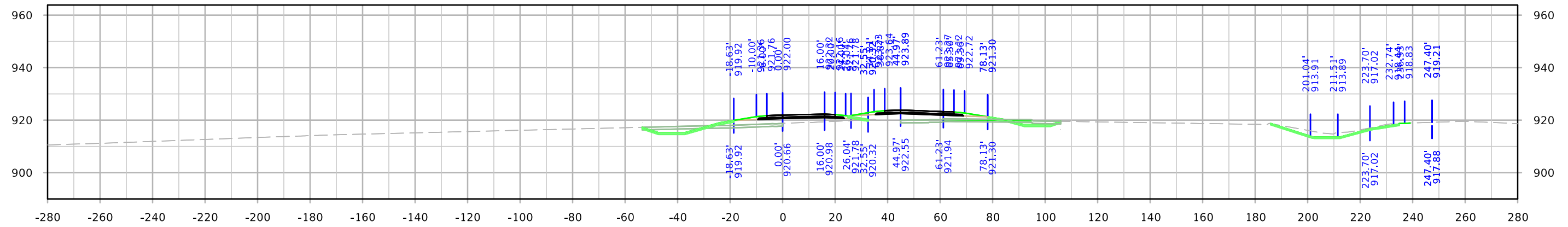

I-80 Ramp C Preliminary

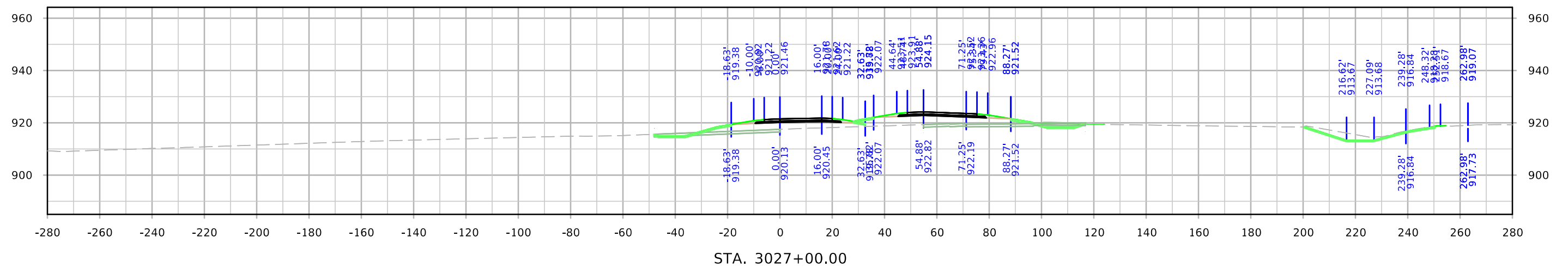
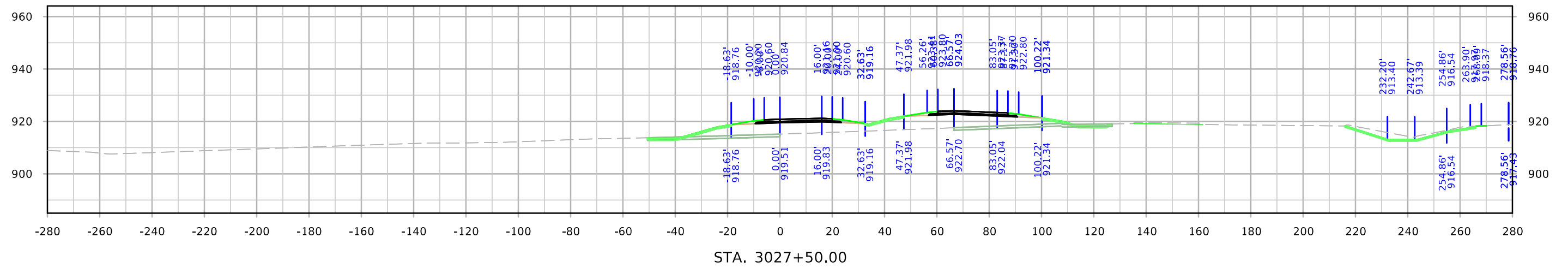
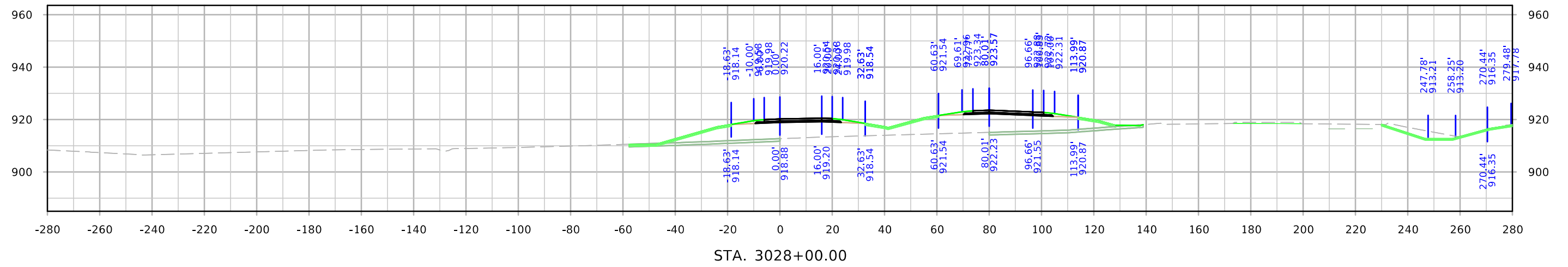

I-80 Ramp C Preliminary

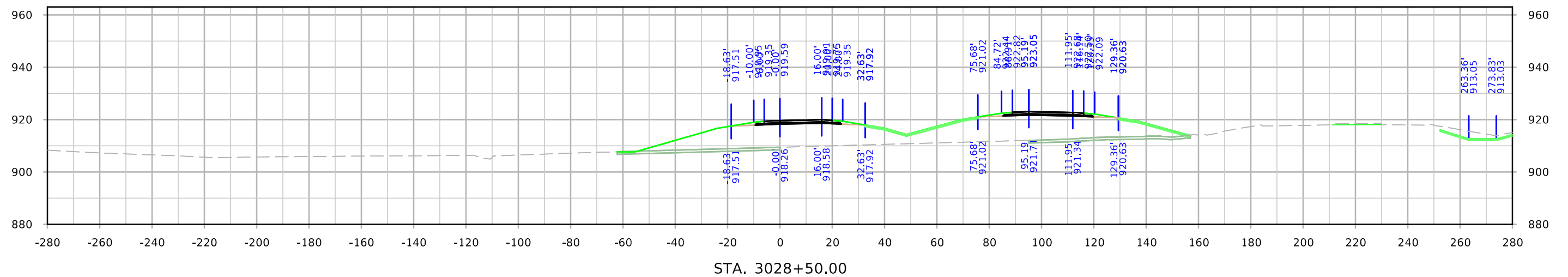
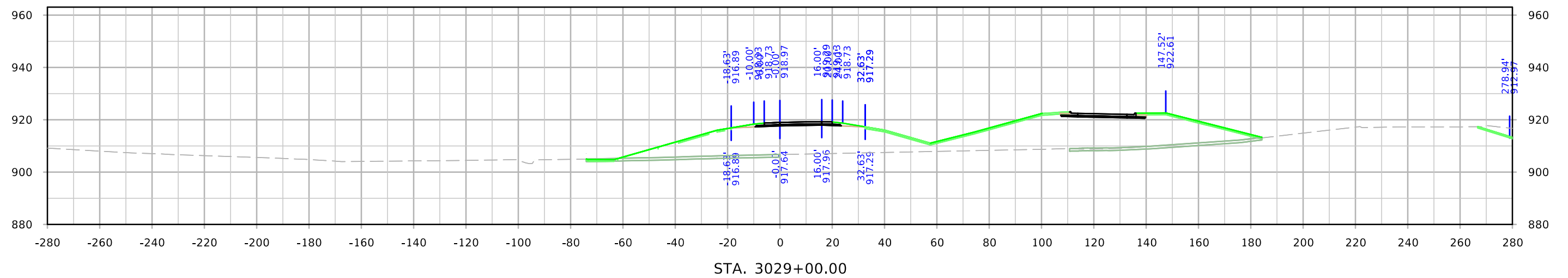
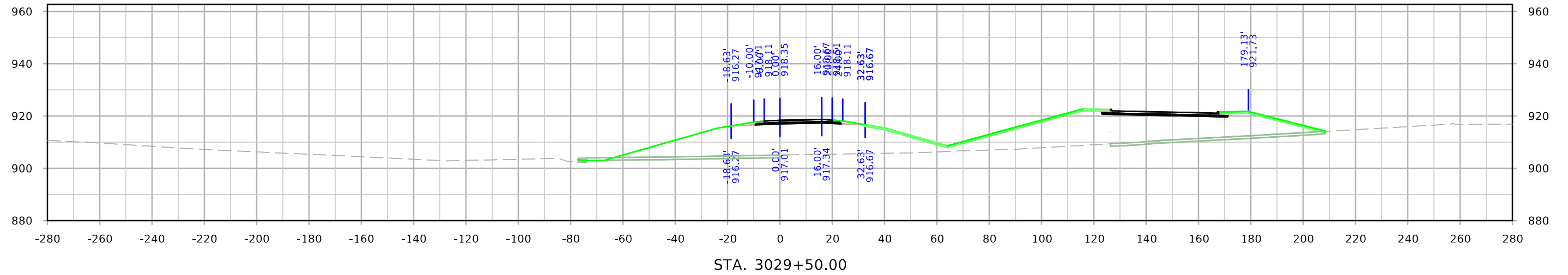

I-80 Ramp C Preliminary

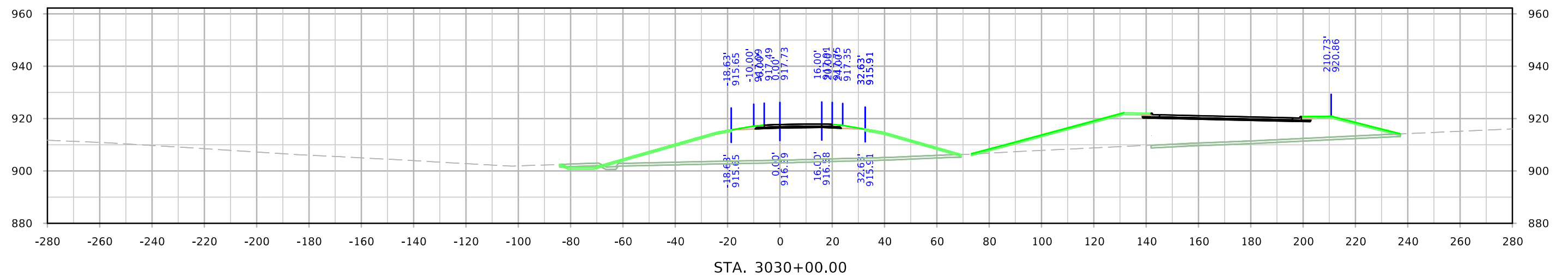
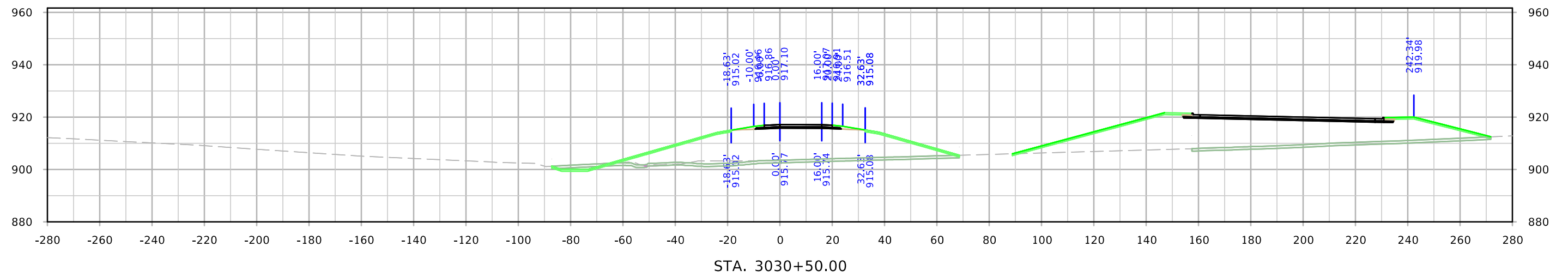
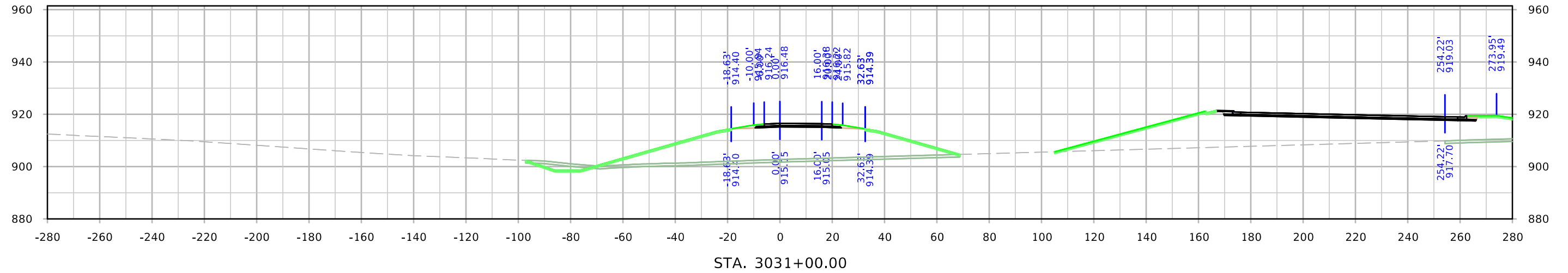

I-80 Ramp C Preliminary

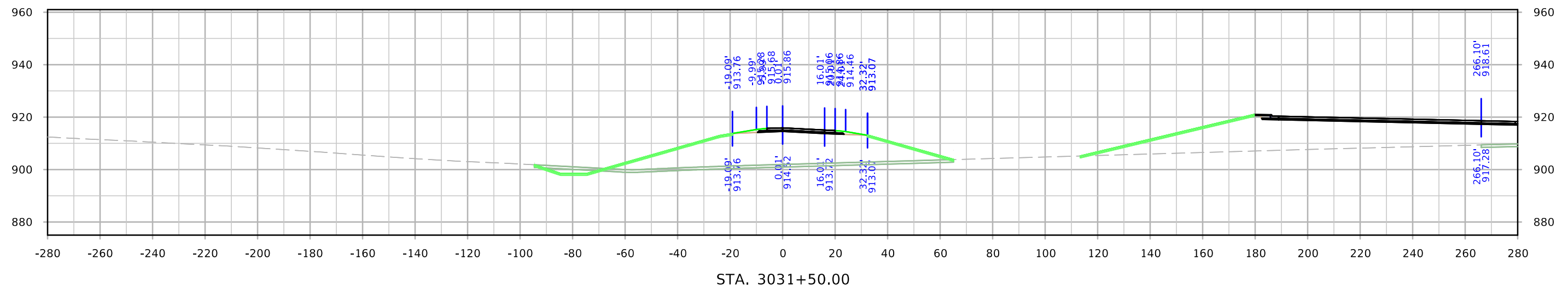
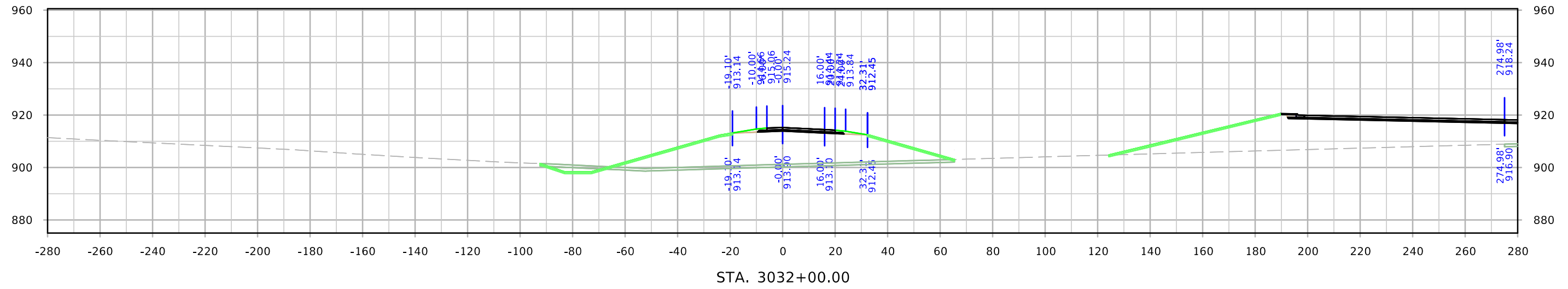
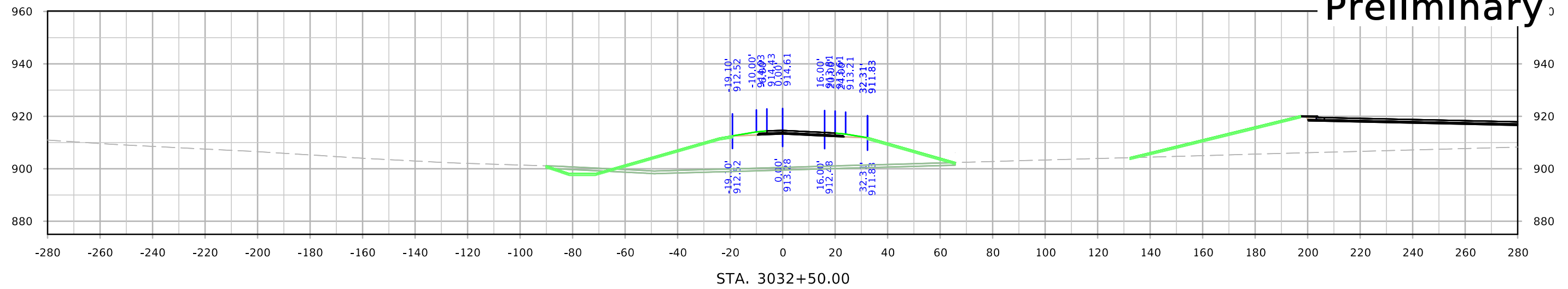

I-80 Ramp C Preliminary

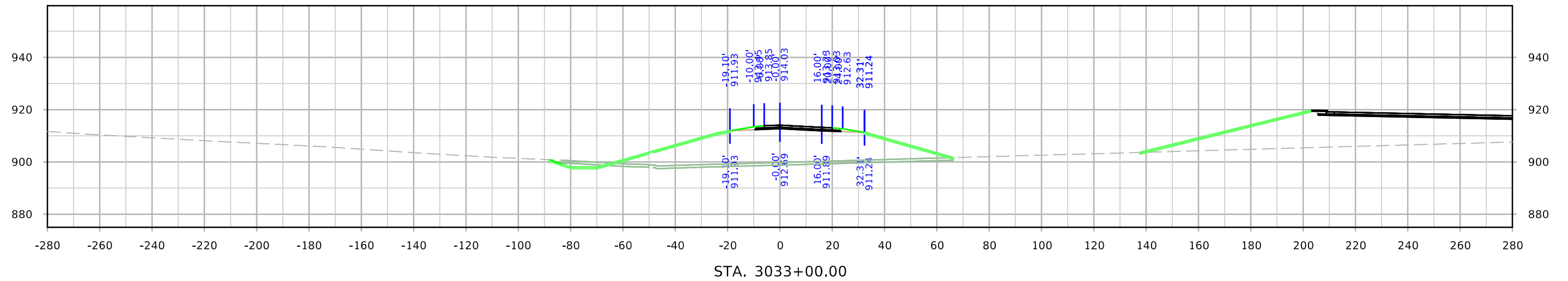
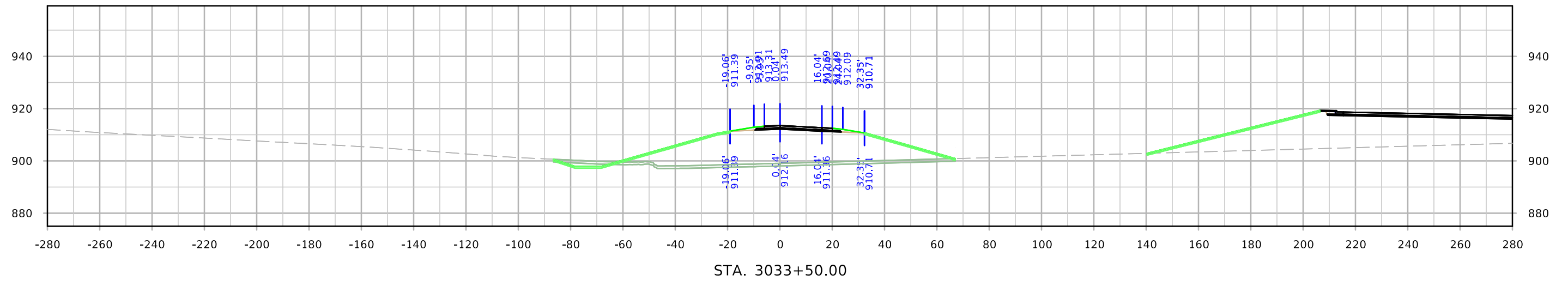
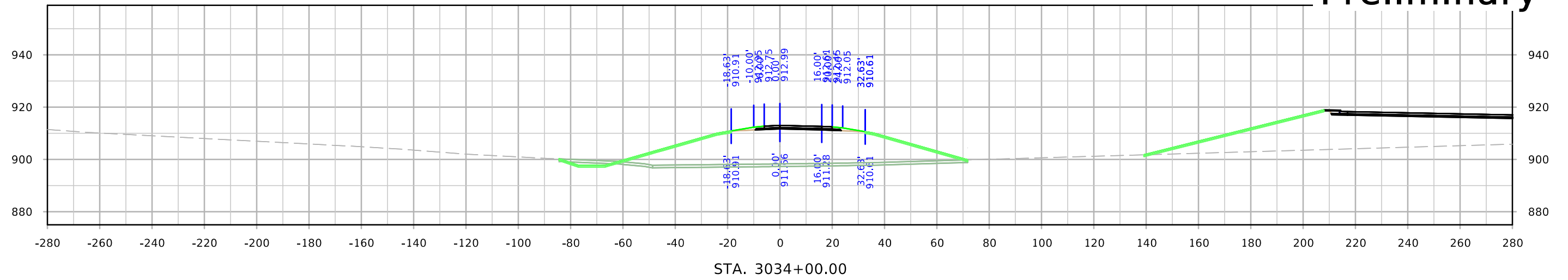

I-80 Ramp C Preliminary

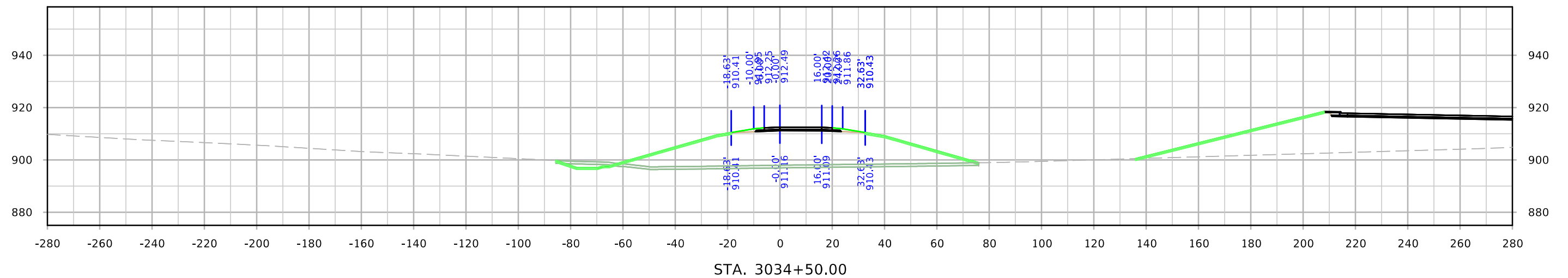
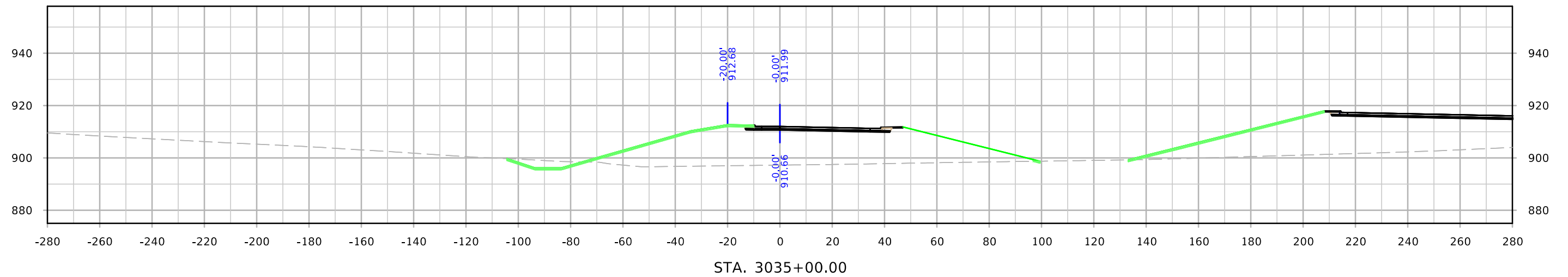
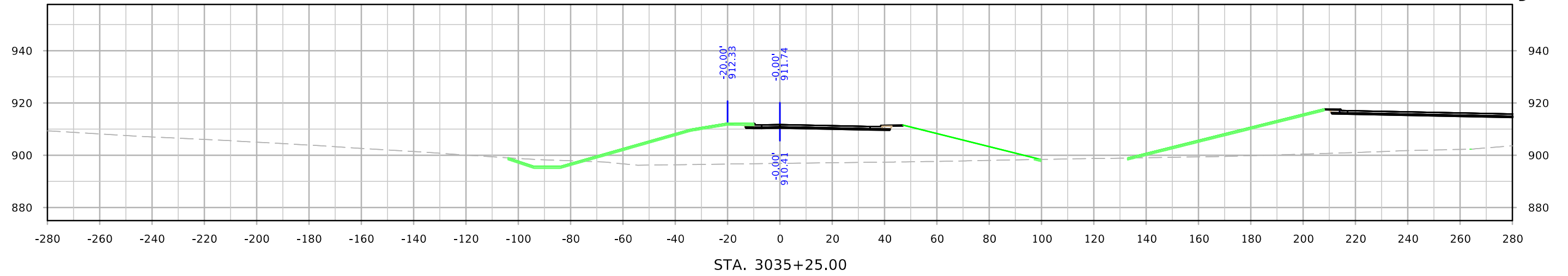

I-80 Ramp E Preliminary

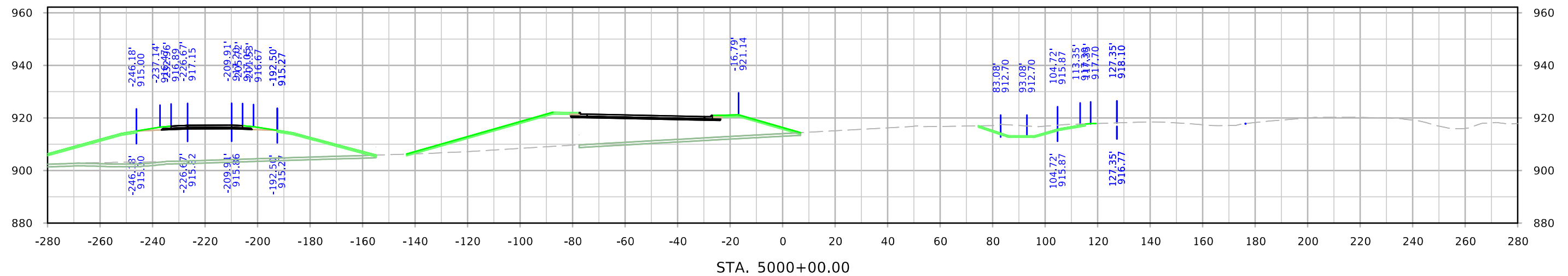
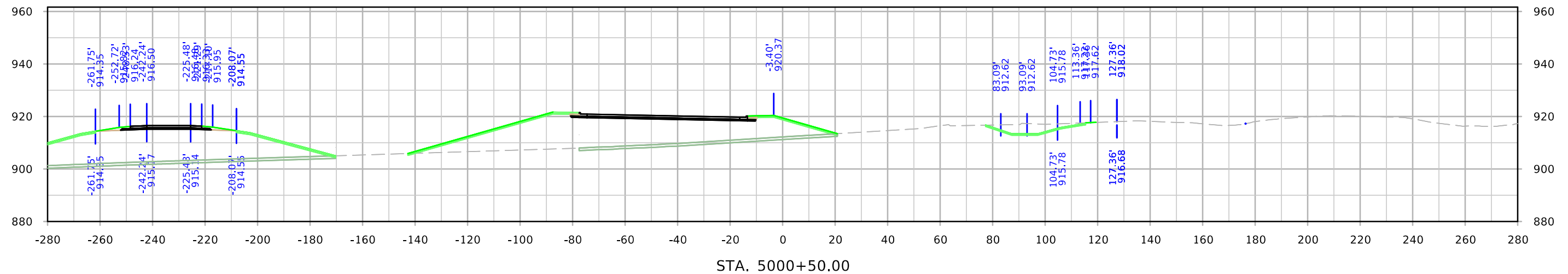
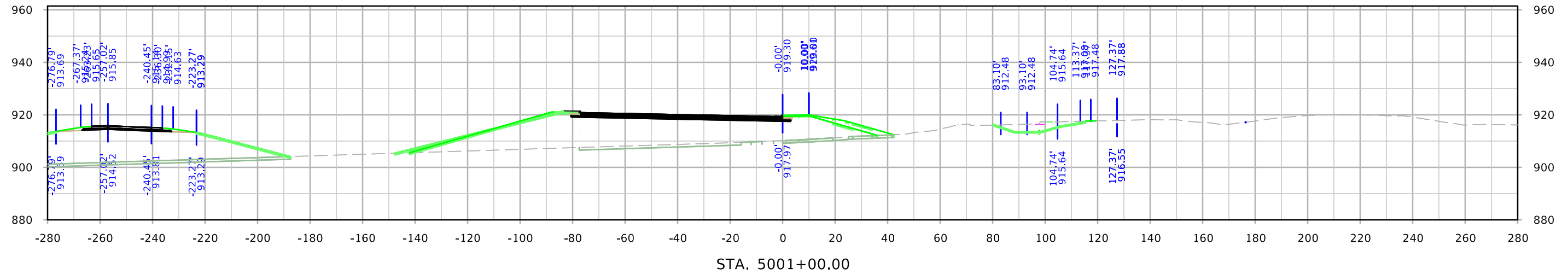

I-80 Ramp E Preliminary

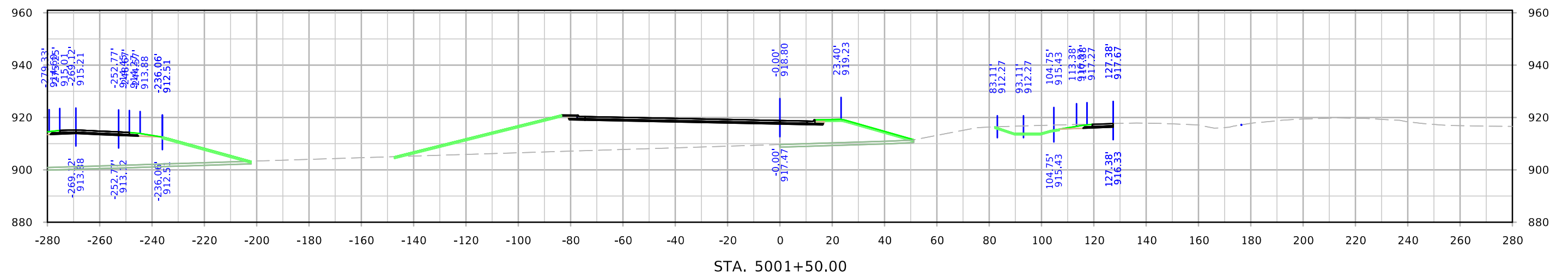
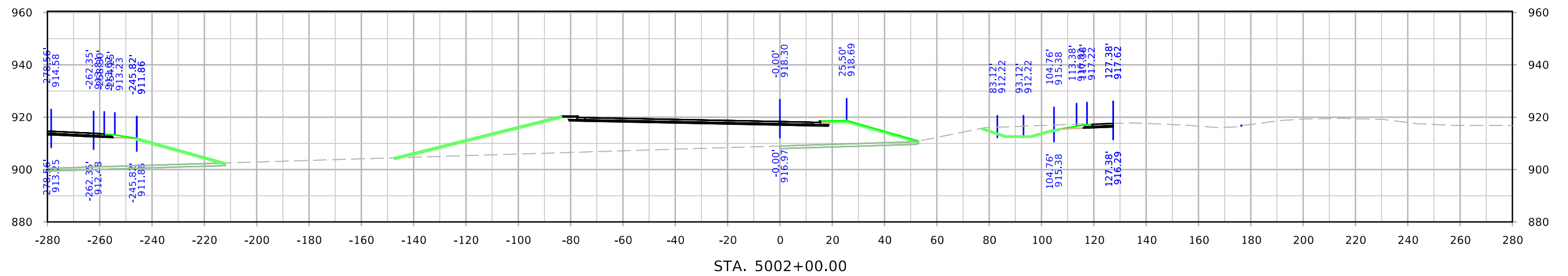
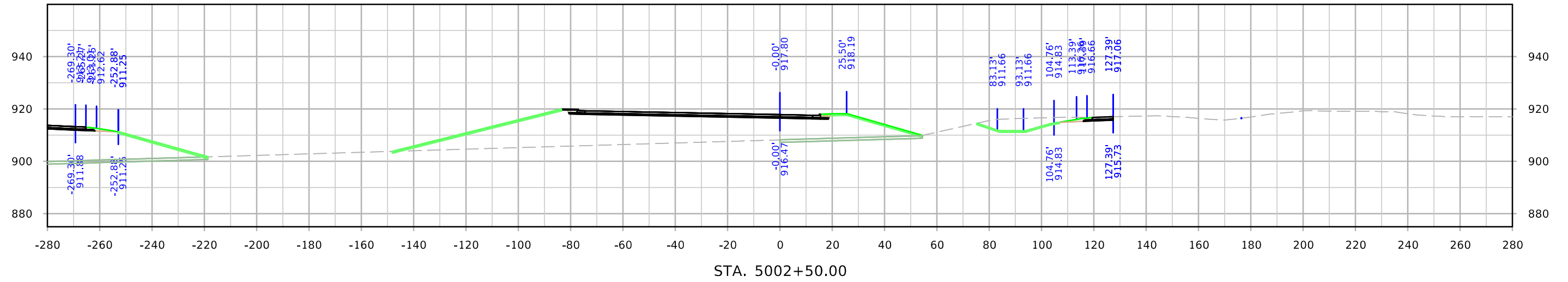

I-80 Ramp E Preliminary

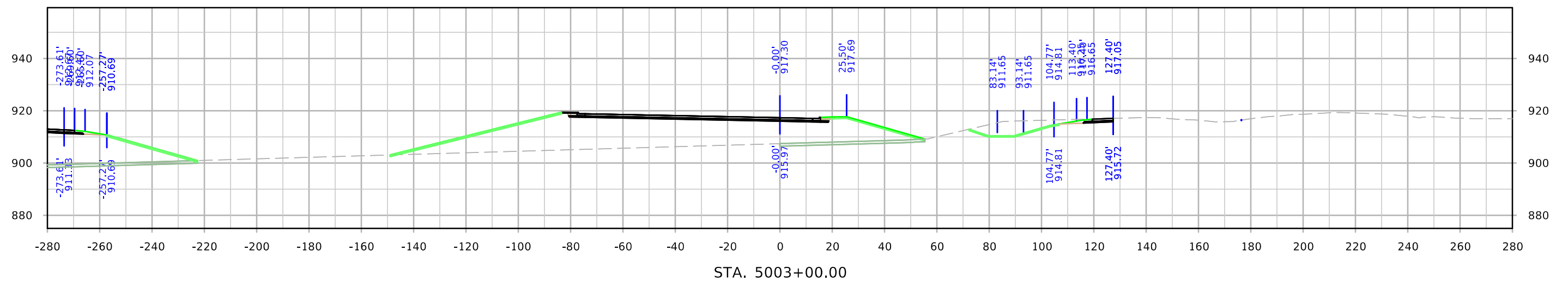
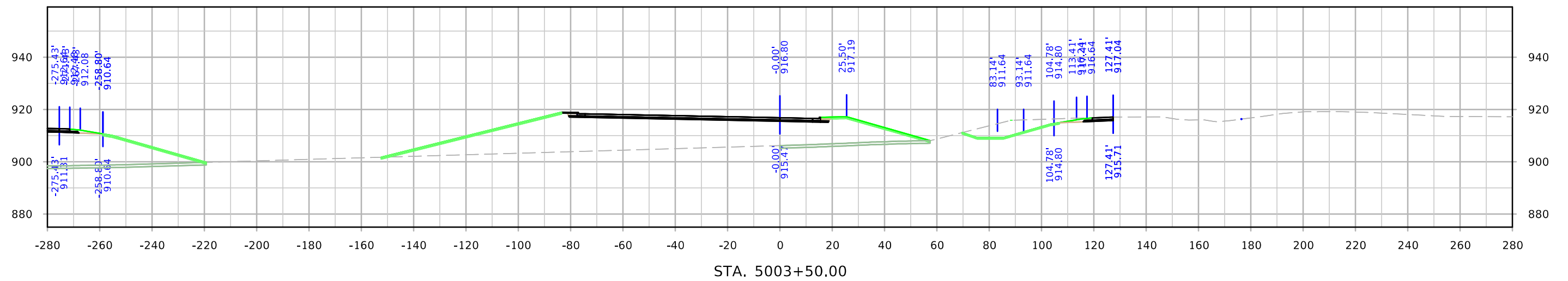
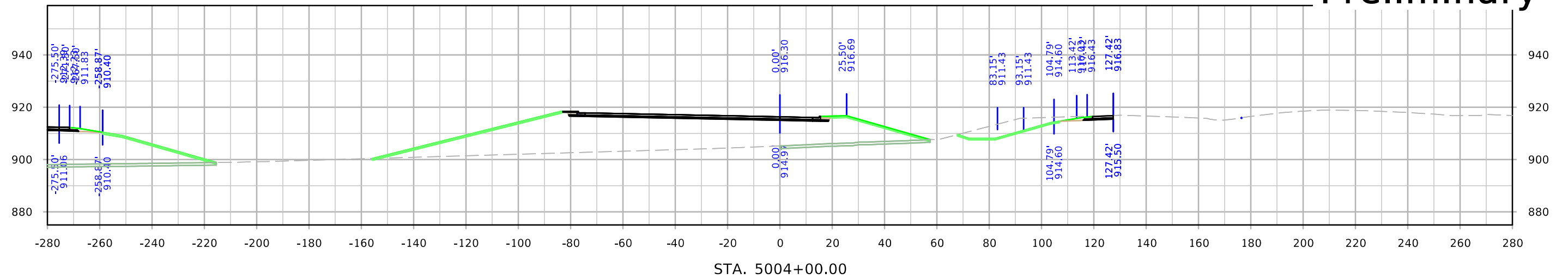

I-80 Ramp E Preliminary

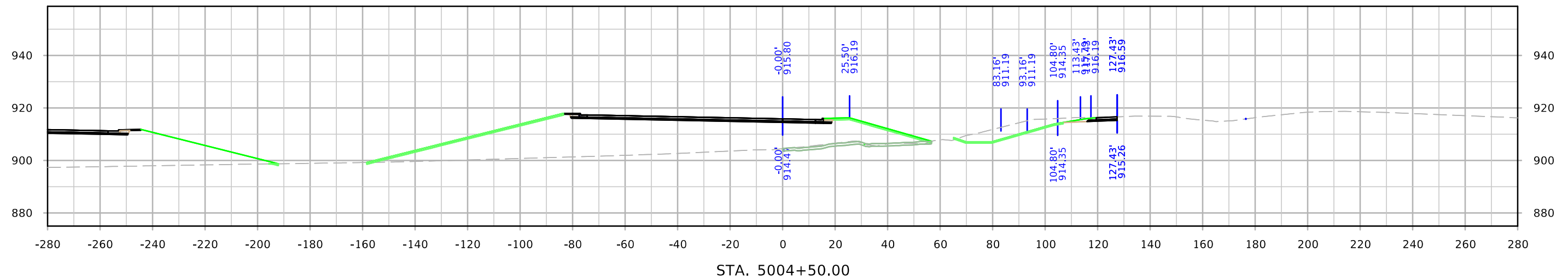
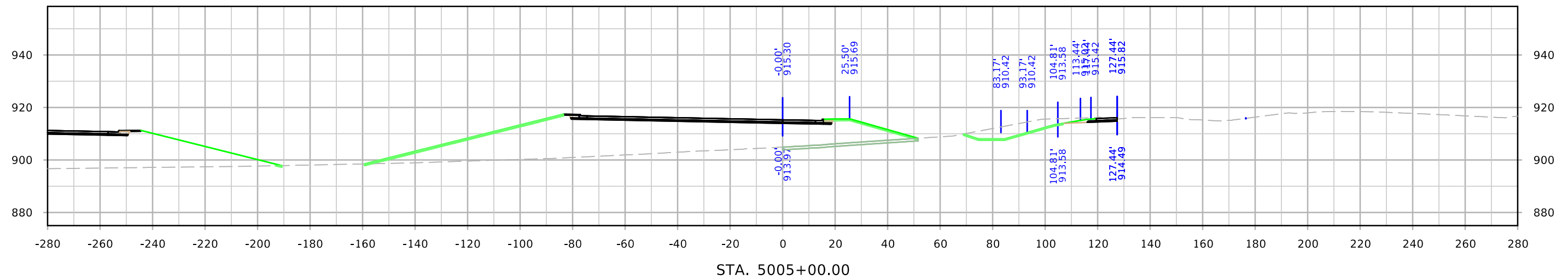
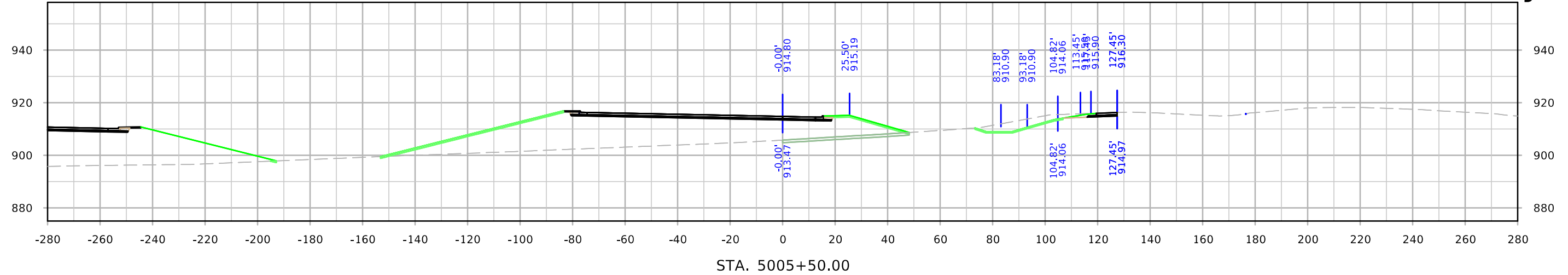

I-80 Ramp E Preliminary

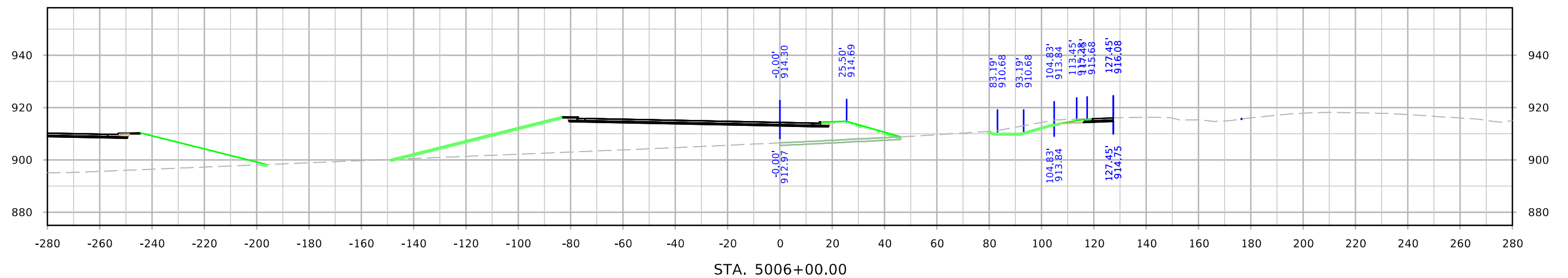
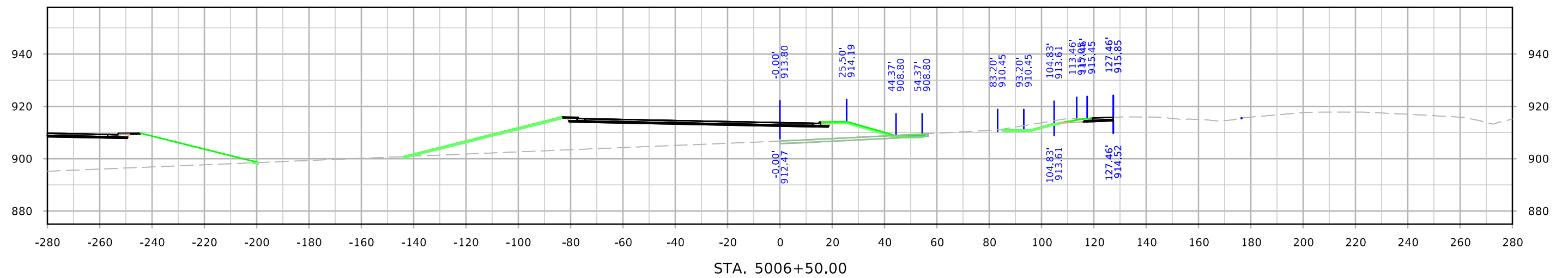
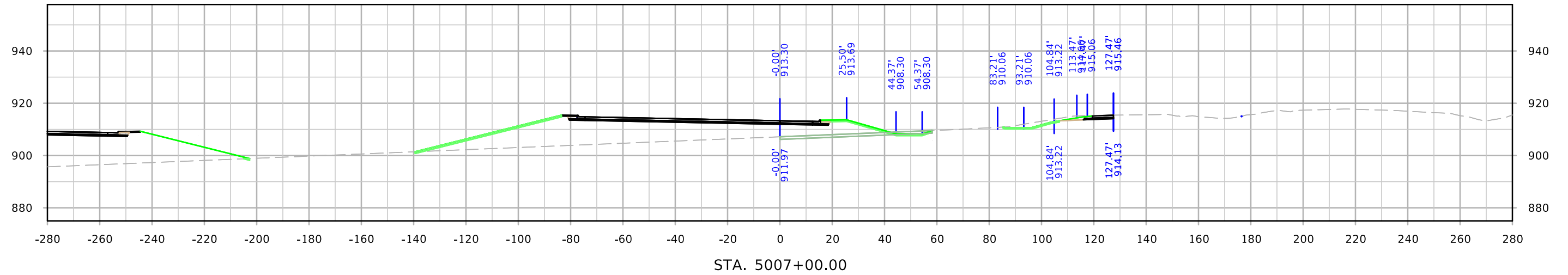

I-80 Ramp E Preliminary

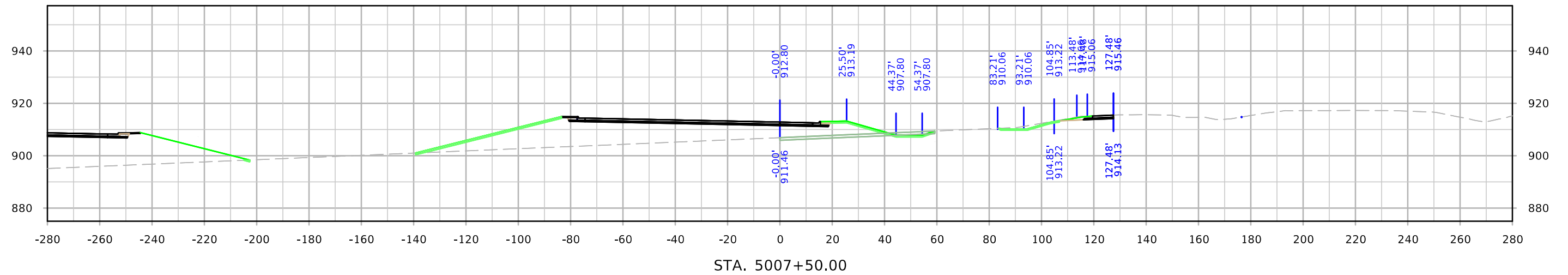
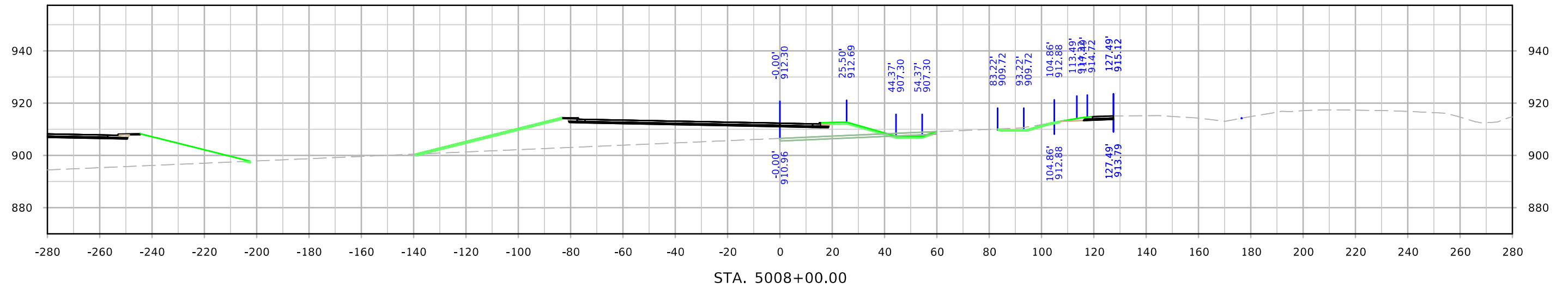
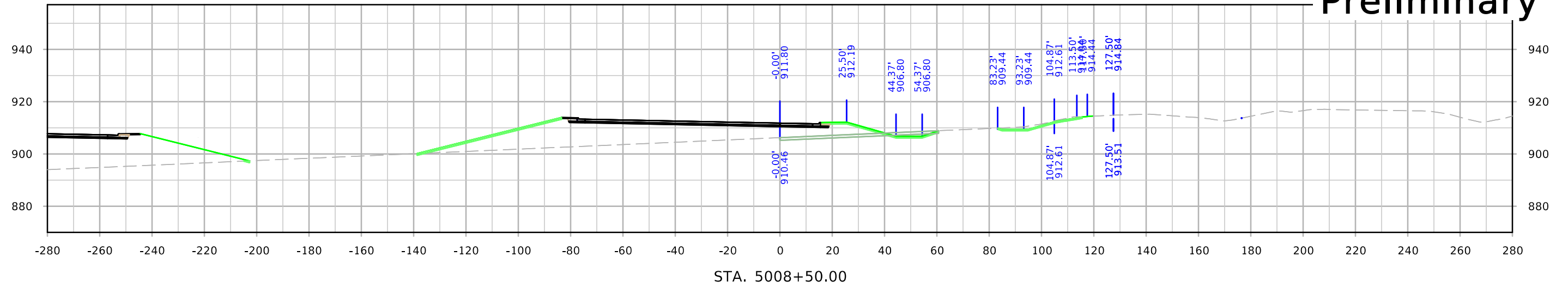

I-80 Ramp E Preliminary

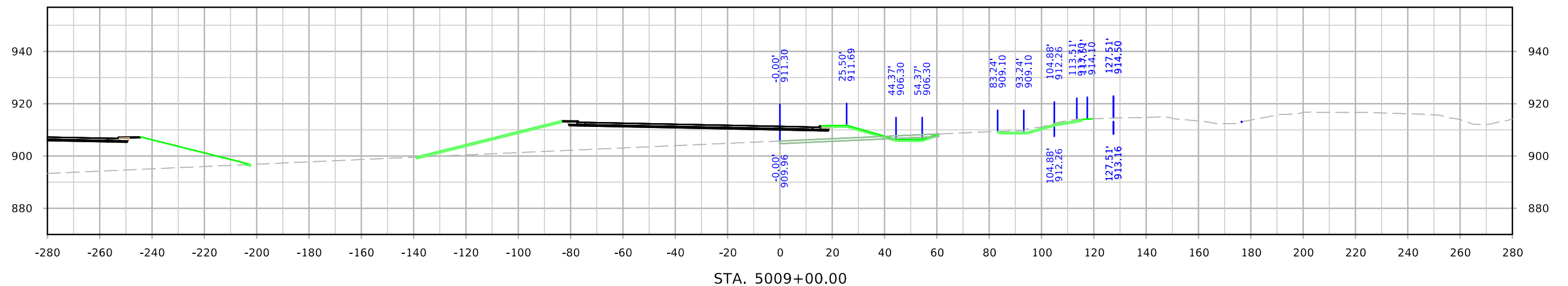
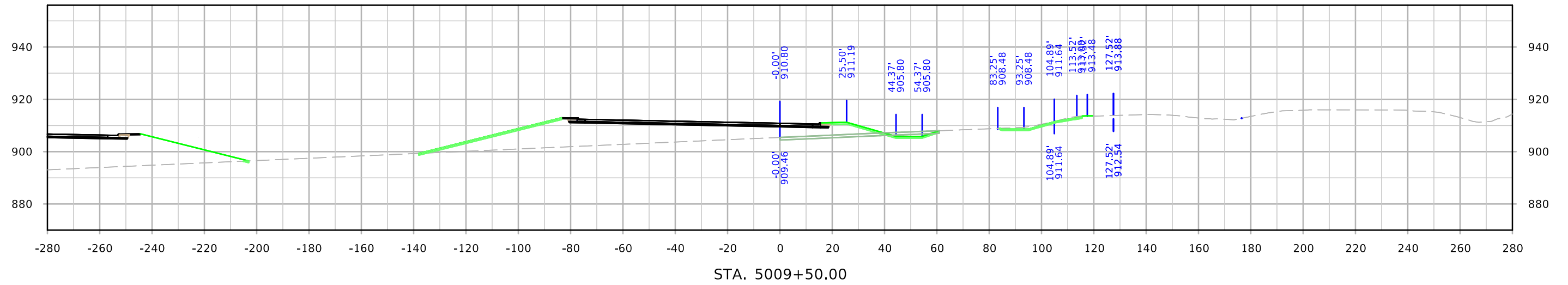
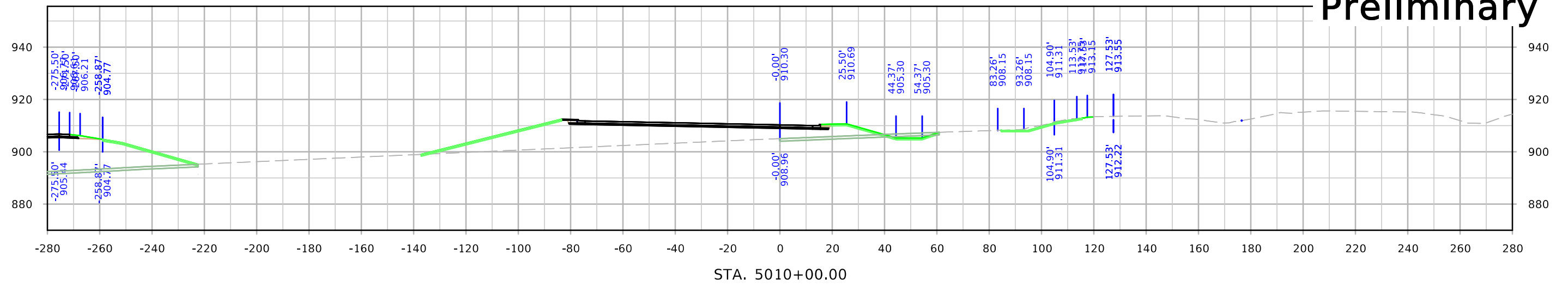

I-80 Ramp E Preliminary

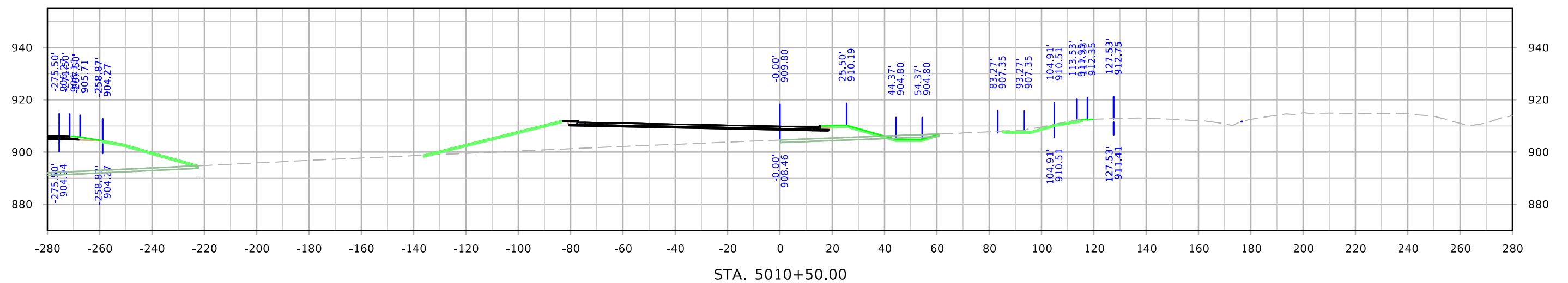
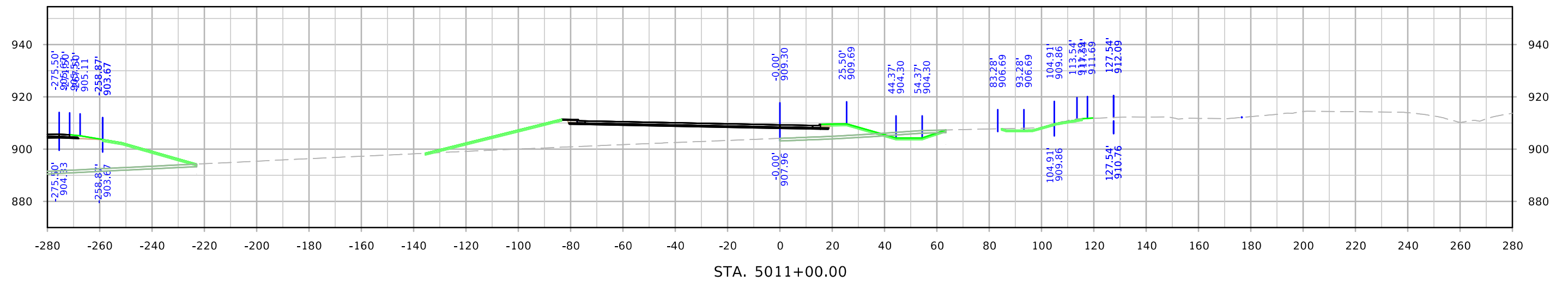
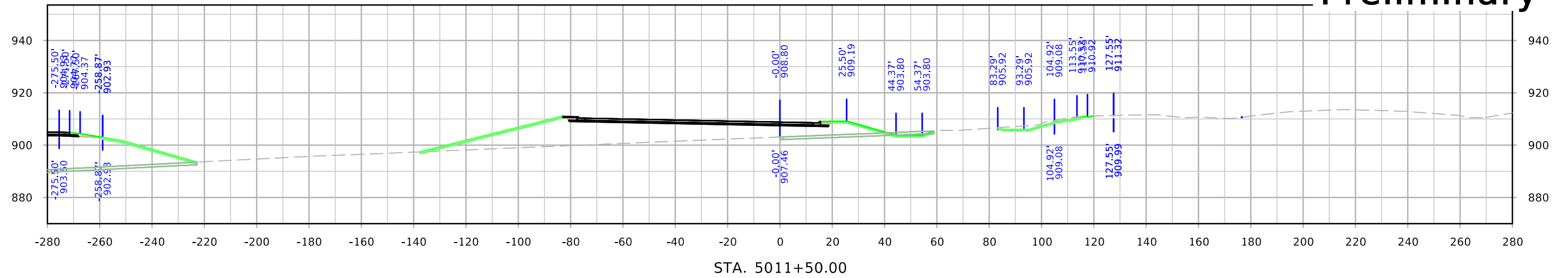

I-80 Ramp E Preliminary

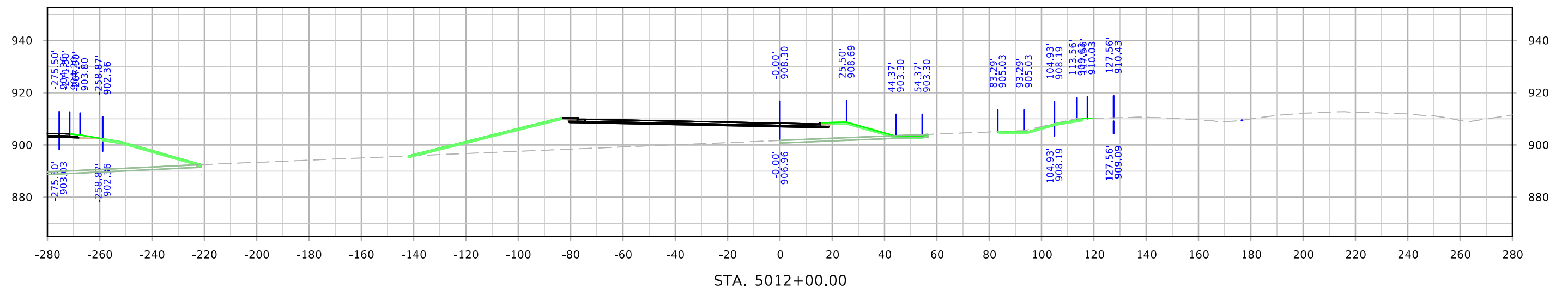
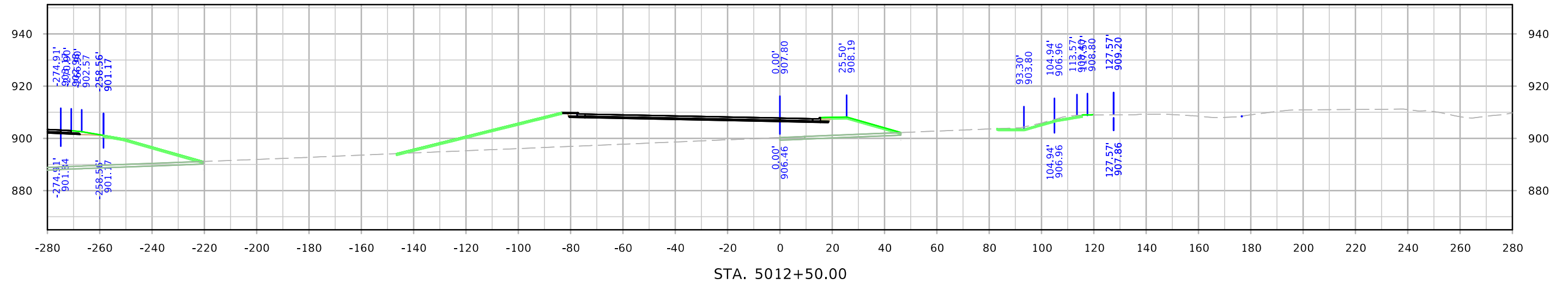
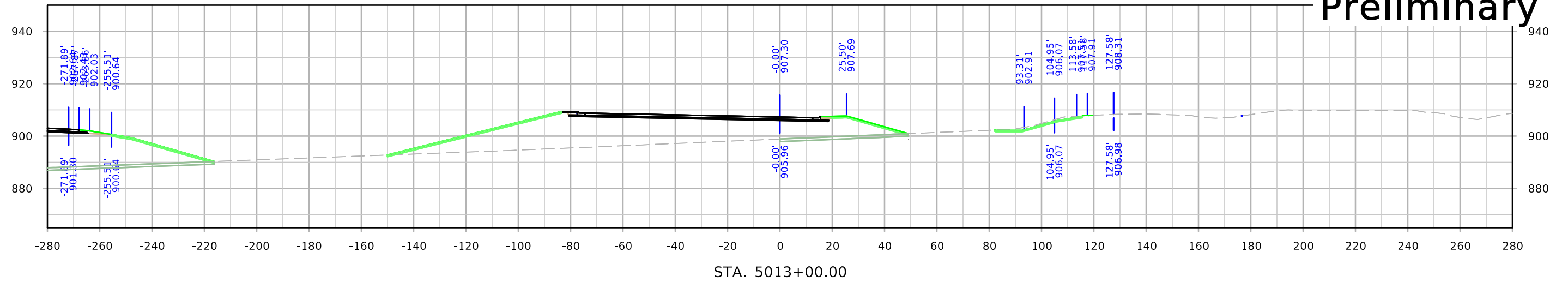

I-80 Ramp E Preliminary

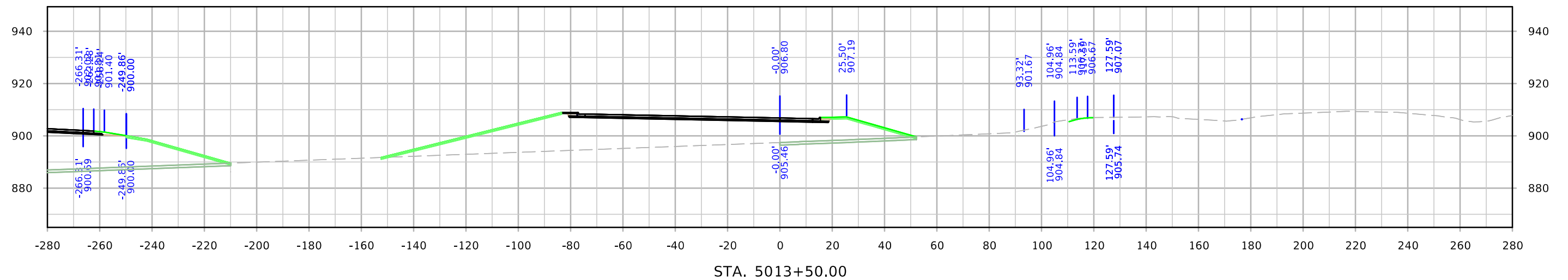
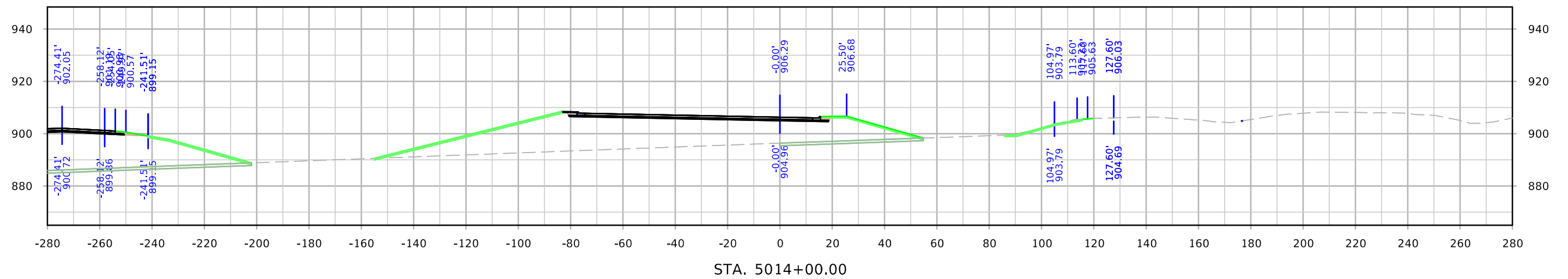
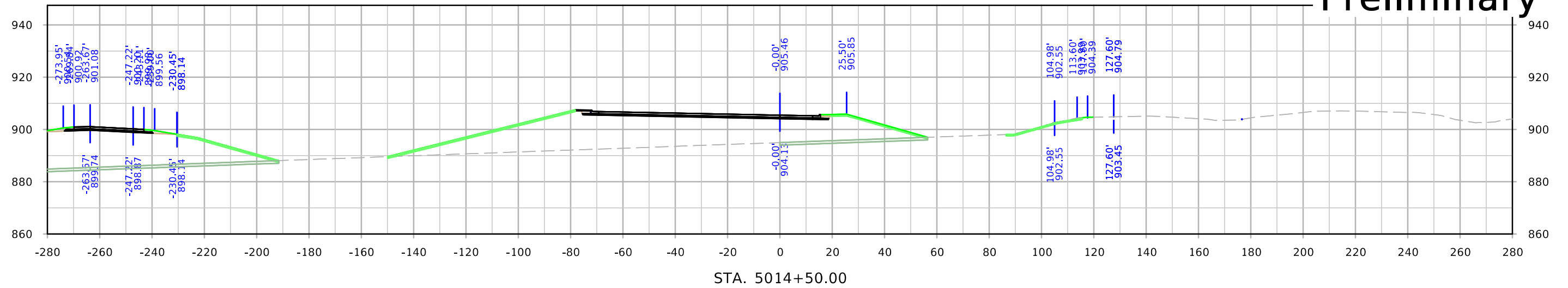

I-80 Ramp E Preliminary

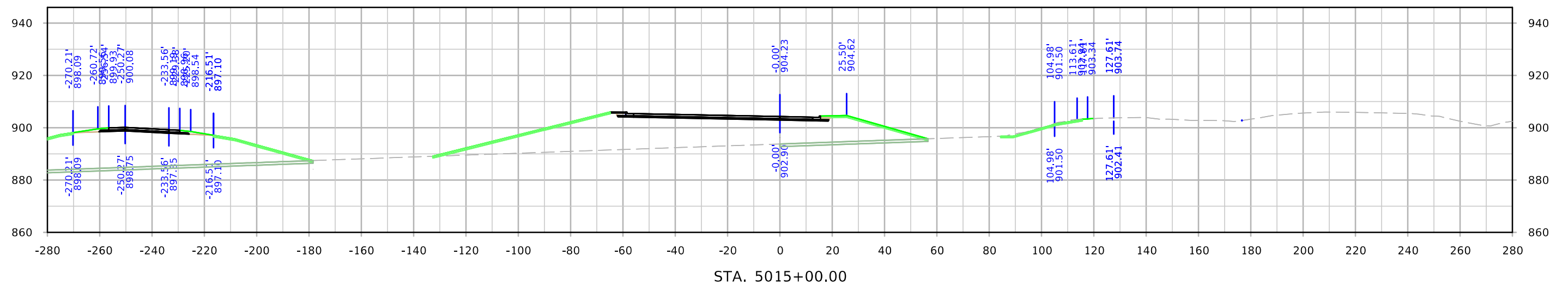
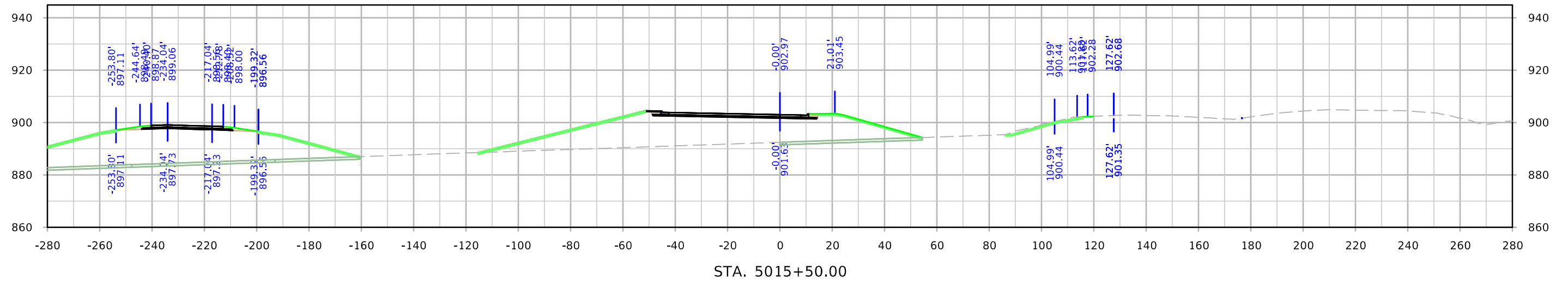
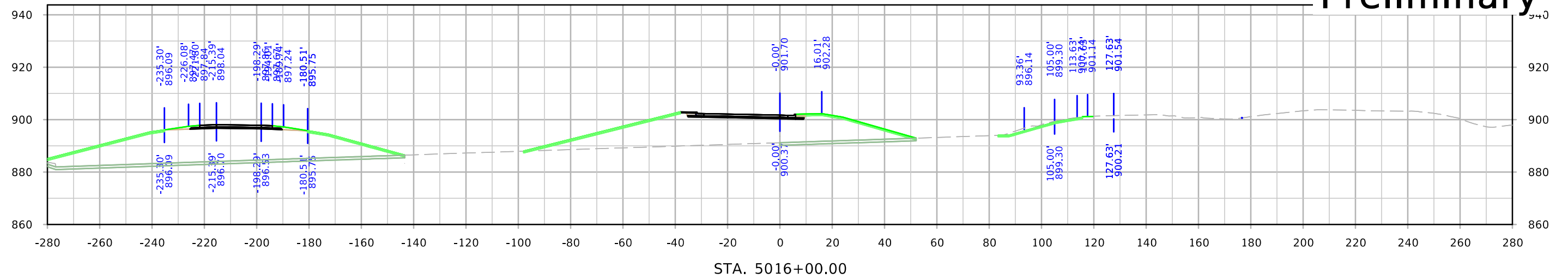

I-80 Ramp E Preliminary

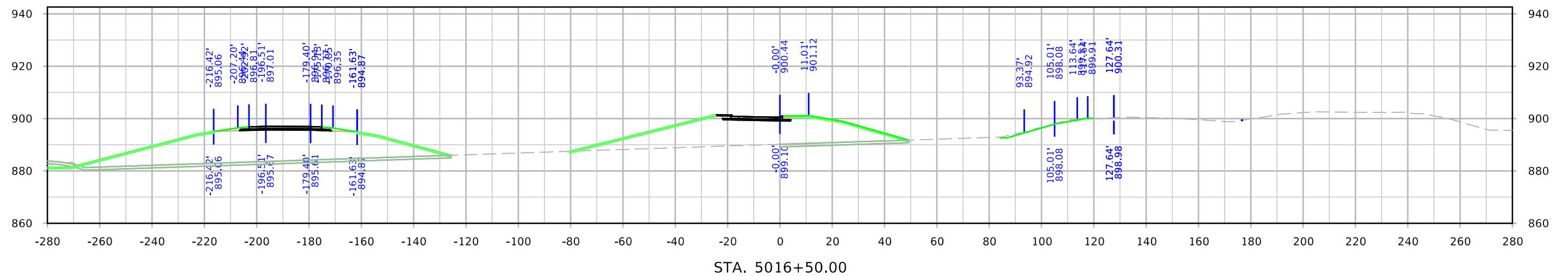
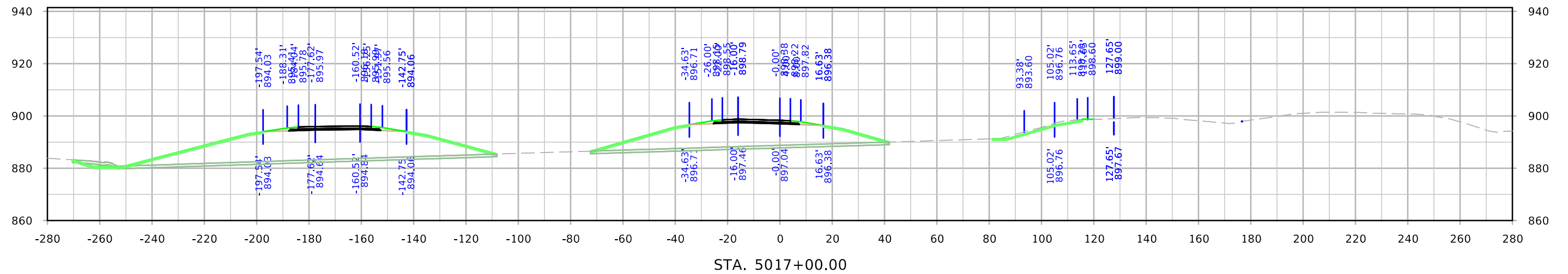
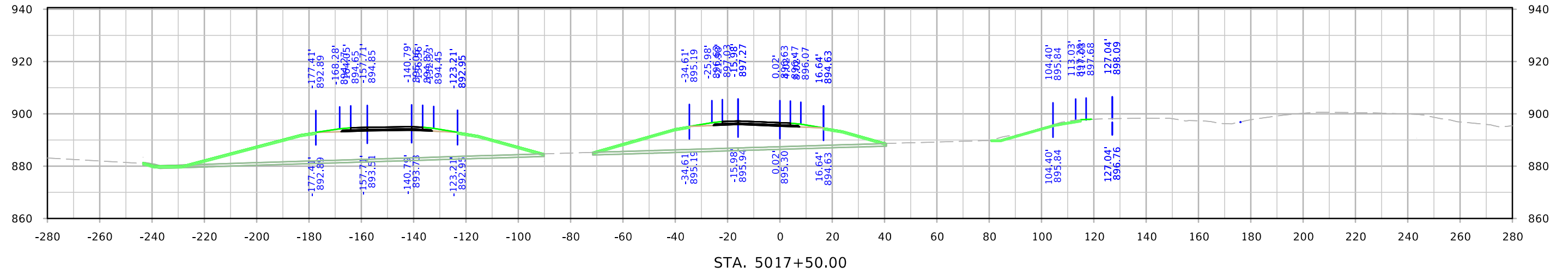

I-80 Ramp E Preliminary

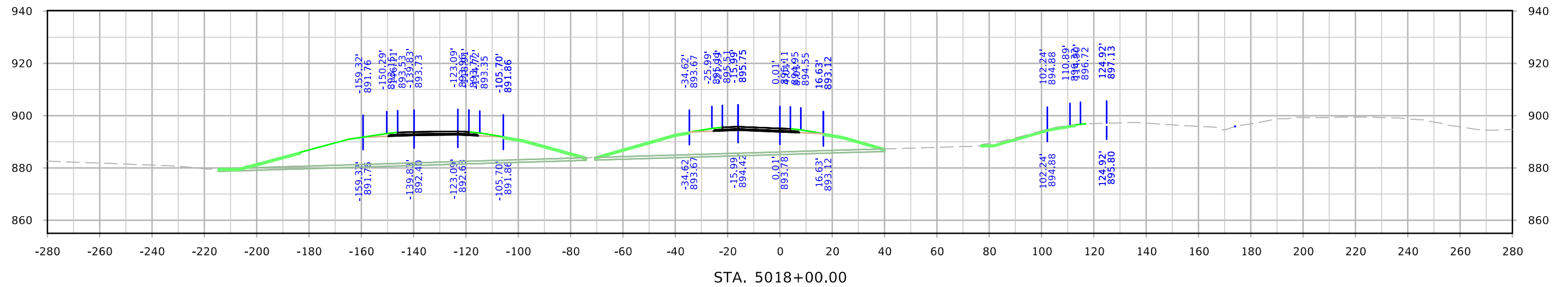
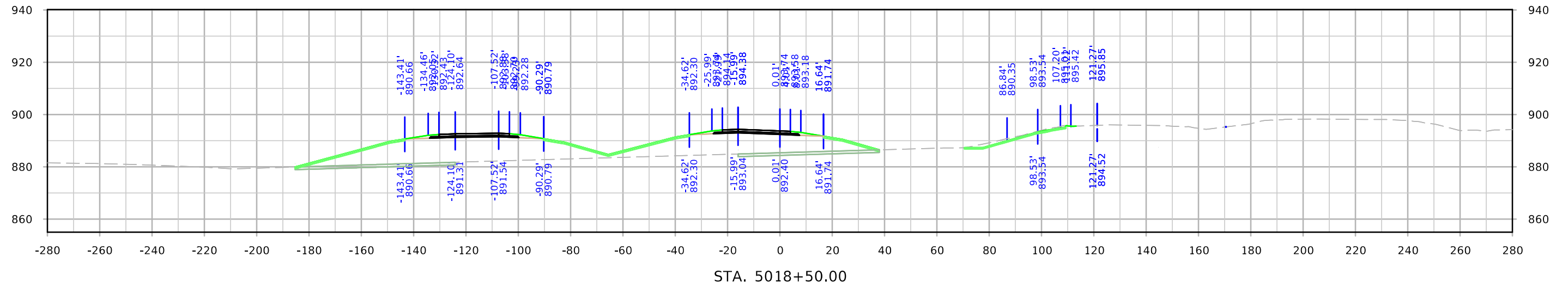
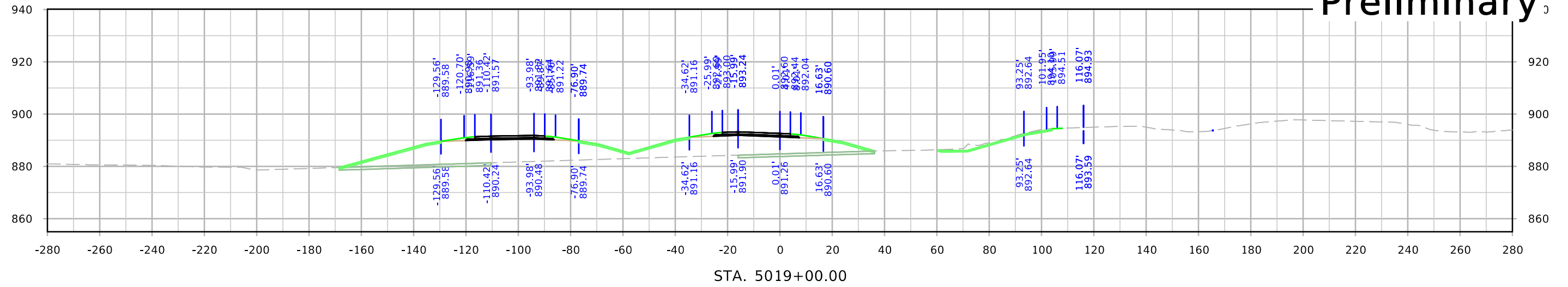

I-80 Ramp E Preliminary

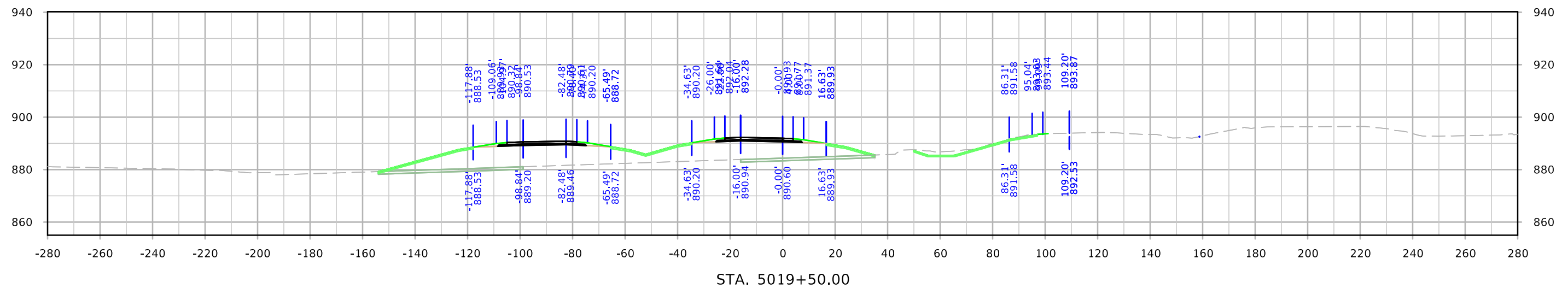
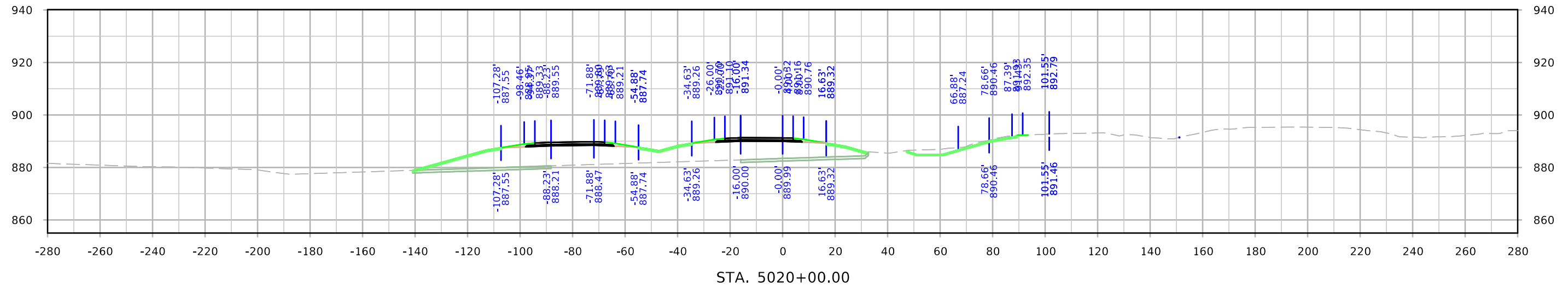
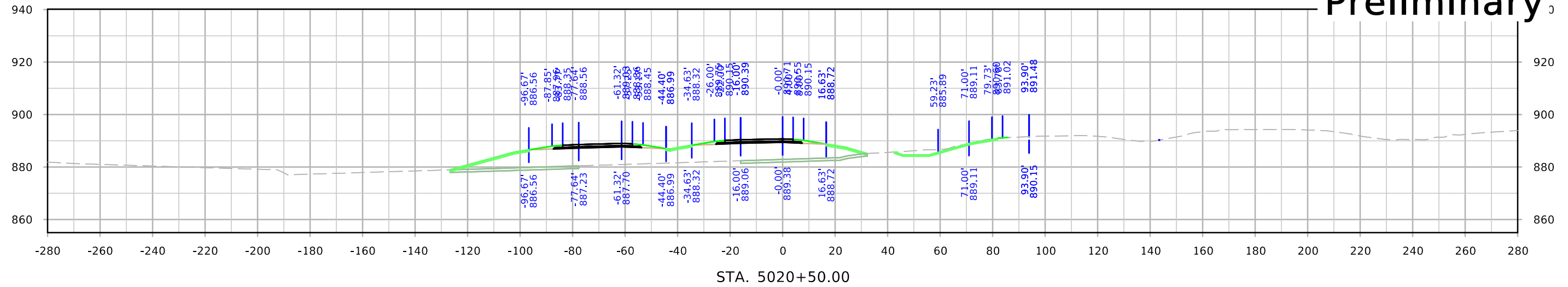

I-80 Ramp E Preliminary

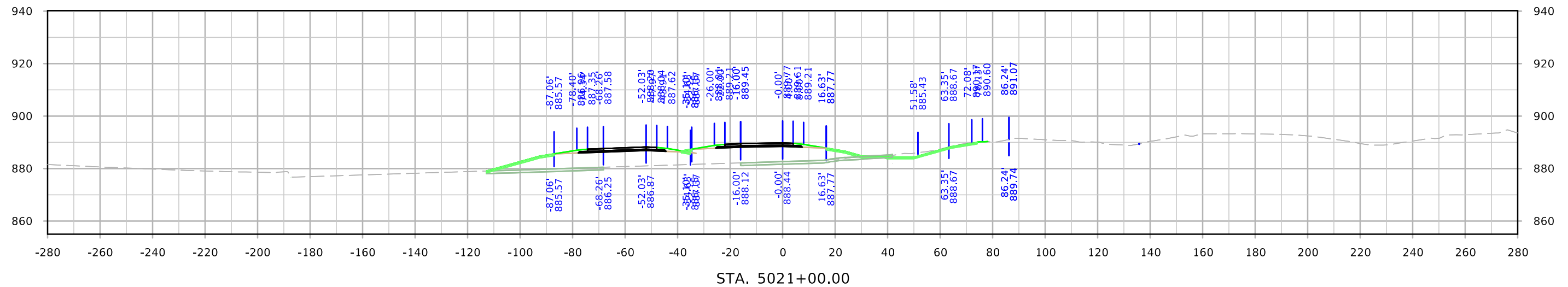
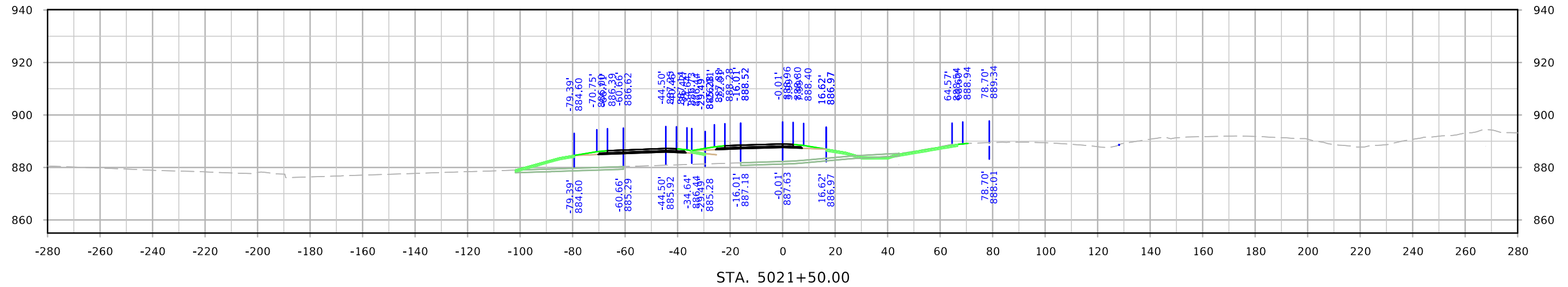
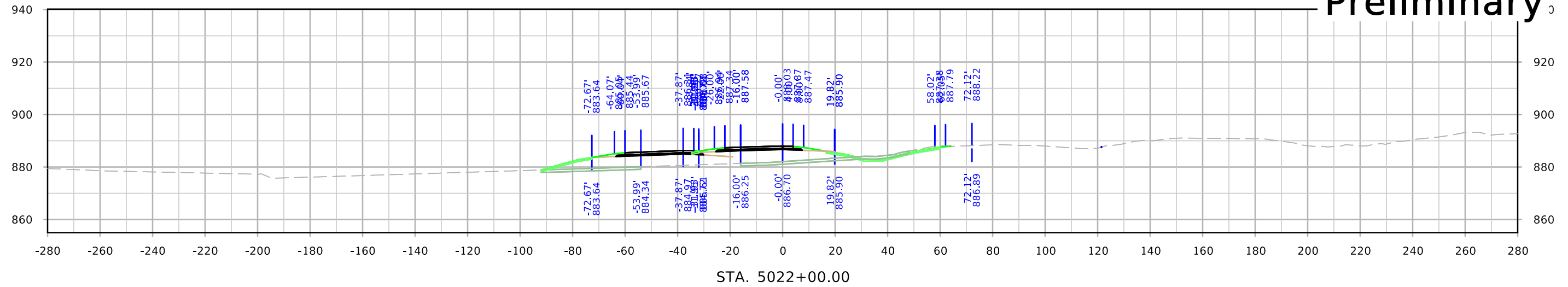

I-80 Ramp E Preliminary

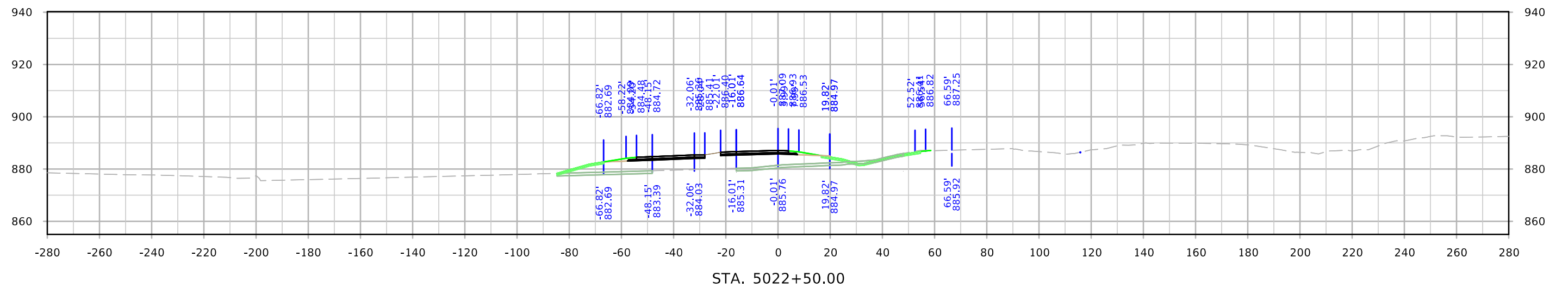
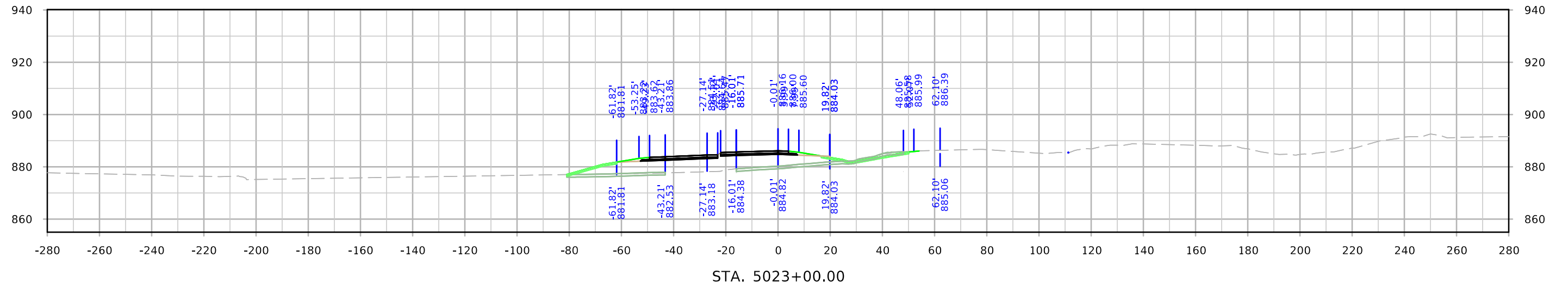
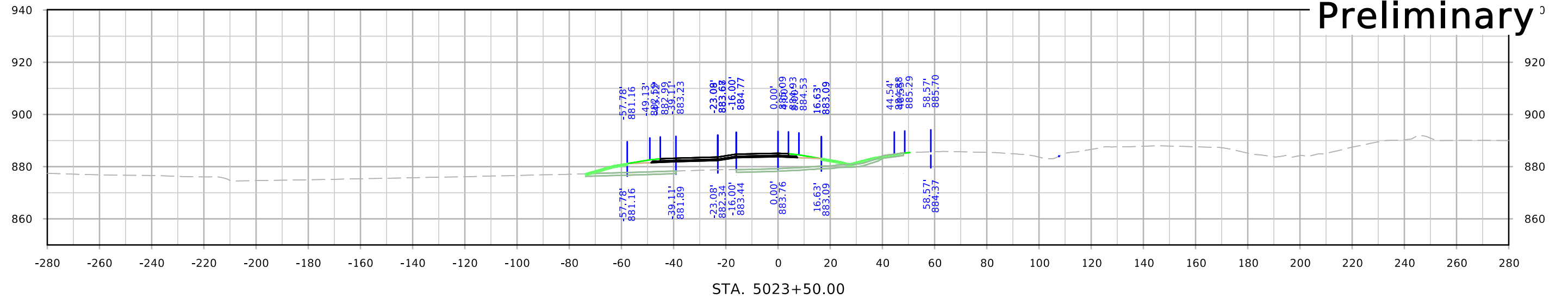

I-80 Ramp E
Preliminary

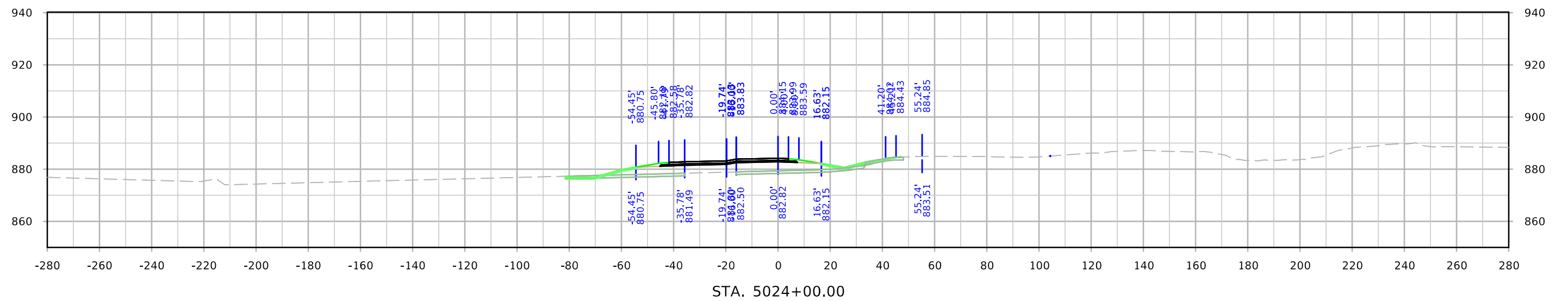
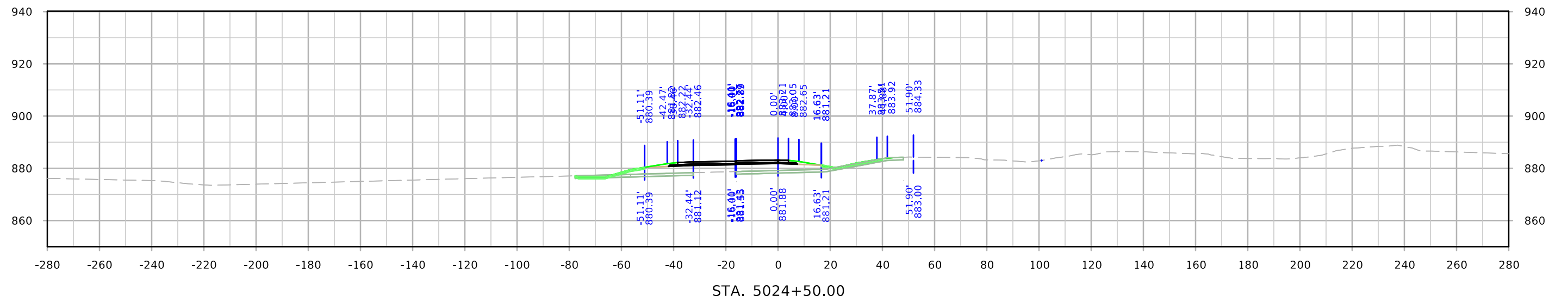
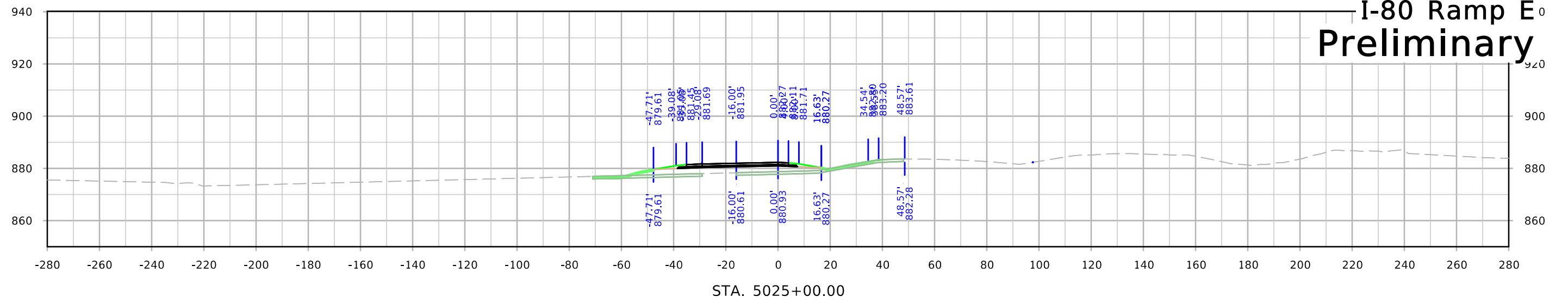

I-80 Ramp E
Preliminary

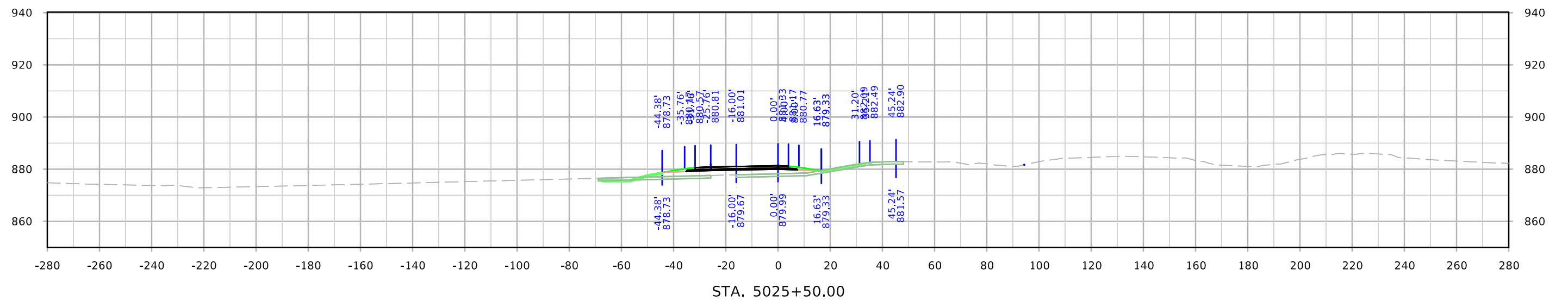
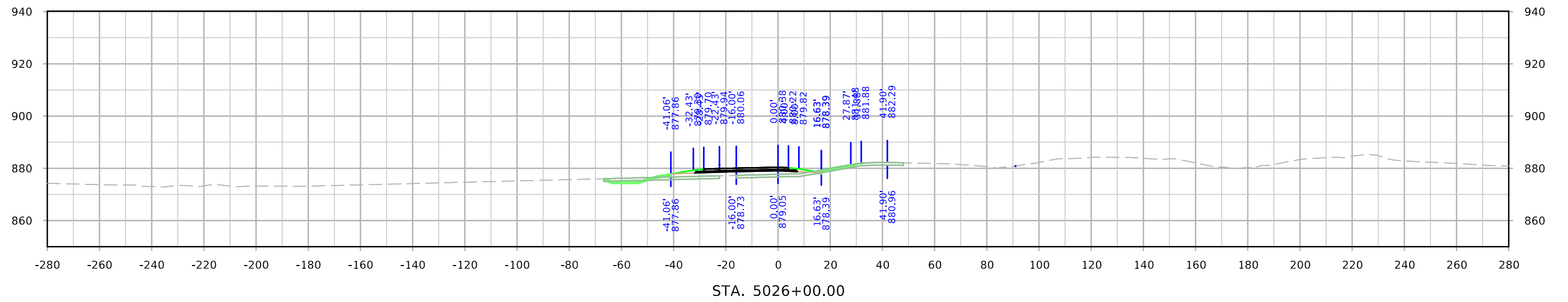
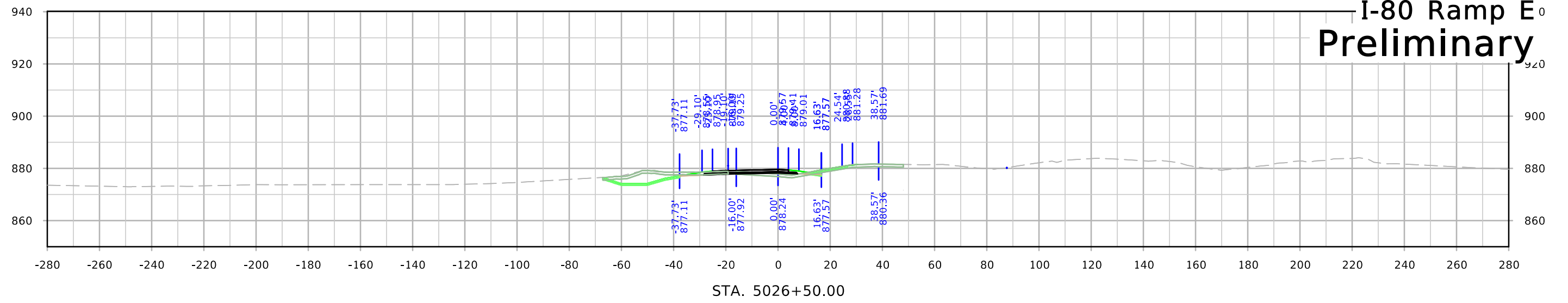

I-80 Ramp E
Preliminary

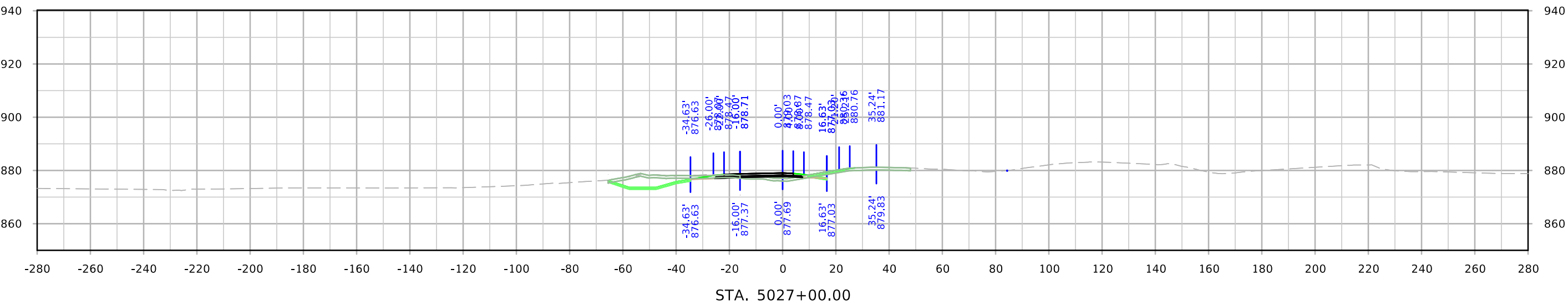
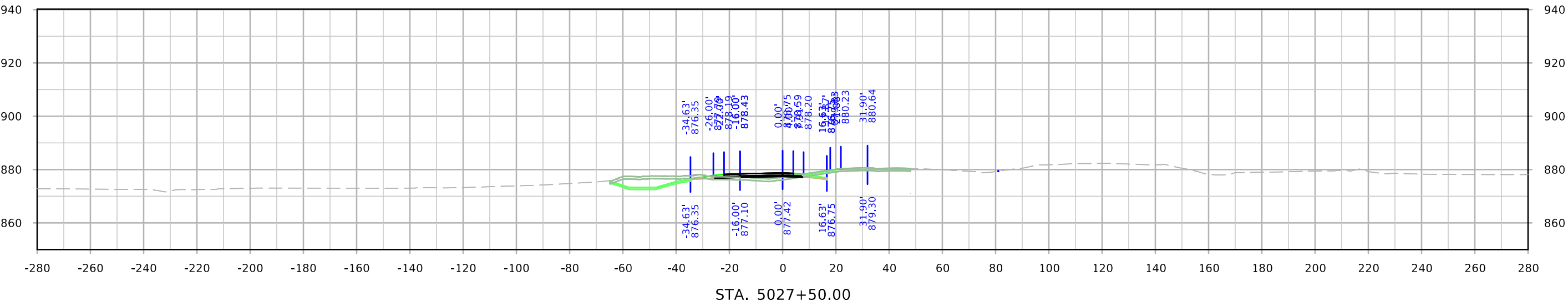
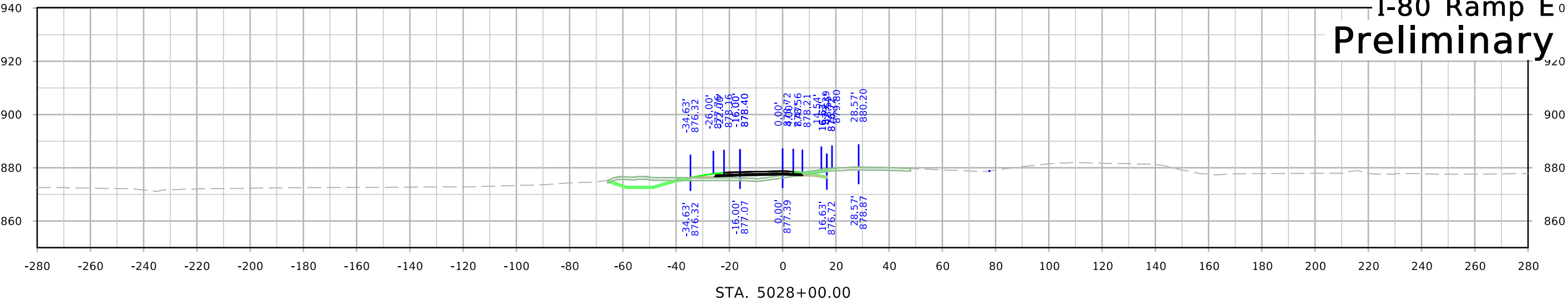

I-80 Ramp E
Preliminary

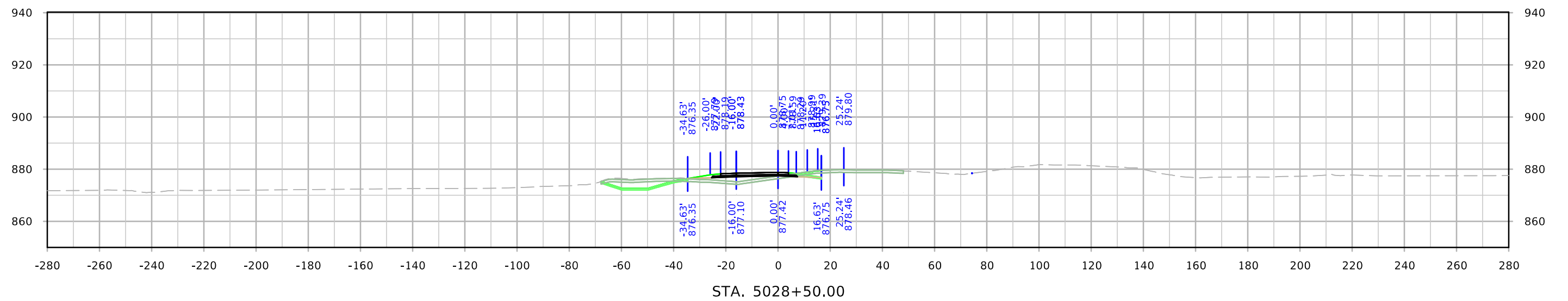
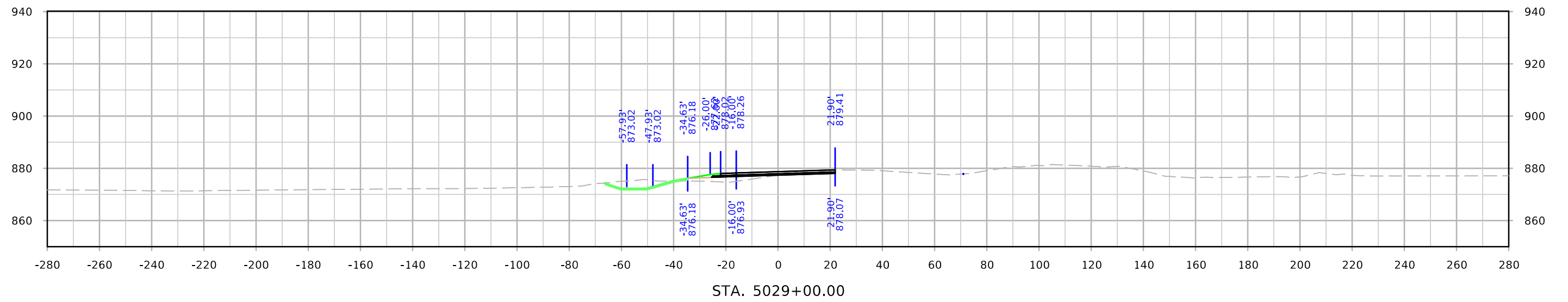
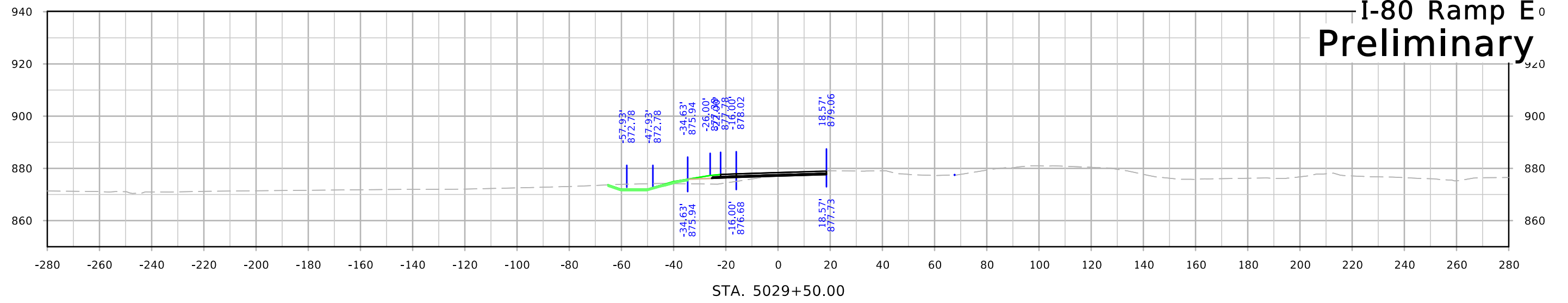

I-80 Ramp E Preliminary

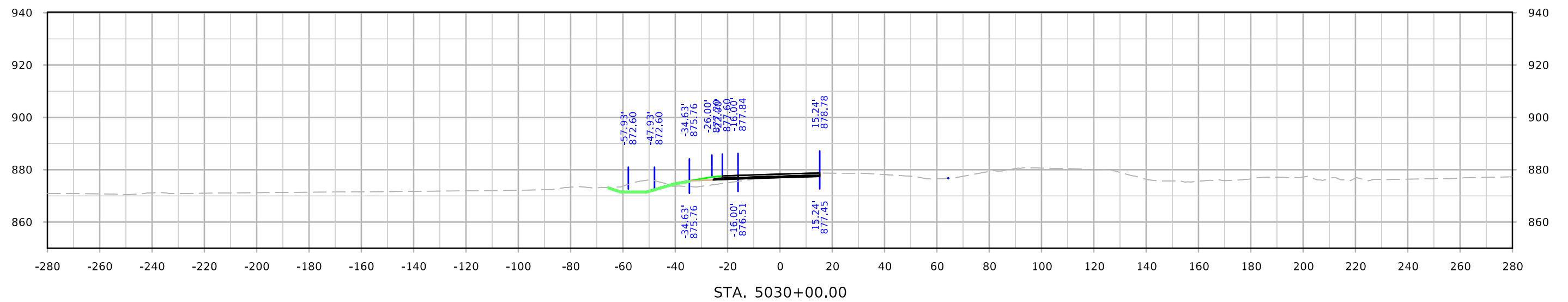
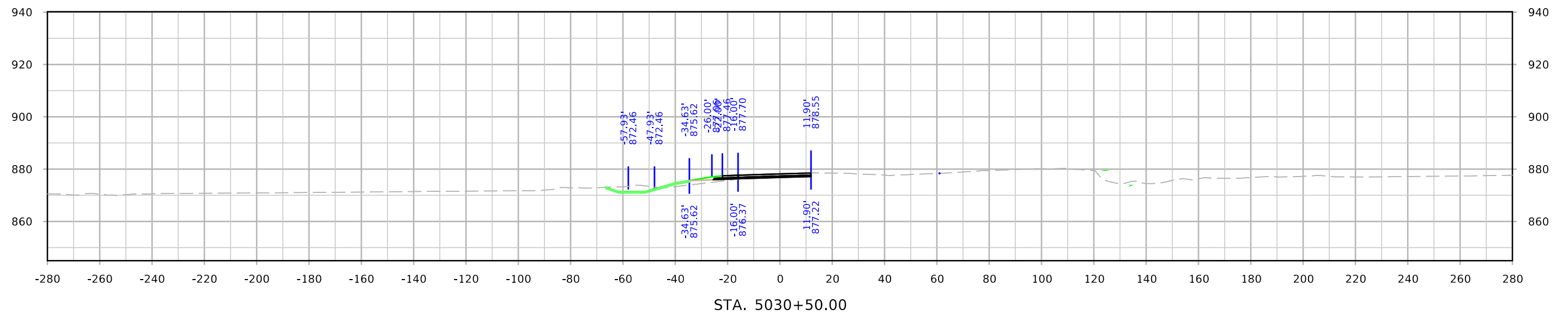

I-80 Ramp E Preliminary

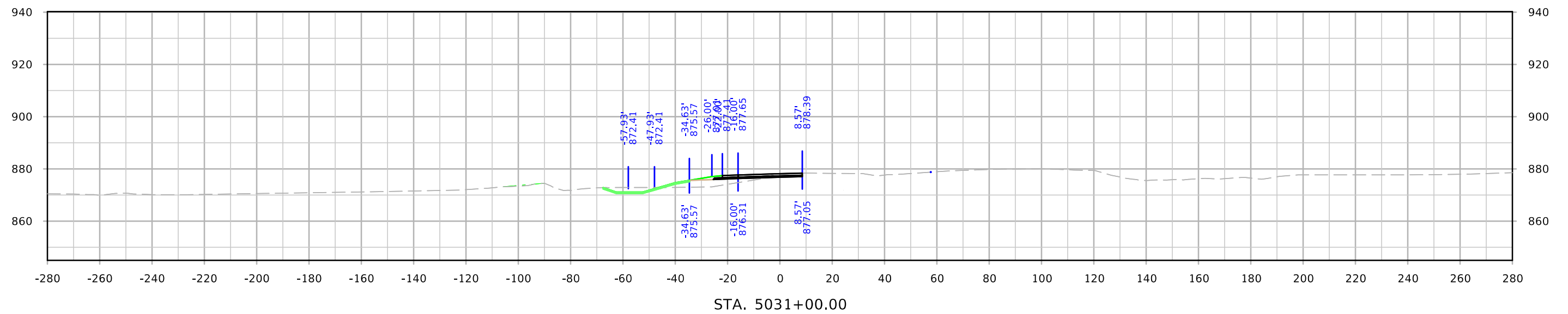
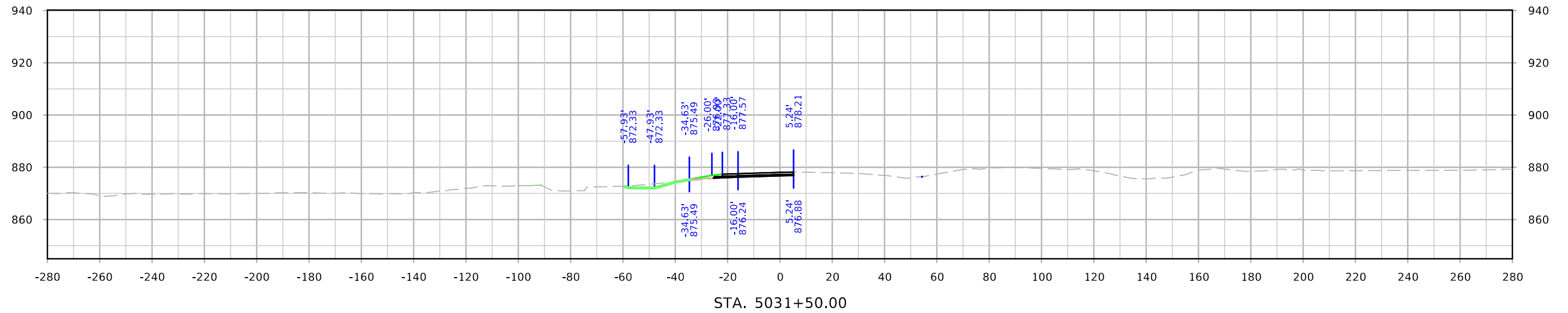

I-80 Ramp E Preliminary

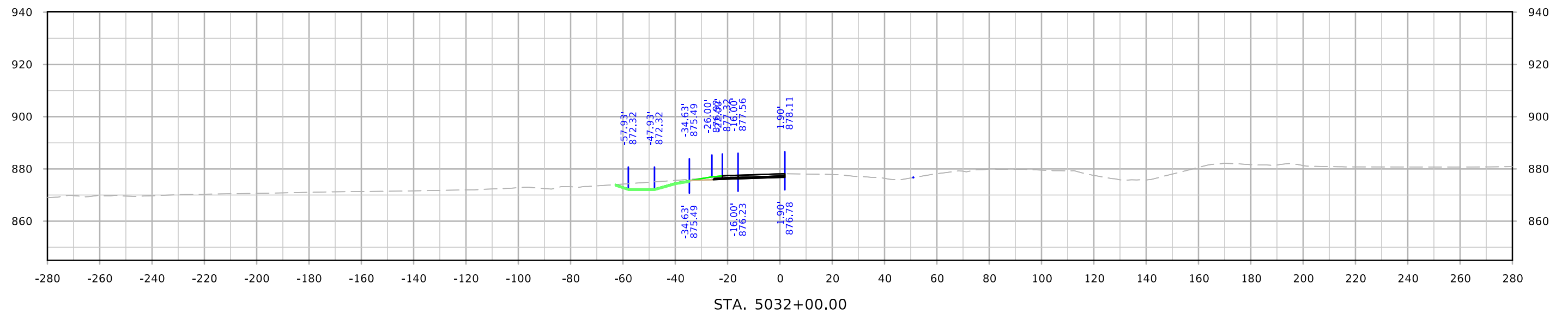
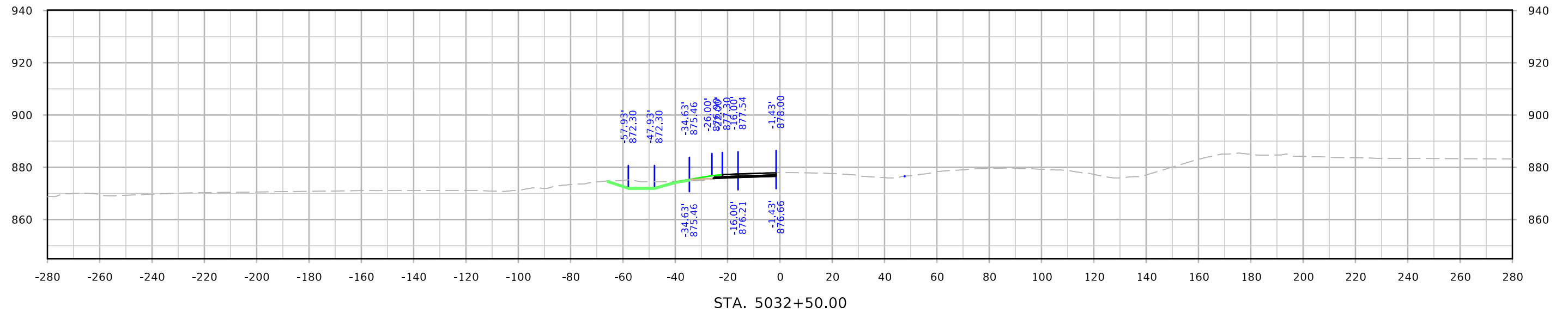

I-80 Ramp E Preliminary

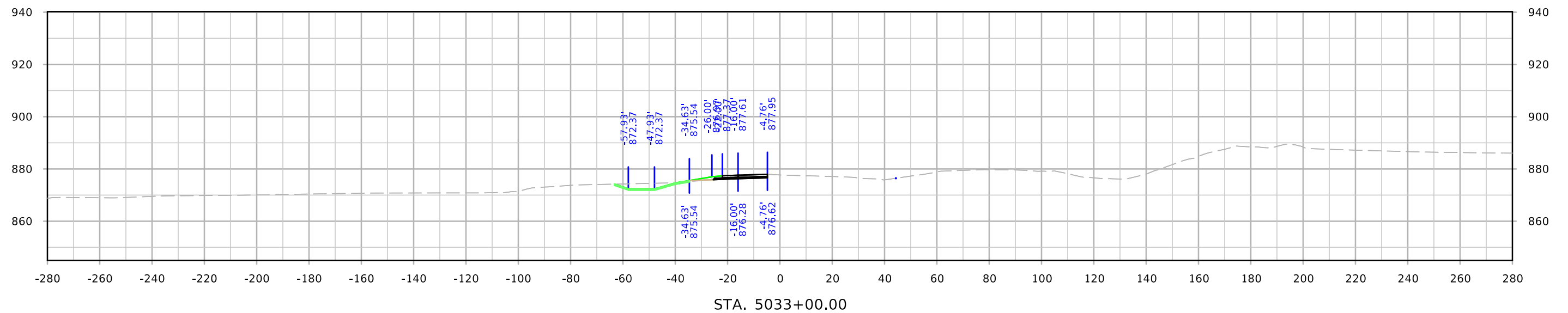
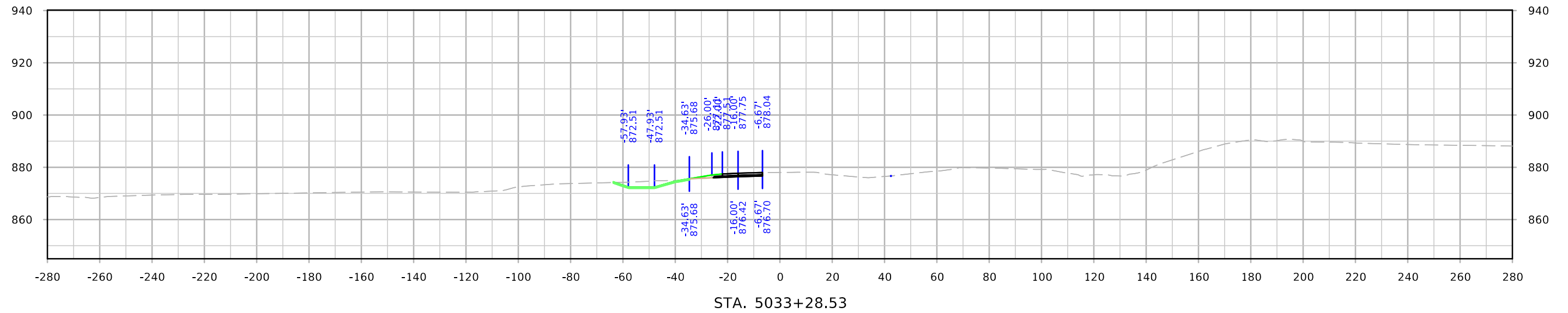

I-80 Ramp G Preliminary

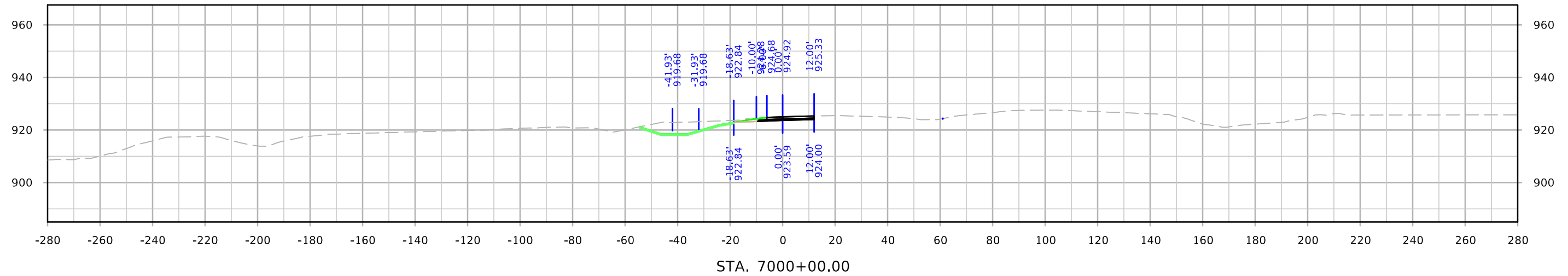
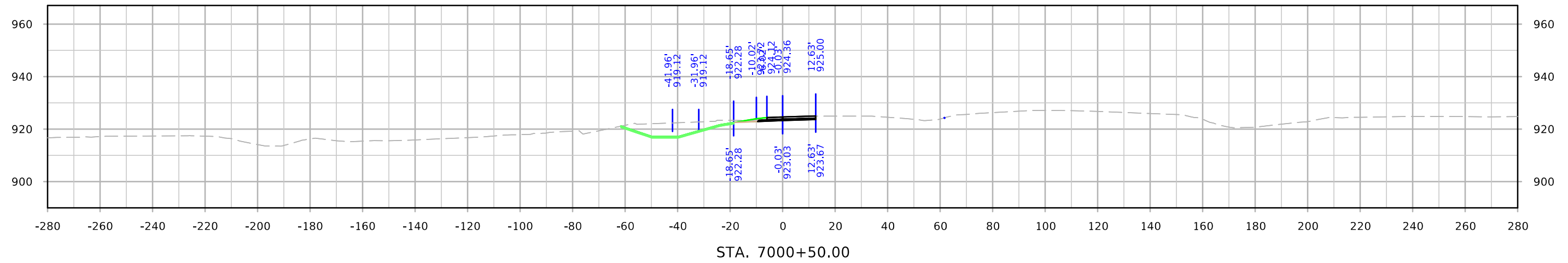
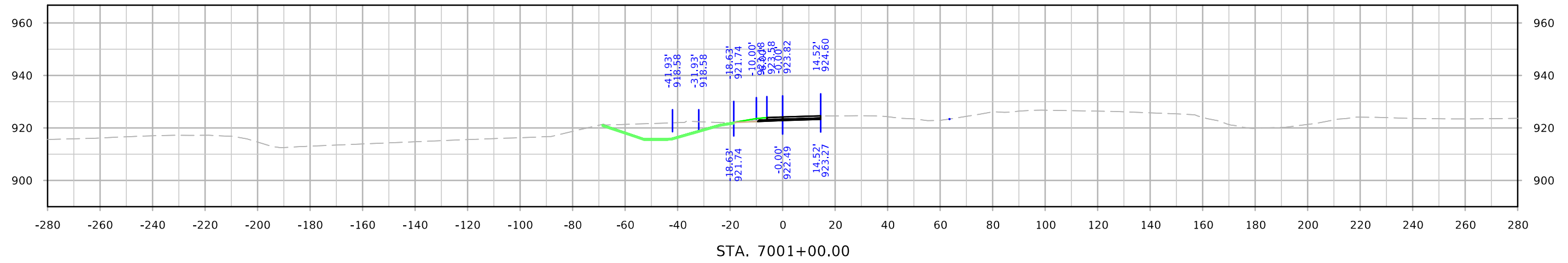

I-80 Ramp G Preliminary

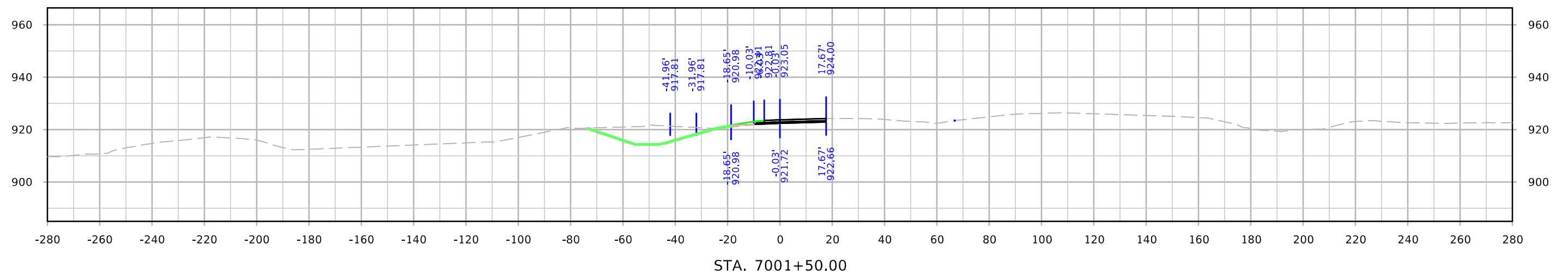
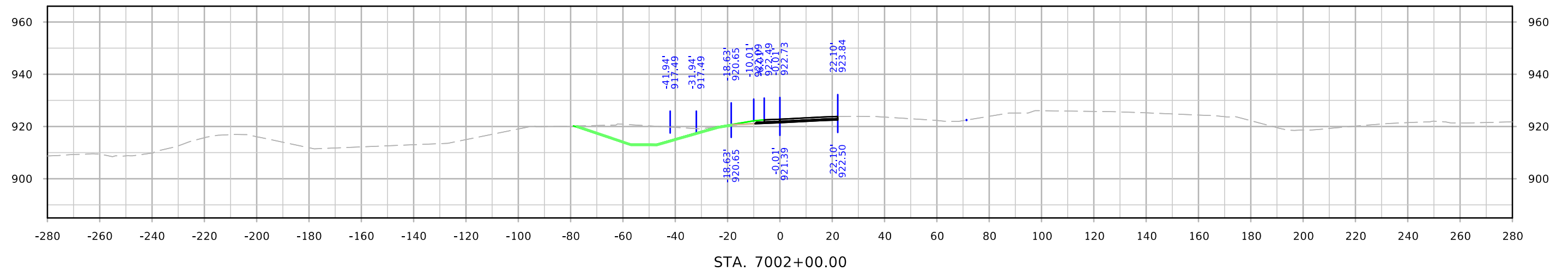
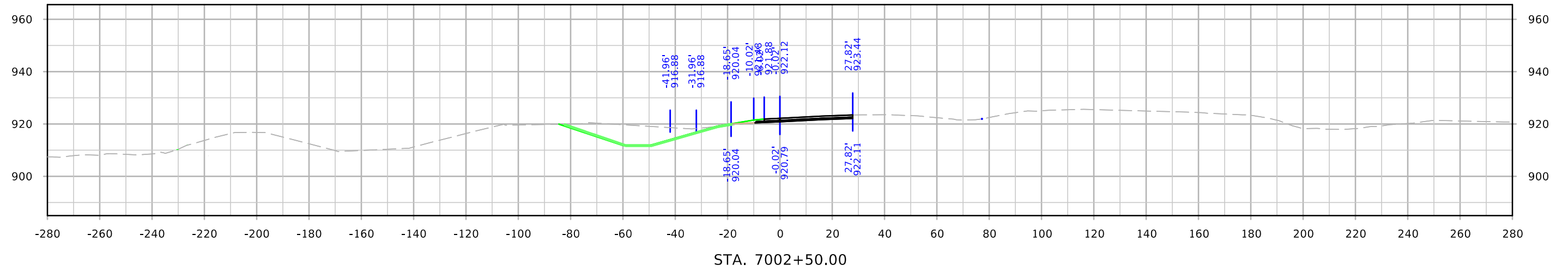

I-80 Ramp G Preliminary

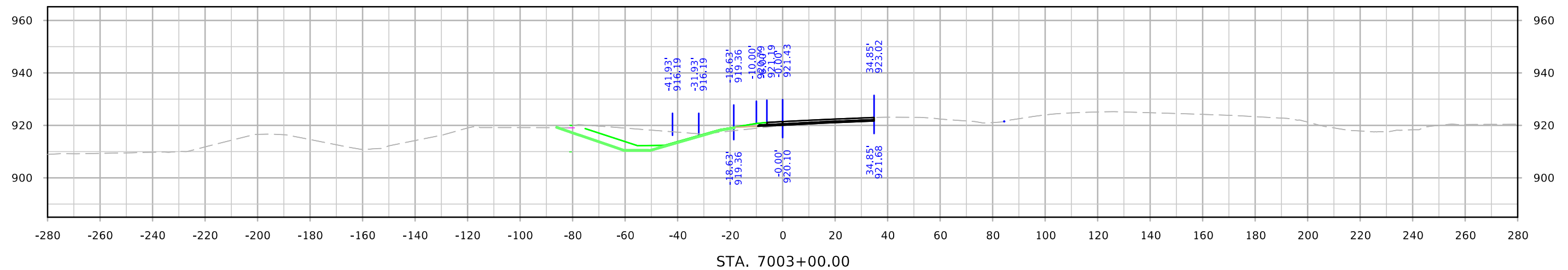
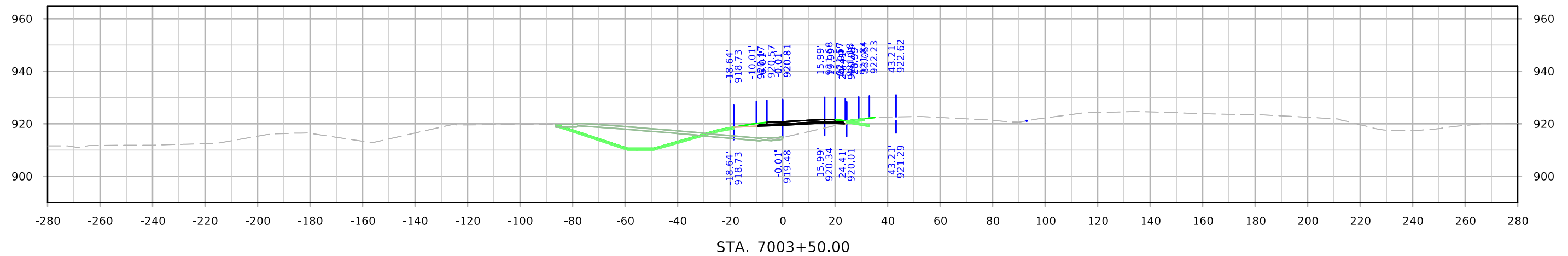
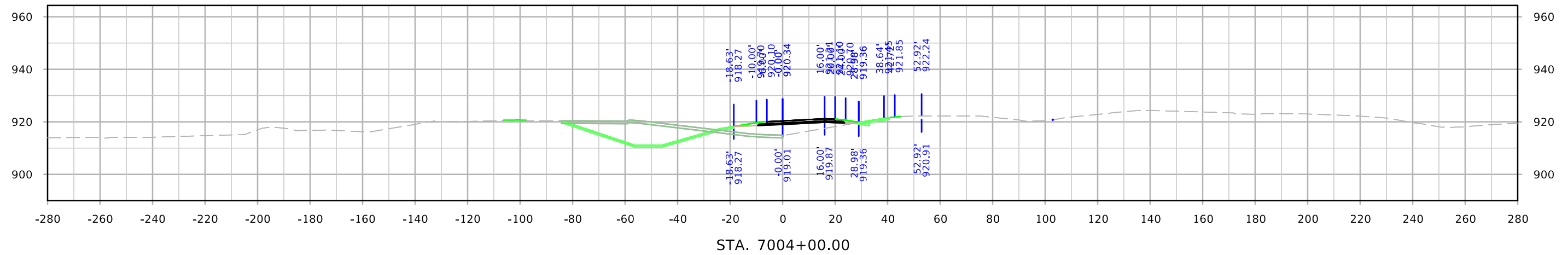

I-80 Ramp G Preliminary

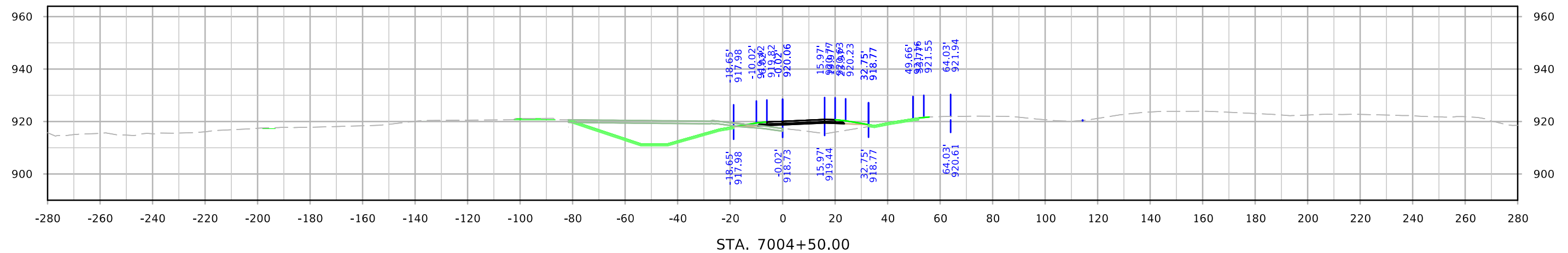
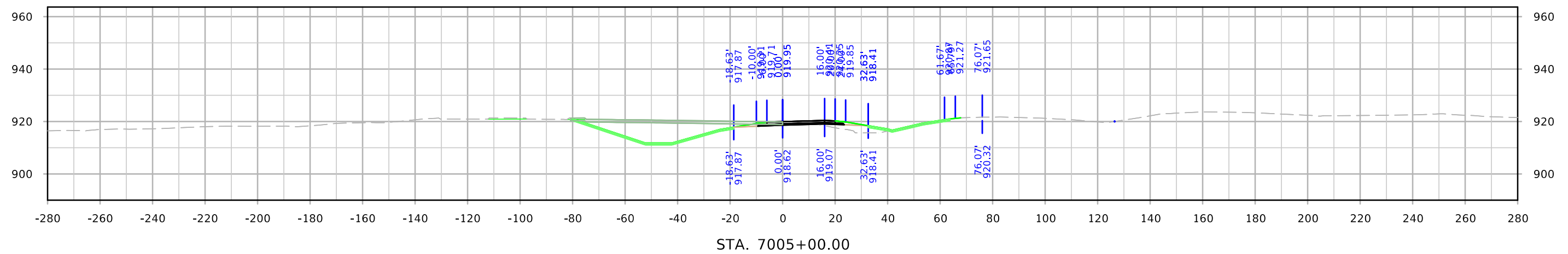
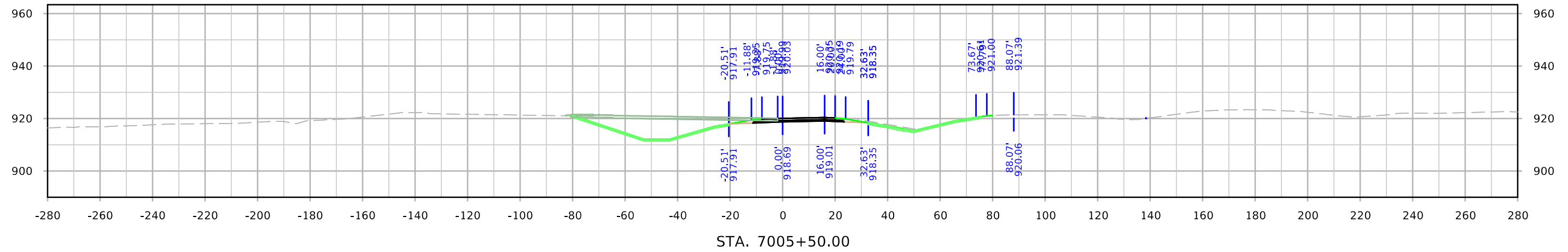

I-80 Ramp G Preliminary

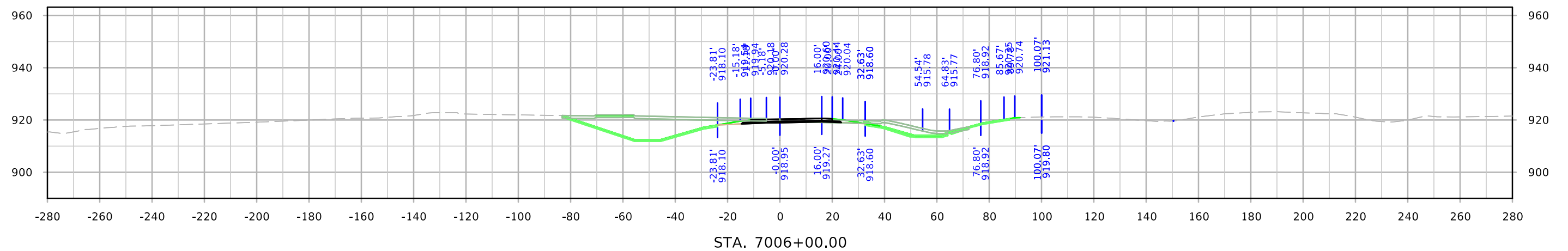
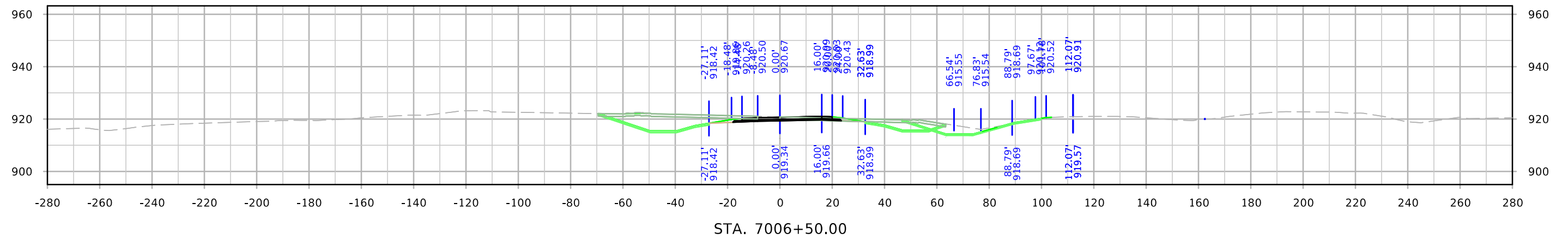
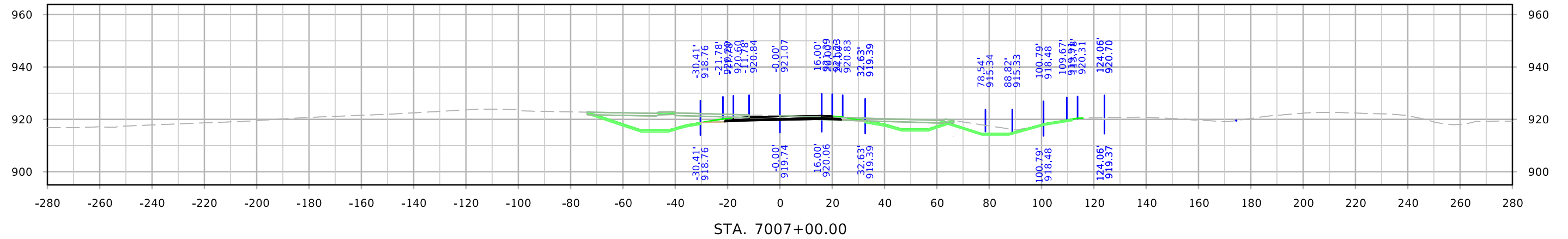

I-80 Ramp G Preliminary

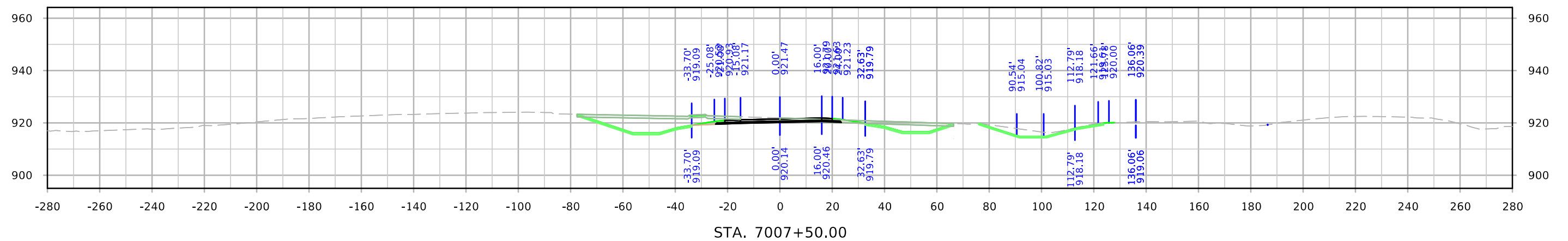
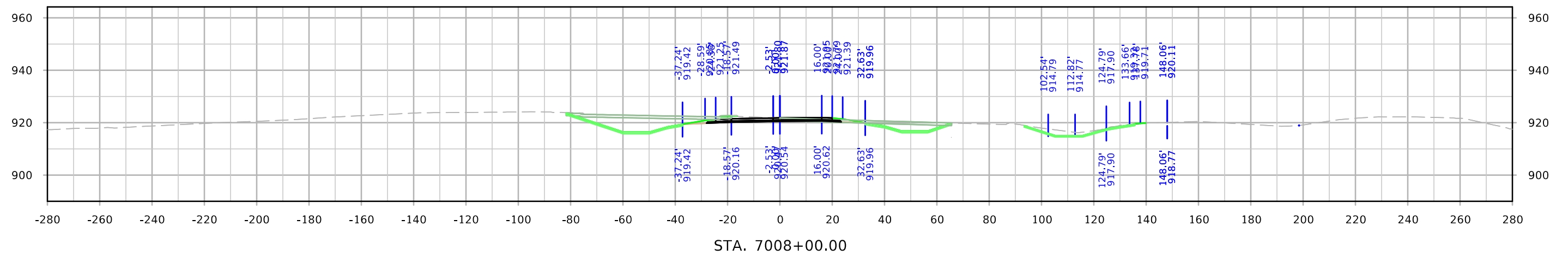
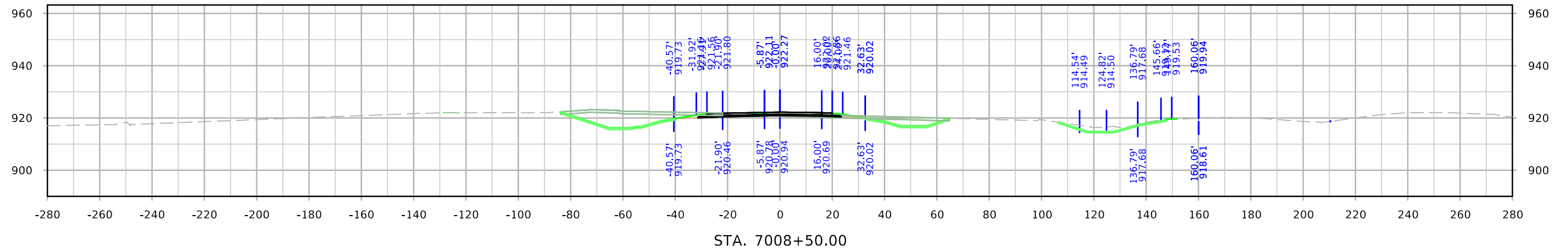

I-80 Ramp G Preliminary

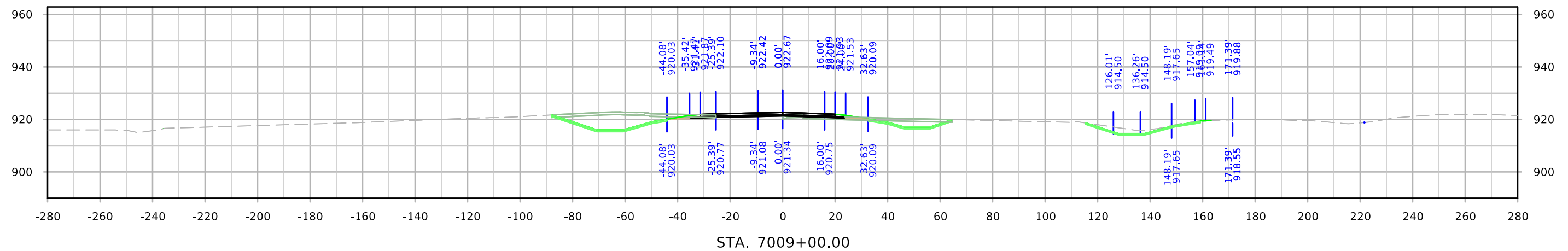
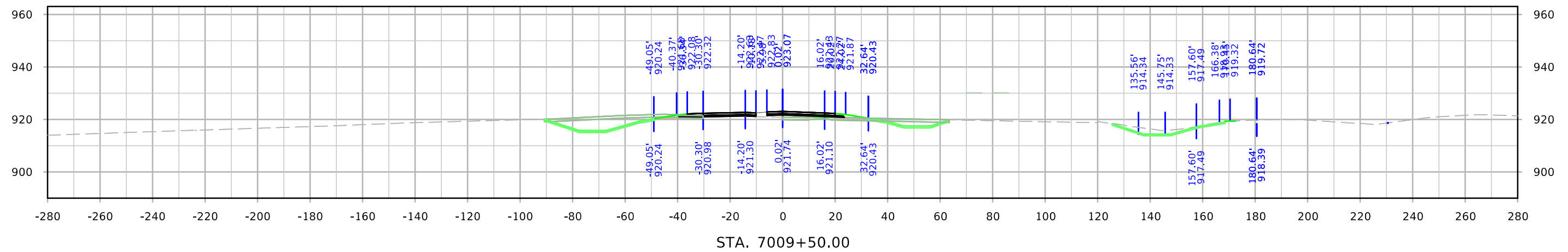
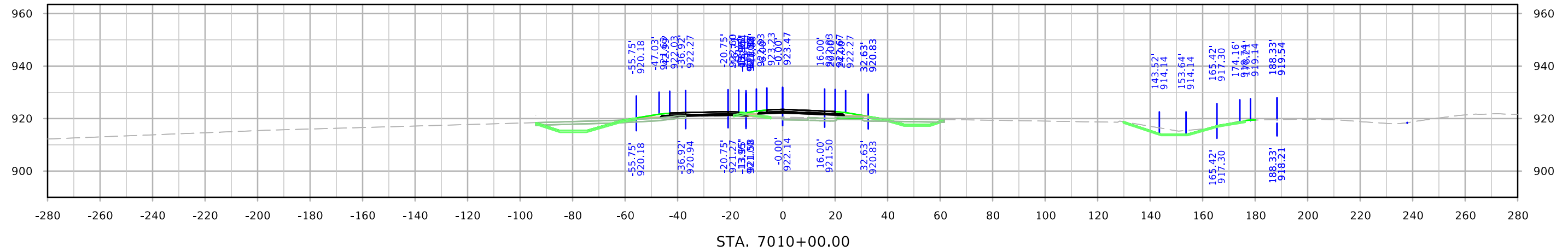

I-80 Ramp G Preliminary

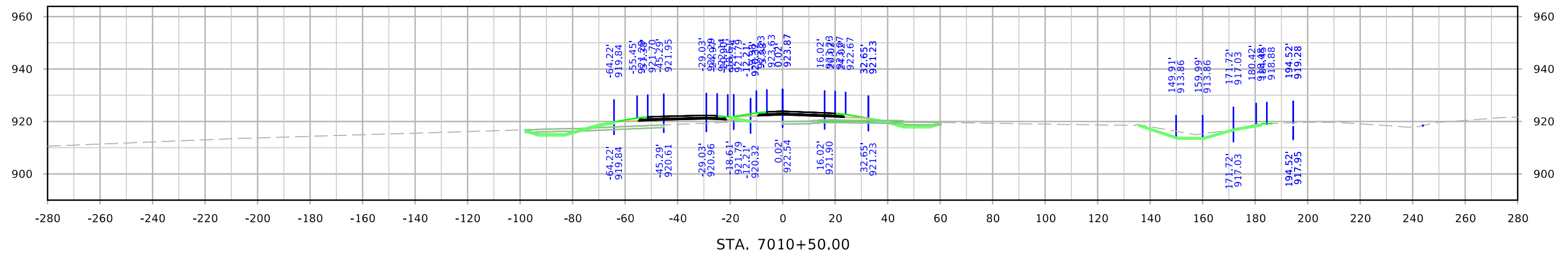
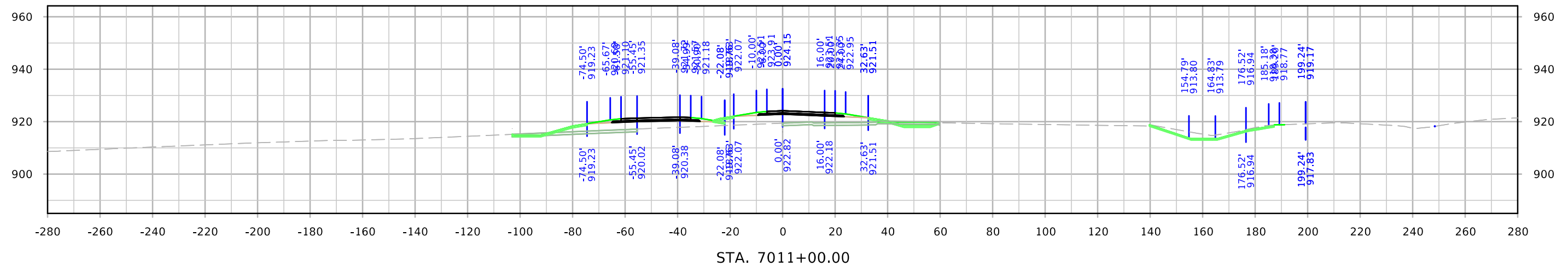
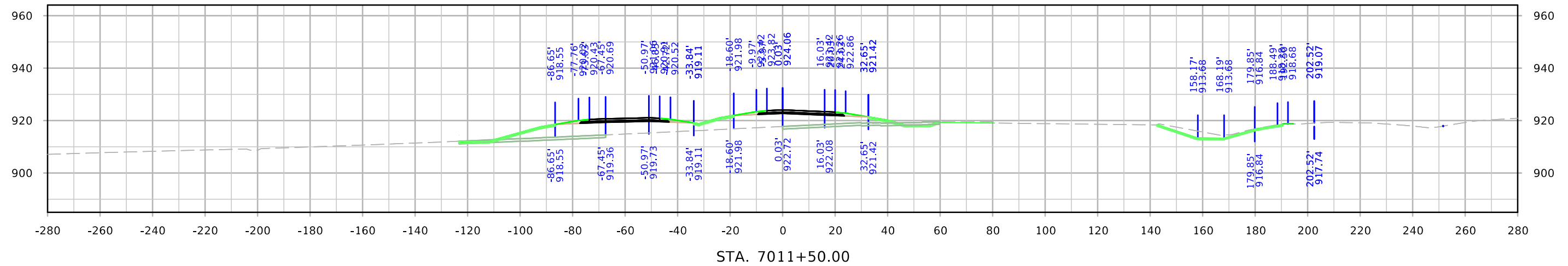

I-80 Ramp G Preliminary

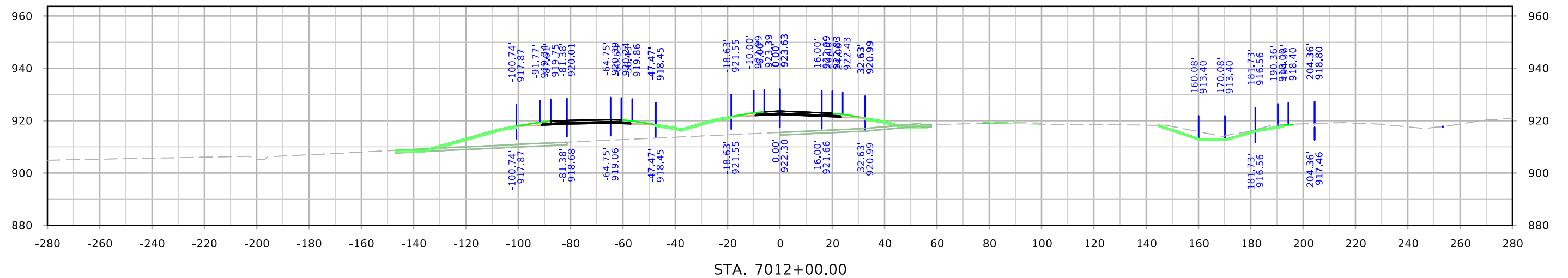
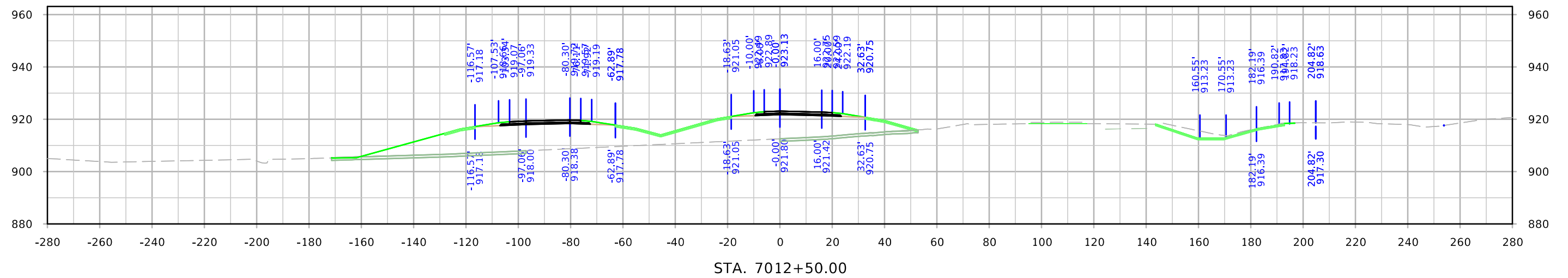
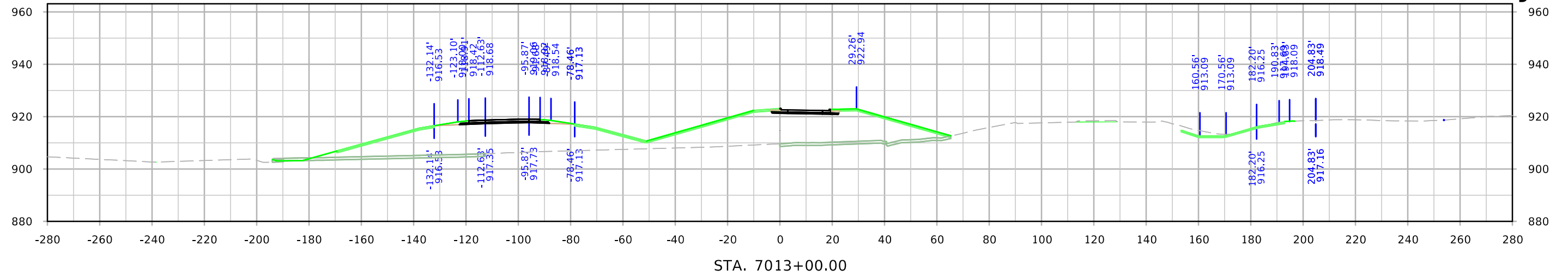

I-80 Ramp G Preliminary

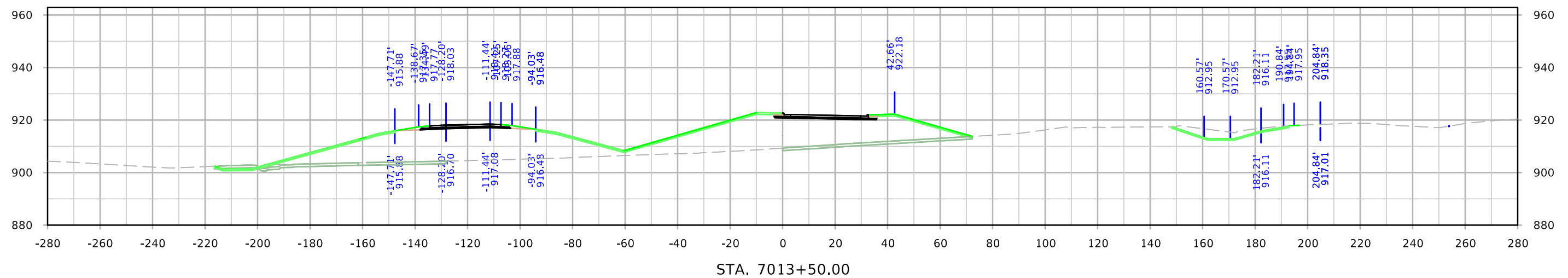
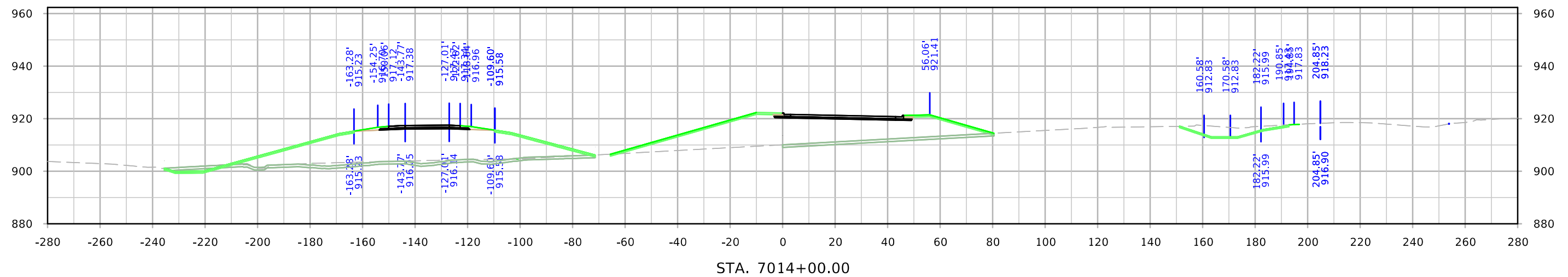
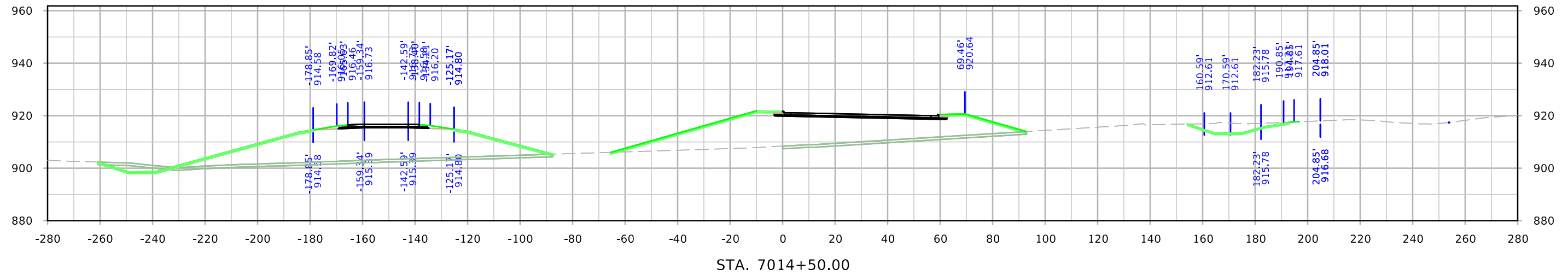

I-80 Ramp G Preliminary

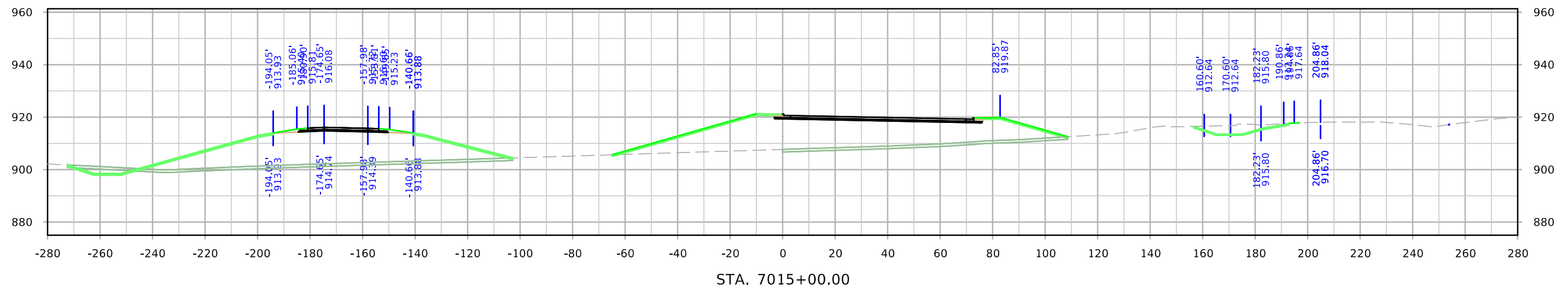
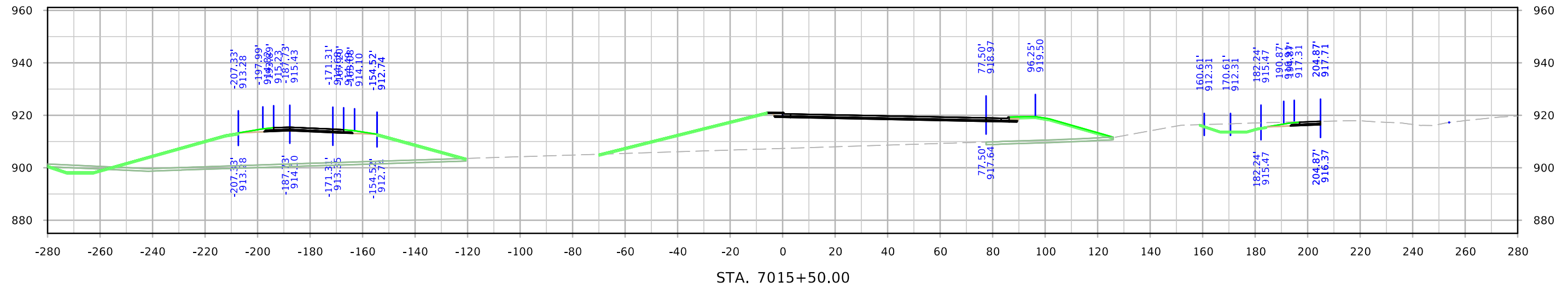
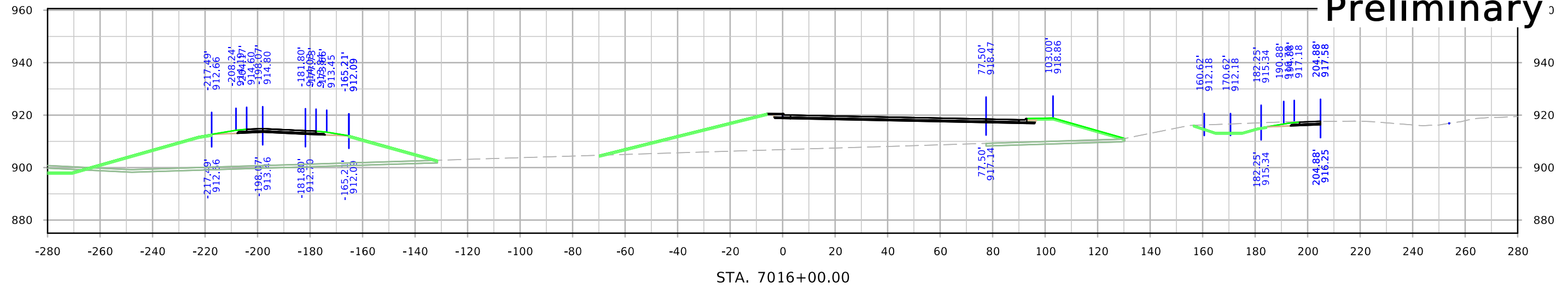

I-80 Ramp G Preliminary

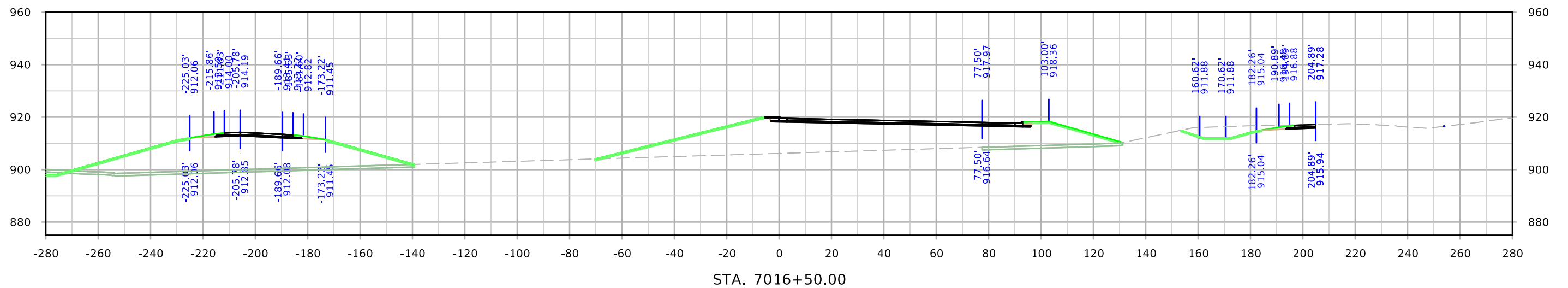
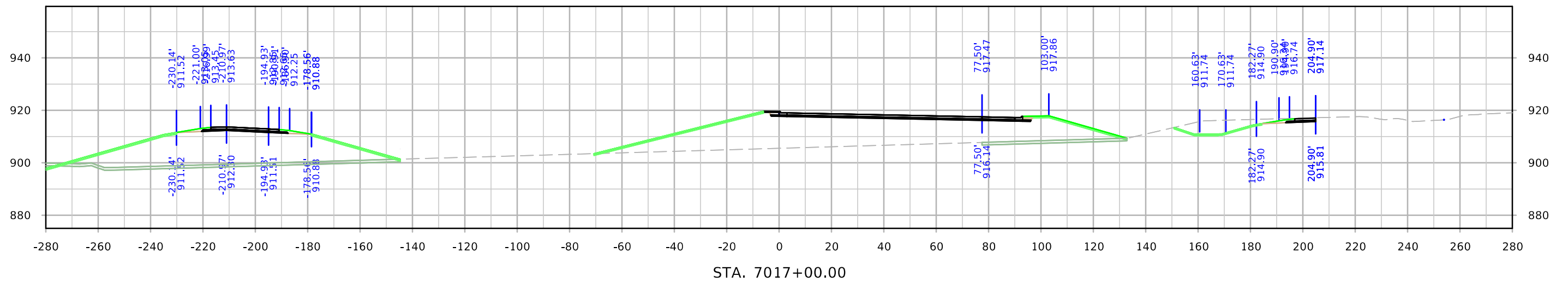
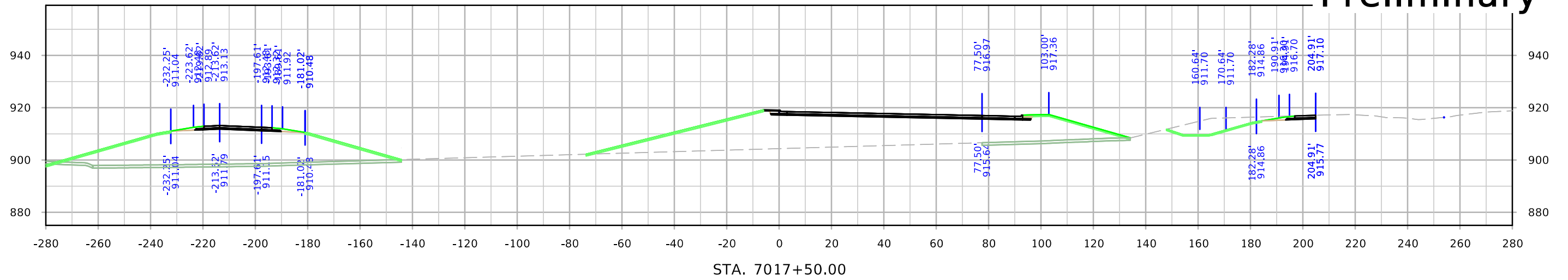

I-80 Ramp G Preliminary

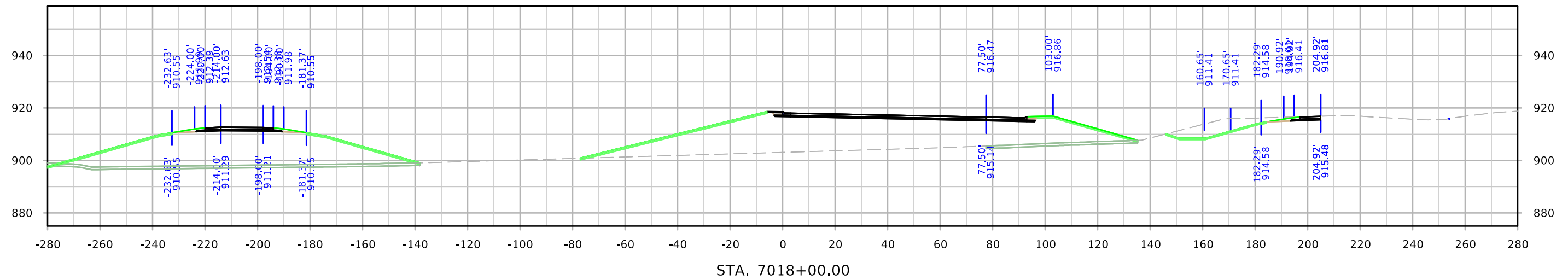
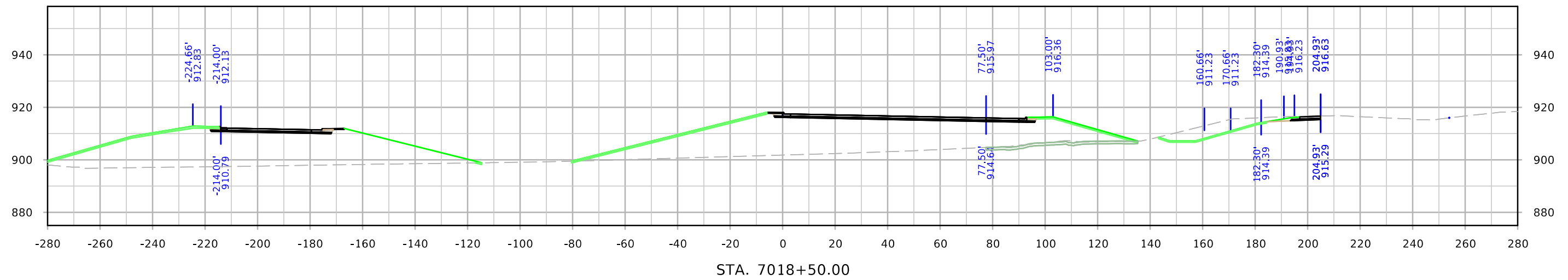
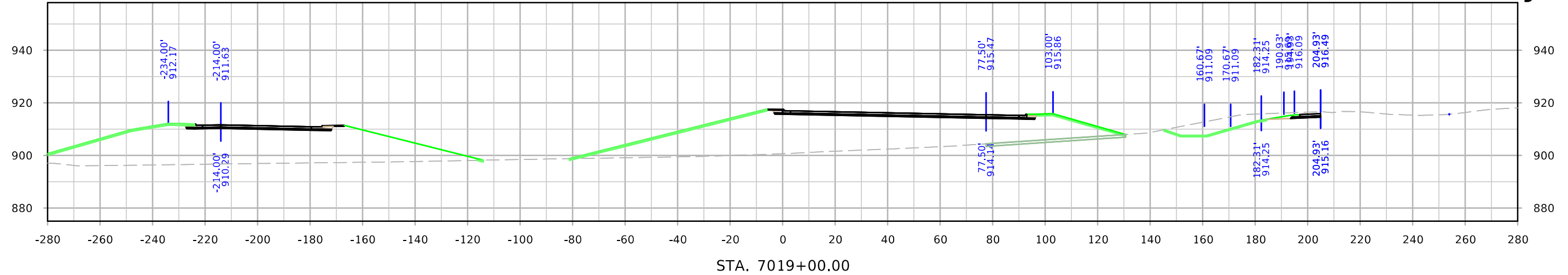

I-80 Ramp G Preliminary

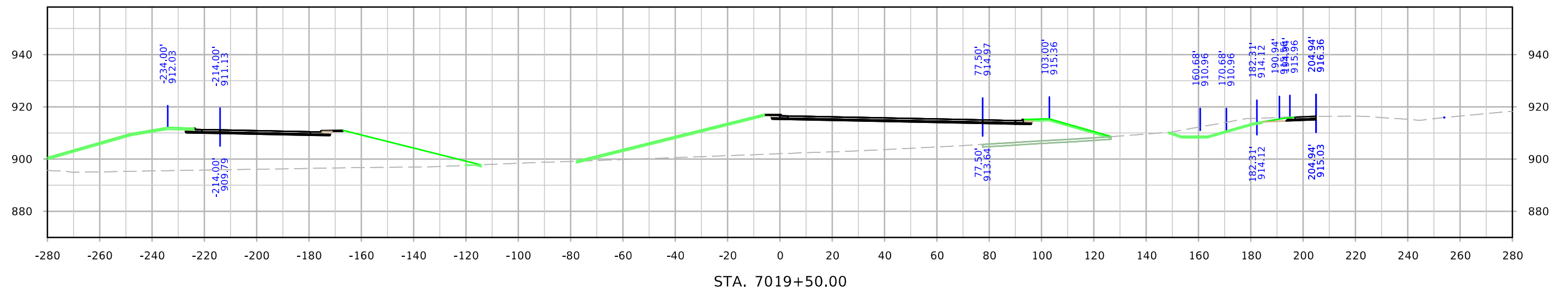
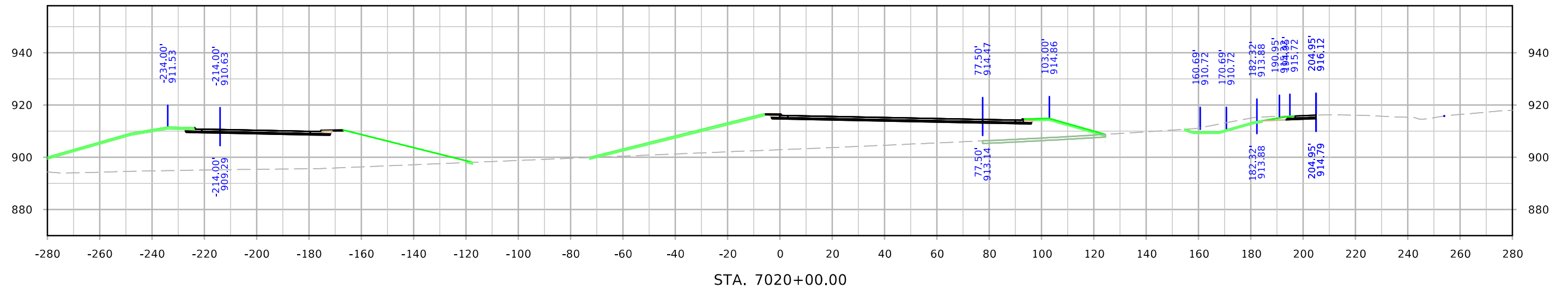
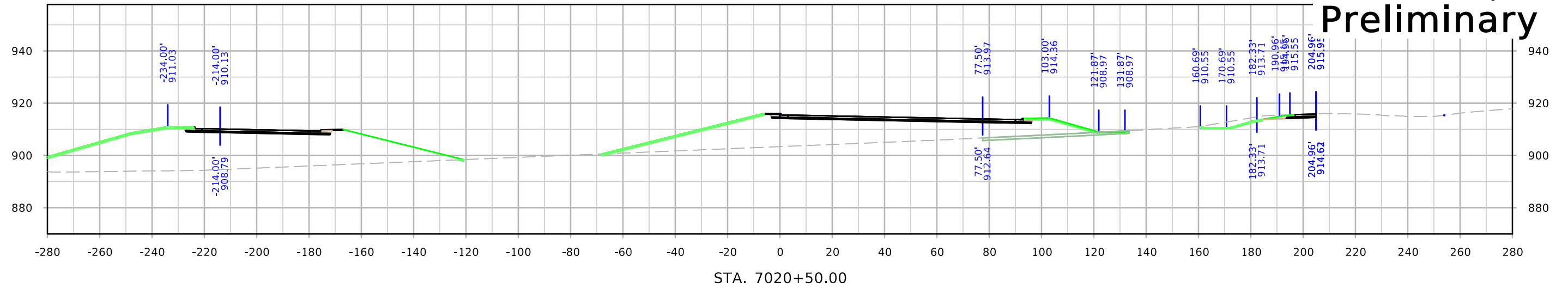

I-80 Ramp G Preliminary

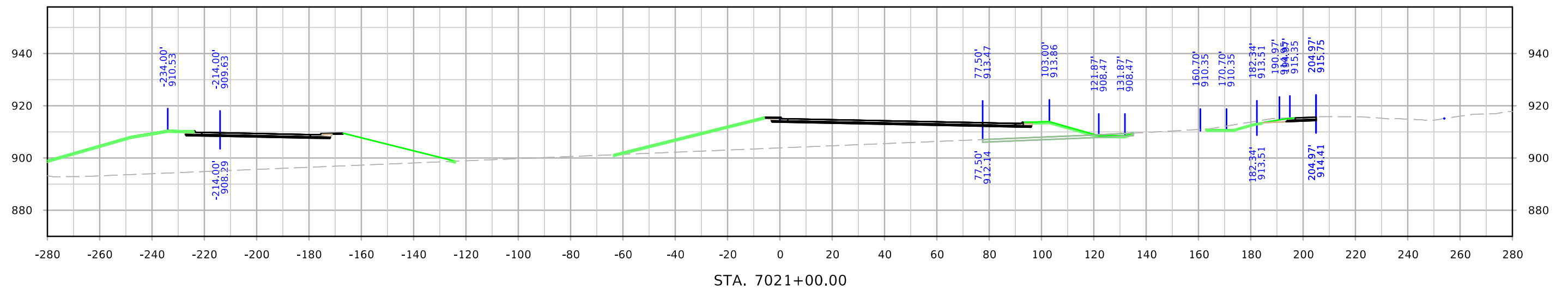
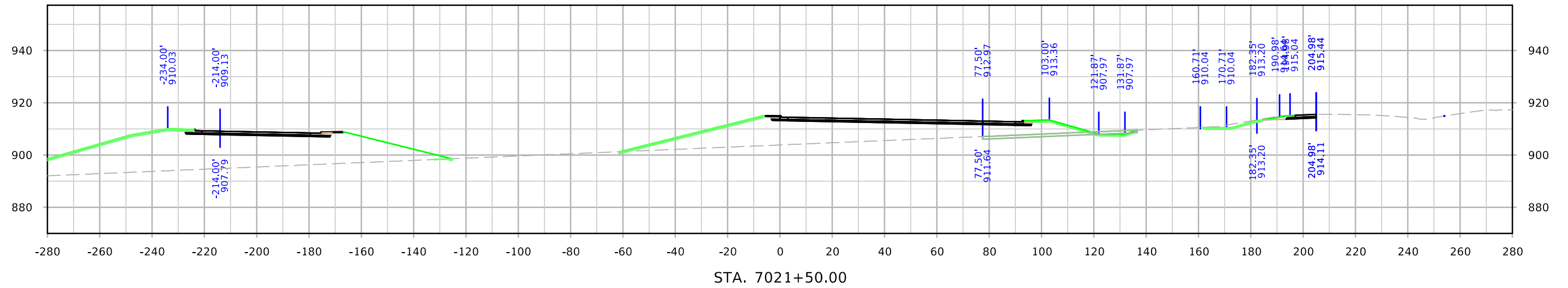
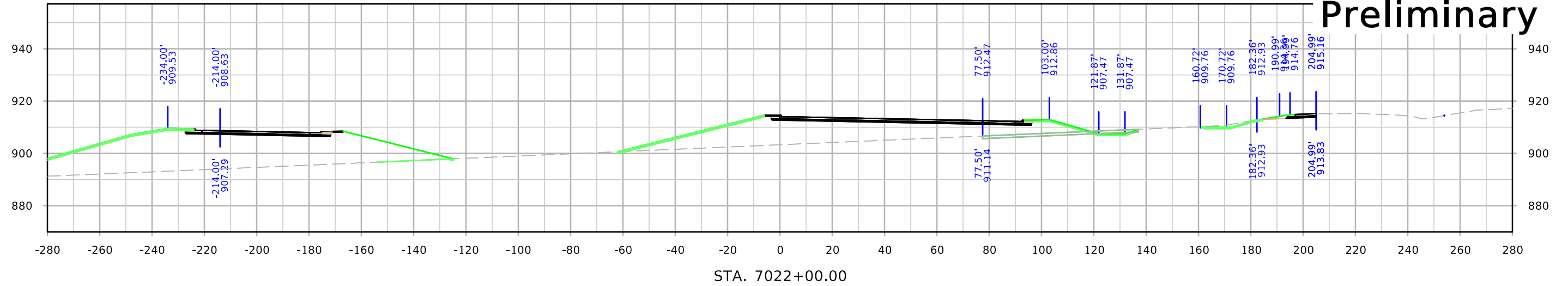

I-80 Ramp G Preliminary

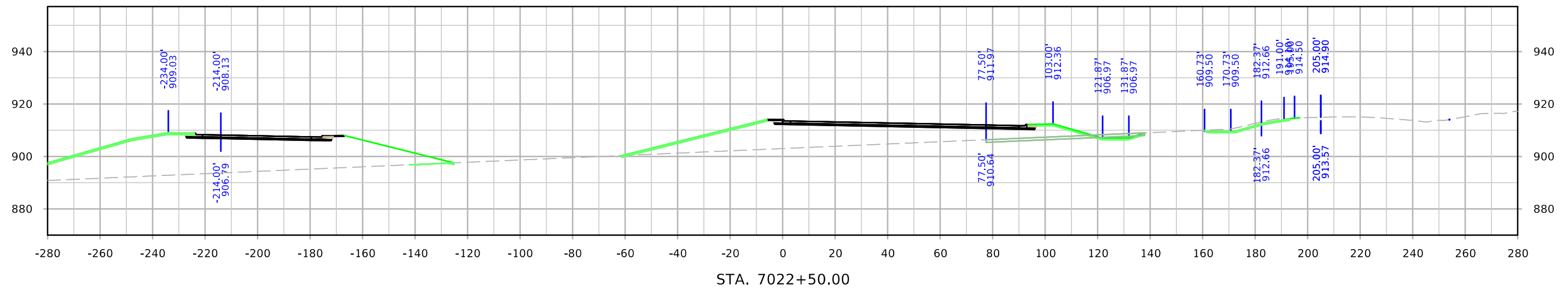
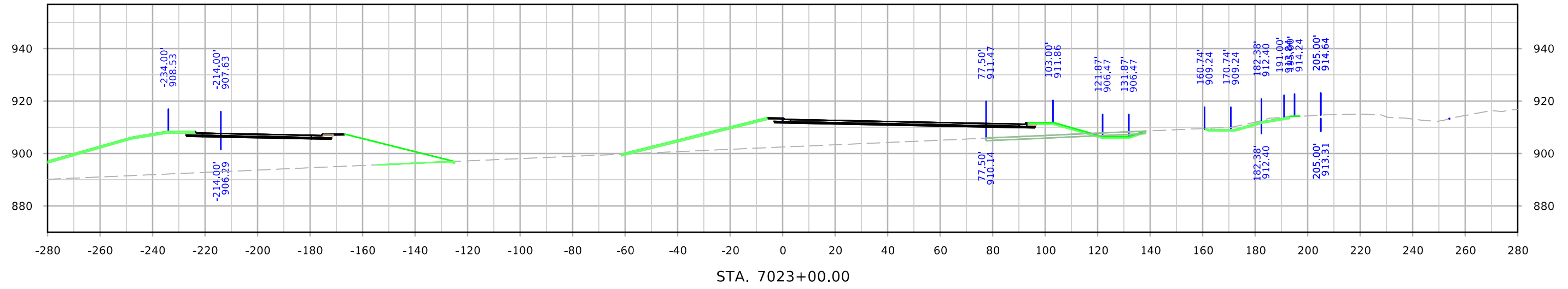
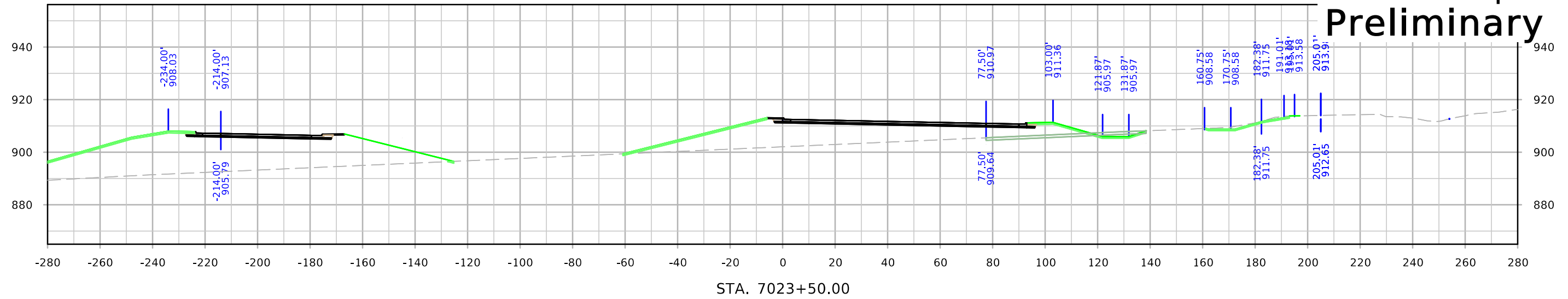

I-80 Ramp G Preliminary

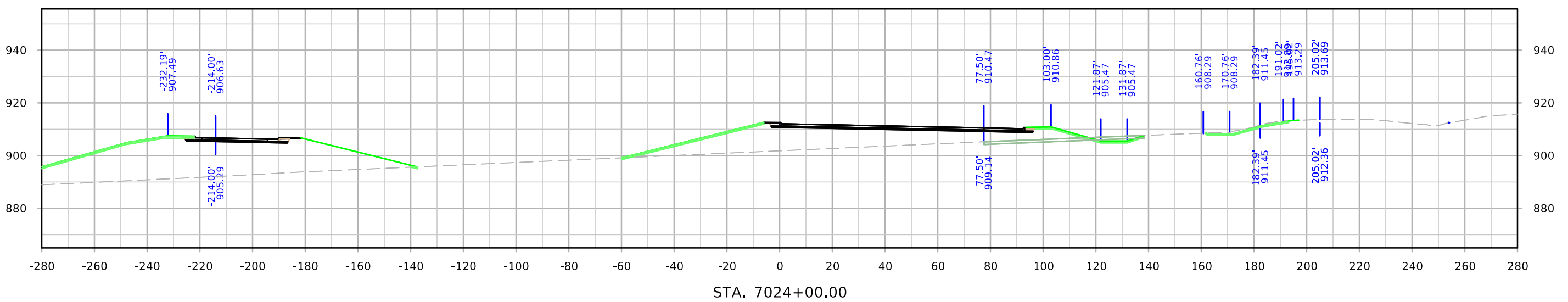
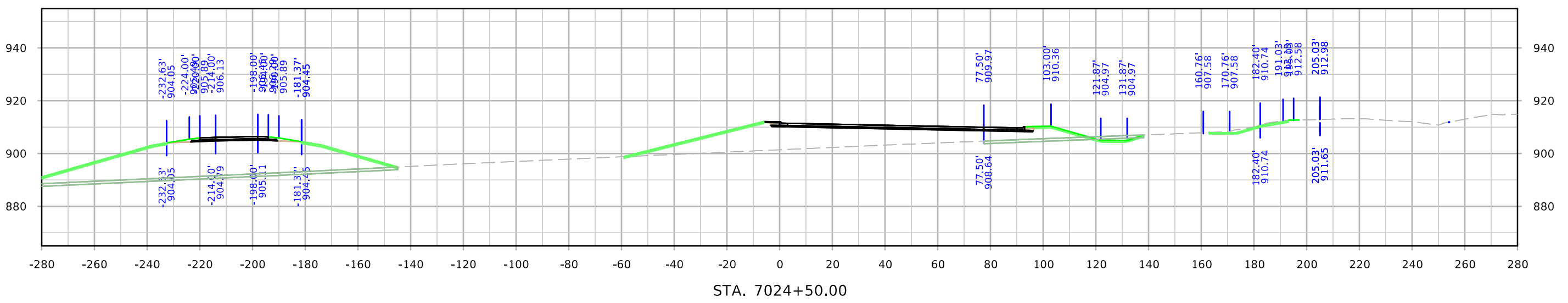
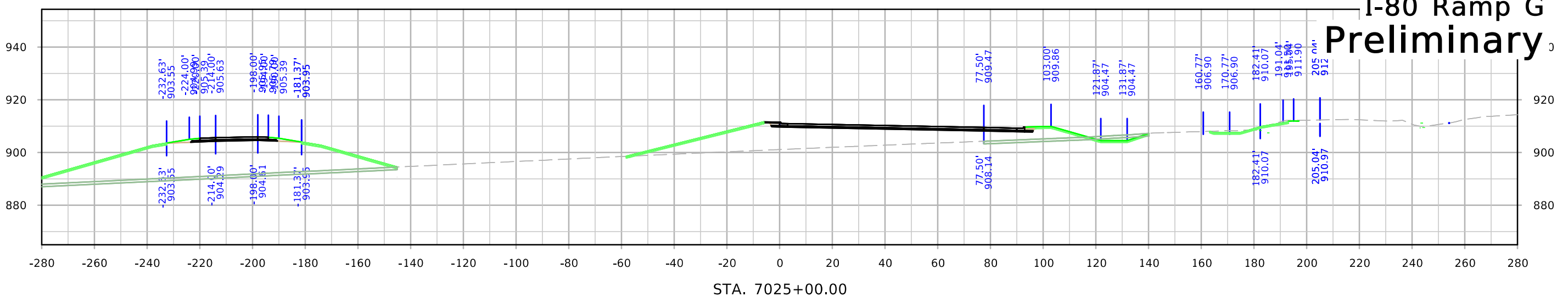

I-80 Ramp G Preliminary

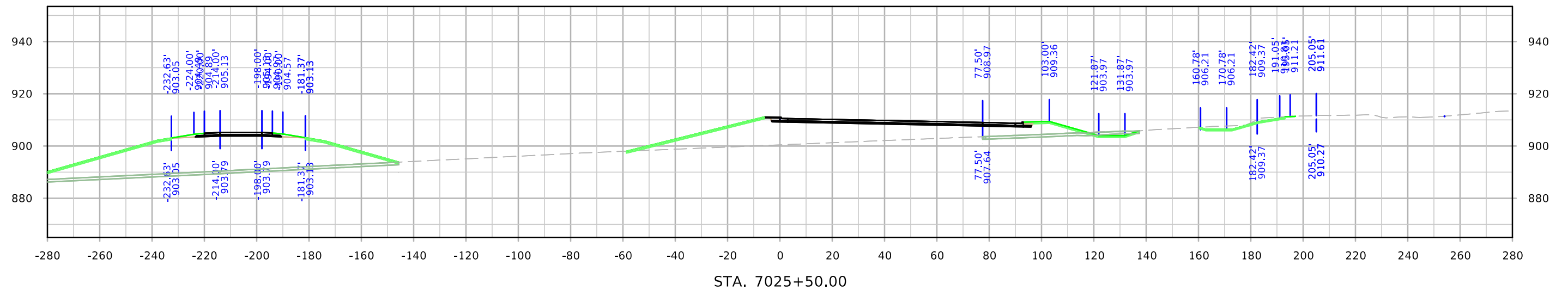
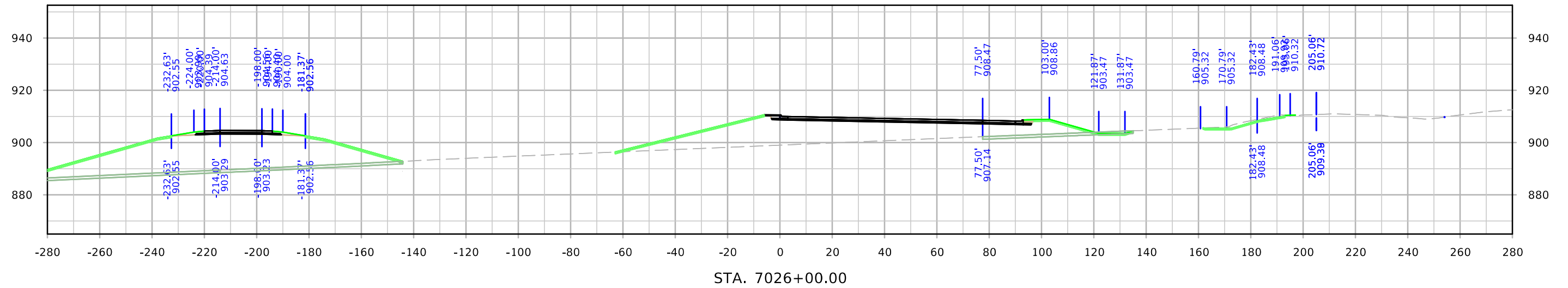
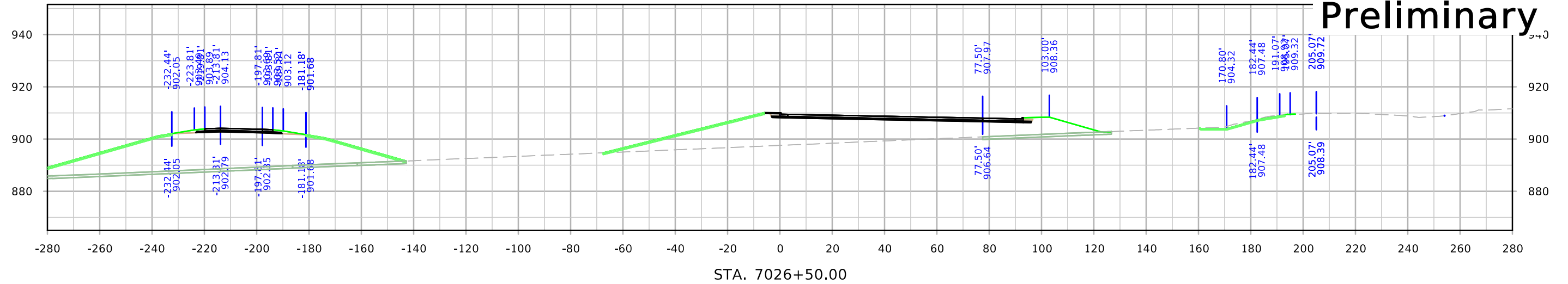

I-80 Ramp G Preliminary

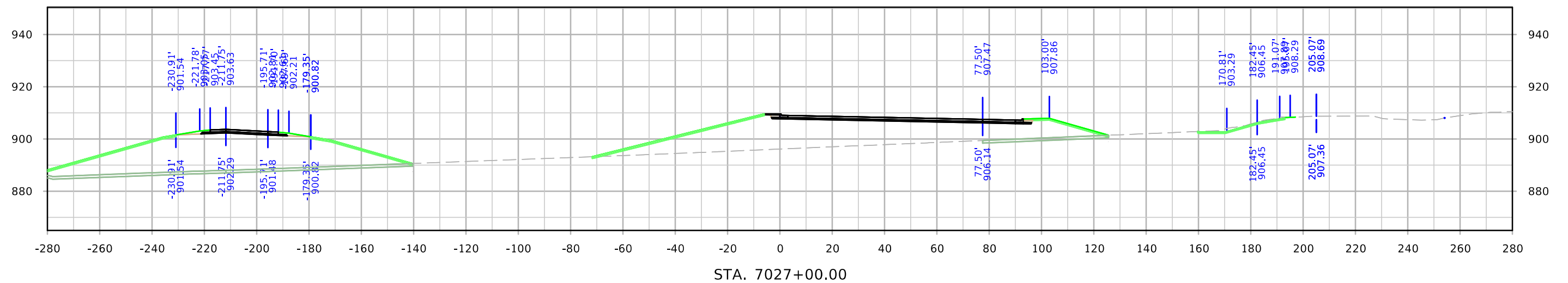
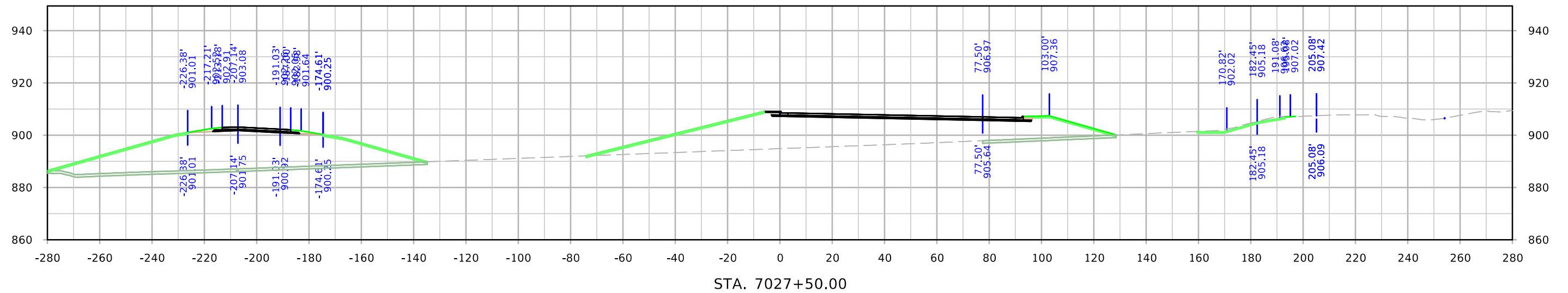
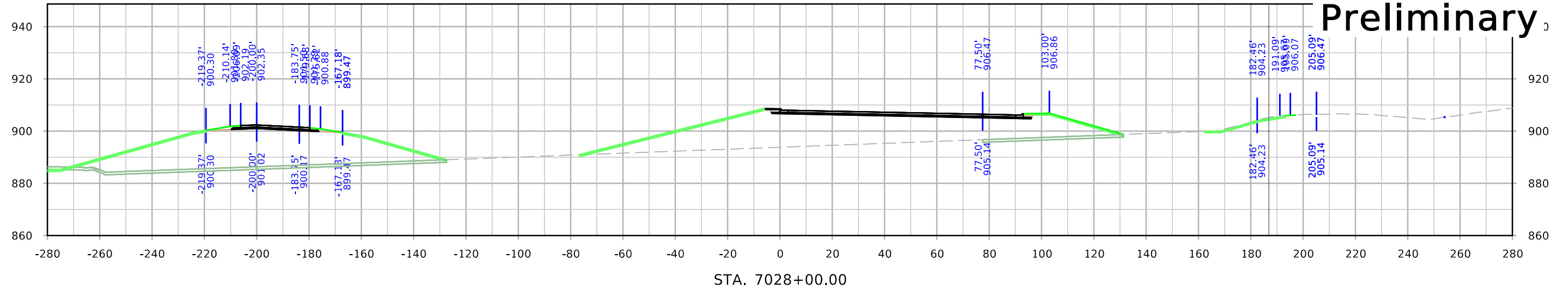

I-80 Ramp G Preliminary

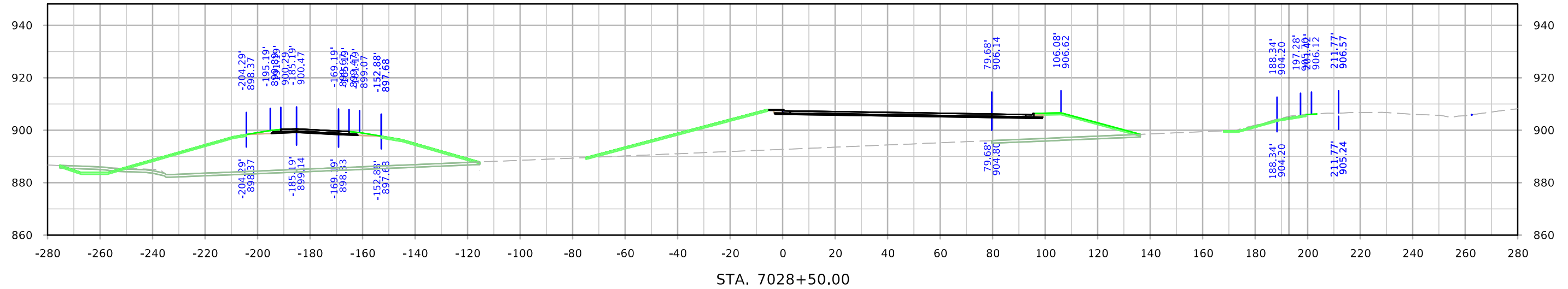
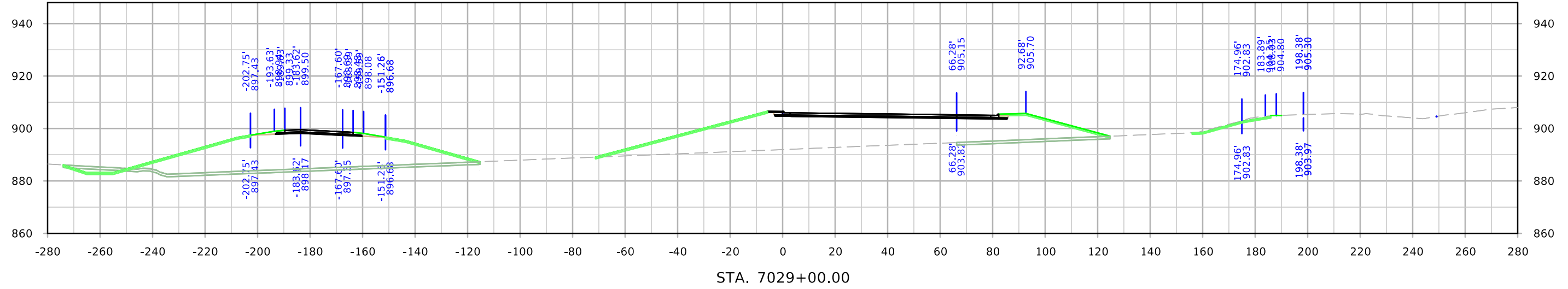
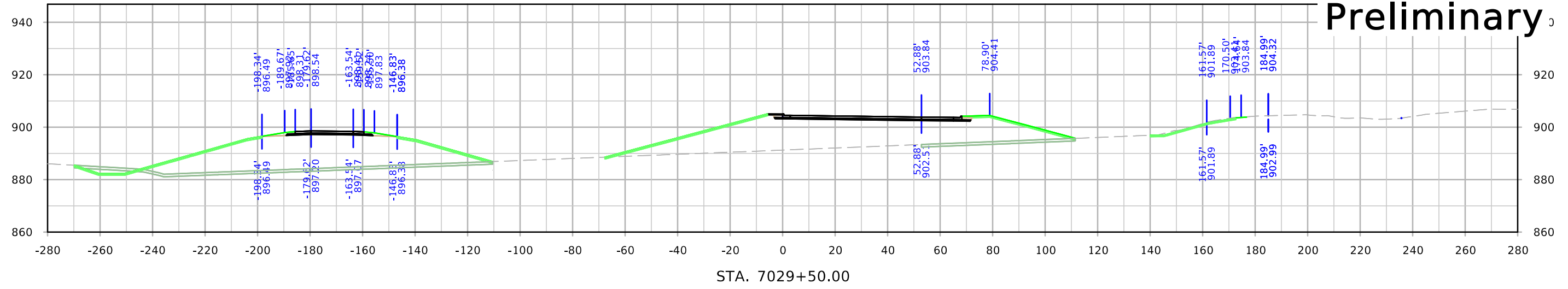

I-80 Ramp G Preliminary

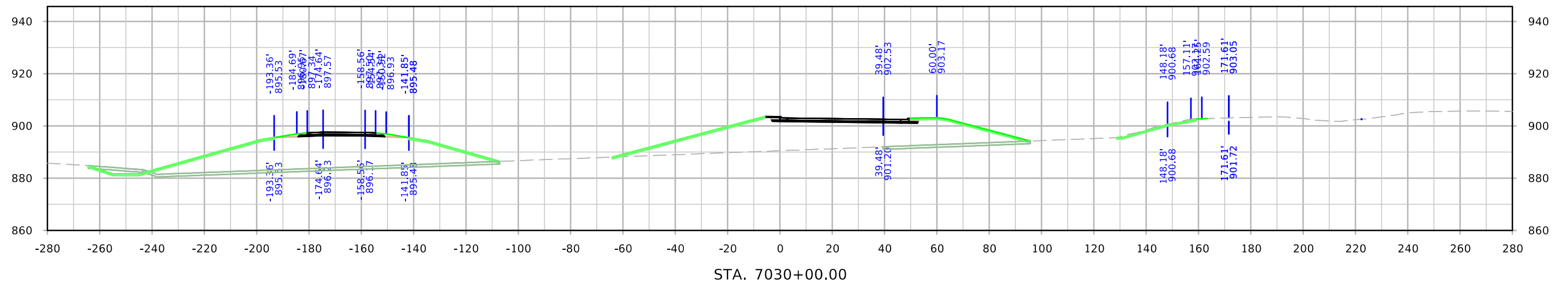
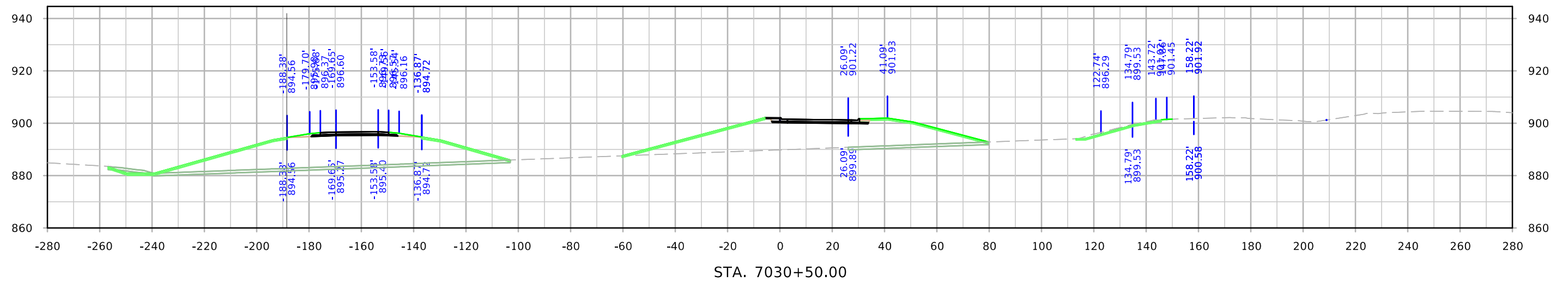
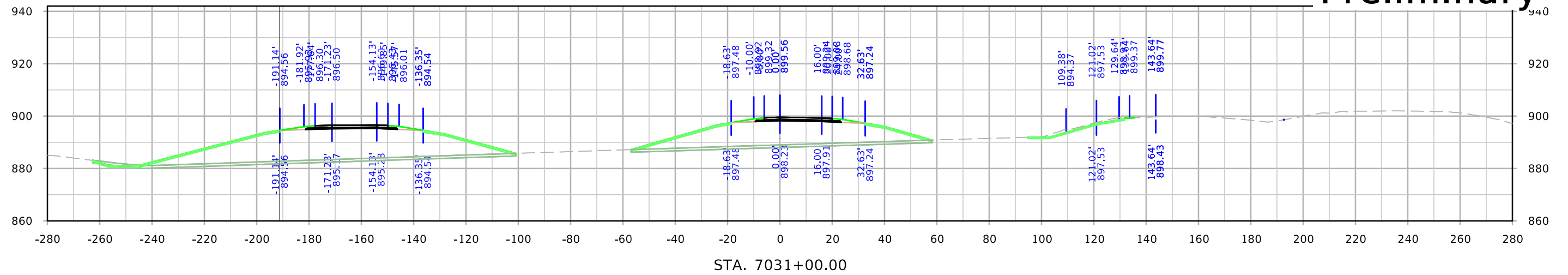

I-80 Ramp G Preliminary

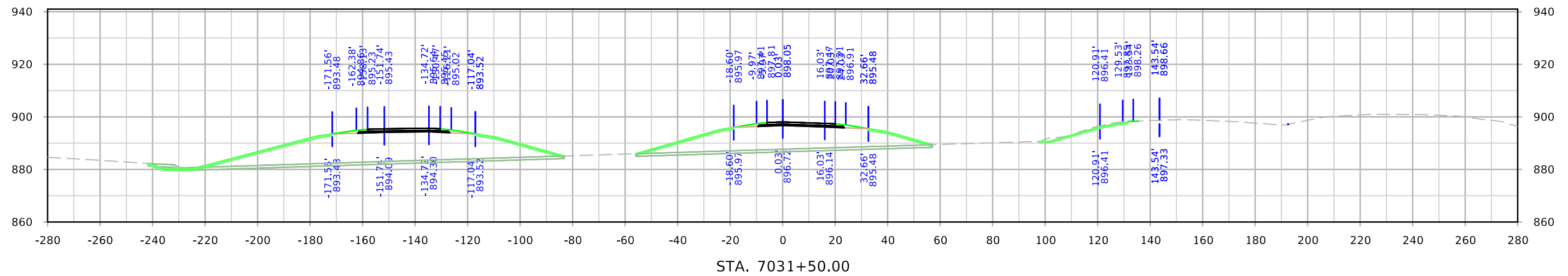
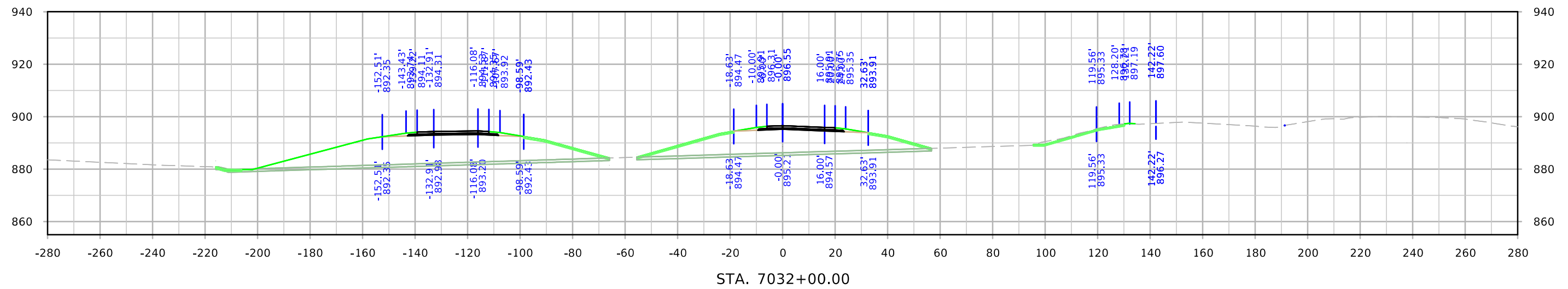
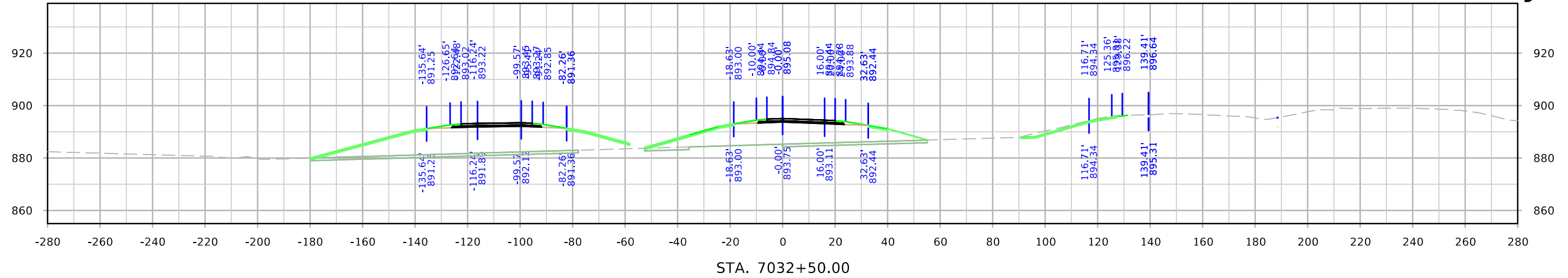

I-80 Ramp G Preliminary

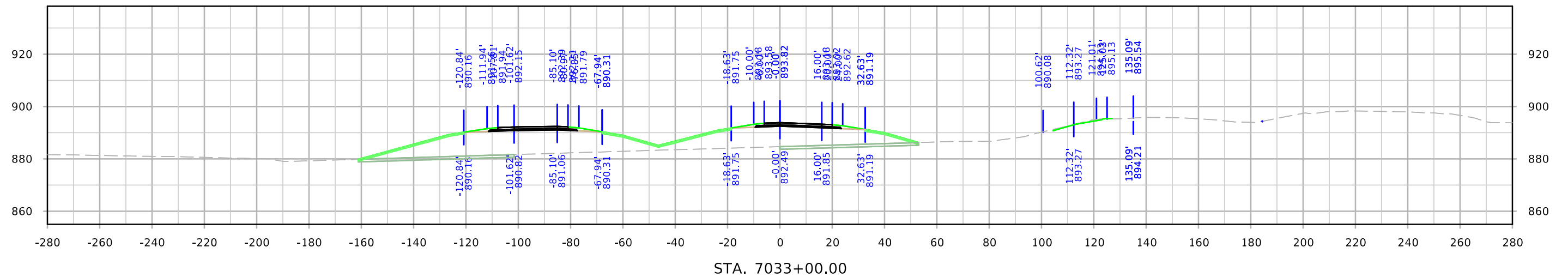
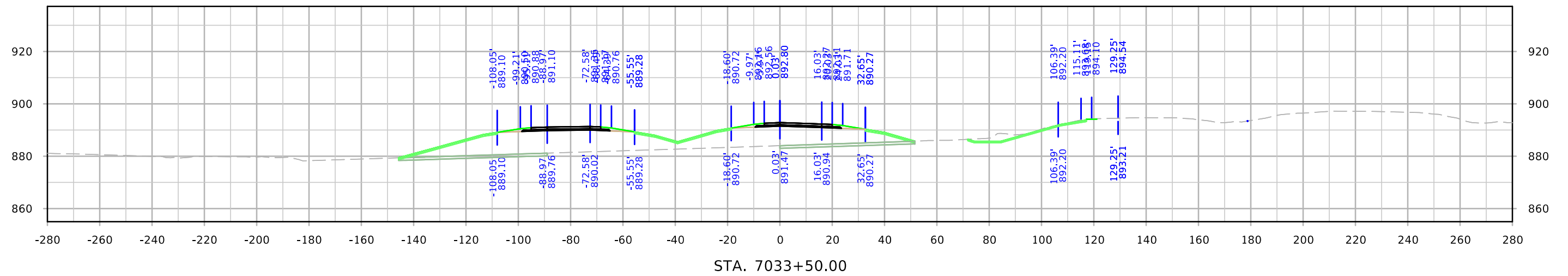
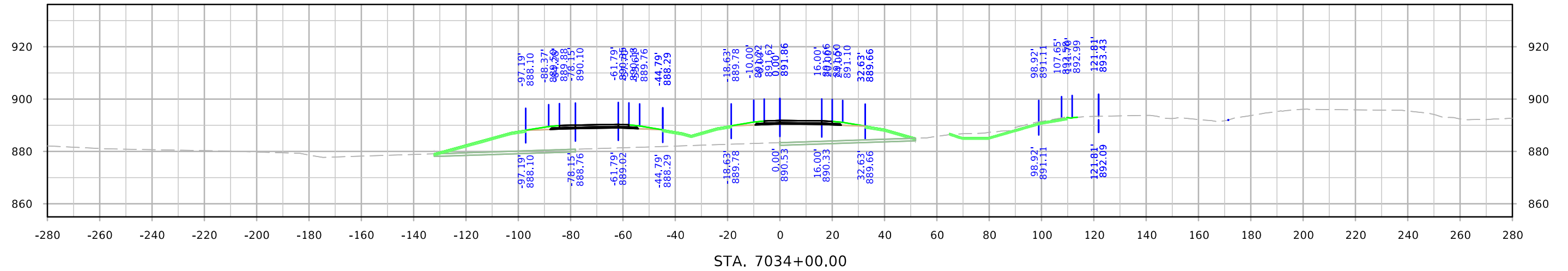

I-80 Ramp G Preliminary

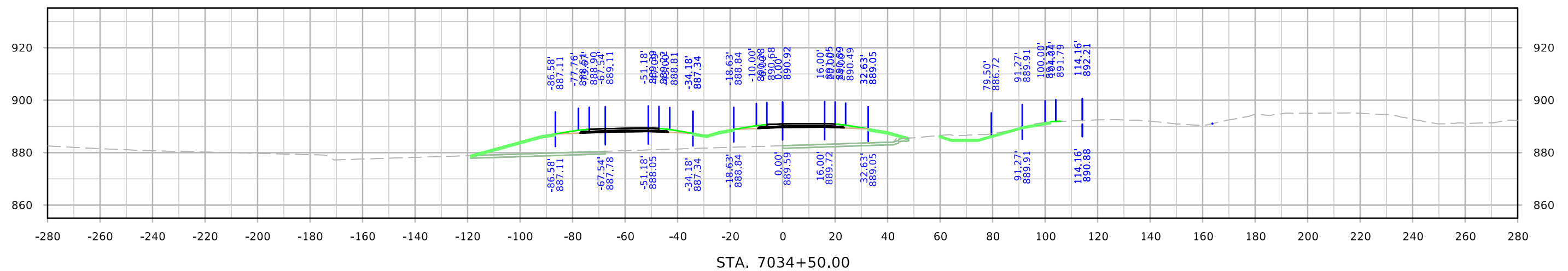
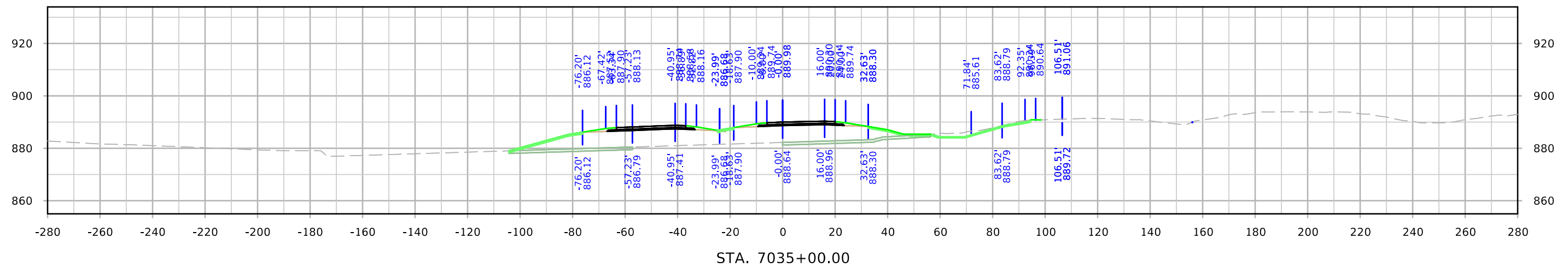
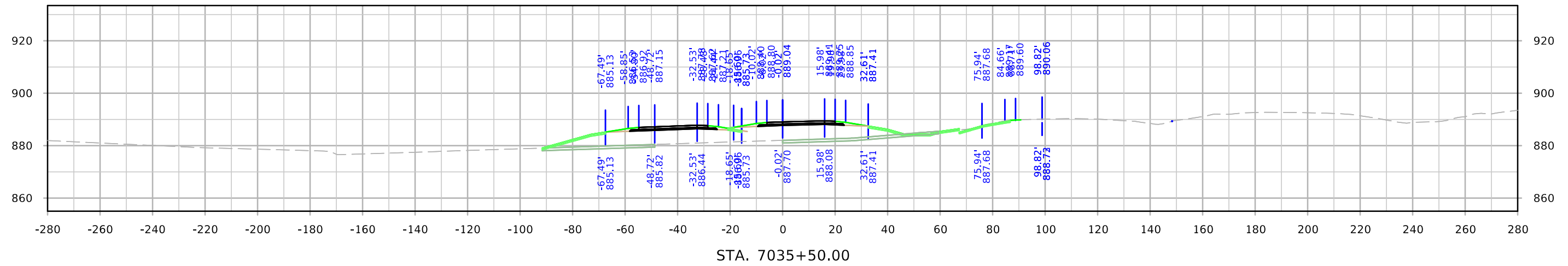

I-80 Ramp G Preliminary

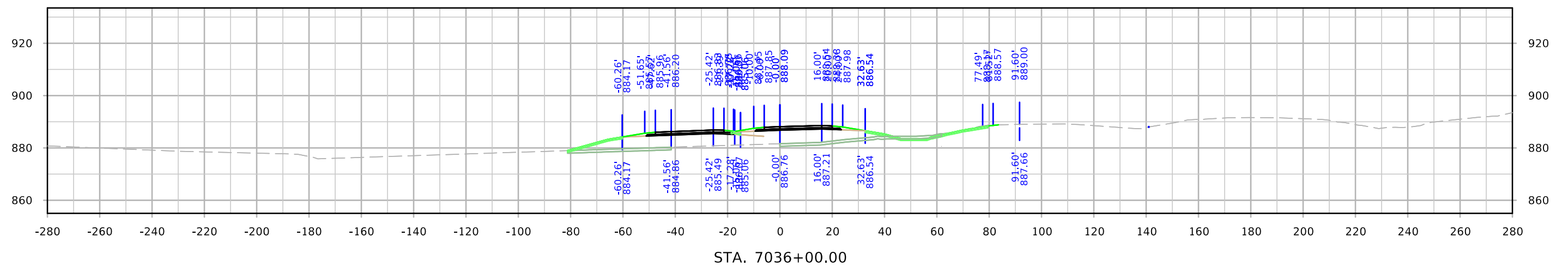
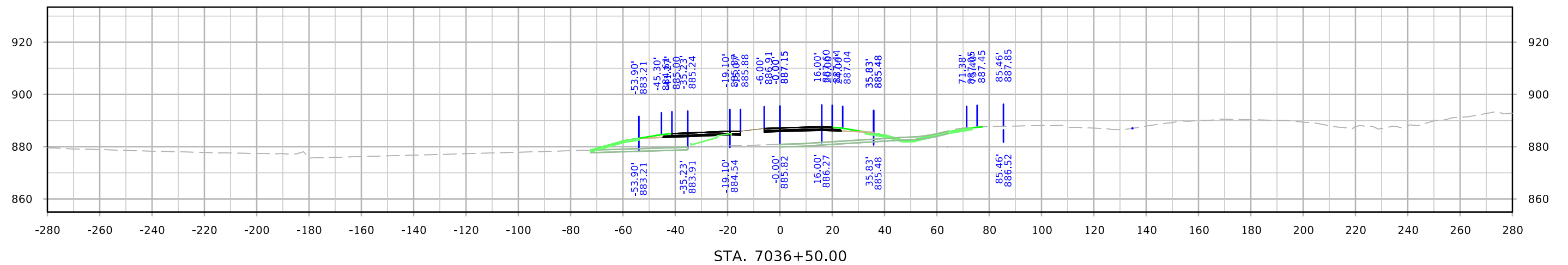
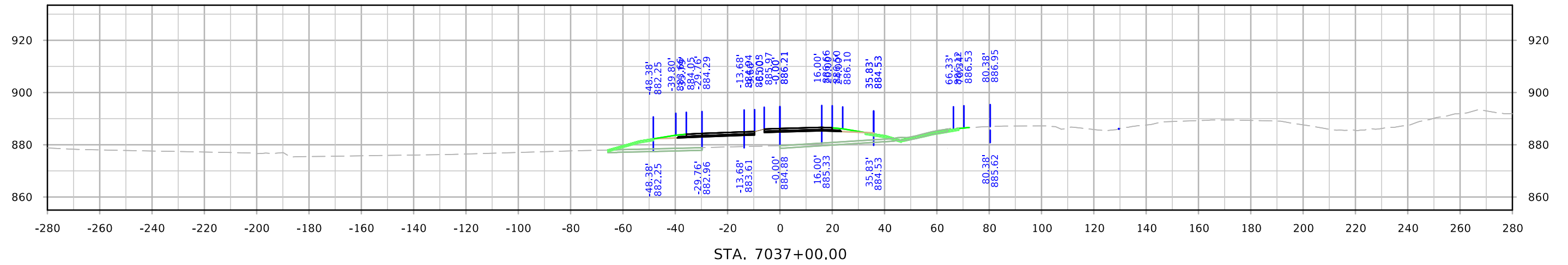

I-80 Ramp G Preliminary

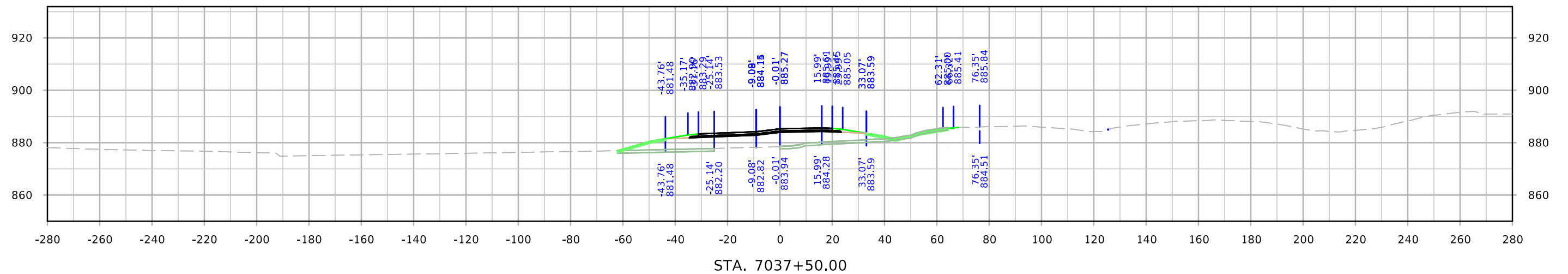
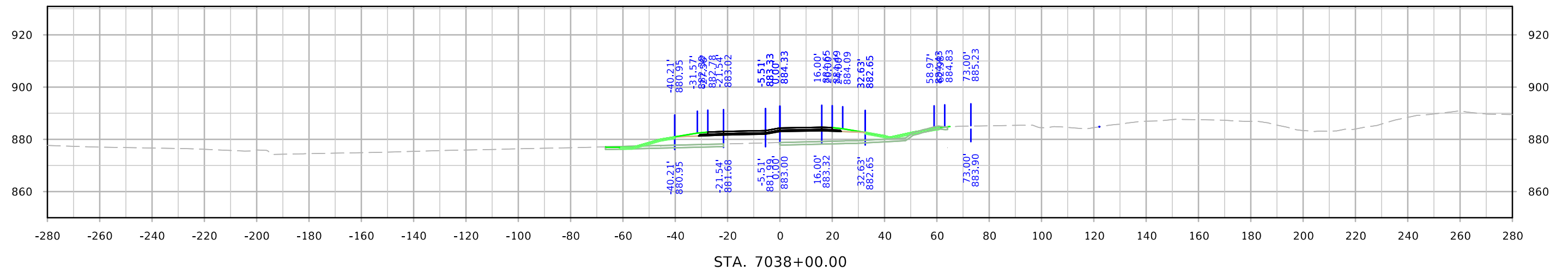
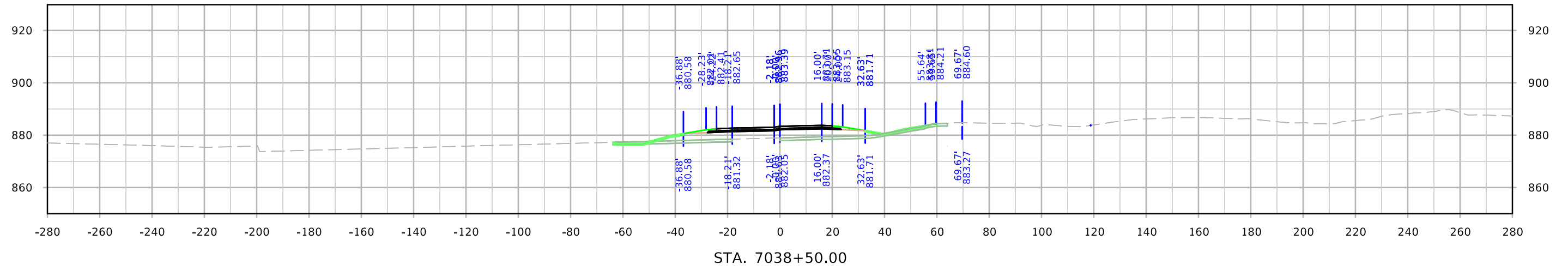

I-80 Ramp G Preliminary

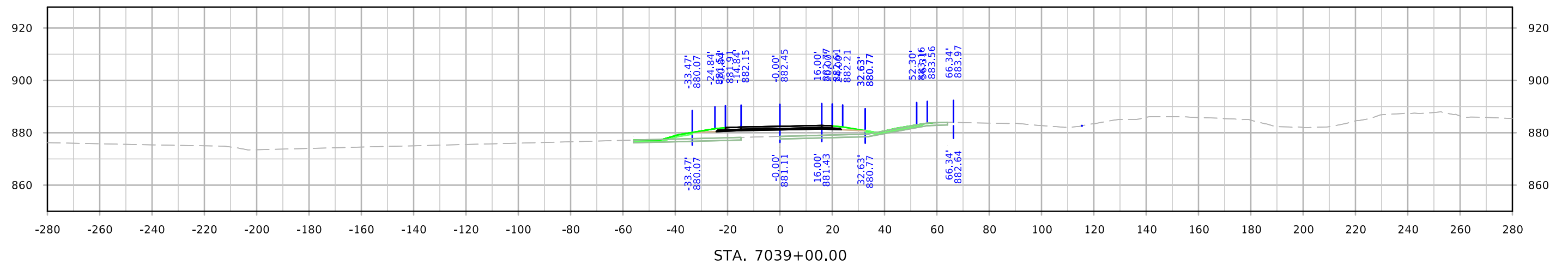
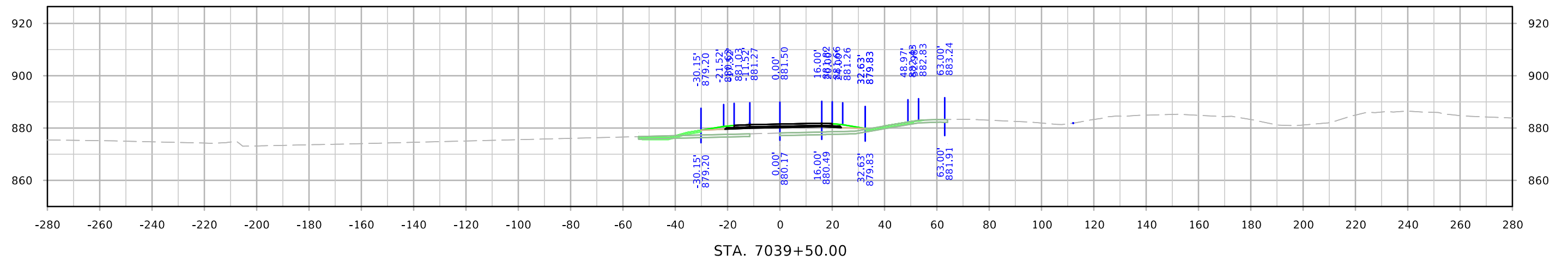
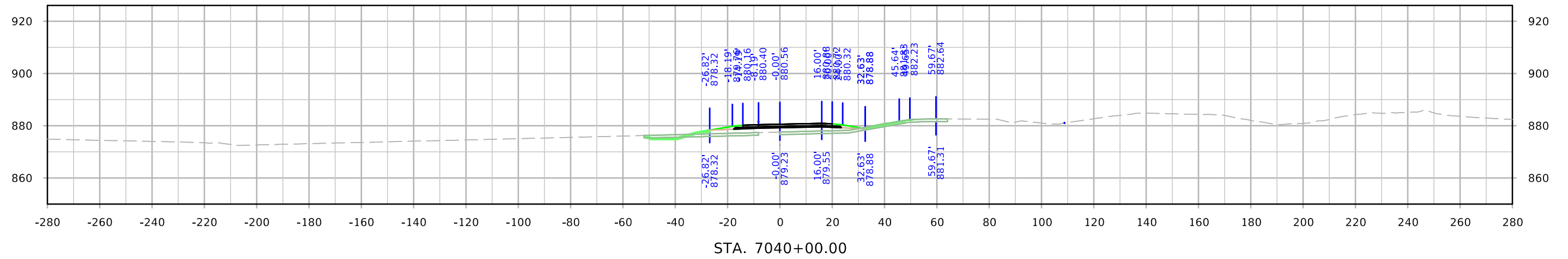

I-80 Ramp G Preliminary

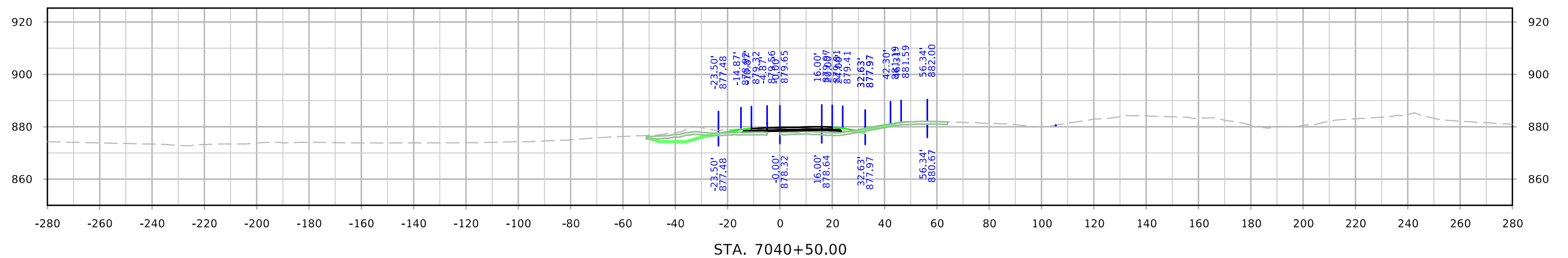
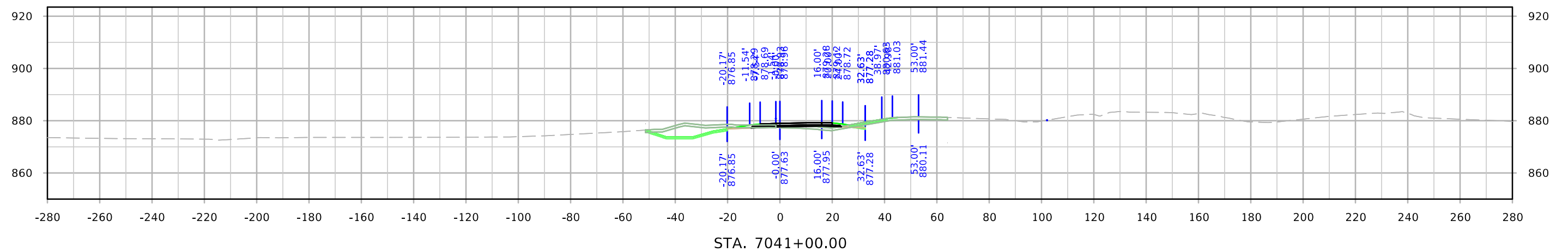
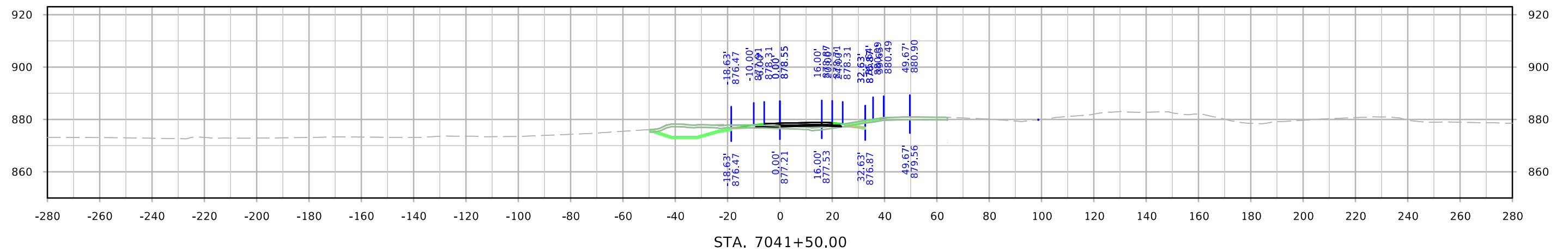

I-80 Ramp G Preliminary

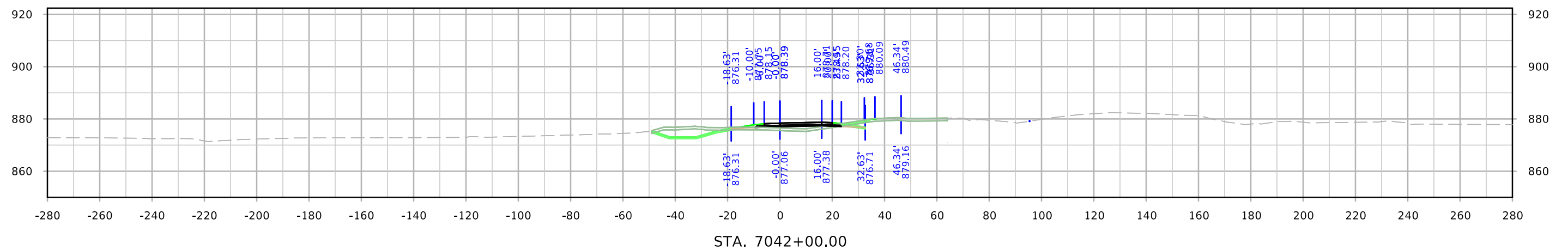
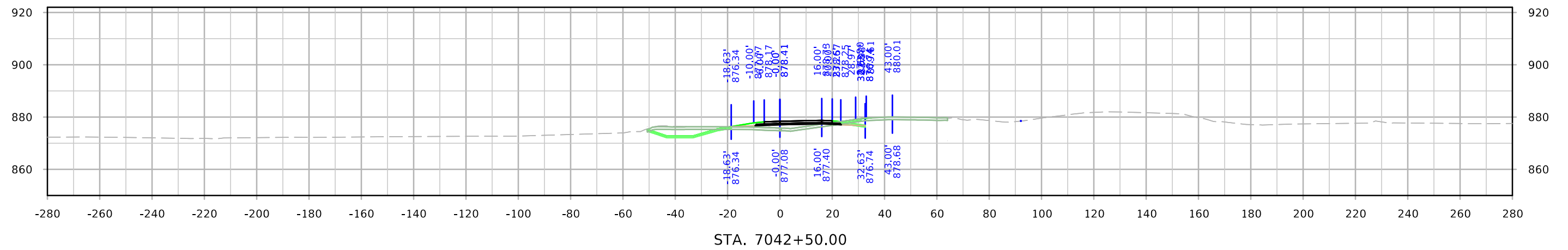
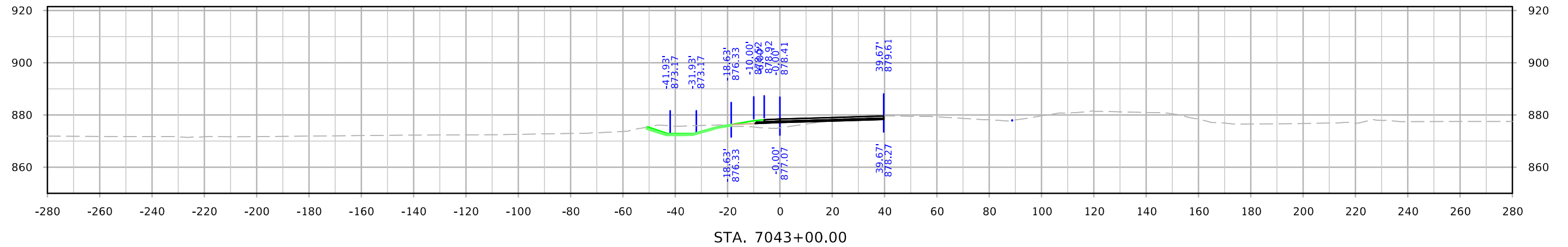

I-80 Ramp G Preliminary

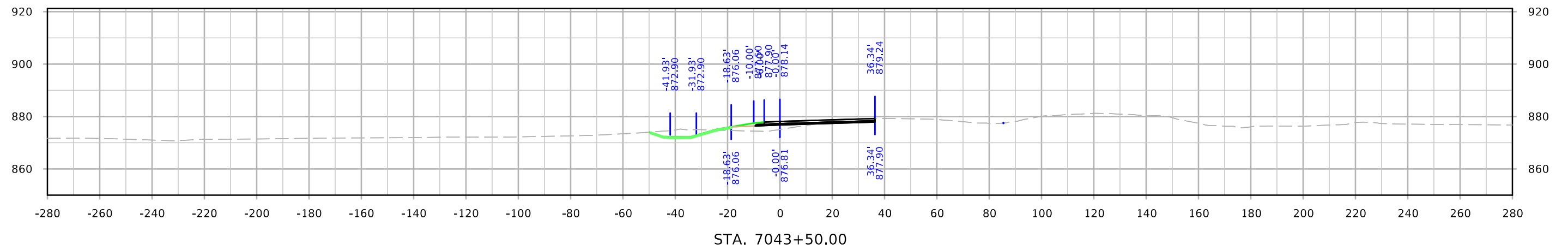
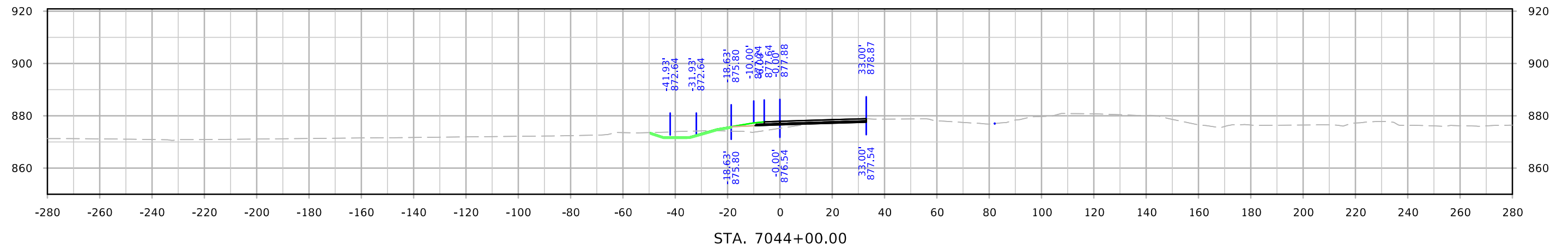
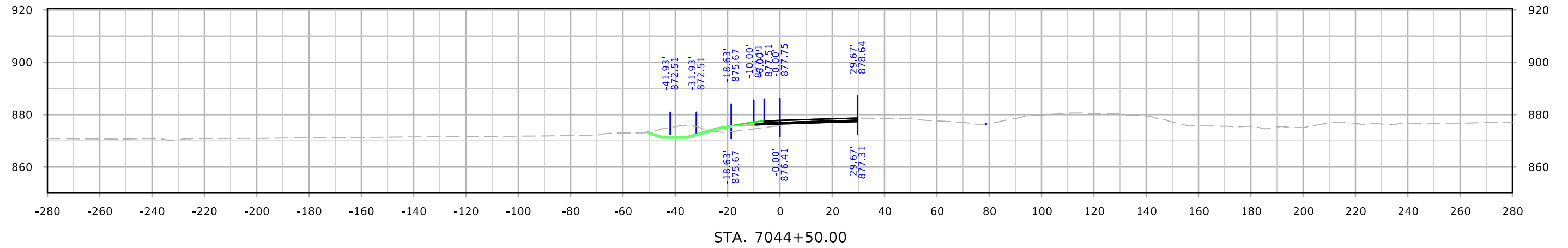

I-80 Ramp G Preliminary

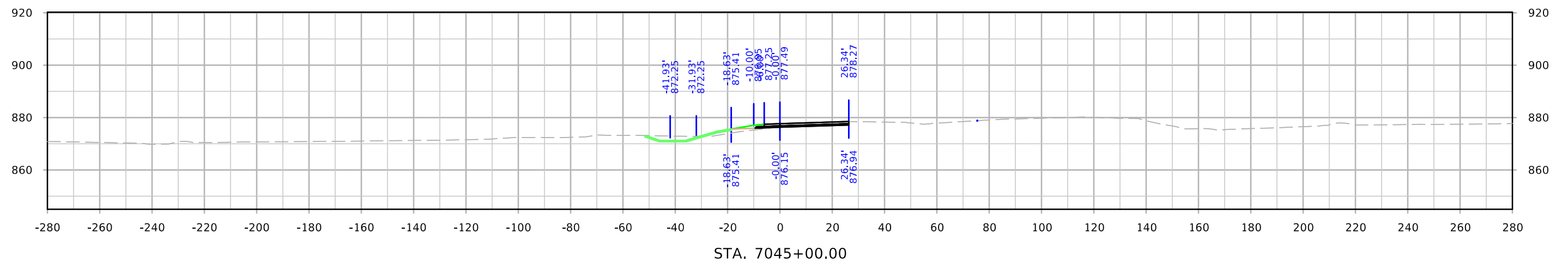
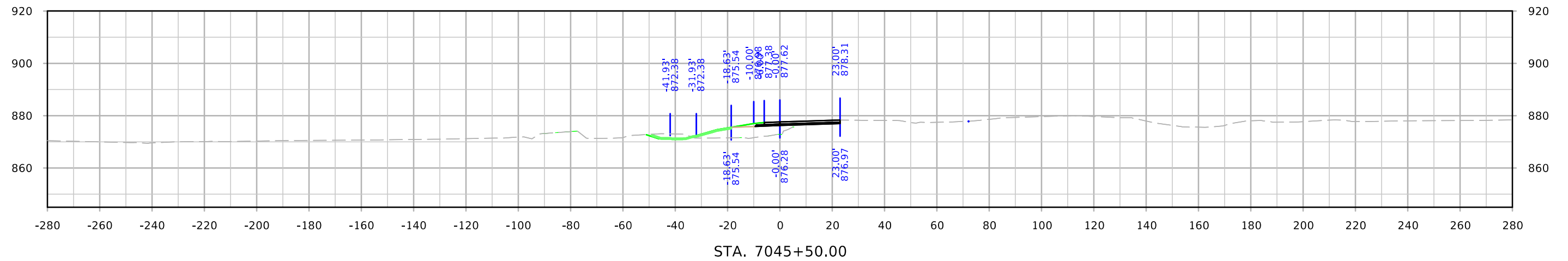
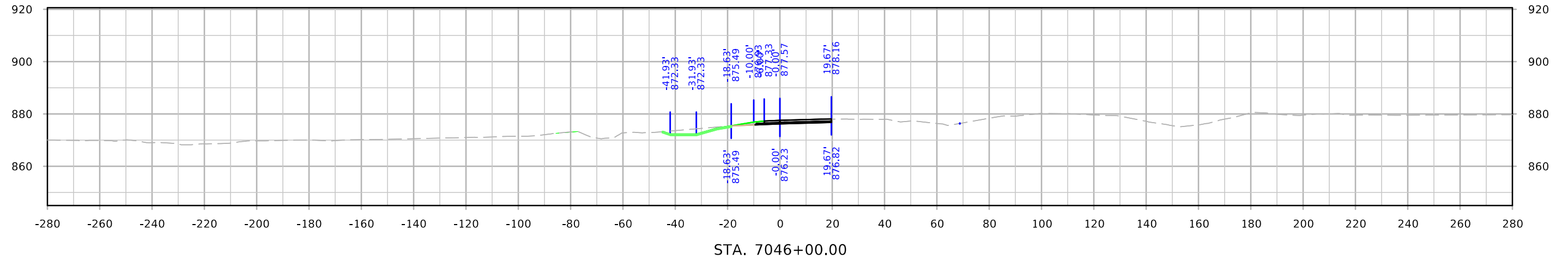

I-80 Ramp G Preliminary

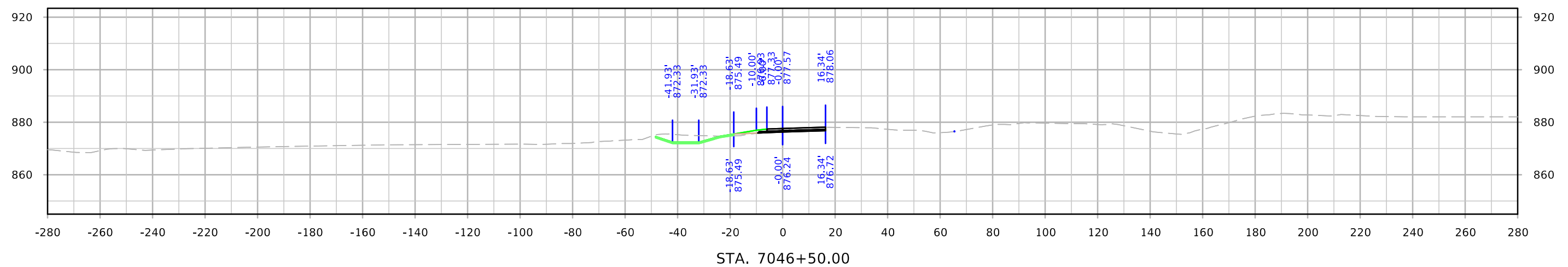
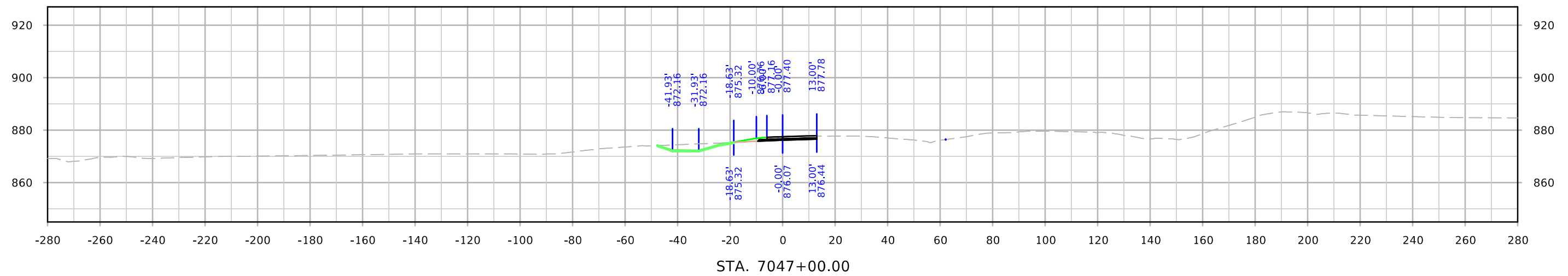
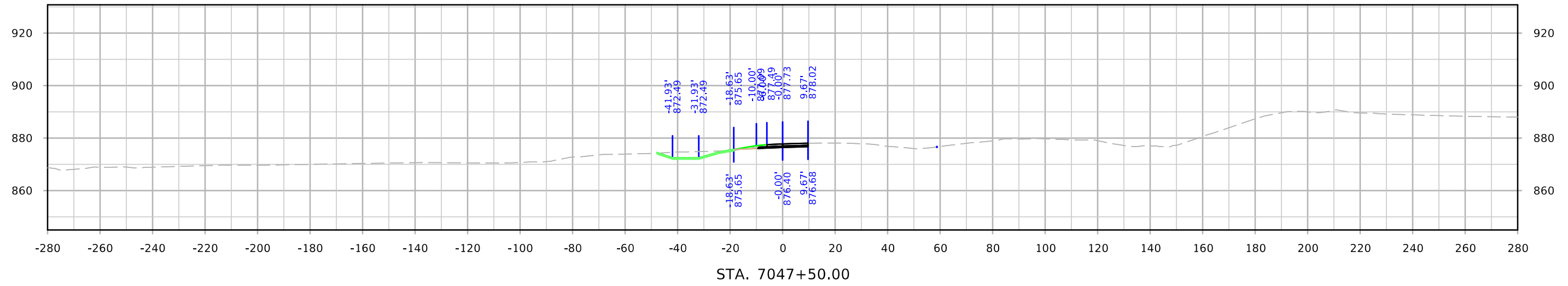

I-80 Ramp G Preliminary

