



Iowa Department of Transportation

Highway Division

PLANS OF PROPOSED IMPROVEMENT ON THE

PRIMARY ROAD SYSTEM LOUISA COUNTY PCC PAVEMENT - GRADE AND NEW

US 61 From Approx. 2 Miles South
of Ia. 92 (130th St.) N. To Muscatine Co. Line

SCALES: As Noted

Refer to the Proposal Form for list of applicable specifications.

Value Engineering Saves. Refer to Article 1105.15 of the Specifications.



REVISIONS

TOTAL

PROJECT IDENTIFICATION NUMBER

09-58-061-030

PROJECT NUMBER

NHS-061-3(48)--19-58

R.O.W. PROJECT NUMBER

NHSN-061-3(55)--2R-58

NHSN-061-3(55)--2R-58

LETTING DATE

PCC PAVEMENT - GRADE AND NEW
NHS-061-3(48)--19-58

LOUISA CO.

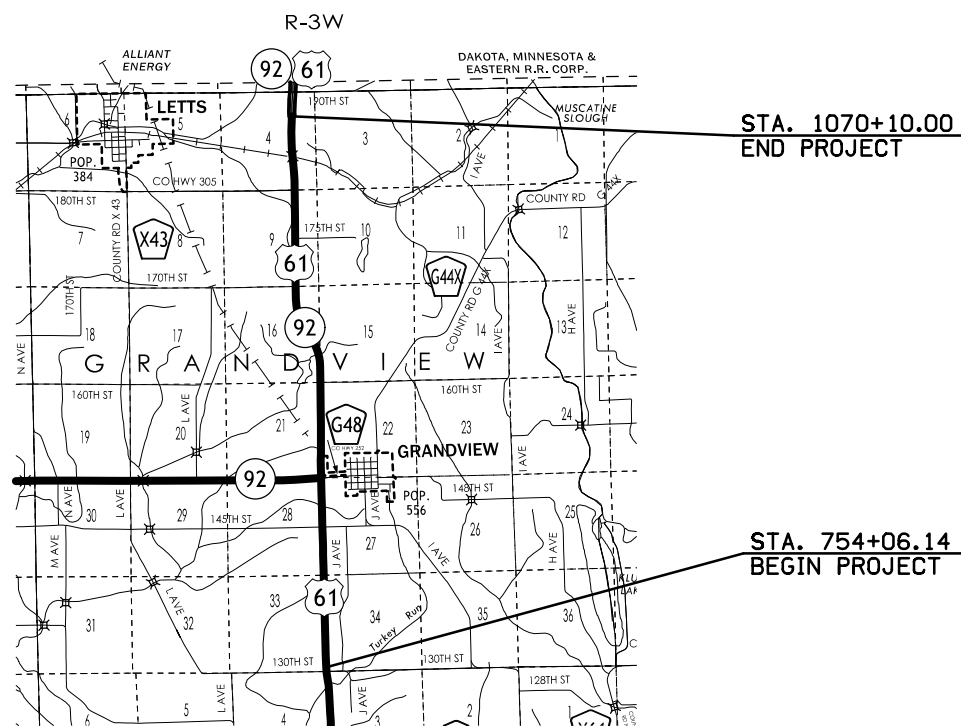

MILEAGE SUMMARY			105-1
			09-27-94
Div.	Location	Lin. Ft.	Miles
1	RURAL:		
	Sta. 754+06.14 to Sta. 1070+10.00	31,603.86	
	Deduct Dual Bridges Sta. 956+40 +/-	240.00	
	Deduct Dual Bridges Sta. 964+95 +/-	205.00	
	Deduct Single Bridge Sta. 1037+40 +/-	200.00	
	TOTAL:	30,958.86	5.863

DESIGN DATA RURAL			
2015	AADT	5700	V.P.D.
2035	AADT	--	V.P.D.
20--	DHV	--	V.P.H.
	TRUCKS	16 %	
	Total		
	Design ESALs	--	

INDEX OF SEALS		
SHEET NO.	NAME	TYPE
A.1	Jim Schoenrock	Primary Signature Block
X	Robert L. Stanley	Soils Signature Block

PRELIMINARY PLANS

Subject to change by final design.

D5 PLAN - Date: 09-21-2012

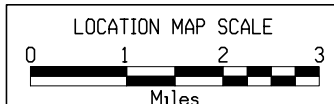
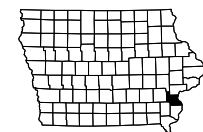

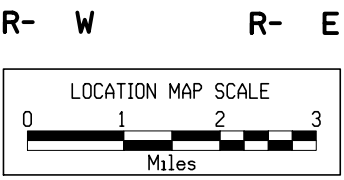
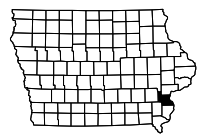
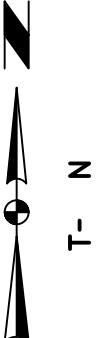
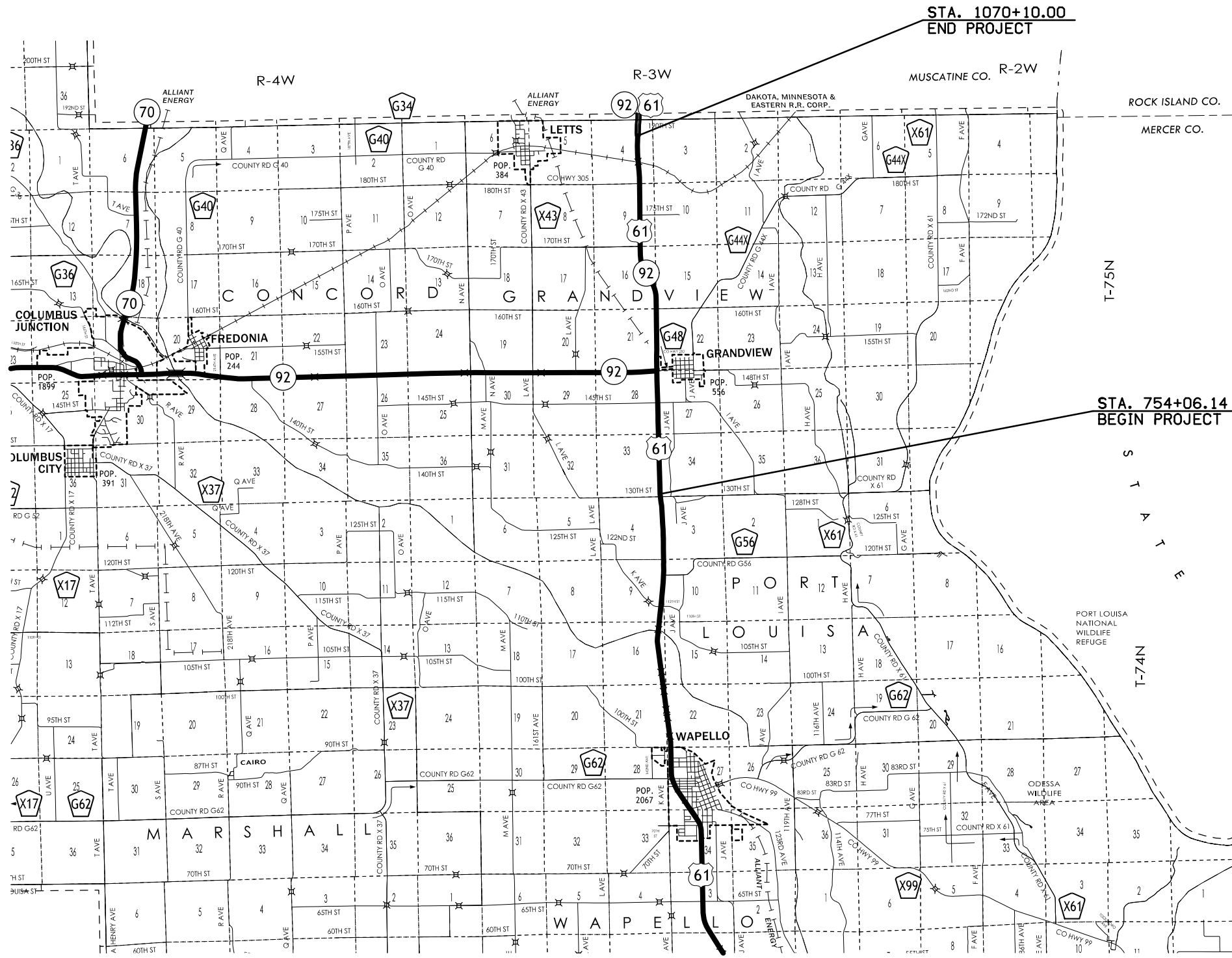

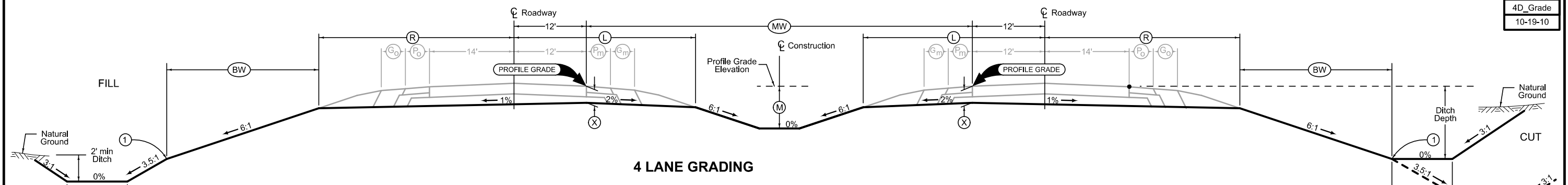

Normal section shown may be modified appropriately in areas of super-elevated curves or other locations specifically designated by the Engineer.

See Plan & Profile sheets and cross sections for additional details of ditches and backslopes.

① Refer to project plan and cross sections for specific location of foreslope change.

LOCATION		DIMENSIONS						
ROAD IDENTIFICATION	STATION TO STATION	L	R	X	BW	MW	M	
		Feet	Feet	Inches	Feet	Feet	Feet	
US 61	754+06 986+83	29.2	33.1	18	20.4	82	4	
US 61	986+83 1048+90	29.2	33.1	18	20.4	82-184	4	
US 61	1048+90 1070+10	29.2	33.1	18	20.4	82-70	4	

LOCATION			DIMENSIONS						
INTERCHANGE	RAMP	STATION TO STATION	L	R	C	X	BW _L	BW _R	
			Feet	Feet	Feet	Inches	Feet	Feet	
US 61\ IA 92	A	1556+28 1570+50	30.4	16.1	16	16	21.2	21.5	
US 61\ IA 92	B	2543+50 2556+69	30.4	16.1	16	16	21.2	21.5	
US 61\ IA 92	C	3544+80 3556+42	30.4	16.1	16	16	21.2	21.5	
US 61\ IA 92	D	4556+50 4580+50	30.4	16.1	16	16	21.2	21.5	
US 61\ 170th	A	5564+70 5579+25	30.4	16.1	16	16	21.2	21.5	
US 61\ 170th	B	6551+00 6564+12	30.4	16.1	16	16	21.2	21.5	
US 61\ 170th	C	7550+50 7565+89	30.4	16.1	16	16	21.2	21.5	
US 61\ 170th	D	8563+94 8579+00	30.4	16.1	16	16	21.2	21.5	

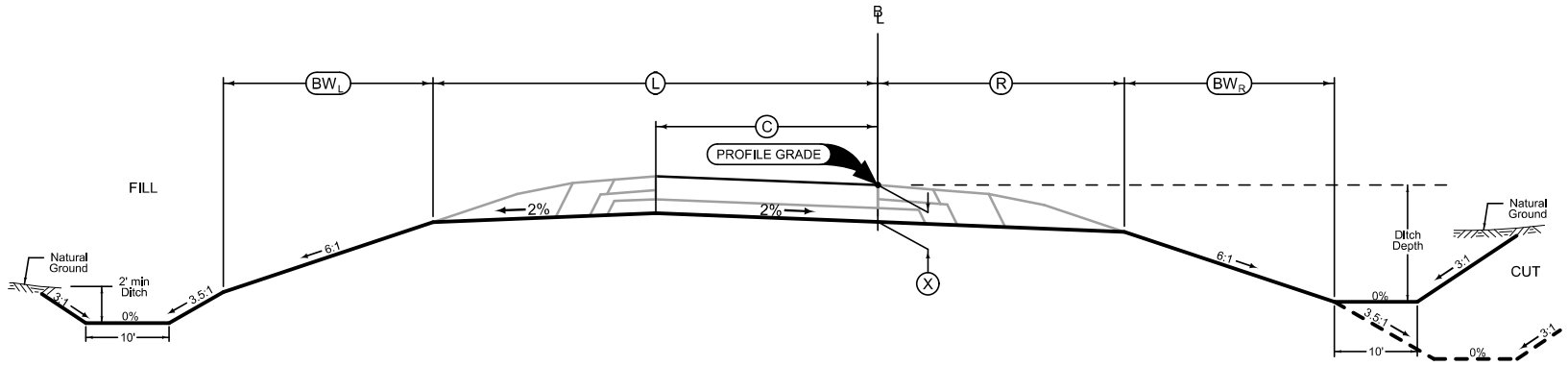

Section view is in direction of traffic.
Normal sections shown may be appropriately modified for areas specifically designated by the Engineer such as intersections or super-elevated curves.

LOCATION		DIMENSIONS				
ROAD IDENTIFICATION	STATION TO STATION	L	R	FS	BS	DW
		Feet	Feet			Feet
145th	2803+75 2818+03	13	13	3:1	2.5:1	10
175th	9970+20 10001+25	12	12	3:1	2.5:1	10

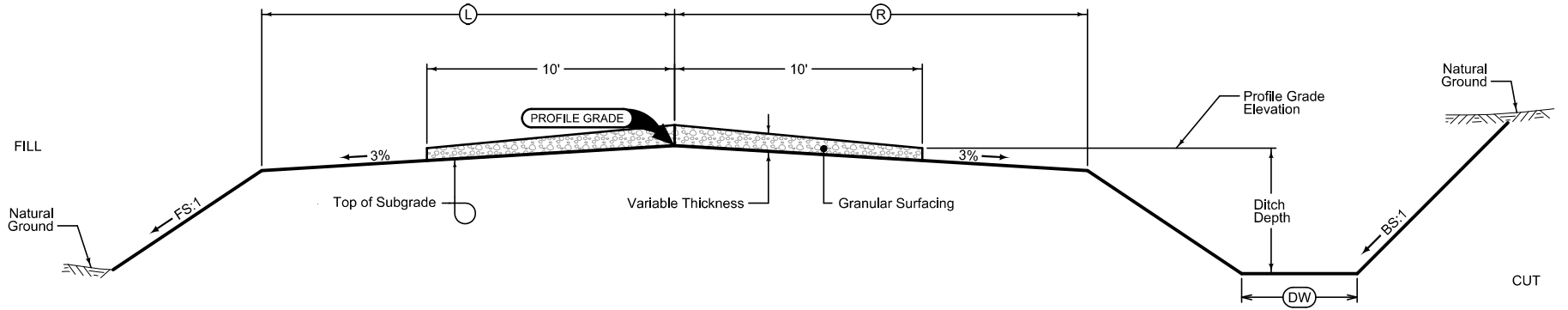

Normal section shown may be modified appropriately in areas of super-elevated curves or other locations specifically designated by the Engineer.

See plan & profile sheets and cross sections for additional details of ditches and backslopes.

Place Granular Surfacing as follows:
Grading design application rate is ___ tons per mile.
Paving design application rate is ___ tons per mile.

LOCATION		DIMENSIONS			
ROAD IDENTIFICATION	STATION TO STATION	(L)	(X)	FS	
		Feet	Inches		
DET61_905	301+26.75 - 304+55.63	12.5-29.2	20/21	3	
DET61_905	311+33.17 - 315+71.08	30.4-16.7	20/21	3	
DET61_985	400+86.04 - 406+65.05	16.3-29.2	20/21	3	
DET61_985	433+27.32 - 438+24.79	29.2-12.5	20/21	3	

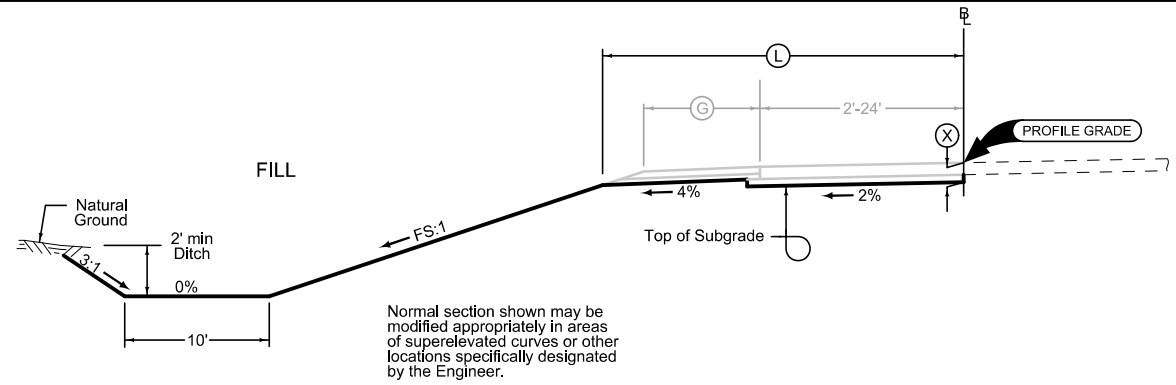

DETOUR TAPER GRADING

Detour-1
xx

LOCATION		DIMENSIONS			
ROAD IDENTIFICATION	STATION TO STATION	(L)	(R)	(X)	FS
		Feet	Feet	Inches	
DET61_905	304+55.63 - 311+33.17	17.2	17.2	20/21	3
DET61_985	406+65.05 - 433+27.32	17.2	17.2	20/21	3

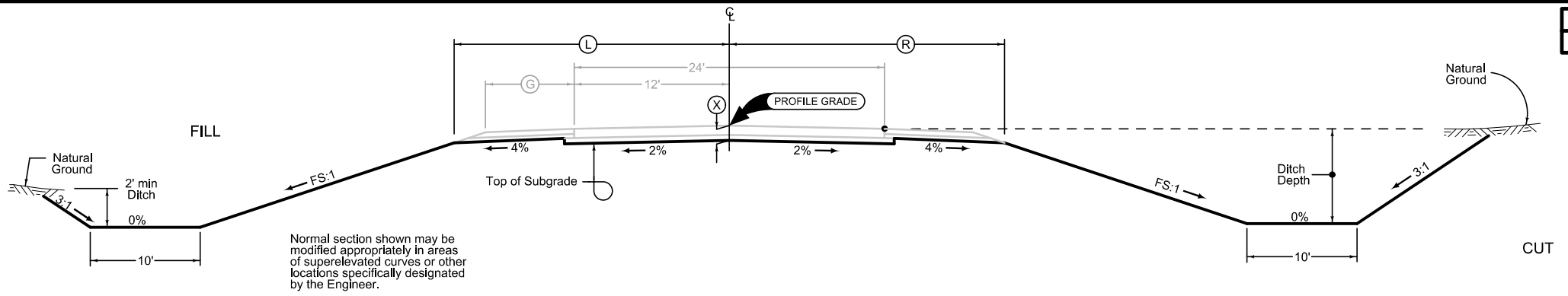

2 LANE DETOUR GRADING

Detour-2
xx

Combination Shoulder

Shoulder Jointing:
Longitudinal joint: B

		4_C_ 10-19-10		
Direction of Travel	BEGIN STATION	END STATION	(P) Feet	(G) Feet
Both	754+06	1012+02	4	2
SB	1012+02	1070+10	4	2

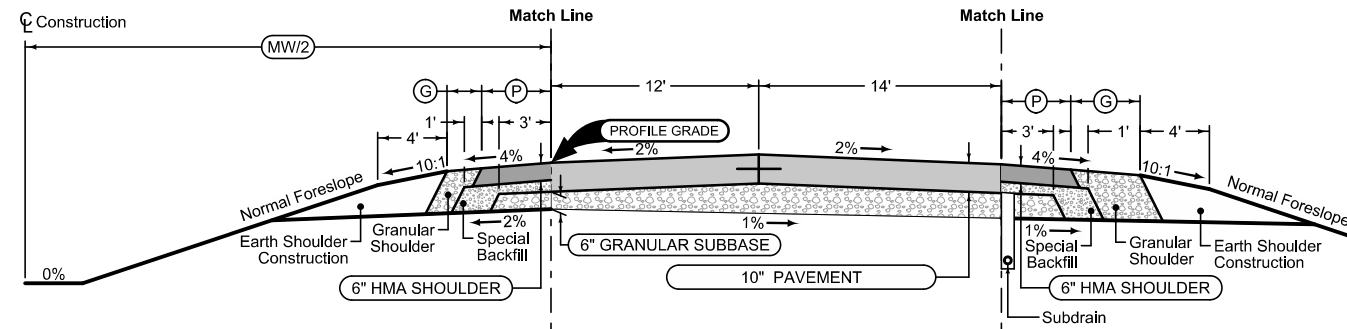

Section shown in the direction of traffic.

Mainline Jointing:
Transverse joints: CD at 20' spacing
Longitudinal joint: L-2

		4DP_ 10-19-10		
Direction of Travel	BEGIN STATION	END STATION	(MW) Feet	
Both	754+06	986+83	82	
SB	986+83	1048+90	82	
SB	1048+90	1070+10	82-70	
NB	1986+83	2011+90	Var	

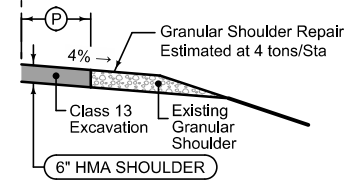

Combination Shoulder

Shoulder Jointing:
Longitudinal joint: B

		4_C_ 10-19-10		
Direction of Travel	BEGIN STATION	END STATION	(P) Feet	(G) Feet
SB	754+06	769+60	4	4
Both	769+60	1012+02	4	4
SB	1012+02	1070+10	4	4

HMA Shoulder

Shoulder Jointing:
Longitudinal joint: B

		3R_Shldr_Paved_ 04-19-11		
Direction of Travel	STATION TO STATION		(P) Feet	
NB	754+06	769+60	4	

See Tab 100-24 for pavement quantities.

See Tab 112-9 for shoulder quantities.

US 61

HMA Shoulder

Shoulder Jointing:
Longitudinal joint: B

3R_Shldr_Paved_04-19-11		
STATION TO STATION		(P) Feet
2011+90	2049+21	8

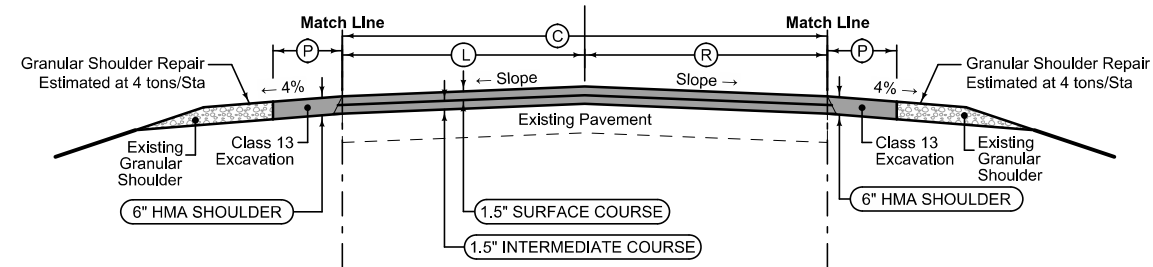

3R_Overlay_04-19-11				
STATION TO STATION		(C) Feet	(L) Feet	(R) Feet
2011+90	2049+21	24	12	12

HMA Shoulder

Shoulder Jointing:
Longitudinal joint: B

3R_Shldr_Paved_04-19-11		
STATION TO STATION		(P) Feet
2011+90	2049+21	8

See Tab 100-24 for pavement quantities.
See Tab 112-9 for shoulder quantities.

US 61 - NB

Granular Shoulder

2_G_SR_10-19-10		
STATION TO STATION		(G) Feet
2818+00	2825+90.00	6

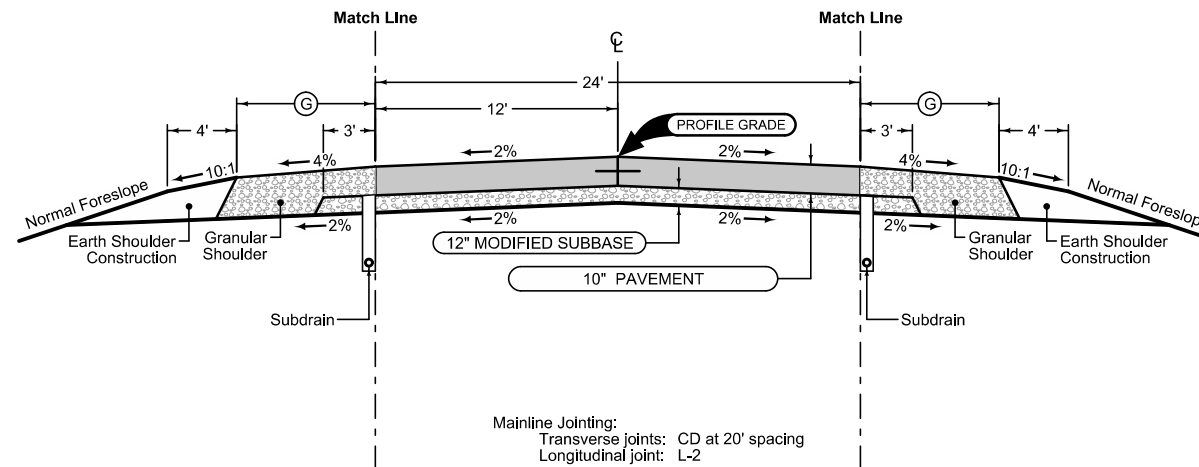

Mainline Jointing:
Transverse joints: CD at 20' spacing
Longitudinal joint: L-2

2P_10-19-10		
STATION TO STATION		(G) Feet
2818+00	2825+90.00	6

Granular Shoulder

2_G_SR_10-19-10		
STATION TO STATION		(G) Feet
2818+00	2825+90.00	6

See Tab 100-24 for pavement quantities.
See Tab 112-9 for shoulder quantities.

145th St

Granular Shoulder

2_G_SR_10-19-10		
STATION TO STATION		Ⓞ Feet
3945+47	8970+20	6

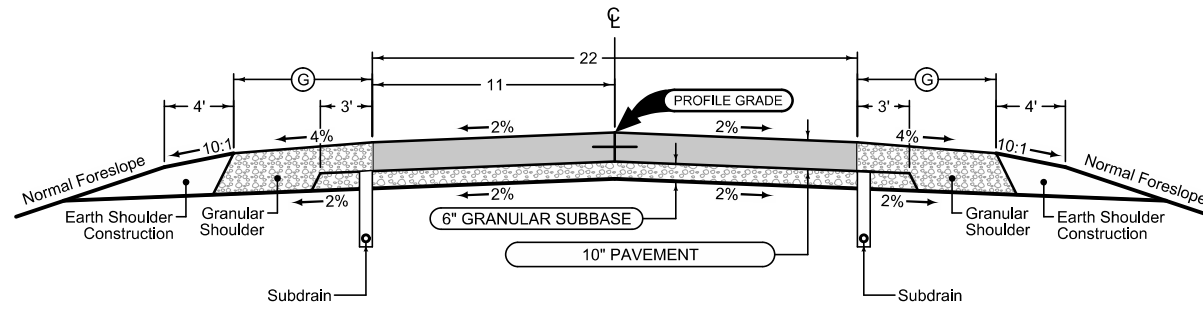

Granular Shoulder

2_G_SR_10-19-10		
STATION TO STATION		Ⓞ Feet
3945+47	8970+20	6

Mainline Jointing:
 Transverse joints: CD at 20' spacing
 Longitudinal joint: L-2

2P_10-19-10		
STATION TO STATION		Ⓞ Feet
3945+47	8970+20	6

Sta 3947+47.70 BK = Sta 8958+09.61 AH

See Tab 100-24 for pavement quantities.
 See Tab 112-9 for shoulder quantities.

170th St

Granular Shoulder

2_G_SR_10-19-10		
STATION TO STATION		Ⓞ Feet
961+82	964+32	6

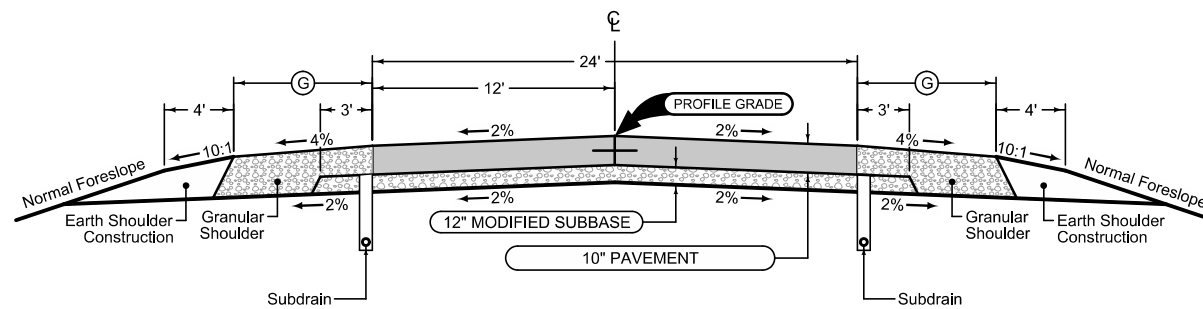

Granular Shoulder

2_G_SR_10-19-10		
STATION TO STATION		Ⓞ Feet
961+82	964+32	6

Mainline Jointing:
 Transverse joints: CD at 20' spacing
 Longitudinal joint: L-2

2P_10-19-10		
STATION TO STATION		Ⓞ Feet
961+82	964+32	6

See Tab 100-24 for pavement quantities.
 See Tab 112-9 for shoulder quantities.

Existing US 61 reconstruction 170th St

Granular Shoulder

2_G_SR_10-19-10		
STATION TO STATION		Ⓞ Feet
851+25	856+37	6

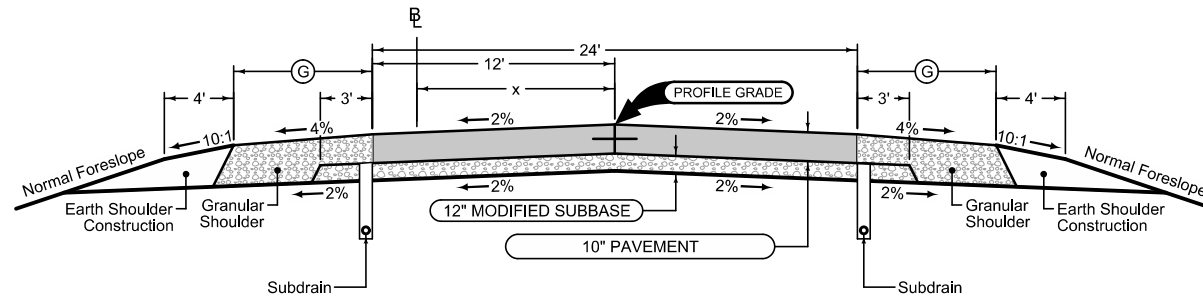

Granular Shoulder

2_G_SR_10-19-10		
STATION TO STATION		Ⓞ Feet
851+25	856+37	6

Mainline Jointing:
 Transverse joints: CD at 20' spacing
 Longitudinal joint: L-2

STATION TO STATION		x Feet
851+25	856+37	12

Granular Shoulder

2_G_SR_10-19-10		
STATION TO STATION		Ⓞ Feet
856+37	863+00	6

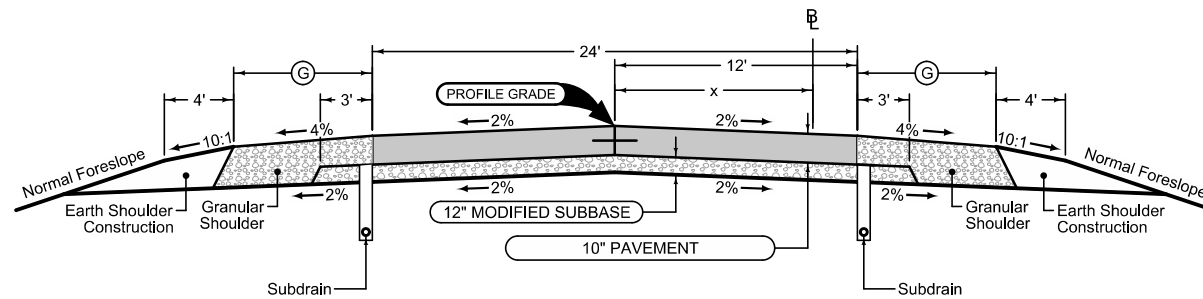

Granular Shoulder

2_G_SR_10-19-10		
STATION TO STATION		Ⓞ Feet
856+37	863+00	6

Mainline Jointing:
 Transverse joints: CD at 20' spacing
 Longitudinal joint: L-2

STATION TO STATION		x Feet
856+37	863+00	12 - 0

See Tab 100-24 for pavement quantities.
 See Tab 112-9 for shoulder quantities.

Existing US 61 reconstruction IA 92

Full Depth PCC Shoulder

Shoulder Jointing:
 Longitudinal joint: L-2 or KT-2
 Transverse joints: C at 20' spacing

2_P_FullPCC_ 10-19-10		
STATION TO STATION		(P) Feet
502+75	503+05	3-8
503+05	513+70	8
516+99	521+60	8

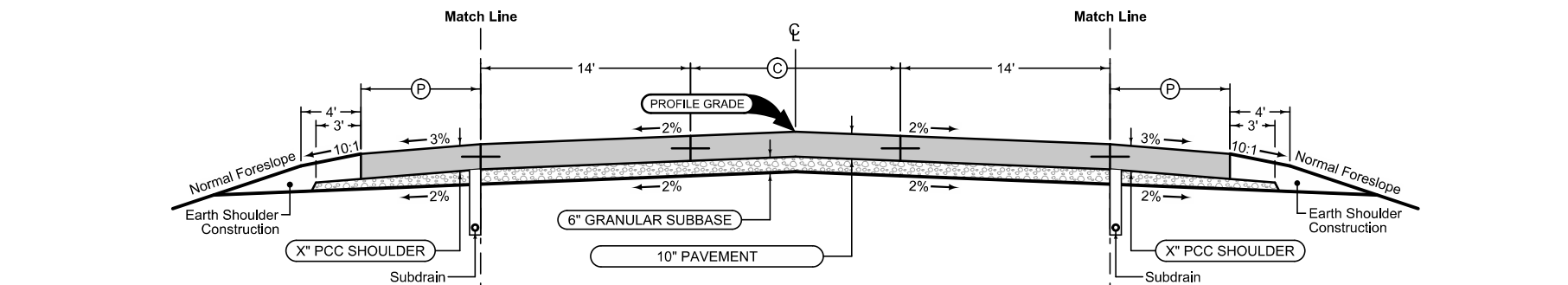

Full Depth PCC Shoulder

Shoulder Jointing:
 Longitudinal joint: L-2 or KT-2
 Transverse joints: C at 20' spacing

2_P_FullPCC_ 10-19-10		
STATION TO STATION		(P) Feet
506+80	521+60	8

Mainline Jointing:
 Transverse joints: CD at 20' spacing
 Longitudinal joint: L-2

2P_TWLT_ 10-19-10		
STATION TO STATION		(C) Feet
502+75	507+07	0-16
507+07	516+87	16
516+87	521+60	16-0

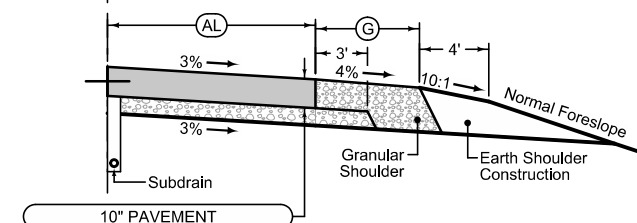
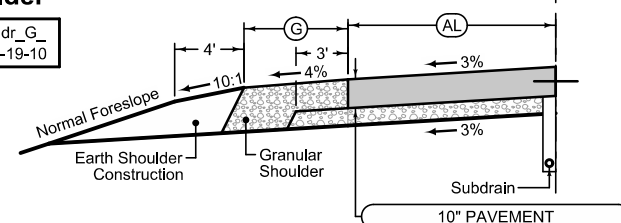

Auxiliary Lane

Longitudinal joint: L or KT
 Transverse joint: Match Mainline

2_AuxLane_PCC_ 10-19-10			
STATION TO STATION		(AL) Feet	(G) Feet
513+70	516+75	10	6

Auxiliary Lane

Granular Shoulder

2_AL_Shldr_G_ 10-19-10			
STATION TO STATION		(AL) Feet	(G) Feet
513+70	516+75	10	6

Auxiliary Lane

Longitudinal joint: L or KT
 Transverse joint: Match Mainline

2_AuxLane_PCC_ 10-19-10			
STATION TO STATION		(AL) Feet	(G) Feet
499+40	502+49	0-10	6
502+49	506+80	10	6

Auxiliary Lane

Granular Shoulder

2_AL_Shldr_G_ 10-19-10			
STATION TO STATION		(AL) Feet	(G) Feet
499+40	502+49	0-10	6
502+49	506+80	10	6

See Tab 100-24 for pavement quantities.
 See Tab 112-9 for shoulder quantities.

IA-92

Granular Shoulder

1R_G_ 10-19-10		
BEGIN STATION	END STATION	(G) Feet
2543+50	2556+69	4
4556+50	4580+50	4

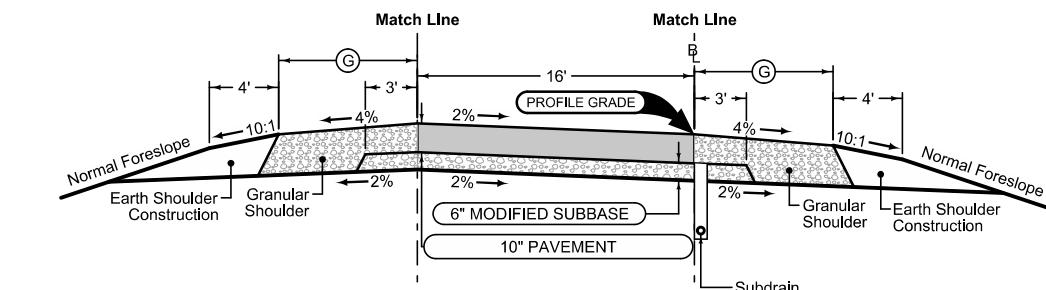

Granular Shoulder

1R_G_ 10-19-10		
BEGIN STATION	END STATION	(G) Feet
2543+50	2556+69	6
4556+50	4580+50	6

Paved Shoulder Alternates

PCC Shoulder Jointing:
 Longitudinal joint: BT-1 or BT-3
 Transverse joints: C at 20' spacing
 HMA Shoulder Jointing:
 Longitudinal joint: B

1R_P_ALT_ 10-19-10		
BEGIN STATION	END STATION	(P) Feet
1556+28	1570+50	4
3544+80	3556+42	4

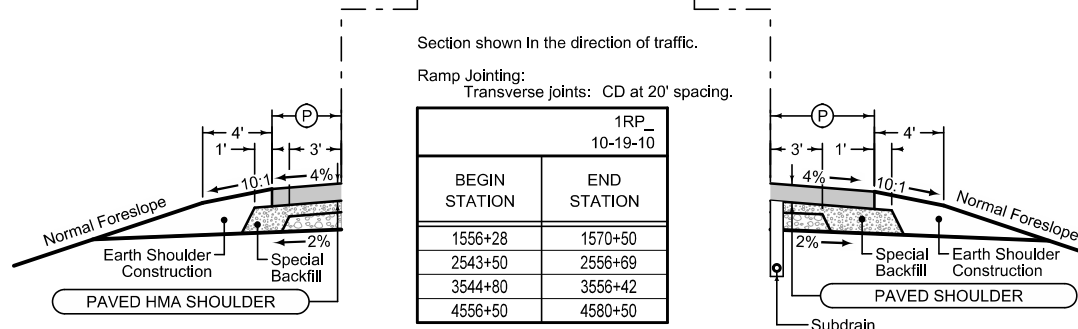

Section shown in the direction of traffic.
 Ramp Jointing:
 Transverse joints: CD at 20' spacing.

1RP_ 10-19-10		
BEGIN STATION	END STATION	(P) Feet
1556+28	1570+50	4
2543+50	2556+69	4
3544+80	3556+42	4
4556+50	4580+50	4

Paved Shoulder Alternates

PCC Shoulder Jointing:
 Longitudinal joint: BT-1 or BT-3
 Transverse joints: C at 20' spacing
 HMA Shoulder Jointing:
 Longitudinal joint: B

1R_P_ALT_ 10-19-10		
BEGIN STATION	END STATION	(P) Feet
1556+28	1570+50	6
3544+80	3556+42	6

See Tab 100-24 for pavement quantities.
 See Tab 112-9 for shoulder quantities.

US-61\IA-92 Interchange Ramps

Granular Shoulder

1R_G_ 10-19-10		
BEGIN STATION	END STATION	Ⓞ Feet
5564+70	5579+25	4
6551+00	6564+12	4
7550+50	7565+89	4
8563+94	8579+00	4

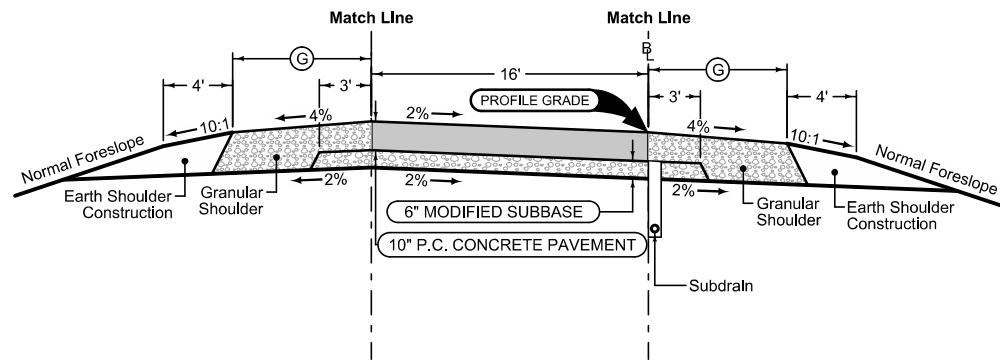

Section shown in the direction of traffic.
Ramp Jointing:
Transverse joints: CD at 20' spacing.

1RP_ 10-19-10		
BEGIN STATION	END STATION	
5564+70	5579+25	
6551+00	6564+12	
7550+50	7565+89	
8563+94	8579+00	

Granular Shoulder

1R_G_ 10-19-10		
BEGIN STATION	END STATION	Ⓞ Feet
5564+70	5579+25	6
6551+00	6564+12	6
7550+50	7565+89	6
8563+94	8579+00	6

See Tab 100-24 for pavement quantities.
See Tab 112-9 for shoulder quantities.

US-61/170th St Interchange Ramps

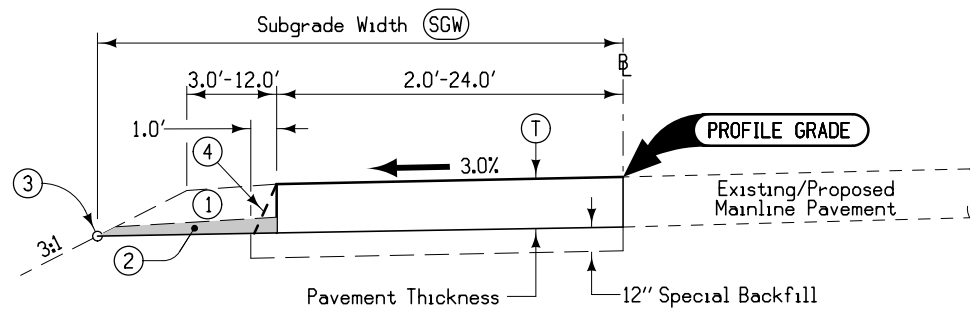

**TYPICAL CROSS SECTION
DETOUR TAPER PAVEMENT ALTERNATES**

DETOUR-3
XX

Location	Pavement Alternates				12" Special Backfill Tons	Granular Shoulders Tons	Earth Shoulder Construction Sta.
	HMA		PCC				
	Ⓣ Inches	Ⓞ Feet	Ⓣ Inches	Ⓞ Feet			
DET61_905							
301+26.75	304+55.63	9	12.5-29.2	8	12.2-28.9	-	-
311+33.17	315+71.08	9	30.4-16.7	8	30.1-16.4	-	-
DET61_985							
400+86.04	406+65.05	9	16.3-29.2	8	16.0-28.9	-	-
433+27.32	438+24.79	9	29.2-12.5	8	28.9-12.2	-	-

- Ⓚ 6" Granular Shoulder quantity calculation based on a vertical pavement face.
- Ⓛ Earth Shoulder Construction
- Ⓜ Subgrade Hinge Point
- Ⓨ Possible 1:1 Slope
- Ⓩ Per Station

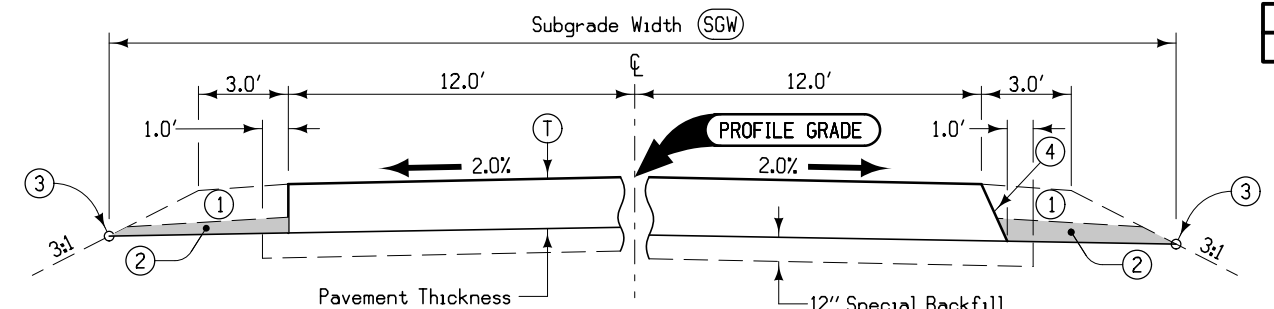

**TYPICAL CROSS SECTION
DETOUR 2-LANE PAVEMENT ALTERNATES**

DETOUR-4
XX

Location	Pavement Alternates				12" Special Backfill Tons	Granular Shoulders Tons	Earth Shoulder Construction Sta.
	HMA		PCC				
	Ⓣ Inches	Ⓞ Feet	Ⓣ Inches	Ⓞ Feet			
DET61_905							
304+55.63	311+33.17	9	34.4	8	33.8	-	-
DET61_985							
406+65.05	433+27.32	9	34.4	8	33.8	-	-

- Ⓚ 6" Granular Shoulder quantity calculation based on a vertical pavement face.
- Ⓛ Earth Shoulder Construction
- Ⓜ Subgrade Hinge Point
- Ⓨ Possible 1:1 Slope
- Ⓩ Per Station

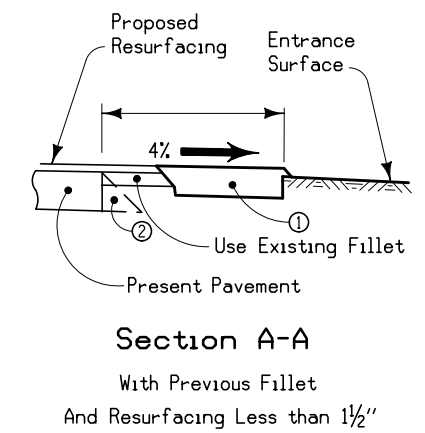
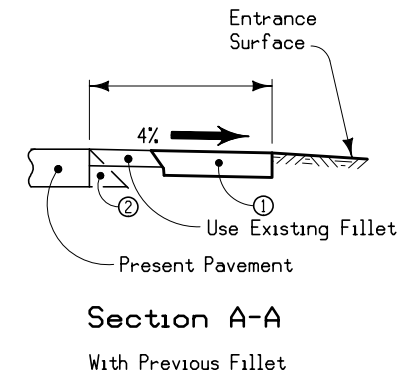
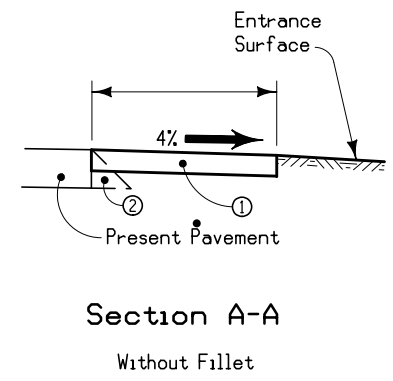
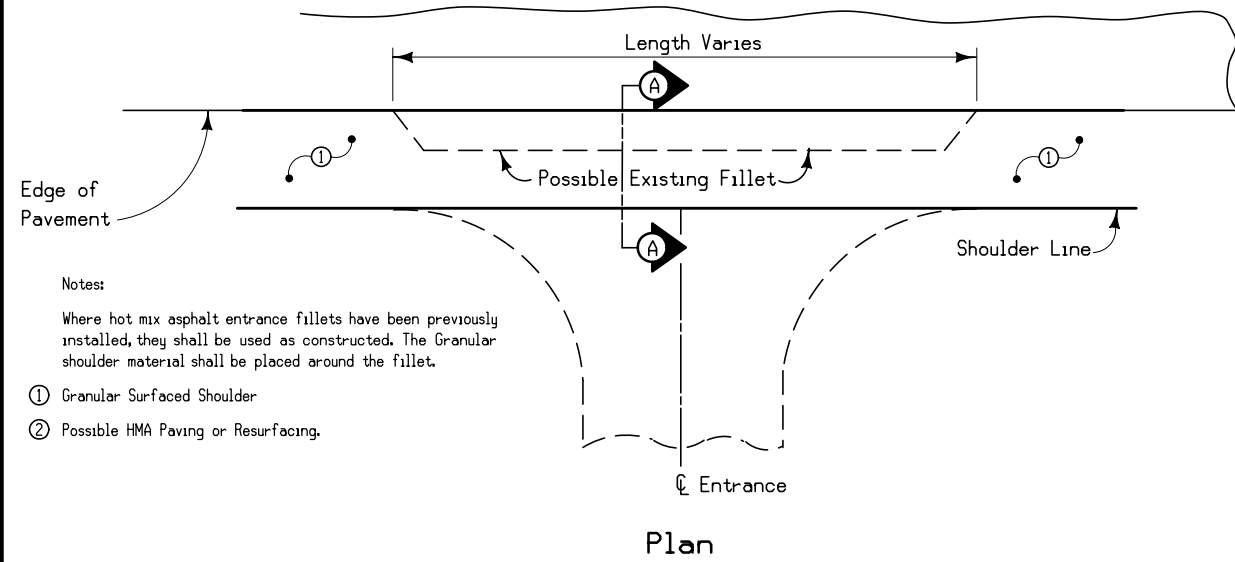

GRANULAR SHOULDER CONSTRUCTION THRU ENTRANCES

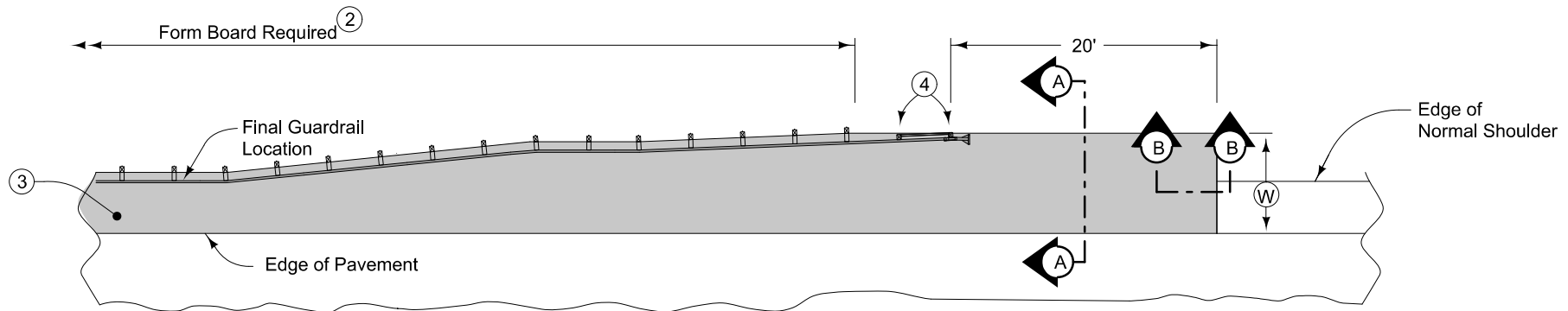

6" HMA Paved Shoulder at guardrail. 7" PCC may be substituted with the following jointing layout:

Match mainline pavement joint spacing. When mainline pavement is 8" or greater in thickness, place additional transverse joints in shoulder at mid-panel of the mainline pavement. Place longitudinal joint at W/2 from edge of mainline pavement when W is greater than 10'. Terminate longitudinal joint at transverse joint less than 10' in length.

Compaction of HMA is required to face of guardrail post. Hand compaction will be allowed under guardrail. Removal & reinstallation of guardrail will be allowed with no additional payment.

Refer to Shoulder tabulation (112-9) for quantities.

- ① 6" subgrade treatment.
- ② When guardrail posts are installed prior to construction of paved shoulder, nail 1" x 6" untreated form boards along the face of guardrail posts for the length shown. This board is to prevent shoulder material from contacting the sides of the posts and altering the function of the guardrail. Form board not required for final 2 posts.
- ③ Continue paved shoulder to existing paved shoulder or 20' beyond the end of guardrail.
- ④ Shoulder may be notched for final 2 posts or post sleeves may be installed through pavement.

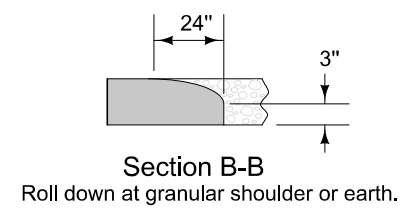
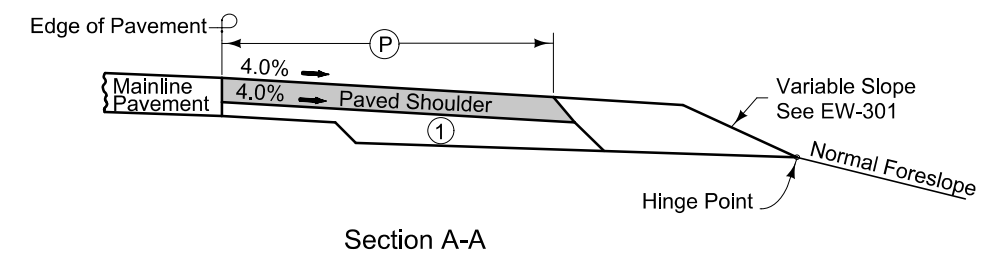
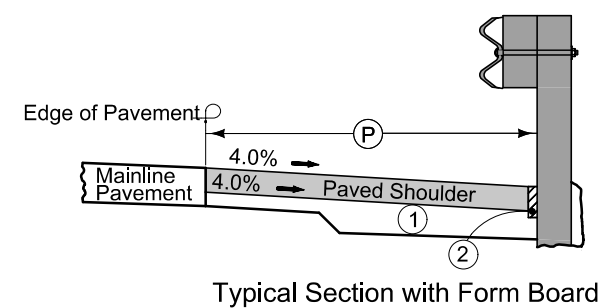

PAVED SHOULDER AT GUARDRAIL

SURVEY SYMBOLS

○ MIS Miscellaneous	--- ENT Centerline BL of Entrance
— LIN Miscellaneous Line	— CON Concrete or A/C Slab
— PIP Pipe Culvert	— ENP Edge Paved Entrance & Park Lot
— TIL Tile Line	— RR Centerline of Railroad Tracks
○ OUT Tile Outlet	— EW Edge of Water
⊠ IN Storm Sewer Intake	— CU Back of Curb
— CUL Culvert	— GU Gutter In Front of Curb
⊗ INB Storm Sewer Beehive Intake	— E1 ELA Underground Electric Line Co. 1
○ MM Mile Marker Post	— E2 ELB Underground Electric Line Co. 2
RRW Railroad Switch	— T1 TLA Underground Telephone Line Co. 1
RRS Railroad Signal	— F04 FOD Underground Fiber Optic Co. 4
RRF Railroad Frog	— GHA Underground High Pres Gas Co 1
□ EB Electrical Box	— F03 FOC Underground Fiber Optic Co. 3
— BRG Bridge	— F0 FOA Underground Fiber Optic Co. 1
— GDL Guard Rail Steel	— BL Topo Breakline
BB BB Billboard	— BLD Building or Foundation
□ SIGN SL Speed Limit Sign	SWP Swamp or Marsh
PPA Power Pole Co. 1	— SWK Sidewalk
○ TA Tower Anchor	⊠ WM Wind Mill
PR Electric Riser Pole	⊕ LP L.P. Tank
○ LUM Luminaire	⊗ TV Satellite TV Dish
⊗ MH Utility Access (Manhole)	BB BB Billboard
□ SIGN SI Sign	○ FLG FLG Flag Poles
PPC Power Pole Co. 3	— RET Retaining Walls
LC Lot Corner	— FCL Chain Link and Security Fence
* TEV Evergreen Tree	— C Centerline BL of Road (ML or SR)
⊗ TDC Tree Deciduous	— FWD Wood Fence
— HDG Hedge Row	⊗ SHR Shrub
⊗ SHR Shrub	— TER Terrace
HT Electrical Highline Tower	
○ TP TPD Telephone Pedestal	
* TSG Traffic Signal	
○ GV GV Gas Valve	
— UV Underground Utility Vault	
— x FW Wire Fence	
— GPR Guard Post (4 or More Posts)	
— BLD Building or Foundation	
— FCL Chain Link and Security Fence	
— BNK Stream Bank	
— EP Edge of Paved Roads (ML or SR)	
— SNP Unpaved Shoulder	
— DIK Centerline of Dike or Dam	
⊗ SNK Sink Hole	
— D Centerline Draw or Stream (Down)	
— DU Centerline Draw or Stream (Up)	
— EG Edge of Gravel Road	
— ENU Edge Unpaved Entrance & Parking	
— SH Paved Shoulder	

UTILITY LEGEND

Alliant Energy
Ann Kreiss
215 Oak Street
Muscatine, IA 52761
563-288-3322
annkreiss@alliantenergy.com

Eastern Iowa Light and Power Cooperative
Dennis Hill
600 East Fifth Street Box 3003
Wilton, IA 52778-3003
563-732-2211
dennis.hill@easterniowa.com

MidAmerican Energy Company
Tom Albertson
106 East Street
Davenport, IA 52801
563-333-8155
ktalbertson@midamerican.com

Windstream
Mike Braughton
One Martha's Way
Hiawatha, IA 52233
319-790-7114
michael.braughton@windstream.com

Windstream Communications of Iowa
Kelly Eggers
101 W Madison
Mt. Pleasant, IA 52641
319-385-5004
kelly.eggers@iowatelecom.com

PLAN VIEW COLOR LEGEND OF PLAN AND PROFILE SHEETS

LINEWORK	Design Color No.	Description
Green	(2)	Existing Topographic Features and Labels
Blue	(1)	Proposed Alignment, Stationing, Tic Marks, and Alignment Annotation
Magenta	(5)	Existing Utilities
SHADING	Design Color No.	Description
Yellow	(4)	Highlight for Critical Notes or Features
Red	(3)	Delineates Restricted Areas
Lavender	(9)	Temporary Pavement Shading
Gray, Light	(48)	Proposed Pavement Shading
Gray, Med	(80)	Proposed Granular Shading
Gray, Dark	(112)	Proposed Grade and Pave Shading "In conjunction with a paving project"
Brown, Light	(236)	Grading Shading
Tan	(8)	Proposed Sidewalk Shading
Blue, Light	(230)	Proposed Sidewalk Landing Shading
Pink	(11)	Proposed Sidewalk Ramp Shading

PROFILE VIEW COLOR LEGEND OF PLAN AND PROFILE SHEETS

LINEWORK	Design Color No.	Description
Green	(2)	Existing Ground Line Profile
Blue	(1)	Proposed Profile and Annotation
Magenta	(5)	Existing Utilities
Blue, Light	(230)	Proposed Ditch Grades, Left
Black	(0)	Proposed Ditch Grades, Median
Rust	(14)	Proposed Ditch Grades, Right

Symbol	Description
○	Reference Point
—	Station
—	Survey Line
▲	Section Corner
—	Ground Line Intercept
///	Saw Cut
—	Guardrail
—	Trench Drain
—	HighTension Cable Guardrail
—	Sheet Pile
▨	Pavement Removal
▩	Clearing & Grubbing Area

Symbol	Description
▲	Proposed Right-of-Way
△	Existing Right of Way
▲△	Existing and Proposed Right-of-Way
▲△	Easement and Existing Right-of-Way
○	Easement (Temporary)
⊗	Easement
C/A	Access Control
— —	Property Line

PLAN AND PROFILE LEGEND AND SYMBOL INFORMATION SHEET

(COVERS SHEET SERIES D, E, F, & K)

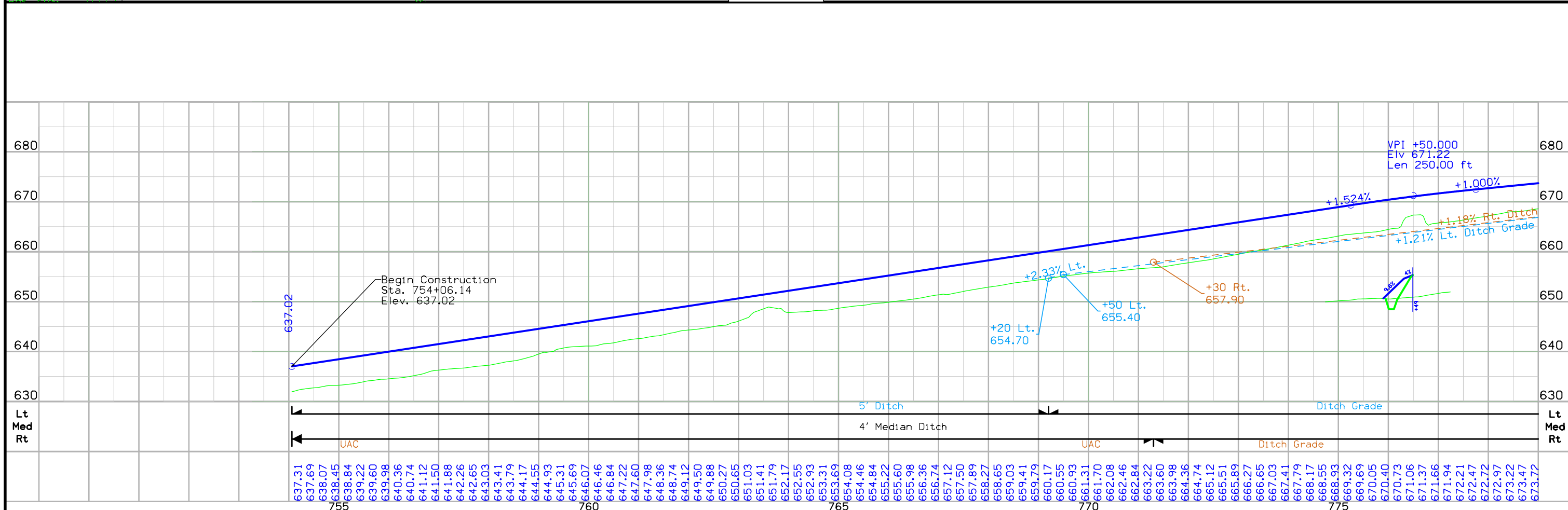
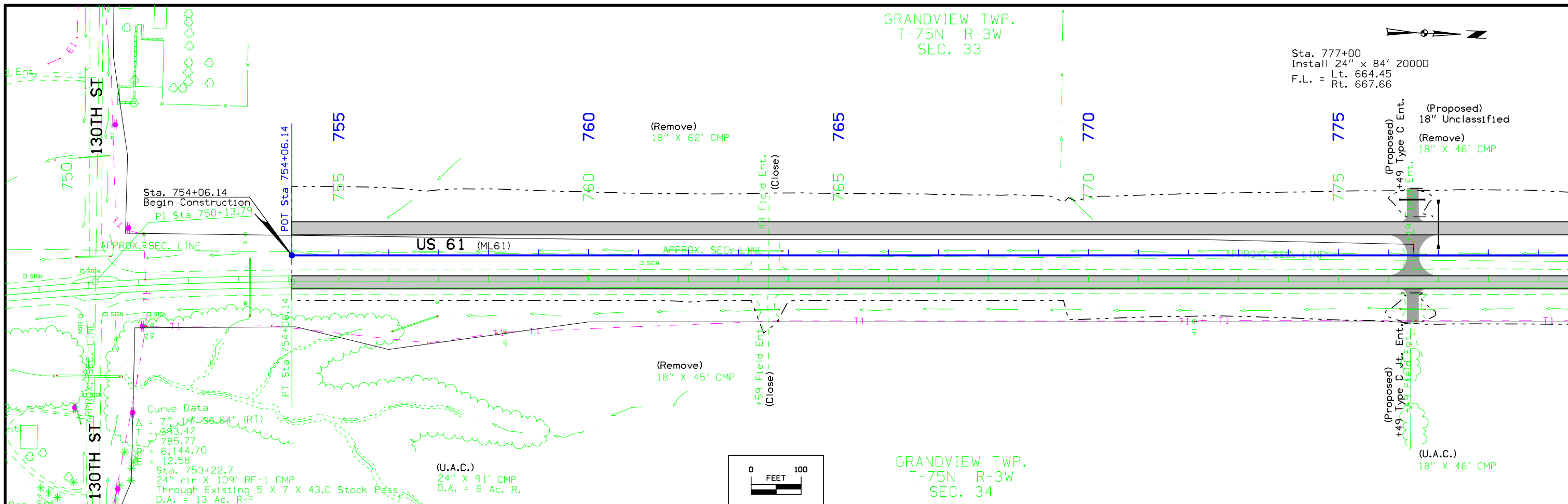

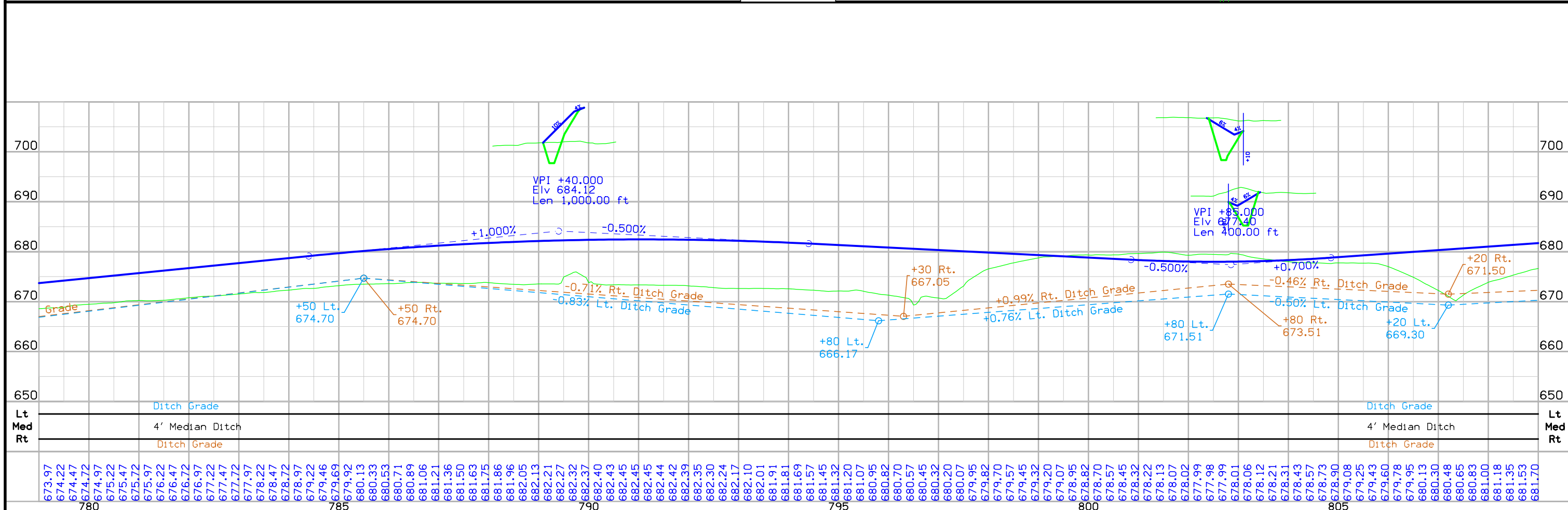
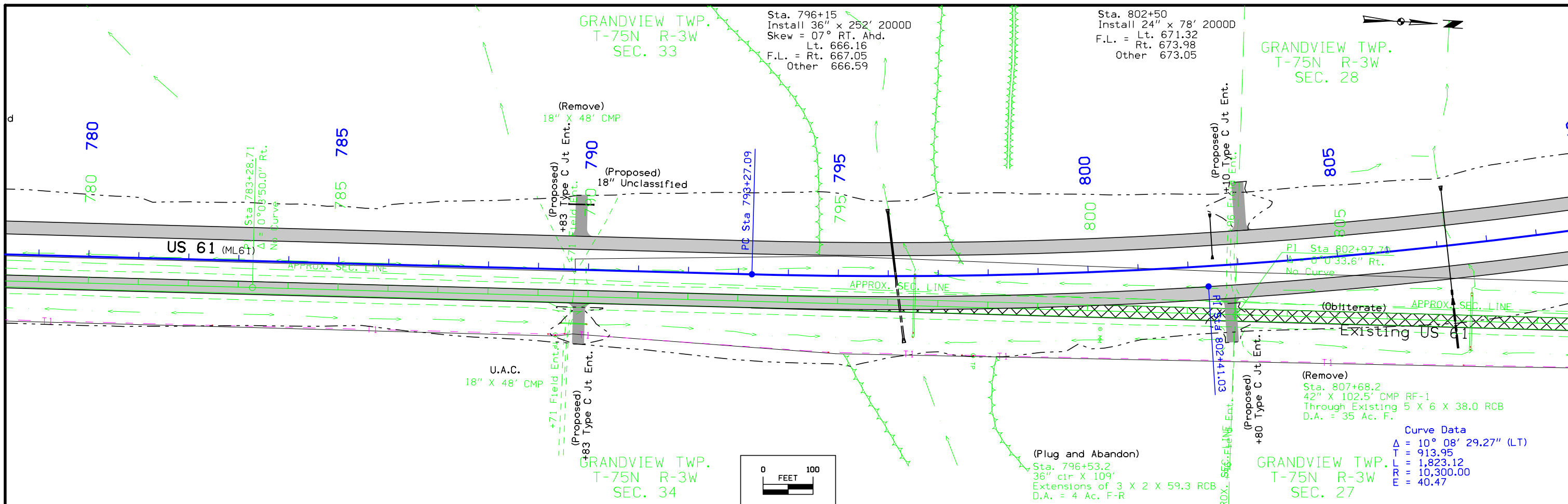

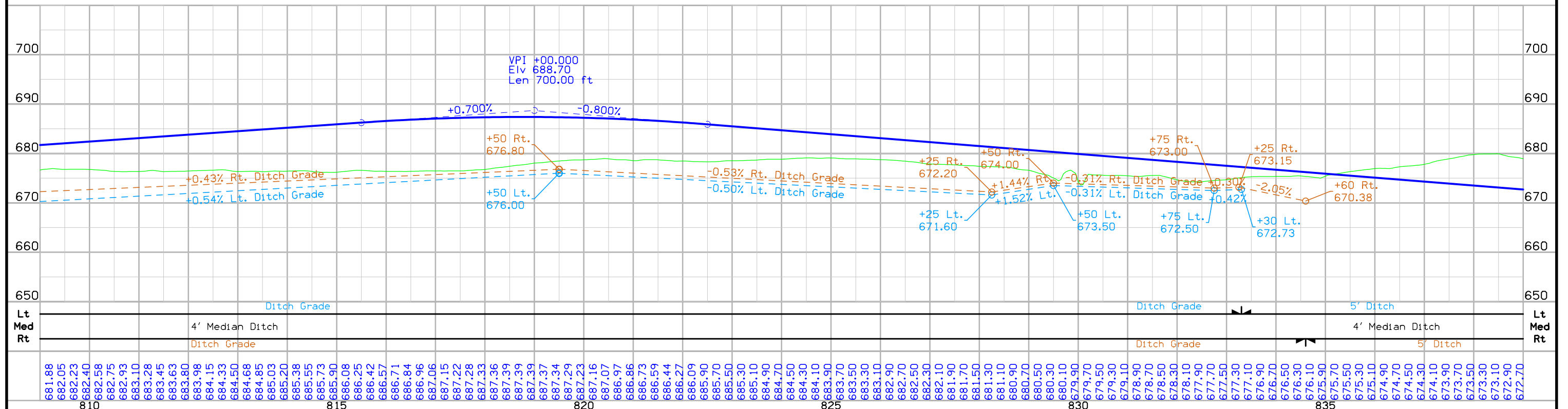
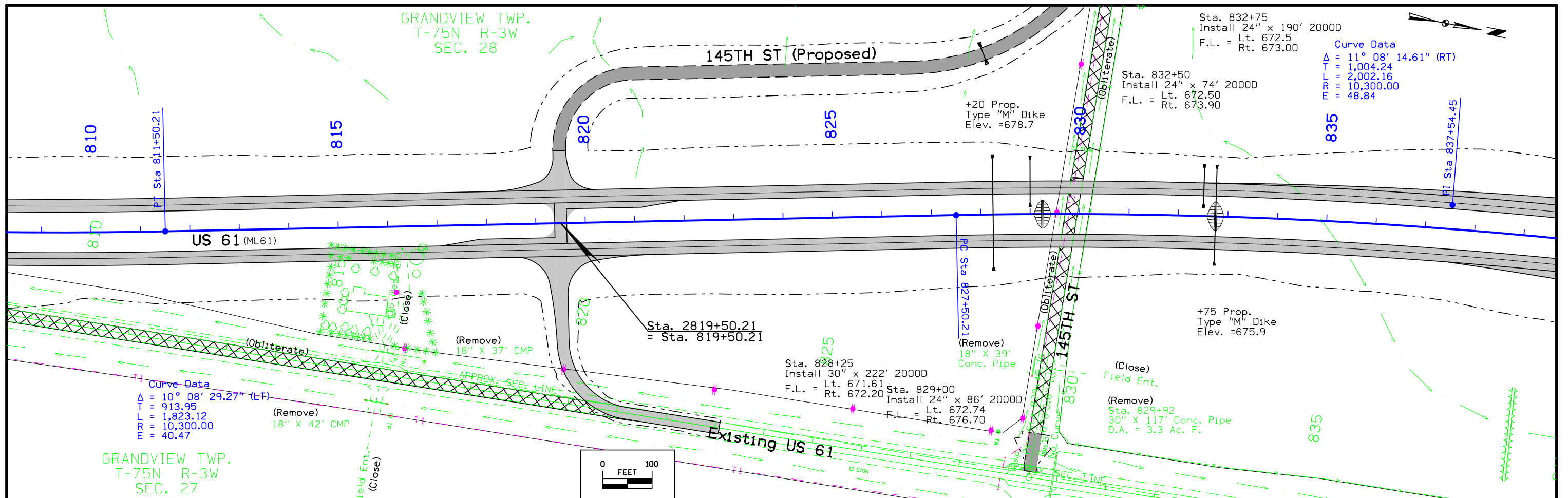

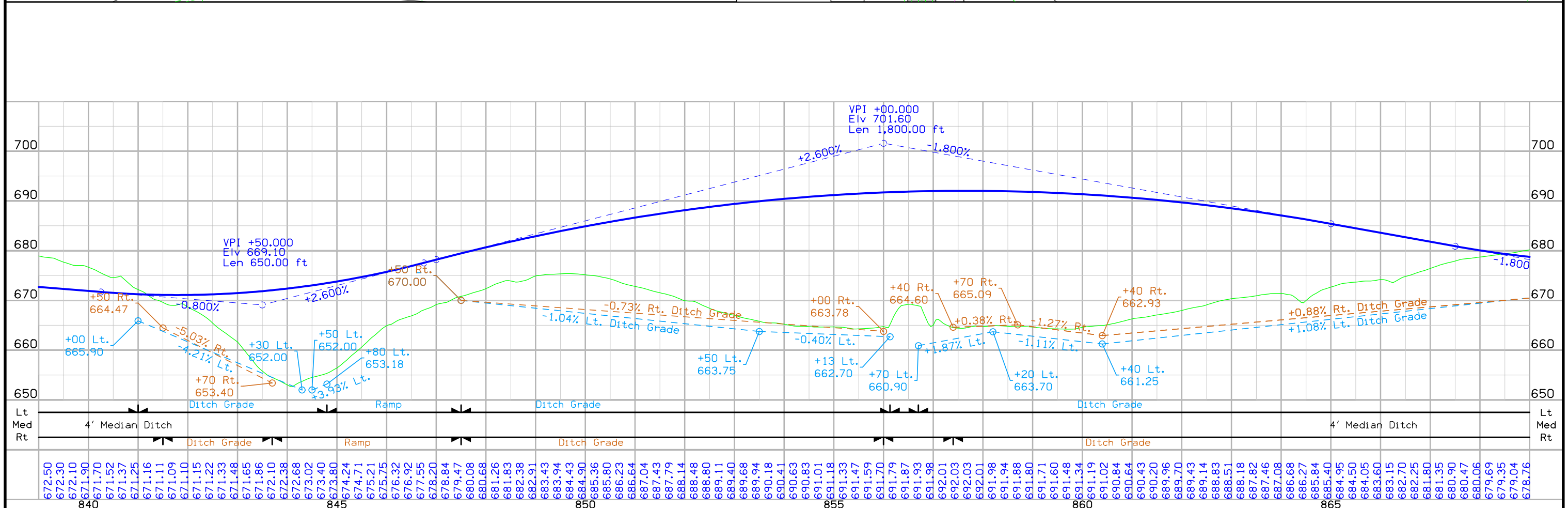
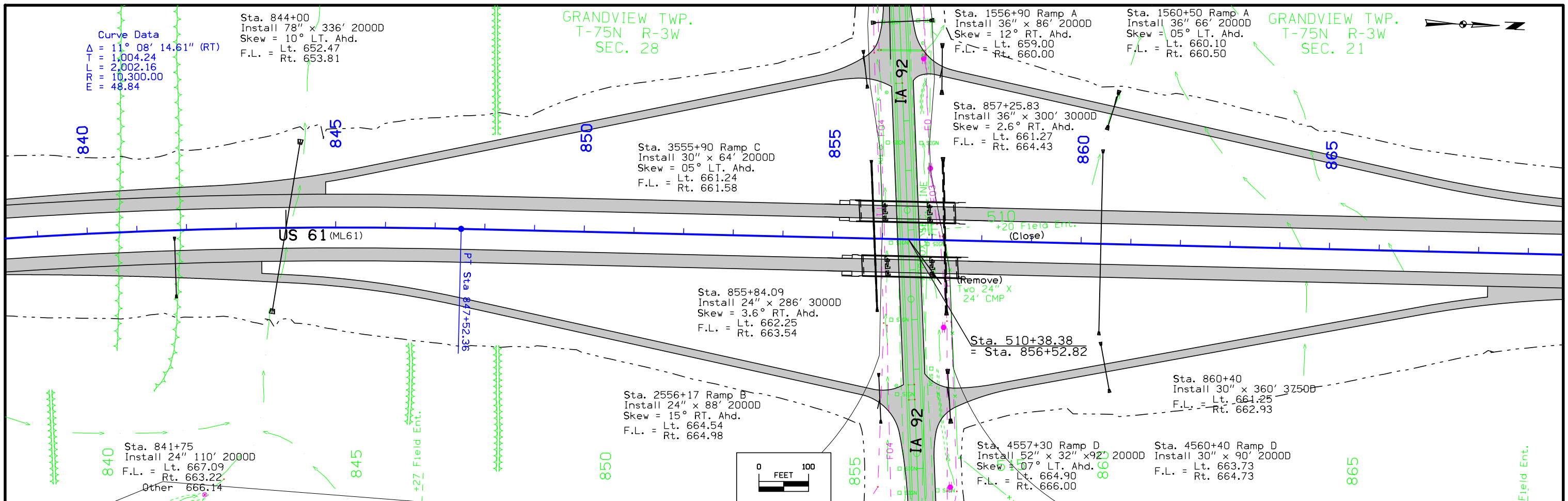

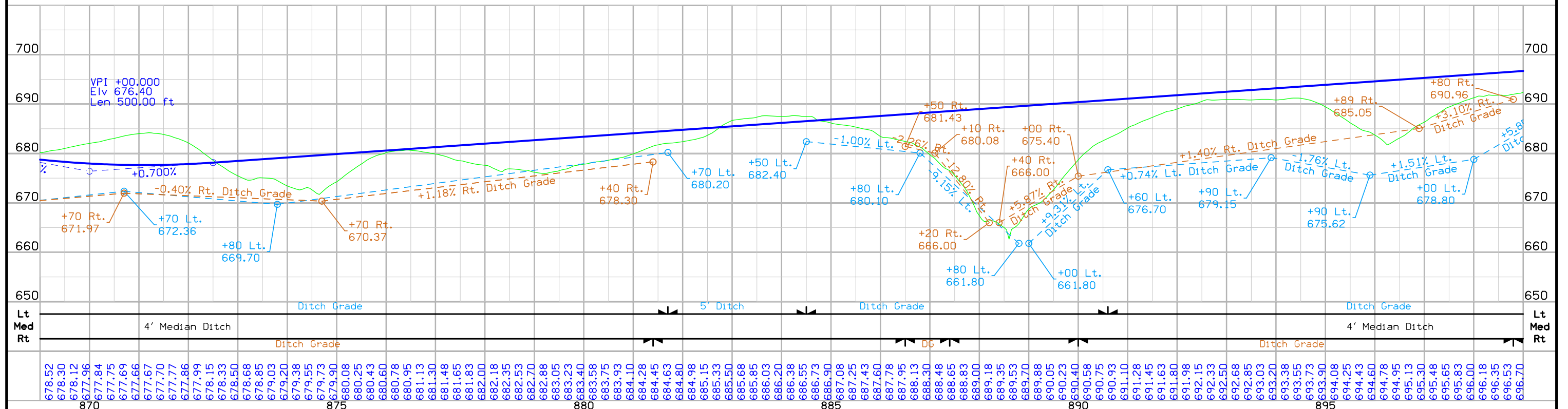
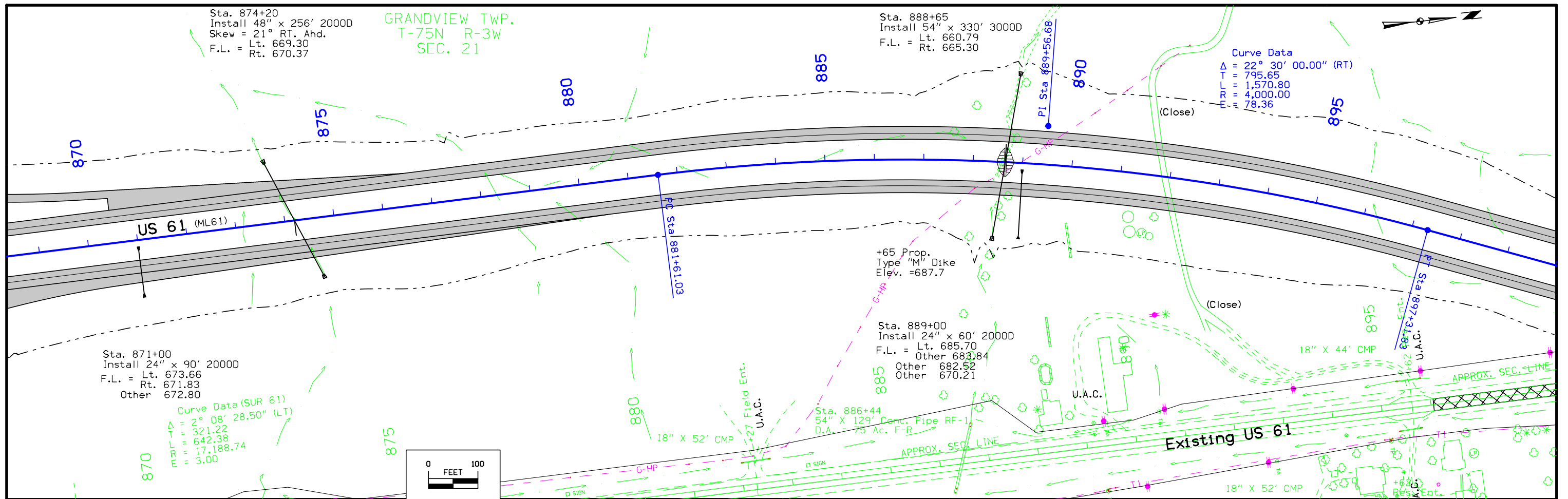

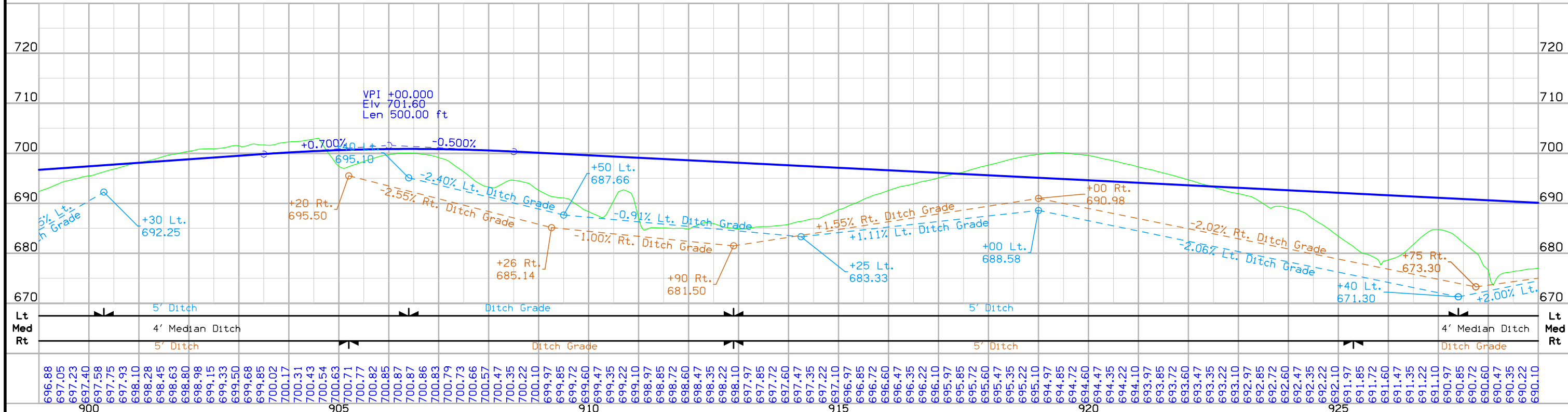
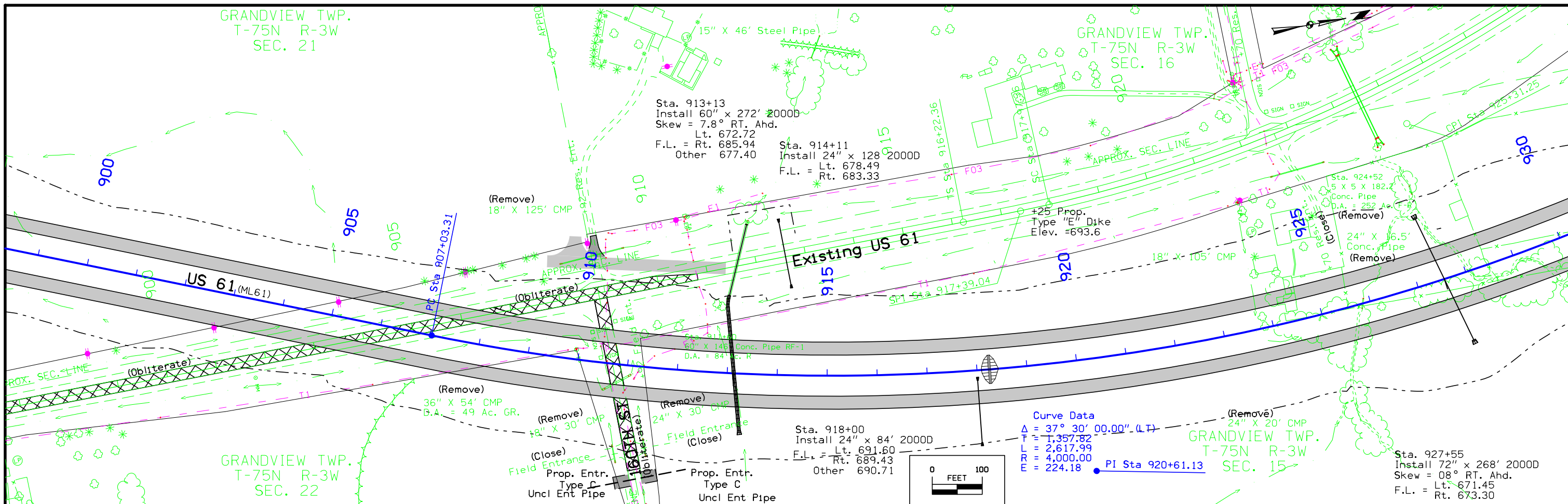

C	ENGLISH	IOWA DOT	DESIGN TEAM	Schoenrock\Drake\Thede	LOUISA COUNTY	PROJECT NUMBER	NHS-061-3(48)--19-58	SHEET NUMBER	D.7
---	---------	----------	-------------	------------------------	---------------	----------------	----------------------	--------------	-----

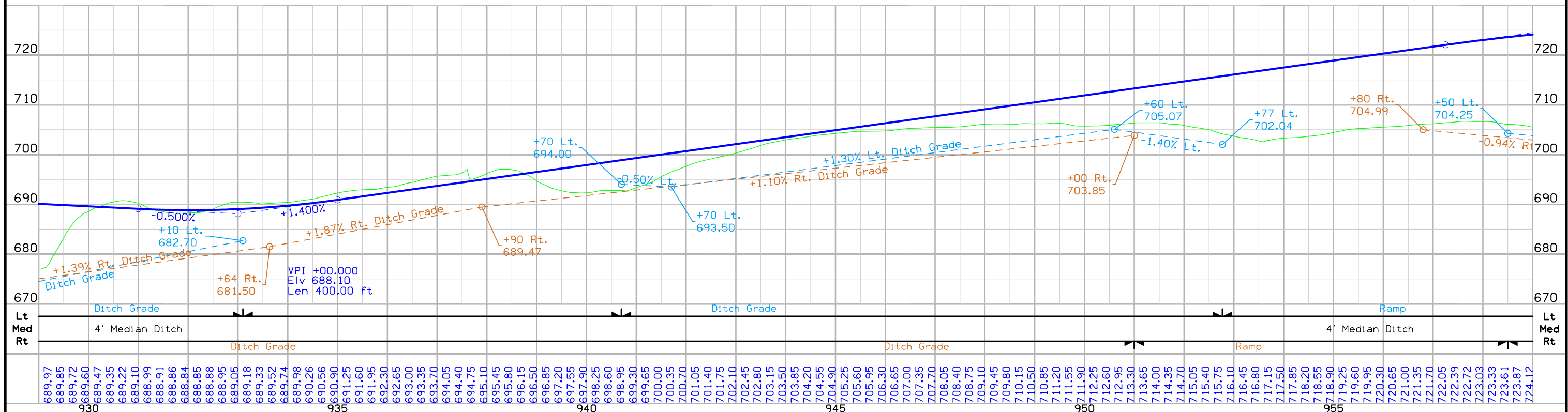
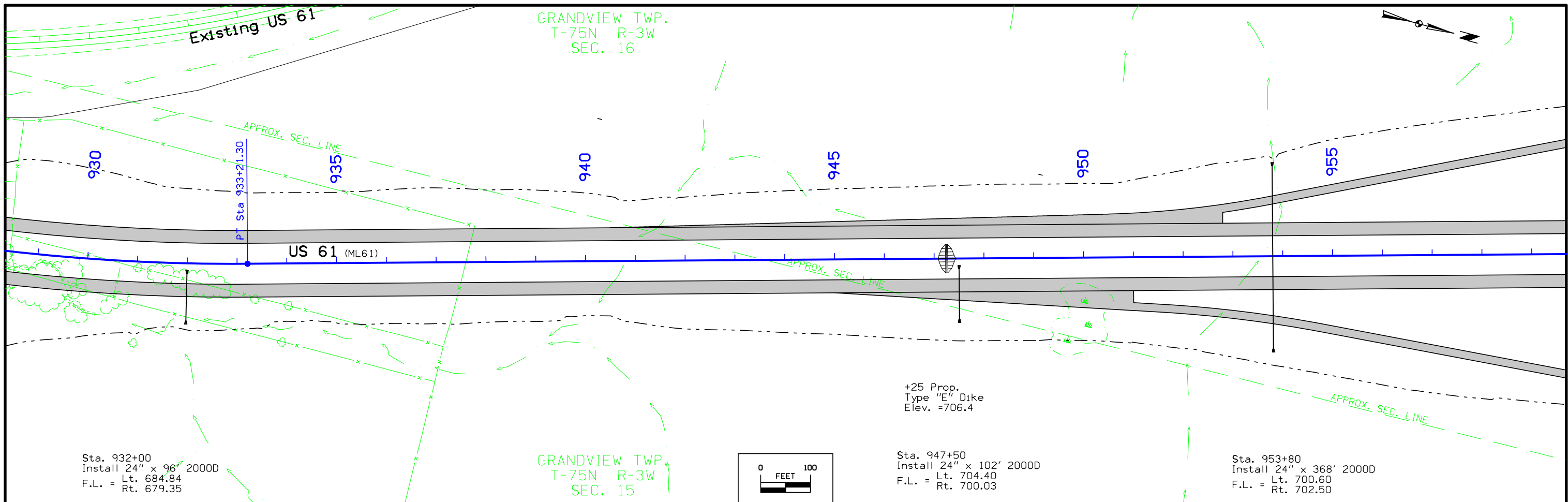

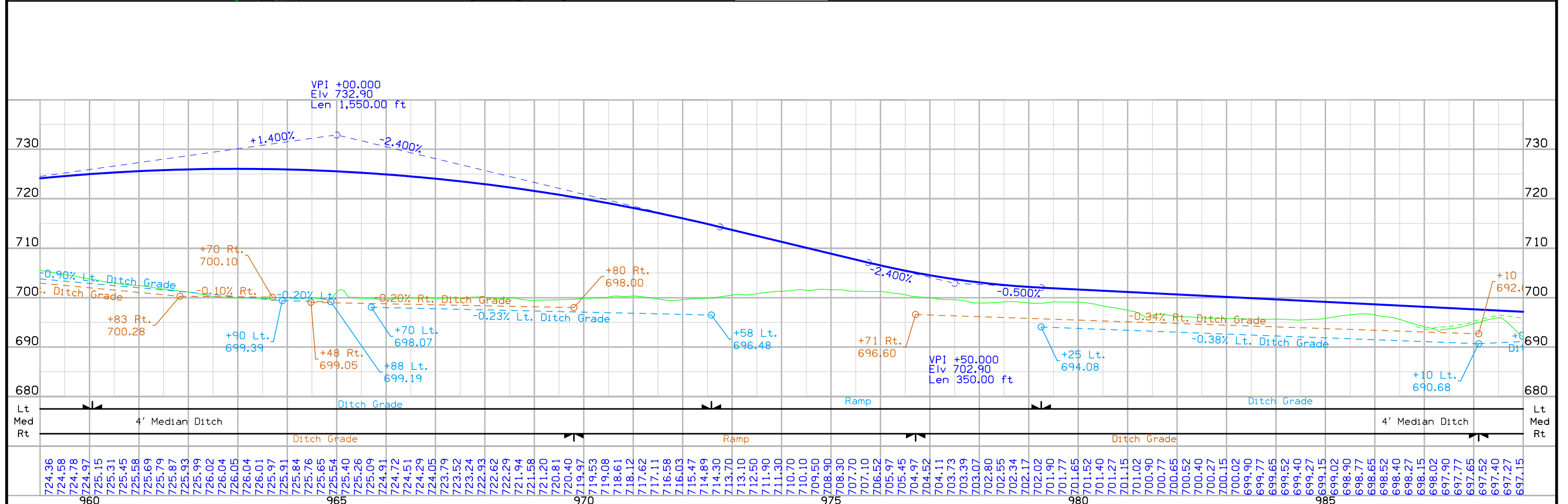
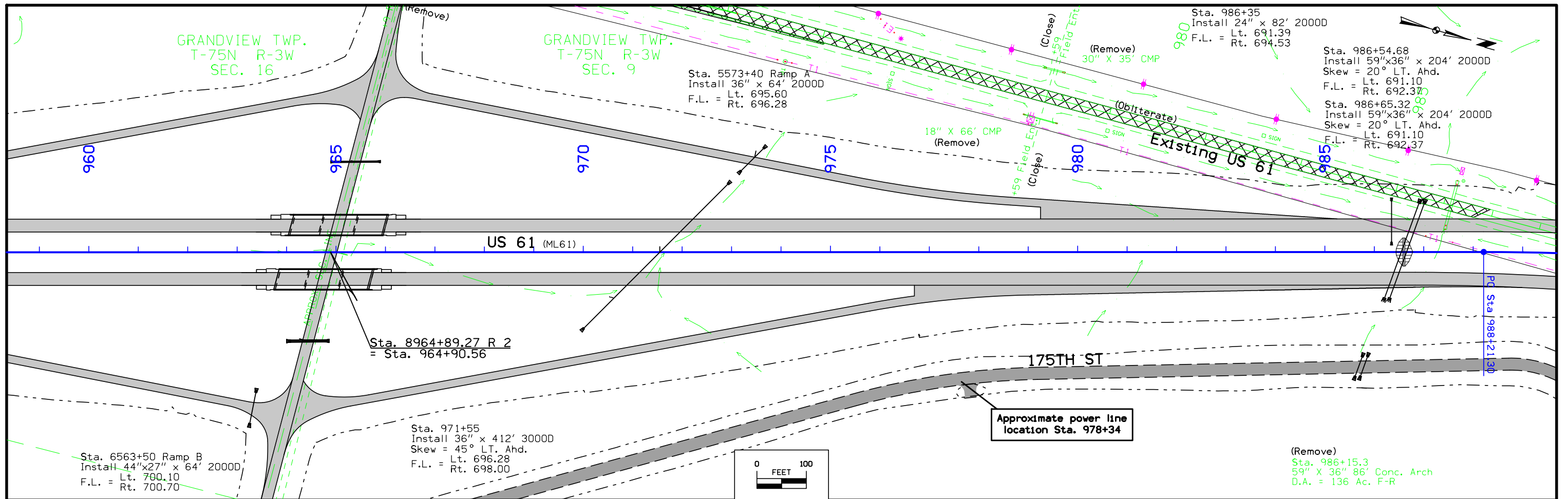

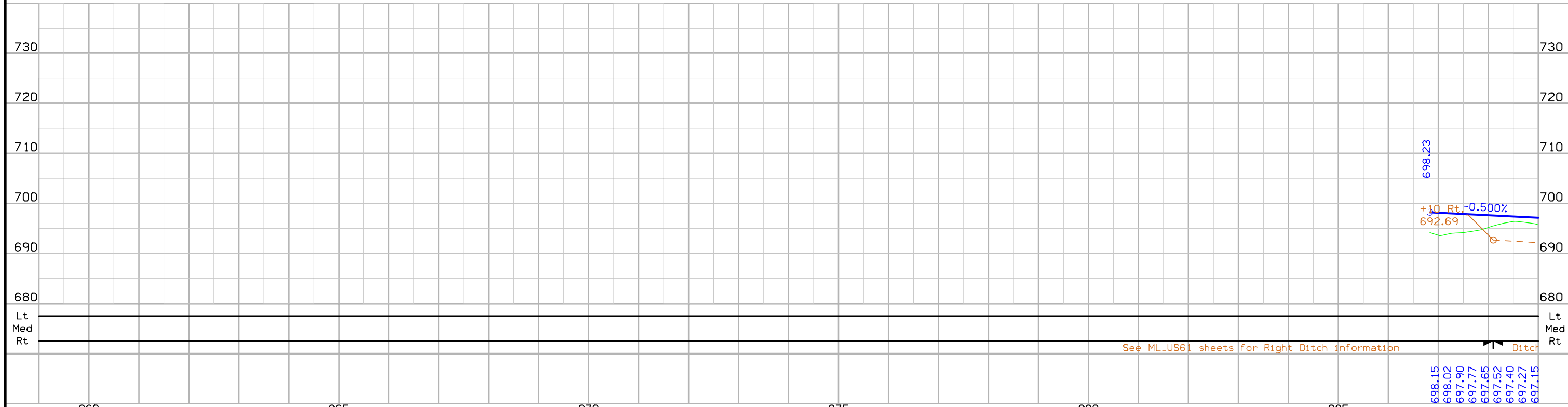
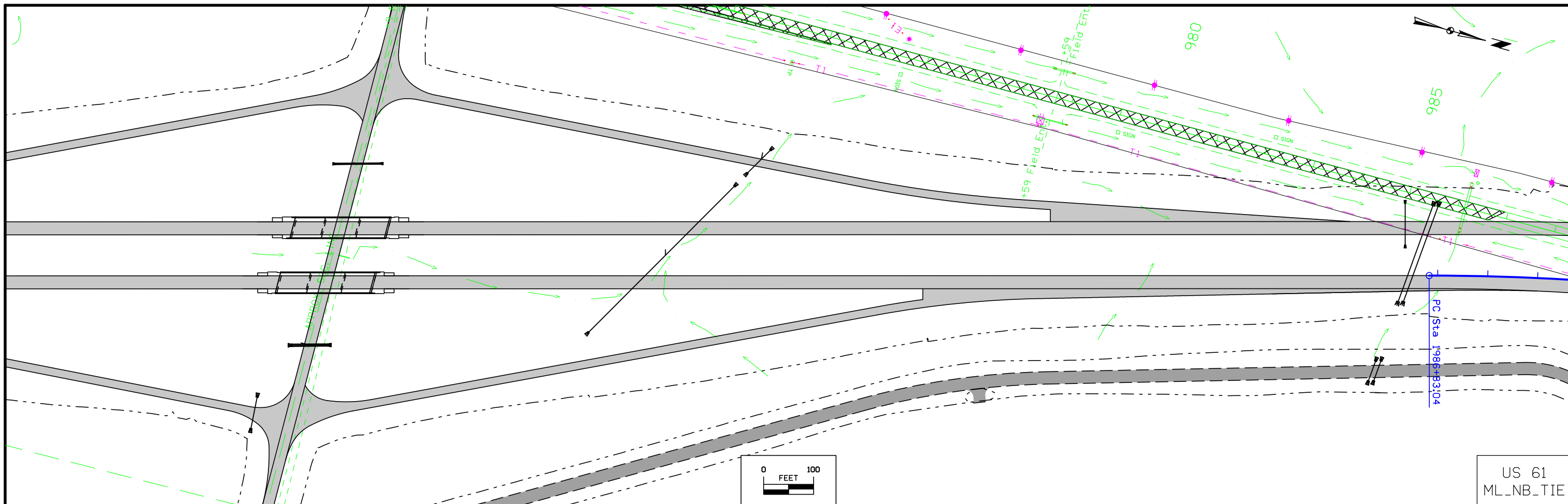

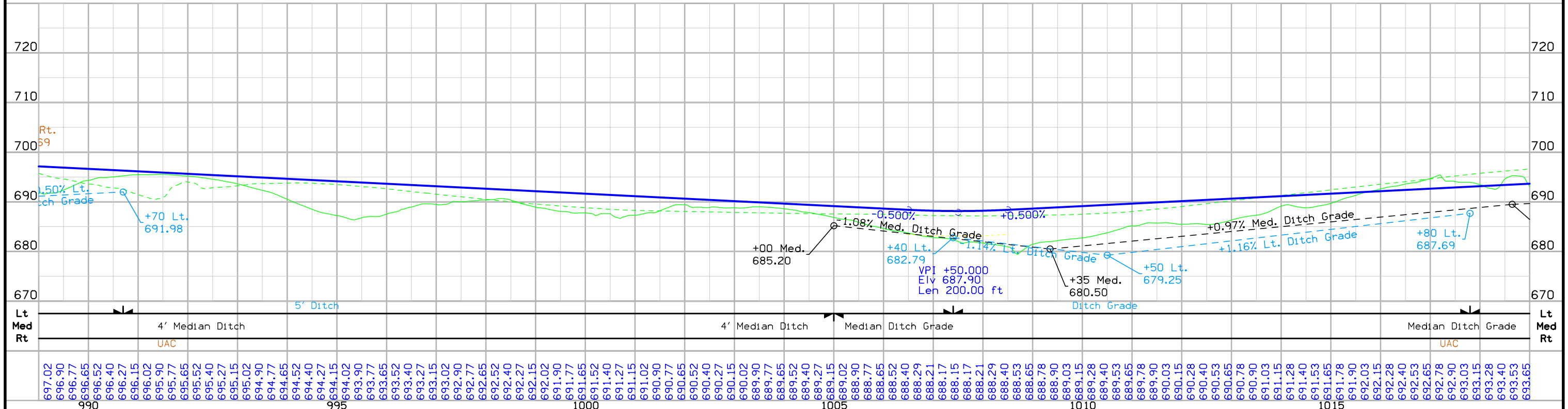
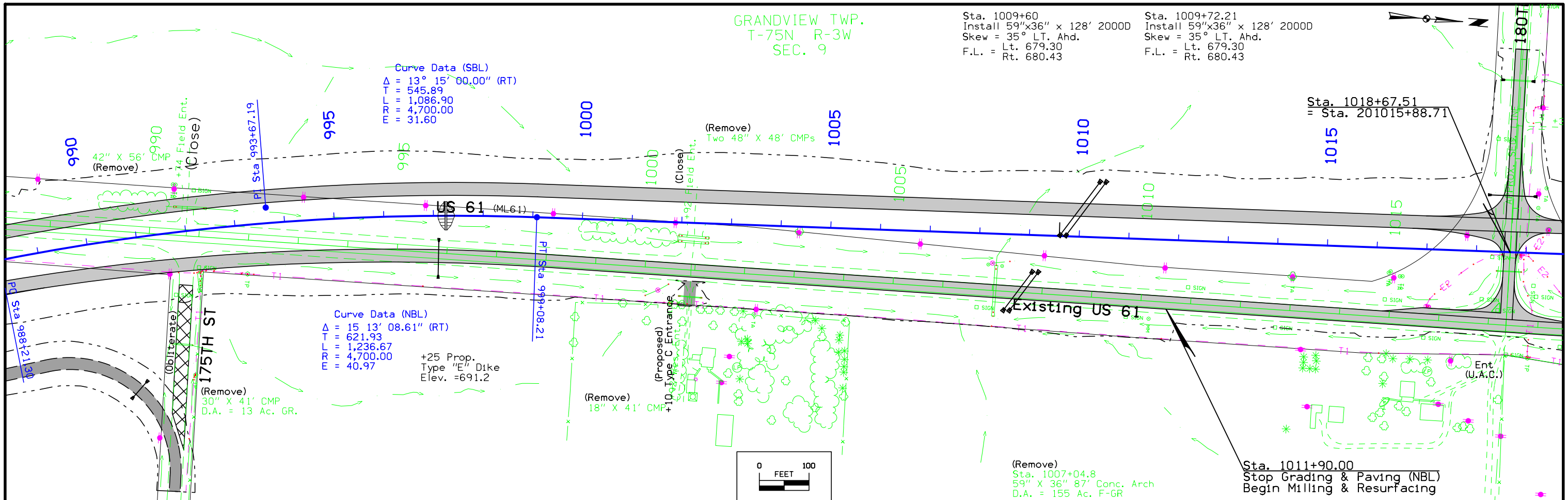

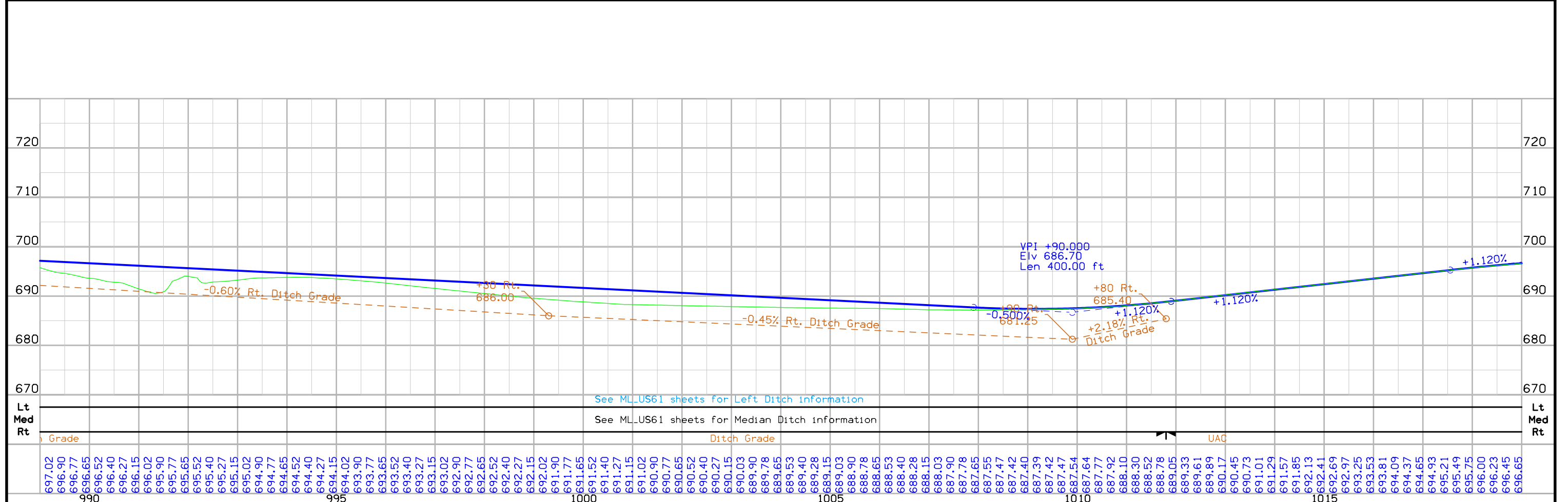
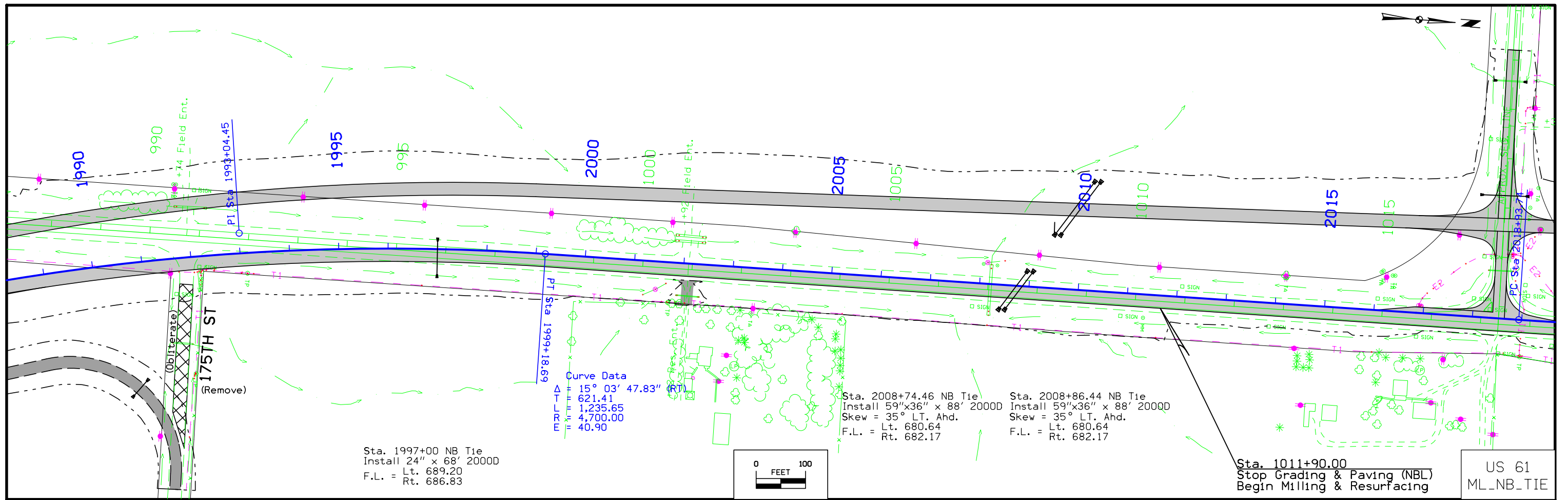

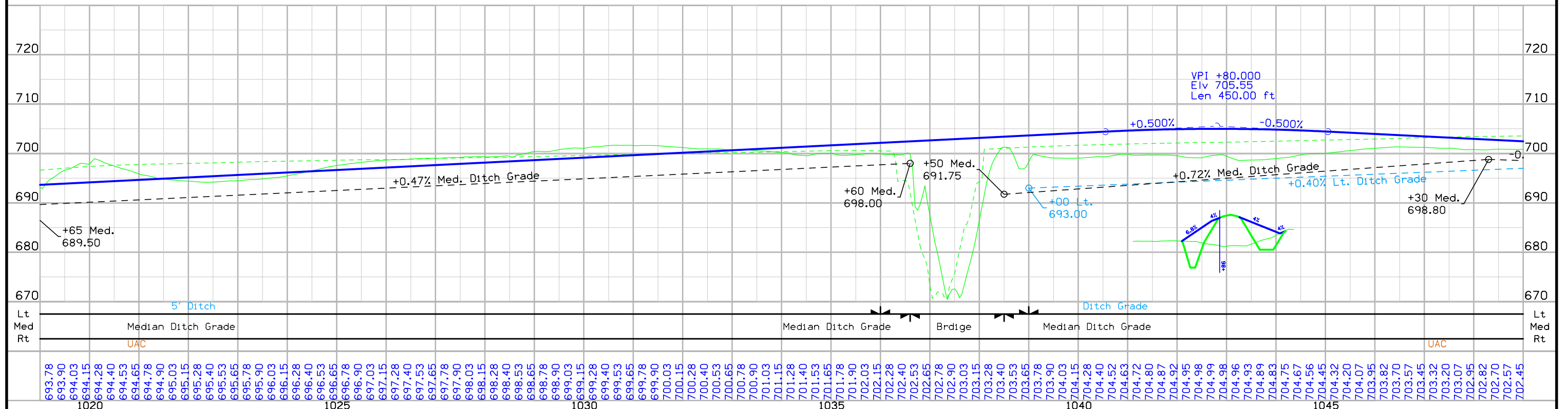
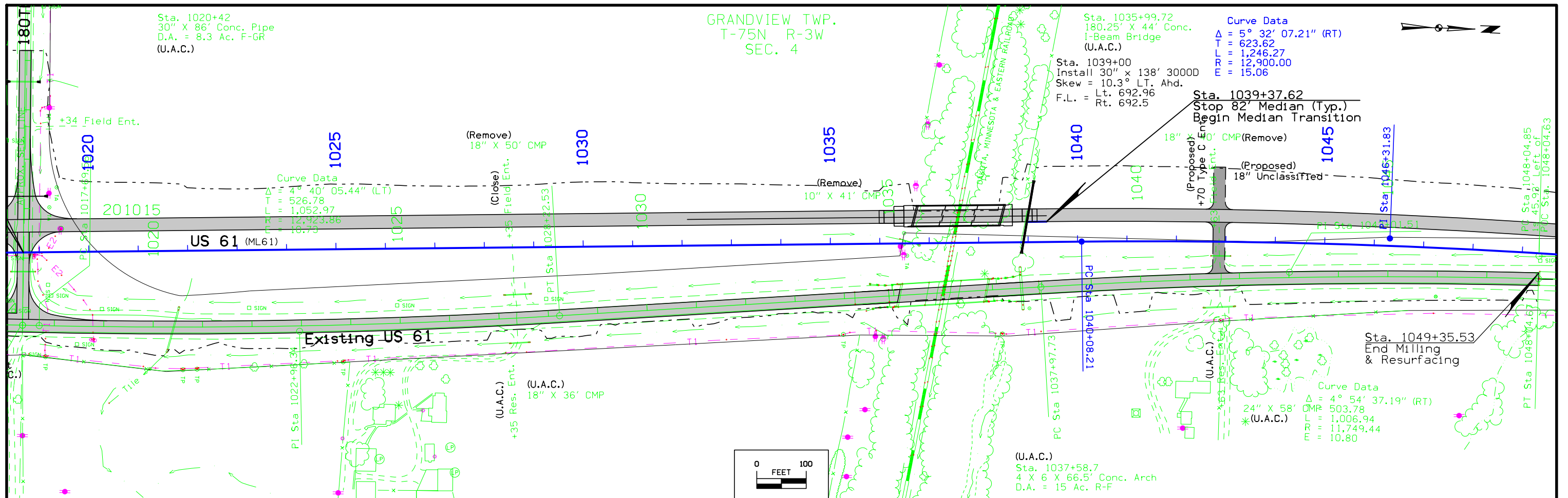

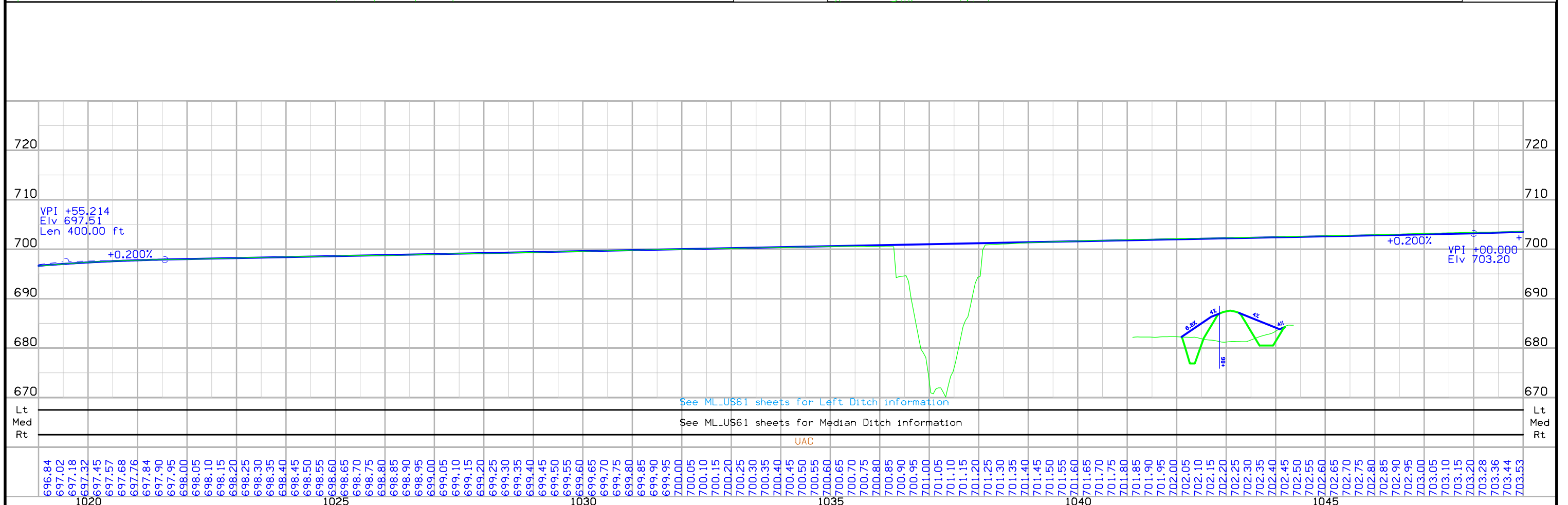
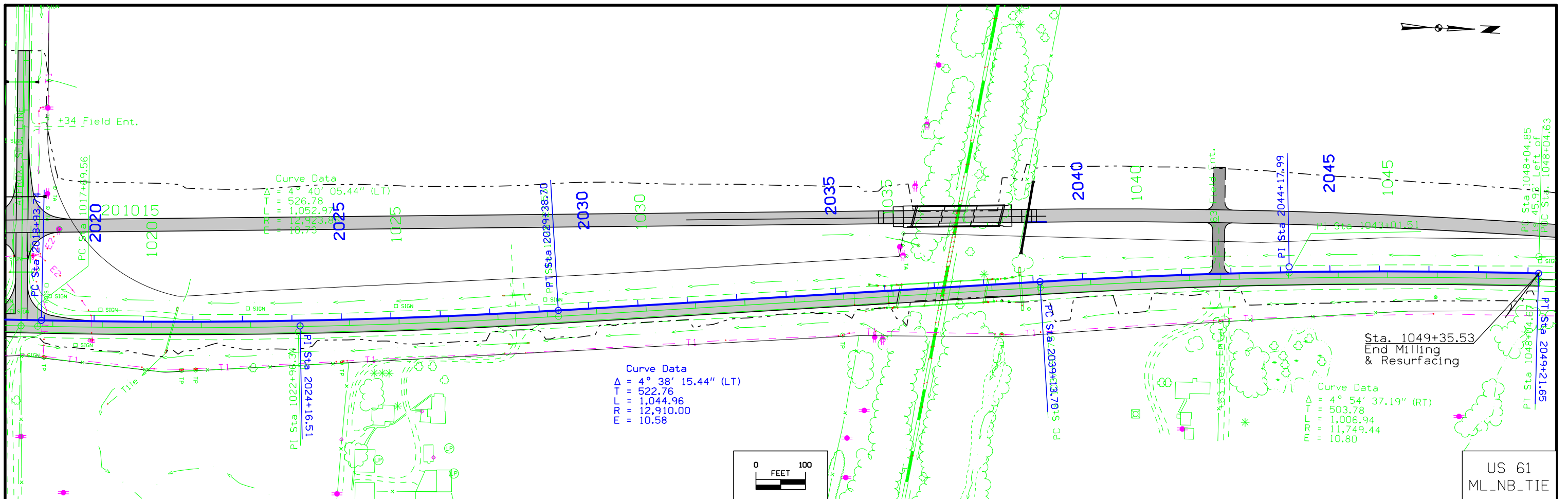

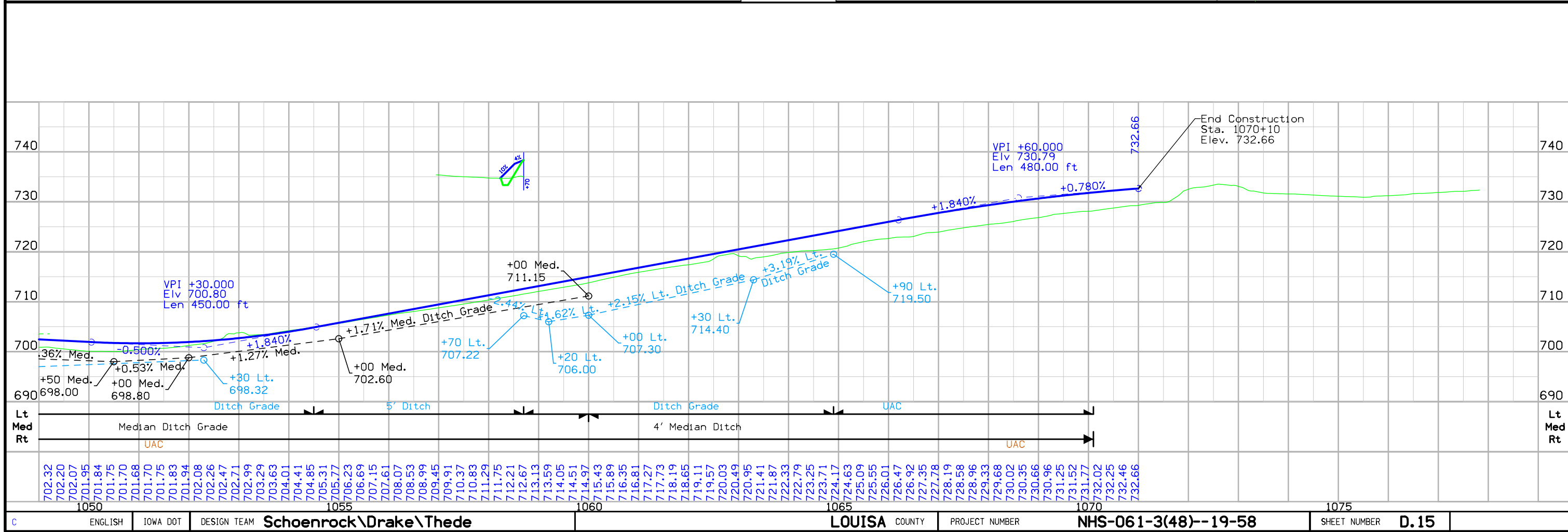
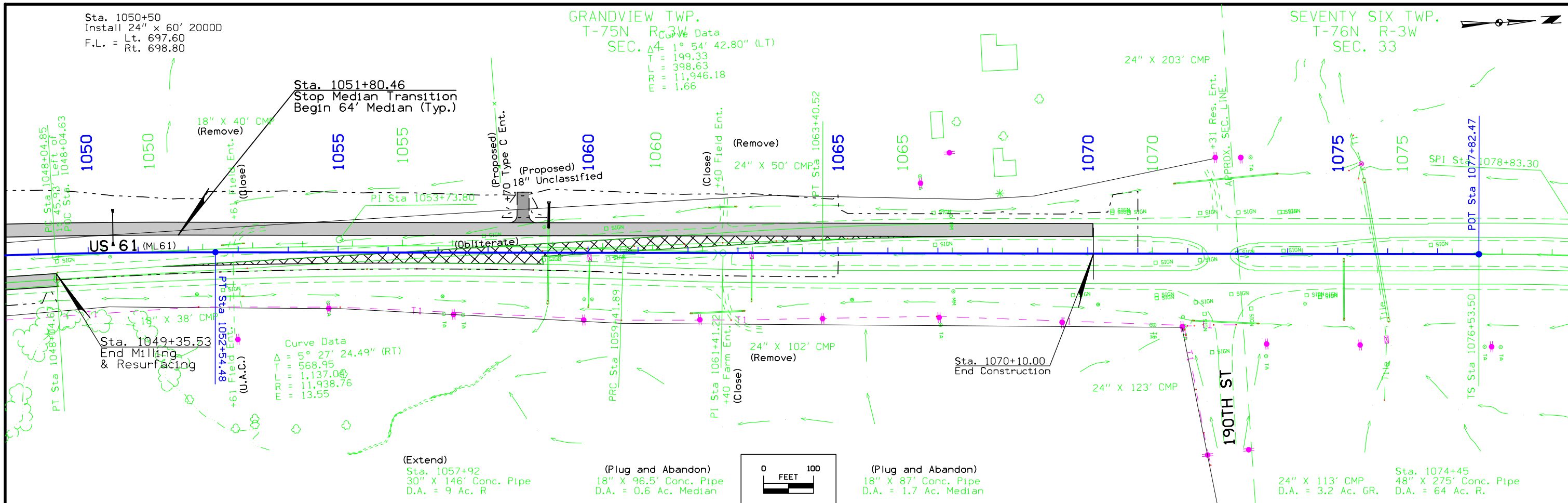

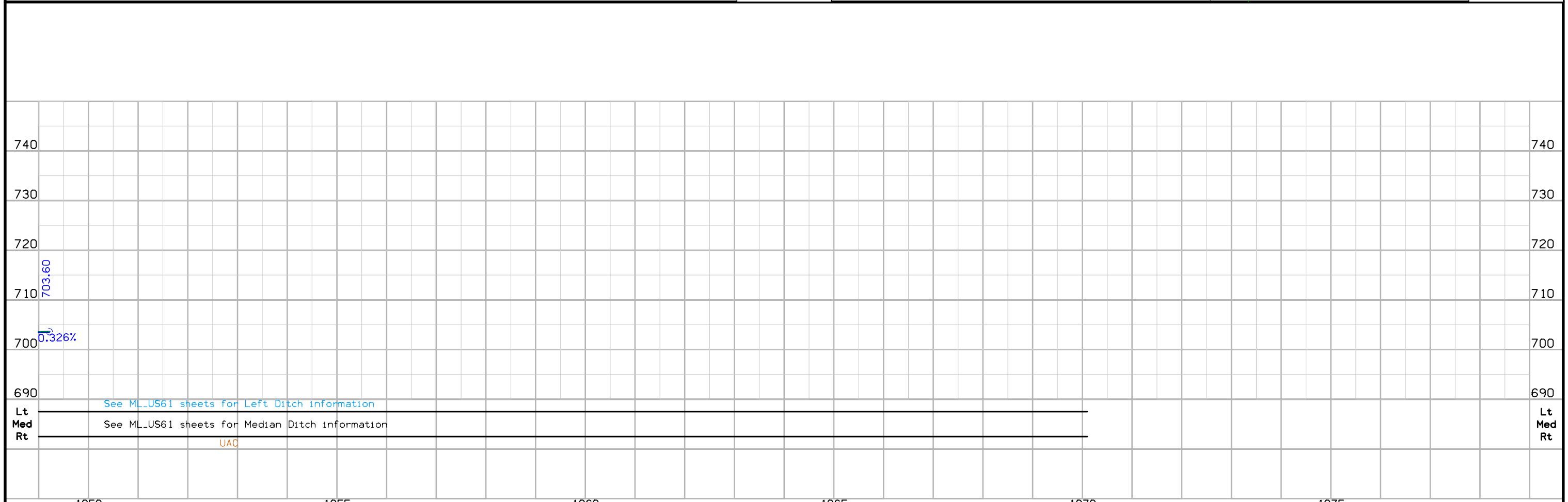
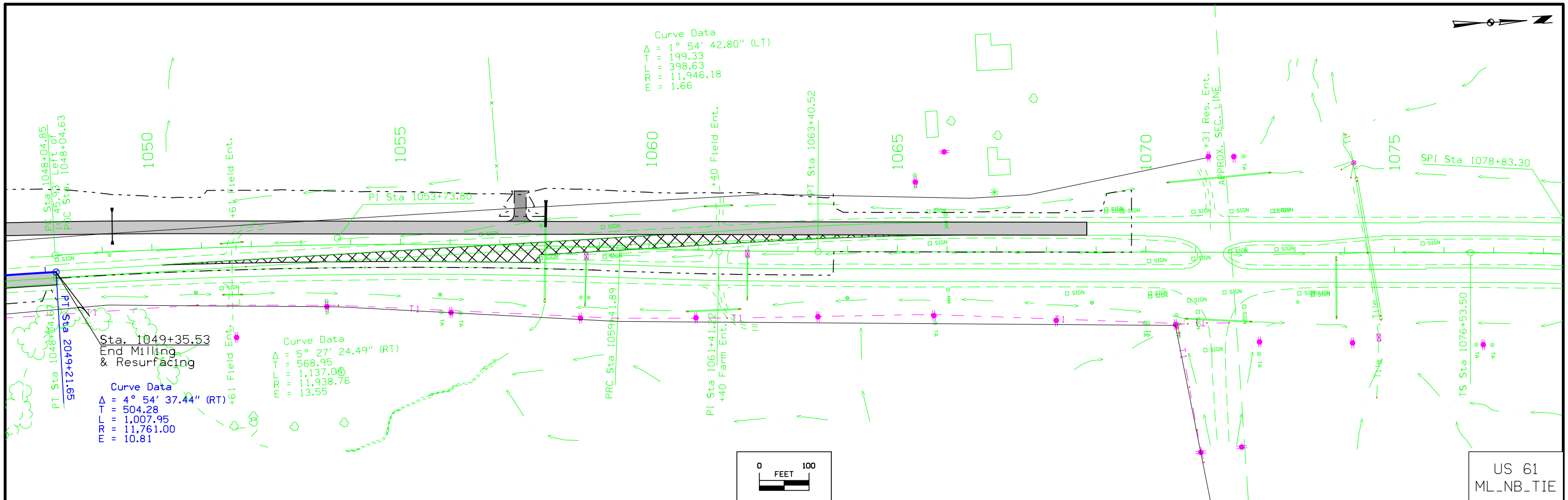

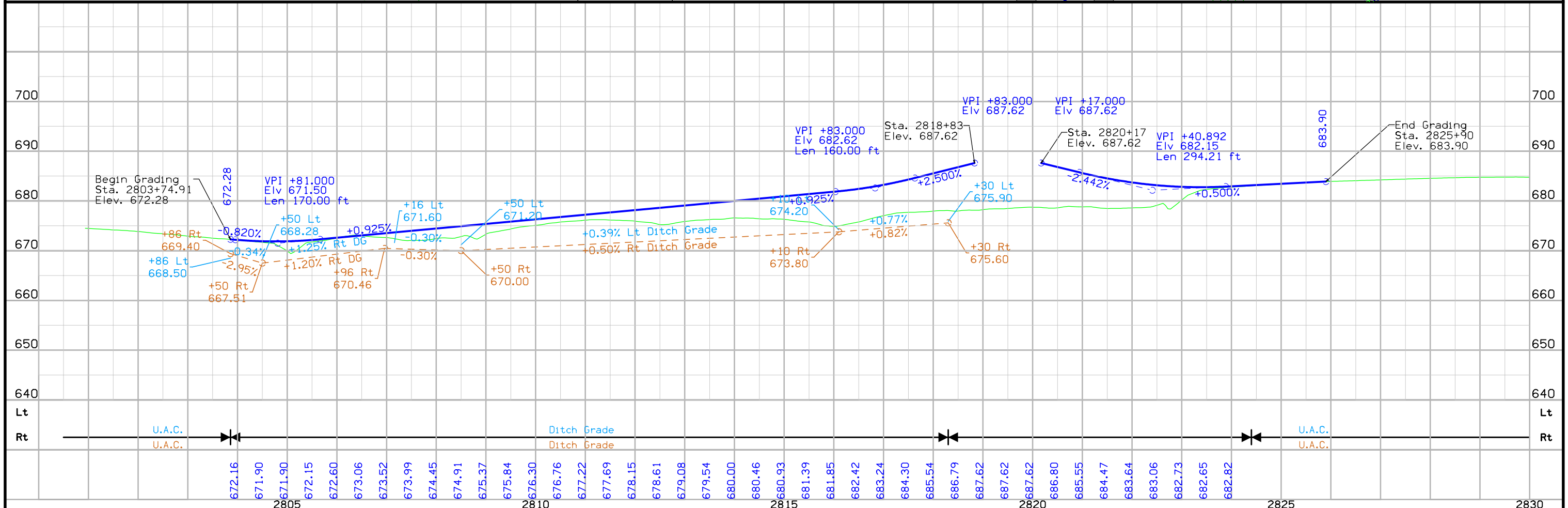
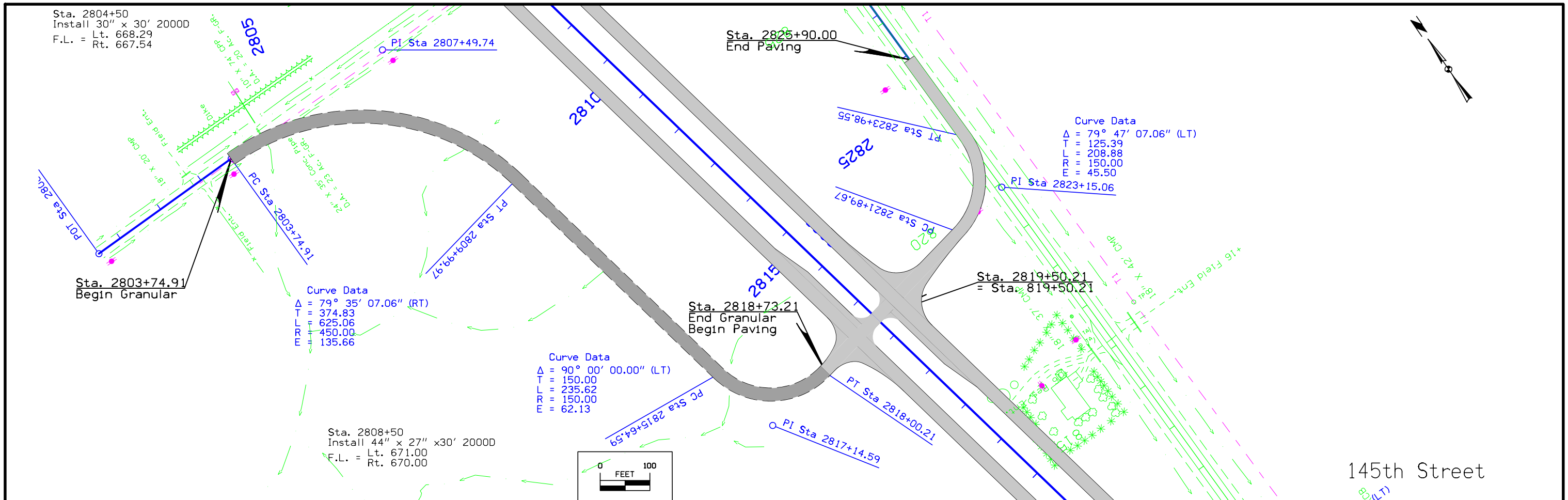

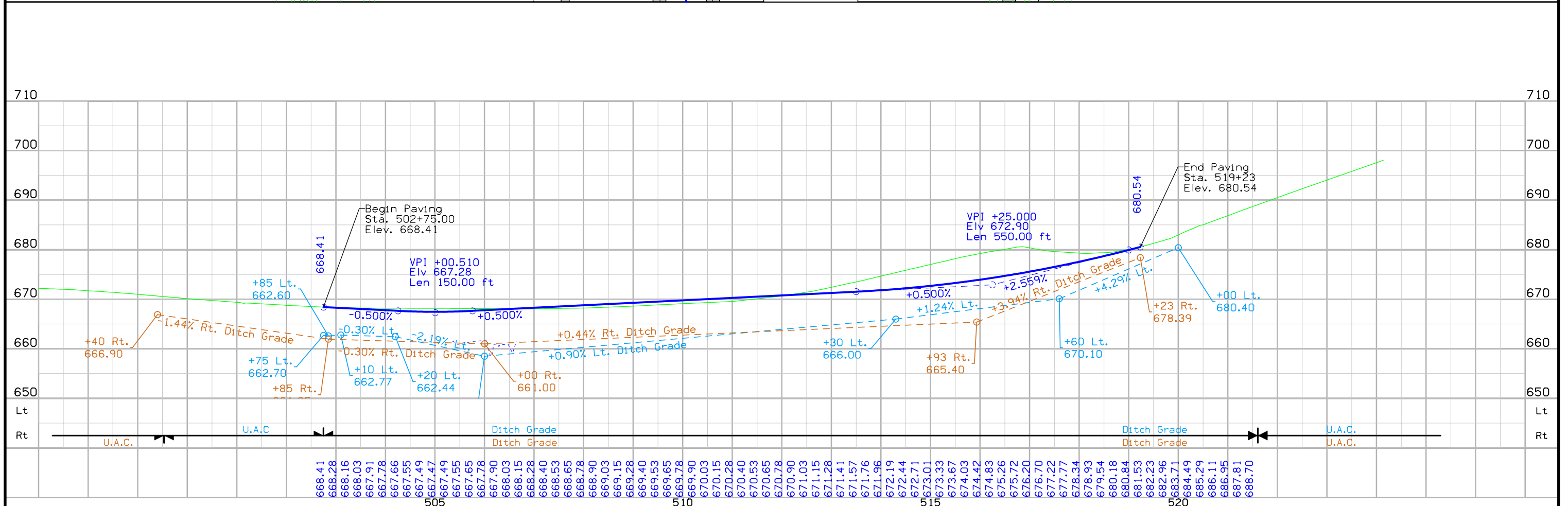
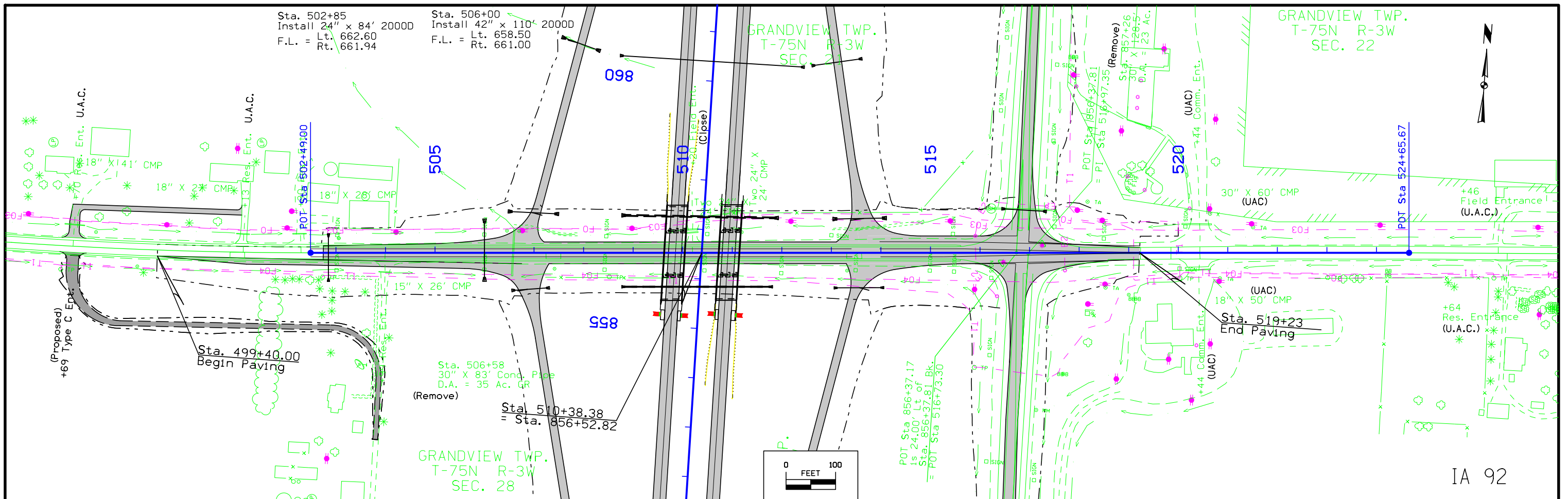

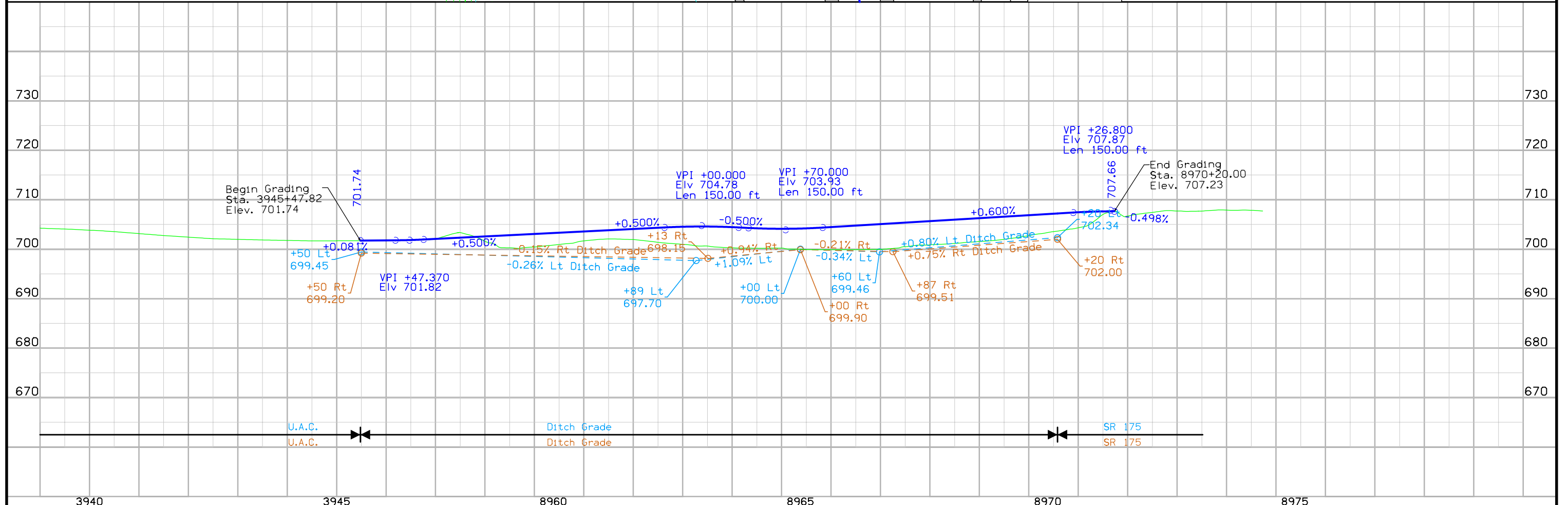
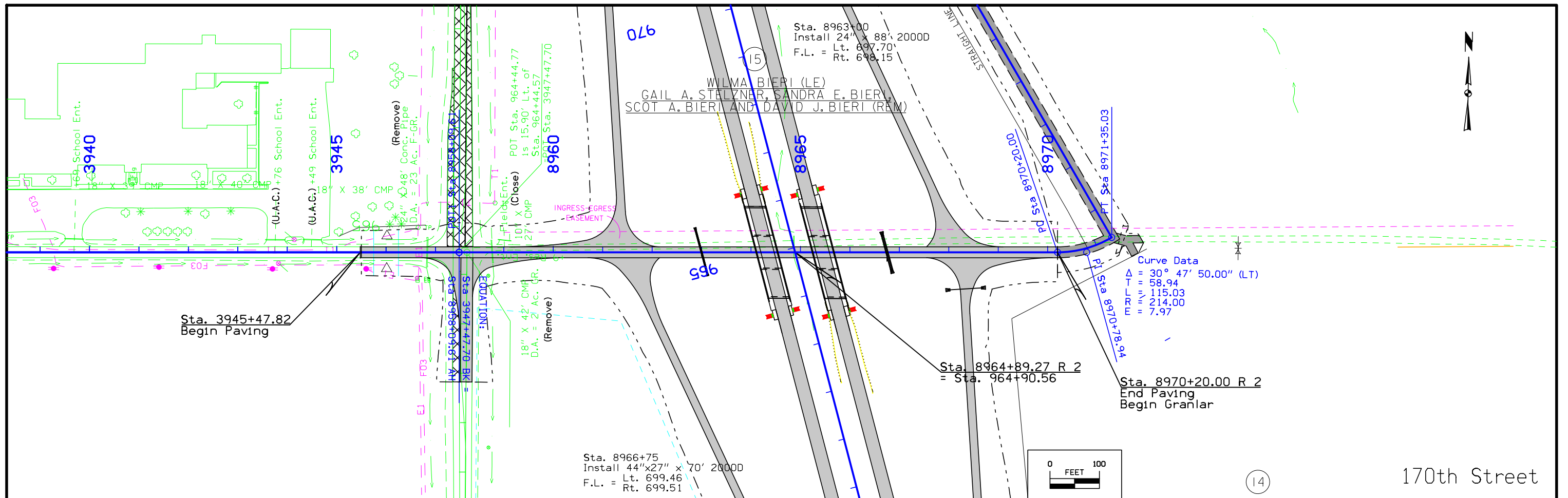

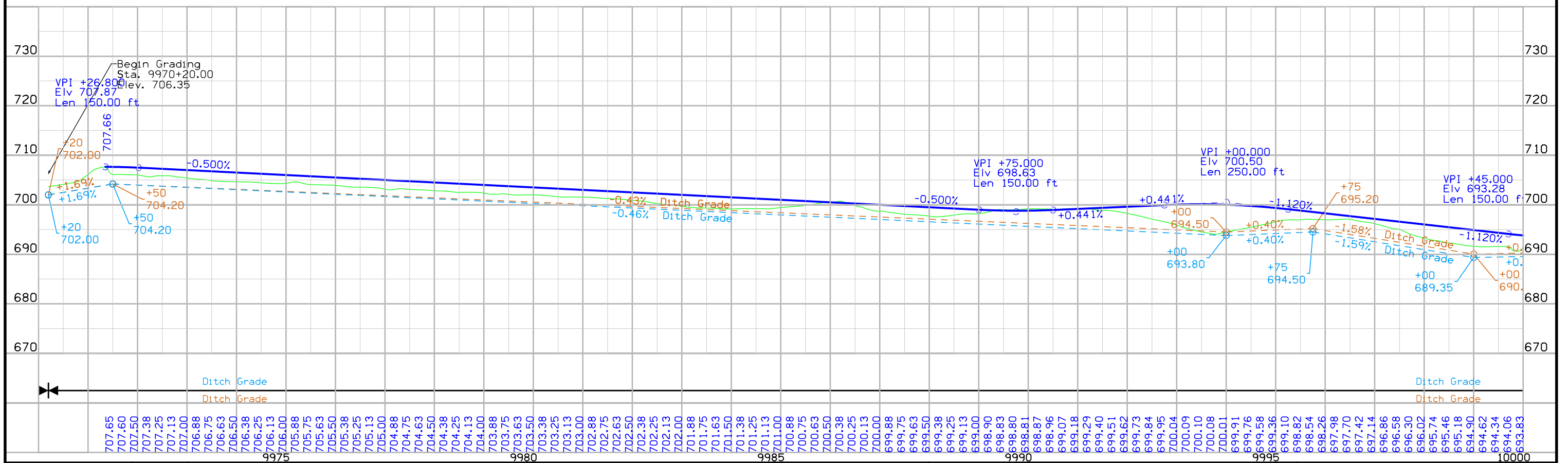
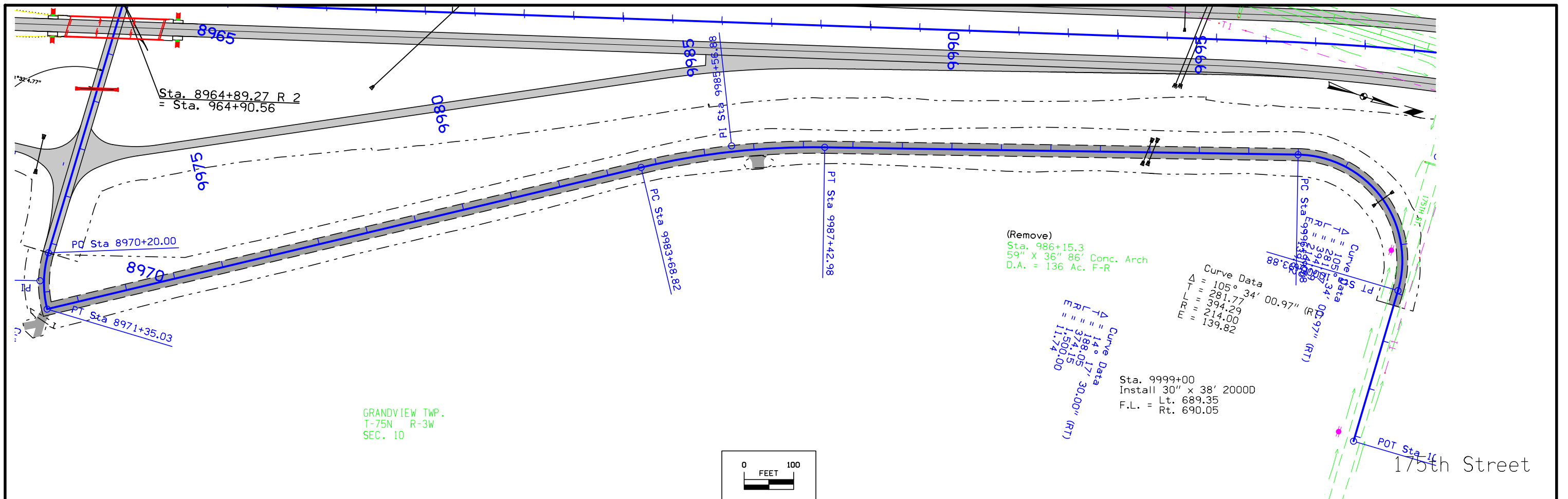

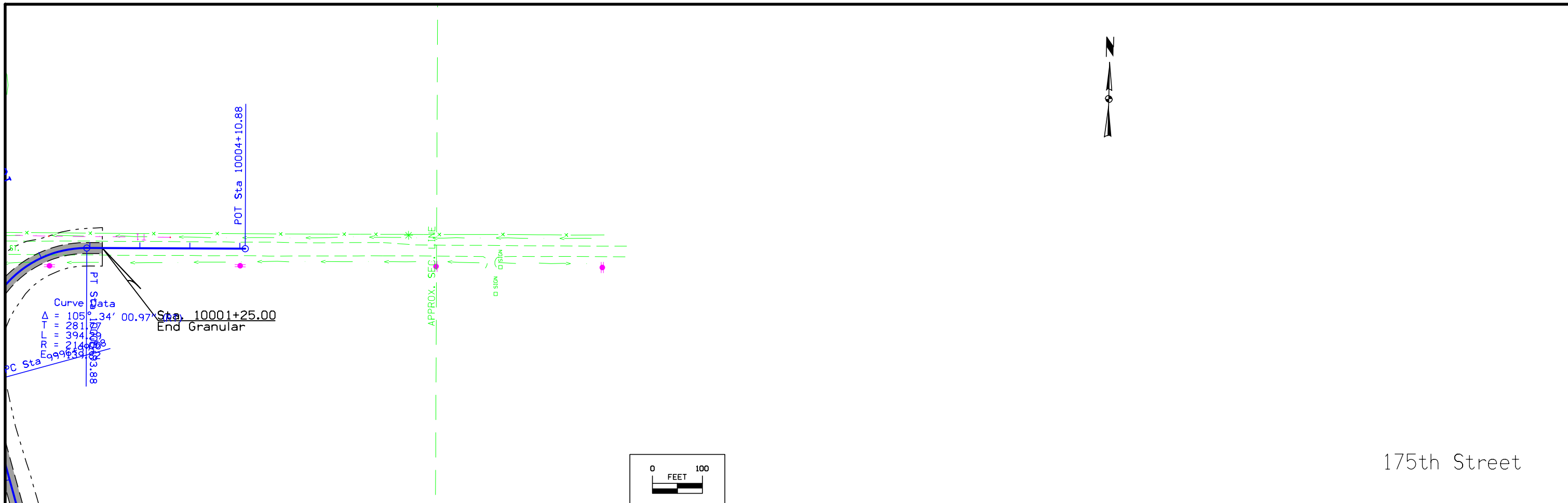

175th Street

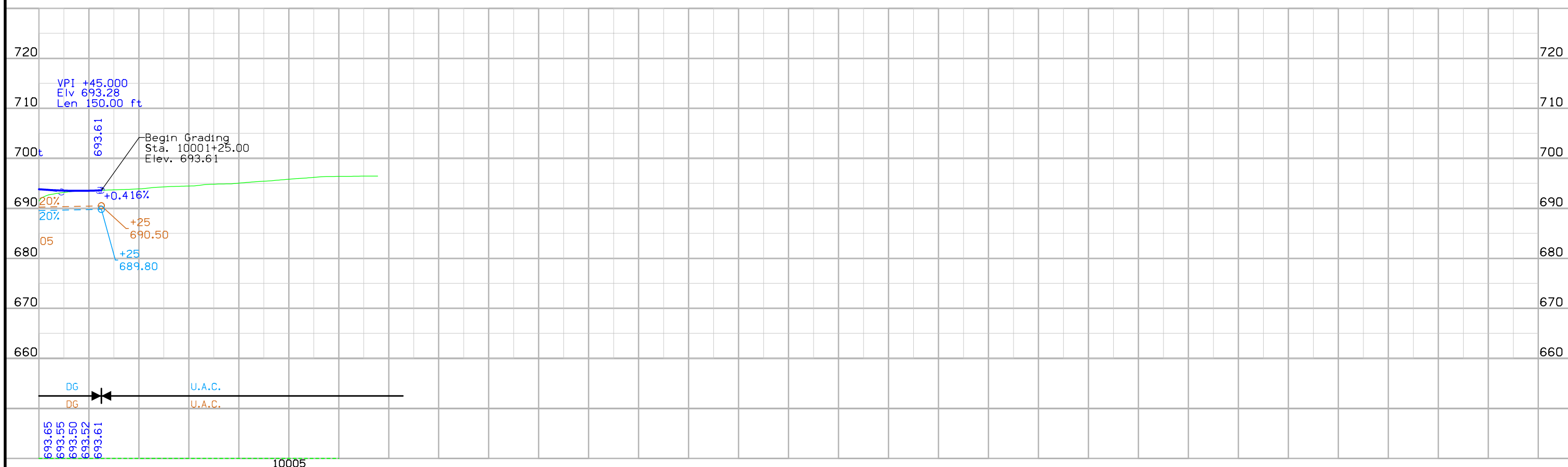

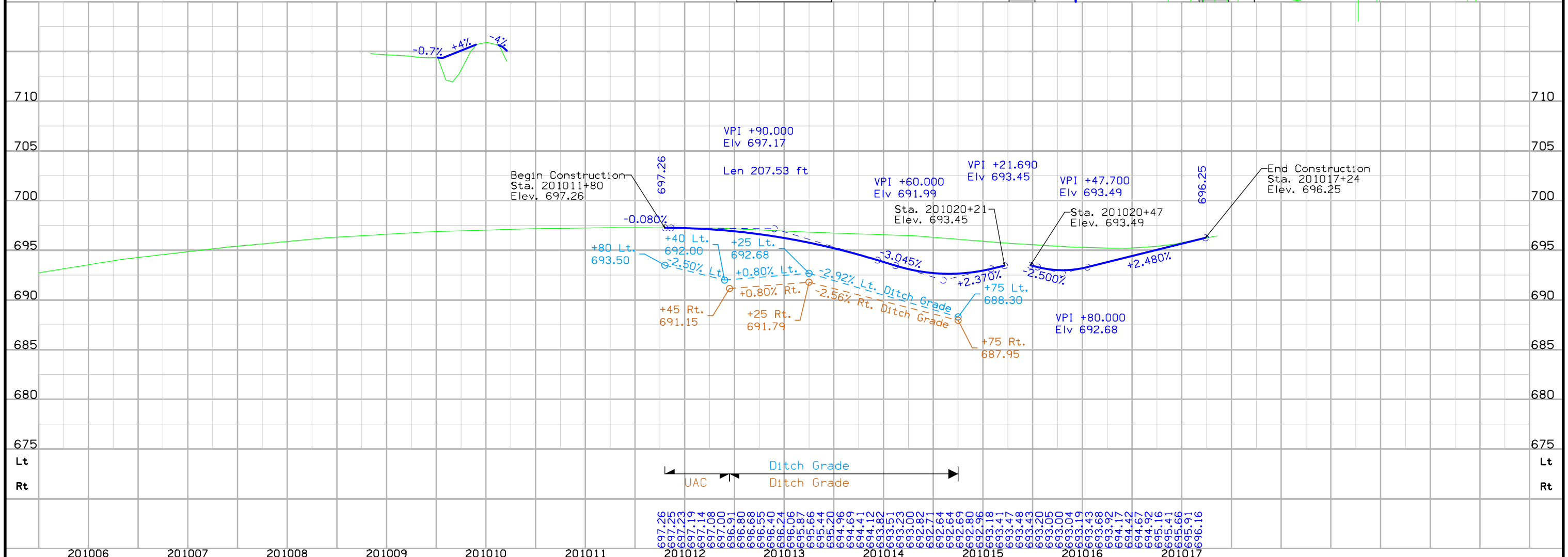
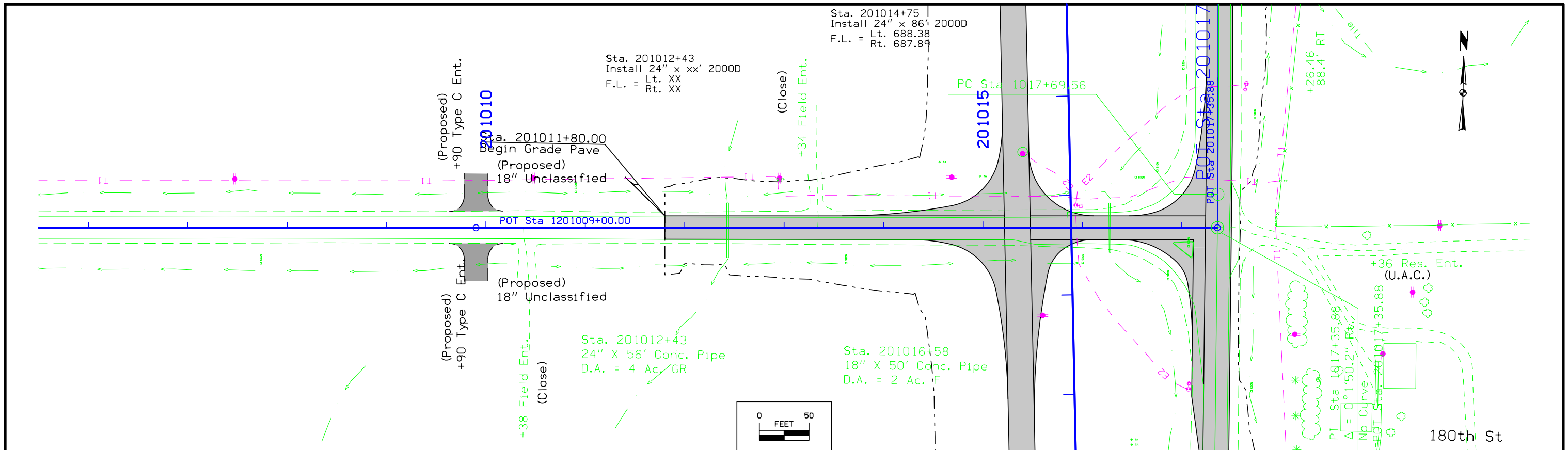

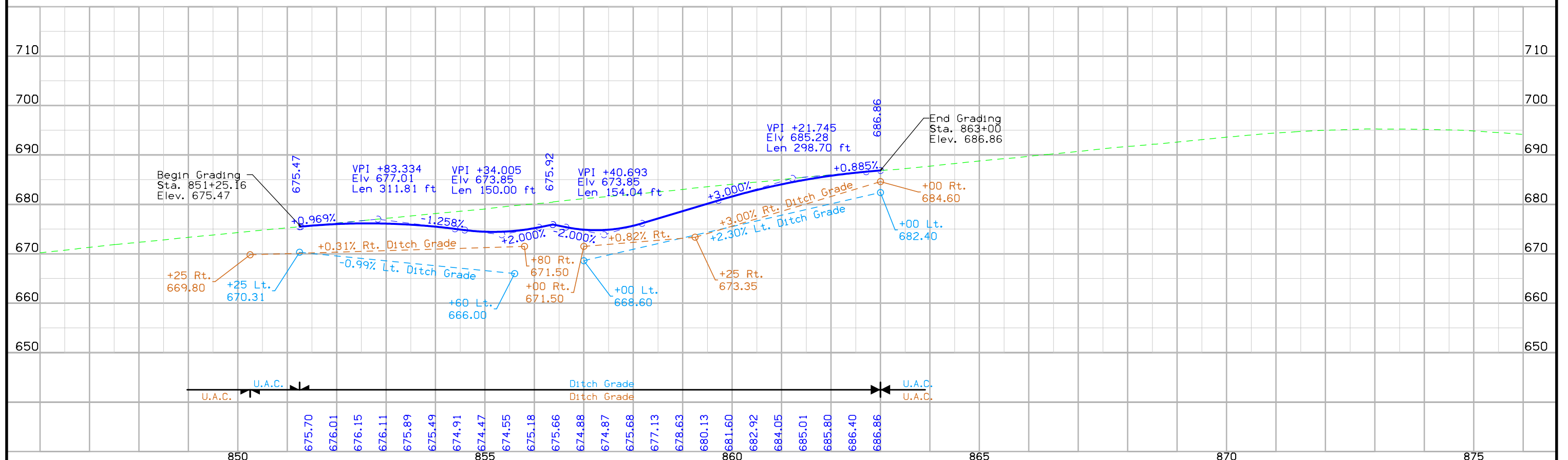
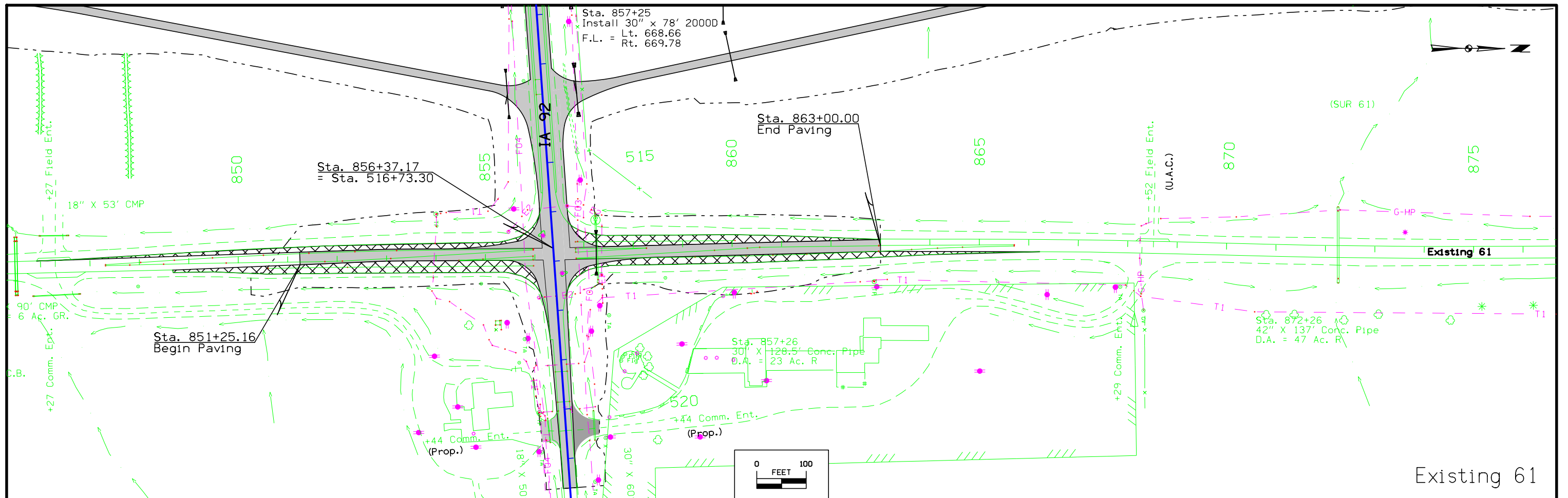

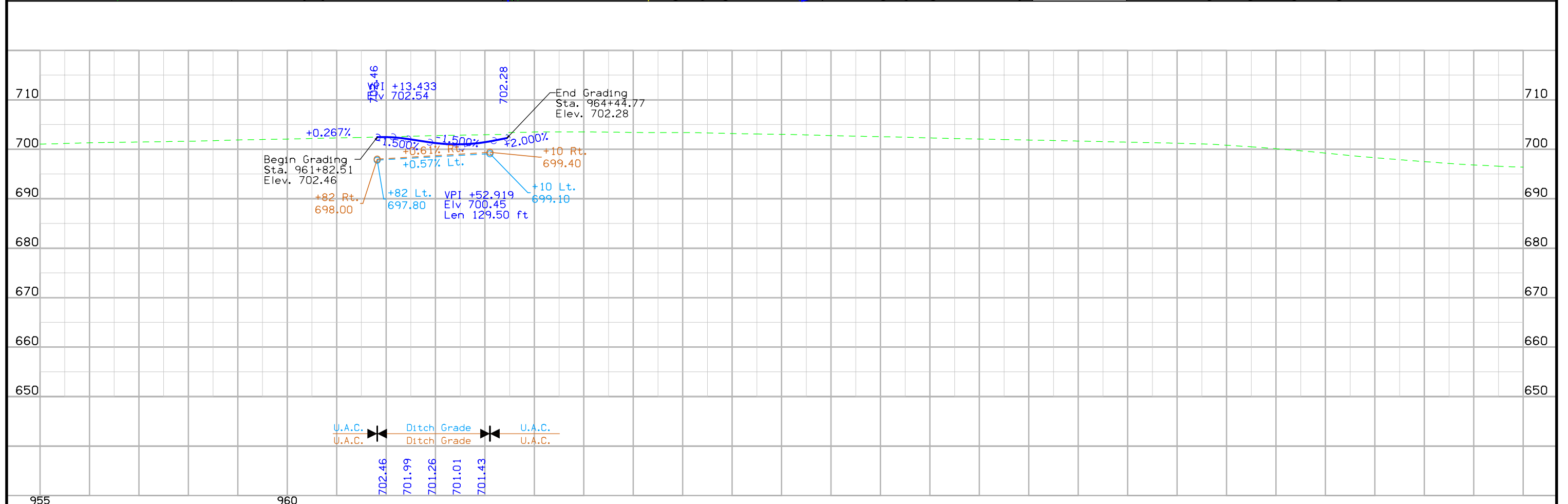
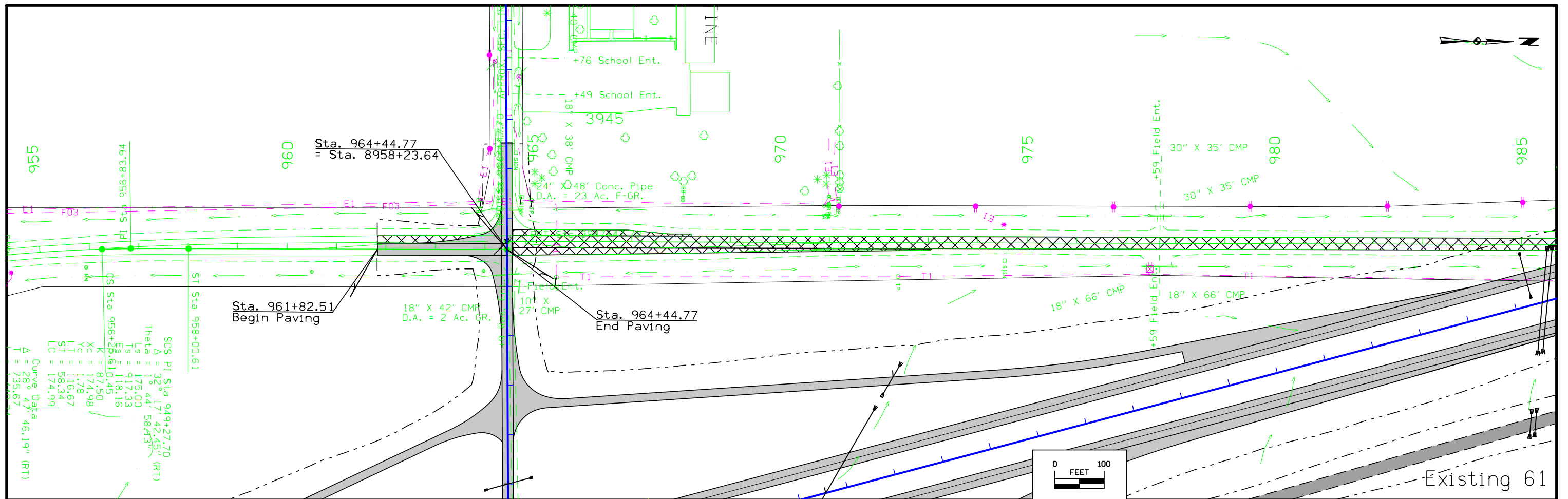

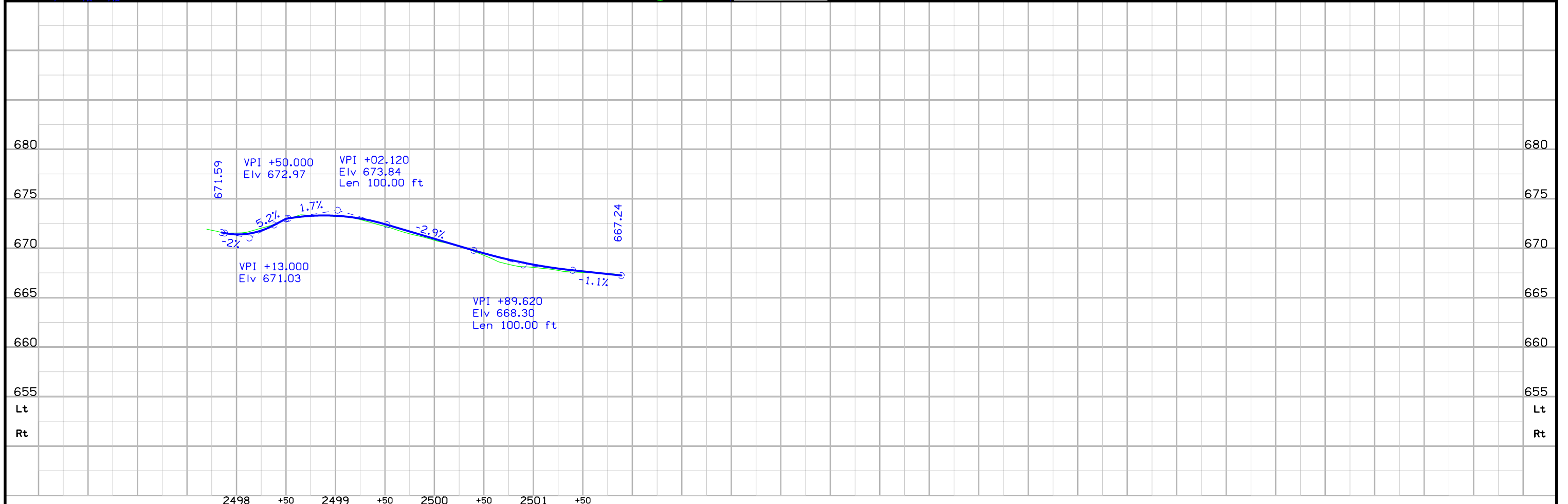
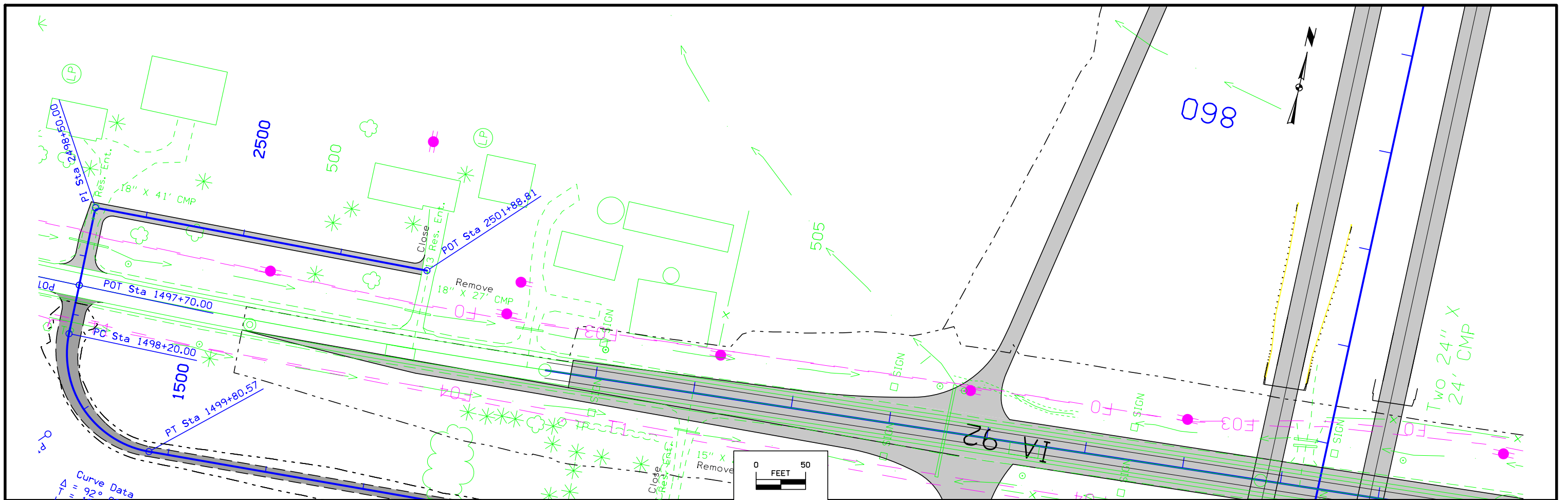

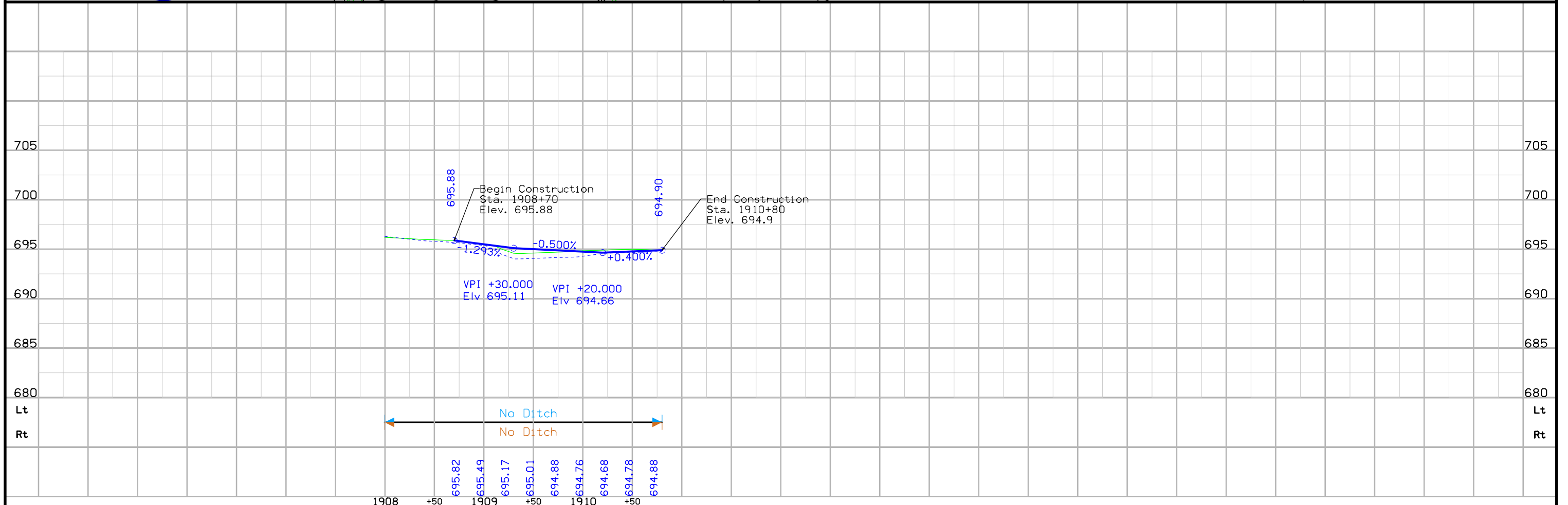
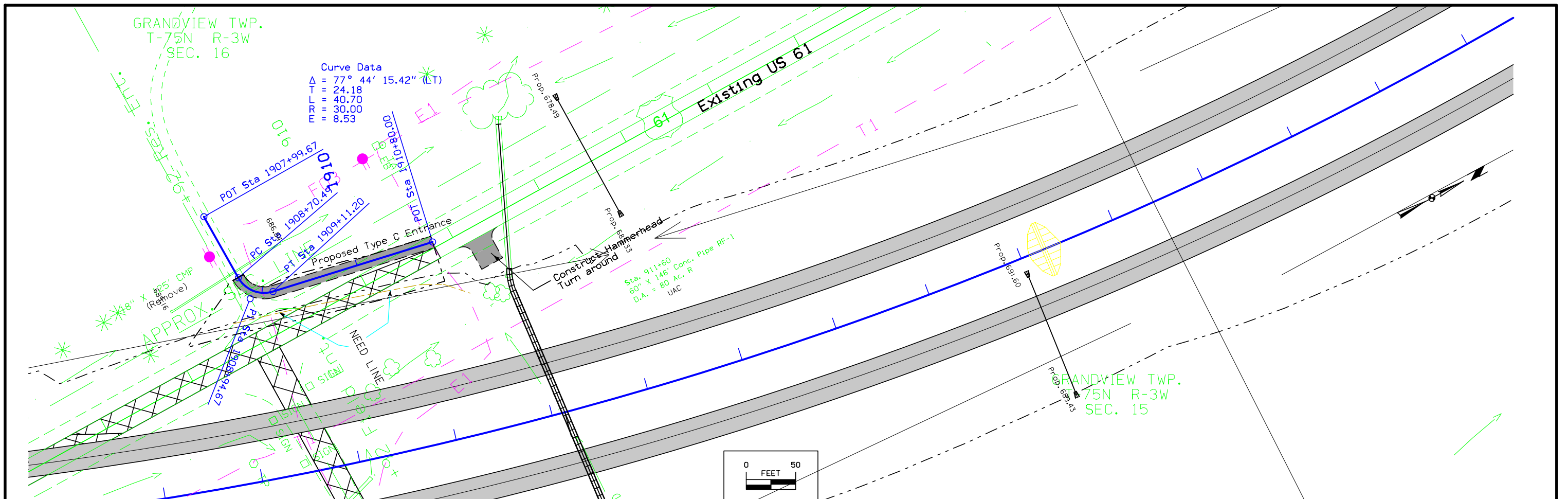

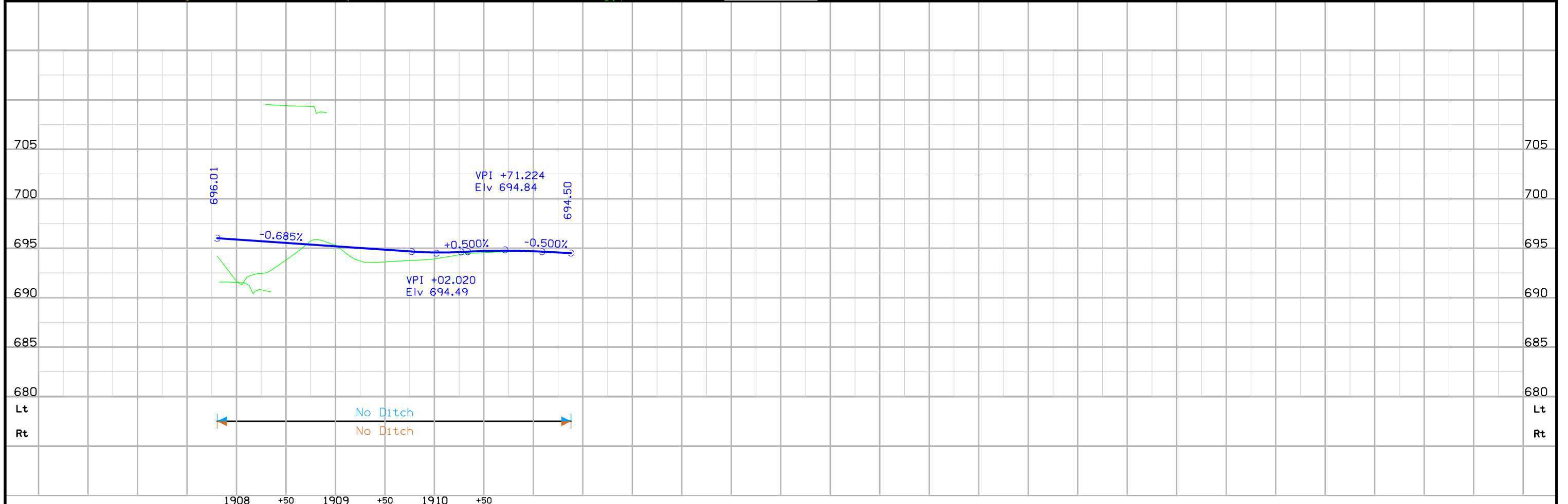
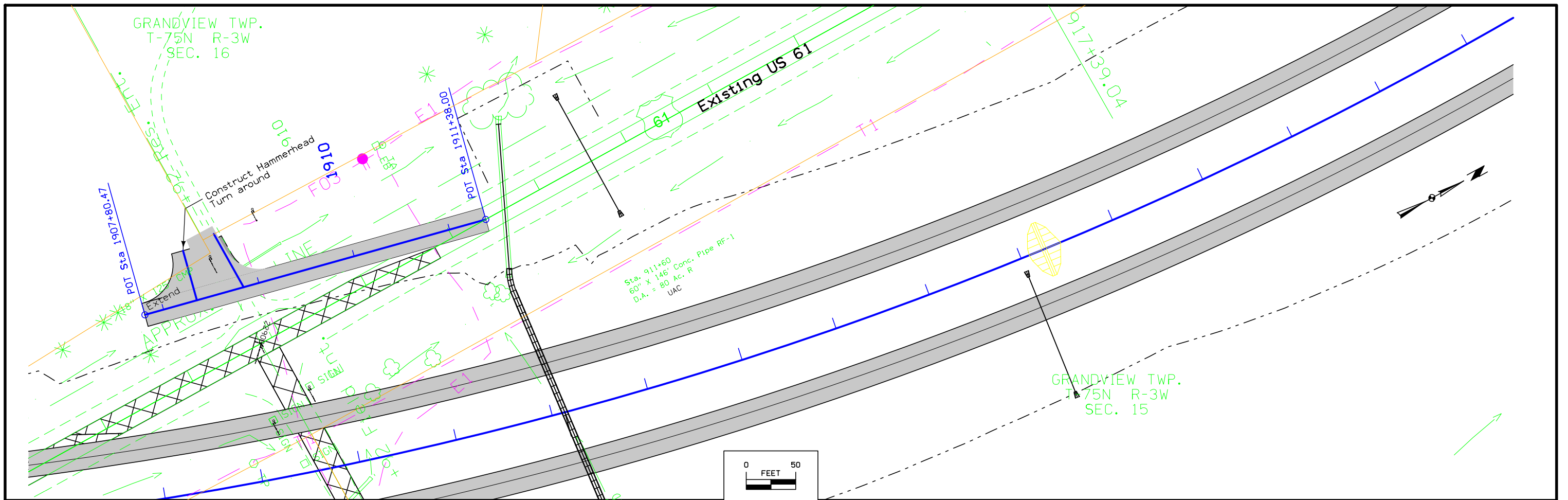

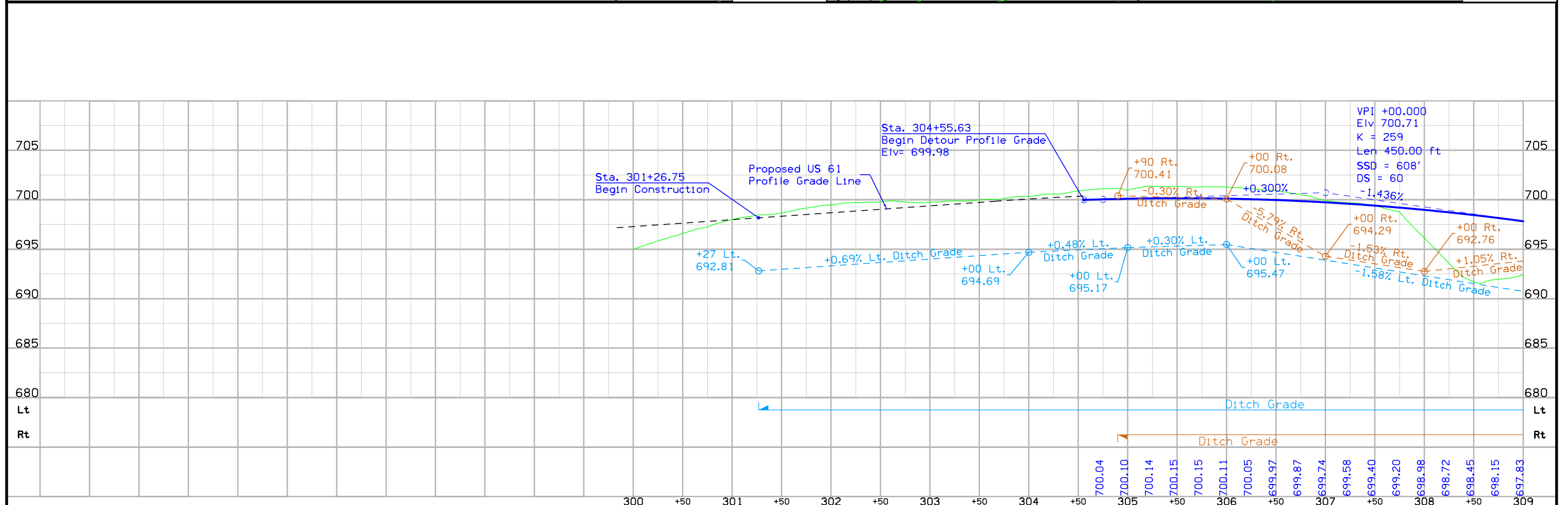
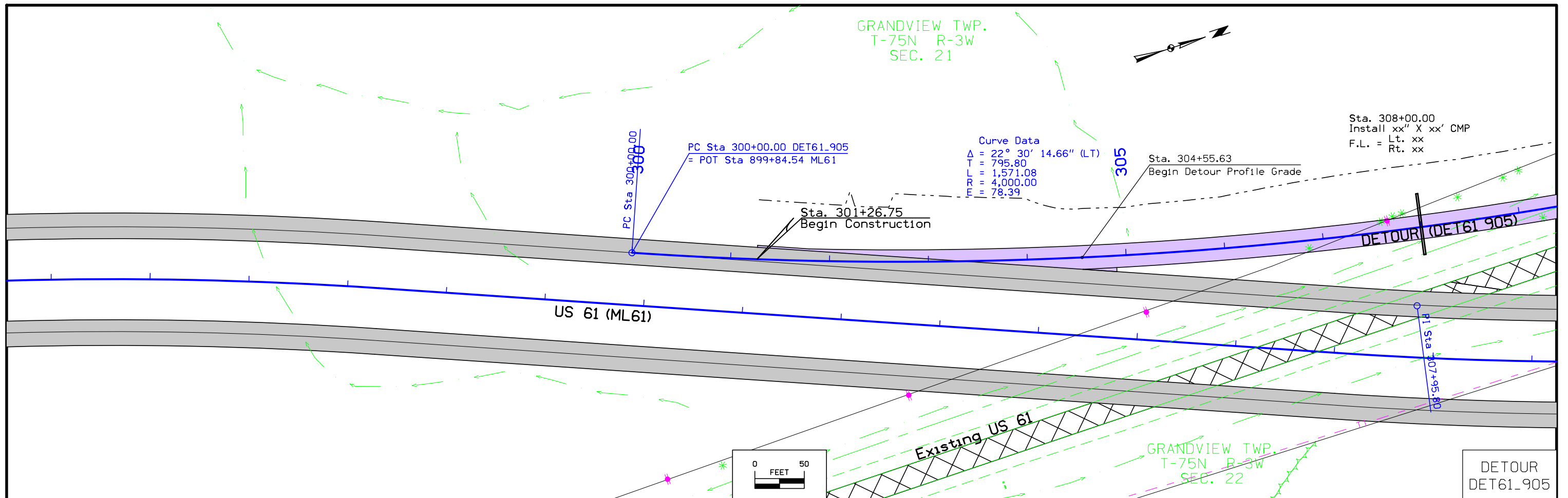

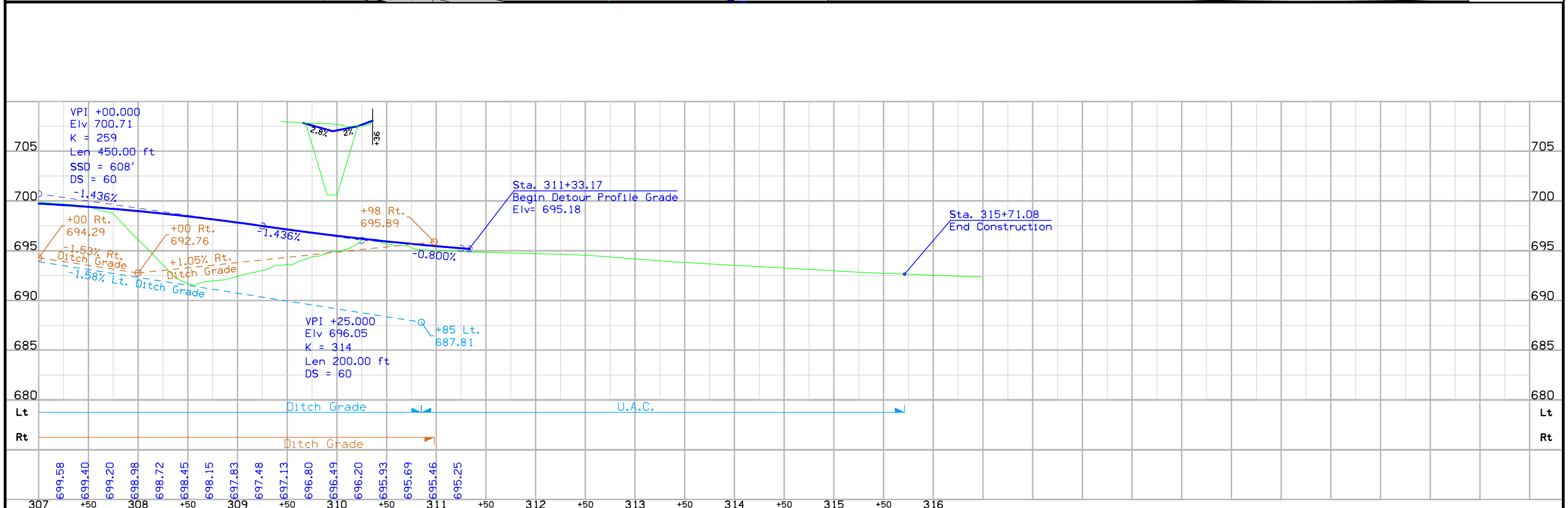
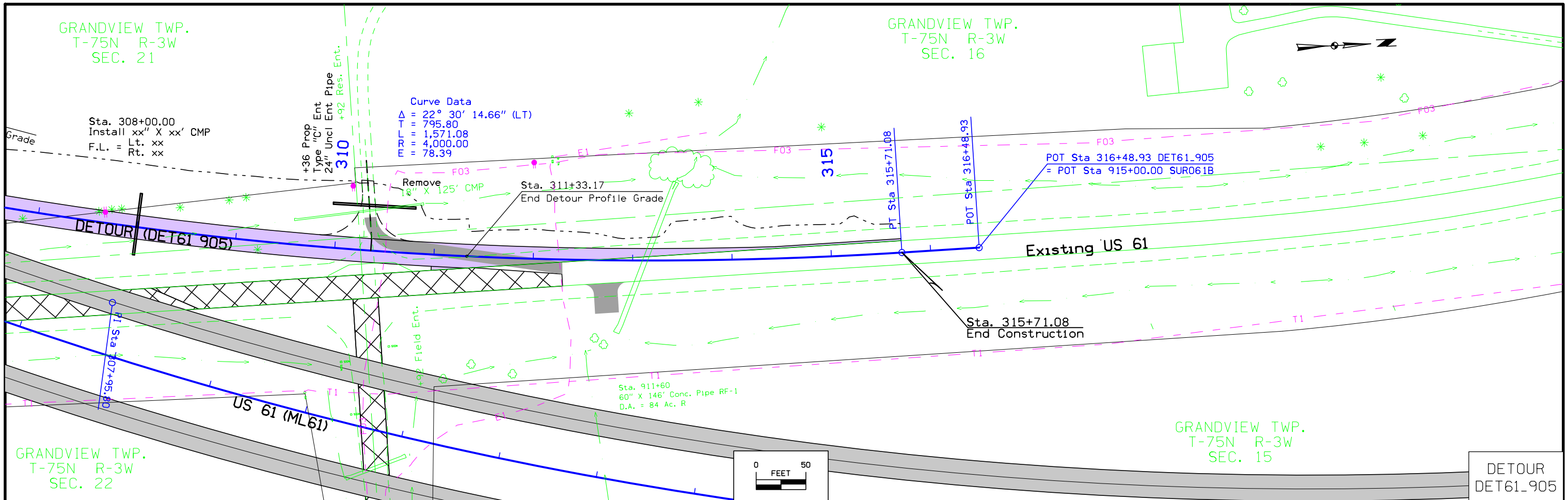

GRANDVIEW TWP.
T-75N R-3W
SEC. 9

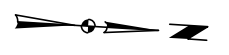

Curve Data
Δ = 8° 21' 05.81" (LT)
T = 666.59
L = 1,330.82
PR = 9,130.00
E = 24.30

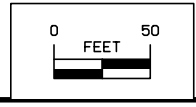
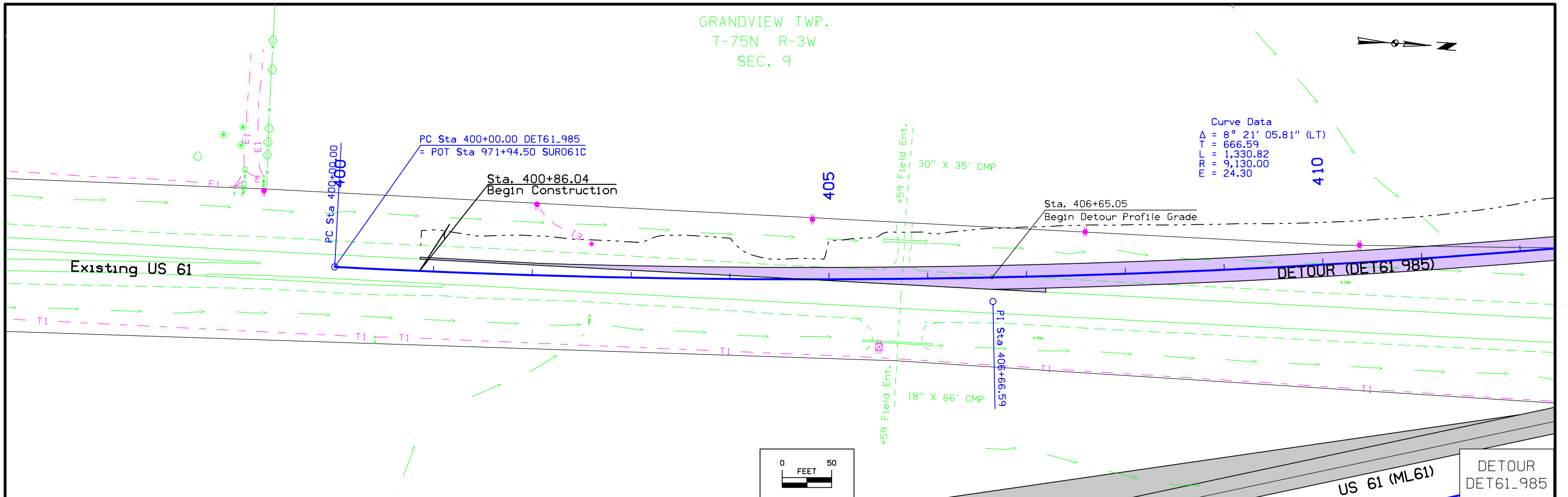

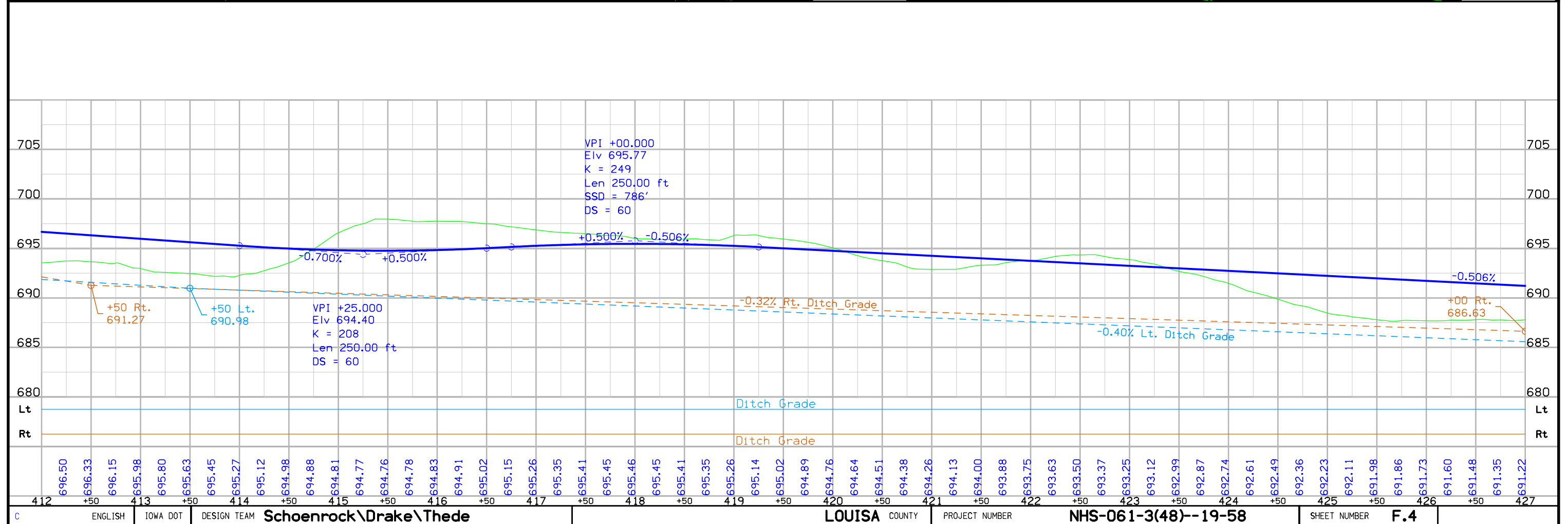
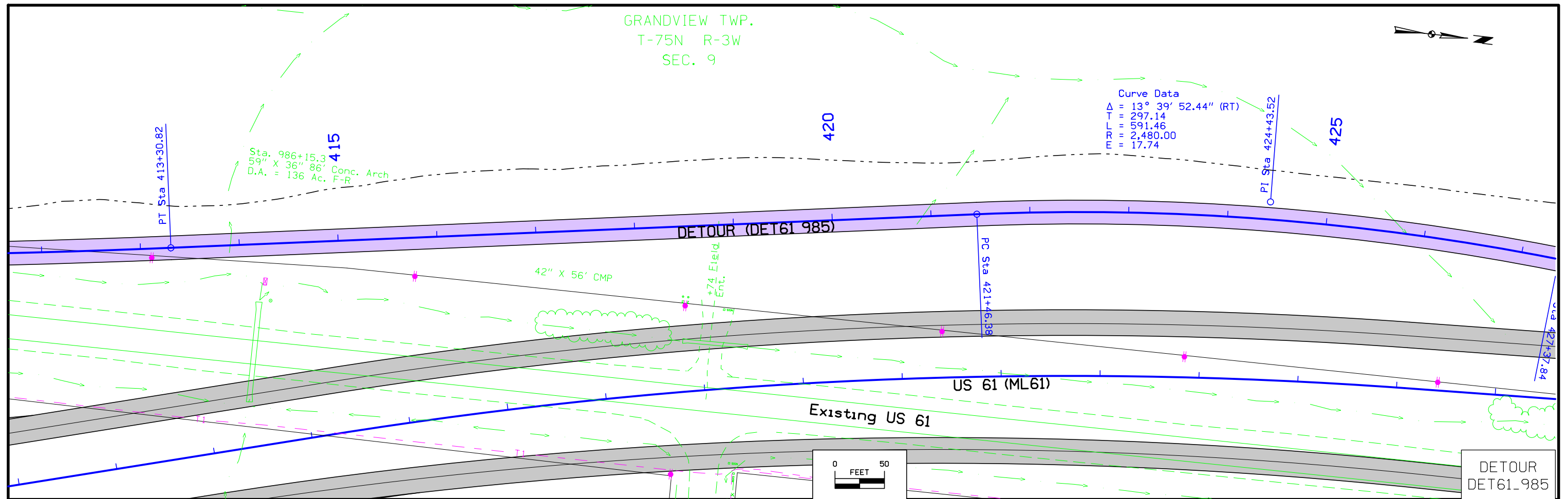

GRANDVIEW TWP.
T-75N R-3W
SEC. 9

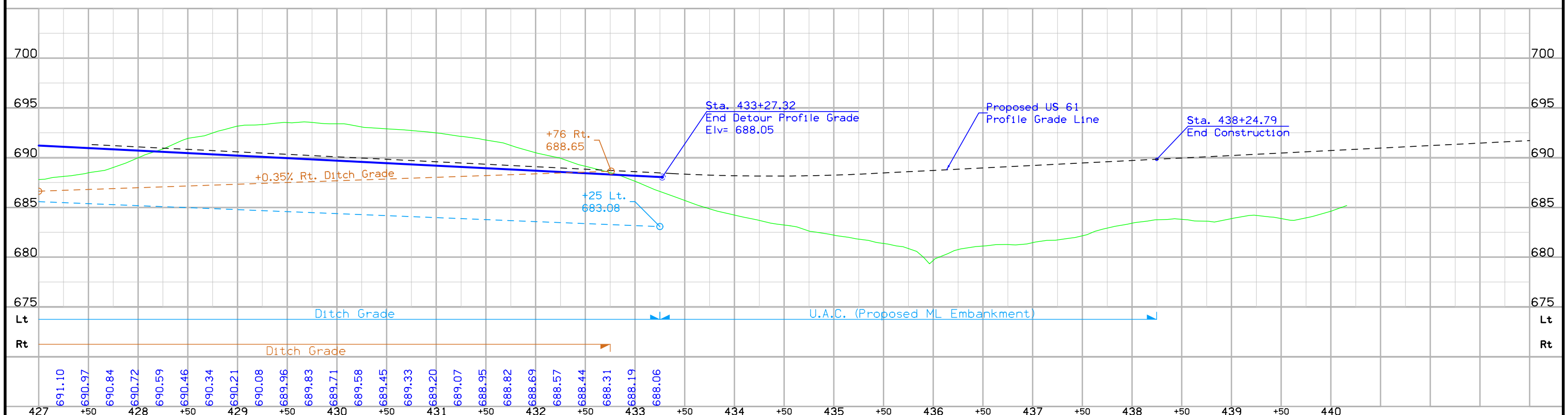
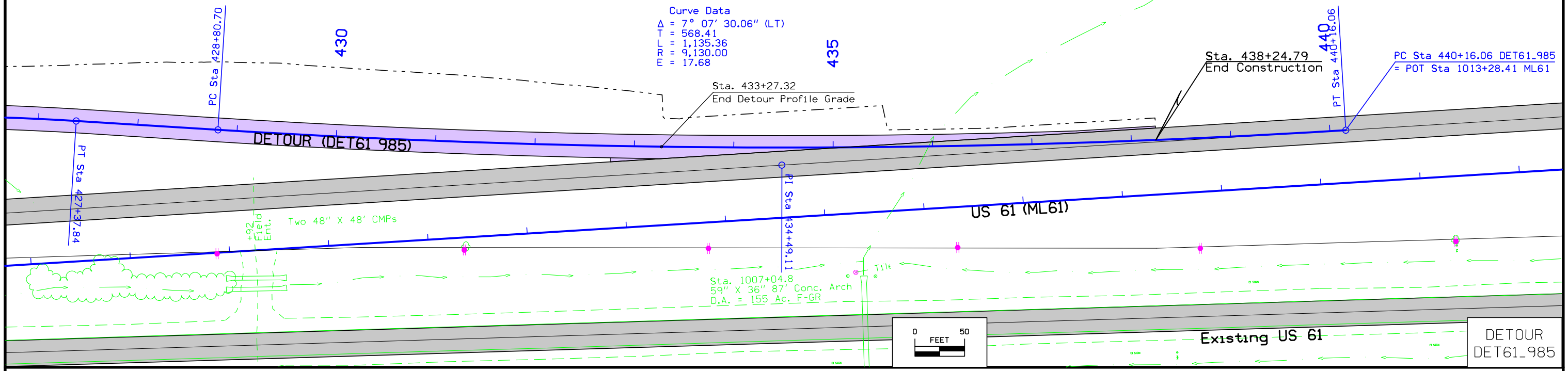

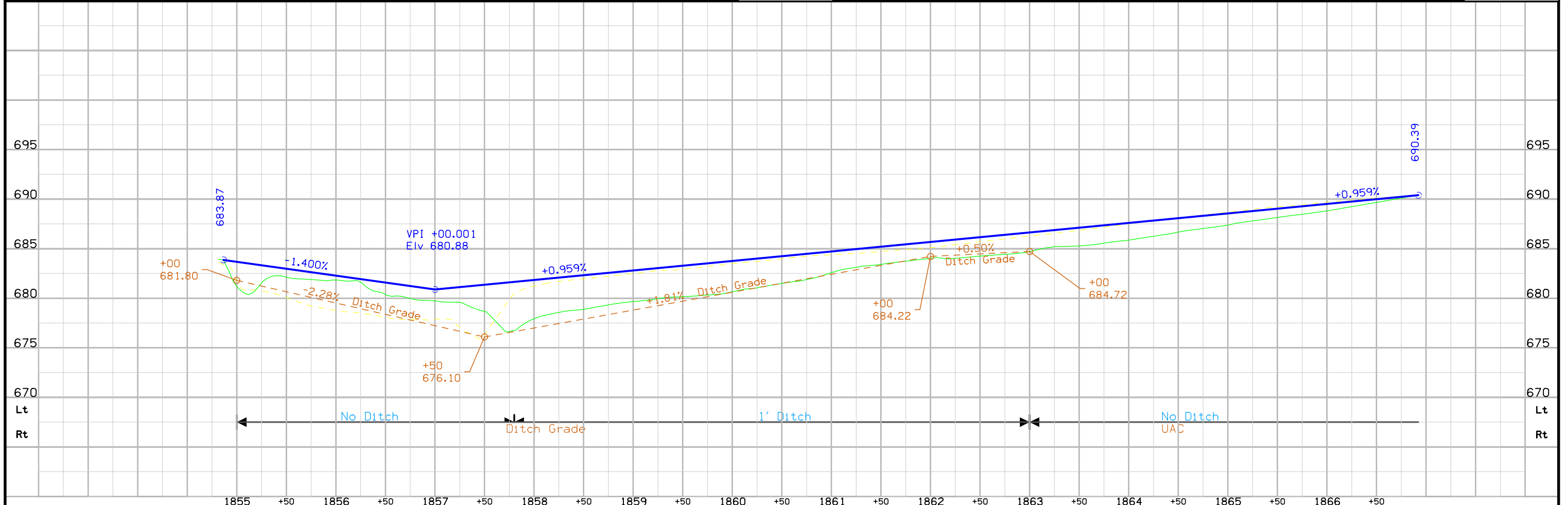
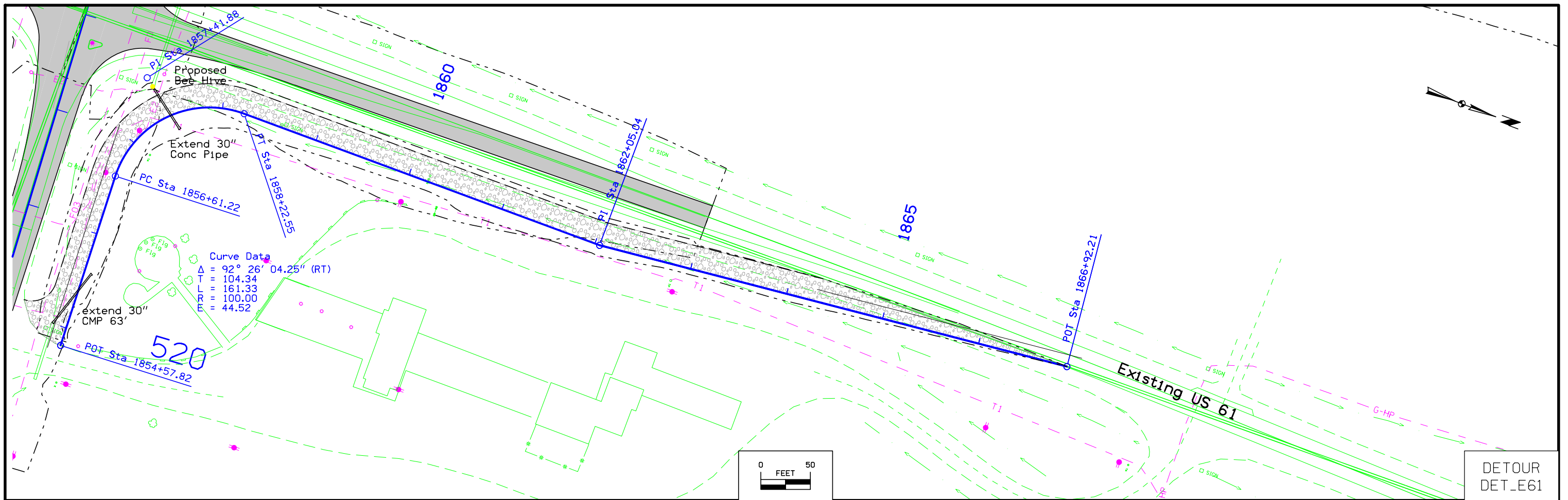

SURVEY INFORMATION

General Information

The coordinates used on this project are the same as IDOT GPS Network survey. IDOT GPS Control network monuments & benchmarks found in the area were held fixed in the Horizontal Calibration of this project.

State Plane Coordinate values of all Horizontal control in the area were converted to the IDOT network adjustment values then held fixed in the calibration.

12-2006 ASI Points (4,5,6,7,8,15,16,17,19,20,506,507) were held fixed in Horizontal and Vertical RTK Calibration of this project 1-2006 ASI Point (506) "A CBN Point Ardon Az Mk Reset" was held fixed in Horizontal RTK Calibration of this project 4-2000 ASI Points [143,144,147,505] were held in the Horizontal and Vertical RTK Calibration of this project 14 -2001 IDOT Points (38-50,52) Horizontal Calibration of this project

Vertical Datum

This survey is relative to NAVD 88 vertical datum. NGS datasheets show a vertical difference of 0.20' (88 Lower than 29) between NAVD88 to NGVD29.

A Bench level run was made between two 2006 ASI monument points, holding the published elevations of 2006ASI16 & 2006ASI4 fixed in the adjustment.

Vertical Equations:

All ASI Marks found near this project were held fixed vertically in the calibration

BM # 505 this survey	Elev. = 720.91 (NAVD 88 datum)
=USGS 1 DRL 1964	Elev. = 720.91 (NAVD 88 datum)
=USGS 1 DRL 1964	Elev. = 721.105 (NAVD 29 datum)

BM # 507 this survey	Elev. = 696.820 (NAVD 88 datum)
=USGS 4 DRL 1964	Elev. = 696.820 (NAVD 88 datum)
=USGS 4 DRL 1964	Elev. = 697.020 (NAVD 29 datum)

ASI Marks 16,7 and 4 were held fixed in the digital level run. The ASI published elevations on BM 516 (6), BM 607 (7) & BM 504 (4) were held fixed in a digital level run. A bench level run directly between BM 516 & BM 504 was observed. The total length of the run was 8.1 miles with a missed closure of 0.055 feet. The least squared adjustment values of the marks along the level run were held fixed on this survey.

BM # 516 this survey	Elev. = 634.565 (NAVD 88 datum)
CP#16 (2006ASI survey)	Elev. = 634.565 (NAVD 88 datum)

BM #607 this survey	Elev. = 690.485 (NAVD 88 datum)
CP#7 (2006ASI survey)	Elev. = 690.485 (NAVD 88 datum)

BM # 504 this survey	Elev. = 733.210 (NAVD 88 datum)
CP# 4 (2006ASI survey)	Elev. = 733.210 (NAVD 88 datum)

Alignments

The mainline alignment is a retrace of the alignments found on the Louisa Co. Plan NHS-61-3(28)—19-58 Paving Plan. Four alignments were created because of the horizontal offsets found along this project. Four Mainline alignments are as follows

ML1 alignment from Sta 720+69.185 to Sta 856+37.808 then 24' Offset Left to Ali ML2
 ML2 alignment from Sta 856+37.17 to Sta 964+44.766 then 15.9' Offset left to ML3
 ML3 alignment from Sta 964+44.766 to Sta 1048+04.672 then 45.93' Offset left to ML4
 ML4 alignment from Sta 1048+04.85 to Sta 1031+79.792

Alignment Equations

Begin Alignment ML1

POT Sta 720+69.185 This Survey (Fd IDOT Hinge Nail)
 = POT Sta 720+70.66 AB Stationing Ahead Louisa Co. Plan NHS-61-3(28)—19-58 Paving Plan
 = POT Sta 720+71.51 AB Stationing Back Louisa Co. Plan NHS-61-3(28)—19-58 Paving Plan
 = Equation found on AB Plan

PI Sta 741+45.164 This Survey (Fd Rusted Nail)
 = PI Sta 741+46.49 AB Stationing Louisa Co. Plan NHS-61-3(28)—19-58 Paving Plan

PI Sta 750+13.793 This Survey (Fd IDOT Hinge Nail)
 = PI Sta 750+15.08 AB Stationing Louisa Co. Plan NHS-61-3(28)—19-58 Paving Plan

PT Sta 754+06.141 This Survey (Fd IDOT Hinge Nail)
 = PT Sta 754+07.50 AB Stationing Louisa Co. Plan NHS-61-3(28)—19-58 Paving Plan

ML1 Stationing held fixed here backed up and carried forward from AB POT Equation Point where

POT Sta 754+14.22 This Survey (Computed point using plan distance of 7.98 ahead of AB PT Sta 754+07.50)
 = POT Sta 754+14.22 AB Stationing Ahead (Louisa Co. Plan NHS-61-3(28)—19-58 Paving Plan)
 = POT Sta 754+15.48 AB Stationing Back (Louisa Co. Plan NHS-61-3(28)—19-58 Paving Plan)

PI Sta 783+28.707 This Survey (Fd IDOT Hinge Nail)
 =PI Sta 783+29.09 AB Stationing (Louisa Co. Plan NHS-61-3(28)—19-58 Paving Plan)

PI Sta 802+97.698 This Survey (Fd IDOT Hinge Nail)
 =PI Sta 802+98.09 AB Stationing (Louisa Co. Plan NHS-61-3(28)—19-58 Paving Plan)

PI Sta 829+43.759 This Survey (Fd IDOT Hinge Nail)
 =PI Sta 829+44.20 AB Stationing (Louisa Co. Plan NHS-61-3(28)—19-58 Paving Plan)

PI Sta 850+40.91 This Survey (Reset from Ref Ties)
 =PI Sta 850+40.70 AB Stationing (Louisa Co. Plan NHS-61-3(28)—19-58 Paving Plan)

PI Sta 856+37.808 This Survey = End of ML1(Reset on Ia 92 East West Alignment A1)
 =PI Sta 516+97.353 This Survey Ia 92 Alignment
 =PI Sta 516+97.35 Ia 92 AB Stationing (Louisa Co. Plan Page 7 F-61-3(2)—20-58 1972 AB Plan)

SURVEY INFORMATION

Begin Alignment ML2

PI Sta 856+37.17 This Survey = Begin End of ML2(Reset on Ia 92 East West Alignment A1)
 =PI Sta 516+73.30 This Survey Ia 92 Alignment
 =24.00 Lt of Plan Sta 856+37.10 AB Stationing (Louisa Co. Plan Page 7 F-61-3(2)—20-58 1972 AB Plan)

ML2 Stationing held fixed backed up and carried forward here

PI Sta 866+44.03 This Survey
 =PI Sta 866+44.03 AB Stationing (Louisa Co. Plan NHS-61-3(28)—19-58 Paving Plan)

PI Sta 872+86.412 This Survey
 =PI Sta 872+86.41 AB Stationing (Louisa Co. Plan NHS-61-3(28)—19-58 Paving Plan)

PI Sta 872+86.412 This Survey
 =PI Sta 872+86.41 AB Stationing (Louisa Co. Plan NHS-61-3(28)—19-58 Paving Plan)

TS Sta 916+22.363 This Survey (Fd IDOT Hinge Nail)
 =TS Sta 916+22.62 AB Stationing (Louisa Co. Plan NHS-61-3(28)—19-58 Paving Plan)

PI Sta 925+37.882 This Survey
 =PI Sta 925+37.14 AB Stationing (Louisa Co. Plan NHS-61-3(28)—19-58 Paving Plan)

PI Sta 949+27.699 This Survey (Fd Rebar)
 =PI Sta 949+28.05 AB Stationing (Louisa Co. Plan NHS-61-3(28)—19-58 Paving Plan)

PI Sta 964+44.766 This Survey = End of ML2(Fd Bent Nail Reset Mag Nail)
 =PI Sta 964+45.00 Ia 92 AB Stationing (Louisa Co. Plan Page 7 F-61-3(2)—20-58 1972 AB Plan)

Begin Alignment ML3

=PI Sta 964+47.70 This Survey (Fd IDOT Hinge Nail)
 =16.00 Lt of Sta 965+45.0 AB O.R. Stationing (Louisa Co. Plan NHS-61-3(28)—19-58 Paving Plan)
 =15.90 Lt of ML2 Alignment Sta 964+44.568 This Survey
 =PI Sta 3947+47.70 170th St. Alignment This Survey

ML3 Stationing held fixed here backed up and carried forward from AB Equation Point where

Sta 967+45.0 (OR Back)
 =Sta 967+47.7 (OR Ahead)
 =Sta 967+47.70 This Survey

PI Sta 990+77.64 This Survey (Fd IDOT Hinge Nail)
 =PI Sta 990+77.67 AB Stationing (Louisa Co. Plan NHS-61-3(28)—19-58 Paving Plan)

POT Sta 1017+35.88 This Survey (Fd IDOT Hinge Nail)
 =POT Sta 1017+36.06 AB Stationing (Louisa Co. Plan NHS-61-3(28)—19-58 Paving Plan)
 =PI Sta 201017+35.88 Hwy 305 Stationing This Survey

PI Sta 1022+96.34 This Survey (Fd IDOT Hinge Nail)
 =PI Sta 1022+96.58 AB Stationing (Louisa Co. Plan NHS-61-3(28)—19-58 Paving Plan)

PI Sta 1043+01.51 This Survey (Computed)
 =PI Sta 1043+01.66 AB Stationing (Louisa Co. Plan NHS-61-3(28)—19-58 Paving Plan)
 =PI Sta 13+11.145 AB Stationing (Louisa Co. Plan NHSX-61-4(91)—3H-70 Metric PCC Plan)

PT Sta 1048+04.67 This Survey End ML3(Computed)
 =PT Sta 1048+04.85 AB Stationing (Louisa Co. Plan NHS-61-3(28)—19-58 Paving Plan)
 =PT Sta 14+64.518 Metric Back (Louisa Co. Plan NHSX-61-4(91)—3H-70 Metric PCC Plan)
 = 14.00 Meters East and Rt of PC Sta 14+63.946 AB Stationing (Louisa Co. Plan NHSX-61-4(91)—3H-70 Metric PCC Plan)

Begin Alignment ML4

PC Sta 1048+04.85 This Survey Begin ML4
 =PC Sta 14+63.946 AB Stationing (Louisa Co. Plan NHSX-61-4(91)—3H-70 Metric PCC Plan)
 = 14.00 Meters West and Lt of AB PT Sta 1048+04.85 (Louisa Co. Plan NHS-61-3(28)—19-58 Paving Plan)
 = 14.00 Meters West and Lt of PC Sta 14+64.518 Metric Survey Stationing (Louisa Co. Plan NHSX-61-4(91)—3H-70 Metric PCC Plan)

PI Sta 1053+73.80 This Survey
 =PI Sta 16+37.362 AB Stationing (Louisa Co. Plan NHSX-61-4(91)—3H-70 Metric PCC Plan)

PRC Sta 1059+41.89 This Survey
 =PRC Sta 18+10.520 AB Stationing (Louisa Co. Plan NHSX-61-4(91)—3H-70 Metric PCC Plan)

PT Sta 1063+40.52 This Survey (Fd rebar 12" Deep)
 =PT Sta 19+32.022 AB Stationing (Louisa Co. Plan NHSX-61-4(91)—3H-70 Metric PCC Plan)

PI Sta 1085+07.72 This Survey
 =PI Sta 25+92.602 AB Stationing (Louisa Co. Plan NHSX-61-4(91)—3H-70 Metric PCC Plan)

SURVEY INFORMATION

500	462467.616	2273734.222	620.860	745+93.43	44.622	BM	CUT "X" ON INLET END 24" RCP APRON
501	462920.412	2274164.798	625.316	750+07.98	528.711	BM	SET RR SPK N SIDE PP
502	463699.336	2273704.220	642.039	758+33.56	101.091	BM	SET RR SPK W. SIDE POST
503	465076.810	2273645.842	661.157	772+12.10	79.880	BM	SET 60D SPK N. SIDE POST
504	494637.280	2272212.175	733.210	1071+16.15	423.003	BM	LOUISA CO MONU ASI4 BERNTSEN ROD_CAP W/5" LID =2006ASI4 COUNTY MONU EL=733.210
505	502407.282	2260995.217	720.910	1085+84.77	-12729.140	BM	USGSMONU 1DRL1964(88_3RD) =2000ASI505
506	466801.640	2273599.106	675.929	789+37.66	78.995	BM	SET 60D SPK N. SIDE POST
507	472331.305	2283889.326	696.820	842+01.12	10508.096	BM	USGSMONU 4DRL1964(88_3RD) =2006ASI507
508	467637.700	2273595.354	676.356	797+73.53	96.858	BM	FD 60D SPK S. SIDE POST =BM80A 1994 AB PLAN NHS-61-3(28)--19-58 EL=676.62
509	468630.801	2273523.754	674.477	807+68.16	50.878	BM	SET MAG NAIL ON INLET 42" CMP
510	469513.418	2273530.603	679.603	816+50.31	80.398	BM	SET 60D SPK N. SIDE POST
511	469840.387	2273375.350	679.255	819+81.16	-66.404	BM	FD RR SPK E SIDE PP
512	470774.475	2273536.391	678.926	829+10.80	118.580	BM	FD RR SPK W SIDE PP =BM2 1969 AB PLAN F-61-3(2)--20-58 EL=686.16
513	470771.510	2273301.301	679.740	829+13.88	-116.509	BM	FD RR SPK NE SIDE PP =BM83 1994 AB PLAN NHS-61-3(28)--19-58 EL=680.05
514	471982.739	2273429.060	665.057	841+21.43	42.328	BM	FD IHC BM ON IN HDWL 5X5 RCB =BM84 1994 AB PLAN NHS-61-3(28)--19-58 EL=665.40 =BM3 1969 AB PLAN CM:F-61-3(2)--20-58 CM:EL=672.50
515	472411.996	2273423.842	664.847	845+50.67	48.140	BM	FD IHC BM ON IN HDWL 4X3 RCB =BM4 1969 AB PLAN F-61-3(2)--20-58 EL=672.12
517	473550.471	2273195.308	673.245	856+93.06	-137.92	BM	FD RR SPK S SIDE PP =BM5 1969 AB PLAN F-61-3(2)--20-58 EL=680.47 =BM85 1994 AB PLAN NHS-61-3(28)--19-58 EL=673.60
518	474692.835	2273459.063	694.834	868+36.69	129.762	BM	FD 60D SPK IN W. SIDE RR TIE =BM86 1994 AB PLAN NHS-61-3(28)--19-58 EL=695.10
519	475084.620	2273392.134	688.245	872+26.64	54.455	BM	CUT "X" ON INLET 42" RCP
520	476366.386	2273454.289	688.468	885+06.57	124.662	BM	SET RR SPK W SIDE PP
521	476797.336	2273275.148	687.524	889+39.22	-50.339	BM	FD RR SPK E SIDE PP =BM88A 1994 AB PLAN NHS-61-3(28)--19-58 EL=687.85
522	477967.691	2273235.837	703.155	901+09.90	-78.428	BM	FD RR SPK E SIDE PP =BM89A 1994 AB PLAN NHS-61-3(28)--19-58 EL=703.62
523	478916.656	2273191.488	692.868	910+59.24	-113.676	BM	FD RR SPK E SIDE PP =BM90A 1994 AB PLAN NHS-61-3(28)--19-58 EL=693.27
524	480060.092	2273122.020	690.880	922+29.00	-126.922	BM	SET RR SPK S SIDE PP
525	480325.153	2273284.743	677.247	924+51.49	92.007	BM	FD REBAR ON INLET HDWL 5 X 5 RCB
526	481229.595	2272687.139	697.155	935+21.26	-56.645	BM	60D SPK IN W. SIDE POST
527	482230.921	2272231.860	692.565	946+22.62	55.159	BM	CUT "X" INLET HDWL 5 X 7 CONC ARCH
528	482988.829	2272044.941	697.068	954+21.97	61.168	BM	SET RR SPK S SIDE PP
529	483951.658	2271859.135	701.099	963+93.03	-101.68	BM	RR SPK N. SIDE LUM
530	485229.521	2271861.004	699.139	976+73.97	-73.14	BM	SET RR SPK E SIDE PP
531	486172.066	2271971.039	693.852	986+15.51	44.84	BM	CUT "X" INLET APRON 36" RCP
532	486598.656	2271830.504	696.123	990+43.31	-92.10	BM	FD RR SPK E SIDE PP =BM96A 1994 AB PLAN NHS-61-3(28)--19-58 EL=696.57
533	487610.255	2271821.126	689.807	1000+54.95	-92.96	BM	SET RR SPK S SIDE PP
534	488105.163	2271826.674	683.398	1005+49.80	-83.25	BM	FD RR SPK E SIDE PP =BM97A 1994 AB PLAN NHS-61-3(28)--19-58 EL=683.83
535	489059.761	2271822.201	693.297	1015+04.40	-79.70	BM	FD RR SPK E SIDE PP =BM97B 1994 AB PLAN NHS-61-3(28)--19-58 EL=693.83
536	489586.168	2271942.103	694.470	1020+28.87	47.084	BM	CUT "X" IN INLET 30" RCP
537	491058.445	2271764.244	703.240	1035+08.76	-23.140	BM	CUT "X" SW WING OF BRIDGE
538	491313.326	2271801.104	698.631	1037+59.33	36.317	BM	CUT "X" ON INLET END 4 X 6 CONC ARCH CULV
539	492709.803	2271853.611	701.907	1051+65.53	181.358	BM	SET RR SPK W SIDE PP
540	493880.012	2271876.516	722.422	1063+41.12	130.682	BM	SET RR SPK W SIDE PP
541	495009.556	2271938.946	719.518	1074+72.39	129.170	BM	CUT "X" ON INLET 48" RCP
542	495825.173	2272052.885	746.493	1083+38.46	120.163	BM	SET RR SPK E SIDE PP
600	473414.390	2270752.840	666.488	855+77.79	-2605.582	BM	SET RR SPK S SIDE PP
602	473635.646	2274960.208	699.131	857+60.16	1627.76	BM	SET RR SPK S SIDE PP
607	478771.186	2274038.620	690.485	909+05.66	732.022	BM	LOUISA CO MONU ASI7 BERNTSEN ROD_CAP W/5" LID =2006ASI7 COUNTY MONU EL=690.485
Along Ia 92							
601	473382.163	2272321.826	664.184	506+55.77	41.073	BM	CUT "X" INLET APRON 30" R

C.P. NO STATIONING
 C.P. 38, Fd 5/8" Rebar 6" Deep
 N=453672.150 E=2273644.760

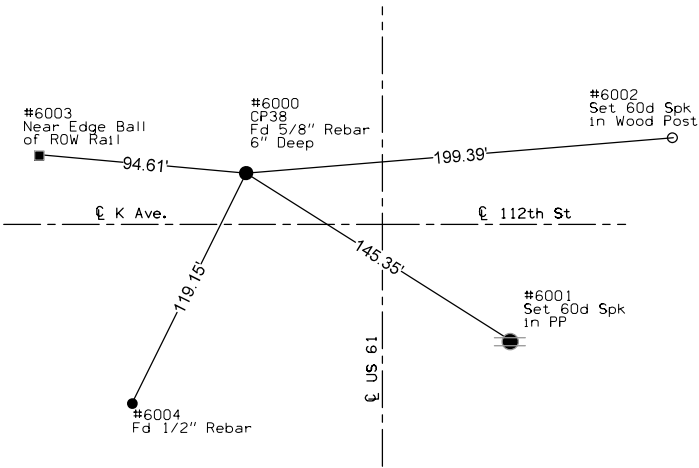

C.P. NO STATIONING
 C.P. 39, Fd Feno Monument 6" Deep
 N=456670.060 E=2273992.528

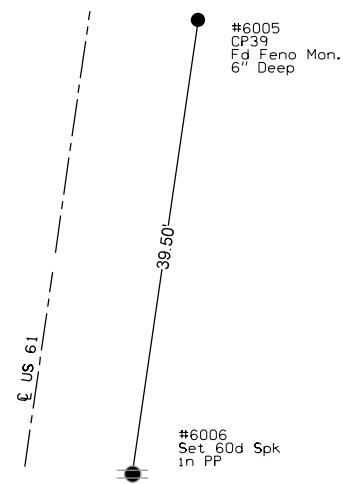

C.P. STA 730+15.98 LEFT 141.45
 C.P. 40, Fd 5/8" Rebar 6" Deep
 N=460882.277 E=2273676.773

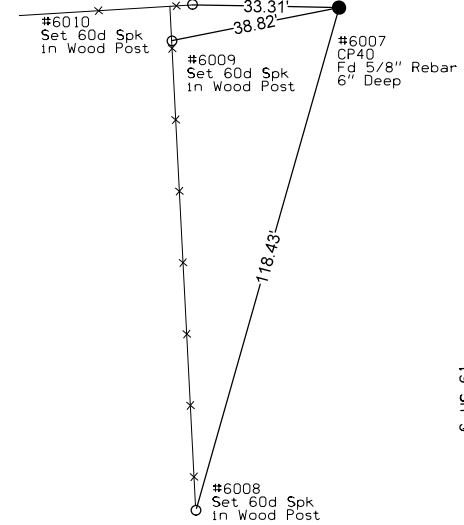

C.P. STA 735+13.36 RIGHT 28.16
 C.P. 60, Set 5/8" Rebar 6" Deep
 N=461387.799 E=2273820.305

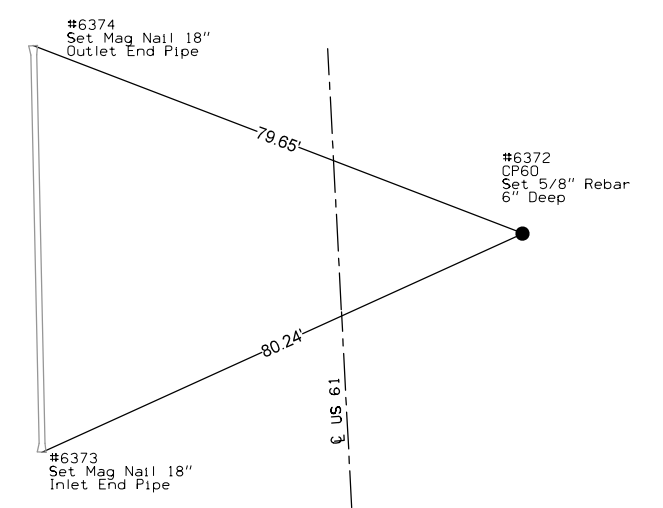

C.P. STA 744+54.24 RIGHT 33.57
 C.P. 61, Set 5/8" Rebar 6" Deep
 N=462328.360 E=2273744.772

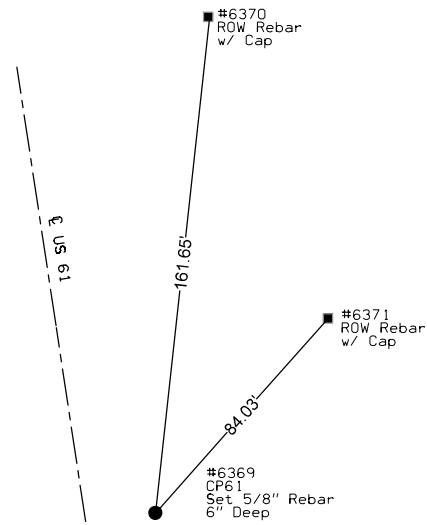

C.P. STA 750+13.26 LEFT 12.58
 C.P. 105, Fd IDOT Hinge Nail
 N=462876.072 E=2273625.301

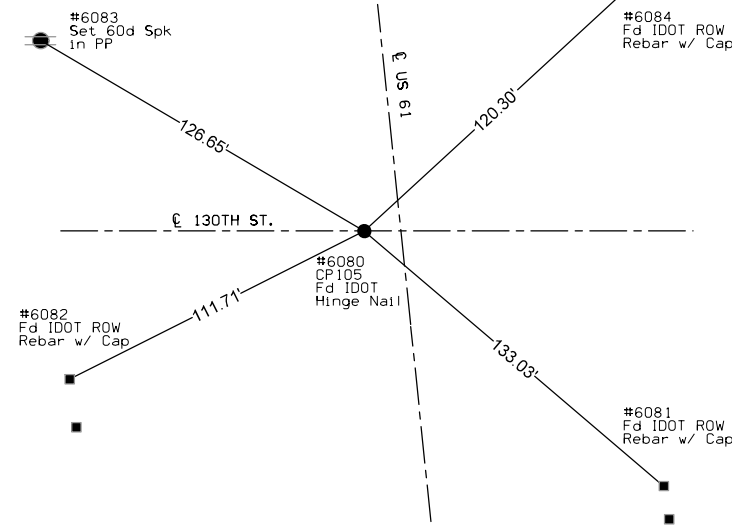

C.P. STA 756+79.91 RIGHT 30.36
 C.P. 62, Set 5/8" Rebar 6" Deep
 N=463543.834 E=2273637.658

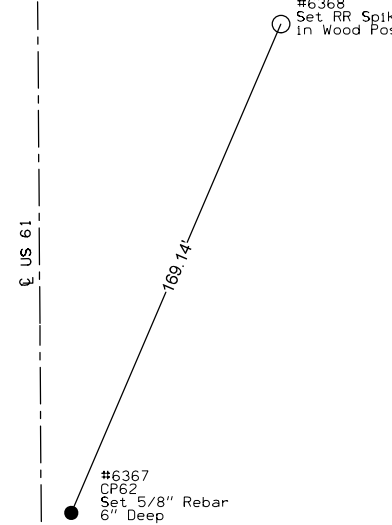

C.P. STA 764+69.07 RIGHT 28.21
 C.P. 63, Set 5/8" Rebar 6" Deep
 N=464332.650 E=2273614.226

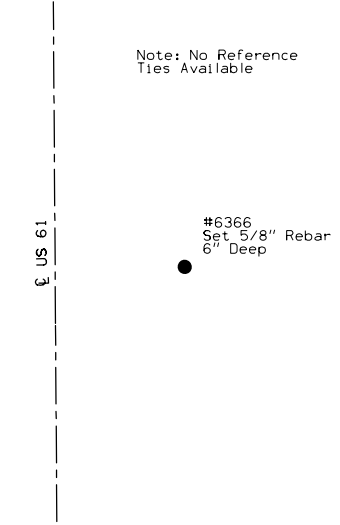

Note: No Reference Ties Available

C.P. STA 772+32.84 RIGHT 28.71
 C.P. 64, Set 5/8" Rebar 6" Deep
 N=465096.155 E=2273594.135

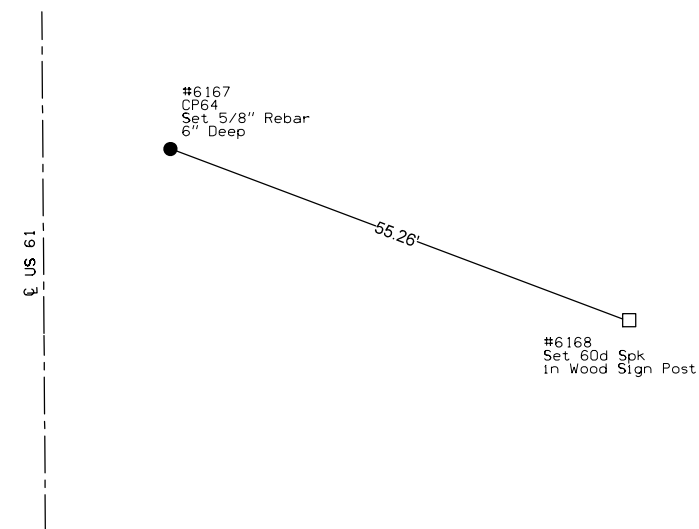

C.P. STA 780+21.33 RIGHT 28.06
 C.P. 41, Fd 5/8" Rebar 6" Deep
 N=465884.348 E=2273572.214

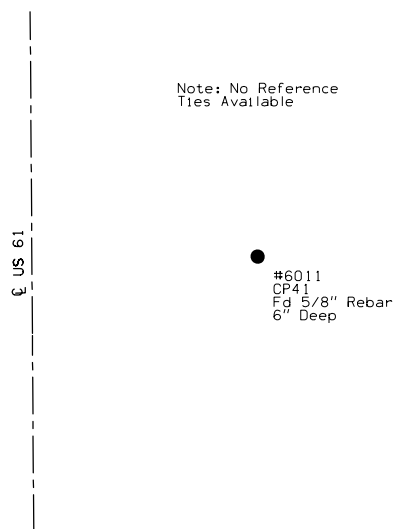

Note: No Reference Ties Available

C.P. STA 783+28.71 RIGHT 0.00
 C.P. 109, Fd IDOT Hinge Nail
 N=466190.853 E=2273535.880

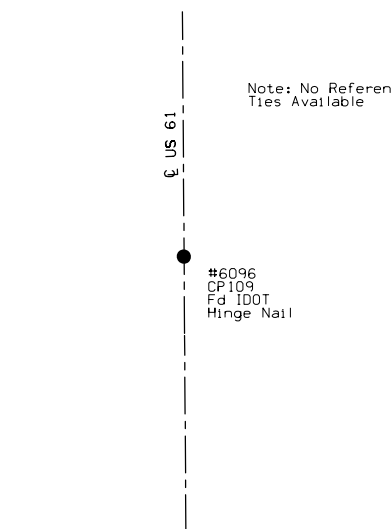

Note: No Reference Ties Available

C.P. STA 789+37.88 RIGHT 33.02
 C.P. 65, Set 5/8" Rebar 6" Deep
 N=466800.674 E=2273553.141

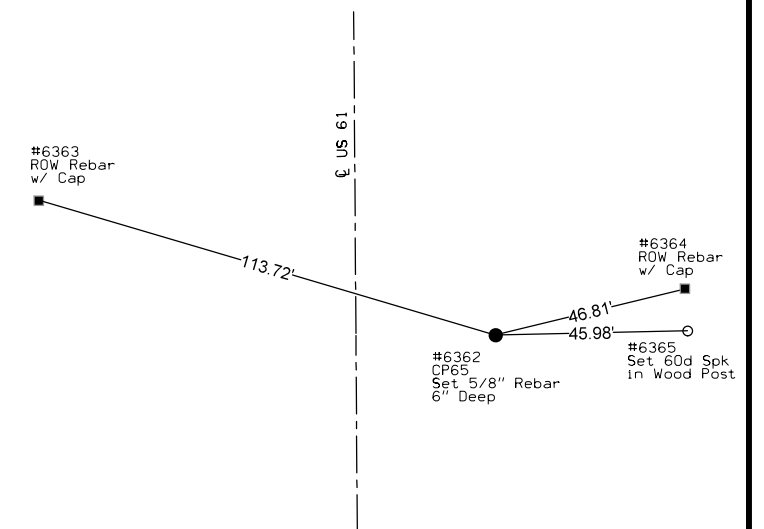

C.P. STA 796+72.42 RIGHT 29.08
 C.P. 66, Set 5/8" Rebar 6" Deep
 N=467534.865 E=2273530.216

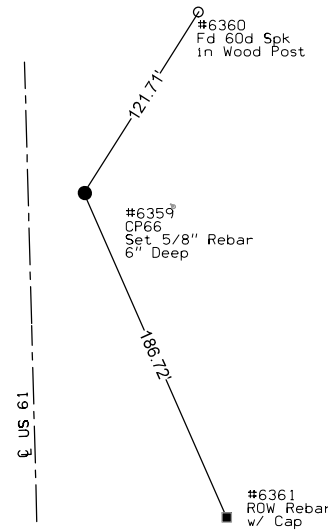

C.P. STA 802+95.23 LEFT 85.07
 C.P. 42, Fd IDOT Alum. Cap 6" Deep
 N=468154.520 E=2273400.000

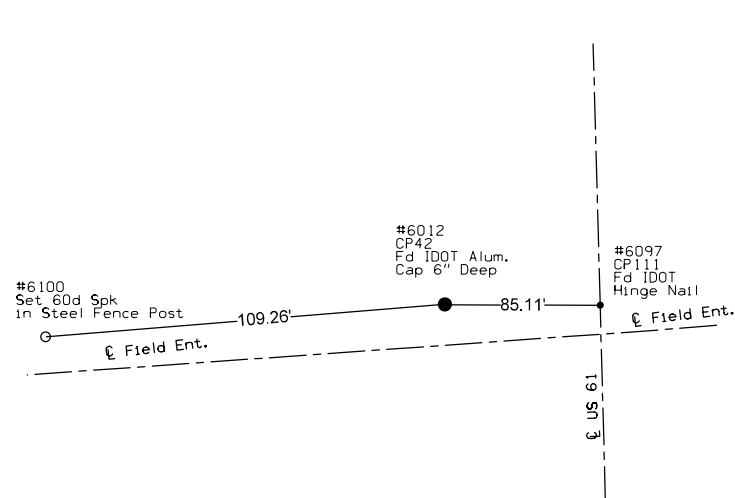

C.P. STA 802+95.66 RIGHT 36.43
 C.P. 67, Set 5/8" Rebar 6" Deep
 N=468158.085 E=2273521.362

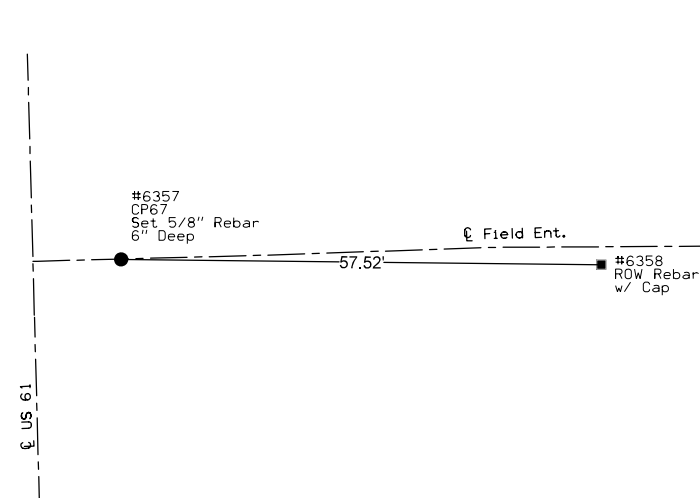

C.P. STA 802+97.70 RIGHT 0.00
 C.P. 111, Fd IDOT Hinge Nail
 N=468159.186 E=2273484.978

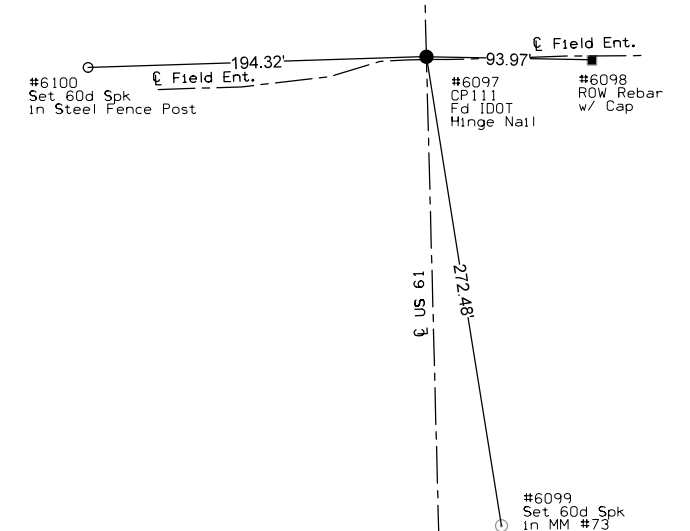

C.P. STA 809+01.74 RIGHT 28.99
 C.P. 68, Set 5/8" Rebar 6" Deep
 N=468763.772 E=2273498.442

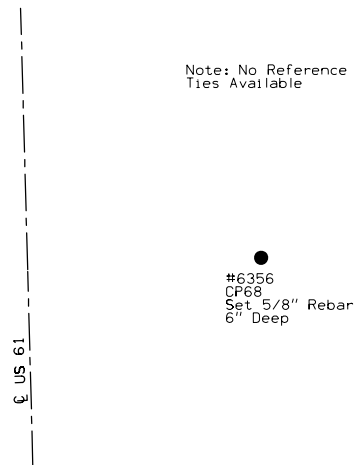

C.P. STA 816+47.02 RIGHT 30.28
 C.P. 69, Set 5/8" Rebar 6" Deep
 N=469508.837 E=2273480.582

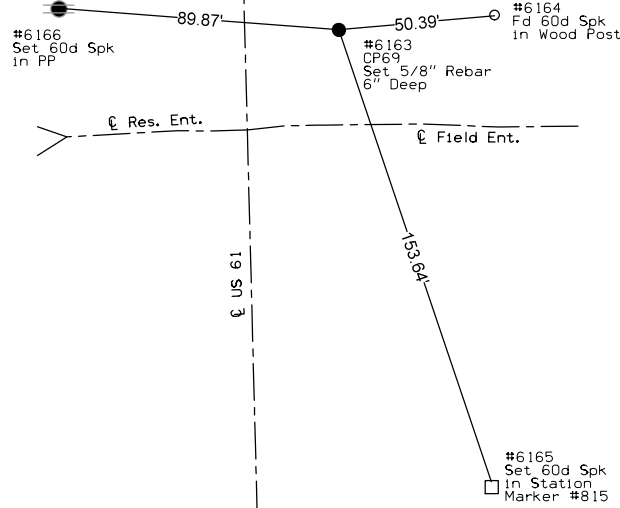

C.P. STA 823+23.44 RIGHT 28.02
 C.P. 70, Set 5/8" Rebar 6" Deep
 N=470184.980 E=2273460.949

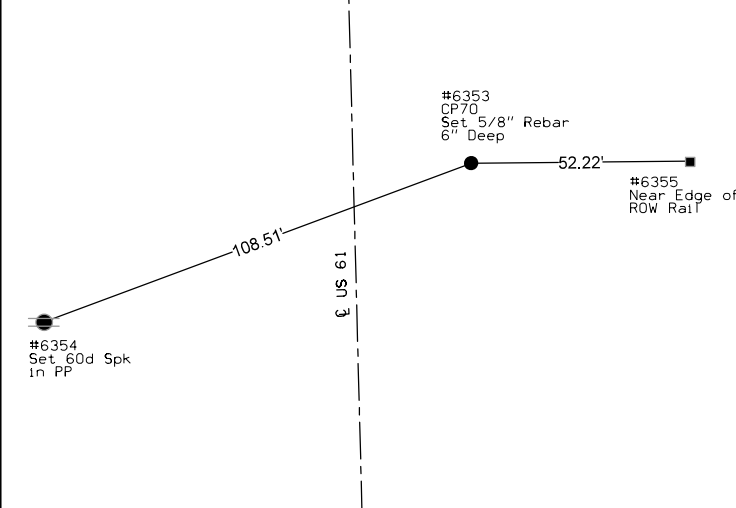

C.P. STA 829+43.76 RIGHT 0.00
 C.P. 113, Fd IDOT Hinge Nail
 N=470804.374 E=2273417.004

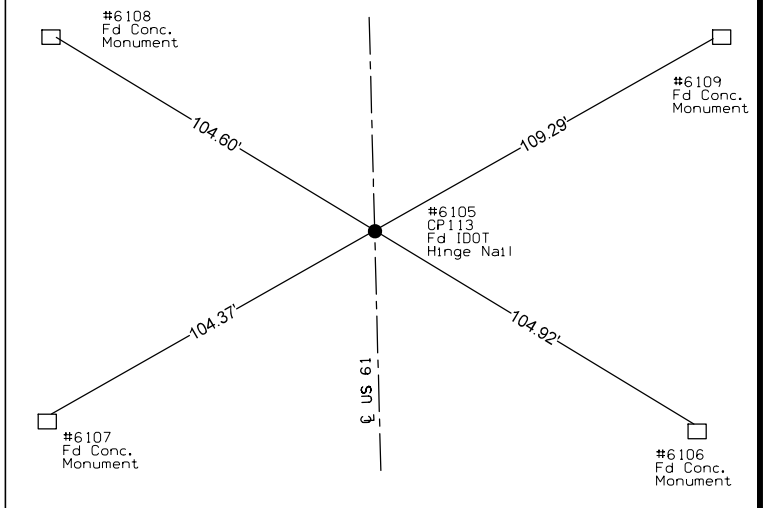

C.P. STA 830+41.33 RIGHT 28.83
 C.P. 43, Fd 5/8" Rebar 6" Deep
 N=470902.650 E=2273443.314

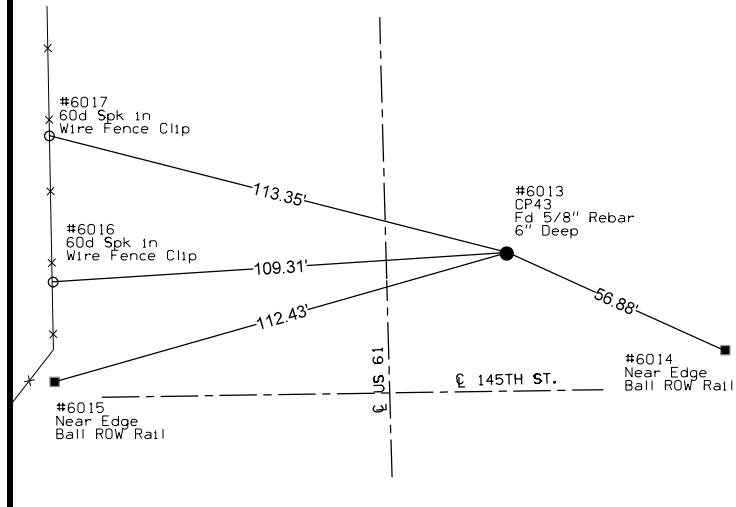

C.P. STA 838+33.65 LEFT 85.90
 C.P. 71, Set 5/8" Rebar 6" Deep
 N=471691.762 E=2273308.265

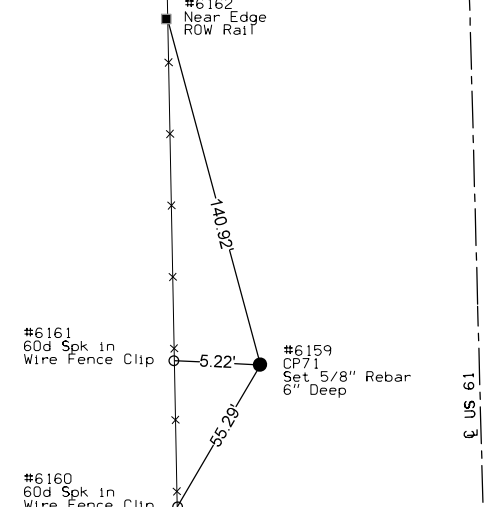

C.P. STA 846+13.34 RIGHT 58.70
 C.P. 72, Set 5/8" Rebar 6" Deep
 N=472474.913 E=2273432.785

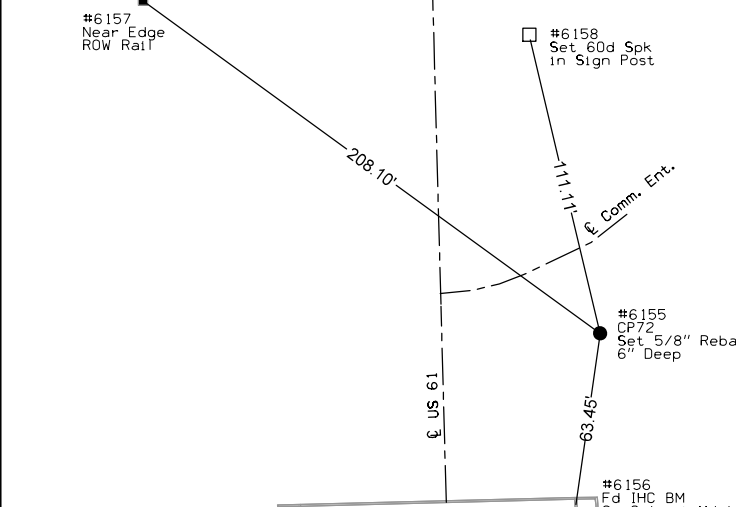

C.P. STA 856+36.30 LEFT 24.00
 C.P. 120, Set Mag Nail
 N=473495.996 E=2273333.793

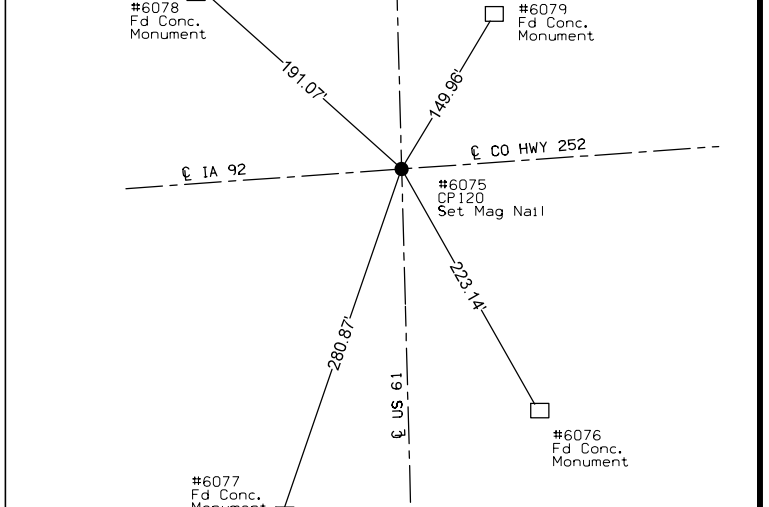

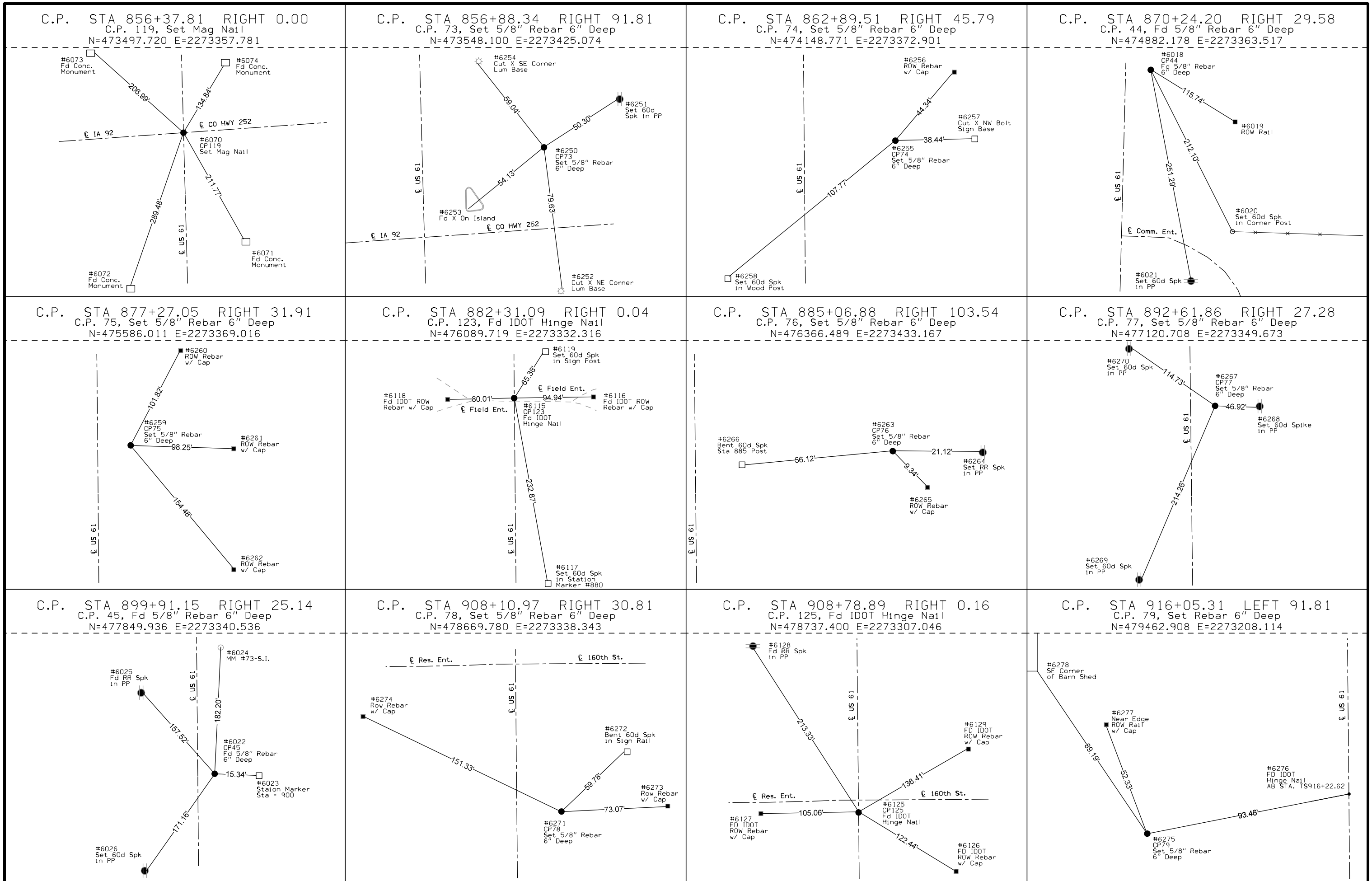

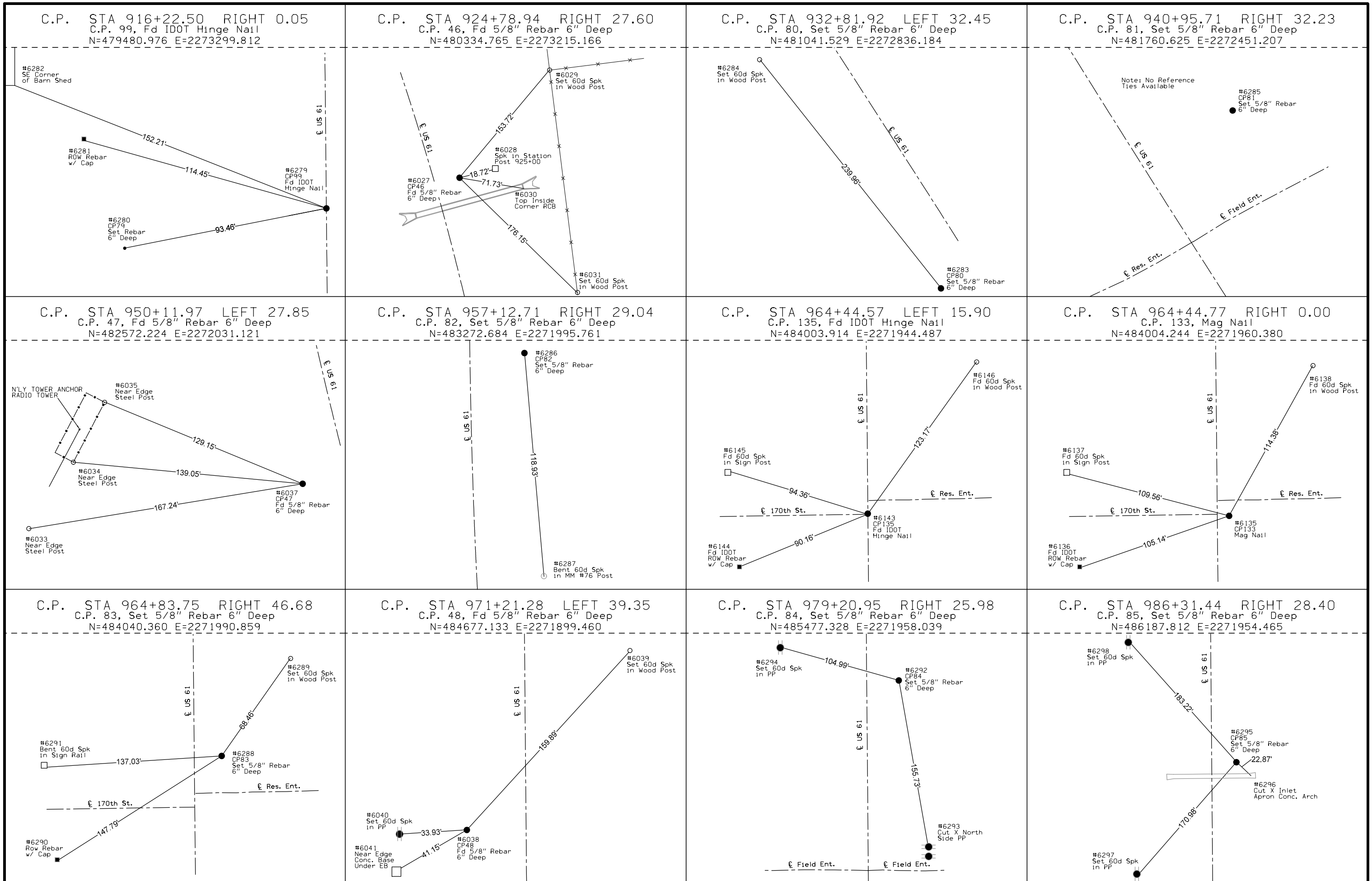

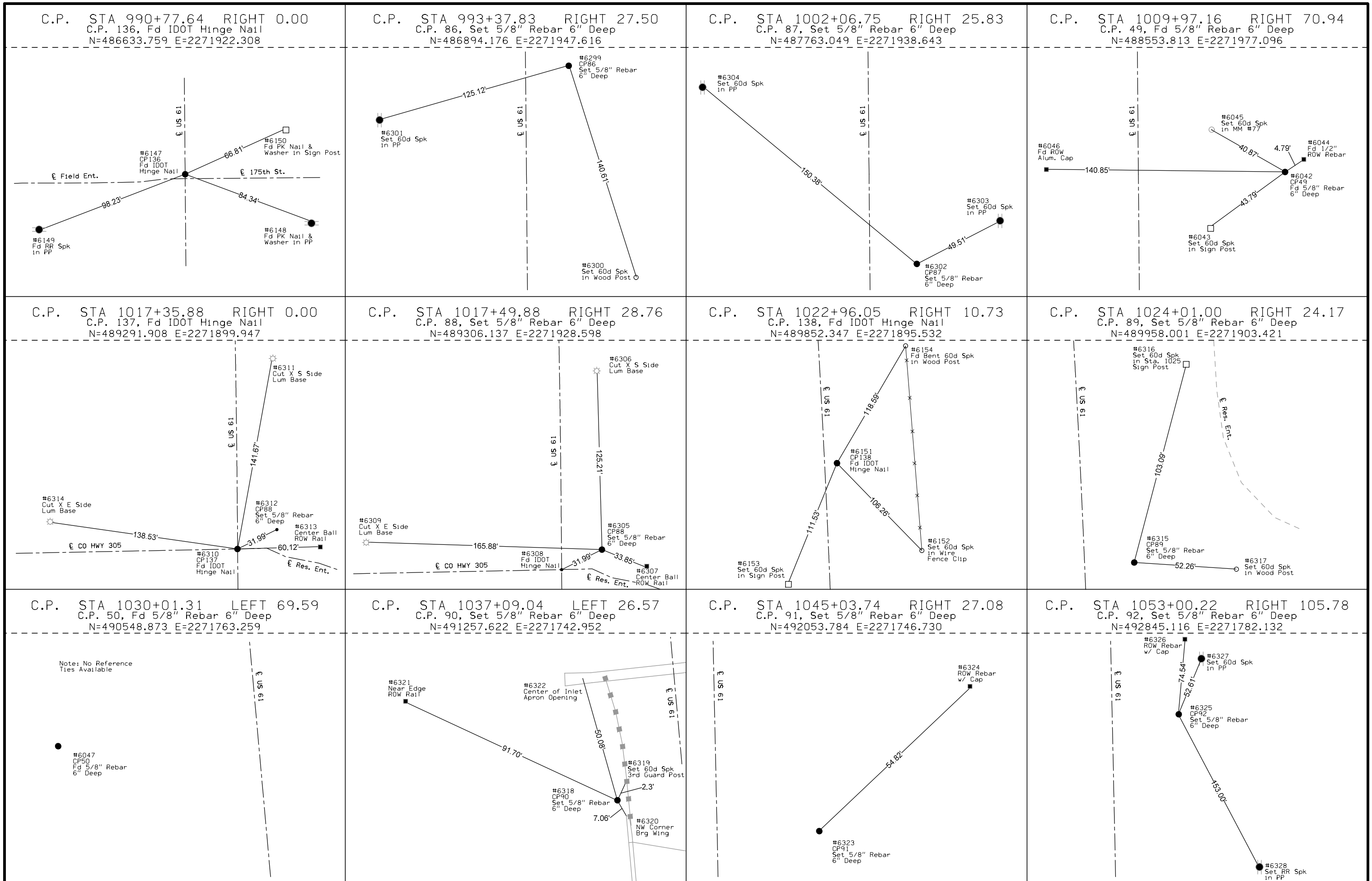

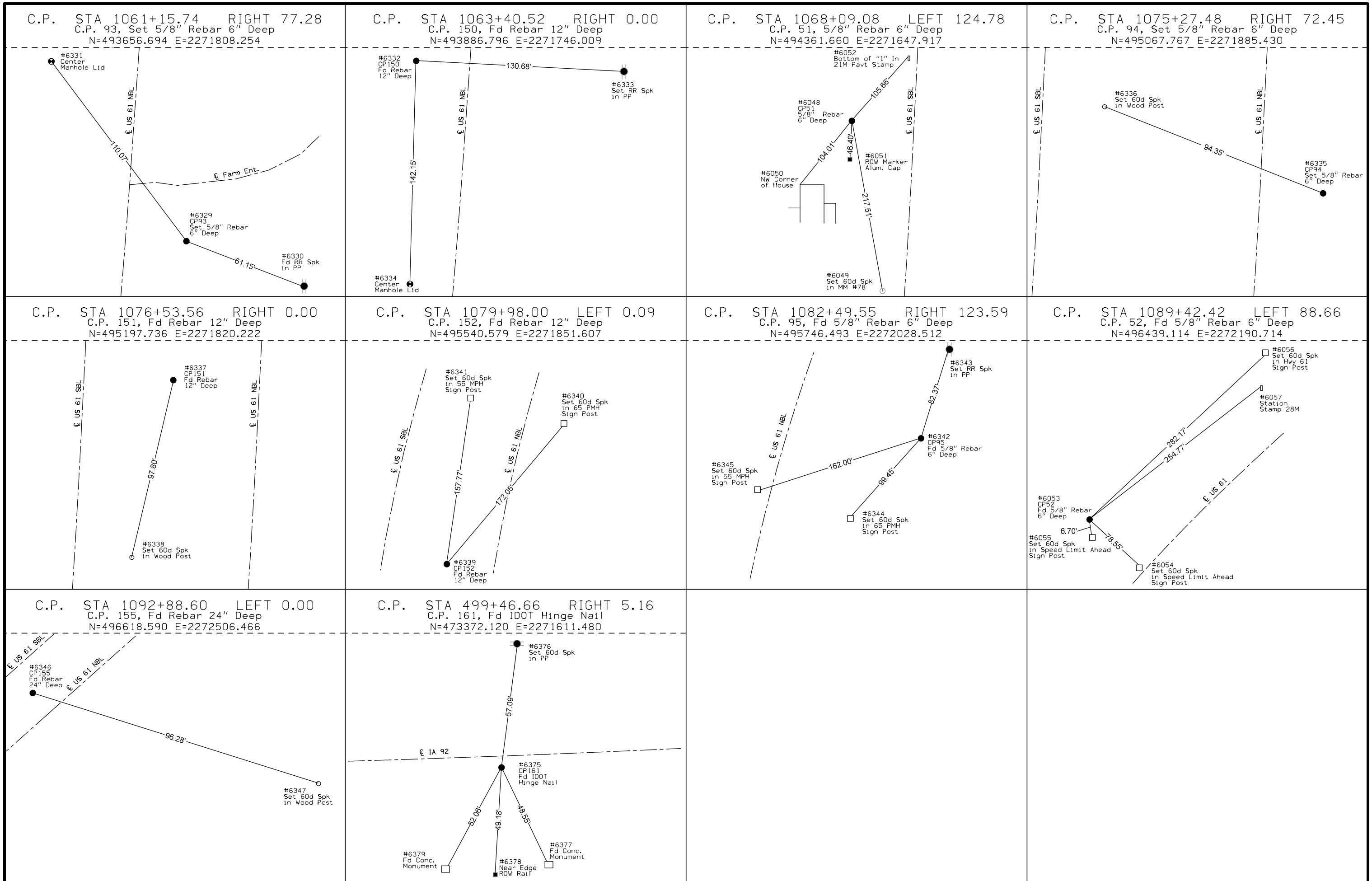

TRAFFIC CONTROL PLAN

Existing US-61:
- Maintain one lane of traffic in each direction.

Sideroads: 130th St., 145th St. IA-92, 160th St., 170th St., 175th St., 180th St., 190th St.
- Maintain traffic in each direction except as noted below.

IA-92:
- Stage 1, IA-92 will be closed during reconstruction from Sta 490+40 to 512+00.

180th St.:
- Closed to traffic during reconstruction.

TABULATION OF SPECIAL EVENTS

Event	Location	Date
None provided at this time.		

COORDINATED OPERATIONS

Other work in progress during the same period of time will include the construction of the projects listed. Coordinate operations with those of other contractors working within the same area.

Project	Type of Work

STAGING NOTES

STAGE I TRAFFIC:

- Maintain traffic in the existing lanes at all times for the following roadways:
US 61, 130th St., 160th St., 170th St., 175th St., 180th St(G-48), and 190th St.
- Detour IA 92 traffic during construction on IA 92.
- Close 145th St. West of US 61.
- All farmstead and field entrances are to remain open to traffic at all times.

STAGE I CONSTRUCTION:

Phase 1.

- Construct cross over at Sta. 1100+00
- Construction of all Stage I pipes and culverts.
- Grade US 61:
SB lanes from Sta. 754+06 and Sta. 805+00.
NB and SB lanes from Sta. 805+00 and Sta. 902+00.
SB lanes from Sta. 902+00 to 905+60.
NB lanes from Sta. 907+50 to 910+75.
NB and SB lanes from Sta. 910+75 to 985+80.
NB lanes from Sta. 985+80 to 990+25.
SB lanes from Sta. 993+30 to Sta. 1070+10.
- Grade crossover at Sta. 760+00.
- Grade relocated 145th St.
- Grade detour pavement on US 61 between Sta. 903+00 and Sta. 914+00.
- Grade and surface 175th St, maintain connection to existing US 61.
- Grade 170th St. East of existing US.
- Grade detour pavement on US 61 between Sta. 980+00 and Sta. 1006+00.
- Grade all ramps at IA 92 interchange and 170th St interchange.

Phase 2.

- Pave all sections of roadway previously graded in Phase 1 construction.
- Grade and Pave IA 92 from Sta. 499+40 to Sta. 512+00
- Build NB & SB bridges at the IA 92 Interchange
- Build NB & SB bridges at the 170th St. Interchange
- Build the US 61 SB bridge over the DM&E RR
- Construct lighting at both the IA 92 and 170th St. interchanges.
- Grade and Pave 180th St.

STAGE II TRAFFIC: See F sheets for Detour Locations

- Maintain traffic on US 61 using the cross over at 760+00 to new SB Lanes, use SB on and off ramps at IA 92, detour at 905+00 to existing US 61 lanes, detour at 985+00 to new SB lanes, cross over at 1100+00.
- Maintain traffic on existing 130th St., 175th St., 180th St(G-48), and 190th St.
- Close 160th St.
- Open new 145th St.
- Maintain traffic on IA 92 using detour pavement

STAGE II CONSTRUCTION:

Phase 1.

- Grade and Pave US 61:
NB lanes from 754+06 to 805+00
NB lanes from 902+00 to 907+50
NB lanes from 990+25 to 1049+35
SB lanes from 905+60 to 910+75
SB lanes from 985+80 to 993+30
- Grade and Pave IA 92 from Sta. 512+00 to 520+92
- Remove and reconstruct existing US 61 from 848+65 to 863+00
- Finish Grade and Pave 145th St.
- Finish Grade and Pave 170th St.
- Finish Grade and Pave tie-in of 180th St.(G-48) with proposed US 61.

STAGE III TRAFFIC:

- Open new US 61.
- Open all side roads to final traffic.

STAGE III CONSTRUCTION:

- Remove detour pavement between Sta. 903+00 and Sta. 914+00.
- Remove detour pavement between Sta. 980+00 and Sta. 1006+00.
- Remove and reconstruct existing US 61 from 961+82 to 170th St.
- Obliterate existing US 61 from 803+50 to 823+00
- Obliterate existing US 61 from 964+45 to 985+00
- Construct signing.
- Construct erosion control.

GRANDVIEW TWP.
T-75N R-3W
SEC. 28



Curve Data
 $\Delta = 8^\circ 45' 28.96''$ (LT)
 $TT = 153.16$
 $LT = 305.71$
 $RI = 2,000.00$
 $e = 5.86$
 $w = 5.4\%$
 $L = 168'$
 $x = 62'$

POT Sta 506+75.00 (SR092) =
 PI Sta 1556+06.08 (SR92A) =
 PI Sta 3556+64.71 (SR92C) =

POC Sta 842+50.00, 87.00' LT =
 POT Sta 3542+50.00
 See Detail Sheet "U.xx"

POC Sta 843+50.00, 107.00' RT =
 POT Sta 2543+50.00
 Point 'M' Standard Road Plan PV-410

Curve Data
 $\Delta = 9^\circ 33' 22.01''$ (RT)
 $TT = 167.17$
 $LT = 333.57$
 $RI = 2,000.00$
 $e = 5.97$
 $w = 5.4\%$
 $L = 168'$
 $x = 62'$

POT Sta 513+75.00 (SR092) =
 PI Sta 2556+89.90 (SR92B) =
 PI Sta 4556+49.96 (SR92D) =

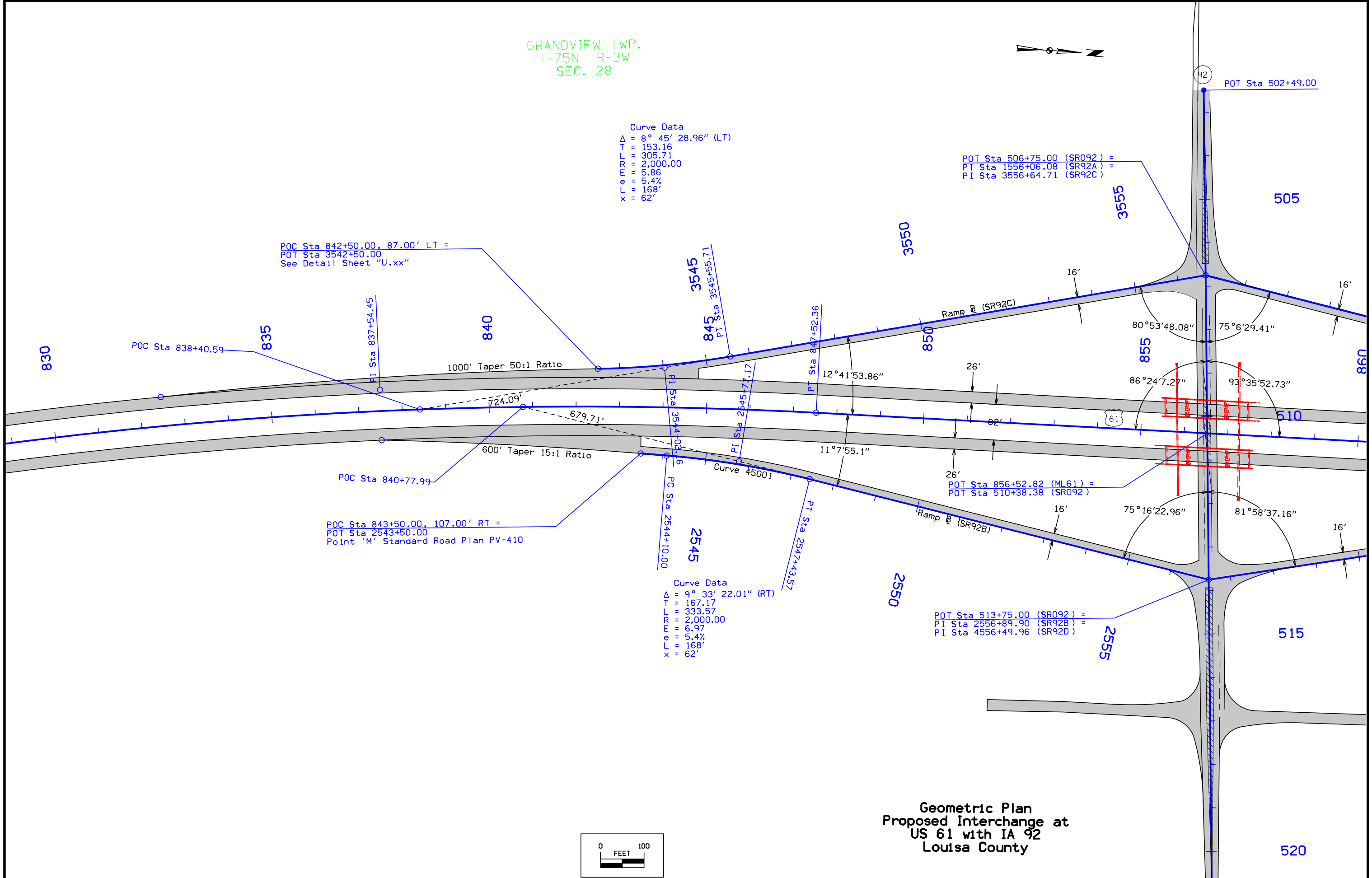

Geometric Plan
 Proposed Interchange at
 US 61 with IA 92
 Louisa County

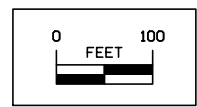

GRANDVIEW TWP.
T-75N R-3W
SEC. 21

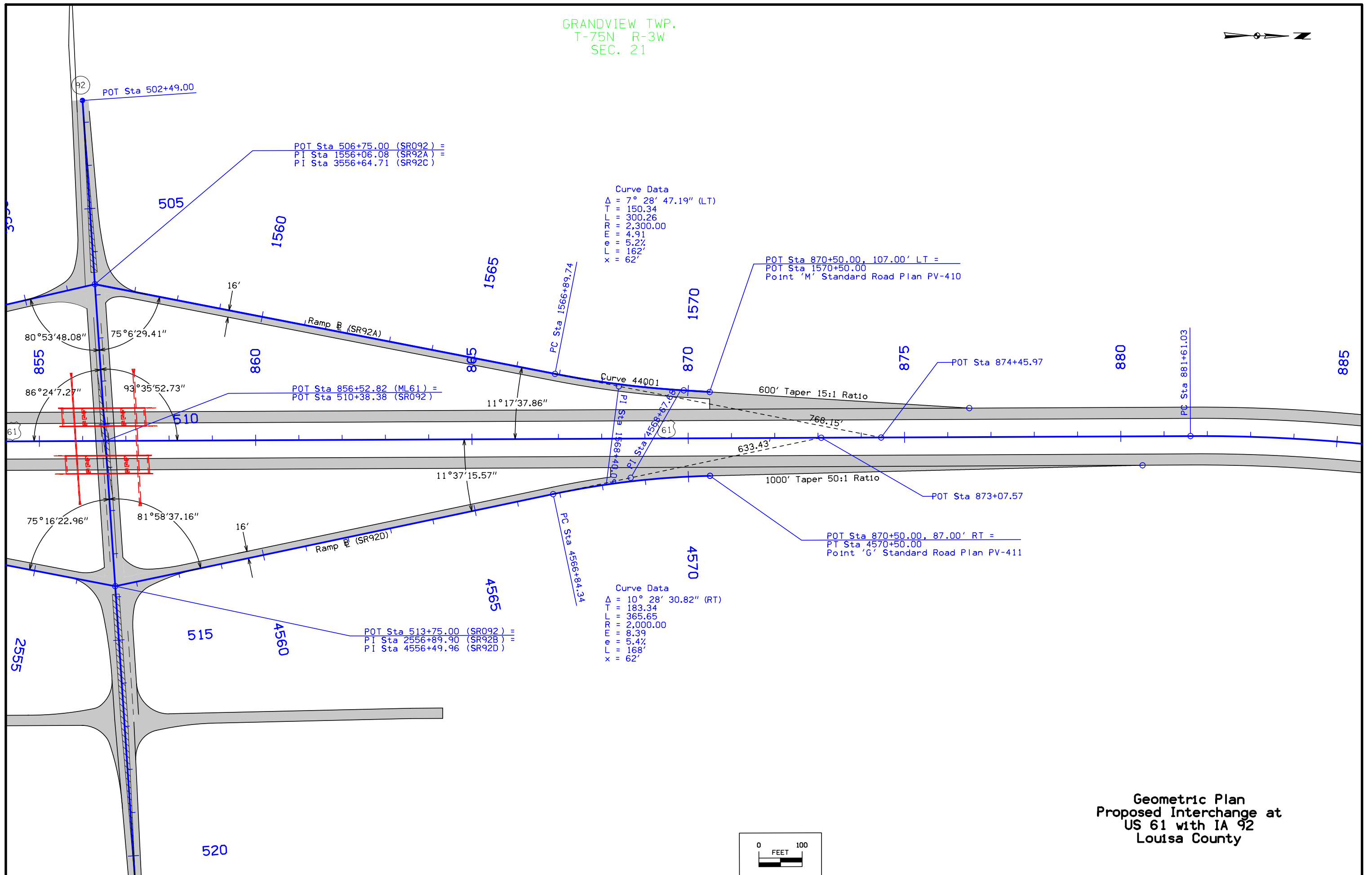

Geometric Plan
Proposed Interchange at
US 61 with IA 92
Louisa County

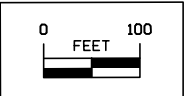

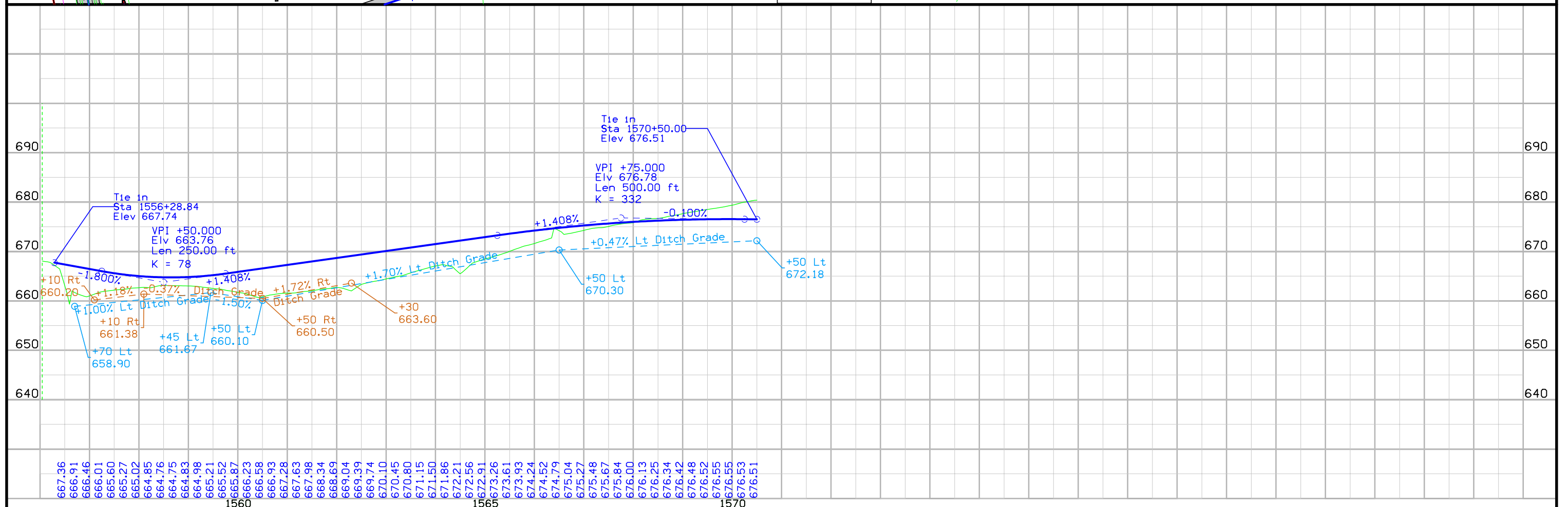
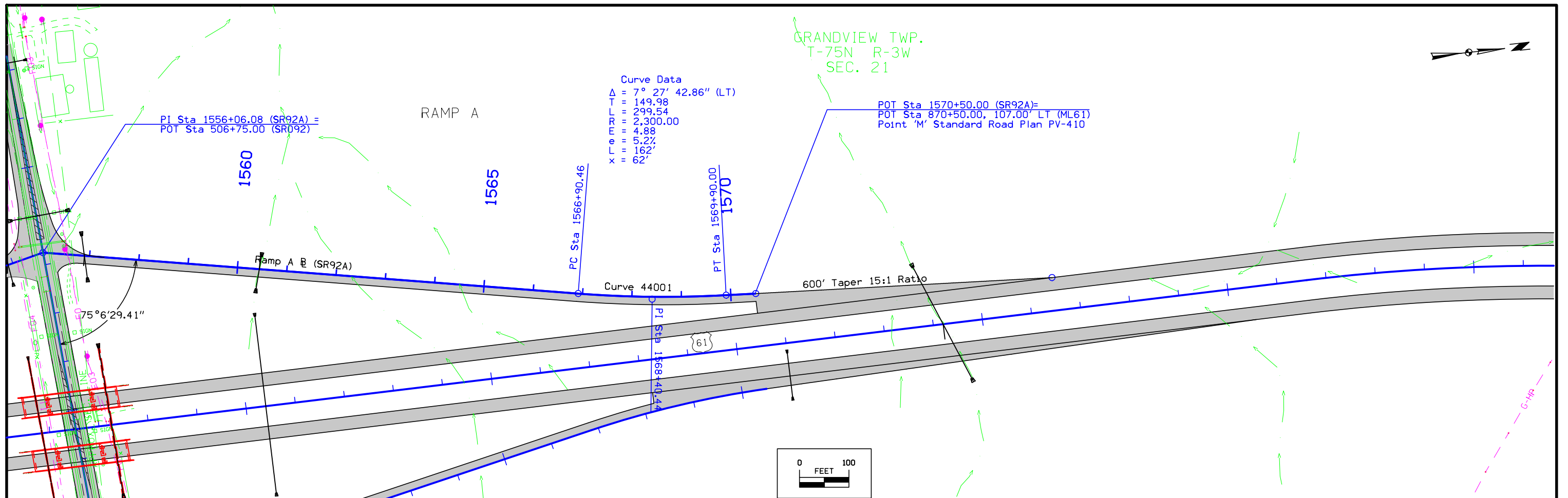

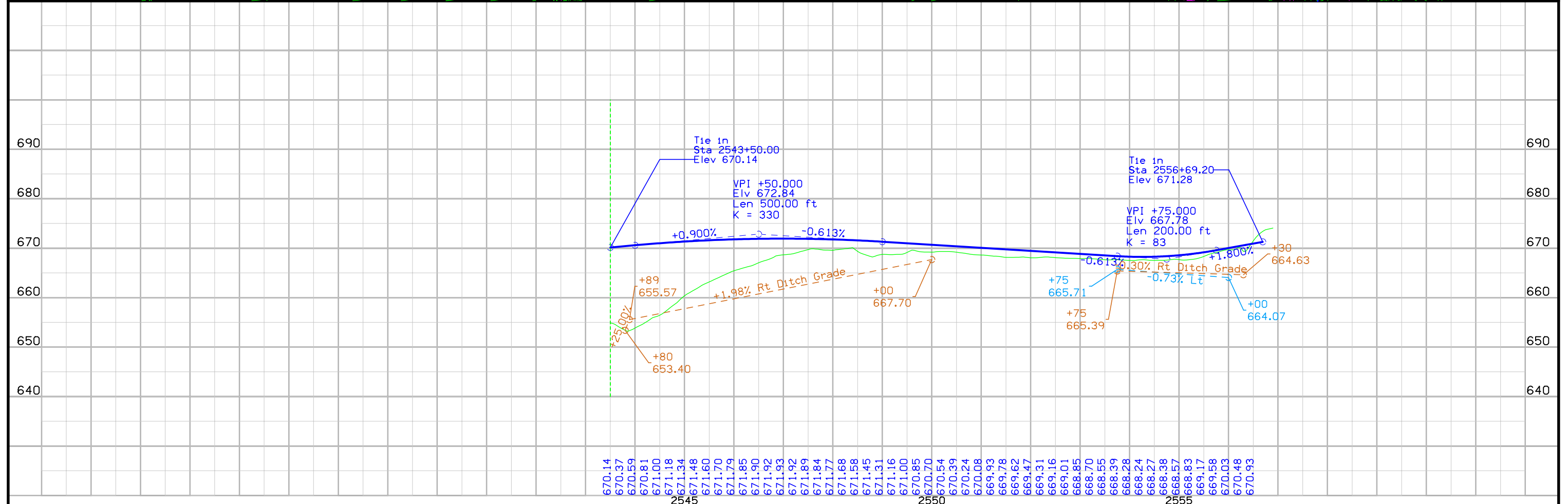
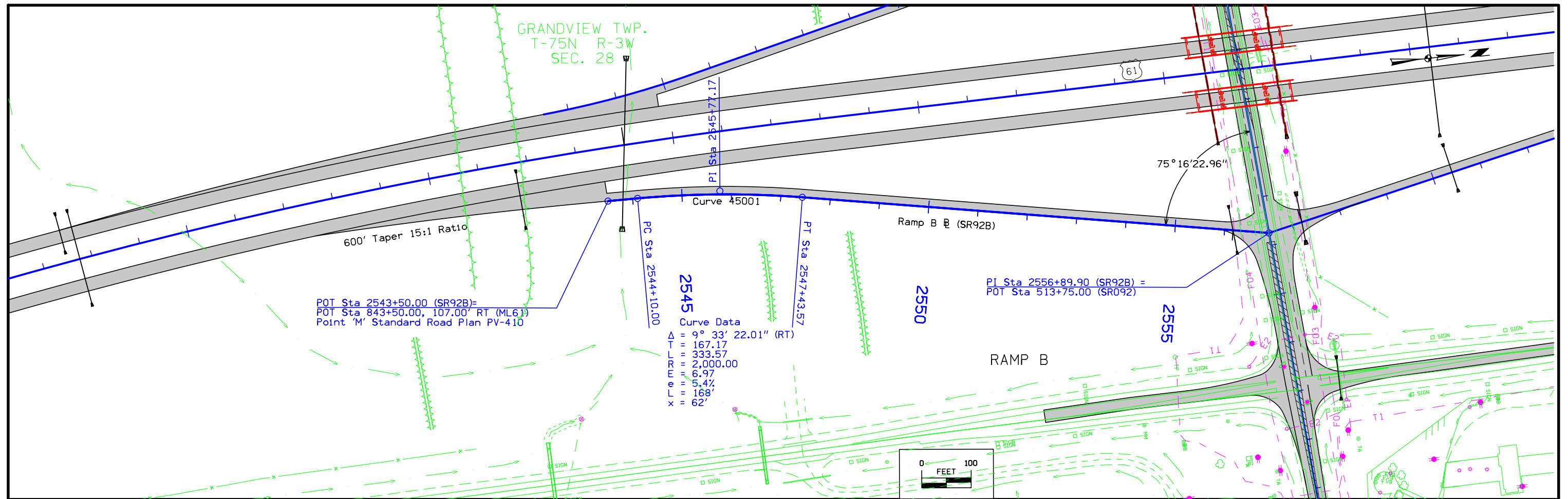

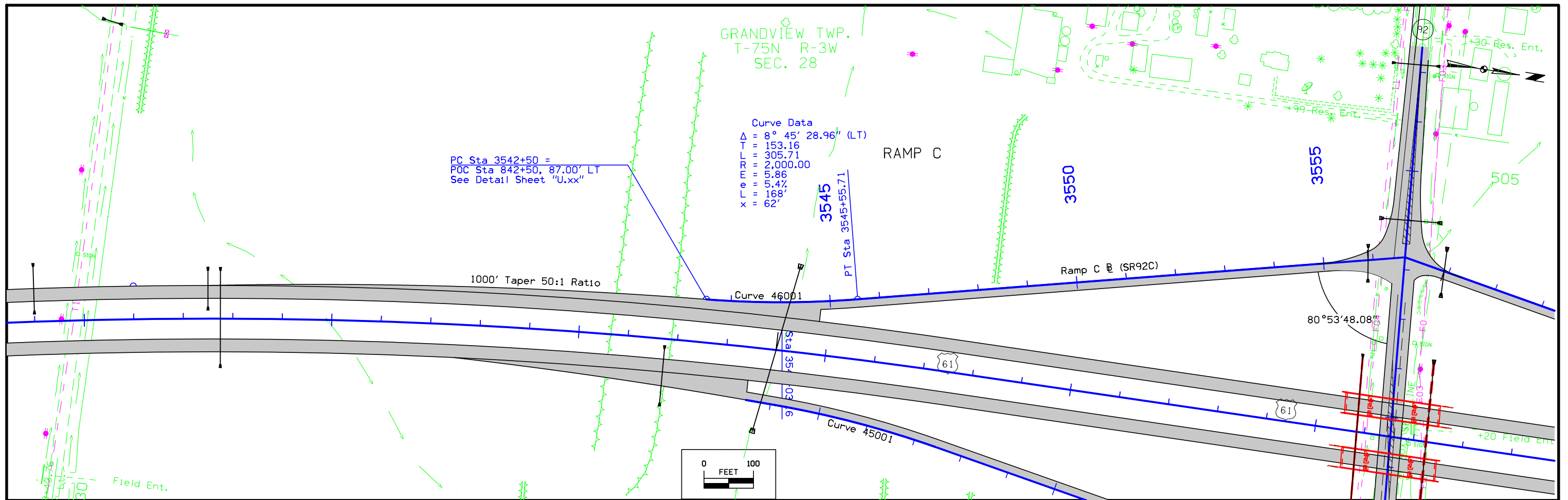

Curve Data
 $\Delta = 8^\circ 45' 28.96"$ (LT)
 $TT = 153.16$
 $PT = 305.71$
 $PC = 2,000.00$
 $PE = 5.86$
 $FL = 5.4\%$
 $FR = 1.68\%$
 $X = 62'$

PC Sta 3542+50 =
 POC Sta 842+50, 87.00' LT
 See Detail Sheet "U.xx"

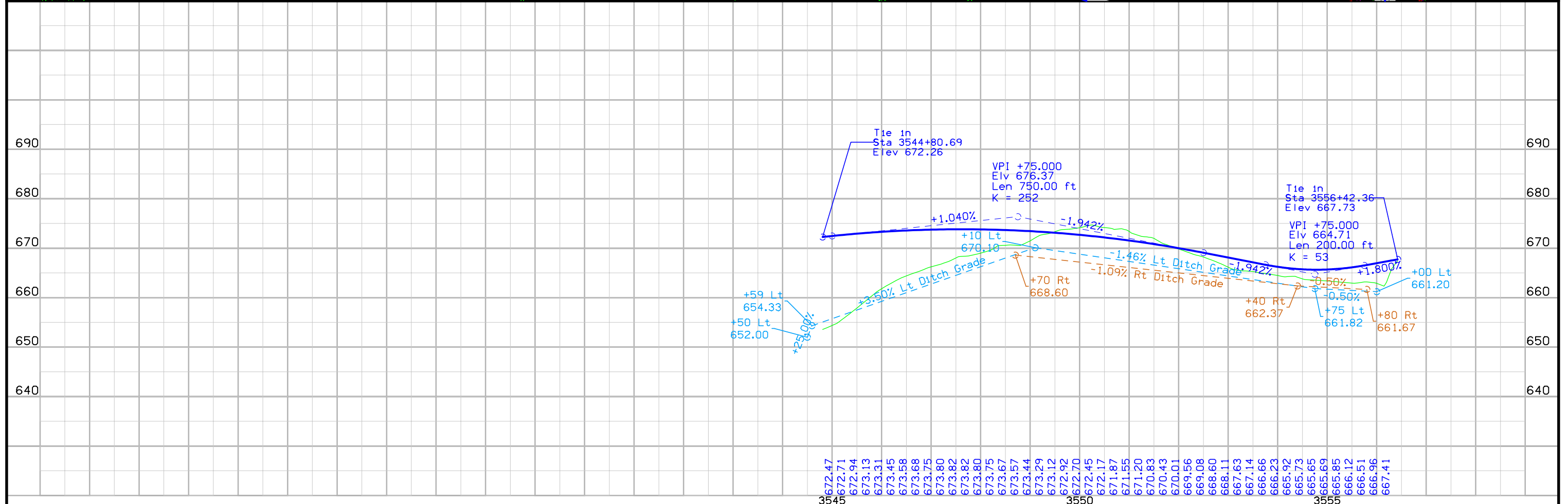
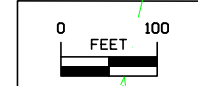

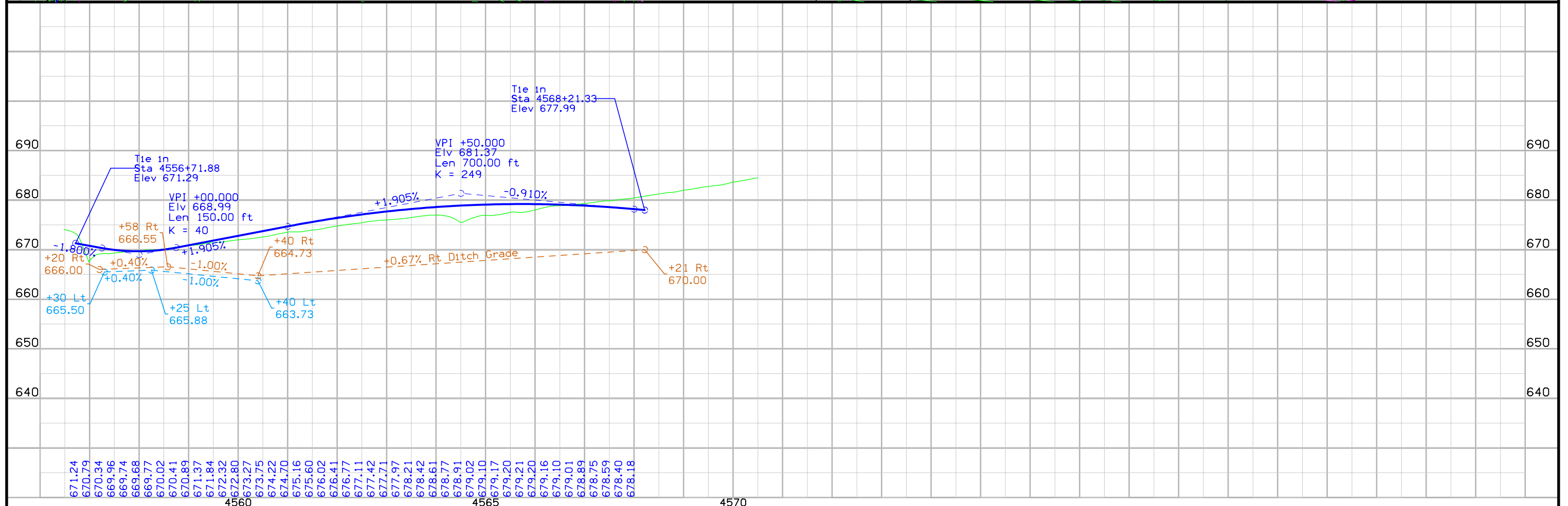
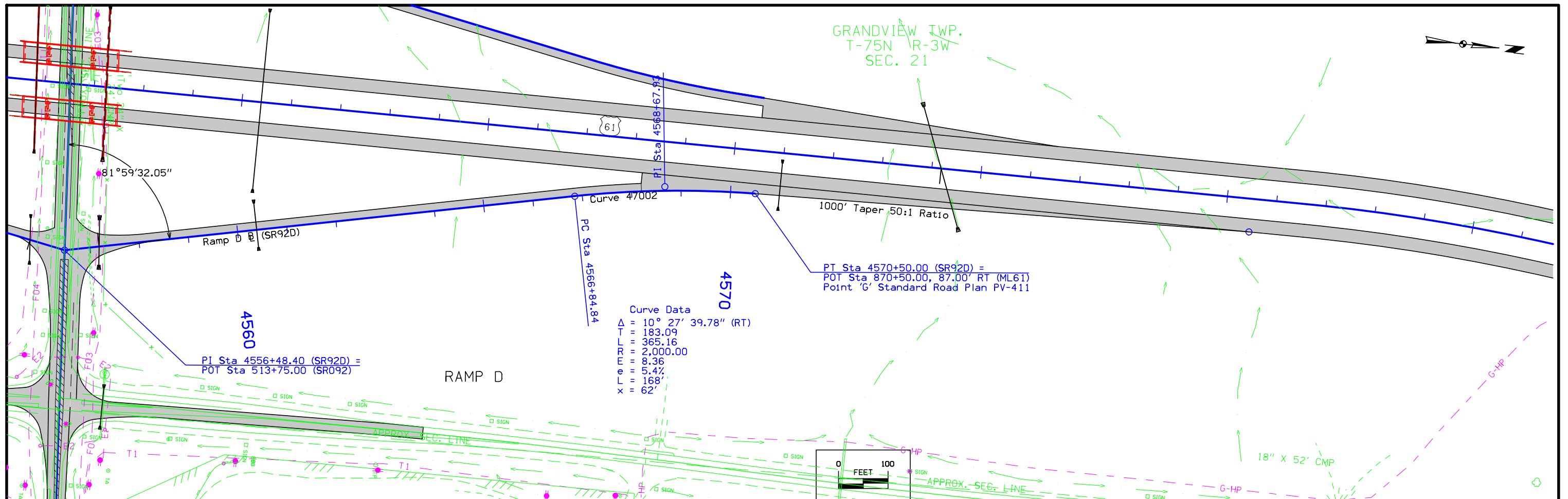

GRANDVIEW TWP.
T-75N R-3W
SEC. 16

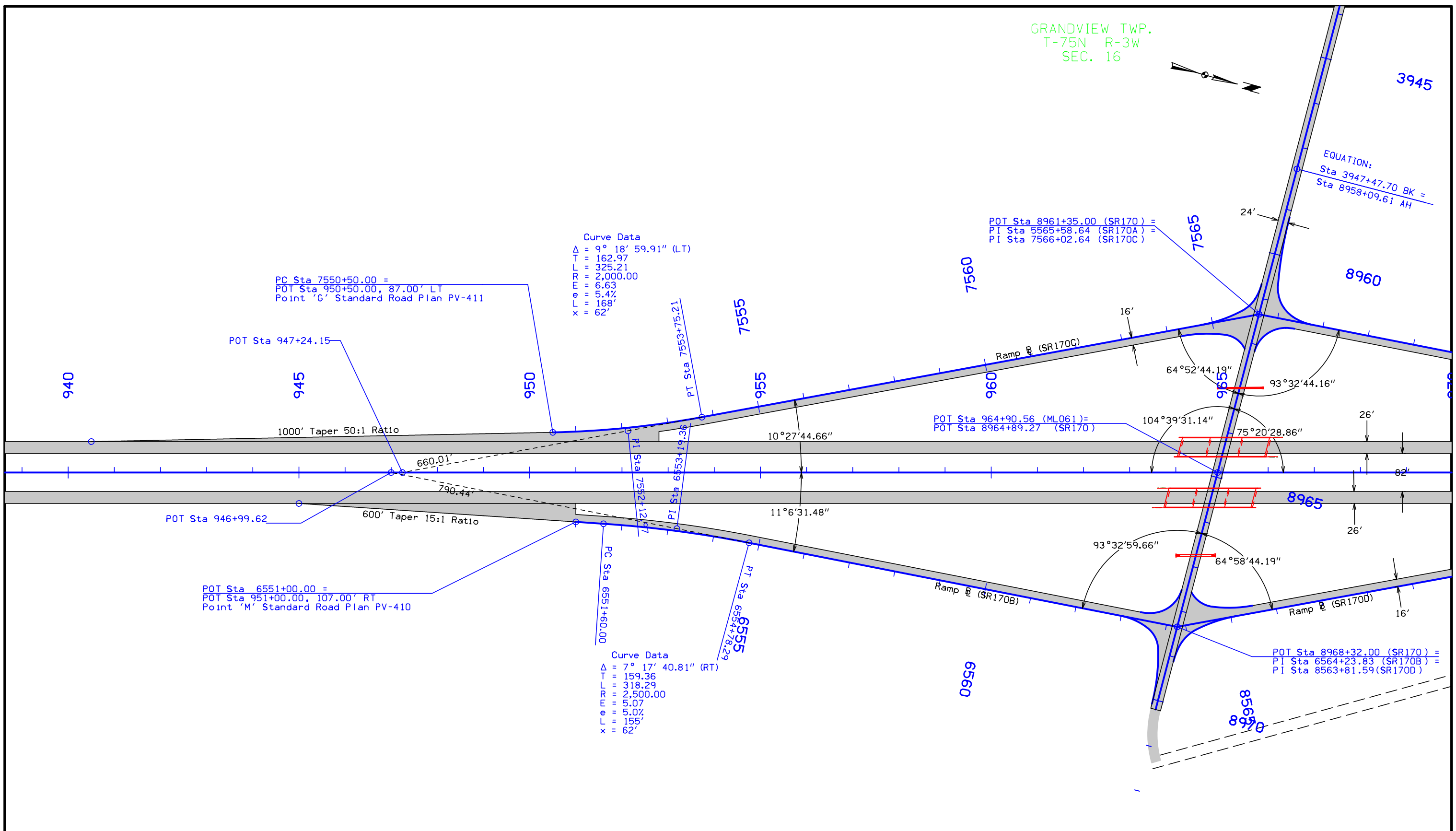

**Geometric Plan
Proposed Interchange of
US 61 with 170th Street
Louisa County**

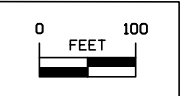

GRANDVIEW TWP.
T-75N R-3W
SEC. 16

GRANDVIEW TWP.
T-75N R-3W
SEC. 9

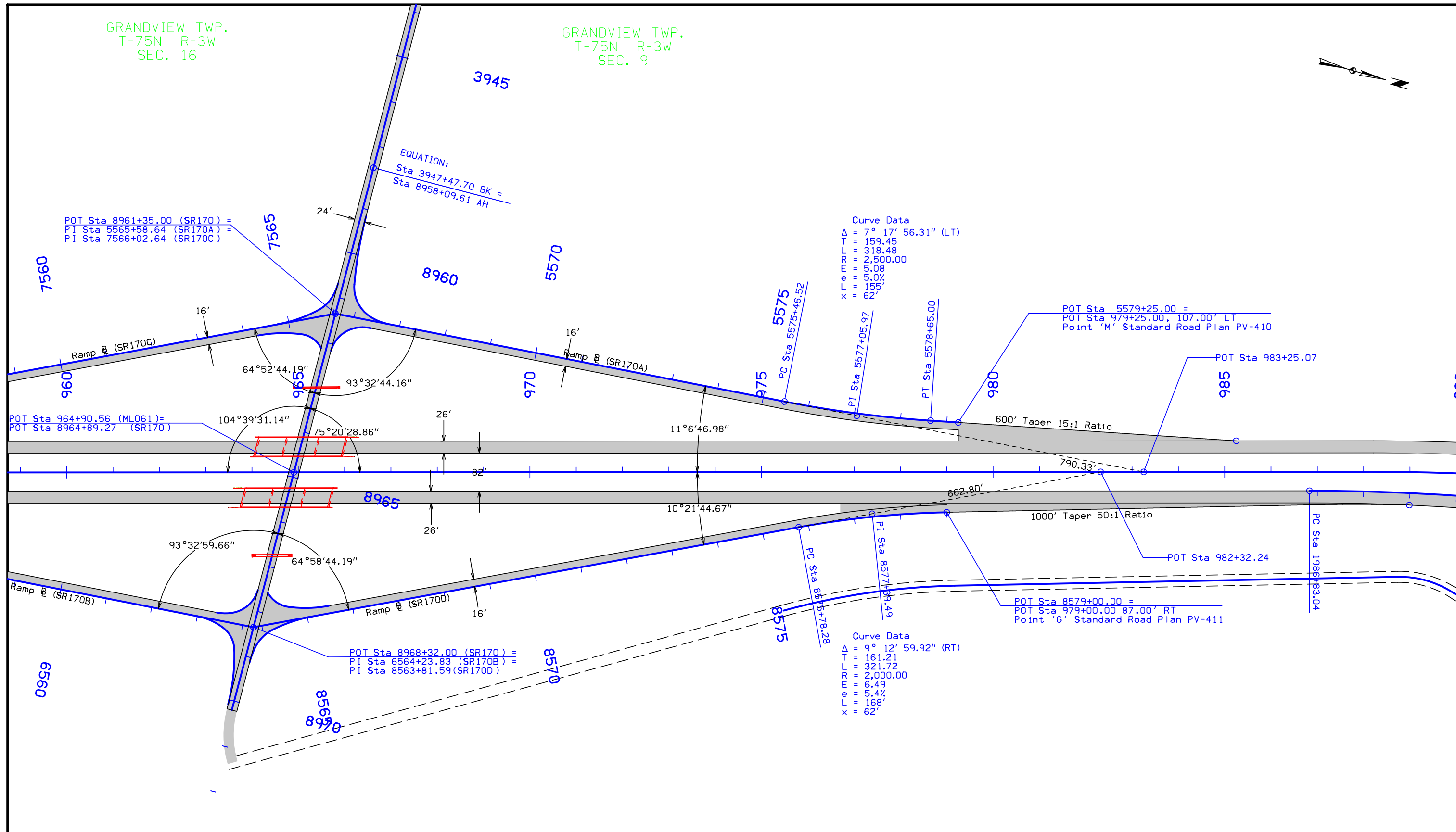

Curve Data
Δ = 7° 17' 56.31" (LT)
T = 159.45
L = 318.48
R = 2,500.00
e = 5.08
f = 15.5
x = 62'

Curve Data
Δ = 9° 12' 59.92" (RT)
T = 161.21
L = 321.72
R = 2,000.00
e = 6.49
f = 5.4
x = 62'

**Geometric Plan
Proposed Interchange of
US 61 with 170th Street
Louisa County**

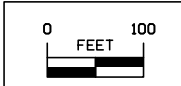

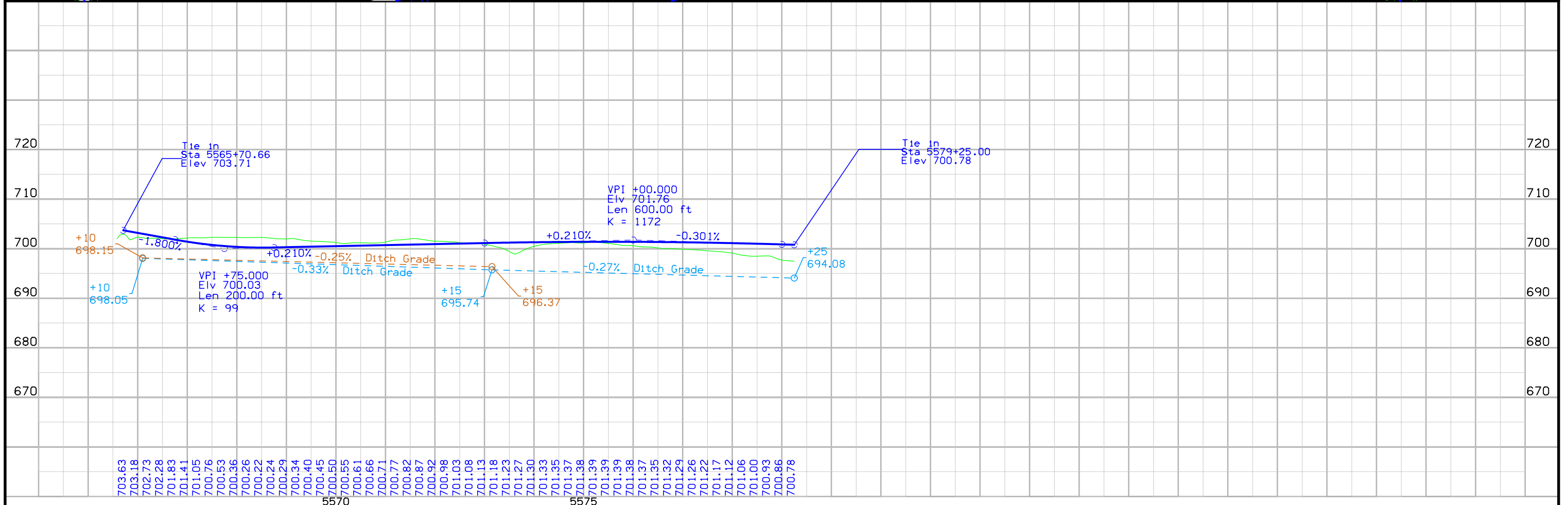
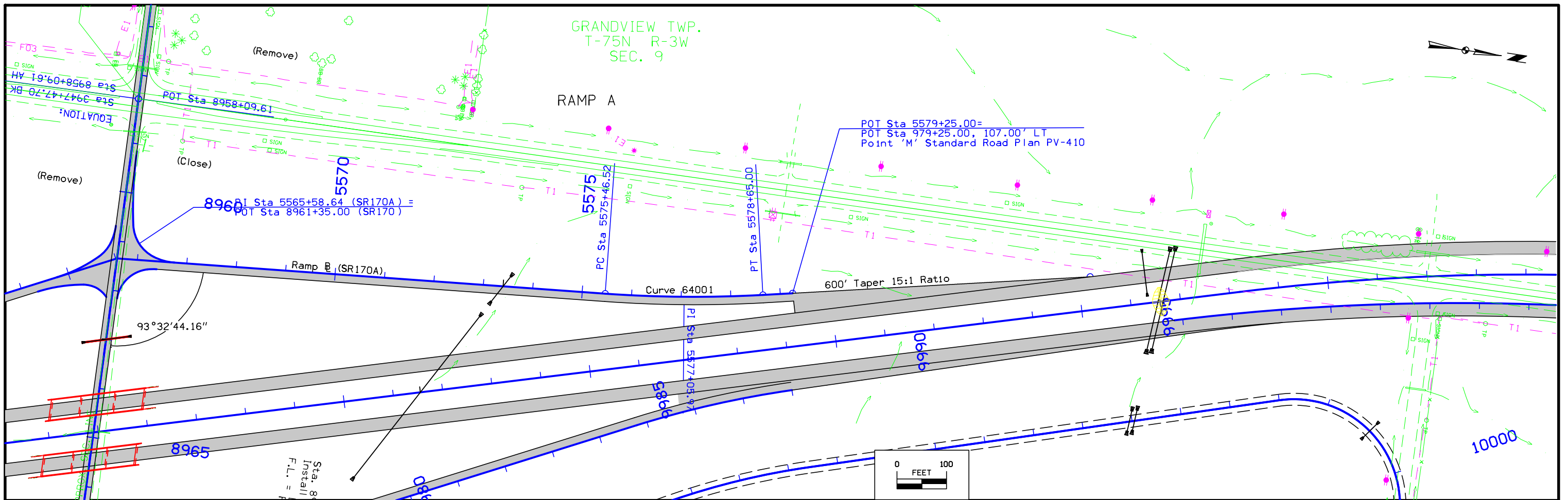

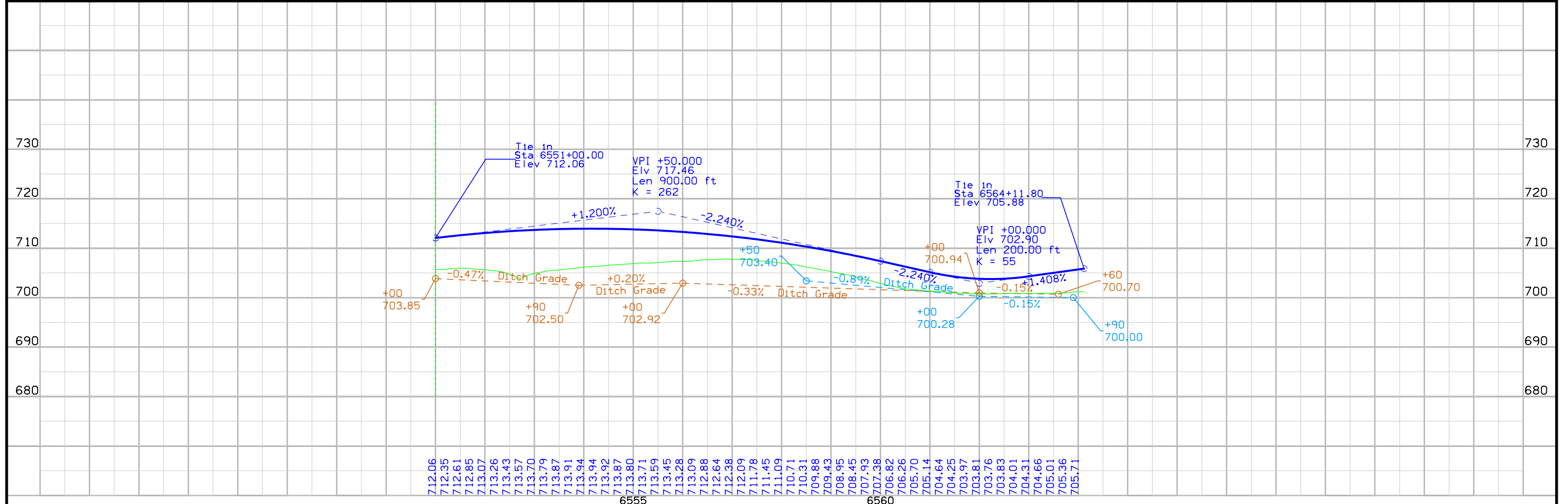
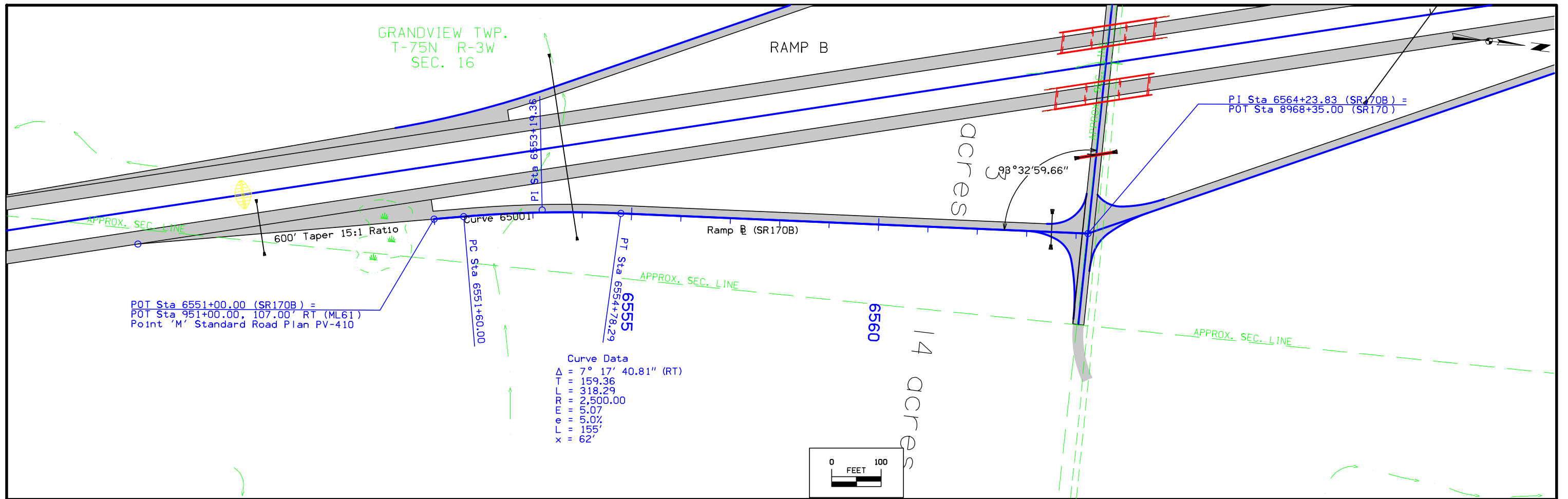

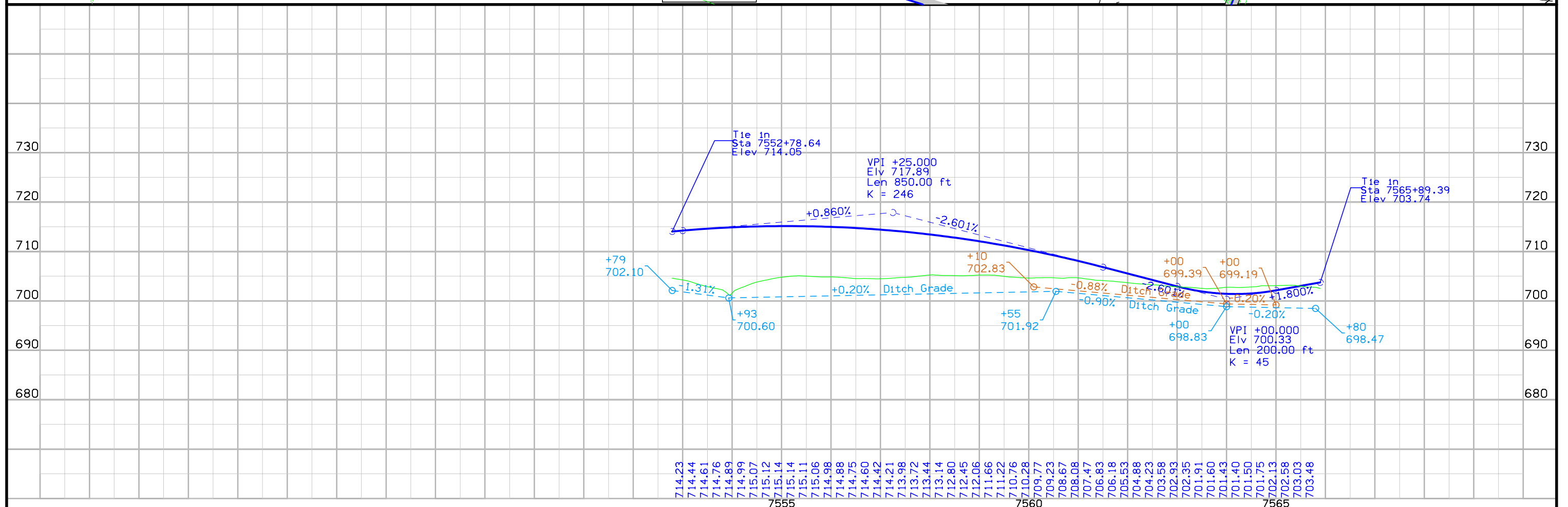
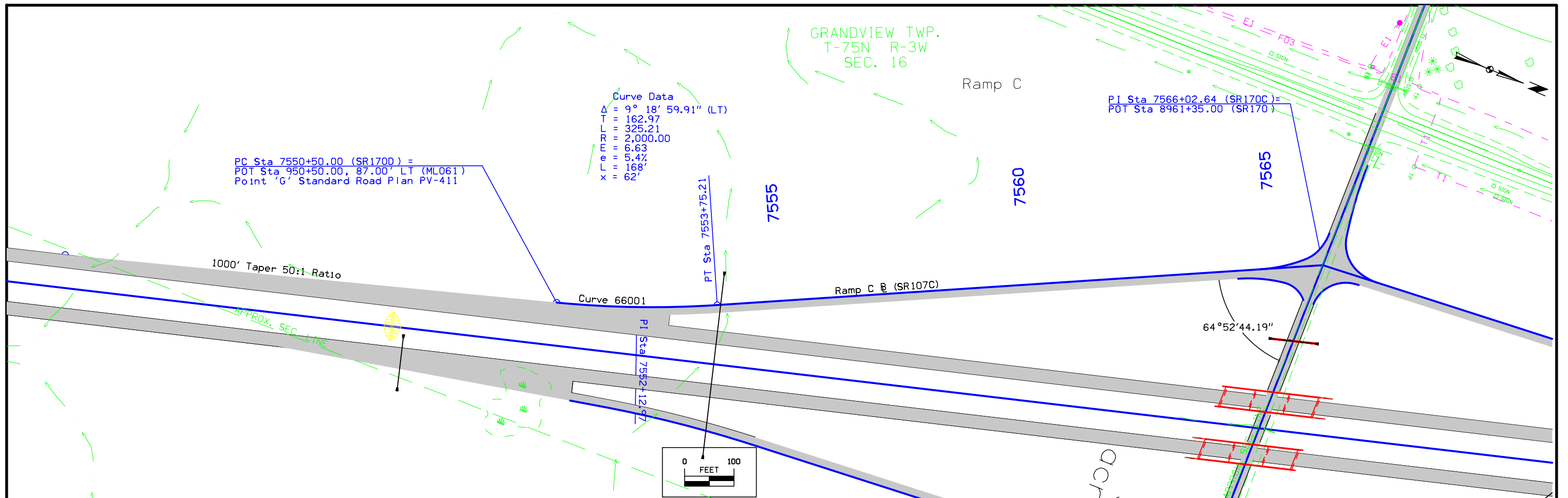

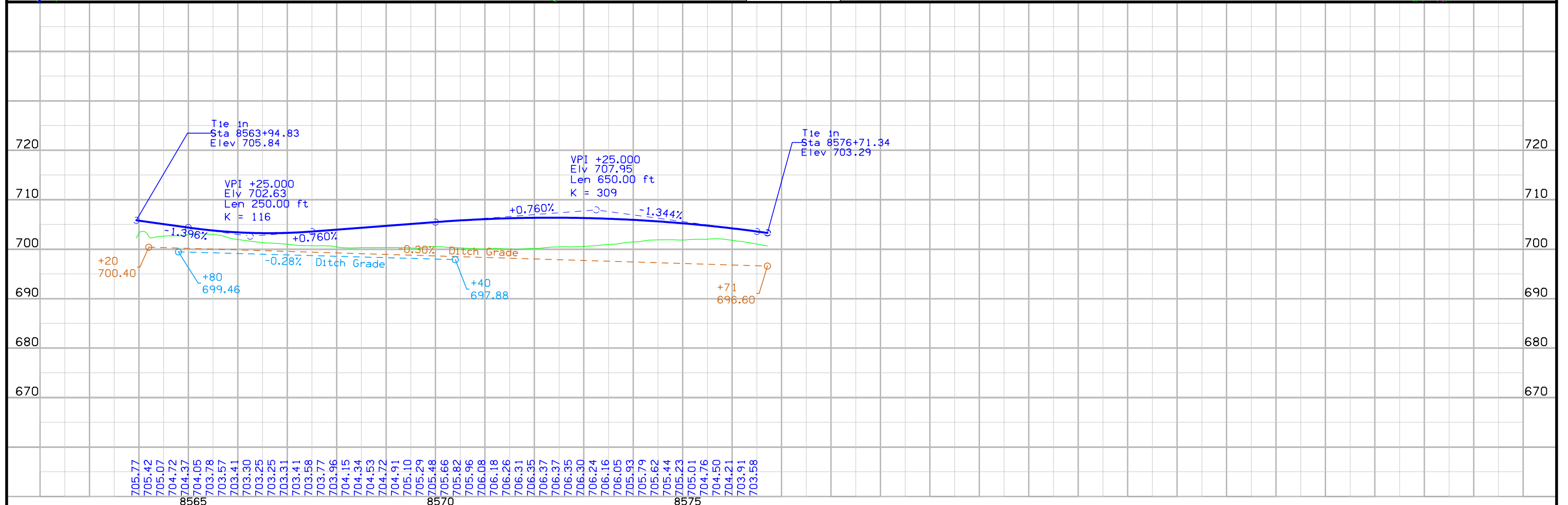
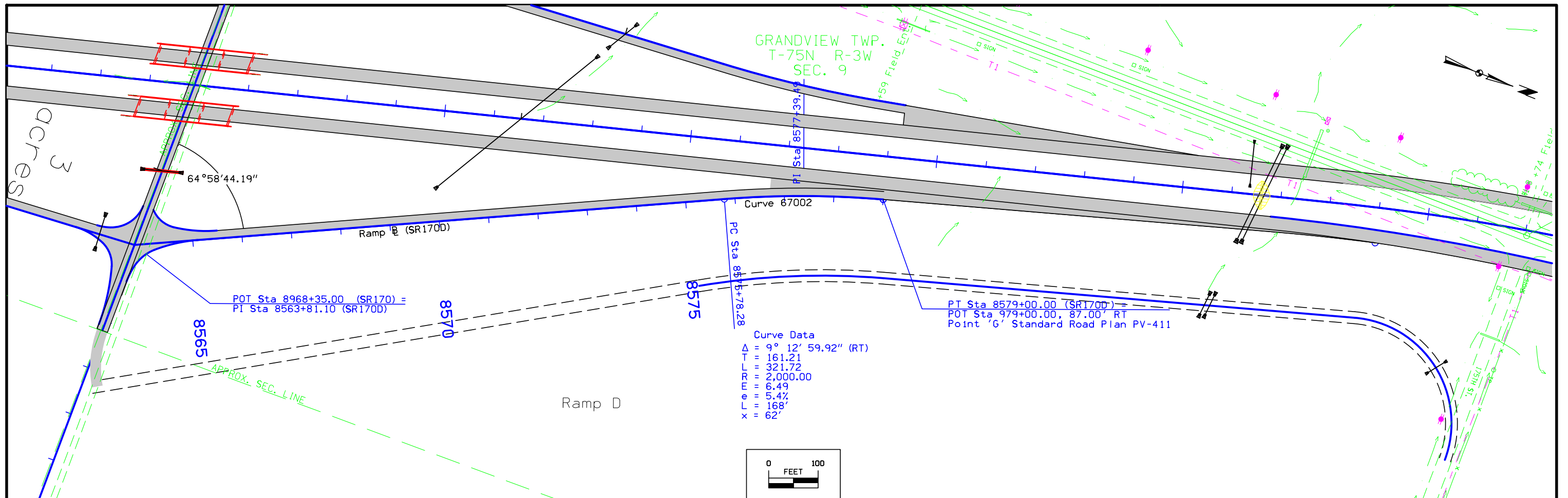

BENCH MARK NO. 517 STA. 856+93.06 137.92' LT. EL. 673.245 FOUND RR SPIKE SOUTH SIDE OF POWER POLE (STATIONING ALONG EXISTING US 61 \bar{C} ALIGNMENT; SEE D SHEETS FOR DETAILS)

① GRADING SURFACE ② 3.1:1 NORMAL BERM SLOPE ③ RL-13 GRADING ④ MEASURED FROM EDGE OF DRIVING LANE TO TOE OF BERM ⑤ FRAME PIER

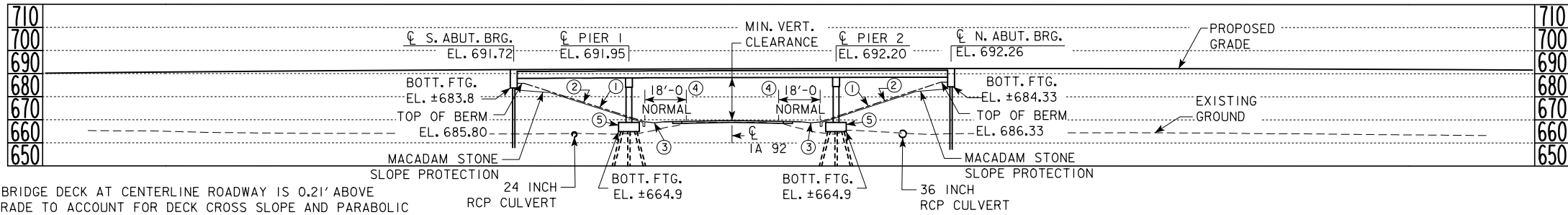

NOTE: TOP OF BRIDGE DECK AT CENTERLINE ROADWAY IS 0.21' ABOVE THE PROFILE GRADE TO ACCOUNT FOR DECK CROSS SLOPE AND PARABOLIC CROWN.

SOUTHBOUND BRIDGE LONGITUDINAL SECTION ALONG \bar{C} ROADWAY

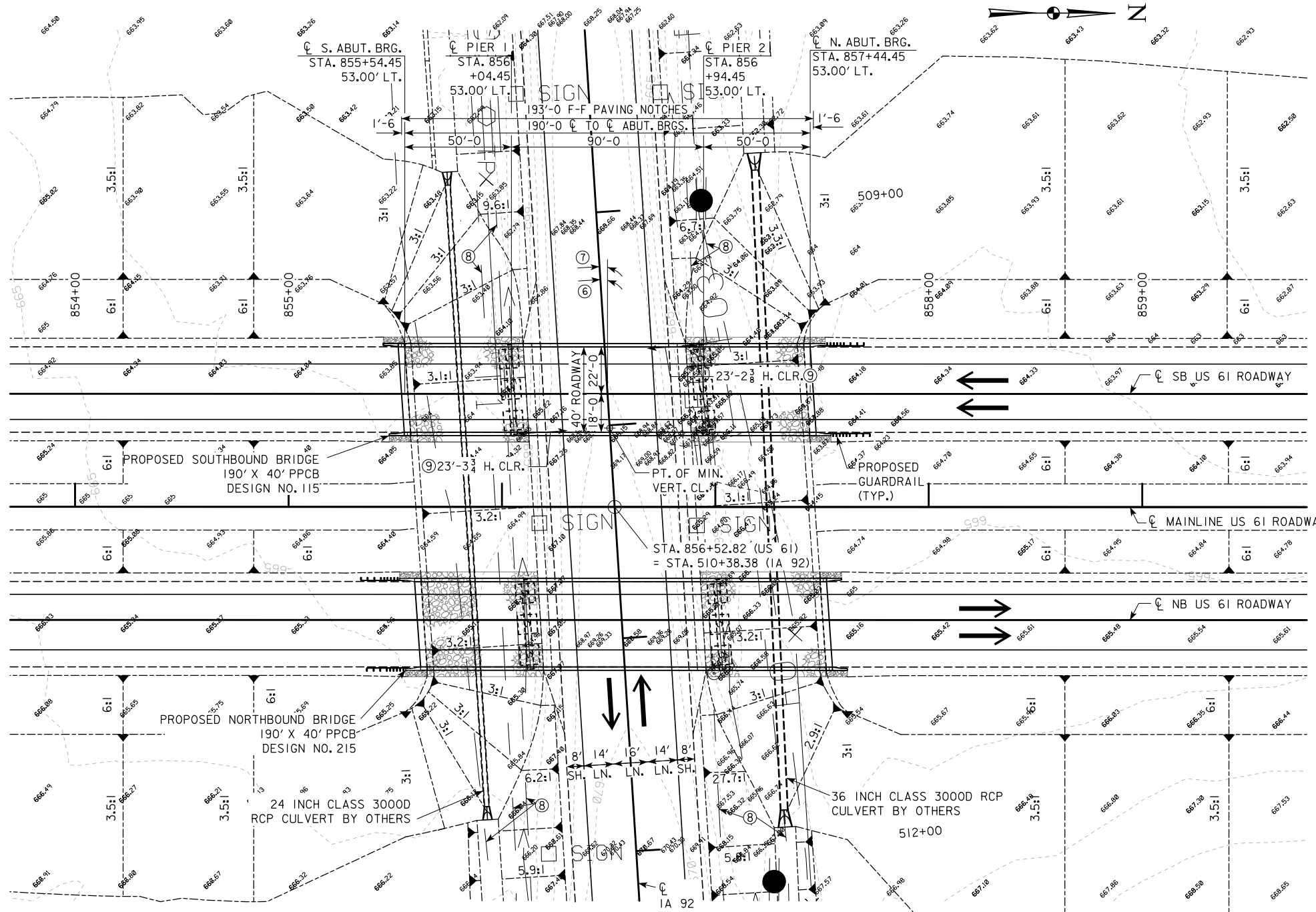

SOUTHBOUND BRIDGE SITUATION PLAN

- ⑥ BRIDGE SKEW 4°
- ⑦ ROADWAY SKEW 3° 35' 52.80". ROADWAY SKEW ANGLE IS MEASURED FROM LINE NORMAL TO \bar{C} OF US 61 TO ROADWAY SURVEY \bar{C} OF IA 92. ROADWAY \bar{C} OF US 61 ALONG \bar{C} OF SOUTHBOUND LANES.
- ⑧ CONTRACTOR TO VERIFY LOCATION AND DEPTH OF FIBER OPTIC AND TELEPHONE UTILITIES PRIOR TO GRADING WORK; NOTIFY ENGINEER OF CONFLICTS WITH PROPOSED GRADING
- ⑨ MEASURED FROM EDGE OF DRIVING LANE TO FACE OF PIER WALL

UTILITIES LEGEND:

- F0 - FIBER OPTIC - WINDSTREAM
- F03 - FIBER OPTIC - PAETEC
- F04 - FIBER OPTIC - MUTUAL TEL. CO. OF MORNING SUN, IA
- T1 - TELEPHONE - WINDSTREAM
- - POWER POLE - EASTERN IOWA LIGHT AND POWER

2.6000% -1.8000%

VPI STA = 856+00.00 VC = 1,800'
VPI ELEV = 701.60

PROPOSED PROFILE GRADE US 61

0.5000%

VPI STA = 505+00.51 VPI STA = 517+25.00
VPI ELEV = 667.28 VPI ELEV = 673.40

PROPOSED PROFILE GRADE IA 92

MINIMUM VERTICAL CLEARANCE

OVERHEAD STATION = 856+50.49, 36.92' LT
OVERHEAD ELEVATION = 691.84
DEPTH OF SUPERSTRUCTURE = 3.83'
IA 92 STATION = 510+01.39
IA 92 ELEVATION = 669.79
MINIMUM VERTICAL CLEARANCE = 18.22'

TRAFFIC ESTIMATE

2016 AADT	5,629	V.P.D.
2036 AADT	7,677	V.P.D.
2021 DHV	-	V.P.H.
TRUCKS	18 %	
TOTAL DESIGN ESALS	-	

LOCATION

SOUTHBOUND U.S. 61 OVER IA 92
T-75 N R-3 W
SECTION 28
GRANDVIEW TOWNSHIP
LOUISA COUNTY
BRIDGE MAINT. NO.
LATITUDE 41.276543°
LONGITUDE -91.199562°



TYPE TL-4 BRIDGE RAILING PROPOSED

DESIGN FOR 4° SKEW R.A.
190'-0" X 40'-0" PRETENSIONED PRESTRESSED CONCRETE BEAM BRIDGE
 50'-0" END SPANS 90'-0" INTERIOR SPAN
SOUTHBOUND BRIDGE SITUATION PLAN
 STATION 856+49.45, 53.00' LT BTB BEAM
LOUISA COUNTY
 IOWA DEPARTMENT OF TRANSPORTATION - HIGHWAY DIVISION
 DESIGN SHEET NO. 1 OF 4 FILE NO. 30755 DESIGN NO. 115

**BERM SLOPE LOCATION TABLE
SOUTHBOUND BRIDGE**

	SOUTH ABUTMENT			NORTH ABUTMENT		
	STATION	OFFSET	ELEV	STATION	OFFSET	ELEV
A1	856+09.73	79.58' LT	668.88	856+86.09	79.58' LT	668.90
A2	856+11.42	53.00' LT	669.01	856+87.54	53.00' LT	669.03
A3	856+12.83	30.42' LT	669.12	856+88.98	30.42' LT	669.15
B1	855+56.46	79.58' LT	685.80	857+39.31	79.58' LT	686.33
B2	855+58.97	53.00' LT	685.80	857+39.94	53.00' LT	686.33
B3	855+60.54	30.42' LT	685.80	857+41.52	30.42' LT	686.33
D1	855+44.41	95.02' LT	685.80	857+51.43	94.99' LT	686.33
D2	855+88.76	137.09' LT	665.79	856+99.42	135.45' LT	664.96
W1	855+44.40	79.58' LT	690.98	857+51.41	79.58' LT	691.57
W2	855+47.20	30.42' LT	691.11	857+54.21	30.42' LT	691.69

W - END WING / EROSION STONE
BERM SLOPE TABLE ELEVATIONS REFLECT GRADING SURFACE

- ⑥ BRIDGE SKEW 4°
- ⑦ ROADWAY SKEW 3° 35' 52.80". ROADWAY SKEW ANGLE IS MEASURED FROM LINE NORMAL TO CL OF US 61 TO ROADWAY SURVEY CL OF IA 92. ROADWAY CL OF US 61 ALONG CL OF SOUTHBOUND LANES.
- ⑧ CONTRACTOR TO VERIFY LOCATION AND DEPTH OF FIBER OPTIC AND TELEPHONE UTILITIES PRIOR TO GRADING WORK; NOTIFY ENGINEER OF CONFLICTS WITH PROPOSED GRADING

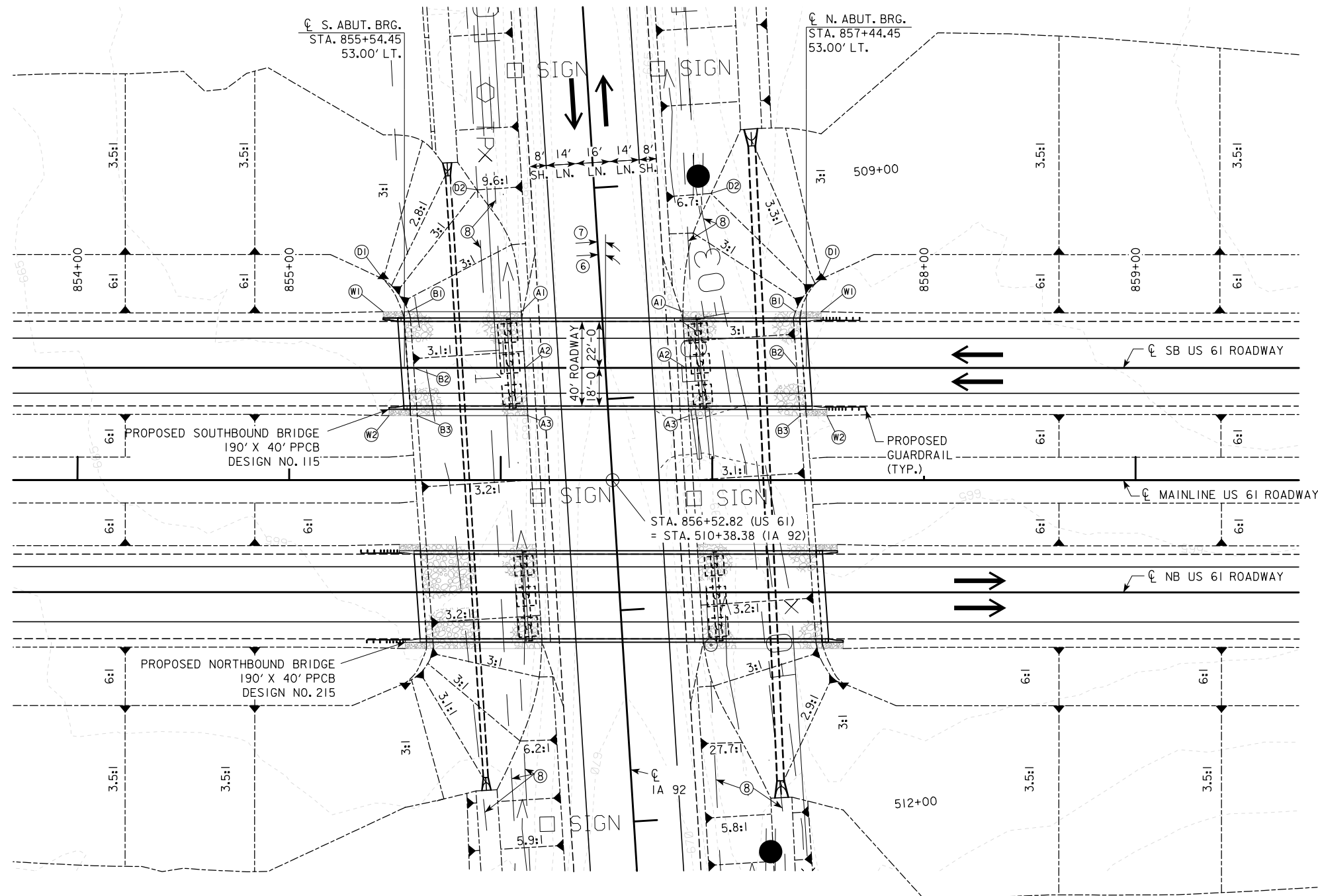

SITE PLAN

DESIGN FOR 4° SKEW R.A.
**190'-0 X 40'-0 PRETENSIONED PRESTRESSED
 CONCRETE BEAM BRIDGE**
 50'-0 END SPANS 90'-0 INTERIOR SPAN
SB BRIDGE SITUATION (SITE) PLAN
 STATION 856+49.45, 53.00' LT BTB BEAM
LOUISA COUNTY
 IOWA DEPARTMENT OF TRANSPORTATION - HIGHWAY DIVISION
 DESIGN SHEET NO. 2 OF 4 FILE NO. 30755 DESIGN NO. 115

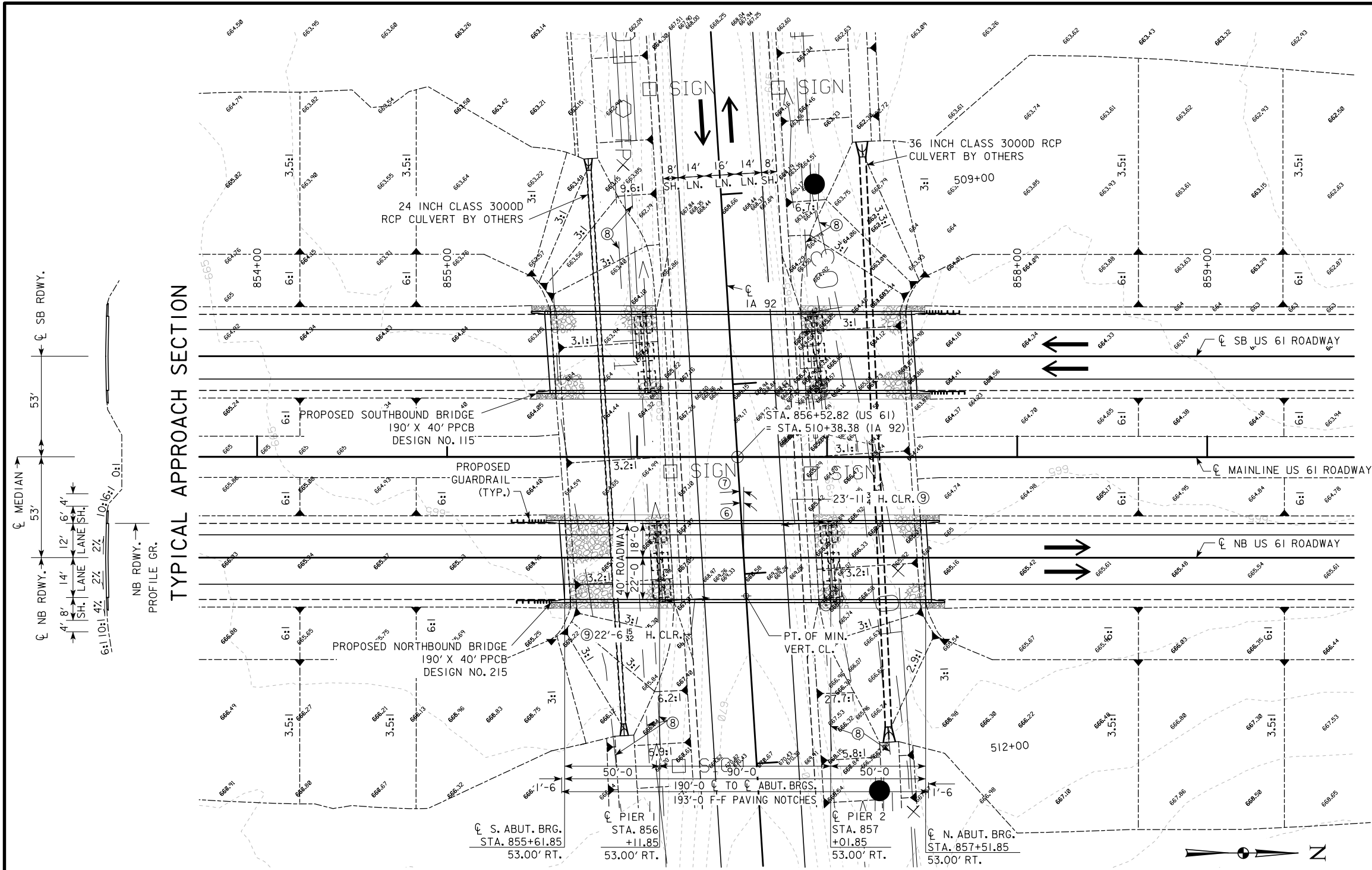

- ⑥ BRIDGE SKEW 4°
- ⑦ ROADWAY SKEW 3° 35' 52.80". ROADWAY SKEW ANGLE IS MEASURED FROM LINE NORMAL TO CL OF US 61 TO ROADWAY SURVEY CL OF IA 92. ROADWAY CL OF US 61 ALONG CL OF SOUTHBOUND LANES.
- ⑧ CONTRACTOR TO VERIFY LOCATION AND DEPTH OF FIBER OPTIC AND TELEPHONE UTILITIES PRIOR TO GRADING WORK; NOTIFY ENGINEER OF CONFLICTS WITH PROPOSED GRADING
- ⑨ MEASURED FROM EDGE OF DRIVING LANE TO FACE OF PIER WALL

UTILITIES LEGEND:
 F0 - FIBER OPTIC - WINDSTREAM
 F03 - FIBER OPTIC - PAETEC
 F04 - FIBER OPTIC - MUTUAL TEL. CO. OF MORNING SUN, IA
 T1 - TELEPHONE - WINDSTREAM
 ● - POWER POLE - EASTERN IOWA LIGHT AND POWER

2.6000% -1.8000%
 VPI STA = 856+00.00 VC = 1,800'
 VPI ELEV = 701.60

PROPOSED PROFILE GRADE US 61

0.5000%
 VPI STA = 505+00.51 VPI STA = 517+25.00
 VPI ELEV = 667.28 VPI ELEV = 673.40

PROPOSED PROFILE GRADE IA 92

MINIMUM VERTICAL CLEARANCE
 OVERHEAD STATION = 856+57.41, 73.09' RT
 OVERHEAD ELEVATION = 691.77
 DEPTH OF SUPERSTRUCTURE = 3.83'
 IA 92 STATION = 511+11.61
 IA 92 ELEVATION = 670.33
 MINIMUM VERTICAL CLEARANCE = 17.61'

TRAFFIC ESTIMATE

2016 AADT	5,629	V.P.D.
2036 AADT	7,677	V.P.D.
2021 DHV	-	V.P.H.
TRUCKS	18	%
TOTAL DESIGN ESALS	-	-

LOCATION
 NORTHBOUND U.S. 61 OVER IA 92
 T-75 N R-3 W
 SECTION 28
 GRANDVIEW TOWNSHIP
 LOUISA COUNTY
 BRIDGE MAINT. NO.
 LATITUDE 41.276559°
 LONGITUDE -91.199175°



TYPE TL-4 BRIDGE RAILING PROPOSED
 DESIGN FOR 4° SKEW R.A.
190'-0 X 40'-0 PRETENSIONED PRESTRESSED CONCRETE BEAM BRIDGE
 50'-0 END SPANS 90'-0 INTERIOR SPAN
NORTHBOUND BRIDGE SITUATION PLAN
 STATION 856+56.85, 53.00' RT BTB BEAM
LOUISA COUNTY
 IOWA DEPARTMENT OF TRANSPORTATION - HIGHWAY DIVISION
 DESIGN SHEET NO. 3 OF 4 FILE NO. 30755 DESIGN NO. 215

NORTHBOUND BRIDGE SITUATION PLAN

BENCH MARK NO. 517 STA. 856+93.06 137.92' LT EL. 673.245 FOUND RR SPIKE SOUTH SIDE OF POWER POLE (STATIONING ALONG EXISTING US 61 CL ALIGNMENT; SEE D SHEETS FOR DETAILS)

- ① GRADING SURFACE ② 3.2:1 NORMAL BERM SLOPE ③ RL-13 GRADING ④ MEASURED FROM EDGE OF DRIVING LANE TO TOE OF BERM ⑤ FRAME PIER

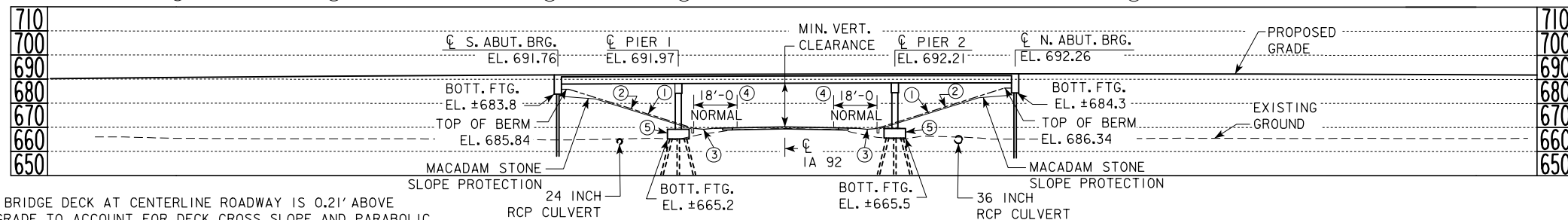

NOTE: TOP OF BRIDGE DECK AT CENTERLINE ROADWAY IS 0.21' ABOVE THE PROFILE GRADE TO ACCOUNT FOR DECK CROSS SLOPE AND PARABOLIC CROWN.

NORTHBOUND BRIDGE LONGITUDINAL SECTION ALONG CL ROADWAY

**BERM SLOPE LOCATION TABLE
NORTHBOUND BRIDGE**

	SOUTH ABUTMENT			NORTH ABUTMENT		
	STATION	OFFSET	ELEV	STATION	OFFSET	ELEV
A1	856+16.65	30.42' RT	669.43	856+92.90	30.42' RT	669.45
A2	856+18.06	53.00' RT	669.54	856+94.22	53.00' RT	669.56
A3	856+19.39	79.58' RT	669.67	856+96.21	79.58' RT	669.70
B1	855+64.78	30.42' RT	685.84	857+45.76	30.42' RT	686.34
B2	855+66.36	53.00' RT	685.84	857+47.33	53.00' RT	686.34
B3	855+68.12	79.58' RT	685.84	857+49.63	79.58' RT	686.34
D1	855+54.87	95.90' RT	685.84	857+61.88	96.05' RT	686.34
D2	856+09.15	123.31' RT	666.74	857+14.24	124.00' RT	668.84
W1	855+52.09	30.42' RT	691.14	857+59.09	30.42' RT	691.69
W2	855+54.88	79.58' RT	691.03	857+61.89	79.58' RT	691.57

W - END WING / EROSION STONE
BERM SLOPE TABLE ELEVATIONS REFLECT GRADING SURFACE

- ⑥ BRIDGE SKEW 4°
- ⑦ ROADWAY SKEW 3° 35' 52.80". ROADWAY SKEW ANGLE IS MEASURED FROM LINE NORMAL TO C_L OF US 61 TO ROADWAY SURVEY C_L OF IA 92. ROADWAY C_L OF US 61 ALONG C_L OF SOUTHBOUND LANES.
- ⑧ CONTRACTOR TO VERIFY LOCATION AND DEPTH OF FIBER OPTIC AND TELEPHONE UTILITIES PRIOR TO GRADING WORK; NOTIFY ENGINEER OF CONFLICTS WITH PROPOSED GRADING

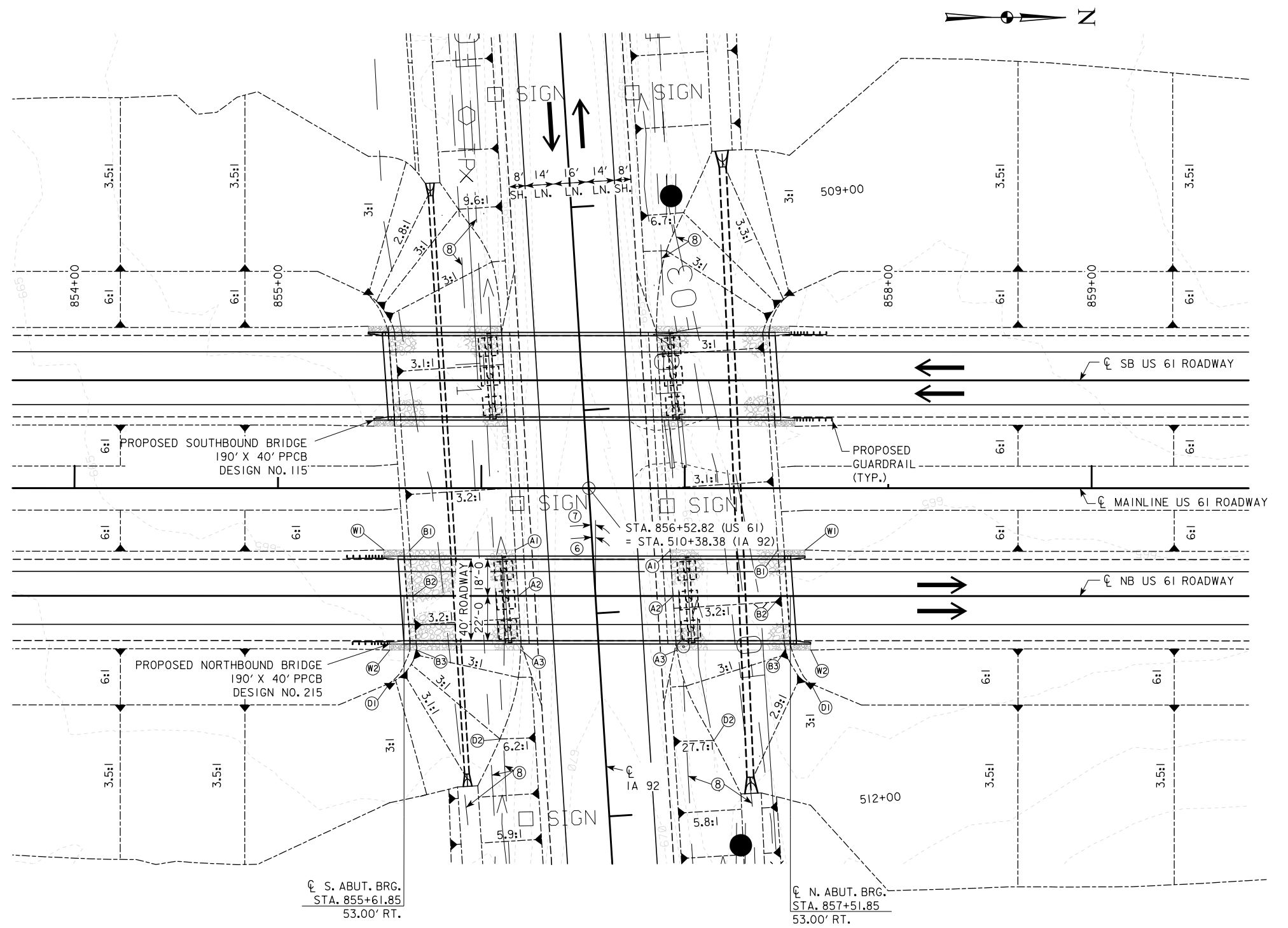

SITE PLAN

DESIGN FOR 4° SKEW R.A.
**190'-0 X 40'-0 PRETENSIONED PRESTRESSED
 CONCRETE BEAM BRIDGE**
 50'-0 END SPANS 90'-0 INTERIOR SPAN
NB BRIDGE SITUATION (SITE) PLAN
 STATION 856+56.85, 53.00' RT BTB BEAM
LOUISA COUNTY
 IOWA DEPARTMENT OF TRANSPORTATION - HIGHWAY DIVISION
 DESIGN SHEET NO. 4 OF 4 FILE NO. 30755 DESIGN NO. 215

BENCH MARK NO. 529 STA. 963+93.03 101.68' LT EL. 701.099 RR SPIKE IN NORTH SIDE OF LUMINAIRE (STATIONING ALONG EXISTING US 61 CL ALIGNMENT; SEE D SHEETS FOR DETAILS)

- ① GRADING SURFACE
- ② 3.6:1 NORMAL BERM SLOPE
- ③ 3.9:1 NORMAL BERM SLOPE
- ④ RL-13 GRADING
- ⑤ MEASURED FROM EDGE OF DRIVING LANE TO TOE OF BERM
- ⑥ FRAME PIER

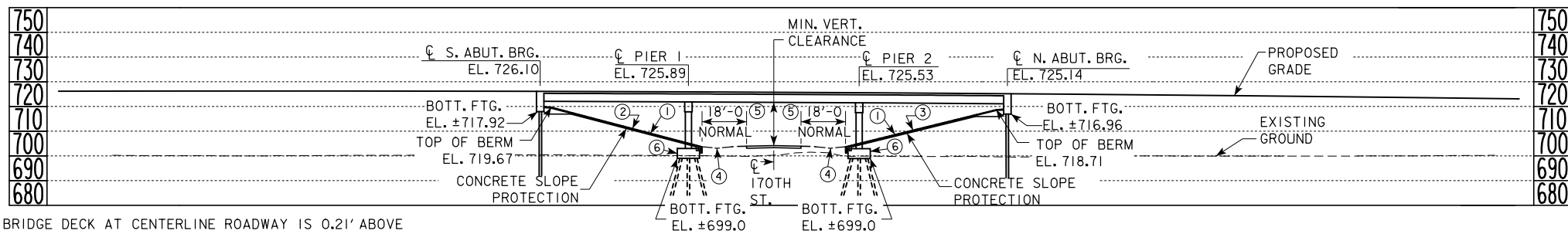

- ⑦ BRIDGE SKEW 15°
- ⑧ ROADWAY SKEW 14° 39' 31.32". ROADWAY SKEW ANGLE IS MEASURED FROM LINE NORMAL TO CL OF US 61 TO PROPOSED ROADWAY CL OF 170TH STREET. ROADWAY CL OF US 61 ALONG CL OF SOUTHBOUND LANES.
- ⑨ MEASURED FROM EDGE OF DRIVING LANE TO FACE OF PIER WALL
- ⑩ 24" RCP BY OTHERS

UTILITIES LEGEND:

- E1 - ELECTRIC - EASTERN IOWA LIGHT AND POWER
- F03 - FIBER OPTIC - PAETEC
- T1 - TELEPHONE - WINDSTREAM COMMUNICATIONS

NOTE: UTILITY MAIN LINES ALONG EXISTING US 61 ALIGNMENT; SERVICE LINES FROM MAINS MAY BE PRESENT ALONG EXISTING FARMSTEAD ACCESS DRIVE

SOUTHBOUND BRIDGE LONGITUDINAL SECTION ALONG CL ROADWAY

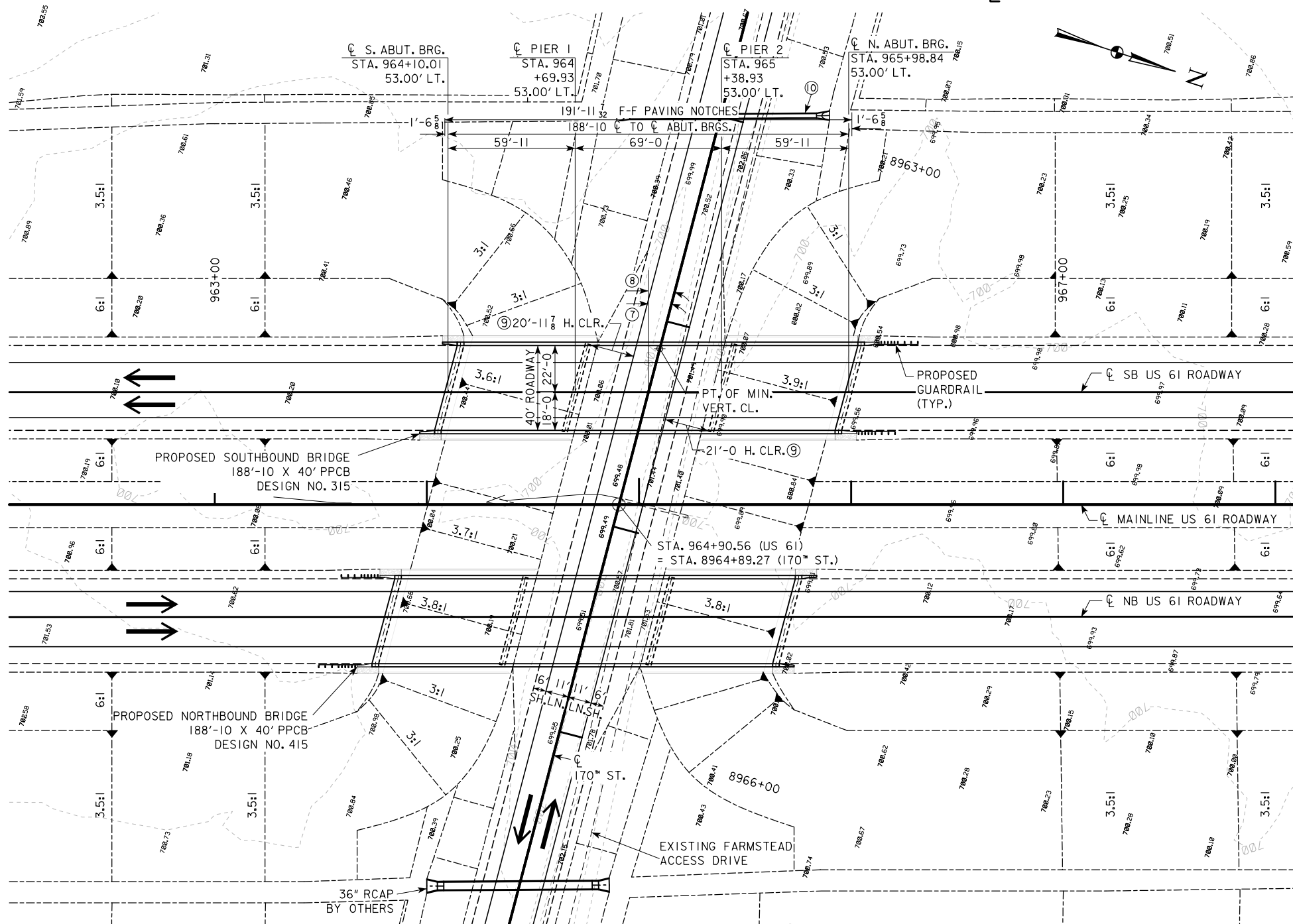

1.4000% -2.4000%

VPI STA = 965+00.00 VC = 1,550'
VPI ELEV = 732.90

PROPOSED PROFILE GRADE US 61

-0.500% 0.600%

VPI STA = 8964+70.00 VC = 150'
VPI ELEV = 703.93

PROPOSED PROFILE GRADE 170TH STREET

MINIMUM VERTICAL CLEARANCE

OVERHEAD STATION = 965+09.79, 73.50' LT
OVERHEAD ELEVATION = 725.35
DEPTH OF SUPERSTRUCTURE = 4.08'
170TH ST. STATION = 8964+13.30
170TH ST. ELEVATION = 704.22
MINIMUM VERTICAL CLEARANCE = 17.05'

TRAFFIC ESTIMATE

2016 AADT	6,225	V.P.D.
2036 AADT	8,489	V.P.D.
2021 DHV	-	V.P.H.
TRUCKS	18 %	
TOTAL DESIGN ESALS	-	

LOCATION

SOUTHBOUND U.S. 61 OVER 170TH STREET
T-75 N R-3 W
SECTION 16
GRANDVIEW TOWNSHIP
LOUISA COUNTY
BRIDGE MAINT. NO.
LATITUDE 41.305540°
LONGITUDE -91.198829°



TYPE TL-4 BRIDGE RAILING PROPOSED

DESIGN FOR 15° SKEW L.A.
188'-10 X 40'-0 PRETENSIONED PRESTRESSED CONCRETE BEAM BRIDGE
59'-11 END SPANS 69'-0 INTERIOR SPAN
SOUTHBOUND BRIDGE SITUATION PLAN
STATION 965+04.43, 53.00' LT B BEAM
LOUISA COUNTY
IOWA DEPARTMENT OF TRANSPORTATION - HIGHWAY DIVISION
DESIGN SHEET NO. 1 OF 4 FILE NO. 30755 DESIGN NO. 315

SOUTHBOUND BRIDGE SITUATION PLAN

BERM SLOPE LOCATION TABLE SOUTHBOUND BRIDGE

	SOUTH ABUTMENT			NORTH ABUTMENT		
	STATION	OFFSET	ELEV	STATION	OFFSET	ELEV
A1	964+81.40	79.58' LT	703.76	965+41.37	79.58' LT	703.81
A2	964+74.45	53.00' LT	703.69	965+34.39	53.00' LT	703.72
A3	964+68.54	30.42' LT	703.67	965+28.52	30.42' LT	703.68
B1	964+21.79	79.58' LT	719.67	966+01.10	79.58' LT	718.71
B2	964+14.67	53.00' LT	719.67	965+94.18	53.00' LT	718.71
B3	964+08.62	30.42' LT	719.67	965+88.13	30.42' LT	718.71
G1	964+07.35	96.83' LT	719.67	966+13.28	97.14' LT	718.71
G2	964+46.56	137.67' LT	700.95	965+79.32	140.65' LT	700.20
G3	964+87.42	79.58' LT	702.79	965+35.15	79.58' LT	702.79
W1	964+07.35	79.58' LT	725.42	966+13.28	79.58' LT	724.33
W2	963+96.63	30.42' LT	725.56	966+02.57	30.42' LT	724.54

W - END WING / EROSION STONE
 BERM SLOPE TABLE ELEVATIONS REFLECT GRADING SURFACE
 NOTE: ADJUST STANDARD ROAD PLAN RL-13 GRADING AS NECESSARY TO ACHIEVE ELEVATIONS SHOWN AT G3 POINTS.

- ⑦ BRIDGE SKEW 15°
- ⑧ ROADWAY SKEW 14° 39' 31.32". ROADWAY SKEW ANGLE IS MEASURED FROM LINE NORMAL TO CL OF US 61 TO PROPOSED ROADWAY CL OF 170° STREET. ROADWAY CL OF US 61 ALONG CL OF SOUTHBOUND LANES.
- ⑩ 24" RCP BY OTHERS

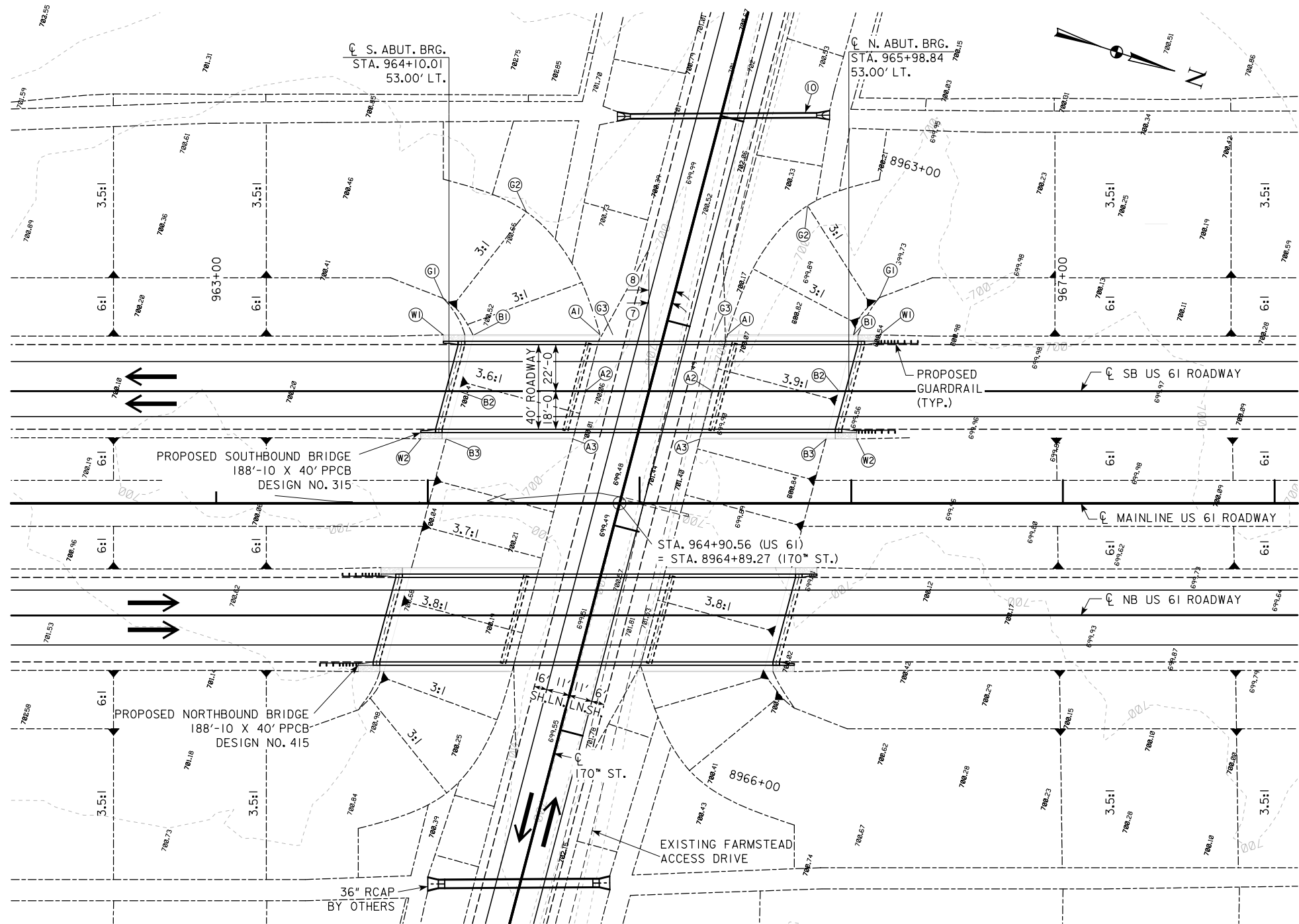

SOUTHBOUND BRIDGE SITE PLAN



DESIGN FOR 15° SKEW L.A.
**188'-10 X 40'-0 PRETENSIONED PRESTRESSED
 CONCRETE BEAM BRIDGE**
 59'-11 END SPANS 69'-0 INTERIOR SPAN
SB BRIDGE SITUATION PLAN-SITE
 STATION 965+04.43, 53.00' LT B BEAM
LOUISA COUNTY
 IOWA DEPARTMENT OF TRANSPORTATION - HIGHWAY DIVISION
 DESIGN SHEET NO. 2 OF 4 FILE NO. 30755 DESIGN NO. 315

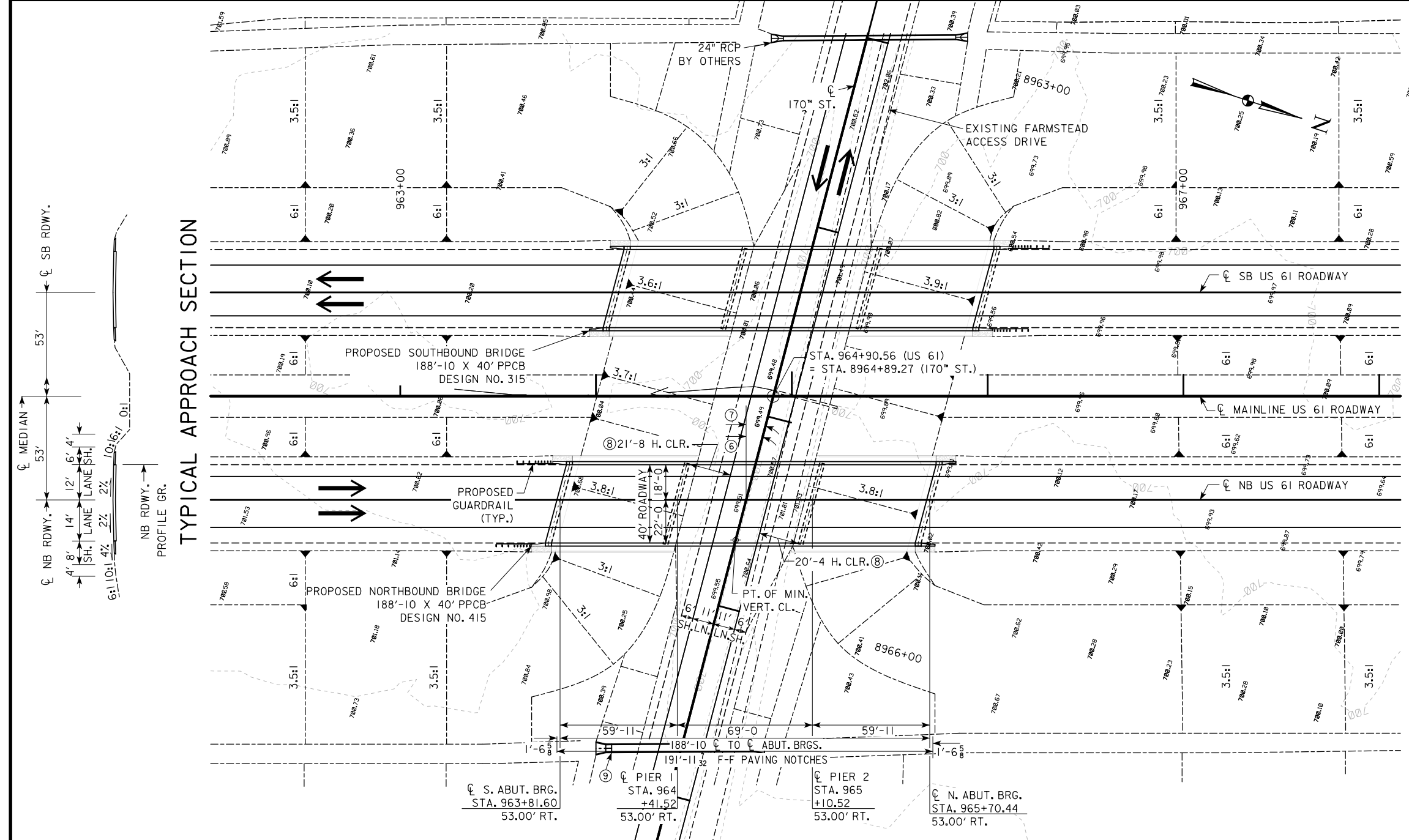

NORTHBOUND BRIDGE SITUATION PLAN

BENCH MARK NO. 529 STA. 963+93.03 101.68' LT EL. 701.099 RR SPIKE IN NORTH SIDE OF LUMINAIRE (STATIONING ALONG EXISTING US 61 CL ALIGNMENT; SEE D SHEETS FOR DETAILS)

- ① GRADING SURFACE
- ② 3.8:1 NORMAL BERM SLOPE
- ③ RL-13 GRADING
- ④ MEASURED FROM EDGE OF DRIVING LANE TO TOE OF BERM
- ⑤ FRAME PIER

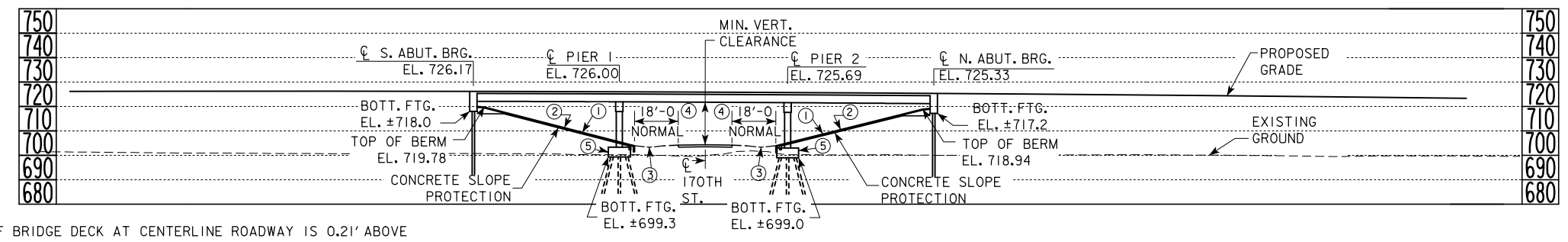

NORTHBOUND BRIDGE LONGITUDINAL SECTION ALONG CL ROADWAY

NOTE: TOP OF BRIDGE DECK AT CENTERLINE ROADWAY IS 0.21' ABOVE THE PROFILE GRADE TO ACCOUNT FOR DECK CROSS SLOPE AND PARABOLIC CROWN.

- ⑥ BRIDGE SKEW 15°
- ⑦ ROADWAY SKEW 14° 39' 31.32". ROADWAY SKEW ANGLE IS MEASURED FROM LINE NORMAL TO CL OF US 61 TO PROPOSED ROADWAY CL OF 170th STREET. ROADWAY CL OF US 61 ALONG CL OF NORTHBOUND LANES.
- ⑧ MEASURED FROM EDGE OF DRIVING LANE TO FACE OF PIER WALL
- ⑨ 36" RCAP BY OTHERS

UTILITIES LEGEND:

E1 - ELECTRIC - EASTERN IOWA LIGHT AND POWER
 F03 - FIBER OPTIC - PAETEC
 T1 - TELEPHONE - WINDSTREAM COMMUNICATIONS

NOTE: UTILITY MAIN LINES ALONG EXISTING US 61 ALIGNMENT; SERVICE LINES FROM MAINS MAY BE PRESENT ALONG EXISTING FARMSTEAD ACCESS DRIVE

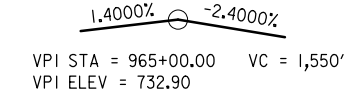

PROPOSED PROFILE GRADE US 61

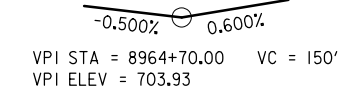

PROPOSED PROFILE GRADE 170th STREET

MINIMUM VERTICAL CLEARANCE

OVERHEAD STATION = 964+71.34, 73.50' RT
 OVERHEAD ELEVATION = 725.53
 DEPTH OF SUPERSTRUCTURE = 4.08'
 170th ST. STATION = 8965+65.24
 170th ST. ELEVATION = 704.50
 MINIMUM VERTICAL CLEARANCE = 16.95'

TRAFFIC ESTIMATE

2016 AADT	6,225	V.P.D.
2036 AADT	8,489	V.P.D.
202L DHV	-	V.P.H.
TRUCKS	18	%
TOTAL DESIGN ESALs	-	

LOCATION

NORTHBOUND U.S. 61 OVER 170th STREET
 T-75 N R-3 W
 SECTION 16
 GRANDVIEW TOWNSHIP
 LOUISA COUNTY
 BRIDGE MAINT. NO.
 LATITUDE 41.305537°
 LONGITUDE -91.198430°



TYPE TL-4 BRIDGE RAILING PROPOSED

188'-10 X 40'-0 PRETENSIONED PRESTRESSED CONCRETE BEAM BRIDGE

DESIGN FOR 15° SKEW L.A.
 59'-11 END SPANS 69'-0 INTERIOR SPAN
NORTHBOUND BRIDGE SITUATION PLAN
 STATION 964+76.70, 53.00' RT B BEAM

LOUISA COUNTY
 IOWA DEPARTMENT OF TRANSPORTATION - HIGHWAY DIVISION
 DESIGN SHEET NO. 3 OF 4 FILE NO. 30755 DESIGN NO. 415

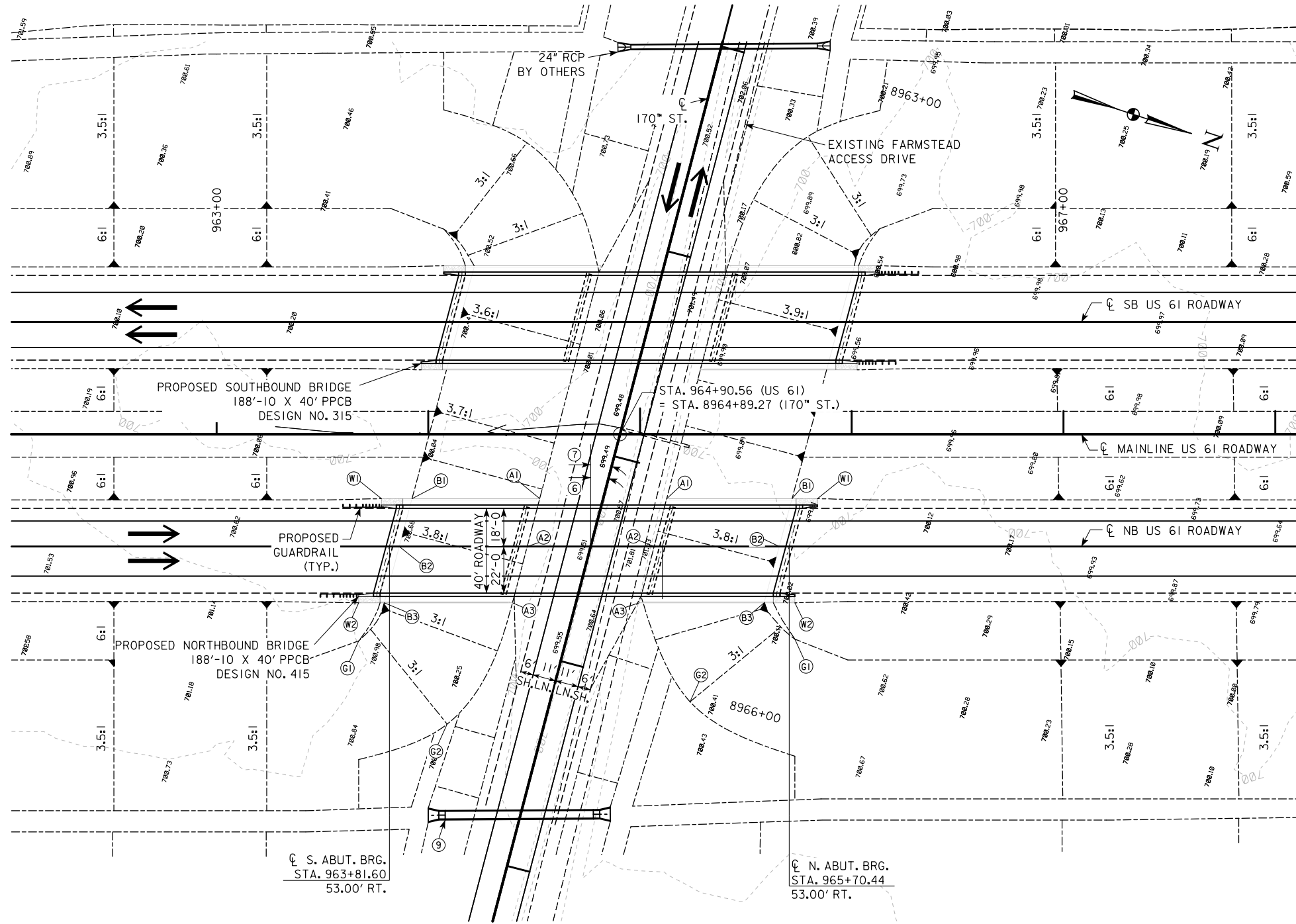

NORTHBOUND BRIDGE SITE PLAN

BERM SLOPE LOCATION TABLE NORTHBOUND BRIDGE						
	SOUTH ABUTMENT			NORTH ABUTMENT		
	STATION	OFFSET	ELEV	STATION	OFFSET	ELEV
A1	964+52.63	30.42' RT	703.83	965+12.58	30.42' RT	703.76
A2	964+46.72	53.00' RT	703.96	965+06.67	53.00' RT	703.87
A3	964+39.76	79.58' RT	704.12	965+00.28	79.58' RT	704.03
B1	963+92.31	30.42' RT	719.78	965+71.83	30.42' RT	718.94
B2	963+86.29	53.00' RT	719.78	965+65.78	53.00' RT	718.94
B3	963+79.21	79.58' RT	719.78	965+58.65	79.58' RT	718.94
G1	963+67.16	97.61' RT	719.78	965+73.09	96.77' RT	718.94
G2	964+08.93	136.90' RT	700.31	965+23.62	126.33' RT	700.38
W1	963+77.87	30.42' RT	725.61	965+83.81	30.42' RT	724.67
W2	963+67.16	79.58' RT	725.51	965+73.09	79.58' RT	724.63

- W - END WING / EROSION STONE
 BERM SLOPE TABLE ELEVATIONS REFLECT GRADING SURFACE
- ⑥ BRIDGE SKEW 15°
 - ⑦ ROADWAY SKEW 14° 39' 31.32". ROADWAY SKEW ANGLE IS MEASURED FROM LINE NORMAL TO CL OF US 61 TO PROPOSED ROADWAY CL OF 170° STREET. ROADWAY CL OF US 61 ALONG CL OF NORTHBOUND LANES.
 - ⑨ 36" RCAP BY OTHERS



DESIGN FOR 15° SKEW L.A.
188'-10 X 40'-0 PRETENSIONED PRESTRESSED CONCRETE BEAM BRIDGE
 59'-11 END SPANS 69'-0 INTERIOR SPAN
NB BRIDGE SITUATION PLAN-SITE
 STATION 964+76.70, 53.00' RT B BEAM
LOUISA COUNTY
 IOWA DEPARTMENT OF TRANSPORTATION - HIGHWAY DIVISION
 DESIGN SHEET NO. 4 OF 4 FILE NO. 30755 DESIGN NO. 415

BENCH MARK NO. 538 STA. 1037+59.33 36.32' RT EL. 698.631 CUT X ON OUTLET END OF 4X6 CONC. CATTLE PASS (STATIONING ALONG EXISTING US 61 CL ALIGNMENT; SEE D SHEETS FOR DETAILS)

① GRADING SURFACE ② 2.9:1 NORMAL BERM SLOPE ③ 2.6:1 NORMAL BERM SLOPE ④ MEASURED FROM CL OF RAILROAD TRACKS TO TOE OF BERM

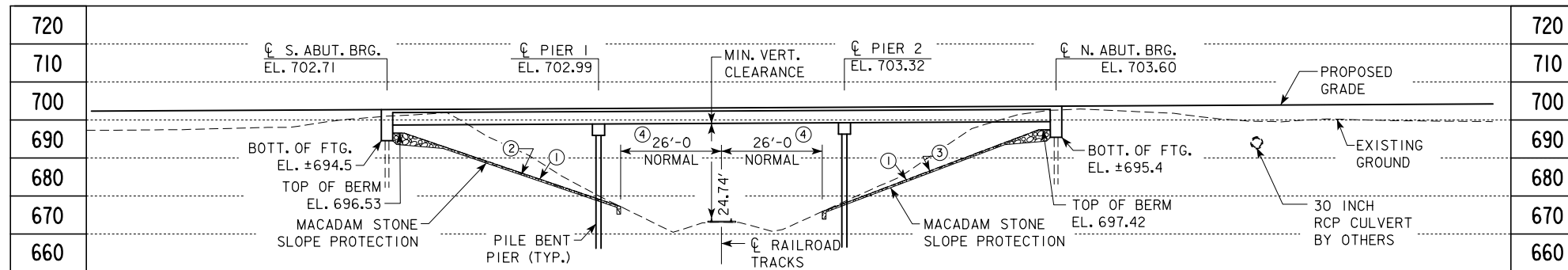

NOTE: TOP OF BRIDGE DECK AT CENTERLINE ROADWAY IS 0.21' ABOVE THE PROFILE GRADE TO ACCOUNT FOR DECK CROSS SLOPE AND PARABOLIC CROWN.

SOUTHBOUND BRIDGE LONGITUDINAL SECTION ALONG CL ROADWAY

- ⑤ BRIDGE SKEW 15°
- ⑥ RAILROAD SKEW 11° 53' 28.32". RAILROAD SKEW ANGLE IS MEASURED FROM LINE NORMAL TO CL OF US 61 TO CENTERLINE OF EXISTING RAILROAD TRACKS. ROADWAY CL OF US 61 ALONG CL OF SOUTHBOUND LANES.
- ⑦ MEASURED FROM CENTERLINE OF RAILROAD TRACKS TO FACE OF PIER COLUMN

UTILITIES LEGEND:

- TI - TELEPHONE - WINDSTREAM COMMUNICATIONS
- - EASTERN IOWA LIGHT AND POWER UTILITY POLE
- ⊕ - DAKOTA, MINNESOTA AND EASTERN RAILROAD UTILITY POLE

0.5000%

VPI STA = 1007+50.00 VPI STA = 1042+80.00
VPI ELEV = 687.90 VPI ELEV = 705.55

PROPOSED PROFILE GRADE US 61

MINIMUM VERTICAL CLEARANCE

OVERHEAD STATION = 1037+60.40, 73.50' LT
OVERHEAD ELEVATION = 702.81
DEPTH OF SUPERSTRUCTURE = 4.08'
TOP OF RAIL ELEVATION = 673.99
MINIMUM VERTICAL CLEARANCE = 24.74'

TRAFFIC ESTIMATE

2016 AADT	6,298	V.P.D.
2036 AADT	8,589	V.P.D.
2021 DHV	-	V.P.H.
TRUCKS	18	%
TOTAL DESIGN ESALS	-	

LOCATION

SOUTHBOUND U.S. 61 OVER
DAKOTA, MINNESOTA AND EASTERN RAILROAD
T-75 N R-3 W
SECTION 4
GRANDVIEW TOWNSHIP
LOUISA COUNTY
BRIDGE MAINT. NO.
LATITUDE 41.325262°
LONGITUDE -91.201579°

0 ENGLISH 40
SCALE IN FEET

TYPE TL-4 BRIDGE RAILING PROPOSED

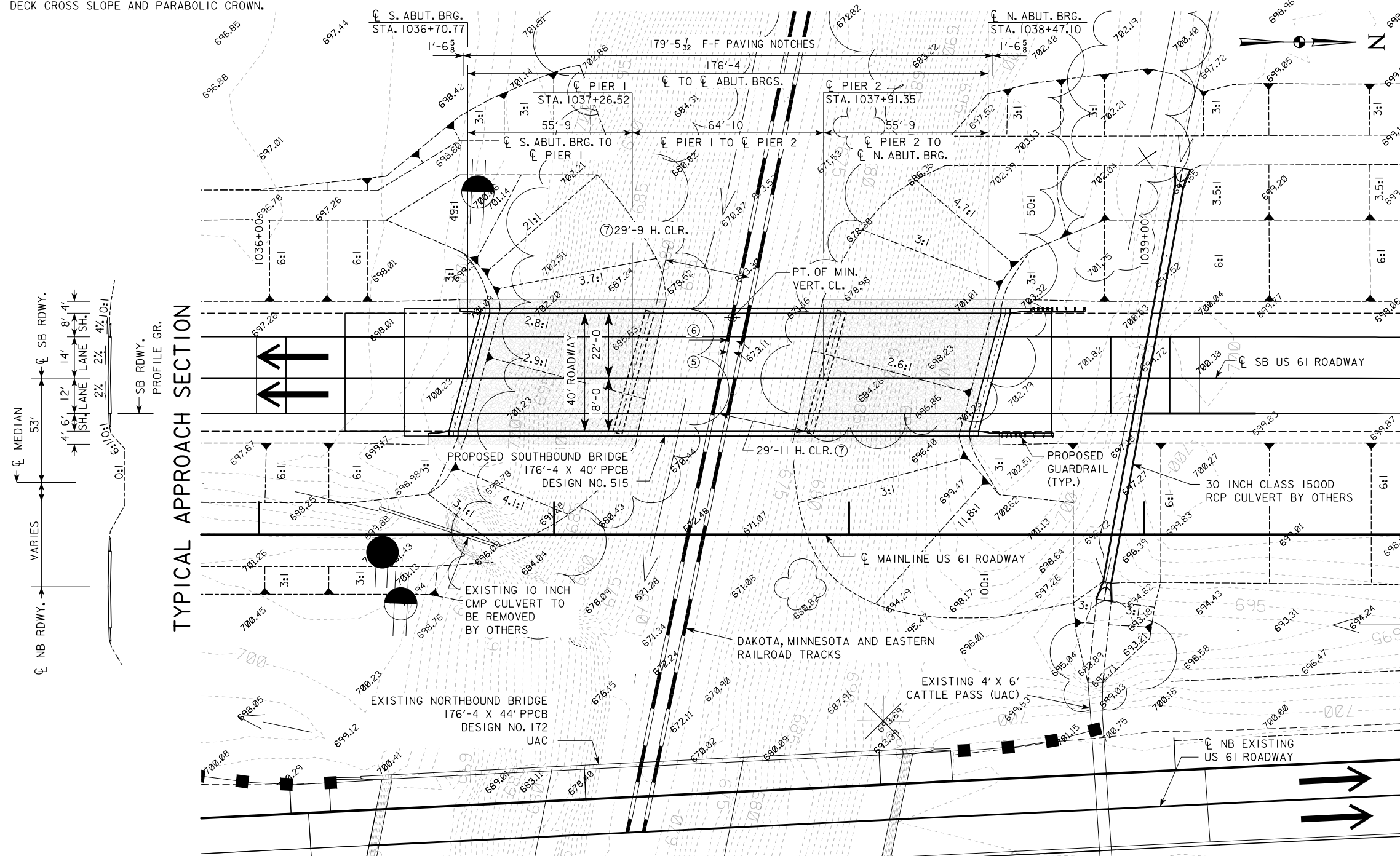

SOUTHBOUND BRIDGE SITUATION PLAN

DESIGN FOR 15° SKEW L.A.
176'-4 X 40'-0 PRETENSIONED PRESTRESSED CONCRETE BEAM BRIDGE
59'-9 END SPANS 64'-10 INTERIOR SPAN
SOUTHBOUND BRIDGE SITUATION PLAN
STATION 1037+58.94, 53.00' LT B BEAM
LOUISA COUNTY
IOWA DEPARTMENT OF TRANSPORTATION - HIGHWAY DIVISION
DESIGN SHEET NO. 1 OF 2 FILE NO. 30755 DESIGN NO. 515

BERM SLOPE LOCATION TABLE SOUTHBOUND BRIDGE

	SOUTH ABUTMENT			NORTH ABUTMENT		
	STATION	OFFSET	ELEV	STATION	OFFSET	ELEV
A1	1037+37.96	79.58' LT	678.00	1037+91.10	79.58' LT	676.00
A2	1037+32.37	53.00' LT	677.20	1037+85.51	53.00' LT	675.80
A3	1037+27.61	30.42' LT	677.20	1037+80.75	30.42' LT	675.20
B1	1036+82.55	79.58' LT	696.53	1038+49.50	79.58' LT	697.42
B2	1036+75.43	53.00' LT	696.53	1038+42.44	53.00' LT	697.42
B3	1036+69.01	30.42' LT	696.53	1038+36.39	30.42' LT	697.42
G1	1036+68.11	96.01' LT	696.53	1038+61.55	96.26' LT	697.42
G2	1036+68.11	133.66' LT	696.00	1038+34.41	135.06' LT	694.00
G3	1036+68.11	121.93' LT	696.00	1038+32.62	125.06' LT	694.00
G4	1037+18.18	133.66' LT	694.00	1038+61.55	135.06' LT	696.85
G5	1037+14.63	121.93' LT	694.00	1038+61.55	125.06' LT	696.85
G6	1036+57.40	13.77' LT	696.53	1038+50.83	13.52' LT	697.42
G7	1036+81.10	4.16' LT	687.00	1038+08.84	23.48' LT	692.66
G8	1036+79.37	9.41' LT	687.00	1038+50.83	27.98' LT	697.01
W1	1038+68.11	79.58' LT	702.01	1038+61.55	79.58' LT	702.98
W2	1038+57.40	30.42' LT	702.08	1038+50.83	30.42' LT	703.04

W - END WING / EROSION STONE
BERM SLOPE TABLE ELEVATIONS REFLECT GRADING SURFACE

- ⑤ BRIDGE SKEW 15°
- ⑥ RAILROAD SKEW 11° 53' 28.32". RAILROAD SKEW ANGLE IS MEASURED FROM LINE NORMAL TO CL OF US 61 TO CENTERLINE OF EXISTING RAILROAD TRACKS. ROADWAY CL OF US 61 ALONG CL OF SOUTHBOUND LANES.

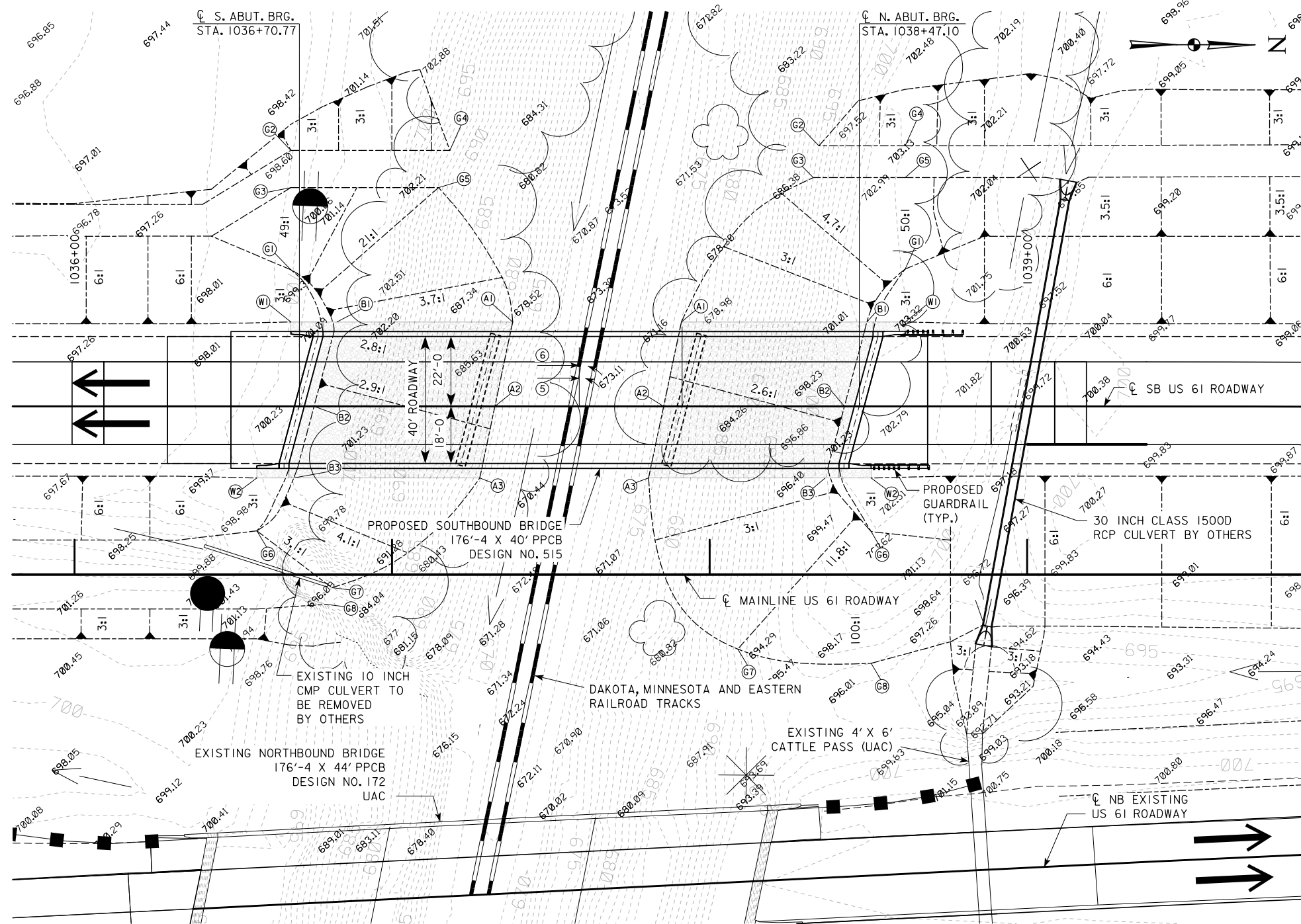

SOUTHBOUND BRIDGE SITE PLAN



DESIGN FOR 15° SKEW L.A.
**176'-4 X 40'-0 PRETENSIONED PRESTRESSED
 CONCRETE BEAM BRIDGE**
 59'-9 END SPANS 64'-10 INTERIOR SPAN
SB BRIDGE SITUATION PLAN-SITE
 STATION 1037+58.94, 53.00' LT B BEAM
LOUISA COUNTY
 IOWA DEPARTMENT OF TRANSPORTATION - HIGHWAY DIVISION
 DESIGN SHEET NO. 2 OF 2 FILE NO. 30755 DESIGN NO. 515

LINE STYLE LEGEND OF CROSS SECTION SHEETS (ROAD)

- - - - - - Existing Ground Line
- Proposed Template
- Proposed Topsoil Placement
- - - - - Additional Topsoil Removal
- Subgrade Treatment
- - - - - Granular Shoulder
- Pavement
- - - - - Existing Pipe\RCB
- Proposed Pipe\RCB
- Proposed Dike
- All Elements Associated with Proposed Entrances

LINE STYLE LEGEND OF CROSS SECTION SHEETS (SOILS)

- TS——— Topsoil (Class 10)
- TS A——— Topsoil (Type A Disposal)
- TS B——— Topsoil (Type B Disposal)
- TS C——— Topsoil (Type C Disposal)
- CL 10——— Class 10 Materials
- SEL LO——— Select Loams And Clay-Loams
- SEL SA——— Select Sand
- UNS A——— Unsuitable Type A Disposal
- UNS B——— Unsuitable Type B Disposal
- UNS C——— Unsuitable Type C Disposal
- SHALE——— Shale
- WASTE——— Waste
- B&W LS——— Broken and Weathered Rock
- ROCK——— Solid Rock
- BLDRS——— Boulders

Note: All layer lines and descriptions identify layers above the line.

Note: Vertical or near vertical lines connecting soil layers at edges of cross sections are only for the purpose of calculating template quantities and do not depict soil stratification.

SYMBOL LEGEND OF CROSS SECTION SHEETS

- Existing ROW
|
Existing Right-of-Way Limit
- Proposed ROW
|
Proposed Right-of-Way Limit
- Temporary ROW
|
Temporary Right-of-Way Limit

**CROSS SECTION
LEGEND AND SYMBOL
INFORMATION SHEET**

(COVERS SHEET SERIES W, X, Y, & Z)

US 61 Preliminary

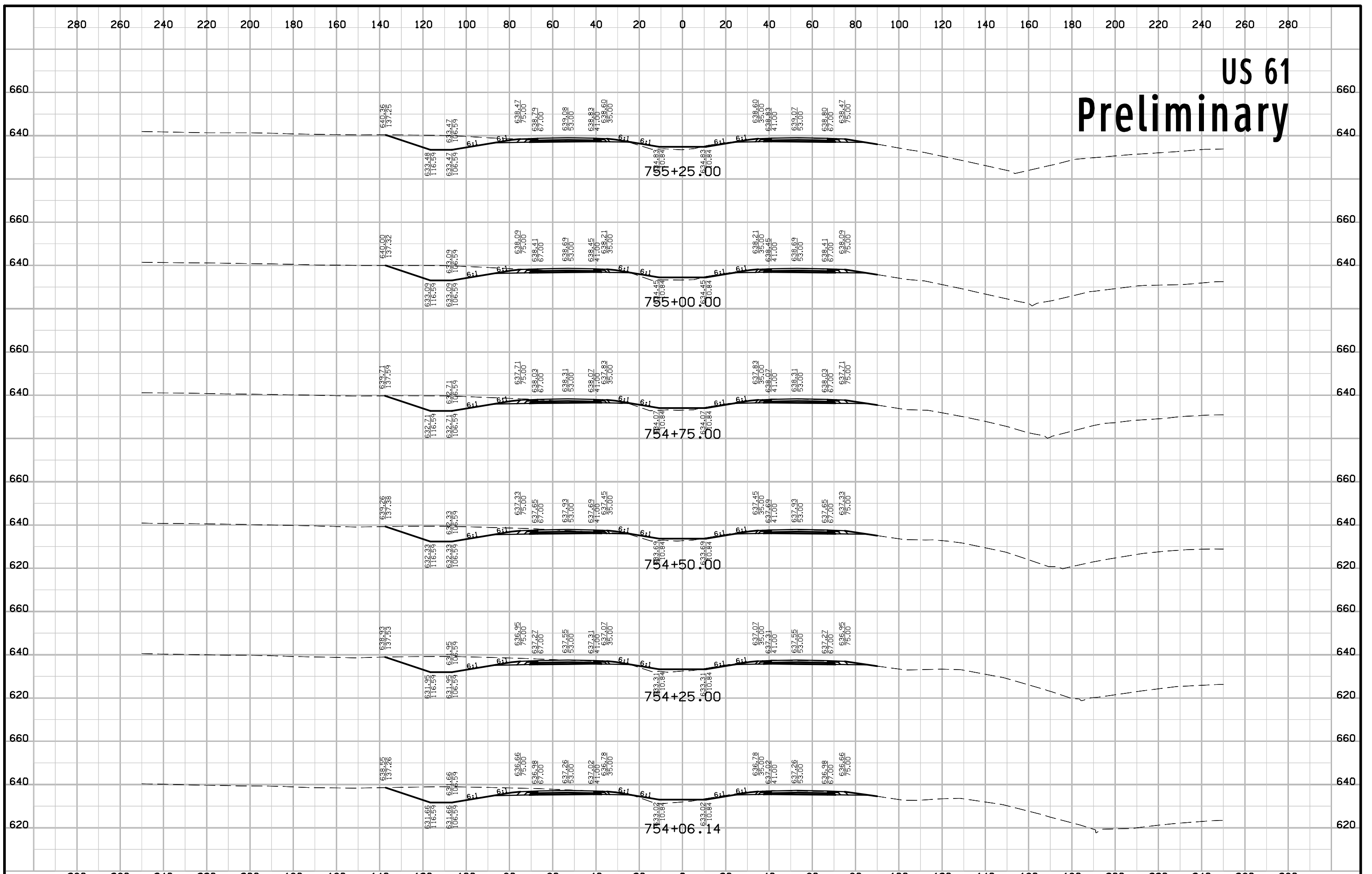

US 61 Preliminary

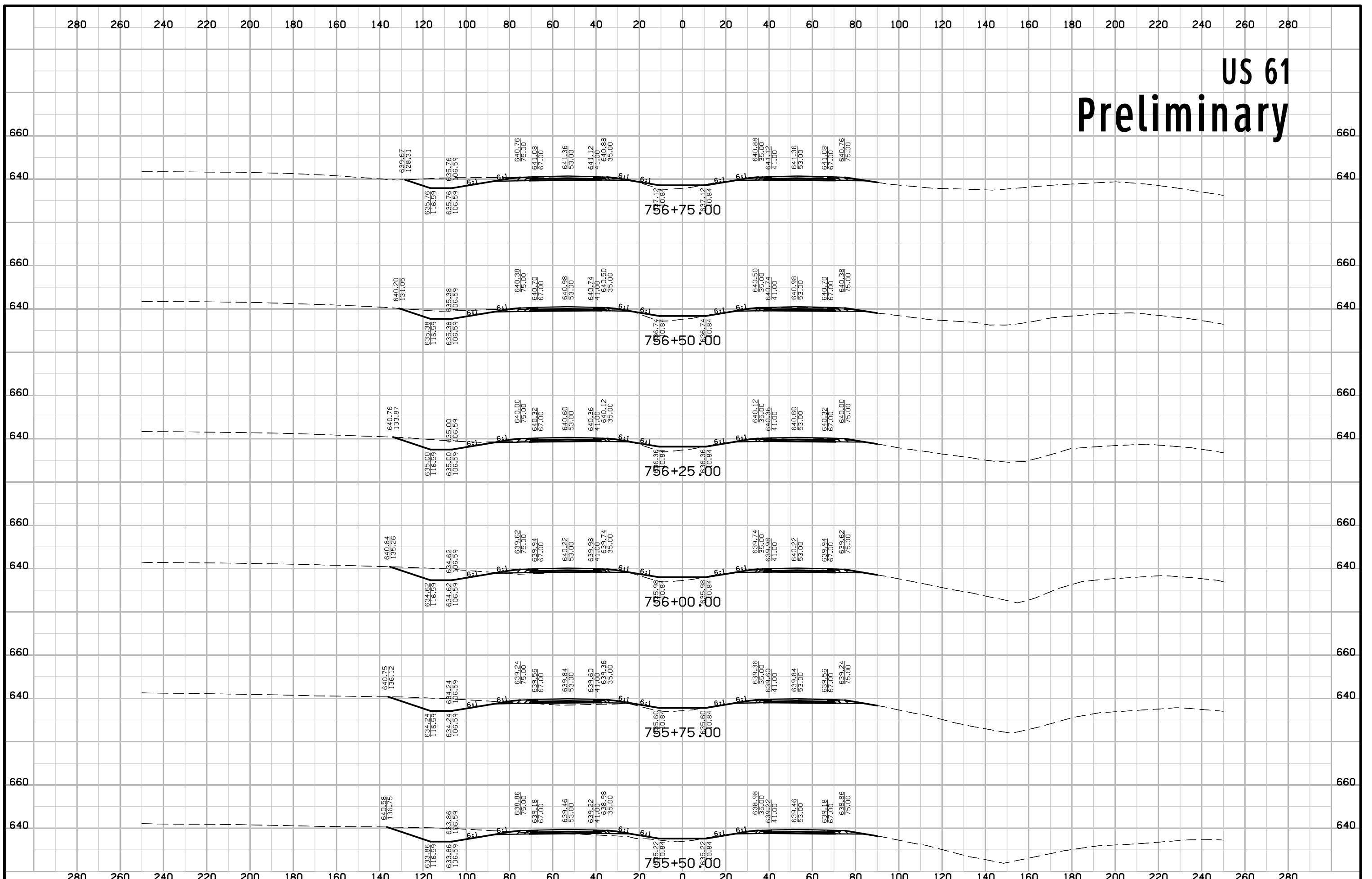

US 61 Preliminary

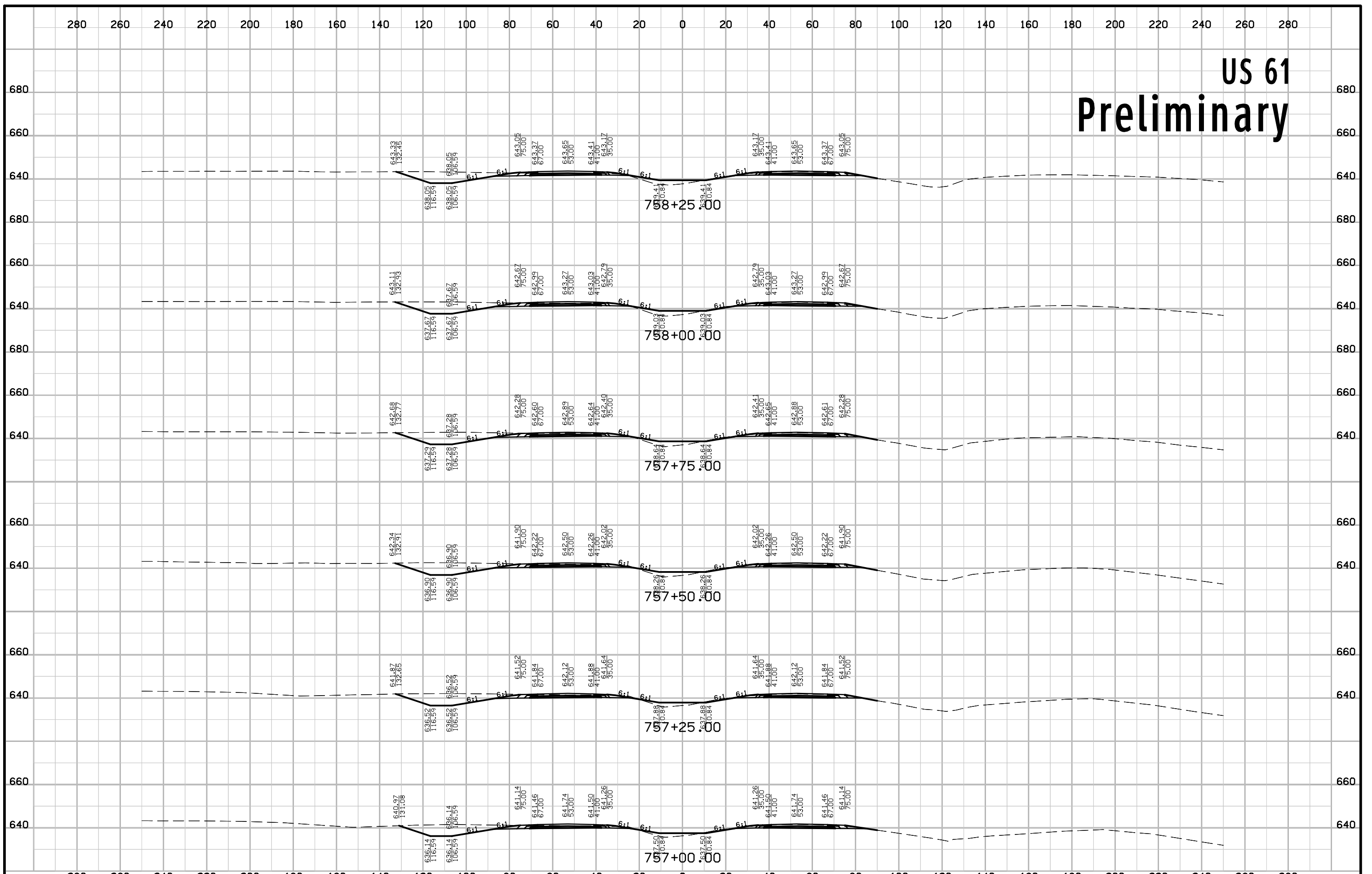

US 61 Preliminary

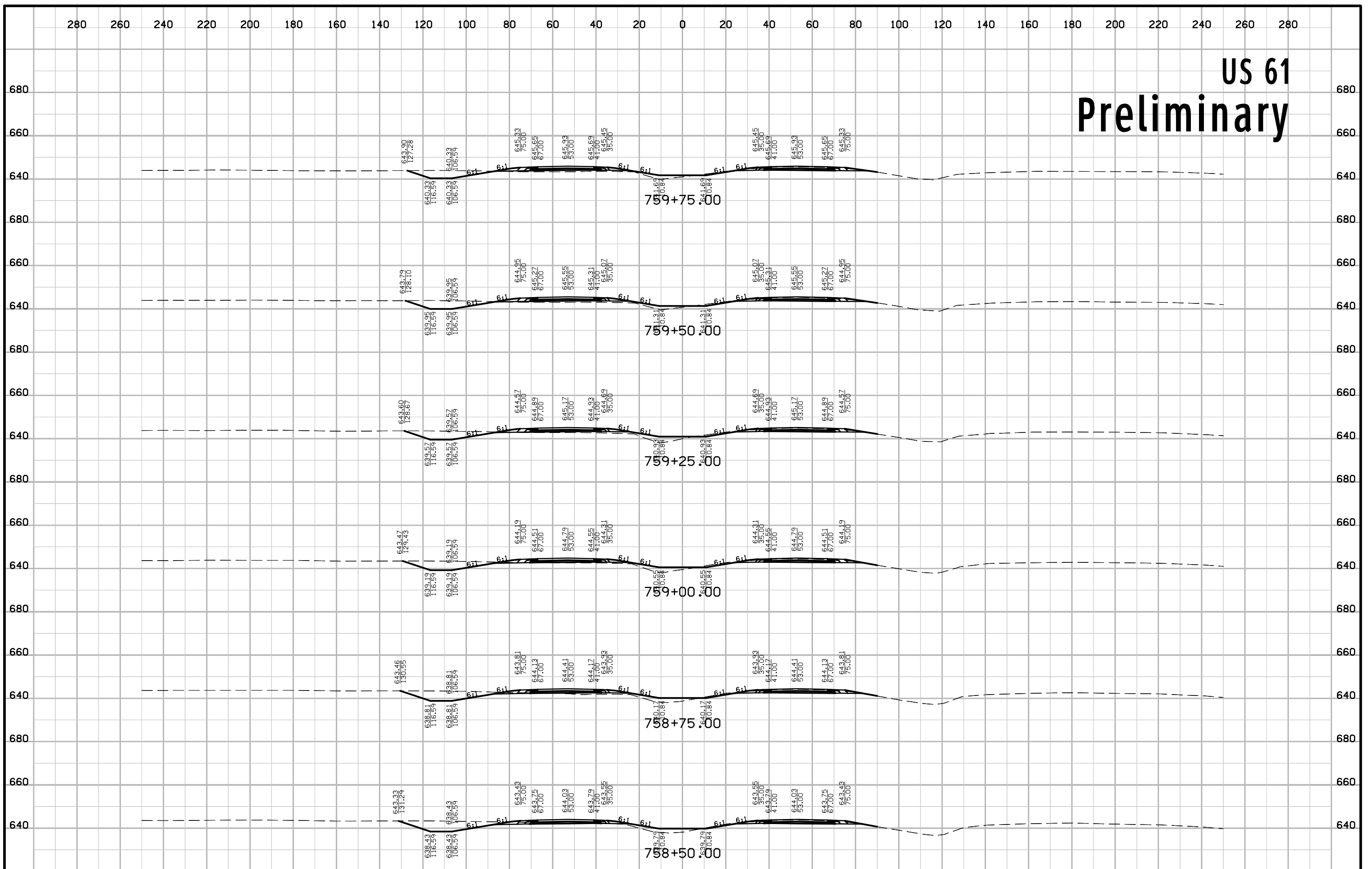

US 61 Preliminary

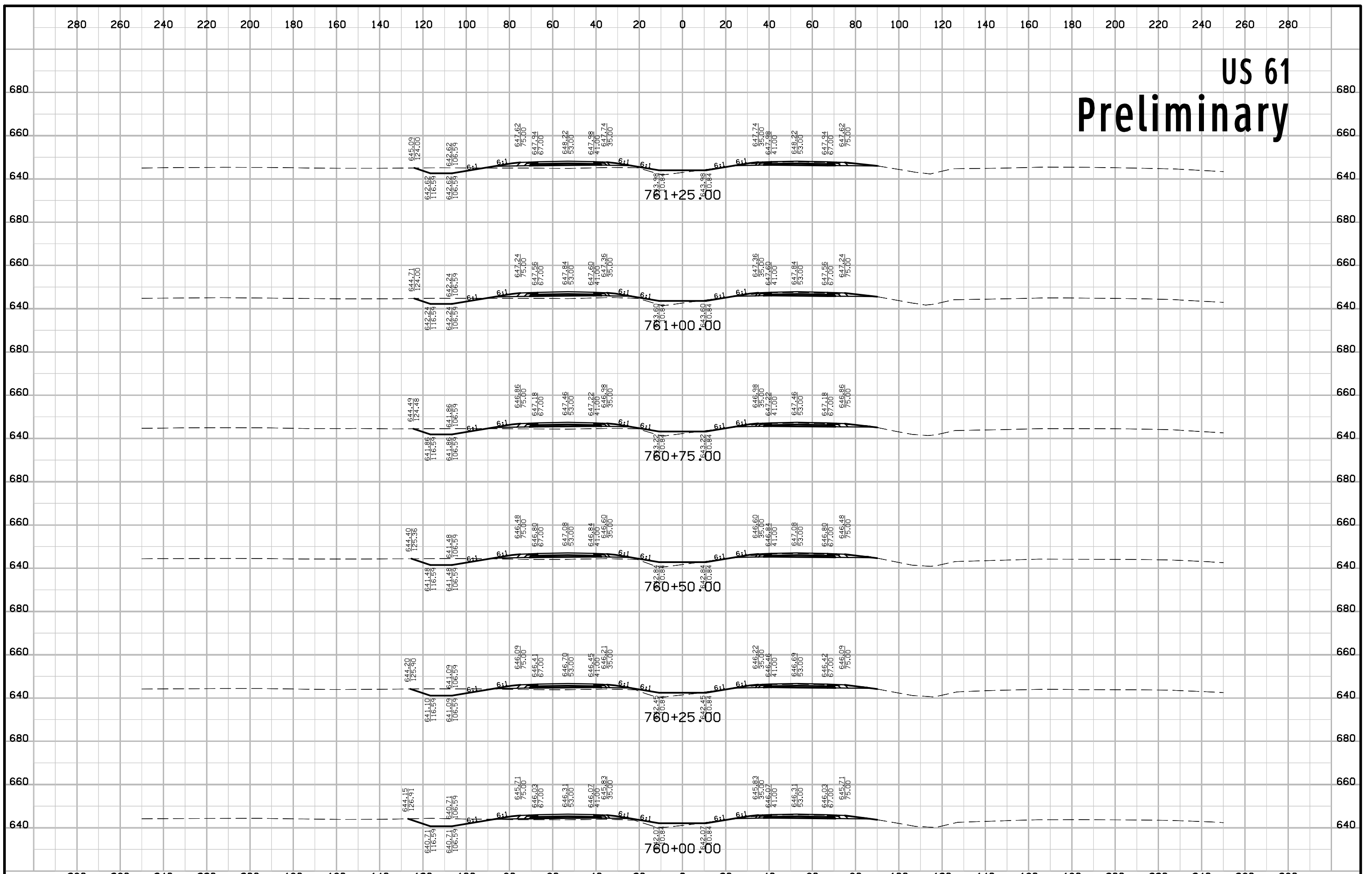

US 61 Preliminary

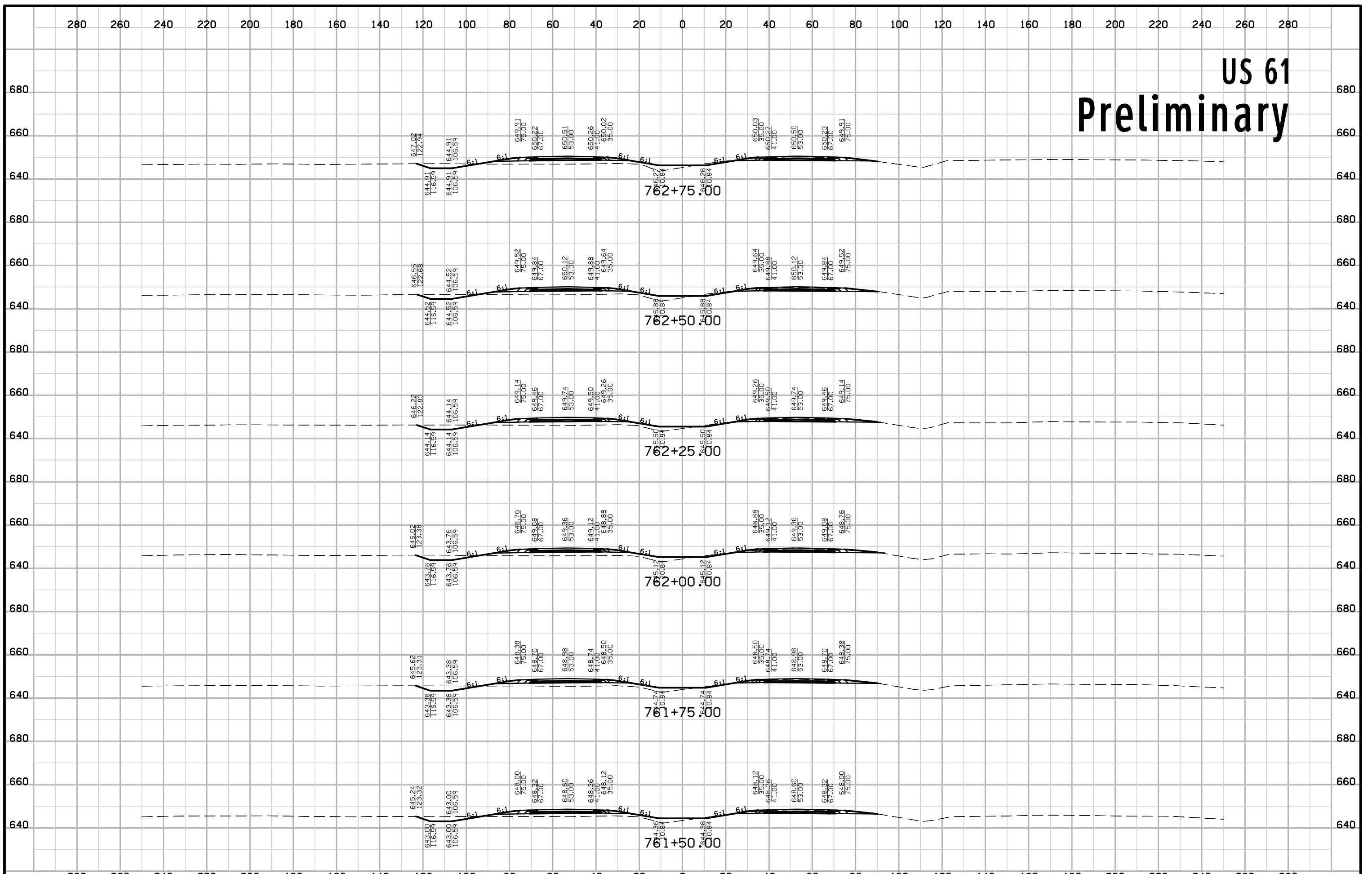

US 61 Preliminary

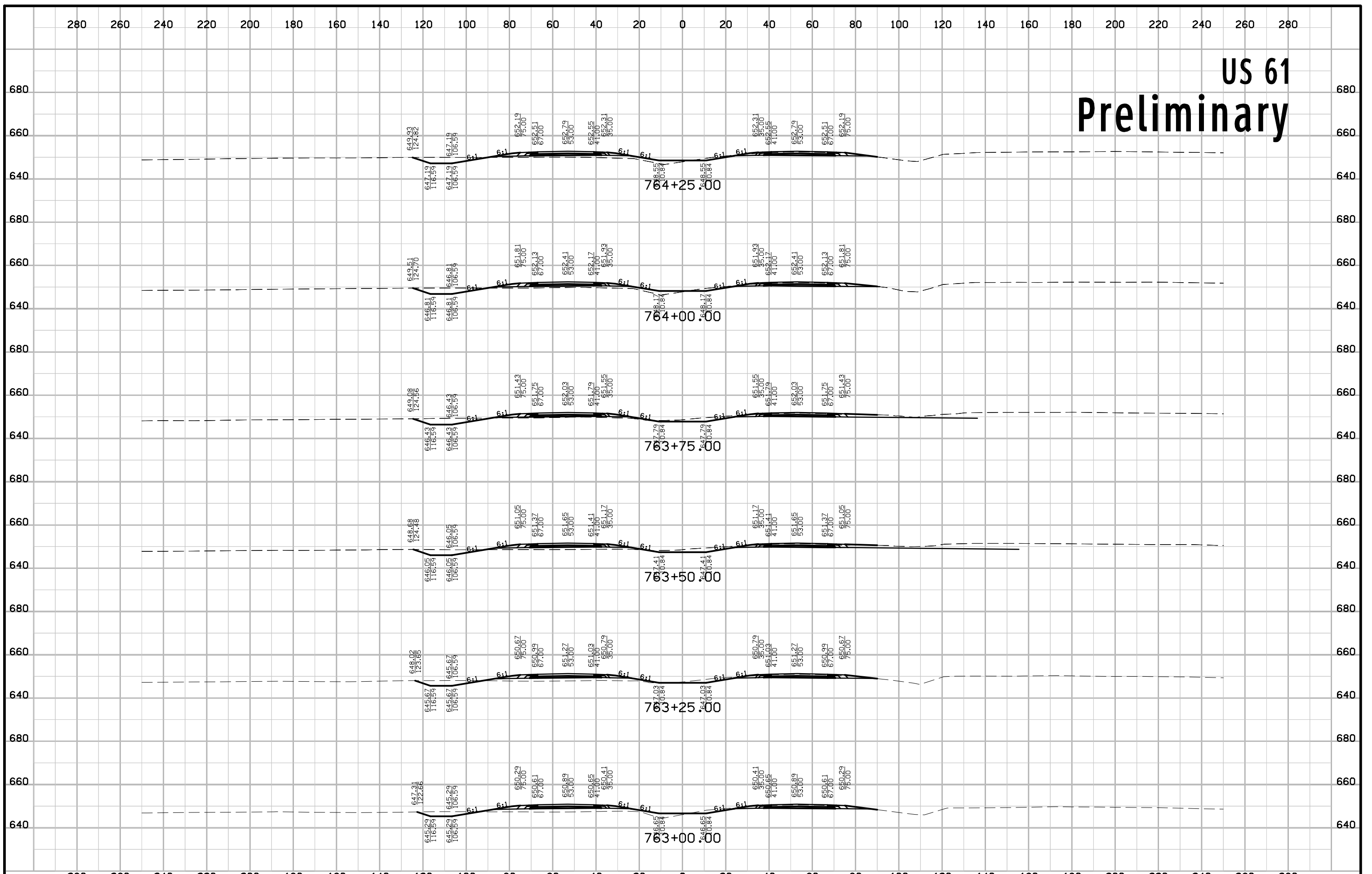

US 61 Preliminary

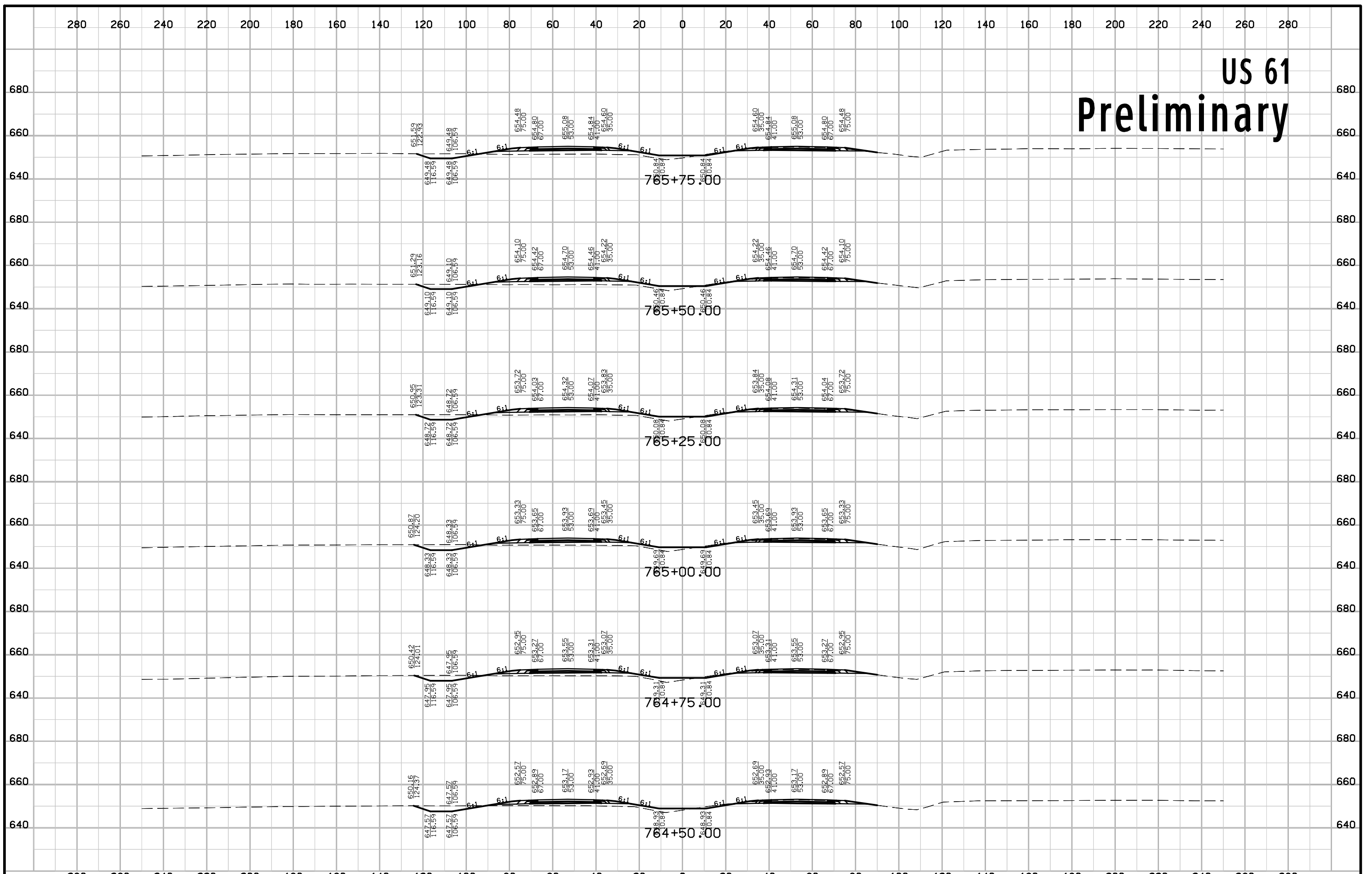

US 61 Preliminary

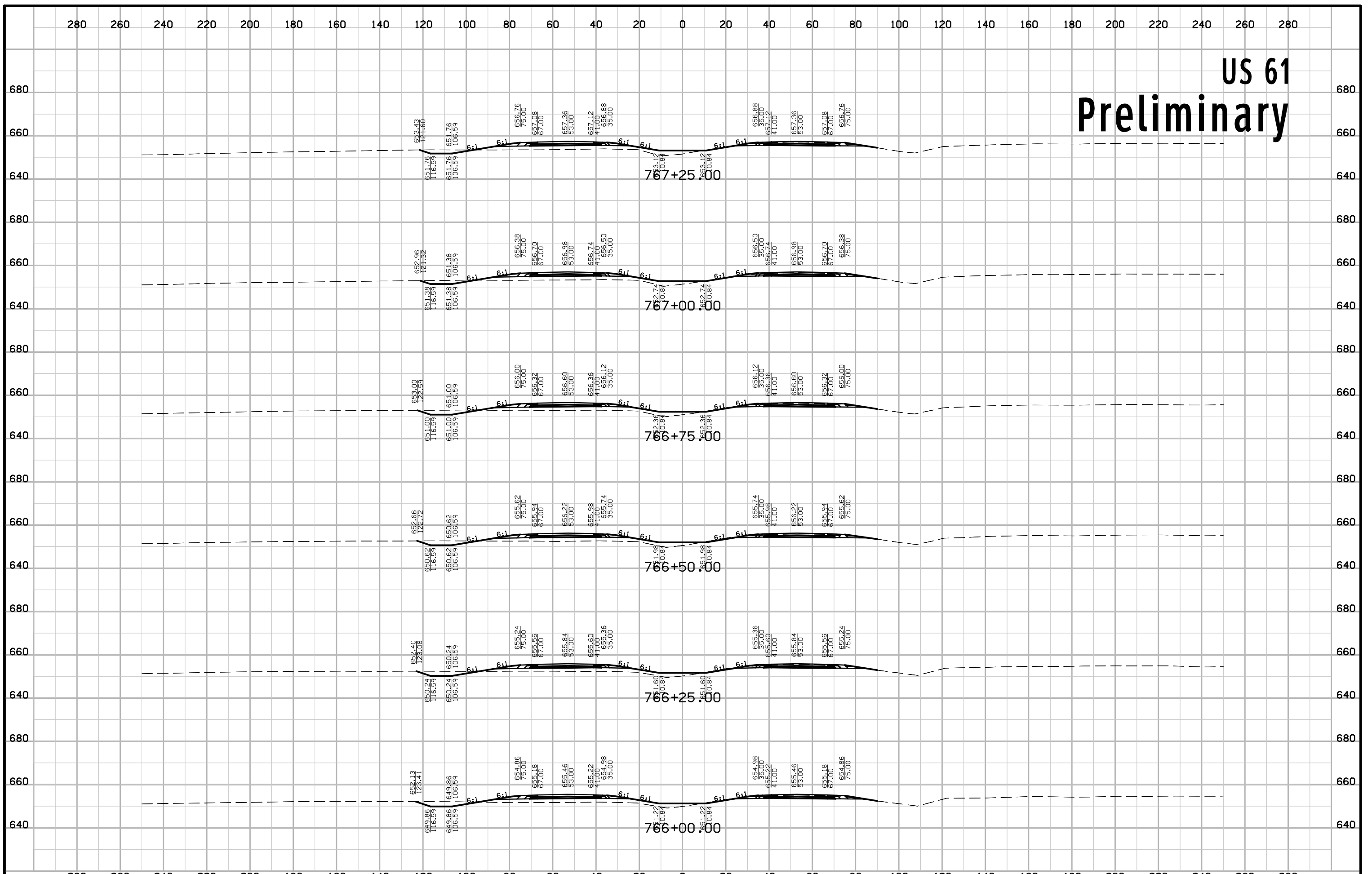

US 61 Preliminary

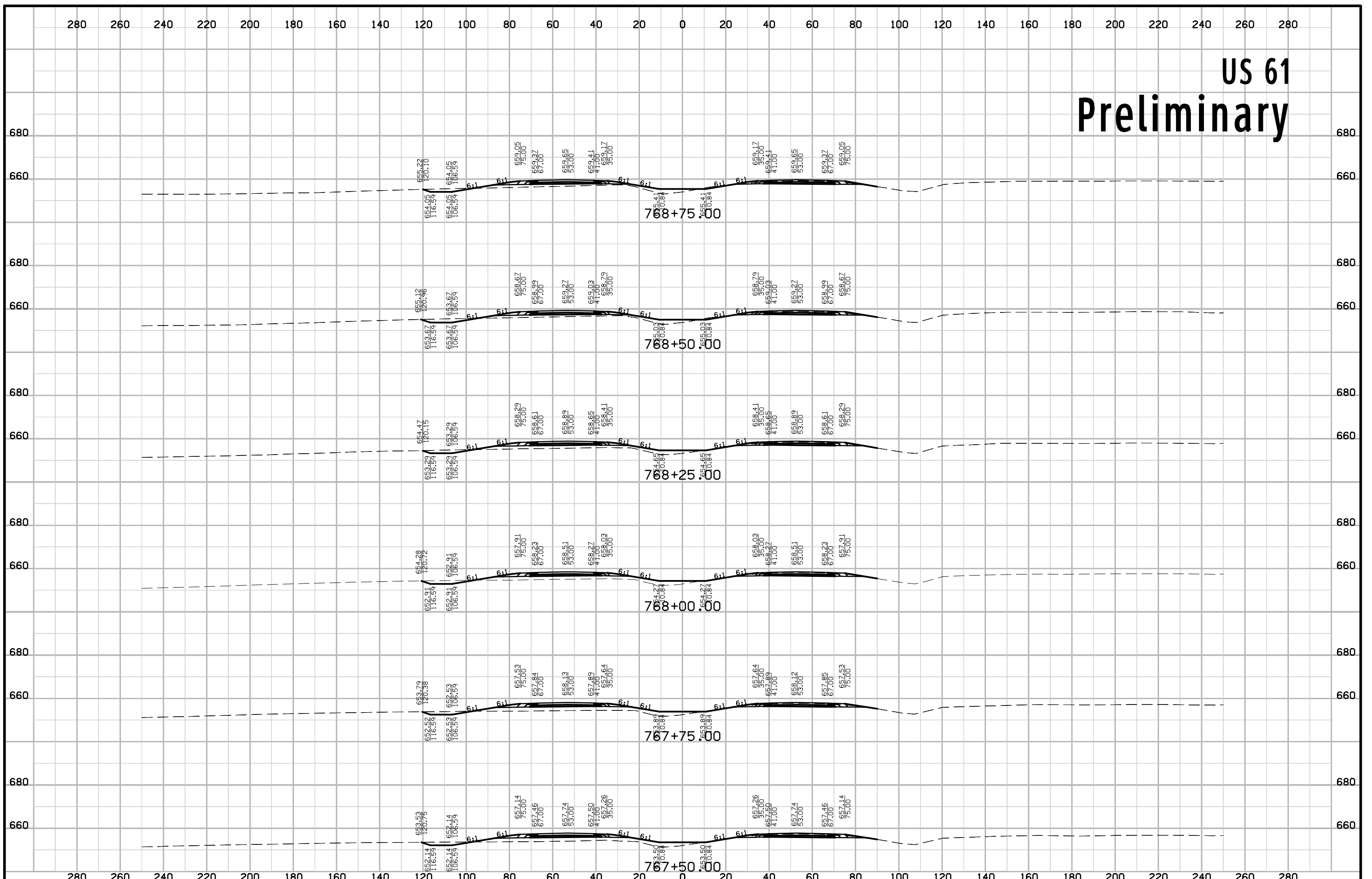

US 61 Preliminary

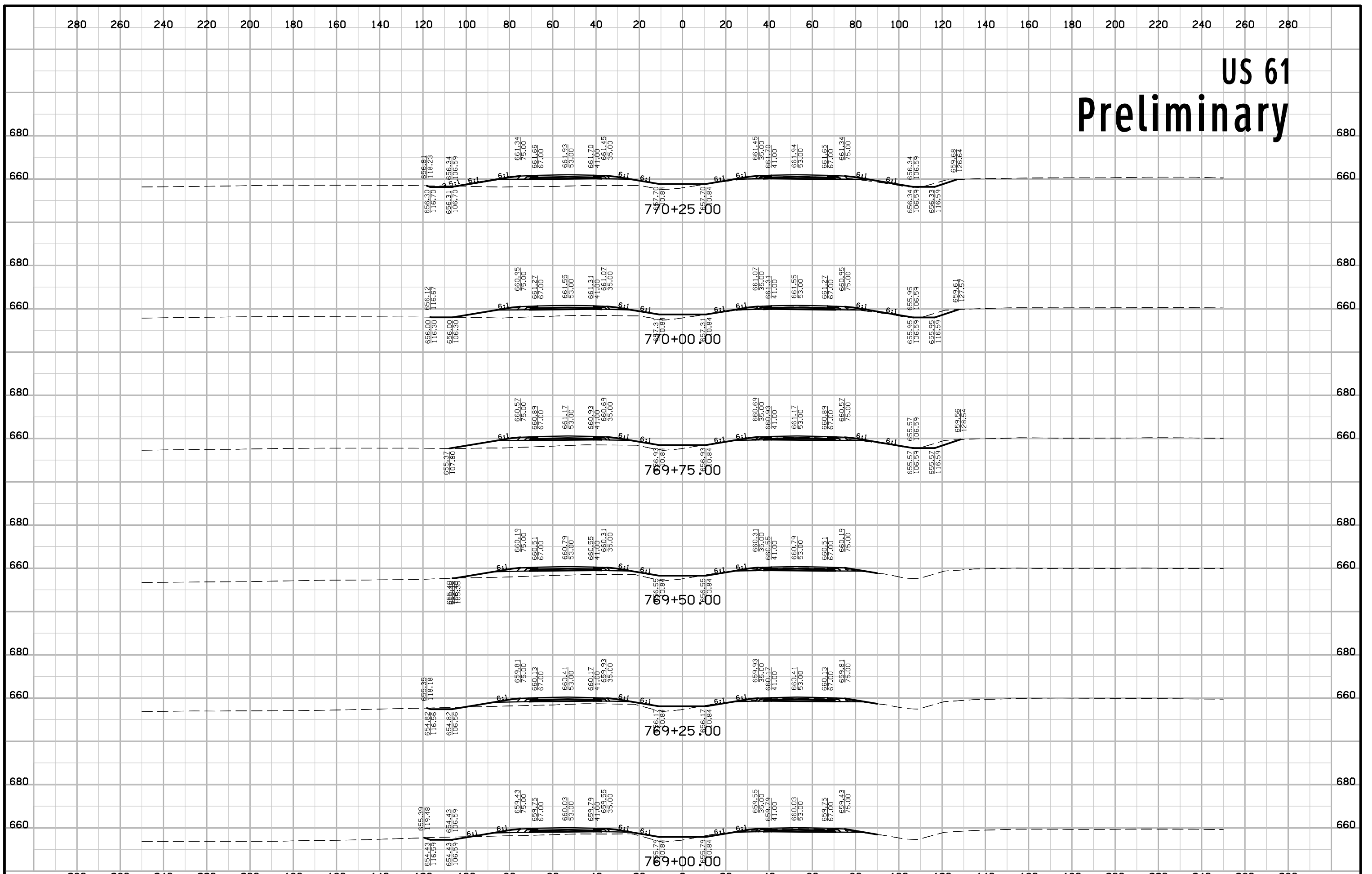

US 61 Preliminary

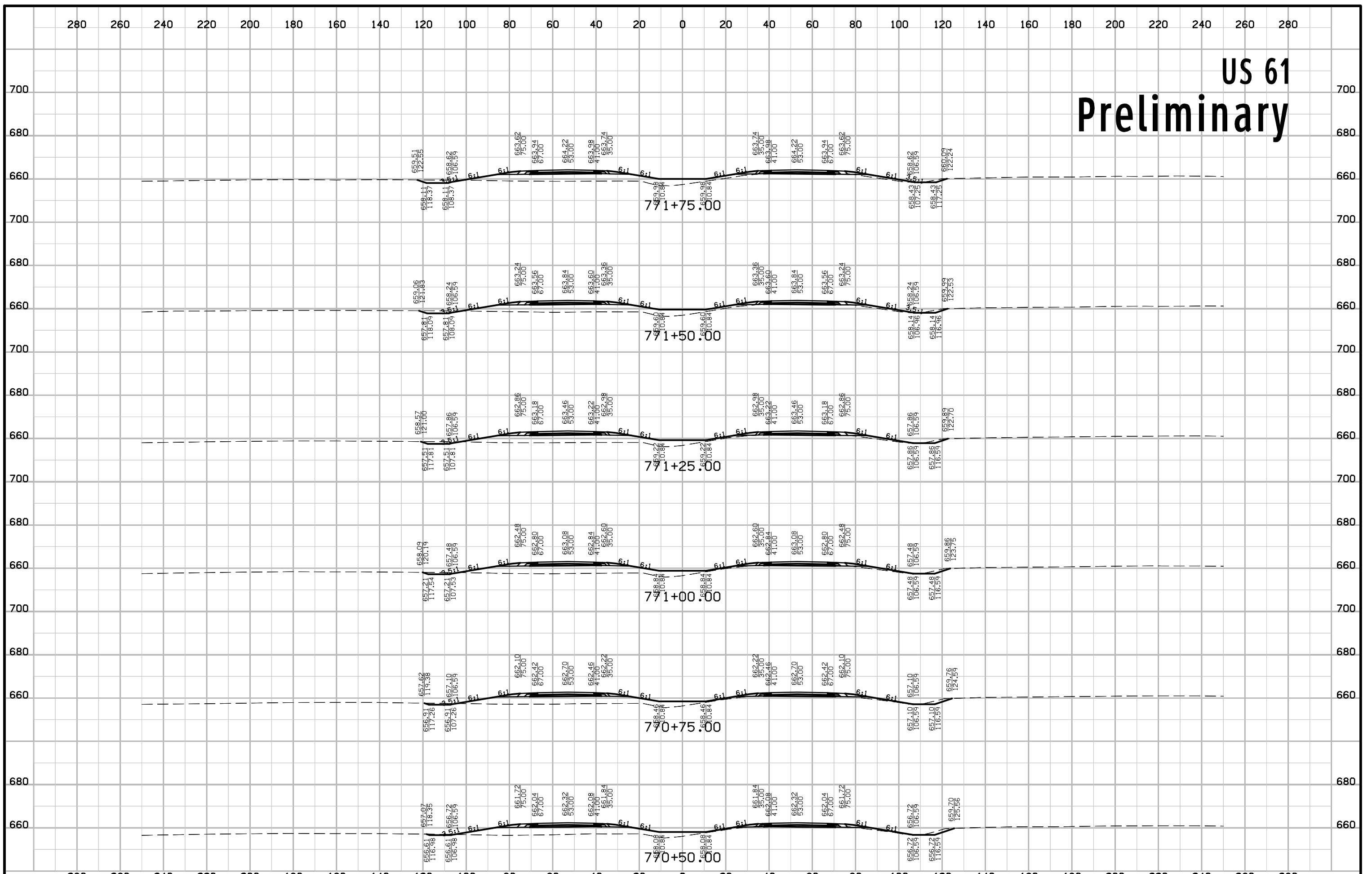

US 61 Preliminary

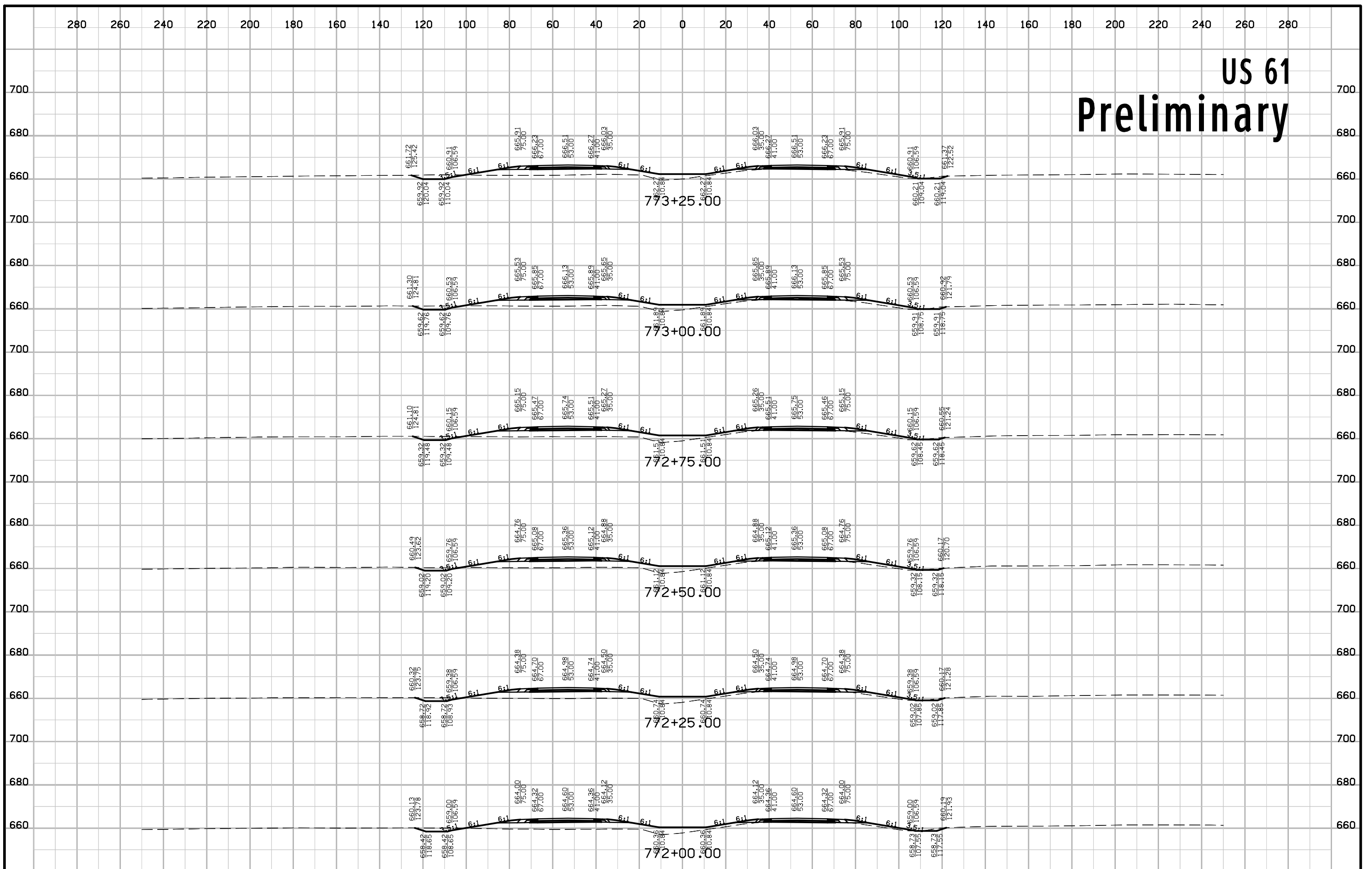

US 61 Preliminary

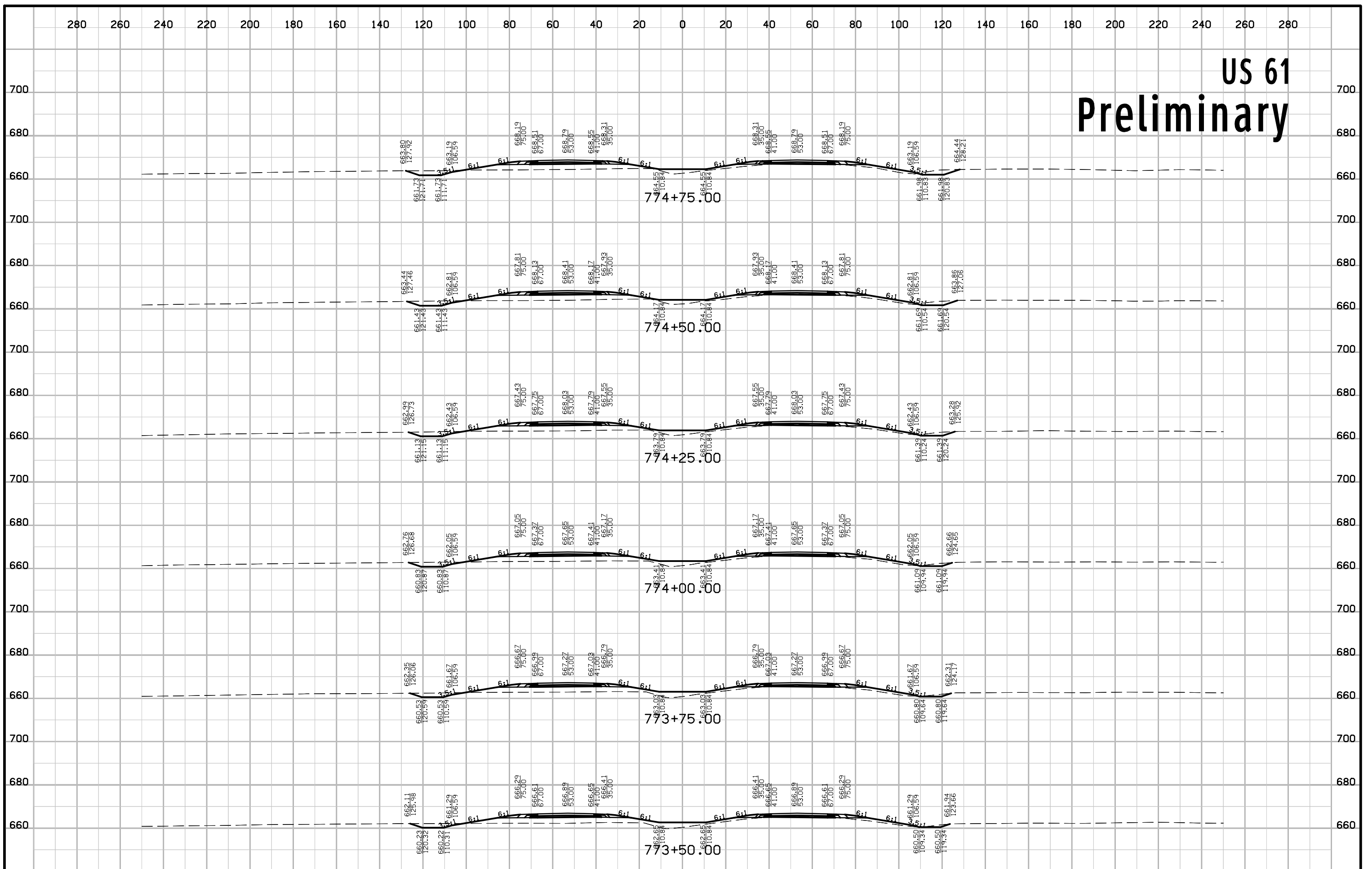

US 61 Preliminary

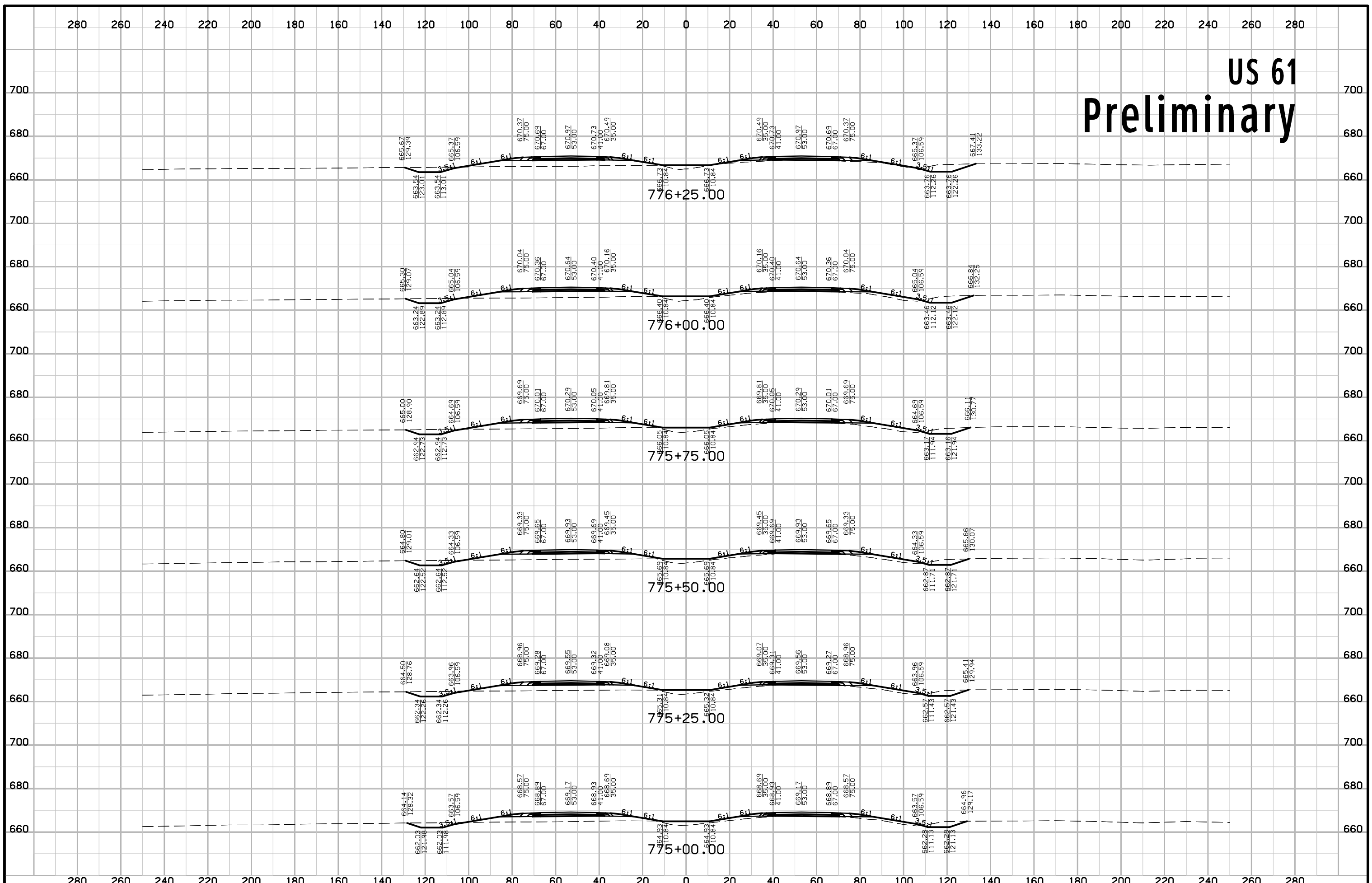

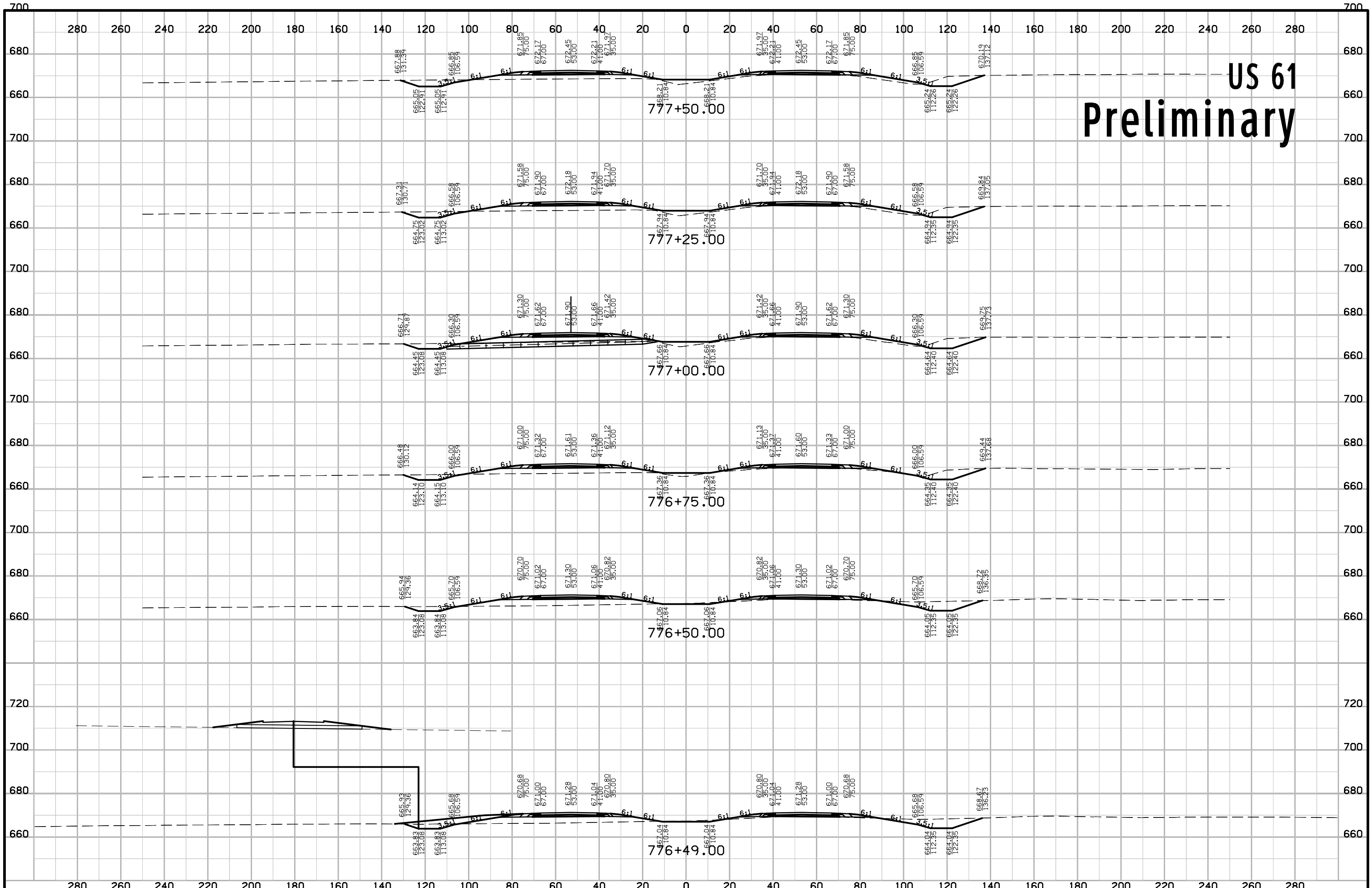

US 61 Preliminary

US 61 Preliminary

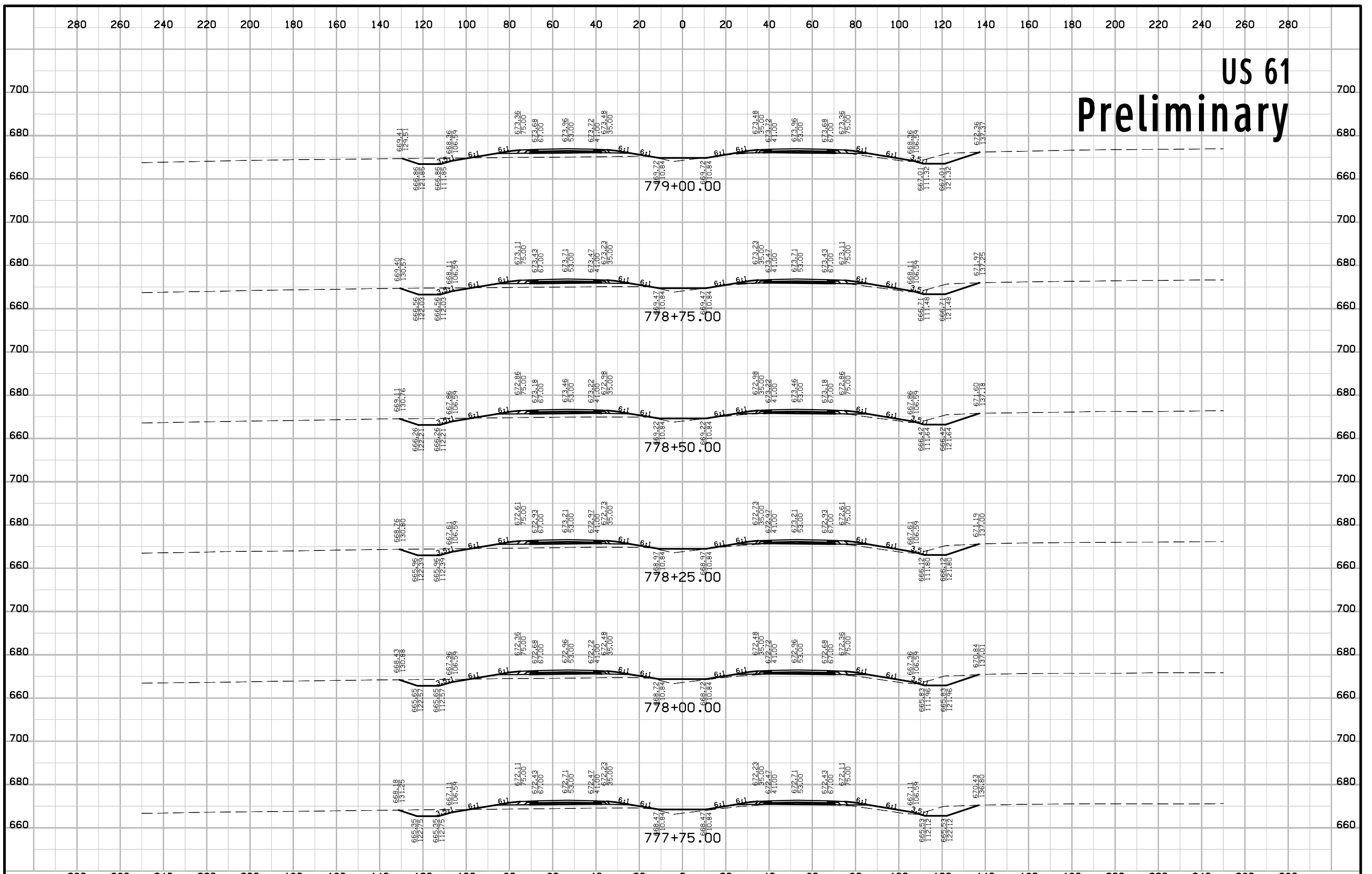

US 61 Preliminary

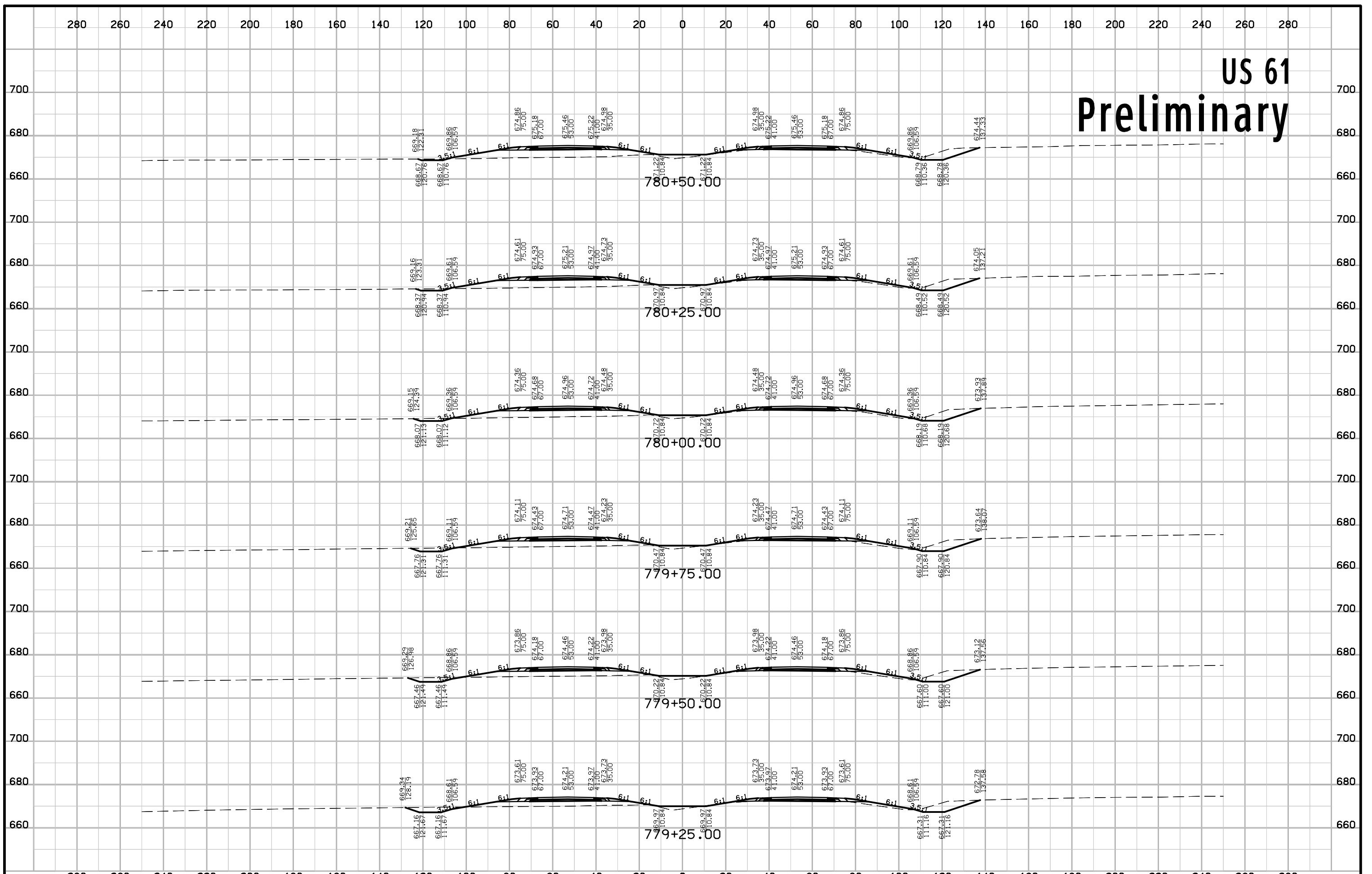

US 61 Preliminary

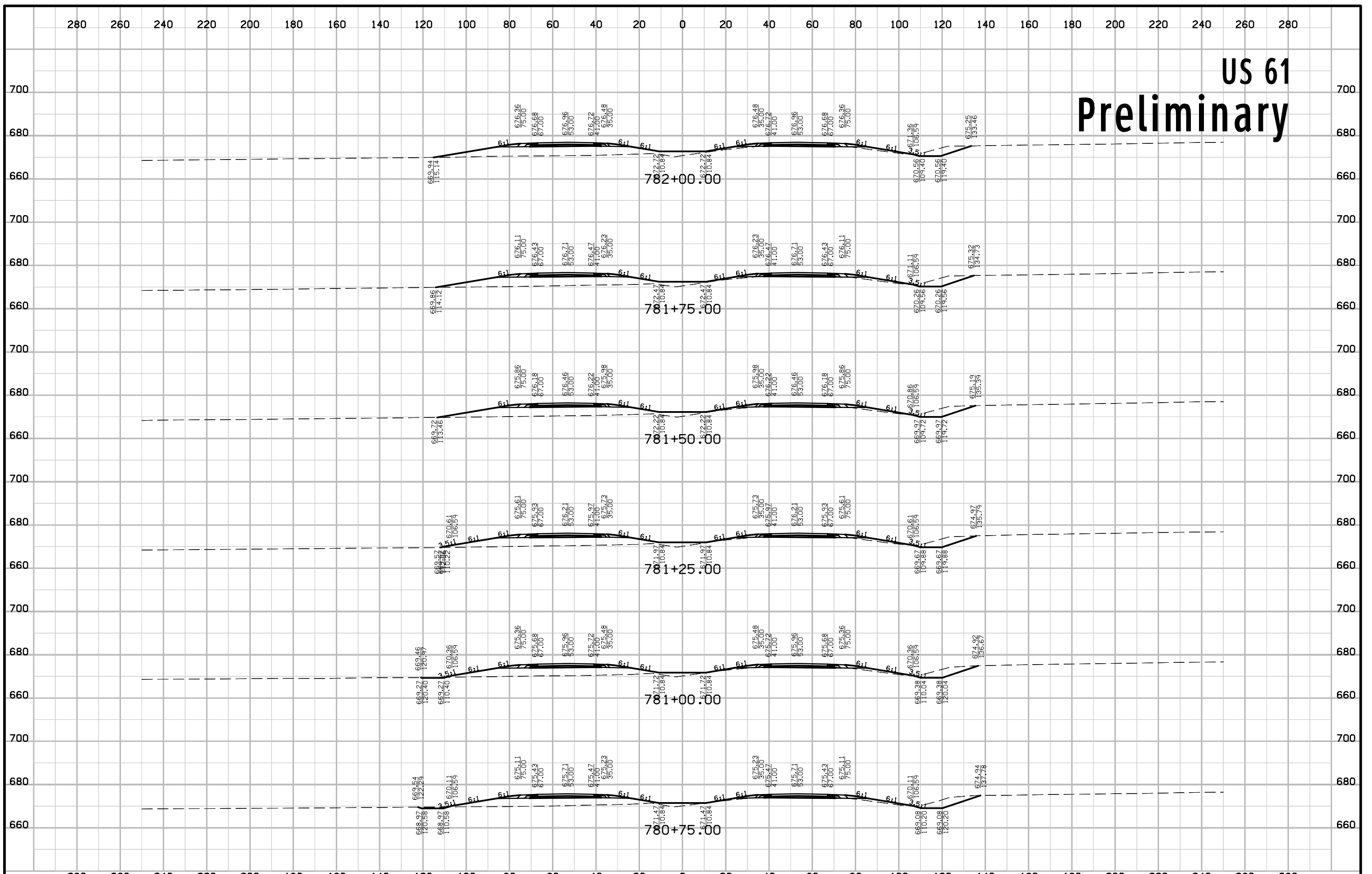

US 61 Preliminary

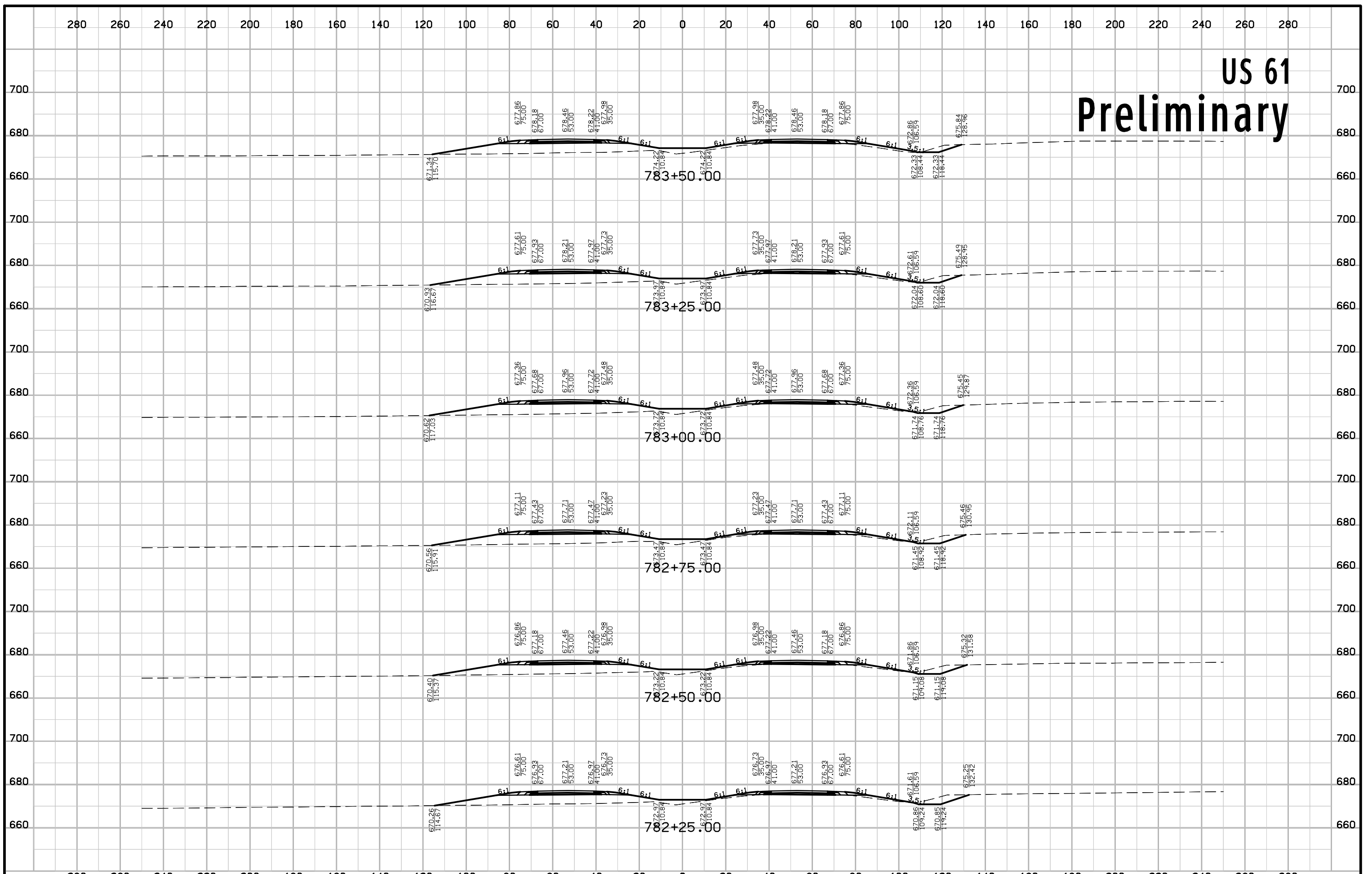

US 61 Preliminary

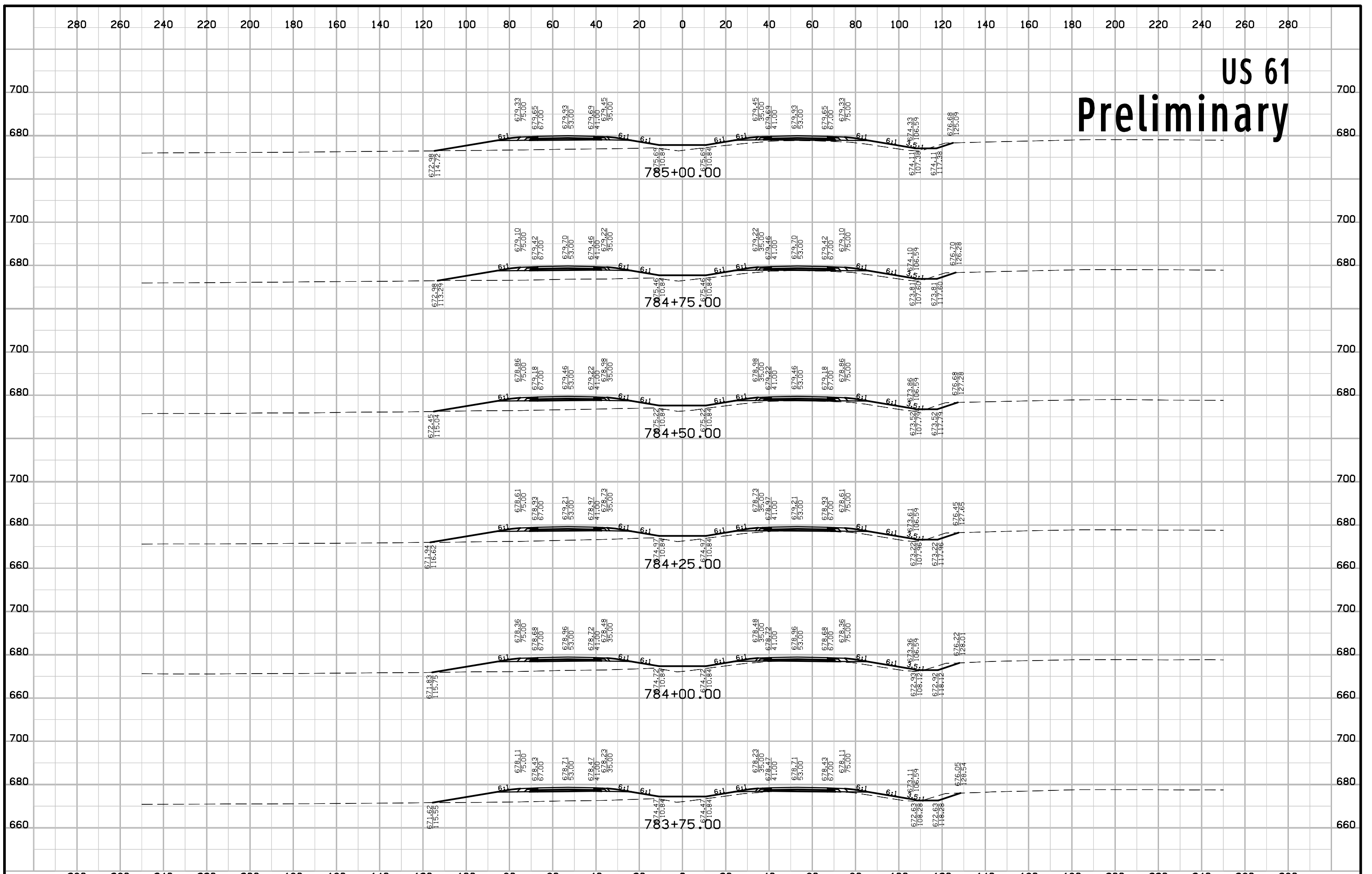

US 61 Preliminary

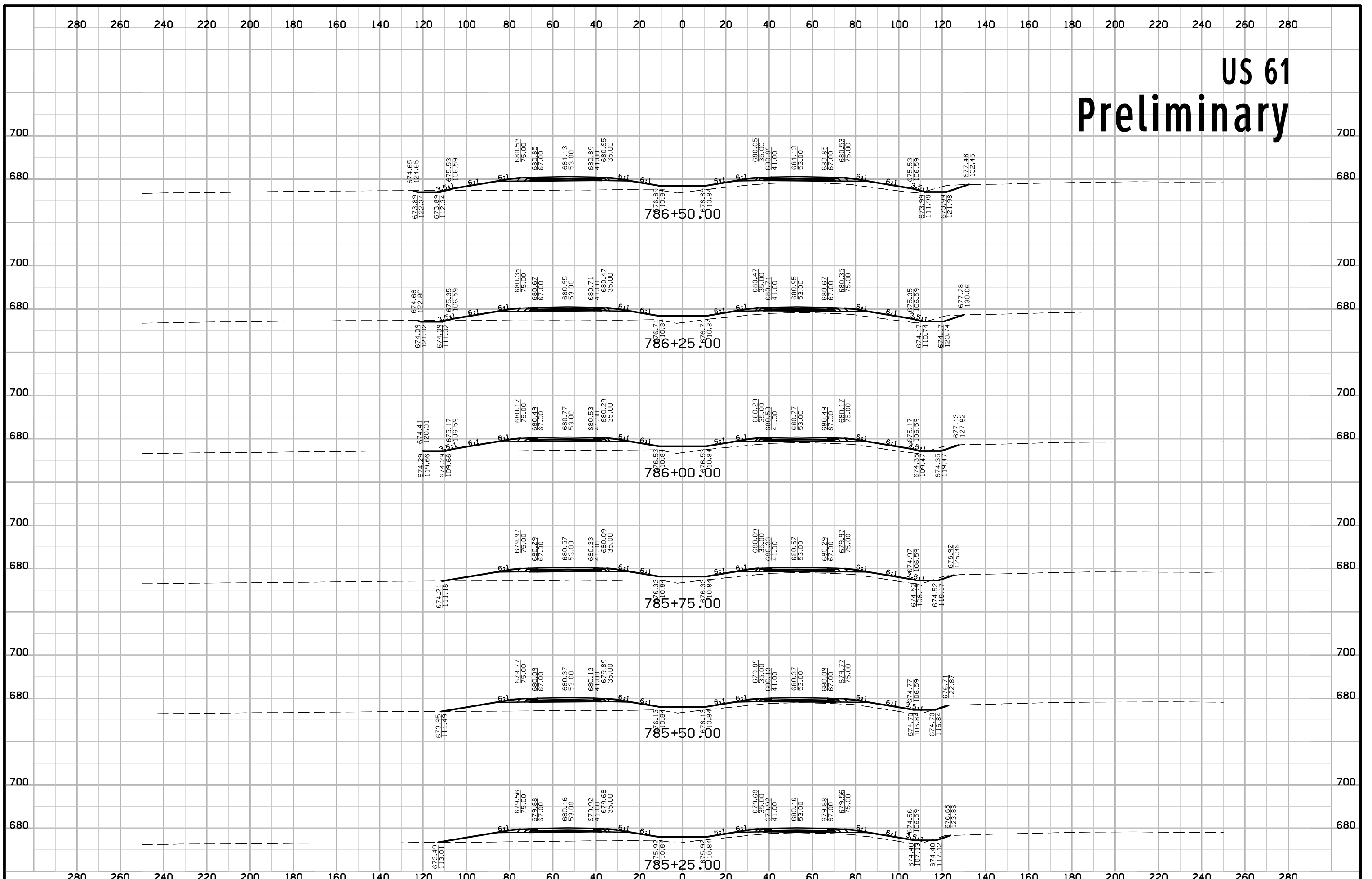

US 61 Preliminary

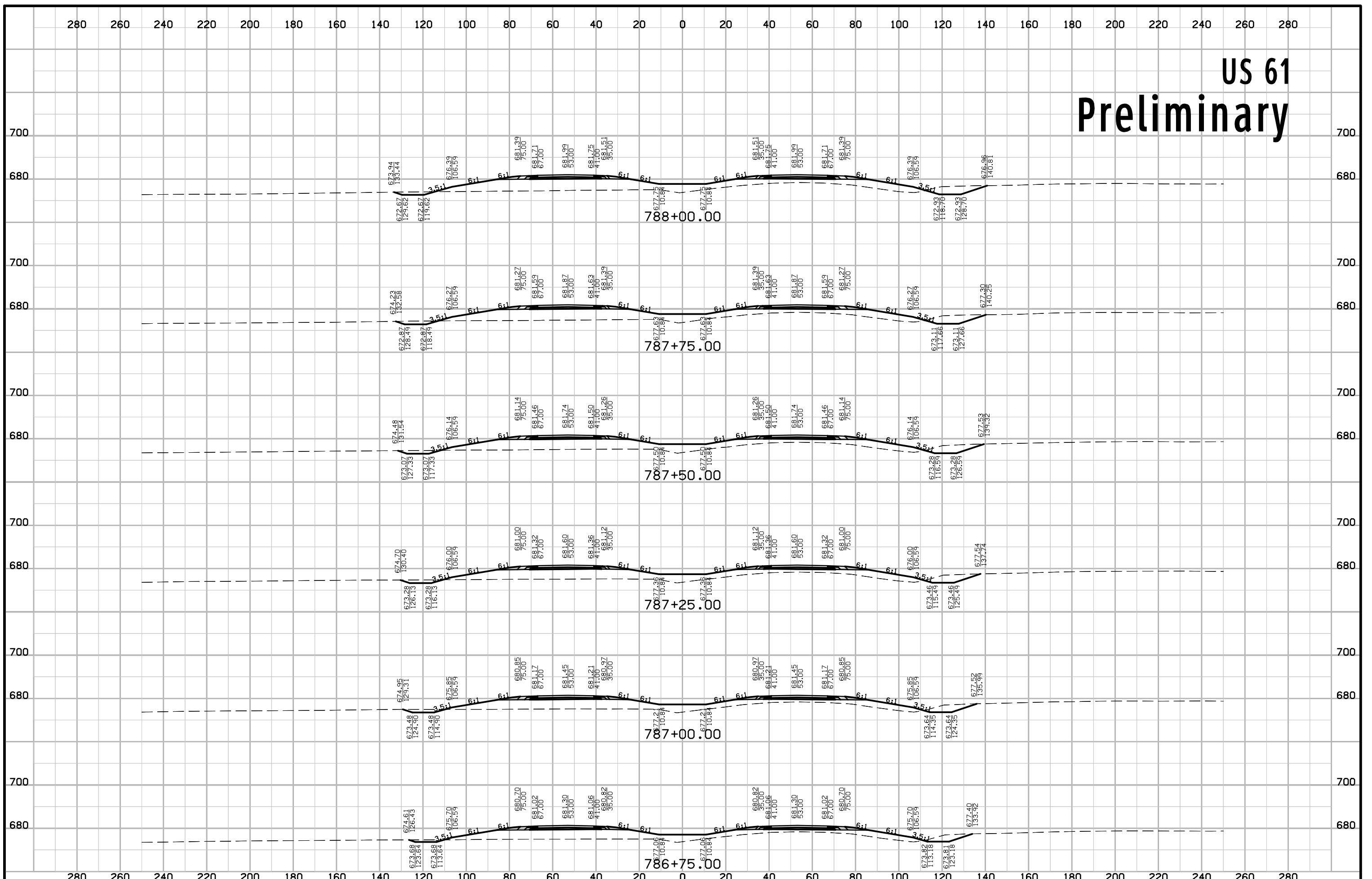

US 61 Preliminary

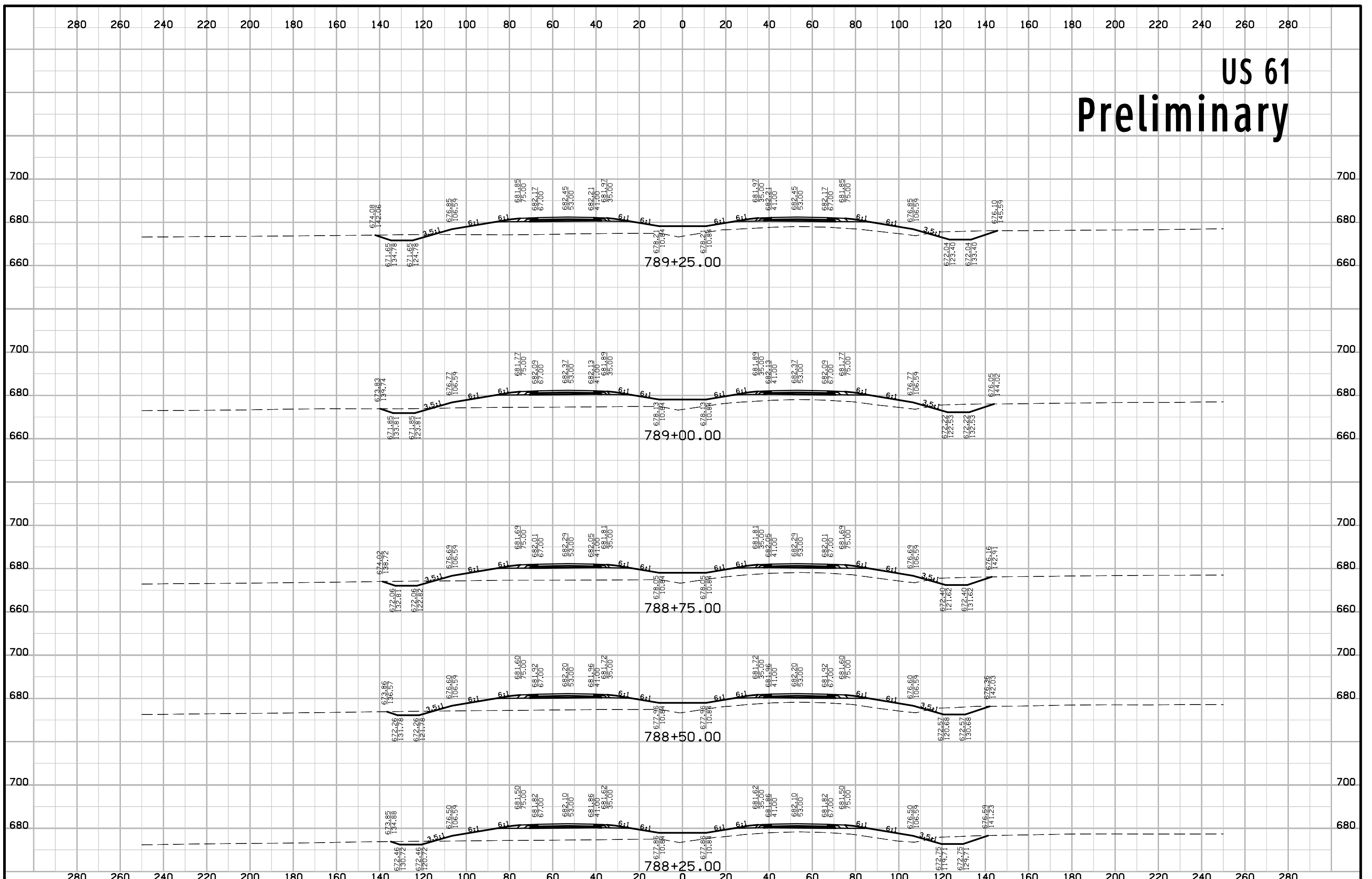

US 61 Preliminary

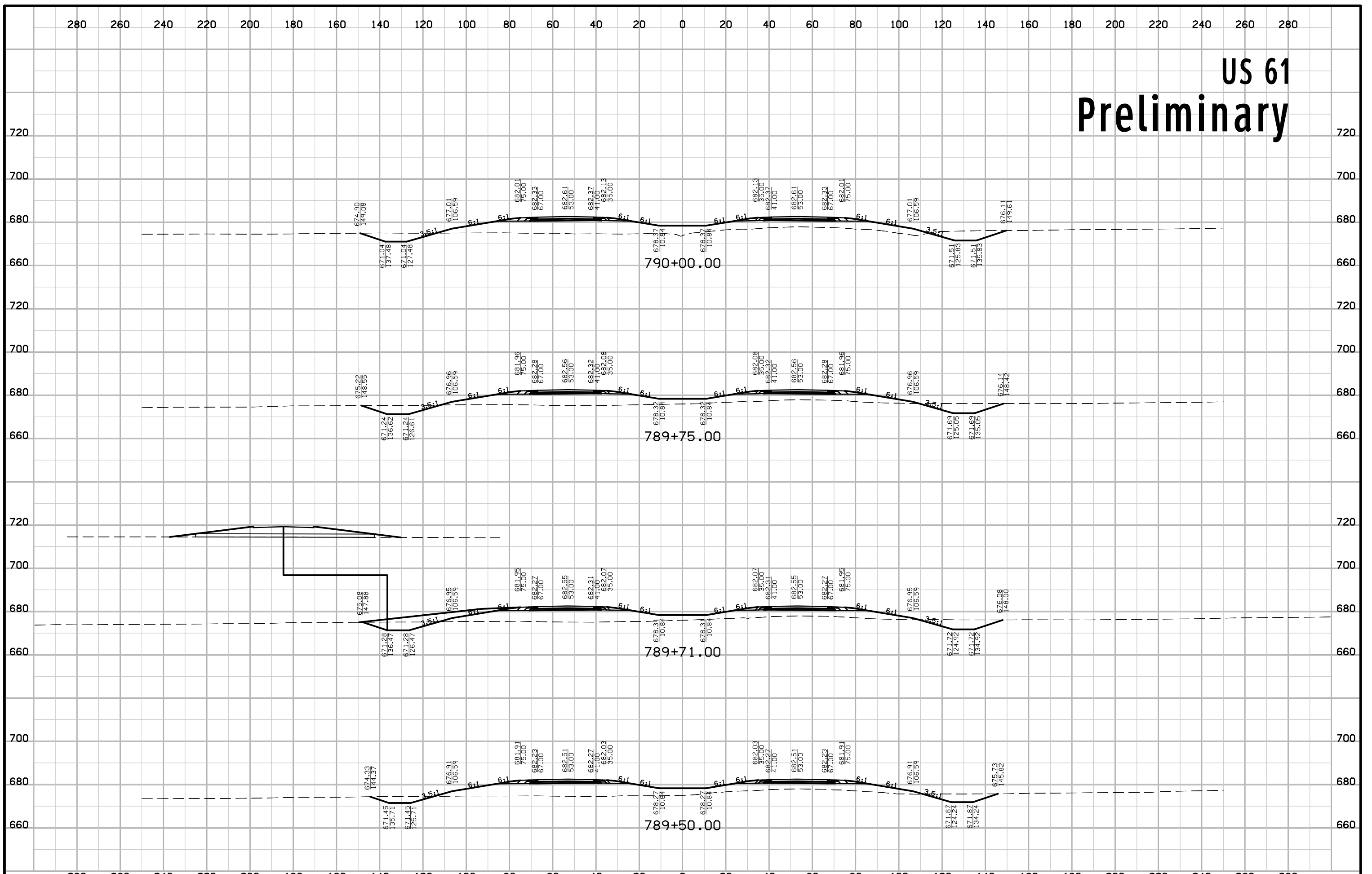

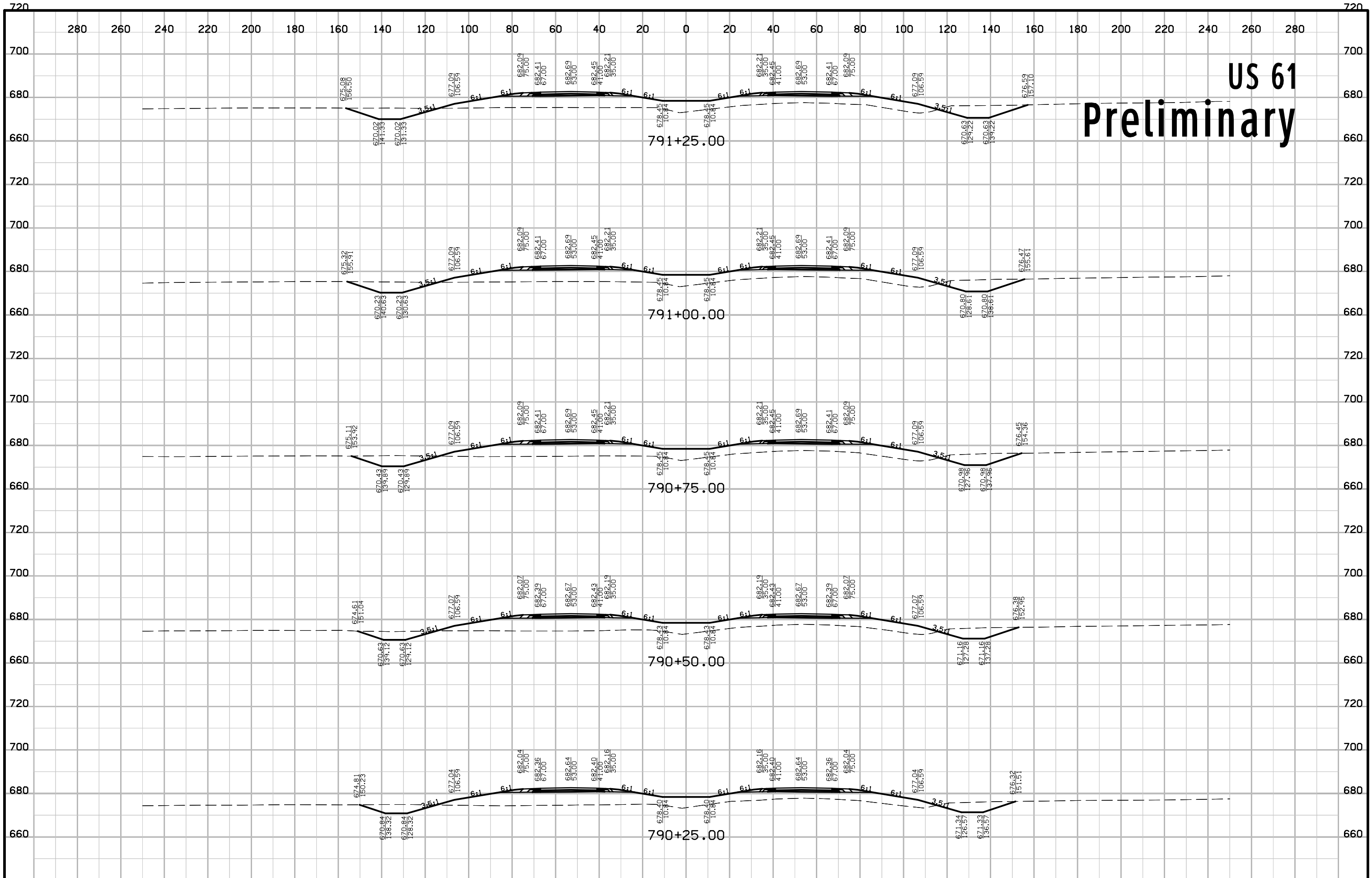

US 61 Preliminary

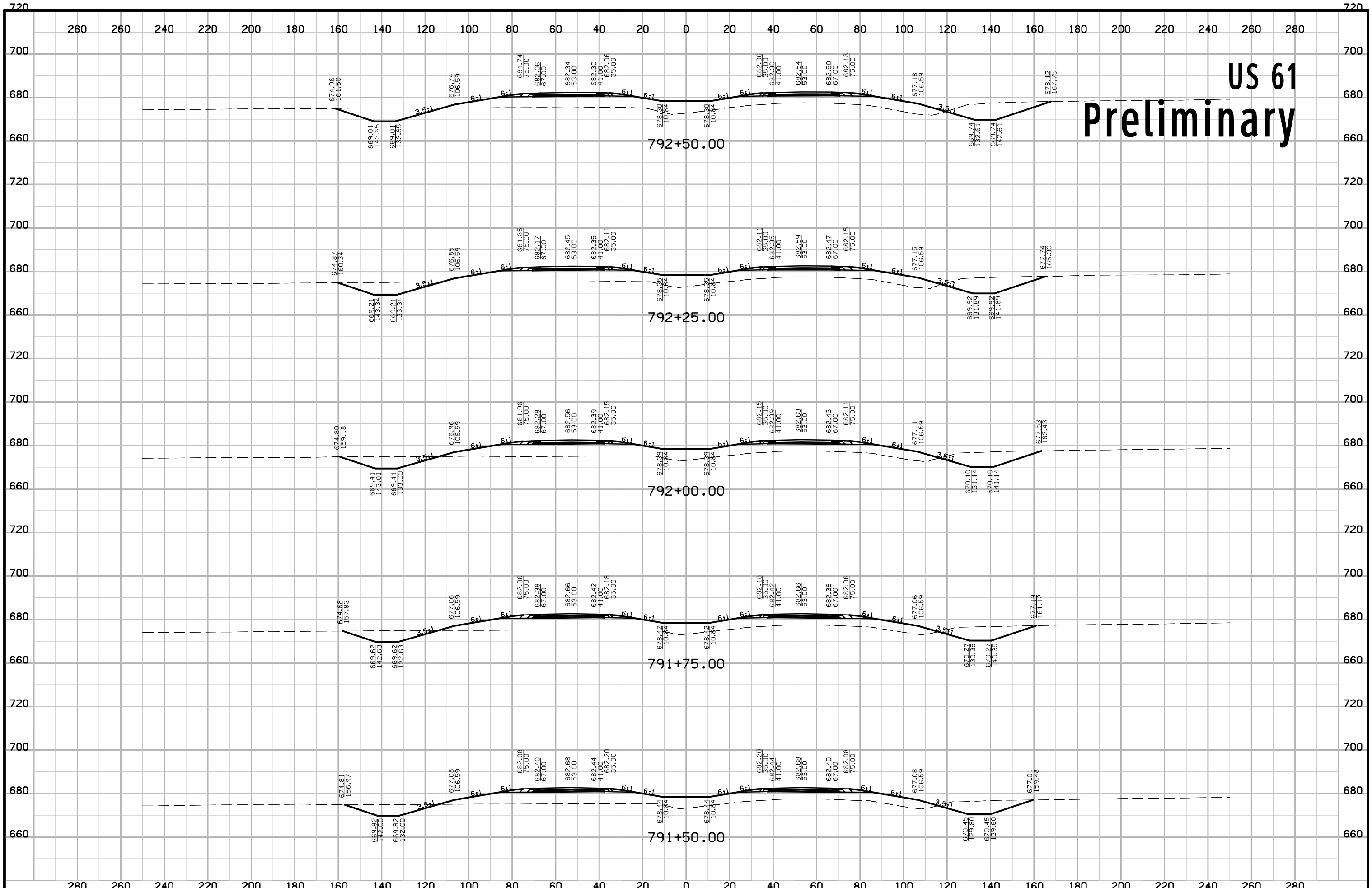

US 61 Preliminary

US 61 Preliminary

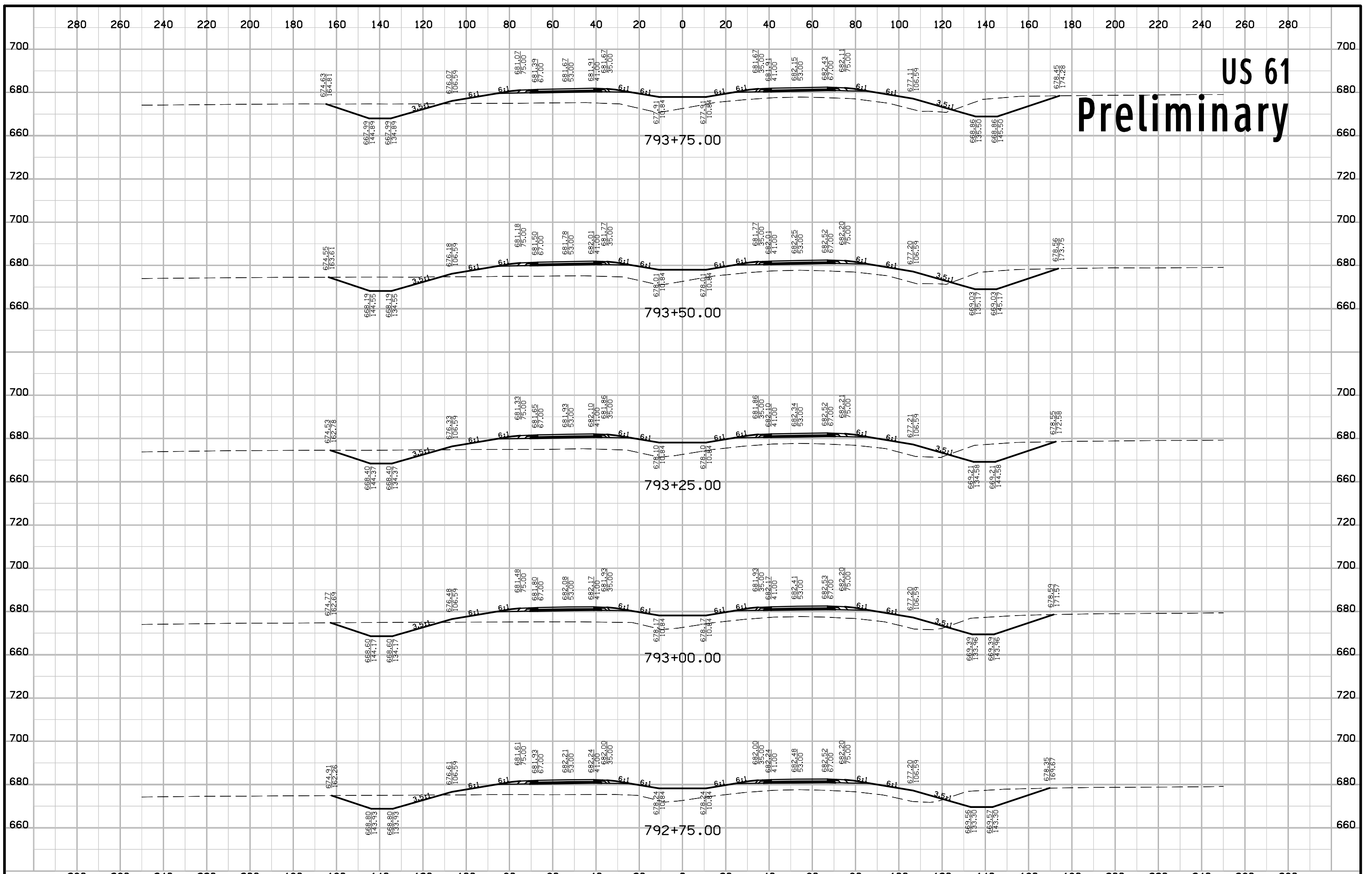

US 61 Preliminary

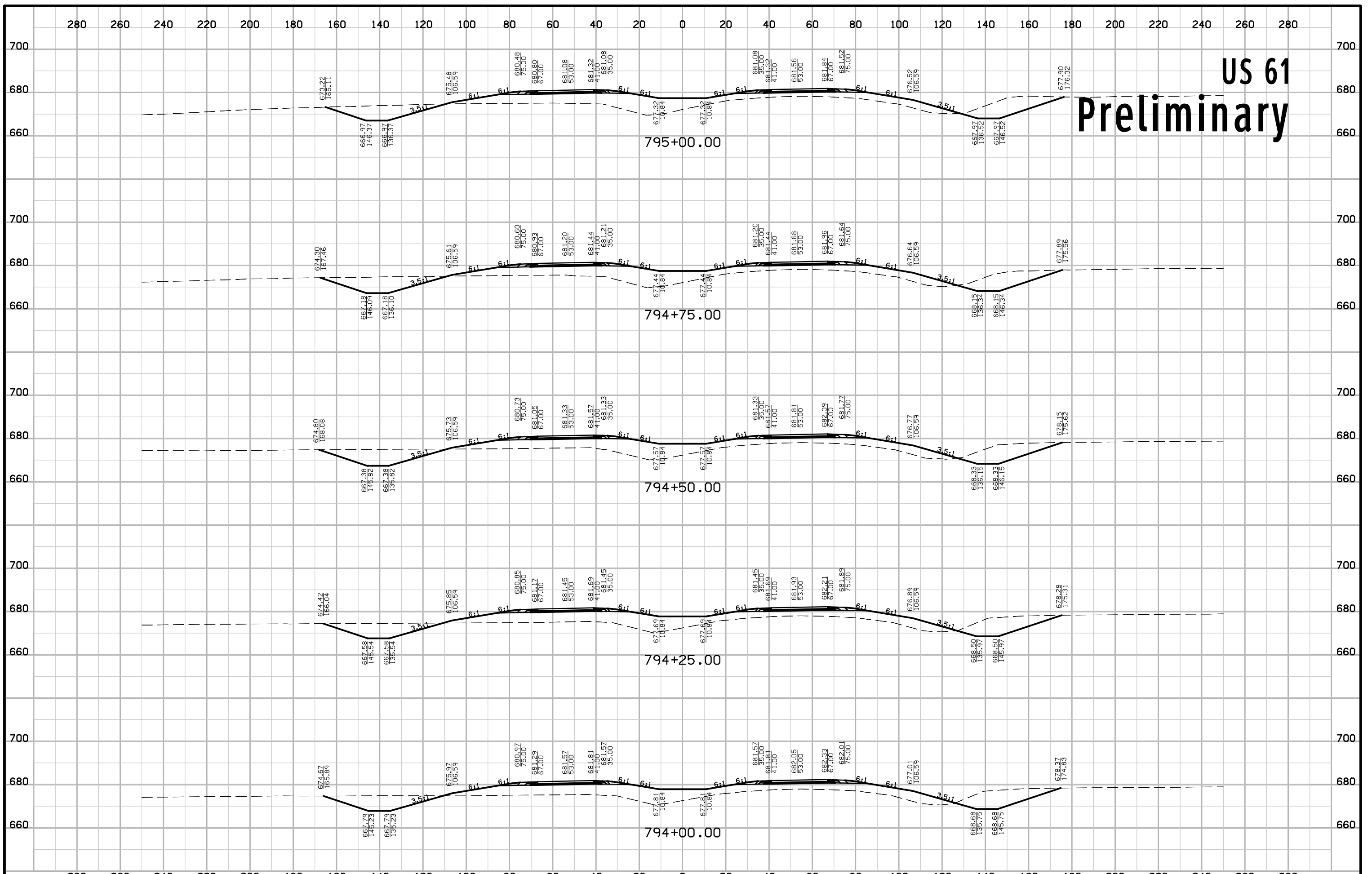

US 61 Preliminary

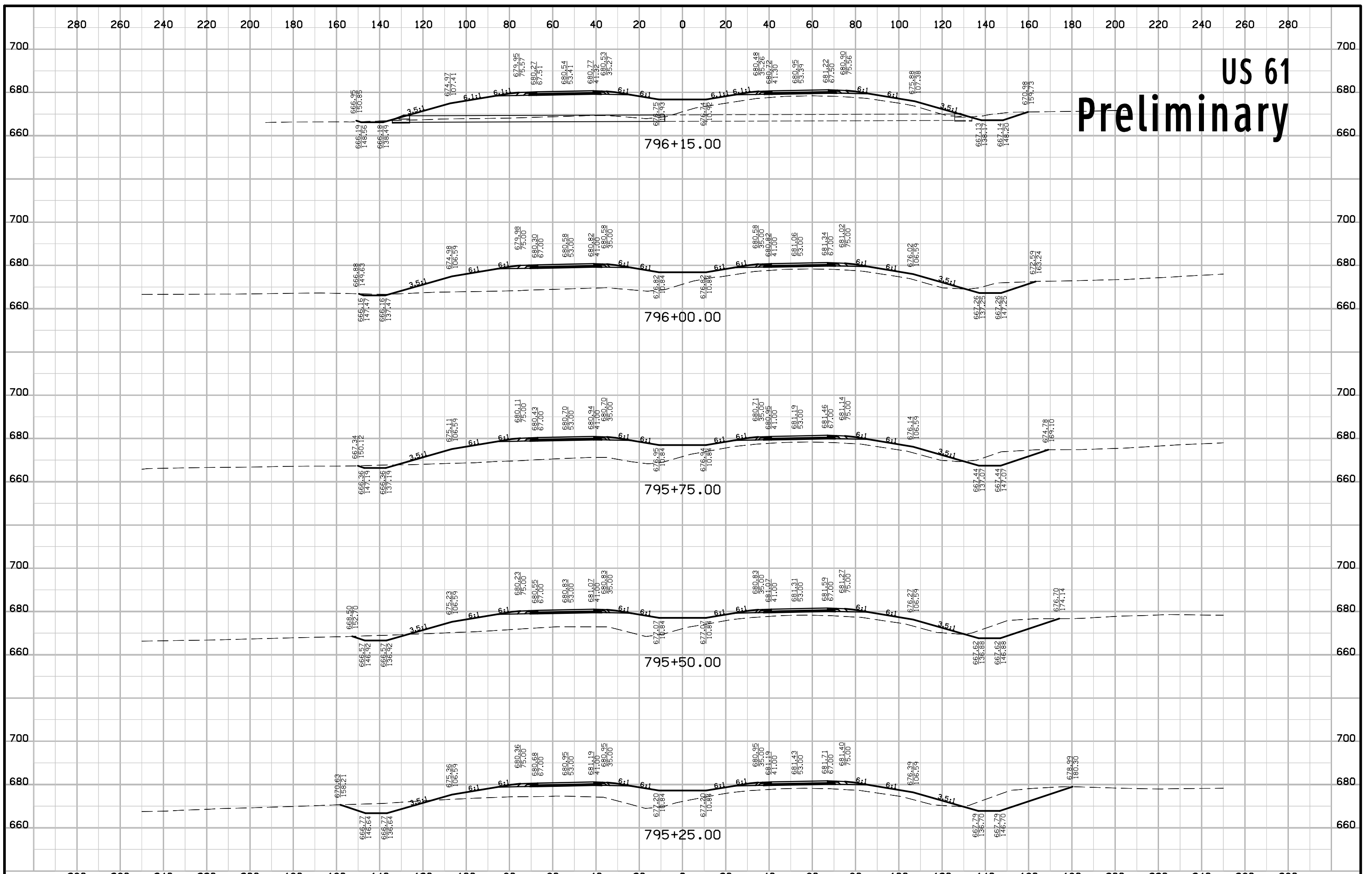

US 61 Preliminary

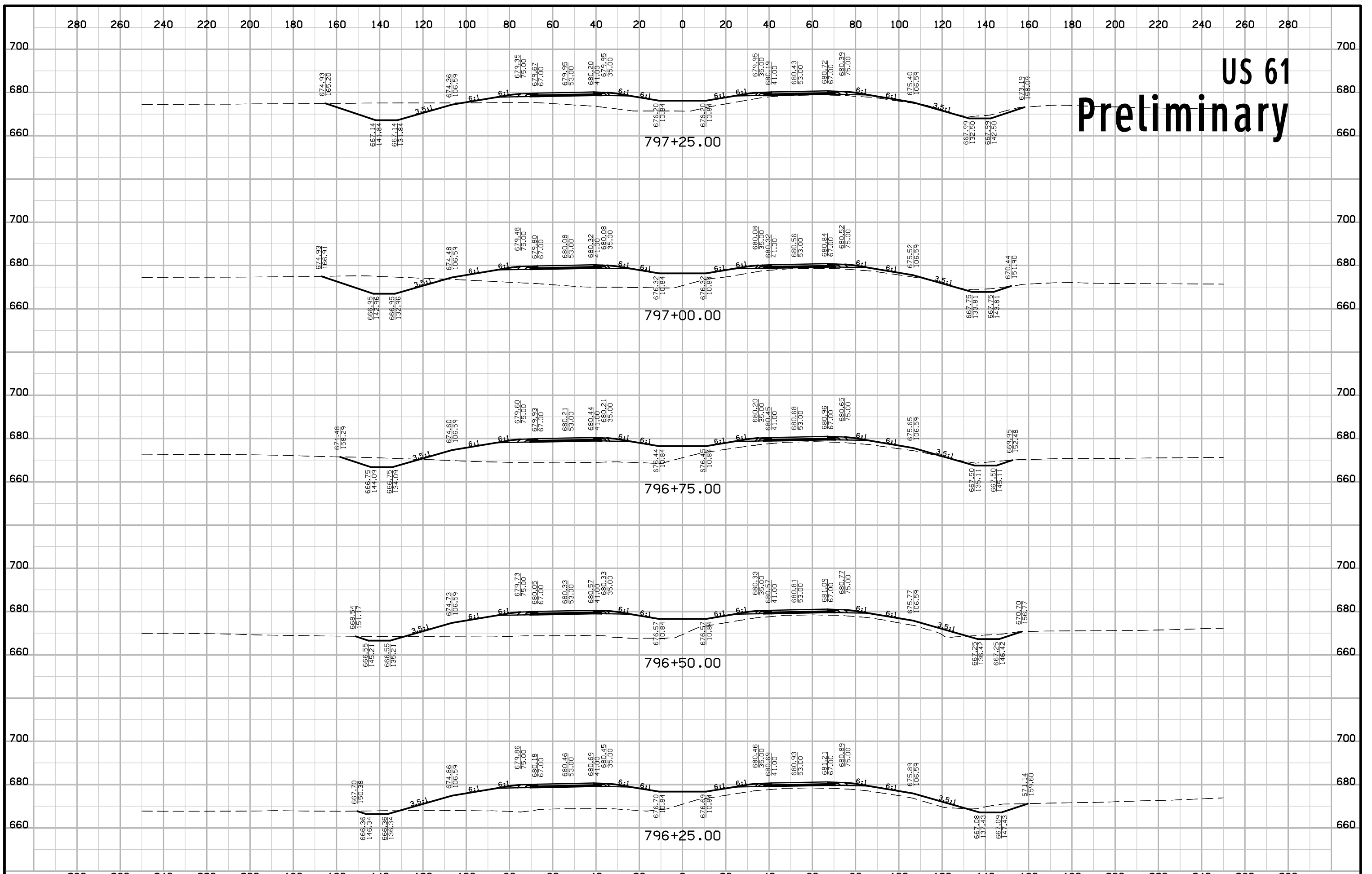

US 61 Preliminary

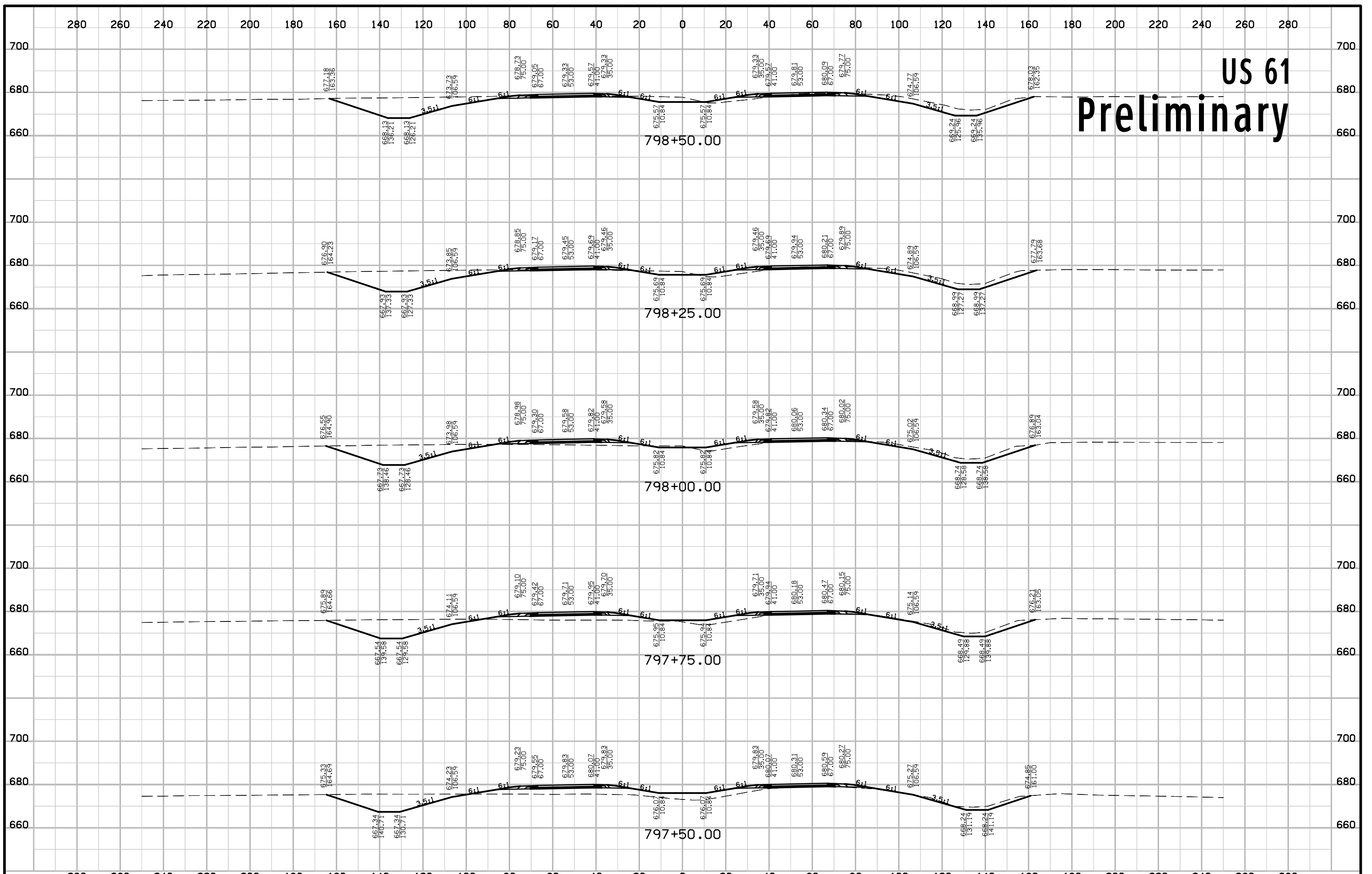

US 61 Preliminary

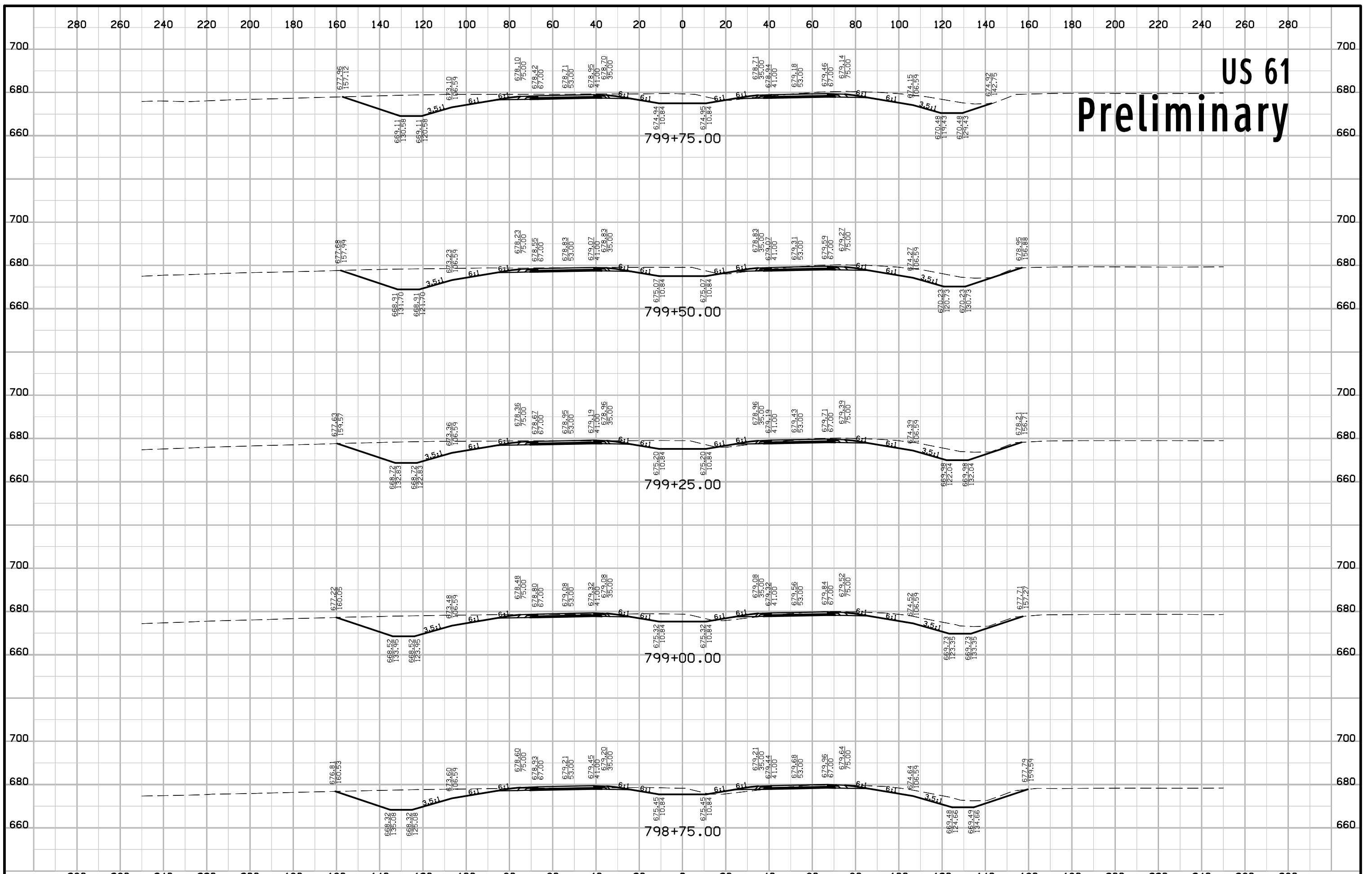

US 61 Preliminary

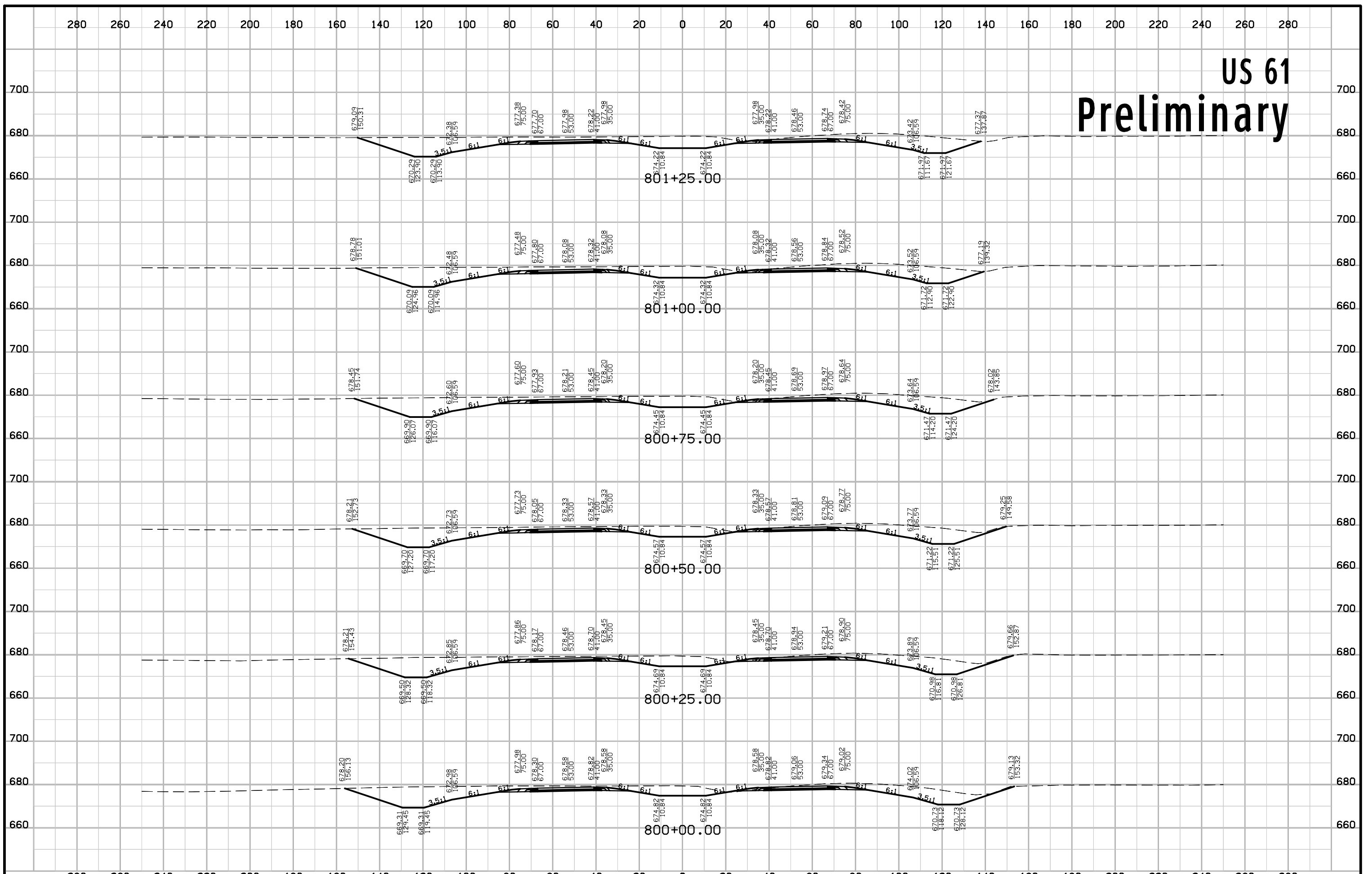

US 61 Preliminary

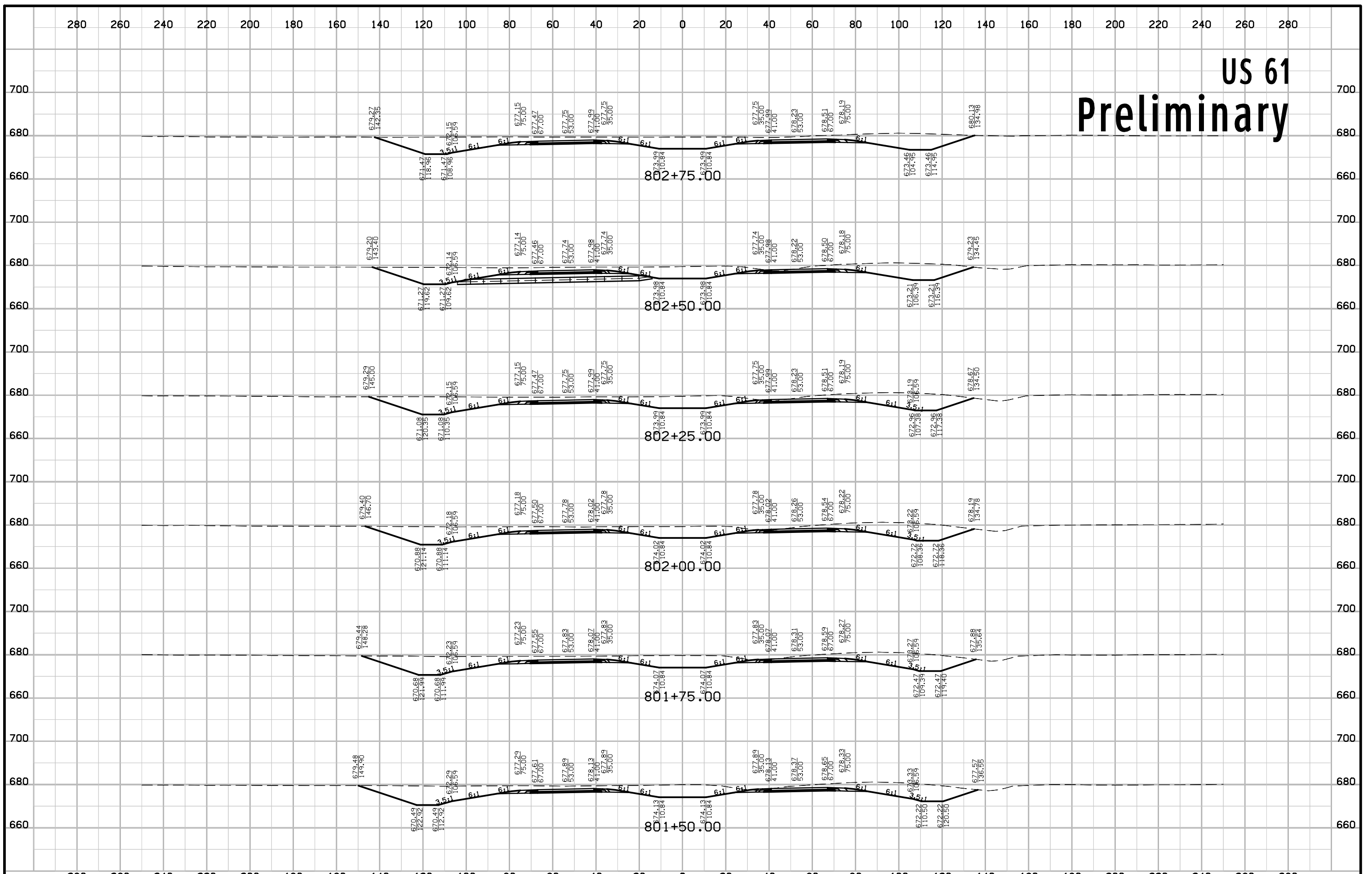

US 61 Preliminary

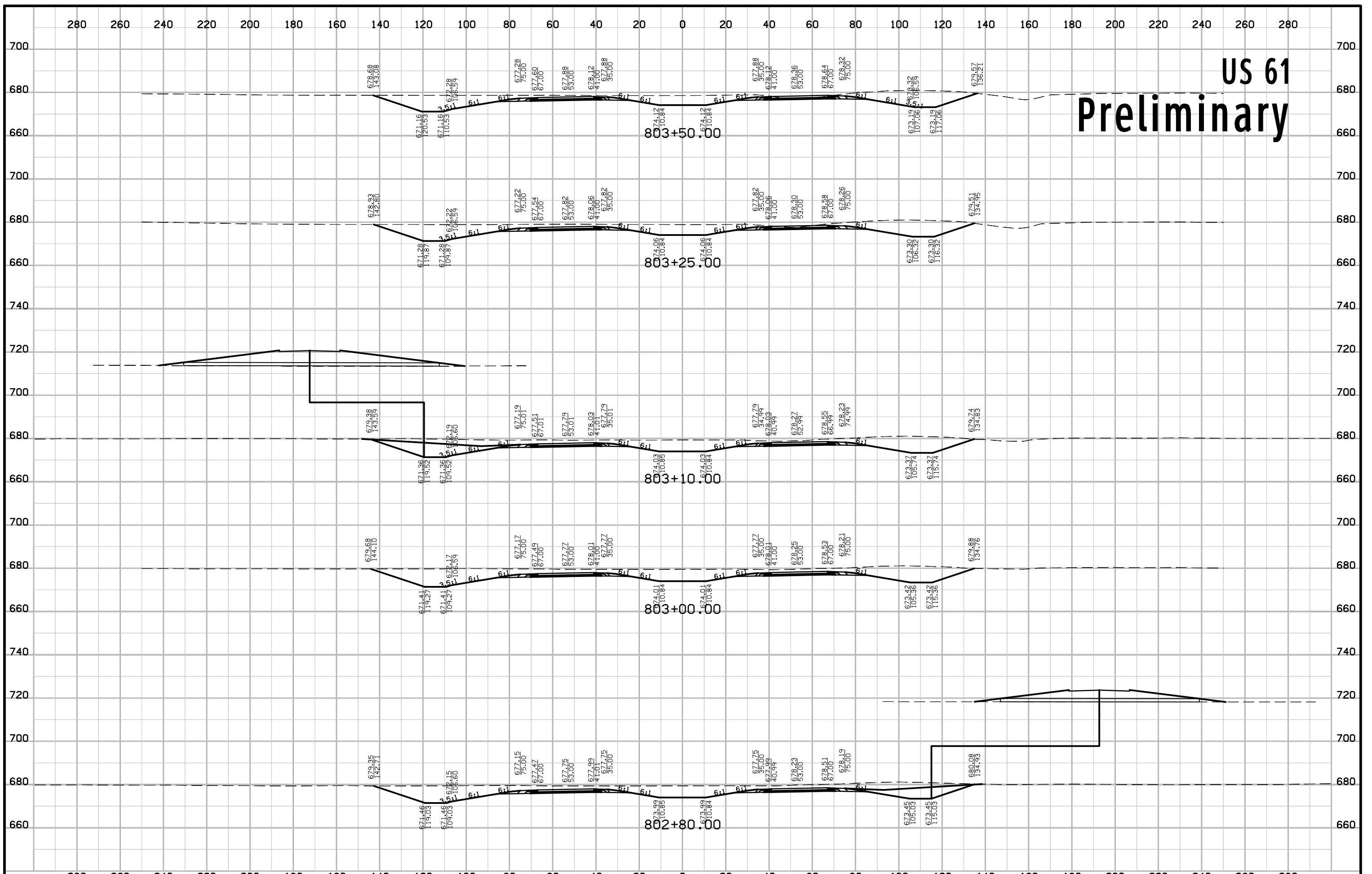

US 61 Preliminary

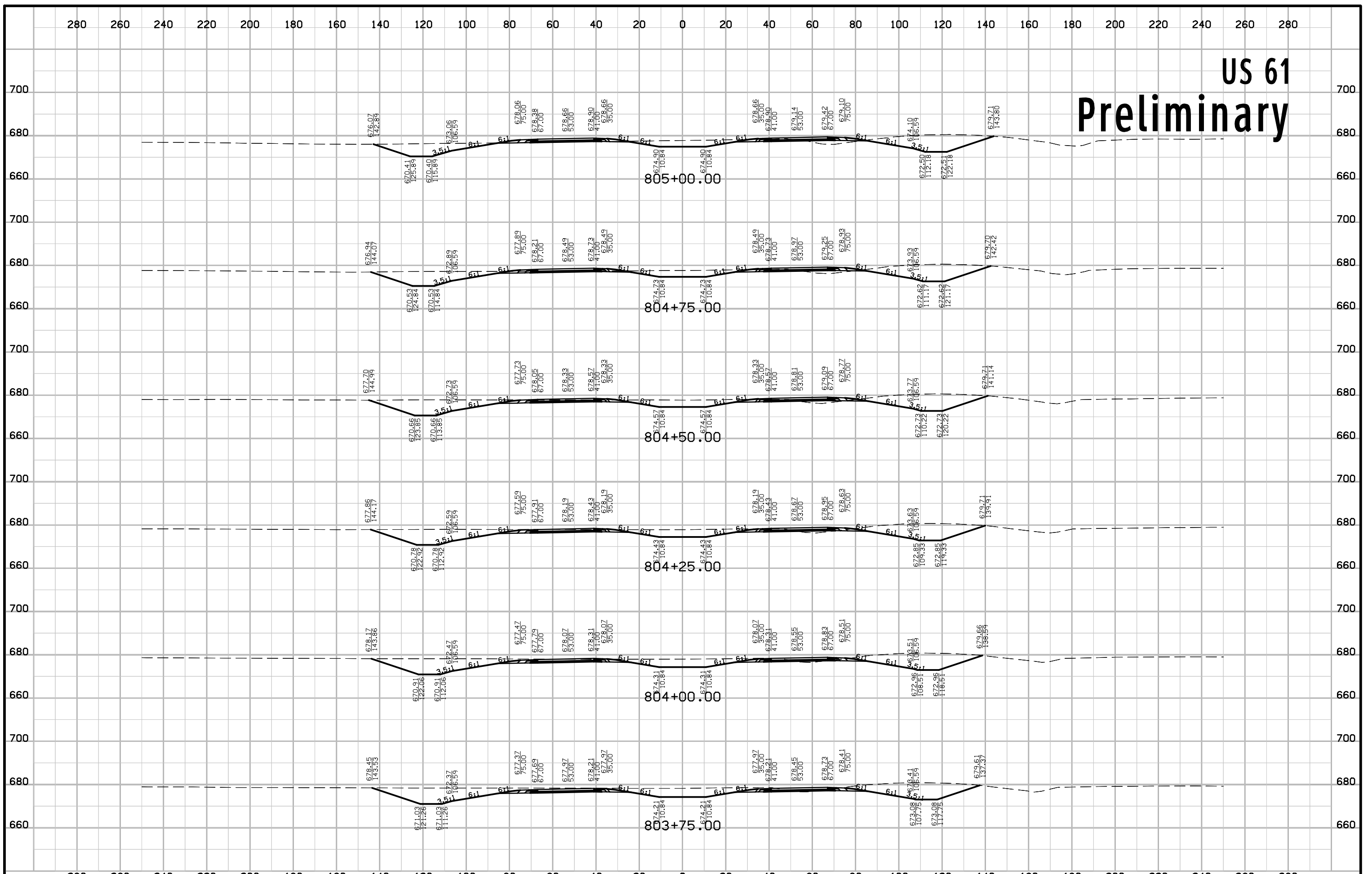

US 61 Preliminary

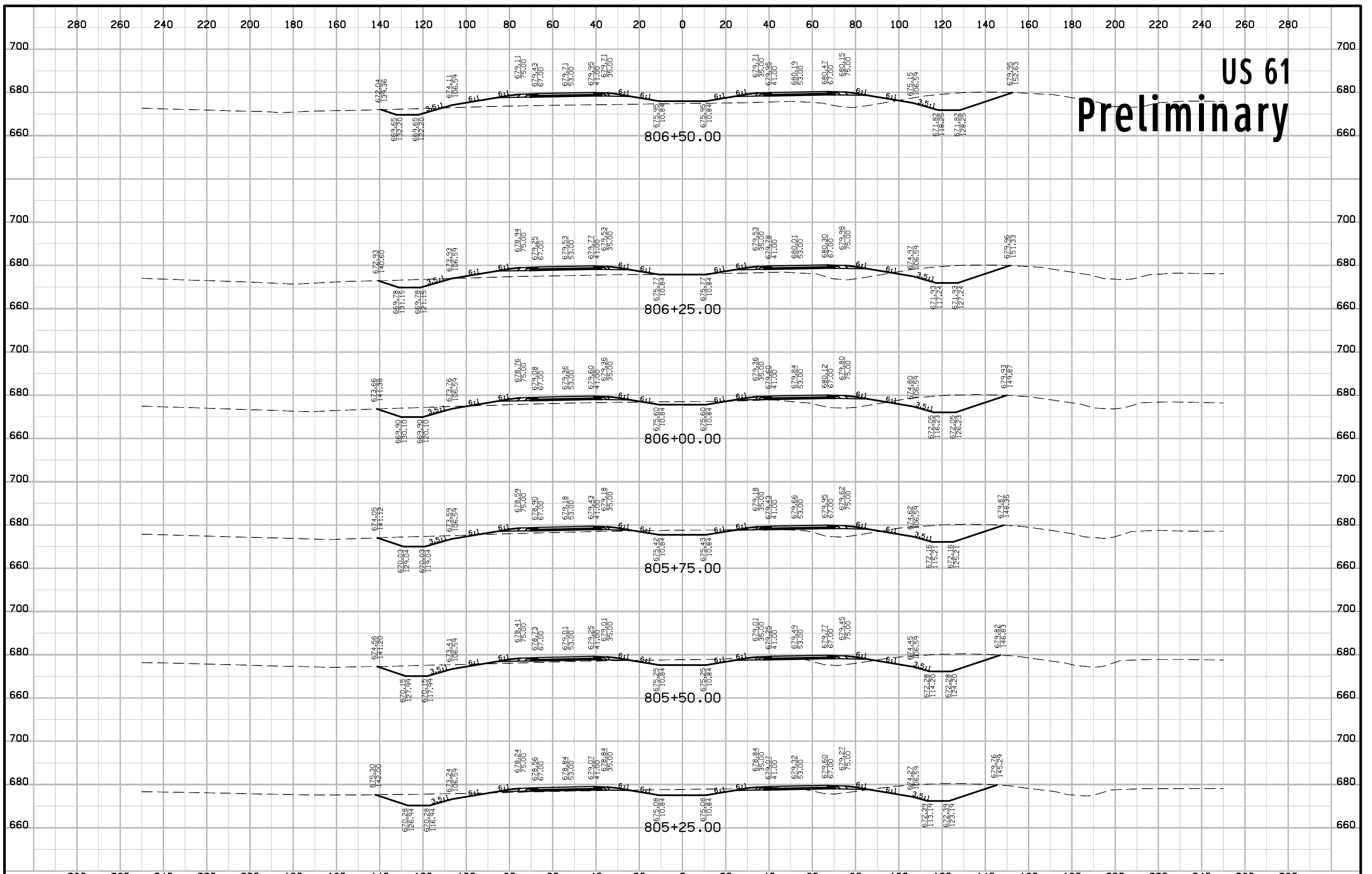

US 61 Preliminary

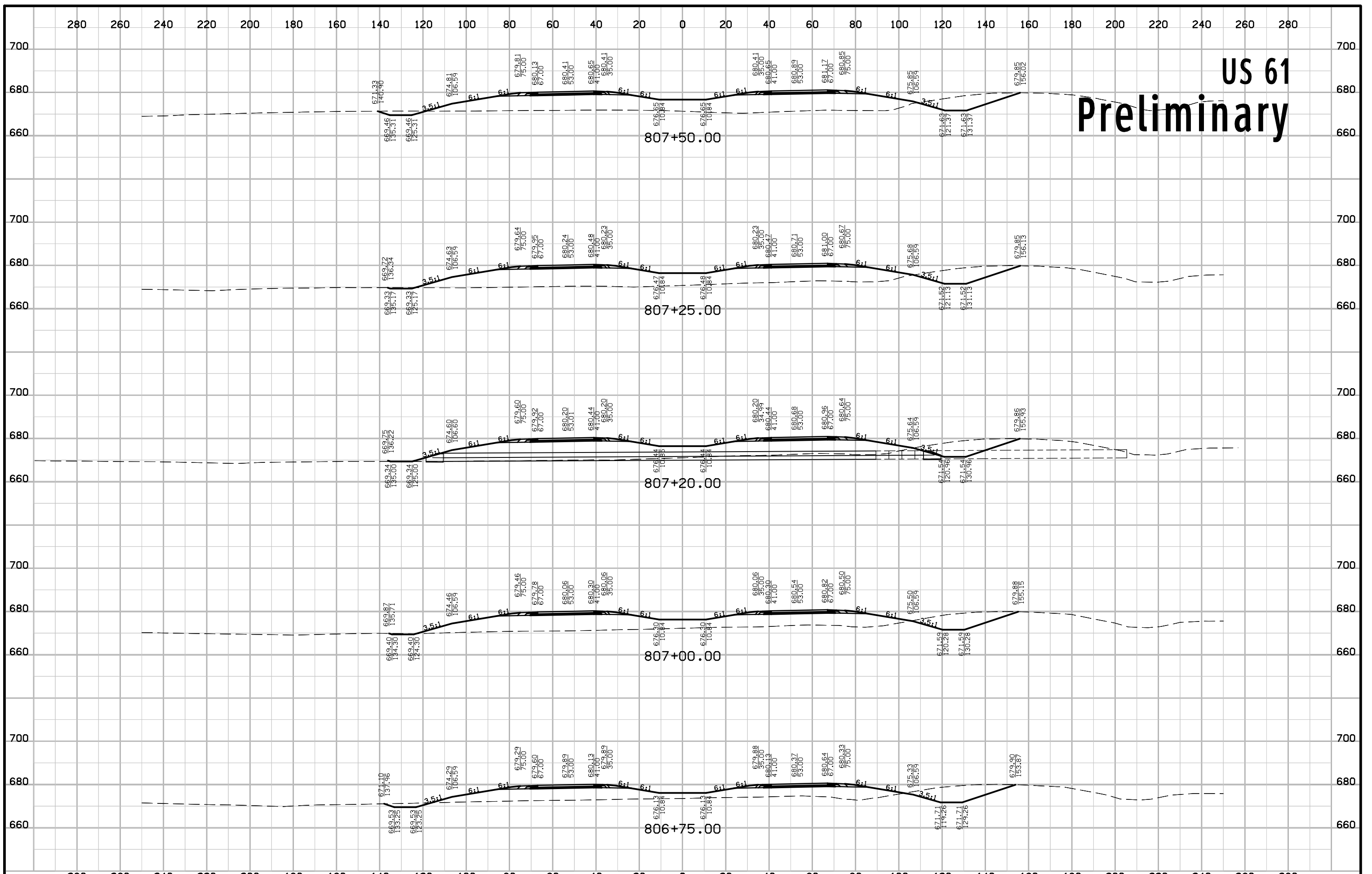

US 61 Preliminary

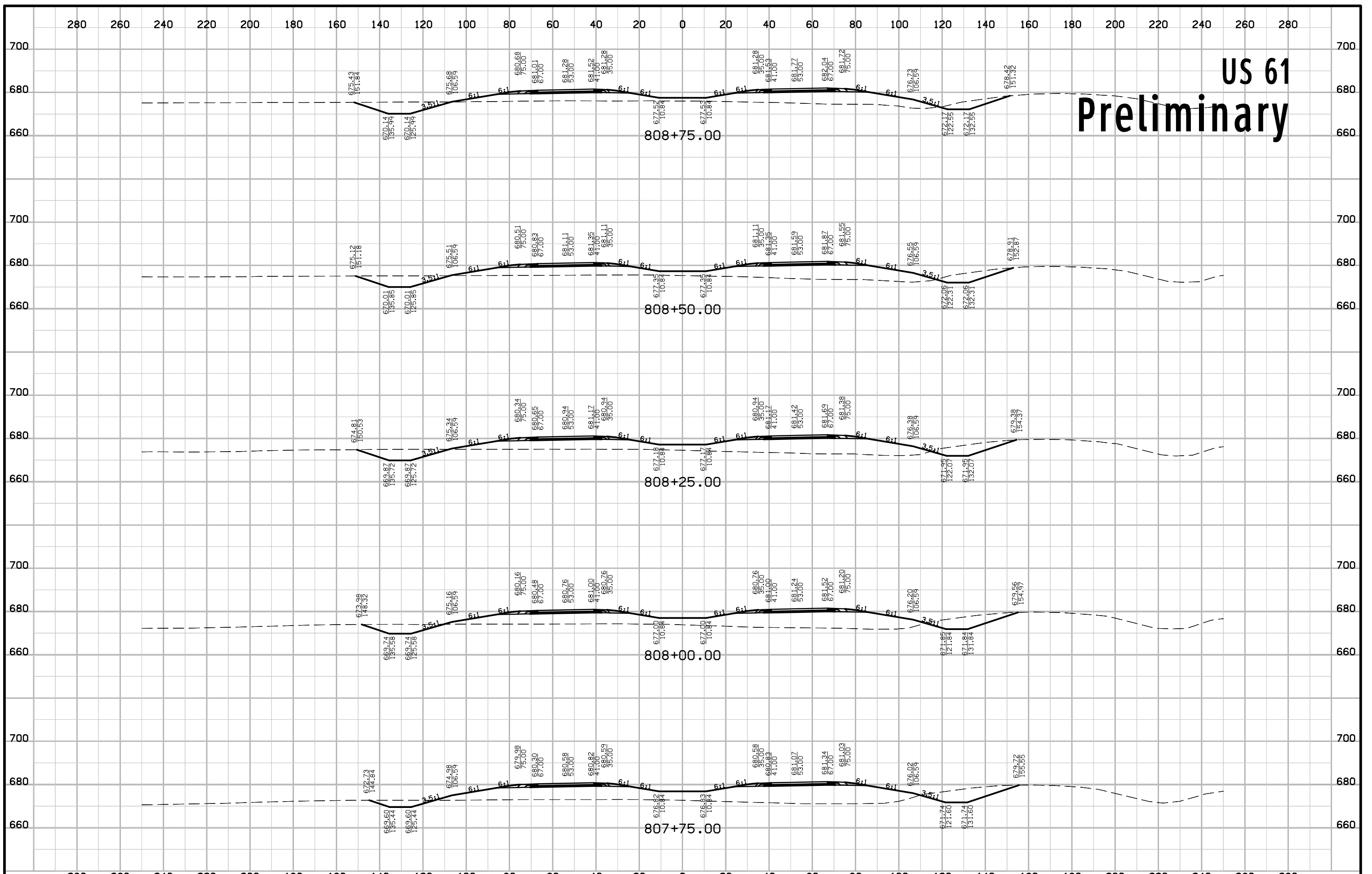

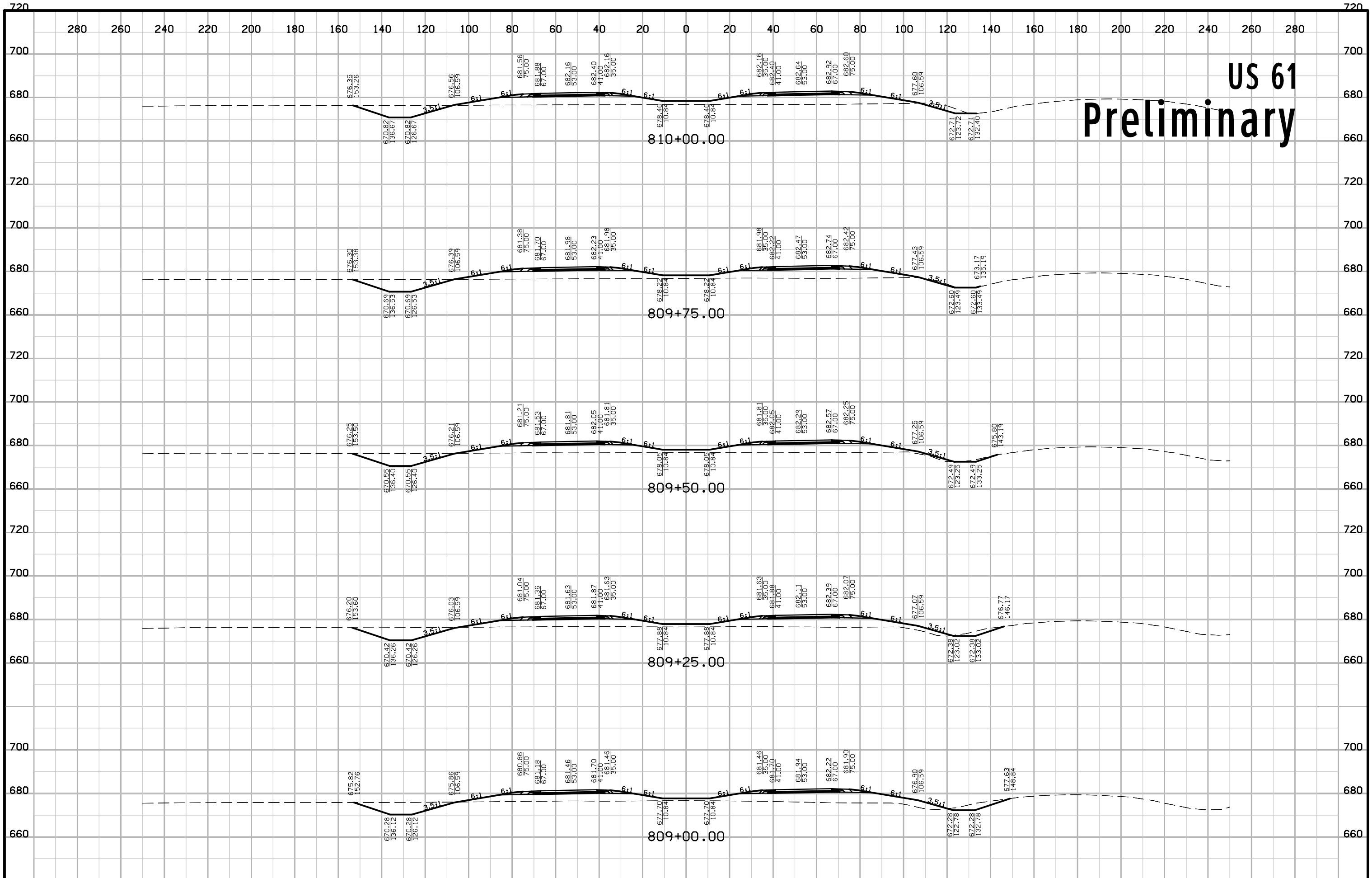

US 61 Preliminary

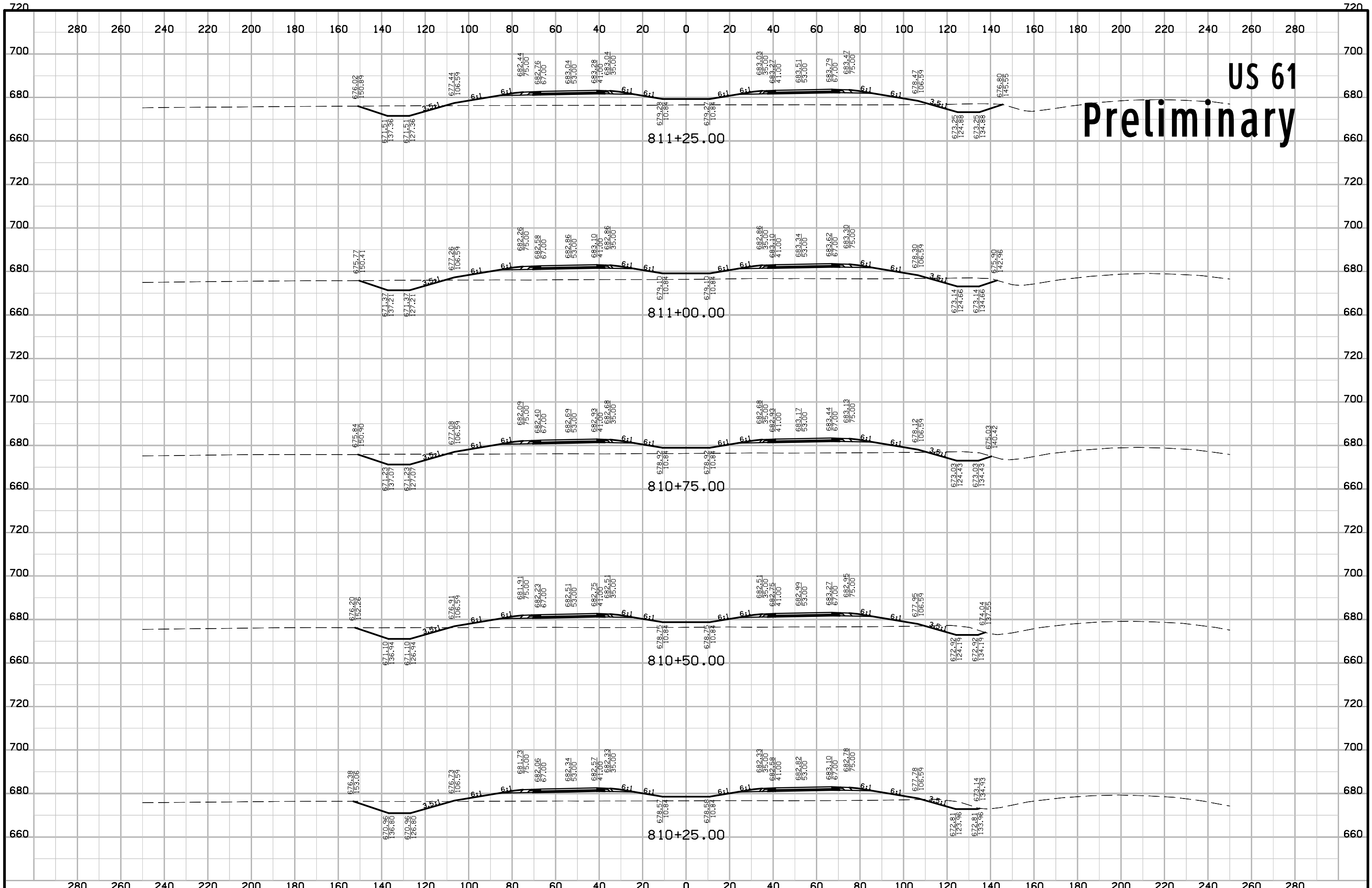

US 61
Preliminary

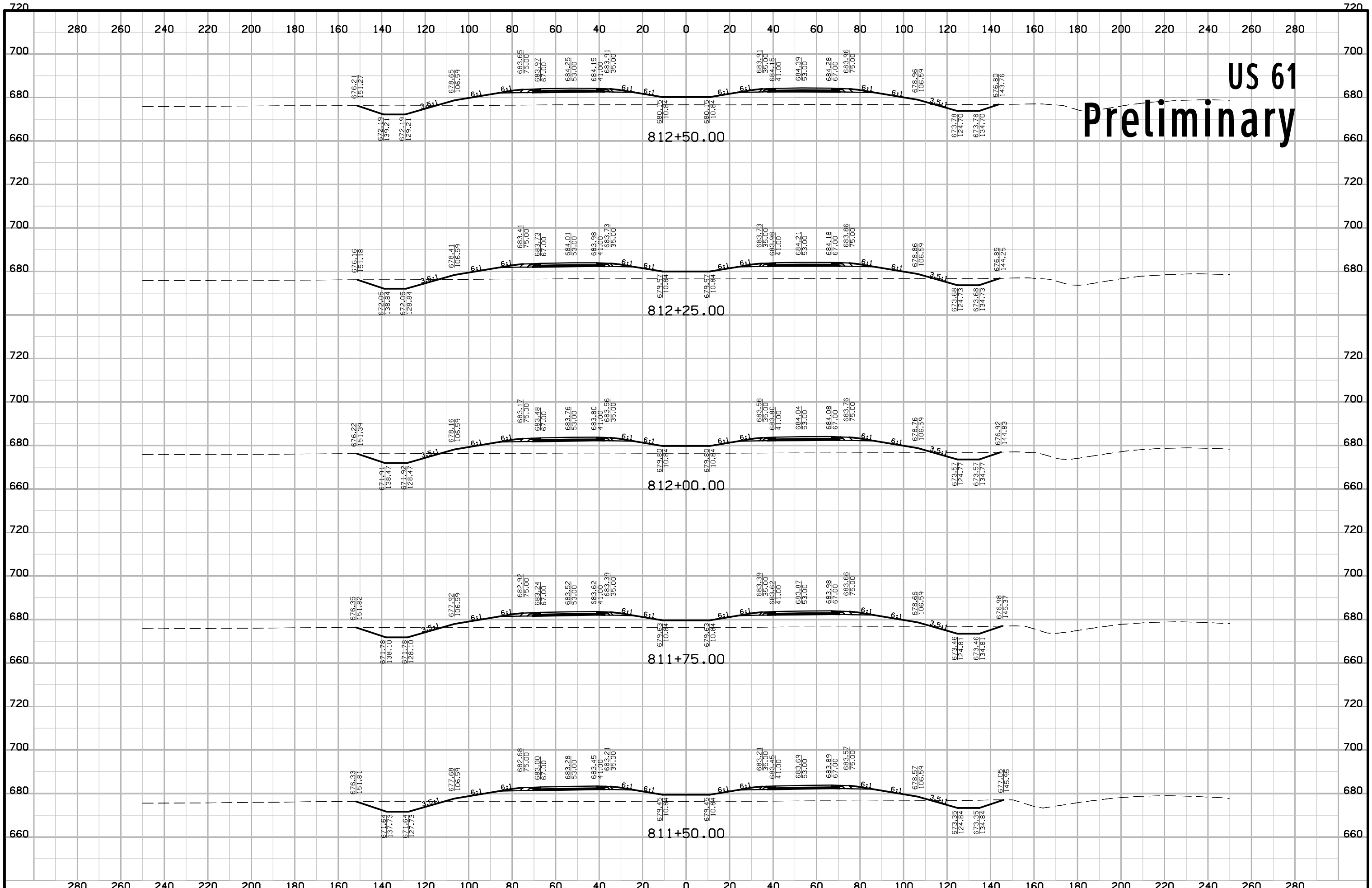

US 61 Preliminary

US 61 Preliminary

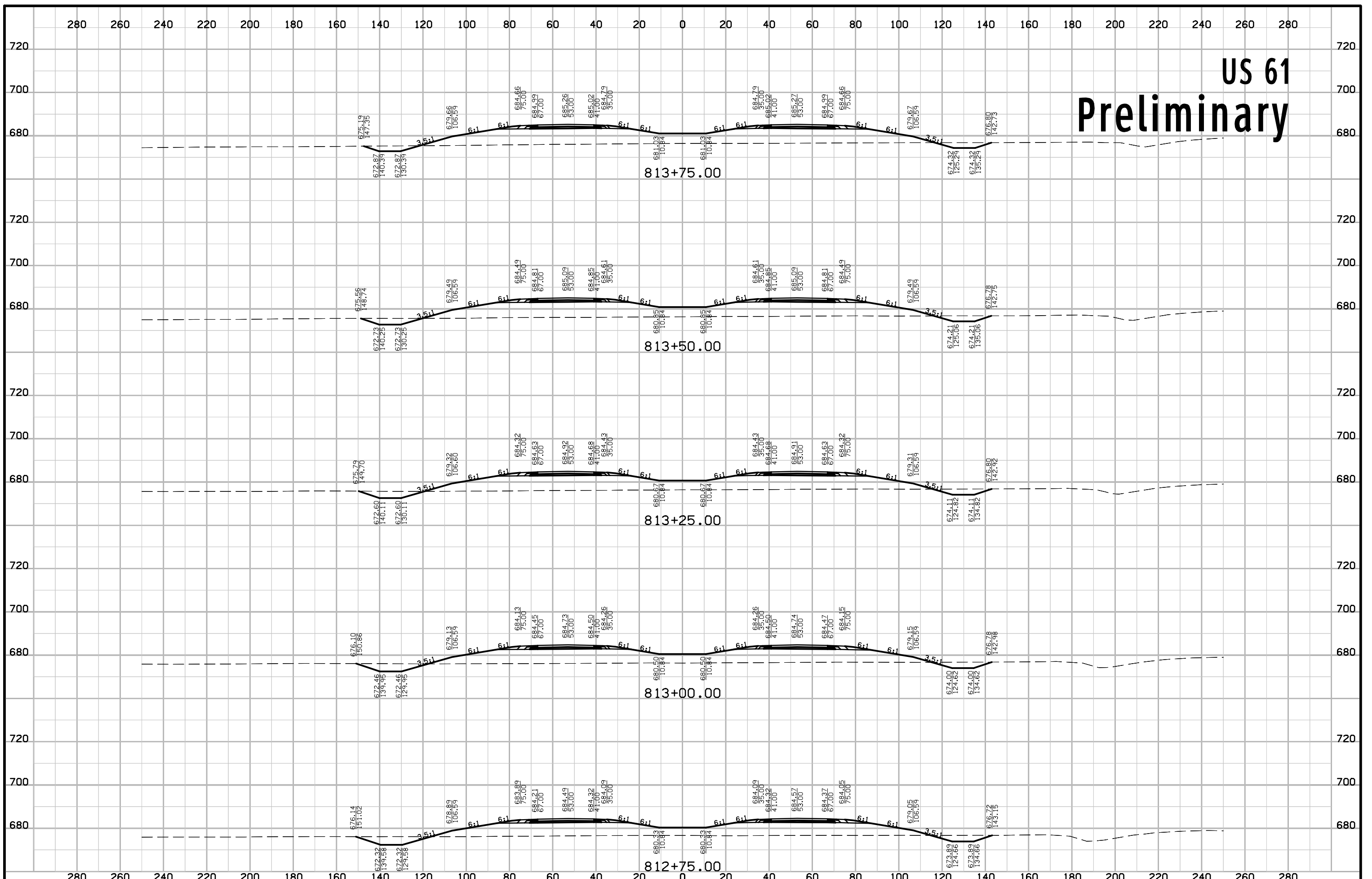

US 61 Preliminary

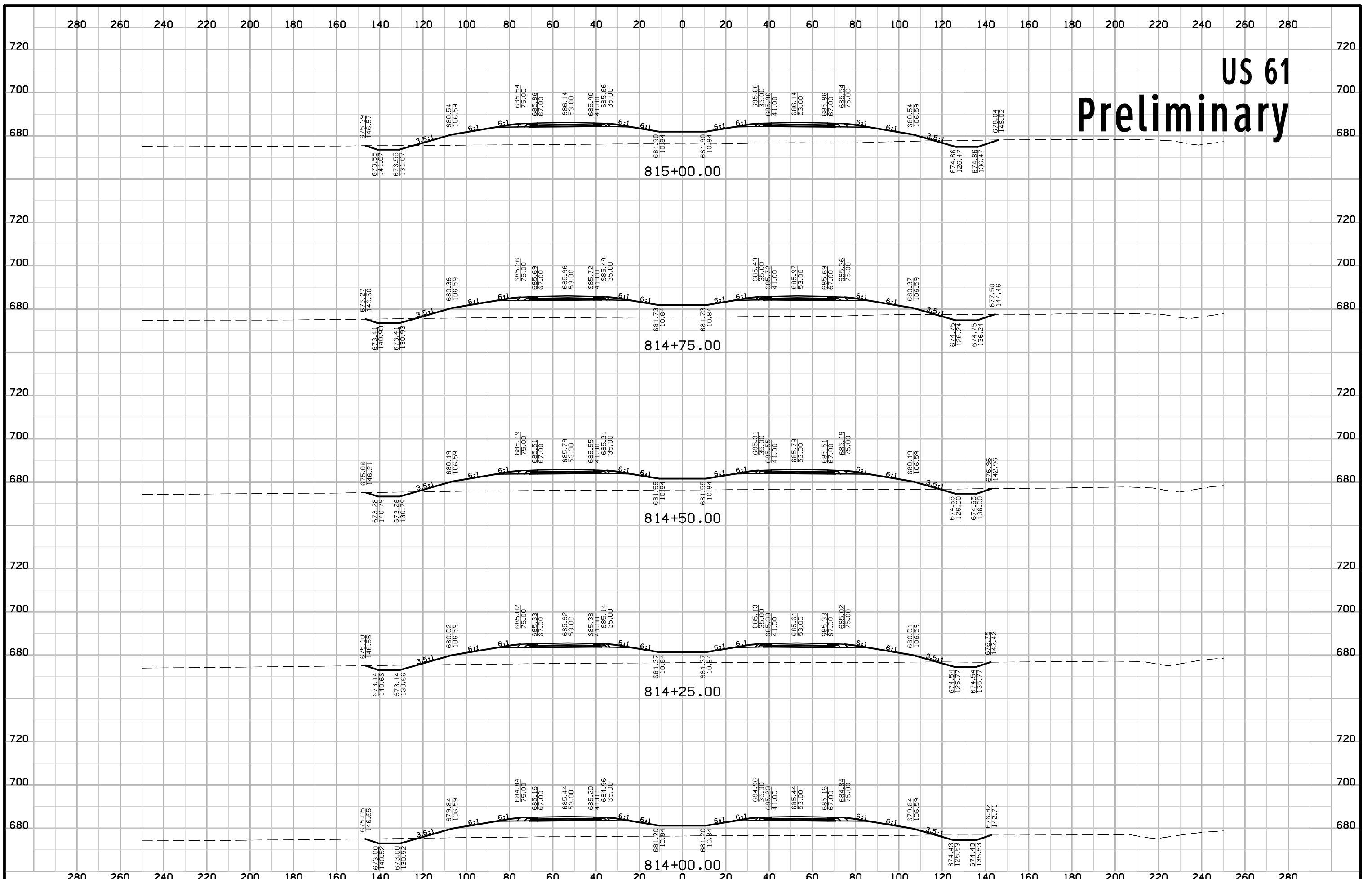

US 61 Preliminary

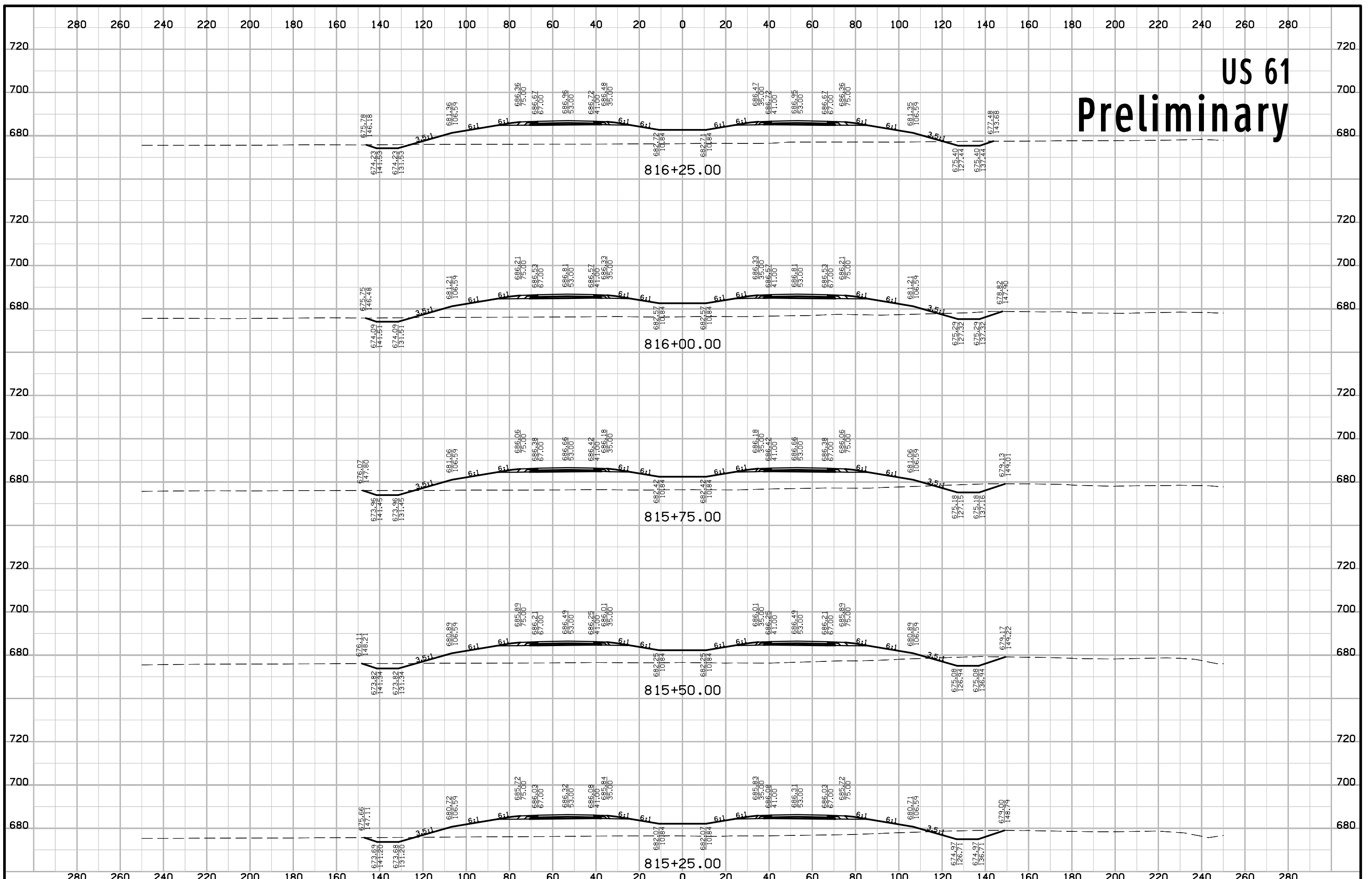

US 61 Preliminary

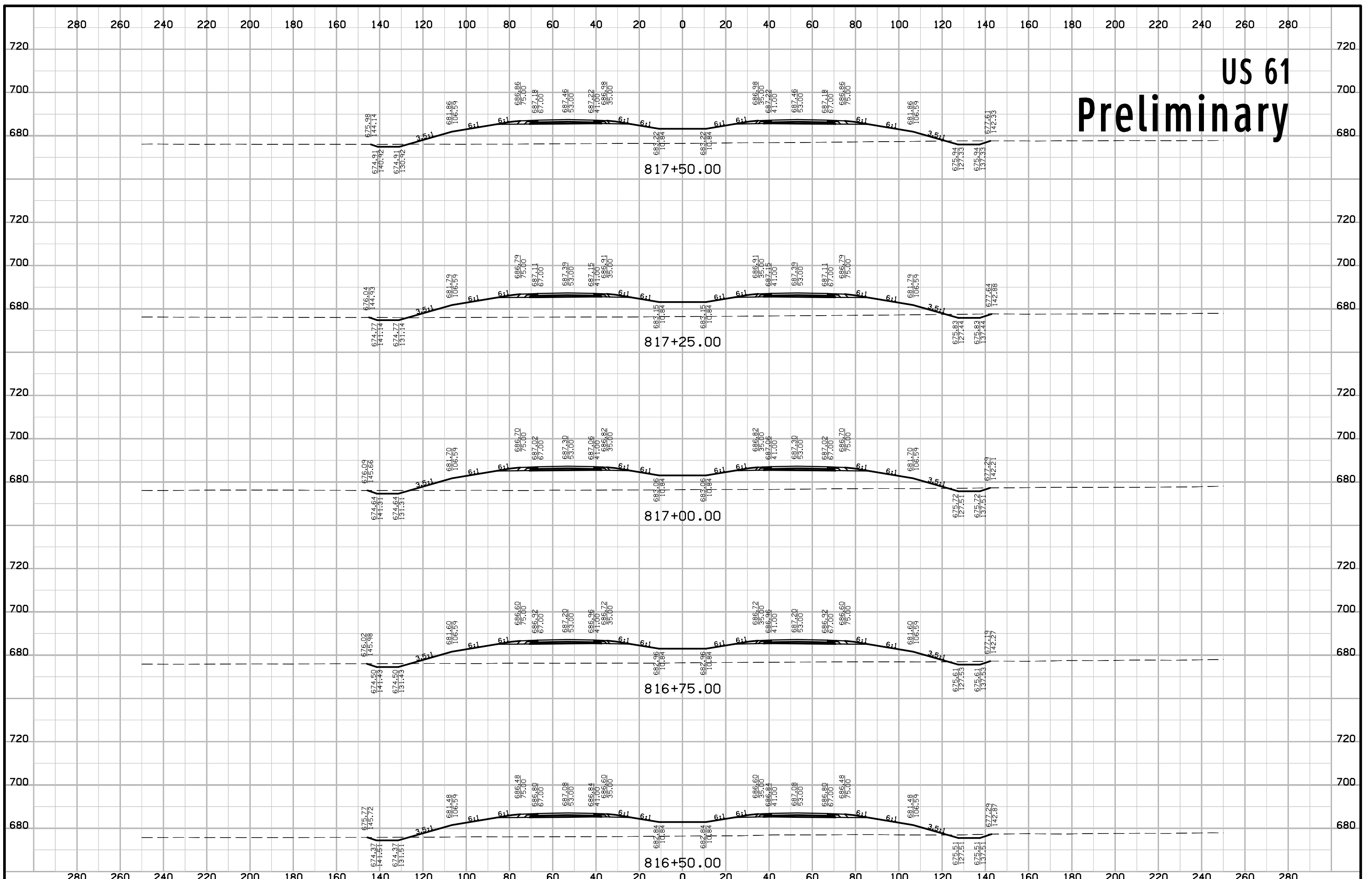

US 61 Preliminary

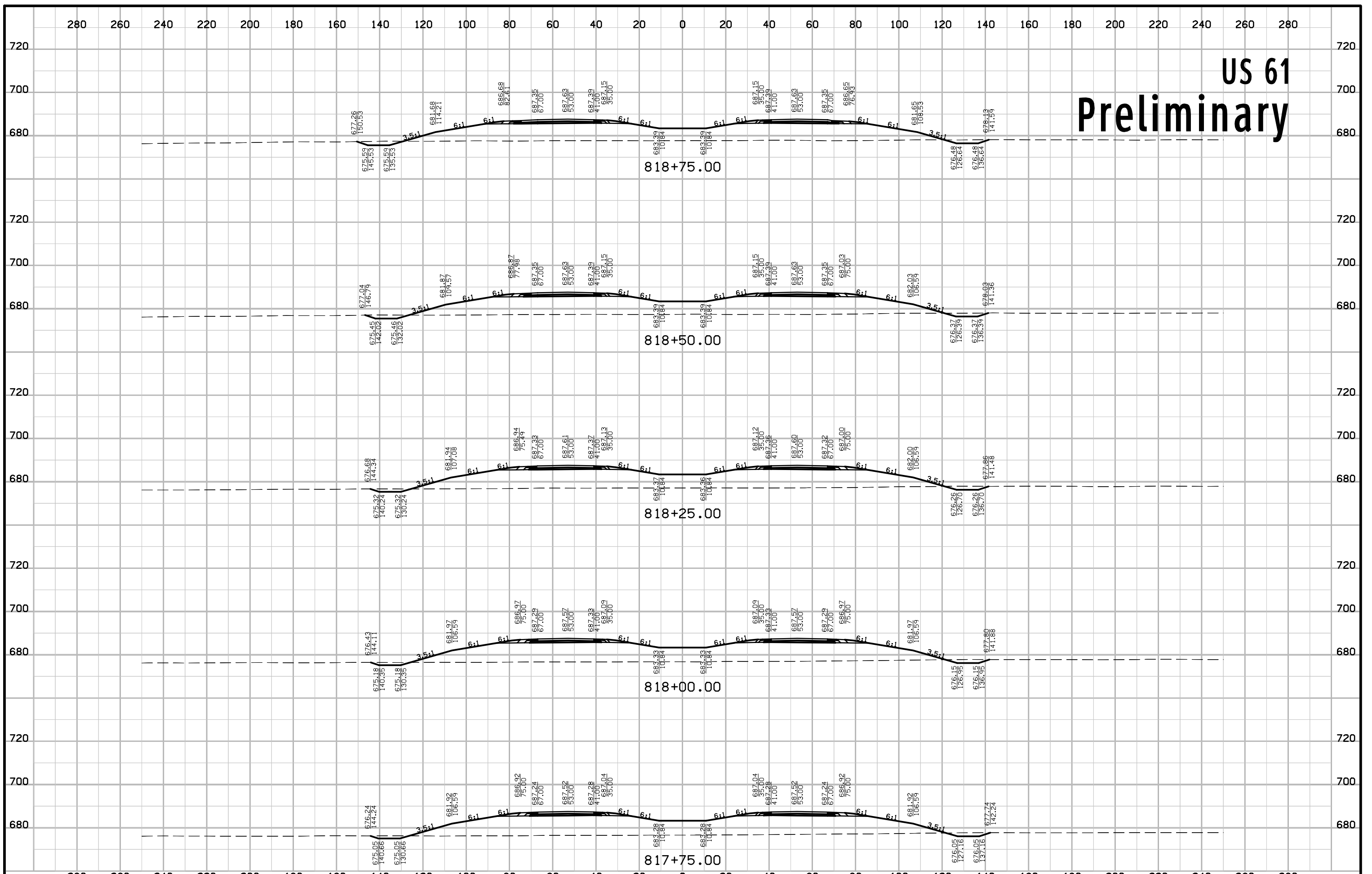

US 61 Preliminary

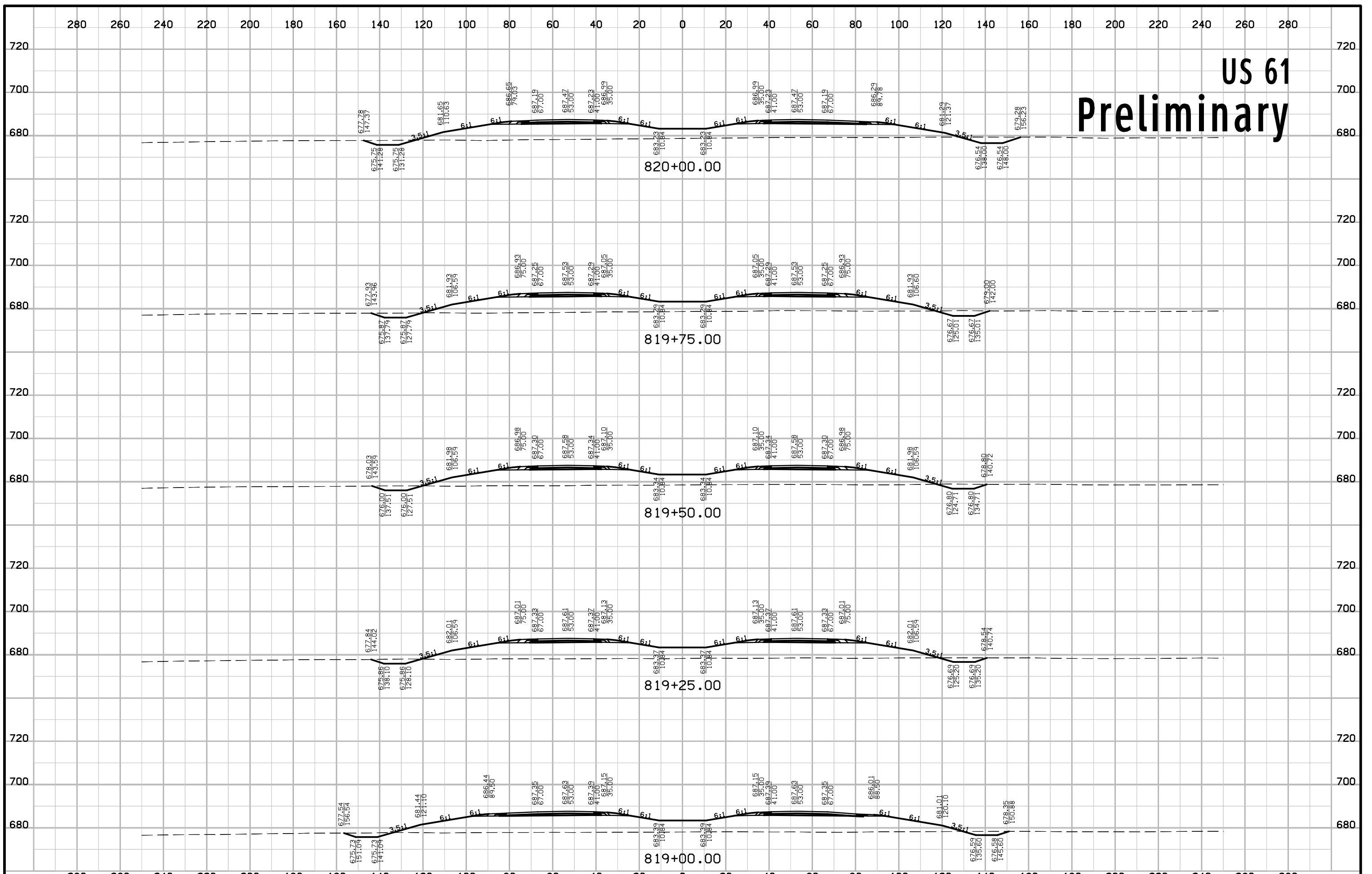

US 61 Preliminary

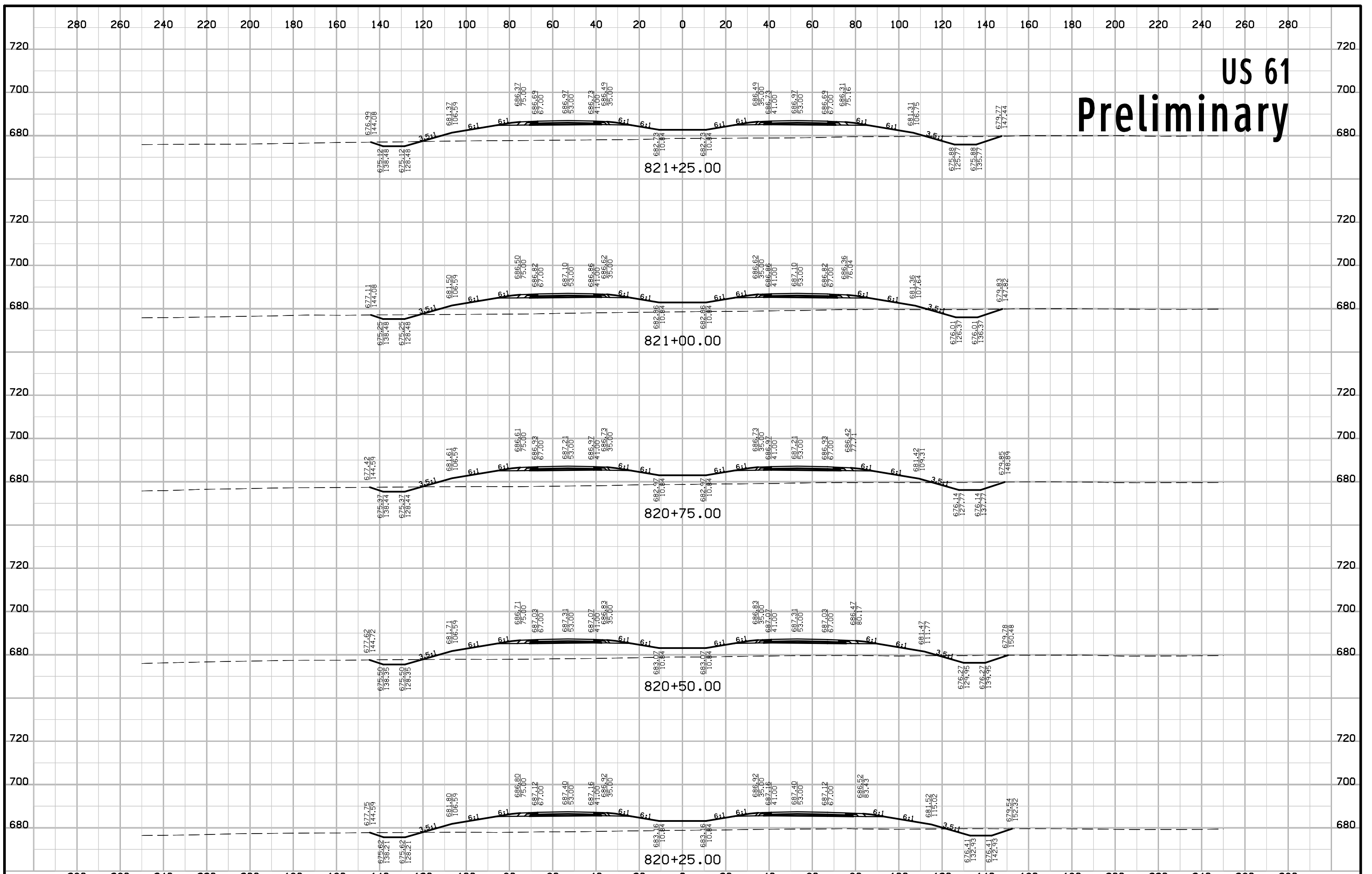

US 61 Preliminary

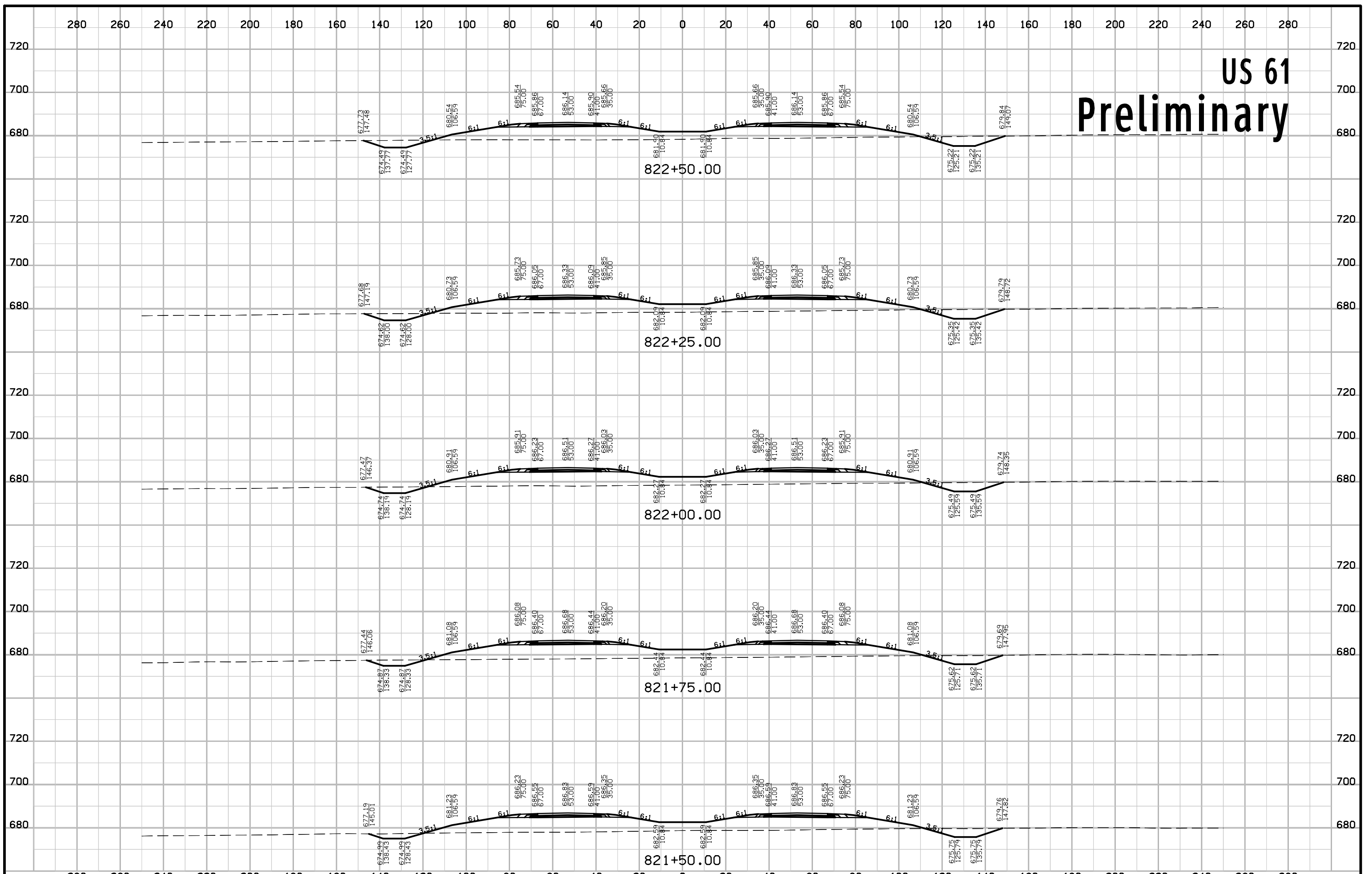

US 61 Preliminary

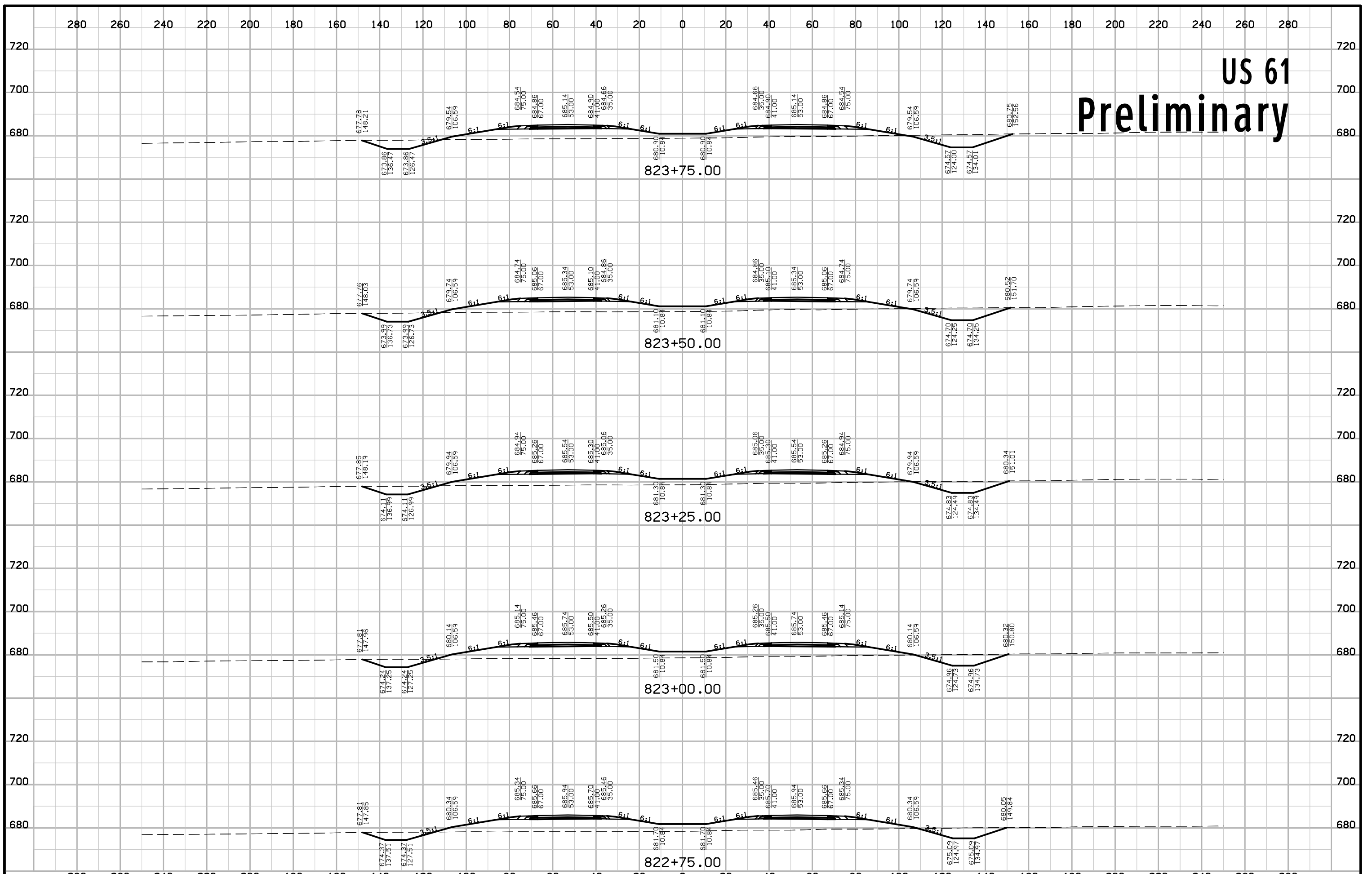

US 61 Preliminary

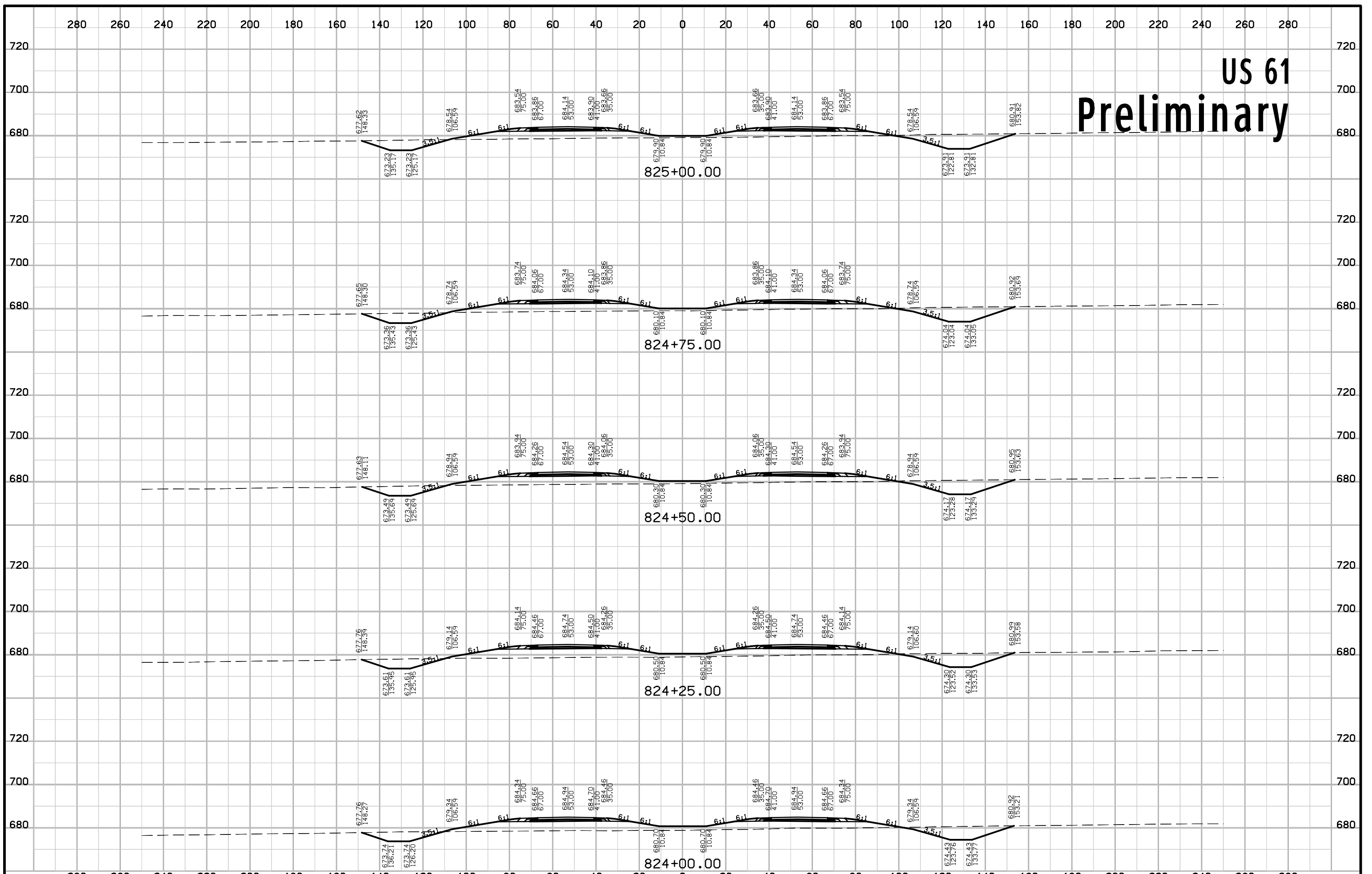

US 61 Preliminary

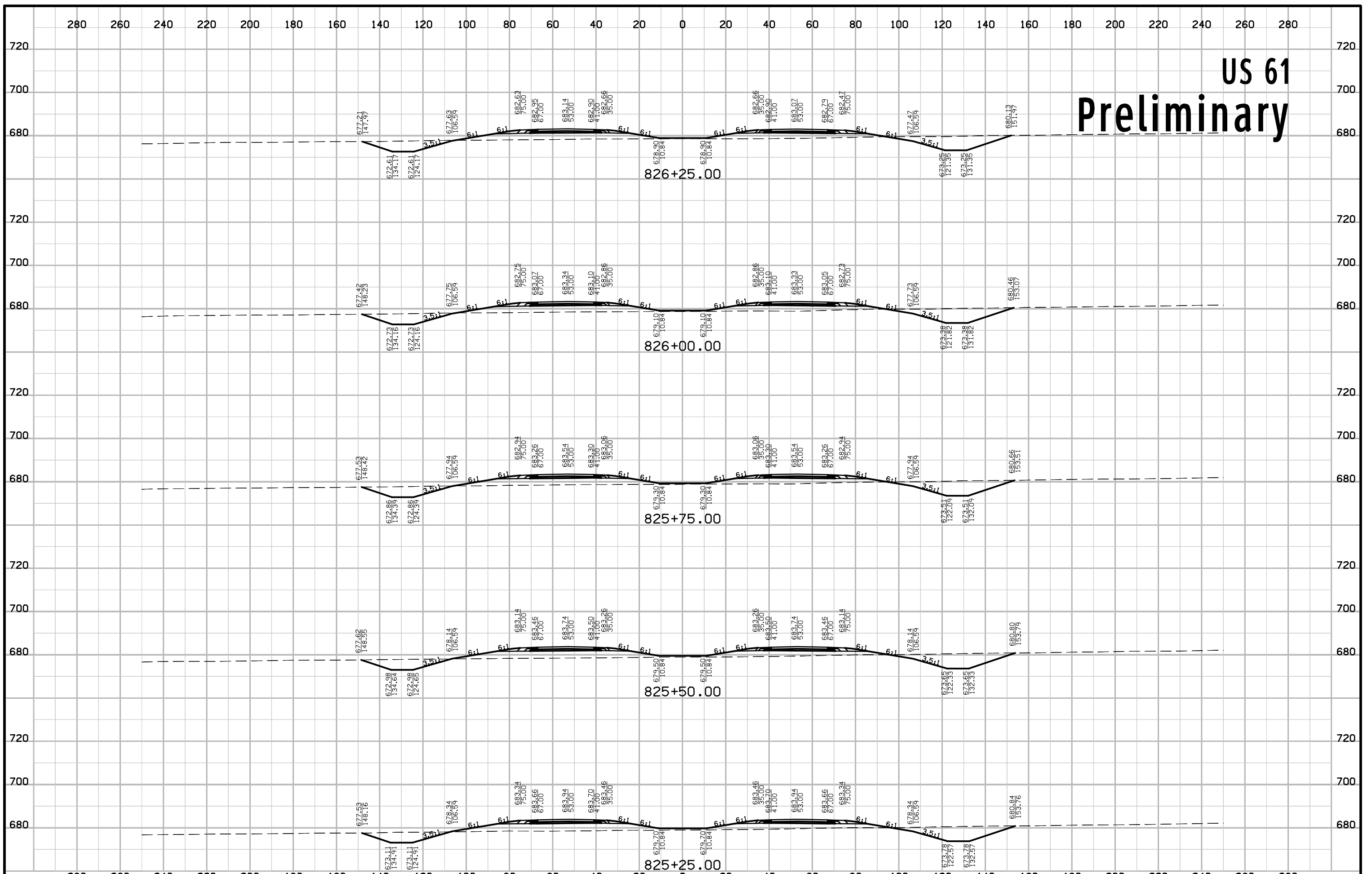

US 61 Preliminary

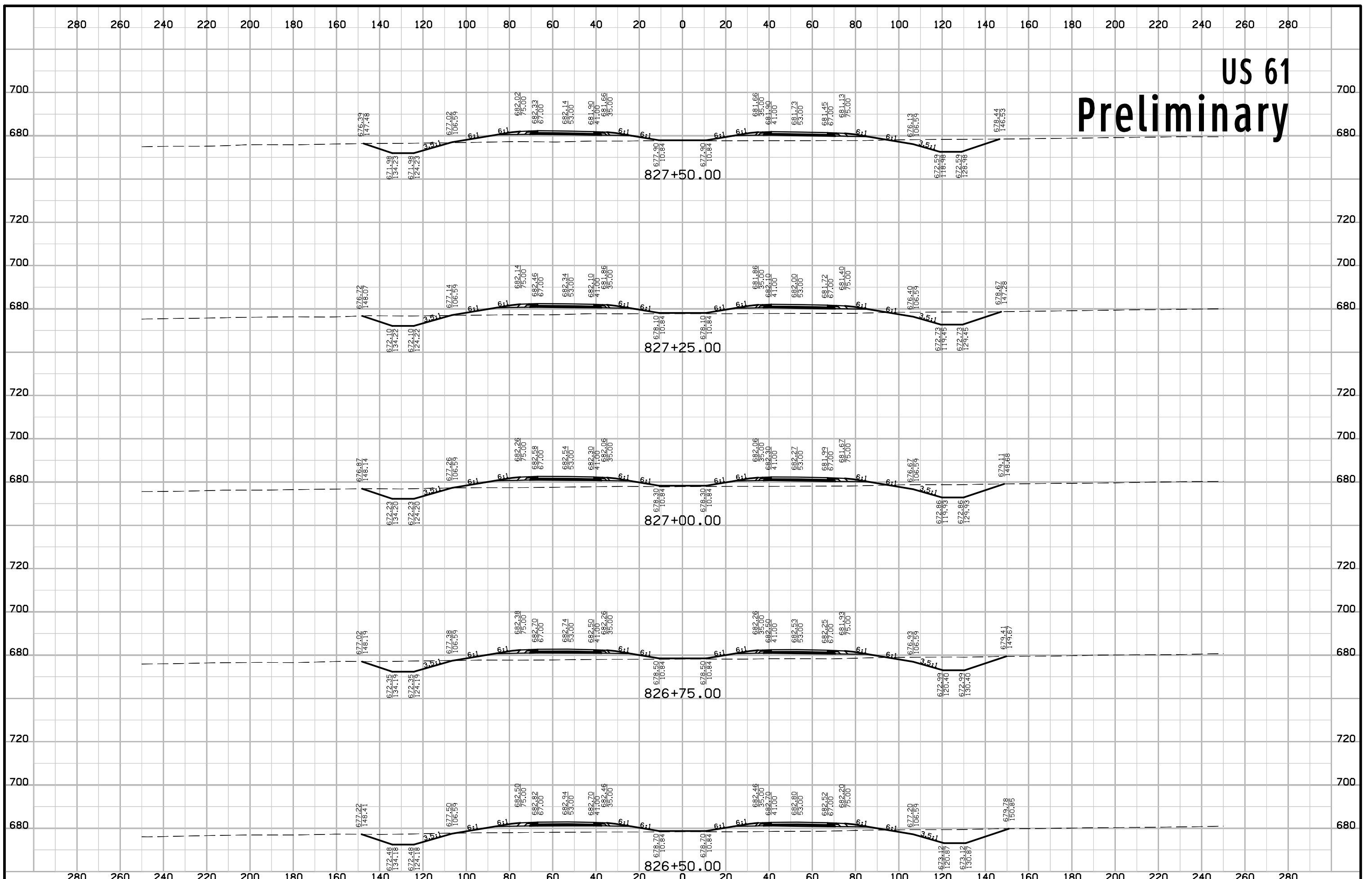

US 61 Preliminary

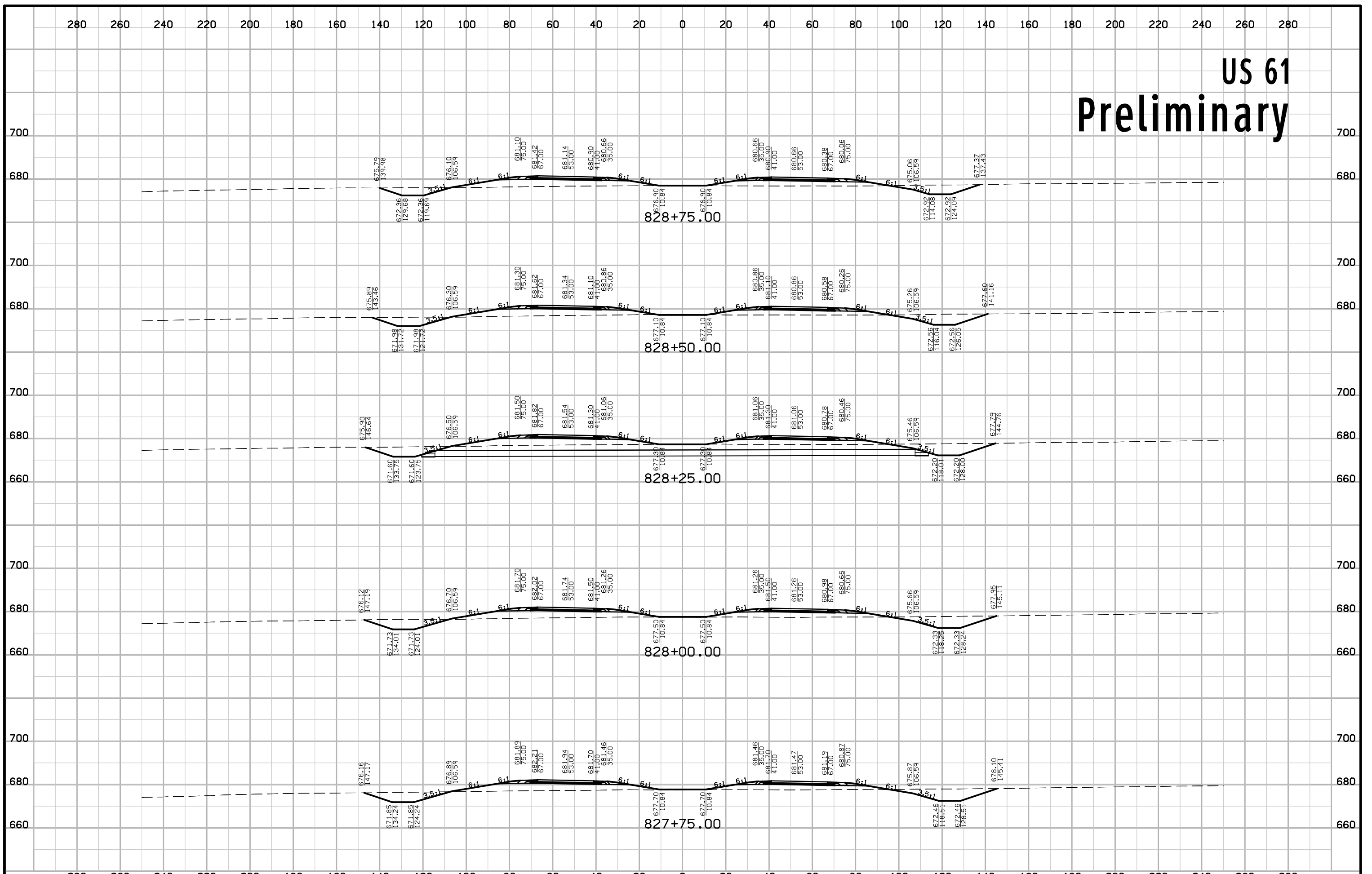

US 61 Preliminary

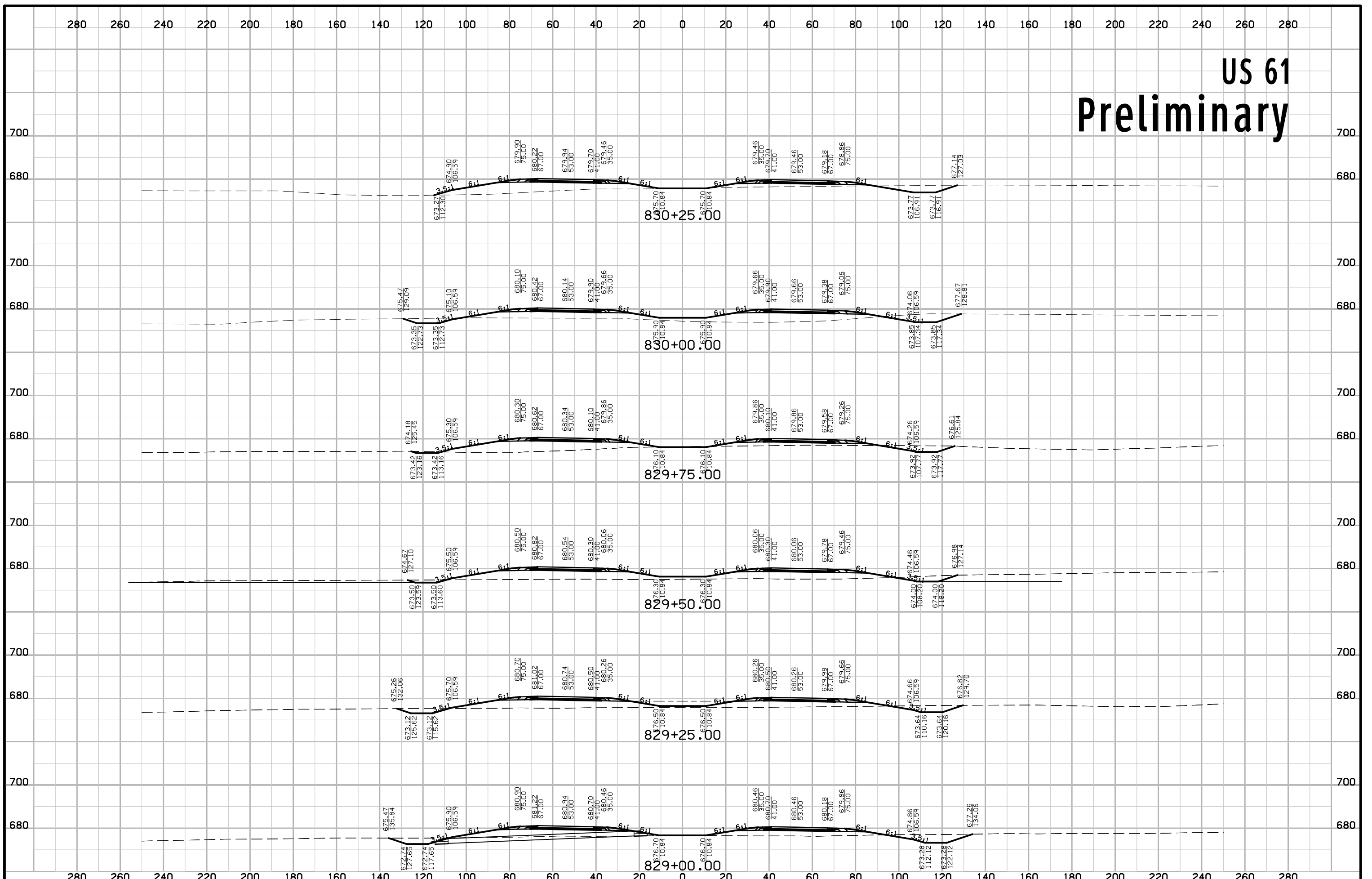

US 61 Preliminary

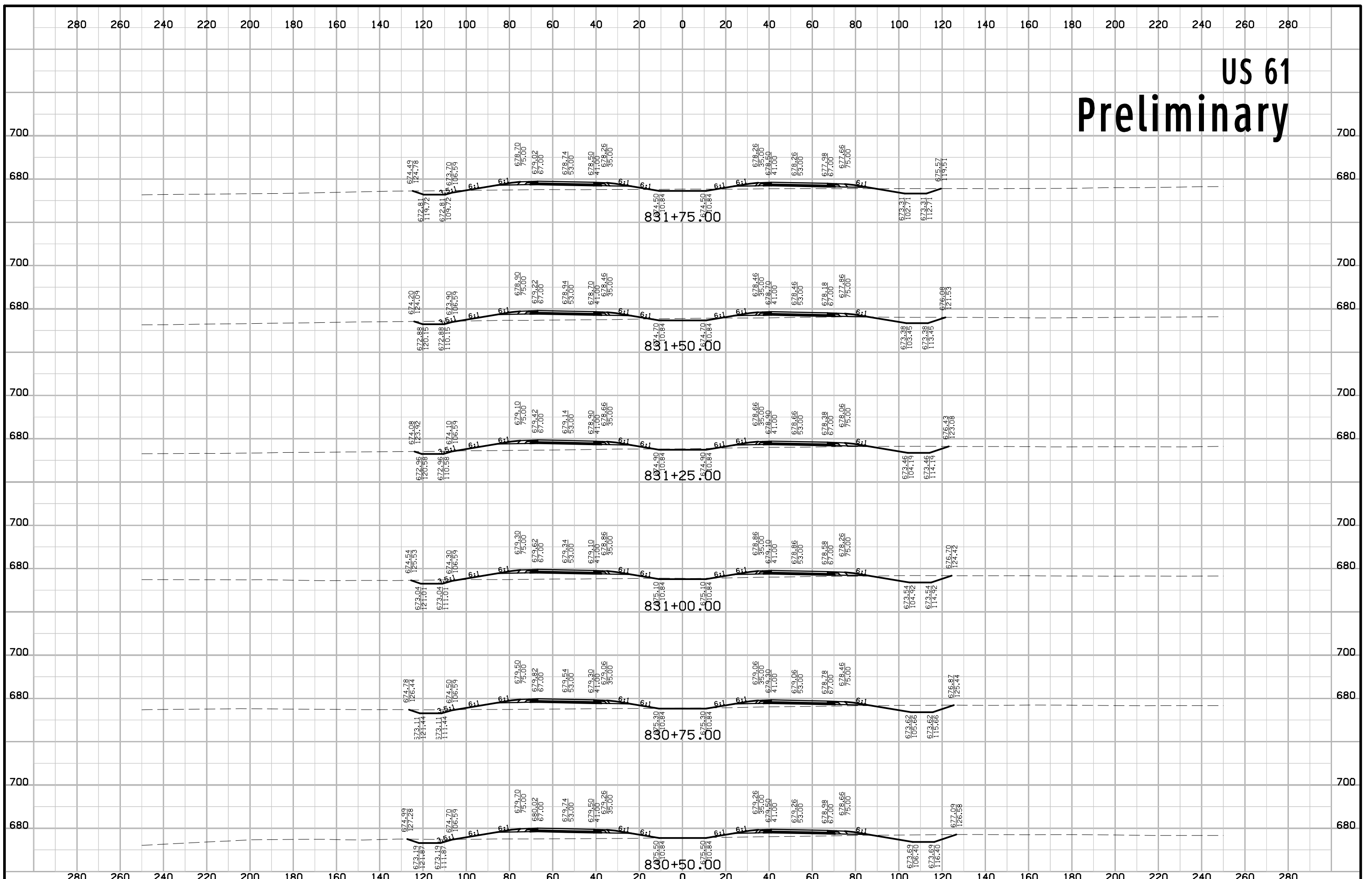

US 61 Preliminary

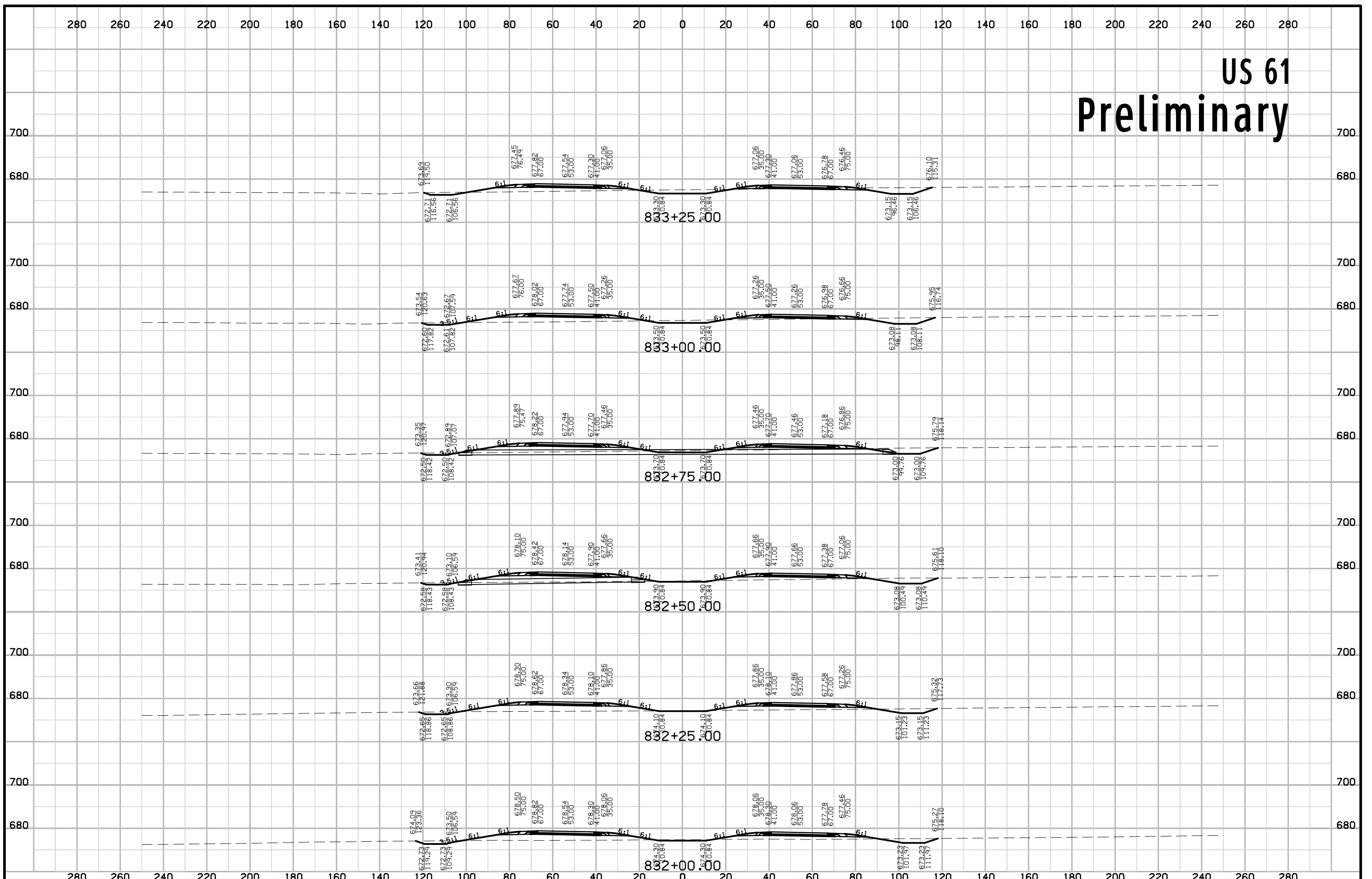

US 61 Preliminary

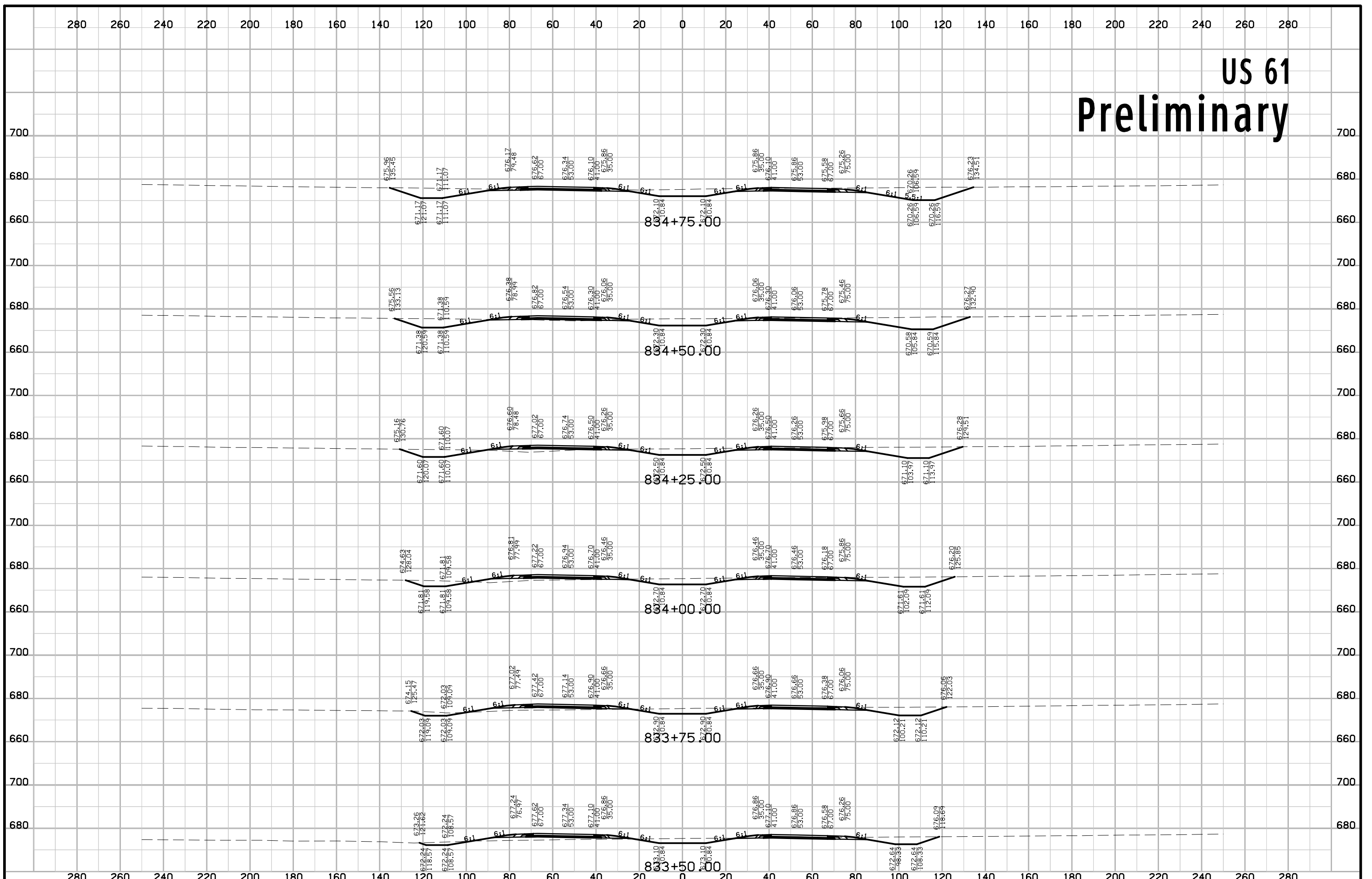

US 61 Preliminary

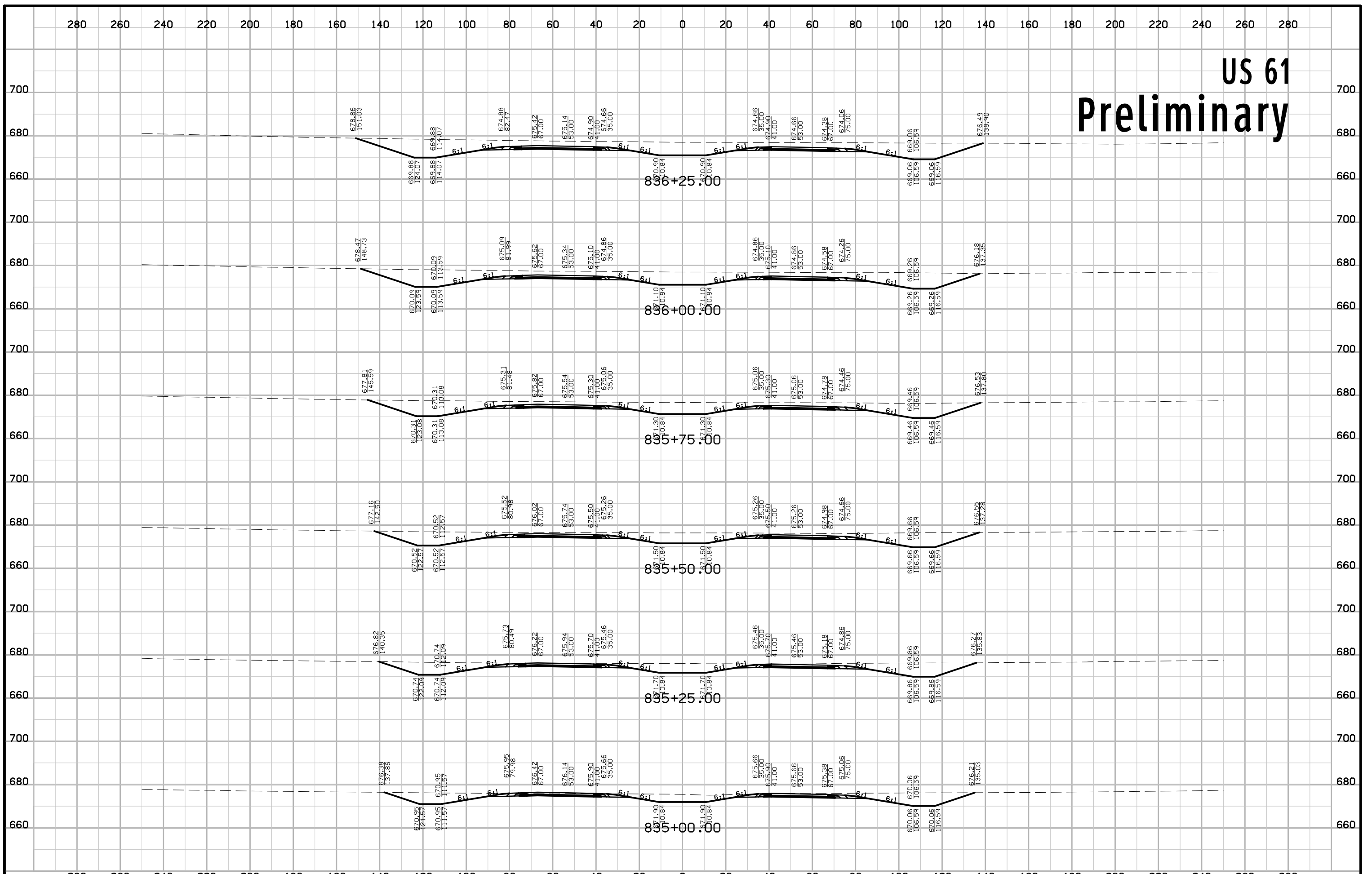

US 61 Preliminary

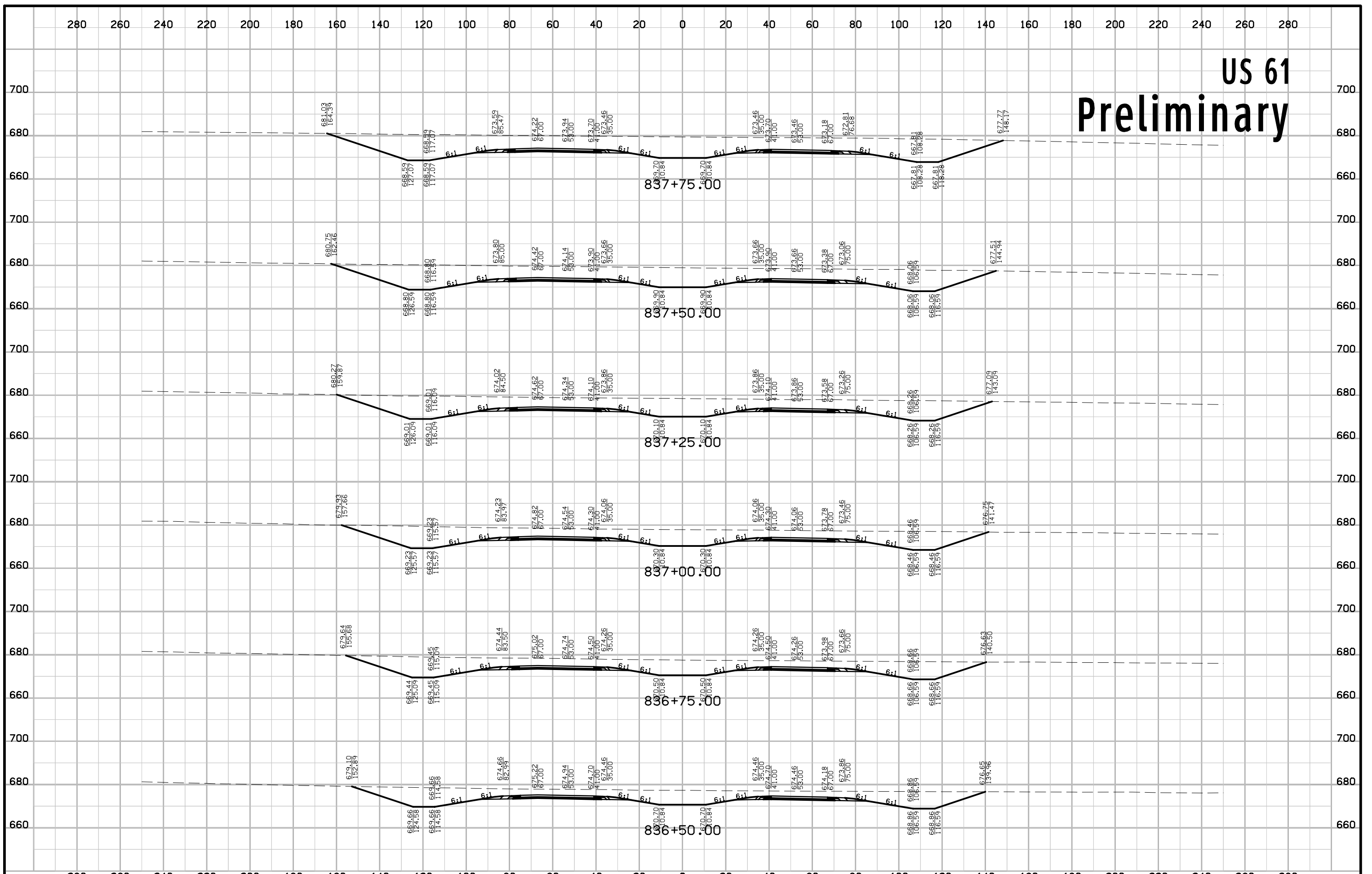

US 61 Preliminary

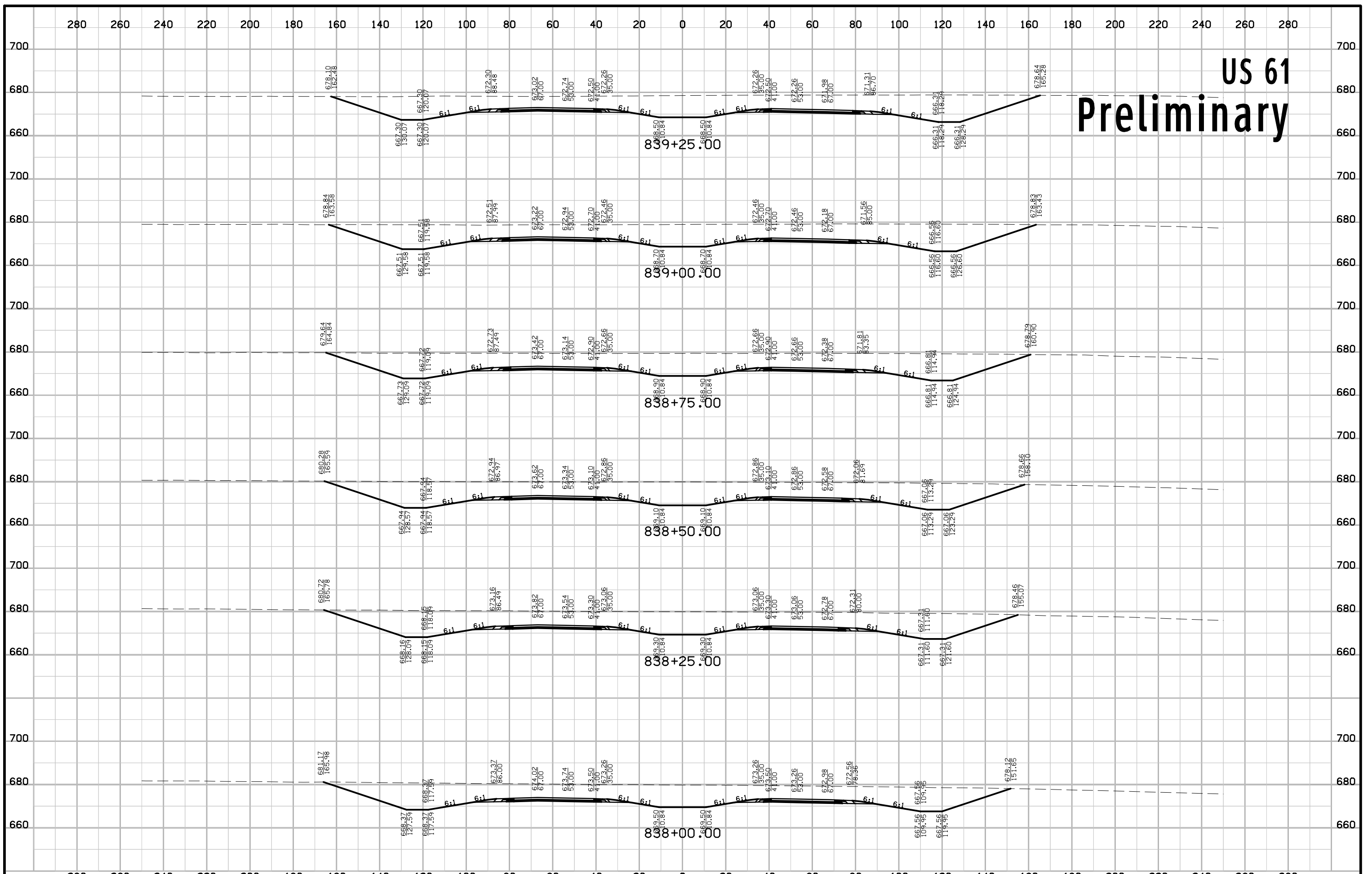

US 61 Preliminary

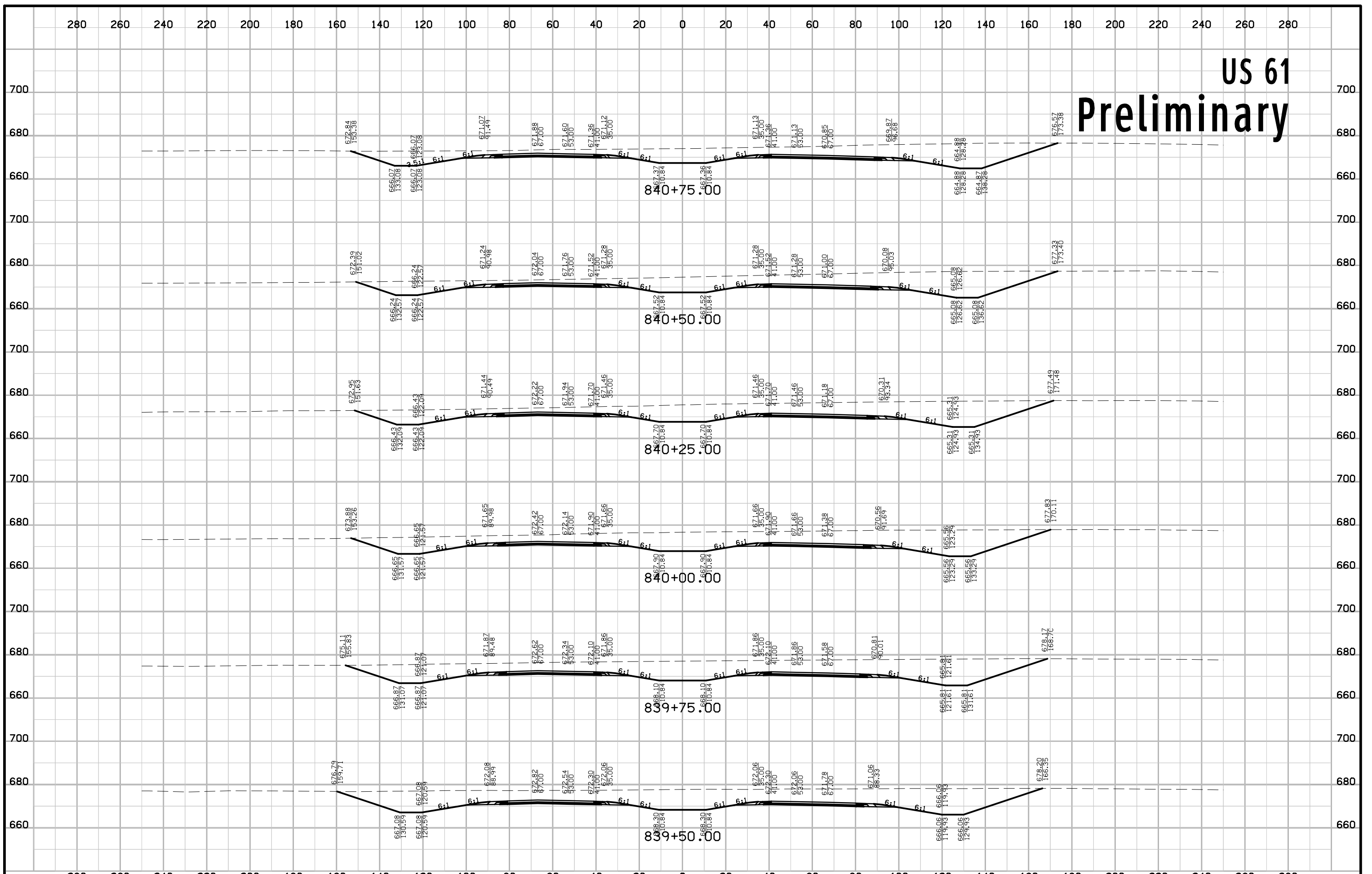

US 61 Preliminary

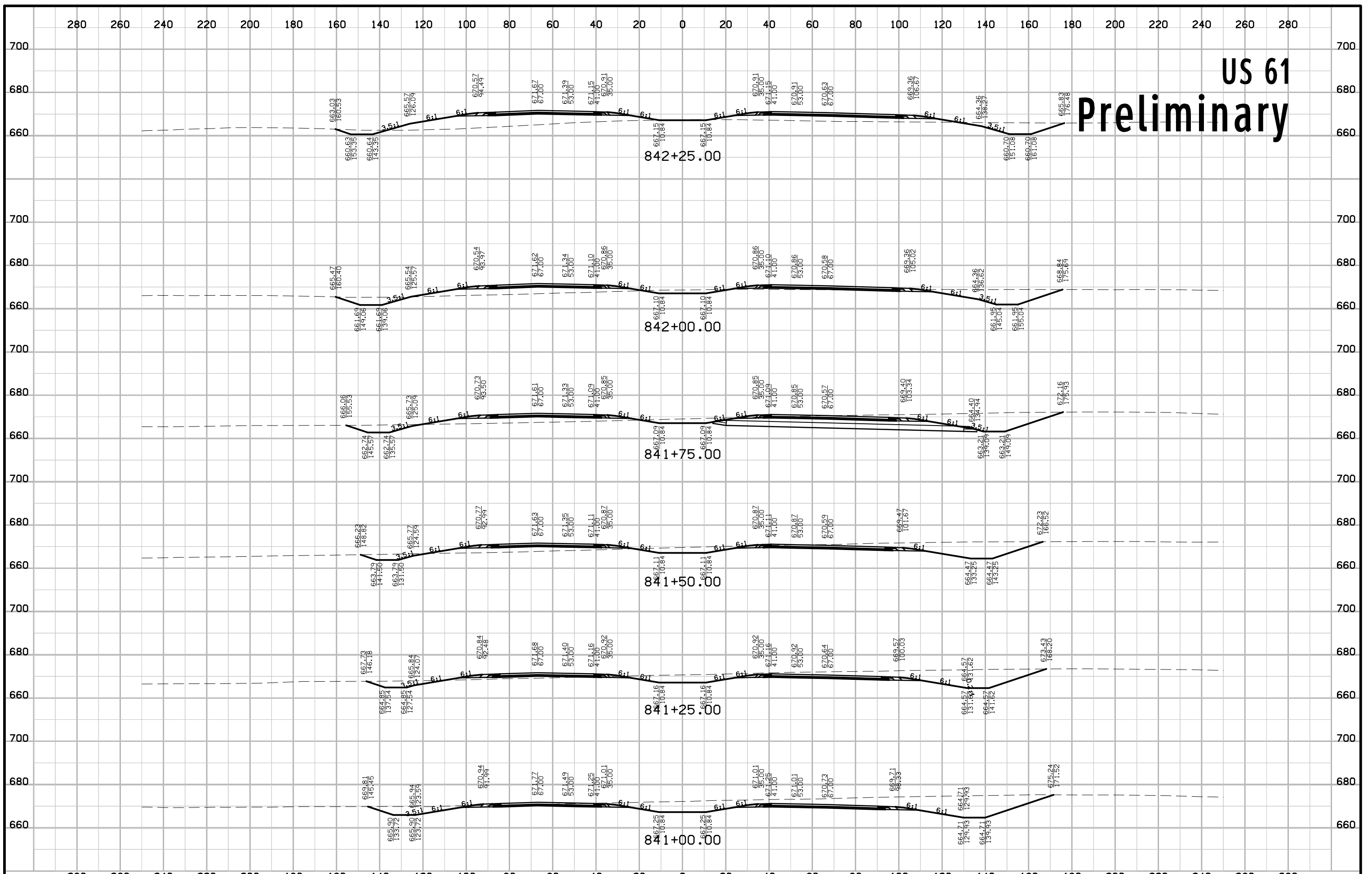

US 61 Preliminary

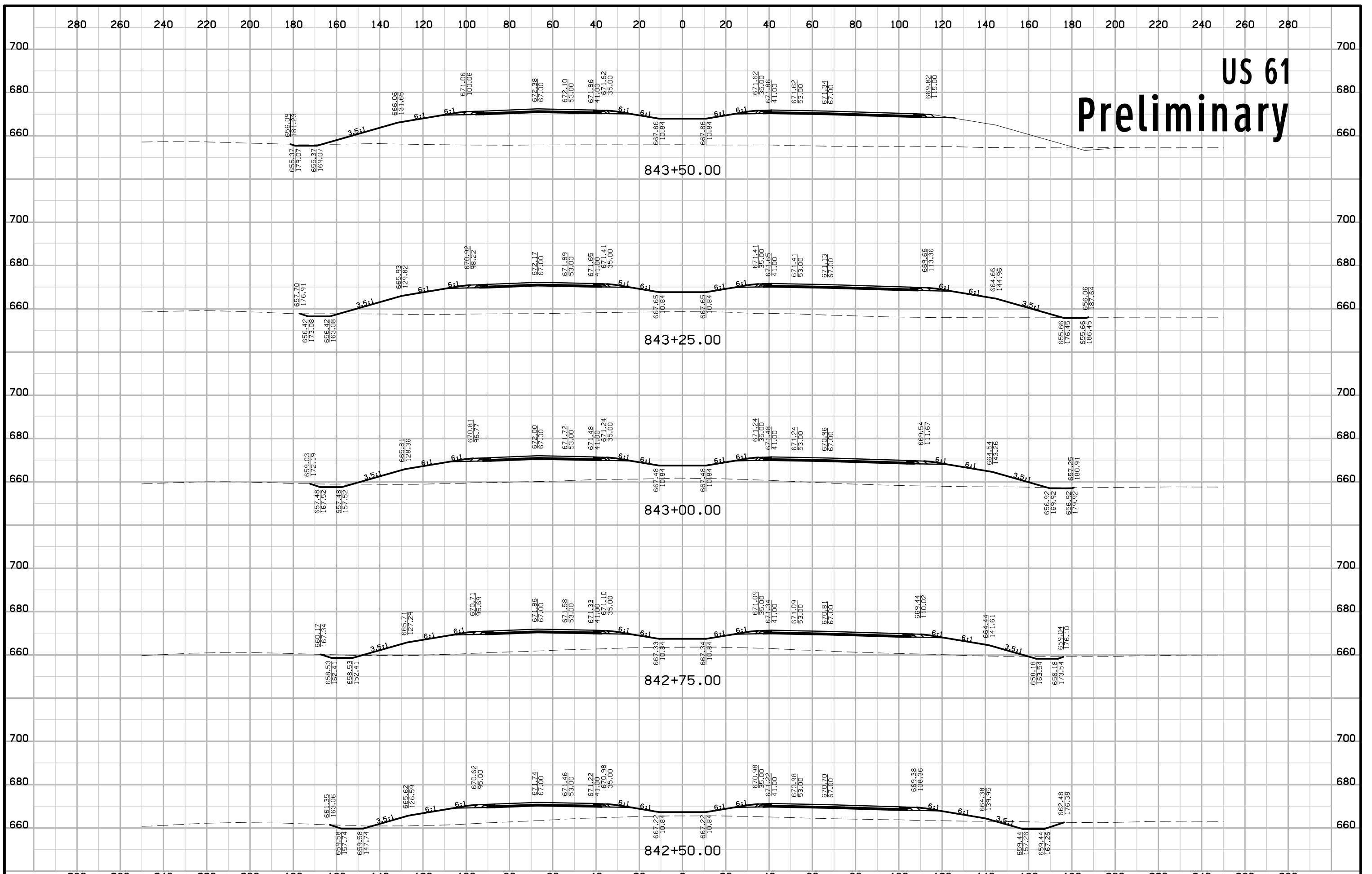

US 61 Preliminary

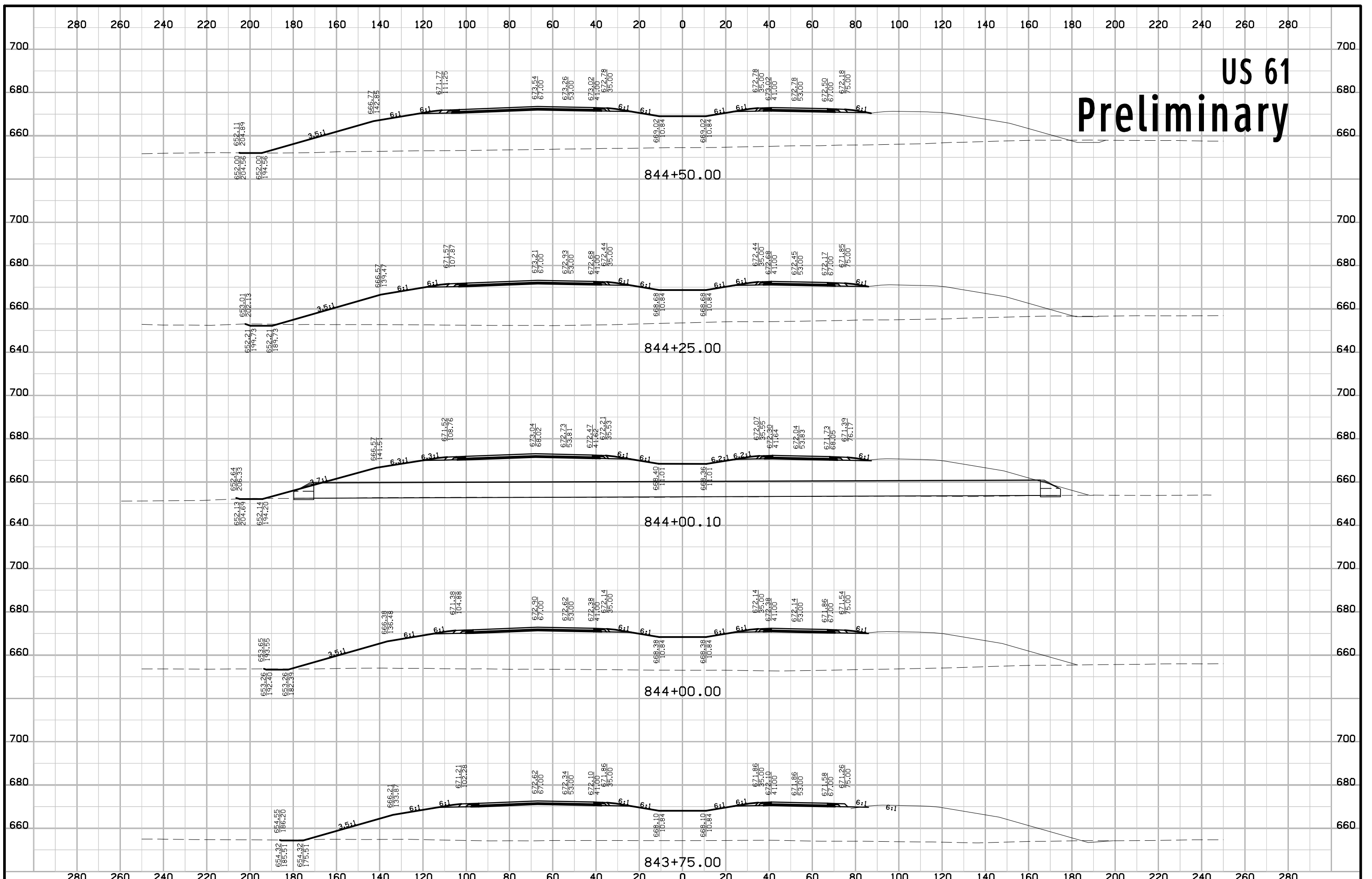

US 61 Preliminary

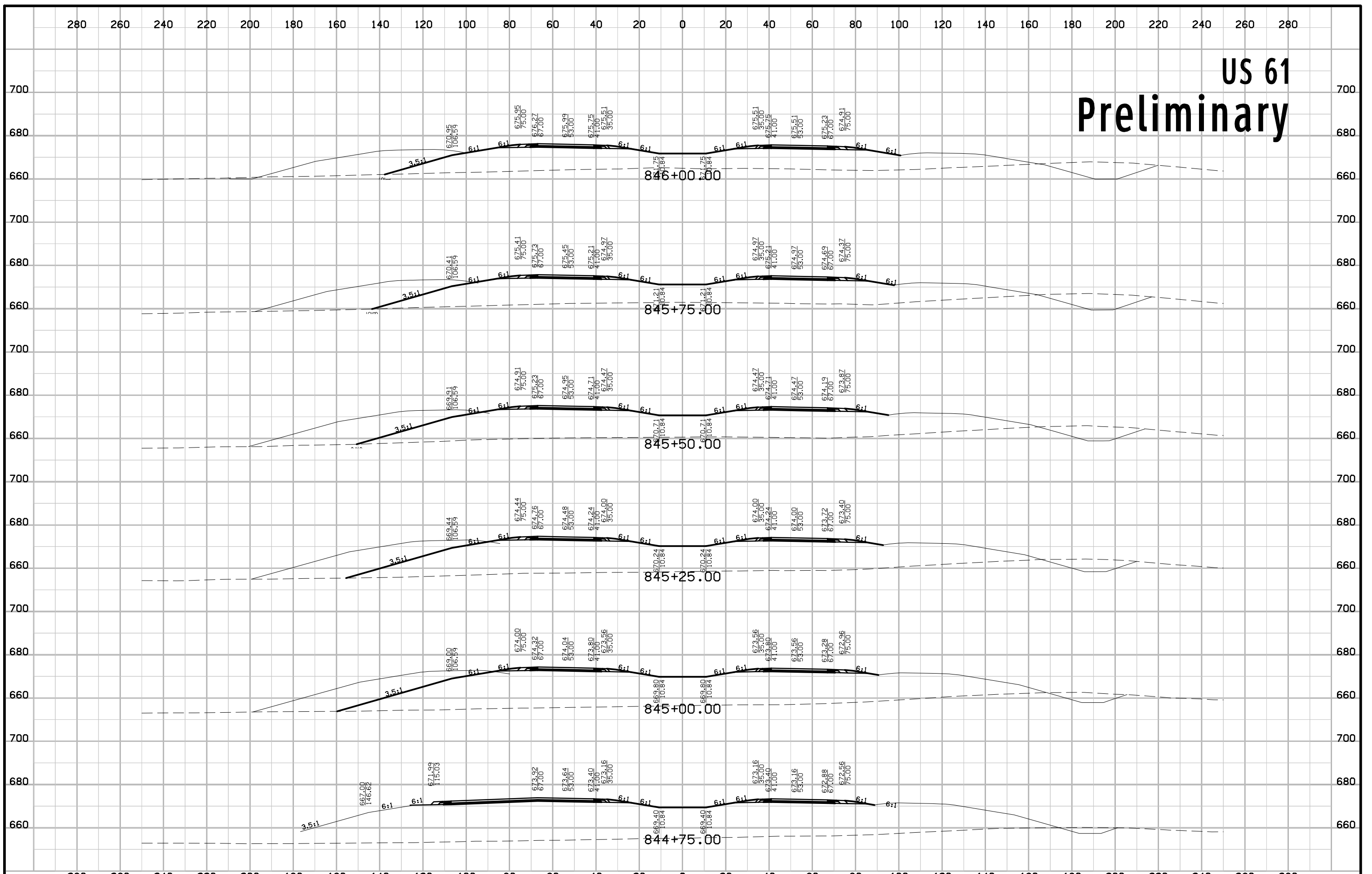

US 61 Preliminary

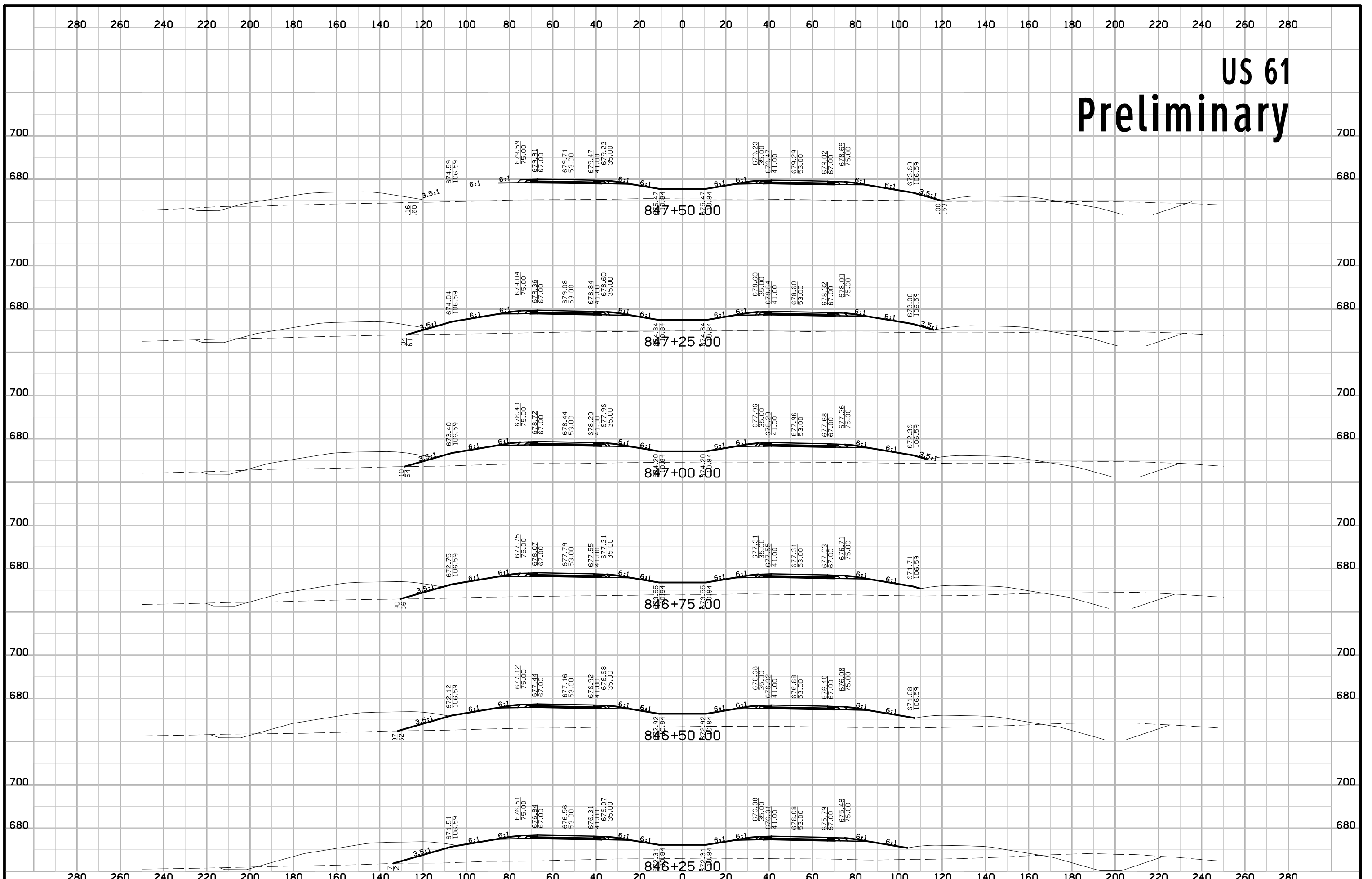

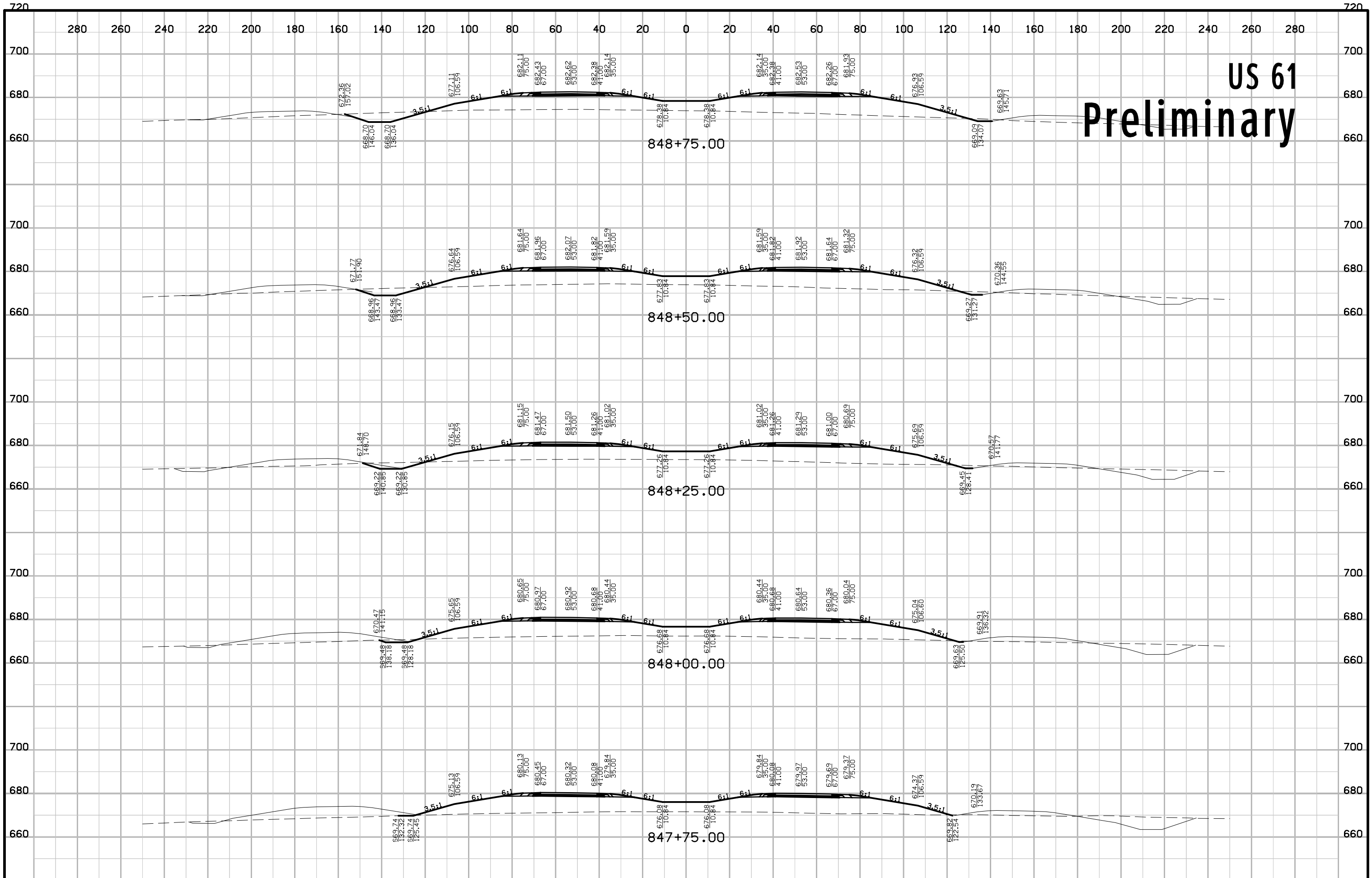

US 61 Preliminary

US 61 Preliminary

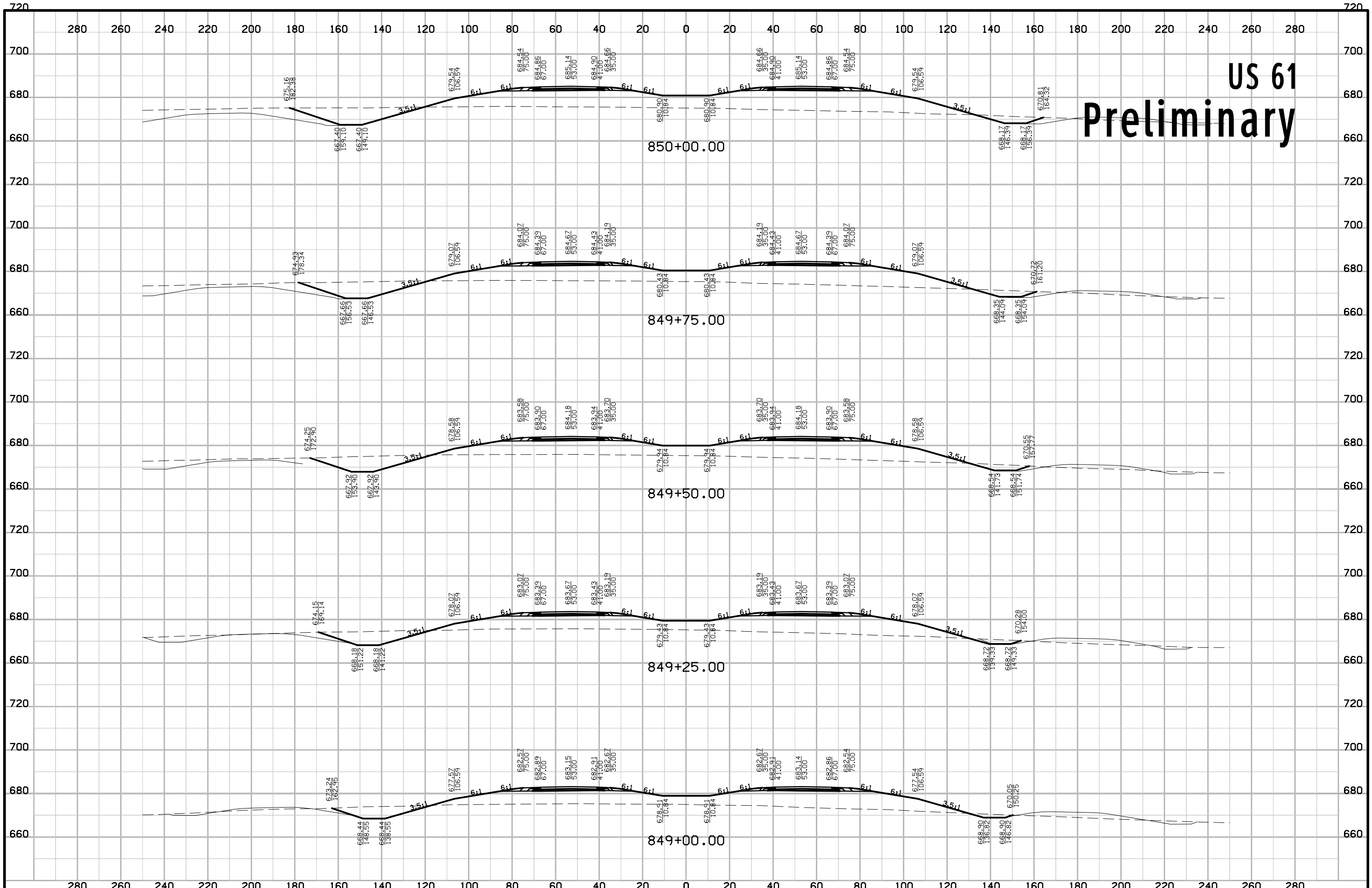

US 61 Preliminary

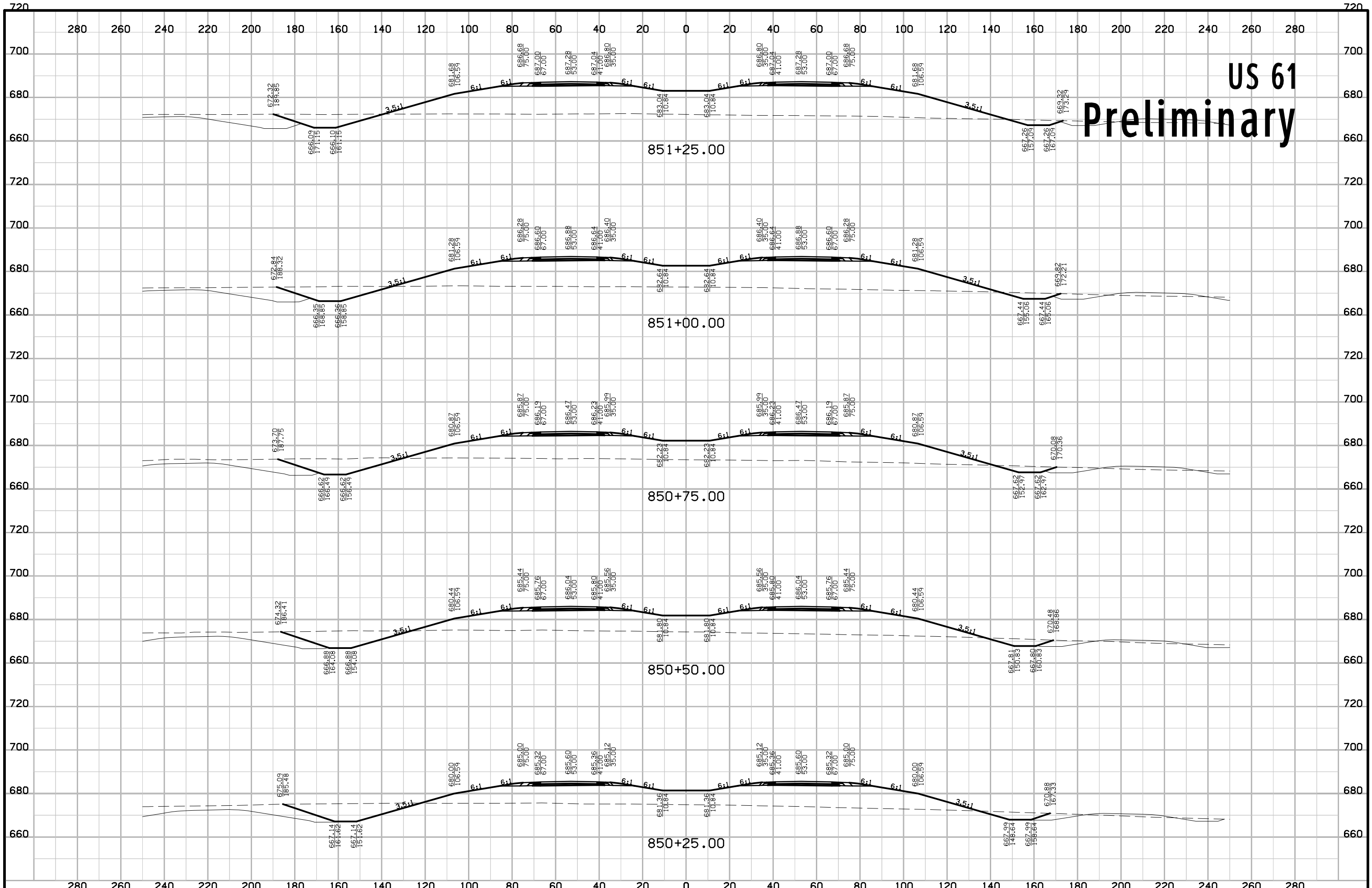

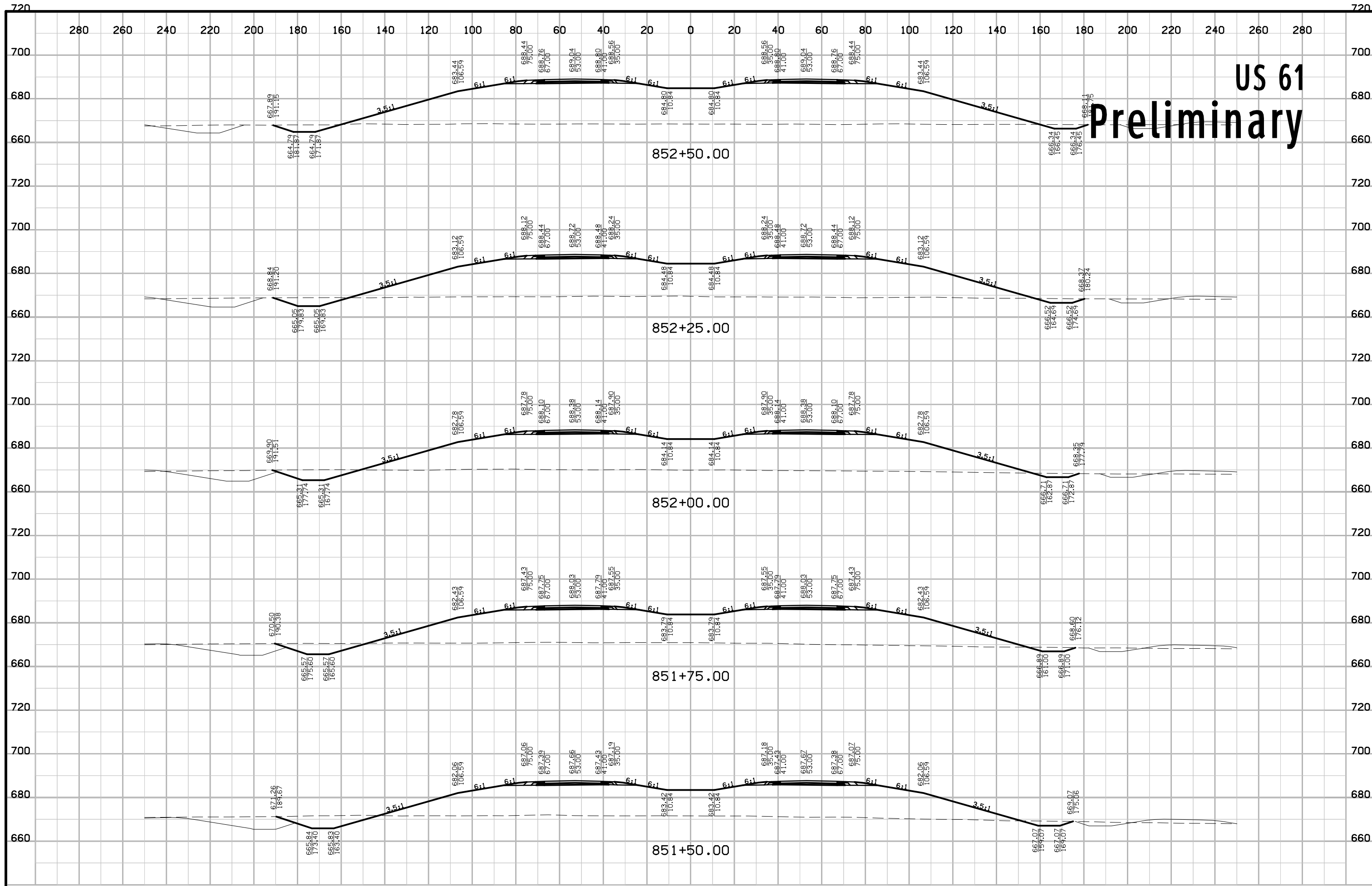

US 61 Preliminary

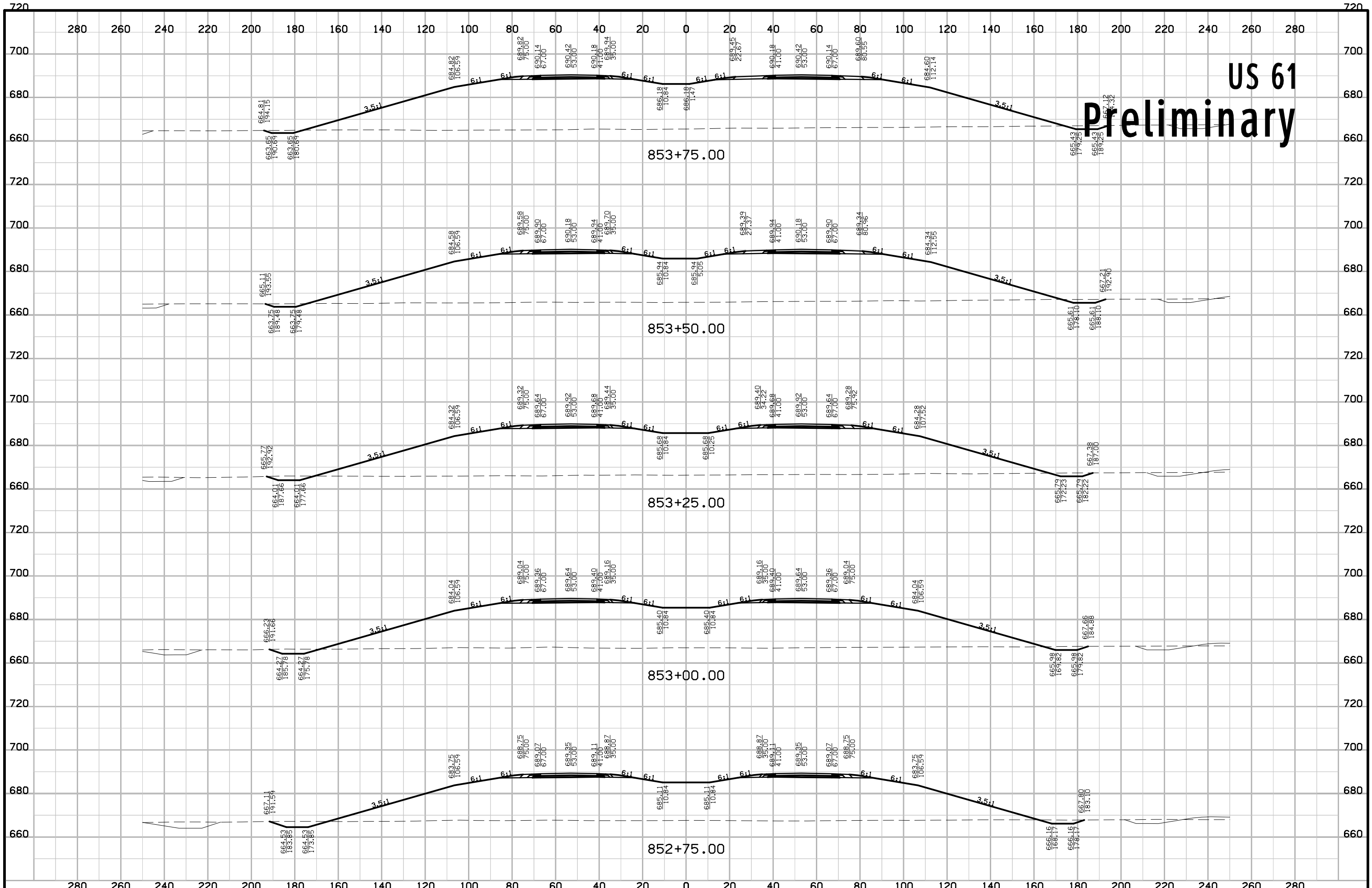

US 61 Preliminary

US 61 Preliminary

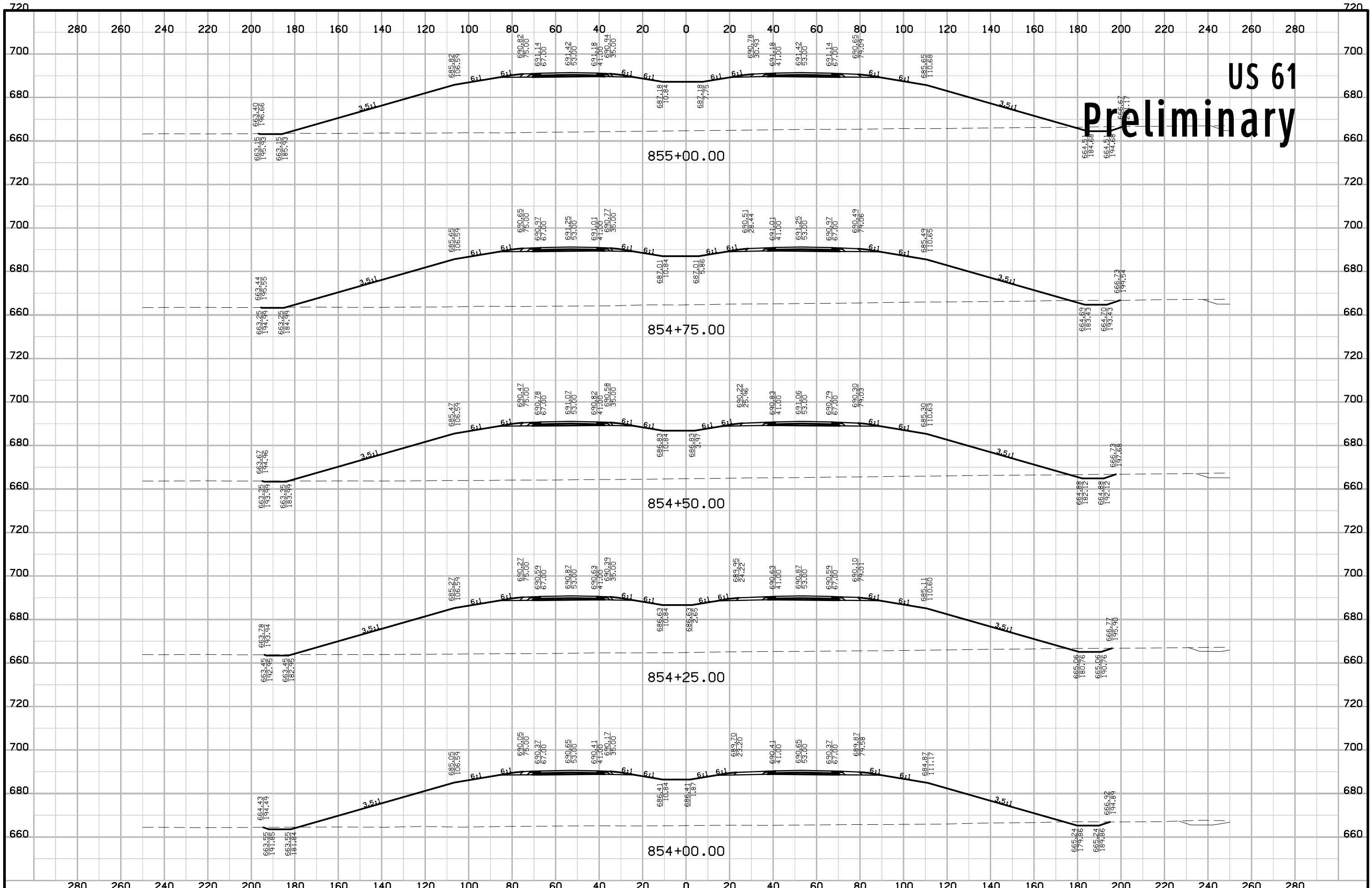

US 61 Preliminary

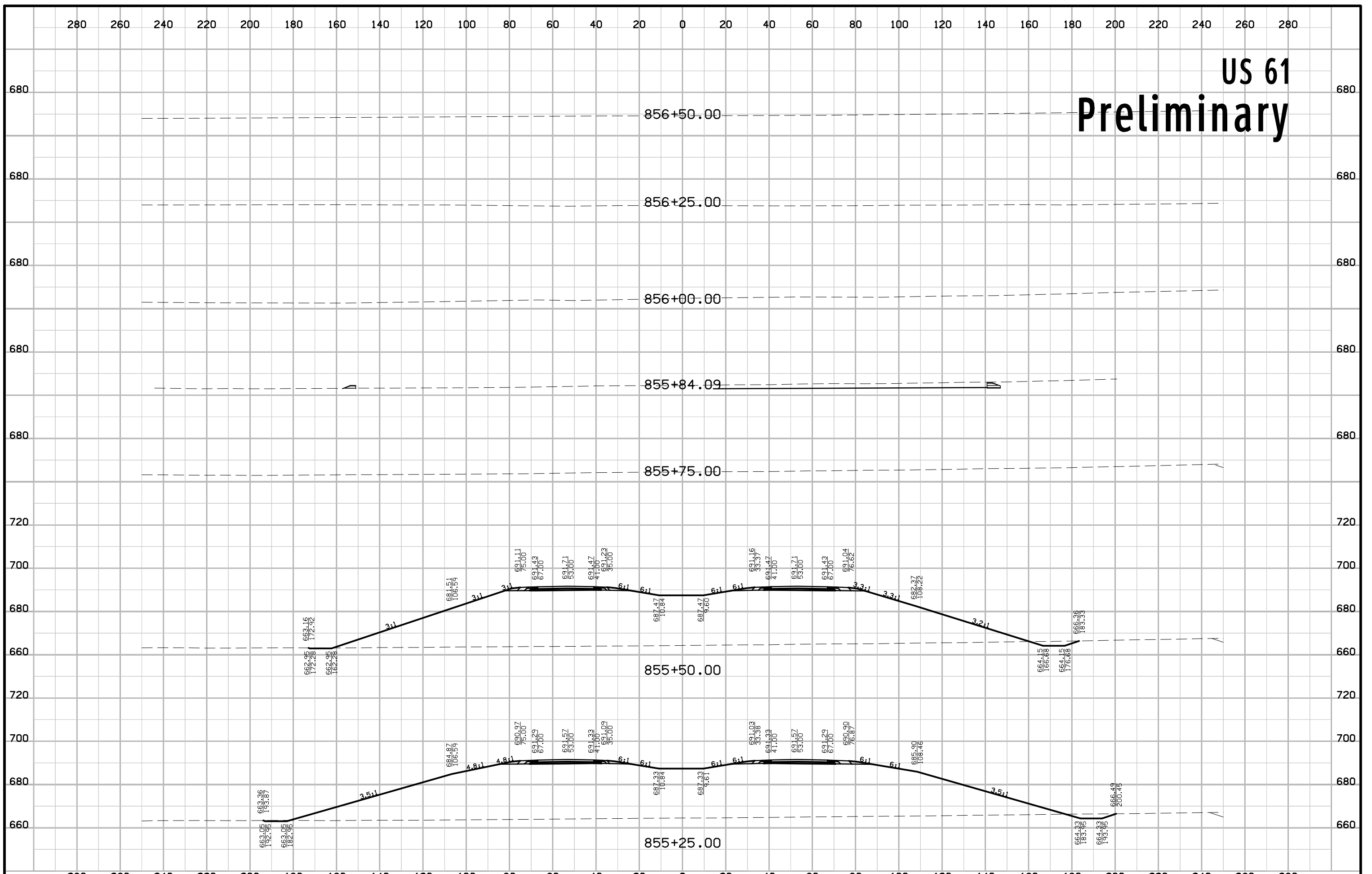

US 61 Preliminary

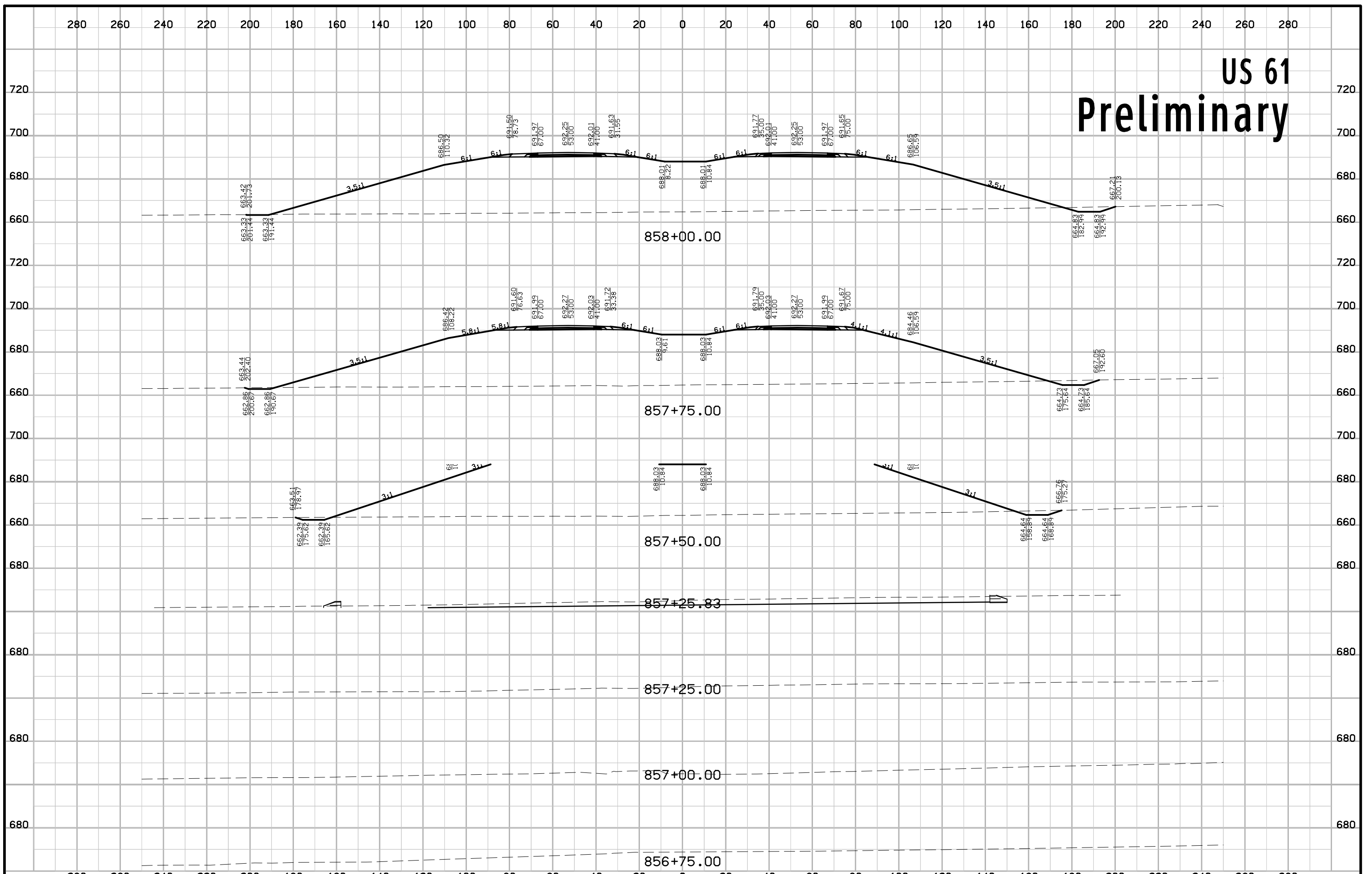

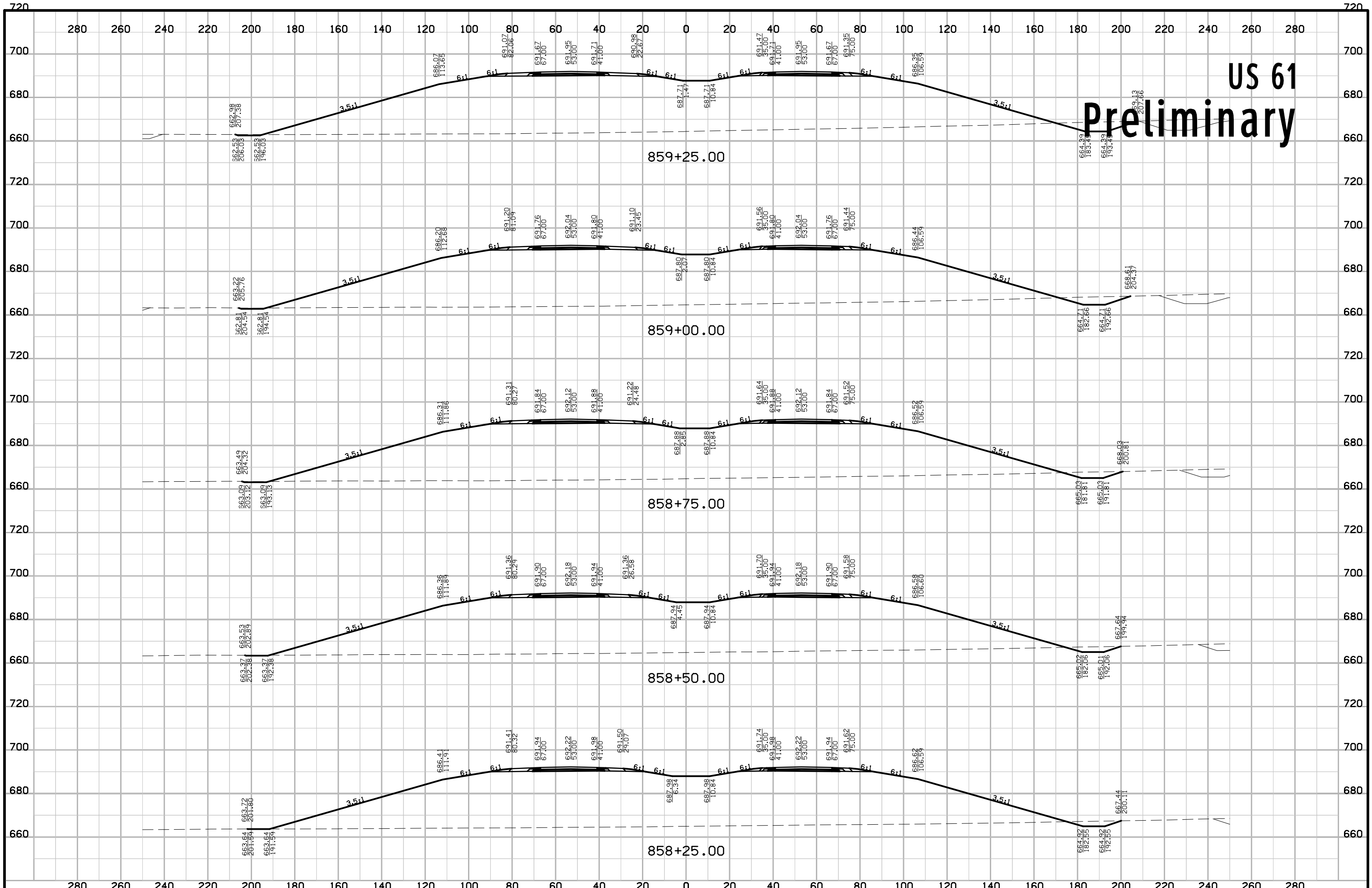

US 61 Preliminary

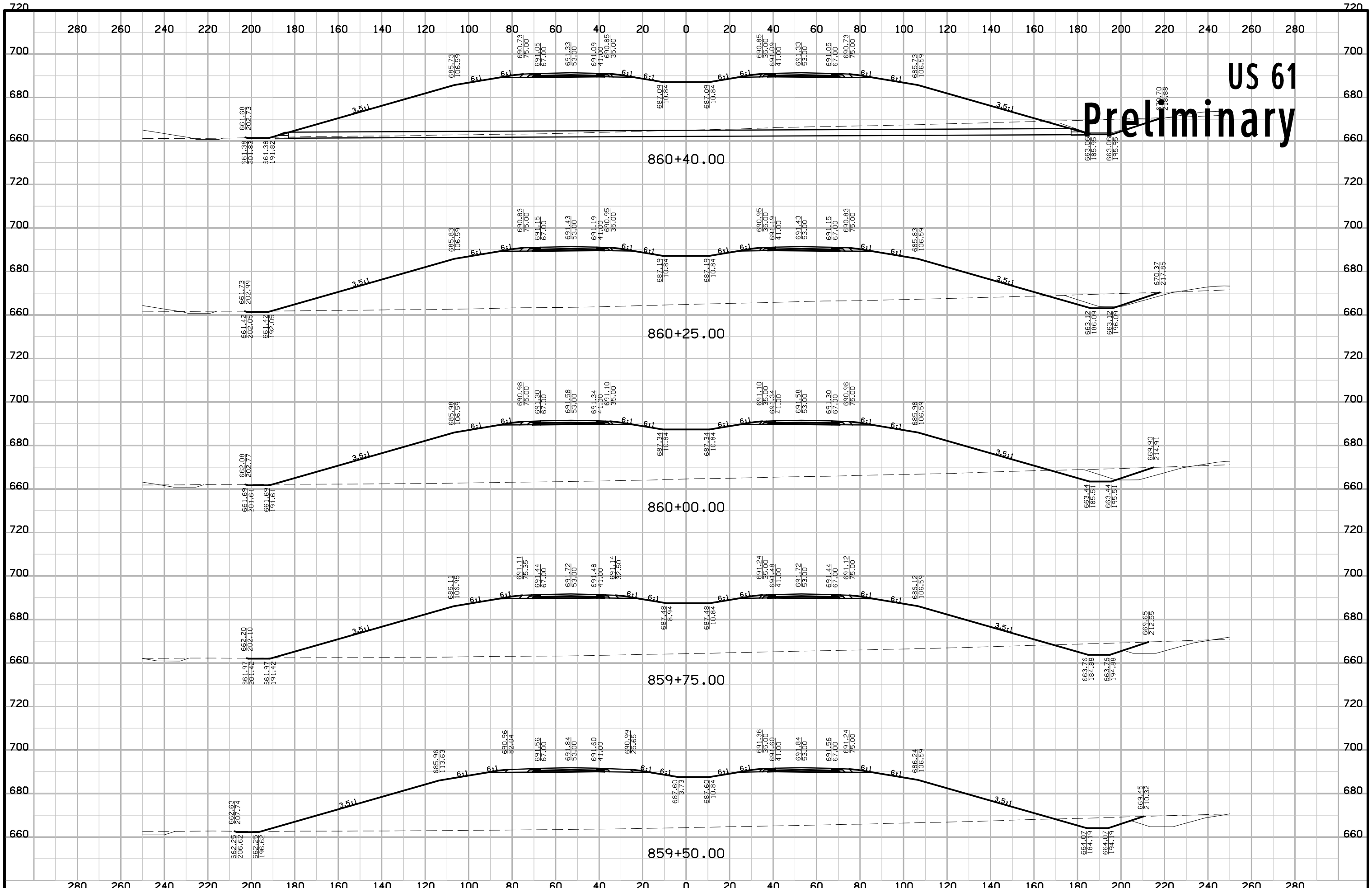

US 61 Preliminary

US 61 Preliminary

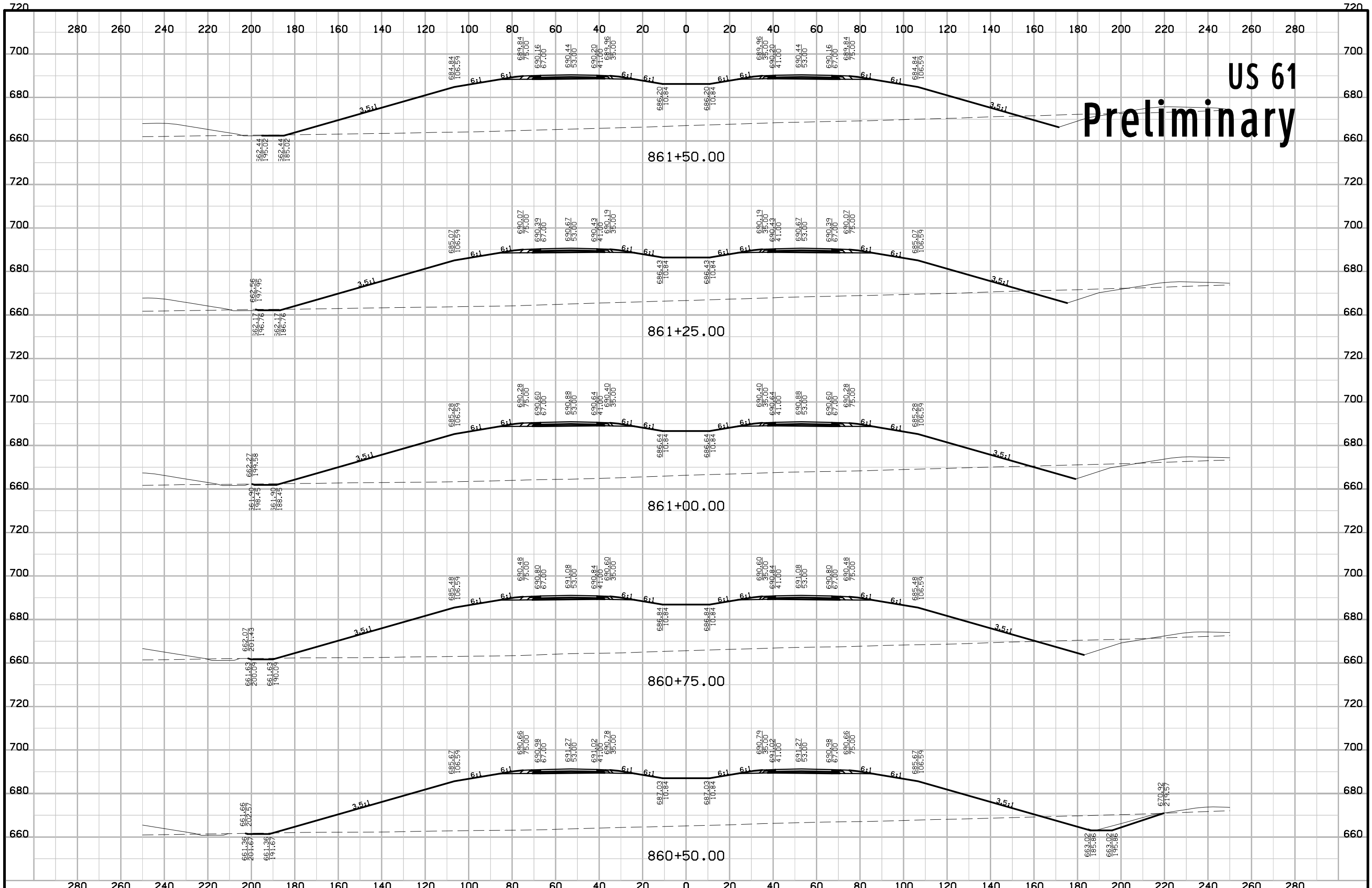

US 61 Preliminary

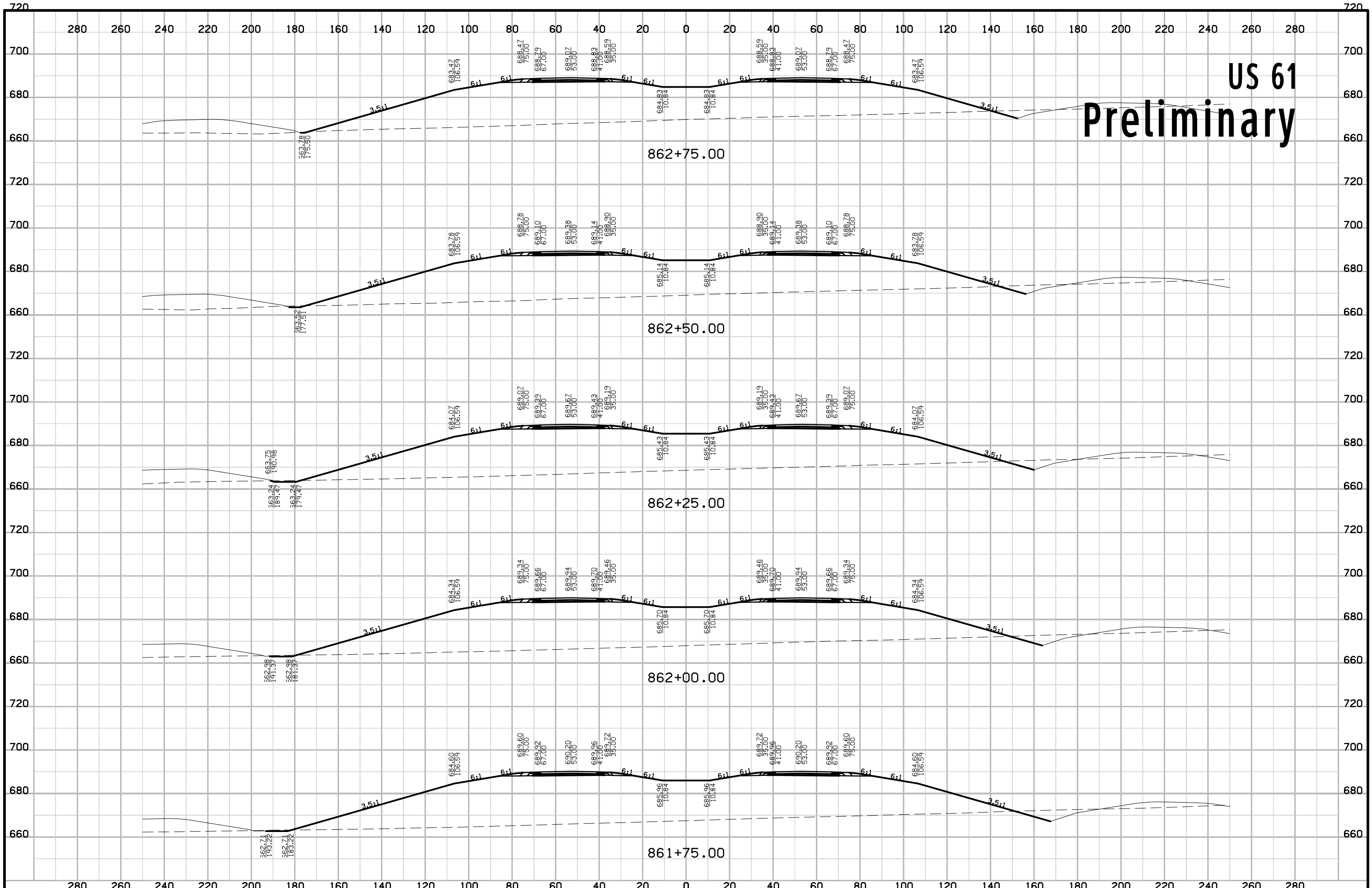

US 61 Preliminary

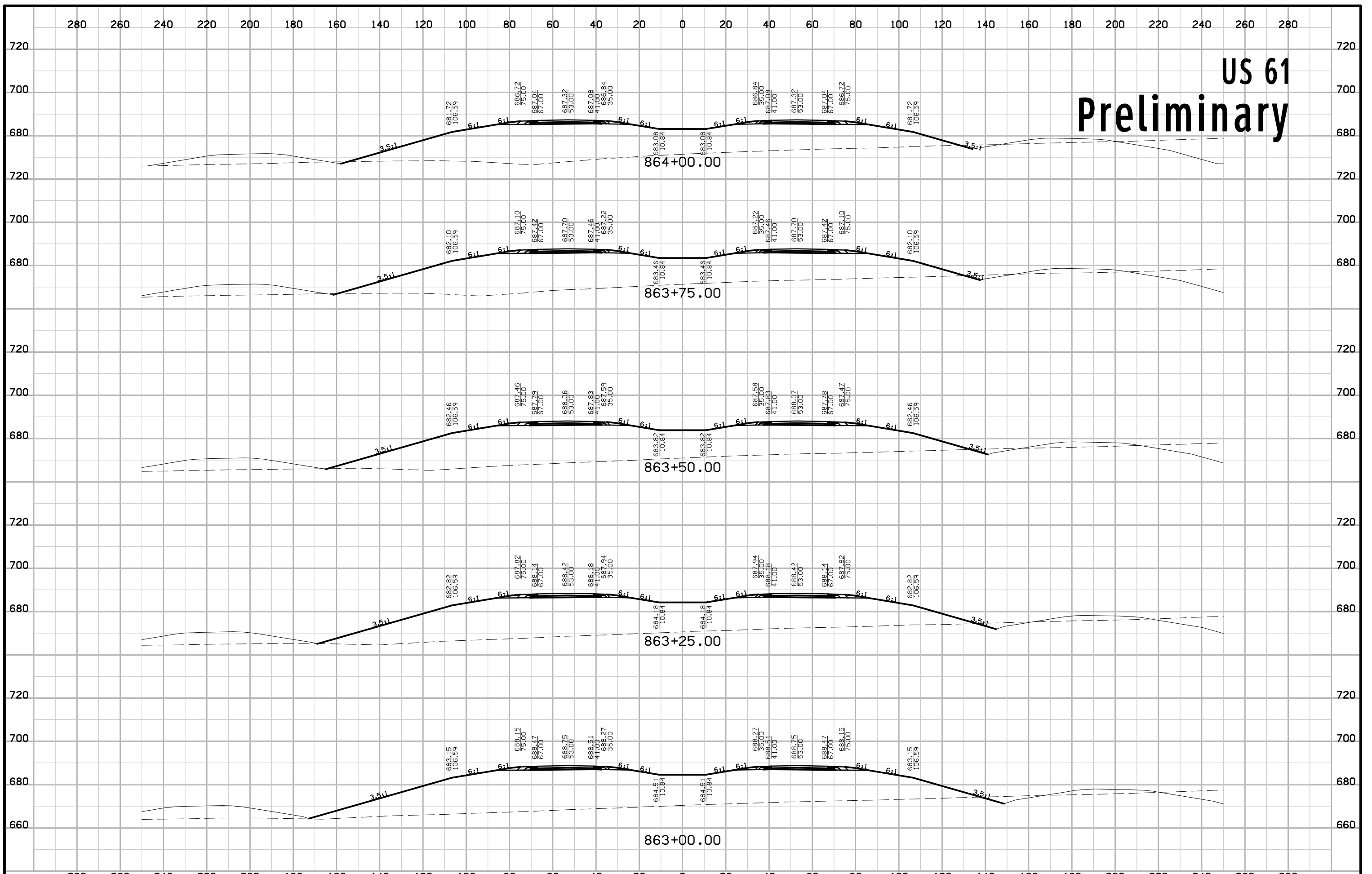

US 61 Preliminary

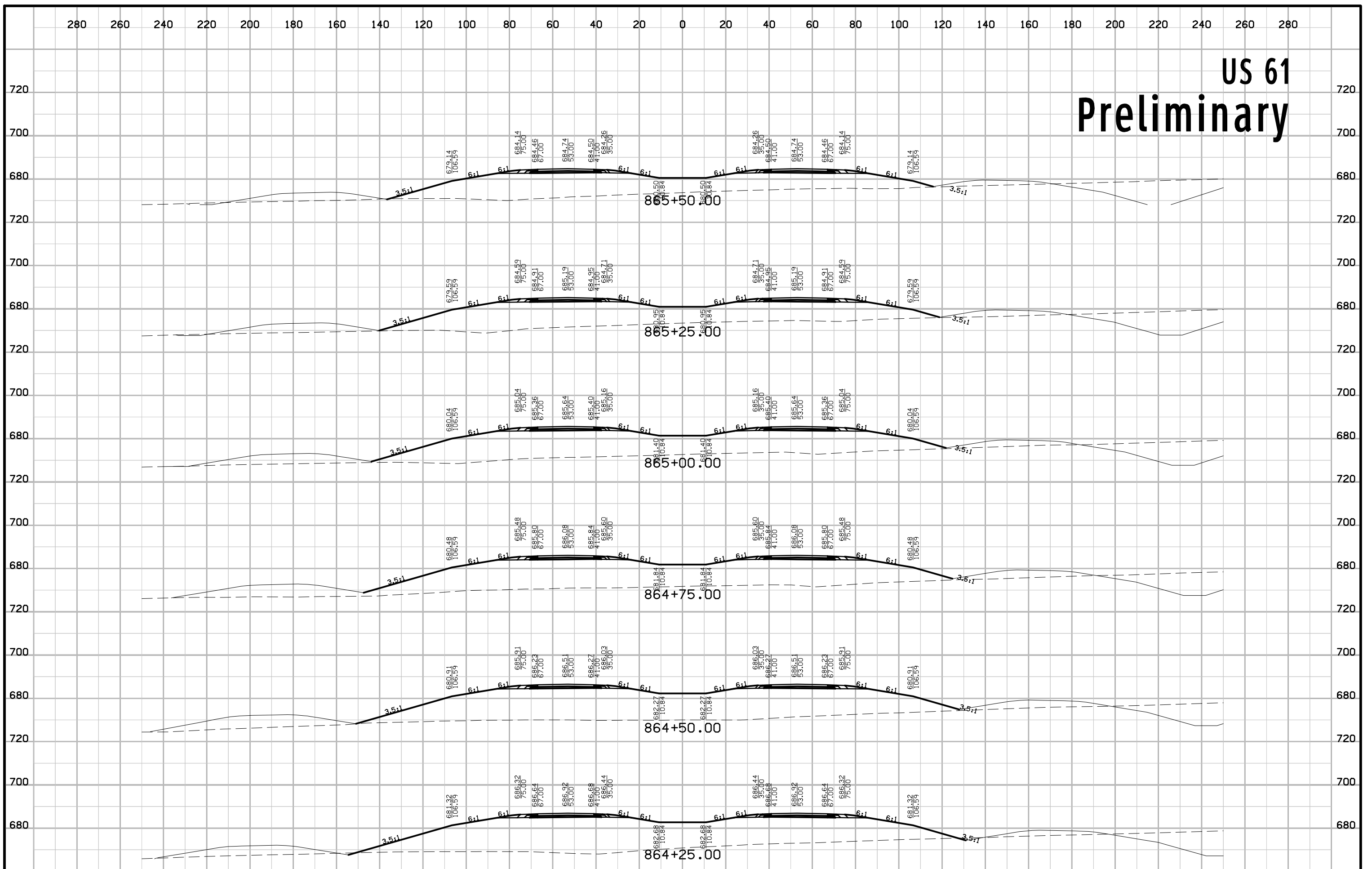

US 61 Preliminary

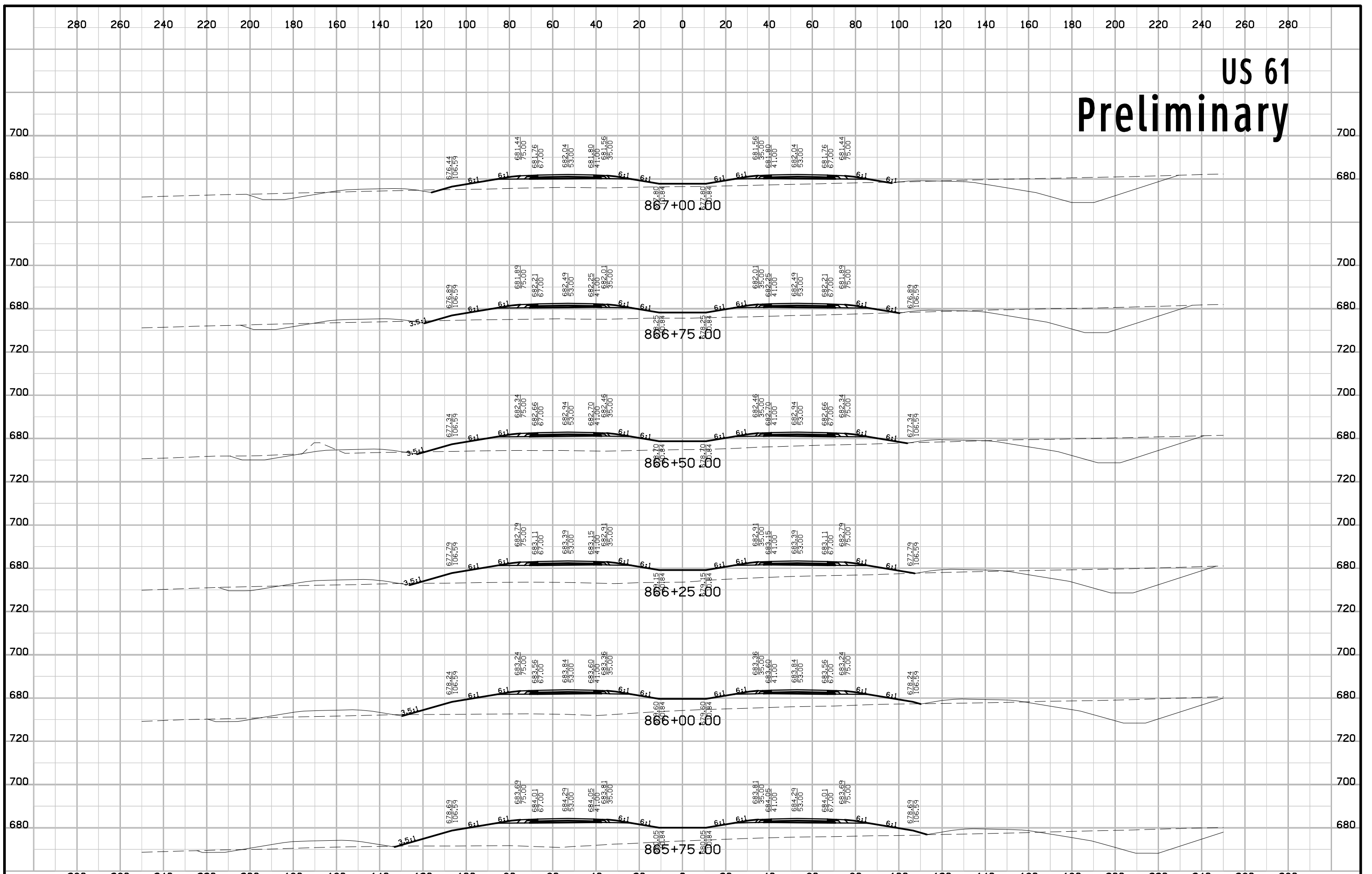

US 61 Preliminary

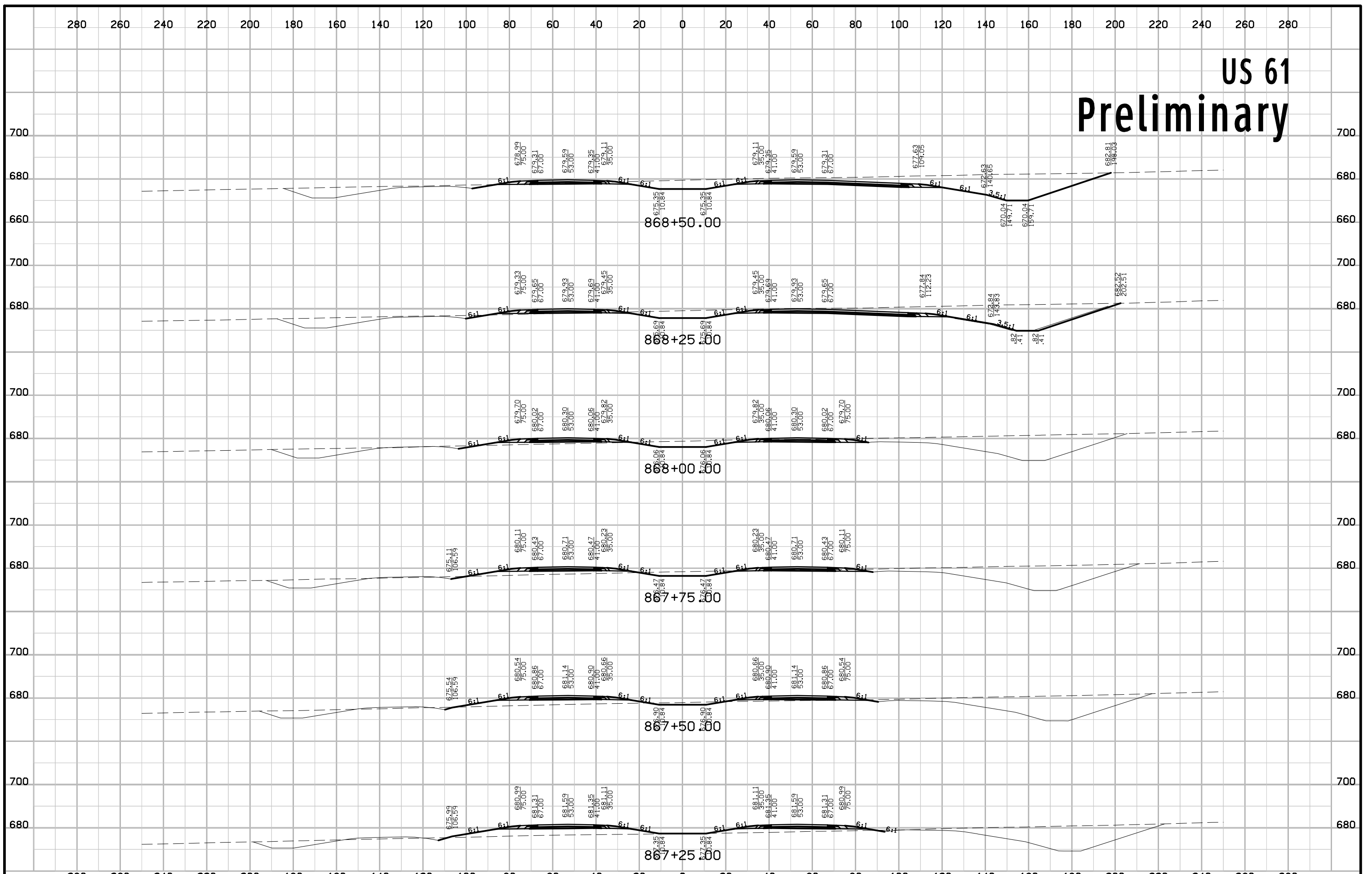

US 61 Preliminary

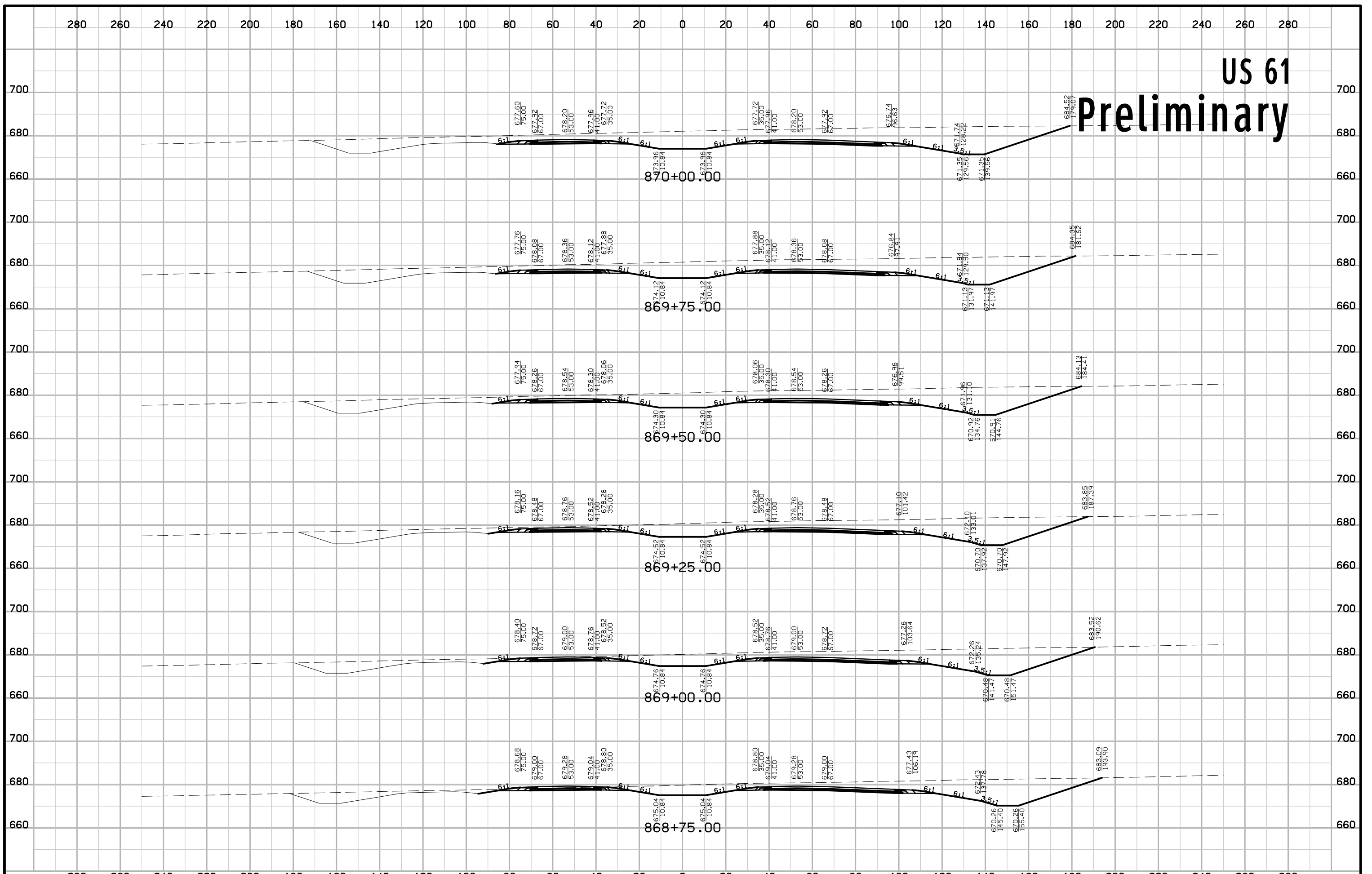

US 61 Preliminary

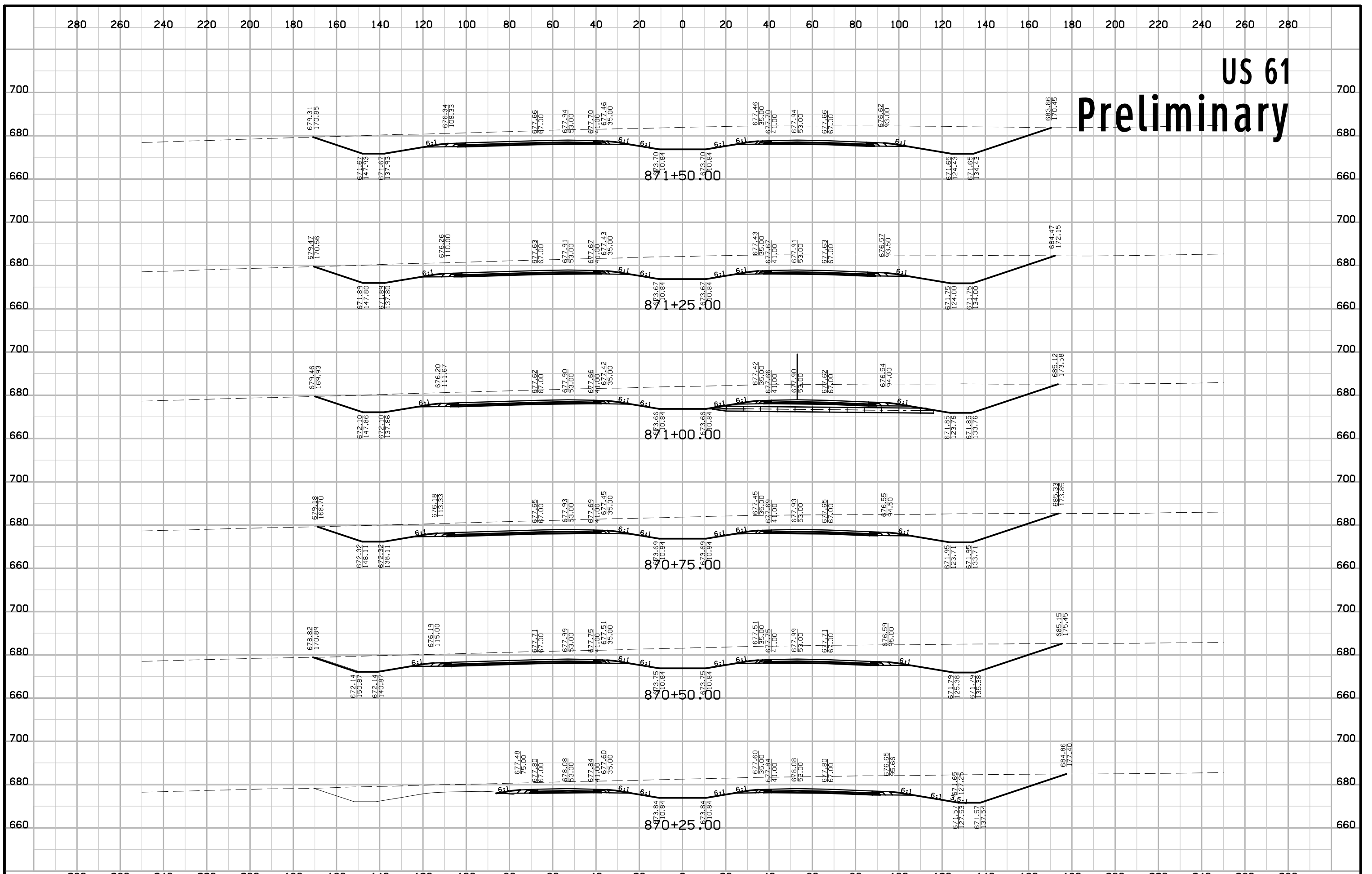

US 61 Preliminary

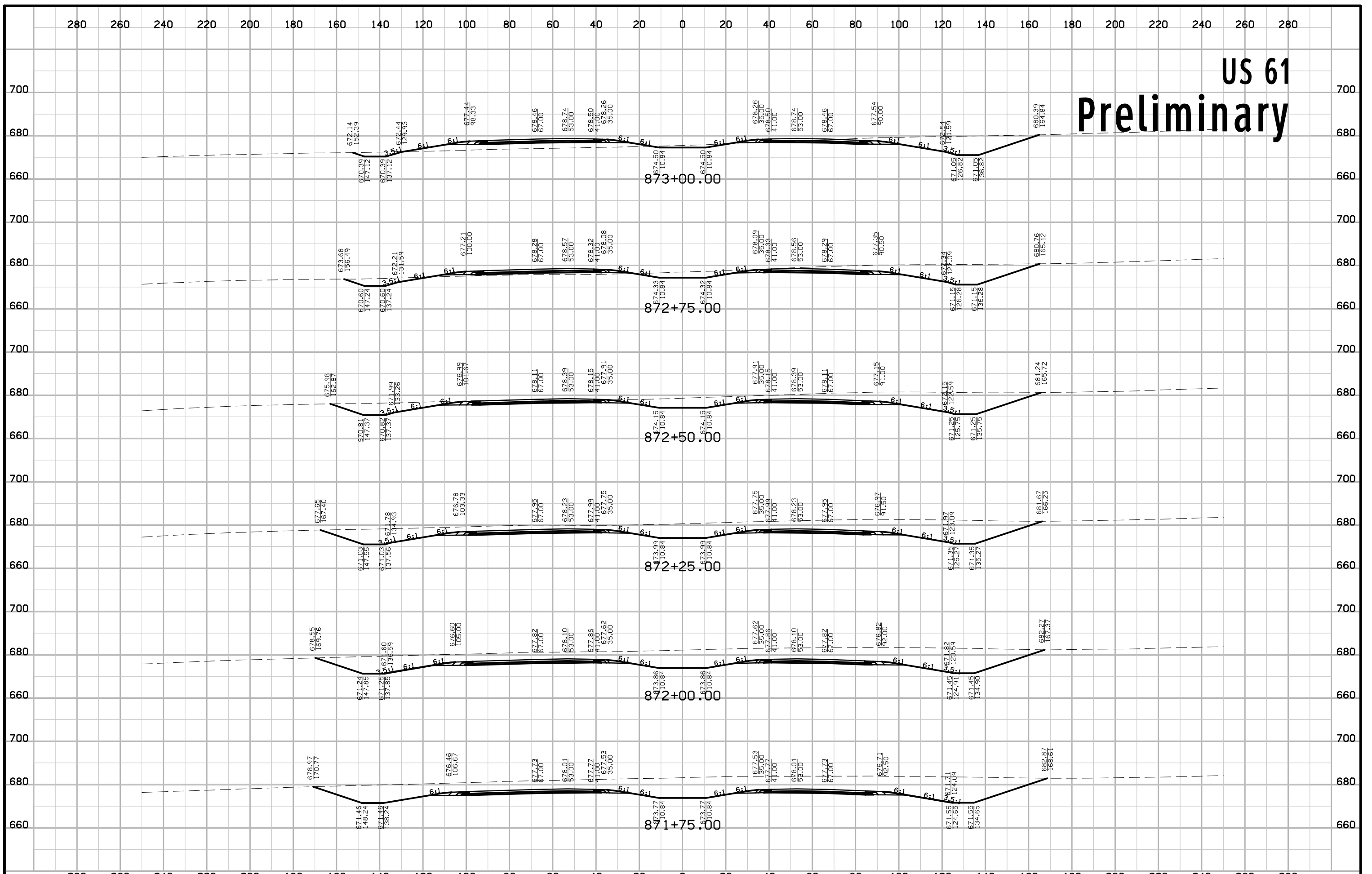

US 61 Preliminary

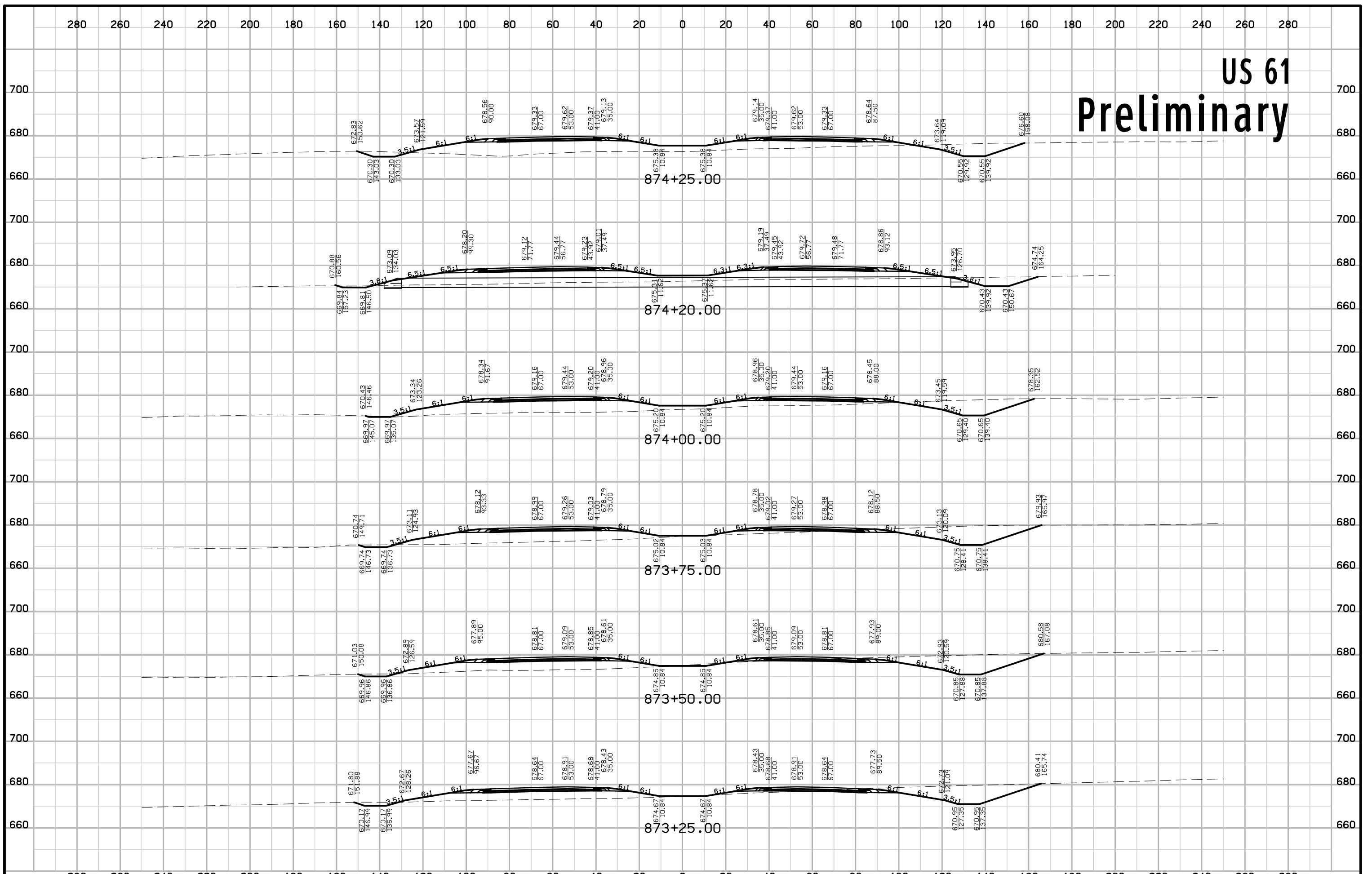

US 61 Preliminary

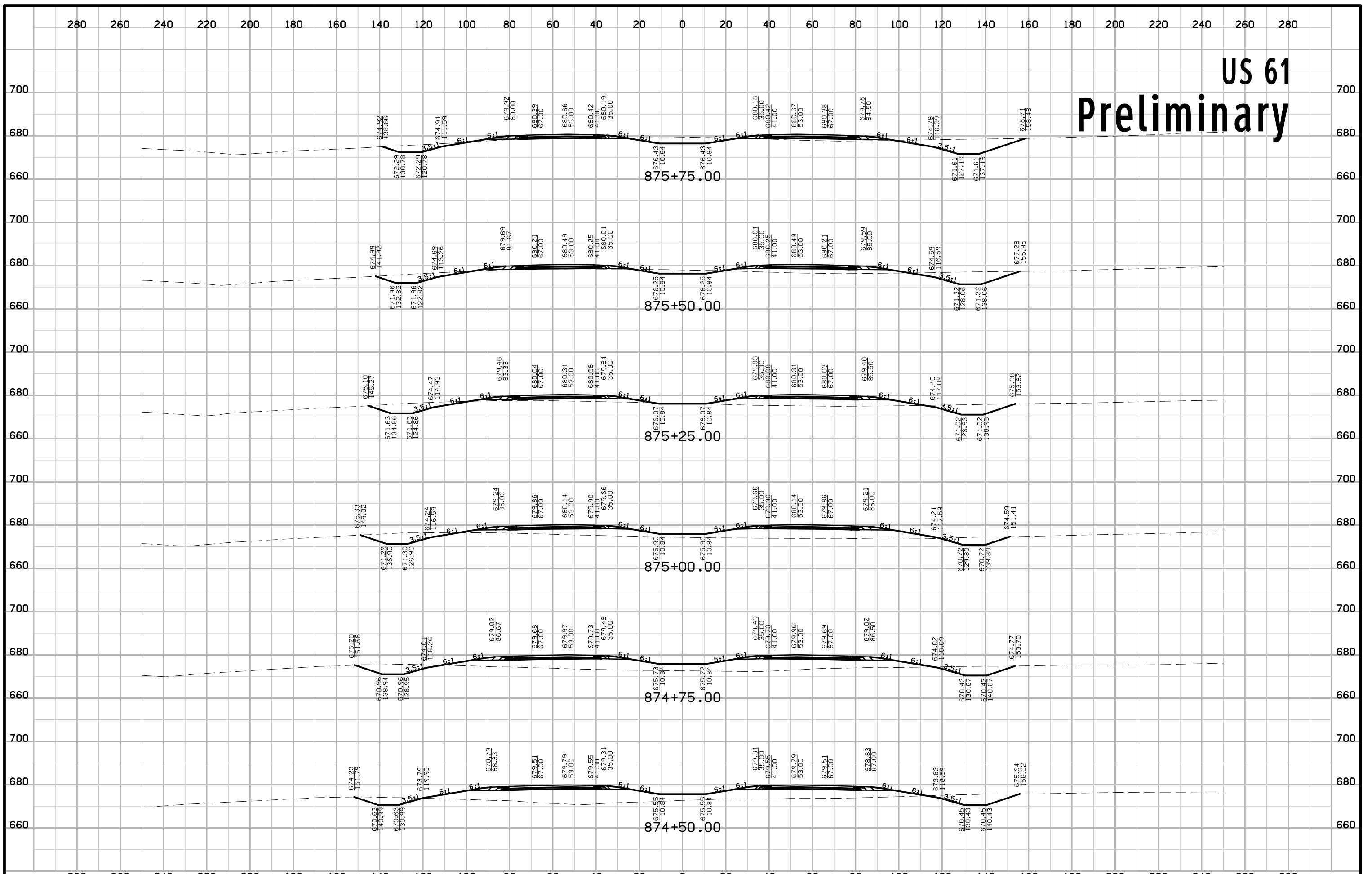

US 61 Preliminary

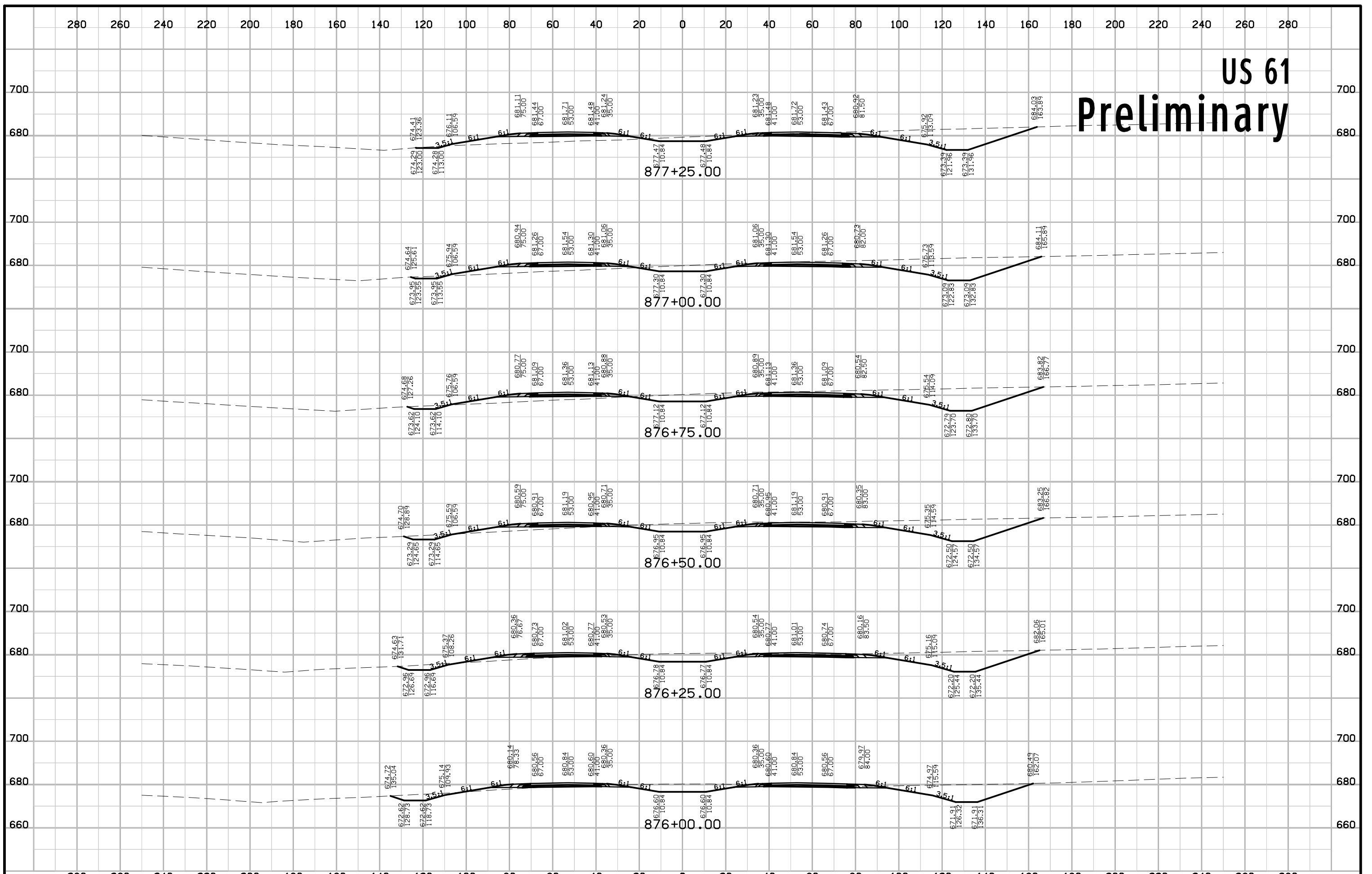

US 61 Preliminary

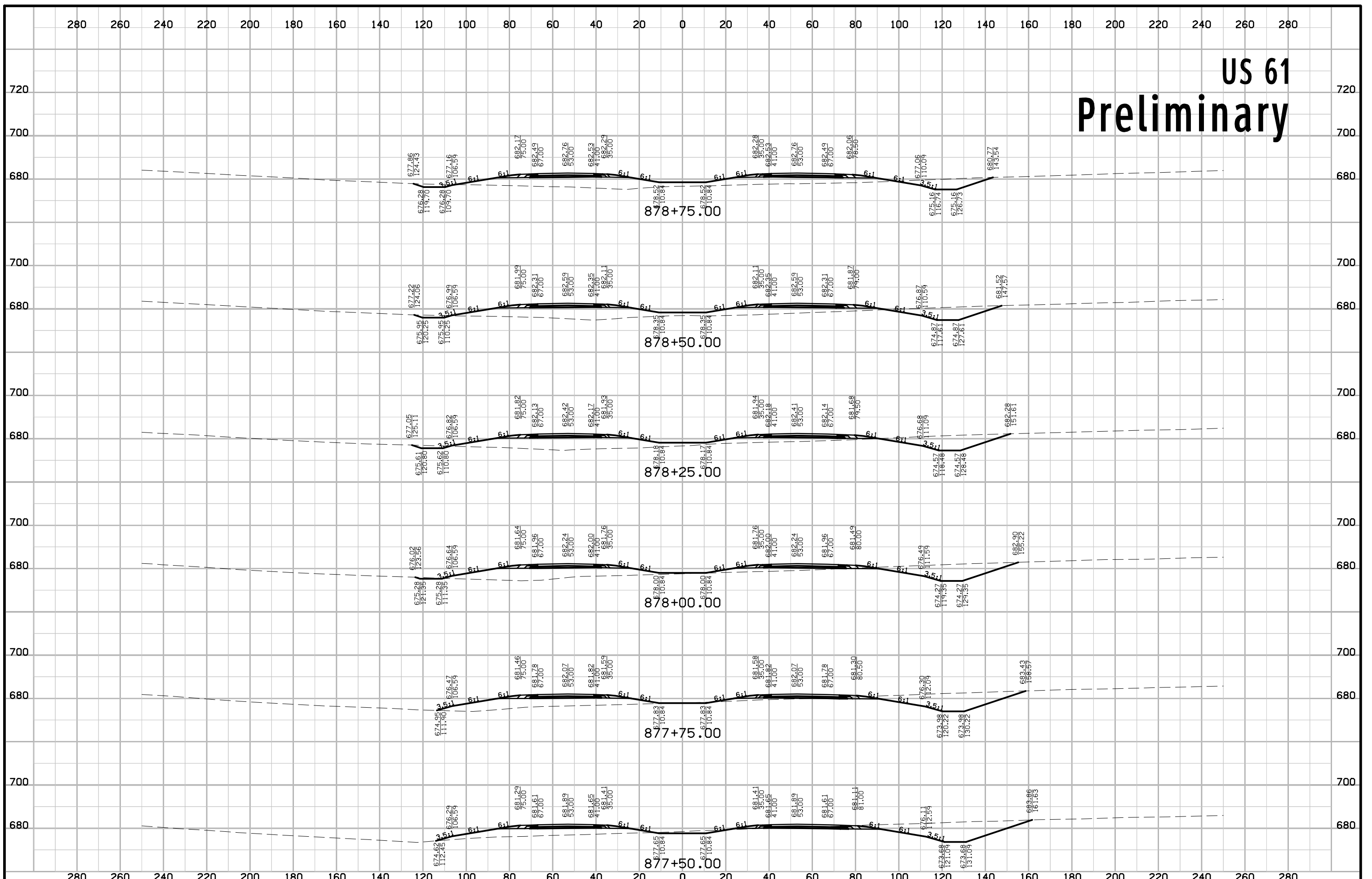

US 61 Preliminary

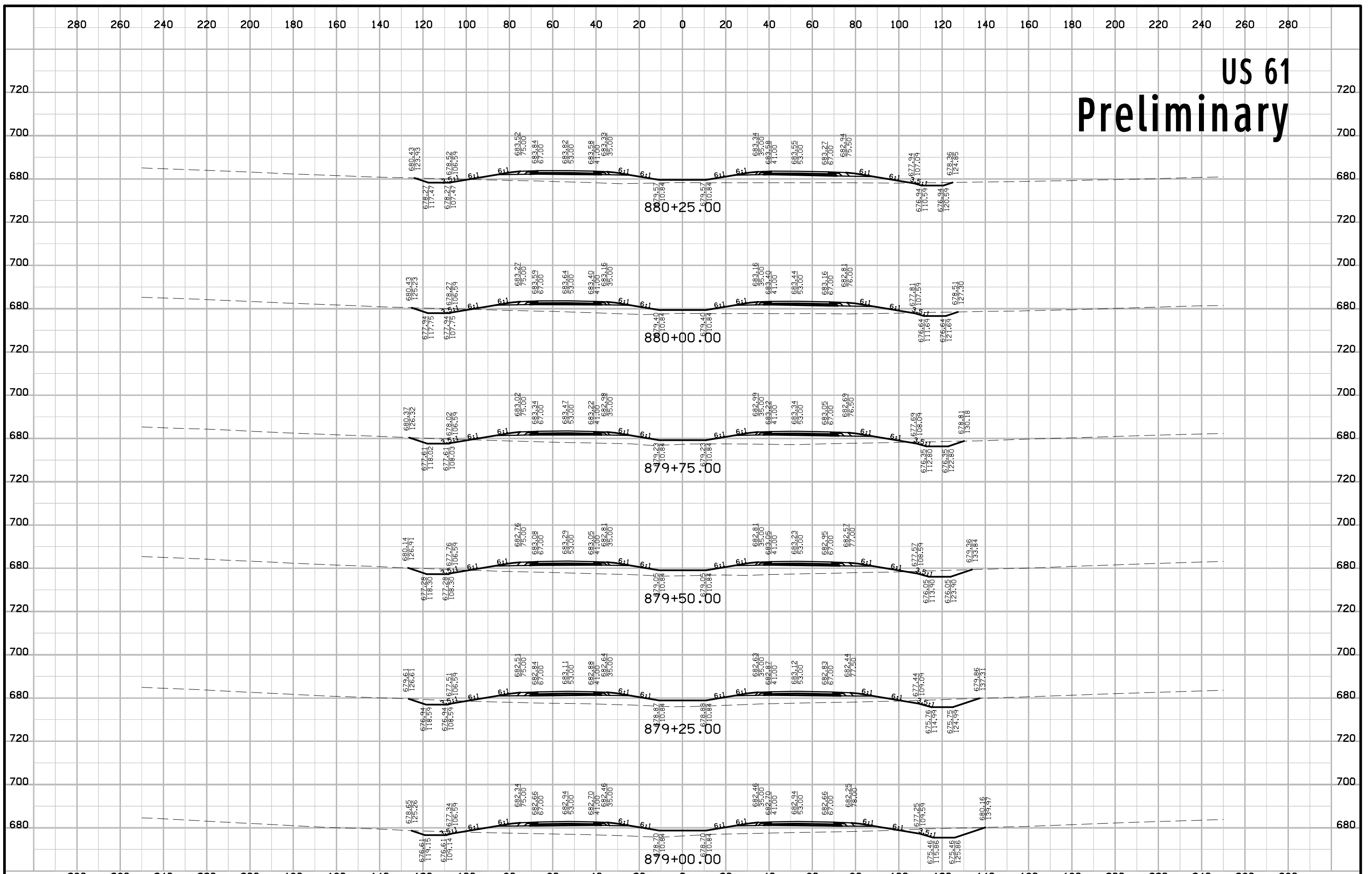

US 61 Preliminary

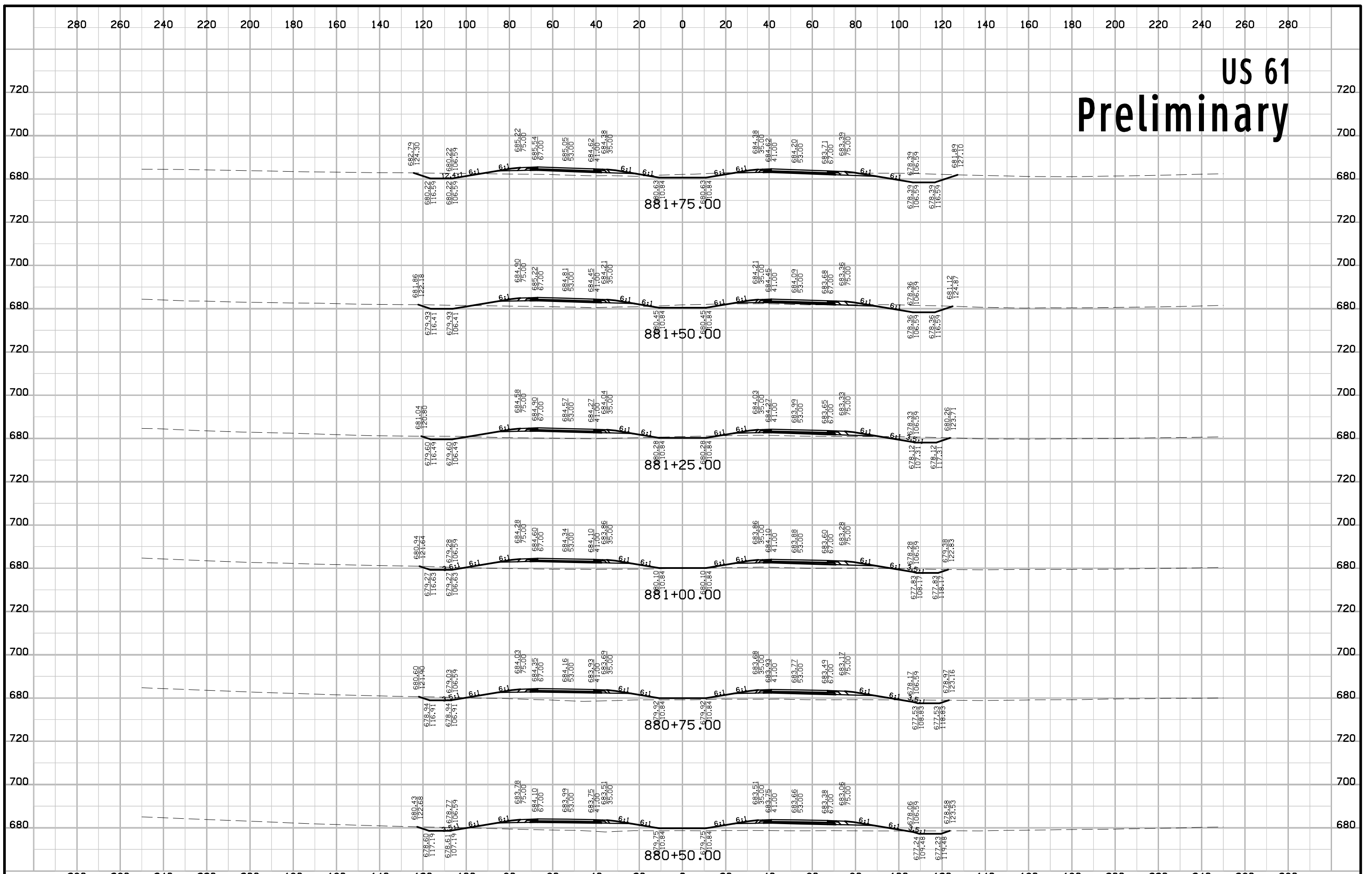

US 61 Preliminary

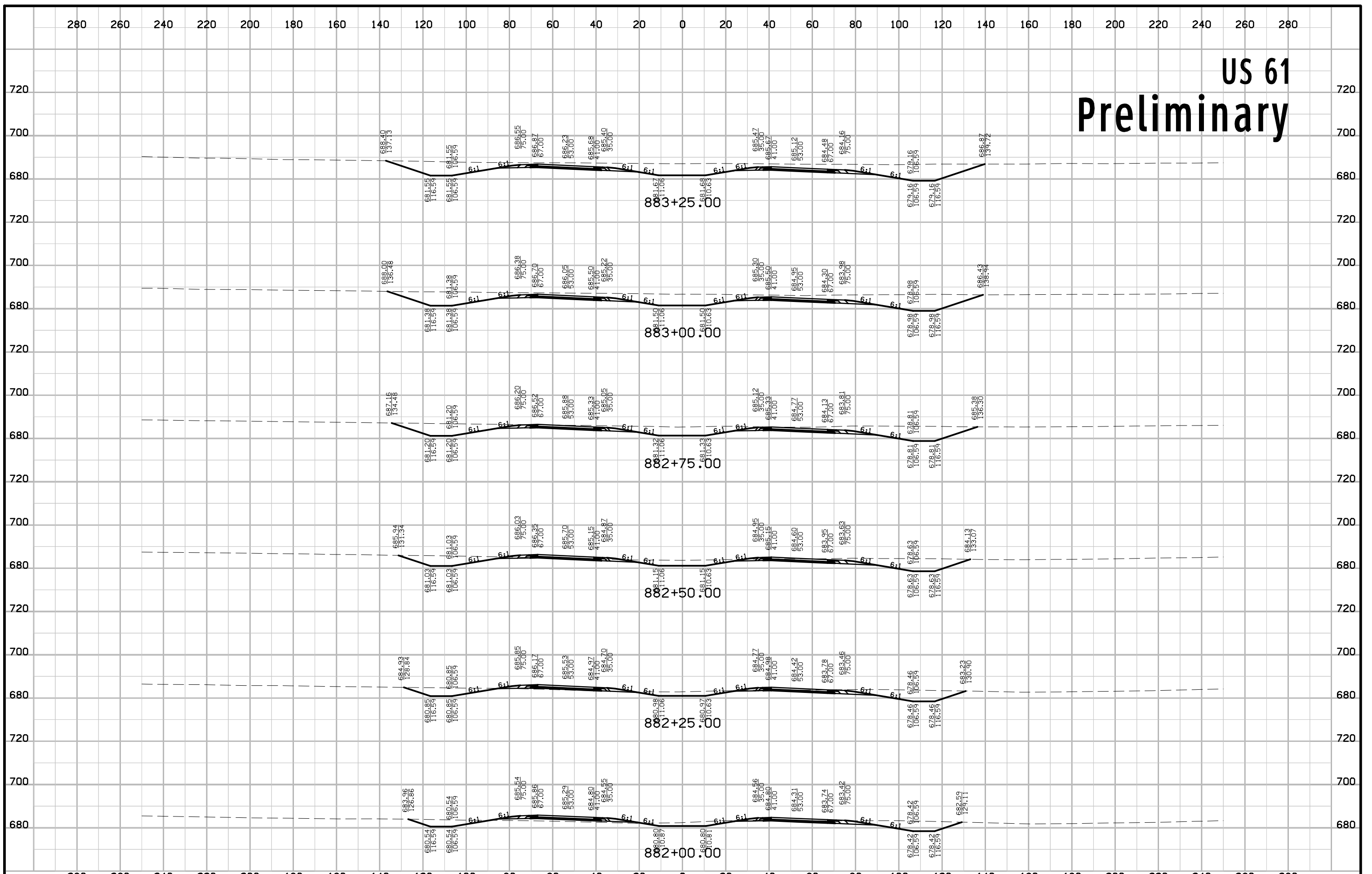

US 61 Preliminary

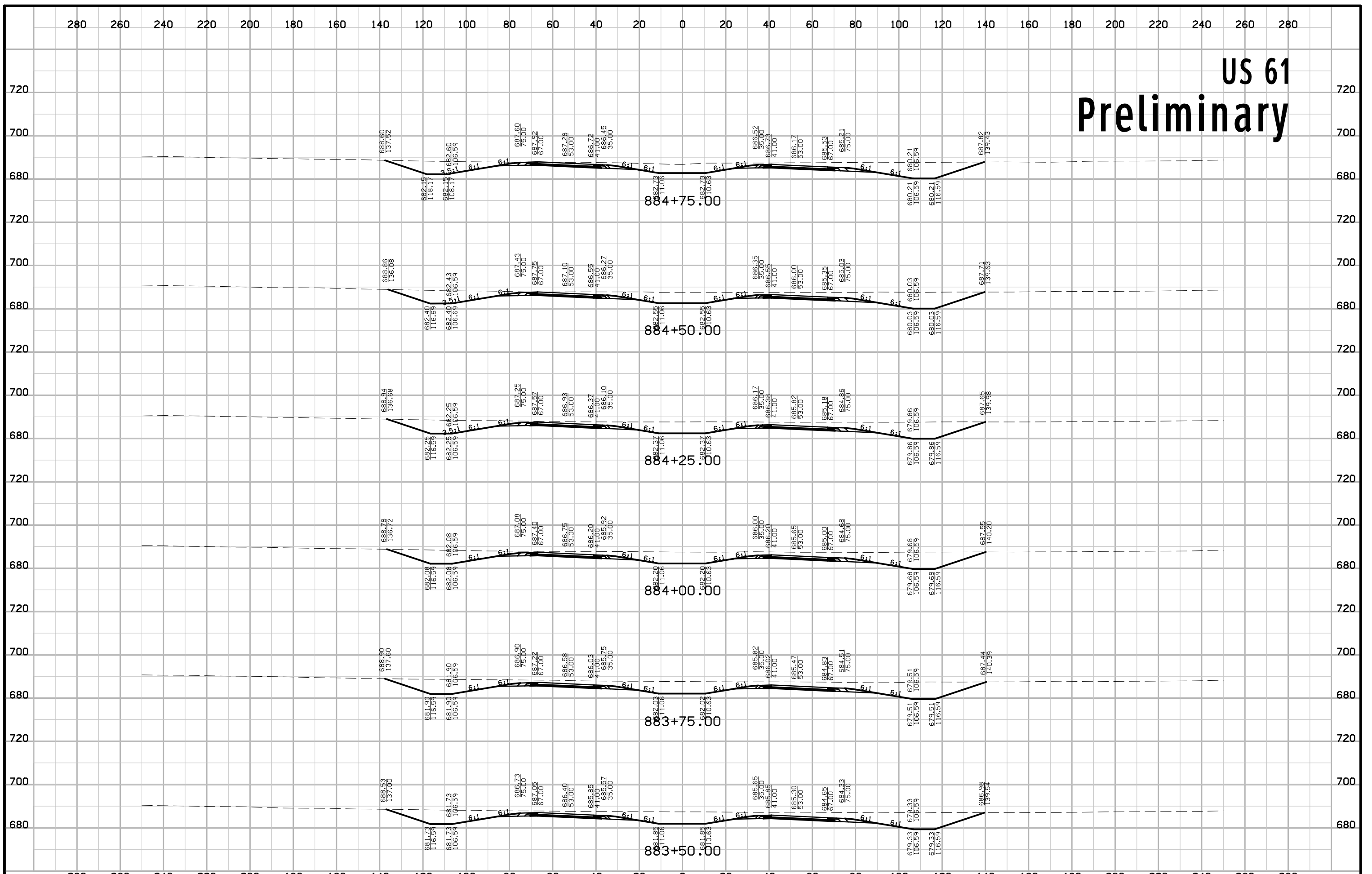

US 61 Preliminary

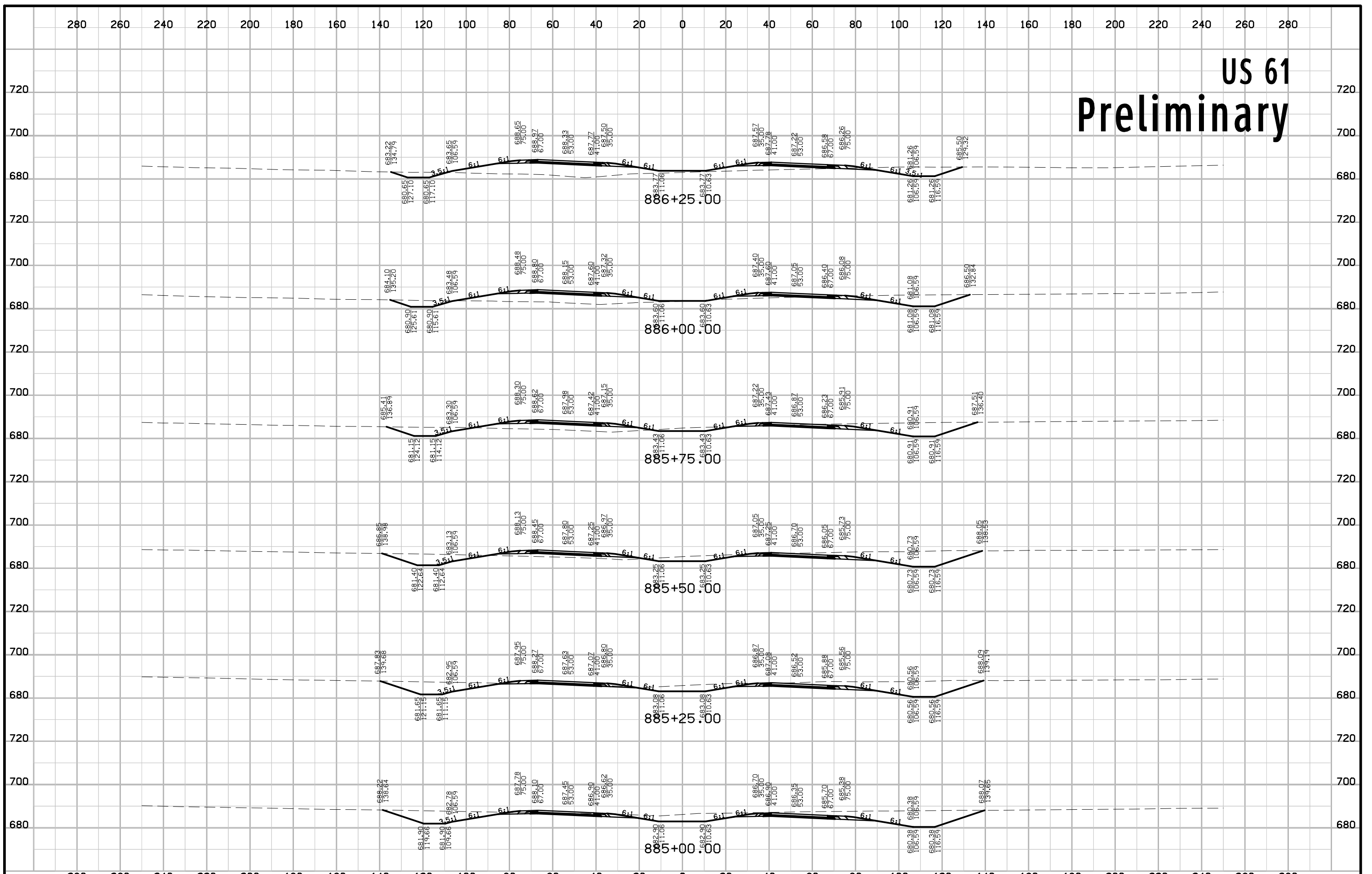

US 61 Preliminary

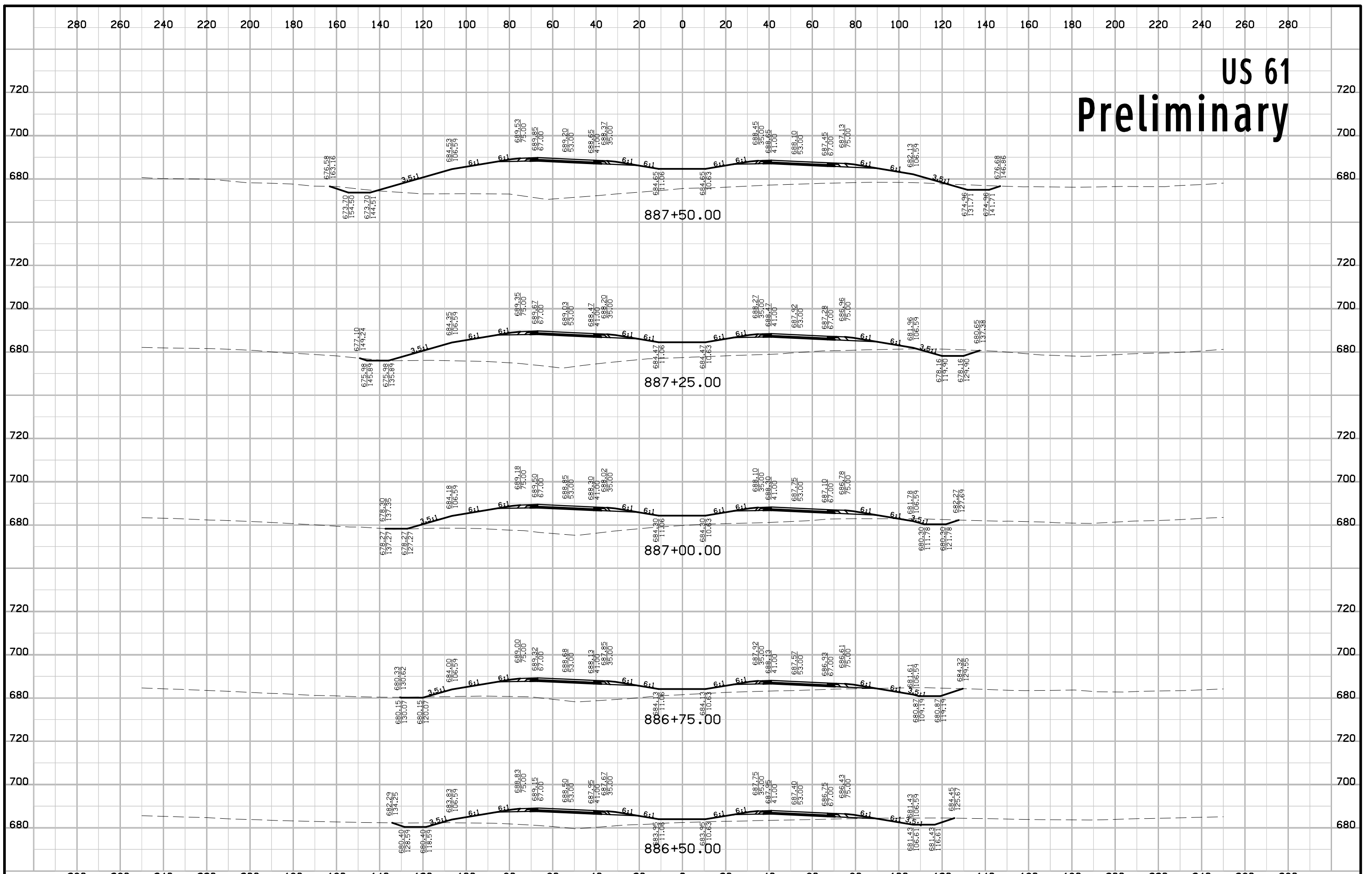

US 61 Preliminary

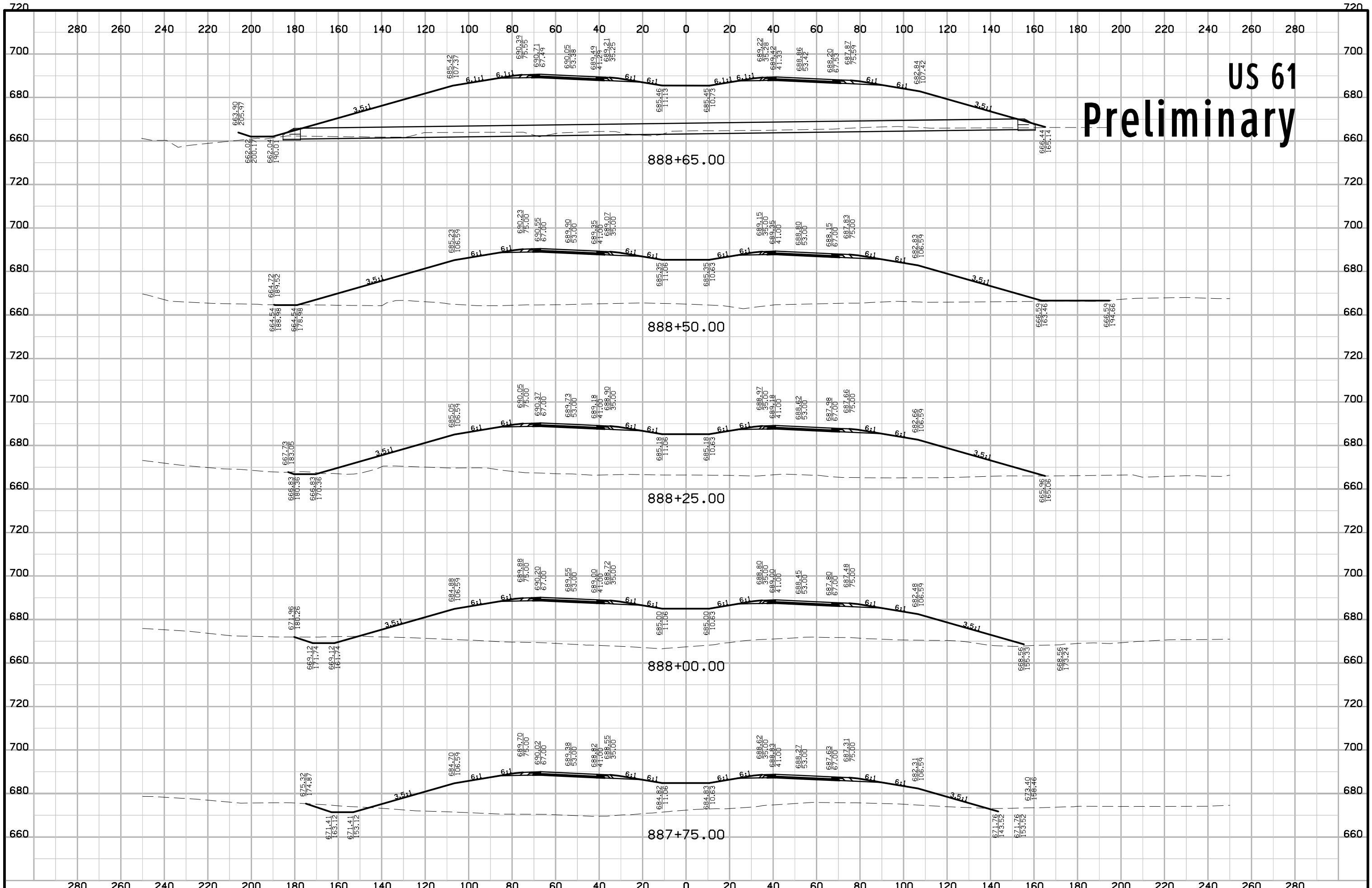

US 61 Preliminary

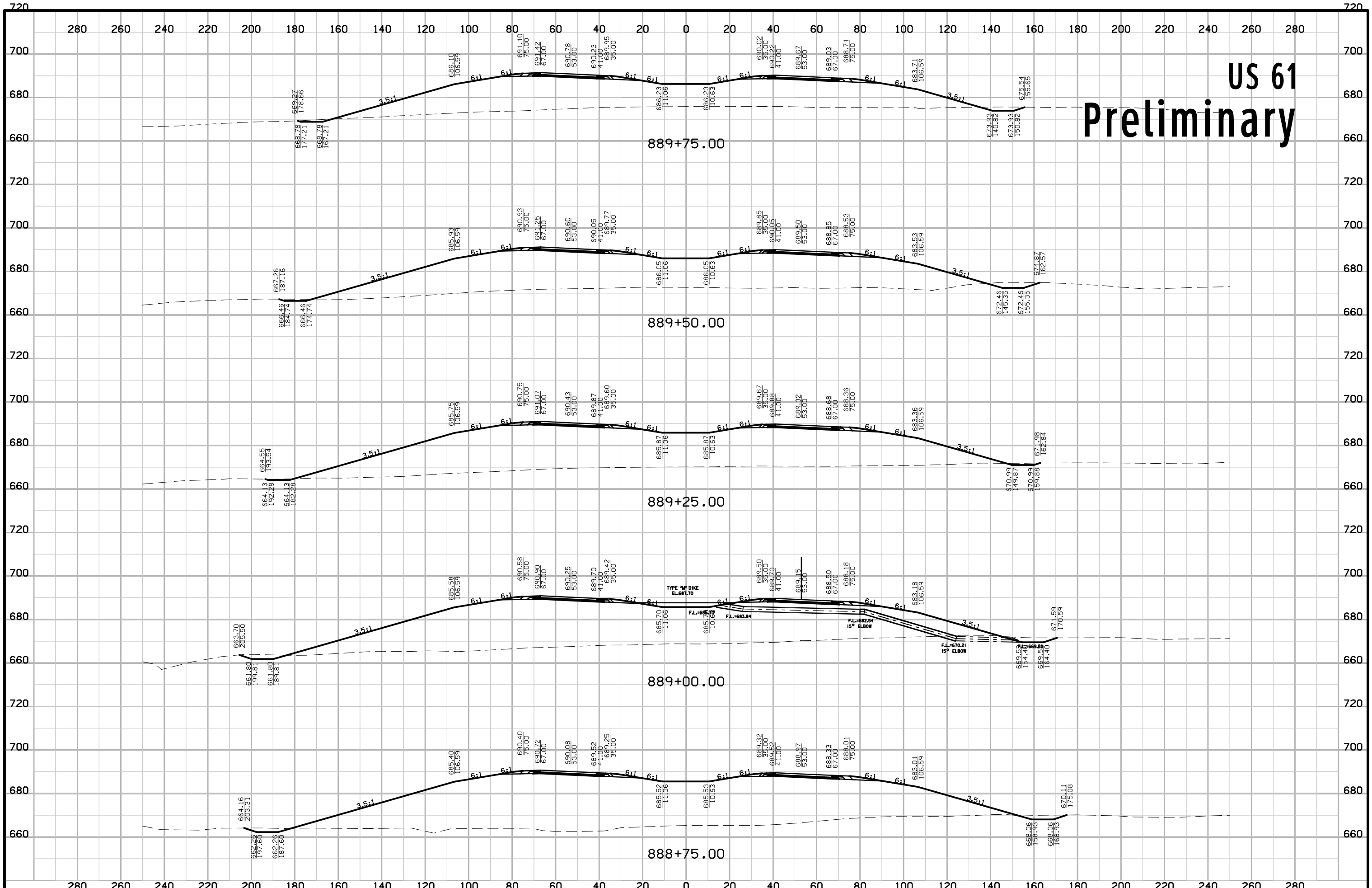

US 61 Preliminary

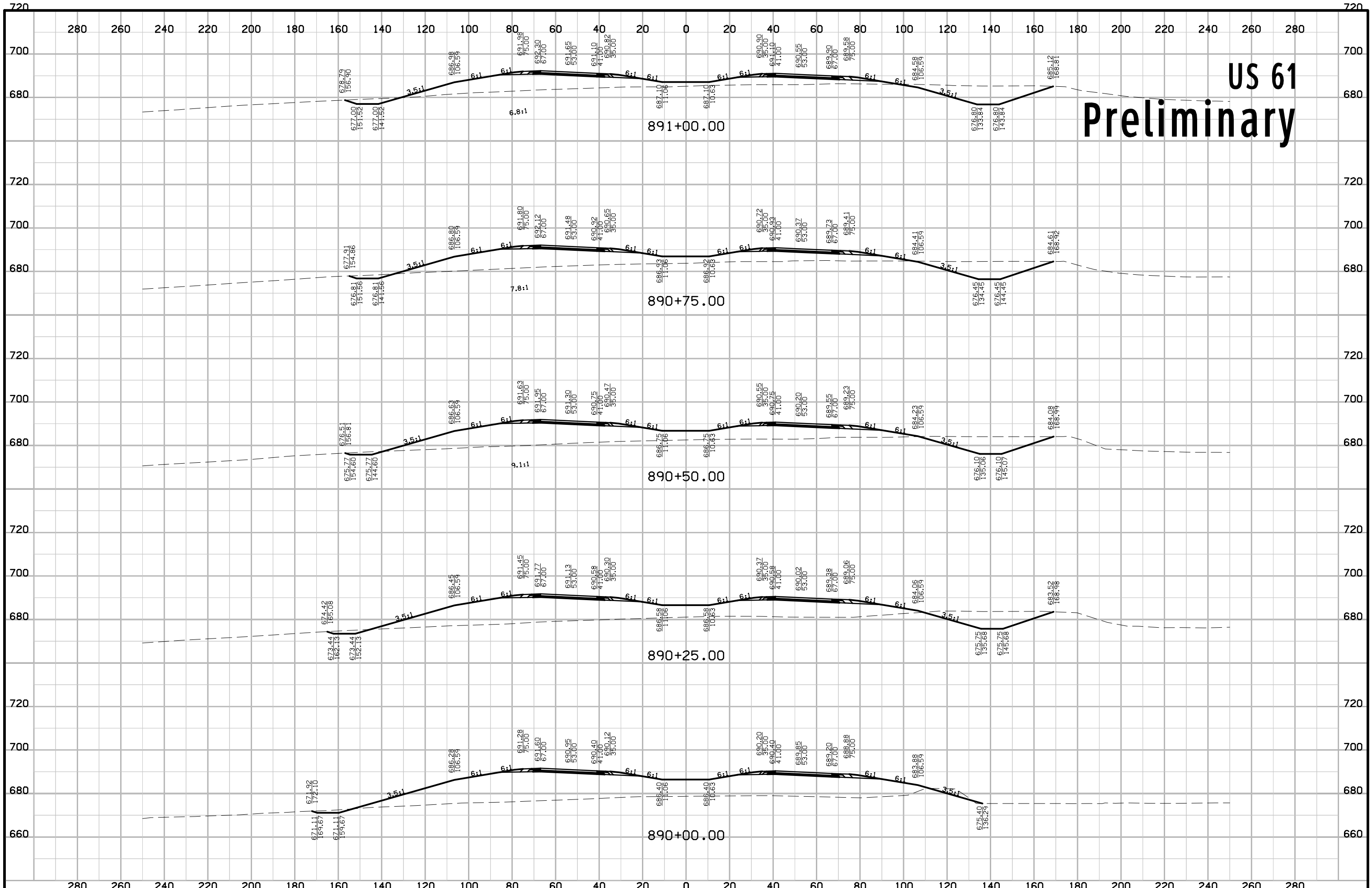

US 61 Preliminary

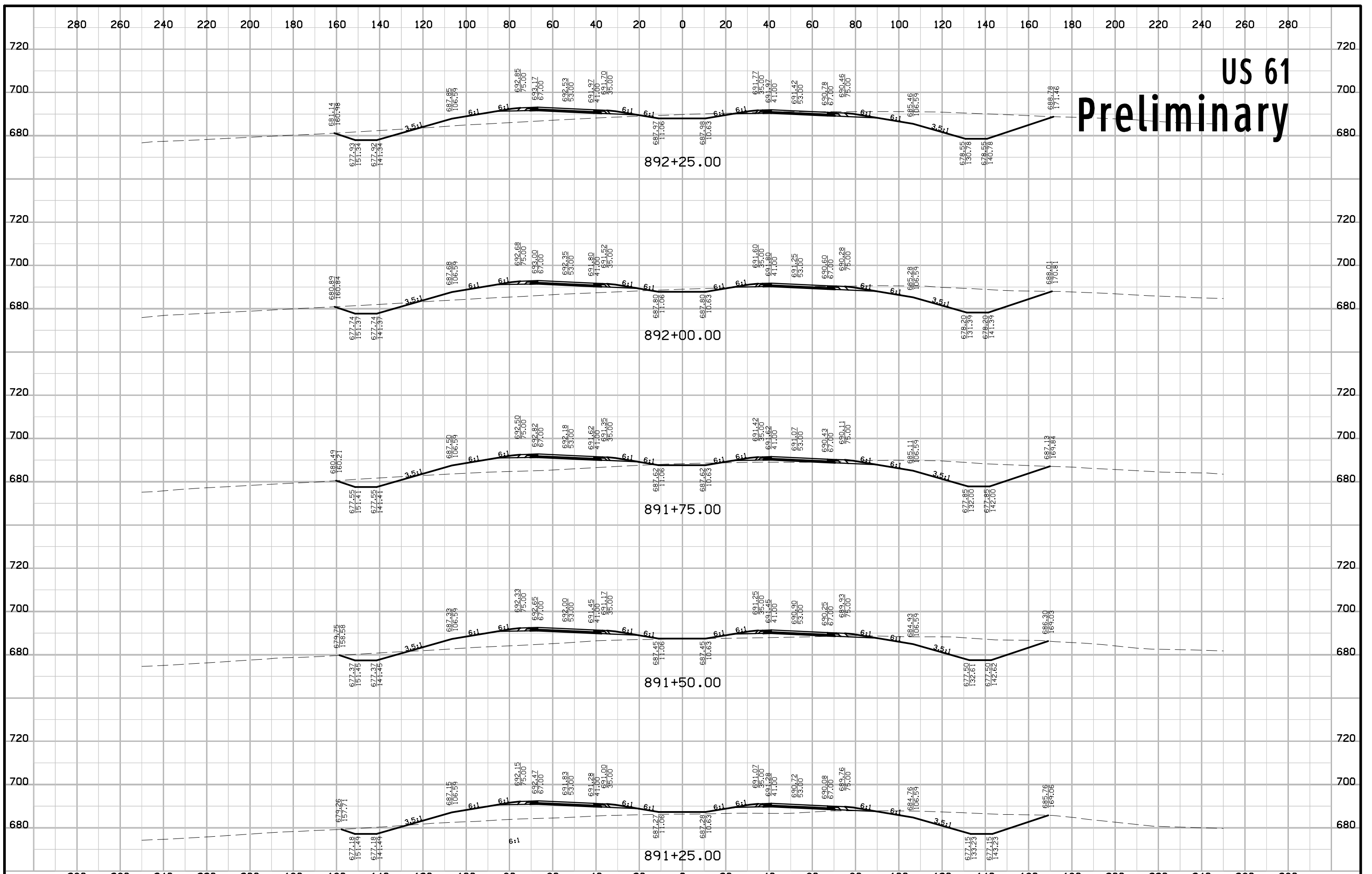

US 61 Preliminary

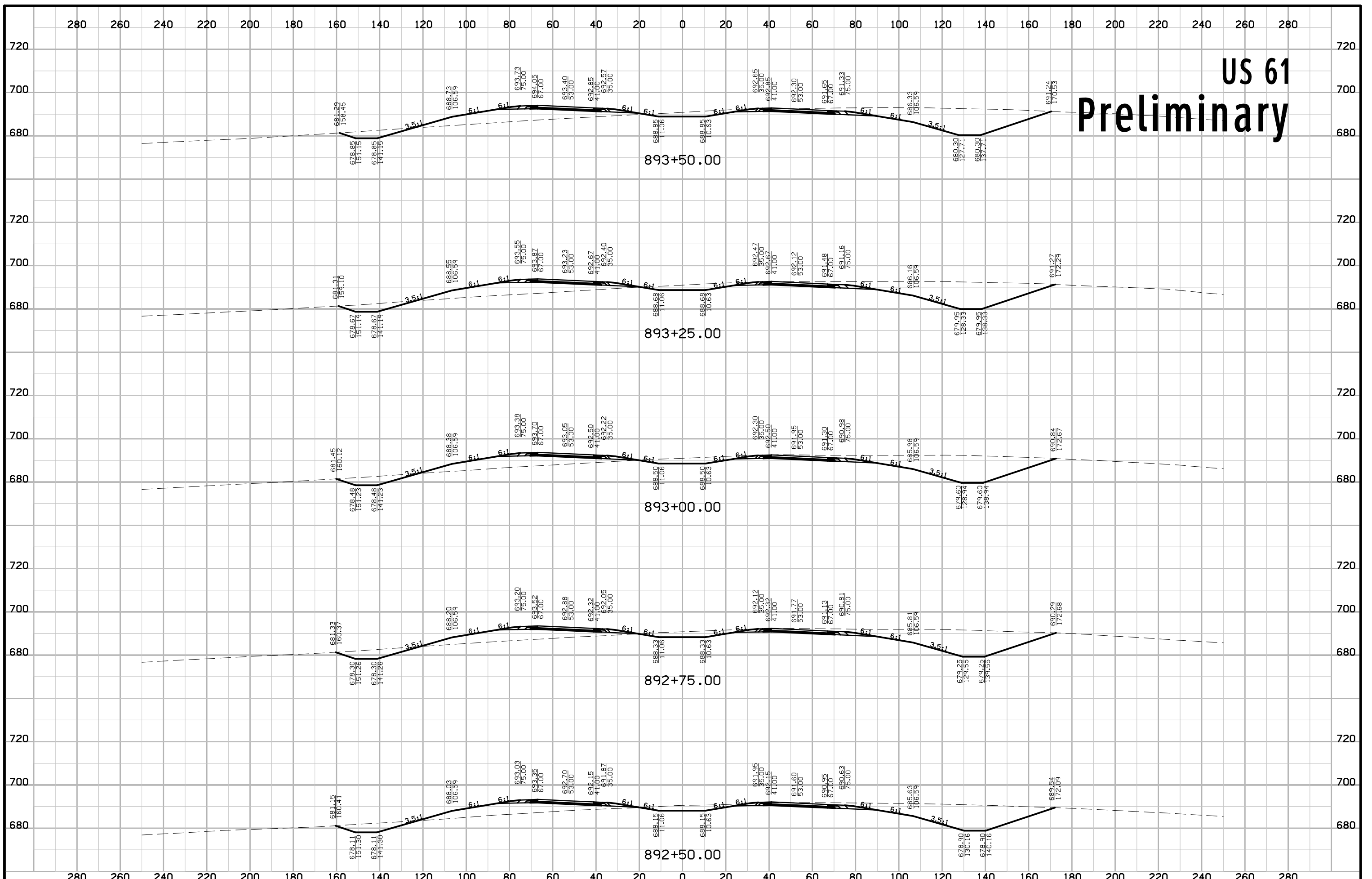

US 61 Preliminary

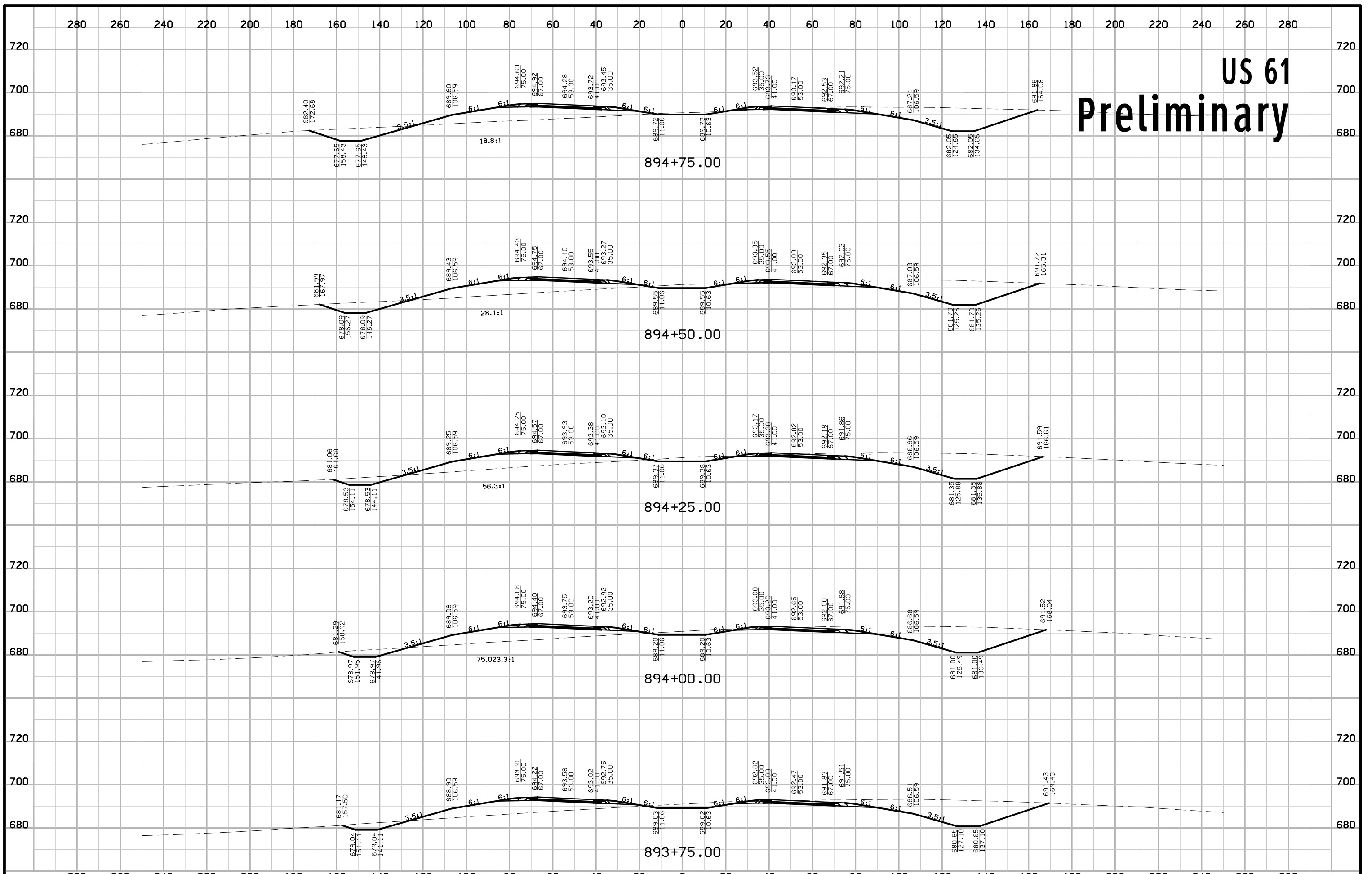

US 61 Preliminary

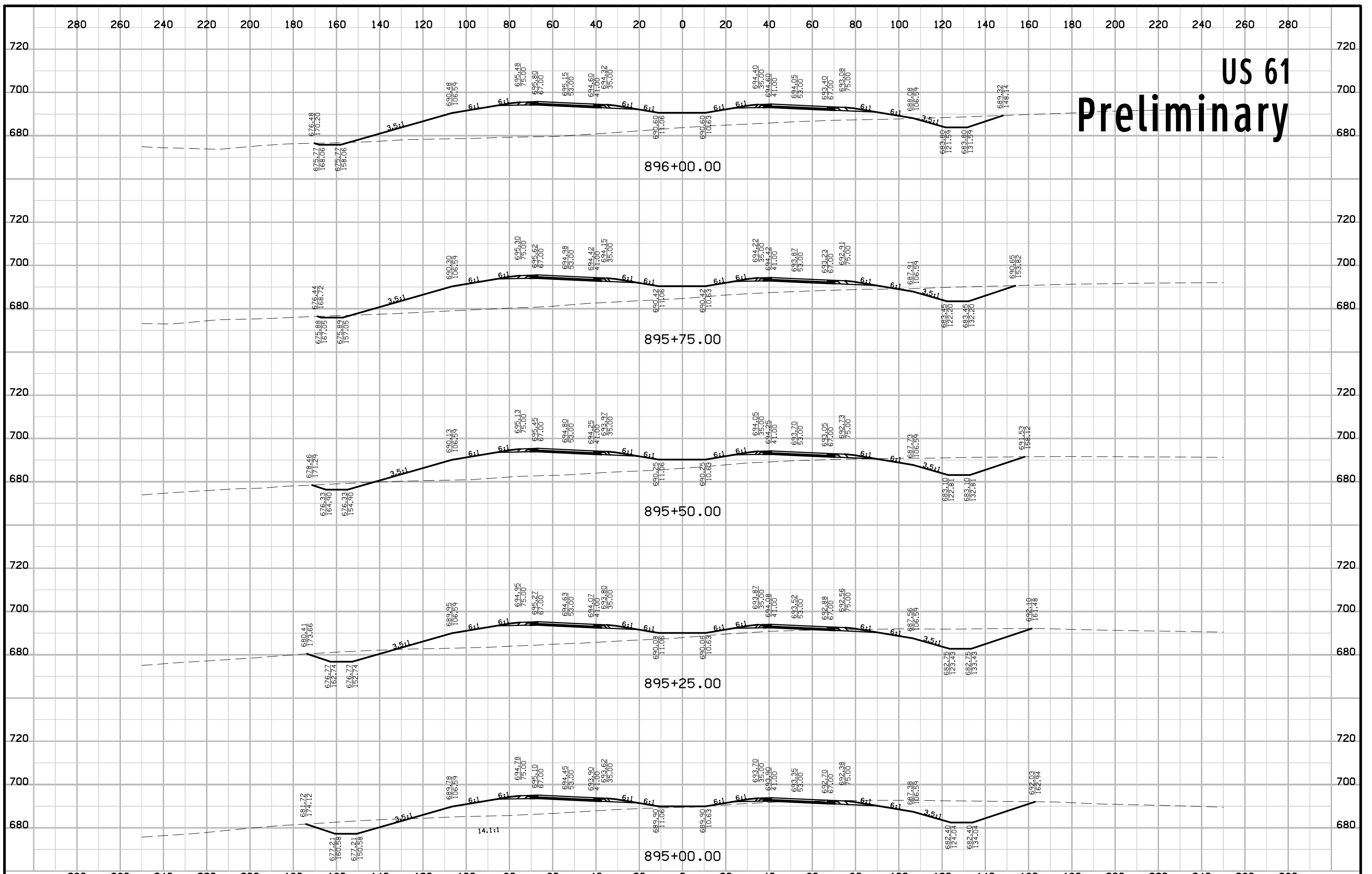

US 61 Preliminary

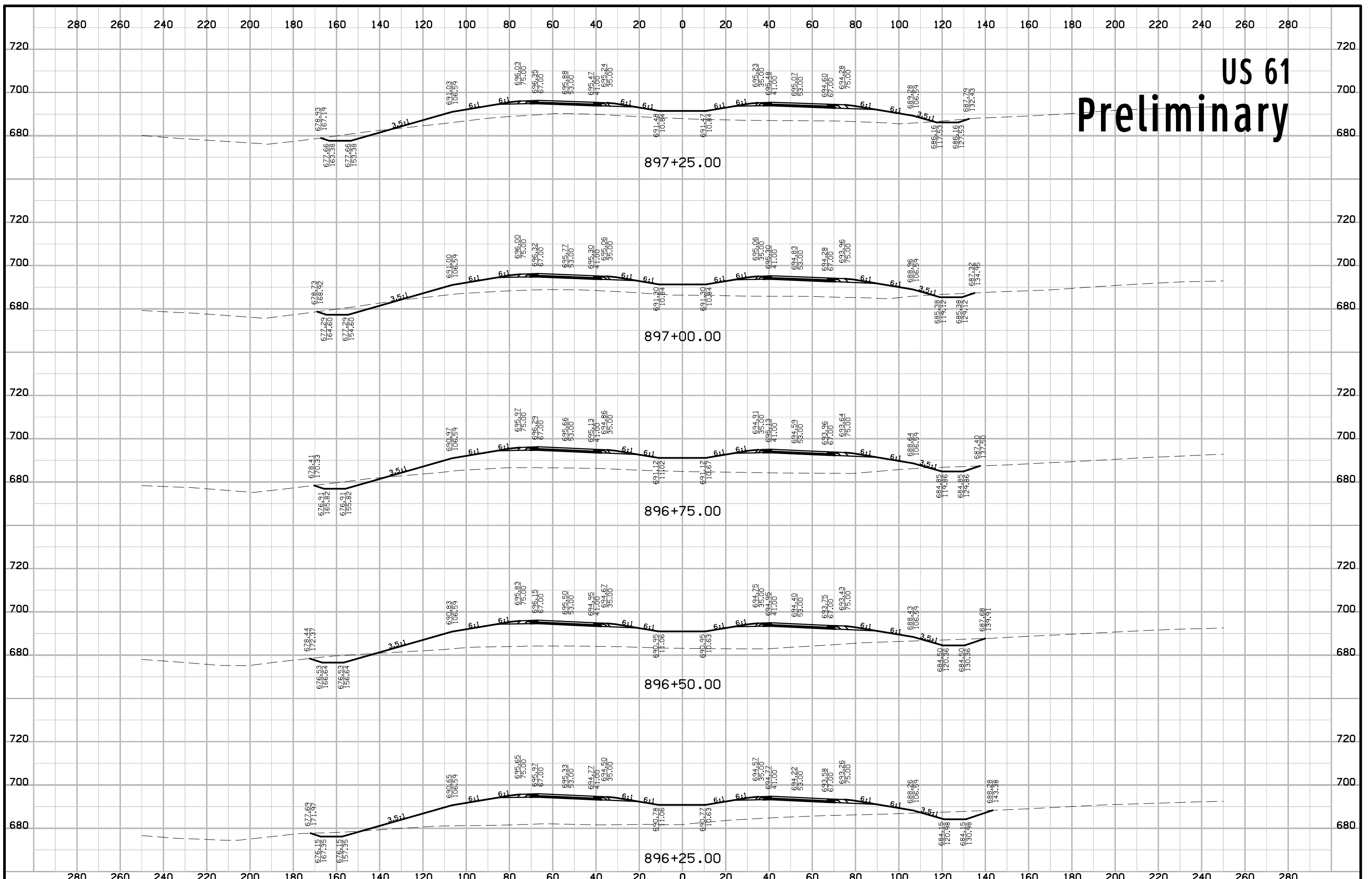

US 61 Preliminary

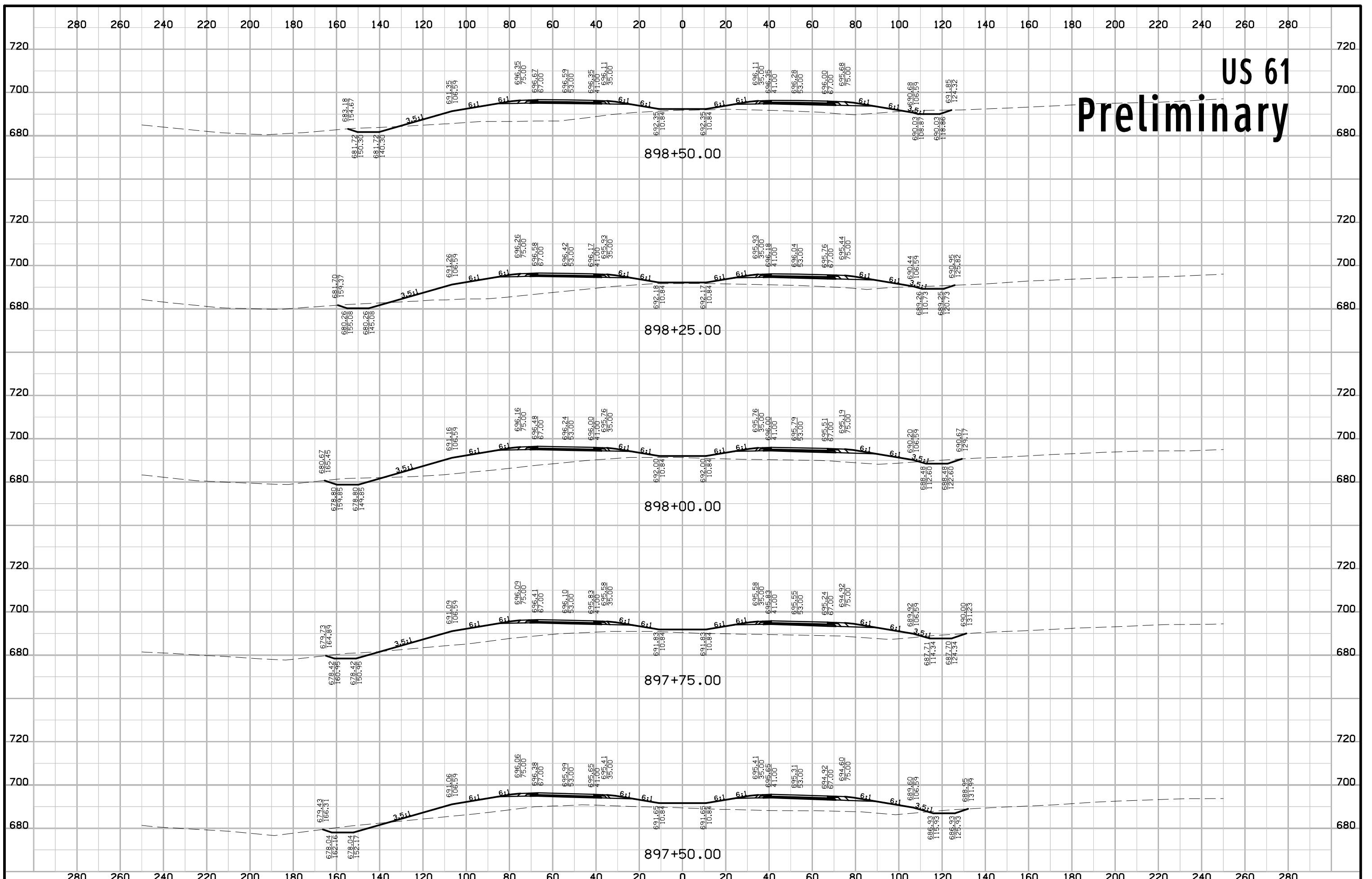

US 61 Preliminary

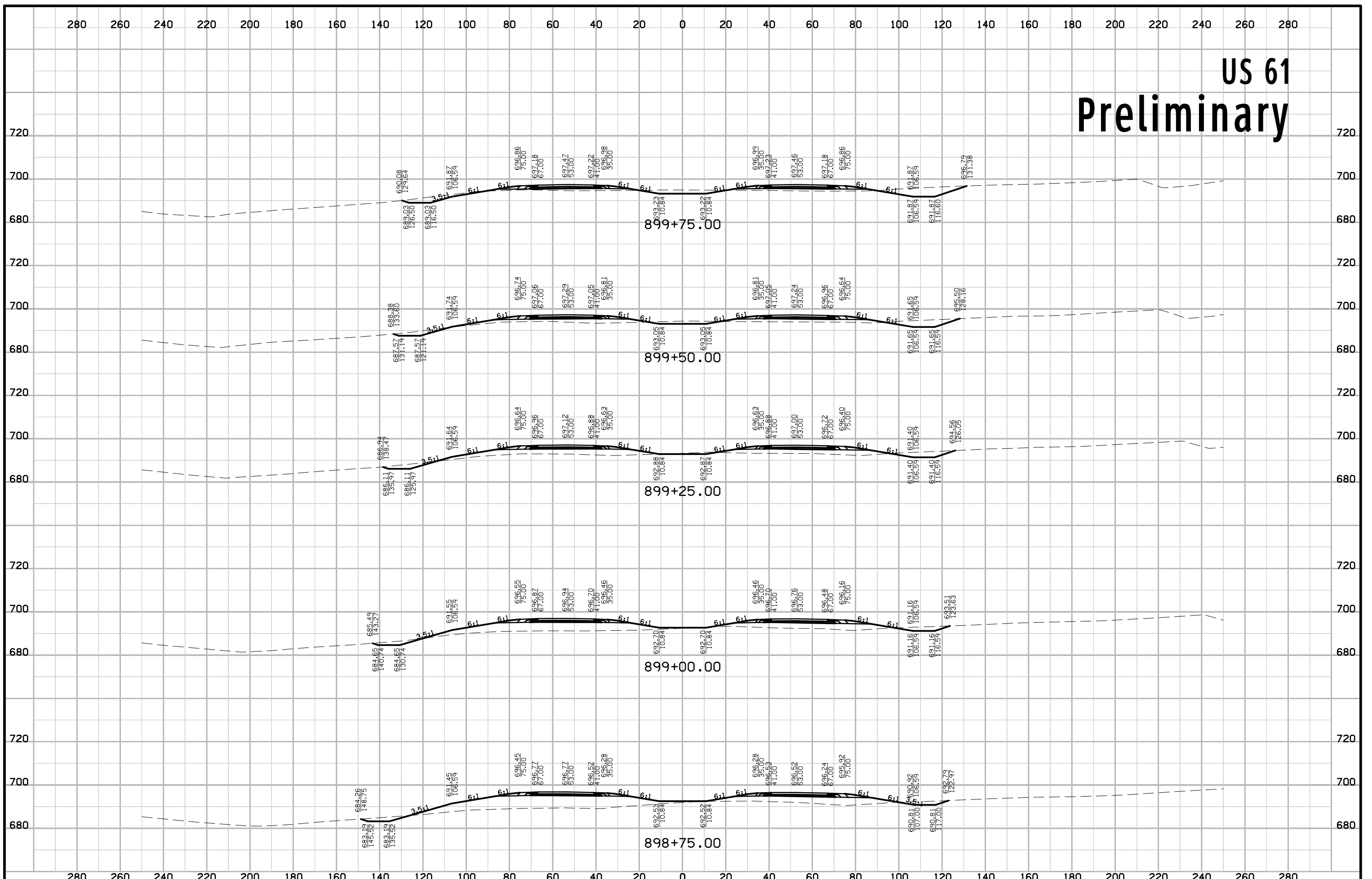

US 61 Preliminary

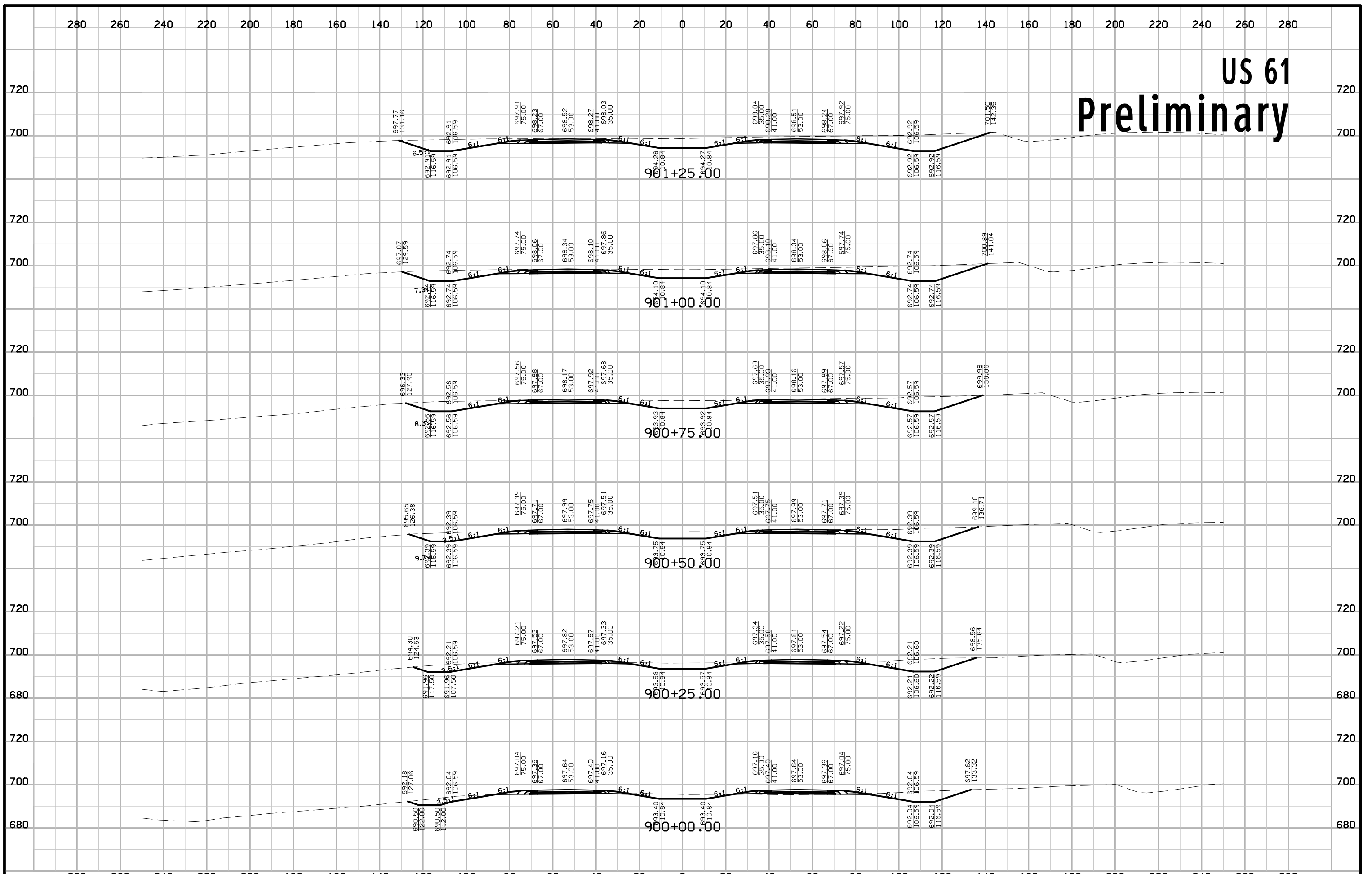

US 61 Preliminary

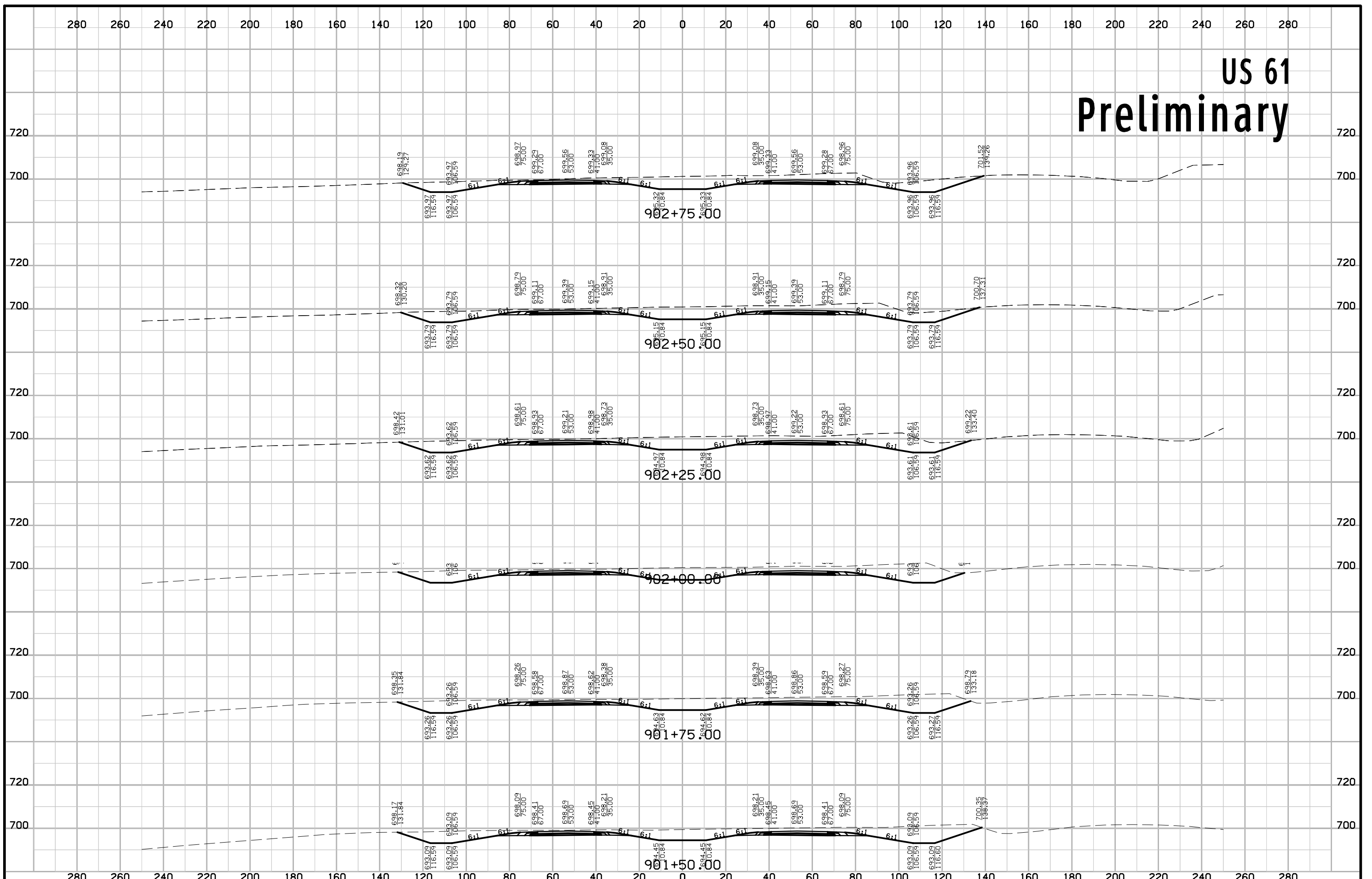

US 61 Preliminary

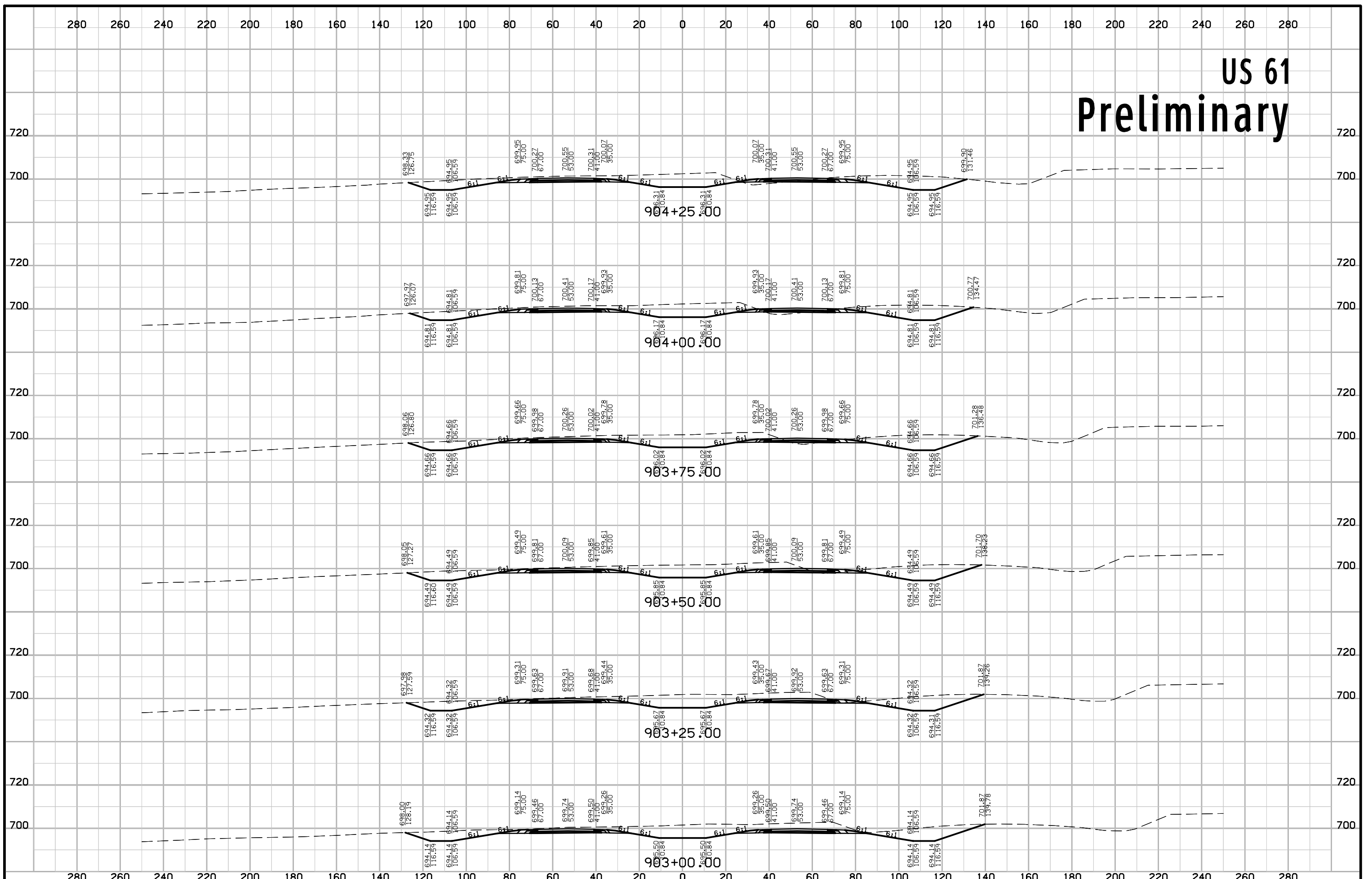

US 61 Preliminary

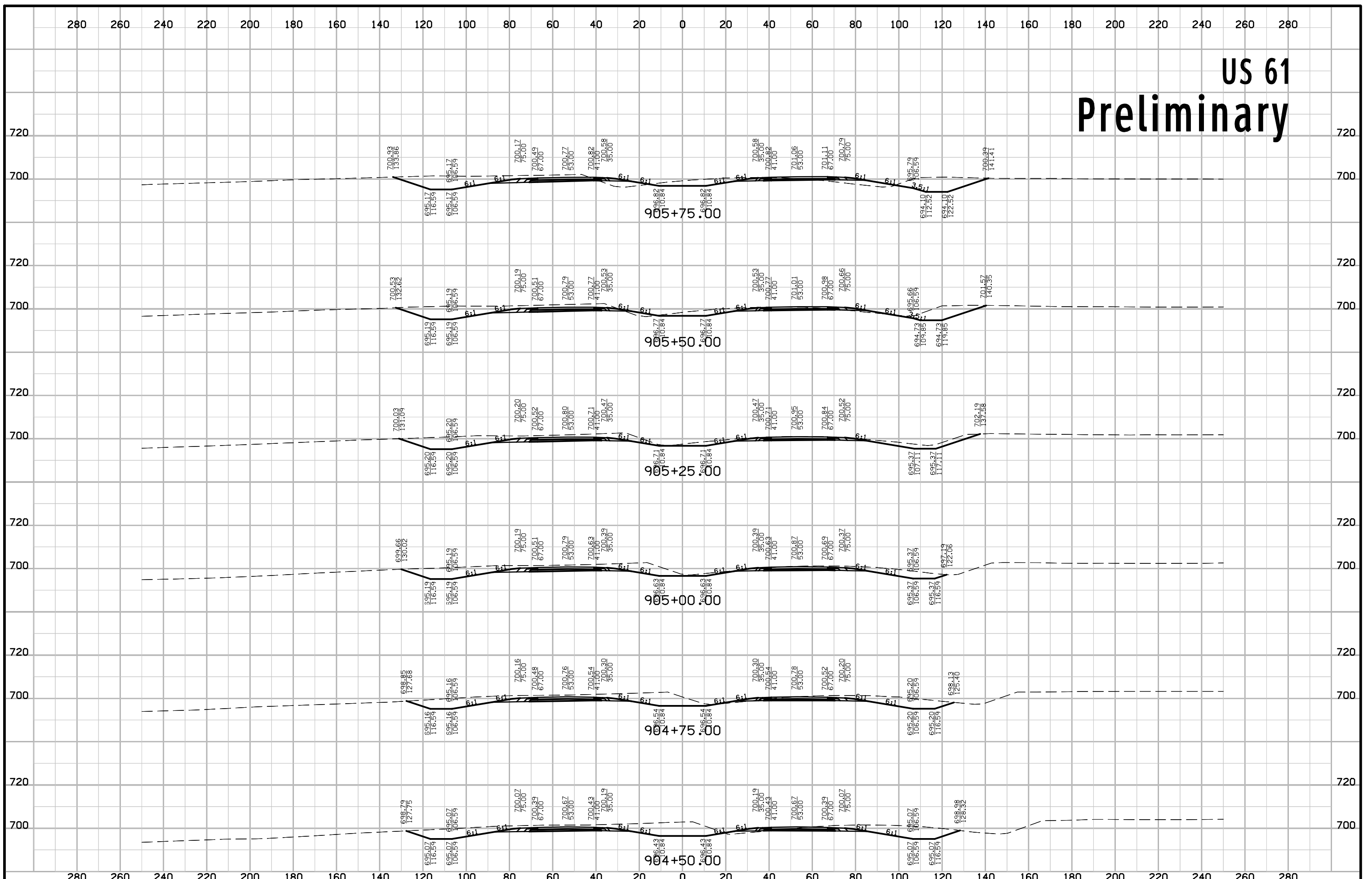

US 61 Preliminary

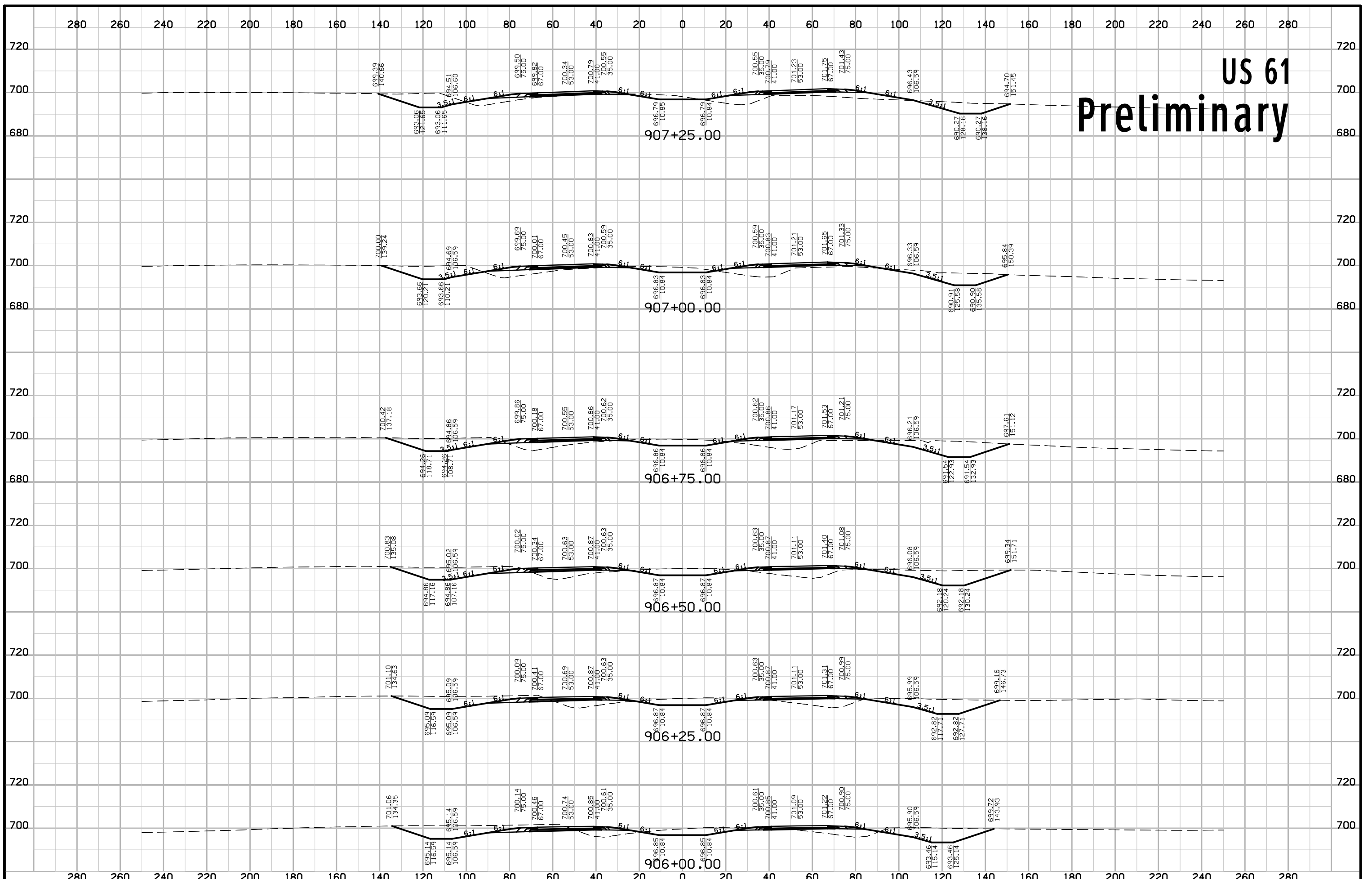

US 61 Preliminary

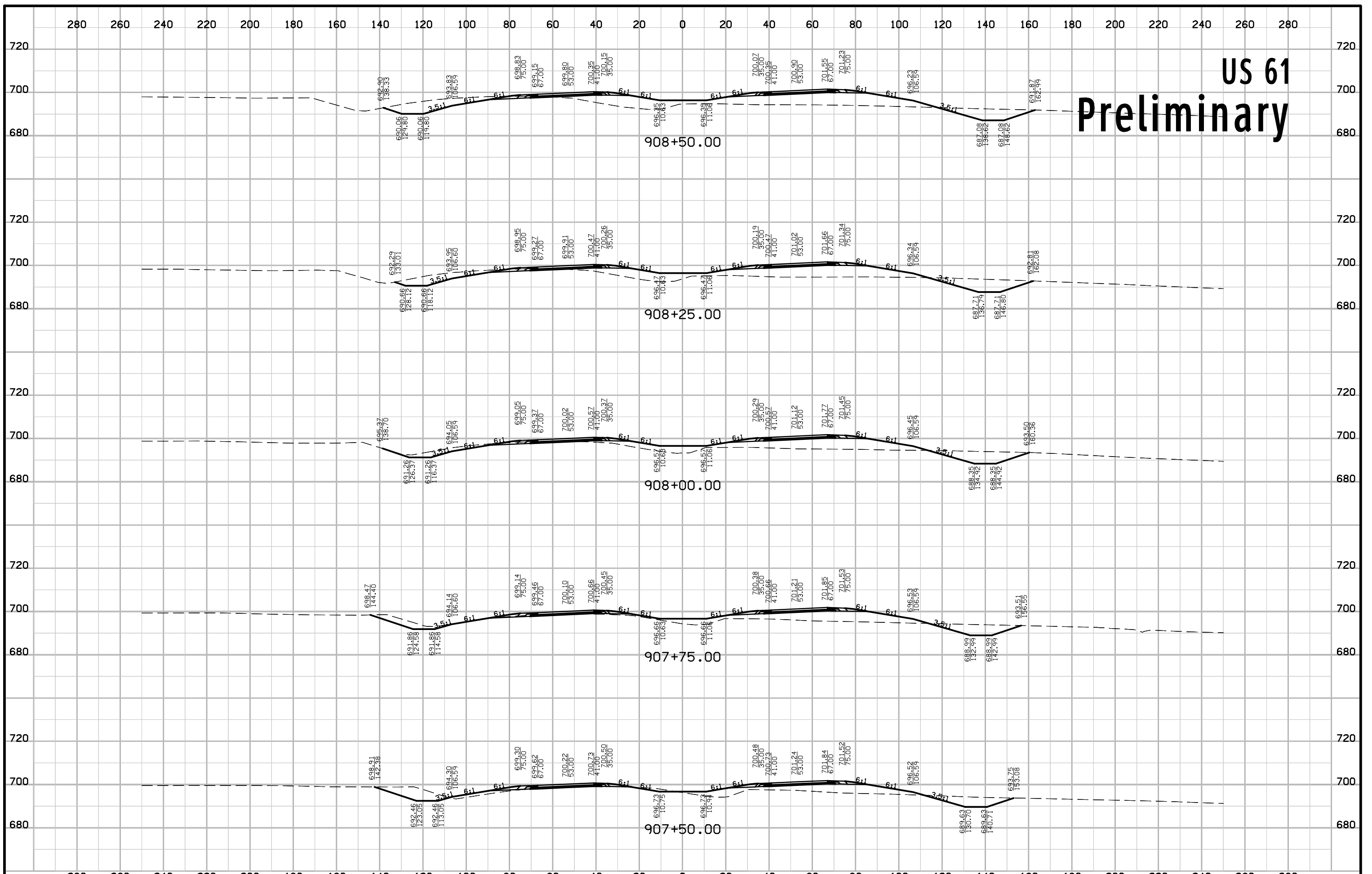

US 61 Preliminary

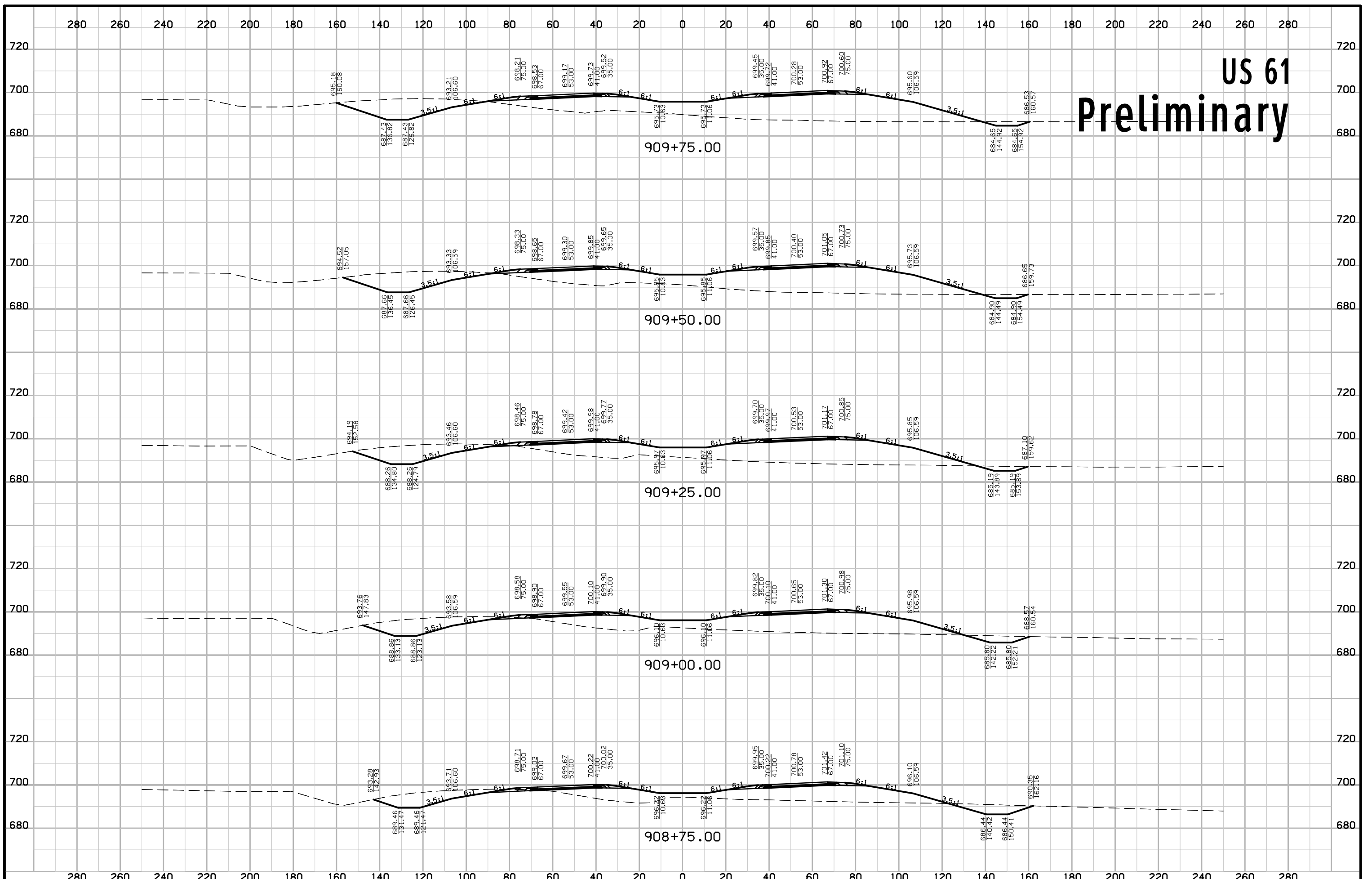

US 61 Preliminary

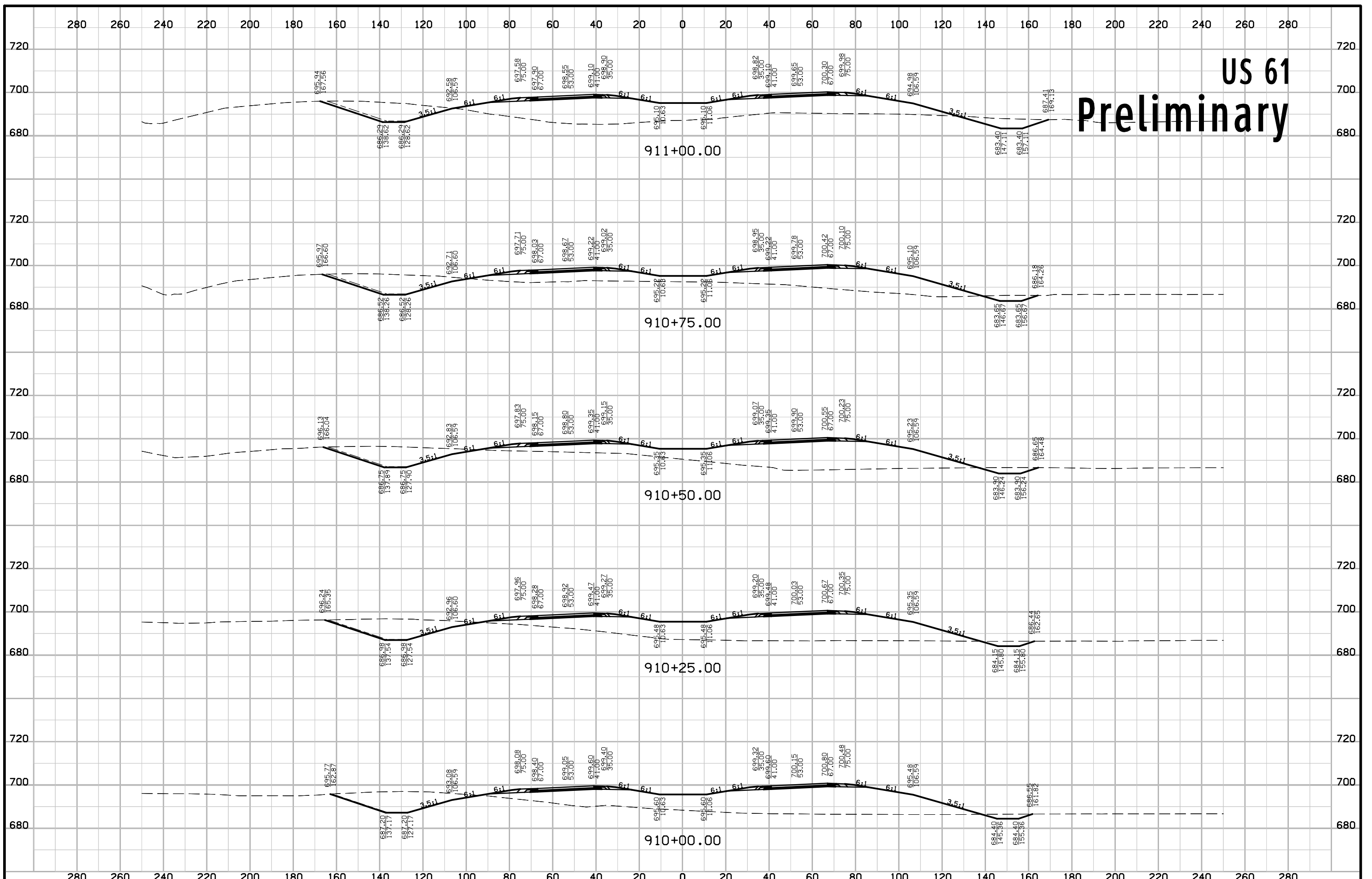

US 61 Preliminary

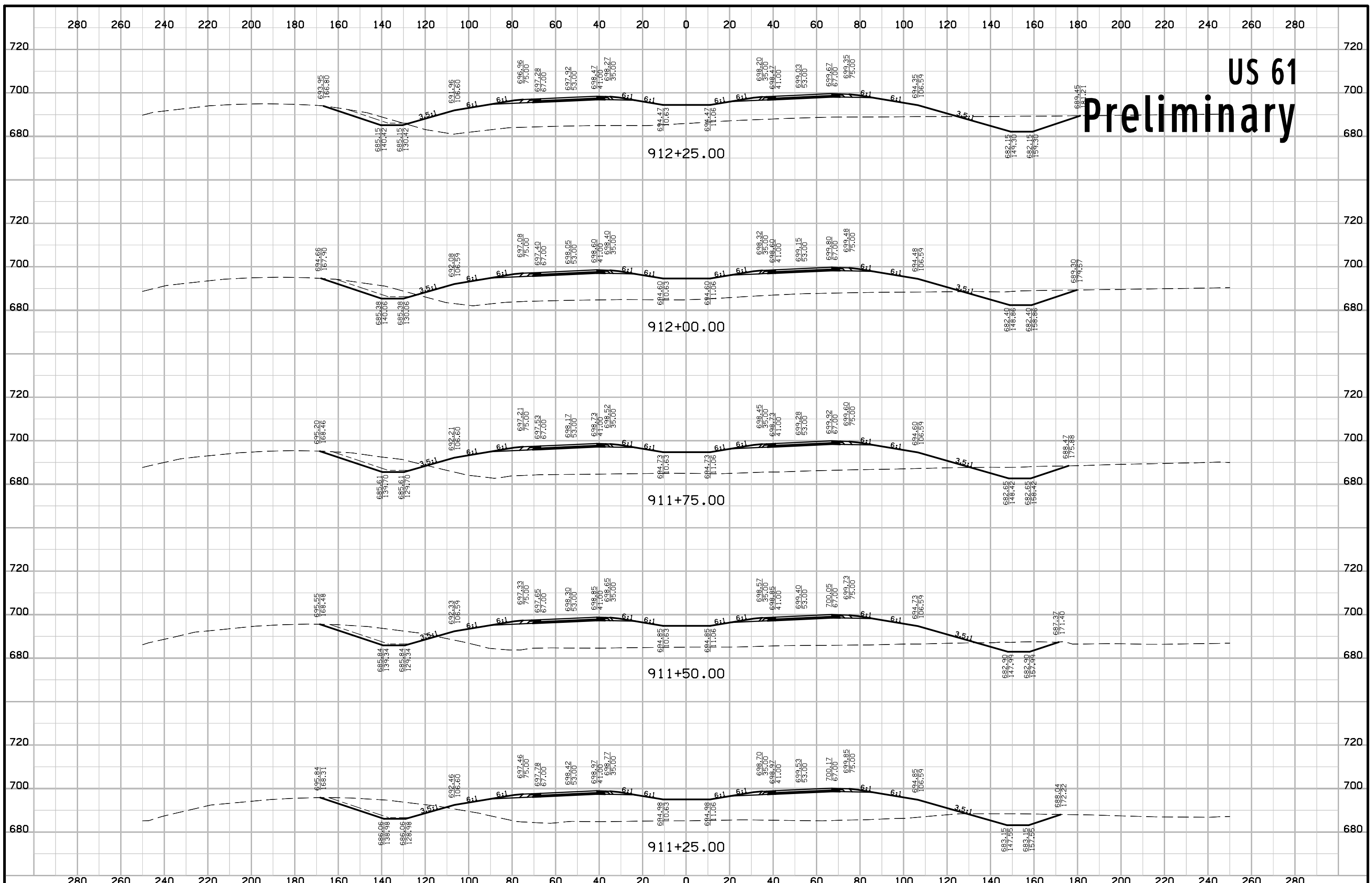

US 61 Preliminary

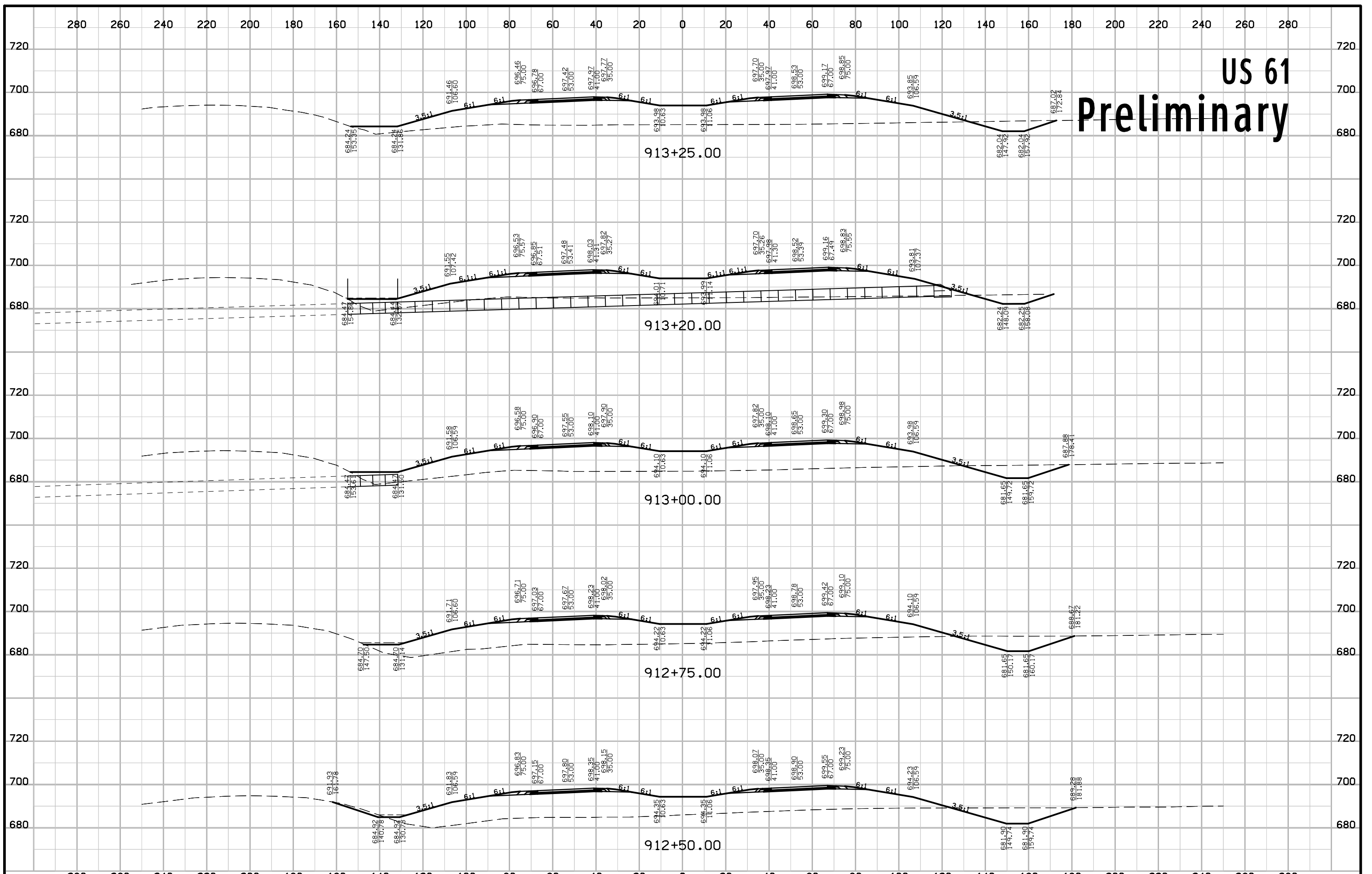

US 61 Preliminary

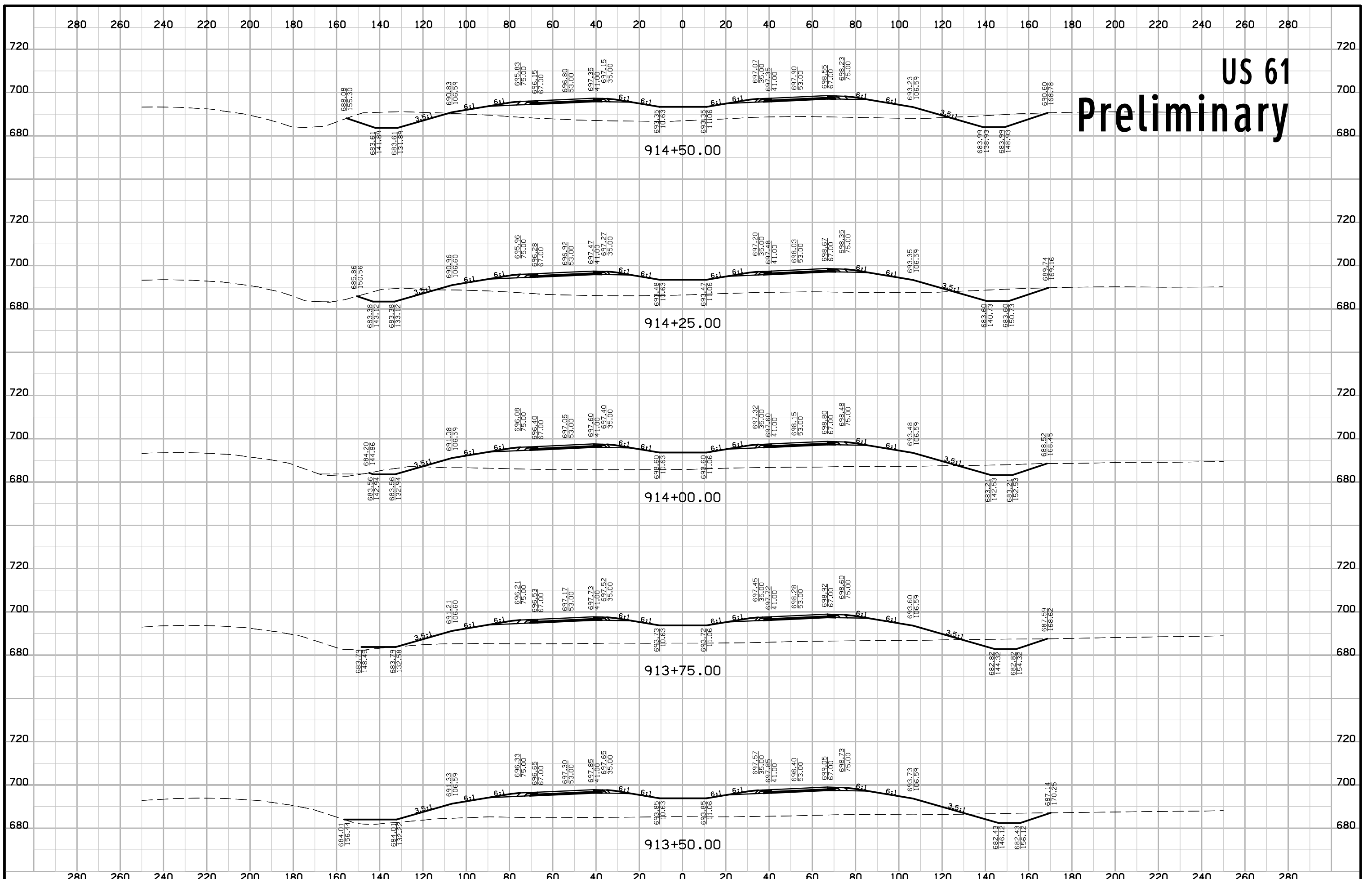

US 61 Preliminary

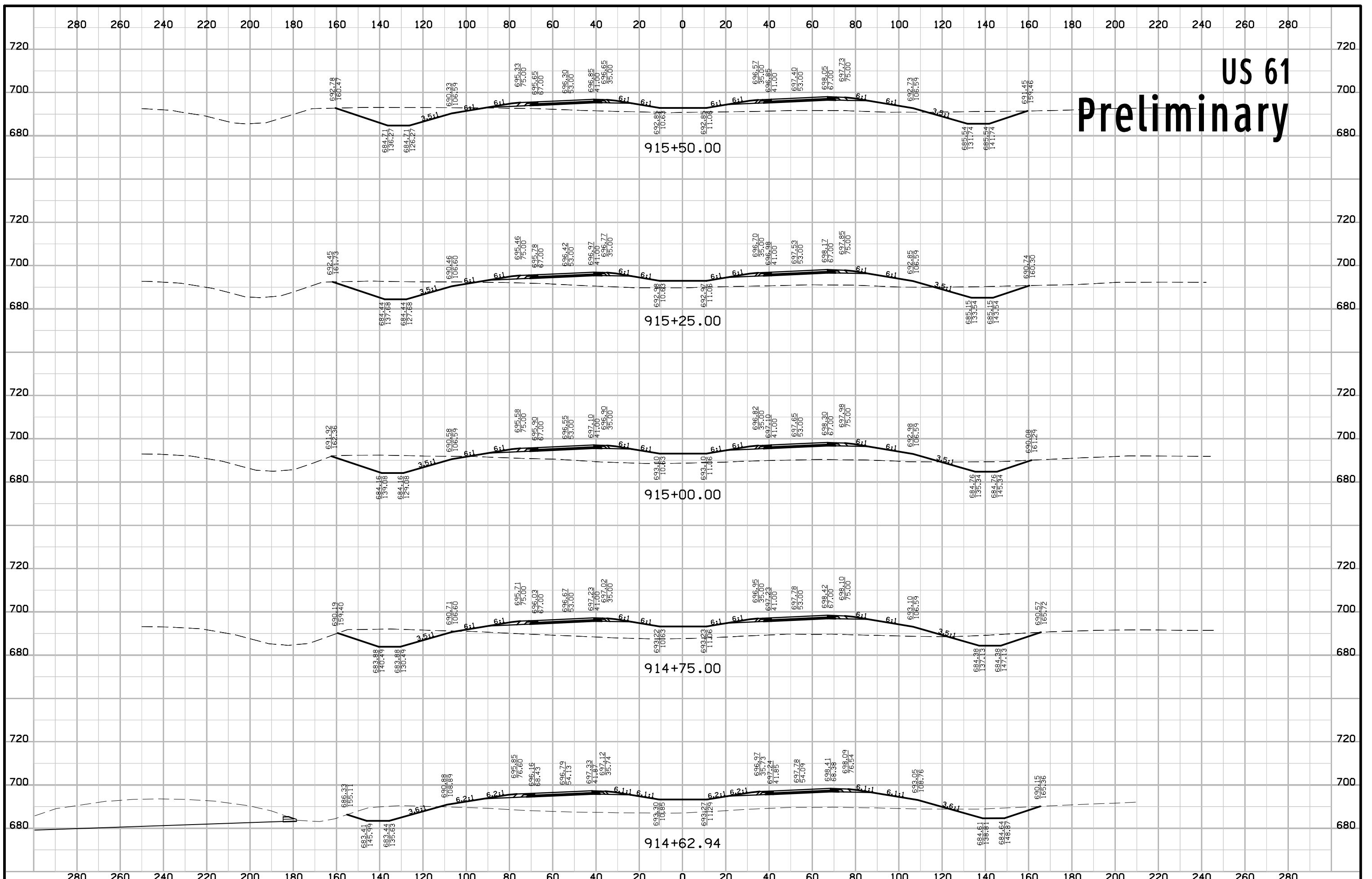

US 61 Preliminary

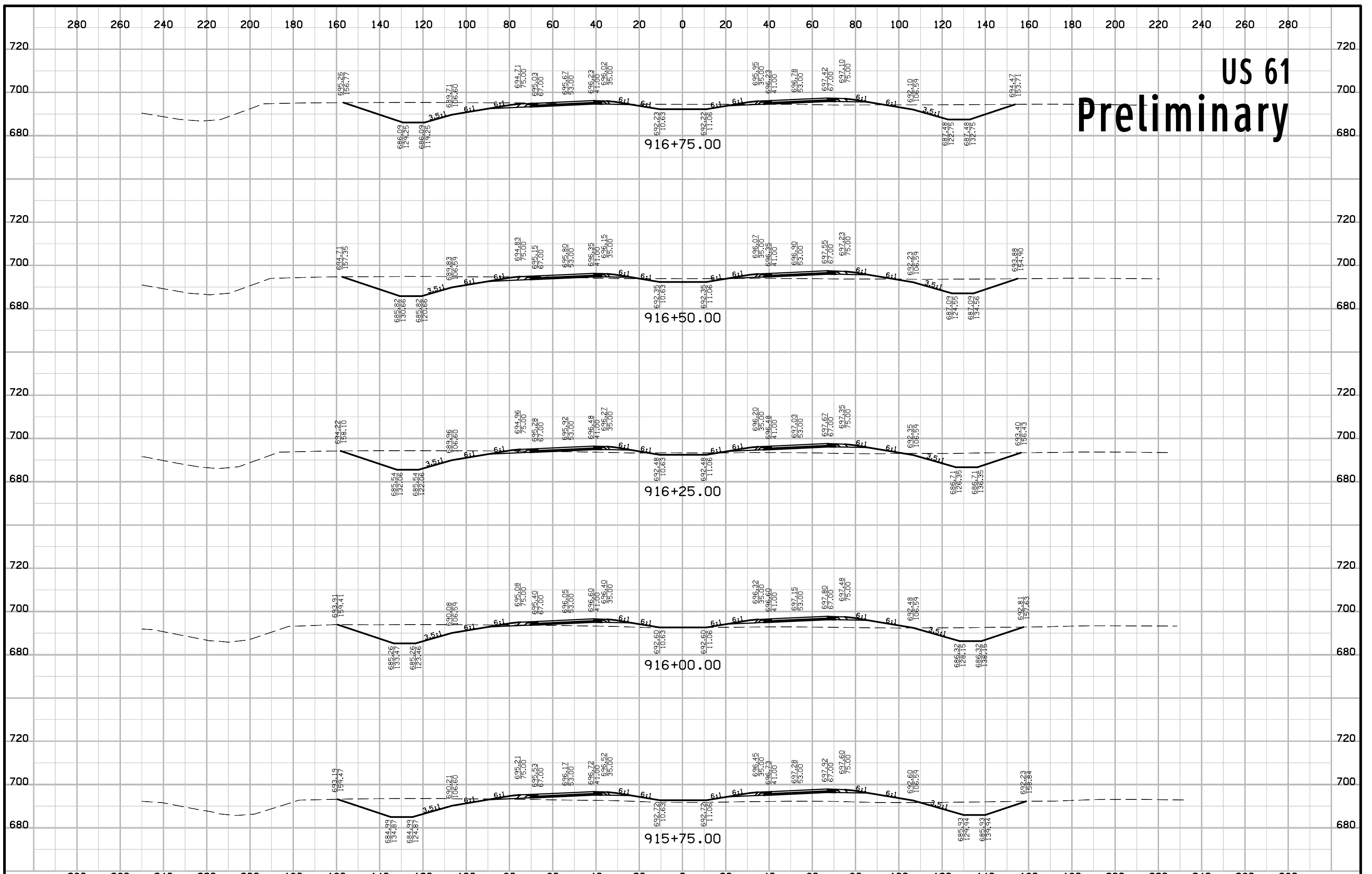

US 61 Preliminary

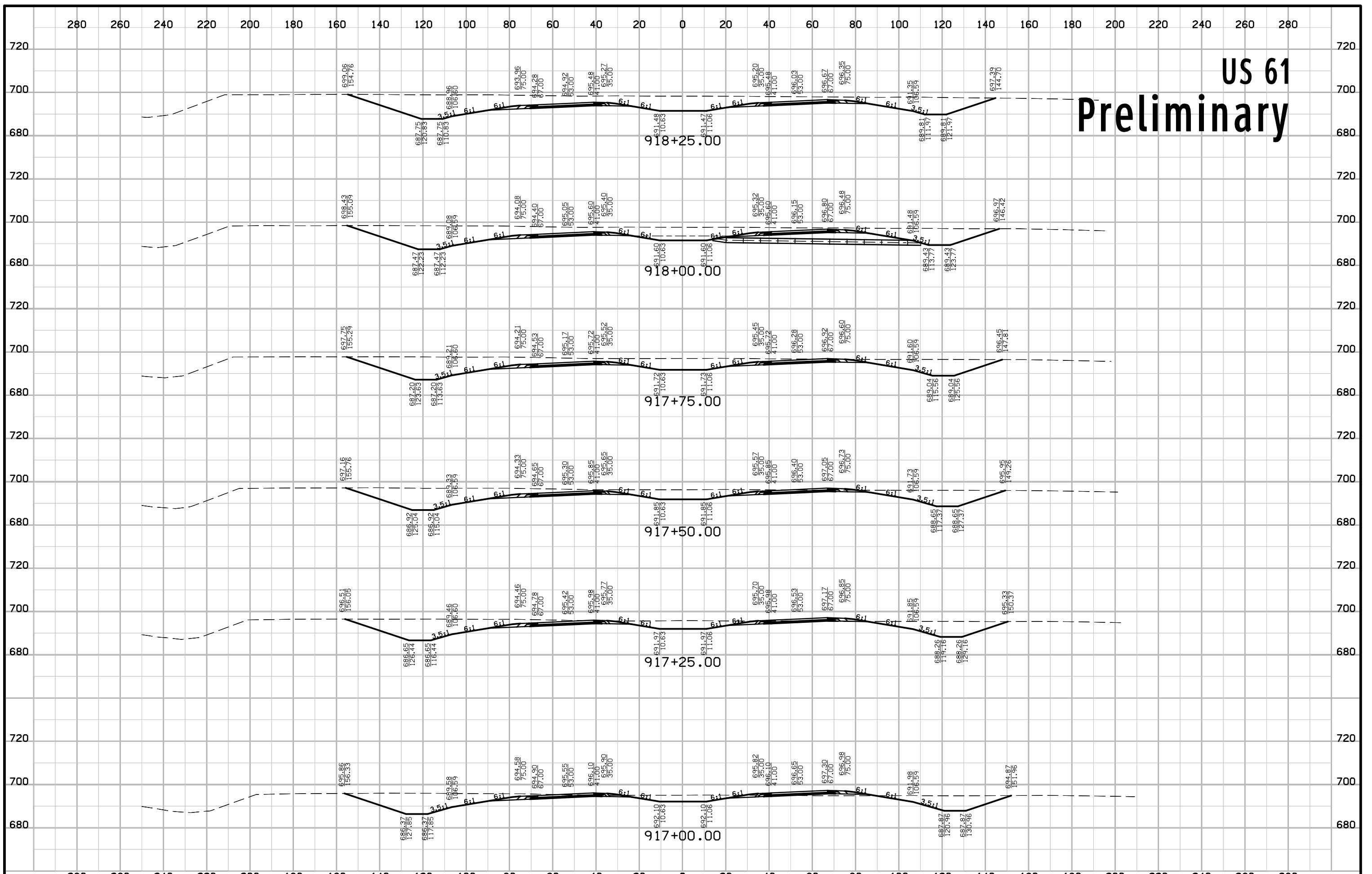

US 61 Preliminary

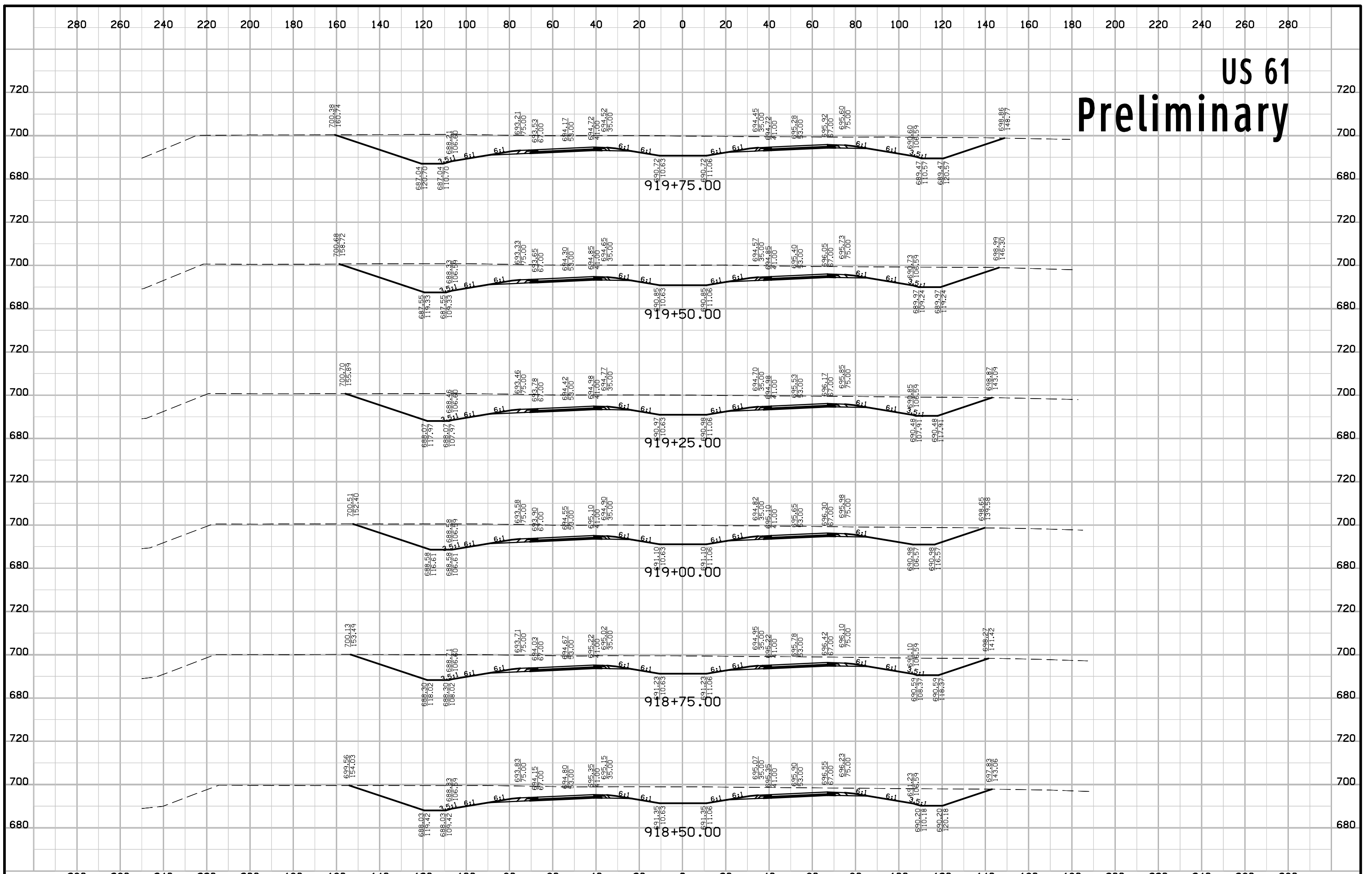

US 61 Preliminary

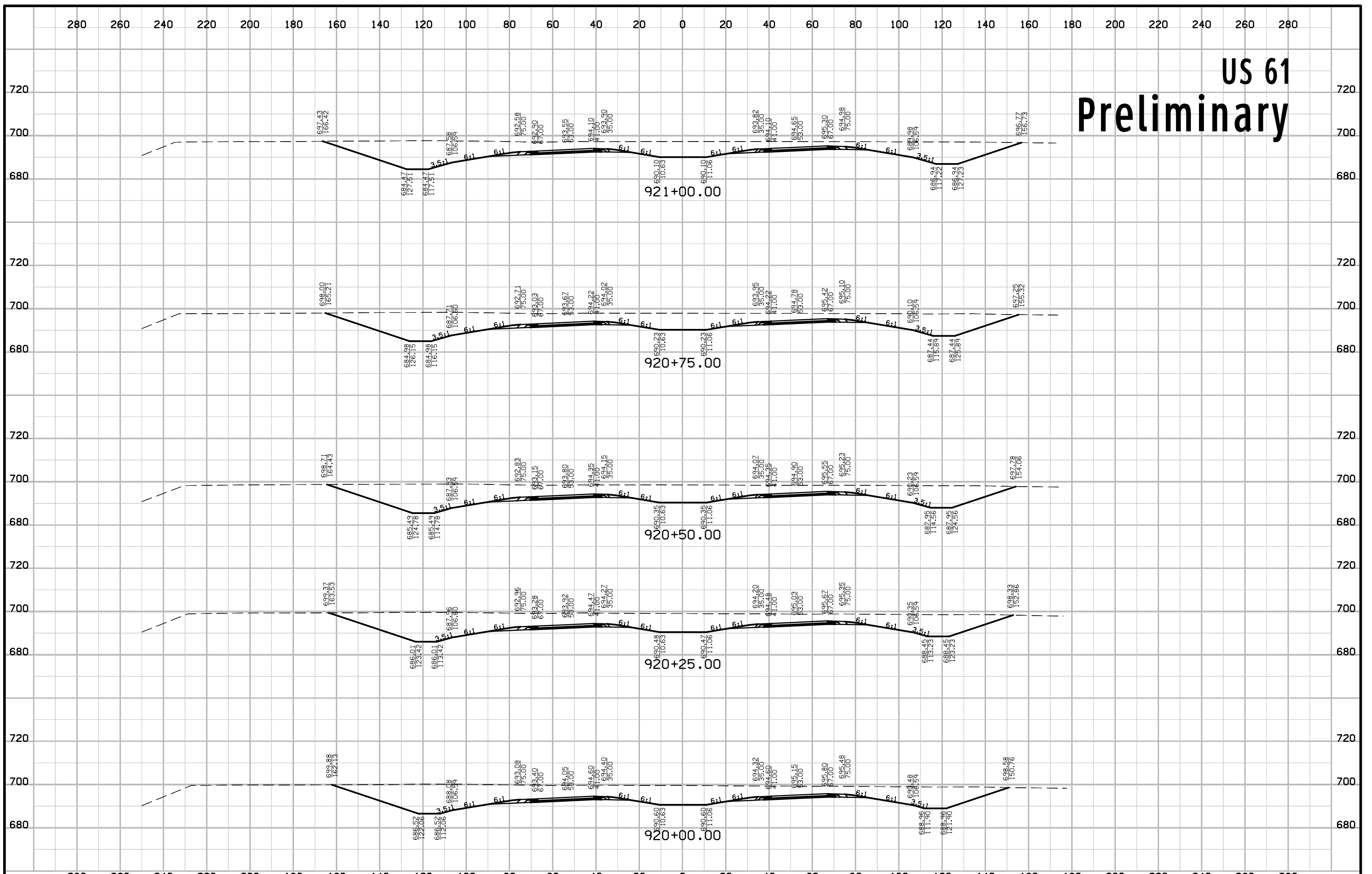

US 61 Preliminary

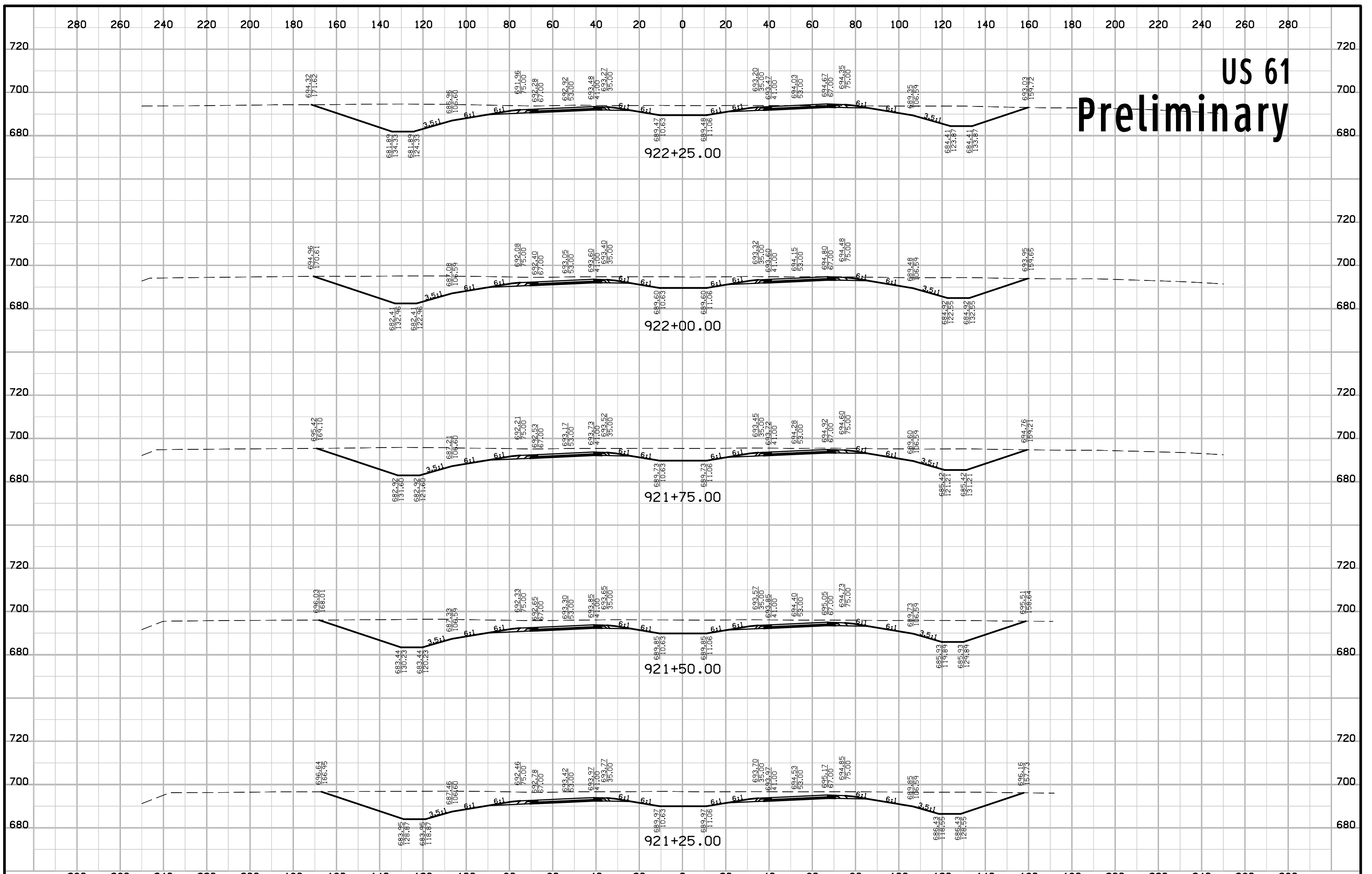

US 61 Preliminary

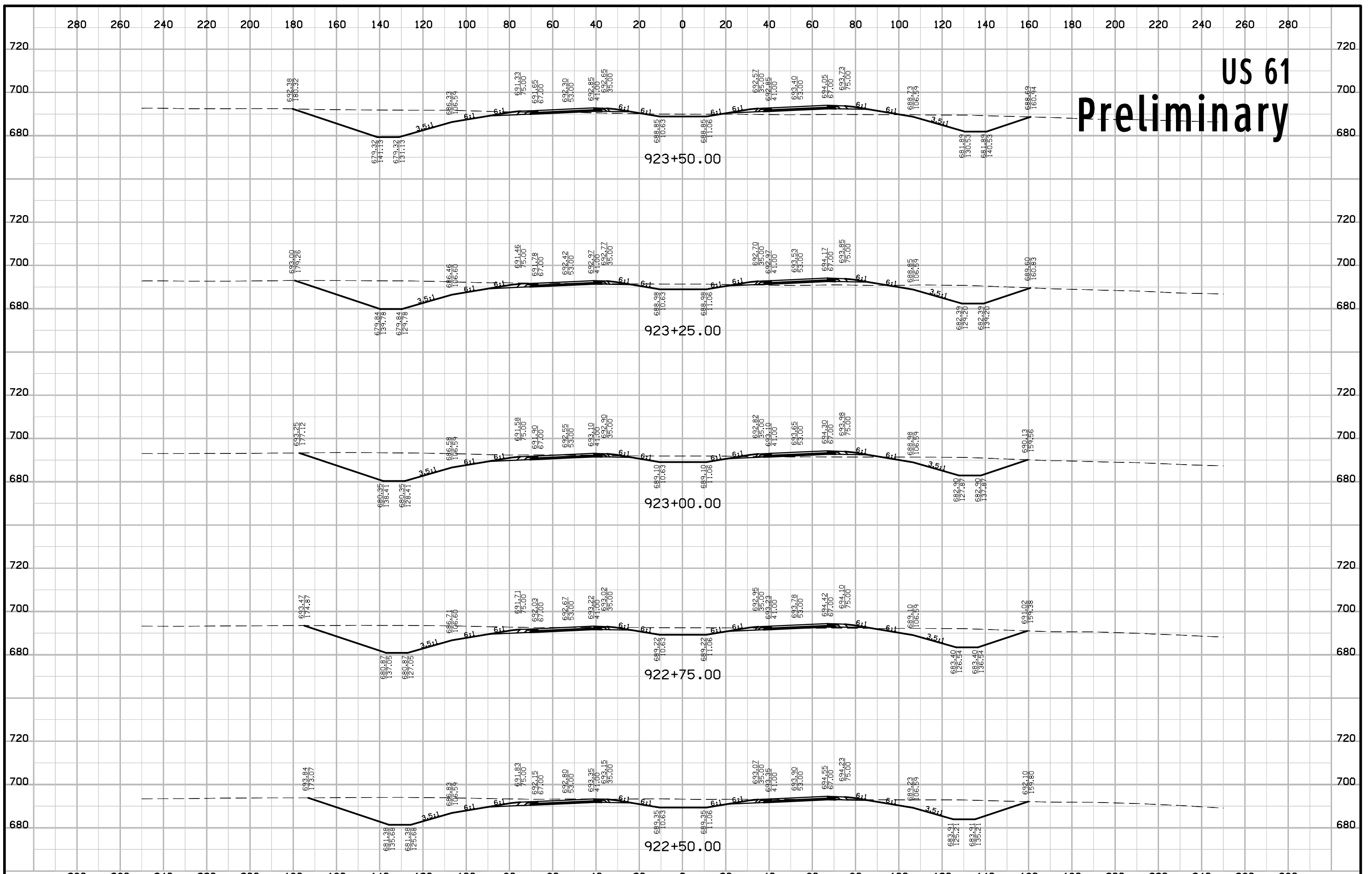

US 61 Preliminary

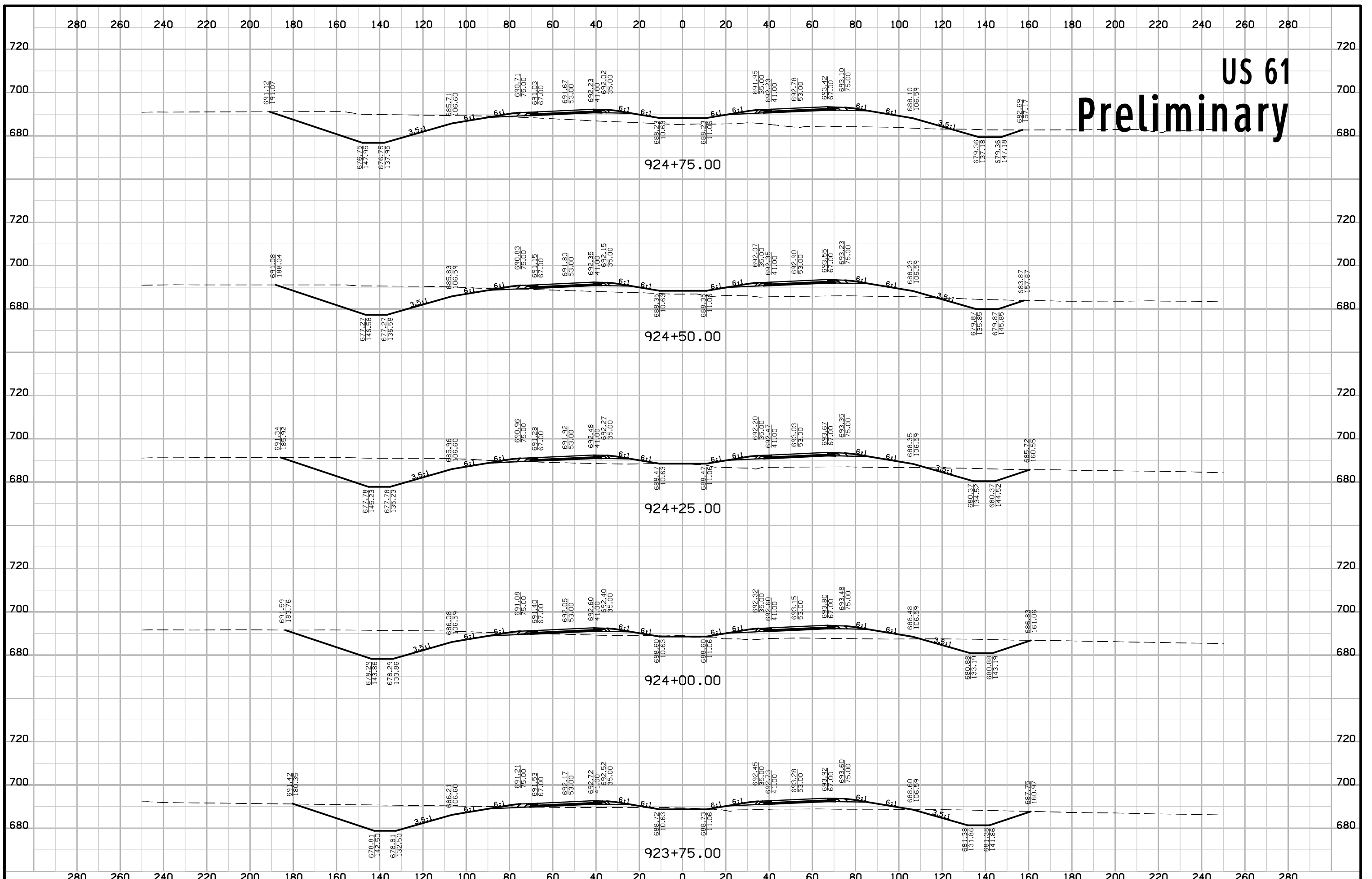

US 61 Preliminary

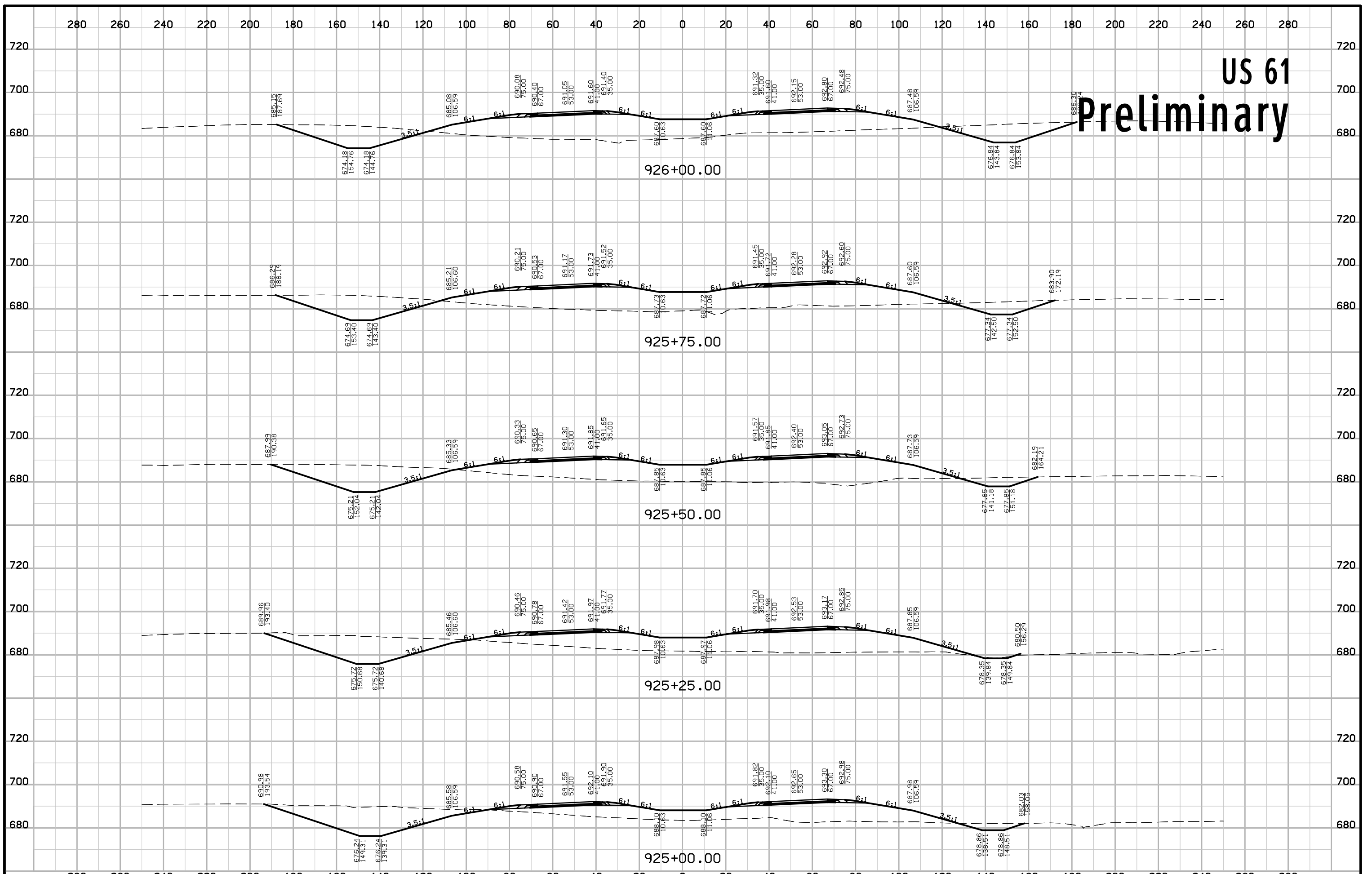

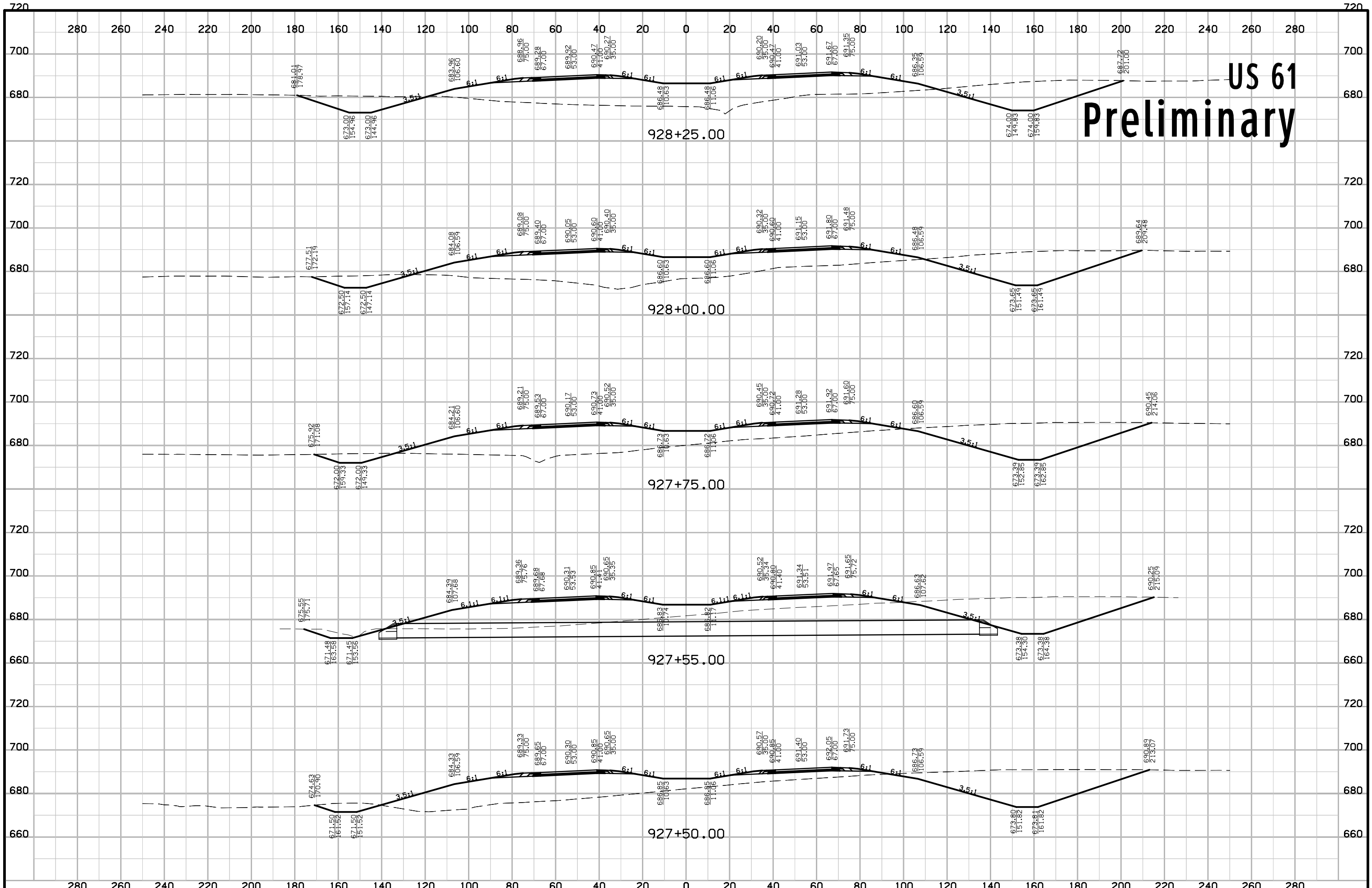

US 61 Preliminary

US 61 Preliminary

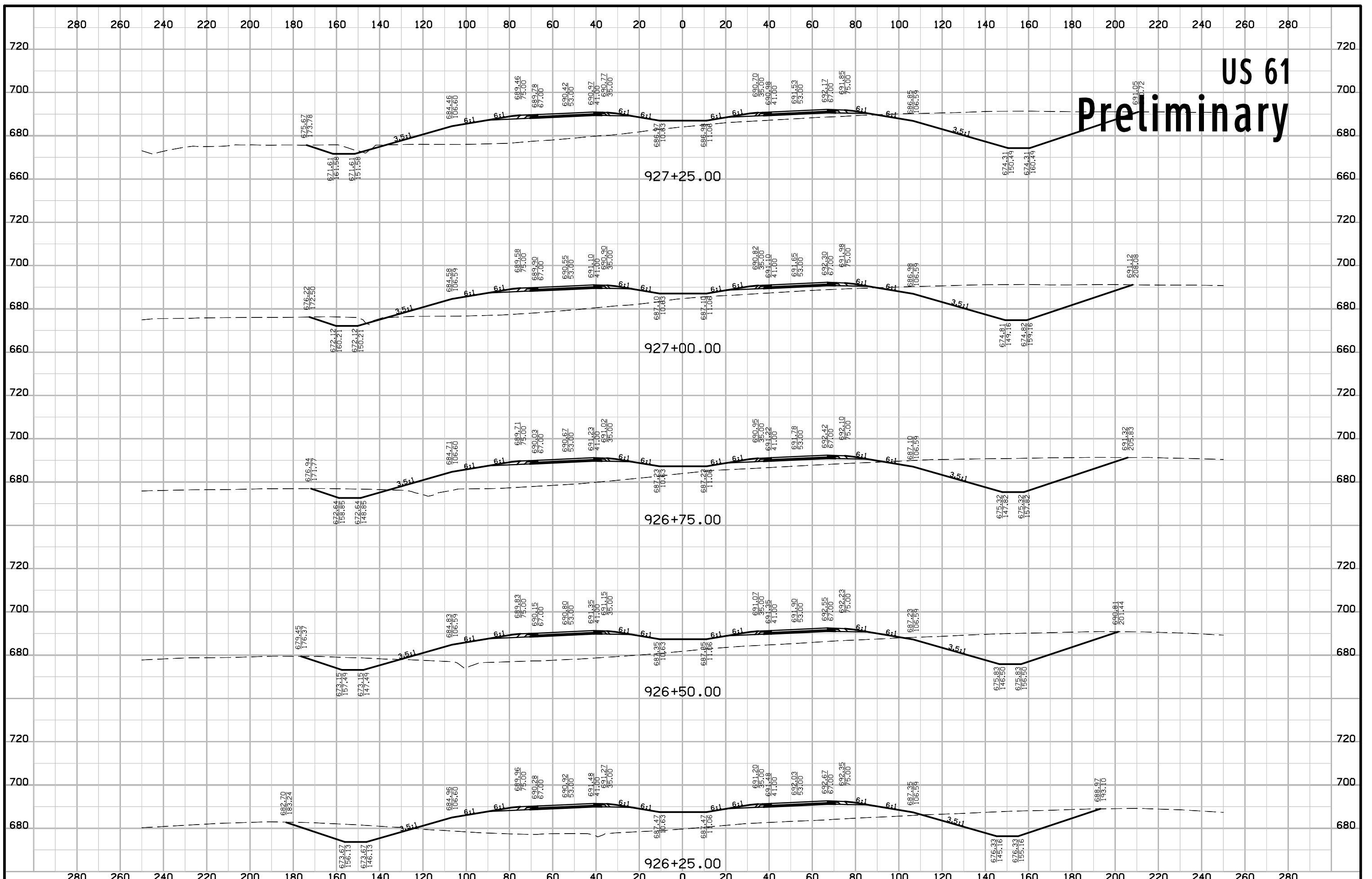

US 61 Preliminary

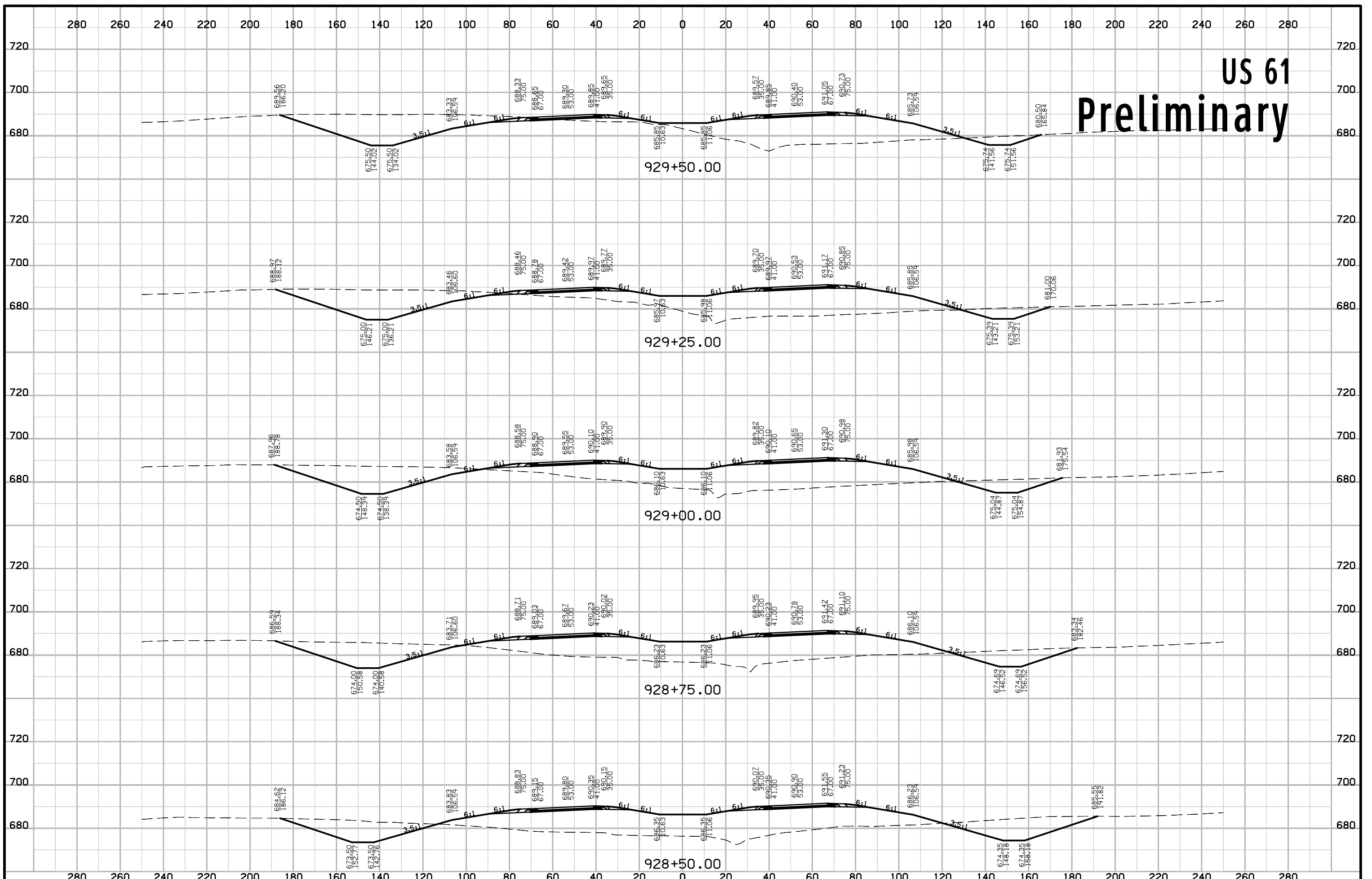

US 61 Preliminary

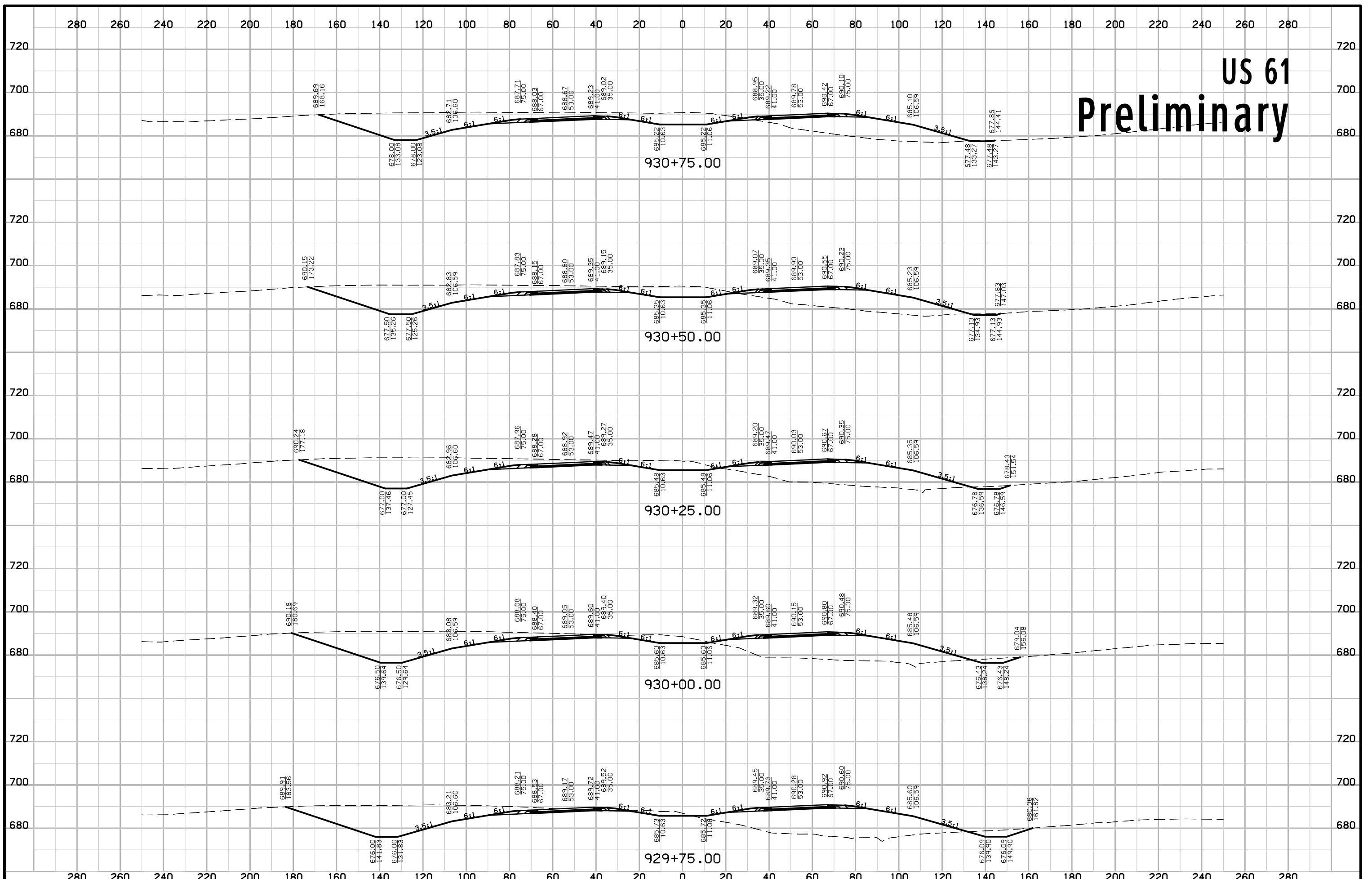

US 61 Preliminary

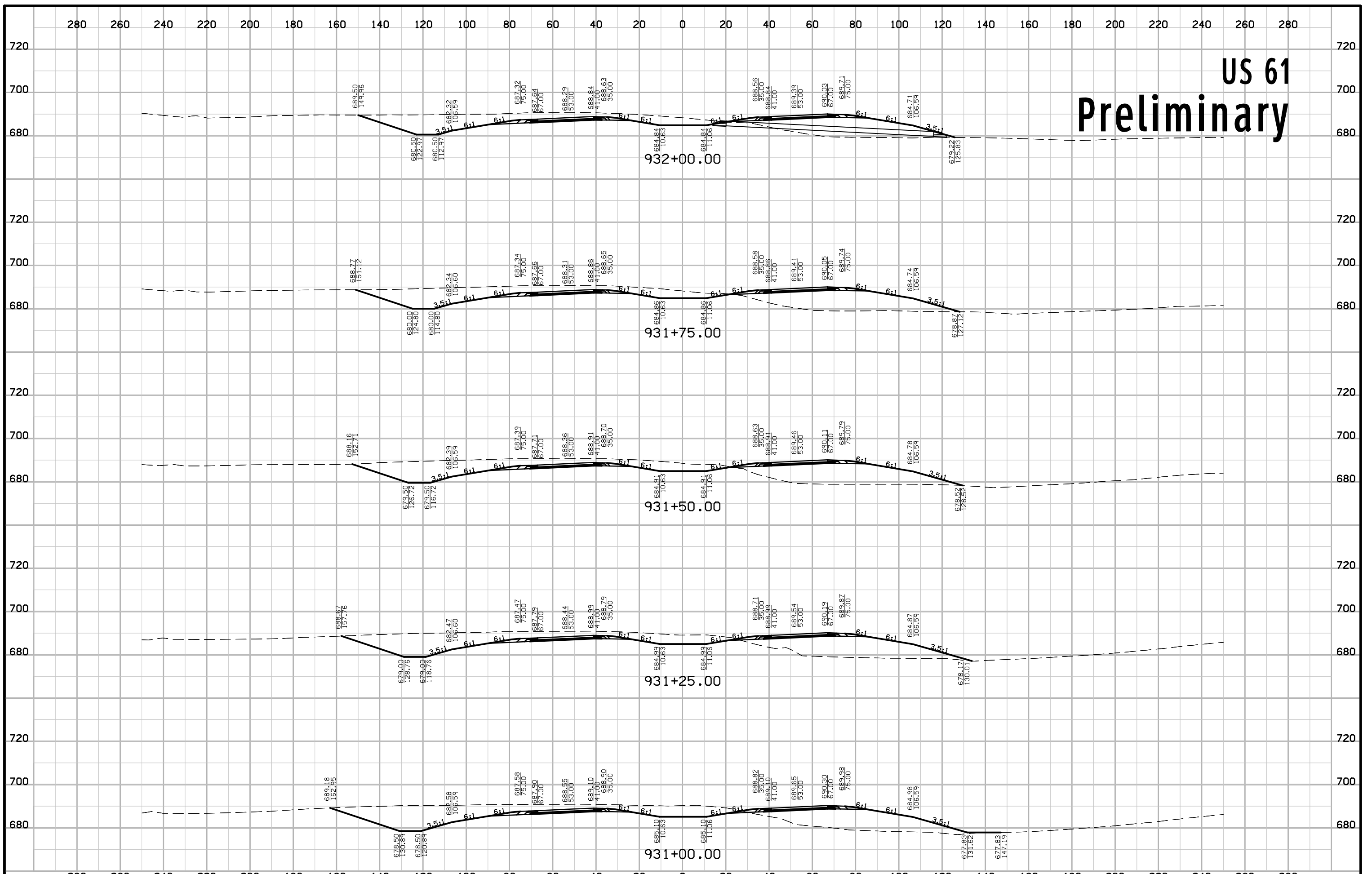

US 61 Preliminary

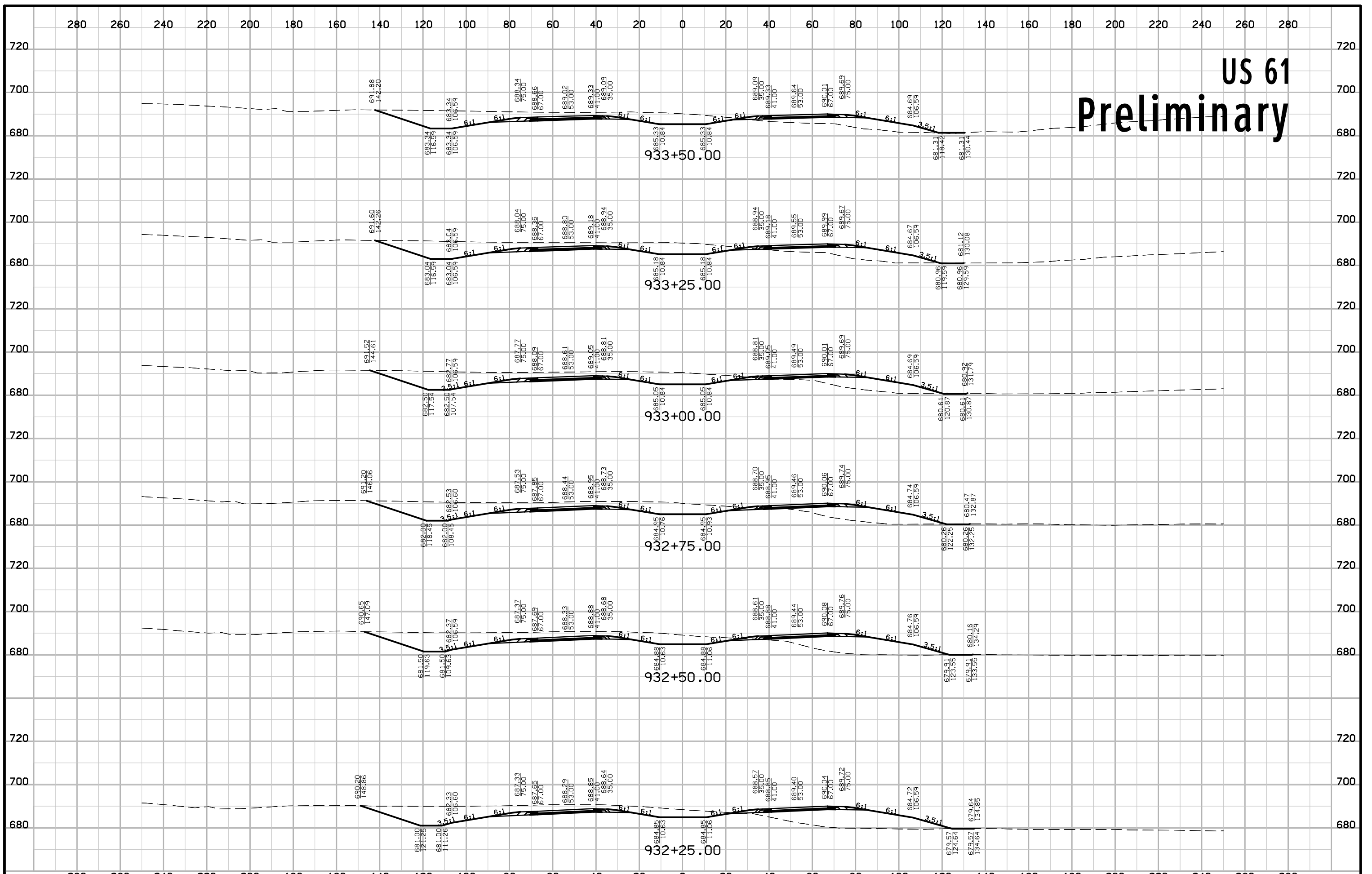

US 61 Preliminary

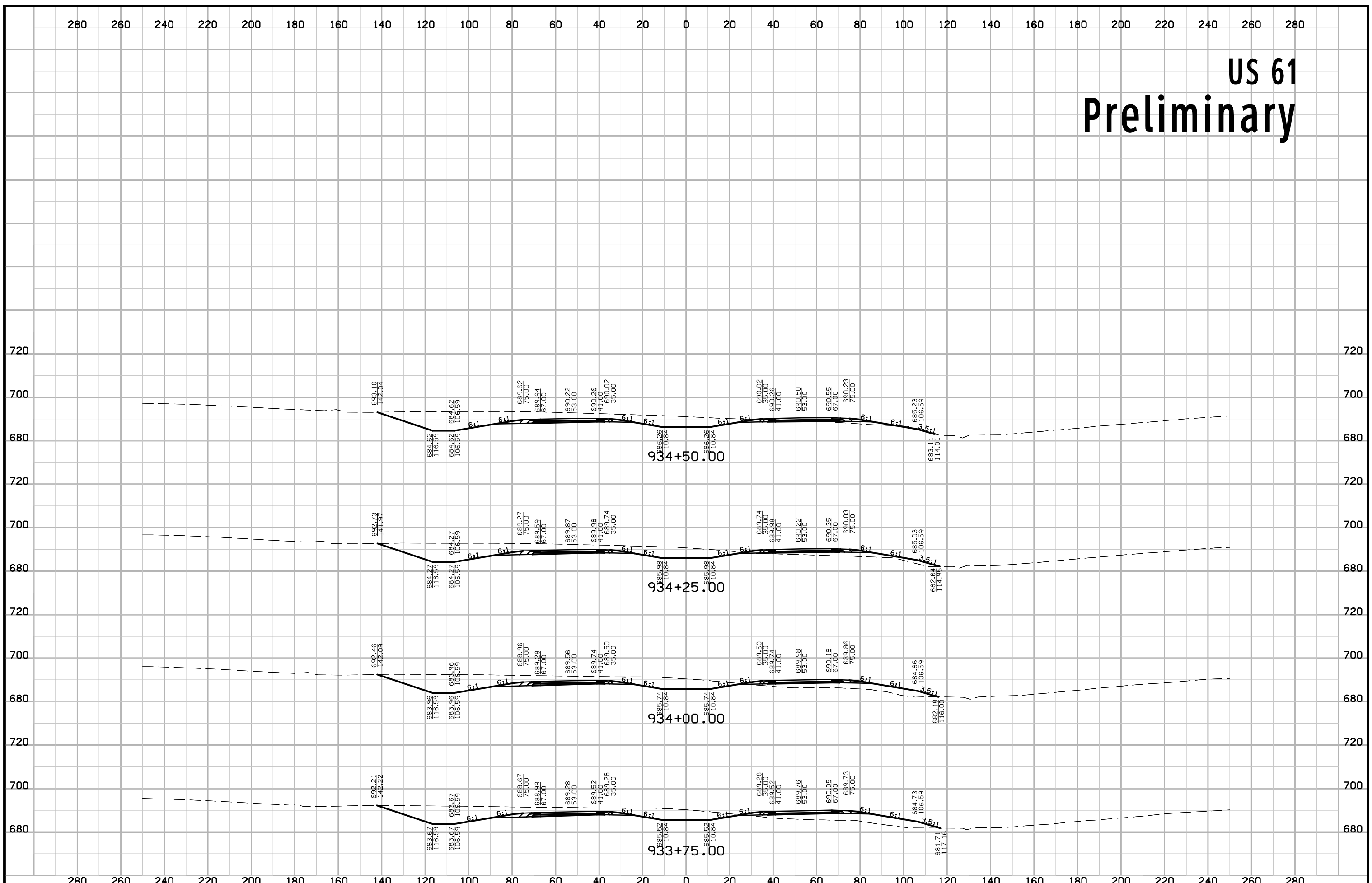

US 61 Preliminary

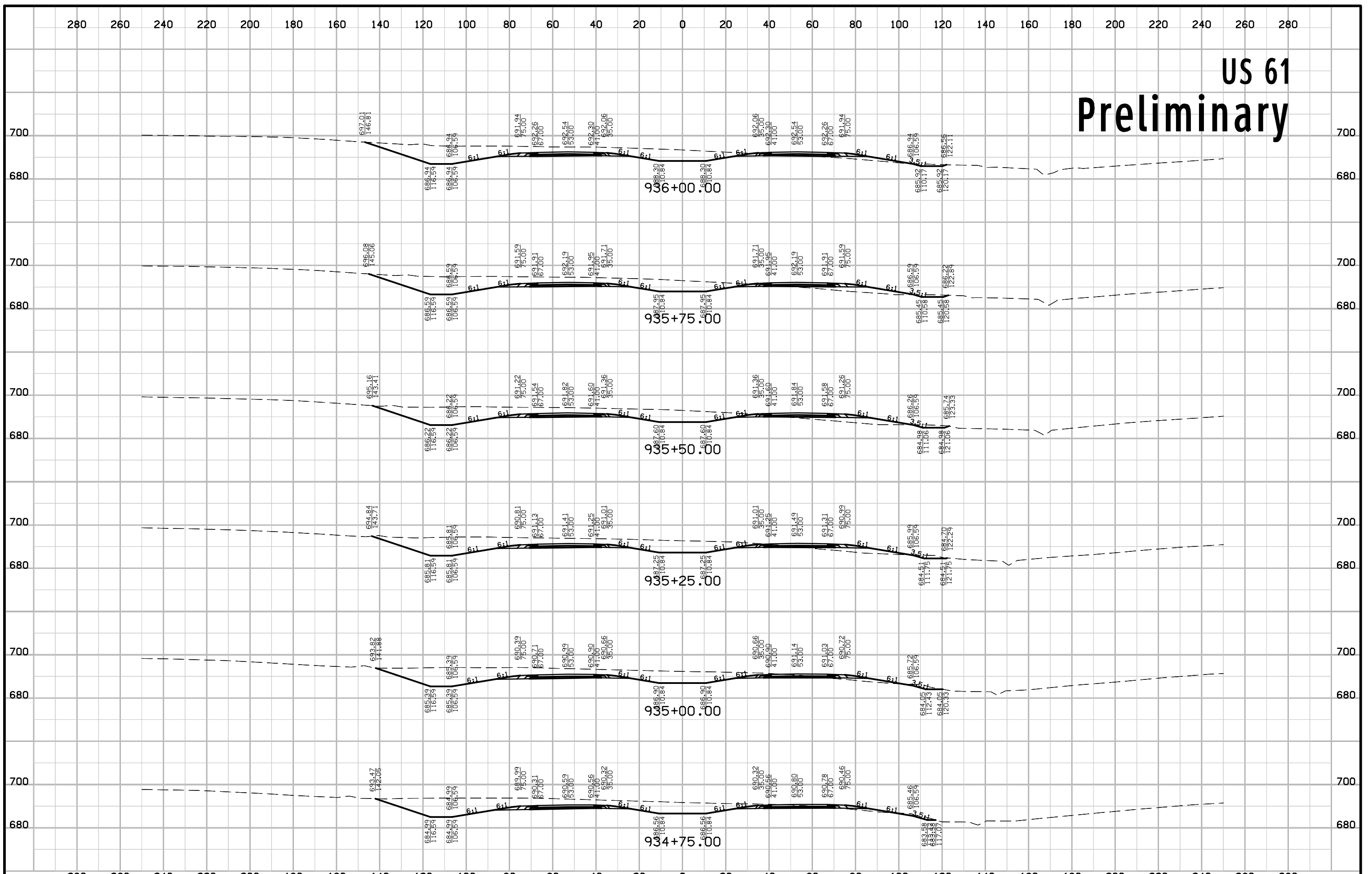

US 61 Preliminary

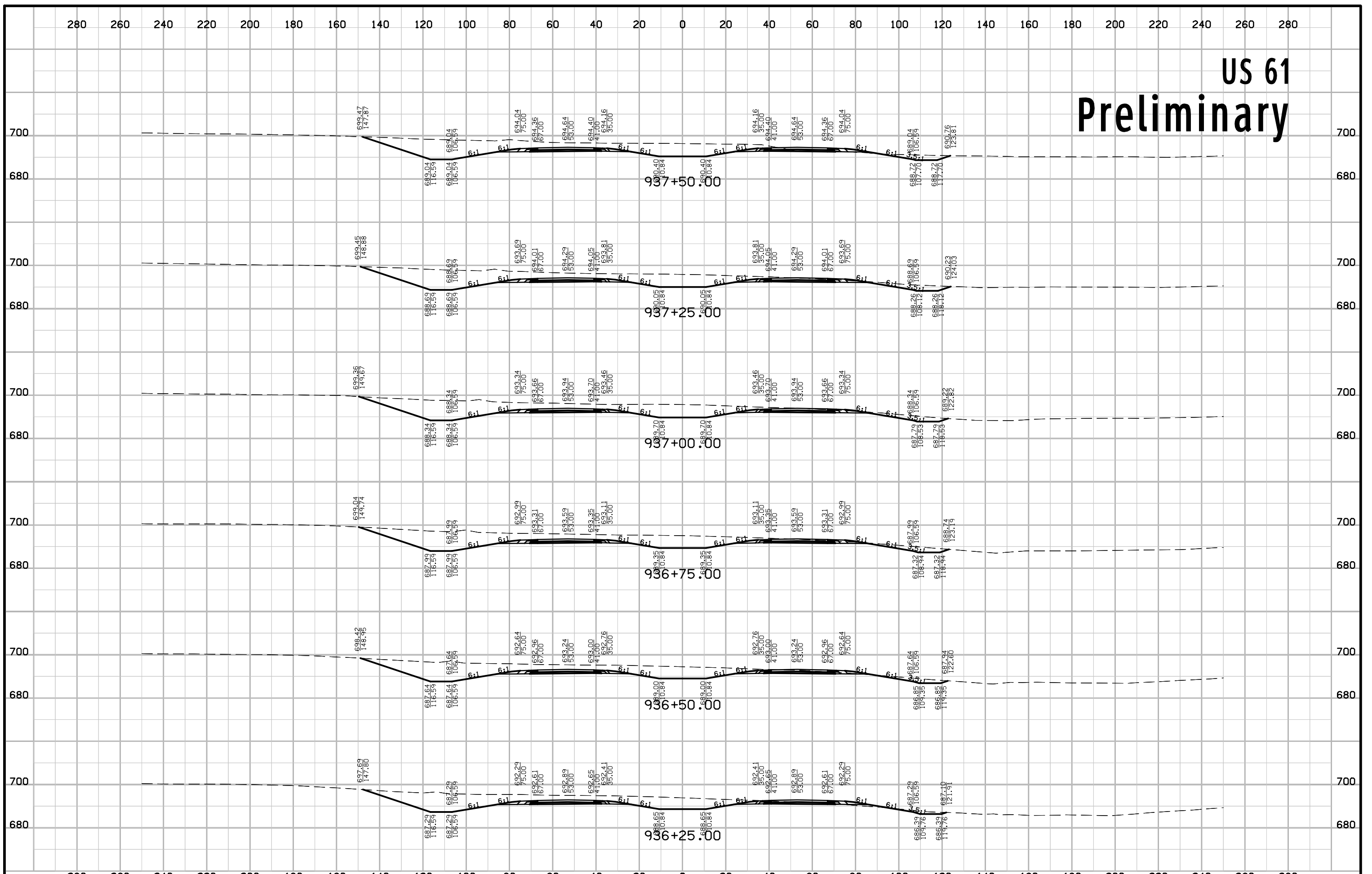

US 61 Preliminary

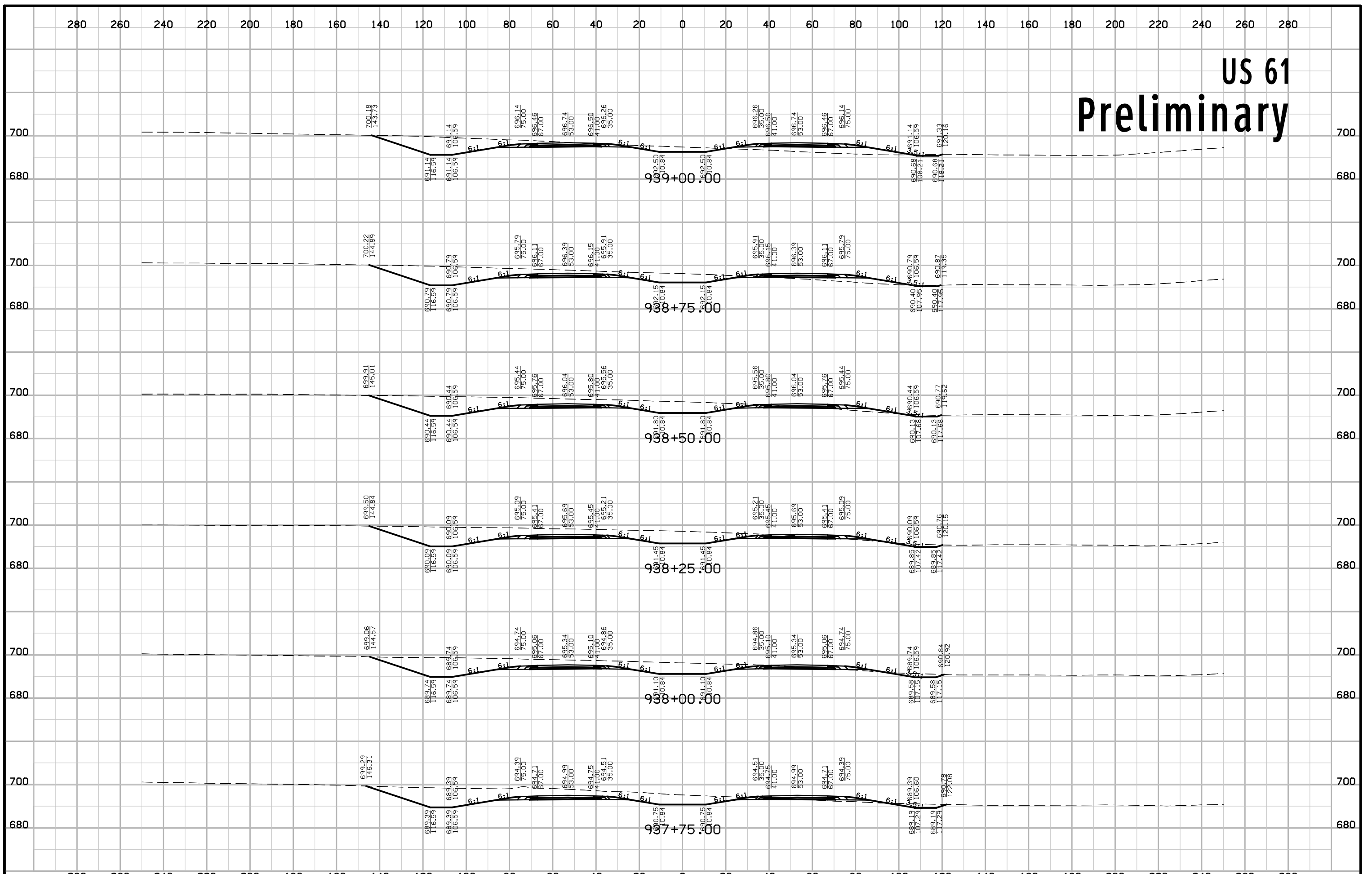

US 61 Preliminary

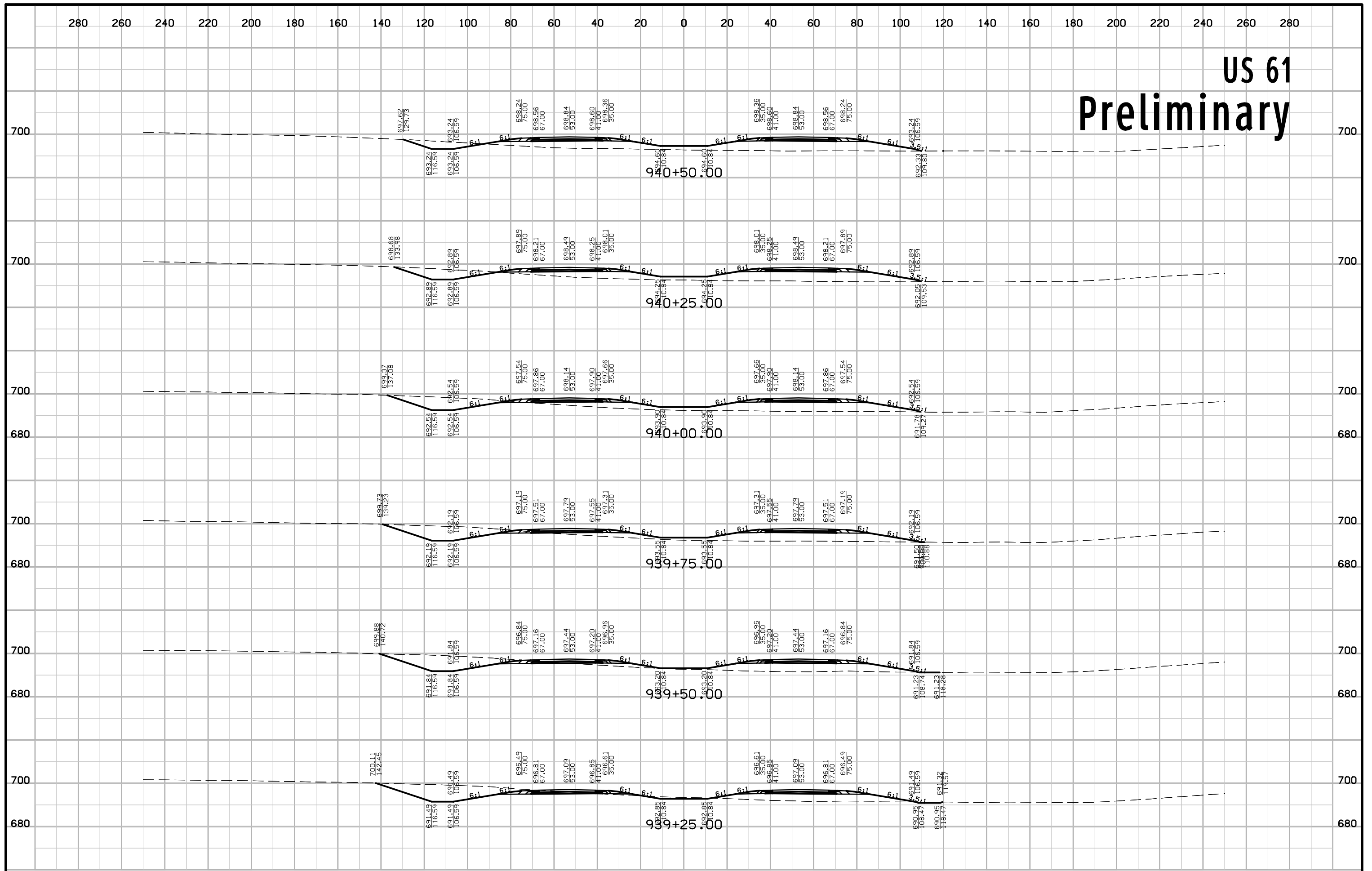

US 61 Preliminary

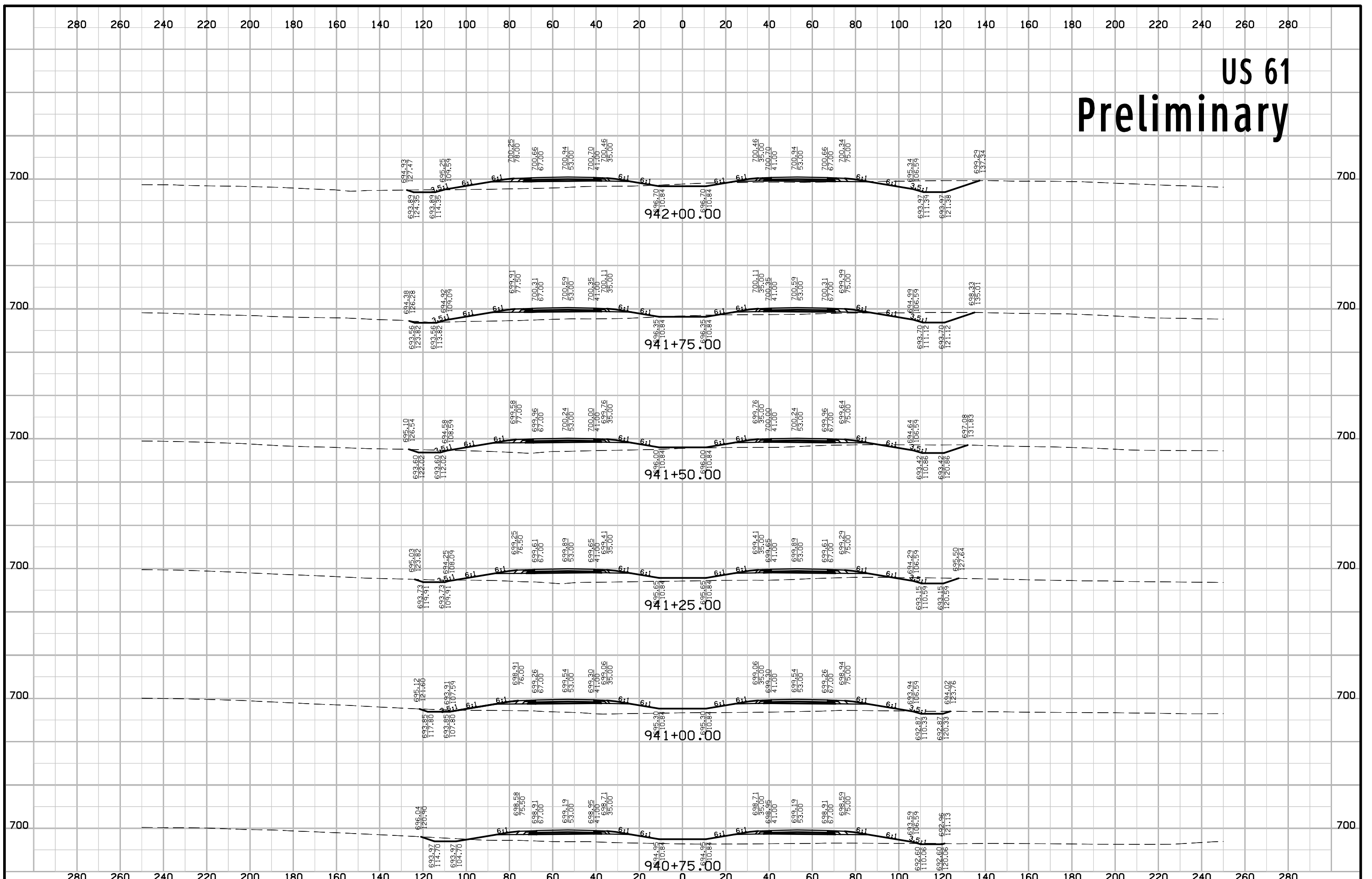

US 61 Preliminary

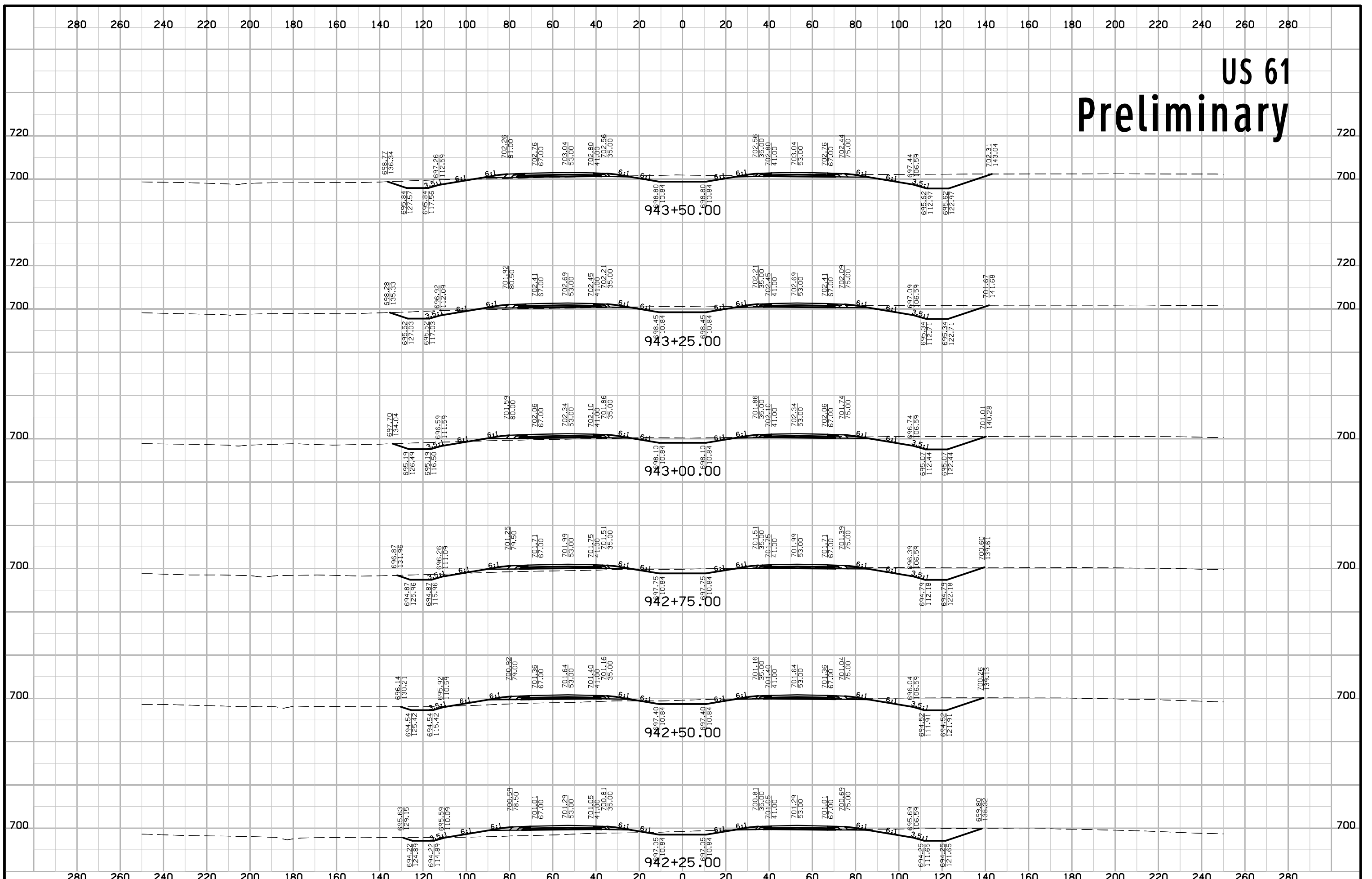

US 61 Preliminary

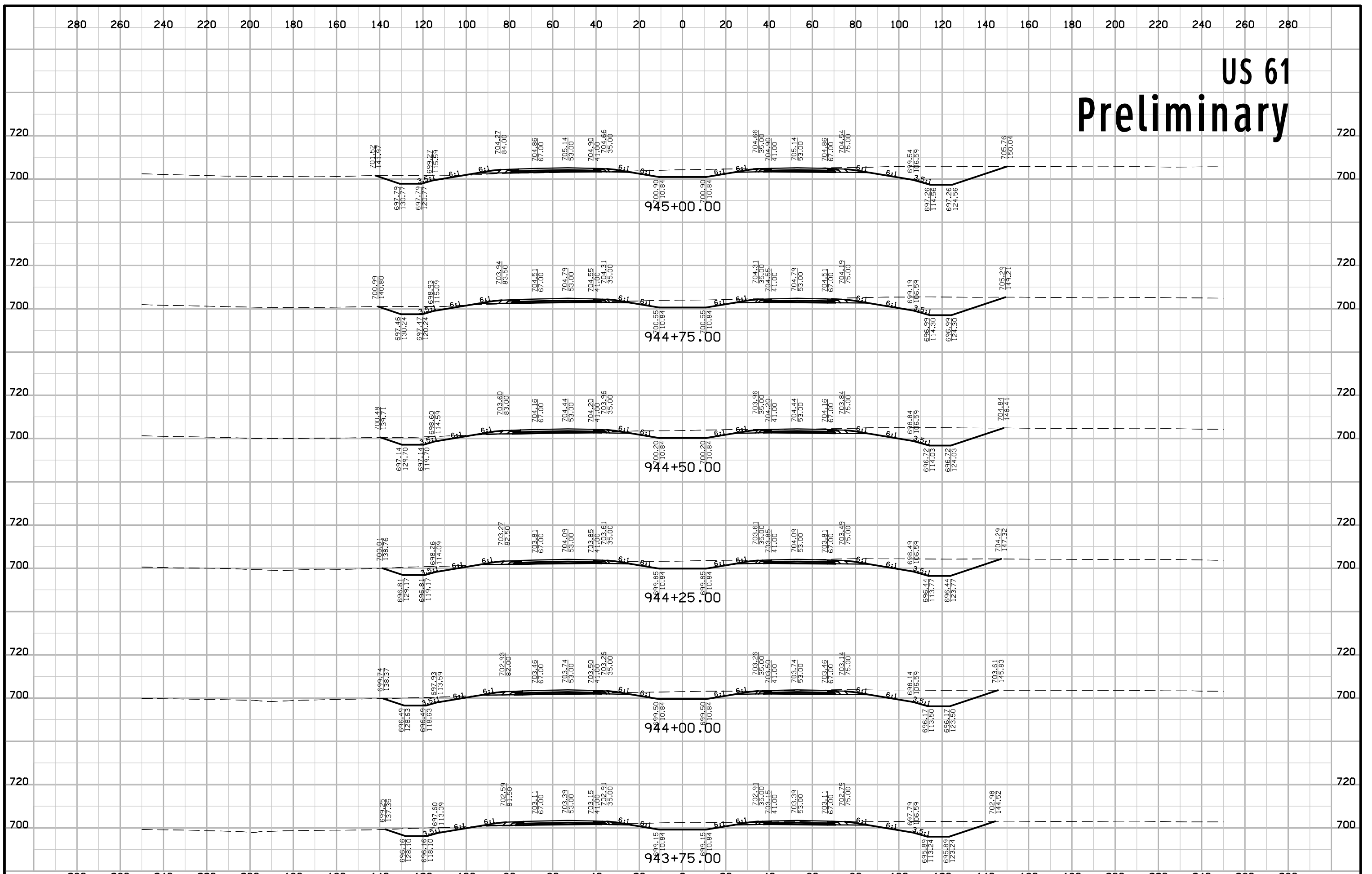

US 61 Preliminary

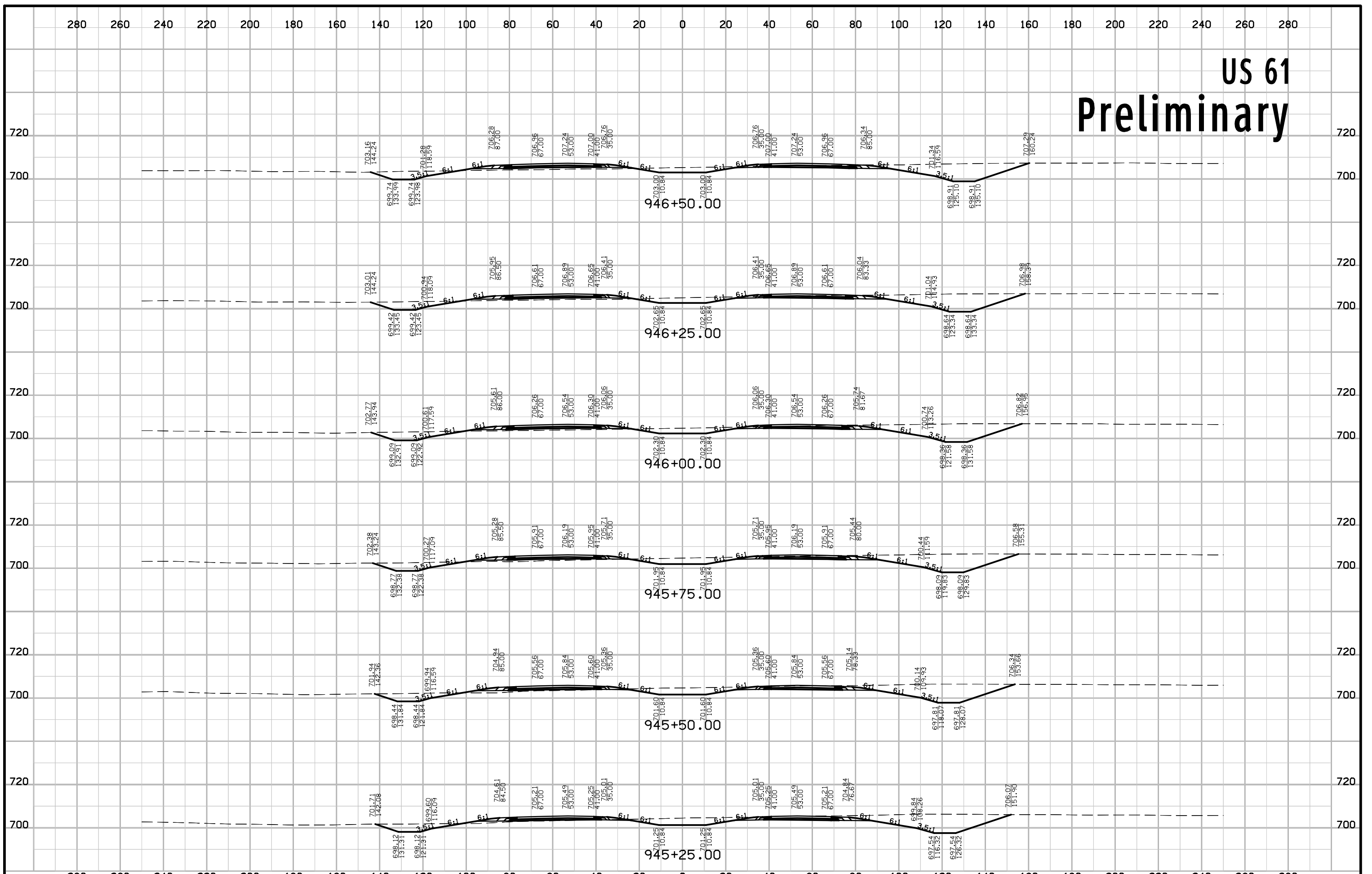

US 61 Preliminary

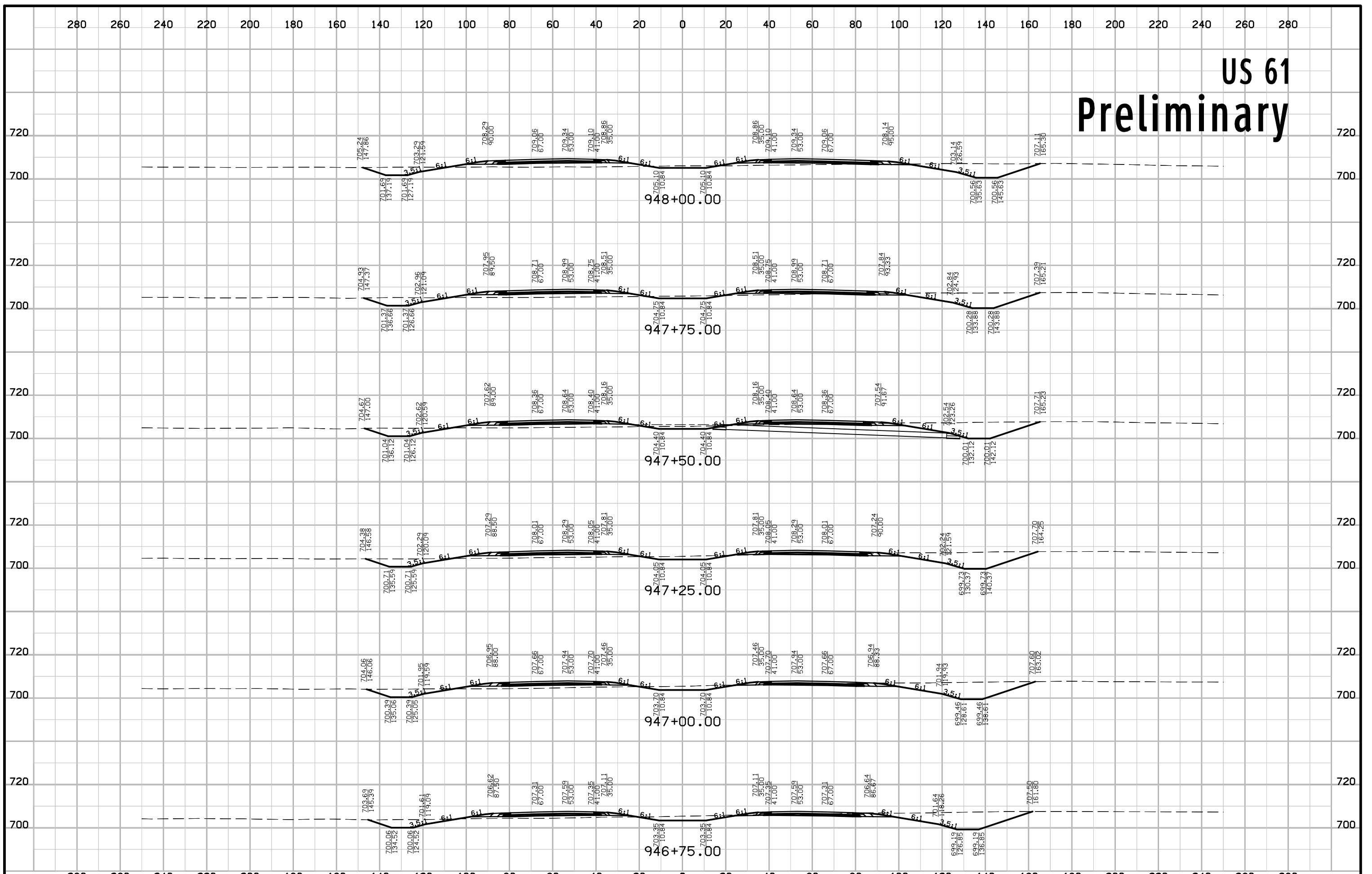

US 61 Preliminary

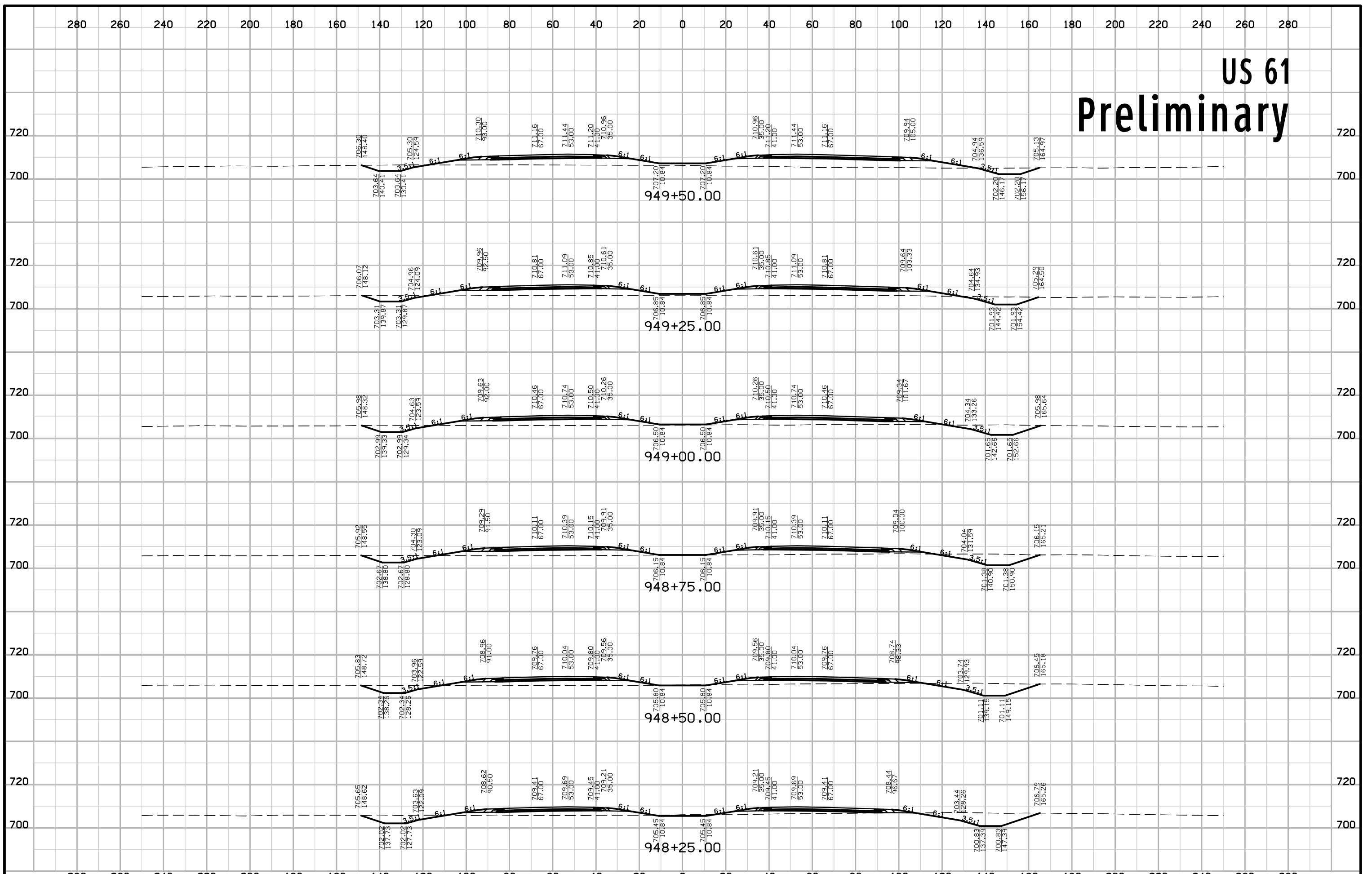

US 61 Preliminary

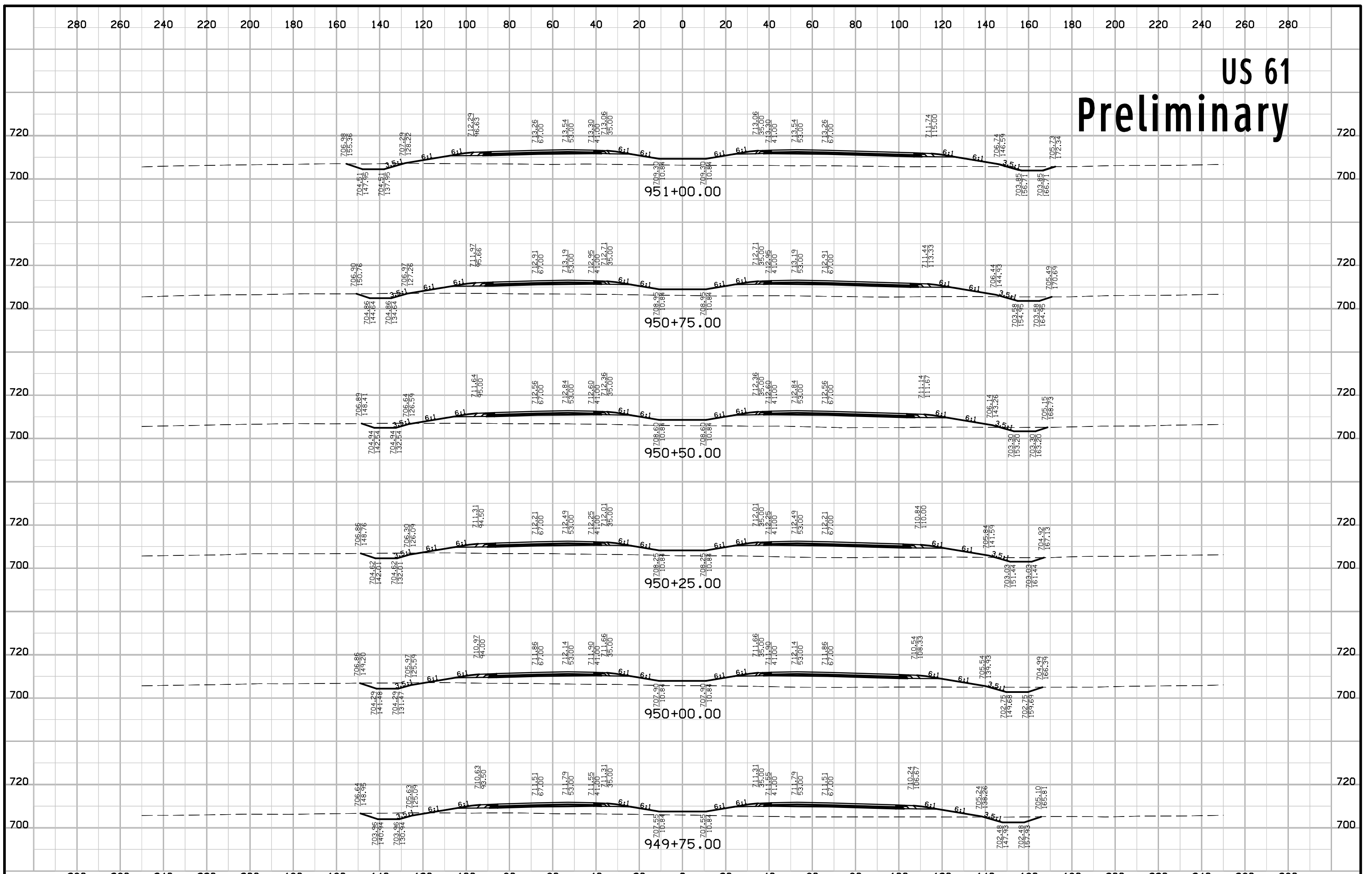

US 61 Preliminary

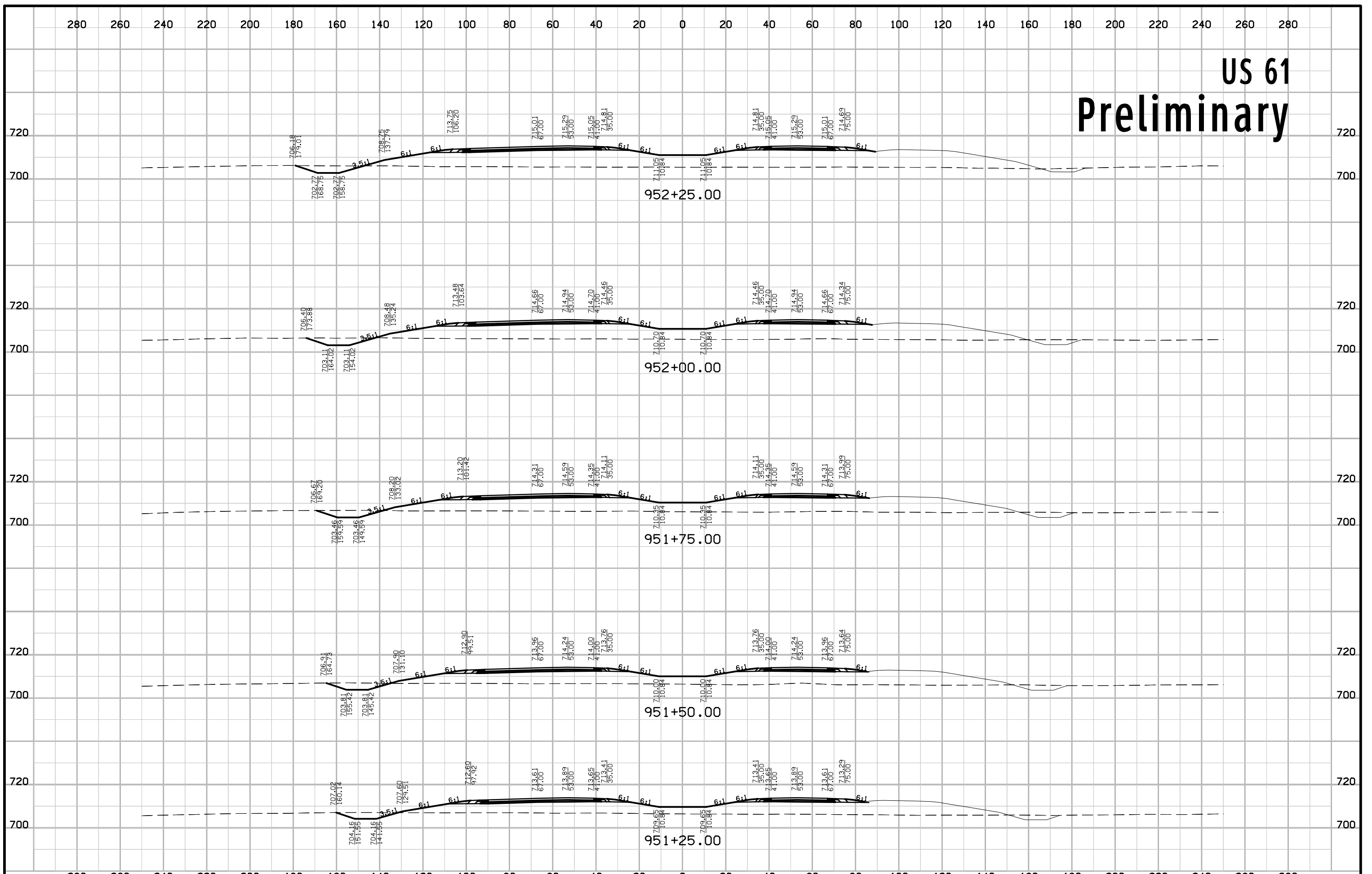

US 61 Preliminary

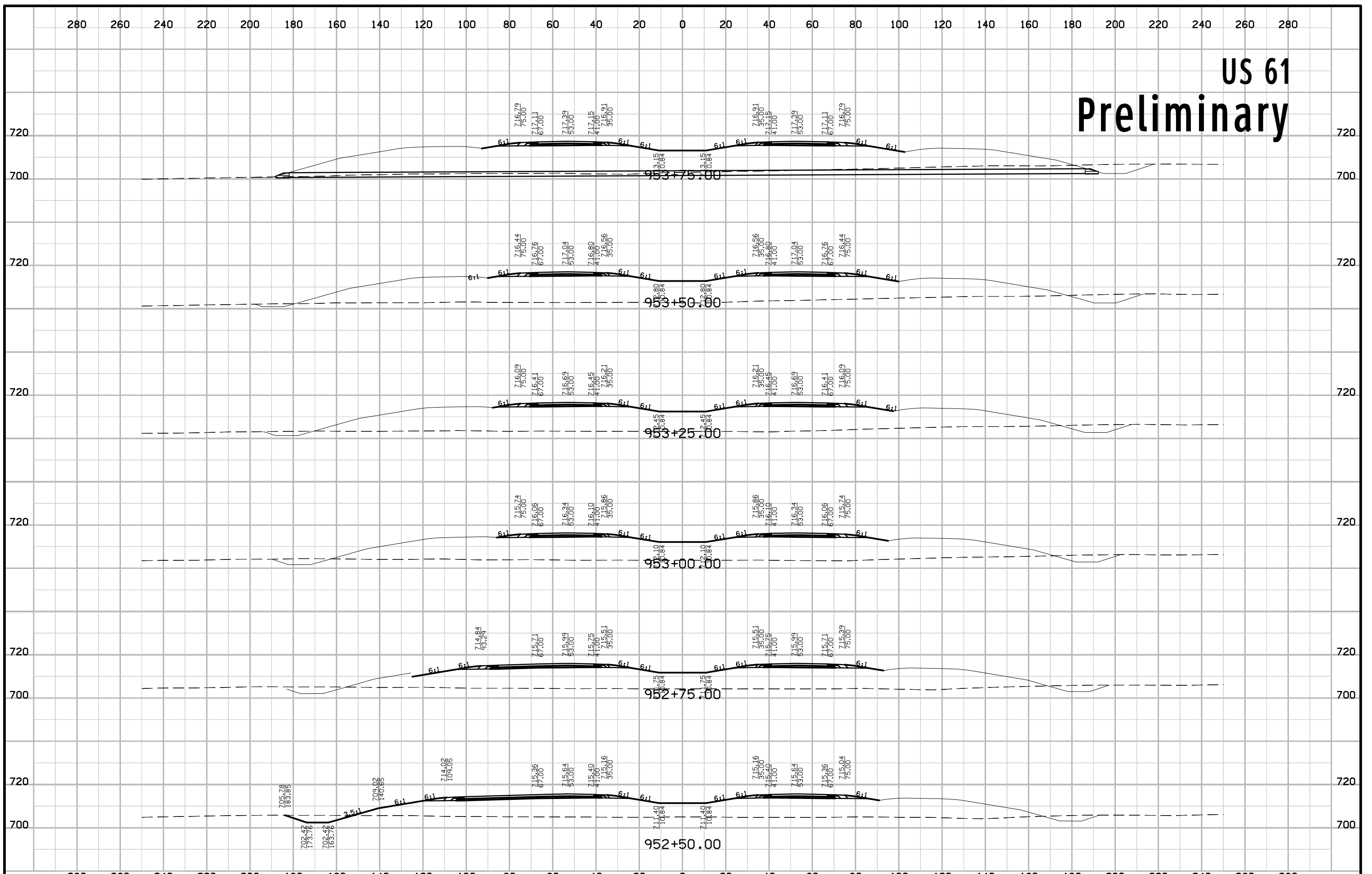

US 61 Preliminary

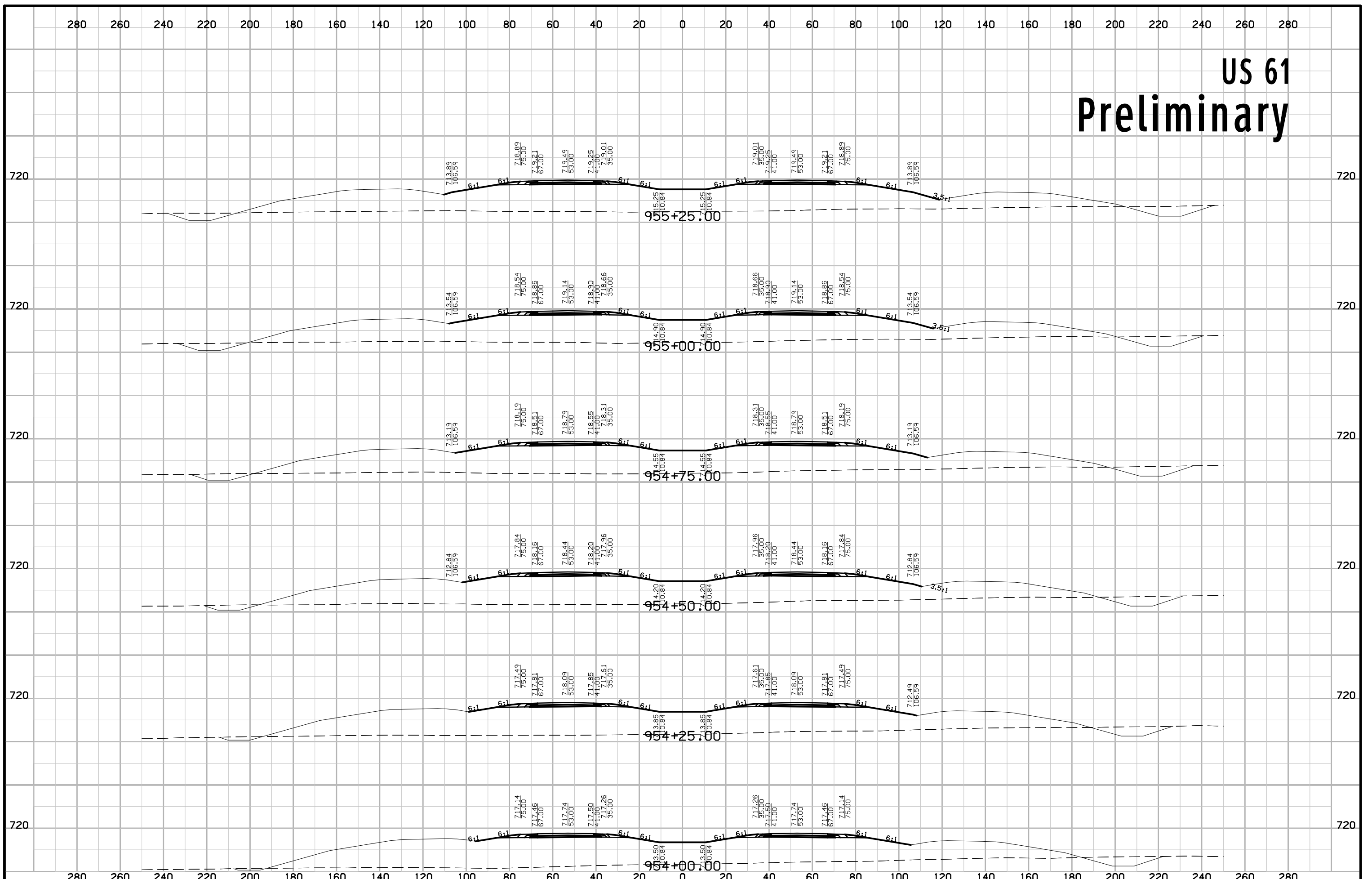

US 61 Preliminary

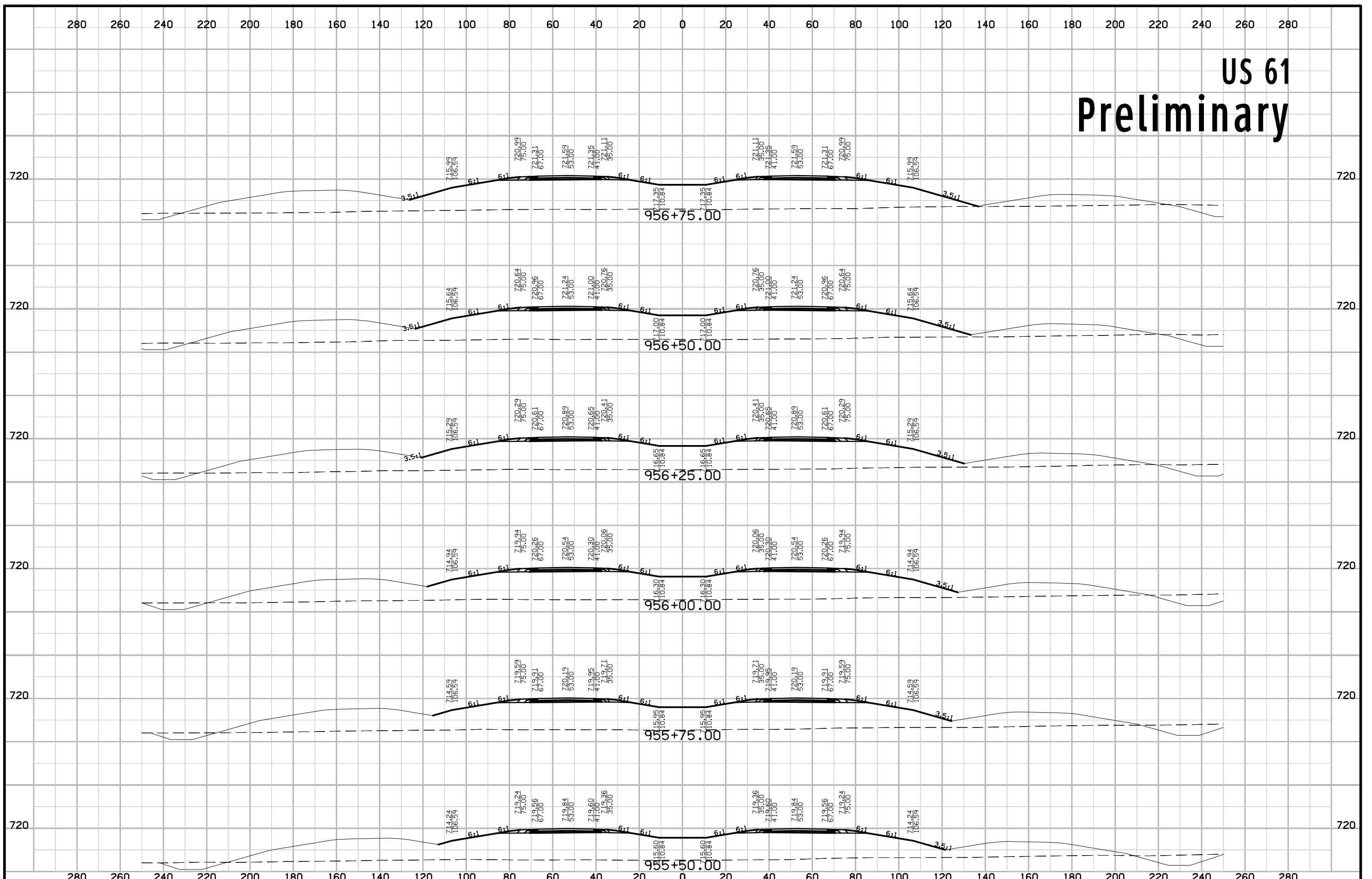

US 61 Preliminary

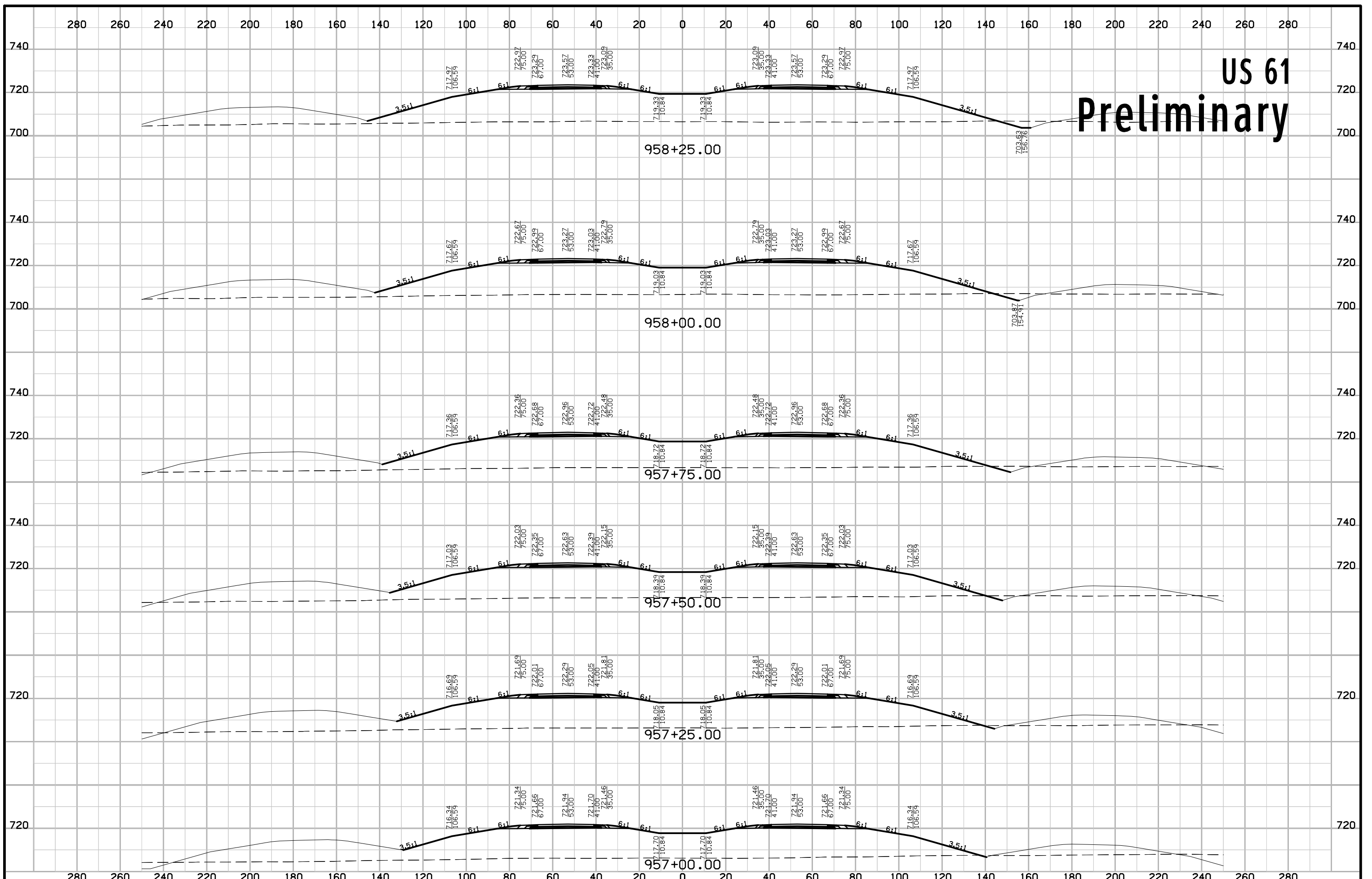

US 61 Preliminary

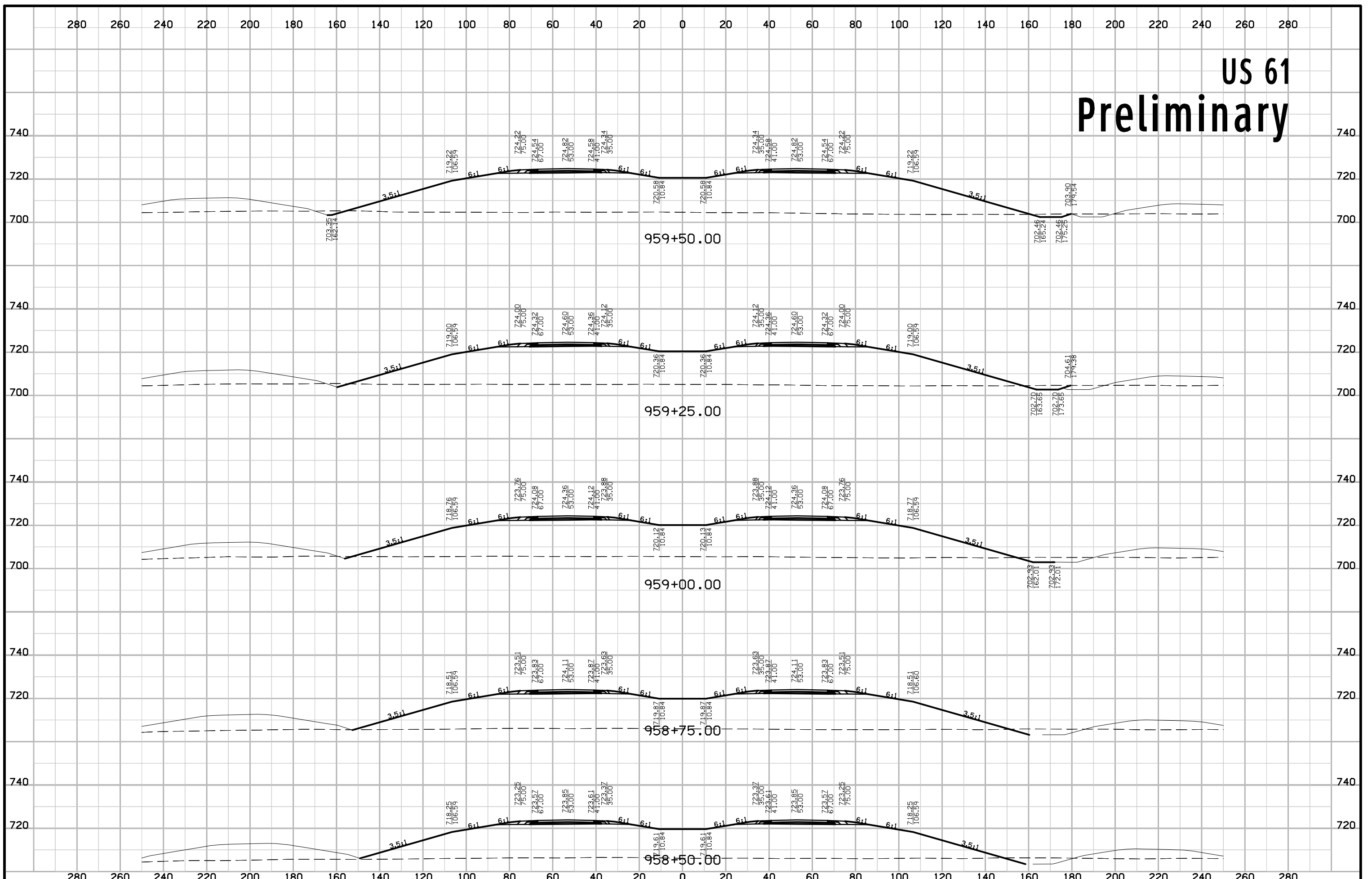

US 61 Preliminary

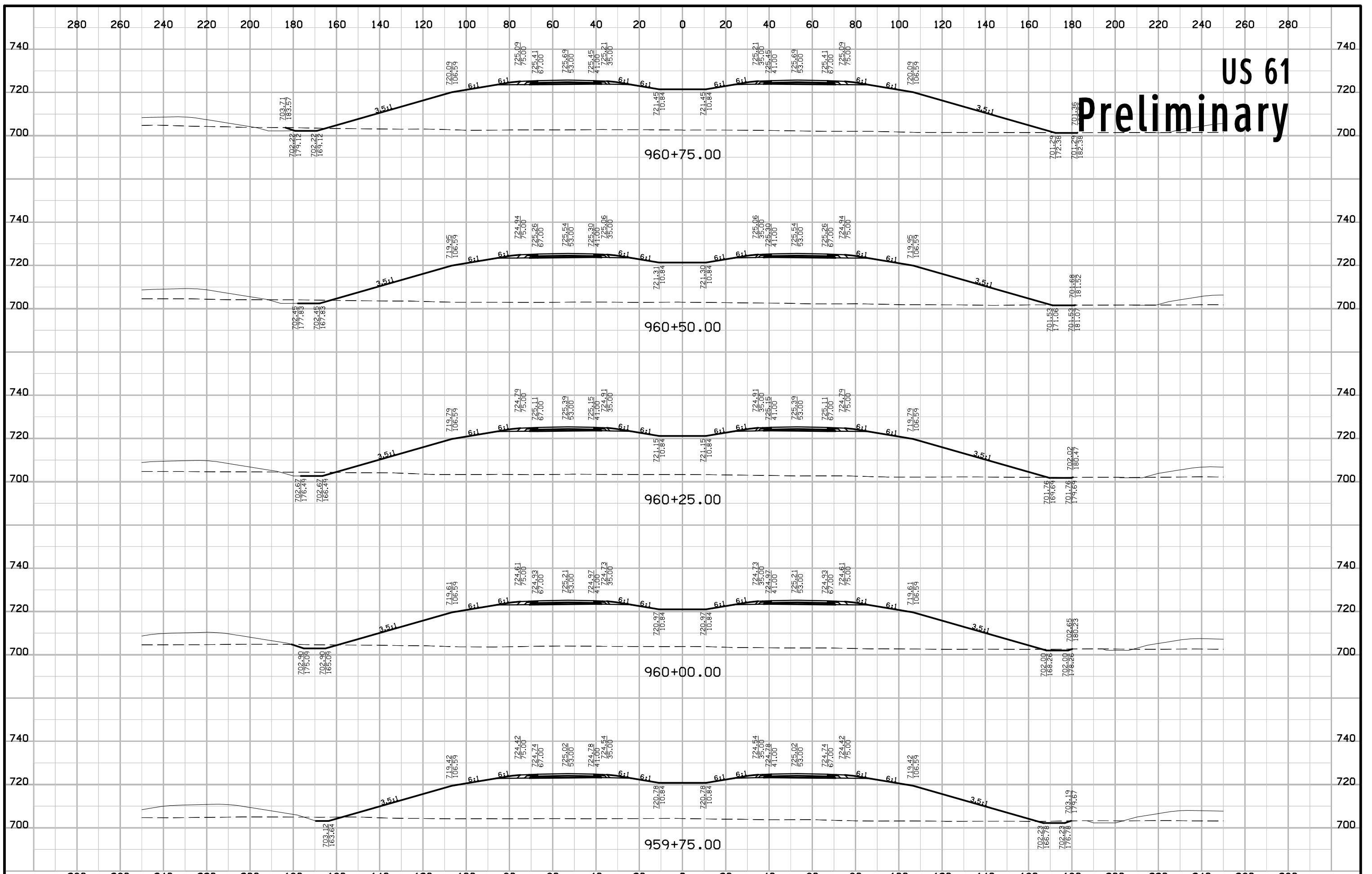

US 61 Preliminary

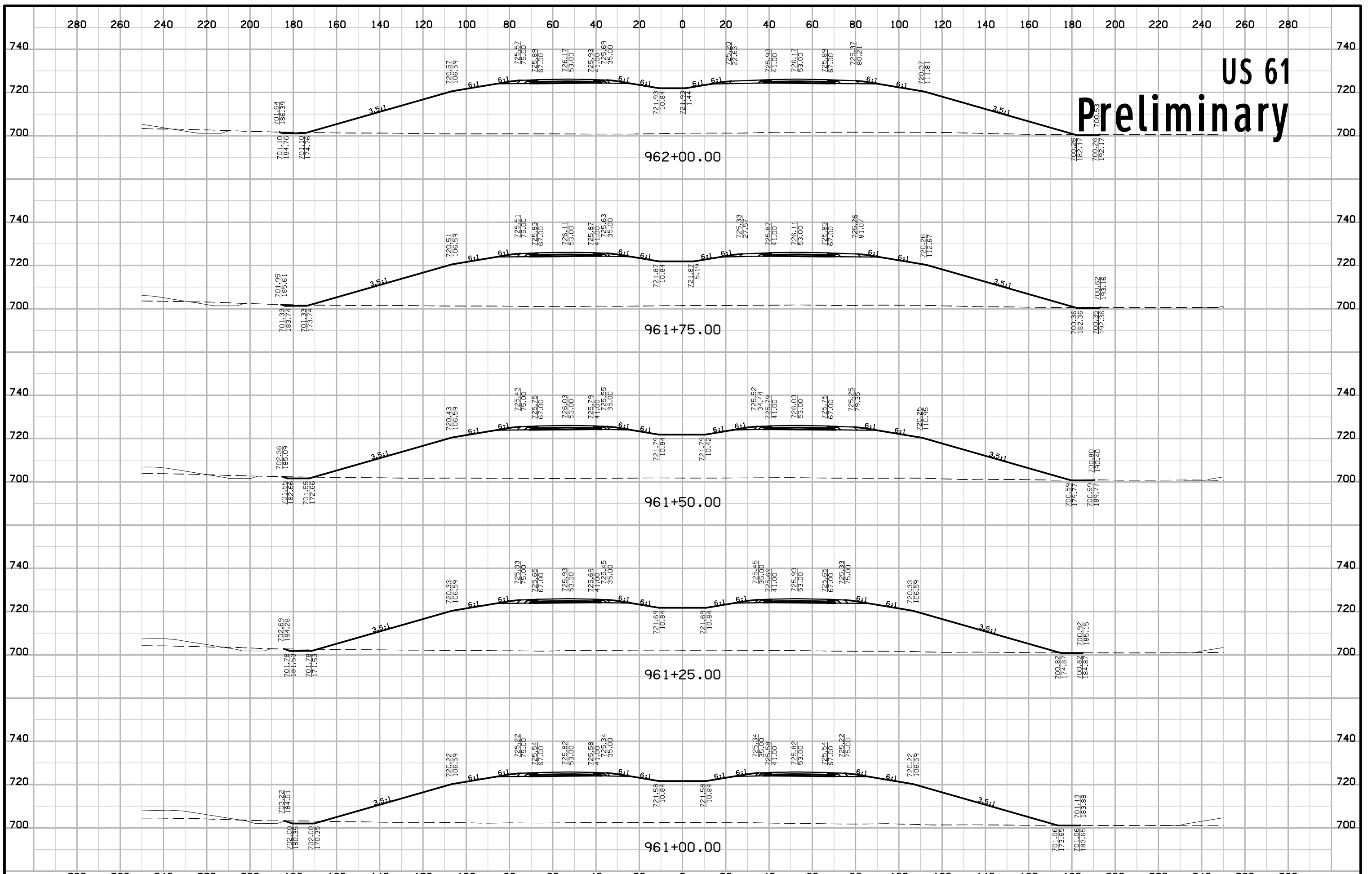

US 61 Preliminary

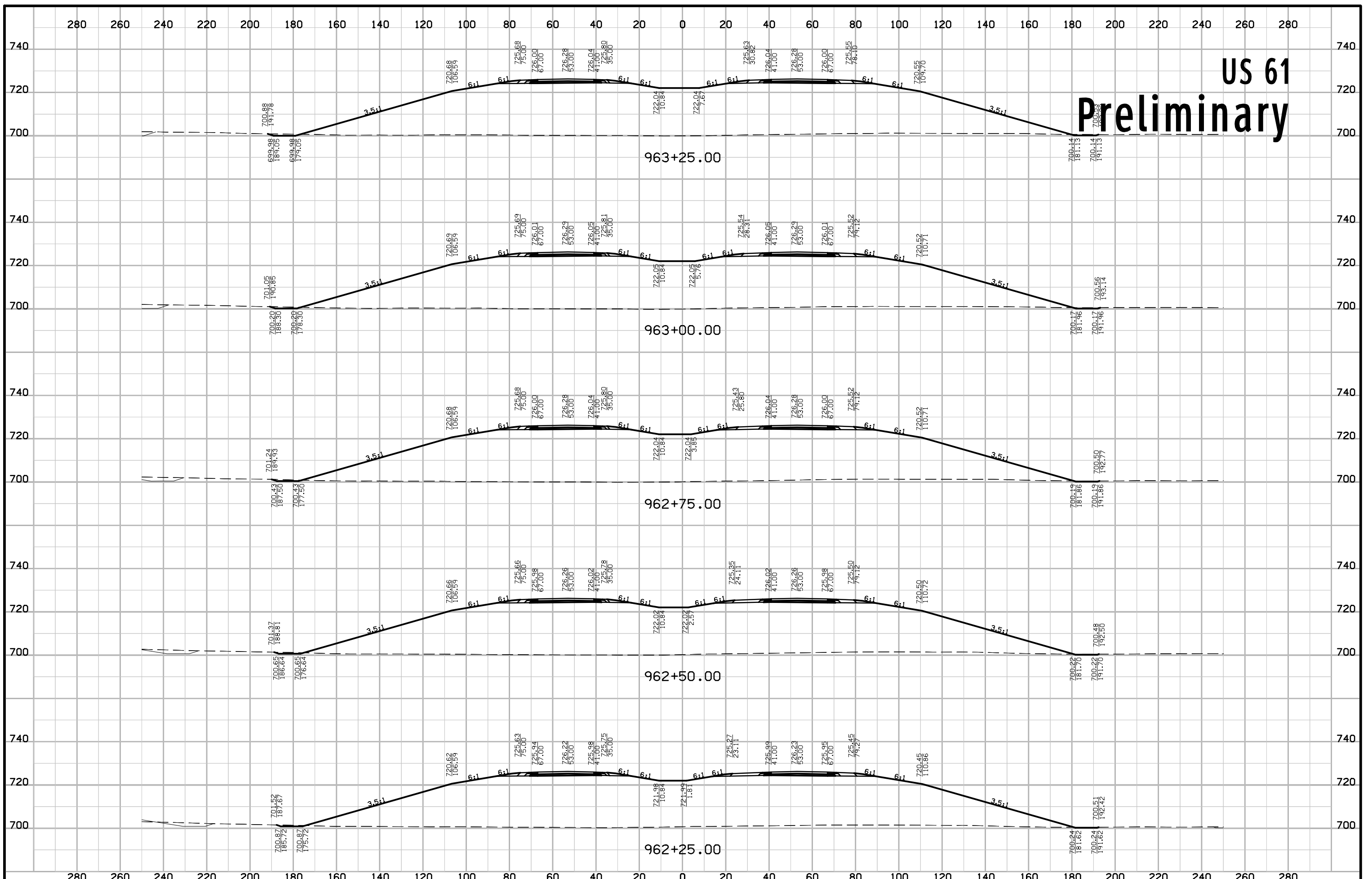

US 61 Preliminary

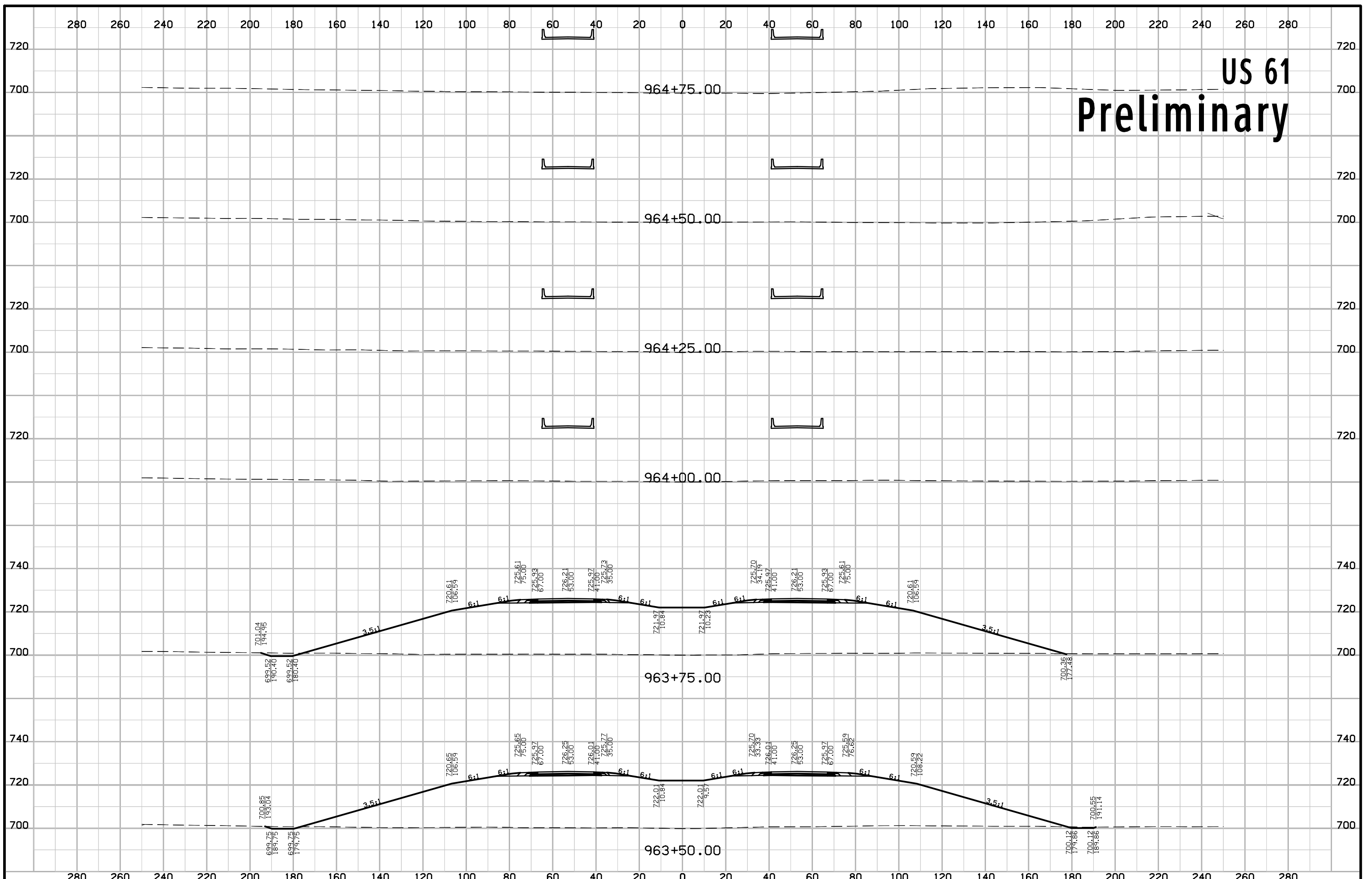

US 61 Preliminary

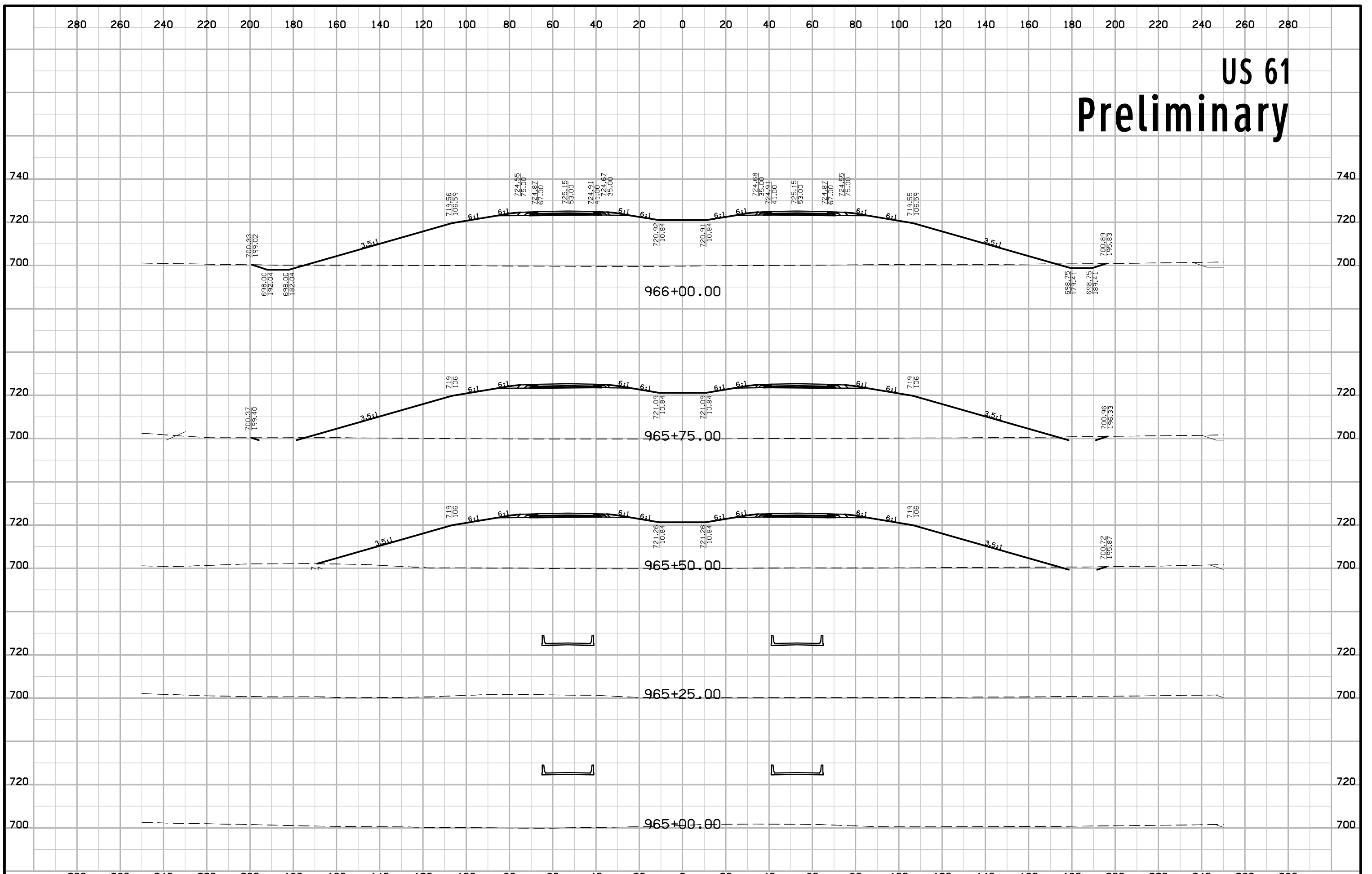

US 61 Preliminary

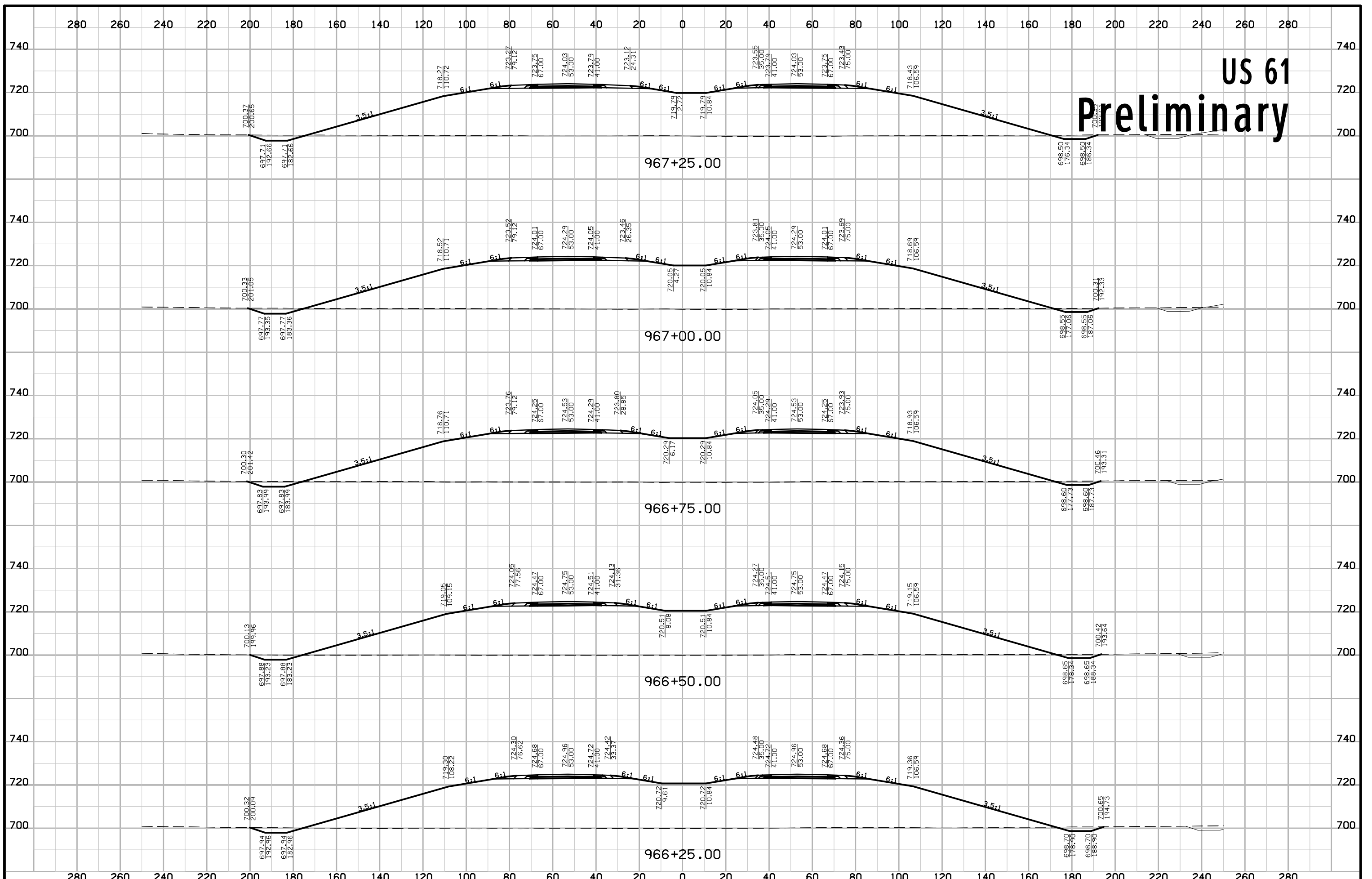

US 61 Preliminary

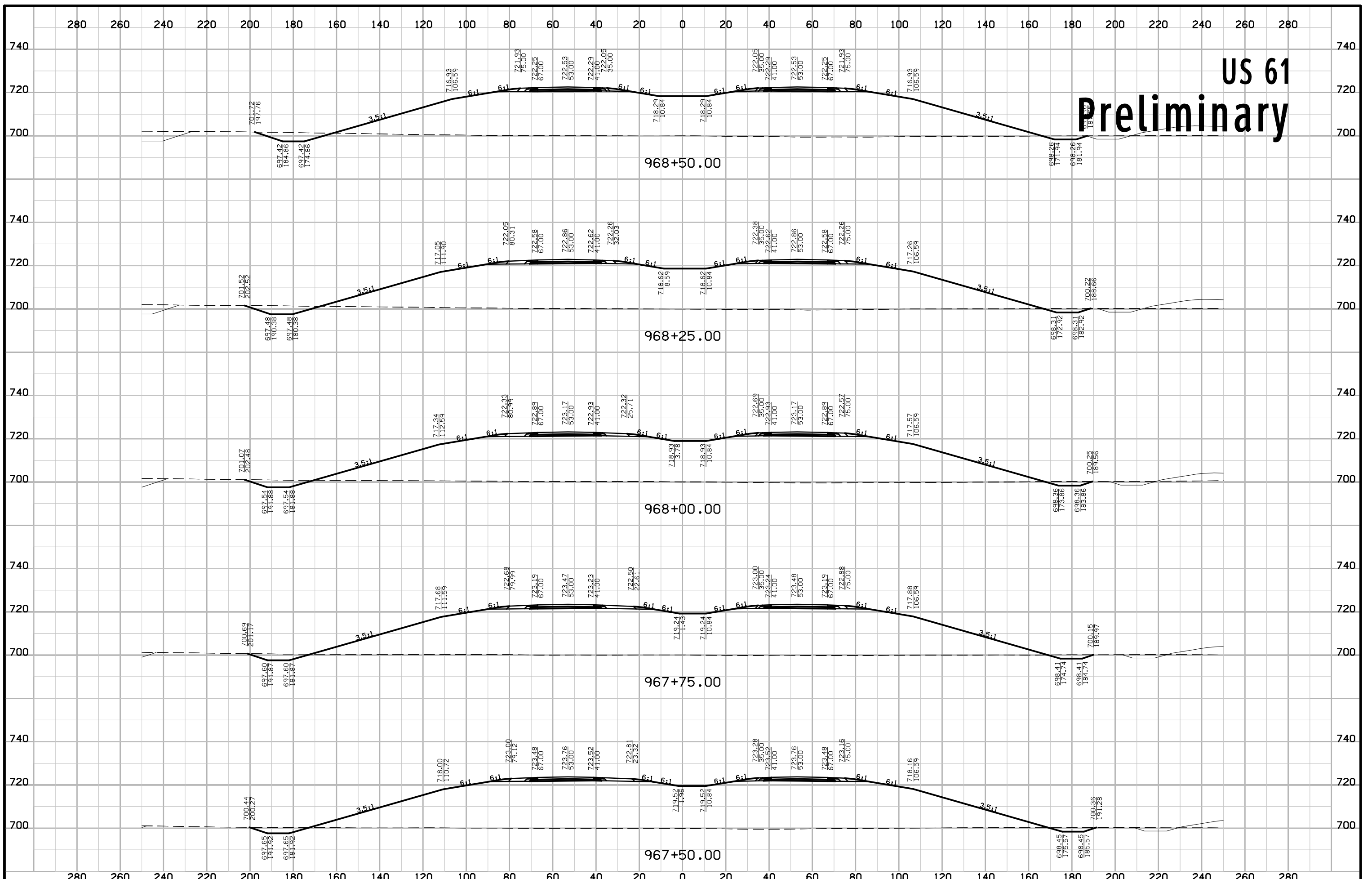

US 61 Preliminary

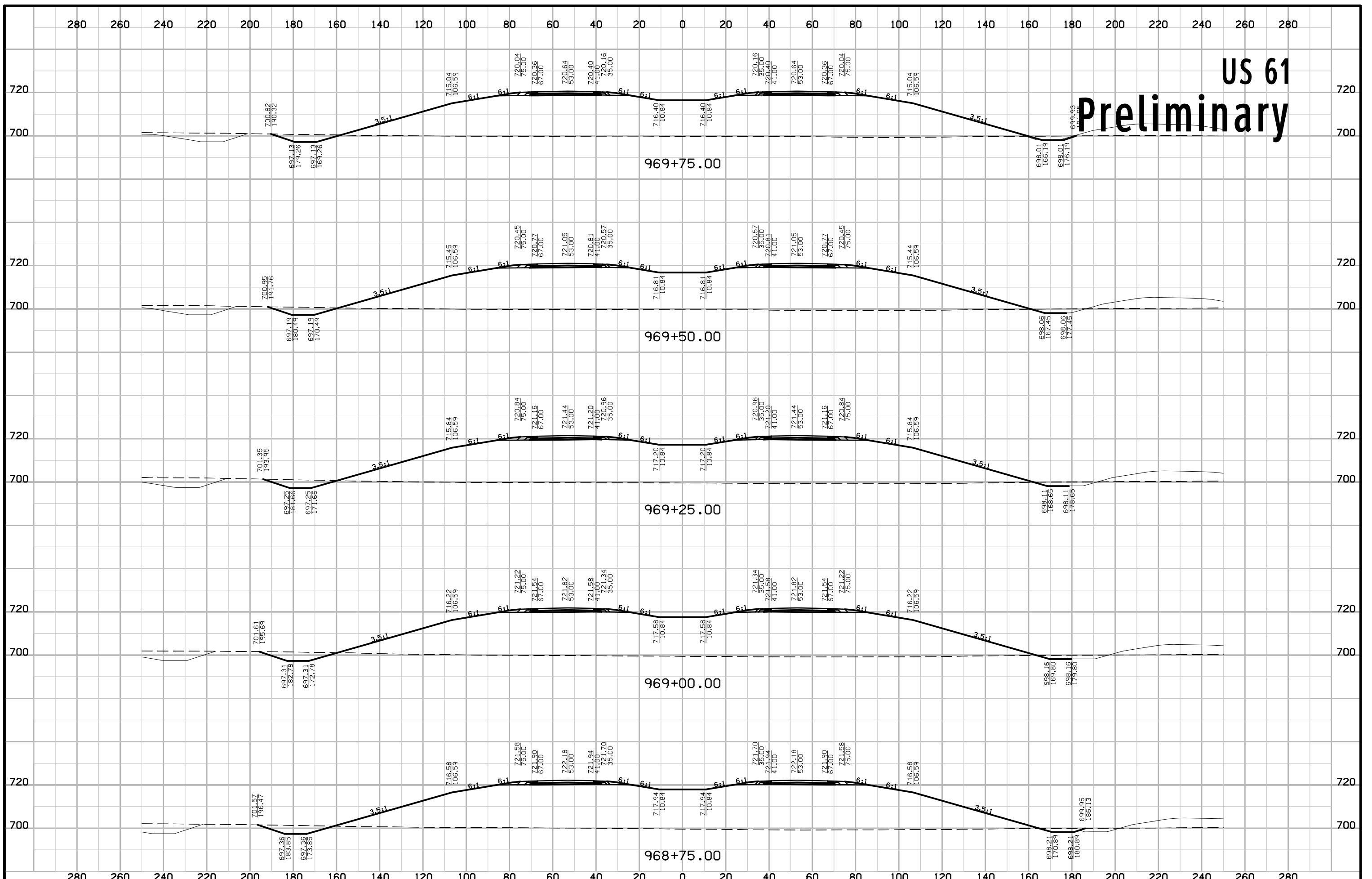

US 61 Preliminary

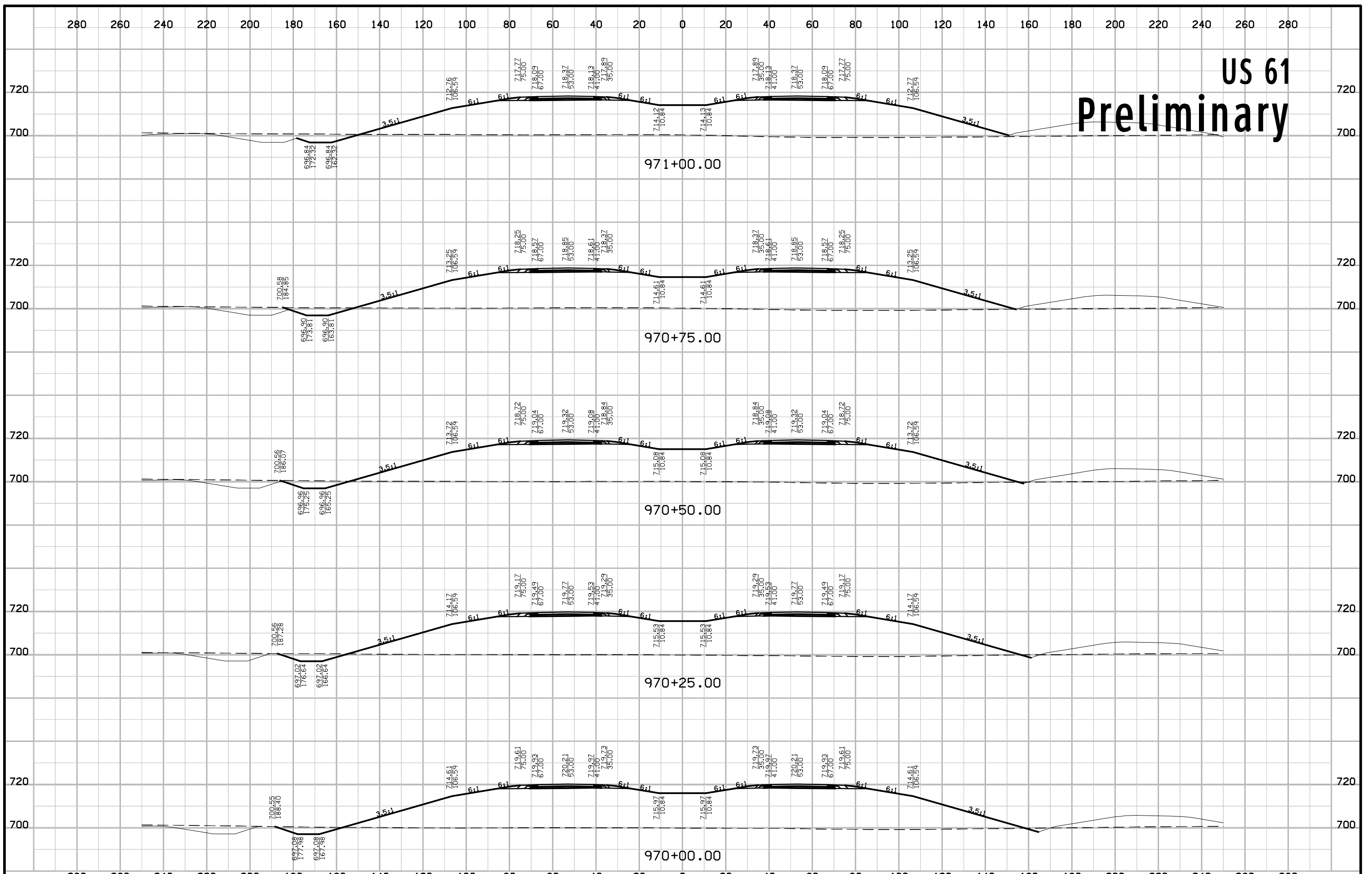

US 61 Preliminary

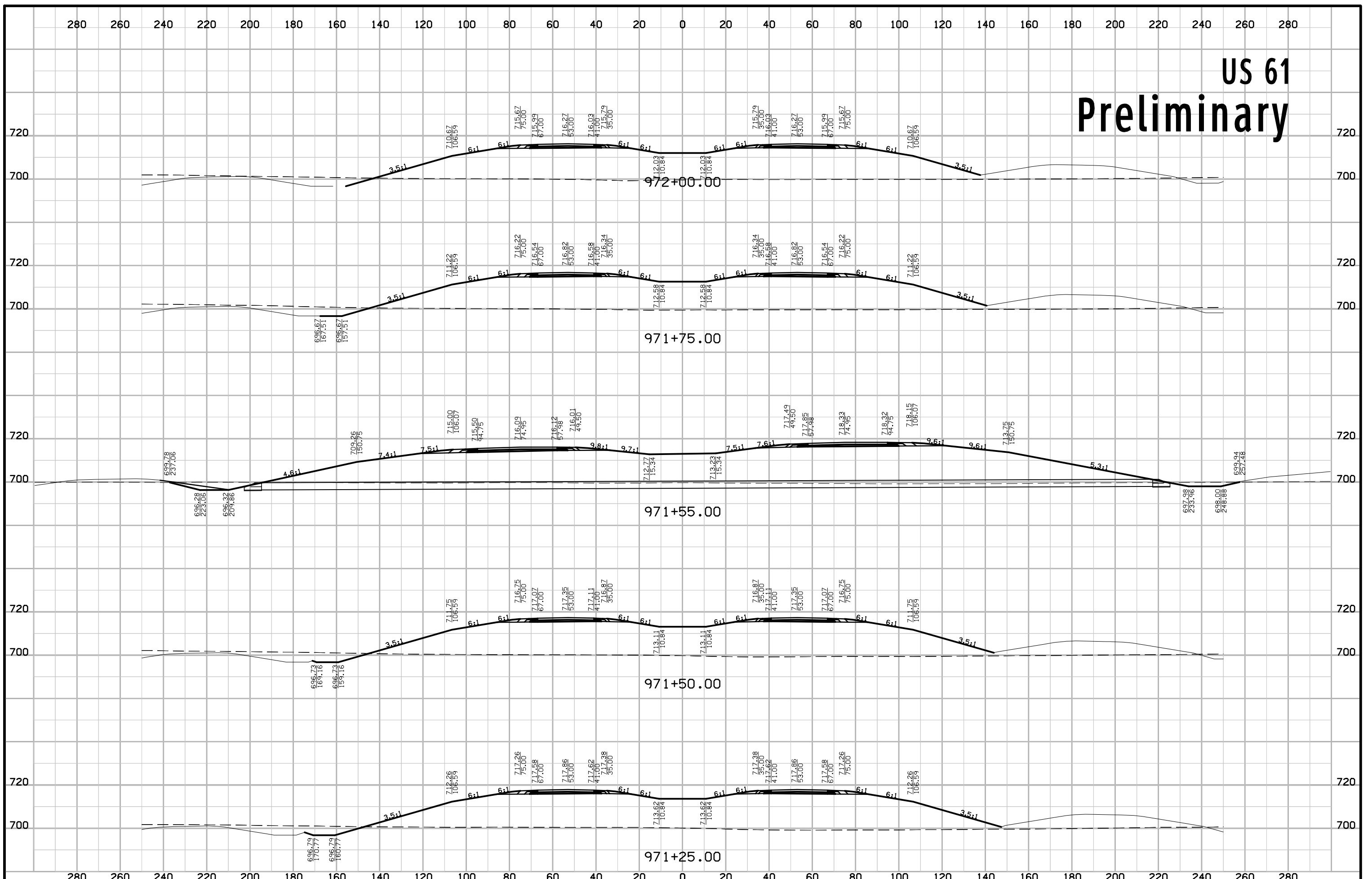

US 61 Preliminary

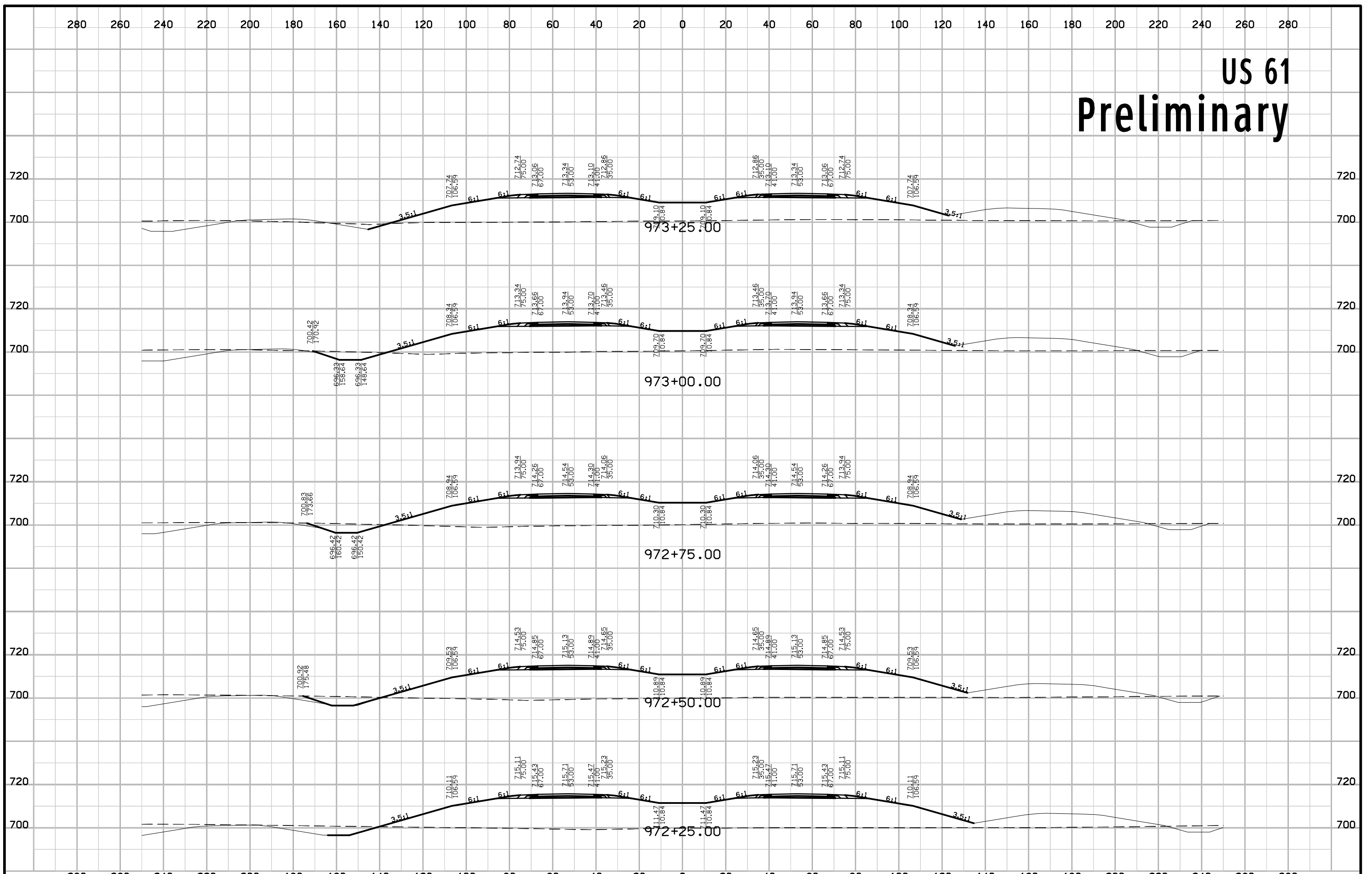

US 61 Preliminary

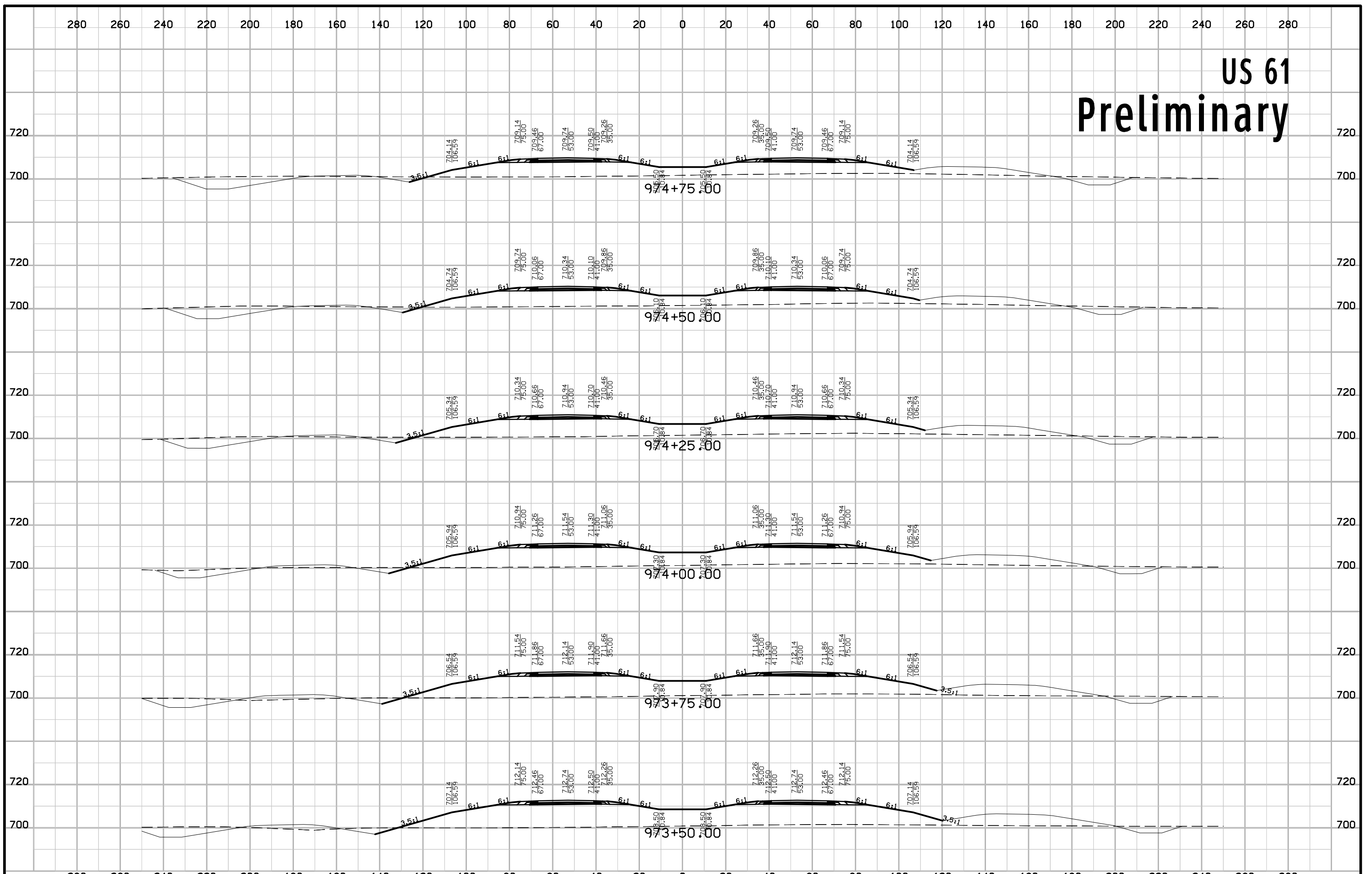

US 61 Preliminary

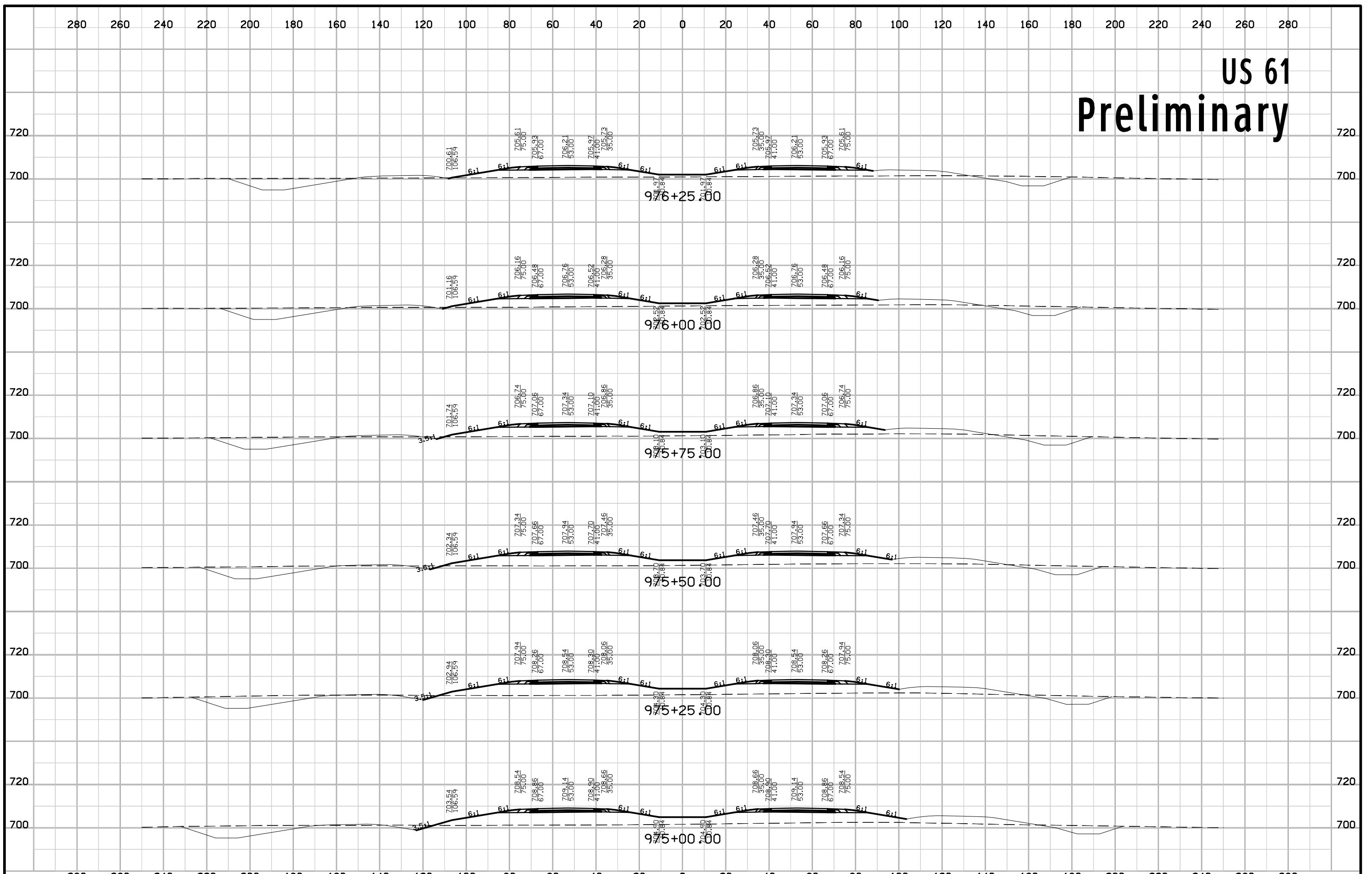

US 61 Preliminary

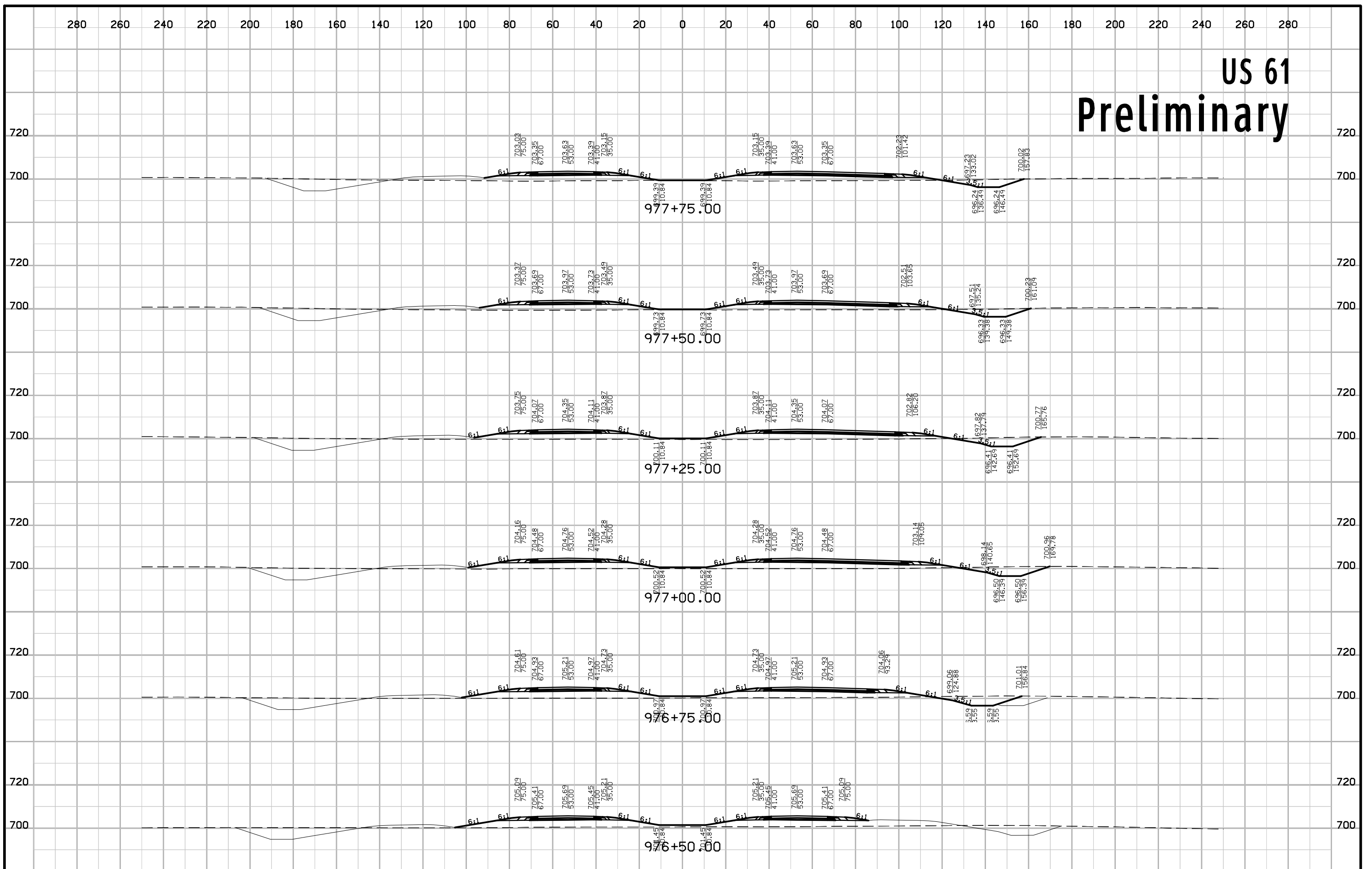

US 61 Preliminary

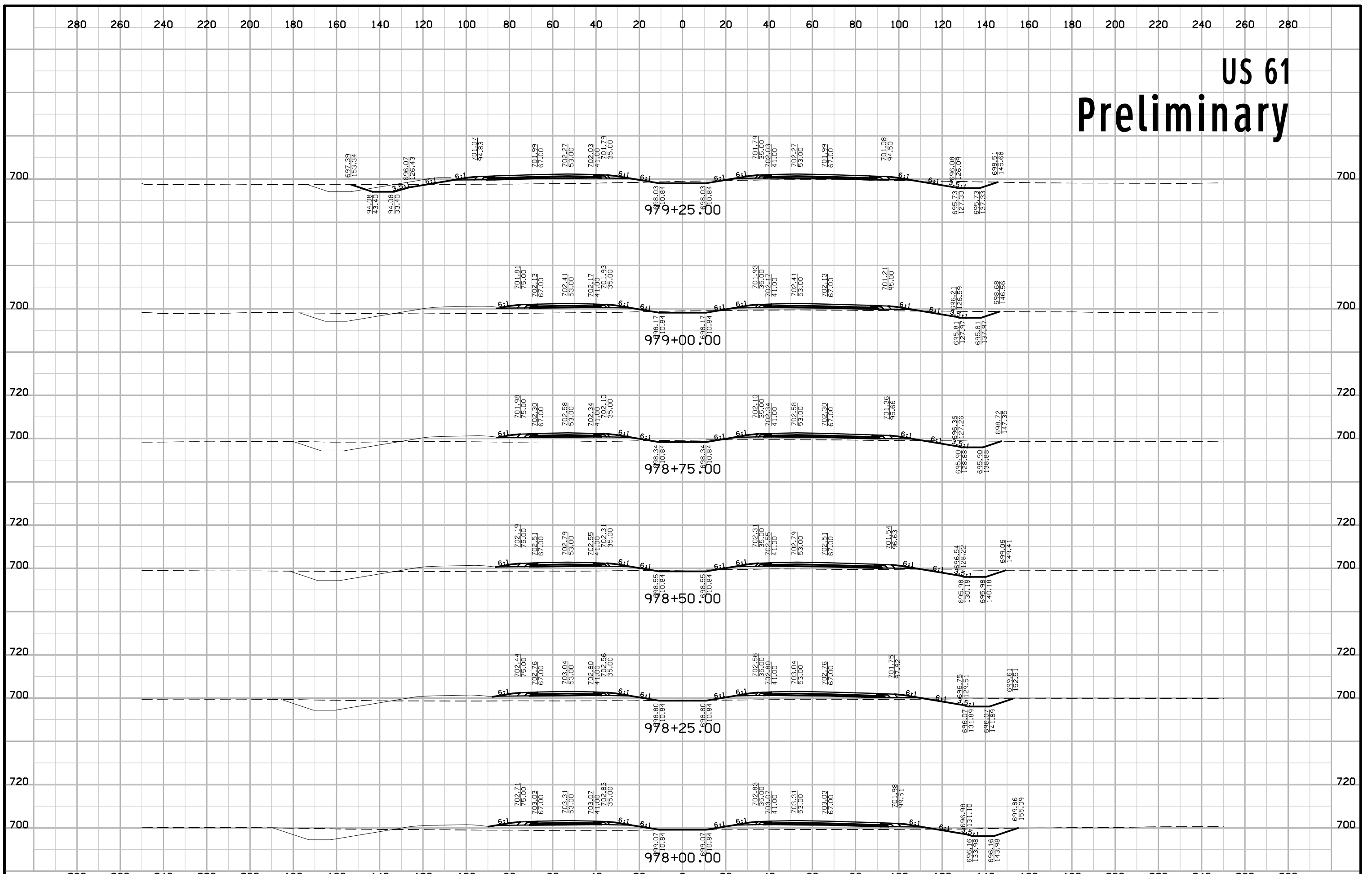

US 61 Preliminary

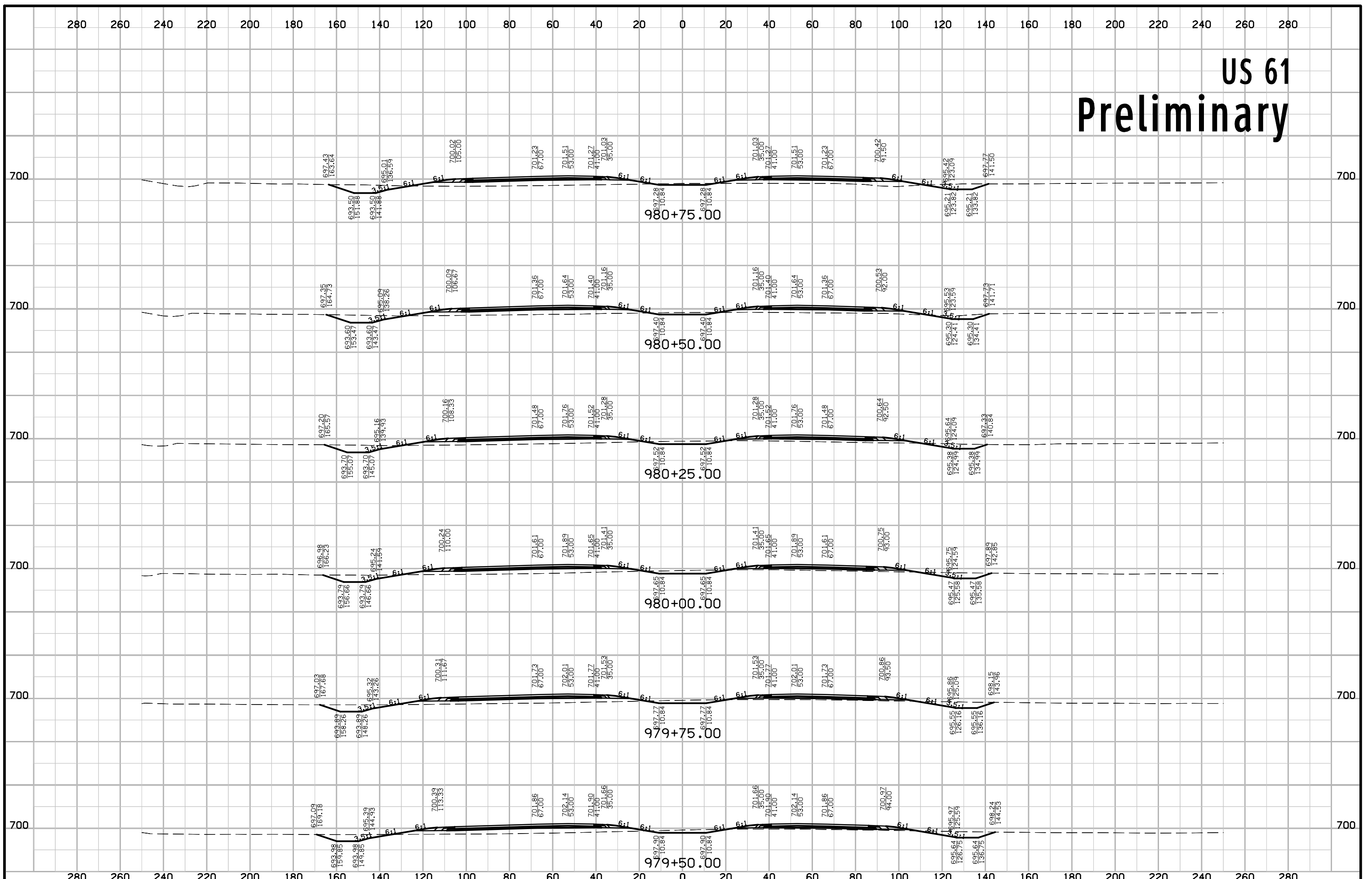

US 61 Preliminary

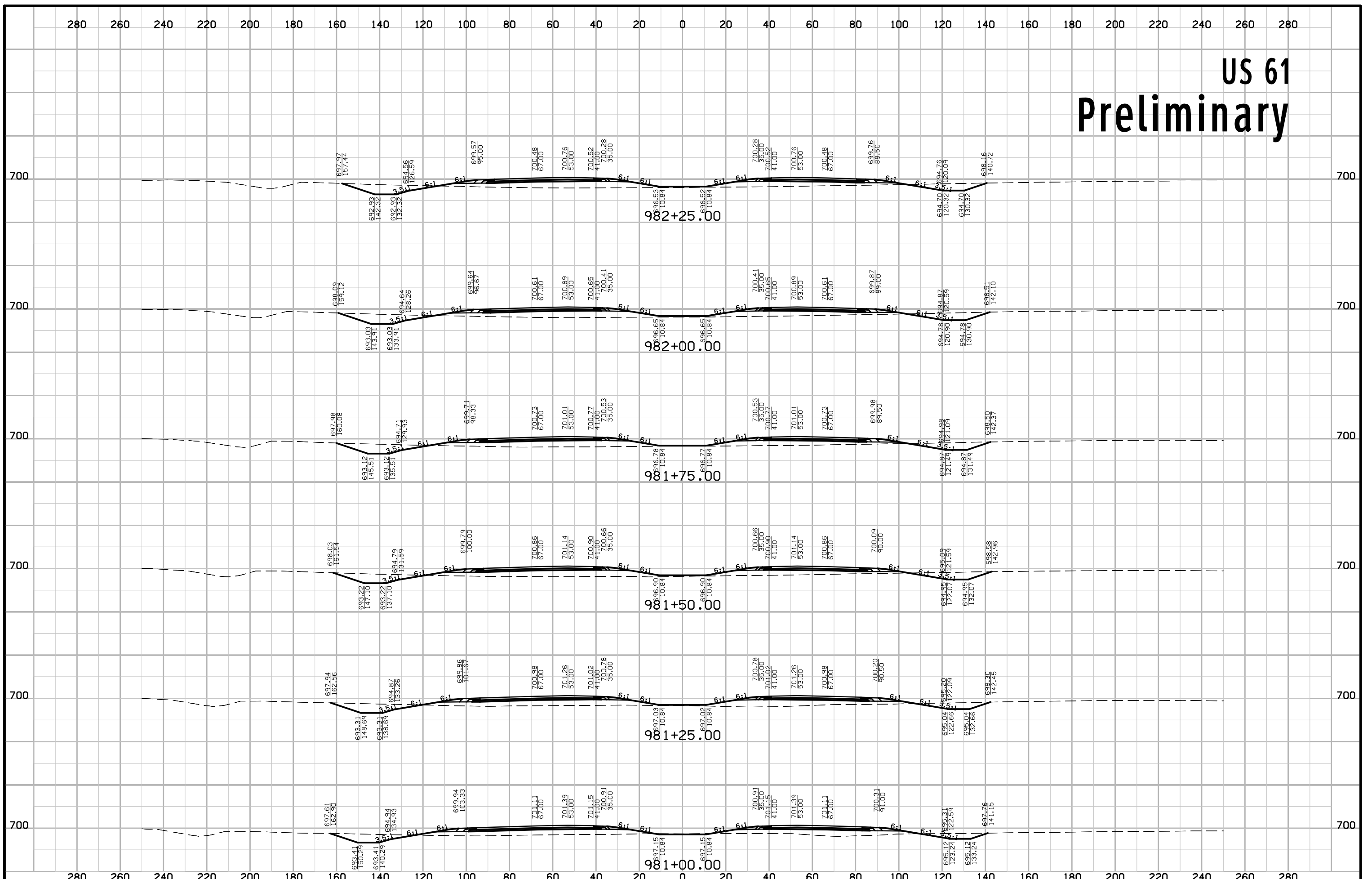

US 61 Preliminary

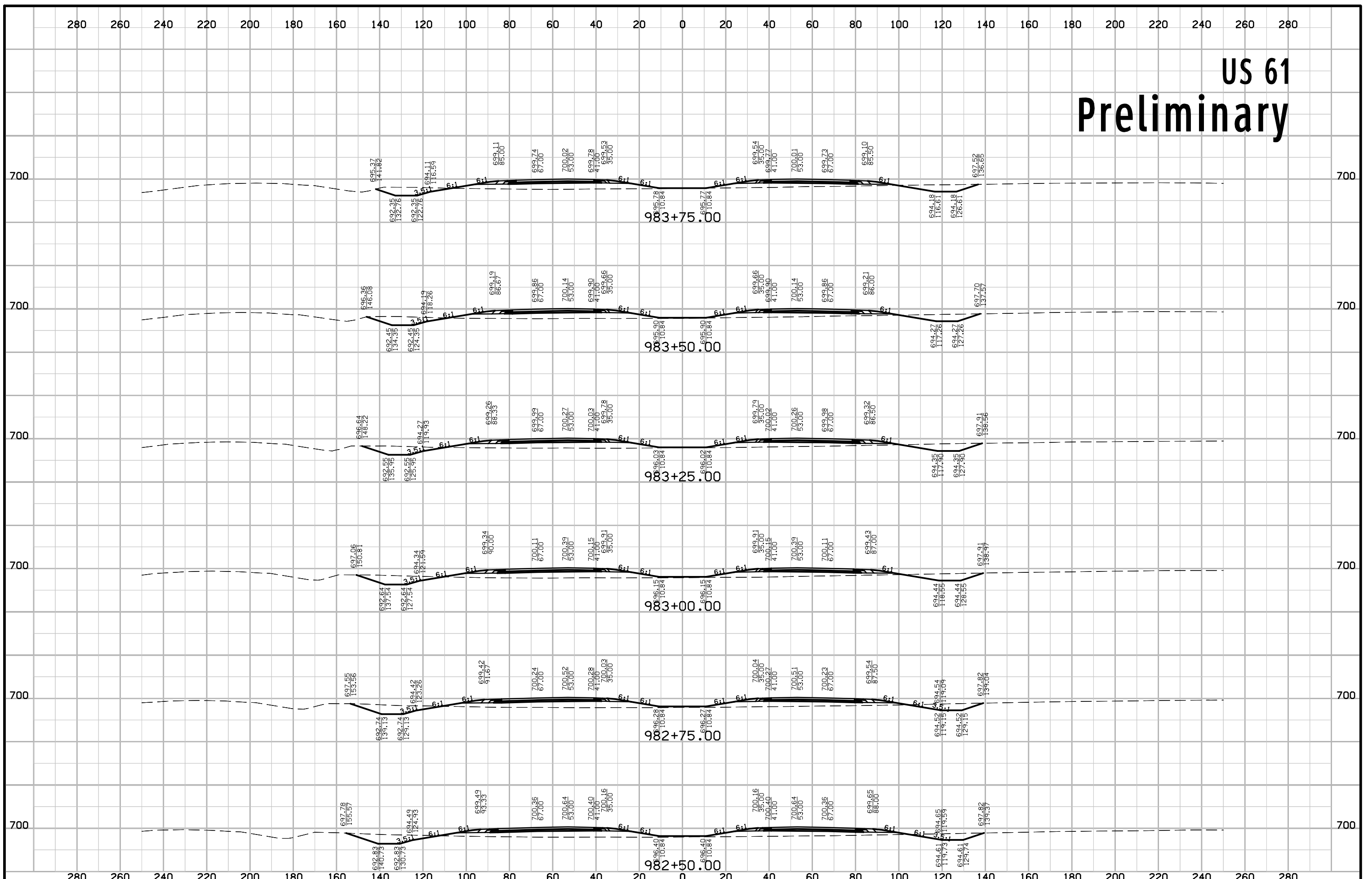

US 61 Preliminary

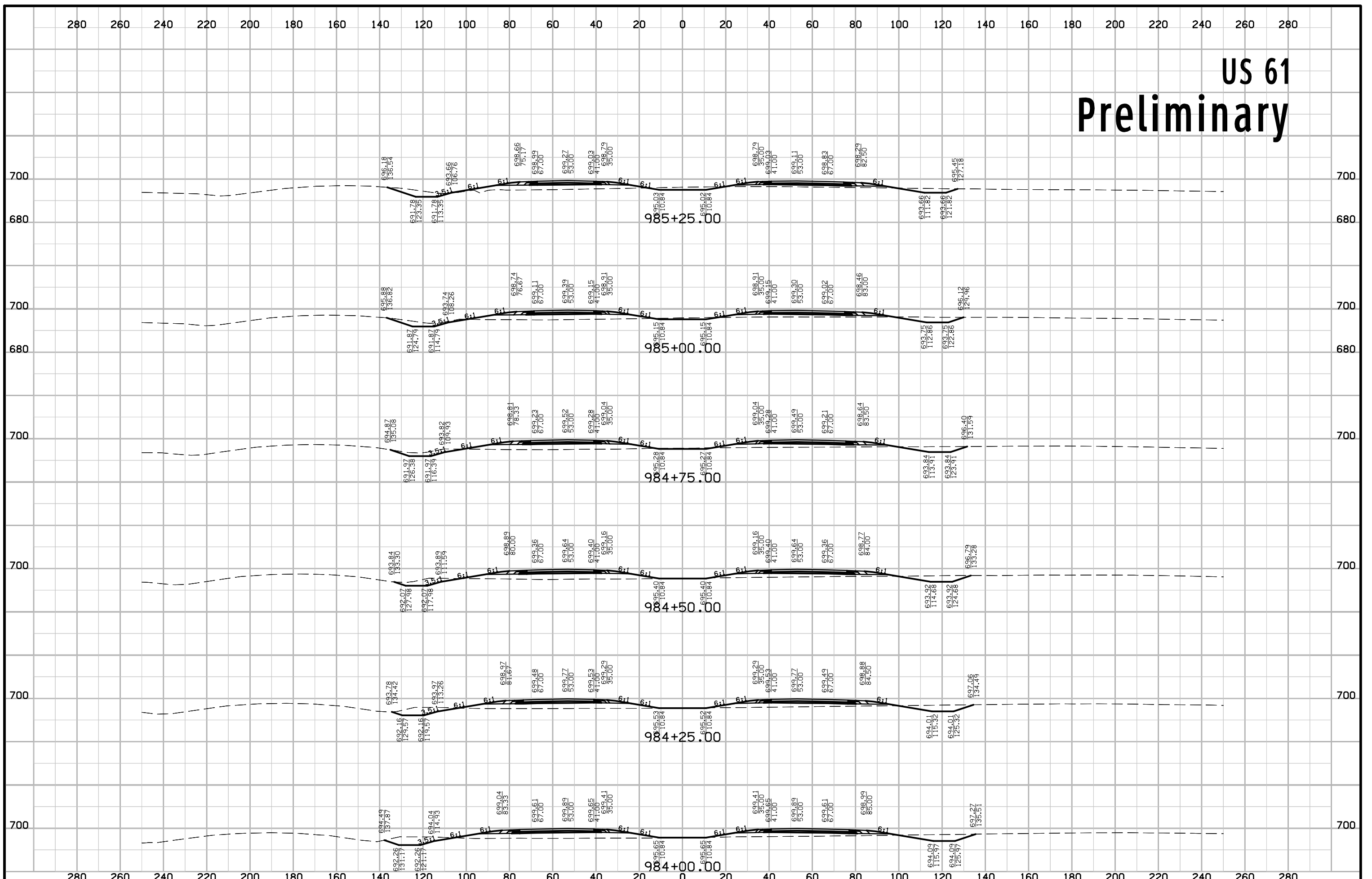

US 61 Preliminary

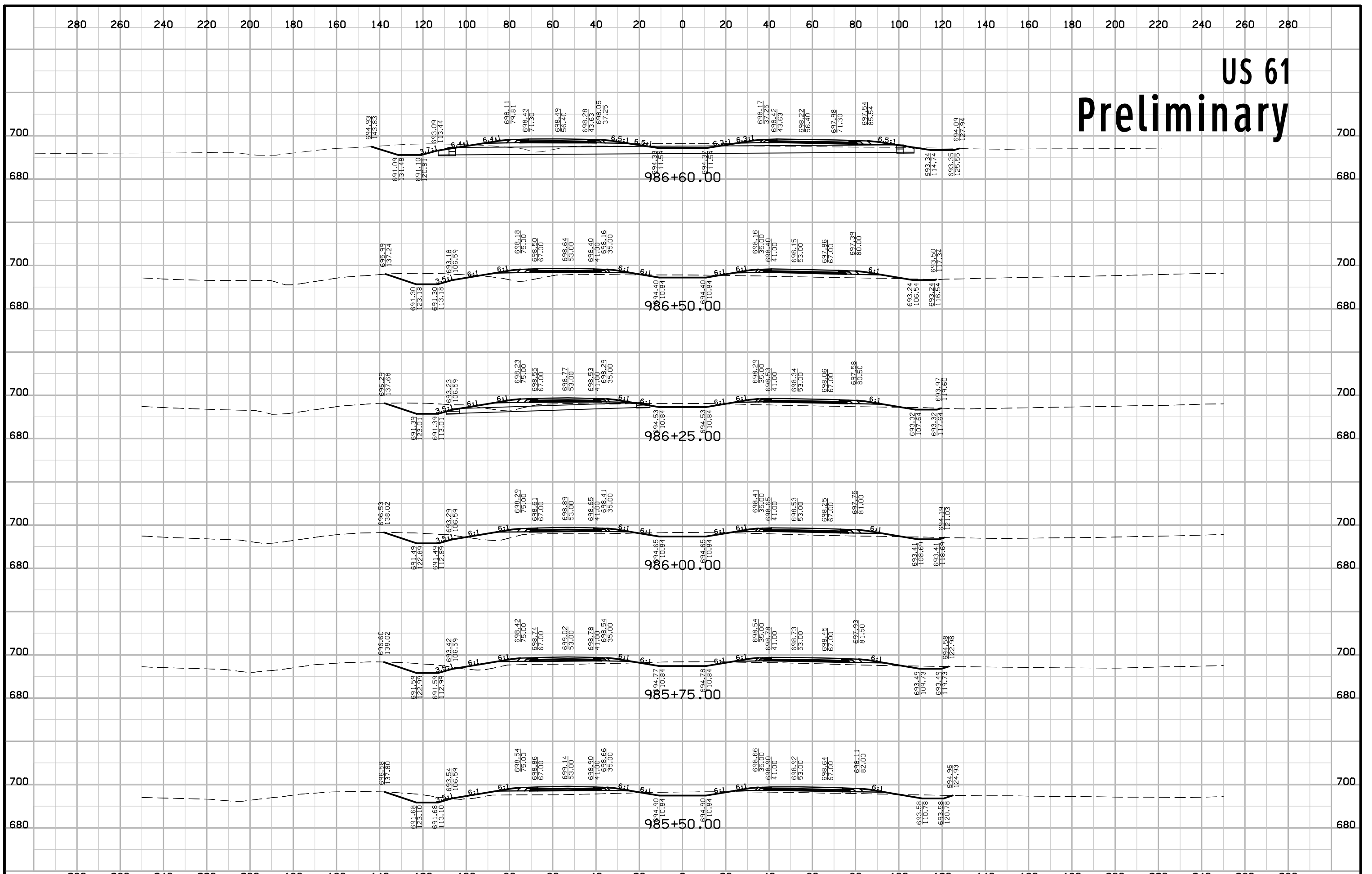

US 61 Preliminary

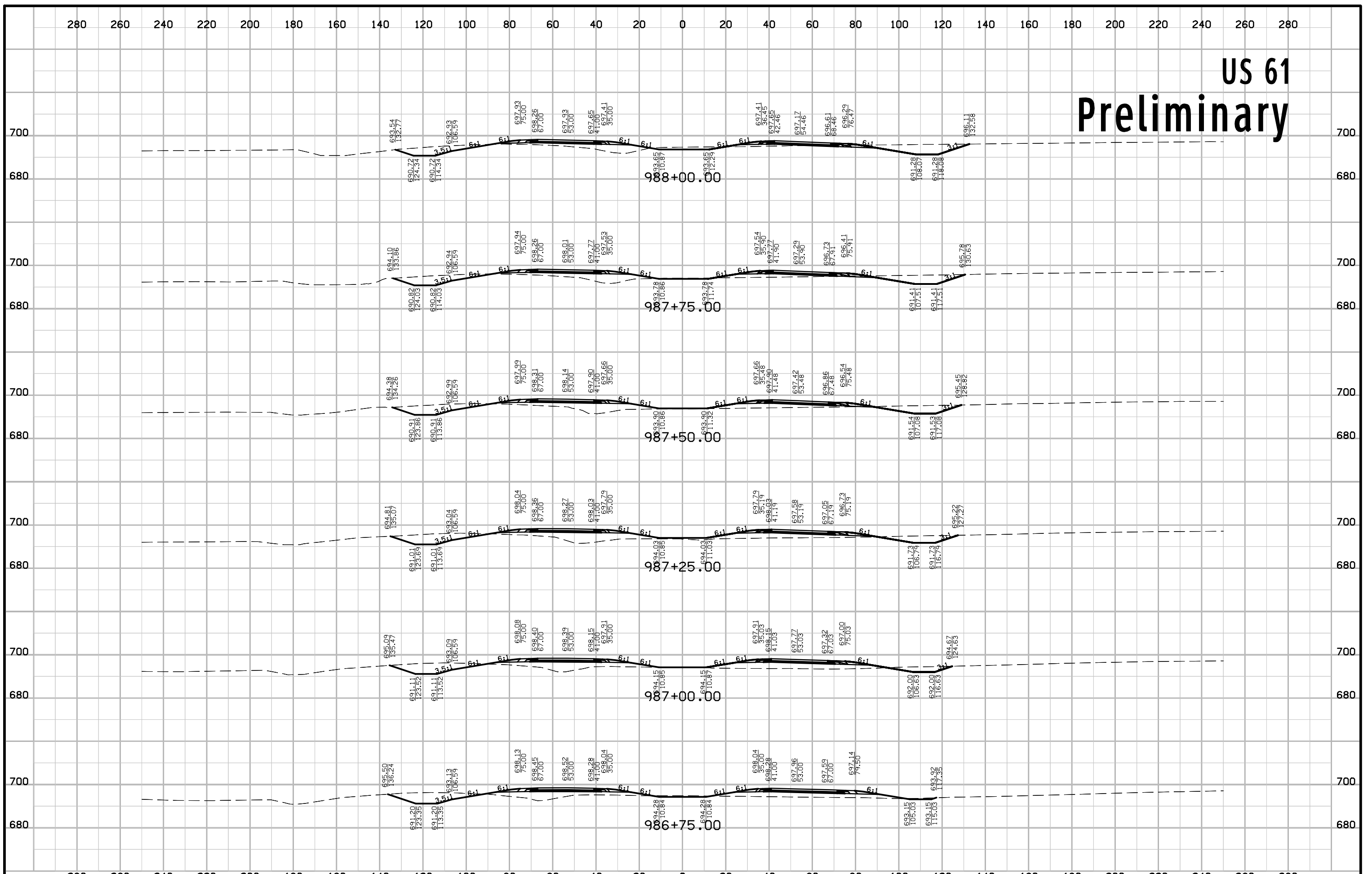

US 61 Preliminary

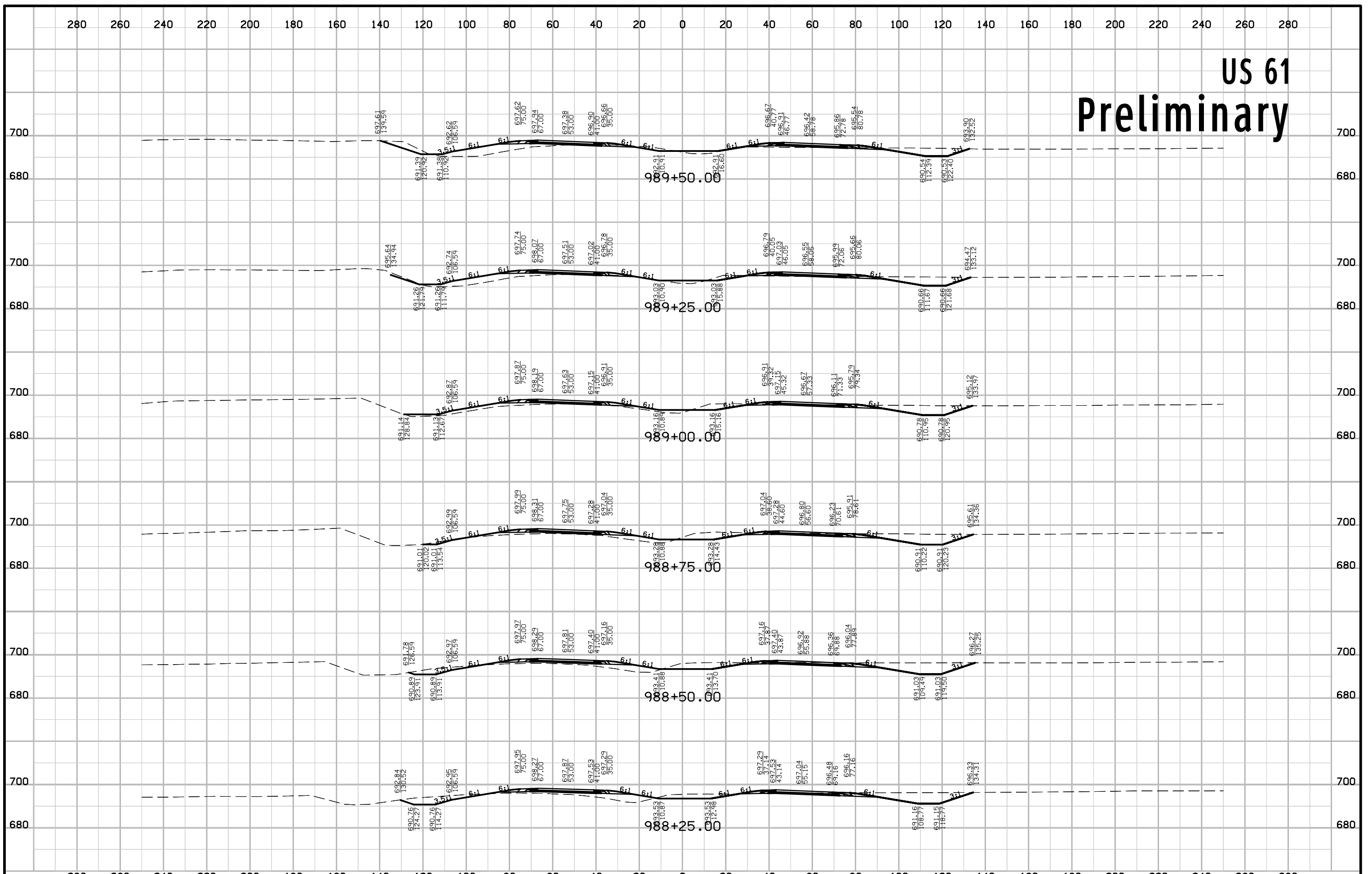

US 61 Preliminary

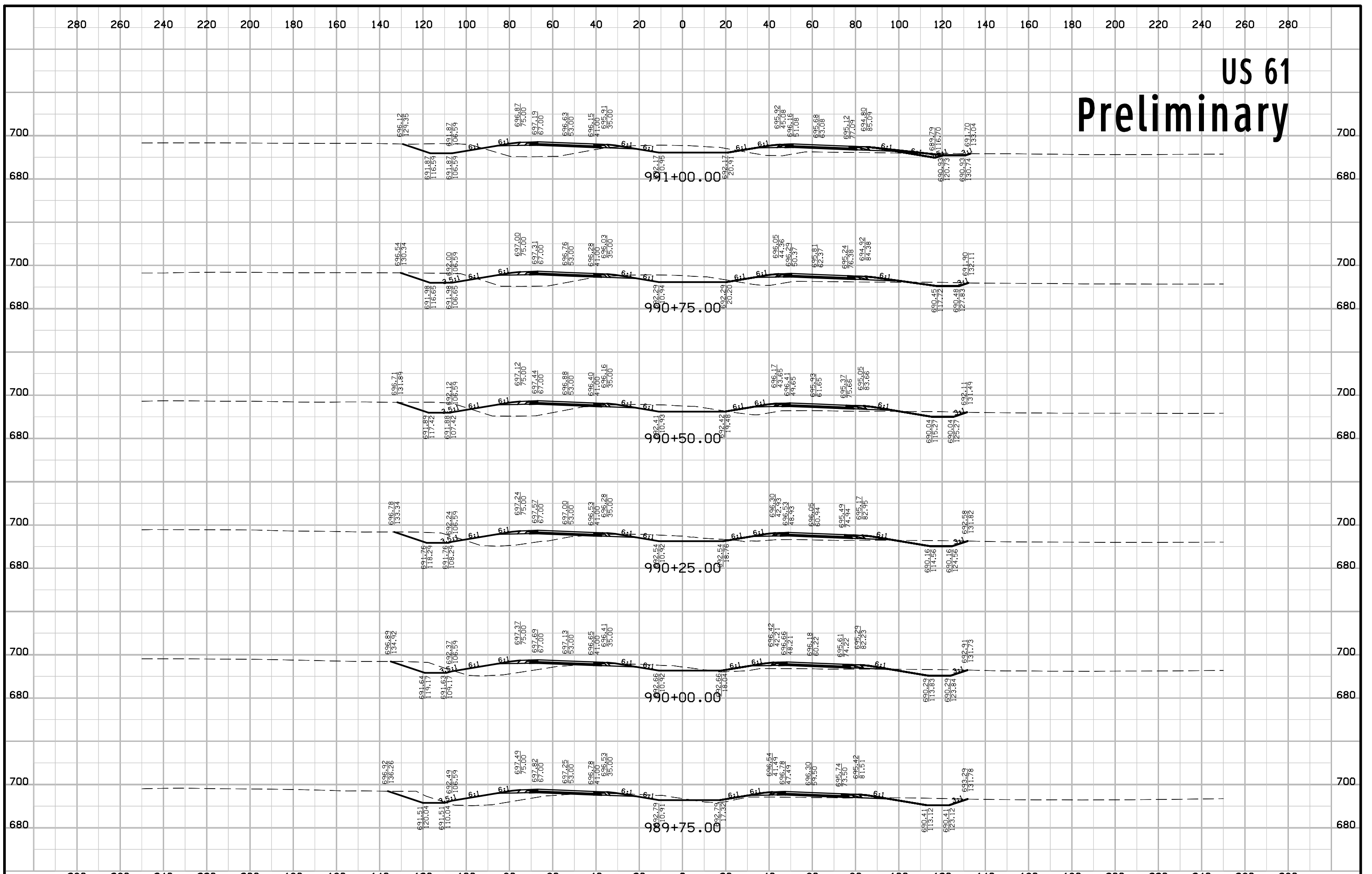

US 61 Preliminary

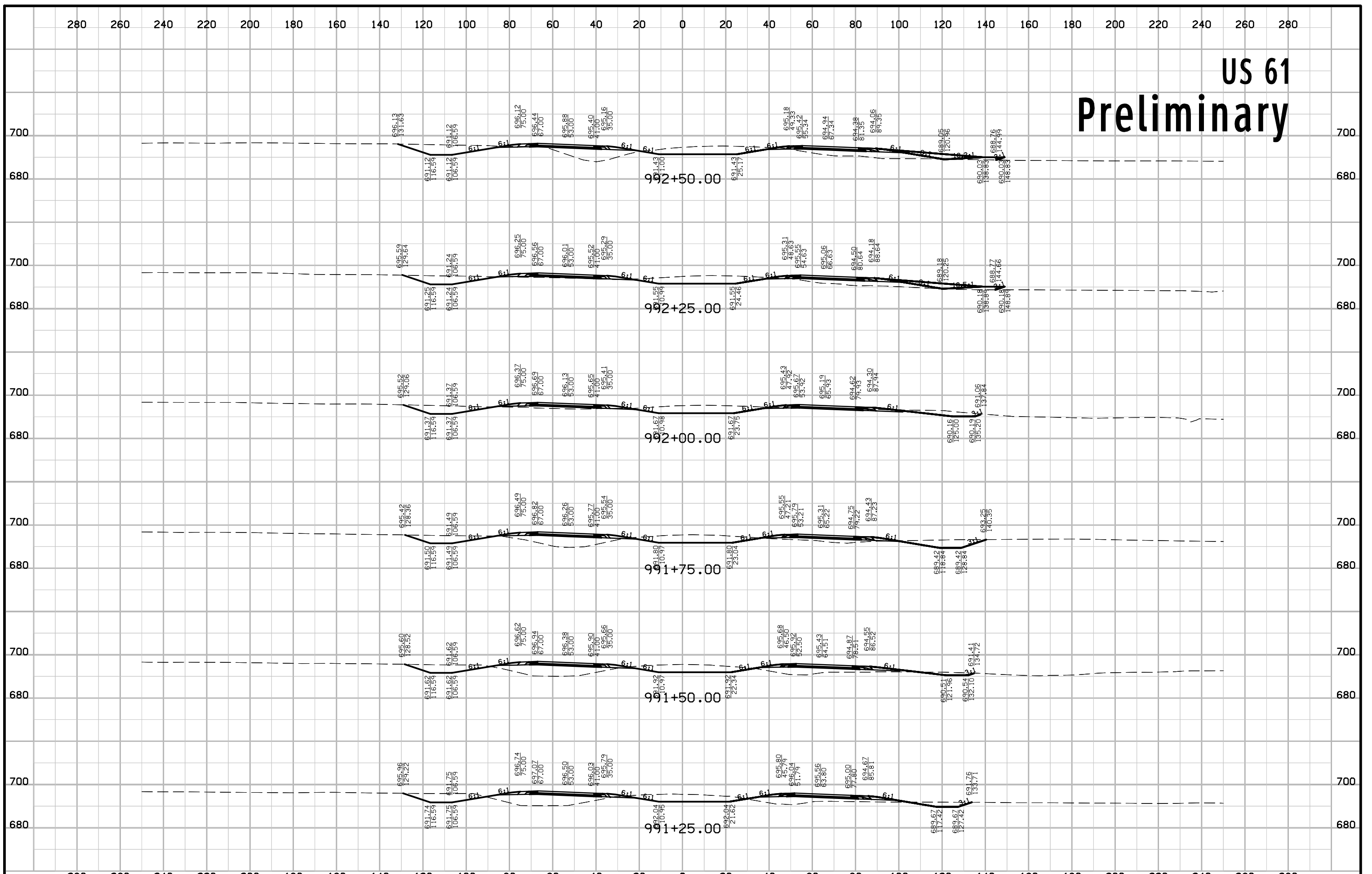

US 61 Preliminary

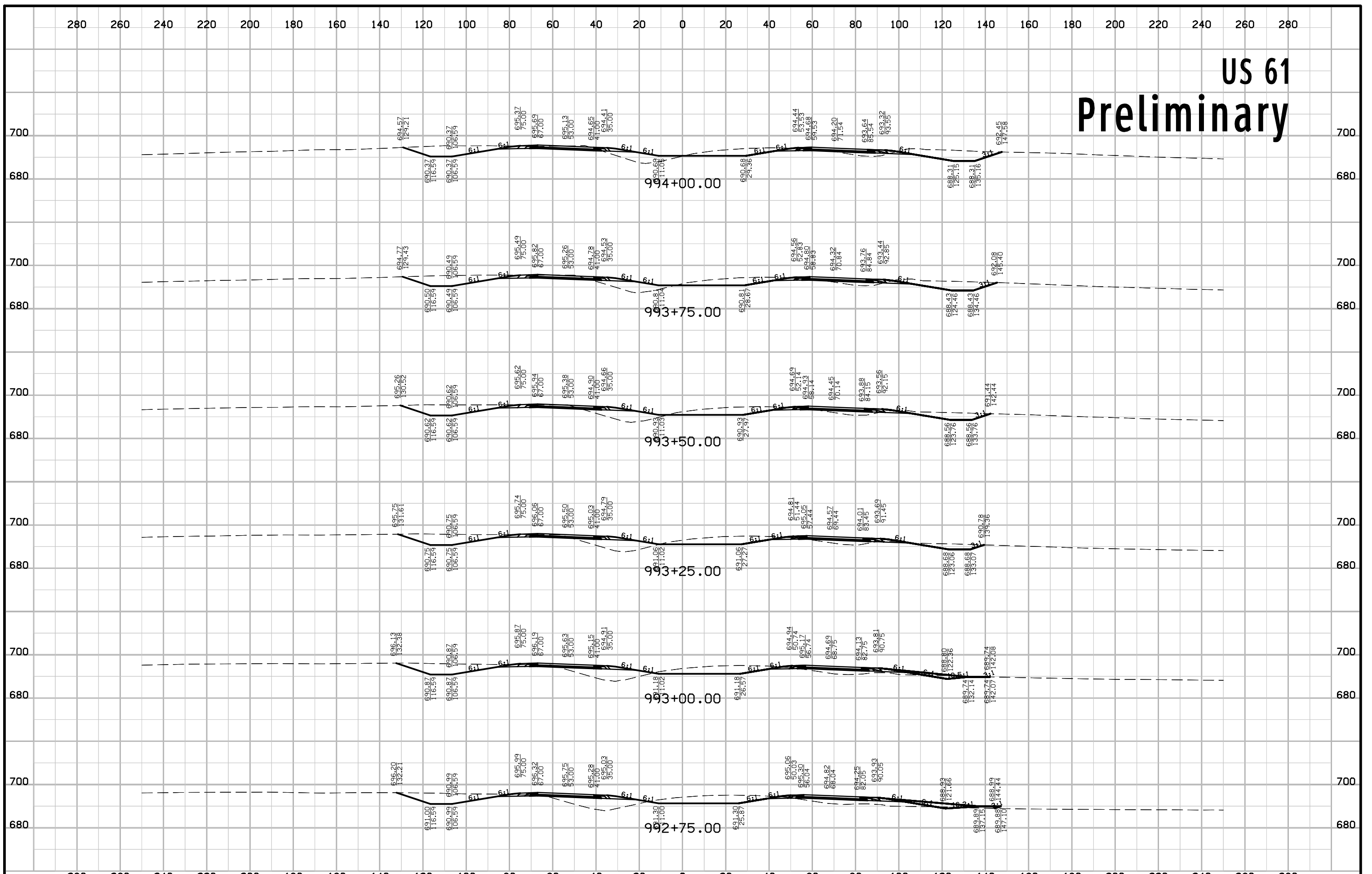

US 61 Preliminary

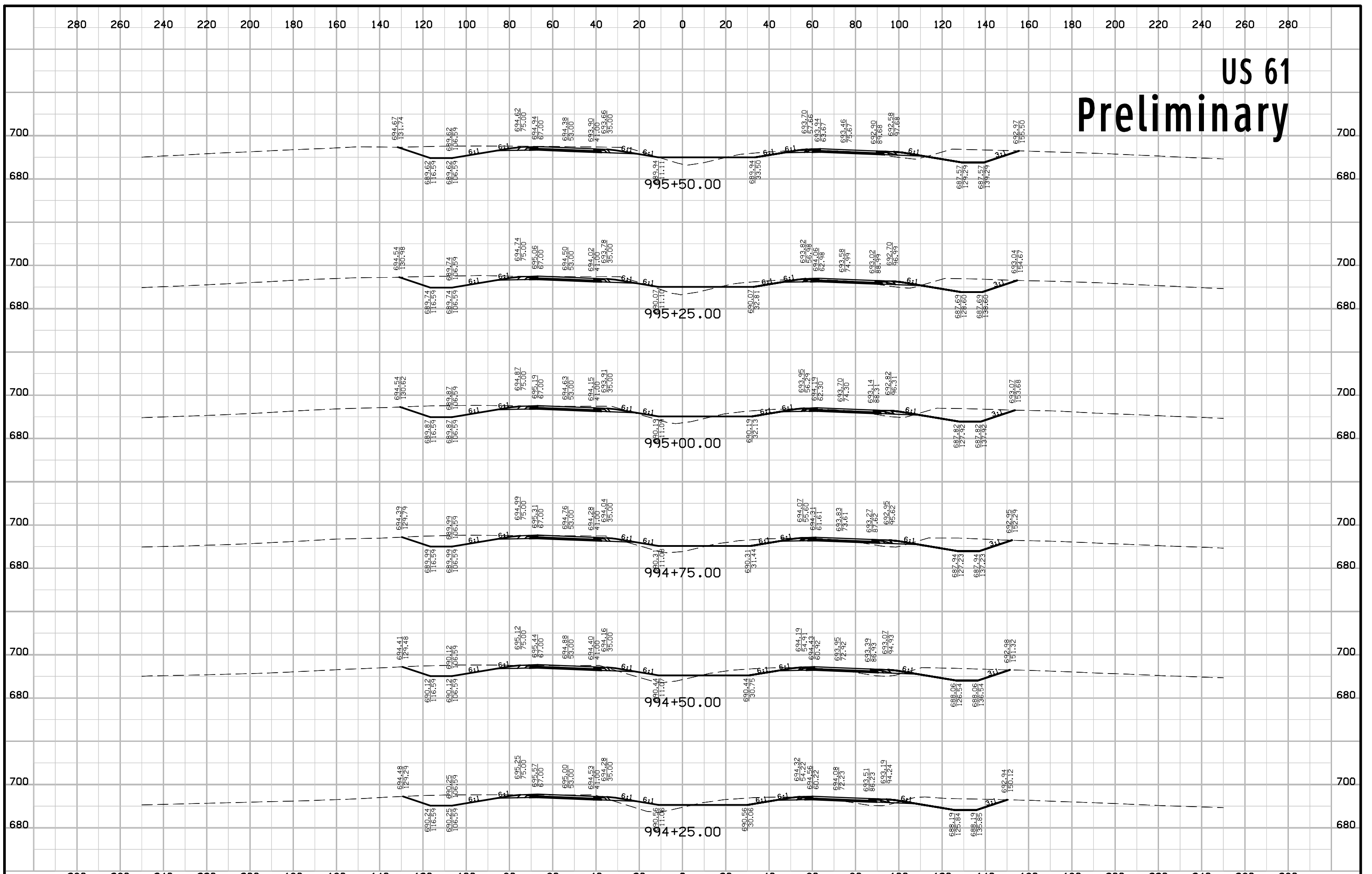

US 61 Preliminary

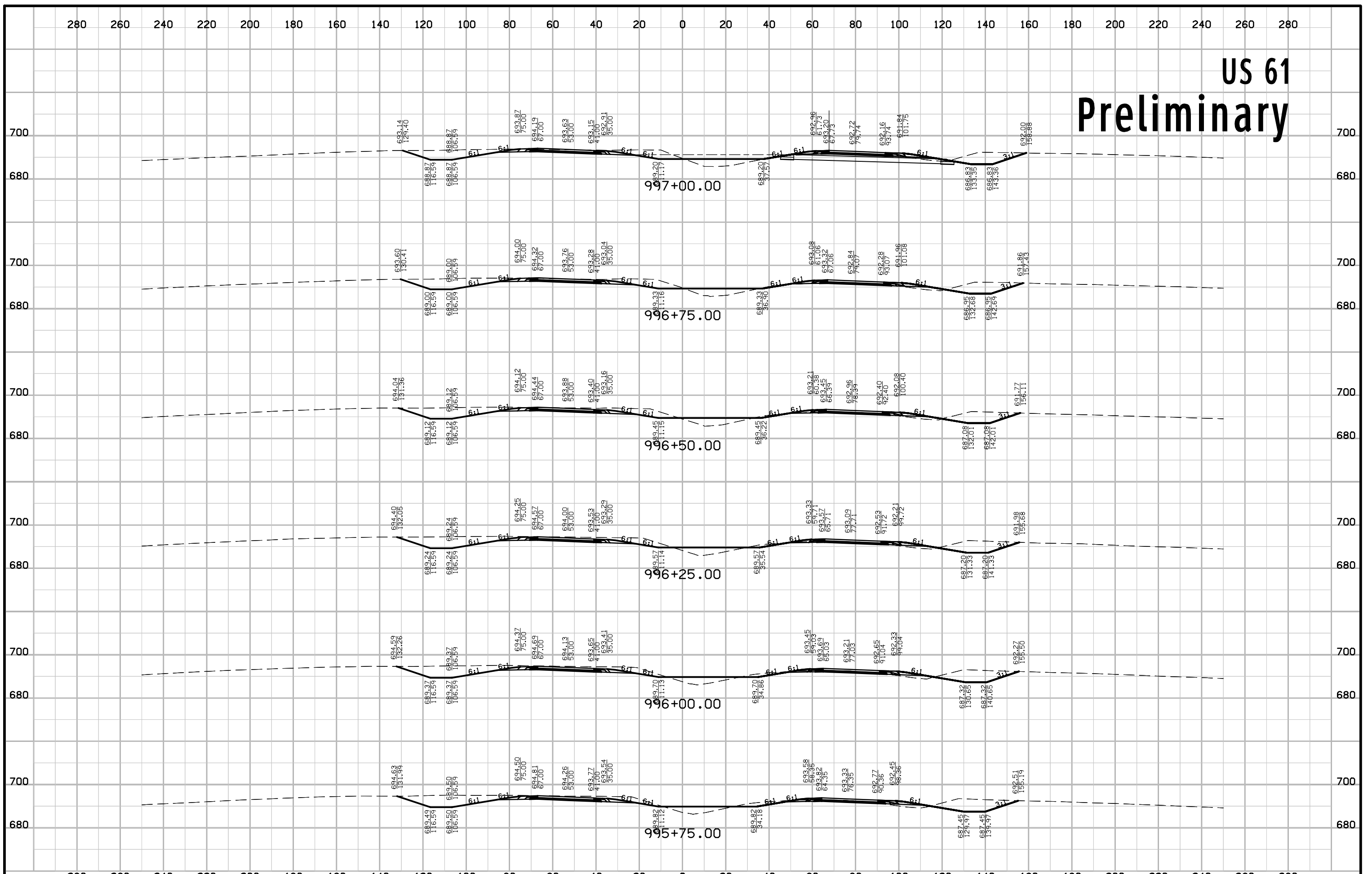

US 61 Preliminary

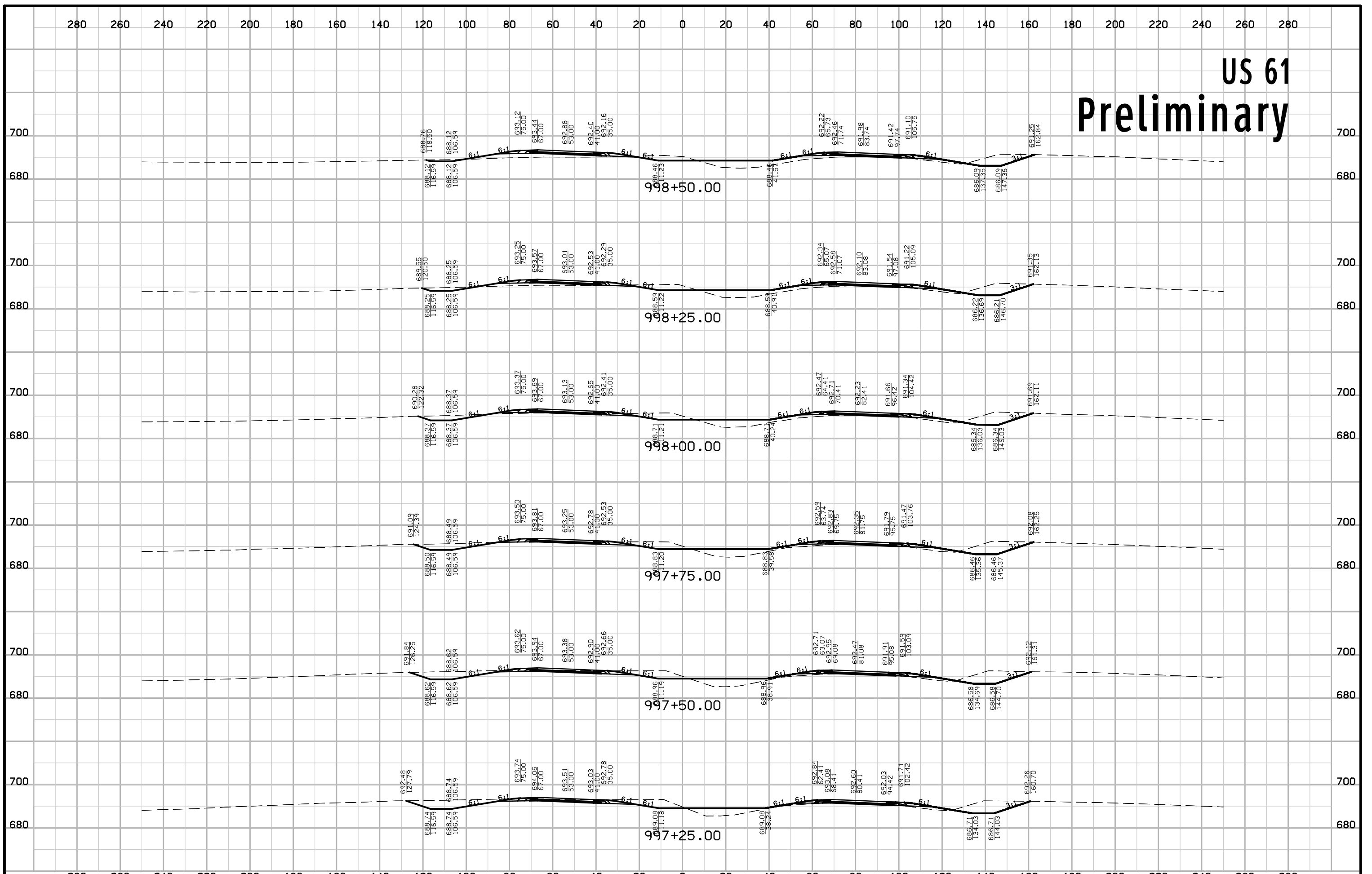

US 61 Preliminary

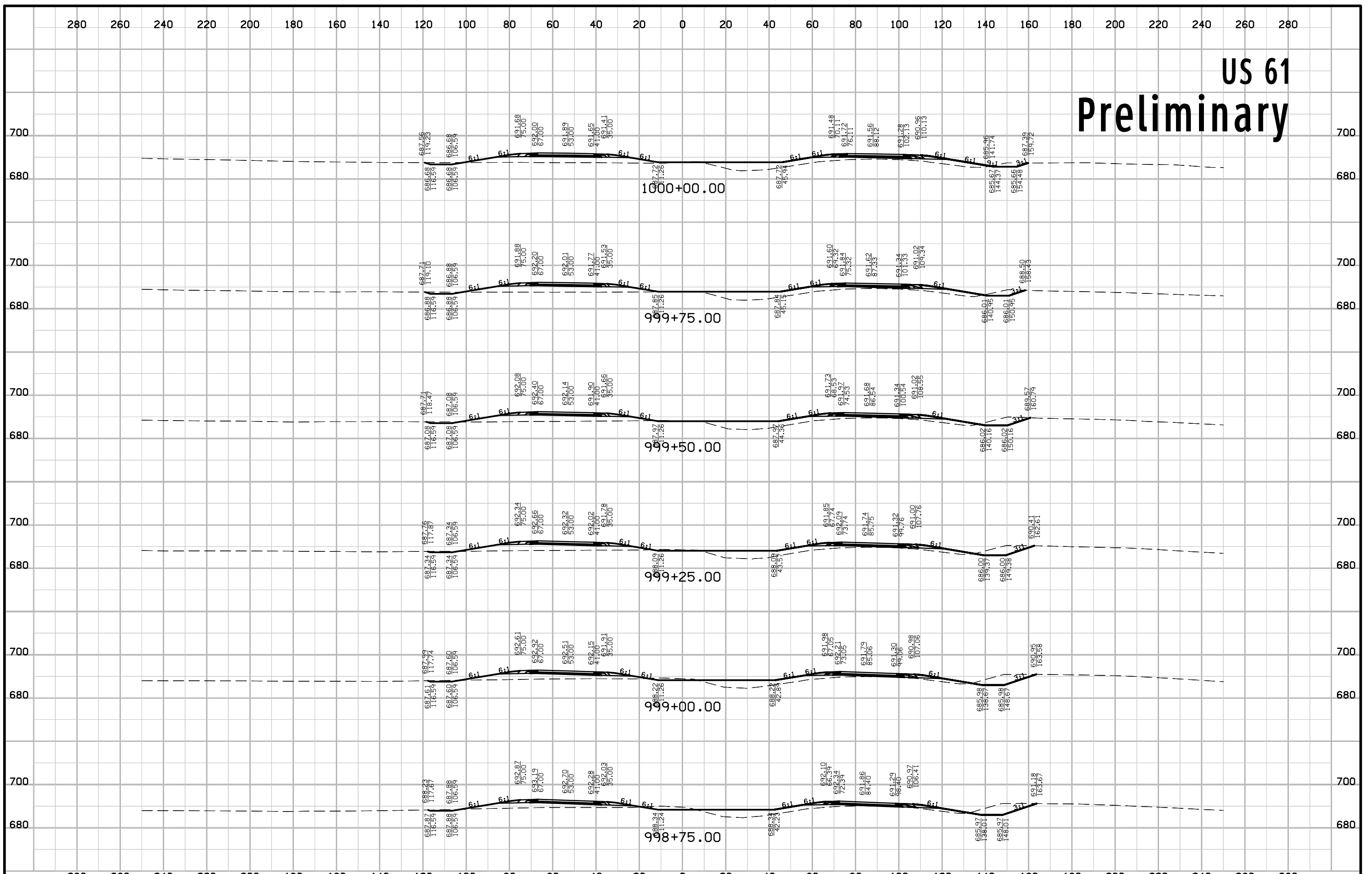

US 61 Preliminary

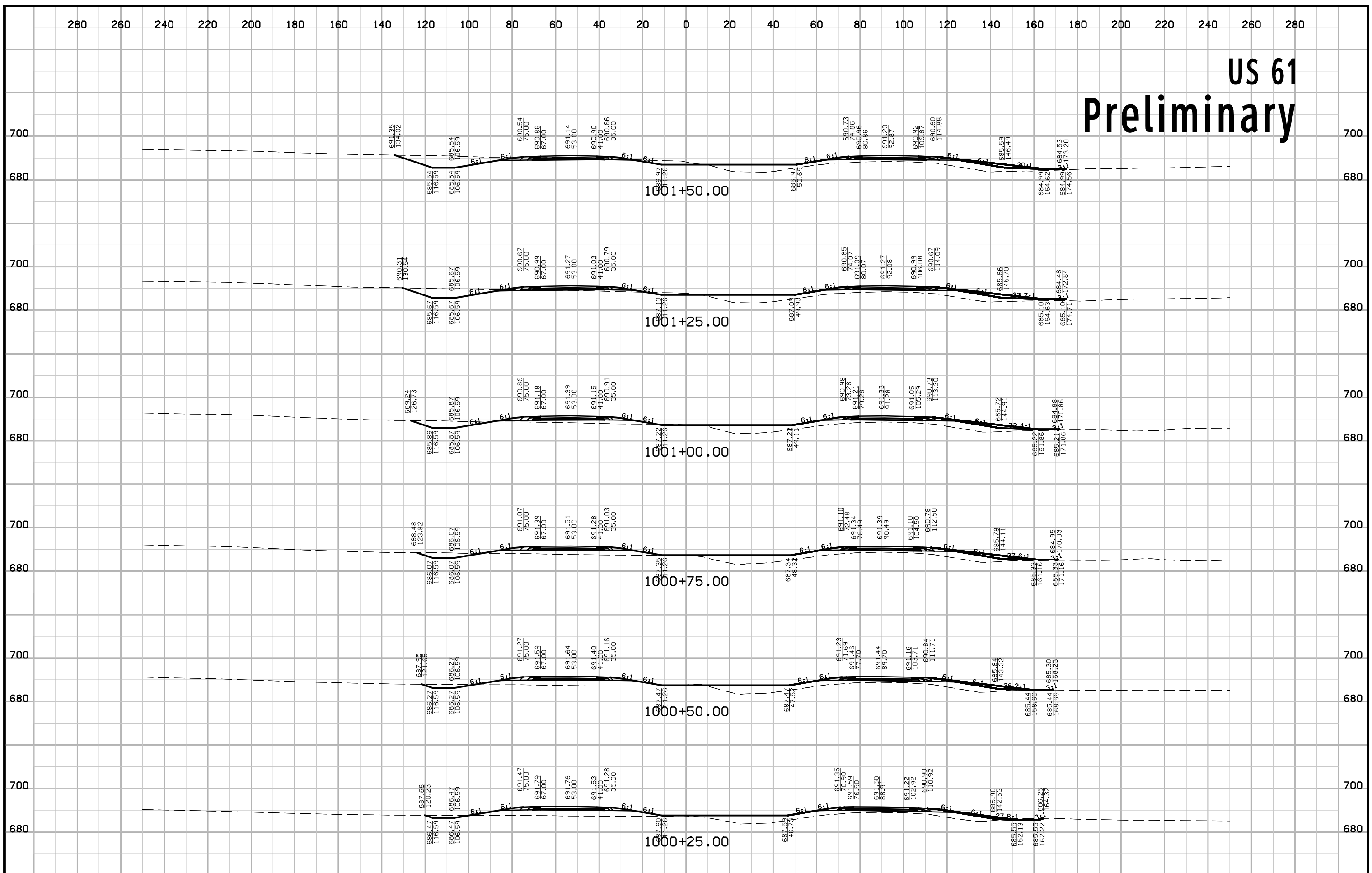

US 61 Preliminary

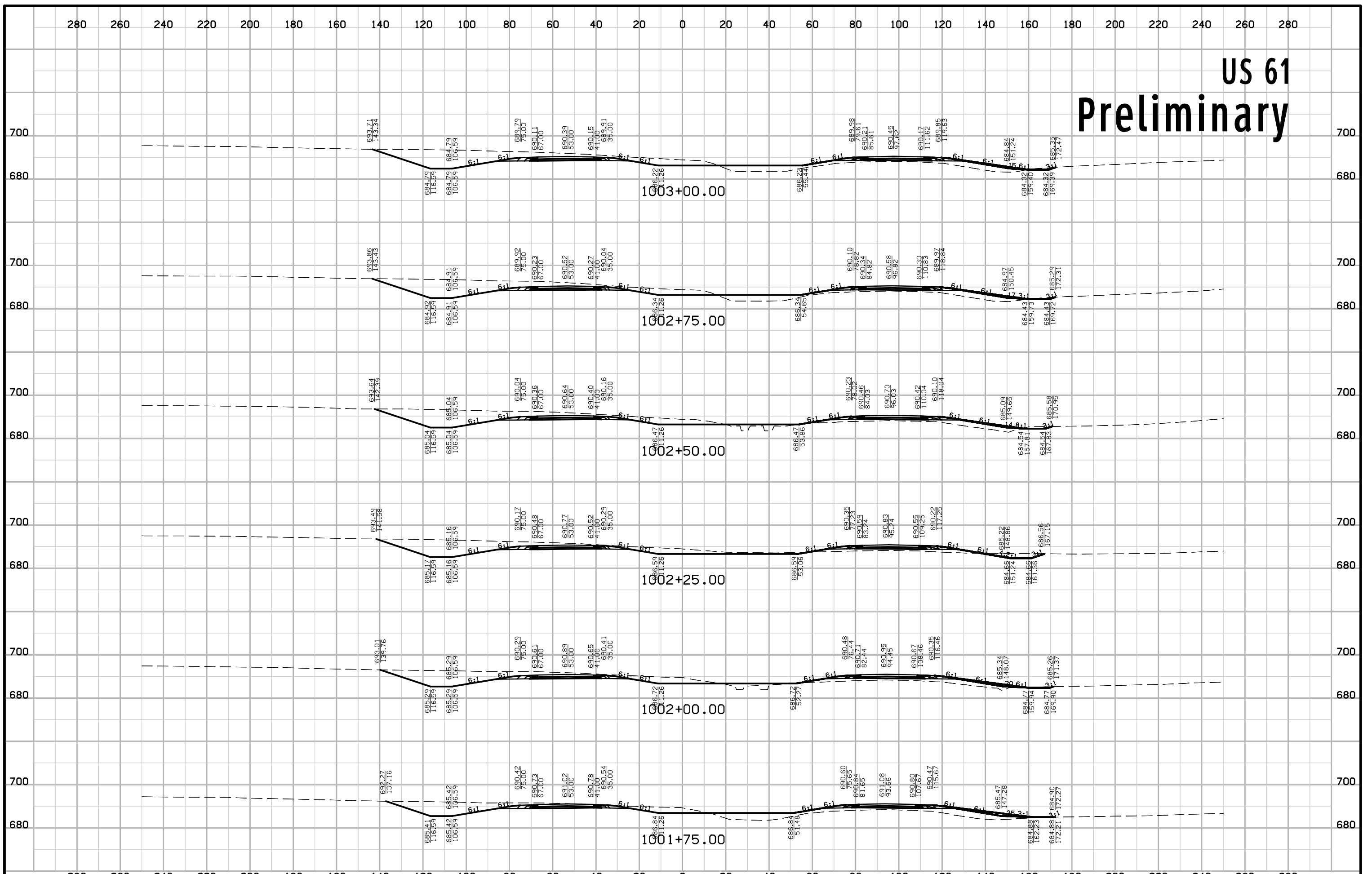

US 61 Preliminary

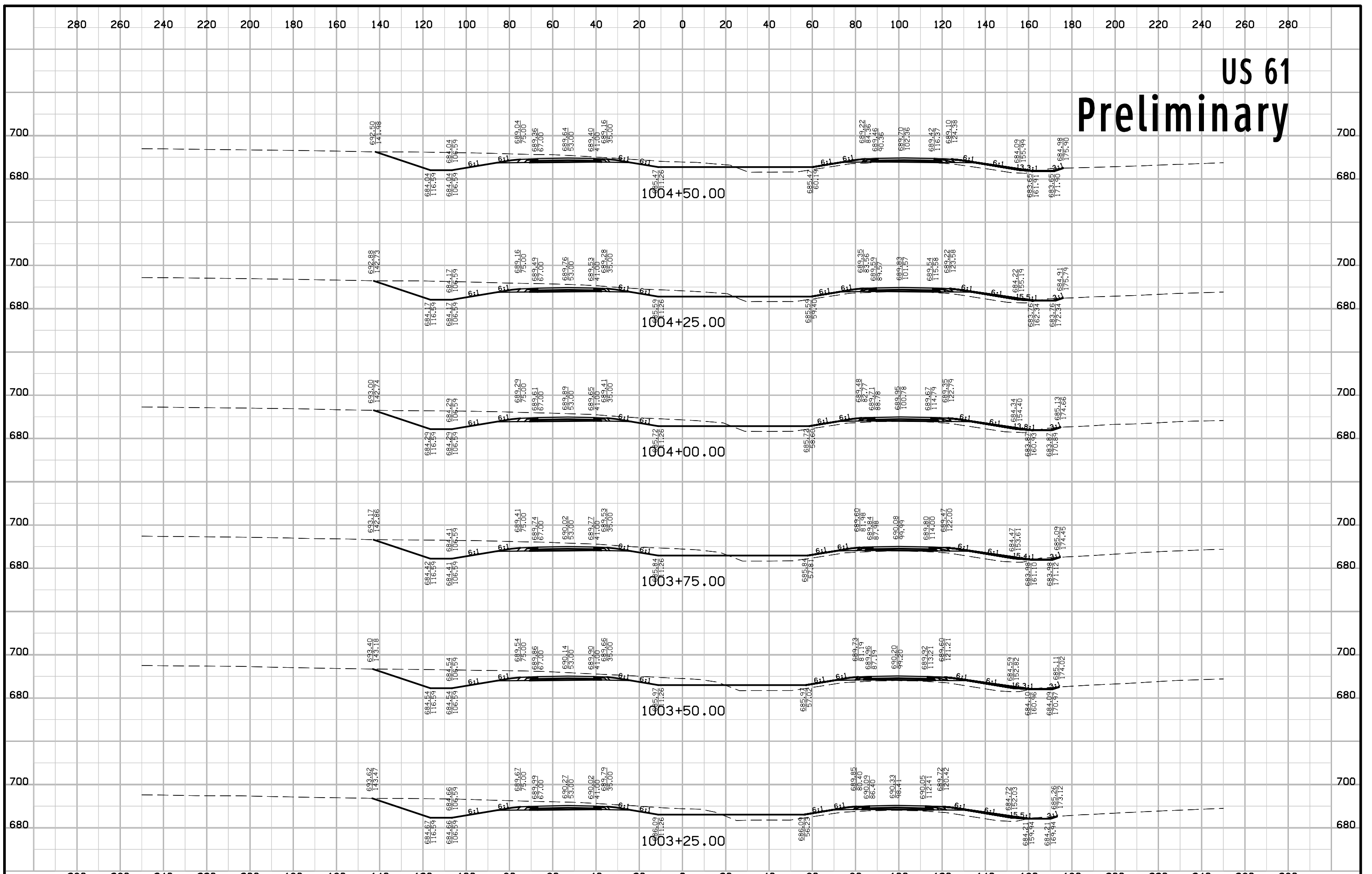

US 61 Preliminary

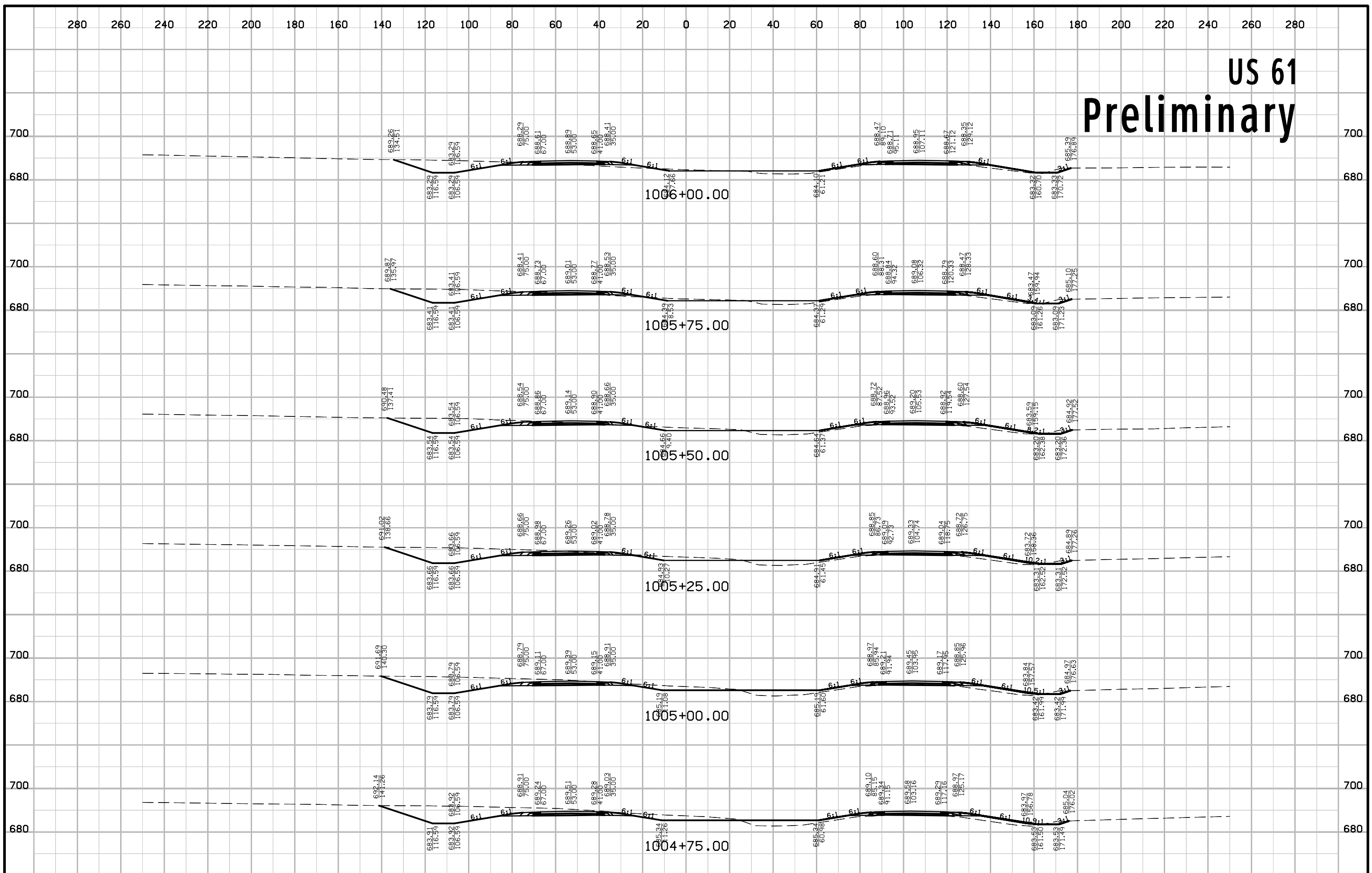

US 61 Preliminary

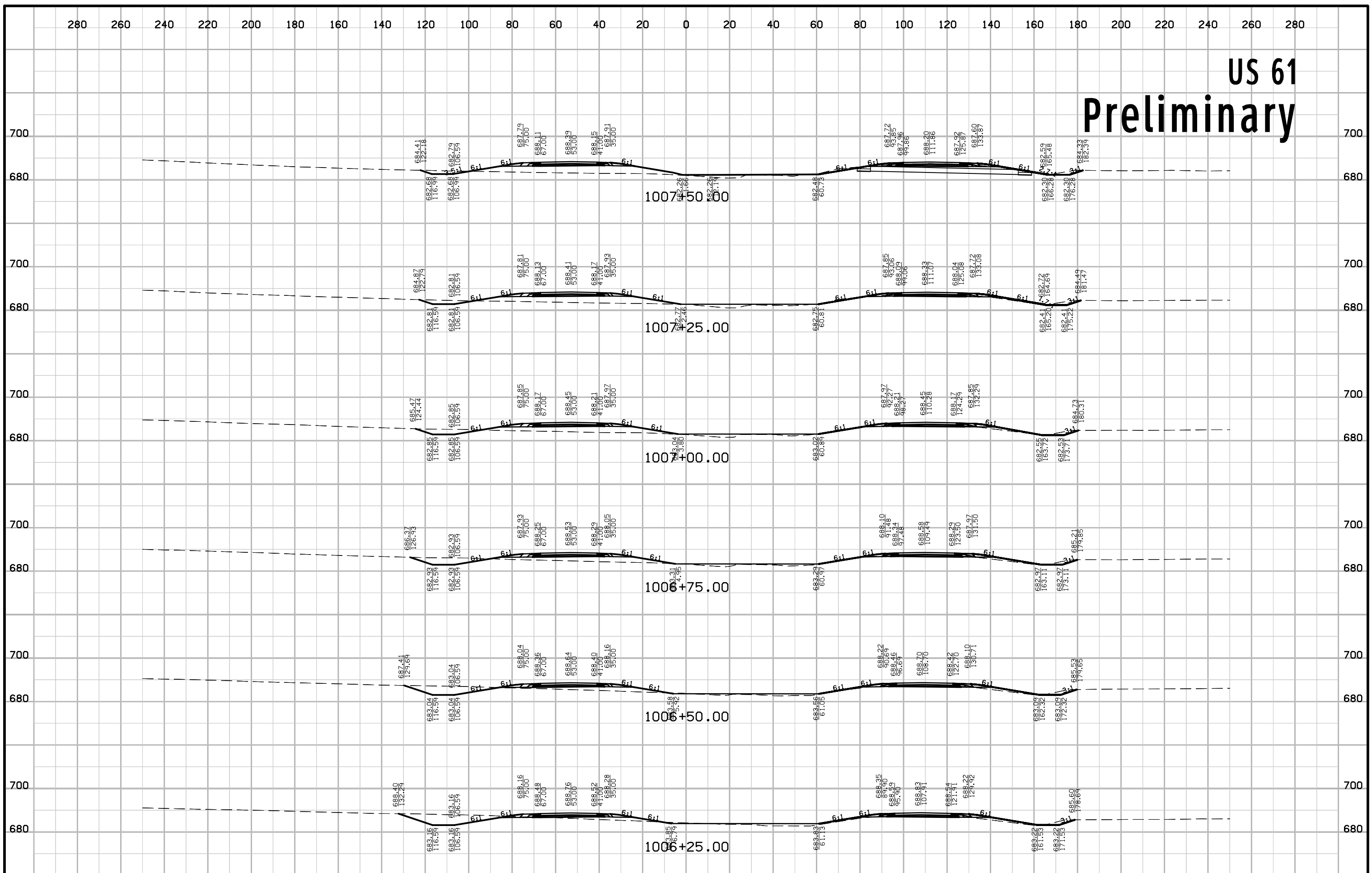

US 61 Preliminary

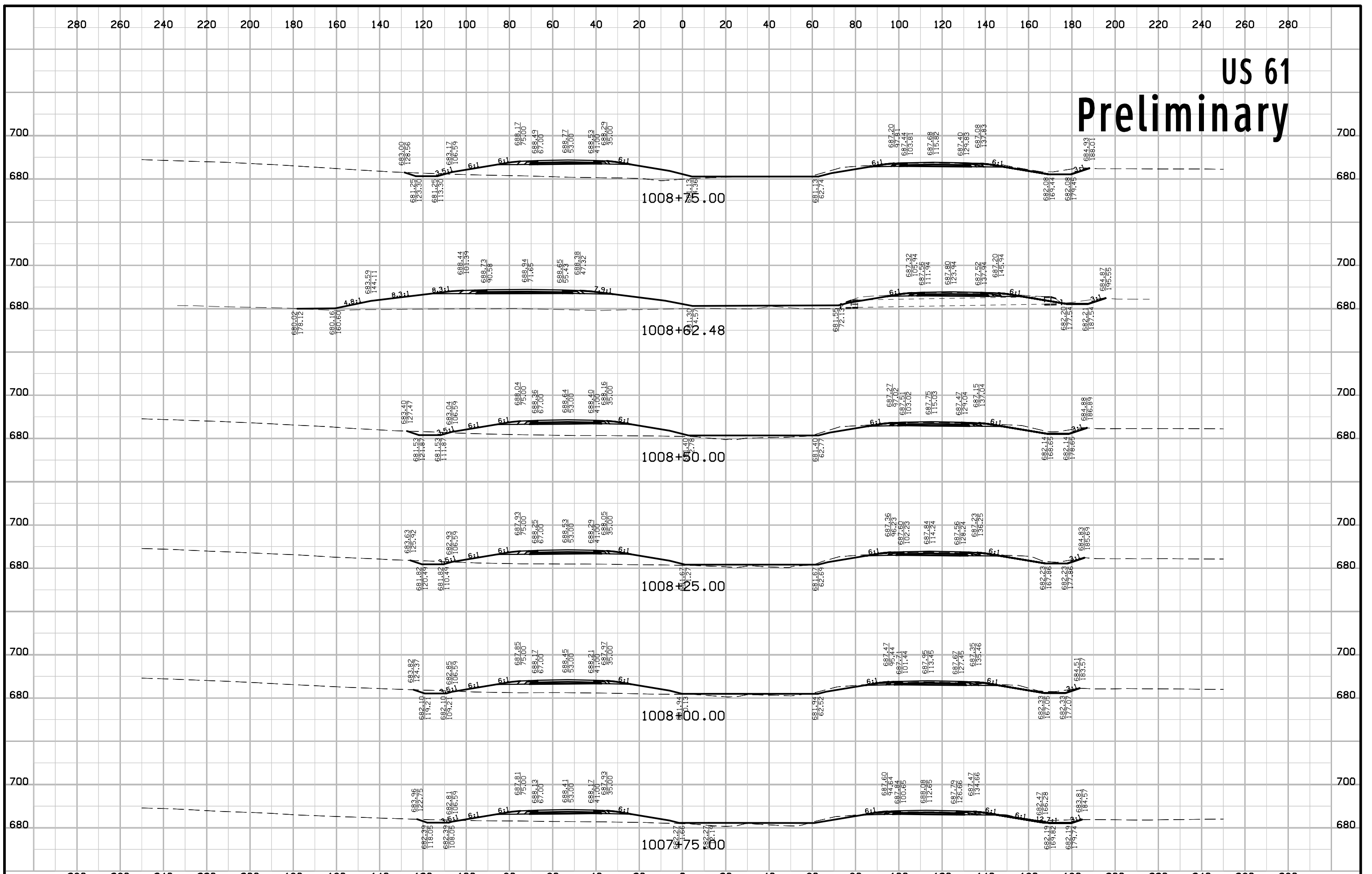

US 61 Preliminary

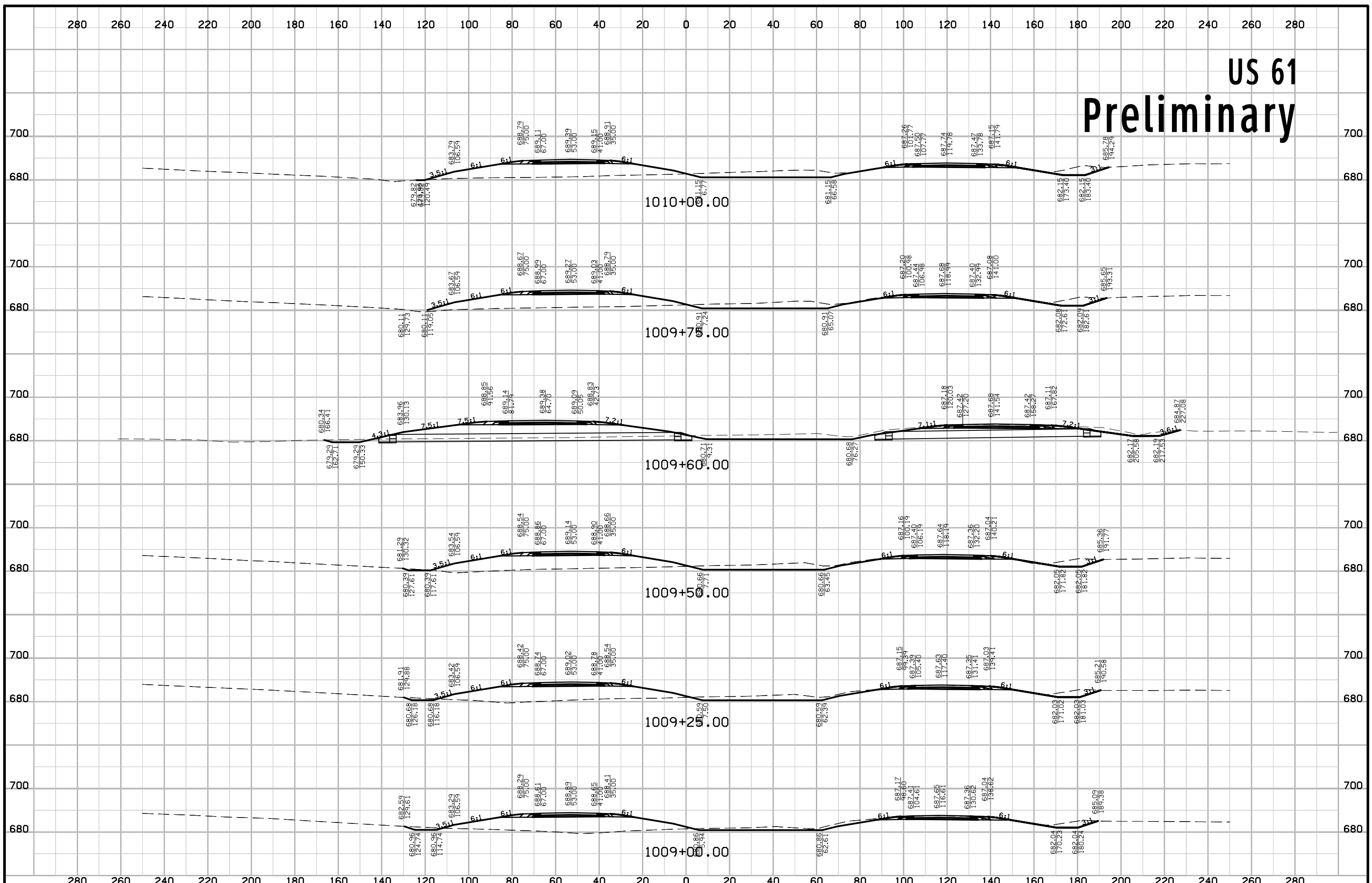

US 61 Preliminary

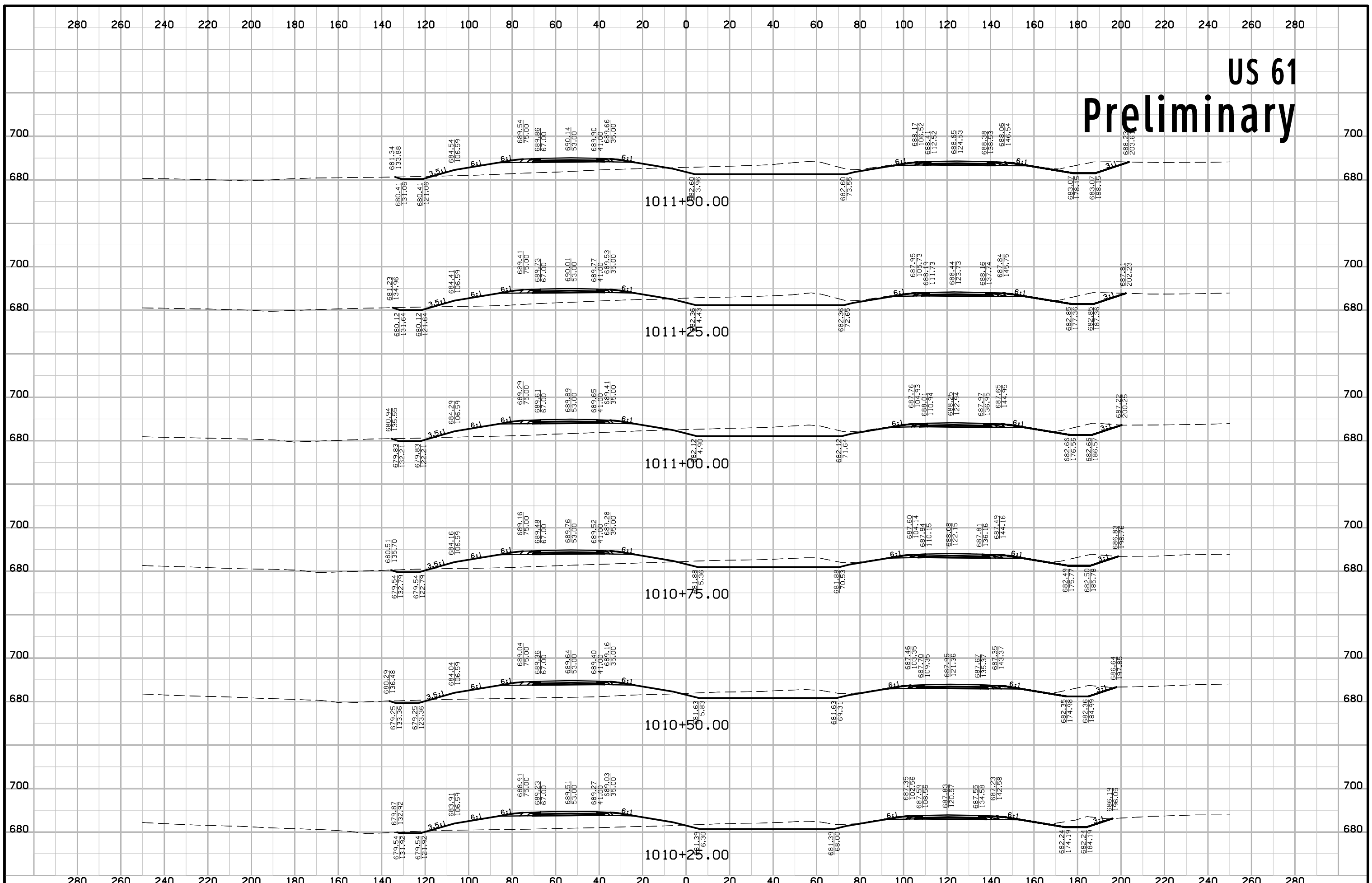

US 61 Preliminary

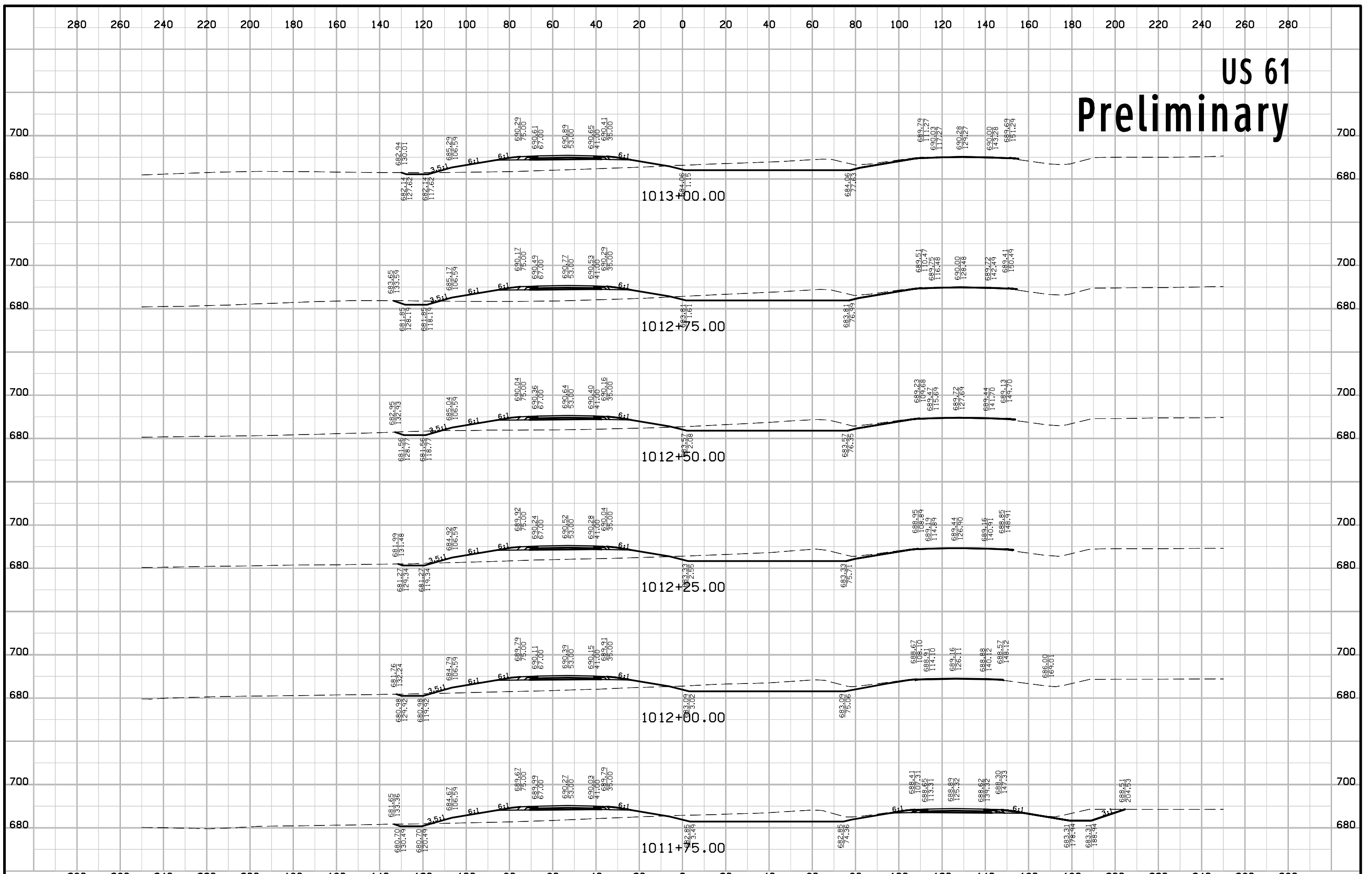

US 61 Preliminary

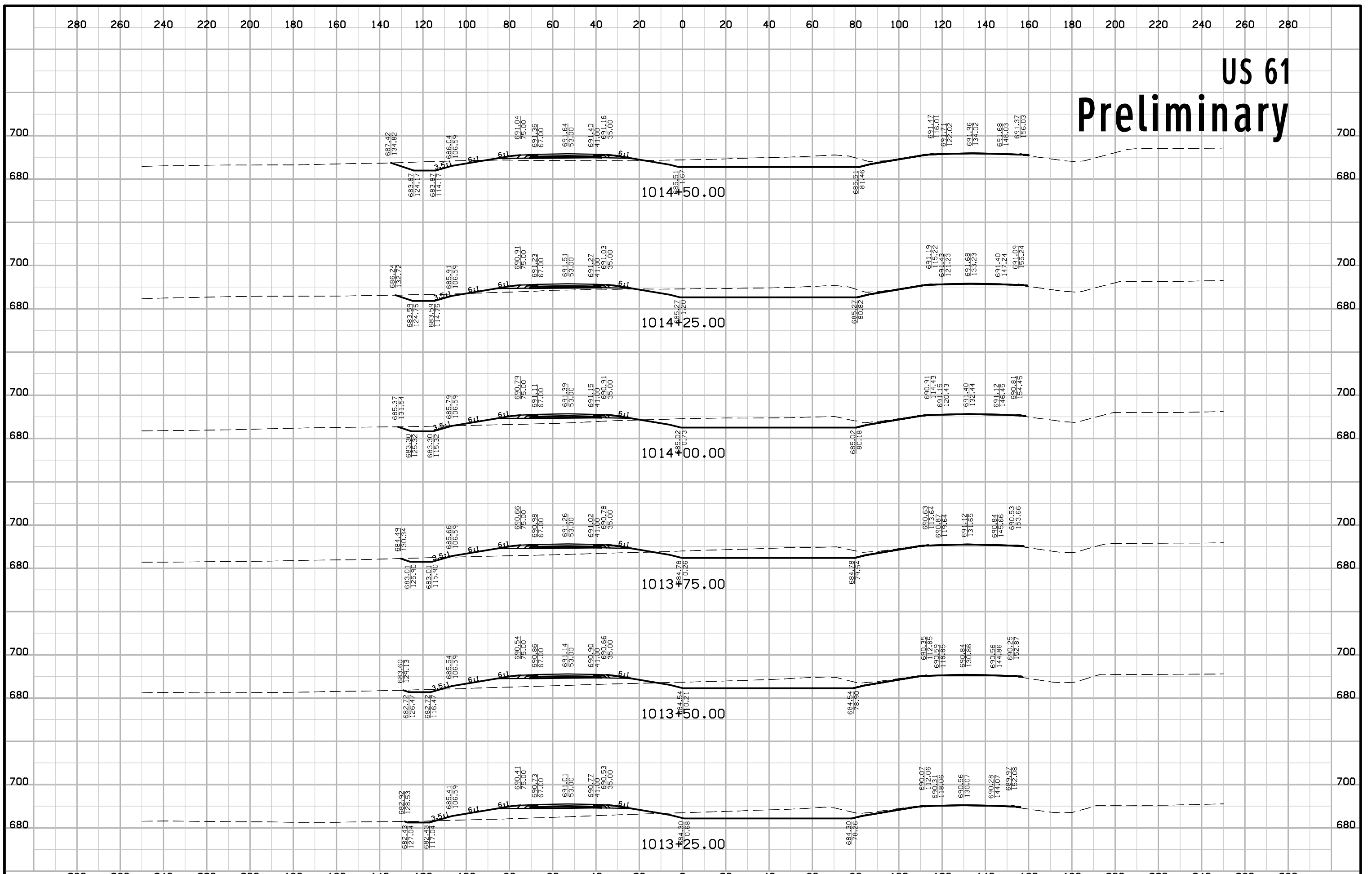

US 61 Preliminary

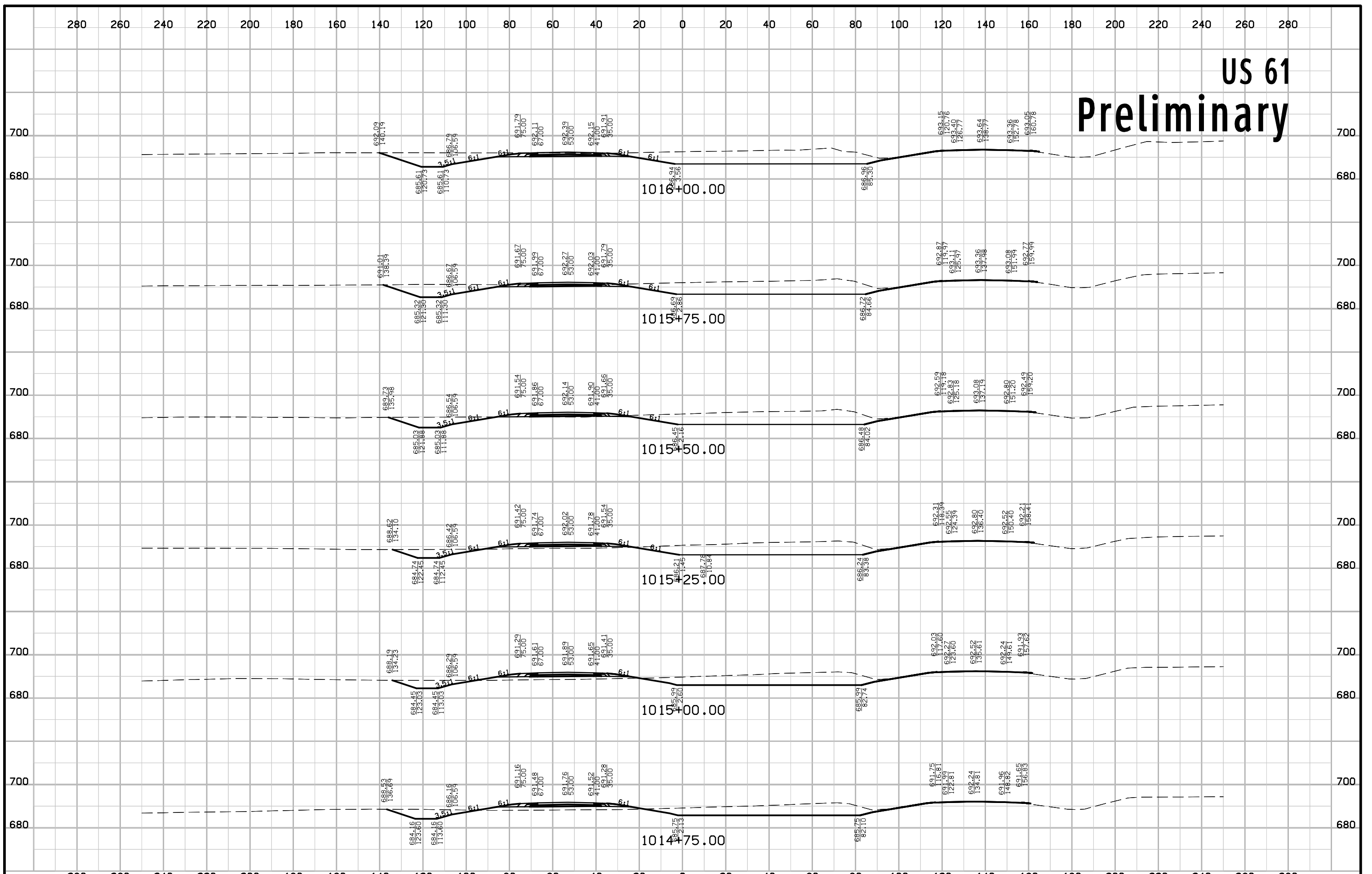

US 61 Preliminary

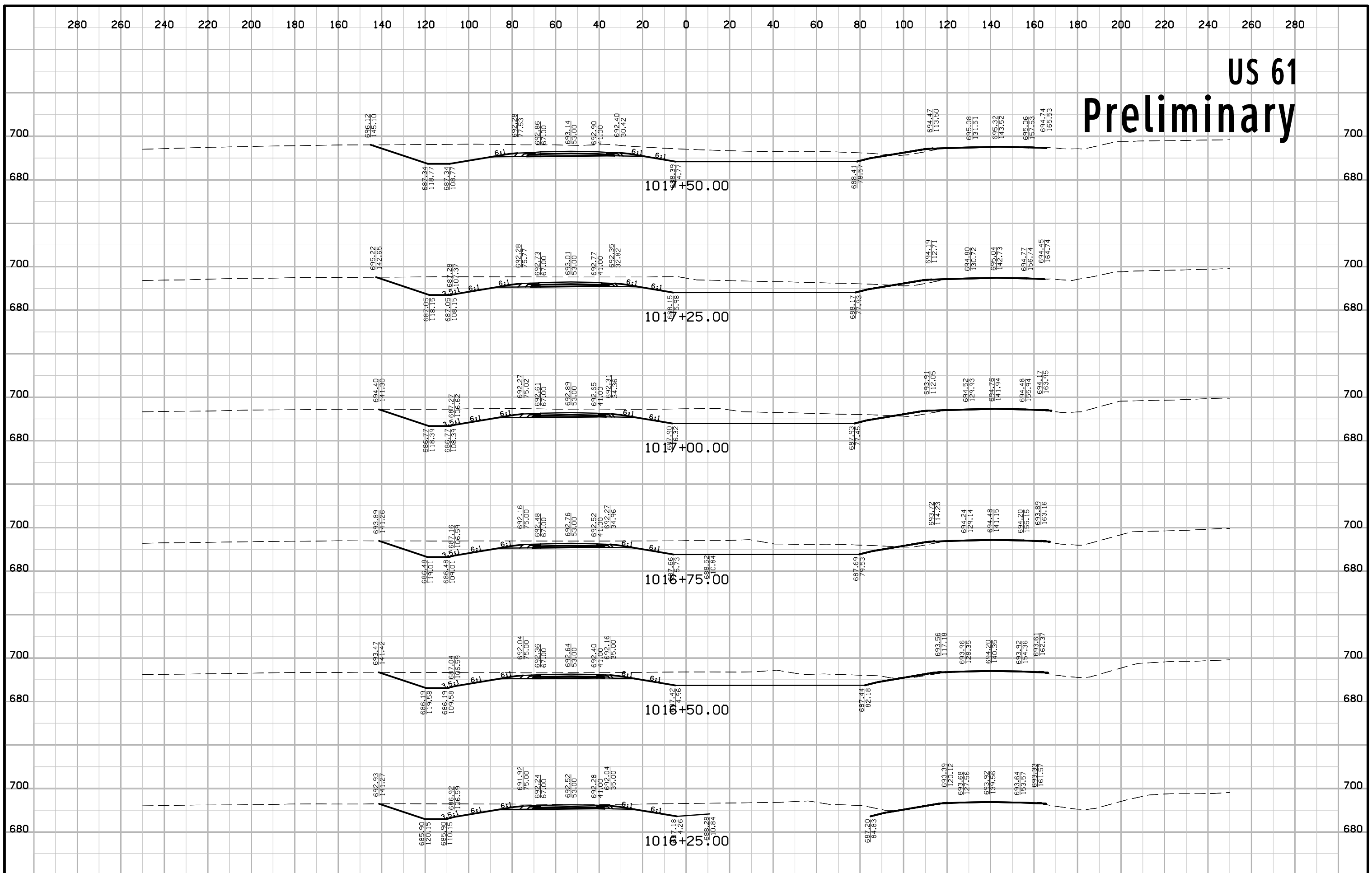

US 61 Preliminary

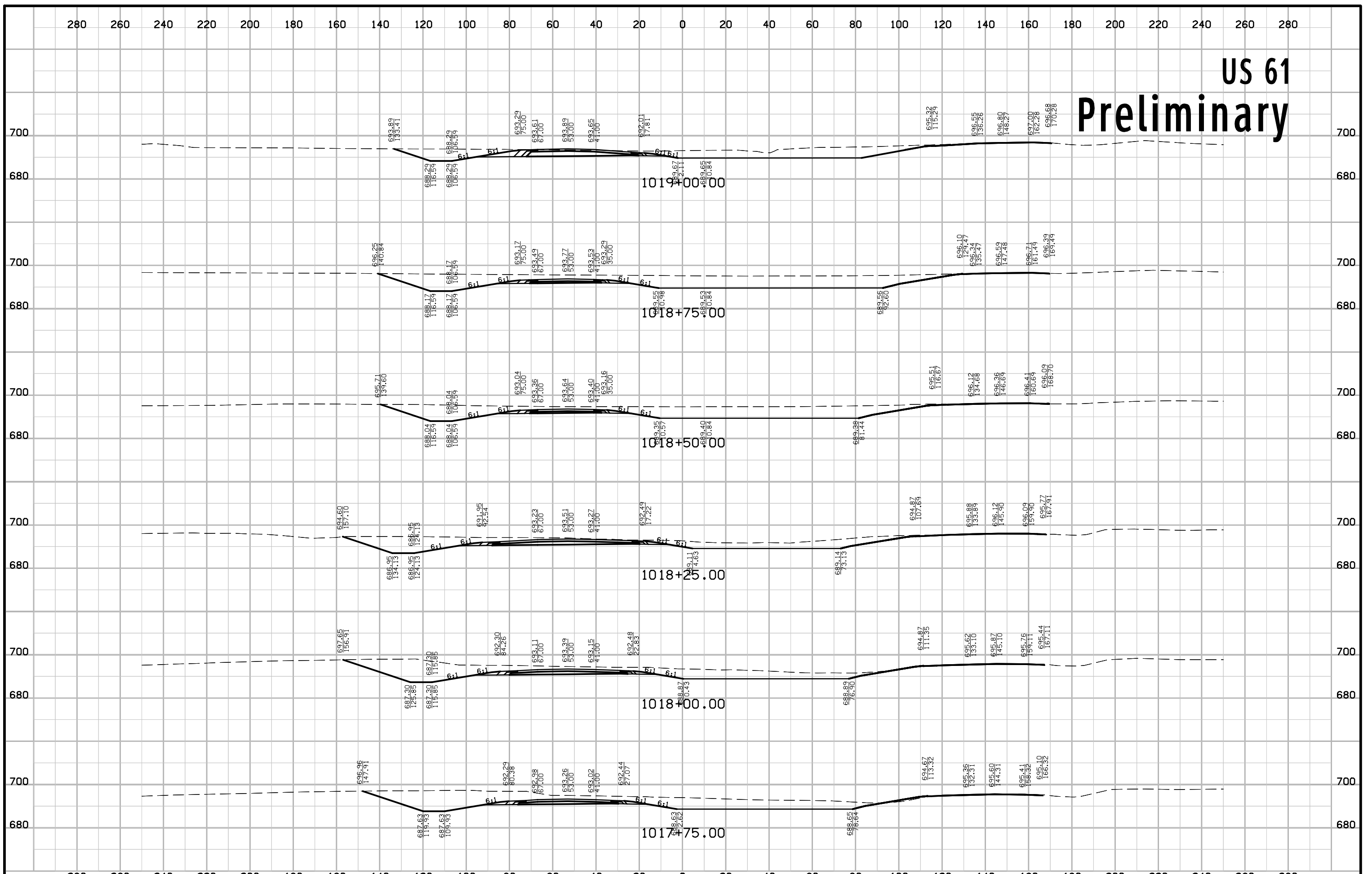

US 61 Preliminary

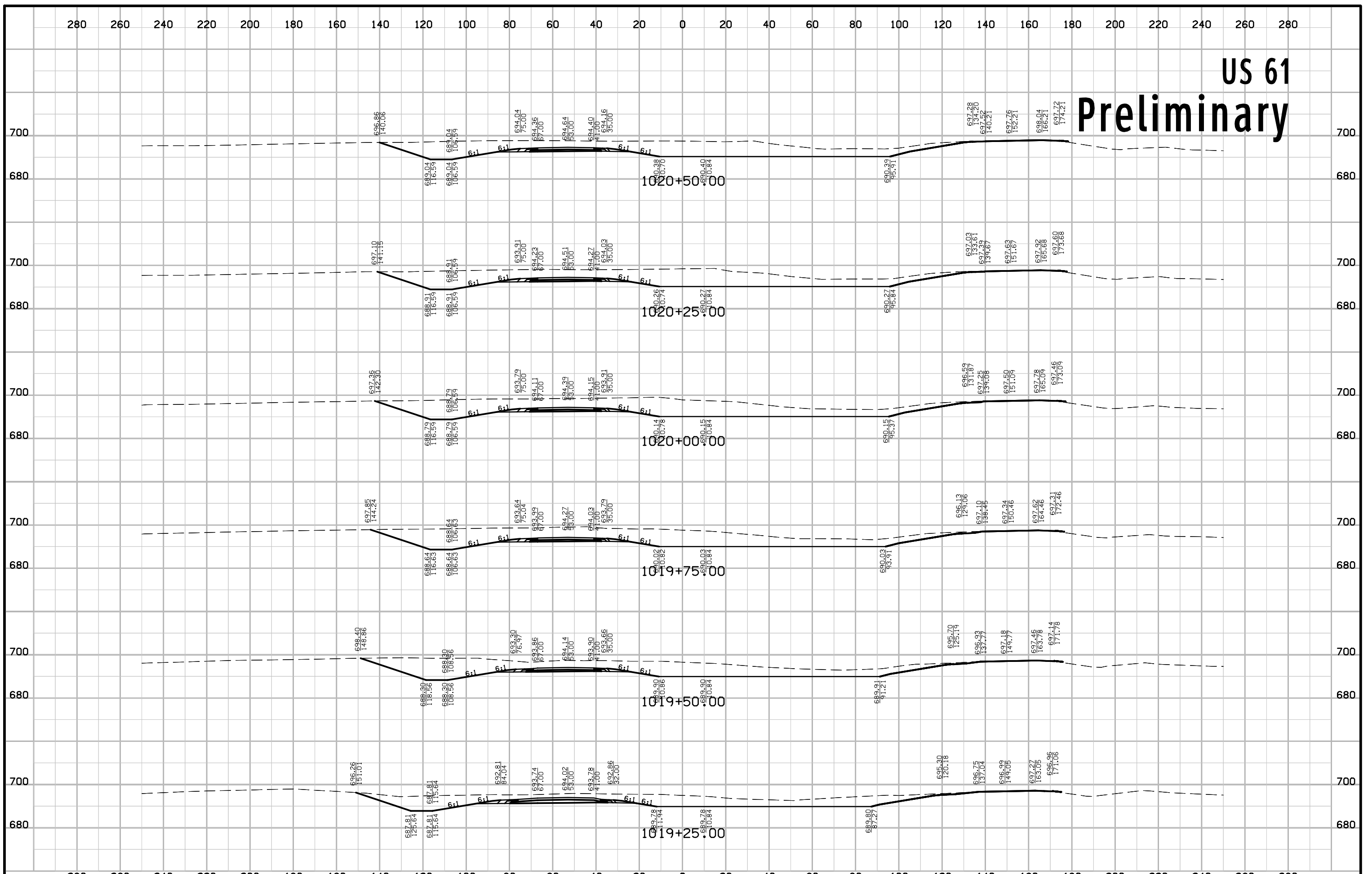

US 61 Preliminary

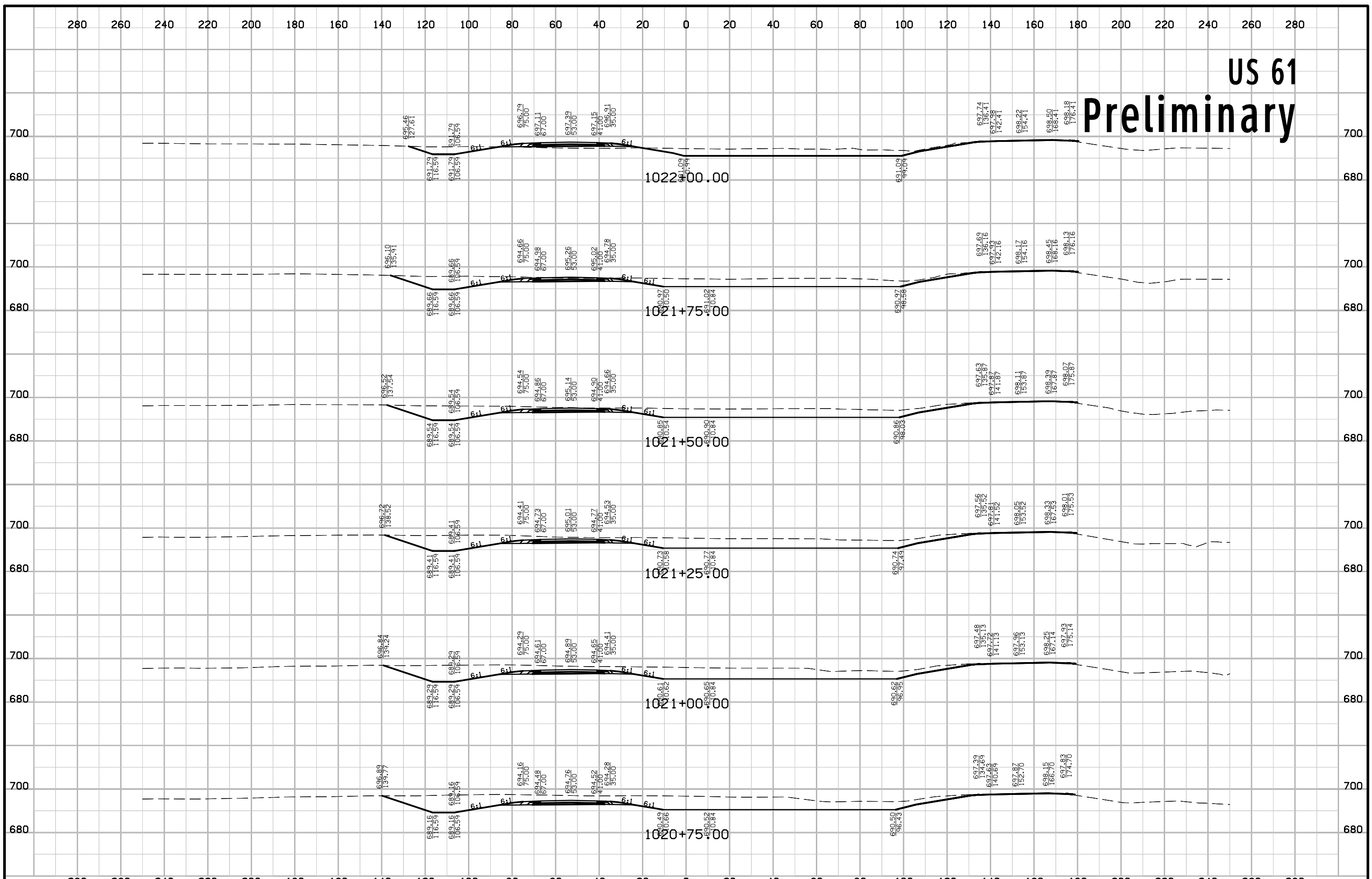

US 61

Preliminary

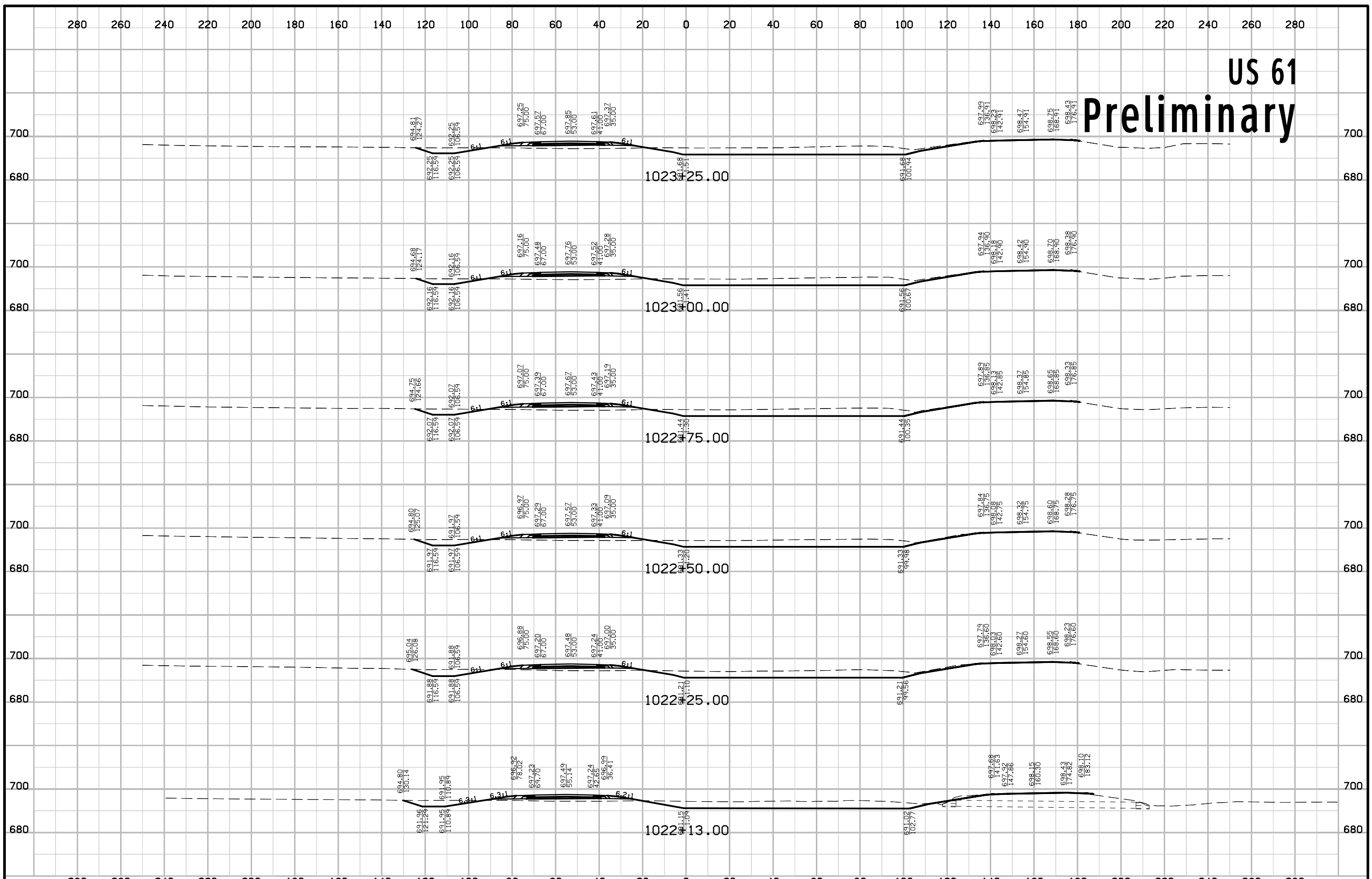

US 61

Preliminary

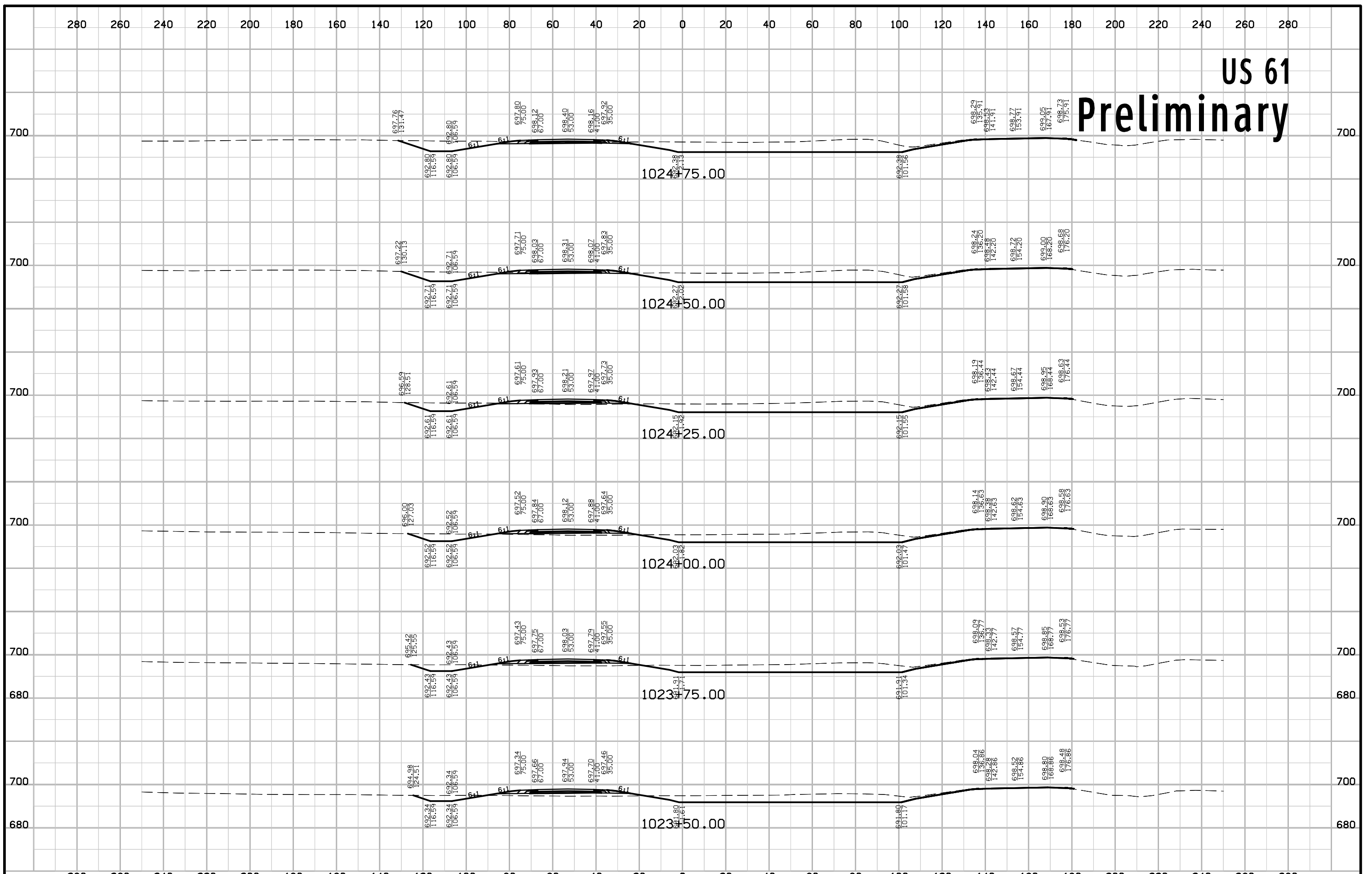

US 61 Preliminary

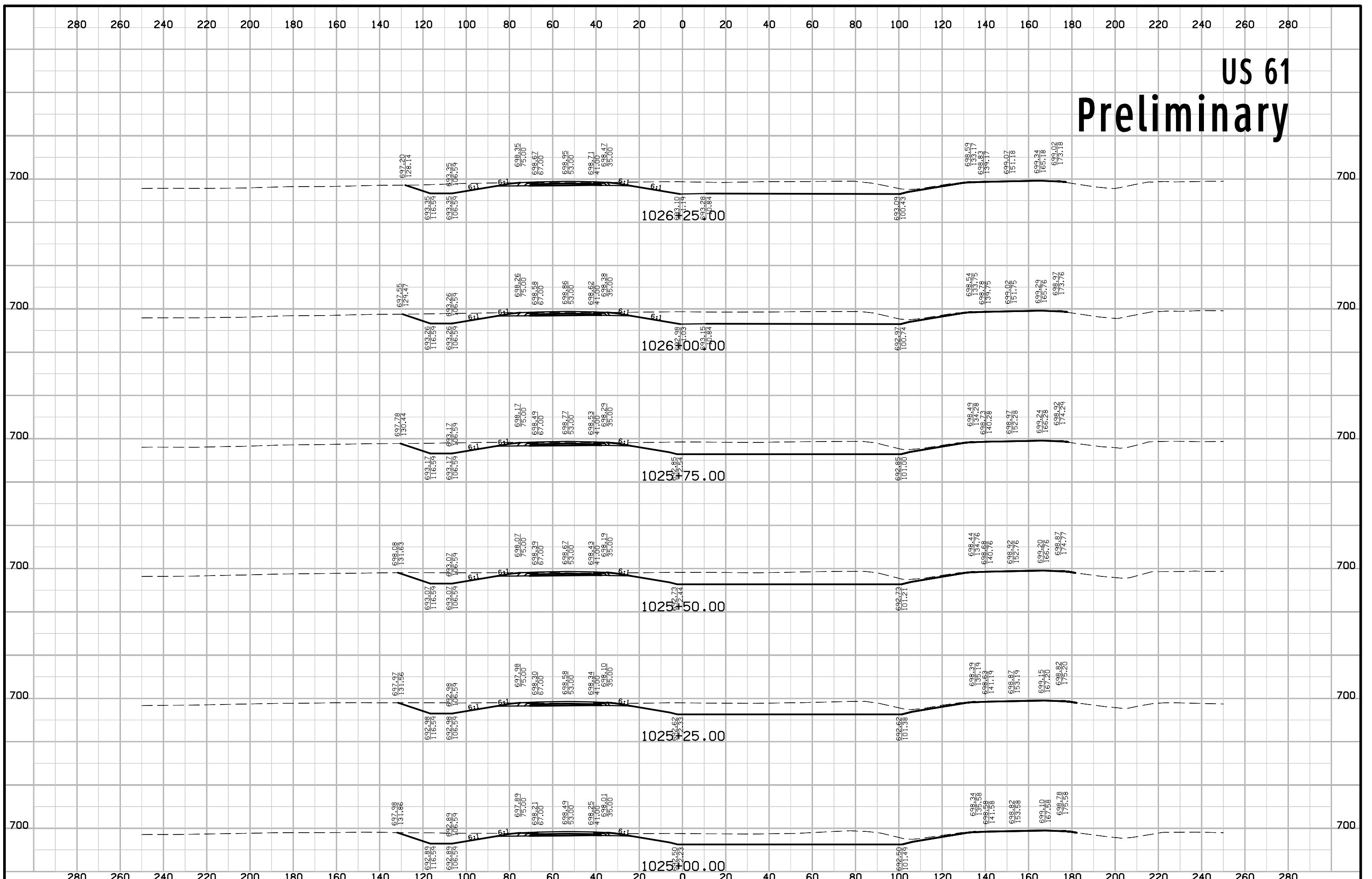

US 61 Preliminary

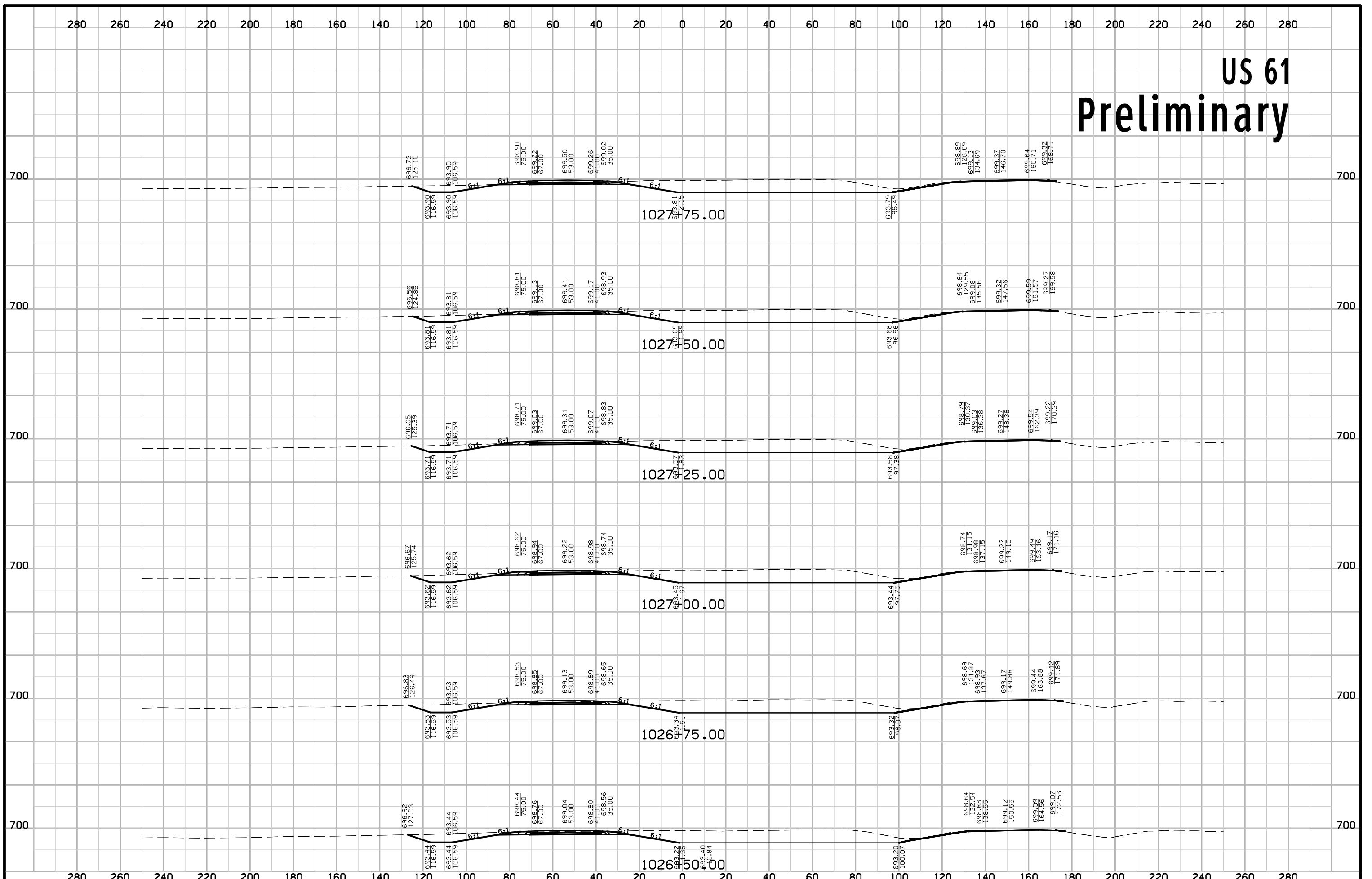

US 61 Preliminary

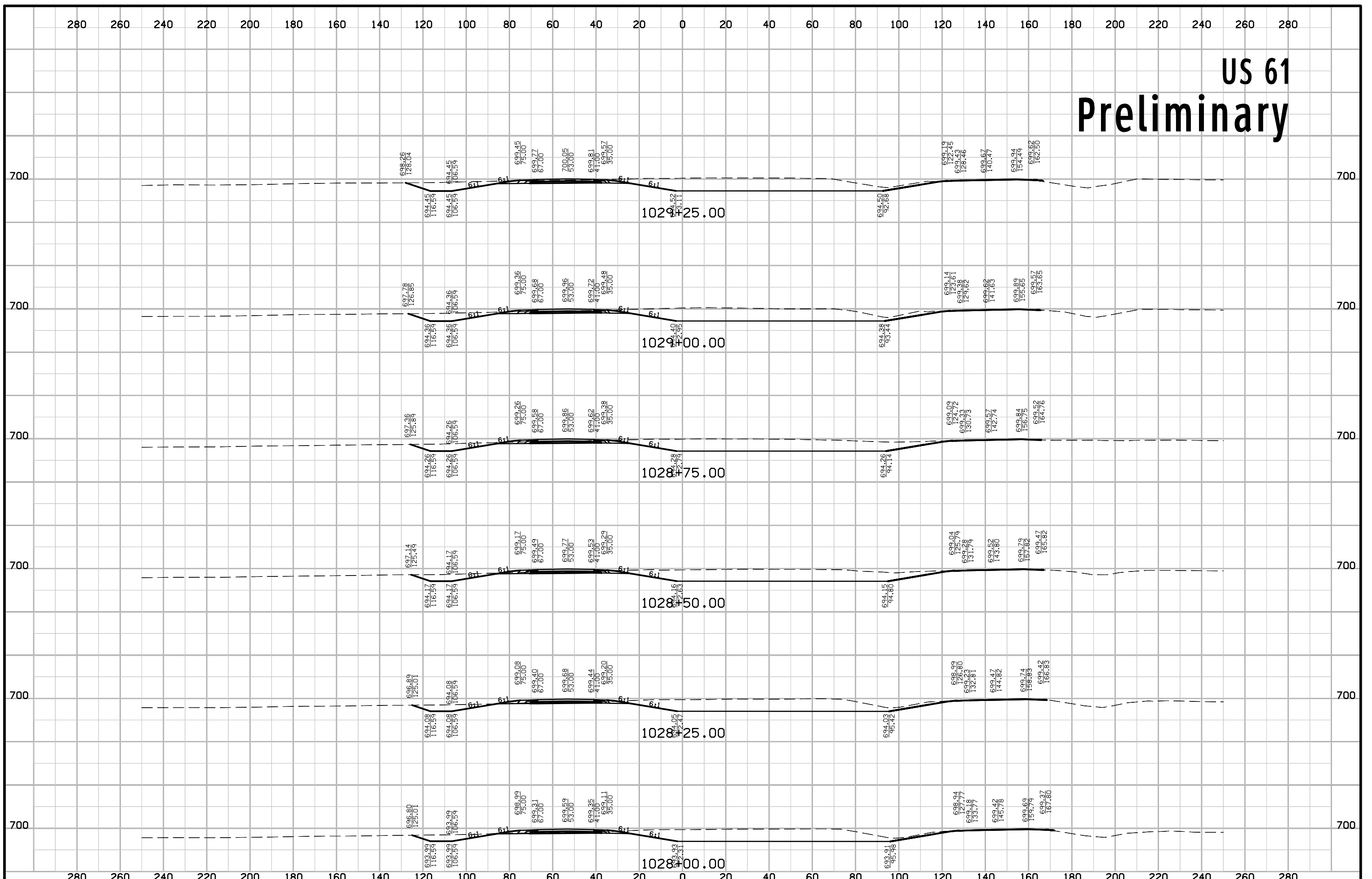

US 61 Preliminary

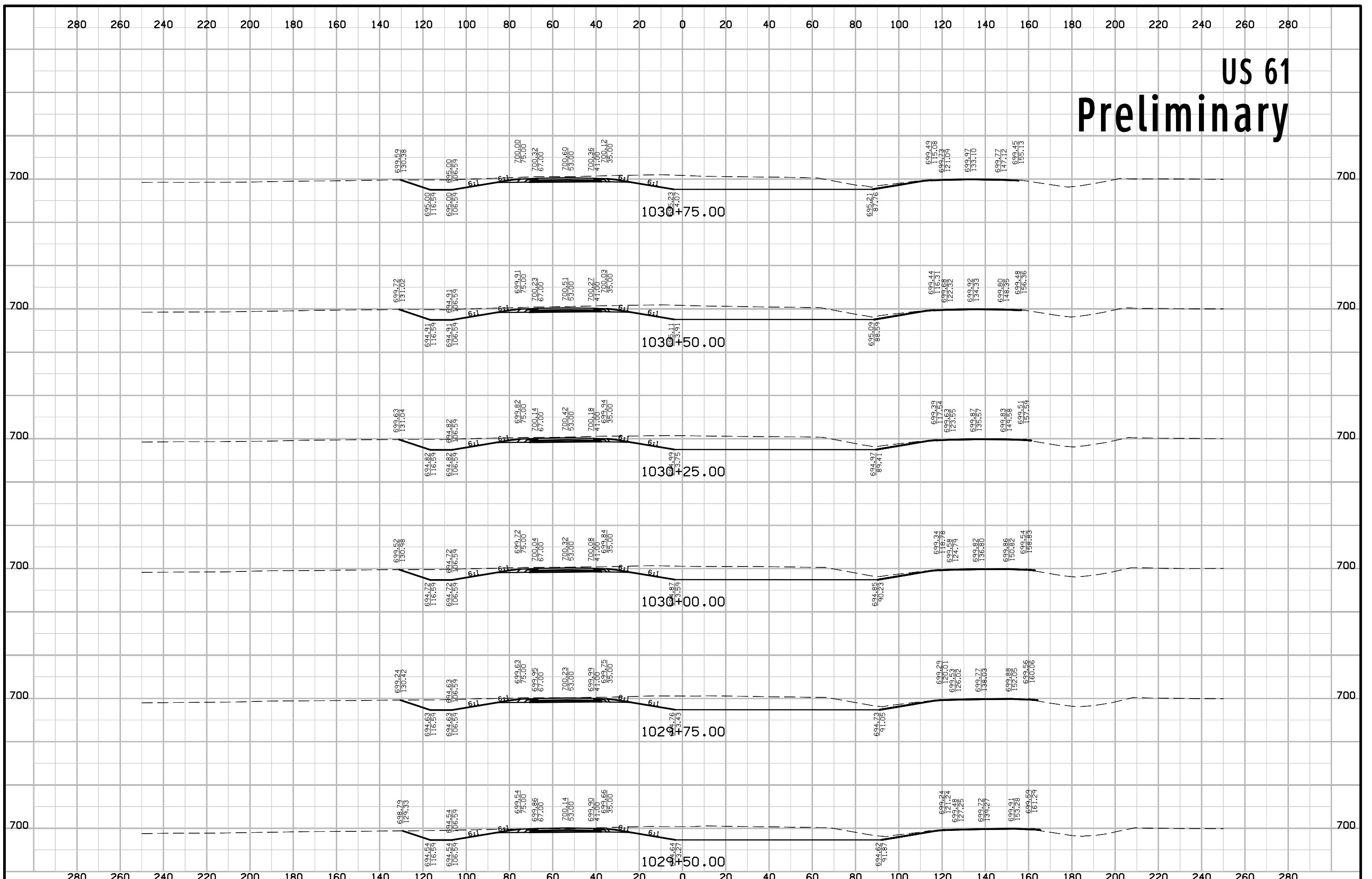

US 61 Preliminary

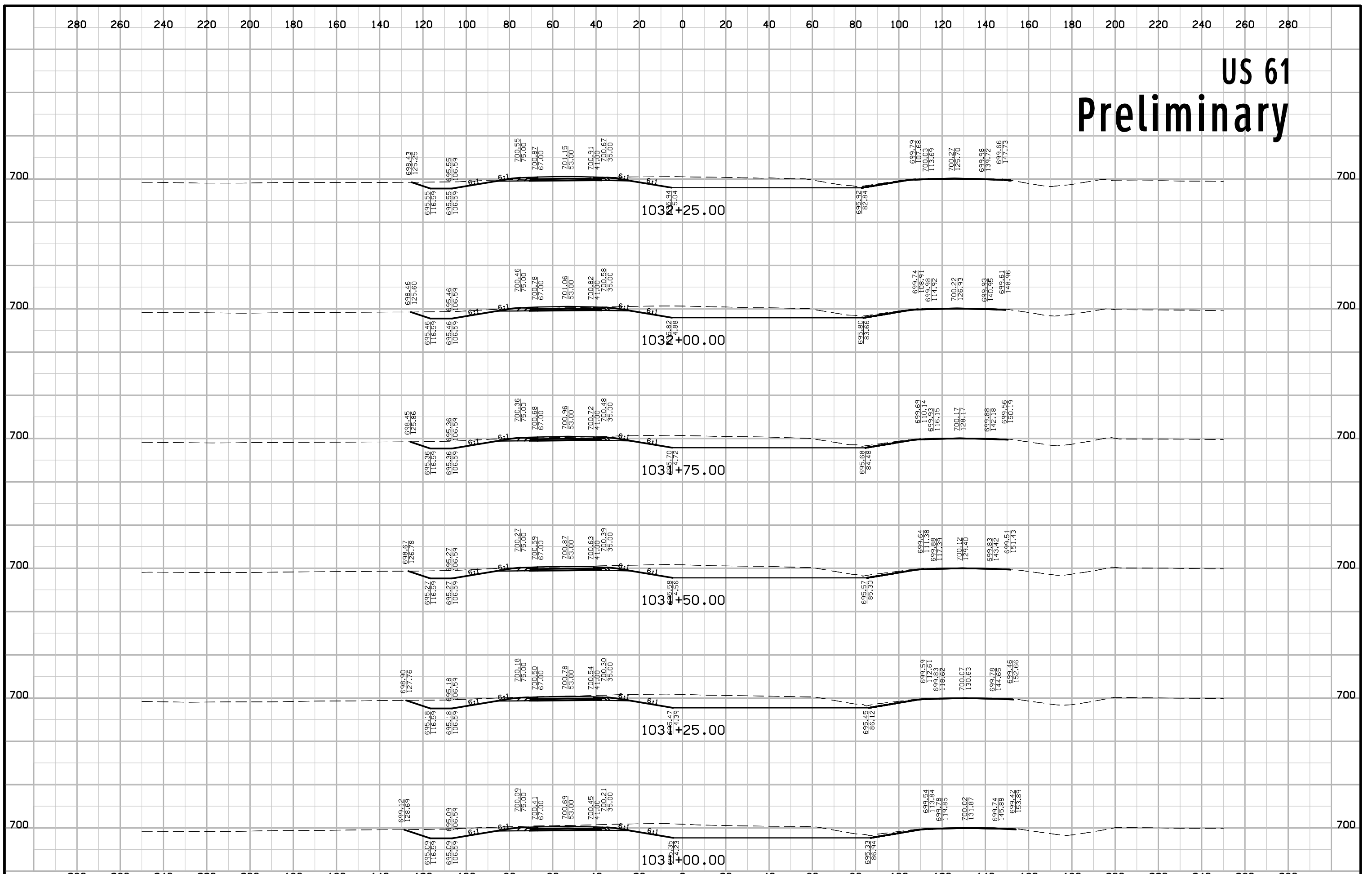

US 61 Preliminary

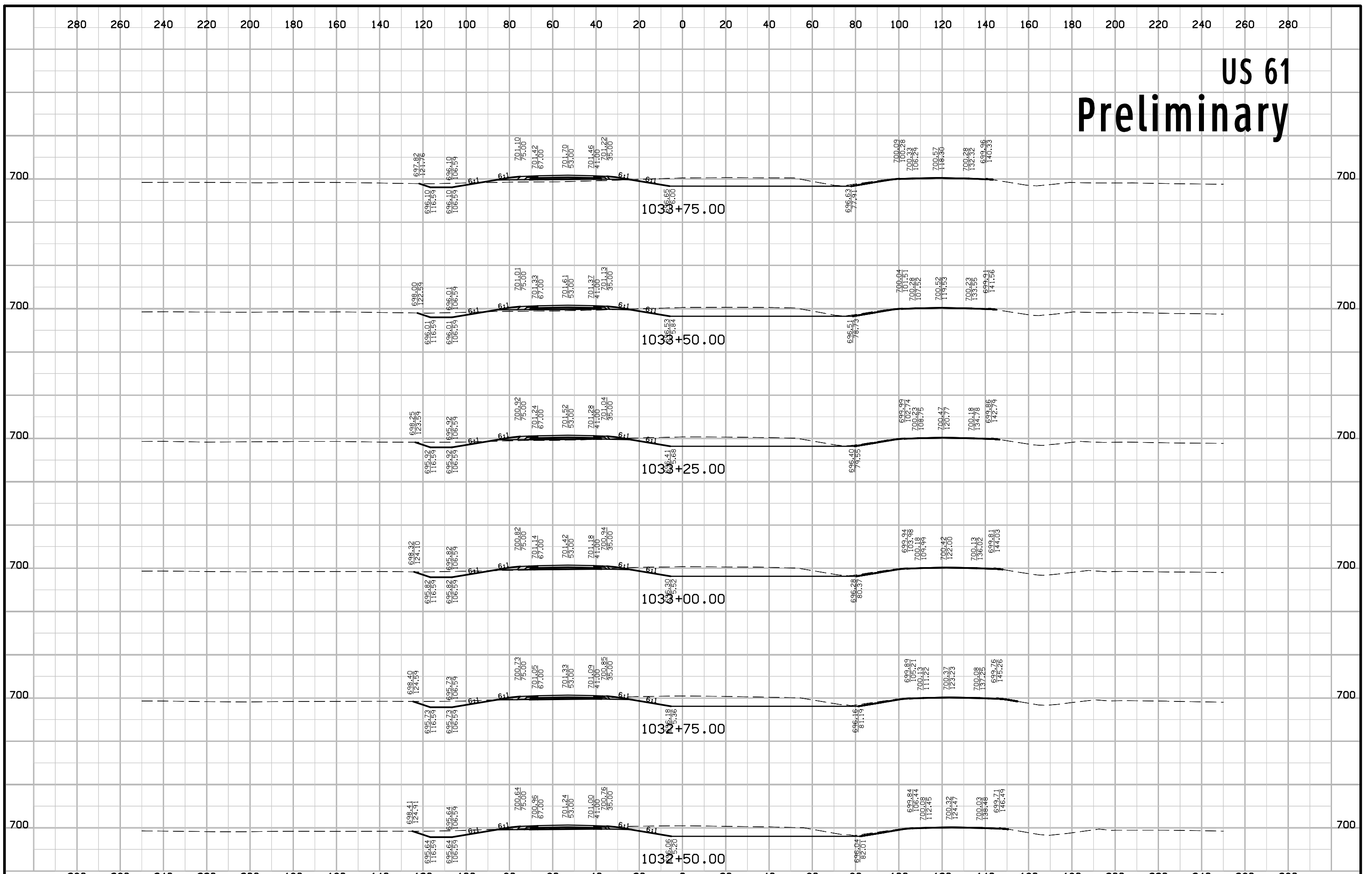

US 61 Preliminary

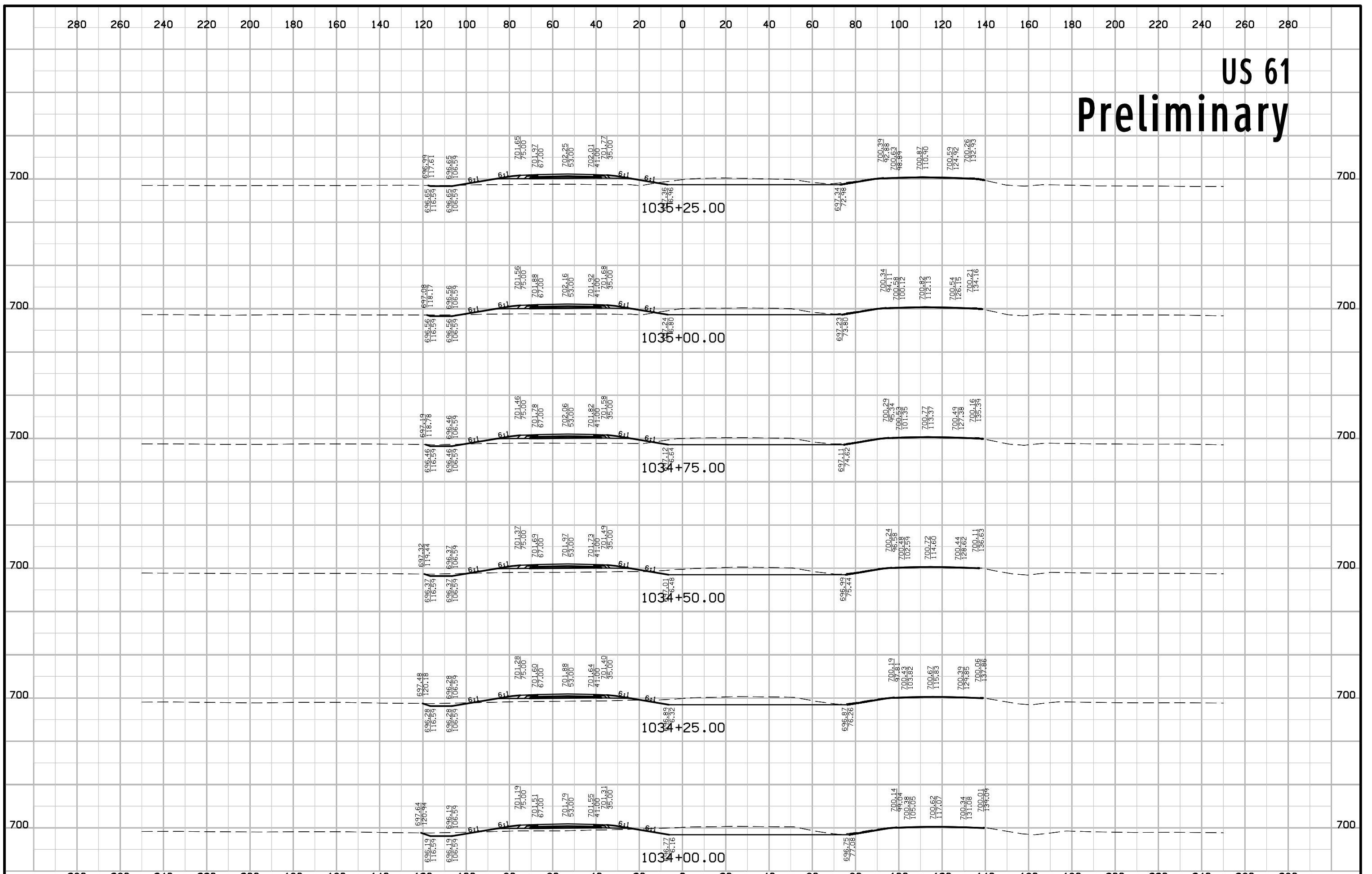

US 61 Preliminary

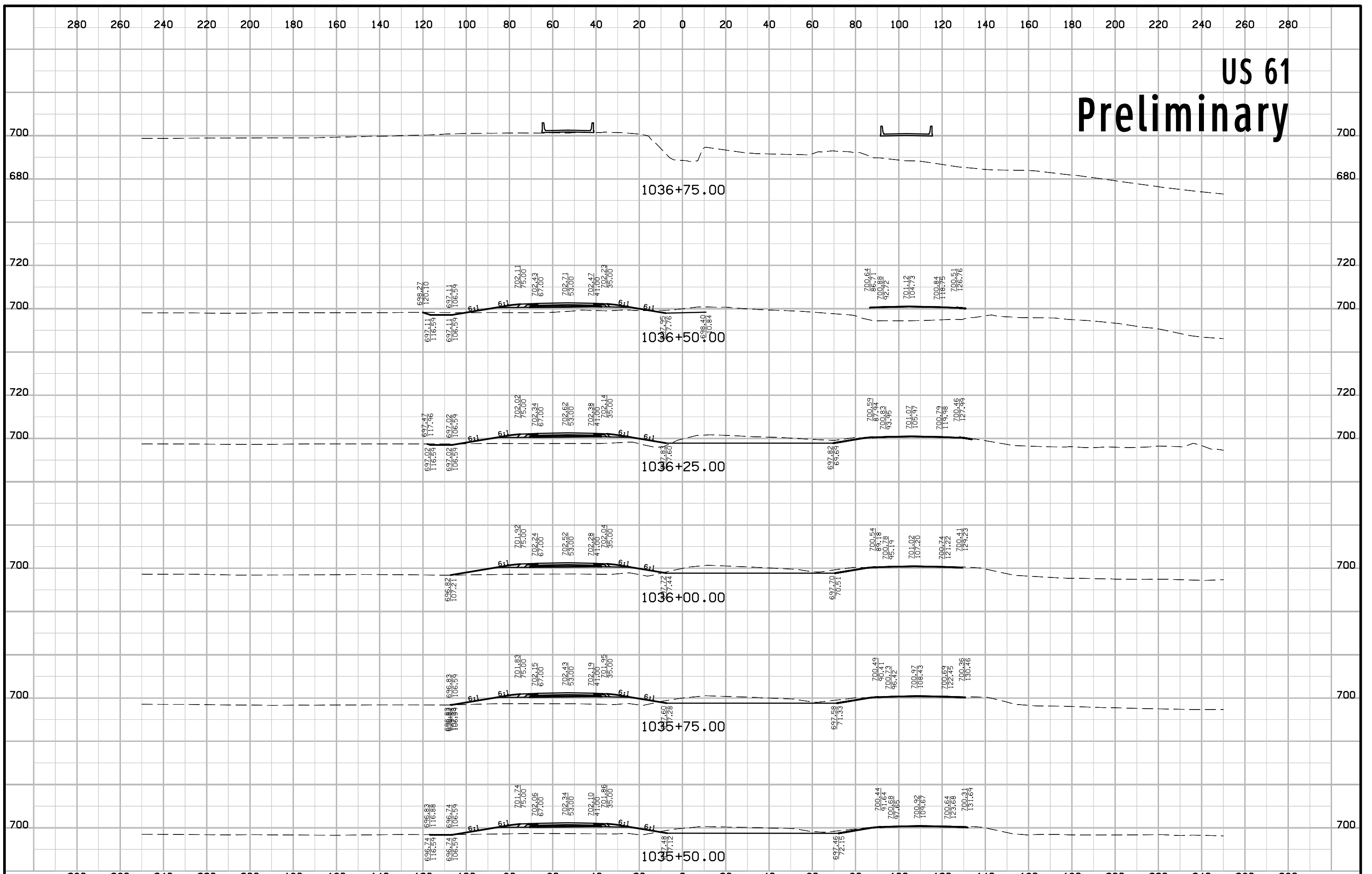

US 61 Preliminary

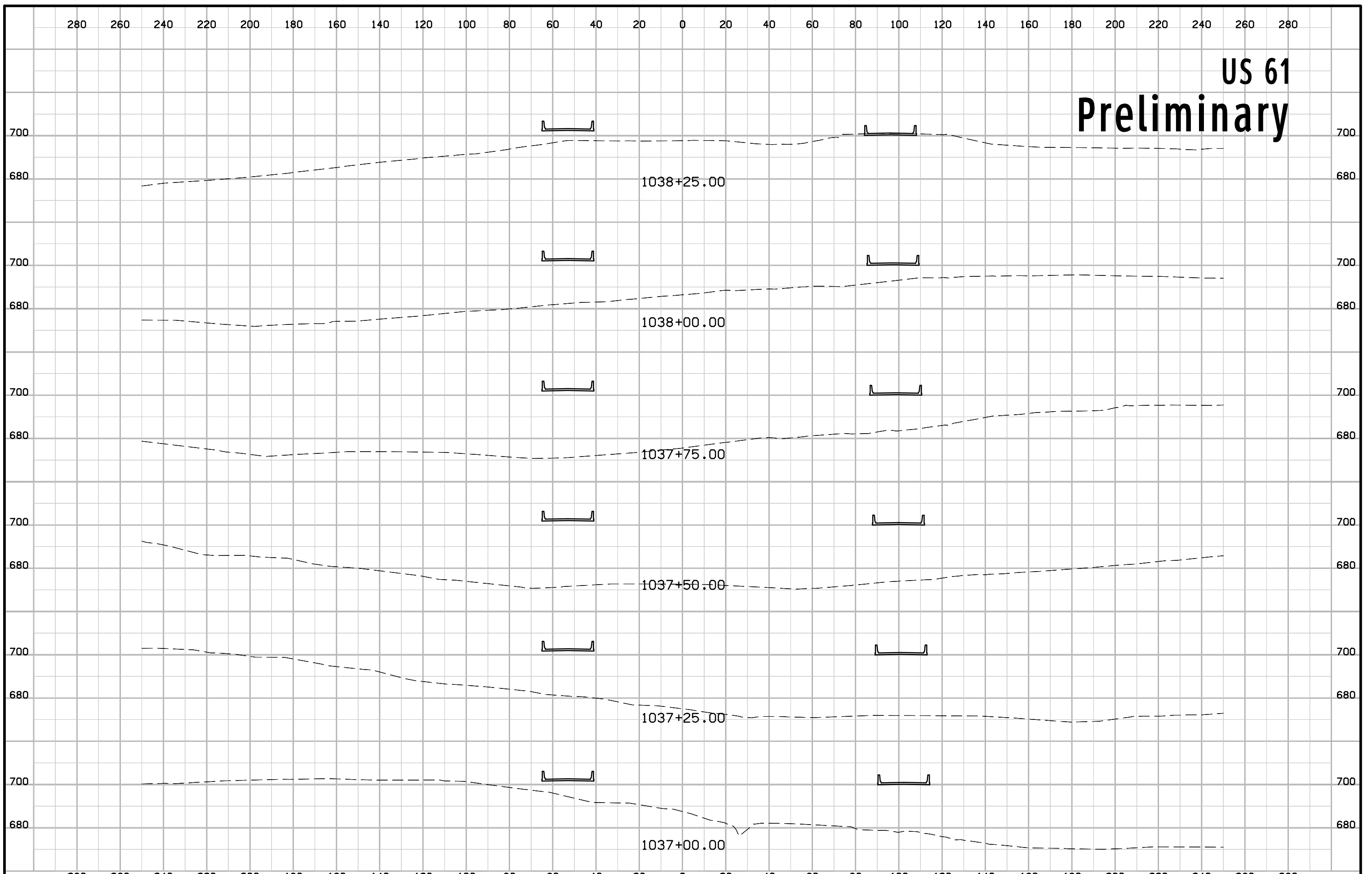

US 61 Preliminary

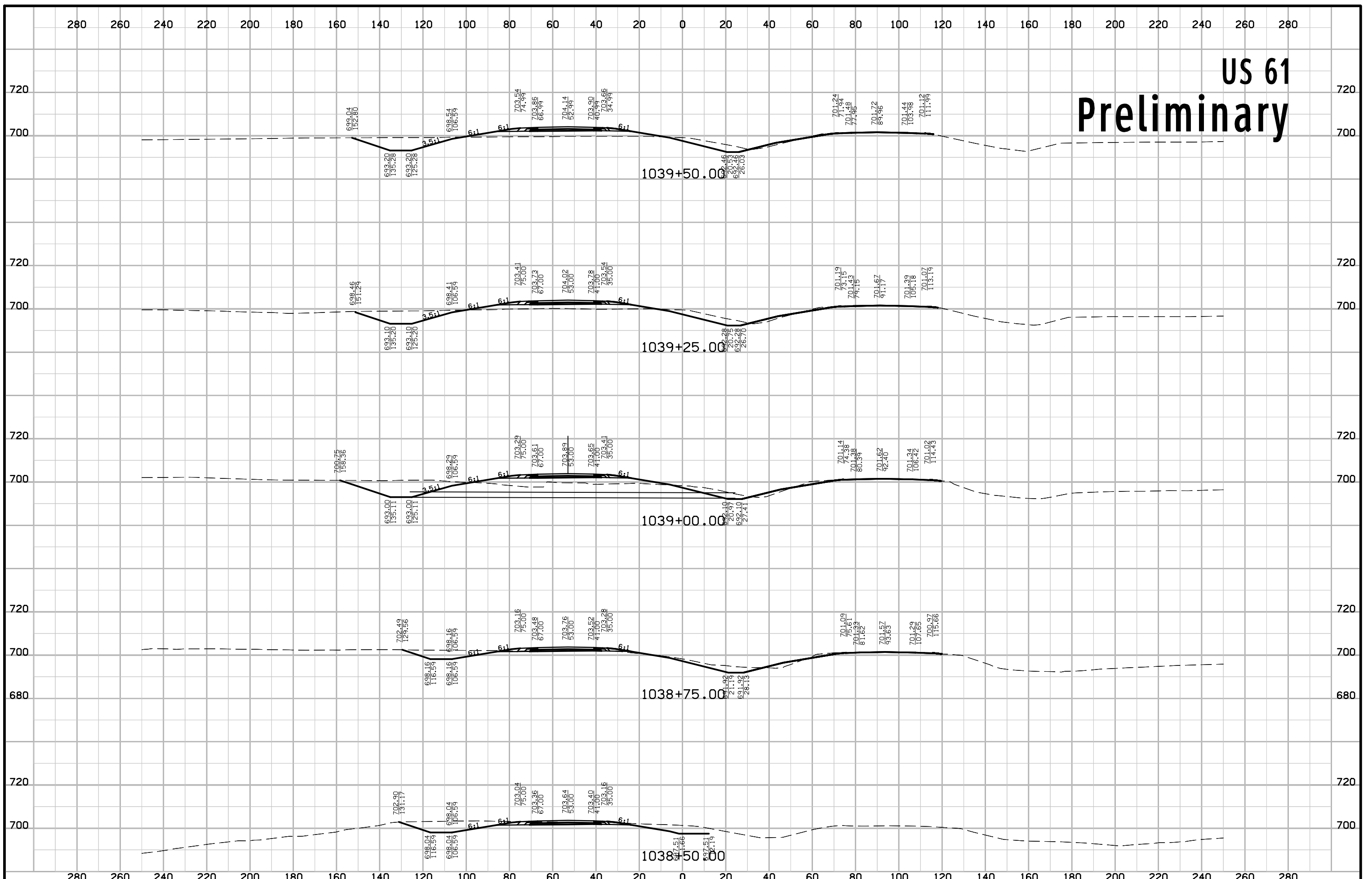

US 61 Preliminary

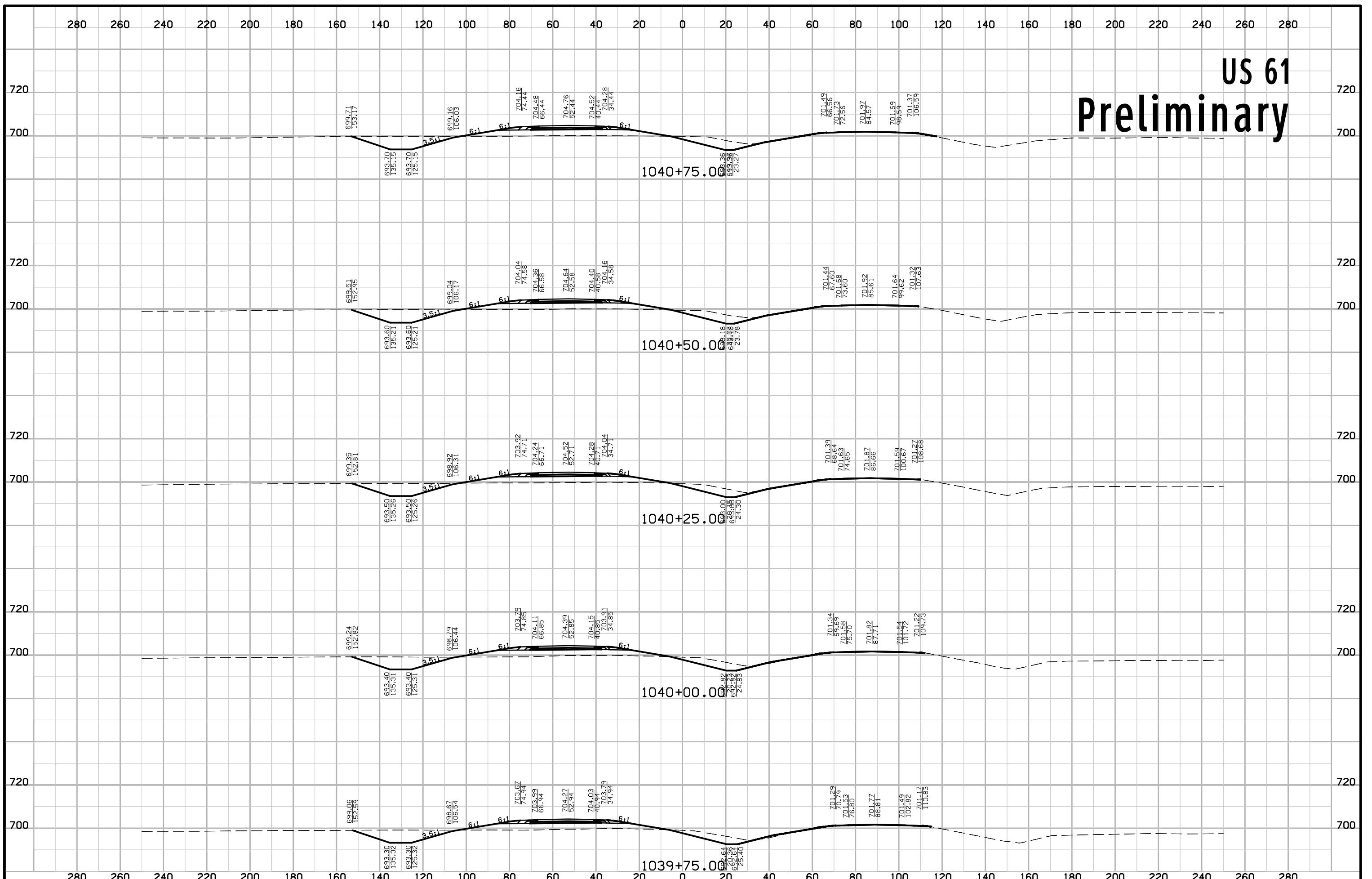

US 61 Preliminary

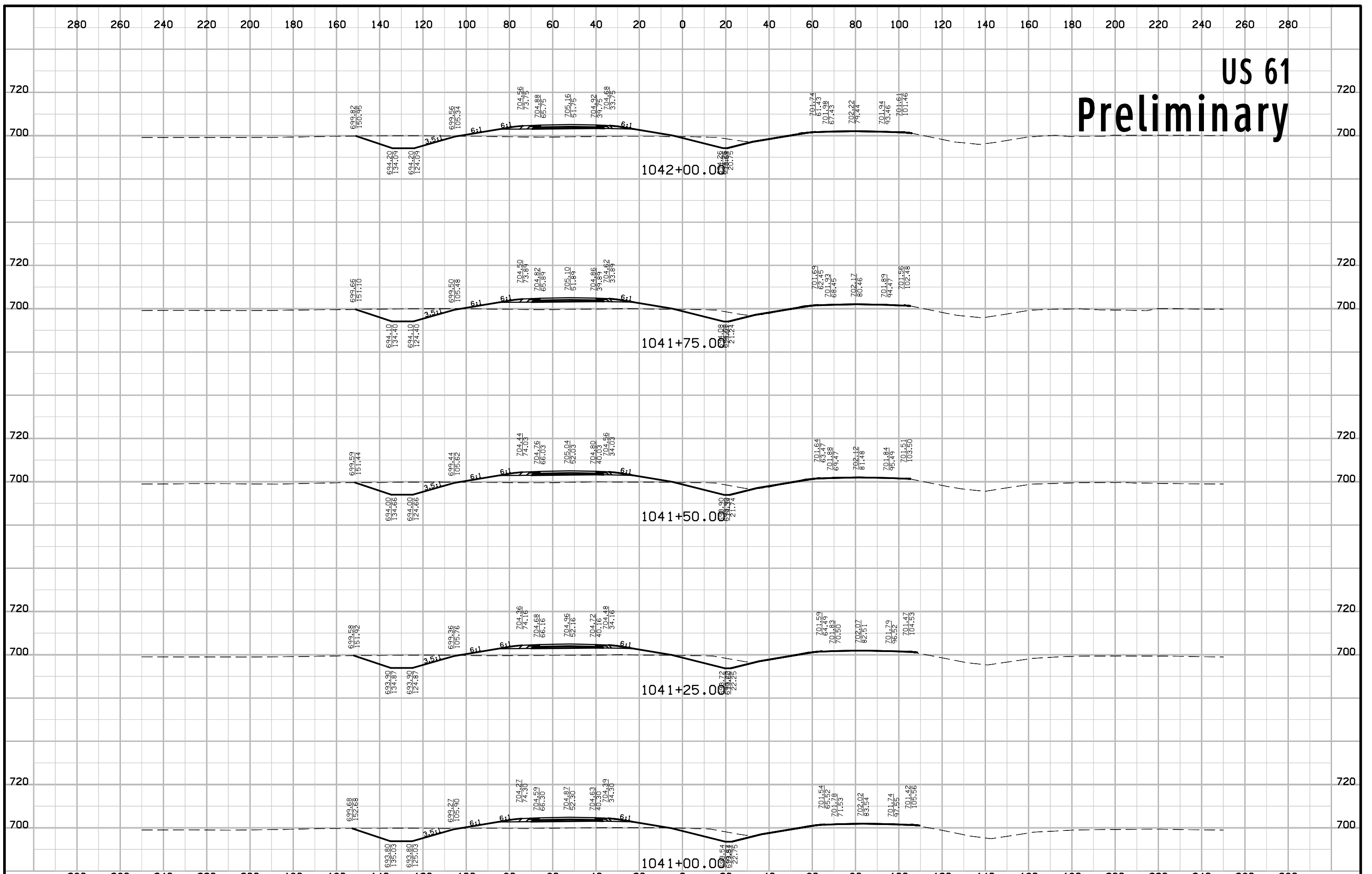

US 61 Preliminary

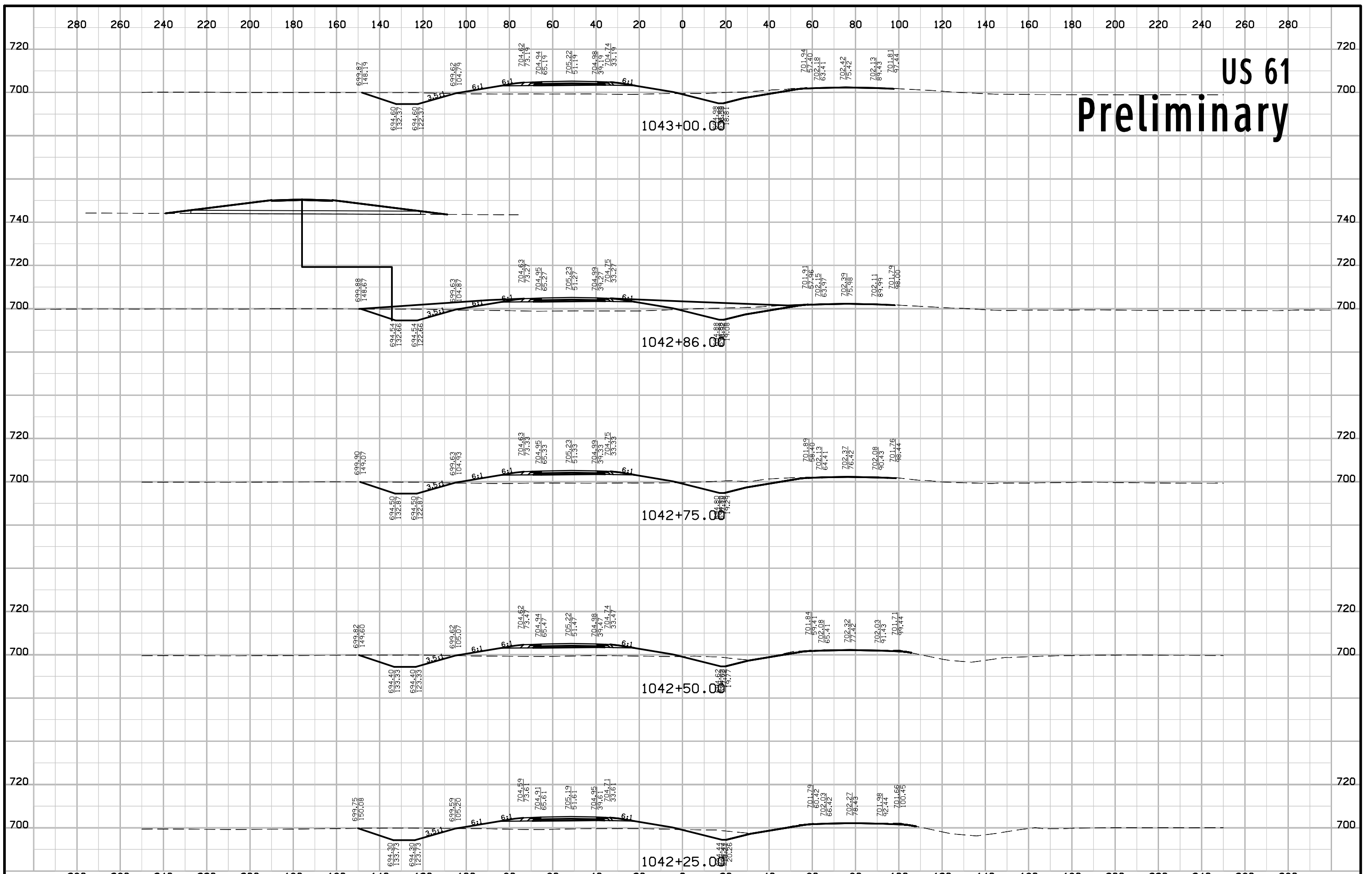

US 61 Preliminary

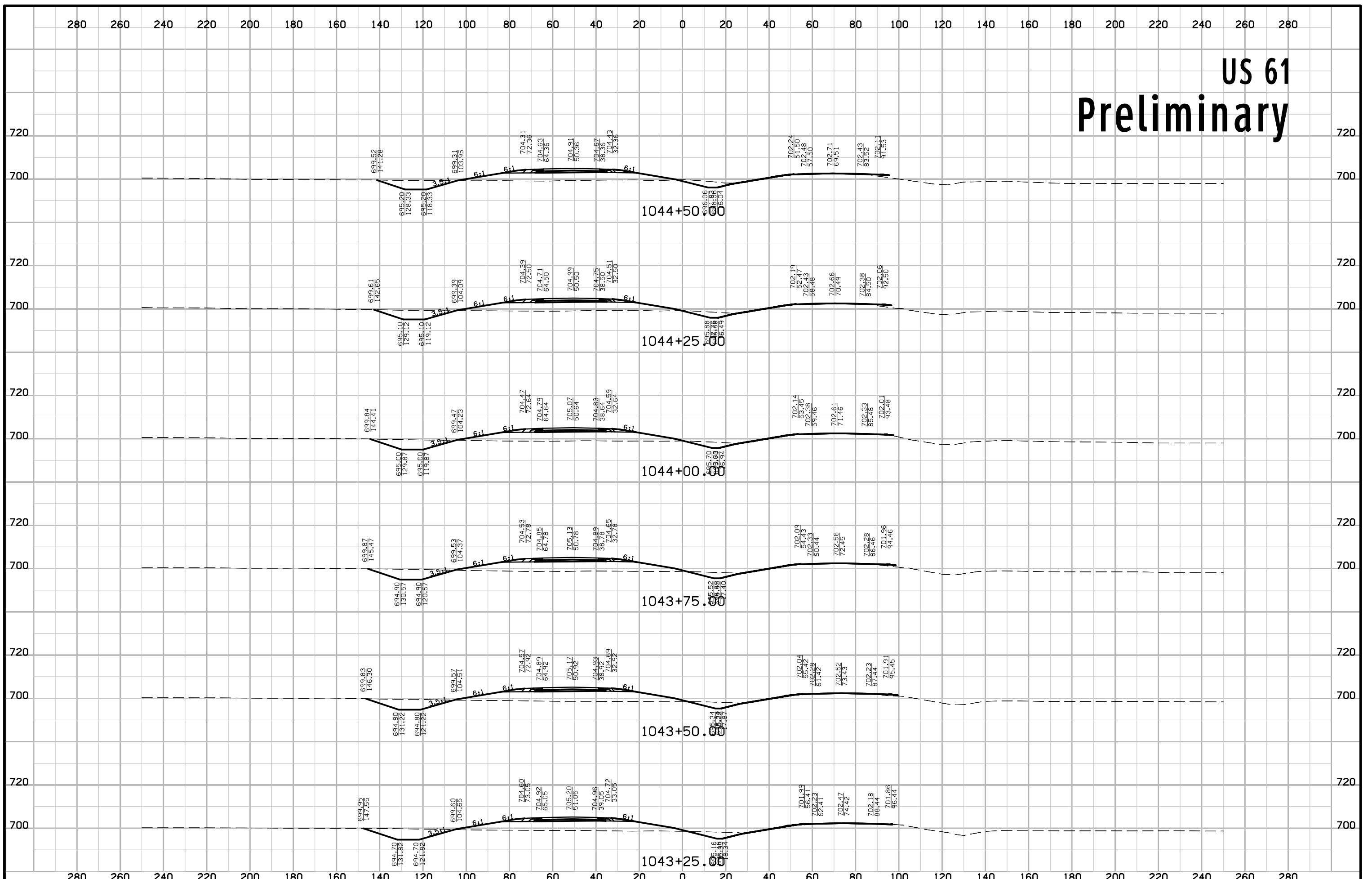

US 61 Preliminary

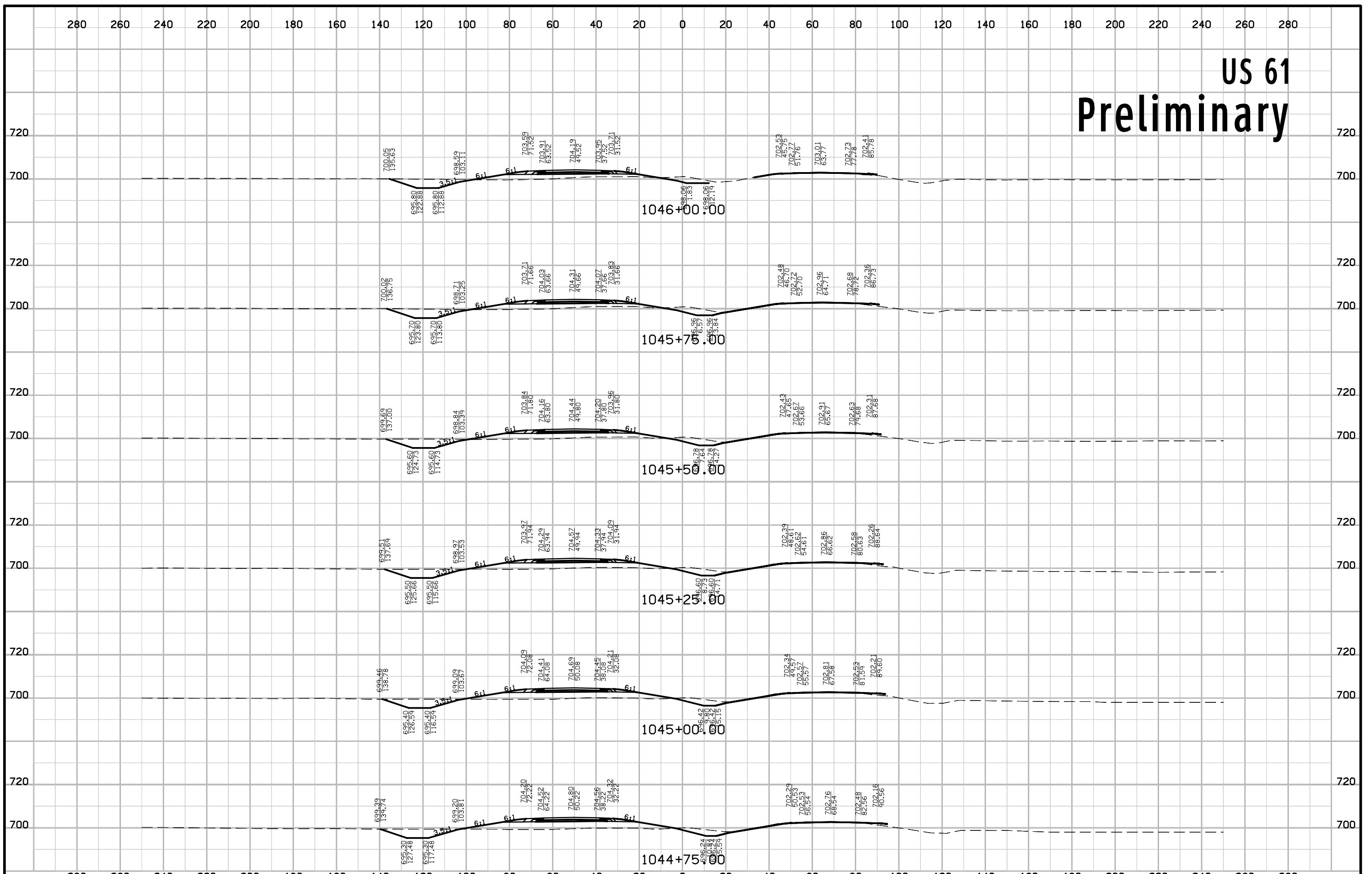

US 61 Preliminary

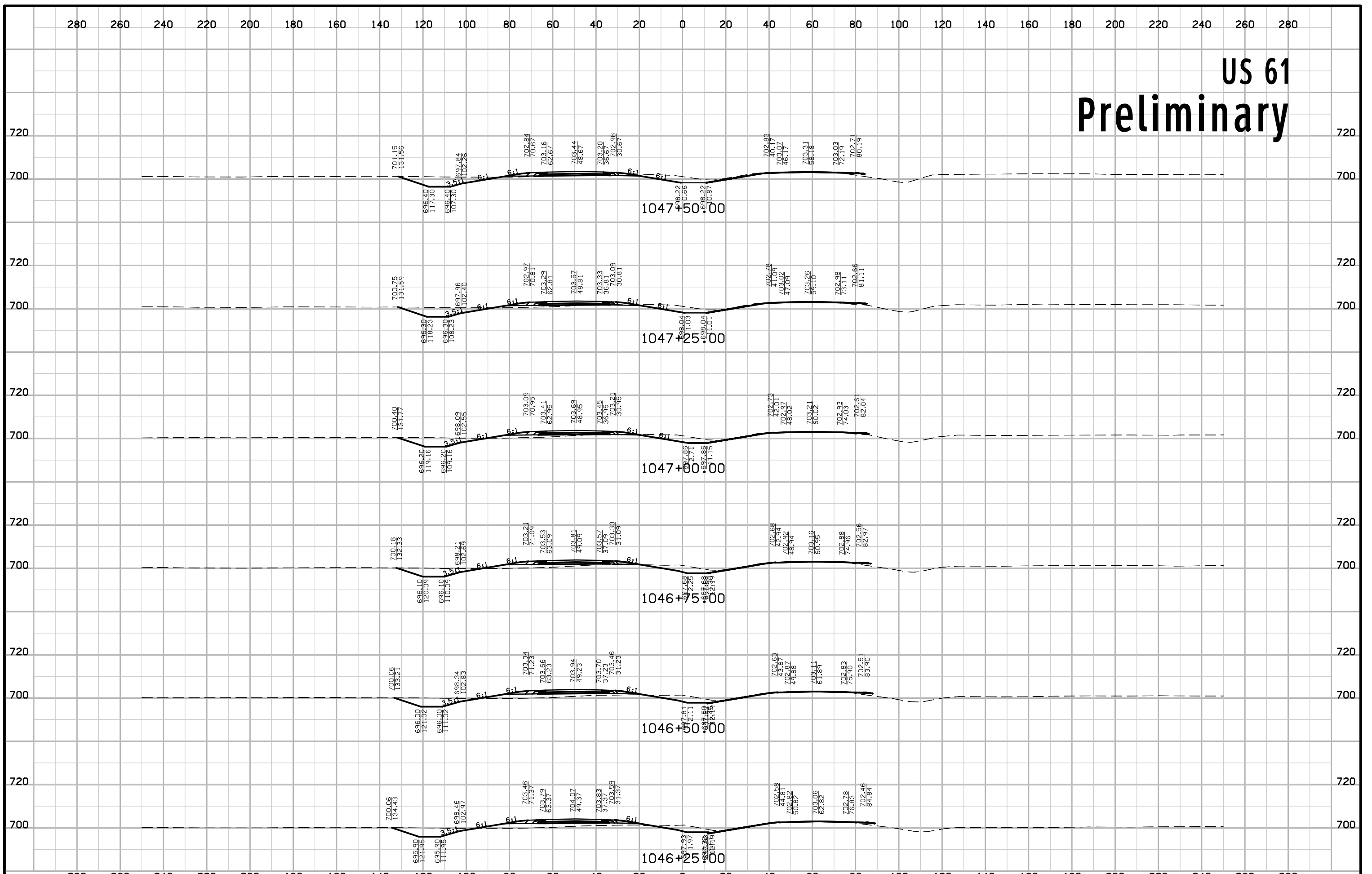

US 61 Preliminary

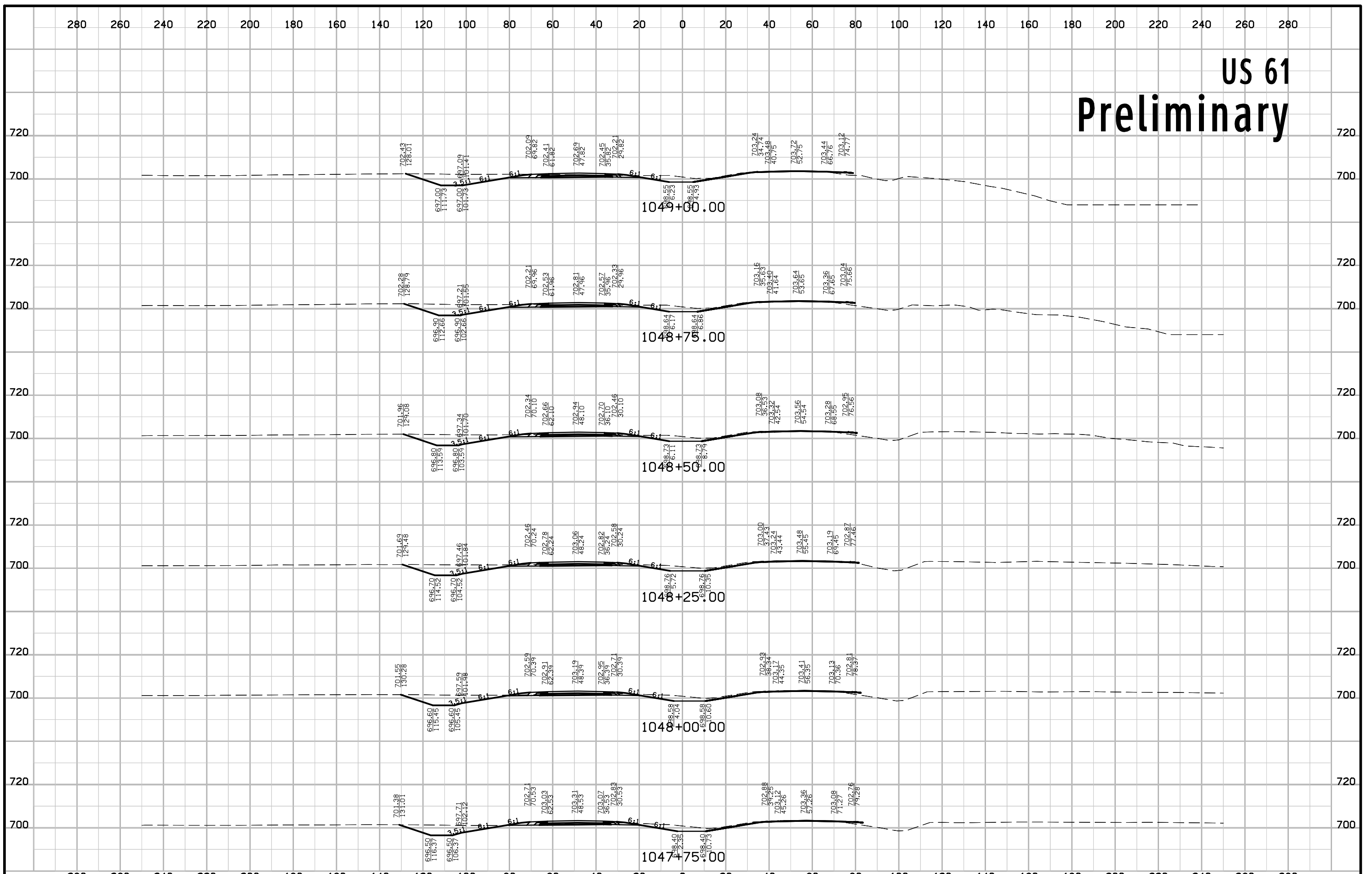

US 61 Preliminary

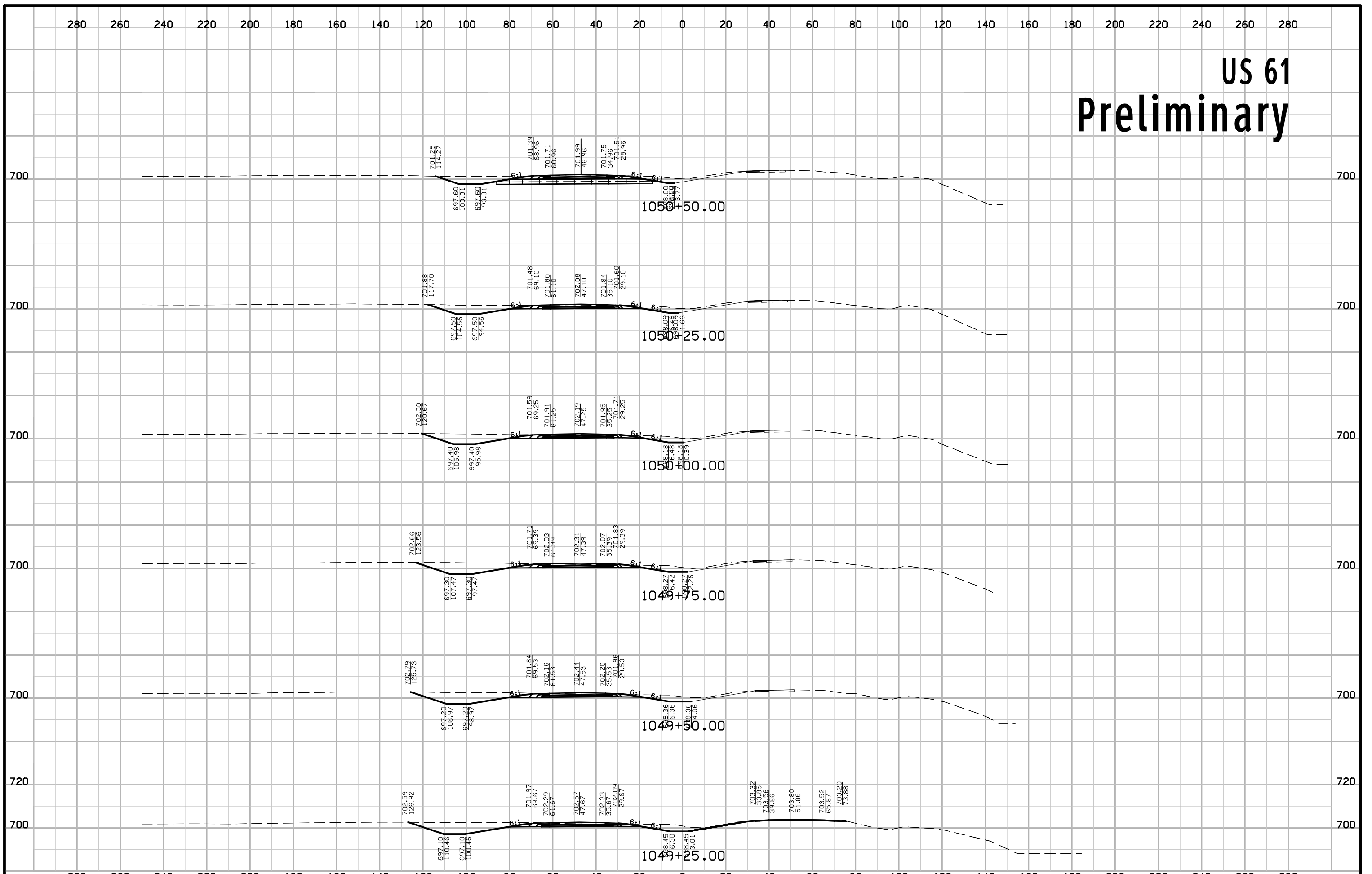

US 61 Preliminary

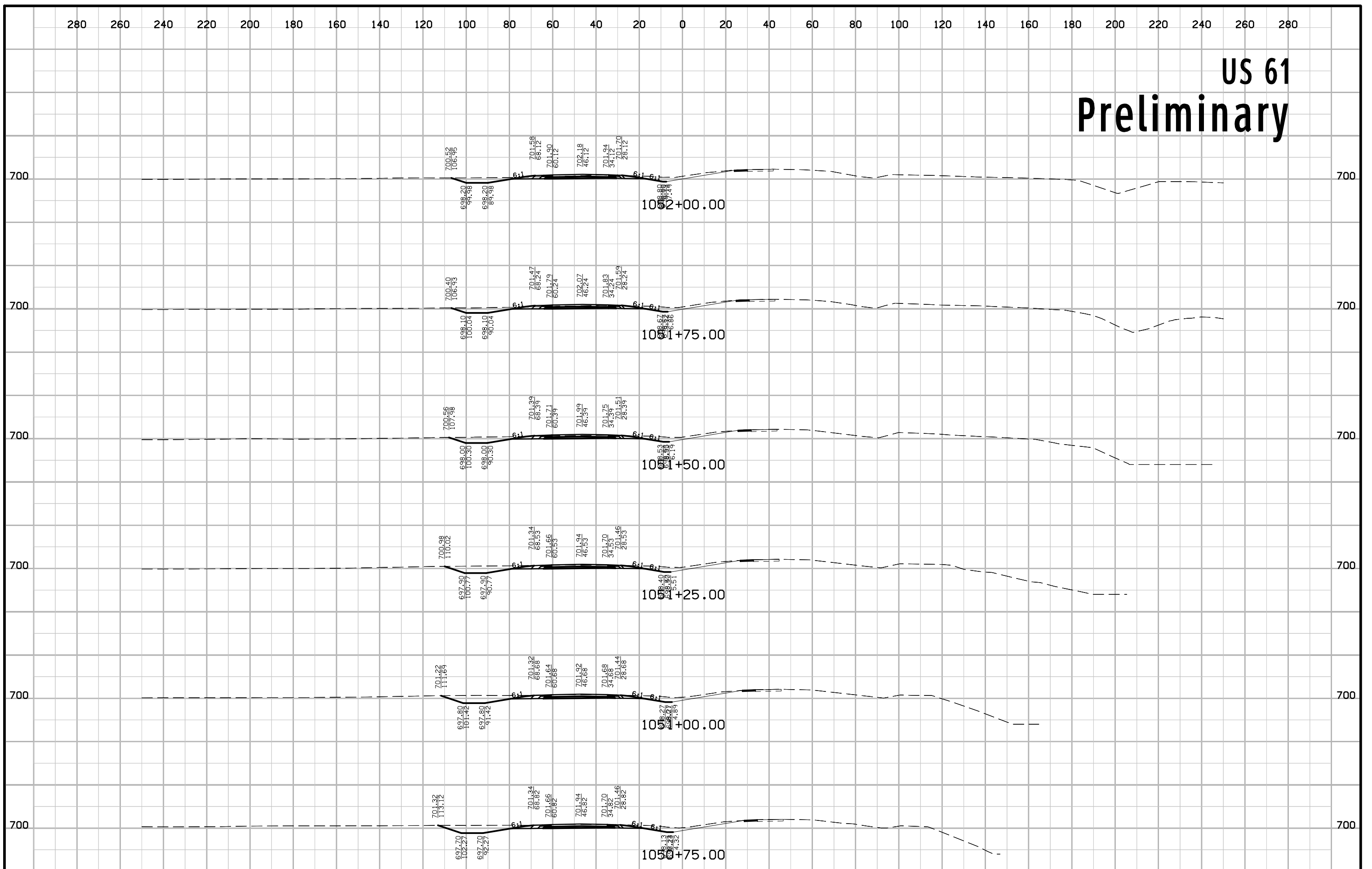

US 61 Preliminary

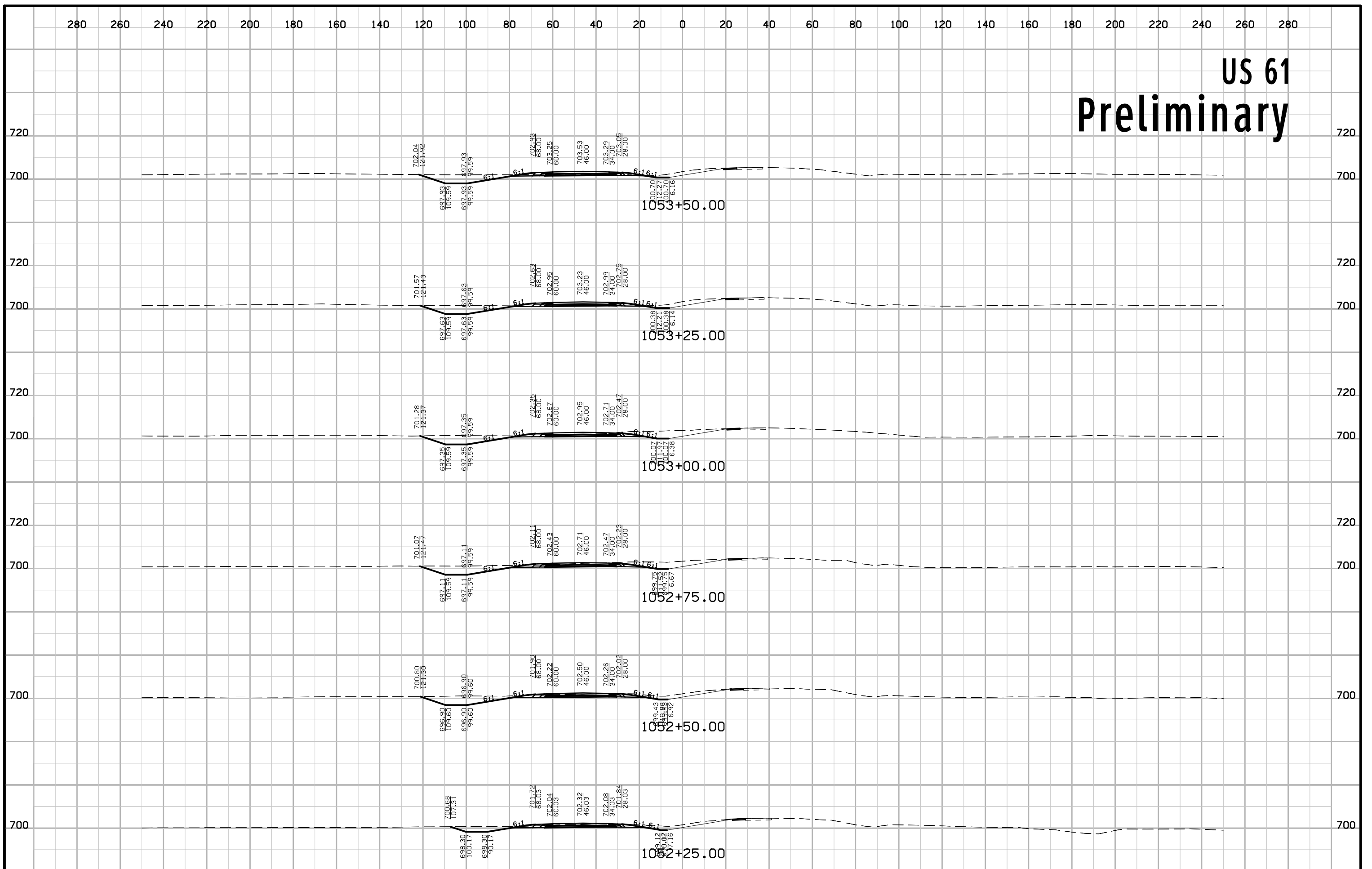

US 61 Preliminary

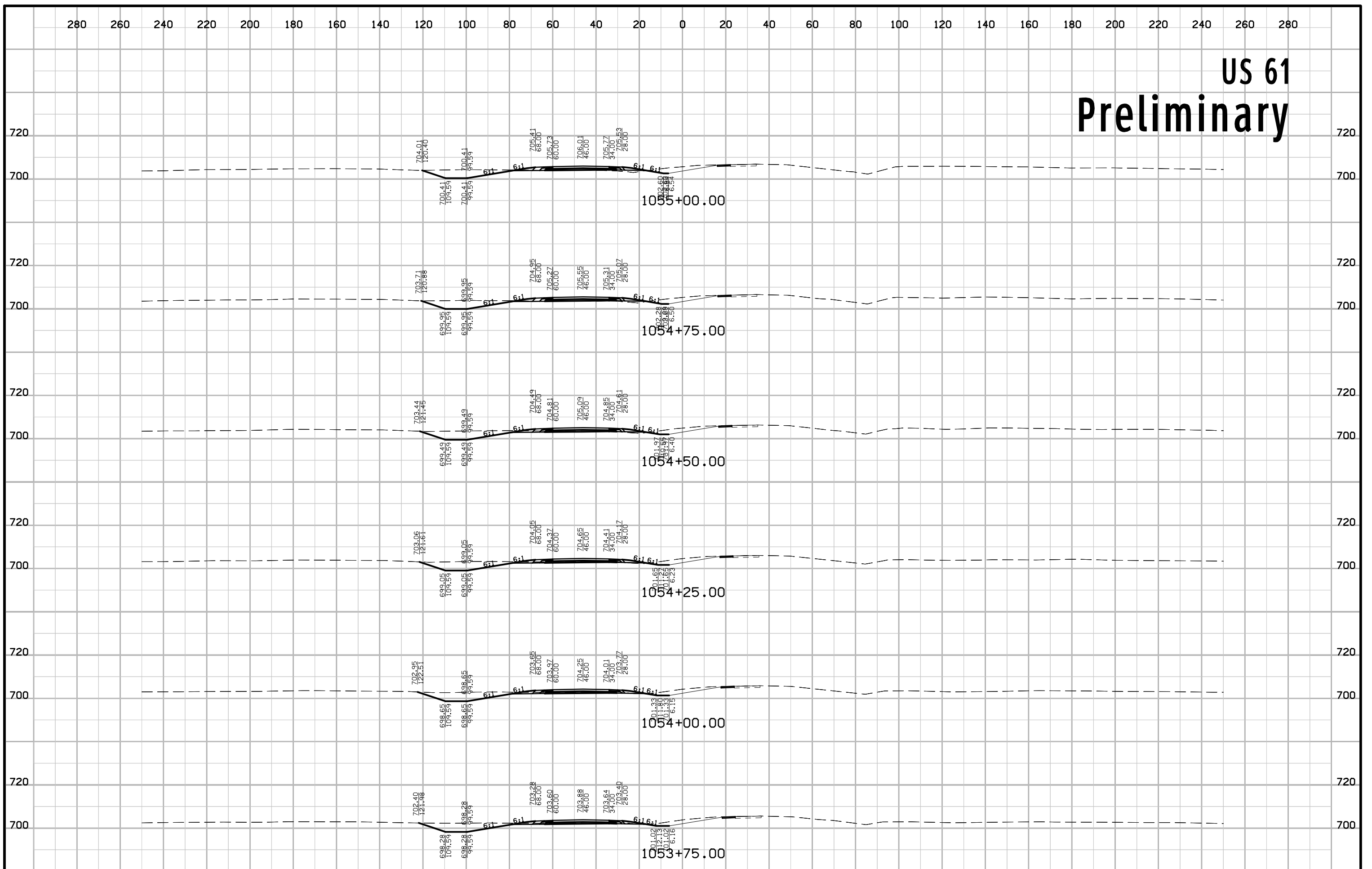

US 61 Preliminary

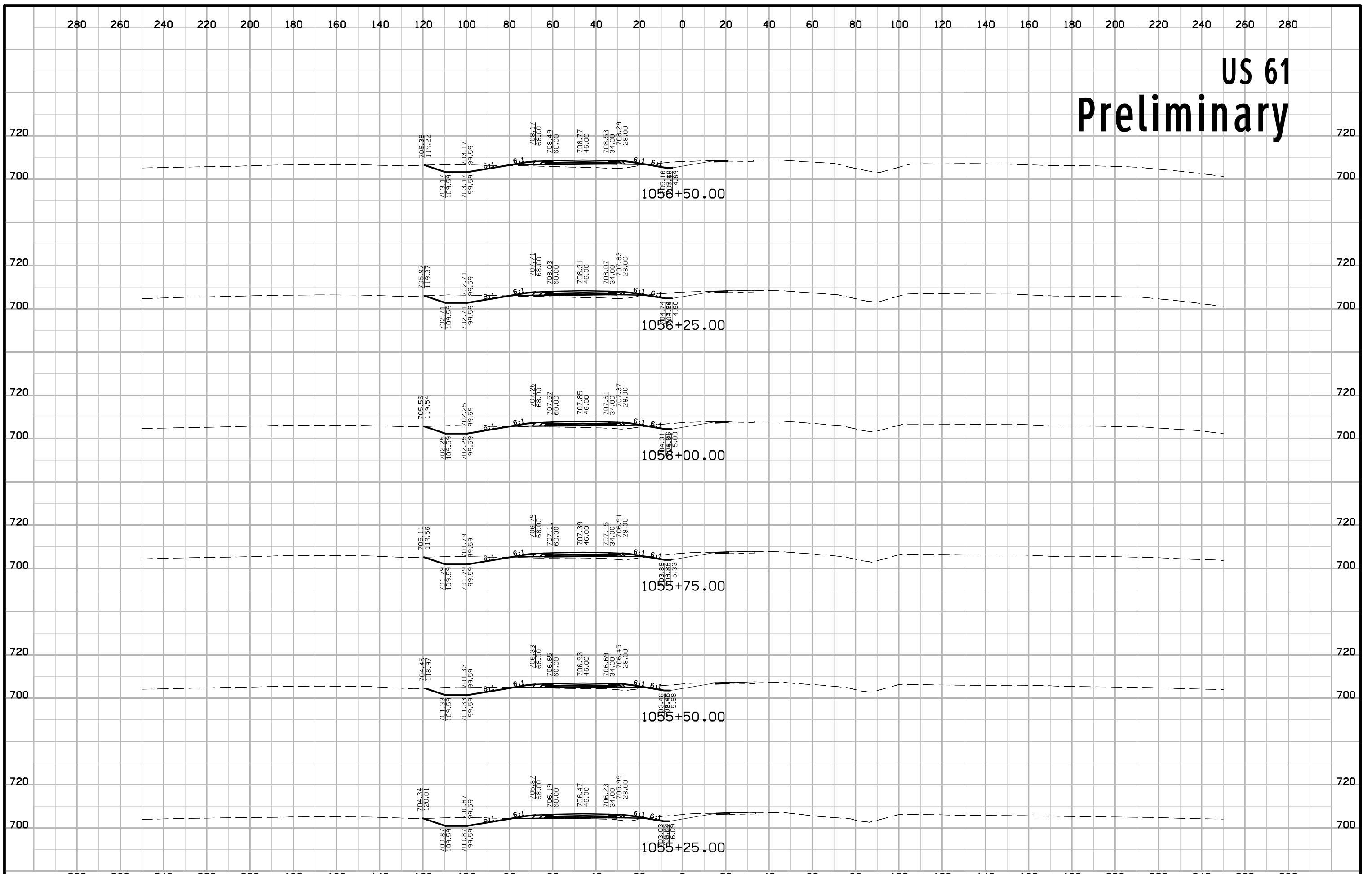

US 61 Preliminary

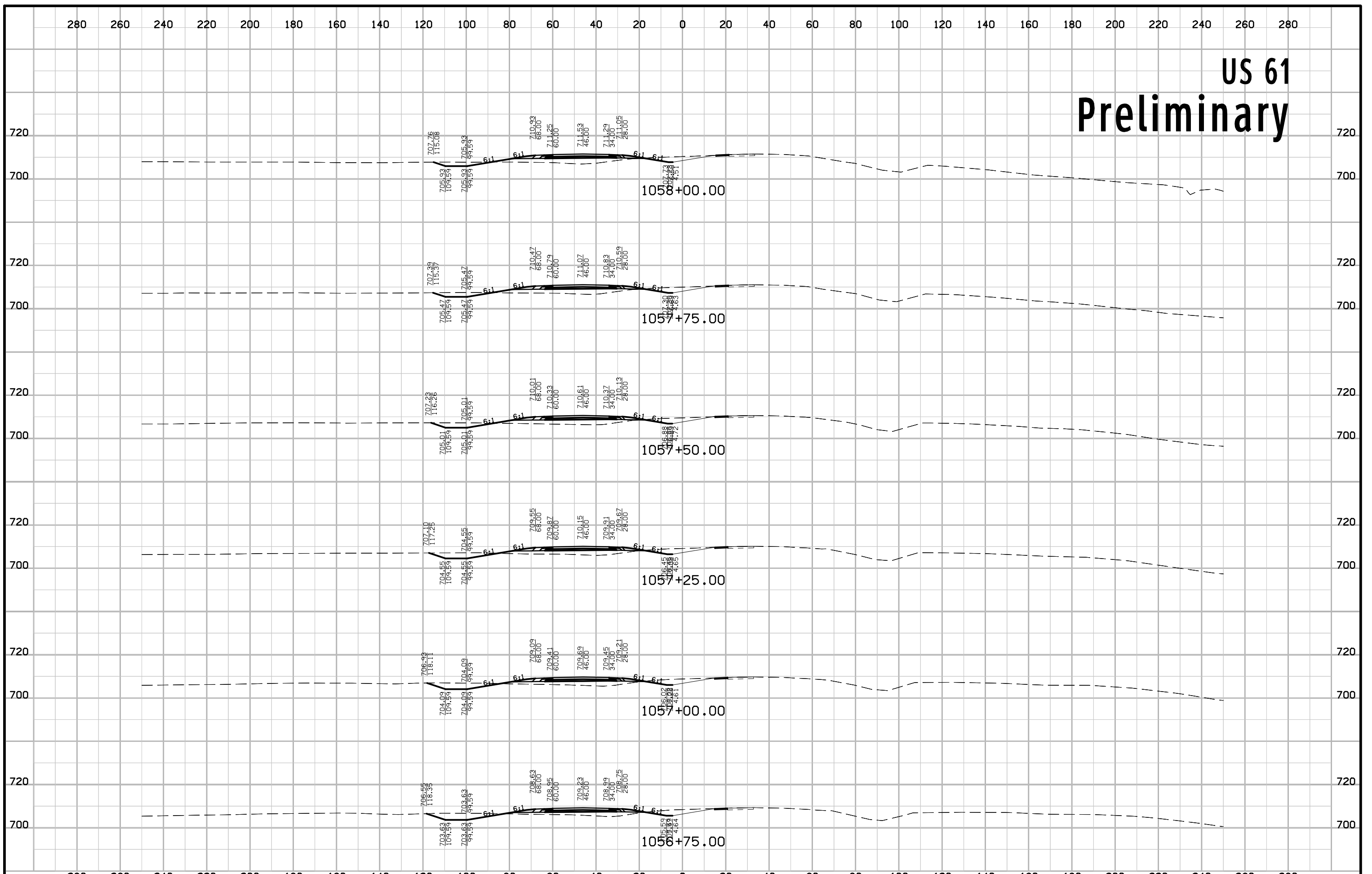

US 61 Preliminary

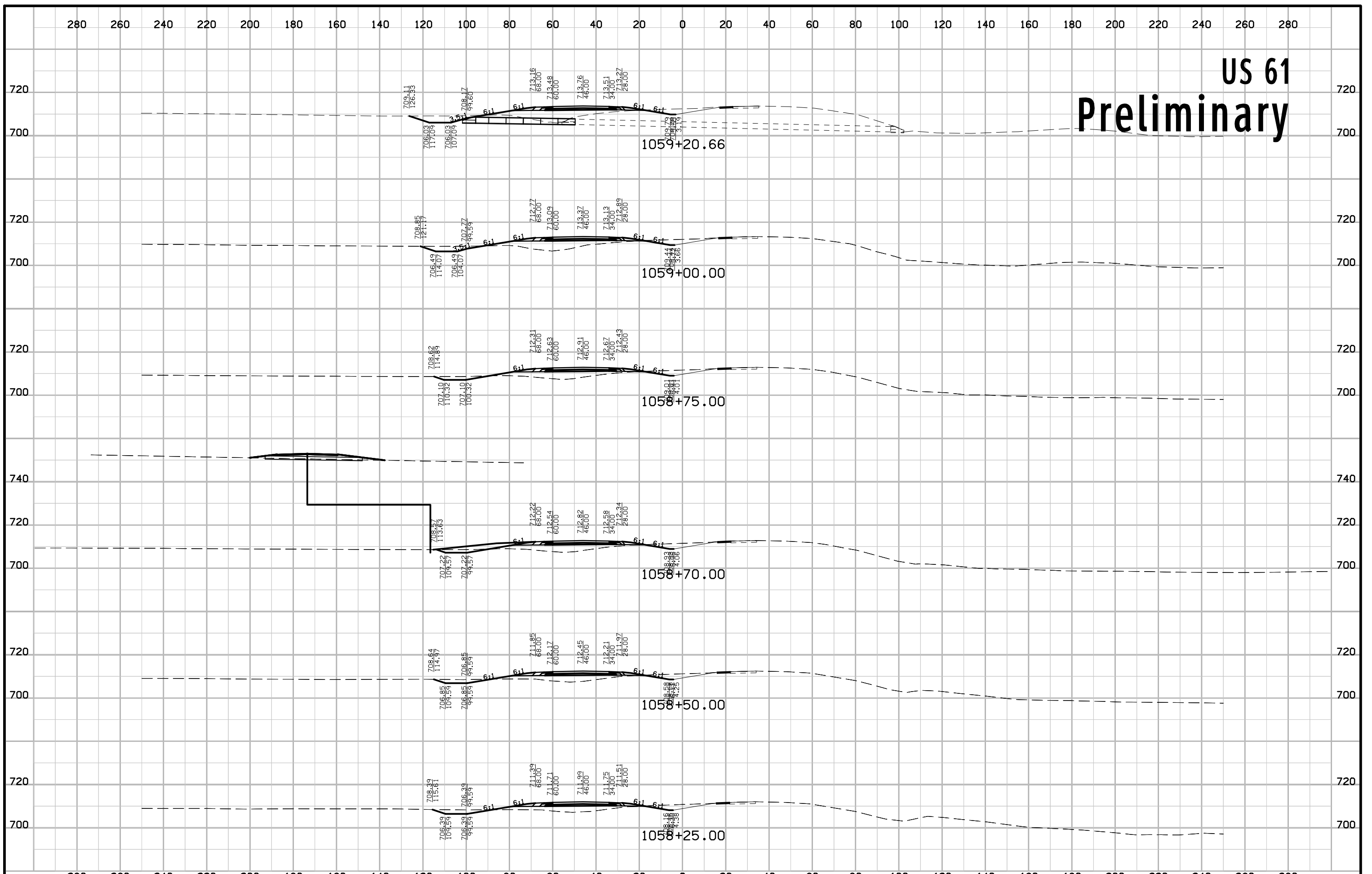

US 61 Preliminary

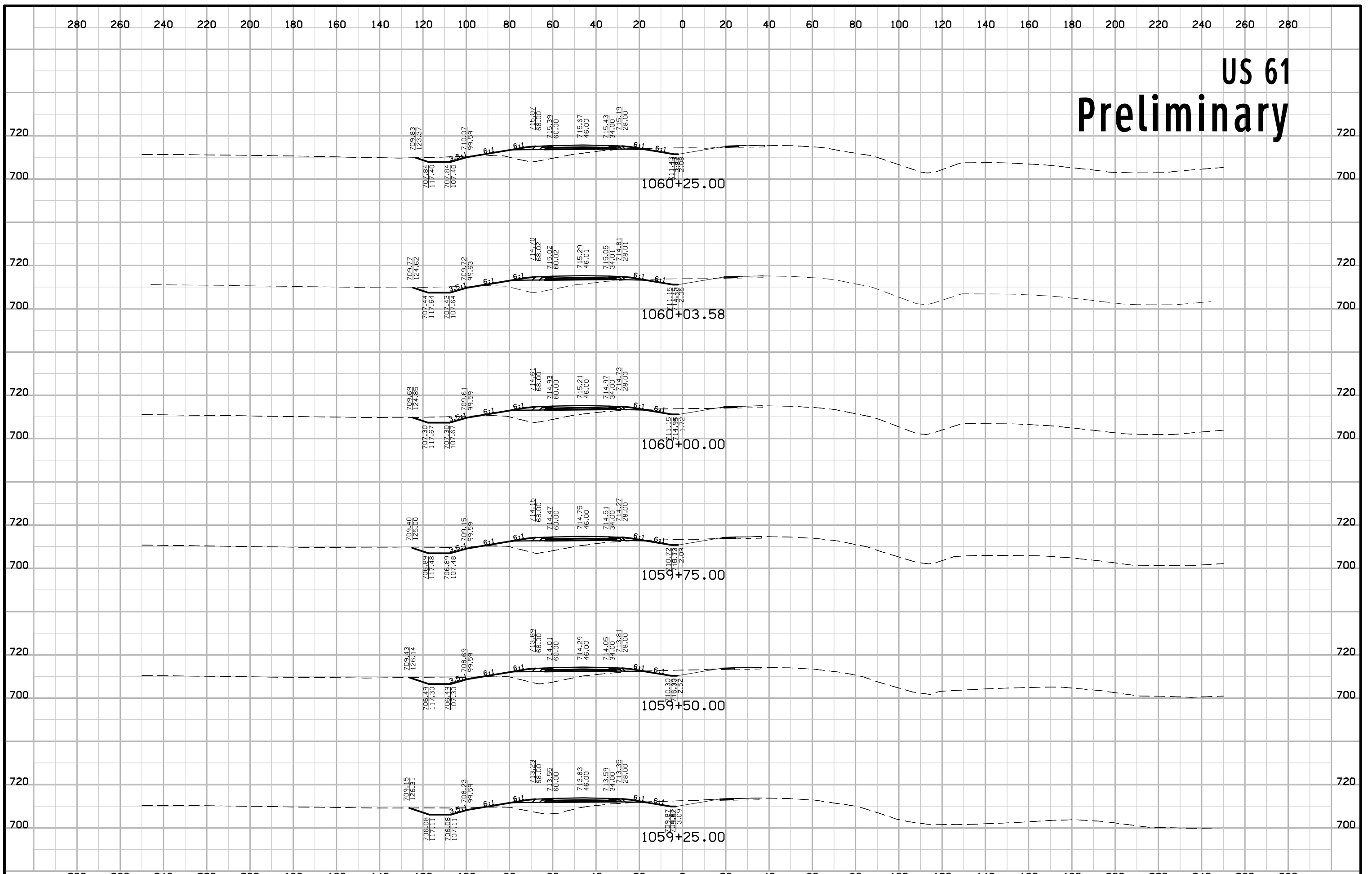

US 61 Preliminary

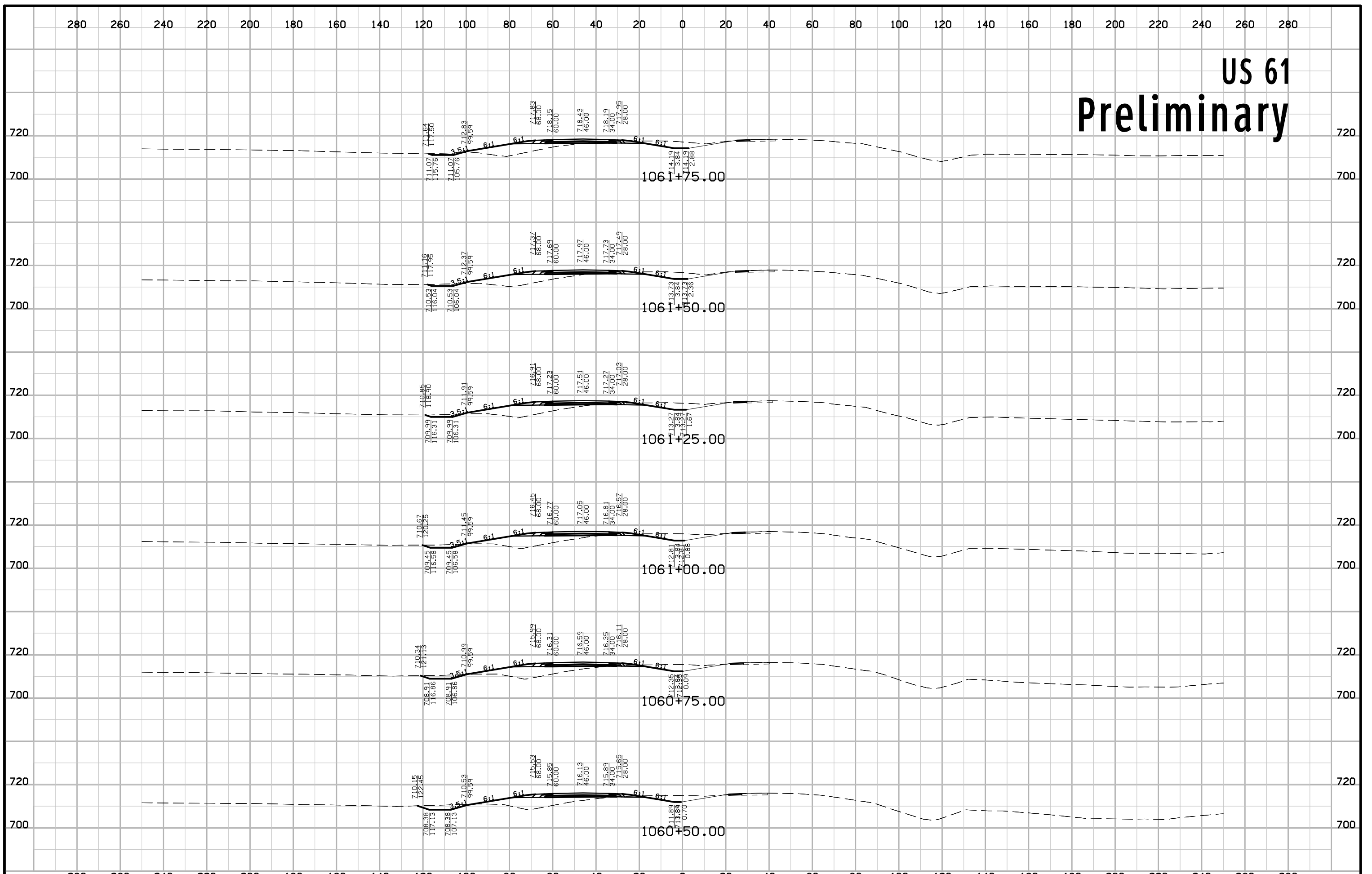

US 61 Preliminary

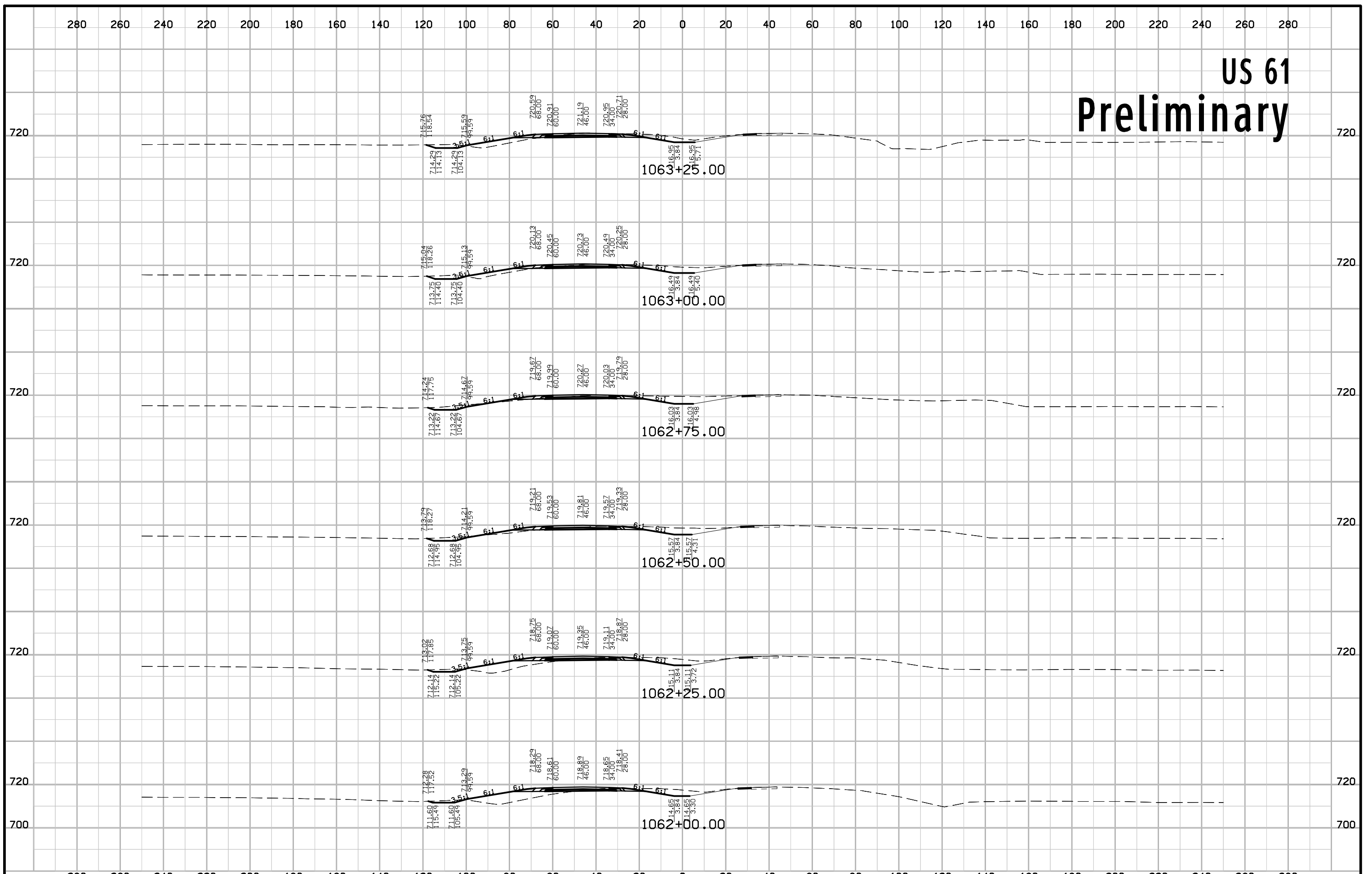

US 61 Preliminary

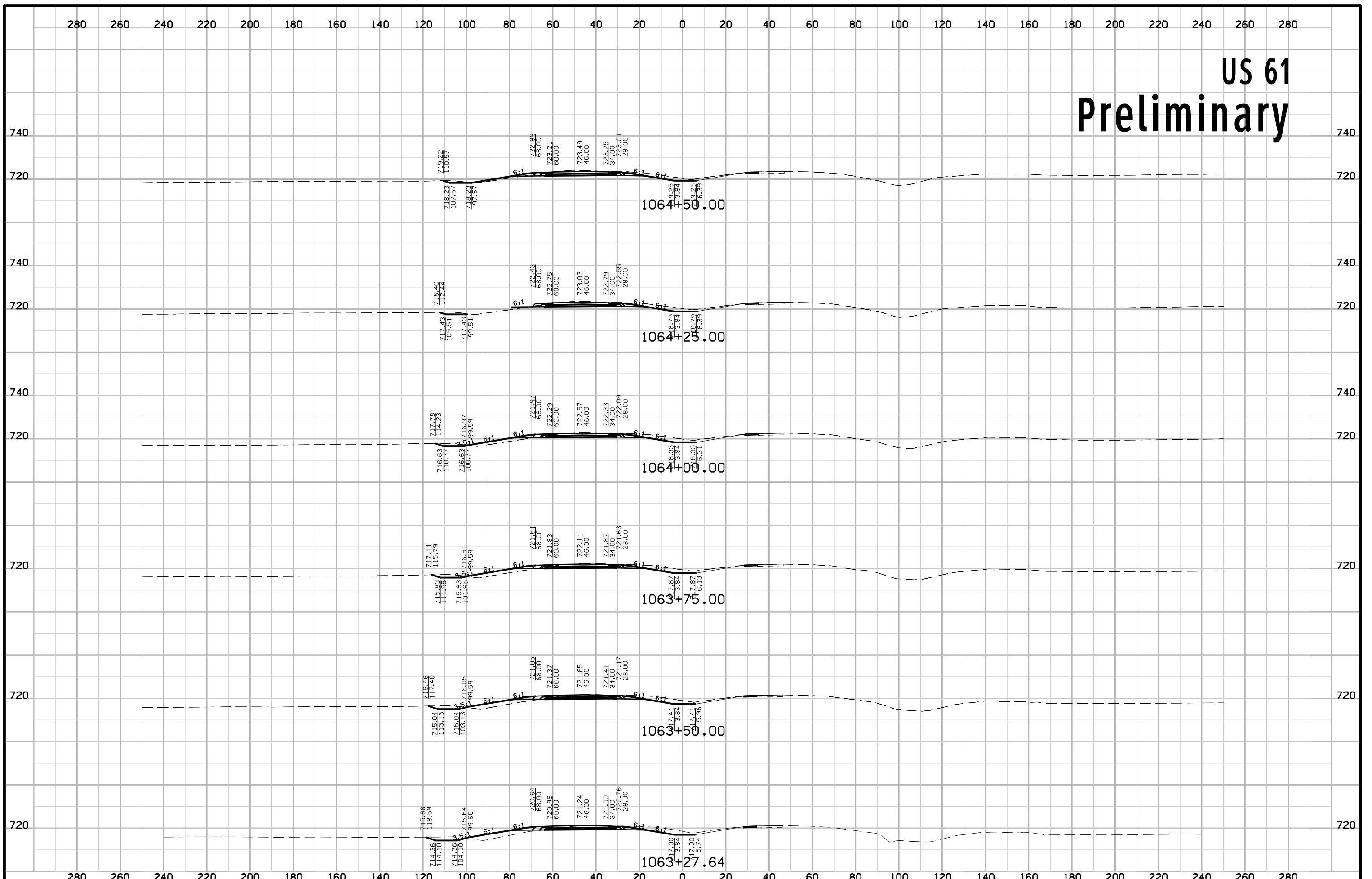

US 61 Preliminary

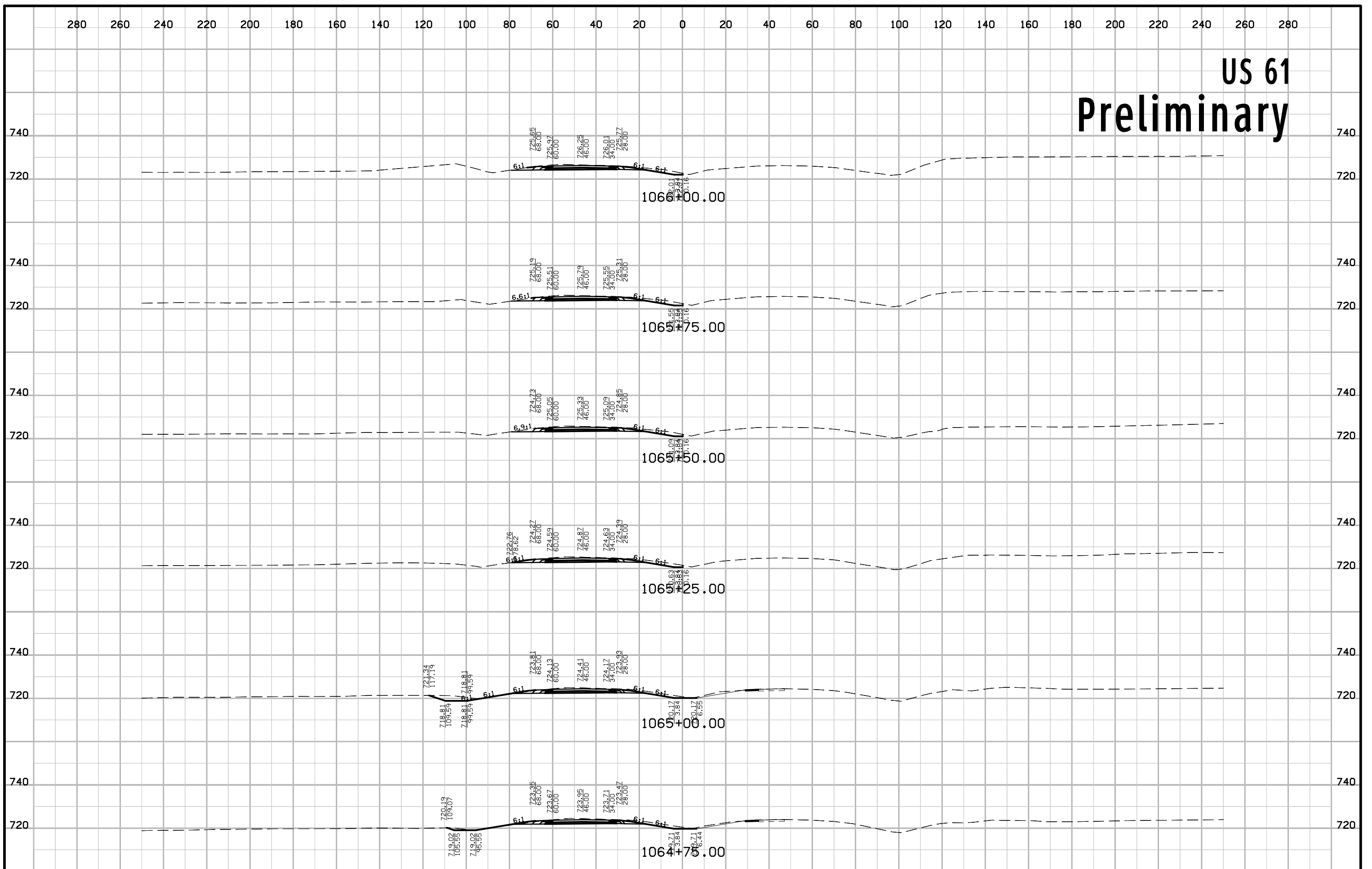

US 61 Preliminary

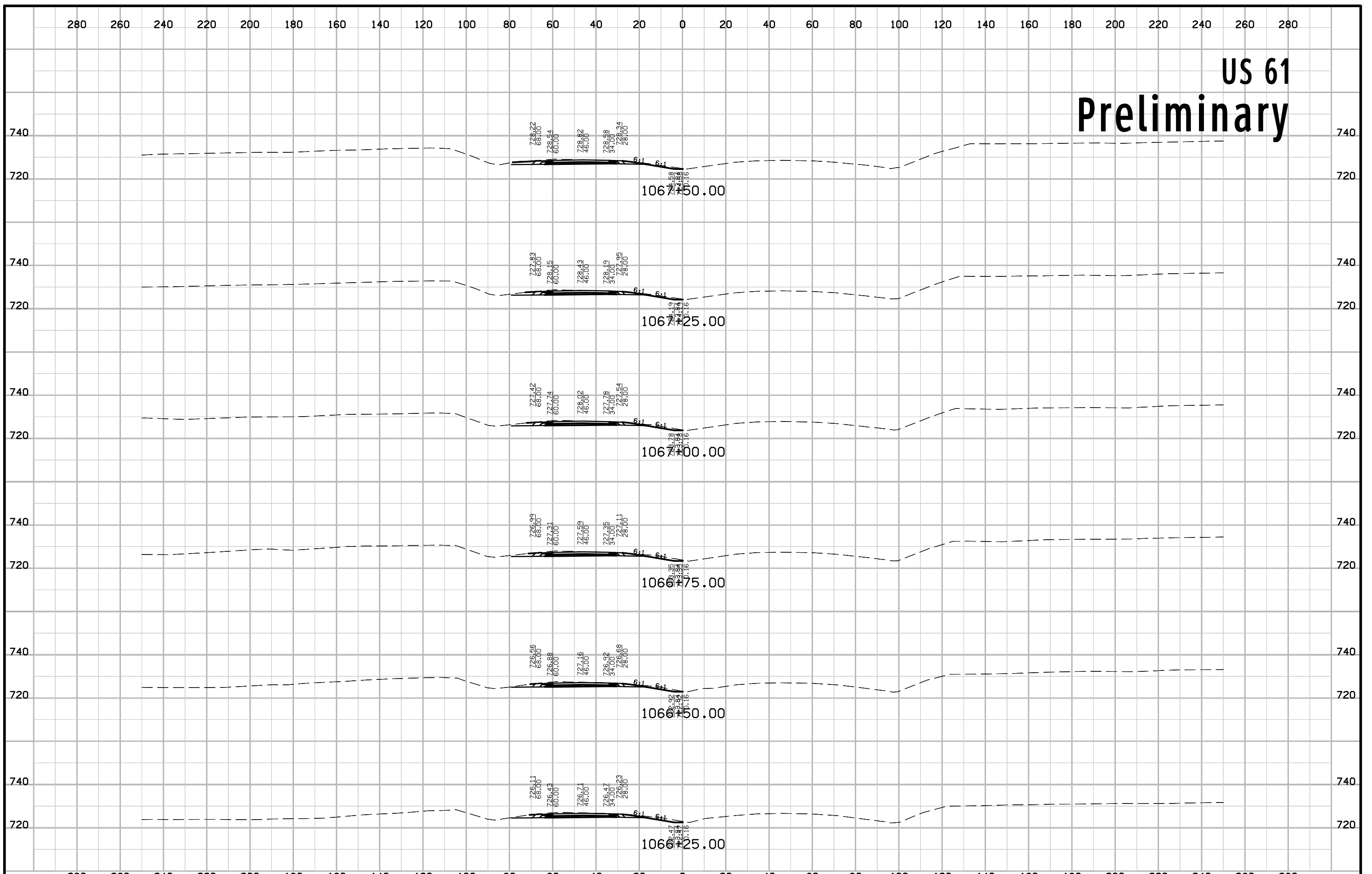

US 61 Preliminary

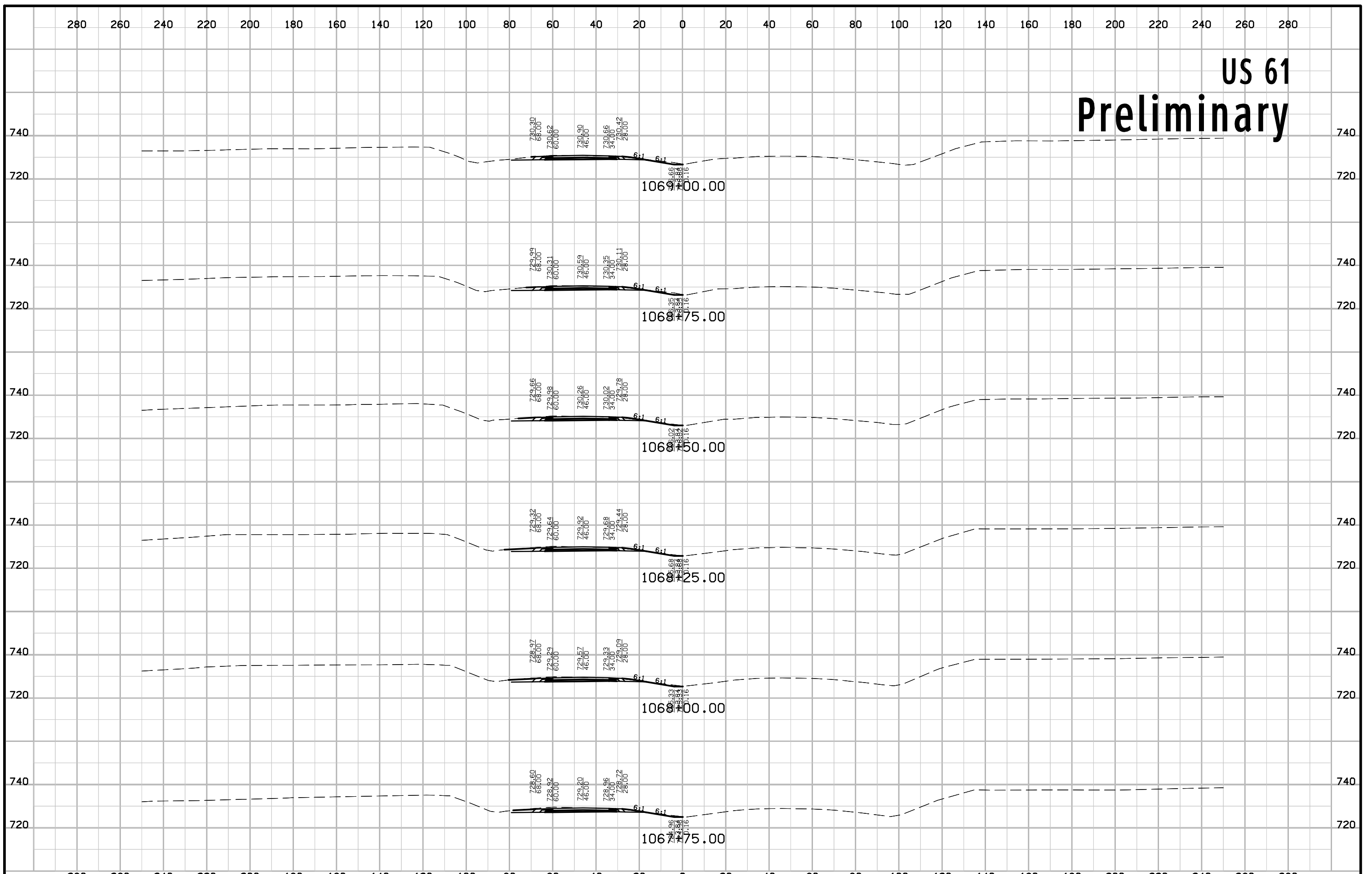

US 61 Preliminary

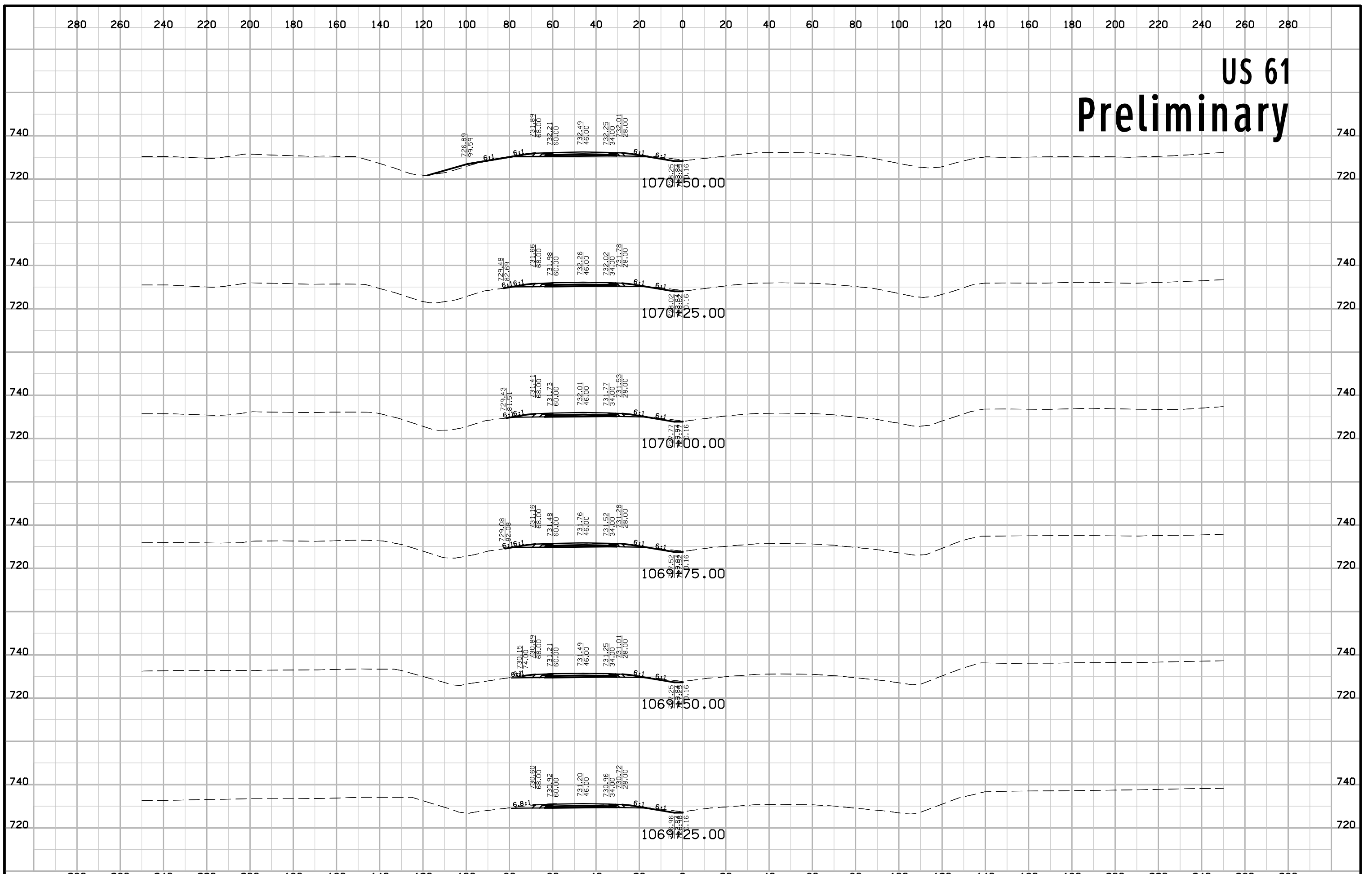

US 61 Preliminary

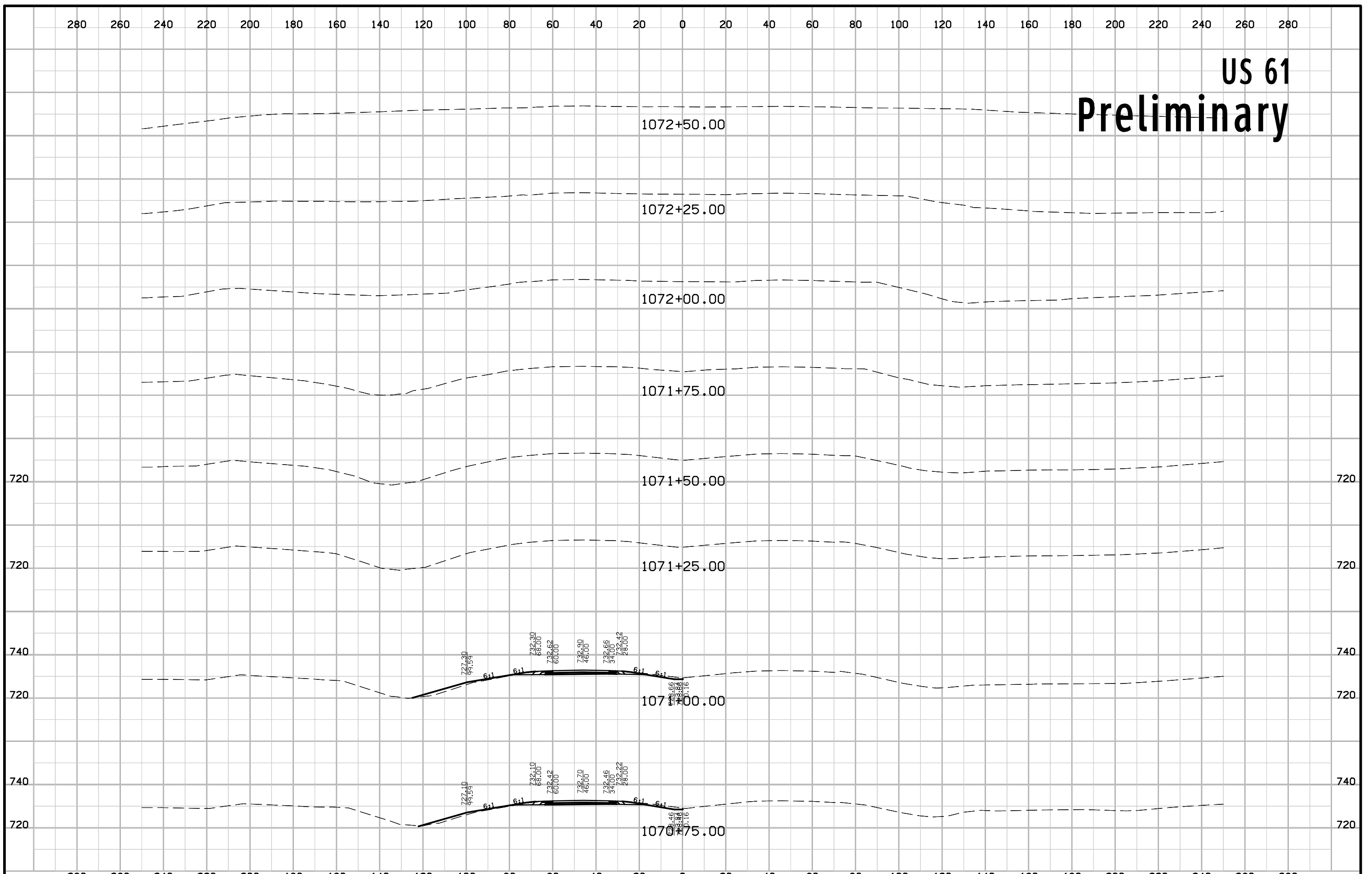

US 61 Preliminary

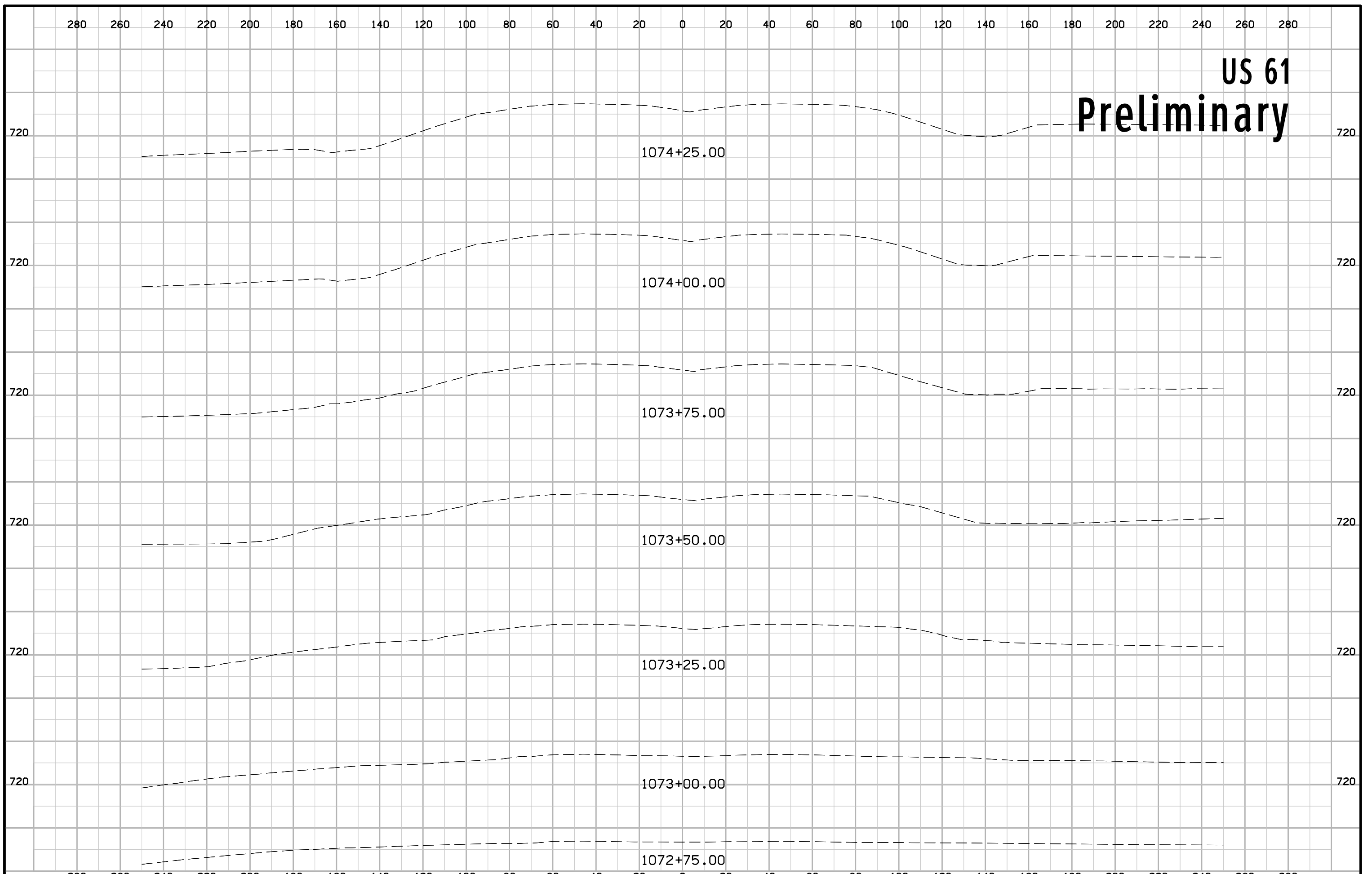

US 61 Preliminary

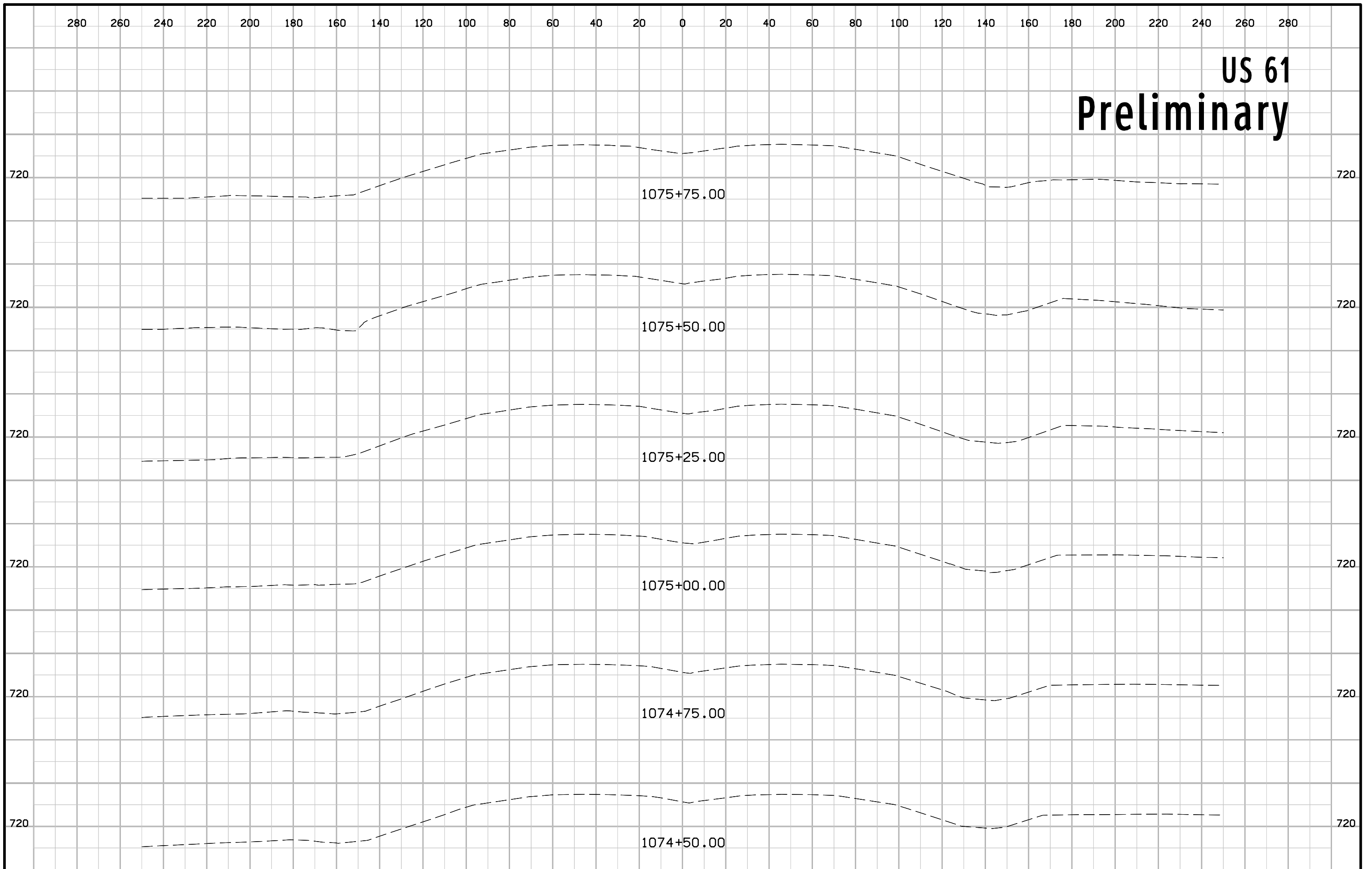

US 61 Preliminary

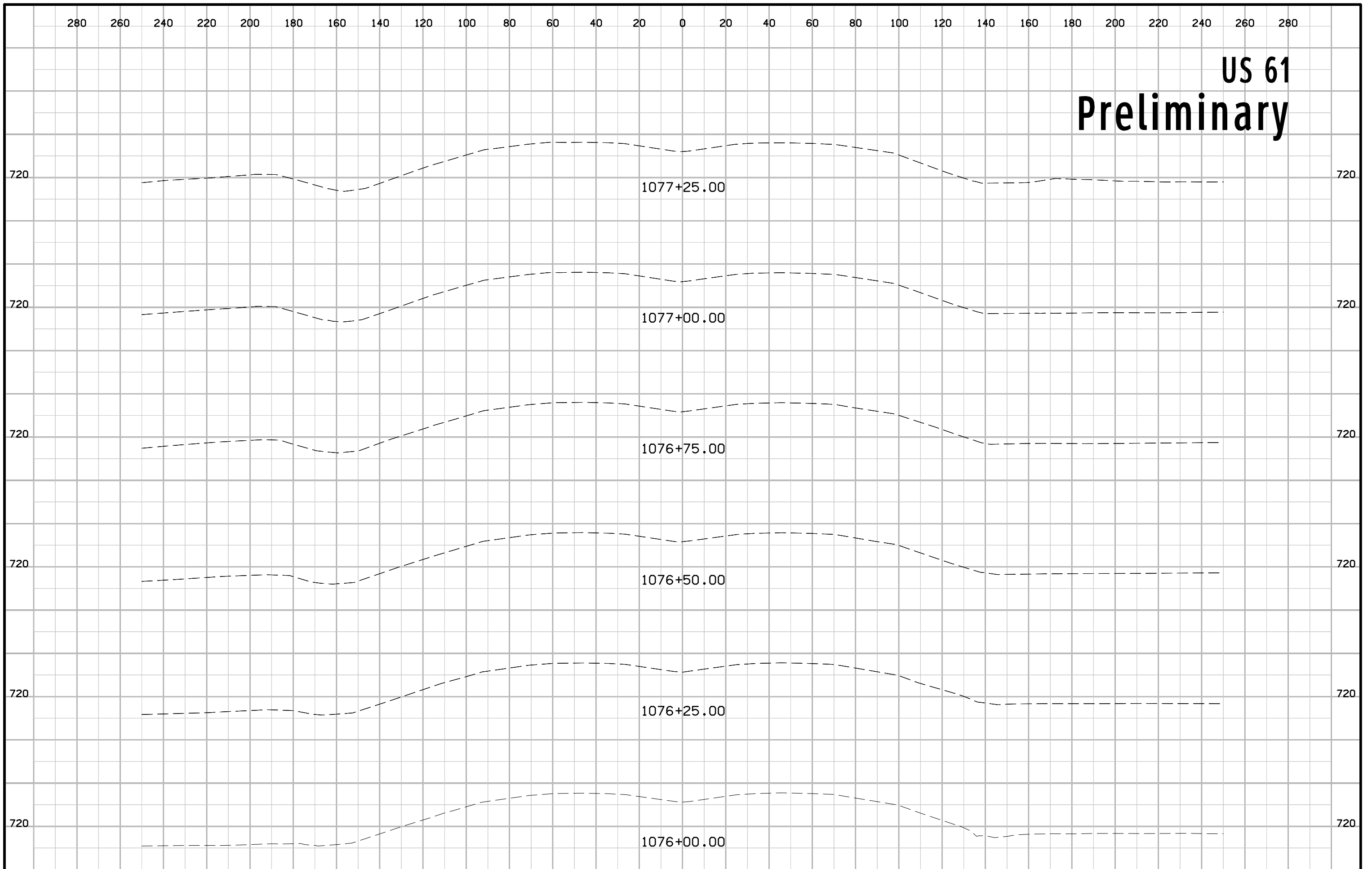

US 61 Preliminary

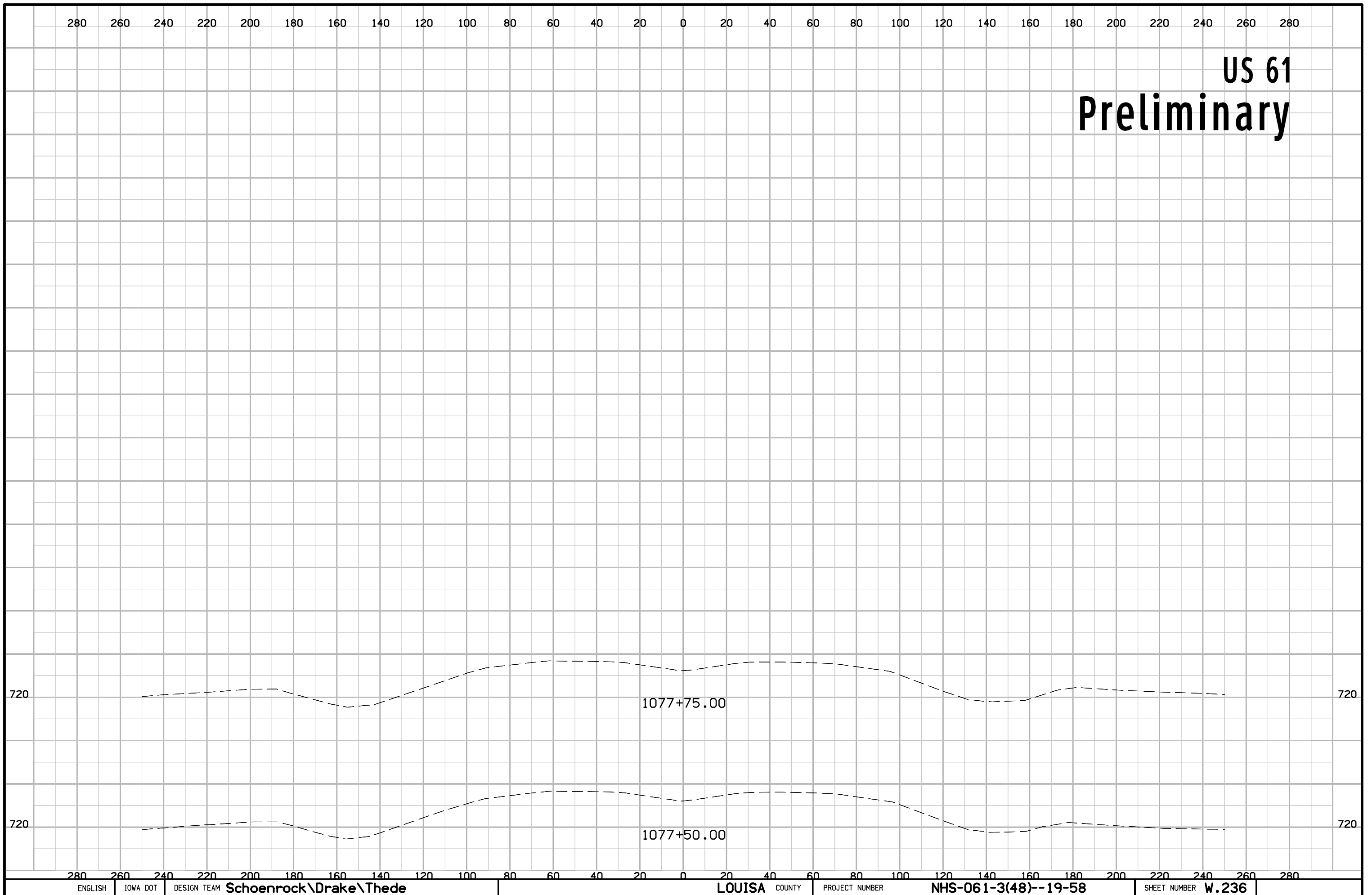

IA 92 Preliminary

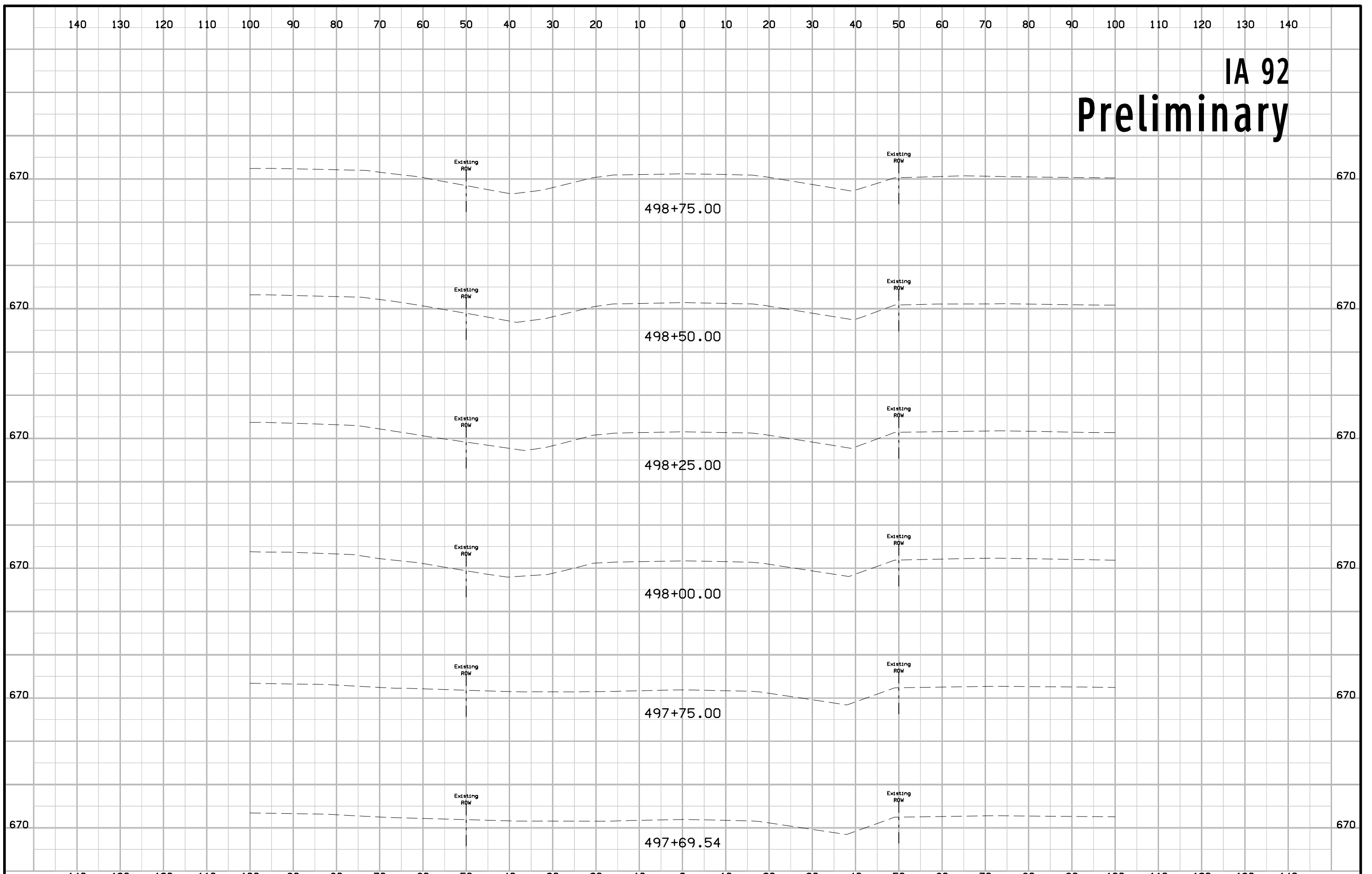

IA 92 Preliminary

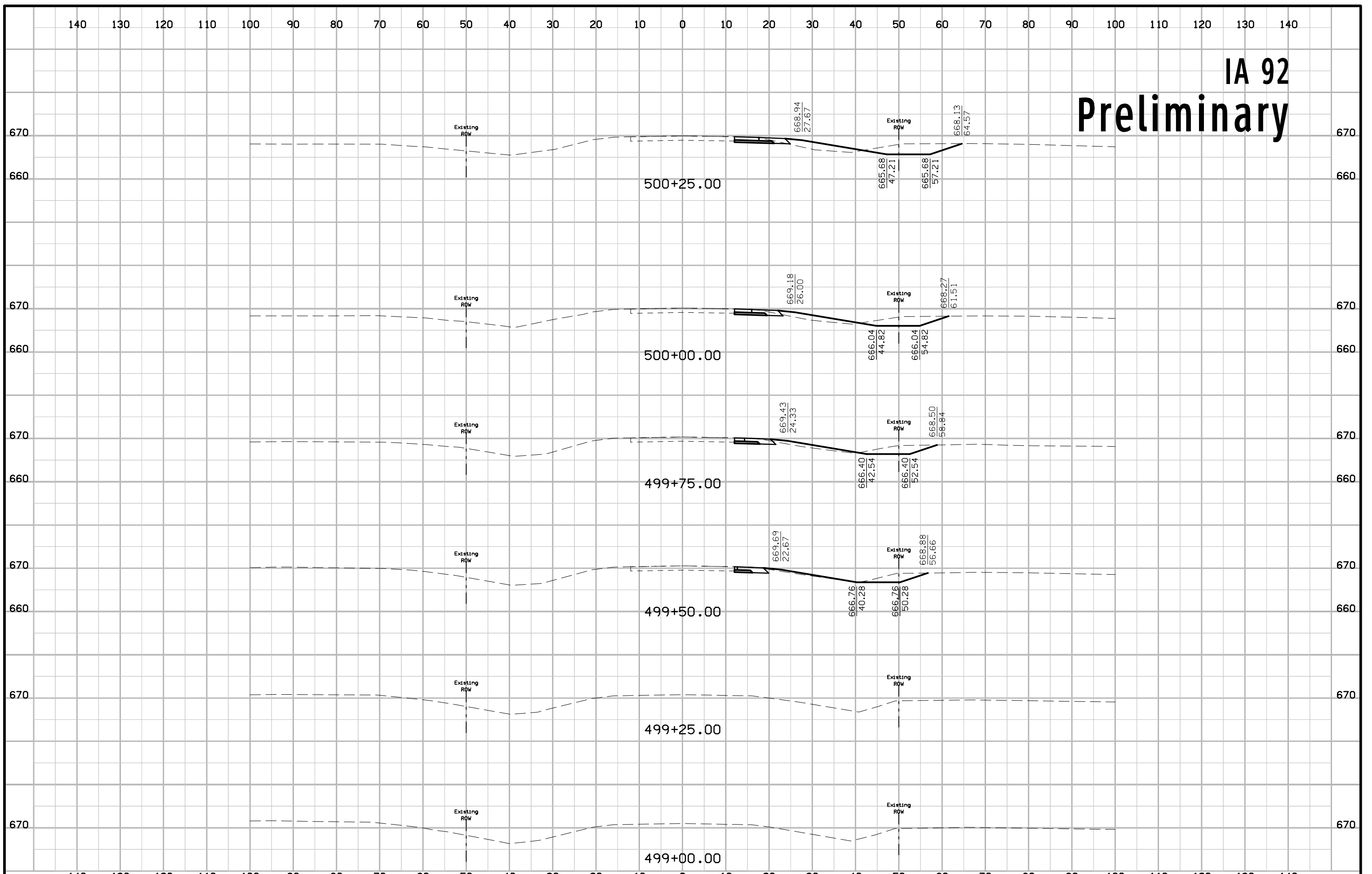

IA 92 Preliminary

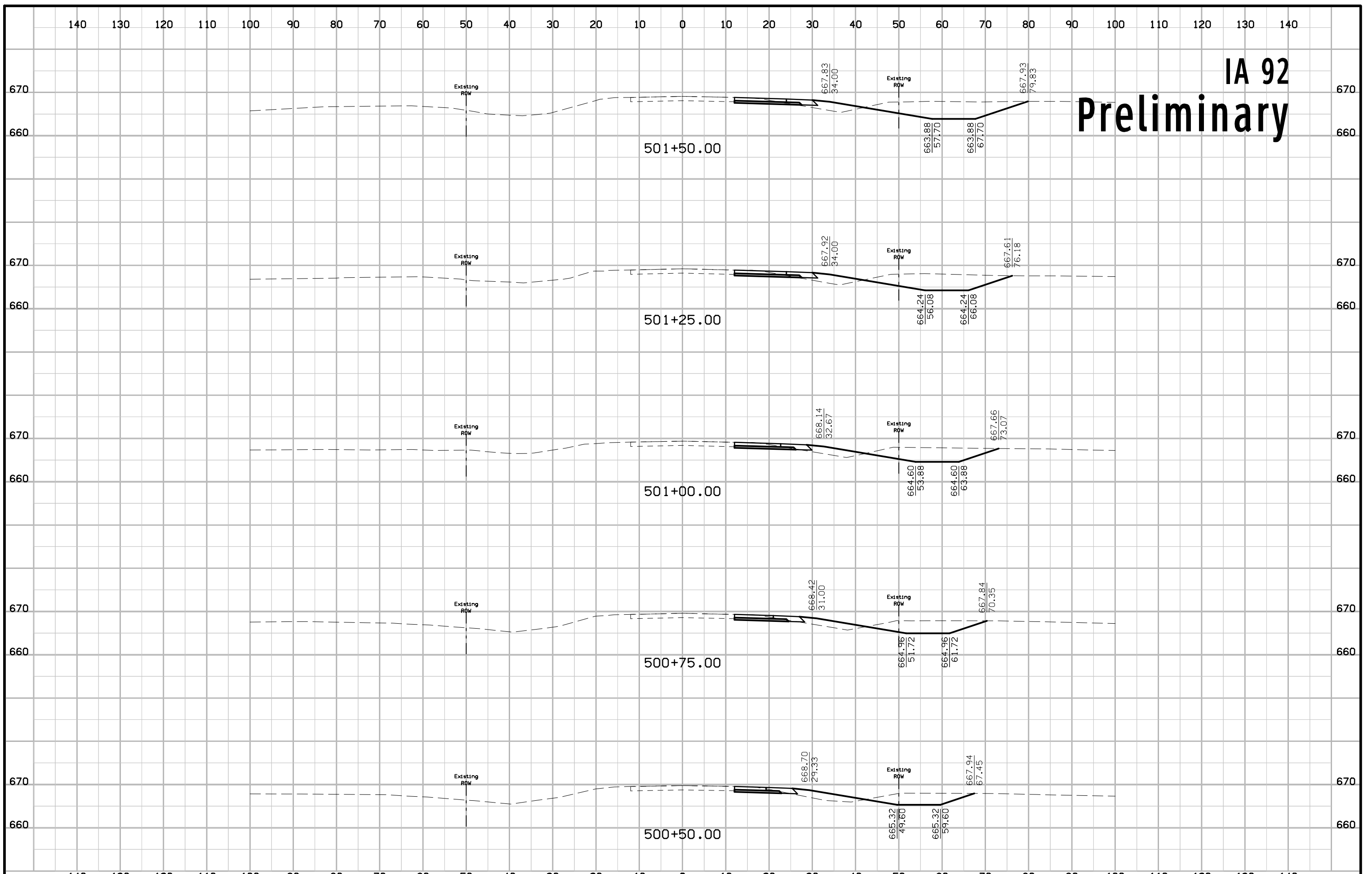

IA 92 Preliminary

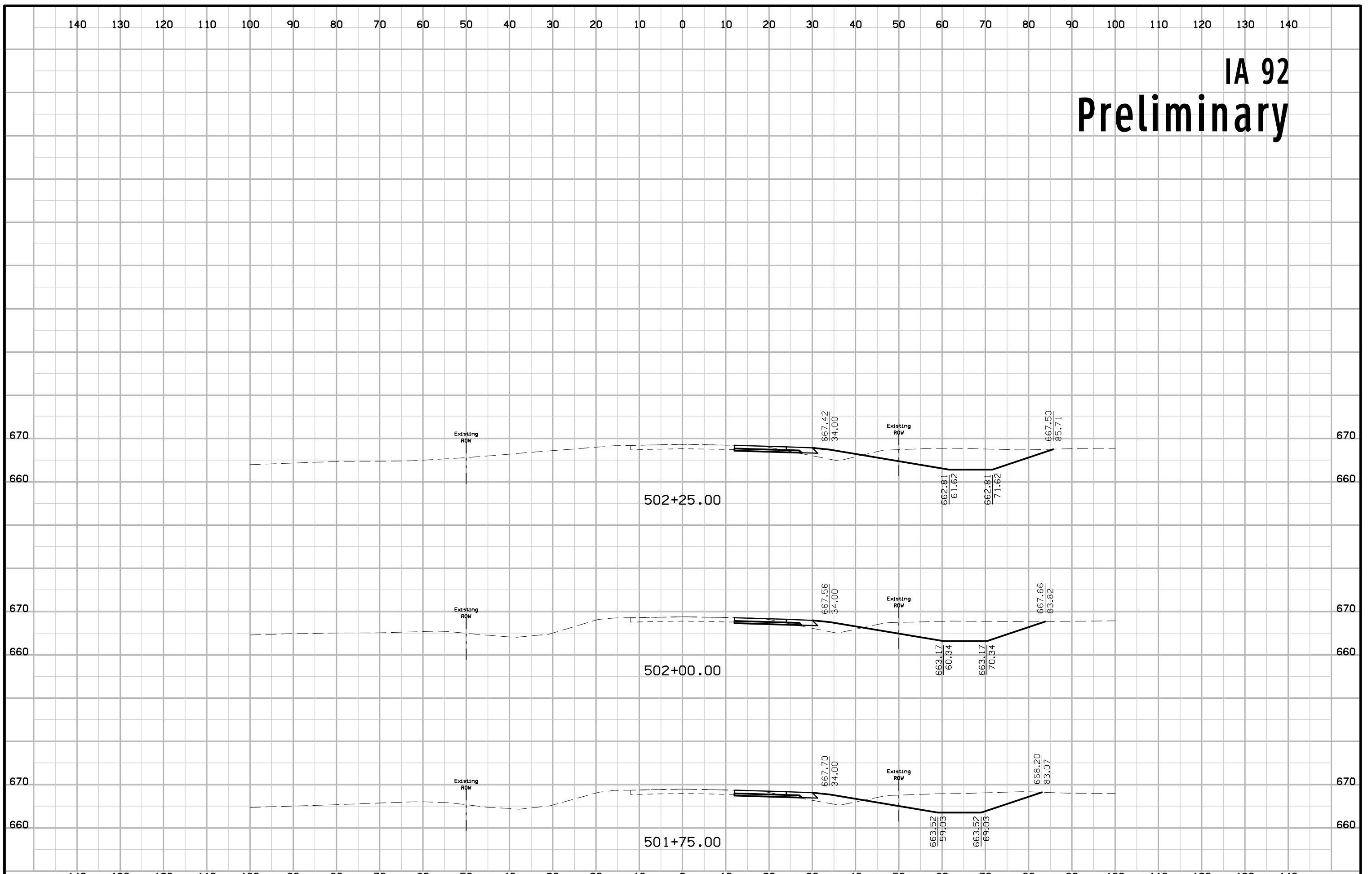

IA 92 Preliminary

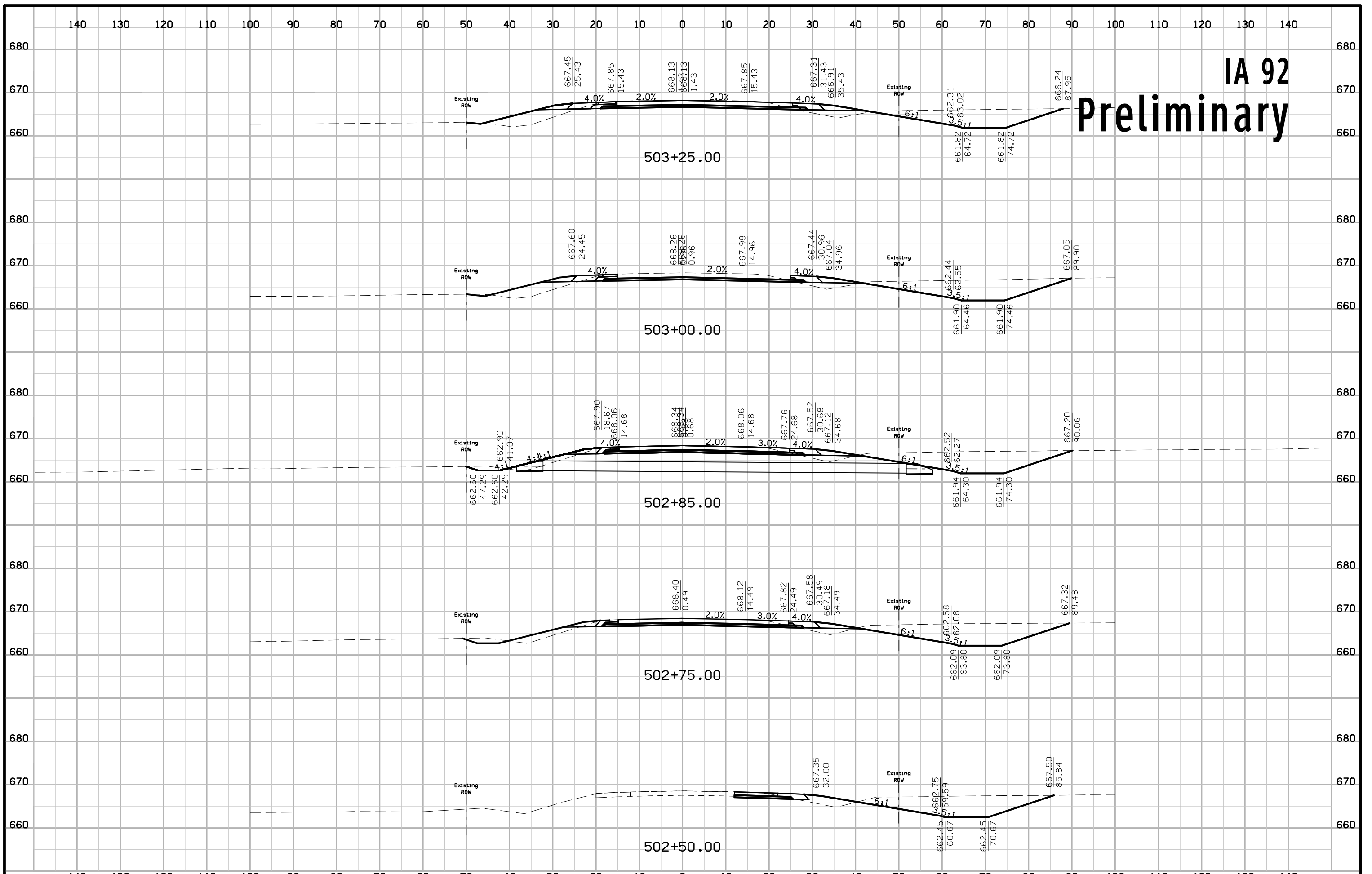

IA 92 Preliminary

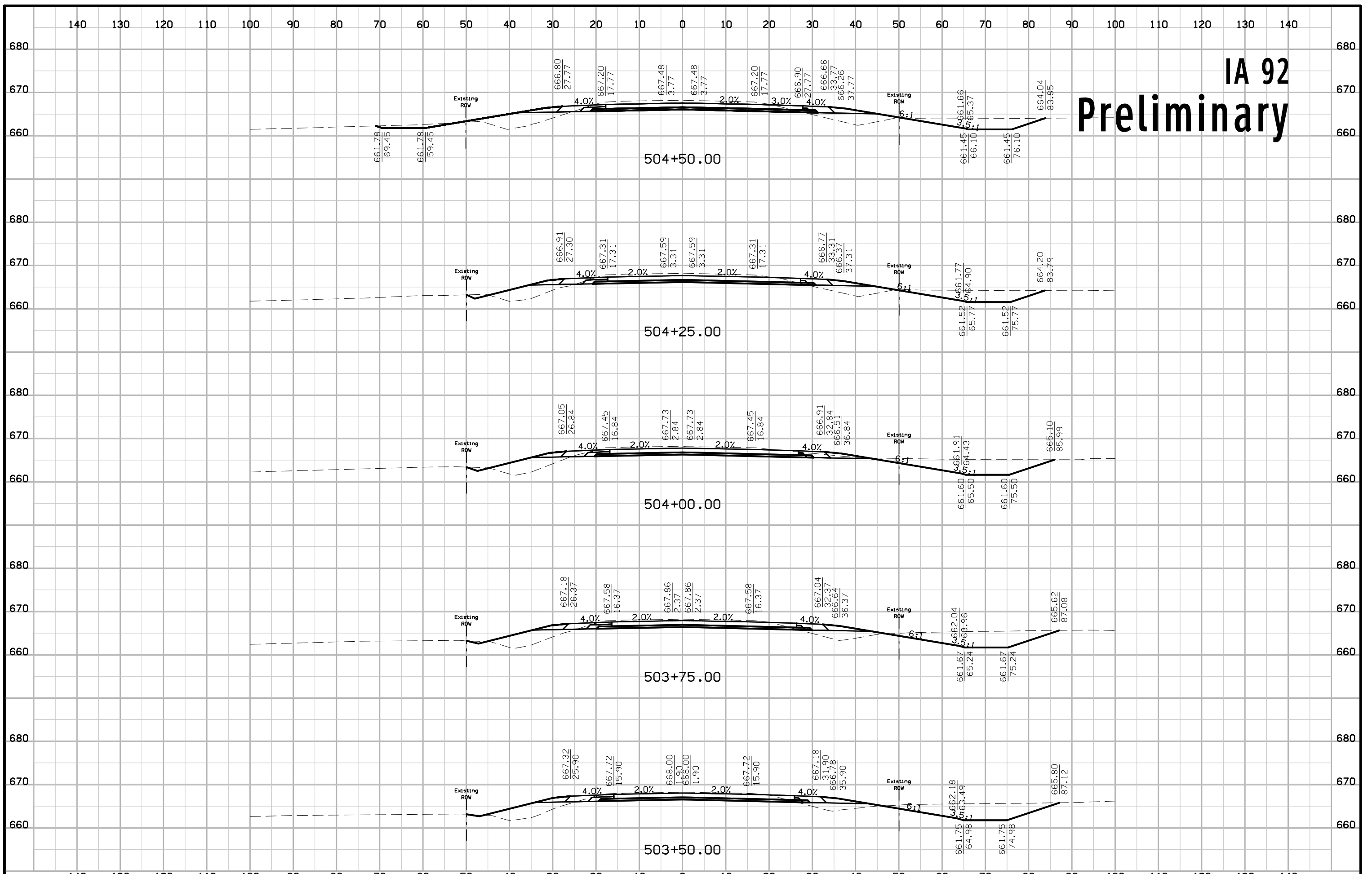

IA 92 Preliminary

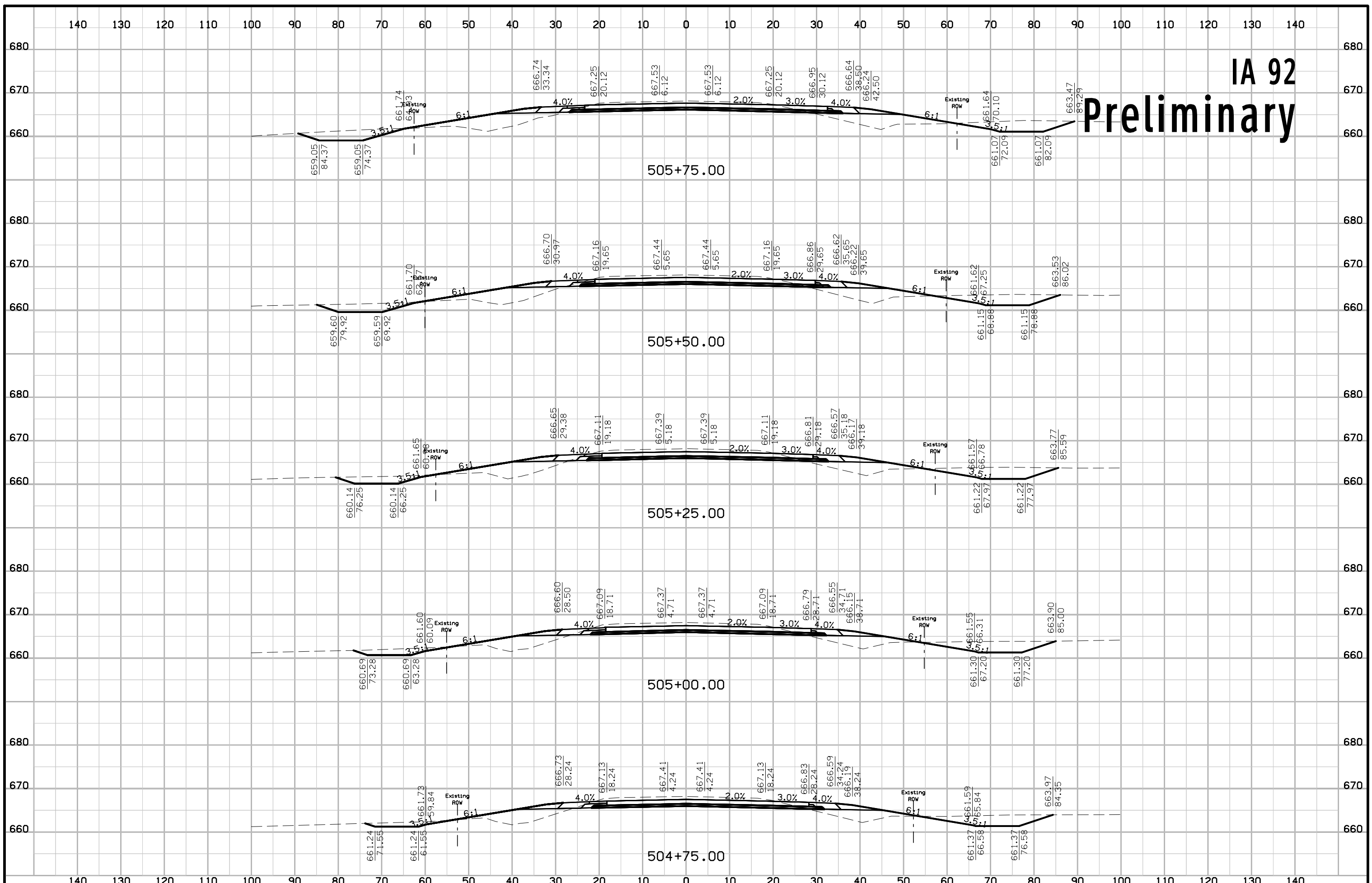

IA 92 Preliminary

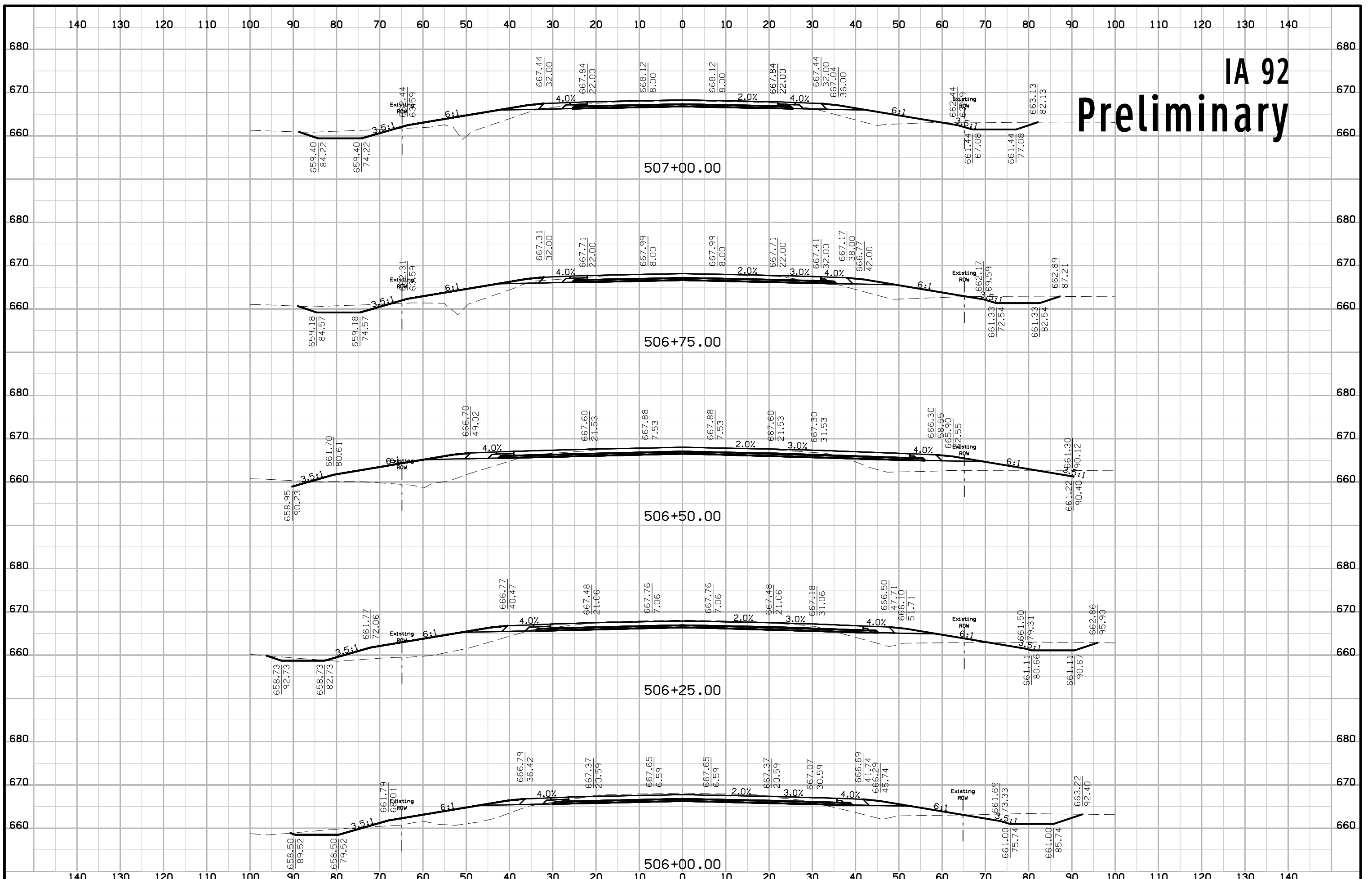

IA 92 Preliminary

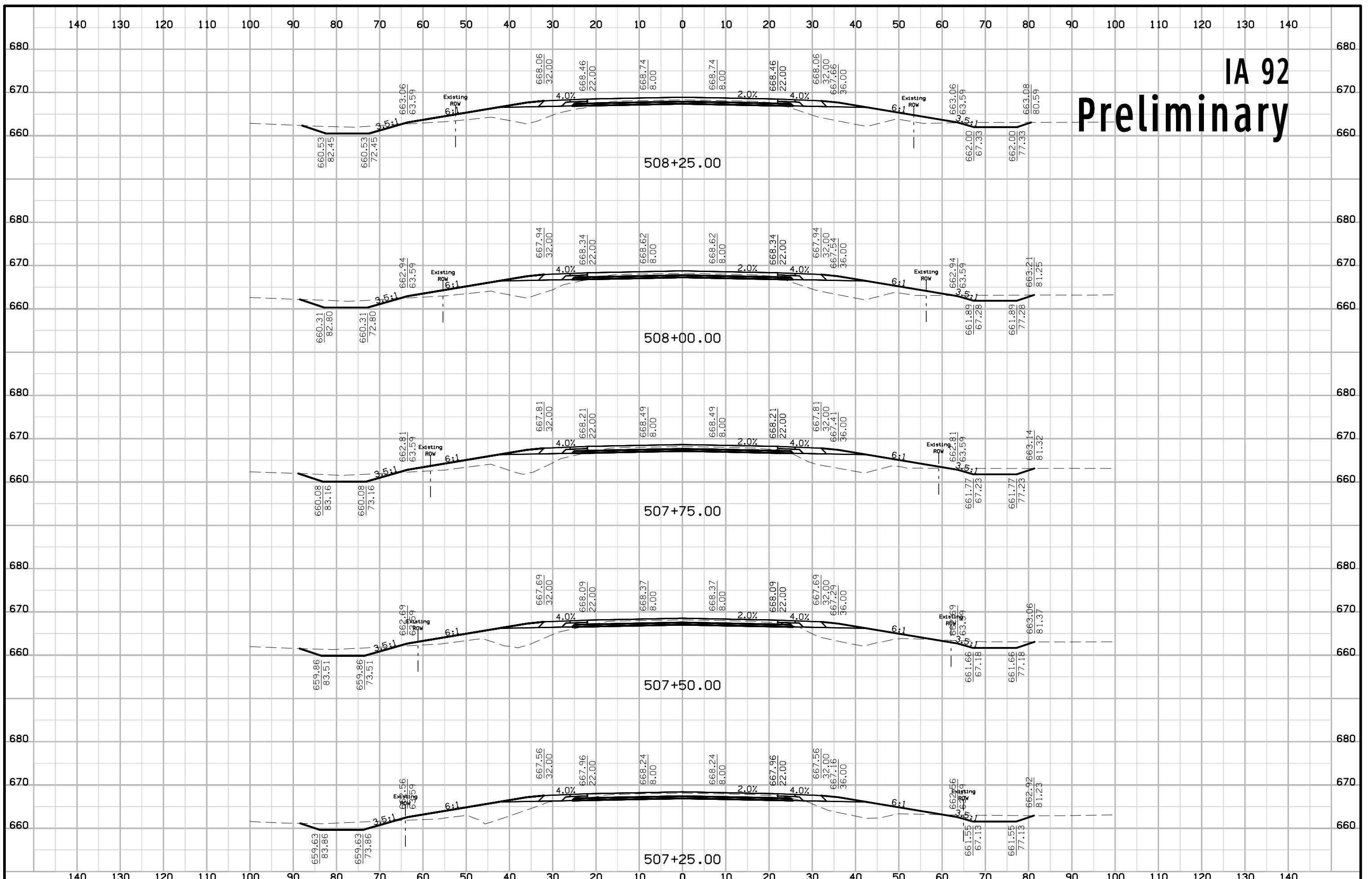

IA 92 Preliminary

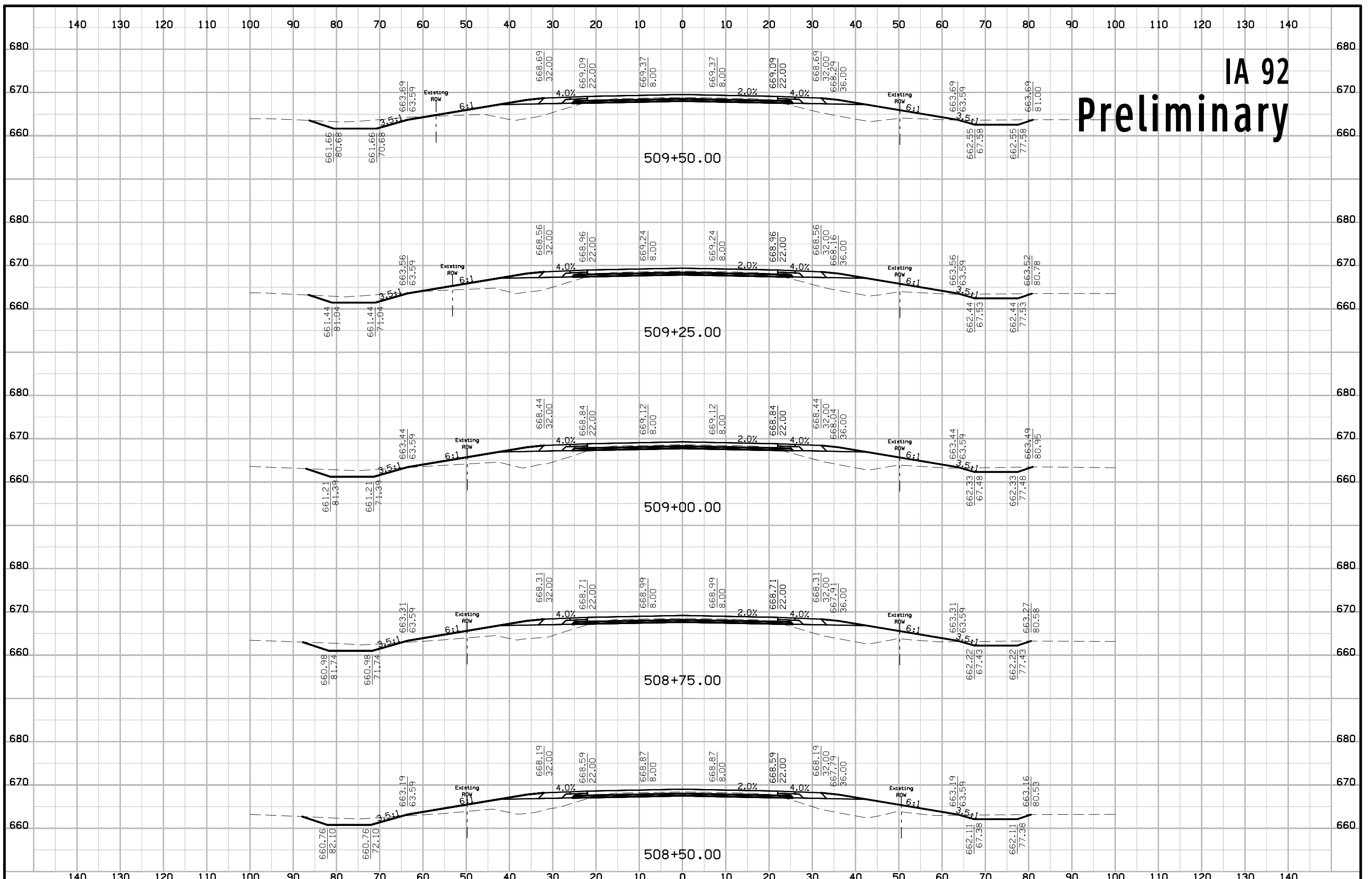

IA 92 Preliminary

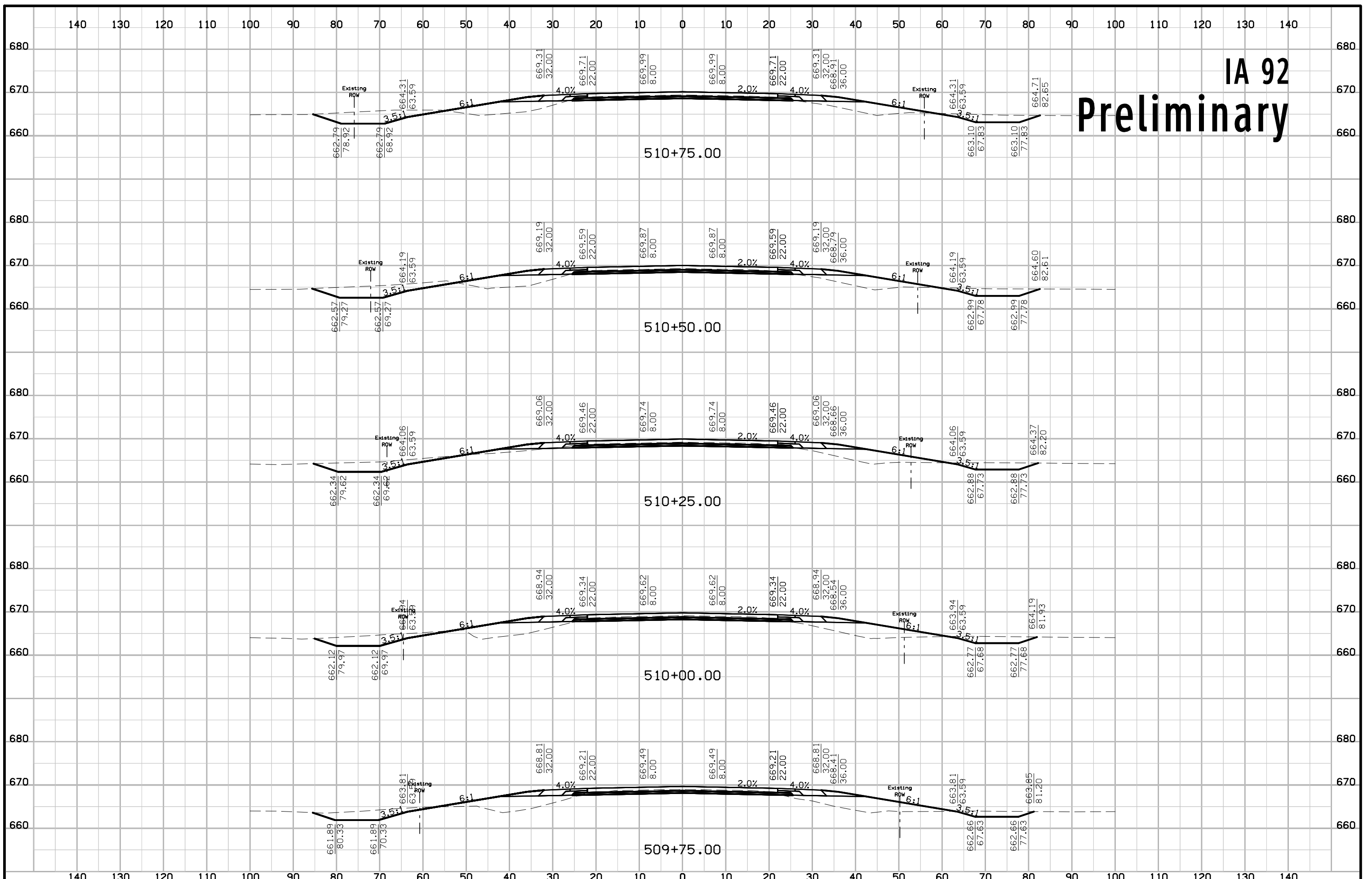

IA 92 Preliminary

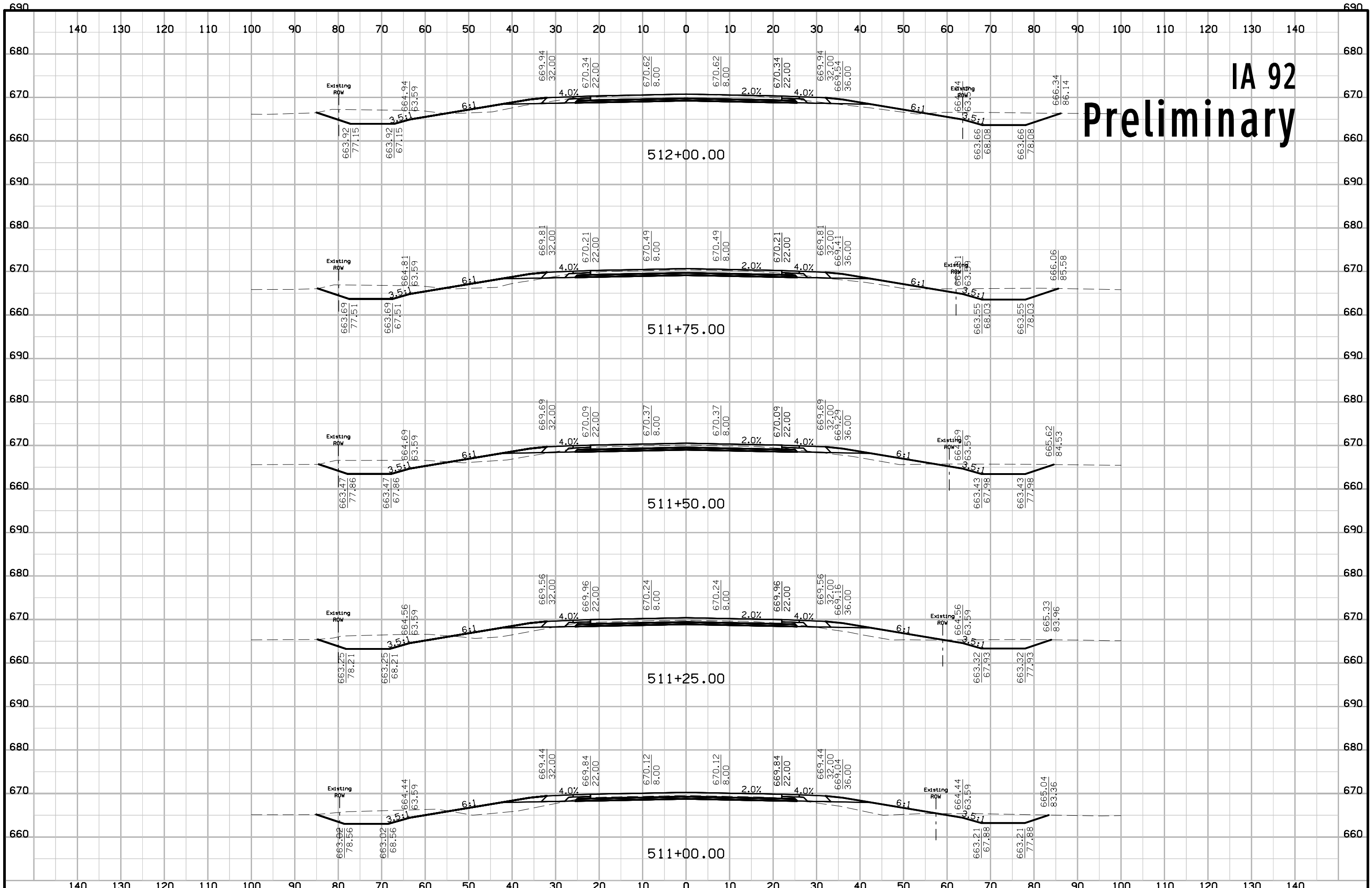

IA 92 Preliminary

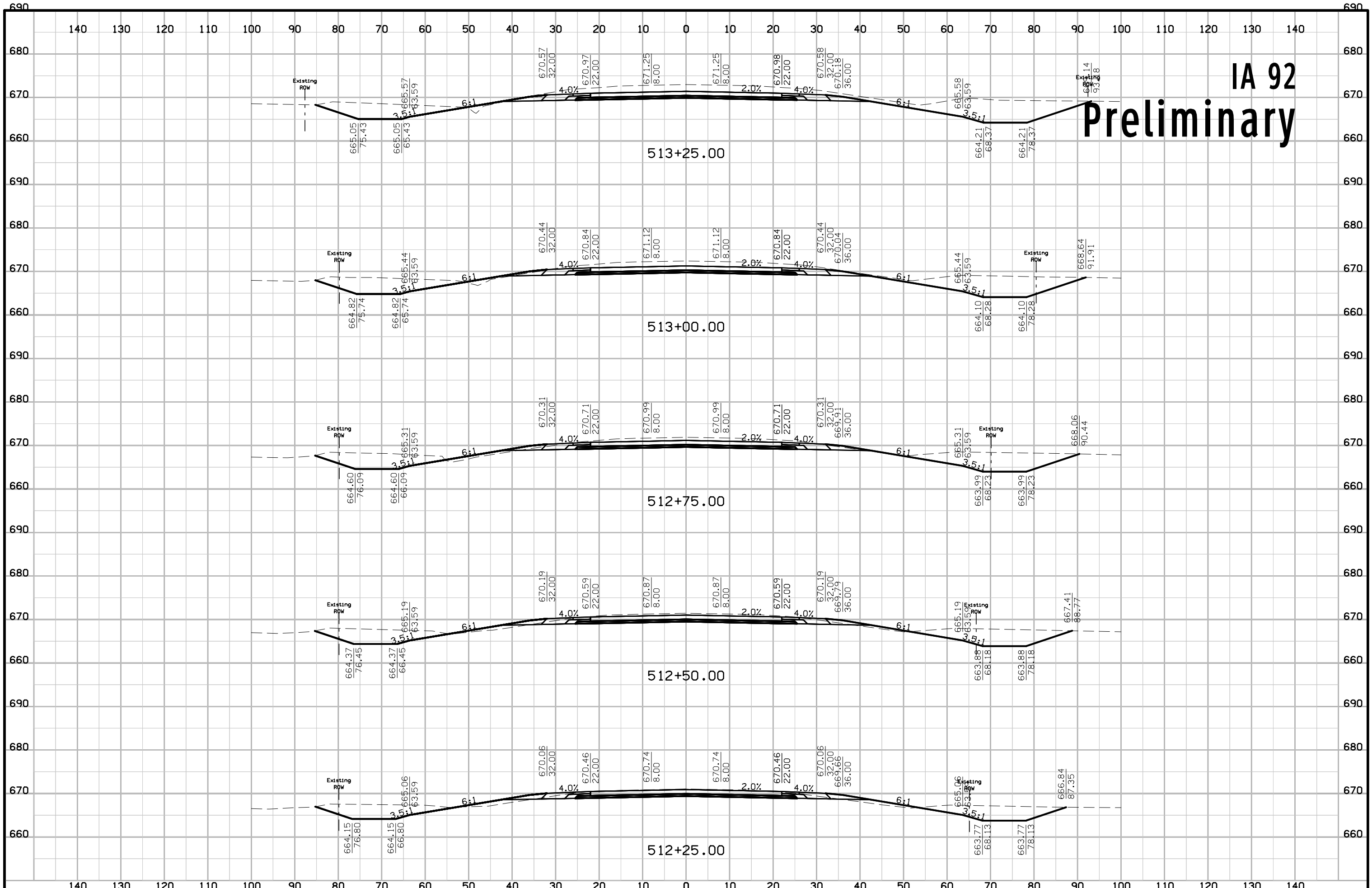

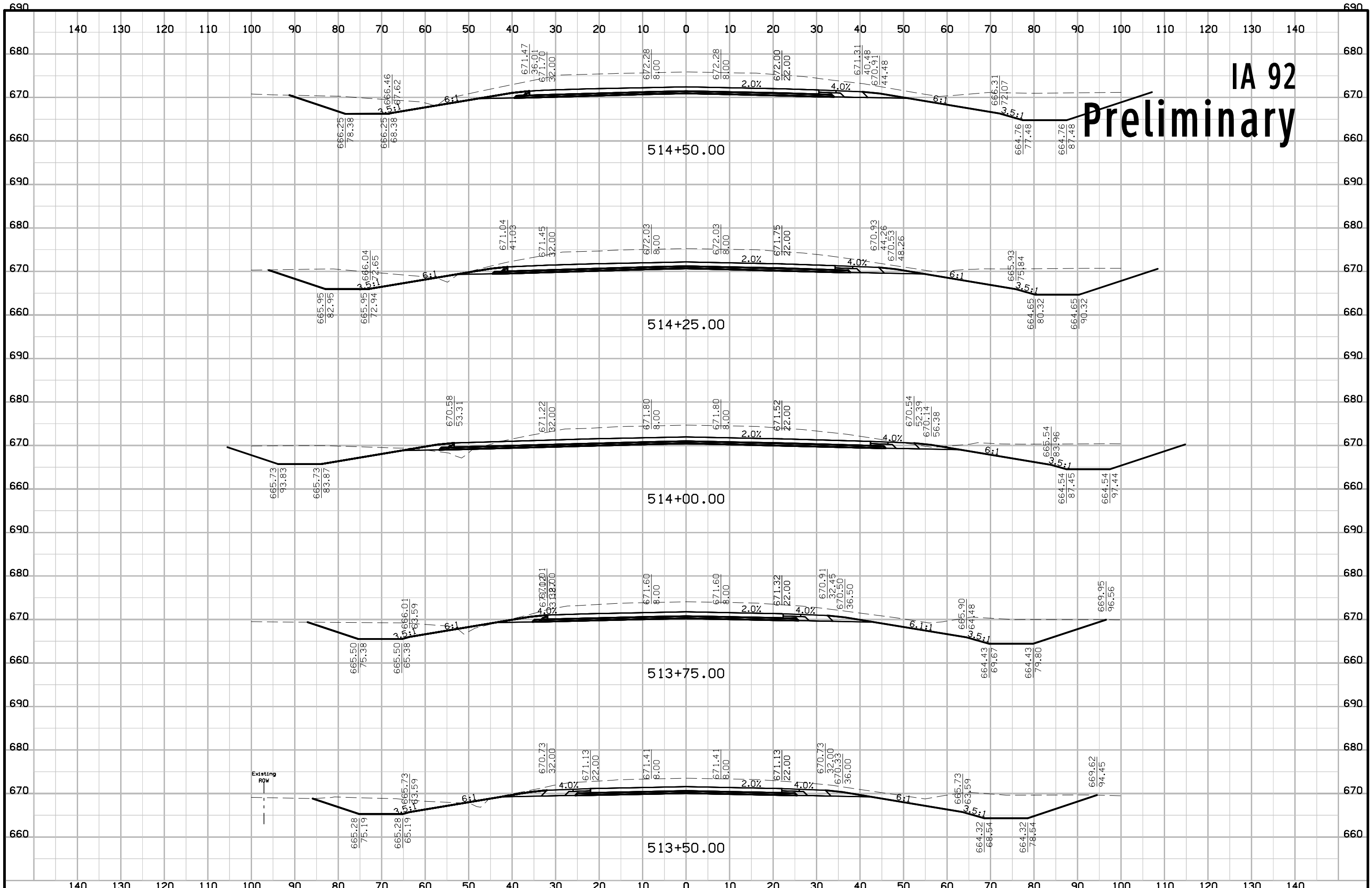

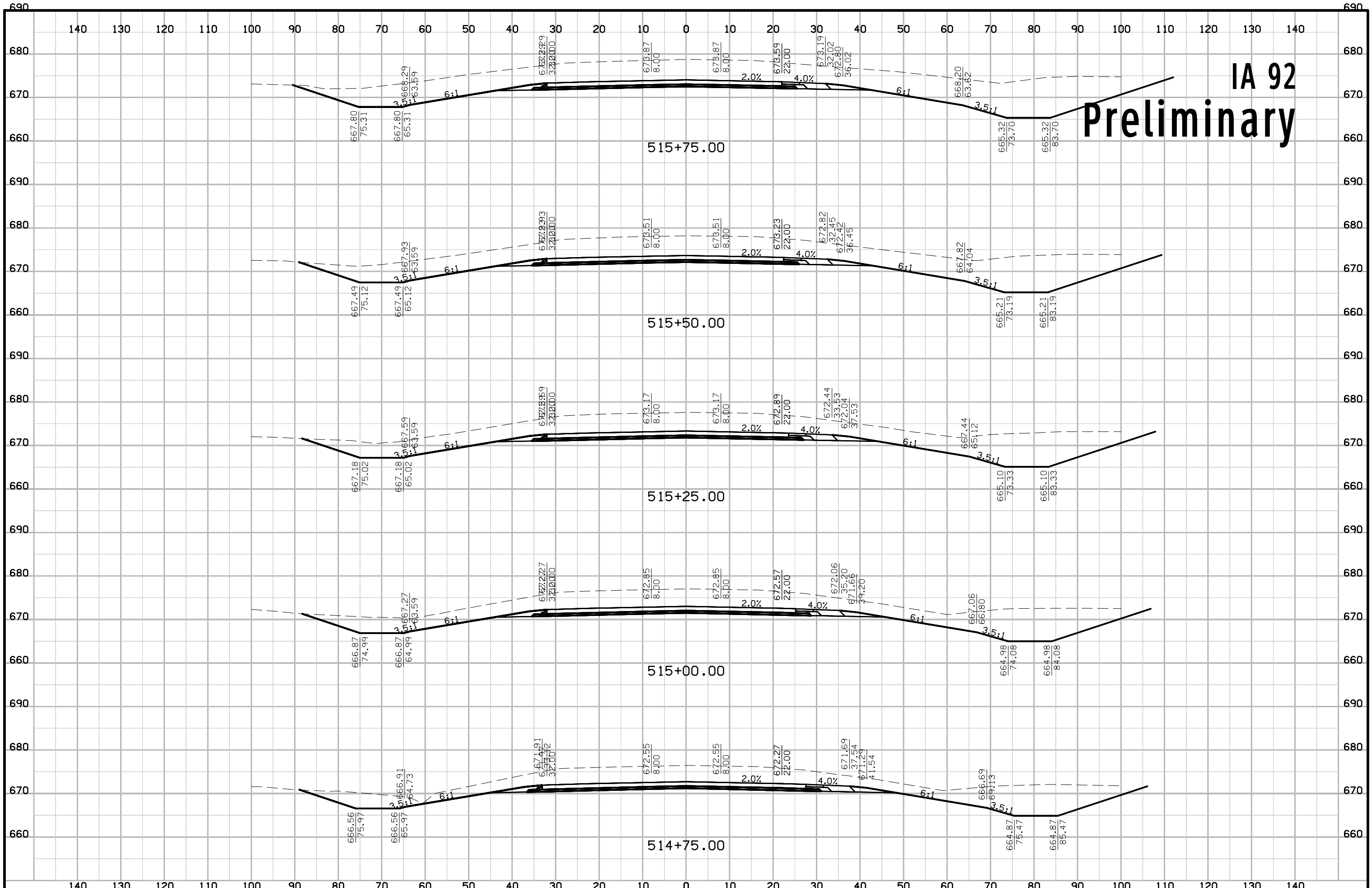

IA 92
Preliminary

IA 92 Preliminary

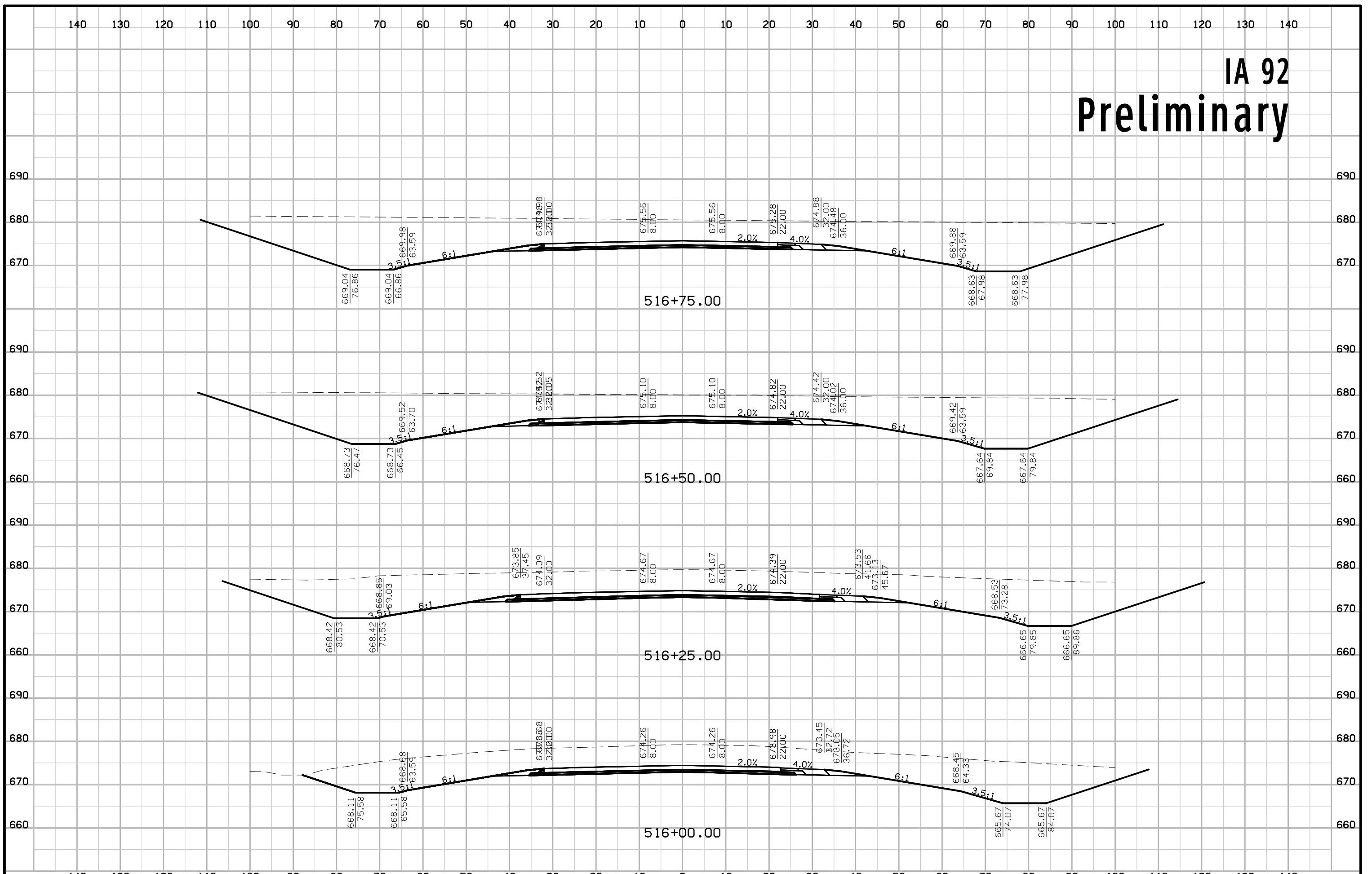

IA 92 Preliminary

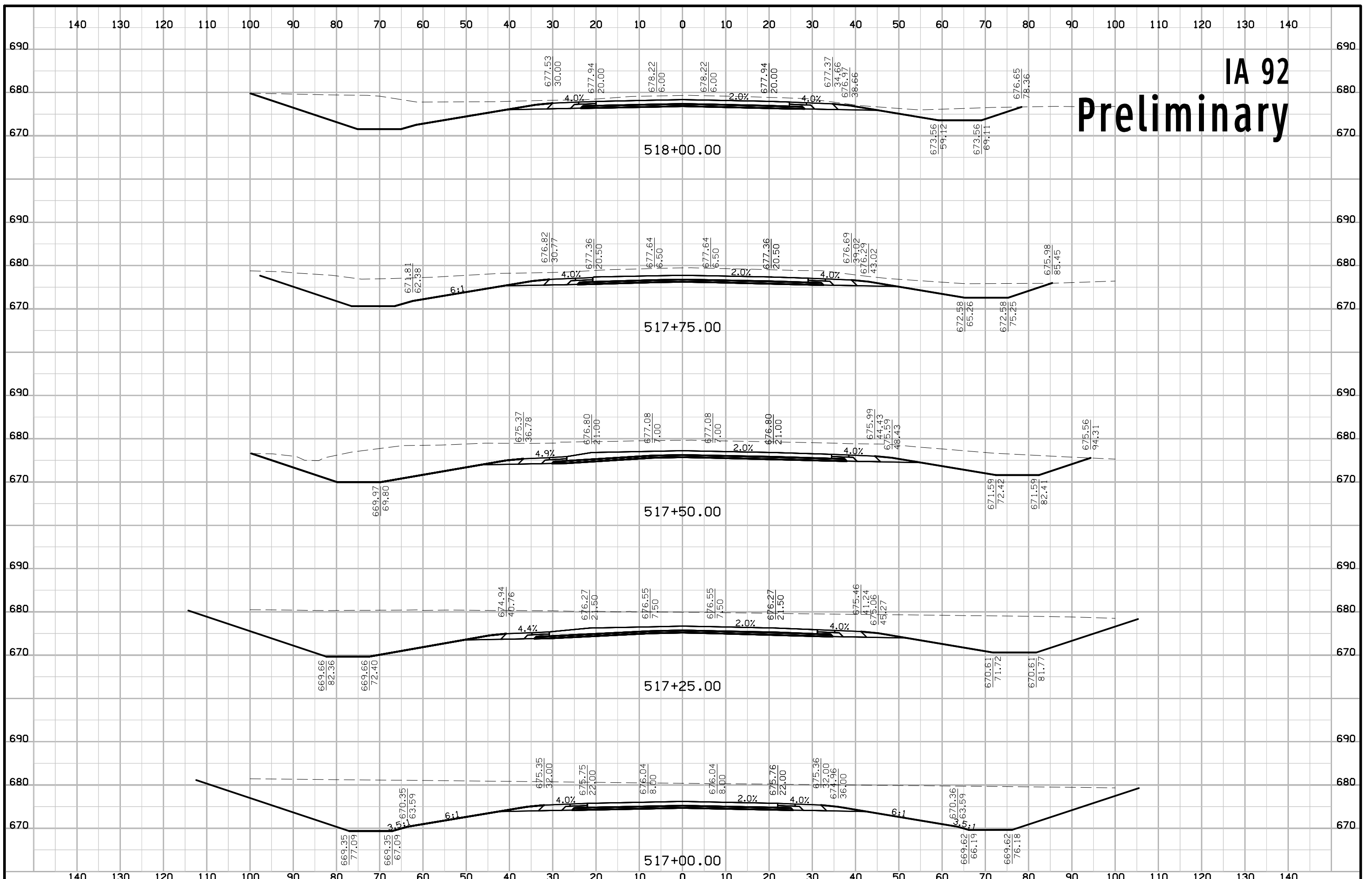

IA 92 Preliminary

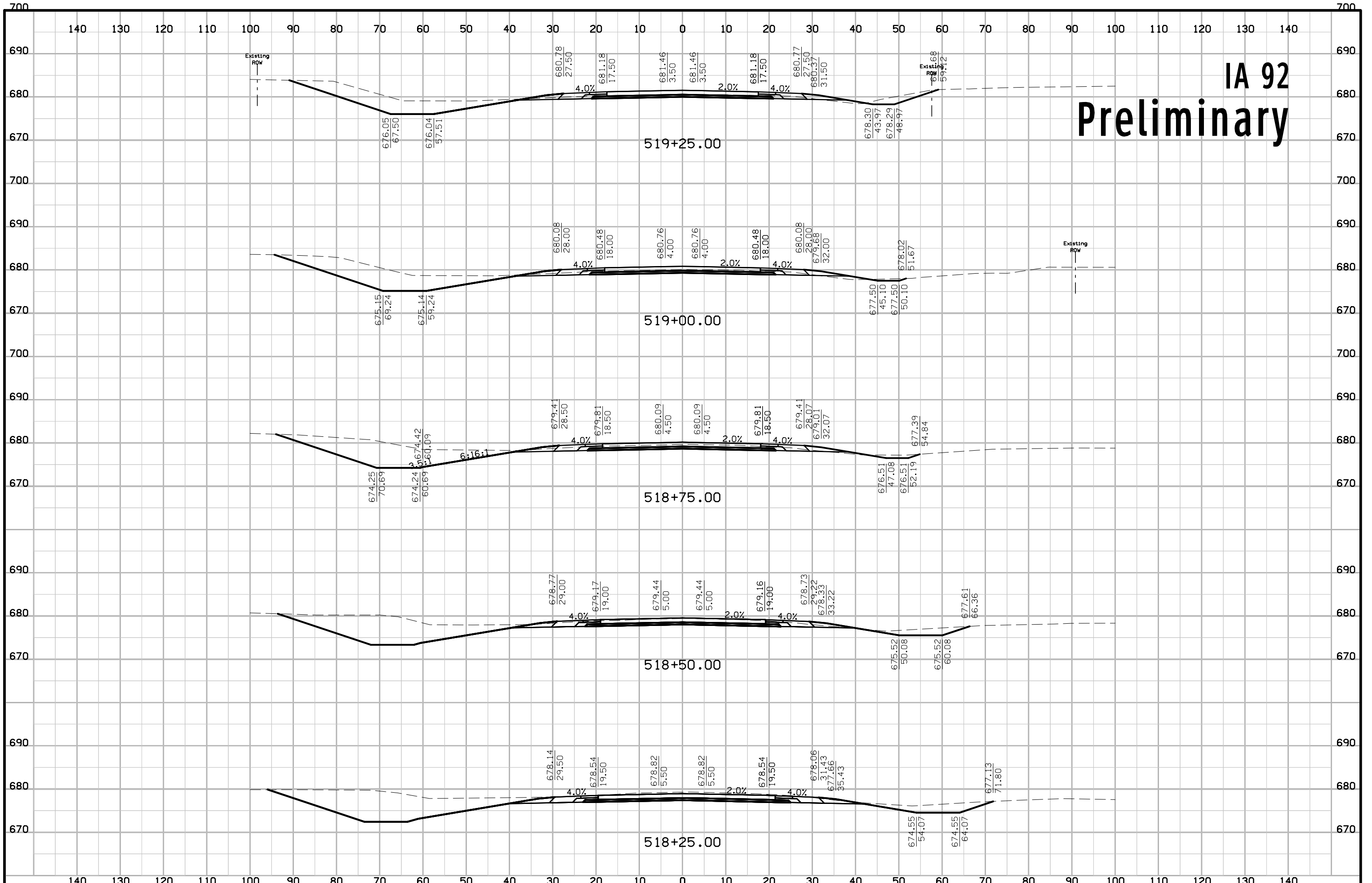

IA 92 Preliminary

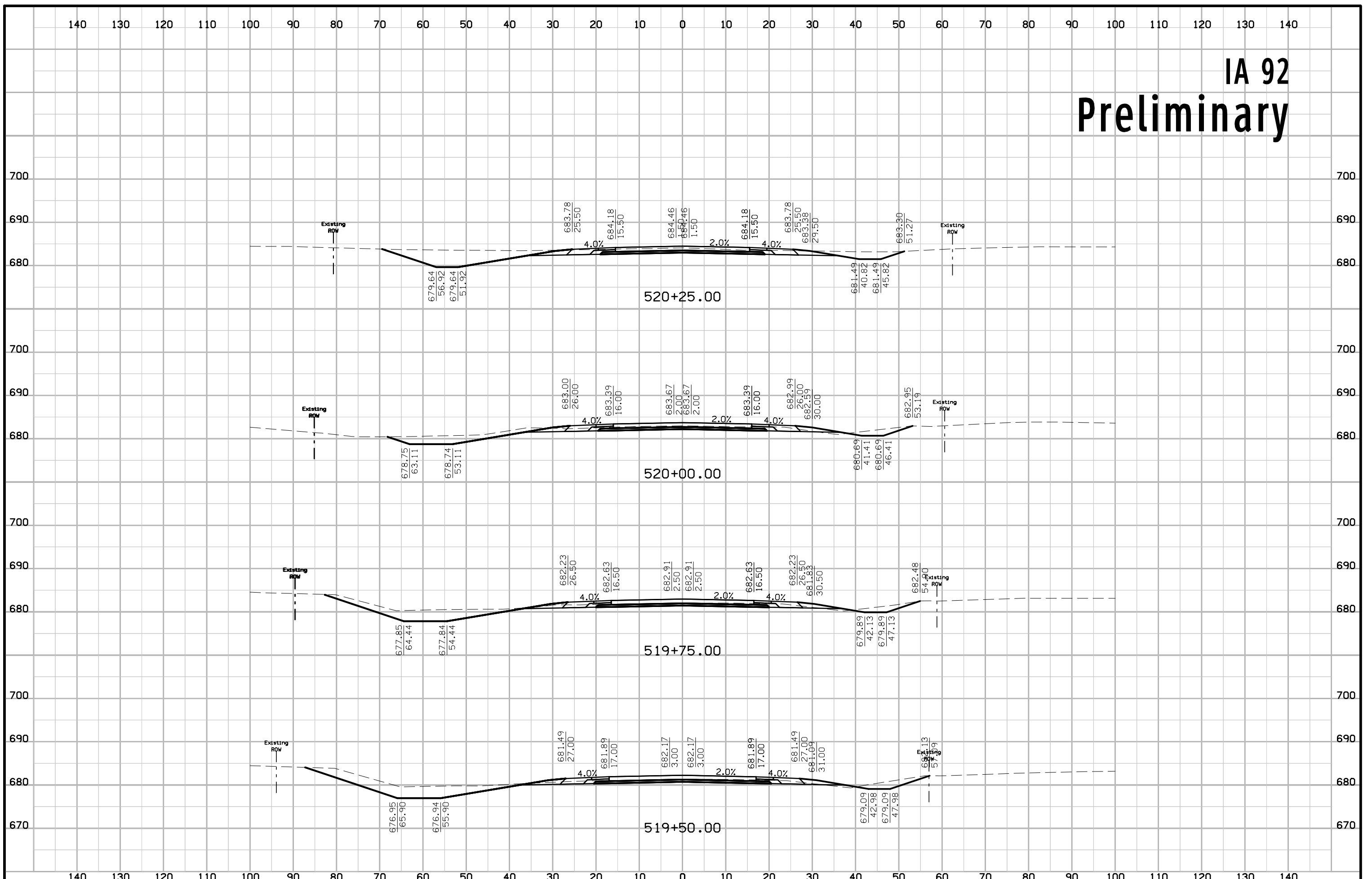

IA 92 Preliminary

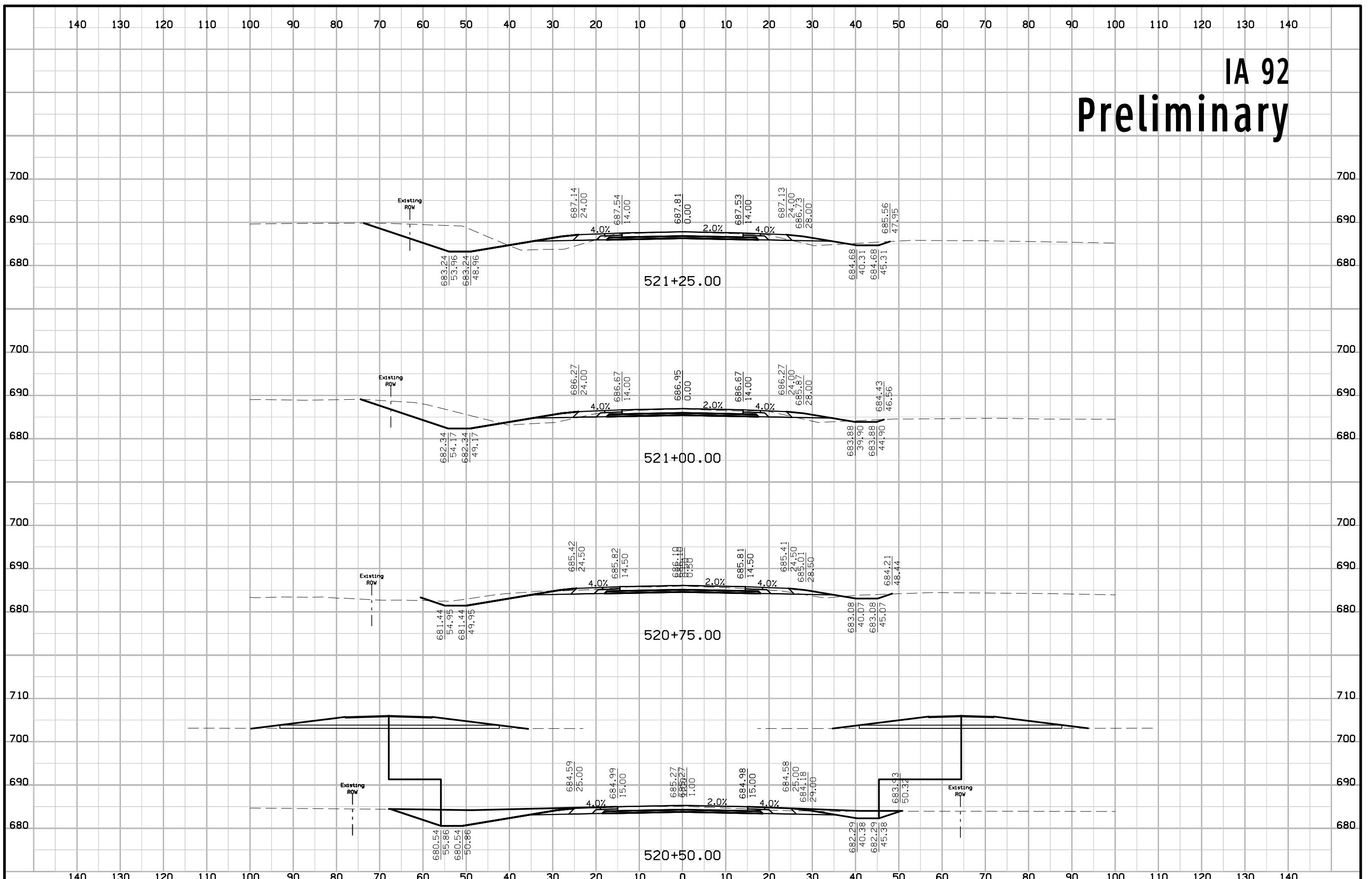

IA 92 Preliminary

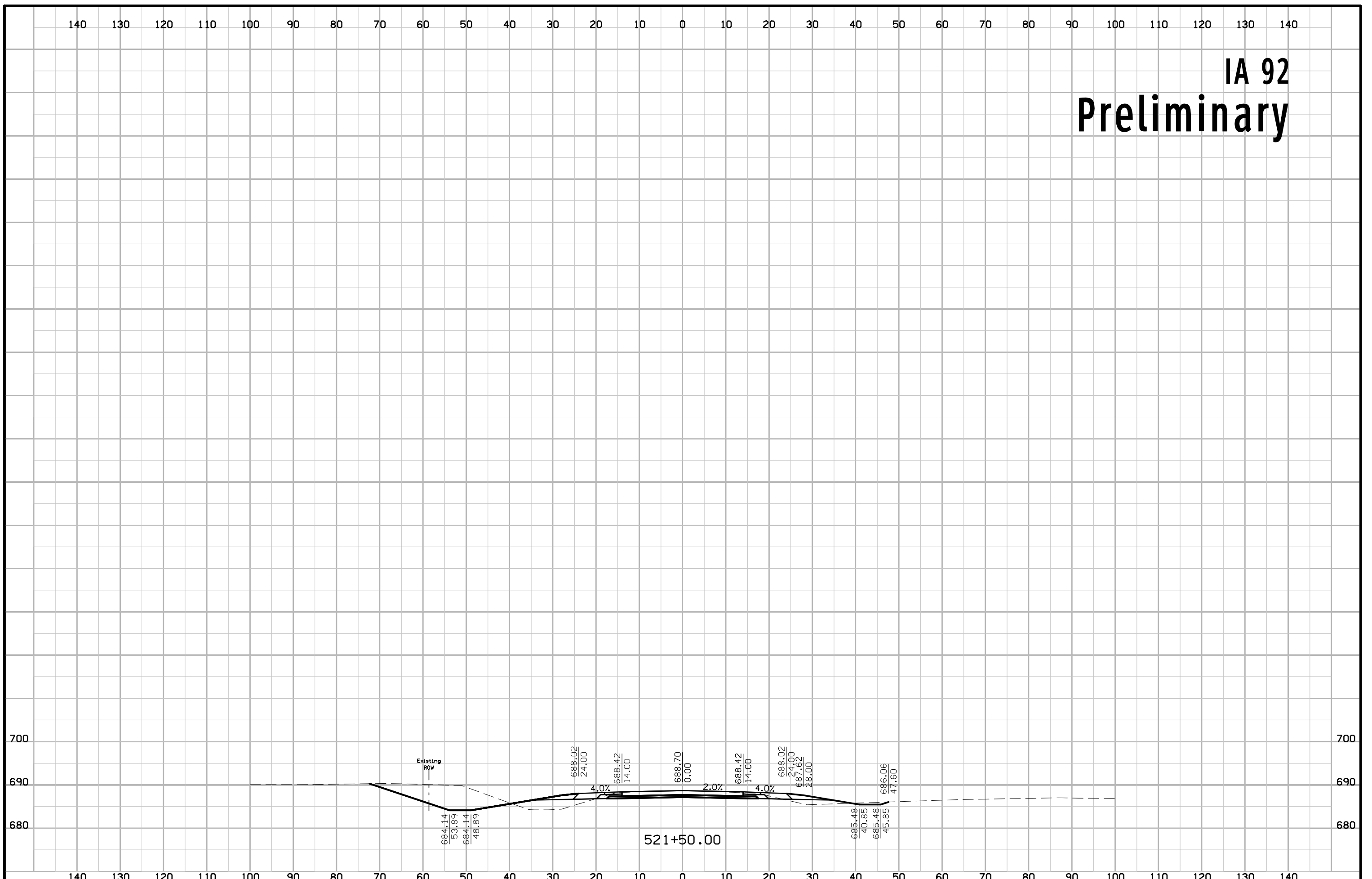

145th St Preliminary

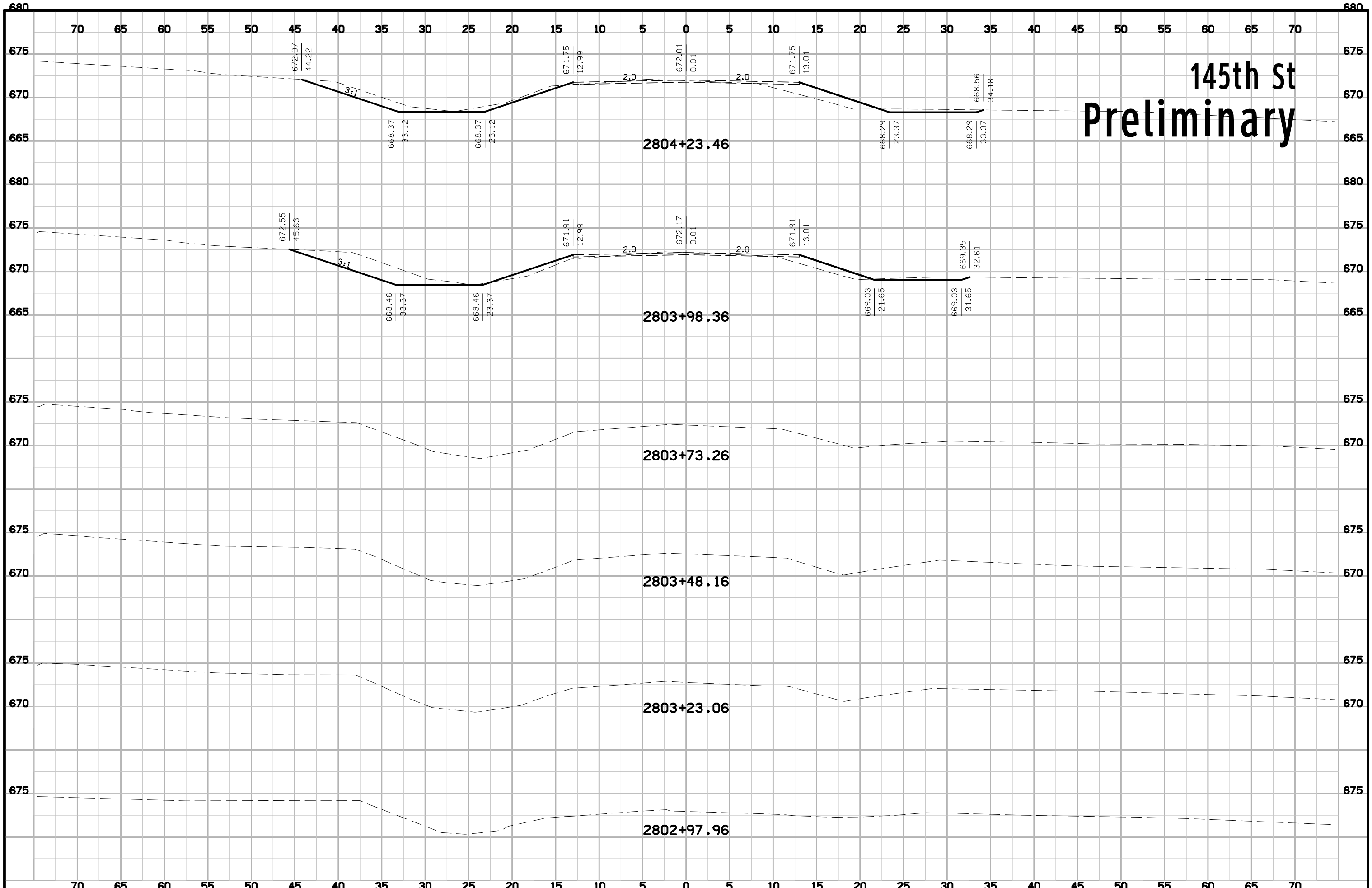

145th St Preliminary

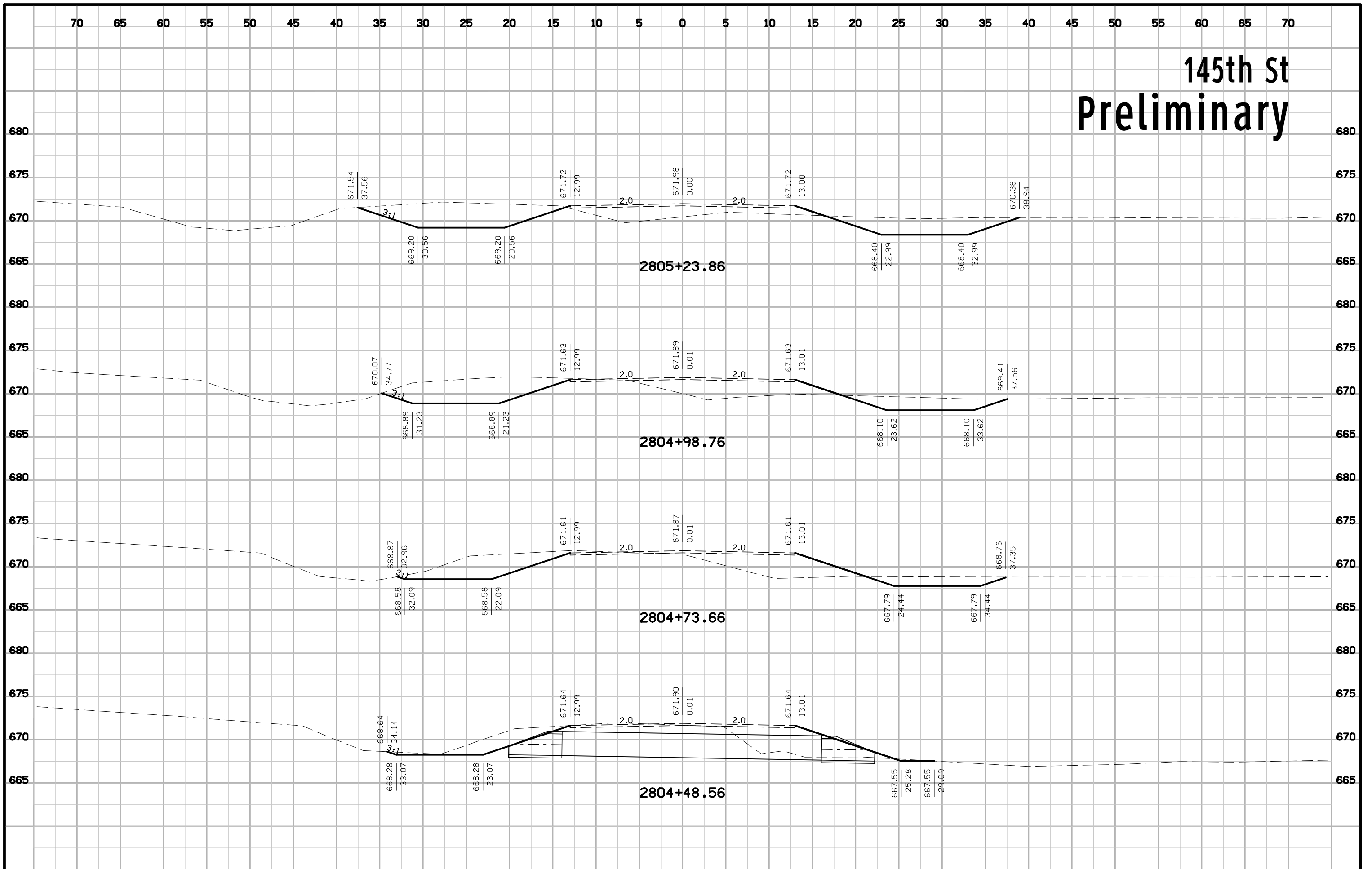

145th St Preliminary

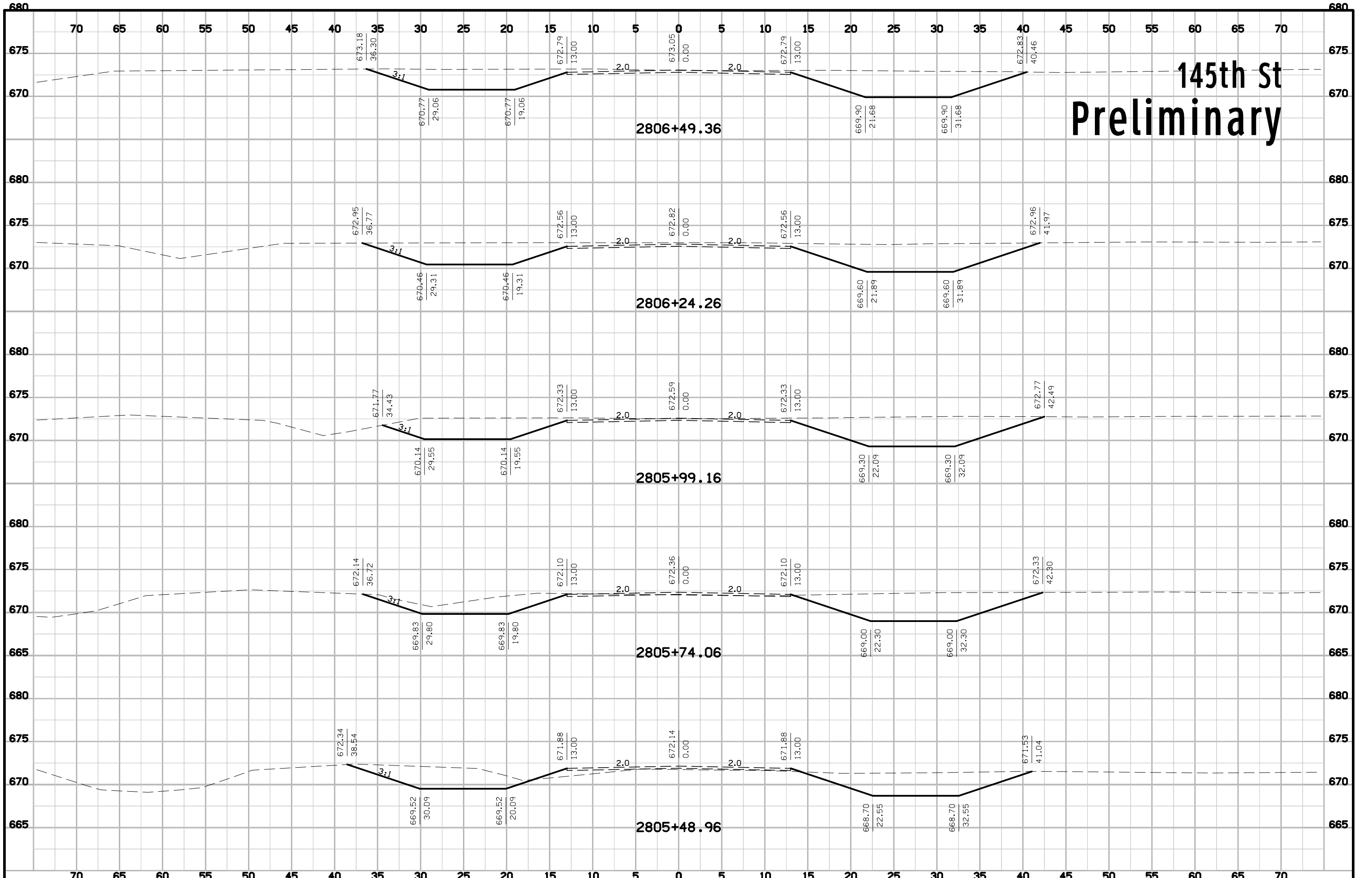

145th St Preliminary

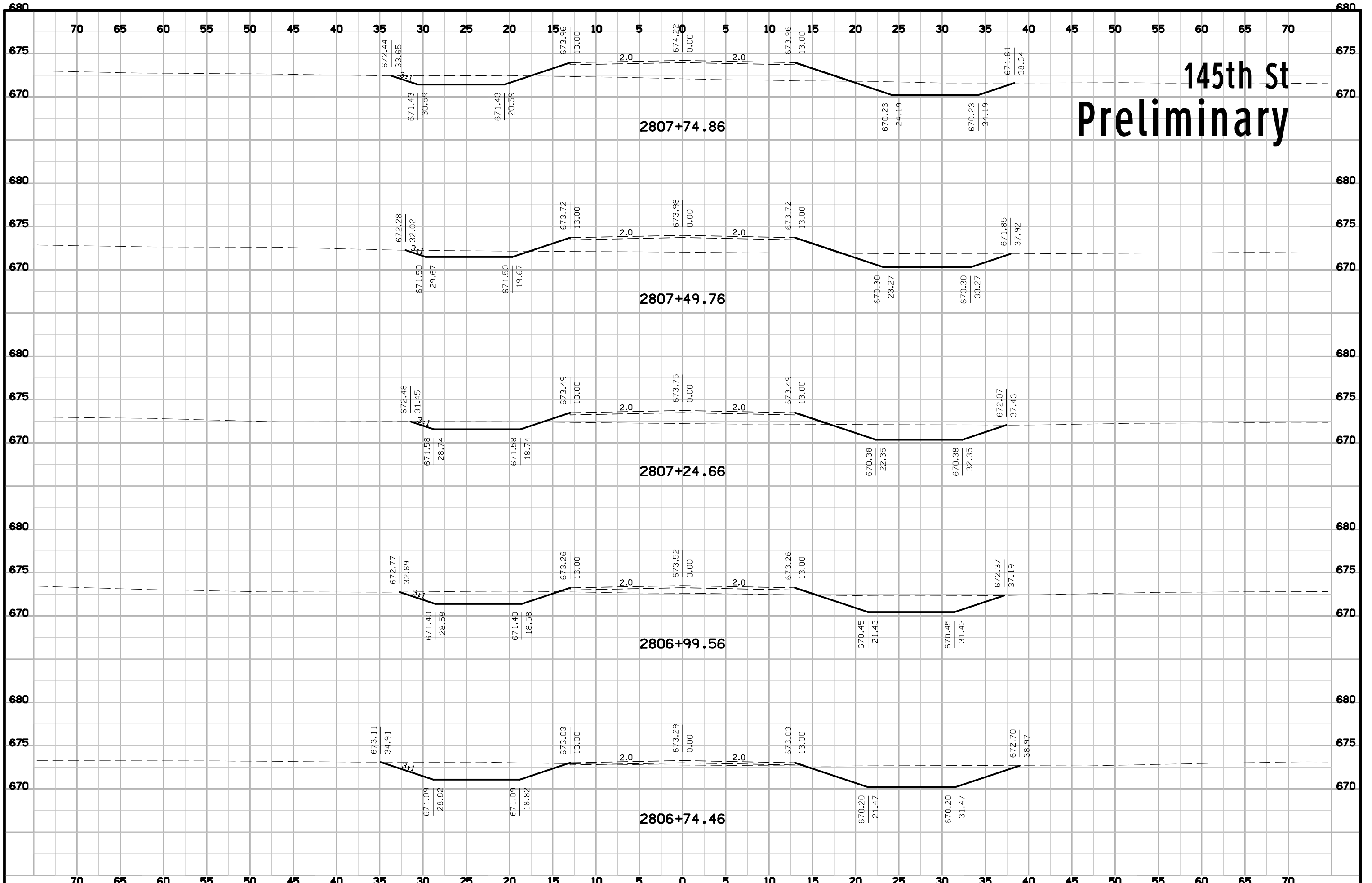

145th St Preliminary

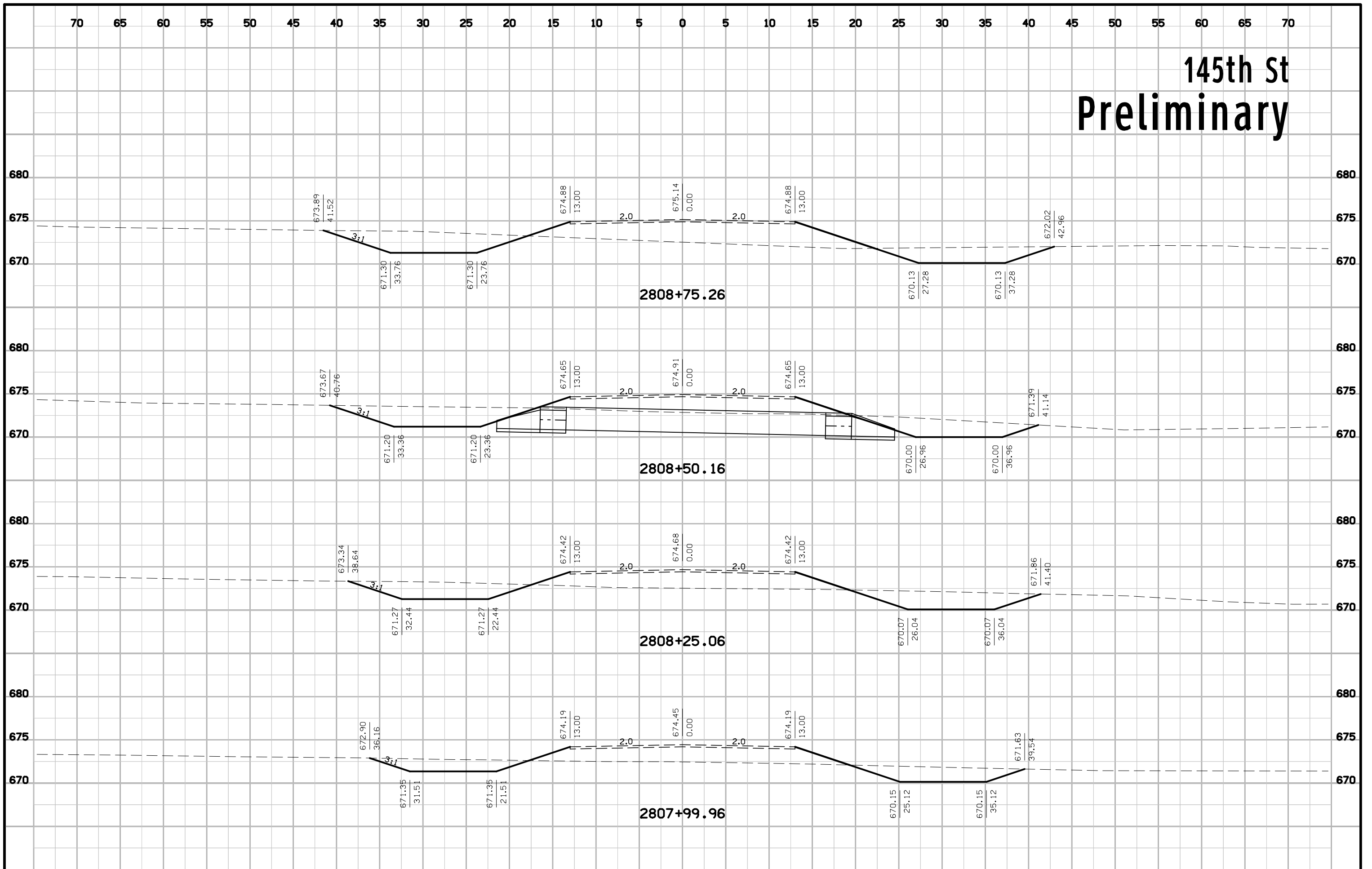

145th St Preliminary

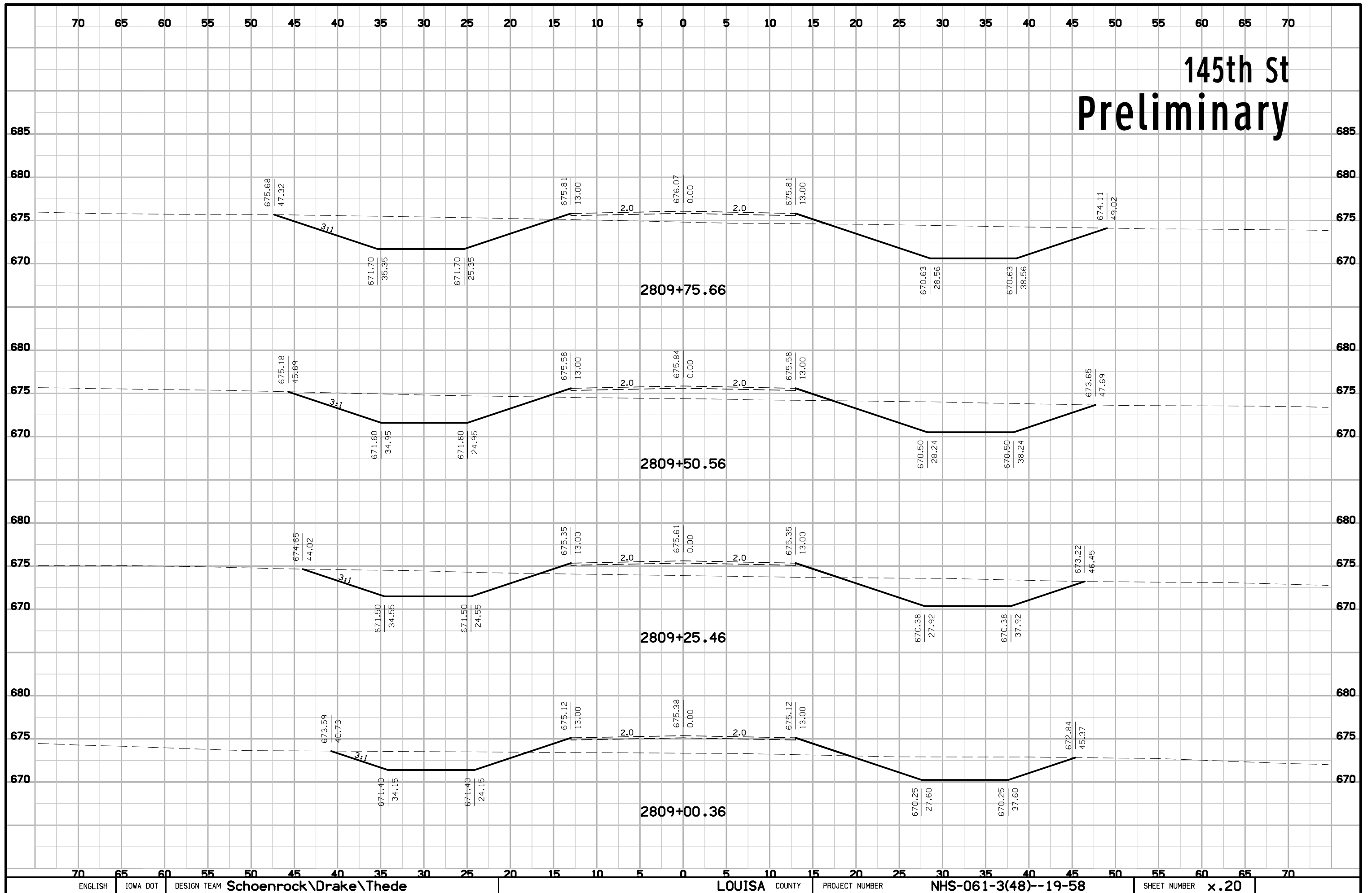

145th St Preliminary

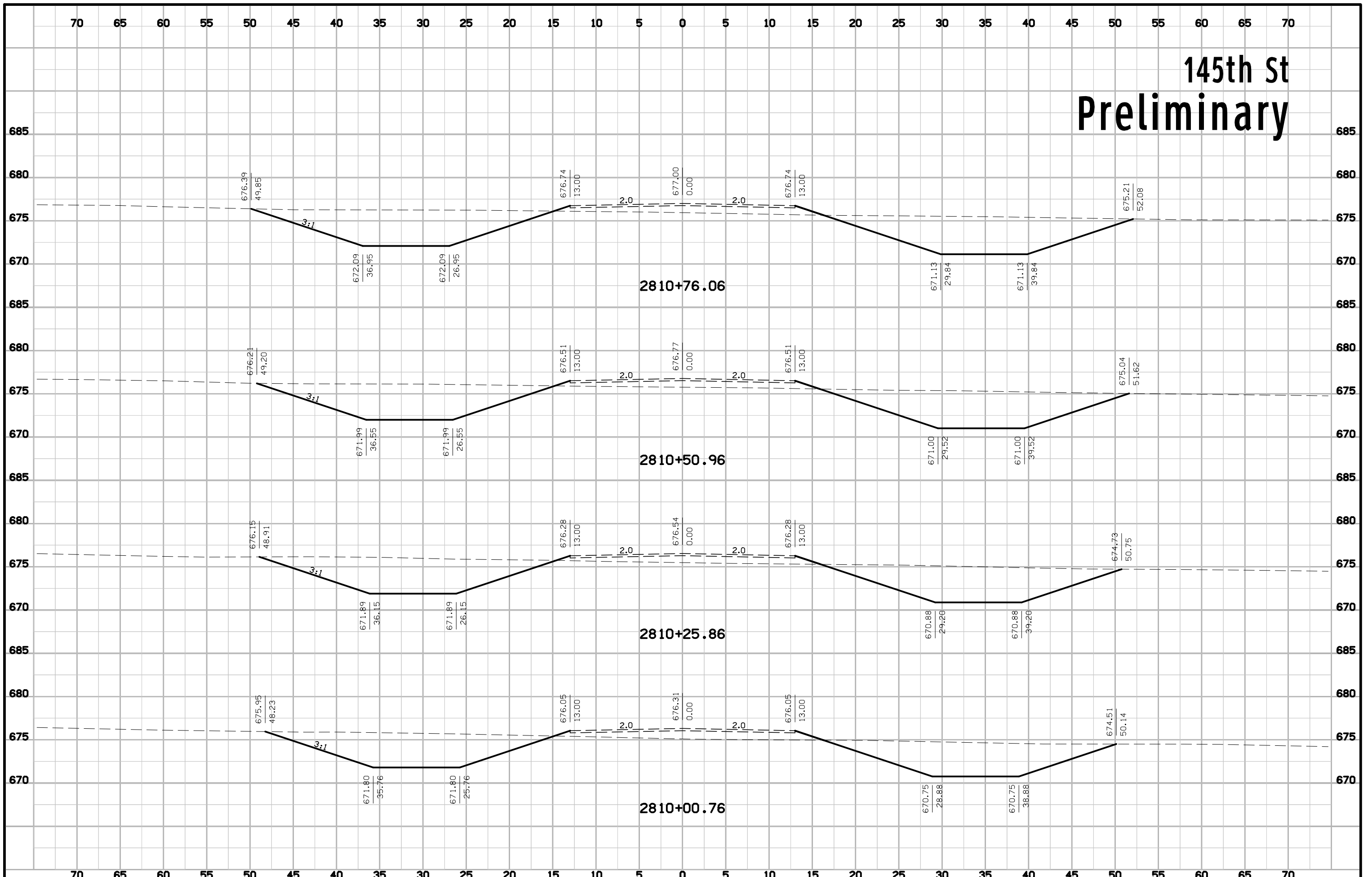

145th St Preliminary

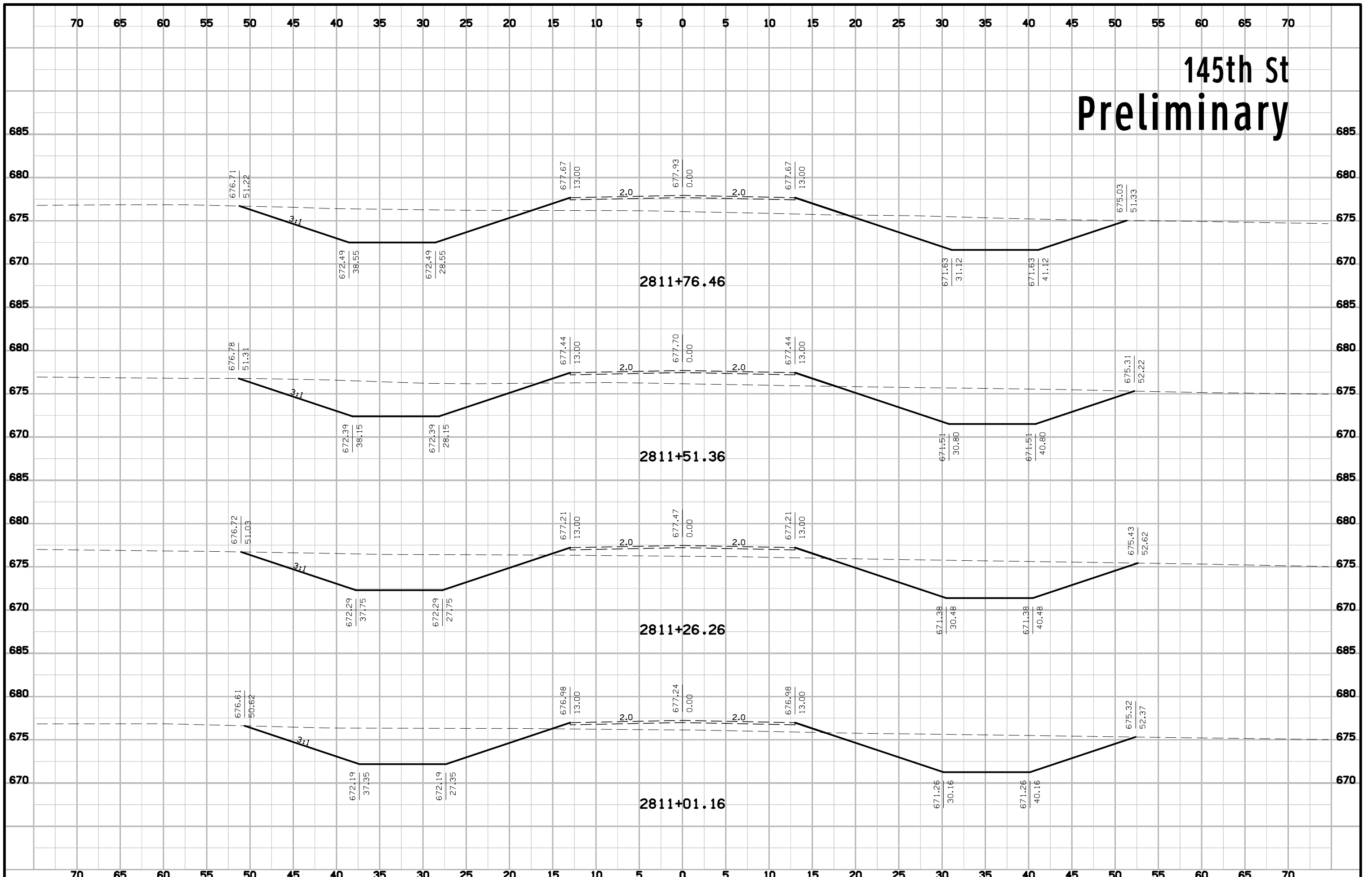

145th St Preliminary

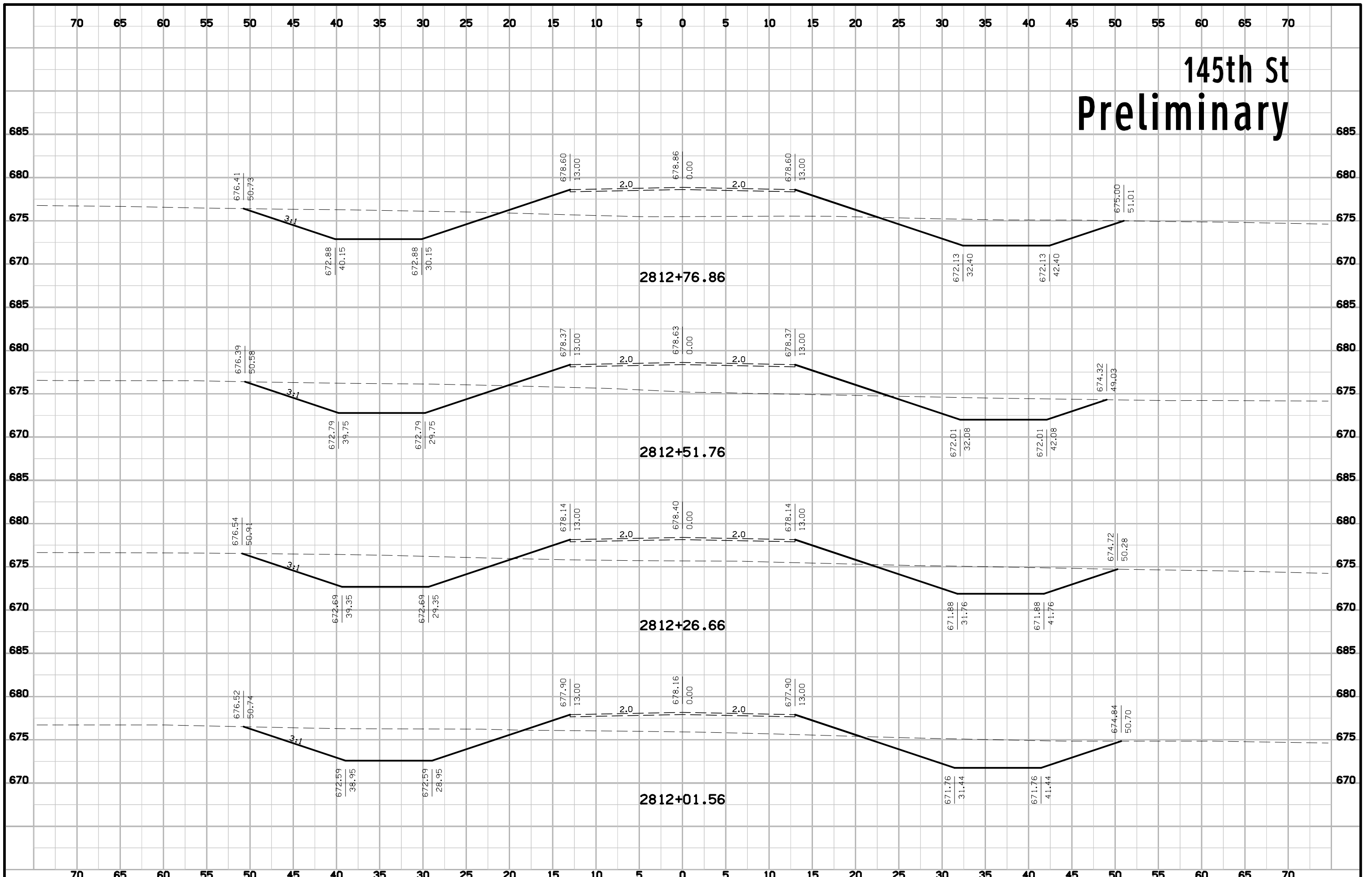

145th St Preliminary

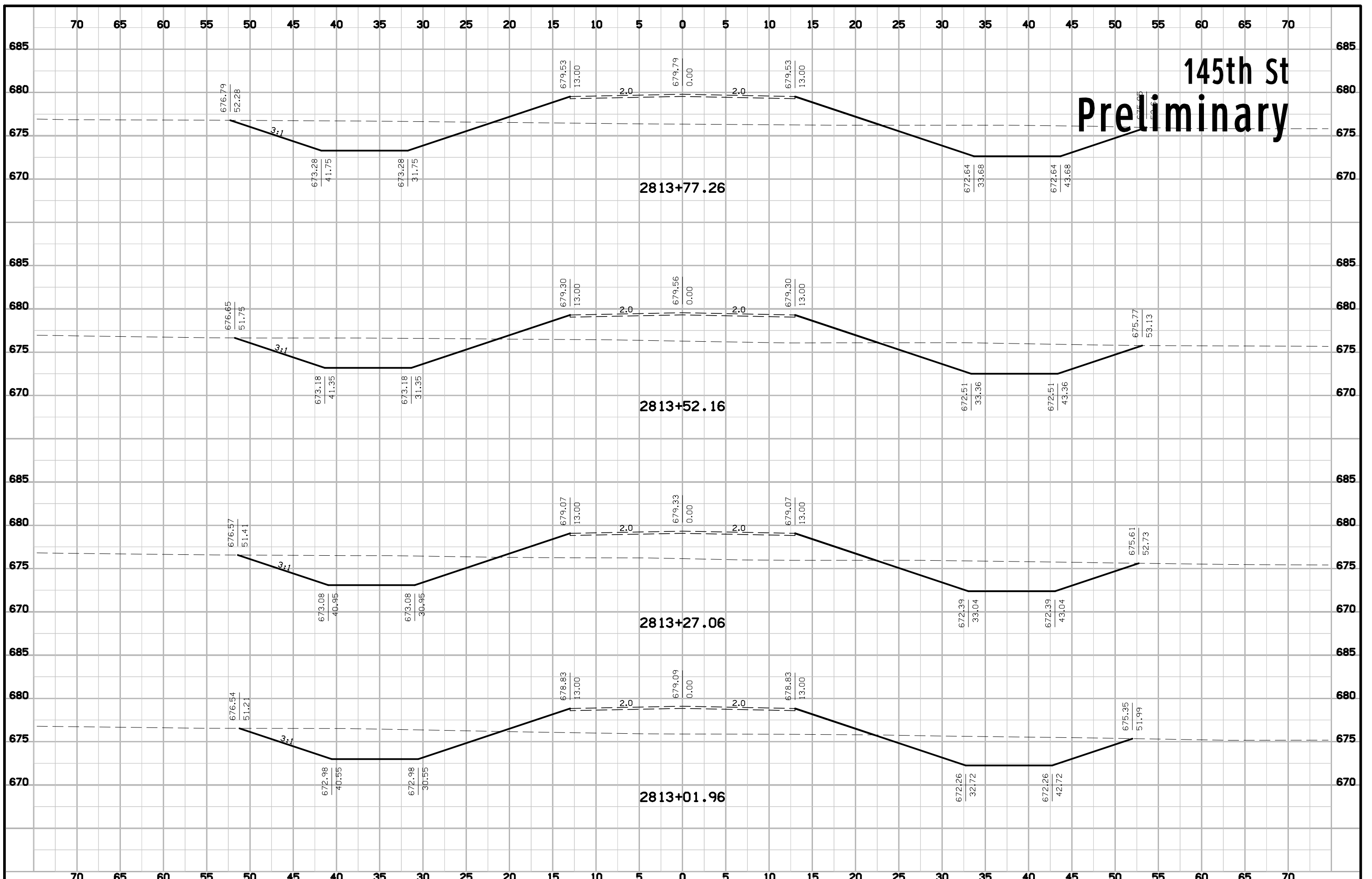

145th St Preliminary

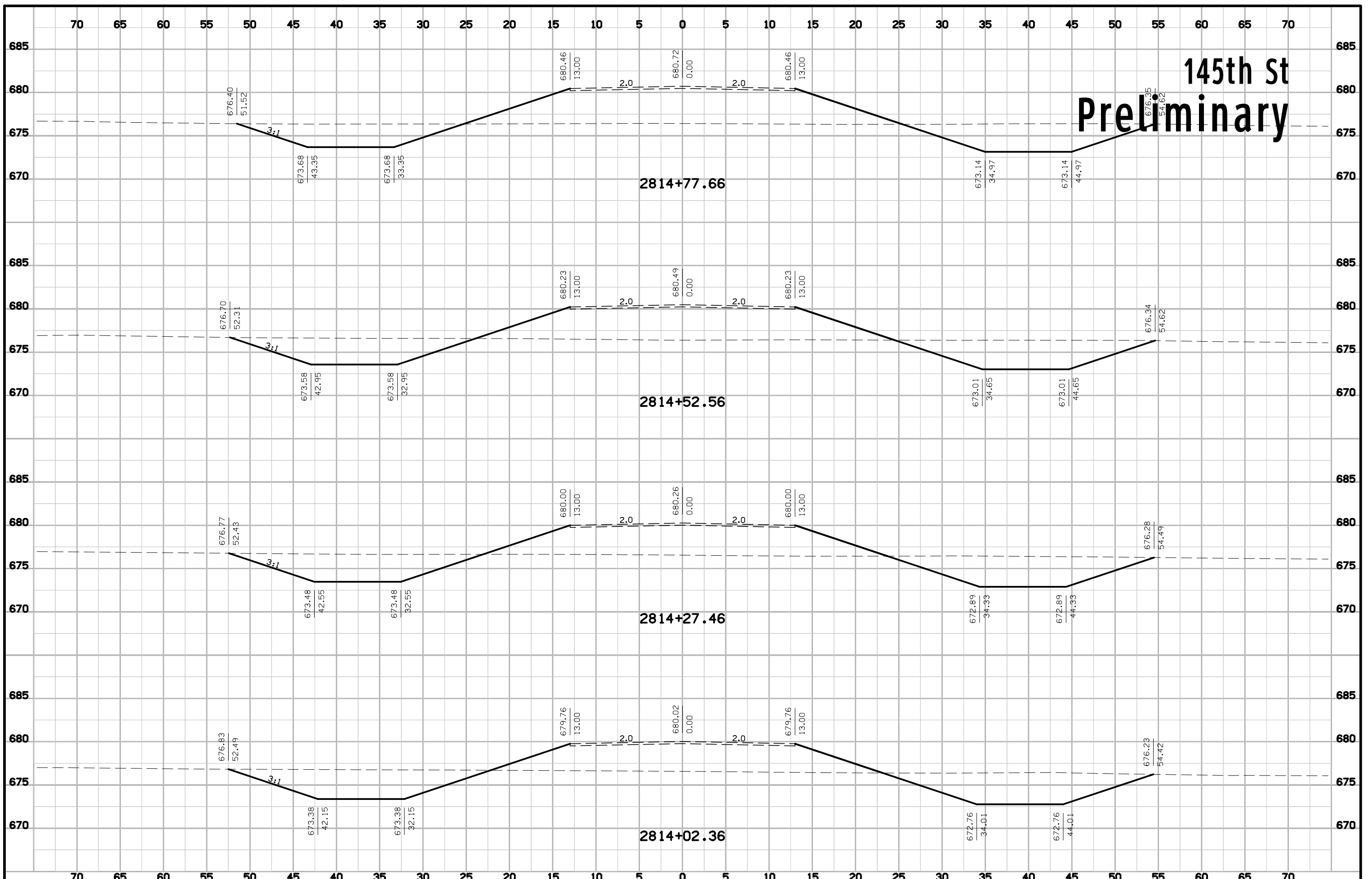

145th St Preliminary

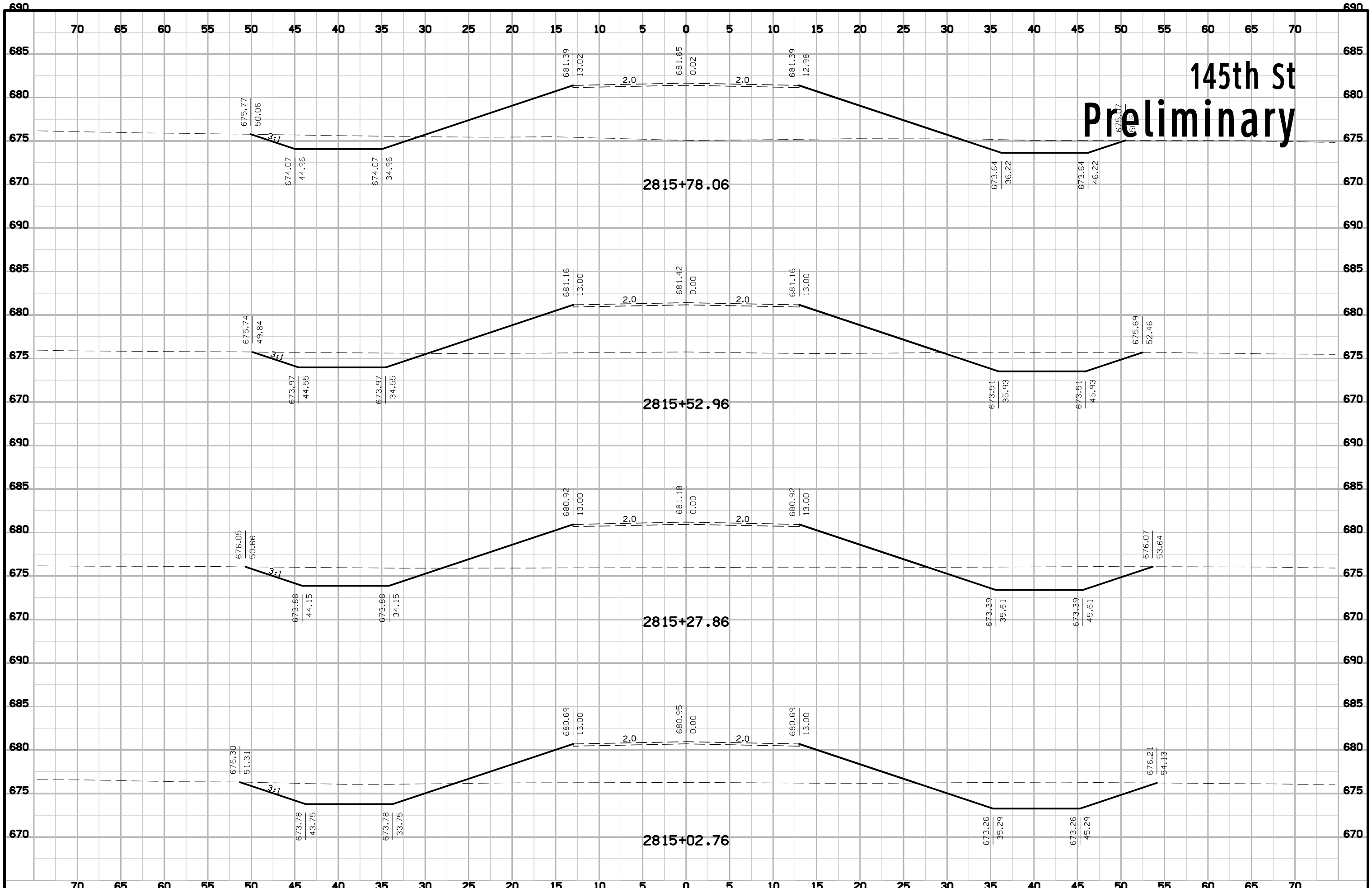

145th St Preliminary

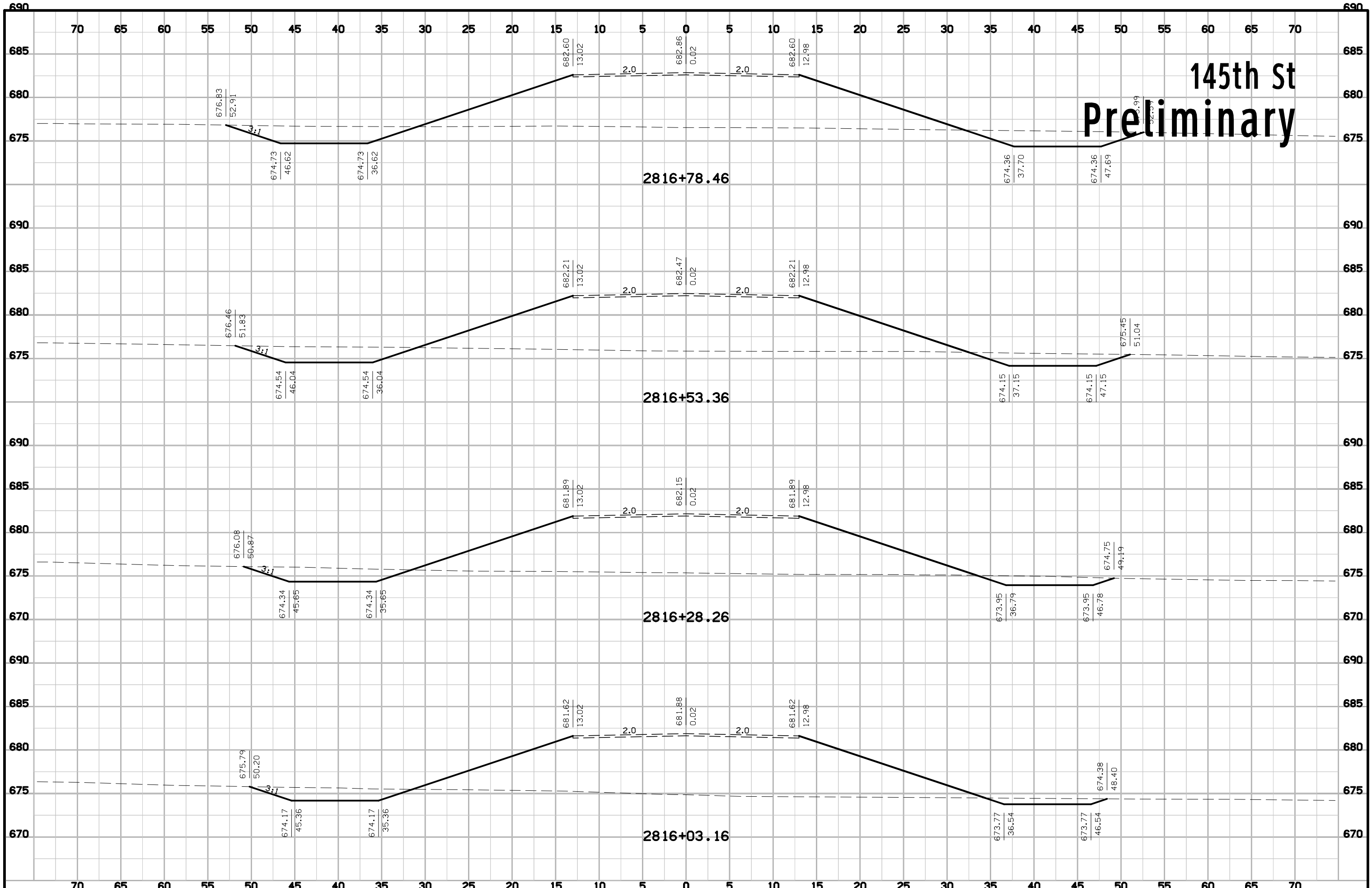

145th St Preliminary

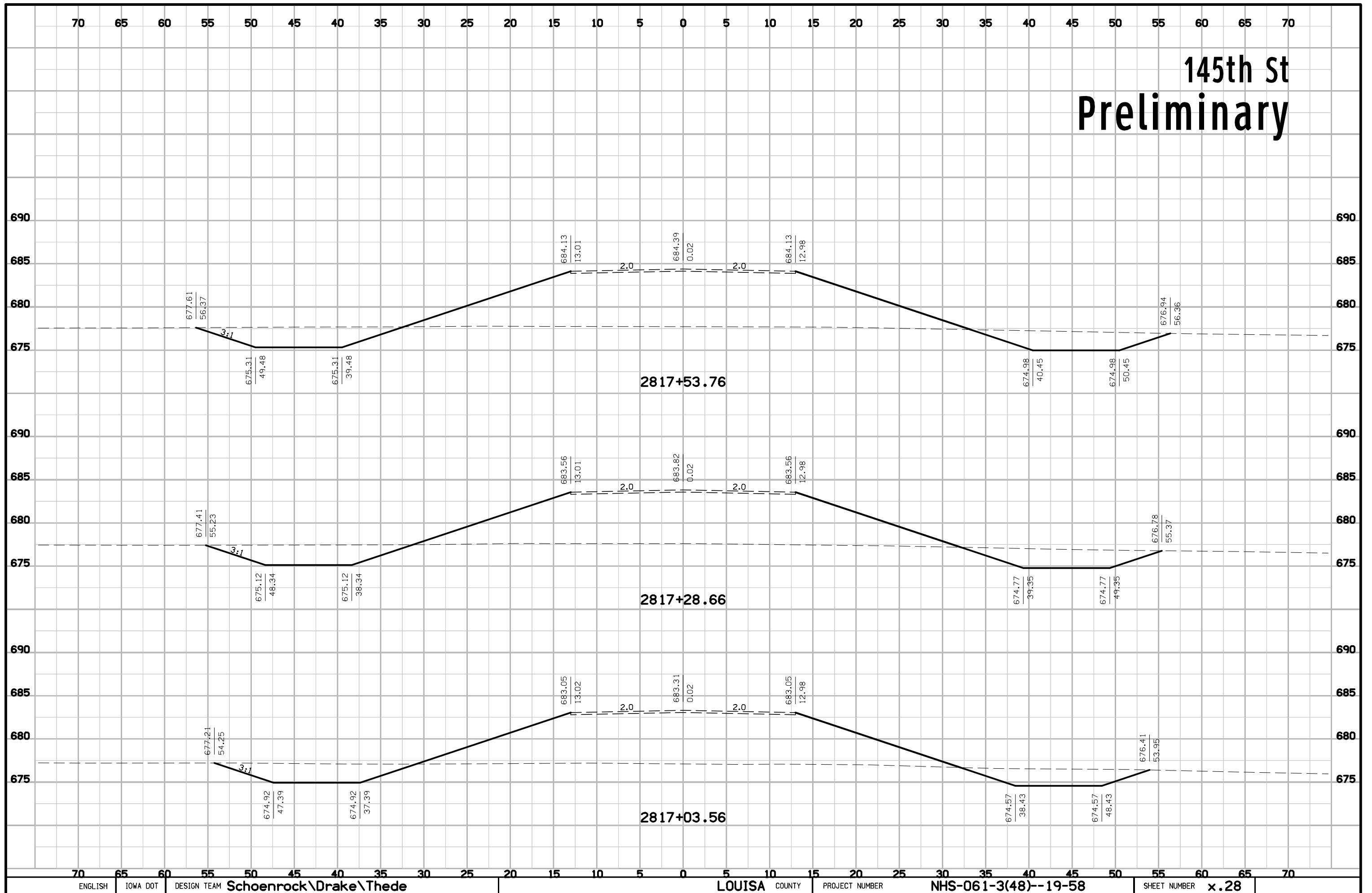

145th St Preliminary

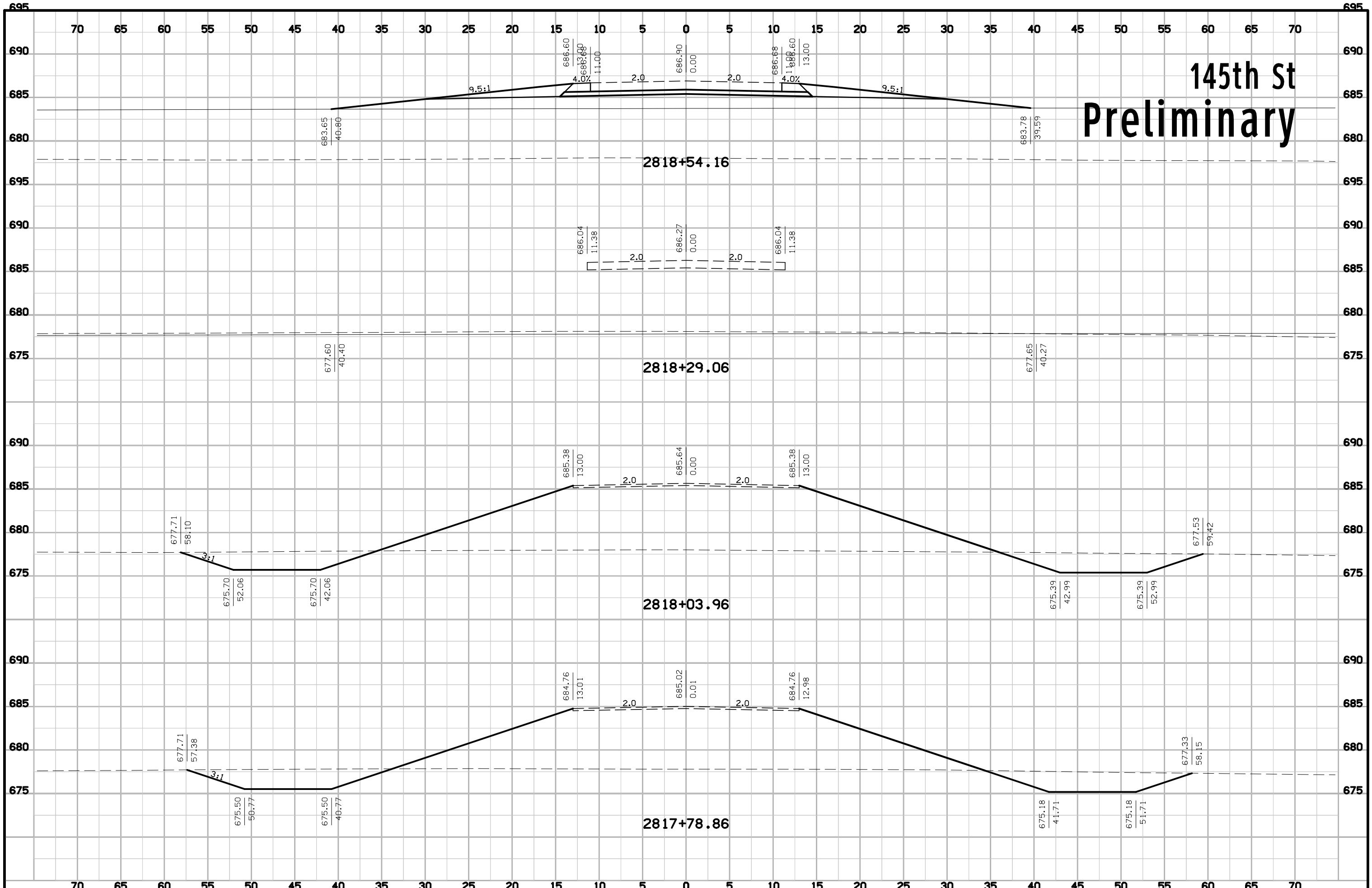

145th St Preliminary

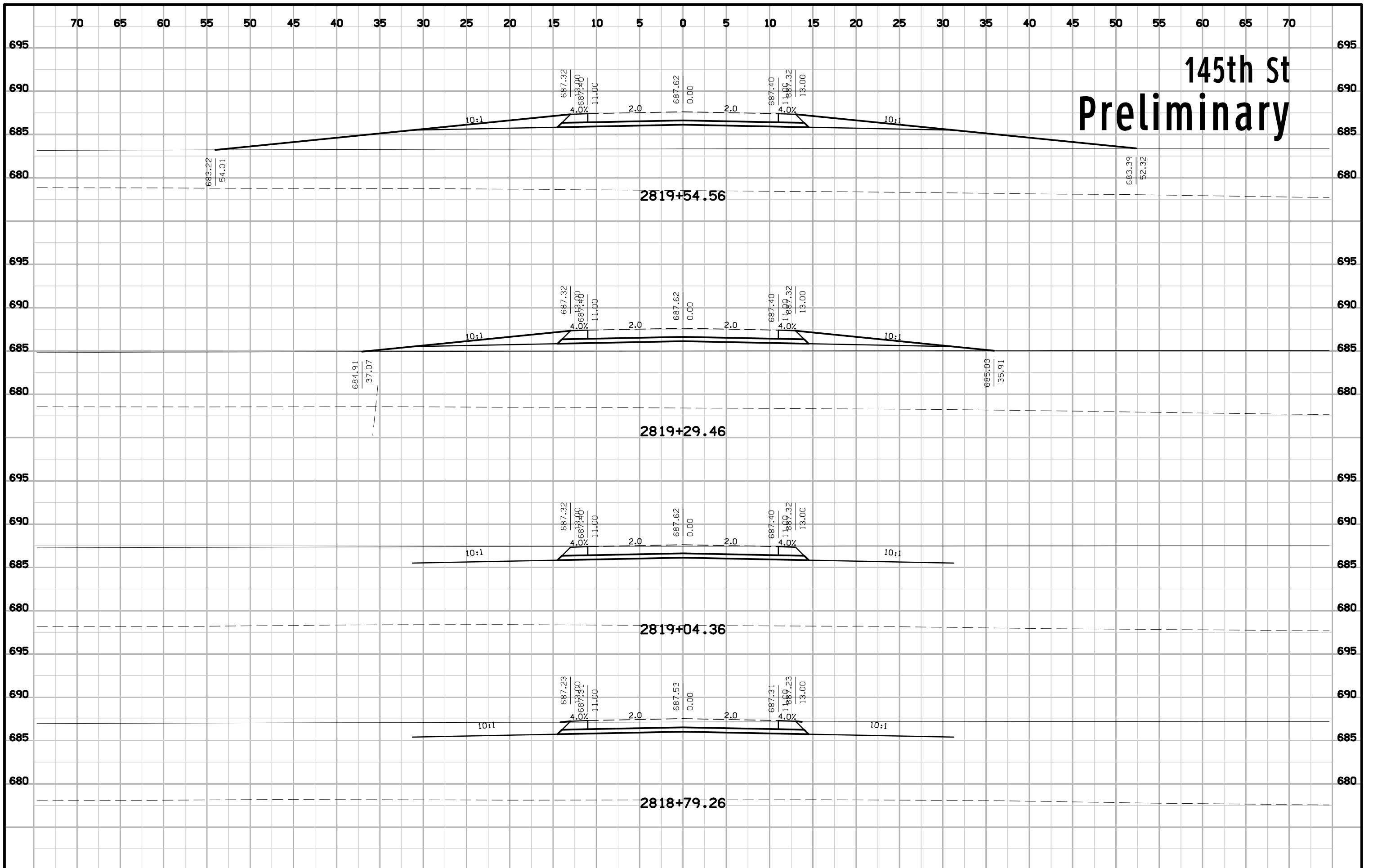

145th St Preliminary

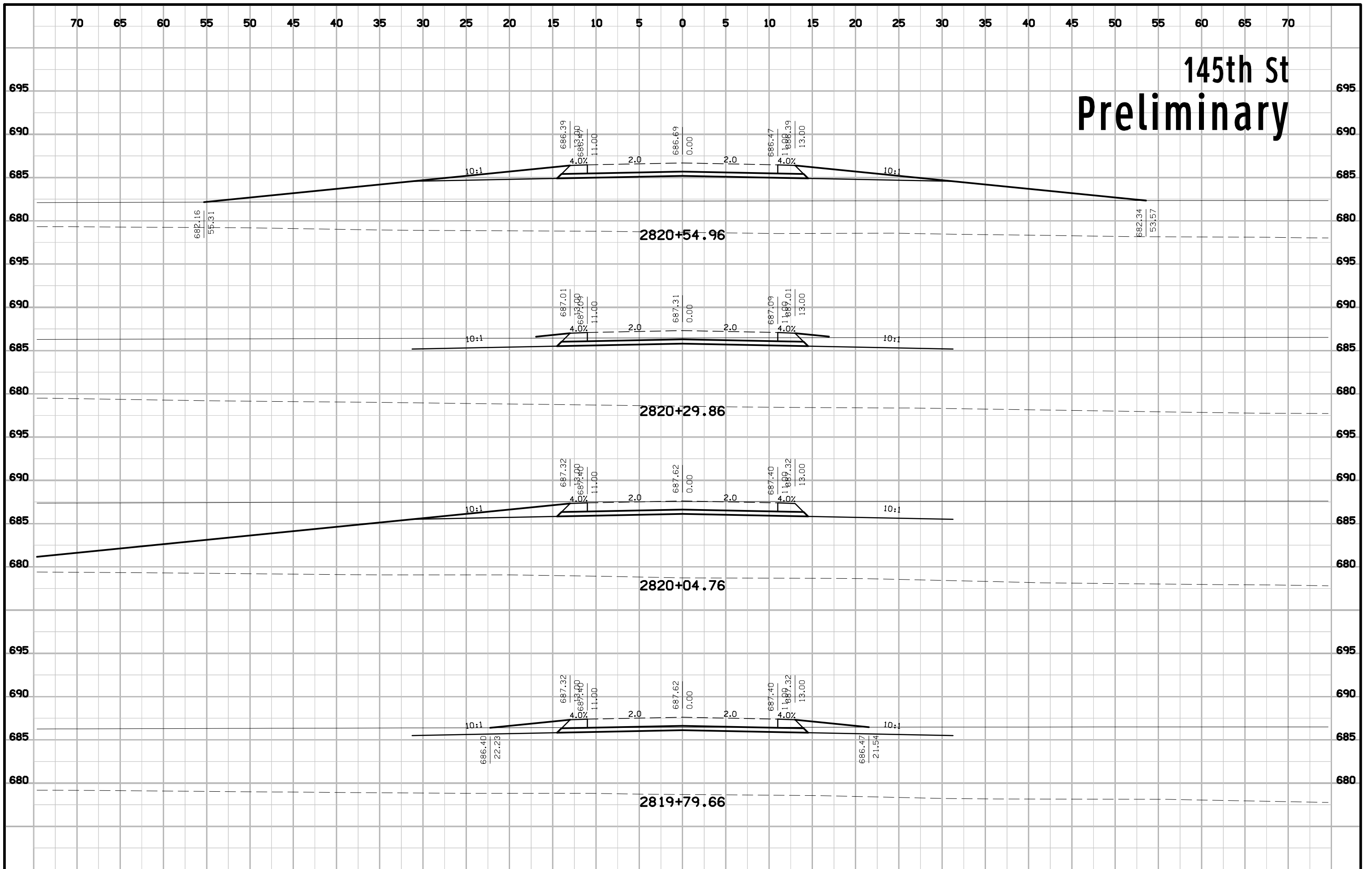

145th St Preliminary

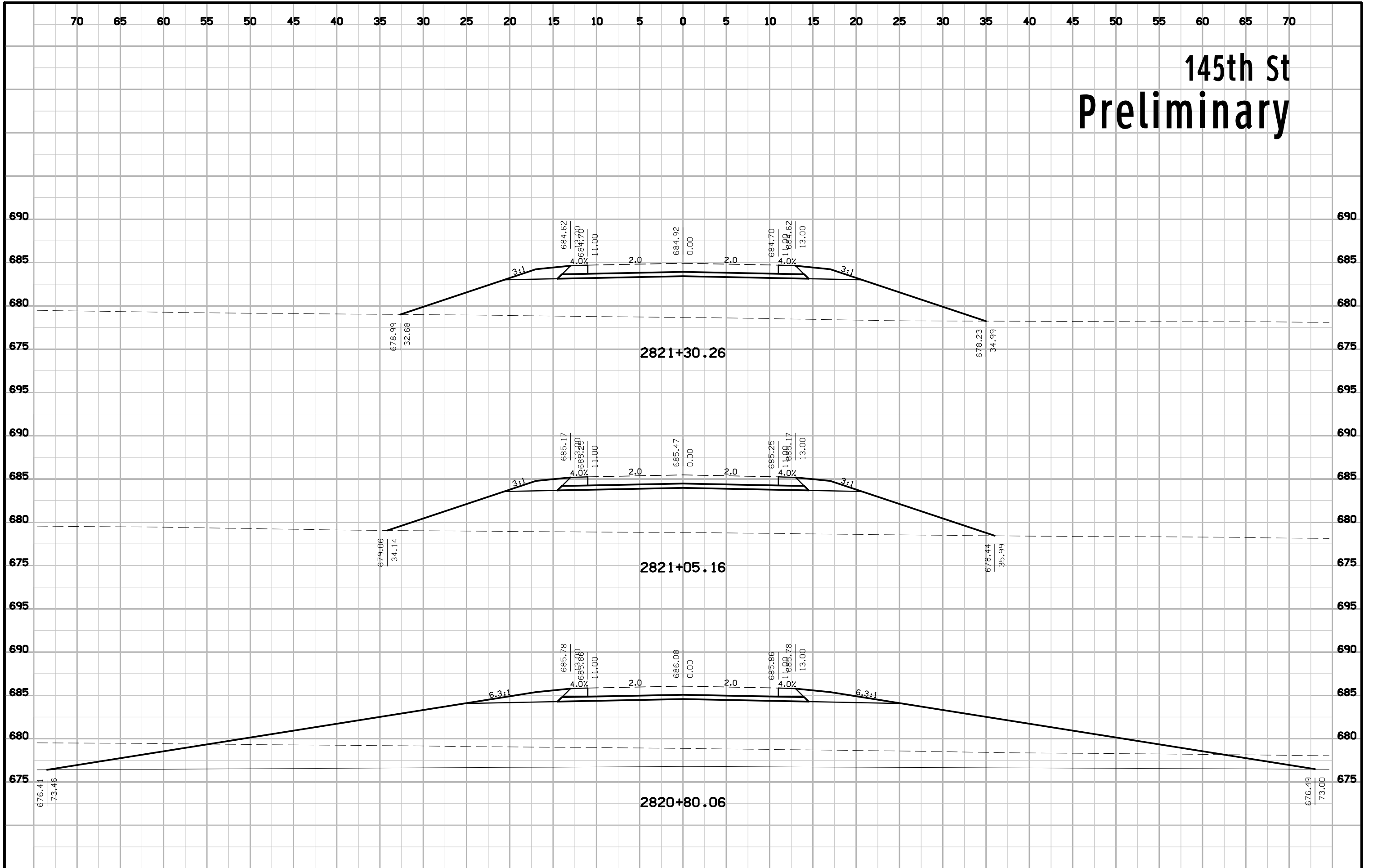

145th St Preliminary

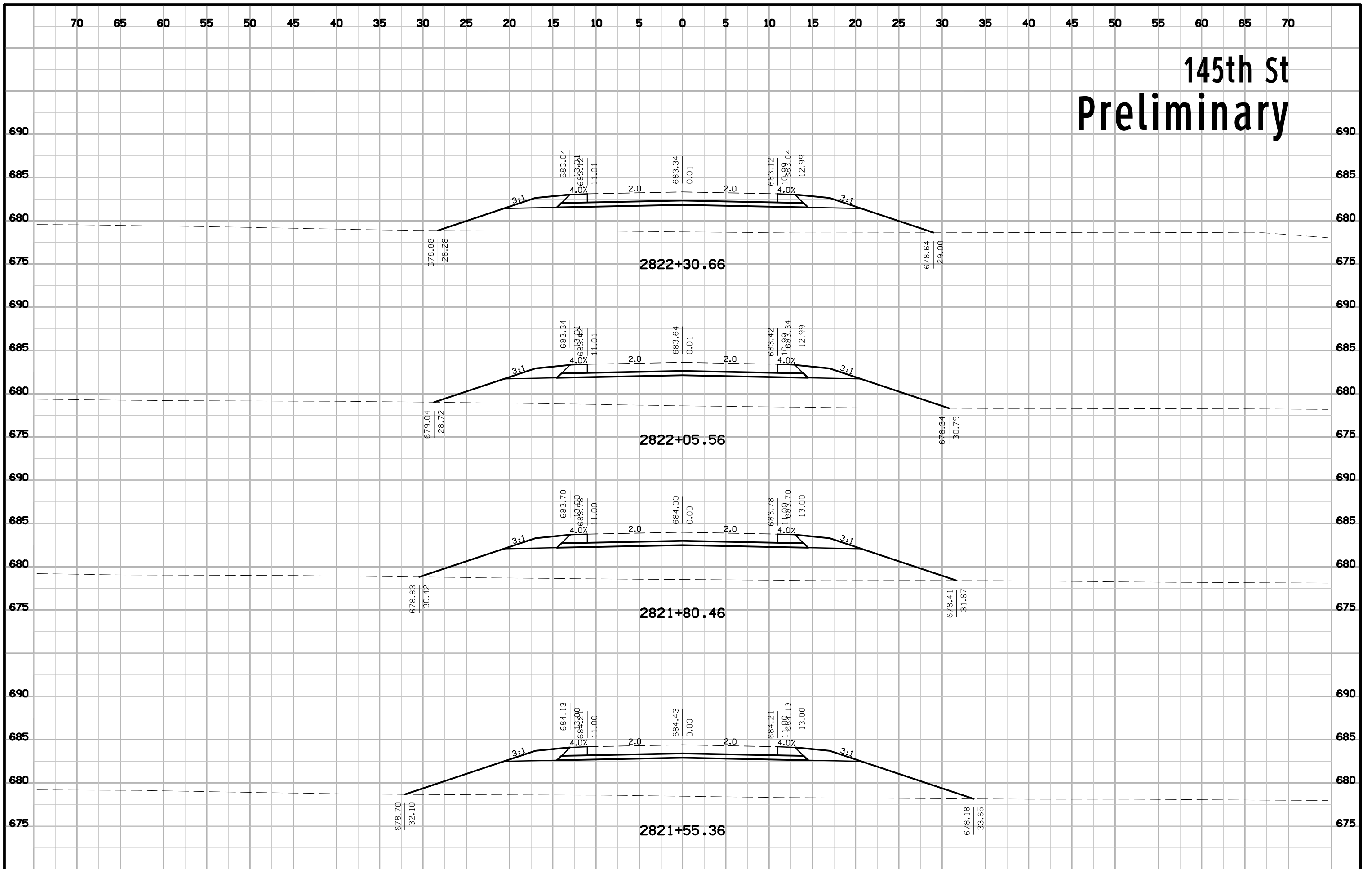

145th St Preliminary

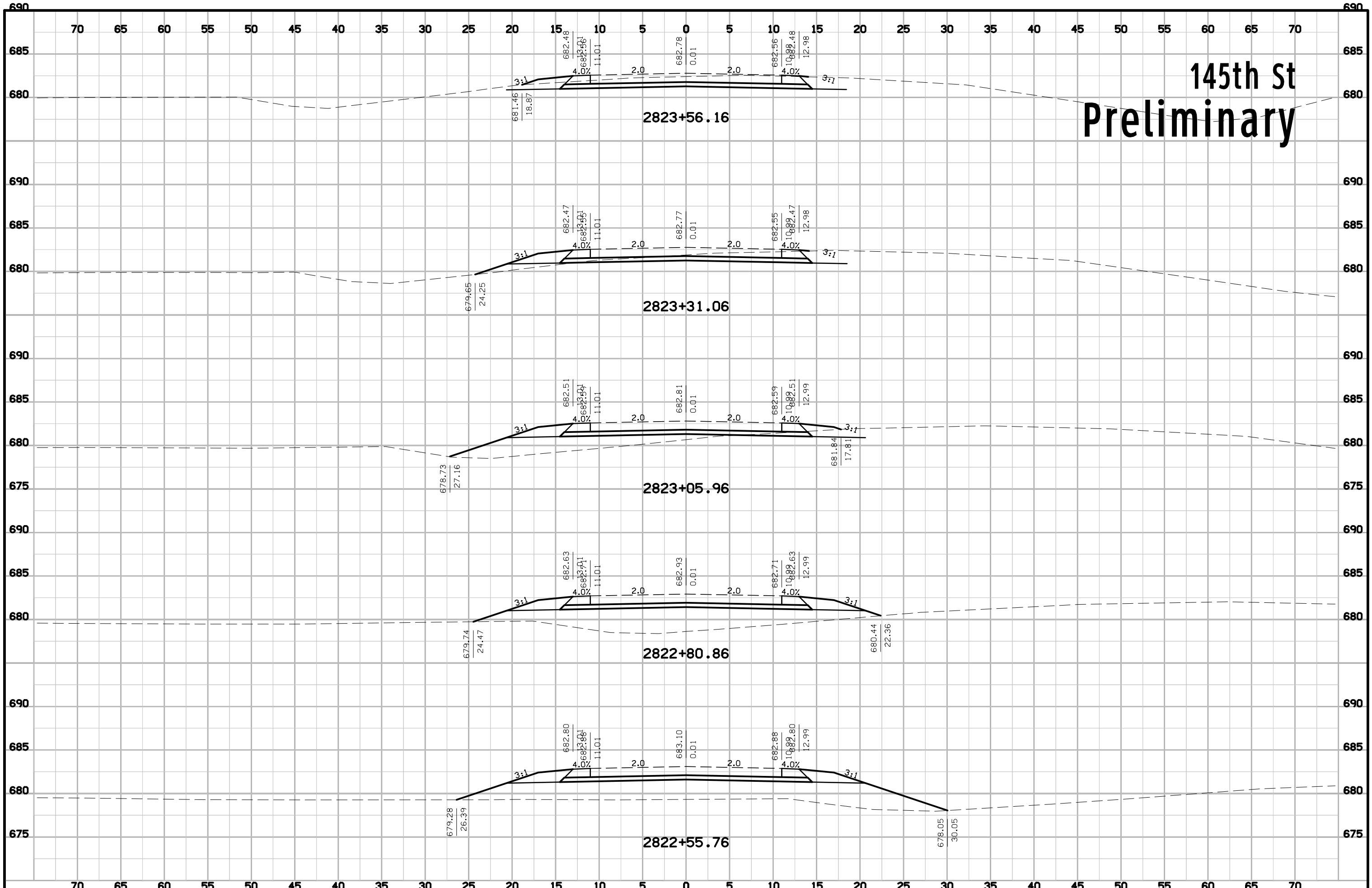

145th St Preliminary

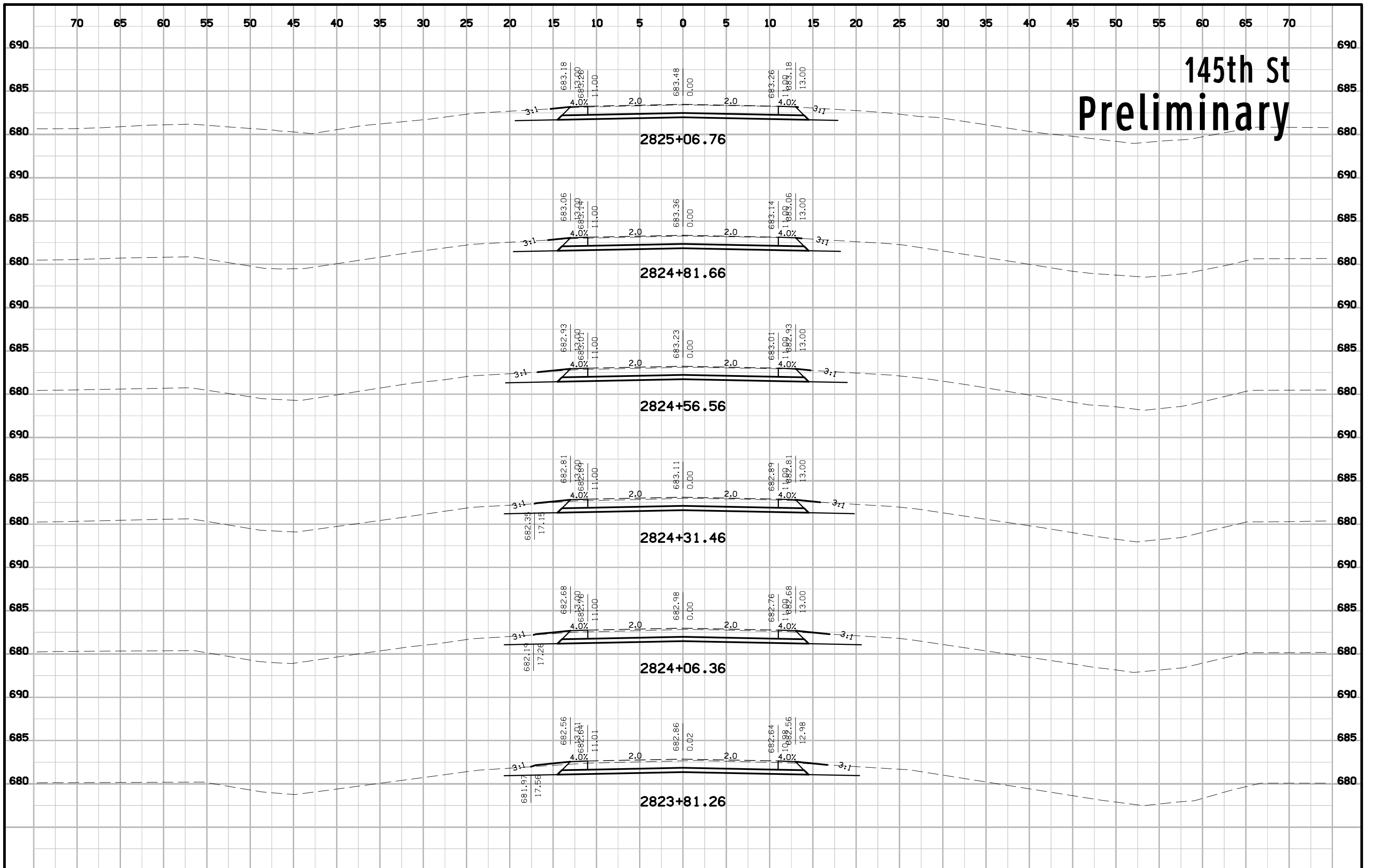

145th St Preliminary

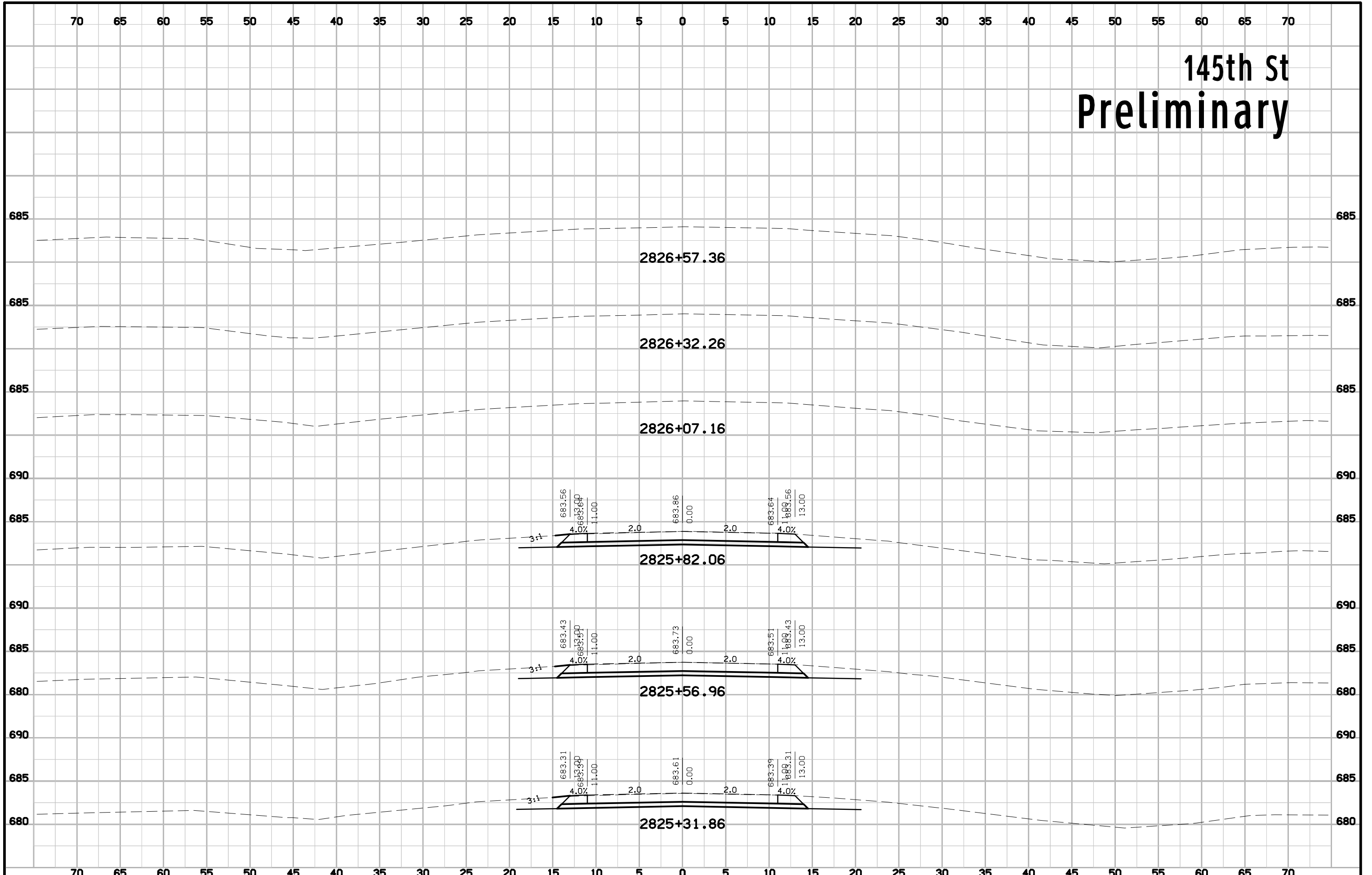

170th St Preliminary

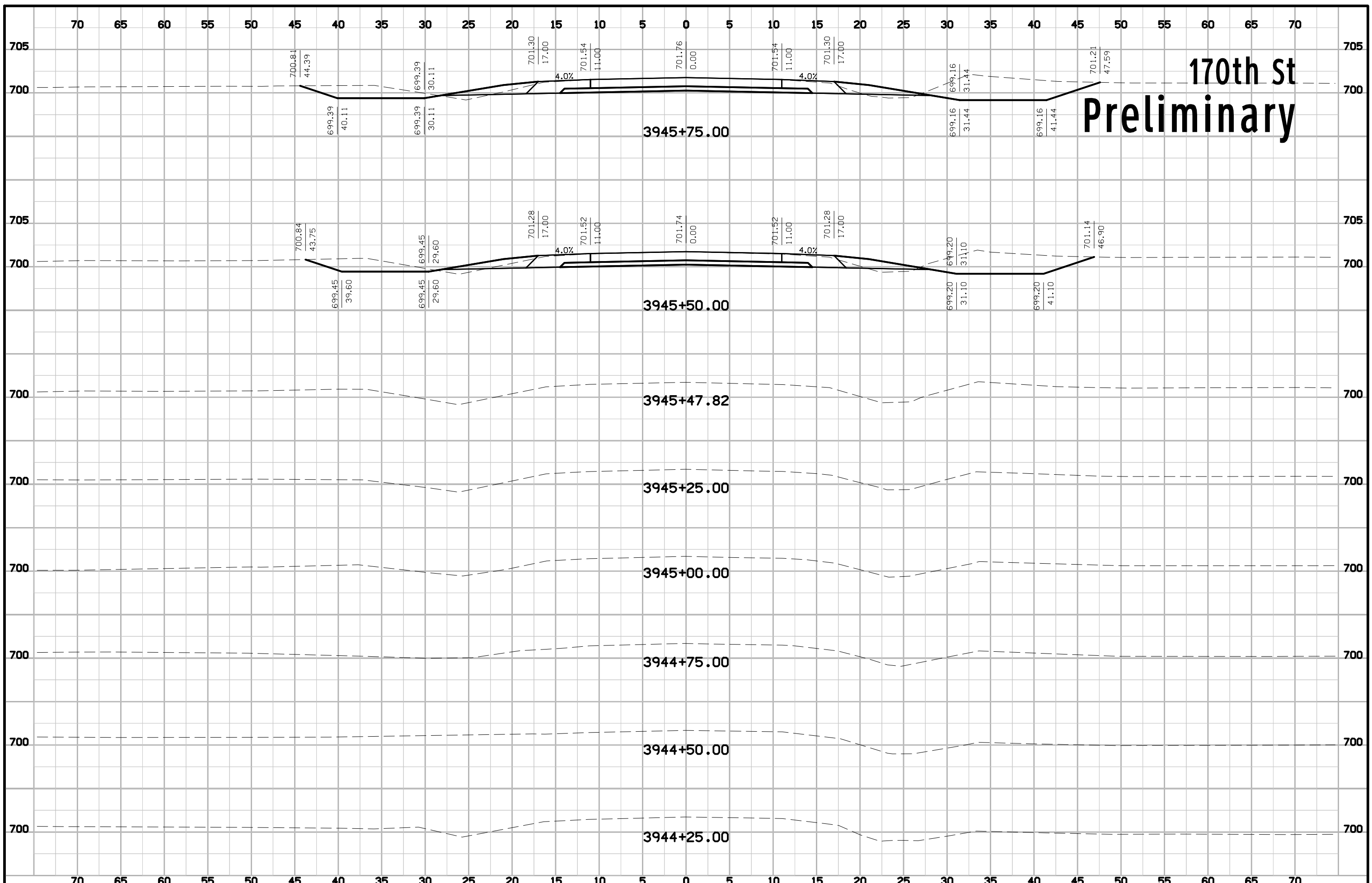

170th St Preliminary

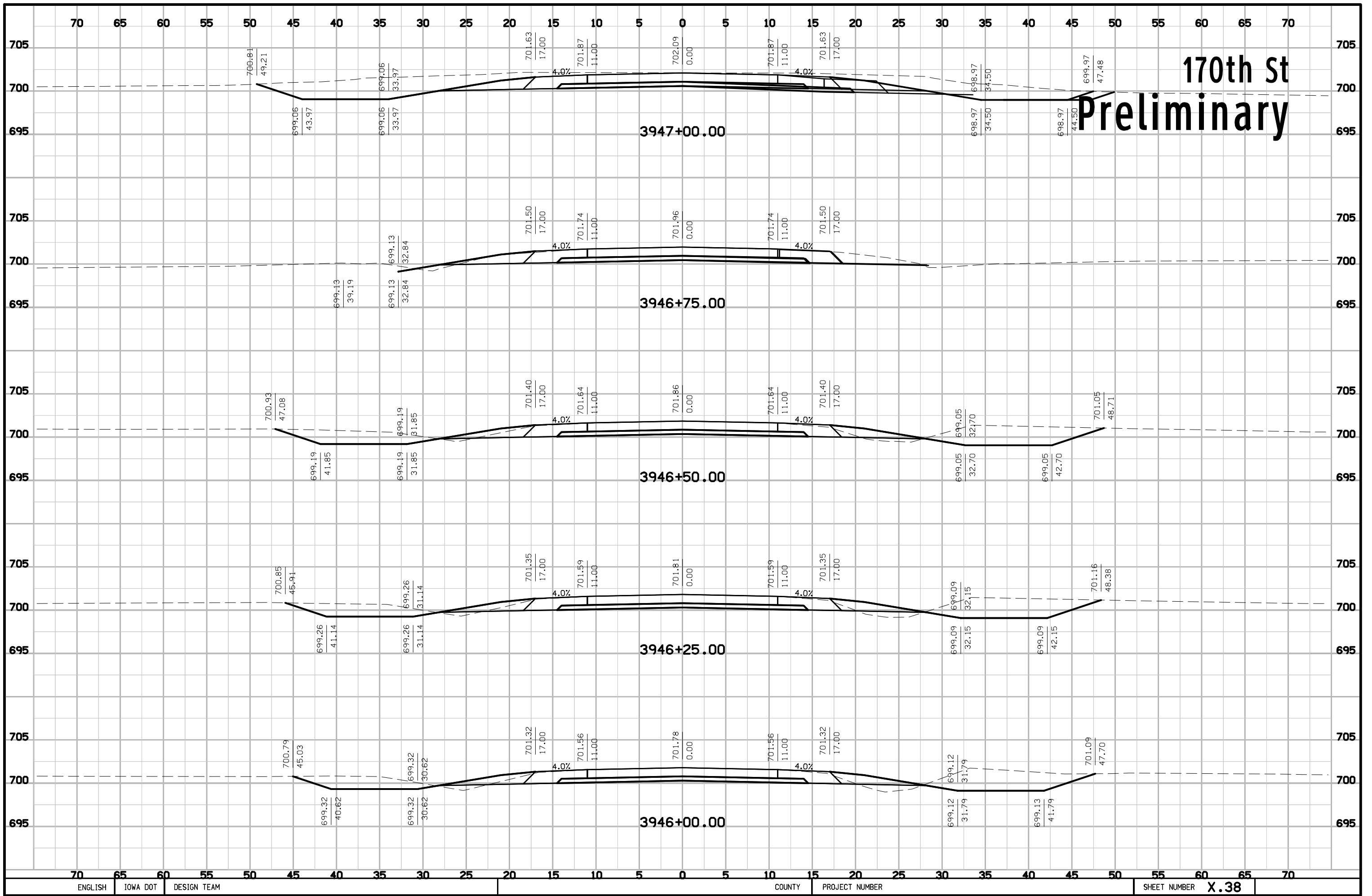

170th St Preliminary

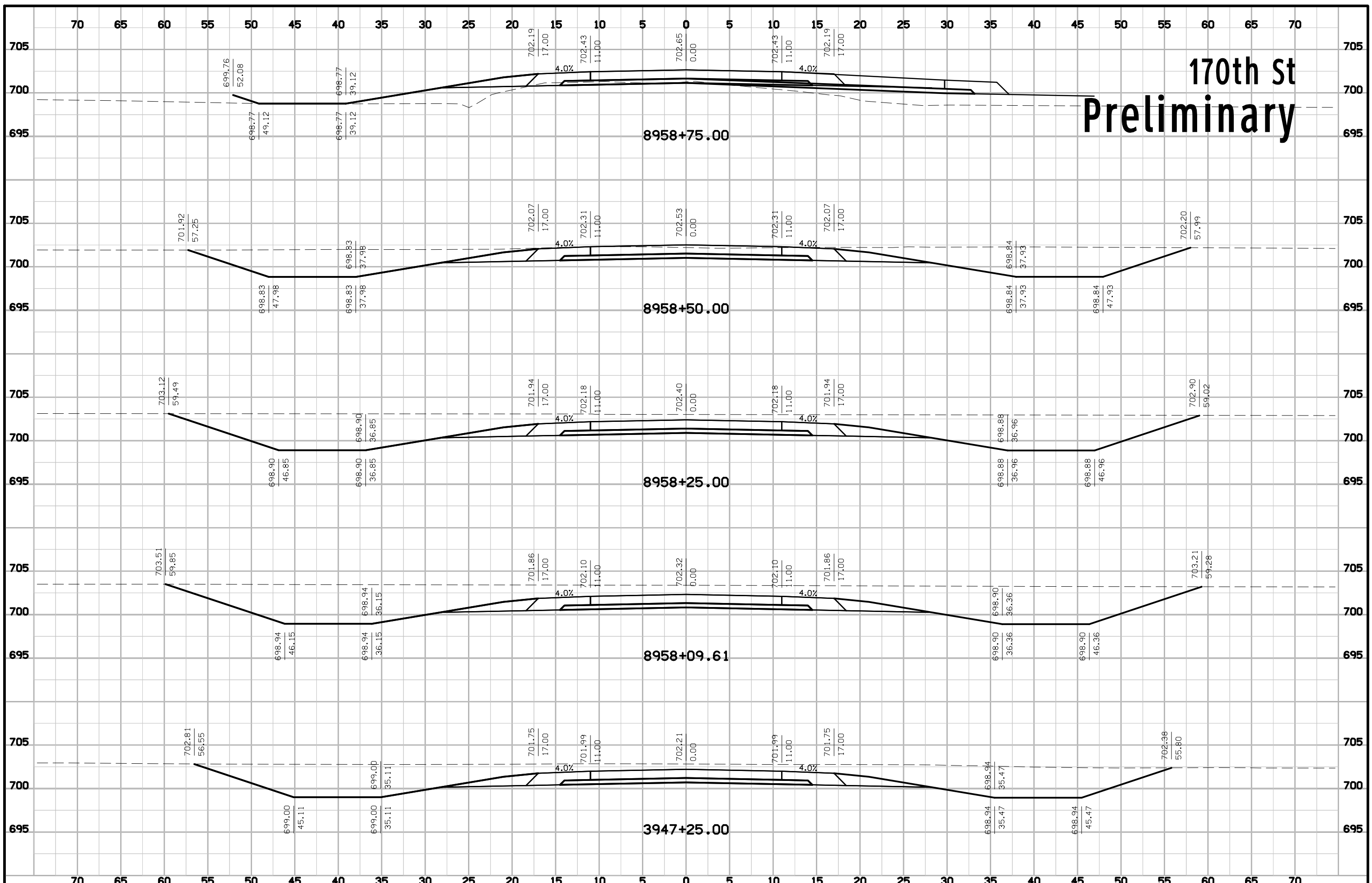

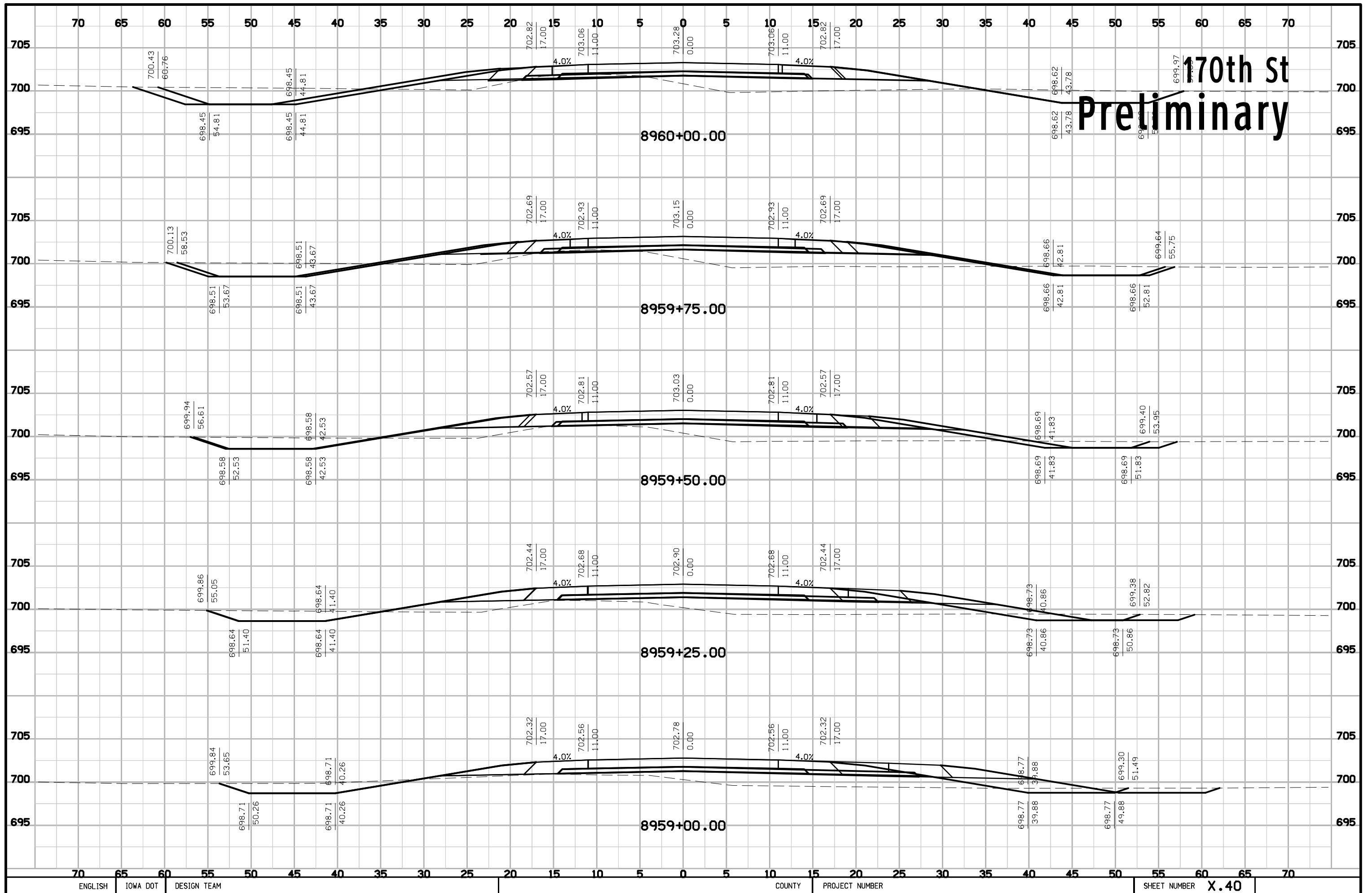

170th St Preliminary

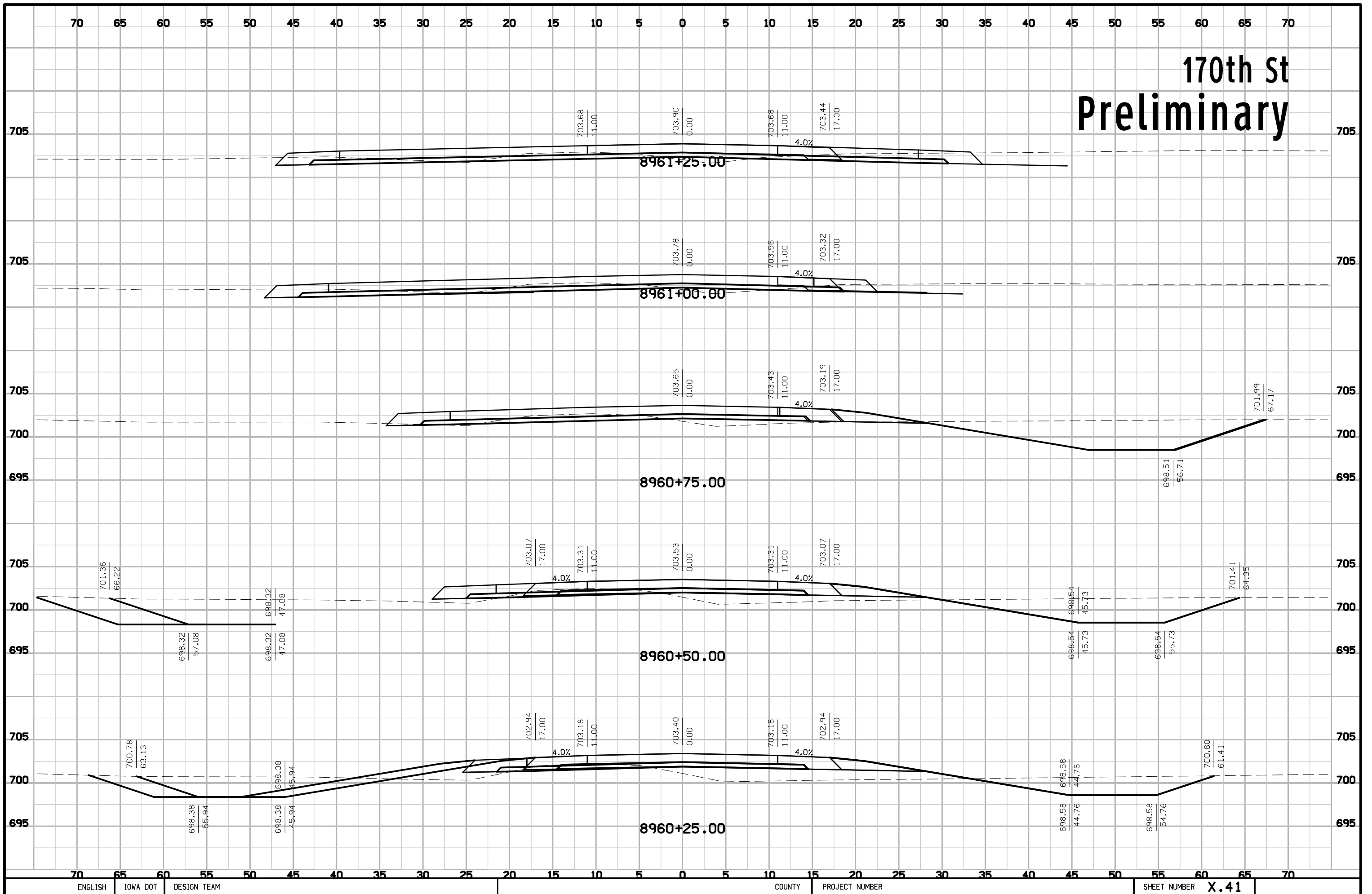

170th St Preliminary

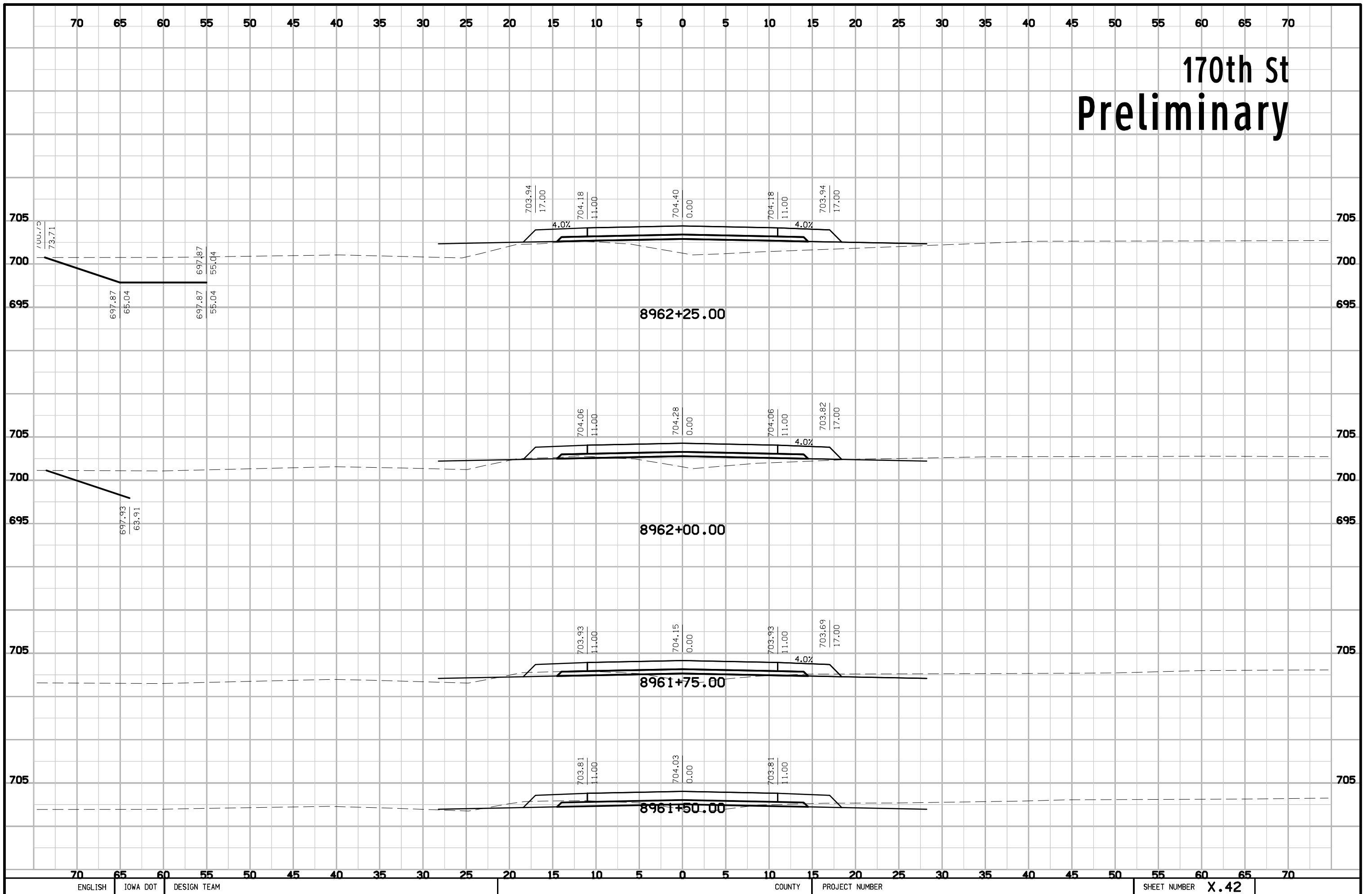

170th St Preliminary

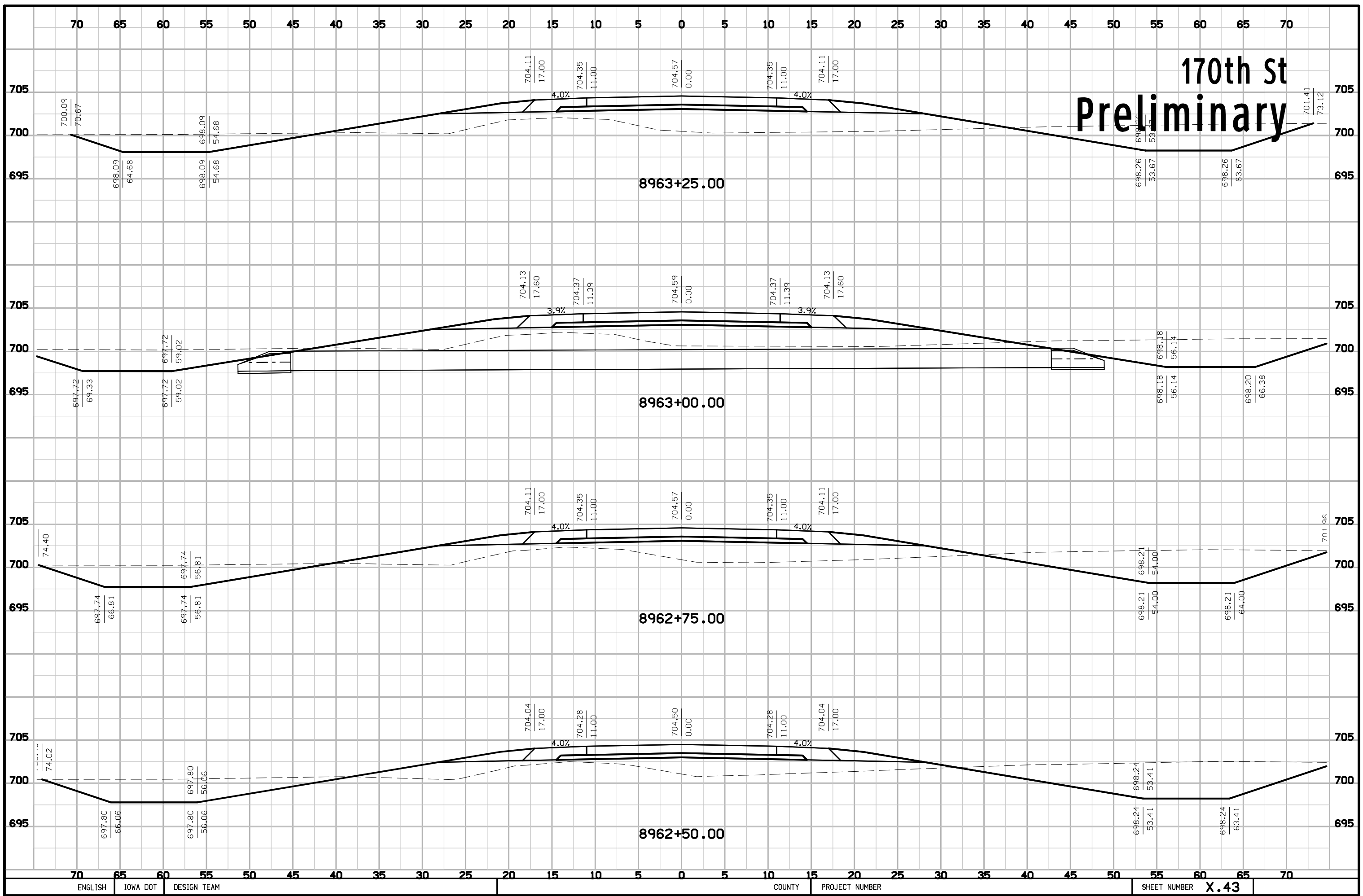

170th St Preliminary

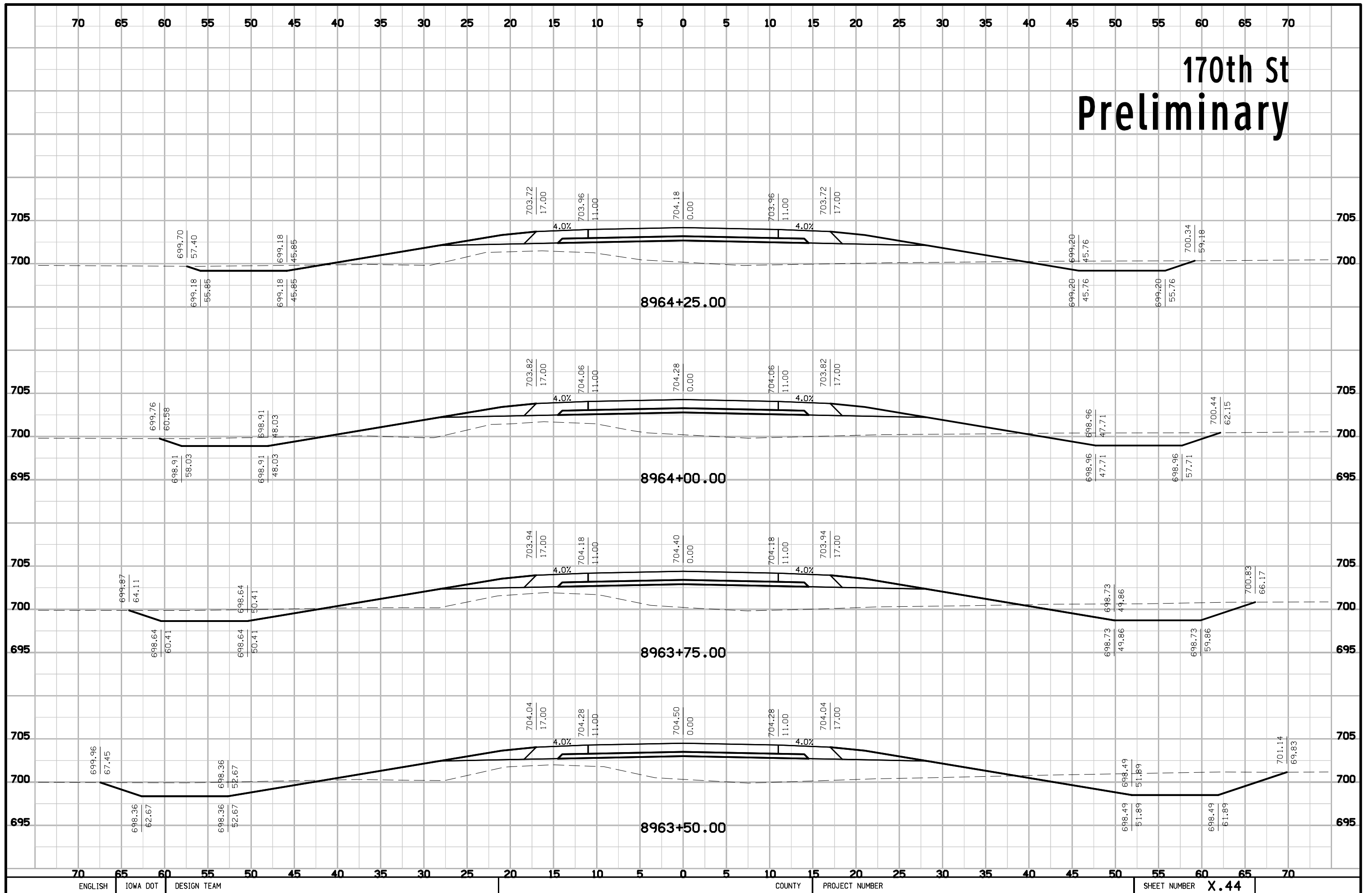

170th St Preliminary

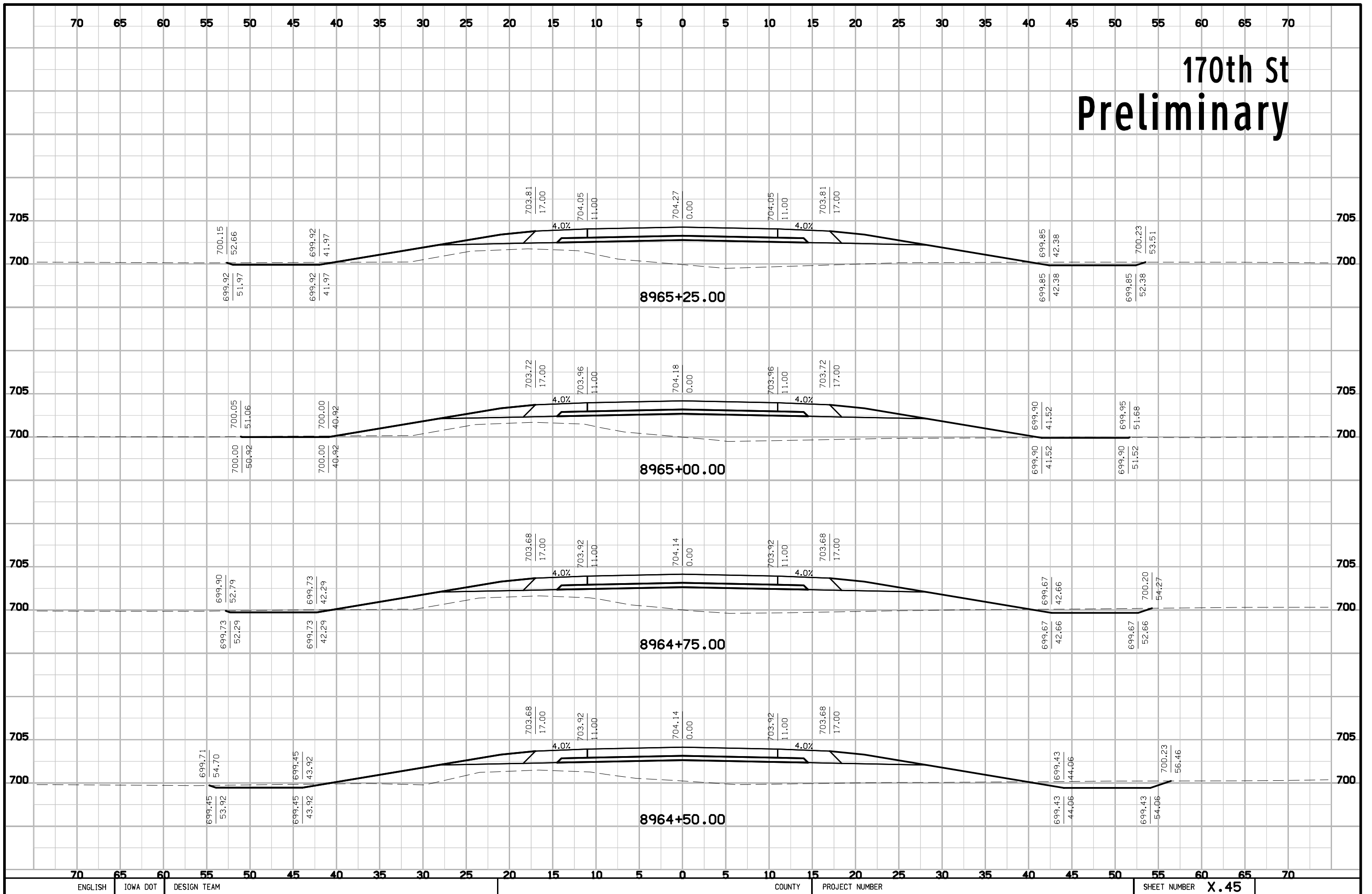

170th St Preliminary

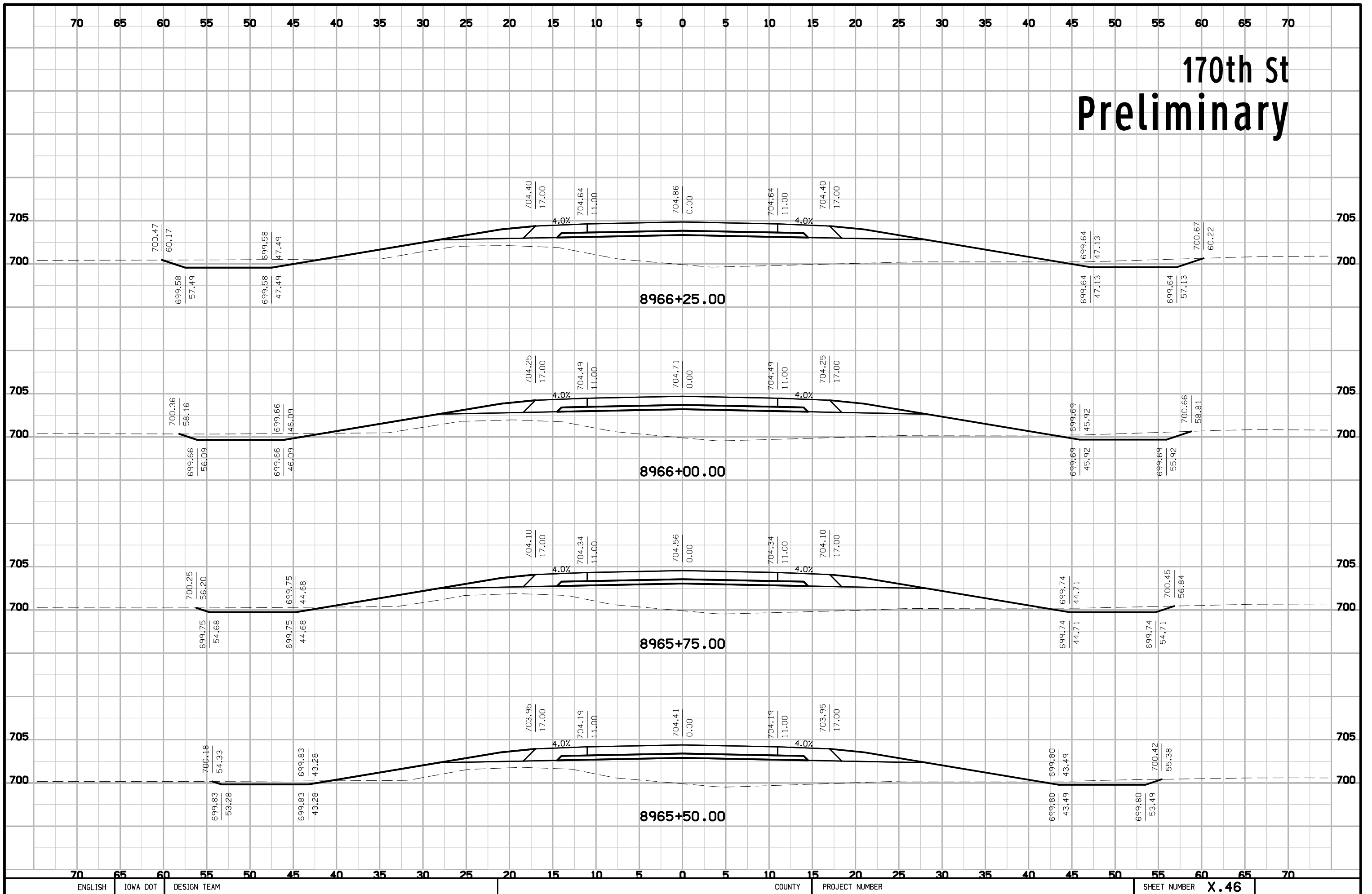

170th St Preliminary

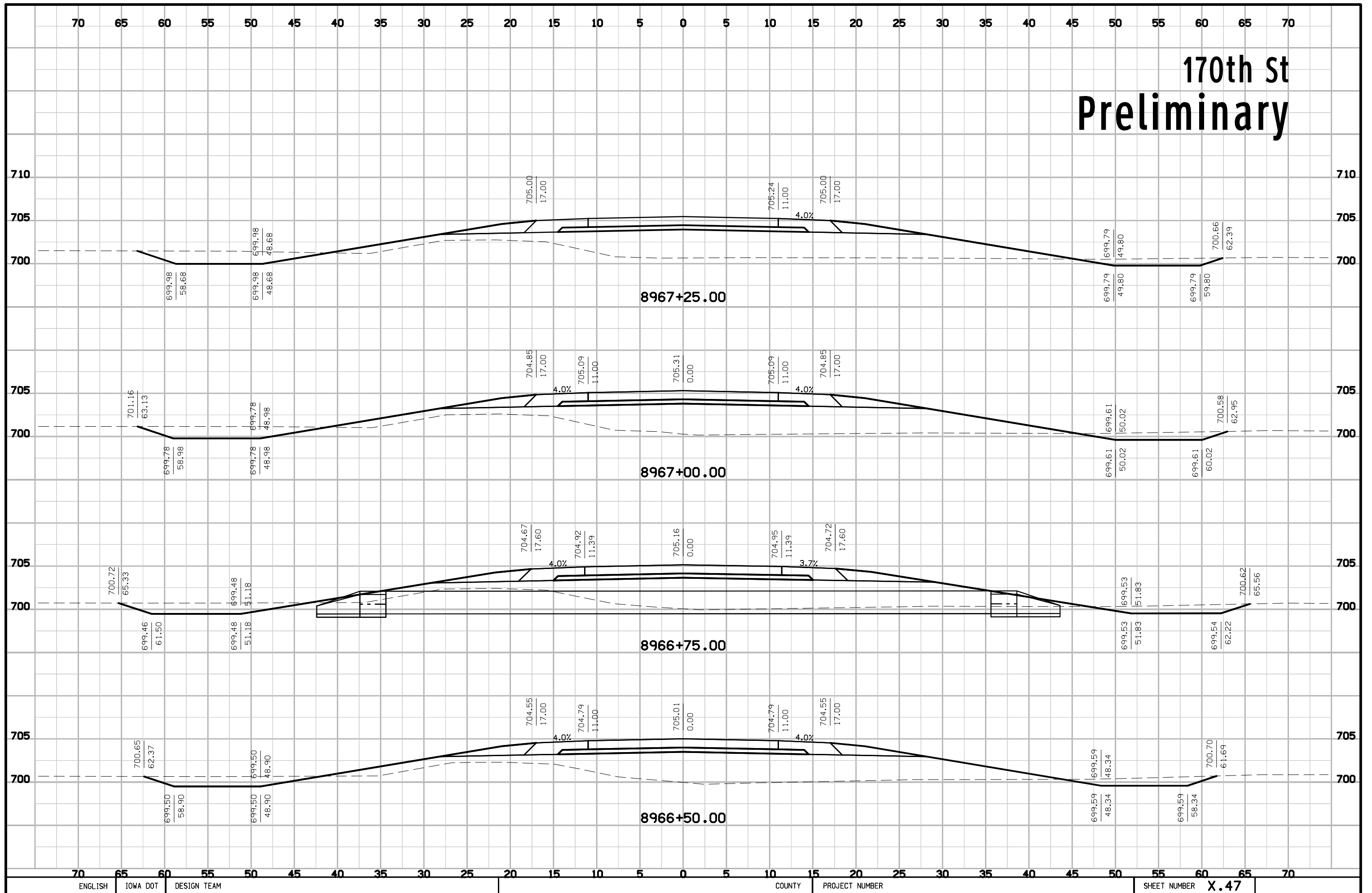

170th St Preliminary

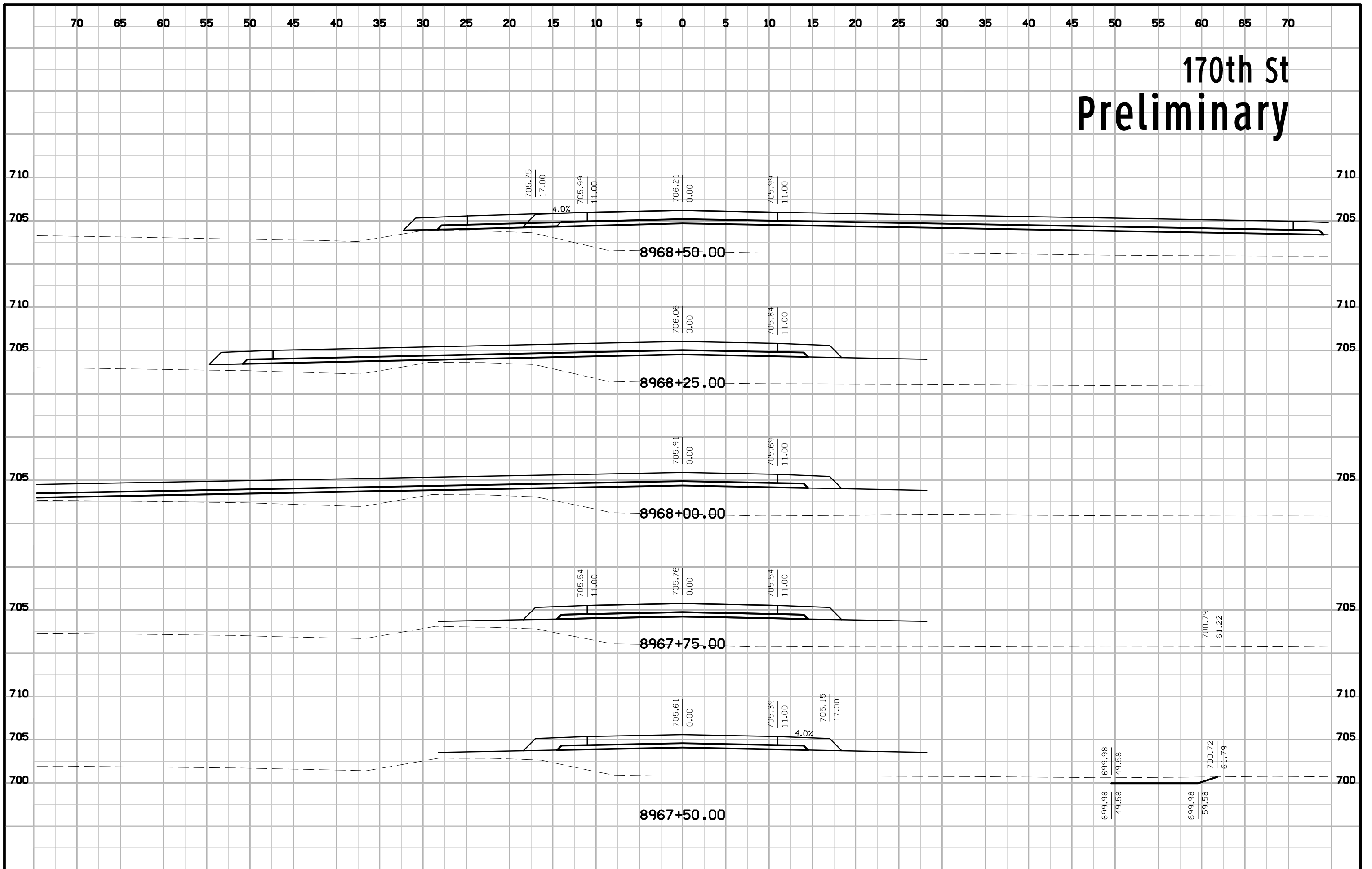

170th St Preliminary

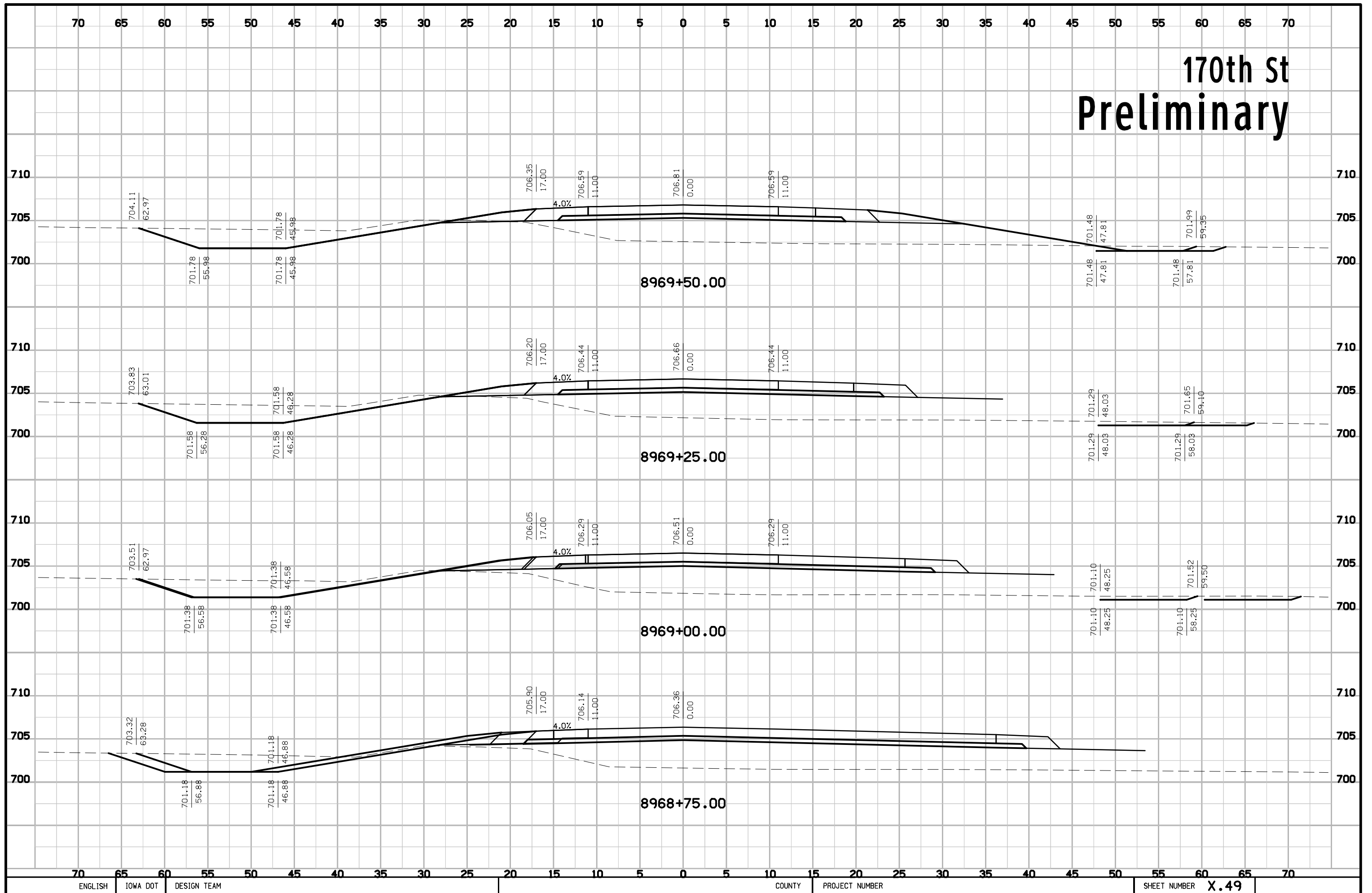

170th St Preliminary

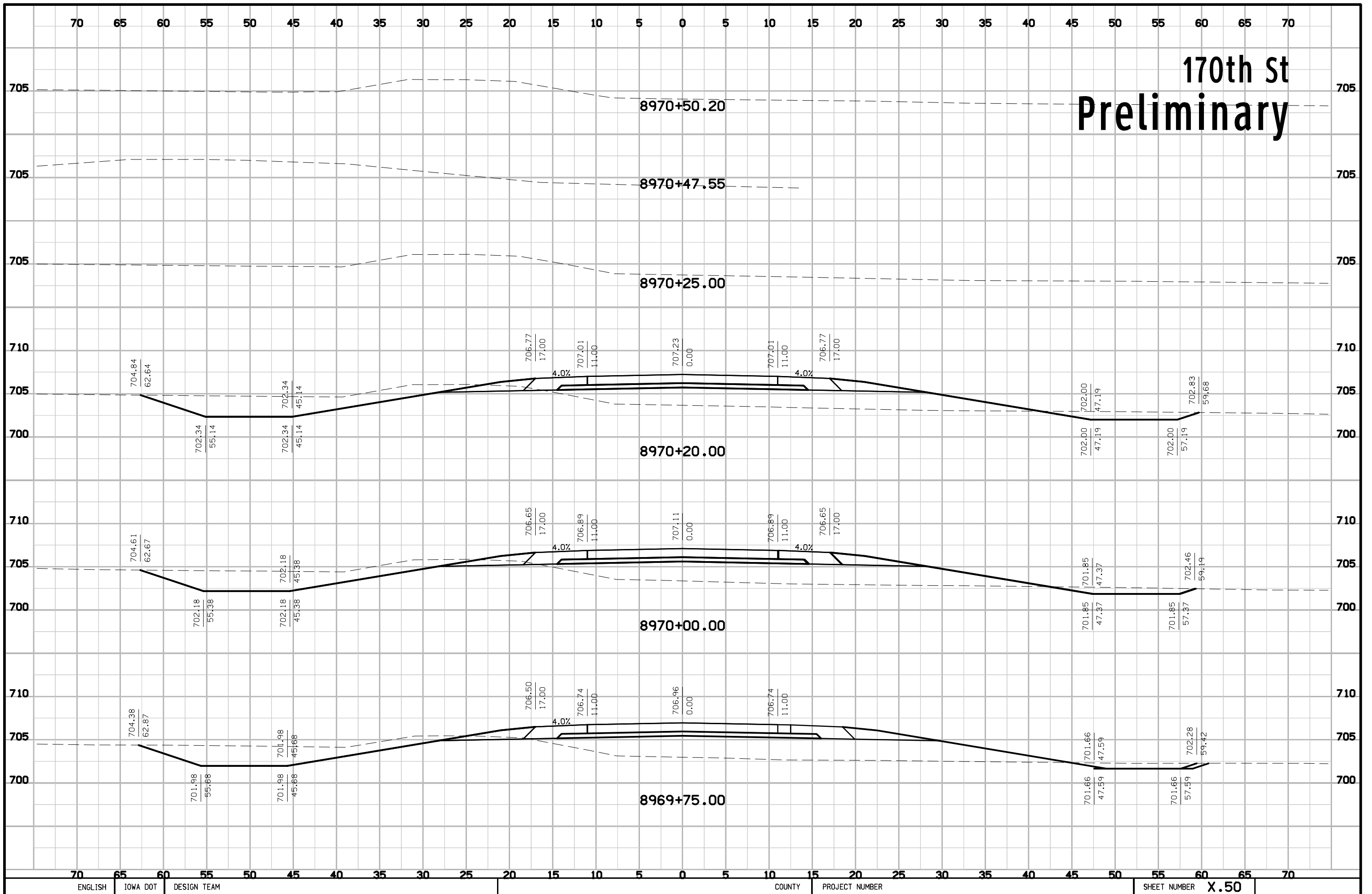

170th St Preliminary

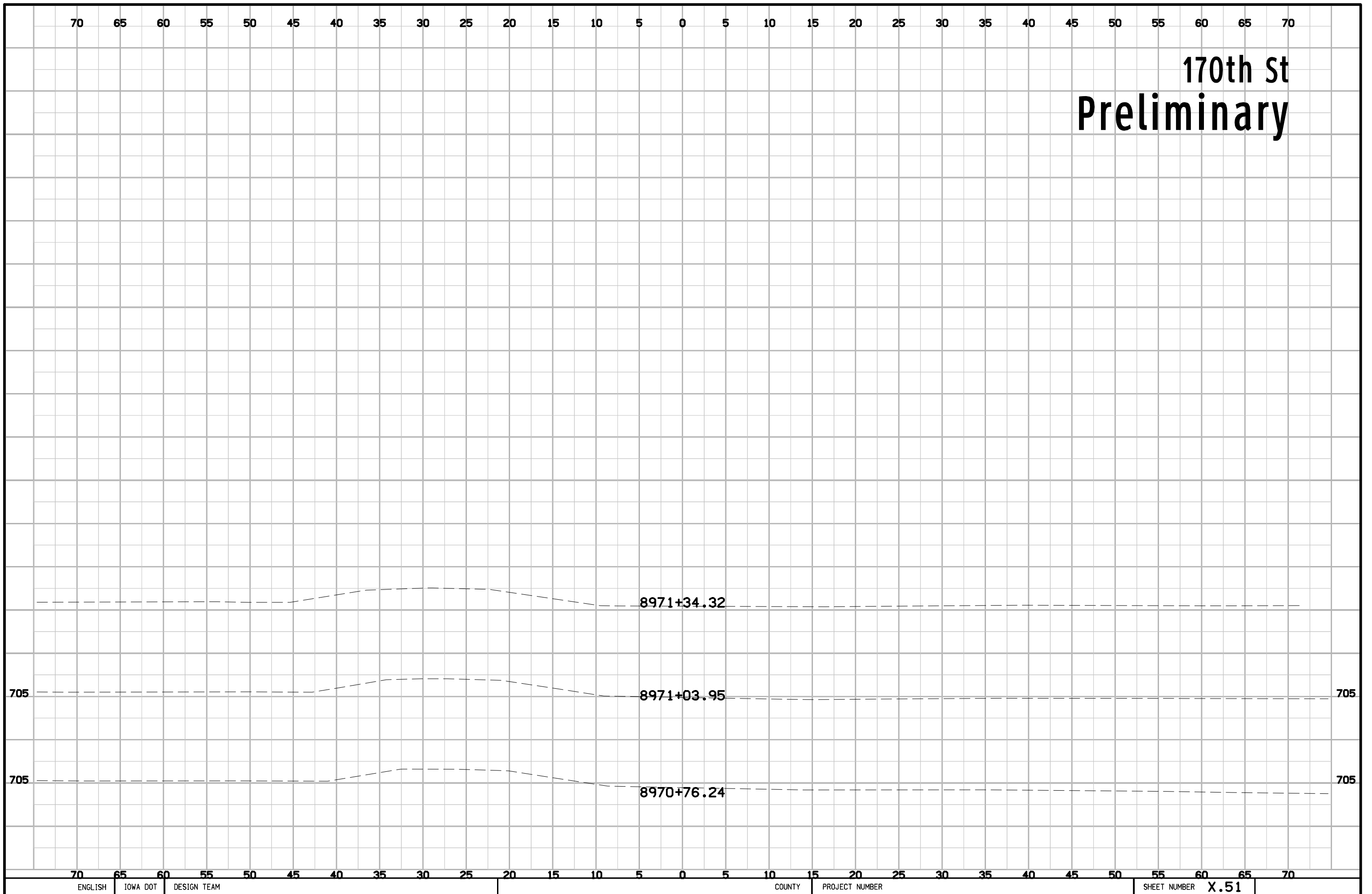

175th St Preliminary

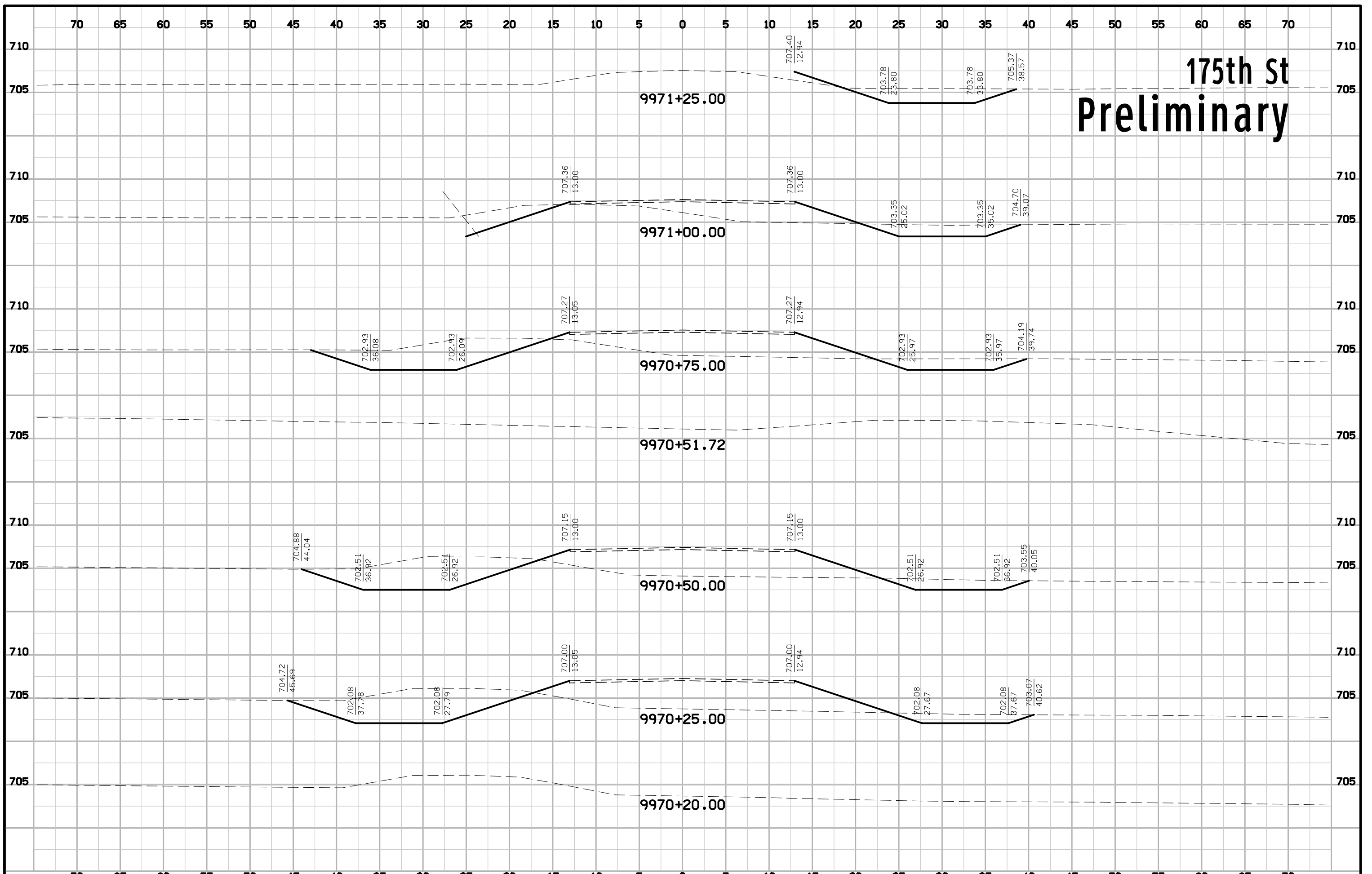

175th St Preliminary

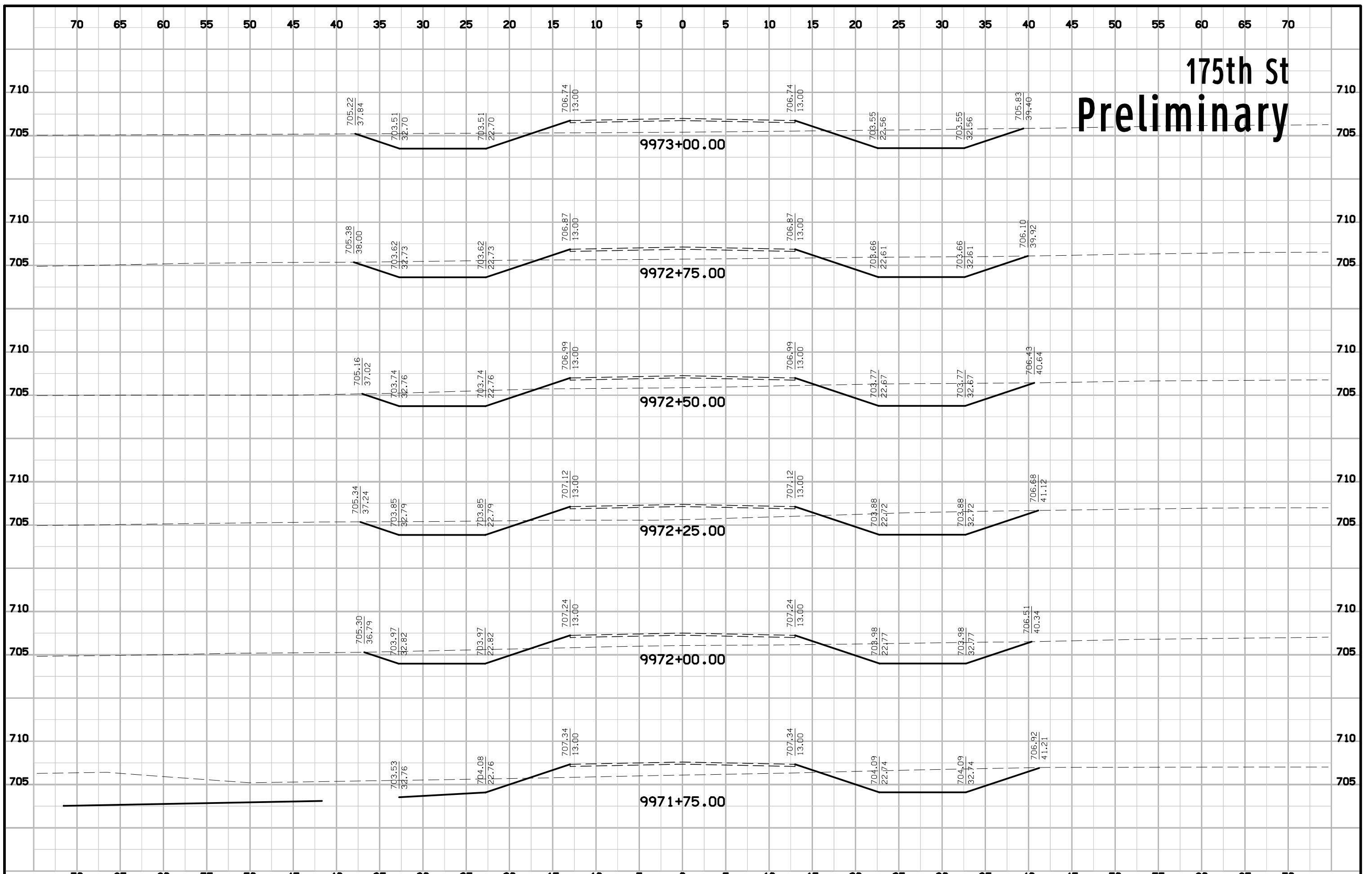

175th St Preliminary

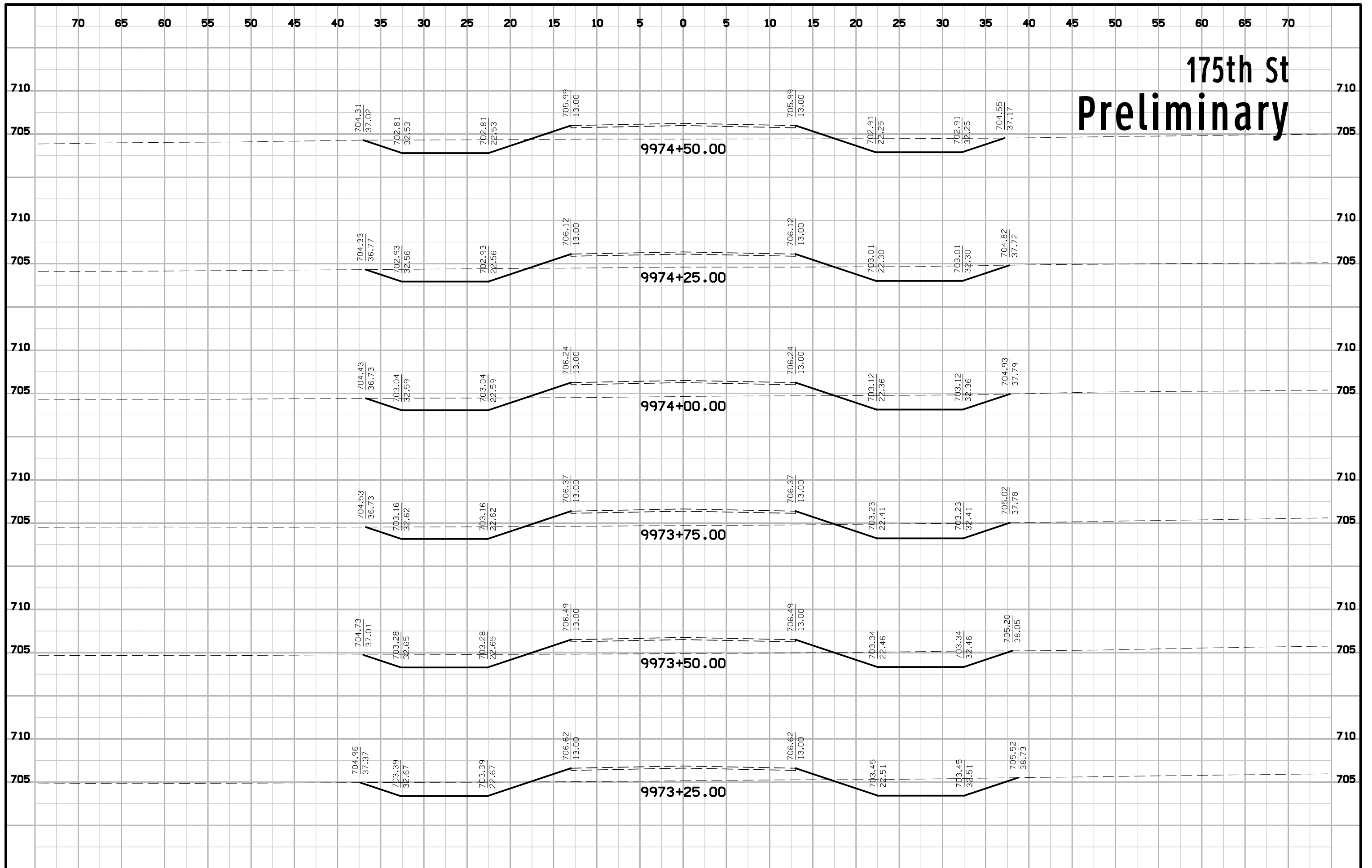

175th St Preliminary

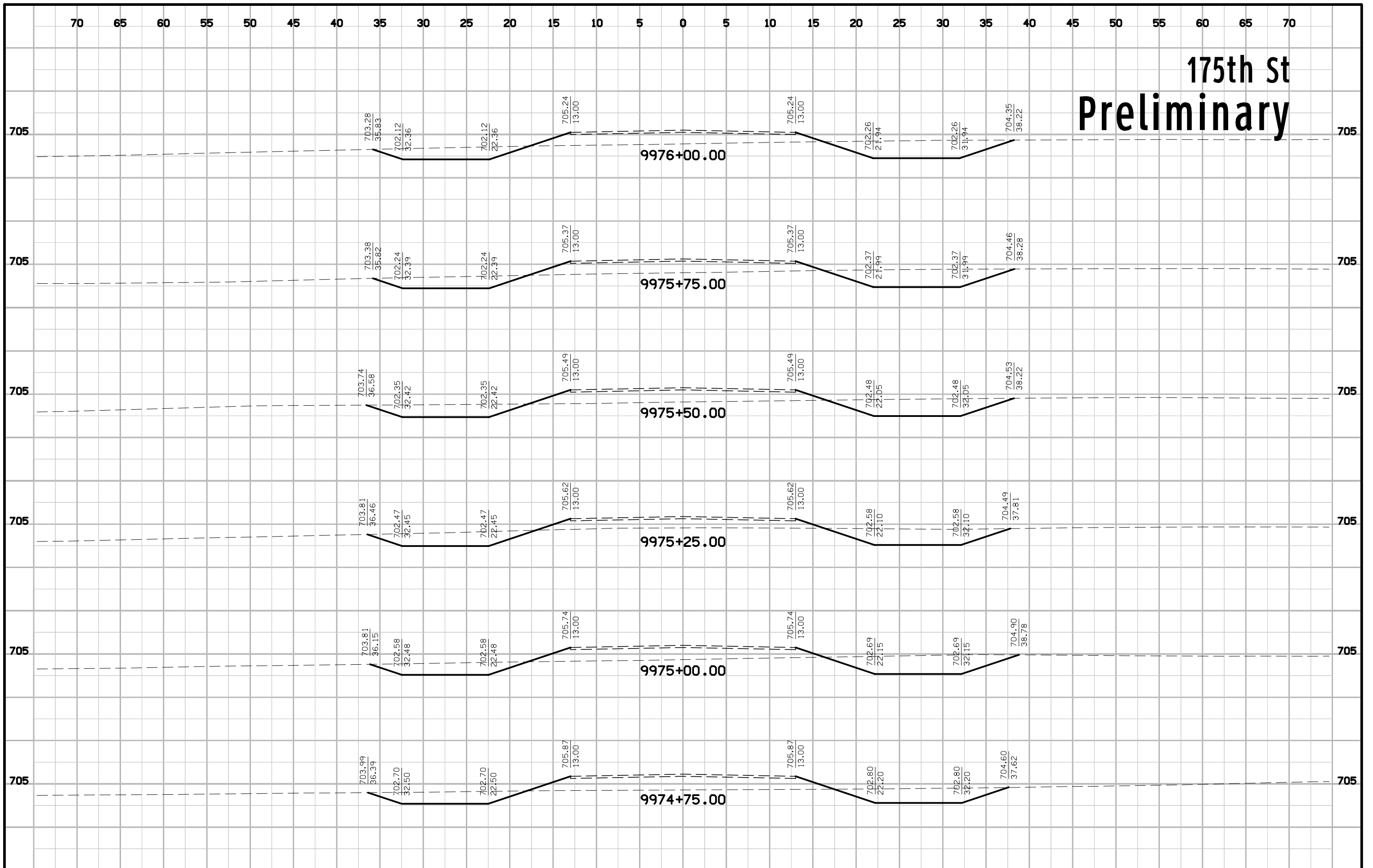

175th St Preliminary

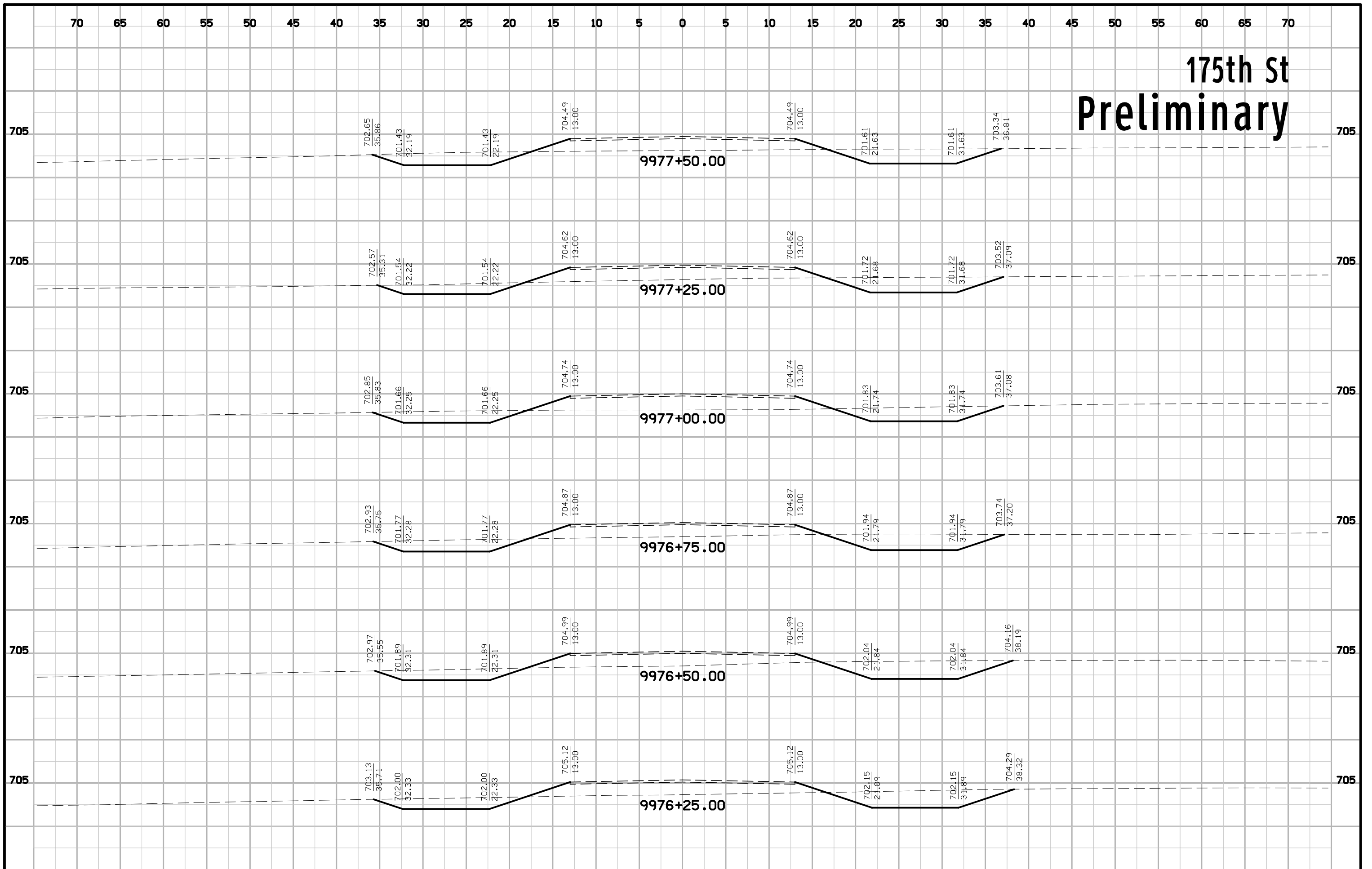

175th St Preliminary

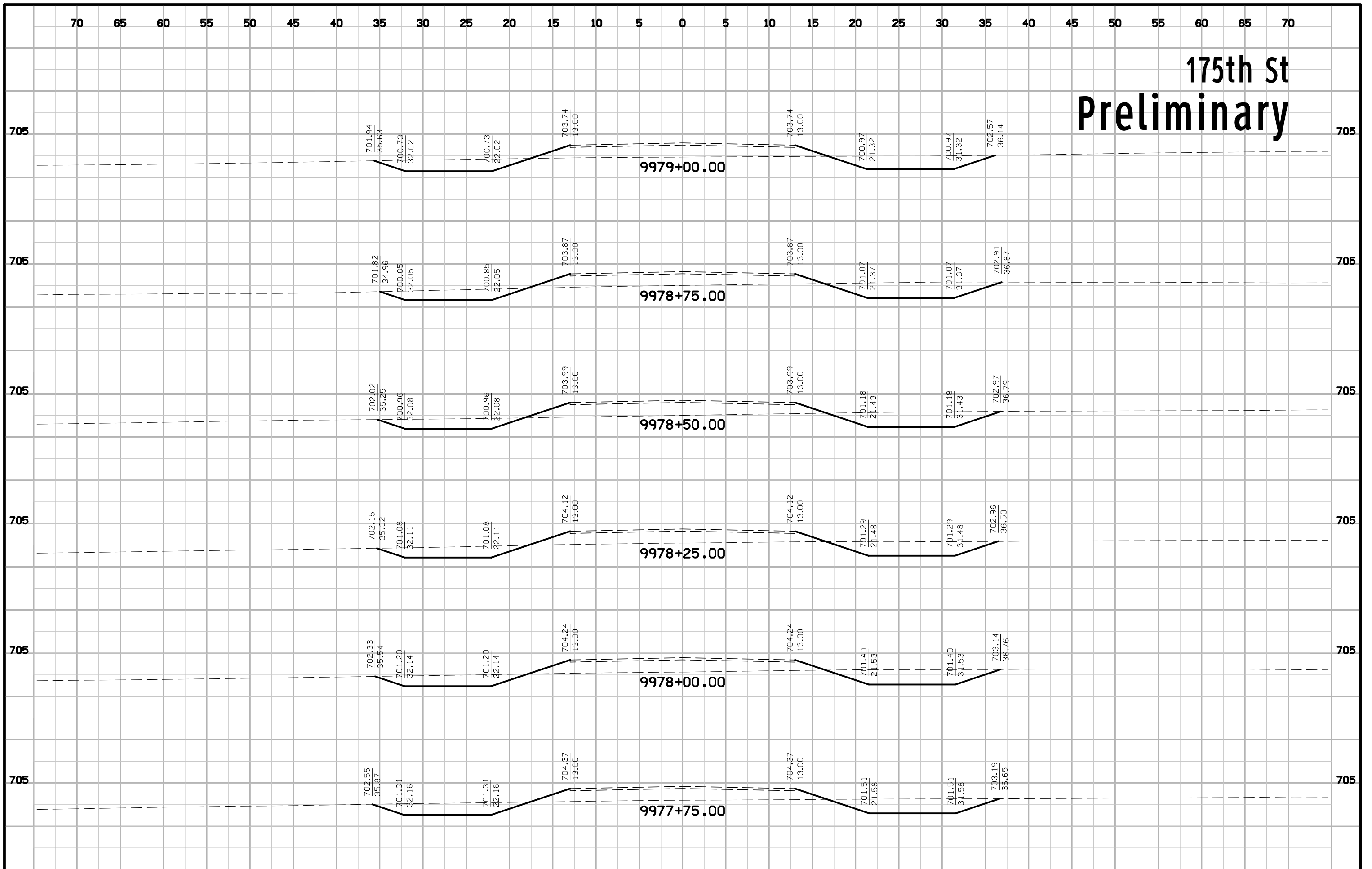

175th St Preliminary

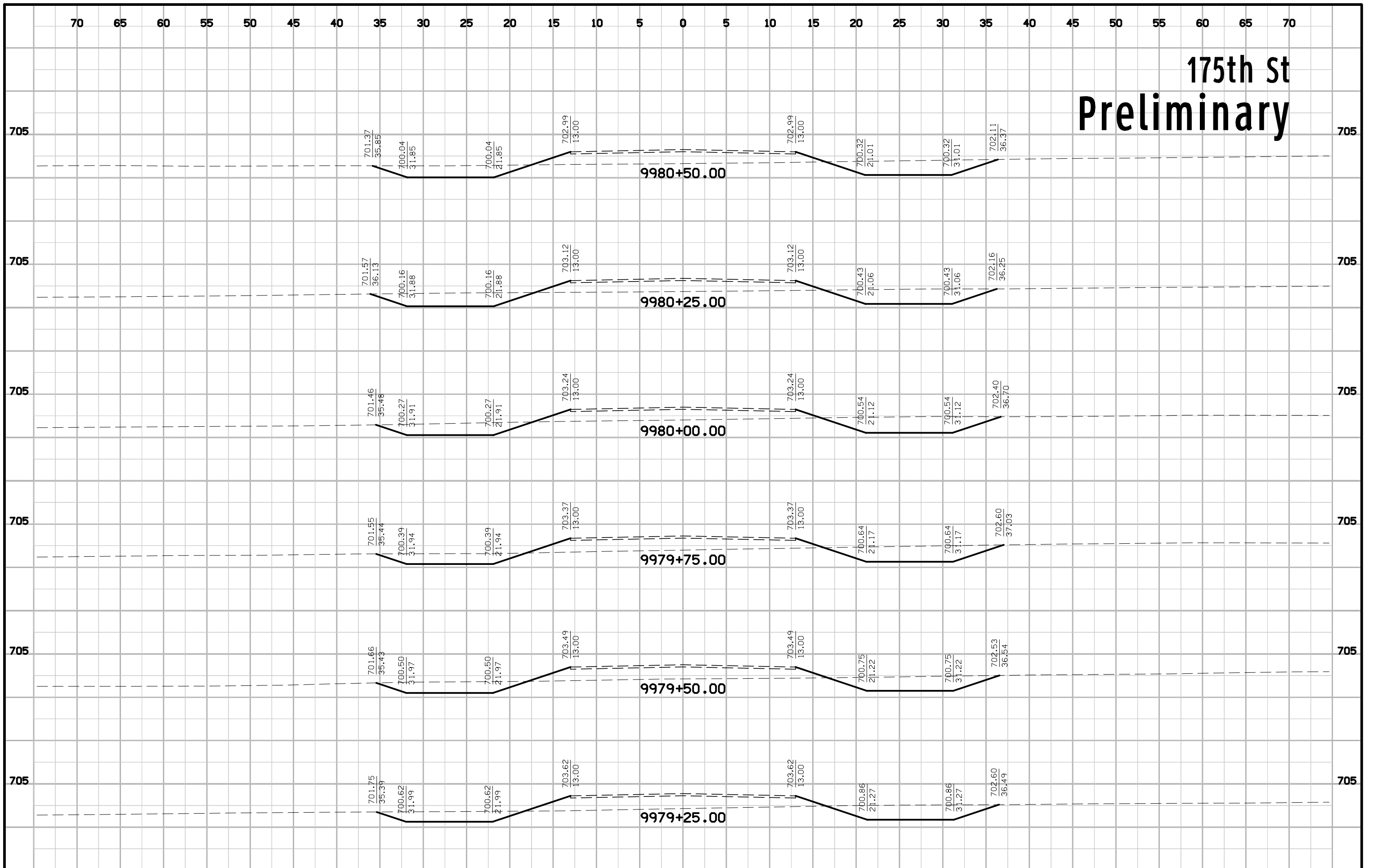

175th St Preliminary

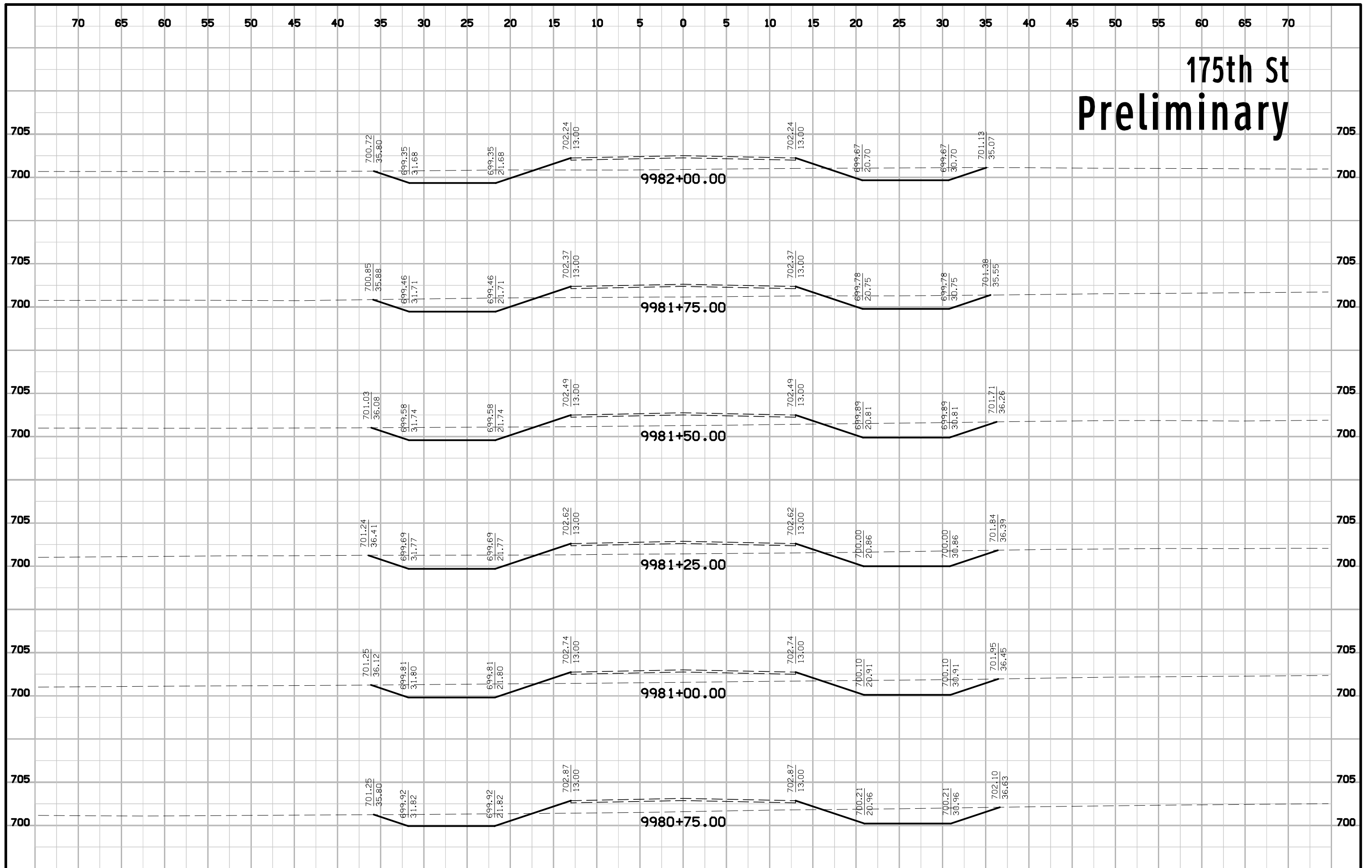

175th St Preliminary

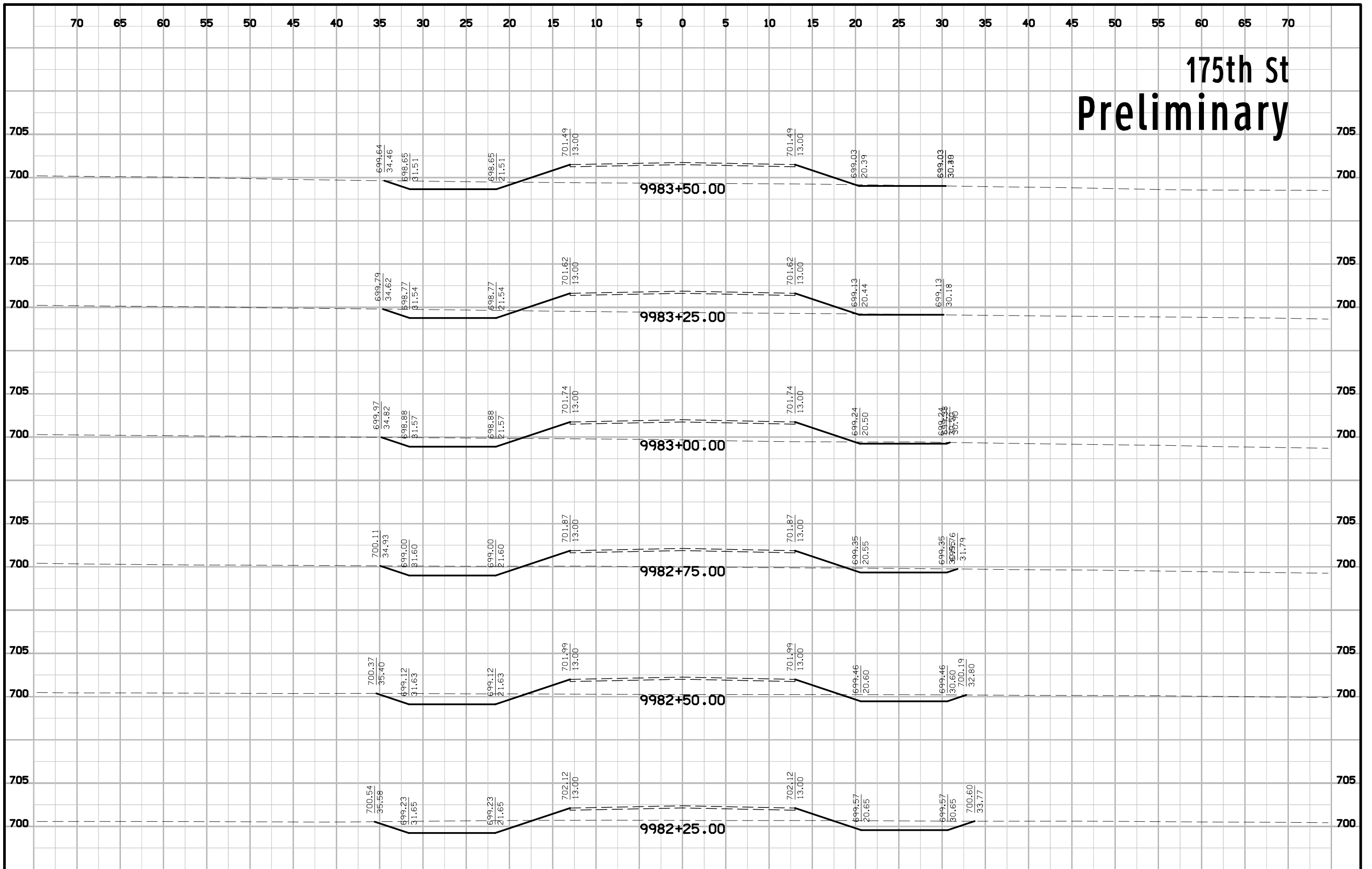

175th St Preliminary

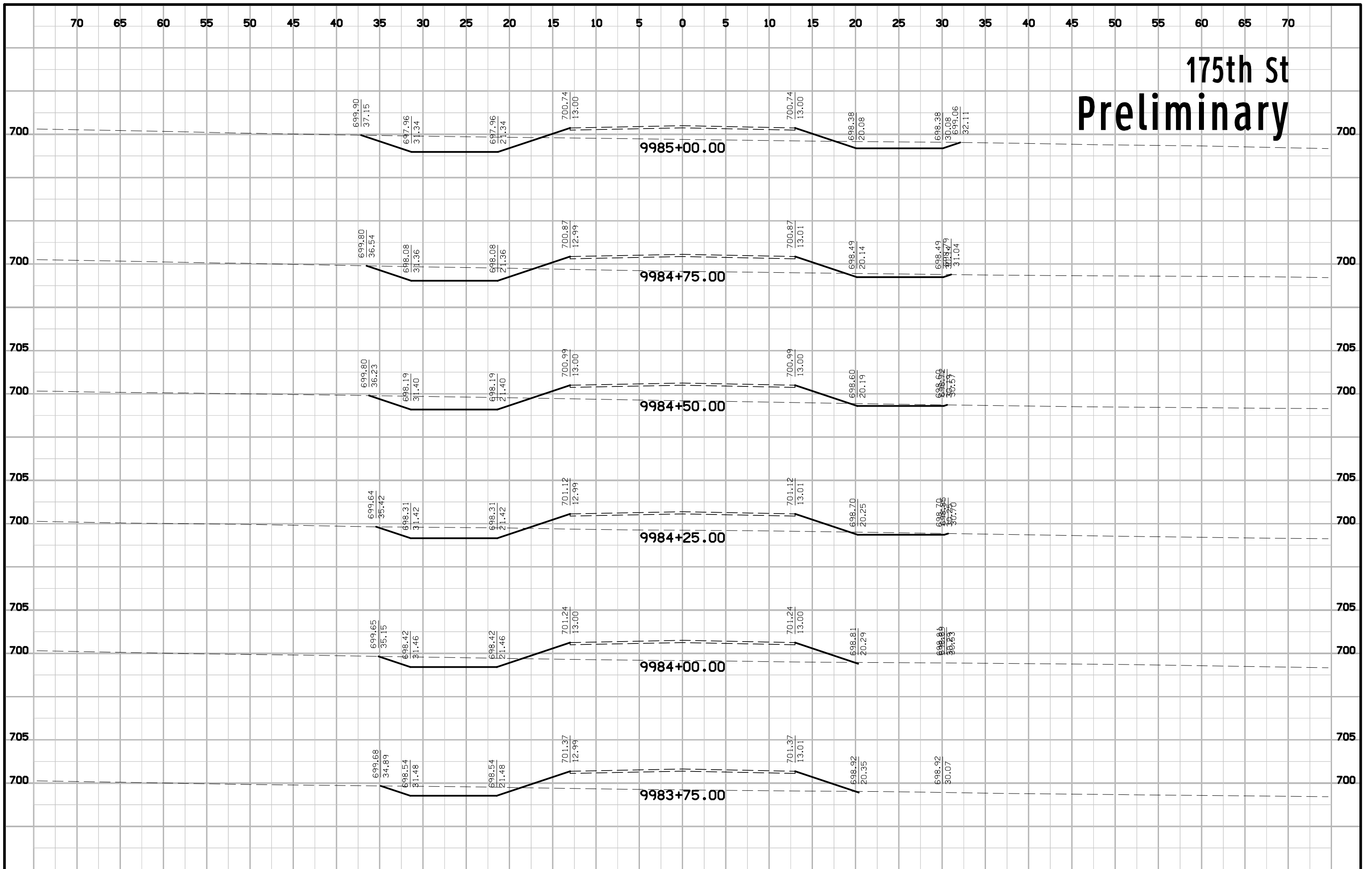

175th St Preliminary

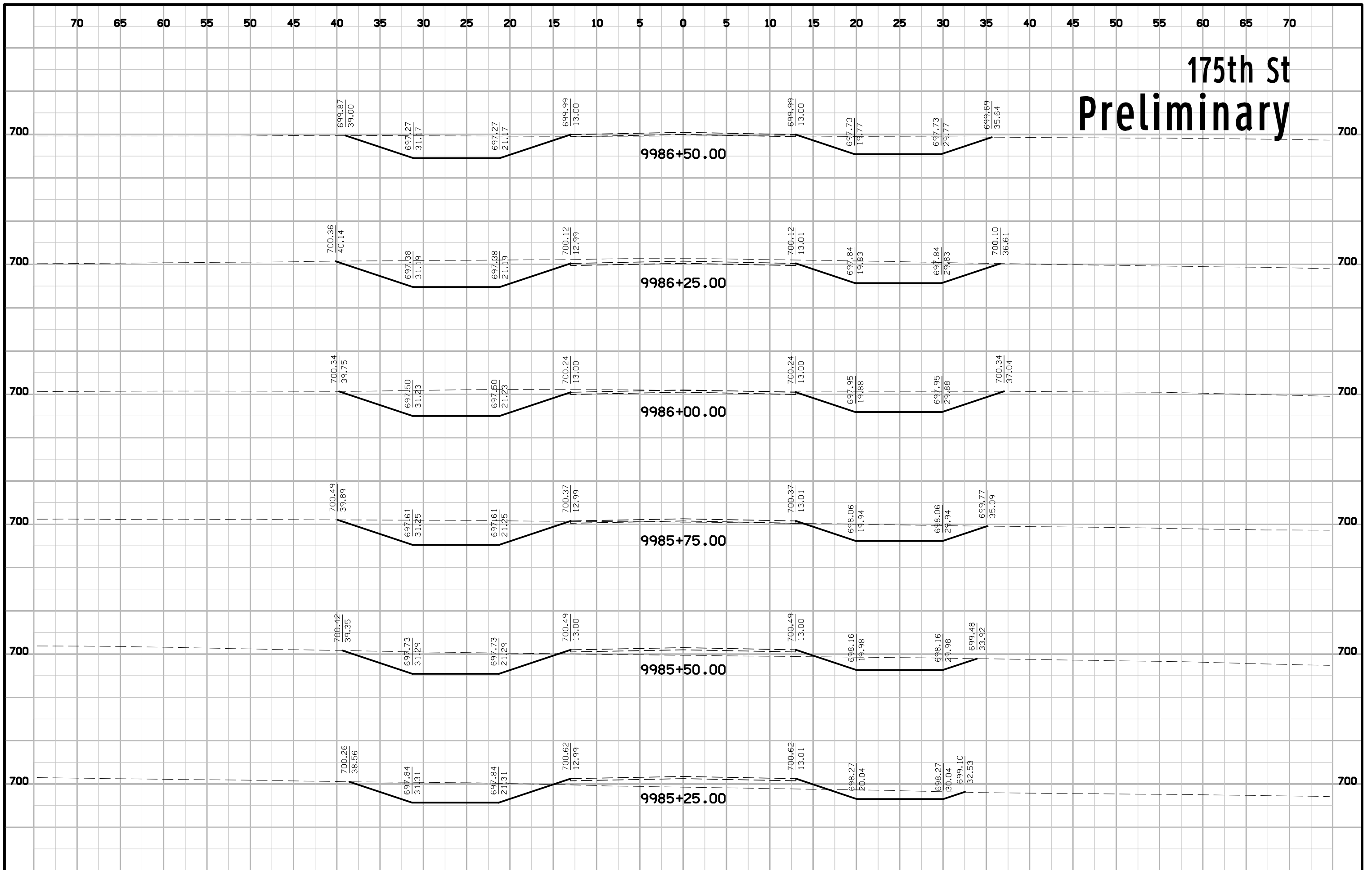

175th St Preliminary

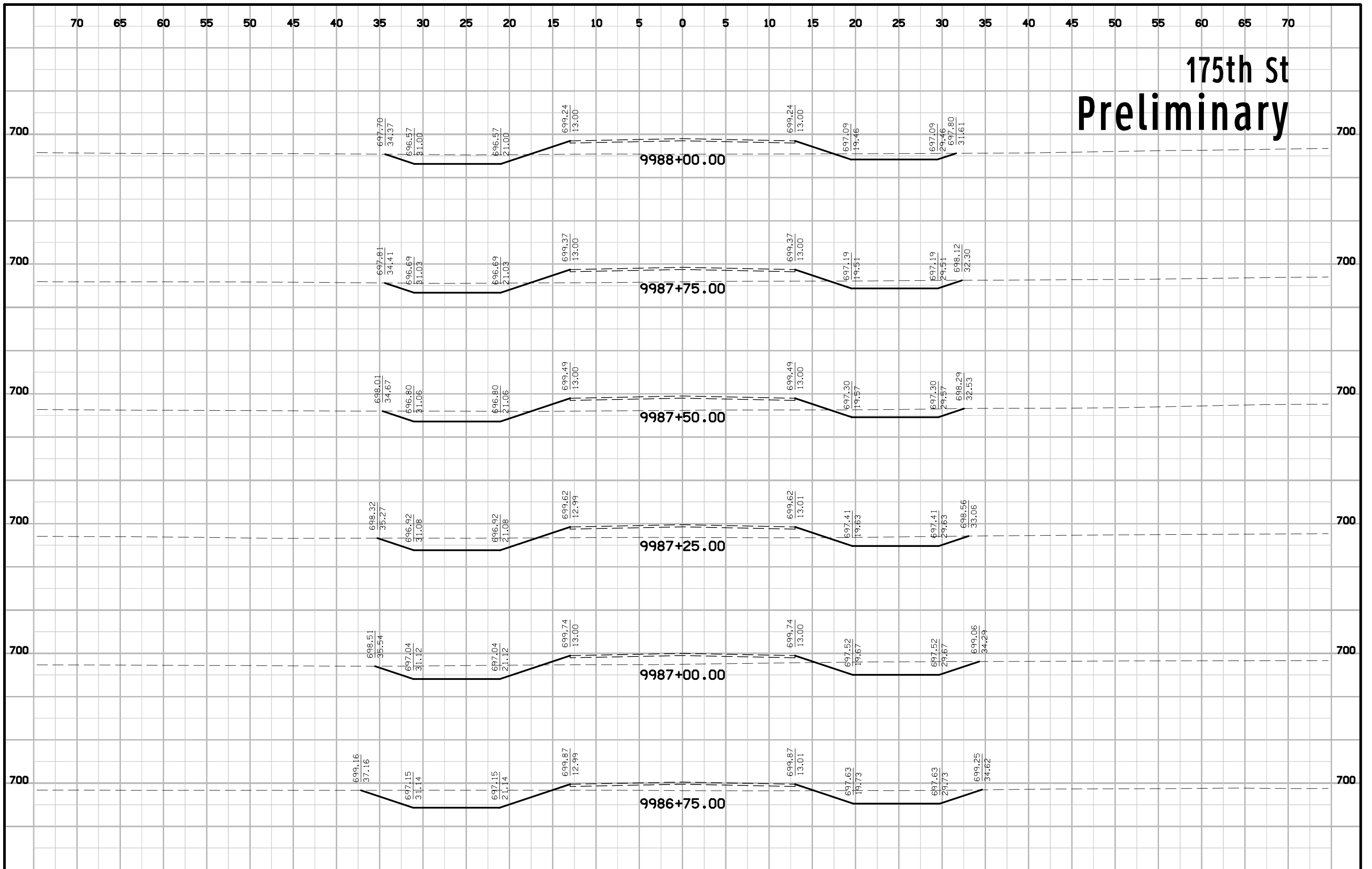

175th St Preliminary

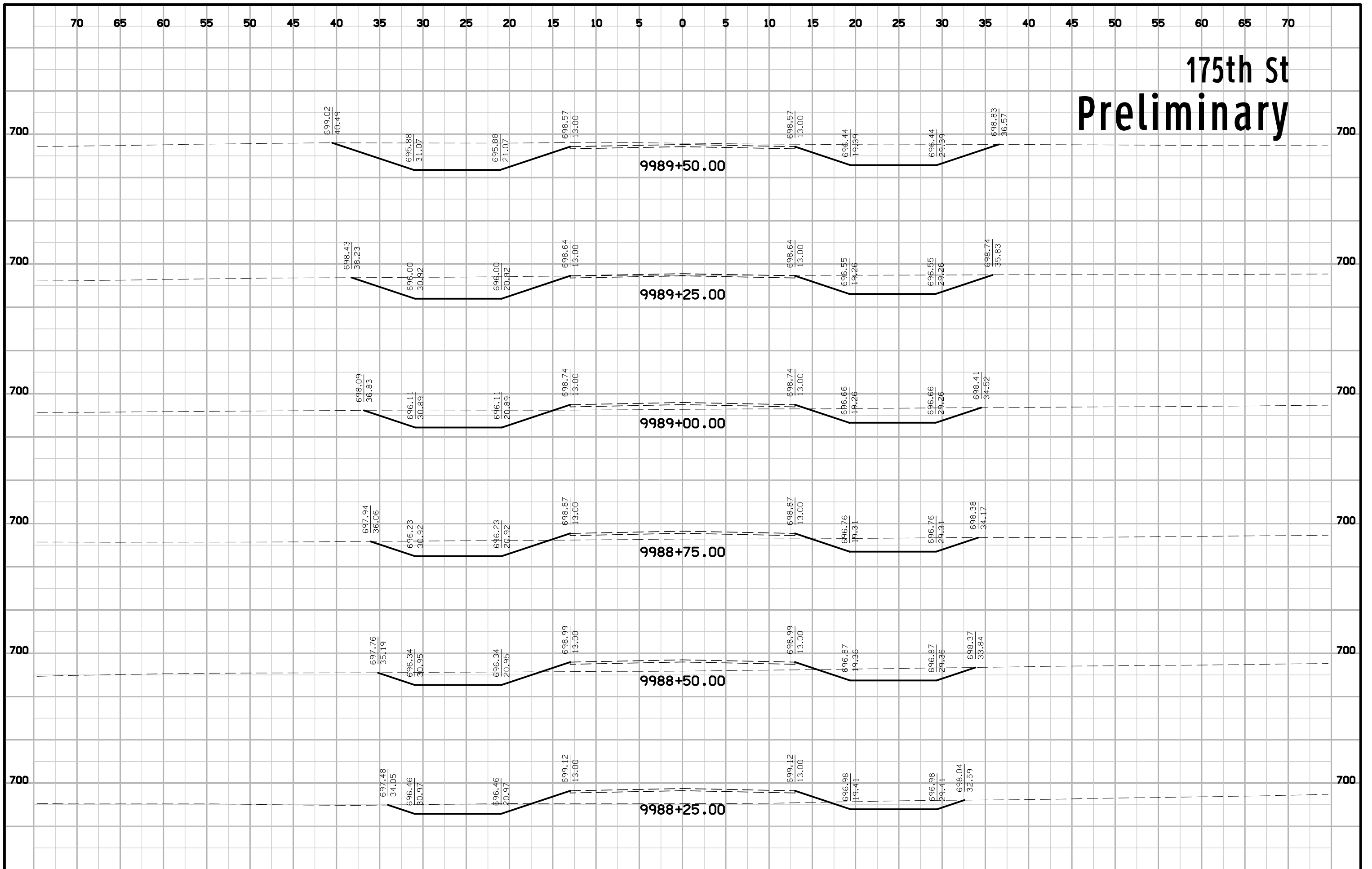

175th St Preliminary

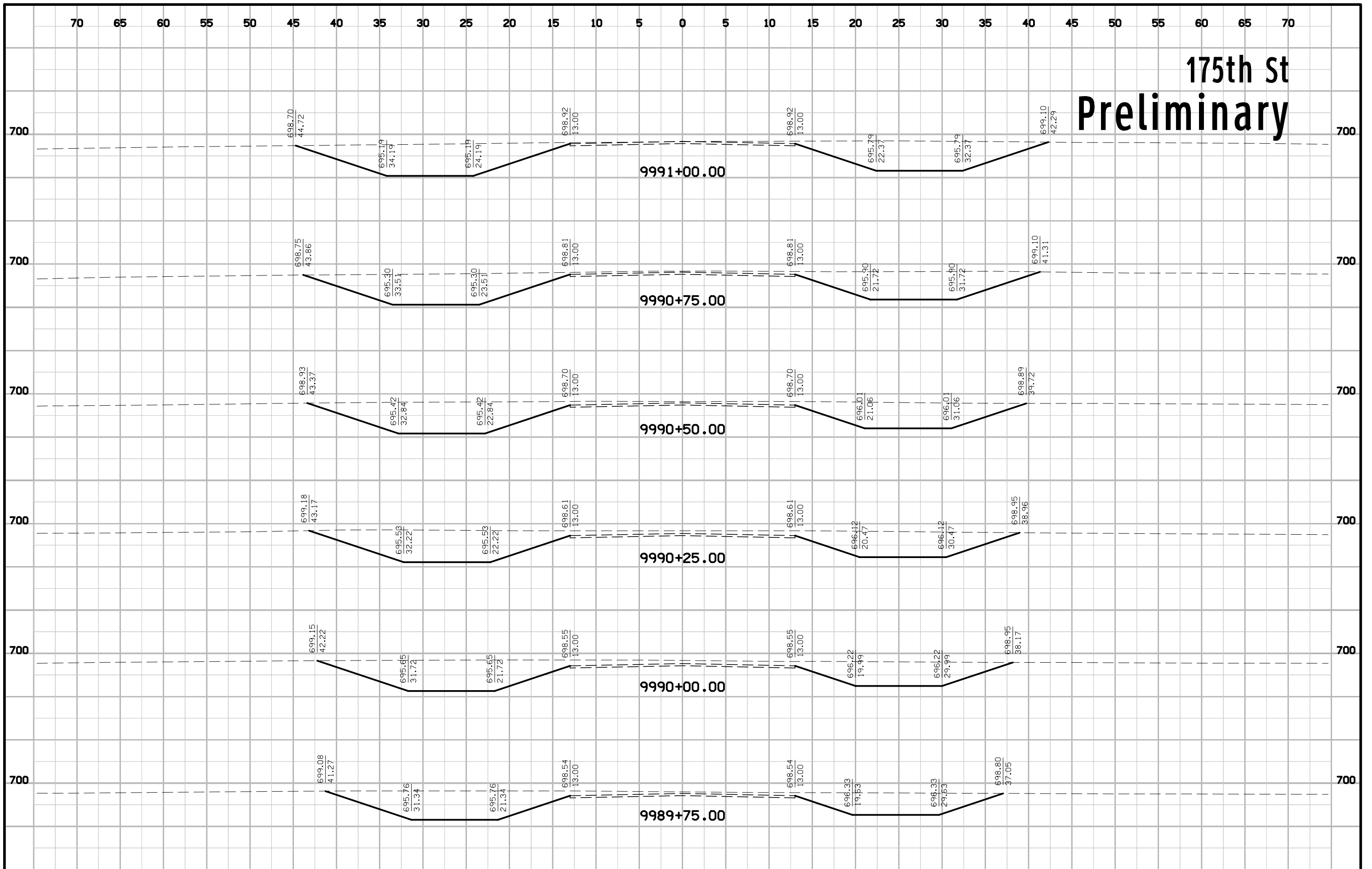

175th St Preliminary

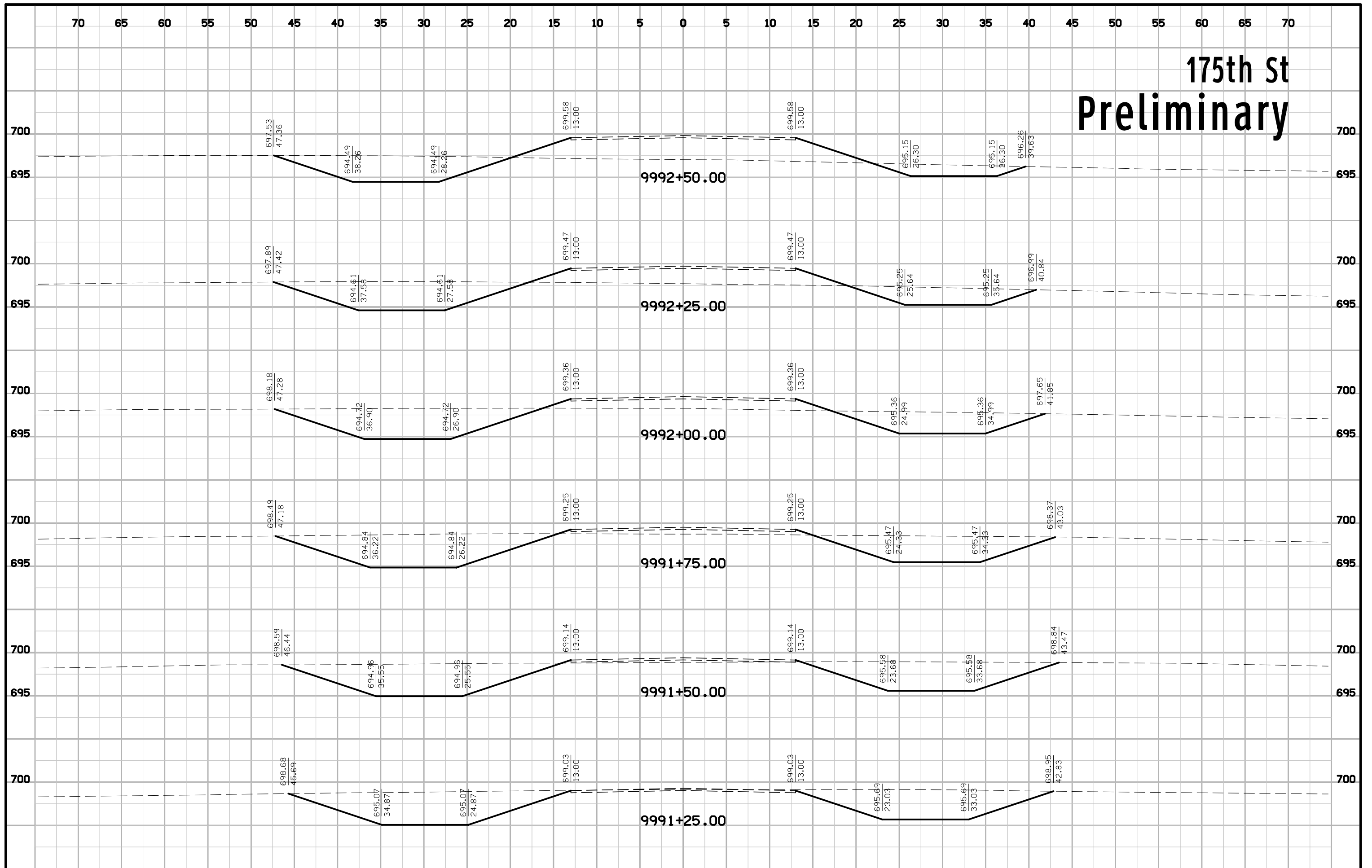

175th St Preliminary

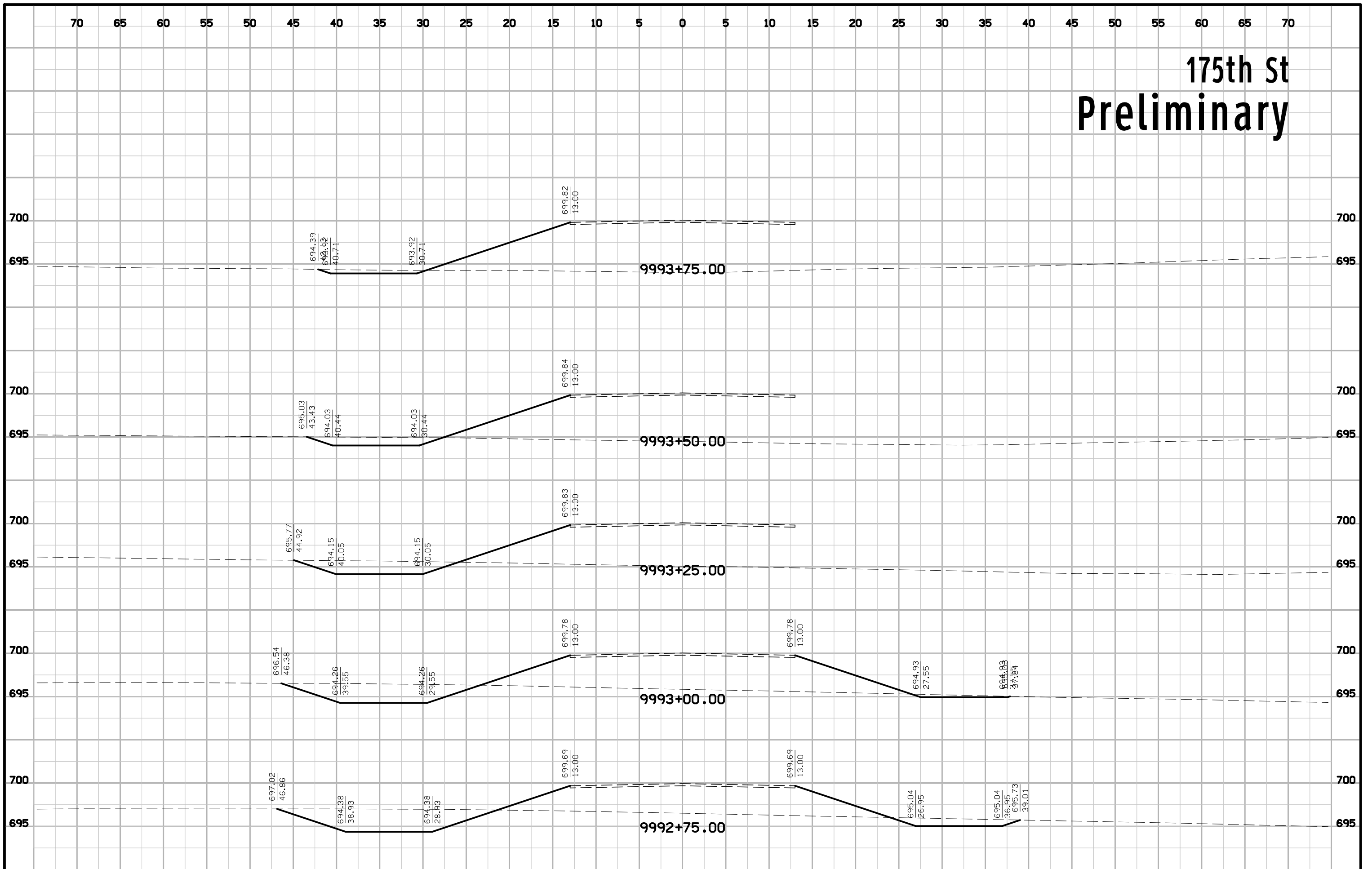

175th St Preliminary

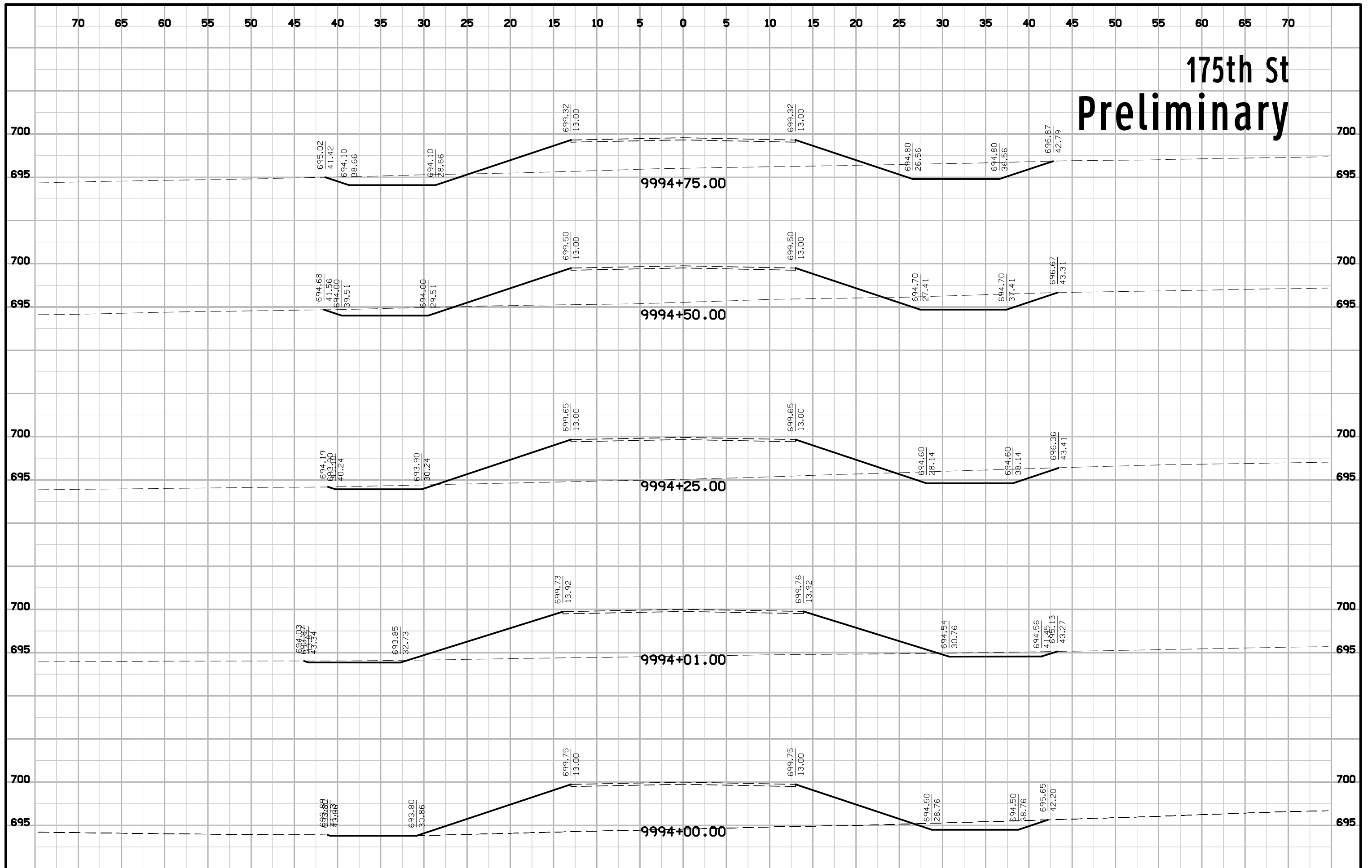

175th St Preliminary

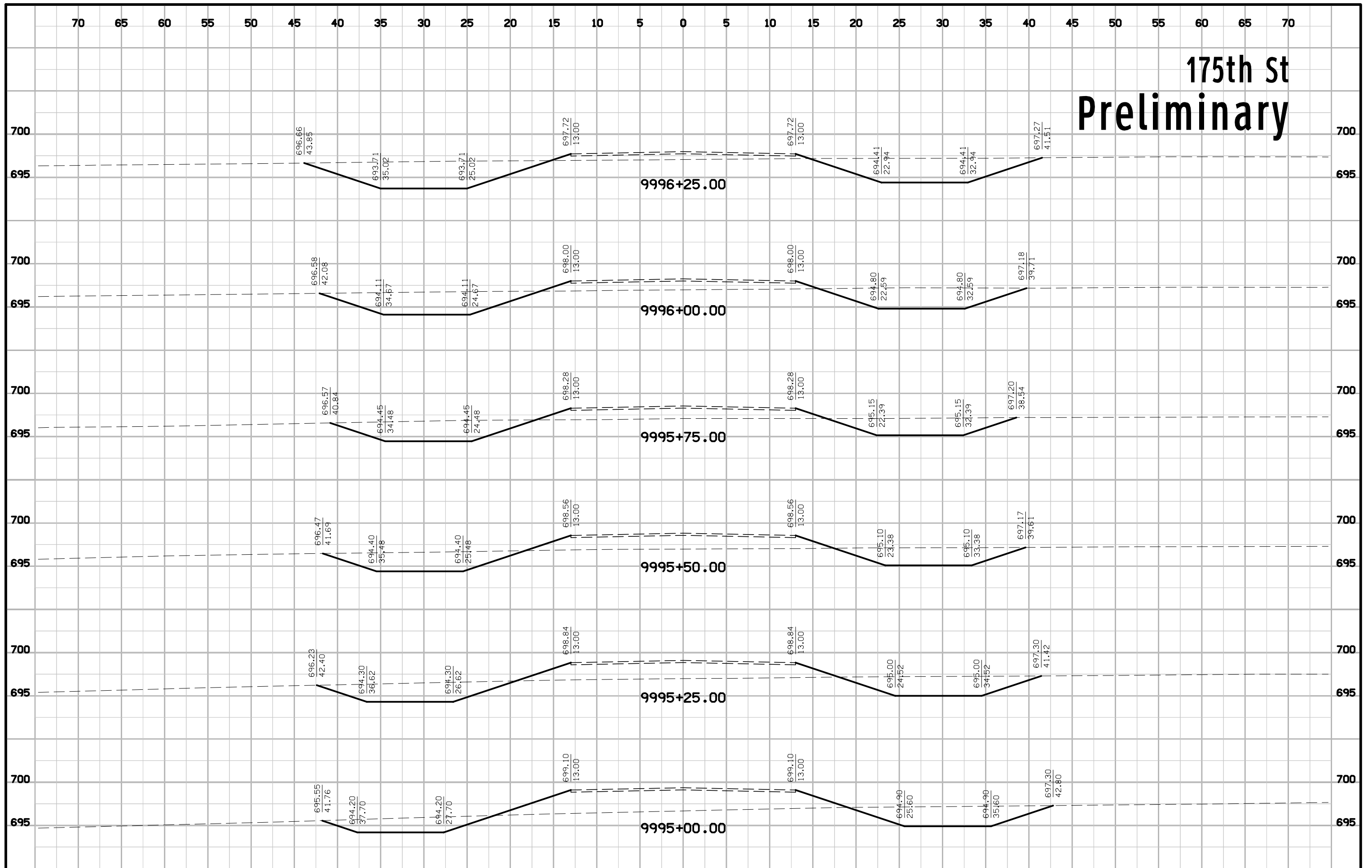

175th St Preliminary

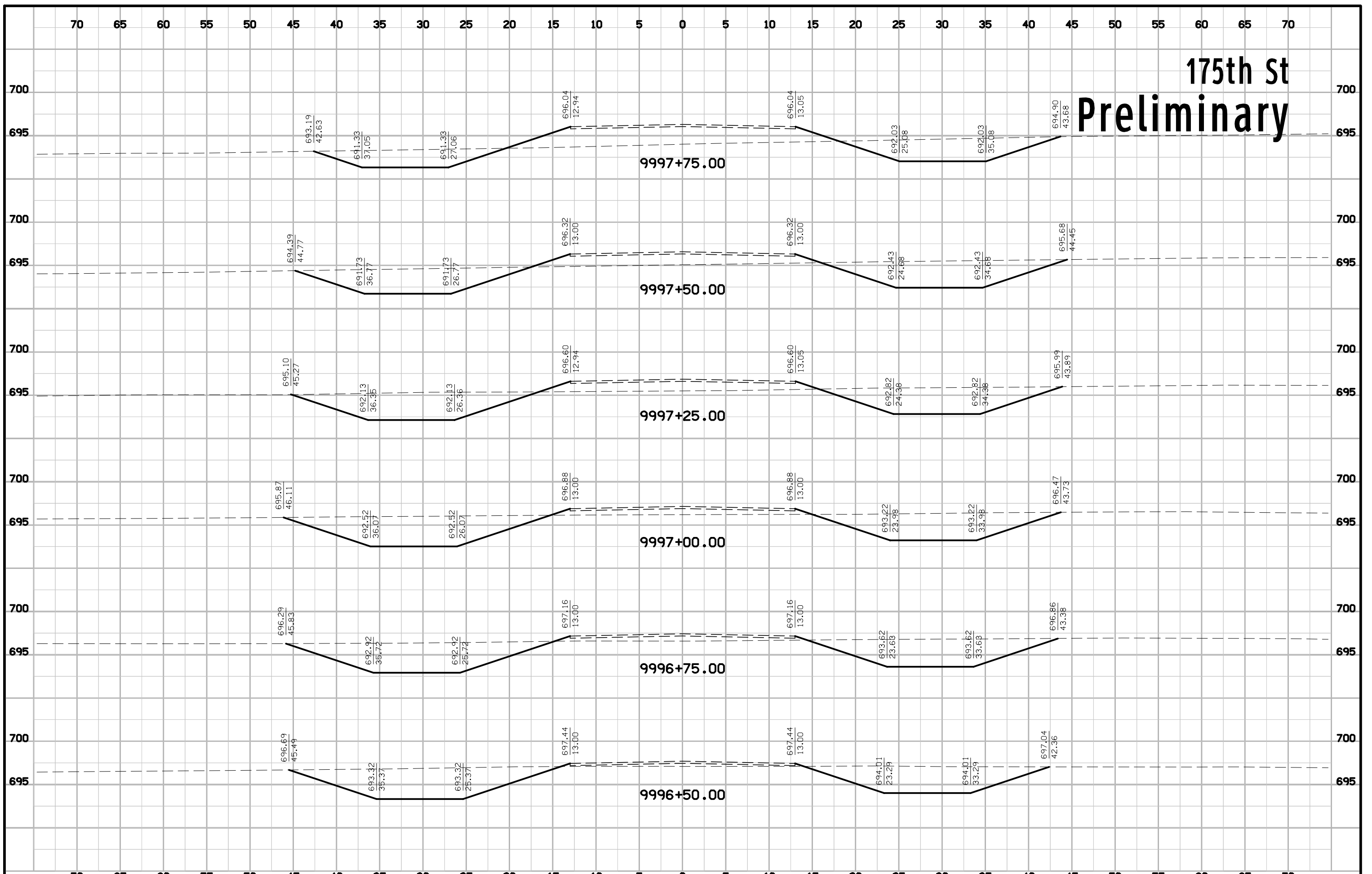

175th St Preliminary

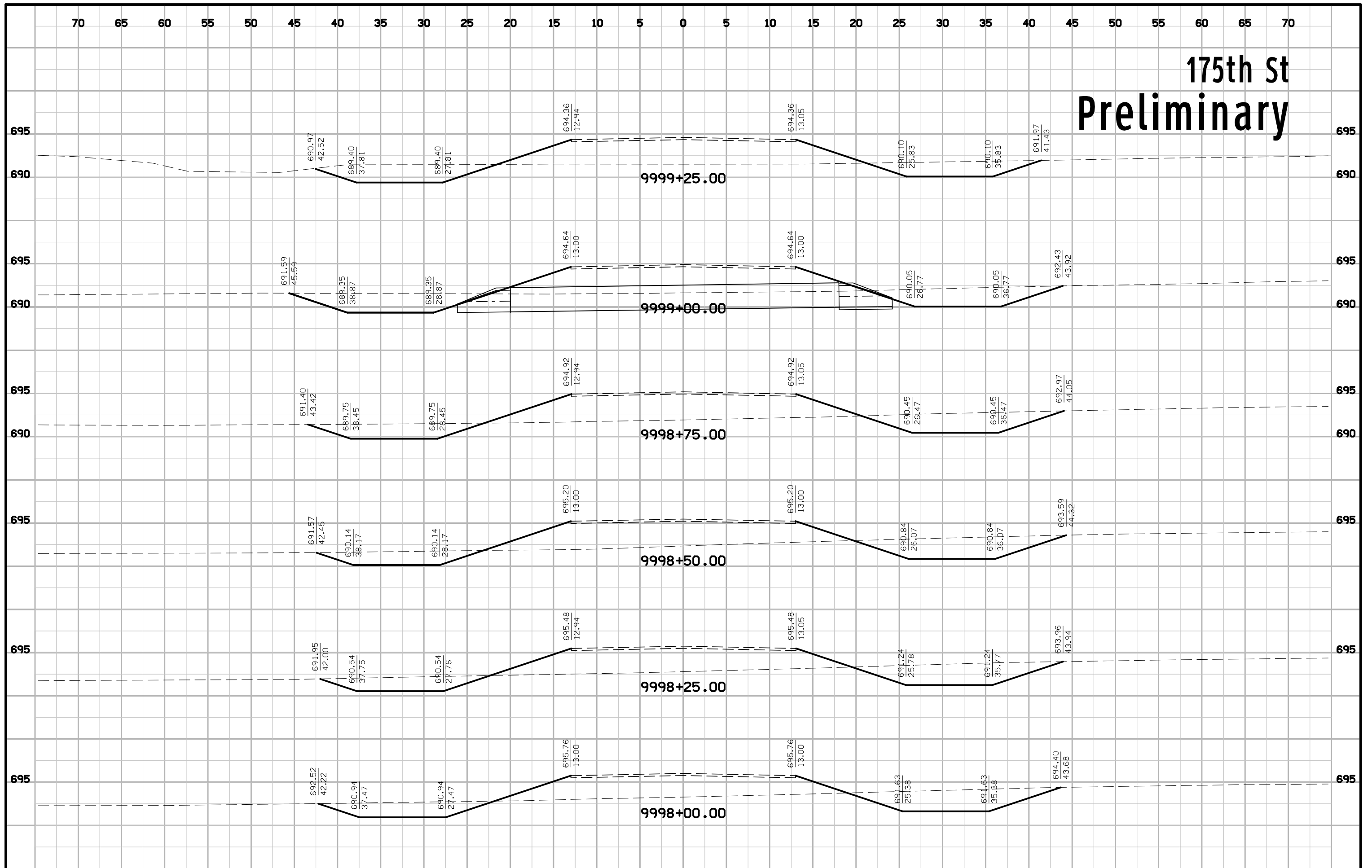

175th St Preliminary

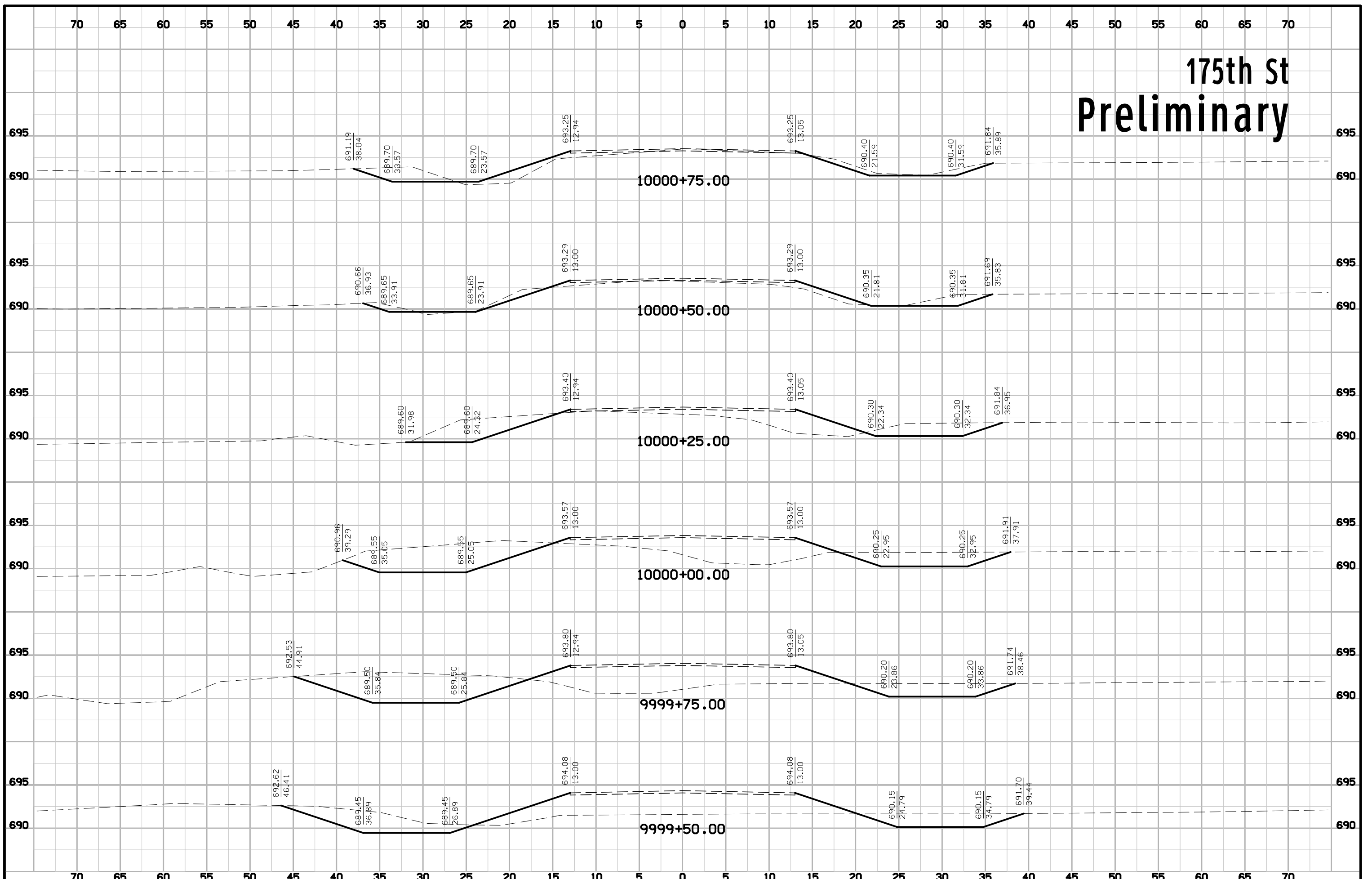

175th St Preliminary

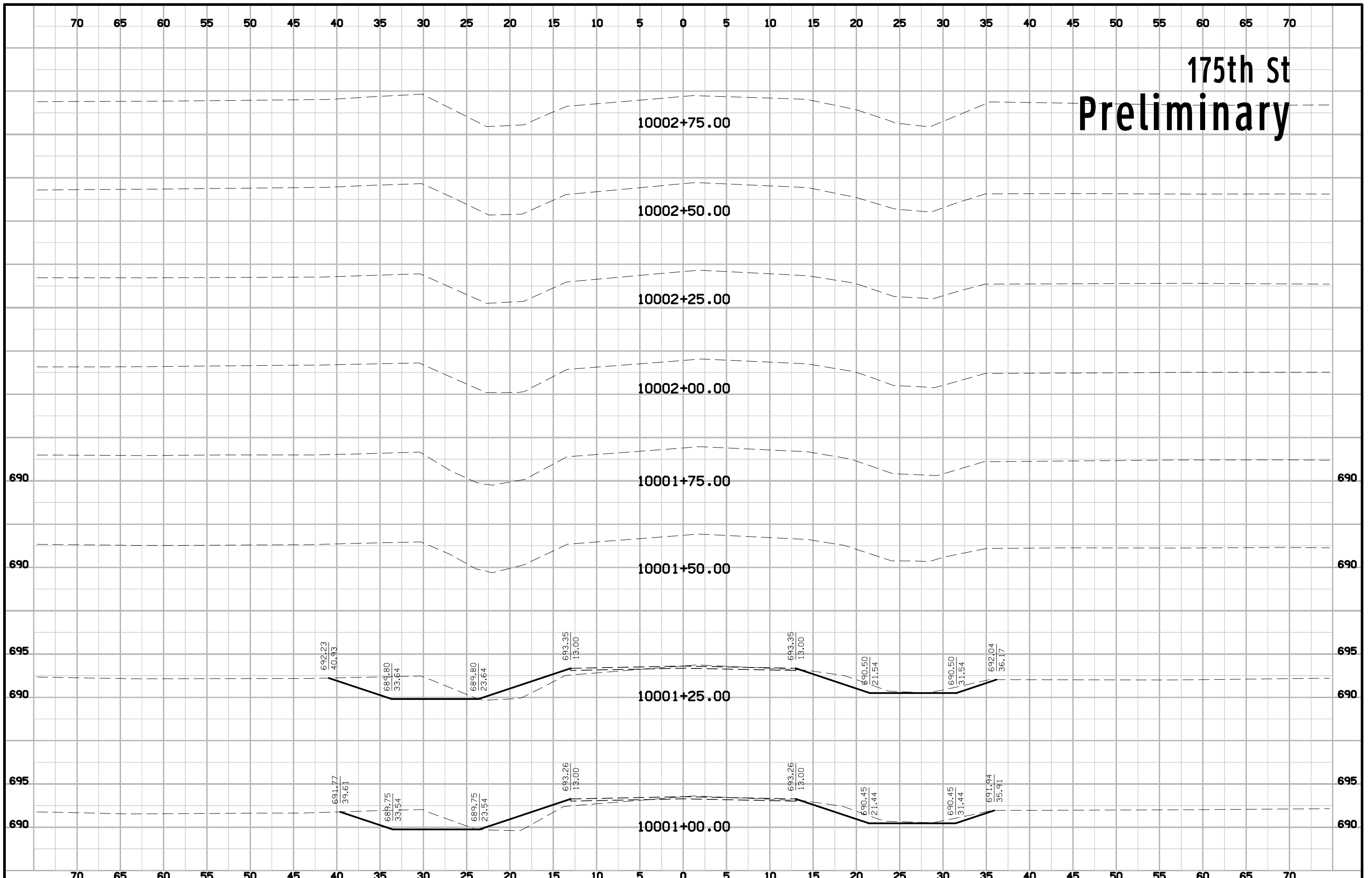

175th St Preliminary

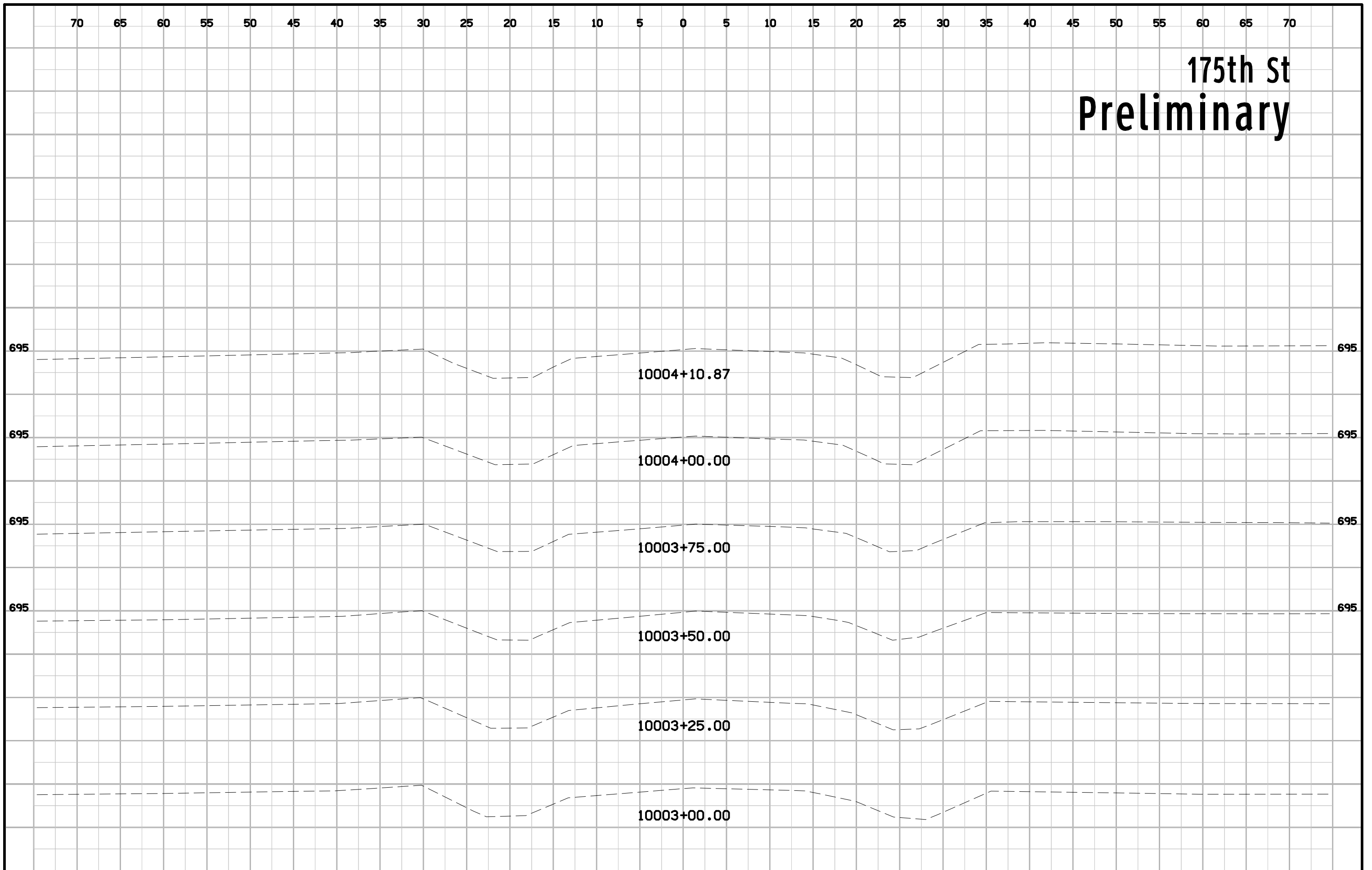

180th St Preliminary

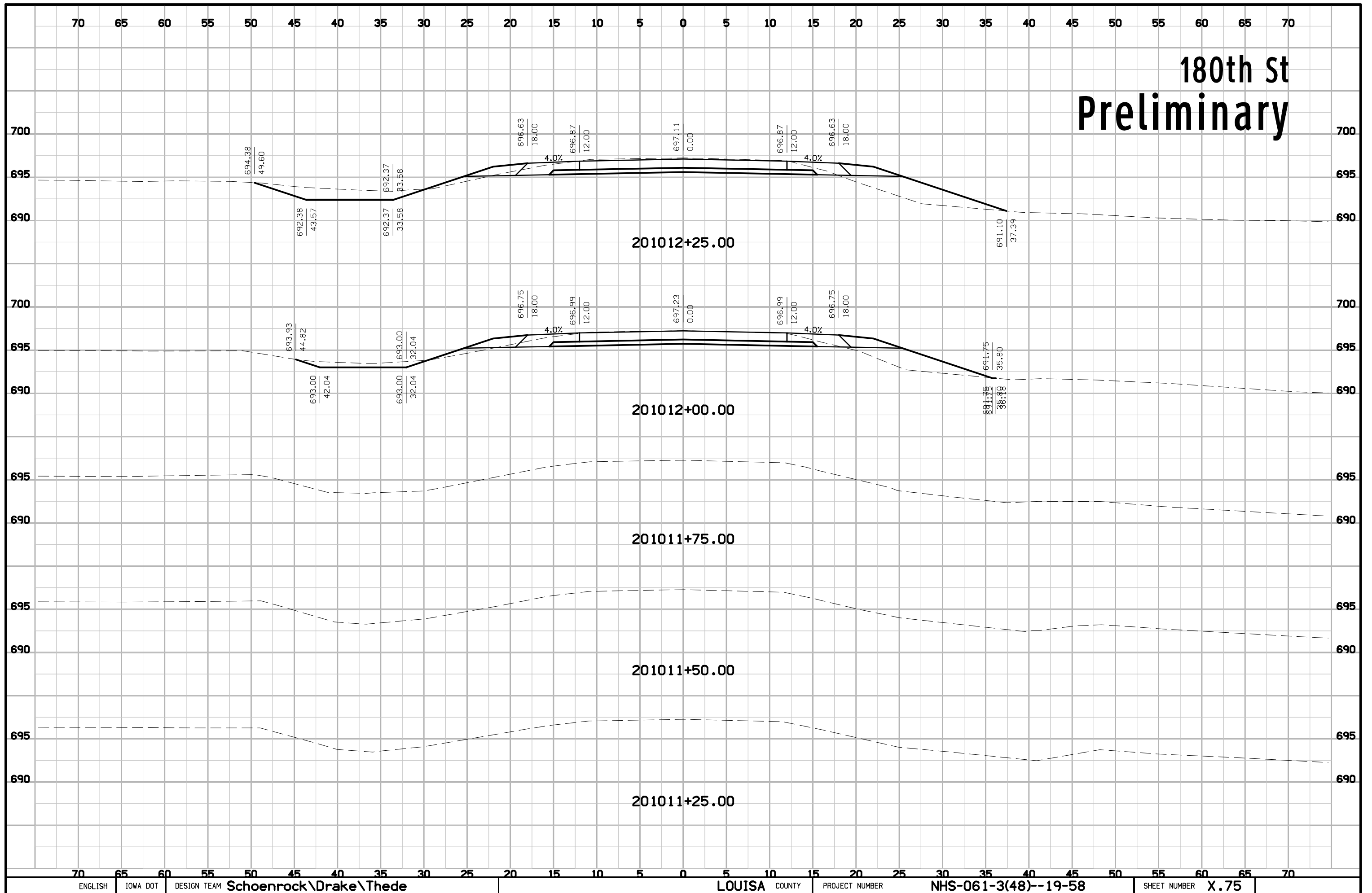

180th St Preliminary

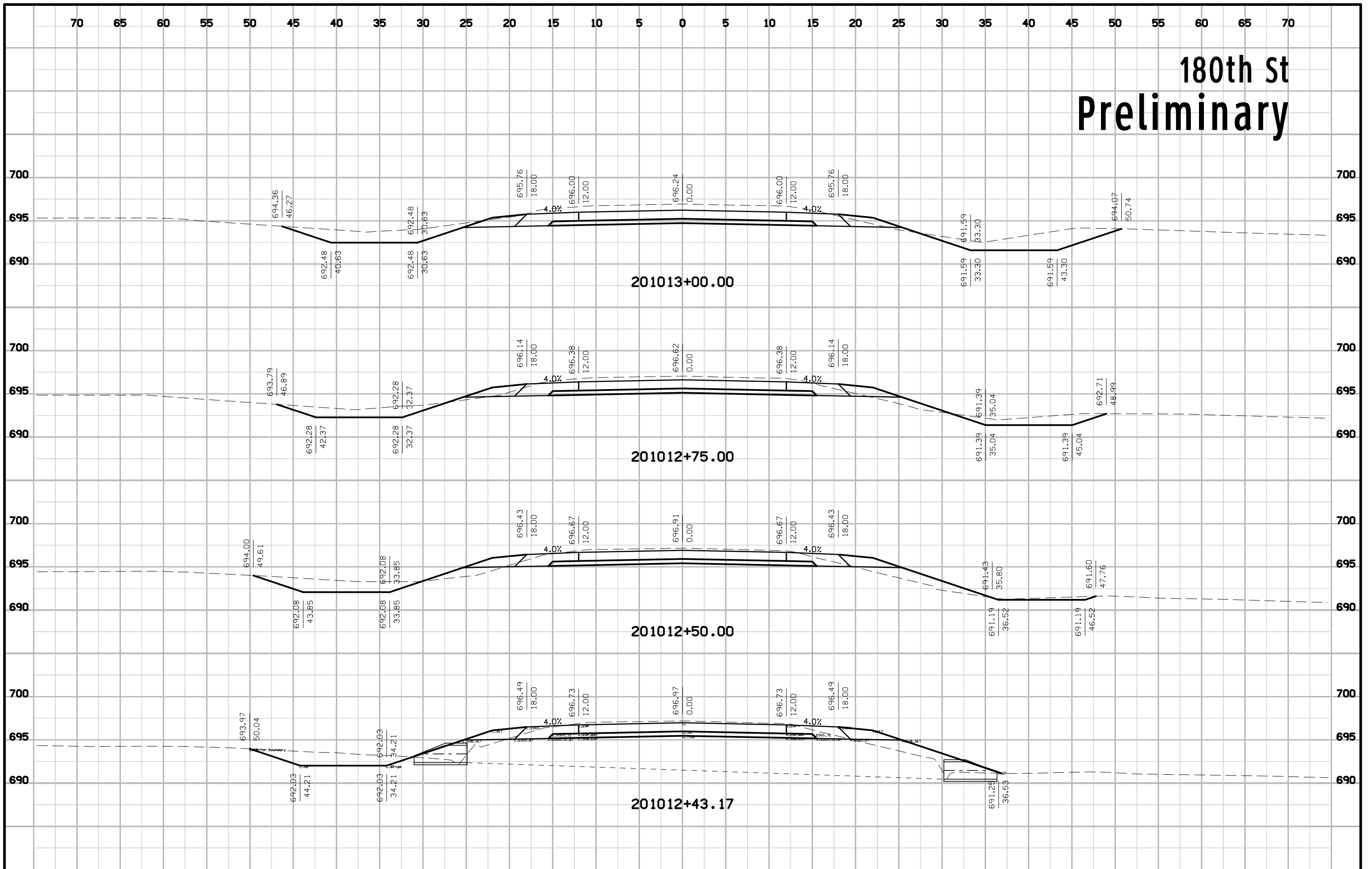

180th St Preliminary

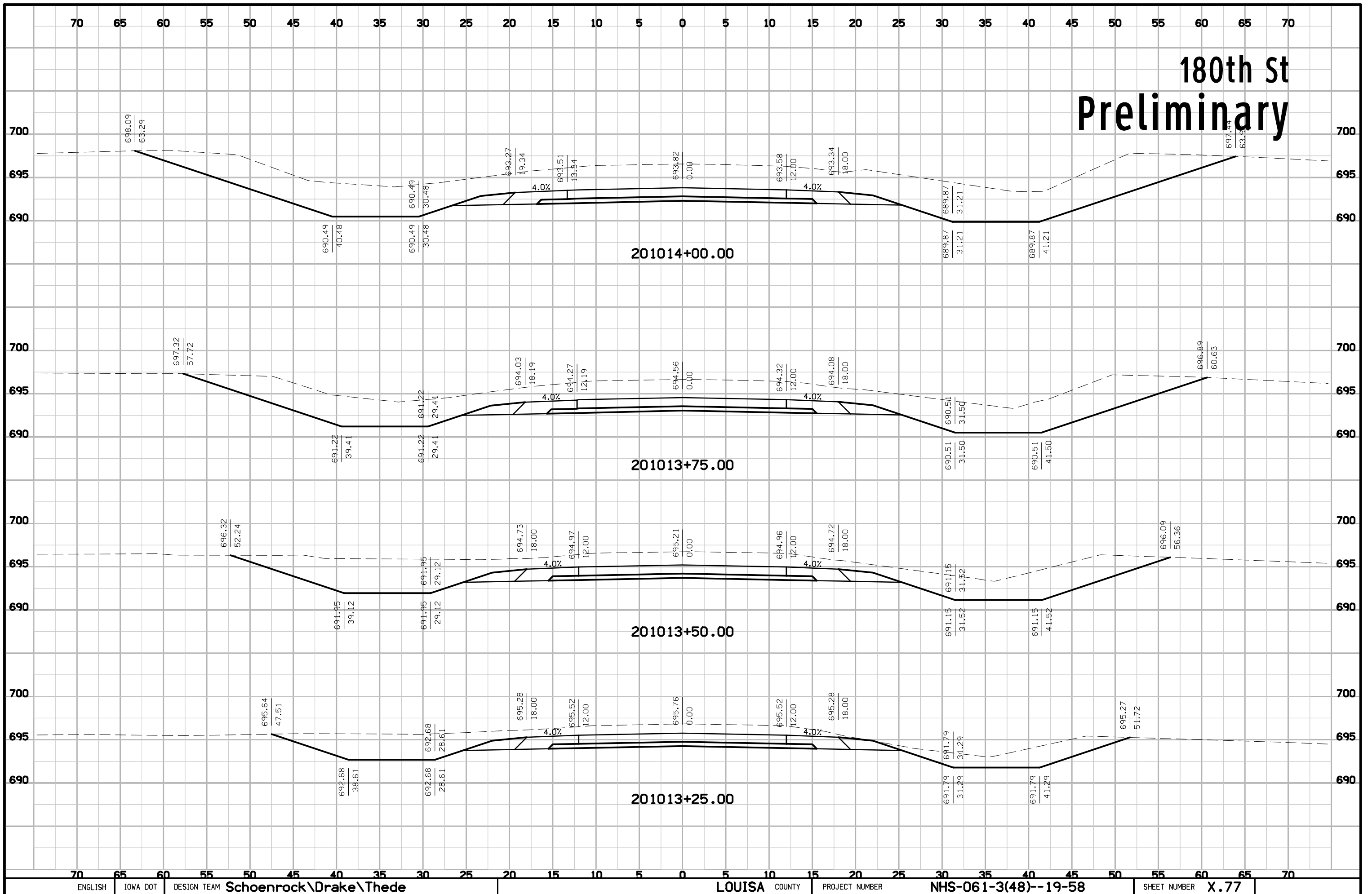

180th St Preliminary

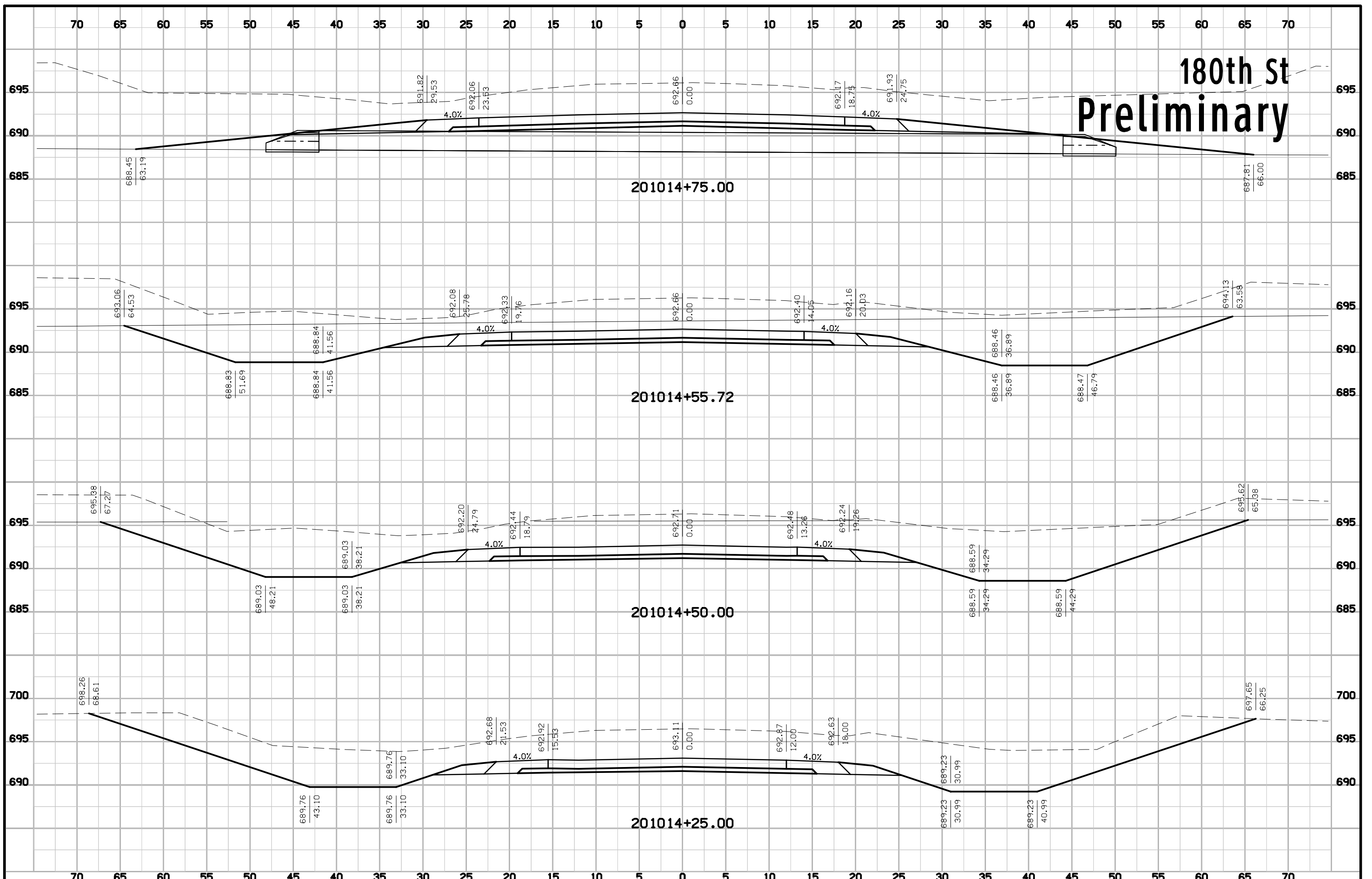

180th St Preliminary

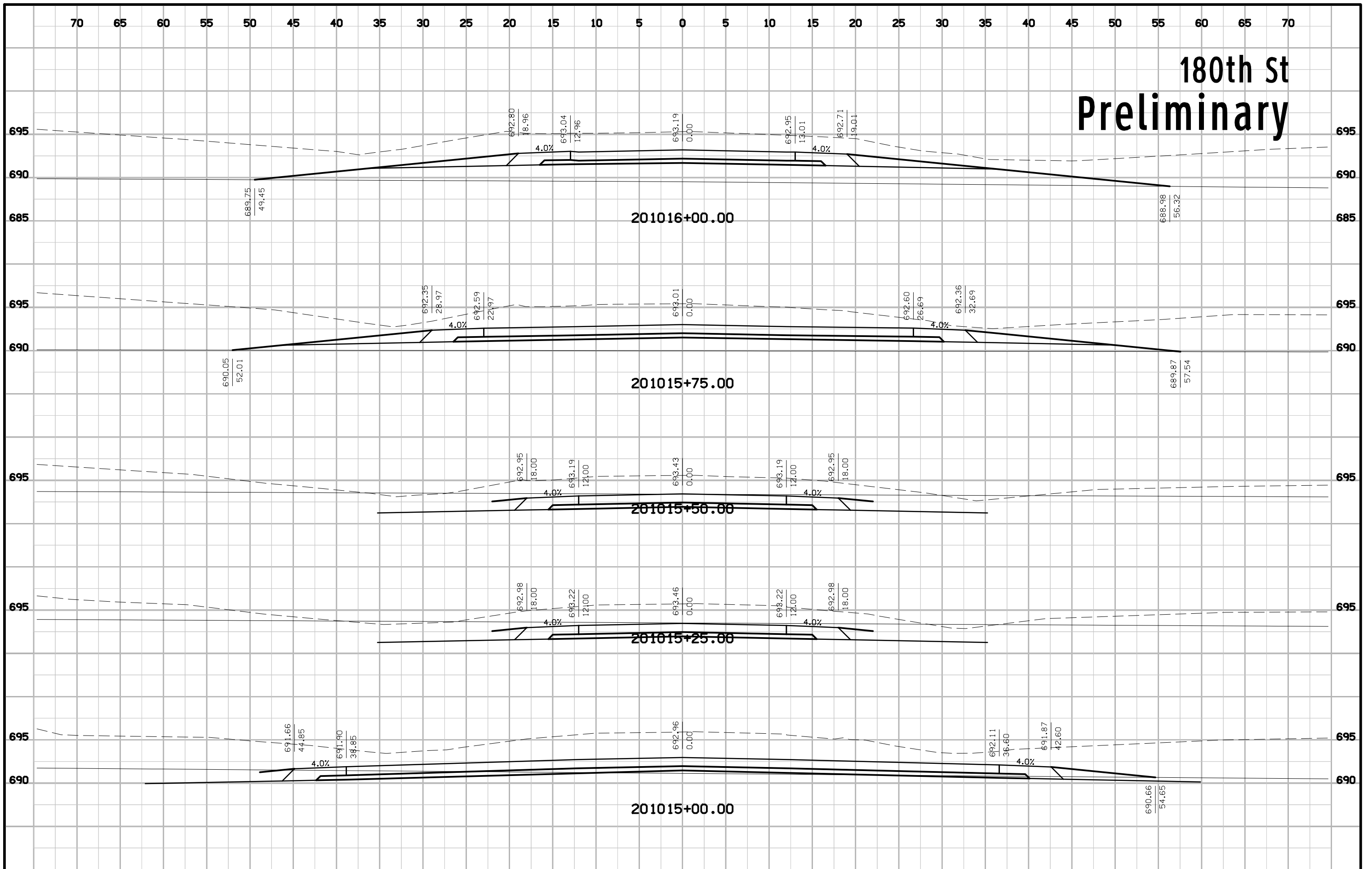

180th St Preliminary

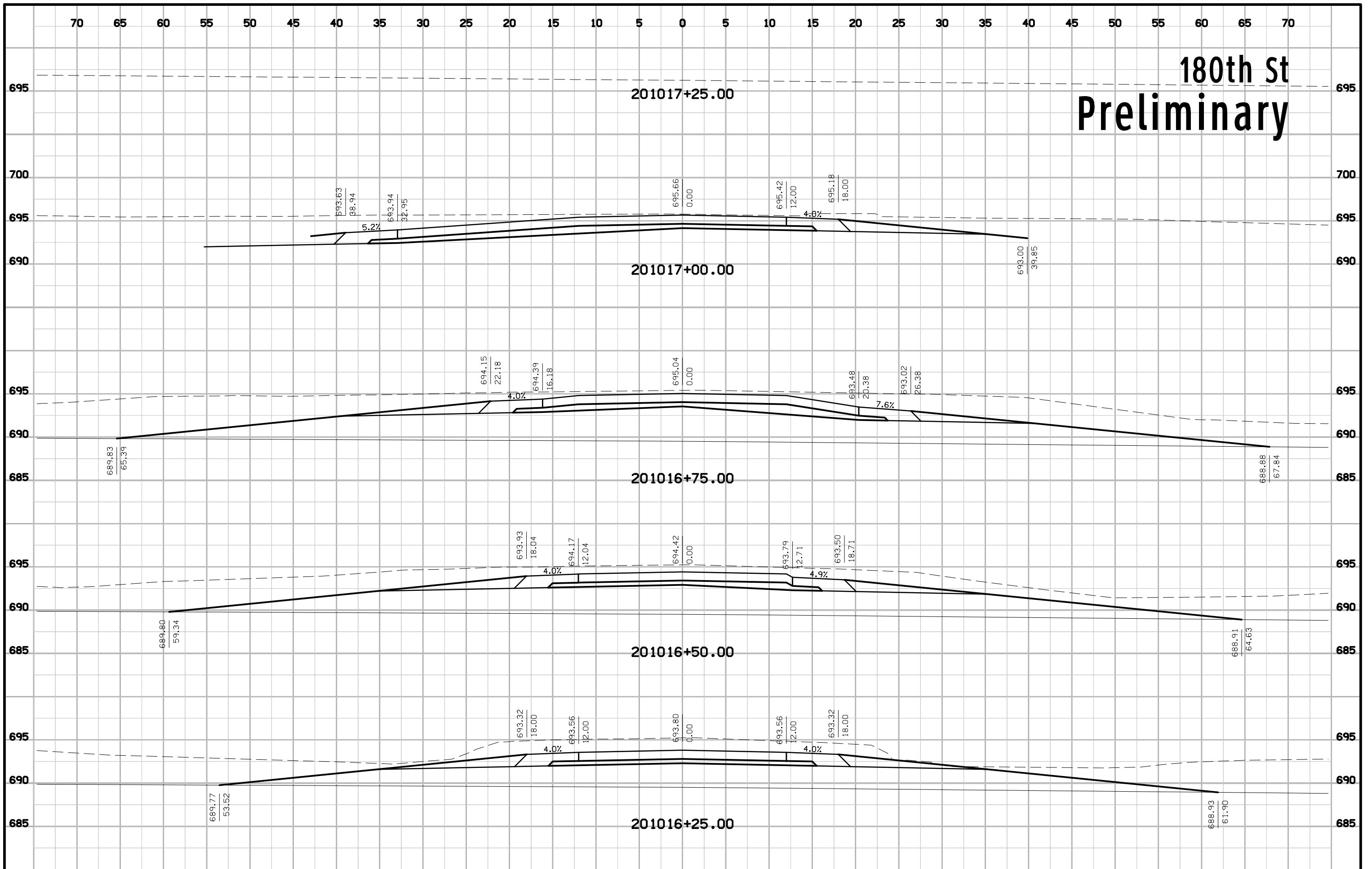

Existing 61 Preliminary

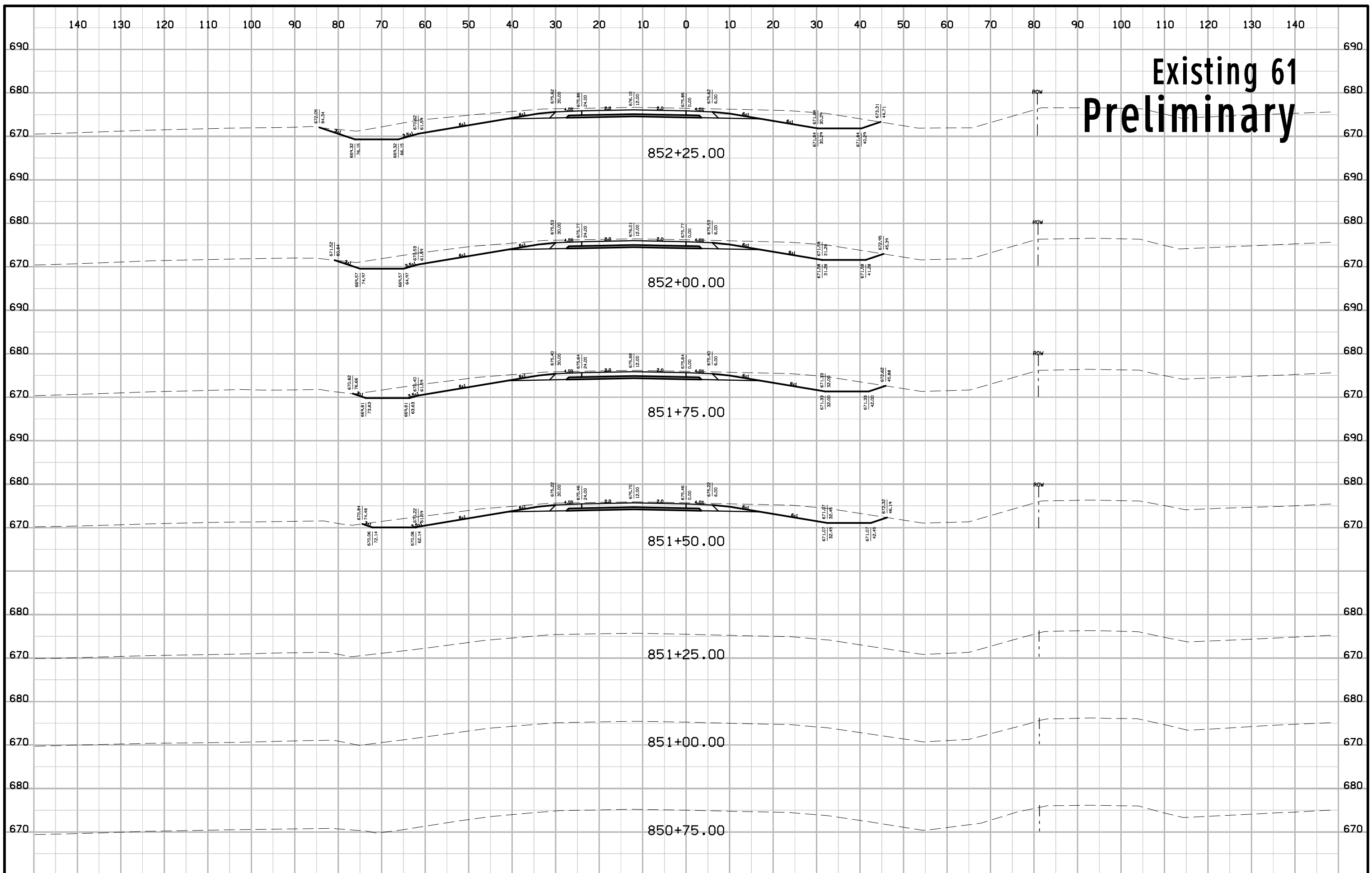

Existing 61 Preliminary

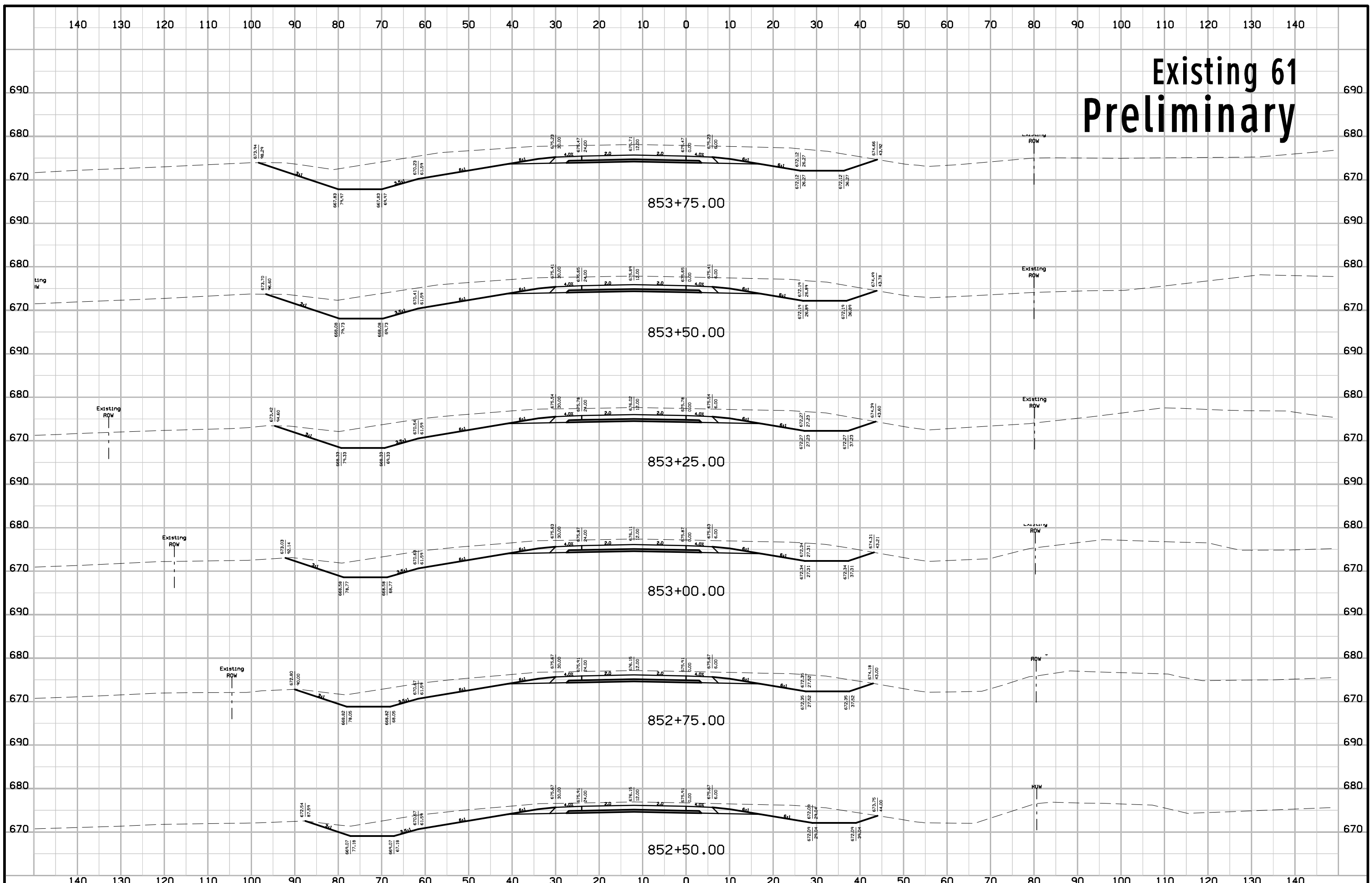

Existing 61 Preliminary

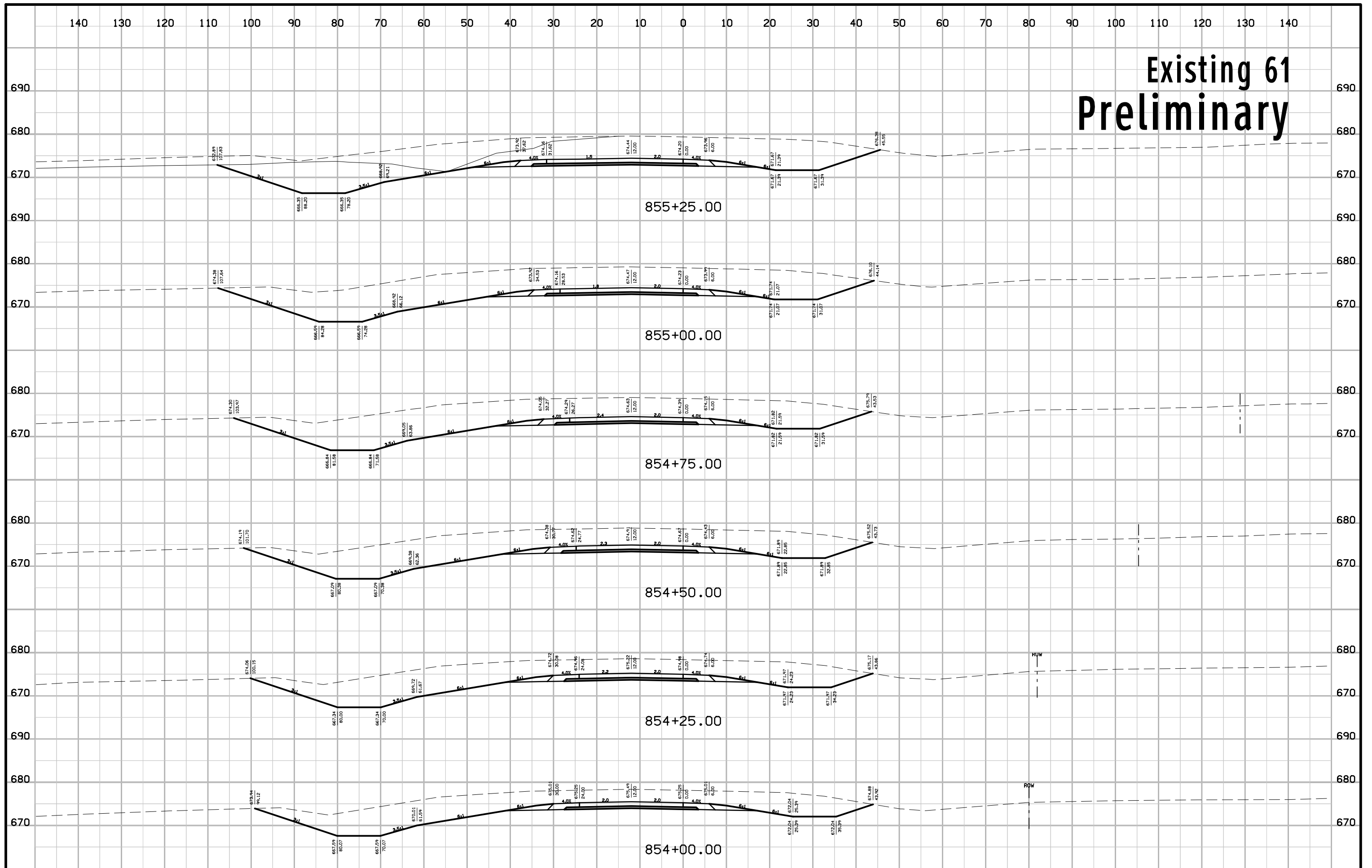

Existing 61 Preliminary

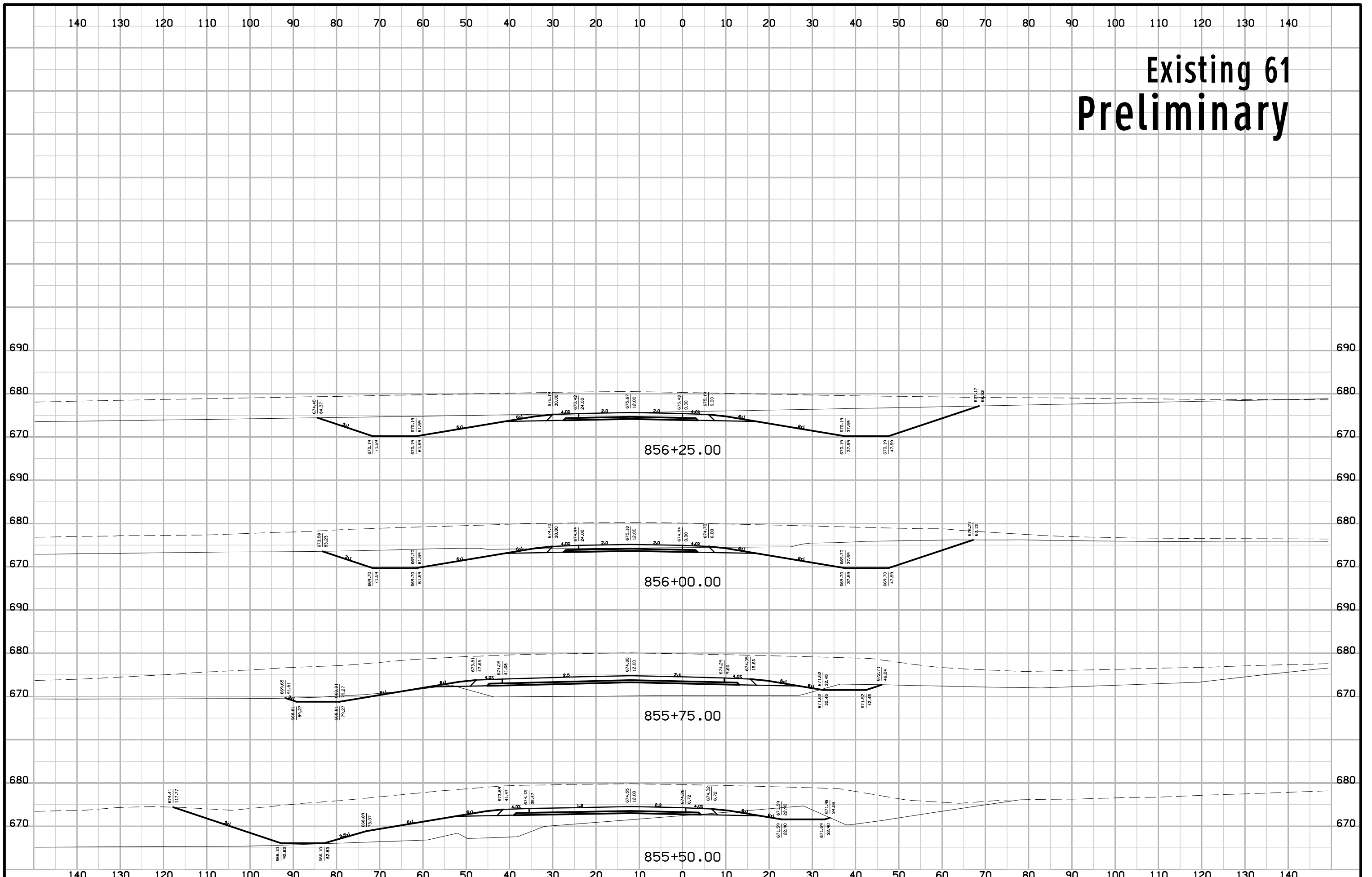

Existing 61 Preliminary

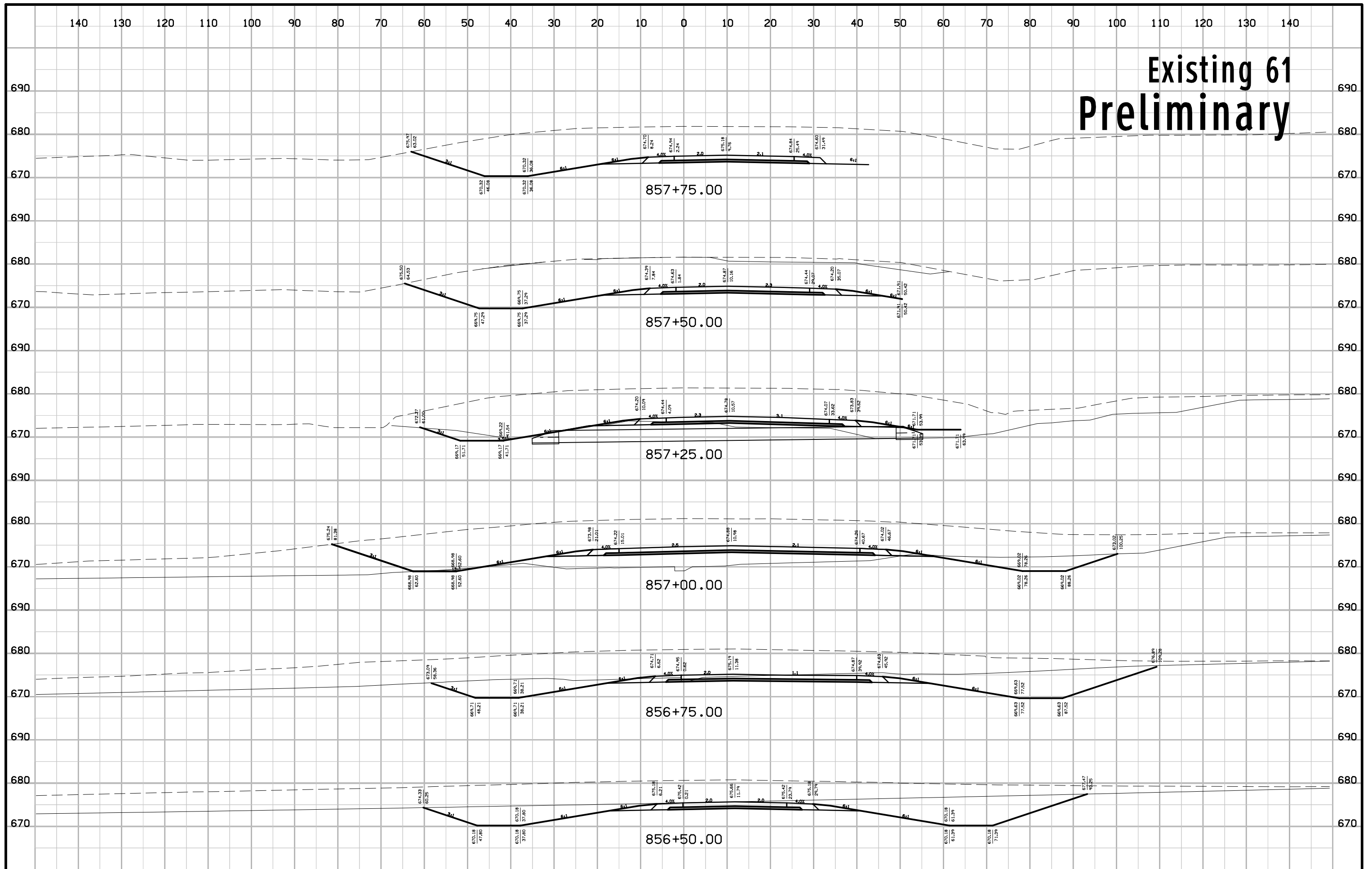

Existing 61 Preliminary

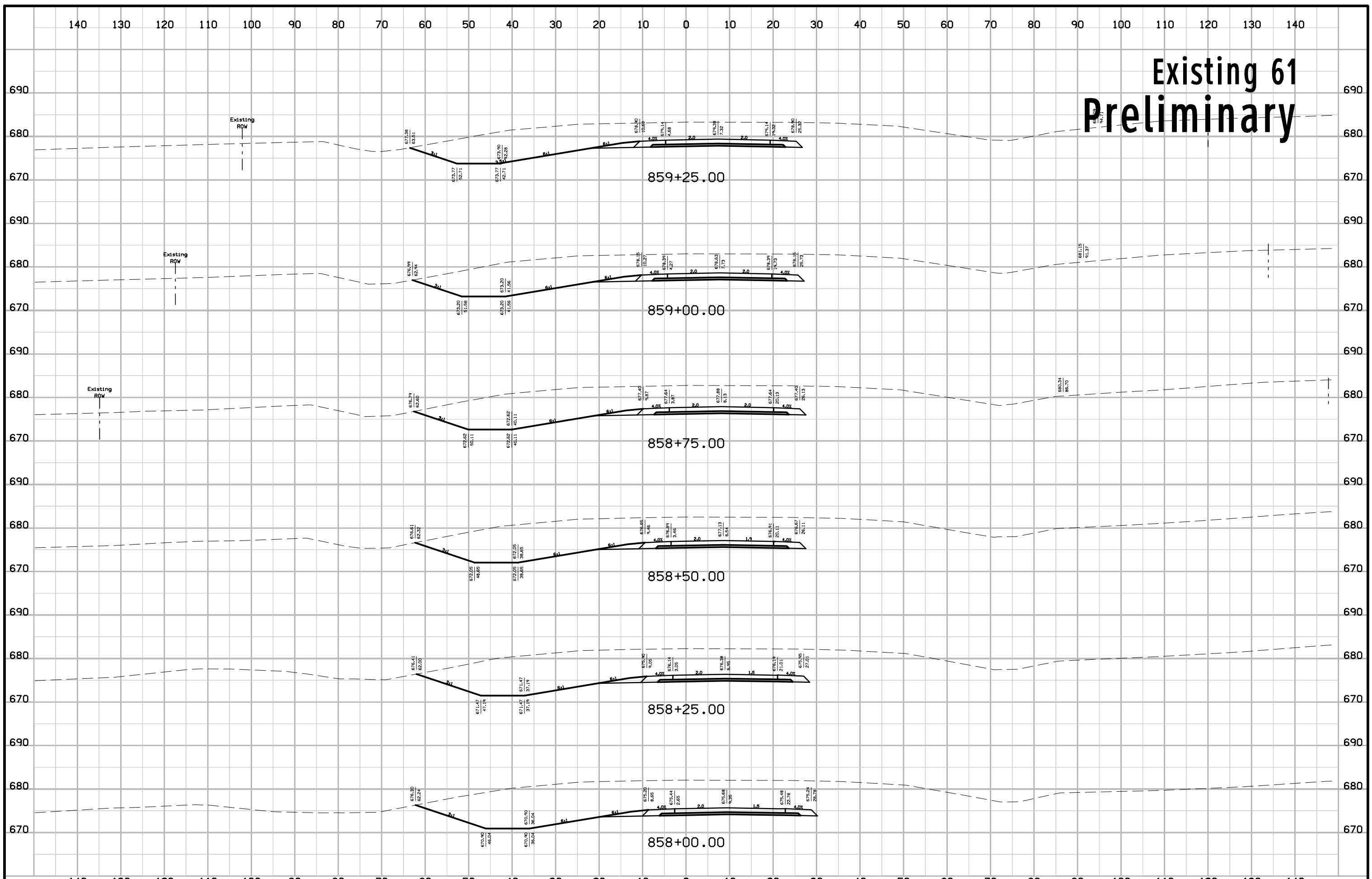

Existing 61 Preliminary

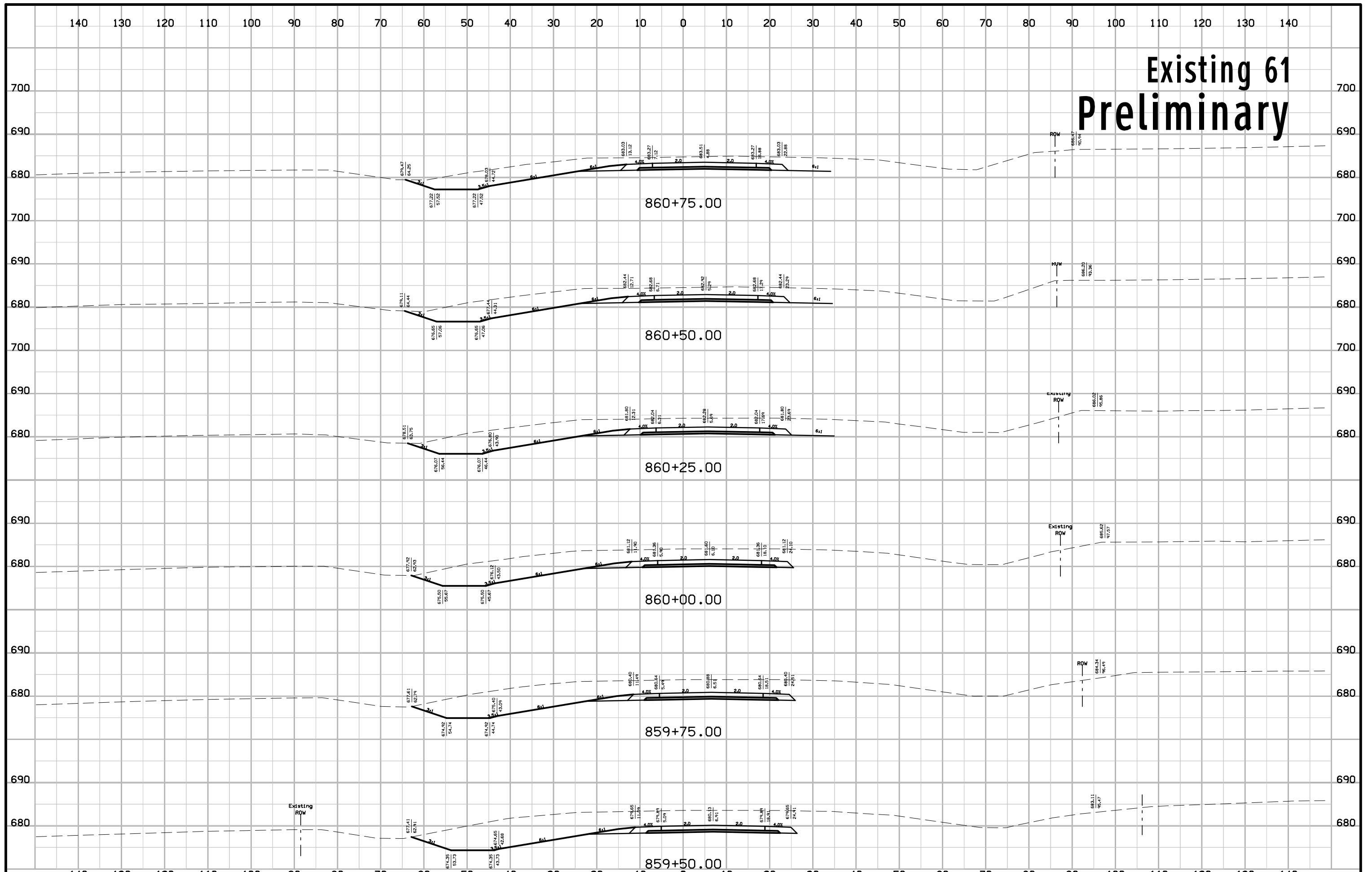

Existing 61 Preliminary

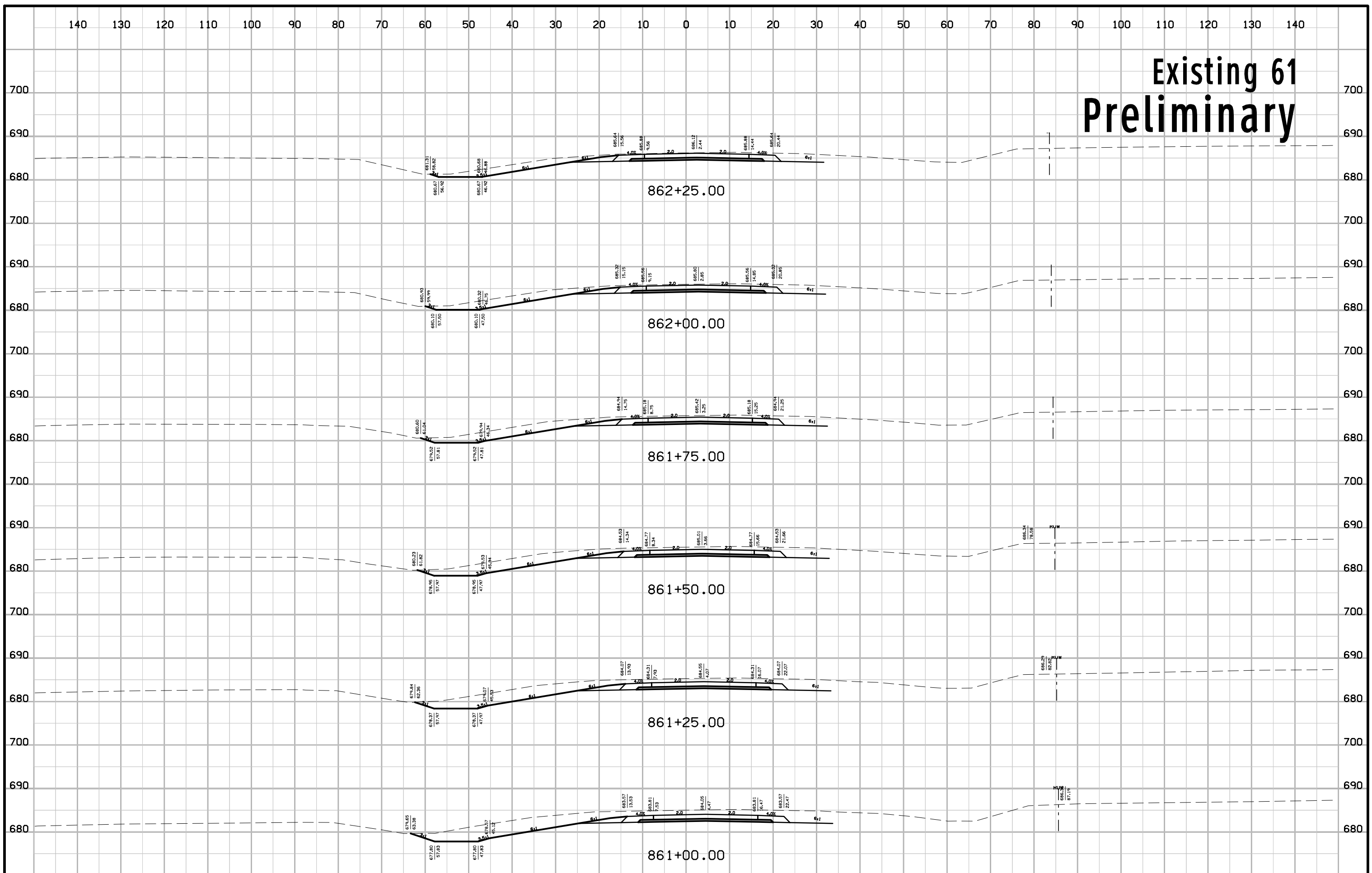

Existing 61 Preliminary

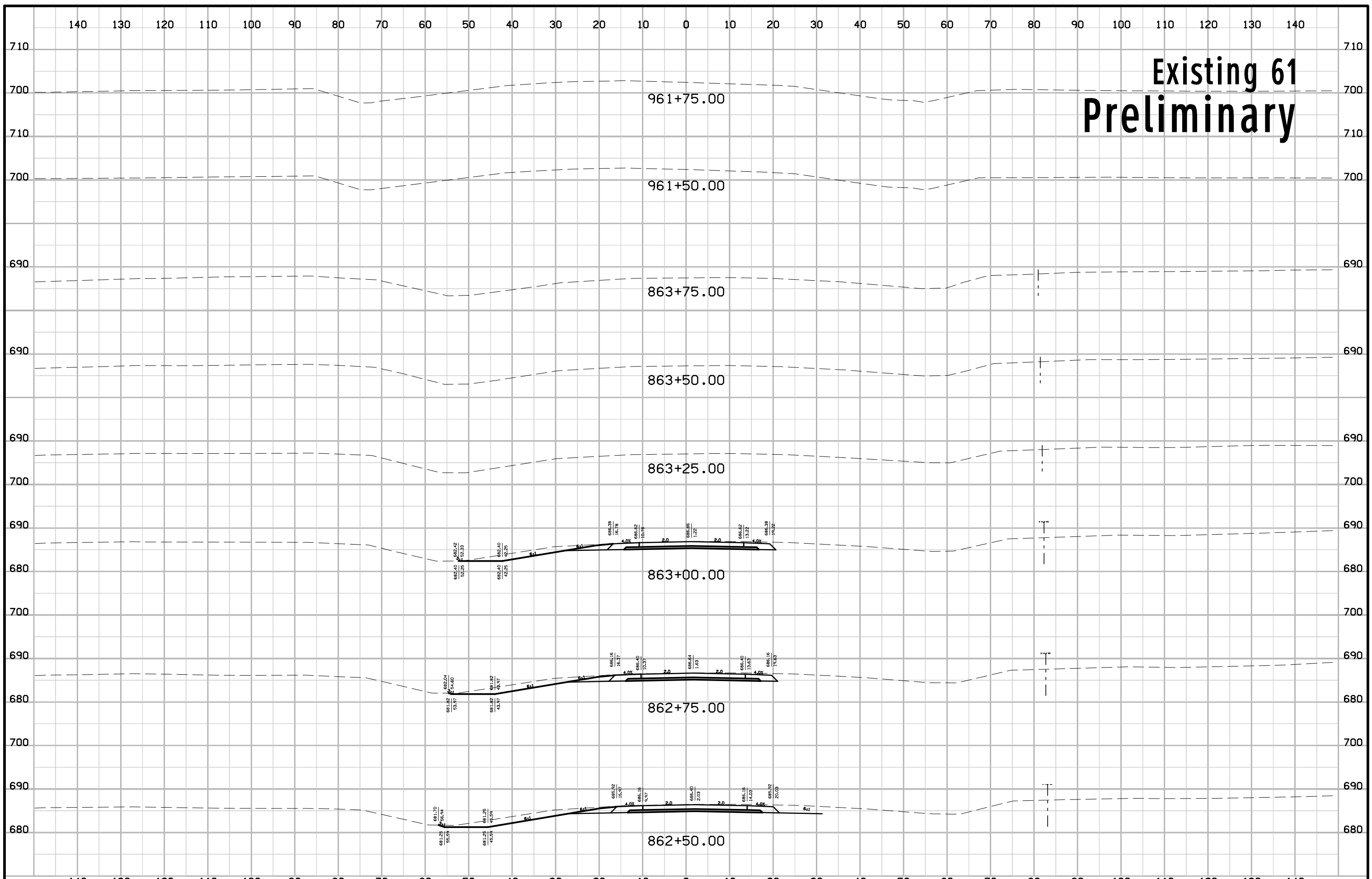

Existing 61 Preliminary

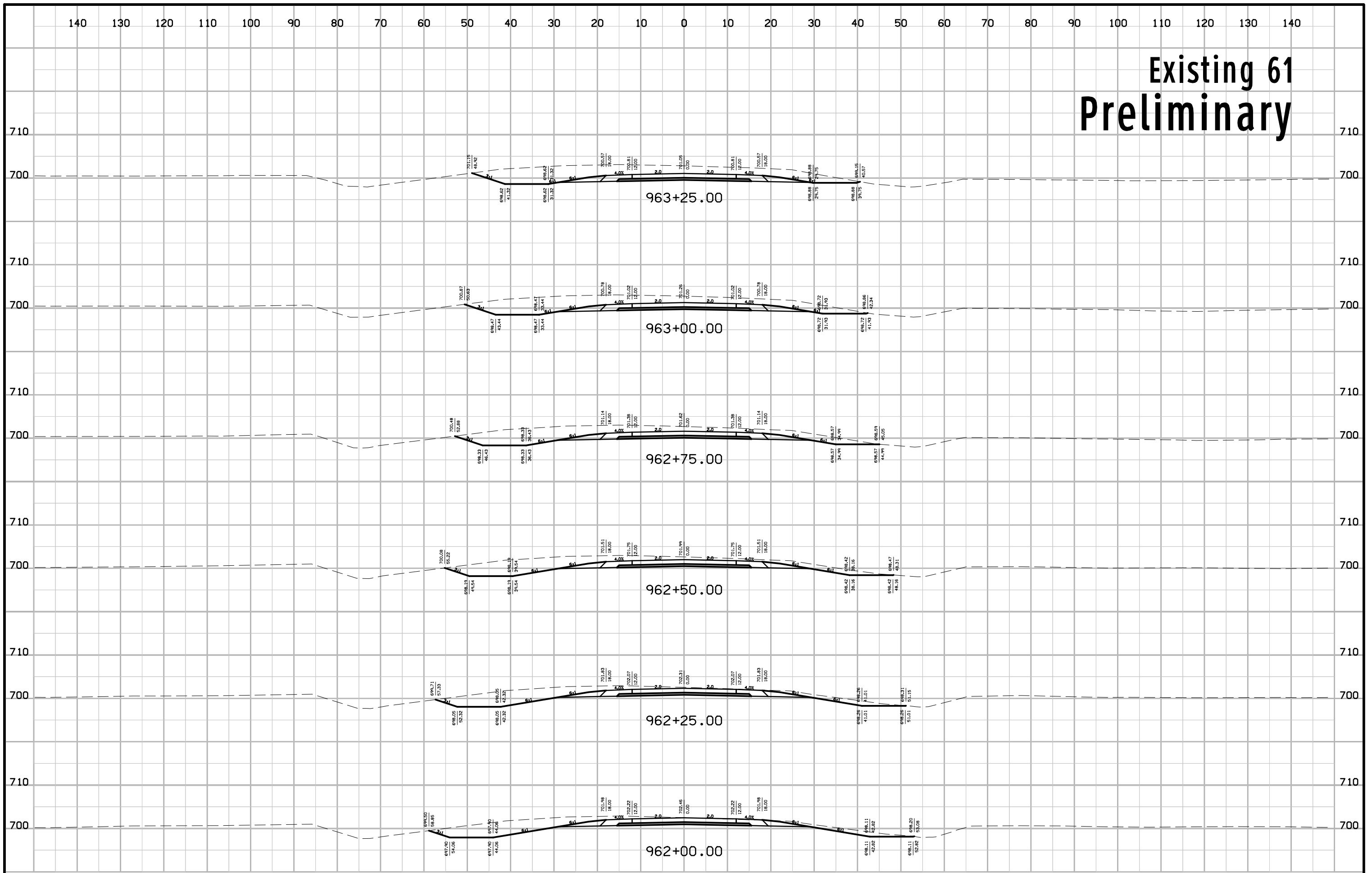

Existing 61 Preliminary

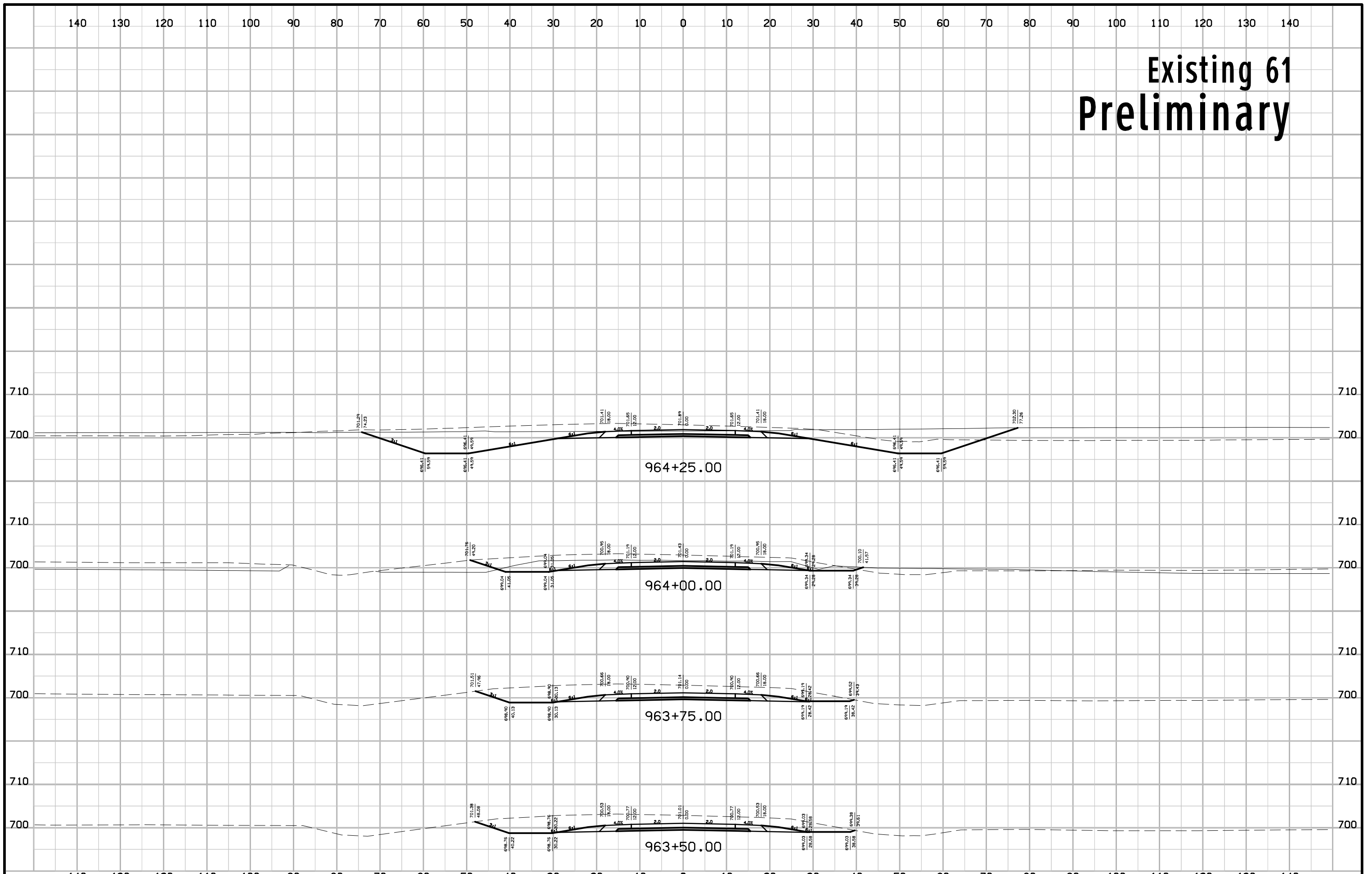

Entrance 497 Preliminary

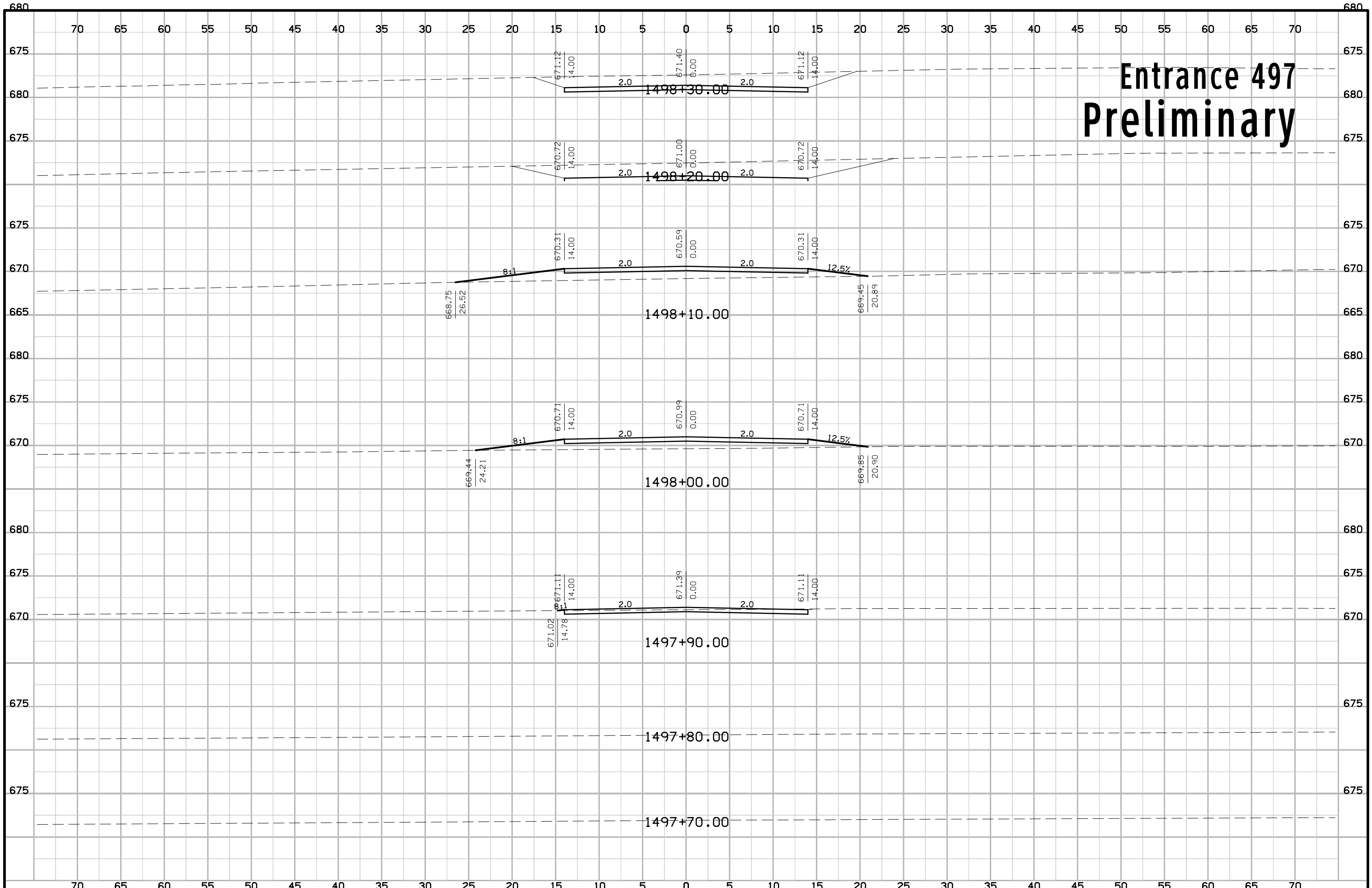

Entrance 497 Preliminary

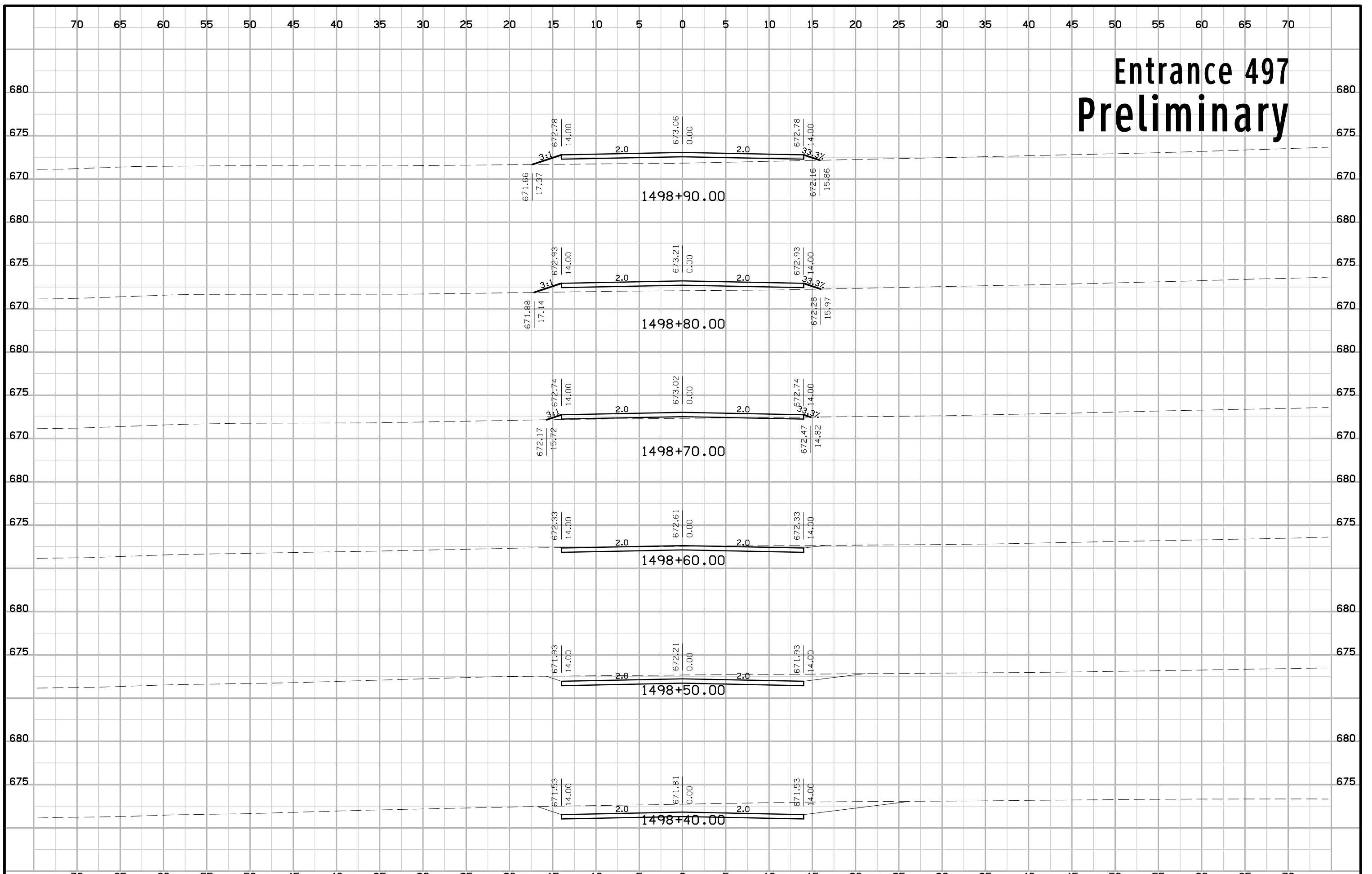

Entrance 497 Preliminary

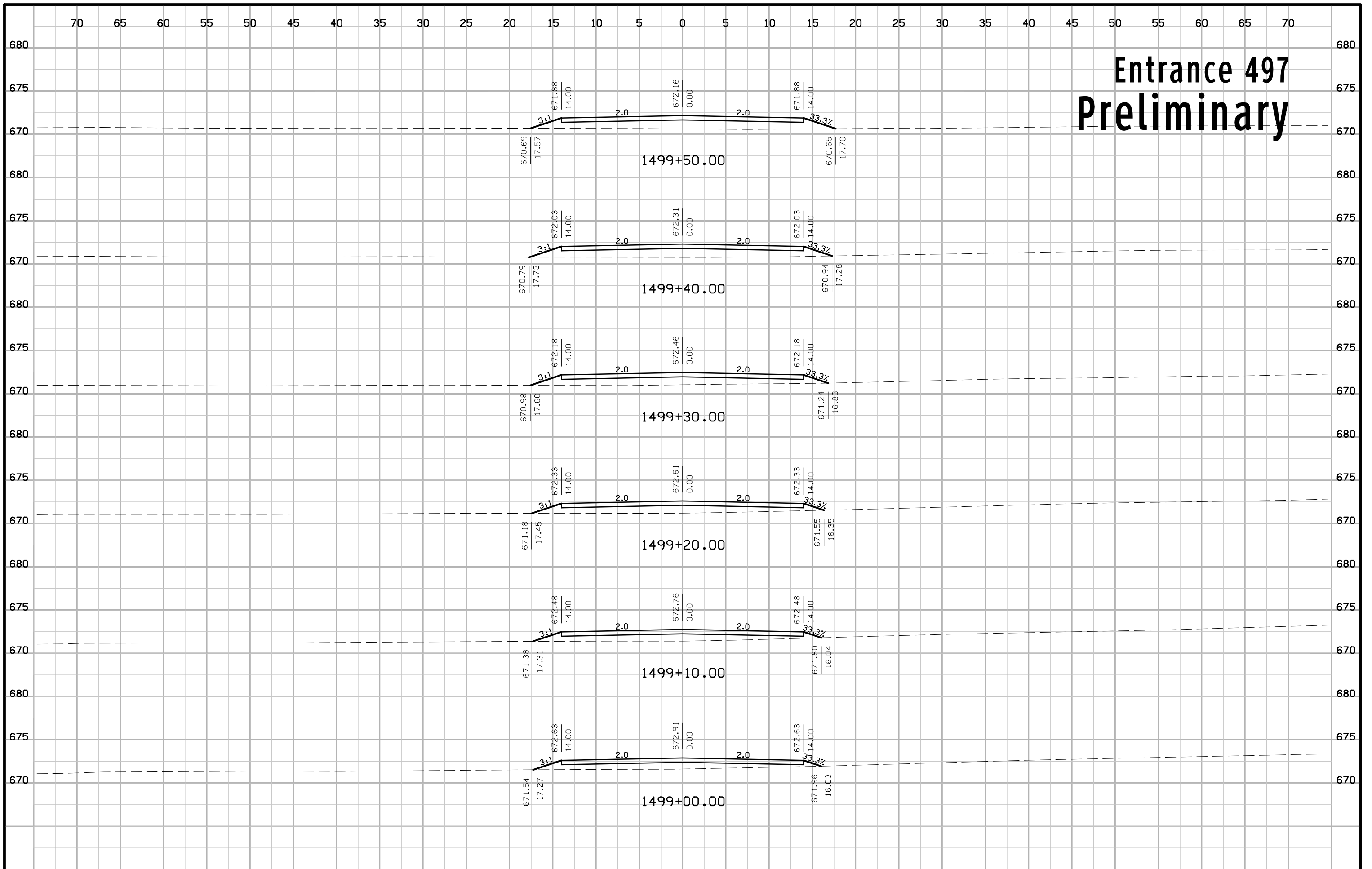

Entrance 497 Preliminary

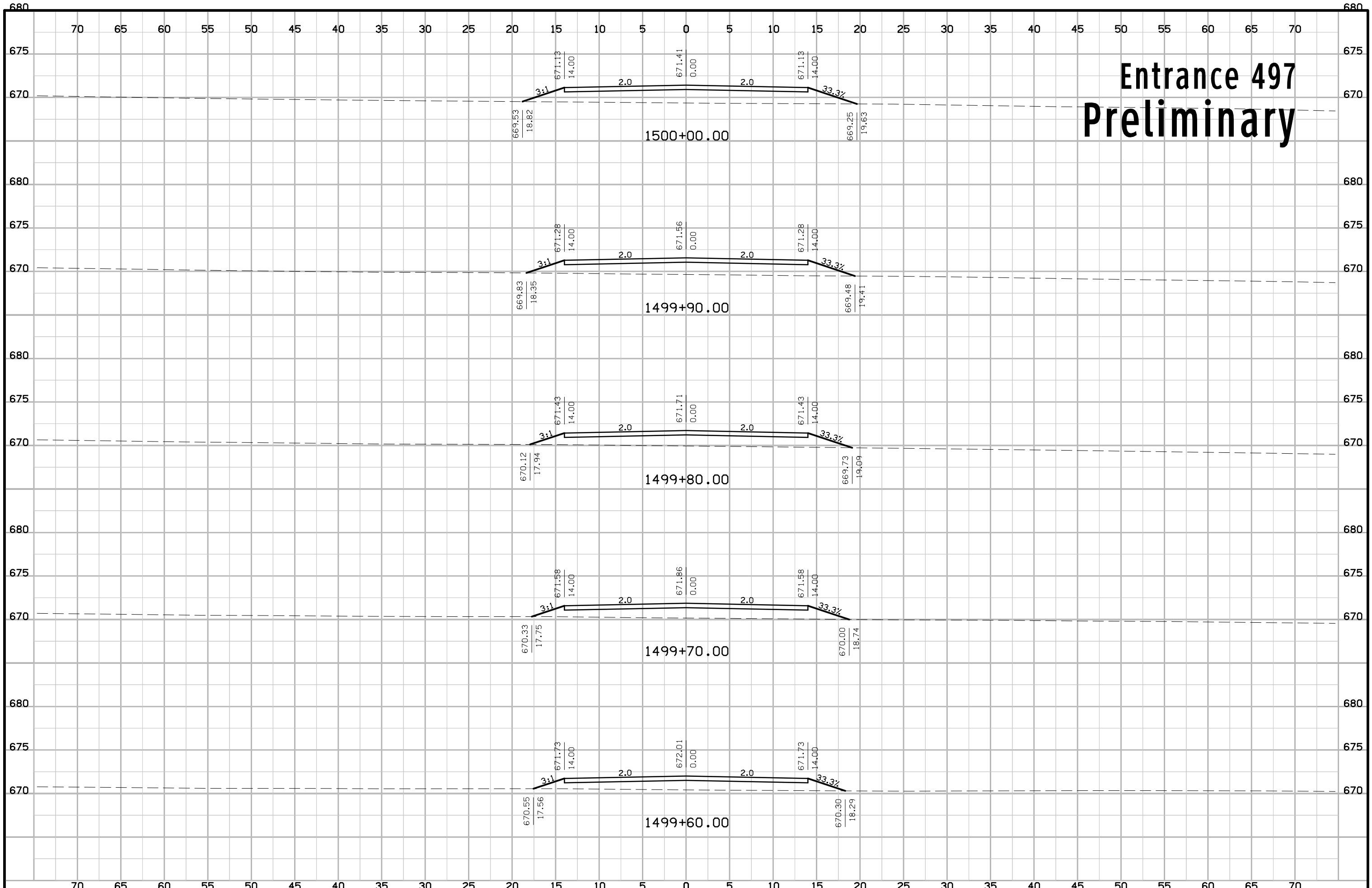

Entrance 497 Preliminary

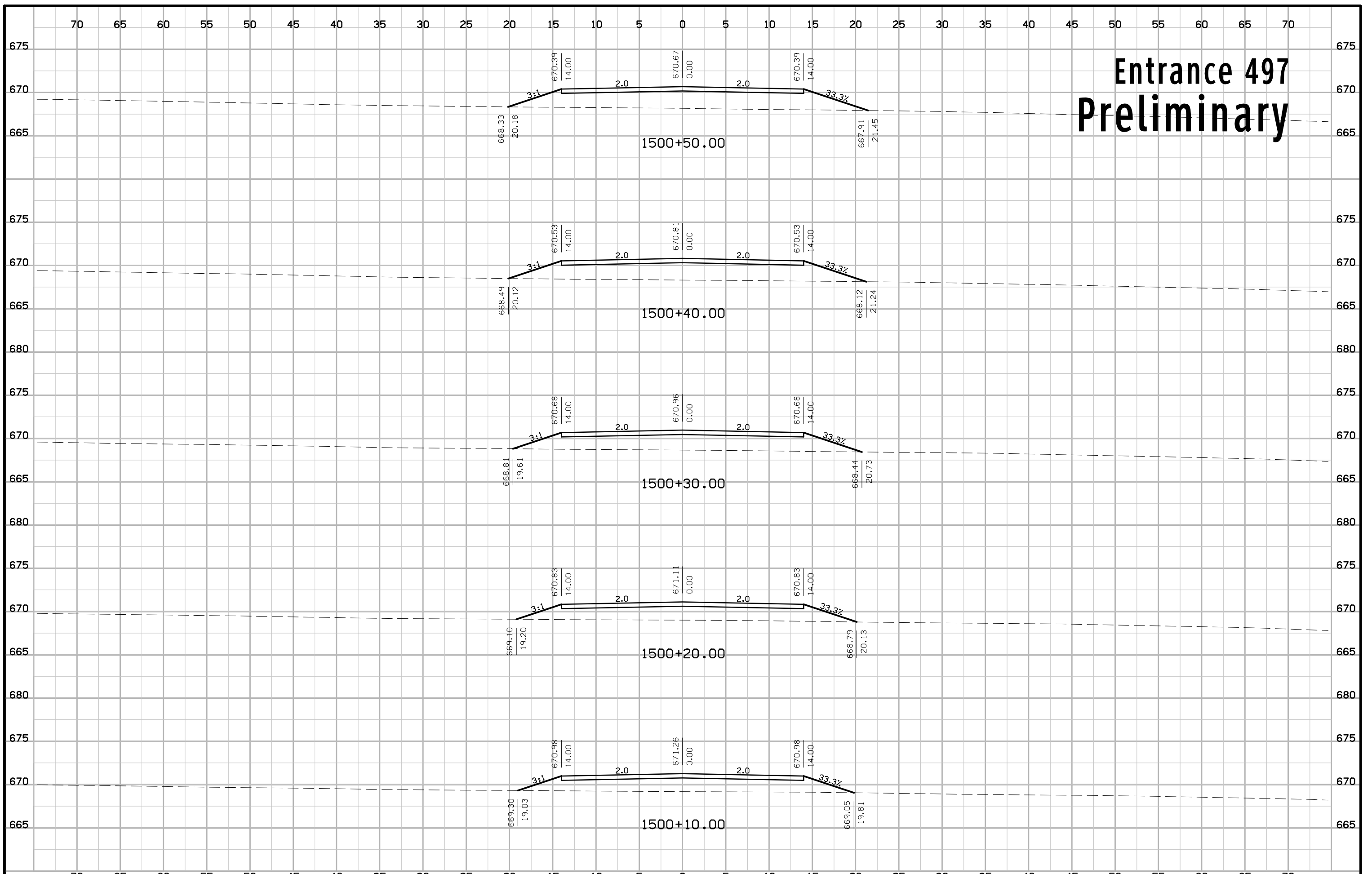

Entrance 497 Preliminary

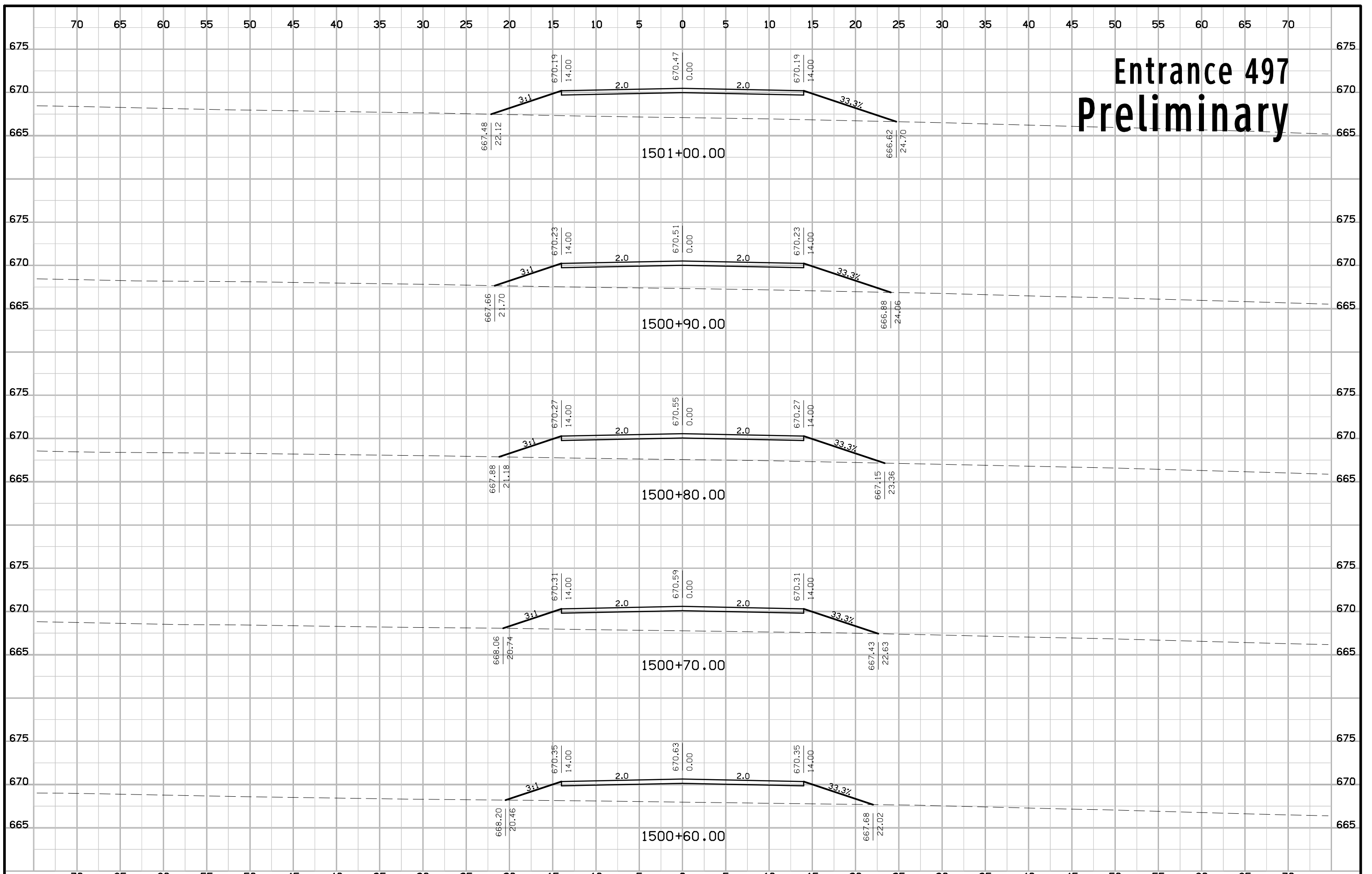

Entrance 497 Preliminary

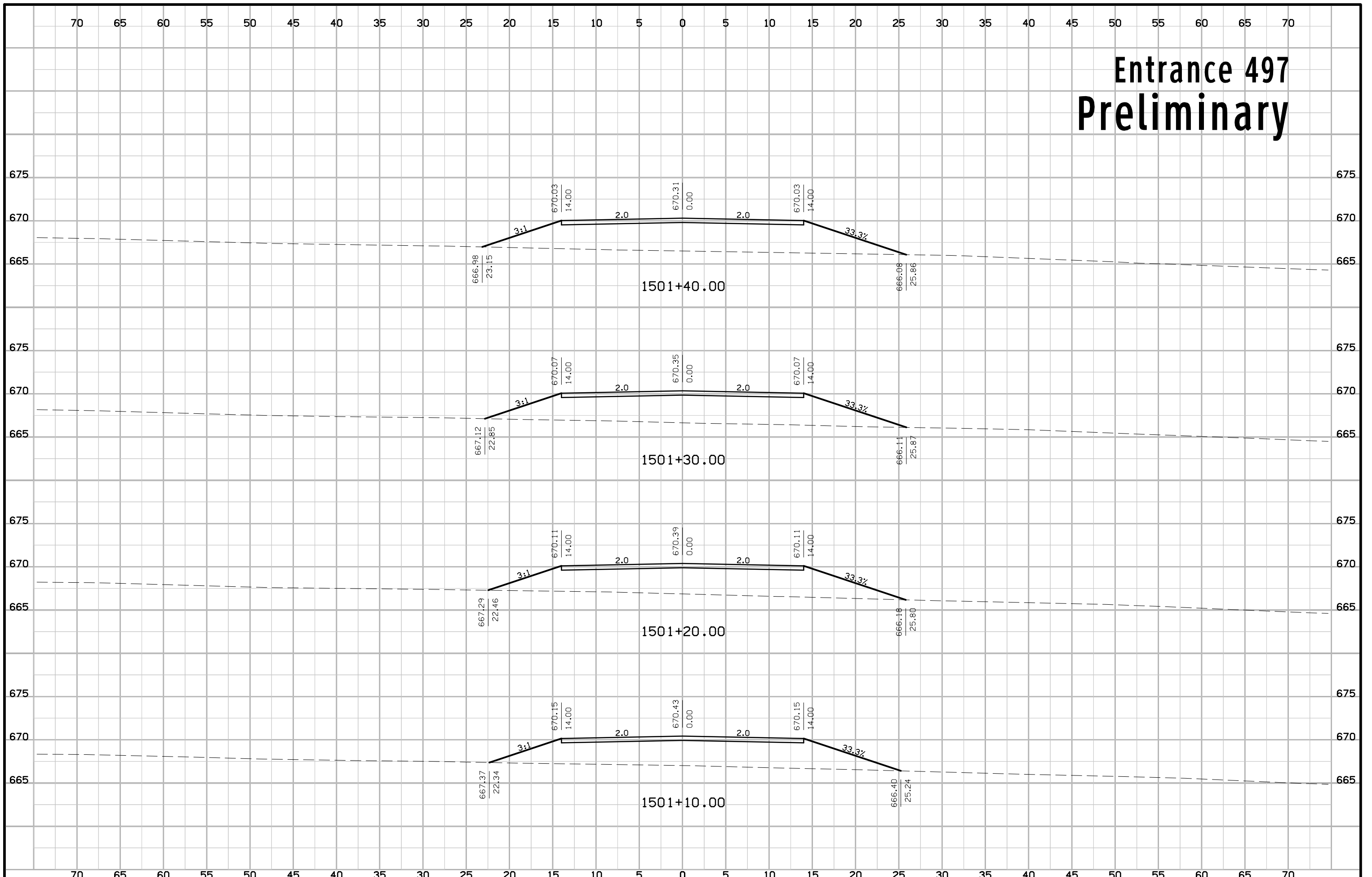

Entrance 497 Preliminary

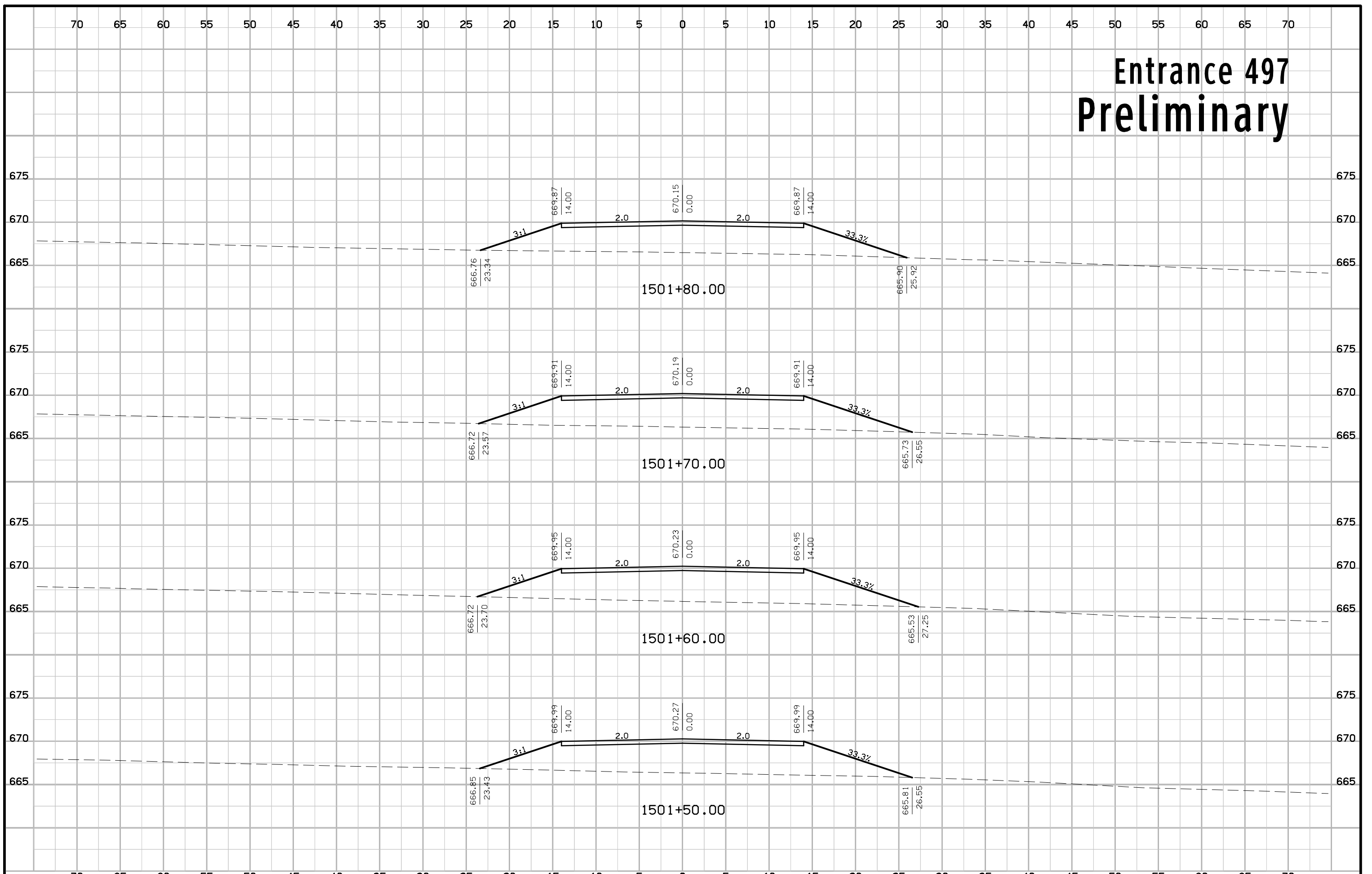

Entrance 497 Preliminary

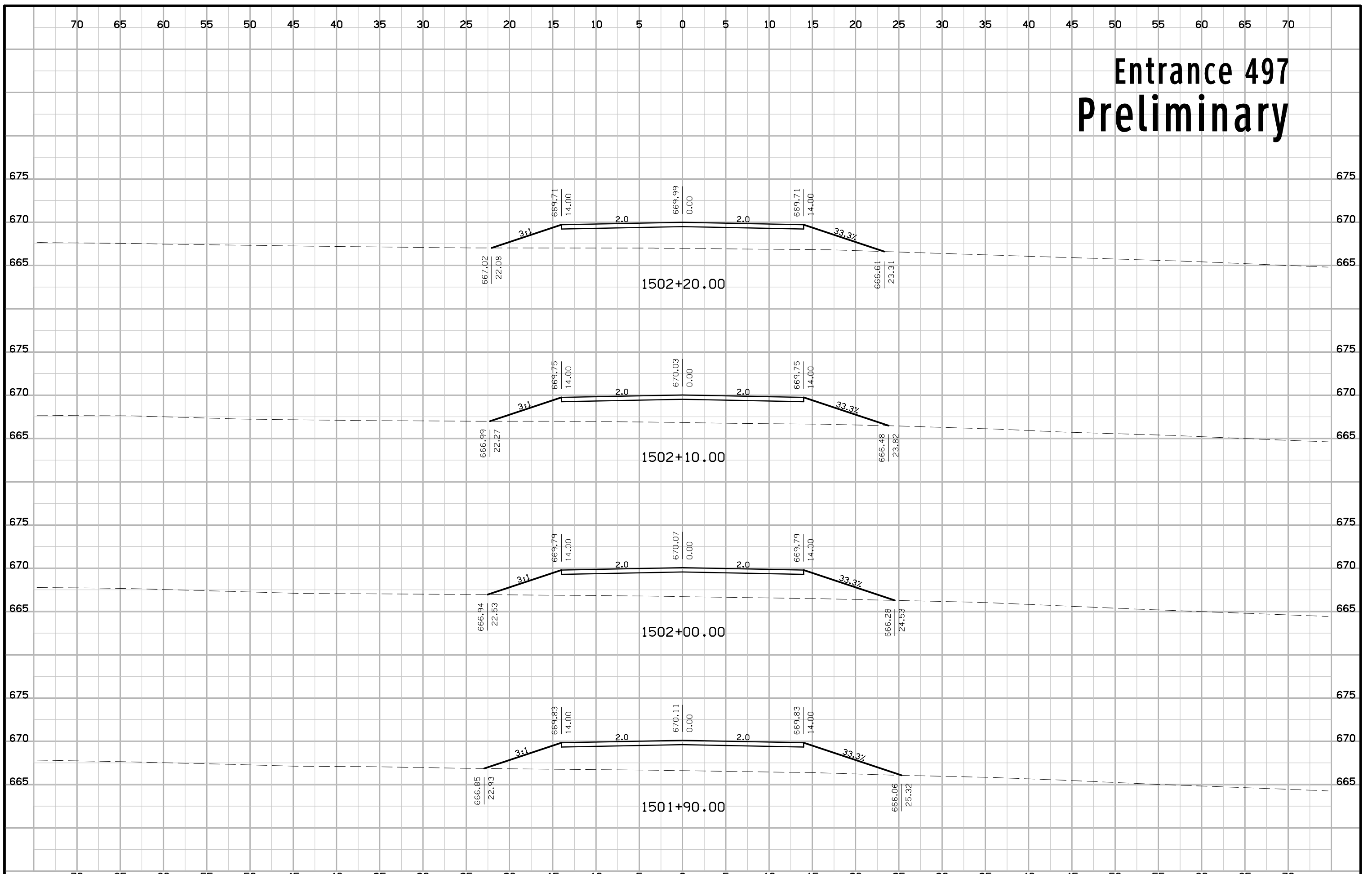

Entrance 497 Preliminary

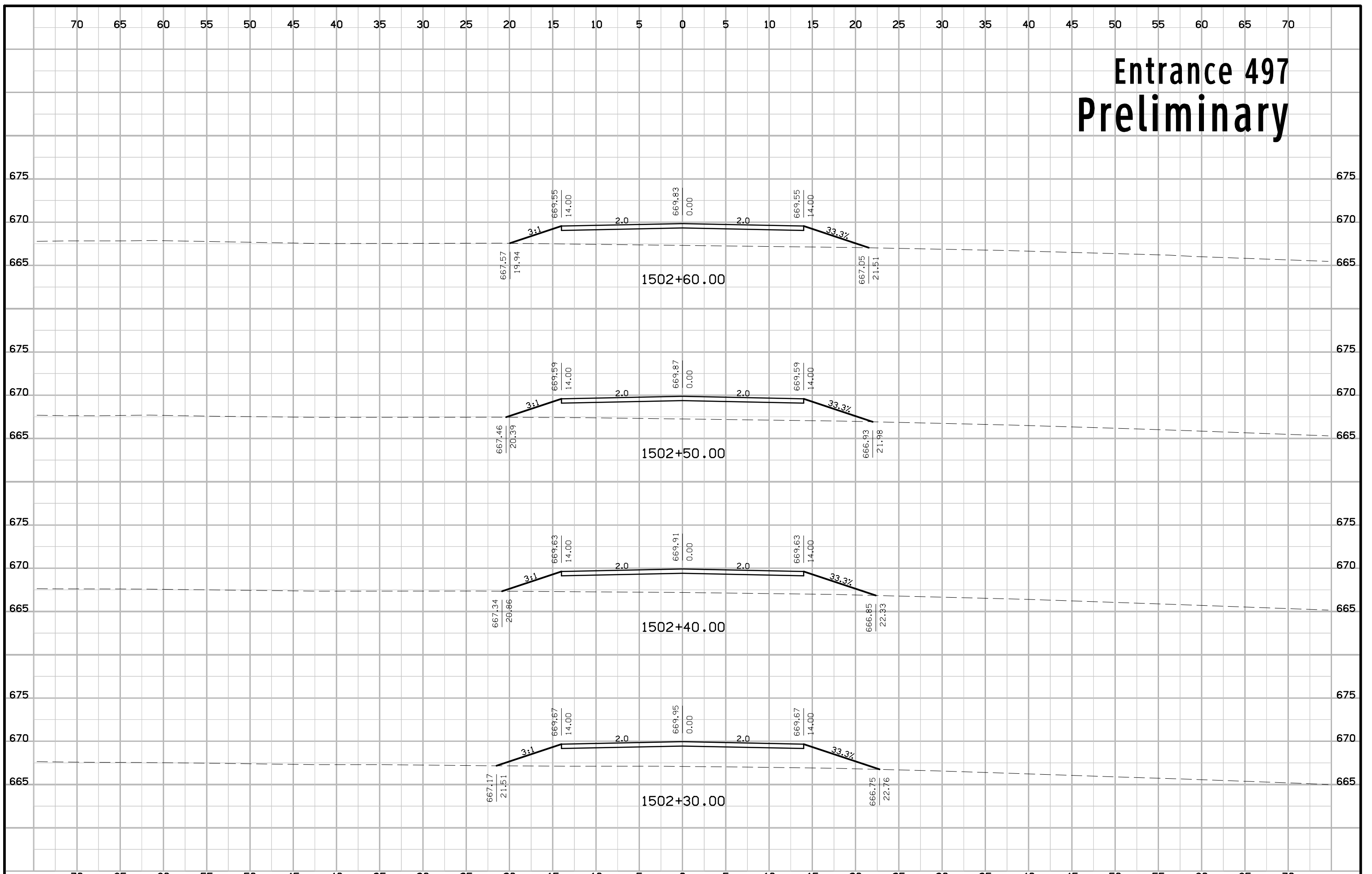

Entrance 497 Preliminary

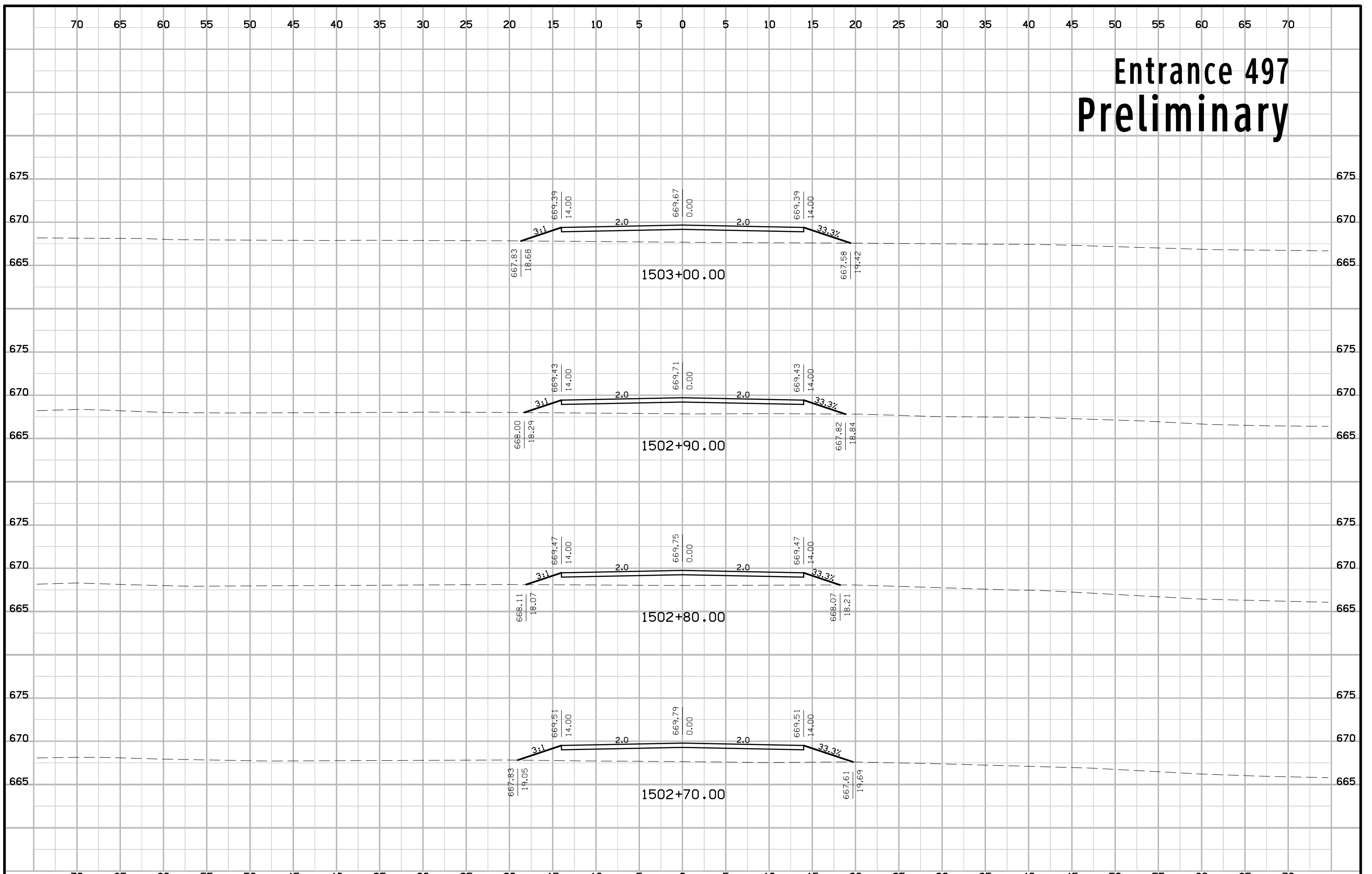

Entrance 497 Preliminary

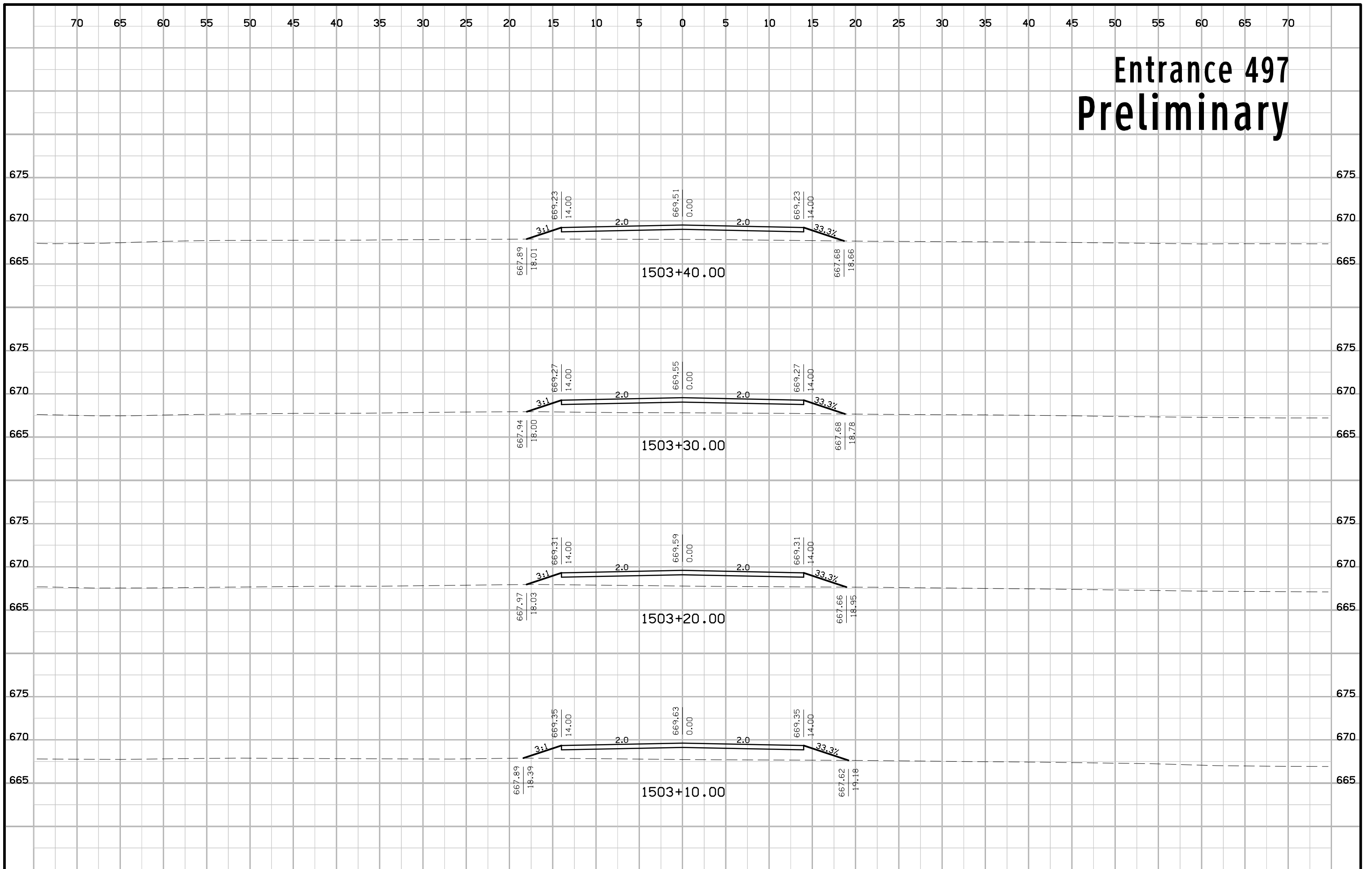

Entrance 497 Preliminary

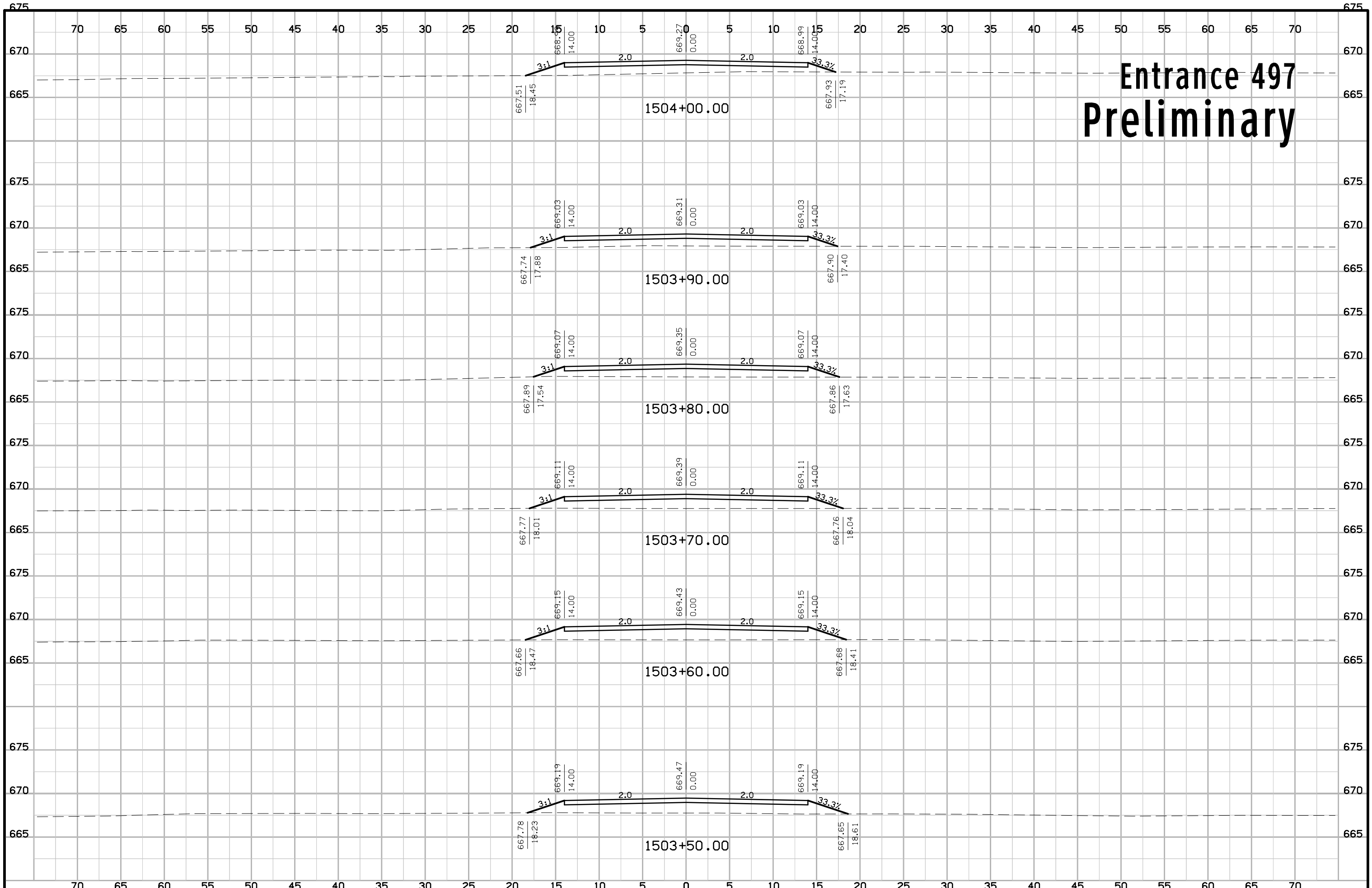

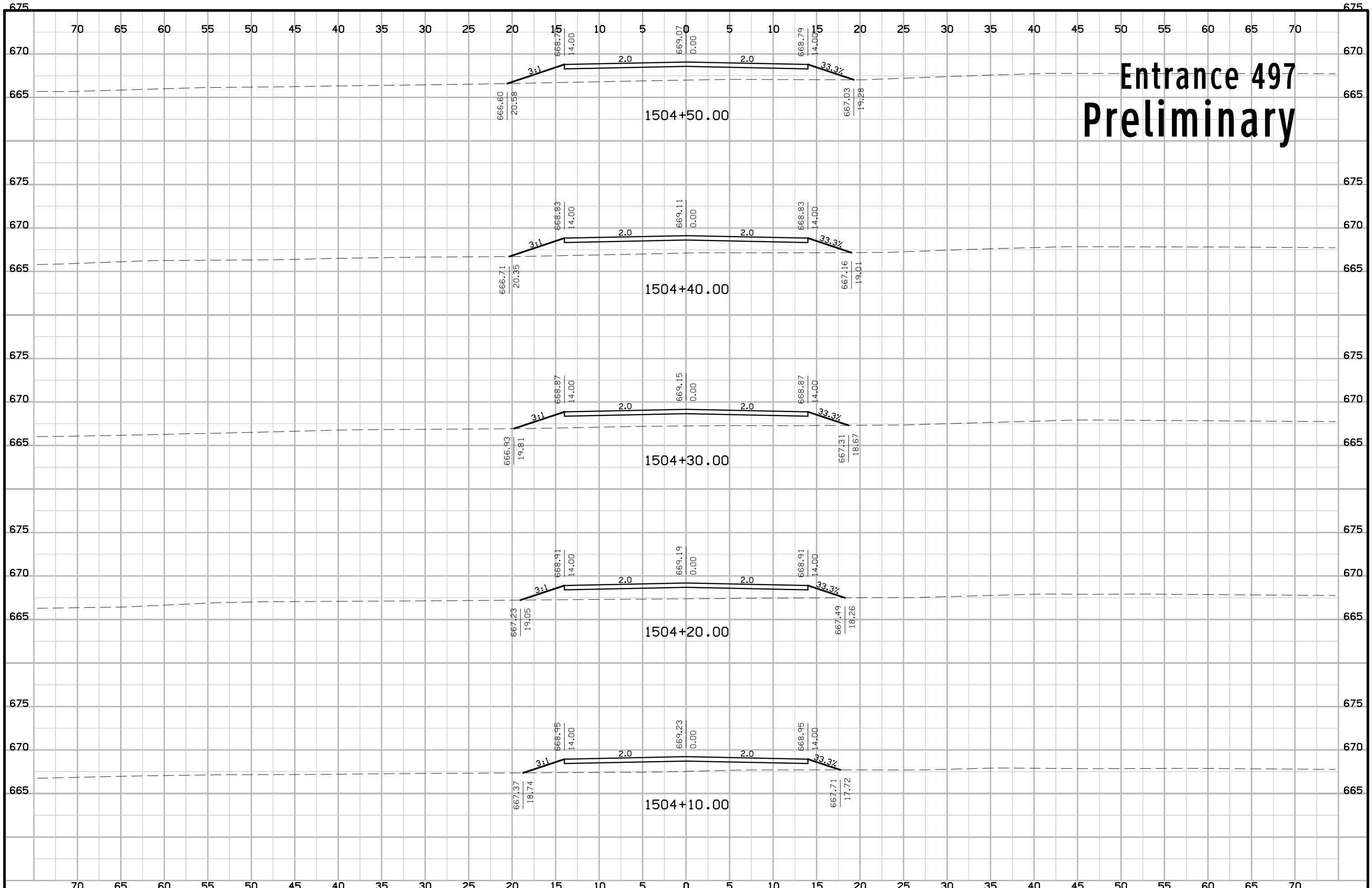

Entrance 497 Preliminary

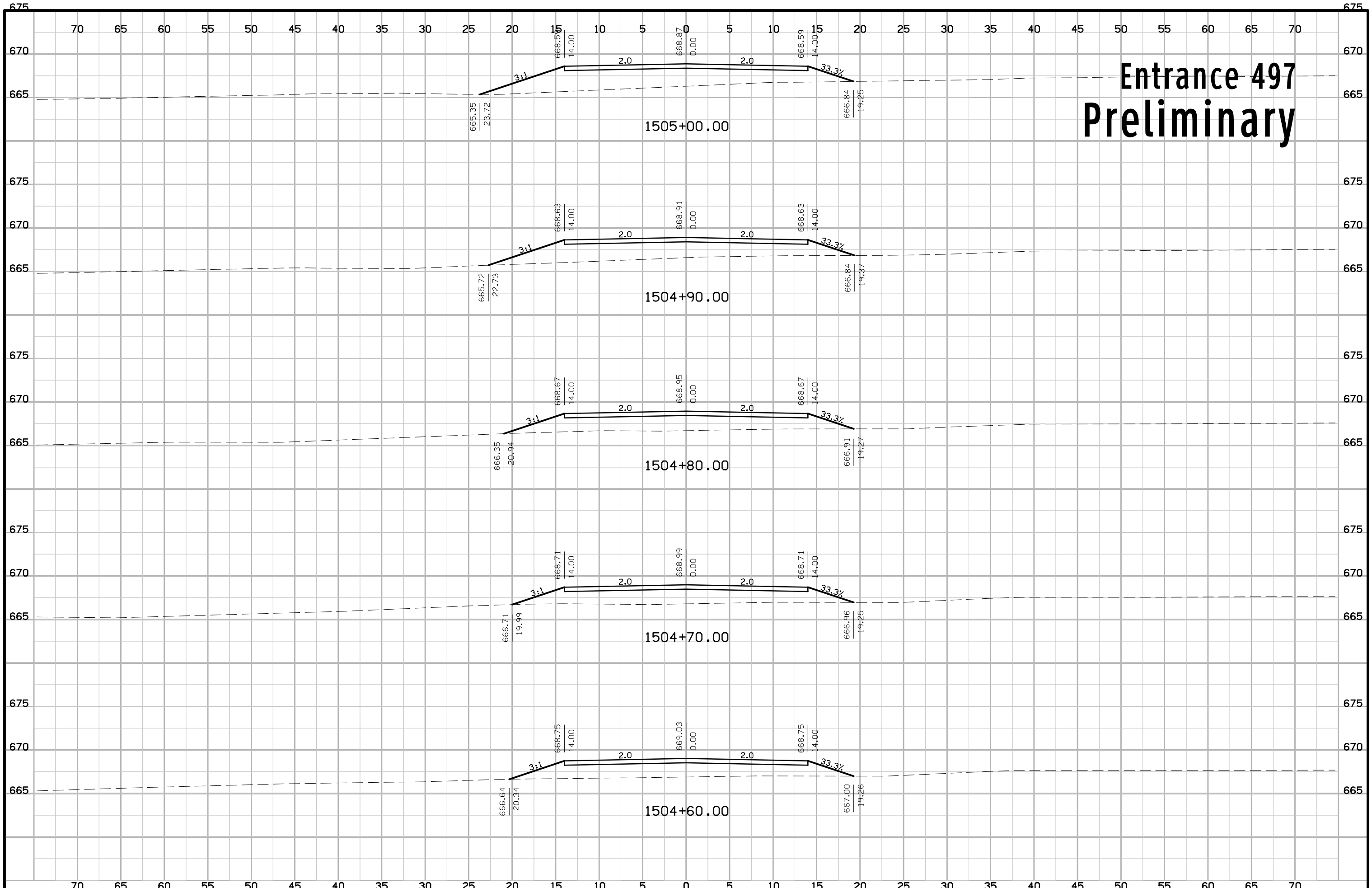

Entrance 497 Preliminary

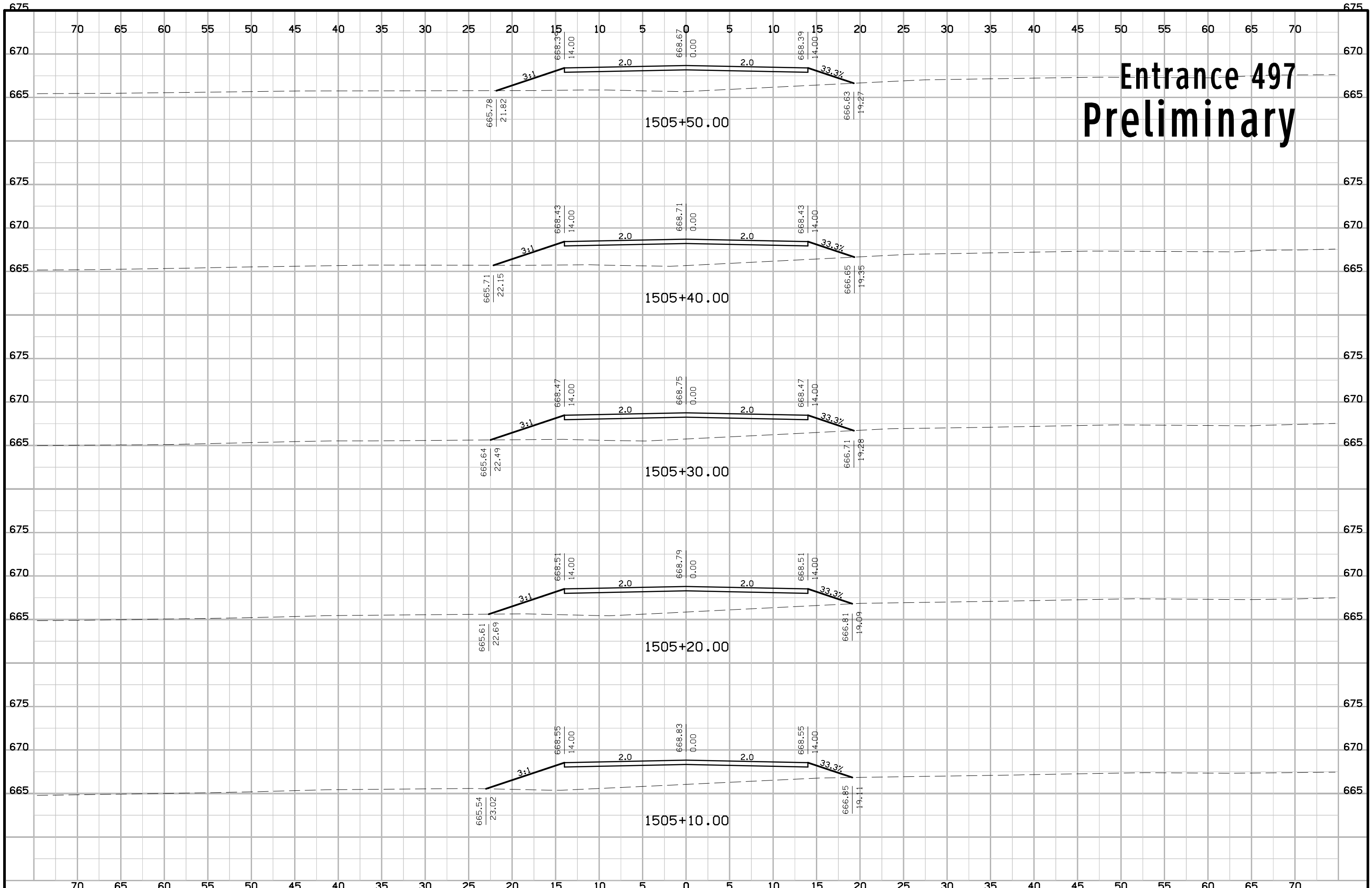

Entrance 497 Preliminary

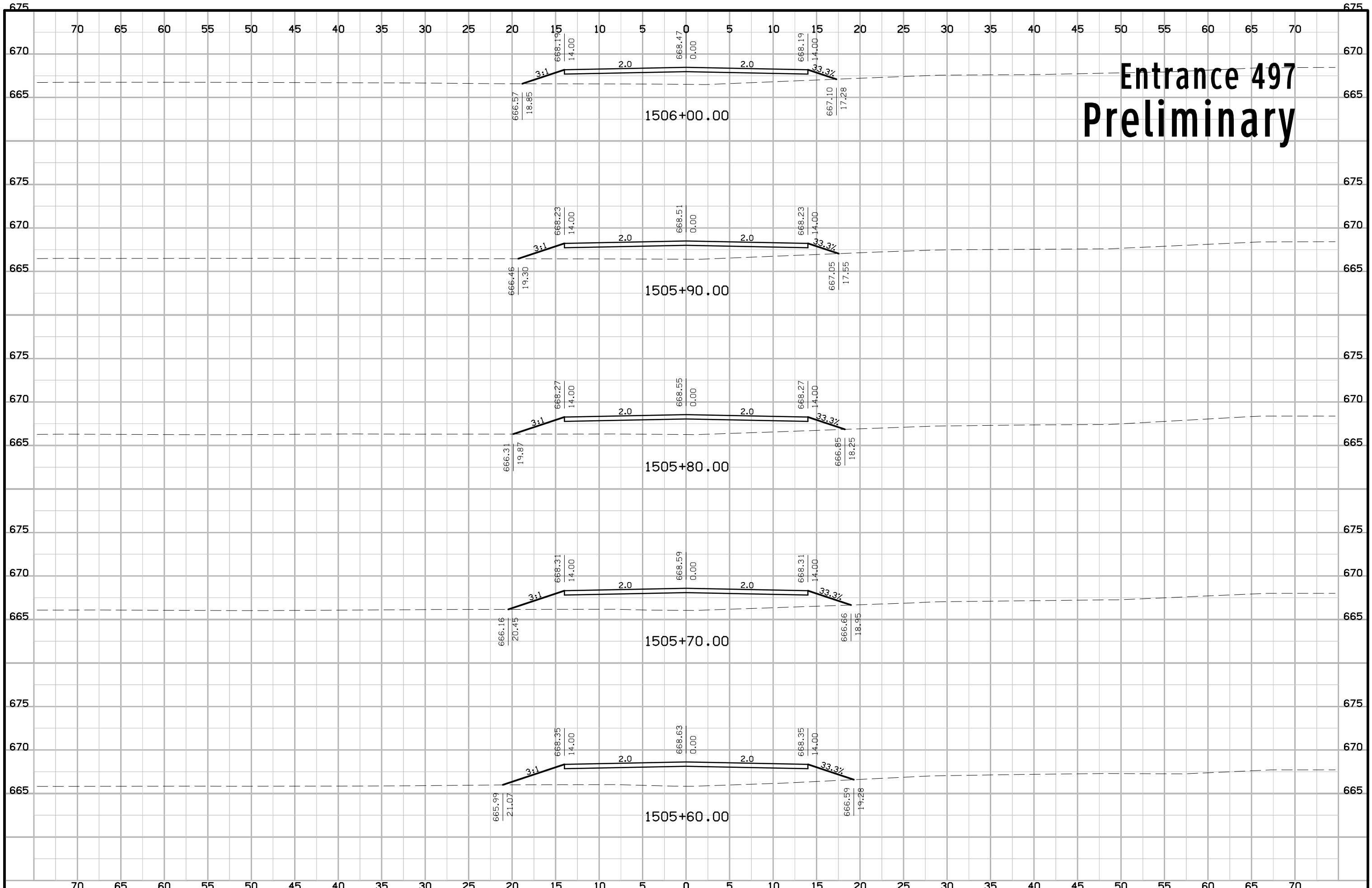

Entrance 497 Preliminary

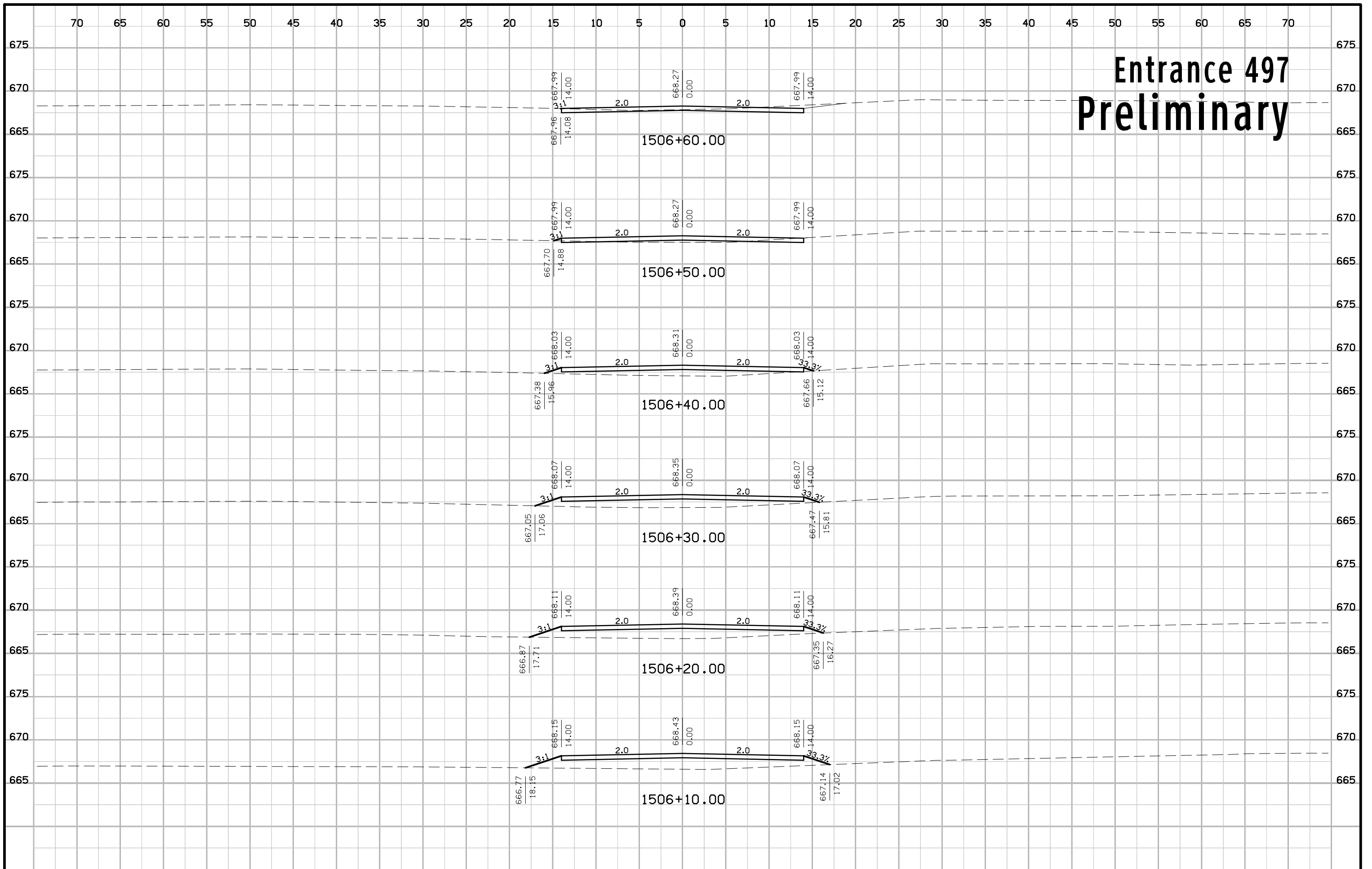

Entrance 497 Preliminary

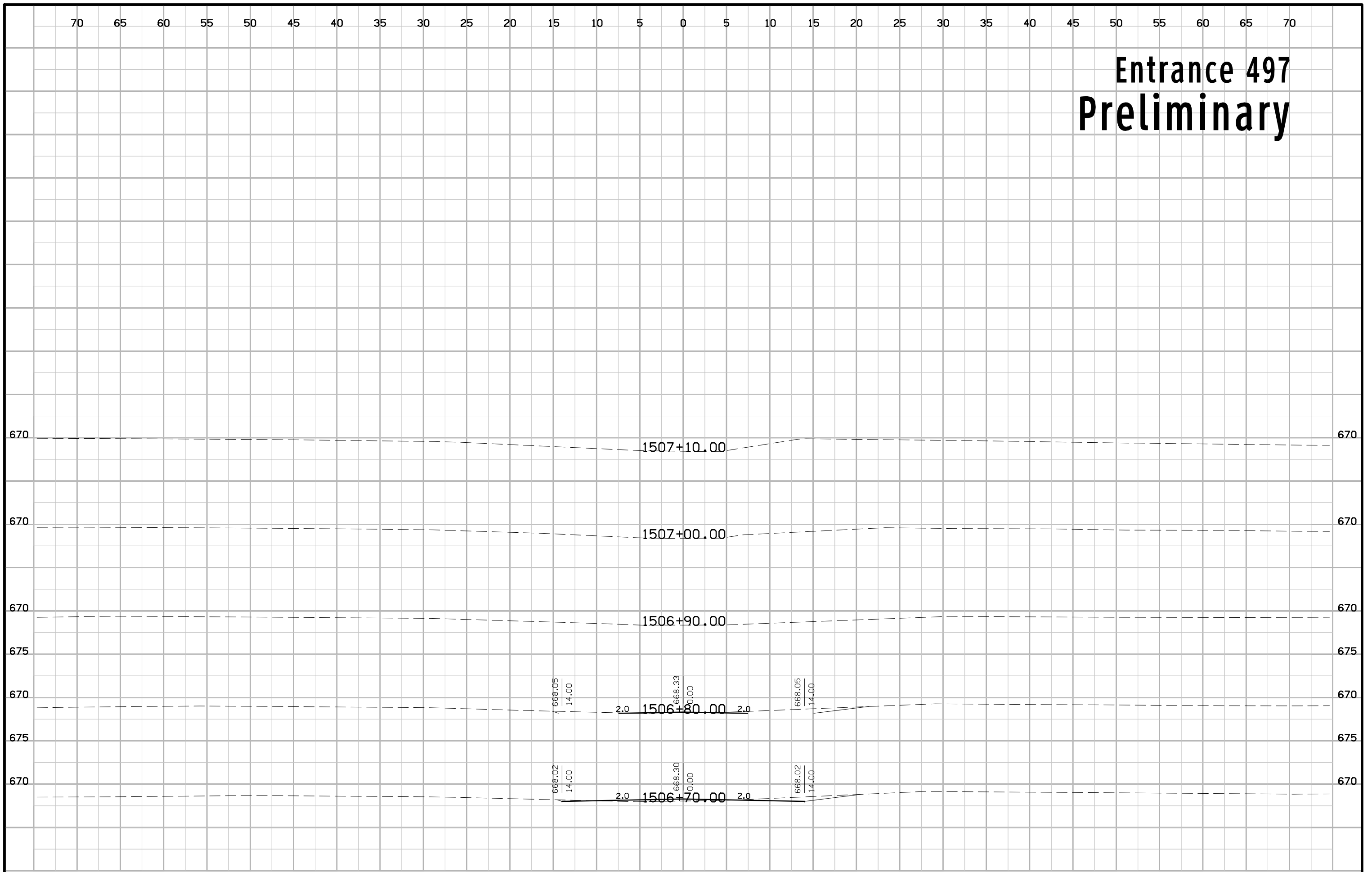

ENT 910 Preliminary

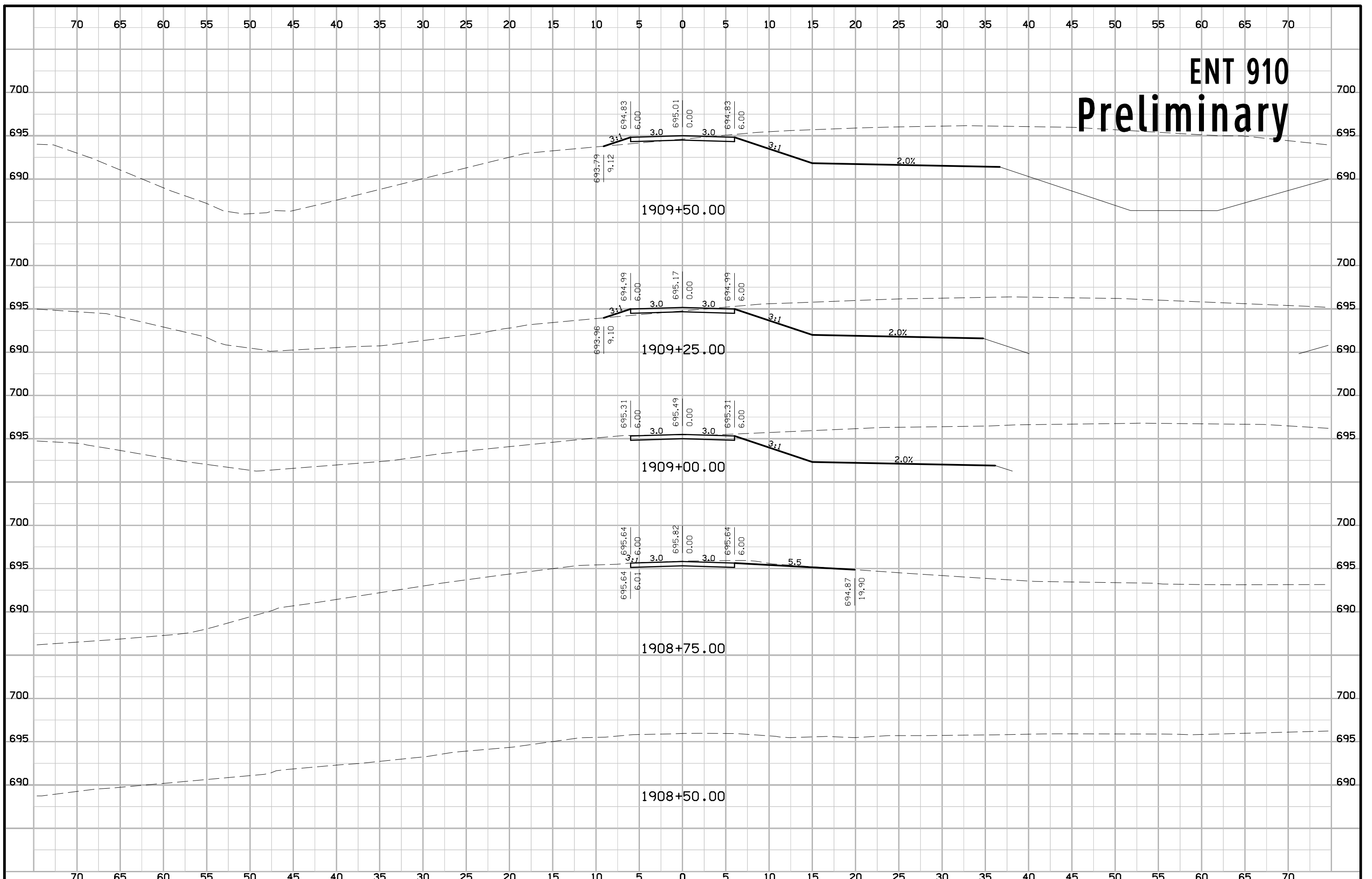

ENT 910 Preliminary

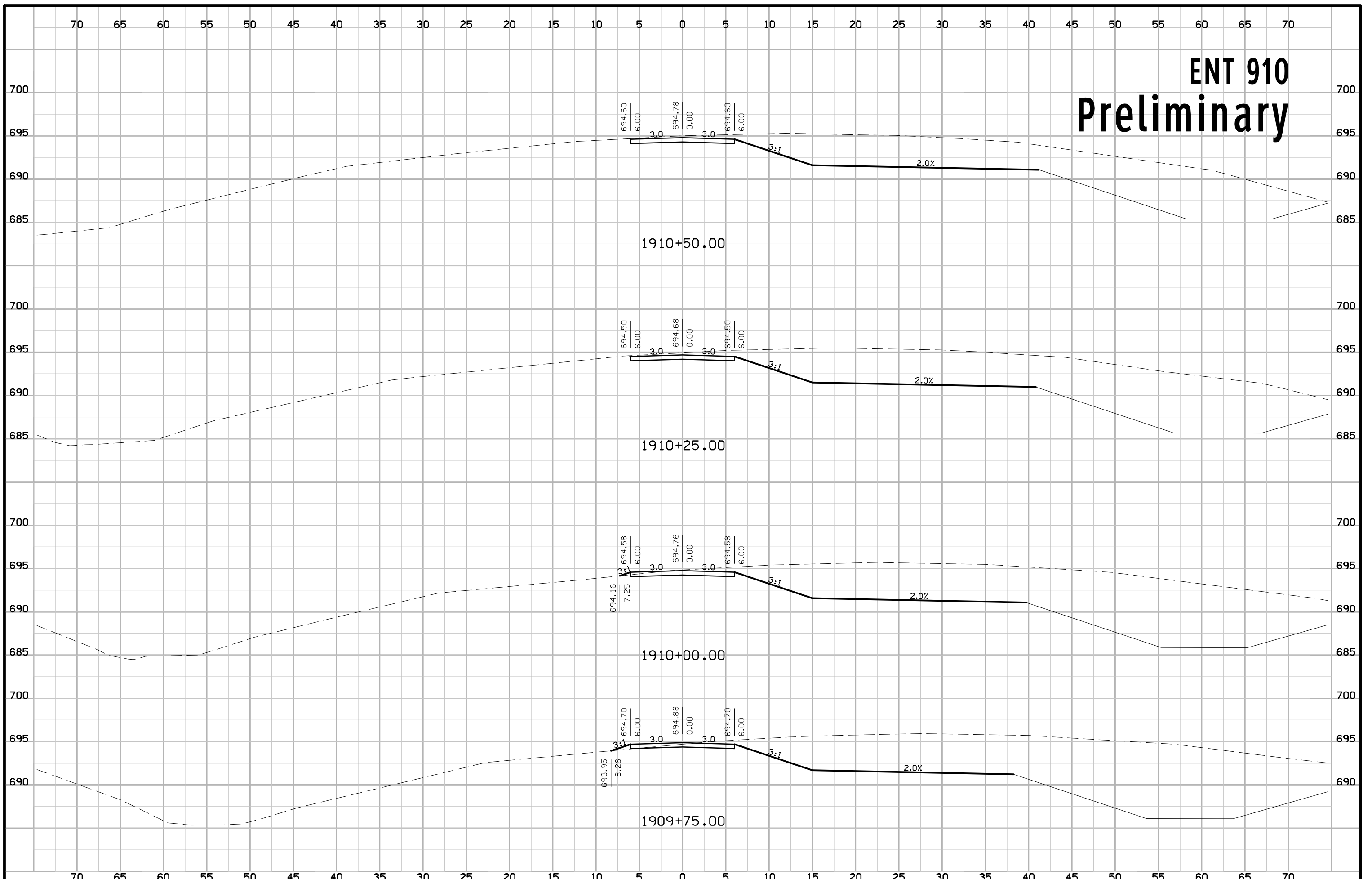

ENT 910 Preliminary

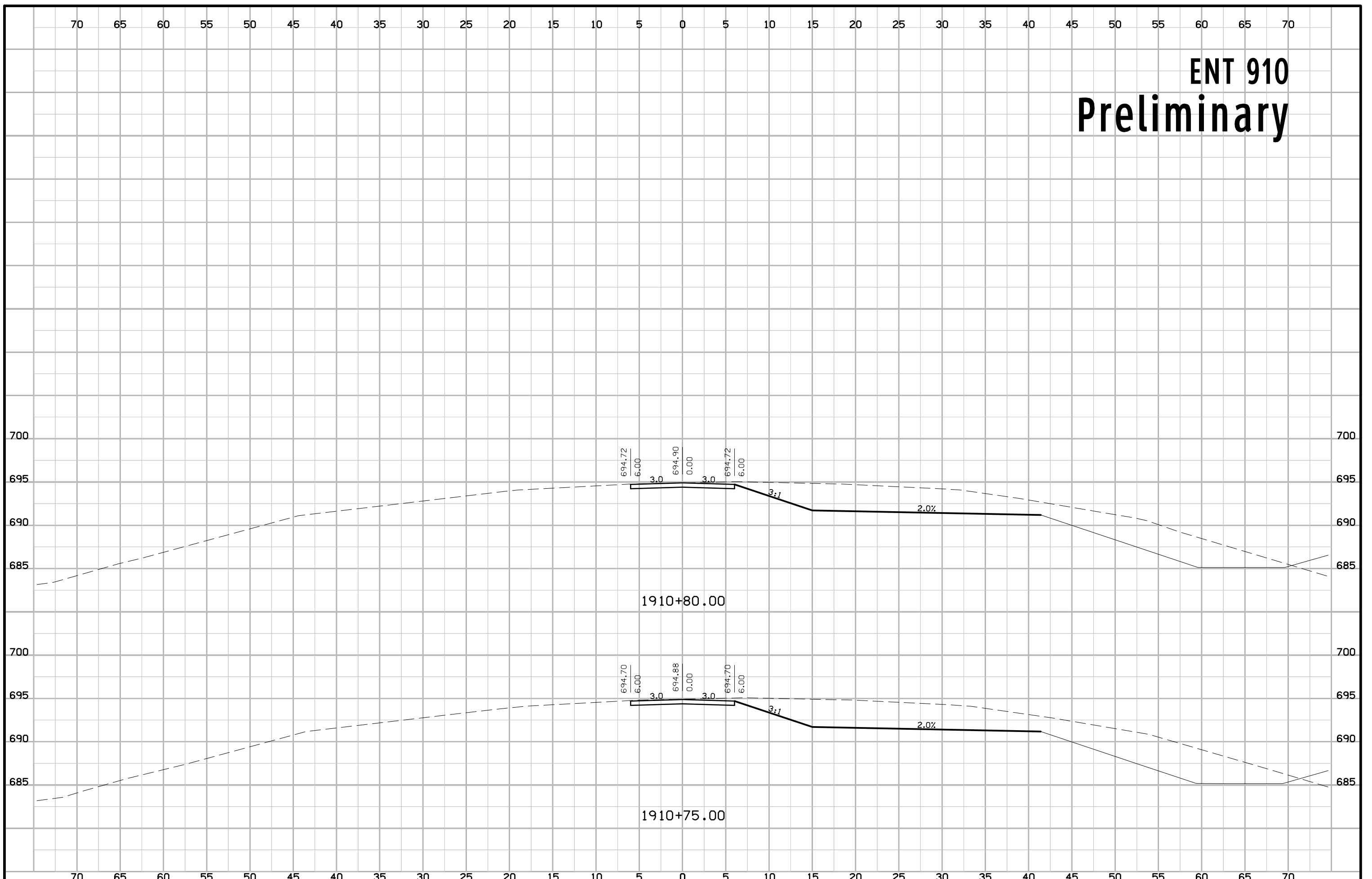

DET61_905 Preliminary

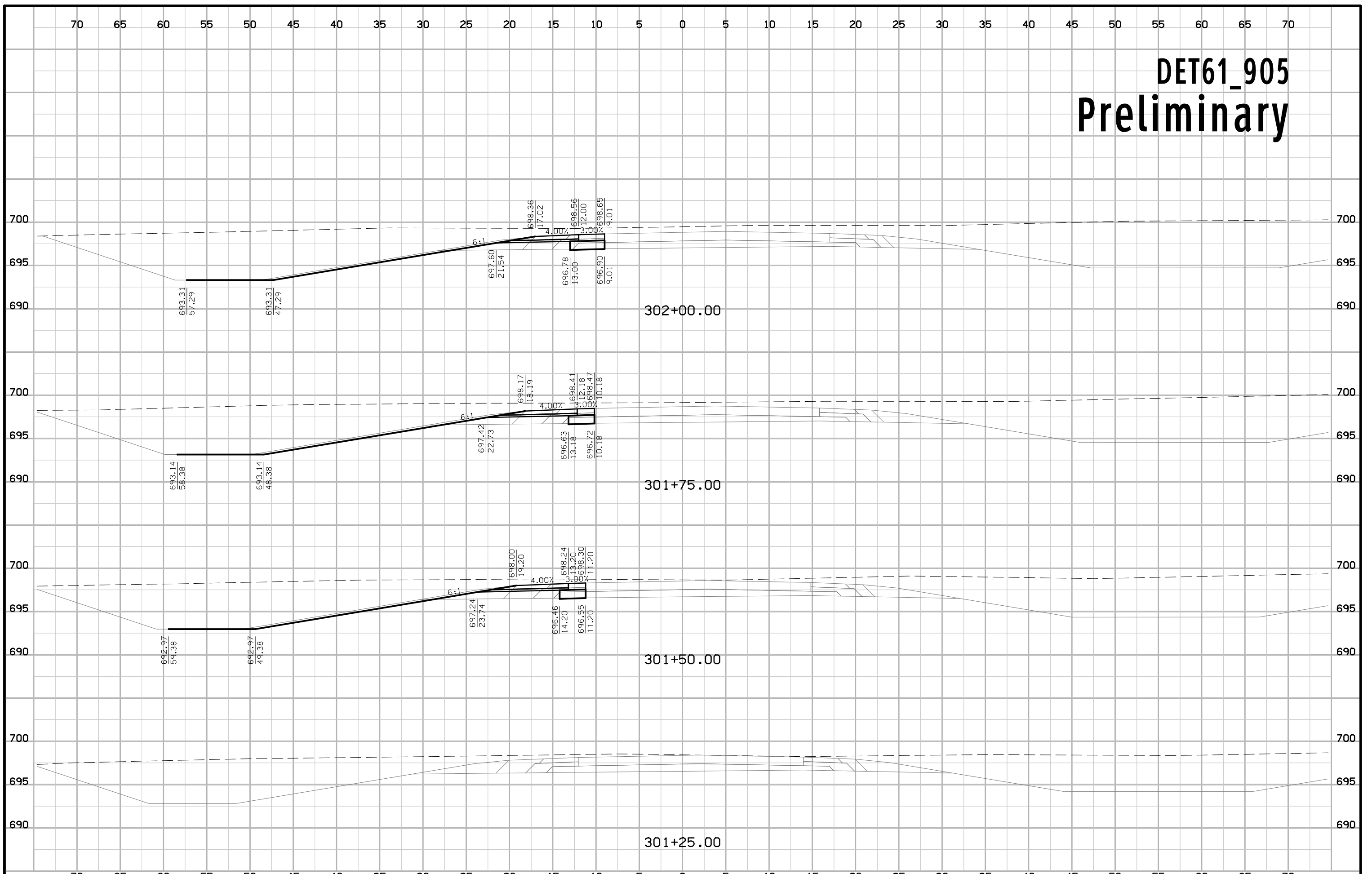

DET61_905 Preliminary

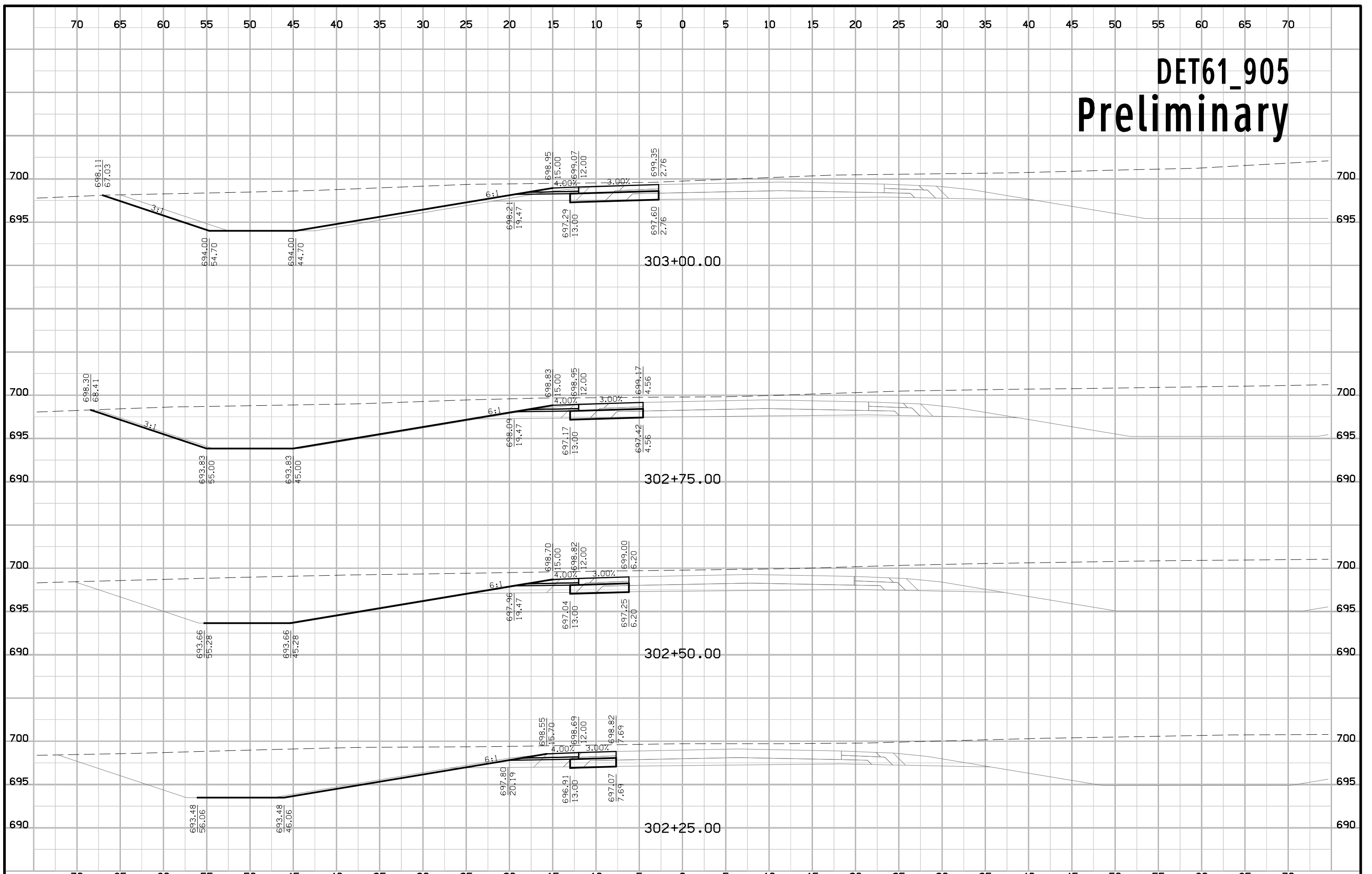

DET61_905 Preliminary

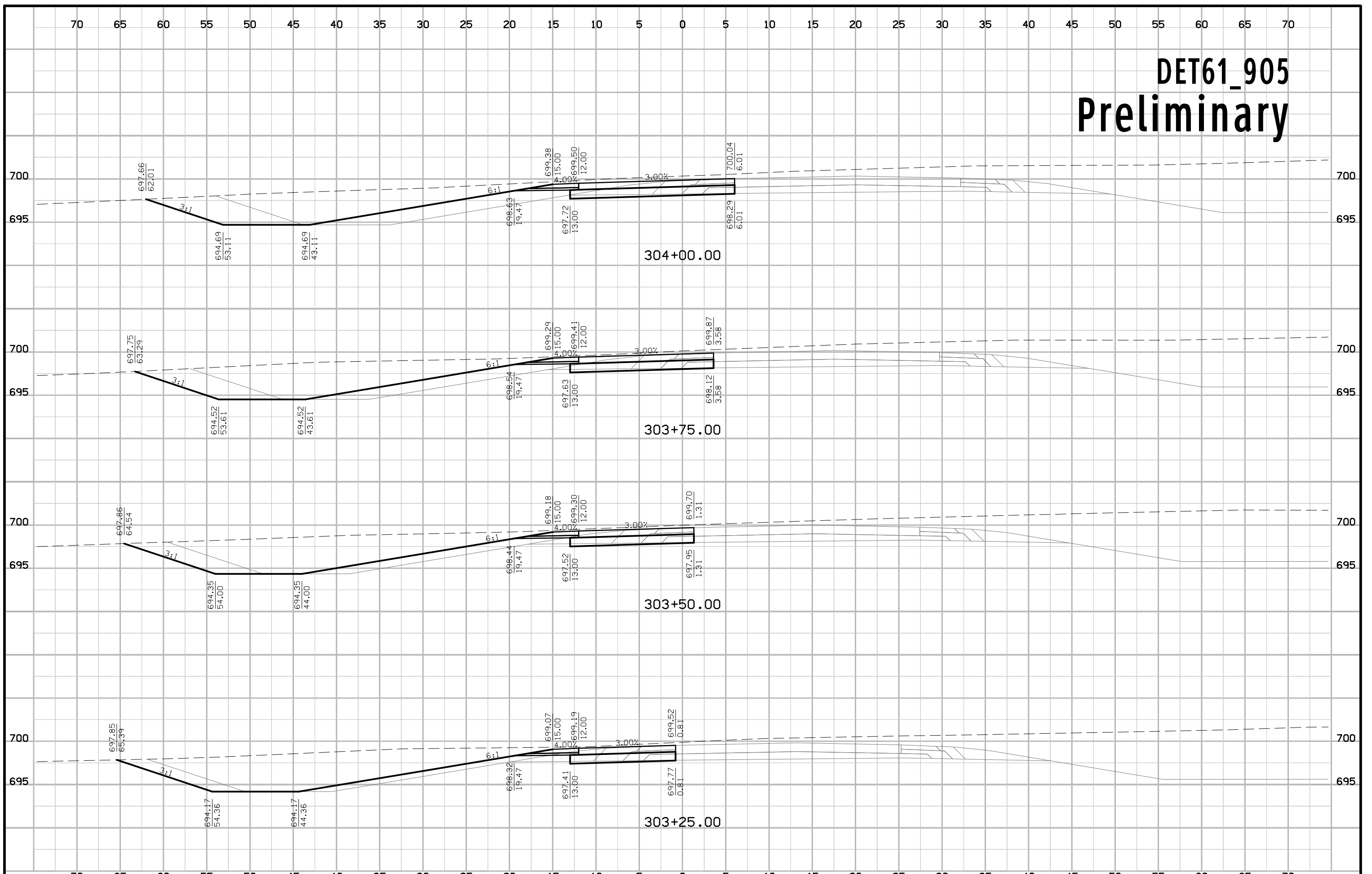

DET61_905 Preliminary

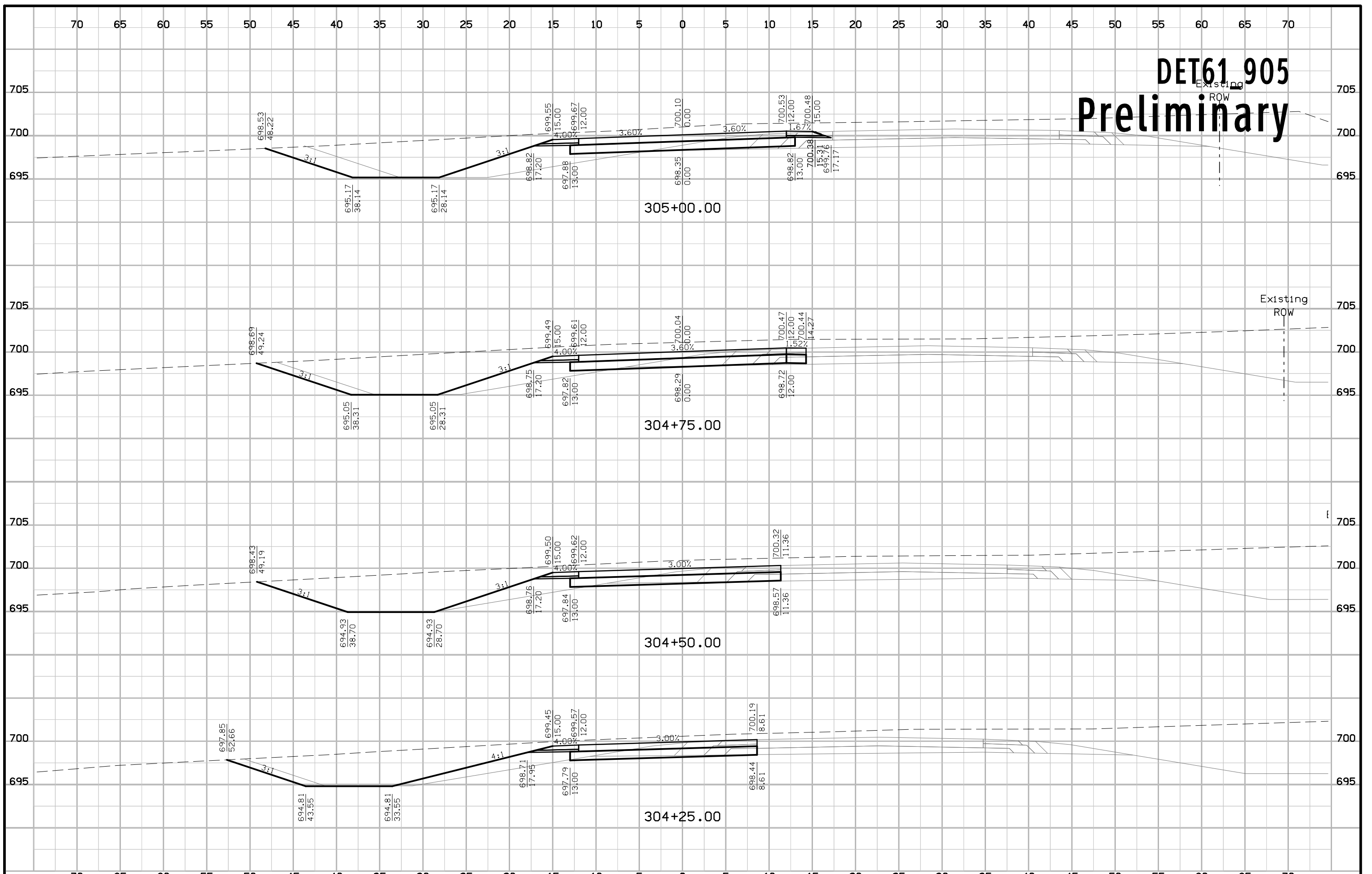

DET61_905 Preliminary

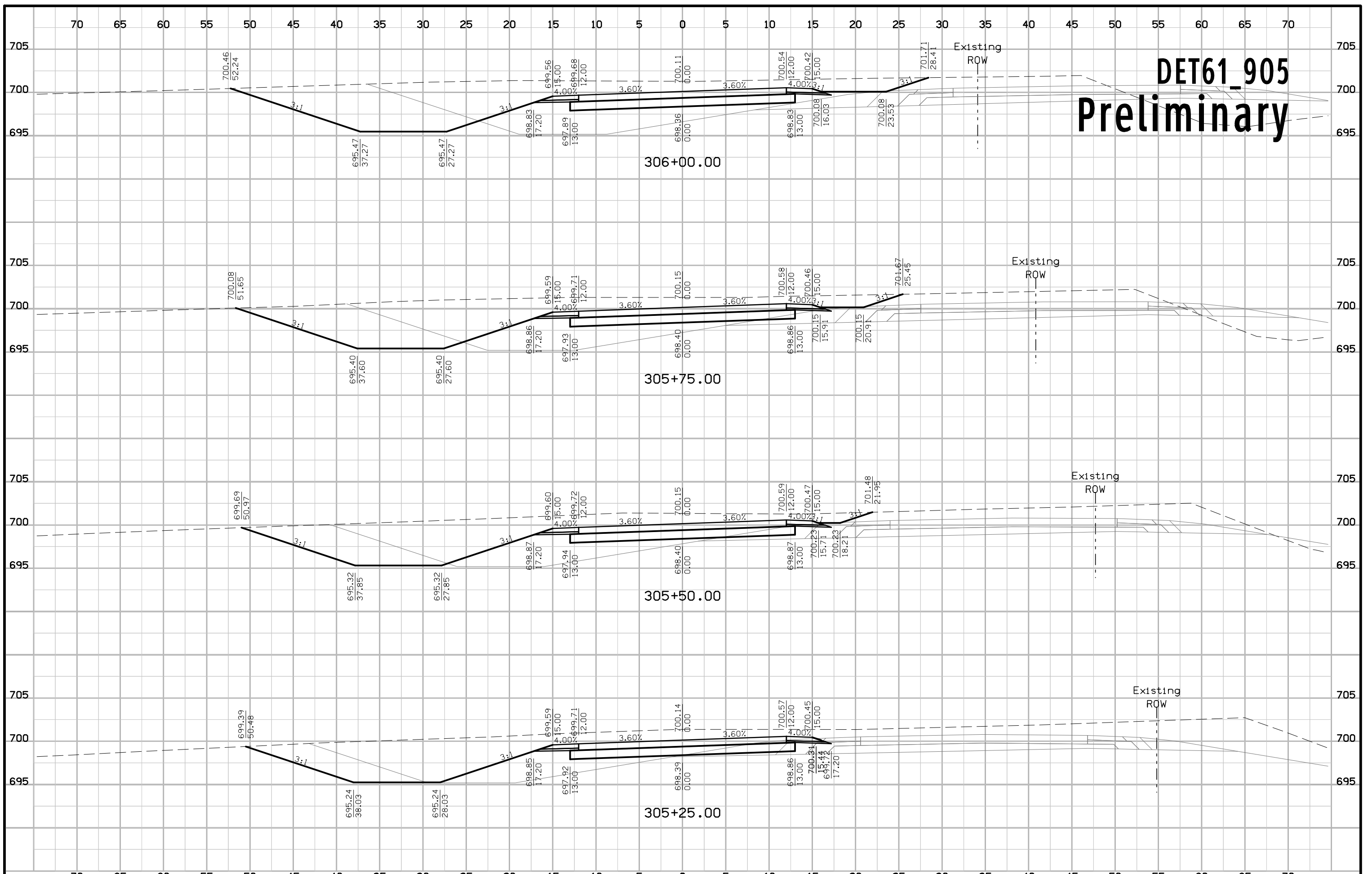

DET61_905 Preliminary

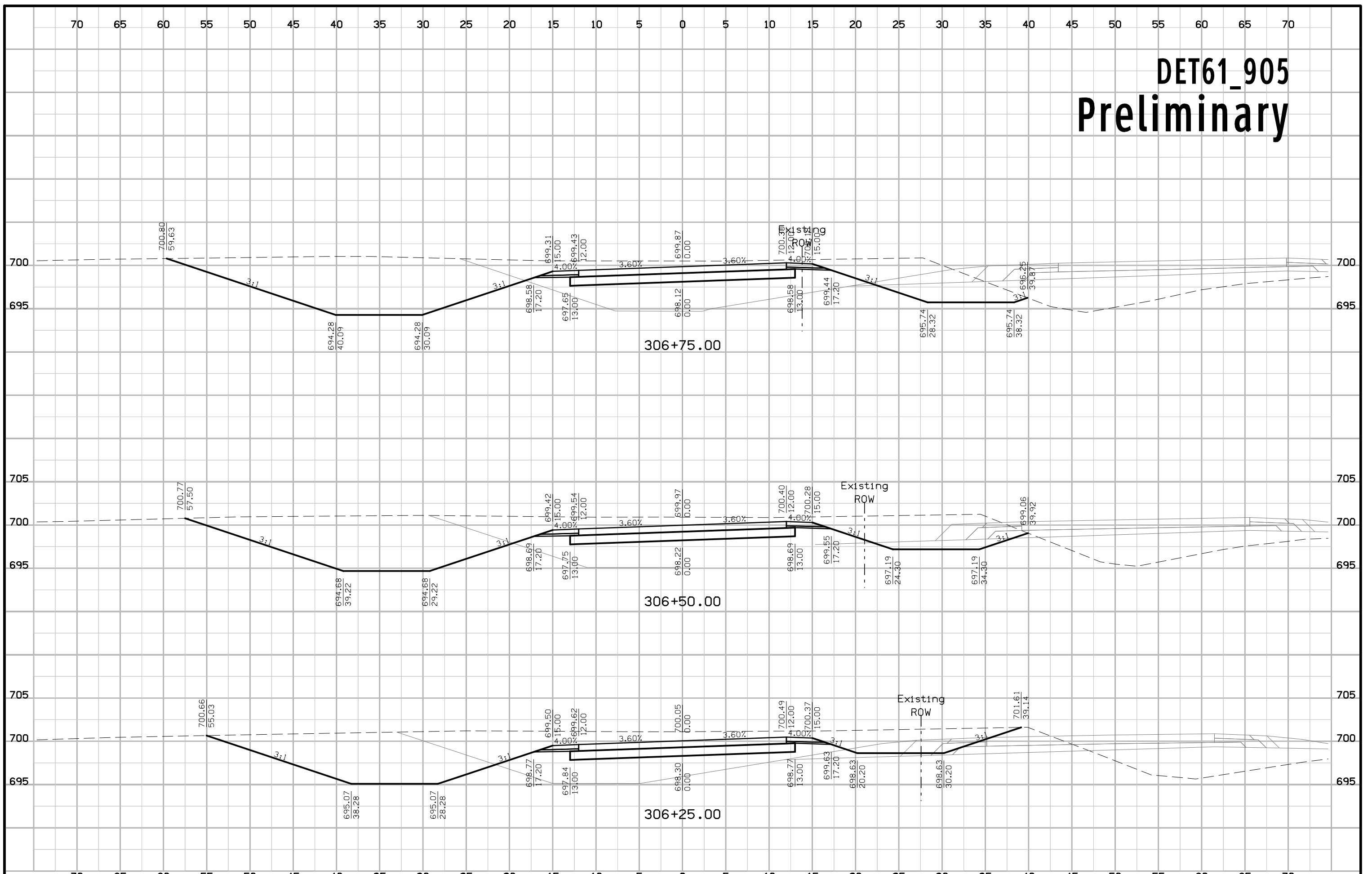

DET61_905 Preliminary

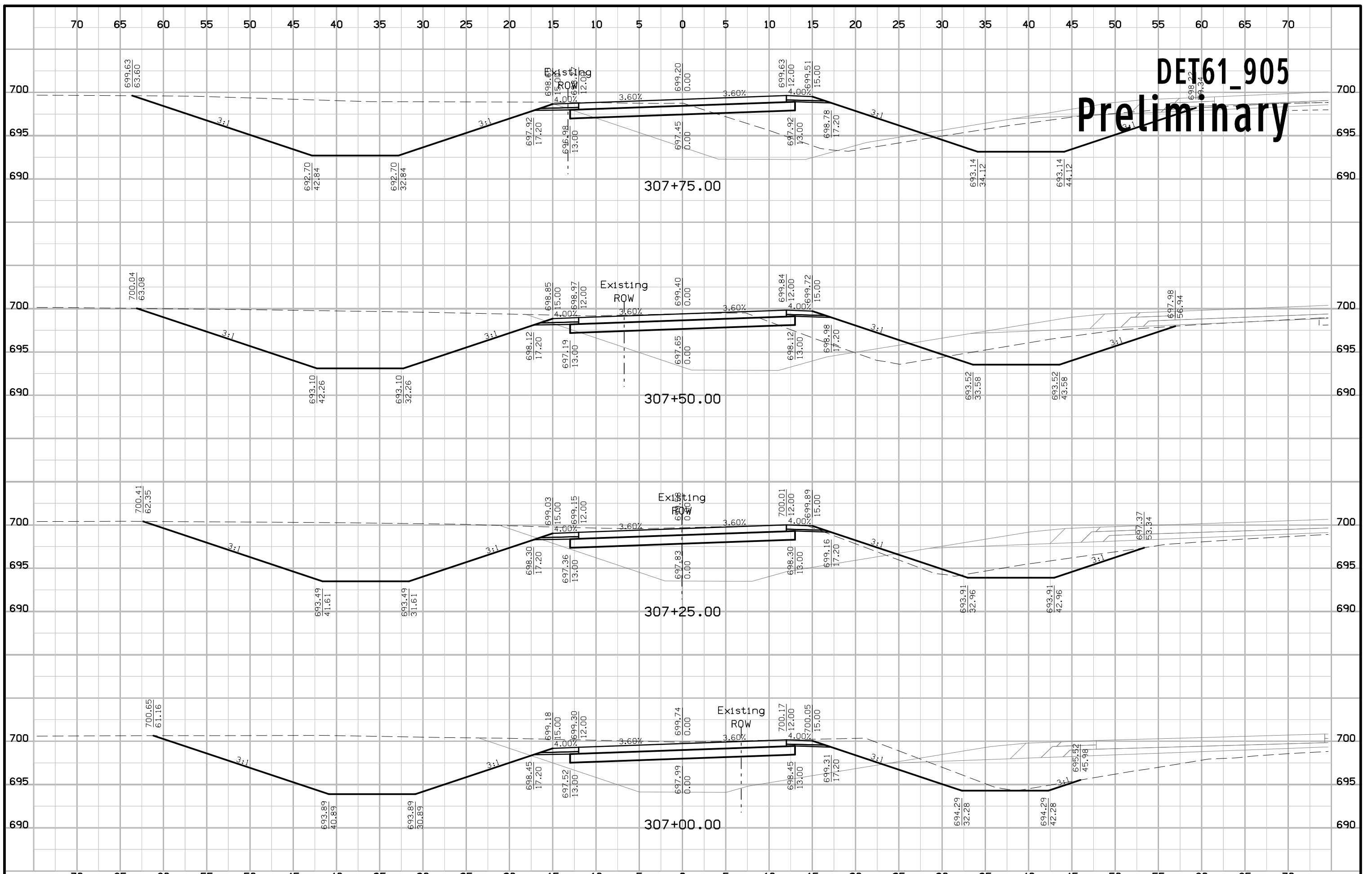

DET61_905 Preliminary

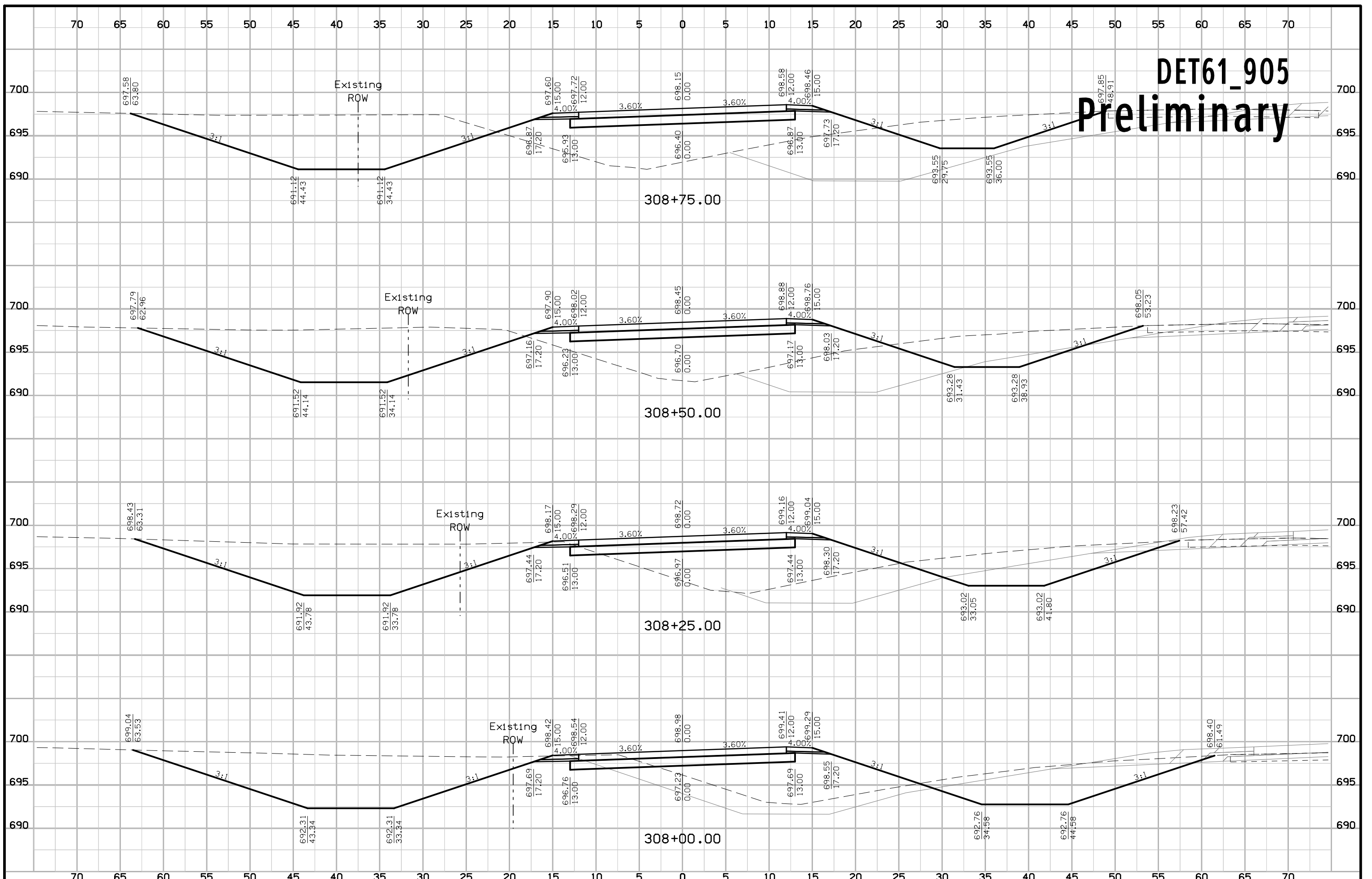

DET61_905 Preliminary

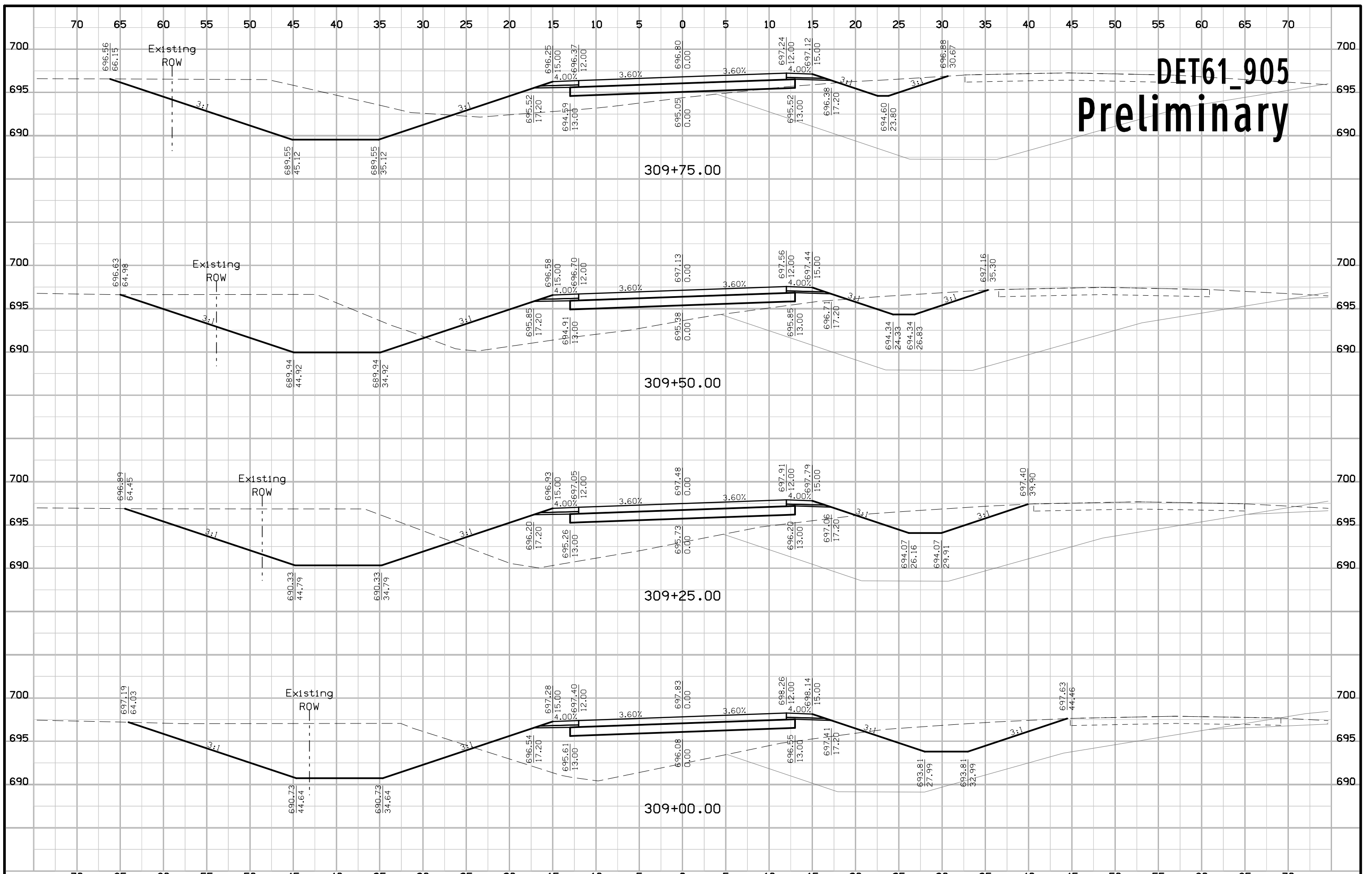

DET61_905 Preliminary

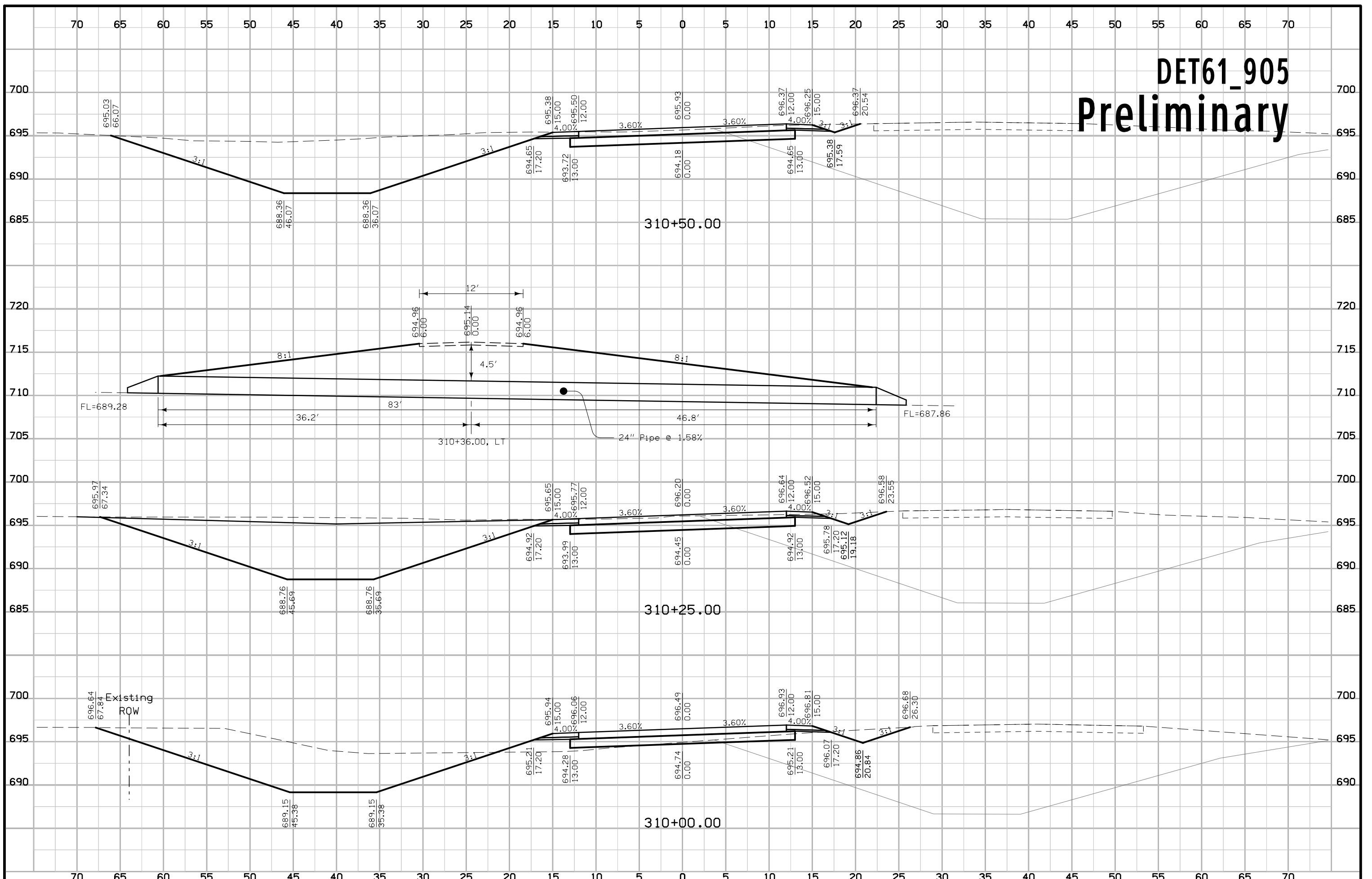

DET61_905 Preliminary

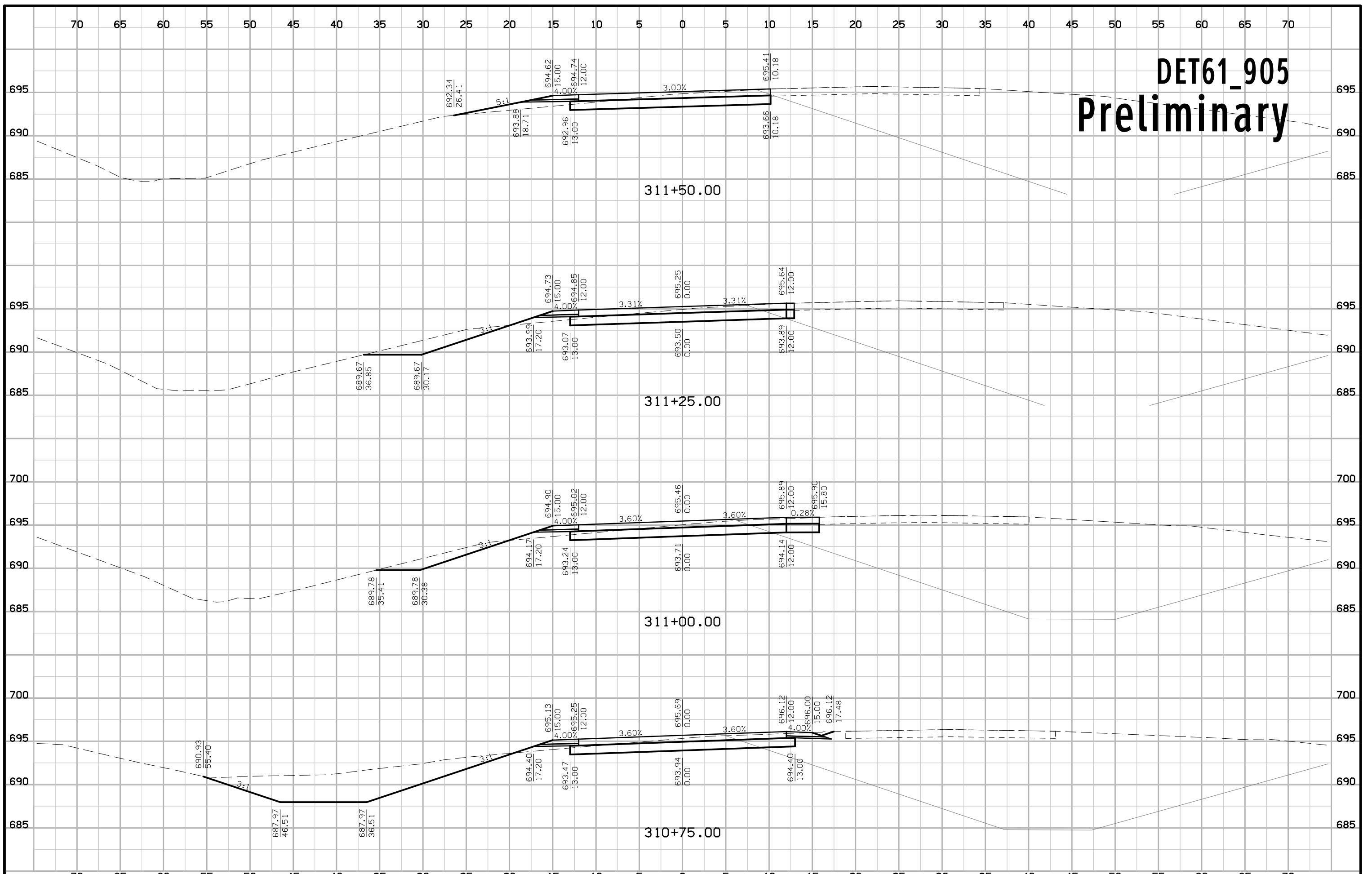

DET61_905 Preliminary

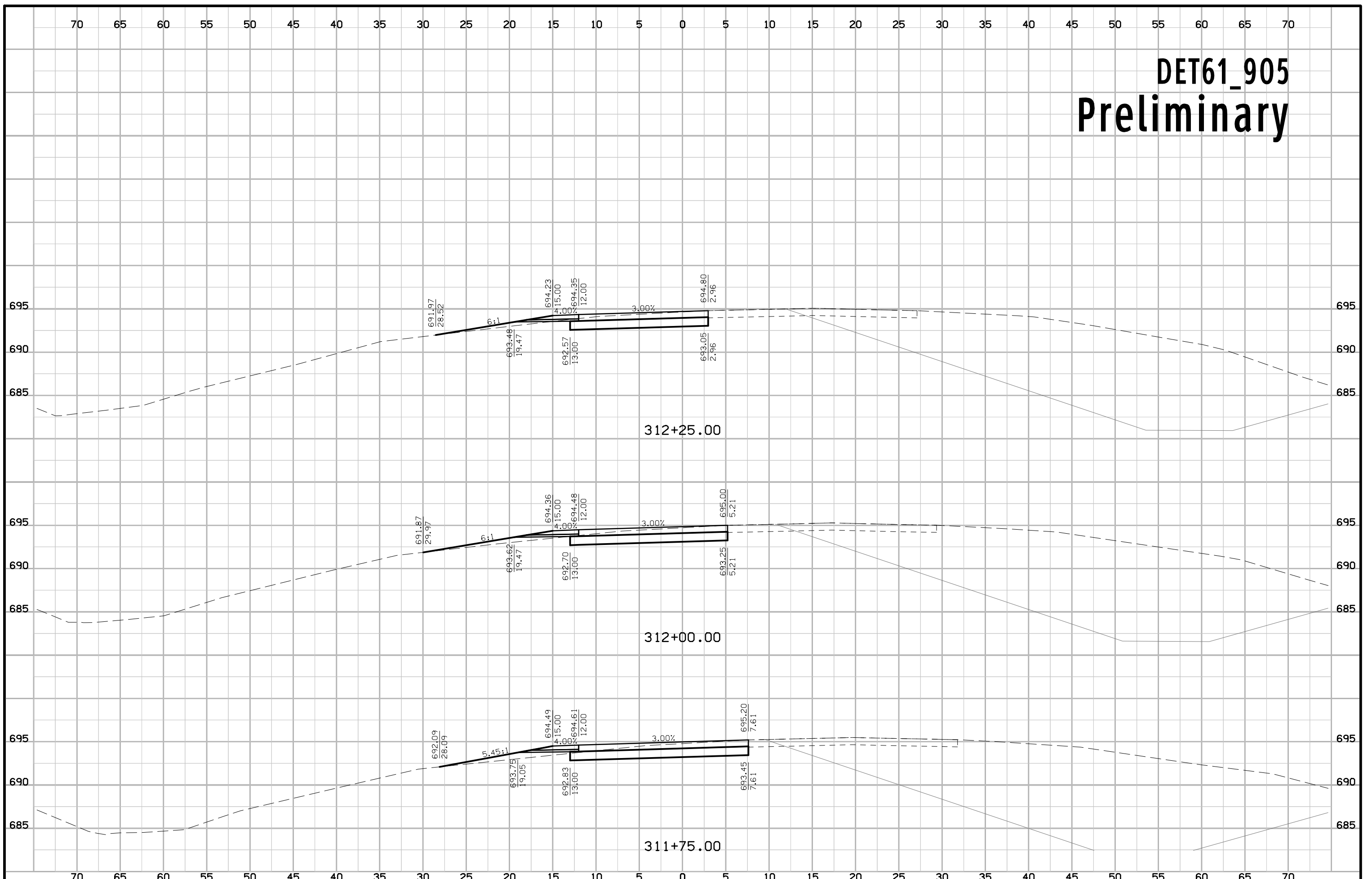

DET61_905 Preliminary

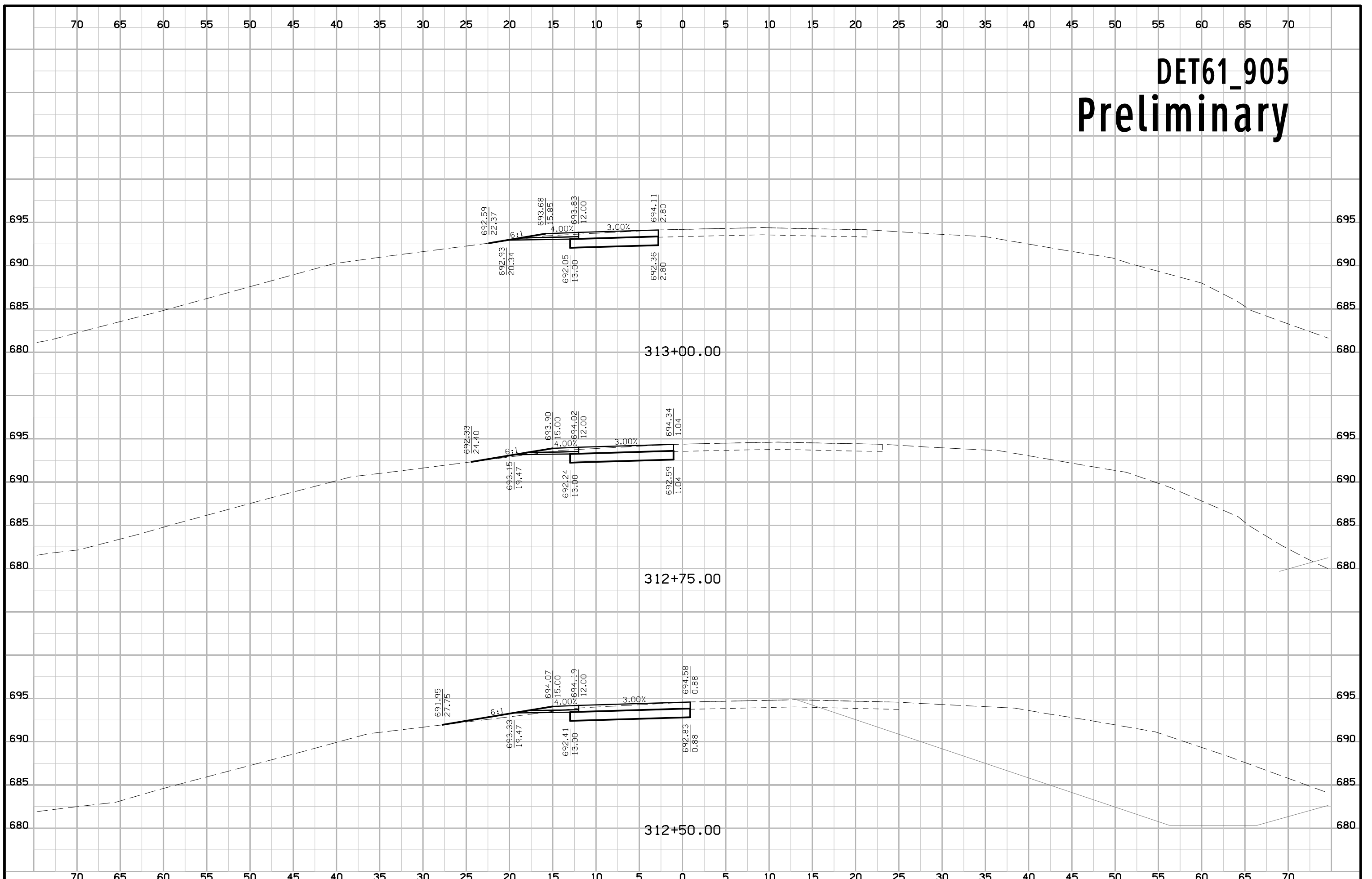

DET61_905 Preliminary

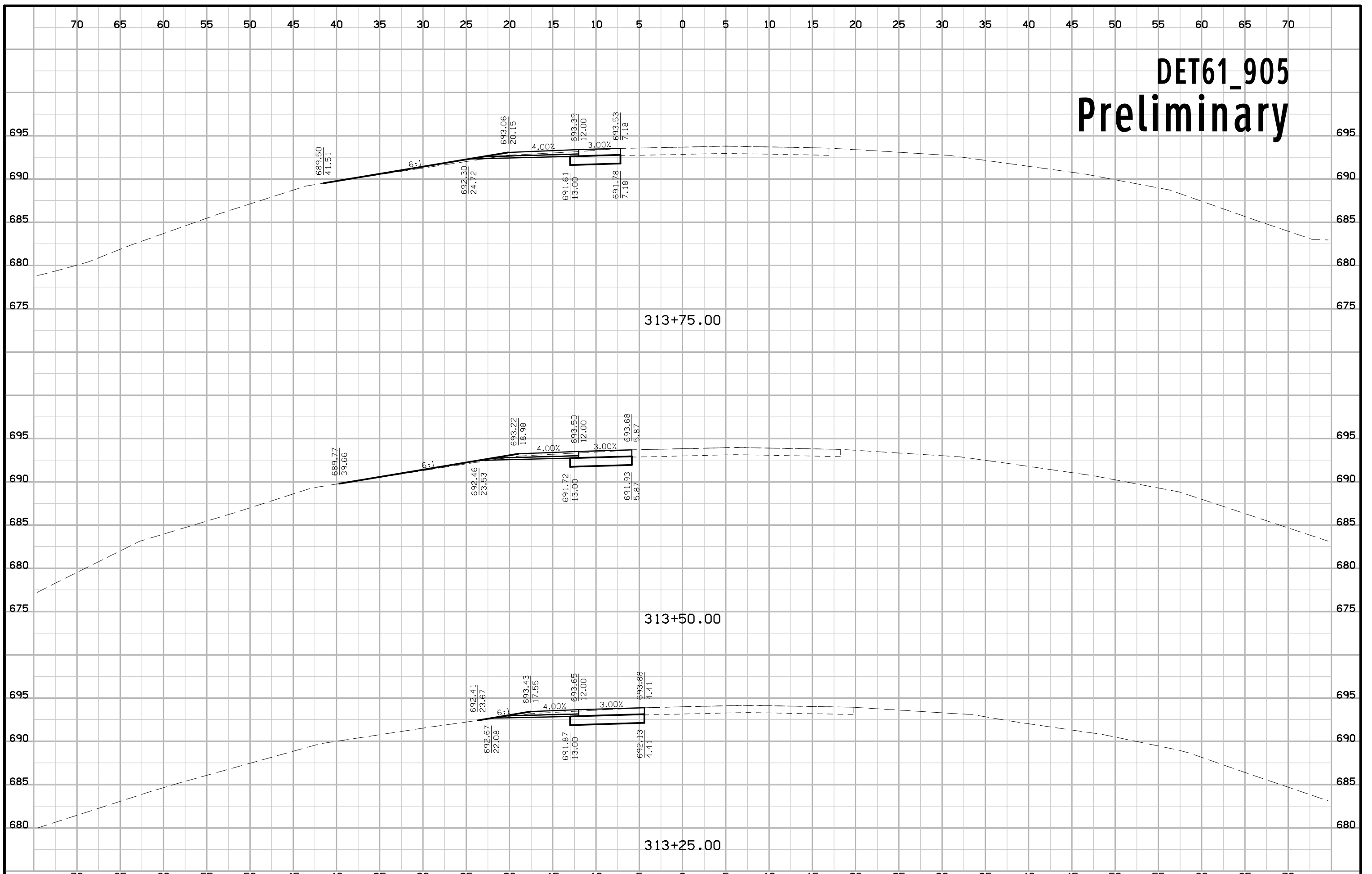

DET61_905 Preliminary

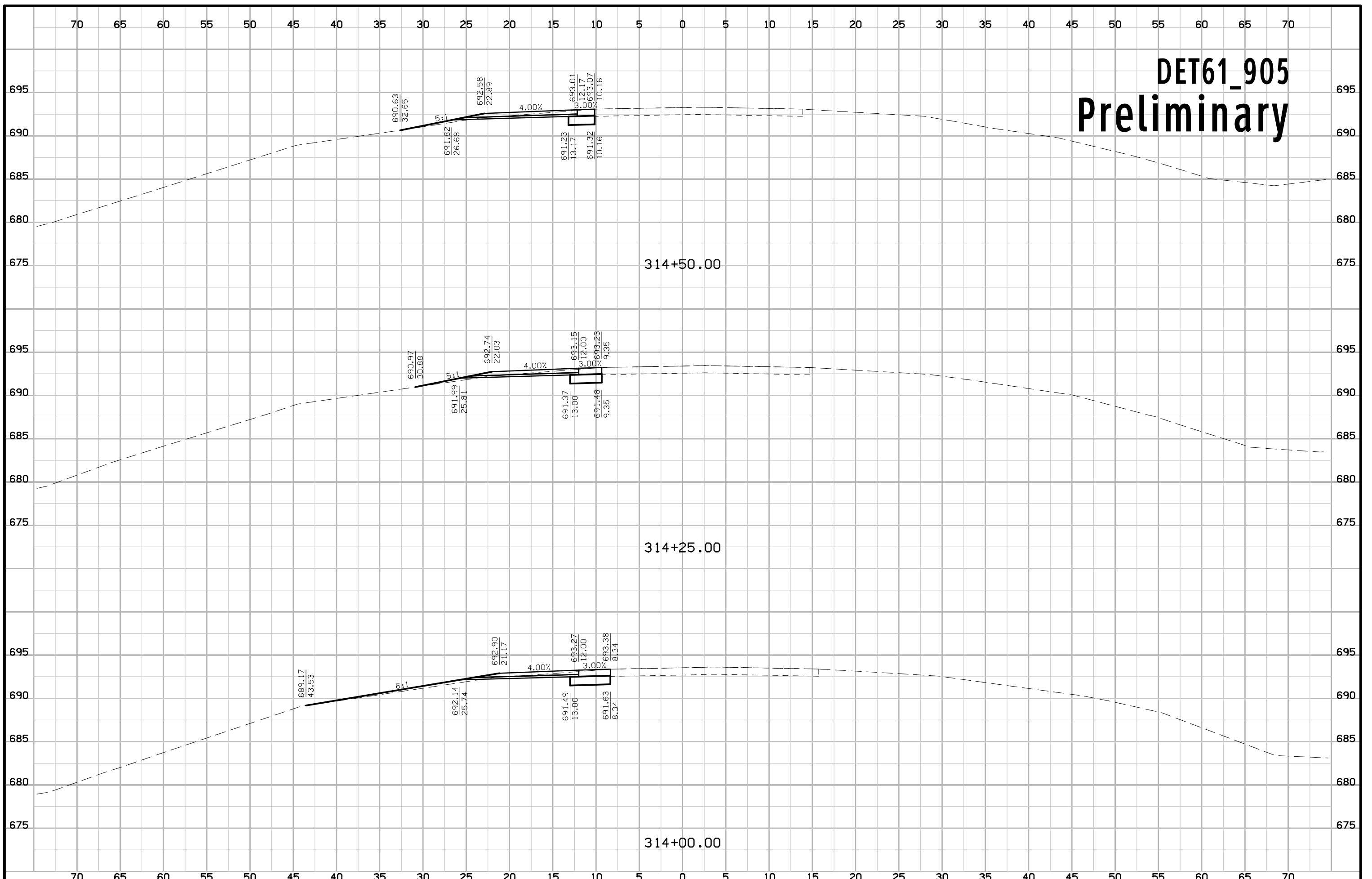

DET61_905 Preliminary

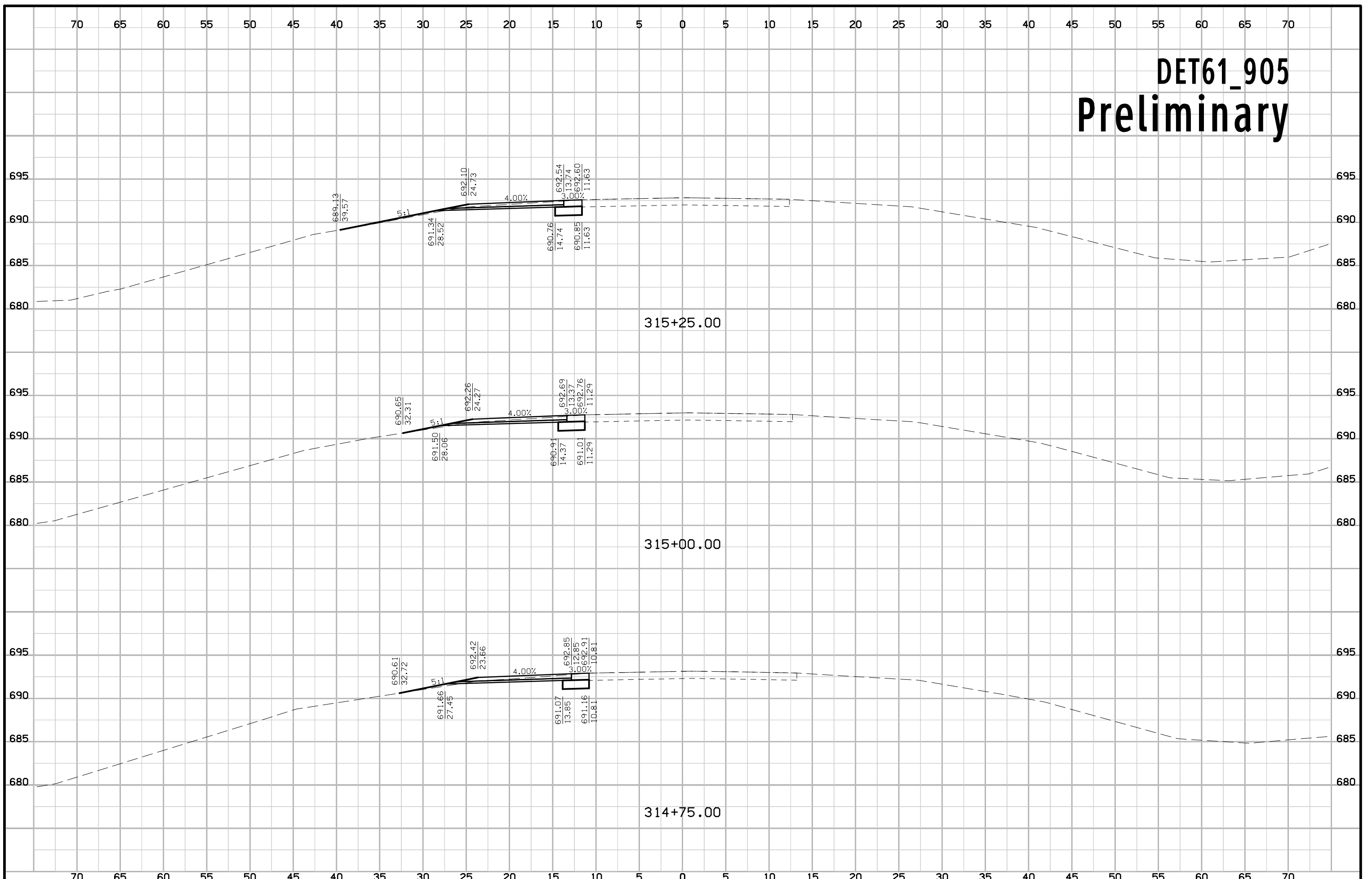

DET61_905 Preliminary

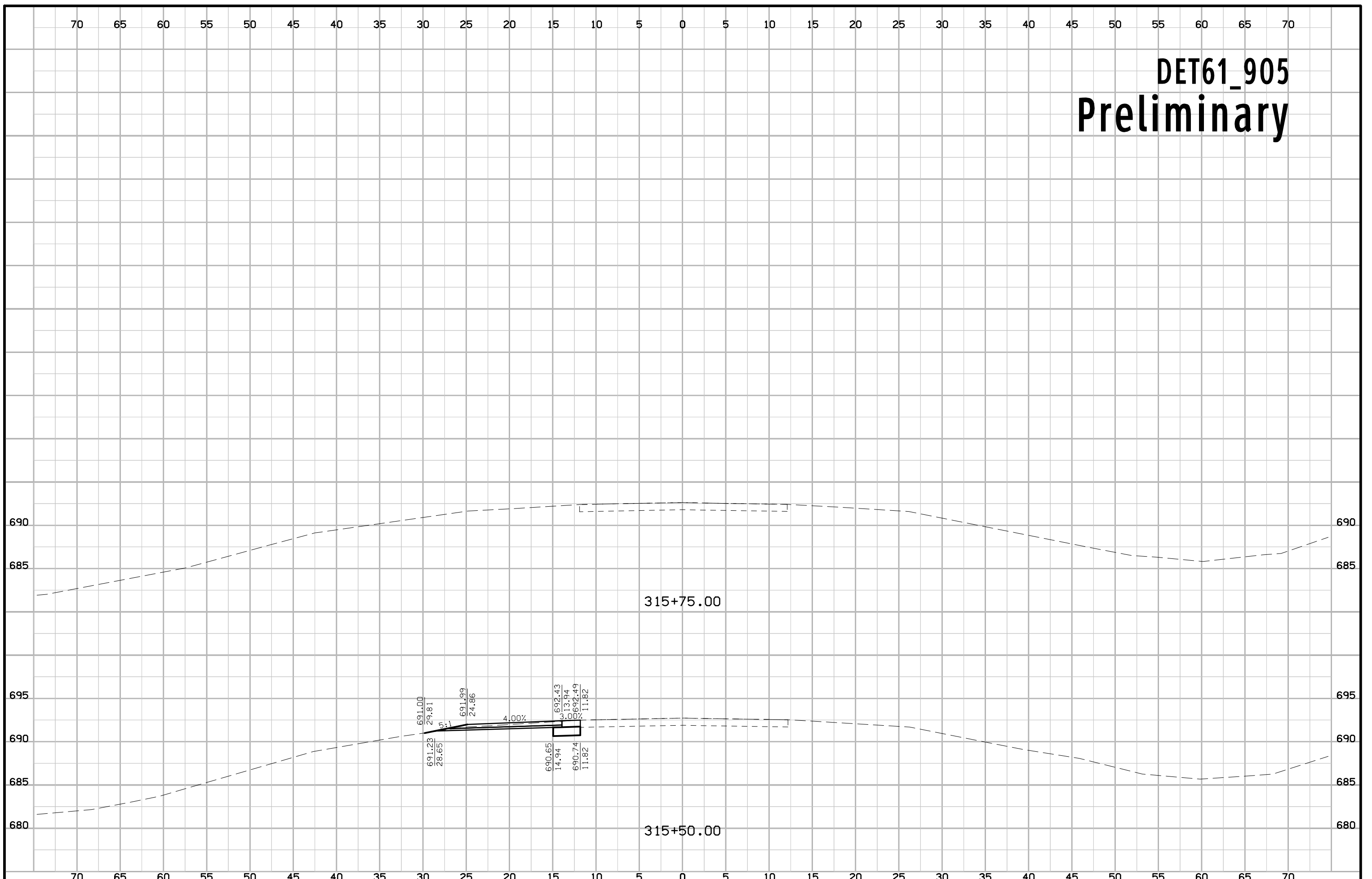

DET61_985 Preliminary

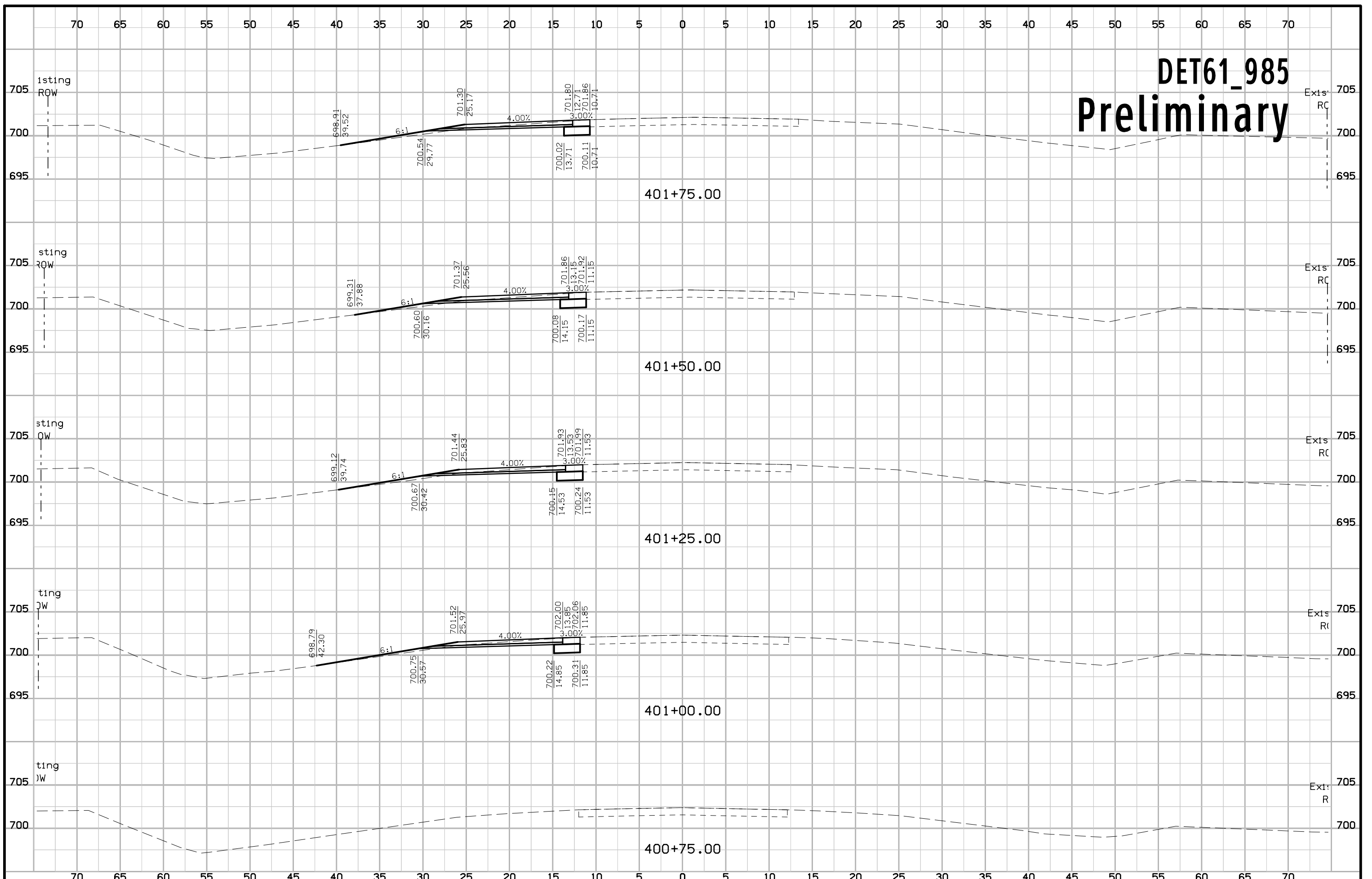

DET61_985 Preliminary

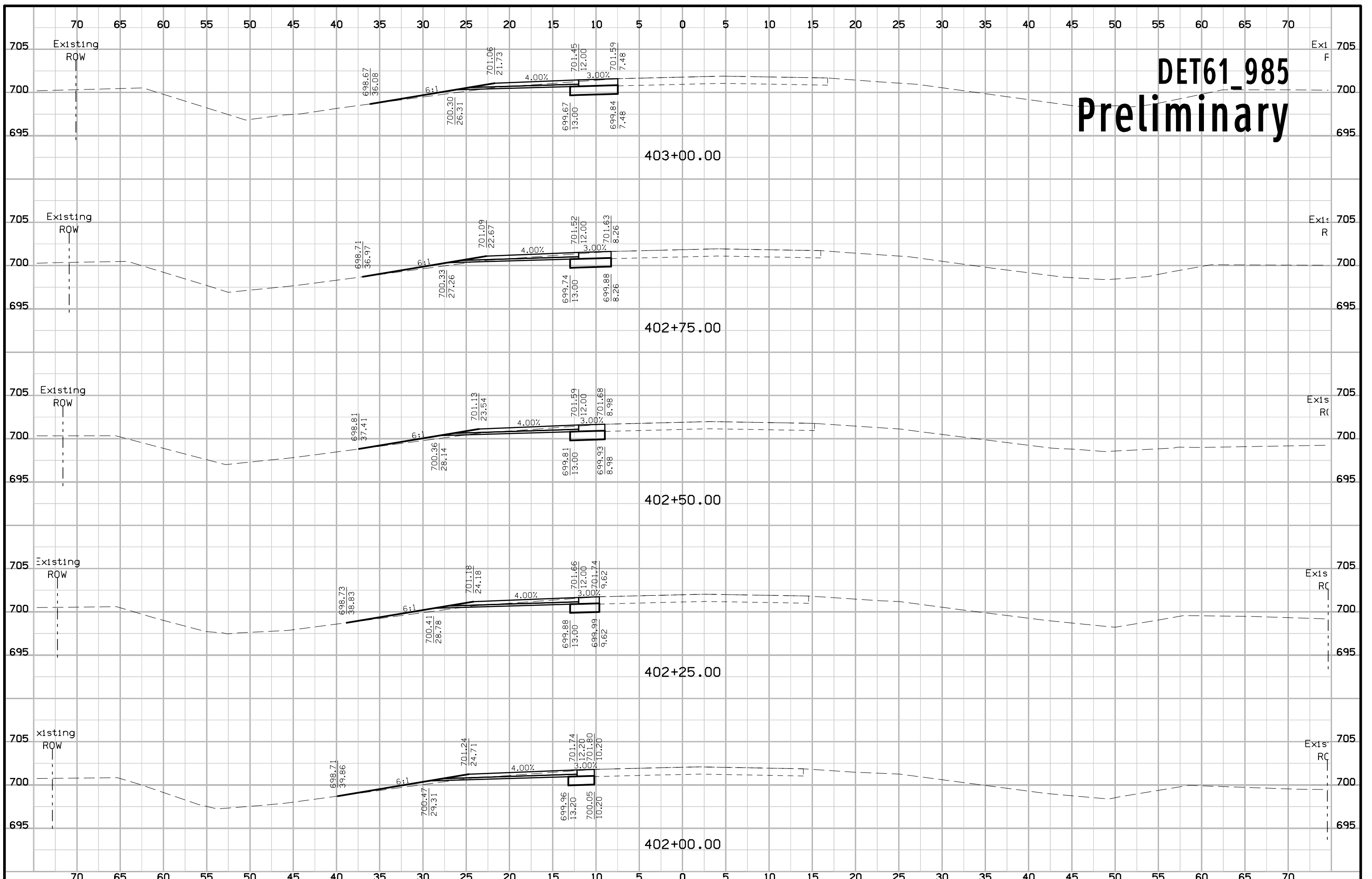

DET61_985 Preliminary

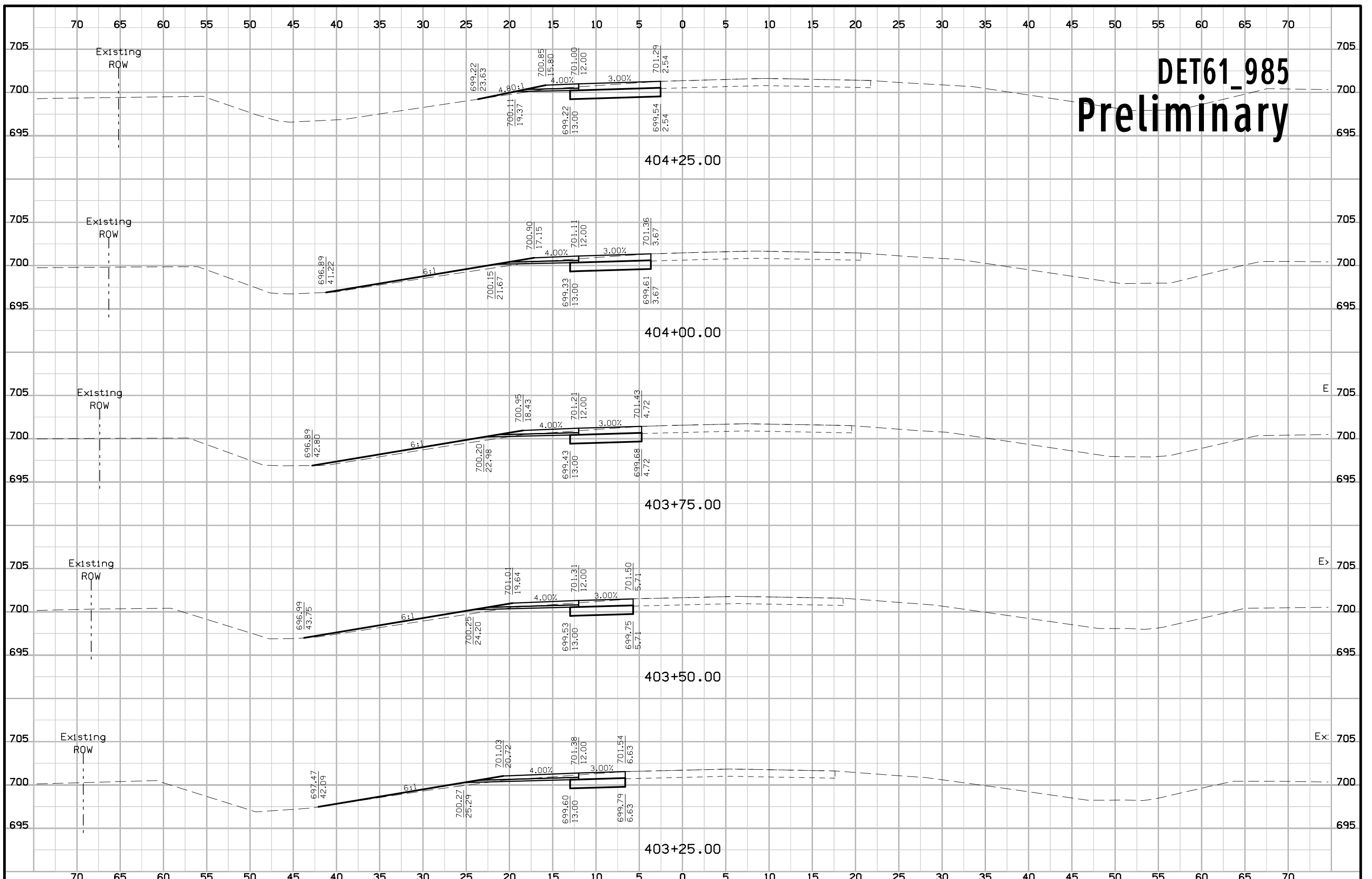

DET61_985 Preliminary

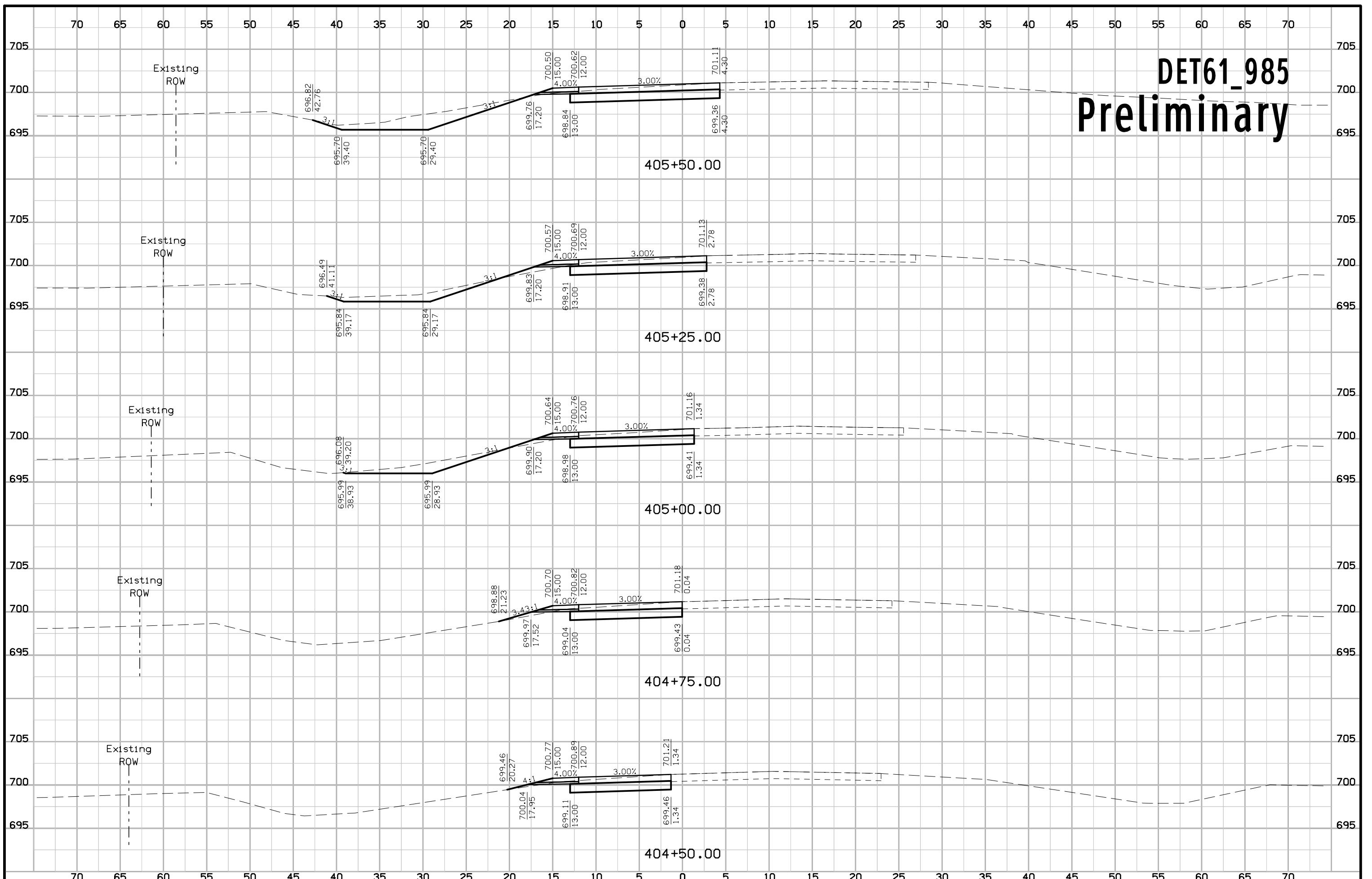

DET61_985 Preliminary

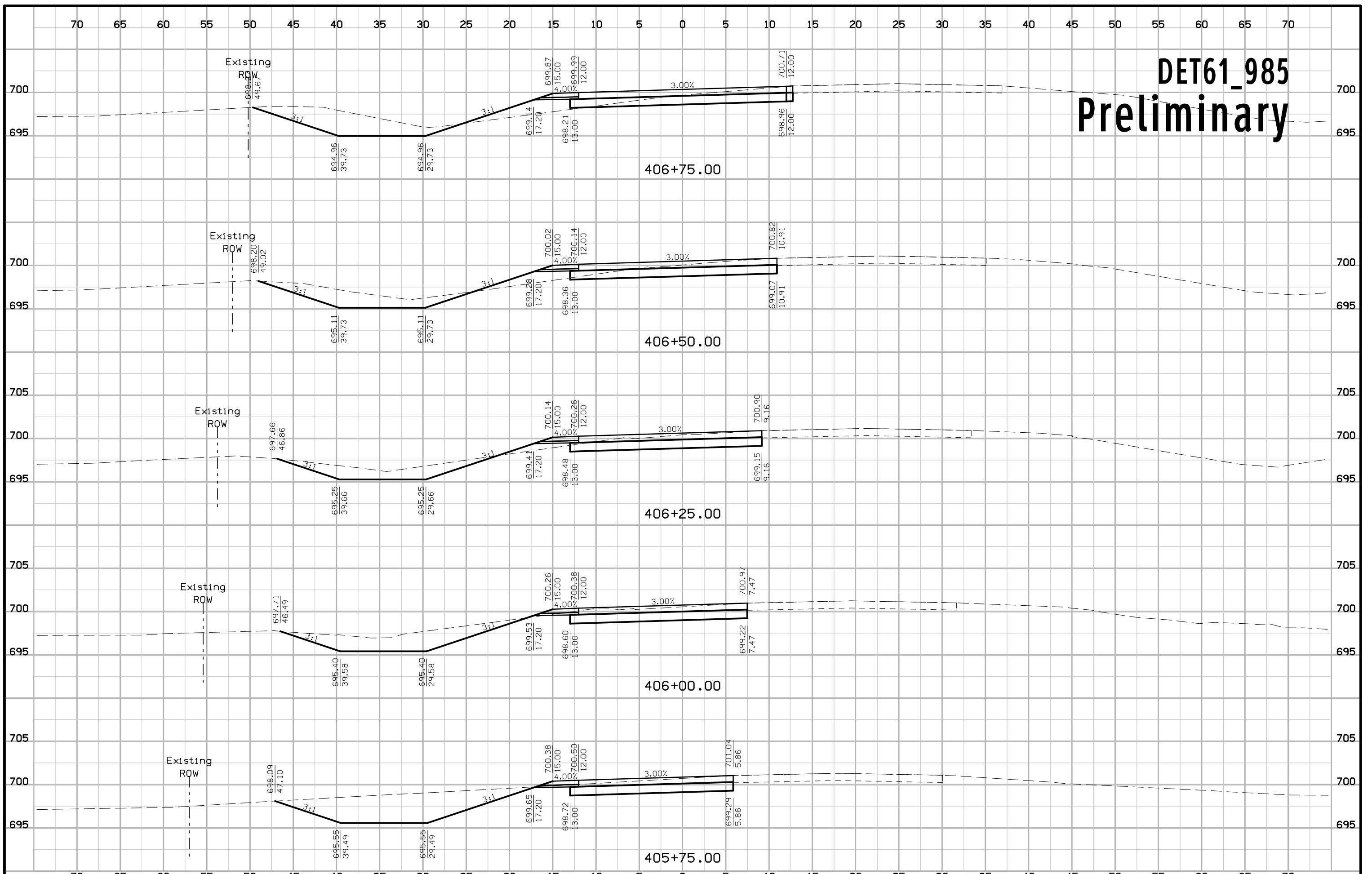

DET61_985 Preliminary

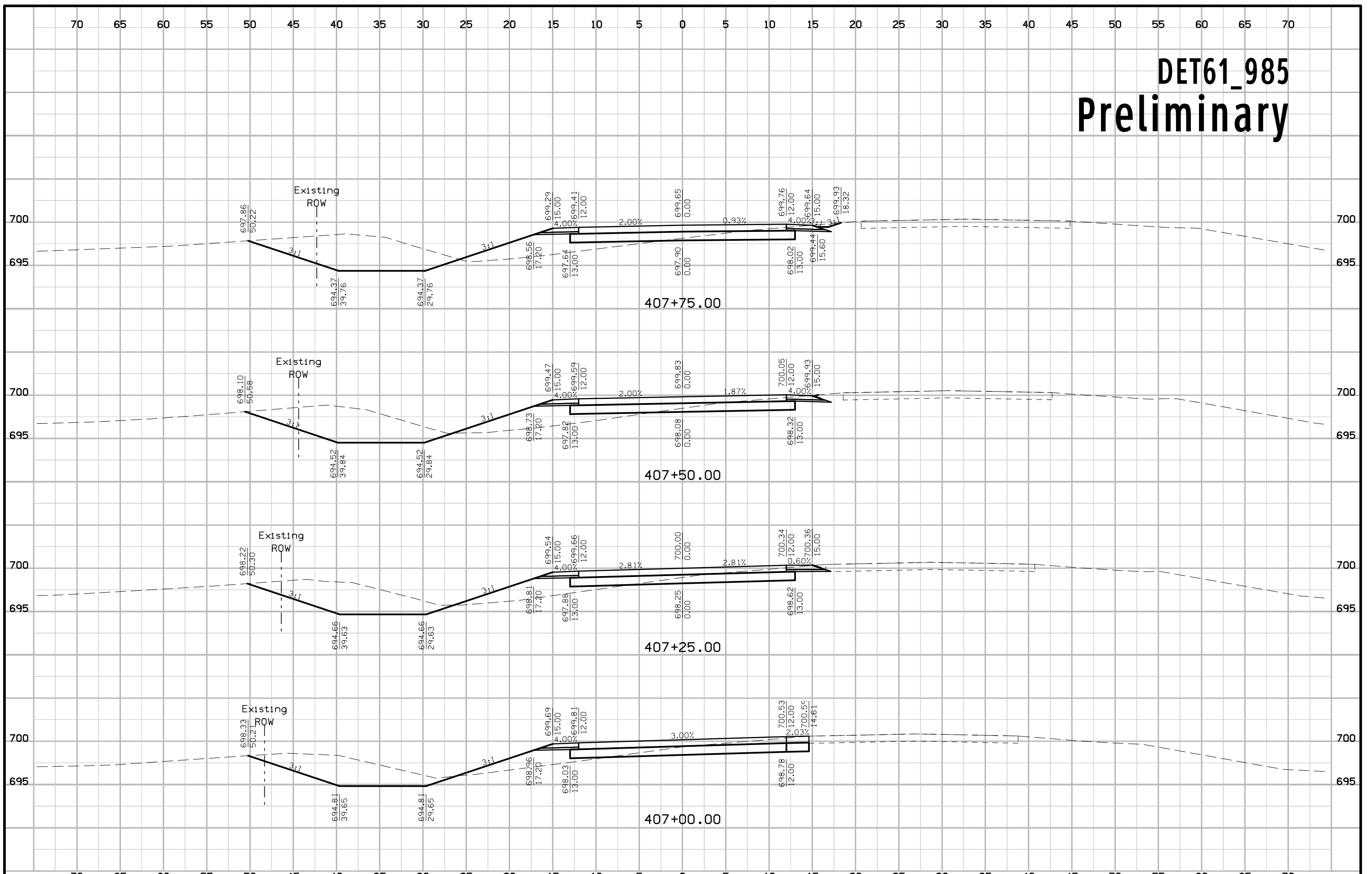

DET61_985 Preliminary

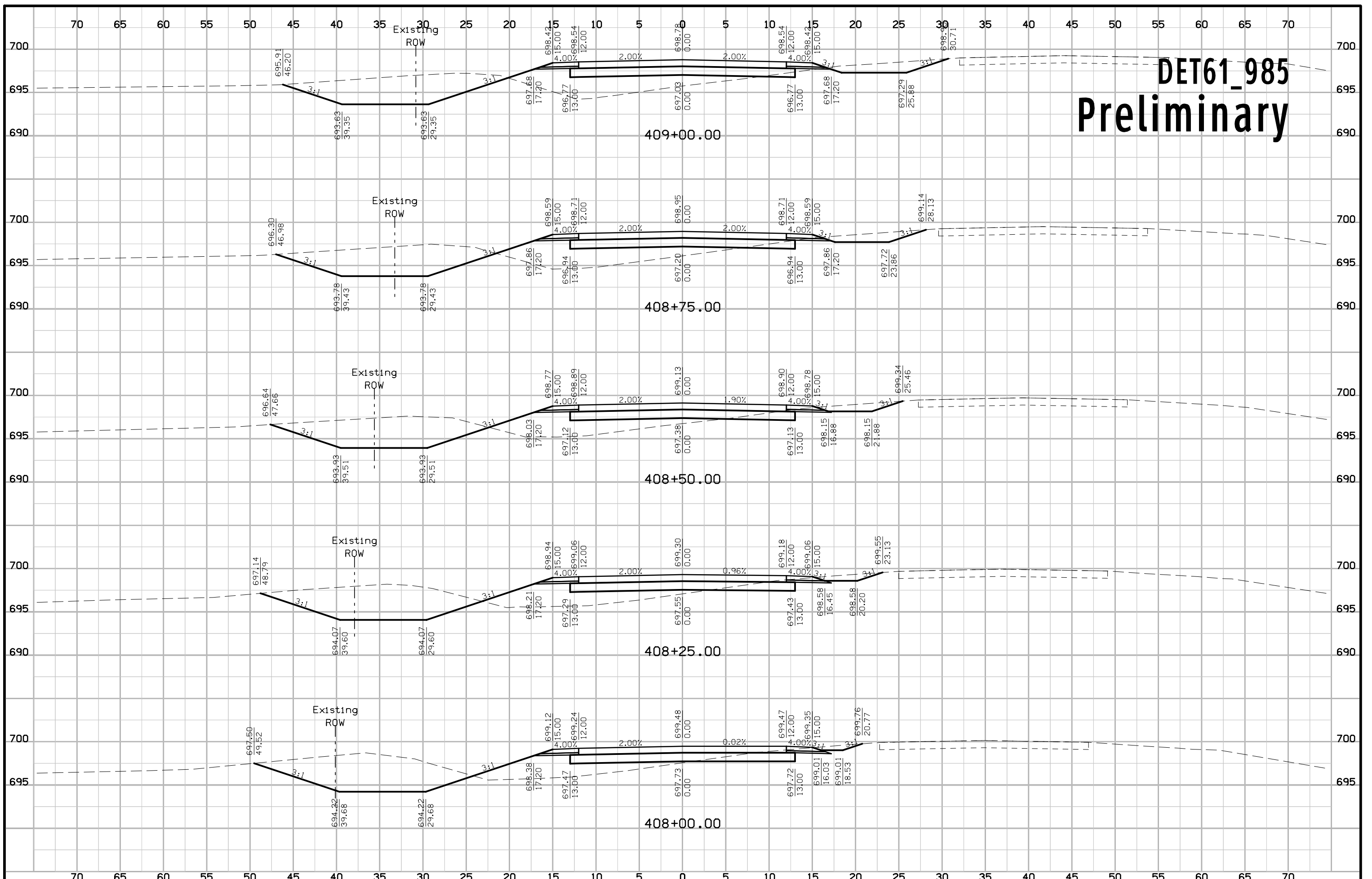

DET61_985 Preliminary

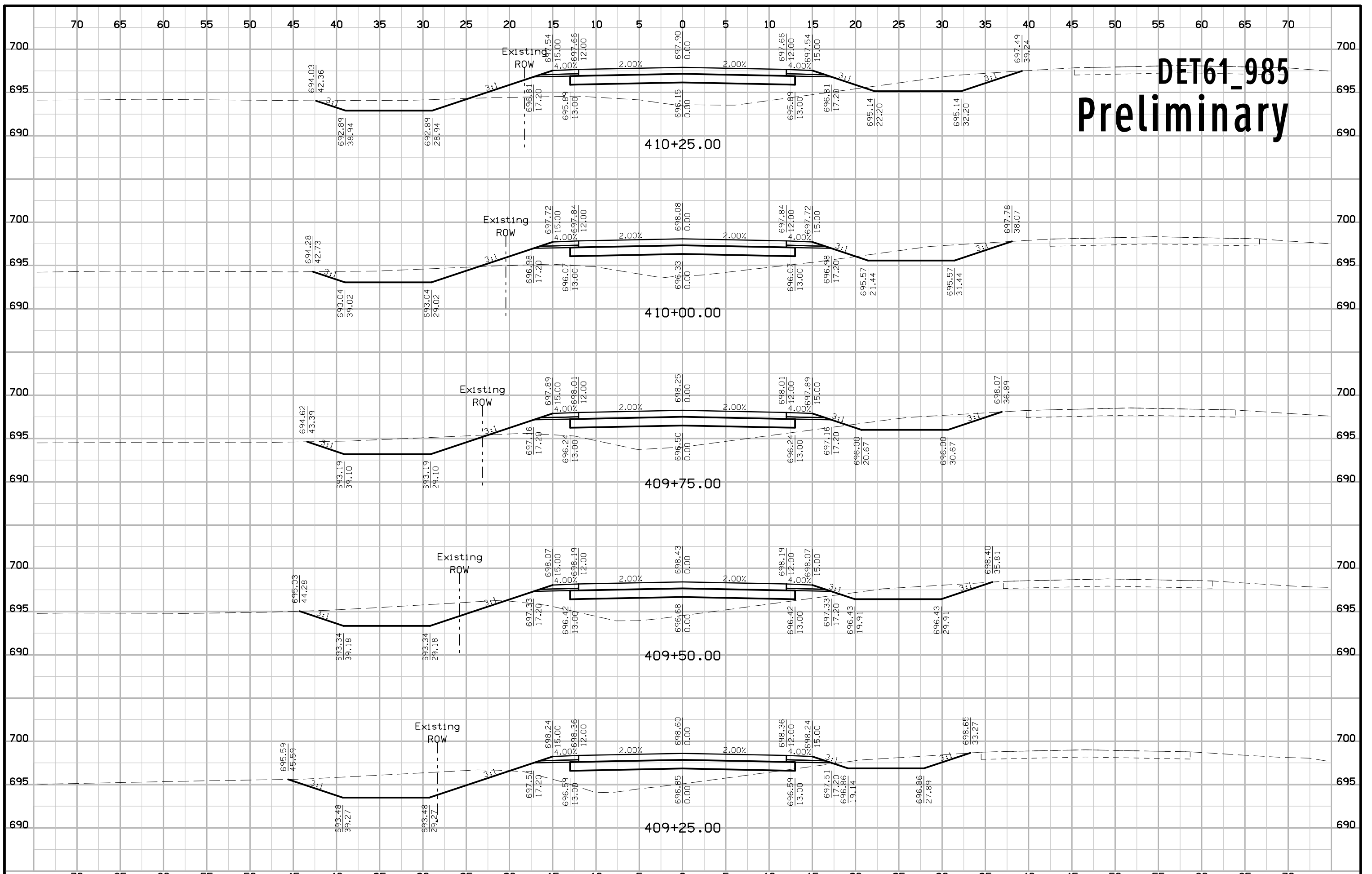

DET61_985 Preliminary

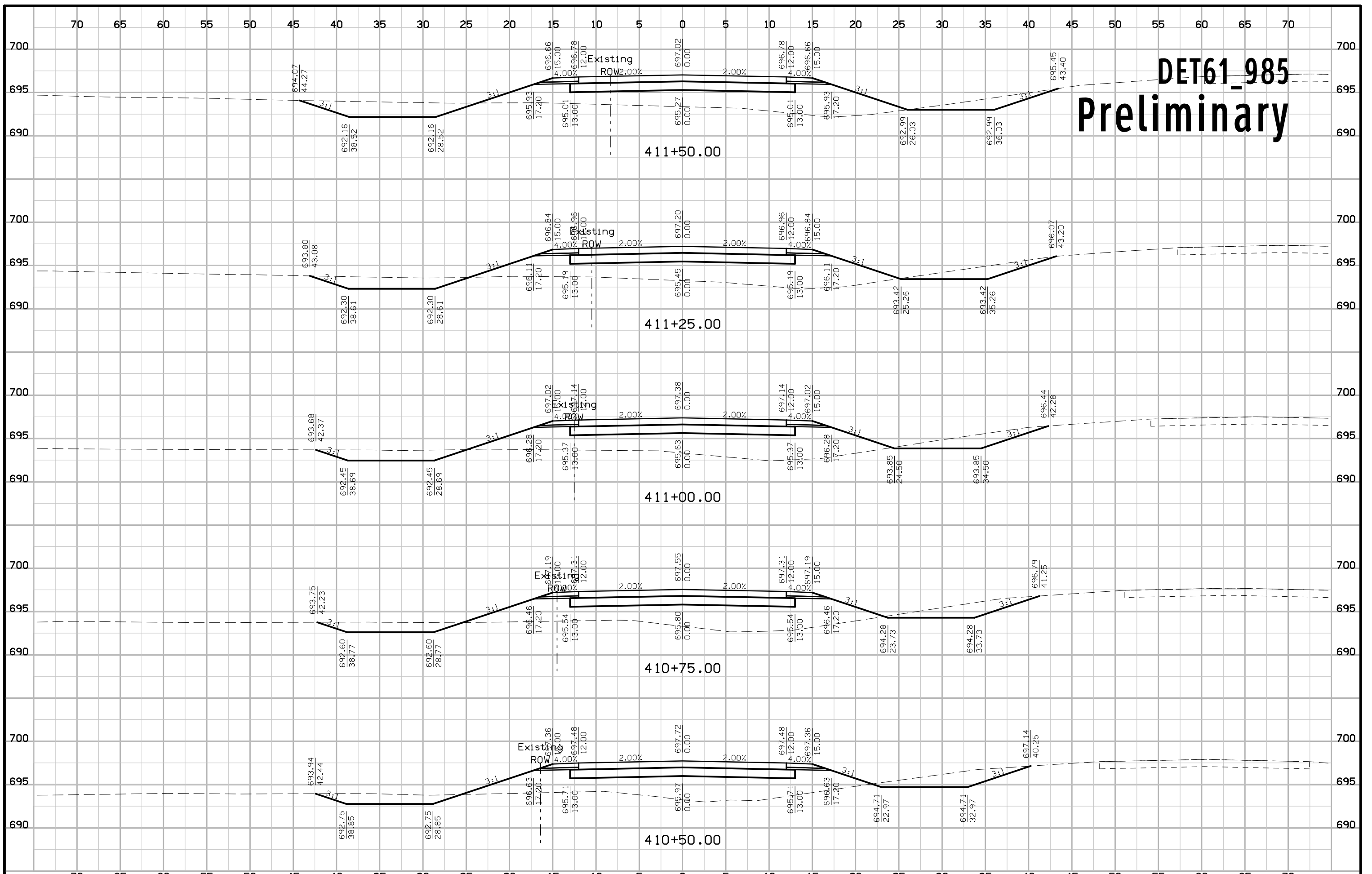

DET61_985 Preliminary

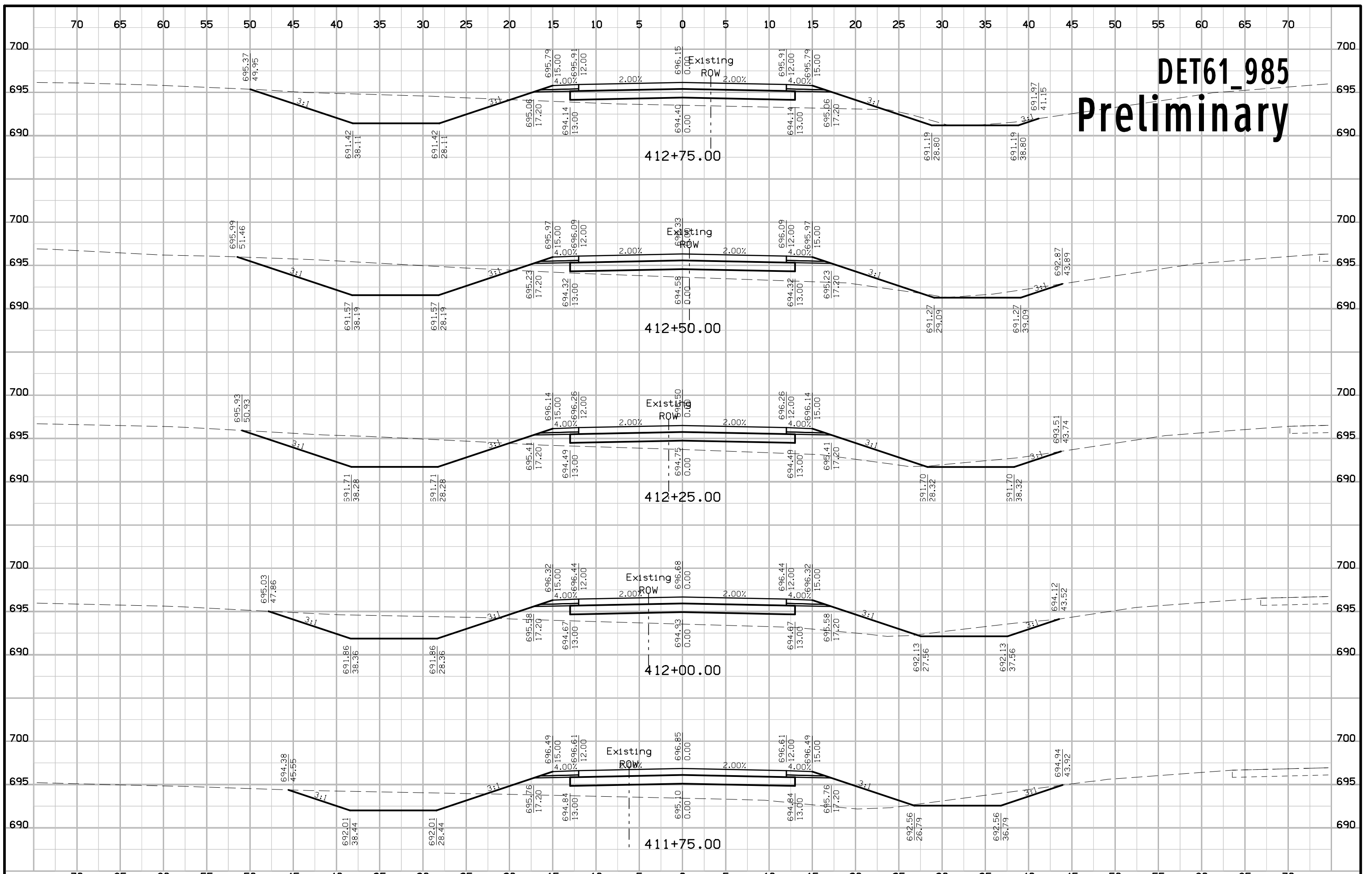

DET61_985 Preliminary

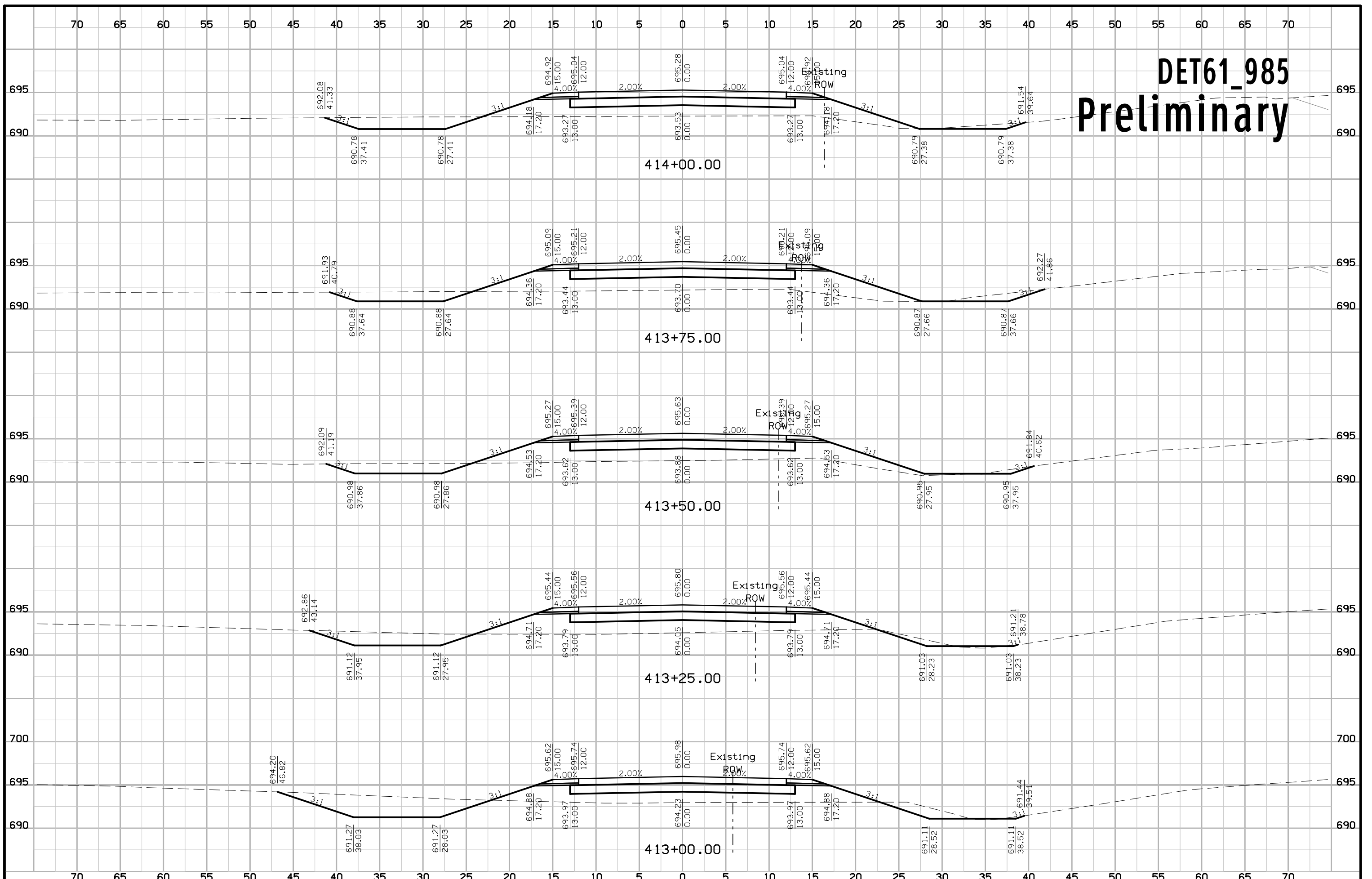

DET61_985 Preliminary

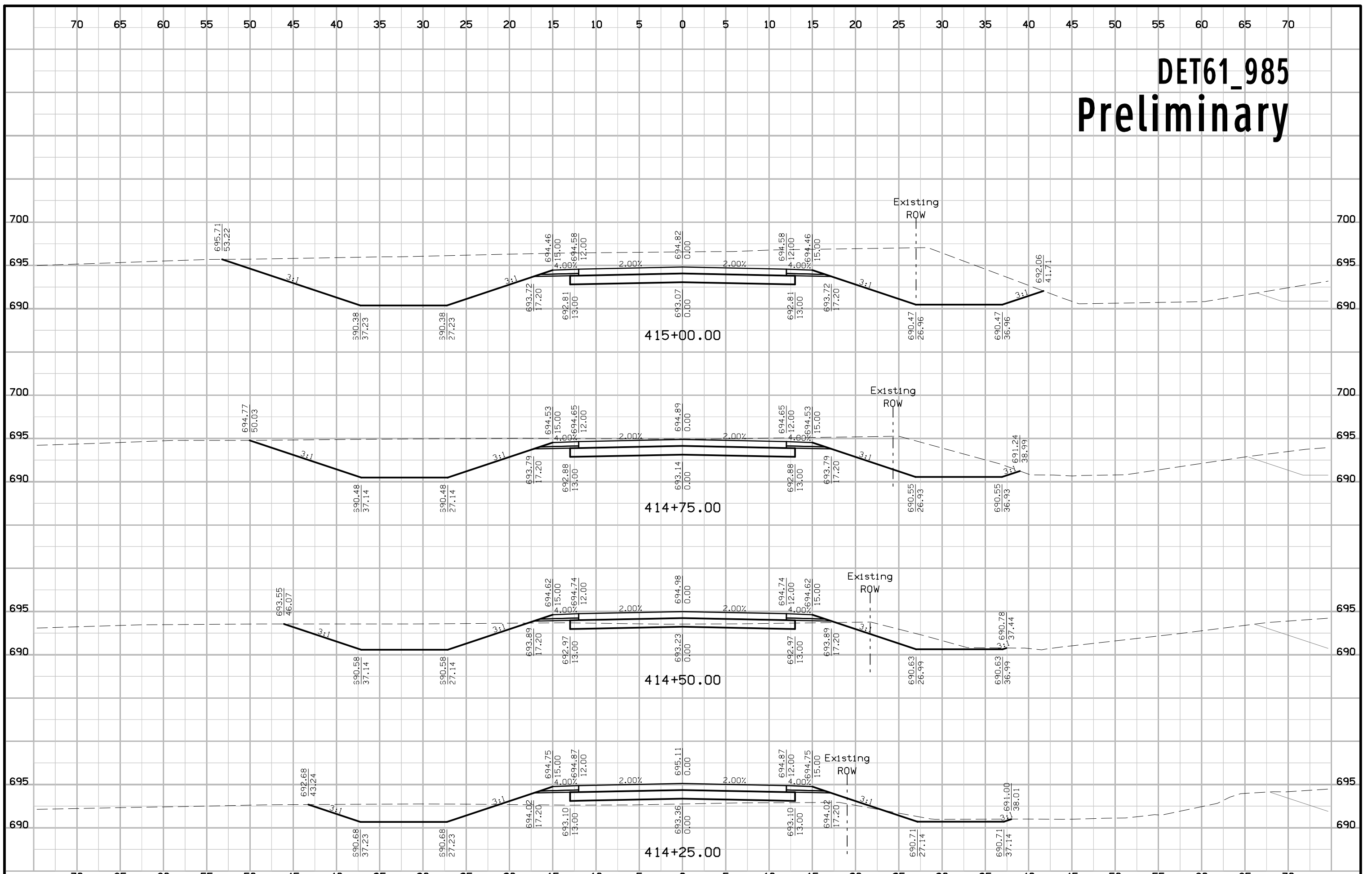

DET61_985 Preliminary

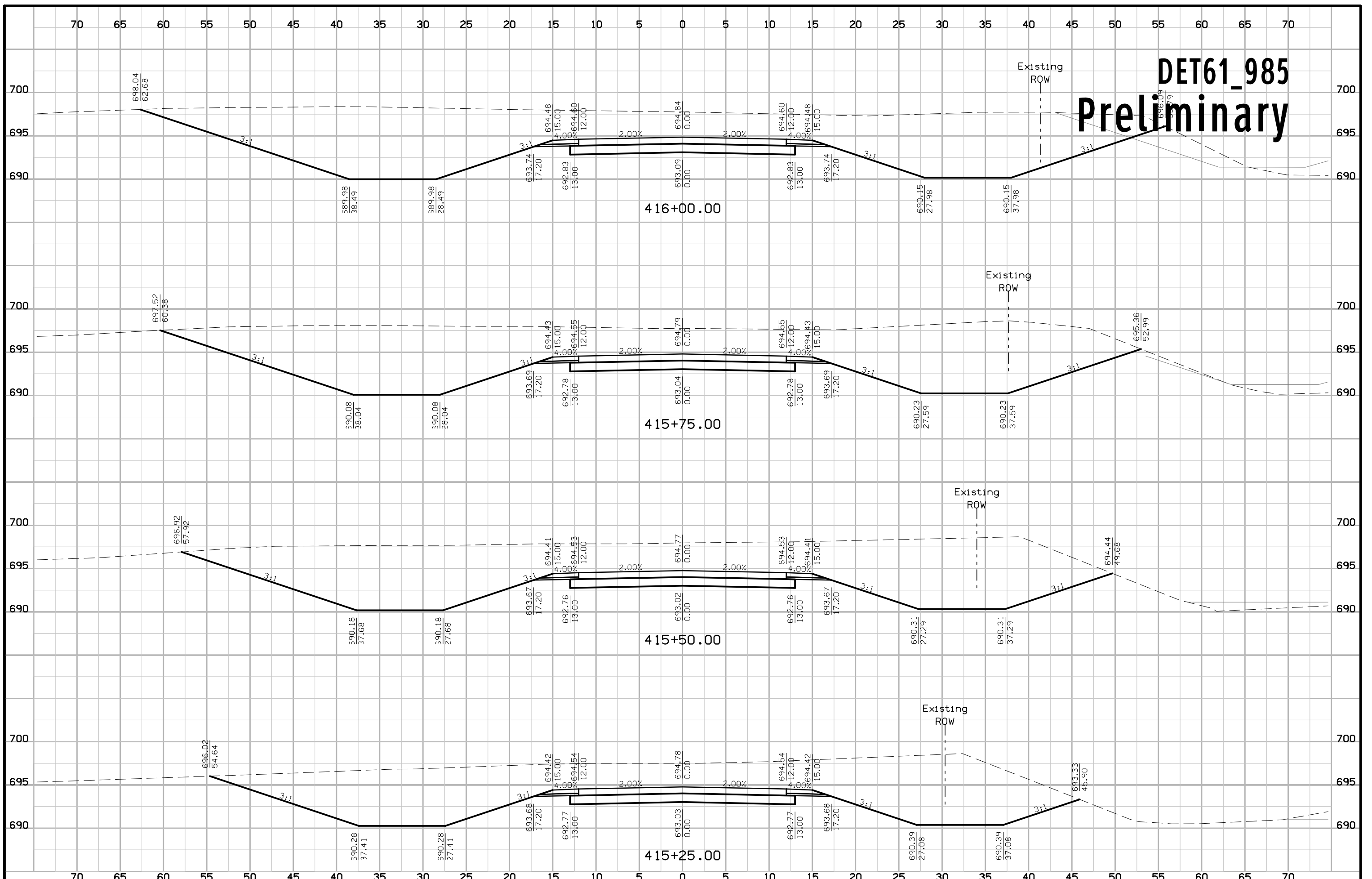

DET61_985 Preliminary

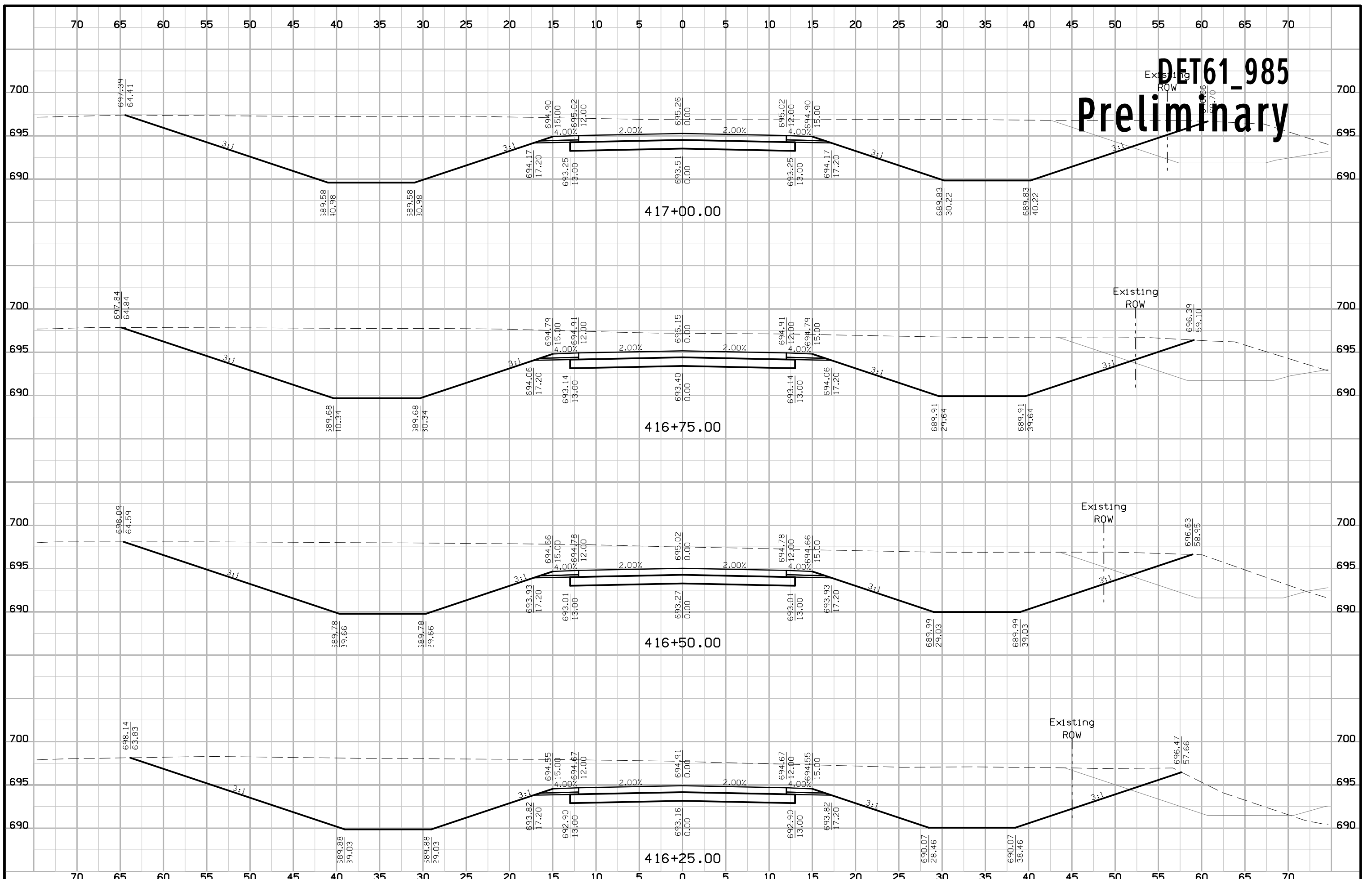

DET61_985 Preliminary

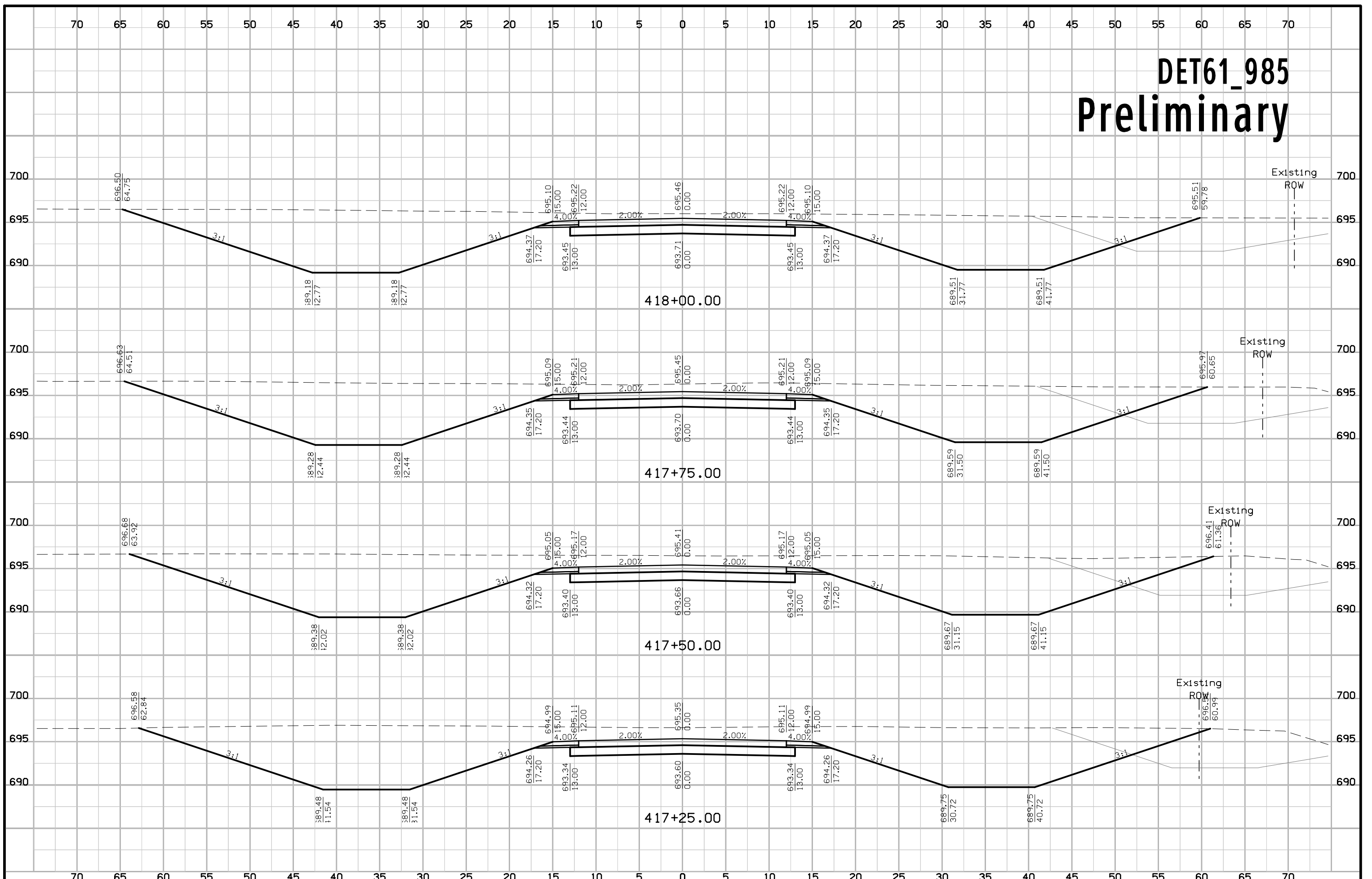

DET61_985 Preliminary

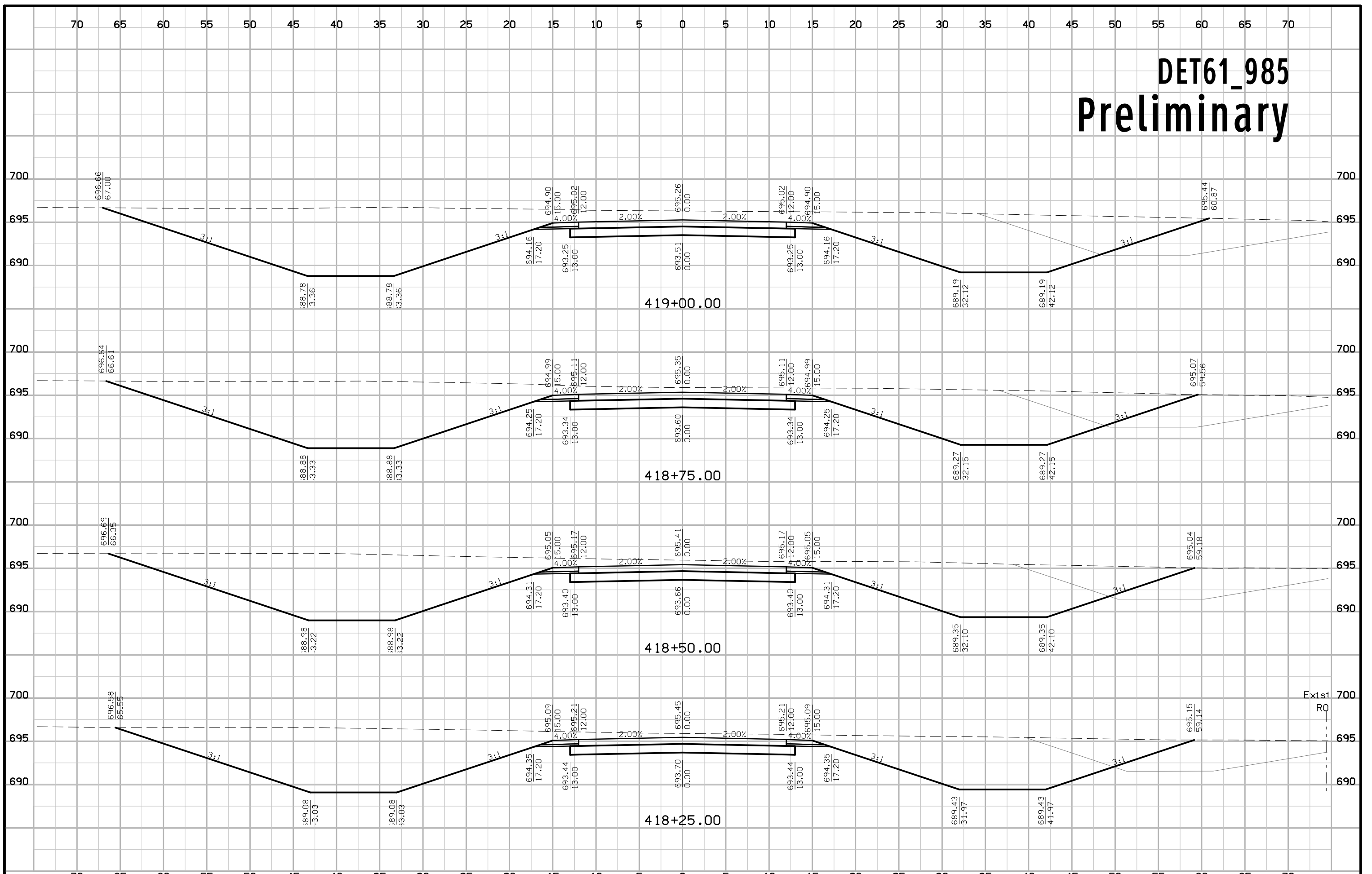

DET61_985 Preliminary

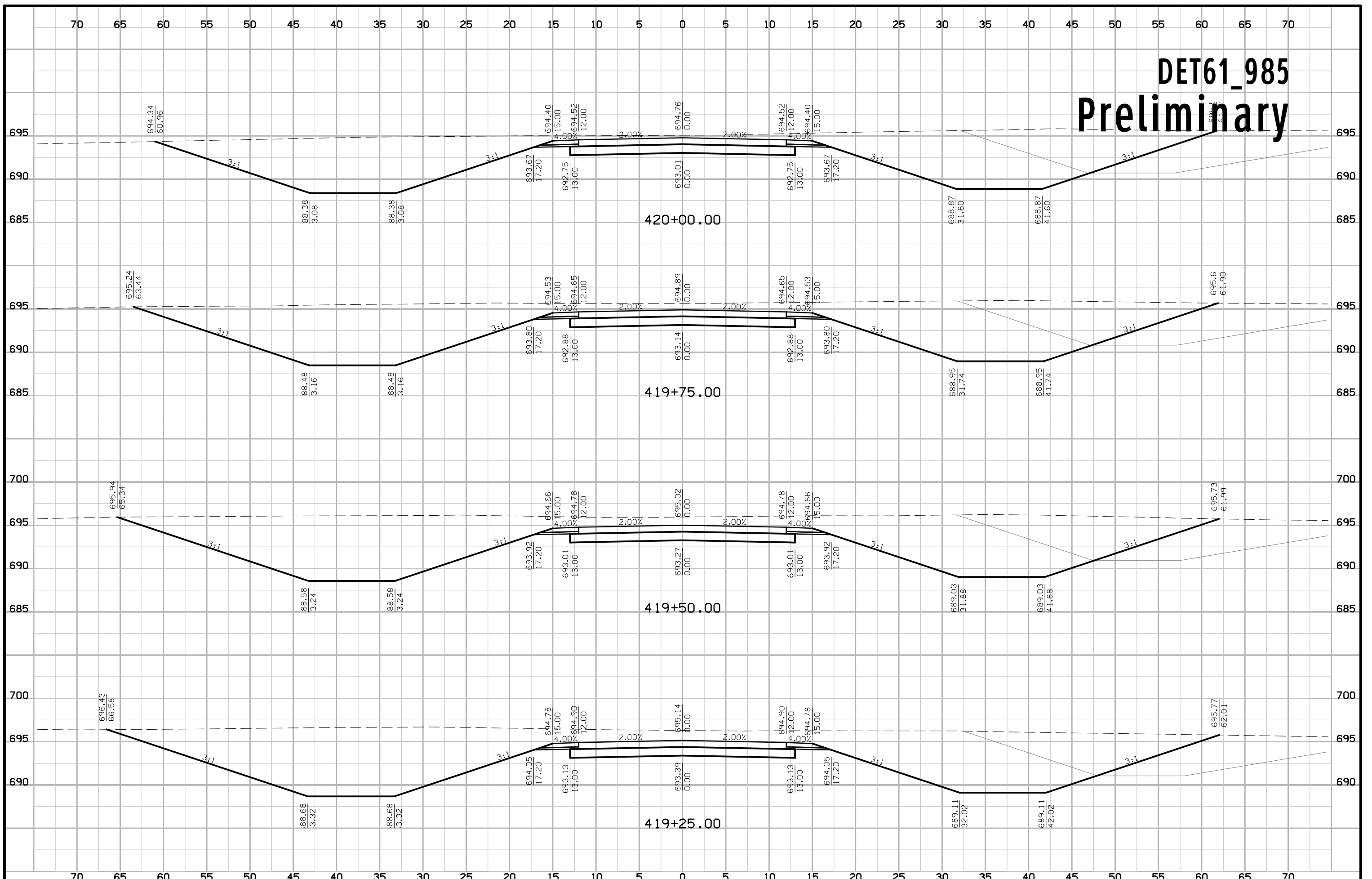

DET61_985 Preliminary

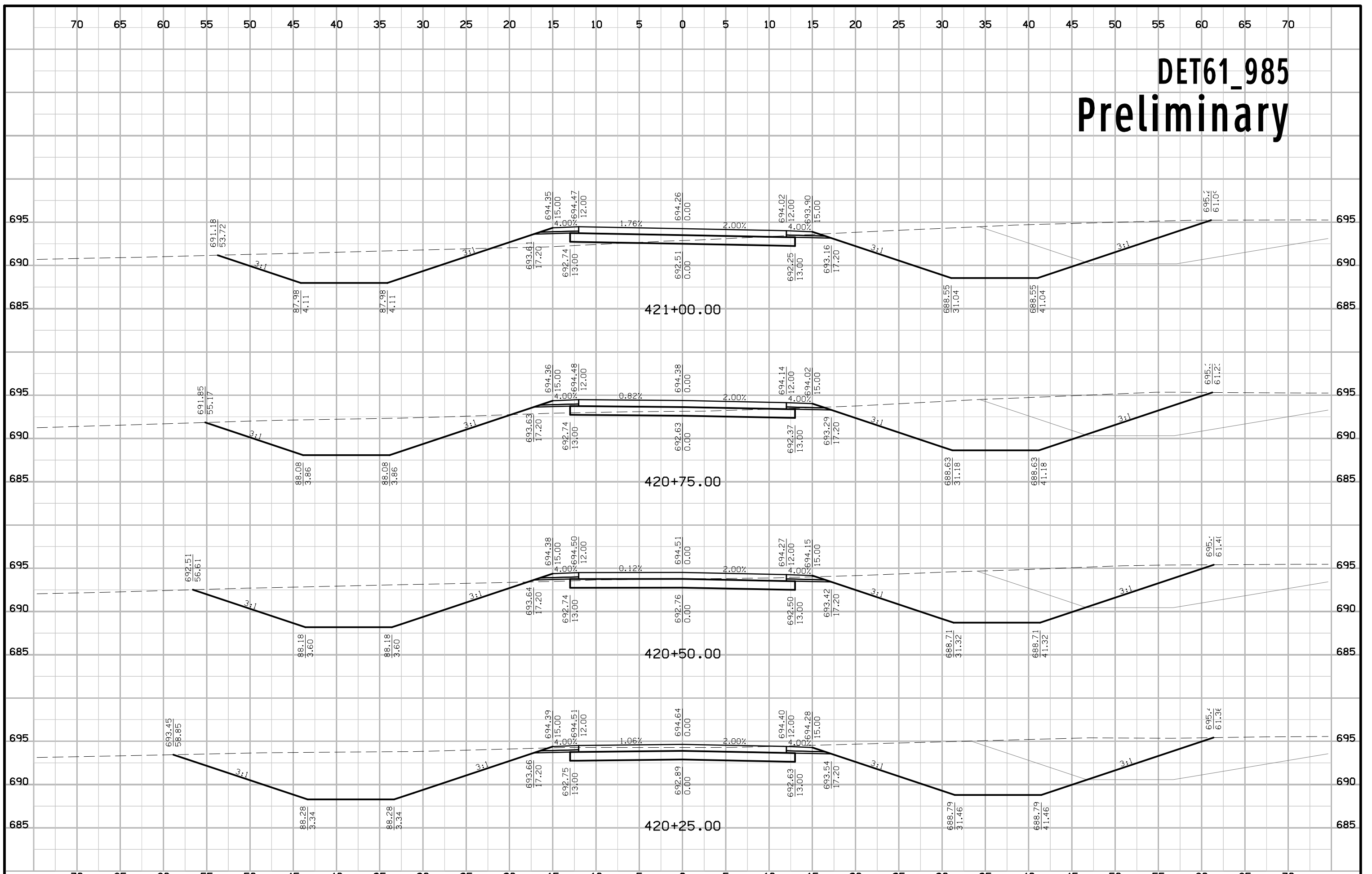

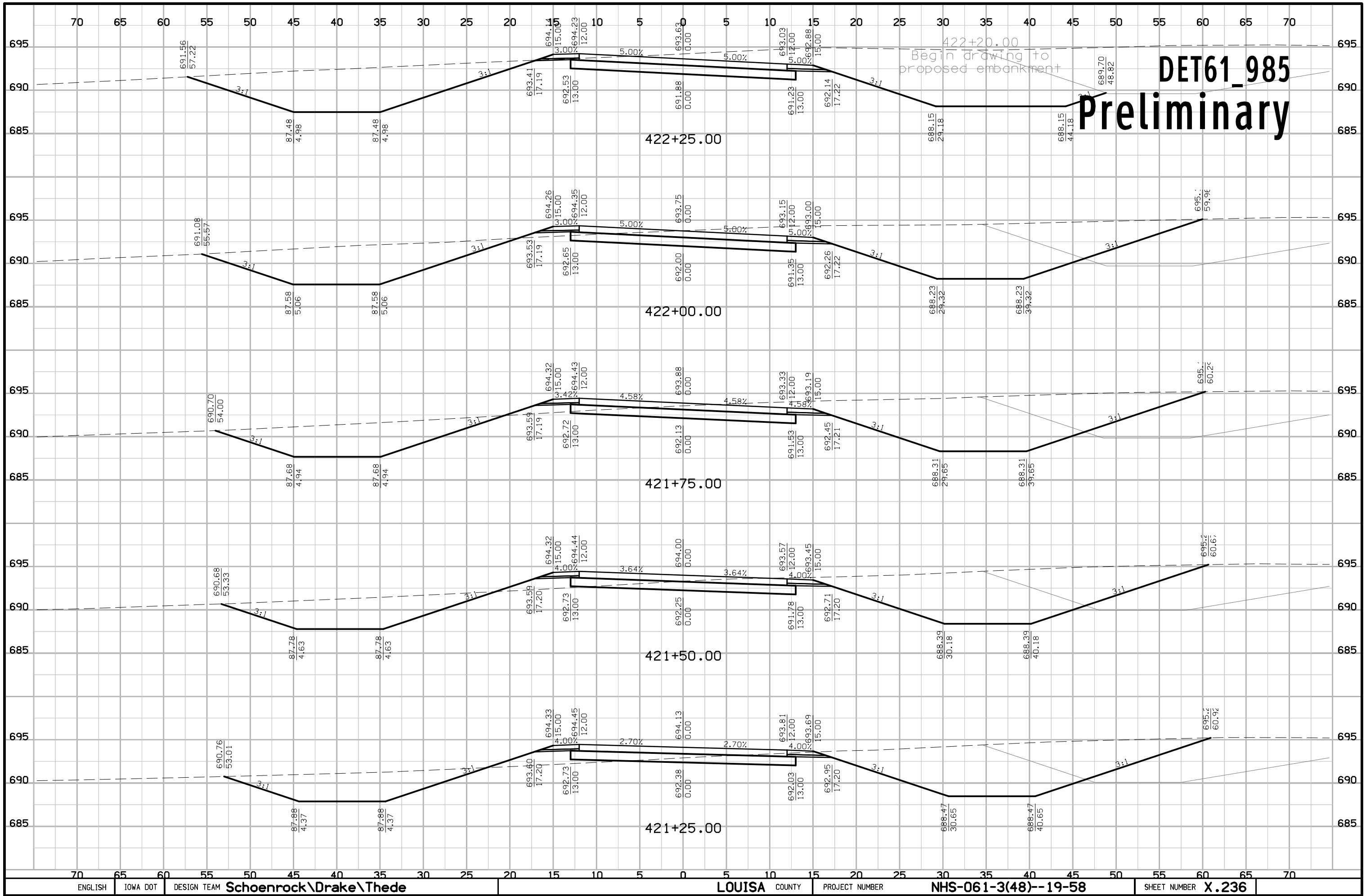

DET61_985 Preliminary

DET61_985 Preliminary

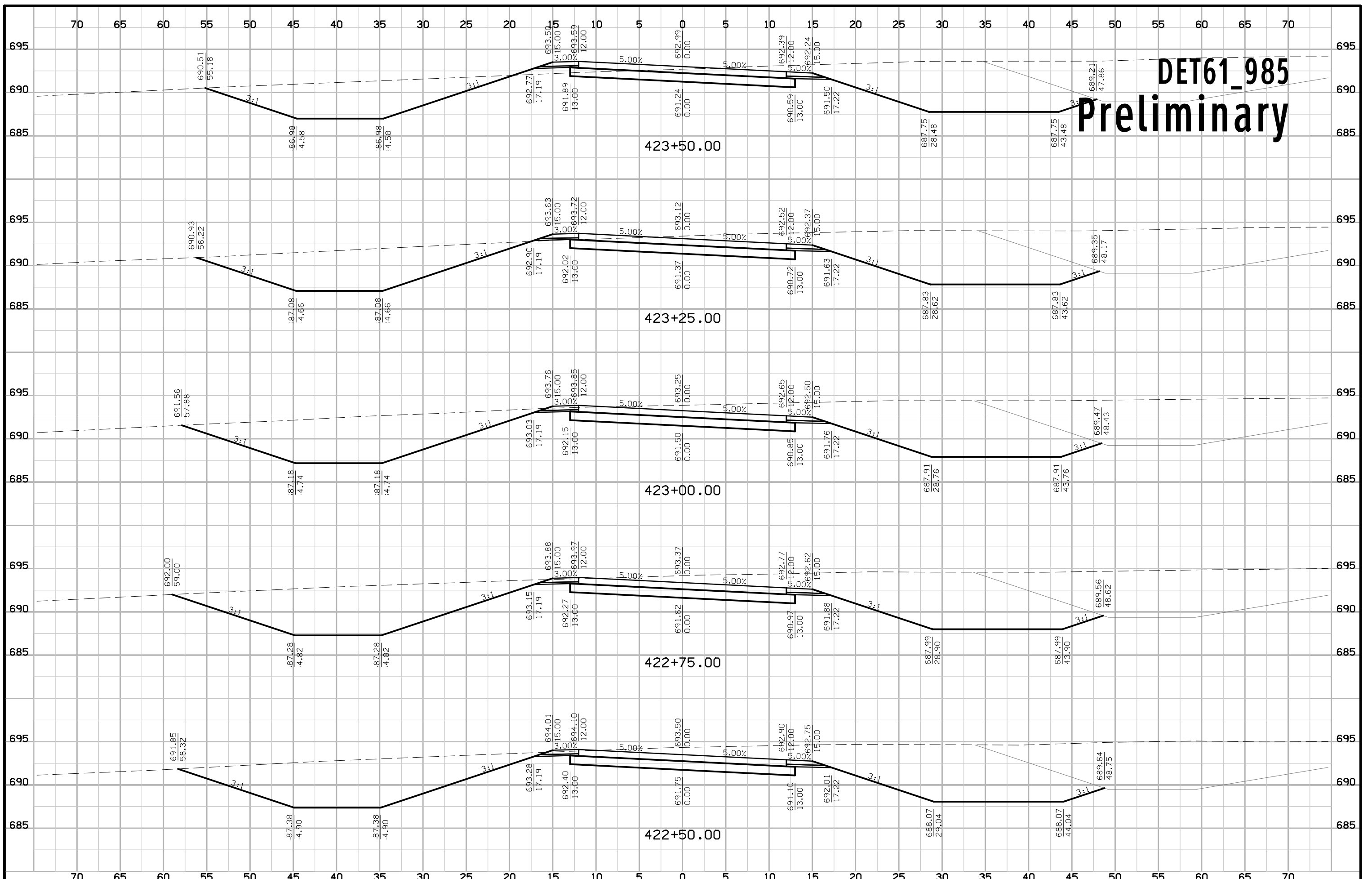

DET61_985 Preliminary

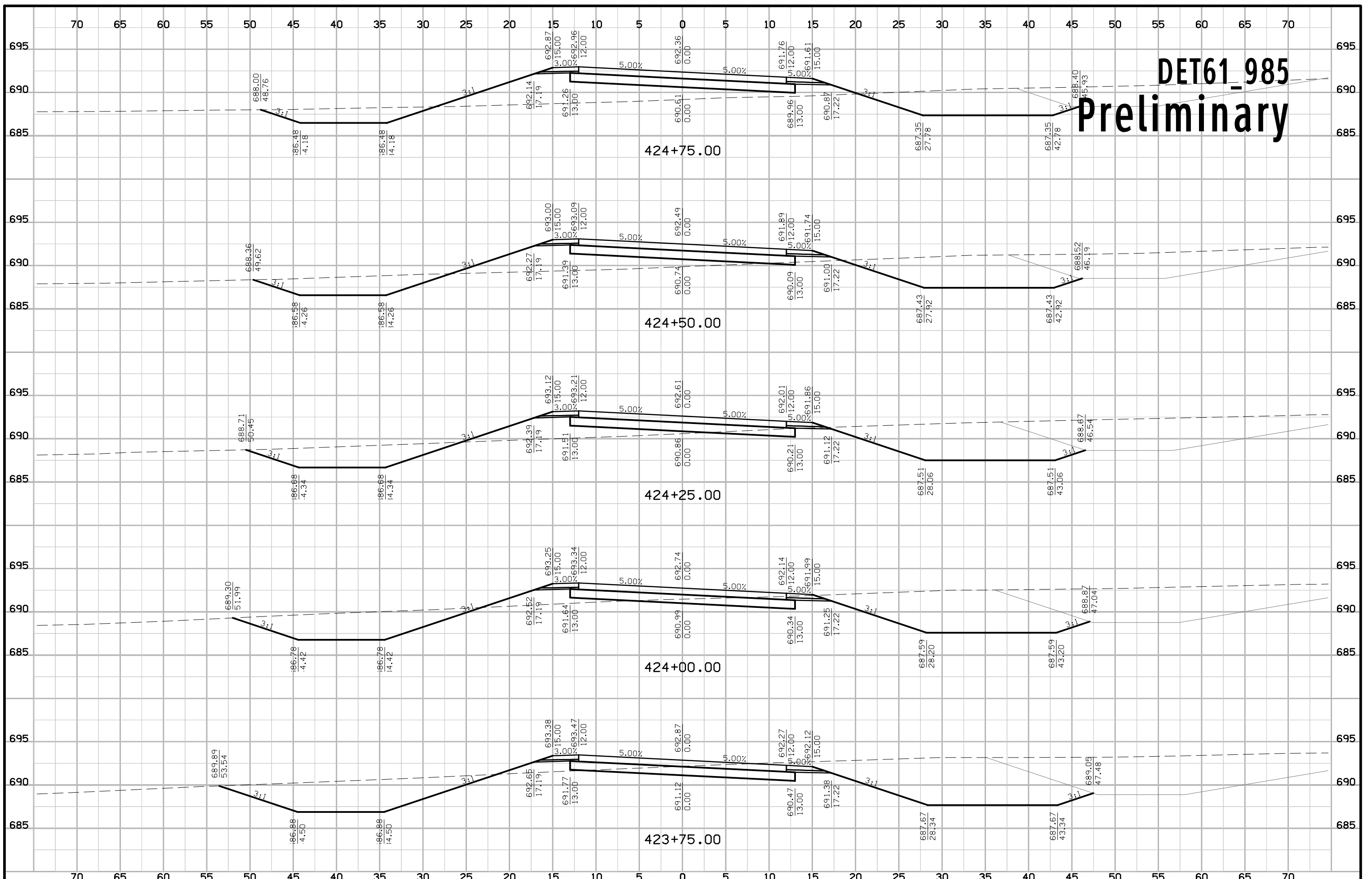

DET61_985 Preliminary

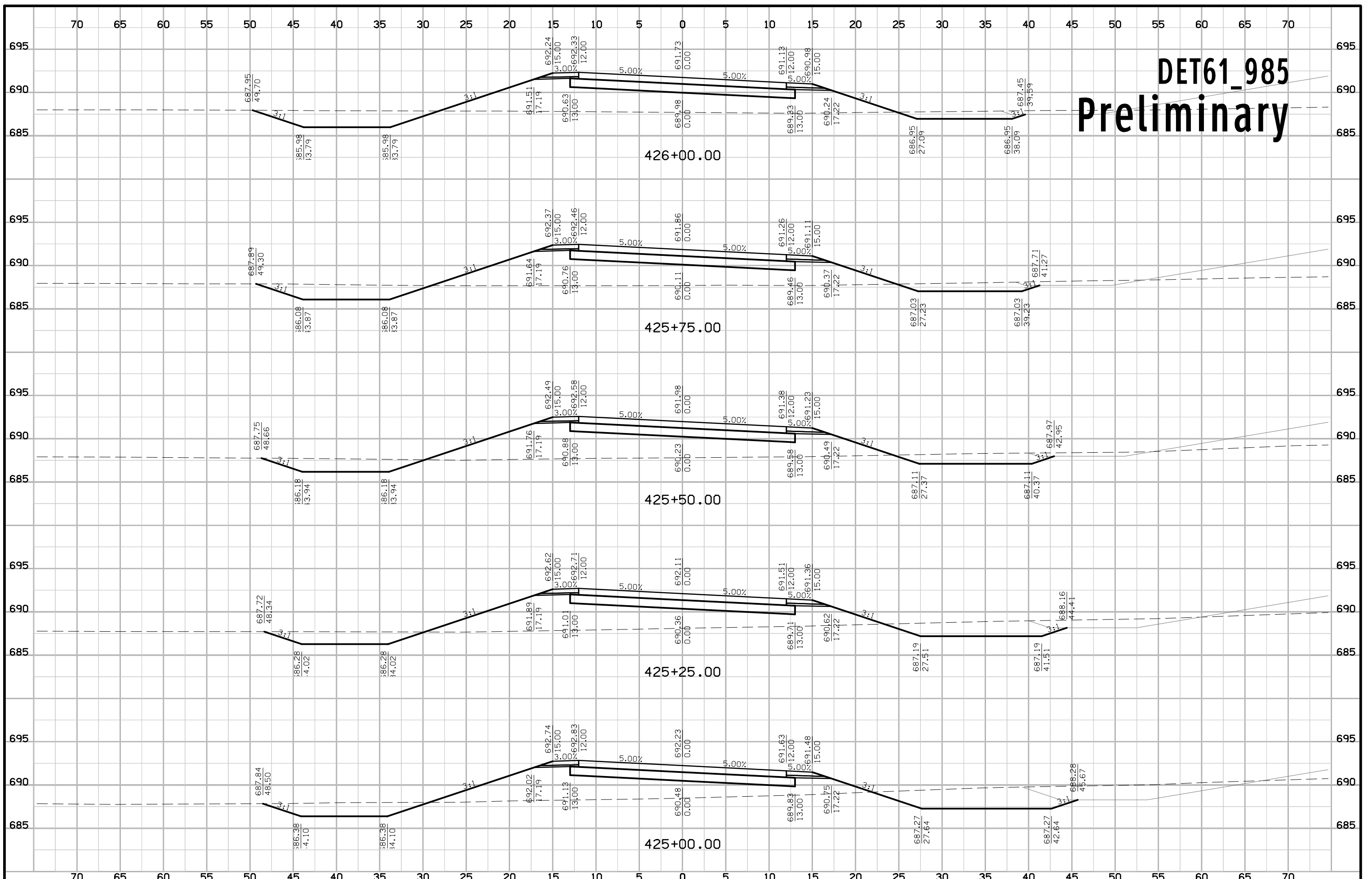

DET61_985 Preliminary

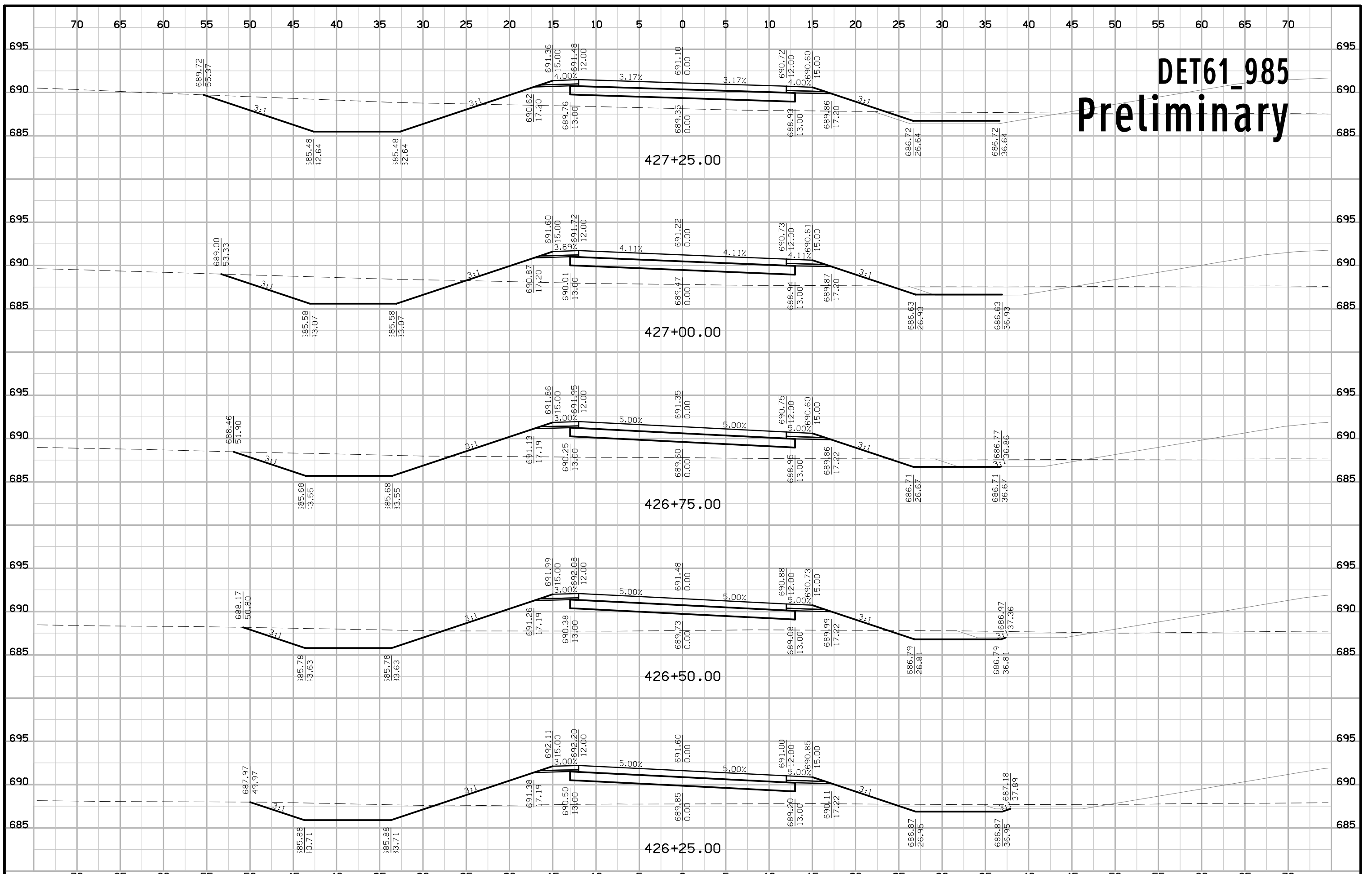

DET61_985 Preliminary

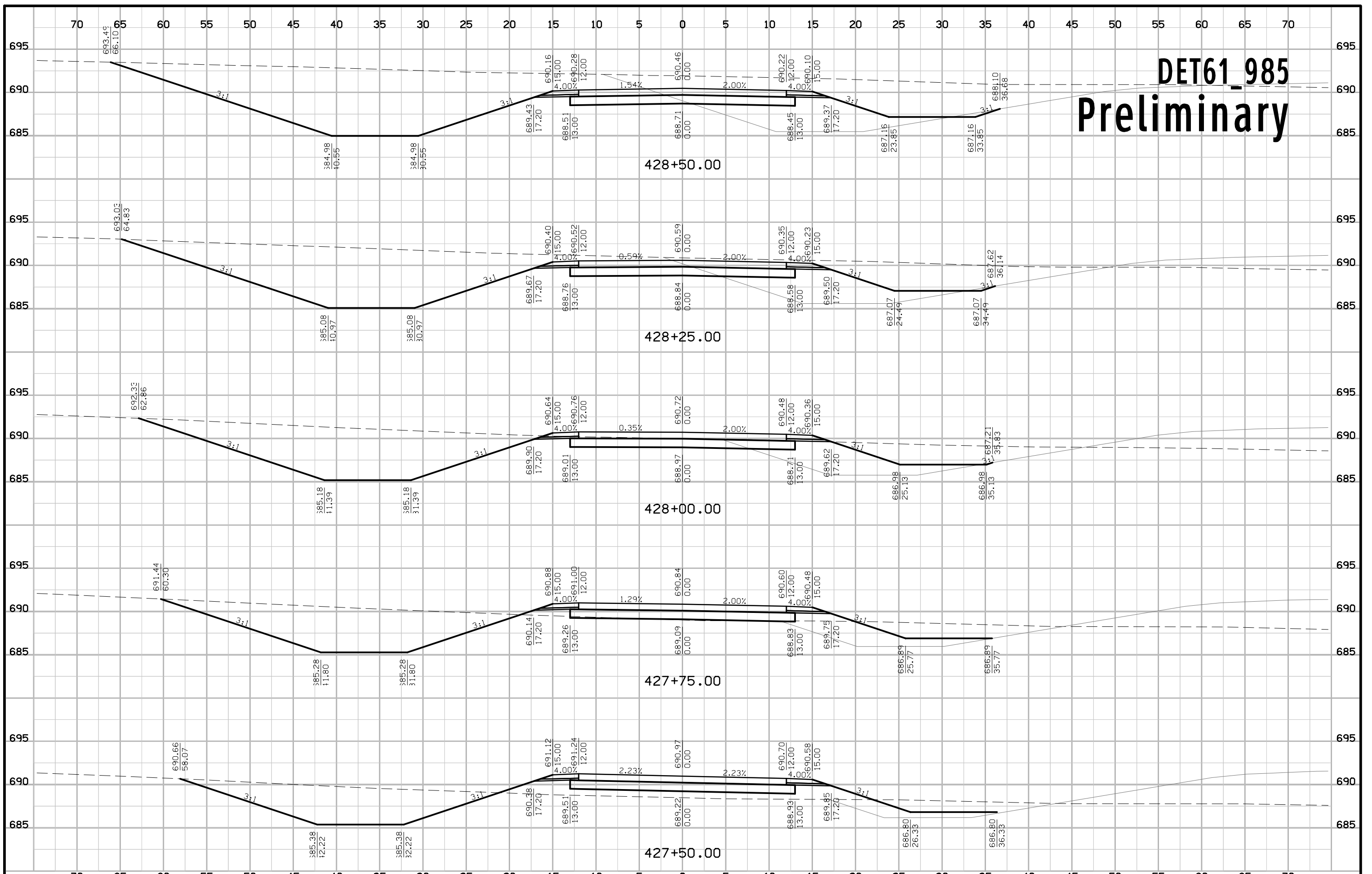

DET61_985 Preliminary

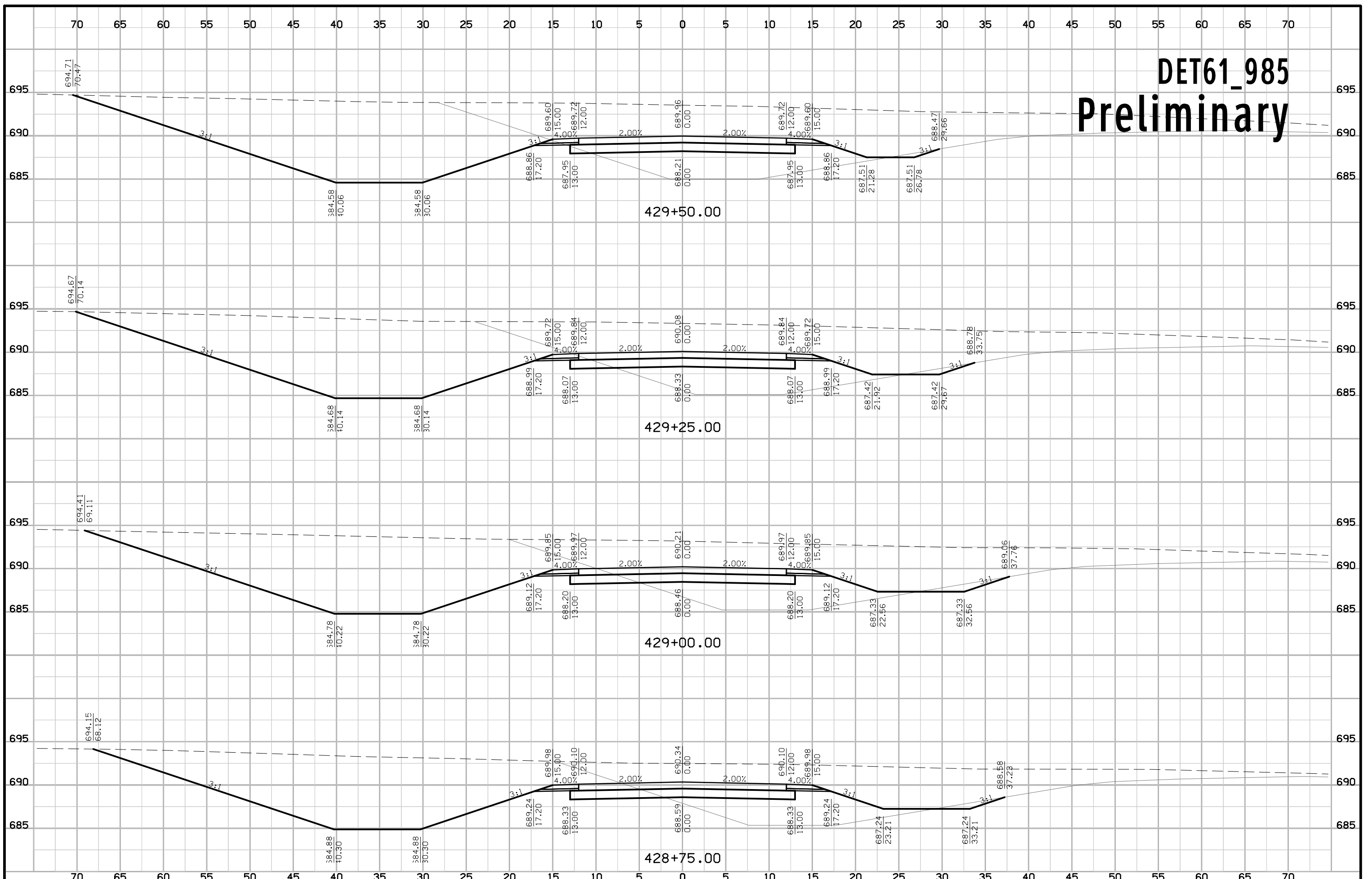

DET61_985 Preliminary

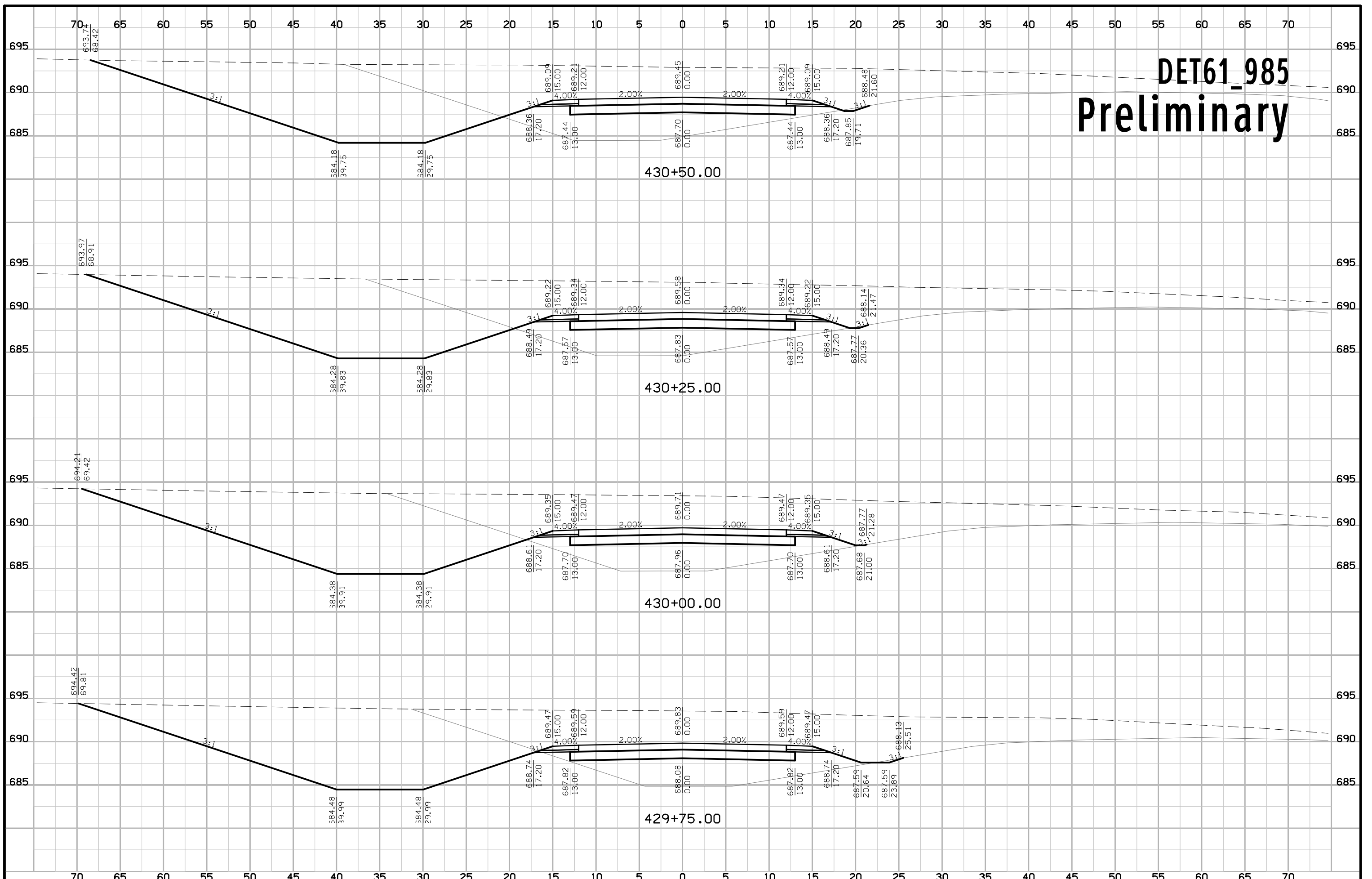

DET61_985 Preliminary

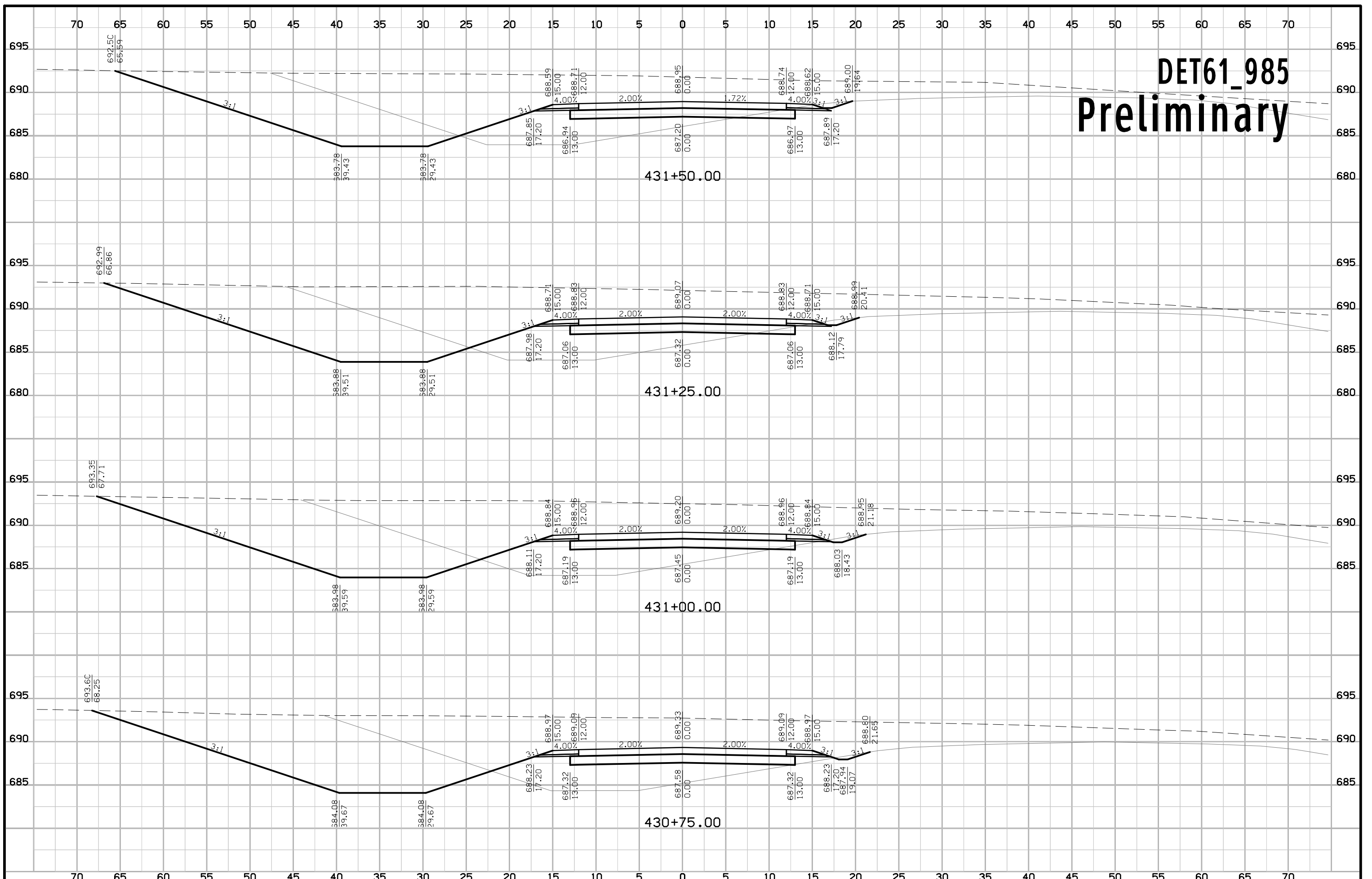

DET61_985 Preliminary

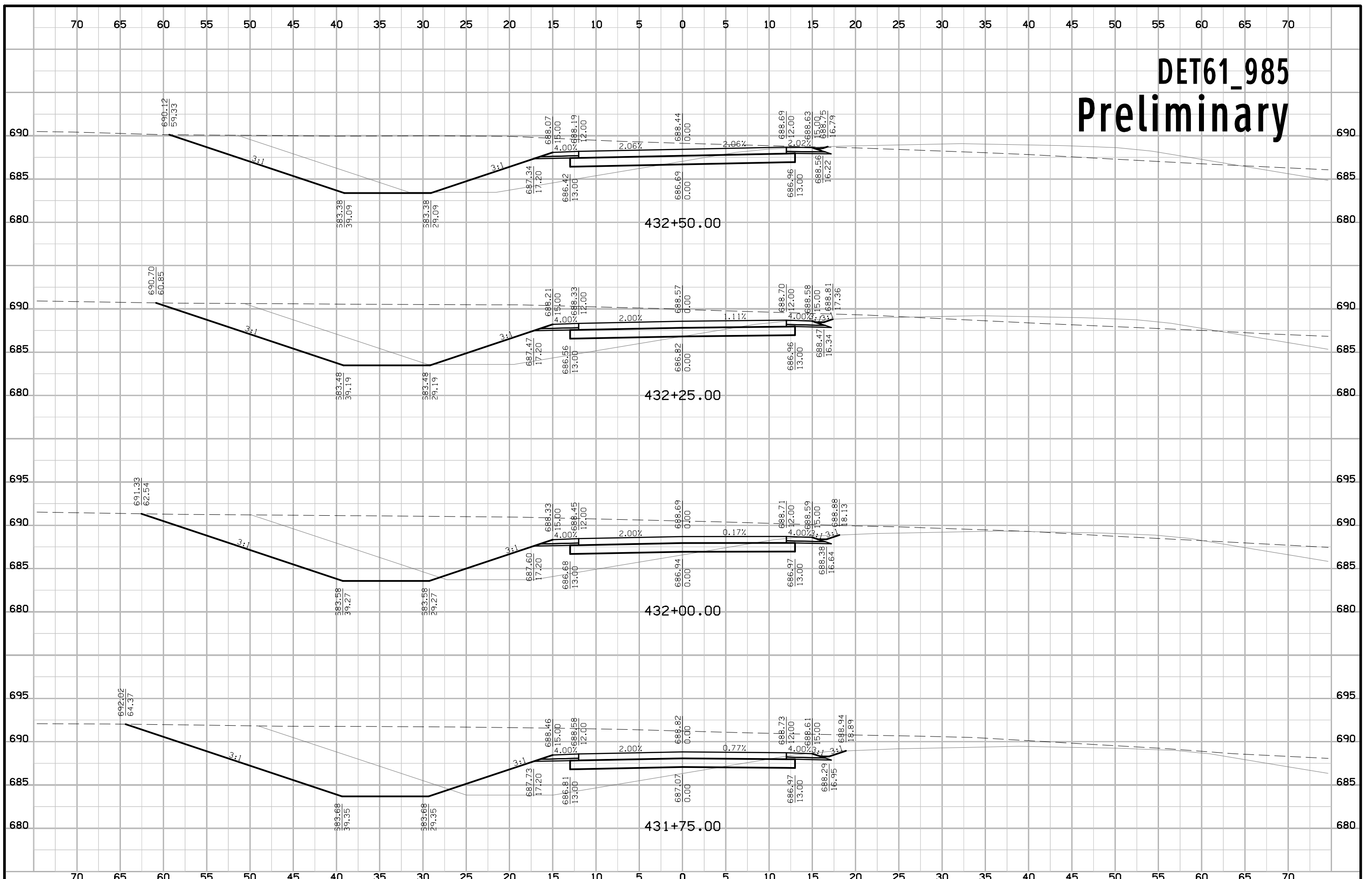

DET61_985 Preliminary

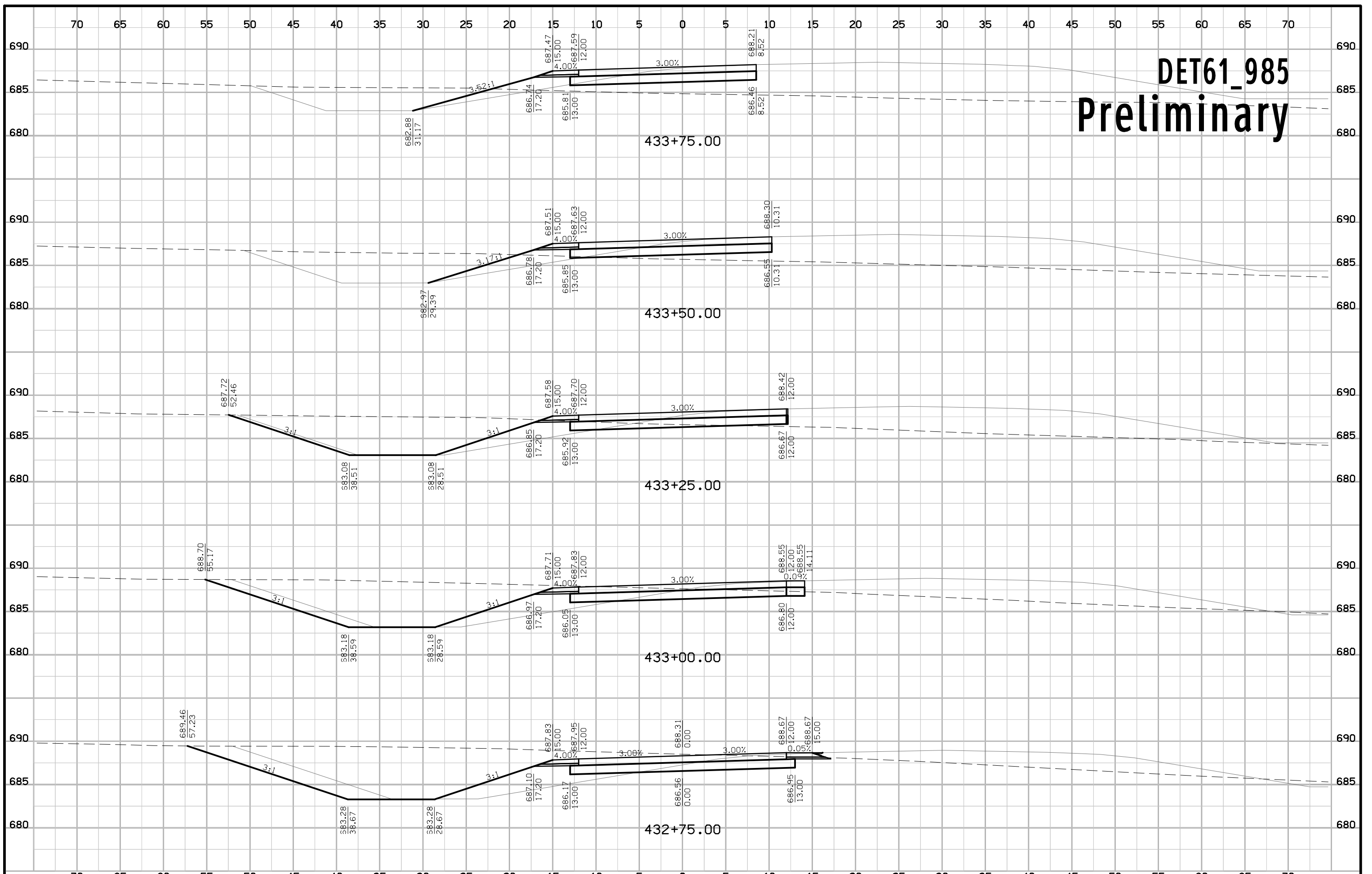

DET61_985 Preliminary

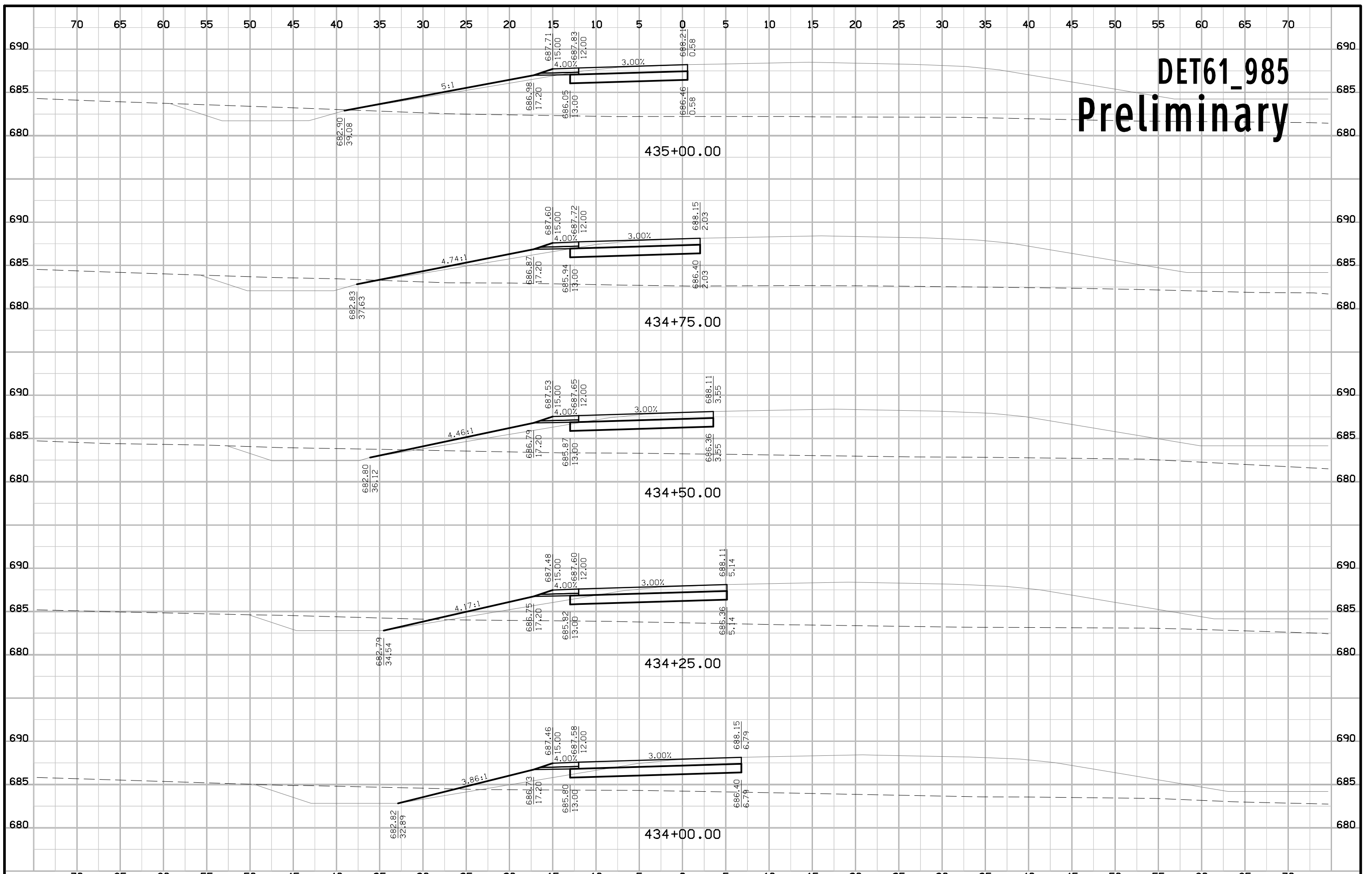

DET61_985 Preliminary

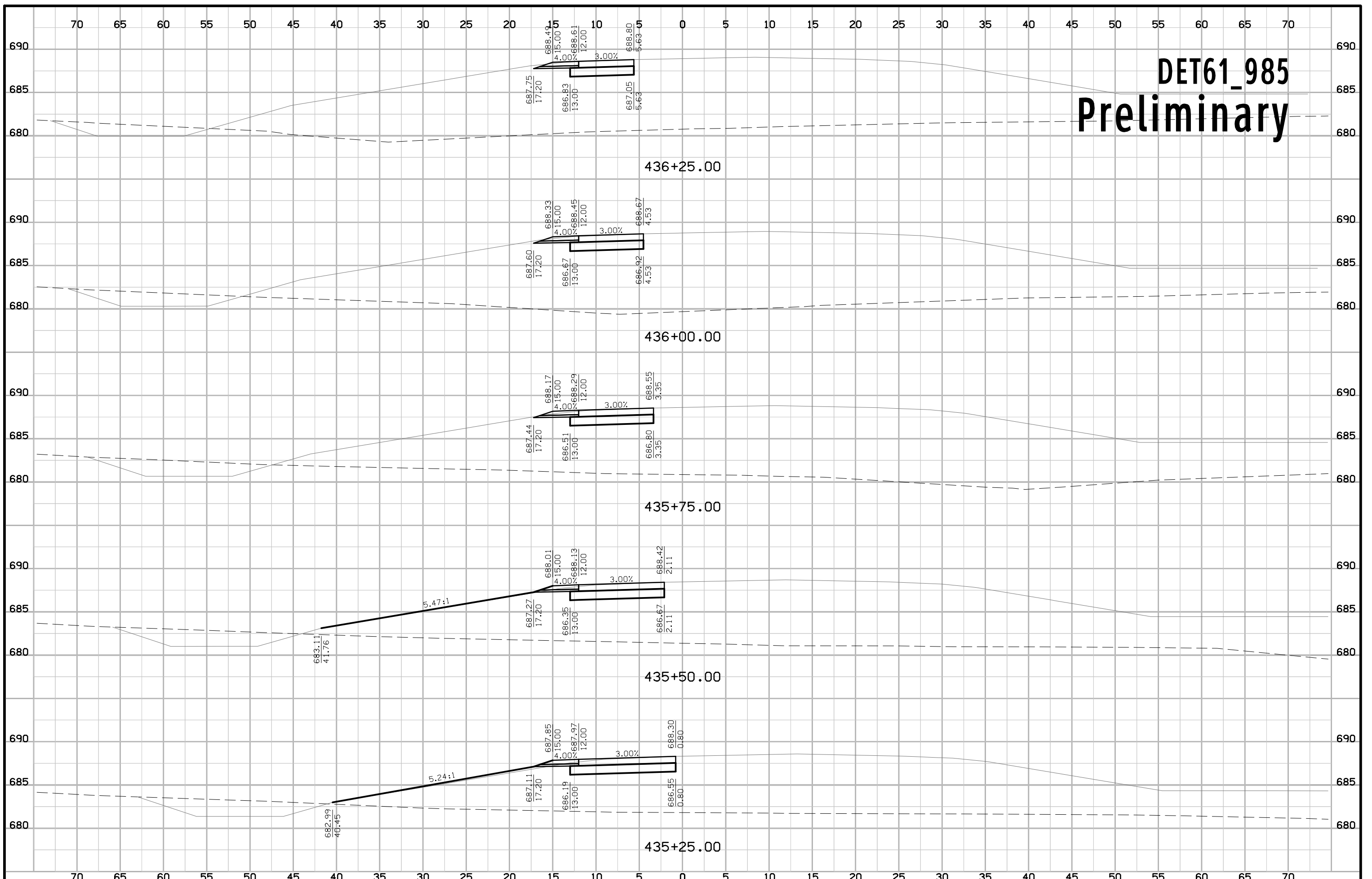

DET61_985 Preliminary

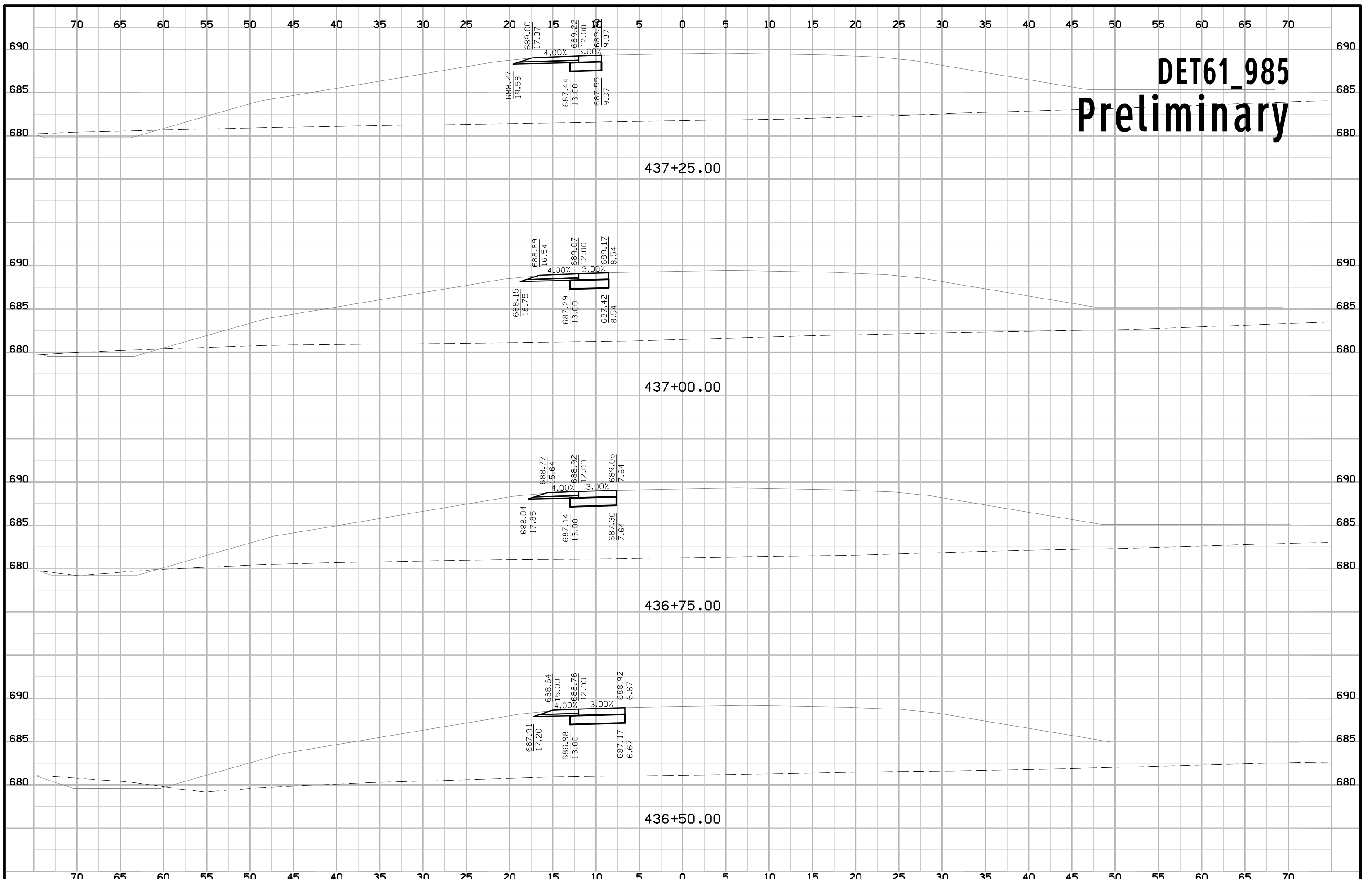

DET61_985 Preliminary

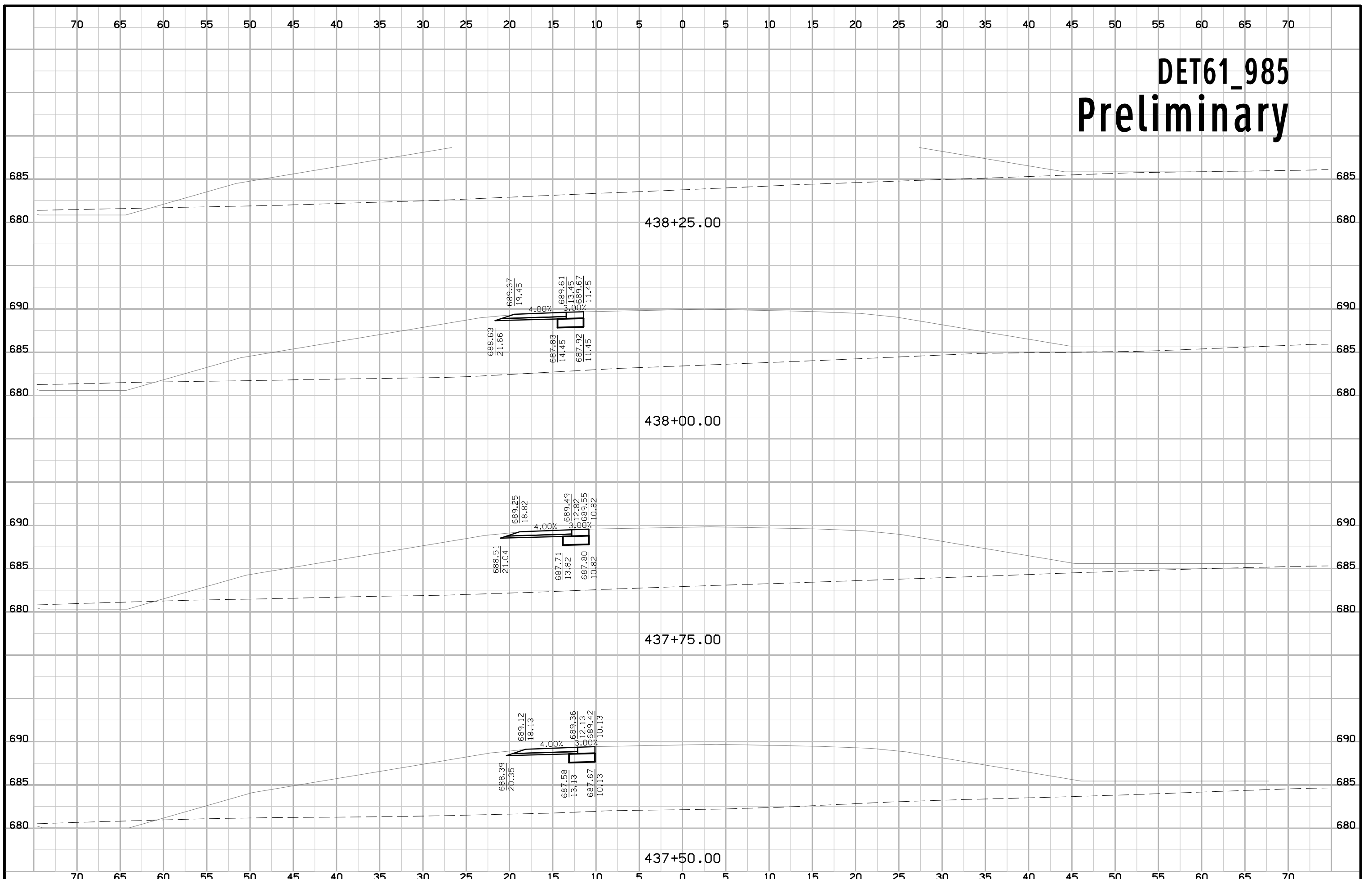

Detour IA 92 Preliminary

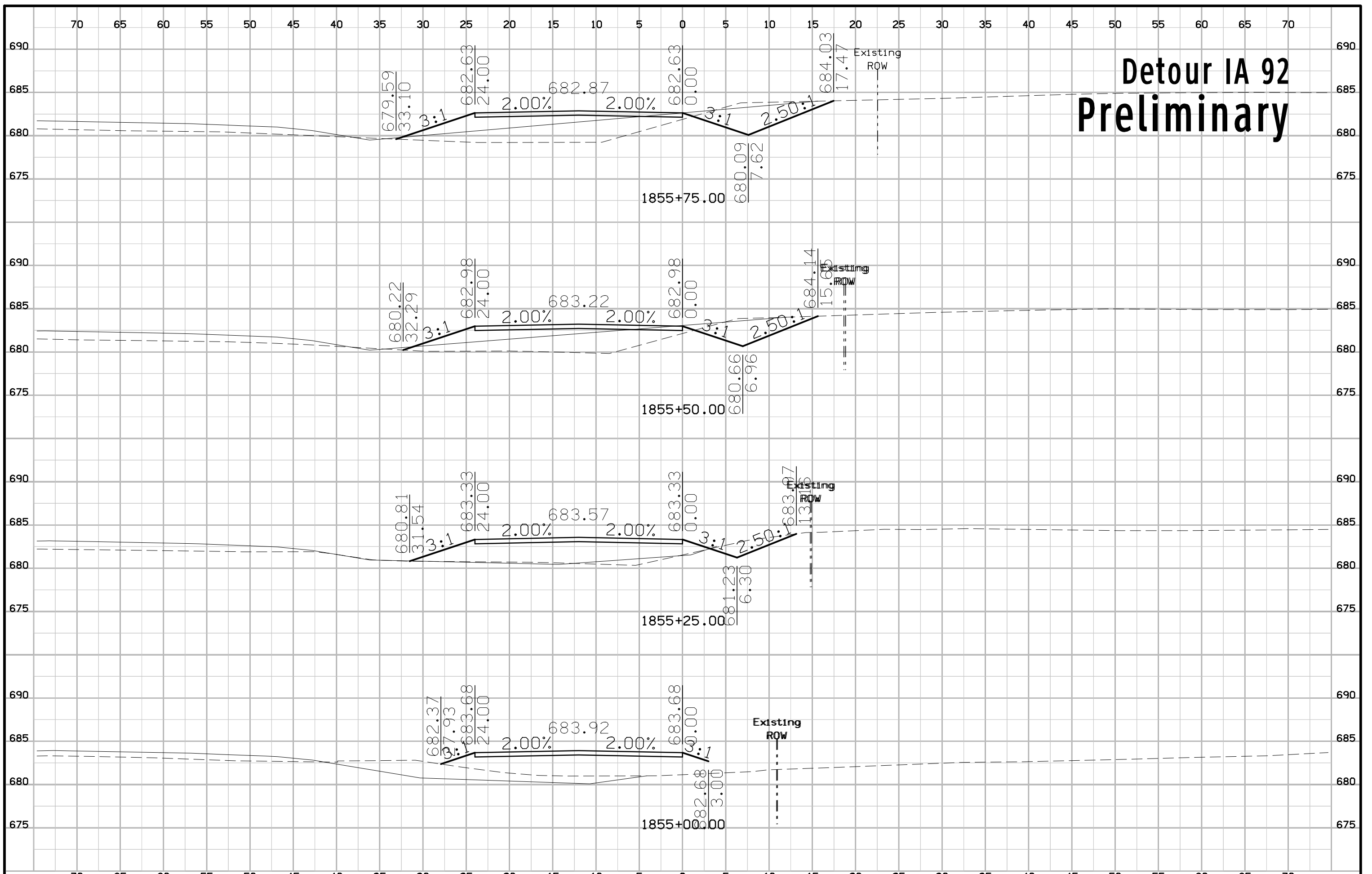

Detour IA 92 Preliminary

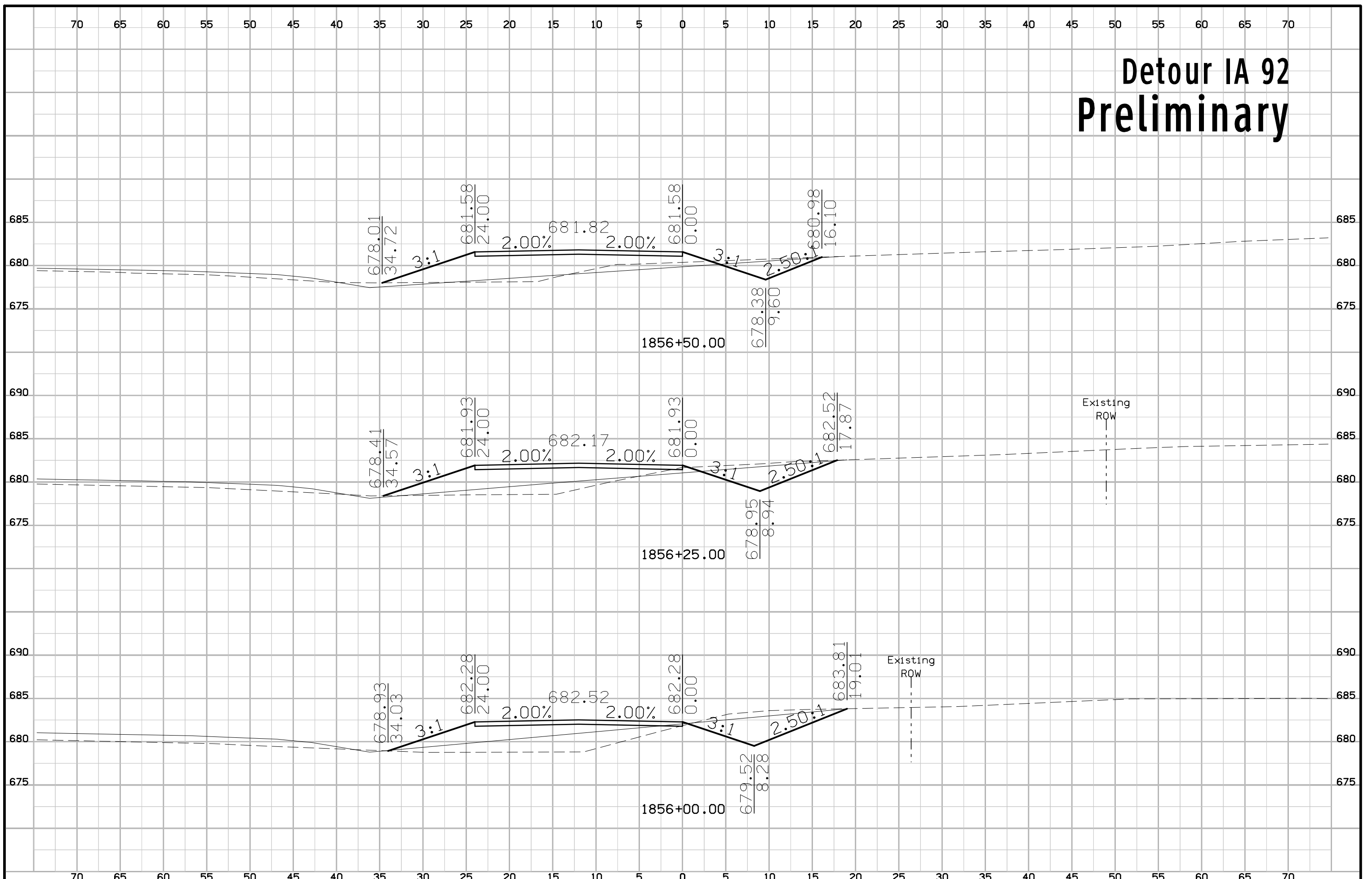

Detour IA 92 Preliminary

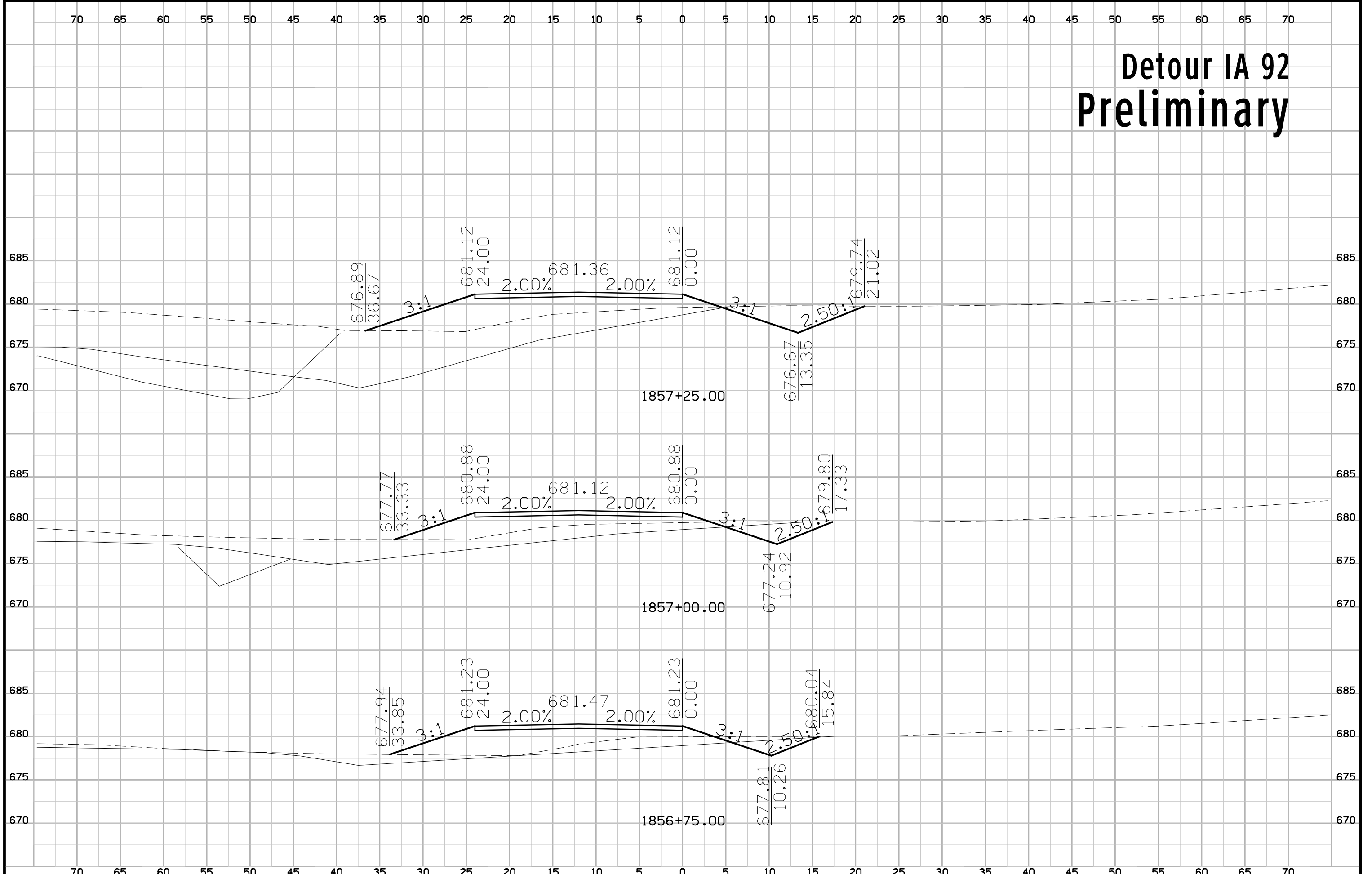

Detour IA 92 Preliminary

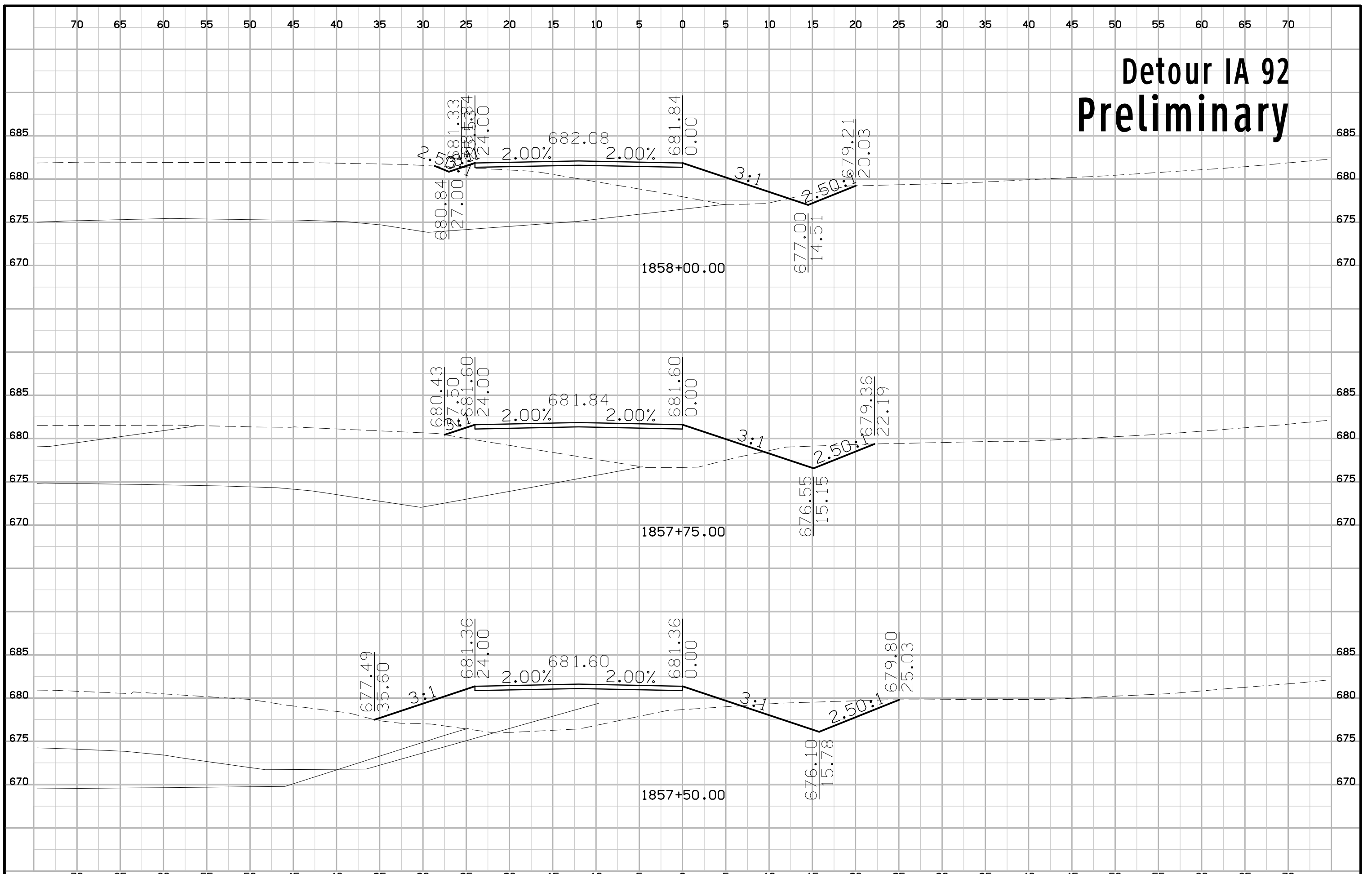

Detour IA 92 Preliminary

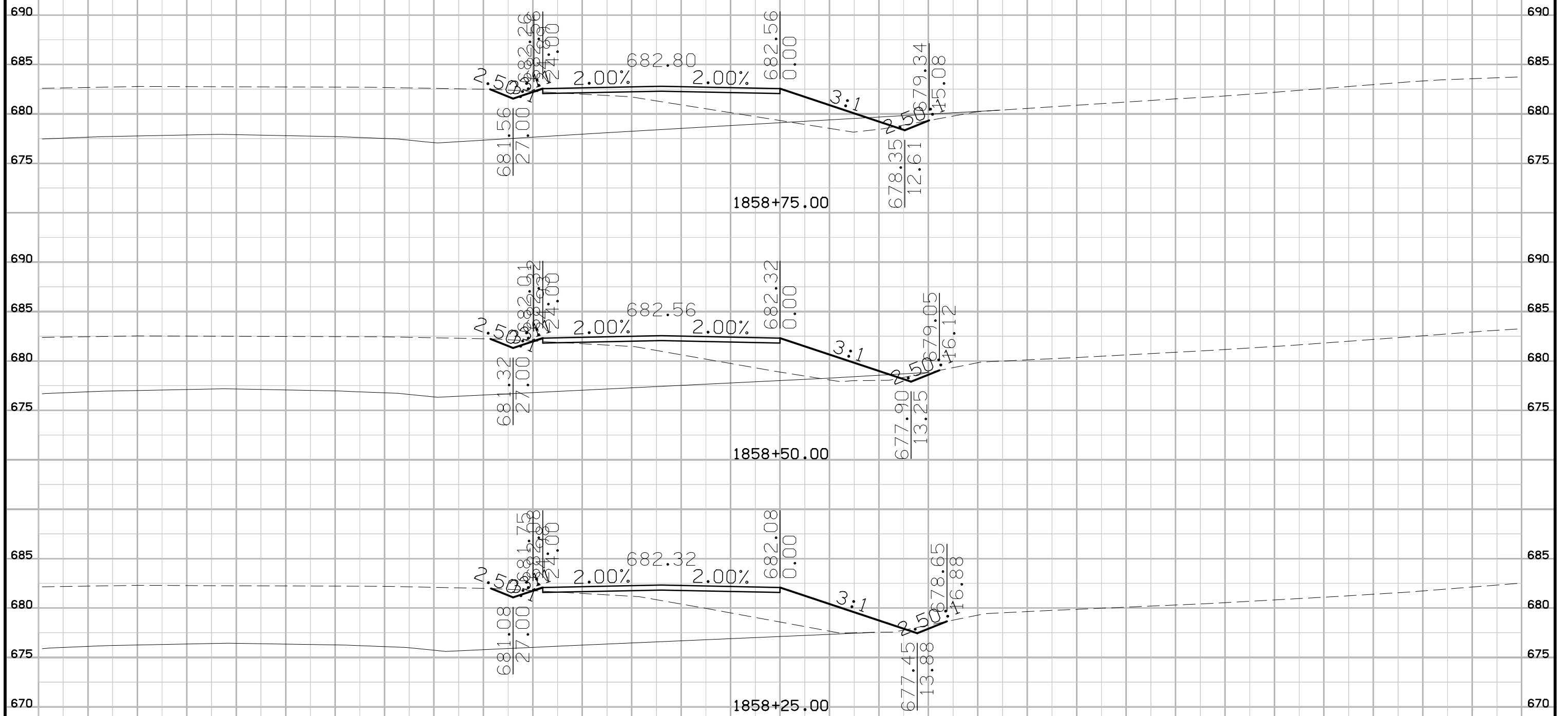

Detour IA 92 Preliminary

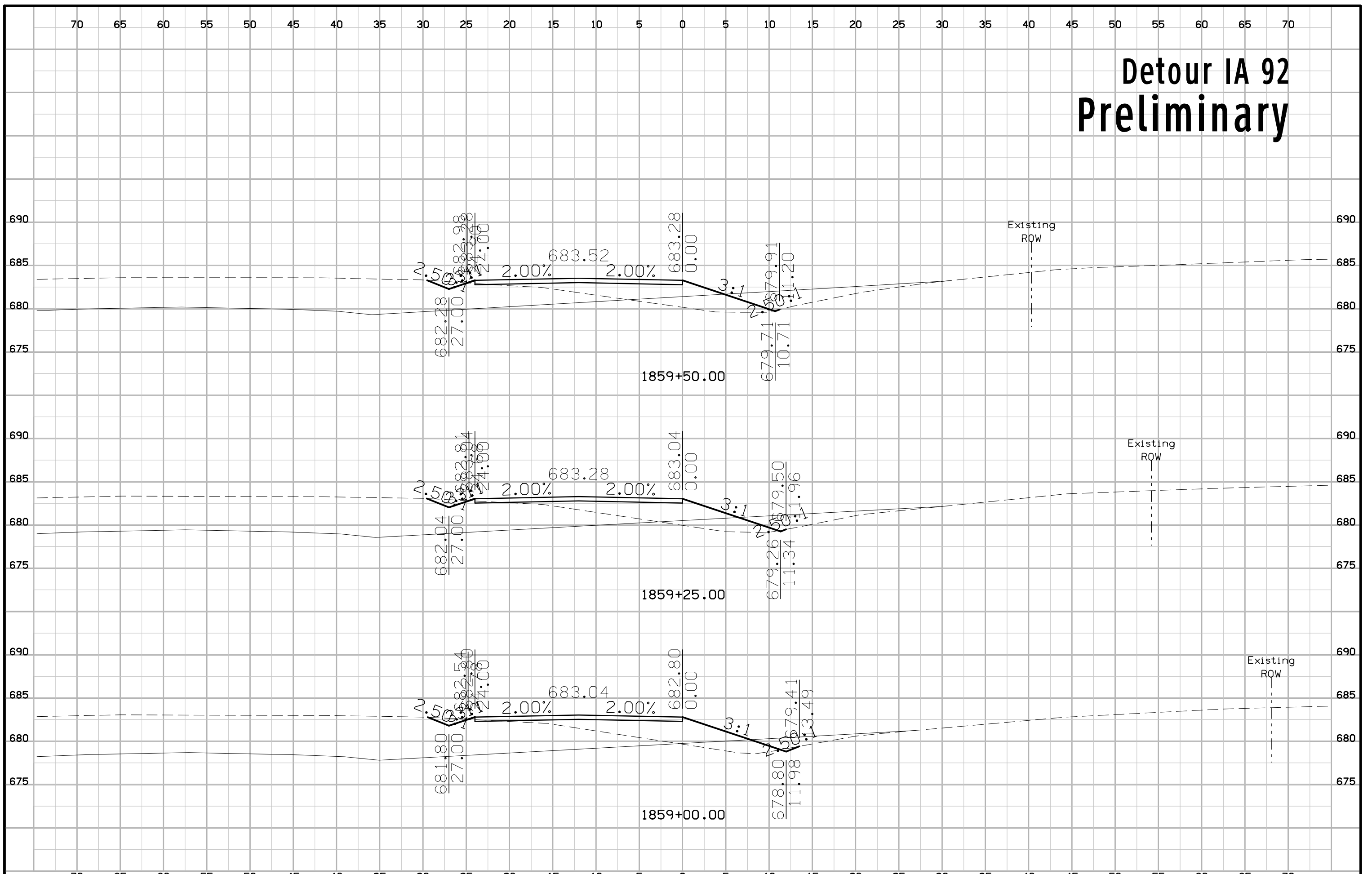

Detour IA 92 Preliminary

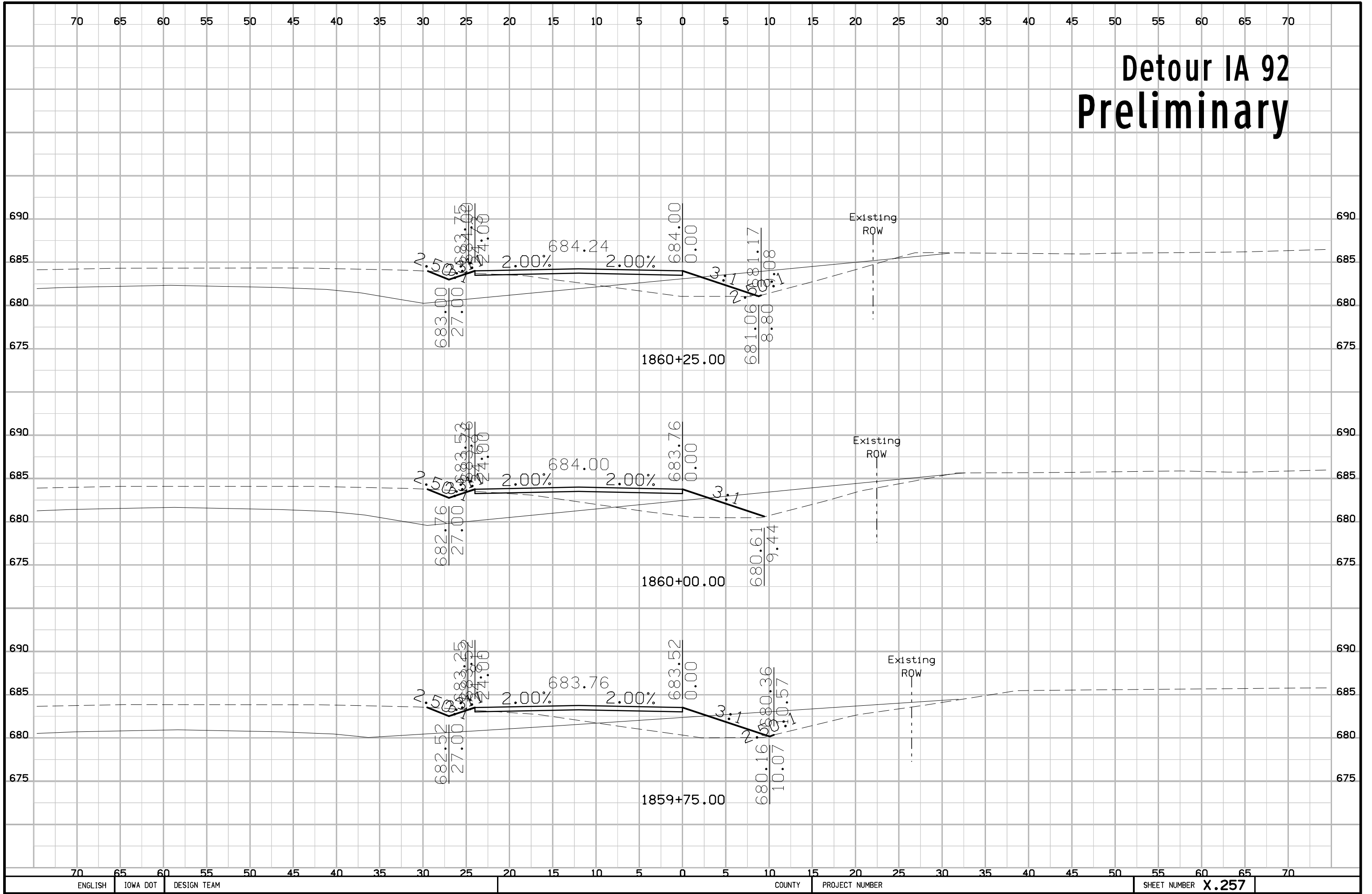

Detour IA 92 Preliminary

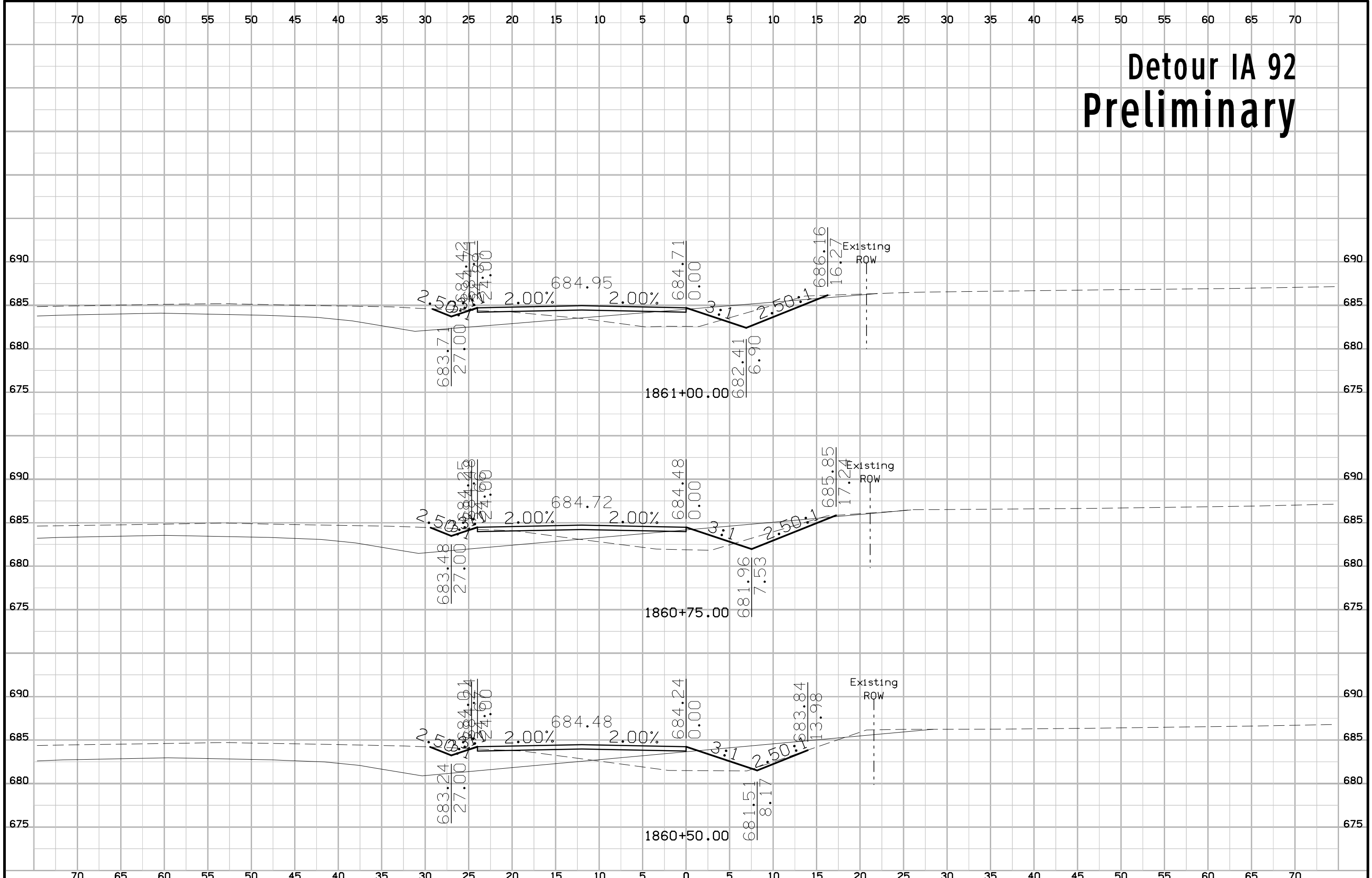

Detour IA 92 Preliminary

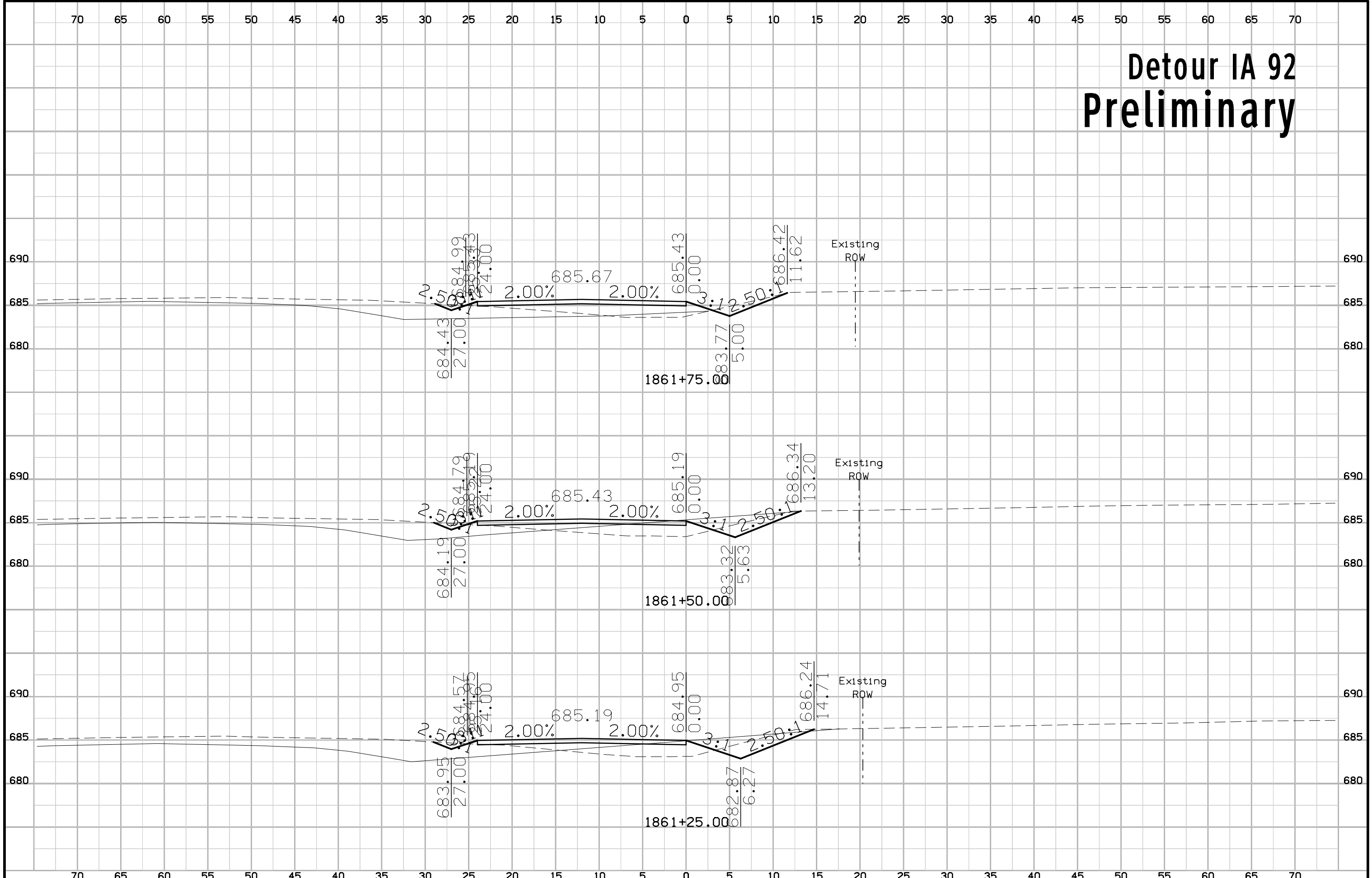

Detour IA 92 Preliminary

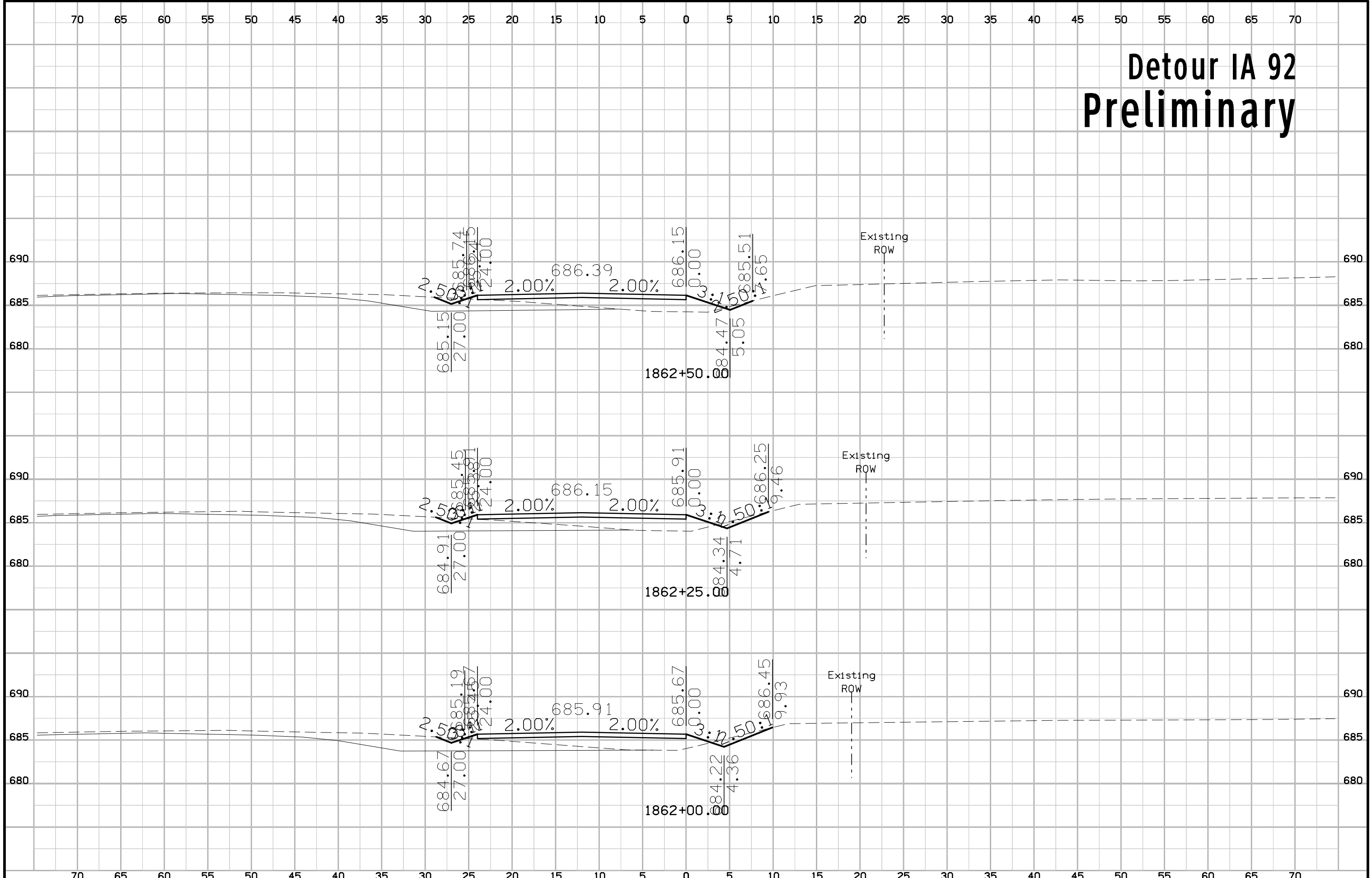

Detour IA 92 Preliminary

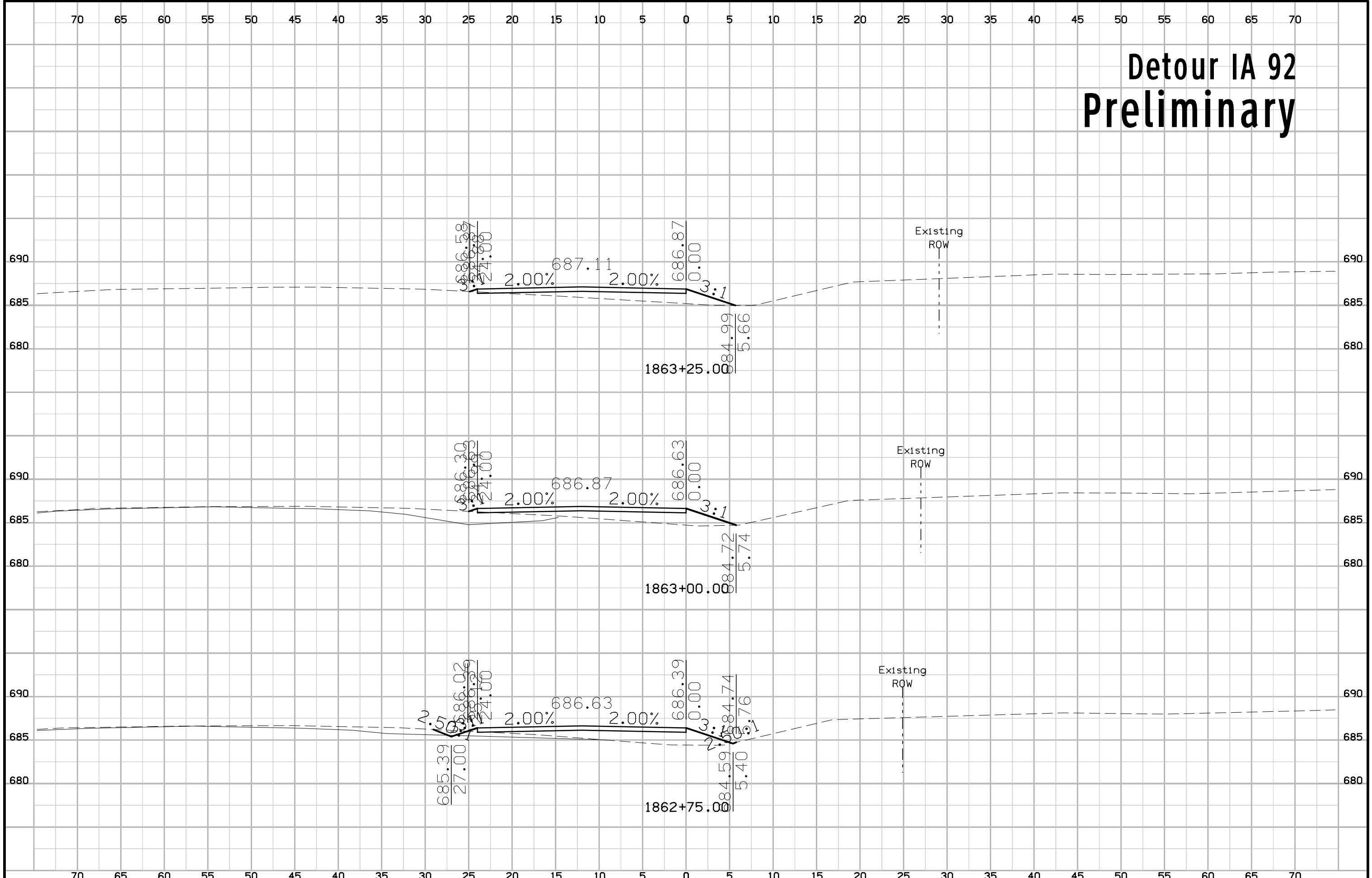

Detour IA 92 Preliminary

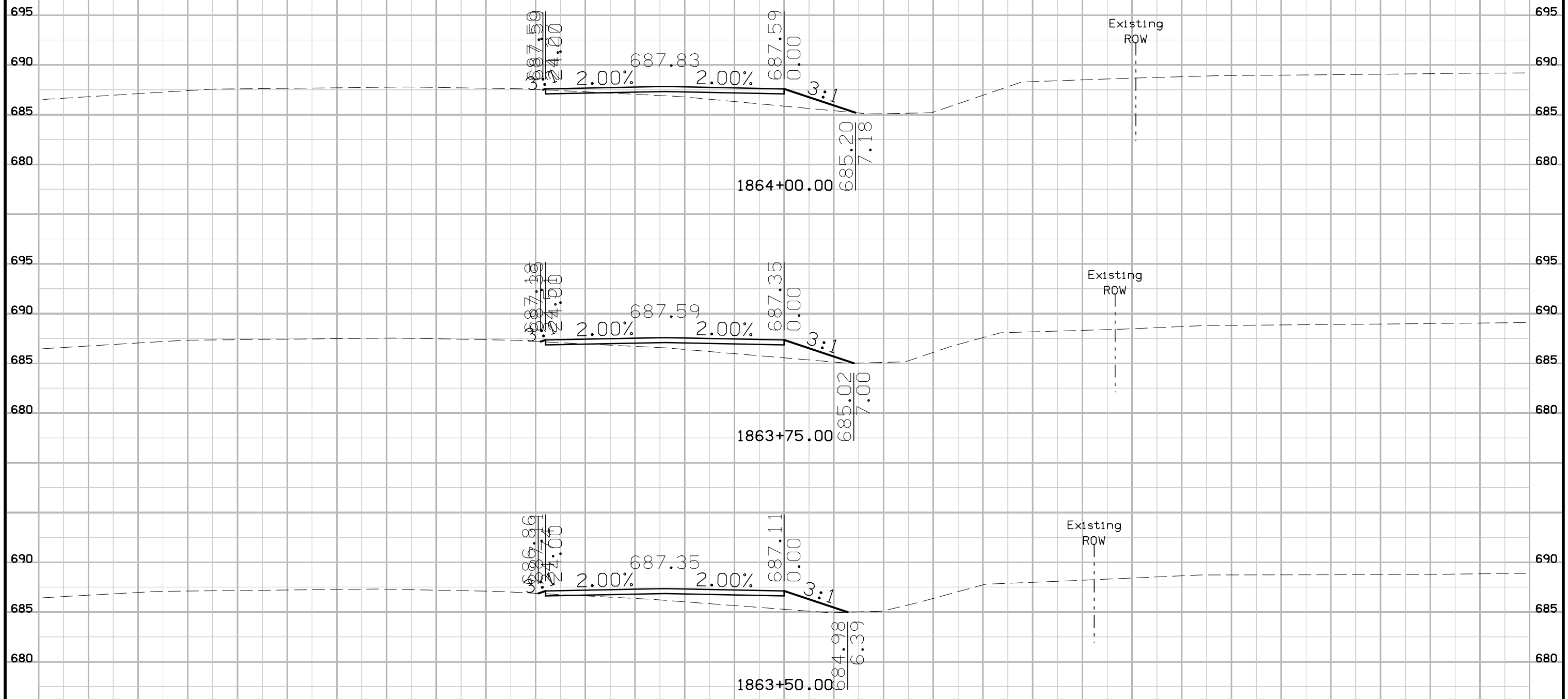

Detour IA 92 Preliminary

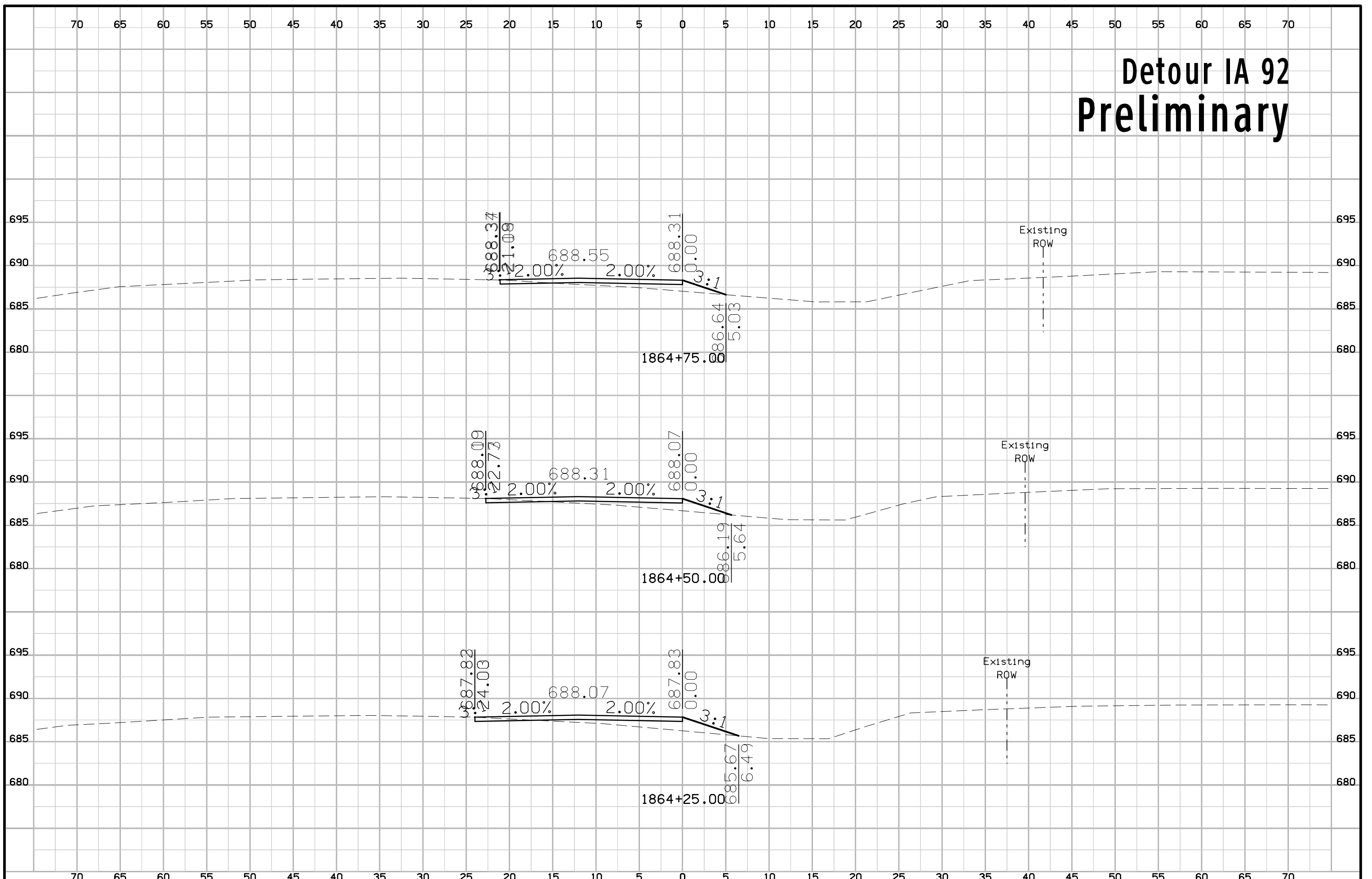

Detour IA 92 Preliminary



Detour IA 92 Preliminary

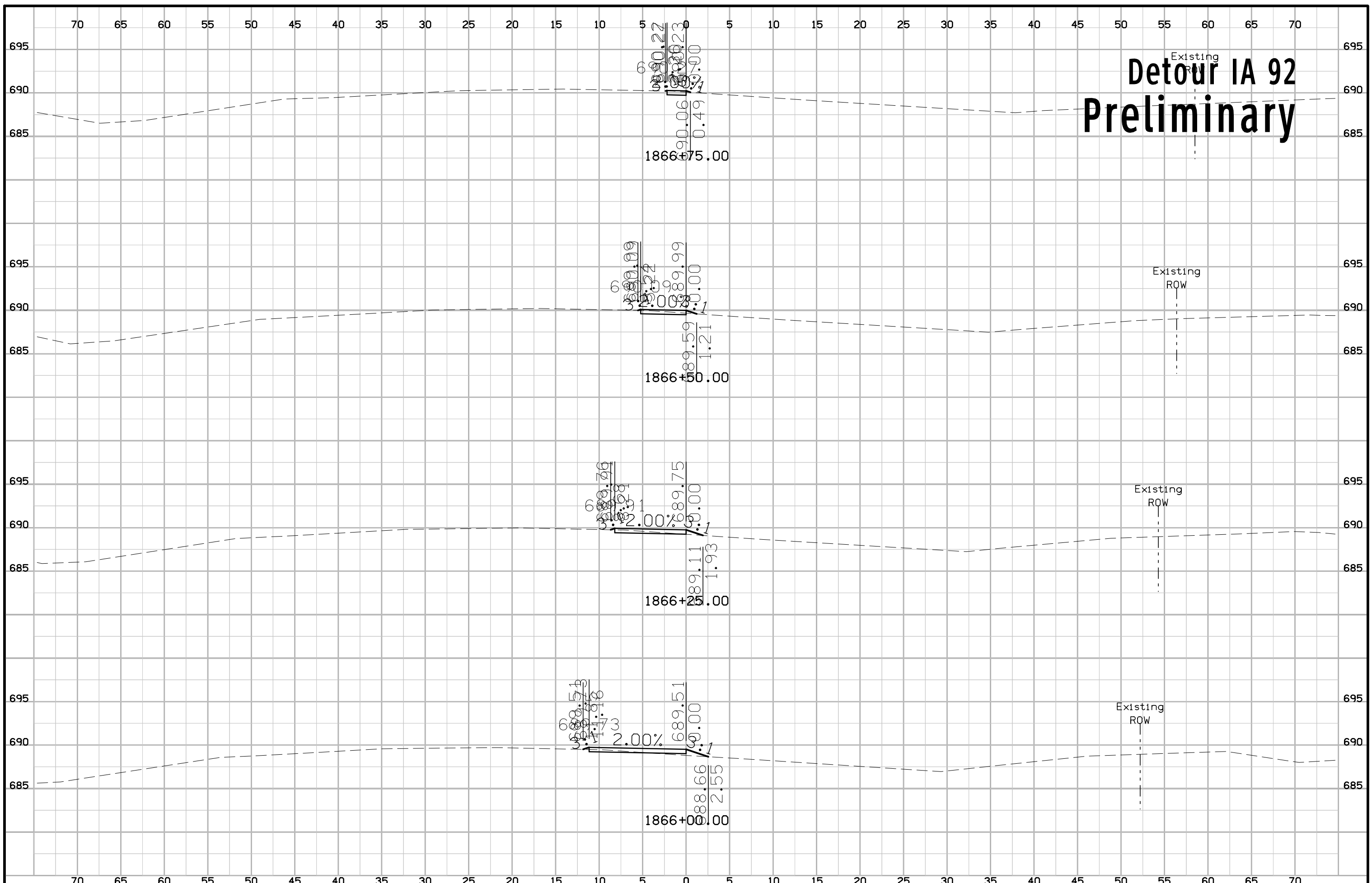

Detour IA 92 Preliminary

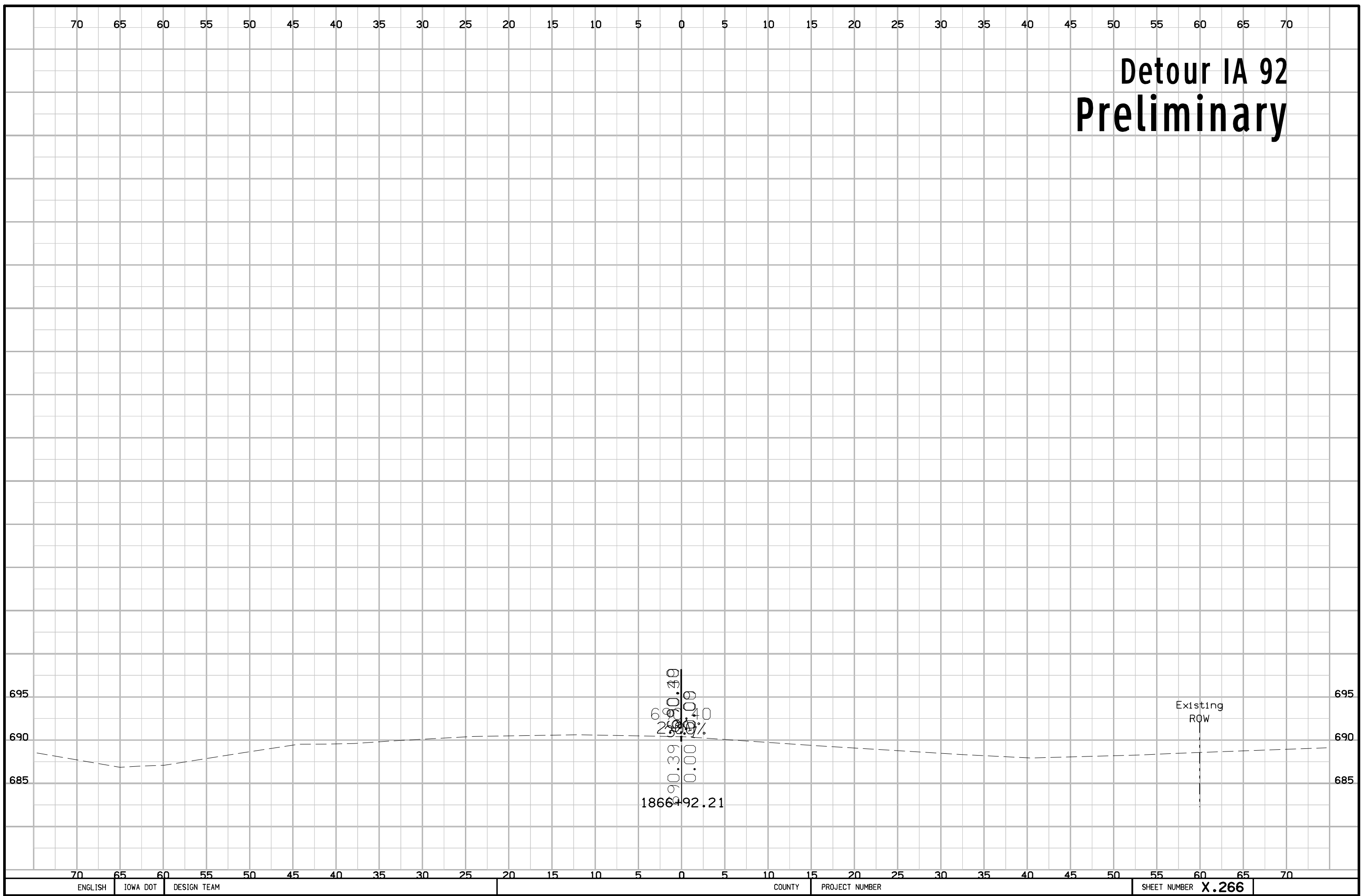

IA92 / US61 Ramp A Preliminary

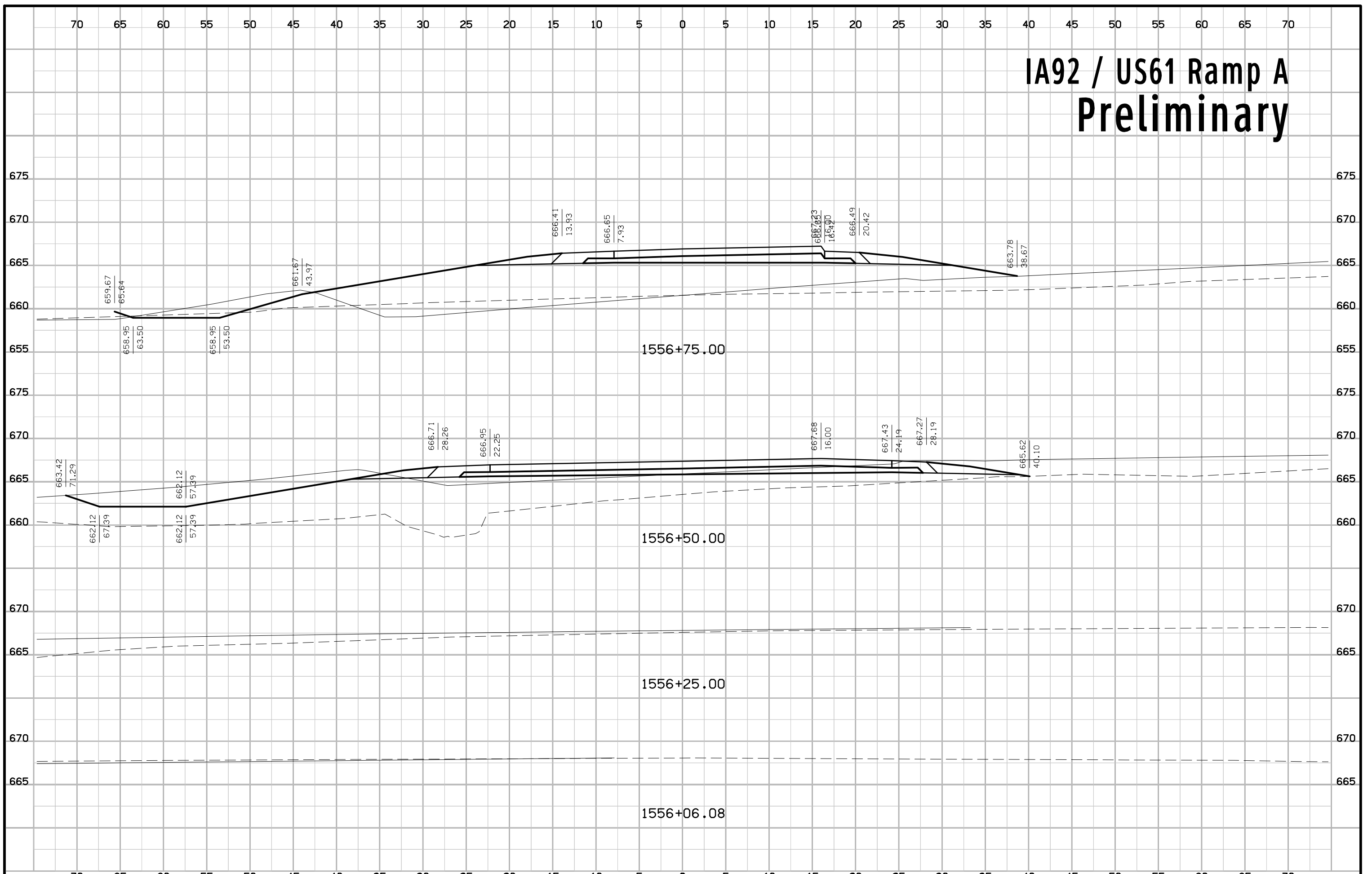

IA92 / US61 Ramp A Preliminary

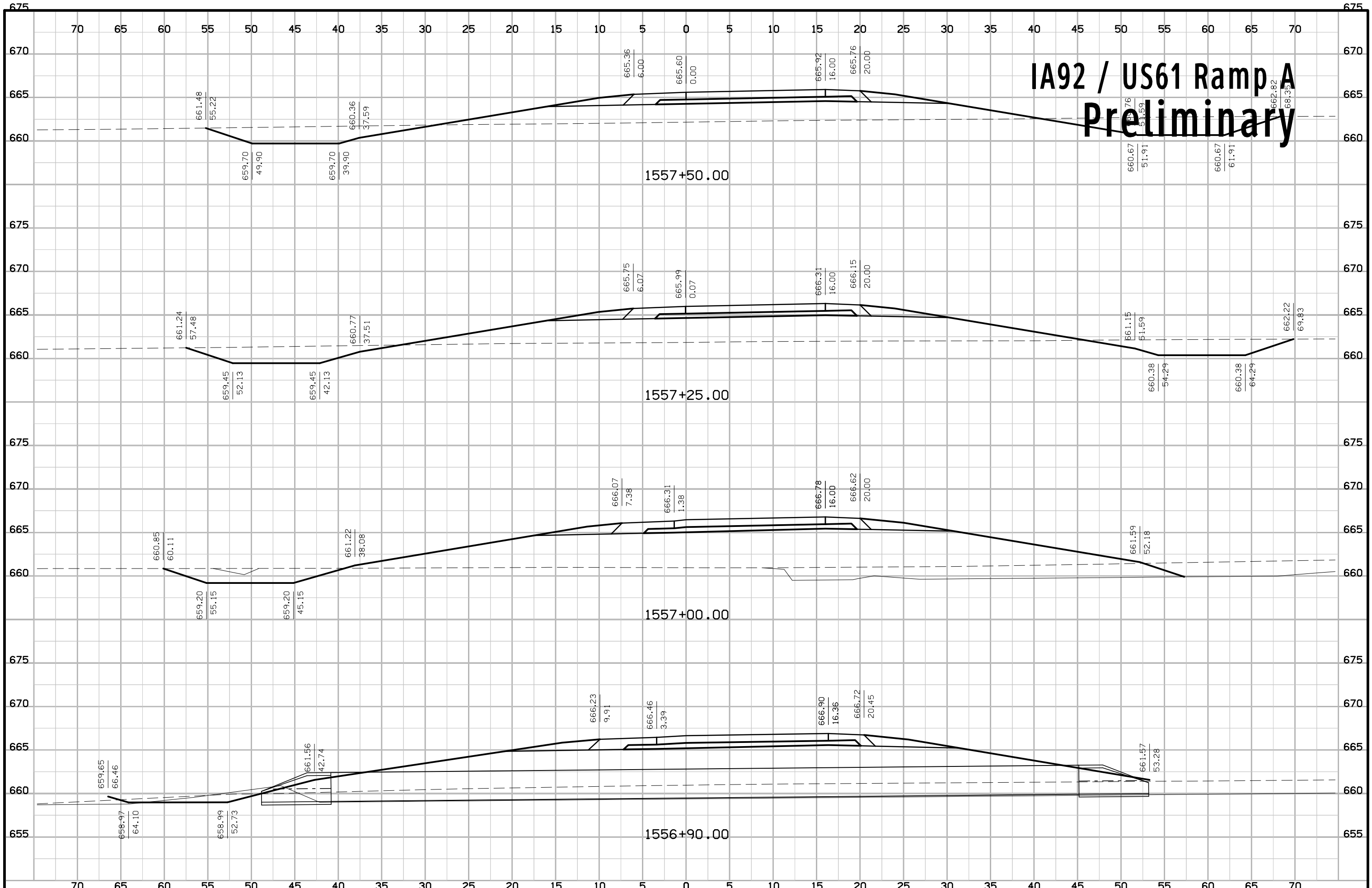

IA92 / US61 Ramp A Preliminary

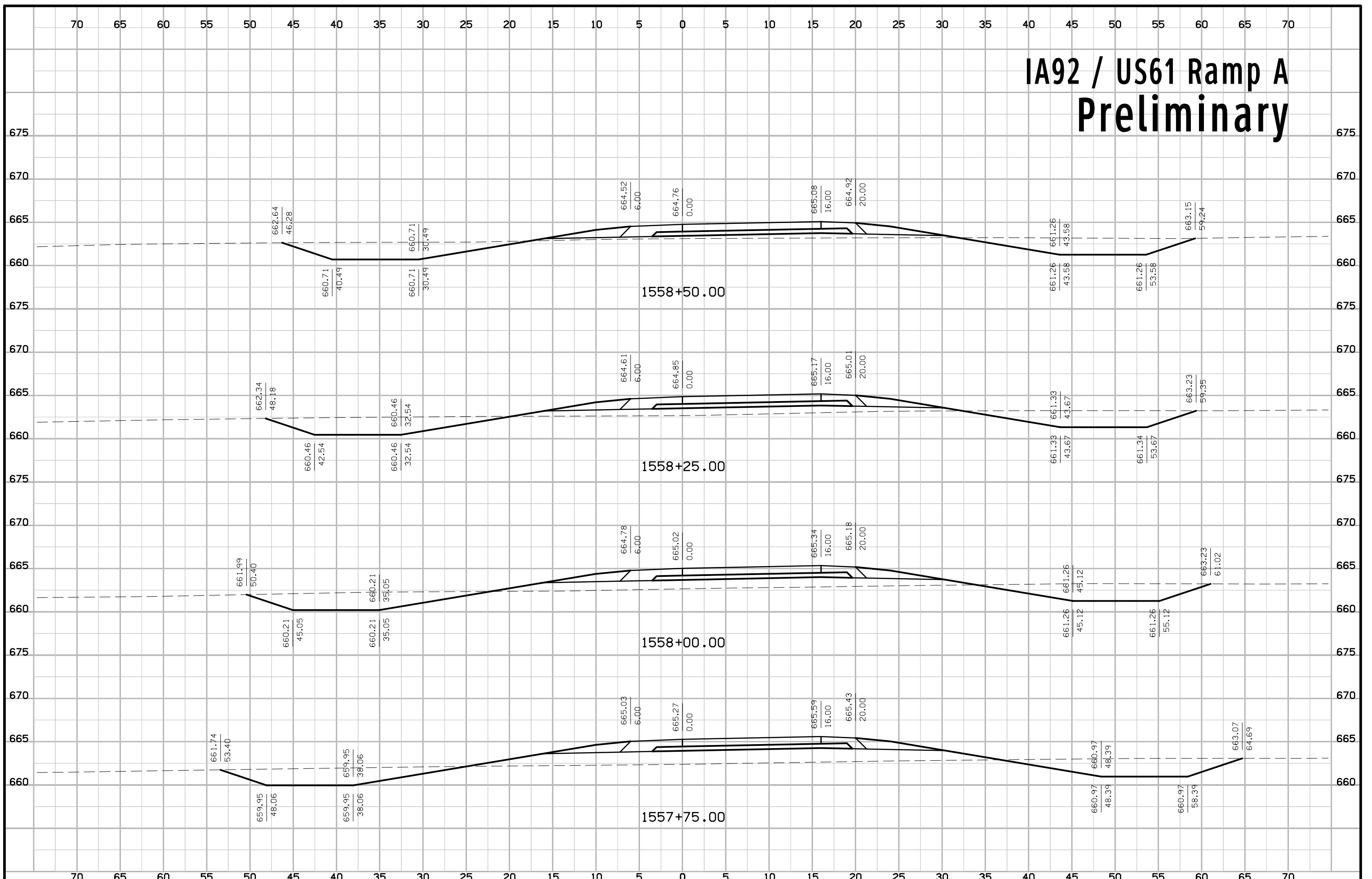

IA92 / US61 Ramp A Preliminary

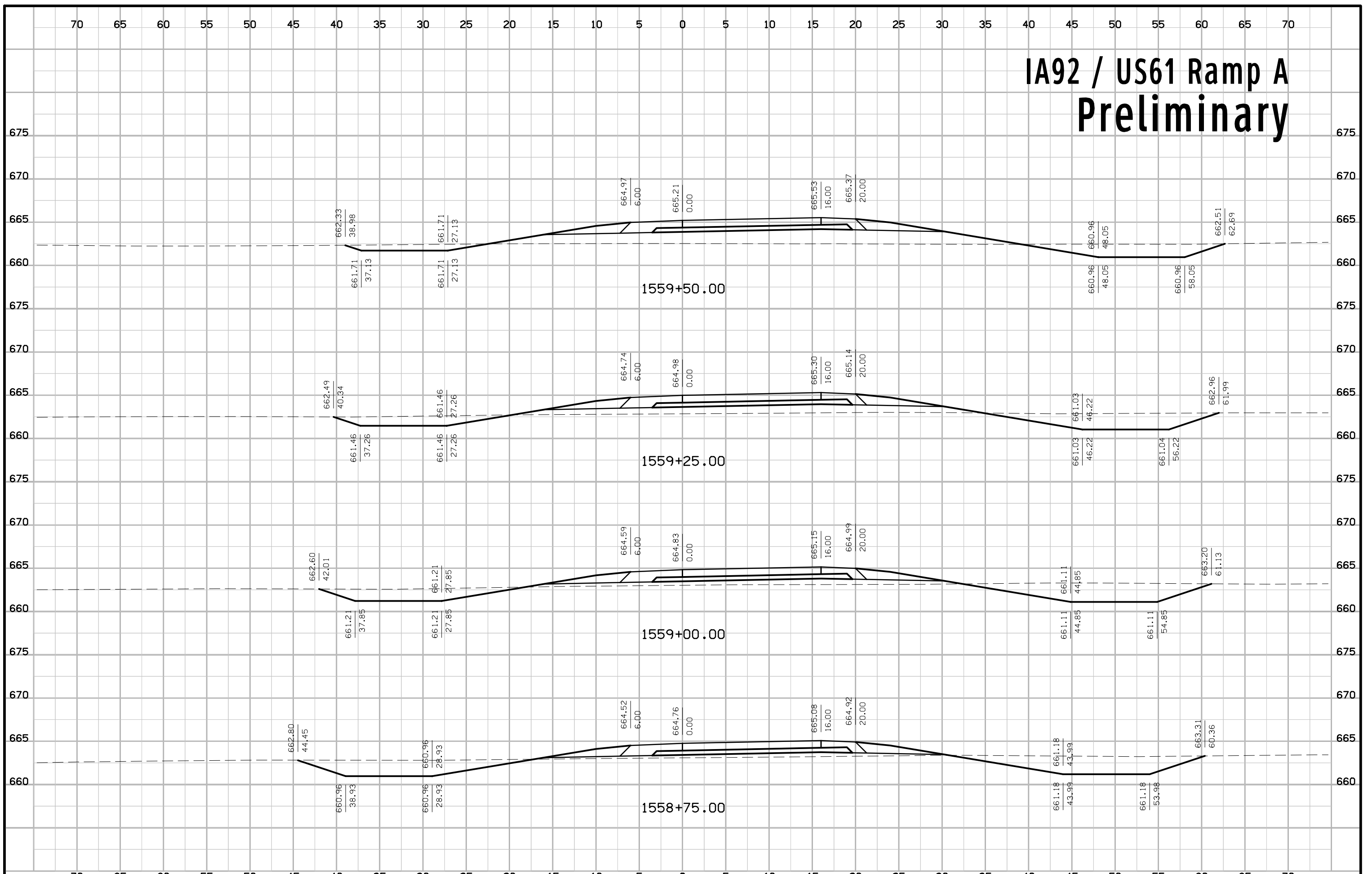

IA92 / US61 Ramp A Preliminary

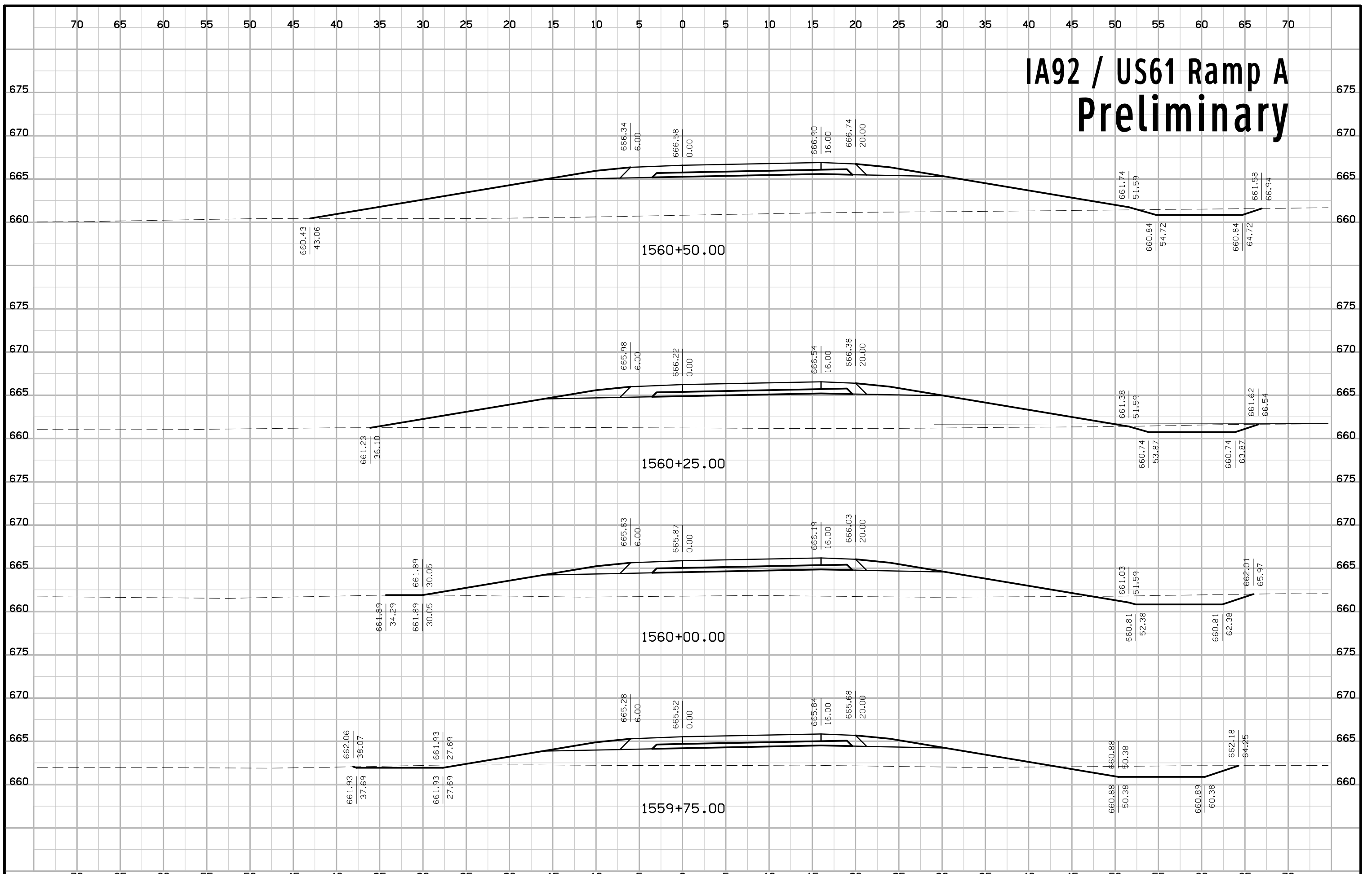

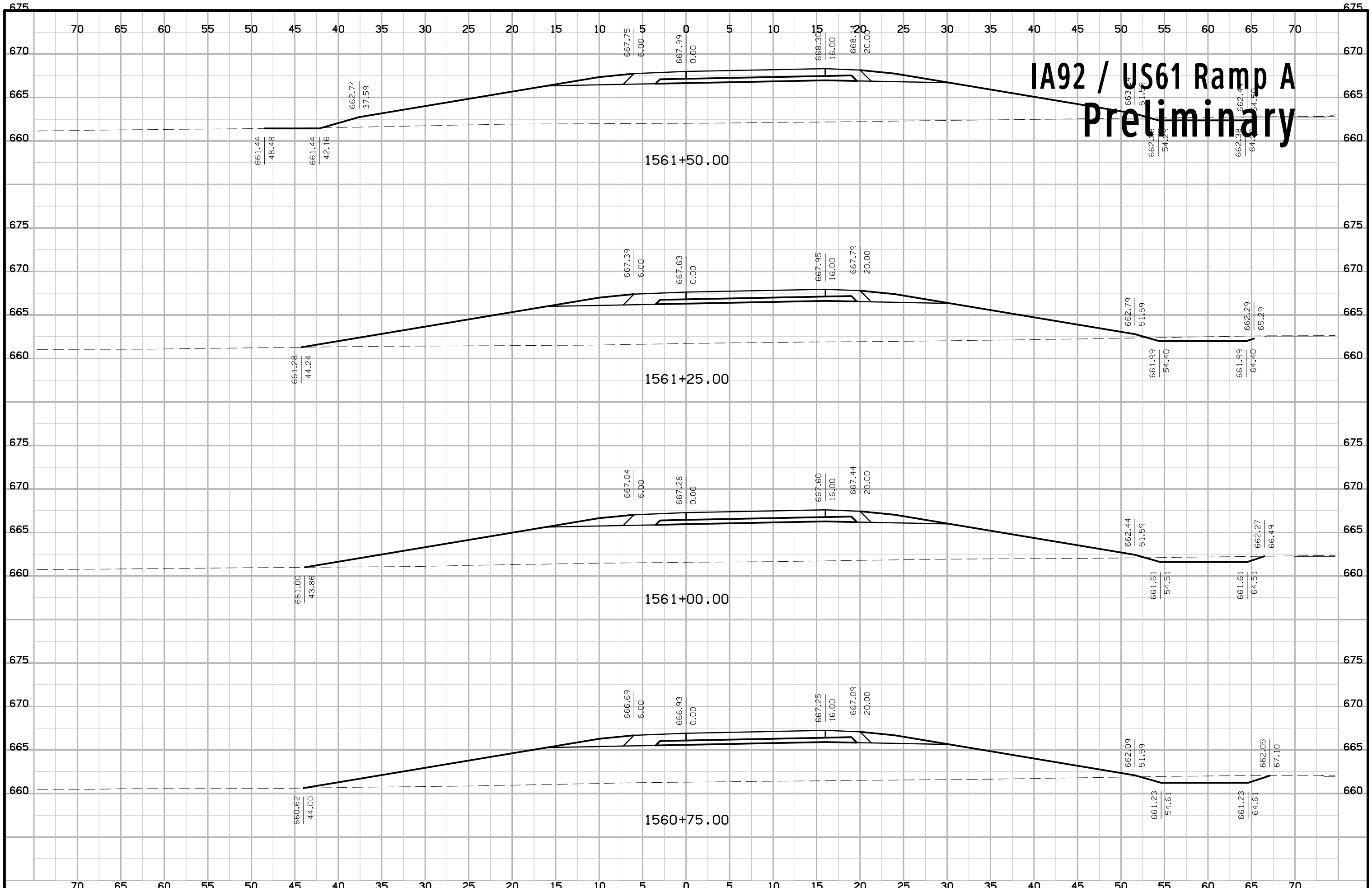

IA92 / US61 Ramp A Preliminary

IA92 / US61 Ramp A Preliminary

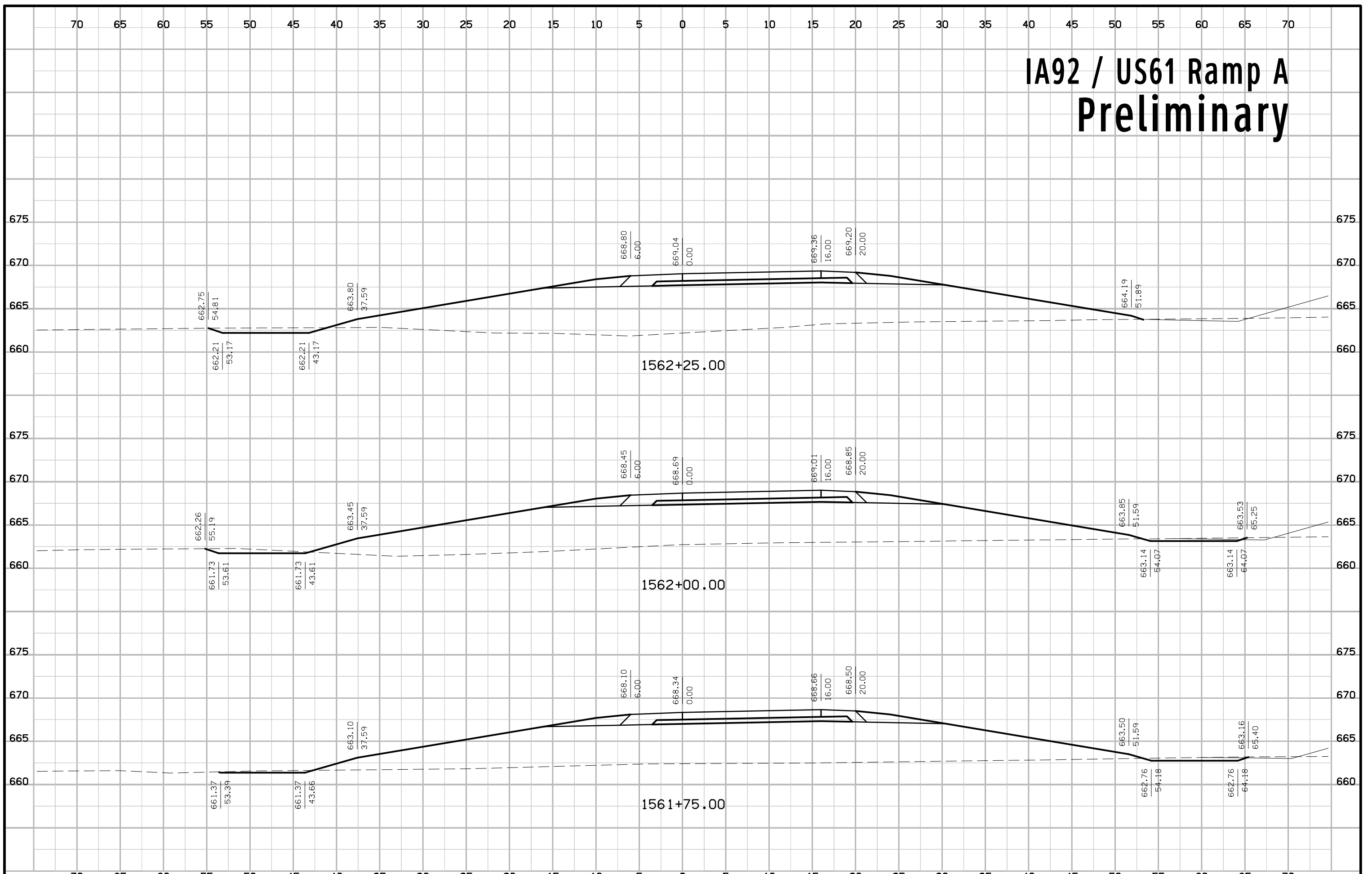

IA92 / US61 Ramp A Preliminary

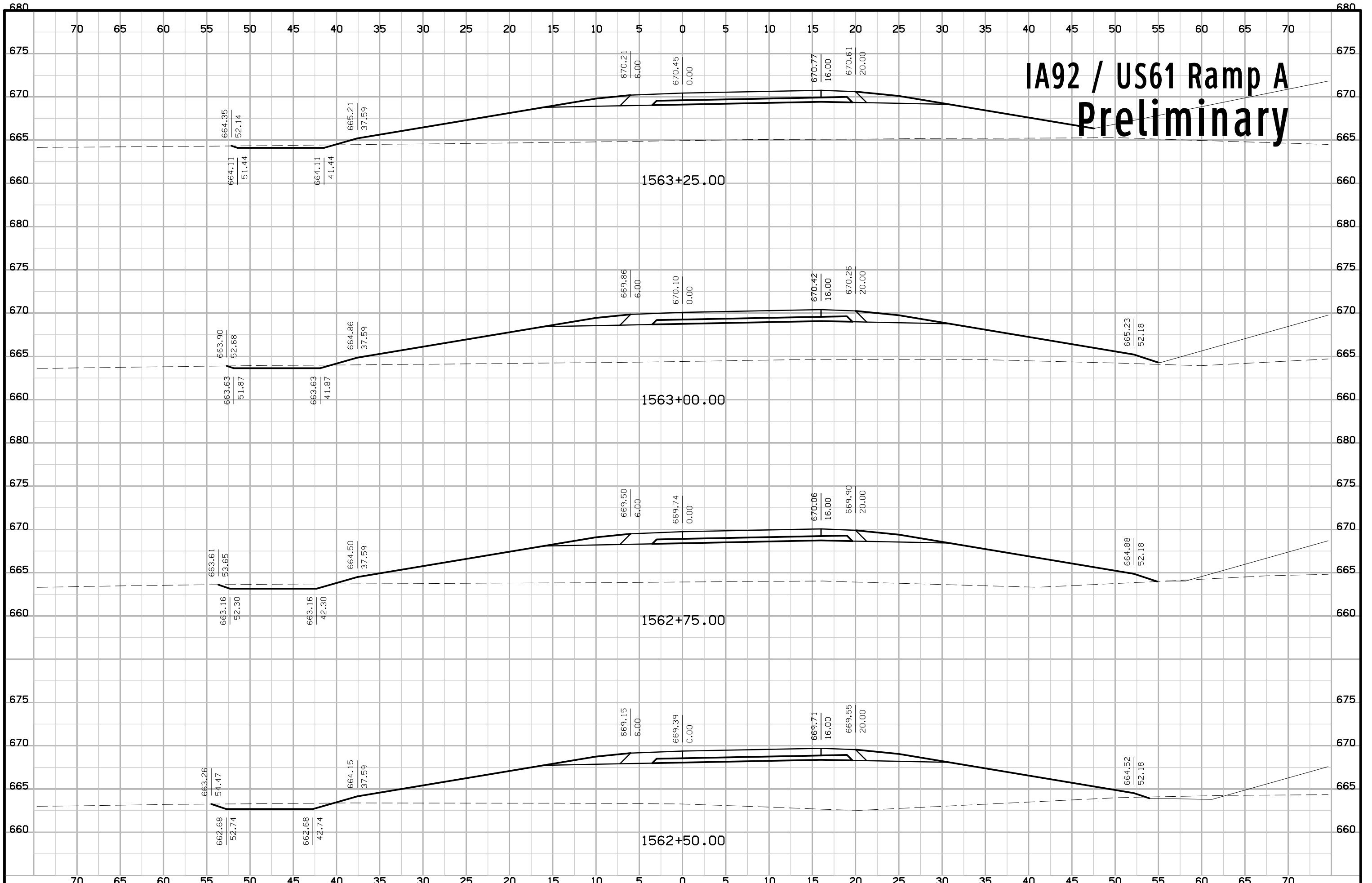

IA92 / US61 Ramp A Preliminary

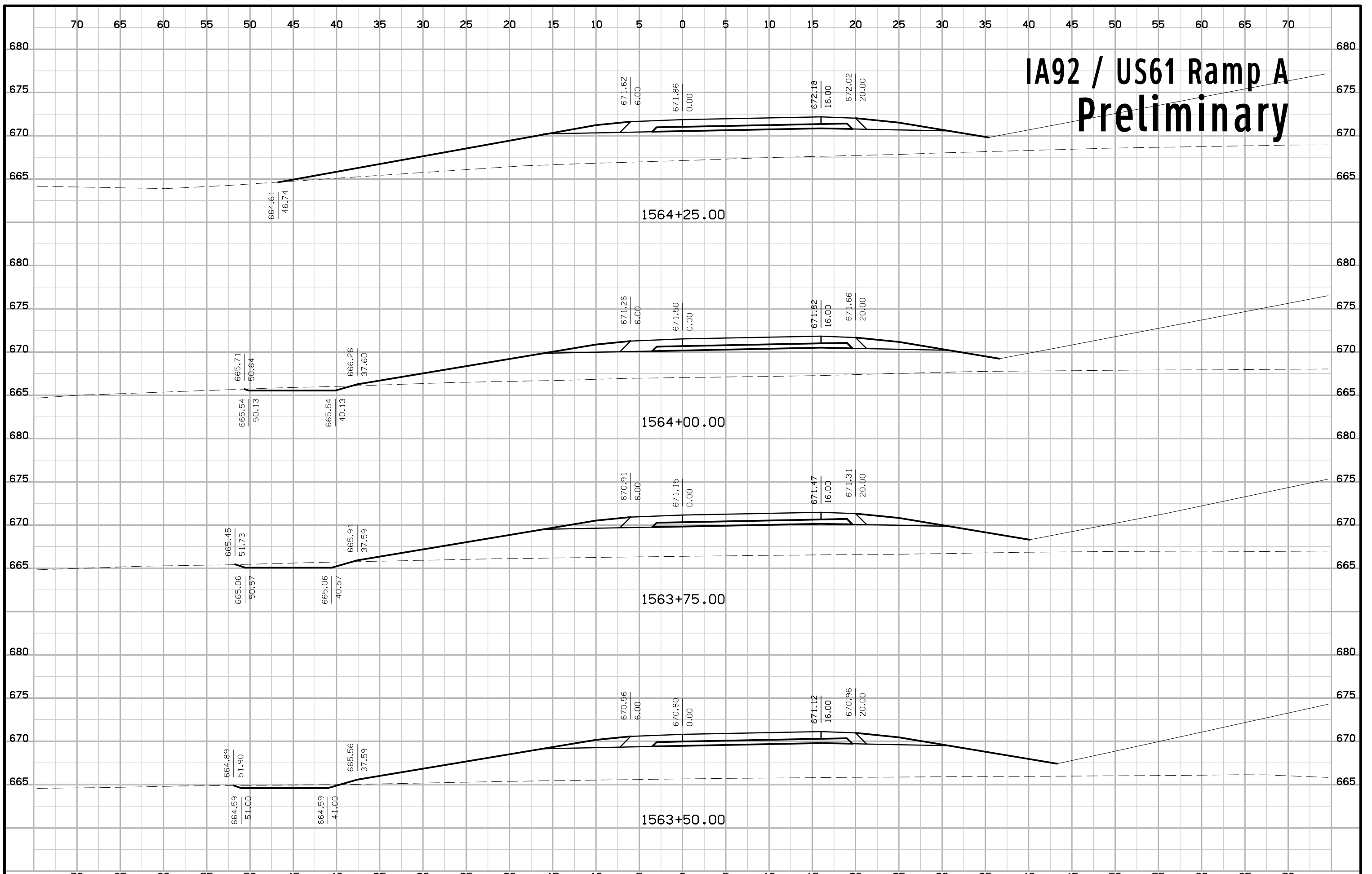

IA92 / US61 Ramp A Preliminary

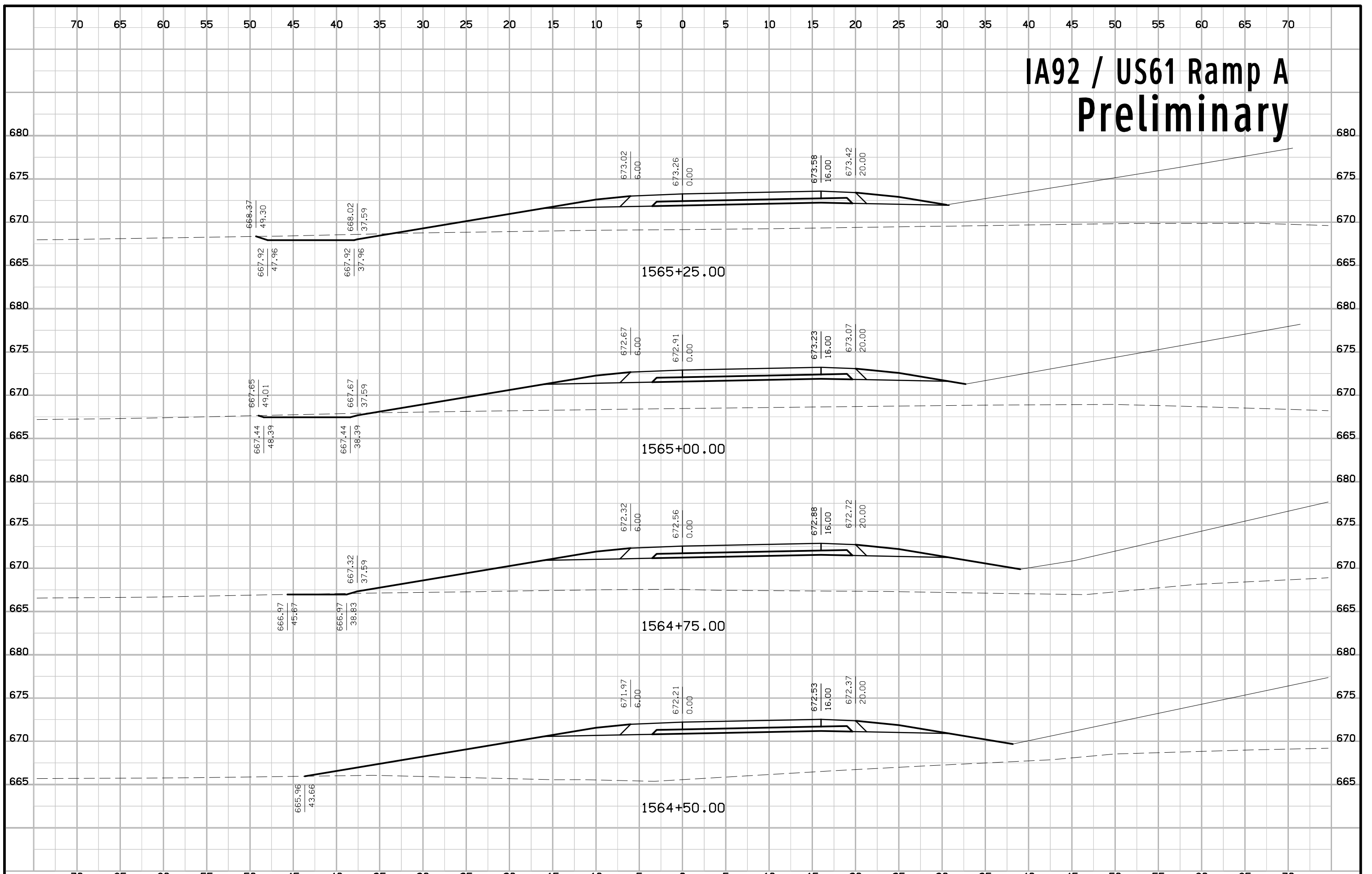

IA92 / US61 Ramp A Preliminary

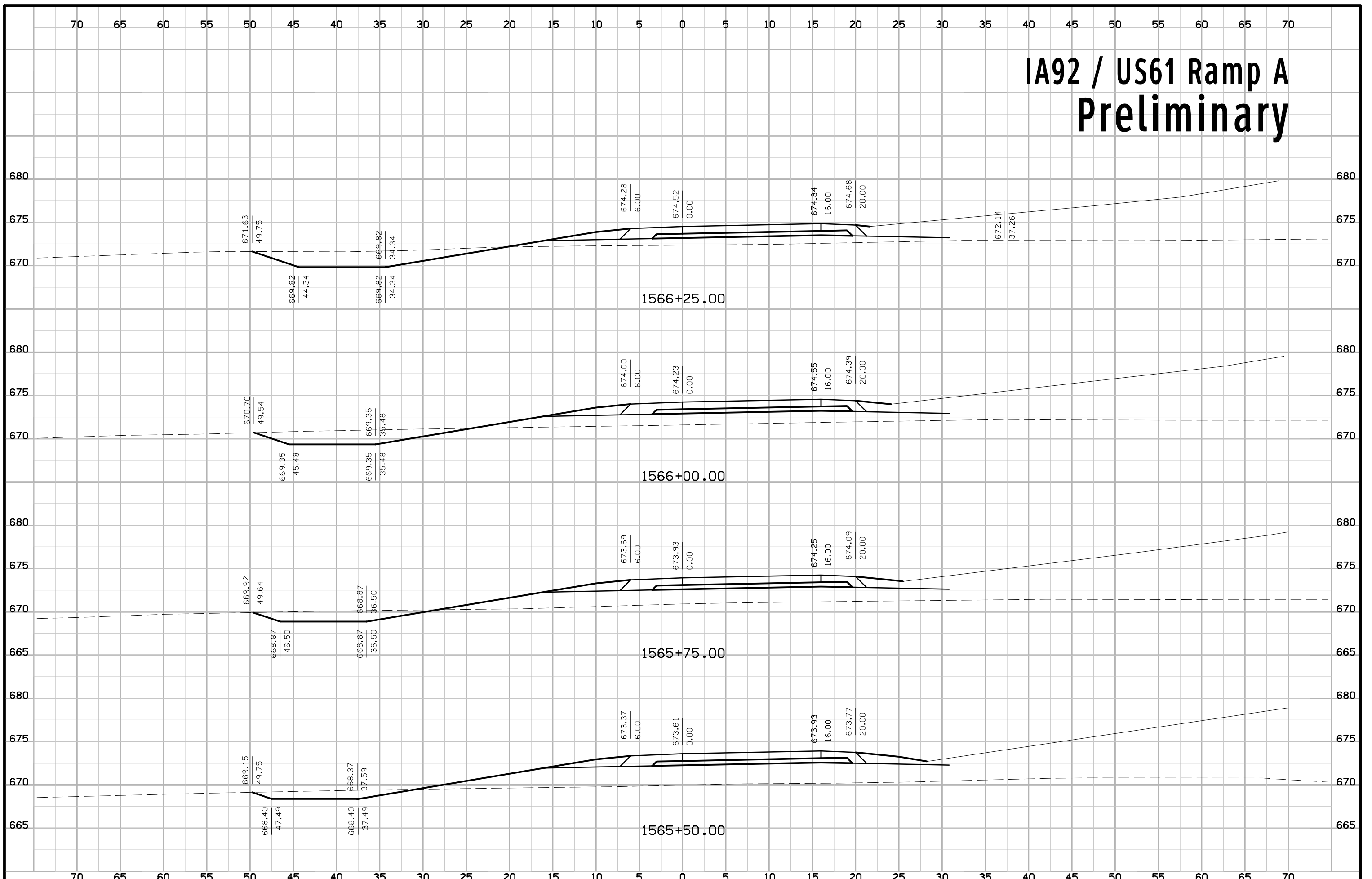

IA92 / US61 Ramp A Preliminary

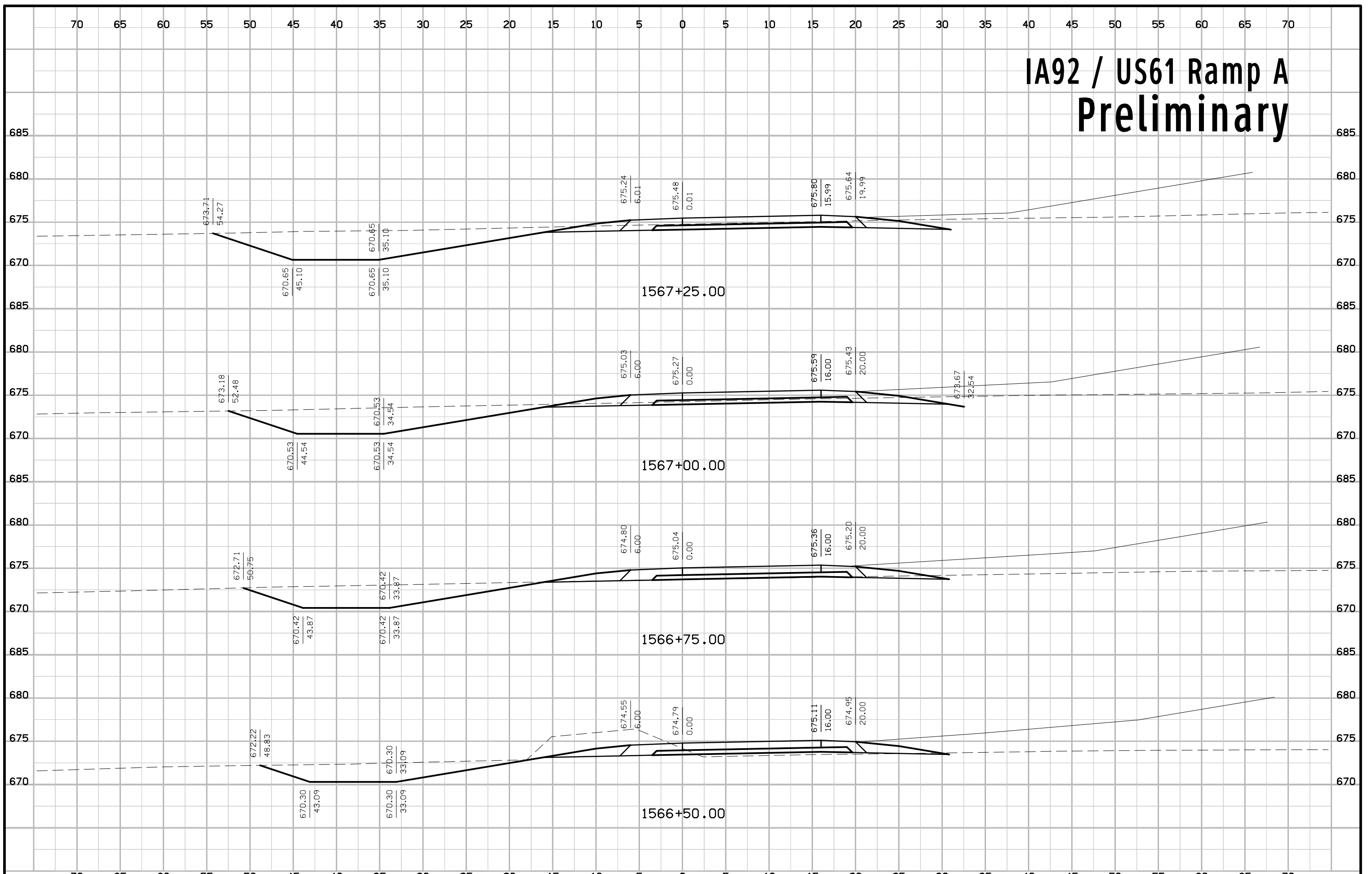

IA92 / US61 Ramp A Preliminary

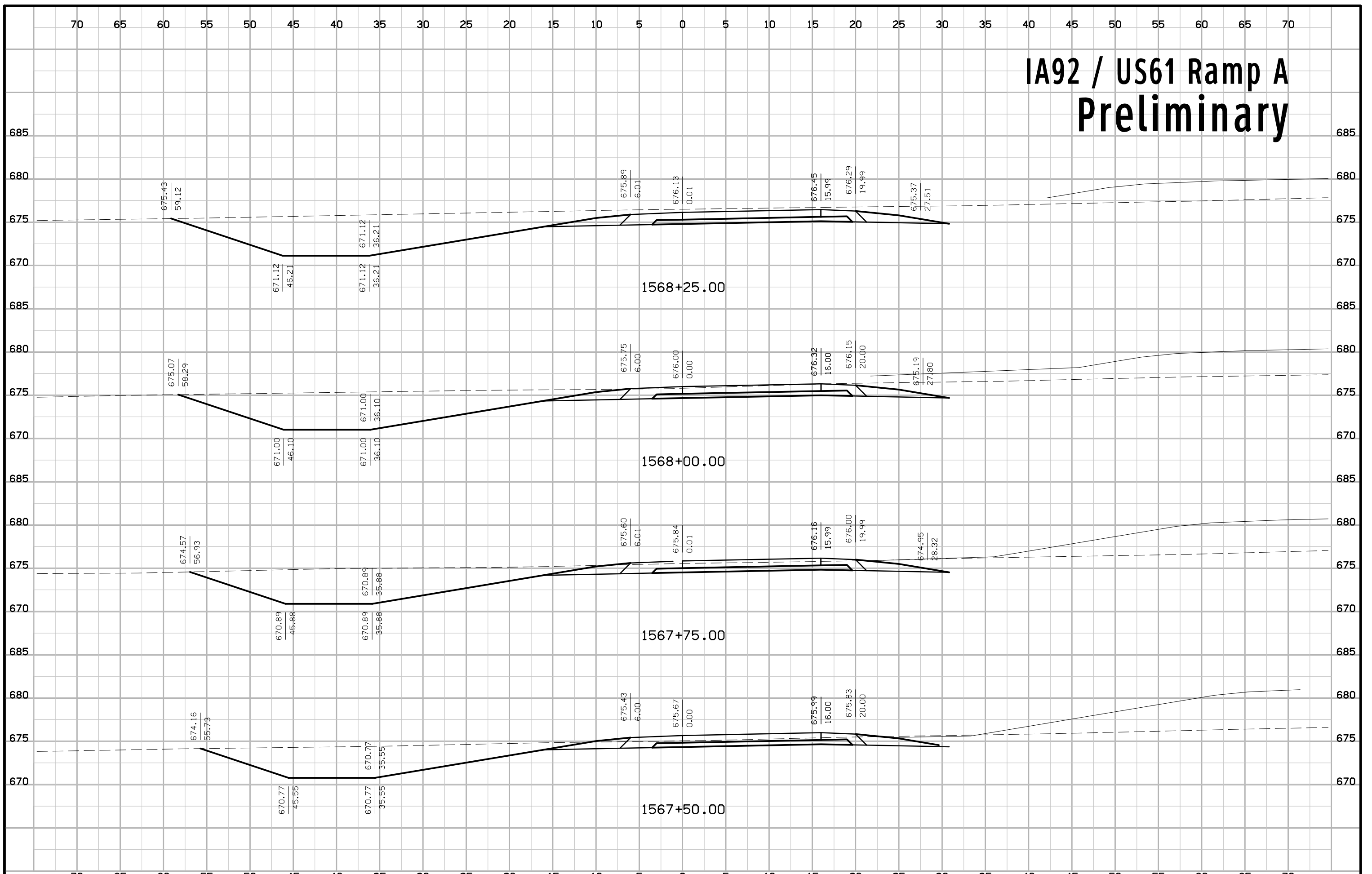

IA92 / US61 Ramp A Preliminary

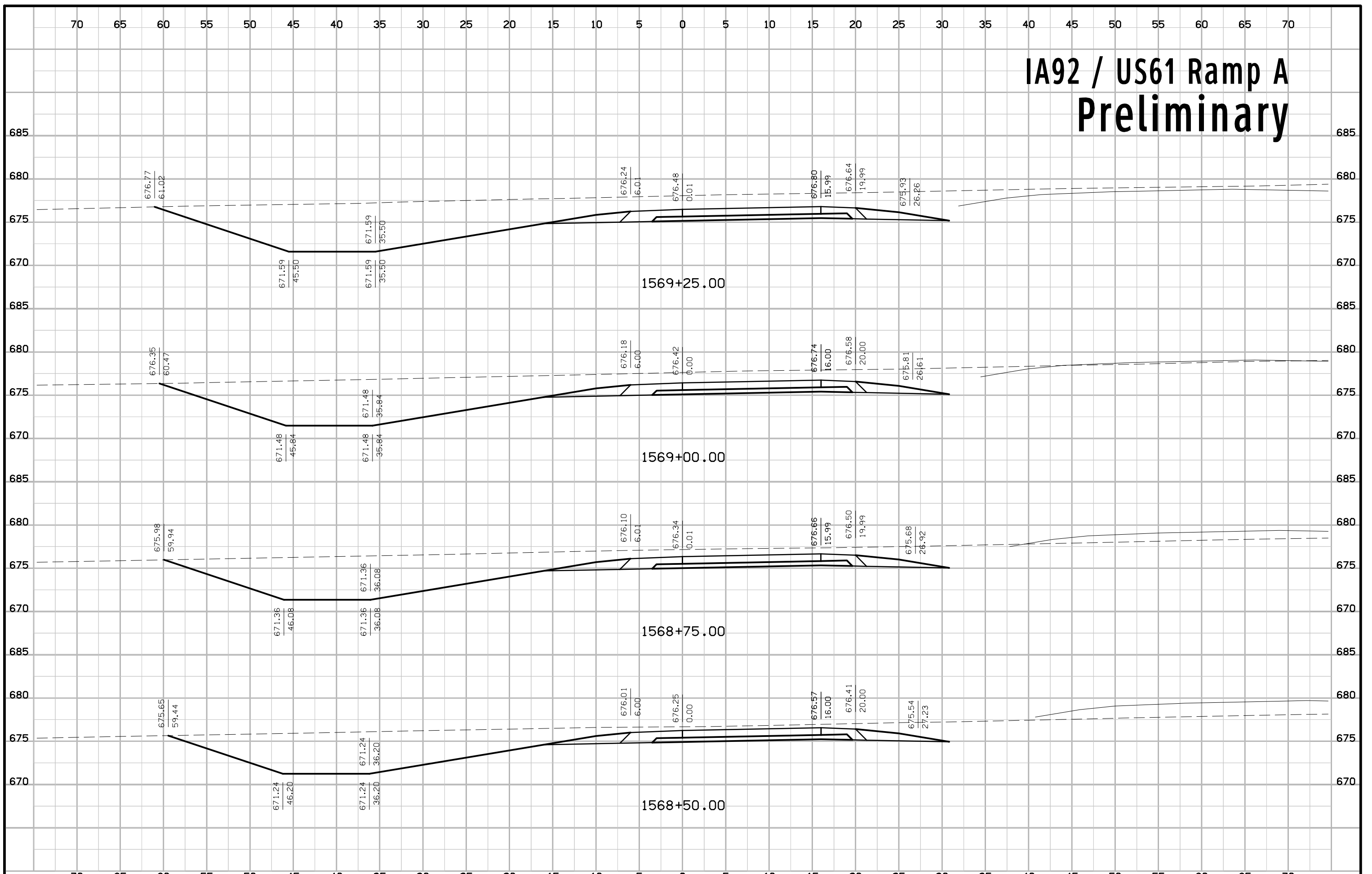

IA92 / US61 Ramp A Preliminary

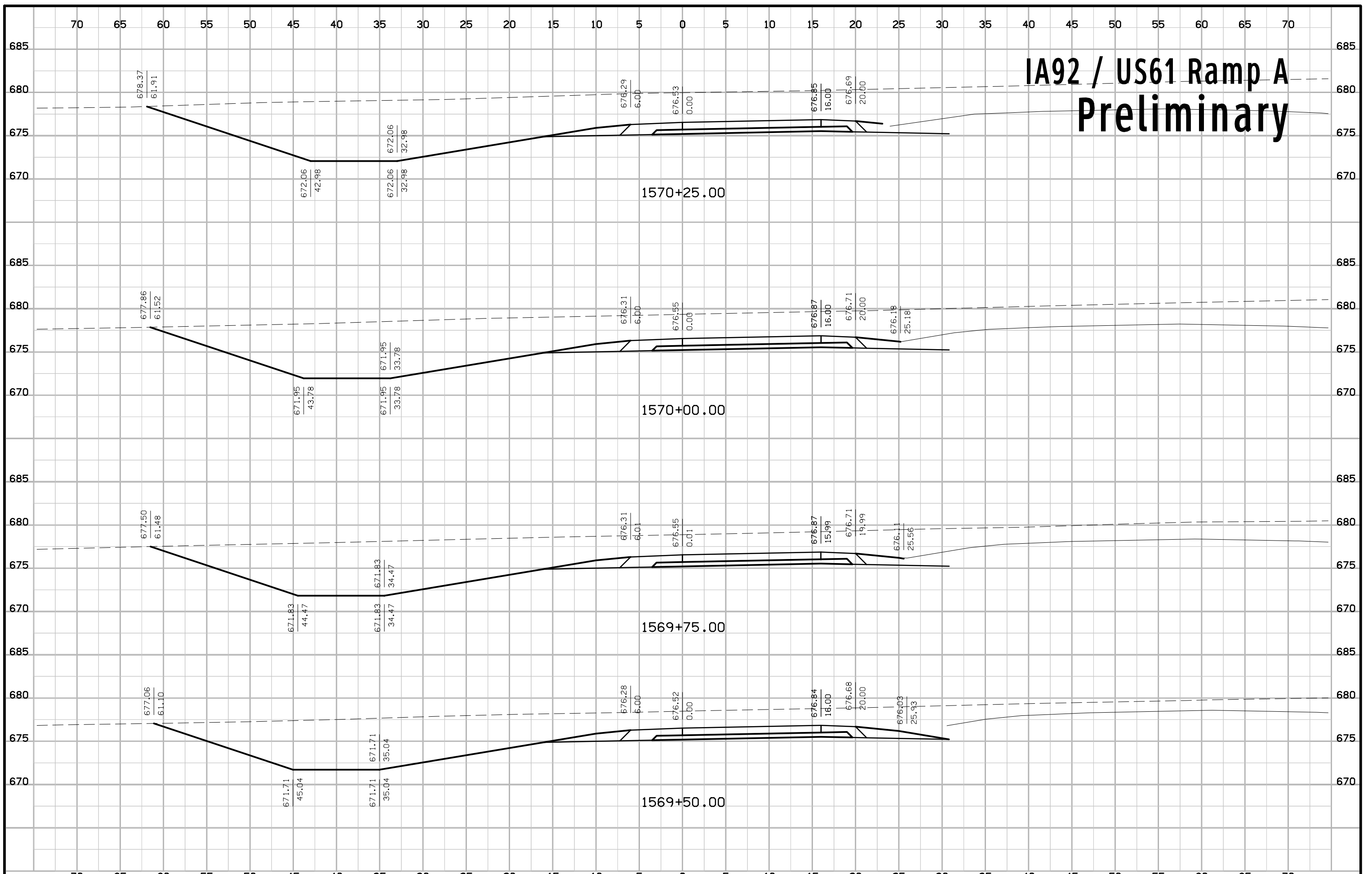

IA92 / US61 Ramp A Preliminary

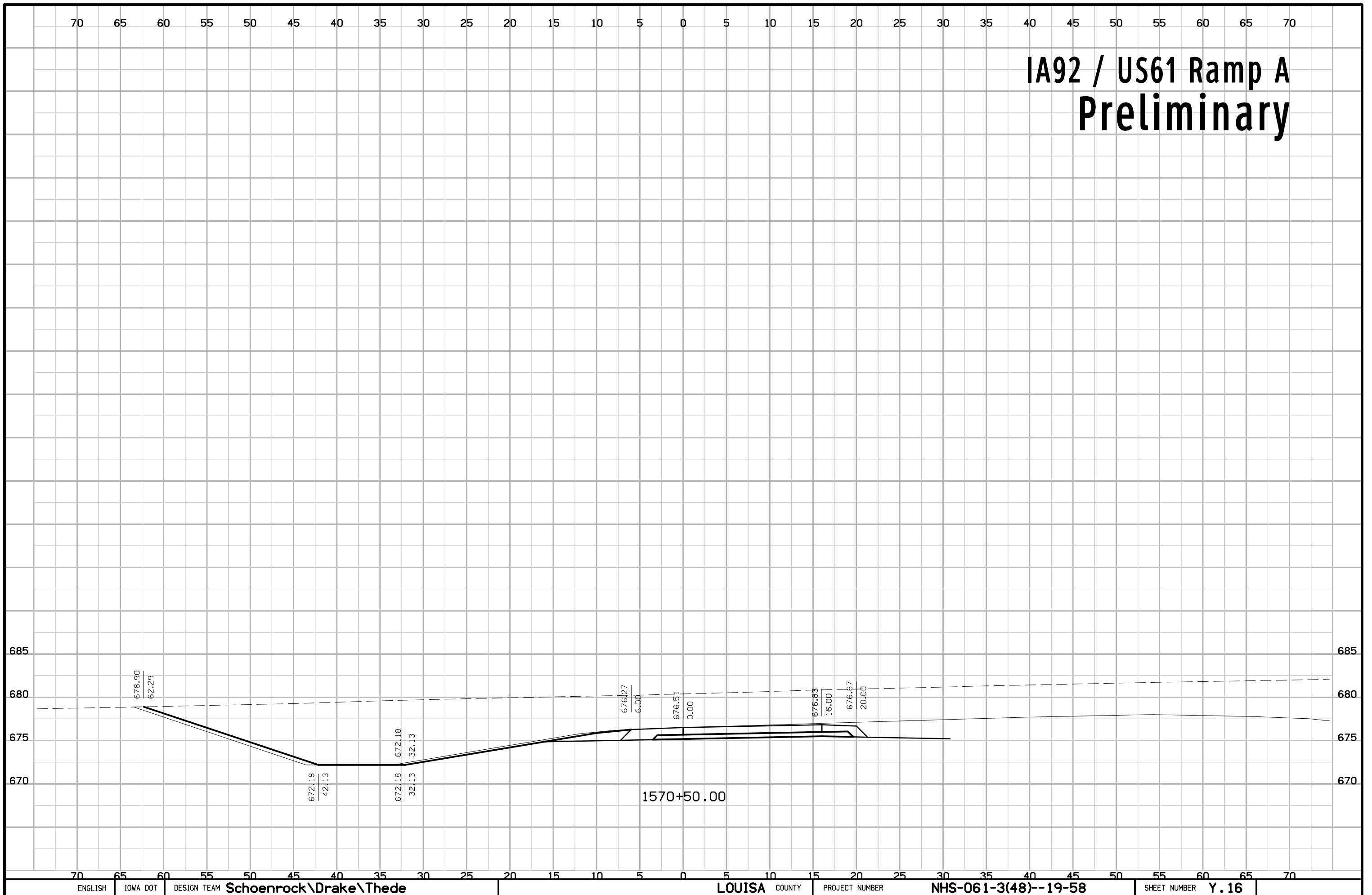

IA92 / US61 Ramp B Preliminary

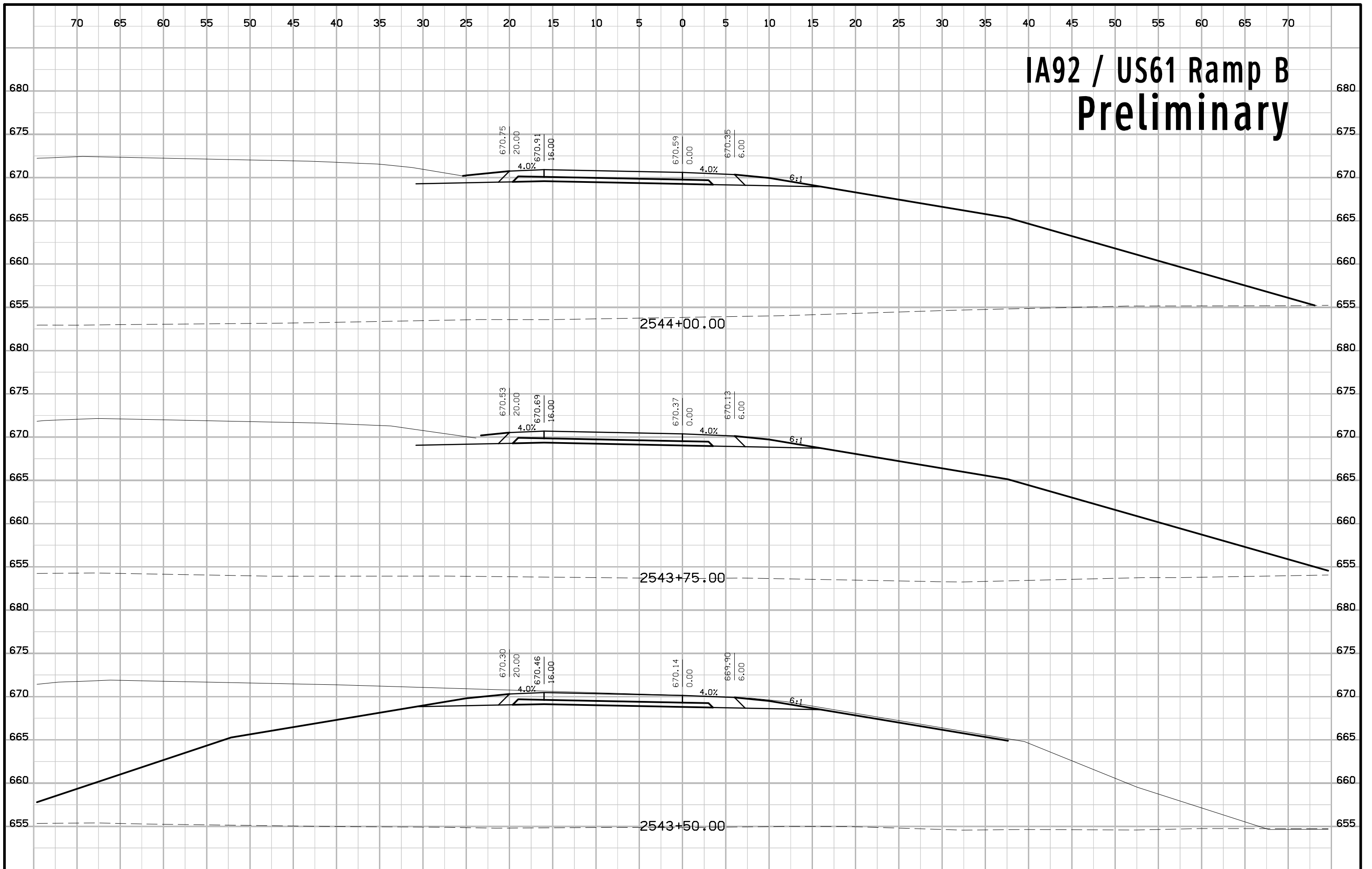

IA92 / US61 Ramp B Preliminary

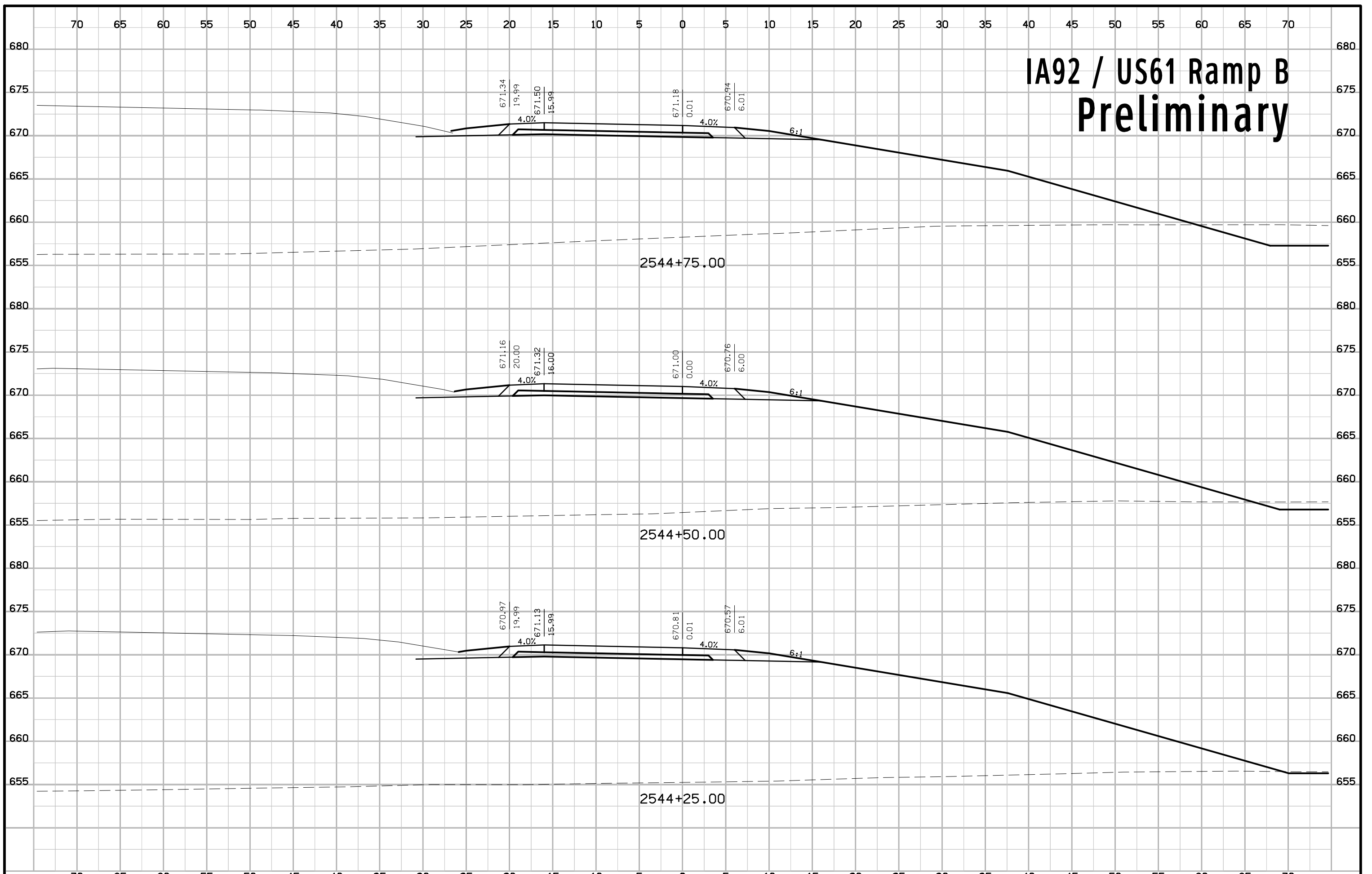

IA92 / US61 Ramp B Preliminary

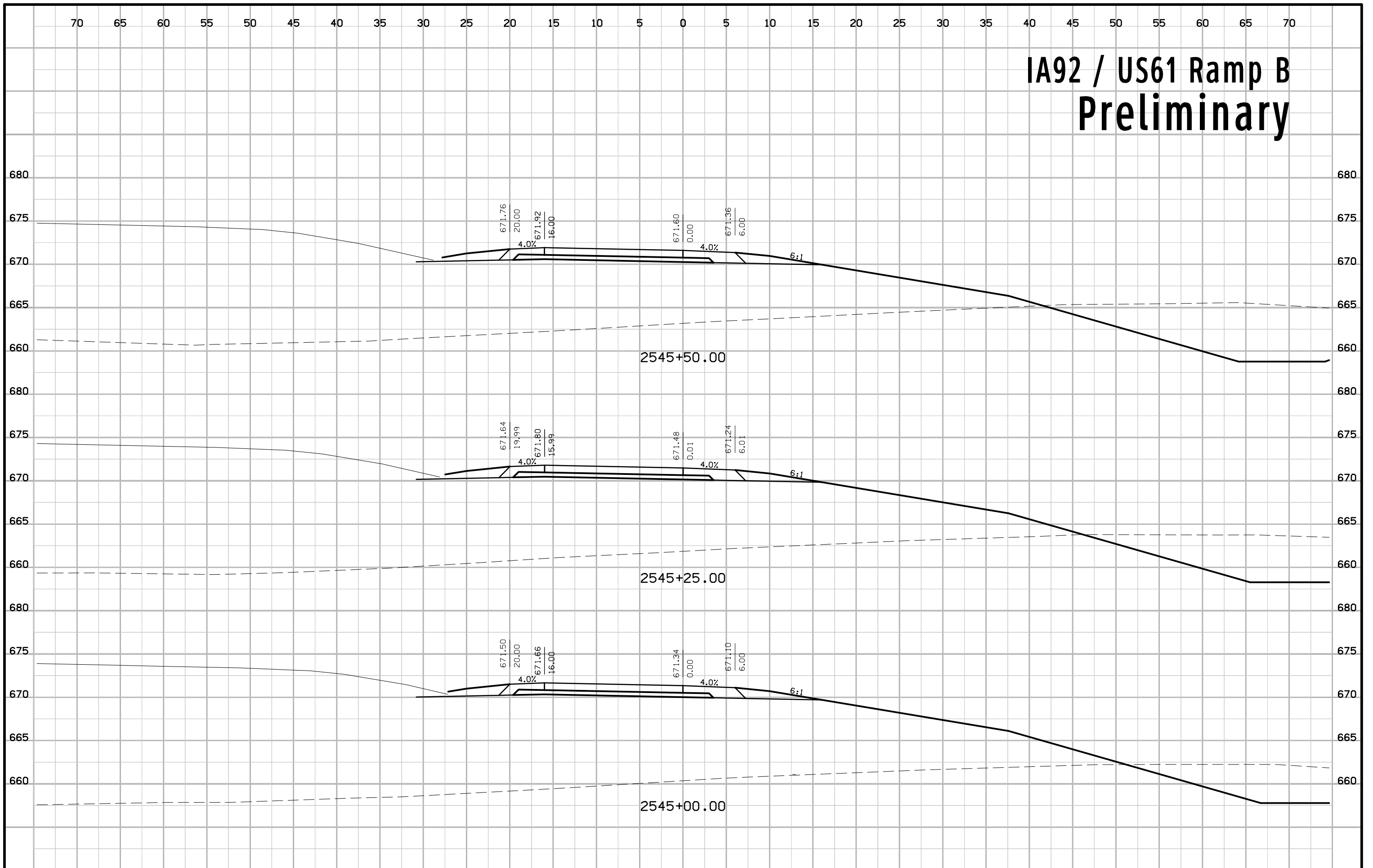

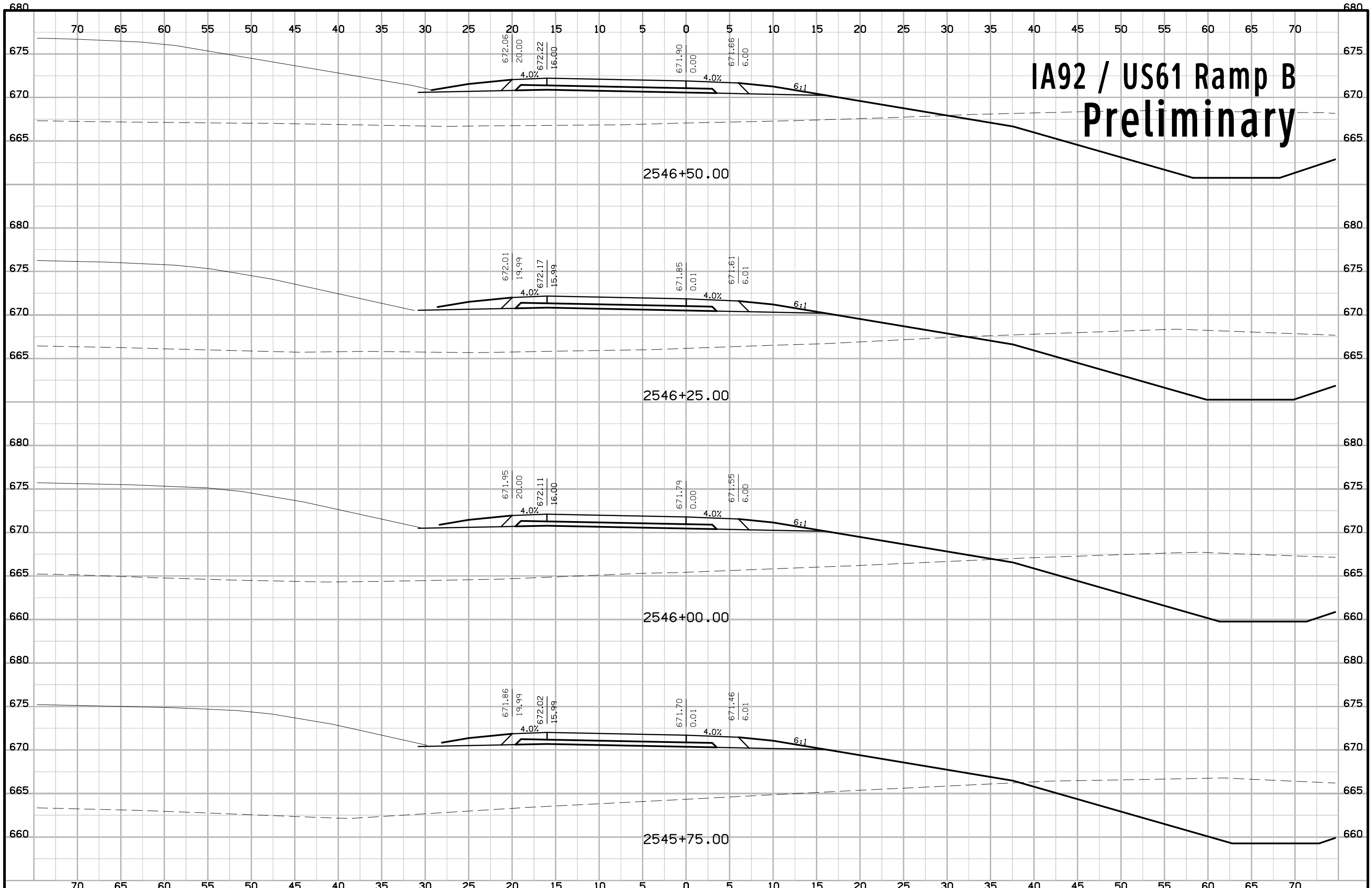

IA92 / US61 Ramp B Preliminary

IA92 / US61 Ramp B Preliminary

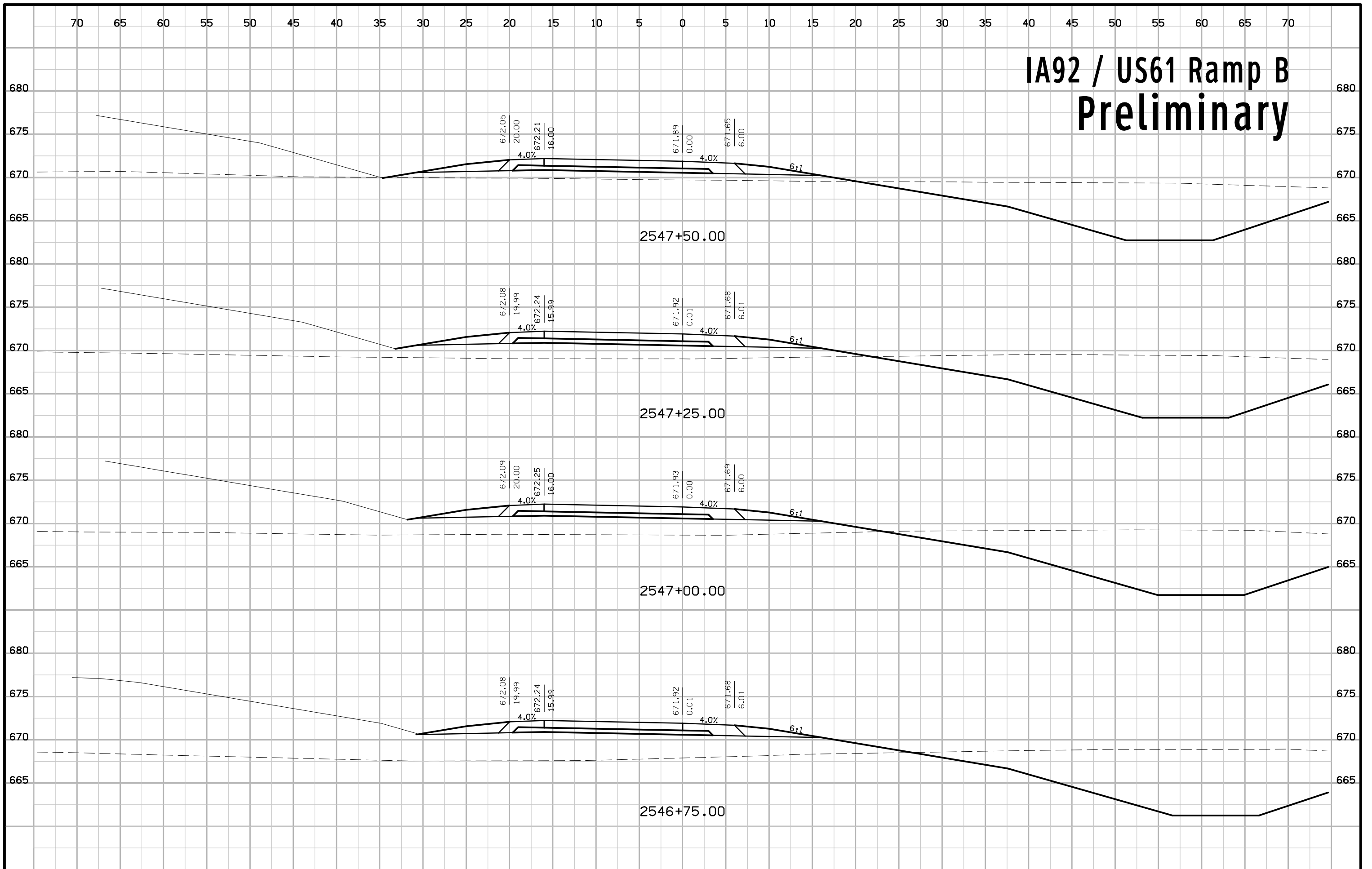

IA92 / US61 Ramp B Preliminary

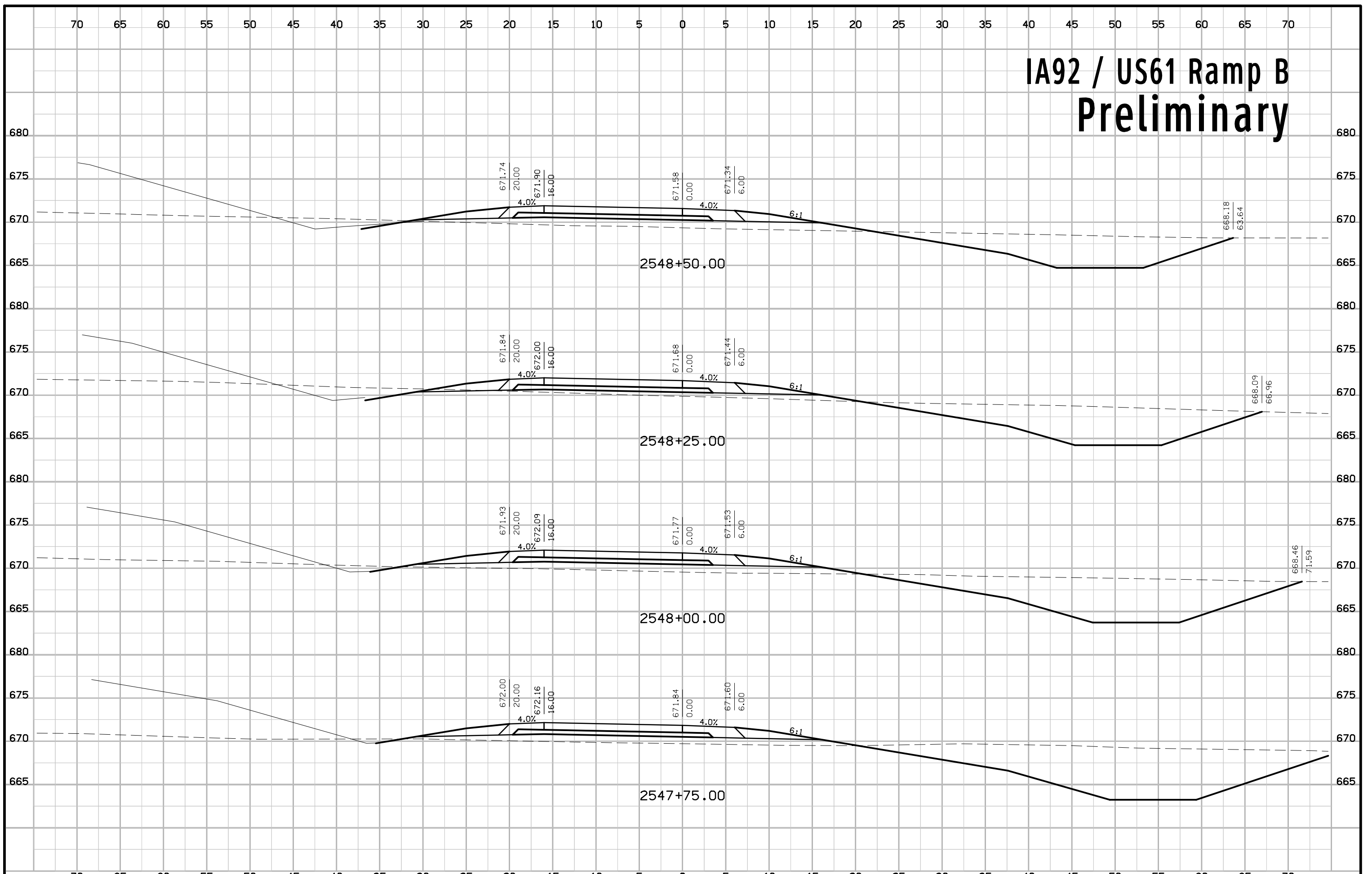

IA92 / US61 Ramp B Preliminary

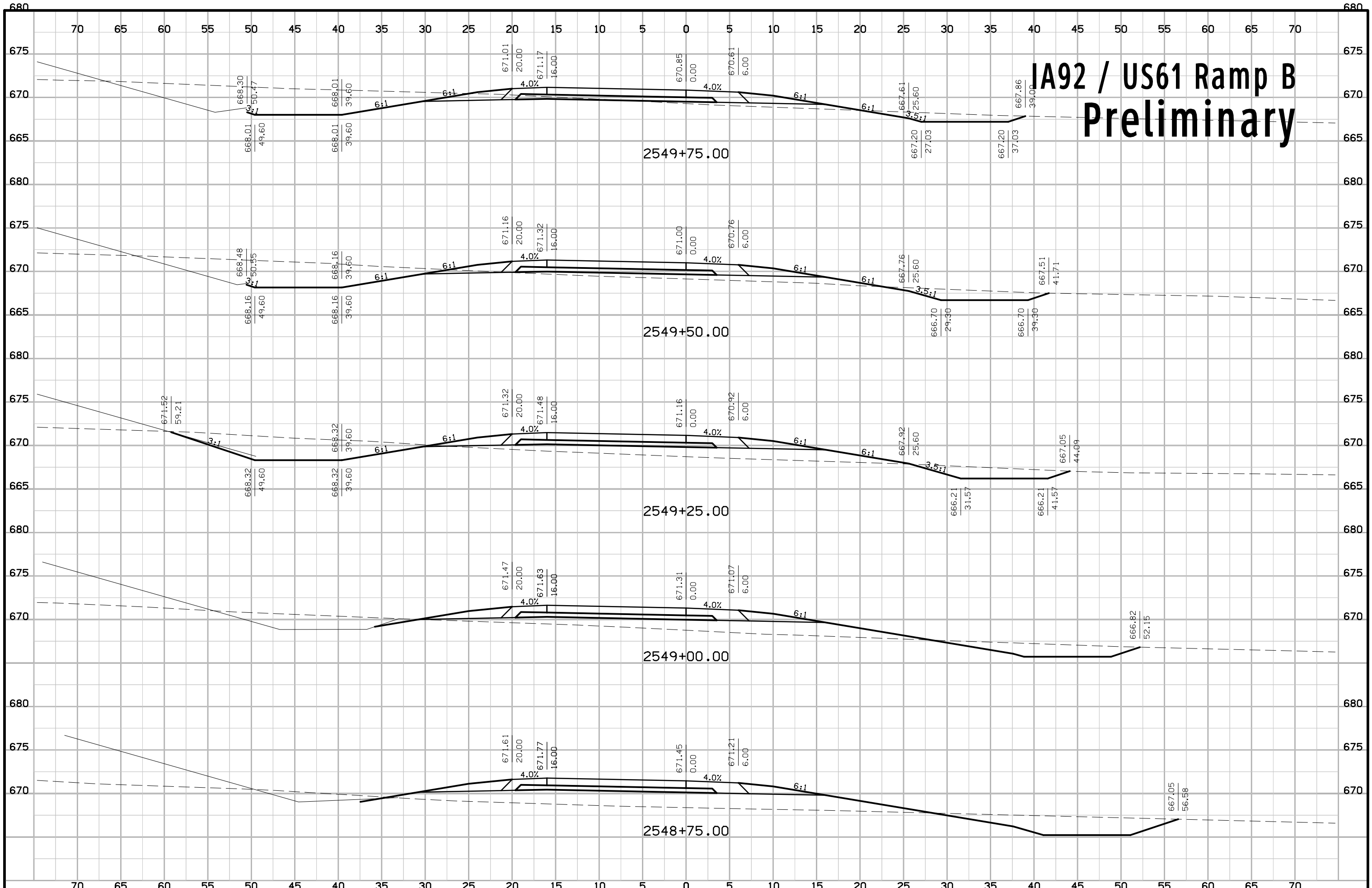

IA92 / US61 Ramp B Preliminary

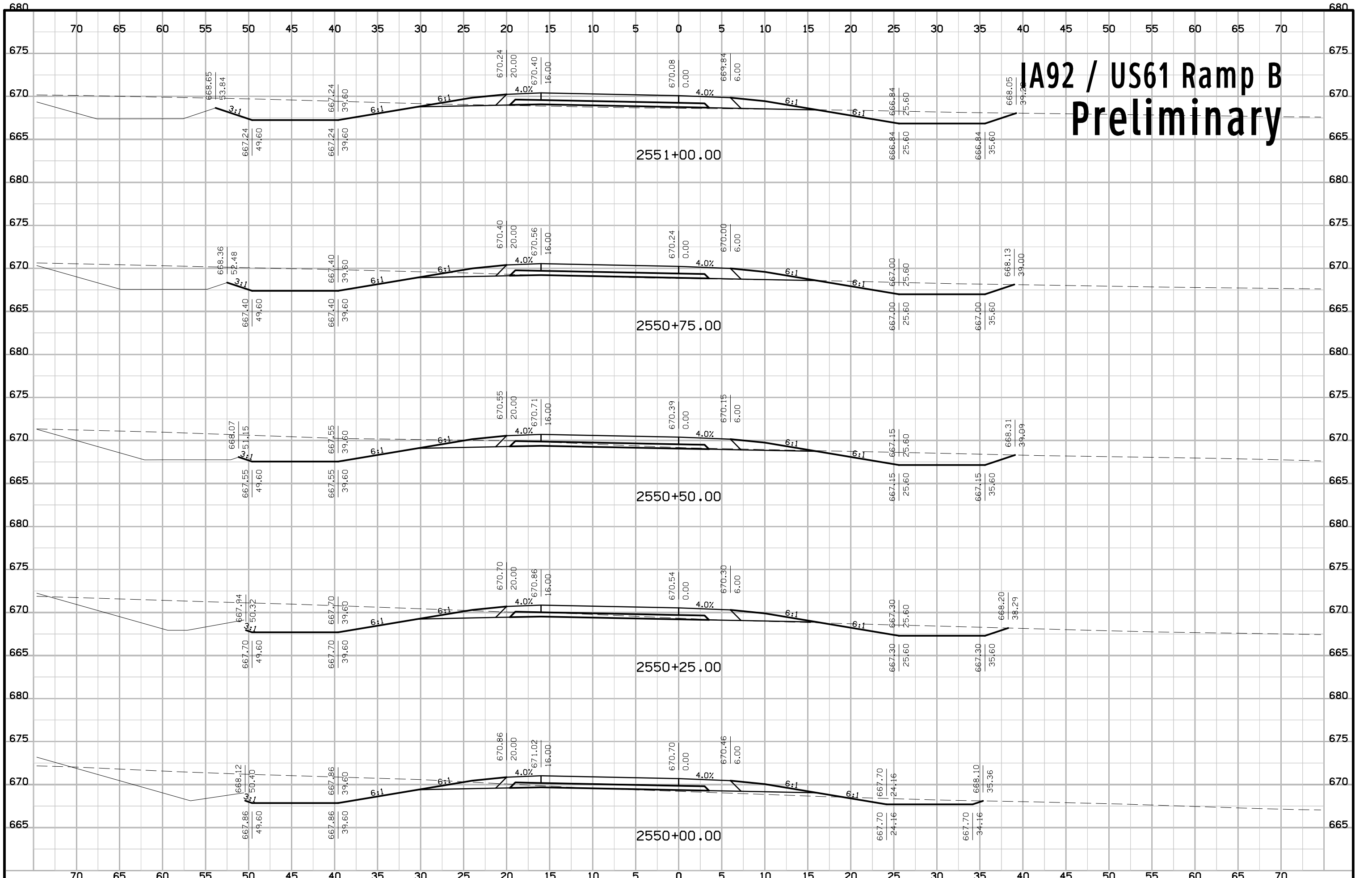

IA92 / US61 Ramp B Preliminary

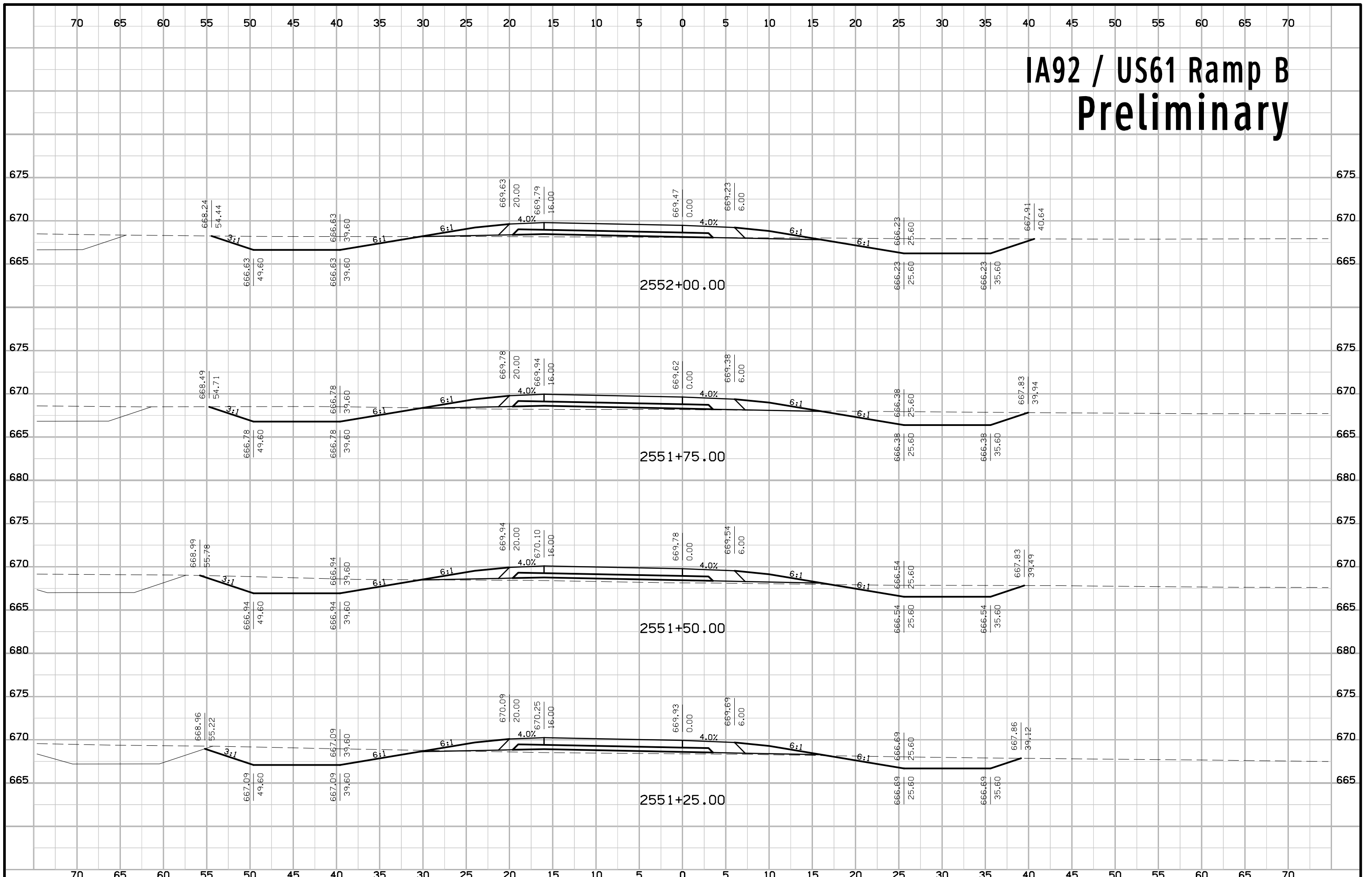

IA92 / US61 Ramp B Preliminary

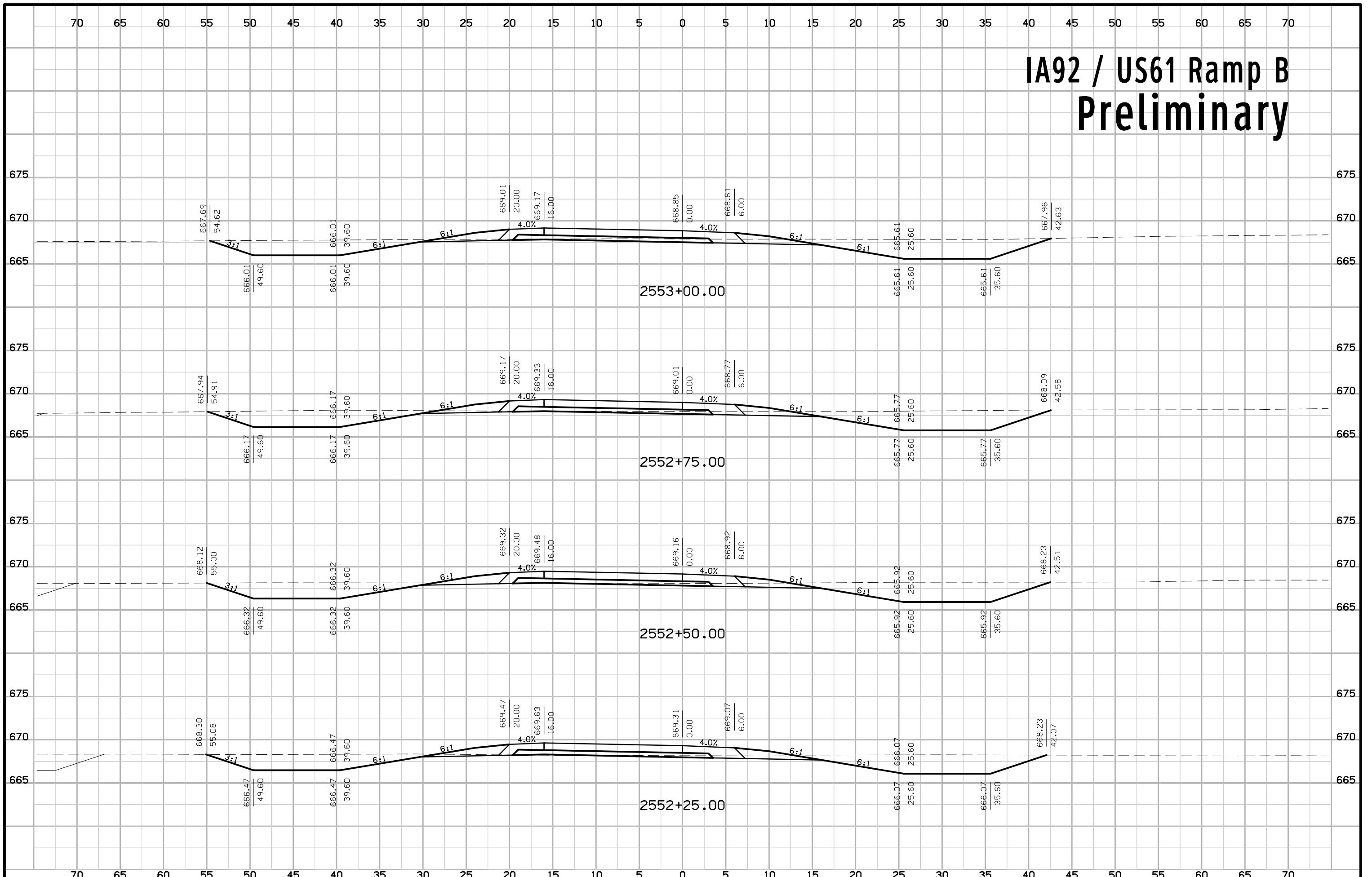

IA92 / US61 Ramp B Preliminary

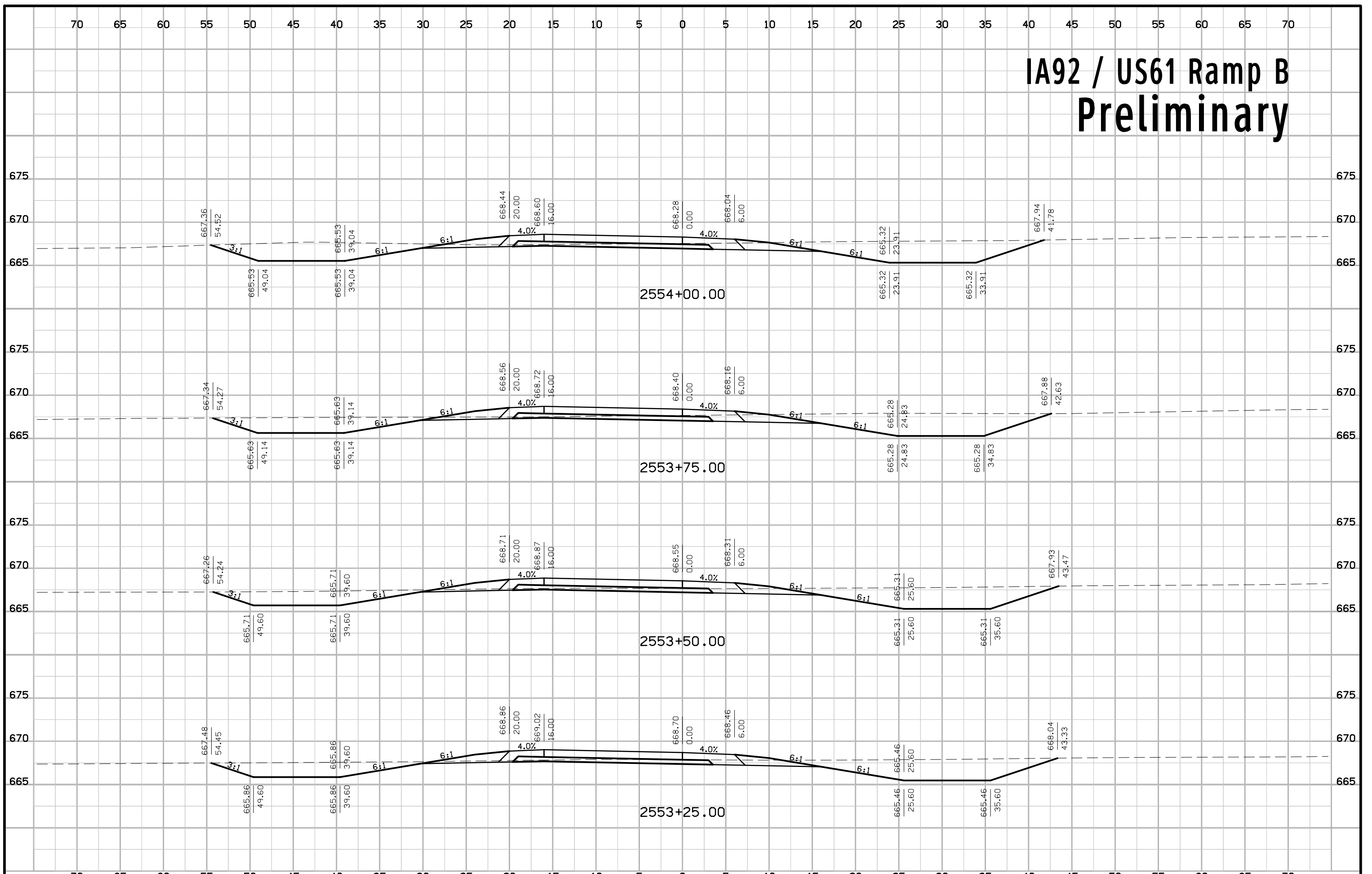

IA92 / US61 Ramp B Preliminary

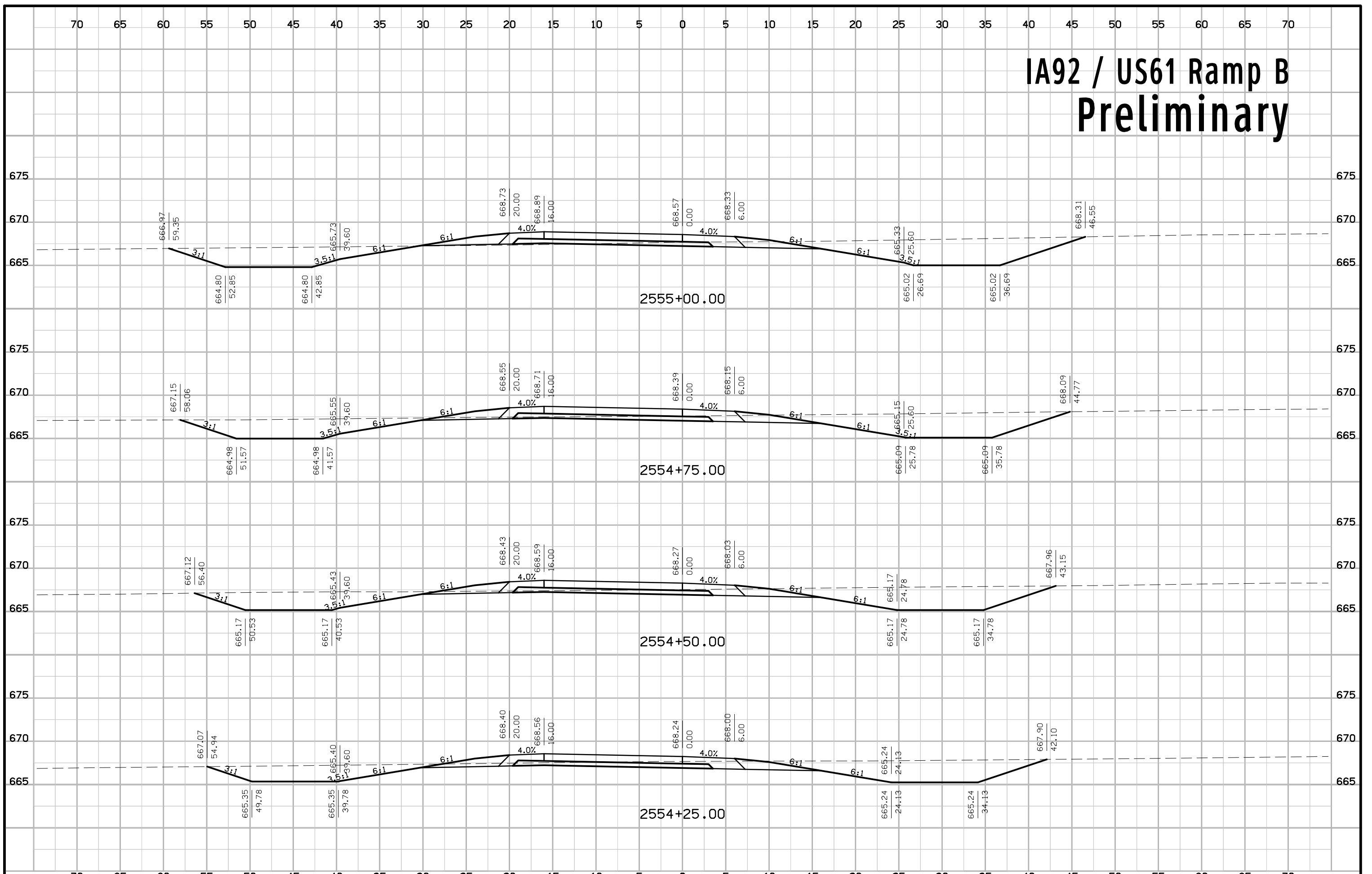

IA92 / US61 Ramp B Preliminary

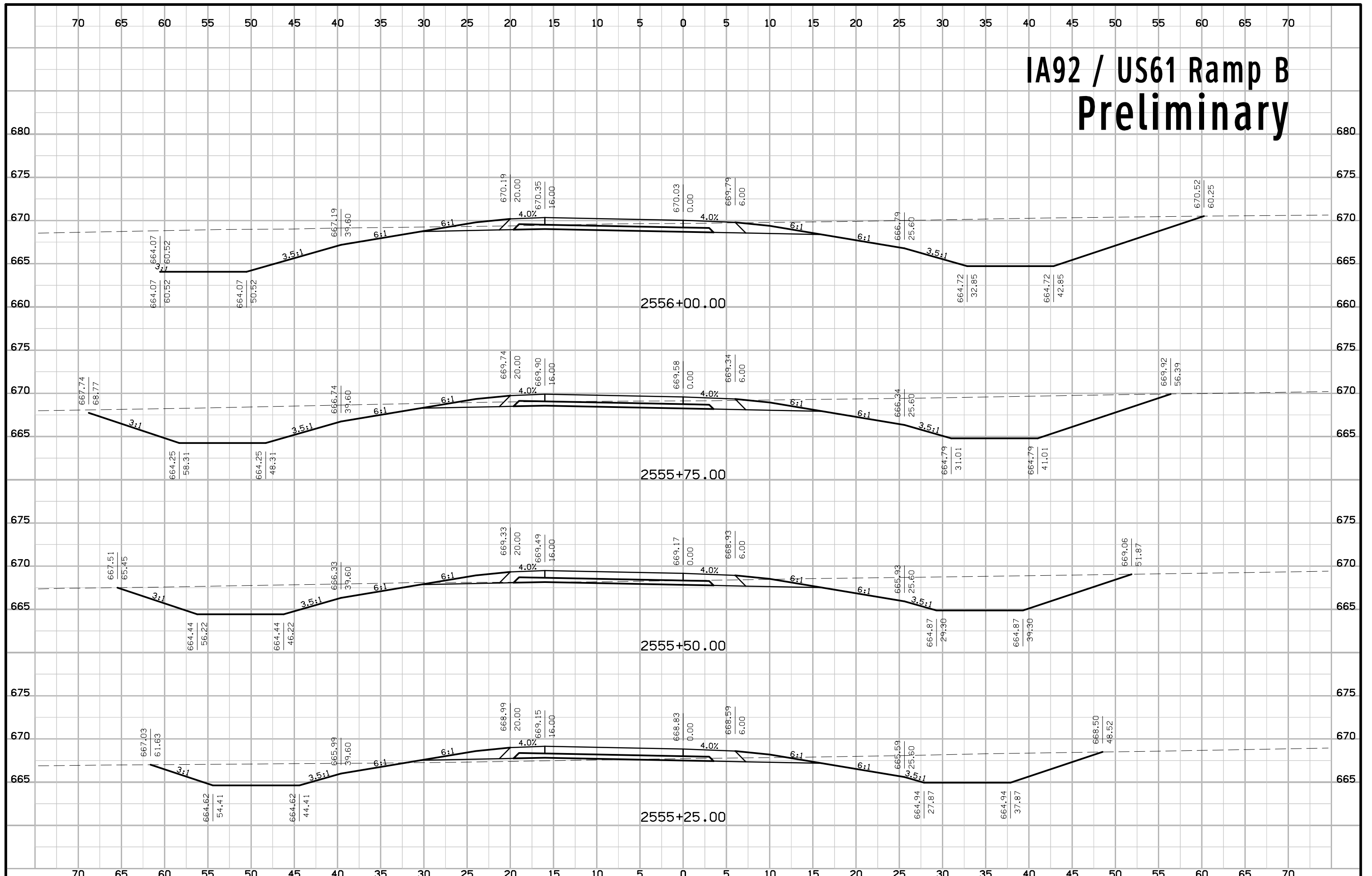

IA92 / US61 Ramp B Preliminary

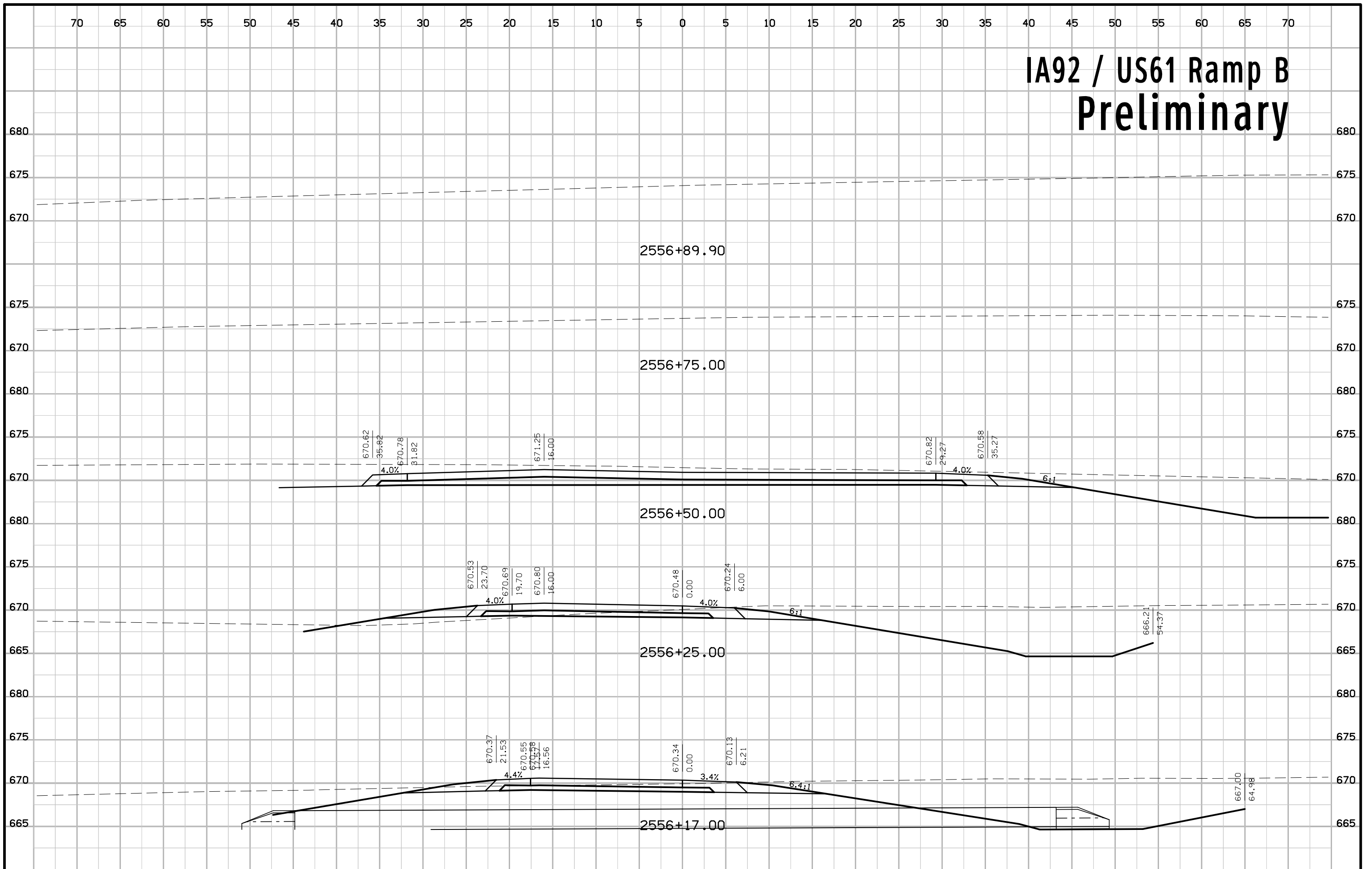

IA92 / US61 Ramp C Preliminary

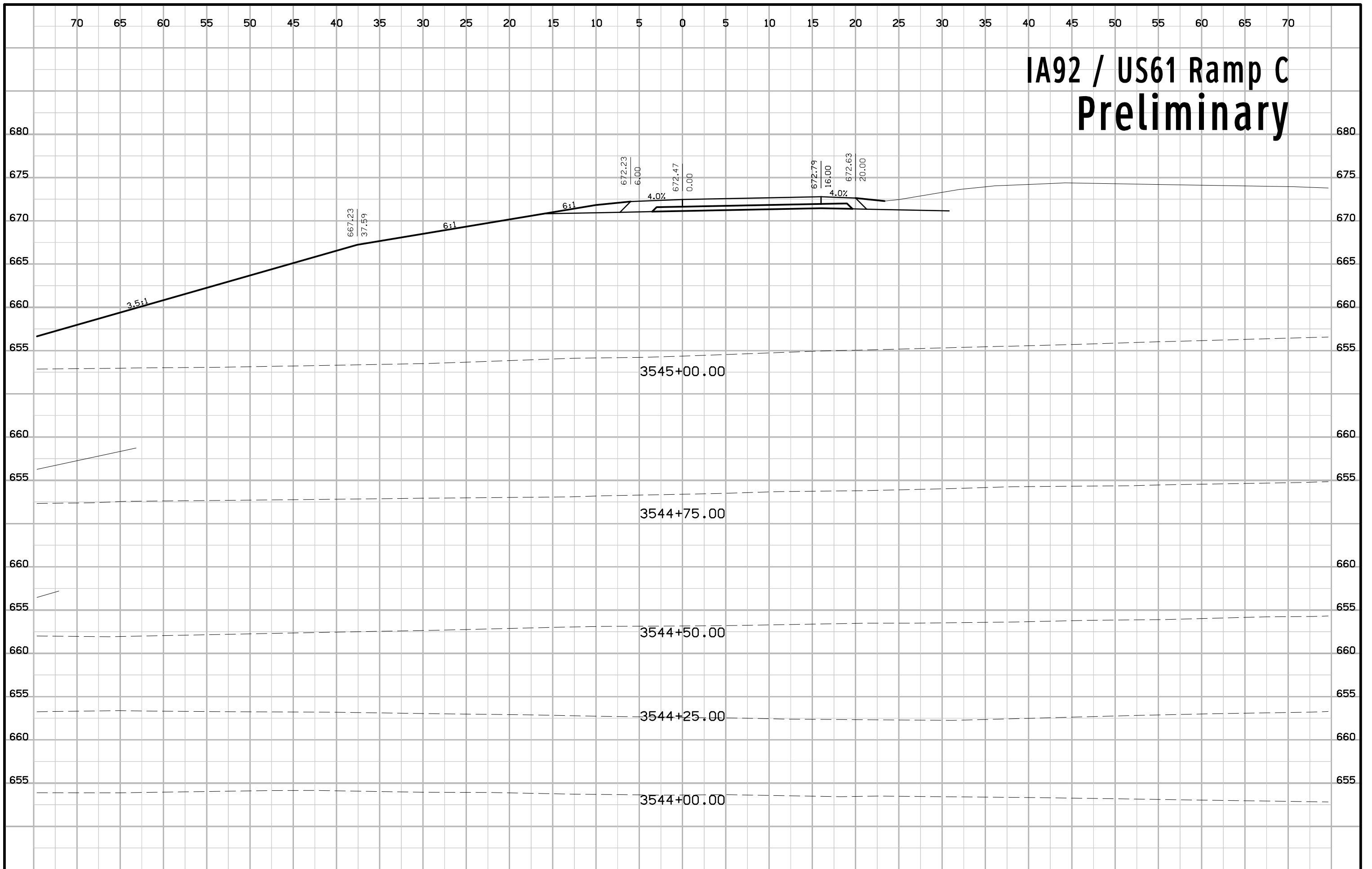

IA92 / US61 Ramp C Preliminary

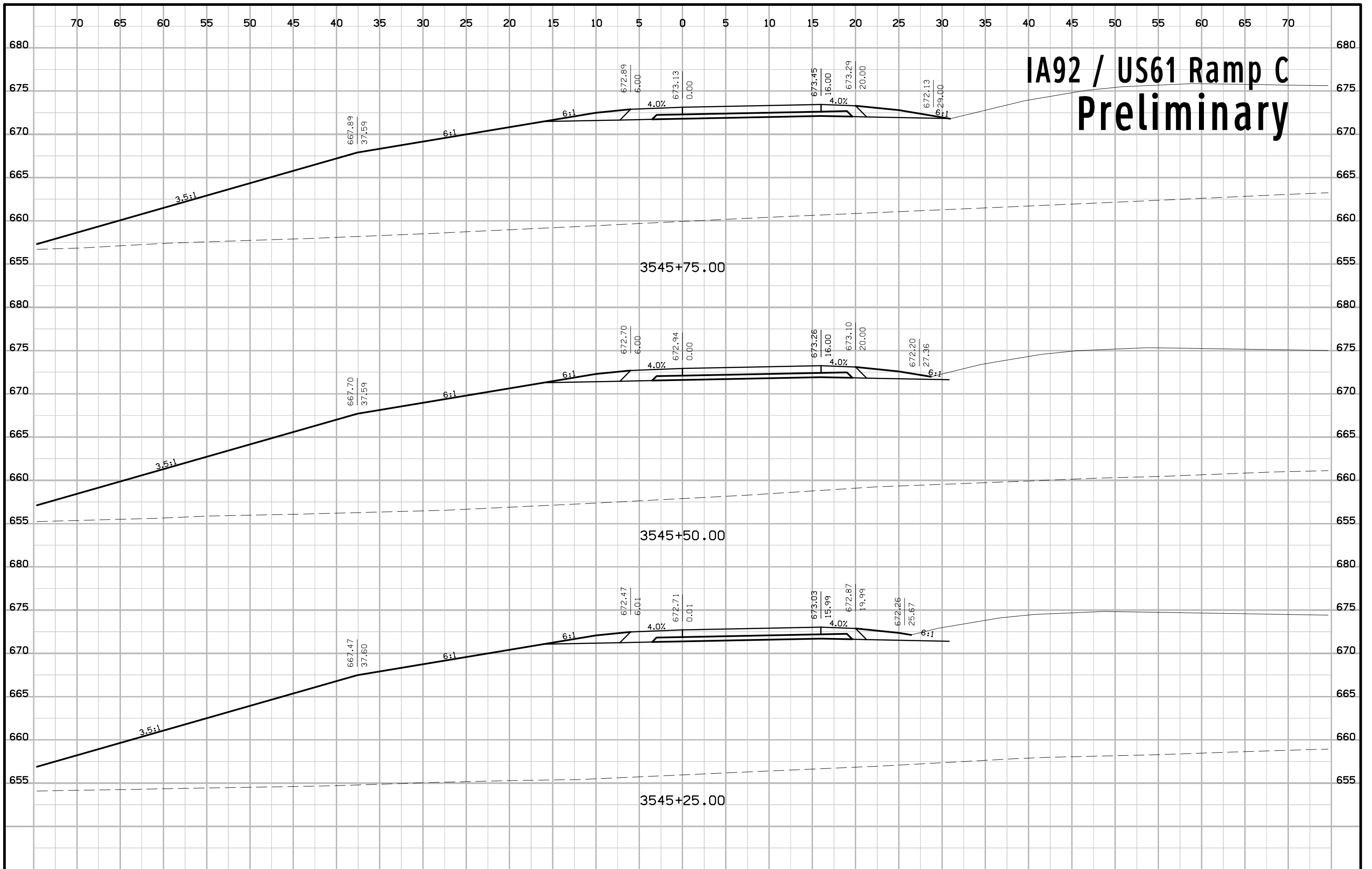

IA92 / US61 Ramp C Preliminary

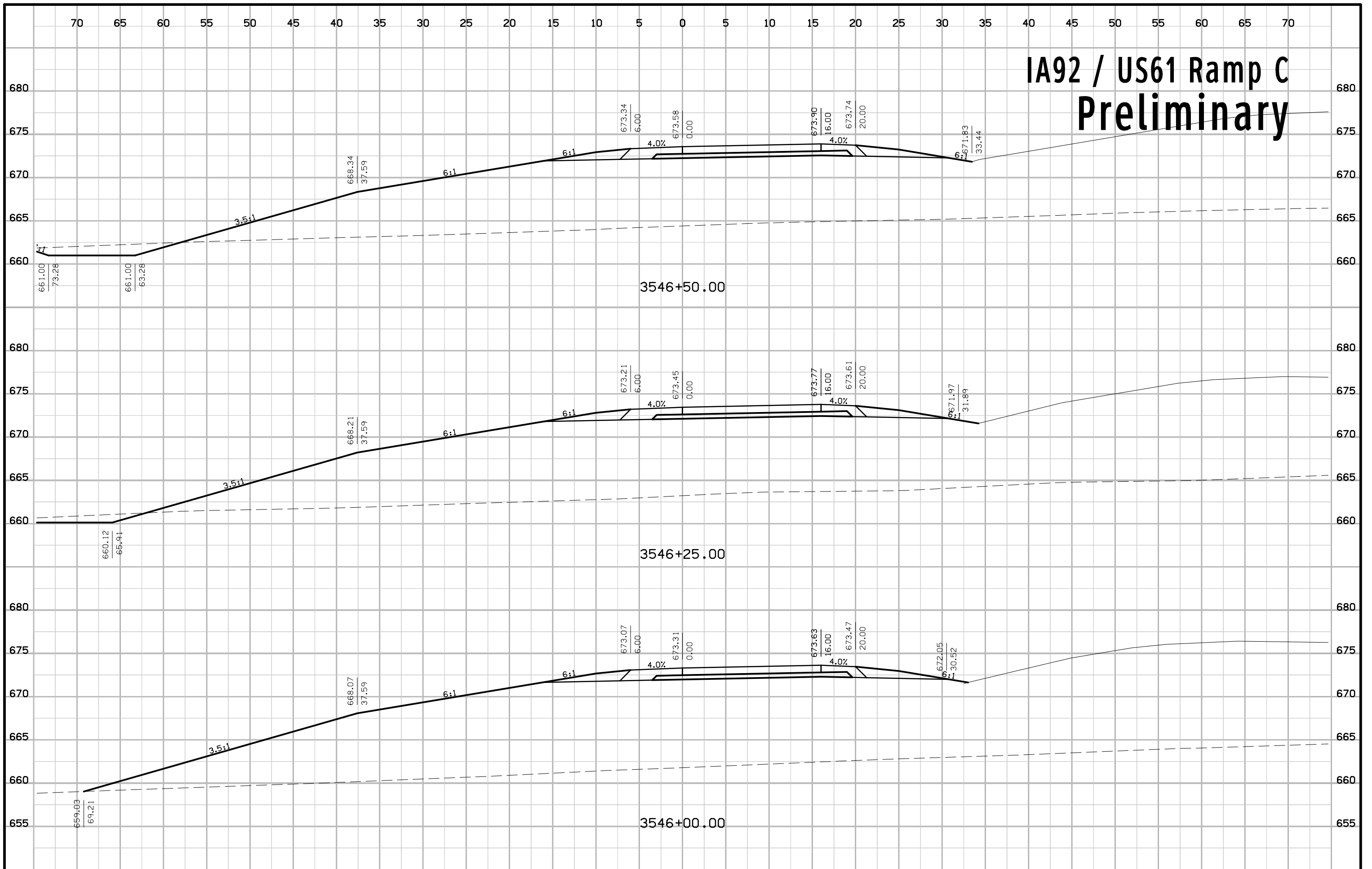

IA92 / US61 Ramp C Preliminary

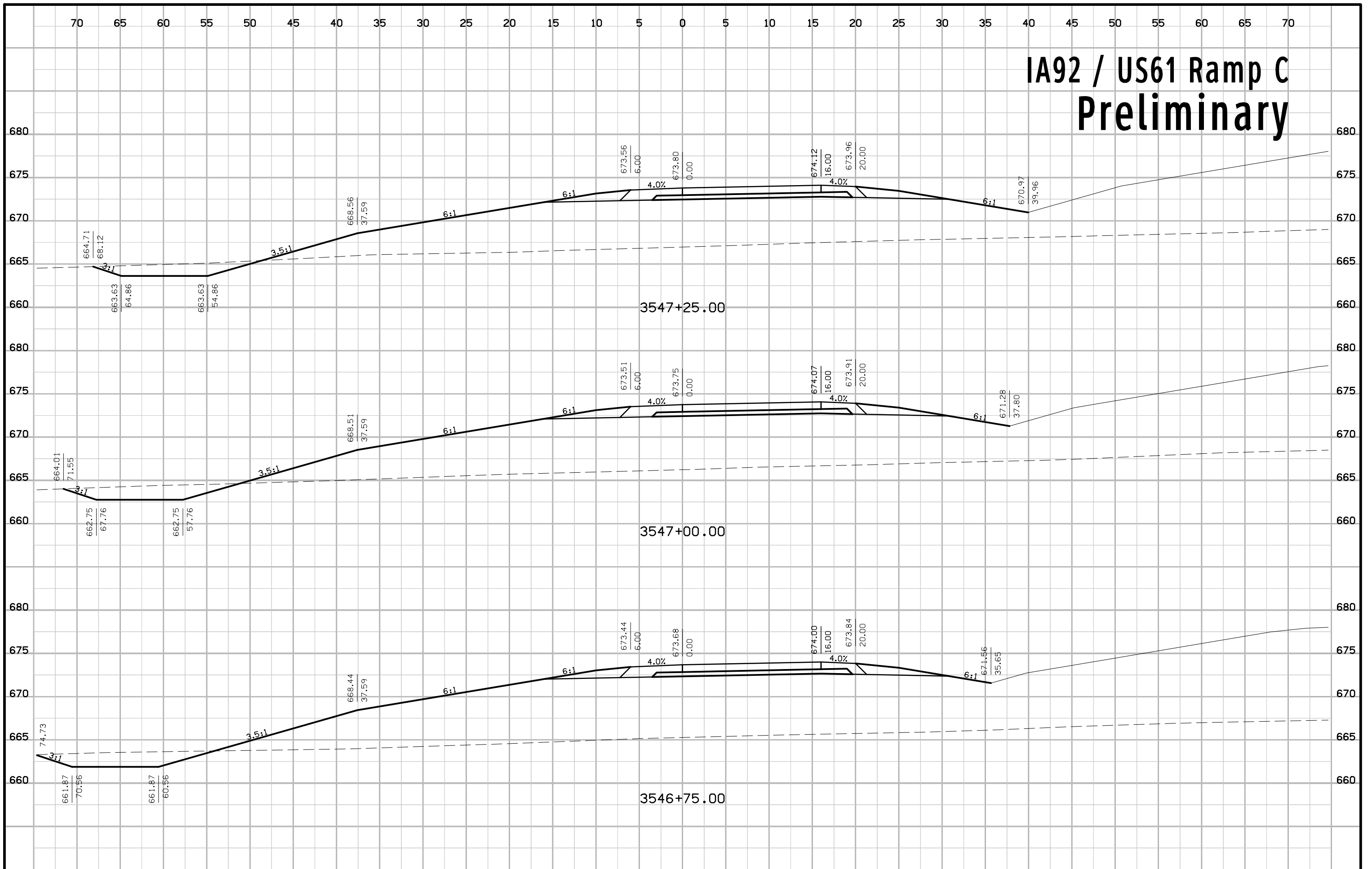

IA92 / US61 Ramp C Preliminary

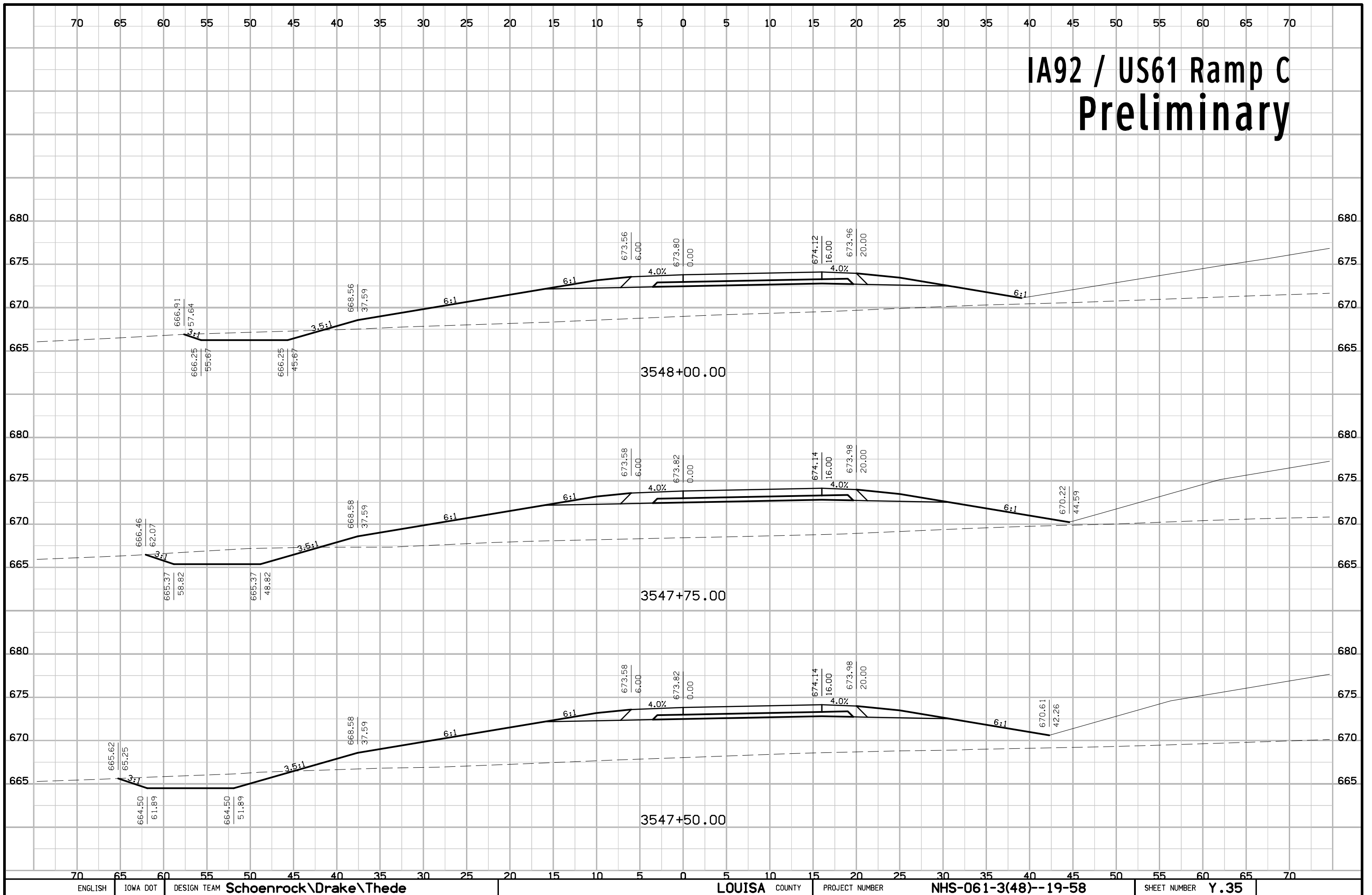

IA92 / US61 Ramp C Preliminary

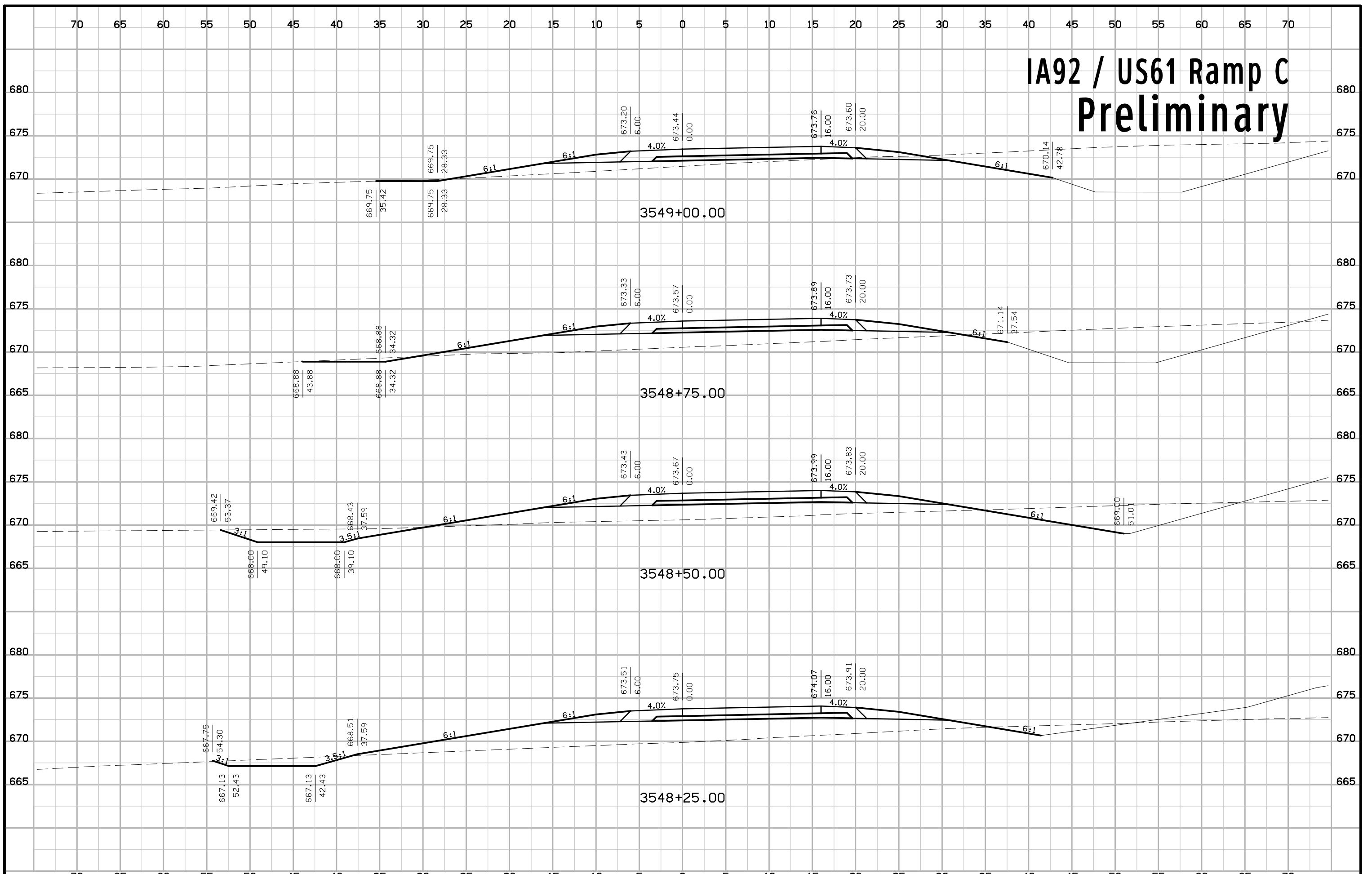

IA92 / US61 Ramp C Preliminary

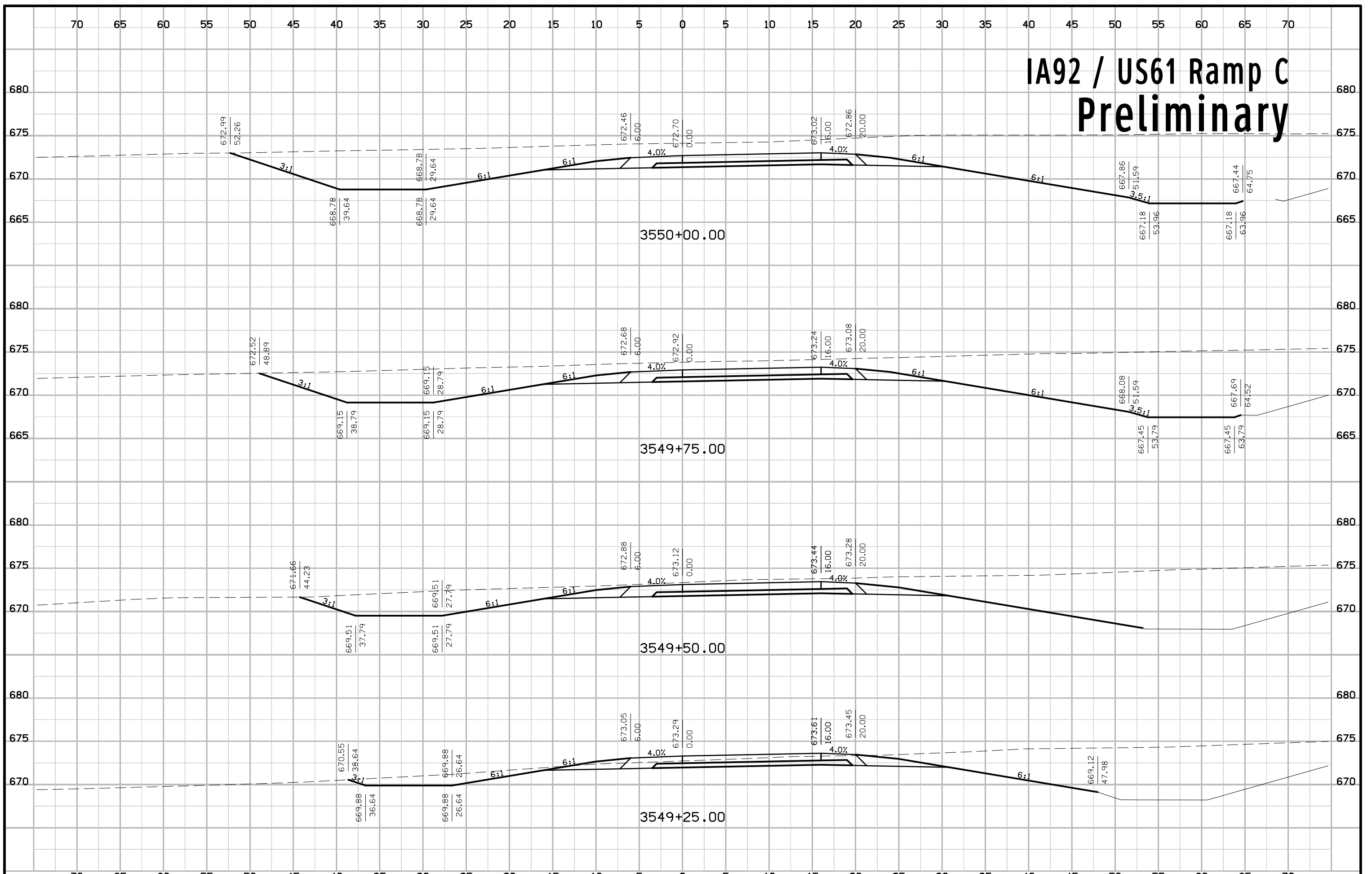

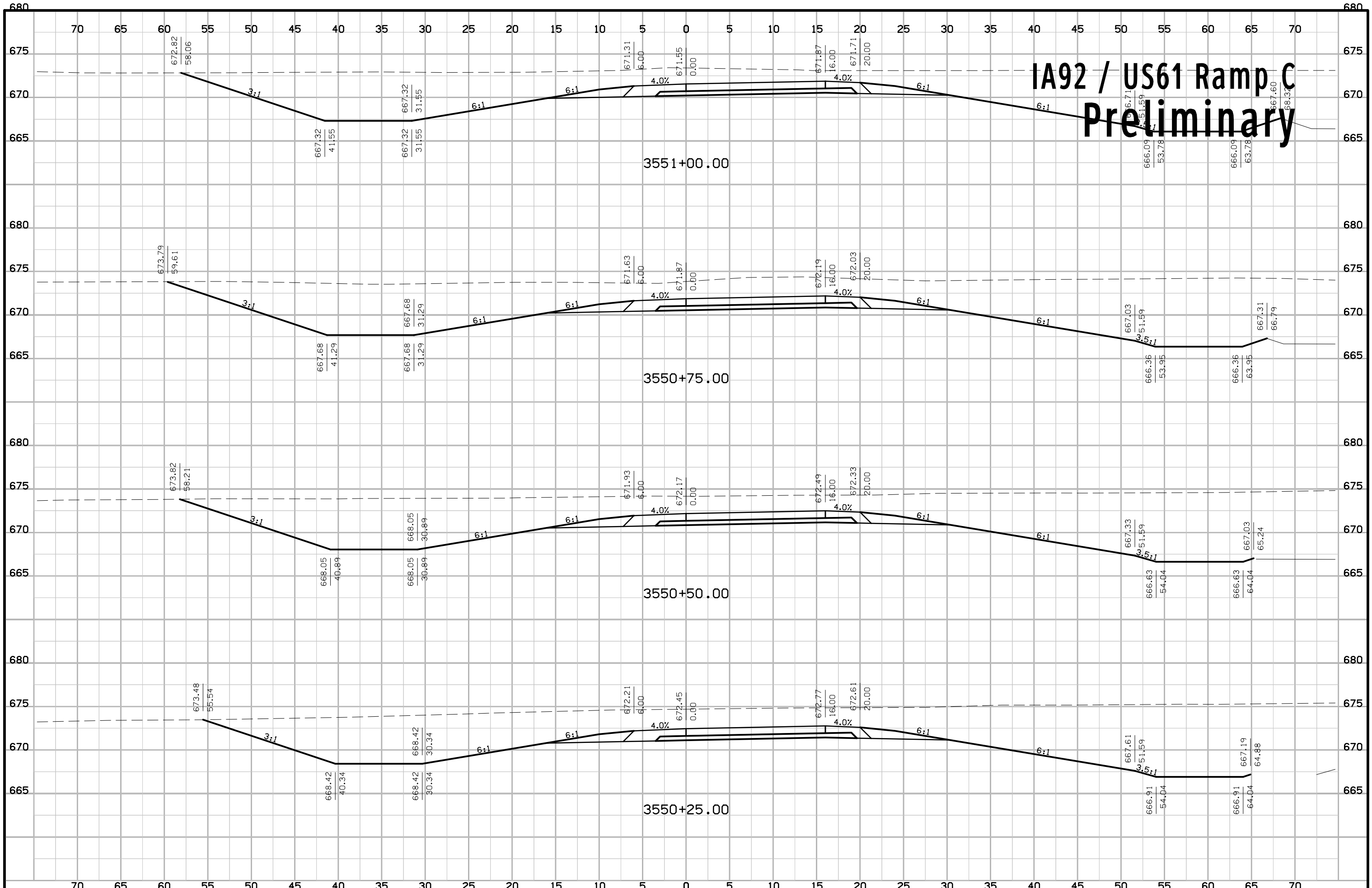

IA92 / US61 Ramp C Preliminary

IA92 / US61 Ramp C Preliminary

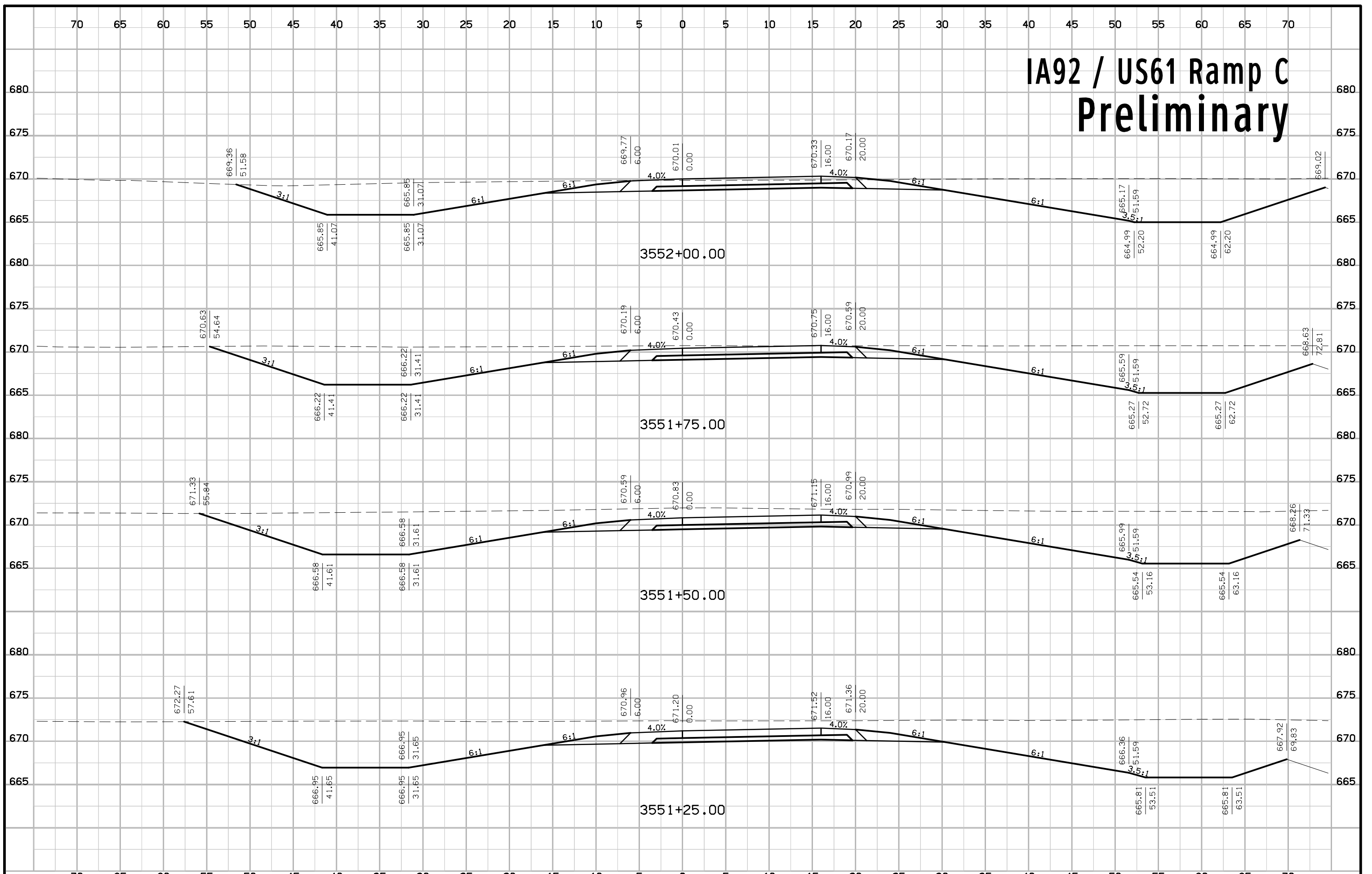

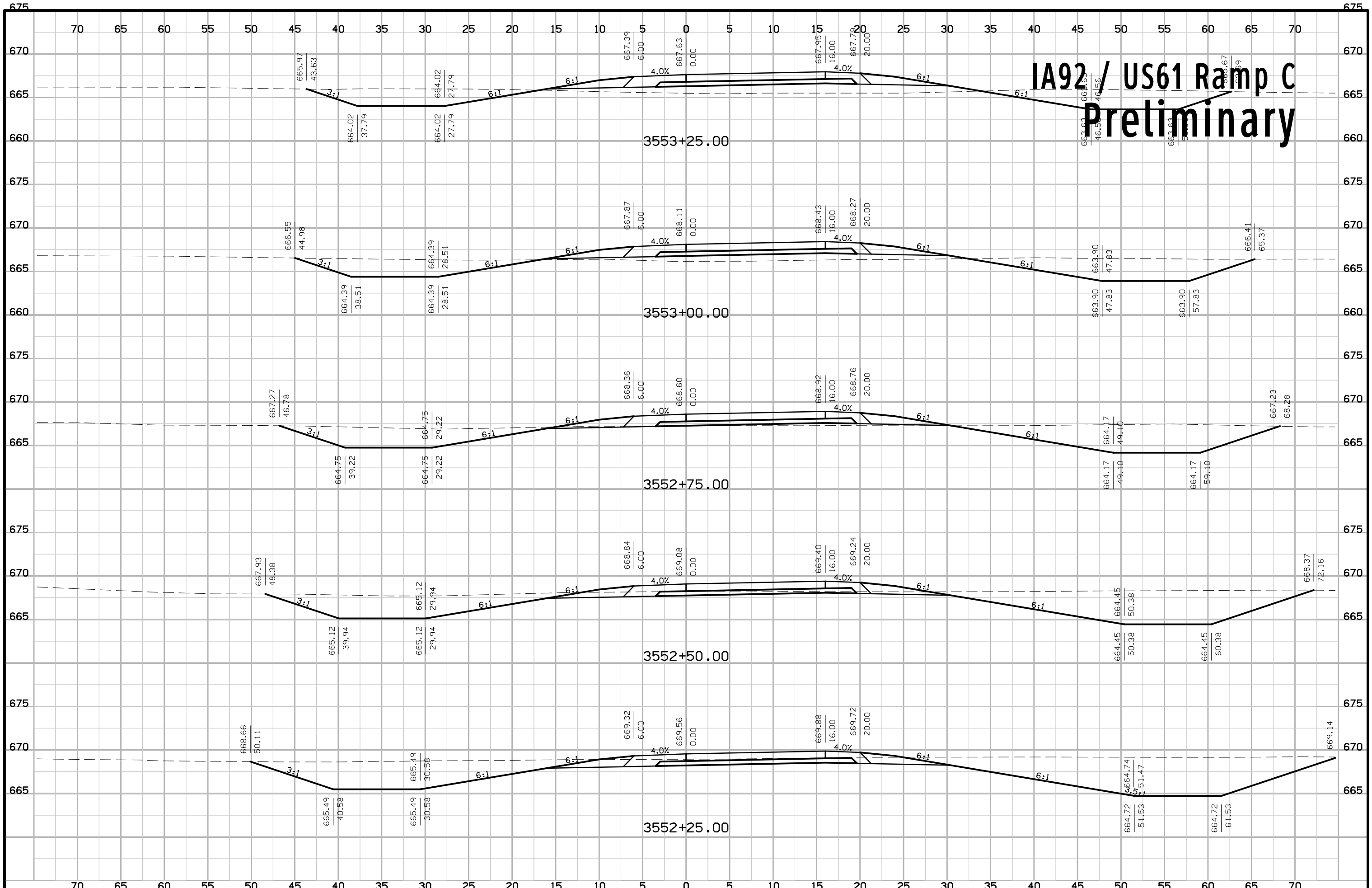

IA92 / US61 Ramp C Preliminary

IA92 / US61 Ramp C Preliminary

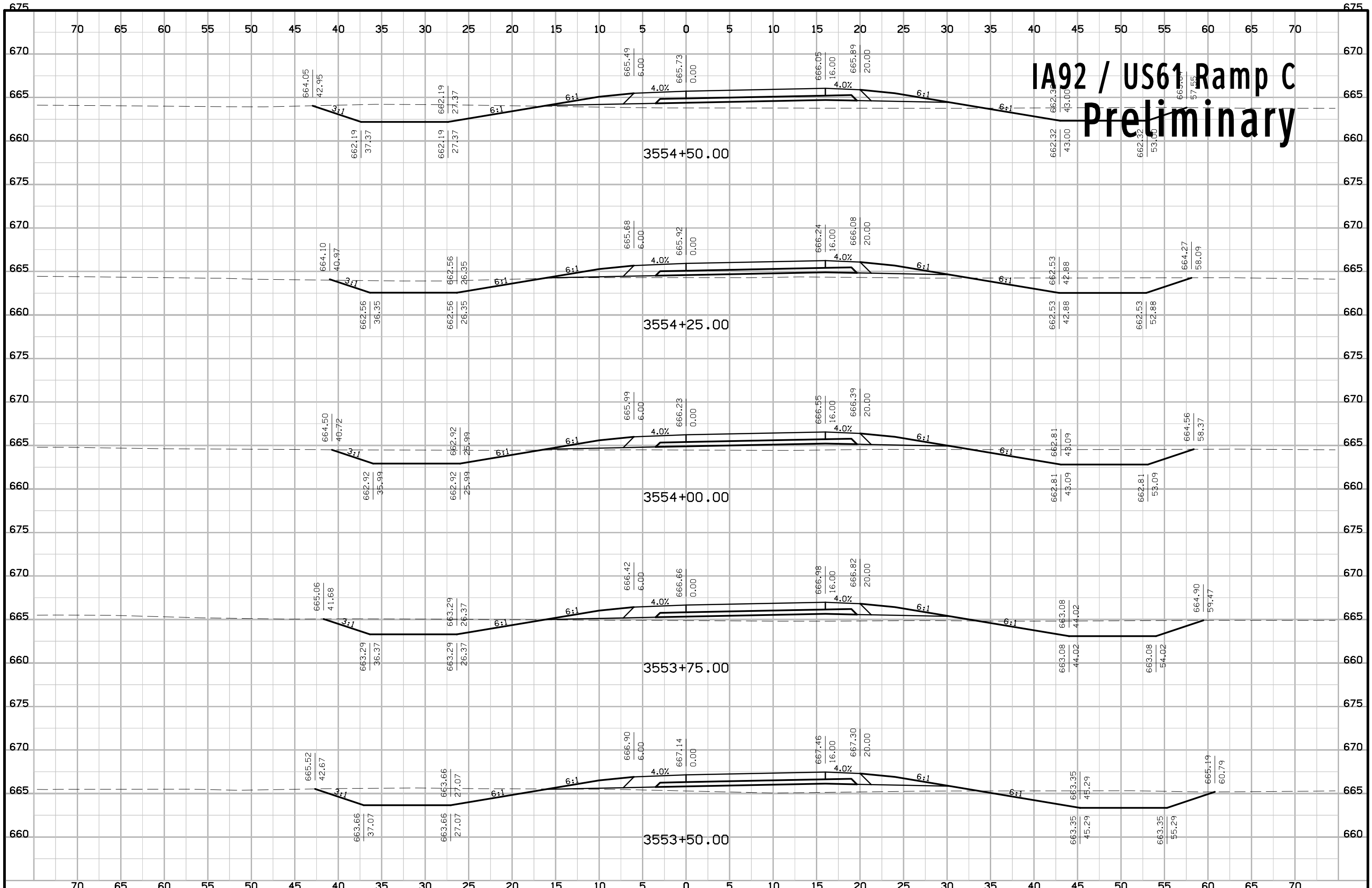

IA92 / US61 Ramp C Preliminary

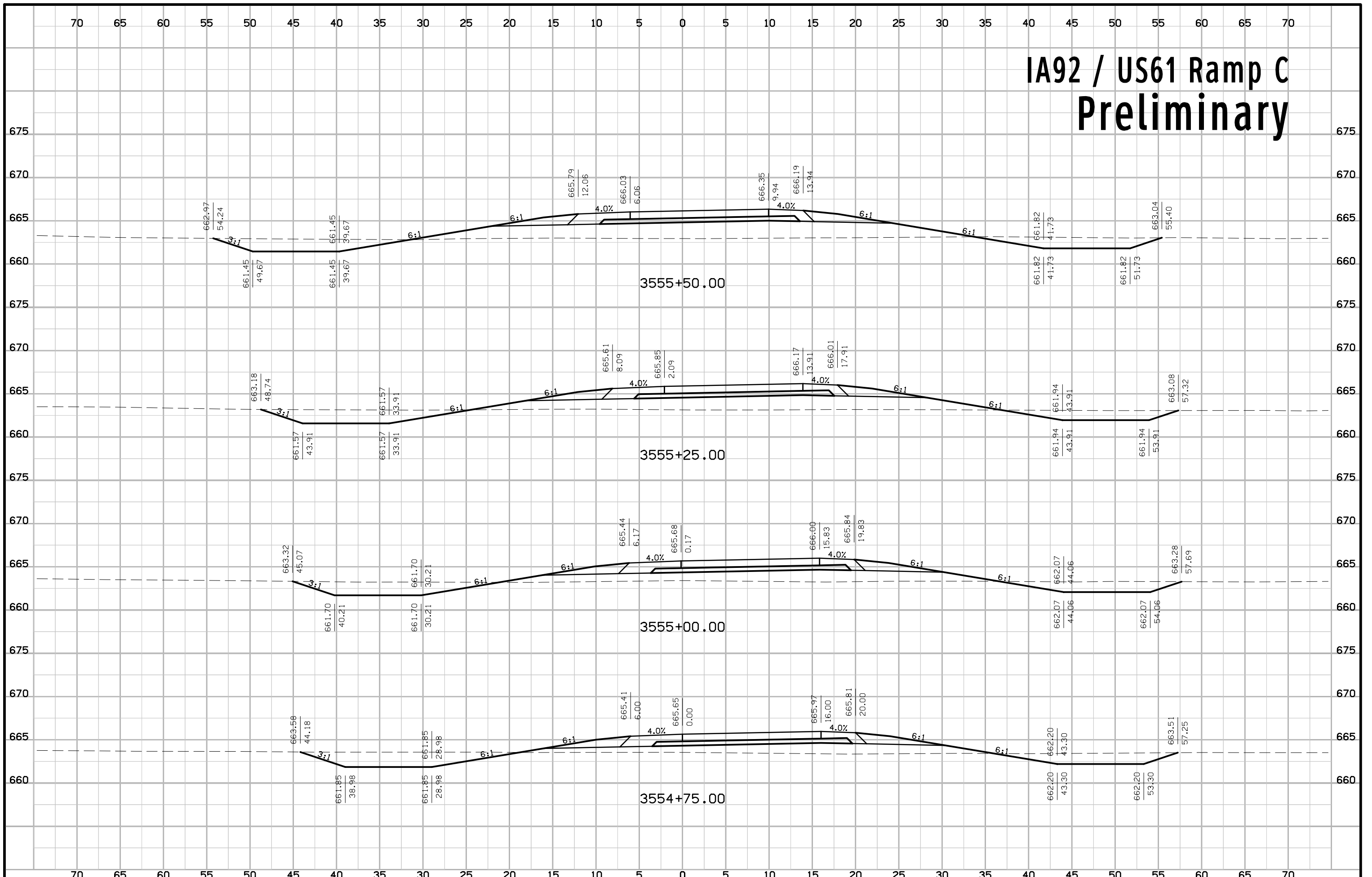

IA92 / US61 Ramp C Preliminary

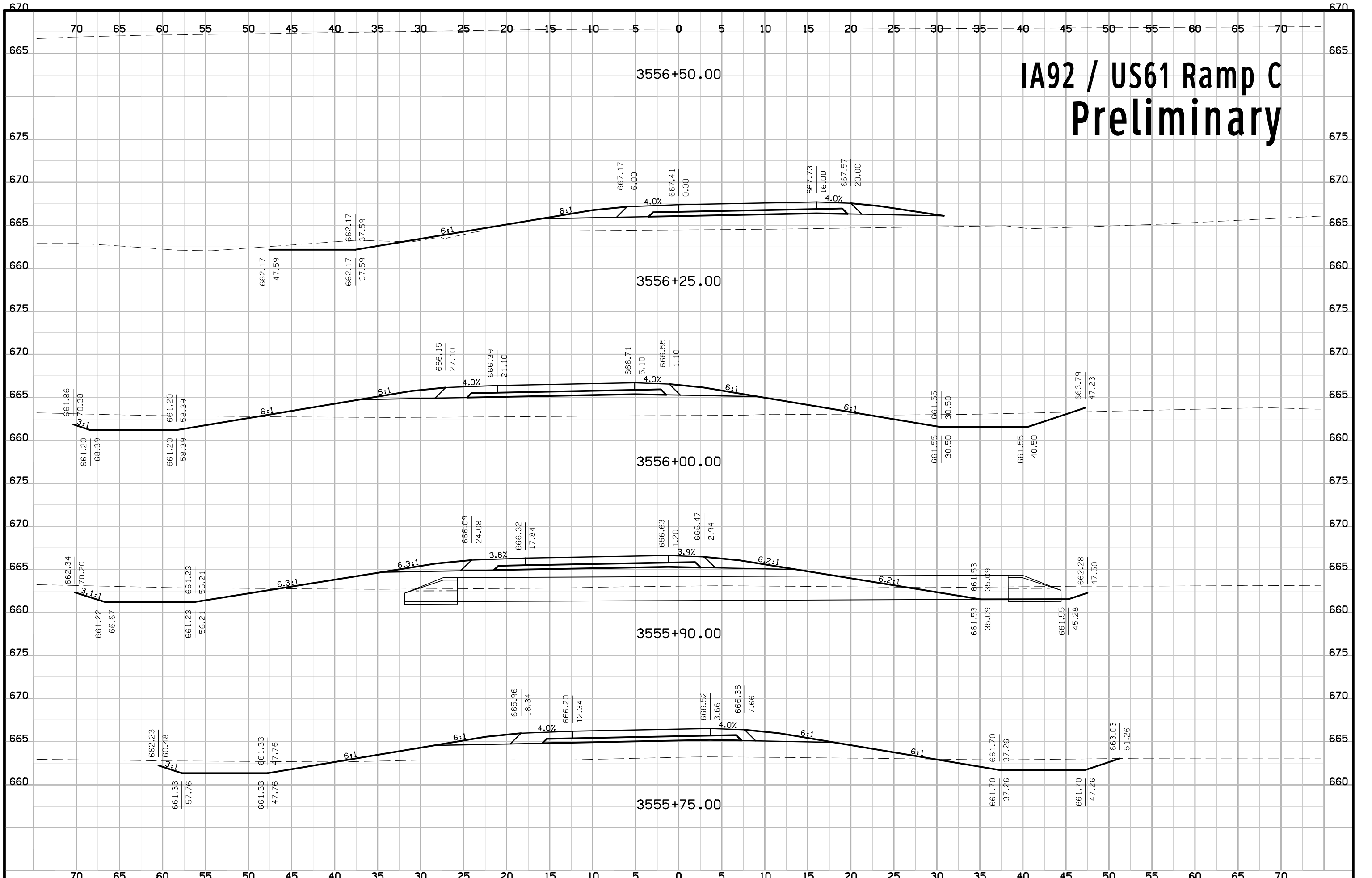

IA92 / US61 Ramp D Preliminary

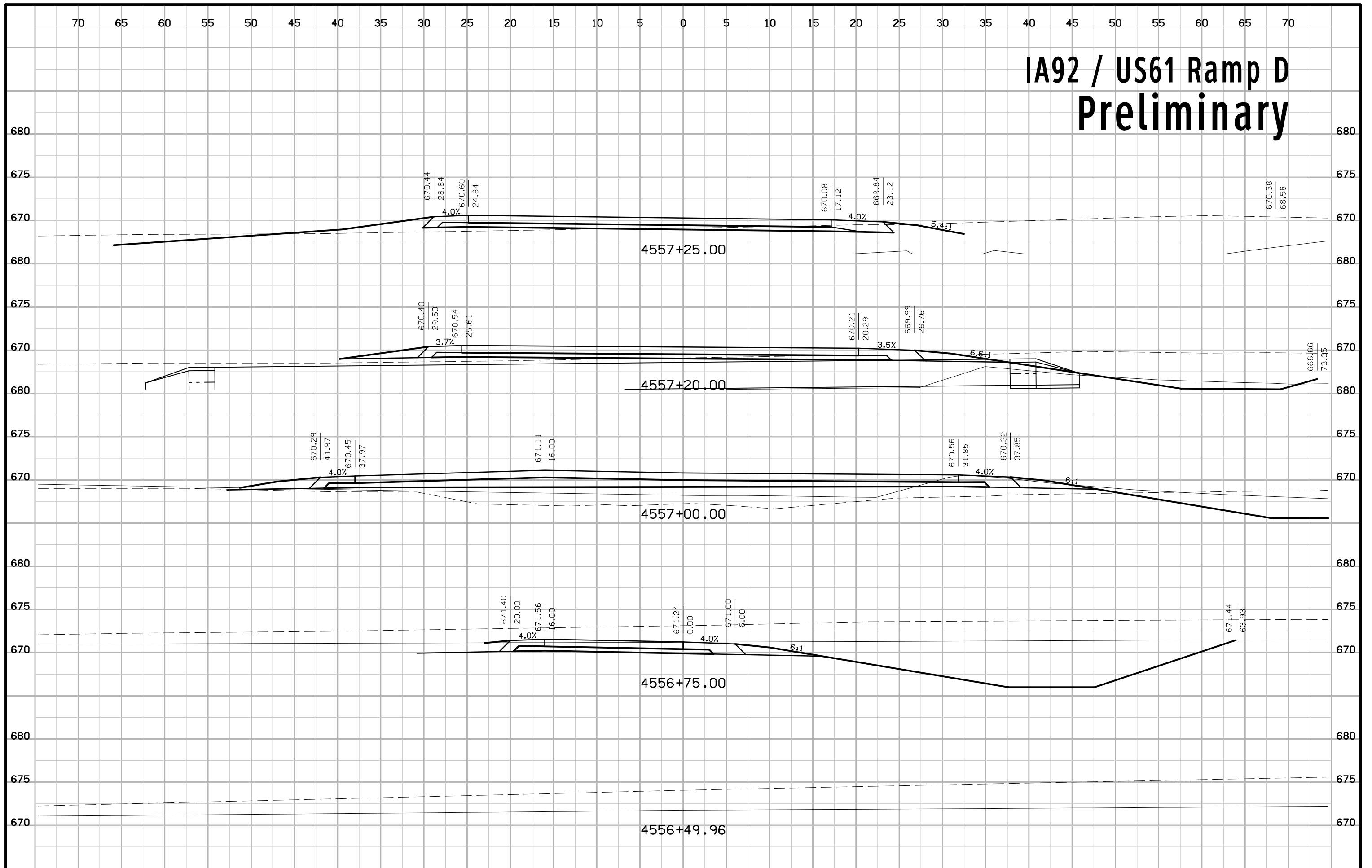

IA92 / US61 Ramp D Preliminary

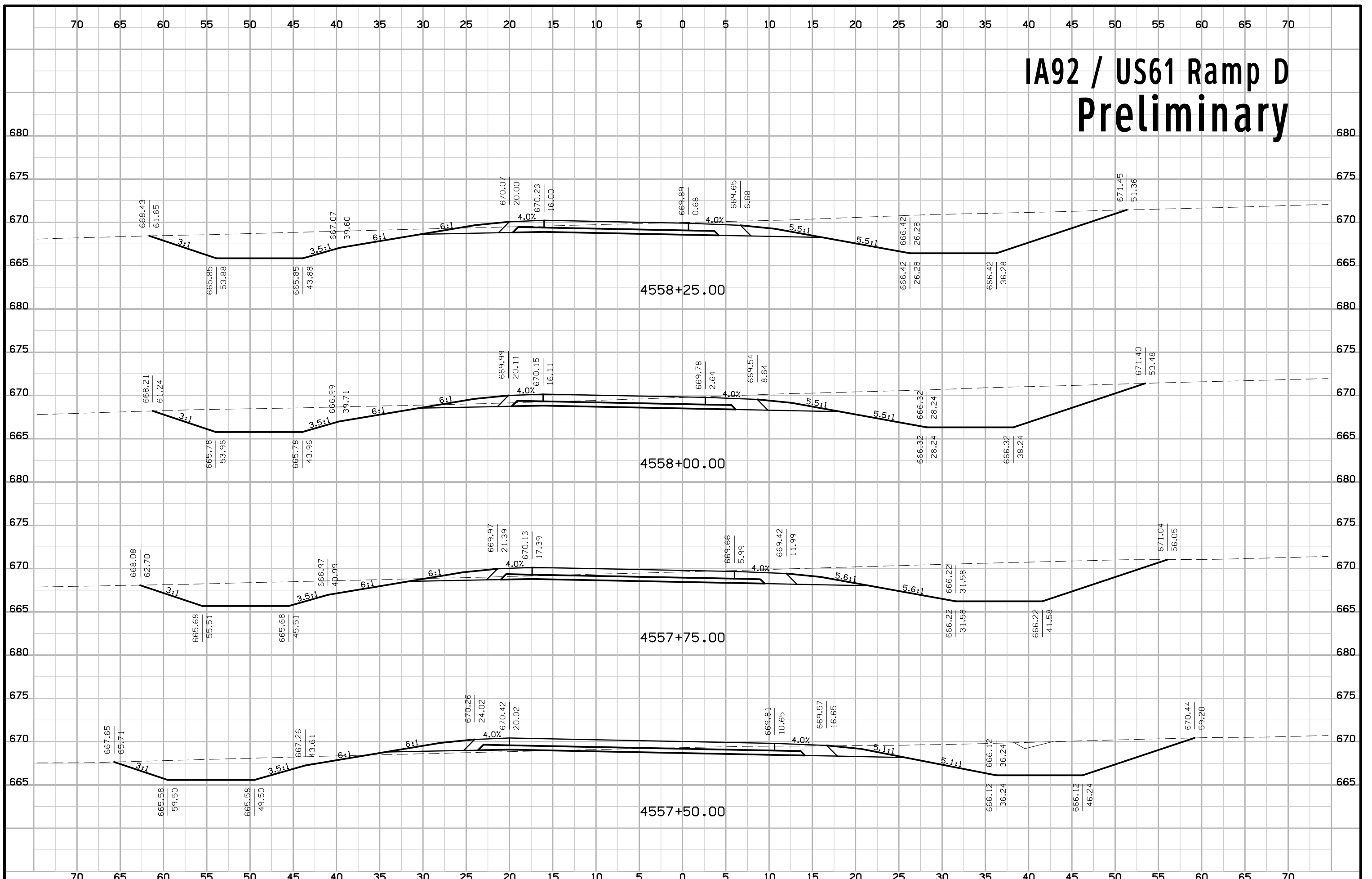

IA92 / US61 Ramp D Preliminary

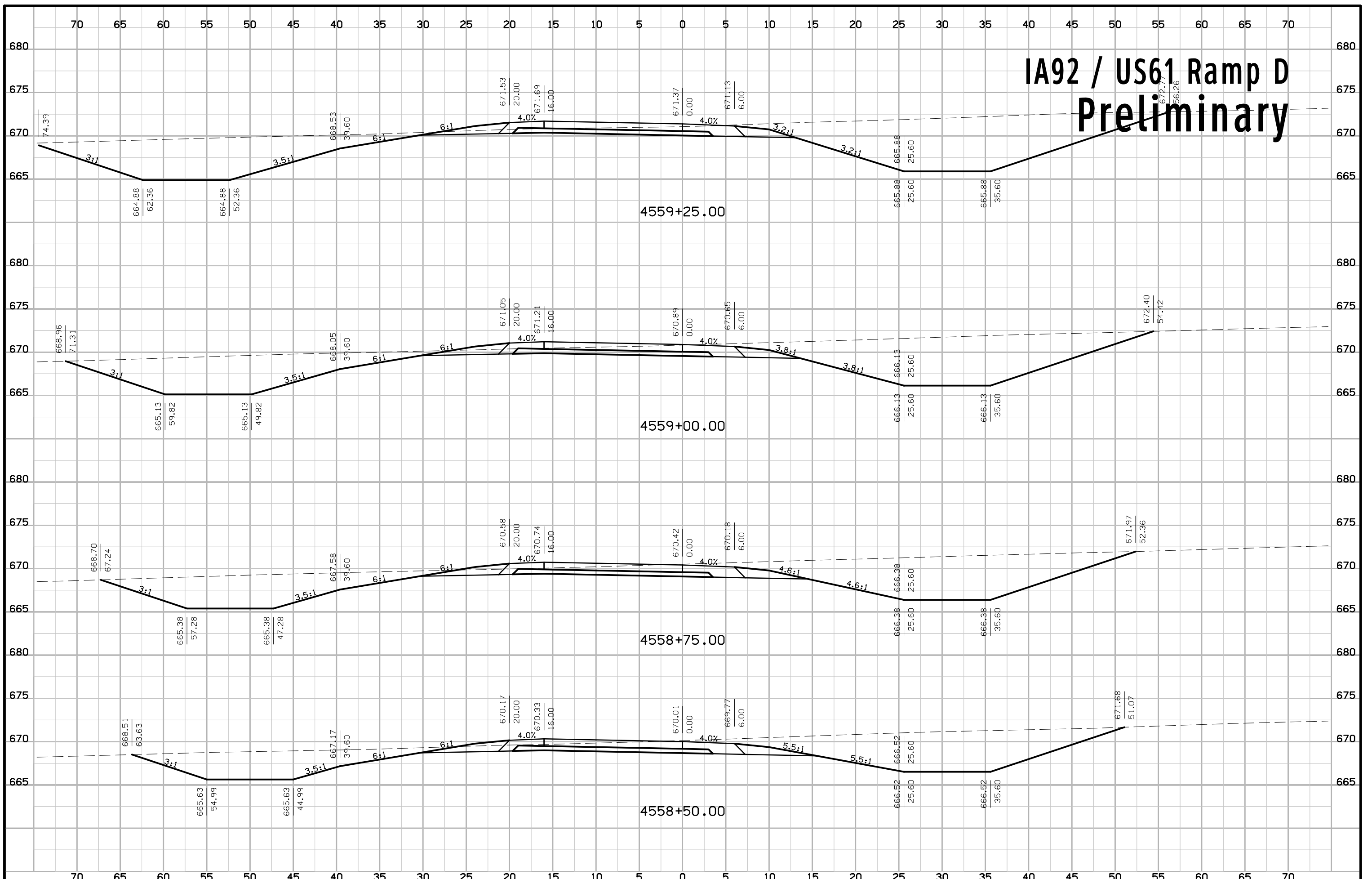

IA92 / US61 Ramp D Preliminary

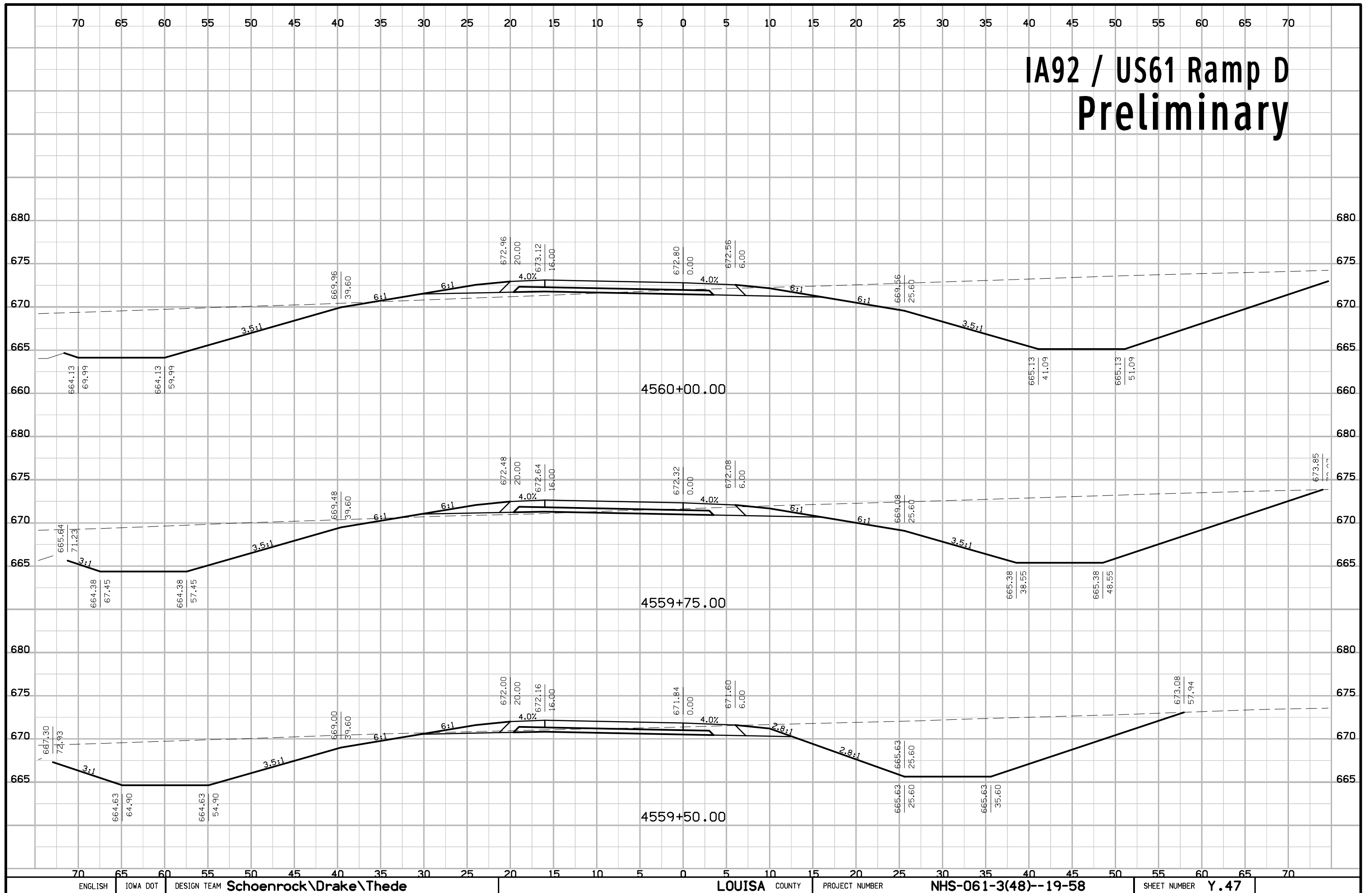

IA92 / US61 Ramp D Preliminary

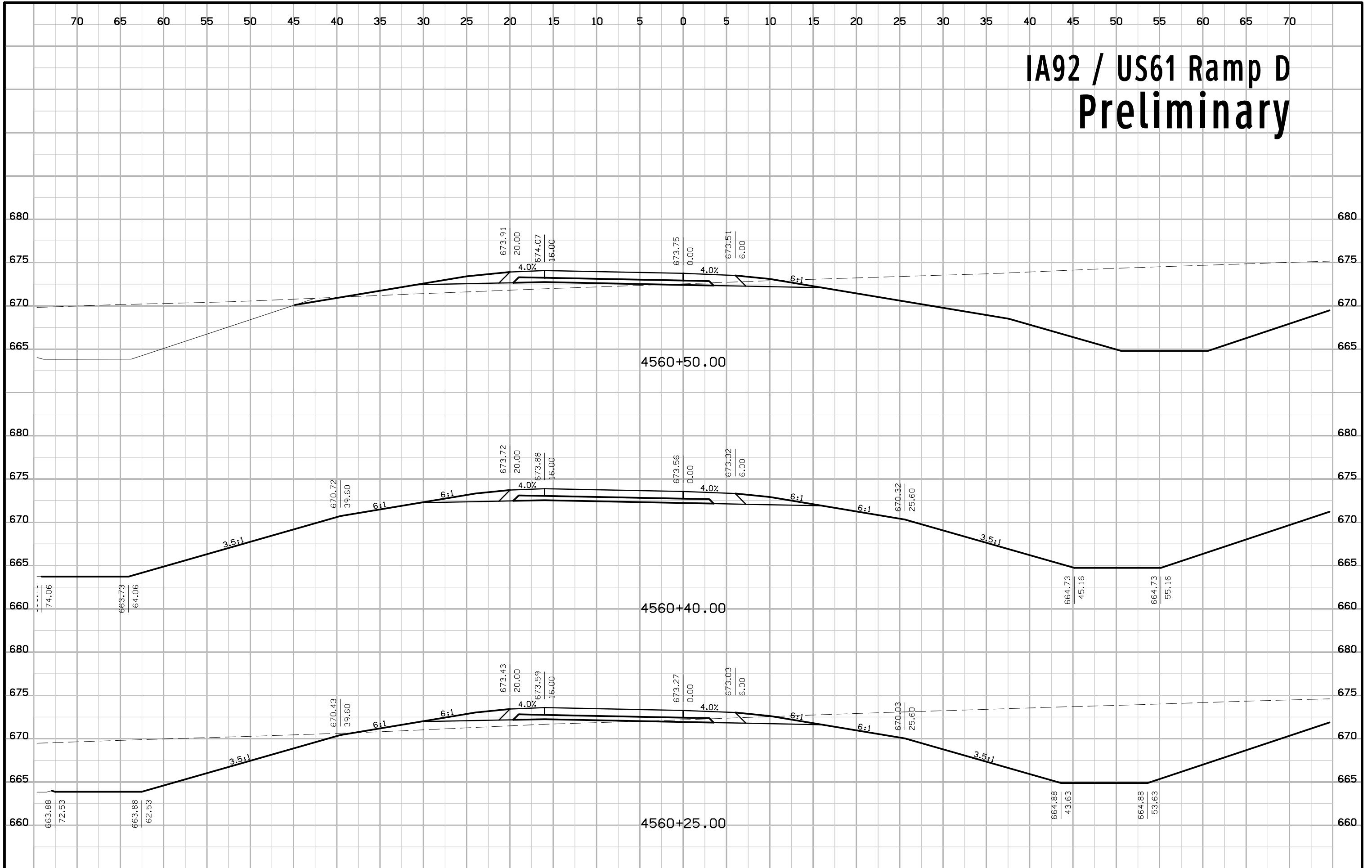

IA92 / US61 Ramp D Preliminary

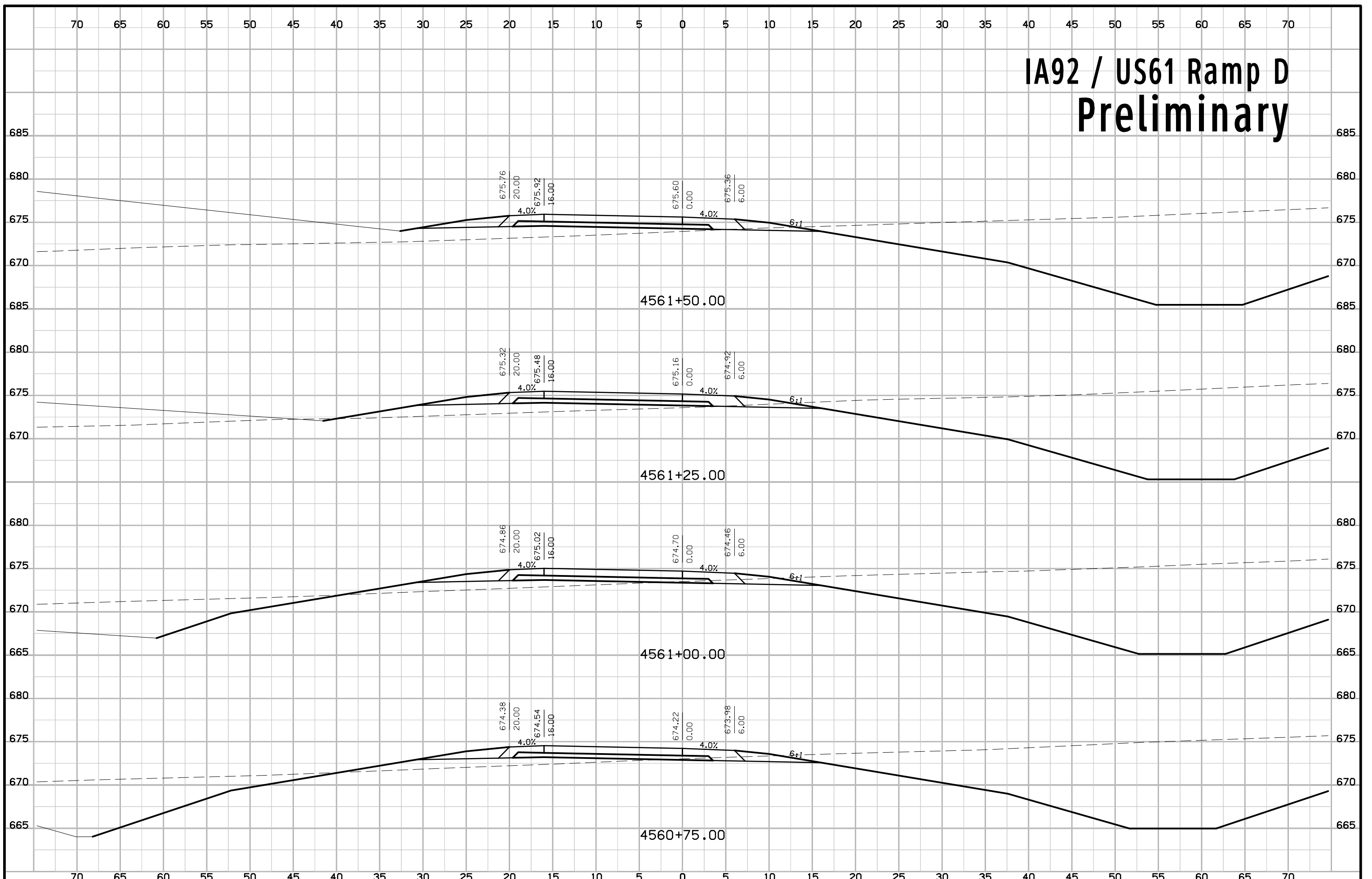

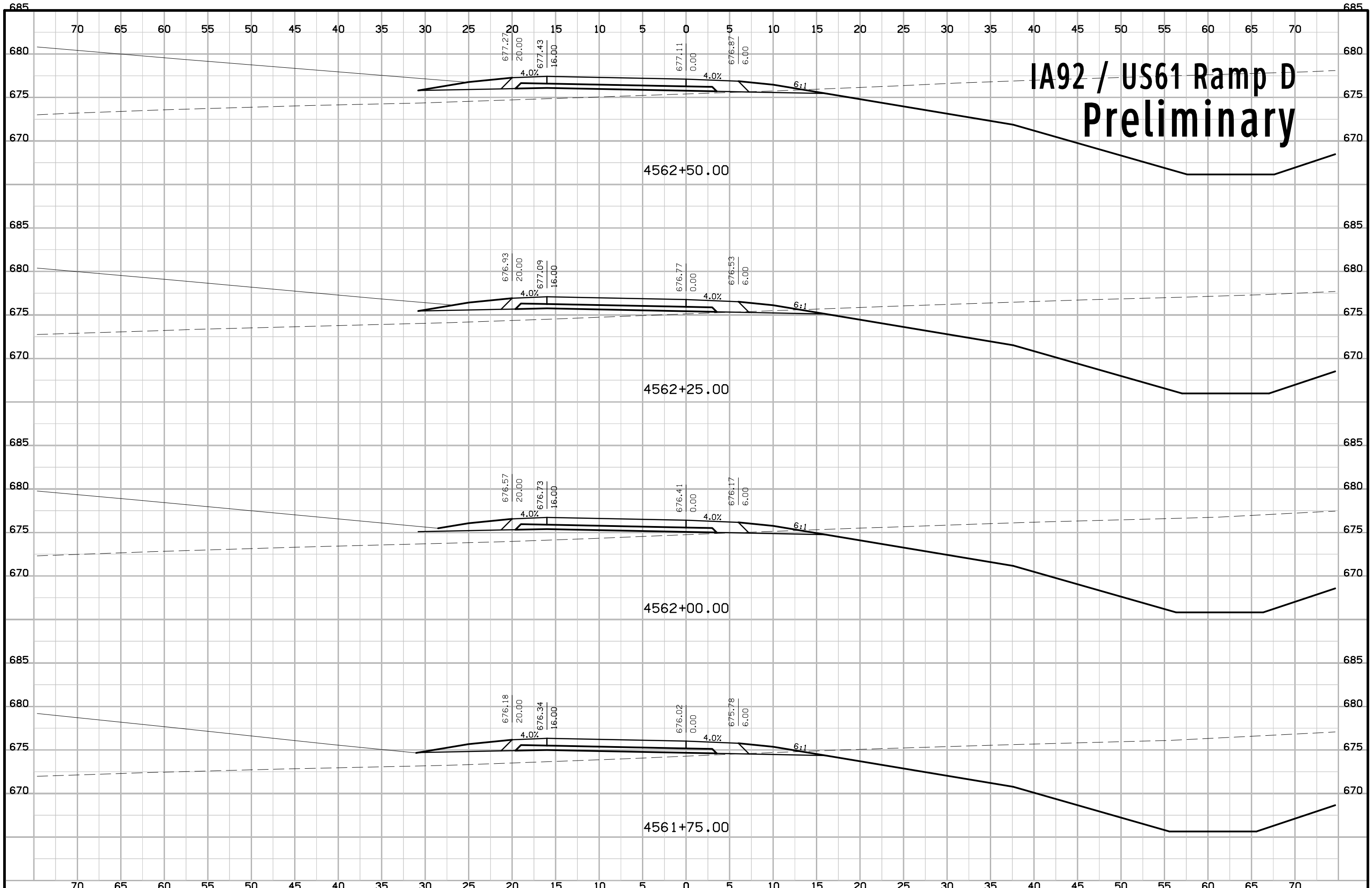

IA92 / US61 Ramp D Preliminary

IA92 / US61 Ramp D Preliminary

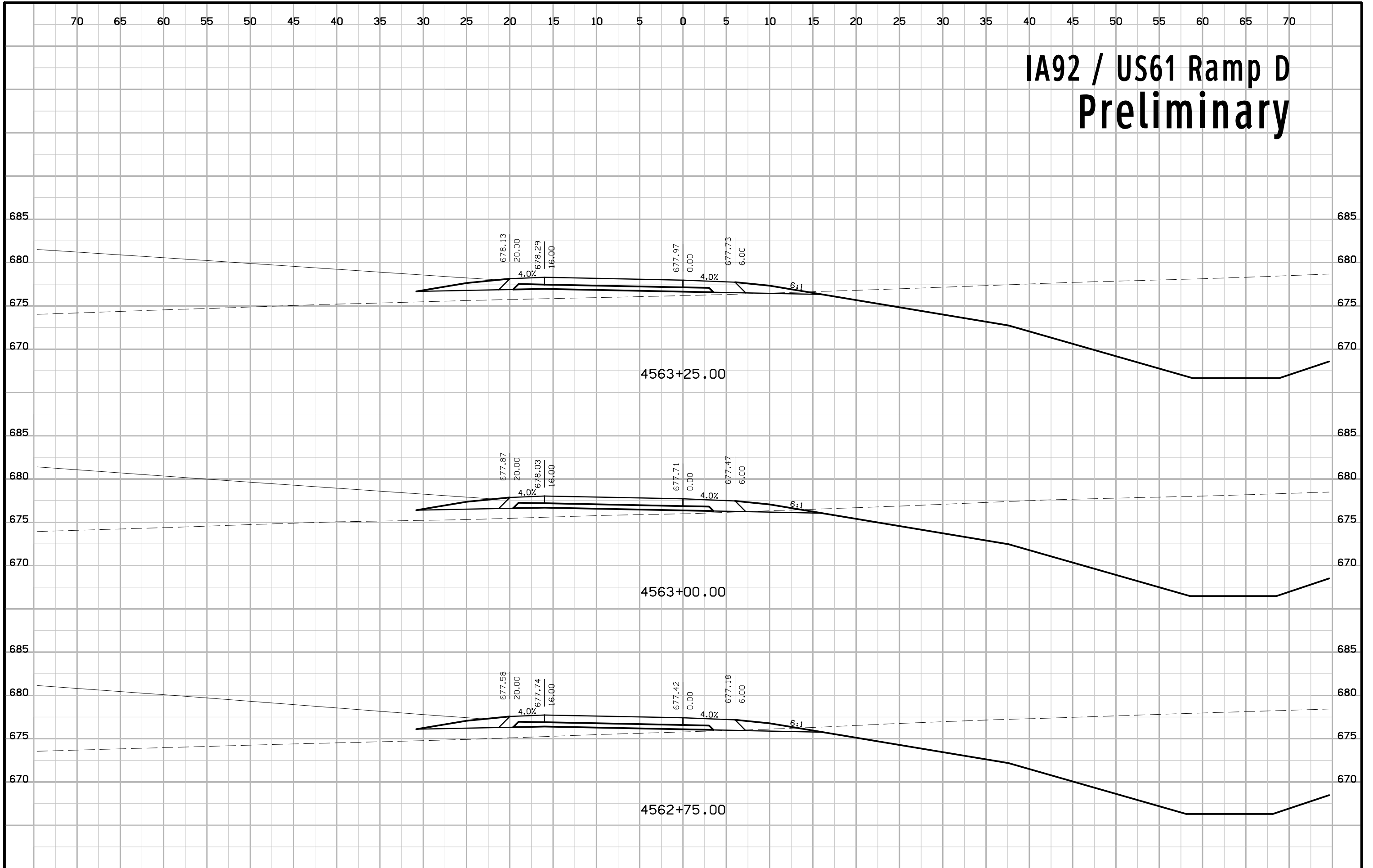

IA92 / US61 Ramp D Preliminary

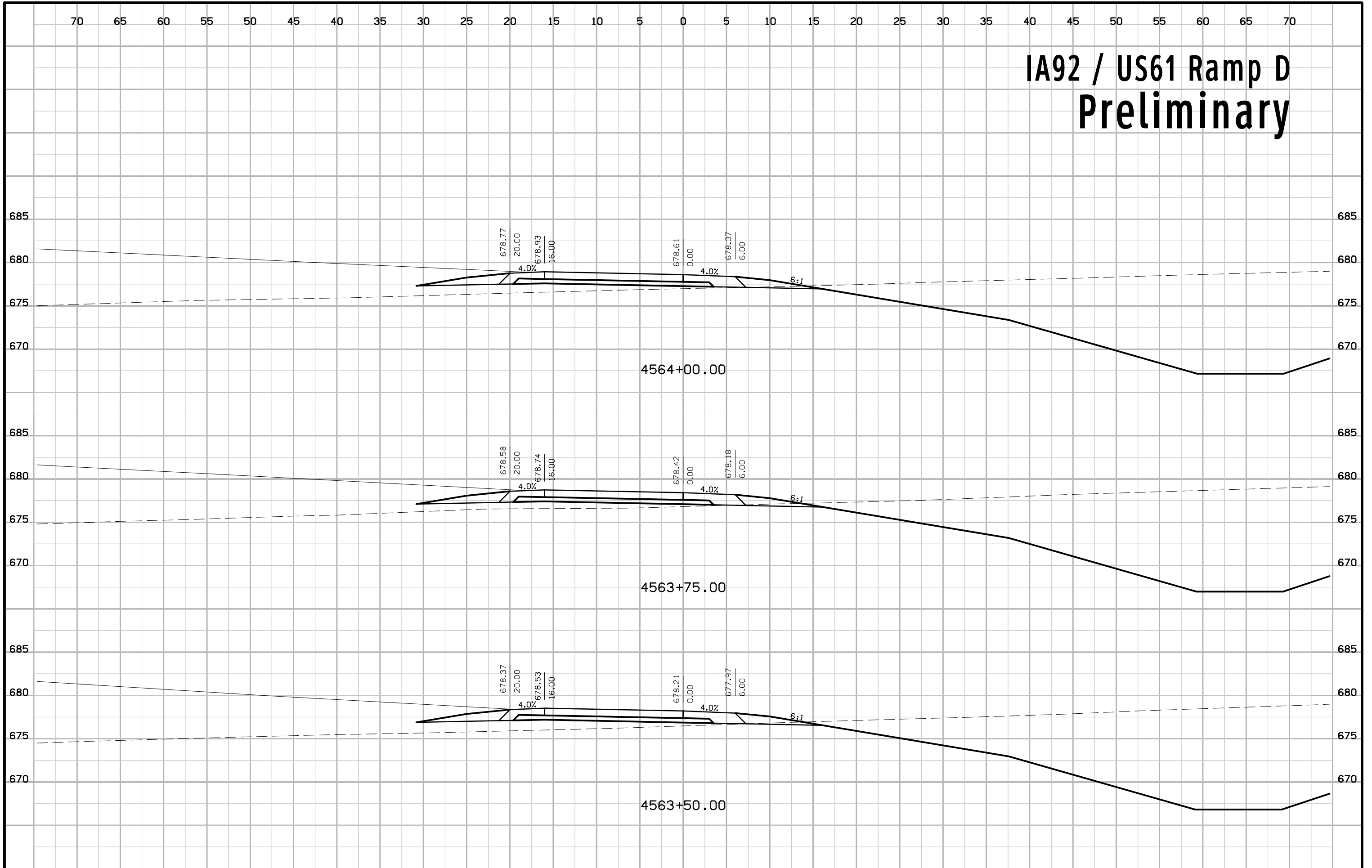

IA92 / US61 Ramp D Preliminary

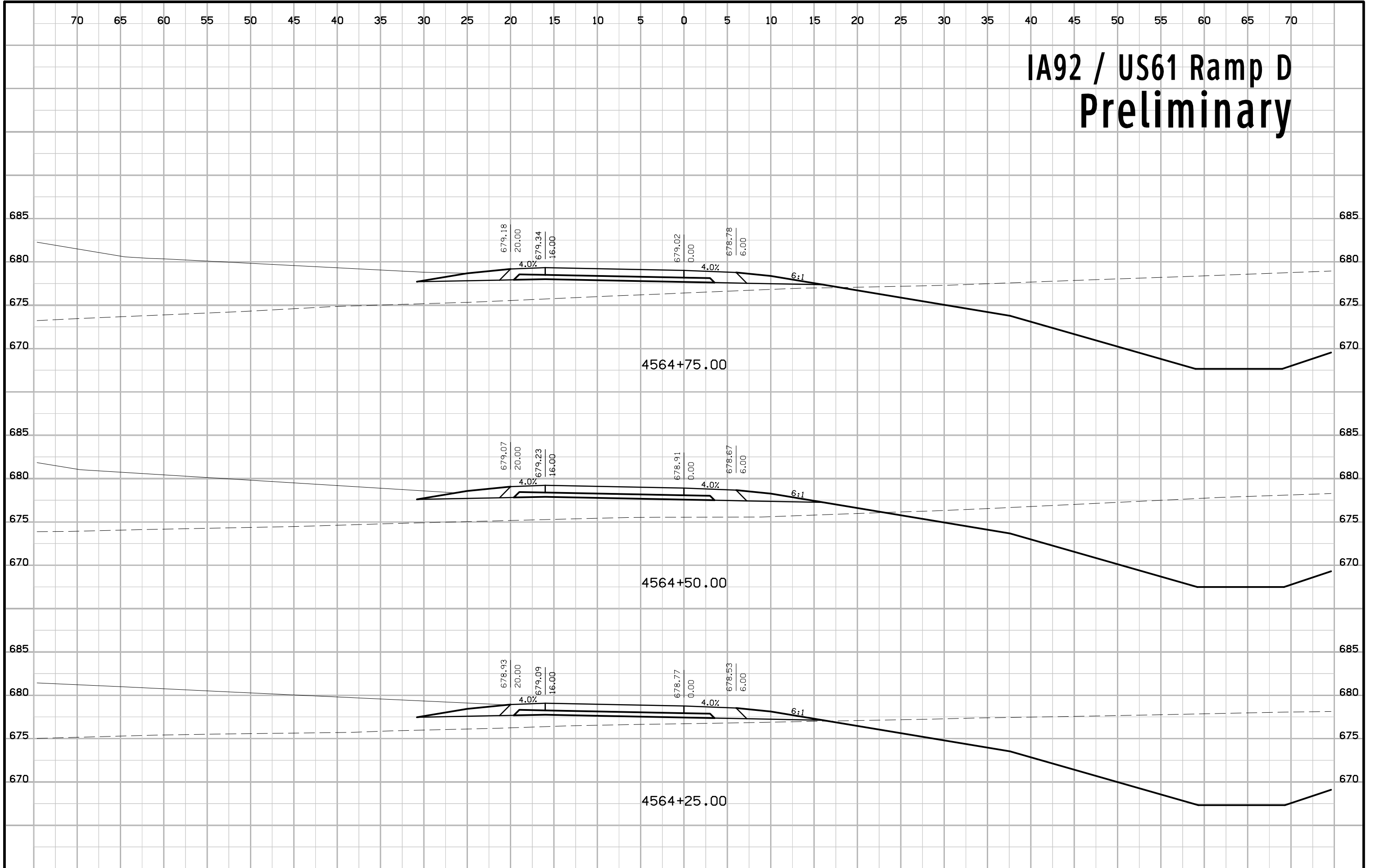

IA92 / US61 Ramp D Preliminary

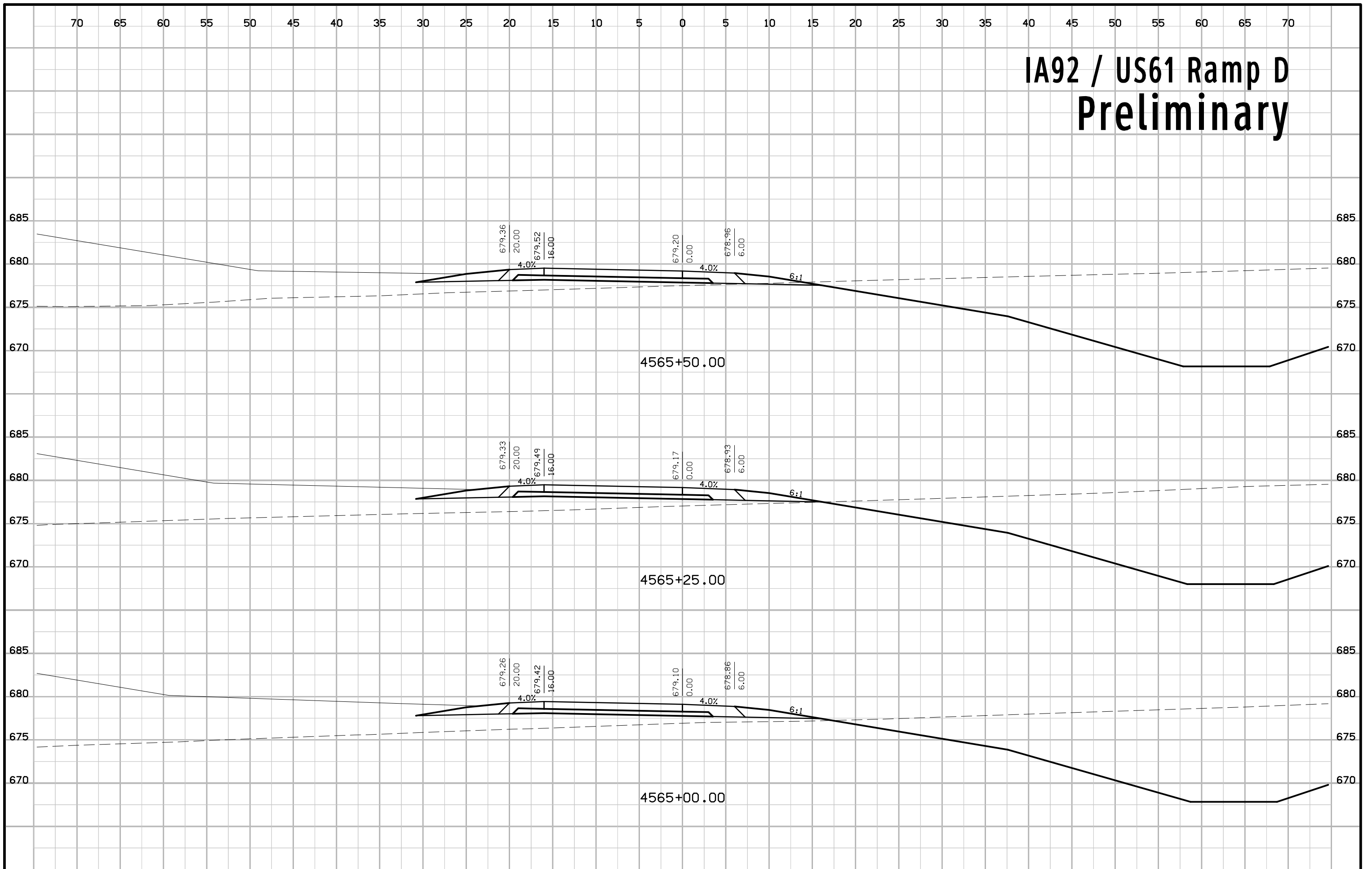

IA92 / US61 Ramp D Preliminary

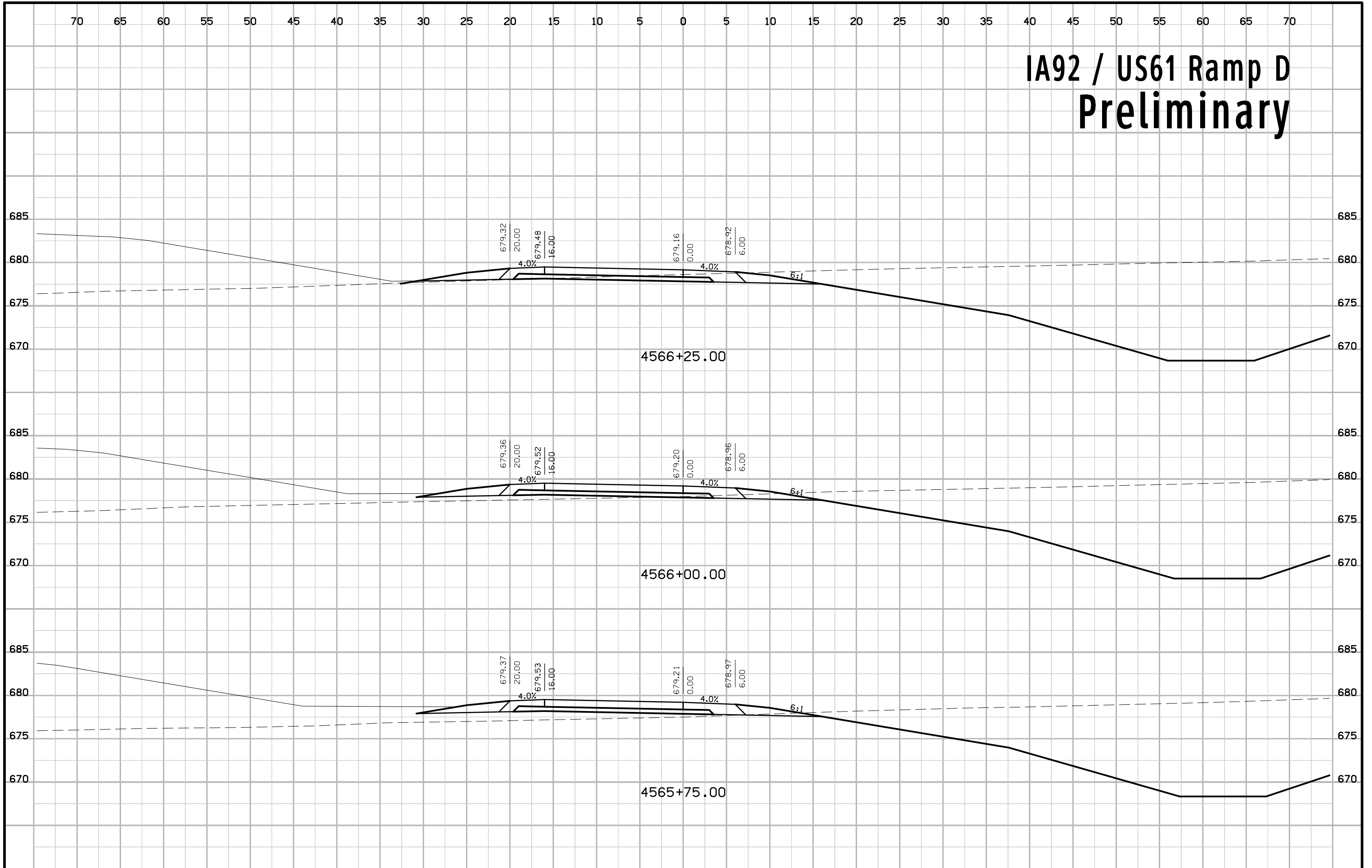

IA92 / US61 Ramp D Preliminary

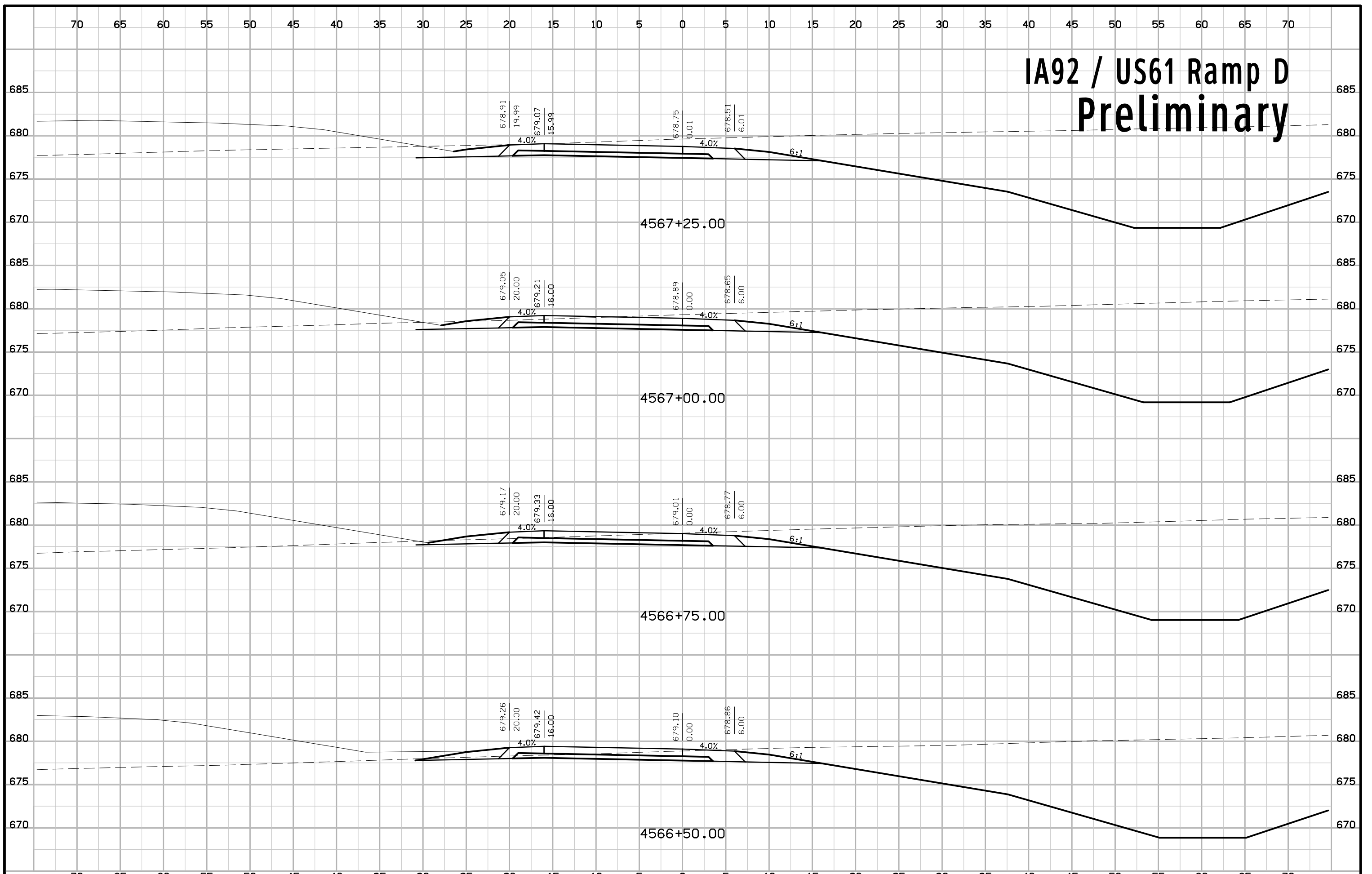

IA92 / US61 Ramp D Preliminary

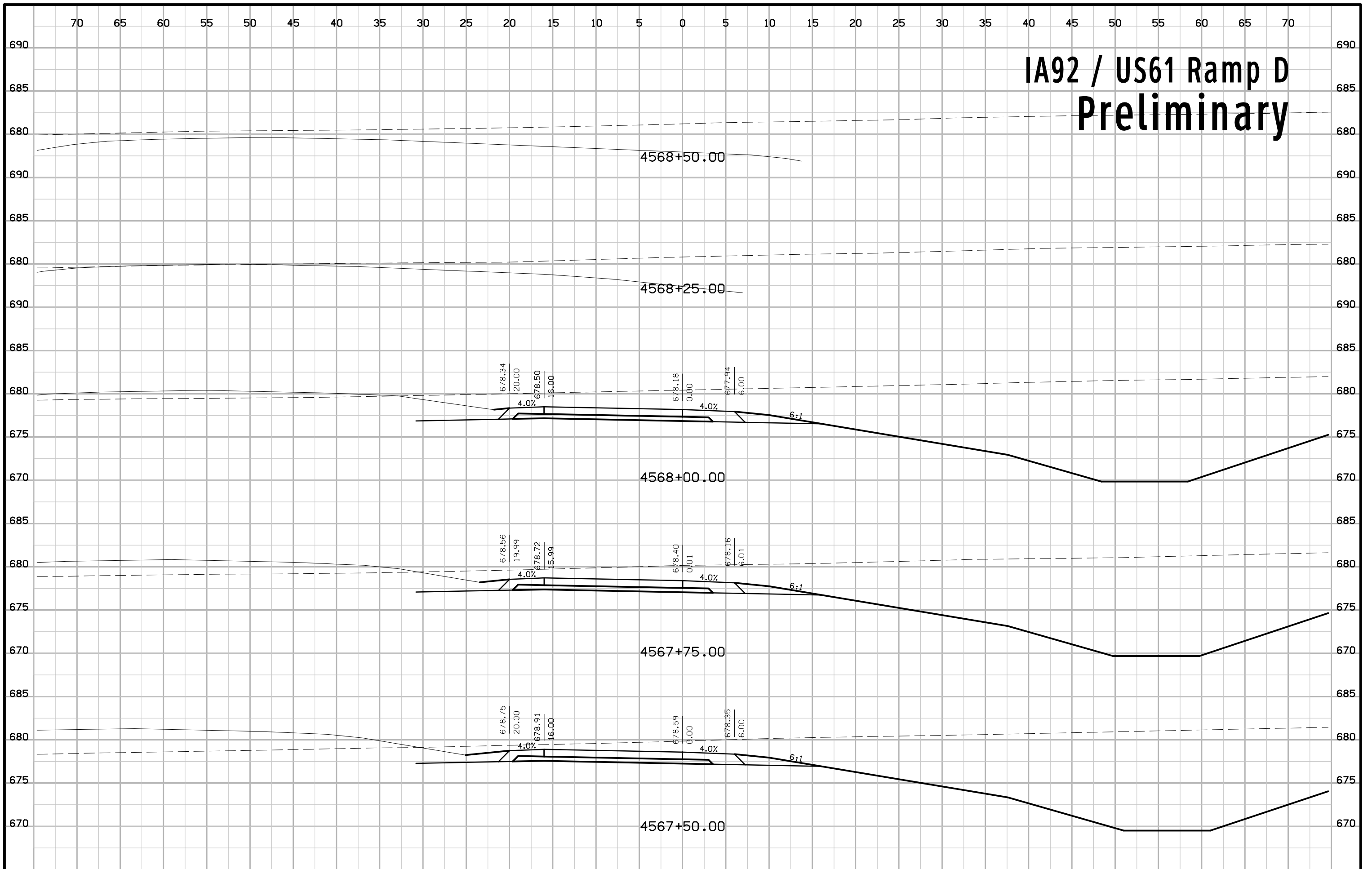

IA92 / US61 Ramp D Preliminary

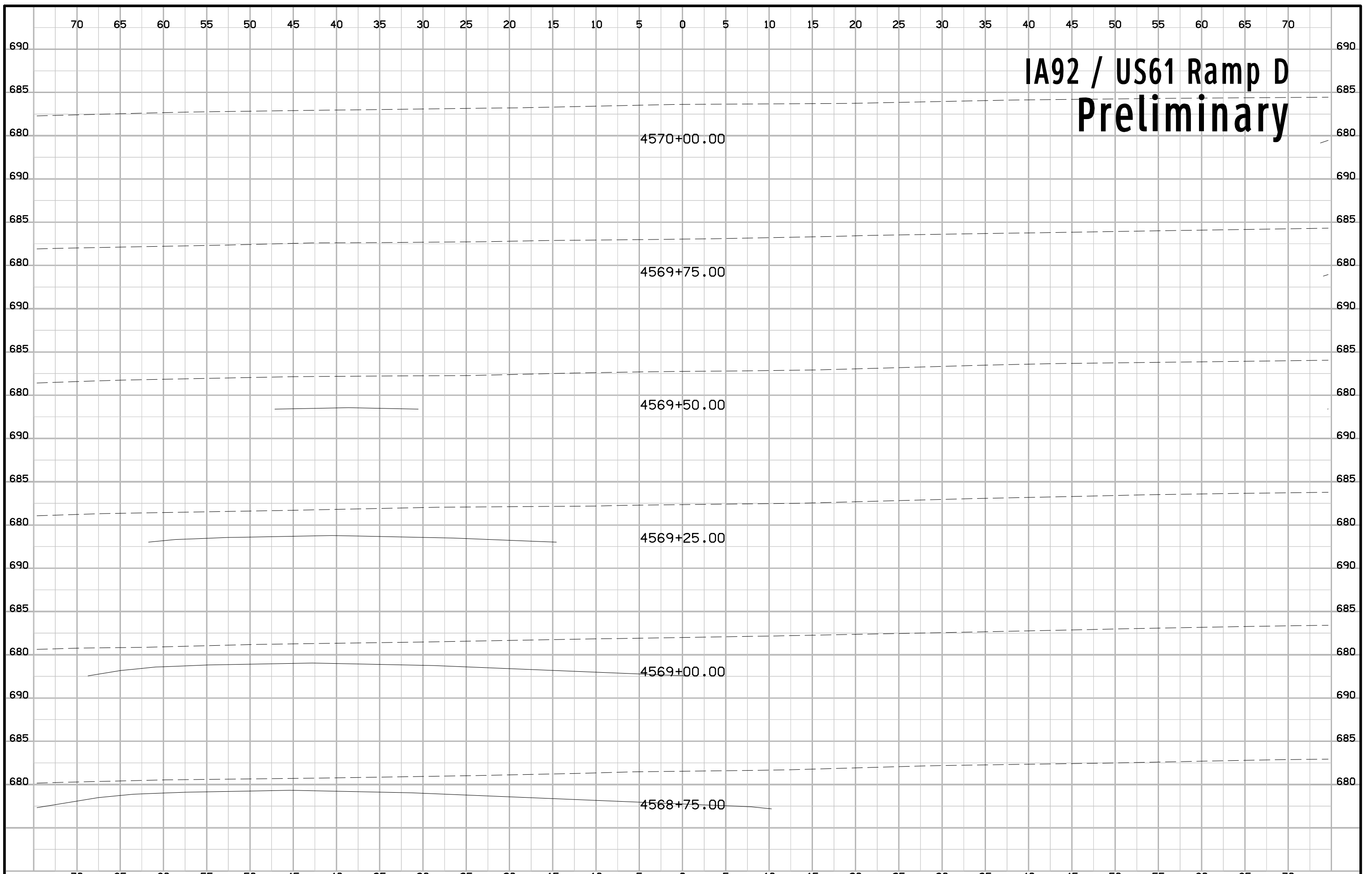

IA92 / US61 Ramp D Preliminary

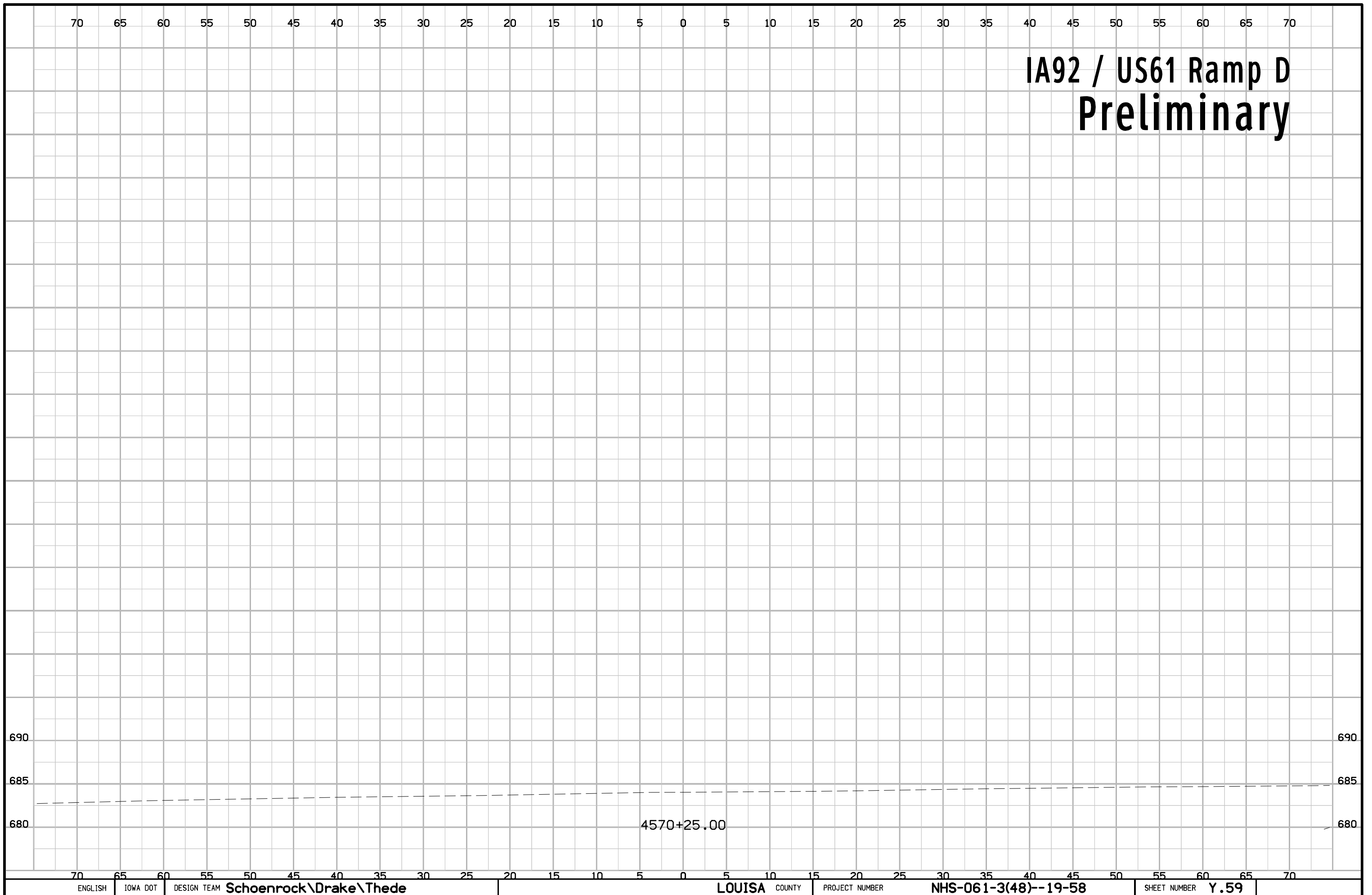

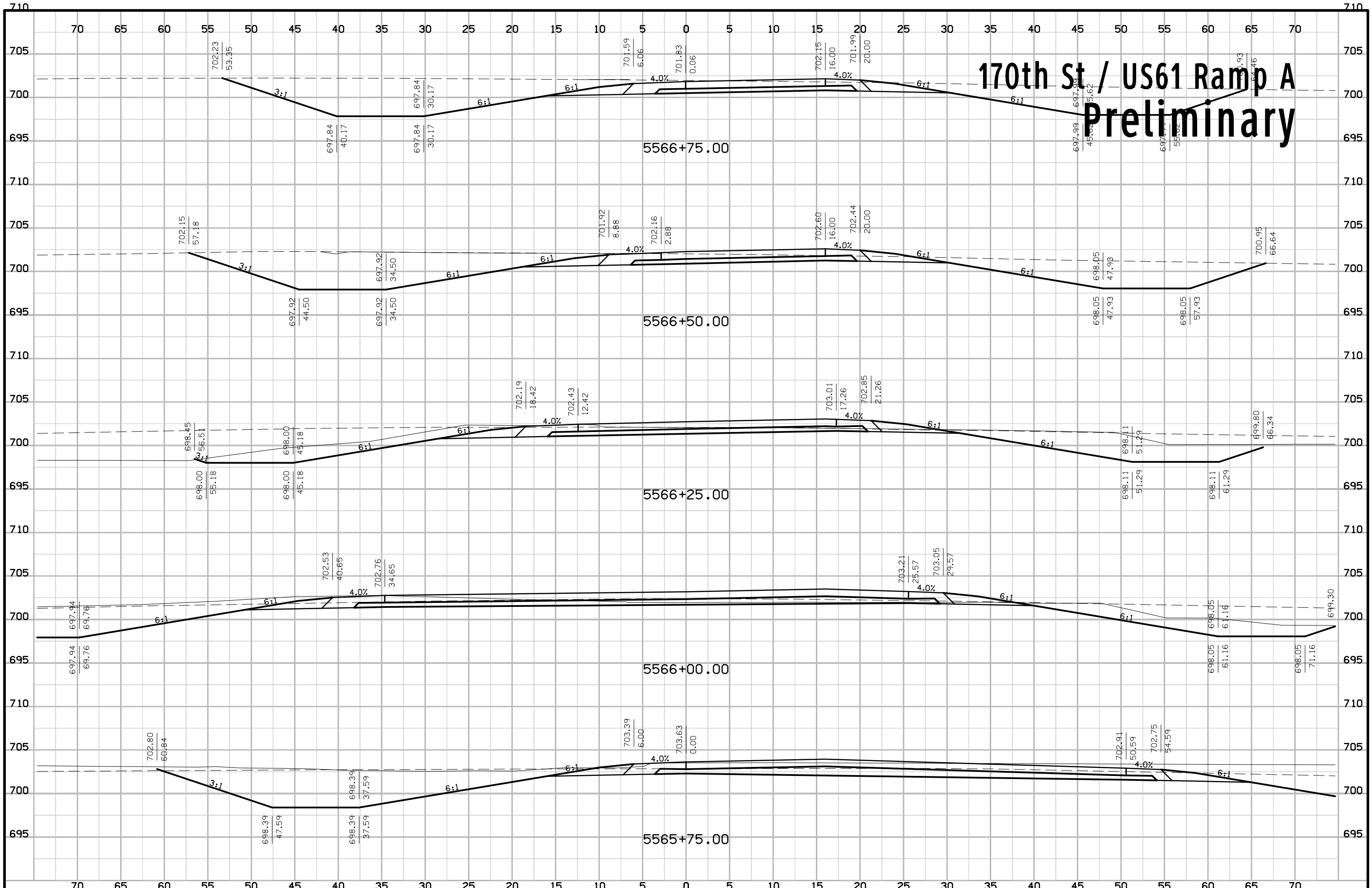

170th St / US61 Ramp A Preliminary

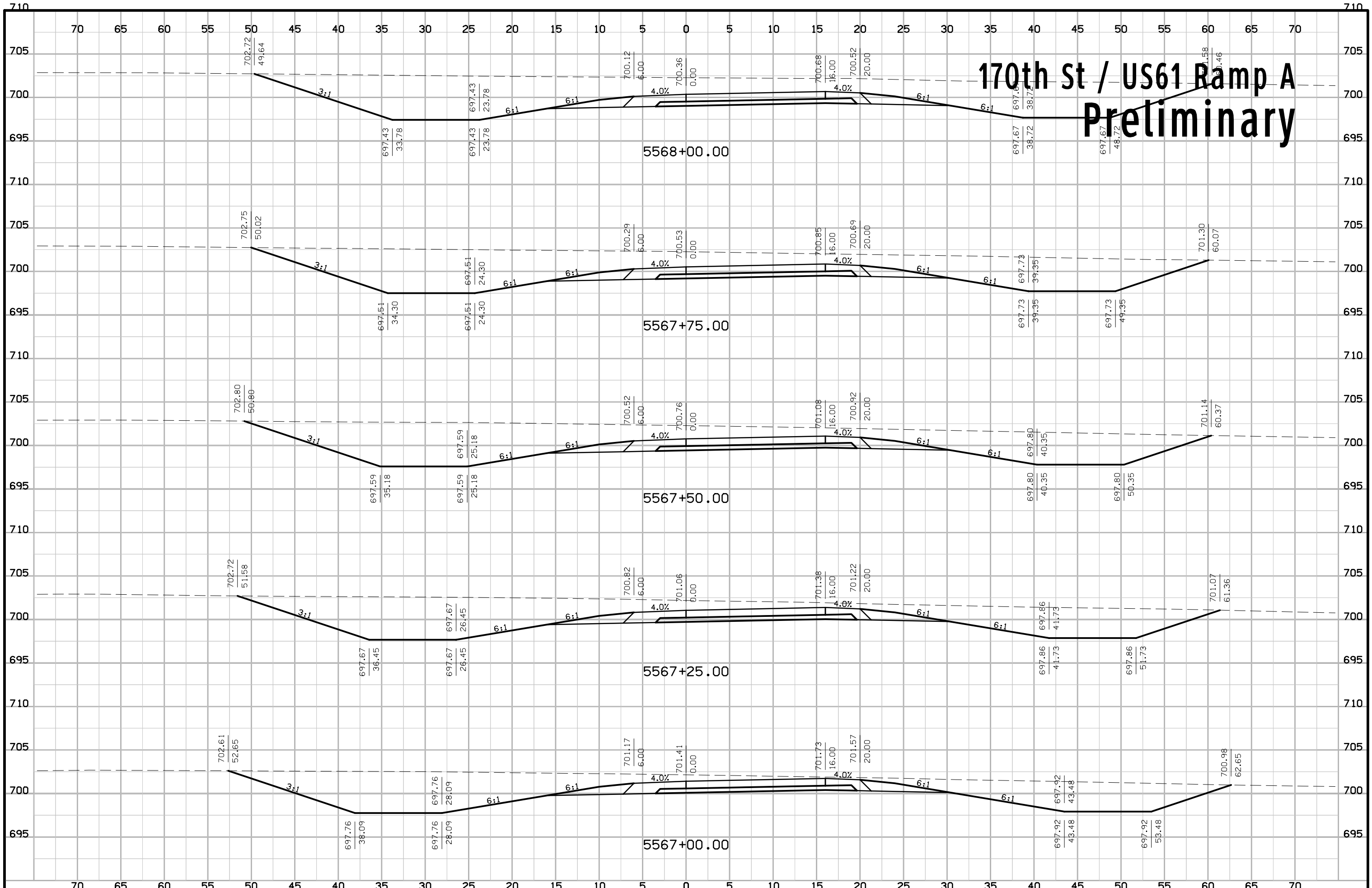

170th St / US61 Ramp A Preliminary

170th St / US61 Ramp A Preliminary

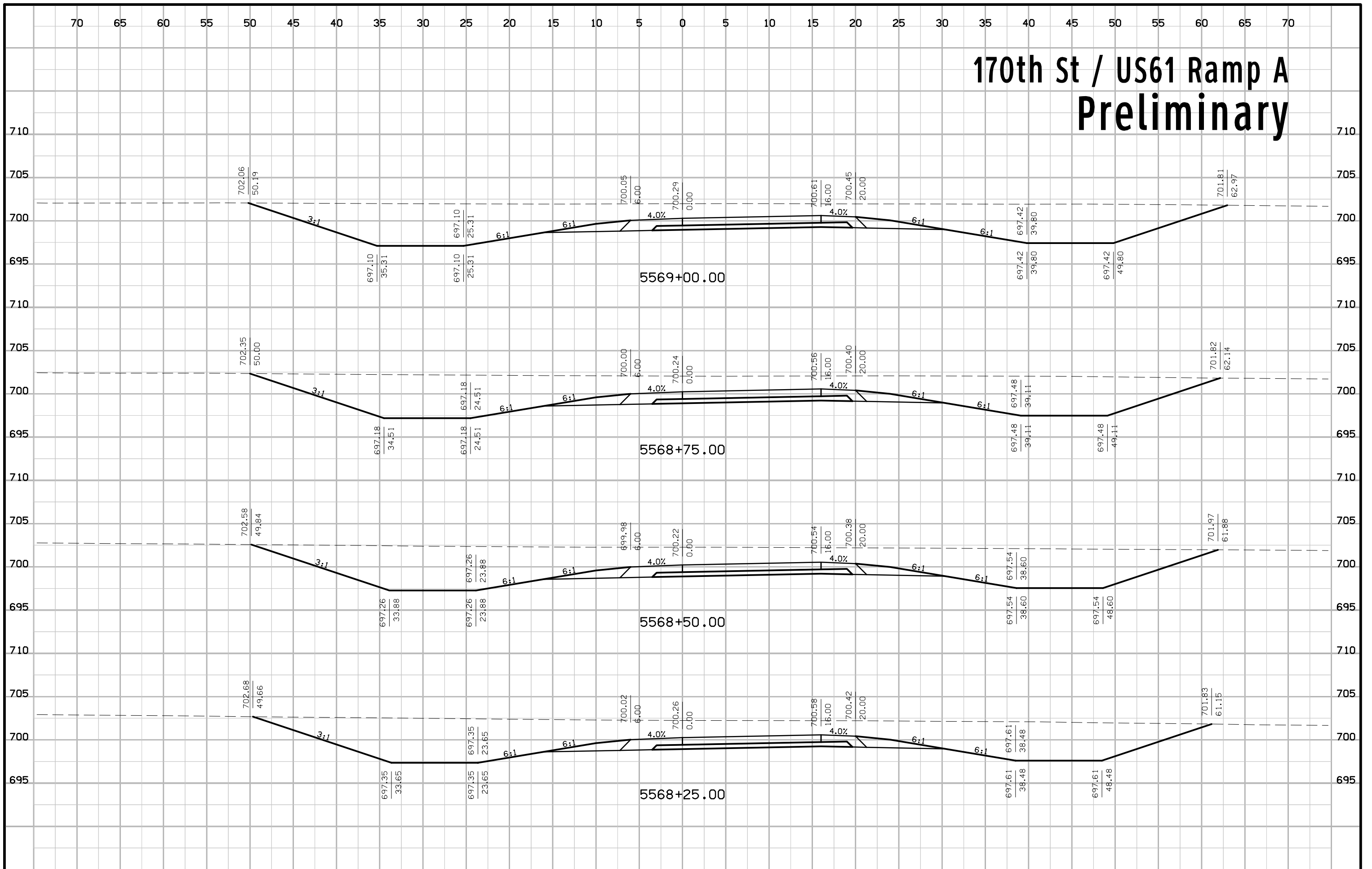

170th St / US61 Ramp A Preliminary

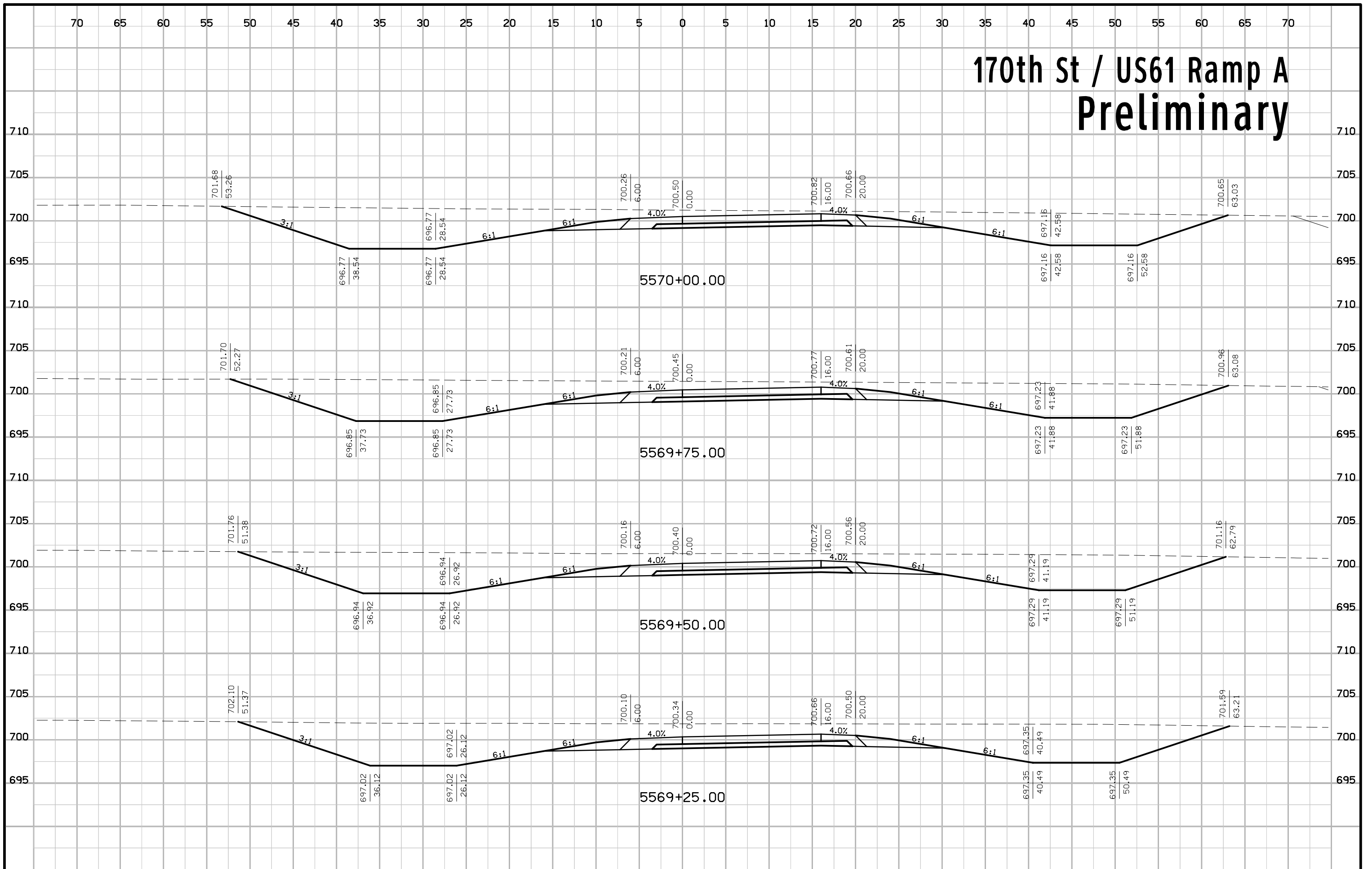

170th St / US61 Ramp A Preliminary

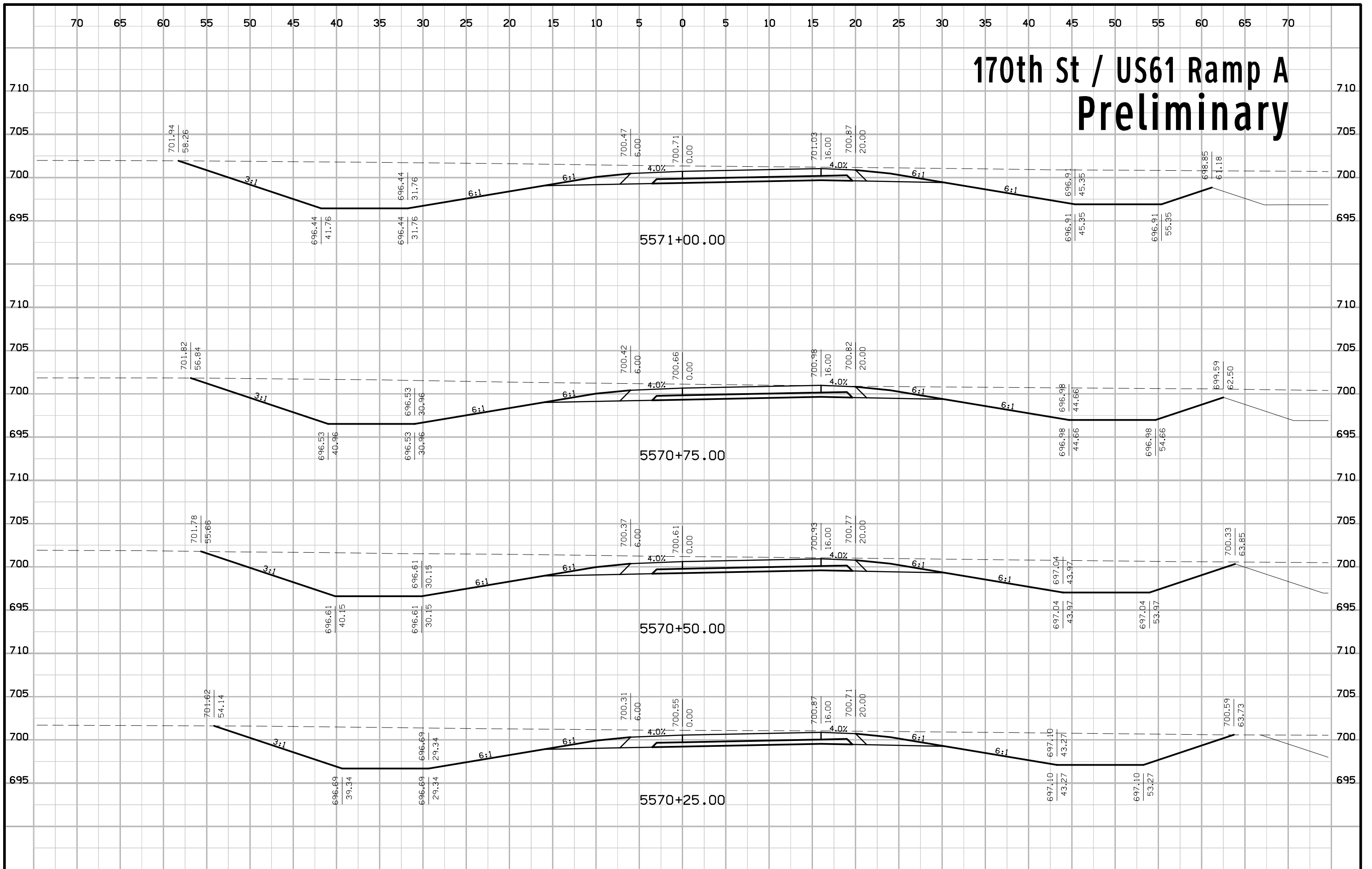

170th St / US61 Ramp A Preliminary

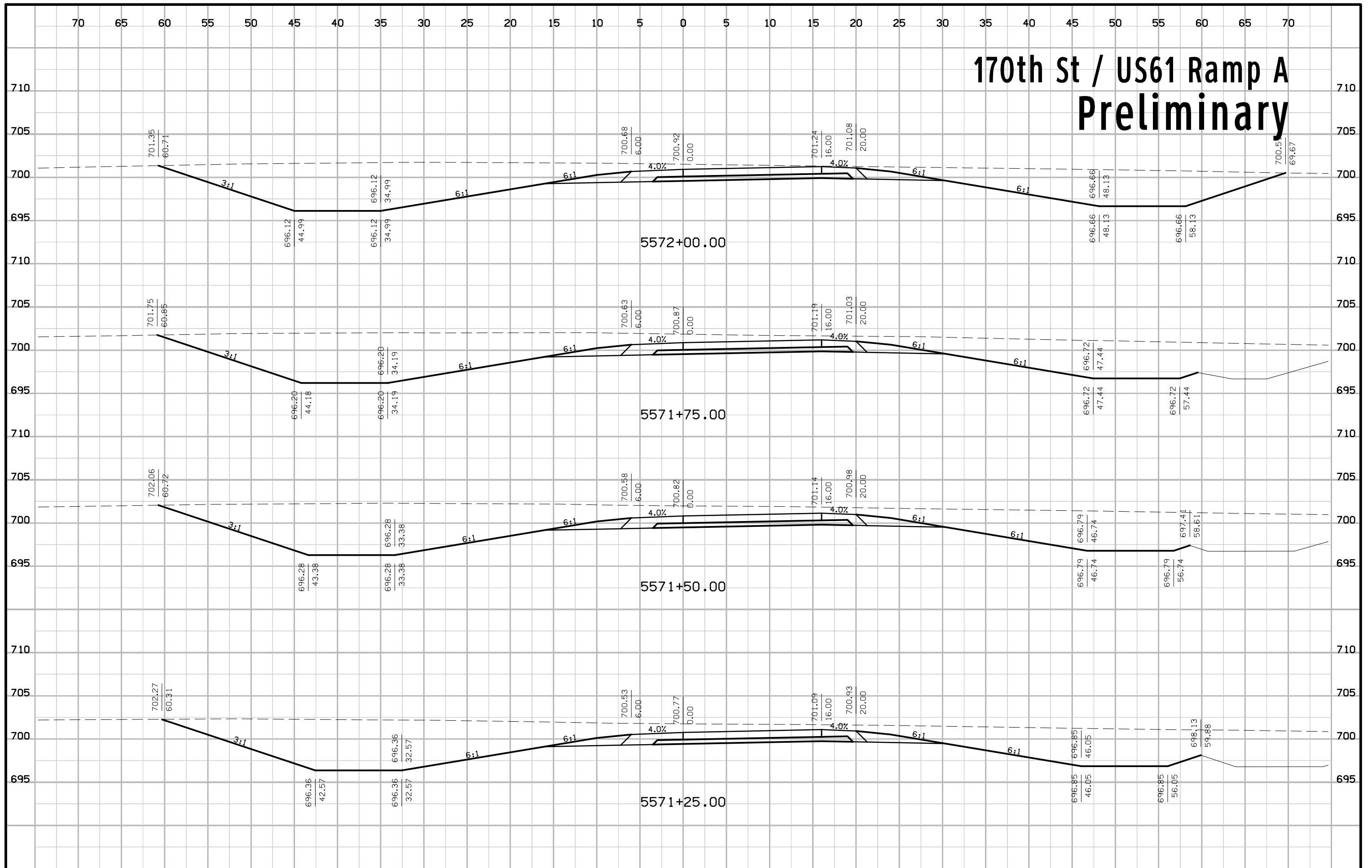

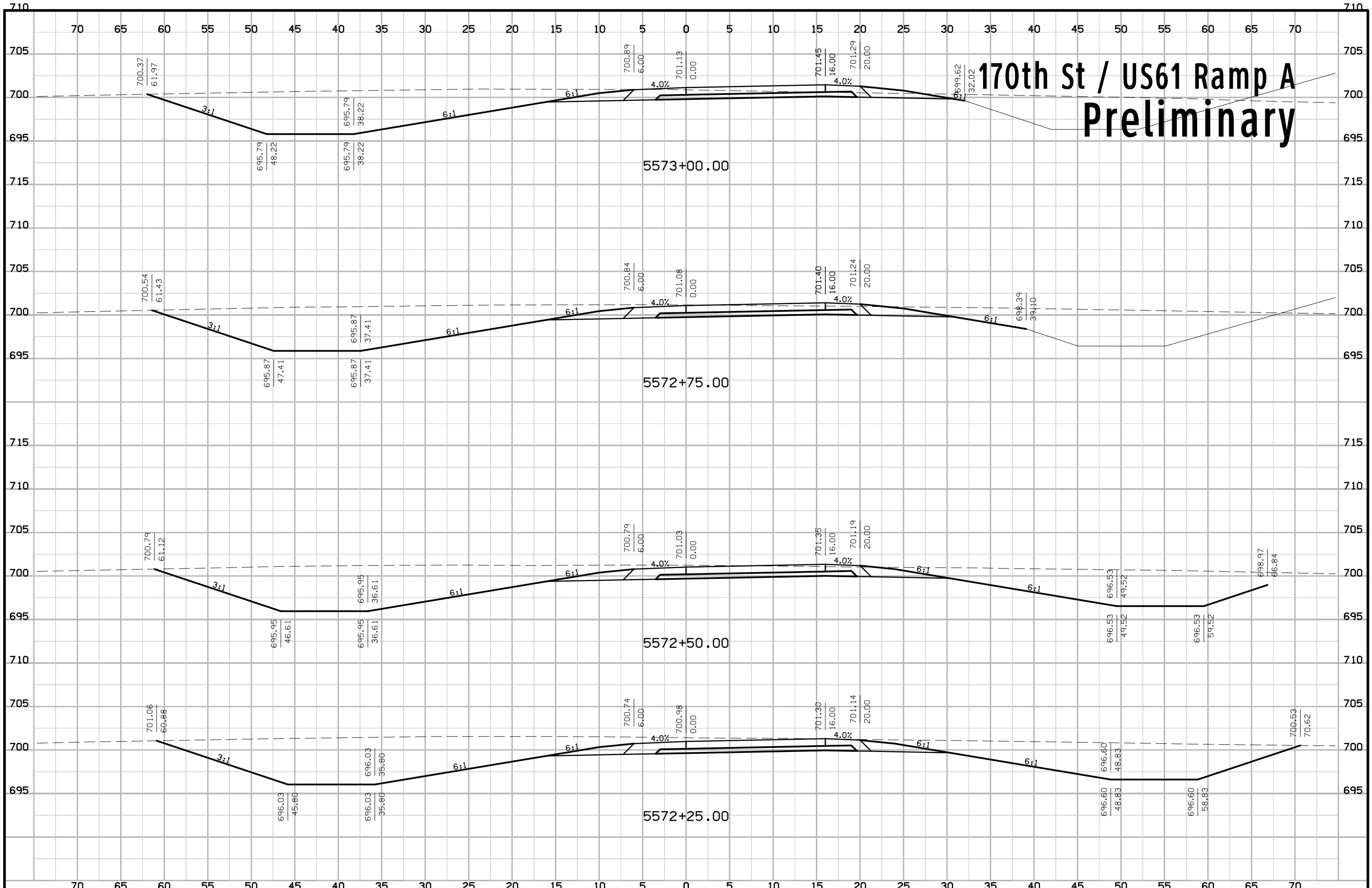

170th St / US61 Ramp A Preliminary

170th St / US61 Ramp A Preliminary

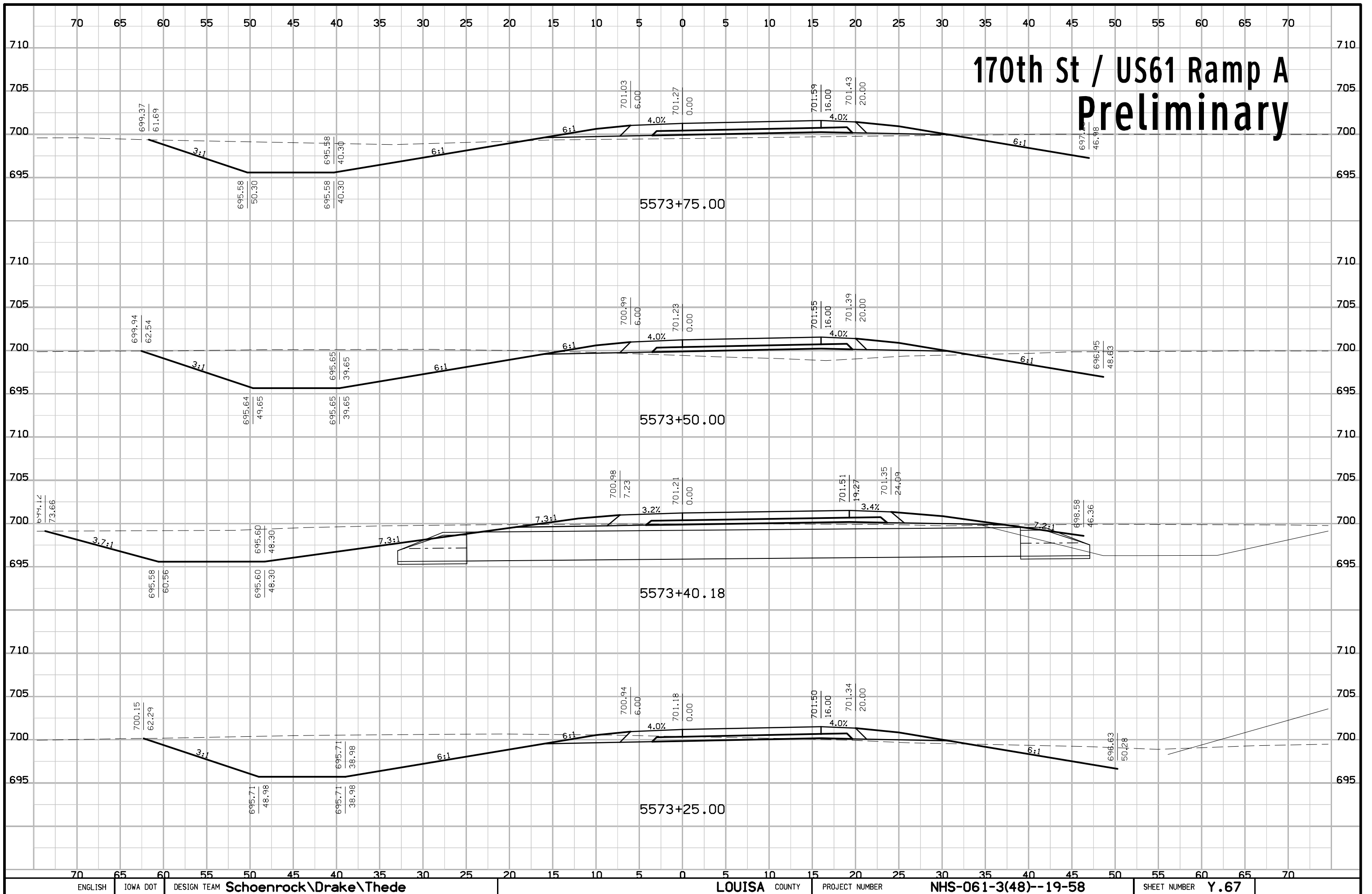

170th St / US61 Ramp A Preliminary

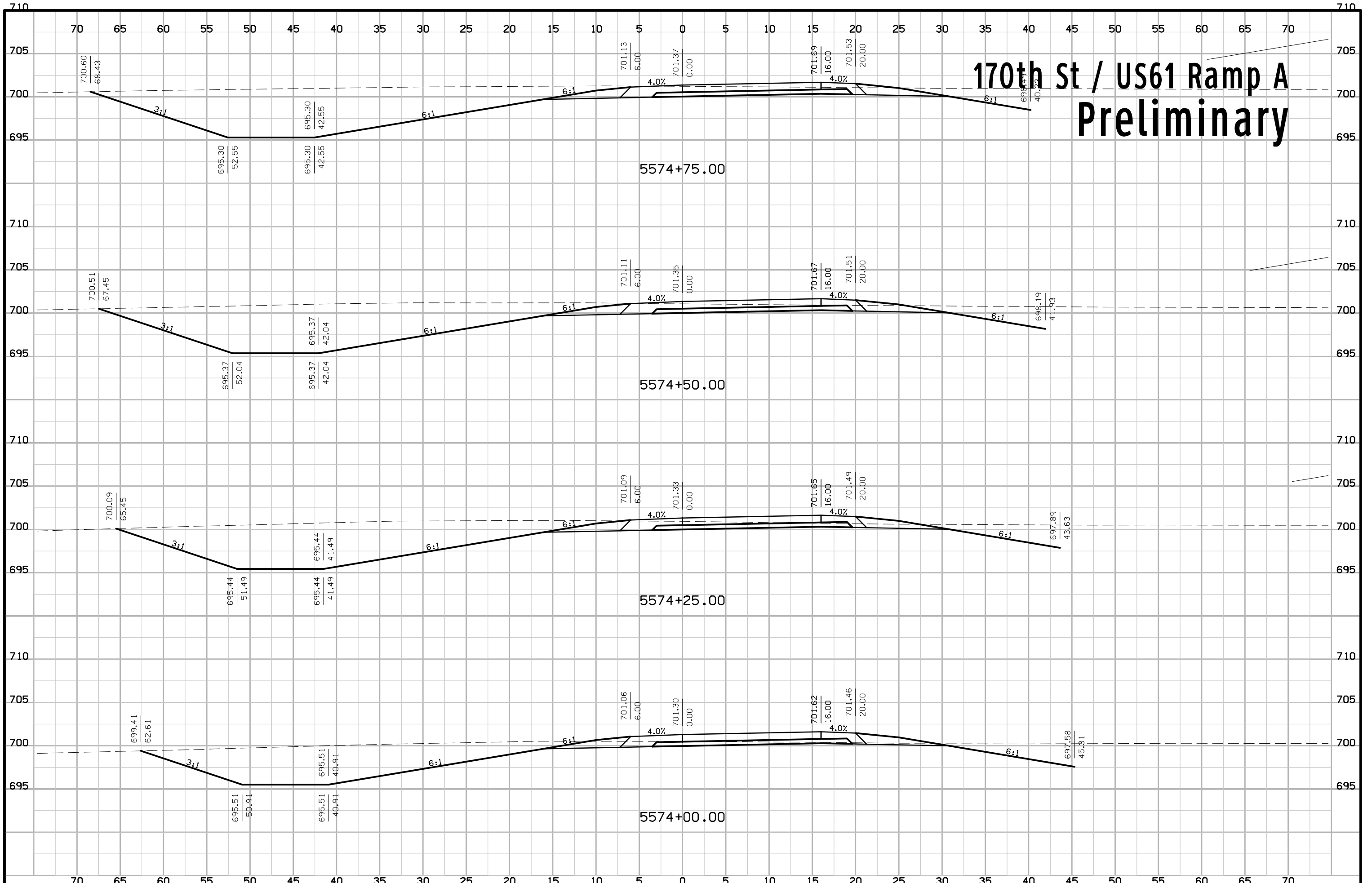

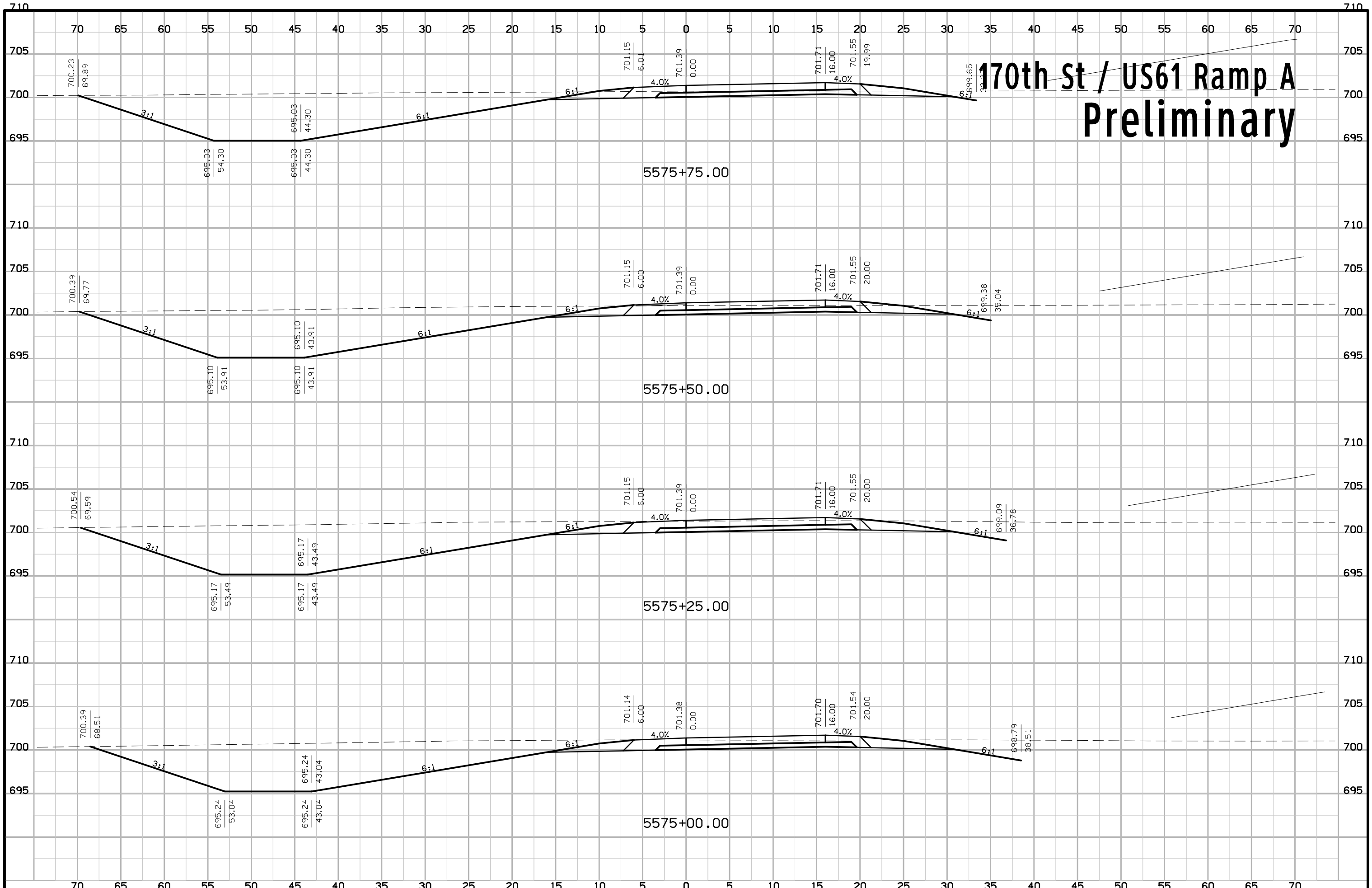

170th St / US61 Ramp A Preliminary

170th St / US61 Ramp A Preliminary

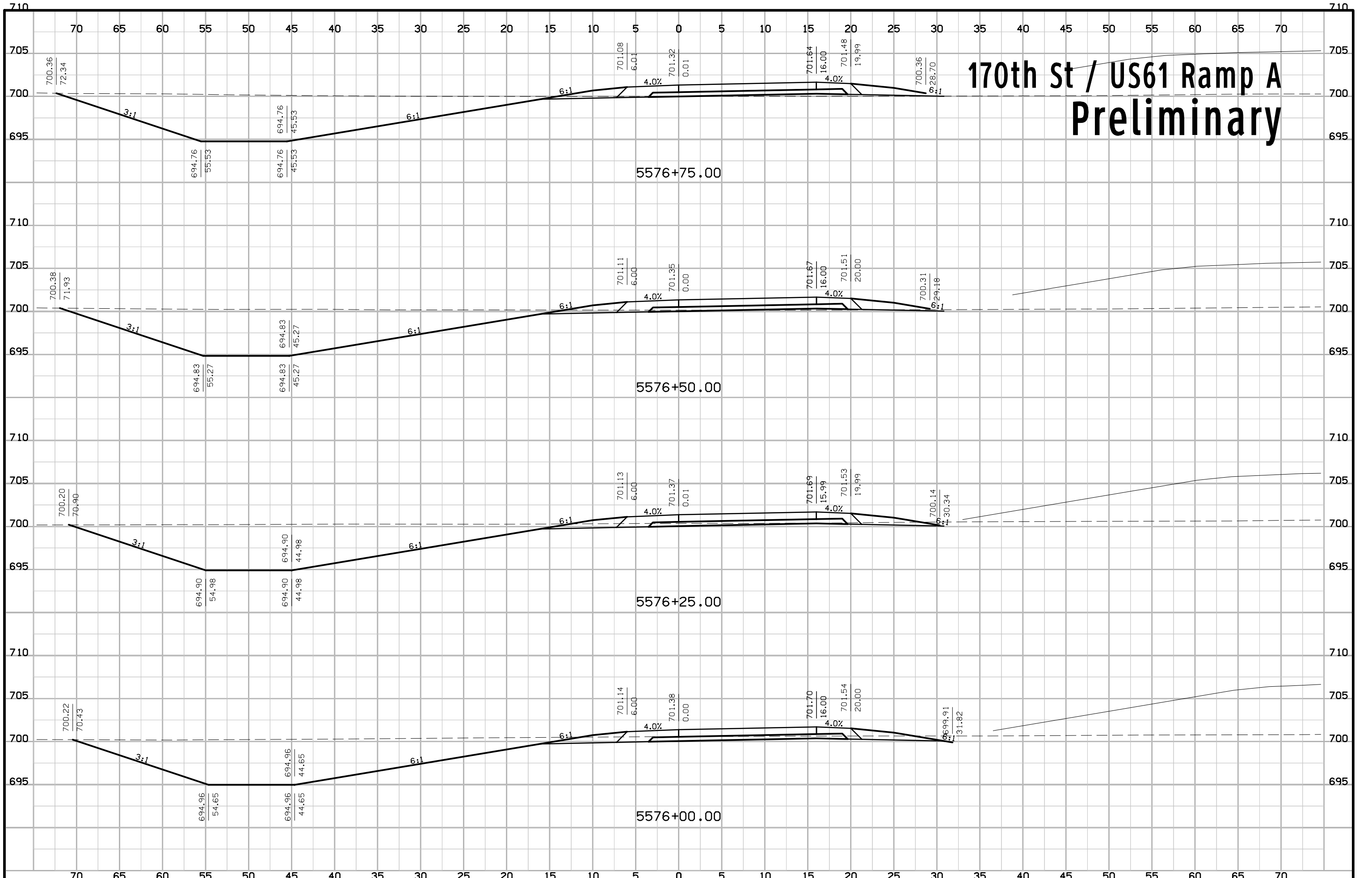

170th St / US61 Ramp A Preliminary

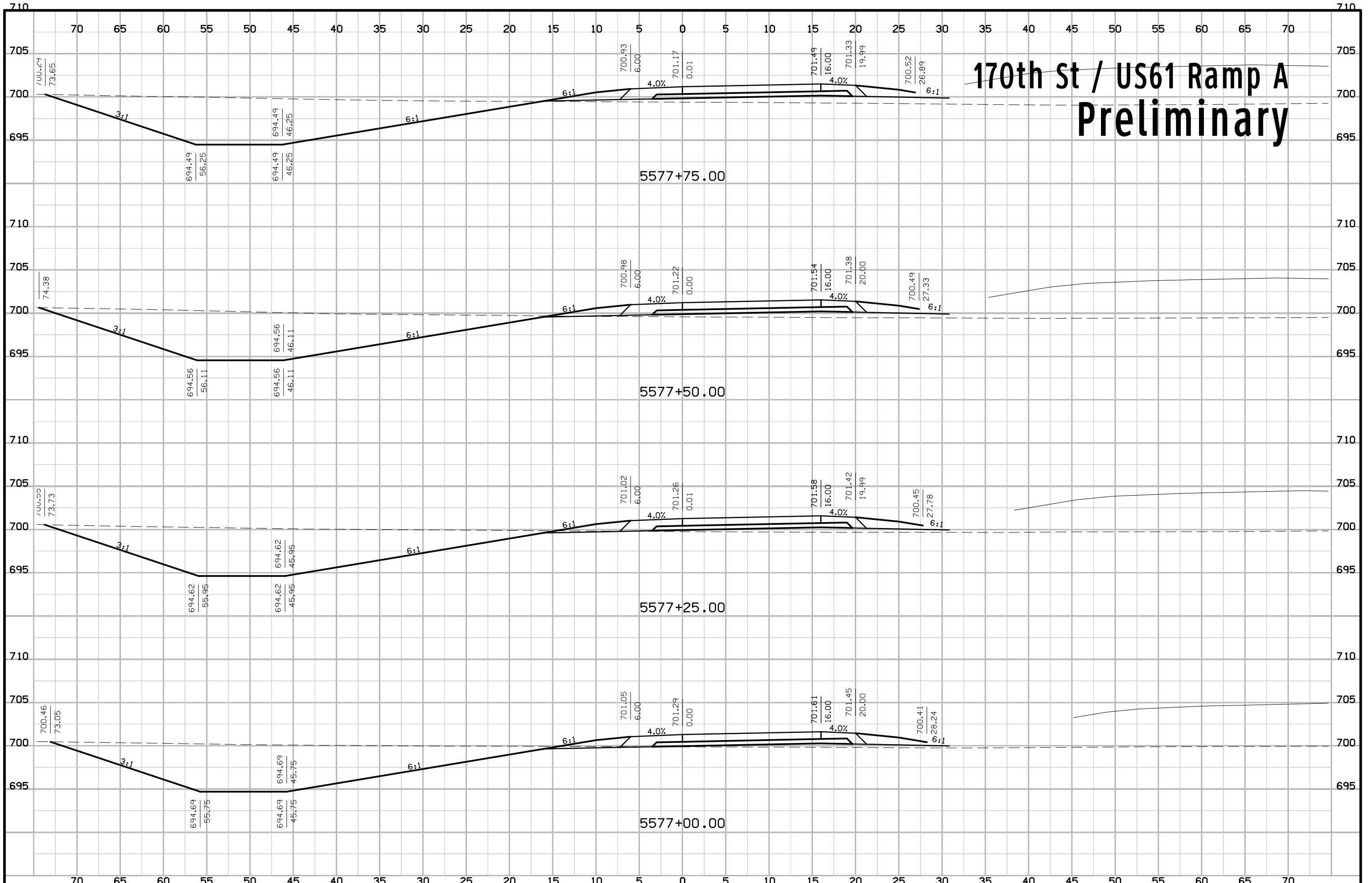

170th St / US61 Ramp A Preliminary

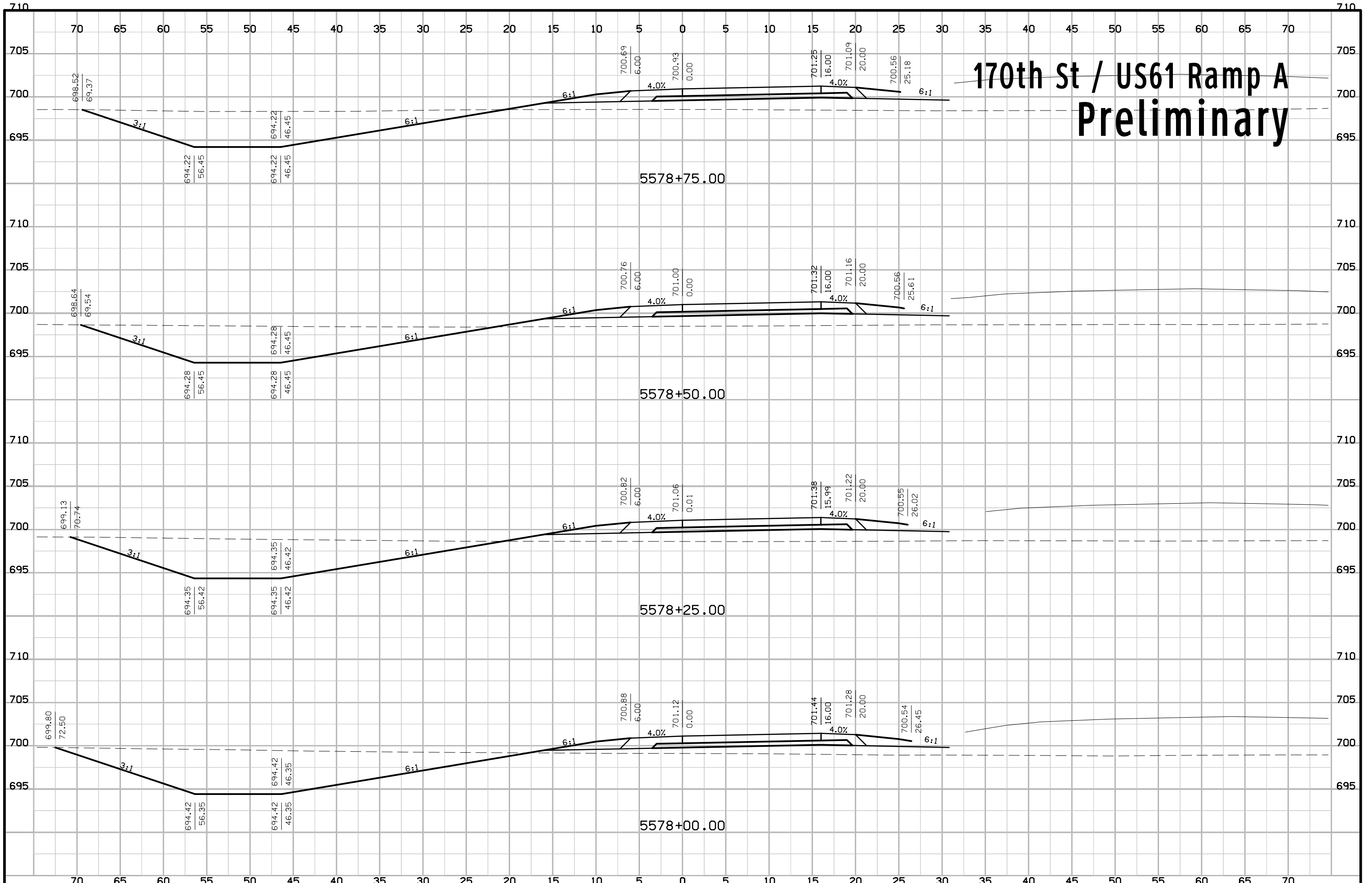

170th St / US61 Ramp A Preliminary

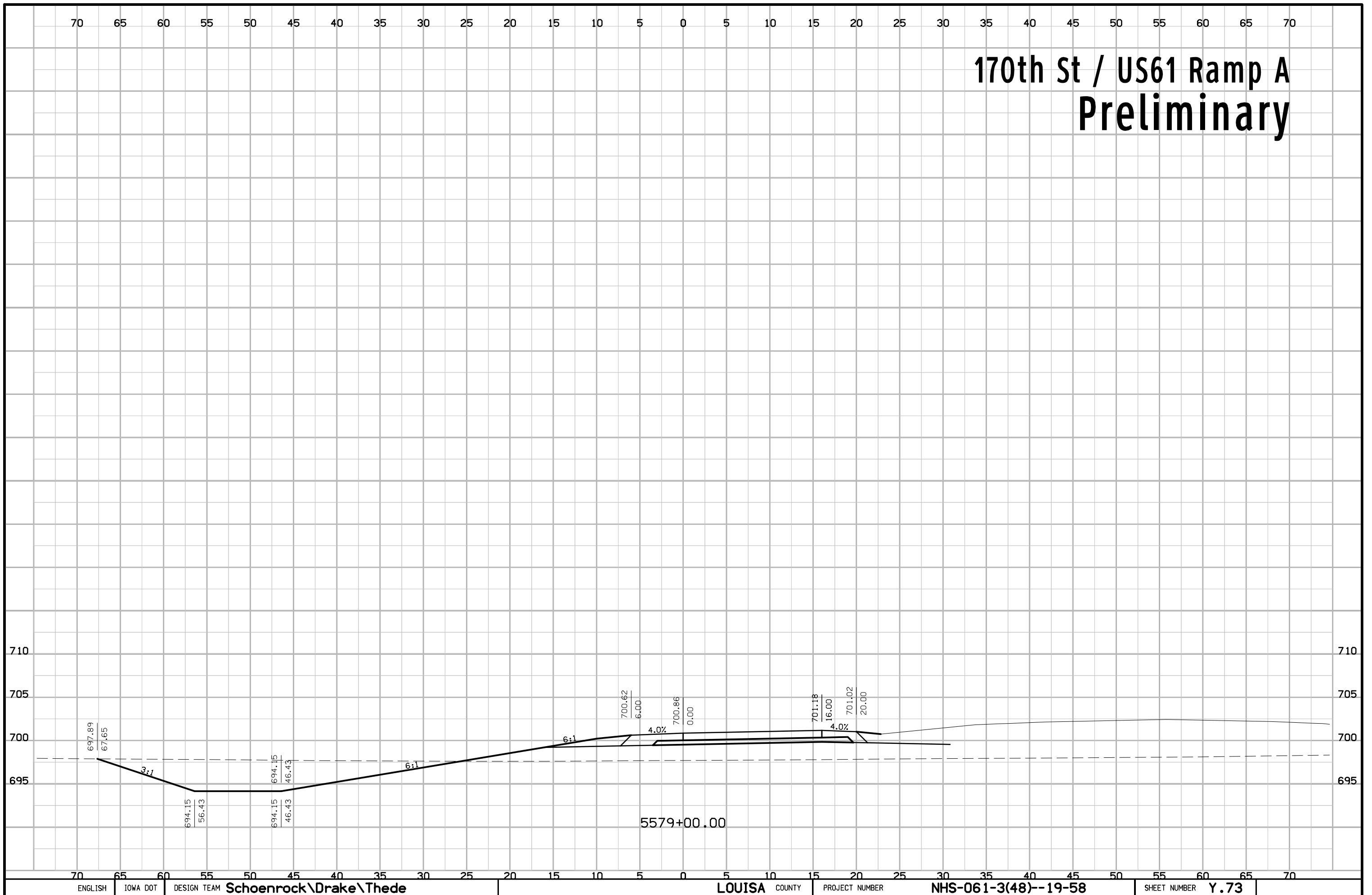

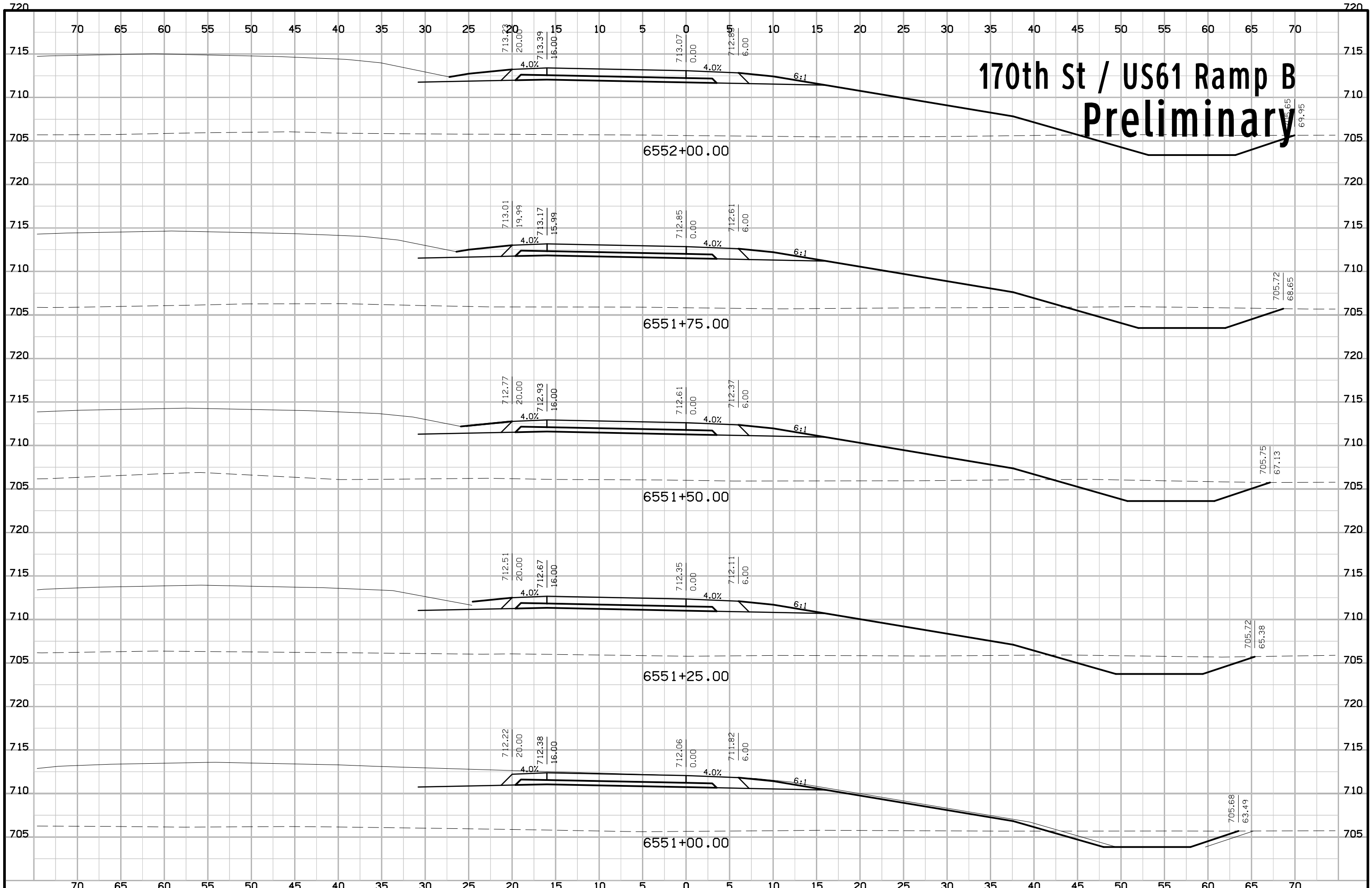

170th St / US61 Ramp B Preliminary

170th St / US61 Ramp B Preliminary

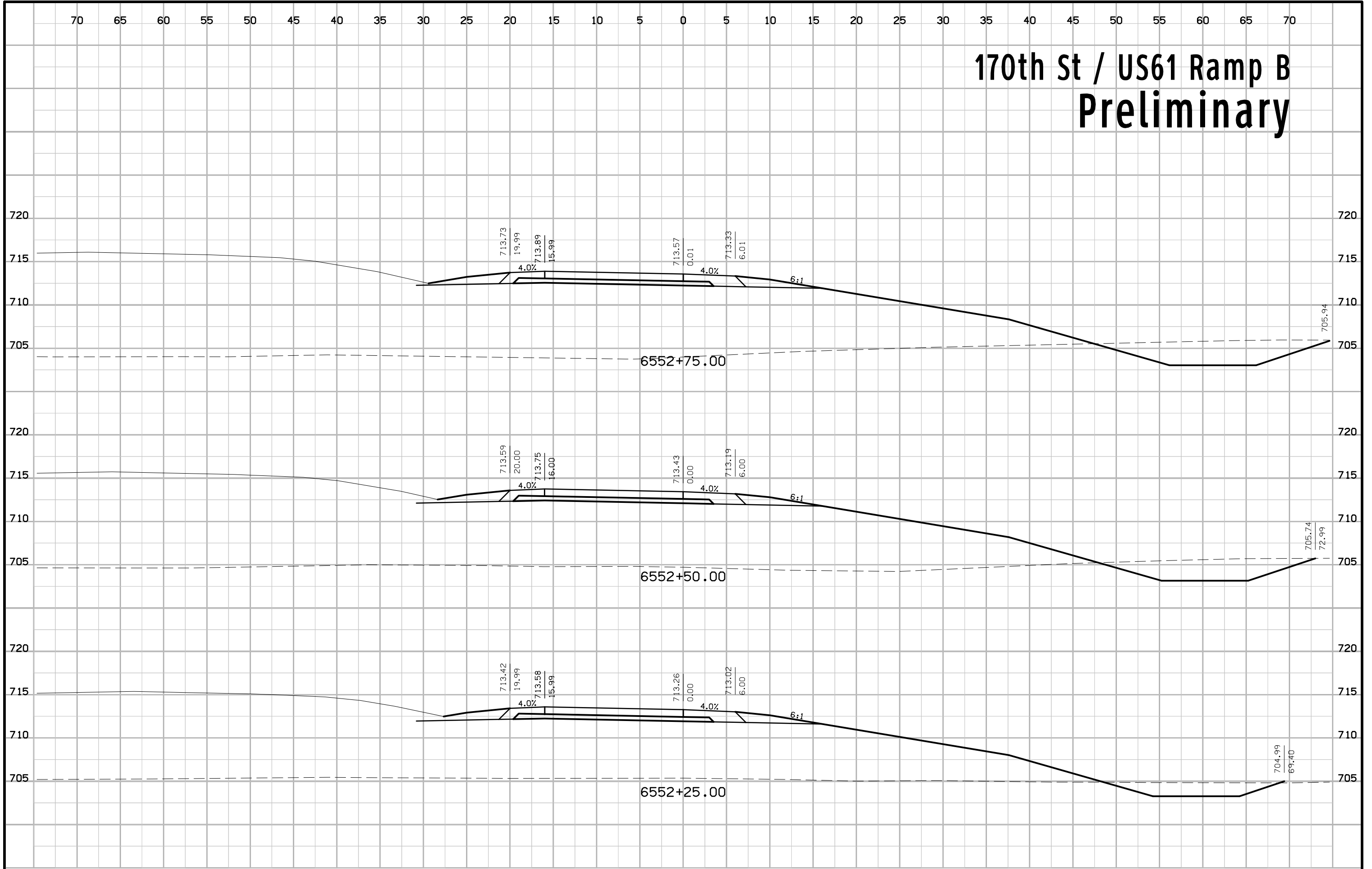

170th St / US61 Ramp B Preliminary

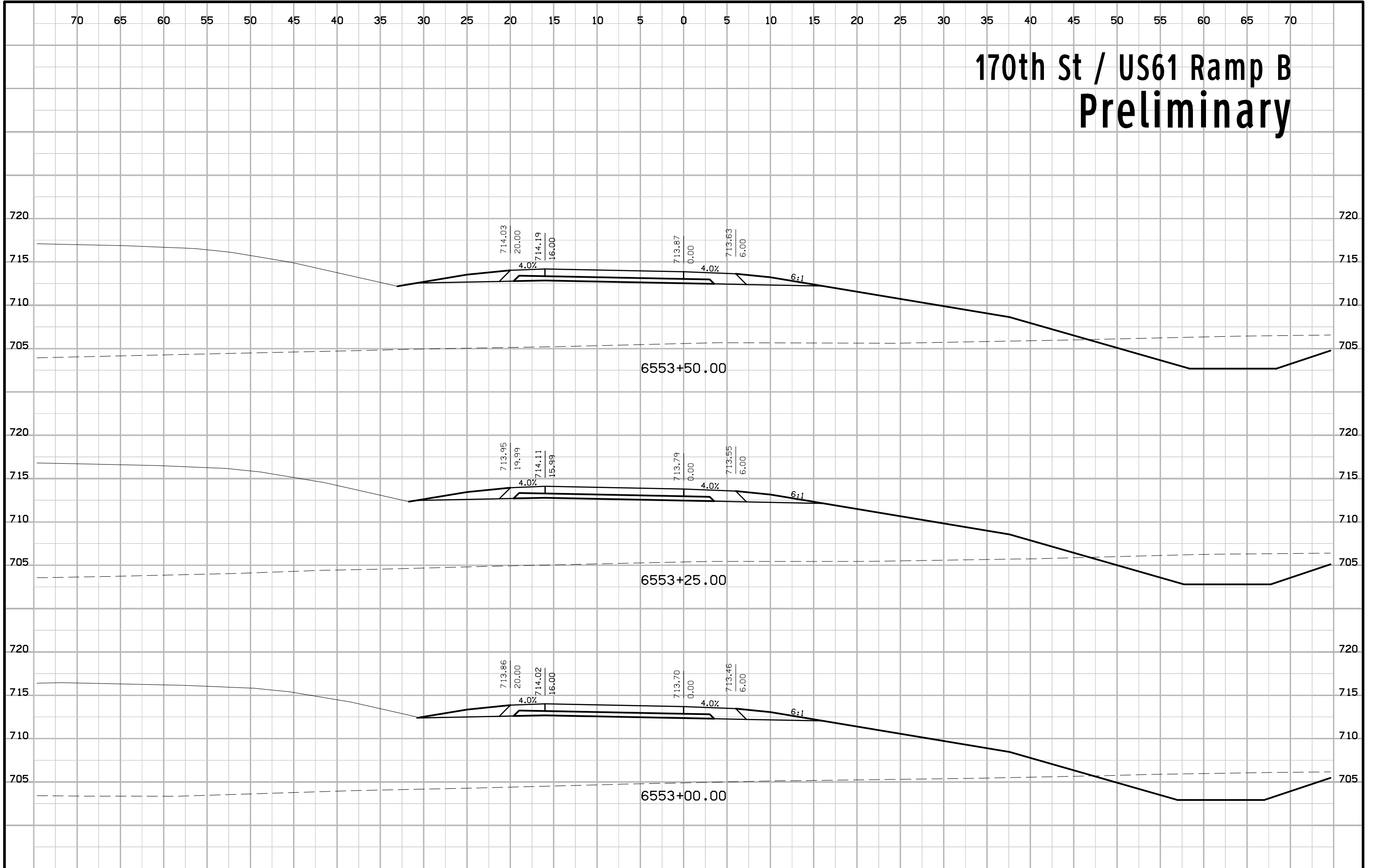

170th St / US61 Ramp B Preliminary

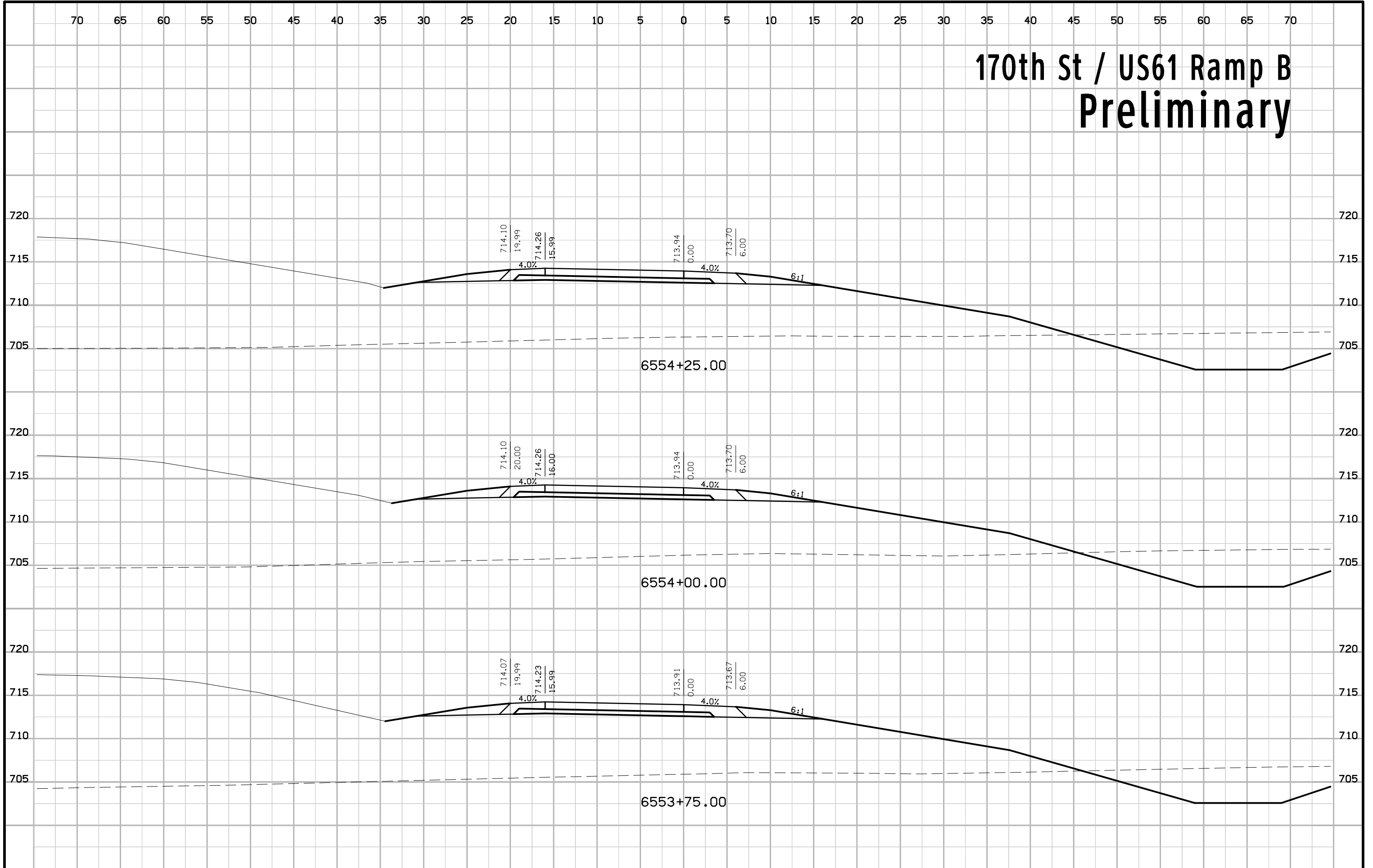

170th St / US61 Ramp B Preliminary

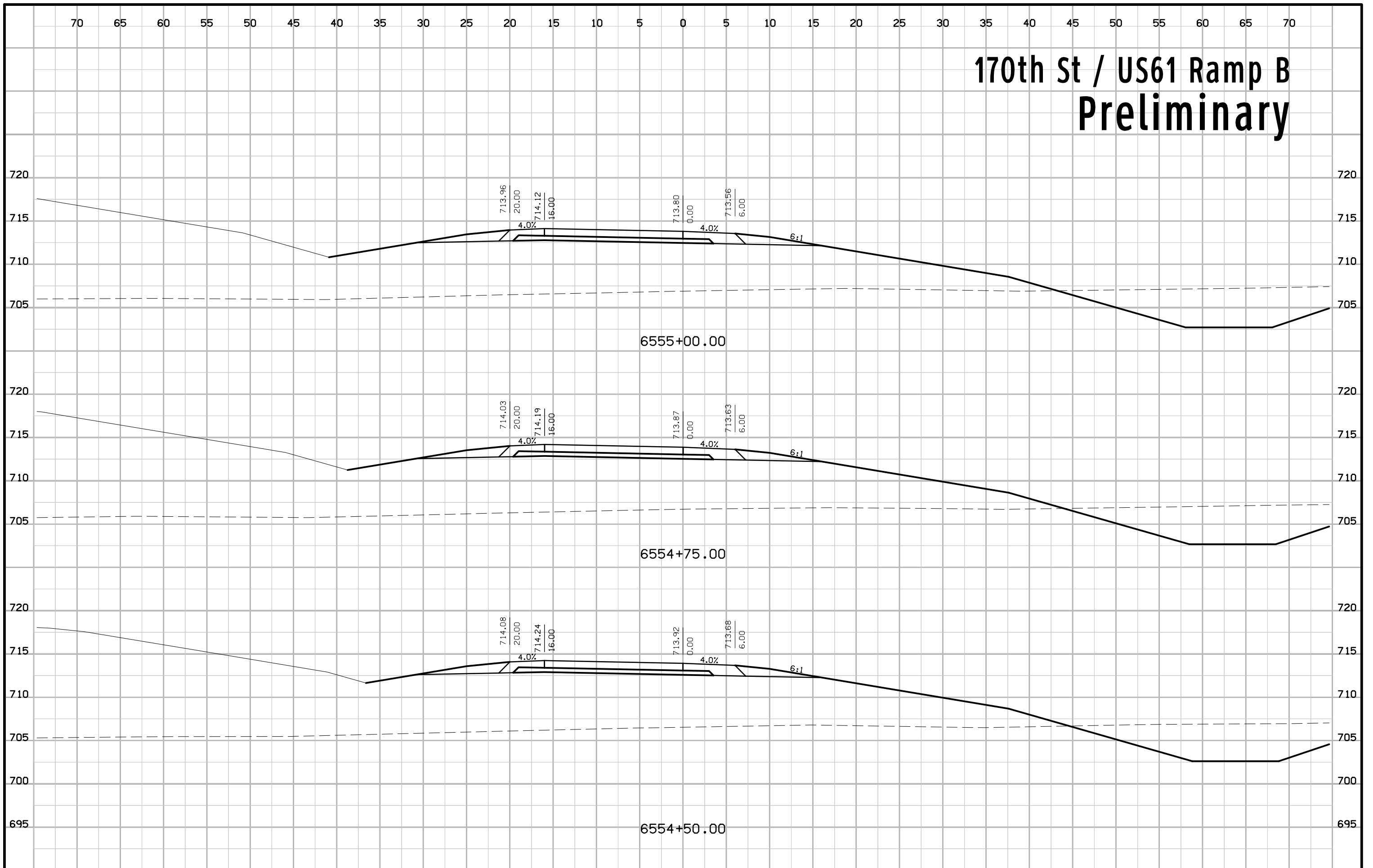

170th St / US61 Ramp B Preliminary

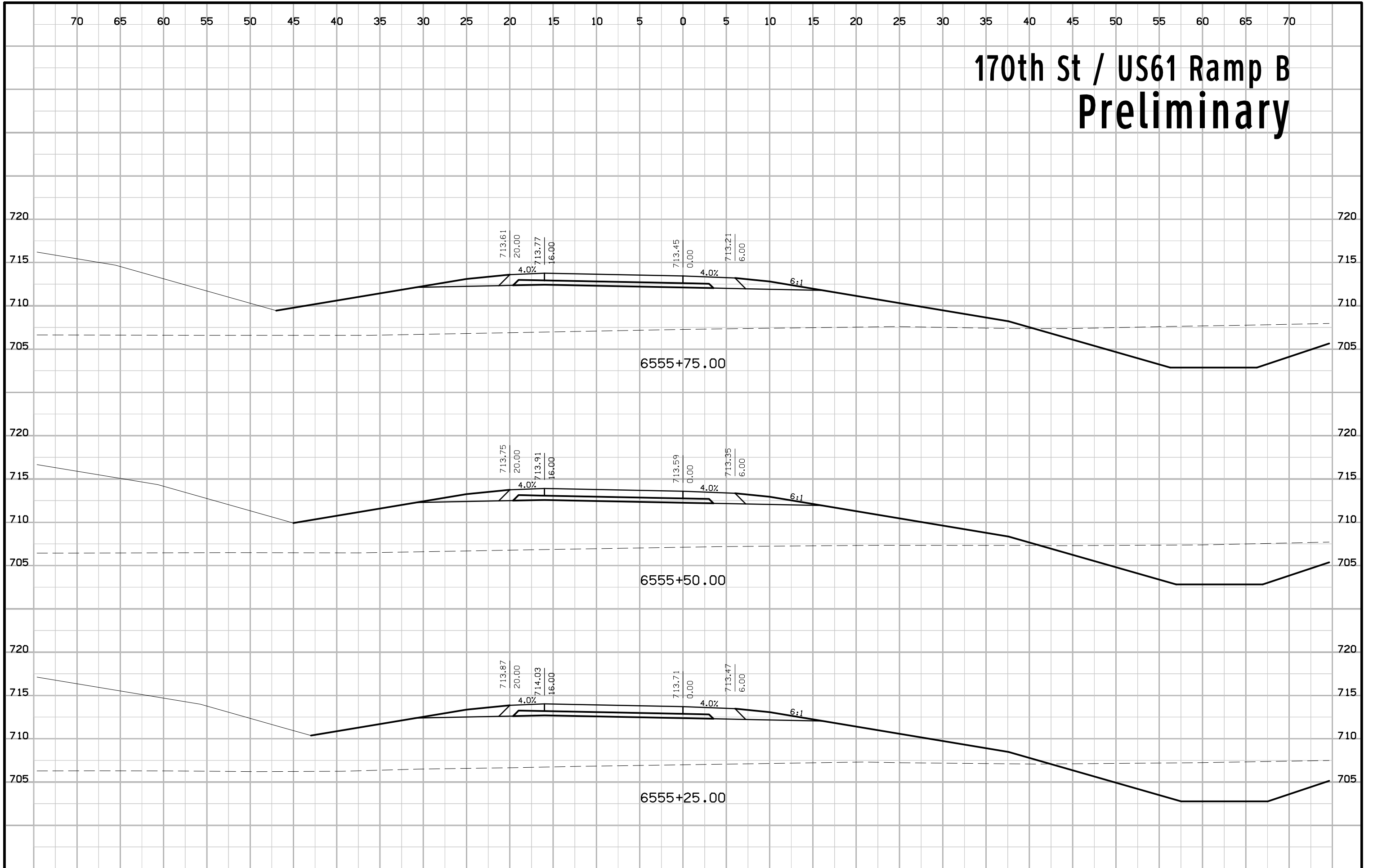

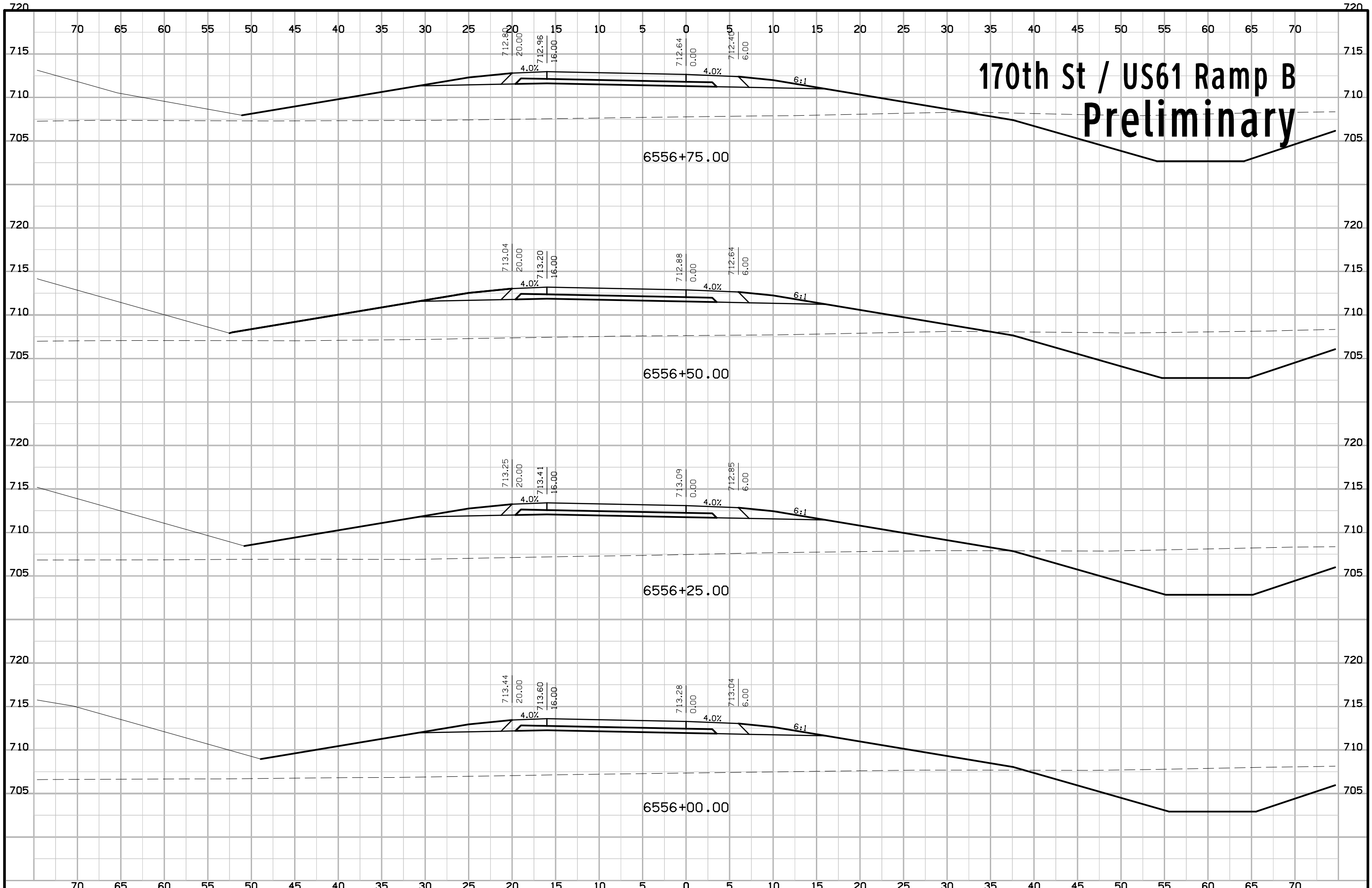

170th St / US61 Ramp B Preliminary

170th St / US61 Ramp B Preliminary

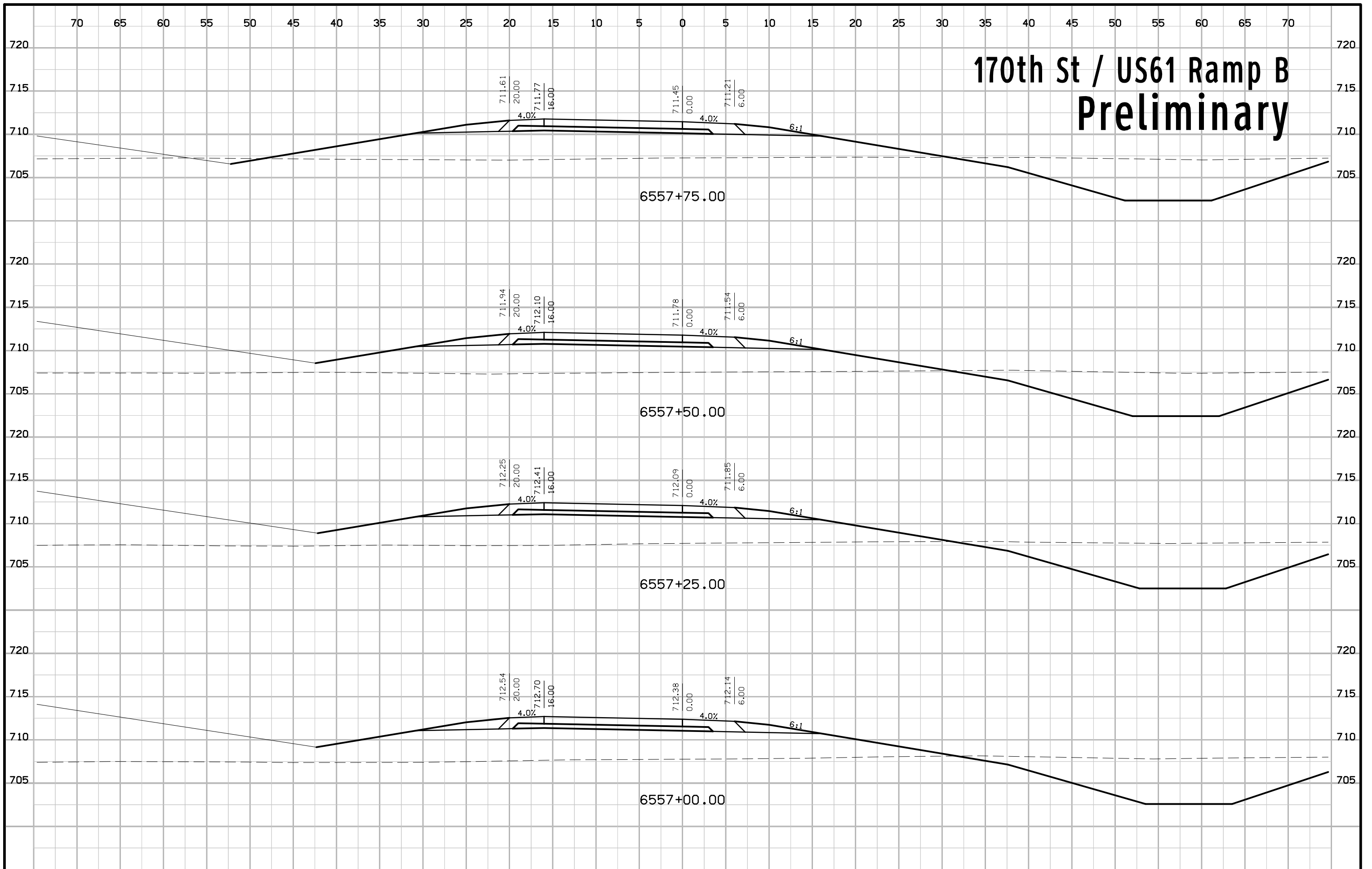

170th St / US61 Ramp B Preliminary

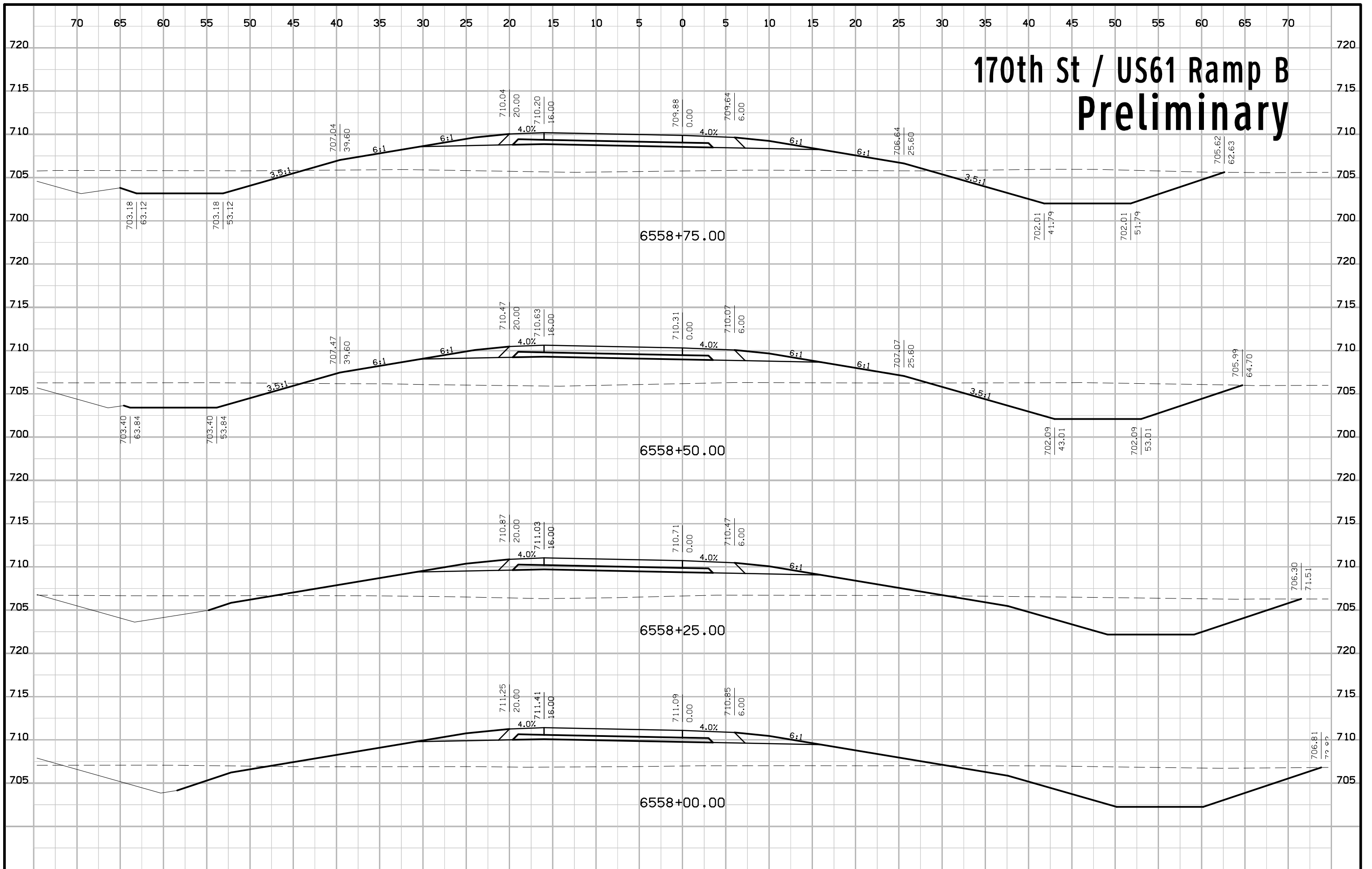

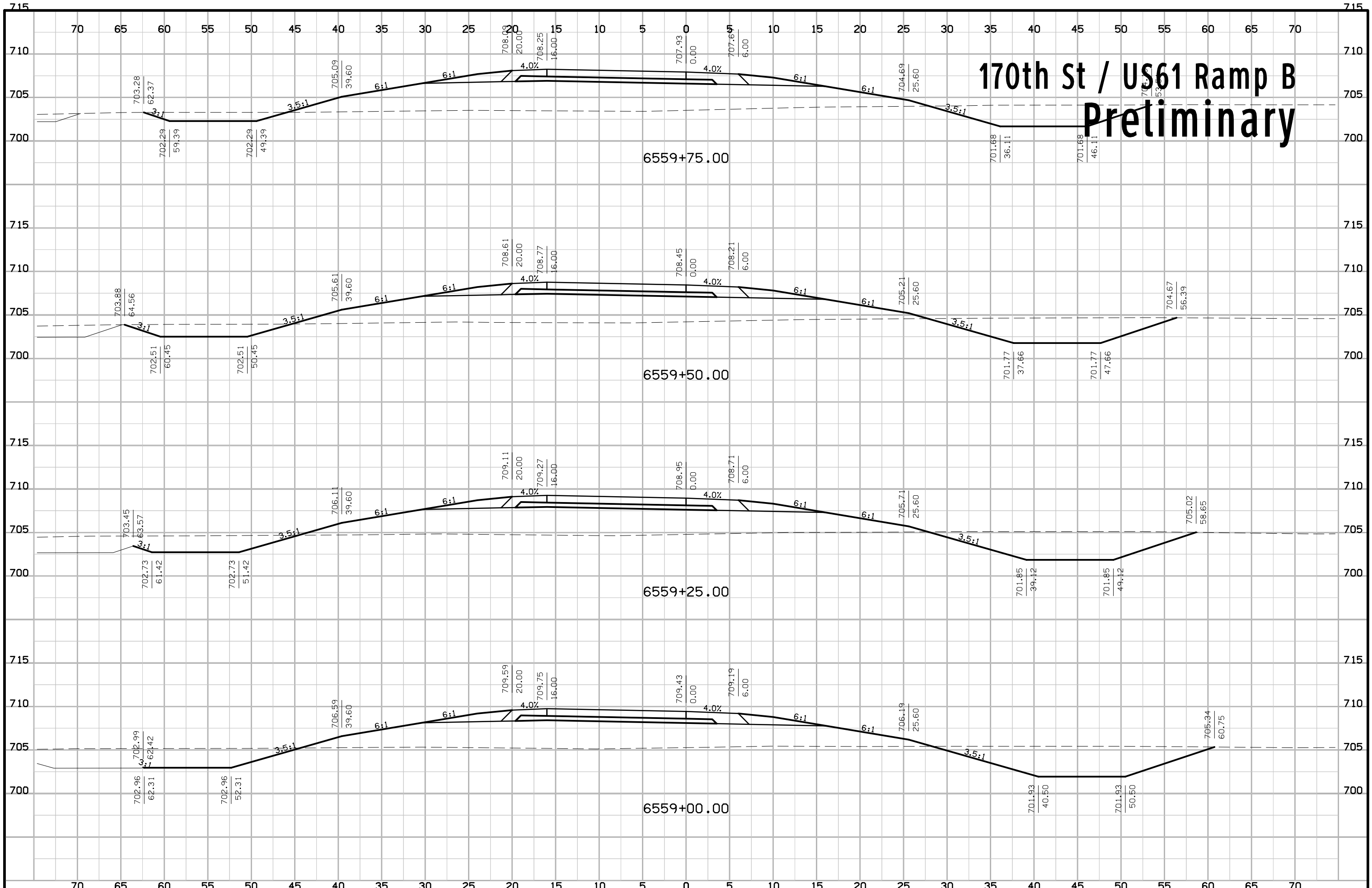

170th St / US61 Ramp B Preliminary

170th St / US61 Ramp B Preliminary

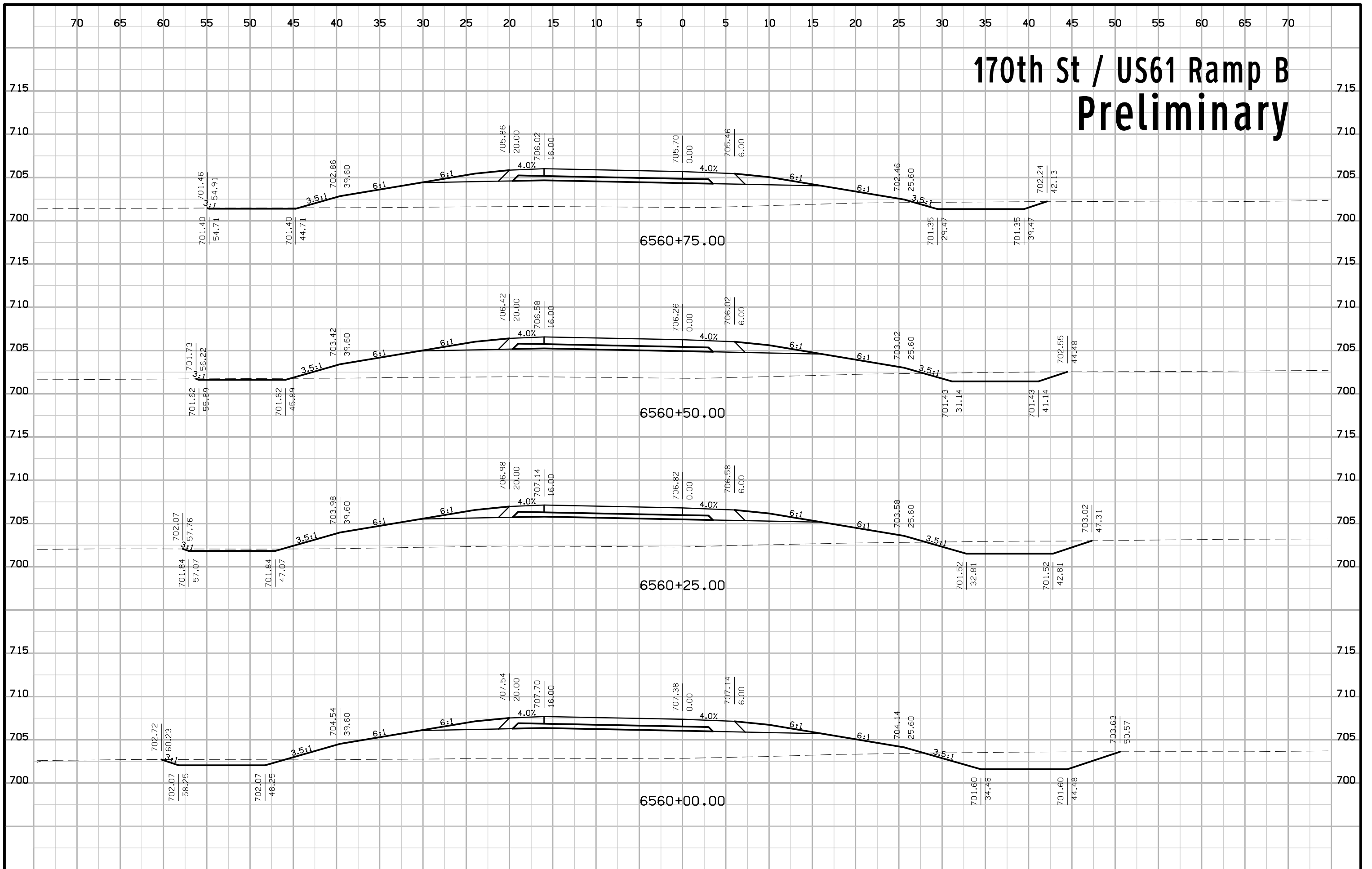

170th St / US61 Ramp B Preliminary

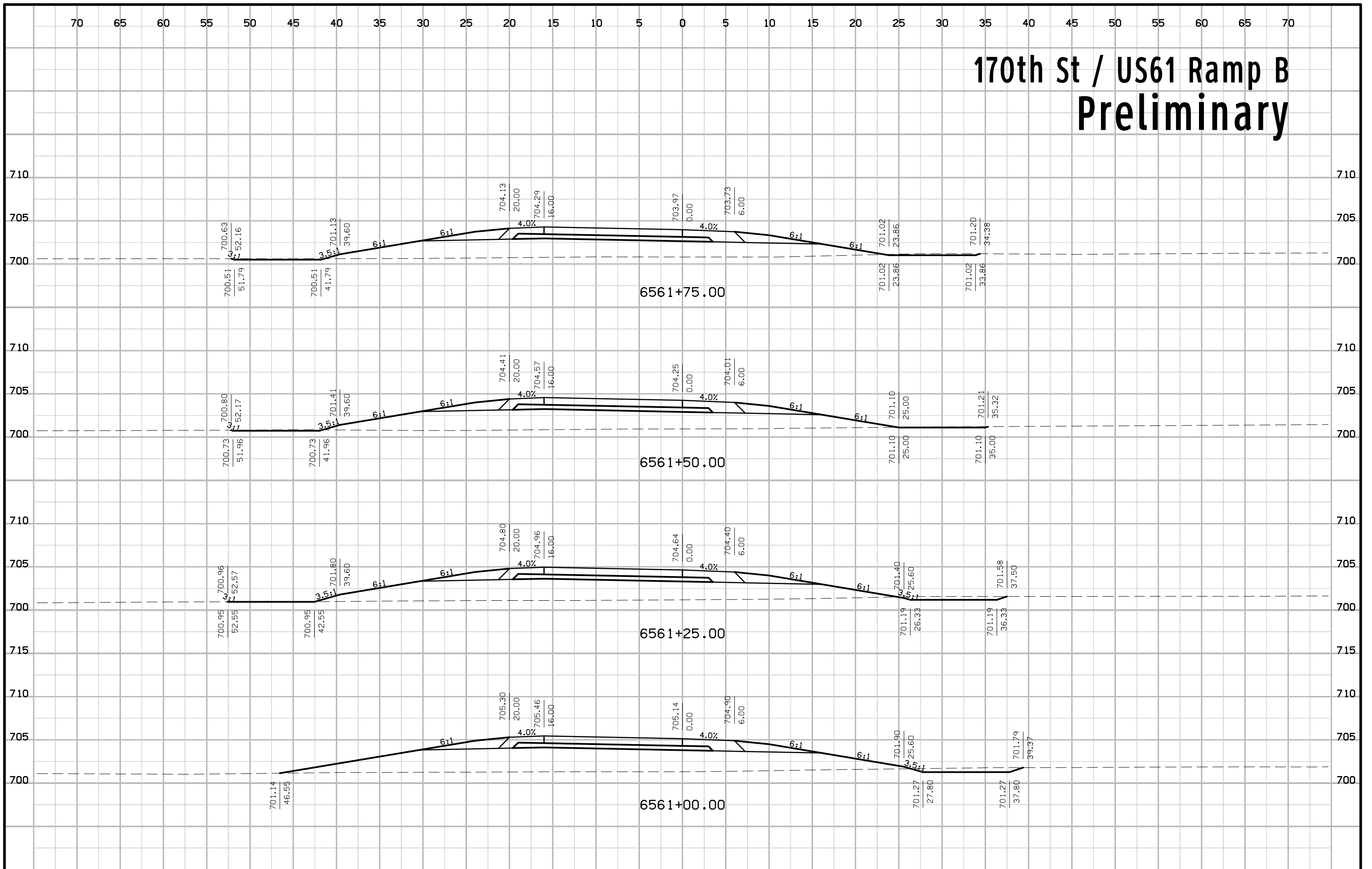

170th St / US61 Ramp B Preliminary

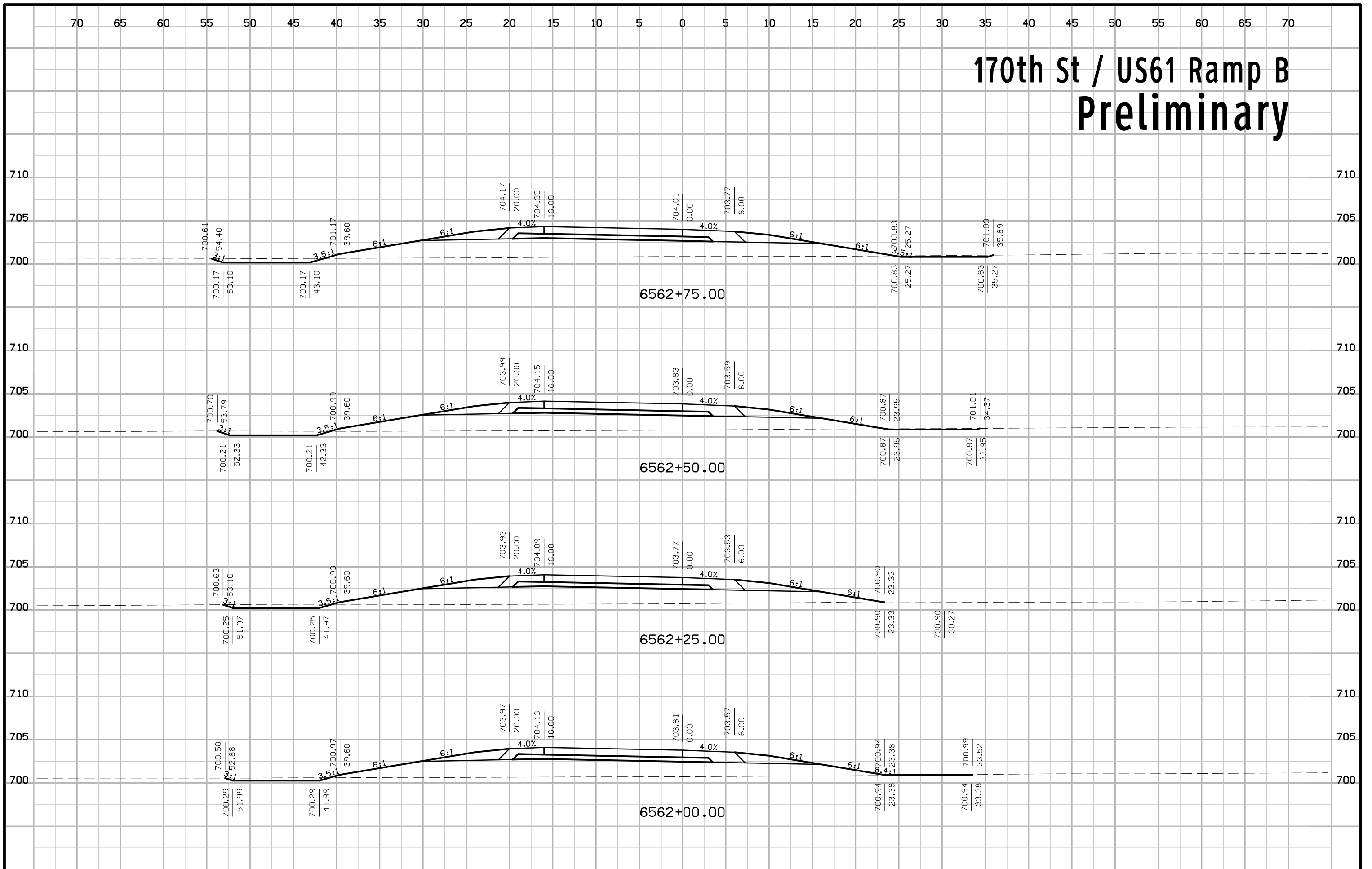

170th St / US61 Ramp B Preliminary

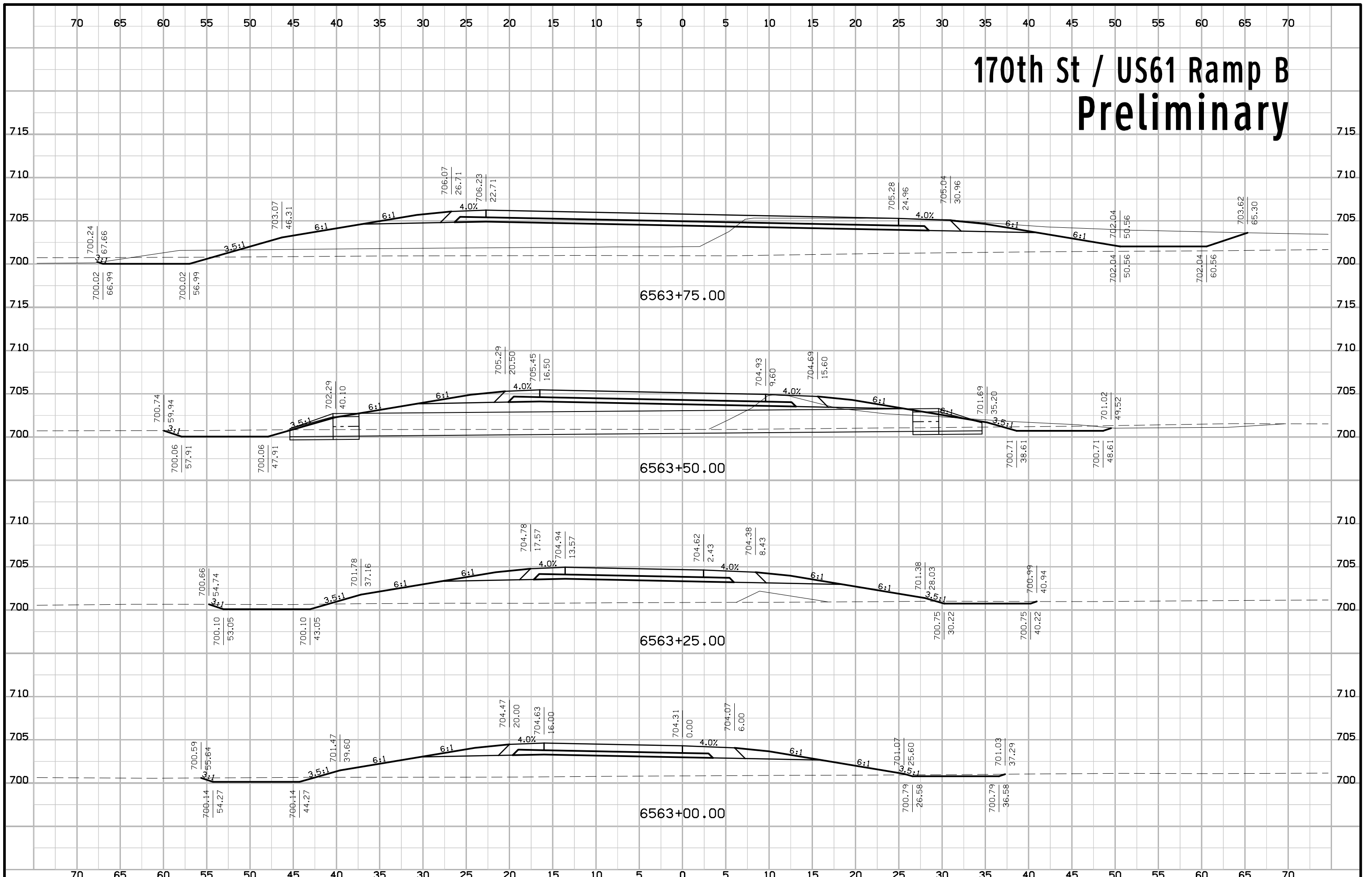

170th St / US61 Ramp B Preliminary

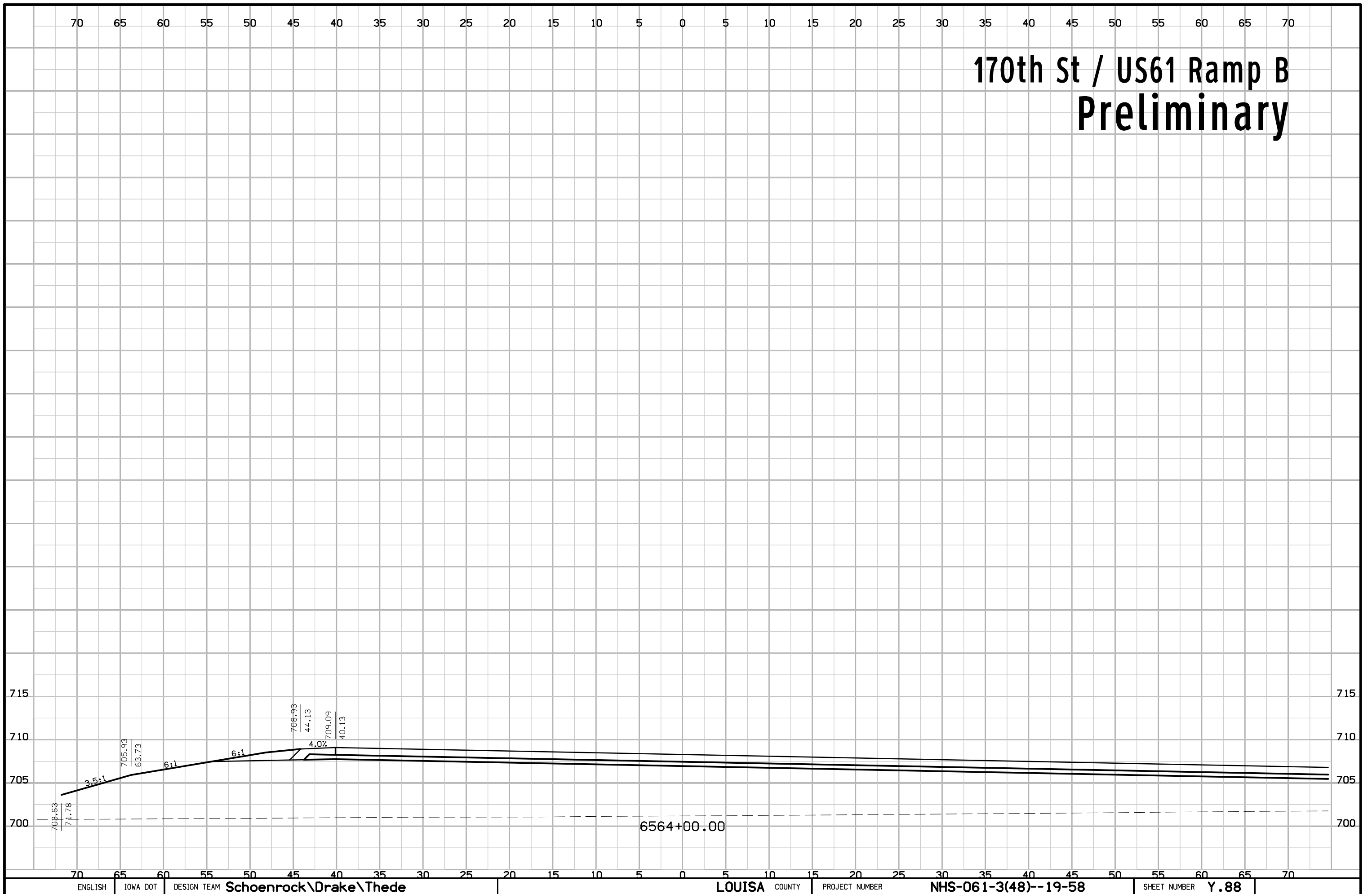

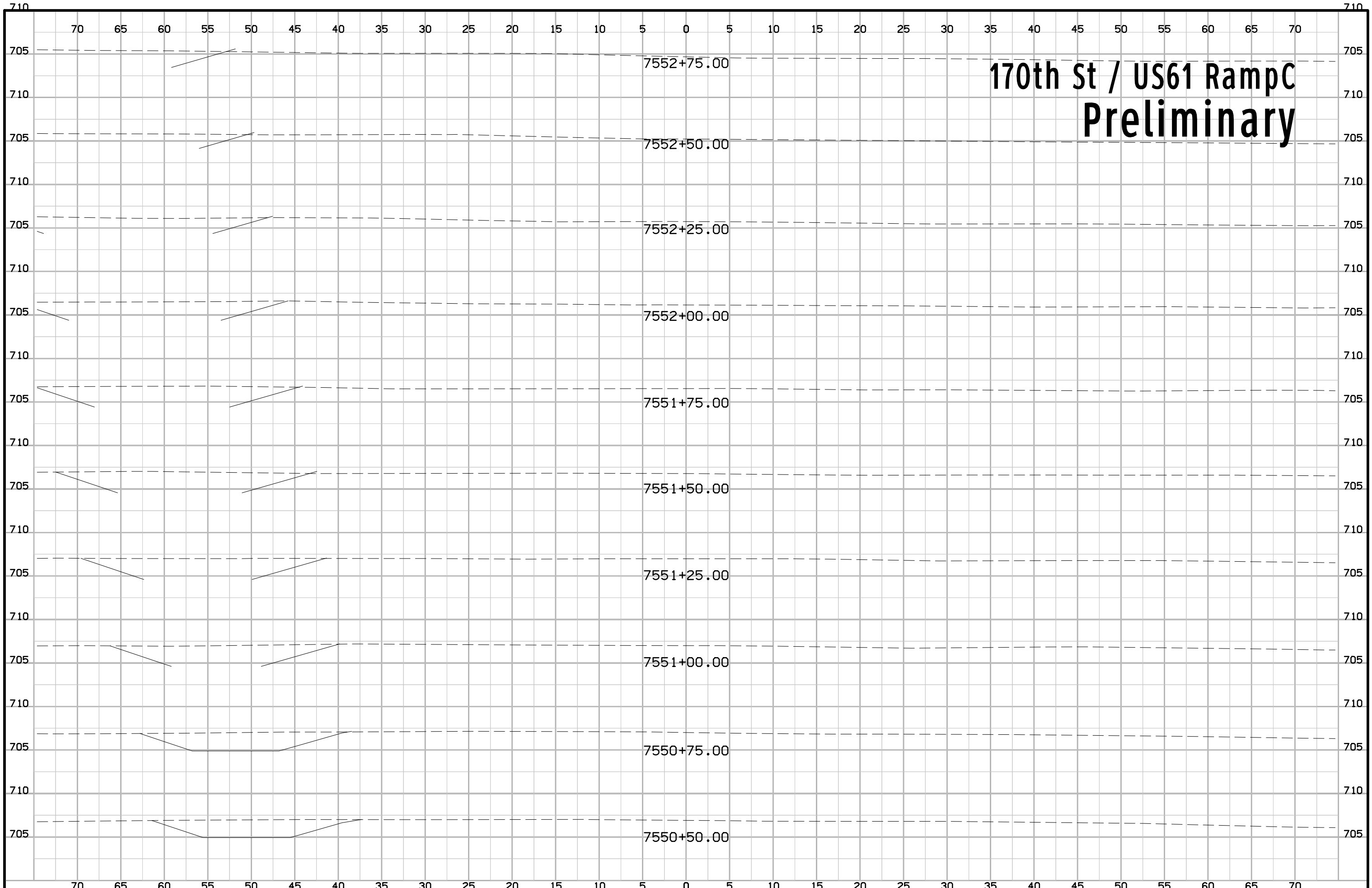

170th St / US61 Ramp C Preliminary

170th St / US61 RampC Preliminary

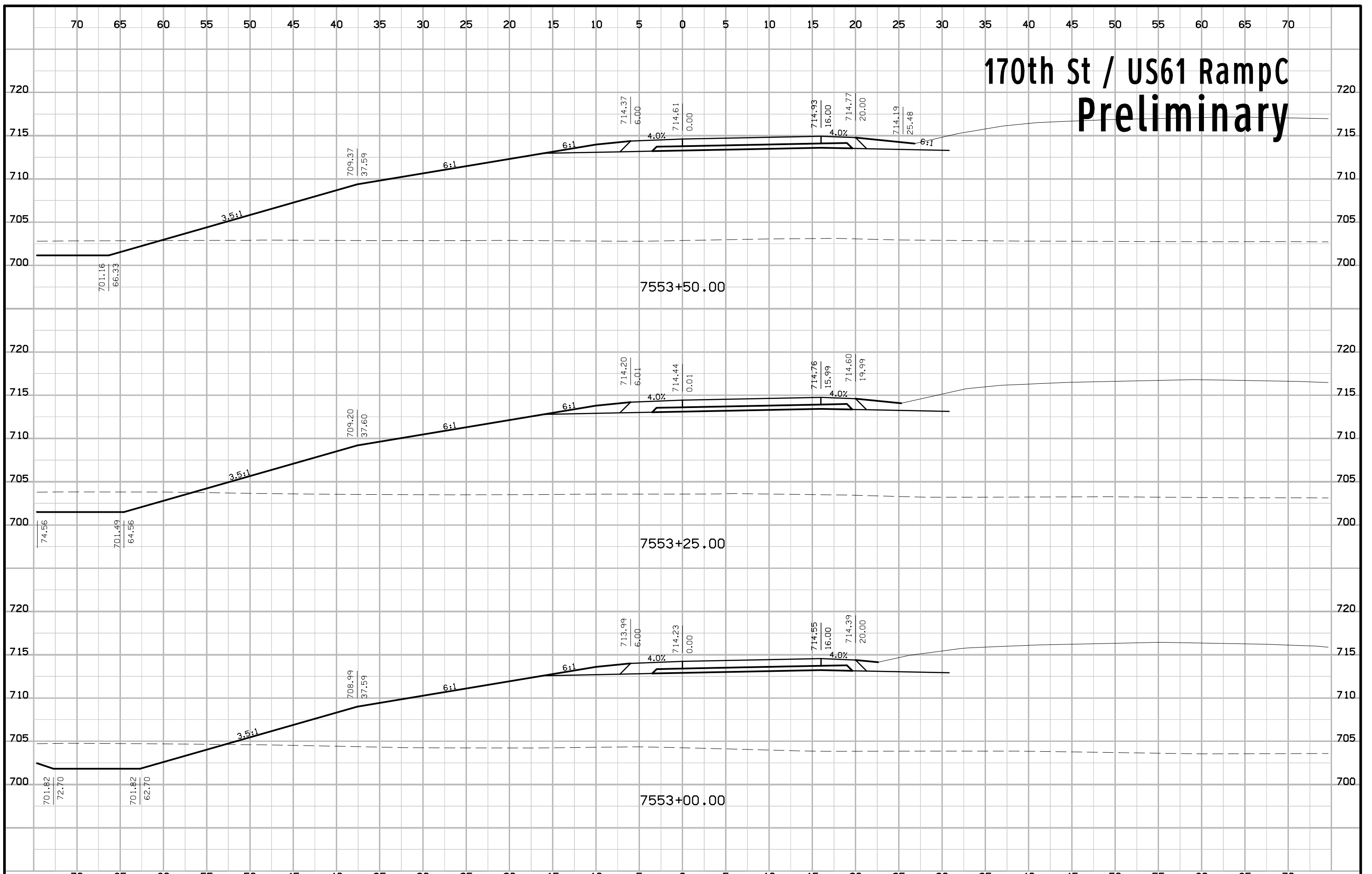

170th St / US61 RampC Preliminary

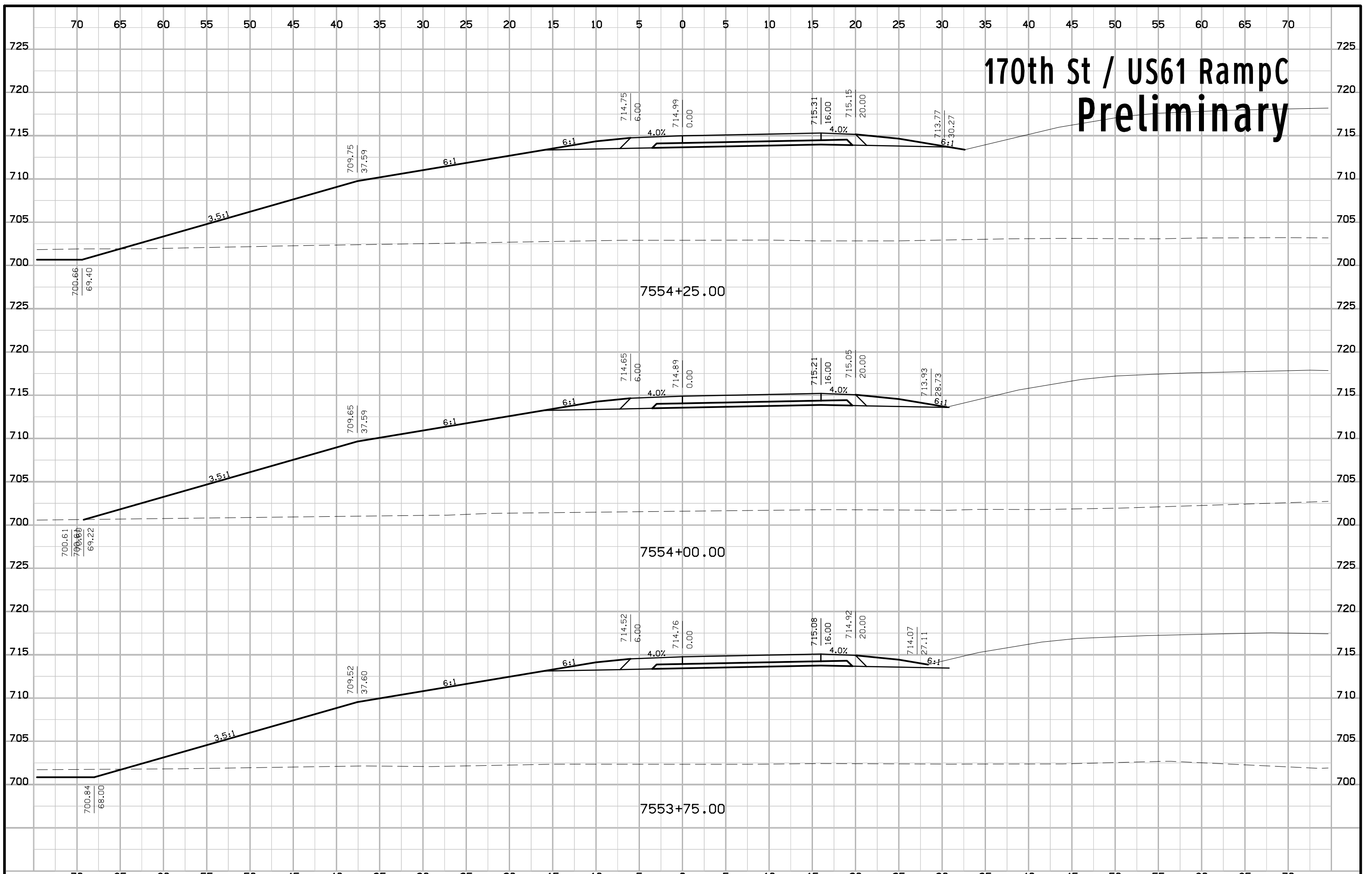

170th St / US61 RampC Preliminary

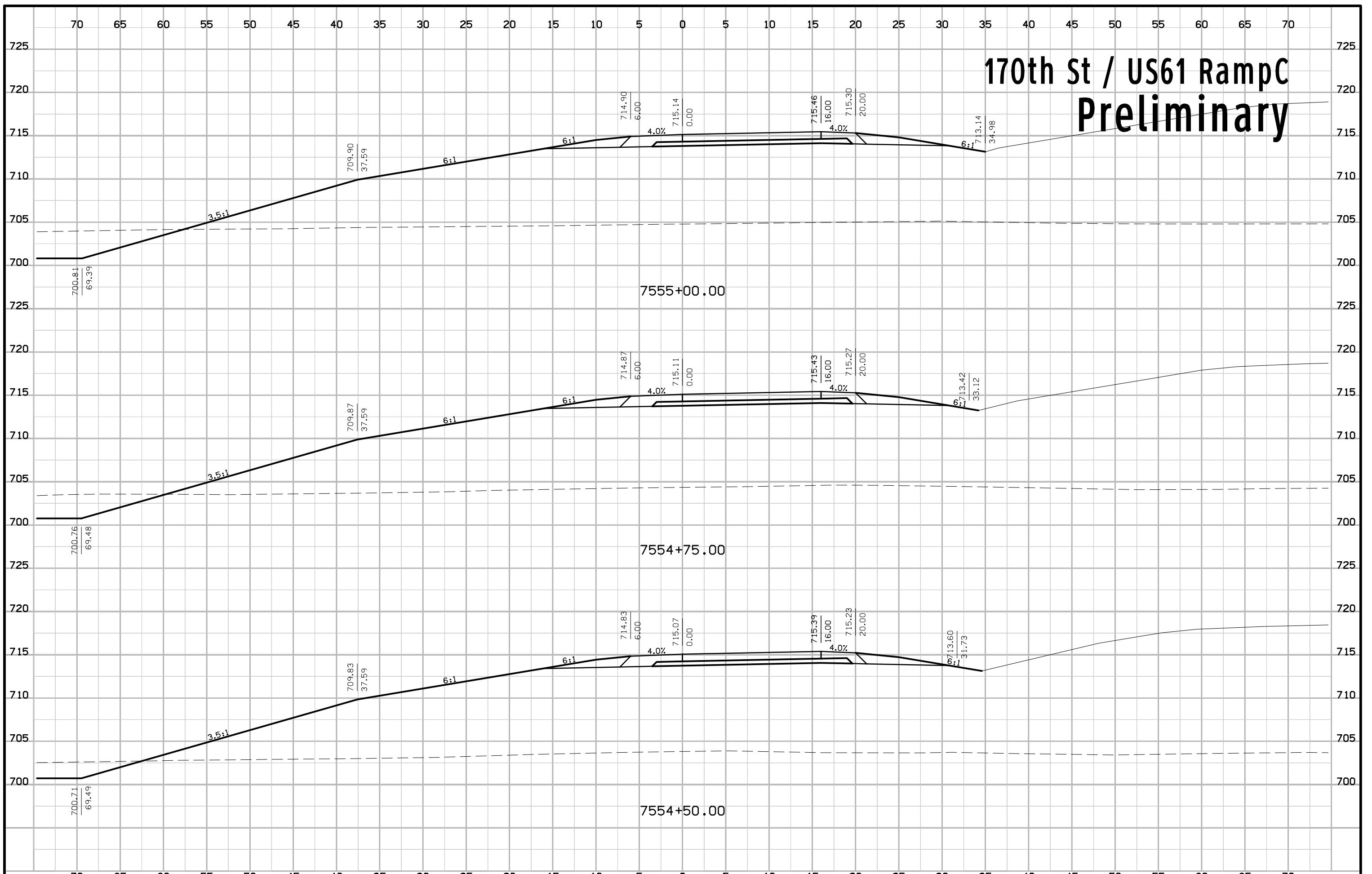

170th St / US61 RampC Preliminary

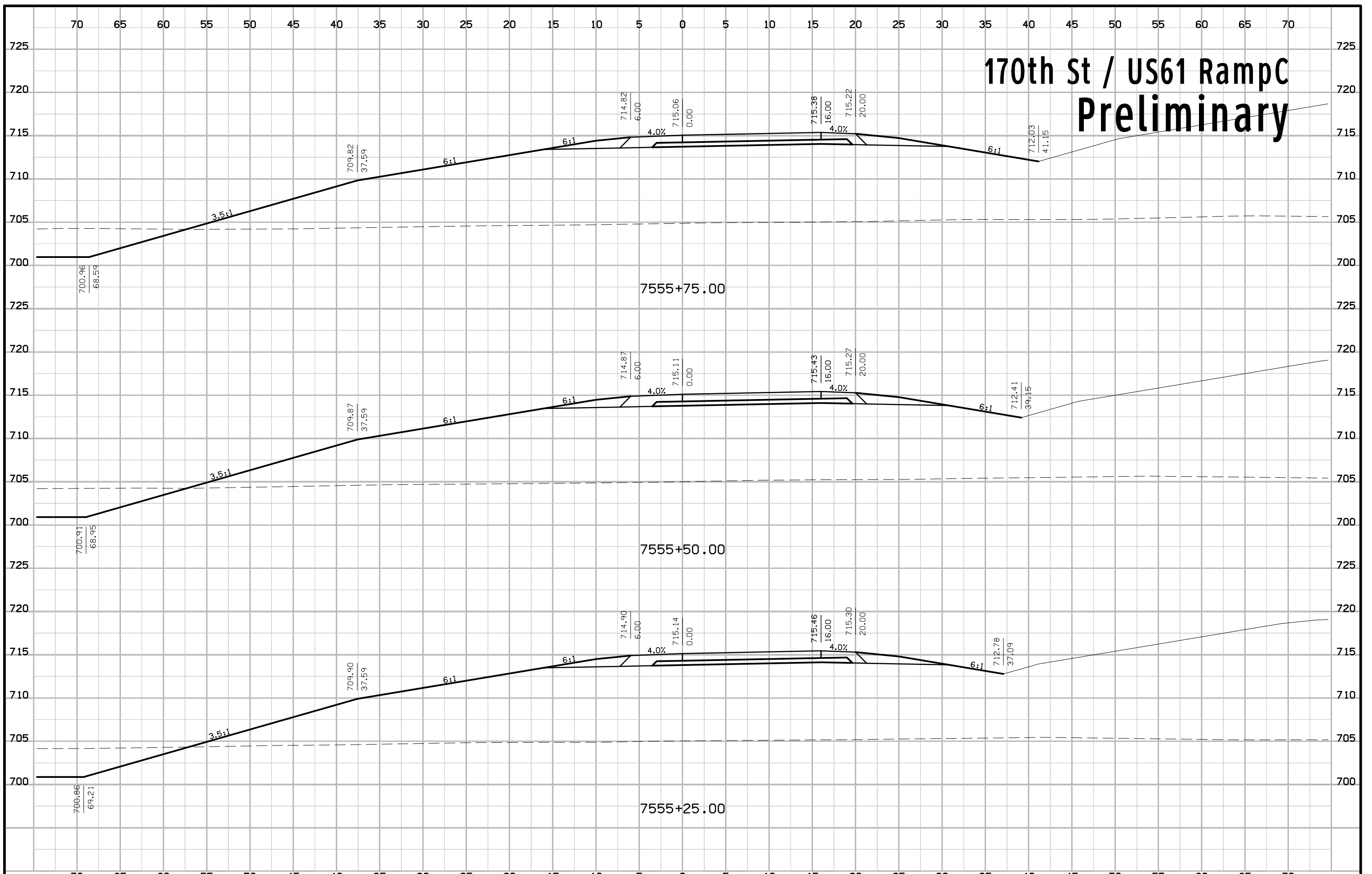

170th St / US61 RampC Preliminary

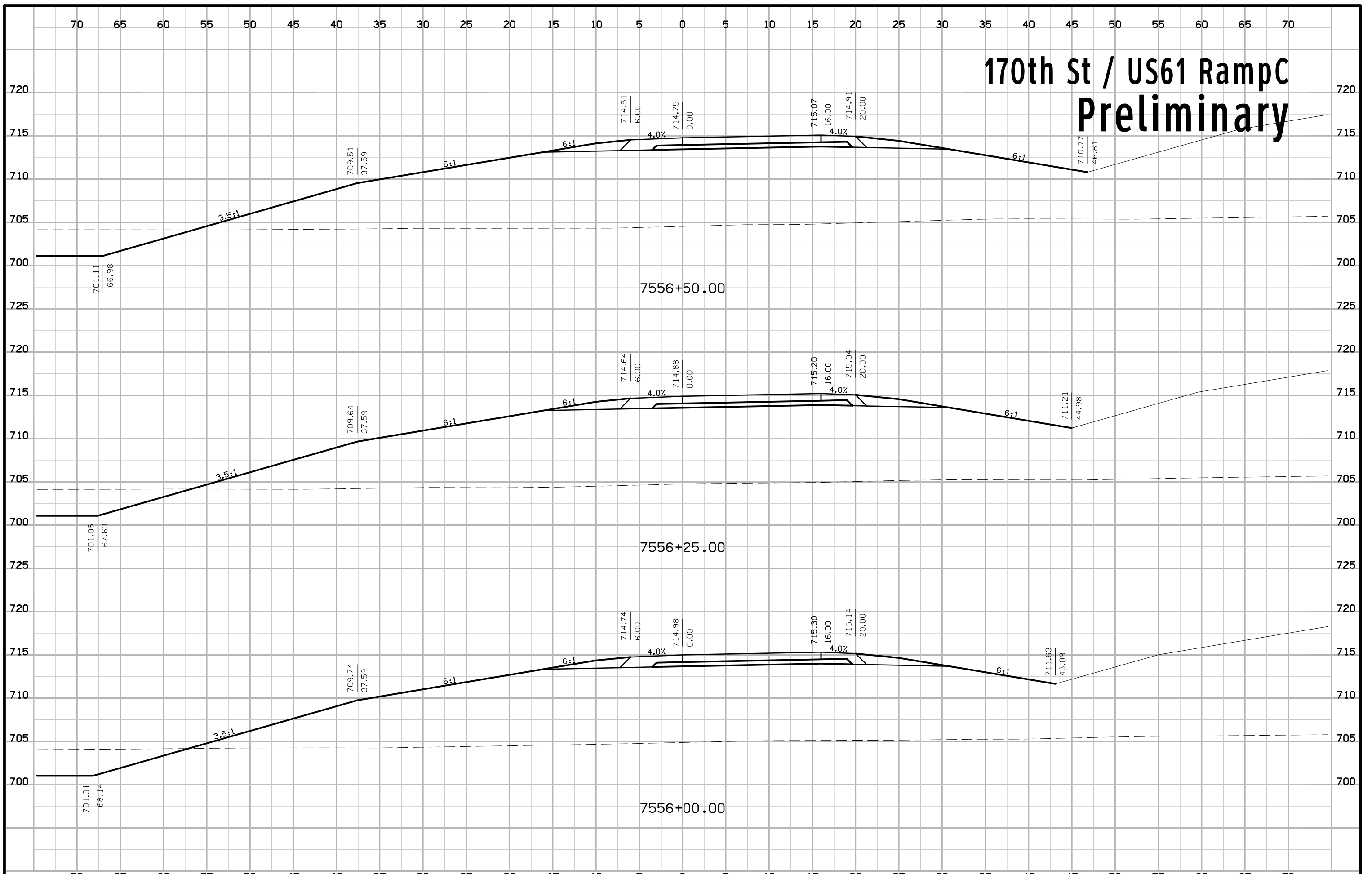

170th St / US61 RampC Preliminary

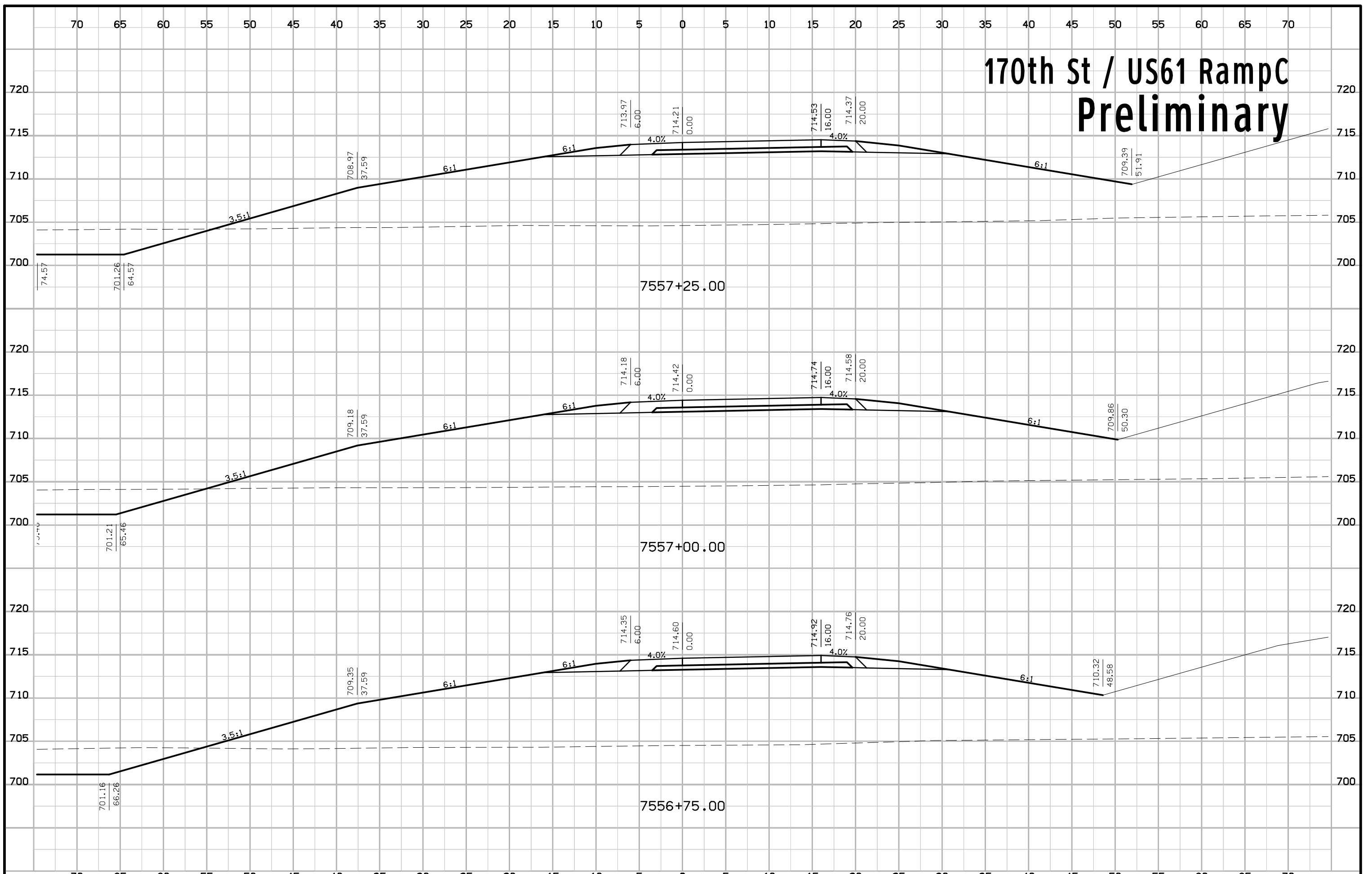

170th St / US61 RampC Preliminary

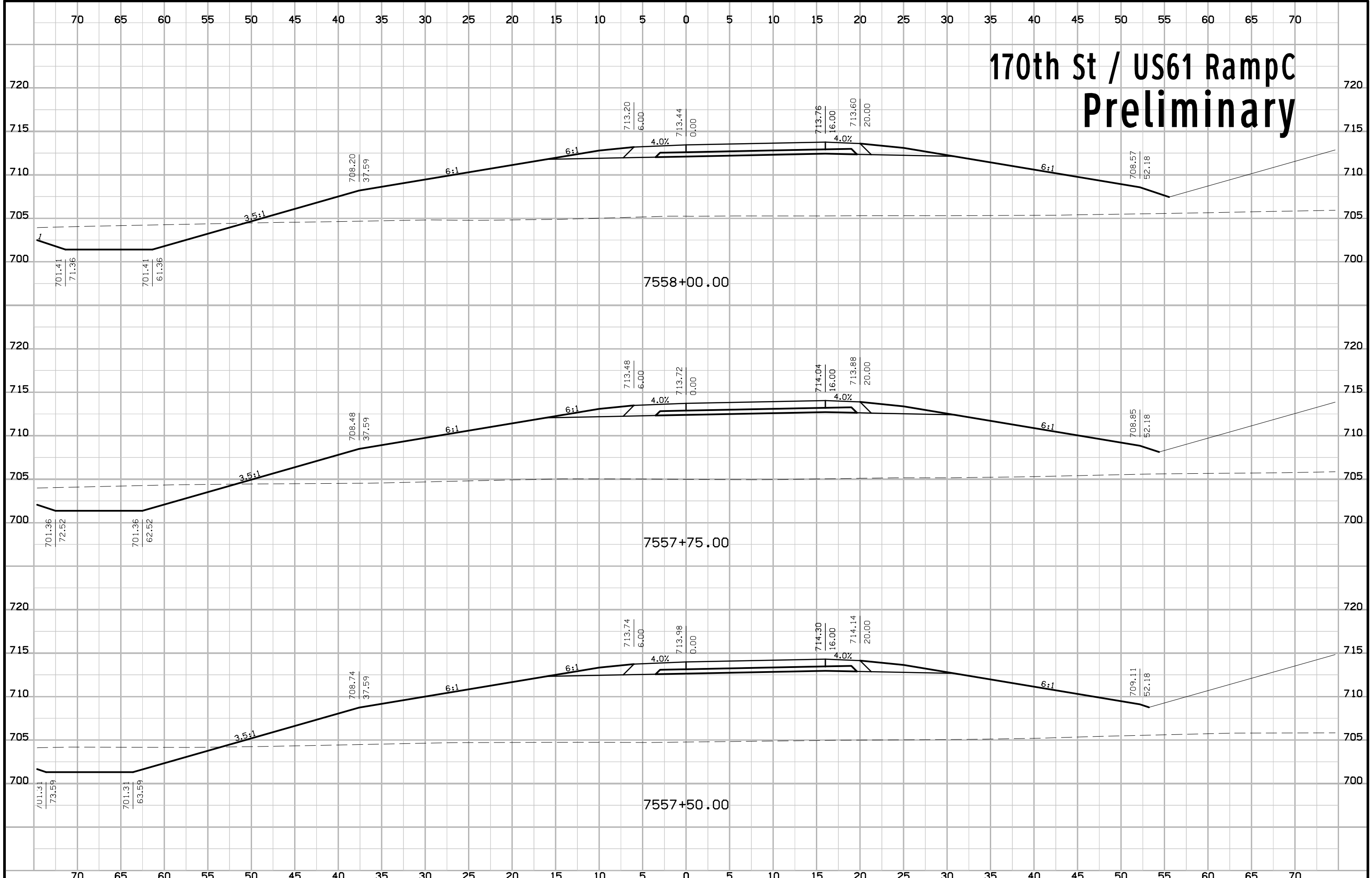

170th St / US61 RampC Preliminary

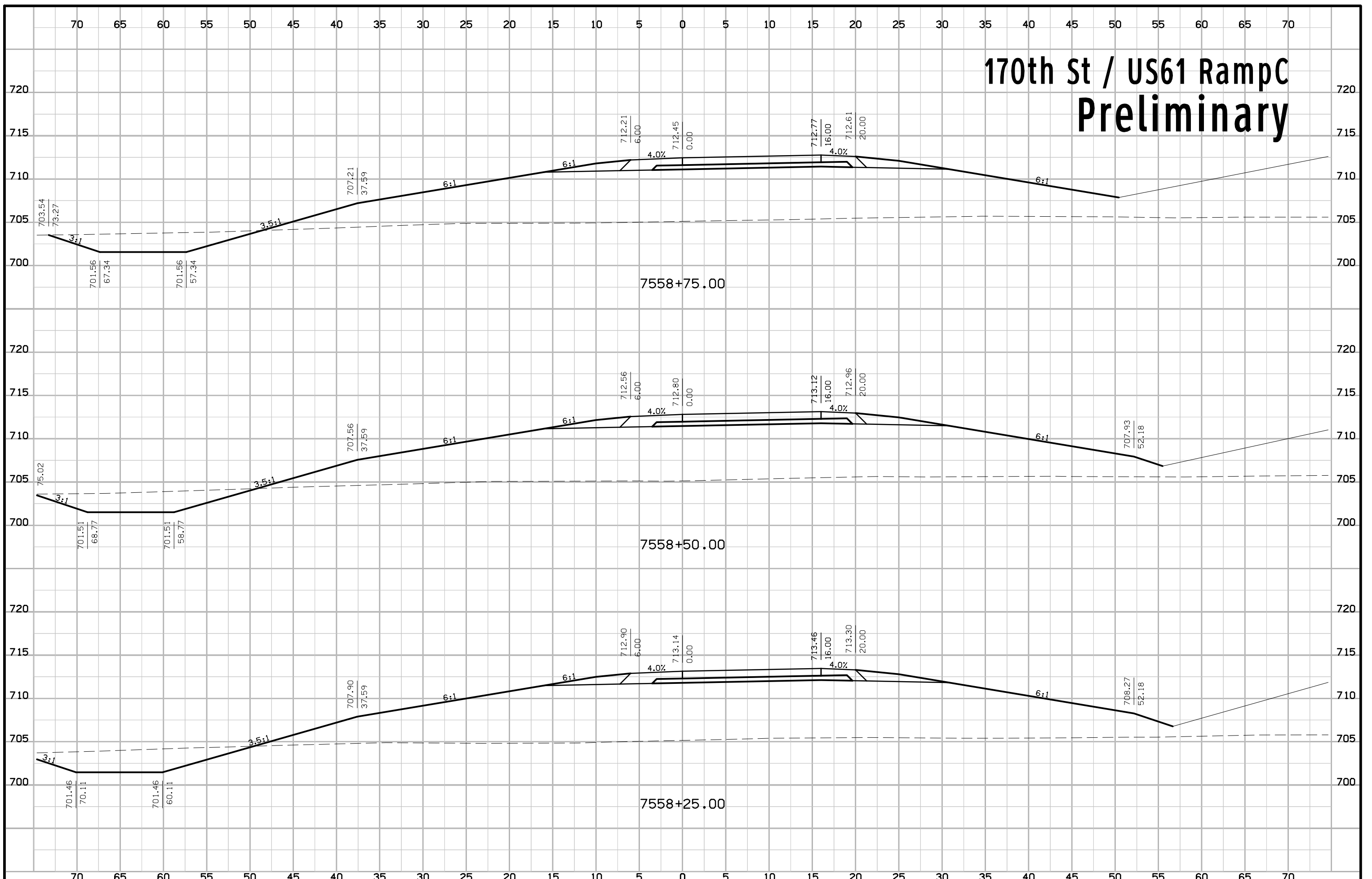

170th St / US61 Ramp C Preliminary

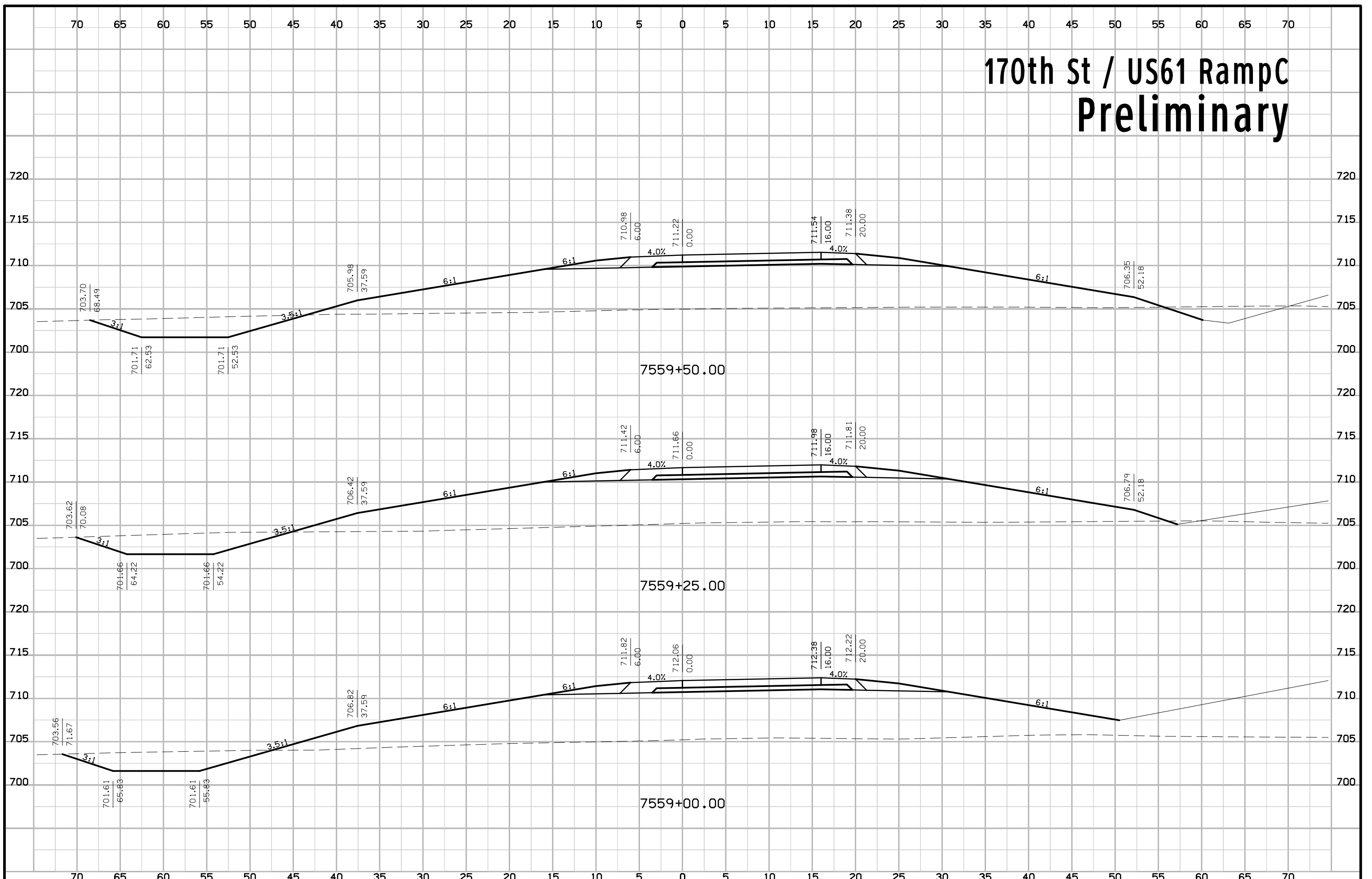

170th St / US61 RampC Preliminary

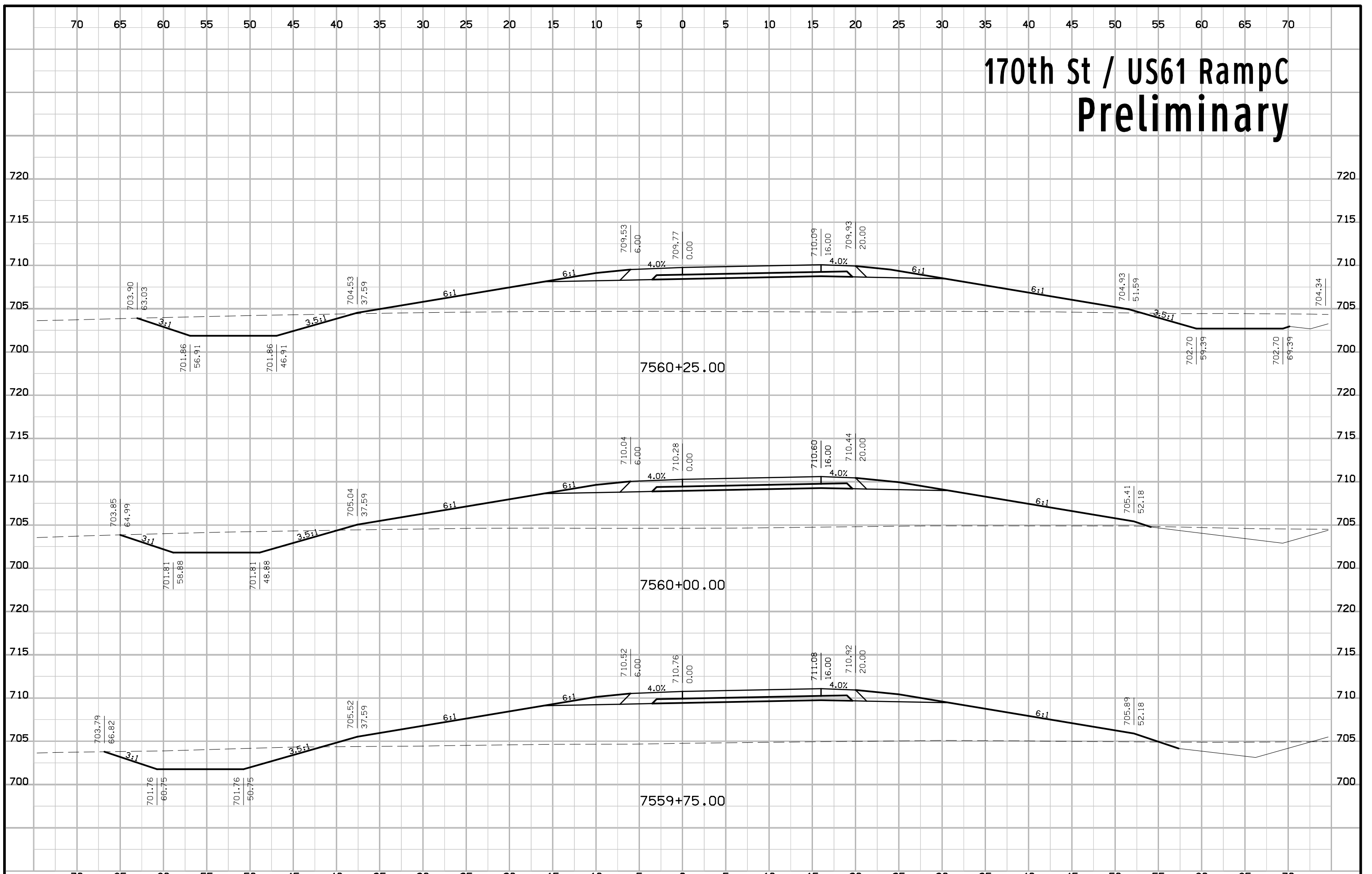

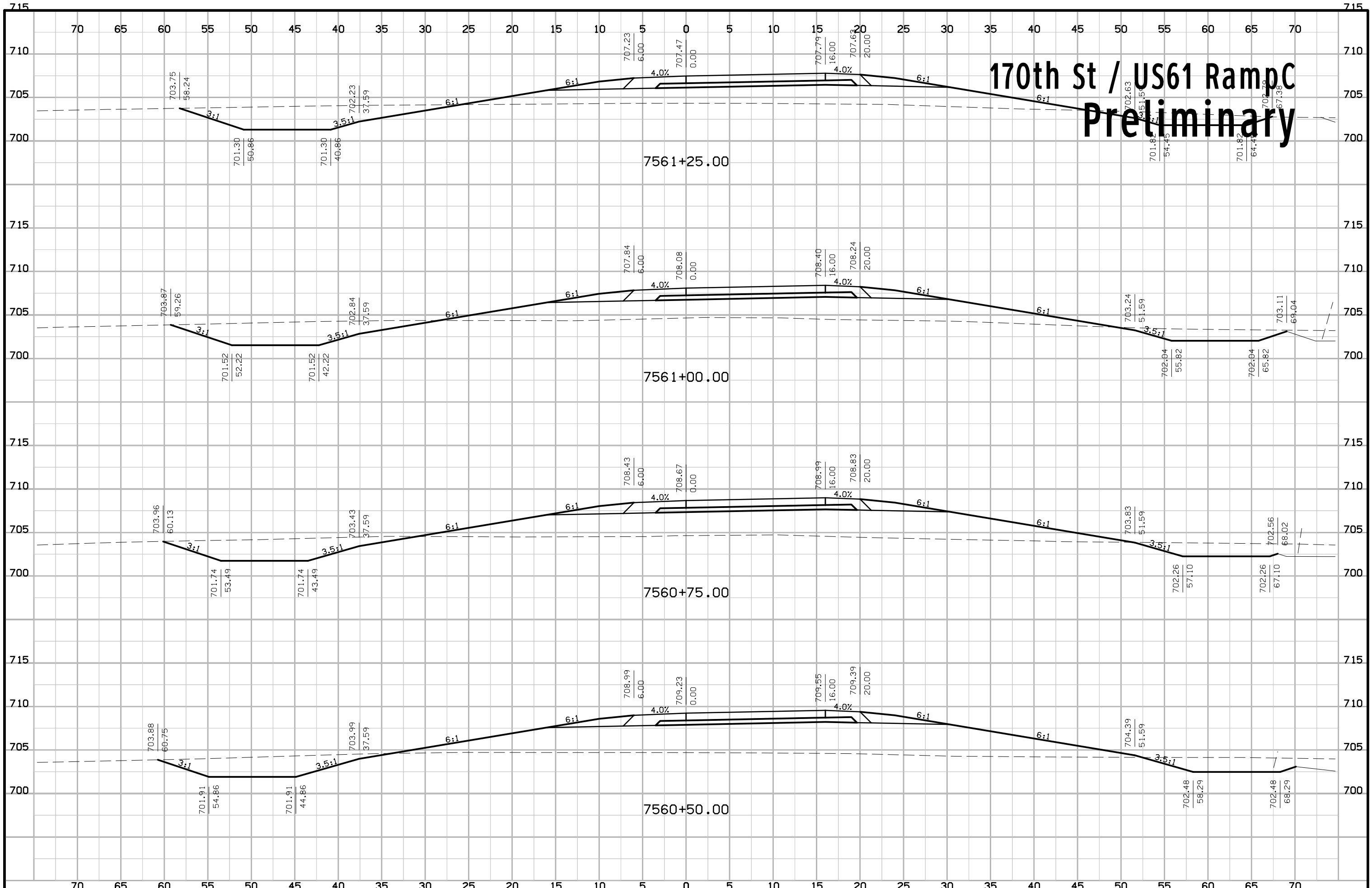

170th St / US61 Ramp Preliminary

170th St / US61 RampC Preliminary

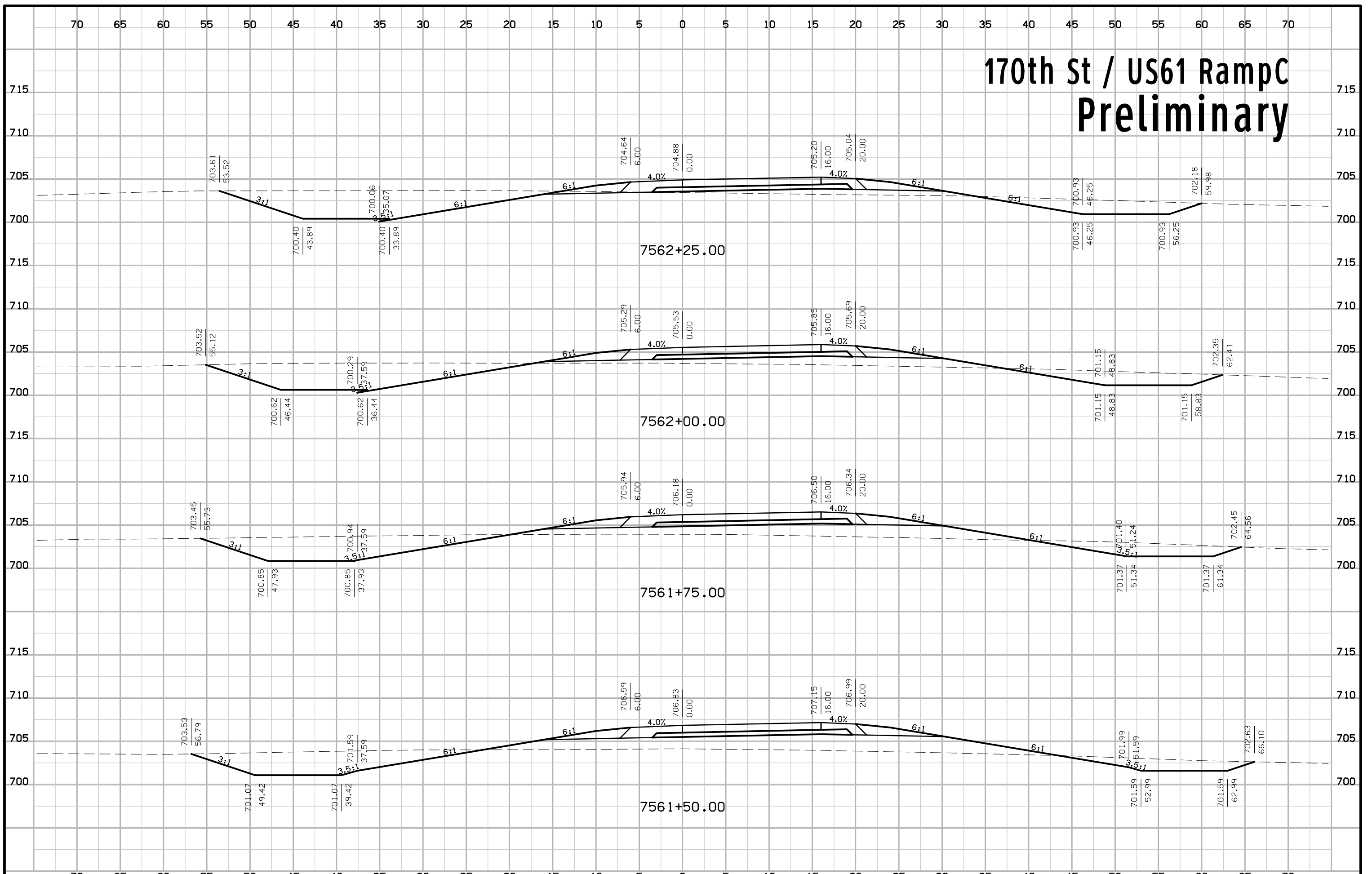

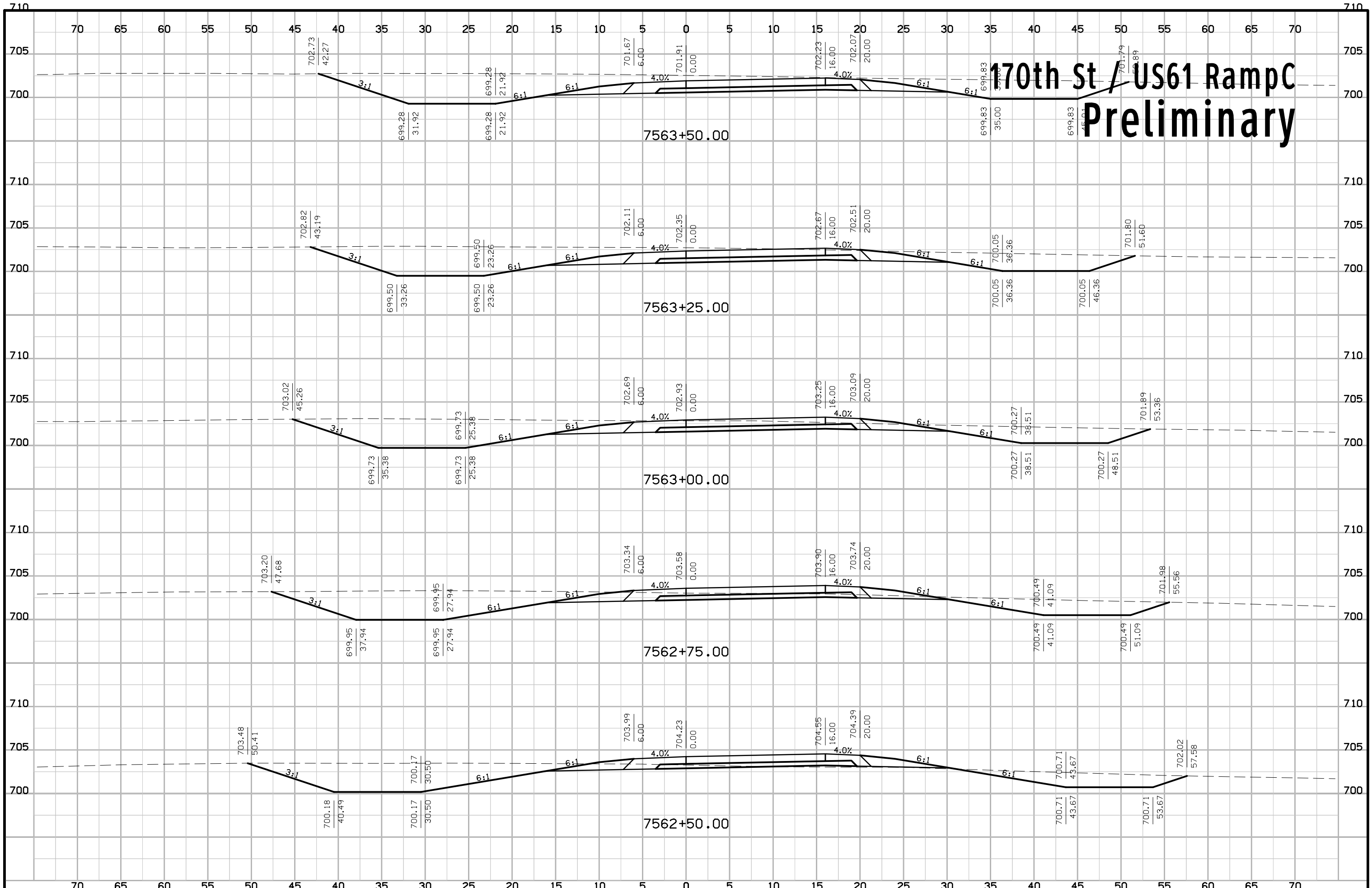

170th St / US61 Ramp C Preliminary

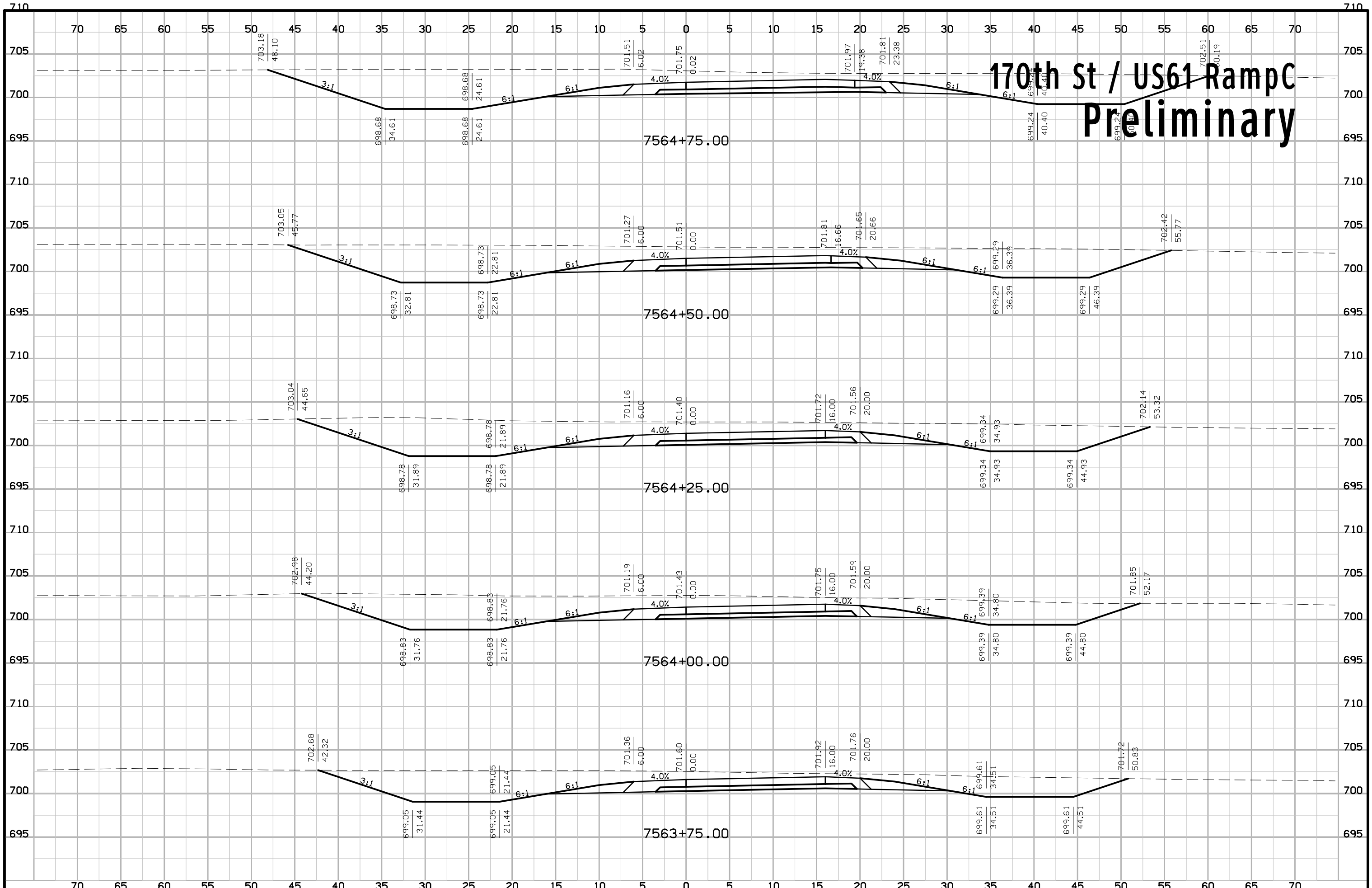

170th St / US61 Ramp C Preliminary

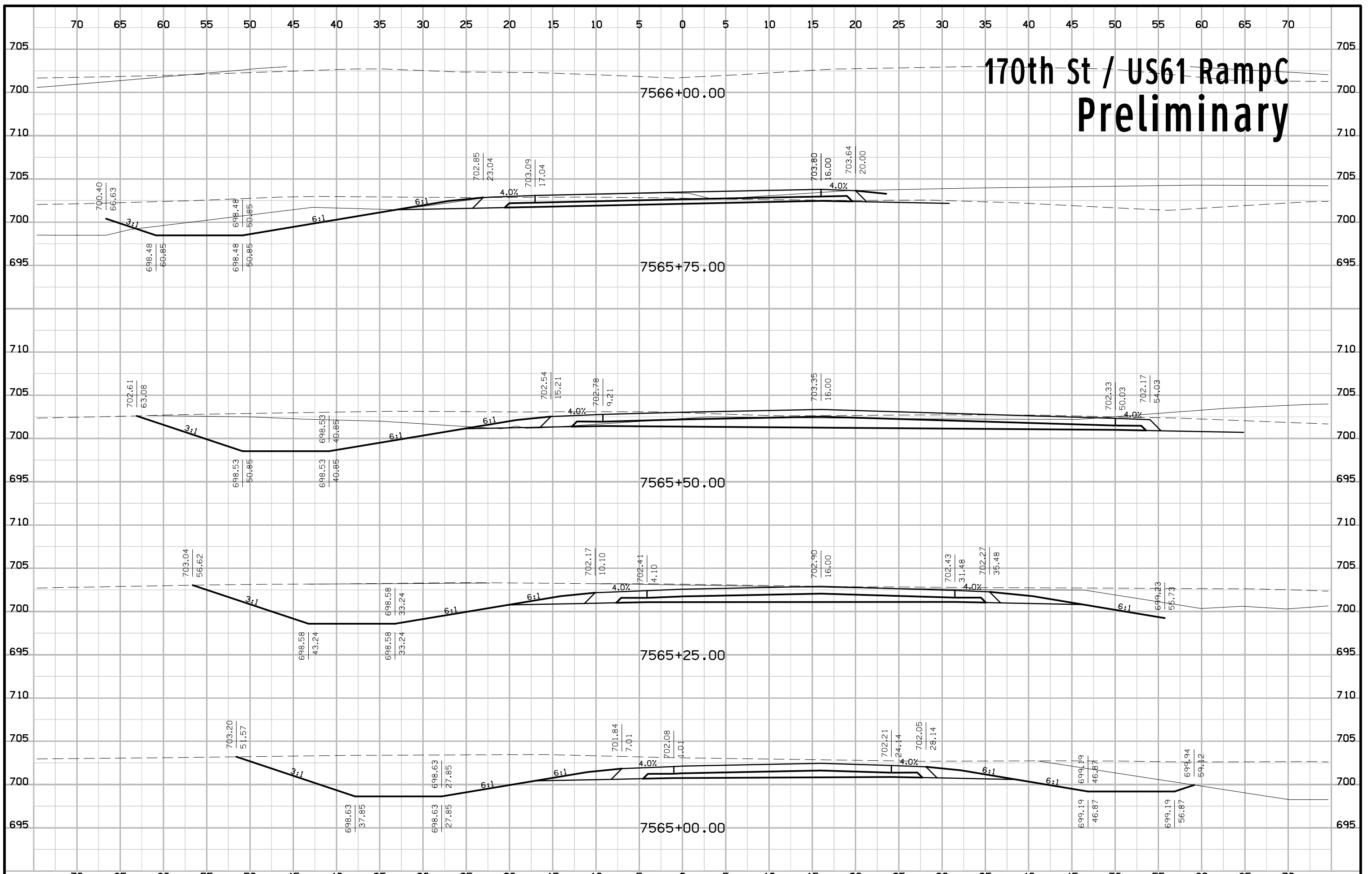

170th St / US61 Ramp D Preliminary

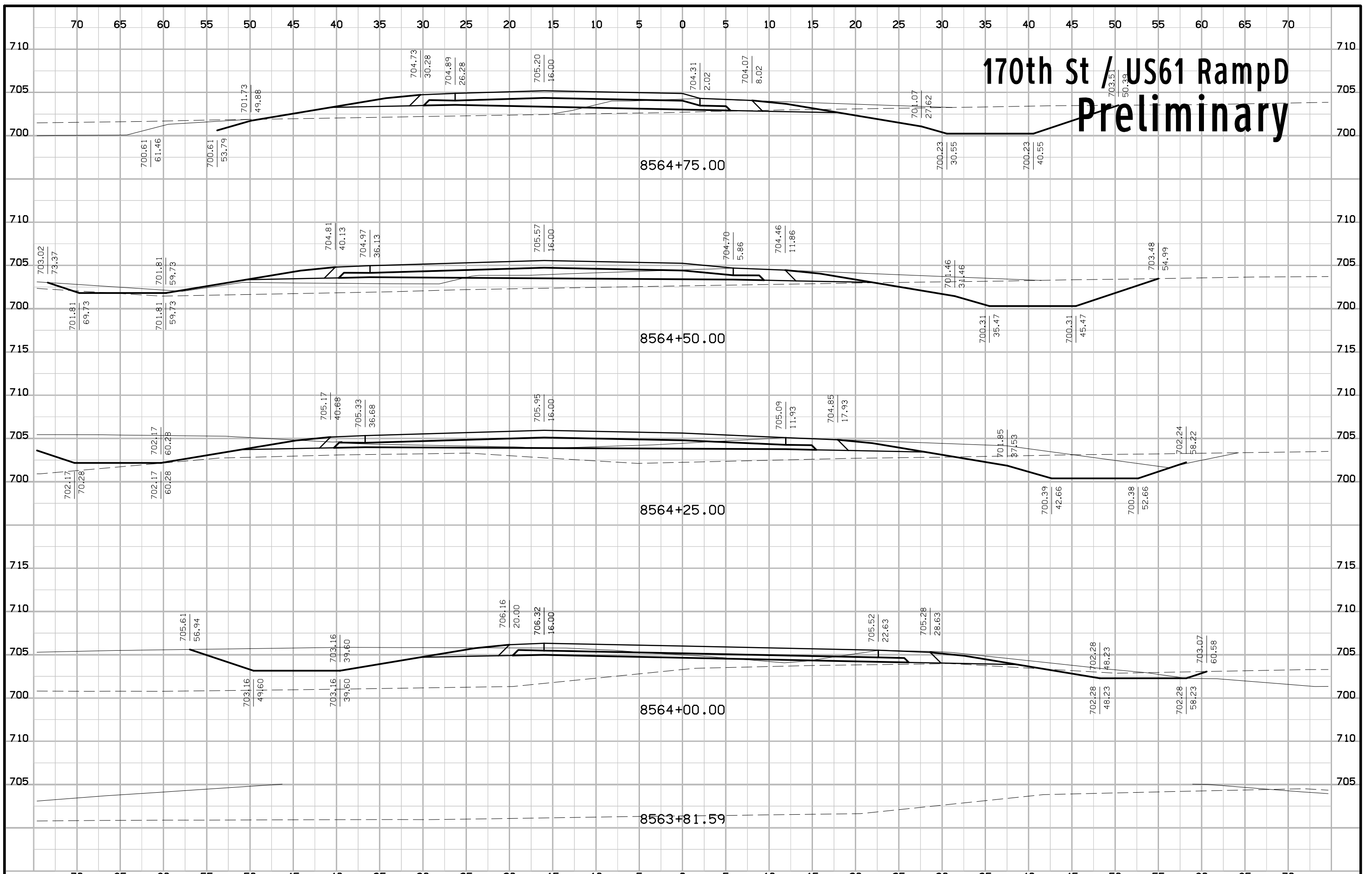

170th St / US61 RampD Preliminary

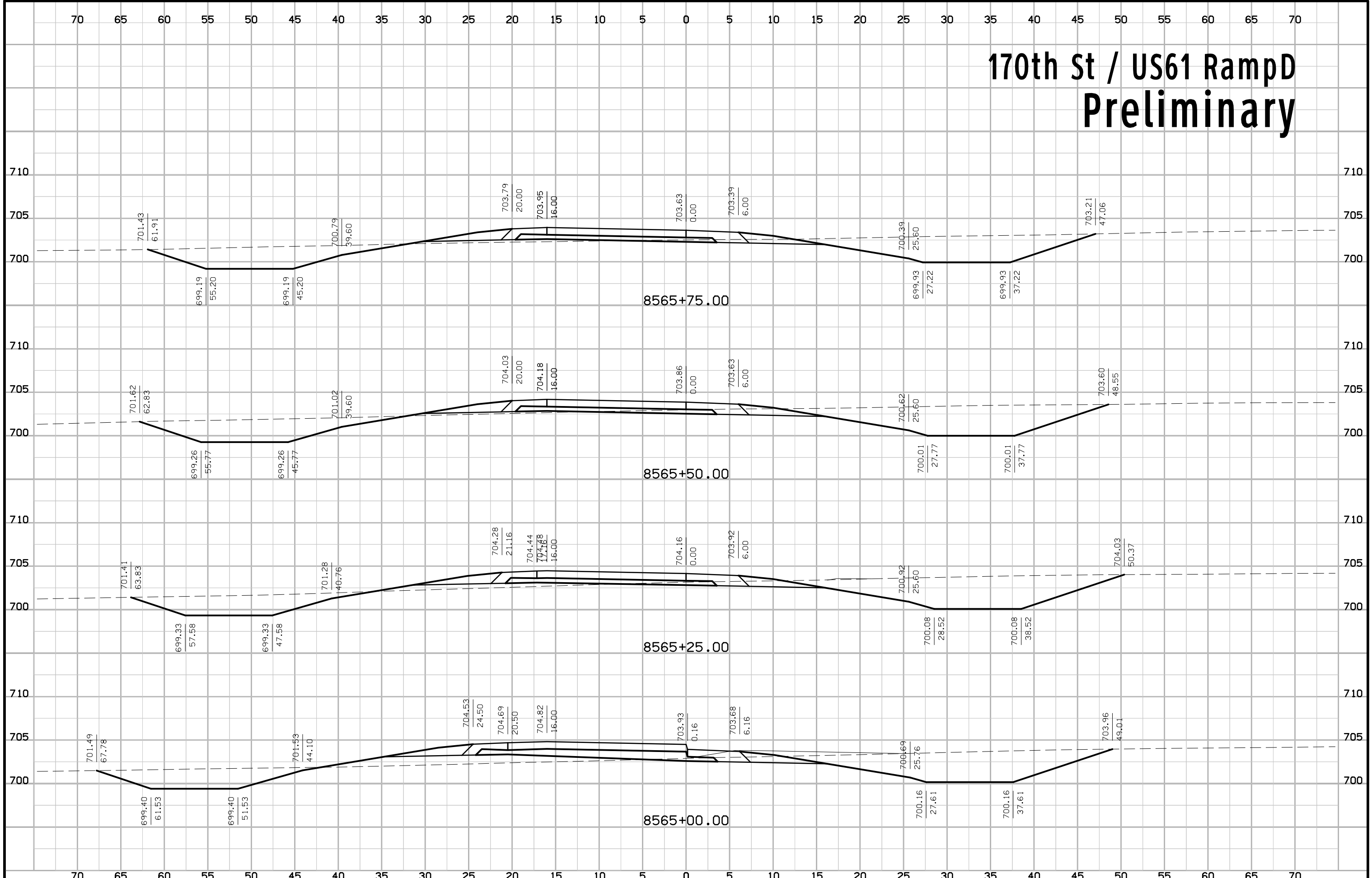

170th St / US61 RampD Preliminary

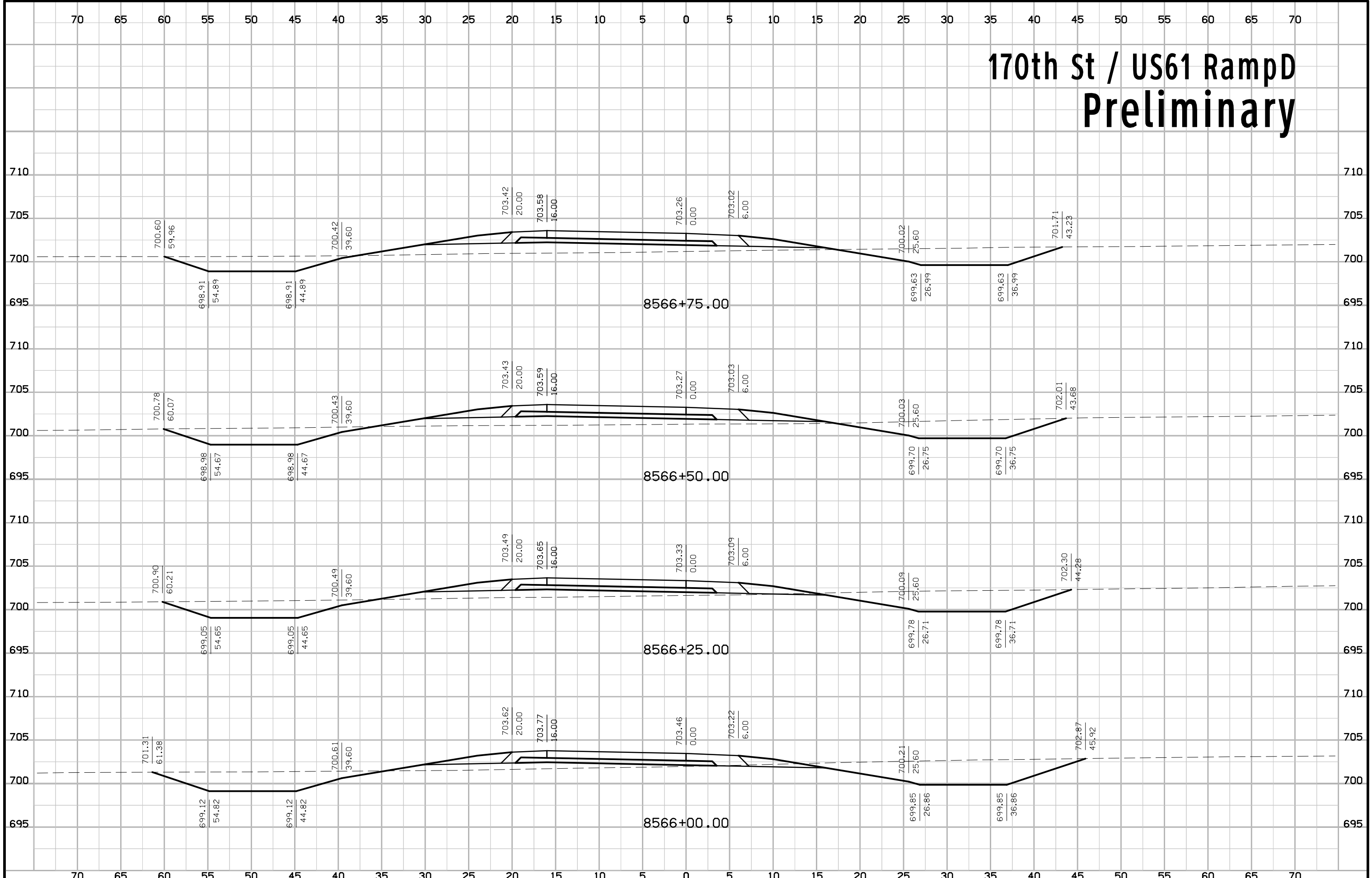

170th St / US61 RampD Preliminary

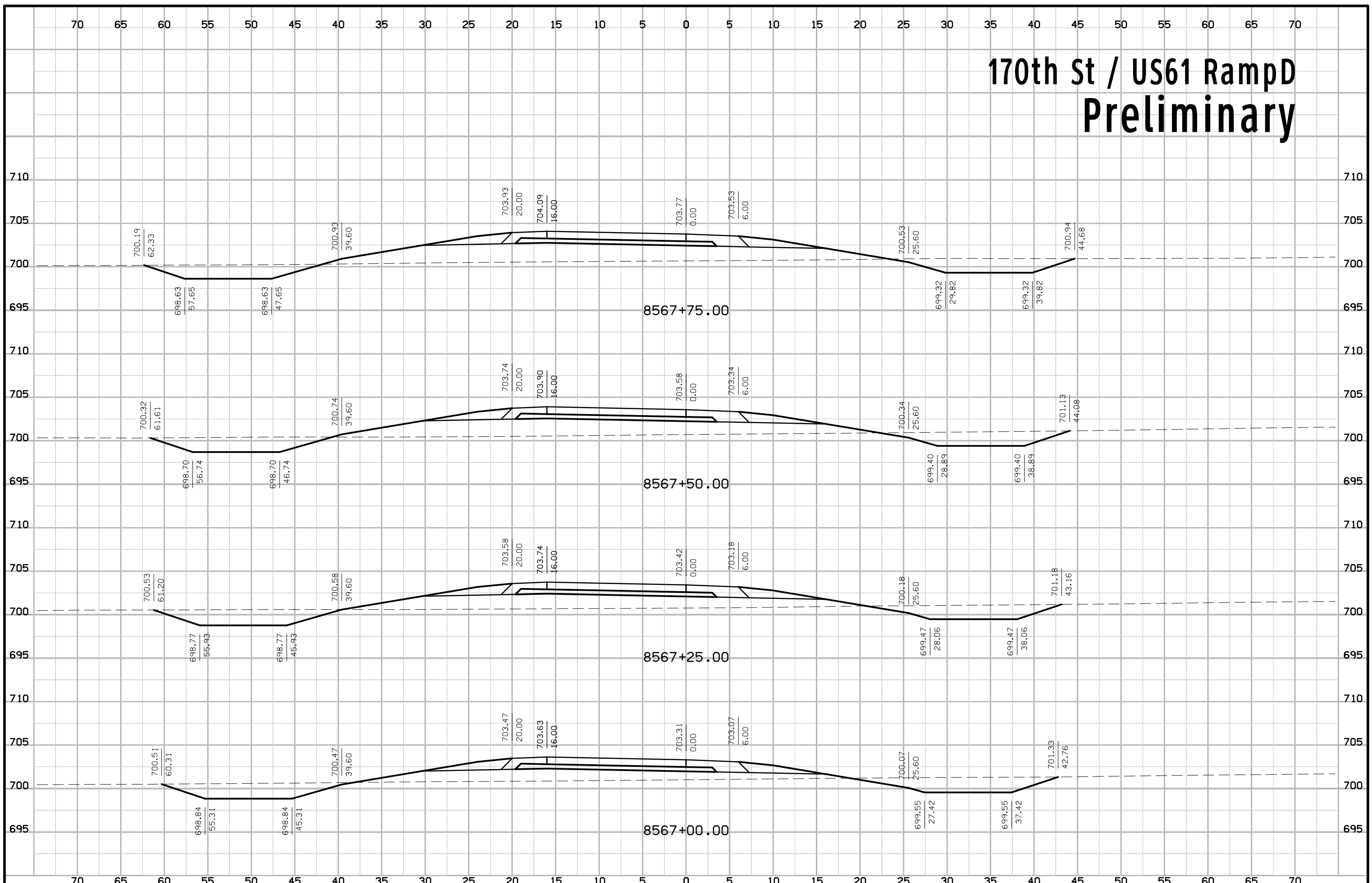

170th St / US61 RampD Preliminary

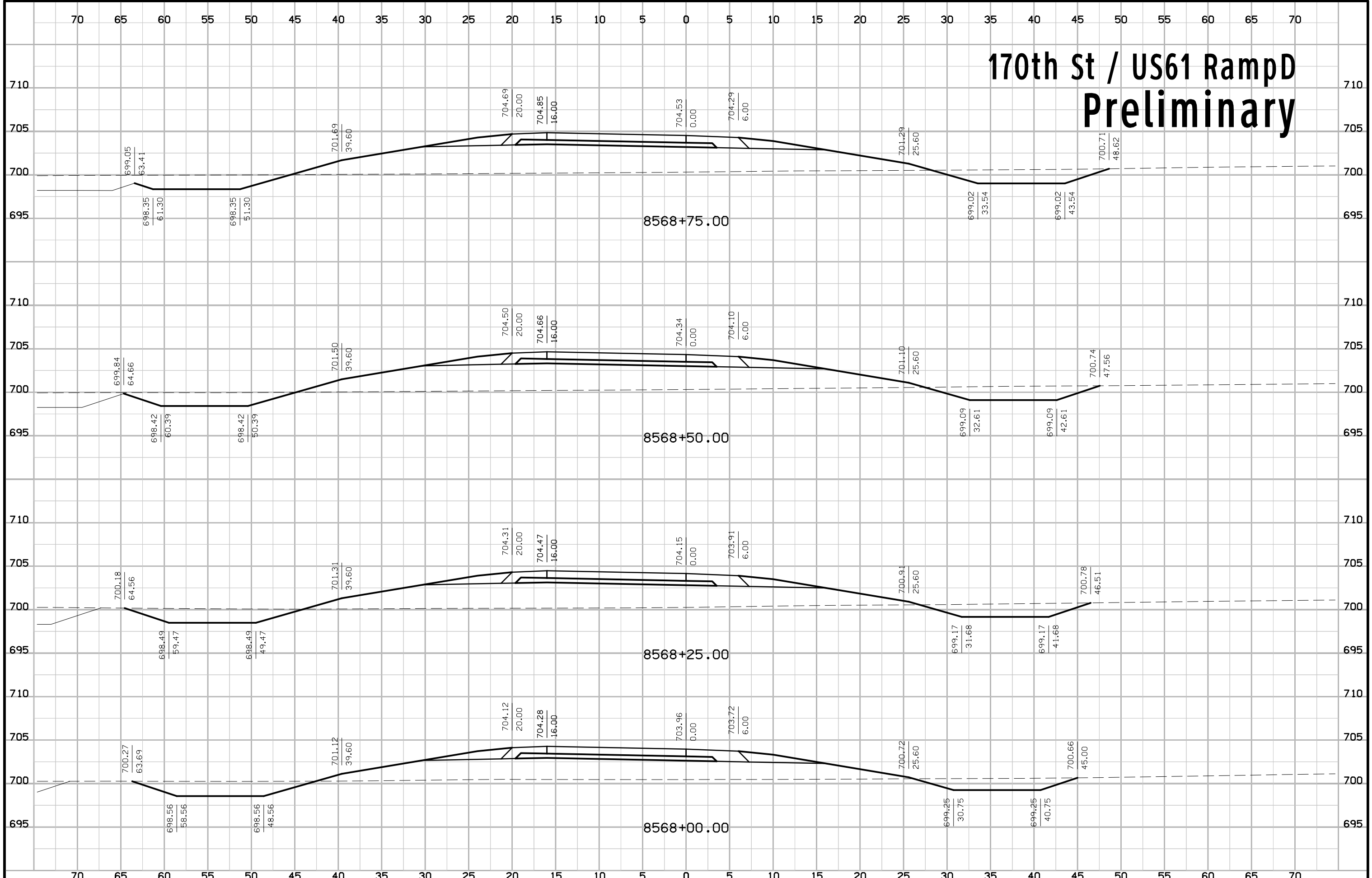

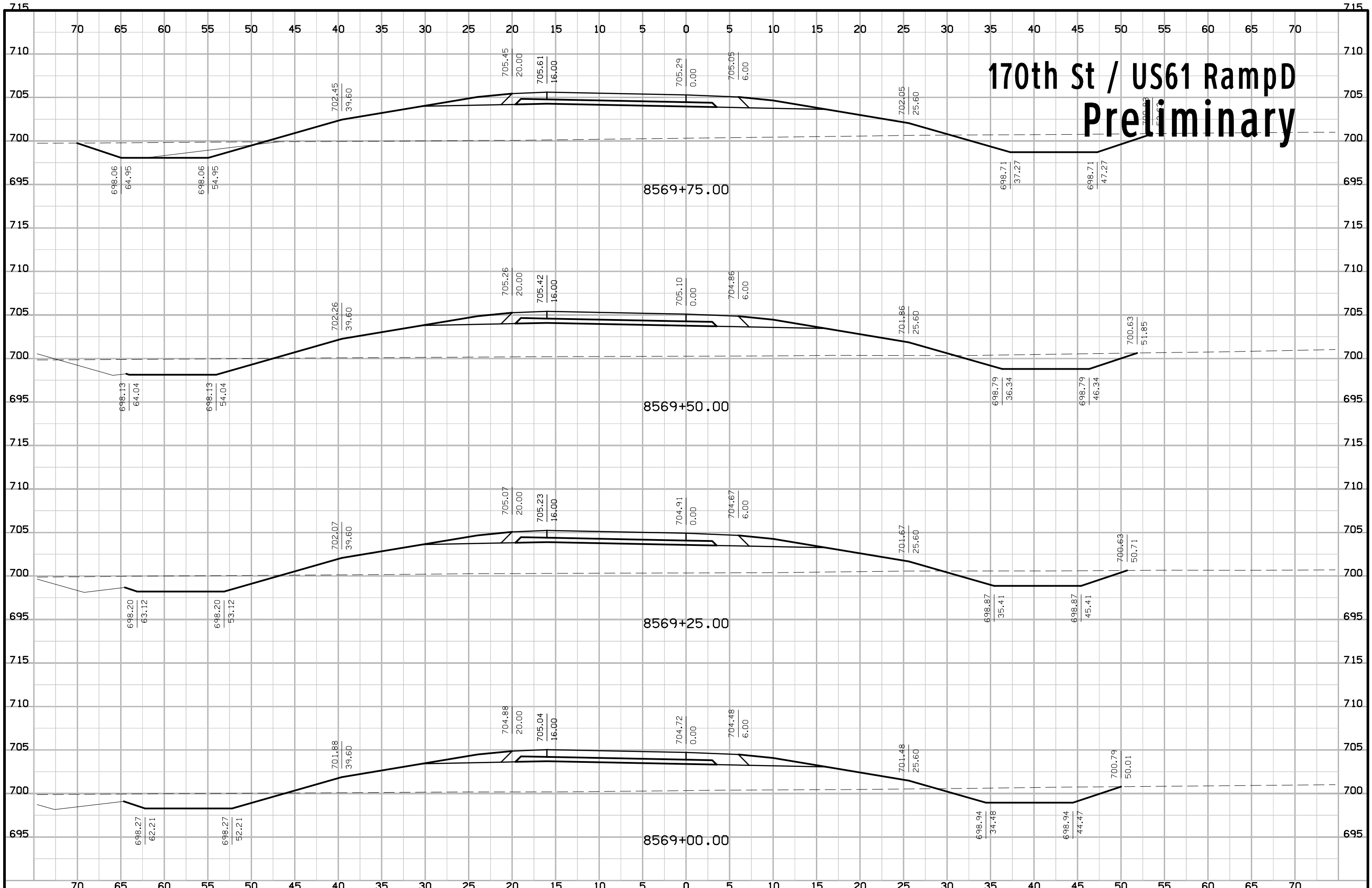

170th St / US61 RampD Preliminary

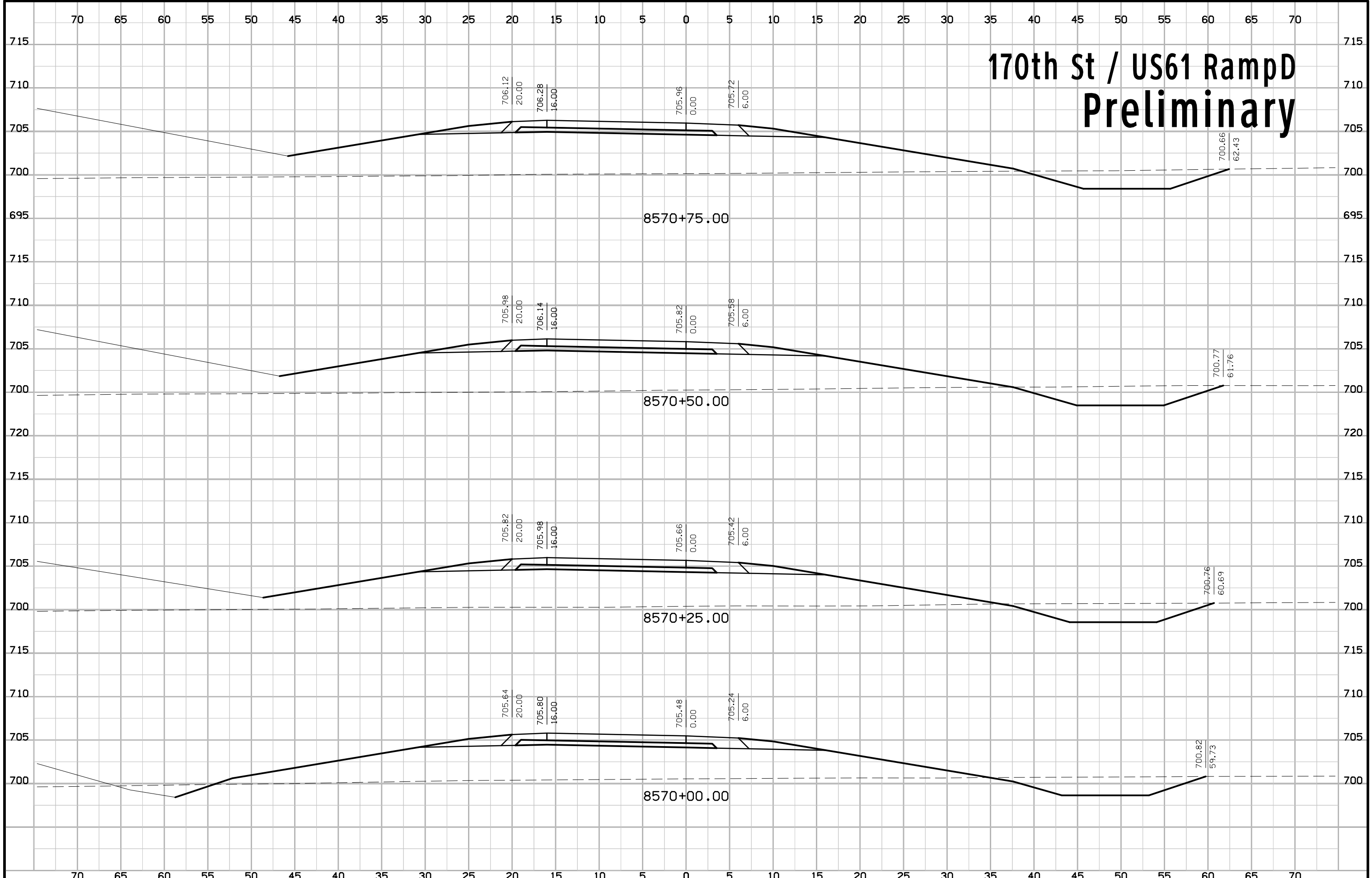

170th St / US61 RampD Preliminary

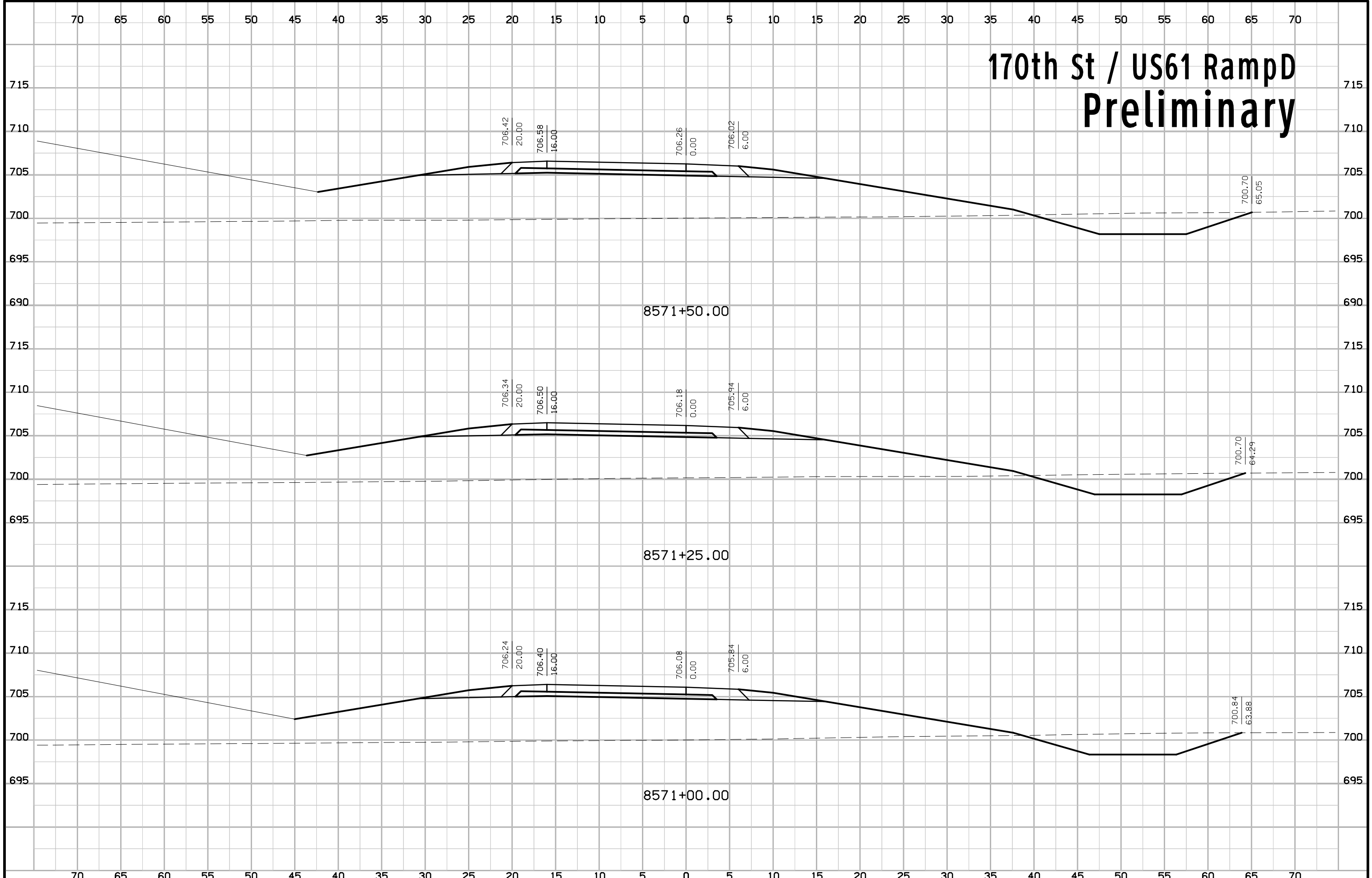

170th St / US61 RampD Preliminary

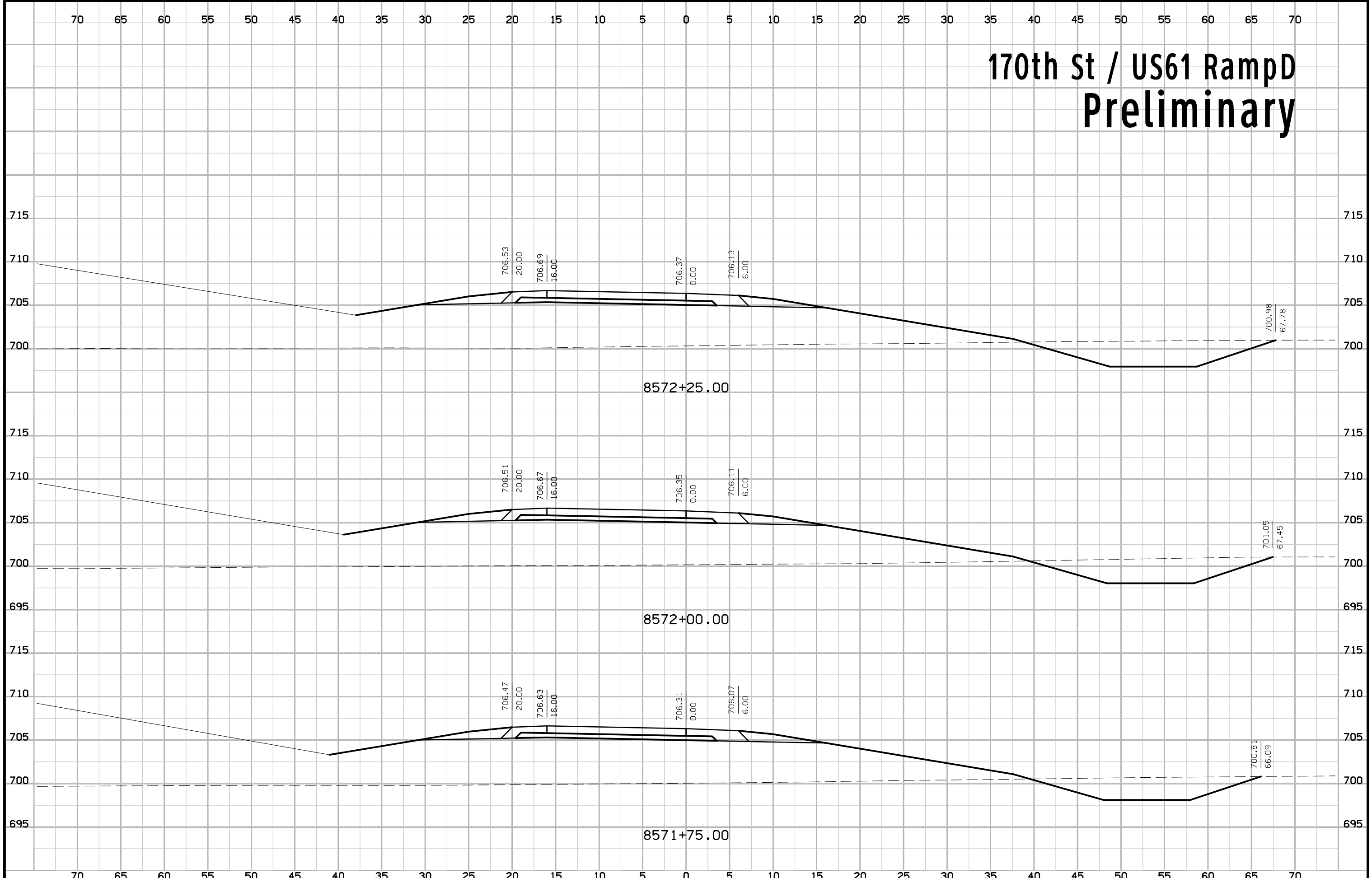

170th St / US61 RampD Preliminary

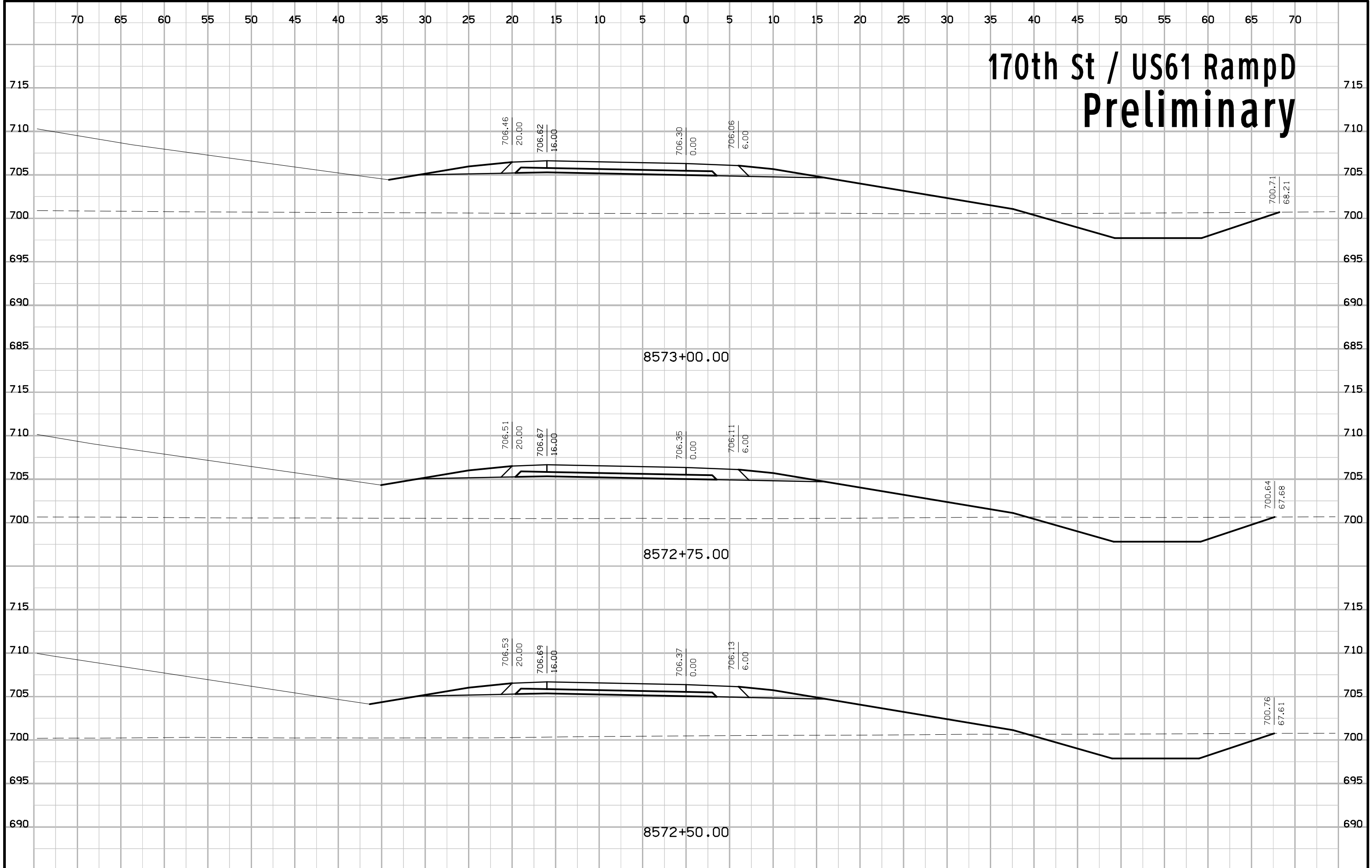

170th St / US61 RampD Preliminary

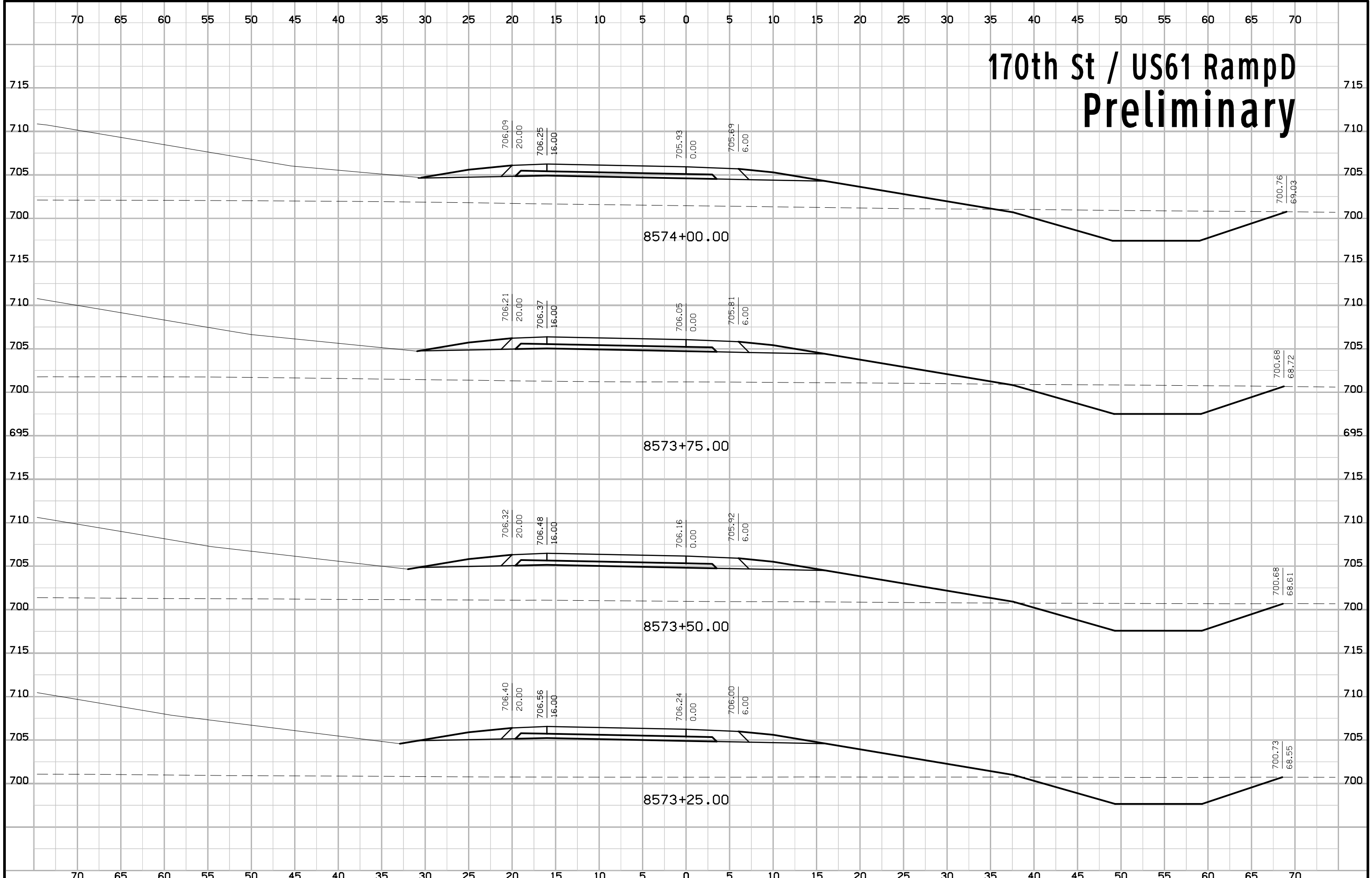

170th St / US61 RampD Preliminary

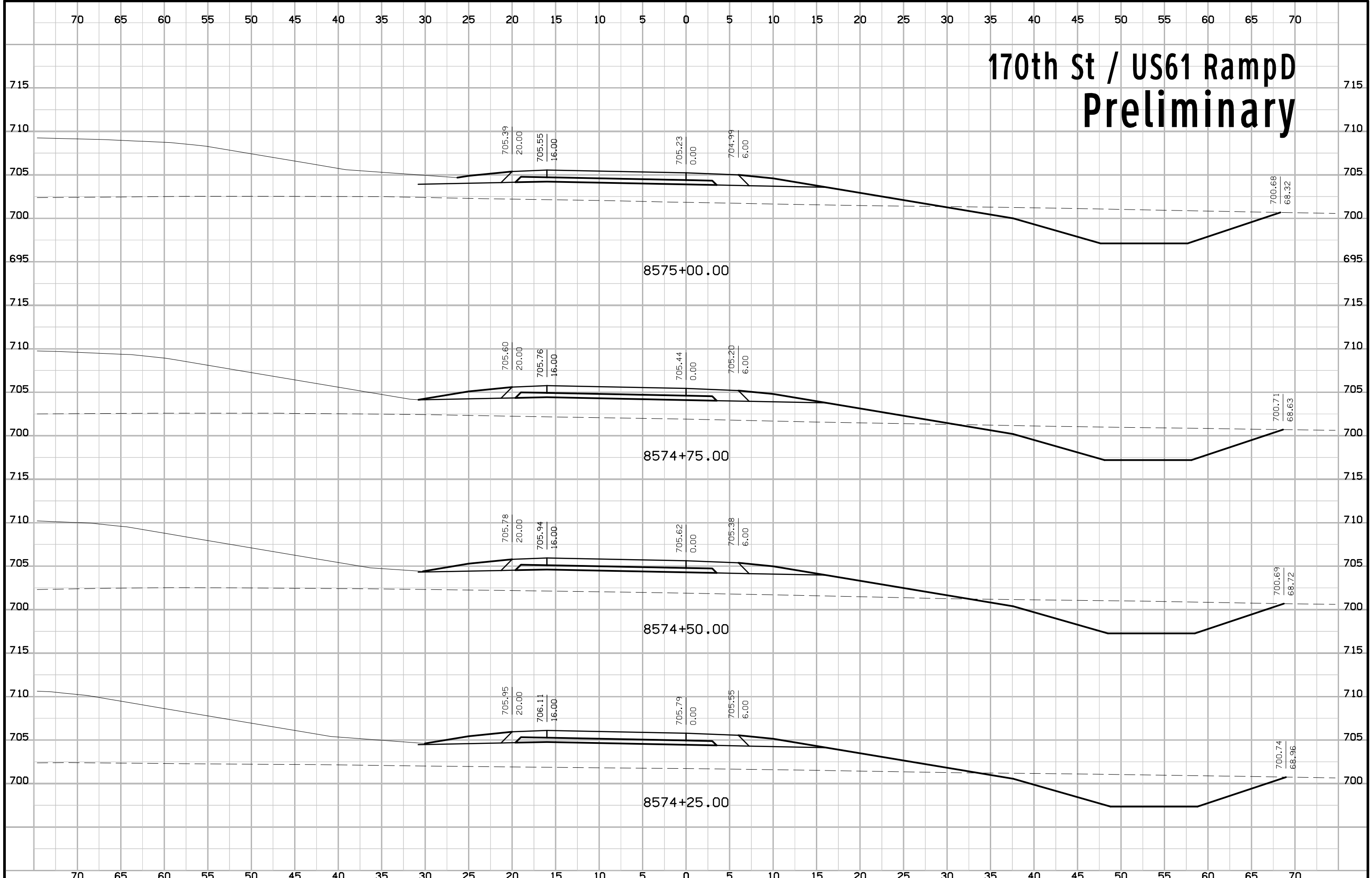

170th St / US61 RampD Preliminary

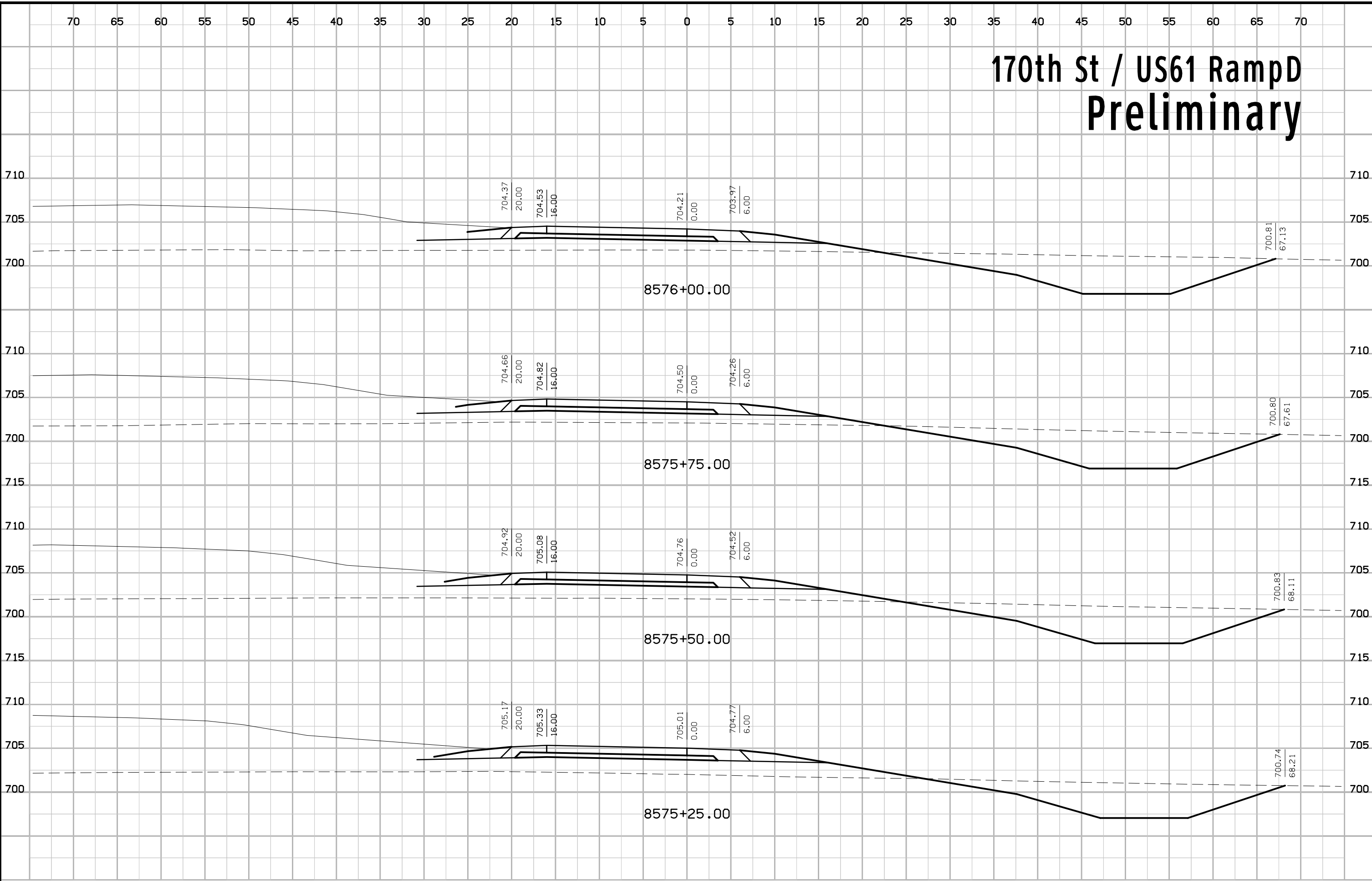

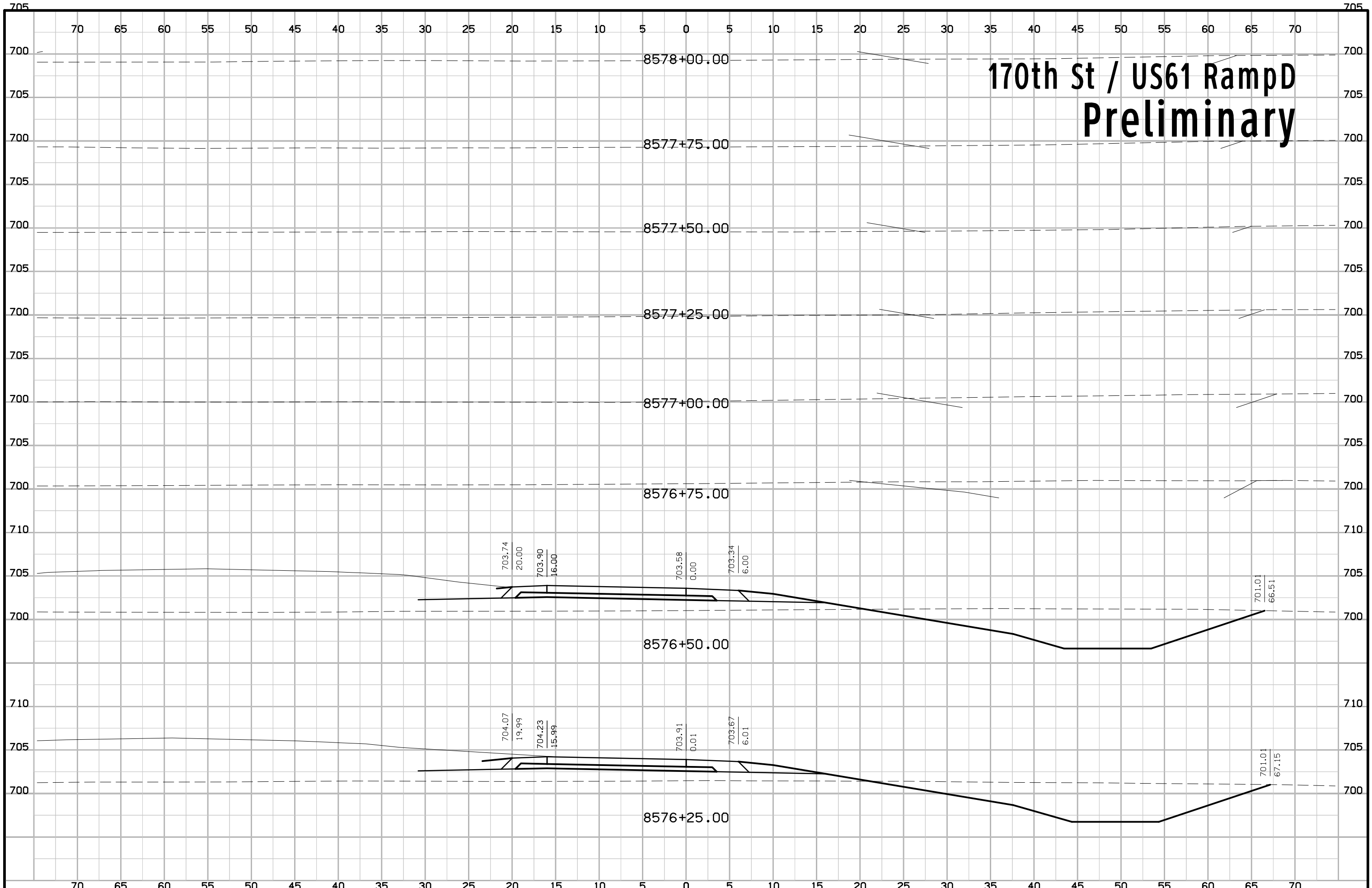

170th St / US61 Ramp D Preliminary

170th St / US61 RampD Preliminary

