

INDEX OF SHEETS	
No.	DESCRIPTION
A Sheets	Title Sheets
A.1	Title Sheet
A.2	Location Map Sheet
A.3	Existing Bridge Information
B Sheets	Typical Cross Sections and Details
B.1 - 5	Typical Cross Sections and Details
D Sheets	Mainline Plan and Profile Sheets
* D.1	Plan & Profile Legend & Symbol Information Sheet
* D.2 - 11	I-380
F Sheets	Detour or Temporary Pavement Sheets
* F.1 - 2	Detour Ramp A Forevergreen Rd Plan Sheet
* F.3 - 4	Detour Ramp C Forevergreen Rd Plan and Profile Sheet
J Sheets	Traffic Control and Staging Sheets
J.1	Traffic Control Plan & Staging Notes
K Sheets	Interchange Sheets
* K.1 - 2	Ireland Ramp Plan and Profile Sheets
	* Color Plan Sheets



Highway Division

PLANS OF PROPOSED IMPROVEMENT ON THE

INTERSTATE ROAD SYSTEM

JOHNSON COUNTY

PCC PAVEMENT - GRADE AND REPLACE

N of US 6 to 1.25 mi N of W Forevergreen Rd

SCALES: As Noted

Refer to the Proposal Form for list of applicable specifications.

Value Engineering Saves. Refer to Article 1105.14 of the Specifications.



REVISIONS

TOTAL	
	26
PROJECT IDENTIFICATION NUMBER	
02-52-080-010-01	
PROJECT NUMBER	
NHS-380-6(326)1--03-52	
R.O.W. PROJECT NUMBER	
IMN-380-6(331)2--0E-52	

Prelim For Information Only

DESIGN DATA RURAL			
2025	AADT	62,779	V.P.D.
2045	AADT	95,253	V.P.D.
2045	DHV	9,530	V.P.H.
	TRUCKS	17	%
	Total Design ESALs	--	

INDEX OF SEALS		
SHEET NO.	NAME	TYPE
A.1	xx	Primary Signature Block
CD.1	xx	Hydraulic Design
CS.1	xx	Geotechnical Design
RR.1	xx	Erosion Control
V.1	xx	Structural Signature Block

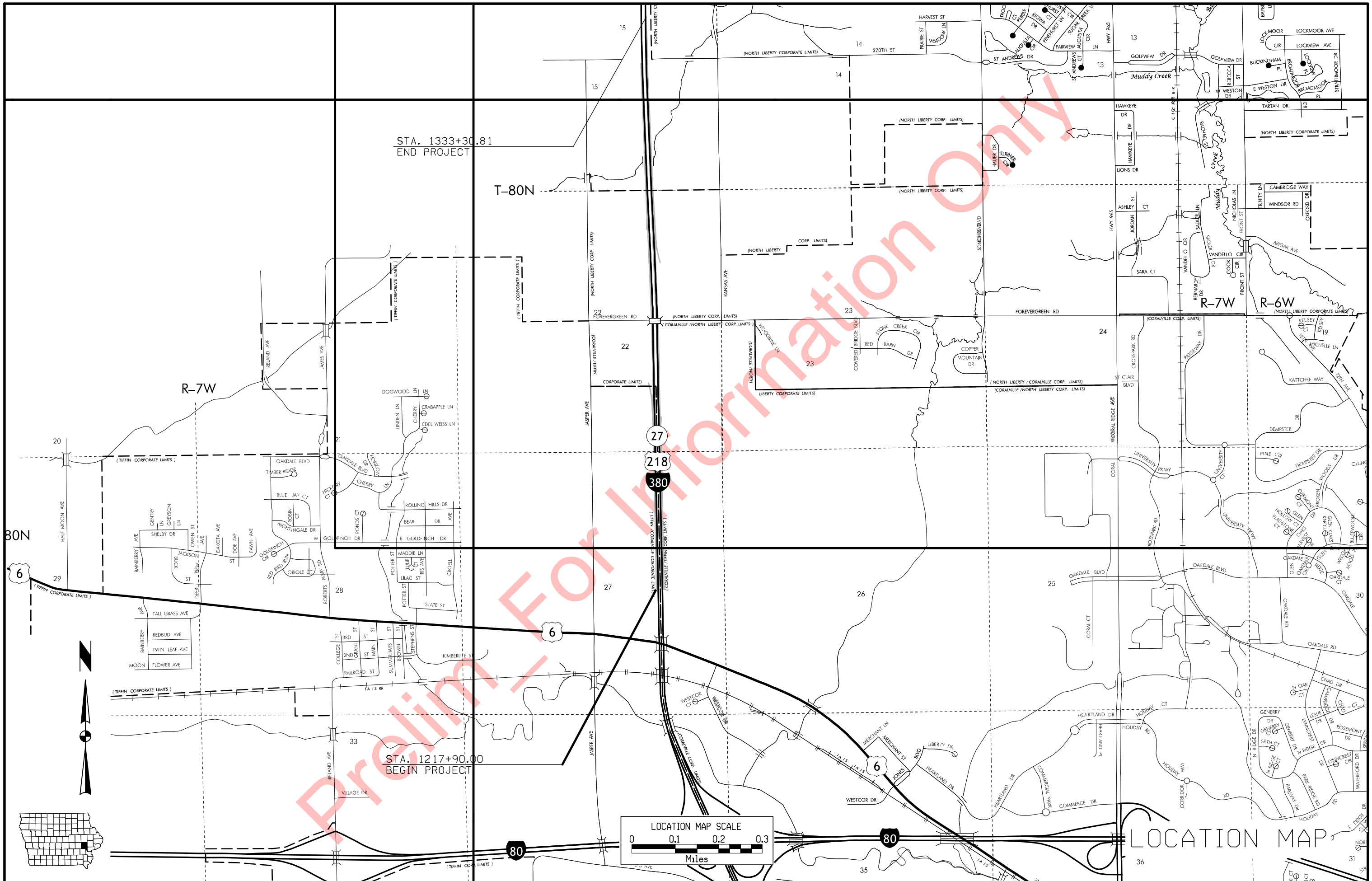

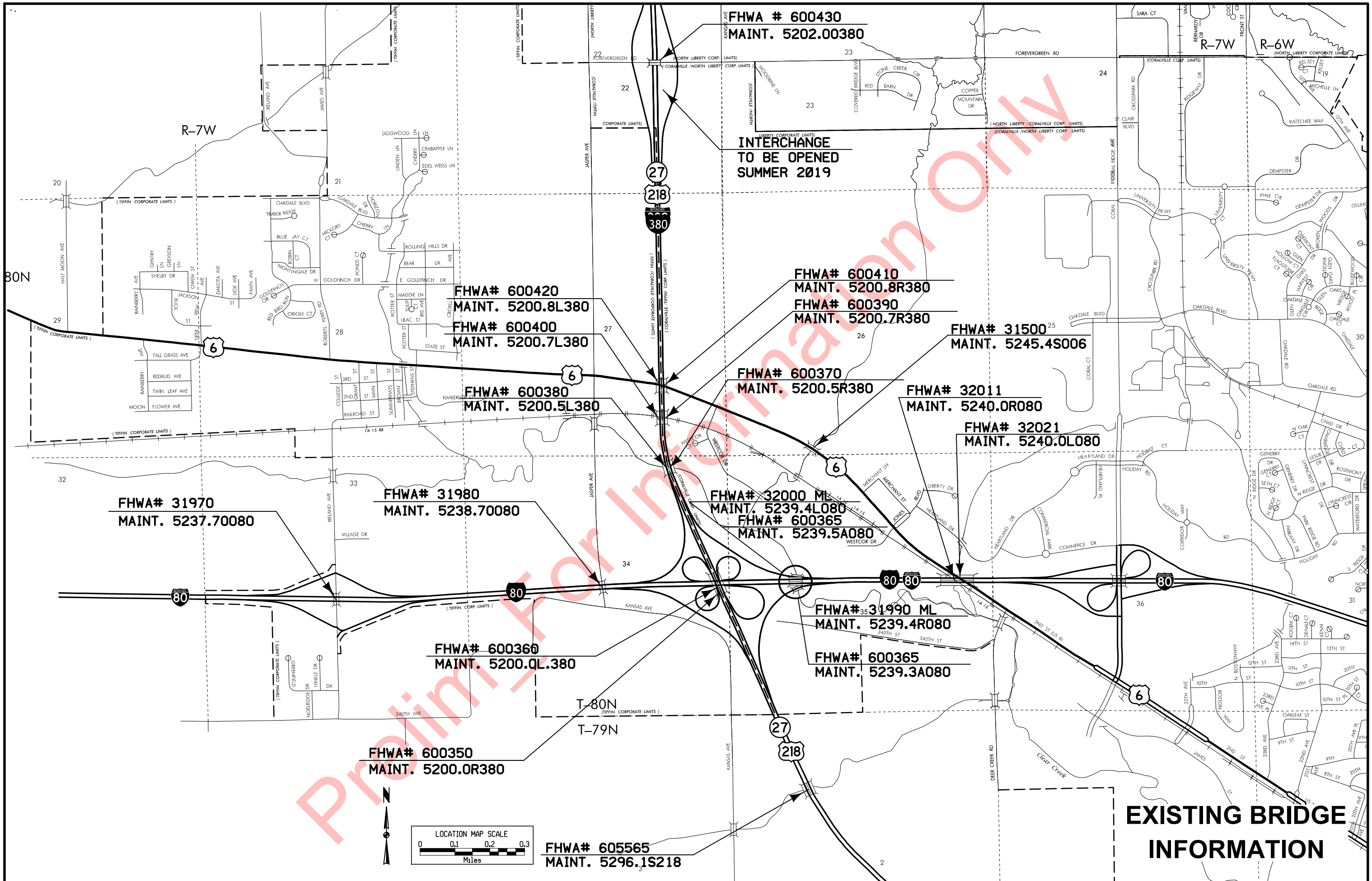

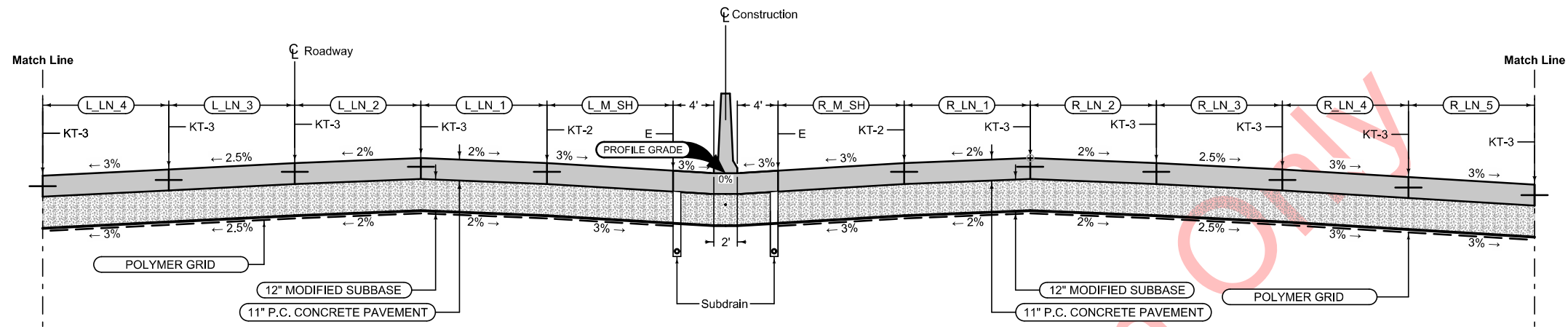

Mainline Jointing:
 Transverse joints: CD at 17' spacing

BEGIN STATION	END STATION	6DP_Closed_											
		L LN 4	L LN 3	L LN 2	L LN 1	L M SH	R M SH	R LN 1	R LN 2	R LN 3	R LN 4	R LN 5	
1217+90.00	1221+90.00	12	12	12	12	24	24	12	12	12	12	12 - 4	

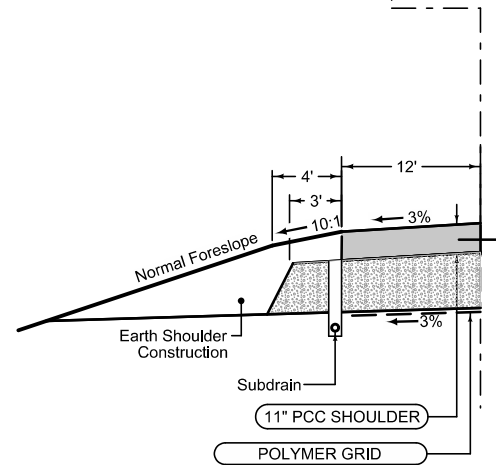

Full Depth PCC Shoulder

Shoulder Jointing:
 Longitudinal joint: L-2 or KT-2
 Transverse joints: CD at 17' spacing

6D_Closed_P_FullPCC_MODIFIED		
BEGIN STATION	END STATION	L O SH Feet
1217+90.00	1221+90.00	12

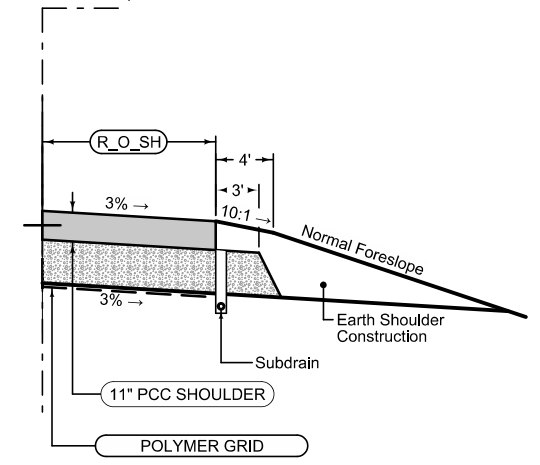

Full Depth PCC Shoulder

Shoulder Jointing:
 Longitudinal joint: L-2 or KT-2
 Transverse joints: CD at 17' spacing

6D_Closed_P_FullPCC_MODIFIED		
BEGIN STATION	END STATION	R O SH Feet
1217+90.00	1220+89.85	6
1220+89.85	1221+90.00	6 - 8

Prelim For Information

See Tab 100-24 for pavement quantities.
 Shoulder quantities included with mainline pavement.

INTERSTATE 380

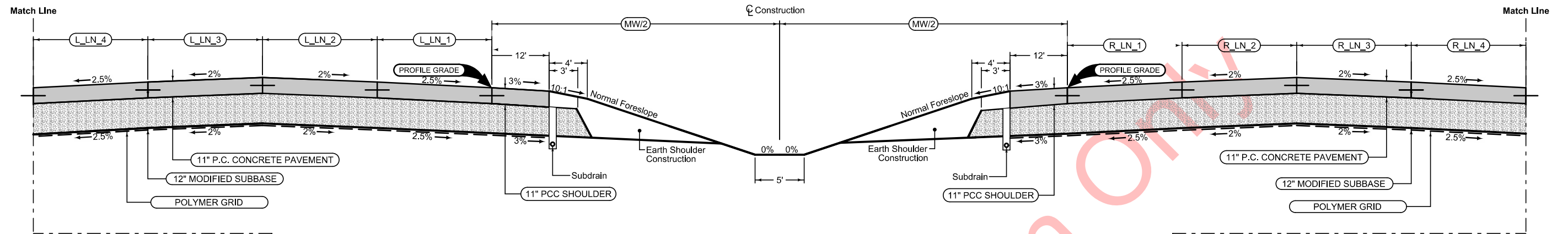

Mainline Jointing:
 Transverse joints: CD at 17' spacing

BEGIN STATION	END STATION	(MW) Feet	(L_LN_4) Feet	(L_LN_3) Feet	(L_LN_2) Feet	(L_LN_1) Feet	(R_LN_1) Feet	(R_LN_2) Feet	(R_LN_3) Feet	(R_LN_4) Feet
1221+90.00	1223+89.85	58	12	12	12	12	12	12	12	12
1223+89.85	1256+00.00	58	12	12	12	12	12	12	12	12
1256+00.00	1257+30.32	58	12	12	12	12	12	12	12	--
1257+30.32	1286+19.68	58	--	12	12	12	12	12	12	--
1286+19.68	1287+25.00	58	--	12	12	12	12	12	12	12
1287+25.00	1306+25.00	58	12	12	12	12	12	12	12	12
1306+25.00	1314+50.00	58	--	12	12	12	12	12	12	12
1314+50.00	1324+00.00	58	--	12	12	12	12	12	12	--

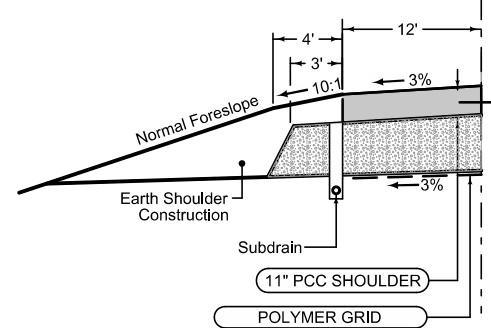

Full Depth PCC Shoulder

Shoulder Jointing:
 Longitudinal joint: L-2 or KT-2
 Transverse joints: CD at 17' spacing

6D_Dprs_P_FullPCC_MODIFIED		
BEGIN STATION	END STATION	(L_O_SH) Feet
1221+90.00	1245+00.00	12
Ramp Taper		
1257+30.32	1287+25.00	12
Ramp Taper		
1293+25.20	1306+25.00	6
1306+25.00	1307+15.00	18 - 12
1307+15.00	1324+00.00	12

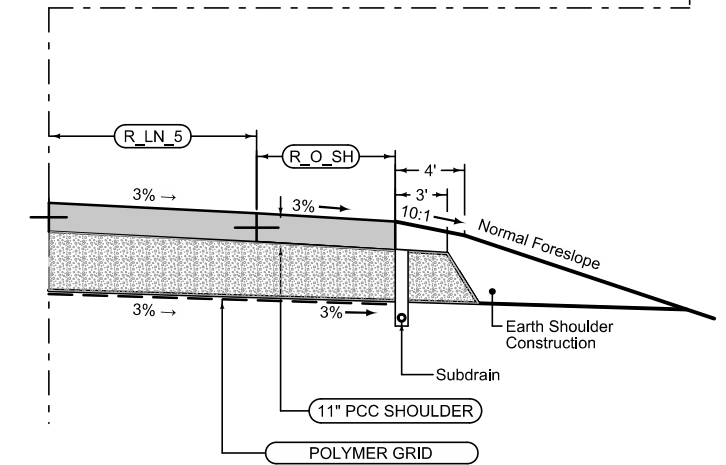

Shoulder Jointing:
 Longitudinal joint: L-2 or KT-2
 Transverse joints: CD at 17' spacing

6D_Dprs_P_FullPCC_MODIFIED			
BEGIN STATION	END STATION	(R_LN_5) Feet	(R_O_SH) Feet
1221+90.00	1223+89.85	4 - 0	8 - 12
1223+89.85	1250+00.00	--	12
Ramp Taper			
1256+00.00	1286+19.68	--	12
Ramp Taper			
1298+49.94	1314+50.00	--	6
1314+50.00	1315+40.00	--	18 - 12
1315+40.00	1324+00.00	--	12

See Tab 100-24 for pavement quantities.
 Shoulder quantities included with mainline pavement.

INTERSTATE 380

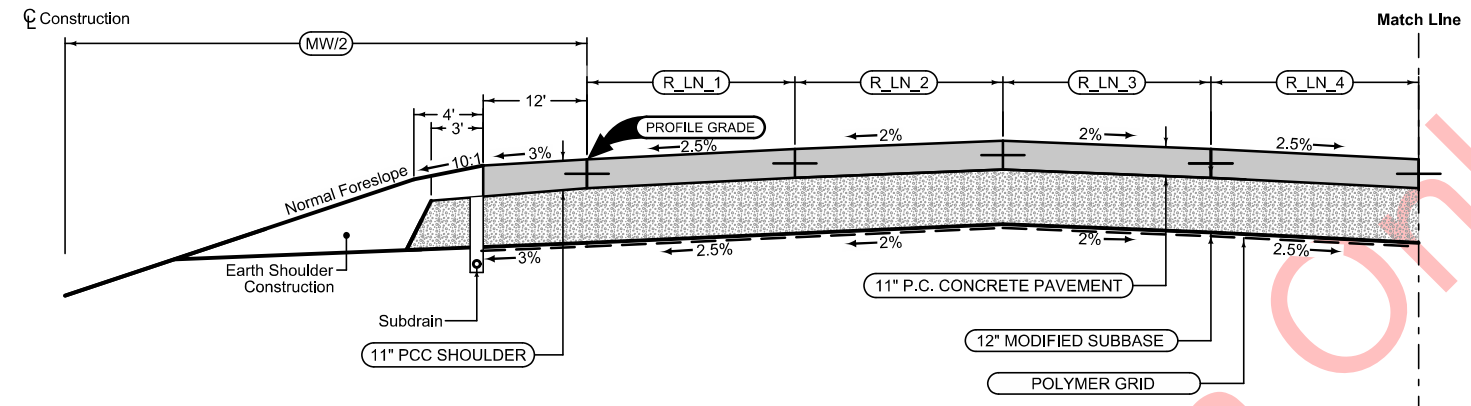

Mainline Jointing:
Transverse joints: CD at 17' spacing

BEGIN STATION	END STATION	(MW/2) Feet	(R_LN_1) Feet	(R_LN_2) Feet	(R_LN_3) Feet
1324+00.00	1326+00.00	29	12	12	12

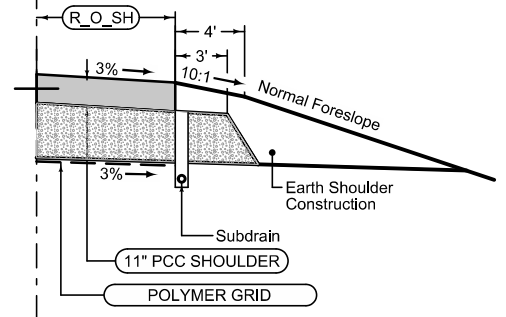

Full Depth PCC Shoulder

Shoulder Jointing:
Longitudinal joint: L-2 or KT-2
Transverse joints: CD at 17' spacing

6D_Dprs_P_FullPCC_MODIFIED		
BEGIN STATION	END STATION	(R_O_SH) Feet
1324+00.00	1326+00.00	12

See Tab 100-24 for pavement quantities.
Shoulder quantities included with mainline pavement.

INTERSTATE 380

Paved Shoulder

PCC Shoulder Jointing:
 Longitudinal joint: BT-2 or BT-3
 Transverse joints: CD at 15' spacing

1R_P_ALT_10-16-18		
BEGIN STATION	END STATION	(P) Feet
3557+28.66	3559+71.50	4

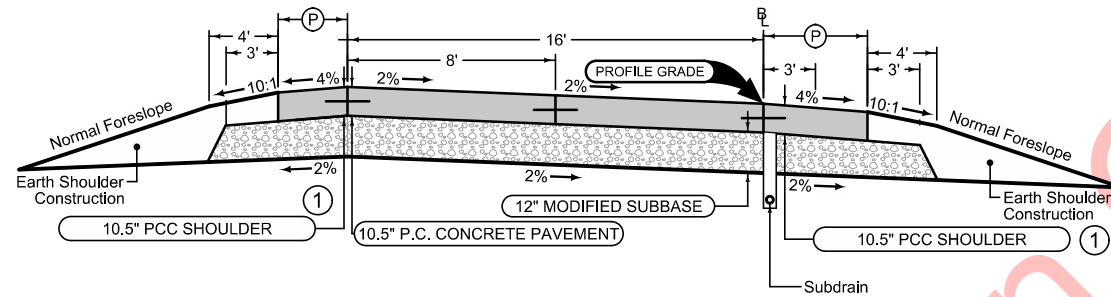

Section shown in the direction of traffic.

Ramp Jointing:
 See 'L' Sheets and
 Standard Road Plan PV-411

2RP_04-16-13	
BEGIN STATION	END STATION
3557+28.66	3559+71.50

Paved Shoulder

PCC Shoulder Jointing:
 Longitudinal joint: BT-2 or BT-3
 Transverse joints: CD at 15' spacing

1R_P_ALT_10-16-18		
BEGIN STATION	END STATION	(P) Feet
3557+28.66	3559+71.50	6

① Bid as 10.5" PC Concrete Pavement

See Tab 100-24 or 100-25 for pavement quantities.

**FOREVERGREEN ROAD - RAMP 'C'
 (Southbound Entrance)**

Paved Shoulder

PCC Shoulder Jointing:
 Longitudinal joint: BT-1 or BT-5
 Transverse joints: C at 15' spacing
 HMA Shoulder Jointing:
 Longitudinal joint: B

1R_P_ALT_10-16-18		
BEGIN STATION	END STATION	(P) Feet
4583+57.99	4586+21.34	4

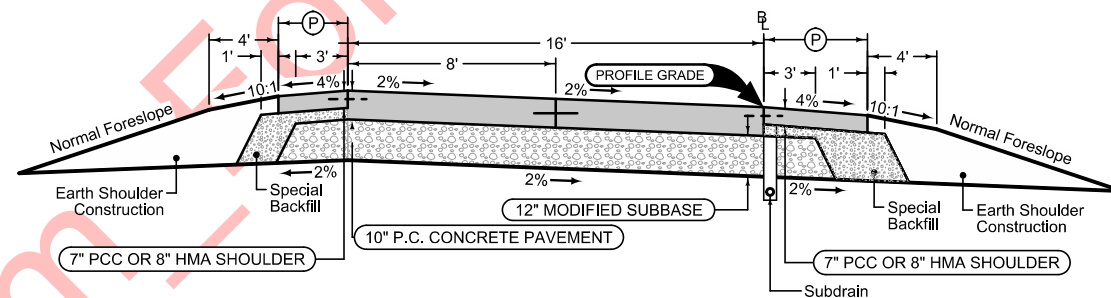

Section shown in the direction of traffic.

Ramp Jointing:
 See 'L' Sheets and
 Standard Road Plan PV-411

2RP_04-16-13	
BEGIN STATION	END STATION
4583+57.99	4586+21.34

Paved Shoulder

PCC Shoulder Jointing:
 Longitudinal joint: BT-1 or BT-5
 Transverse joints: C at 15' spacing
 HMA Shoulder Jointing:
 Longitudinal joint: B

1R_P_ALT_10-16-18		
BEGIN STATION	END STATION	(P) Feet
4583+57.99	4586+21.34	6

See Tab 100-24 or 100-25 for pavement quantities.

**FOREVERGREEN ROAD - RAMP 'D'
 (Northbound Entrance)**

LOCATION			DIMENSIONS						Earth Shoulder Construction Station
ROAD IDENTIFICATION	STATION TO STATION		HMA			PCC			
			PW Feet	T Inches	SGW Feet	PW Feet	T Inches	SGW Feet	
ML 380	1237+54.92	1255+00.00	22	11.5	37.7	22	9.0	36.0	17.5
Ramp C Detour	51255+00.00	51258+33.06	22	11.5	37.7	22	9.0	36.0	3.9
Ramp C Detour	51258+88.72	51262+13.83	22	11.5	37.7	22	9.0	36.0	4.0
Ramp A Detour	61282+49.67	61286+93.73	22	11.5	37.7	22	9.0	36.0	5.0
Ramp A Detour	61287+70.97	61290+50.00	22	11.5	37.7	22	9.0	36.0	3.4
ML 380	1290+50.00	1299+83.89	22	11.5	37.7	22	9.0	36.0	9.4

D_Detour
MODIFIED

Quantity calculations based on vertical pavement edges.
Normal section shown may be modified appropriately in areas of superelevated curves or other locations specifically designated by the Engineer.
① Possible HMA 1:1 slope
Refer to typical 8301 for details of Drain for subgrade treatment trench

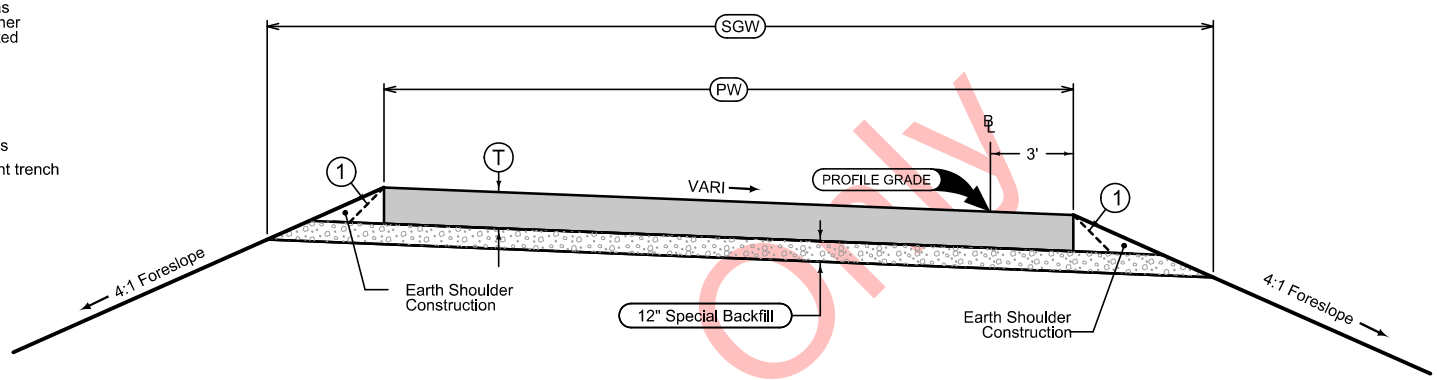

DETOUR PAVING

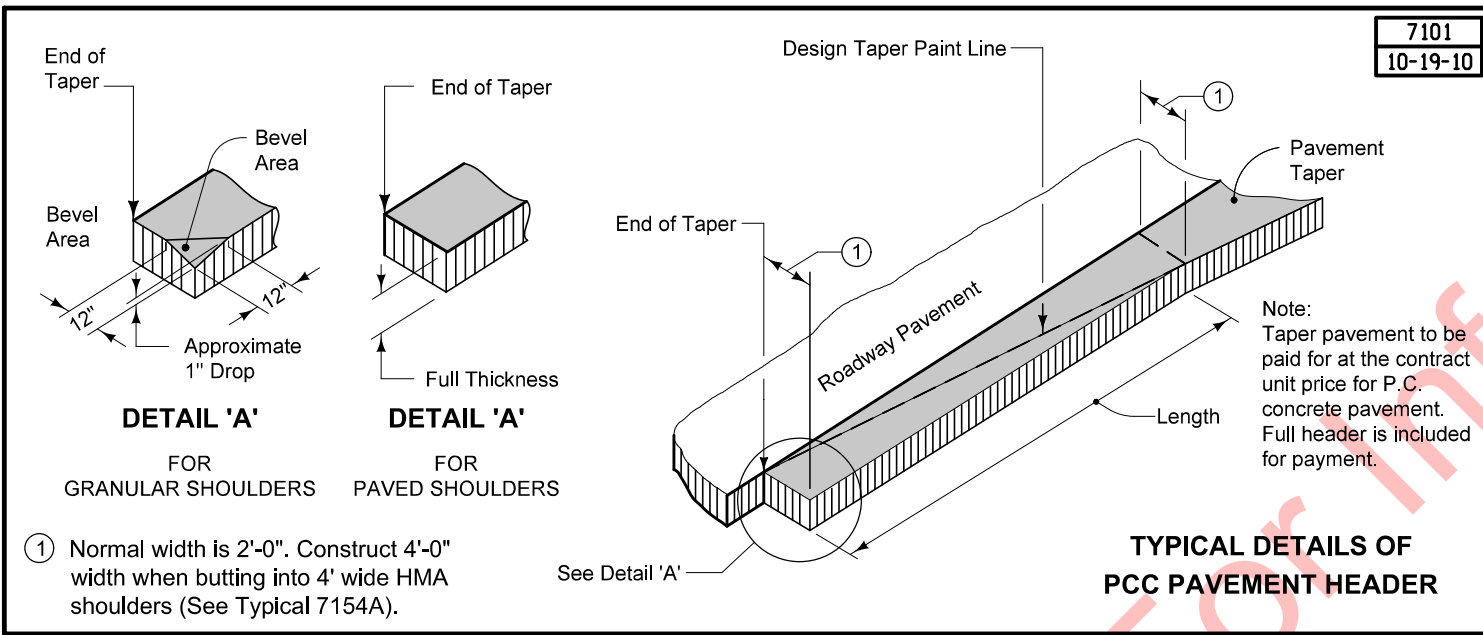

7101
10-19-10

① Normal width is 2'-0". Construct 4'-0" width when butting into 4' wide HMA shoulders (See Typical 7154A).

Note:
Taper pavement to be paid for at the contract unit price for P.C. concrete pavement. Full header is included for payment.

Prelim For Information

SURVEY SYMBOLS

	TDC Tree Deciduous		SHR Shrub
	D Centerline Draw or Stream (Down)		MM Mile Marker Post
	EG Edge of Gravel Road		GP Guard Post (Less Than 4 Posts)
	Linn County REC		FLG Flag Poles
	BNK Stream Bank		EB Electrical Box
	EP Edge of Paved Roads (ML or SR)		TPD Telephone Pedestal
	EW Edge of Water		WHD Water Hydrant
	ENU Edge Unpaved Entrance & Parking		SL Speed Limit Sign
	TEV Evergreen Tree		SNK Sink Hole
	HDG Hedge Row		CIS Cistern
	SNP Unpaved Shoulder		SEP Septic Tank
	WM Wind Mill		Central Iowa Power Coop (CIPCO)
	SI Sign		TP Telephone Pole
	TV Satellite TV Dish		TVP TV Pedestal Symbol
	IN Storm Sewer Intake		WV Water Valve
	MH Utility Access (Manhole)		WH Water Hydrant
	LUM Luminaire		GUY Guy Wire
	LP Tank		EB Electrical Box
	GP Guard Post (Less Than 4 Posts)		UB Utility Box
	SCR Section Corner		LUM Luminaire
	DU Centerline Draw or Stream (Up)		INT Storm Sewer Intake
	OUT Tile Outlet		HT Highline Tower
	FW Wire Fence		INTBH Intake (Beehive)
	ROW Right of Way Rail		INTBH Storm Sewer Intake (Beehive)
	DIK Centerline of Dike or Dam		MH Electrical Manhole
	RIP Rip-Rap		MH Storm Sewer Manhole
	GDL Guard Rail Steel		MH Sanitary Sewer Manhole
	PRISER Power Riser Pole		MH Fiber Optic Manhole
	INB Storm Sewer Beehive Intake		MH Manhole
	LC Lot Corner		
	ITC Midwest (Formerly Alliant Energy)		
	SWP Swamp or Marsh		
	ENT Centerline BL of Entrance		
	FHD Fire Hydrants		
	RET Retaining Walls		
	STP Stump		
	WV Water Valve		
	FCL Chain Link and Security Fence		
	WEL Well		
	TPA Telephone Pole Co. 1		
	FWD Wood Fence		
	RR Centerline of Railroad Tracks		
	MidAmerican Energy		
	BM Bench Mark		
	C Centerline BL of Road (ML or SR)		
	BIN Grain Bin		
	SI Sign		
	TFR Tree Fruit		

UTILITY LEGEND

	Linn County REC Josh Pflannebecker 319-377-1587 Ext. 607 jpfannebecker@linncountyrec.com	Electrical Service / Buried Electrical Lines
	ITC Midwest Chad Levl 319-297-6765 clevl@itctransco.com	Overhead Electrical Transmission
	Iowa DOT Timothy Zelmet 319-626-2386 Timothy.Zelmet@iowadot.us	Buried Electrical Lines
	MidAmerican Energy Nate Johnson 563-333-8648 N.Johnson@midamerican.com	Overhead Electrical Transmission
	Central Iowa Power Coop (CIPCO) Dan Ketchum 319-734-4313 Dan.ketchum@cipco.net	Overhead Electrical Transmission
	Unclamed MidAmerican Joe Retek 319-341-4457 jiretek@midamerican.com	Buried Electrical Lines
	MidAmerican Steven DellaBetta 319-298-5163 amdellabetta@midamerican.com	Buried Gas - Intermediate Pressure
	Magellan Bill Saehler 319-330-0959 Bill.Saehler@magellanp.com	Buried Gas - Hi-Pressure Gas
	Iowa Communications Network (ICN) Timothy Flickinger 515-725-4699 timothy.flickinger@iowa.gov	Fiber Optic
	South Slope COOP Randy Cline (Primary) 319-626-2211 randy@southslope.com	Fiber Optic
	Century Link (Formerly Qwest) Bob Wegener (Primary) 815-382-3605 bwegener@terratechllc.net	Fiber Optic
	Transmission Windstream/PAETEC Dave Harris 515-297-8391 Dharris@pearce-services.com	Fiber Optic
	Local Windstream Brian Otto 402-436-5200 brian.otto@windstream.com	Fiber Optic
	Aureon Formerly INS Jeff Klocko 515-830-0445 jeff.klocko@aureon.com	Fiber Optic
	University of Iowa Chris Hatland (Primary) 319-335-1357 chris_hatland@uiowa.edu	Fiber Optic
	Unite Private Network/IM ON Dan Hogan (Primary UPN) 515-326-4237 dan.hogan@upnfiber.com	Fiber Optic
	Randy Schoon (Primary IMON) 319-261-4640 randys@imon.net	Fiber Optic
	City of Coralville Ryan Foley 319-248-1720 rfoley@coralville.org	Fiber Optic
	Mediacom Darwin Driscoll (Primary) 845-204-5742 ddriscoll@mediacomcc.com	Fiber Optic
	Unclamed City of Coralville Ryan Foley 319-248-1720 rfoley@coralville.org	Fiber Optic Sanitary Sewer
	City of Coralville Ryan Foley 319-248-1720 rfoley@coralville.org	Sanitary Sewer
	Iowa DOT Timothy Zelmet 319-626-2386 Timothy.Zelmet@iowadot.us	Storm Sewer
	Windstream Brian Otto 402-436-5200 brian.otto@windstream.com	Telephone
	South Slope COOP Mark Ditch 319-626-2211 mark@southslope.com	Telephone
	Mediacom Darwin Driscoll (Primary) 845-204-5742 ddriscoll@mediacomcc.com	Buried Television Cable
	City of Coralville Dan Holderness 319-248-1720 dholderness@coralville.com	Water
	City of Timin Benjamin A. Carhoff, P.E. 319-545-7215 bcarhoff@hart-frederick.com	Water

PLAN VIEW COLOR LEGEND OF PLAN AND PROFILE SHEETS

LINEWORK	Design Color No.	Description
Green	(2)	Existing Topographic Features and Labels
Blue	(1)	Proposed Alignment, Stationing, Tic Marks, and Alignment Annotation
Magenta	(5)	Existing Utilities
SHADING		
Design Color No.	Description	
Yellow	(4)	Highlight for Critical Notes or Features
Red	(3)	Delineates Restricted Areas
Lavender	(9)	Temporary Pavement Shading
Gray, Light	(48)	Proposed Pavement Shading
Gray, Med	(80)	Proposed Granular Shading
Gray, Dark	(112)	Proposed Grade and Pave Shading "In conjunction with a paving project"
Brown, Light	(236)	Grading Shading
Tan	(8)	Proposed Sidewalk Shading
Blue, Light	(230)	Proposed Sidewalk Landing Shading
Pink	(11)	Proposed Sidewalk Ramp Shading

PROFILE VIEW COLOR LEGEND OF PLAN AND PROFILE SHEETS

LINEWORK	Design Color No.	Description
Green	(2)	Existing Ground Line Profile
Blue	(1)	Proposed Profile and Annotation
Magenta	(5)	Existing Utilities
Blue, Light	(230)	Proposed Ditch Grades, Left
Black	(0)	Proposed Ditch Grades, Median
Rust	(14)	Proposed Ditch Grades, Right

Symbol	Description
	Reference Point
	Station
	Survey Line
	Section Corner
	Ground Line Intercept
	Saw Cut
	Guardrail
	Trench Drain
	HighTension Cable Guardrail
	Sheet Pile
	Pavement Removal
	Clearing & Grubbing Area

Symbol	Description
	Proposed Right-of-Way
	Existing Right of Way
	Existing and Proposed Right-of-Way
	Easement and Existing Right-of-Way
	Easement (Temporary)
	Easement
	Access Control
	Property Line

PLAN AND PROFILE LEGEND AND SYMBOL INFORMATION SHEET

(COVERS SHEET SERIES D, E, F, & K)

CLEAR CREEK TWP.
T-80N R-7W
SEC. 27

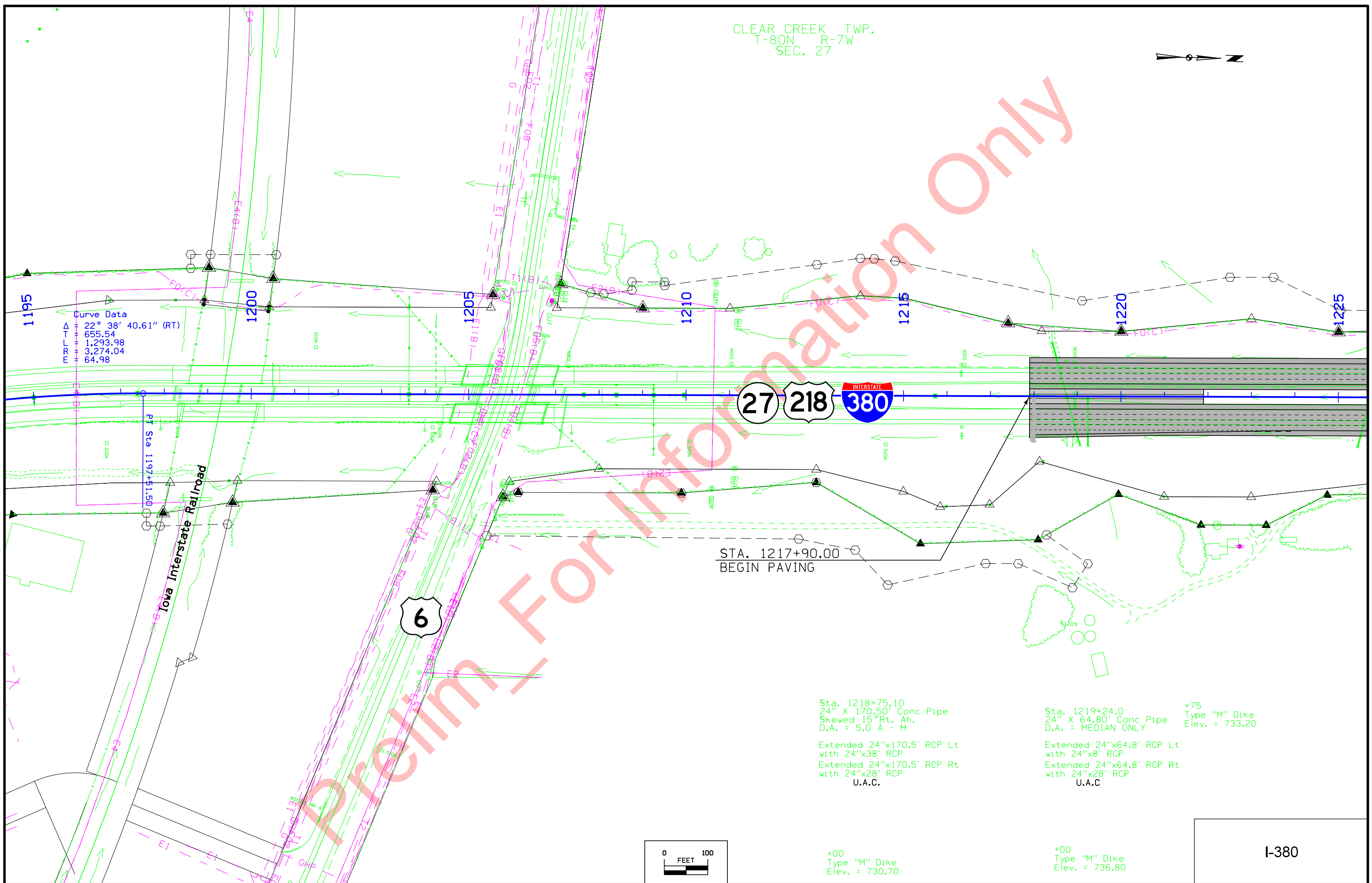
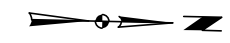

Curve Data
Δ 22° 38' 40.61" (RT)
655.54
1,293.98
3,274.04
64.98

Iowa Interstate Rail Road
PI Sta 1197+51.50

27 218 INTERSTATE 380

6

STA. 1217+90.00
BEGIN PAVING

Sta. 1218+75.10
24" X 170.50' Conc Pipe
Skewed 15° Rt. Ah.
D.A. = 5.0 A - H

Extended 24"x170.5' RCP Lt
with 24"x38' RCP
Extended 24"x170.5' RCP Rt
with 24"x28' RCP
U.A.C.

Sta. 1219+24.0
24" X 64.80' Conc Pipe
D.A. = MEDIAN ONLY

+75
Type "M" Dike
Elev. = 733.20

Extended 24"x64.8' RCP Lt
with 24"x8' RCP
Extended 24"x64.8' RCP Rt
with 24"x28' RCP
U.A.C.

+00
Type "M" Dike
Elev. = 730.70

+00
Type "M" Dike
Elev. = 736.80

I-380

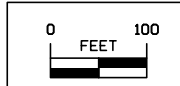

Lt. No Bench
 Bench Grade Rt. Bench Grade NB Bench Grade BG

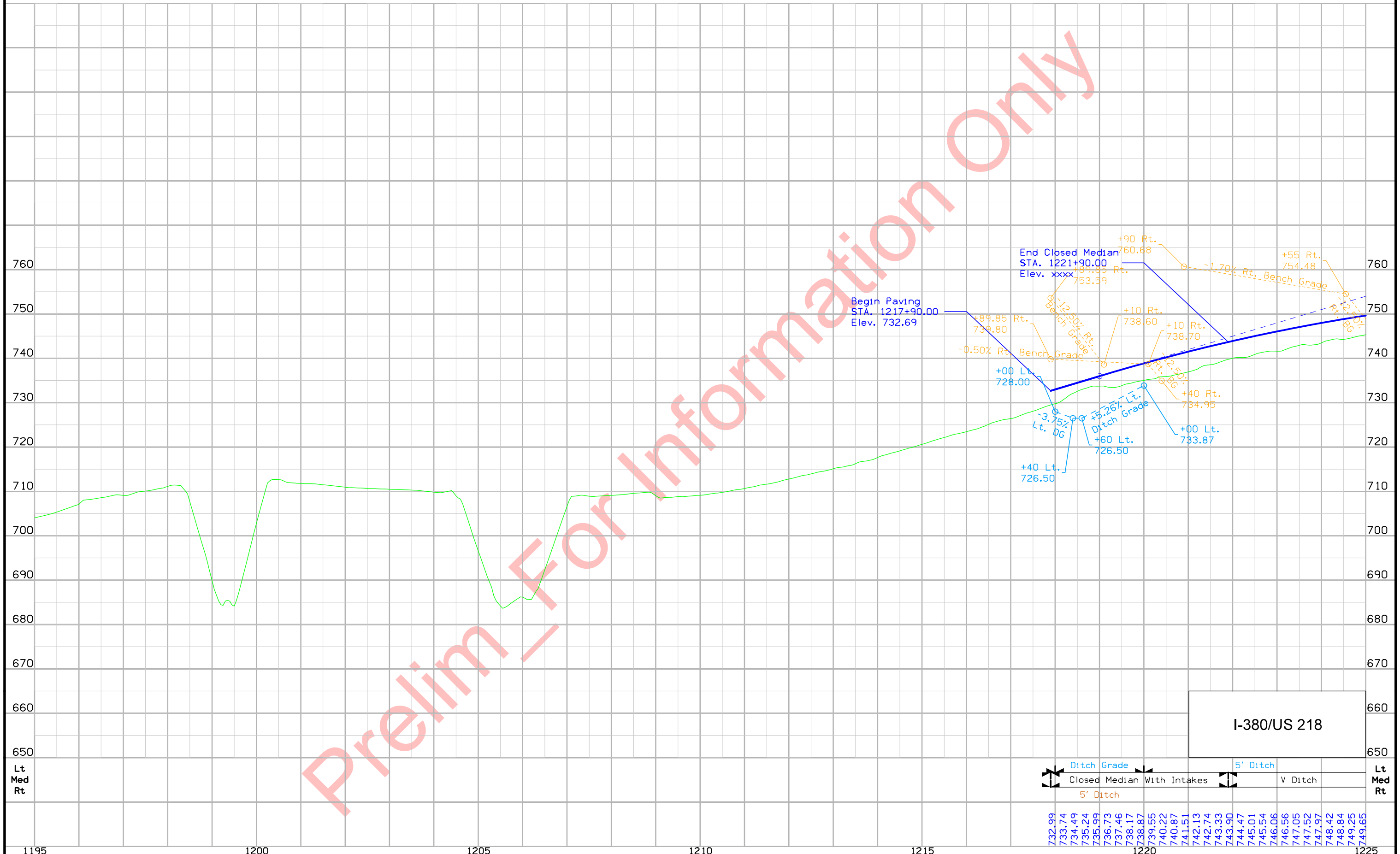

Prelim For Information Only

I-380/US 218

Ditch Grade	5' Ditch
Closed Median With Intakes	V Ditch
5' Ditch	
732.99	748.42
733.74	748.84
734.49	749.25
735.24	749.65
735.99	
736.73	
737.46	
738.17	
738.87	
739.55	
740.22	
740.87	
741.51	
742.13	
742.74	
743.33	
743.90	
744.47	
745.01	
745.54	
746.06	
746.56	
747.05	
747.52	
747.97	

Sta. 1254+99.5
24" X 105' Conc Pipe
D.A. = MEDIAN
(U.A.C.)

CLEAR CREEK TWP.
T-80N R-7W
SEC. 27

RCB extension and SW-513
Constructed by
City of Tiffin



Sta. 1241+23.32
30" X 42.84' CONC PIPE
W/30" X 25.90' PLASTIC EXT.
D.A. = MEDIAN ONLY A - R
Extended 30"x42.84' RCP Lt
with 30" x 12' RCP
Removed 30"x25.90' Plastic Ext.
Replaced with 30"x26' RCP
Extended 30"x68.84' RCP Rt
with 30" x 86' CMP
U.A.C.

+25
Type "M" Dike
Elev. = 747.30

Sta. 1225+75.22
30" X 194.70' Conc Pipe
D.A. = 4.0 A - R
Extended 30"x194.7' RCP Lt
with 30" x 28' RCP
Extended 30"x194.7' RCP Rt
with 30" x 28' RCP
U.A.C.

Sta. 1241+29.40
Skew 15 deg Rt Ahd
6 X 6 X 272.60' RCB
D.A. = 164.0A - R
Extended Rt
with 6"x6"x44' RCB
U.A.C.

+80
Type "M" Dike
Elev. = 750.20

Sta. 1245+00.00
Installed 30"x158' RCP
(Trenchless 94')
U.A.C.

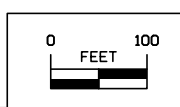

I-380

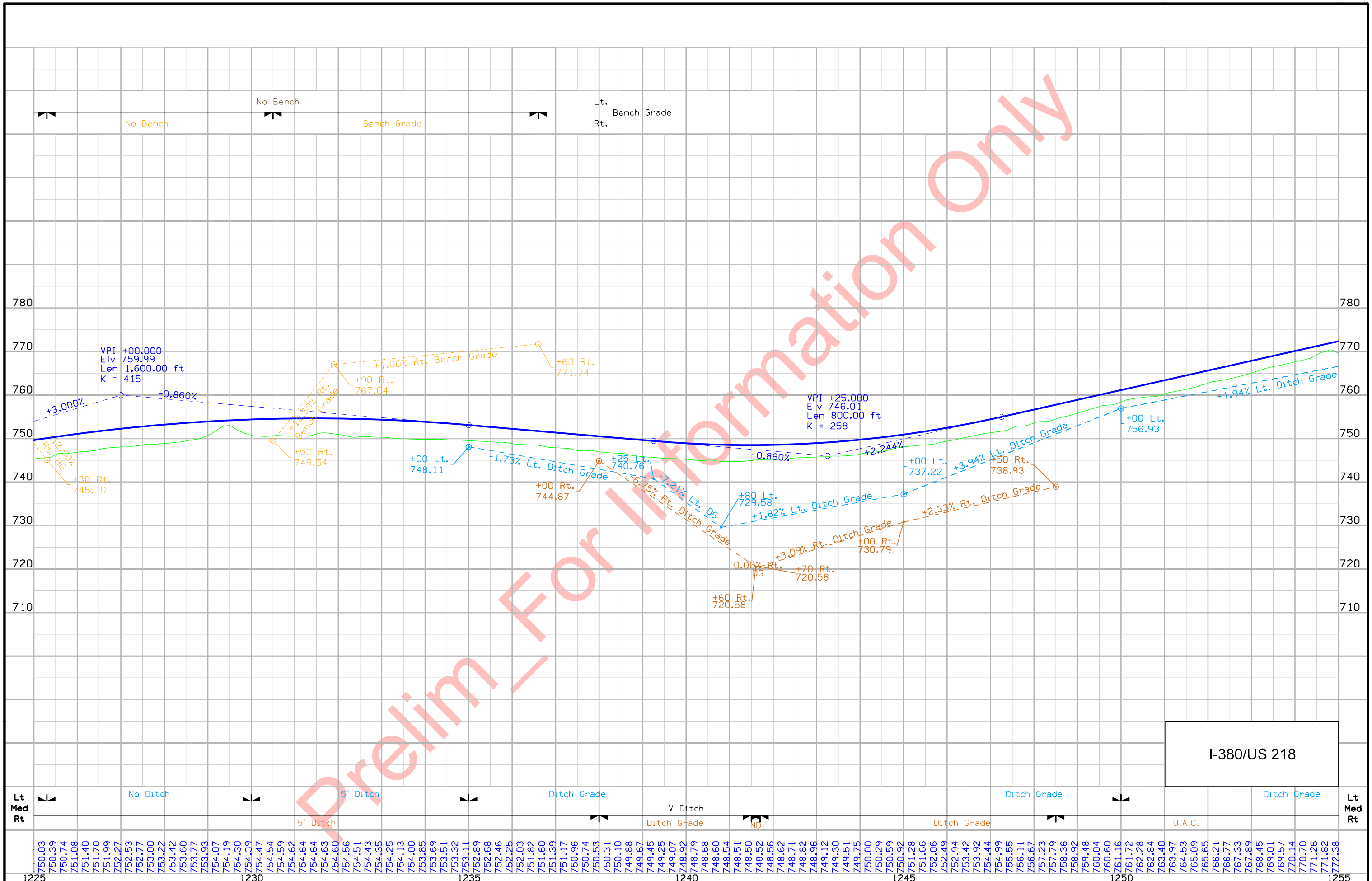

I-380/US 218

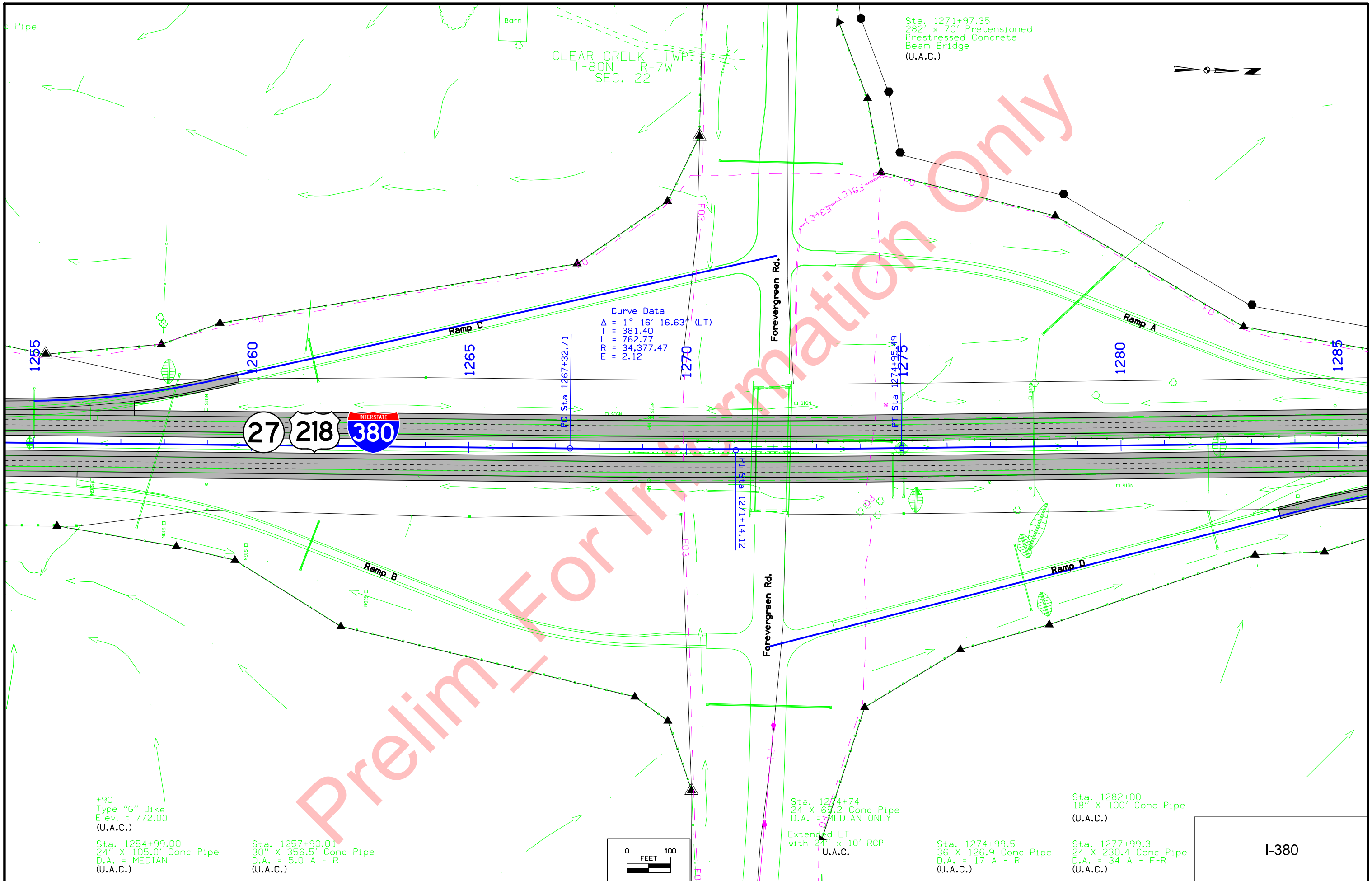

CLEAR CREEK TWP.
T-80N R-7W
SEC. 22

Sta. 1271+97.35
282' x 70' Pretensioned
Prestressed Concrete
Beam Bridge
(U.A.C.)

Curve Data
 $\Delta = 1^\circ 16' 16.63''$ (LT)
 $T = 381.40$
 $L = 762.77$
 $RR = 34,377.47$
 $e = 2.12$

+90
Type "G" Dike
Elev. = 772.00
(U.A.C.)

Sta. 1254+99.00
24" X 105.0' Conc Pipe
D.A. = MEDIAN
(U.A.C.)

Sta. 1257+90.01
30" X 356.5' Conc Pipe
D.A. = 5.0 A - R
(U.A.C.)

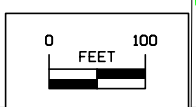

Sta. 1274+74
24 X 65.2 Conc Pipe
D.A. = MEDIAN ONLY
Extended LT
with 24" x 10' RCP
(U.A.C.)

Sta. 1274+99.5
36 X 126.9 Conc Pipe
D.A. = 17 A - R
(U.A.C.)

Sta. 1282+00
18" X 100' Conc Pipe
(U.A.C.)

Sta. 1277+99.3
24 X 230.4 Conc Pipe
D.A. = 34 A - F-R
(U.A.C.)

I-380

Prelim For Information Only

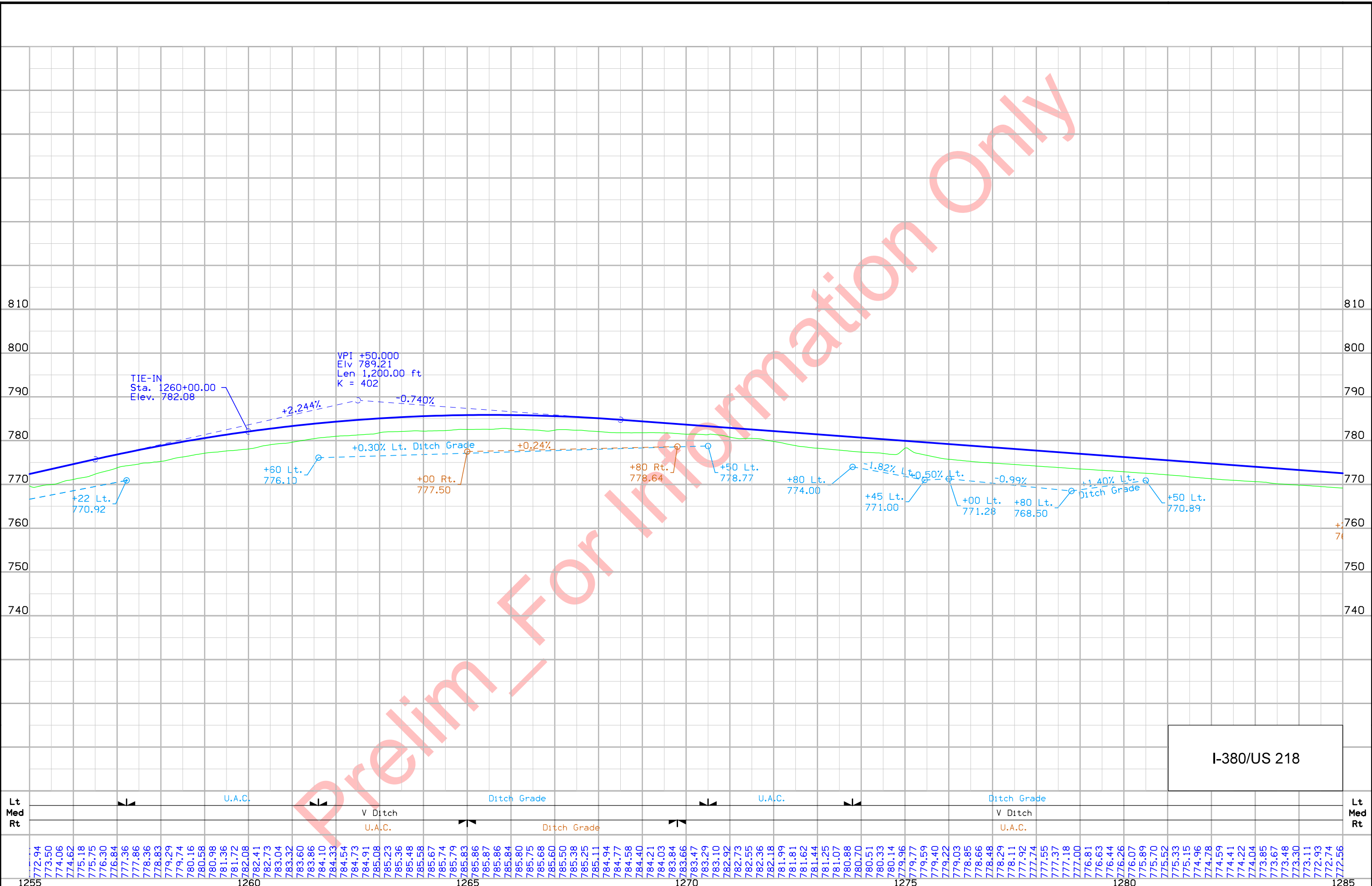

FILE NO.	ENGLISH	DESIGN TEAM	HOLST \ BENNETT	JOHNSON COUNTY	PROJECT NUMBER	NHS-380-6(326)1--03-52	SHEET NUMBER	D.7
----------	---------	-------------	-----------------	----------------	----------------	------------------------	--------------	-----

1:46:21 PM 12/19/2019 kschrch pw:\ntPwInt1.dot.int.lan:PWMain\Documents\Projects\5208001002\Design\..LETTING_FOLDERS\..326_Year3_Paving\CADD_Files\Sheet_Files\SHT_52380326_D02.dgn

CLEAR CREEK TWP.
T-80N R-7W
SEC. 22

Sta. 1300+00.00 - 53' LT
Installed 24" X 122' RCP
(Trenchless 80')
Rt. 760.01

CLEAR CREEK TWP.
T-80N R-7W
SEC. 15

Sta. 1309+00.00 - 53' LT
Installed 24" X 132' RCP
(Trenchless 84')
U.A.C.

Sta. 1315+00.3
24" X 64.40' Conc Pipe
D.A. = MEDIAN ONLY A - GR
Extended 24"X64.4' RCP LT
With 24" X 30' RCP
U.A.C.

+20
Type "G" Dike
Elev. = 762.50

+80
Type "G" Dike
Elev. = 766.00

+75
Type "G" Dike
Elev. = 770.80

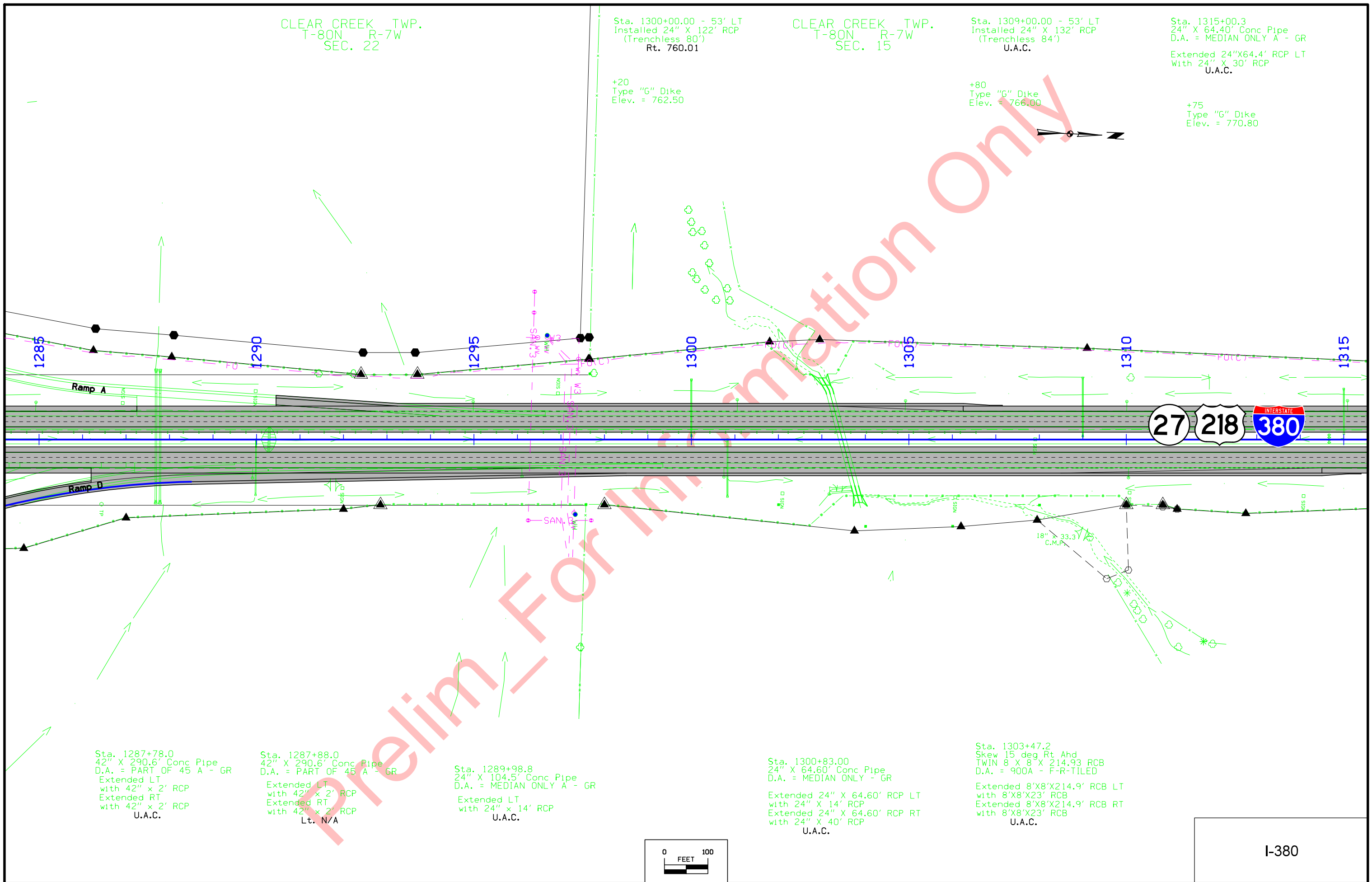

Sta. 1287+78.0
42" X 290.6' Conc Pipe
D.A. = PART OF 45 A - GR
Extended LT
with 42" x 2' RCP
Extended RT
with 42" x 2' RCP
U.A.C.

Sta. 1287+88.0
42" X 290.6' Conc Pipe
D.A. = PART OF 45 A - GR
Extended LT
with 42" x 2' RCP
Extended RT
with 42" x 2' RCP
Lt. N/A

Sta. 1289+98.8
24" X 104.5' Conc Pipe
D.A. = MEDIAN ONLY A - GR
Extended LT
with 24" x 14' RCP
U.A.C.

Sta. 1300+83.00
24" X 64.60' Conc Pipe
D.A. = MEDIAN ONLY - GR
Extended 24" X 64.60' RCP LT
with 24" X 14' RCP
Extended 24" X 64.60' RCP RT
with 24" X 40' RCP
U.A.C.

Sta. 1303+47.2
Skew 15 deg Rt Ahd
TWIN 8 X 8 X 214.93 RCB
D.A. = 900A - F-R-TILED
Extended 8'X8'X214.9' RCB LT
with 8'X8'X23' RCB
Extended 8'X8'X214.9' RCB RT
with 8'X8'X23' RCB
U.A.C.

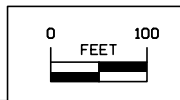

I-380

Prelim For Information Only

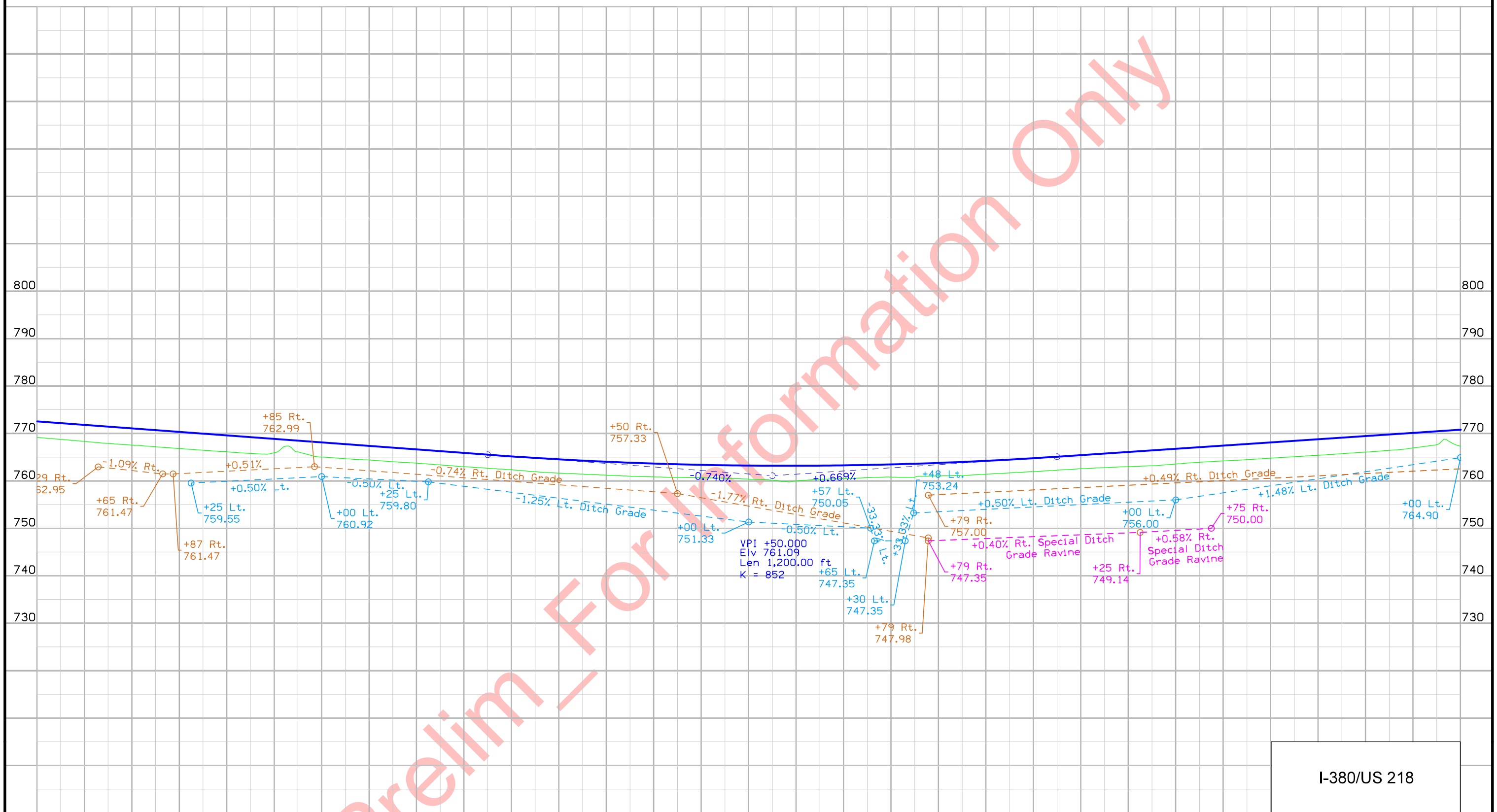

I-380/US 218

Lt Med Rt	U.A.C.	Ditch Grade	V Ditch	Ditch Grade	Lt Med Rt
772.37					1285
772.19					
772.00					
771.82					
771.63					
771.45					
771.26					
771.08					
770.89					
770.71					
770.52					
770.34					
770.15					
769.97					
769.78					
769.60					
769.41					
769.23					
769.04					
768.86					
768.67					
768.49					
768.30					
768.12					
767.93					
767.75					
767.56					
767.38					
767.19					
767.01					
766.82					
766.64					
766.45					
766.27					
766.08					
765.90					
765.71					
765.53					
765.35					
765.17					
765.01					
764.85					
764.69					
764.55					
764.41					
764.28					
764.16					
764.04					
763.94					
763.84					
763.74					
763.66					
763.58					
763.51					
763.44					
763.39					
763.34					
763.30					
763.26					
763.23					
763.21					
763.20					
763.20					
763.21					
763.22					
763.25					
763.28					
763.32					
763.36					
763.42					
763.48					
763.55					
763.62					
763.71					
763.80					
763.89					
764.00					
764.11					
764.23					
764.36					
764.49					
764.63					
764.78					
764.94					
765.10					
765.27					
765.43					
765.60					
765.77					
765.94					
766.10					
766.27					
766.44					
766.61					
766.77					
766.94					
767.11					
767.27					
767.44					
767.61					
767.78					
767.94					
768.11					
768.28					
768.44					
768.61					
768.78					
768.95					
769.11					
769.28					
769.45					
769.61					
769.78					
769.95					
770.12					
770.28					
770.45					
770.62					
770.79					1315

CLEAR CREEK TWP.
T-80N R-7W
SEC. 15

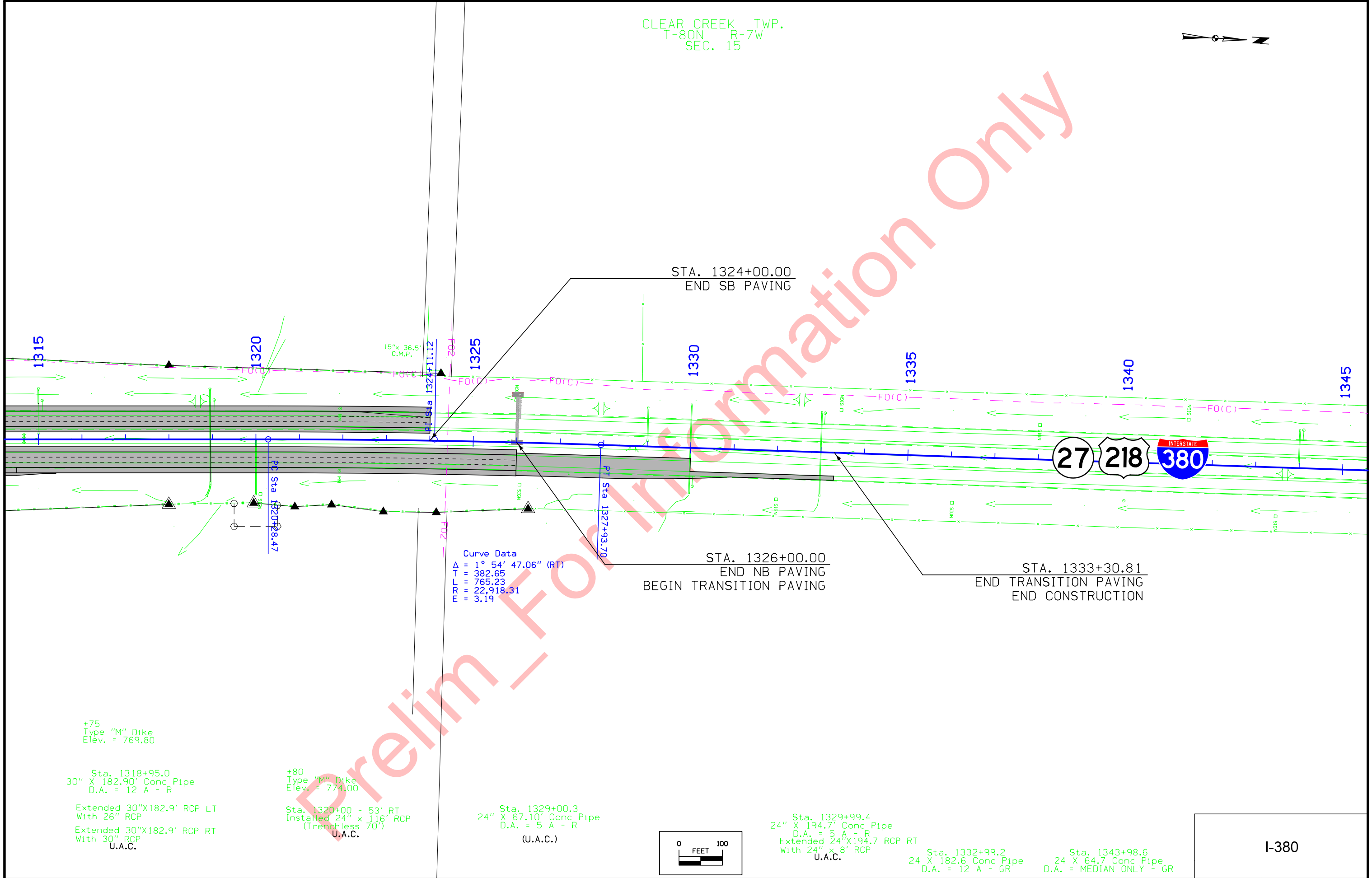
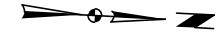

Curve Data
 $\Delta = 1^\circ 54' 47.06''$ (RT)
 $T = 382.65$
 $L = 765.23$
 $P = 22,918.31$
 $E = 3.19$

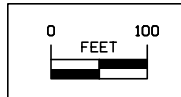

I-380

Prelim - For Information Only

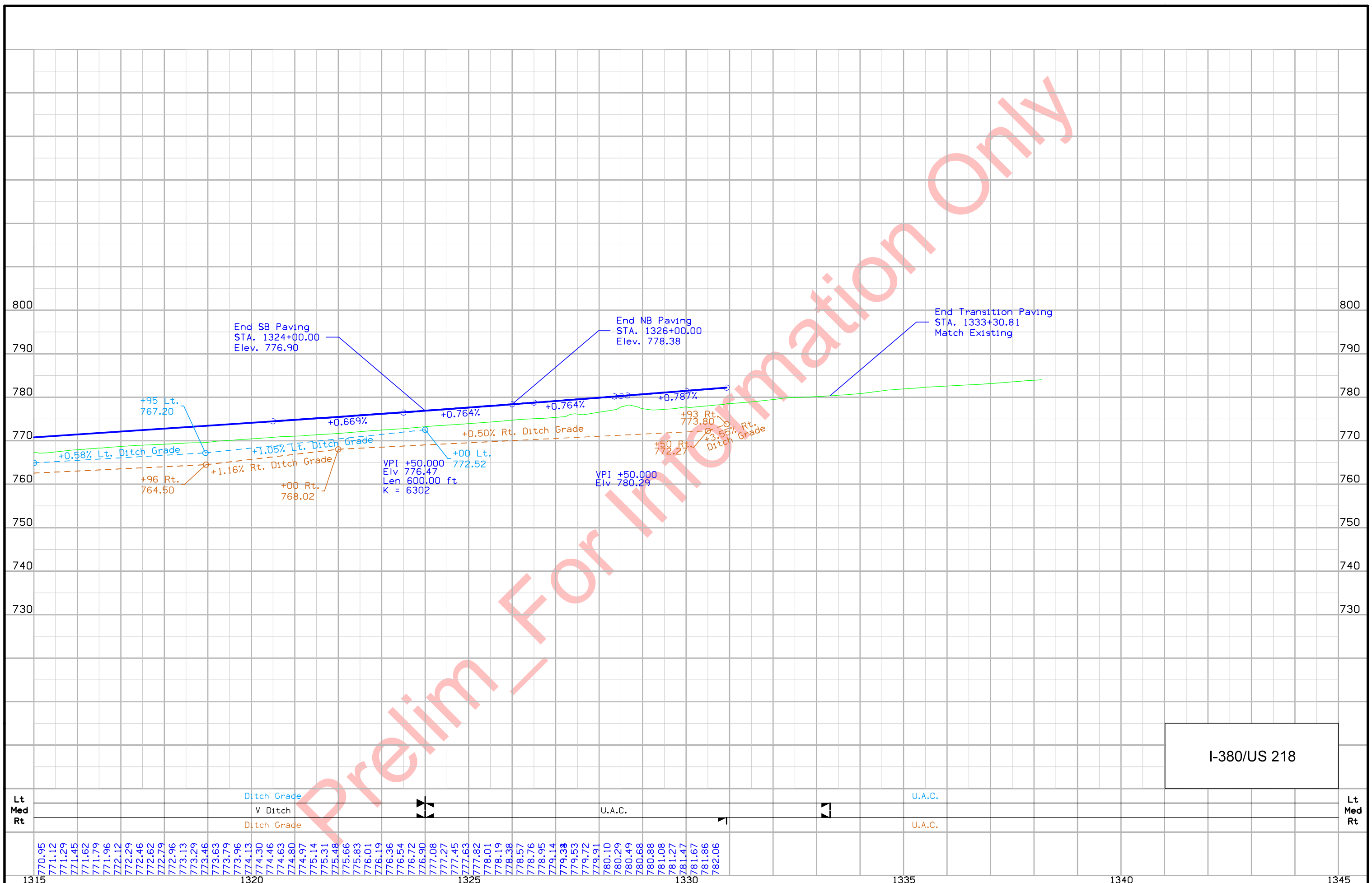

I-380/US 218

Lt		Ditch Grade									U.A.C.						U.A.C.				Lt	
Med		V Ditch																				Med
Rt		Ditch Grade																				Rt
770.95	771.12																					
771.29	771.45																					
771.62	771.79																					
771.96	772.12																					
772.29	772.46																					
772.62	772.79																					
772.96	773.13																					
773.29	773.46																					
773.63	773.79																					
773.96	774.13																					
774.30	774.46																					
774.63	774.80																					
774.97	775.14																					
775.31	775.48																					
775.66	775.83																					
776.01	776.19																					
776.36	776.54																					
776.72	776.90																					
777.08	777.27																					
777.45	777.63																					
777.82	778.01																					
778.19	778.38																					
778.57	778.76																					
778.95	779.14																					
779.38	779.53																					
779.72	779.91																					
780.10	780.29																					
780.49	780.68																					
780.88	781.08																					
781.27	781.47																					
781.67	781.86																					
782.06																						

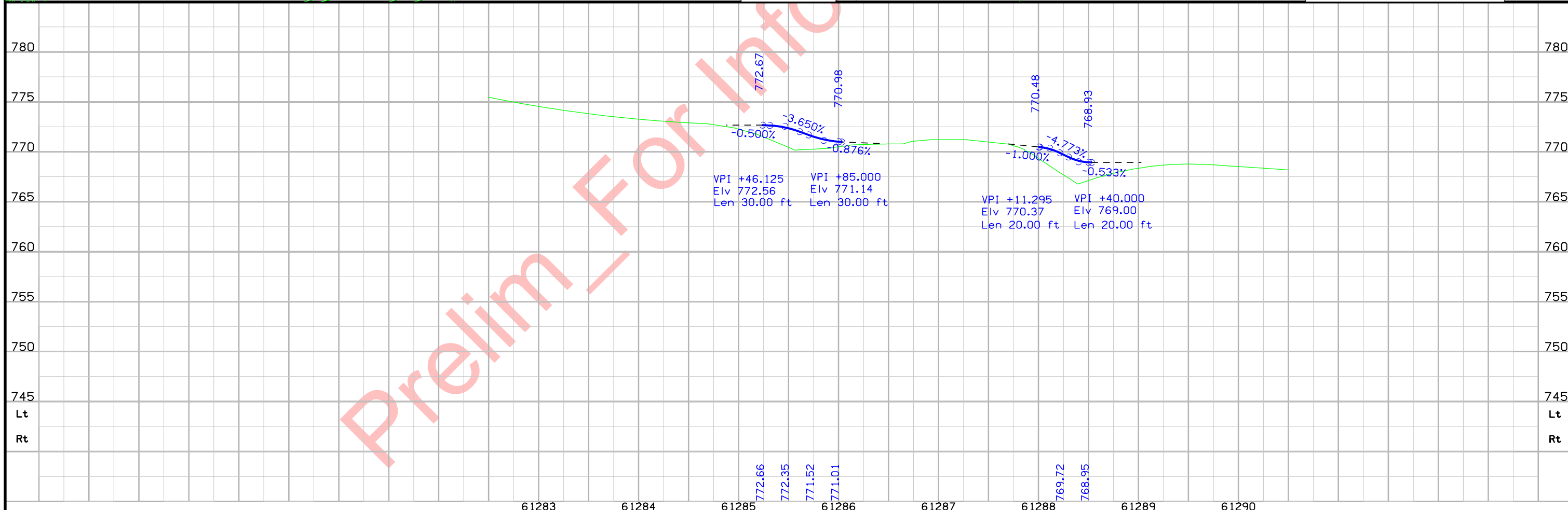
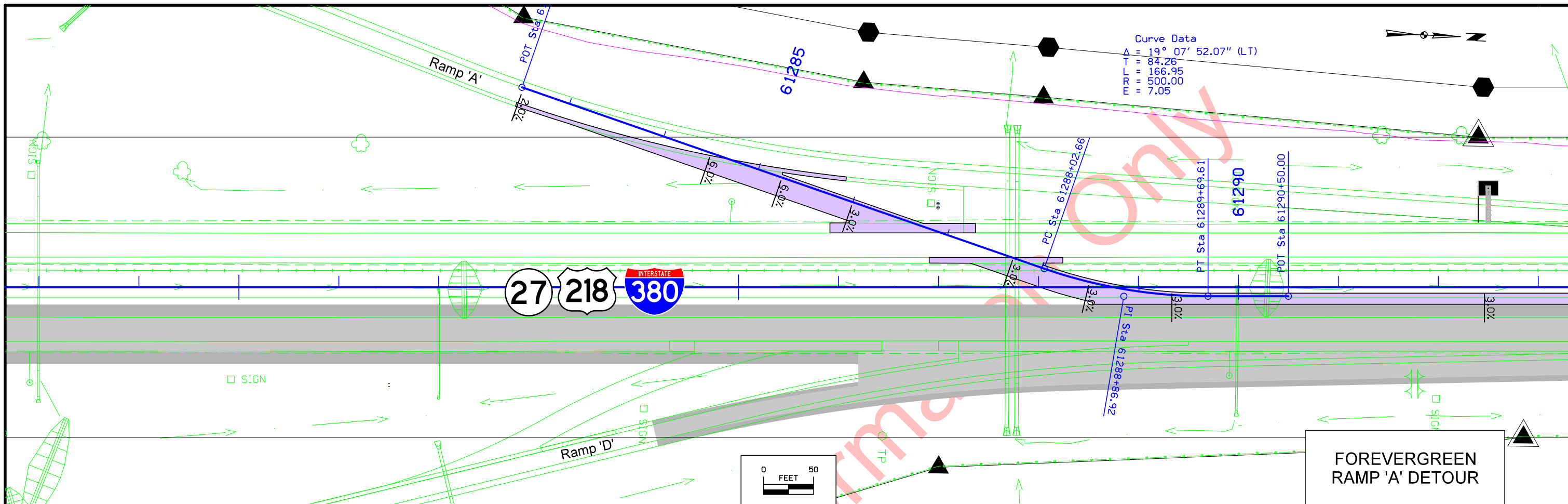

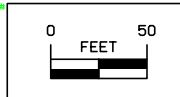
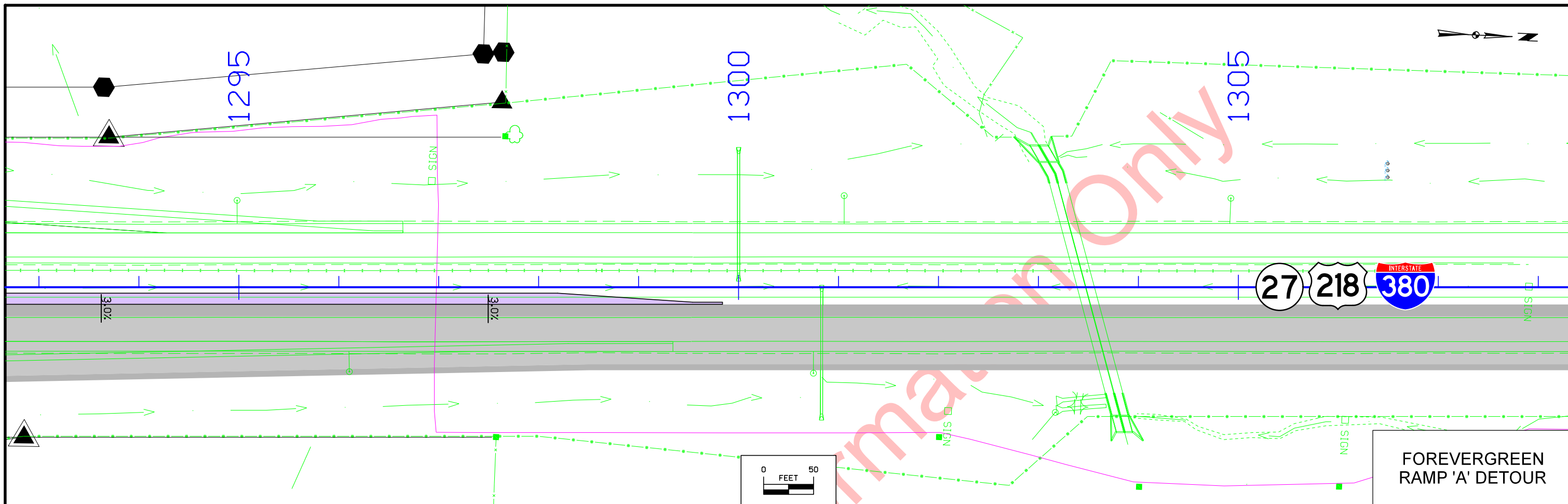

FOREVERGREEN
RAMP 'A' DETOUR

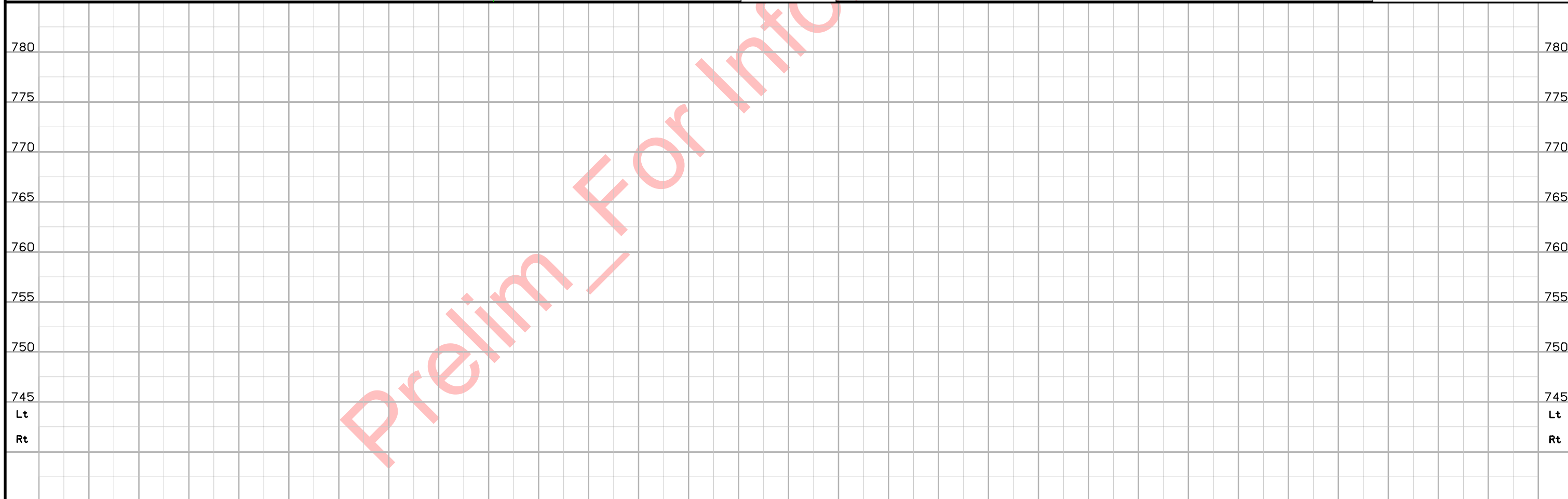

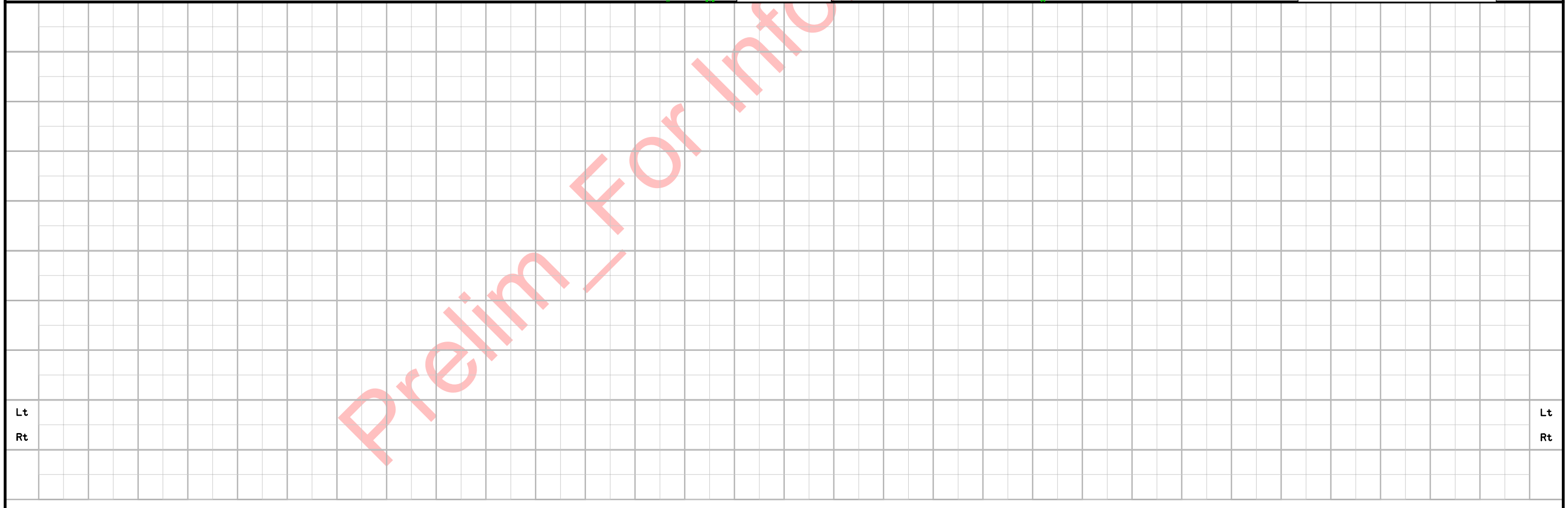
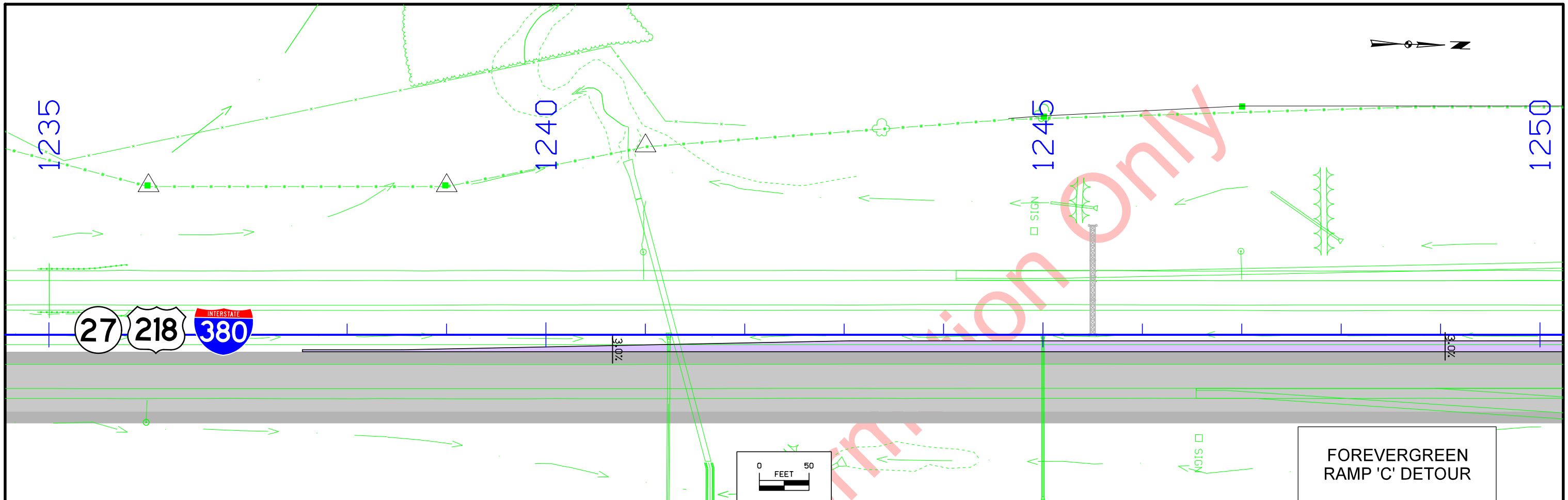

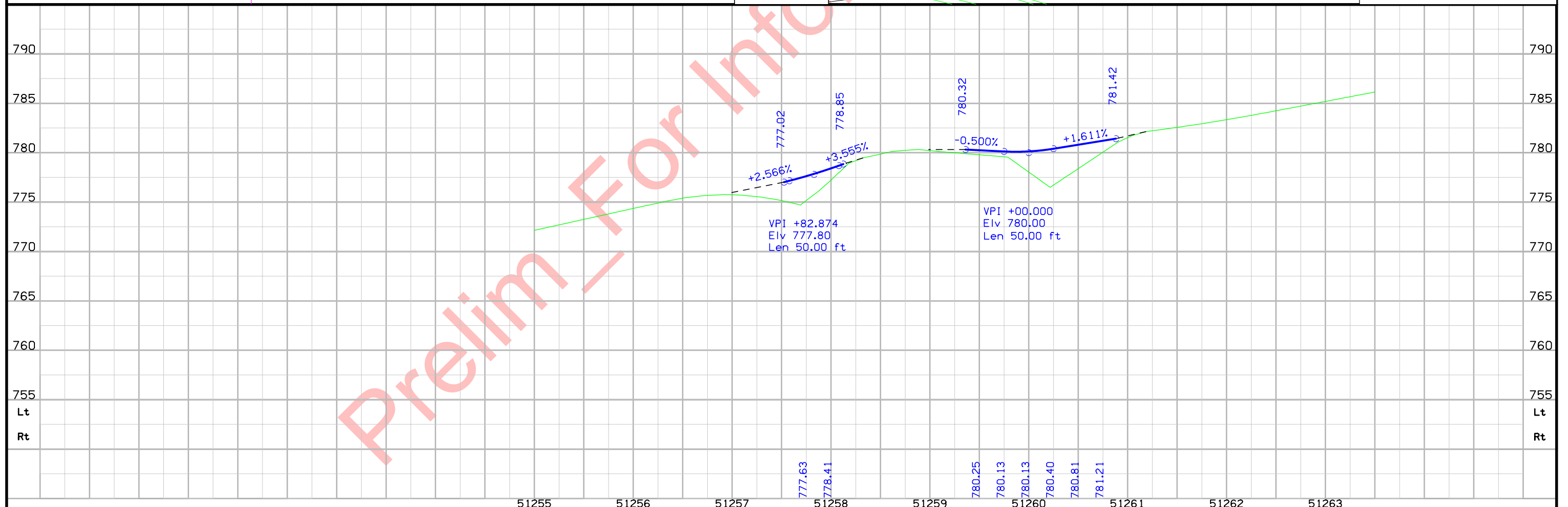
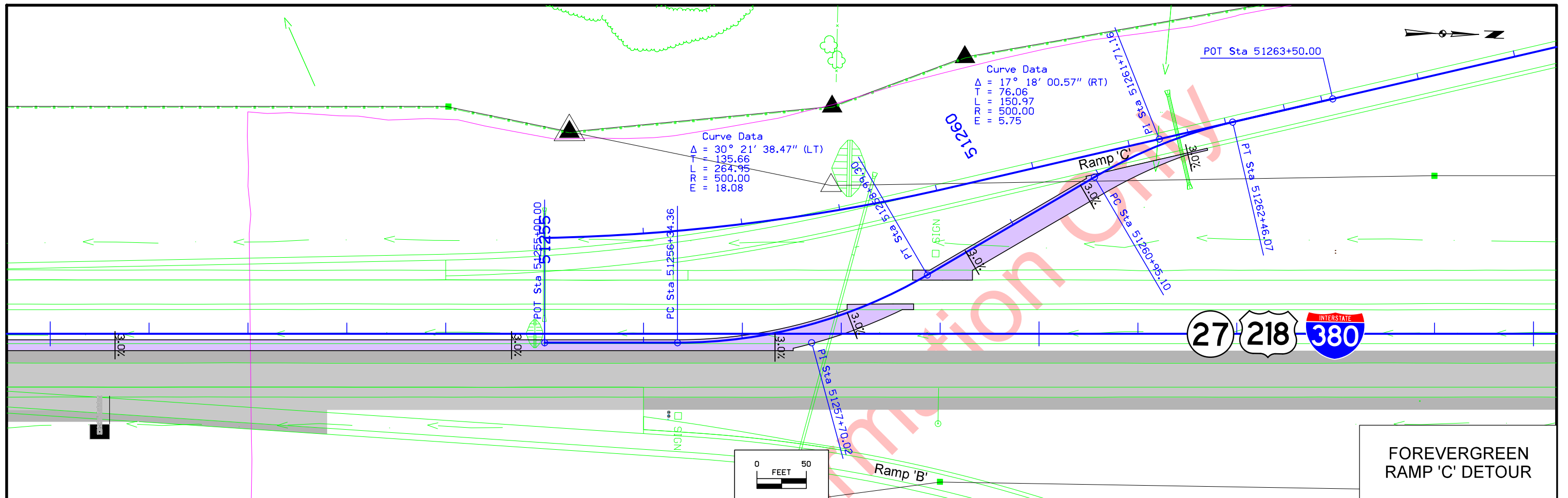

108-23A
08-01-08

TRAFFIC CONTROL PLAN

In Progress

108-26A
08-01-08

STAGING NOTES

See NHS-080-6(372)239--11-52 plans for staging information.

Prelim For Information Only

JOHNSON COUNTY
CLEAR CREEK TWP.
T-80N R-7W
Sec. 22

Curve Data
 $\Delta = 11^\circ 54' 53.15''$ (LT)
 $T = 208.70$
 $L = 415.90$
 $R = 2,000.00$
 $E = 10.86$

POT 3555+00.00 (Ramp C) =
 POT 1255+00.00 (ML380); 97' LT
 Point 'G' Standard Road Plan PV-411

PC Sta 3555+00.00

PI Sta 3557+08.70

PT Sta 3559+15.90

Ramp 'C'



FOREVERGREEN
RAMP 'C'

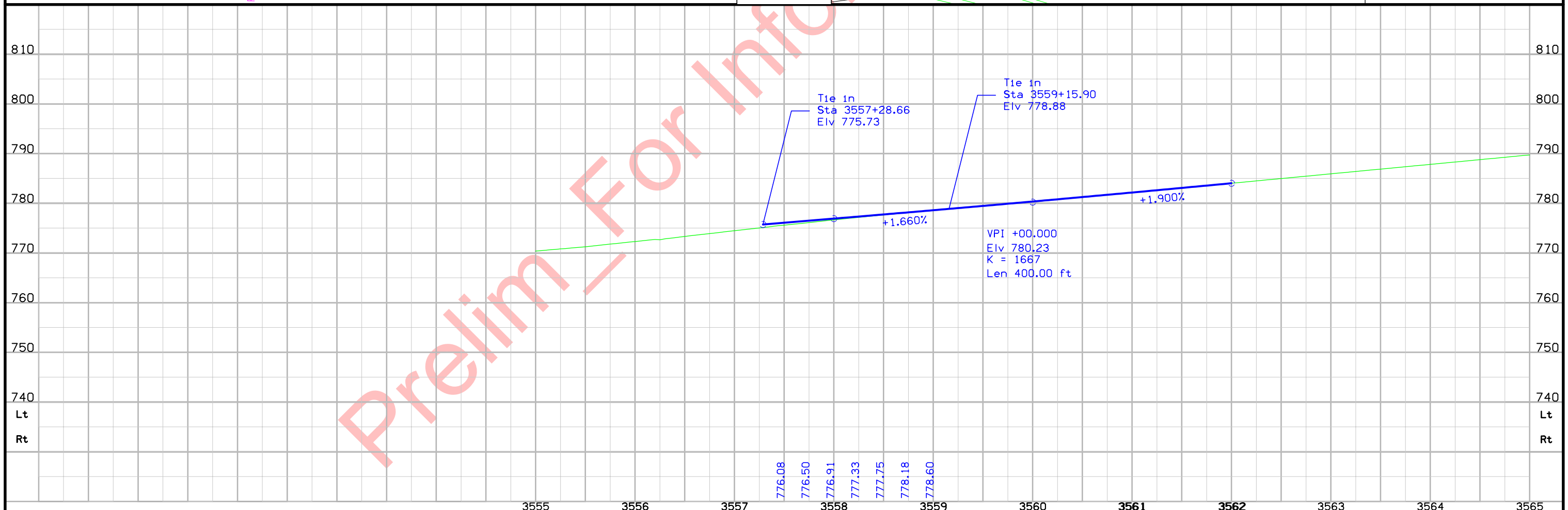
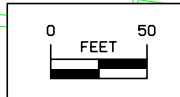

776.08
776.50
776.91
777.33
777.75
778.18
778.60

3555 3556 3557 3558 3559 3560 3561 3562 3563 3564 3565

