

**JOHNSON CO.**

**TRAFFIC SIGNS**  
**NHS-080-6(403)239-11-52**

LETTING DATE  
07-15-2020



### Highway Division

PLANS OF PROPOSED IMPROVEMENT ON THE

# PRIMARY ROAD SYSTEM JOHNSON COUNTY TRAFFIC SIGNS

I-80/380/US 218 Interchange near Iowa City

SCALES: As Noted

Refer to the Proposal Form for list of applicable specifications.

Value Engineering Saves. Refer to Article 1105.14 of the Specifications.



REVISIONS

TOTAL

282

PROJECT IDENTIFICATION NUMBER

02-52-080-010

PROJECT NUMBER

NHS-080-6(403)239-11-52

R.O.W. PROJECT NUMBER

#### INDEX OF SHEETS

No.	DESCRIPTION
<b>A Sheets</b>	<b>Title Sheets</b>
* A.1	Title Sheet
<b>B Sheets</b>	<b>Typical Cross Sections and Details</b>
* B.1	Type A Sign Detail
* B.2	Overhead DMS Details
* B.3	Conspicuity Flag Details
* B.4 - 8	PSST Details
<b>C Sheets</b>	<b>Quantities and General Information</b>
C.1	Estimated Project Quantities
C.1 - 2	Estimate Reference Information
C.3	Standard Road Plans
C.3	Removal of Existing Structures
C.3	Index of Tabulations
C.4	Signing Notes
C.5 - 12	Tabulations (beg. with tab. of incidentals if needed)
<b>N Sheets</b>	<b>Traffic Signing Sheets</b>
* N.1 - 261	Traffic Signing
	* Color Plan Sheets

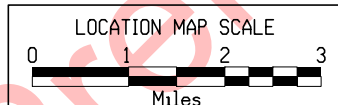
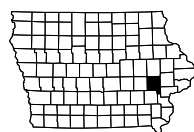
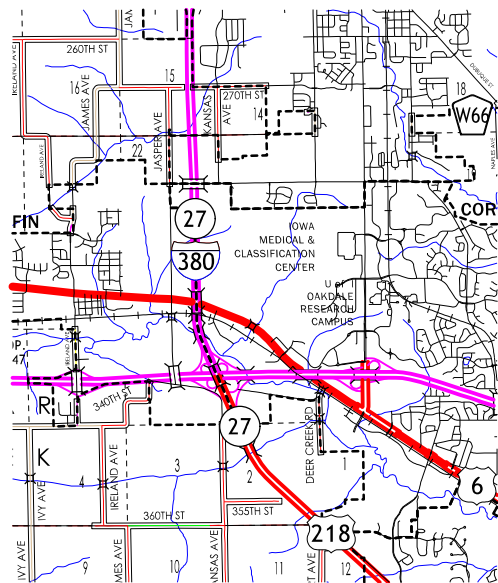

## PRELIMINARY PLANS

Subject to change by final design.

Date: 12/27/2019

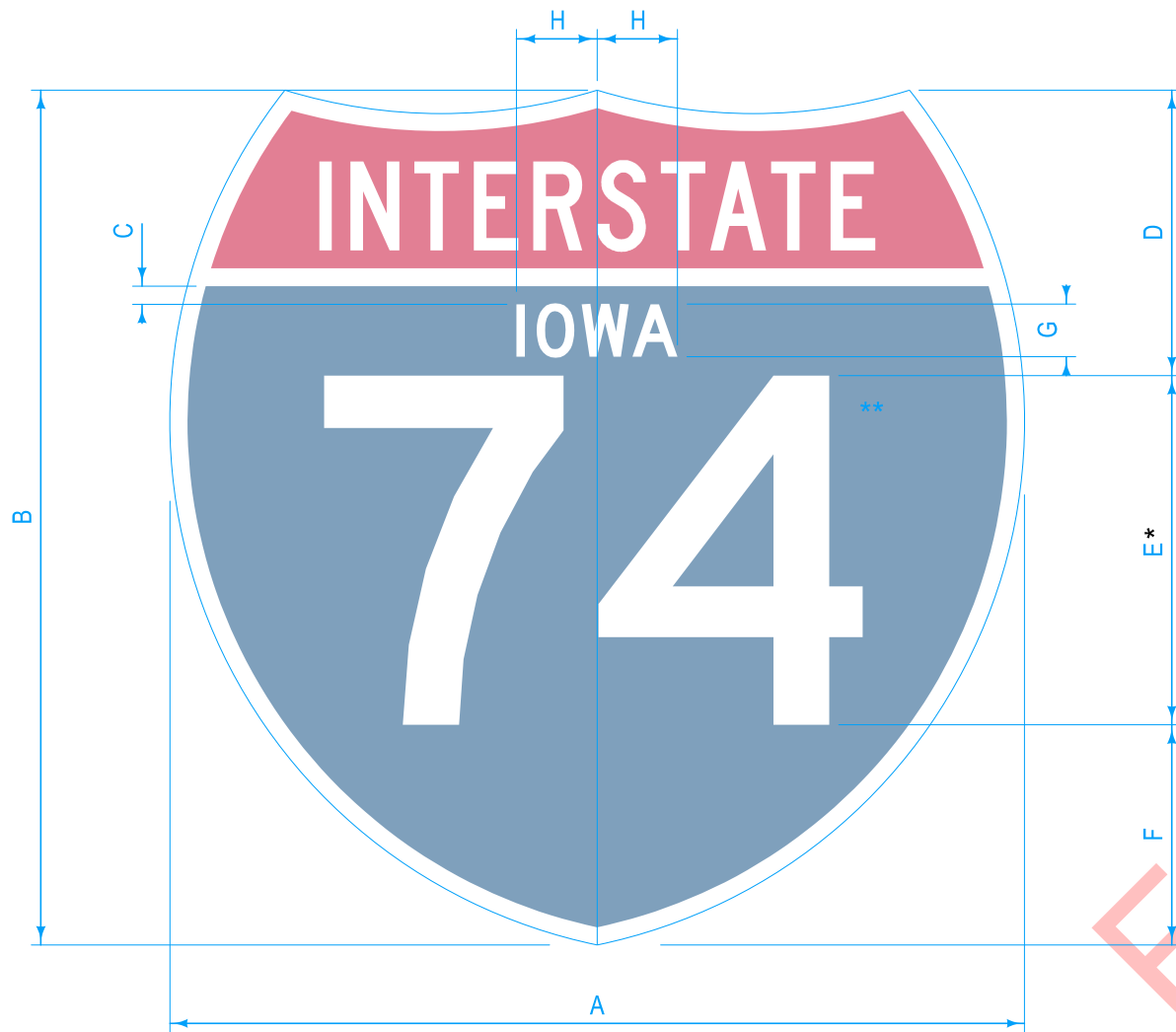

M1-1 (Iowa)  
Stand Alone Route Shield  
(Not for use on guide signs)

\* Series 2000 Standard Alphabets.  
\*\* Optically space numerals about vertical centerline.

SIGN	A	B	C	D	E	F	G	H
1,2 digits	24	24	0.5	8	10 D	6	1.5 D	2.27
1, 2 digits	36	36	0.75	12	15 D	9	2.25 D	3.4
3 digits	30	24	0.5	8	10 C	6	1.5 D	2.27
3 digits	45	36	0.75	12	15 C	9	2.25 D	3.4

Refer to FHWA 'Standard Highway Signs, 2004 Edition' for additional sign layout and dimension information.

TYPE A SIGN DETAIL  
M1-1 (IOWA)

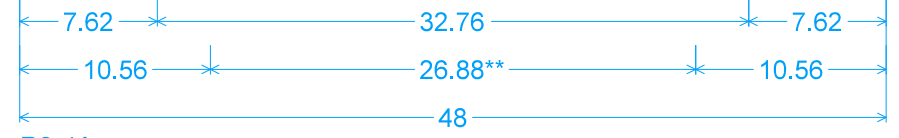

R2-4A;  
3.000" Radius, 0.875" Border, 0.750" Indent, Black on White;  
[MINIMUM] D 2K; [40] D 2K; \*

R2-4 (Iowa)  
Interstate/Freeway/Expressway use only.

\* Series 2000 Standard Alphabets.  
\*\* Optically space numerals about vertical centerline.

TYPE A SIGN DETAIL  
R2-4 (IOWA)

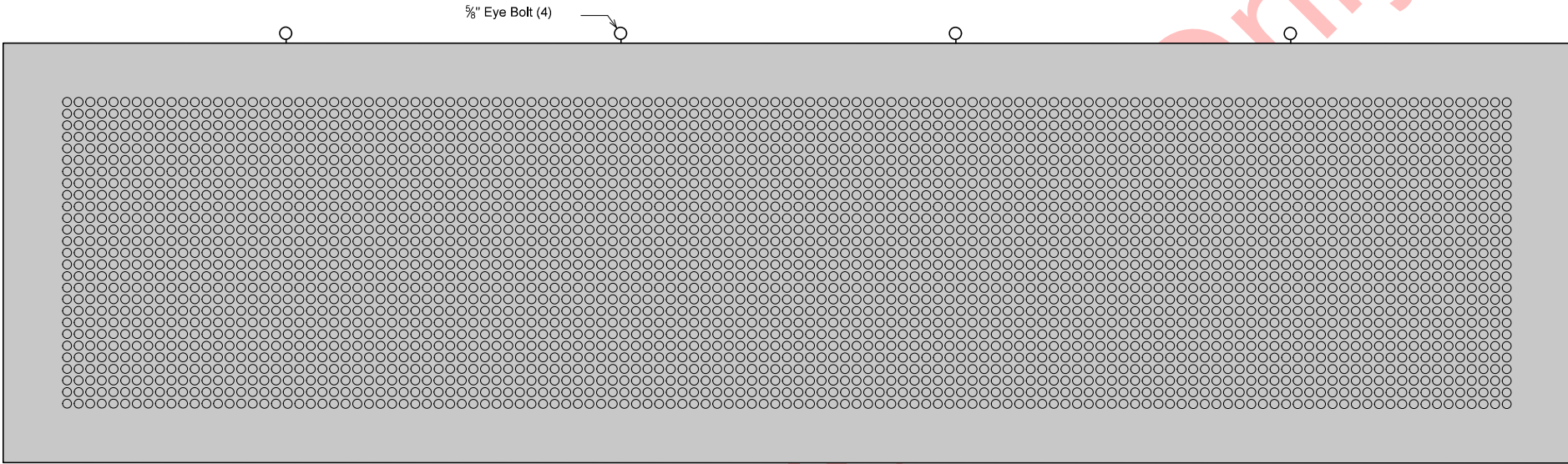

**TRANSPORTATION REQUIREMENTS**

All material and equipment necessary to transport the sign to or from the storage site and/or installation site shall be furnished by the Contractor.

The sign shall be transported in the upright position. At no point in time shall the sign be laid on its side, front, or back.

To avoid damage to the sign during transport, consult the sign manufacturer to determine the correct method to secure the sign to the trailer.

Any damage incurred during transportation shall be the responsibility of the Contractor.

**STORAGE REQUIREMENTS**

All material and equipment necessary to store the sign at the designated site shall be furnished by the Contractor.

The sign shall be stored upright and level. At no point in time shall the sign be laid on its side, front, or back.

The sign must be blocked up at least three inches from the ground. When the sign is not stored on concrete, extra blocking shall be used to provide for settlement.

Remove shipping support legs from the DMS after installation on the support structure.

During transportation and storage, the DMS shall be secured at all times to prevent tipping. The DMS shall be secured with dead man anchors or other suitable methods. The DMS shall not be marred by the selected method. Tipping may be caused by any number of reasons, but high winds and other weather related events are the primary concern while the DMS is on the ground.

Any damage resulting from the failure to properly secure the DMS shall be the responsibility of the Contractor.

**ATTACHMENT HARDWARE**

All materials necessary to attach the DMS to the support structure will be furnished as stated in the Contract Documents.

Dry fit the DMS to the sign truss to determine the actual attachment bracket locations. Adjust the brackets to avoid conflicts between the U Bolts and the internal members of the sign truss. Drill the bolt holes in the Z bracket on the back of the DMS after conflicts are resolved.

After installation of the DMS onto the truss, ensure that all unused hardware (bolts, nuts, washers, etc), construction materials, tools and such are removed from the structure. The Contractor is liable for any damages that result from materials falling into traffic.

**LIFTING REQUIREMENTS**

The following procedures should be followed when lifting the sign for either removal or installation, including lifting the sign from the storage site to the trailer or the reverse, and from the trailer to the support structure or the reverse.

The Contractor shall provide all equipment necessary to lift the DMS.

The crane and lifting bar shall be rated to lift the weight of the sign.

Any damage incurred during lifting shall be the responsibility of the Contractor.

Consult the manufacturer for complete lifting requirements.

The eyebolts used to lift the sign shall be furnished by the Contractor. The rated load of the eyebolts shall not be exceeded. Consult manufacturer for specific information about the eyebolts.

The figures illustrate the correct (left example) and the incorrect (right example) method of lifting a sign. Lift the sign with the lifting bar as shown on the left. Use every lifting point (eyebolt) provided. Not doing so may cause the eyebolts to fail.

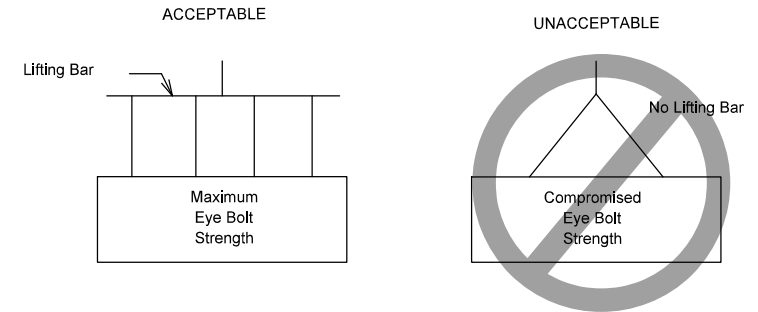

After installation, plug and seal the eyebolt openings as per the manufacturer's requirements. Any damage incurred by improperly sealed openings shall be the responsibility of the Contractor.

**OVERHEAD  
DYNAMIC MESSAGE SIGN  
AND CARE AND HANDLING REQUIREMENTS**

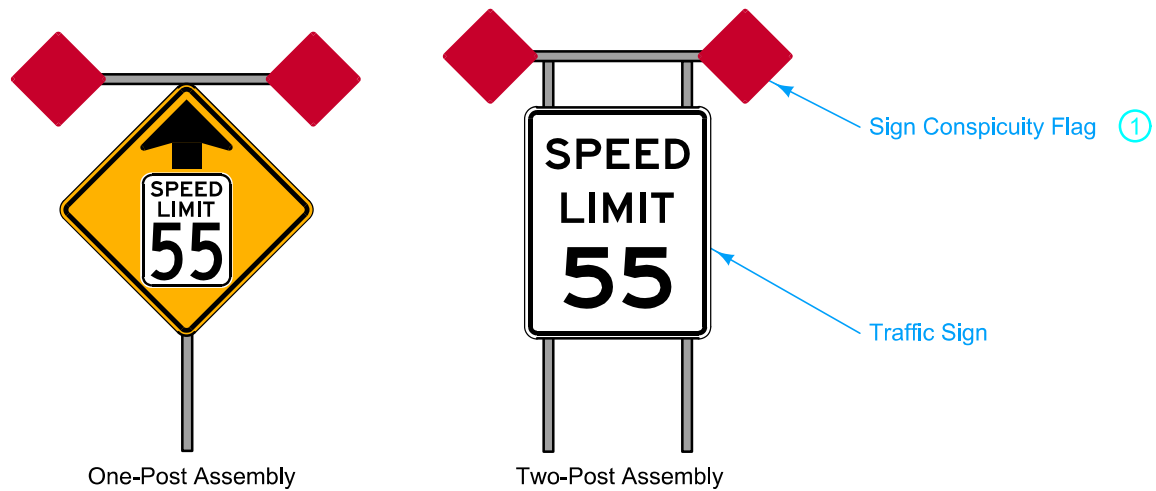

One-Post Assembly

Two-Post Assembly

**SAMPLE SIGN ASSEMBLIES**

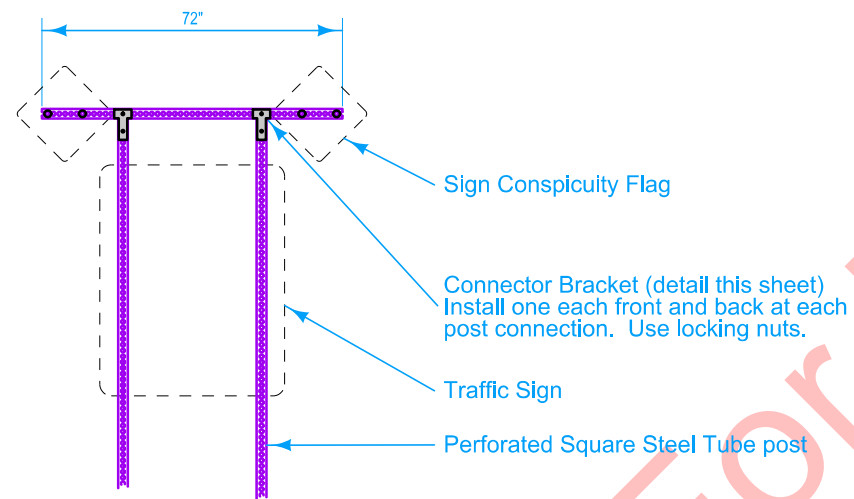

**SIGN ASSEMBLY DETAIL**

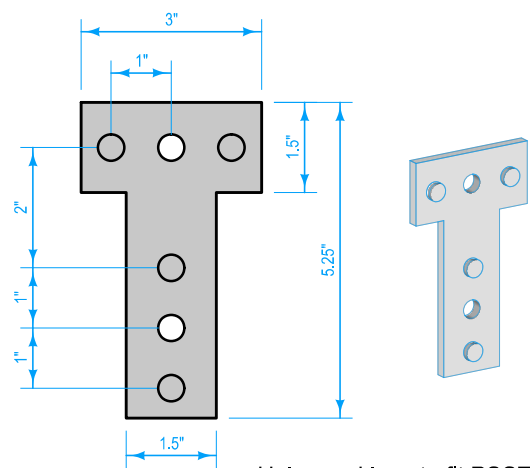

Holes and lugs to fit PSST post.

**CONNECTOR BRACKET DETAIL**

① Sign Conspicuity Flag signs to be retro reflective red sheeting (ASTM Type IV) on sheet aluminum. Sign blanks fabricated per Standard Road Plan SI-173 for 18" x 18" object marker.  
Materials shall conform to Section 4186 of the Standard Specifications.

	REVISION
	07-14-15
<b>SIGN CONSPICUITY FLAGS</b>	TAS STANDARD
REVISION: __	
<b>FOR INSTALLATION ON PERFORATED SQUARE STEEL TUBE POSTS</b>	

Sign post shall be installed according to the manufacturer's instructions

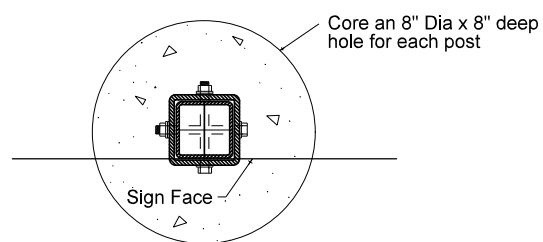
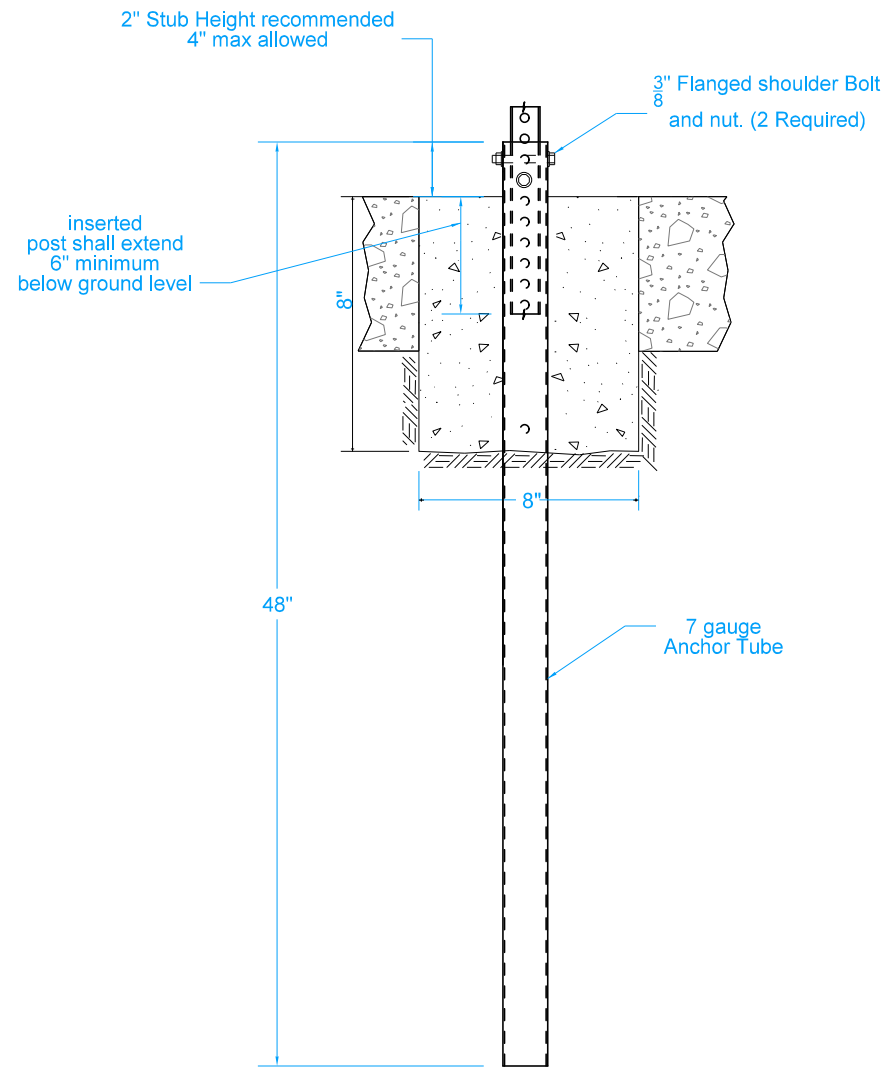

BREAK AWAY CONCRETE INSTALLATION

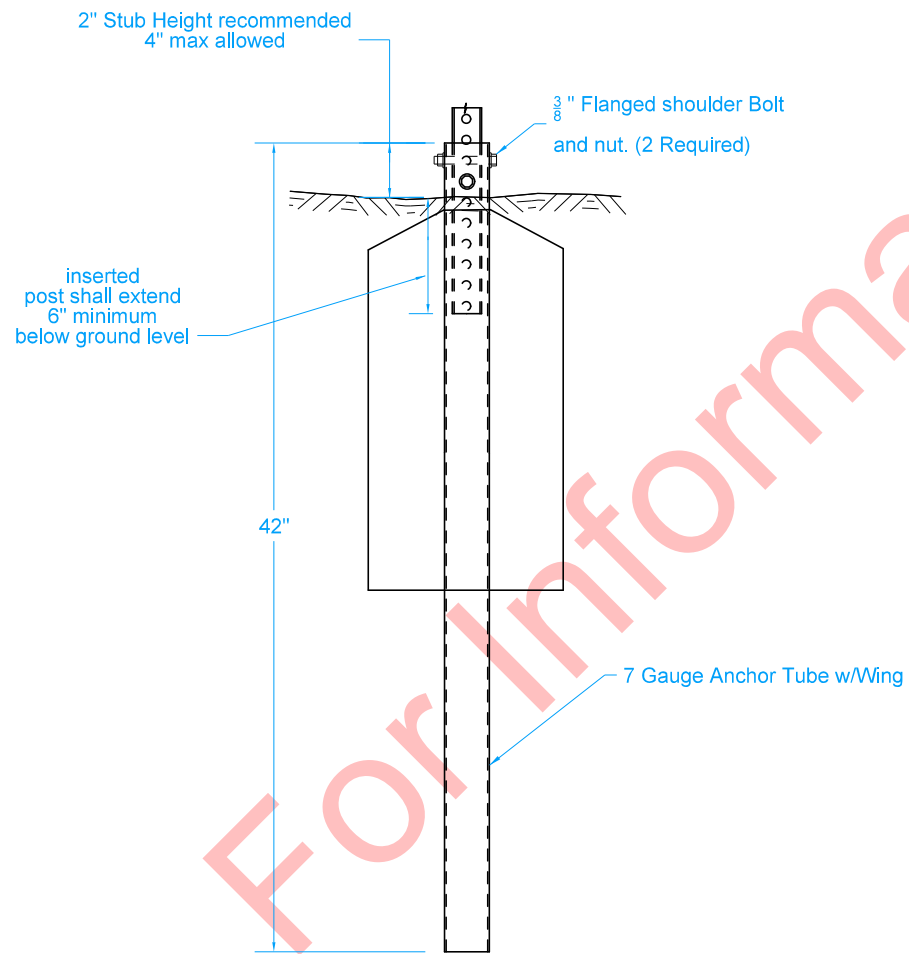

BREAK AWAY SOIL INSTALLATION

2 EACH 3/8" X 3 1/2" FLANGED SHOULDER BOLT & NUT

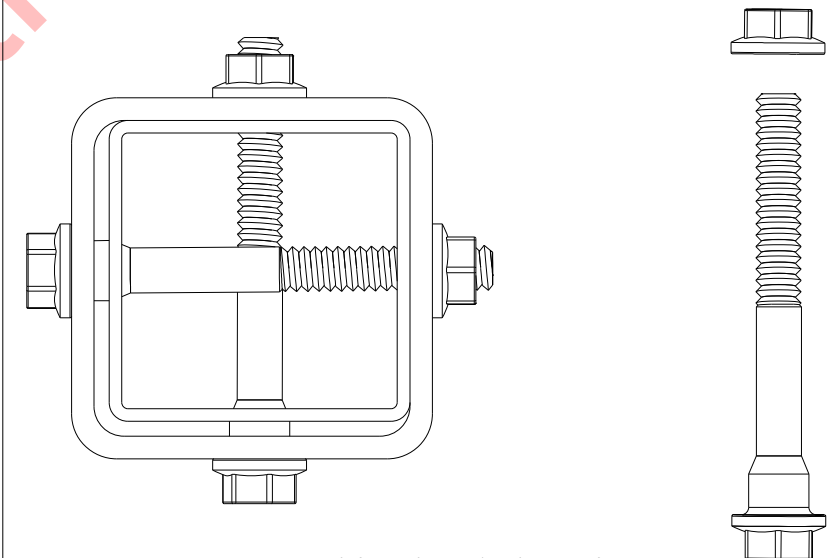

POST TO ANCHOR FASTENER FOR 7 GAUGE ANCHOR TUBE

NOTE: 2" X 2" X 12 gauge perforated post requires 2 1/2" X 2 1/2" X 7 gauge anchor tube.  
2 1/2" X 2 1/2" X 12 gauge perforated post requires 3" X 3" X 7 gauge anchor tube.

	REVISION	
	-	00-00-00
---	---	
REVISION: _	TAS STANDARD	
Perforated Square Steet Tube Anchor and Post		

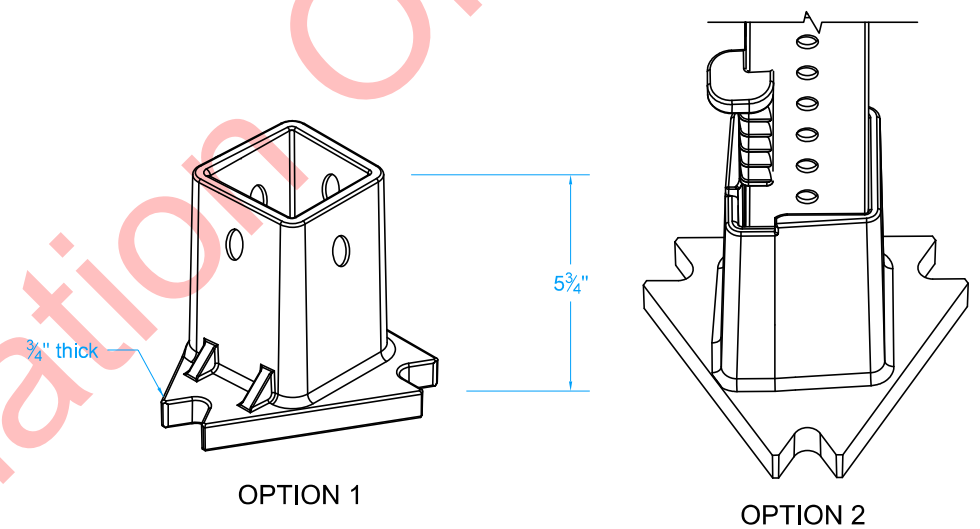
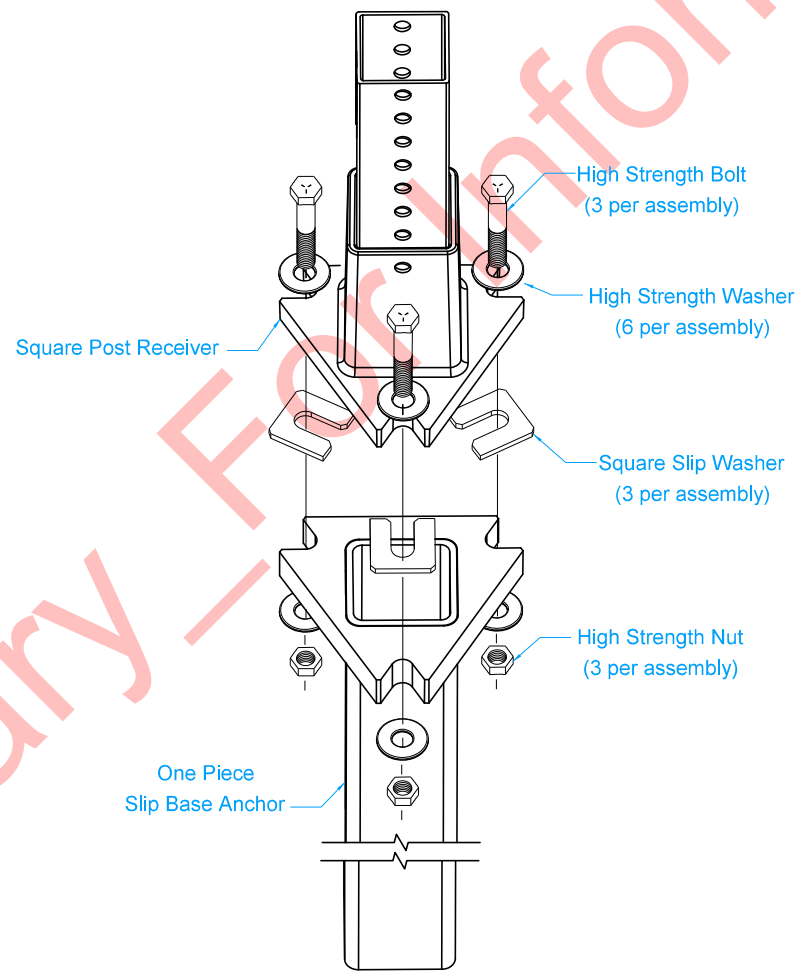
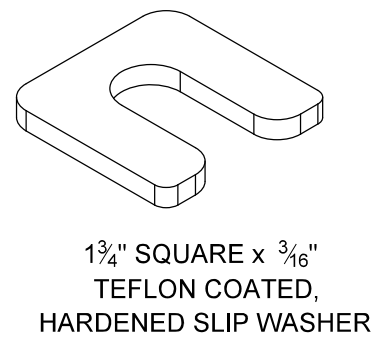
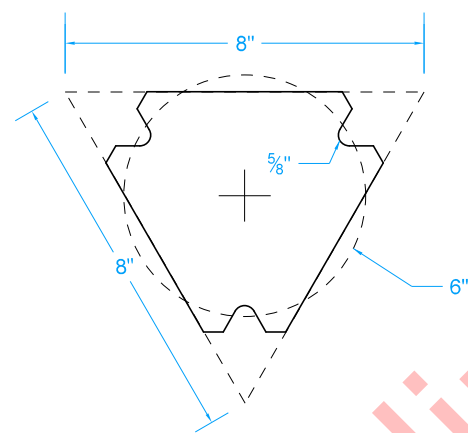
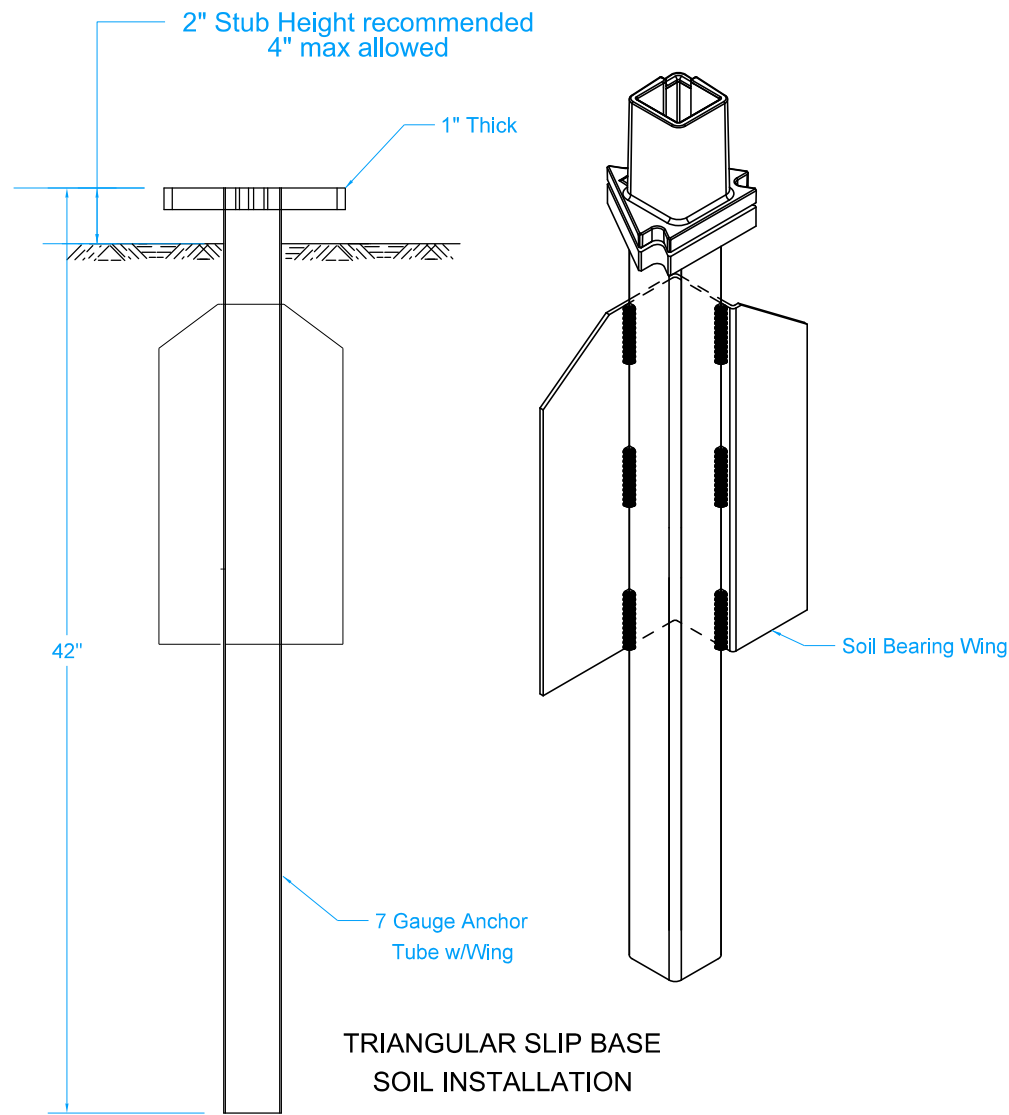

2 1/2" SQUARE POST RECEIVER OPTIONS

2 EACH 3/8" X 3 1/2" FLANGED SHOULDER BOLT & NUT  
(FOR OPTION 1 RECEIVER CONNECTION)

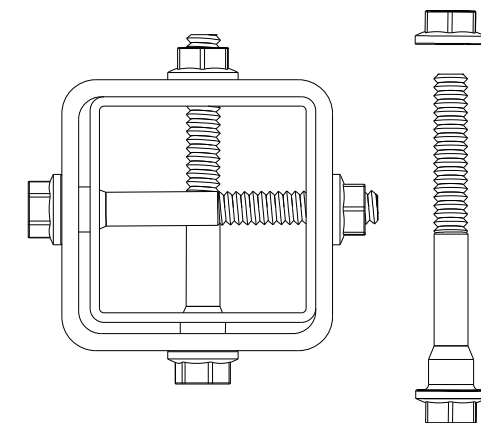

POST TO ANCHOR FASTENER  
FOR 7 GAUGE ANCHOR TUBE

<b>IOWA DOT</b>	REVISION	
	-	00-00-00
---	---	
REVISION: _	TAS STANDARD	
Perforated Square Steel Tube Anchor and Post		

**WINDLOAD COORDINATES AT 90 MPH**

Legend:  Post type not used.

SIGN CENTROID	SIGN AREA (SQ-FT) YIELDING DESIGN													
	SOIL OR CONCRETE SOLID WALL ANCHOR			SLIP BASE REQUIRED										
	2" x 12ga perf.		2-1/2" x 12ga perf.	2-1/2" x 12ga perf.		2-1/2" x 10ga perf.			2-1/4" x 12ga inserted into a 2-1/2" x 12ga perf.			2-3/16" x 10ga inserted into a 2-1/2" x 10ga perf.		
	1 Post	2 Post	1 Post	2 Post	3 Post	1 Post	2 Post	3 Post	1 Post	2 Post	3 Post	1 Post	2 Post	3 Post
16.5	6.48	12.96	10.44	20.88	31.32	13.16	26.32	39.48	18.78	37.56	56.34	23.04	46.08	69.12
16	6.68	13.36	10.76	21.52	32.28	13.57	27.14	40.71	19.36	38.72	58.08	23.75	47.5	71.25
15.5	6.9	13.8	11.11	22.22	33.33	14.01	28.02	42.03	19.99	39.98	59.97	24.52	49.04	73.56
15	7.13	14.26	11.48	22.96	34.44	14.48	28.96	43.44	20.65	41.3	61.95	25.34	50.68	76.02
14.5	7.37	14.74	11.87	23.74	35.61	14.98	29.96	44.94	21.36	42.72	64.08	26.22	52.44	78.66
14	7.64	15.28	12.3	24.6	36.9	15.51	31.02	46.53	22.13	44.26	66.39	27.15	54.3	81.45
13.5	7.92	15.84	12.75	25.5	38.25	16.09	32.18	48.27	22.95	45.9	68.85	28.16	56.32	84.48
13	8.22	16.44	13.24	26.48	39.72	16.7	33.4	50.1	23.83	47.66	71.49	29.23	58.46	87.69
12.5	8.55	17.1	13.77	27.54	41.31	17.37	34.74	52.11	24.78	49.56	74.34	30.41	60.82	91.23
12	8.91	17.82	14.35	28.7	43.05	18.1	36.2	54.3	25.82	51.64	77.46	31.68	63.36	95.04
11.5	9.3	18.6	14.97	29.94	44.91	18.88	37.76	56.64	26.94	53.88	80.82	33.05	66.1	99.15
11	9.72	19.44	15.65	31.3	46.95	19.74	39.48	59.22	28.16	56.32	84.48	34.55	69.1	103.65
10.5	10.18	20.36	16.4	32.8	49.2	20.68	41.36	62.04	29.5	59	88.5	36.2	72.4	108.6
10	10.69	21.38	17.22	34.44	51.66	21.72	43.44	65.16	30.98	61.96	92.94	38.01	76.02	114.03
9.5	11.25	22.5	18.12	36.24	54.36	22.86	45.72	68.58	32.61	65.22	97.83	40.01	80.02	120.03
9	11.88	23.76	19.13	38.26	57.39	24.13	48.26	72.39	34.42	68.84	103.26	42.23	84.46	126.69
8.5	12.58	25.16	20.26	40.52	60.78	25.55	51.1	76.65	36.45	72.9	109.35	44.72	89.44	134.16
8	13.36	26.72	21.52	43.04	64.56	27.14	54.28	81.42	38.72	77.44	116.16	47.51	95.02	142.53

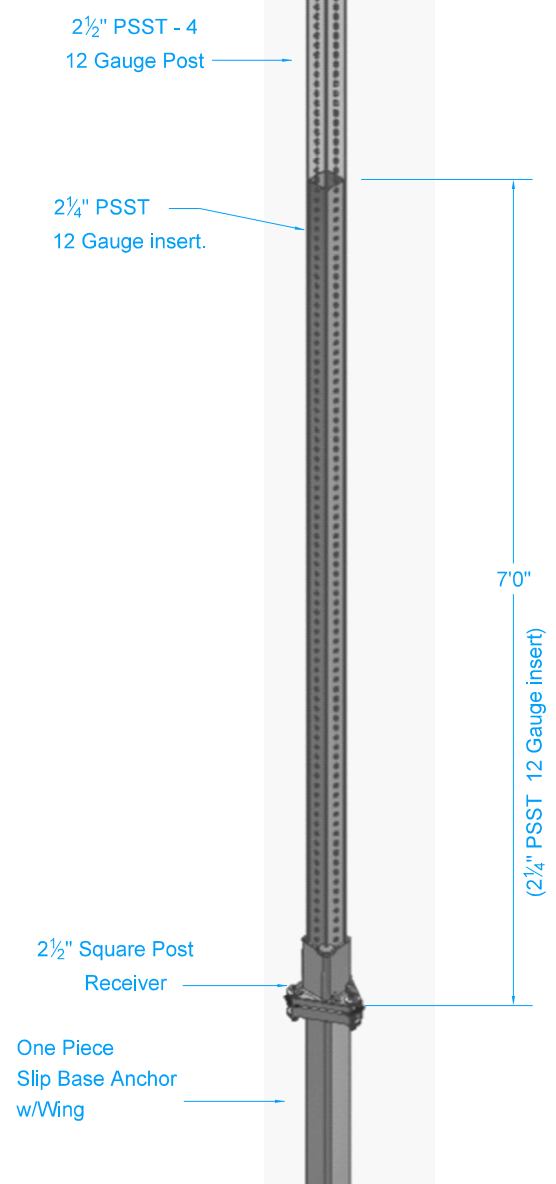

\* NESTING DETAIL FOR PERFORATED SQUARE STEEL TUBE POST

Post Code	a1	a2	b1	b2	b3	c1	c2	c3	d1	d2	d3	e1	e2	e3
-----------	----	----	----	----	----	----	----	----	----	----	----	----	----	----

\* SEE NESTING DETAIL

	REVISION
	- 00-00-00
TAS STANDARD	

REVISION: \_\_

Perforated Square Steel Tube Anchor and Post

NOTE: FASTENER SIZE AND INSTALLATION PROCEDURE SHALL BE ACCORDING TO MANUFACTURER'S RECOMMENDATION.

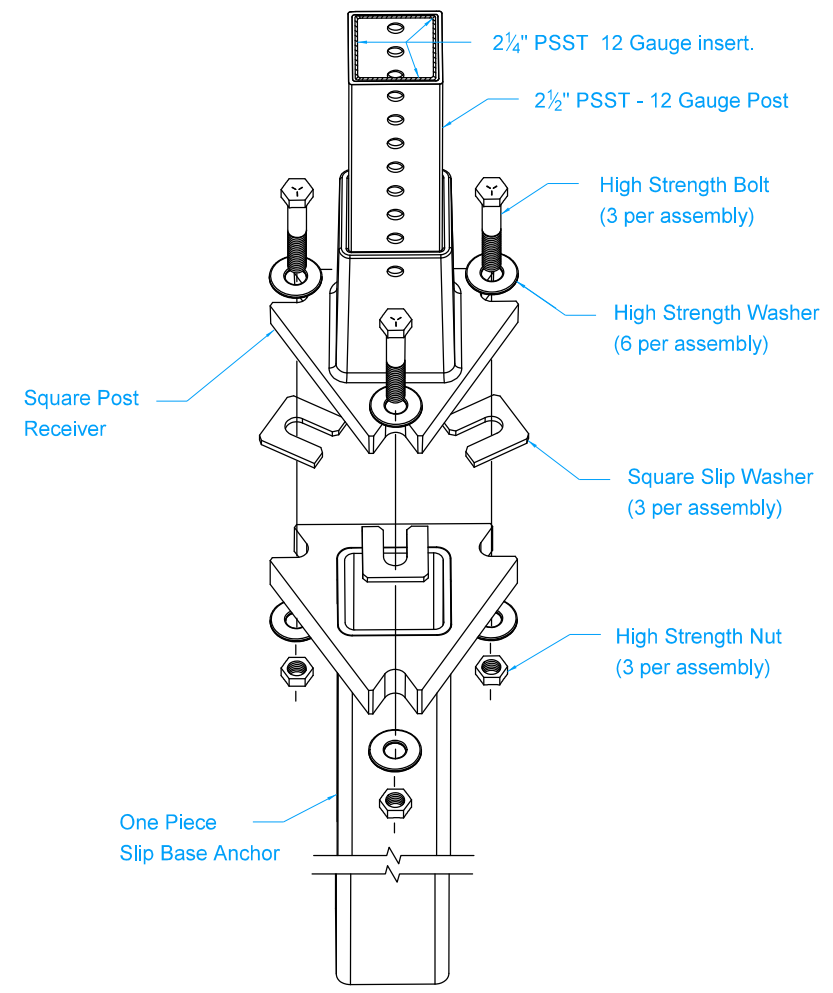

EXPLODED VIEW  
SLIP BASE, RECEIVER AND  
CONNECTION HARDWARE

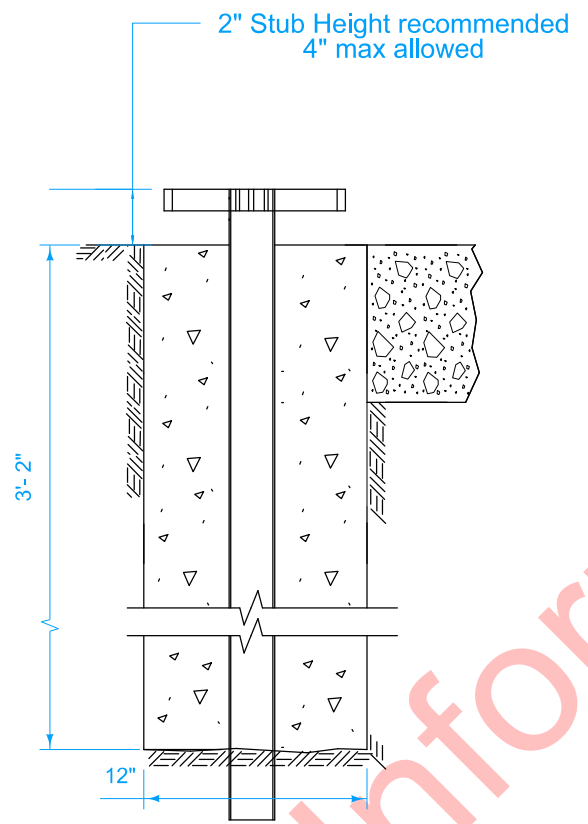

SLIP BASE ANCHOR  
FOOTING DETAIL

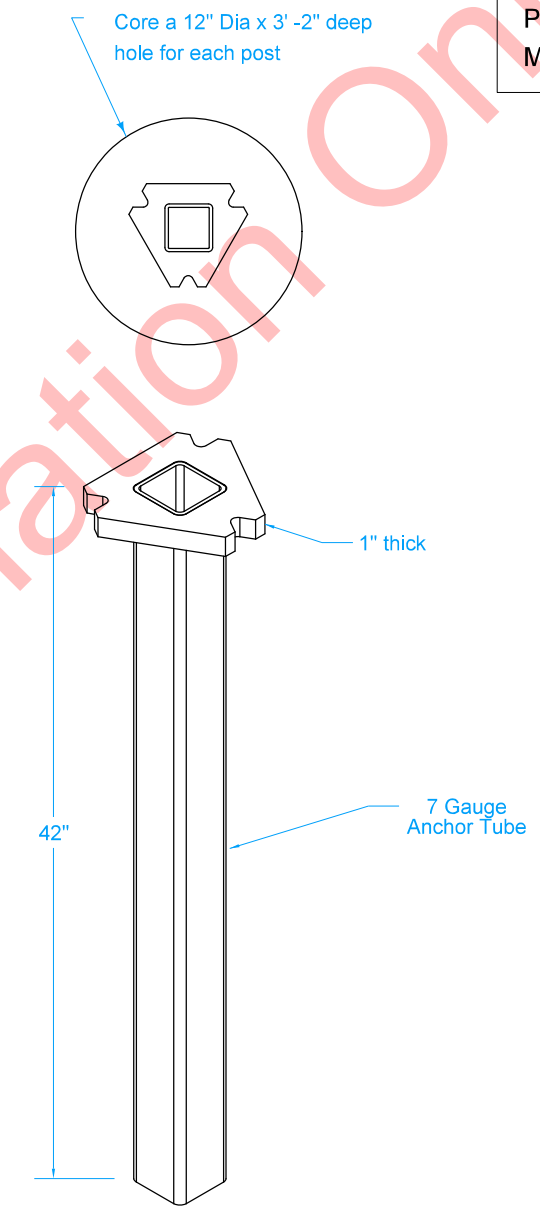

ONE PIECE  
SLIP BASE ANCHOR

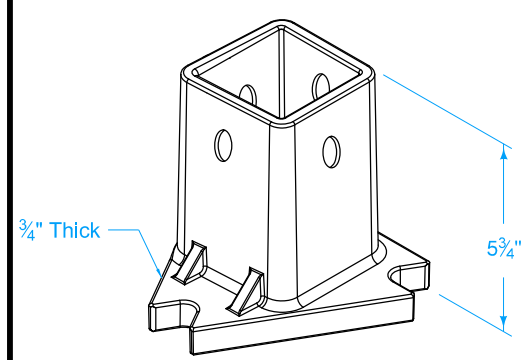

2-1/2" SQUARE POST  
RECEIVER

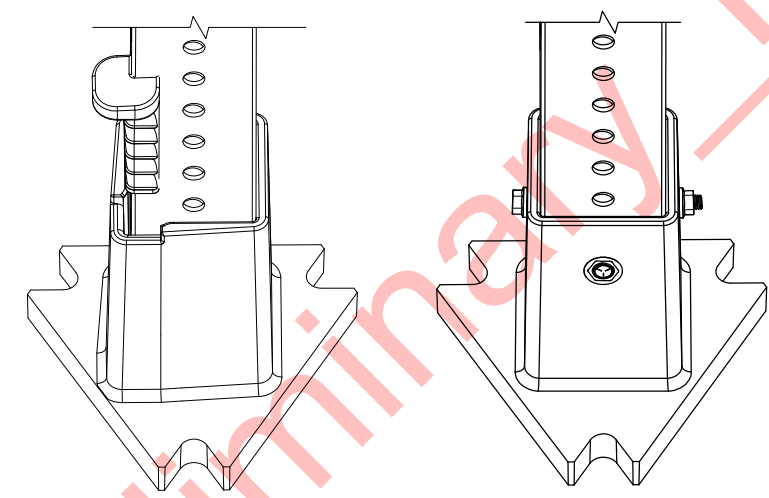

POST CONNECTION OPTIONS

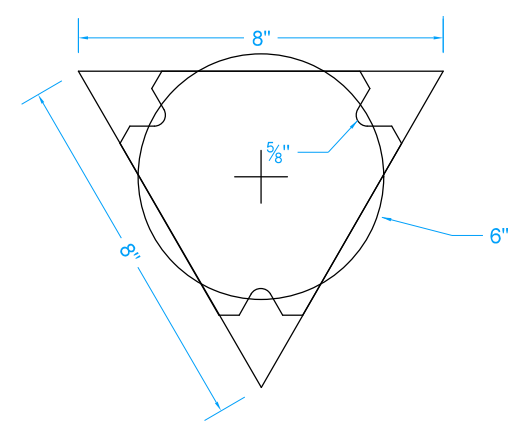

SLIP PLATE DIMENSIONS

DETAILS OF  
PERFORATED SQUARE STEEL TUBE POST TRIANGULAR SLIP BASE

	REVISION	00-00-00
	TAS STANDARD	
REVISION: _		
<b>Perforated Square Steel Tube Anchor and Post</b>		



2½" PSST - 12 Gauge Post

2¼" PSST 12 Gauge Insert

2½" SQUARE POST RECEIVER

ONE PIECE SLIP BASE ANCHOR

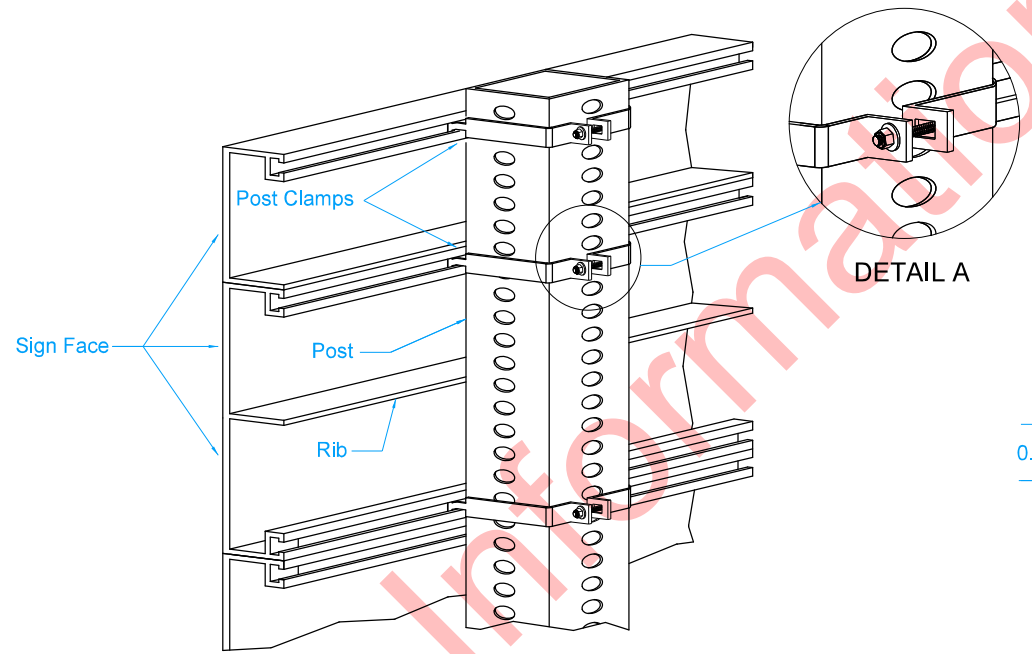

Sign Face

Post

Rib

Post Clamps

DETAIL A

7'-0"

(2¼" PSST 12 Gauge insert)

Install post clamps at top and bottom of the sign, and at each joint for each post.

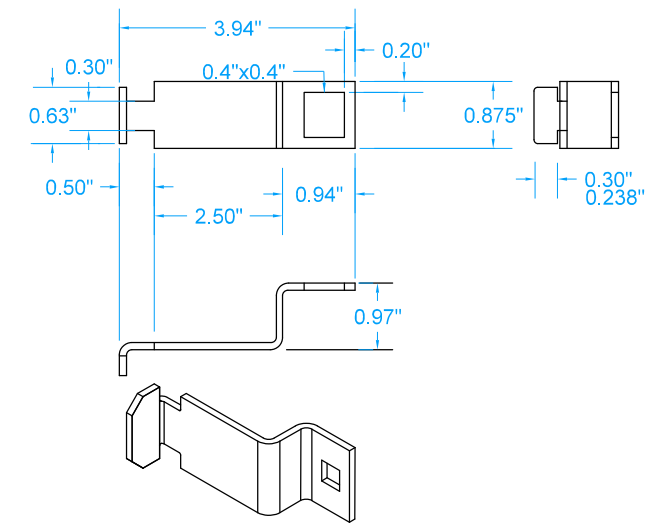

POST CLAMP DETAIL

Post clamp shall be stainless.

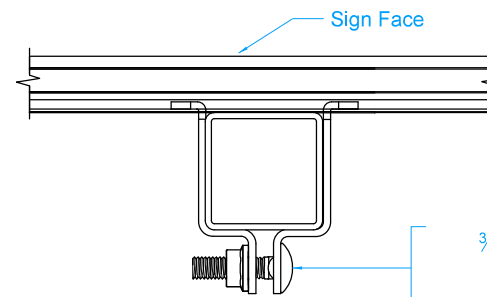

PLAN VIEW

¾" x 16 x 2" Carriage Bolt and Serated Flange Nut  
Bolt and Nut shall be stainless steel

DETAILS OF PERFORATED SQUARE STEEL TUBE POST TYPE "B" SIGN ATTACHMENT

SLIP BASE WITH INSERTED PERFORATED SQUARE STEEL TUBE POST

	REVISION	
	-	00-00-00
---	---	
TAS STANDARD		
REVISION: _		
Perforated Square Steel Tube Anchor and Post		

**ESTIMATED PROJECT QUANTITIES  
(UP TO A 5 DIVISION PROJECT)**

Item No.	Item Code	Item	Unit	Quantities												
				Estimated					As Built							
				Division 1	Division 2	Division 3	Division 4	Division 5	Total	Division 1	Division 2	Division 3	Division 4	Division 5		
1	2102-0425071	SPECIAL BACKFILL	CY	884.5							884.5					
2	2401-6745357	REMOVAL OF CONCRETE FOUNDATIONS, AS PER PLAN	EACH	27							27					
3	2401-6745916	REMOVAL OF SIGN SUPPORT STRUCTURE AND FOUNDATION	EACH	11							11					
4	2402-2720000	EXCAVATION, CLASS 20	CY	4468							4468					
5	2403-0100000	STRUCTURAL CONCRETE (MISCELLANEOUS)	CY	1,098.2							1,098.2					
6	2404-7775005	REINFORCING STEEL, EPOXY COATED	LB	185825							185825					
7	2423-0001010	DYNAMIC MESSAGE SIGN (D.M.S.) INSTALLATION	EACH	1							1					
8	2423-1051320	STEEL CANTILEVER SIGN TRUSS, 32 FT. ARM	EACH	1							1					
9	2423-1051360	STEEL CANTILEVER SIGN TRUSS, 36 FT. ARM	EACH	2							2					
10	2423-1051380	STEEL CANTILEVER SIGN TRUSS, 38 FT. ARM	EACH	3							3					
11	2423-1051400	STEEL CANTILEVER SIGN TRUSS, 40 FT. ARM	EACH	6							6					
12	2423-1060075	STEEL OVERHEAD SIGN TRUSS, 75 FT. SPAN	EACH	1							1					
13	2423-1060085	STEEL OVERHEAD SIGN TRUSS, 85 FT. SPAN	EACH	1							1					
14	2423-1060090	STEEL OVERHEAD SIGN TRUSS, 90 FT. SPAN	EACH	1							1					
15	2423-1060095	STEEL OVERHEAD SIGN TRUSS, 95 FT. SPAN	EACH	1							1					
16	2423-1060100	STEEL OVERHEAD SIGN TRUSS, 100 FT. SPAN	EACH	3							3					
17	2423-1060105	STEEL OVERHEAD SIGN TRUSS, 105 FT. SPAN	EACH	5							5					
18	2423-1060130	STEEL OVERHEAD SIGN TRUSS, 130 FT. SPAN	EACH	1							1					
19	2524-6765010	REMOVE AND REINSTALL SIGN AS PER PLAN	EACH	38							38					
20	2524-6765110	REMOVAL OF TYPE A SIGN	EACH	110							110					
21	2524-6765120	REMOVAL OF TYPE B SIGN	EACH	86							86					
22	2524-9081275	CONCRETE FOOTING FOR BREAKAWAY SIGN POST, 2'-8" DIA. X 7'-6"	EACH	18							18					
23	2524-9081290	CONCRETE FOOTING FOR BREAKAWAY SIGN POST, 2'-8" DIA. X 9'-0"	EACH	25							25					
24	2524-9089100	DELINEATOR, RIGID - TYPE I	EACH	0							0					
25	2524-9089110	DELINEATOR, RIGID - TYPE IA	EACH	0							0					
26	2524-9089200	DELINEATOR, RIGID - TYPE II	EACH	0							0					
27	2524-9210007	REFERENCE LOCATION SIGNS	EACH	0							0					
28	2524-9276010	PERFORATED SQUARE STEEL TUBE POSTS	LF	0.0							0.0					
29	2524-9276021	PERFORATED SQUARE STEEL TUBE POST ANCHOR, BREAK-AWAY SOIL IN STALLATION	EACH	0							0					
30	2524-9276027	PERFORATED SQUARE STEEL TUBE POST ANCHOR, TRIANGULAR SLIP BA SE ASSEMBLY	EACH	0							0					
31	2524-9278046	STEEL BREAKAWAY SIGN POSTS, RECTANGULAR TUBE, 4" X 6"	LF	58.2							58.2					
32	2524-9281210	STEEL BREAKAWAY SIGN POSTS FOR TYPE A OR B SIGNS, W 8 X 21	LF	283.7							283.7					
33	2524-9281426	STEEL BREAKAWAY SIGN POSTS FOR TYPE A OR B SIGNS, W 12 X 26	LF	573.8							573.8					
34	2524-9290009	SIGN MOUNTING BRACKETS, SPECIAL	EACH	1							1					
35	2524-9325001	TYPE A SIGNS, SHEET ALUMINUM	SF	1292							1292					
36	2524-9380001	TYPE B SIGNS, EXTRUDED ALUMINUM STRUCTURAL PANEL	SF	15328							15328					
37	2528-8445110	TRAFFIC CONTROL	LS	1.00							1.00					
38	2555-0000010	DELIVER AND STOCKPILE SALVAGED MATERIALS	LS		1.00						1.00					
39	2599-9999005	('EACH' ITEM) ANCHOR BOLT ASSEMBLY- INSTALL AND SURVEY	EACH	64							64					
40	2599-9999008	('POUNDS' ITEM) ANCHOR BOLT ASSEMBLY - FURNISH	LB	45155							45155					

100-4A  
10-29-02

**ESTIMATE REFERENCE INFORMATION**

Item No.	Item Code	Description
1	2102-0425071	SPECIAL BACKFILL
-	-	-
2	2401-6745357	REMOVAL OF CONCRETE FOUNDATIONS, AS PER PLAN
-	-	-
3	2401-6745916	REMOVAL OF SIGN SUPPORT STRUCTURE AND FOUNDATION Refer to Tabulation 190-62 for location and details.
		This item shall consist of removal of Type B Sign Support Structures and Foundations from the project.
		Each of the following is to be considered a Type B Sign Support Structure: - Overhead sign truss and foundations - Cantilevered sign truss and foundations - Bridge mounted brackets - Monotube sign structure and foundations - Mastarm sign structure and foundation
		The Contractor shall remove each sign support structure identified in the plans. Unless otherwise noted, all sign support structures or parts of sign support structures to be removed shall become property of the Contractor.
		Sign support structures which may be reused shall be match marked, dismantled, and stored as designated in the plans. Dismantling and handling shall be done in such a way to not impair strength or usefulness of the material. All loose parts shall be wired to adjacent members or packed in suitable containers. Dismantled members shall be stored in neat piles at locations specified in the plans or within the right-of-way in the vicinity of the work at points designated by the Engineer.
		When provided in the plans, the Contractor shall deliver the sign support structure to be reused to a DOT

100-4A  
10-29-02

**ESTIMATE REFERENCE INFORMATION**

Item No.	Item Code	Description
		storage area within 50 miles, as designated by the Engineer.
		Unless otherwise provided or ordered, concrete foundations for sign support structures shall be removed 1 foot below natural ground surface. Where portions of the existing concrete foundations lie wholly or in part within the limits for a new structures (culvert, concrete foundation, or other), they shall be removed as necessary to accommodate construction of the proposed structure.
		Holes remaining from the removal of concrete foundations for sign support structures shall be backfilled with suitable earth to the original level or to the natural ground surface in accordance with Article 2402.09.
		Measurement: The Engineer will count each Type B Sign Structure removed
		Payment: For each Type B Sign Support Structure removed, the Contractor shall be paid the contract unit price. This payment shall be full compensation for furnishing all material, equipment, and labor and for performance of all work necessary for removal of the Type B Sign Support Structure from the project and for any backfilling made necessary by these operations.
4	2402-2720000	EXCAVATION, CLASS 20 Refer to Tabulation 190-52 for locations and details.
5	2403-0100000	STRUCTURAL CONCRETE (MISCELLANEOUS)
6	2404-7775005	REINFORCING STEEL, EPOXY COATED Refer to Tabulation 190-52 and the "V" sheets for locations and details.
7	2423-0001010	DYNAMIC MESSAGE SIGN (D.M.S.) INSTALLATION Refer to Tabulation 190-52 and Steel Overhead Sign Truss (SOST) standard drawings for more information.
		Work shall consist of furnishing all labor, equipment, and materials to construct and install

**ESTIMATE REFERENCE INFORMATION**

Item No.	Item Code	Description
		Dynamic Message Sign (DMS), generally including, but not limited to: - Attachment of the DMS to the support structure. - Installation of the conduit between the sign support structure foundation and the RM-42 Handhole. - Transport DMS and associated appurtenances from storage area.
		The following items will be provided by the DOT or the DMS vendor: DMS, DMS-to-sign support structure attachment, and hardware.
		Existing station markers or delineators which may be impacted by the proposed construction shall be removed prior to starting work and replaced when construction is complete. The Contractor shall assume full responsibility for the DOT furnished materials prior to accessing them. This assumption of responsibility shall be documented with an itemized invoice clearly identifying each item and shall be signed and dated by the Contractor and the Engineer. Lacking a signed invoice, the default date of assumption of responsibility for these materials shall be the date the contract between the DOT and the Contractor is signed. Upon the assumption of responsibility for any and all materials, the Contractor shall be wholly liable for safe handling, storage, and installation of the equipment. Any damaged equipment shall be replaced at the Contractor's expense, without additional compensation.
		Contact the Resident Construction Engineer for the storage location of DMS and related equipment.
		Method of Measurement: By count.
		Basis of Payment: The Contractor shall be paid the contract unit price for each Dynamic Message Sign (D.M.S.) installed. This payment shall be considered full compensation for furnishing all material, equipment (except as noted above) and labor, and for the performance of all work necessary, including transport of all provided materials from their present location, to provide DMS installation.
8	2423-1051320	STEEL CANTILEVER SIGN TRUSS, 32 FT. ARM
9	2423-1051360	STEEL CANTILEVER SIGN TRUSS, 36 FT. ARM
10	2423-1051380	STEEL CANTILEVER SIGN TRUSS, 38 FT. ARM
11	2423-1051400	STEEL CANTILEVER SIGN TRUSS, 40 FT. ARM Actual cantilever arm length shall be 39'-6 instead of 40'-0
12	2423-1060075	STEEL OVERHEAD SIGN TRUSS, 75 FT. SPAN
13	2423-1060085	STEEL OVERHEAD SIGN TRUSS, 85 FT. SPAN
14	2423-1060090	STEEL OVERHEAD SIGN TRUSS, 90 FT. SPAN
15	2423-1060095	STEEL OVERHEAD SIGN TRUSS, 95 FT. SPAN
16	2423-1060100	STEEL OVERHEAD SIGN TRUSS, 100 FT. SPAN
17	2423-1060105	STEEL OVERHEAD SIGN TRUSS, 105 FT. SPAN
18	2423-1060130	STEEL OVERHEAD SIGN TRUSS, 130 FT. SPAN Refer to Tabulation 190-52 for locations and details.
		For fabrication and installation of steel overhead sign truss, refer to SOST series standards for dimensions and details. These items shall be constructed as per section 2423 of the Standard Specifications.
19	2524-6765010	REMOVE AND REINSTALL SIGN AS PER PLAN Refer to Tabulations 190-50 and 190-62.
		The Contractor shall remove each sign and the hardware used to secure the sign to another sign, posts, or sign support structure. For signs mounted directly to posts, removal of the sign shall include removal of the posts. Posts may be either wood posts or steel breakaway sign posts. The removal of concrete footings for steel breakaway sign posts will be measured and paid for separately.
		Holes remaining from the removal of wood posts shall be backfilled with suitable earth to the original level or to the natural ground surface in accordance with Article 2402.09 of the Standard Specifications. All steel posts removed shall become the property of the Contractor. Unless otherwise noted, wood posts removed shall remain the property of DOT. The Contractor shall deliver the wood posts to a DOT storage area within 50 miles, as designated by the Engineer.
		**The existing sign shall be removed and stored. The Contractor shall remove the sign and transport it to a DOT storage area within 50 miles, as designated by the Engineer. The Contractor shall transport the sign back to the job site when ready for reinstallation.
		The Contractor shall furnish all necessary hardware to install the signs. When the new installation is similar to the original installation, unless otherwise noted, the existing hardware may be used to reinstall the sign.
		Signs damaged by the Contractor's activities shall be replaced at the Contractor's expense. Replacement materials shall be new. The DOT will furnish all details necessary for fabrication of the replacement materials.
		METHOD OF MEASUREMENT: The Engineer will count each sign removed and reinstalled.
		BASIS OF PAYMENT: For each sign removed and reinstalled, the Contractor shall be paid the contract unit price.
20	2524-6765110	REMOVAL OF TYPE A SIGN Refer to Tabulation 190-62 for location and details.

**ESTIMATE REFERENCE INFORMATION**

Item No.	Item Code	Description
		Item is for the removal of sheet aluminum, galvanized sheet or plywood sign panel from its support structure ie: wood/steel posts, overhead truss or another sign.
		Measurement: Each. The Engineer will count the number of Type A sign panels removed.
		Payment: The Contractor will be paid the contract unit price for each Type A sign panel removed.
21	2524-6765120	REMOVAL OF TYPE B SIGN Refer to Tabulation 190-62 for location and details.
		Item is for the removal of extruded aluminum structural panel from its support structure ie: wood/steel posts, overhead truss or other sign.
		Measurement: Each. The Engineer will count the number of Type B sign panels removed.
		Payment: The Contractor will be paid the contract unit price for each Type B sign panel removed.
22	2524-9081275	CONCRETE FOOTING FOR BREAKAWAY SIGN POST, 2'-8" DIA. X 7'-6"
23	2524-9081290	CONCRETE FOOTING FOR BREAKAWAY SIGN POST, 2'-8" DIA. X 9'-0" Refer to Tabulation(s) 190-50 (and 190-51) for details.
24	2524-9089100	DELINEATOR, RIGID - TYPE I
25	2524-9089110	DELINEATOR, RIGID - TYPE IA
26	2524-9089200	DELINEATOR, RIGID - TYPE II Refer to Tabulation 190-25 for locations and details.
		Removal of existing delineators and mileposts shall be incidental.
27	2524-9210007	REFERENCE LOCATION SIGNS
28	2524-9276010	PERFORATED SQUARE STEEL TUBE POSTS
29	2524-9276021	PERFORATED SQUARE STEEL TUBE POST ANCHOR, BREAK-AWAY SOIL IN STALLATION
30	2524-9276027	PERFORATED SQUARE STEEL TUBE POST ANCHOR, TRIANGULAR SLIP BASE ASSEMBLY Refer to Tabulation(s) 190-50 and/or 190-51 for locations and details.
31	2524-9278046	STEEL BREAKAWAY SIGN POSTS, RECTANGULAR TUBE, 4" X 6" Refer to Tabulation 190-51 for locations and details.
32	2524-9281210	STEEL BREAKAWAY SIGN POSTS FOR TYPE A OR B SIGNS, W 8 X 21
33	2524-9281426	STEEL BREAKAWAY SIGN POSTS FOR TYPE A OR B SIGNS, W 12 X 26 Refer to Tabulation 190-50 for locations and details.
34	2524-9290009	SIGN MOUNTING BRACKETS, SPECIAL Refer to Tabulation 190-51 for locations and details.
		Measurement: Each.
		Payment: The Contractor will be paid the contract unit price for each sign mounting bracket furnished and installed.
35	2524-9325001	TYPE A SIGNS, SHEET ALUMINUM Refer to Tabulation 190-51 and 190-66 for locations and details.
36	2524-9380001	TYPE B SIGNS, EXTRUDED ALUMINUM STRUCTURAL PANEL Refer to Tabulation 190-50 for locations and details.
37	2528-8445110	TRAFFIC CONTROL
38	2555-0000010	DELIVER AND STOCKPILE SALVAGED MATERIALS
39	2599-9999005	('EACH' ITEM) ANCHOR BOLT ASSEMBLY- INSTALL AND SURVEY See Tab 190-52 for locations and details. For accurately installing and surveying anchor bolt assemblies: Measurement: The Engineer shall count Each Anchor Bolt Assembly installed and surveyed. Payment: The Contractor shall be paid the contract unit price for each Anchor Bolt Assembly installed and Surveyed.
40	2599-9999008	('POUNDS' ITEM) ANCHOR BOLT ASSEMBLY - FURNISH See Tab 190-52 for locations and details. For furnishing anchor bolt assemblies: Measurement: The Engineer shall count each Anchor Bolt Assembly. Furnished Payment: The Contractor Shall be paid the contract unit price for each Anchor Bolt Assembly Furnished.

REMOVAL OF EXISTING STRUCTURES			110-2 04-16-13
Location	Description	Remarks	
STA. 566+33.75	SOST 55' Truss	SUR080 (STAGE 2A)	
STA. 665+50	SCST 34' Cantilever	SUR080 (STAGE 2A)	
STA. 1160+92.61	SCST 34' Cantilever	ML380 (STAGE 2A)	
STA. 643+30.24	SOST 85' Truss	SUR080 (STAGE 2C)	
STA. 645+80.29	SOST 85' Truss	SUR080 (STAGE 2C)	
STA. 704+99.45	SOST 90' TRUSS (Not including Median foundation)	SUR080 (STAGE 2D)	
STA. 605+00	SCST 39.5' Cantilever	SUR080 (STAGE 3E)	
STA. 611+50	SCST 39.5' Cantilever	SUR080 (STAGE 3E)	
STA. 680+00	SCST 39.5' Cantilever	SUR080 (STAGE 3E)	

INDEX OF TABULATIONS			111-25 10-18-11
Tabulation	Tabulation Title	Sheet No.	
C Sheets			
100-1C	ESTIMATED PROJECT QUANTITIES (UP TO A 5 DIVISION PROJECT)	C.1	
100-4A	ESTIMATE REFERENCE INFORMATION	C.1 - C.2	
105-4	STANDARD ROAD PLANS	C.3	
110-2	REMOVAL OF EXISTING STRUCTURES	C.3	
110-13	DELIVERY AND STOCKPILING	C.3	
111-25	INDEX OF TABULATIONS	C.3	
190-01	SIGN SUPPORT STRUCTURES	C.9	
190-25	REFERENCE LOCATION SIGNS AND DELINEATORS	C.12	
190-50	MATERIALS FOR TYPE 'B' SIGNS	C.5 - C.6	
190-51	MATERIALS FOR TYPE 'A' SIGNS	C.7 - C.8	
190-52	MATERIALS FOR OVERHEAD SIGN SUPPORT STRUCTURES	C.8	
190-61	EXISTING SIGNS TO BE REINSTALLED	C.9 - C.10	
190-62	REMOVAL OF TYPE A/B SIGN ASSEMBLIES	C.10 - C.11	
190-65	SPECIAL SIGN MOUNTING BRACKETS	C.12	
190-66	SUMMARY OF TYPE 'A' SIGNS	C.12	
259-01	SIGNING NOTES	C.4	

DELIVERY AND STOCKPILING						110-13 04-20-10
Item Description	Quantity	Units	Delivery Location	Contact Name & Number	Remarks	
Removed Type A Signs	1	Each	2600 Coral Ridge Ave. Coralville, IA 52241	Tim Zeimet (319-626-2386)		

STANDARD ROAD PLANS			105-4 10-18-11
The following Standard Road Plans apply to construction work on this project.			
Number	Date	Title	
SI-101	04-19-16	Locations - Type 'A' Signs	
SI-102	04-19-16	Locations - Type 'B' Signs	
SI-112	04-19-16	Footings For Steel Breakaway Posts	
SI-113	10-15-19	Support Structures - Steel Breakaway Posts	
SI-114	04-19-16	Support Structures - Steel Breakaway Posts Rectangular Tube	
SI-119	10-17-17	Support Structures - Mounting Brackets	
SI-121	10-16-18	Fabrication - Sign Legend Components	
SI-123	04-19-16	Fabrication - Type 'B' Signs	
SI-131	10-18-16	Installation - Type 'A' Signs	
SI-132	04-17-18	Installation - Type 'B' Signs	
SI-133	10-17-17	Installation - Type "A" Sign Shim	
SI-171	04-18-17	Reference Location Sign Posts	
SI-172	04-19-16	Delineators	
SI-173	04-19-16	Object Markers	
TC-1	10-15-19	Work Not Affecting Traffic (Two-Lane or Multi-Lane)	
TC-202	04-21-15	Work Within 15 ft of Traveled Way	
TC-402	04-21-15	Work Within 15 ft of Traveled Way	

### SIGNING NOTES

The following tolerances will be allowed on all signs:

Accumulation error of not greater than +/-0.50" per line of copy, not greater than +/-0.50" for spacing between lines of copy, and the margin between lines of copy and the inside edge of the sign border.

The following tolerances will be allowed on each letter or numeral:

nominal height	variation in height	variation in width
4" thru 12"	-1/8" to +3/8"	-1/4" to +1/4"
over 12"	-1/8" to +3/8"	-3/8" to +3/8"

Type B signs can be separated into two categories:

- Major Guide Signs.
- Minor Guide Signs.

Major Guide Signs include the advance and exit direction guide signs for an interchange or intersection.

Minor Guide Signs include all other guide signs such as NEXT EXIT signs, supplemental guide signs, logo signs, exit gore signs, post-interchange mileage signs, ramp destination signs, and ramp logo signs for an interchange, as well as destination signs along sideroads.

Type A signs are not separated into categories, but special consideration should be given to regulatory signs.

Do not remove Type B signs until replacement signs have been installed. If construction activities require the removal of a sign, the existing sign may be relocated to temporary posts, or a temporary plywood sign may be installed to replace the existing sign.

Existing non-regulatory Type A signs are NOT required to remain in place until installation of replacement signs. Existing regulatory Type A signs, particularly Stop signs, should not be removed until replacement signs are installed. This guideline may not apply if the traffic control plans have sufficient temporary signing.

Apply the following during the replacement or modification of signs:

- No more than one of the major guide signs for each direction of travel at an interchange out of service at any one time.
- No major guide sign out of service for more than 8 hours.
- No minor guide out of service for more than 24 hours.

Remove existing signs and posts within 24 hours following the installation of a new replacement sign.

In any case where the plans call for a new sign and posts to be installed at the same station location and offset as an existing sign, install the new posts at a minimum of either 5 ft ahead or behind the existing sign installation. Whenever posts for a replacement sign are erected directly in front of an existing sign, install the new replacement sign and remove the existing sign installation within 24 hours of the time that the new posts are erected.

Where signs are located behind guardrail, locate the near edge of the sign a minimum of 3 ft behind the guardrail posts. The Engineer may approve reducing this distance to a minimum of 1 ft where field conditions warrant.

Unless noted otherwise, leave auxiliary panels, such as exit number panels, in place or reattach to the sign using the existing mounting hardware. Also, when replacing an existing logo sign with a new logo sign, remove the business logo panel(s) from the existing sign and attach to the new sign as directed by the Engineer. Do not damage the auxiliary or logo panels when removing and reattaching them. This work is incidental to other work and no separate payment will be made.

### SIGNING NOTES

The following notes apply to the corresponding sign installations shown on the plan sheets and listed in the tabulations.

- IB INSTALL NEW TYPE B SIGN
- IA INSTALL NEW TYPE A SIGN

Install new signs at the location identified in the plans.

For installation of new signs on existing posts:

- if the new sign is taller than the existing sign, furnish the necessary hardware to extend the sign above the posts. Refer to Standard Road Plan SI-132.
- if the new sign is shorter than the existing sign:
  - for wood posts and perforated square tube posts, install the sign at the proper height and cut off the excess post length.
  - for steel posts, install the sign at the top of the posts.

For installation of new signs on an existing sign support structure, refer to note (L).

Payment for installing Type A signs or Type B signs includes furnishing hardware for mounting, extending signs above existing posts, and cutting off wood posts.

- MS MODIFY EXISTING SIGN

Modify the copy on the existing sign as shown in the plans.

Deliver existing copy which is removed to a DOT storage area within 50 mi, as designated by the Engineer.

Install the new copy as needed to make sign modifications.

Payment for Modification of Existing Sign includes removal of existing copy and installation of new copy.

- MB INSTALL SPECIAL MOUNTING BRACKET

Install special mounting brackets at the locations identified in the plans. Refer to Tabulations 190-10, 190-51, and/or 190-65.

- PW INSTALL NEW WOOD POSTS
- PB INSTALL NEW BREAKAWAY STEEL POSTS AND FOOTING
- PP INSTALL NEW PERFORATED SQUARE TUBE POSTS AND ANCHORS

Install new wood posts, breakaway steel posts and footings, or perforated square tube posts and anchors at the locations indicated in the plans. Refer to Tabulations 190-51 and 190-50 for post size and footing information.

If note (RR) accompanies (PW), (PB), or (PP), install an existing sign on the new posts.

- RR REMOVE AND REINSTALL SIGN:

Do not remove existing major Type B guide signs on posts until the new posts are installed. Promptly remove sign and install at the new location.

Existing major Type B guide signs on overhead support structures, minor Type B guide signs, plywood signs, and Type A signs may be removed and stored. Transport the signs to a DOT storage area within 50 mi, as designated by the Engineer. Transport the signs back to the job site when ready for installation at the new location.

Replace signs damaged by the Contractor's activities at no additional cost to the Contracting Authority.

Payment for Remove and Reinstall Sign includes sign removal, delivery to the DOT storage area (if applicable), and reinstallation.

- RA REMOVE TYPE A SIGN ASSEMBLY
- RB REMOVE TYPE B SIGN ASSEMBLY

Type A Sign Assembly consists of one or more signs installed on one or more wood posts, either directly mounted to the post or mounted to the post with special sign mounting brackets.

### SIGNING NOTES

Type B Sign Assembly consists of the main sign, all auxiliary signs and brackets, and the wood or steel posts.

Unless stated otherwise in the plans, remove all posts with the signs and brackets.

Remove each sign assembly identified in the plans. Sign posts removed become the property of the Contractor. All other materials removed remain the property of the DOT.

Disassemble each sign assembly removed before delivering to the DOT. For Type A sign assemblies, unbolt all signs, special mounting brackets, and posts from each other. For Type B assemblies, unbolt all extruded aluminum panels, brackets, and posts from each other. Do not damage the disassembled materials.

Place backfill in holes remaining from the removal of wood posts and restore to the normal surrounding conditions.

Deliver the removed signs, special sign mounting brackets, and extruded aluminum panels to a DOT storage area within 50 mi, as designated by the Engineer.

The concrete footings for steel posts are not considered part of the sign assembly. Refer to note RF for concrete footing removal.

Payment for Removal of Type A Sign Assembly or Removal of Type B Sign Assembly includes sign assembly removal and disassembly, post removal (if applicable), delivery to the DOT storage area, placing backfill in holes, and restoration of the surrounding conditions.

- RF REMOVE EXISTING CONCRETE FOOTING FOR STEEL POST

Remove existing concrete footings to a depth of 1 ft below ground. Place backfill in holes remaining from removal and restore to the normal surrounding conditions. This work is incidental to other work and no separate payment will be made.

- RS REMOVE EXISTING TYPE B SIGN SUPPORT STRUCTURE

The following are considered Type B Sign Support Structures:

- Overhead sign truss and foundation,
- Cantilevered sign truss and foundation, or
- Bridge mounted brackets.

For removal purposes, wood and steel post are not considered Type B Support Structures.

Unless stated otherwise in the plans, existing overhead trusses, cantilevered trusses, and bridge brackets which are removed become the property of the Contractor. If stated in the plans, deliver overhead trusses, cantilevered trusses, and bridge brackets to a DOT storage area within 50 mi, as designated by the Engineer.

Payment for Removal of Sign Support Structure and Foundation includes sign support structure removal, delivery to the DOT storage area (if applicable), and restoration of the surrounding conditions.

- L MODIFY SIGN SUPPORT ANGLES NEEDED TO INSTALL SIGNS ON EXISTING SIGN SUPPORTS STRUCTURES

Refer to the sign support structure details for information on the required angle brackets.

Provided all specifications are met, the existing sign support angles may be reused. Install existing sign support angles to be reused only on the sign support structure from which they were removed.

Sign support angles removed and not reused become the property of the Contractor.

When reusing the existing sign support angles with a shorter replacement sign, the sign support angles may need to be trimmed. Refer to the sign support details to determine if and where to trim the sign support angles.

Do not use existing fasteners. Use new stainless steel bolts and nuts to install the existing or new sign support angles to the sign support structure.

### SIGNING NOTES

Removal of existing sign support angles is incidental to removal of the sign.

Reinstalling and/or modifying existing sign support angles; furnishing and installing new sign support angles (if required); and furnishing and installing new fasteners is incidental to work associated with Type B signs.

SIGN INSTALLATION QUALITY CONTROL NOTES

Post lengths have been derived from the proposed grading cross sections. Field verify post lengths.

Slight differences between the design template and the actual conditions should be expected. These variations should be resolved by doing some localized shaping and grading. Obtain material needed to meet the site requirements of SI-113 from the footing excavation and/or the area immediately adjacent to the footing. Ensure reshaping work does not substantially change foreslopes or the drainage in the vicinity of the sign.

Significant differences between the design template and the actual field conditions need to be resolved in this manner:

Survey the location and draw the actual template on the cross section. Recalculate each post length and compare to the maximum allowable leg length. If all of the maximum leg lengths are less than or equal to the maximum allowable leg length, then the proposed post design will be sufficient. If any leg is greater than the maximum allowable leg length, then submit the cross section with the actual template drawn (including offsets and elevation from the survey shown) to the Engineer. The Engineer may forward this information on to the design Engineer in order to complete a new post design.

Install the footings, stub posts, and posts according to the following tolerances:

- elevation difference from the edge of pavement to the bottom of the sign within 6 inches of the dimension shown.
- elevation difference of less than 2 inches between the top of the highest post and the lowest post at a site.

Footing construction is the controlling activity that substantially affects the quality of the site installation. Verify the elevation difference between the stubs is exactly the same as the elevation difference between the post lengths. If the Engineer requests, submit documentation detailing the site field shots in order to verify site installation.









MATERIALS FOR TYPE 'A' SIGNS

TYPE A SIGNING TYPICALS	SIGN NUMBER	DIR OF TRAVEL	SIGN LOCATION STATION	WOOD POSTS		PERFORATED SQUARE STEEL TUBE						Steel Rect. Tube			TYPE A SIGN MOUNTING BRACKETS					INSTALLATION			REMARKS		
				NO. OF POSTS	4 x 6		LEG 1 FT	LEG 2 FT	LEG 3 FT	ANCHOR			NO. OF POSTS	POST LENGTH FT	ANCHORS EACH	ONE POST BRACKET	TWO POST	AUXILIARY	H	F	F1	TYPE		DIM 'X' FT	SEE SIGNING NOTES
					FT	FT				CONC	SOIL	SLIPBASE													
	M3-2	EB	590+00	-	-	-	-	-	-	-	-	-	-	-	-	-	-	-	-	-	1	30	IA,PP	STAGE 3E	
	M1-1	EB	590+00	-	-	-	-	-	-	-	-	-	-	-	-	-	-	-	-	-	1	30	IA,PP	STAGE 3E	
	Conspicuity	EB	592+00	-	-	-	-	-	-	-	-	-	-	-	-	-	-	-	-	-	1	-12	IA,PP	STAGE 3E	
	Conspicuity	EB	592+00	-	-	-	-	-	-	-	-	-	-	-	-	-	-	-	-	-	1	-12	IA,PP	STAGE 3E	
	W3-5	EB	592+00	-	-	-	-	-	-	-	-	-	-	-	-	-	-	-	-	-	1	-12	IA,PP	STAGE 3E	
	Conspicuity	EB	603+00	-	-	-	-	-	-	-	-	-	-	-	-	-	-	-	-	-	1	-12	IA,PP	STAGE 3E	
	Conspicuity	EB	603+00	-	-	-	-	-	-	-	-	-	-	-	-	-	-	-	-	-	1	-12	IA,PP	STAGE 3E	
	R2-1	EB	603+00	-	-	-	-	-	-	-	-	-	-	-	-	-	-	-	-	-	1	-12	IA,PP	STAGE 3E	
	R2-4	EB	603+00	-	-	-	-	-	-	-	-	-	-	-	-	-	-	-	-	-	1	-12	IA,PP	STAGE 3E	
	W4-3	WB	717+50	-	-	-	-	-	-	-	-	-	-	-	-	-	-	-	-	-	1	30	IA,PP	STAGE 3E	
	W4-3	WB	5513+00(IA965C)	-	-	-	-	-	-	-	-	-	-	-	-	-	-	-	-	-	1	24	IA,PP	STAGE 3E	
	W4-3	WB	5513+00(IA965C)	-	-	-	-	-	-	-	-	-	-	-	-	-	-	-	-	-	1	18	IA,PP	STAGE 3E	
	M3-4	WB	703+50	-	-	-	-	-	-	-	-	-	-	-	-	-	-	-	-	-	1	30	IA,PP	STAGE 3E	
	M1-1	WB	703+50	-	-	-	-	-	-	-	-	-	-	-	-	-	-	-	-	-	1	30	IA,PP	STAGE 3E	
	W4-1	WB	5527+00(ML380E)	-	-	-	-	-	-	-	-	-	-	-	-	-	-	-	-	-	1	12	IA,PP	STAGE 3E	
	M3-4	WB	607+50	-	-	-	-	-	-	-	-	-	-	-	-	-	-	-	-	-	1	30	IA,PP	STAGE 3E	
	M1-1	WB	607+50	-	-	-	-	-	-	-	-	-	-	-	-	-	-	-	-	-	1	30	IA,PP	STAGE 3E	
	W4-1	SB	551+50 (ML380B)	-	-	-	-	-	-	-	-	-	-	-	-	-	-	-	-	-	1	30	IA,PP	STAGE 3E	

MATERIALS FOR OVERHEAD SIGN SUPPORT STRUCTURES

LOCATION				SPAN LENGTH	STRUCTURE DESIGNATION	SIGN TRUSS STANDARD SERIES	INSIDE FOUNDATION OFFSET FT	OUTSIDE FOUNDATION OFFSET FT	ADDITIONAL STEM HEIGHT 'L'		FOUNDATION QUANTITIES					
REFERENCE LOCATION SIGN	STATION	PROJECT STAGE	DIRECTION OF TRAVEL						INSIDE FT	OUTSIDE FT	EXCAVATION (CLASS 20) CY	REINFORCING EPOXY-COATED STEEL LB	STRUCTURAL CONCRETE CY	SPECIAL BACKFILL CY	ANCHOR BOLT ASSEMBLIES	
															NUMBER EACH	TOTAL LB
Stage 1 North Foundation	598+50	STAGE 1A	EB	100'	Foundation	SOST	0.0	-	-	102.5	5033	1	2	-	-	
Stage 1 North Foundation	613+50	STAGE 1A	EB	105'	Foundation	SOST	0.0	-	-	102.5	5033	1	2	-	-	
Stage 1 North Foundation	2530+00	STAGE 1A	EB	90'	Truss	SOST	57.0	33.0	3.0	4.0	188.5	7046	1	2	1552.5	-
Stage 1 North Foundation	1558+75	STAGE 1A	WB	100'	Foundation	SOST	-	20.0	-	-	105.9	5272	1	2	-	-
Stage 1 South Foundation	677+50	STAGE 1B	WB	105'	Foundation	SOST	0.0	-	-	-	102.5	5033	1	2	-	-
Stage 1 South Foundation	598+50	STAGE 2A	EB	100'	Foundation	SOST	-	100.0	-	-	90.6	5431	1	2	-	-
80-52-239 S005A/S005	605+00	STAGE 2A	EB	39.5'	Cantilever	SCST	-	94.0	-	-	173.6	6351	1	-	2	2063.2
Stage 1 South Foundation	613+50	STAGE 2A	EB	105'	Foundation	SOST	-	100.0	-	-	93.9	5431	1	2	-	-
Stage 1 South Foundation	620+00	STAGE 2A	EB	130'	Foundation	SOST	-	130.0	-	-	104.5	5431	1	2	-	-
Stage 1 East Foundation	5579+50	STAGE 2B	NB	75'	Foundation	SOST	0.0	45.0	-	-	104.5	5113	1	2	-	-
Stage 1 East & West Foundation	1218+00	STAGE 2C	NB	105'	Foundation	SOST	0.0	105.0	-	-	211.9	9828	1	2	-	-
Stage 1 North Foundation	6511+50	STAGE 2C	SB	100'	Truss	SOST	50.0	50.0	2.0	5.0	196.8	7046	1	-	2	1552.5
Stage 1 North Foundation	677+50	STAGE 2D	WB	105'	Foundation	SOST	-	105.0	-	-	104.8	5590	1	2	-	-
380-52-96 M005A/005	1192+50	STAGE 2D	NB	38'	Cantilever	SCST	-	108.6	-	-	115.3	6351	1	-	2	2063.2
80-52-239B S104A/S104	680+00	STAGE 2E	WB	39.5'	Cantilever	SCST	-	93.5	-	-	187.9	6351	1	-	2	2063.2
80-52-239 S006A/S006	612+00	STAGE 2F	EB	39.5'	Cantilever	SCST	-	94.0	-	-	183.8	6351	1	-	2	2063.2
Stage 1 North Foundation	620+00	STAGE 3A	EB	130'	Foundation	SOST	0.0	-	-	-	102.5	5033	1	2	-	-
218-52-96 M001A/M001	1091+00	STAGE 3A	NB	38'	Cantilever	SCST	-	96.5	-	-	184.2	6351	1	-	2	2063.2
Remaining foundations & Truss	1558+75	STAGE 3C	WB	100'	Truss	SOST	80.0	20.0	2.0	4.0	104.9	3286	1	2	2	1552.5
80-52-237 S107A/S107	611+00	STAGE 3C	WB	39.5'	Cantilever	SCST	-	99.1	-	-	178.3	6351	1	-	2	2063.2
80-52-237 S109A/S109	587+00	STAGE 3C	WB	39.5'	Cantilever	SCST	-	102.1	-	-	175.5	6351	1	-	2	2063.2
380-52-2 M008A/M008	1226+50	STAGE 3C	NB	39.5'	Cantilever	SCST	-	100.0	-	-	187.5	6351	1	-	2	2063.2
380-52-2 M011A/M011	1250+50	STAGE 3C	NB	38'	Cantilever	SCST	-	100.0	-	-	188.3	6351	1	-	2	2063.2
380-52-2 M105A/M105	1302+50	STAGE 3C	SB	32'	Cantilever	SCST	-	91.5	-	-	200.2	6351	1	-	2	2063.2
380-52-2 M106A/M106	1292+50	STAGE 3C	SB	36'	Cantilever	SCST	-	100.0	-	-	188.1	6351	1	-	2	2063.2
Stage 1 West Foundation	1192+00	STAGE 3C	SB	105'	Truss	SOST	0.0	105.0	-	-	105.1	5033	1	2	-	-
218-52-96 R001/R002	5579+50	STAGE 3D	NB	75'	Truss	SOST	30.0	45.0	2.0	3.0	103.3	3997	1	2	2	1552.5
DMS(Stage 2 Foundations & Truss)	1218+00	STAGE 3D	NB	105'	Truss	SOST	0.0	105.0	1.0	2.5	-	-	1	2	2	1588.1
380-52-0 M108A/108	1245+50	STAGE 3D	SB	36'	Cantilever	SCST	-	100.0	-	-	187.7	6351	1	-	2	2063.2
380-52-0 M111/M112A/M112	1201+00	STAGE 3D	SB	105'	Truss	SOST	0.0	105.0	2.5	3.0	88.4	3444	1	2	2	1588.1
380-52-0 M112/M112A/M113	1192+00	STAGE 3D	SB	105'	Truss	SOST	0.0	105.0	2.5	2.5	-	-	1	2	2	1588.1
380-52-0 M114/M115	1173+00	STAGE 3D	SB	85'	Truss	SOST	0.0	85.0	2.5	6.0	102.6	3918	1	2	2	1552.5
80-52-239 S003A/S003	598+50	STAGE 3E	EB	100'	Truss	SOST	0.0	100.0	2.5	5.0	-	-	1	2	2	1552.5
80-52-239 S004A/S004	613+50	STAGE 3E	EB	105'	Truss	SOST	0.0	105.0	2.5	5.0	-	-	1	2	2	1588.1
80-52-239 R001A/R001	620+00	STAGE 3E	EB	130'	Truss	SOST	0.0	130.0	2.5	5.0	-	-	1	2	2	1588.1
80-52-239 S102A/S102	677+50	STAGE 3E	WB	105'	Truss	SOST	0.0	105.0	2.5	6.0	-	-	1	2	2	1588.1
218-52-0 M002/M003A/M003	1131+50	STAGE 3E	NB	95'	Truss	SOST	0.0	95.0	0.0	2.5	202.0	6335	1	-	2	1552.5

**SIGN SUPPORT STRUCTURES**

The following Bridge Standards apply to construction work on this project.

Number	Date	Title
SCST-01-17	03-2019	Index and Notes
SCST-02-17	03-2019	Sign Support Views
SCST-03-17	03-2019	Isometric View Typical Truss
SCST-04-17	03-2019	Truss-to-Post Connection Details
SCST-05-17	03-2019	Gusset Plate Connection Details
SCST-06-17	03-2019	Post Base Support Details
SCST-07-17	03-2019	Sign Attachment Details
SCST-08-17	03-2019	Foundation Details - Spread Footing
SOST-01-11	03-2019	Index and Notes 50'-130' Spans
SOST-02-11	03-2019	Elevation Views for Truss Spans 50'-75' Spans
SOST-03-11	03-2019	Elevation Views for Truss Spans 80'-100' Spans
SOST-04-11	03-2019	Elevation Views for Truss Spans 105'-115' Spans
SOST-05-11	03-2019	Elevation Views for Truss Spans 120'-130' Spans
SOST-07-11	03-2019	Support Post Base and DMS Electrical Access Details 105'-130' Spans
SOST-08-11	03-2019	Gusset Plate Connections 50'-130' Spans
SOST-09-11	03-2019	Truss Support and Chord Splice Details 50'-100' Spans
SOST-10-11	03-2019	Truss Support and Chord Splice Details 105'-130' Spans
SOST-11-11	03-2019	Sign Attachment Details 50'-130' Spans
SOST-12-11	03-2019	DMS Runway Details 50'-130' Spans
SOST-13-11	03-2019	DMS Runway Details 50'-130' Spans
SOST-14-11	03-2019	DMS Runway Gate Details 50'-130' Spans
SOST-15-11	03-2019	DMS Ladder Details 50'-130' Spans
SOST-16-11	03-2019	DMS Ladder Security Door Details 50'-130' Spans
SOST-17-11	03-2019	Non-Stage Foundation Details 50'-130' Spans
SOST-18-11	03-2019	Conduit Location Details 50'-130' Spans
SOST-19-11	03-2019	Staged Foundation Construction Notes
SOST-20-11	03-2019	Stage 1 Foundation Details 50'-130' Spans
SOST-21-11	03-2019	Stage 2 Foundation Details 50'-130' Spans

**EXISTING SIGNS TO BE REINSTALLED**

SIGN DESCRIPTION	PROJECT STAGE	DIRECTION OF TRAVEL	LOCATION STATION	NUMBER OF POSTS	SQUARE TUBE STEEL POSTS	PSST		INSTALLATION		SEE SIGNING NOTES
						LEG 1 LF	LEG 2 LF	TYPE	DIM 'X'	
80-52-239A S007 (Reinstall from STA.623+50)	STAGE 1A	EB	623+50	-	-	-	-	3.0	6	RR
80-52-239B S104A/S104 (Reinstall from STA. 665+50)	STAGE 2A	WB	683+50	-	-	-	-	-	-	RR
380-52-2 M005A/005 (Reinstall to new offset)	STAGE 2A	NB	1192+50	-	-	-	-	1.0	30	RR
380-52-2 M006A/M006 (Reinstall from STA.1246+50)	STAGE 2A	NB	1243+50	-	-	-	-	1.0	30	RR
W4-1 Merge Right (Reinstall from STA. 1218+50)	STAGE 2A	NB	1284+00	-	-	-	-	1.0	14	RR
380-52-4 M009A/M009 (Reinstall to new offset)	STAGE 2A	NB	1310+00	SEE TYPE B	SIGNING	NOTES	-	1.0	30	RR,PB
80-52-239 S006 (Reinstall from STA. 613+25)	STAGE 2B	EB	607+50	-	-	-	-	3.0	8	RR
218-52-96 M002A/M002 (Reinstall from STA. 1116+00)	STAGE 2B	NB	1136+75	-	-	-	-	1.0	30	RR
218-52-96 M003 (Reinstall from STA. 1126+50)	STAGE 2B	NB	1141+50	-	-	-	-	3.0	12	RR
218-52-96 M006A/M006 (Reinstall from STA. 1235+50)	STAGE 2B	NB	1235+50	-	-	-	-	1.0	30	RR
380-52-2 M007 (Reinstall from STA. 1253+00)	STAGE 2B	NB	1241+50	-	-	-	-	3.0	14	RR
W4-1 Merge Right (Reinstall from STA. 1301+50)	STAGE 2B	NB	1301+50	-	-	-	-	1.0	14	RR
80-52-239B S104A/S104 (Reinstall from STA. 683+50)	STAGE 2C	WB	697+50	-	-	-	-	-	-	RR
80-52-239B S105 (Reinstall from STA. 676+50)	STAGE 2C	WB	690+00	-	-	-	-	-	-	RR
W4-1 Merge Right (Reinstall from STA.634+00)	STAGE 2C	WB	628+00	-	-	-	-	1.0	15	RR
218-52-96 M002A/M002 (Reinstall from STA. 1136+75)	STAGE 2C	NB	1128+00	-	-	-	-	1.0	30	RR
380-52-2 M006A/M006 (Reinstall from STA.1235+50)	STAGE 2C	NB	1249+00	-	-	-	-	1.0	30	RR
W4-1 Merge Right (Reinstall from STA. 1301+50)	STAGE 2C	NB	1283+00	-	-	-	-	1.0	30	RR,PP
80-52-239B S106 (Reinstall from STA. 690+00)	STAGE 2D	WB	668+00	-	-	-	-	1.0	10	RR
W4-1 Merge Right (Reinstall from STA. 628+00)	STAGE 2D	WB	632+00	-	-	-	-	1.0	18	RR,PP
218-52-96 M002A/M002 (Reinstall from STA. 1128+00)	STAGE 2D	NB	1121+50	-	-	-	-	-	12	RR
W4-1 Merge Right (Reinstall from STA. 1131+50)	STAGE 2D	SB	1131+50	-	-	-	-	1.0	16	RR
M3-3/M1-4/M3-3/M1-5 (Reinstall from STA. 1133+50)	STAGE 2D	SB	1124+50	-	-	-	-	1.0	30	RR,PP
Speed Limit Assembly (Reinstall to new offset)	STAGE 2D	SB	1120+50	1.0	19.4	-	-	1.0	30	RR,PP
80-52-239 S003A/S003 (Reinstall from STA. 541+00)	STAGE 2E	EB	565+00	-	-	-	-	1.0	30	RR
80-52-240 S007A/S007 (Reinstall from STA. 636+00)	STAGE 2E	EB	640+50	-	-	-	-	1.0	30	RR
4-3 Added Lane Symbol (Reinstall from STA. 637+75)	STAGE 2E	EB	646+00	-	-	-	-	1.0	12	RR
80-52-239B S104A/104 (Reinstall from STA. 672+00)	STAGE 2E	WB	680+00	-	-	-	-	-	-	RR
80-52-239B S105 (Reinstall from STA. 668+00)	STAGE 2E	WB	672+00	-	-	-	-	3.0	6	RR
218-52-96 M002A/M002 (Reinstall from STA. 1121+50)	STAGE 2E	NB	1128+00	-	-	-	-	1.0	30	RR
W4-1 Merge Right (Reinstall from STA. 1131+50)	STAGE 2E	SB	1145+50	-	-	-	-	1.0	30	RR,PP
M3-3/M1-4/M3-3/M1-5 (Reinstall from STA. 1124+50)	STAGE 2E	SB	1133+50	-	-	-	-	1.0	30	RR,PP
9-7 Right Lane Exit Only (Reinstall to new offset)	STAGE 2F	EB	595+00	-	-	-	-	1.0	30	RR
Speed Limit Assembly (Reinstall to new offset)	STAGE 2F	EB	603+00	1.0	19.3	-	-	1.0	30	RR,PP
80-52-239 S006A/S006 (Reinstall from STA. 605+00)	STAGE 2F	EB	612+00	-	-	-	-	-	-	RR
80-52-239 S007 (Reinstall from STA. 607+50)	STAGE 2F	EB	613+75	-	-	-	-	3.0	6	RR
80-52-0A M108A/M108 (Reinstall from STA. 1201+50)	STAGE 2F	SB	1204+00	-	-	-	-	1.0	30	RR
80-52-0A M109A/M109 (Reinstall from STA. 1193+00)	STAGE 2F	SB	1197+50	-	-	-	-	1.0	30	RR
218-52-96 M002A/M002 (Reinstall from STA. 1121+50)	STAGE 3A	NB	1128+00	-	-	-	-	1.0	30	RR
380-52-2 M102A/M102 (Reinstall from STA. 1297+00)	STAGE 3A	SB	1299+50	-	-	-	-	1.0	18	RR
80-52-240 S011 (Reinstall from STA. 658+00)	STAGE 3B	EB	658+00	SEE TYPE B	SIGNING	NOTES	-	1.0	30	RR,PB
380-52-2 M103 (Reinstall from STA. 1288+00)	STAGE 3B	SB	1291+25	-	-	-	-	3.0	20	RR
W4-1 Merge Right (Reinstall from STA. 1260+50)	STAGE 3B	SB	1256+00	-	-	-	-	1.0	18	RR

190-61  
10-15-13

EXISTING SIGNS TO BE REINSTALLED

Table with columns: SIGN DESCRIPTION, PROJECT STAGE, DIRECTION OF TRAVEL, LOCATION STATION, NUMBER OF POSTS, SQUARE TUBE STEEL POSTS, PSST (LEG 1 LF, LEG 2 LF), INSTALLATION (TYPE, DIM 'X'), SEE SIGNING NOTES.

190-62  
10-15-13

REMOVAL OF TYPE A/B SIGN ASSEMBLIES

Table with columns: SIGN NUMBER OR DESCRIPTION, LOCATION STATION, DIRECTION OF TRAVEL, TYPE 'A' SIGN ASSEMBLY, TYPE 'B' SIGN ASSEMBLY, REMOVE & REINSTALL EXISTING SIGNS, CONCRETE FOUNDATION, SUPPORT STRUCTURE & FOUNDATION, APPLICABLE SIGNING NOTES, REMARKS.

190-62  
10-15-13

REMOVAL OF TYPE A/B SIGN ASSEMBLIES

Table with columns: SIGN NUMBER OR DESCRIPTION, LOCATION STATION, DIRECTION OF TRAVEL, TYPE 'A' SIGN ASSEMBLY, TYPE 'B' SIGN ASSEMBLY, REMOVE & REINSTALL EXISTING SIGNS, CONCRETE FOUNDATION, SUPPORT STRUCTURE & FOUNDATION, APPLICABLE SIGNING NOTES, REMARKS.

REMOVAL OF TYPE A/B SIGN ASSEMBLIES

Table with columns: SIGN NUMBER OR DESCRIPTION, LOCATION STATION, DIRECTION OF TRAVEL, TYPE 'A' SIGN ASSEMBLY, TYPE 'B' SIGN ASSEMBLY, REMOVE & REINSTALL EXISTING SIGNS, CONCRETE FOUNDATION, SUPPORT STRUCTURE & FOUNDATION, APPLICABLE SIGNING NOTES, REMARKS. Includes rows for various sign assemblies like Speed limit, Route Shield, and M3-2/M1-1.

REMOVAL OF TYPE A/B SIGN ASSEMBLIES

Table with columns: SIGN NUMBER OR DESCRIPTION, LOCATION STATION, DIRECTION OF TRAVEL, TYPE 'A' SIGN ASSEMBLY, TYPE 'B' SIGN ASSEMBLY, REMOVE & REINSTALL EXISTING SIGNS, CONCRETE FOUNDATION, SUPPORT STRUCTURE & FOUNDATION, APPLICABLE SIGNING NOTES, REMARKS. Includes rows for various sign assemblies like 80-52-237, 380-52-2, and 80-52-239.



Preliminary - For Information Only

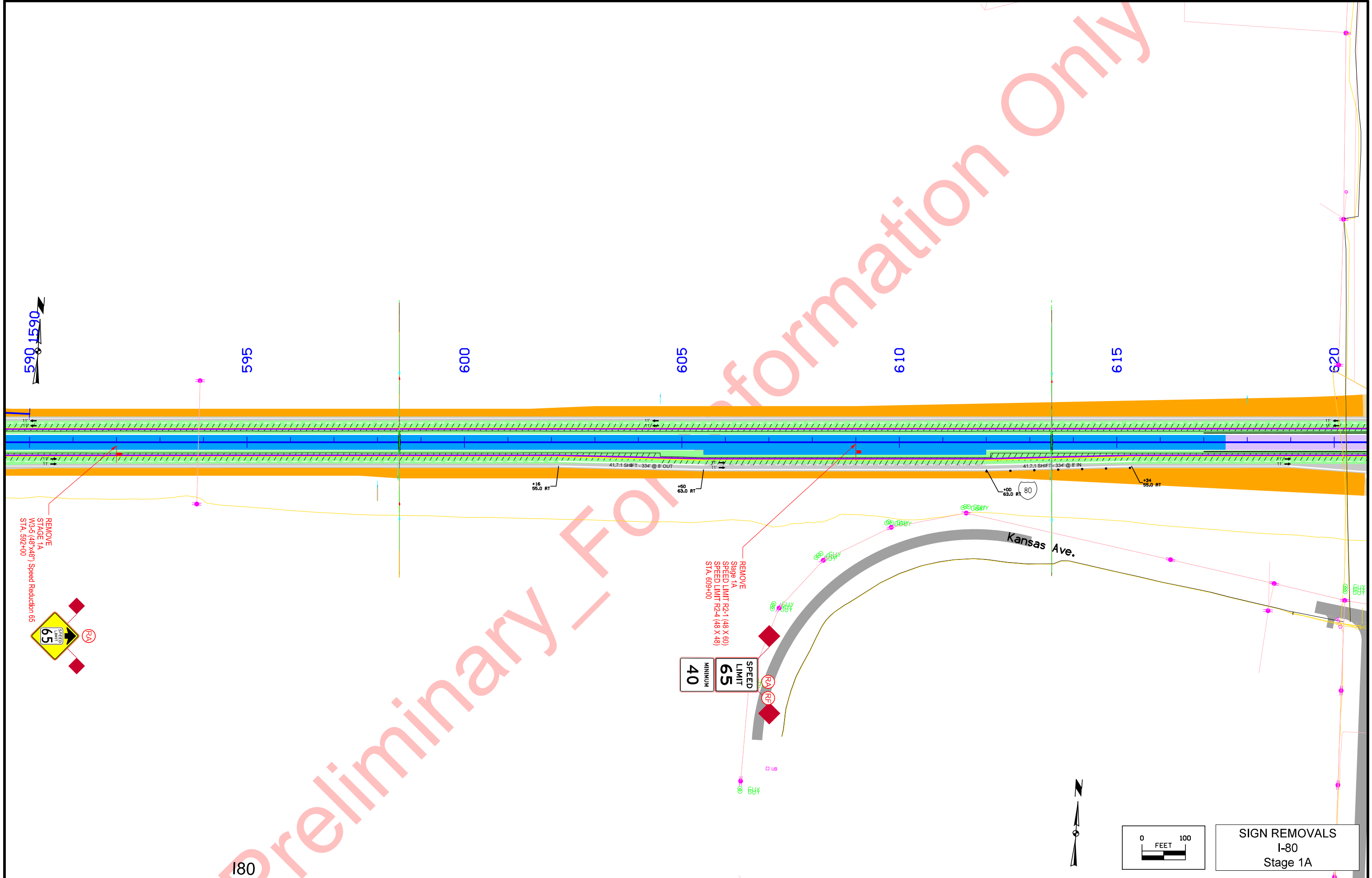

180

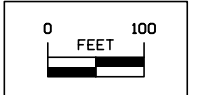

SIGN REMOVALS  
I-80  
Stage 1A

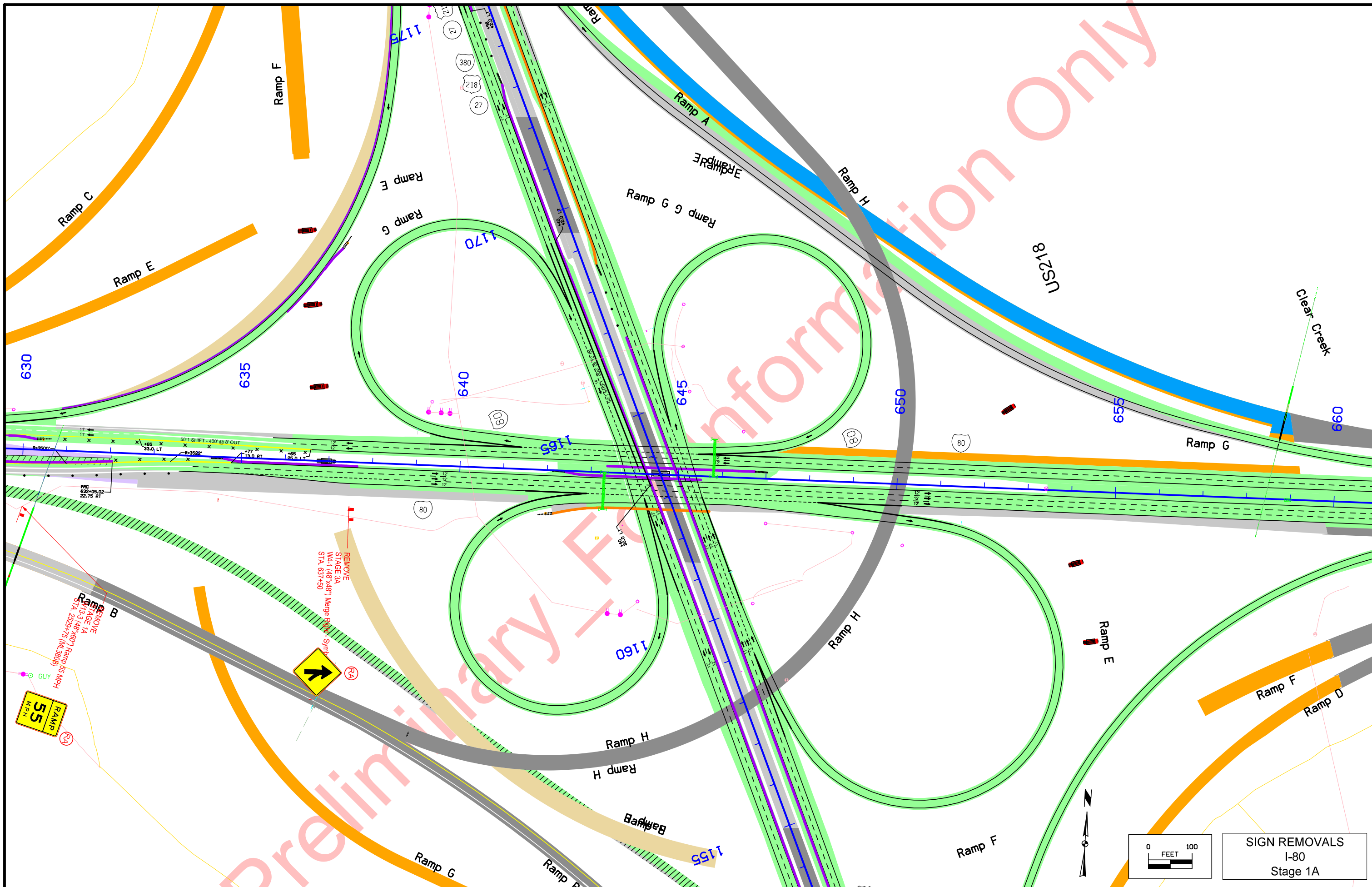

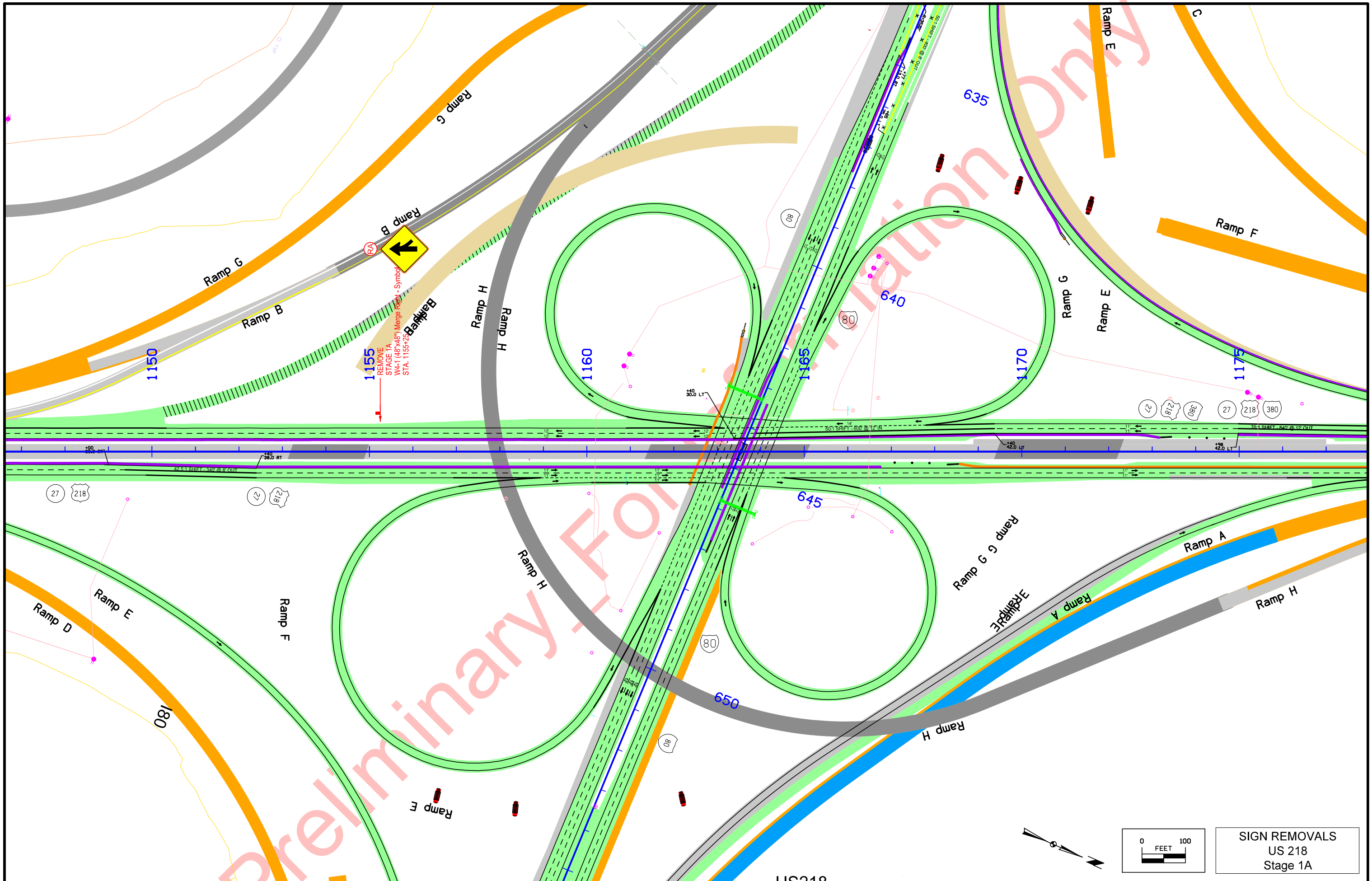

0 100 FEET

SIGN REMOVALS  
US 218  
Stage 1A



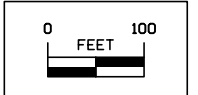
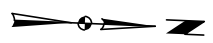
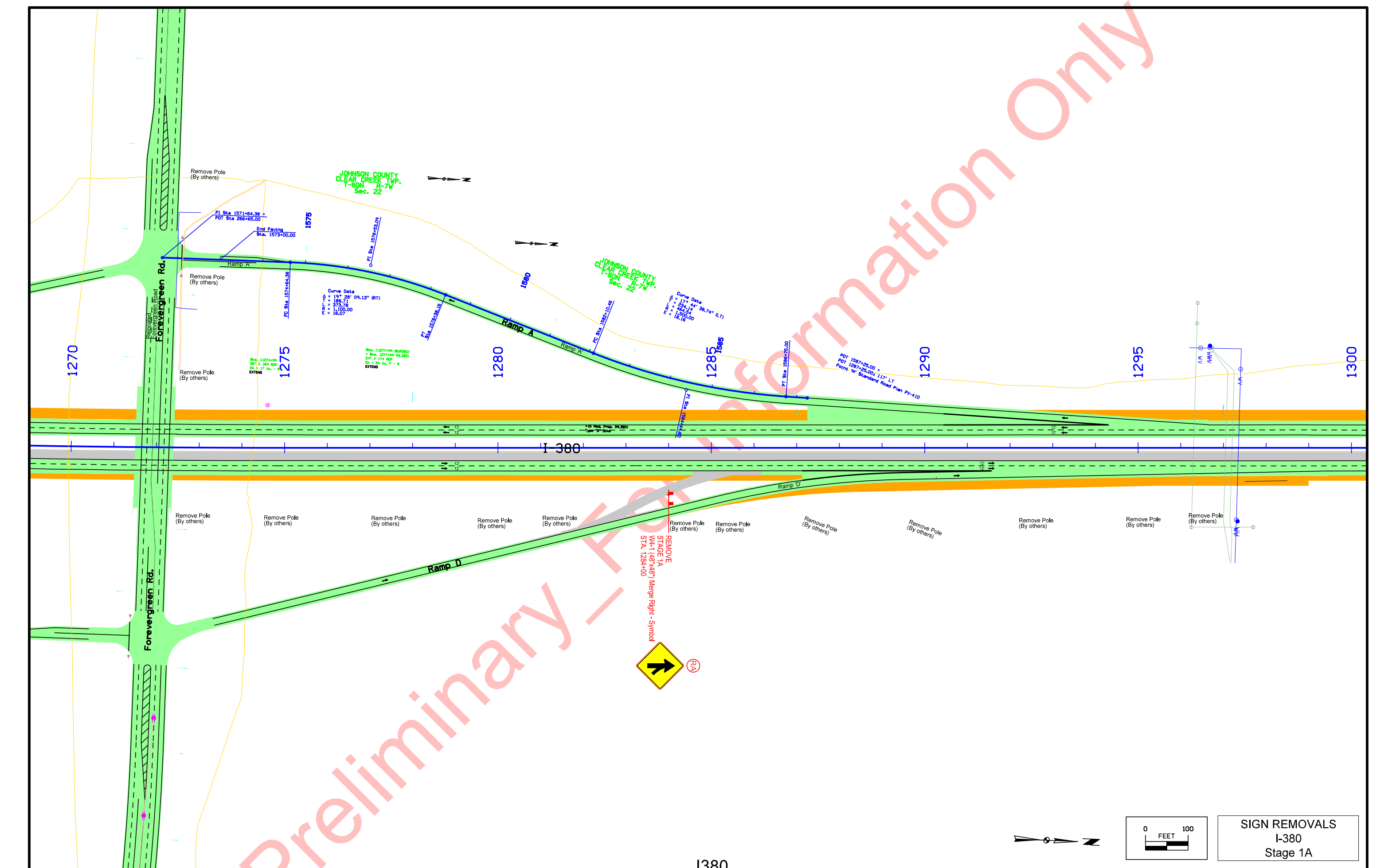

SIGN REMOVALS  
I-380  
Stage 1A

Preliminary - FOI Information Only

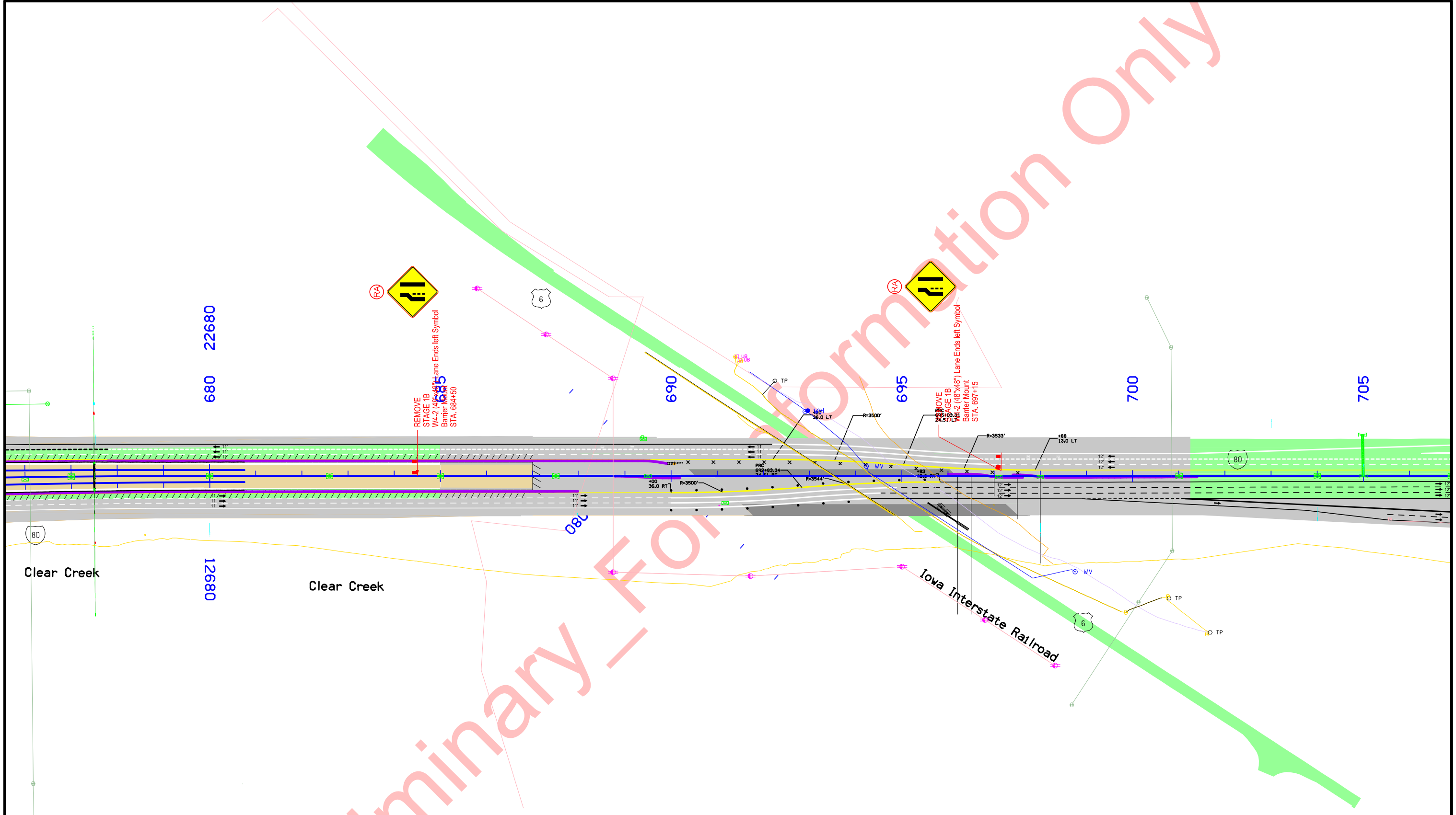

80

Clear Creek

680 22680

12680

Clear Creek

180

690

Iowa Interstate Railroad

695

700

705

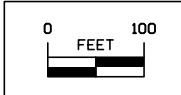

SIGN REMOVALS  
I-80  
Stage 1B

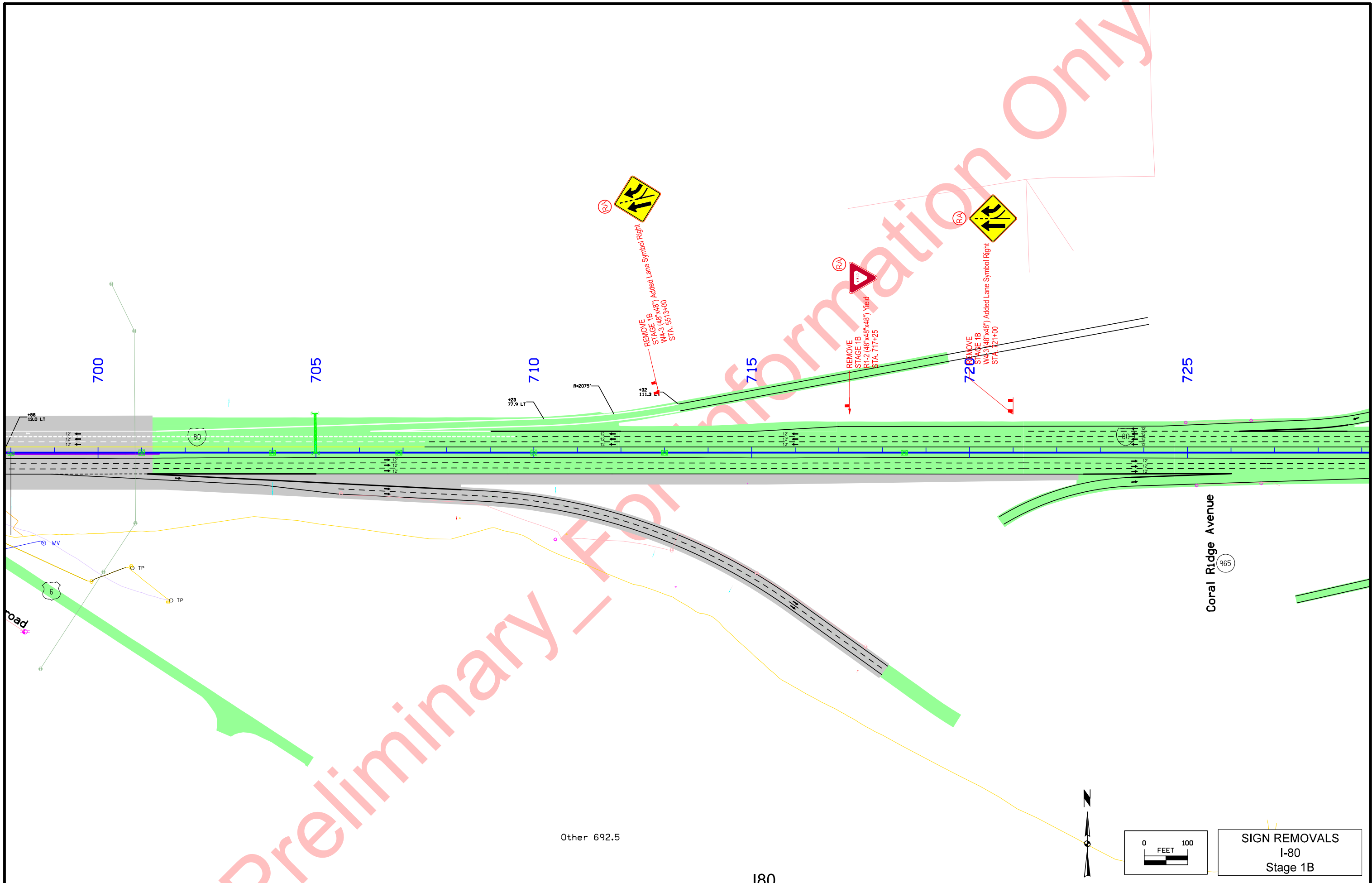

Preliminary - For Information Only

Other 692.5

180

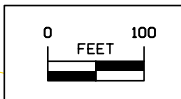

**SIGN REMOVALS**  
I-80  
Stage 1B

FILE NO.	ENGLISH	DESIGN TEAM <b>Abrams \ Hermann</b>	JOHNSON COUNTY	PROJECT NUMBER <b>NHS-080-6(403)239-11-52</b>	SHEET NUMBER <b>N.6</b>
----------	---------	-------------------------------------	----------------	---	-------------------------

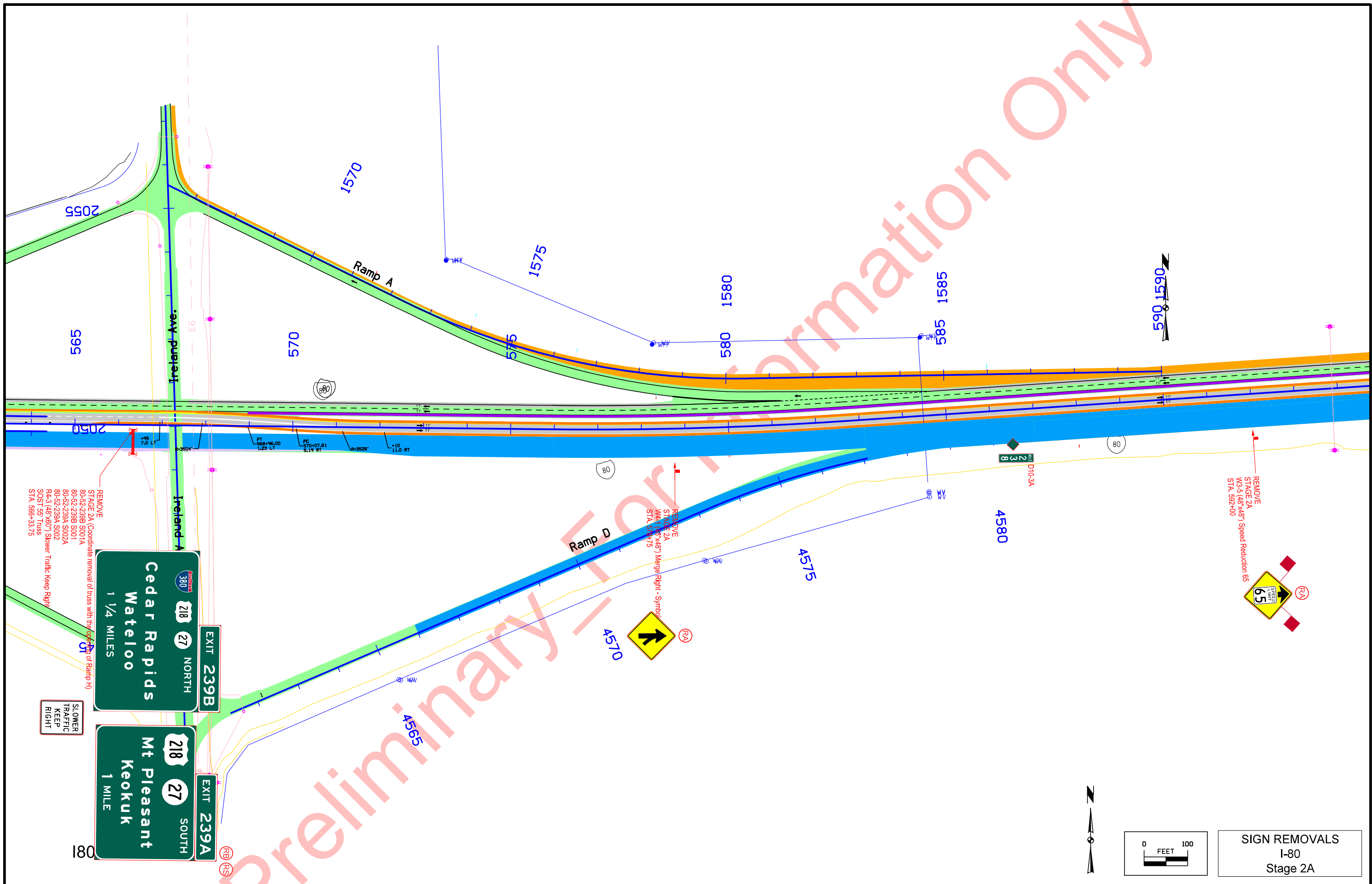

Preliminary For Information Only

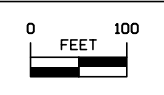

**SIGN REMOVALS**  
I-80  
Stage 2A

Preliminary Information Only

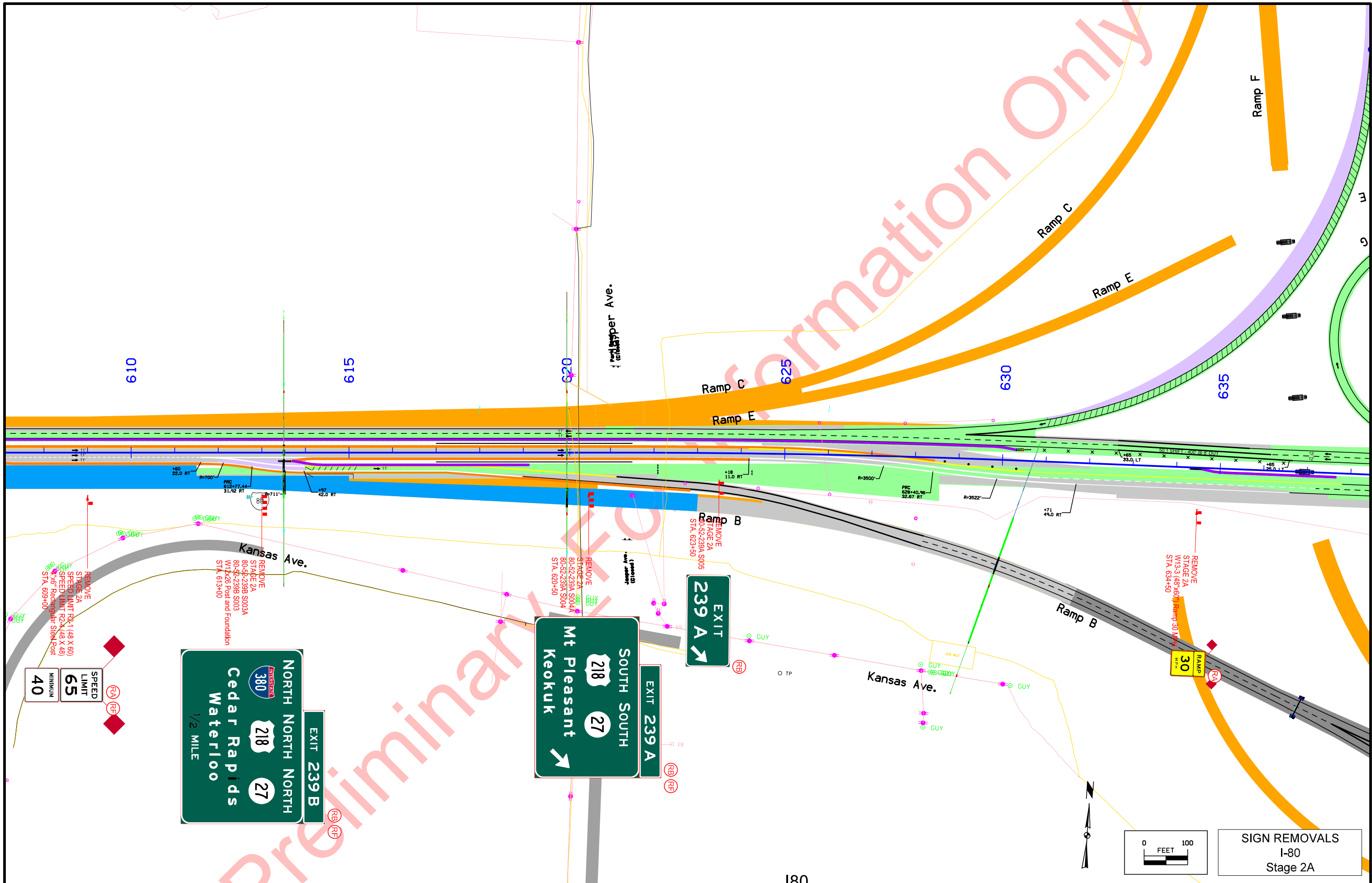

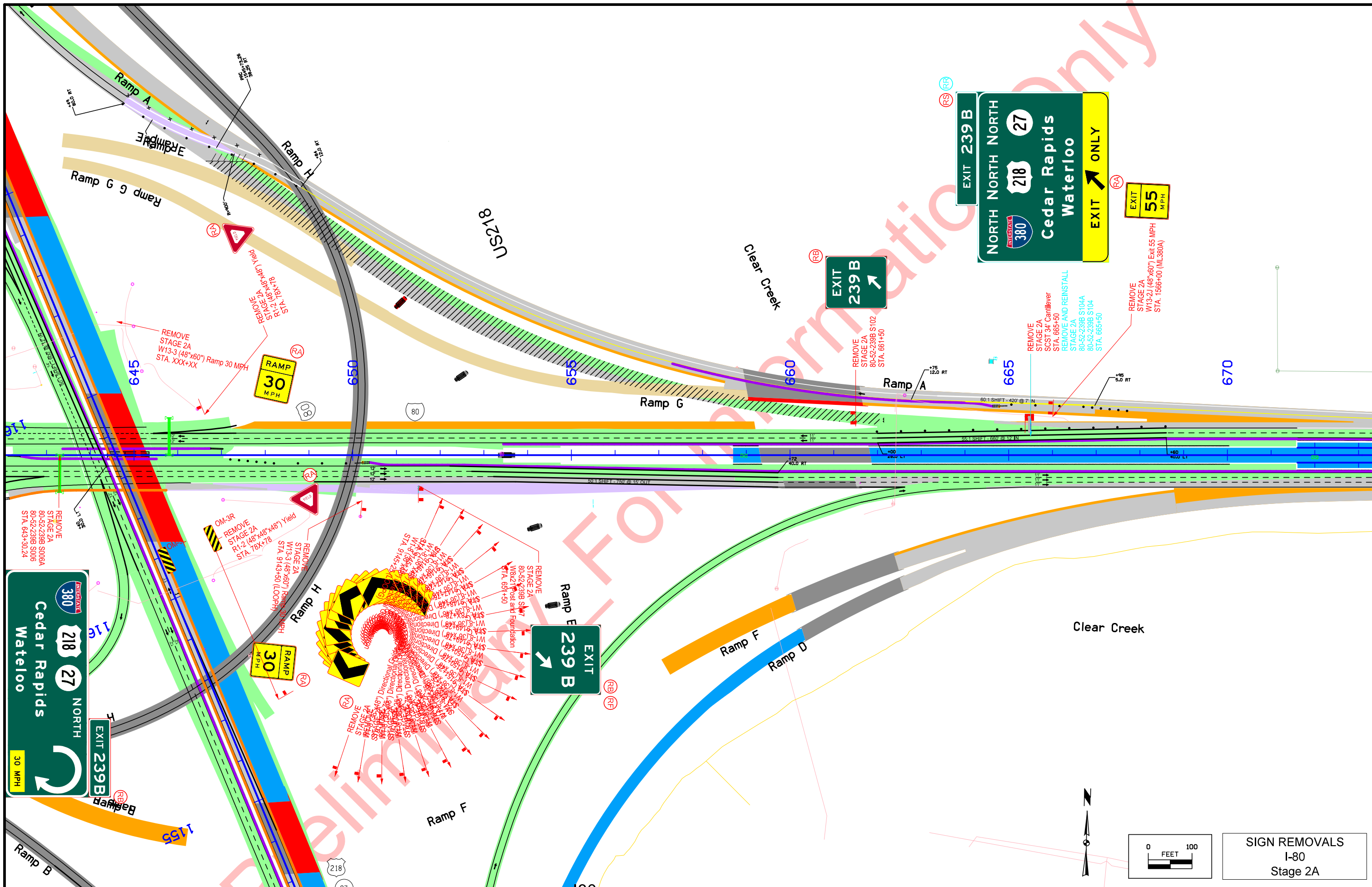



REMOVE STAGE 2A  
80-52-239A, S101A  
80-52-239A, S101  
STA. 683+50

680 22680

685

690

695

700

705



Clear Creek

12680

Clear Creek

Iowa Interstate Railroad

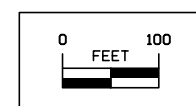

SIGN REMOVALS  
I-80  
Stage 2A

Preliminary - For Information Only

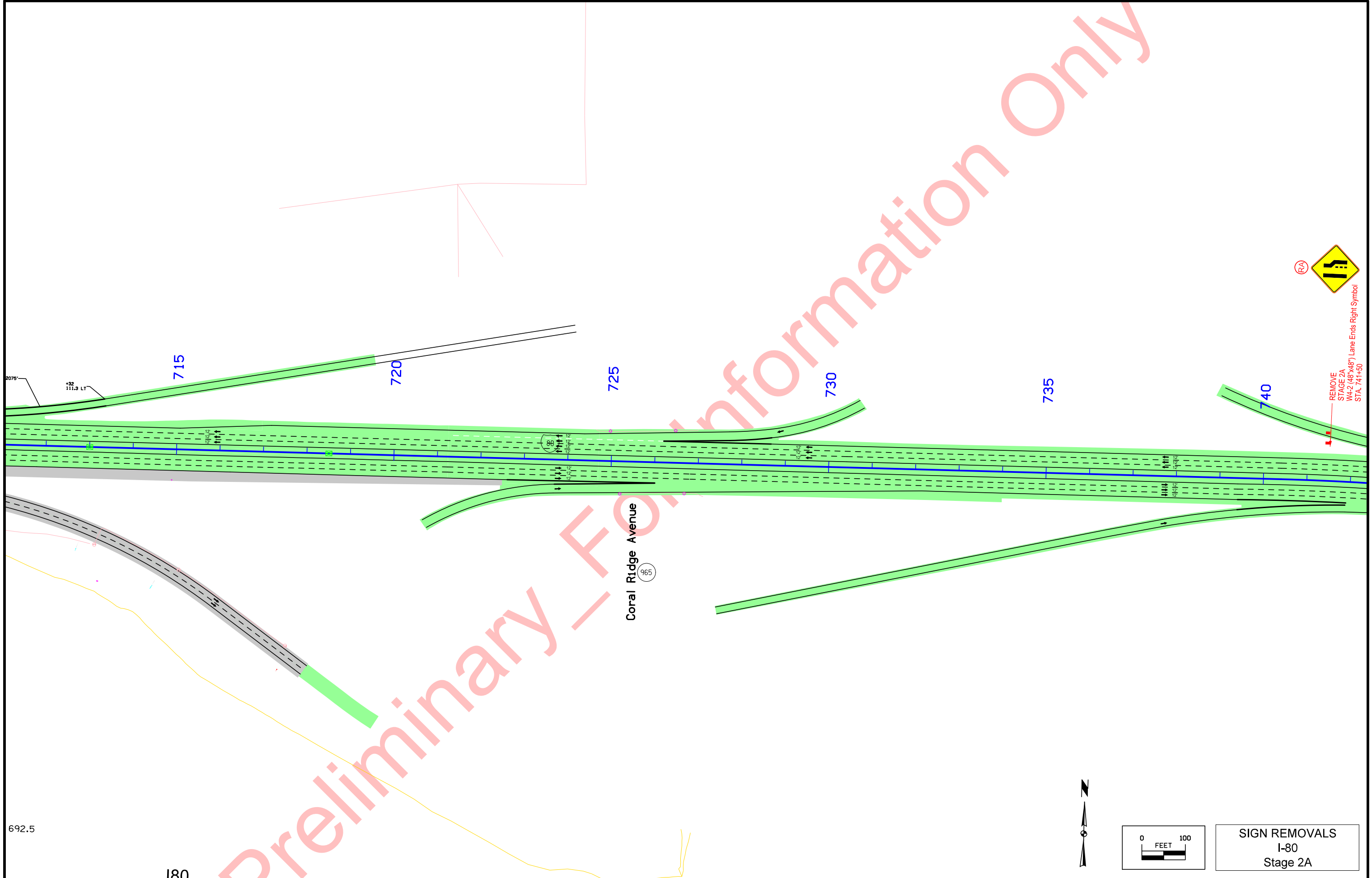

692.5

I80

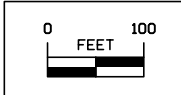

SIGN REMOVALS  
I-80  
Stage 2A



Preliminary - For Information Only

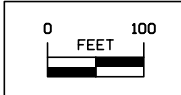
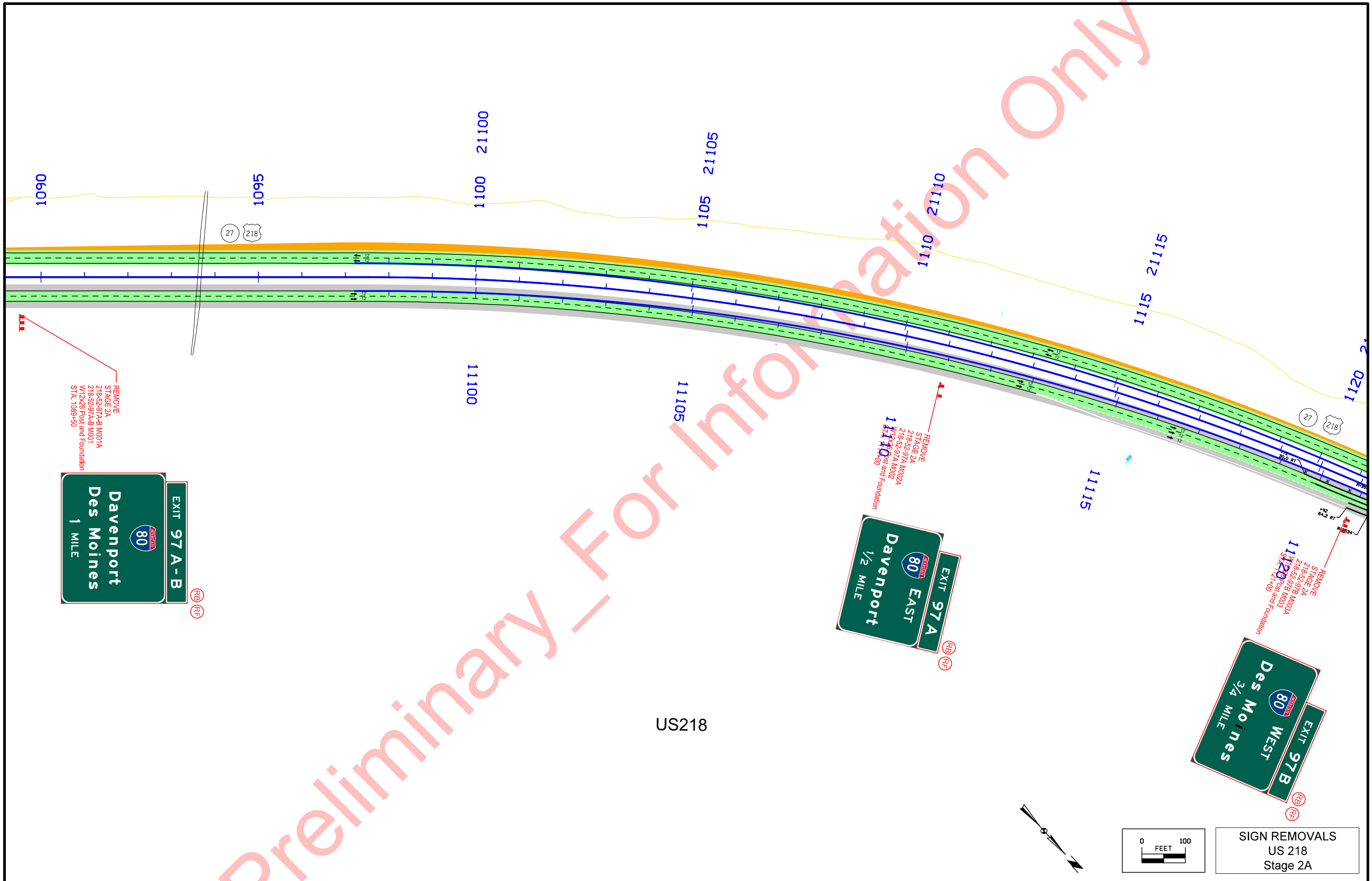

SIGN REMOVALS  
US 218  
Stage 2A

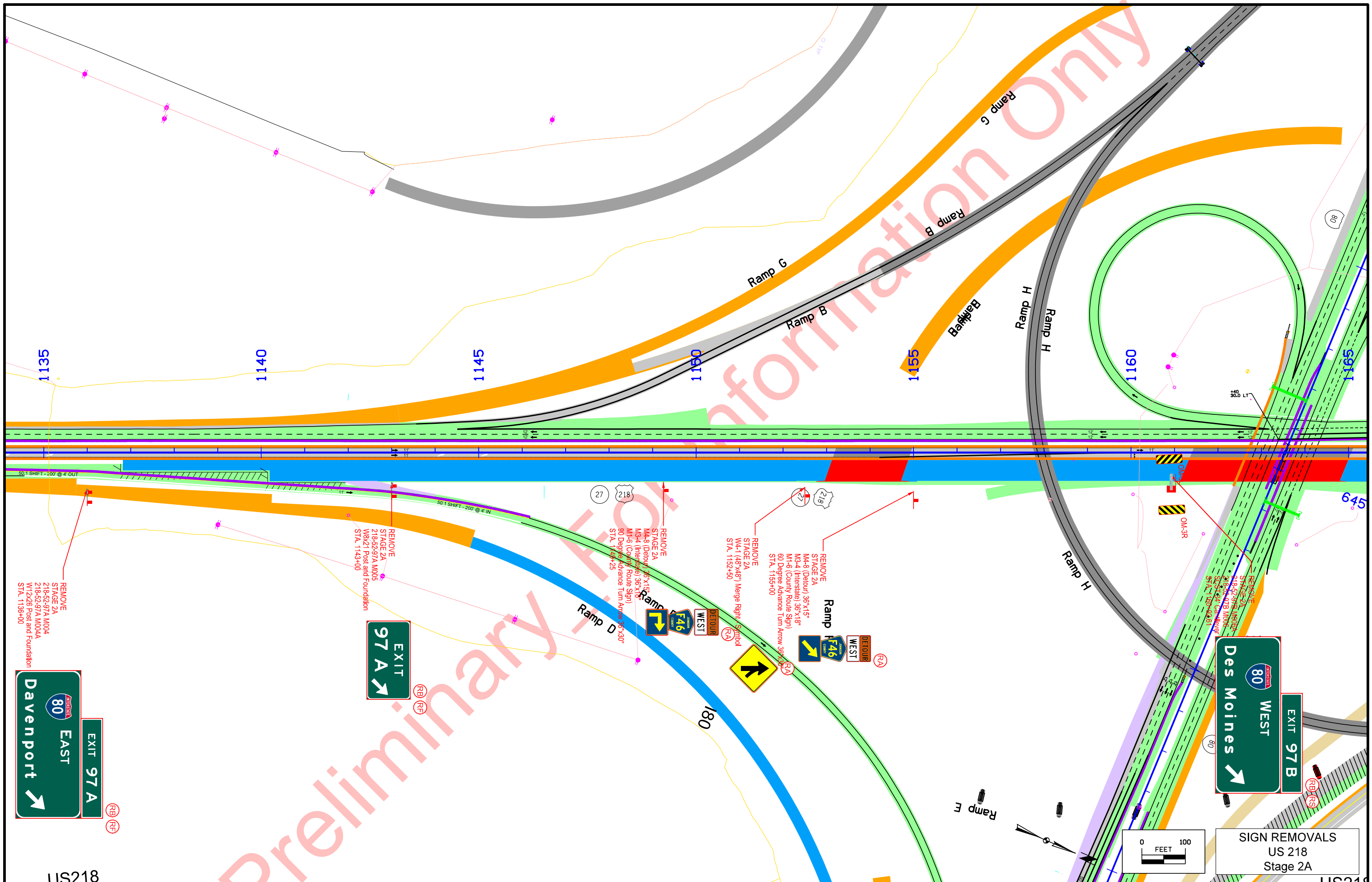

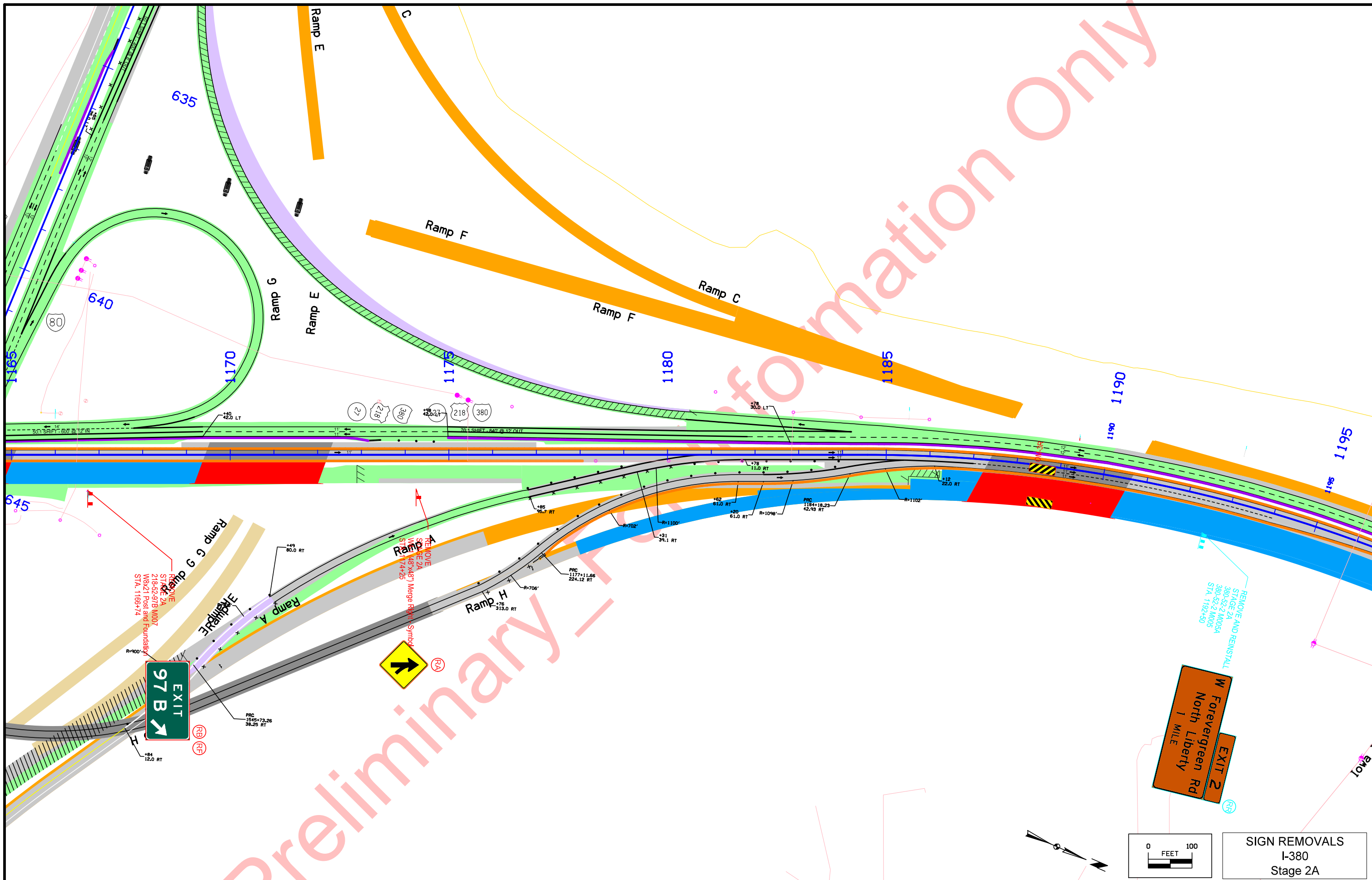

Information Only

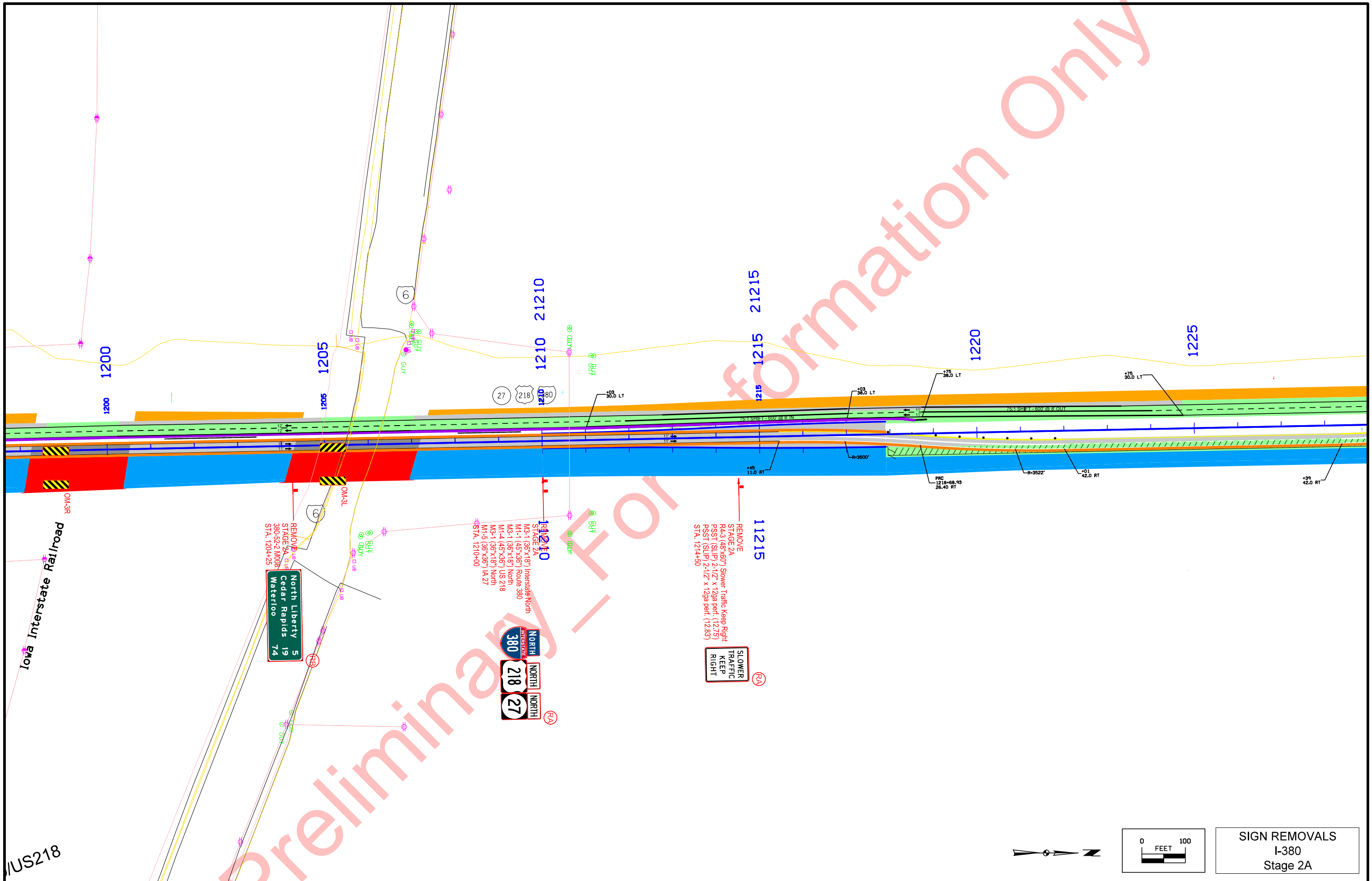

Preliminary FOR INFORMATION ONLY

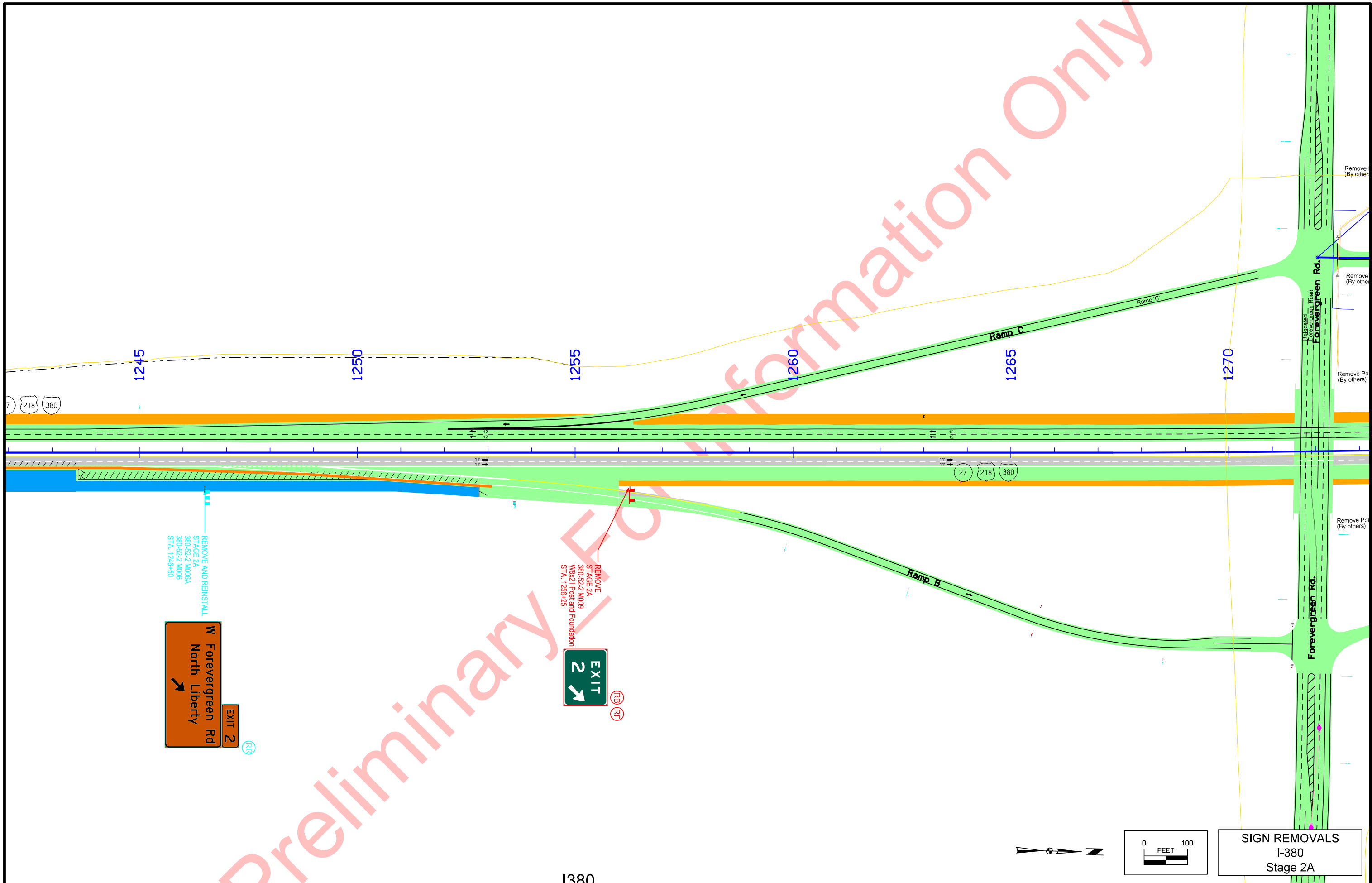

REMOVE AND REINSTALL  
 STAGE 2A  
 380-52-2 M006A  
 380-52-2 M006  
 STA. 1246+50

EXIT 2  
 W Forevergreen Rd  
 North Liberty

REMOVE  
 STAGE 2A  
 380-52-2 M009  
 W&21 Post and Foundation  
 STA. 1255+25

EXIT 2  
 ←

(R9)  
 (R4)

SIGN REMOVALS  
 I-380  
 Stage 2A

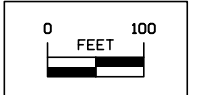
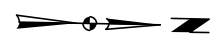
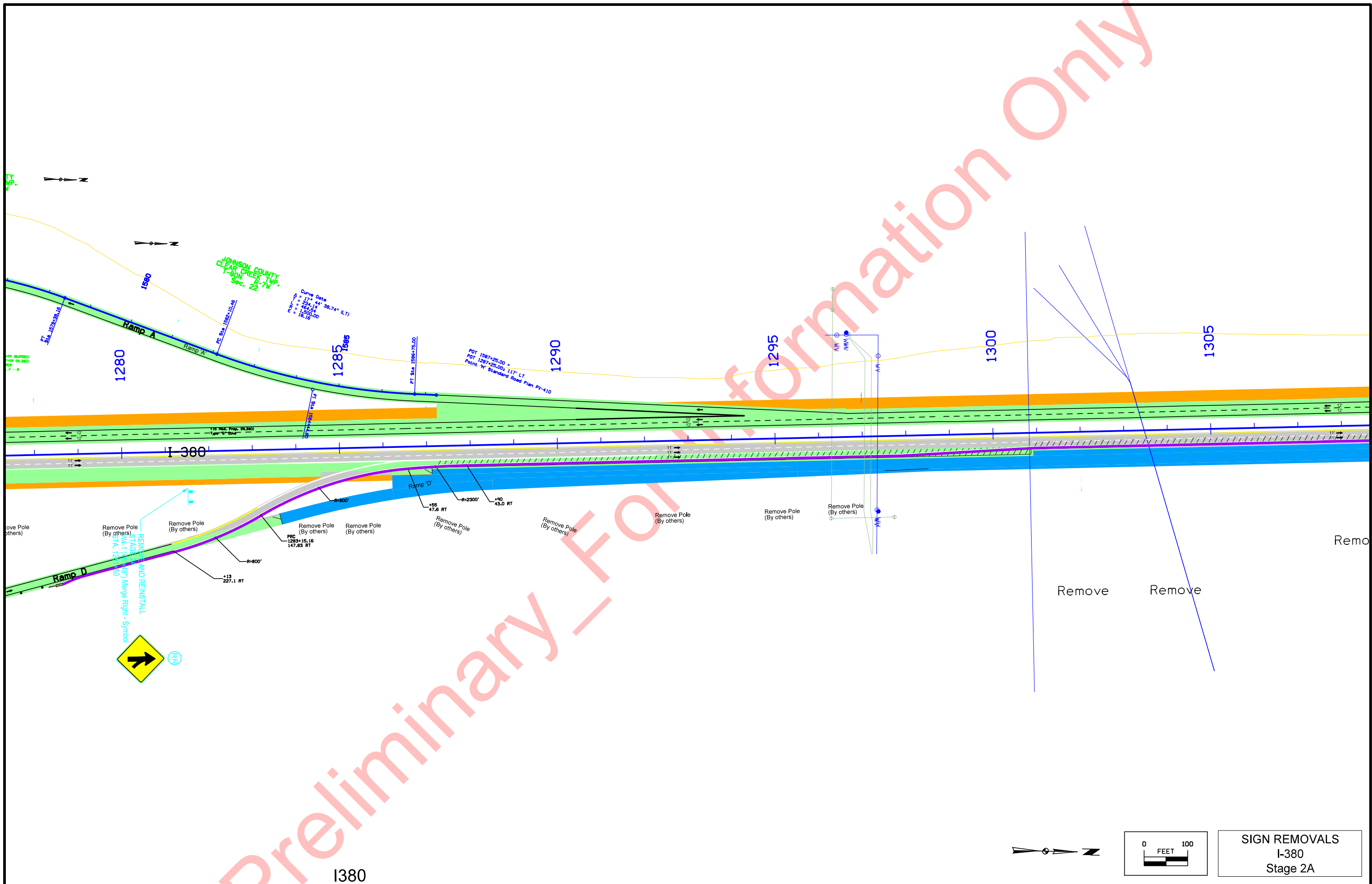

SIGN REMOVALS  
I-380  
Stage 2A

Preliminary - For Information Only

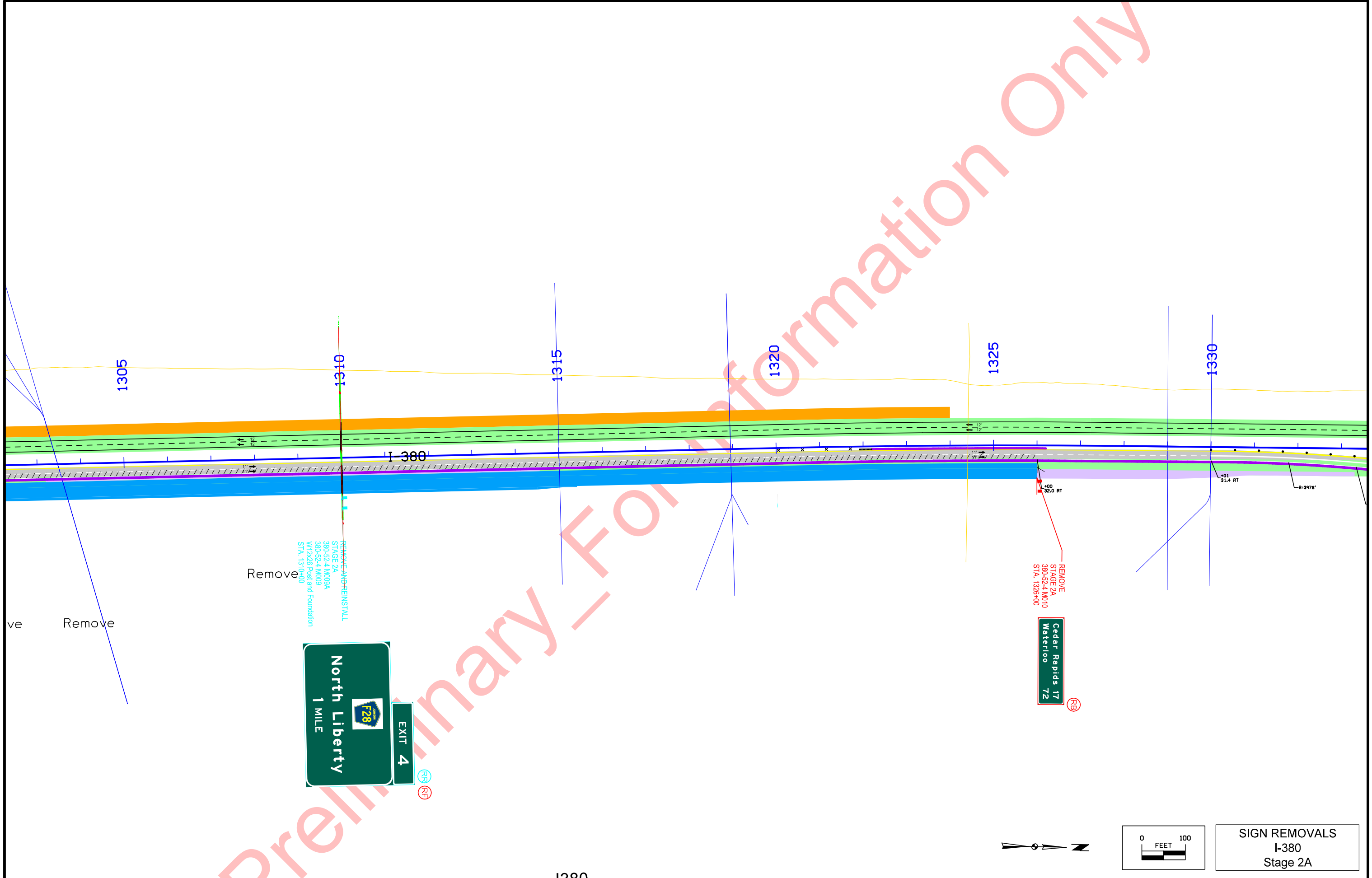

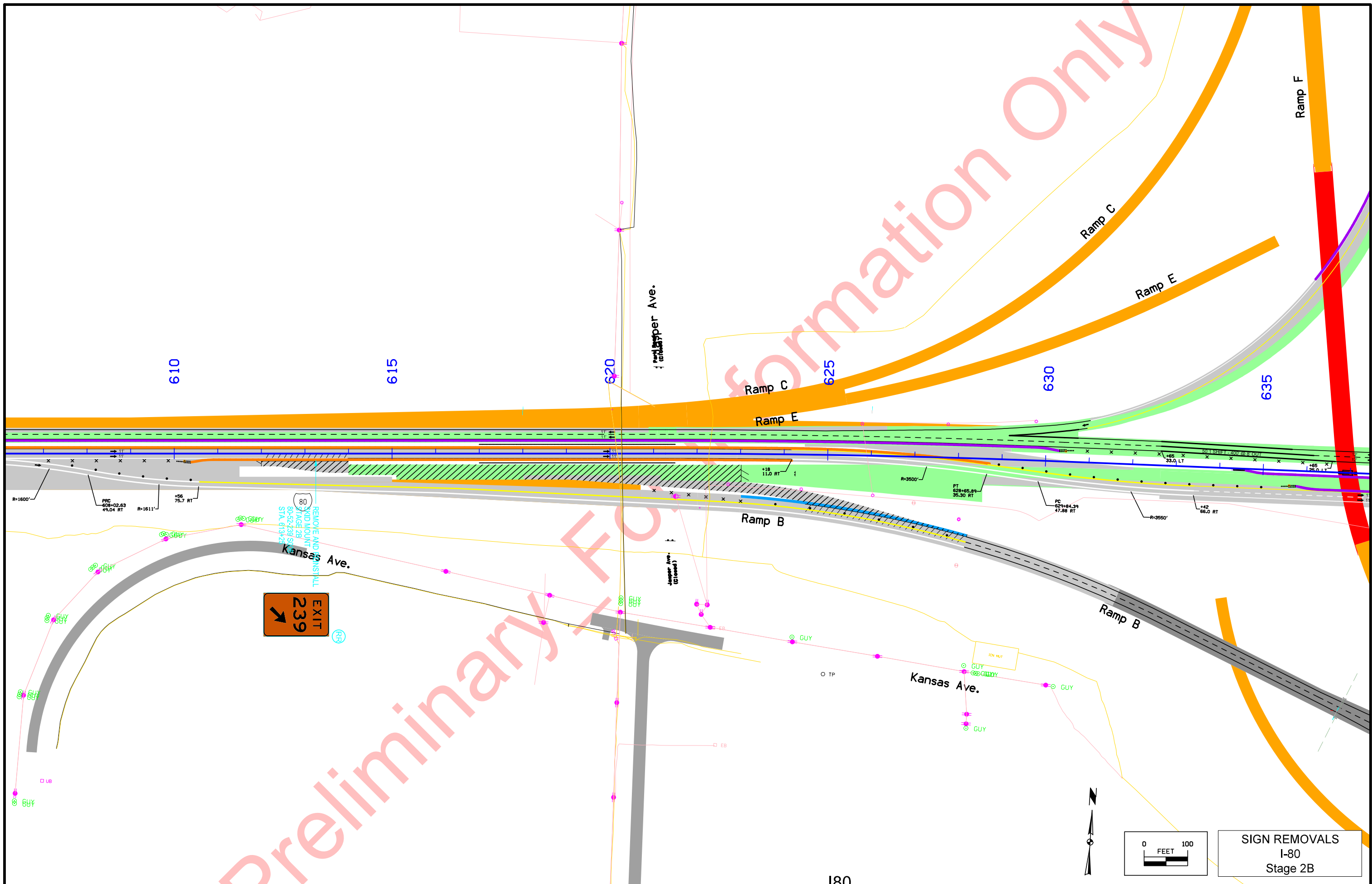

**EXIT 239**

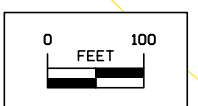

**SIGN REMOVALS**  
I-80  
Stage 2B



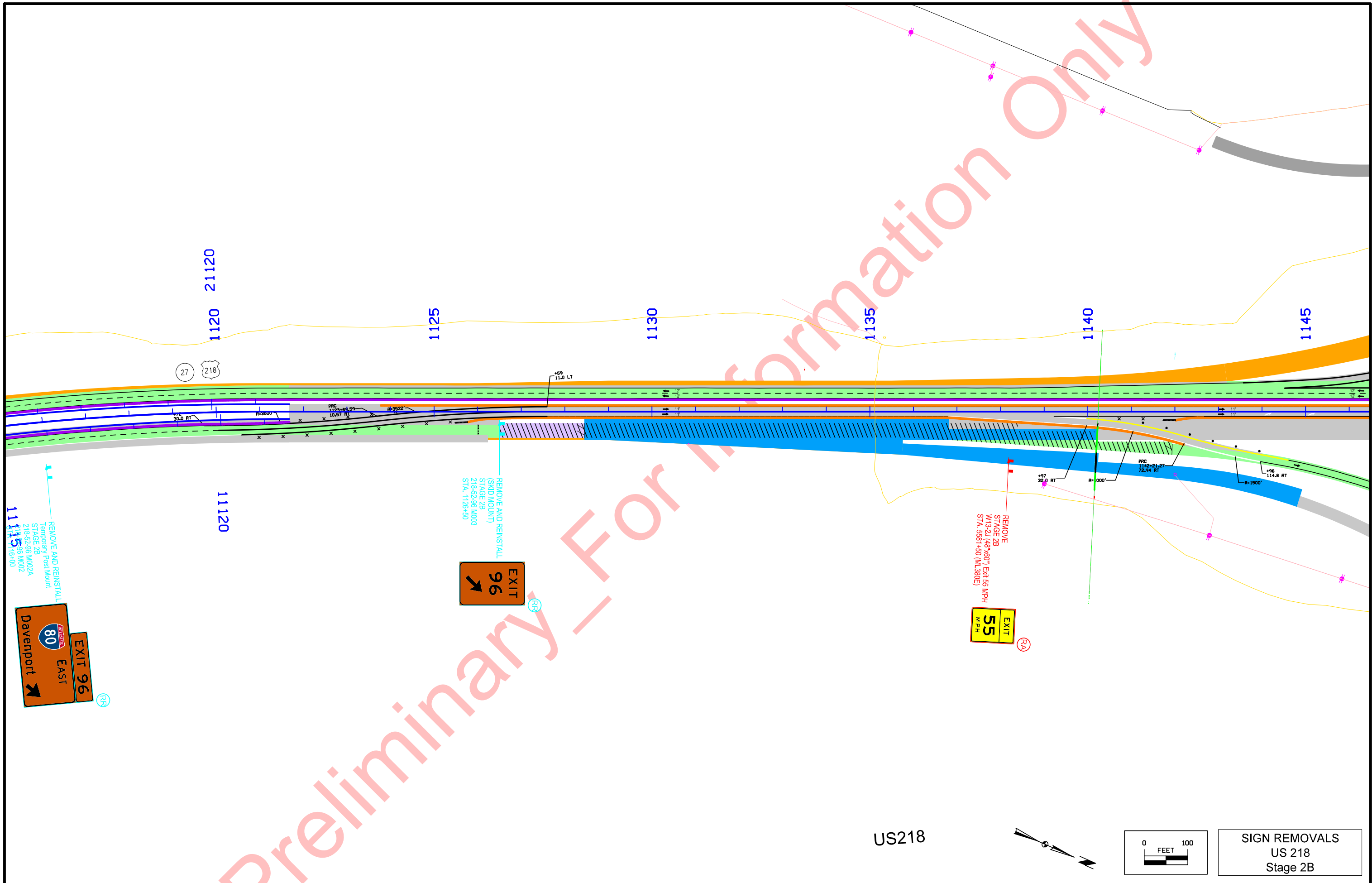

US218

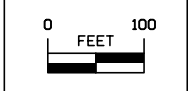

SIGN REMOVALS  
US 218  
Stage 2B

Preliminary - For Information Only

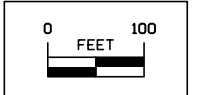
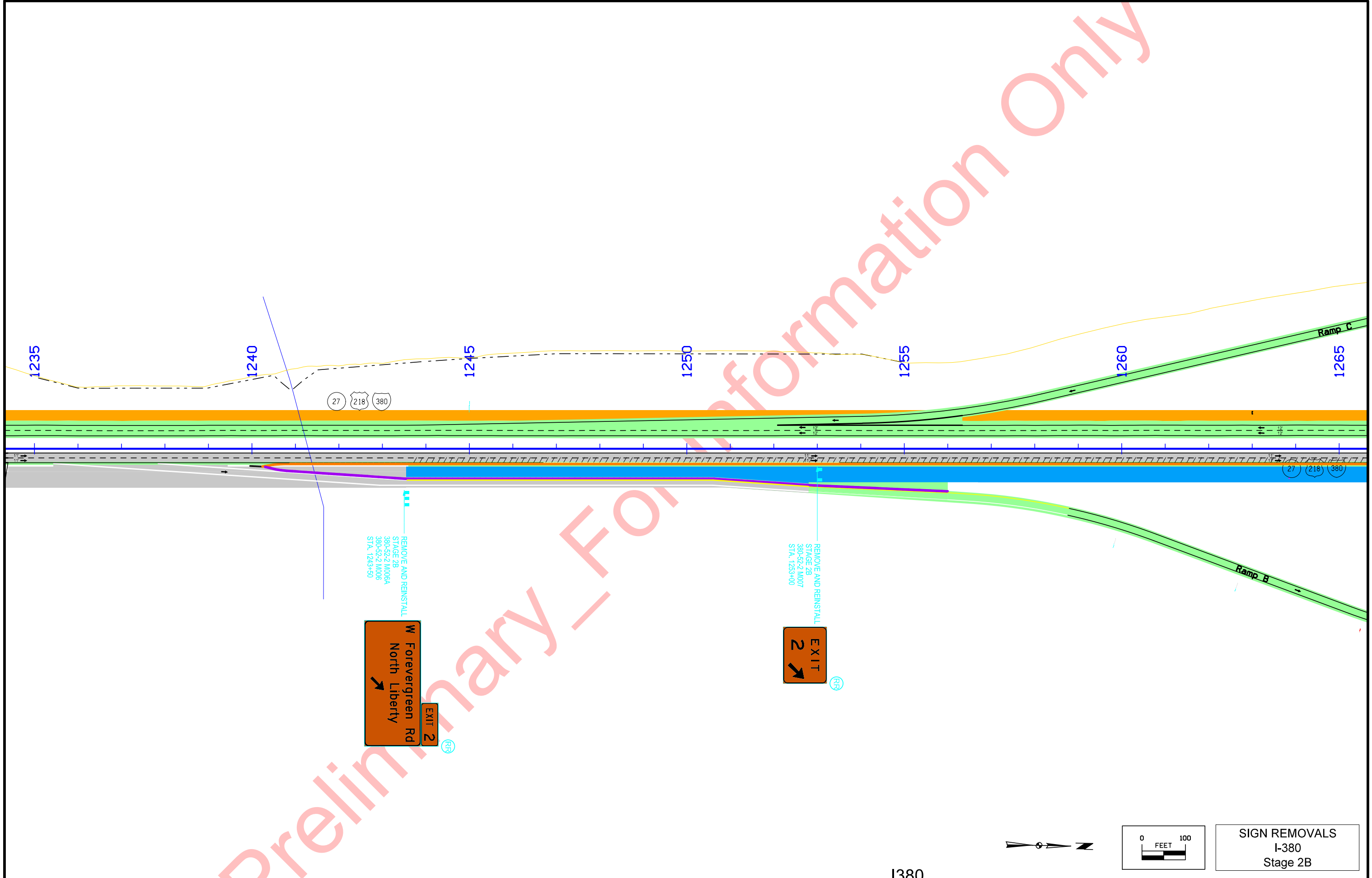

SIGN REMOVALS  
I-380  
Stage 2B

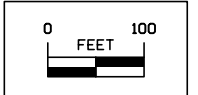
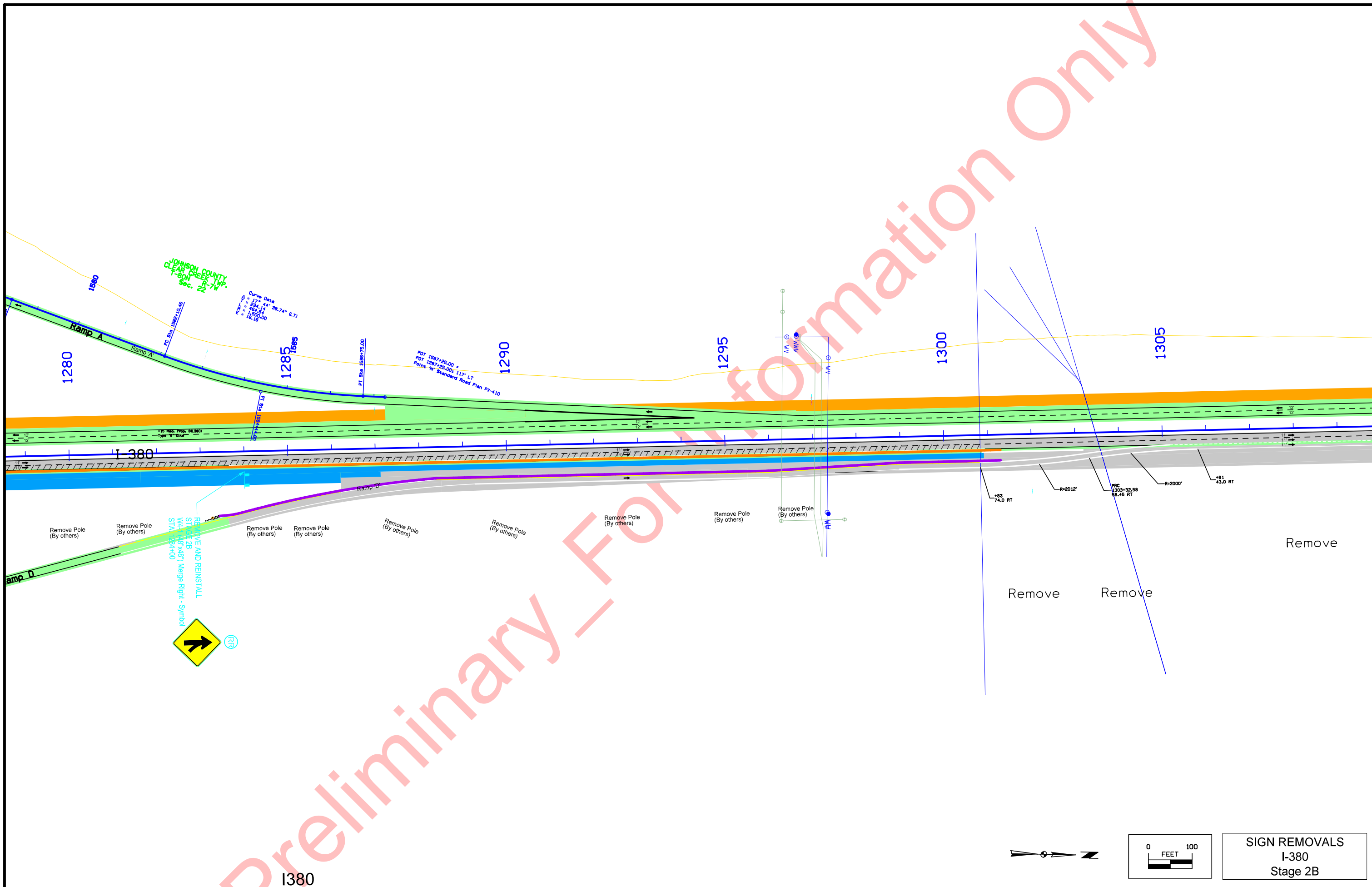

**SIGN REMOVALS**  
I-380  
Stage 2B

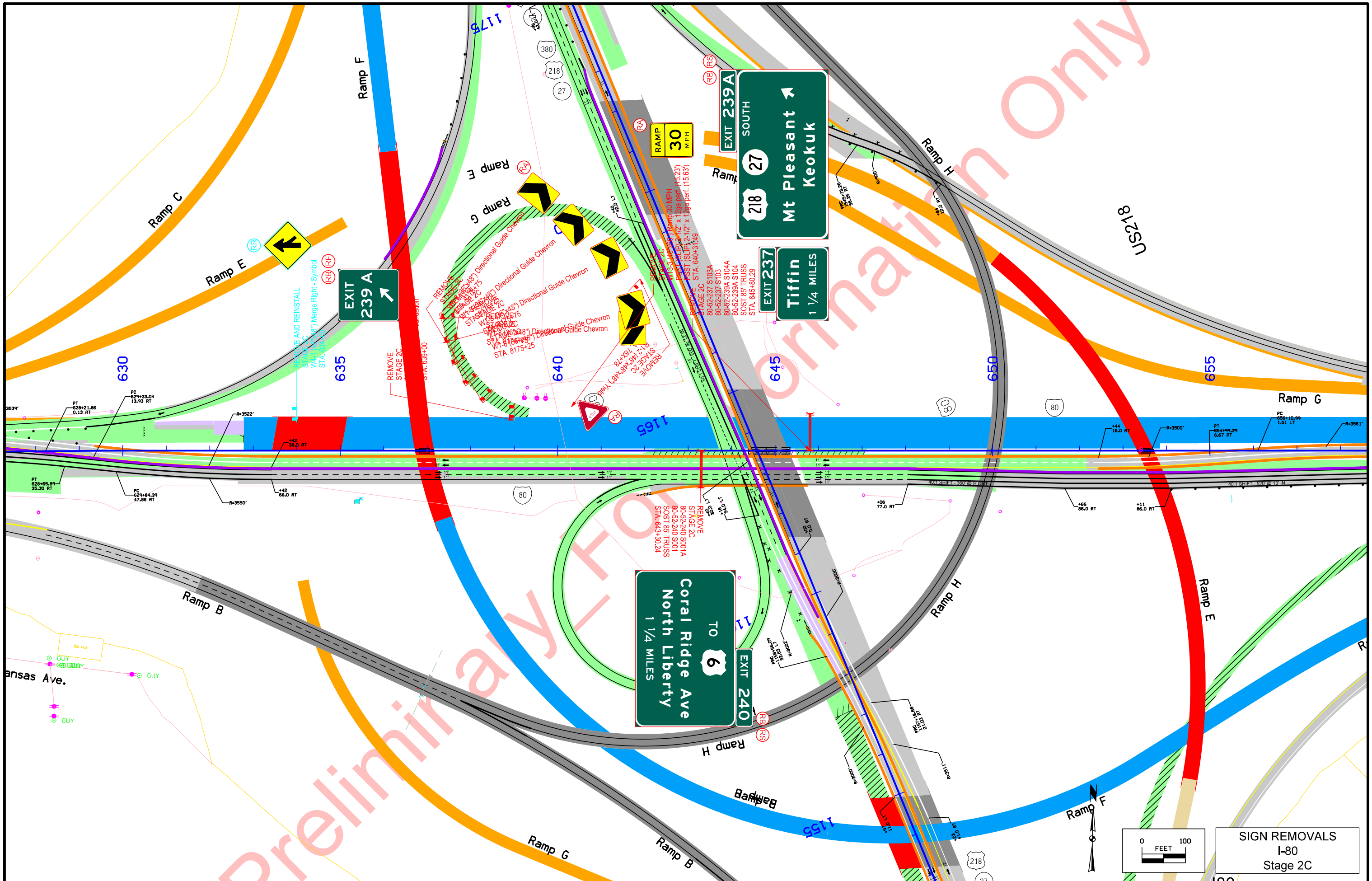

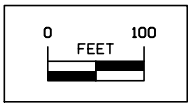
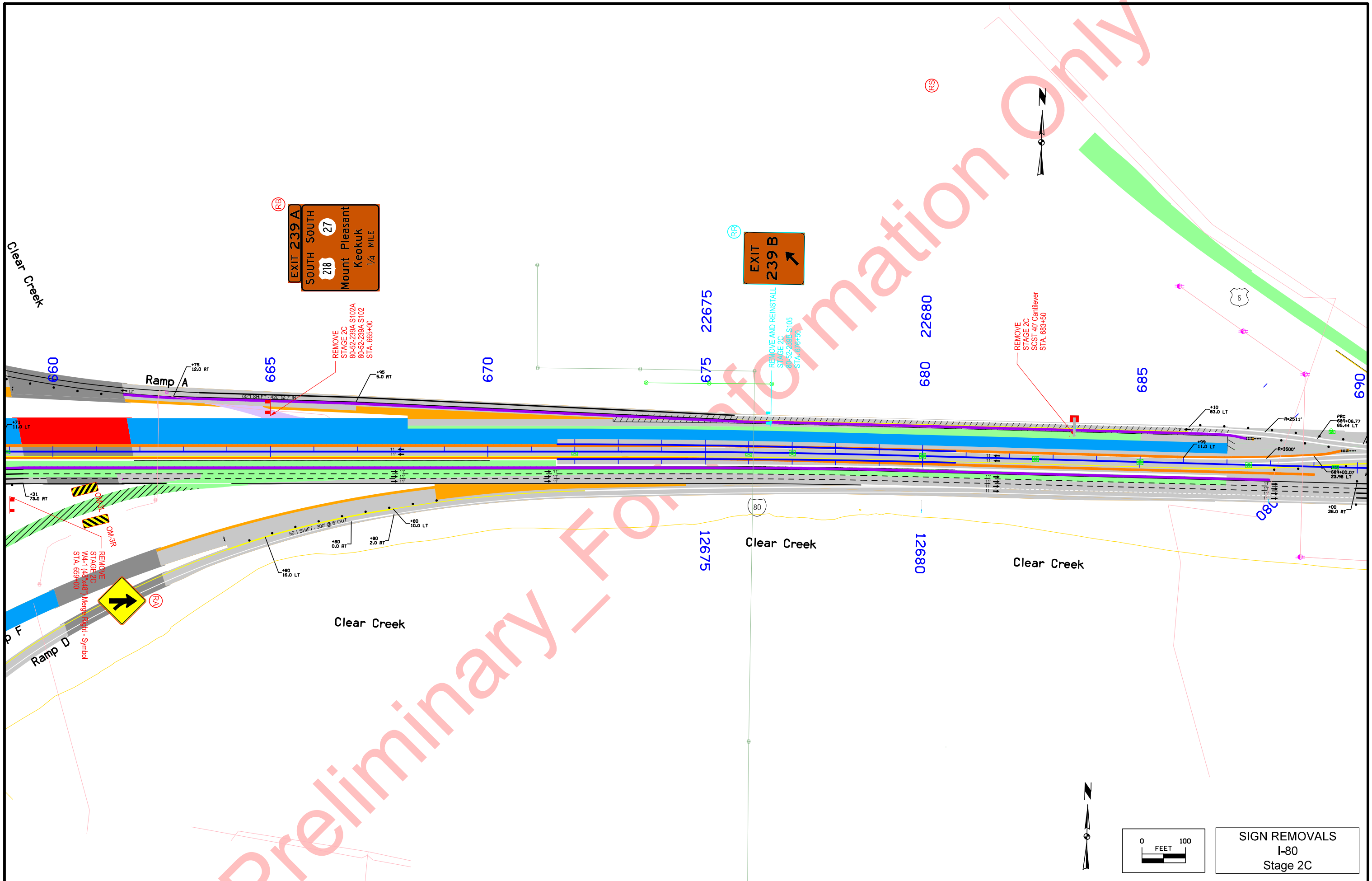

SIGN REMOVALS  
I-80  
Stage 2C

Primary Information Only

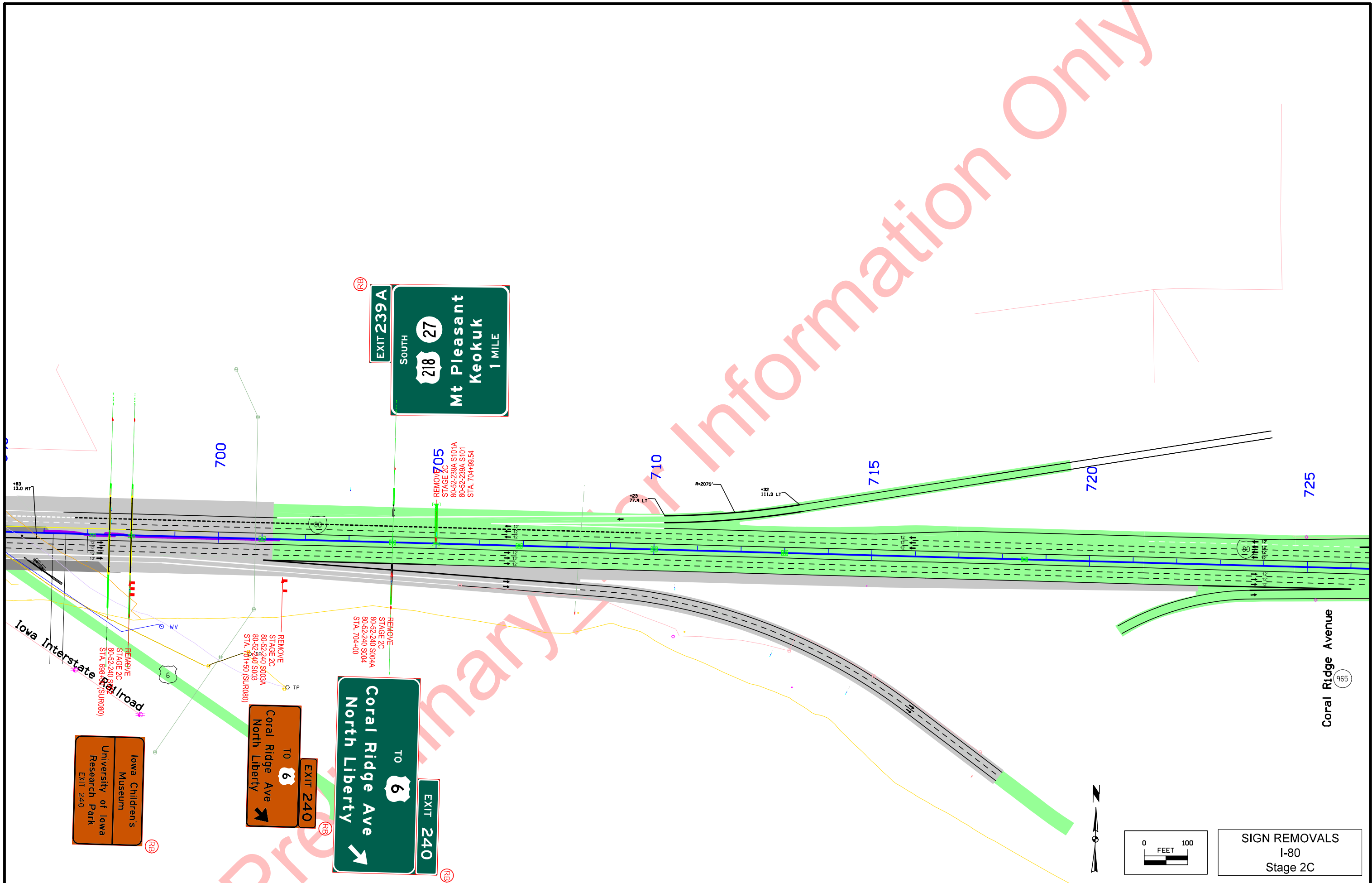

Iowa Children's Museum  
University of Iowa Research Park  
EXIT 240

TO 6  
Coral Ridge Ave  
North Liberty  
EXIT 240

TO 6  
Coral Ridge Ave  
North Liberty  
EXIT 240

EXIT 239A SOUTH  
218 27  
Mt Pleasant  
Keokuk  
1 MILE

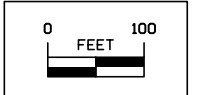

SIGN REMOVALS  
I-80  
Stage 2C

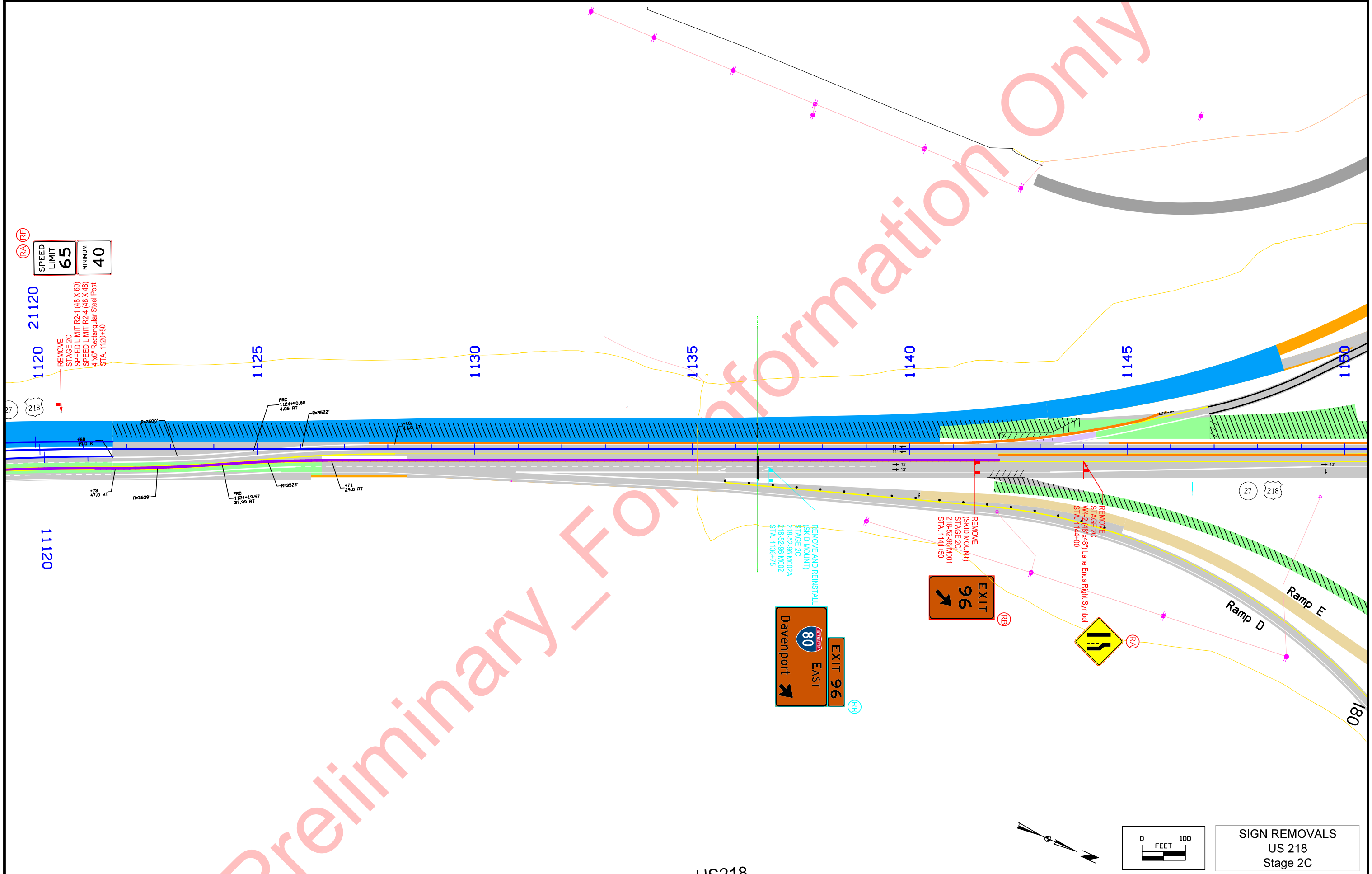

RA (RF)  
 SPEED LIMIT 65  
 MINIMUM 40

REMOVE STAGE 2C  
 SPEED LIMIT R2-1 (48 X 60)  
 SPEED LIMIT R2-4 (48 X 48)  
 4"x6" Rectangular Steel Post  
 STA. 1120+50

REMOVE AND REINSTALL  
 (SKID MOUNT)  
 STAGE 2C  
 218-52-96 M002A  
 218-52-96 M002  
 STA. 1138+75

REMOVE  
 (SKID MOUNT)  
 STAGE 2C  
 218-52-96 M001  
 STA. 1144+50

REMOVE  
 STAGE 2C  
 W-2 (48" X 48") Lane Ends Right Symbol  
 STA. 1144+00

EXIT 96 EAST  
 Davenport

EXIT 96

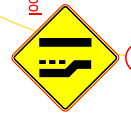

Ramp D

Ramp E

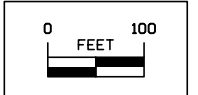

SIGN REMOVALS  
 US 218  
 Stage 2C

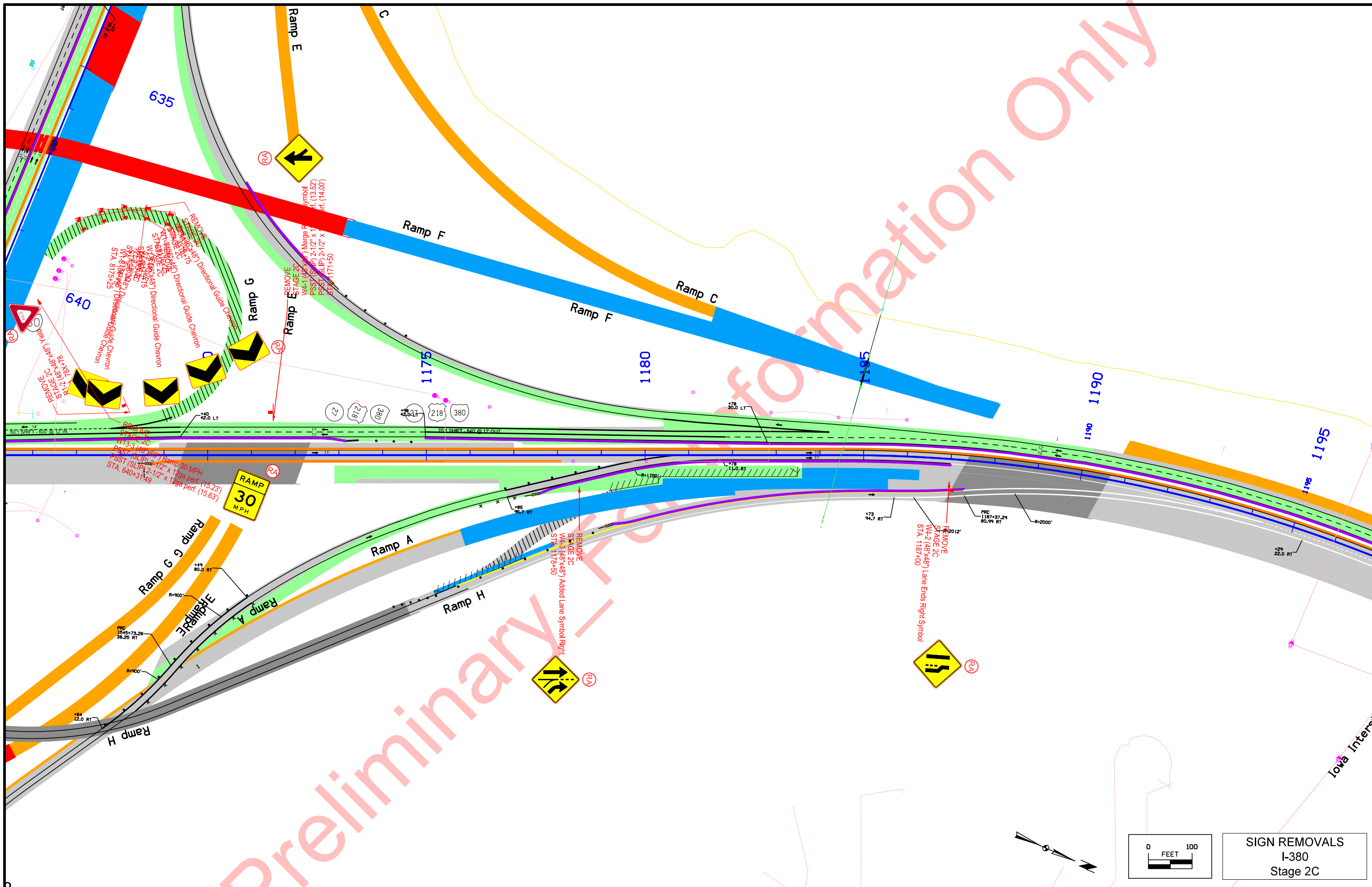

SIGN REMOVALS  
I-380  
Stage 2C

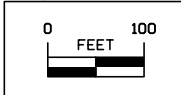



Preliminary FOR INFORMATION ONLY

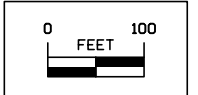
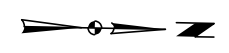
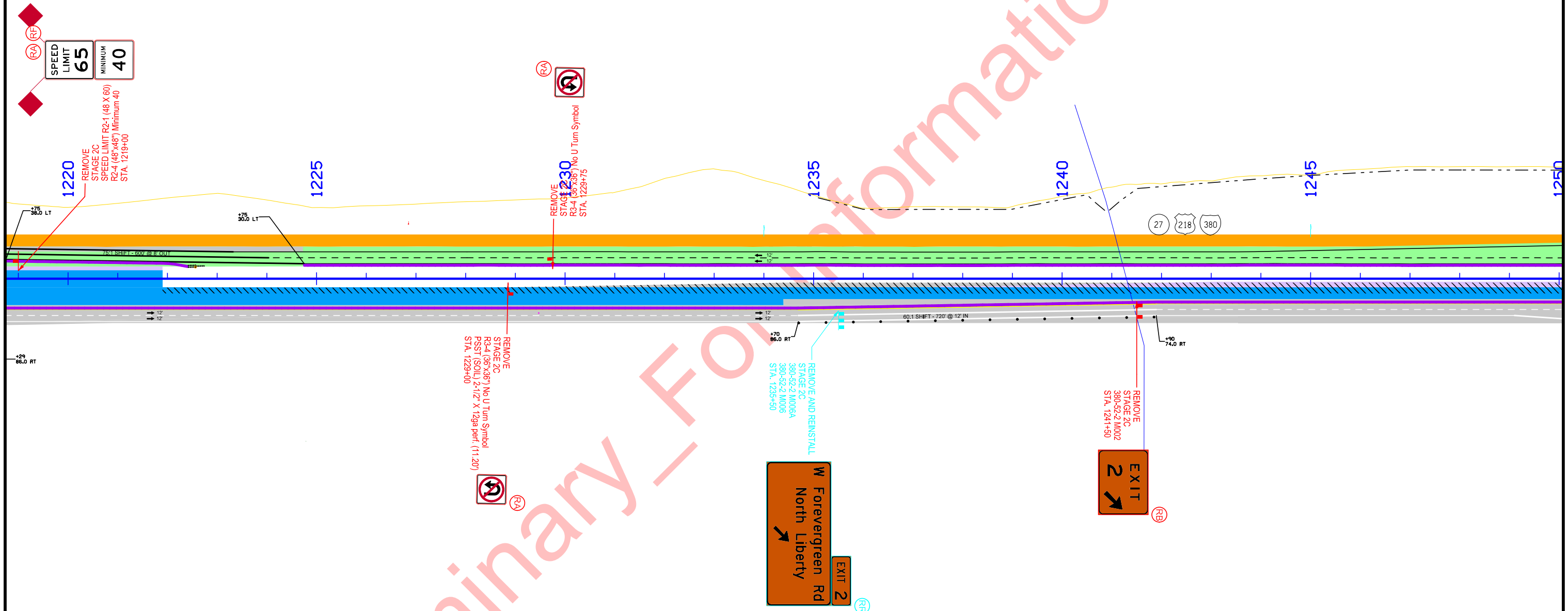

SIGN REMOVALS  
I-380  
Stage 2C

Preliminary - For Information Only

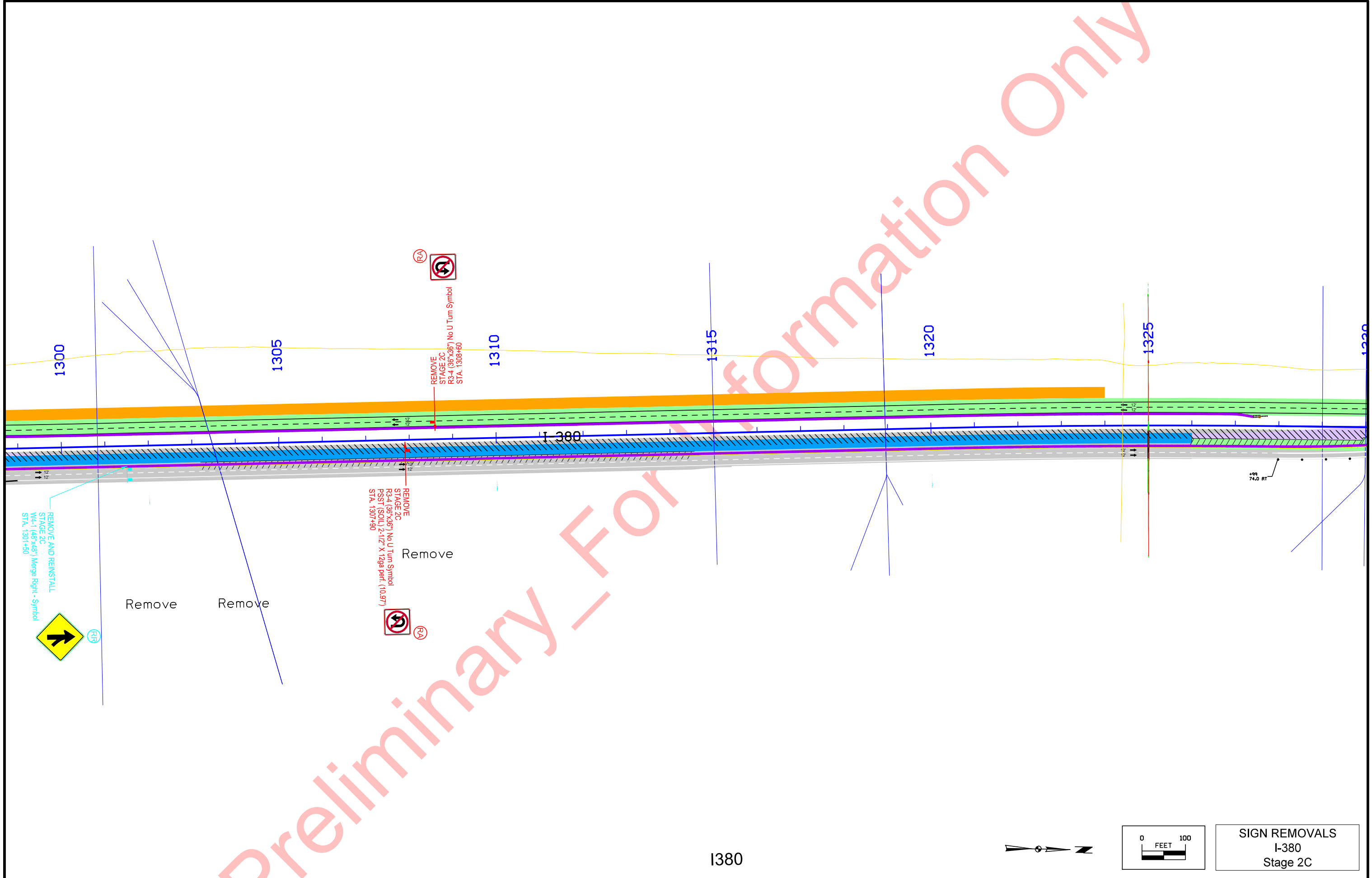

I-380

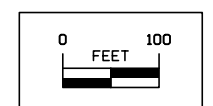
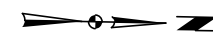

SIGN REMOVALS  
I-380  
Stage 2C

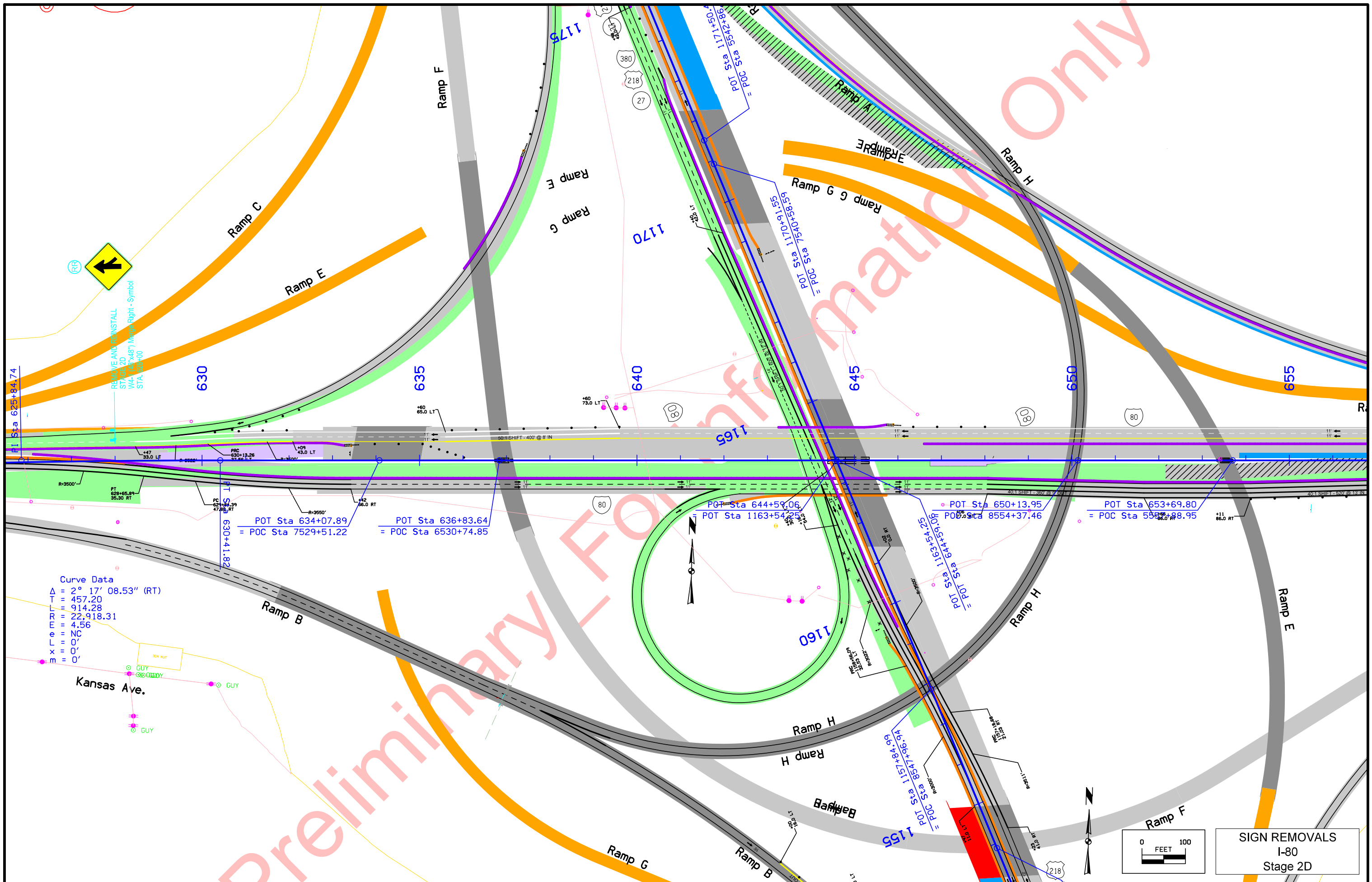

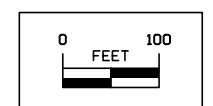
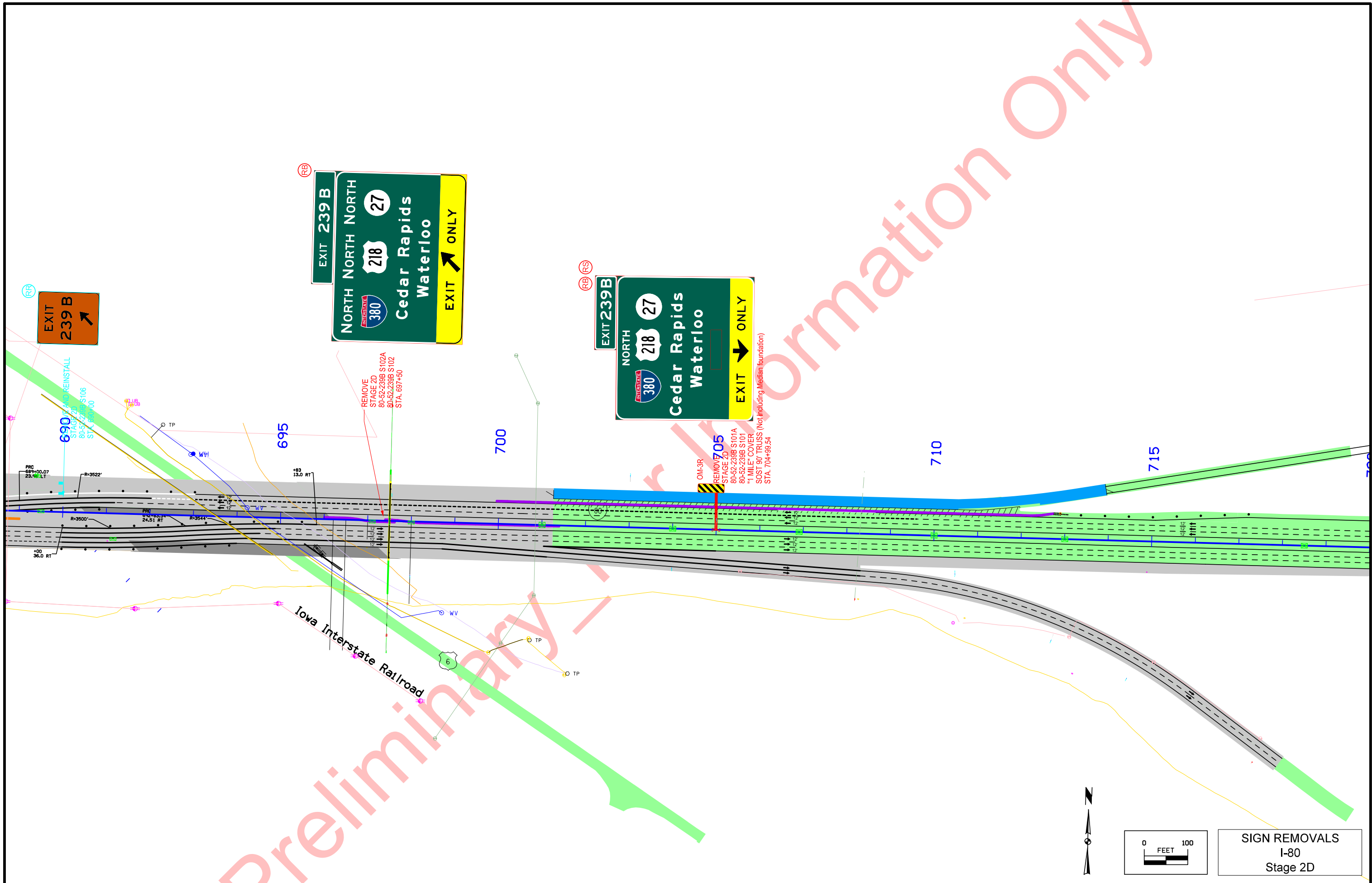

SIGN REMOVALS  
I-80  
Stage 2D

Preliminary FOR INFORMATION ONLY

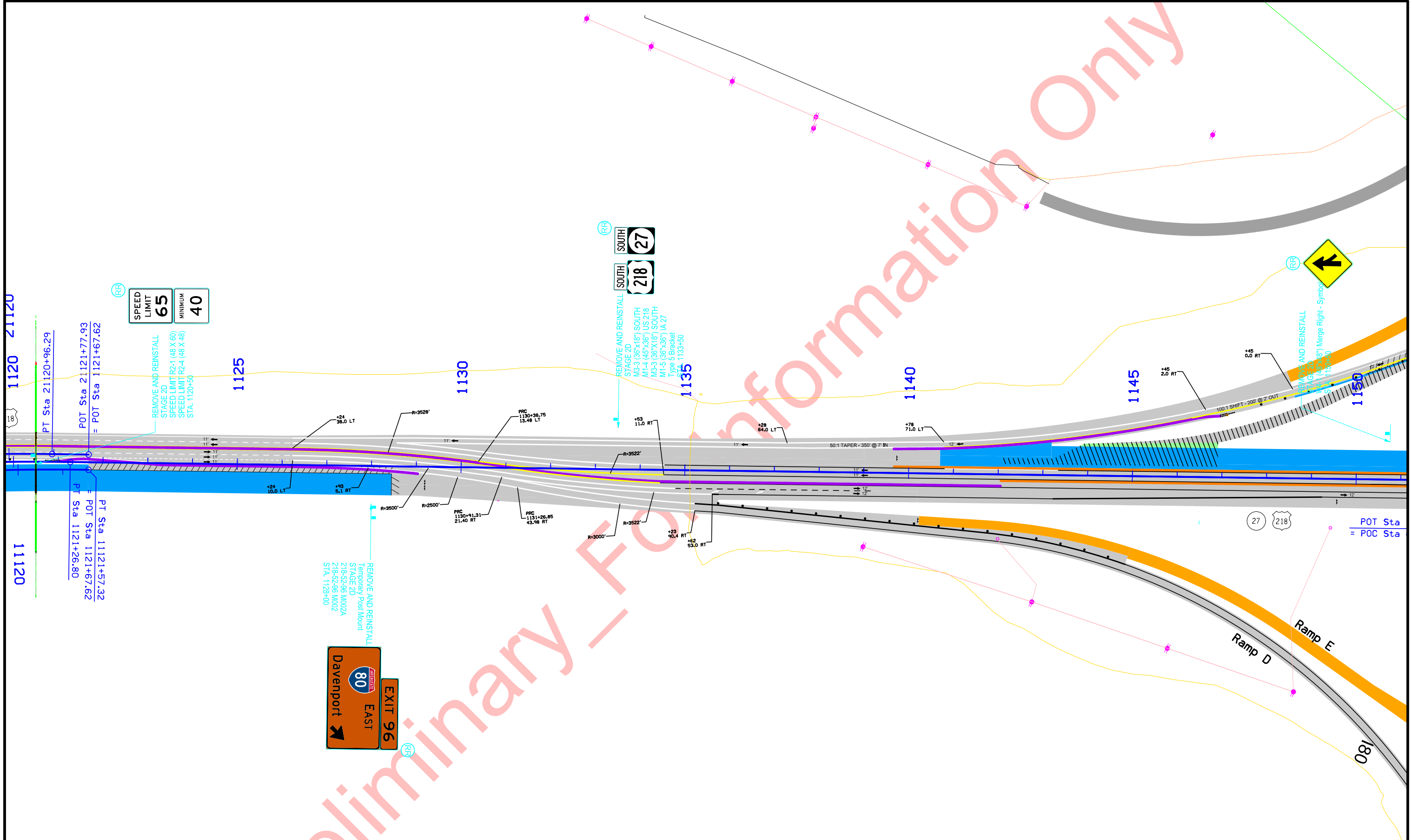

SPEED LIMIT 65  
MINIMUM 40

SOUTH 27  
SOUTH 218



EXIT 96  
EAST  
Davenport

POT Sta = POC Sta

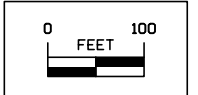
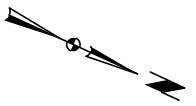

SIGN REMOVALS  
US 218  
Stage 2D

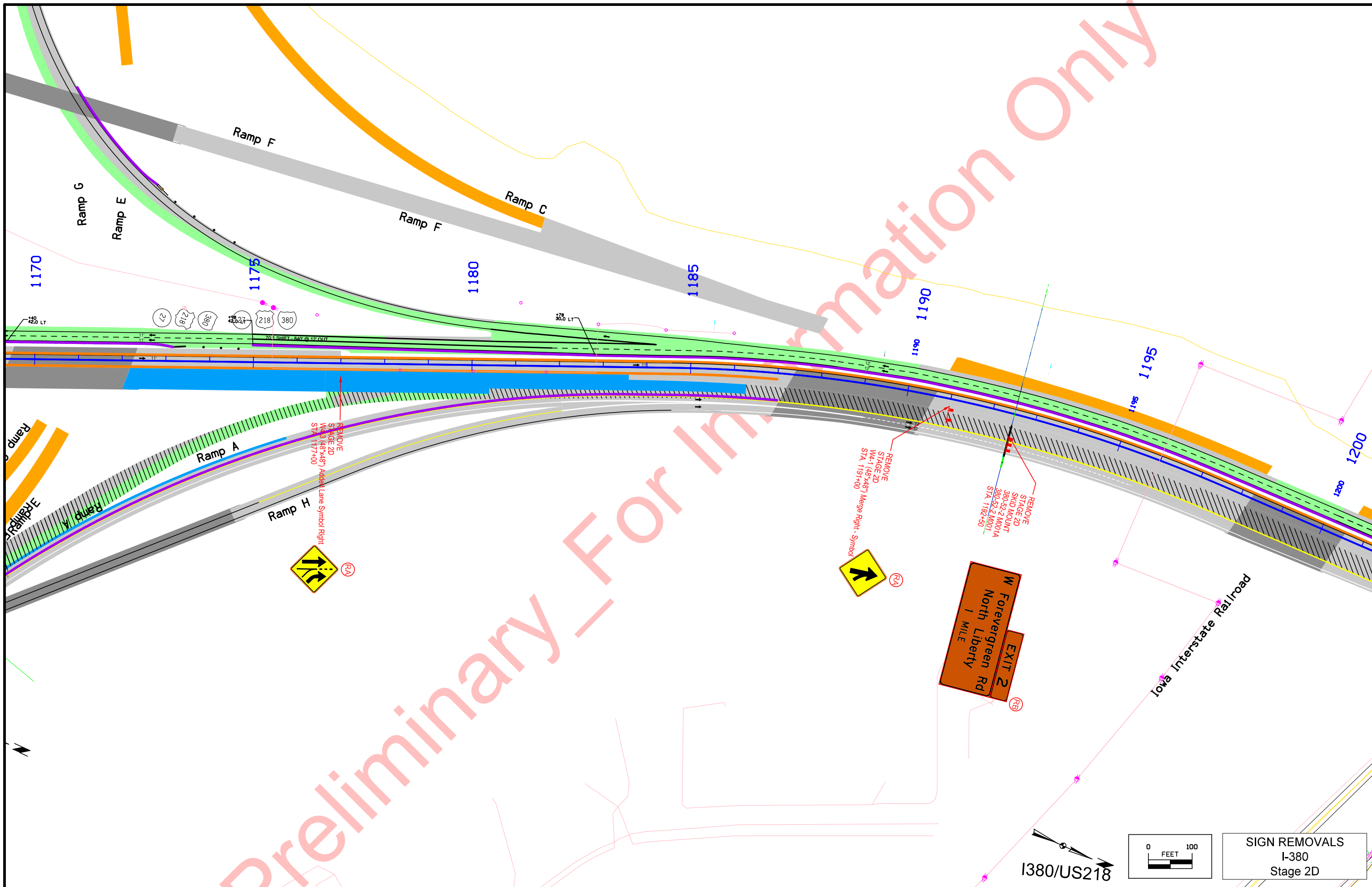

Preliminary - For Information Only

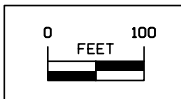

**SIGN REMOVALS**  
I-380  
Stage 2D

Preliminary Information Only

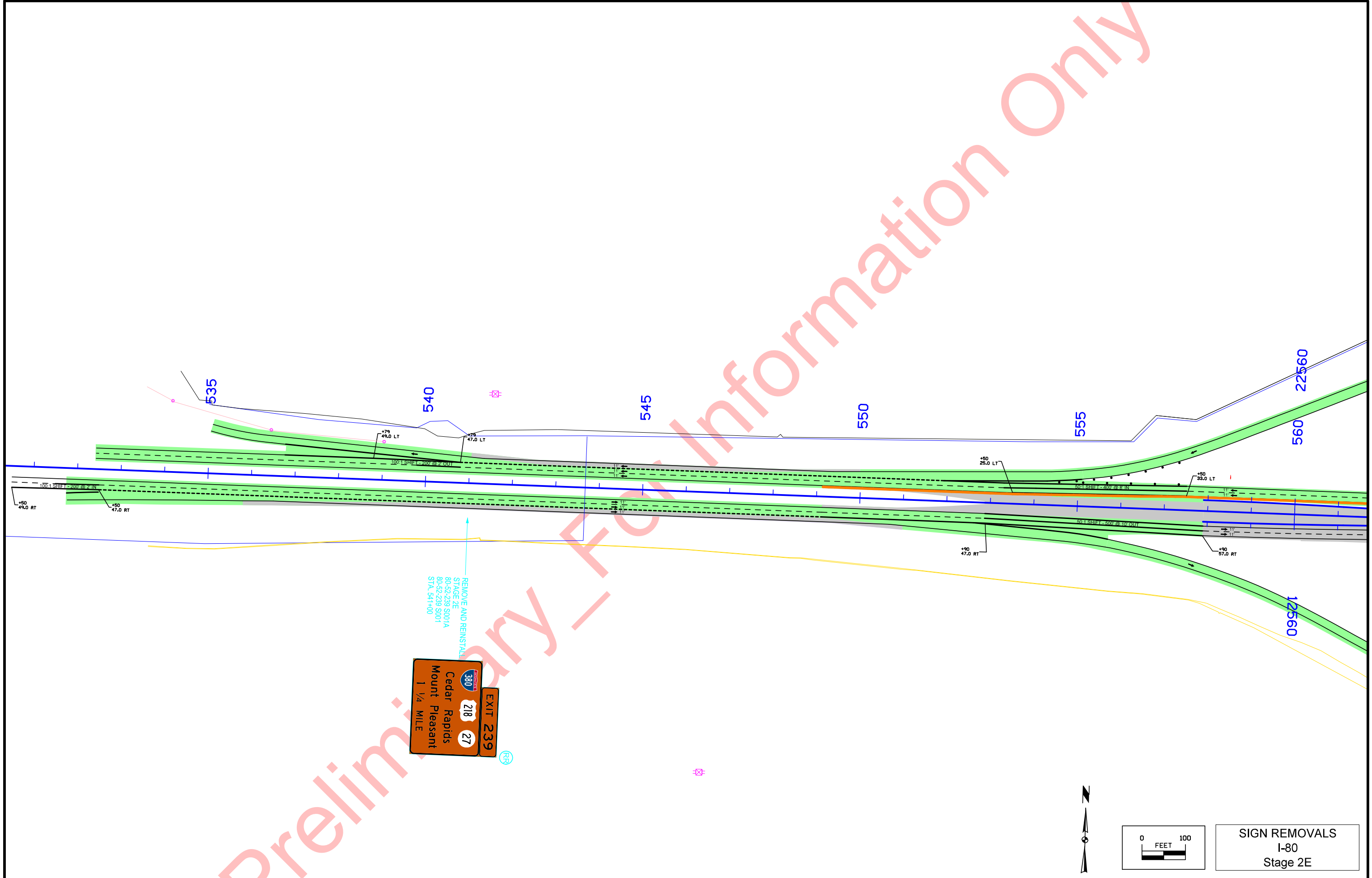

REMOVE AND REINSTALL  
STAGE 2E  
80-52-239 S001A  
80-52-239 S001  
STA. 541+00

EXIT 239  
380  
218 27  
Cedar Rapids  
Mount Pleasant  
1 1/4 MILE

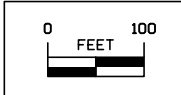

SIGN REMOVALS  
I-80  
Stage 2E

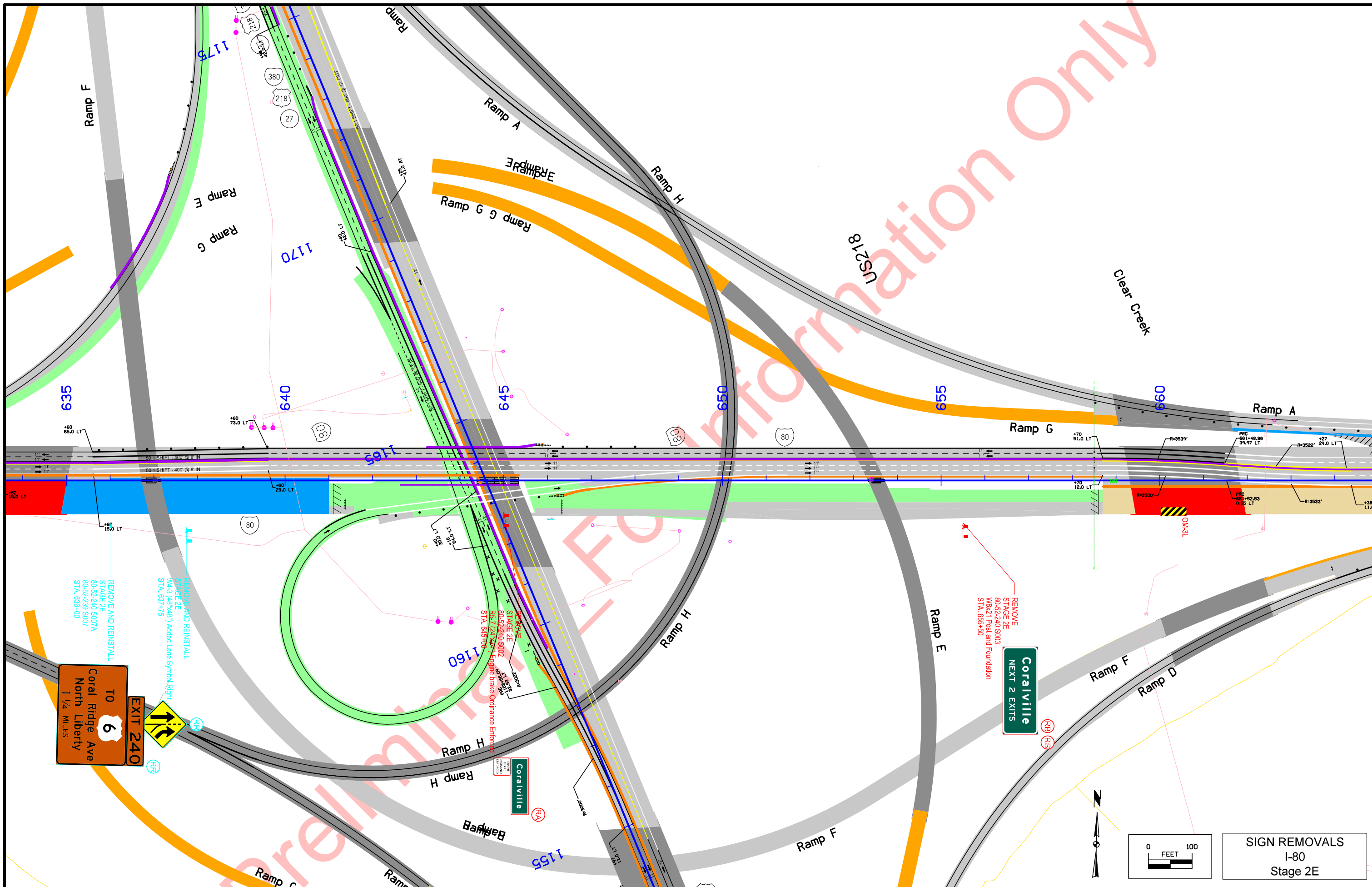

TO  
 6  
 Coral Ridge Ave  
 North Liberty  
 1 1/4 MILES

EXIT 240

Coralville  
 NEXT 2 EXITS

Coralville

SIGN REMOVALS  
 I-80  
 Stage 2E



Information Only

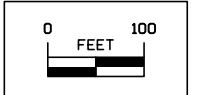
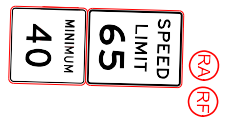
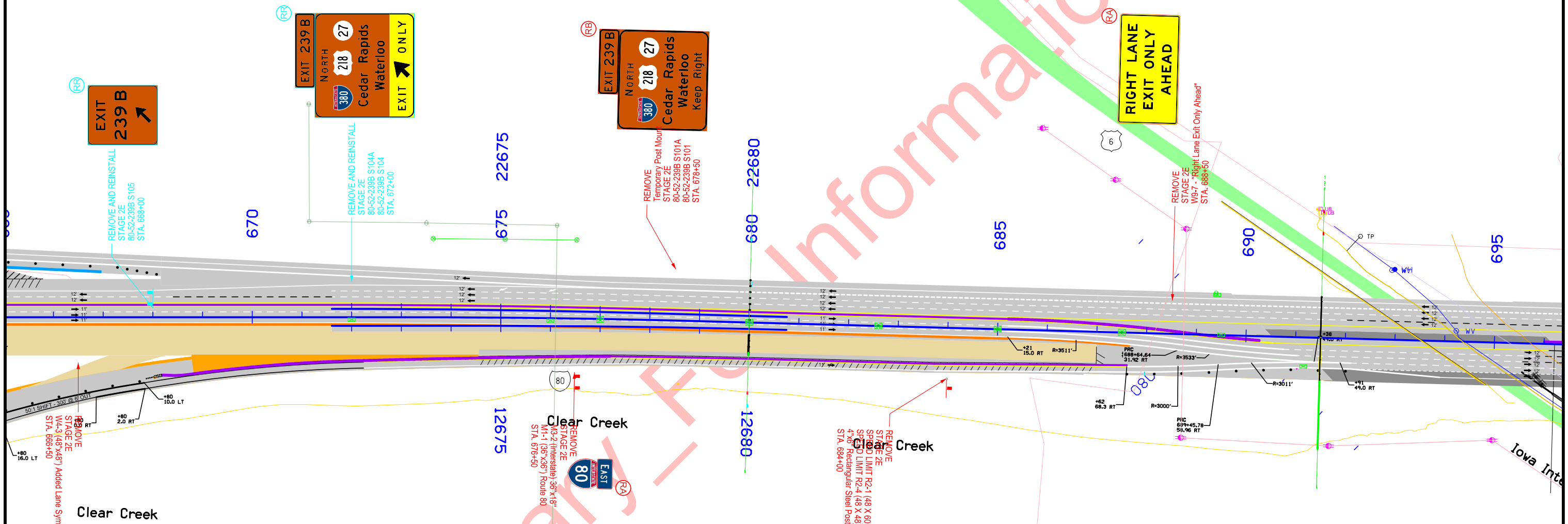

SIGN REMOVALS  
I-80  
Stage 2E

Preliminary Information Only

RIGHT LANE  
EXIT ONLY  
AHEAD



REMOVE  
STAGE 2E  
W9-7 - "Right Lane Exit Only Ahead"  
STA. 688+50

REMOVE  
STAGE 2E  
W4-1 (48"x48") Merge Right - Symbol  
STA. 713+50

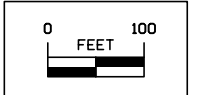
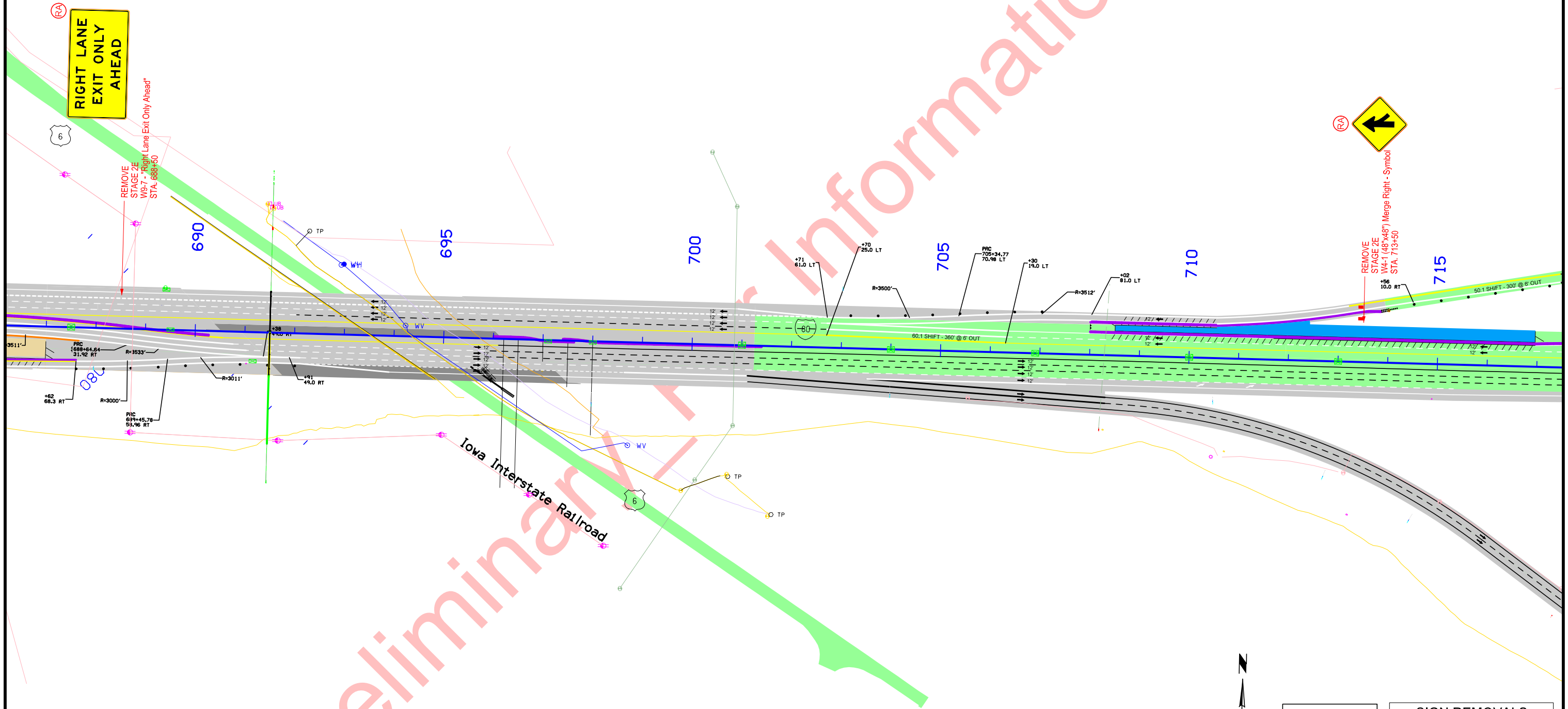

SIGN REMOVALS  
I-80  
Stage 2E

Preliminary Information Only

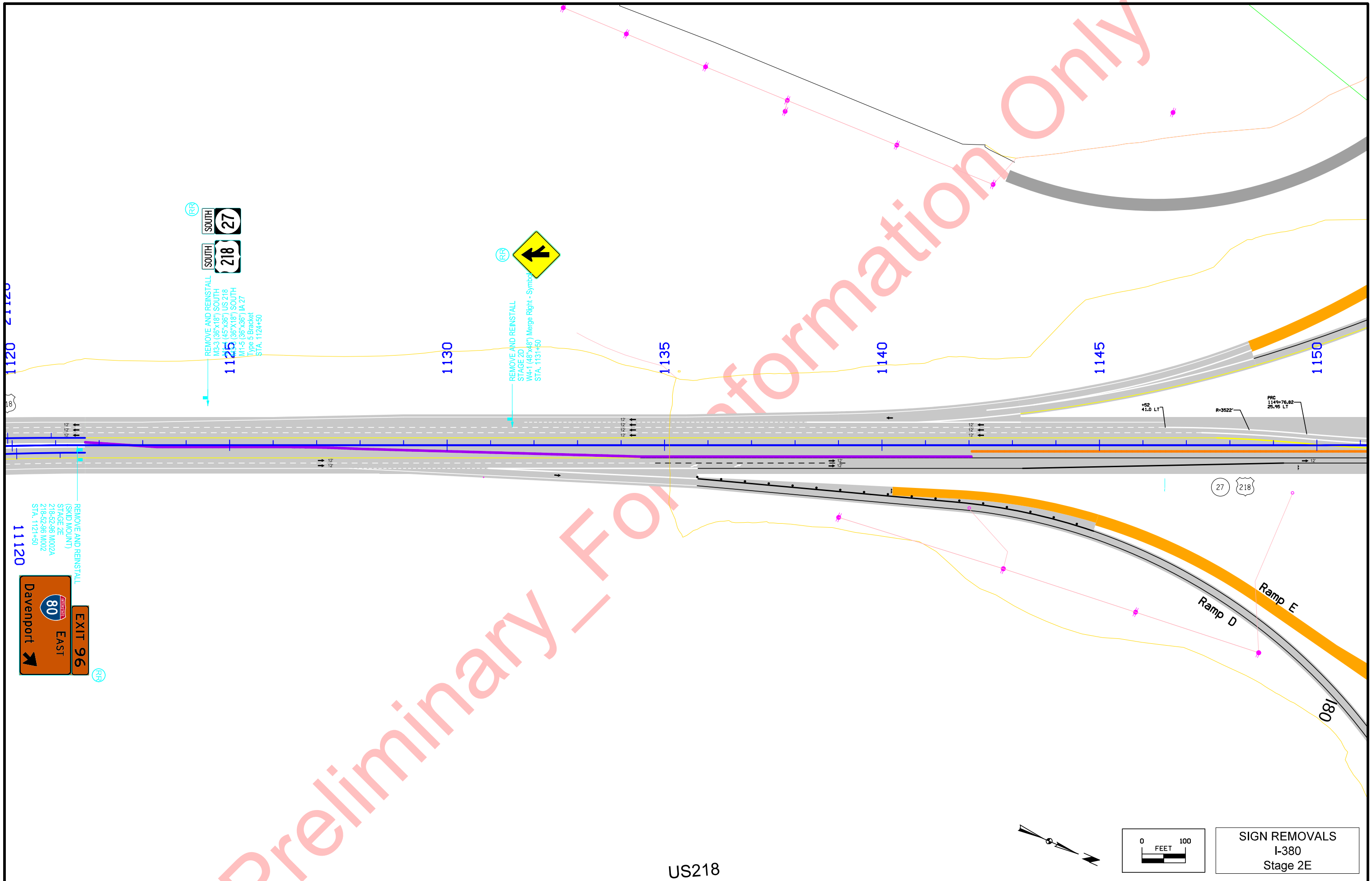

REMOVE AND REINSTALL  
(SKID MOUNT)  
STAGE 2E  
218-52-96 M002A  
218-52-96 M002  
STA. 1121+50

**EXIT 96**  
**80 EAST**  
Davenport

REMOVE AND REINSTALL  
SOUTH 218  
SOUTH 27  
M3-3 (36"x18") SOUTH  
(45"x36") US 218  
M1-5 (36"x36") IA 27  
Type 5 Bracket  
STA. 1124+50

REMOVE AND REINSTALL  
STAGE 2D  
WA-1 (48"x48") Merge Right - Symbol  
STA. 1131+50

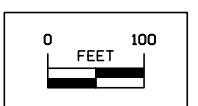

SIGN REMOVALS  
I-380  
Stage 2E

US218

Preliminary Information Only

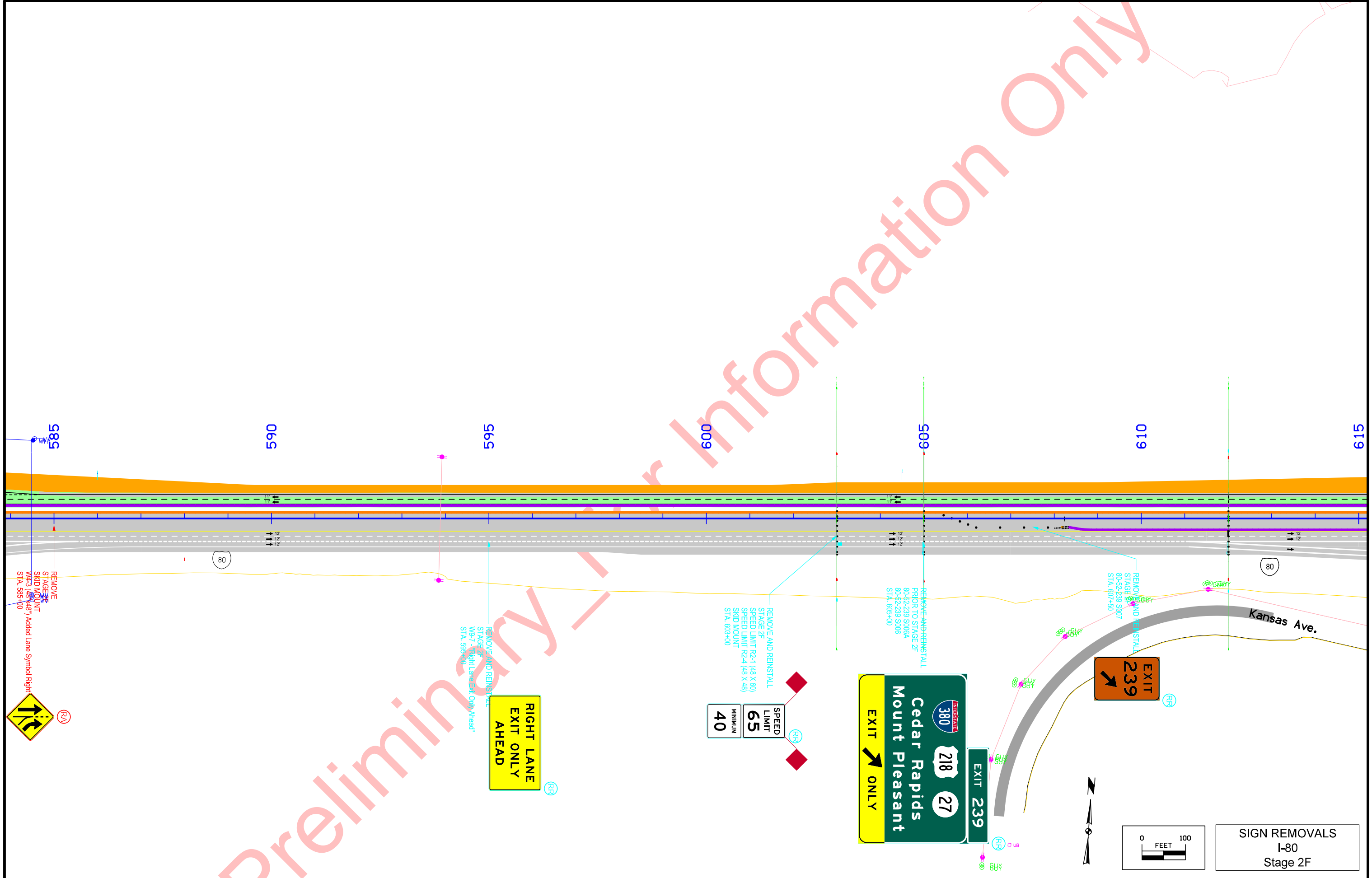

SIGN REMOVALS  
I-80  
Stage 2F

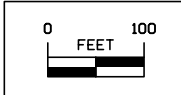

EXIT 239  
Cedar Rapids  
Mount Pleasant  
EXIT ONLY

SPEED LIMIT 65  
MINIMUM 40

RIGHT LANE  
EXIT ONLY  
AHEAD

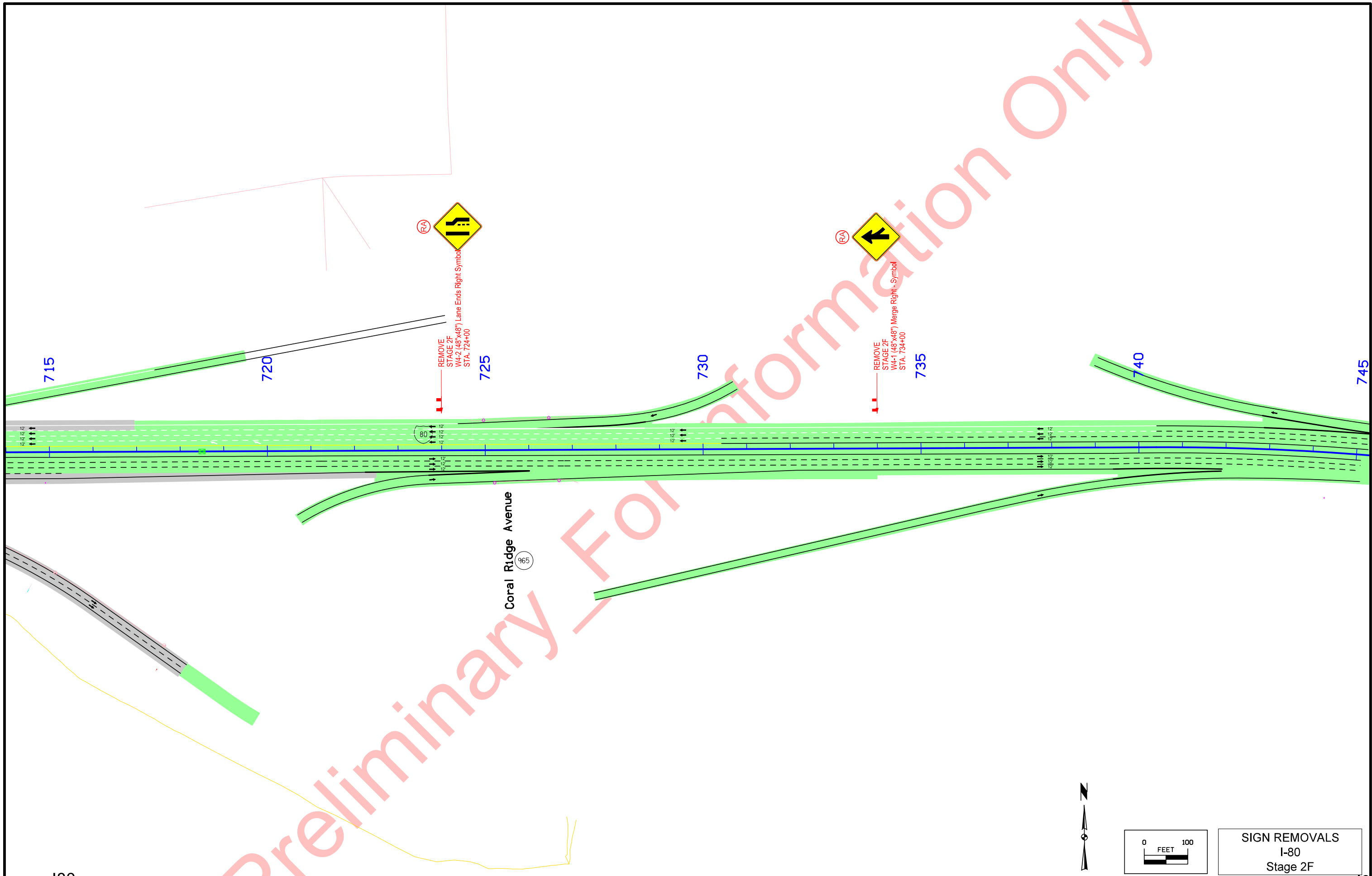

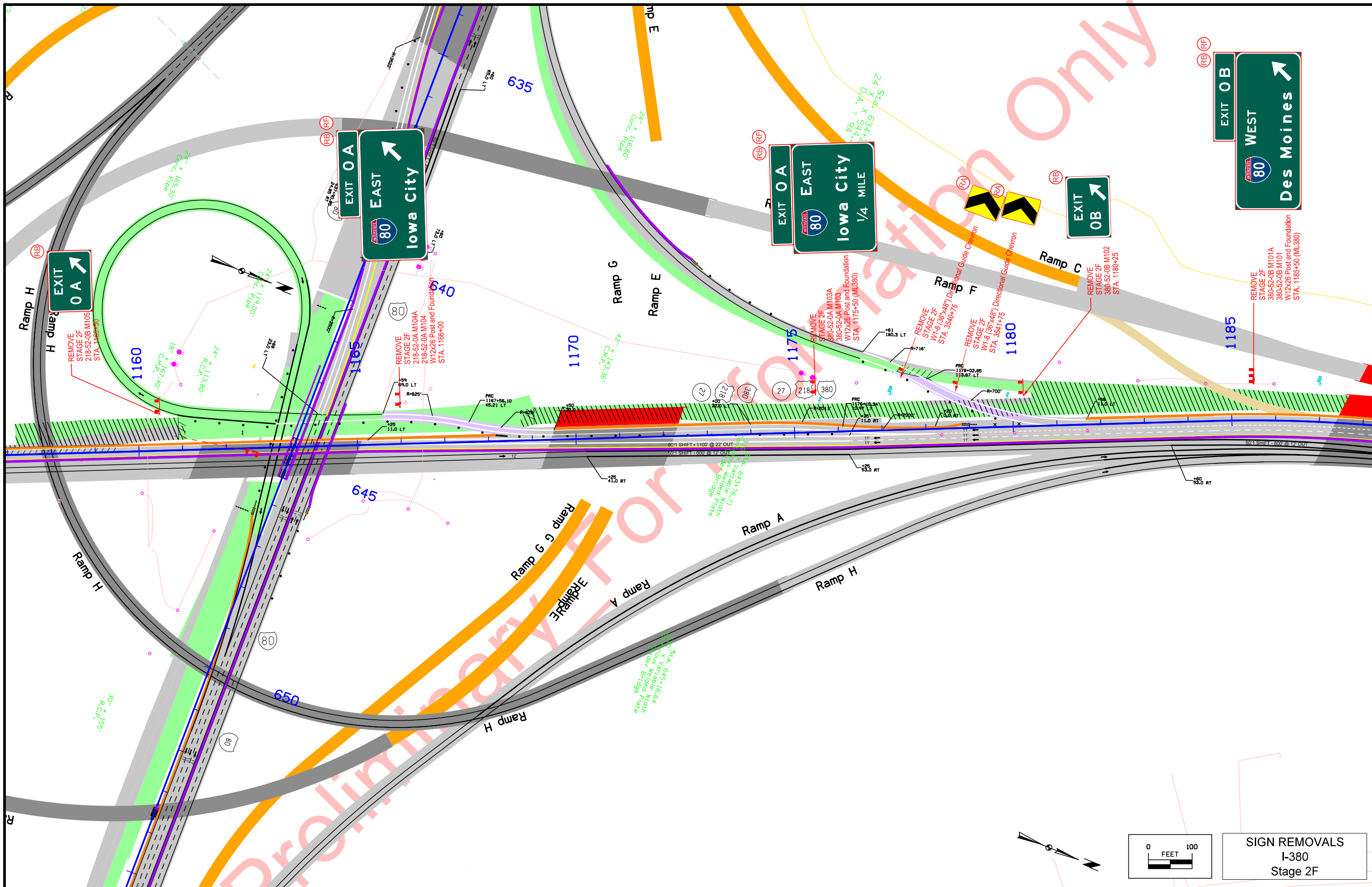

EXIT OB  
WEST  
80  
Des Moines

EXIT OA  
EAST  
80  
Iowa City  
1/4 MILE

EXIT OA  
EAST  
80  
Iowa City

EXIT OA

SIGN REMOVALS  
I-380  
Stage 2F

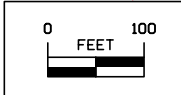



REMOVE AND REINSTALL  
STAGE 2F  
380-52-OB M109A  
380-52-OB M109  
STA. 1193+00 (ML380)



REMOVE AND REINSTALL  
STAGE 2F  
380-52-OA M108A  
380-52-OA M108  
STA. 1201+50 (ML380)

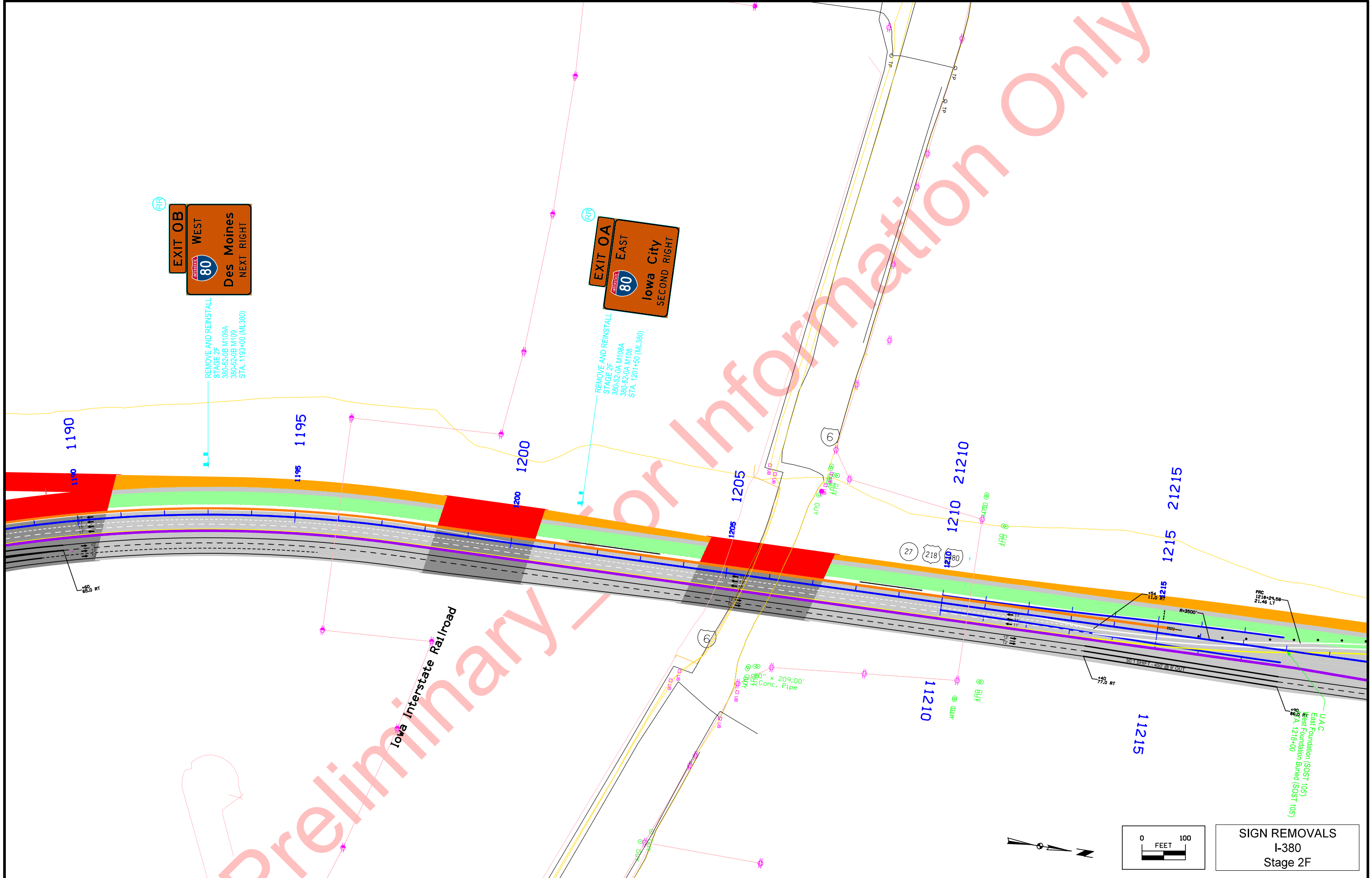

Iowa Interstate Rd/Iroad

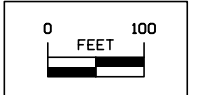

SIGN REMOVALS  
I-380  
Stage 2F

Preliminary - For Information Only

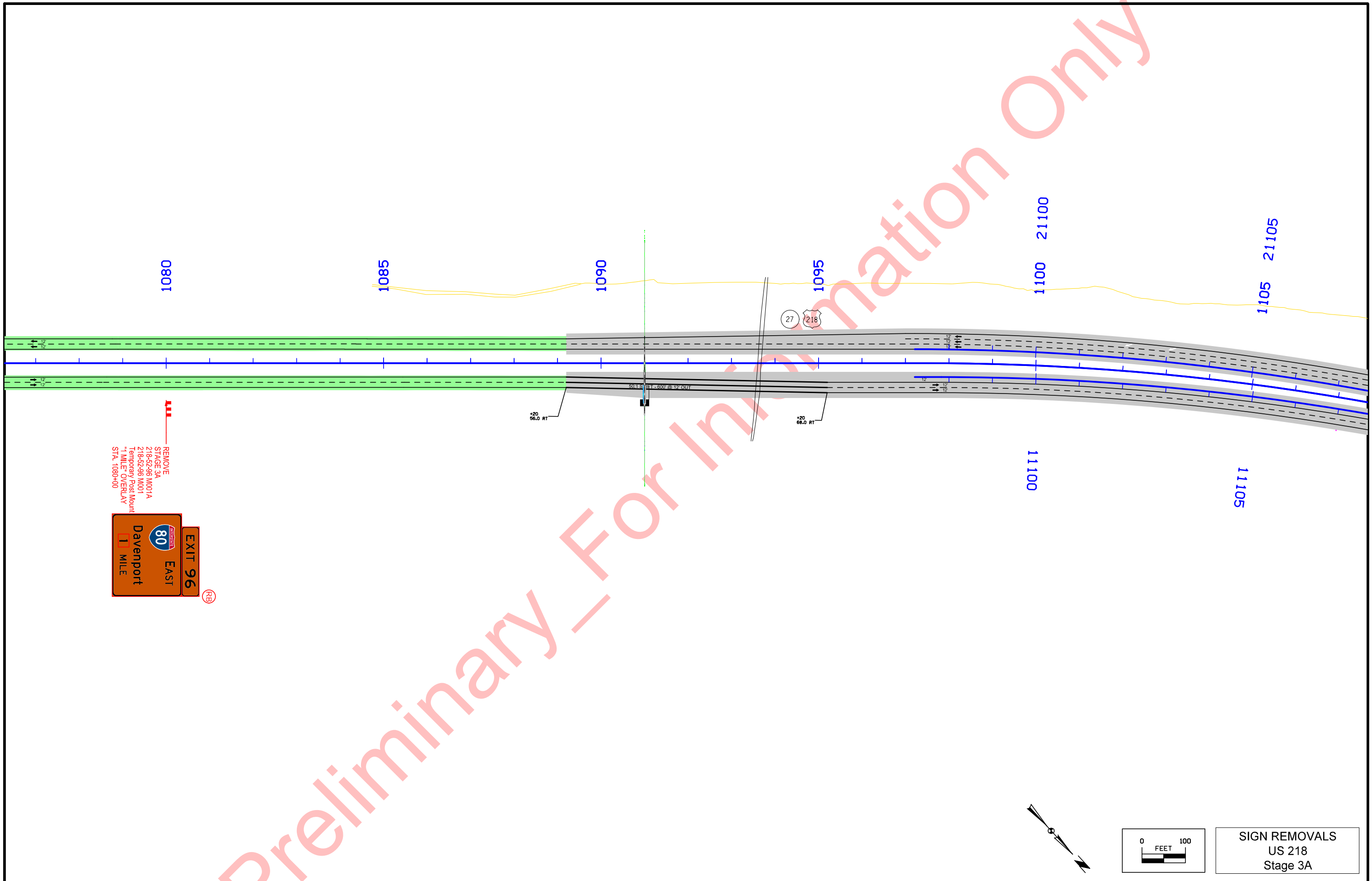

REMOVE  
 STAGE 3A  
 218-52-96 M001A  
 218-52-96 M001  
 Temporary Post Mount  
 1 MILE OVERLAY  
 STA. 1080+00

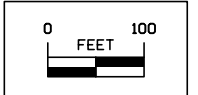

SIGN REMOVALS  
 US 218  
 Stage 3A



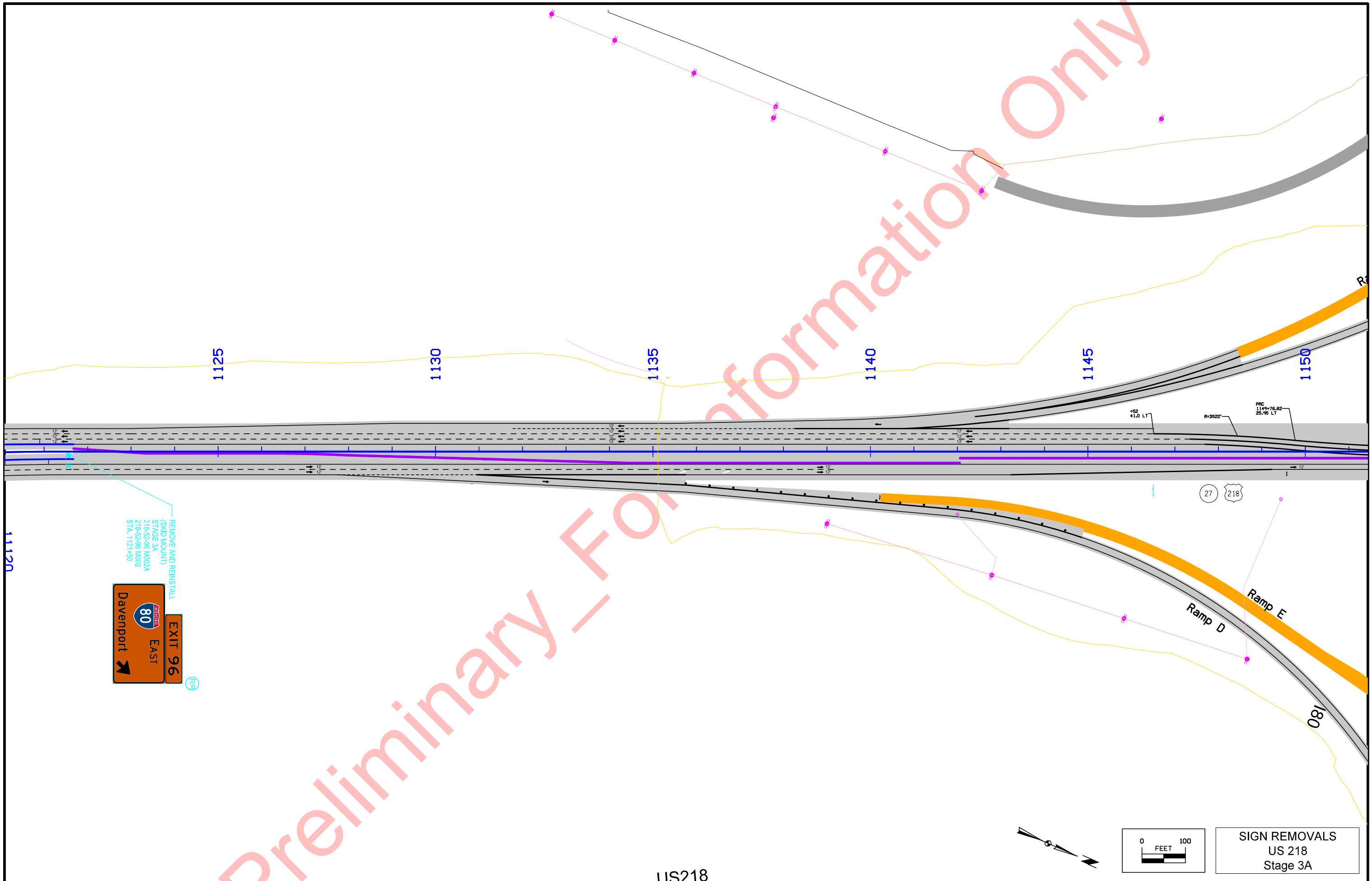

REMOVE AND REINSTALL  
(SKID MOUNT)  
STAGE 3A  
218+52-96 M002A  
218+52-96 M002  
STA. 1121+50

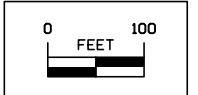

SIGN REMOVALS  
US 218  
Stage 3A



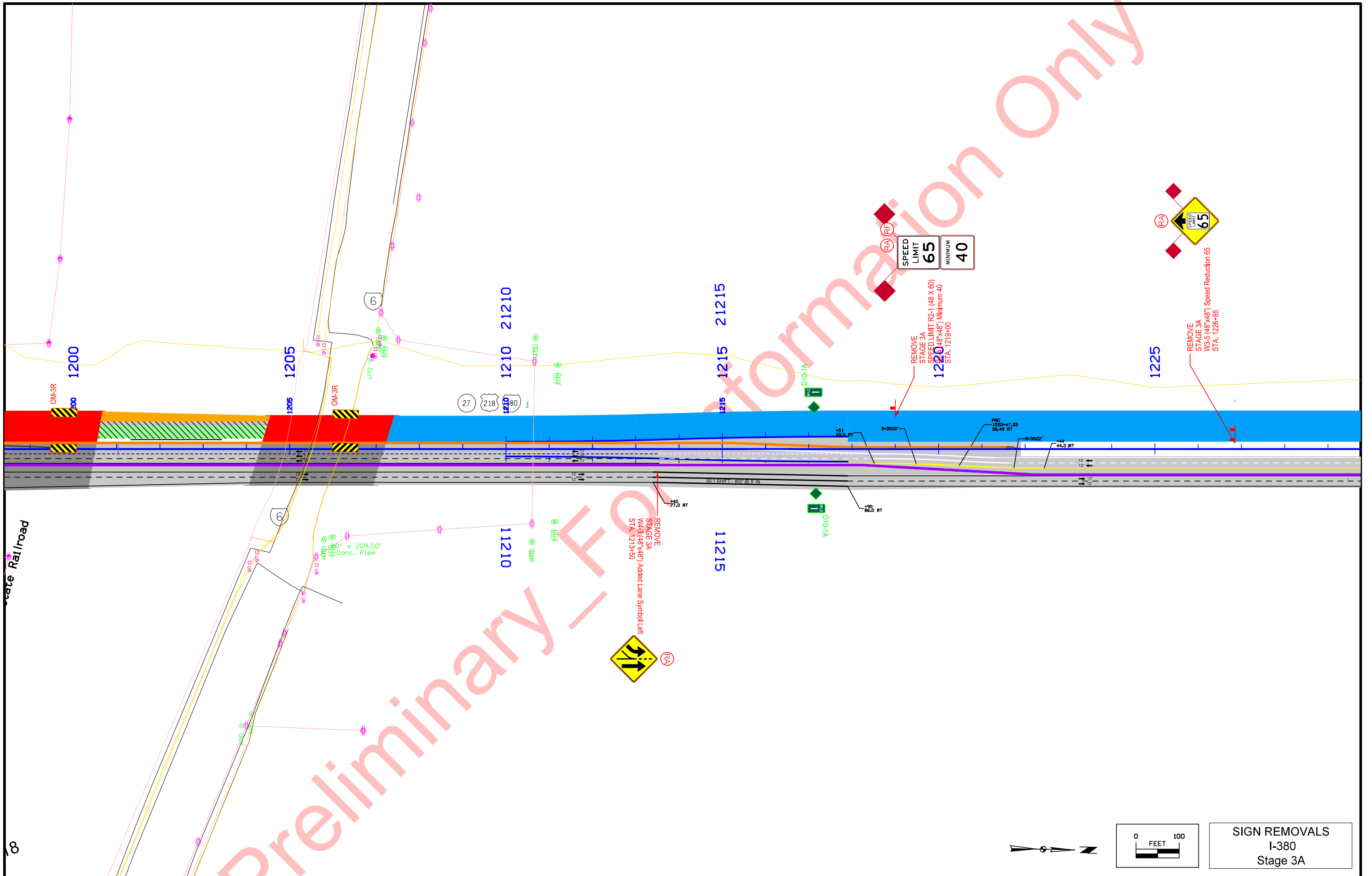

Preliminary - For Information Only



1230

REMOVE STAGE 3A  
380-52-0A M104A  
380-52-0A M104  
W12x26 Post and Foundation  
STA. 1233+00

1235

1240



1245

REMOVE STAGE 3A  
380-52-0B M103A  
380-52-0B M103  
W12x26 Post and Foundation  
STA. 1245+00

1250

1255

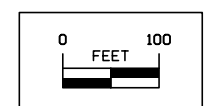
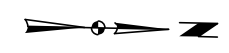
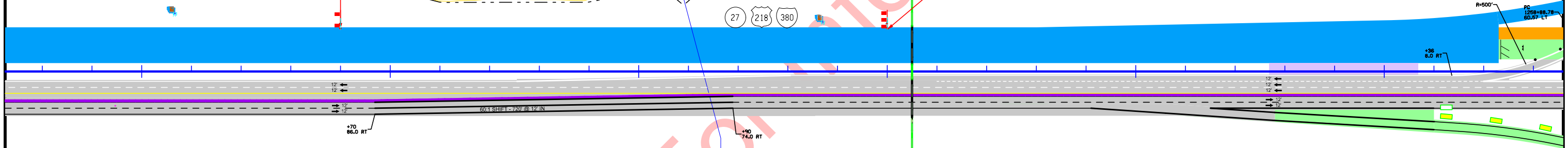

SIGN REMOVALS  
I-380  
Stage 3A

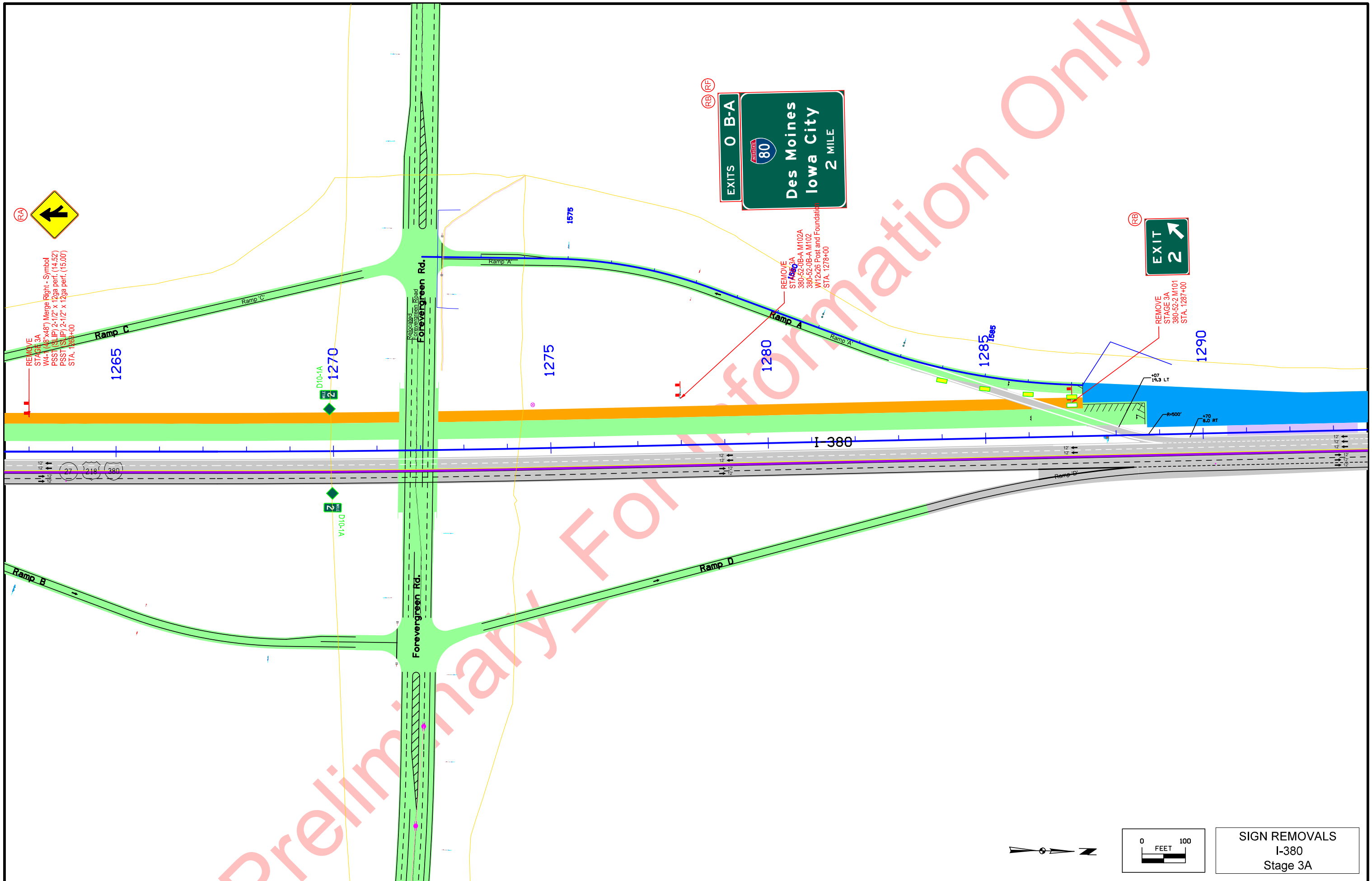

REMOVE  
STAKE 3A  
W4-(48"x48") Merge Right - Symbol  
PSS7 (SIP) 2'-1/2" x 12ga perf. (14.52)  
PSS7 (SIP) 2'-1/2" x 12ga perf. (15.00)  
STA. 1265+00



REMOVE  
STAKE 3A  
380-52-0B-A M102A  
380-52-0B-A M102  
W12x26 Post and Foundation  
STA. 1278+00



REMOVE  
STAKE 3A  
380-52-2 M101  
STA. 1287+00

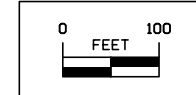
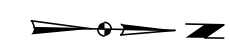

SIGN REMOVALS  
I-380  
Stage 3A

Preliminary - For Information Only

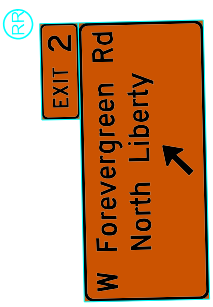

1295

1300

1305

1310

1315

1320

I-380

Remove Pole  
(By others)

Remove Pole  
(By others)

Remove Pole  
(By others)

Remove

Remove

Remove

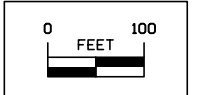
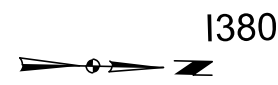

SIGN REMOVALS  
I-380  
Stage 3A

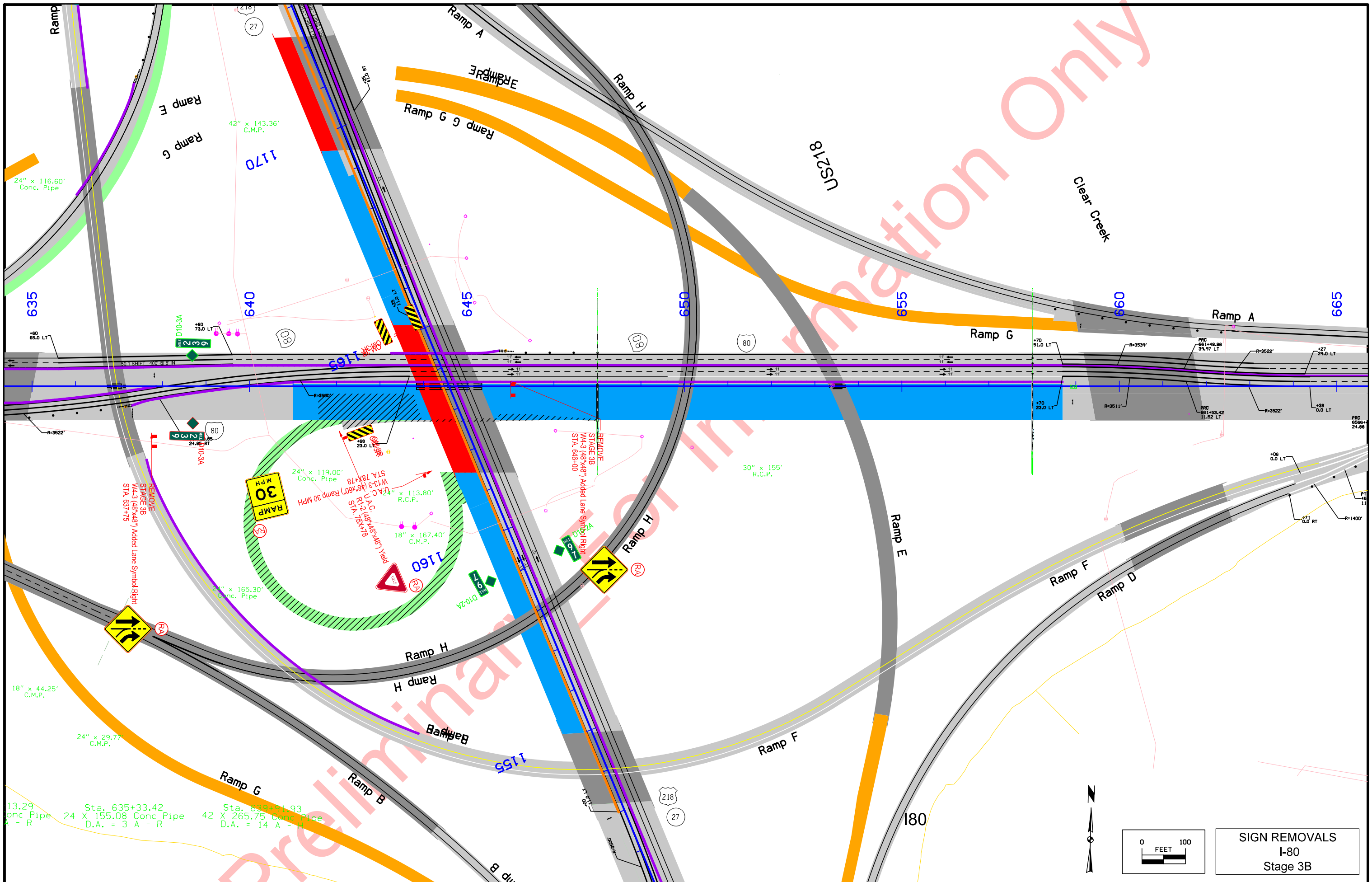

Preliminary FOR INFORMATION ONLY

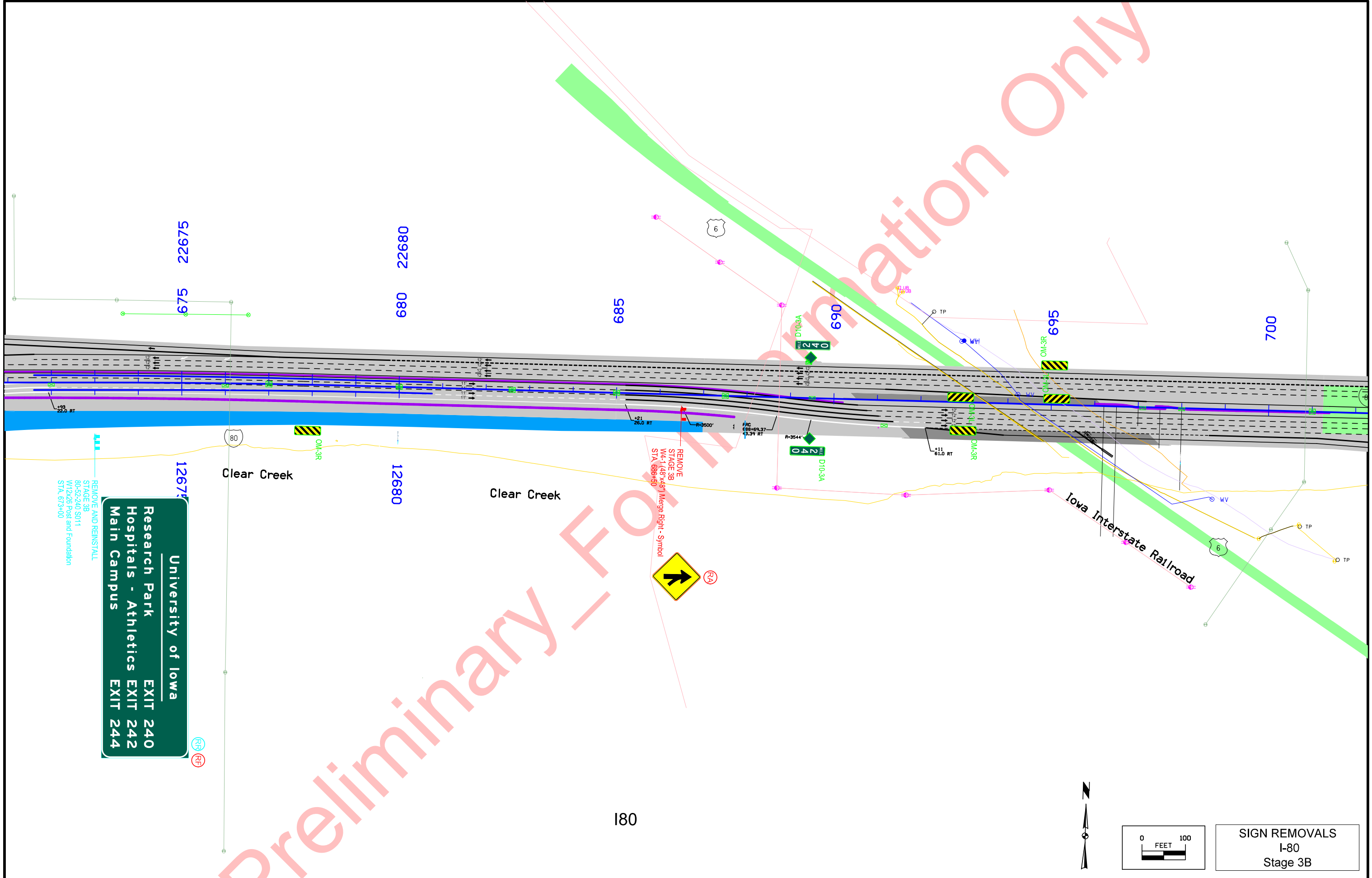

University of Iowa  
Research Park  
Hospitals - Athletics  
Main Campus  
EXIT 240  
EXIT 242  
EXIT 244

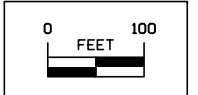

SIGN REMOVALS  
I-80  
Stage 3B

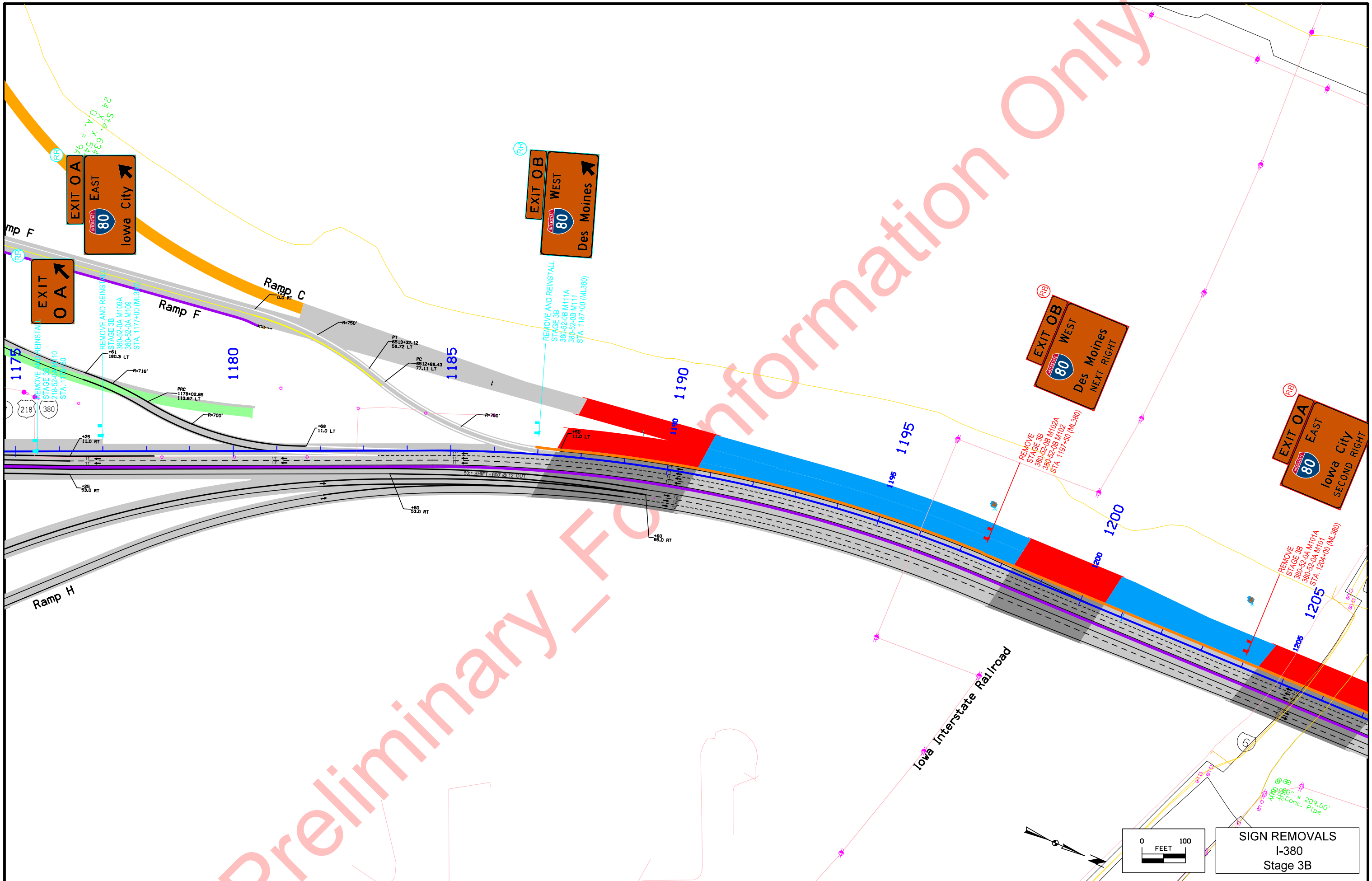

Preliminary FOR INFORMATION ONLY

**SIGN REMOVALS**  
I-380  
Stage 3B



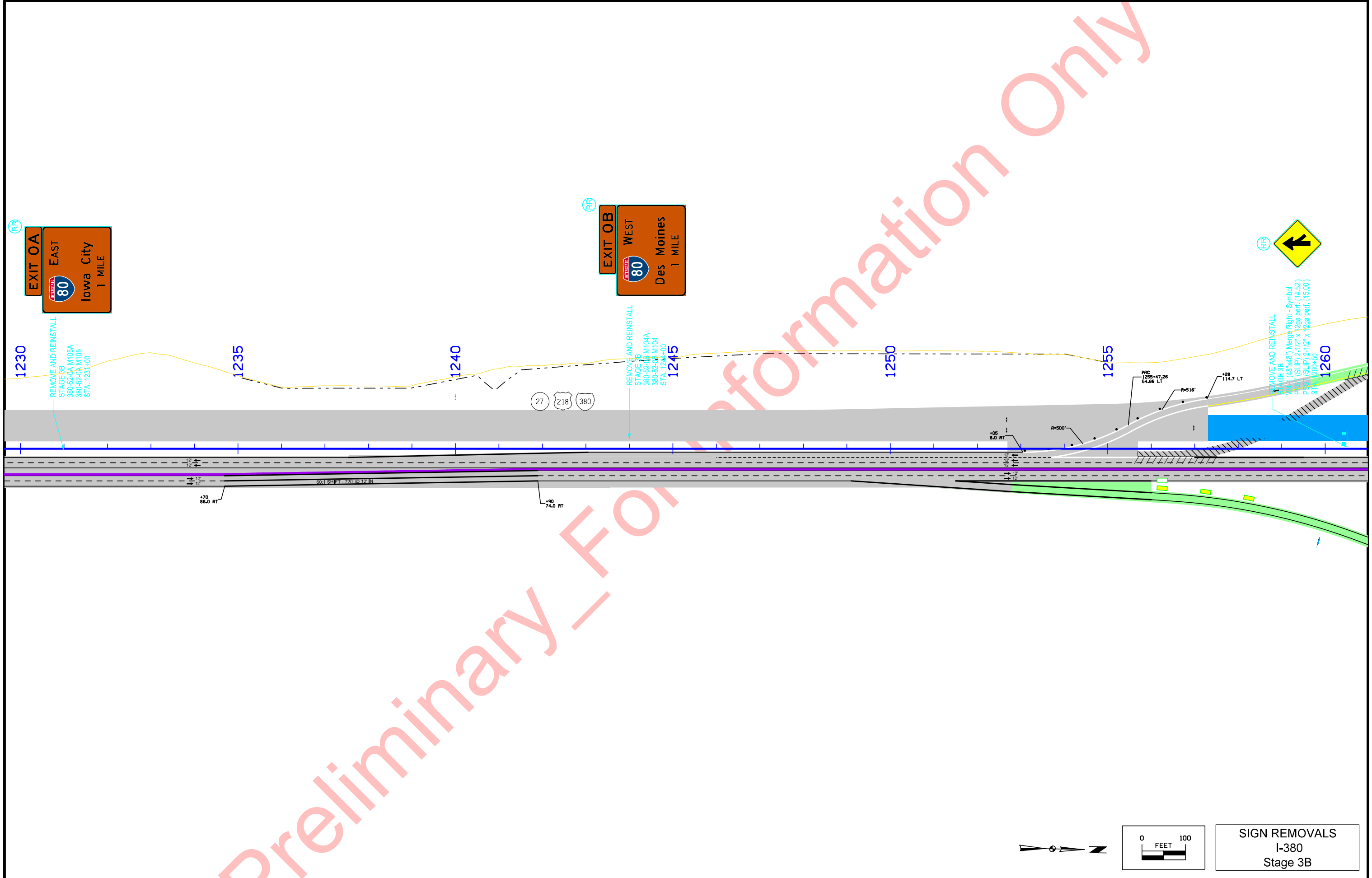

Preliminary - FOI Information Only

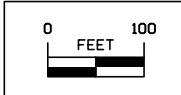
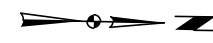

**SIGN REMOVALS**  
I-380  
Stage 3B

FILE NO.	ENGLISH	DESIGN TEAM <b>Abrams \ Hermann</b>	JOHNSON COUNTY	PROJECT NUMBER <b>NHS-080-6(403)239-11-52</b>	SHEET NUMBER <b>N.52</b>
----------	---------	-------------------------------------	----------------	---	--------------------------

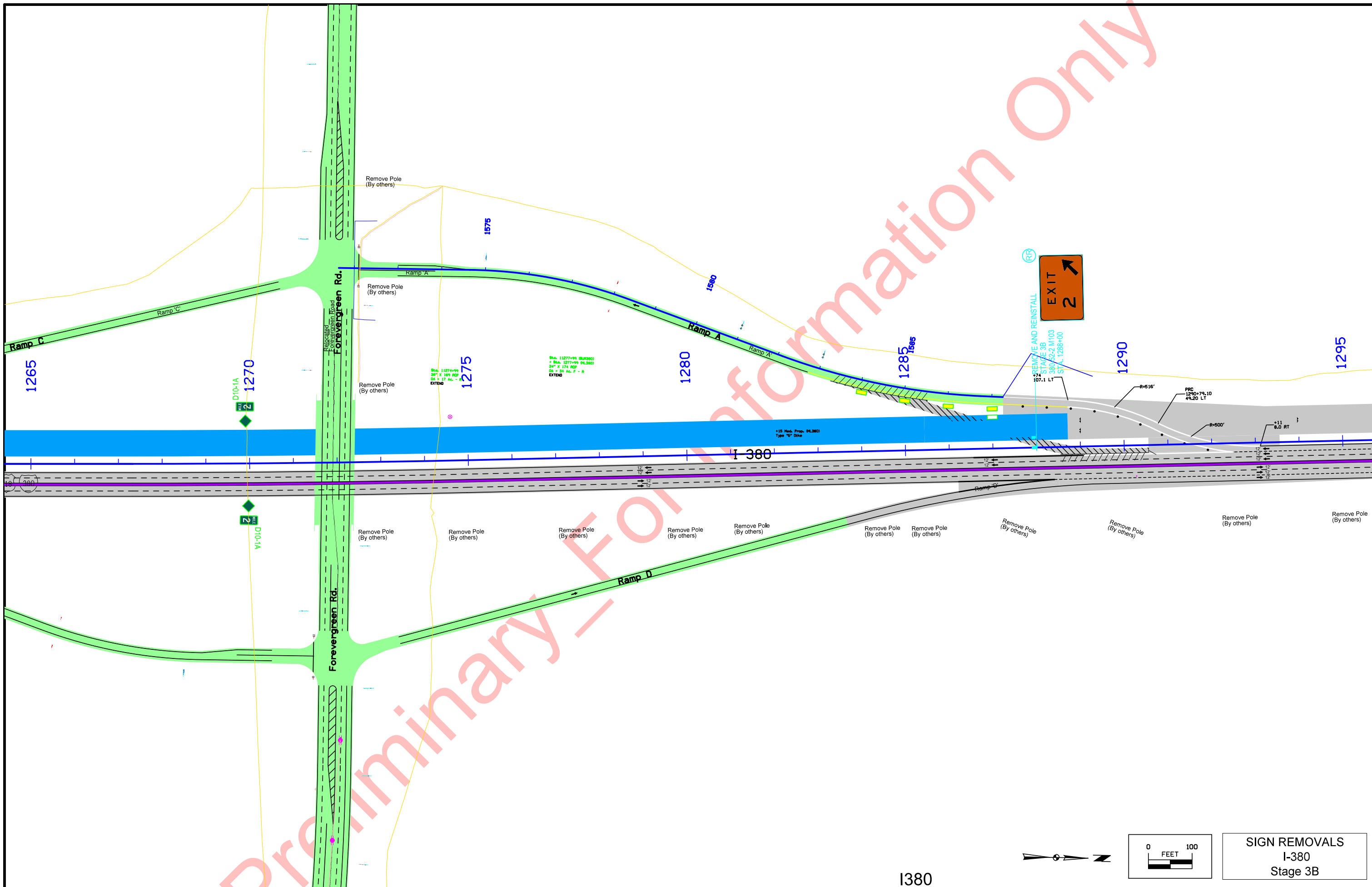

Preliminary FOR INFORMATION ONLY

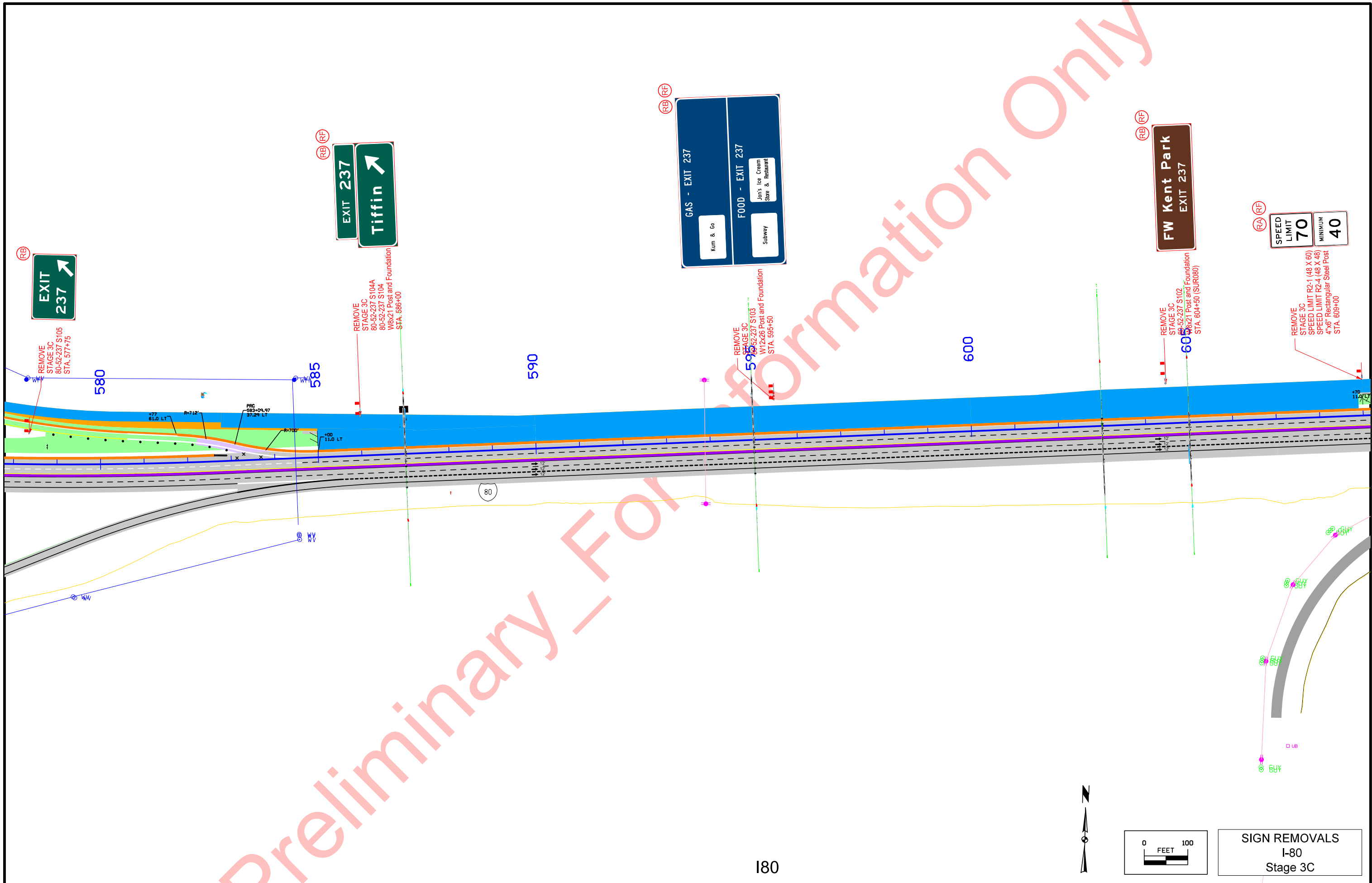

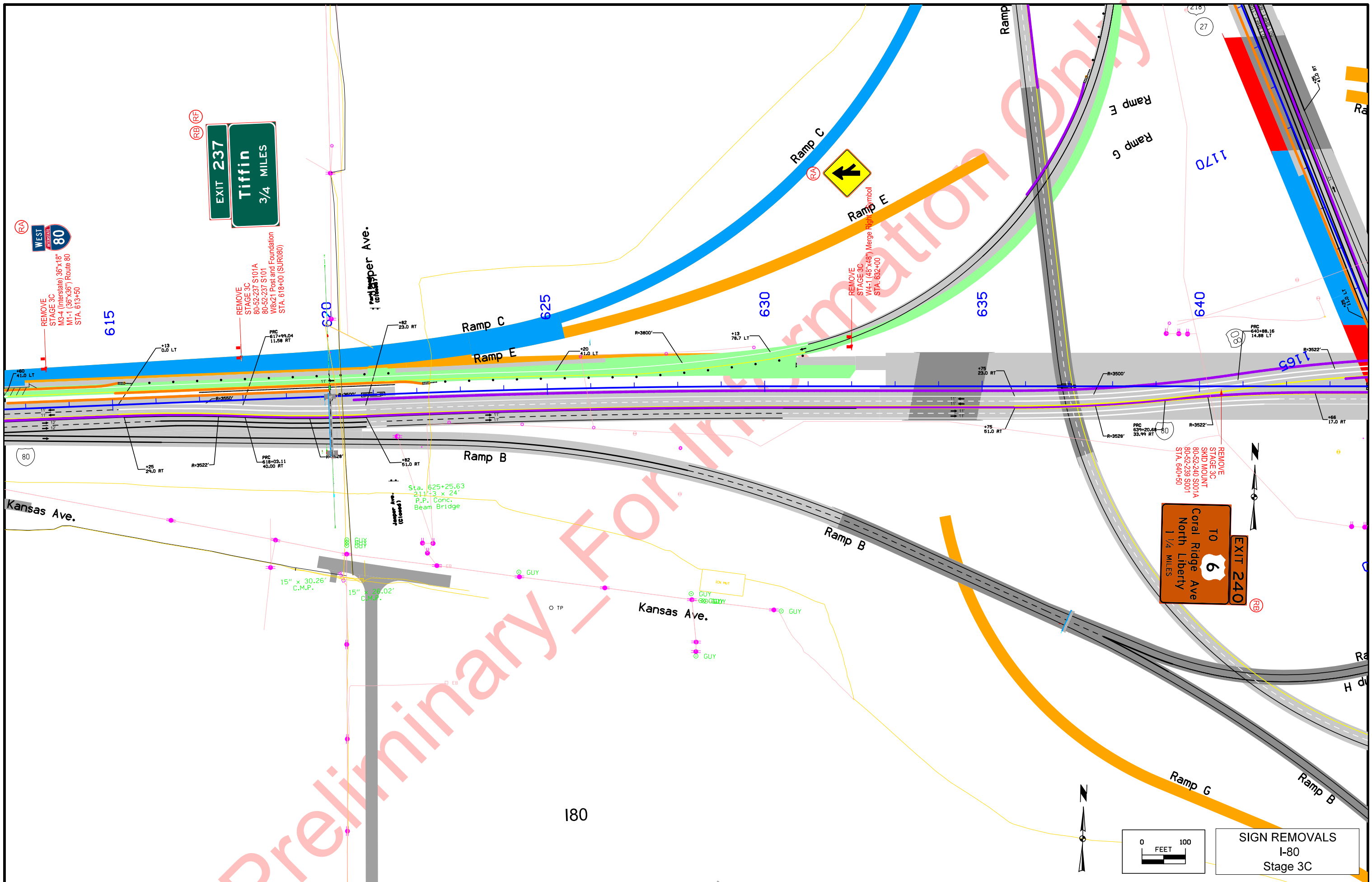

EXIT 237  
Tiffin  
3/4 MILES

TO  
EXIT 240  
6  
Coral Ridge Ave  
North Liberty  
1 1/4 MILES

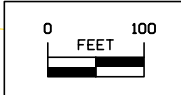

SIGN REMOVALS  
I-80  
Stage 3C

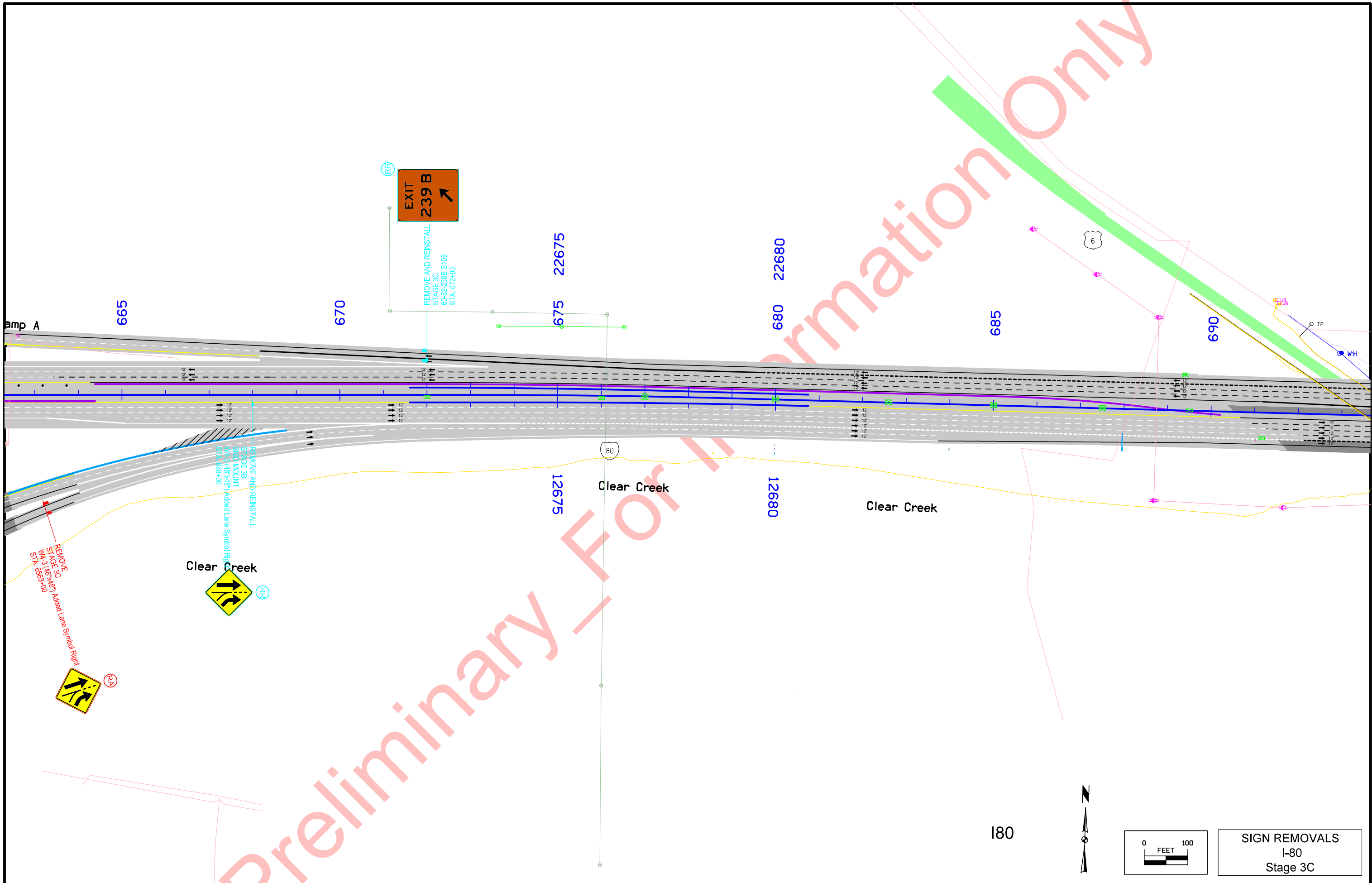

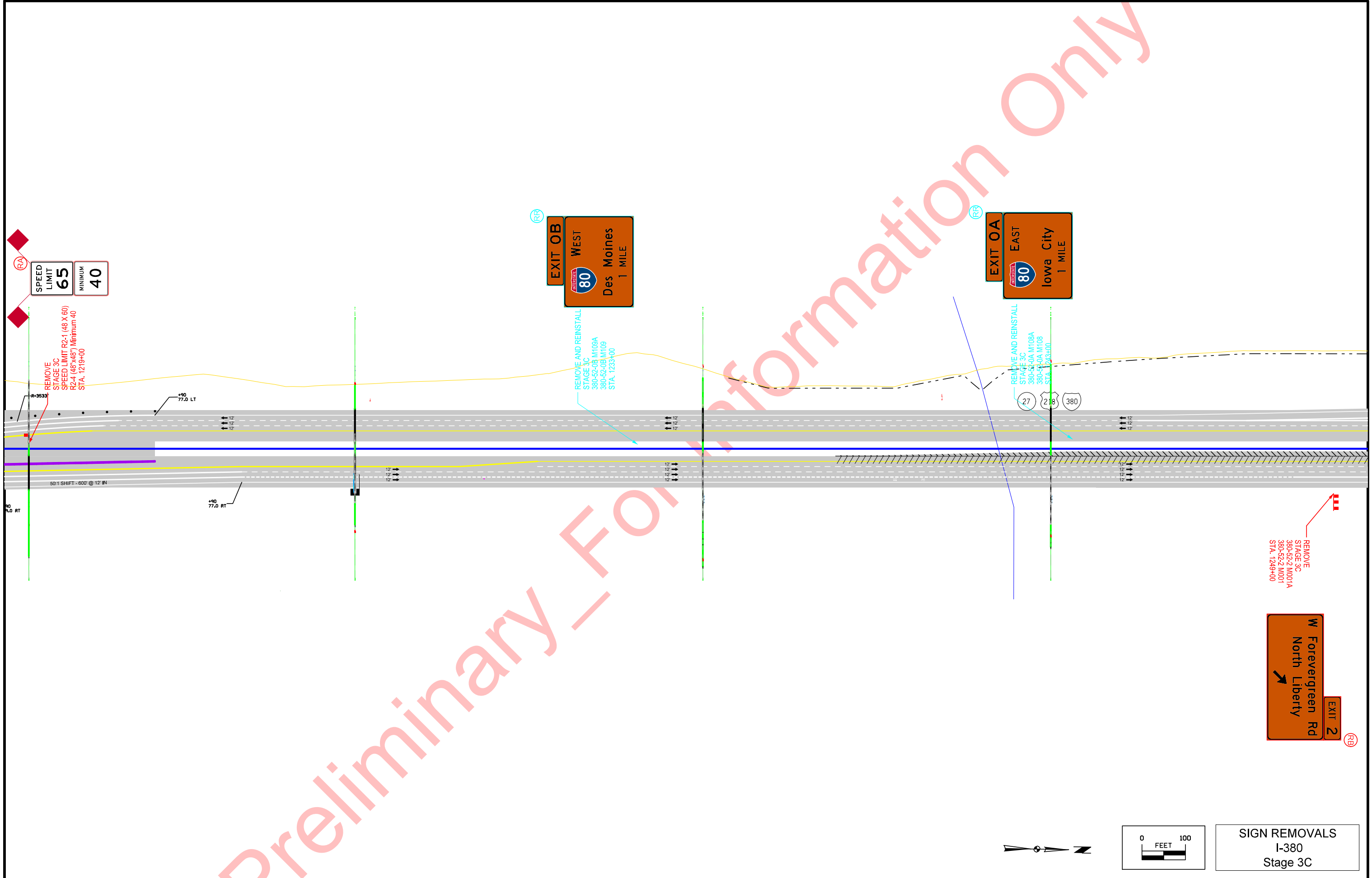

Preliminary - FOIA Information Only

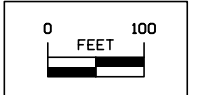
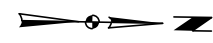

**SIGN REMOVALS**  
I-380  
Stage 3C

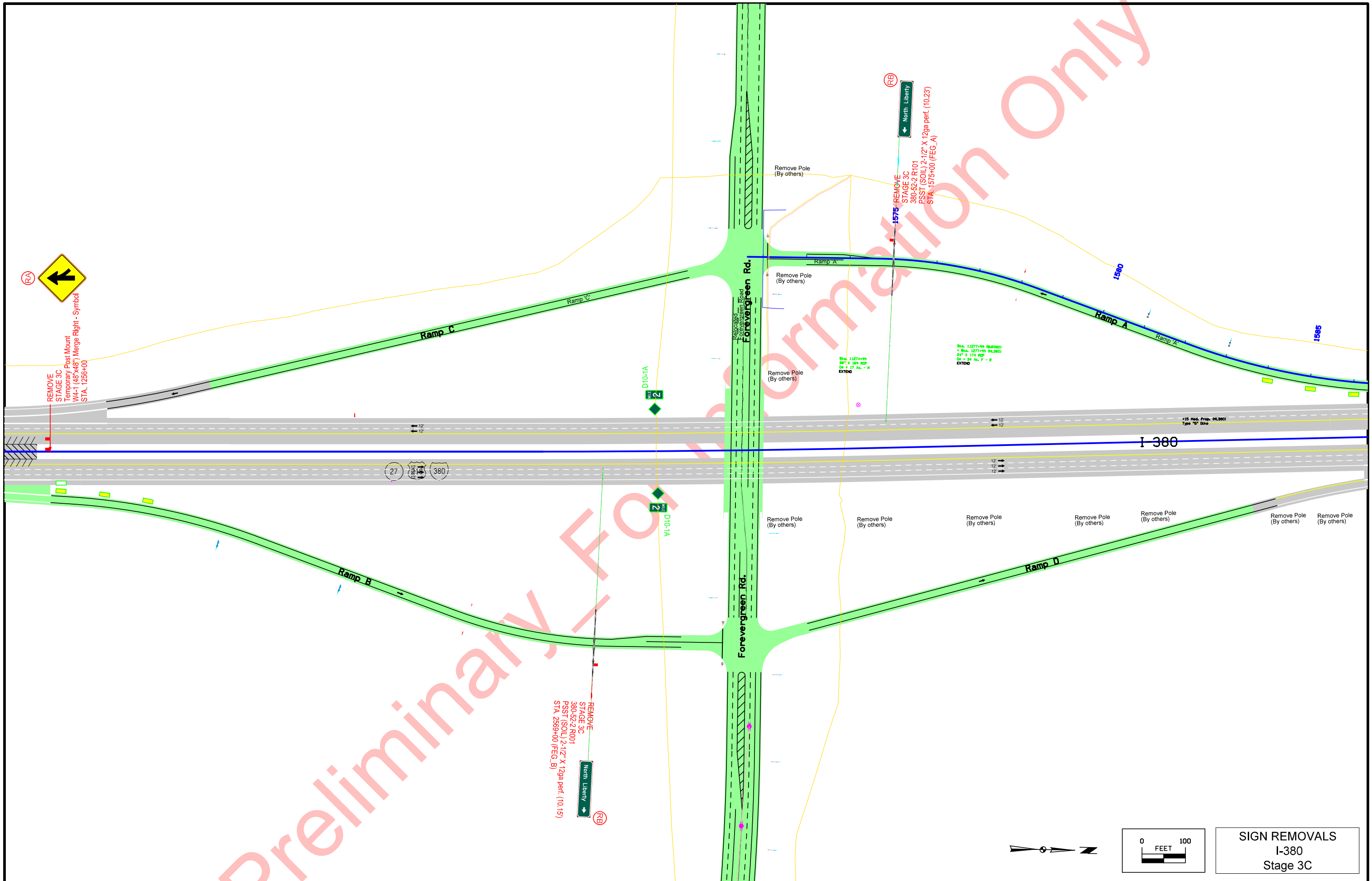

**SIGN REMOVALS**  
I-380  
Stage 3C

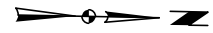
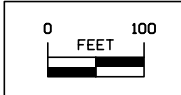

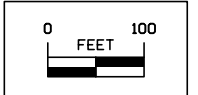
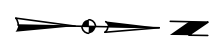
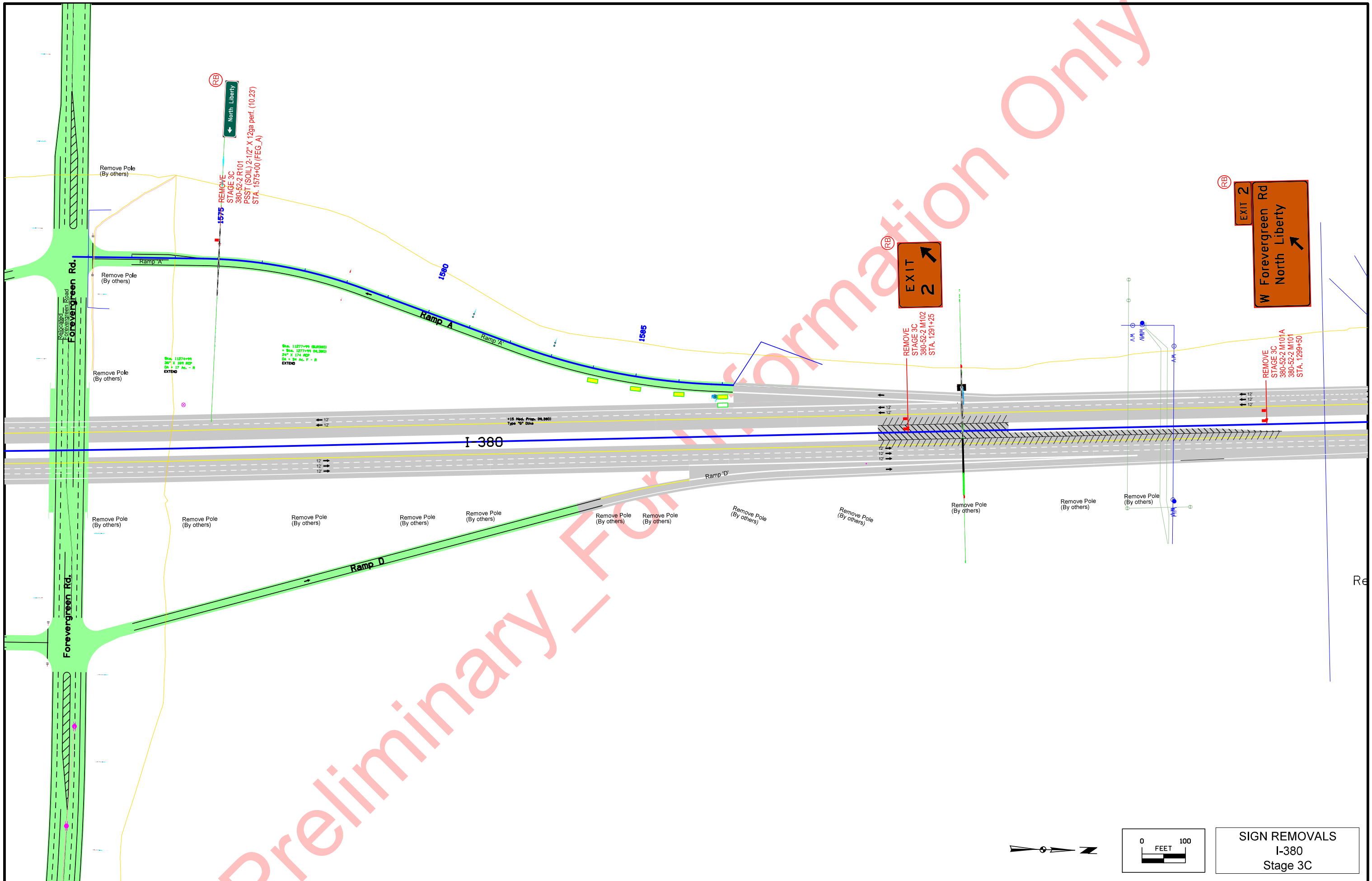

SIGN REMOVALS  
I-380  
Stage 3C



REST AREA  
NEXT RIGHT  
VENDING MACHINES  
WIRELESS INTERNET

EXIT  
237  
↑

REMOVE  
STAGE 3D  
80-52-237 S109  
80-52-237 S109  
W8x21 Post and Foundation  
STA. 582+50

REMOVE AND REINSTALL  
STAGE 3D  
SKID MOUNT  
80-52-237 S109  
STA. 582+50

570

575

580

585

590

595

600

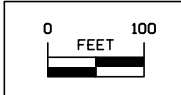
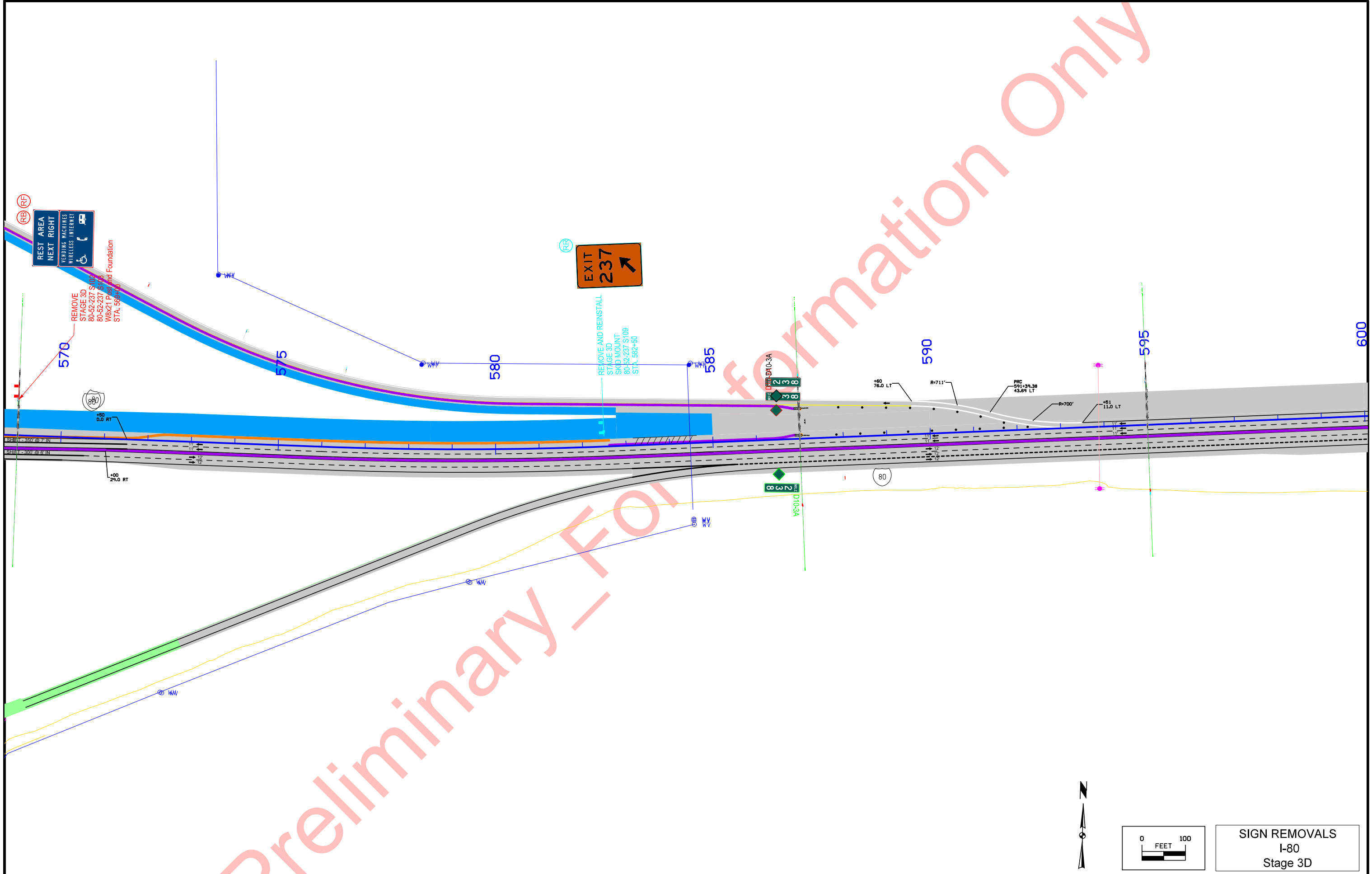

SIGN REMOVALS  
I-80  
Stage 3D

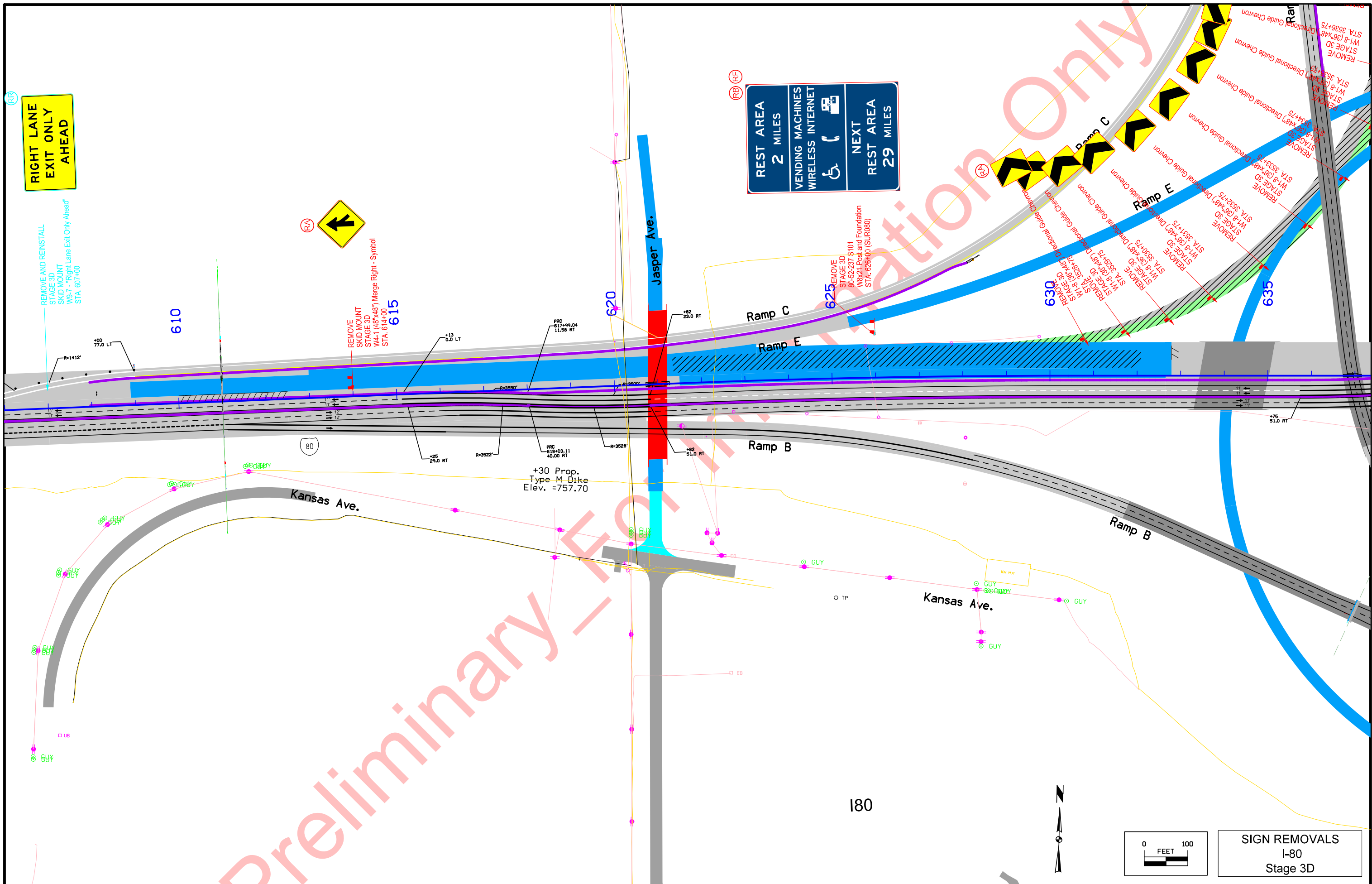

**RIGHT LANE  
EXIT ONLY  
AHEAD**

**REST AREA  
2 MILES**  
VENDING MACHINES  
WIRELESS INTERNET  
**NEXT  
REST AREA  
29 MILES**

**SIGN REMOVALS  
I-80  
Stage 3D**

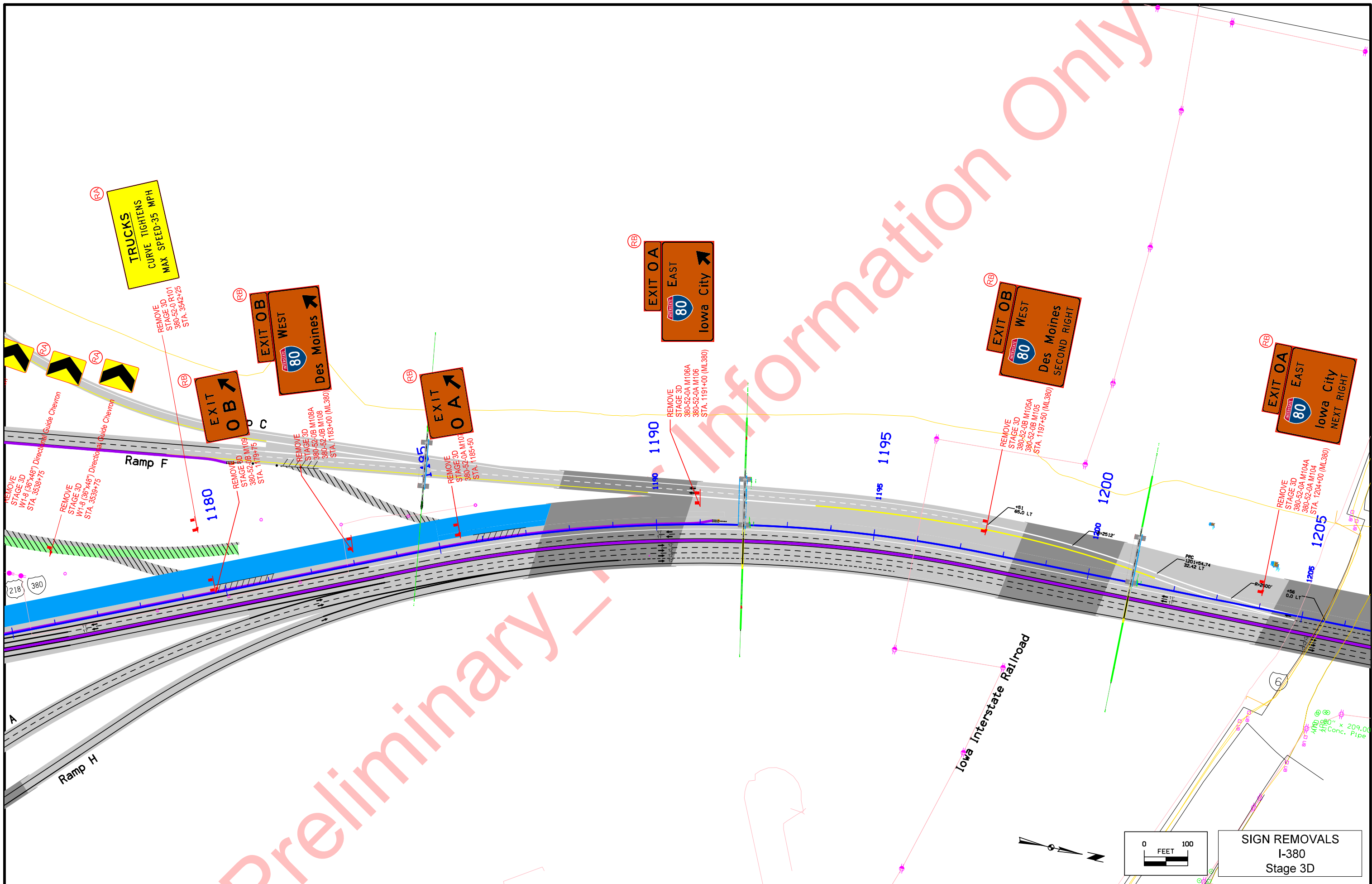

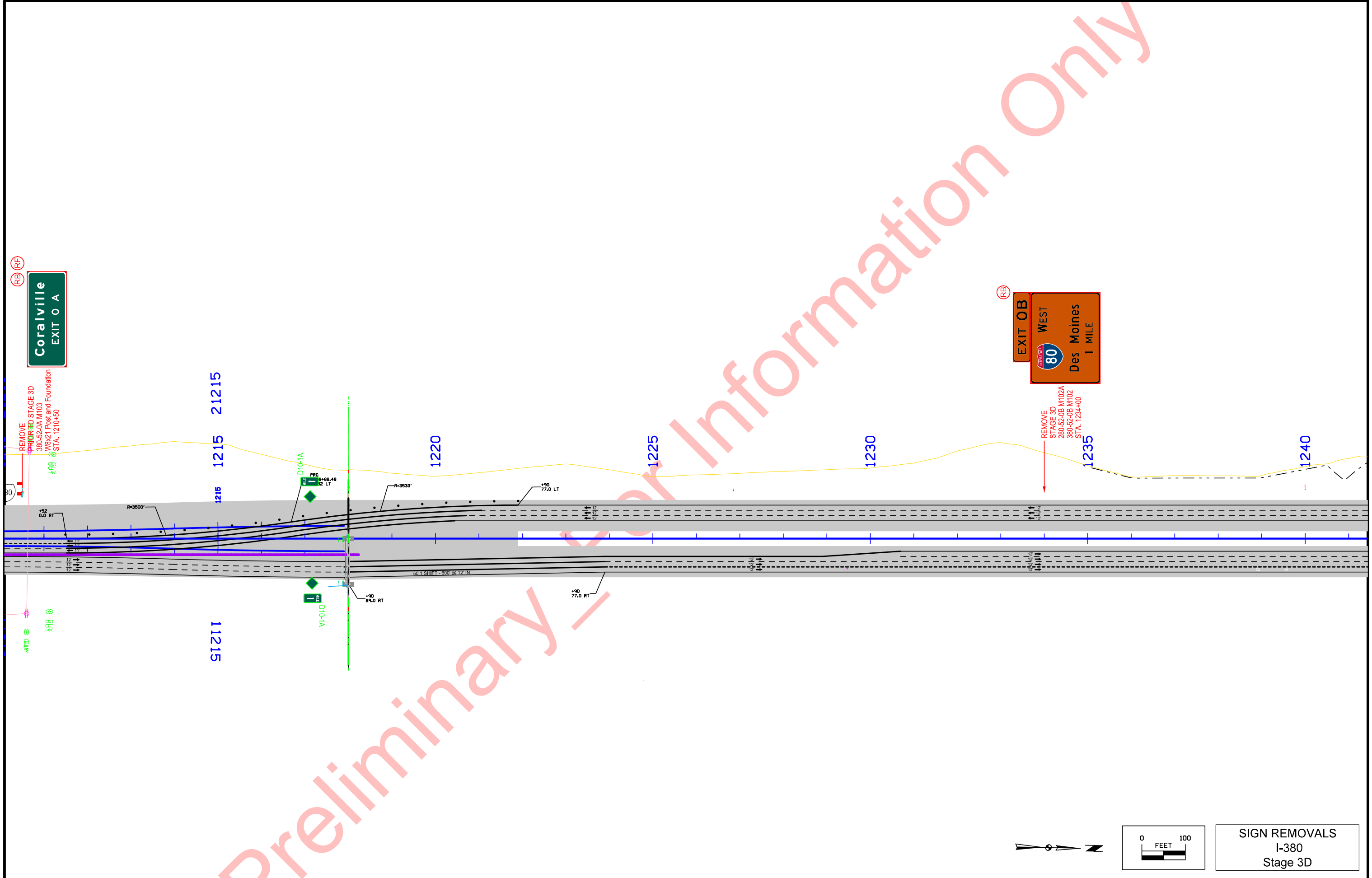

**Coralville**  
EXIT 0 A

**EXIT 0 B**  
WEST  
**80**  
Des Moines  
1 MILE

REMOVE  
STAGE 3D  
380+52-OB M103  
W8x21 Post and Foundation  
STA. 1210+50

REMOVE  
STAGE 3D  
280+52-OB M102A  
380+52-OB M102  
STA. 1234+00



REMOVE  
STAGE 3D  
890-52-0A M101A  
880-52-0A M101  
STA. 1244+50

1240

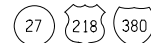

1245

1250

1255

1260

1265

1270

D10-1A

D10-1A

Ramp B

Ramp C

Ramp C

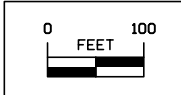
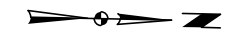

SIGN REMOVALS  
I-380  
Stage 3D

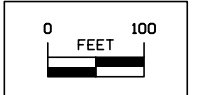
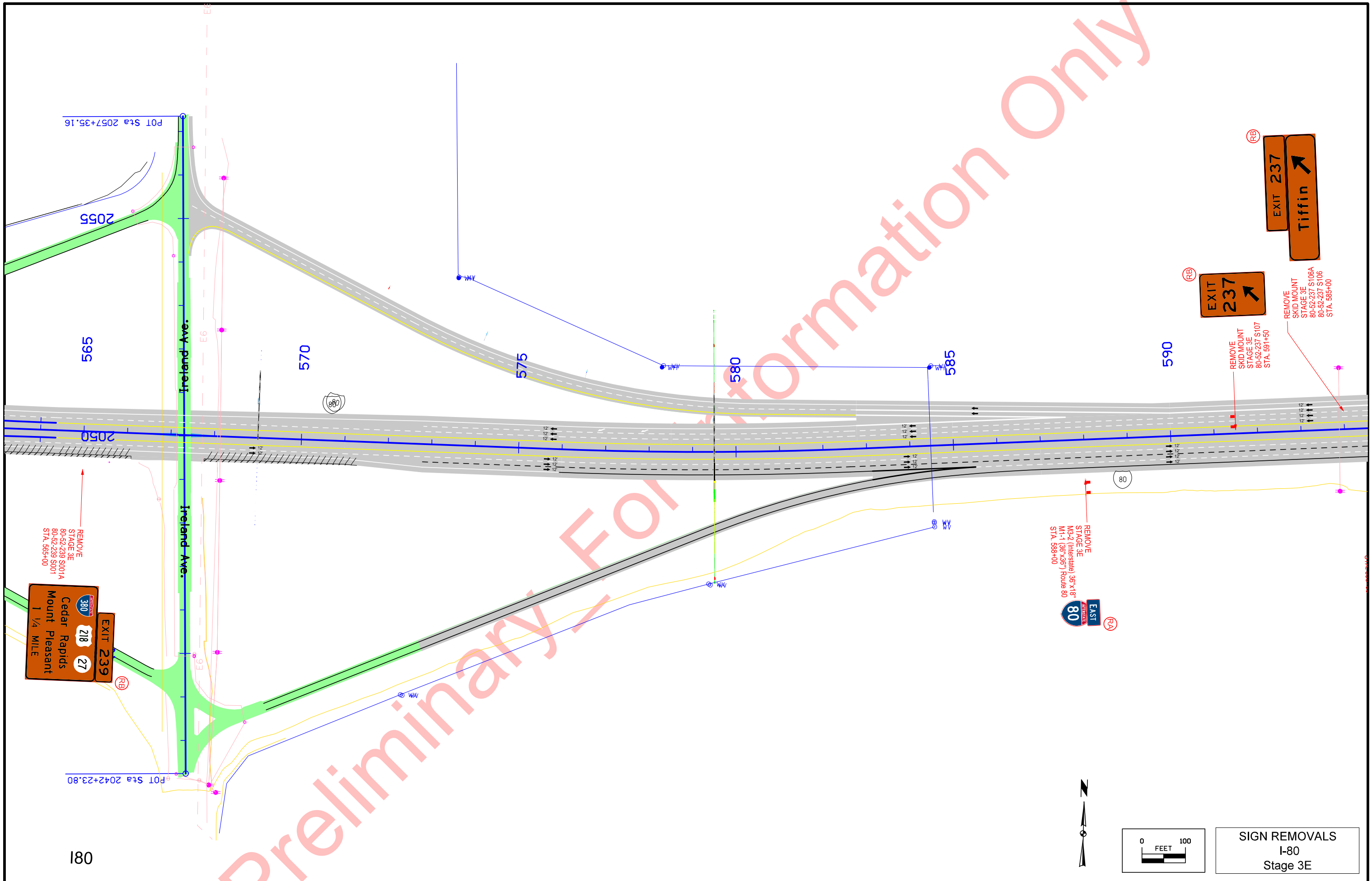

**SIGN REMOVALS**  
I-80  
Stage 3E

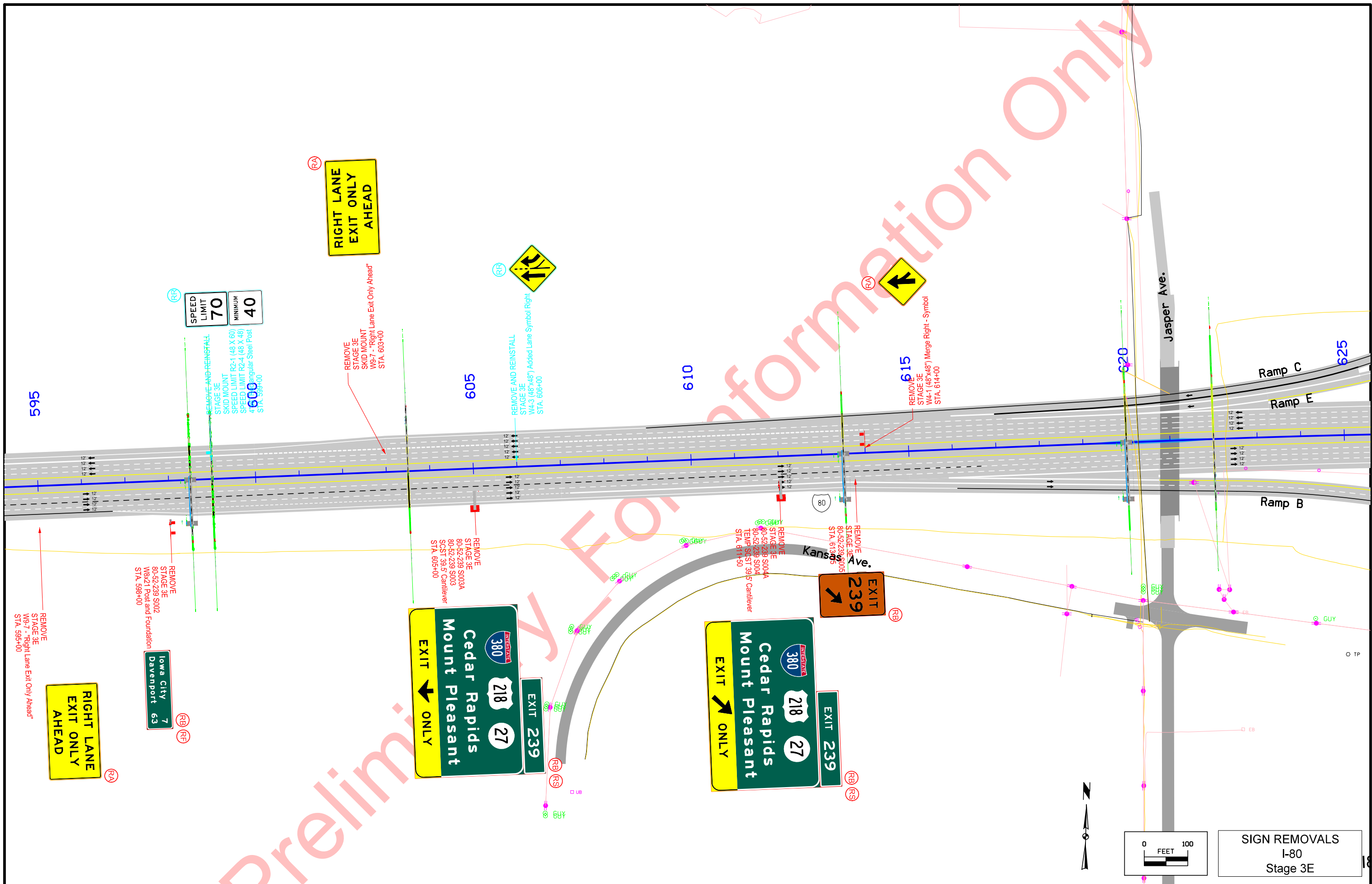

**SPEED LIMIT 70**  
MINIMUM **40**

**RIGHT LANE EXIT ONLY AHEAD**

**EXIT 239**  
Cedar Rapids  
Mount Pleasant

**EXIT 239**  
Cedar Rapids  
Mount Pleasant

**EXIT 239**

**EXIT 7**  
Iowa City  
Davenport 63

**RIGHT LANE EXIT ONLY AHEAD**

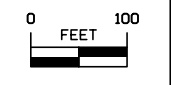

**SIGN REMOVALS**  
I-80  
Stage 3E

Preliminary Information Only

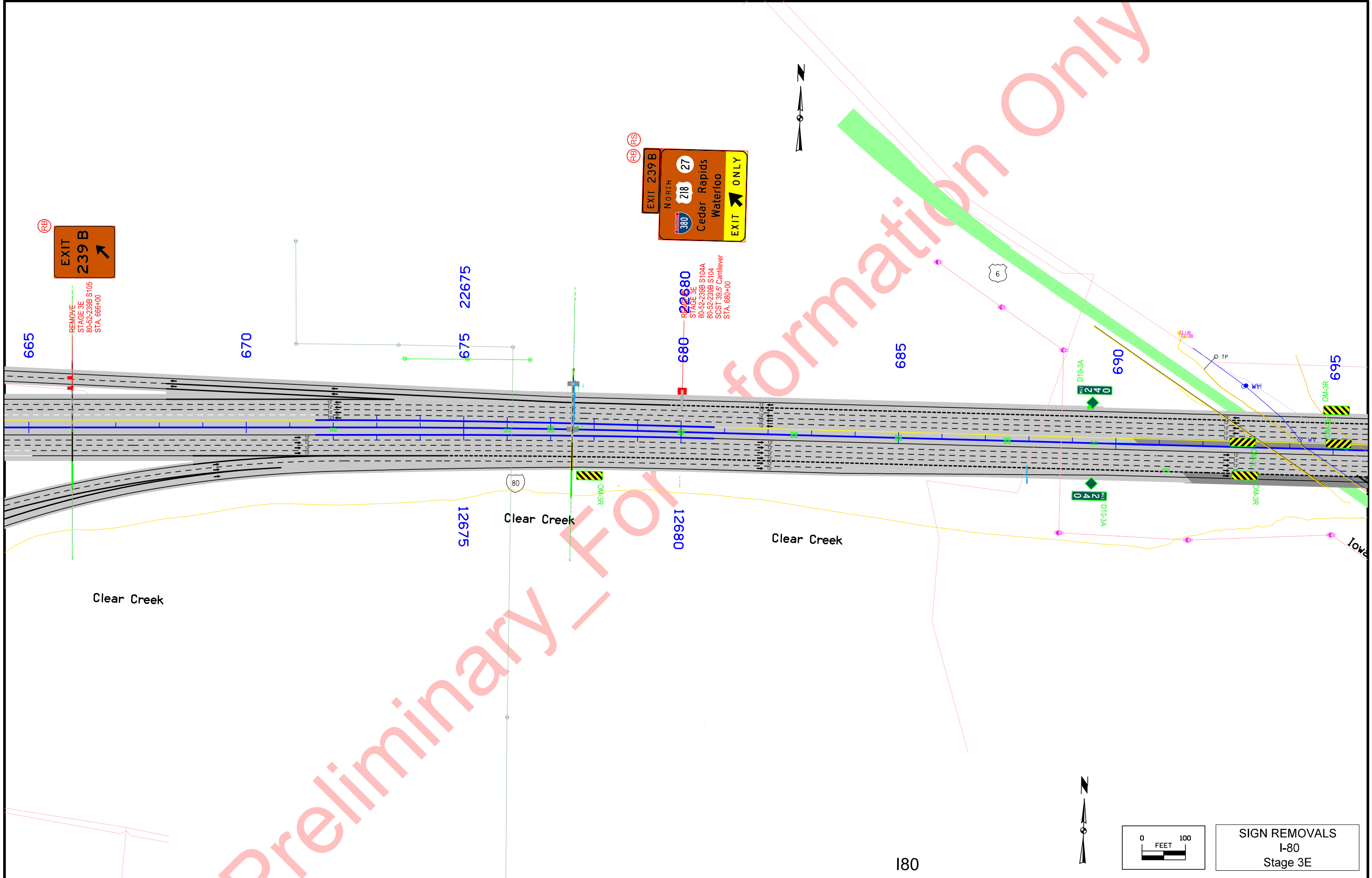





REMOVE  
STAGE 3E  
80-52-239 S102  
80-52-239B S103A  
80-52-239B S103  
"1/2 MILE" Overlay  
STA. 697+50

REMOVE  
STAGE 3E  
80-52-239 S101  
W8x21 Post and Foundation  
STA. 703+00

REMOVE 705 (RF)  
STAGE 3E  
Truss Median Foundation  
STA. 704+99.54

REMOVE  
STAGE 3E  
M3-4 (Interstate) 24"x12"  
MI-1 Route 80  
STA. 706+75

REMOVE  
STAGE 3E  
IWA-3 (68"x48") Added Lane Symbol Right  
STA. 713+50

700

710

715

720

725

Iowa Interstate Railroad

Coral Ridge Avenue 965

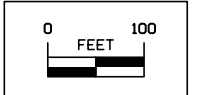

SIGN REMOVALS  
I-80  
Stage 3E

Preliminary For Information Only

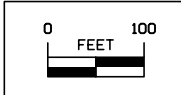
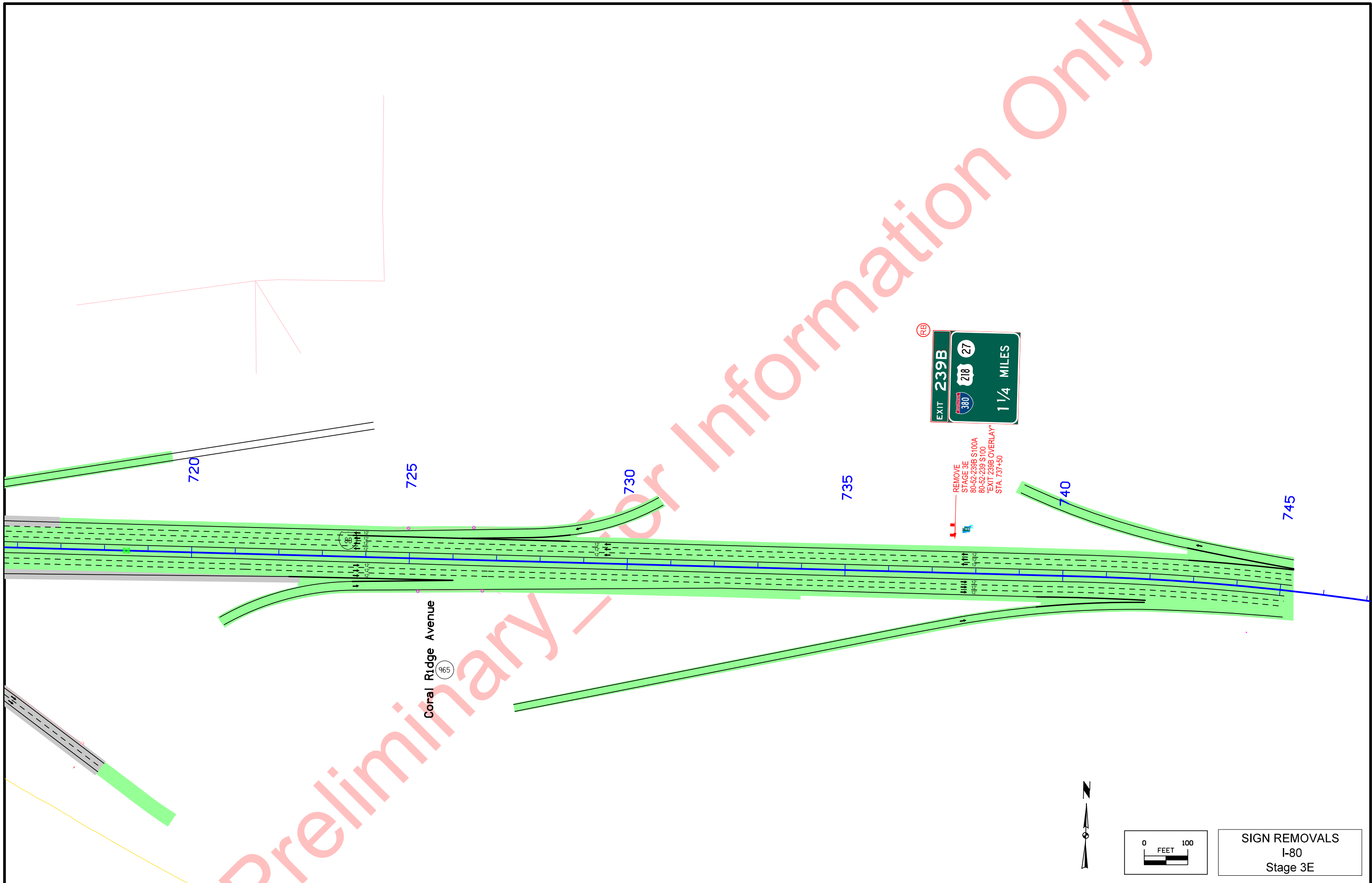

SIGN REMOVALS  
I-80  
Stage 3E

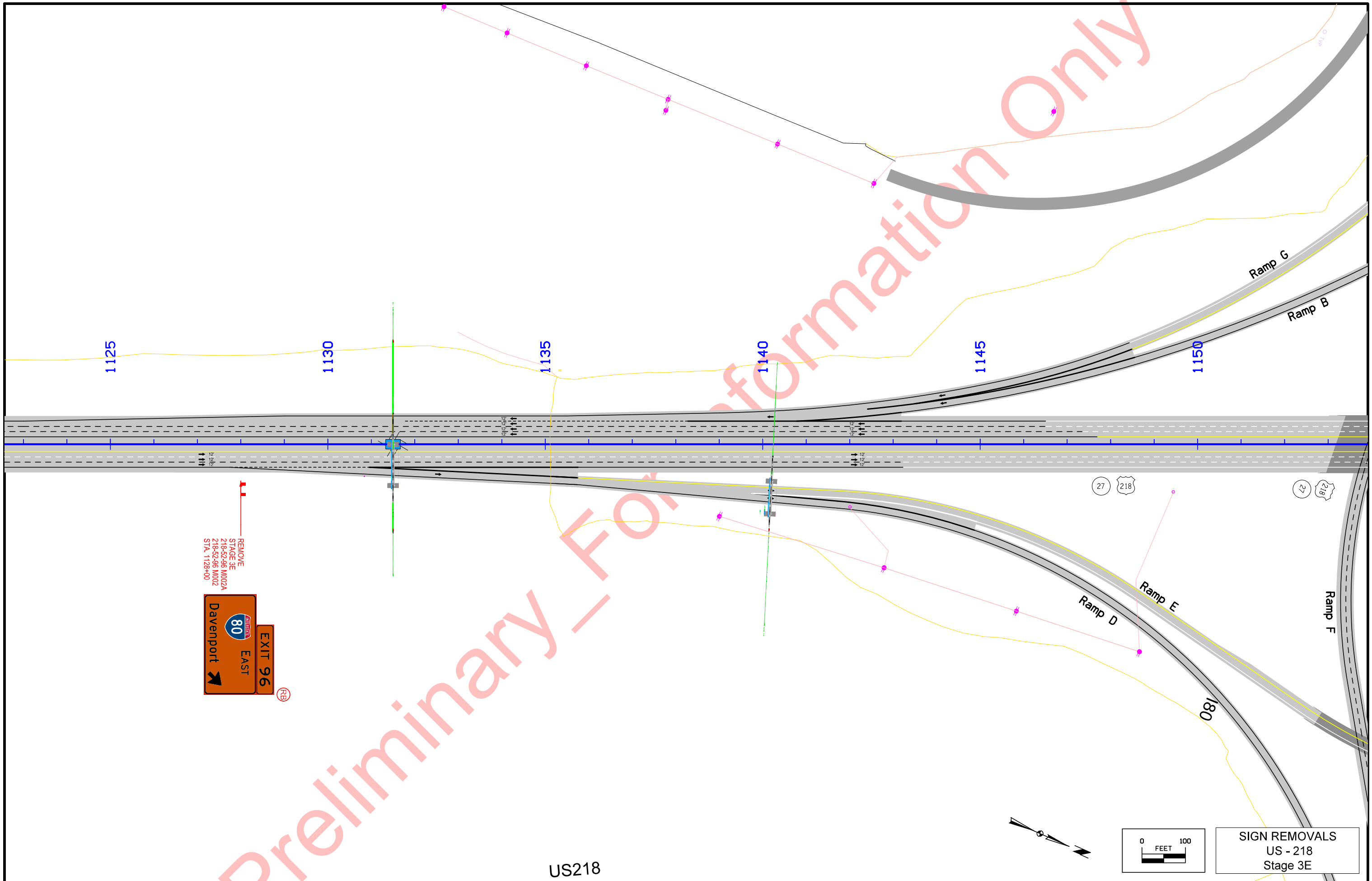

REMOVE  
STAGE 3E  
218-52-96 M002A  
218-52-96 M002  
S/A-1128+00

SIGN REMOVALS  
US - 218  
Stage 3E

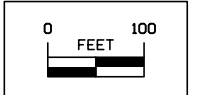
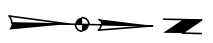
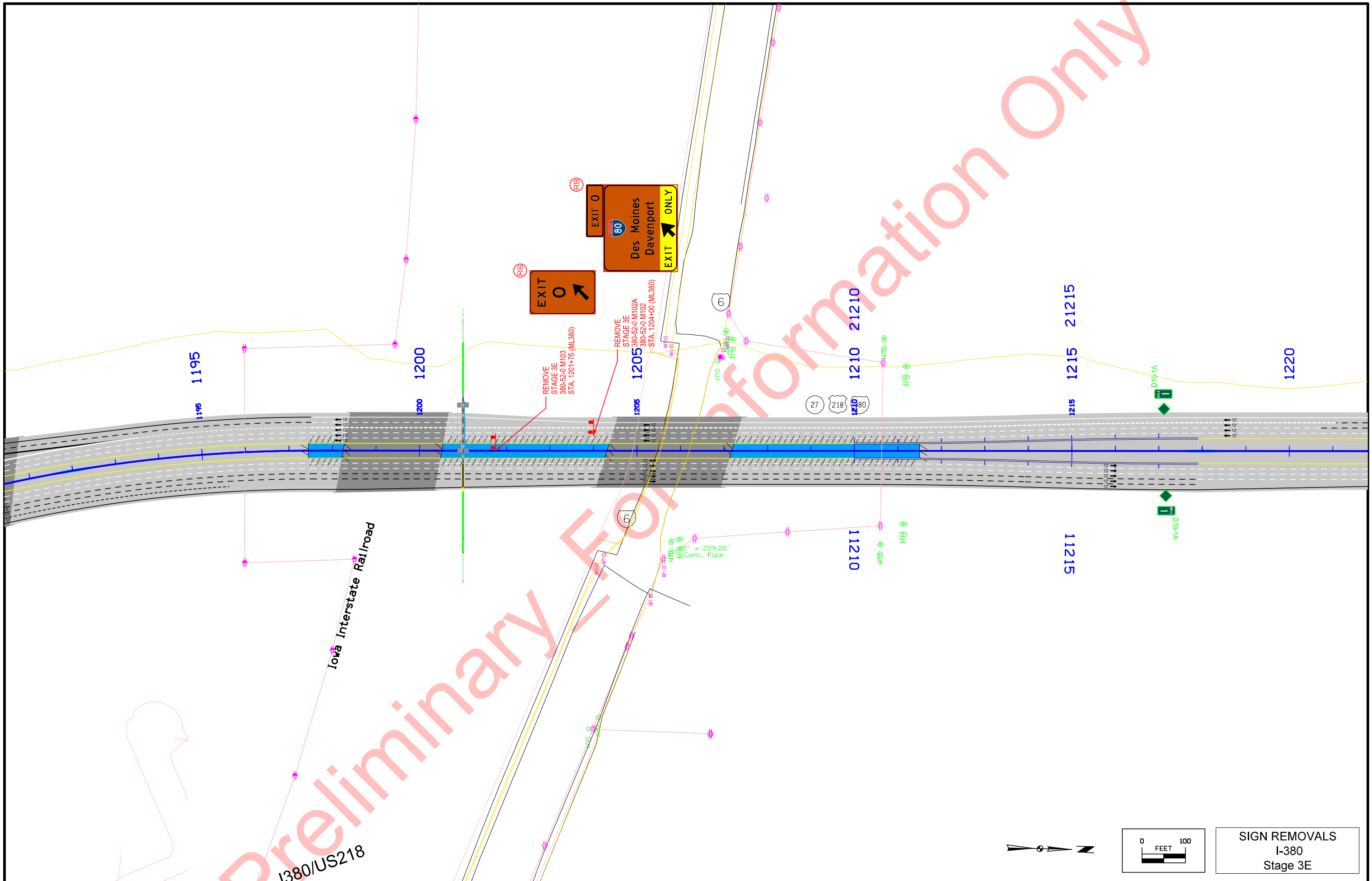

SIGN REMOVALS  
I-380  
Stage 3E

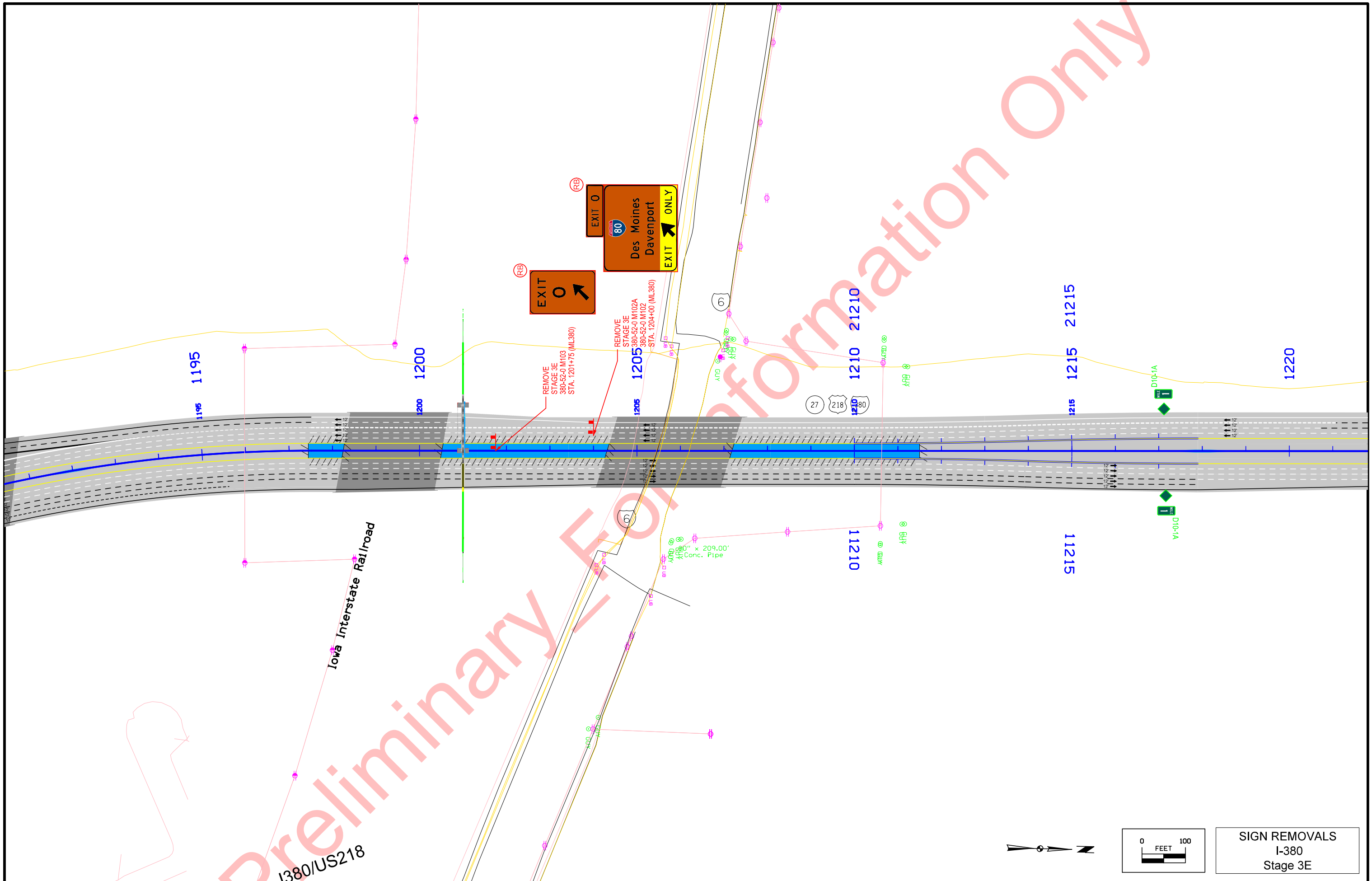

Preliminary Engineering Information Only

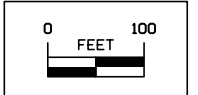
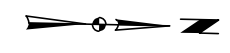

SIGN REMOVALS  
I-380  
Stage 3E

Preliminary - FOI Information Only

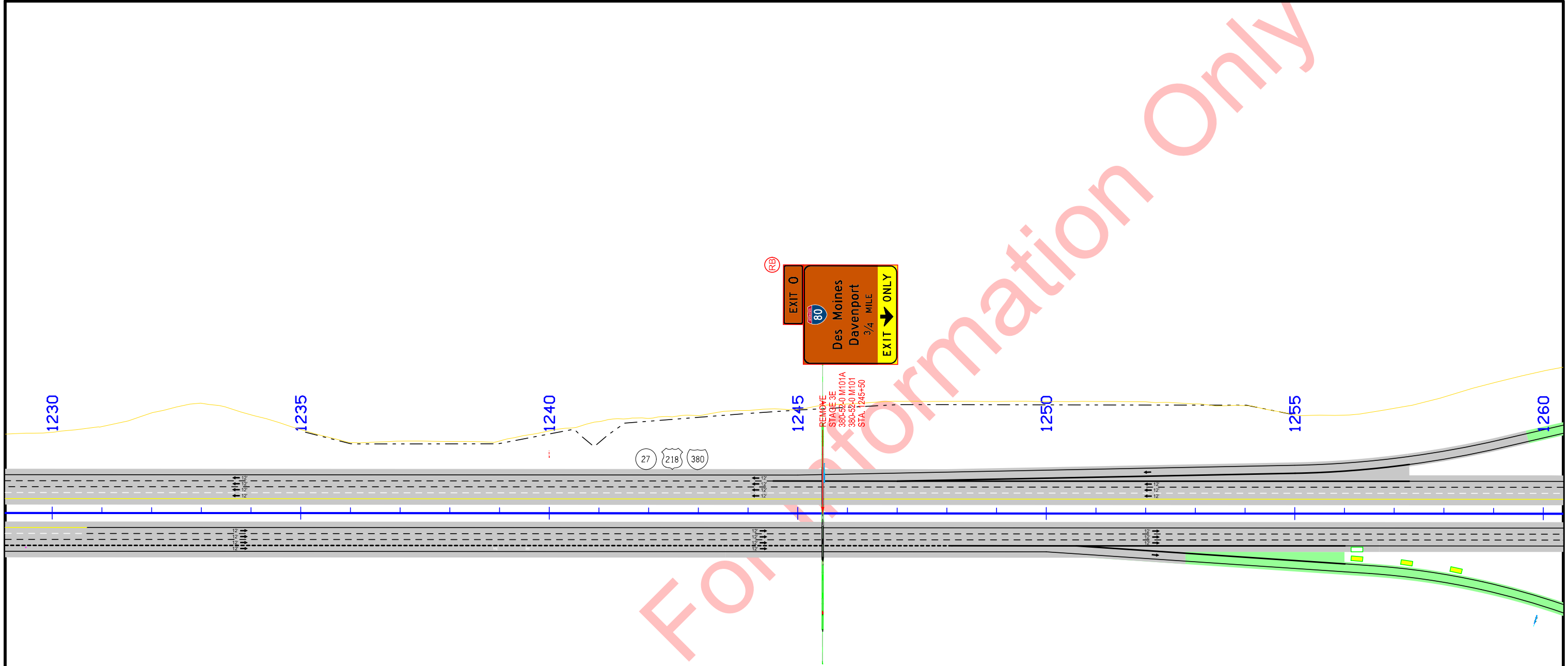

EXIT 0  
80  
Des Moines  
Davenport  
3/4 MILE  
EXIT ONLY

REMOVE  
STAGE 3E  
380-550 M101A  
380-550 M101  
STA. 1245+50

27 218 380

1230

1235

1240

1245

1250

1255

1260

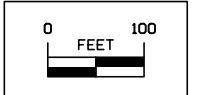
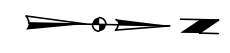

SIGN REMOVALS  
I-380  
Stage 3E

Preliminary Only

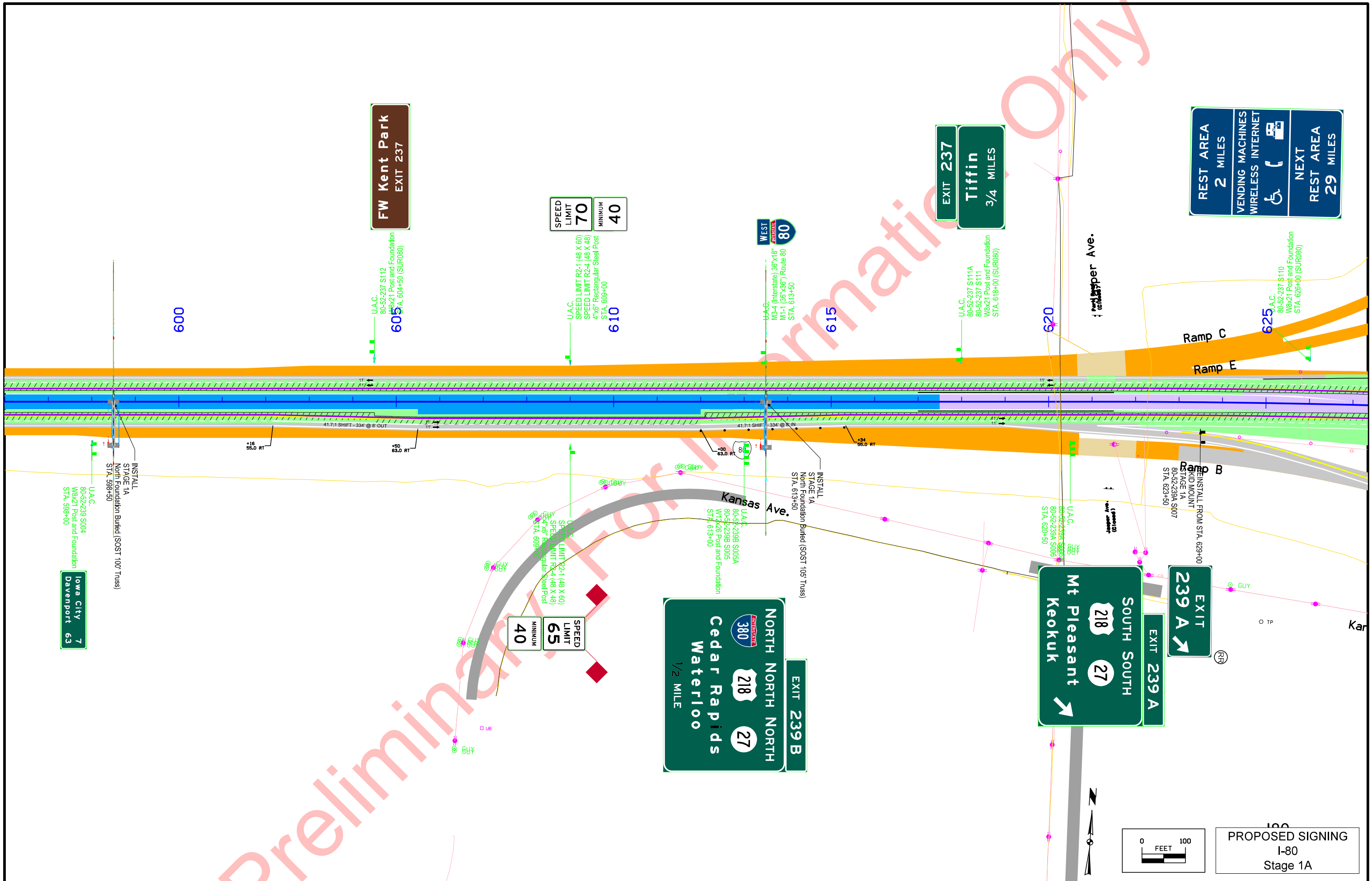

**REST AREA**  
2 MILES

VENDING MACHINES  
WIRELESS INTERNET

**NEXT REST AREA**  
29 MILES

**EXIT 239 A**

**South 27**  
**South 218**

**Mt Pleasant**  
**Keokuk**

**EXIT 239 B**

**North 218**  
**North 27**

**Cedar Rapids**  
**Waterloo**

1/2 MILE

**SPEED LIMIT 65**  
MINIMUM 40

**SPEED LIMIT 70**  
MINIMUM 40

**FW Kent Park**  
**EXIT 237**

**Iowa City**  
**Davenport**

7  
63

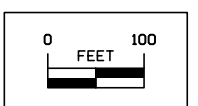

**PROPOSED SIGNING**  
I-80  
Stage 1A

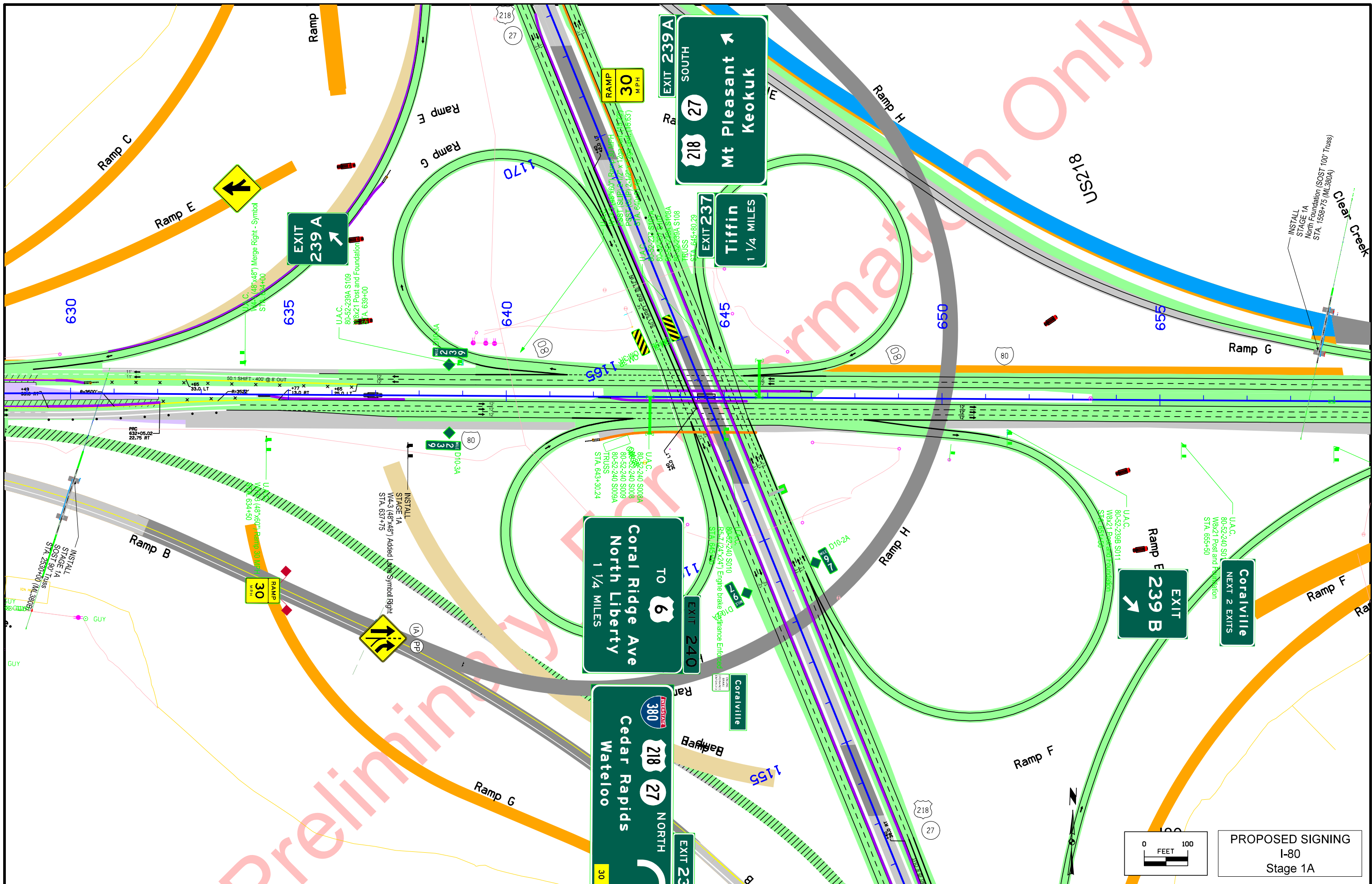



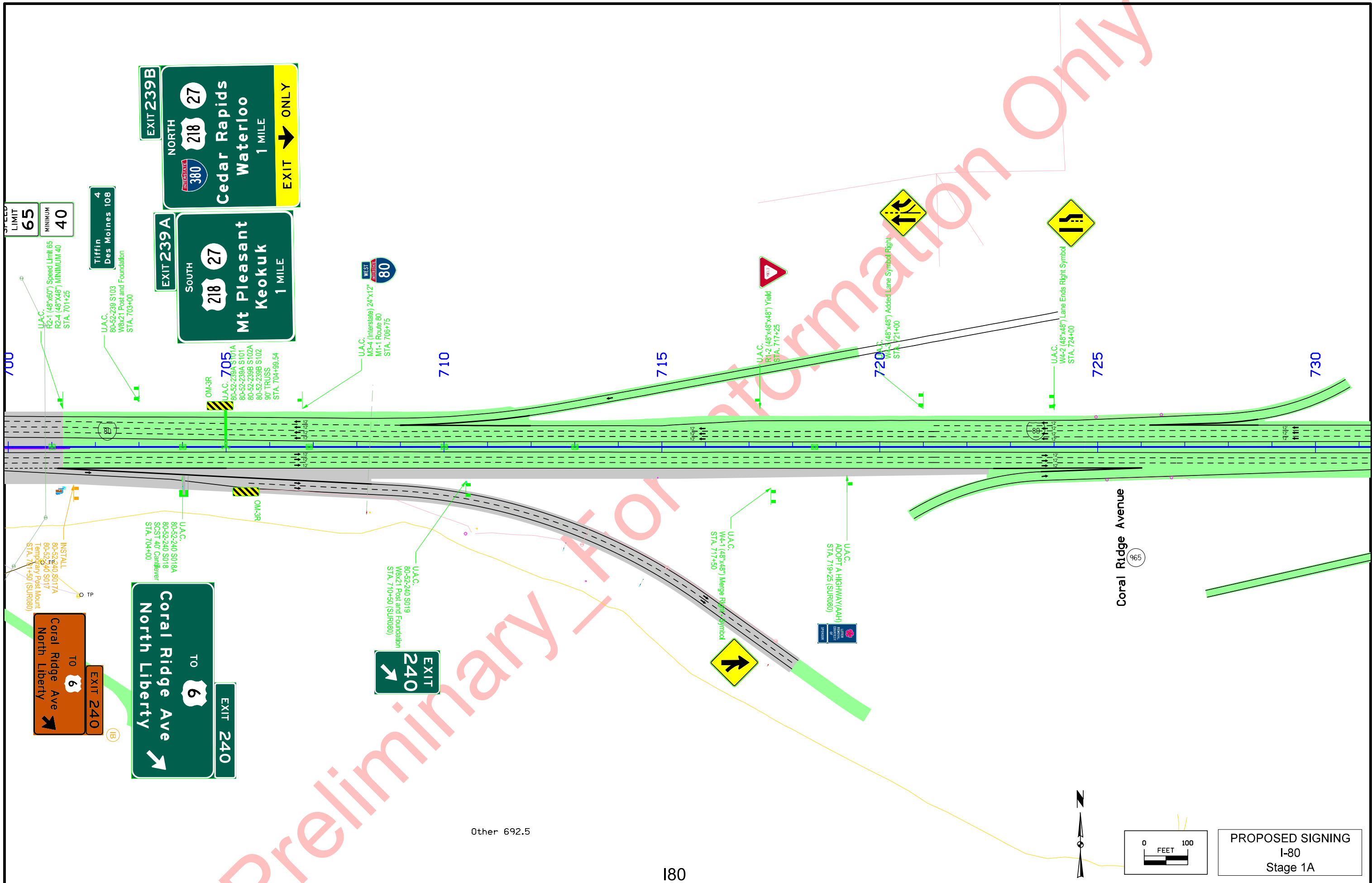

Preliminary - For Information Only

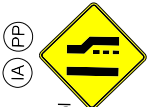
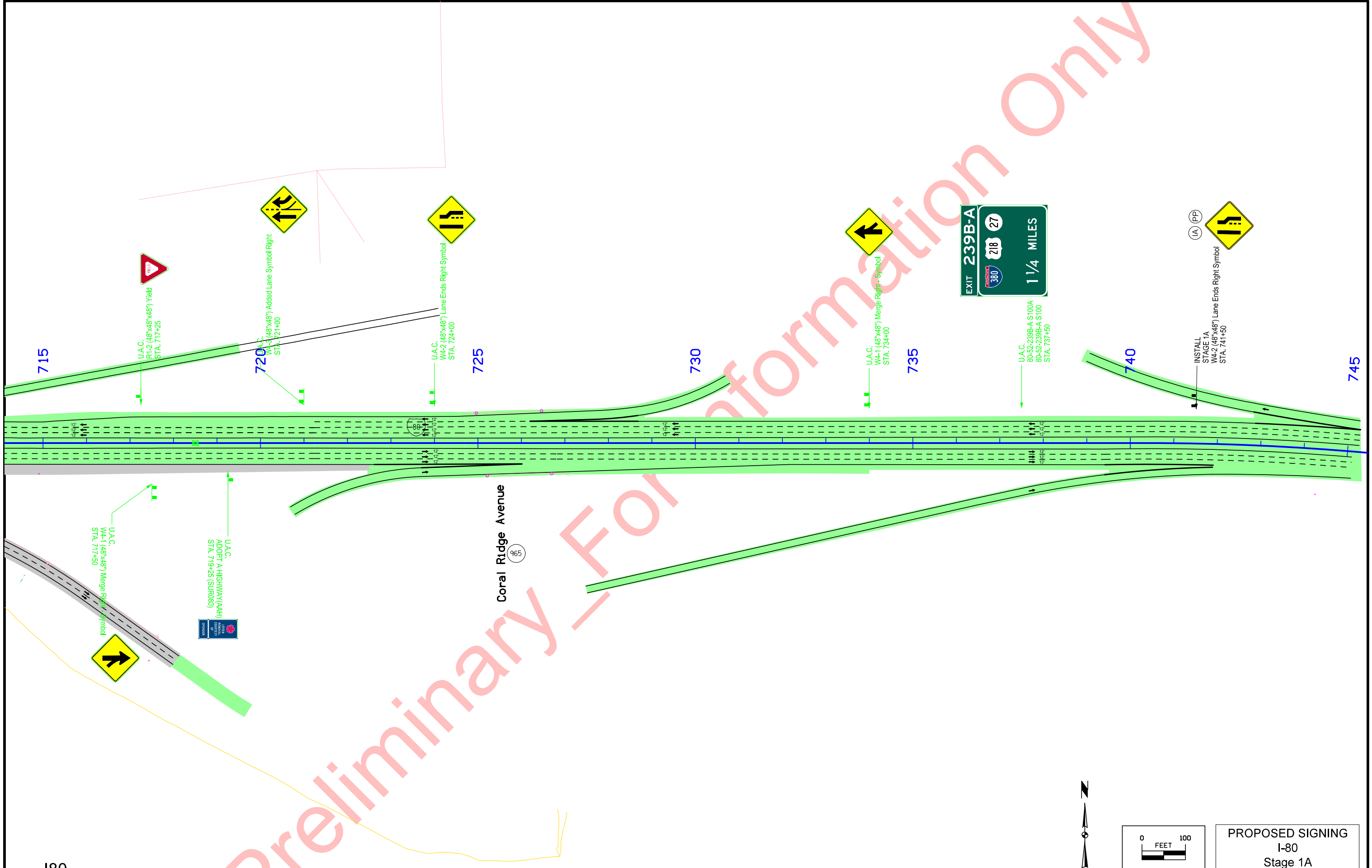

Coral Ridge Avenue  
965

PROPOSED SIGNING  
I-80  
Stage 1A

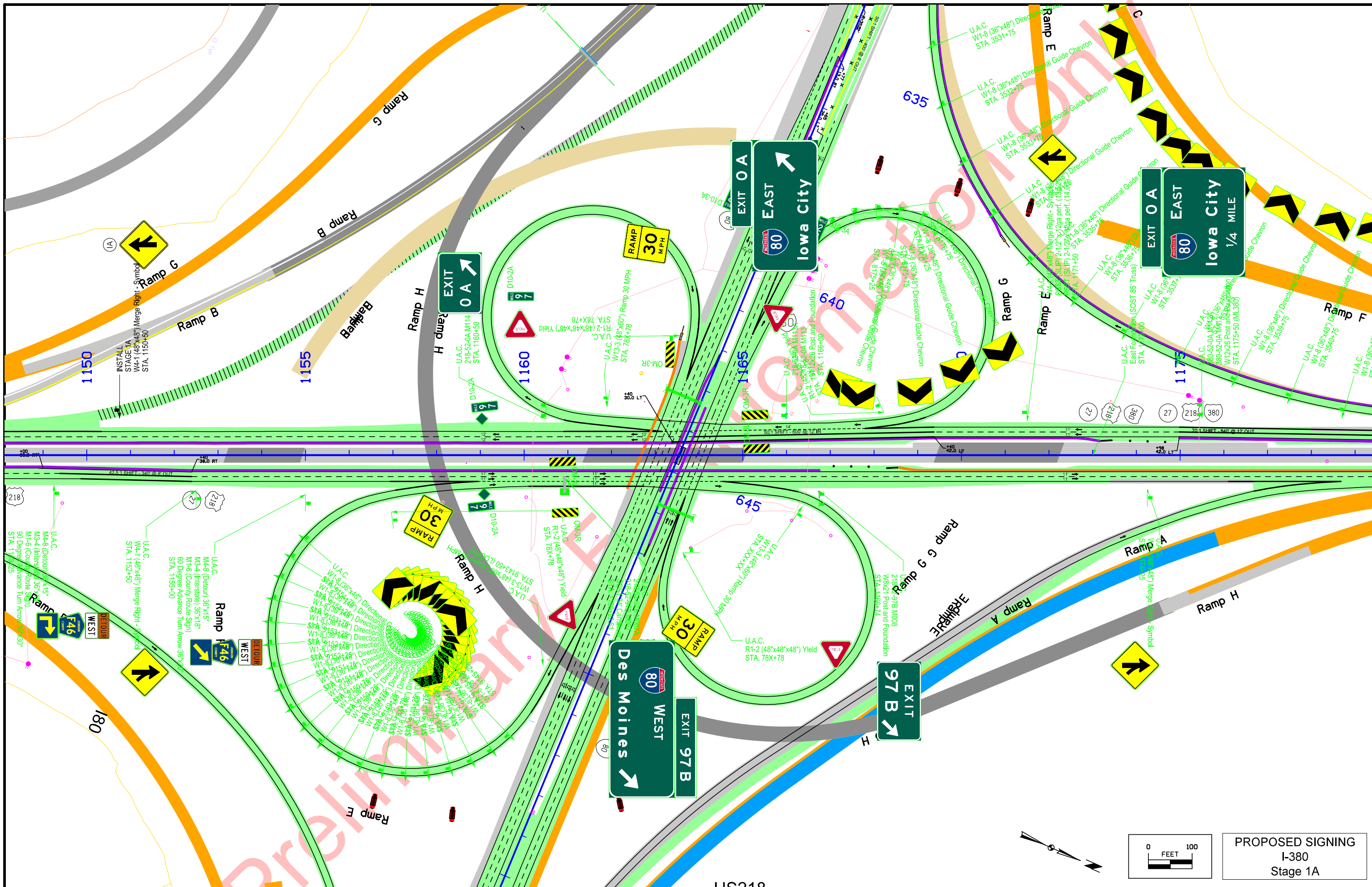

PROPOSED SIGNING  
I-380  
Stage 1A

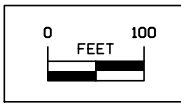

Preliminary For Information Only

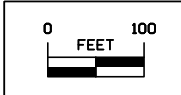
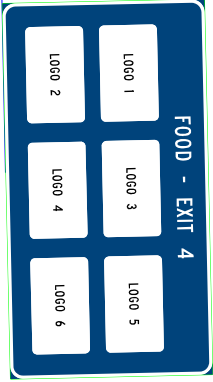
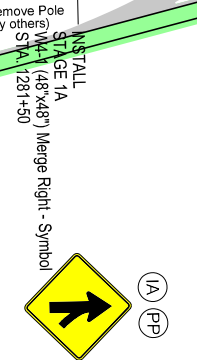
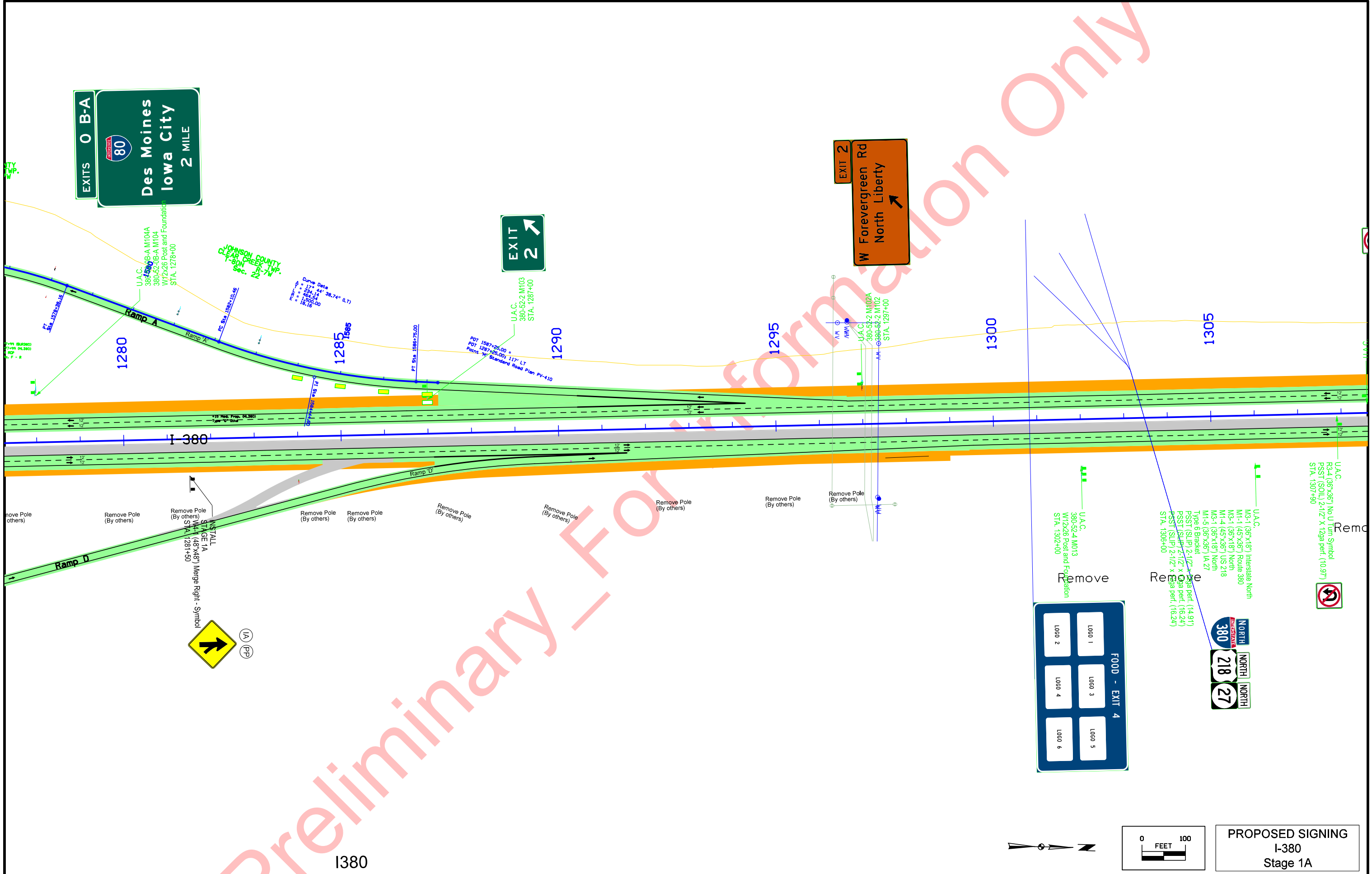
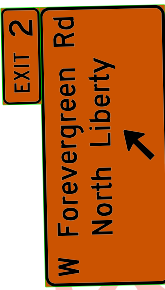

PROPOSED SIGNING  
I-380  
Stage 1A

Preliminary Information Only

**EXIT 239B**  
**NORTH**  
 218 **27**  
 Cedar Rapids Waterloo  
 1 MILE  
**EXIT ONLY**

**EXIT 239A**  
**SOUTH**  
 218 **27**  
 Mt Pleasant Keokuk  
 1 MILE

**EXIT 239A**  
**SOUTH**  
 218 **27**  
 Mt Pleasant Keokuk  
 1/4 MILE

**TO 6**  
**EXIT 240**  
 Coral Ridge Ave  
 North Liberty

**TO 6**  
**EXIT 240**  
 Coral Ridge Ave  
 North Liberty

Iowa Children's Museum  
 University of Iowa Research Park  
**EXIT 240**

**TO 6**  
**EXIT 240**  
 Coral Ridge Ave  
 North Liberty  
 1/4 MILE

**SPEED LIMIT 65**  
**MINIMUM 40**

**SPEED LIMIT 65**  
**MINIMUM 40**

**GAS - EXIT 240**

Kim & Go	Cawys
<b>FOOD - EXIT 240</b>	
Village Inn	McDonalds
Wendys	

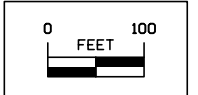

**PROPOSED SIGNING**  
 I-380  
 Stage 1B

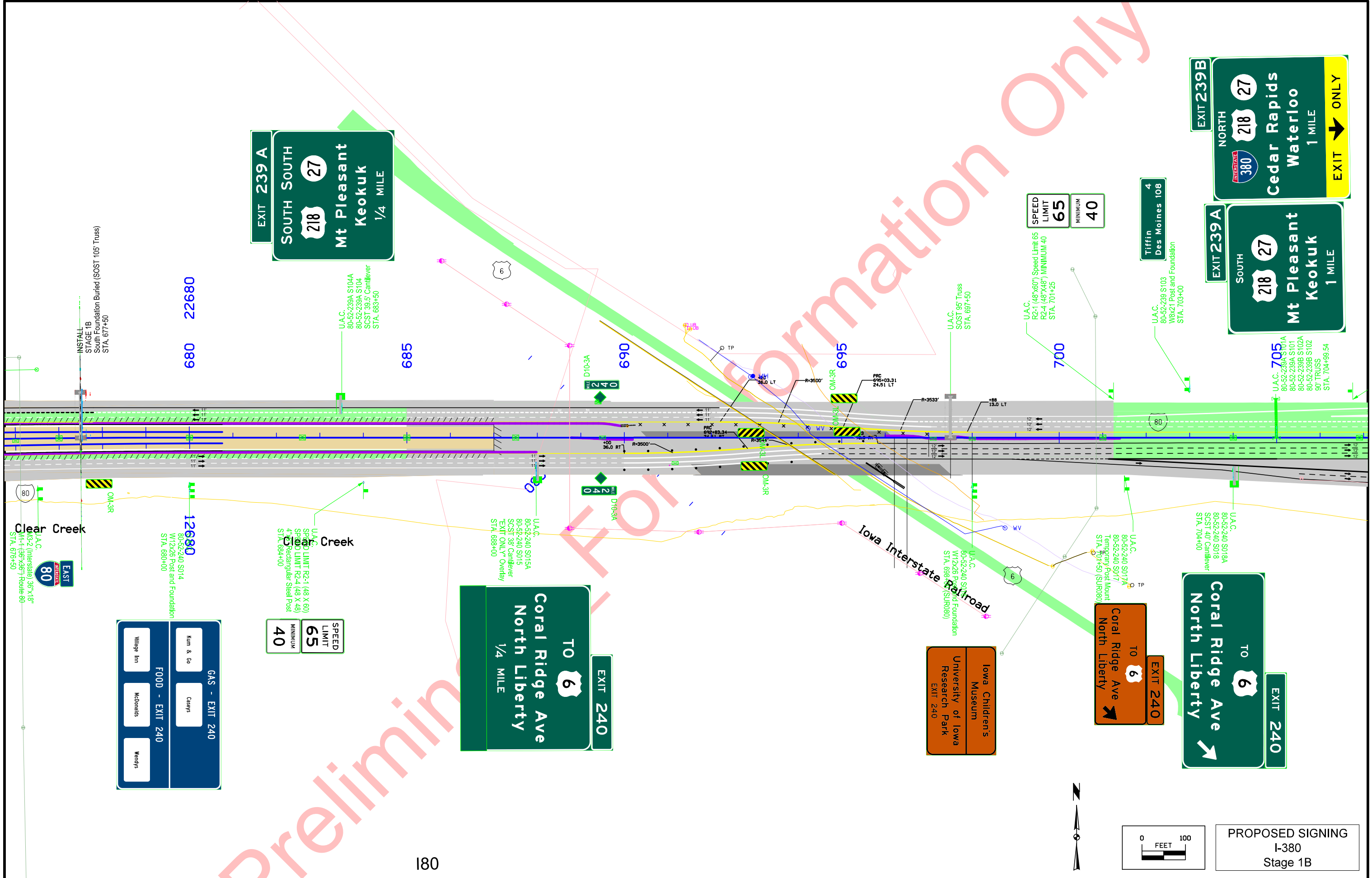

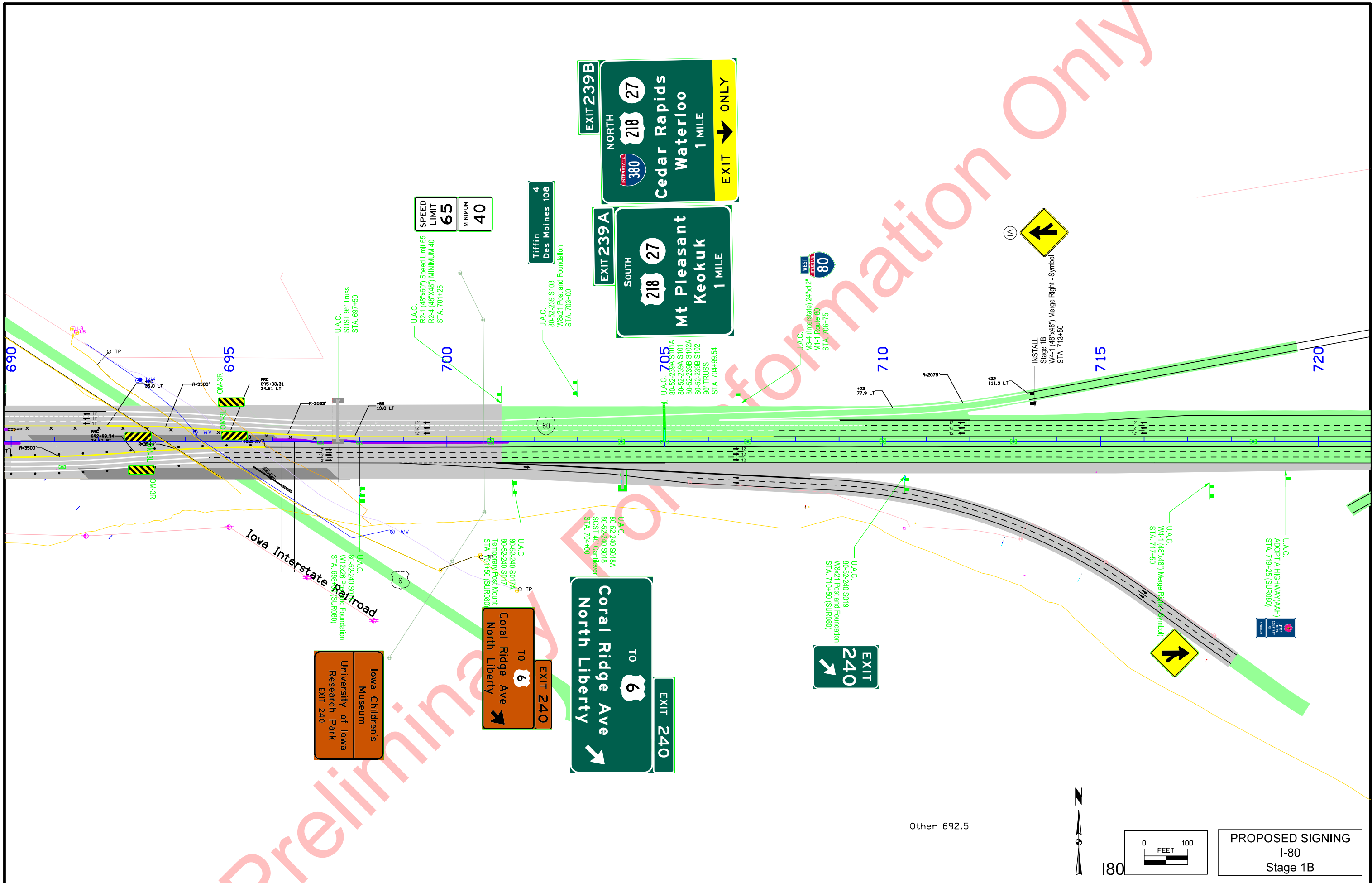

Preliminary - FOI Information Only

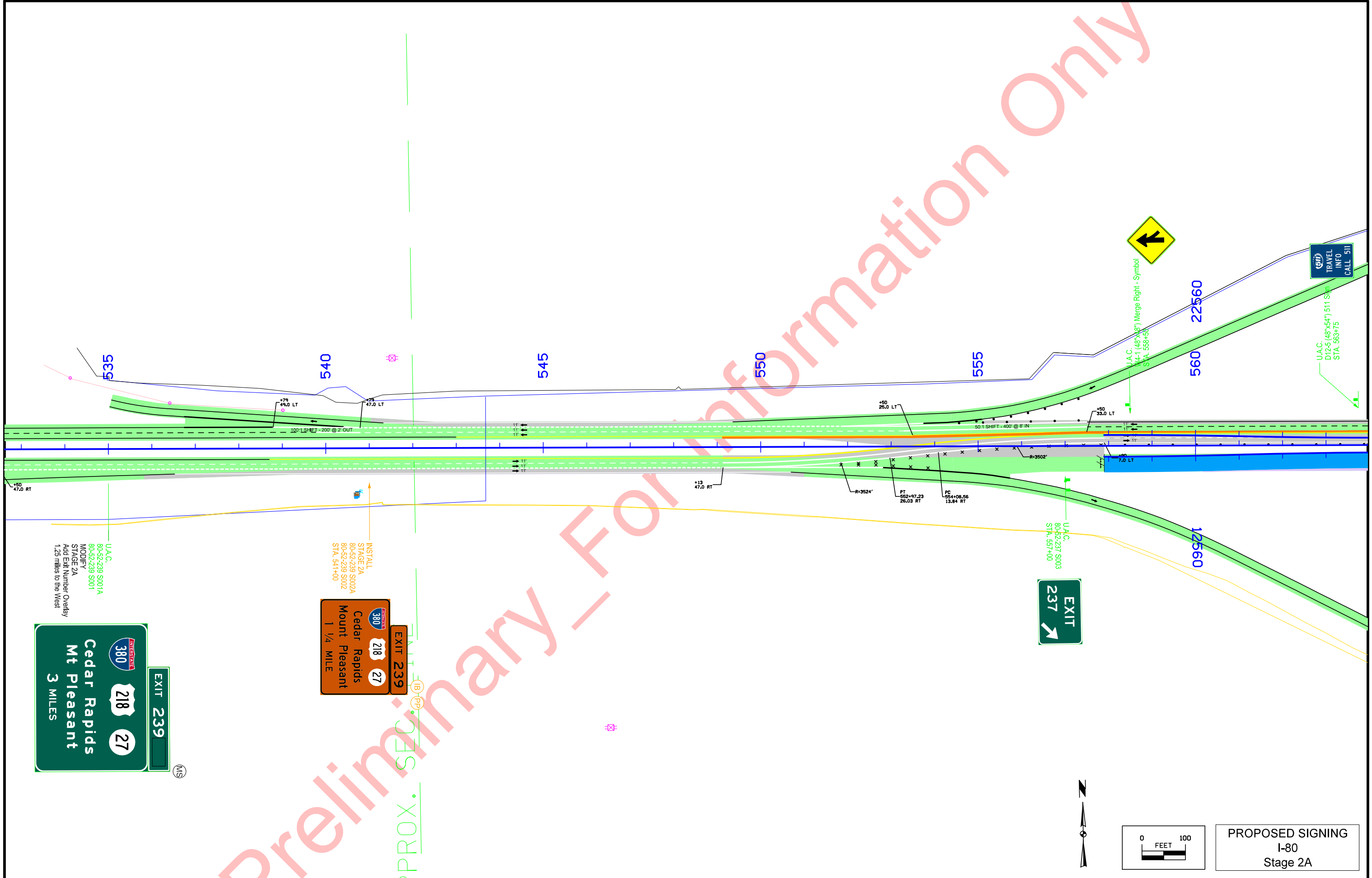

U.A.C.  
80-52-239 S001A  
80-52-239 S001  
MODIFY  
STAGE 2A  
Add Exit Number Overlay  
1.25 miles to the West

U.A.C.  
80-52-237 S003  
80-52-237 S003  
STA. 55+7+00

U.A.C. (48'x48') Merge Right - Symbol  
W4-1  
STA. 558+50

U.A.C. (48'x54') 511 Sign  
STA. 563+75

INSTALL  
STAGE 2A  
80-52-239 S002A  
80-52-239 S002  
STA. 54+1+00

EXIT 239  
EXIT 218  
EXIT 27  
Cedar Rapids  
Mount Pleasant  
1 1/4 MILE

EXIT 239  
Cedar Rapids  
Mt Pleasant  
3 MILES

EXIT 237



511 TRAVEL INFO CALL 511

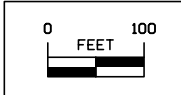

PROPOSED SIGNING  
I-80  
Stage 2A

180

GAS - EXIT 237	
Kum & Go	
FOOD - EXIT 237	
Subway	Jon's Ice Cream Store & Restaurant

**FW Kent Park**  
EXIT 237

**EXIT 237**  
**Tiffin**  
3/4 MILES

**EXIT 239**  
**Cedar Rapids**  
**Mount Pleasant**

**EXIT 239**

**SPEED LIMIT 65**  
MINIMUM 40

**SPEED LIMIT 70**  
MINIMUM 40

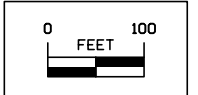

**PROPOSED SIGNING**  
I-80  
Stage 2A

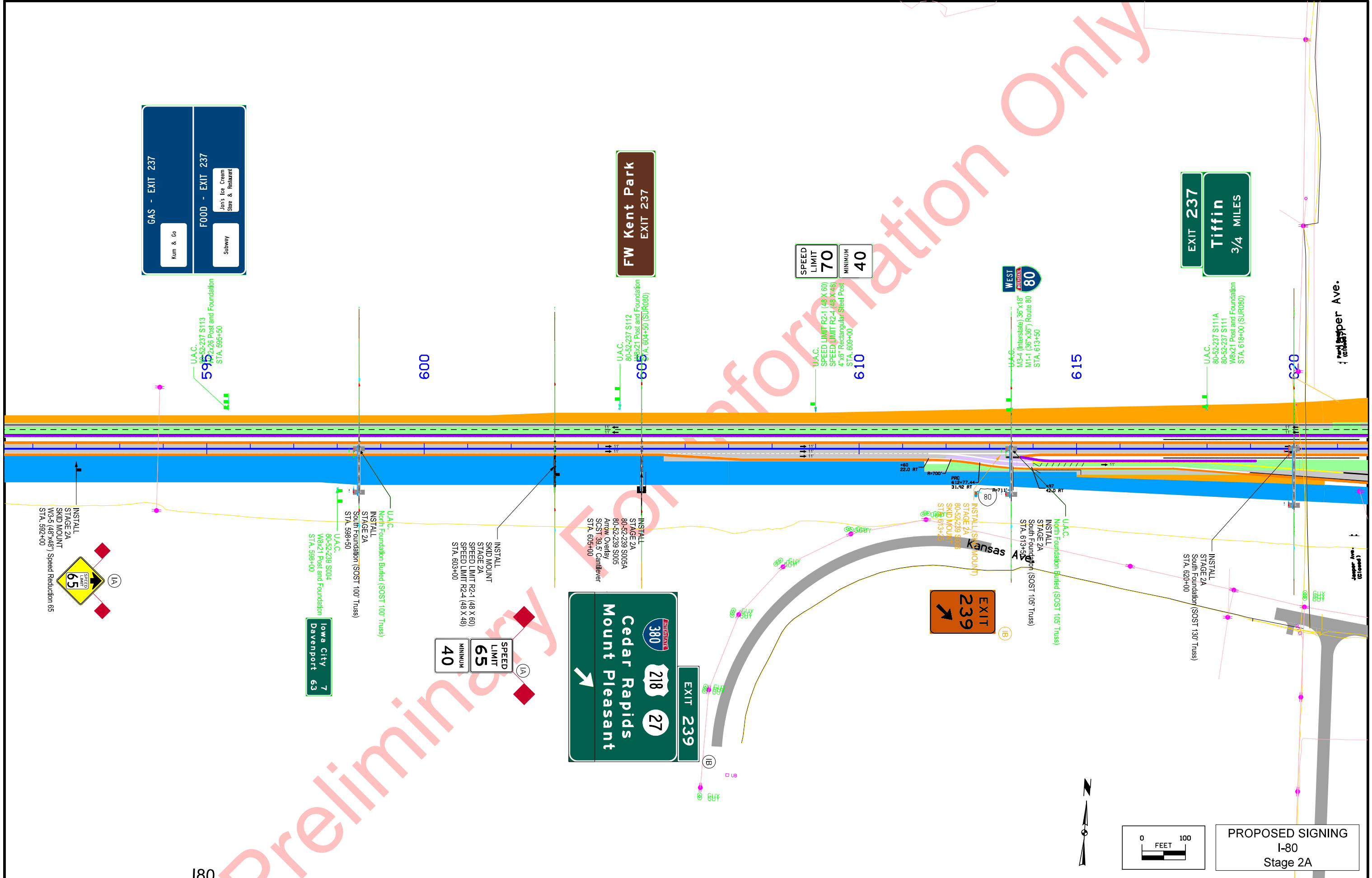



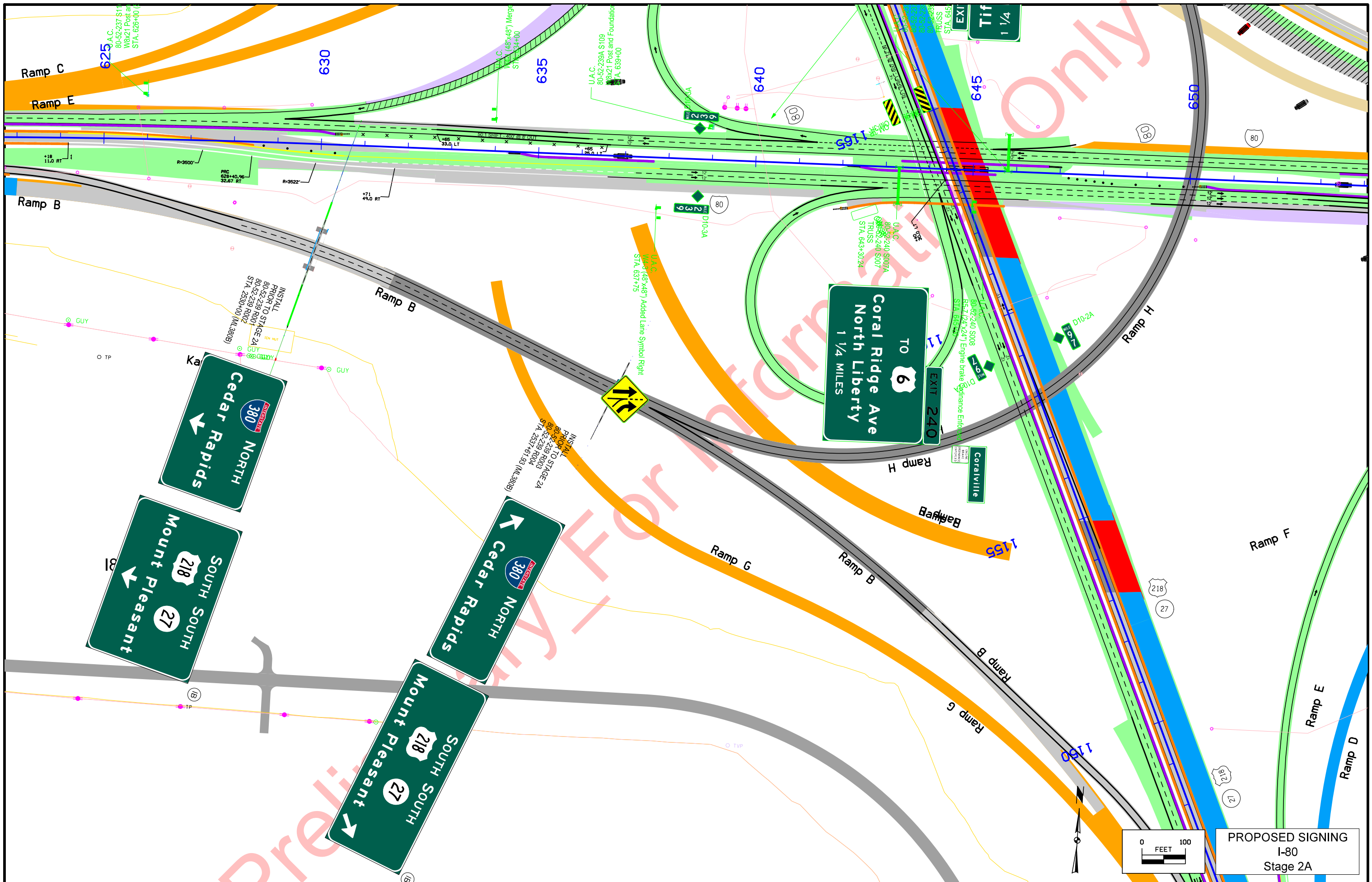

PROPOSED SIGNING  
I-80  
Stage 2A

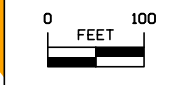

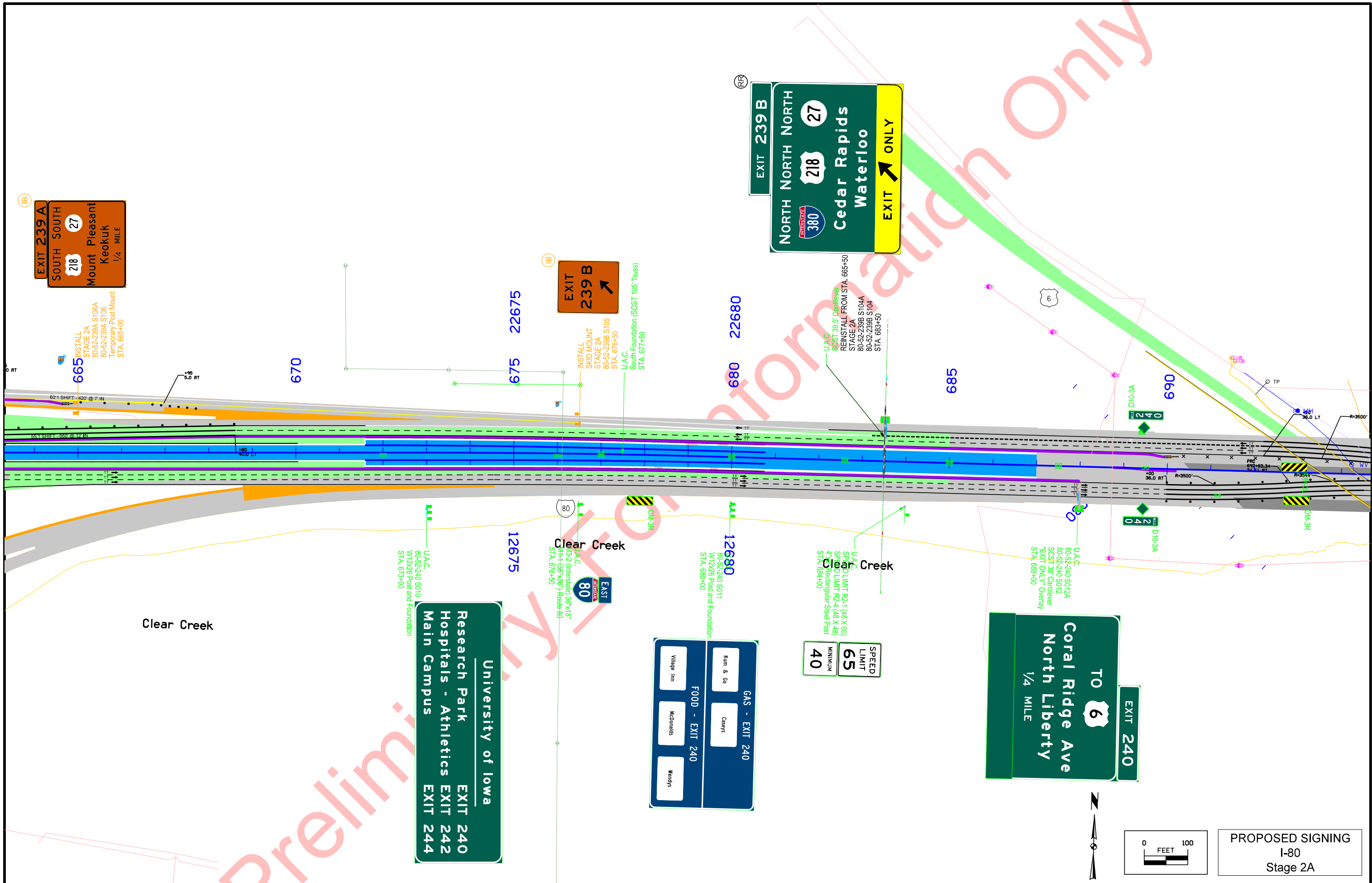

PROPOSED SIGNING  
I-80  
Stage 2A

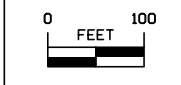

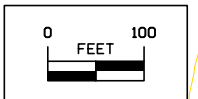
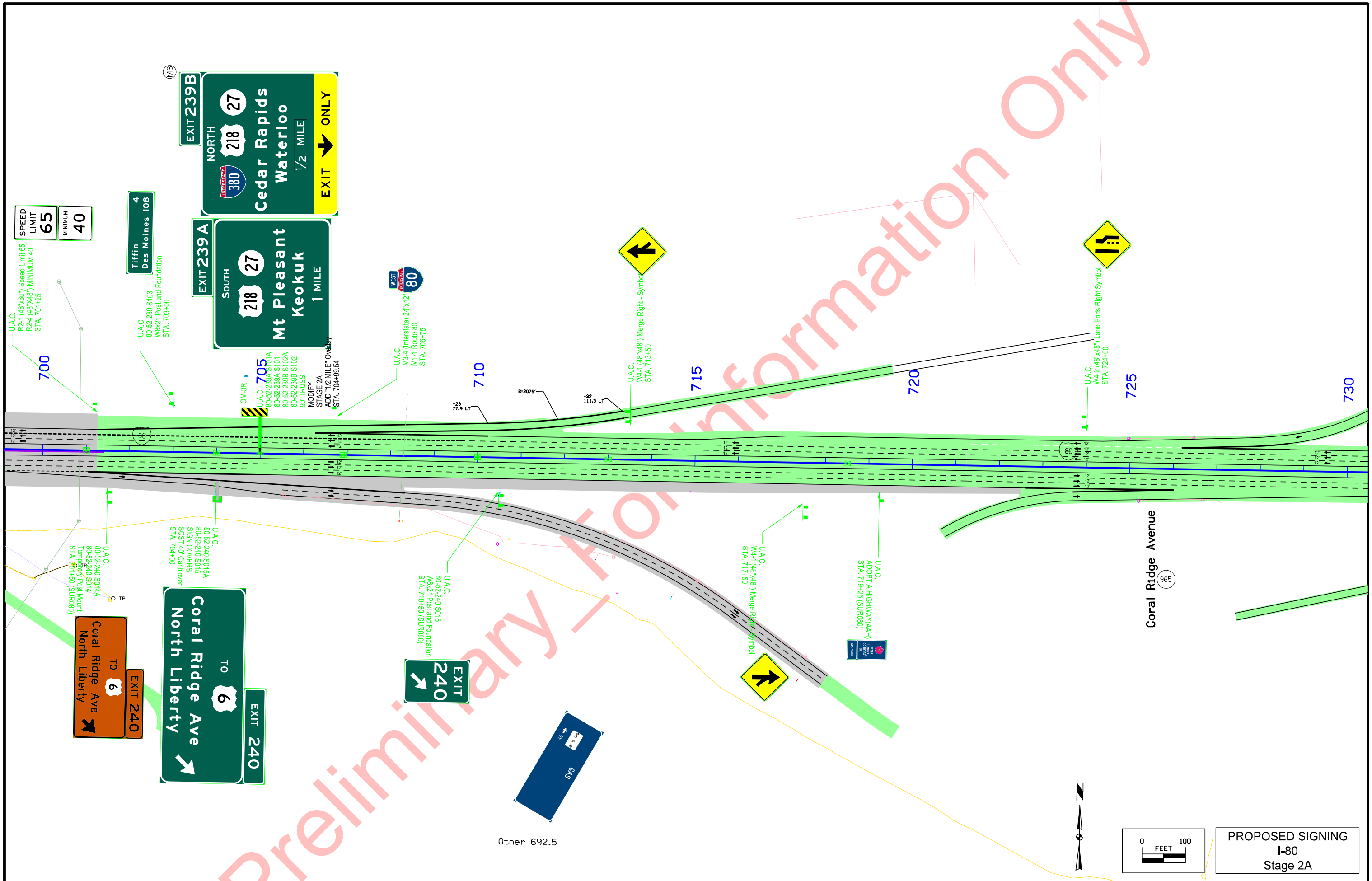

PROPOSED SIGNING  
I-80  
Stage 2A

Preliminary FOR INFORMATION ONLY



U.A.C.  
W4-2 (48"x48") Lane Ends Right-Symbol  
STA. 724+00

725

730



U.A.C.  
W4-1 (48"x48") Merge Right-Symbol  
STA. 734+00

735

(MS)



U.A.C.  
80-52-239B-A S100A  
80-52-239B-A S100  
MODIFY  
STAGE 2A  
"1 MILE" OVERLAY  
STA. 737+50

740

745

750

Coral Ridge Avenue

965

U.A.C.  
STOR ASSEMBLY WITH  
STA. 2520+00

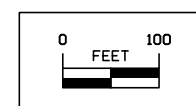

PROPOSED SIGNING  
I-80  
Stage 2A

Preliminary - For Information Only

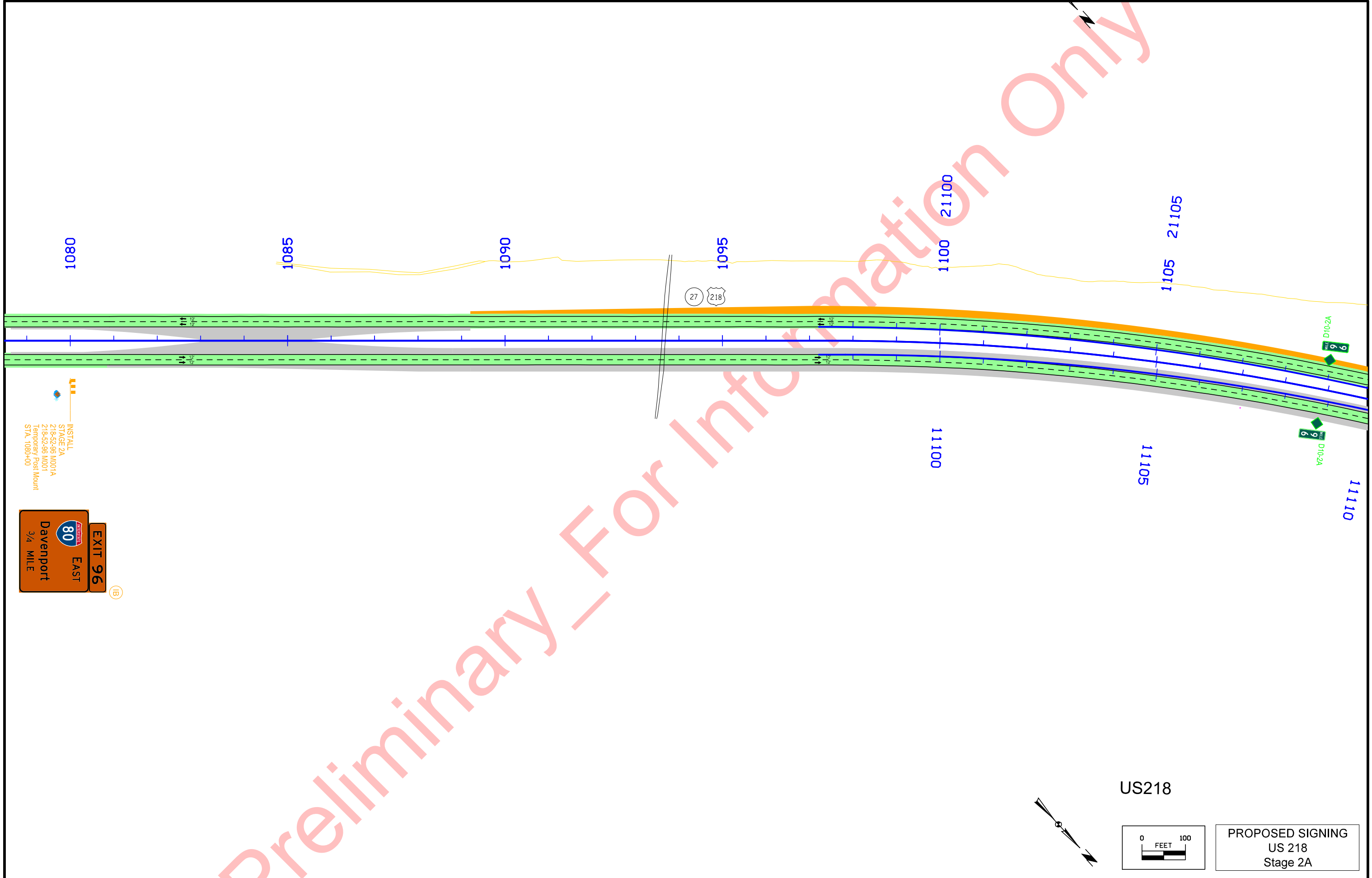

INSTALL  
STAGE 2A  
218-52-96 M001A  
218-52-96 M001  
Temporary Post Mount  
STA. 1080+00

**EXIT 96**  
EAST  
80  
Davenport  
3/4 MILE

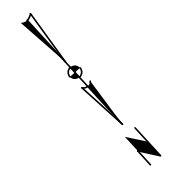

US218

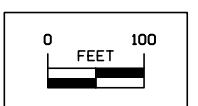

PROPOSED SIGNING  
US 218  
Stage 2A

Preliminary Information Only

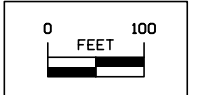
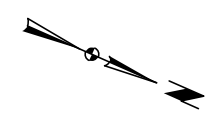
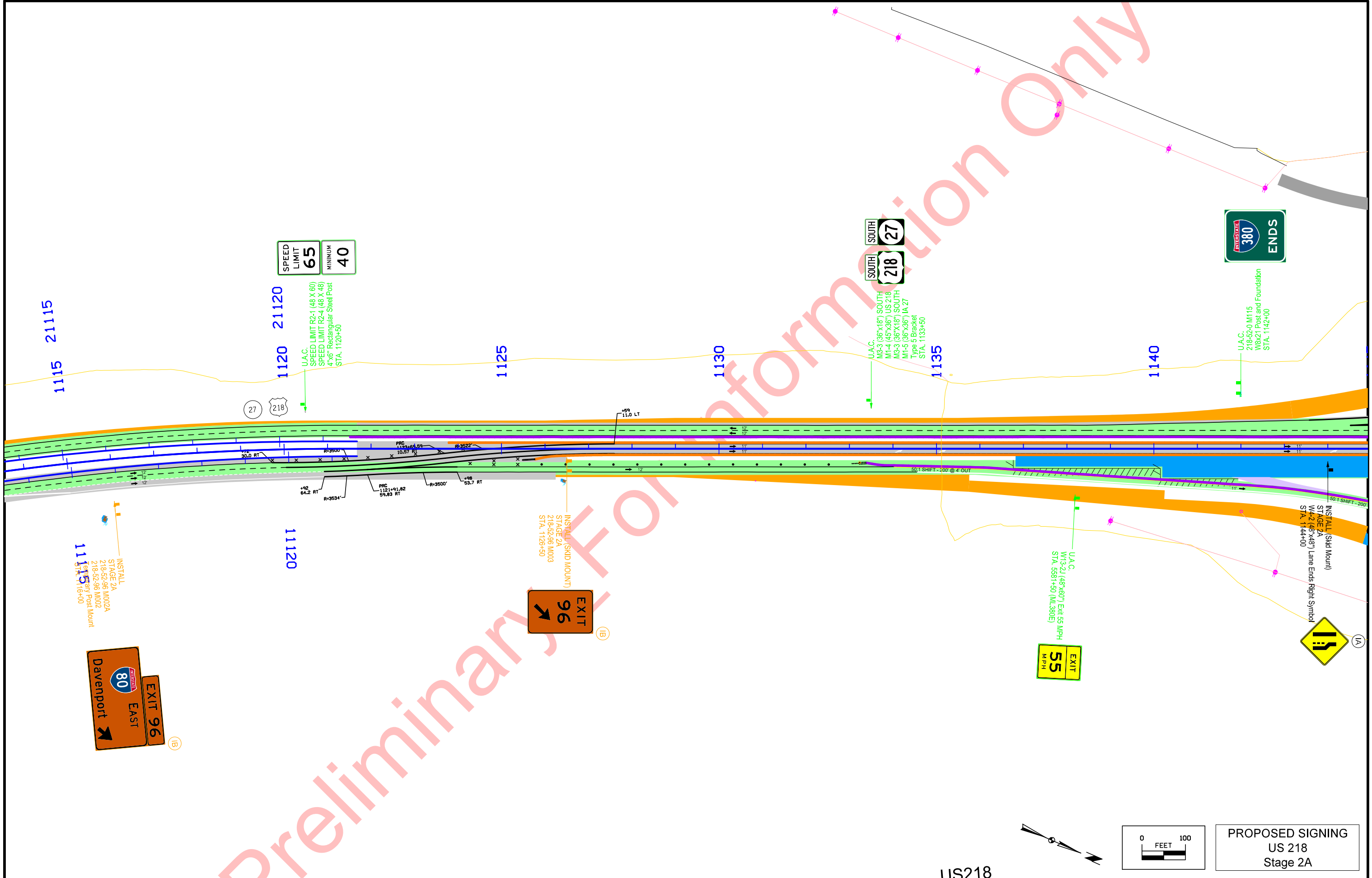

PROPOSED SIGNING  
US 218  
Stage 2A

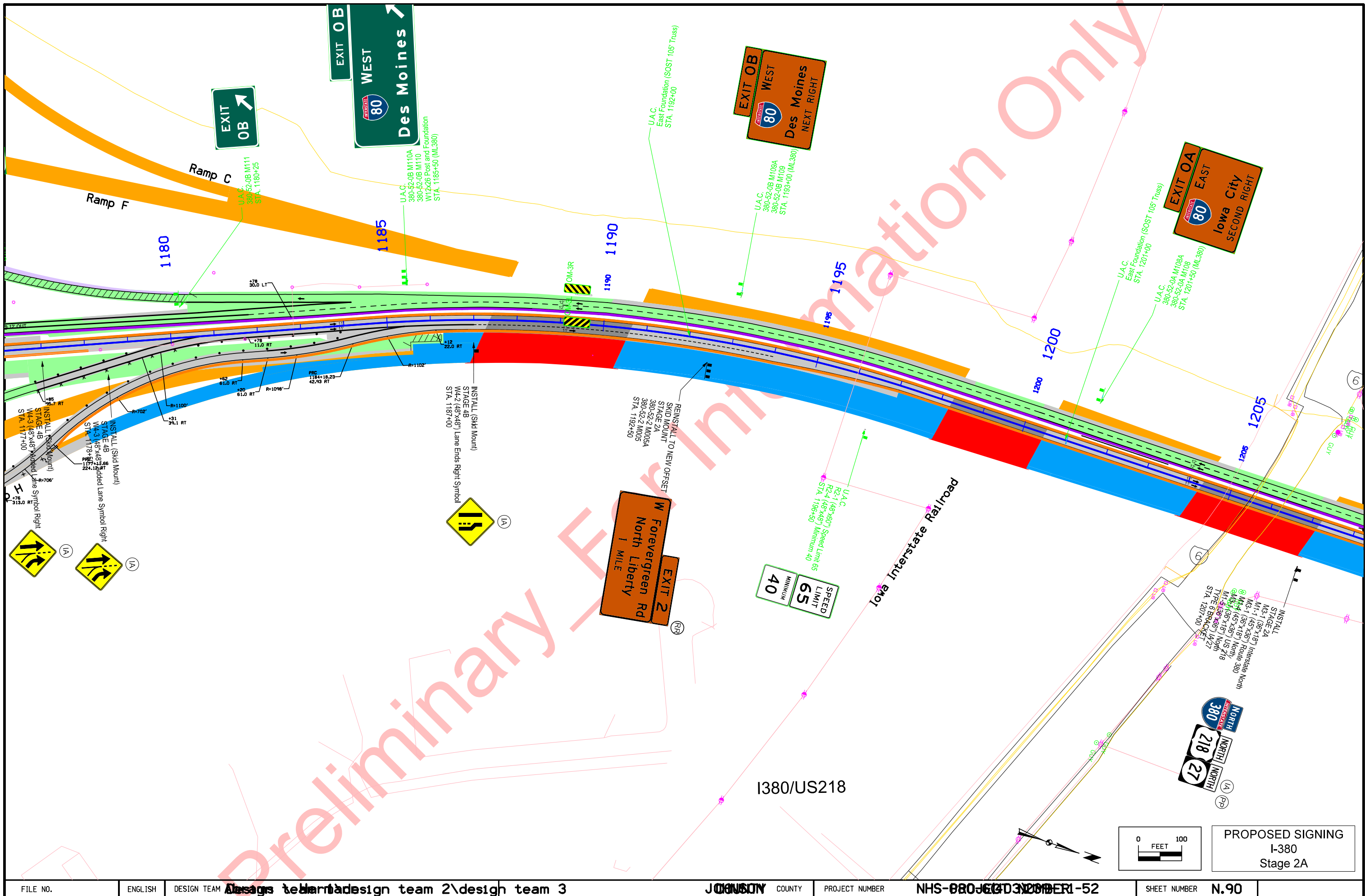

**EXIT OB**  
**WEST**  
**80**  
**Des Moines**  
**1 1/4 MILE**

1245 C  
 380-52-2 M105A  
 380-52-2 M105  
 W12x26 Post and Foundation  
 STA. 1245+00

REINSTALL FROM STA. 1246+50  
 SKID MOUNT  
 STAGE 2A  
 380-52-2 M006A  
 380-52-2 M006  
 STA. 1243+50

**W Forevergreen Rd**  
**North Liberty**  
**EXIT 2**  
 (RR)

INSTALL  
 SKID MOUNT  
 STAGE 2A  
 380-52-2 M007  
 STA. 1253+00

**EXIT 2**  
 (B)



U.A.C.  
 (W-1 (48"x48") Merge Right - Symbol  
 PAST (SLIP) 2-1/2' x 12ga perf. (14.52)  
 PAST (SLIP) 2-1/2' x 12ga perf. (15.00)  
 STA. 1263+00

I380

**PROPOSED SIGNING**  
**I-380**  
**Stage 2A**

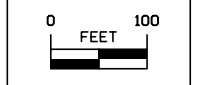



Preliminary For Information Only

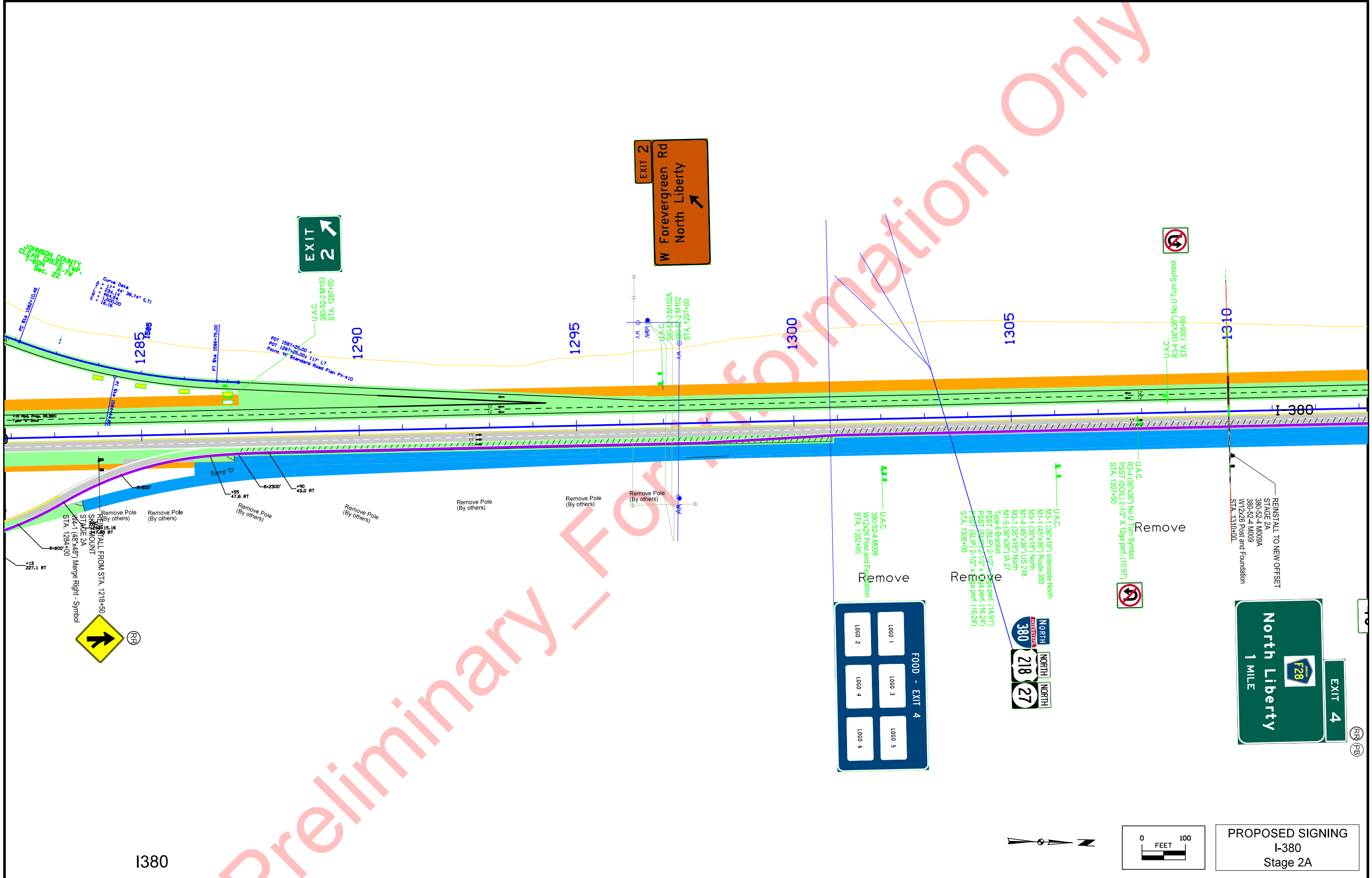

1360

1365

1370

1375

1380

1385

U.A.C.  
380+52.4 M013A  
380+52.4 M013  
W12226 Postland Foundation  
STA. 1358+00

North Liberty  
EXIT 4

U.A.C.  
380+52.4 M014  
STA. 1364+50

EXIT 4

D10-1A  
4

INSTALL  
STAGE 2A  
R4-3 (48"x60") Slower Traffic Keep Right  
STA. 1379+00

(A) (P)

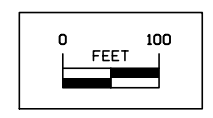
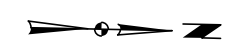

PROPOSED SIGNING  
I-380  
Stage 2A

Preliminary - For Information Only

Preliminary Information Only

GAS - EXIT 237	FOOD - EXIT 237
Kum & Go	Jon's Ice Cream Store & Restaurant
Subway	

FW Kent Park EXIT 237
--------------------------

SPEED LIMIT 70	MINIMUM 40
----------------	------------

WEST Interstate 80
--------------------------

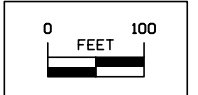
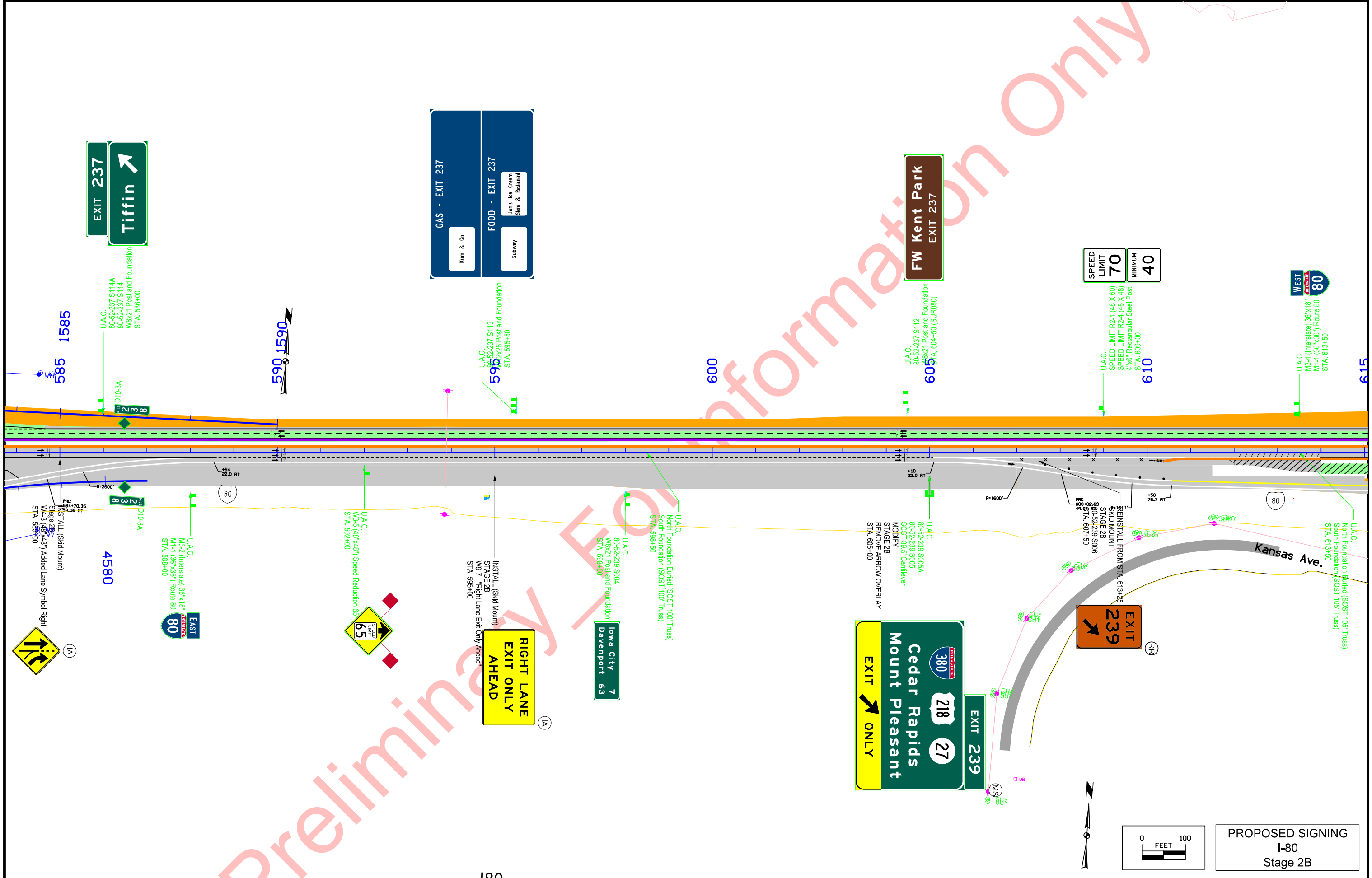

PROPOSED SIGNING  
I-80  
Stage 2B

Preliminary - For Information Only

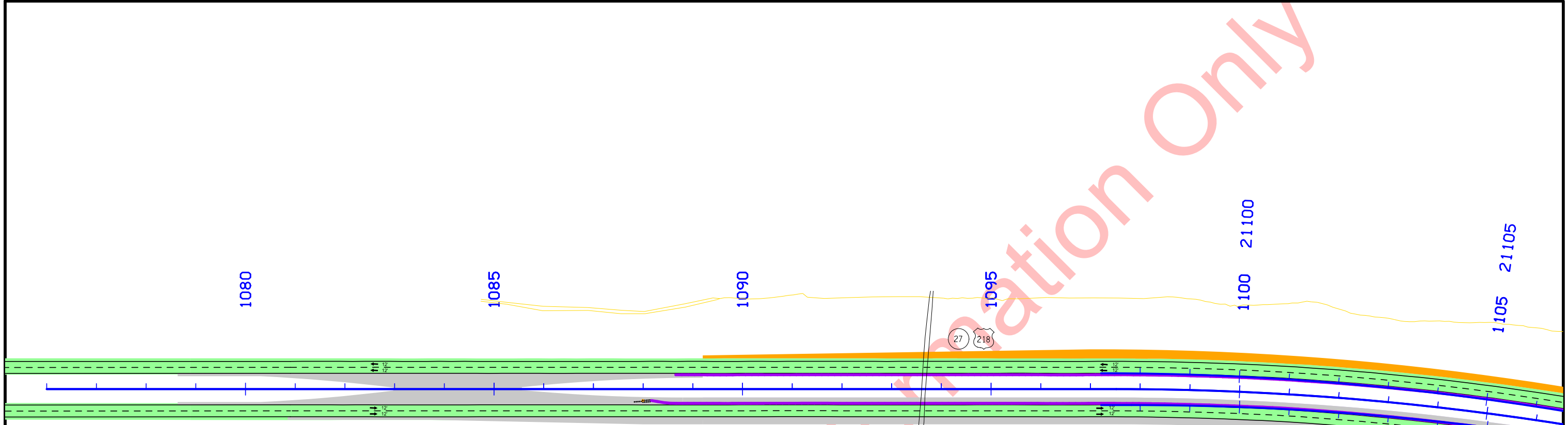

U.A.C.  
 218-52-98 M001A  
 218-52-98 M001  
 Temporary Post Mount  
 MODIFY  
 STAGE 2B  
 ADD 1 MILE OVERLAY  
 STA. 1080+00



US218

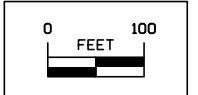
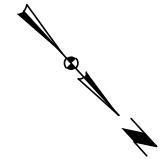

PROPOSED SIGNING  
 US 218  
 Stage 2B

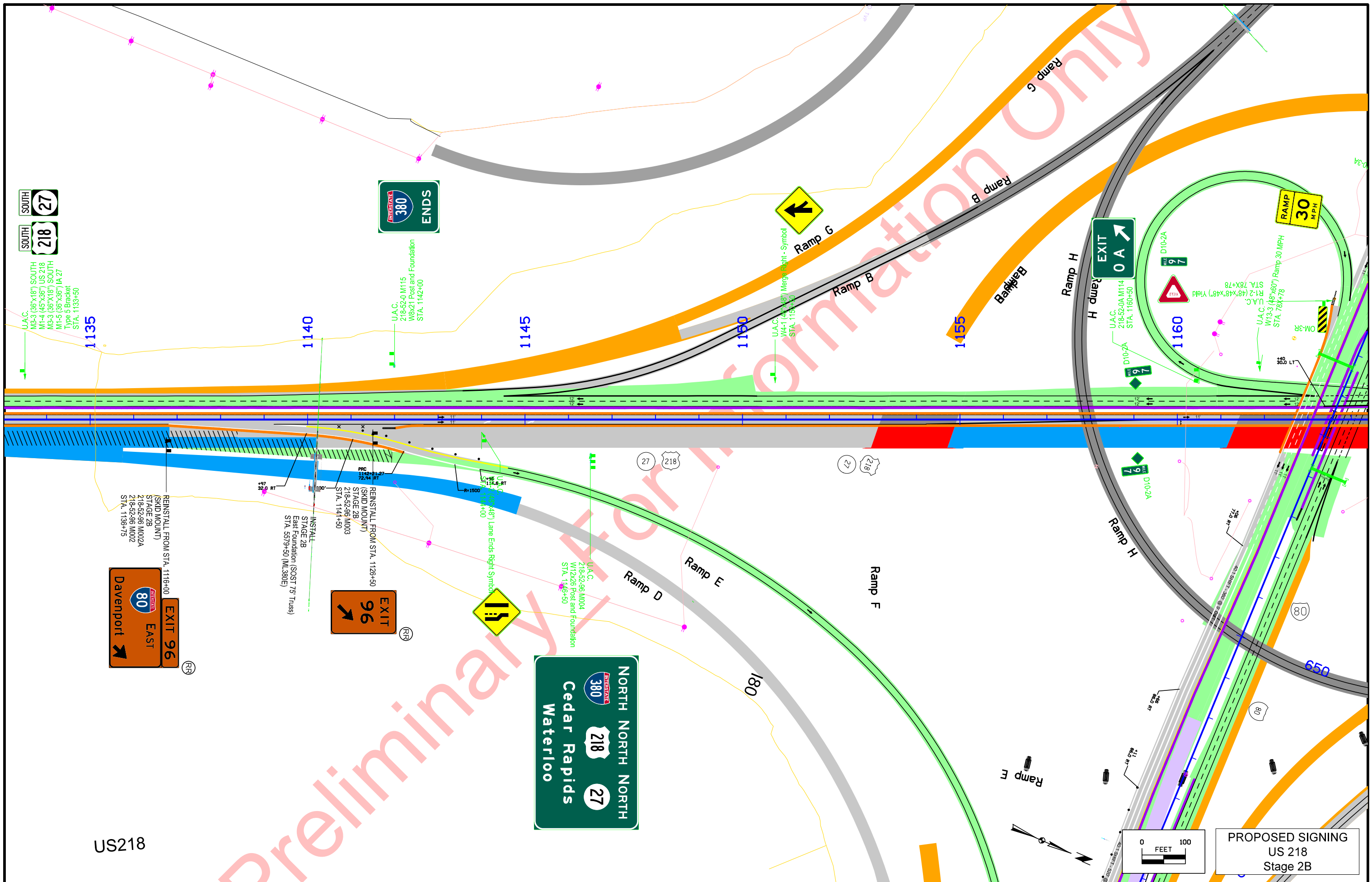

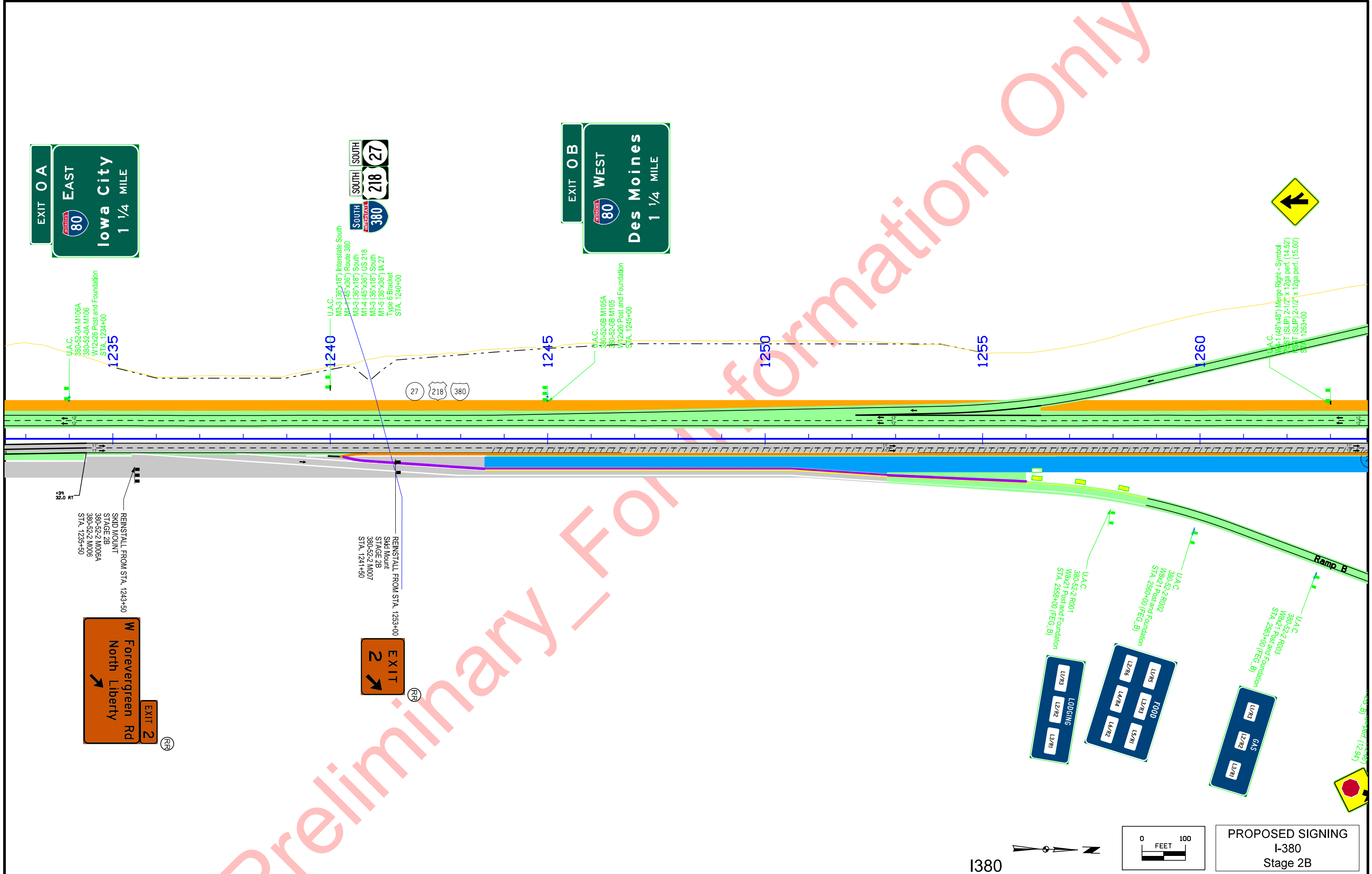

REINSTALL FROM STA. 1243+50  
SKID MOUNT  
STAGE 2B  
380-52-2 M006A  
380-52-2 M006  
STA. 1235+50

REINSTALL FROM STA. 1253+00  
SKID MOUNT  
STAGE 2B  
380-52-2 M007  
STA. 1241+50

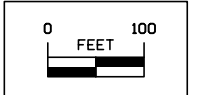
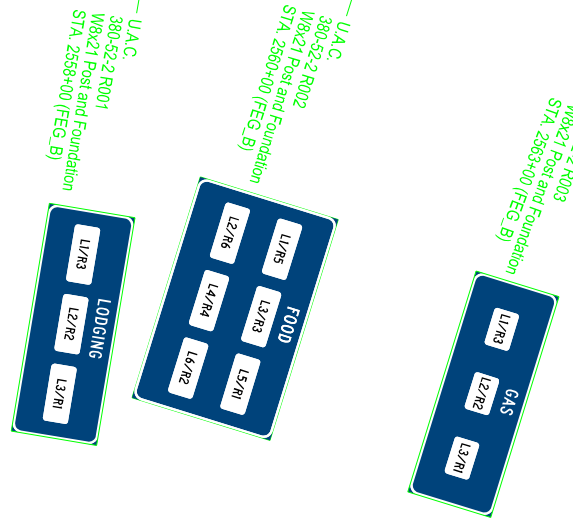
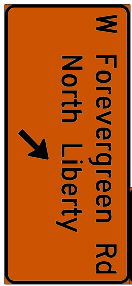

PROPOSED SIGNING  
I-380  
Stage 2B

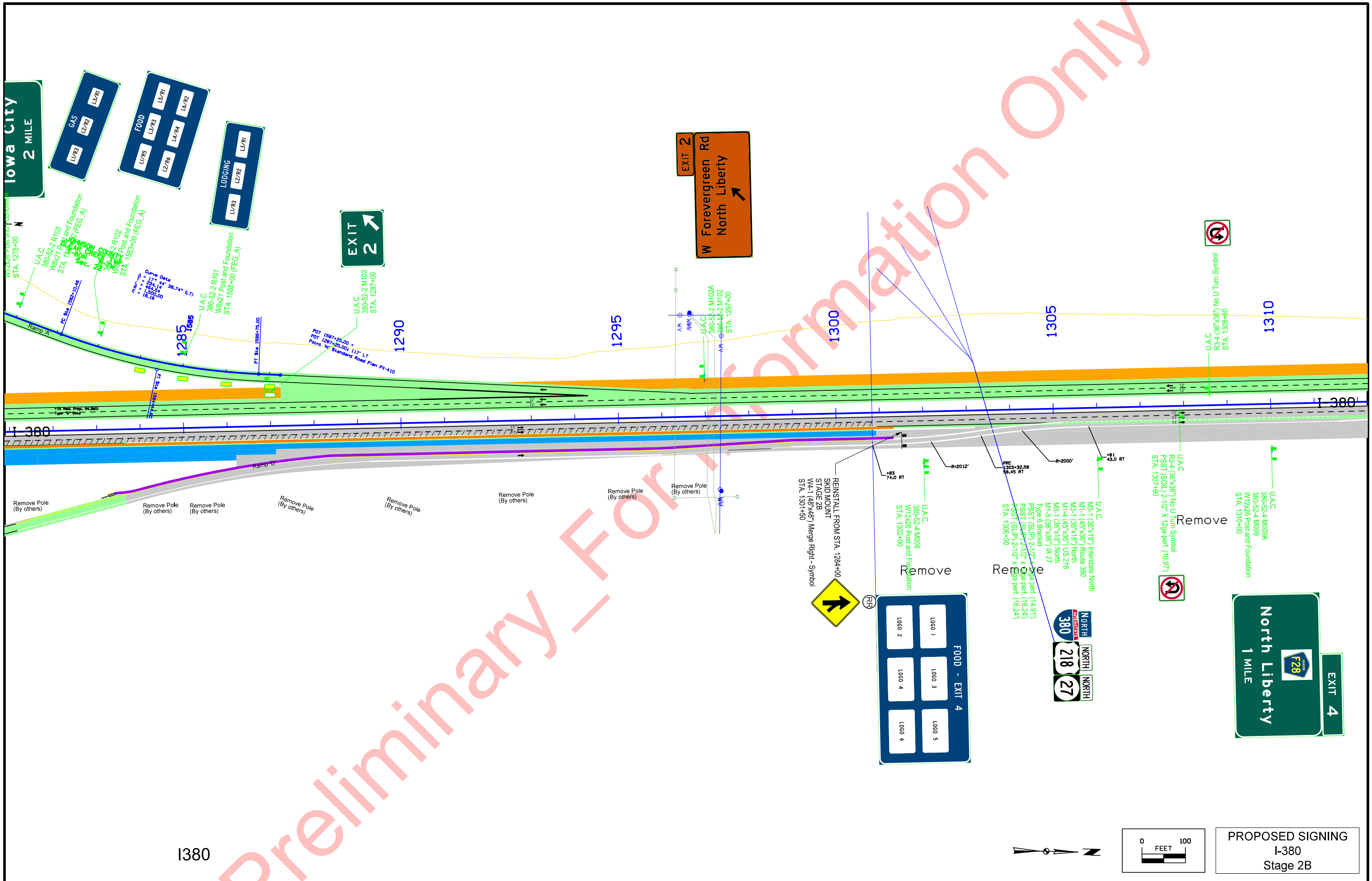

I380

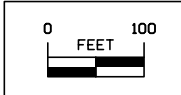

PROPOSED SIGNING  
I-380  
Stage 2B

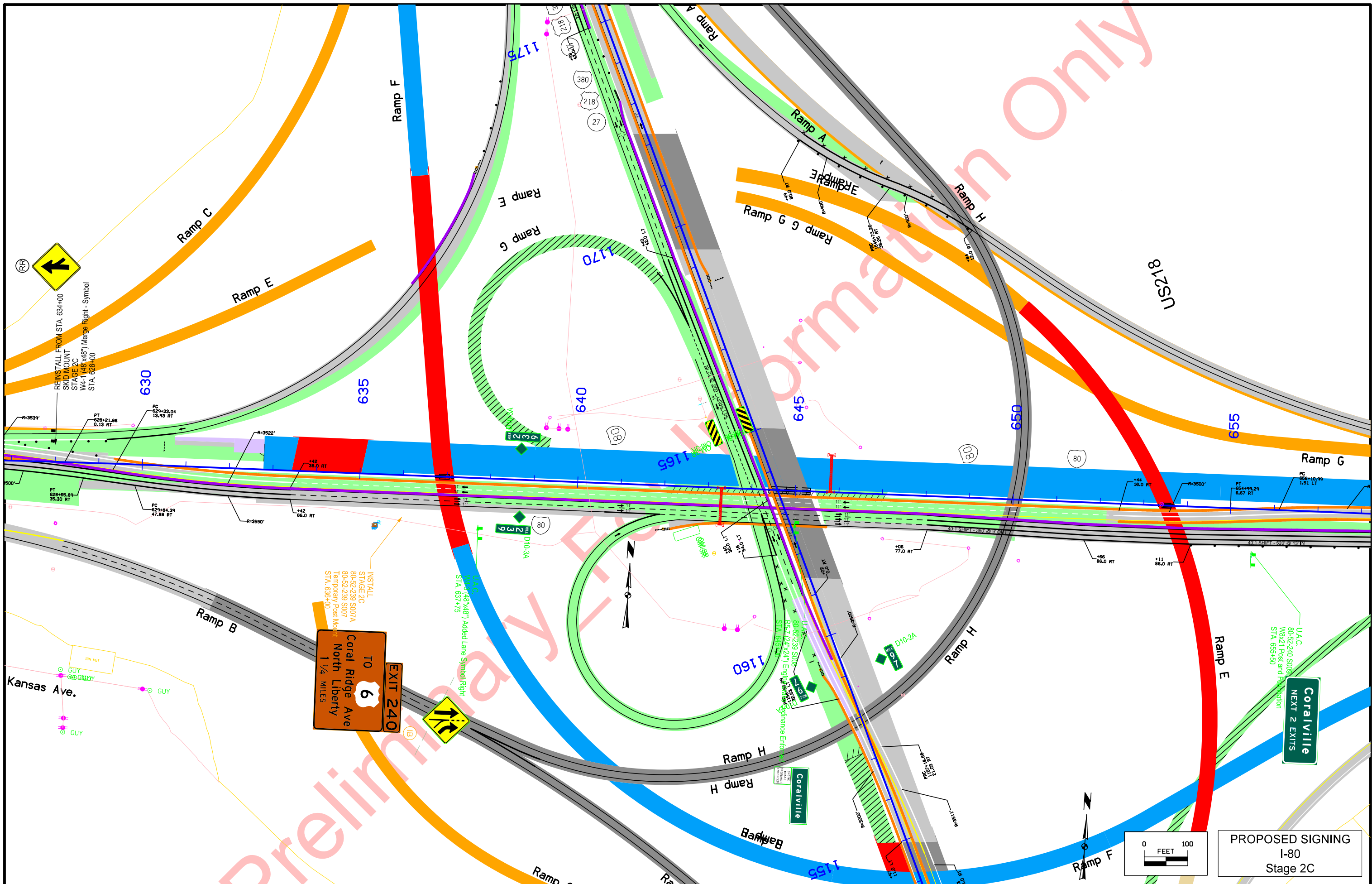

**PROPOSED SIGNING**  
I-80  
Stage 2C

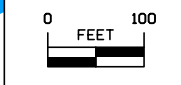

**EXIT 240**  
TO  
**6**  
Coral Ridge Ave  
North Liberty  
1 1/4 MILES

**Coralville**  
NEXT 2 EXITS



Information Only

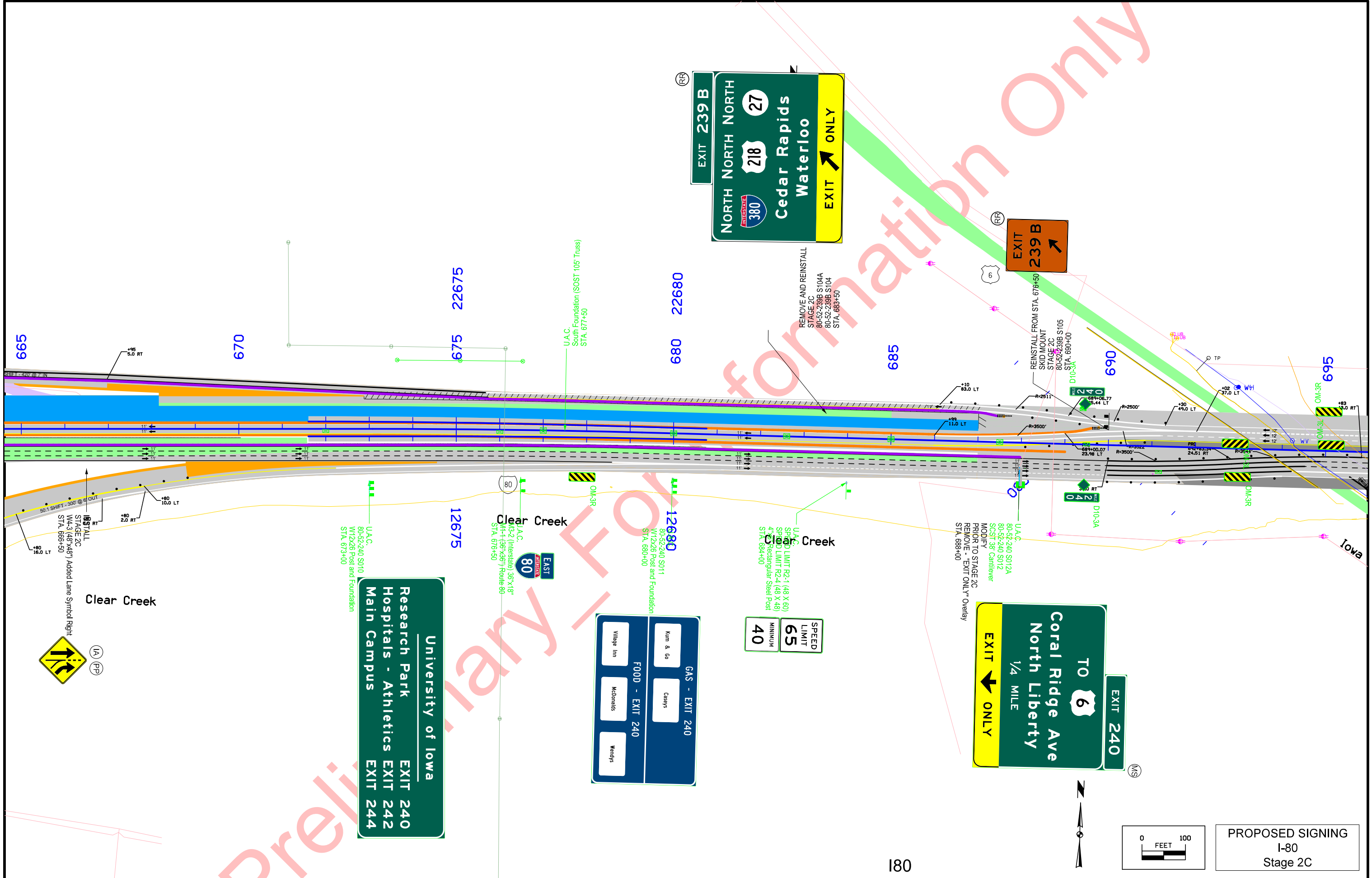

**EXIT 239 B**  
 NORTH NORTH NORTH  
 Cedar Rapids Waterloo  
 EXIT ONLY

**EXIT 239 B**

**EXIT 240**  
 TO 6  
 Coral Ridge Ave  
 North Liberty  
 1/4 MILE  
 EXIT ONLY

**SPEED LIMIT 65**  
 MINIMUM 40

**University of Iowa**  
 Research Park  
 Hospitals - Athletics  
 Main Campus  
 EXIT 240  
 EXIT 242  
 EXIT 244

**GAS - EXIT 240**  
 Kum & Go  
 Caser's  
**FOOD - EXIT 240**  
 Village Inn  
 McDonald's  
 Wendy's

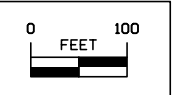

**PROPOSED SIGNING**  
 I-80  
 Stage 2C

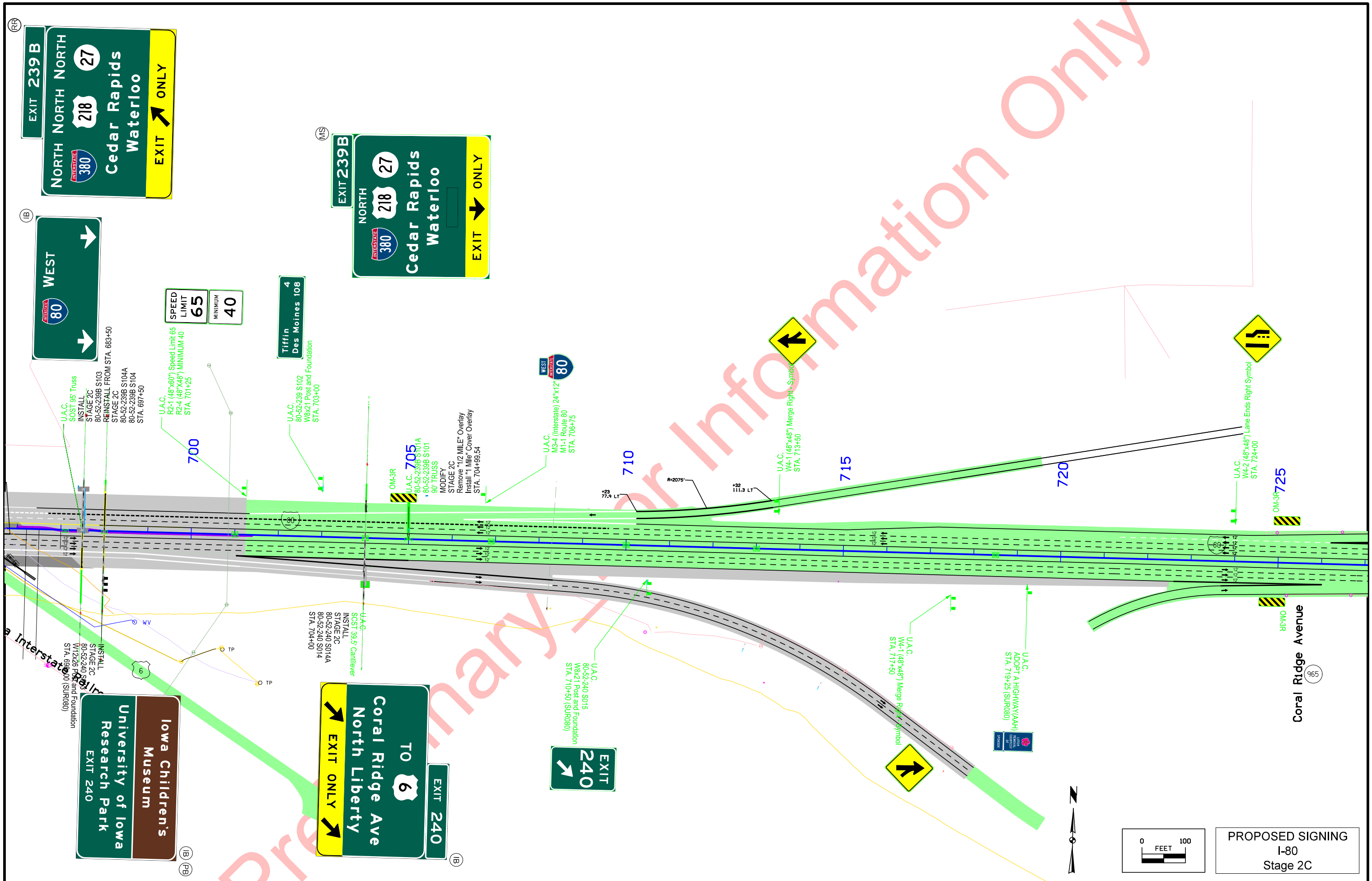

PROPOSED SIGNING  
I-80  
Stage 2C

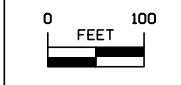

Preliminary Information Only

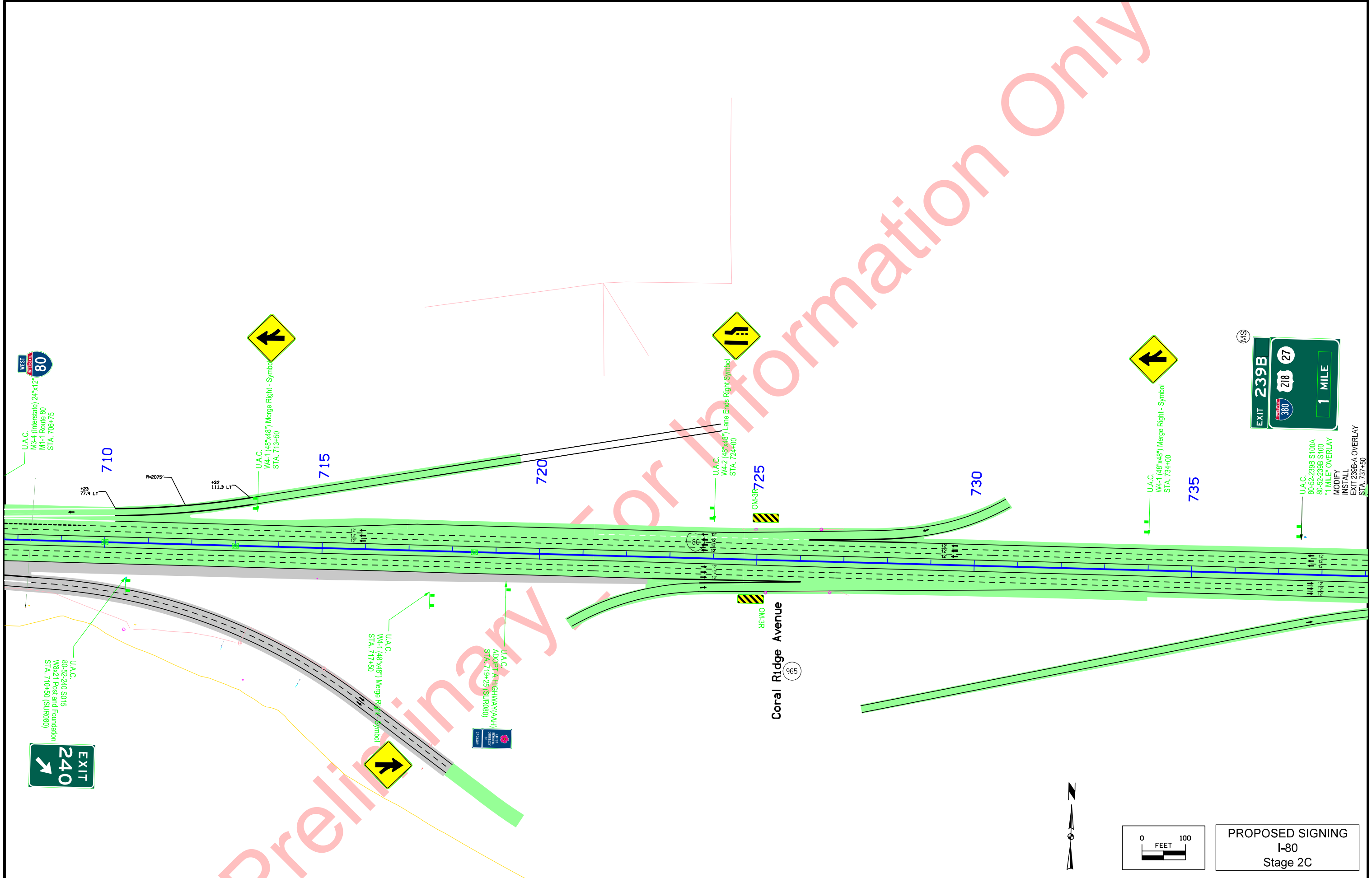

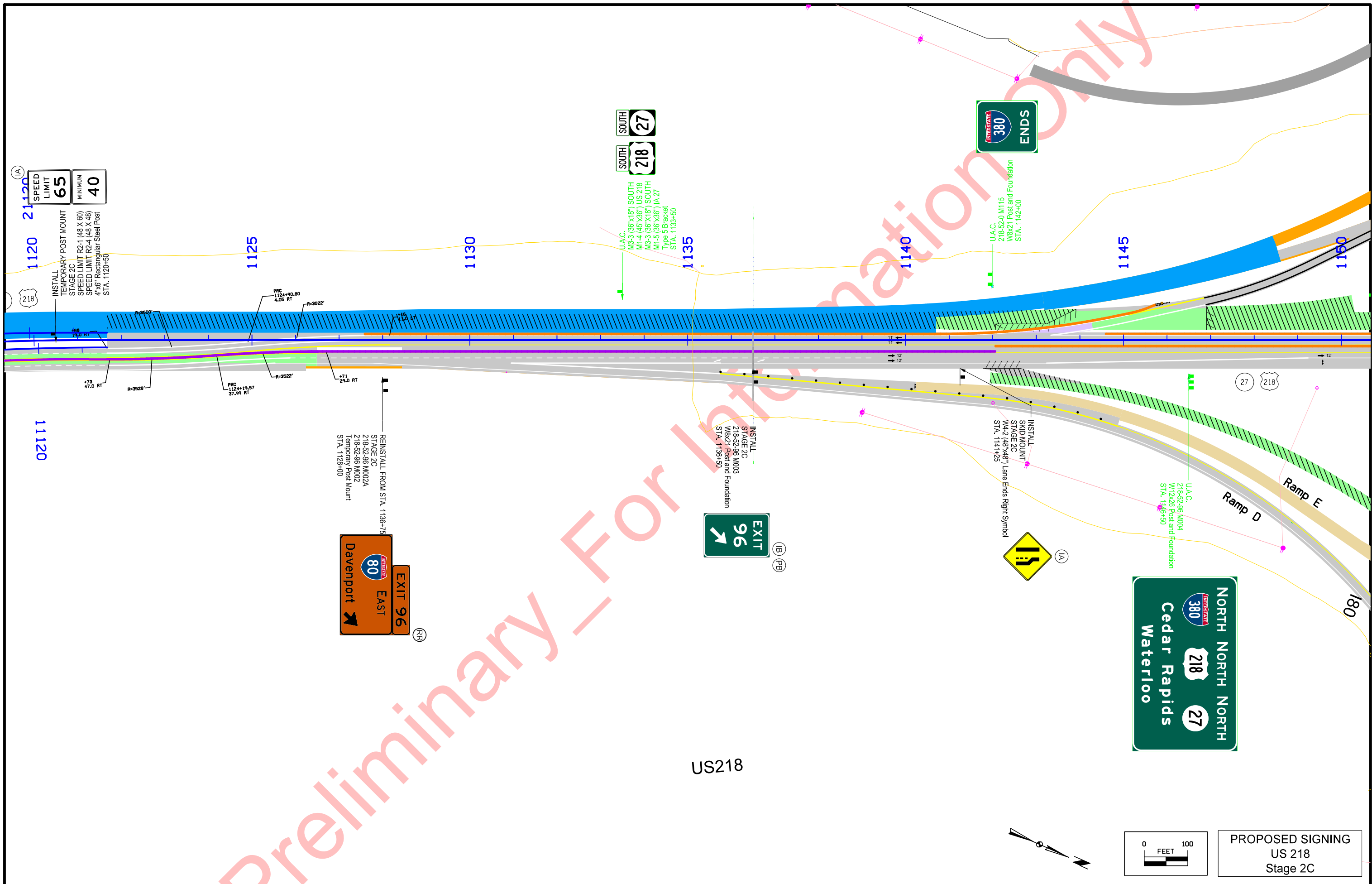

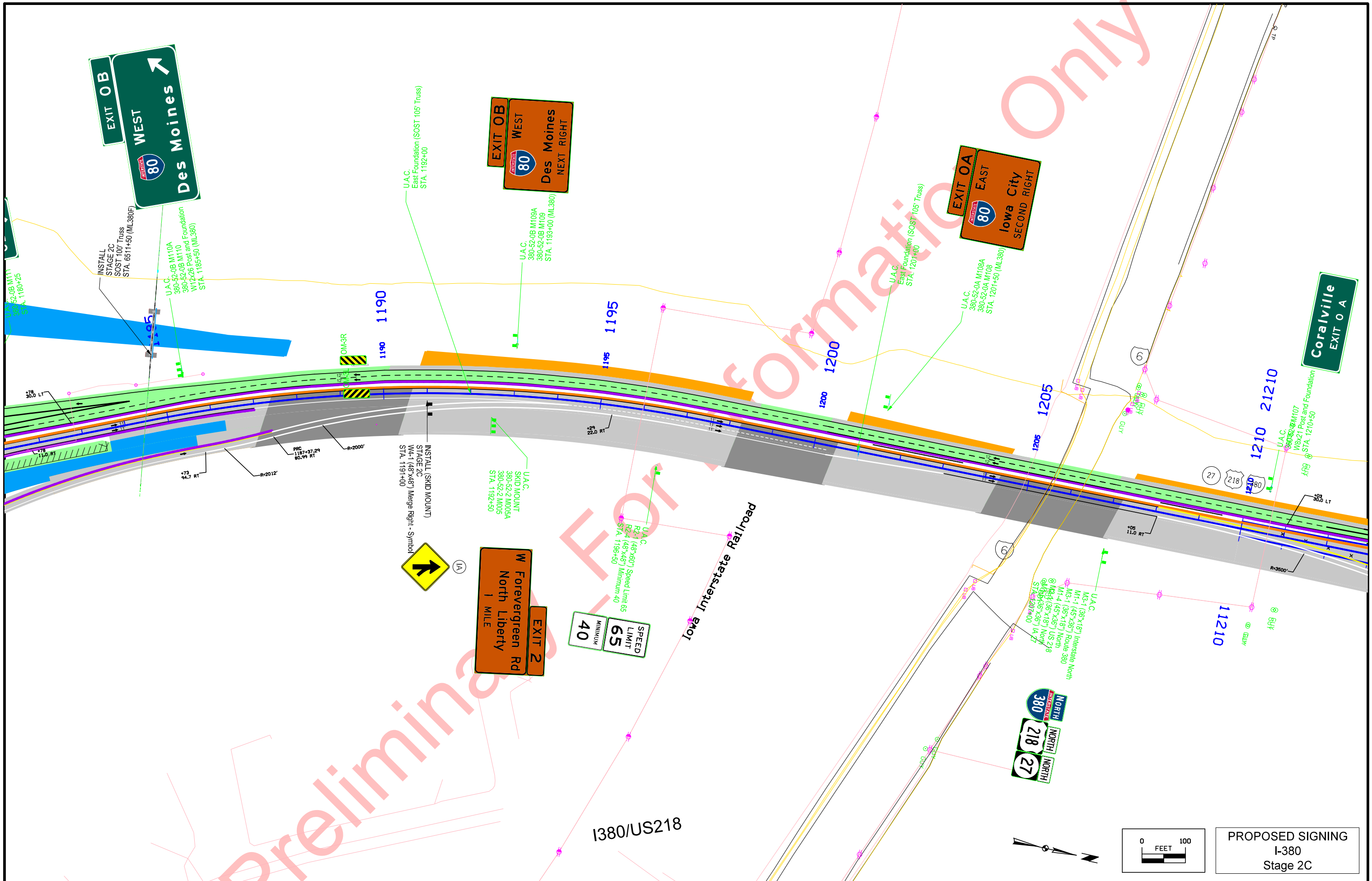

PROPOSED SIGNING  
I-380  
Stage 2C

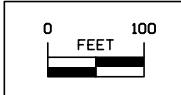

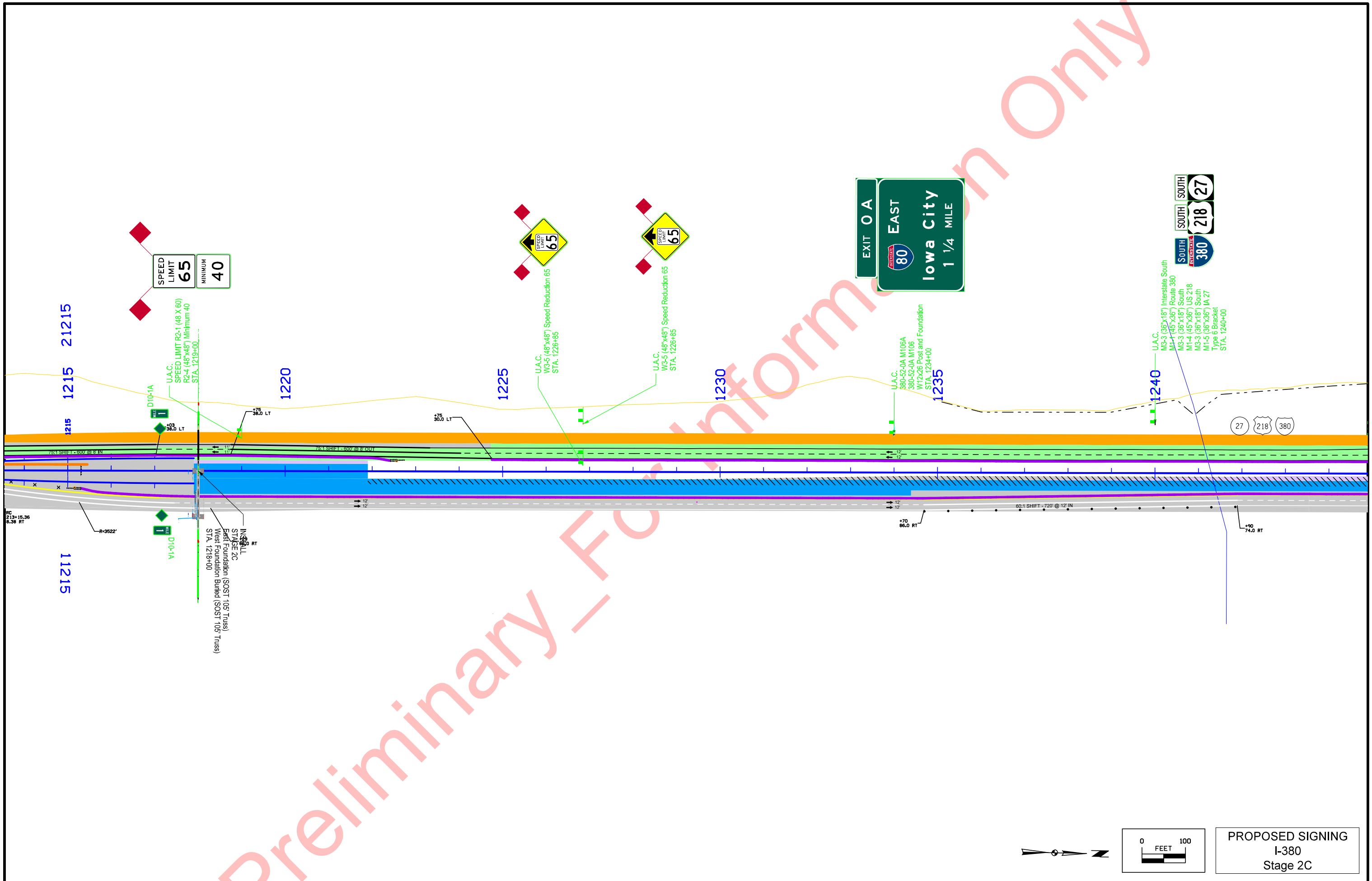

Preliminary - For Information Only

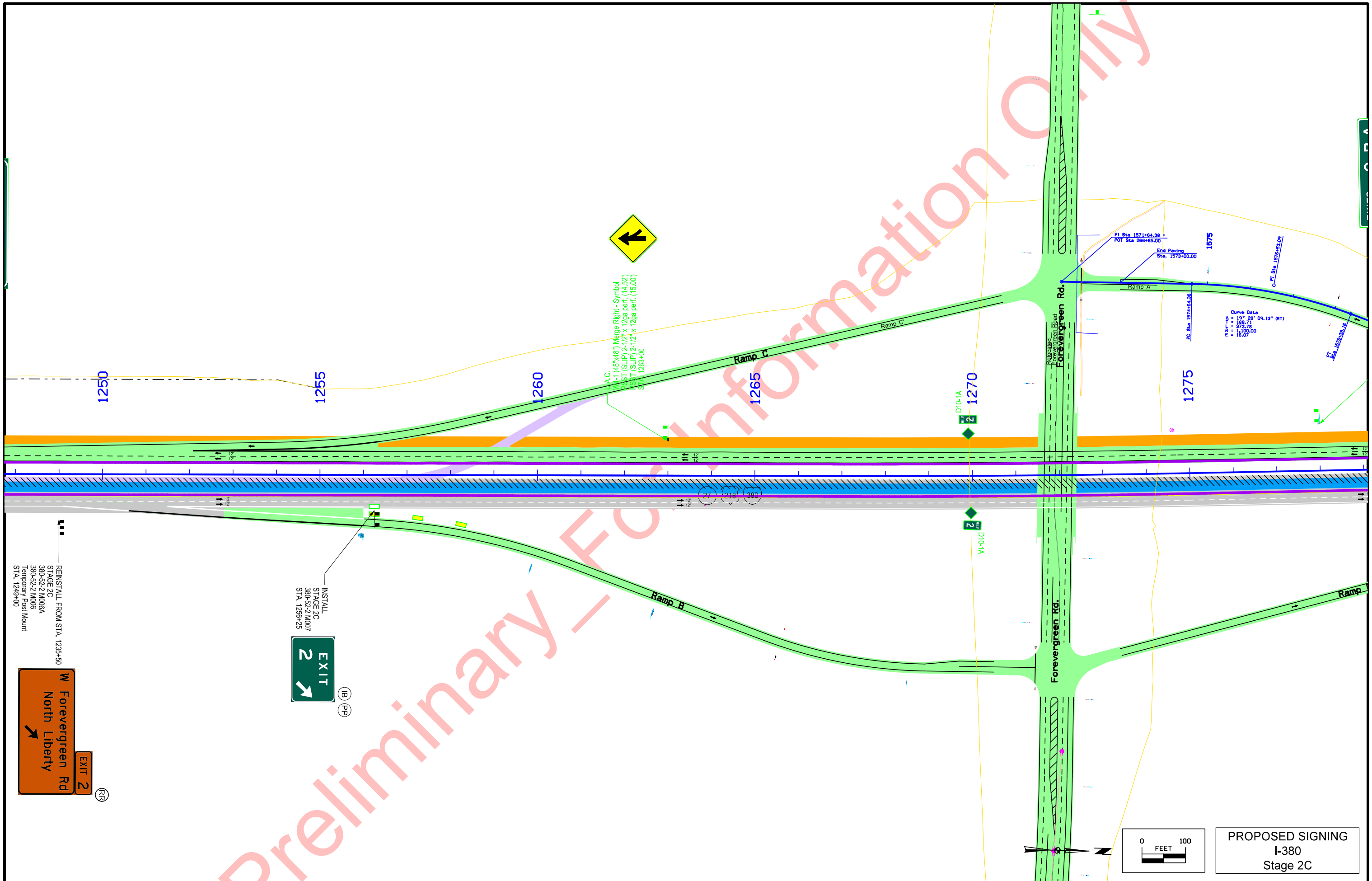

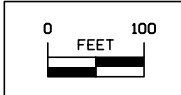
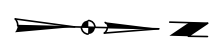
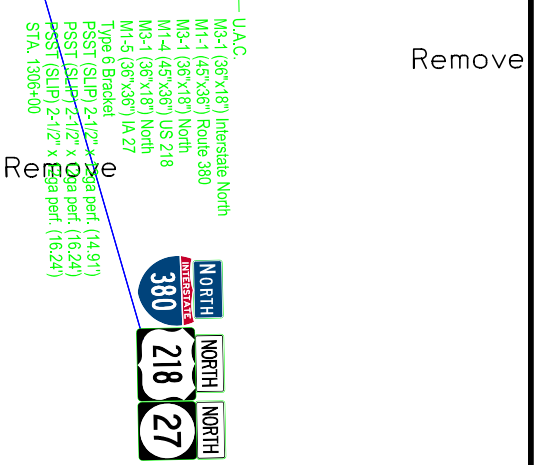
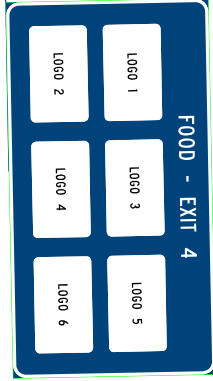
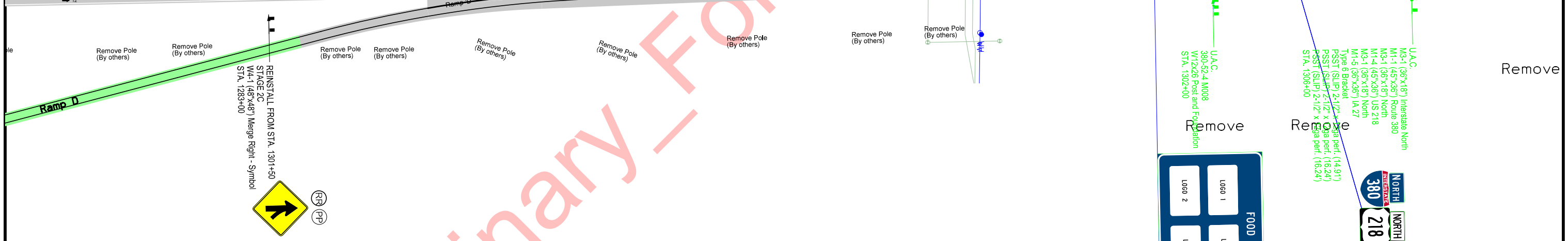
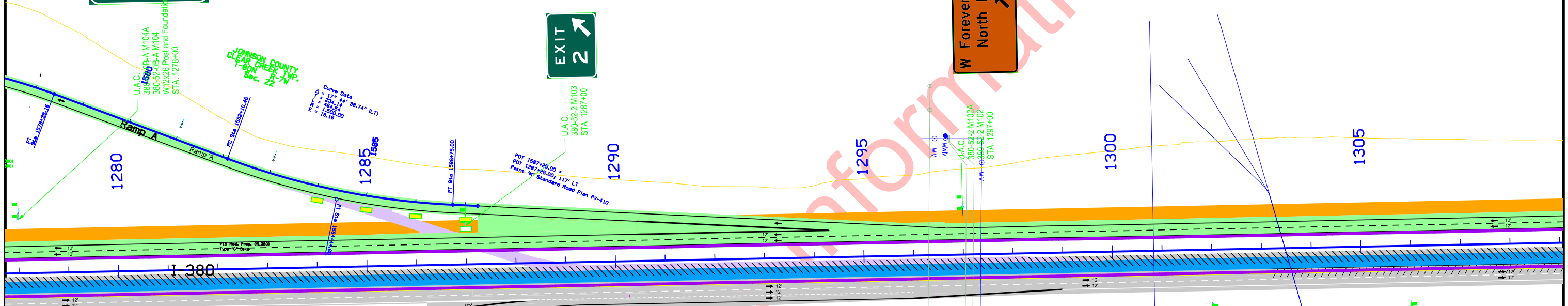
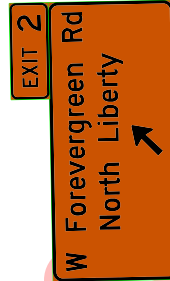

PROPOSED SIGNING  
I-380  
Stage 2C



Preliminary FOR INFORMATION ONLY

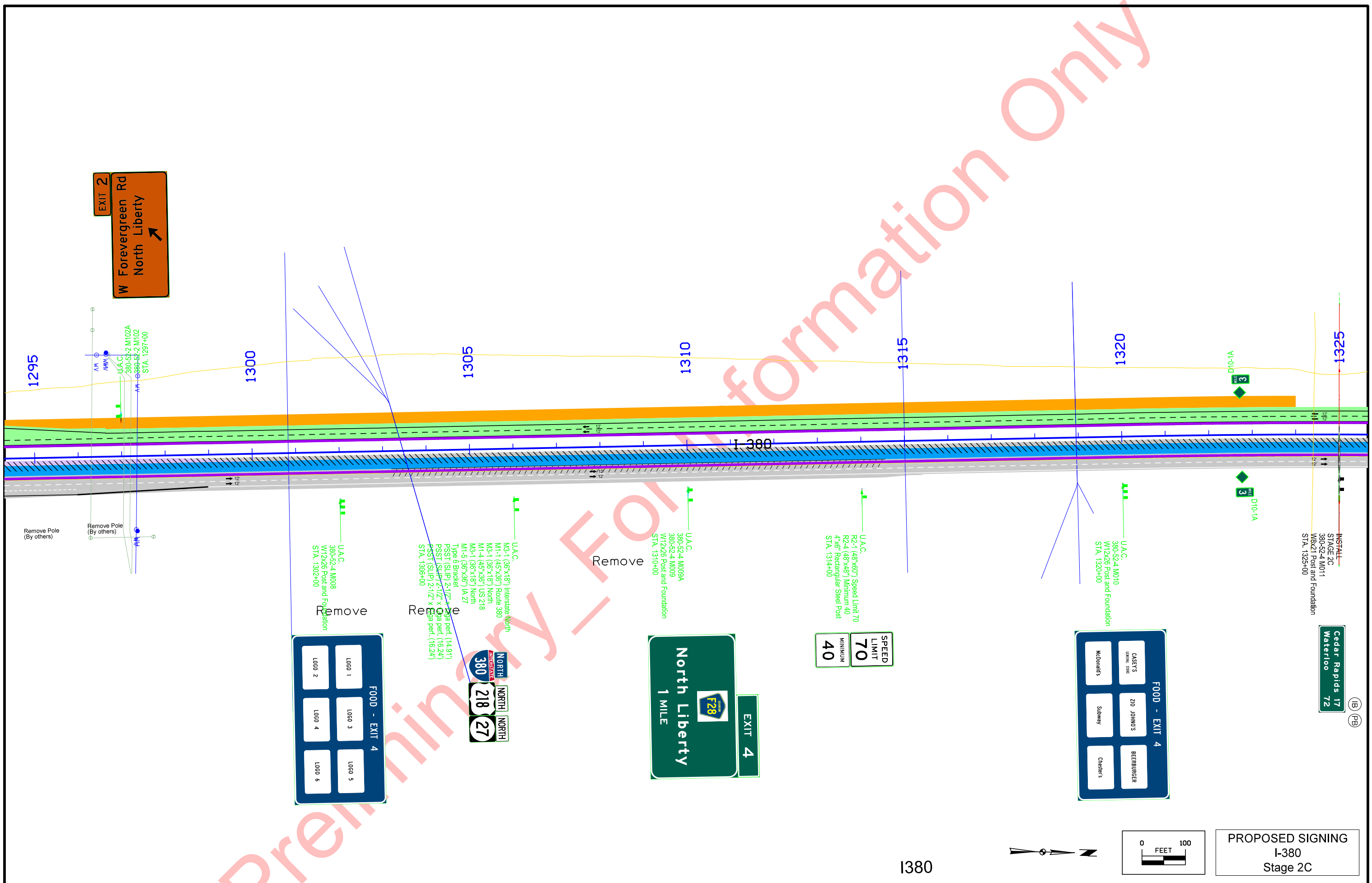

EXIT 2  
W Foreverggreen Rd  
North Liberty

U.A.C.  
380-52-2 M102A  
380-52-2 M102  
STA. 1297+00

1295

1300

1305

1310

1315

1320

1325

I 380

D10-1A  
3

INSTALL  
STAGE 2C  
380-52-4 M011  
W6x21 Post and Foundation  
STA. 1325+00

Cedar Rapids 17  
Waterloo 72

(B)  
(P)

Remove Pole  
(By others)

Remove Pole  
(By others)

U.A.C.  
380-52-4 M008  
W12x26 Post and Foundation  
STA. 1302+00

Remove

FOOD - EXIT 4  
L060 1  
L060 2  
L060 3  
L060 4  
L060 5  
L060 6

Remove

U.A.C.  
M3-1 (36"x18") Interstate North  
M1-1 (45"x36") Route 380  
M3-1 (36"x18") North  
M1-4 (45"x38") US 218  
M3-1 (36"x18") North  
M1-5 (36"x36") IA 21  
Type 6 Bracket  
PSS1 (SLIP) 2-1/2" x 2-1/2" x 1/4" dia perf. (14.91')  
PSS1 (SLIP) 2-1/2" x 2-1/2" x 1/4" dia perf. (16.24')  
PSS1 (SLIP) 2-1/2" x 2-1/2" x 1/4" dia perf. (16.24')  
STA. 1306+00

NORTH 380  
NORTH 218  
NORTH 27

Remove

U.A.C.  
380-52-4 M009A  
380-52-4 M009  
W12x26 Post and Foundation  
STA. 1310+00

EXIT 4  
North Liberty  
1 MILE  
F28

U.A.C.  
R2-1 (48"x60") Speed Limit 70  
R2-4 (48"x48") Minimum 40  
4"x6" Rectangular Steel Post  
STA. 1314+00

SPEED LIMIT 70  
MINIMUM 40

U.A.C.  
380-52-4 M010  
W12x26 Post and Foundation  
STA. 1320+00

FOOD - EXIT 4  
CASEY'S  
McDonald's  
ZIO JOHNOS  
Subway  
BEERBUNGER  
Chester's

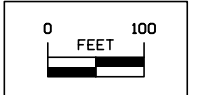

PROPOSED SIGNING  
I-380  
Stage 2C

1380

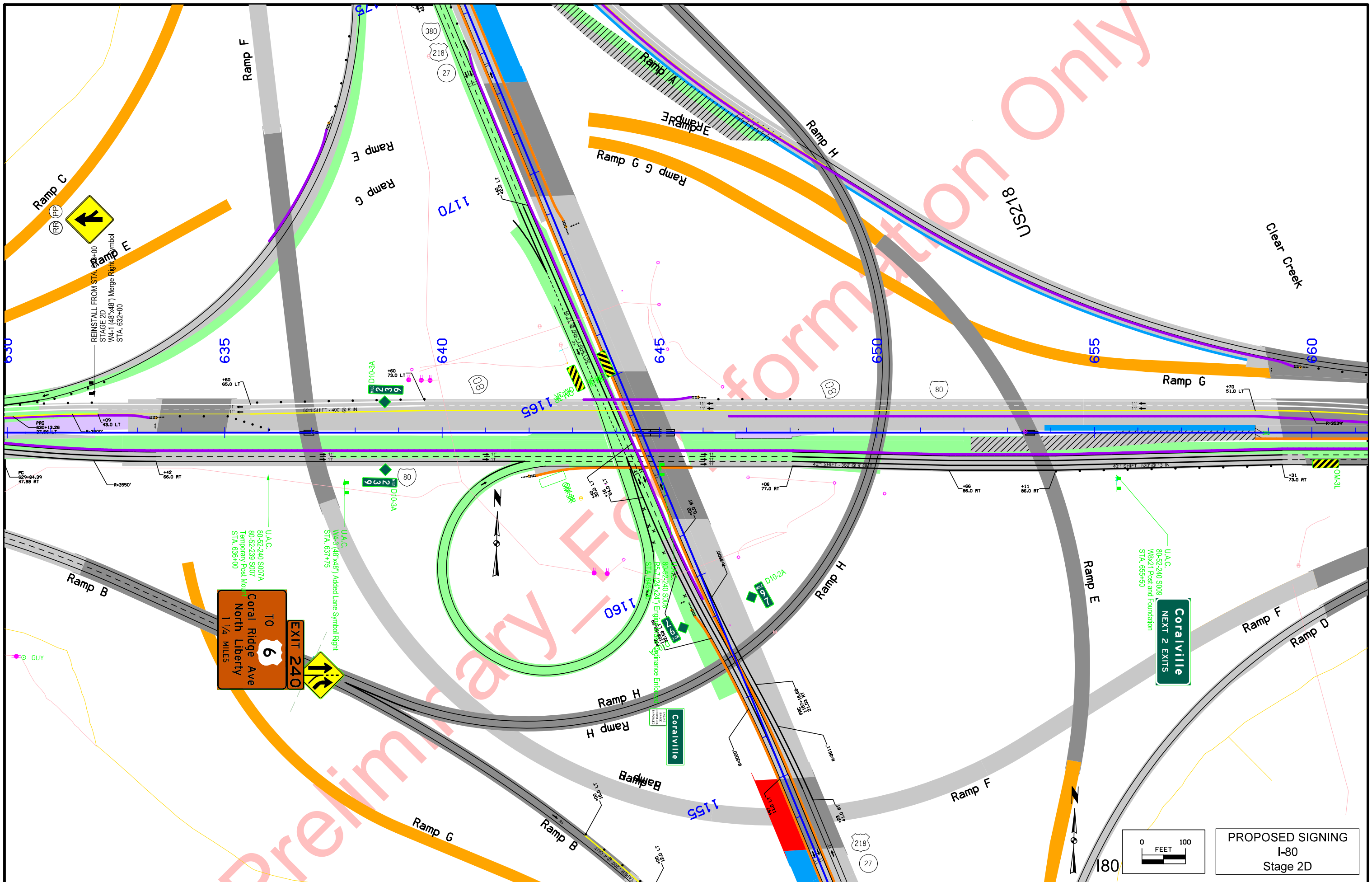

TO  
**6**  
 Coral Ridge Ave  
 North Liberty  
 1 1/4 MILES

**EXIT 240**

**Coralville**  
 NEXT 2 EXITS

**Coralville**

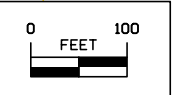

**PROPOSED SIGNING**  
 I-80  
 Stage 2D

Information Only

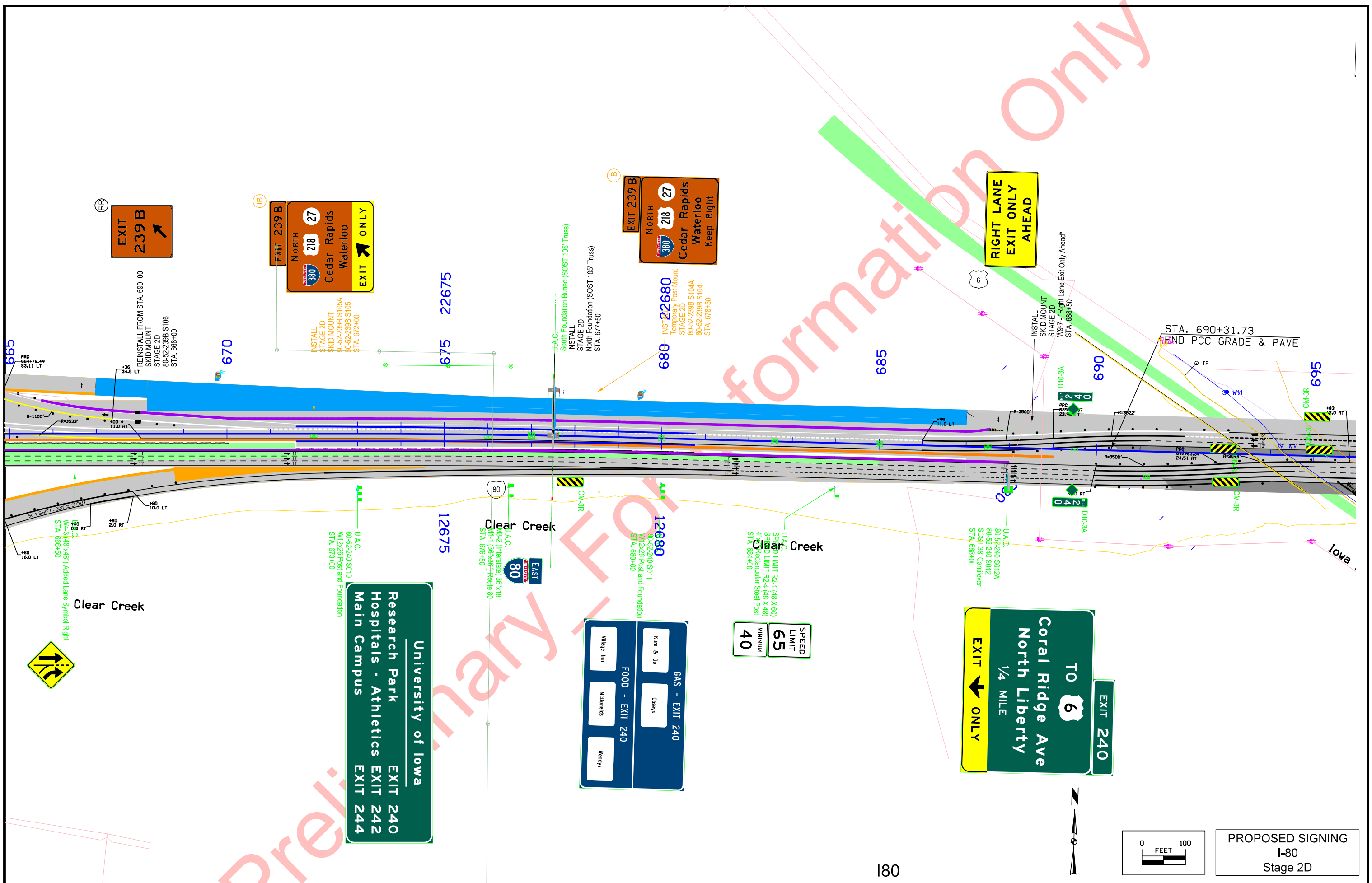

PROPOSED SIGNING  
I-80  
Stage 2D

0 100  
FEET

EXIT 240

TO 6  
Coral Ridge Ave  
North Liberty  
1/4 MILE  
EXIT ONLY

SPEED LIMIT  
65  
MINIMUM  
40

GAS - EXIT 240  
Kum & Go  
Caseys

FOOD - EXIT 240  
Village Inn  
McDonalds  
Wendys

University of Iowa  
Research Park  
Hospitals - Athletics  
Main Campus

EXIT 240  
EXIT 242  
EXIT 244

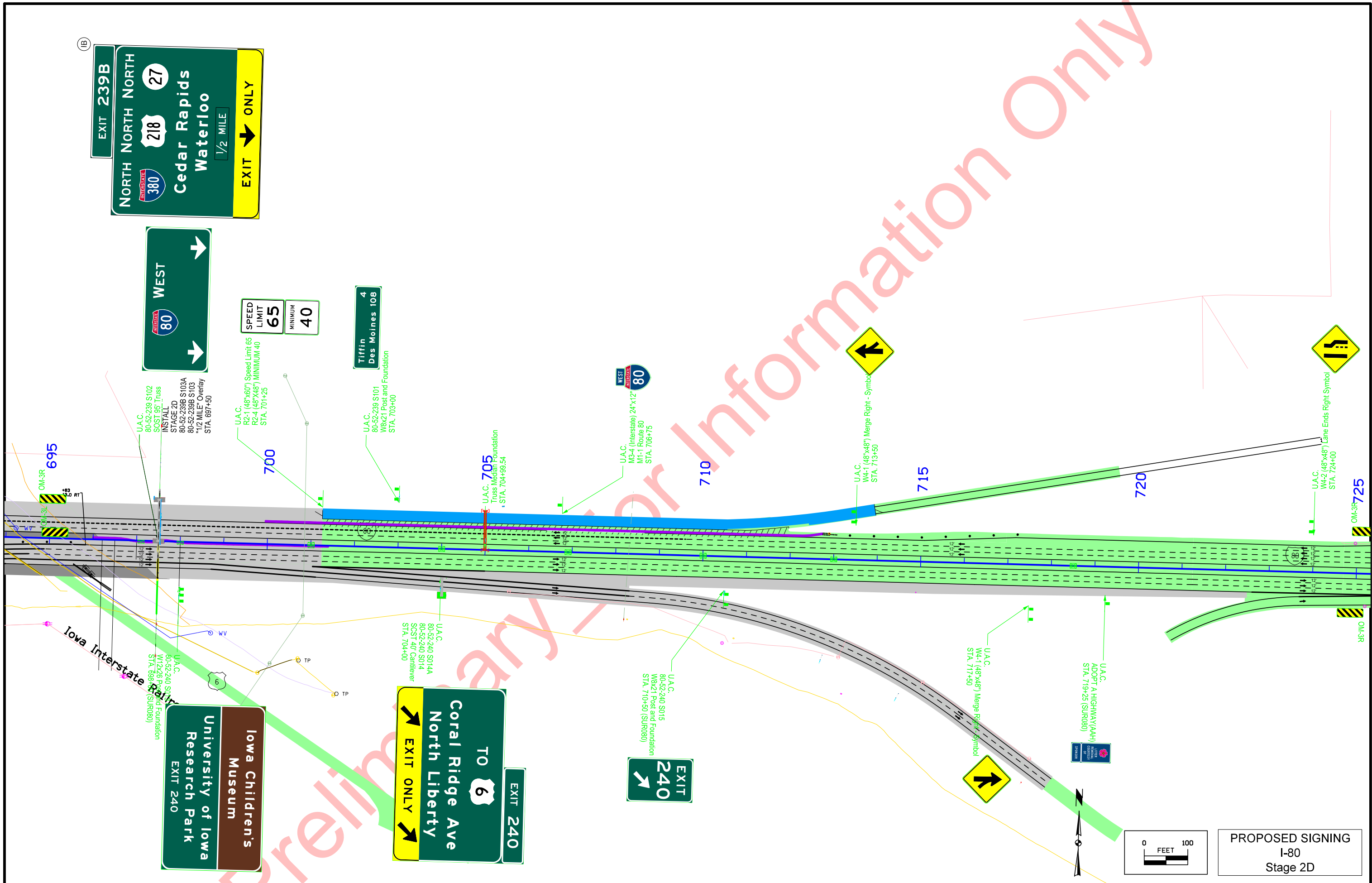

EXIT 239B  
 NORTH NORTH  
 218 27  
 Cedar Rapids  
 Waterloo  
 1/2 MILE  
 EXIT ONLY

WEST  
 80  
 WEST

SPEED LIMIT 65  
 MINIMUM 40

Tiffin  
 Des Moines 108  
 4

EXIT 240  
 TO 6  
 Coral Ridge Ave  
 North Liberty  
 EXIT ONLY

Iowa Children's  
 Museum  
 University of Iowa  
 Research Park  
 EXIT 240

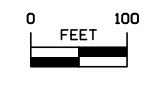

PROPOSED SIGNING  
 I-80  
 Stage 2D

Preliminary Information Only

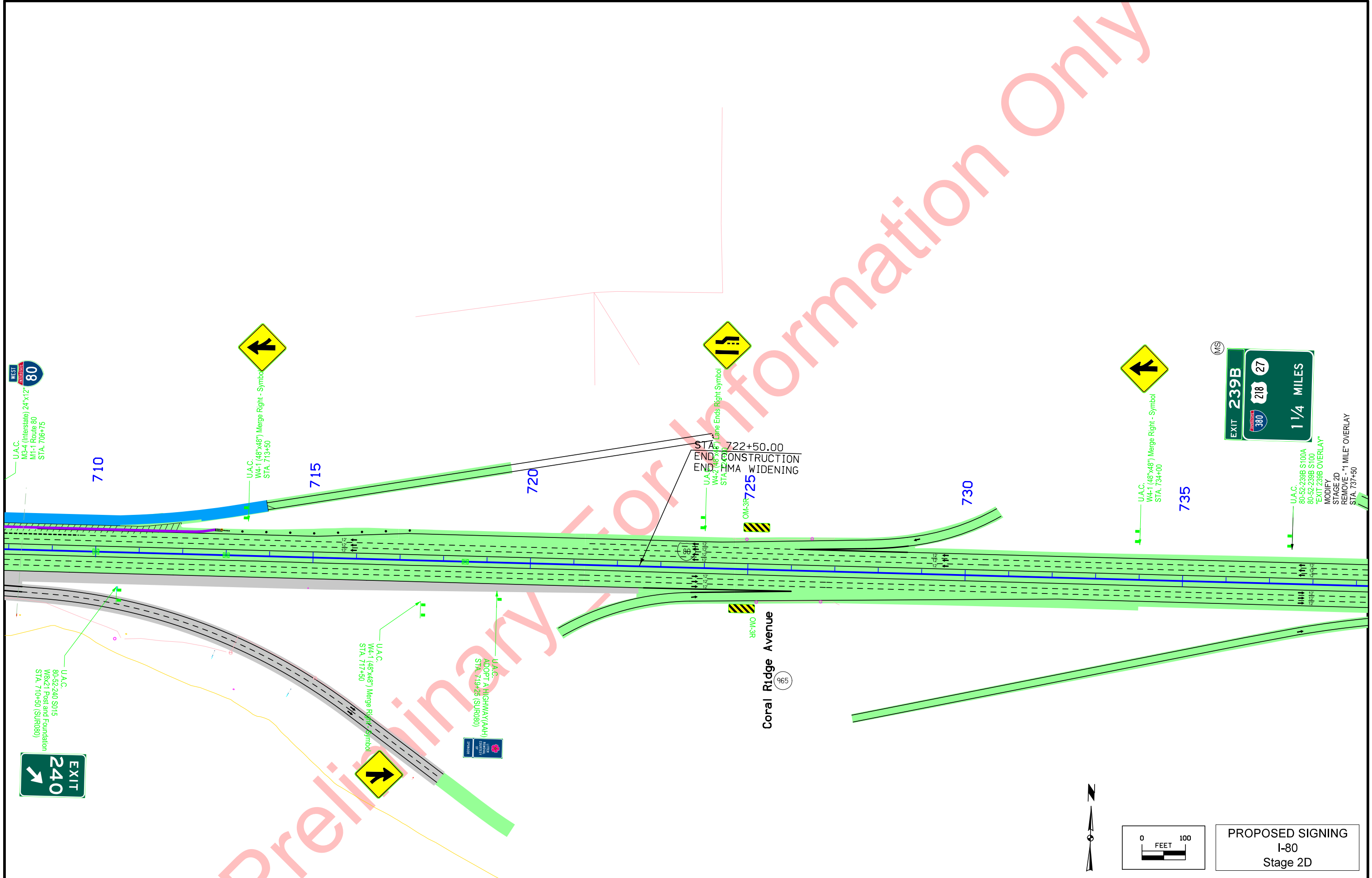

Preliminary For Information Only

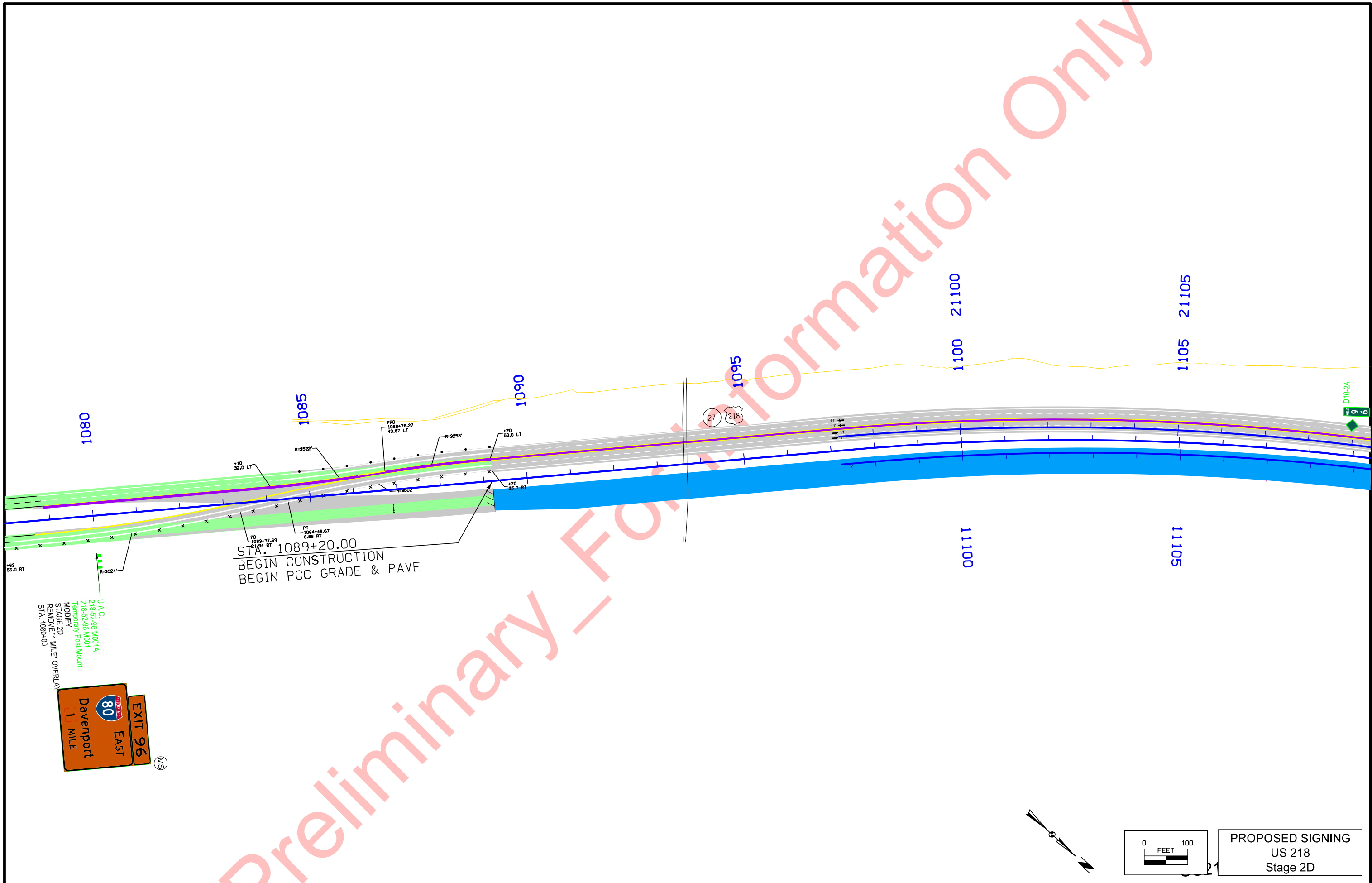

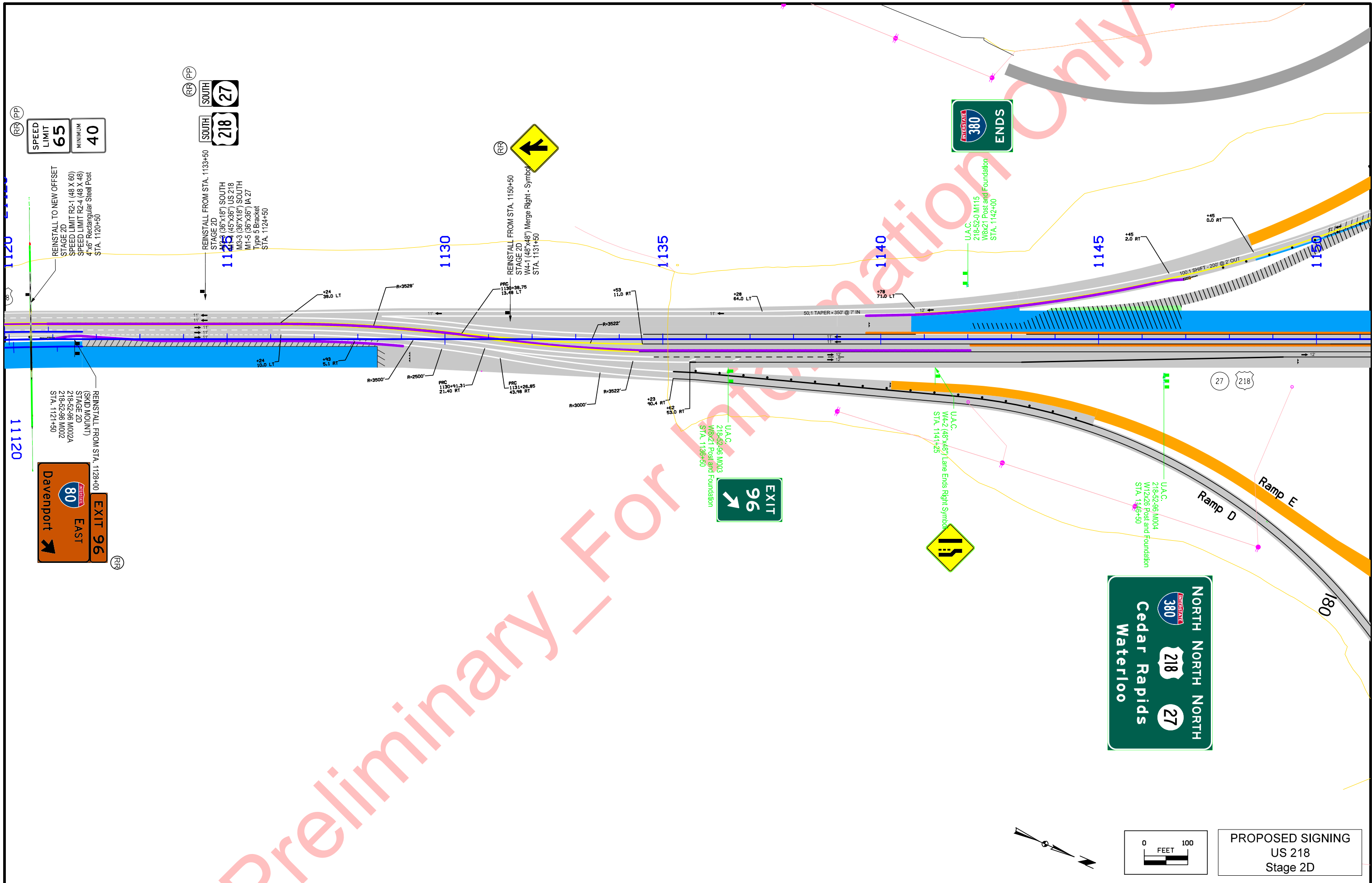

Preliminary - For Information Only

  
  
**PROPOSED SIGNING**  
 US 218  
 Stage 2D

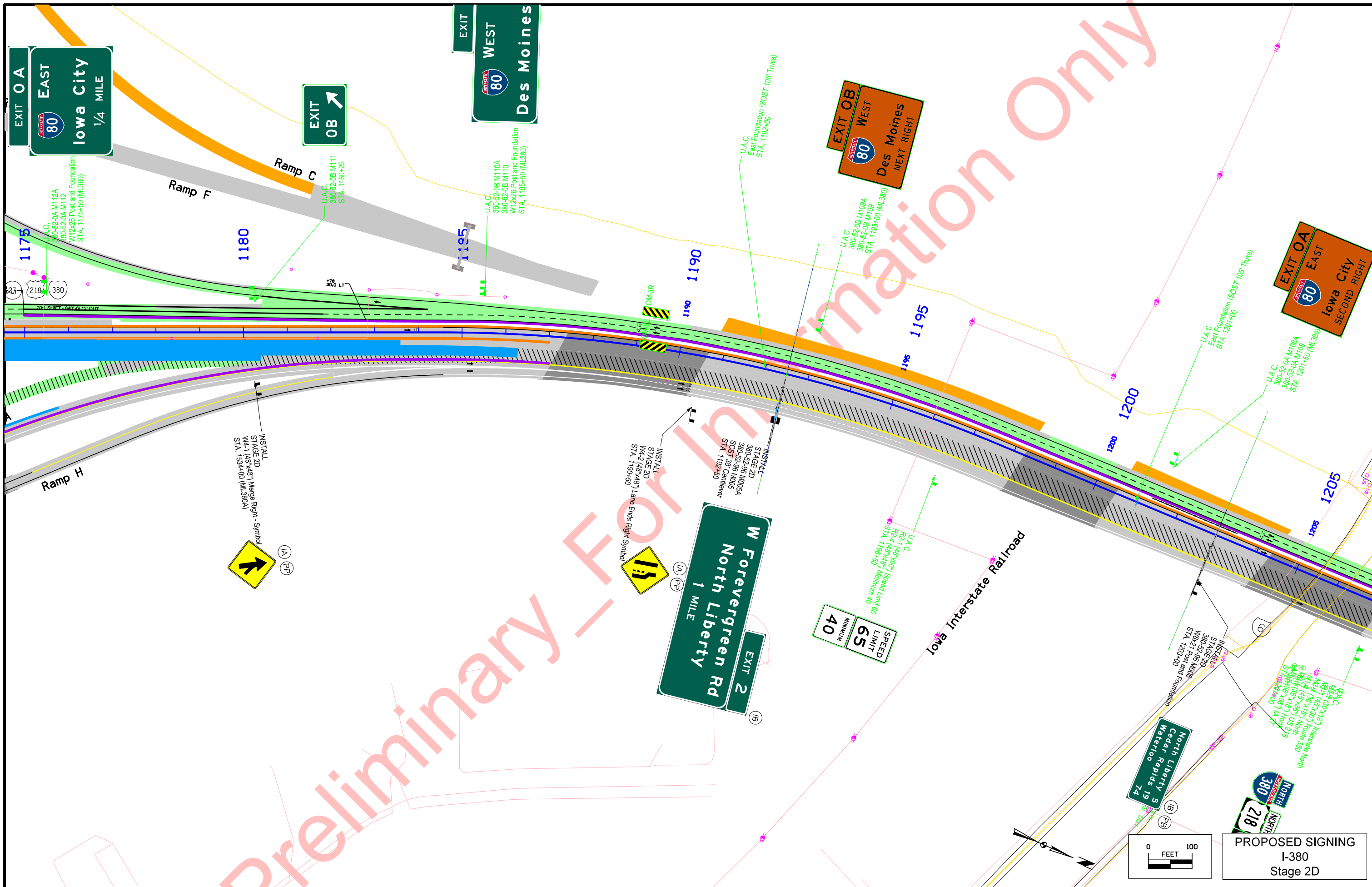

**PROPOSED SIGNING**  
I-380  
Stage 2D

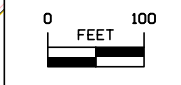



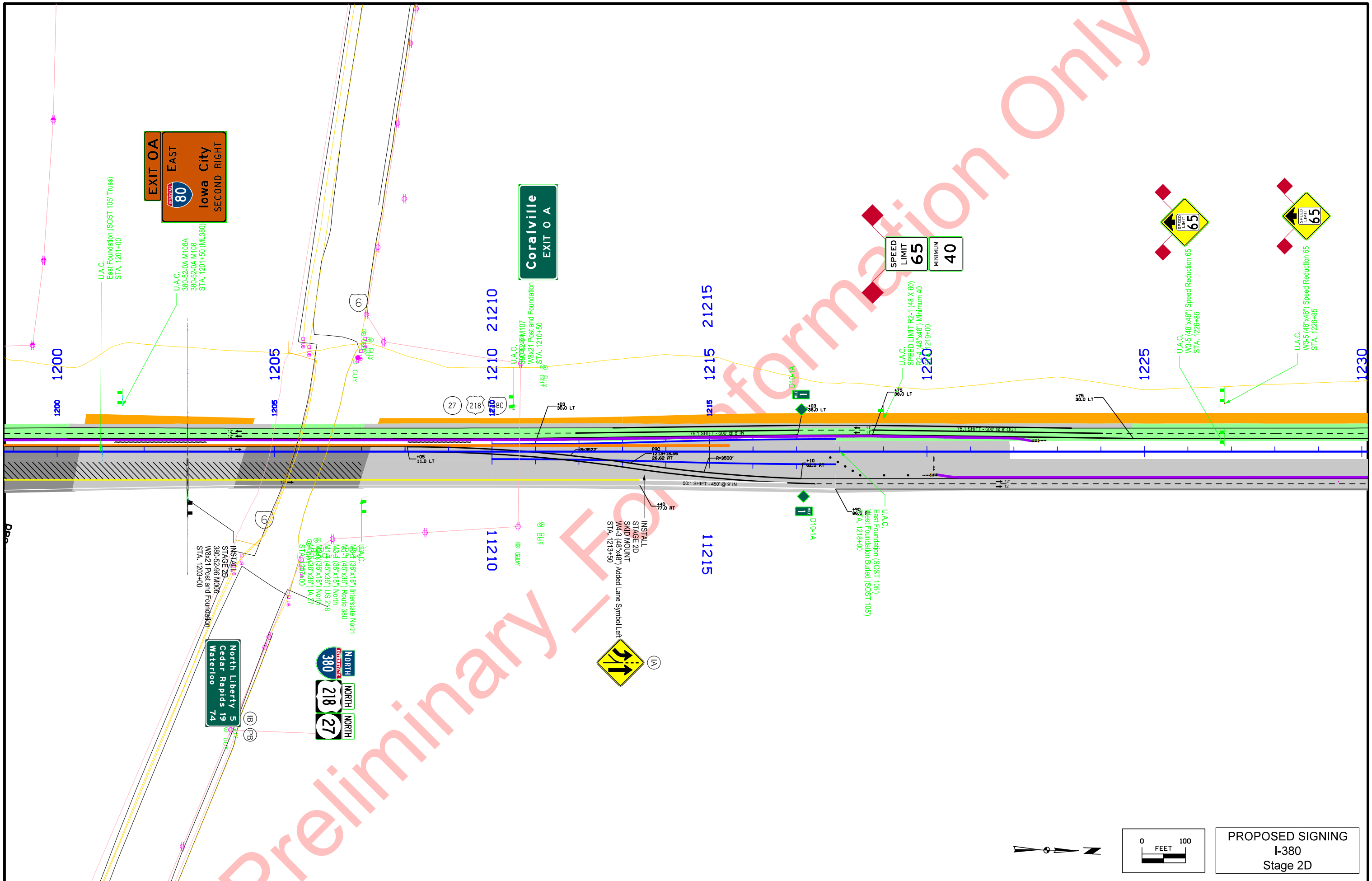

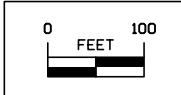
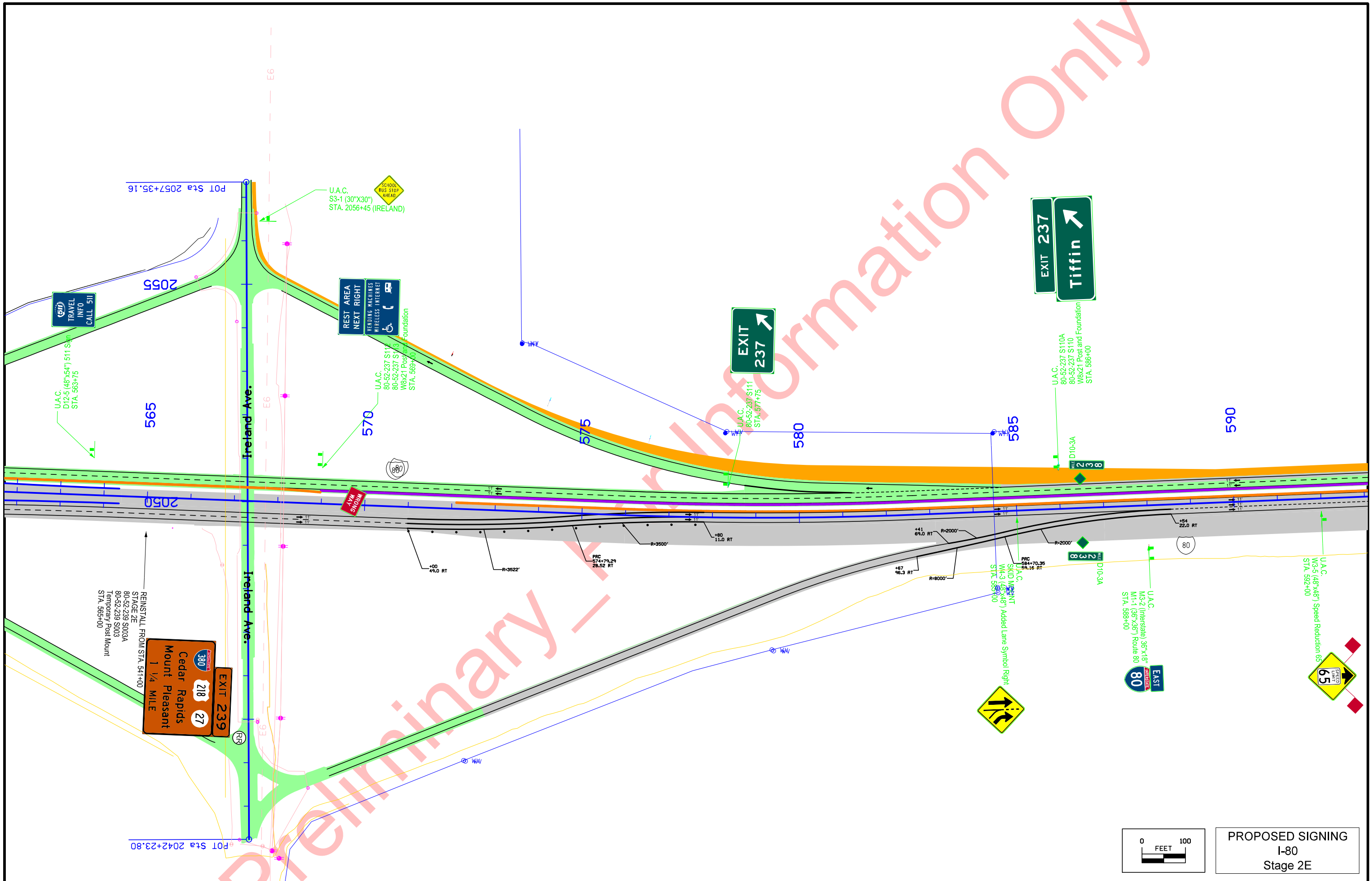

PROPOSED SIGNING  
I-80  
Stage 2E

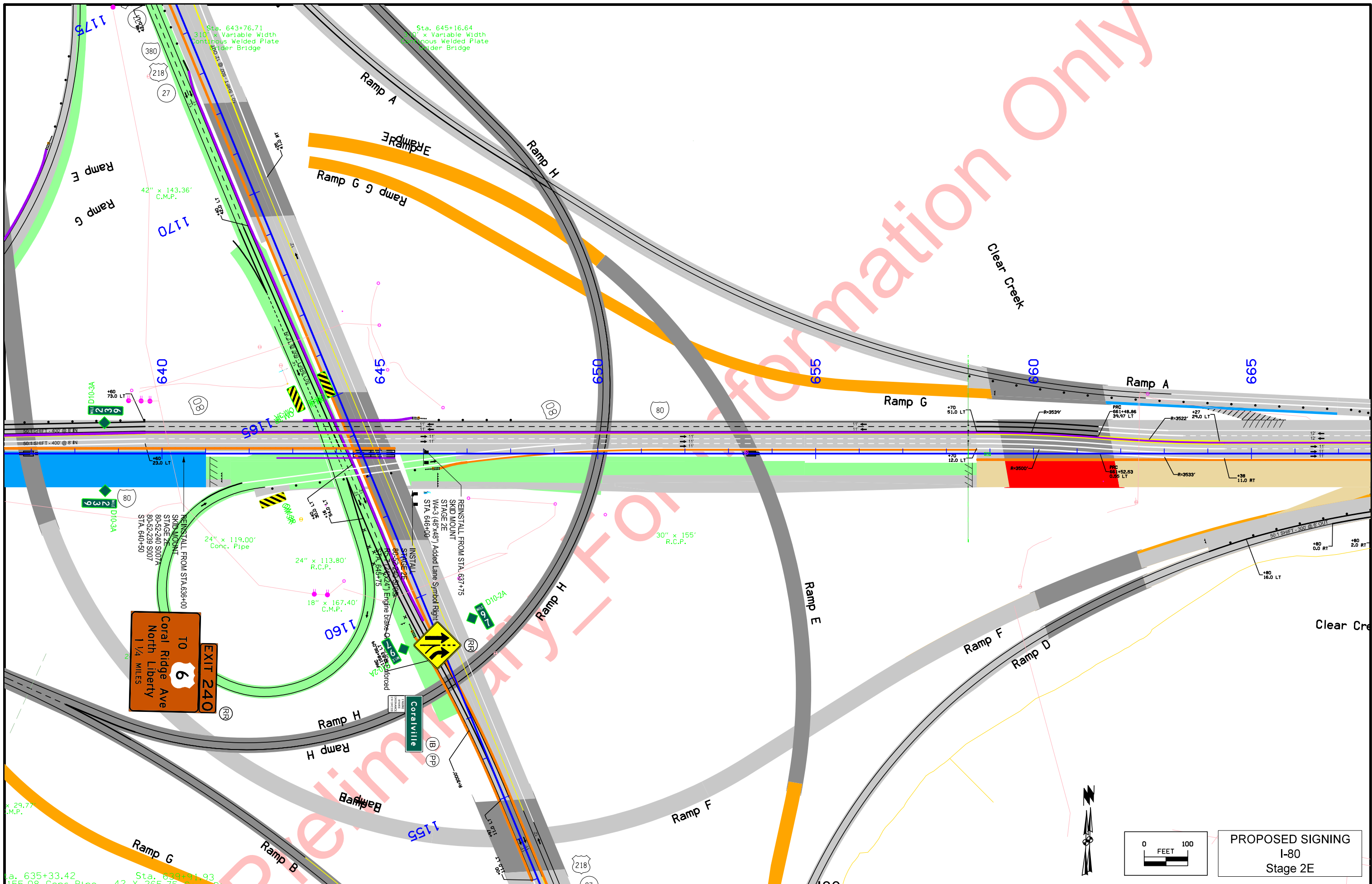

Preliminary Information Only

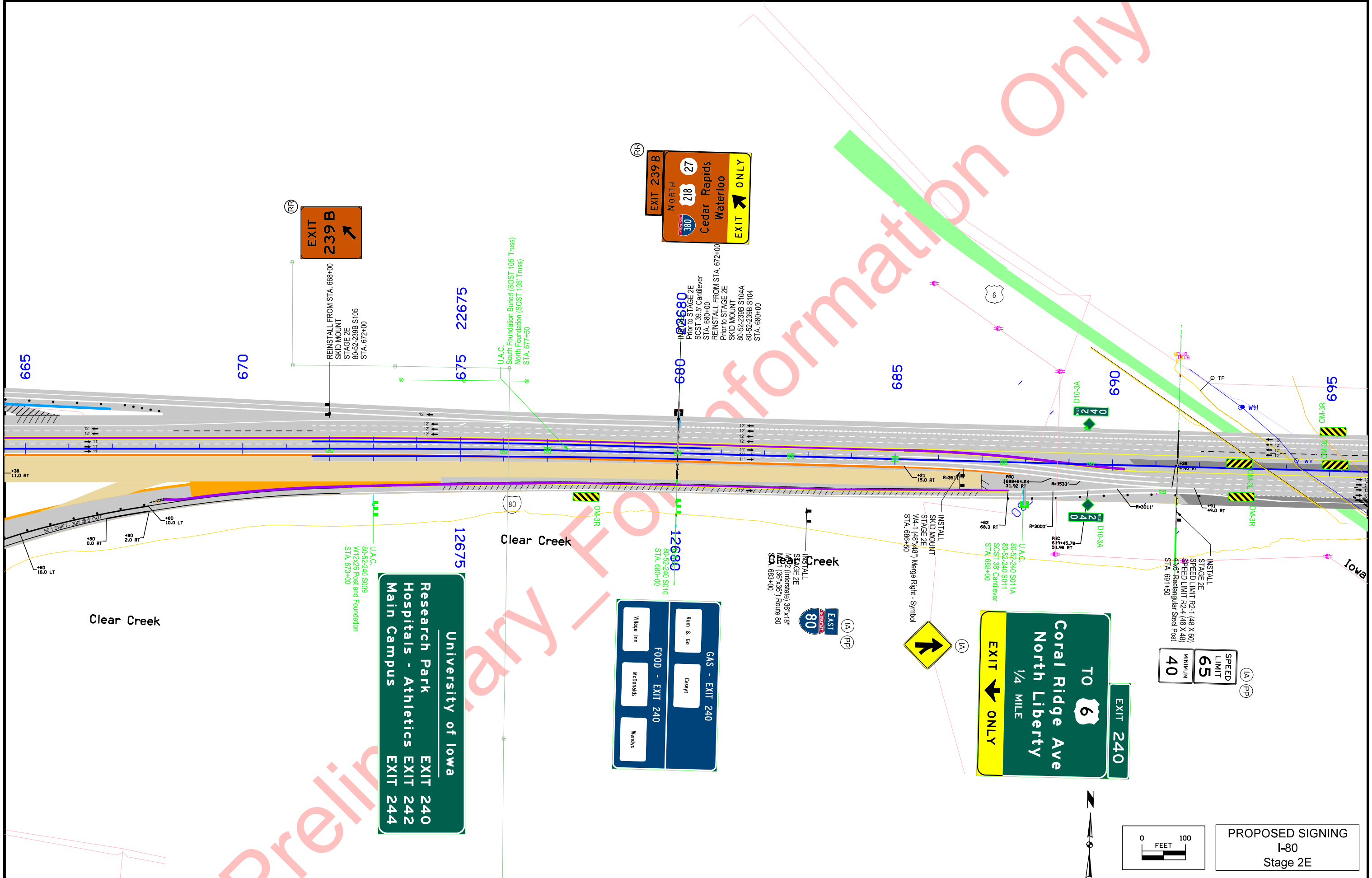

EXIT 239 B

EXIT 239 B NORTH 218 27 Cedar Rapids Waterloo EXIT ONLY

REINSTALL FROM STA. 668+00 SKID MOUNT STAGE 2E 80-52-239B S105 STA. 672+00

REINSTALL FROM STA. 672+00 Prior to STAGE 2E SCST 39.5' Cantilever STA. 680+00 REINSTALL FROM STA. 672+00 Prior to STAGE 2E SKID MOUNT 80-52-239B S104A 80-52-239B S104 STA. 680+00

Clear Creek

University of Iowa  
Research Park  
Hospitals - Athletics  
Main Campus  
EXIT 240  
EXIT 242  
EXIT 244

GAS - EXIT 240  
Kum & Go  
Caseys  
McDonalds  
Wendys  
FOOD - EXIT 240

TO 6  
Coral Ridge Ave  
North Liberty  
1/4 MILE  
EXIT 240  
EXIT ONLY

SPEED LIMIT 65  
MINIMUM 40

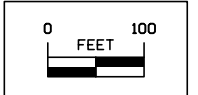

PROPOSED SIGNING  
I-80  
Stage 2E

EXIT 239B  
 NORTH NORTH NORTH  
 218 27  
 Cedar Rapids  
 Waterloo  
 1/2 MILE  
 EXIT ONLY

WEST  
 80

SPEED LIMIT 65  
 MINIMUM 40

Tiffin  
 Des Moines 108  
 4

WEST  
 80

IA (PP)  
 W-4-3

W-4-2

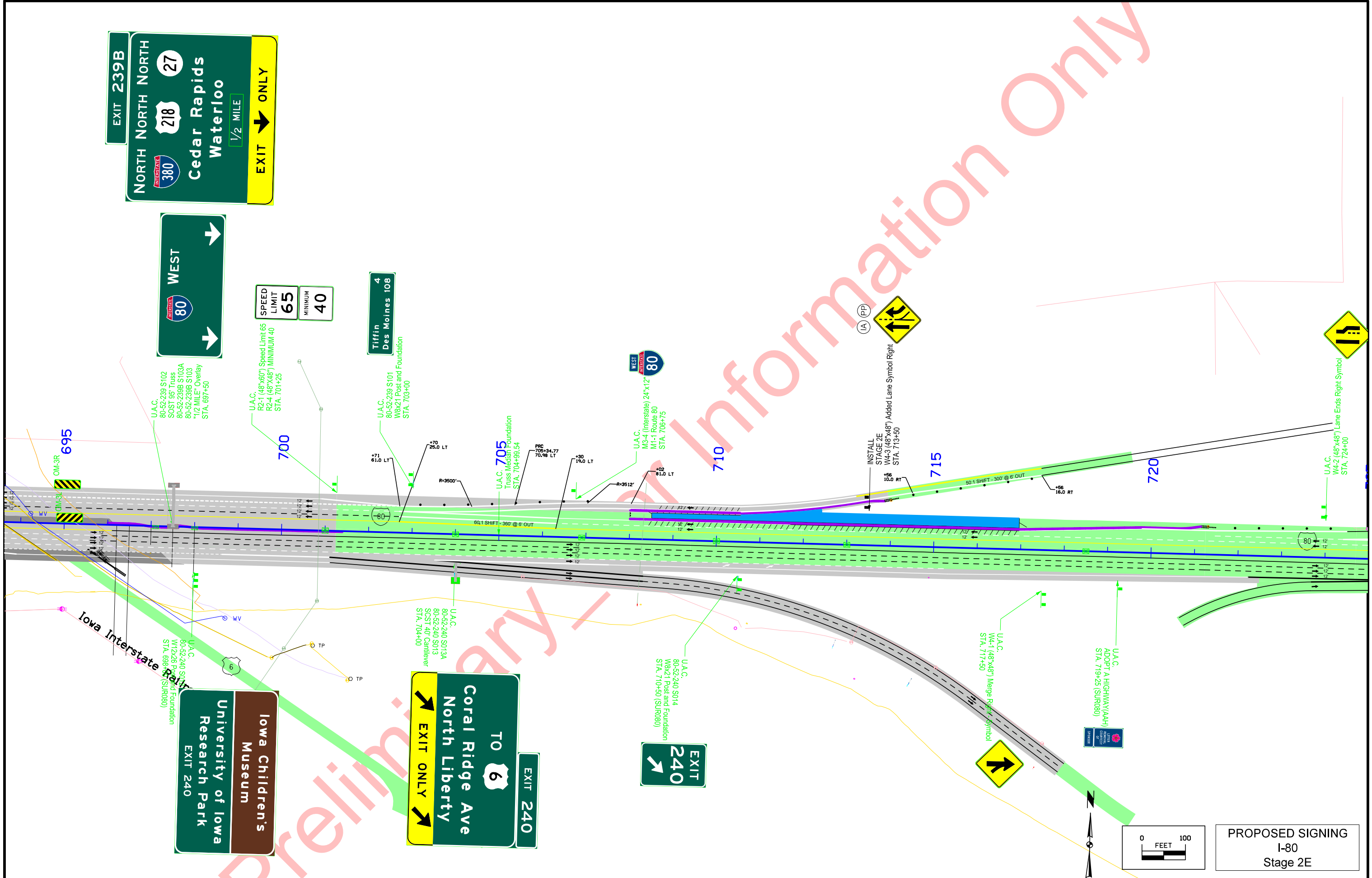

lowa Children's  
 Museum  
 lowa  
 University of lowa  
 Research Park  
 EXIT 240

TO  
 6  
 Coral Ridge Ave  
 North Liberty  
 EXIT ONLY

EXIT 240

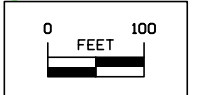

PROPOSED SIGNING  
 I-80  
 Stage 2E

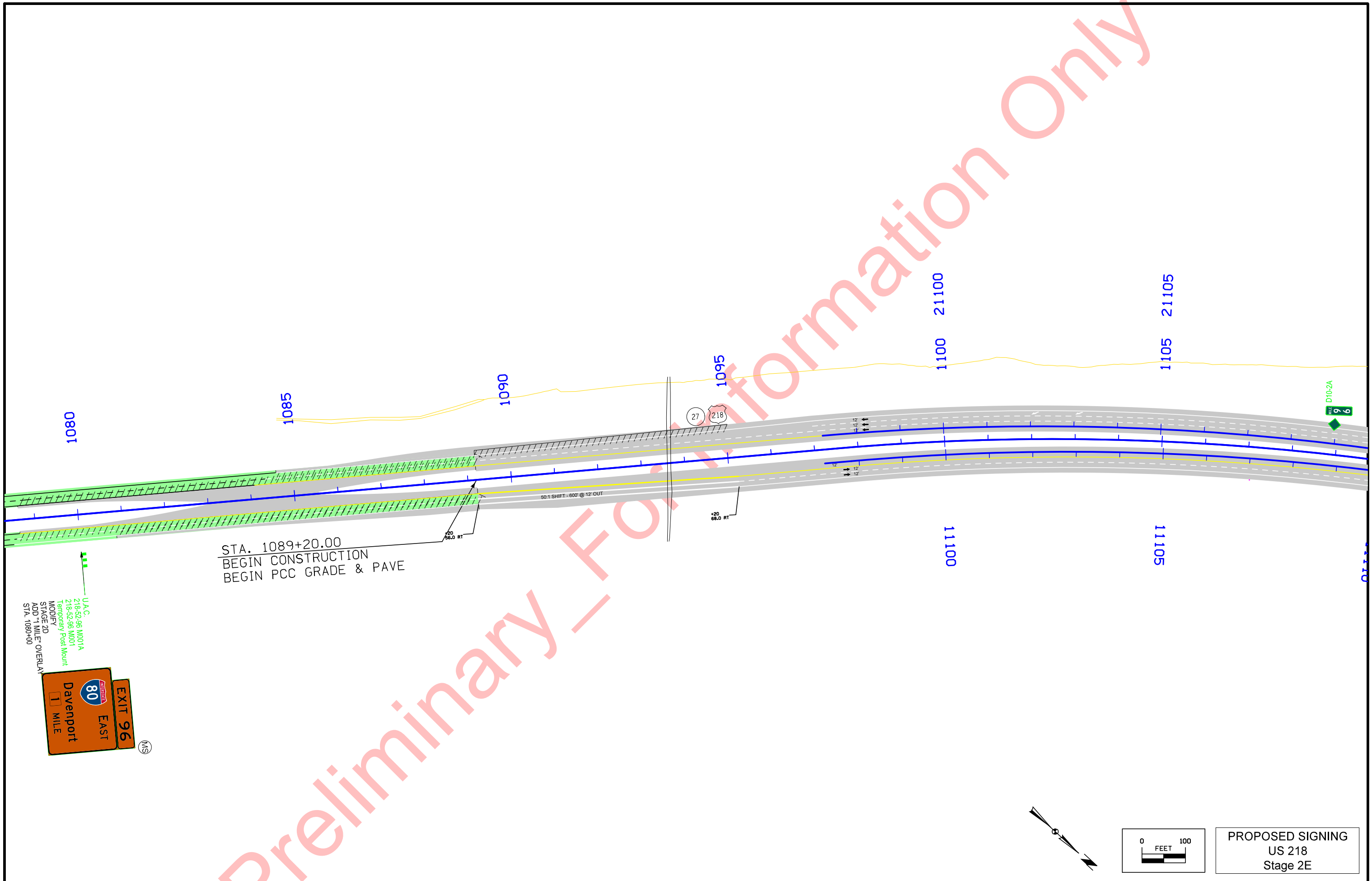

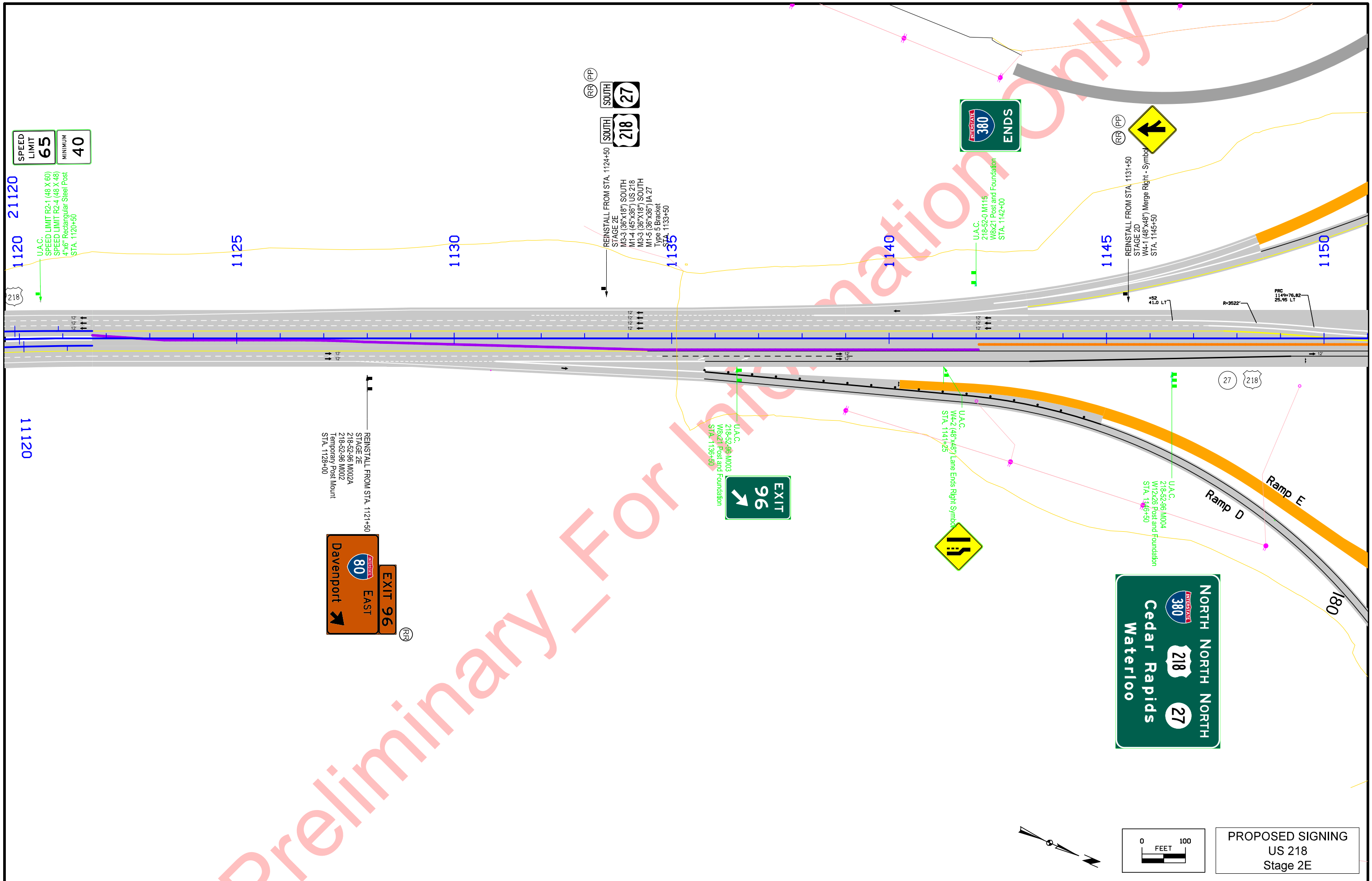

Preliminary - For Information Only

FILE NO.	ENGLISH	DESIGN TEAM <b>Abrams \ Hermann</b>	JOHNSON COUNTY	PROJECT NUMBER <b>NHS-080-6(403)239-11-52</b>	SHEET NUMBER <b>N.122</b>
----------	---------	-------------------------------------	----------------	---	---------------------------

Preliminary For Information Only

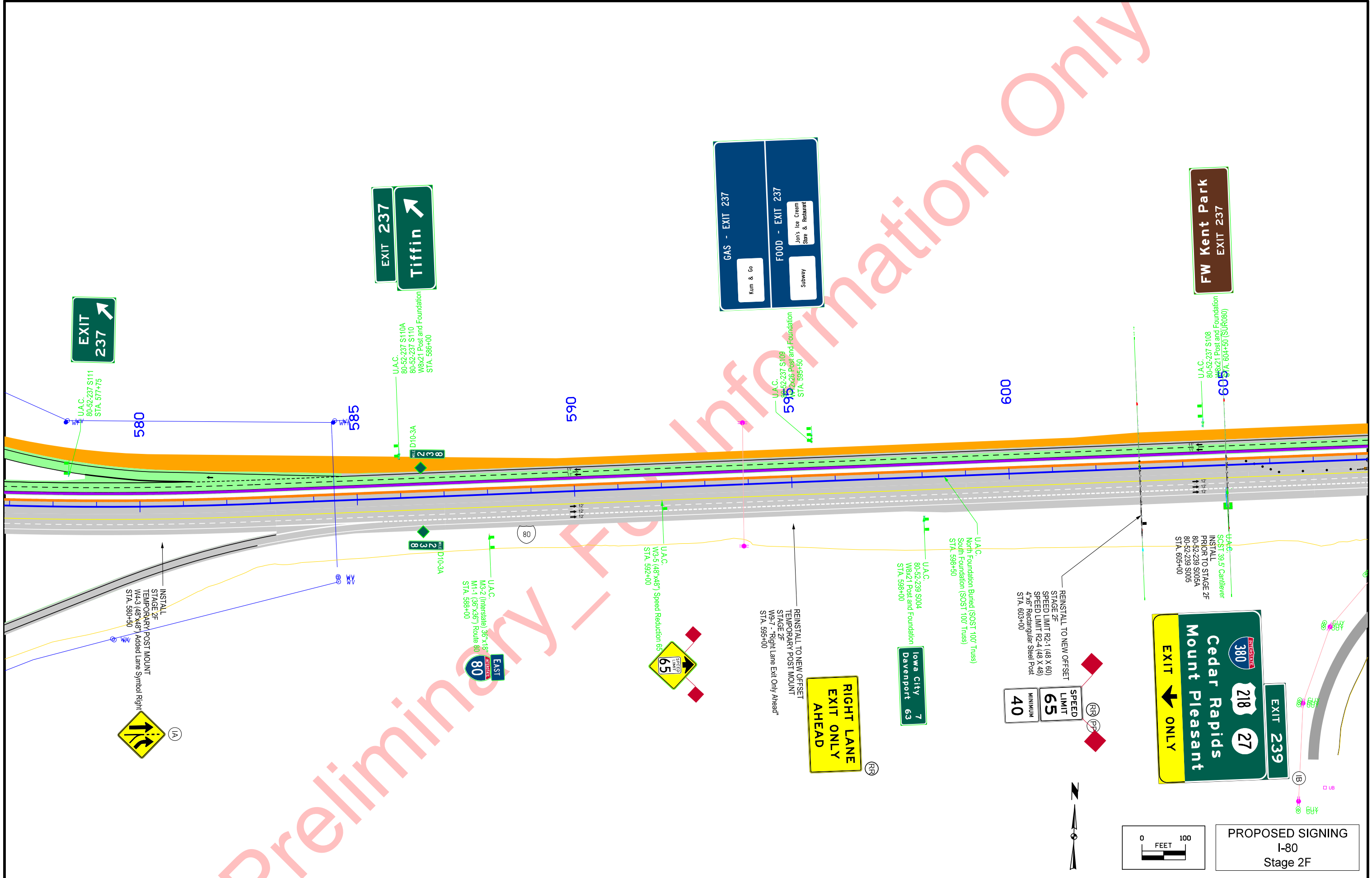

**PROPOSED SIGNING**  
I-80  
Stage 2F

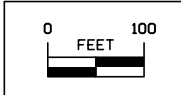

REINSTALL TO NEW OFFSET  
STAGE 2F  
SPEED LIMIT R2-1 (48 X 60)  
SPEED LIMIT R2-4 (48 X 48)  
47x67" Rectangular Steel Post  
STA. 603+00

Iowa City  
Davenport  
7  
63

**RIGHT LANE  
EXIT ONLY  
AHEAD**

REINSTALL TO NEW OFFSET  
TEMPORARY POST MOUNT  
STAGE 2F  
W9-7 "Right Lane Exit Only Ahead"  
STA. 598+00

U.A.C.  
W3-5 (48"x48") Speed Reduction 66  
STA. 592+00

U.A.C.  
M3-2 (Interstate) 36"x18"  
M1-1 (66"x36") Route 80  
STA. 588+00

INSTALL  
STAGE 2F  
TEMPORARY POST MOUNT  
W4-3 (48"x48") Added Lane Symbol Right  
STA. 580+50



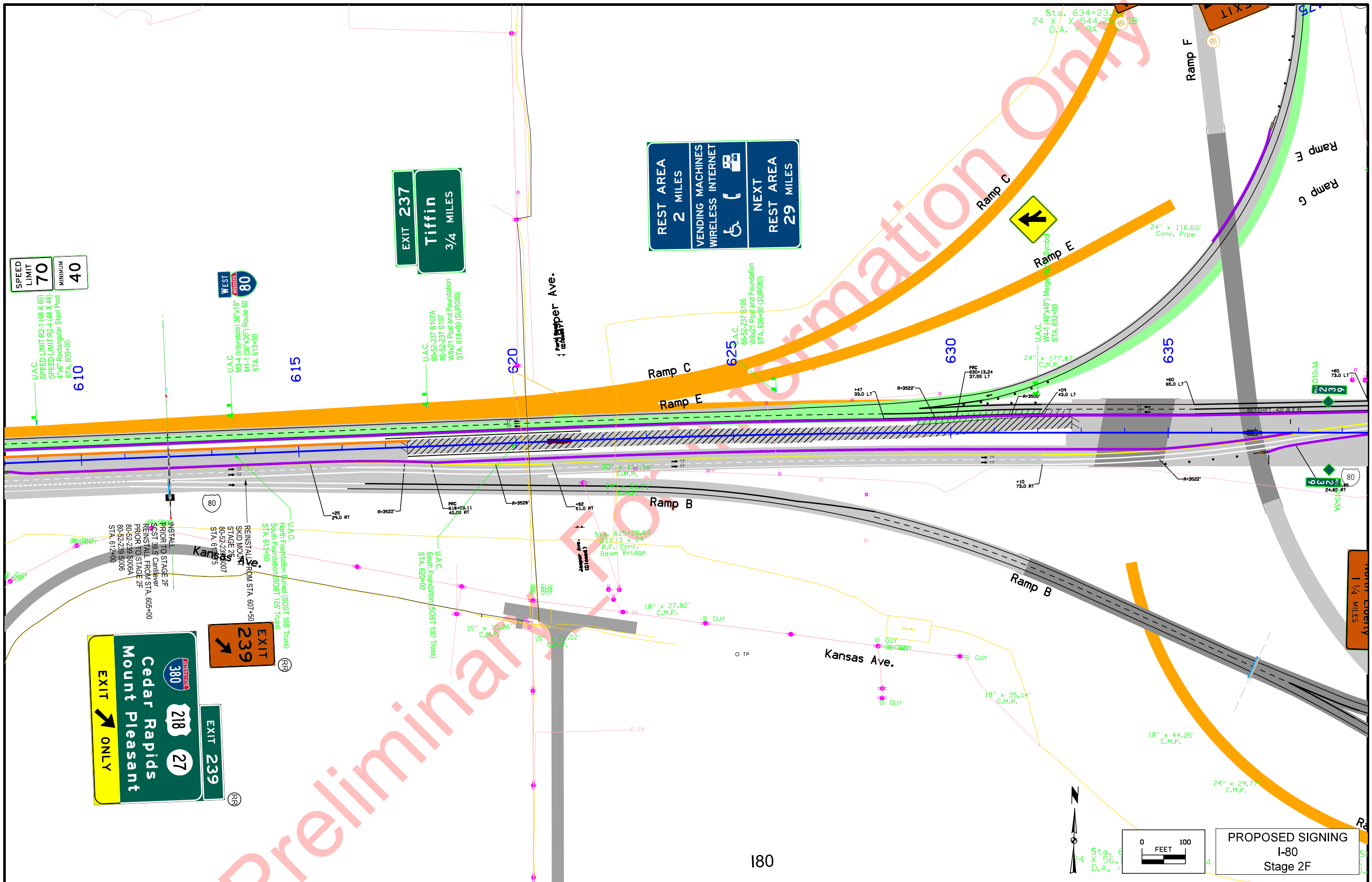

REST AREA  
2 MILES

VENDING MACHINES  
WIRELESS INTERNET

REST AREA  
29 MILES

EXIT 237  
Tiffin  
3/4 MILES

SPEED LIMIT  
70

MINIMUM  
40

WEST  
80

EXIT 239  
Cedar Rapids  
Mount Pleasant  
EXIT ONLY

EXIT 239

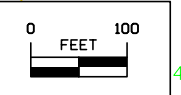

PROPOSED SIGNING  
I-80  
Stage 2F

Preliminary Information Only

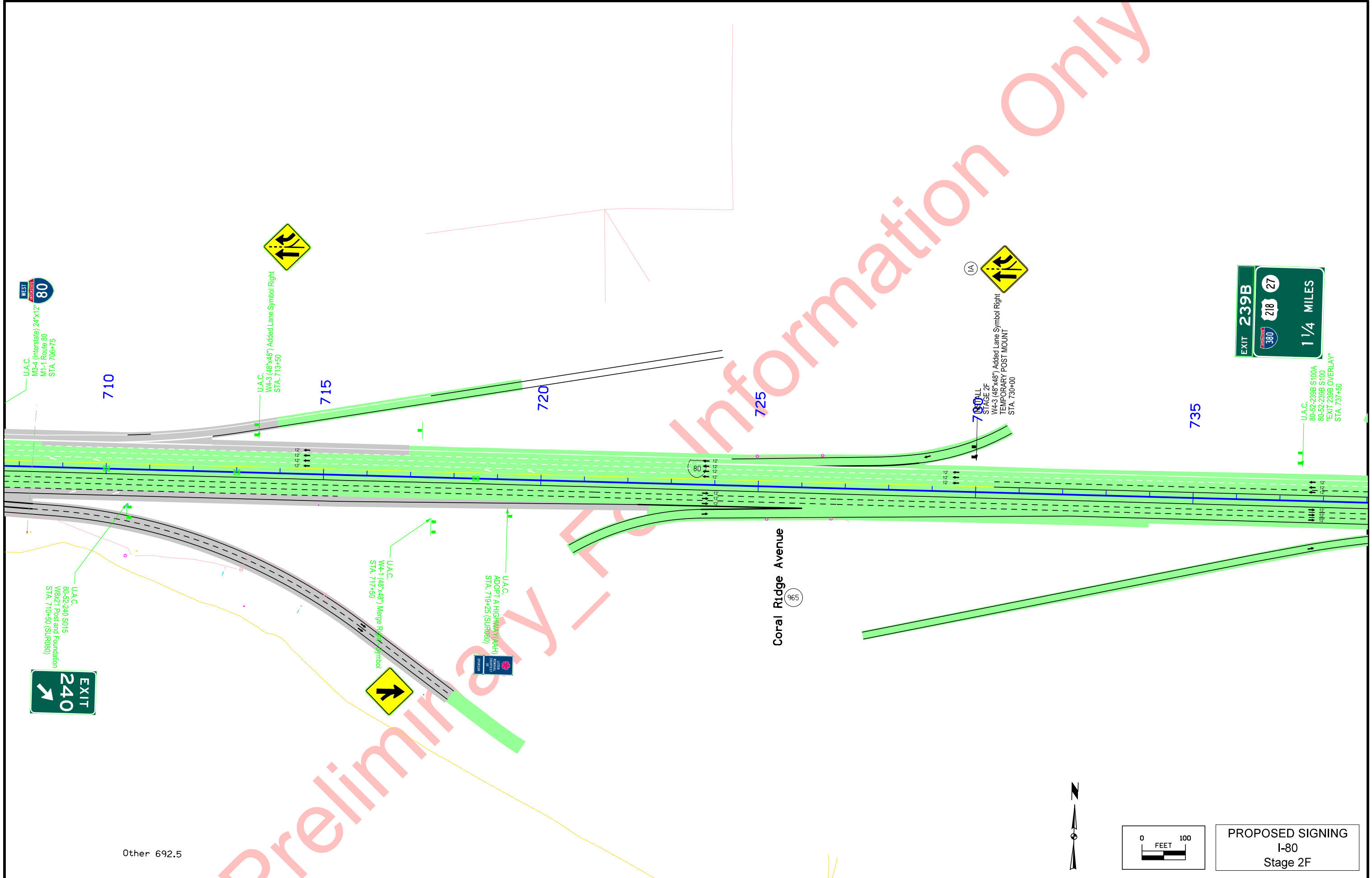

Other 692.5

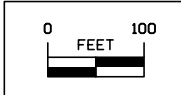

PROPOSED SIGNING  
I-80  
Stage 2F

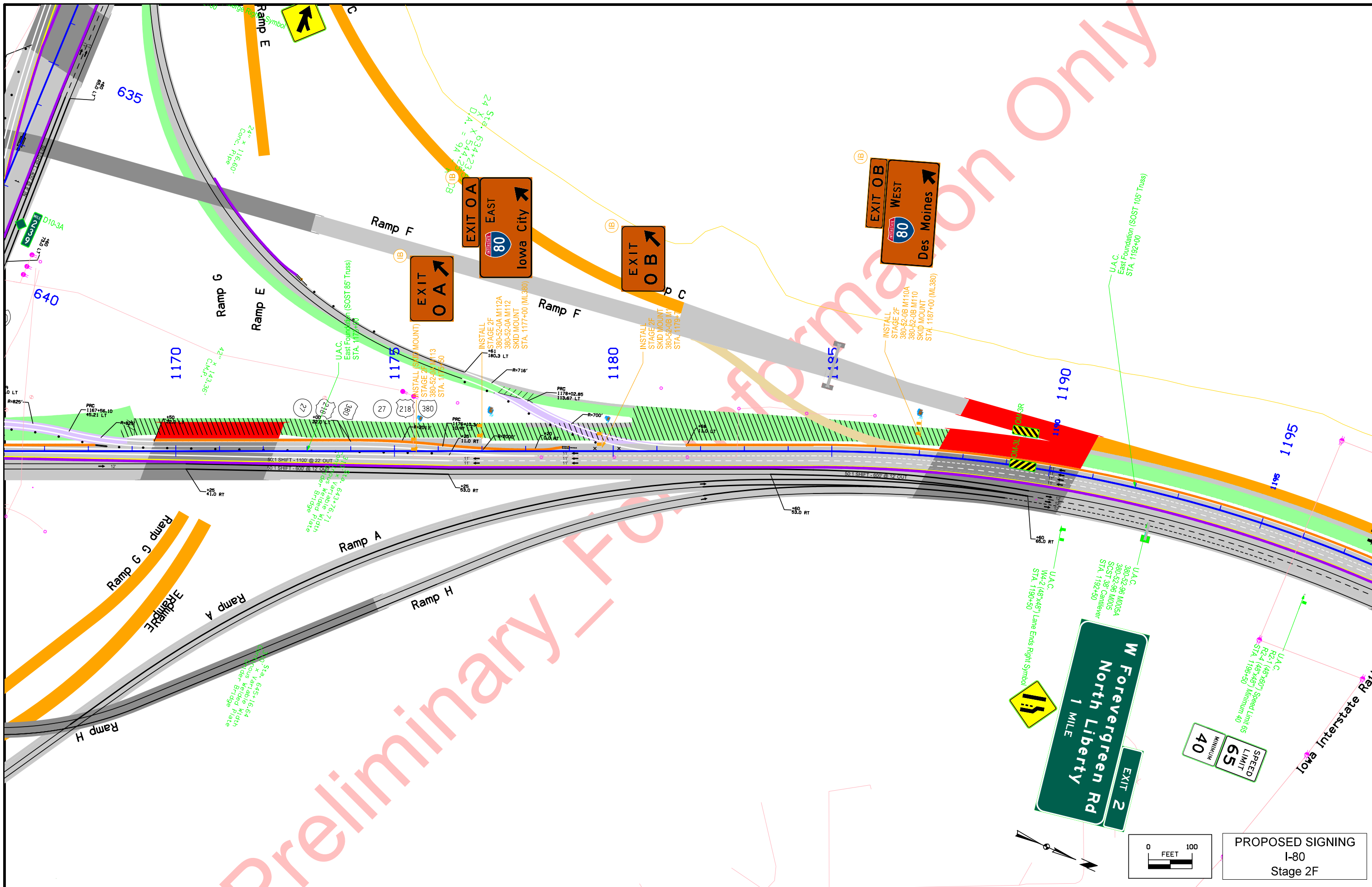

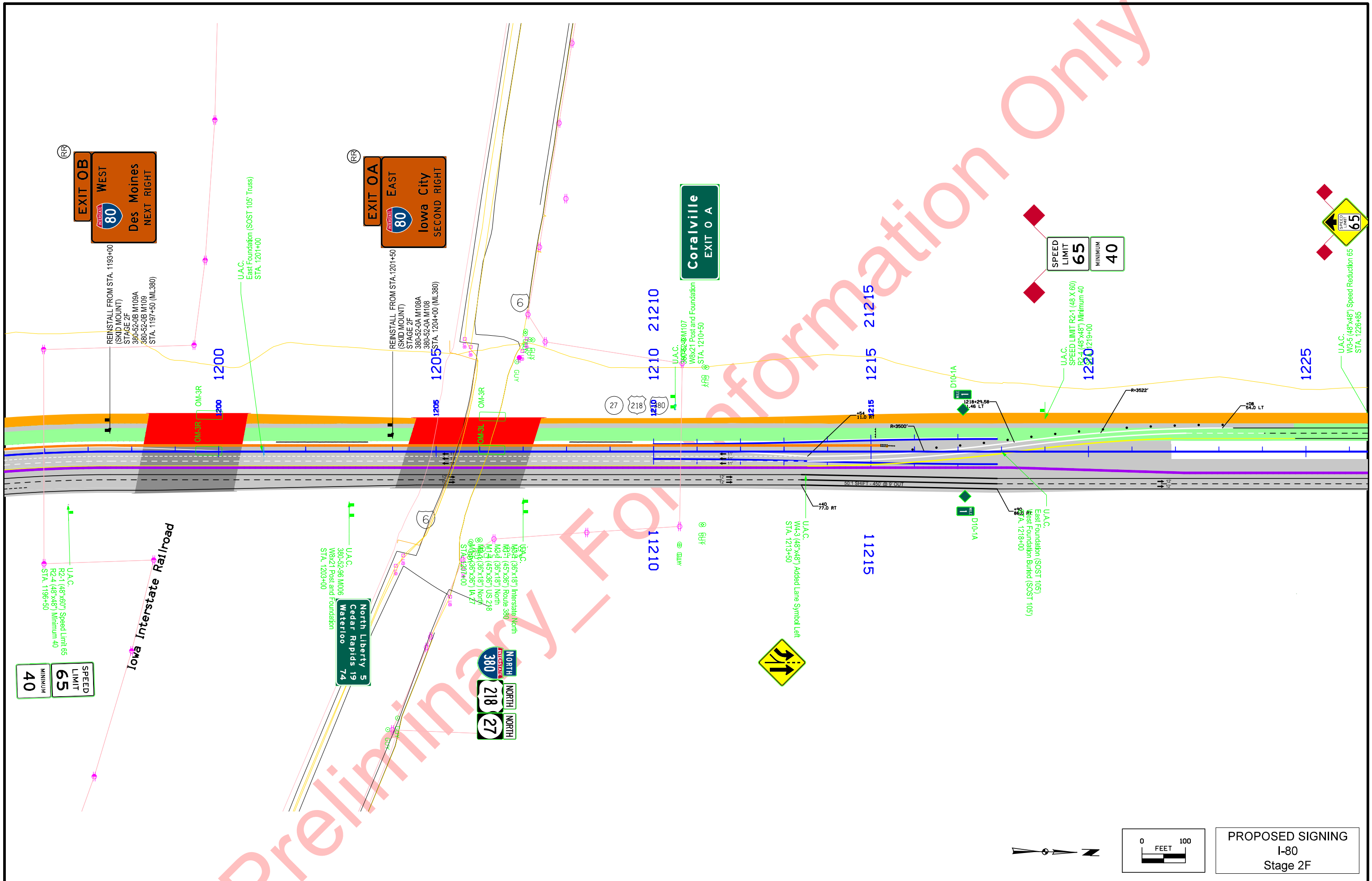

Information Only

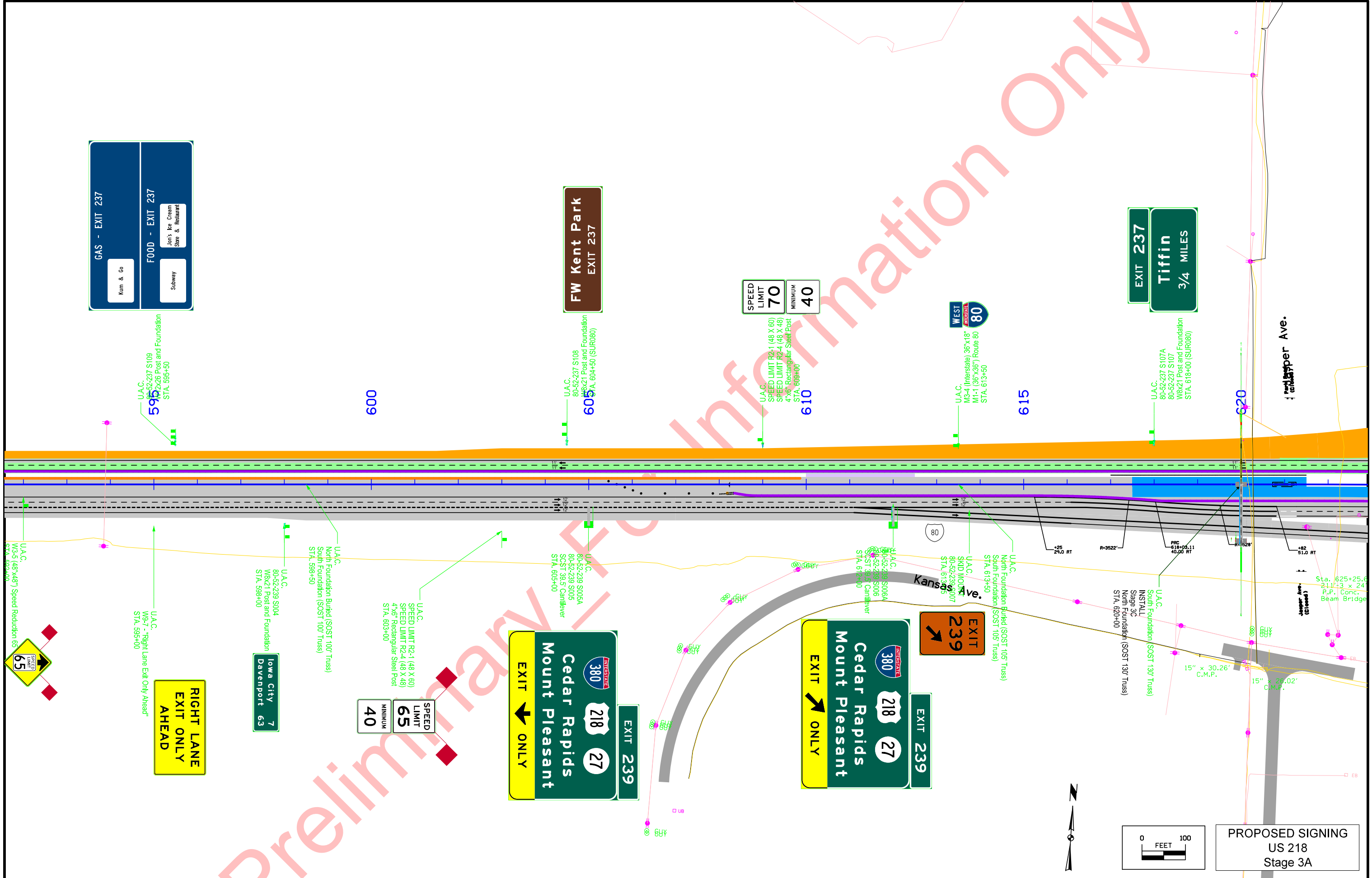

**GAS - EXIT 237**  
Kum & Go

**FOOD - EXIT 237**  
Subway  
Jim's Ice Cream Store & Restaurant

**FW Kent Park**  
EXIT 237

**SPEED LIMIT 70**  
MINIMUM 40

**WEST 80**  
INTERSTATE

**EXIT 237**  
**Tiffin**  
3/4 MILES

**EXIT 239**

**Cedar Rapids**  
**Mount Pleasant**

EXIT ONLY

**EXIT 239**

**Cedar Rapids**  
**Mount Pleasant**

EXIT ONLY

**SPEED LIMIT 65**  
MINIMUM 40

**RIGHT LANE**  
**EXIT ONLY**  
**AHEAD**

**Iowa City**  
**Davenport 63**

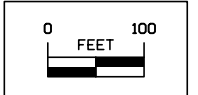

**PROPOSED SIGNING**  
**US 218**  
**Stage 3A**

Preliminary - For Information Only

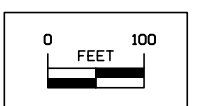
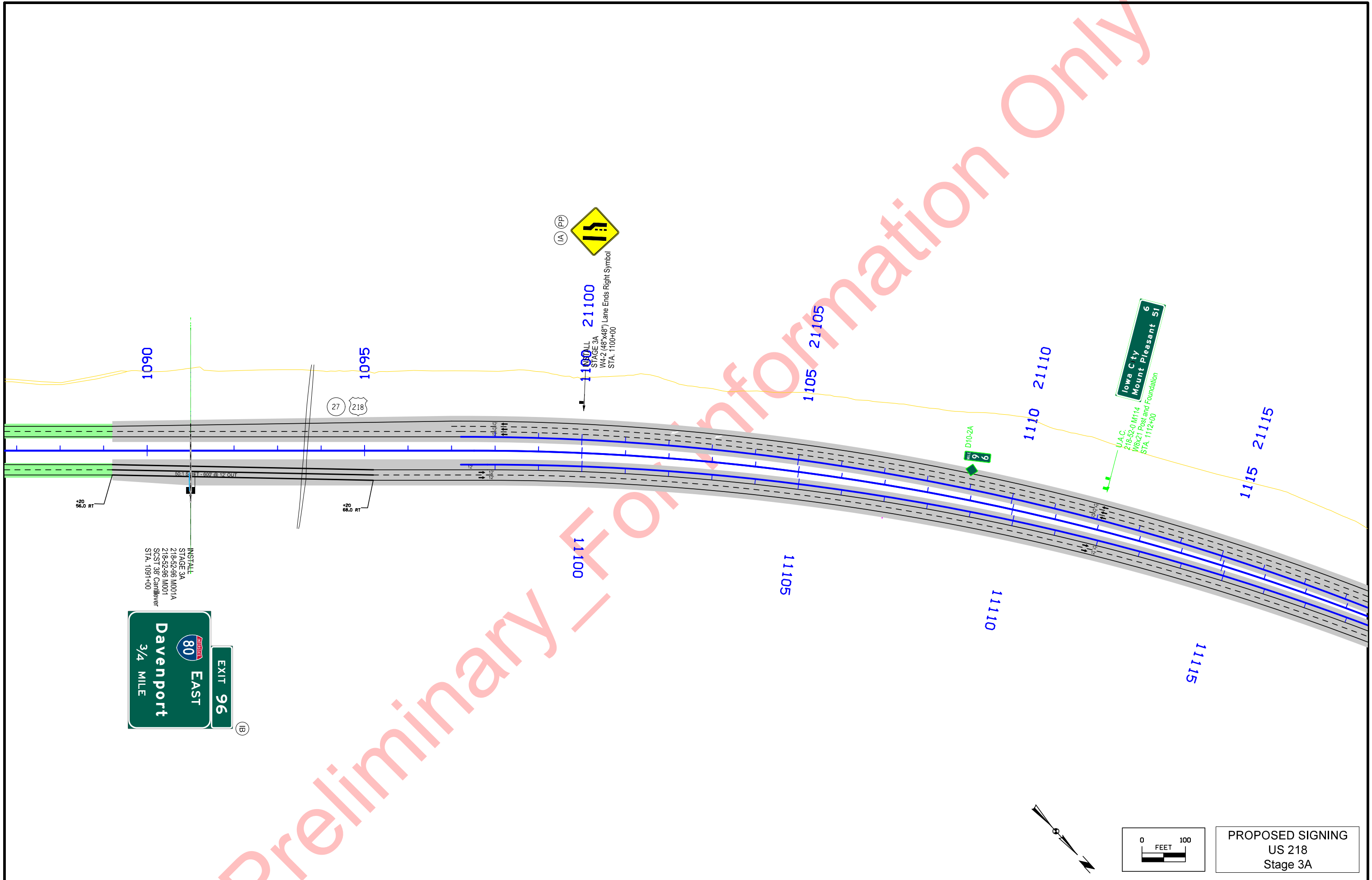

PROPOSED SIGNING  
US 218  
Stage 3A

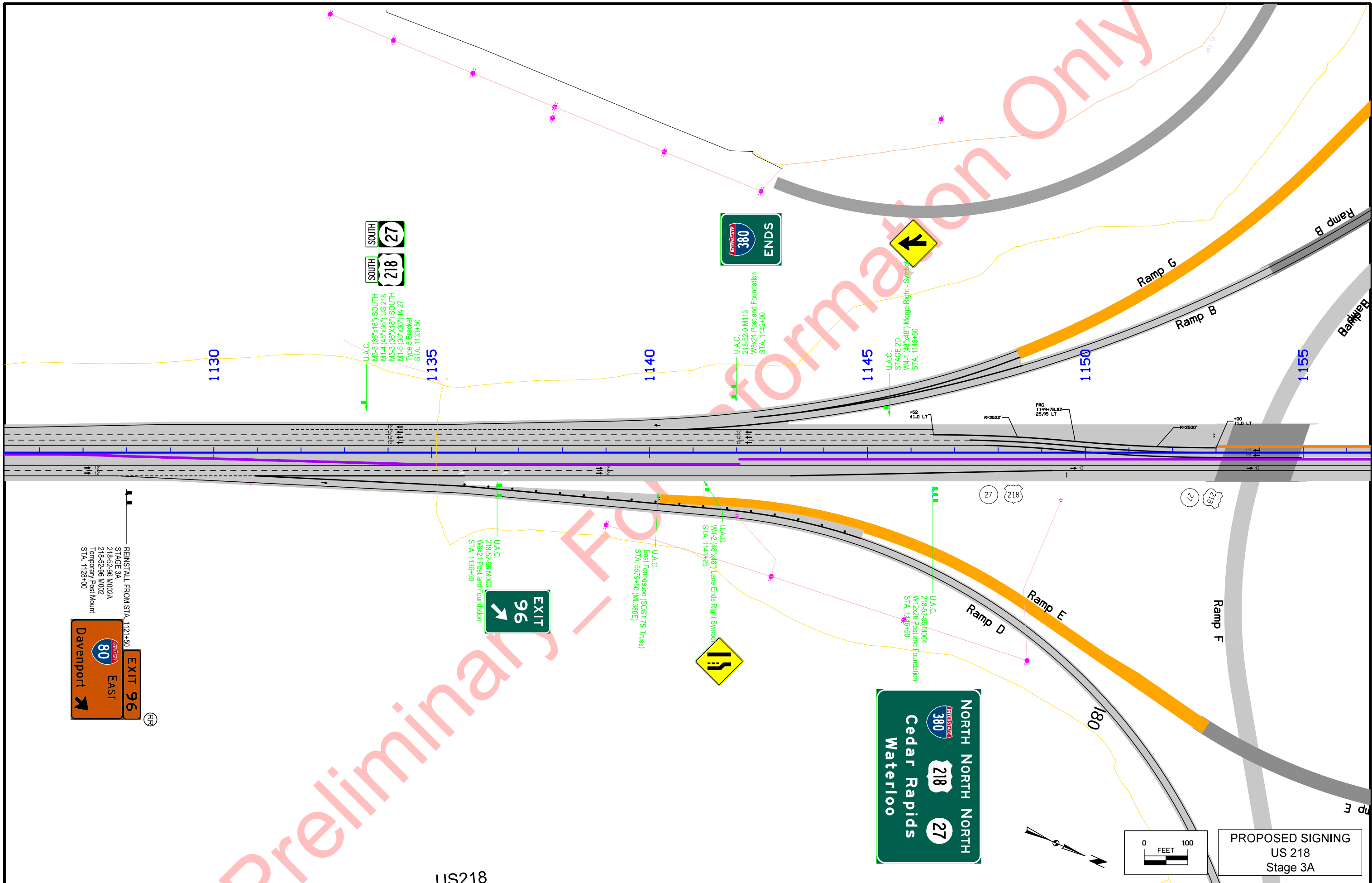

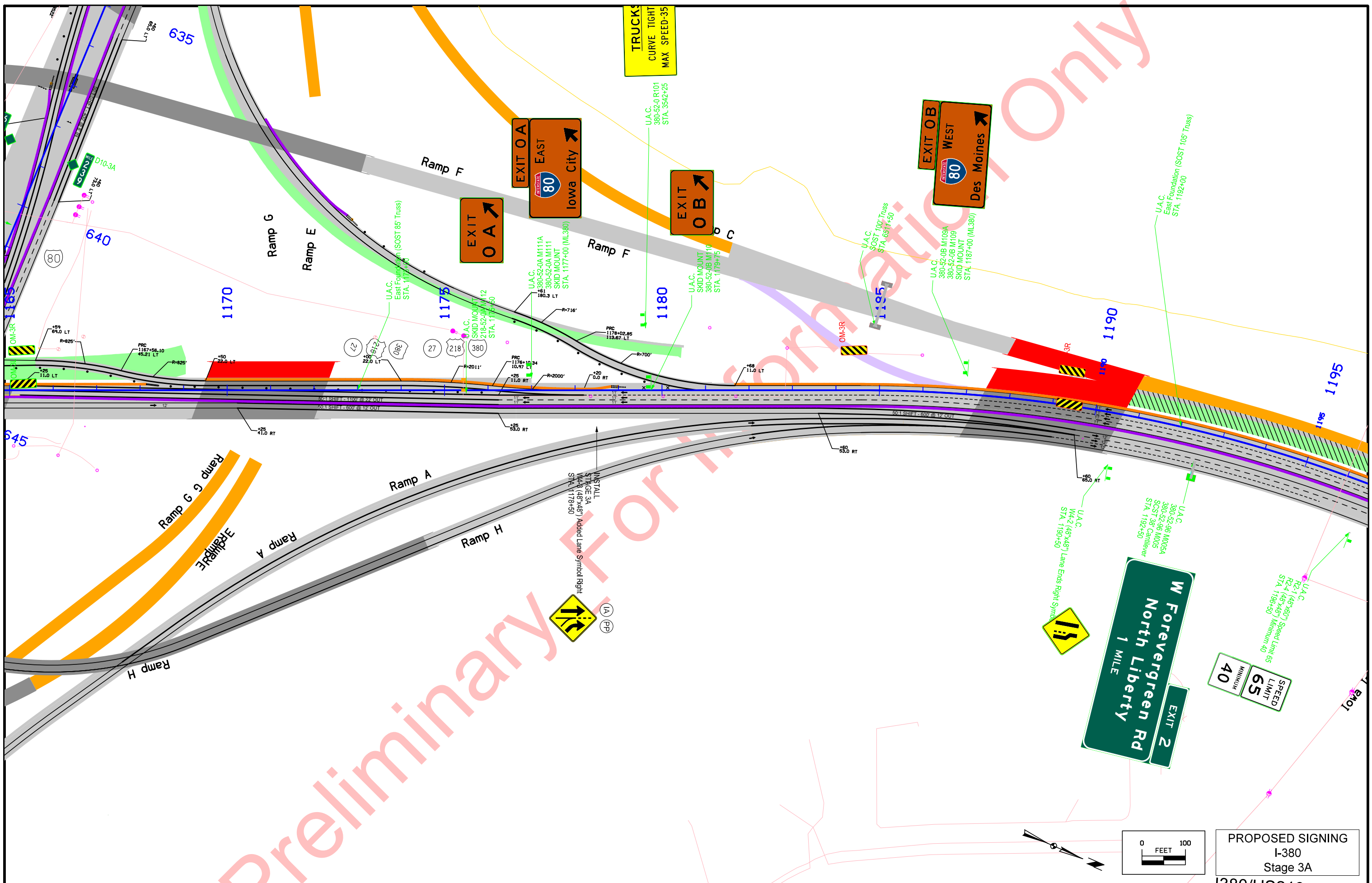



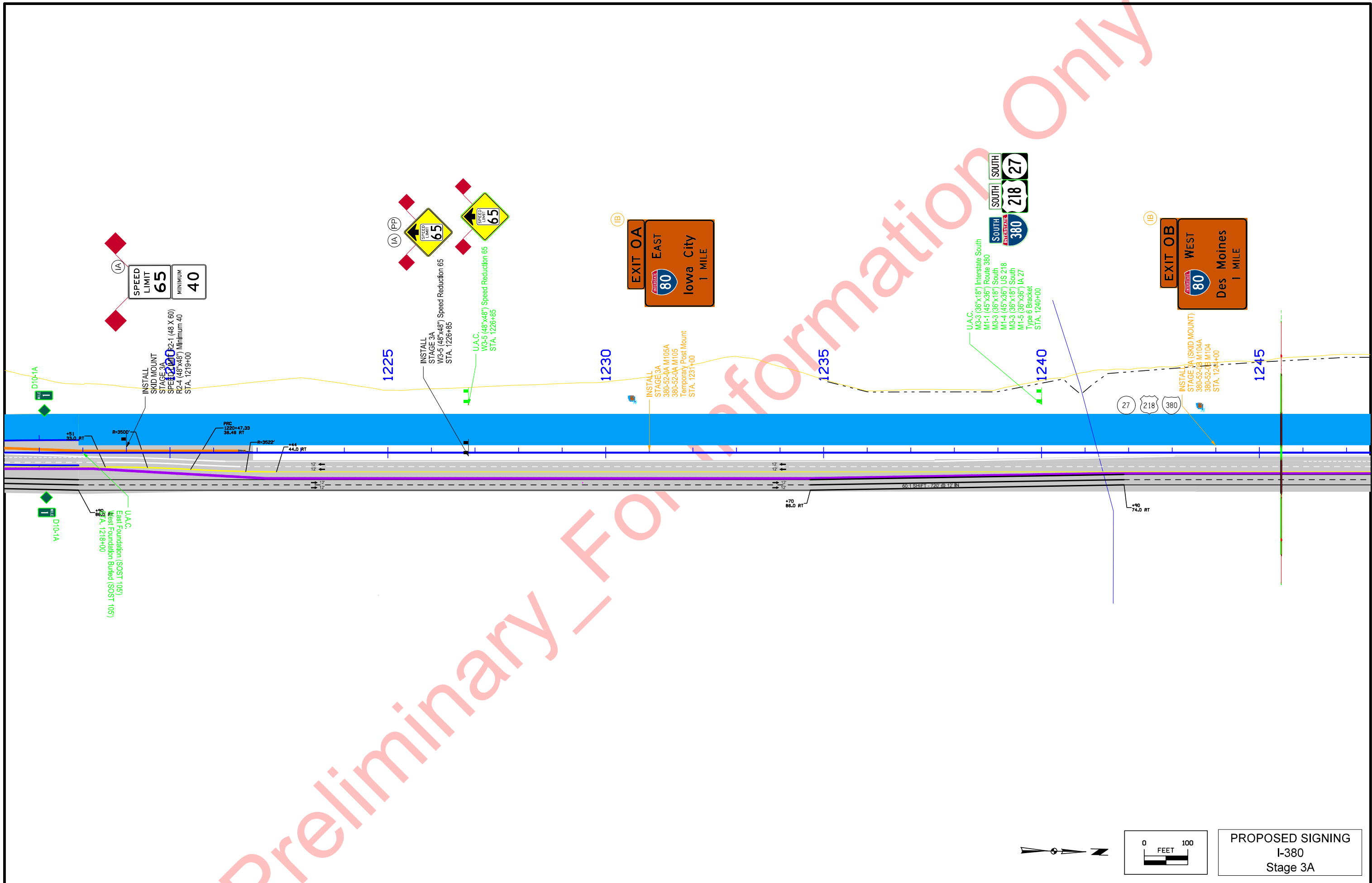

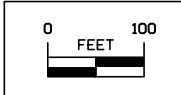
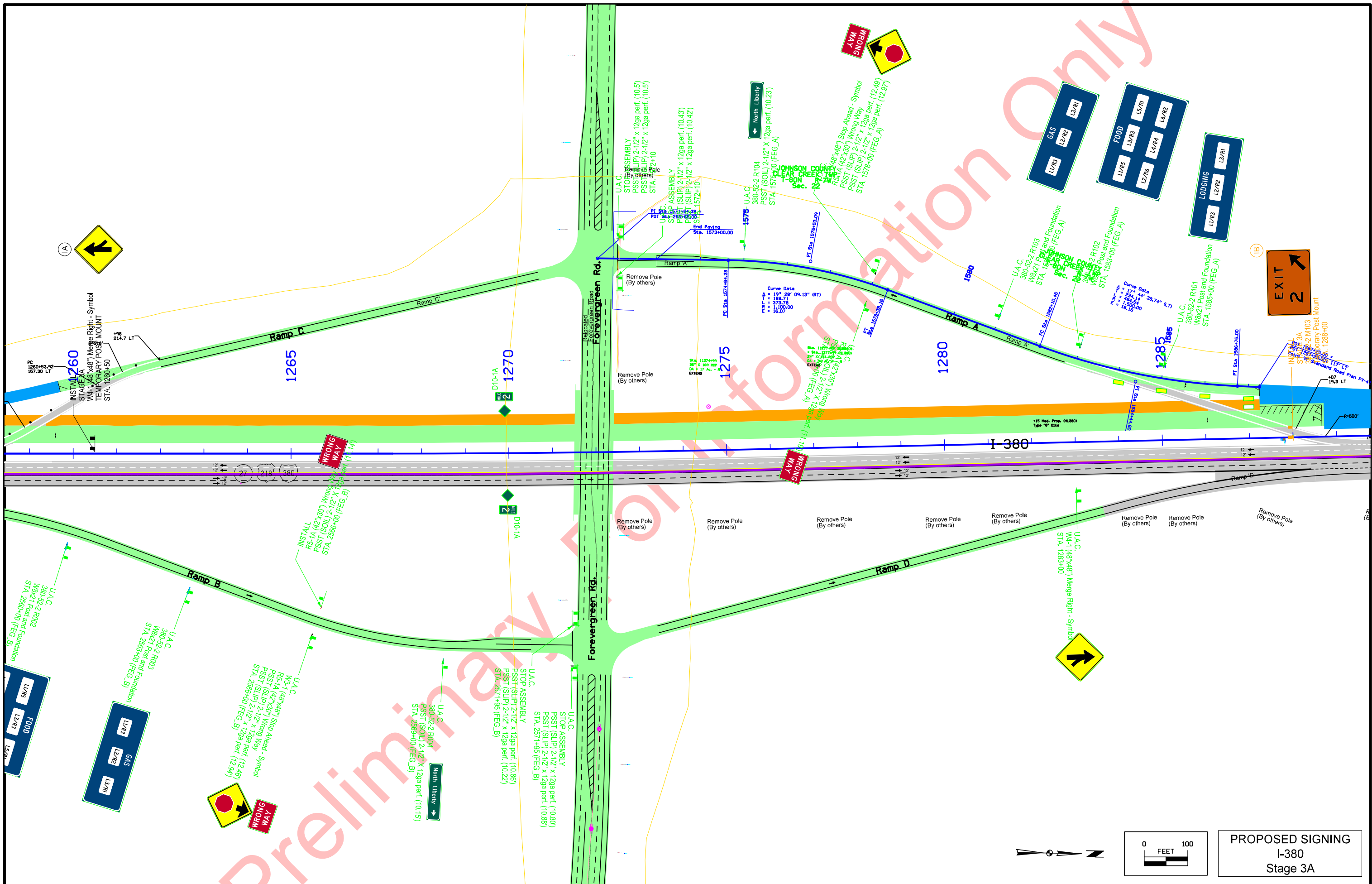

PROPOSED SIGNING  
I-380  
Stage 3A

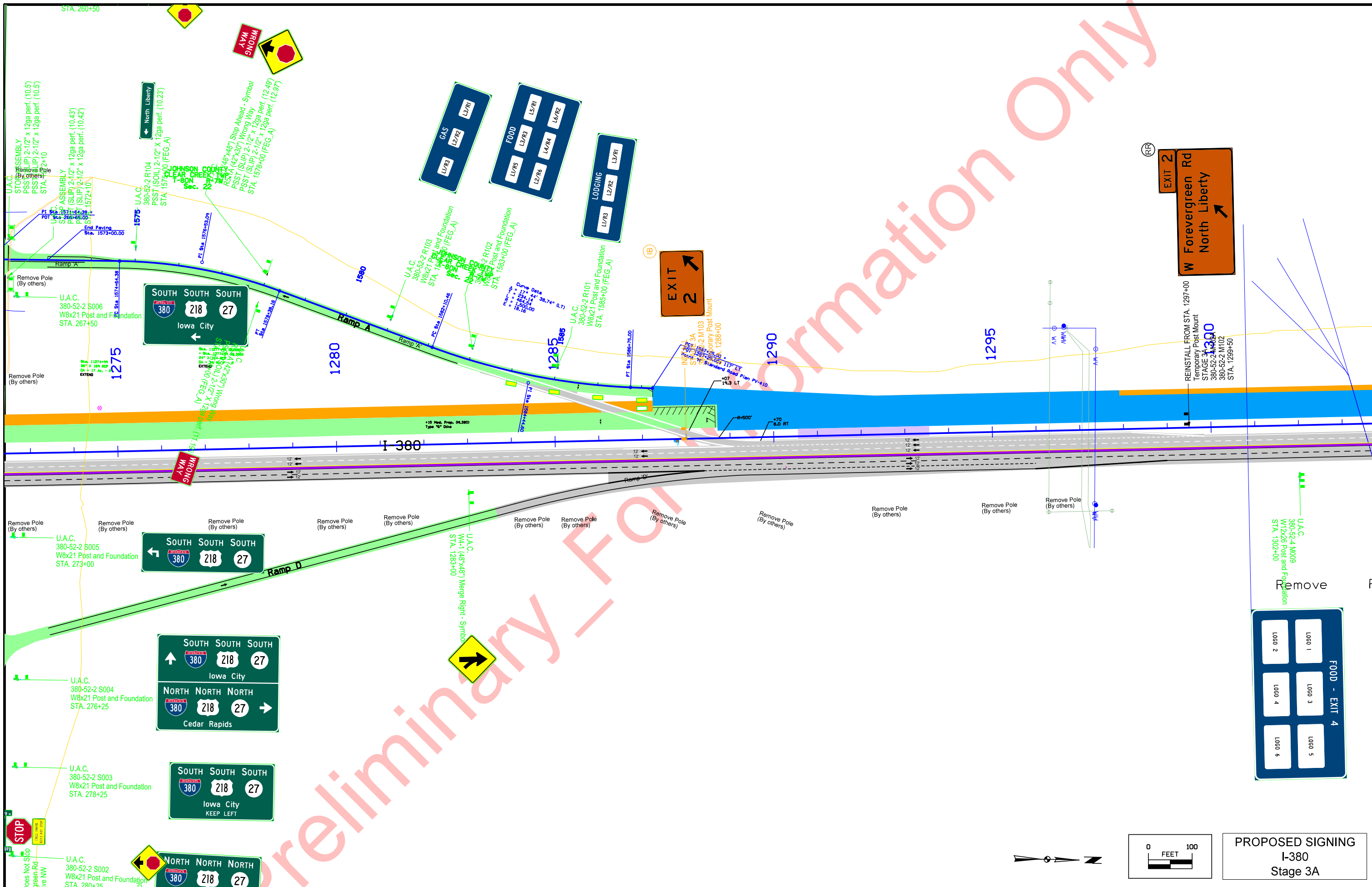

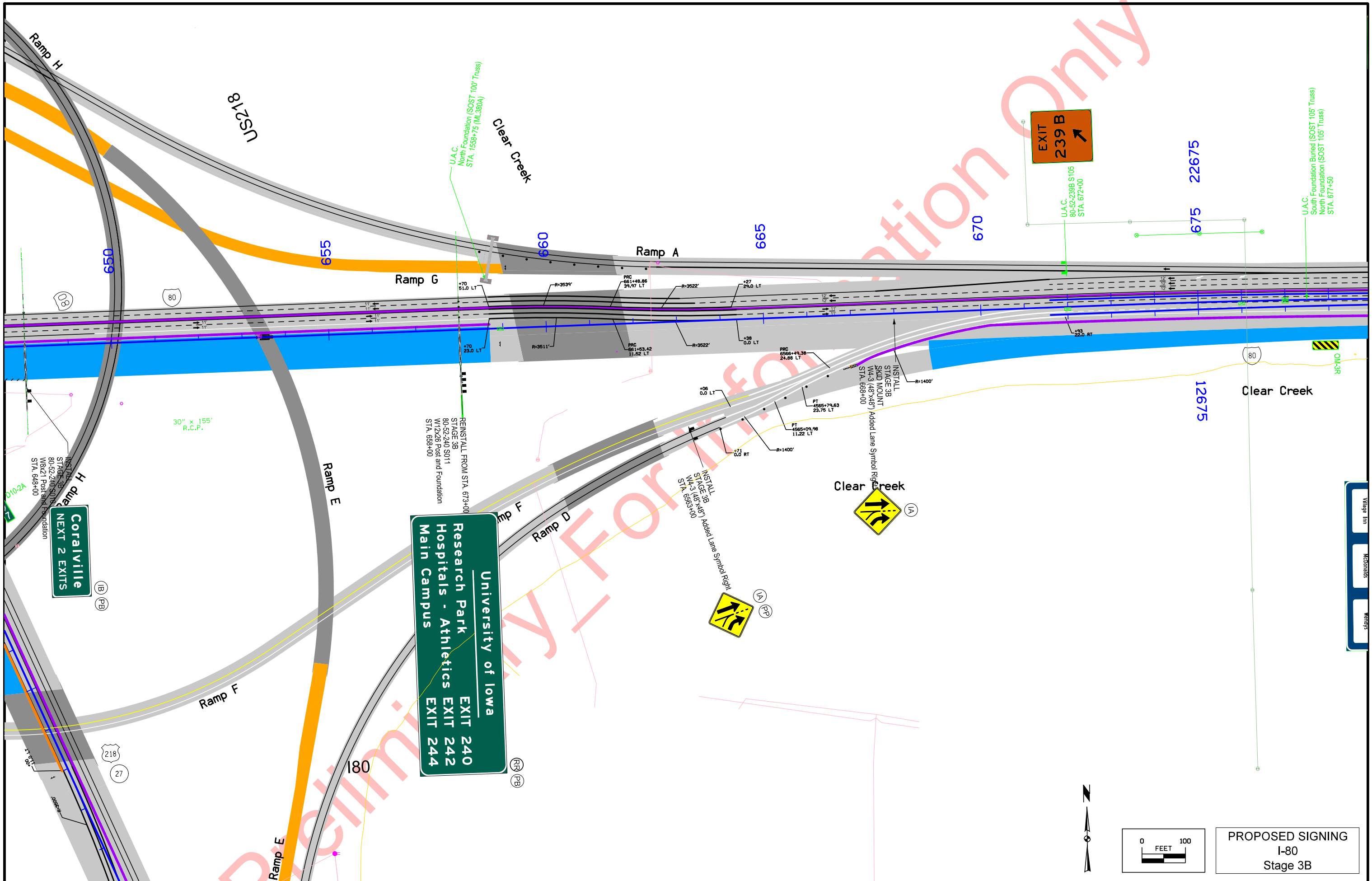

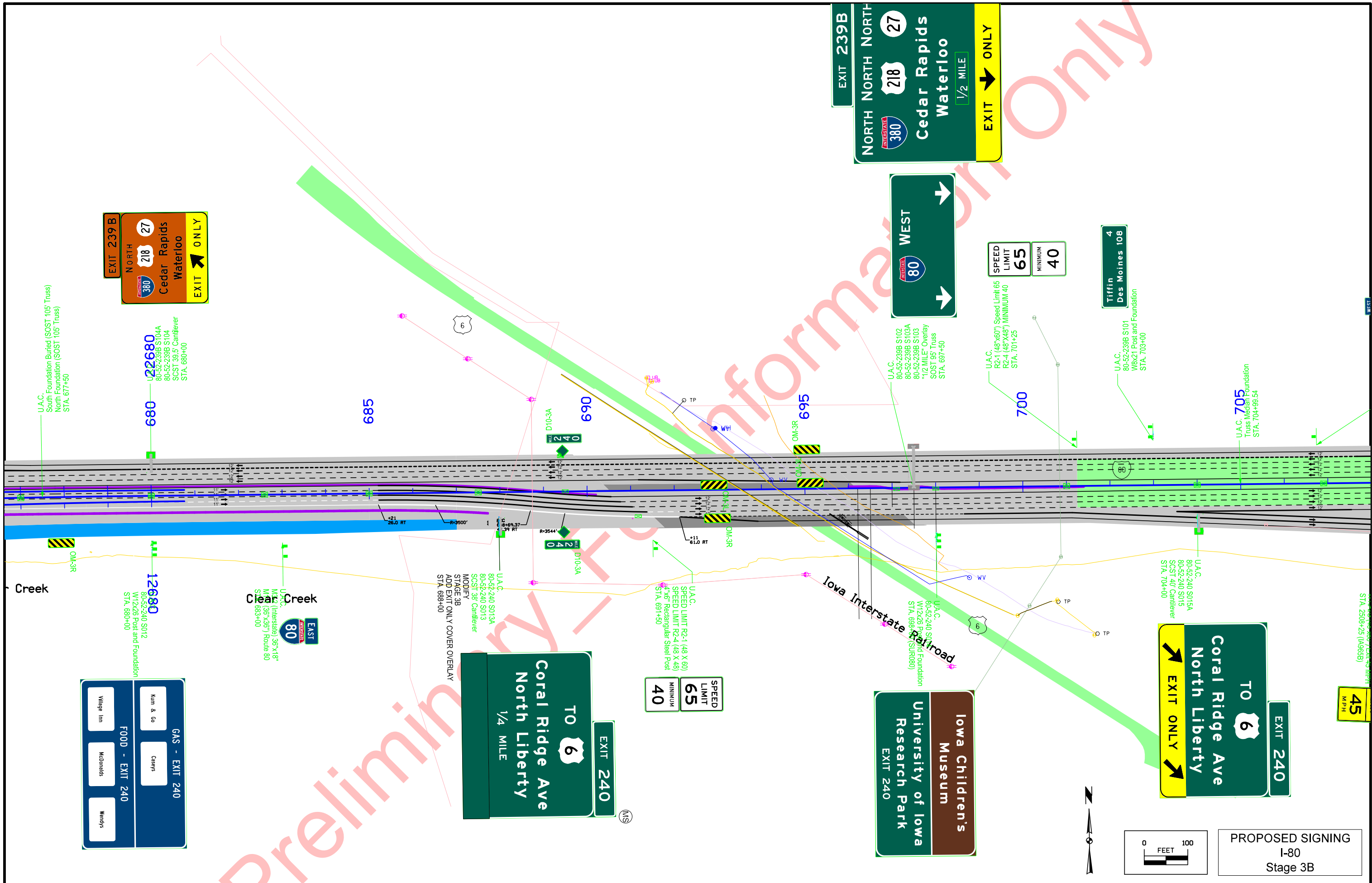

PROPOSED SIGNING  
I-80  
Stage 3B

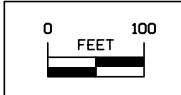

45  
MPH

EXIT 240

TO  
**6**  
Coral Ridge Ave  
North Liberty  
EXIT ONLY

Iowa Children's  
Museum  
University of Iowa  
Research Park  
EXIT 240

SPEED  
LIMIT  
65  
MINIMUM  
40

EXIT 240  
TO  
**6**  
Coral Ridge Ave  
North Liberty  
1/4 MILE

EXIT 239 B  
NORTH  
**218** **27**  
Cedar Rapids  
Waterloo  
EXIT ONLY

SPEED  
LIMIT  
65  
MINIMUM  
40

WEST  
**80**

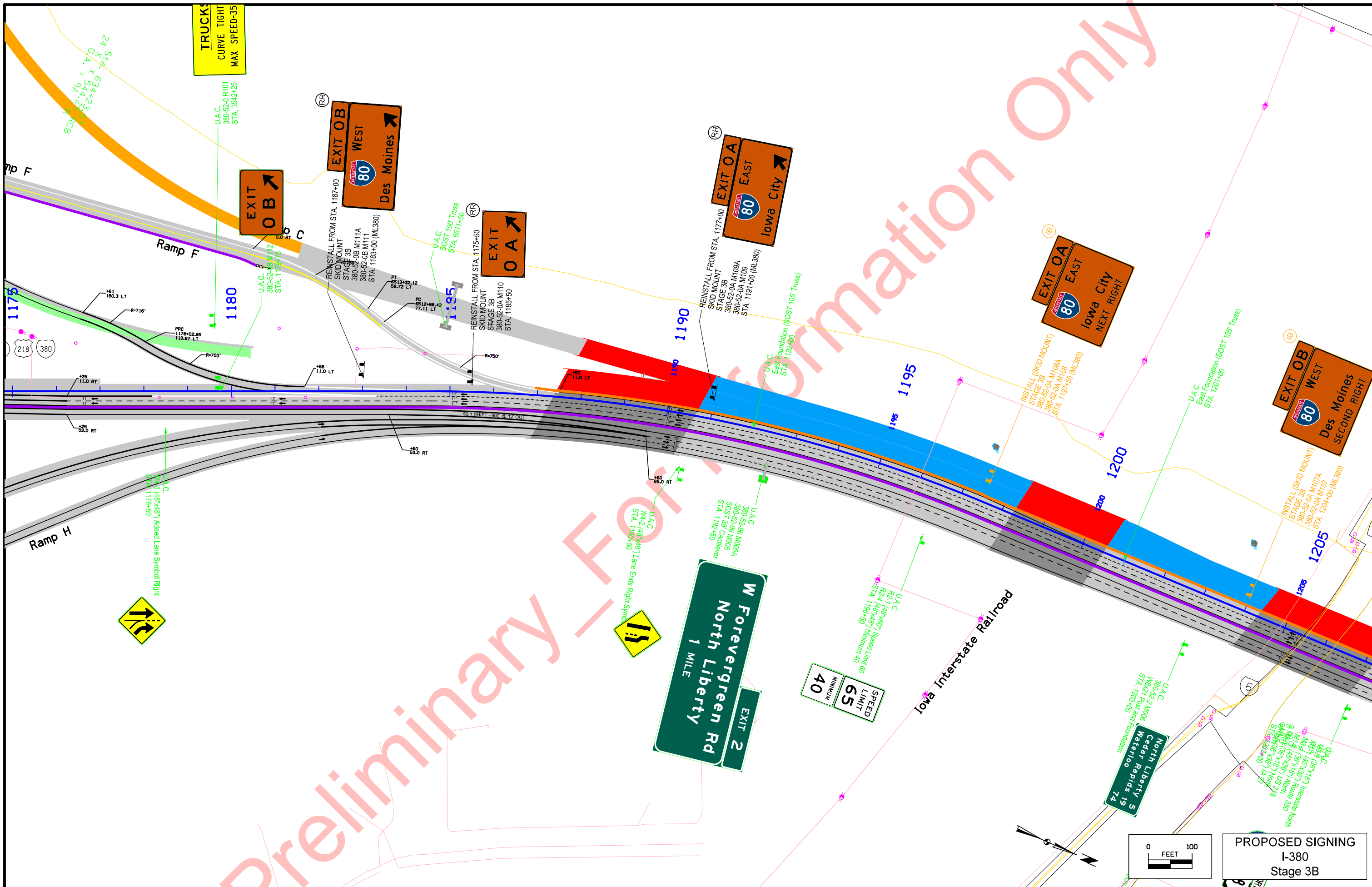

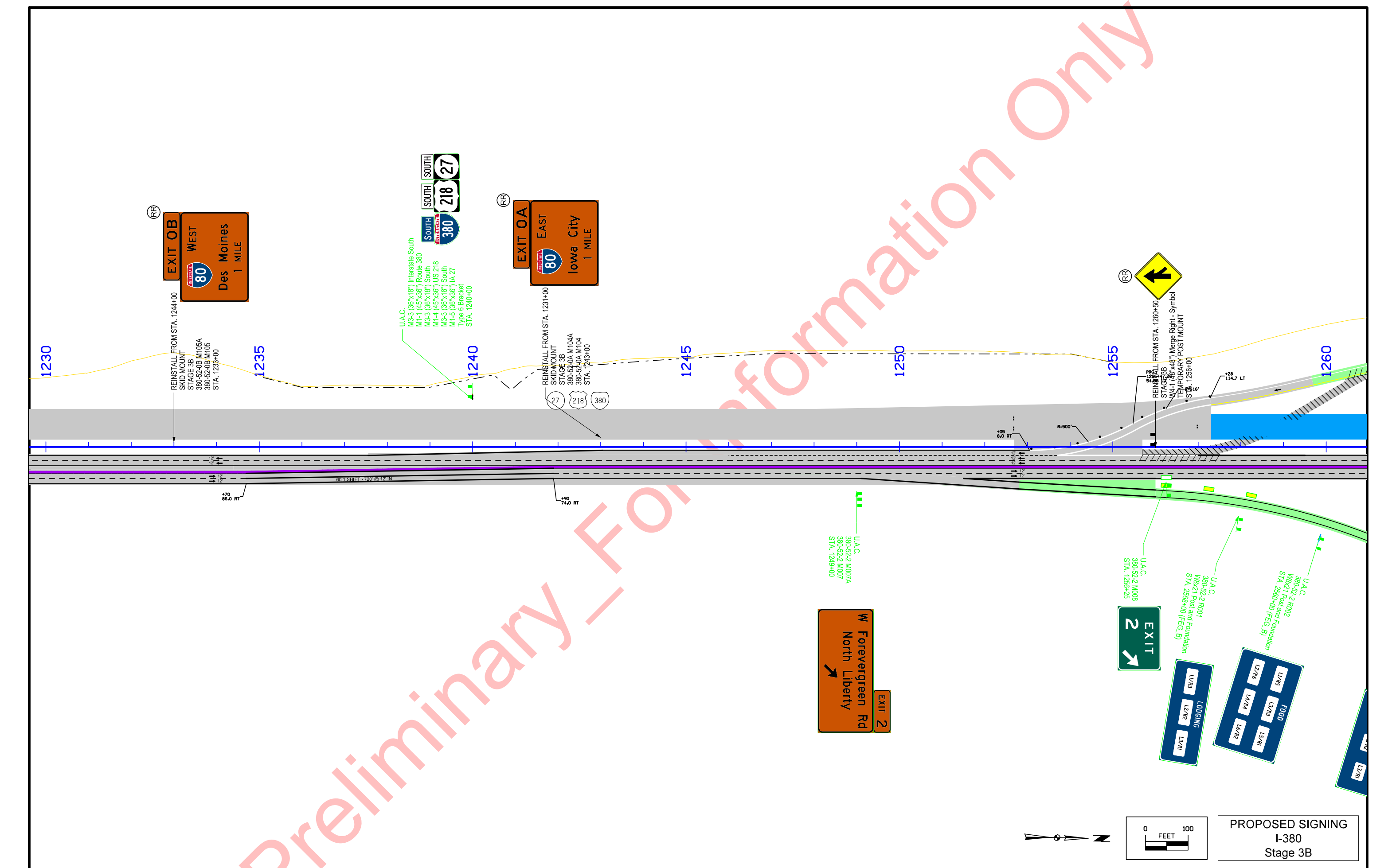

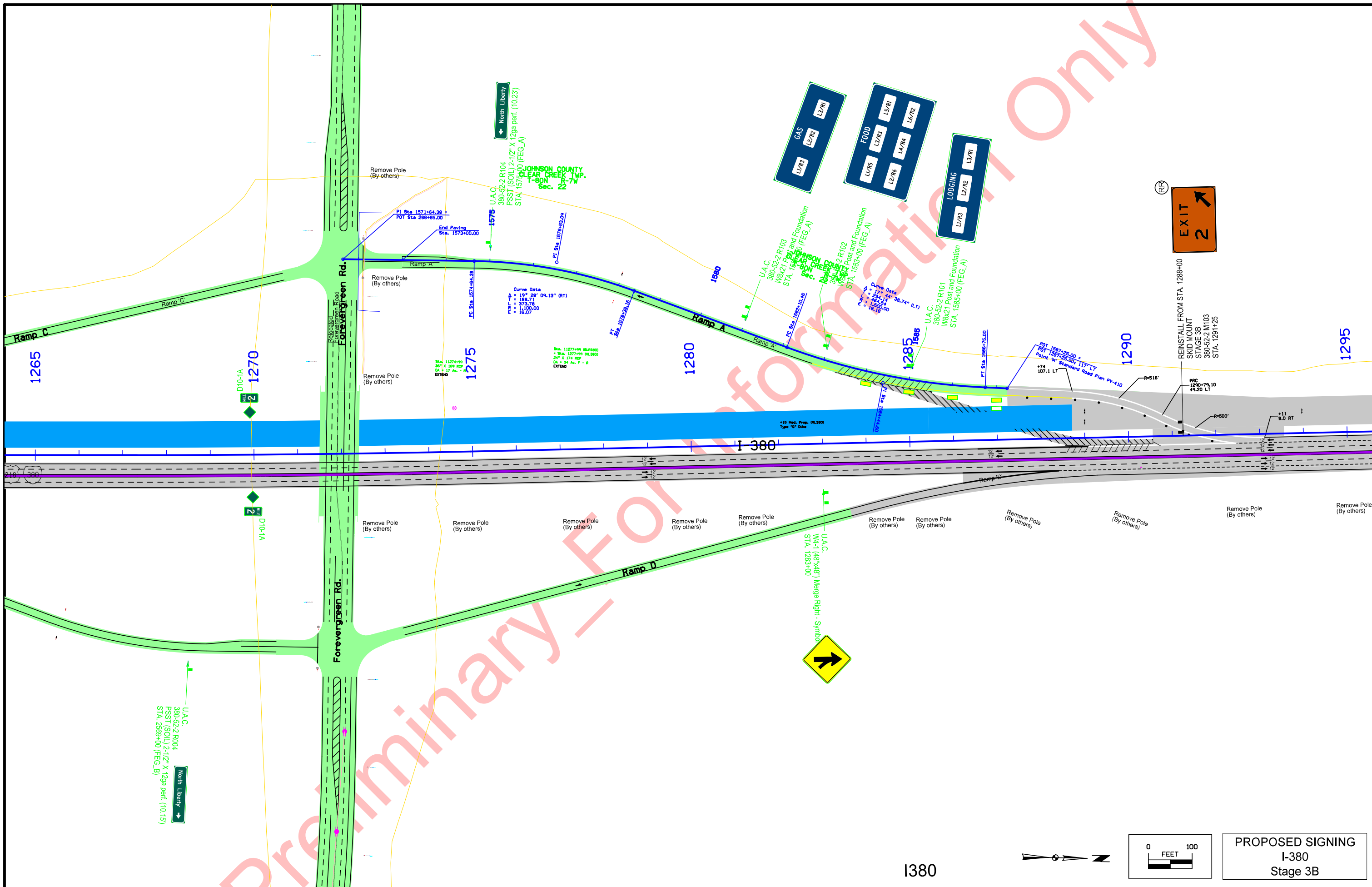

U.A.C.  
380-52-2-R004  
PSST (SOIL) 2-1/2" X 12ga perf. (10.15)  
North Liberty

North Liberty  
380-52-2-R104  
PSST (SOIL) 2-1/2" X 12ga perf. (10.23)  
U.A.C.  
1575

U.A.C.  
W4-1 (48"x48") Merge Right - Symbol  
STA. 1283+00

RR  
EXIT  
2

REINSTALL FROM STA. 1288+00  
SKID MOUNT  
STAGE 3B  
380-52-2-M103  
STA. 1291+25

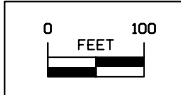

PROPOSED SIGNING  
I-380  
Stage 3B



Preliminary - For Information Only

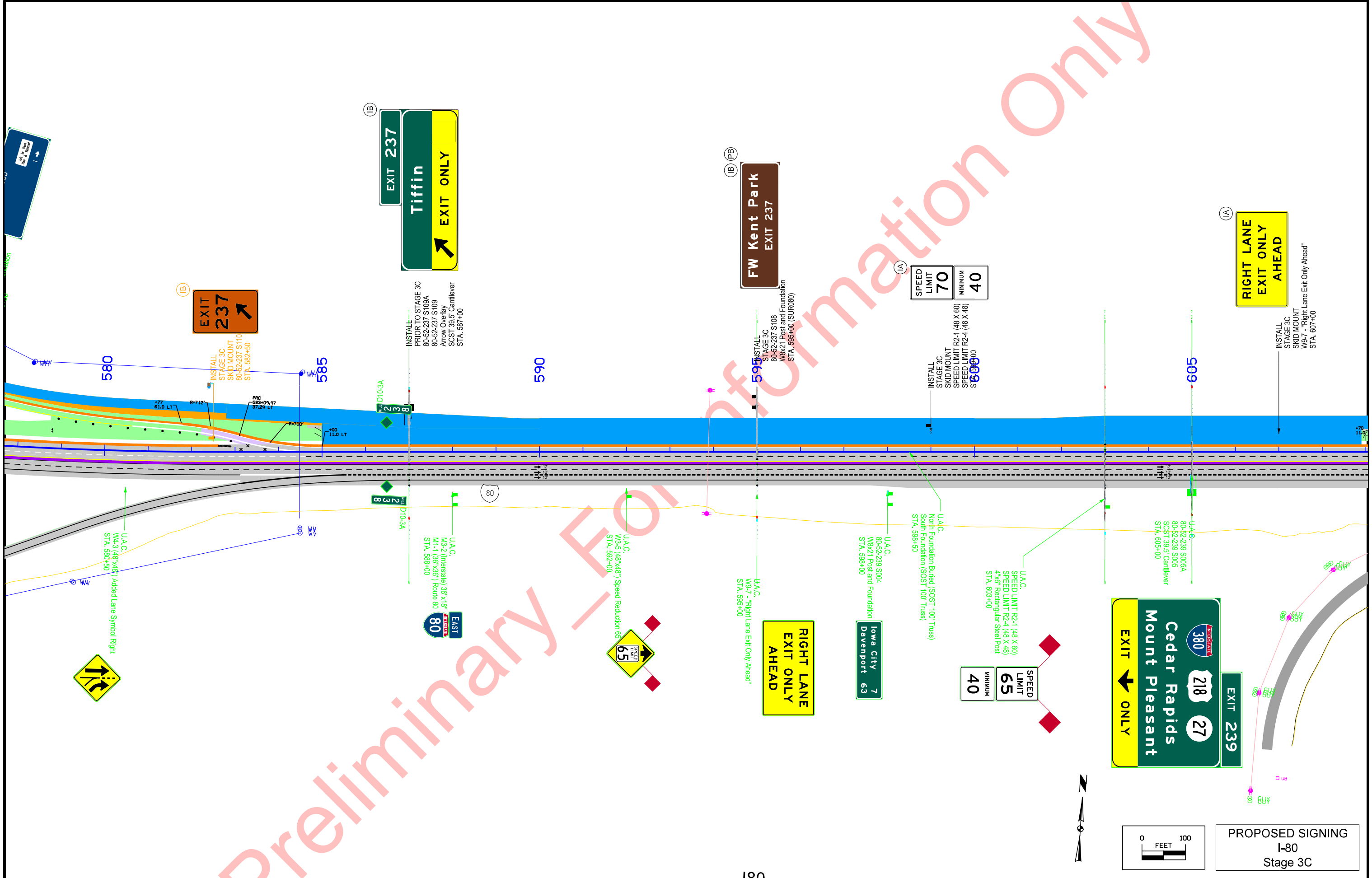

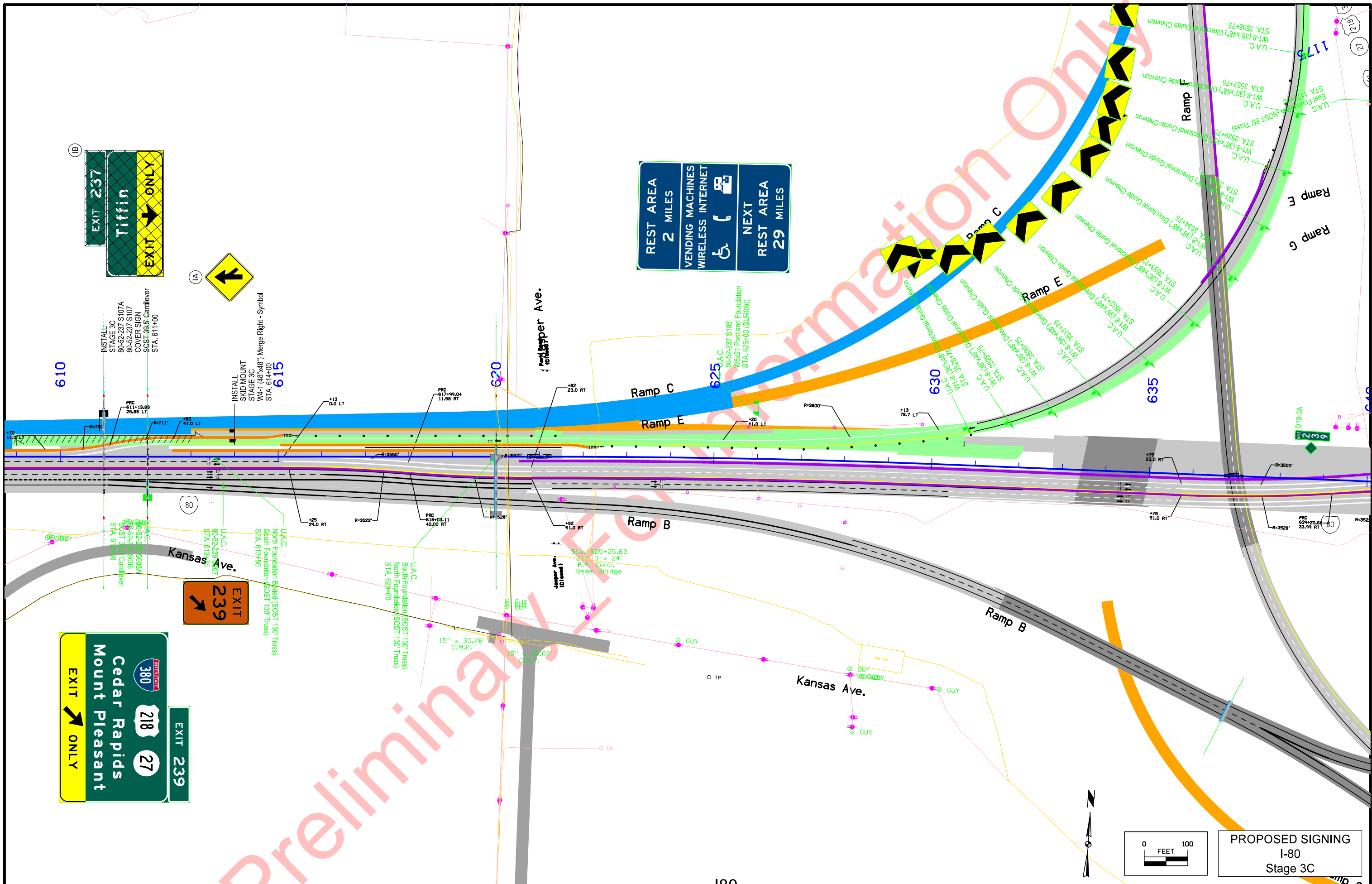

REST AREA  
2 MILES

VENDING MACHINES  
WIRELESS INTERNET

NEXT REST AREA  
29 MILES

EXIT 237  
Tiffin  
EXIT ONLY

EXIT 239  
Cedar Rapids  
Mount Pleasant  
EXIT ONLY

PROPOSED SIGNING  
I-80  
Stage 3C

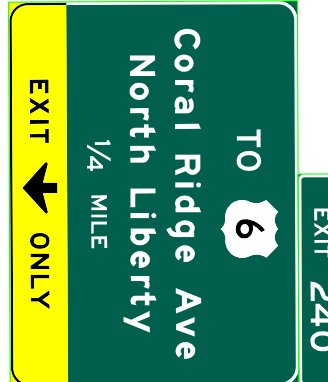

Village Inn	Kum & Go	Wendys
	Cherys	
FOOD - EXIT 240		
GAS - EXIT 240		

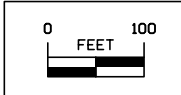
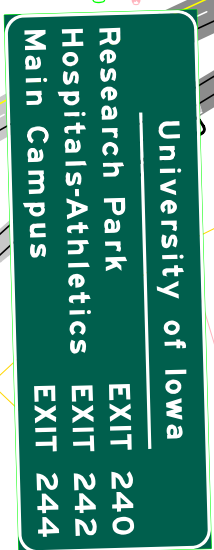

PROPOSED SIGNING  
I-80  
Stage 3C

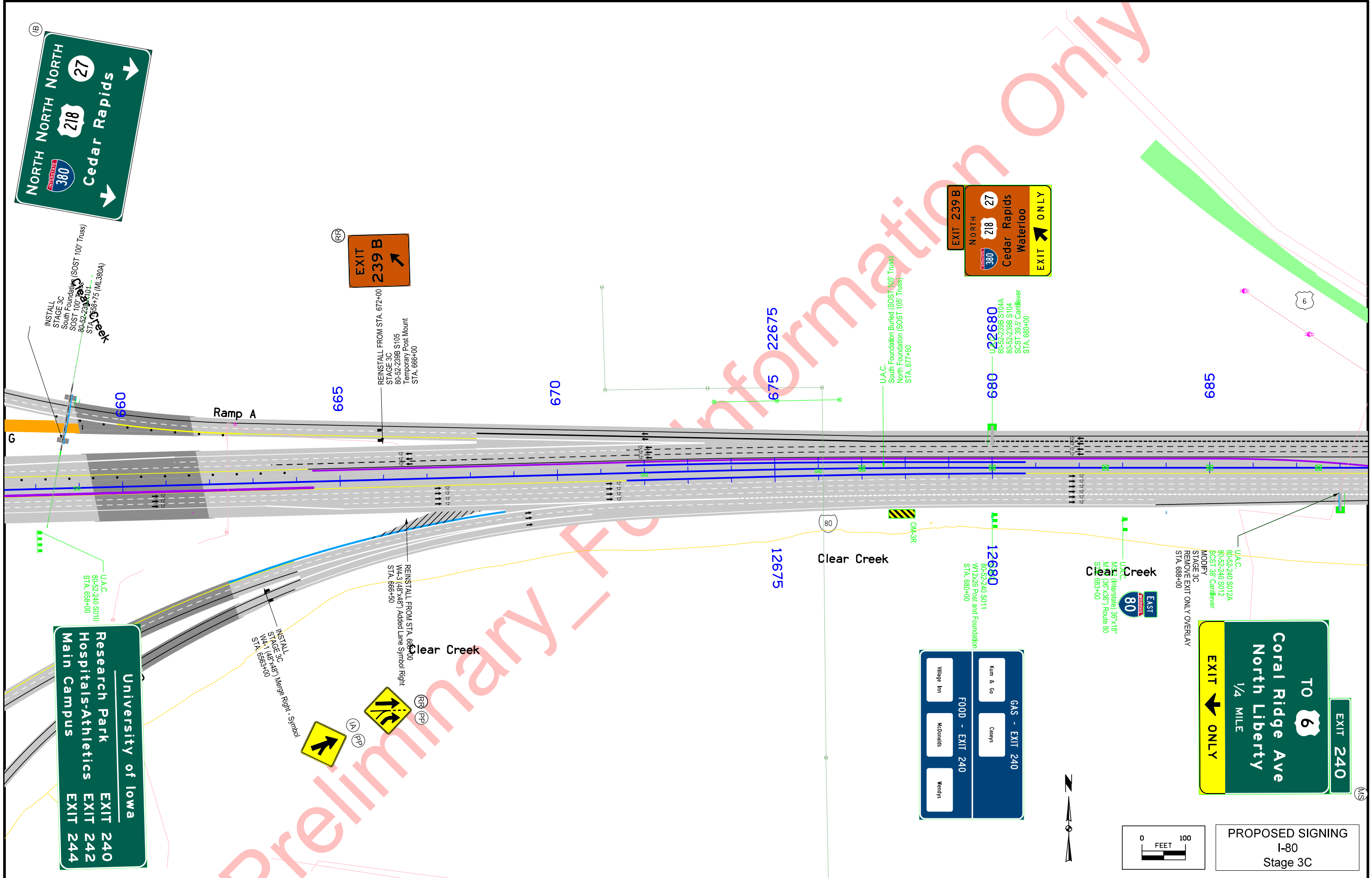

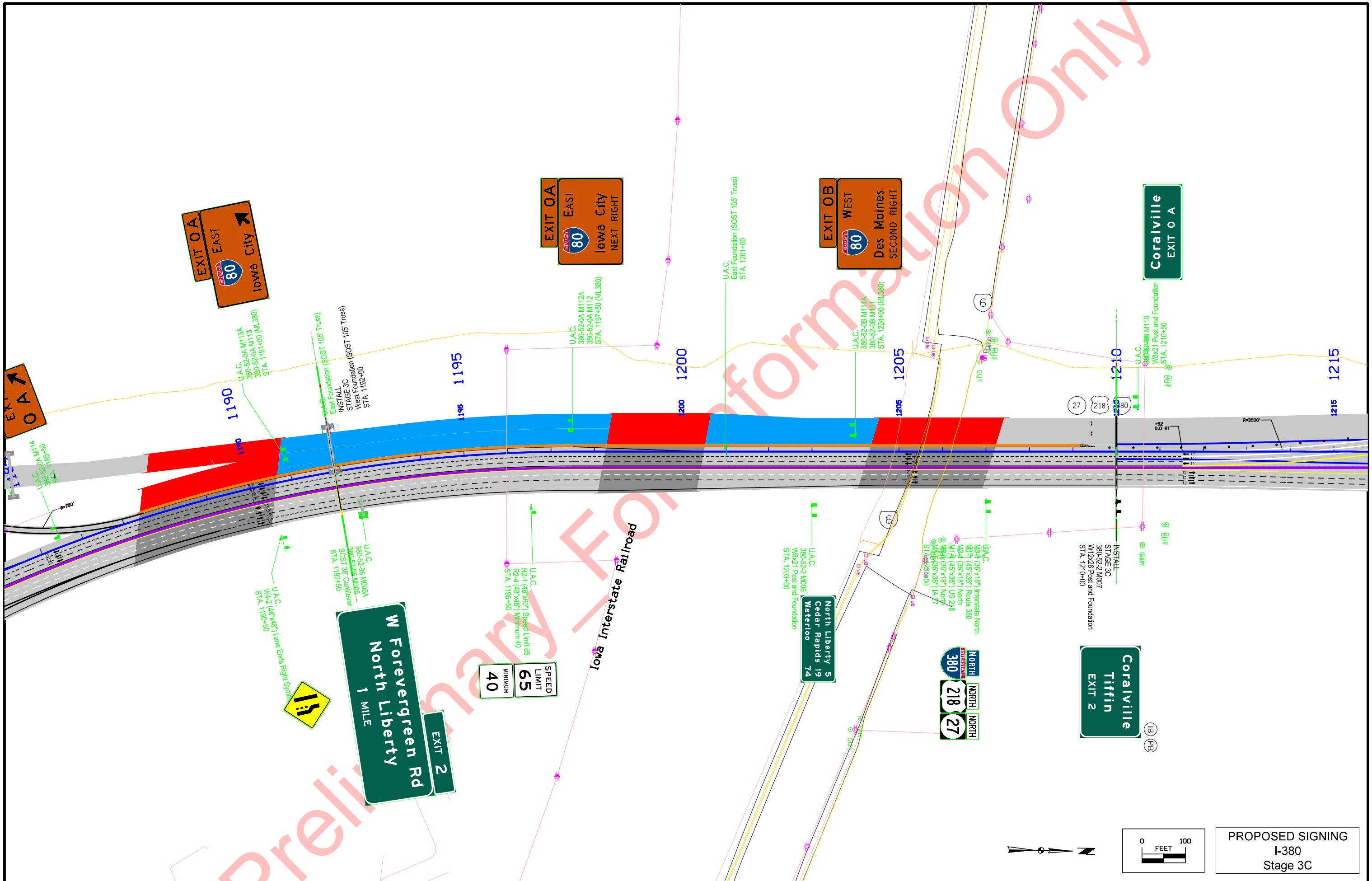

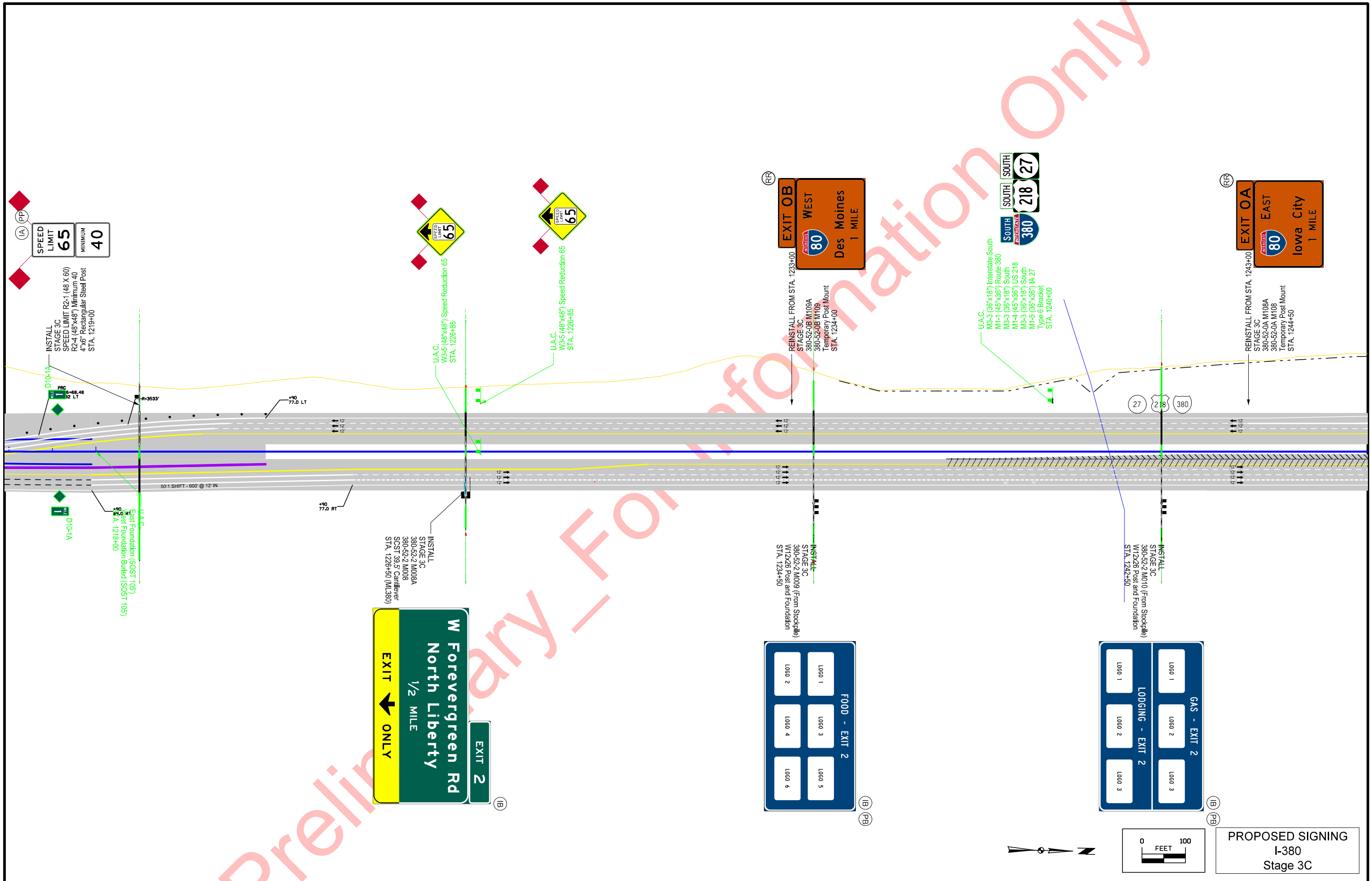

PROPOSED SIGNING  
I-380  
Stage 3C

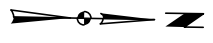
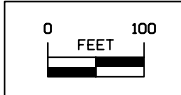

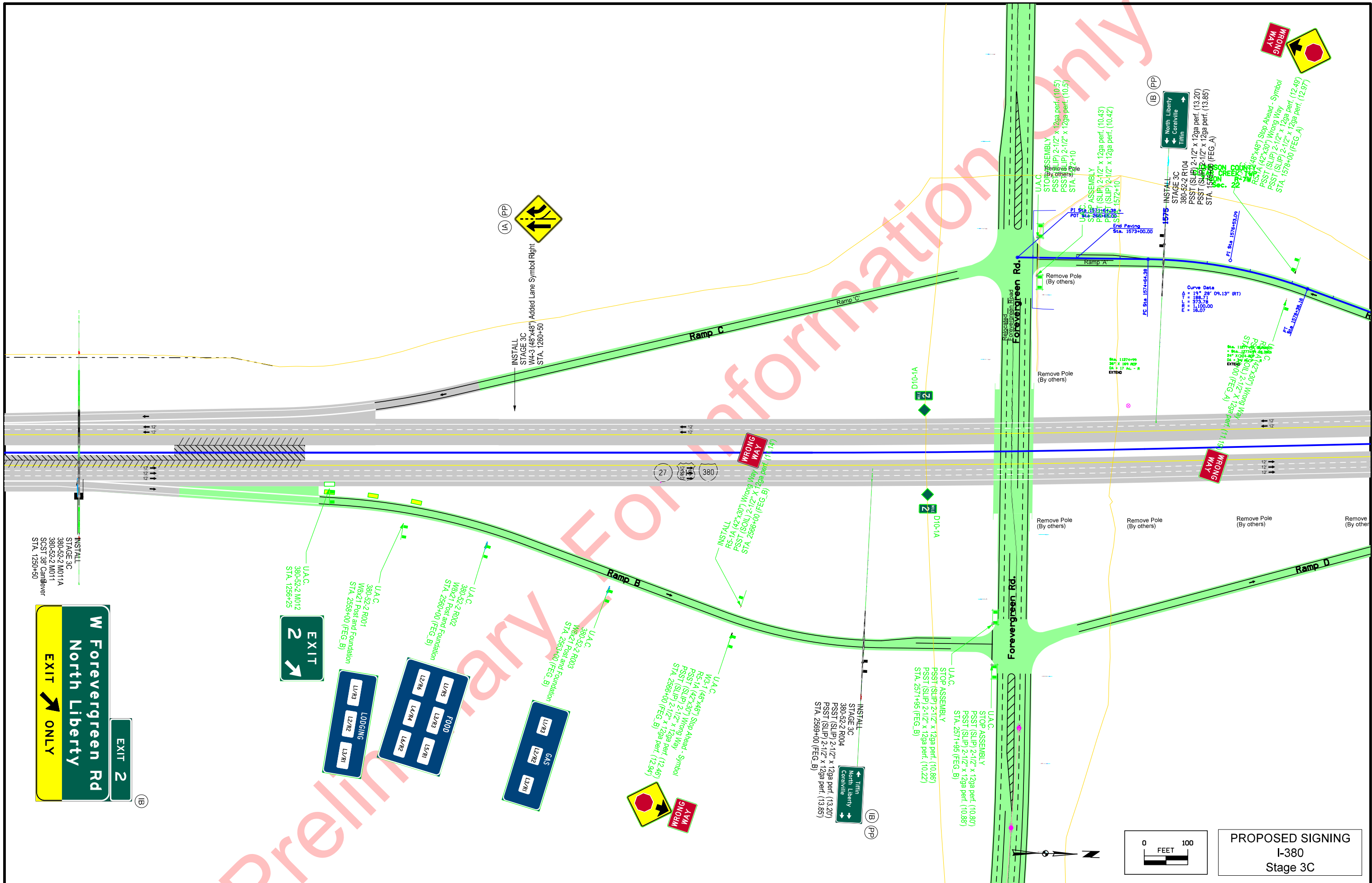

PROPOSED SIGNING  
I-380  
Stage 3C

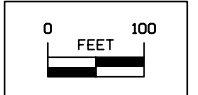

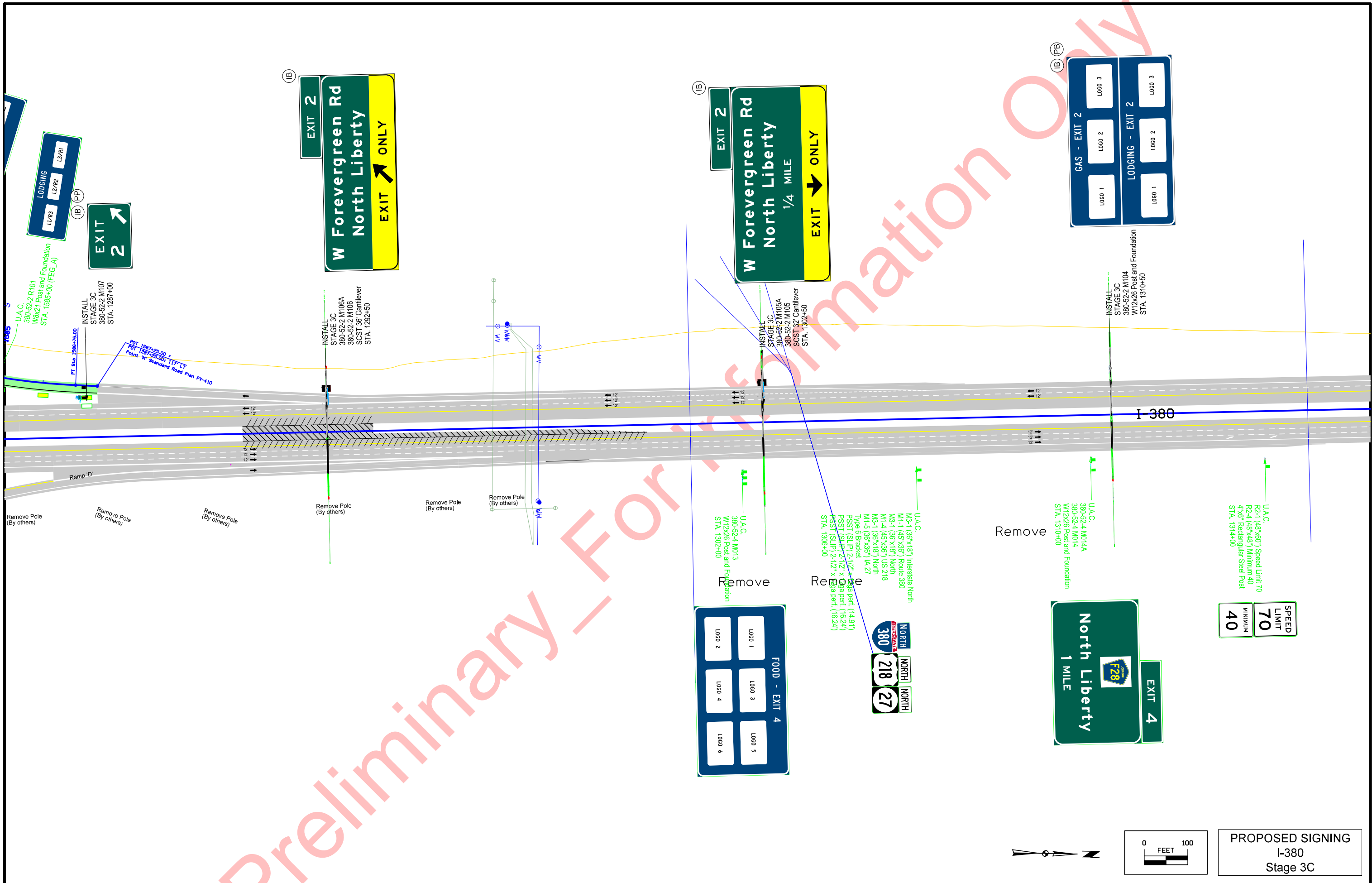

Preliminary - For Information Only

**DMS**

**Coralville Tiffin EXIT 2**

**SPEED LIMIT 70**  
MINIMUM 40

**GAS - EXIT 4**  
LOGO 1 LOGO 2 LOGO 3  
**LODGING - EXIT 4**  
LOGO 1 LOGO 2 LOGO 3

**FOOD - EXIT 4**  
CASEY'S GENERAL STORE McDonald's  
210 JOHN'S Silway  
BERENBURGER Christy's

**GAS - EXIT 2**  
LOGO 1 LOGO 2 LOGO 3  
**LODGING - EXIT 2**  
LOGO 1 LOGO 2 LOGO 3

**FOOD - EXIT 2**  
LOGO 1 LOGO 2 LOGO 3 LOGO 4  
LOGO 5 LOGO 6

**EXIT 4**  
**North Liberty 1 MILE**  
F28

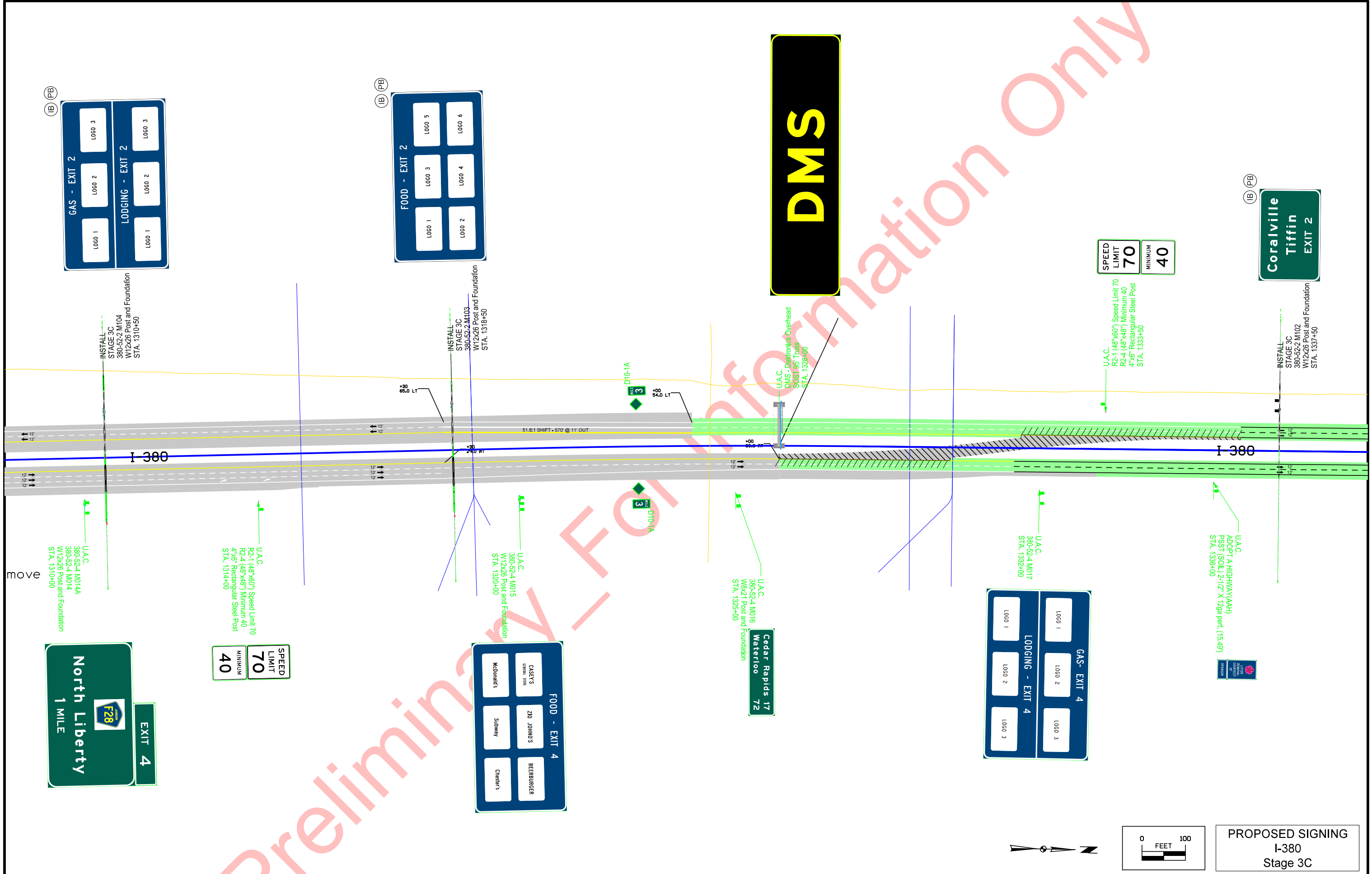

**PROPOSED SIGNING**  
I-380  
Stage 3C

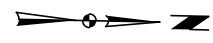
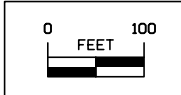



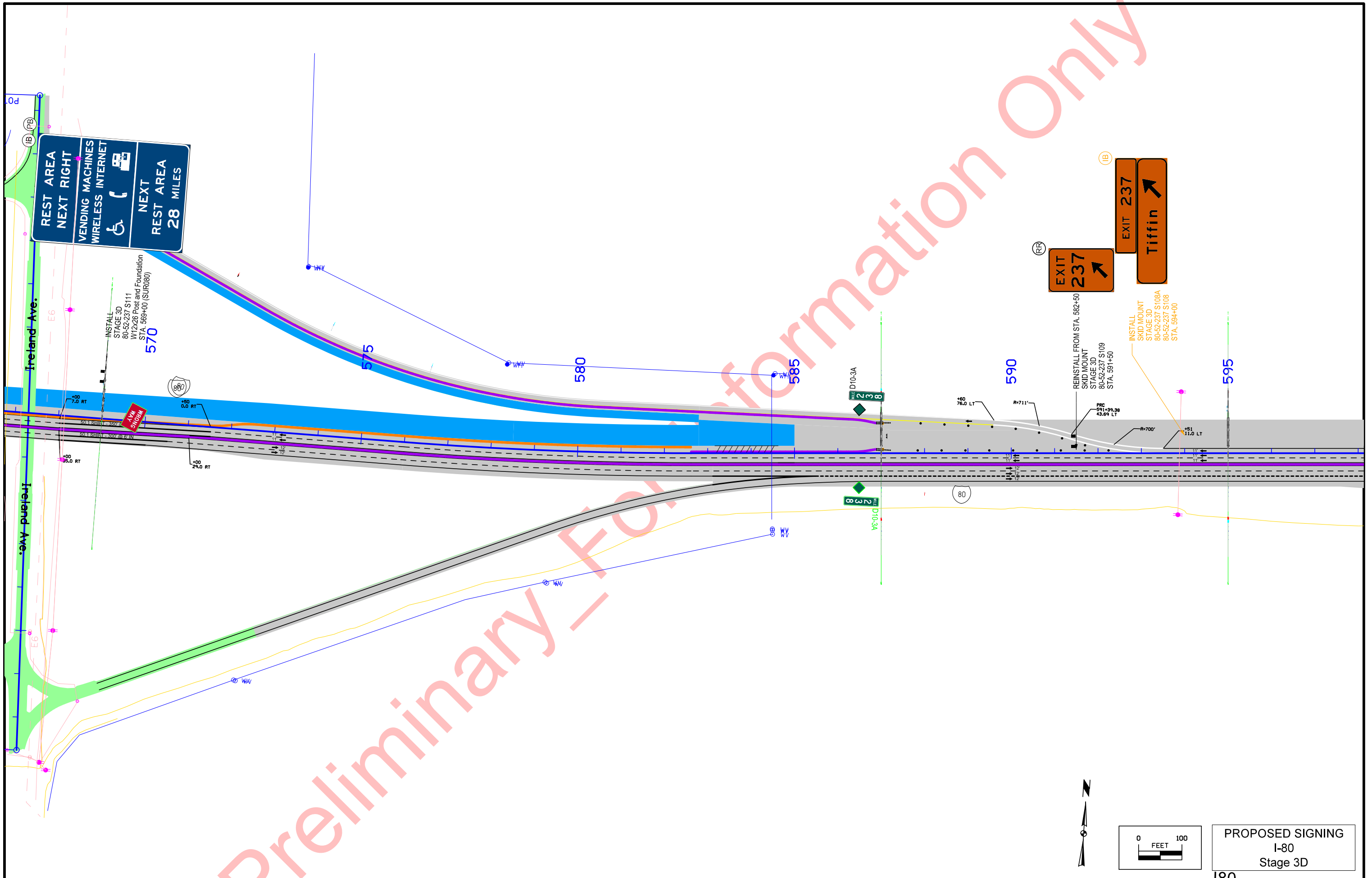

Preliminary - For Information Only

FILE NO.	ENGLISH	DESIGN TEAM <b>Abrams \ Hermann</b>	JOHNSON COUNTY	PROJECT NUMBER <b>NHS-080-6(403)239-11-52</b>	SHEET NUMBER <b>N.148</b>
----------	---------	-------------------------------------	----------------	---	---------------------------

Preliminary Information Only

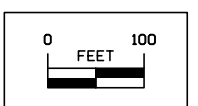
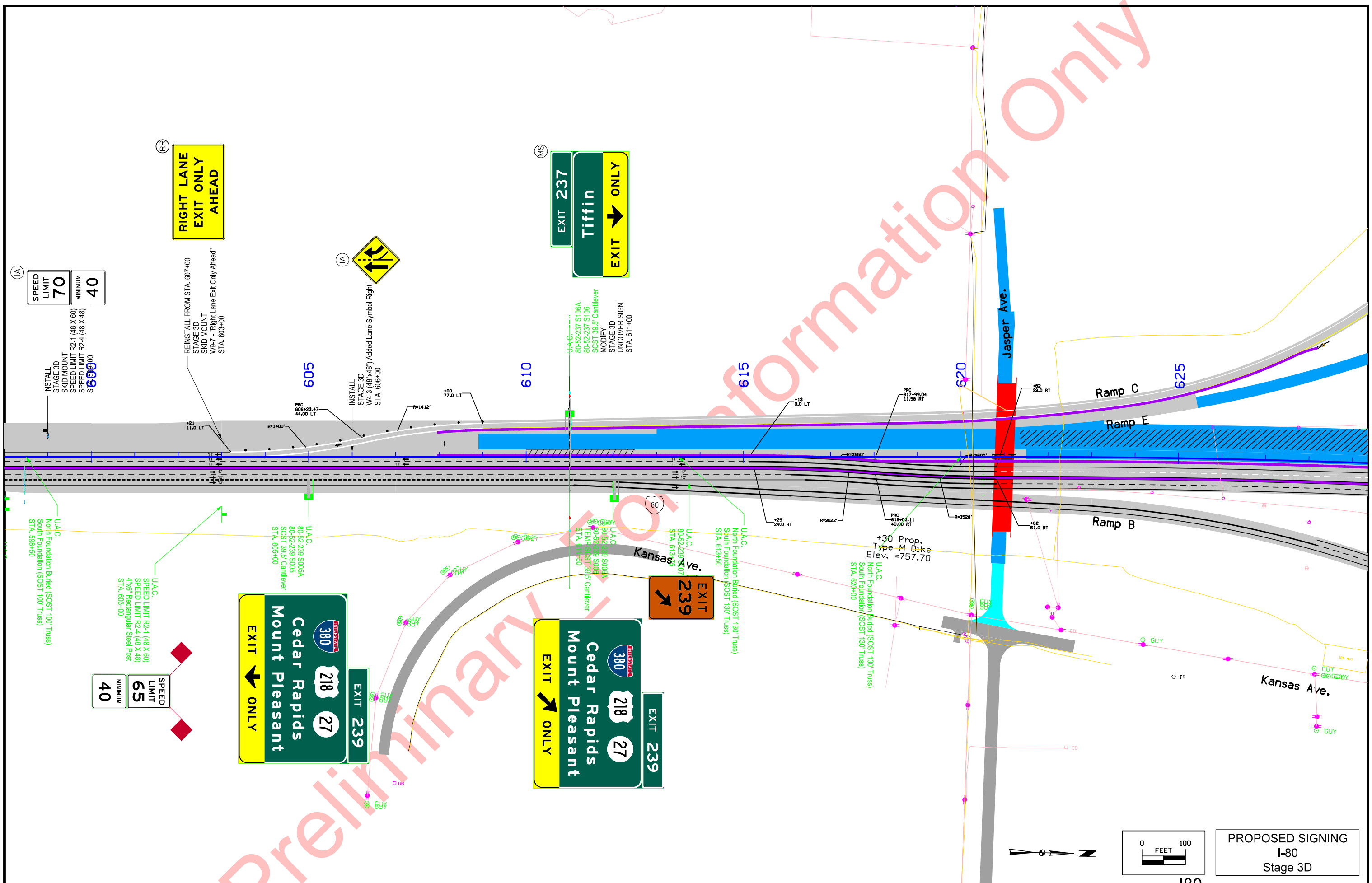

PROPOSED SIGNING  
I-80  
Stage 3D

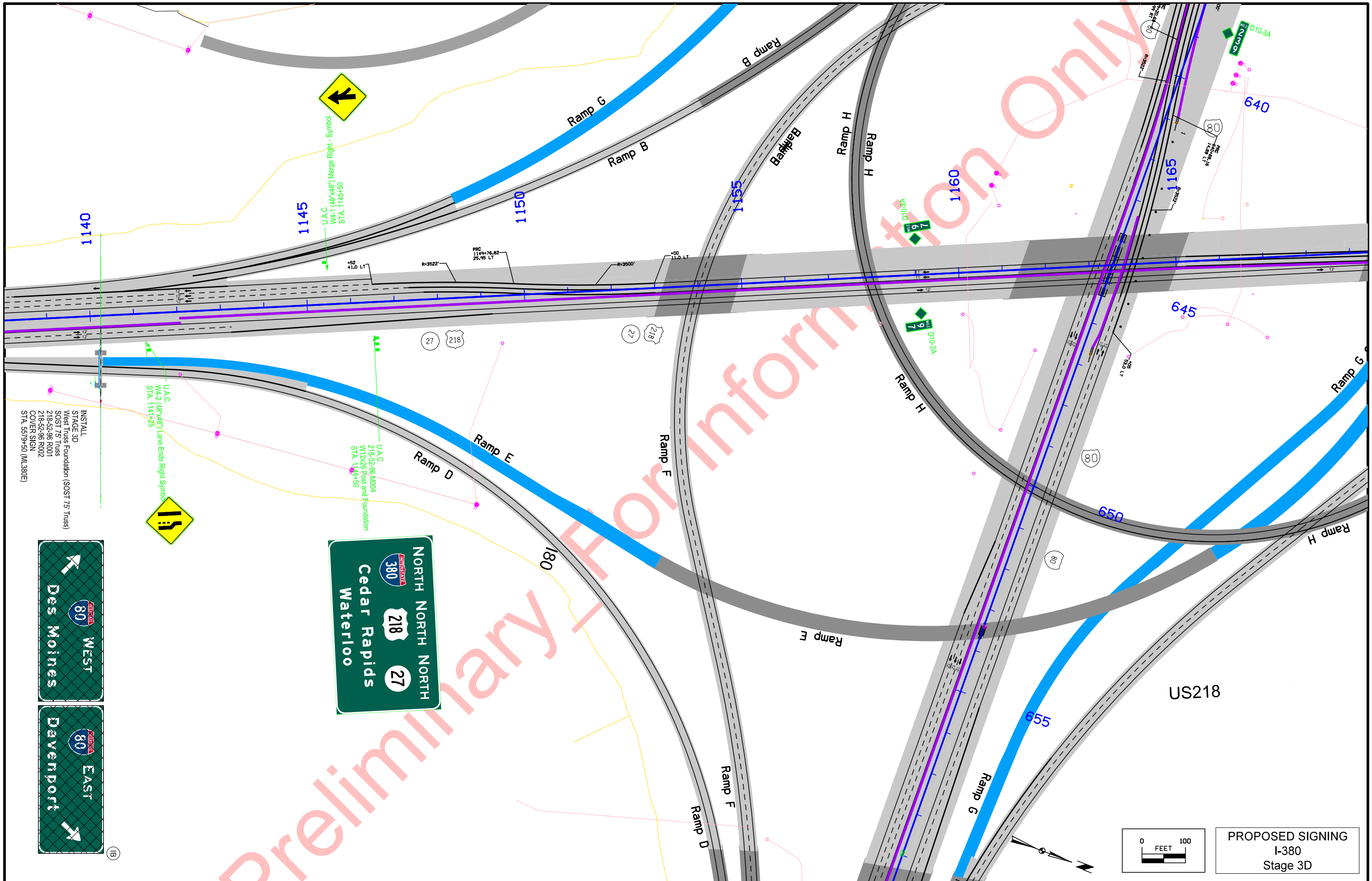

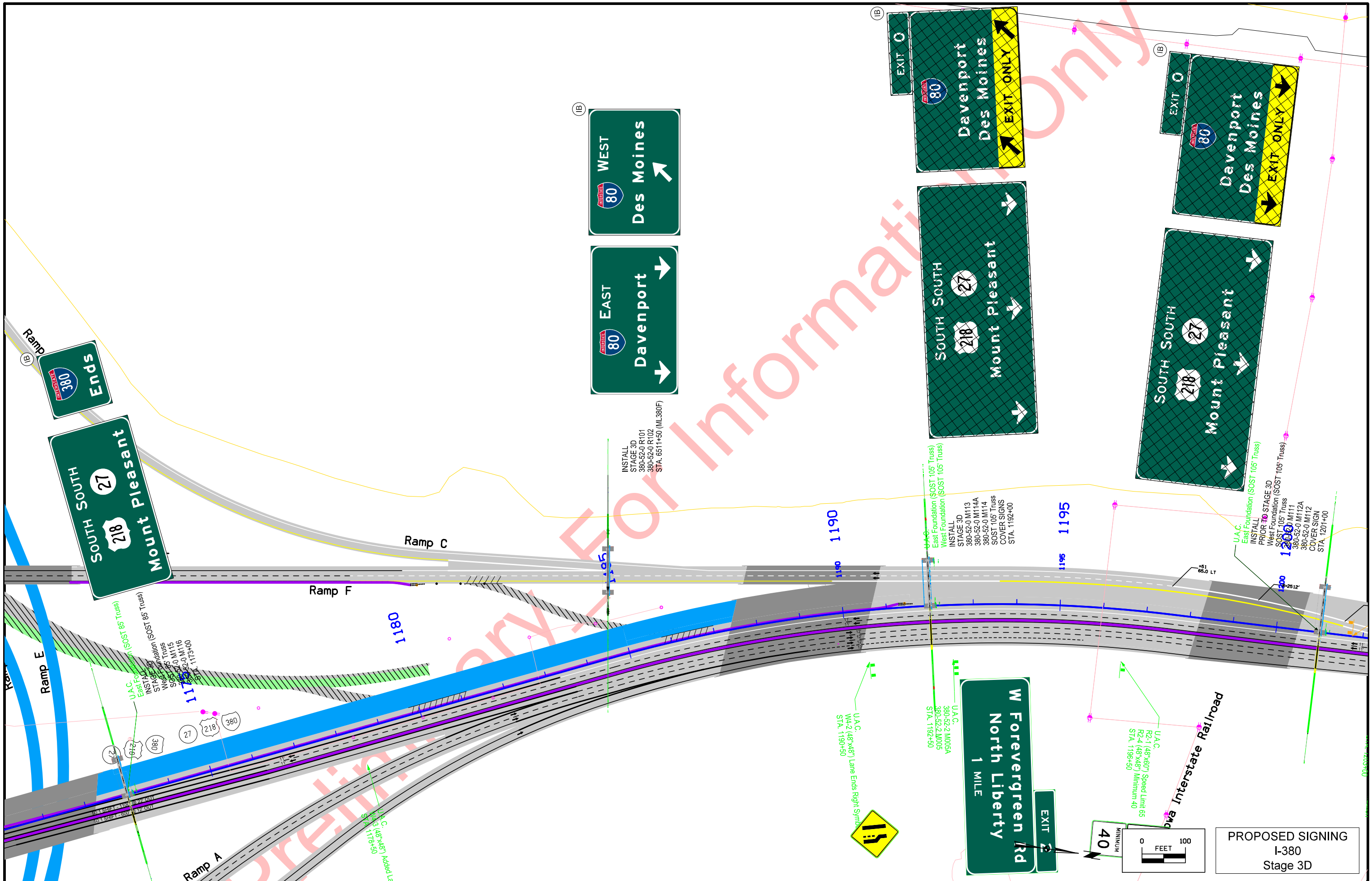

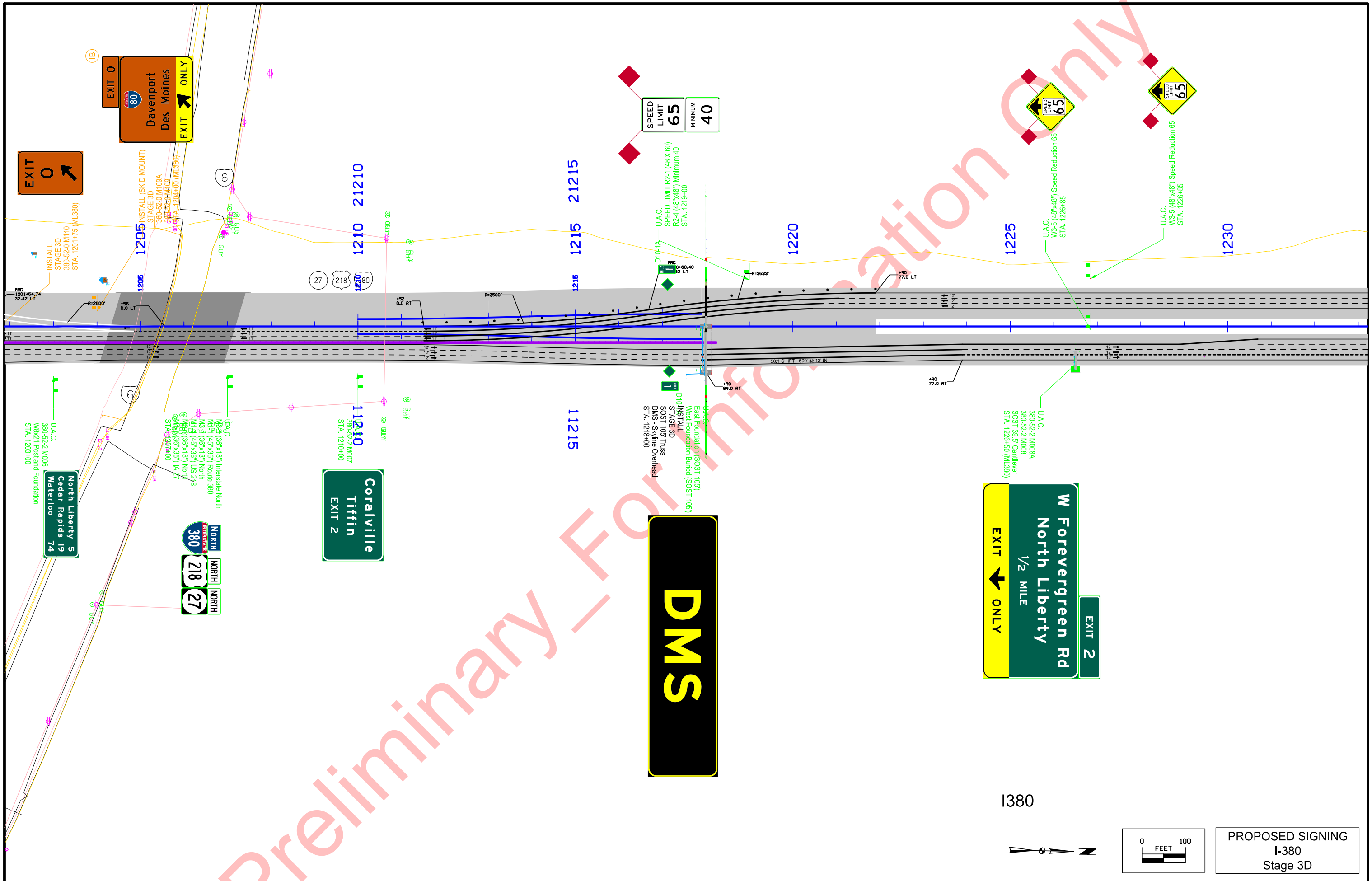

Preliminary - For Information Only

I380

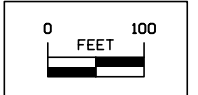
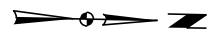

**PROPOSED SIGNING**  
I-380  
Stage 3D

FILE NO.	ENGLISH	DESIGN TEAM <b>Abrams \ Hermann</b>	COUNTY <b>JOHNSON</b>	PROJECT NUMBER <b>NHS-080-6(403)239-11-52</b>	SHEET NUMBER <b>N.152</b>
----------	---------	-------------------------------------	-----------------------	---	---------------------------

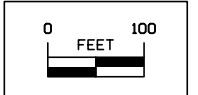
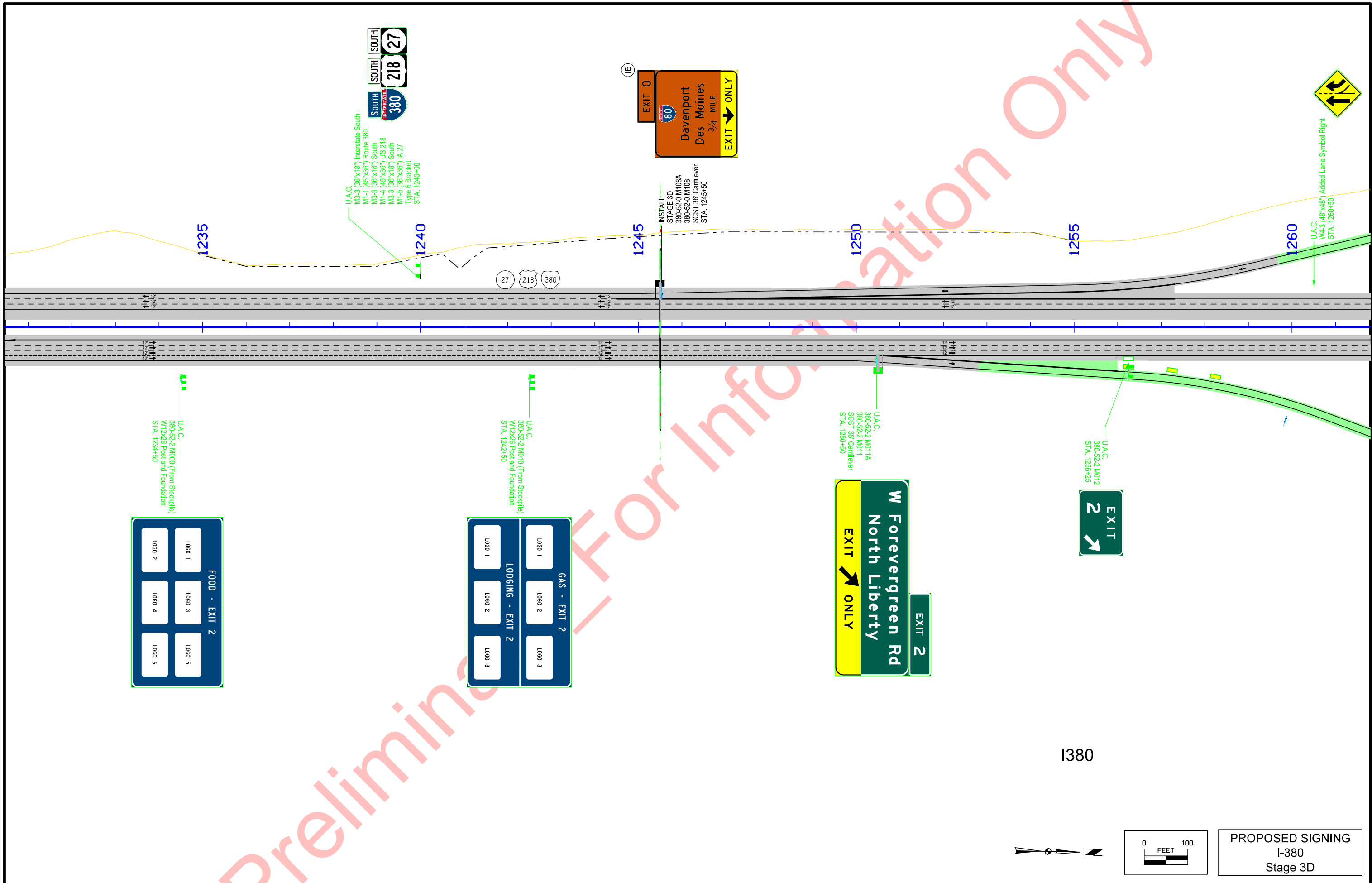

PROPOSED SIGNING  
I-380  
Stage 3D

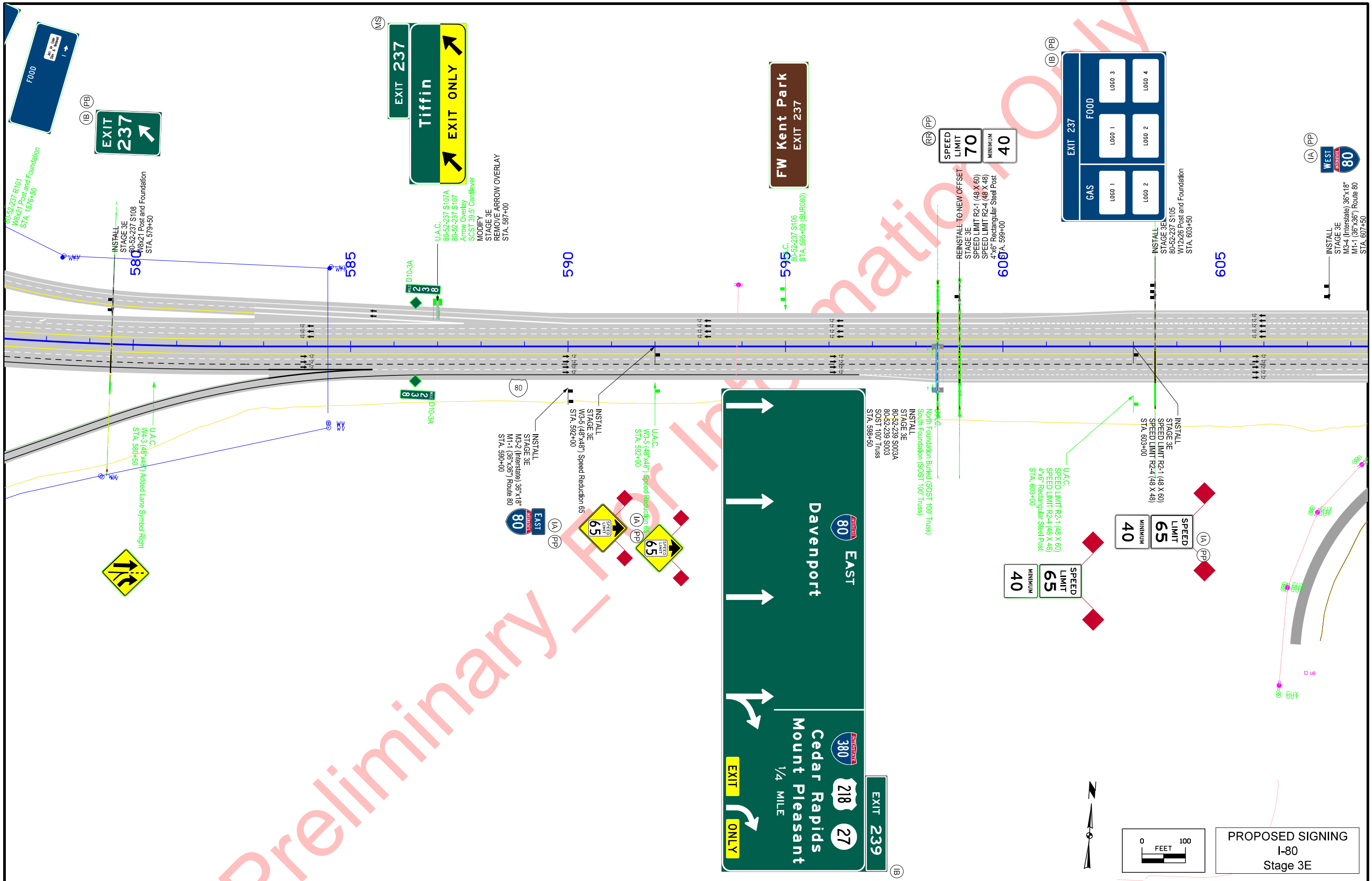

PROPOSED SIGNING  
I-80  
Stage 3E

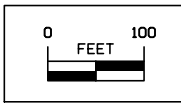

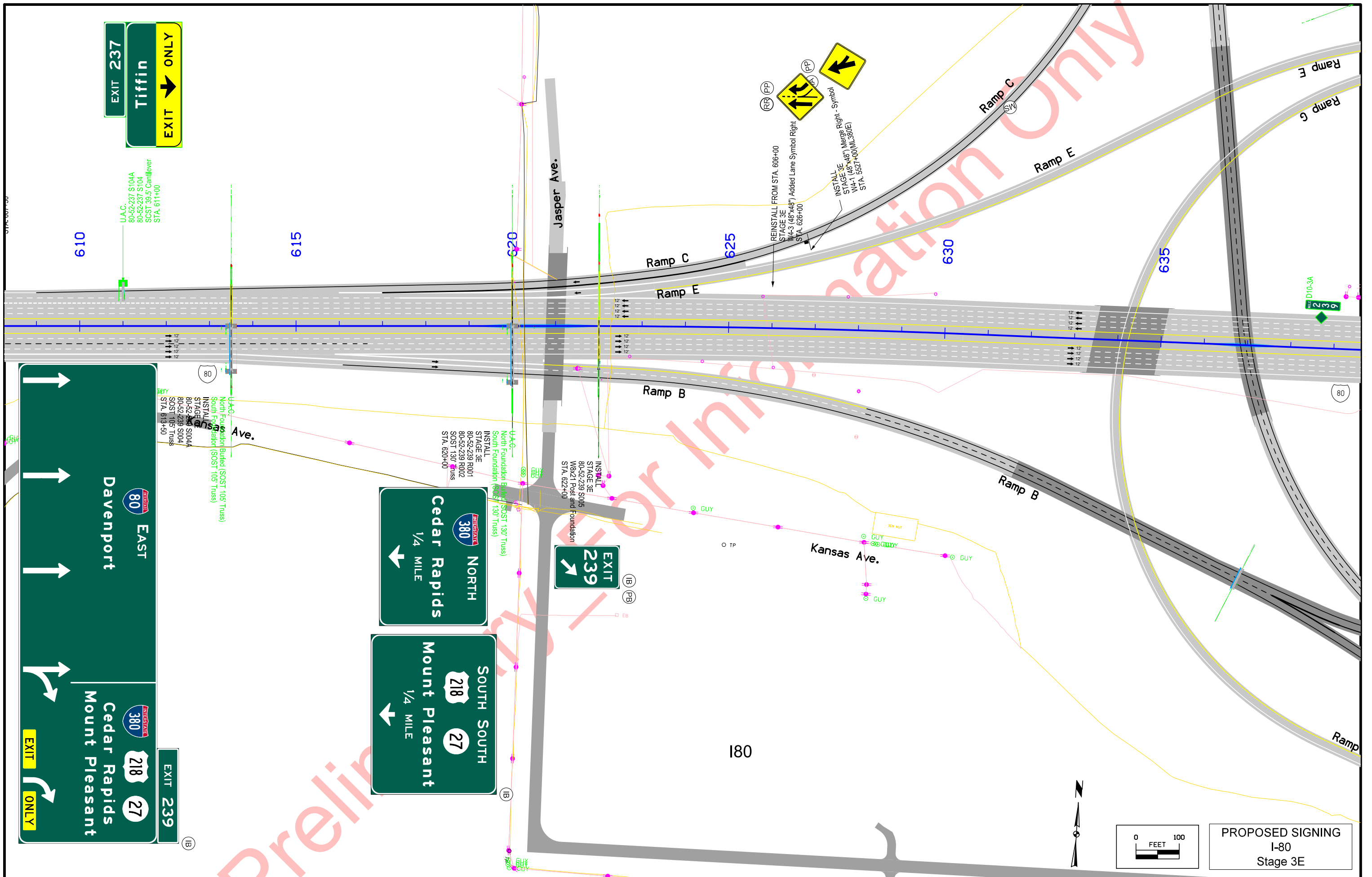



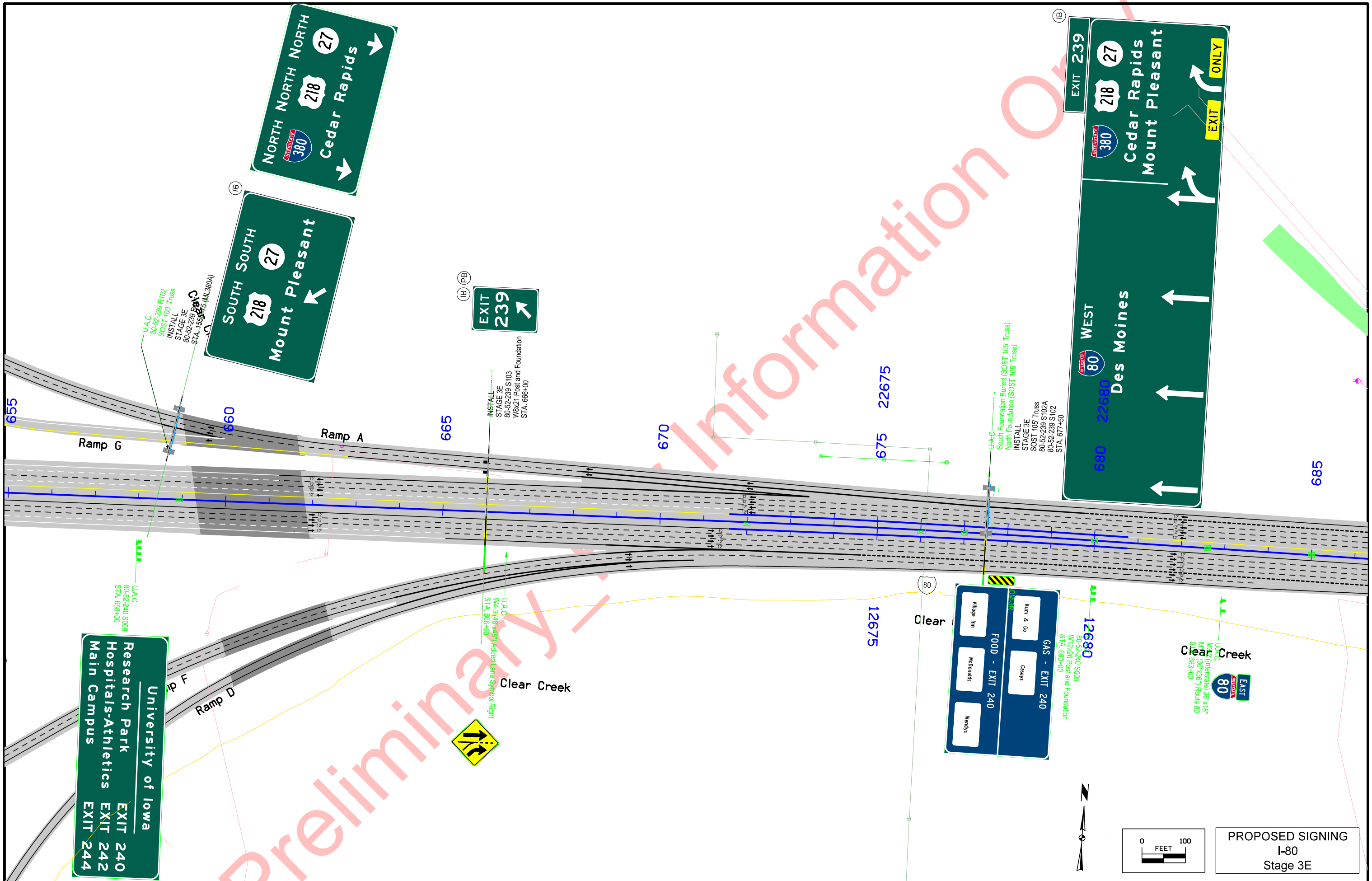

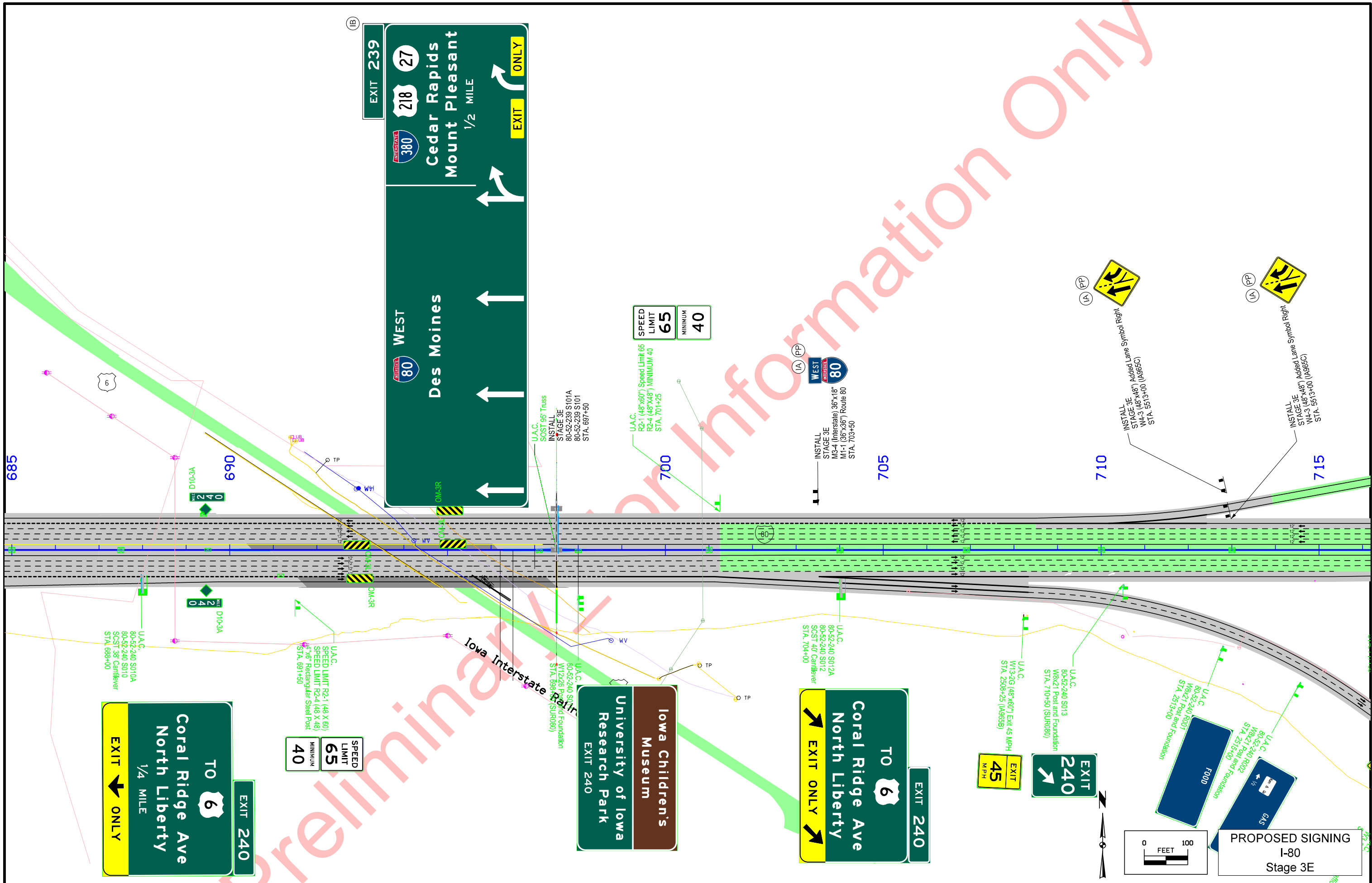

Preliminary Information Only

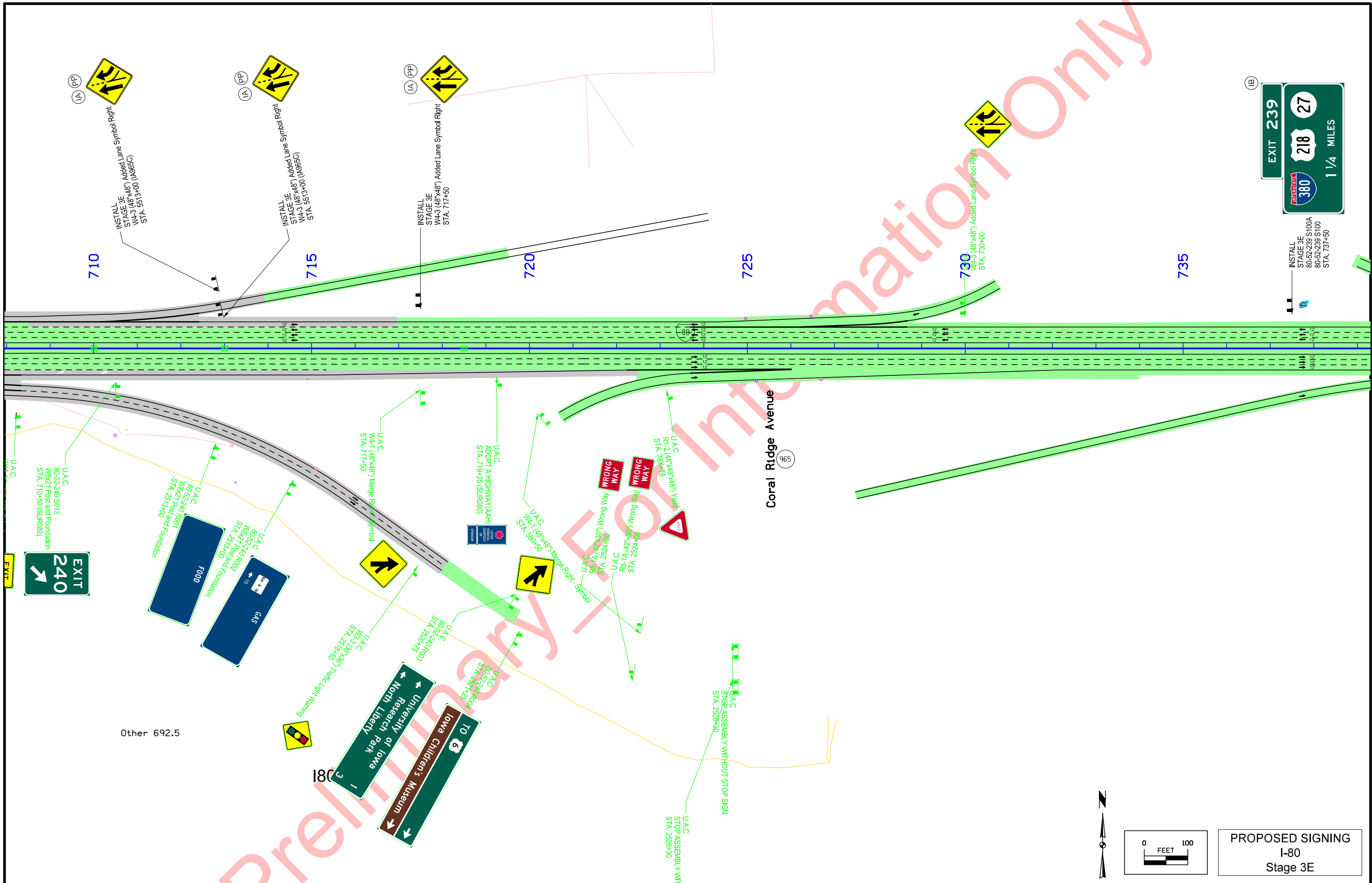

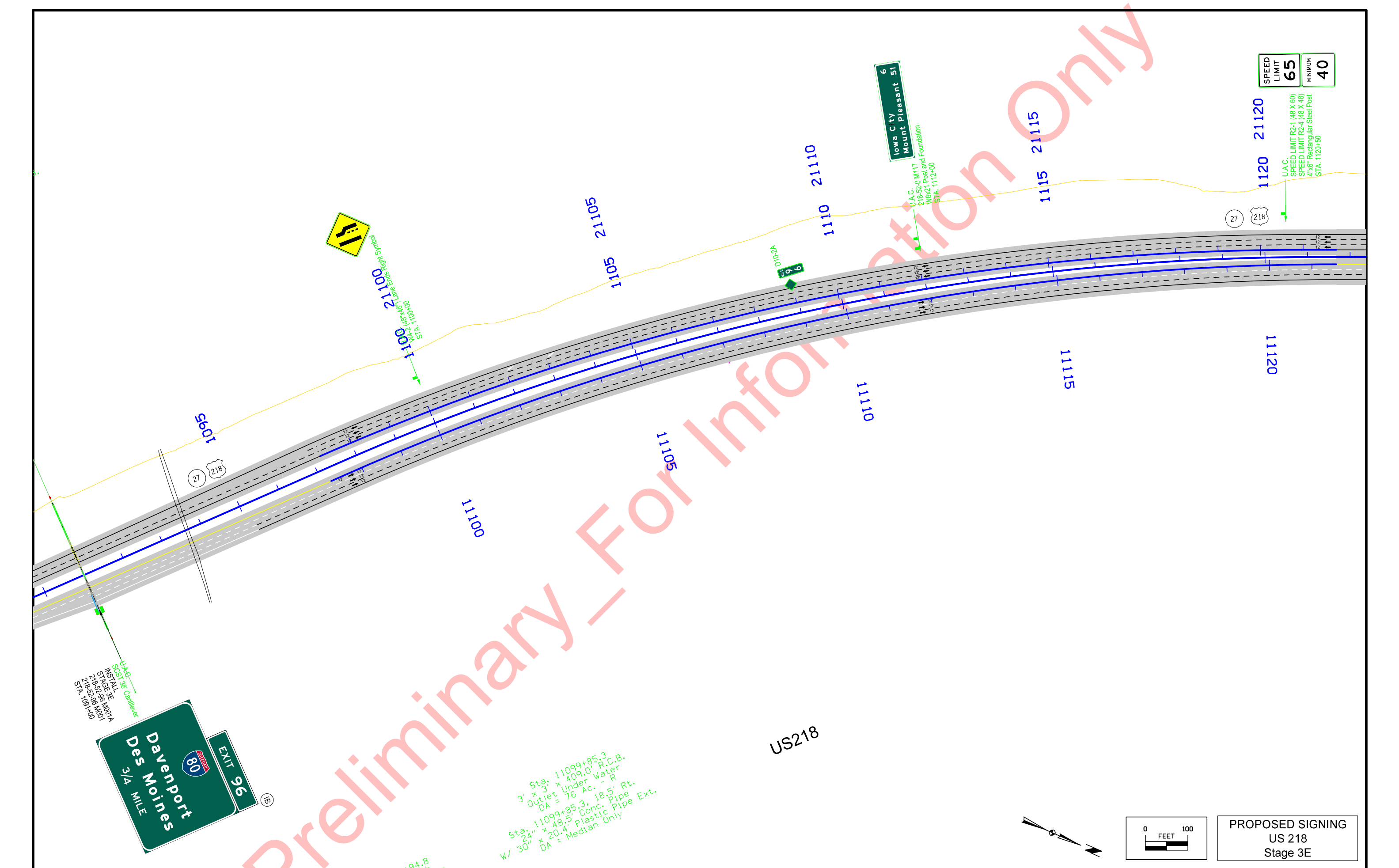

SPEED LIMIT 65  
MINIMUM 40

**Davenport**  
**Des Moines**  
80 MILE  
EXIT 96

Iowa City  
Mount Pleasant St

PROPOSED SIGNING  
US 218  
Stage 3E

Sta. 11099+85.3  
3' x 3' x 409.0' R.C.B.  
Outlet Under Water  
DA = 76 Ac. - R  
Sta. 11099+85.3, 18.5' Rt.  
24" x 48.5' Conc. Pipe  
w/ 30" x 20.4' Plastic Pipe Ext.  
DA = Median Only

U.A.C.  
SCS  
INSTALL  
STAKE 3E  
218-52-96-M01A  
218-52-96-M01  
STA. 109+100

U.A.C.  
SCS  
INSTALL  
STAKE 3E  
218-52-96-M01A  
218-52-96-M01  
STA. 109+100

U.A.C.  
218-52-0 M117  
W8x21 Post and Foundation  
STA. 1112+00

U.A.C.  
SPEED LIMIT R2-1 (48 X 60)  
SPEED LIMIT R2-4 (48 X 48)  
4' x 6' Rectangular Steel Post  
STA. 1120+50

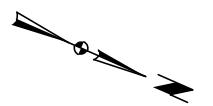
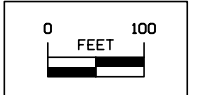

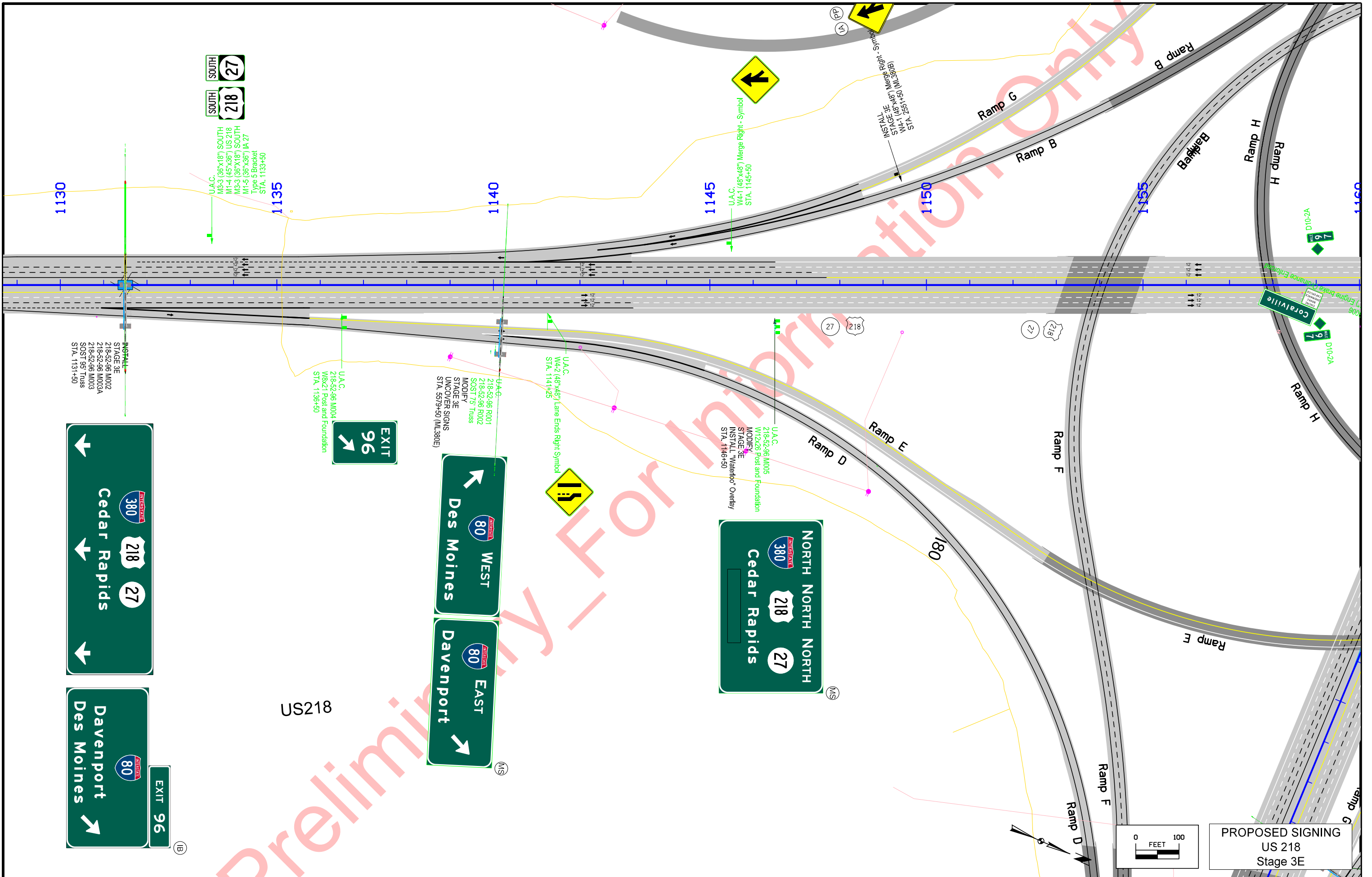

PROPOSED SIGNING  
US 218  
Stage 3E

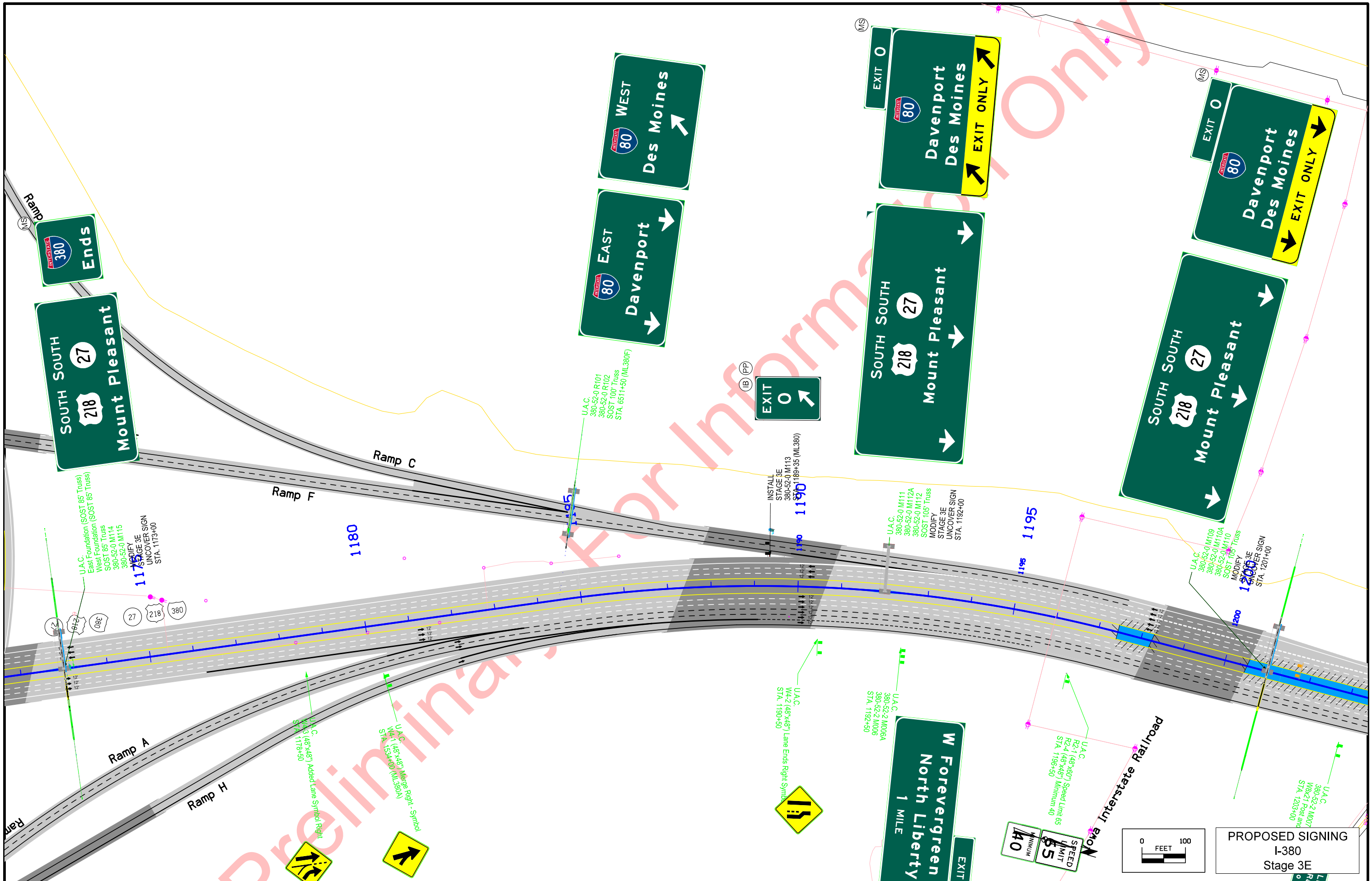

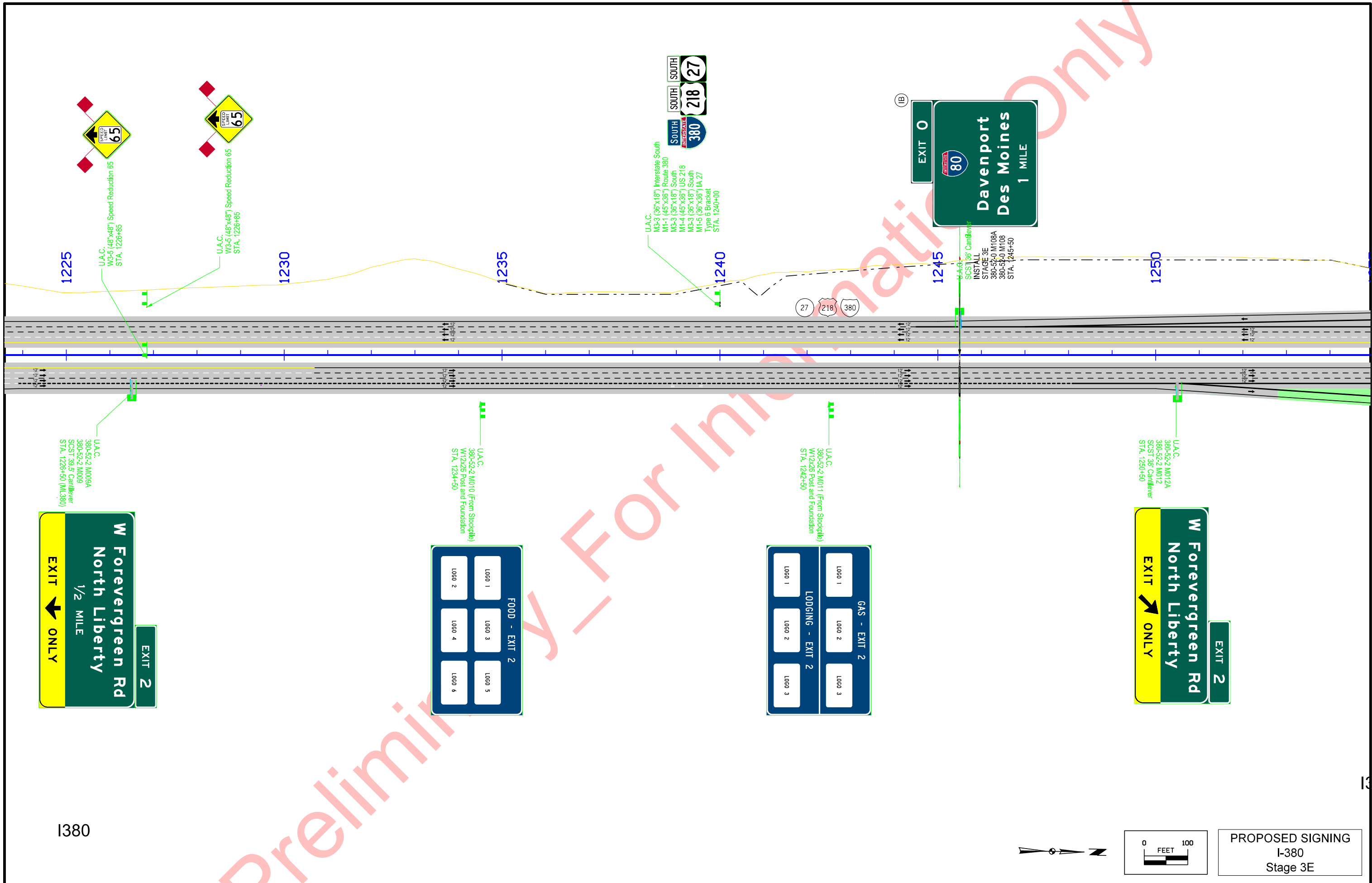

Sign Shown for Design Purposes  
will be Installed in Future Stage (3E)

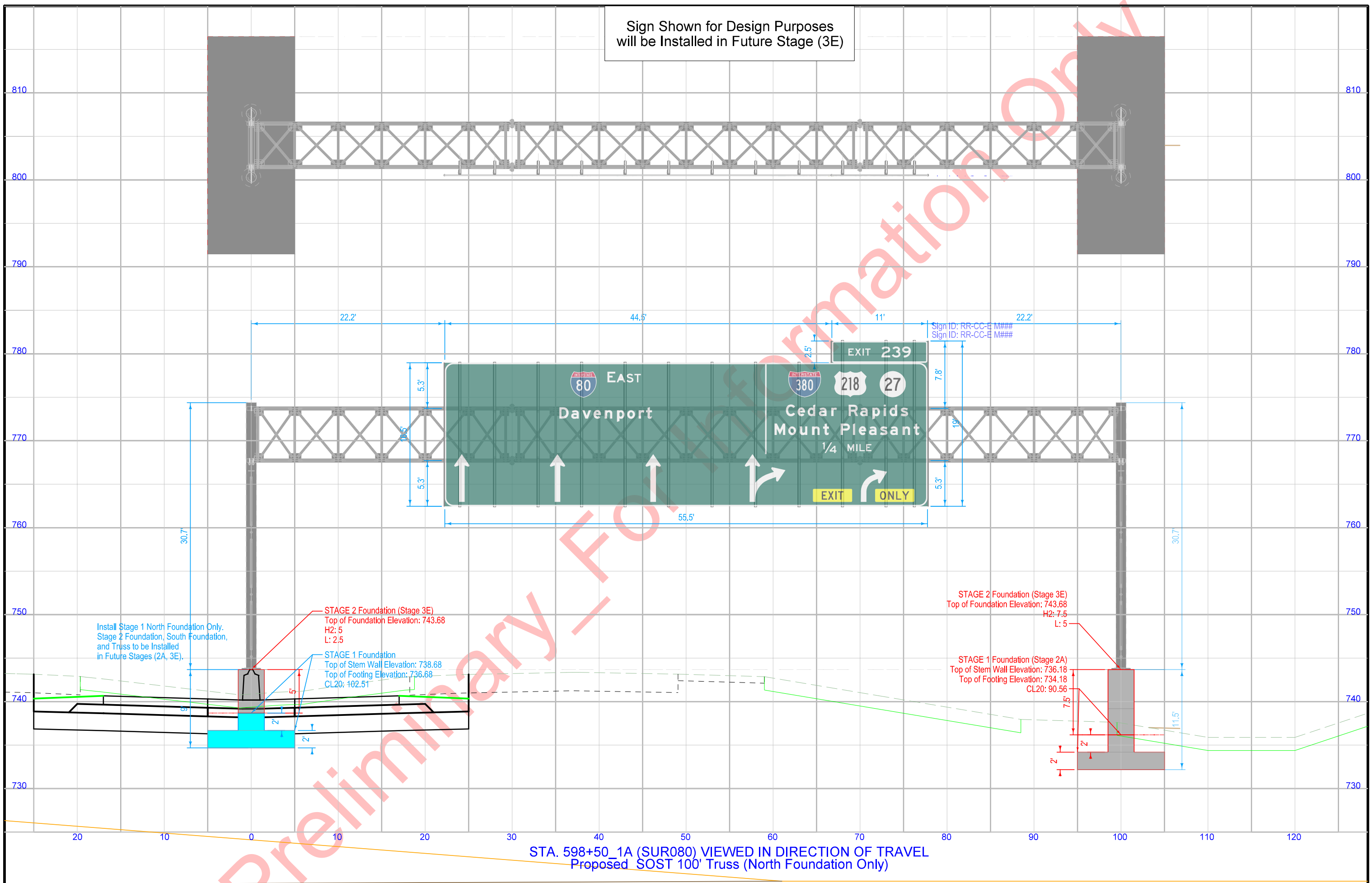



Sign Shown for Design Purposes  
will be Installed in Future Stage (3E)

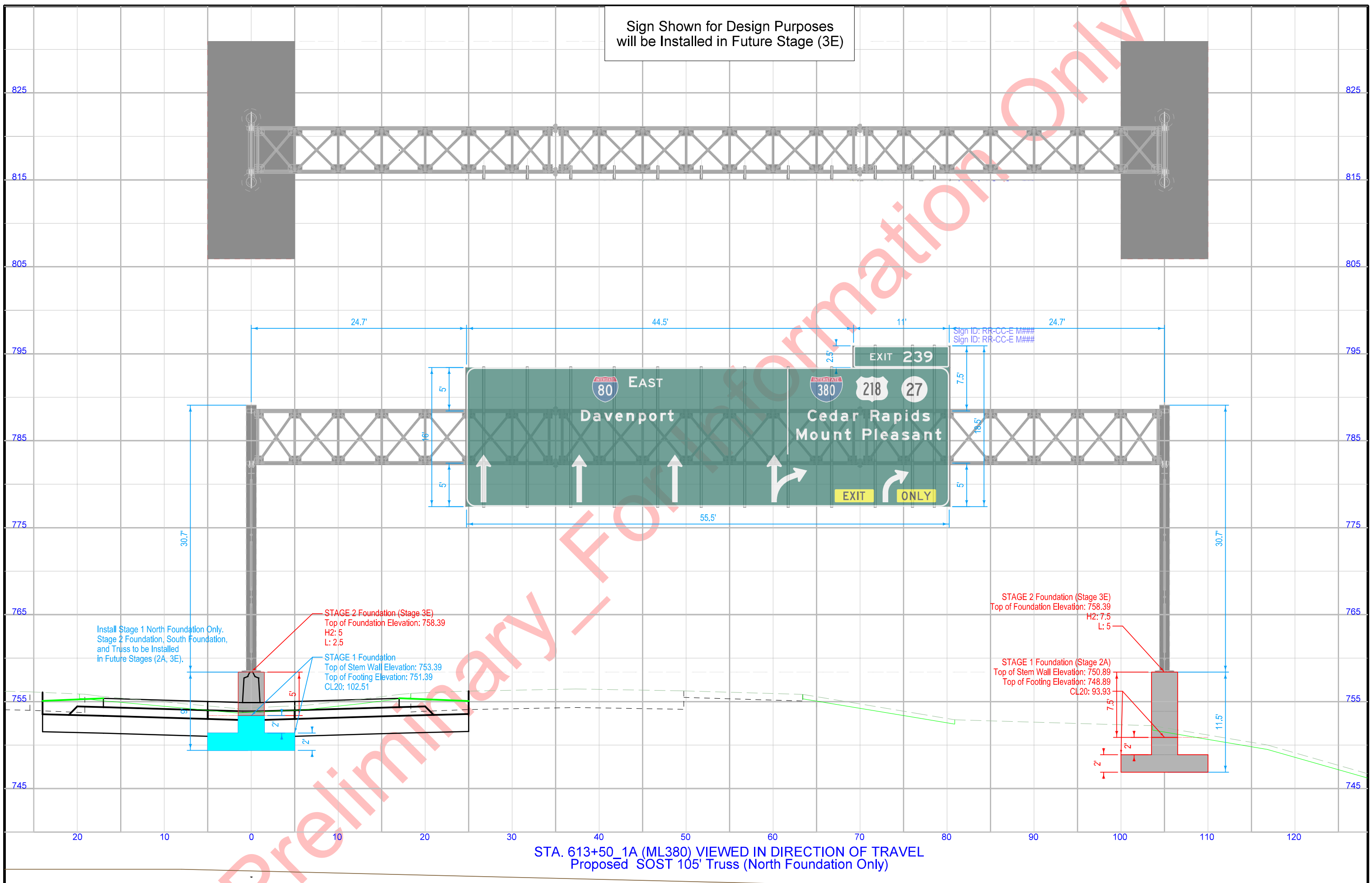

Install Stage 1 North Foundation Only.  
Stage 2 Foundation, South Foundation,  
and Truss to be Installed  
in Future Stages (2A, 3E).

STAGE 2 Foundation (Stage 3E)  
Top of Foundation Elevation: 758.39  
H2: 5  
L: 2.5

STAGE 1 Foundation  
Top of Stem Wall Elevation: 753.39  
Top of Footing Elevation: 751.39  
CL20: 102.51

STAGE 2 Foundation (Stage 3E)  
Top of Foundation Elevation: 758.39  
H2: 7.5  
L: 5

STAGE 1 Foundation (Stage 2A)  
Top of Stem Wall Elevation: 750.89  
Top of Footing Elevation: 748.89  
CL20: 93.93

STA. 613+50\_1A (ML380) VIEWED IN DIRECTION OF TRAVEL  
Proposed SOST 105' Truss (North Foundation Only)

Sign Shown for Design Purposes  
will be Installed in Future Stage (2A)

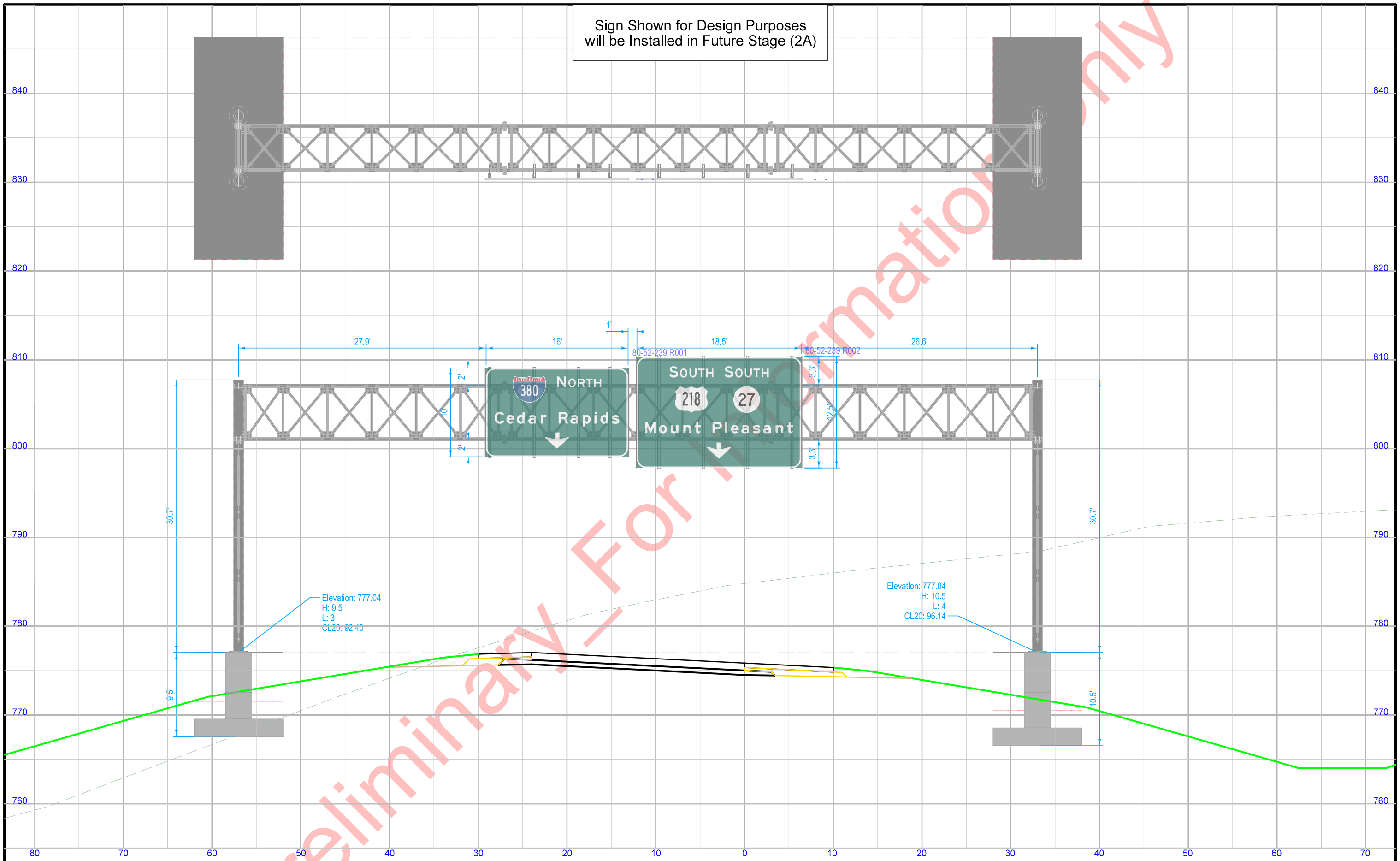

STA. 2530+00\_1A (ML380B) VIEWED IN DIRECTION OF TRAVEL  
Proposed SOST 90' Truss

DMS Shown for Design Purposes  
will be Installed in Future Stages (3C, 3E)

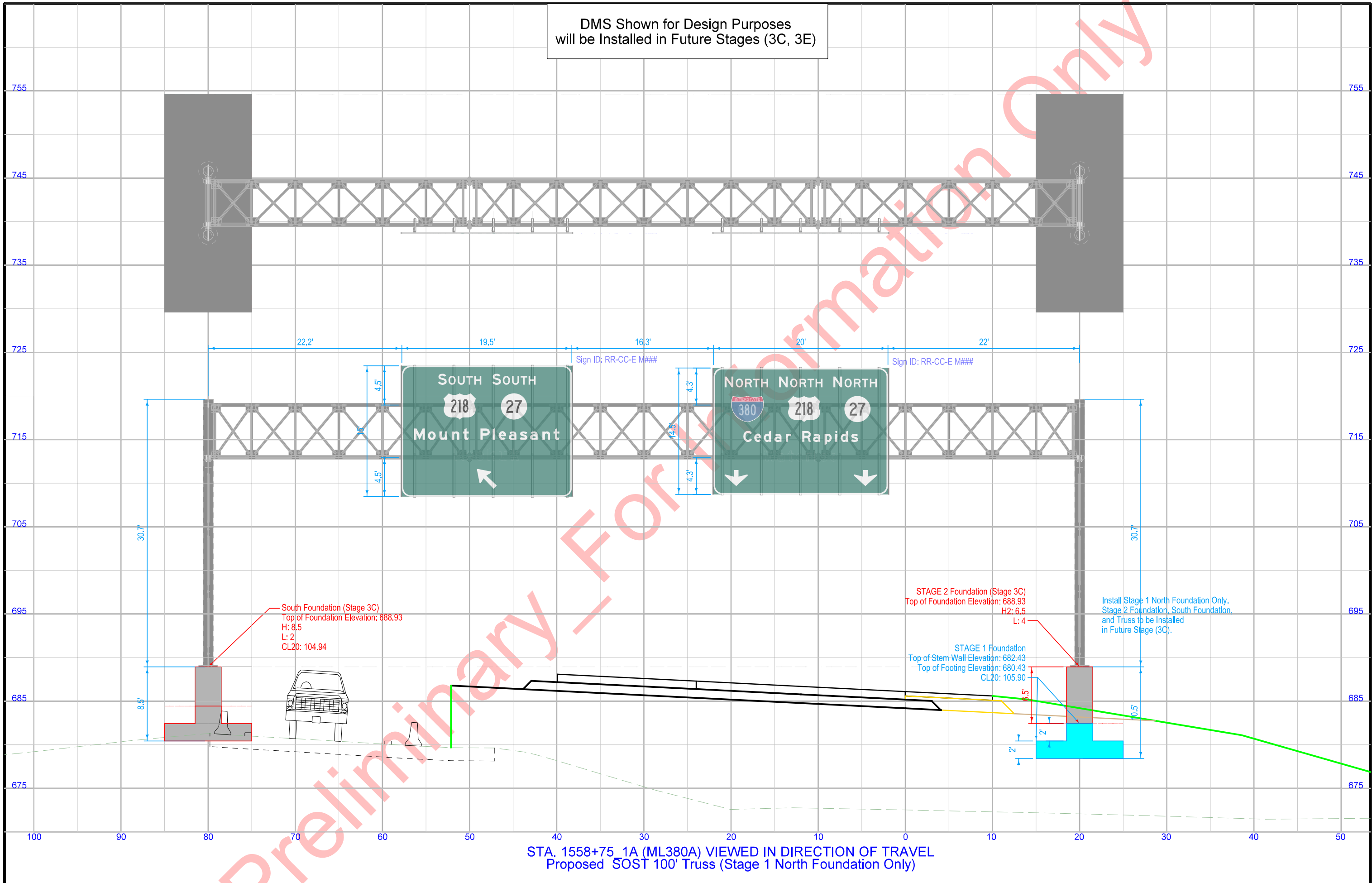

STA. 1558+75 1A (ML380A) VIEWED IN DIRECTION OF TRAVEL  
Proposed SOST 100' Truss (Stage 1 North Foundation Only)

Sign Shown for Design Purposes  
will be Installed in Future Stage (3E)

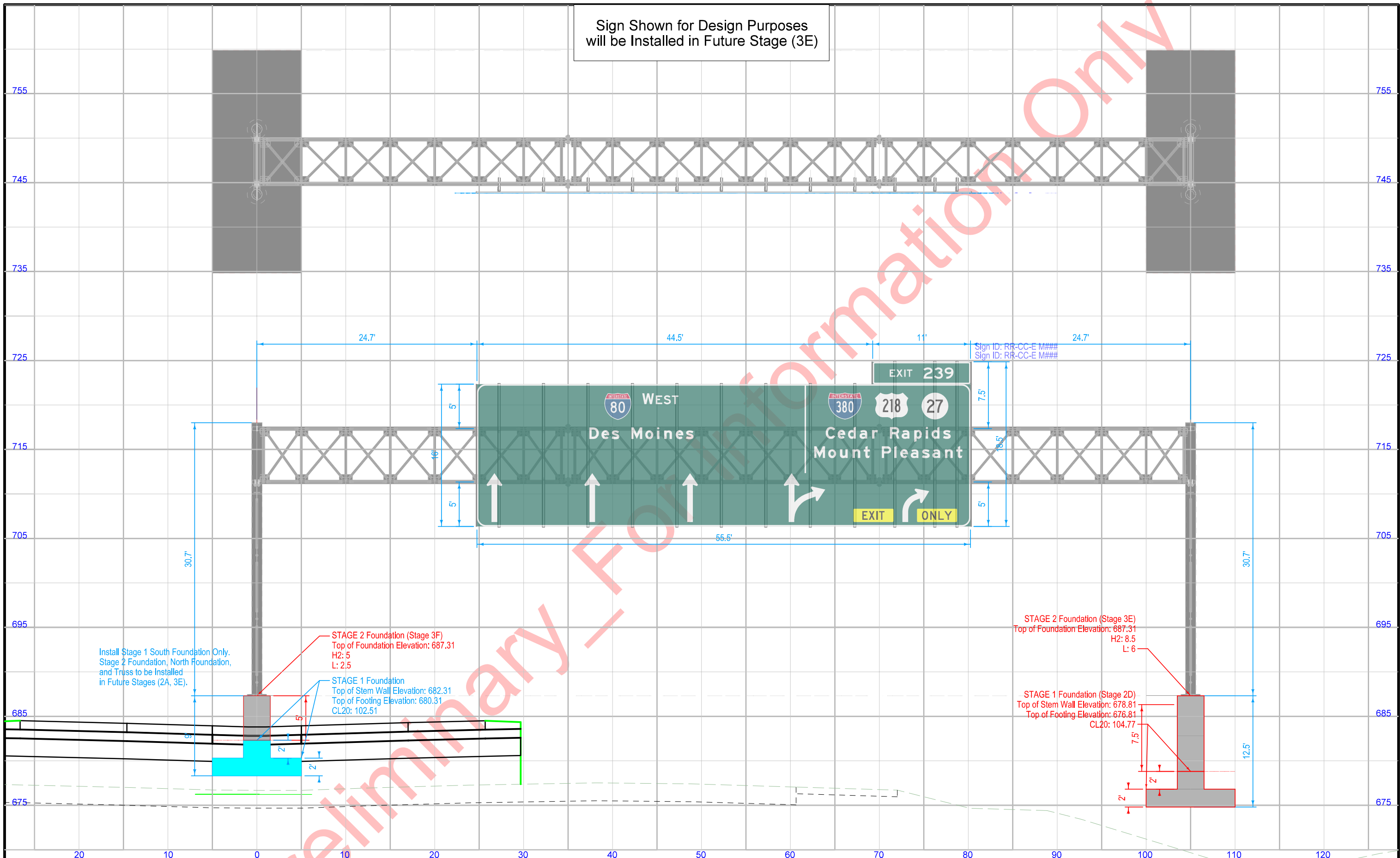

STA. 677+50\_1B (SUR080) VIEWED IN DIRECTION OF TRAVEL  
Proposed SOST 105' Truss (South Foundation Only)

Sign Shown for Design Purposes  
will be Installed in Future Stage (3E)

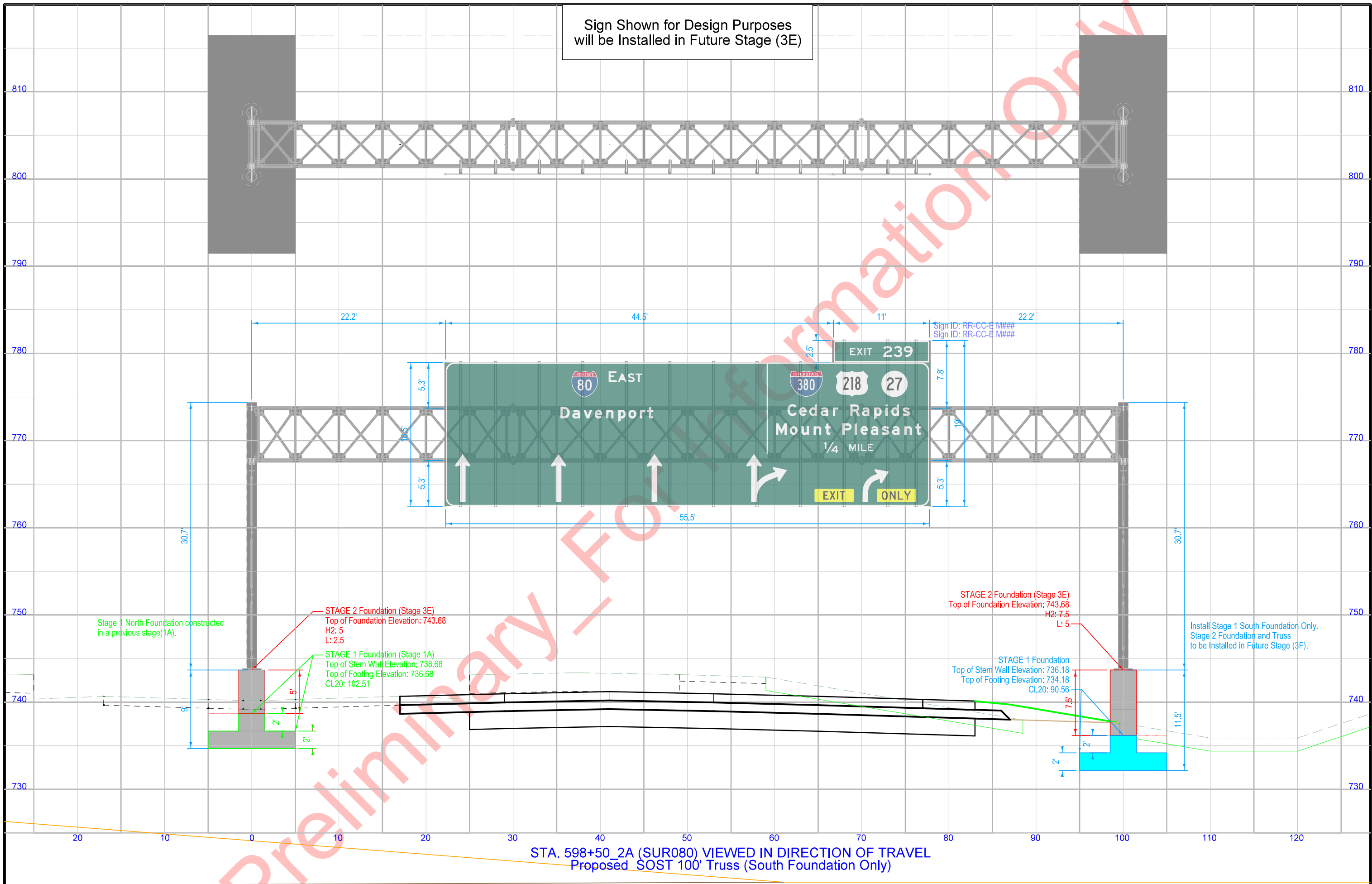

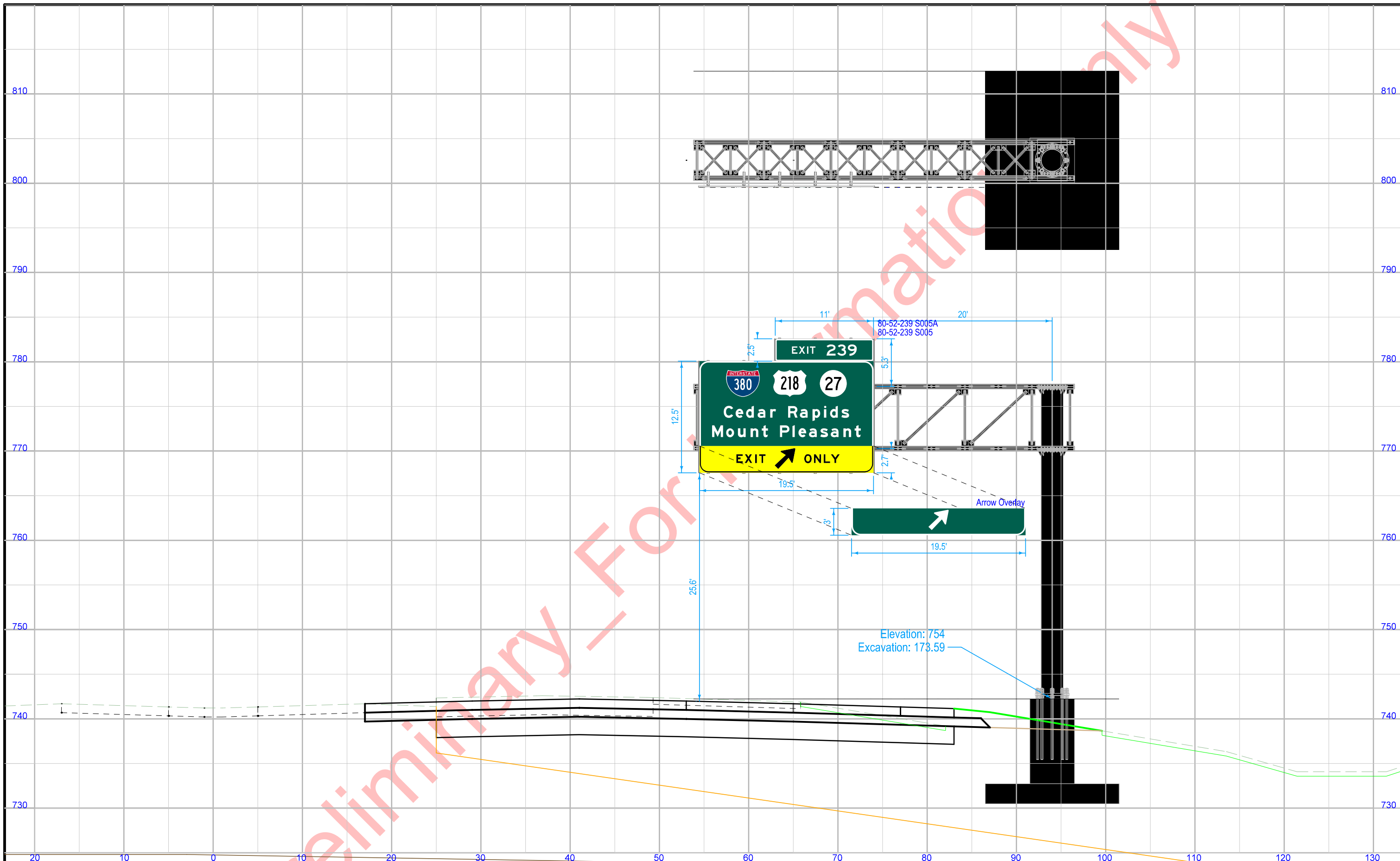

STA. 605+00\_2A (SUR080) VIEWED IN DIRECTION OF TRAVEL  
 Proposed SCST 39.5' Cantilever

Sign Shown for Design Purposes  
will be Installed in Future Stage (3E)

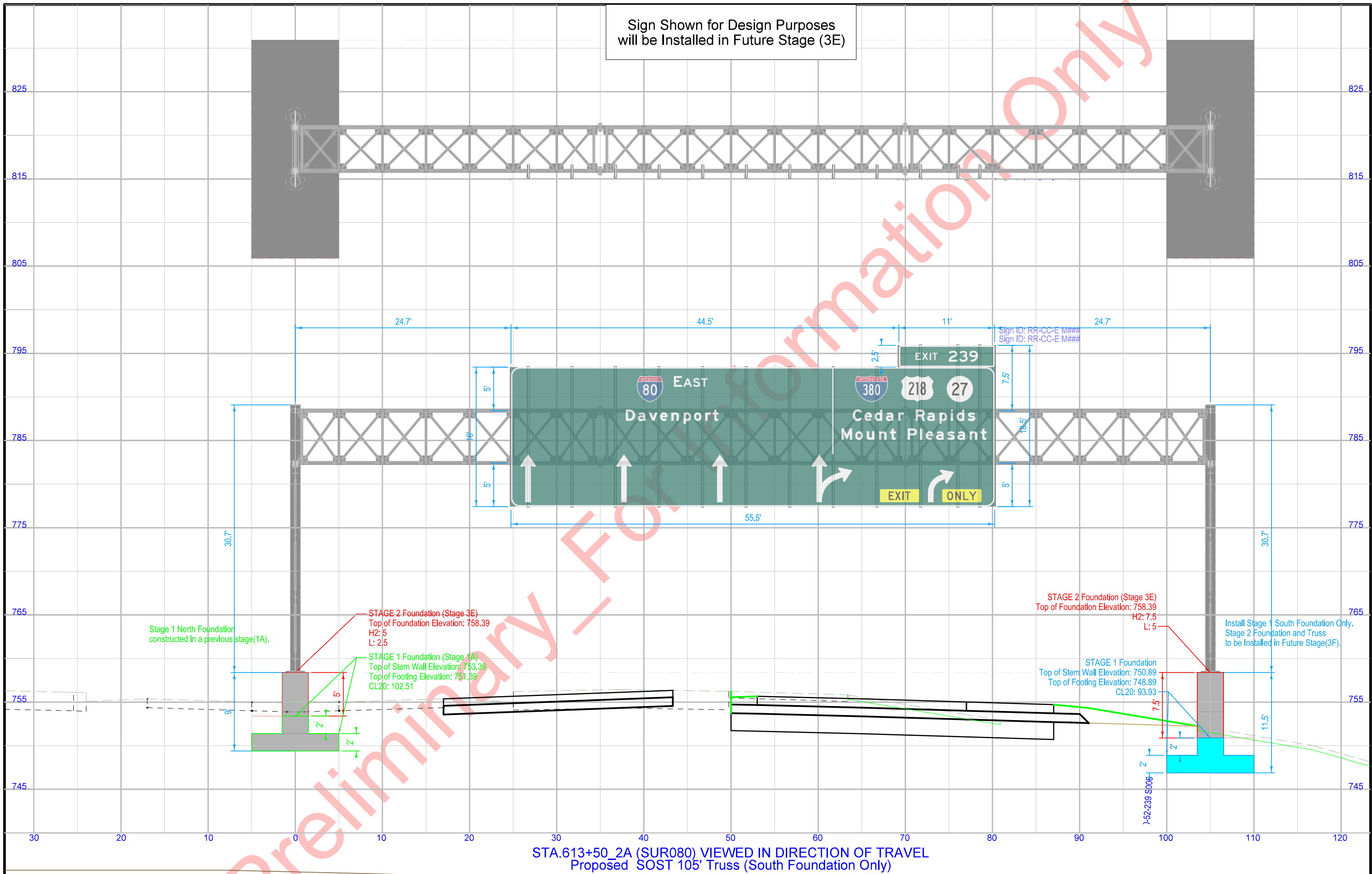

STA.613+50\_2A (SUR080) VIEWED IN DIRECTION OF TRAVEL  
Proposed SOST 105' Truss (South Foundation Only)

Sign Shown for Design Purposes  
will be Installed in Future Stage (3E)

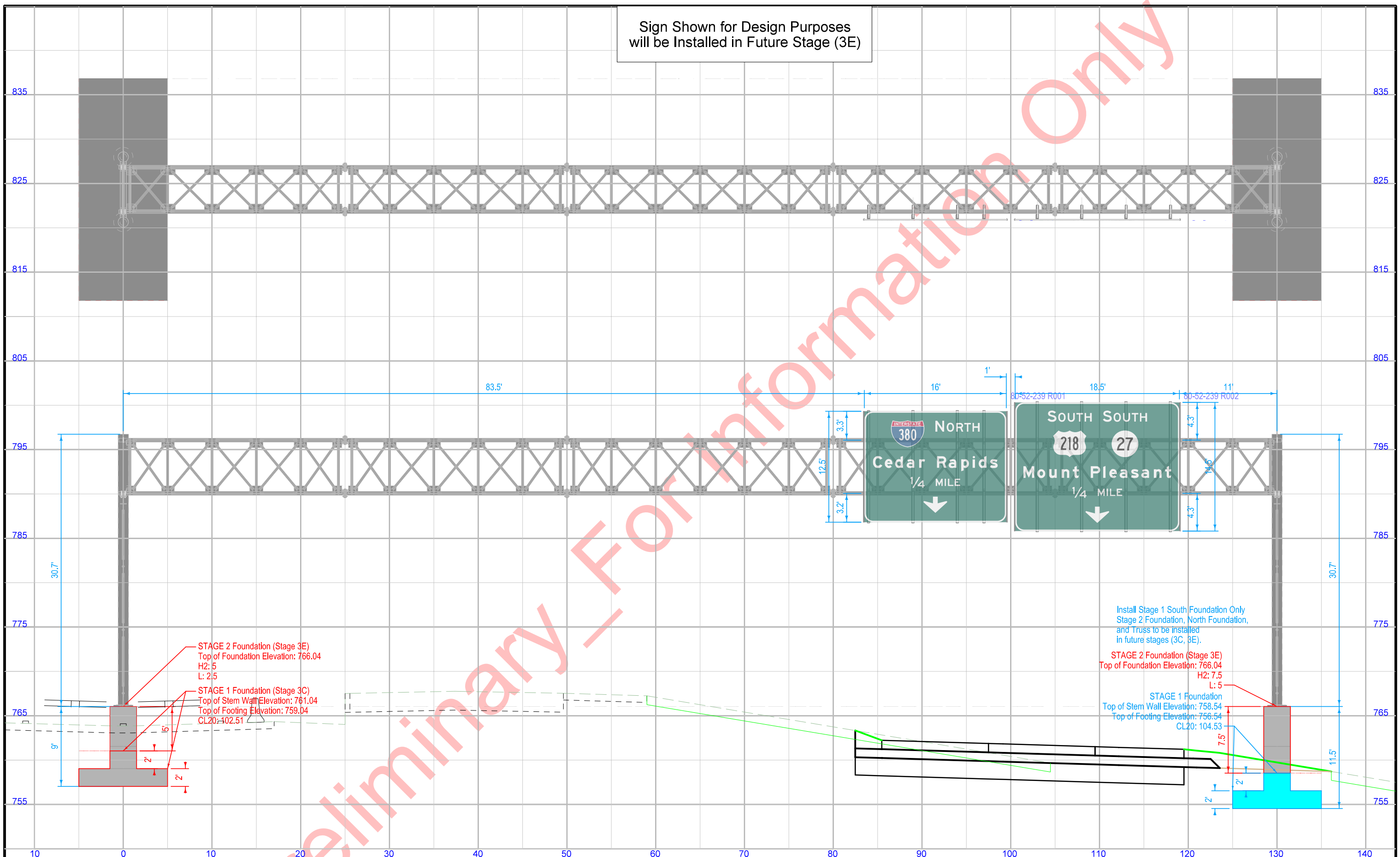

STAGE 2 Foundation (Stage 3E)  
Top of Foundation Elevation: 766.04  
H2: 5  
L: 2.5

STAGE 1 Foundation (Stage 3C)  
Top of Stem Wall Elevation: 761.04  
Top of Footing Elevation: 759.04  
CL20: 402.51

Install Stage 1 South Foundation Only  
Stage 2 Foundation, North Foundation,  
and Truss to be installed  
in future stages (3C, 3E).

STAGE 2 Foundation (Stage 3E)  
Top of Foundation Elevation: 766.04  
H2: 7.5  
L: 5

STAGE 1 Foundation  
Top of Stem Wall Elevation: 758.54  
Top of Footing Elevation: 756.54  
CL20: 104.53

STA. 620+00\_2A (SUR080) VIEWED IN DIRECTION OF TRAVEL  
Proposed SOST 130' Truss (South Foundation Only)



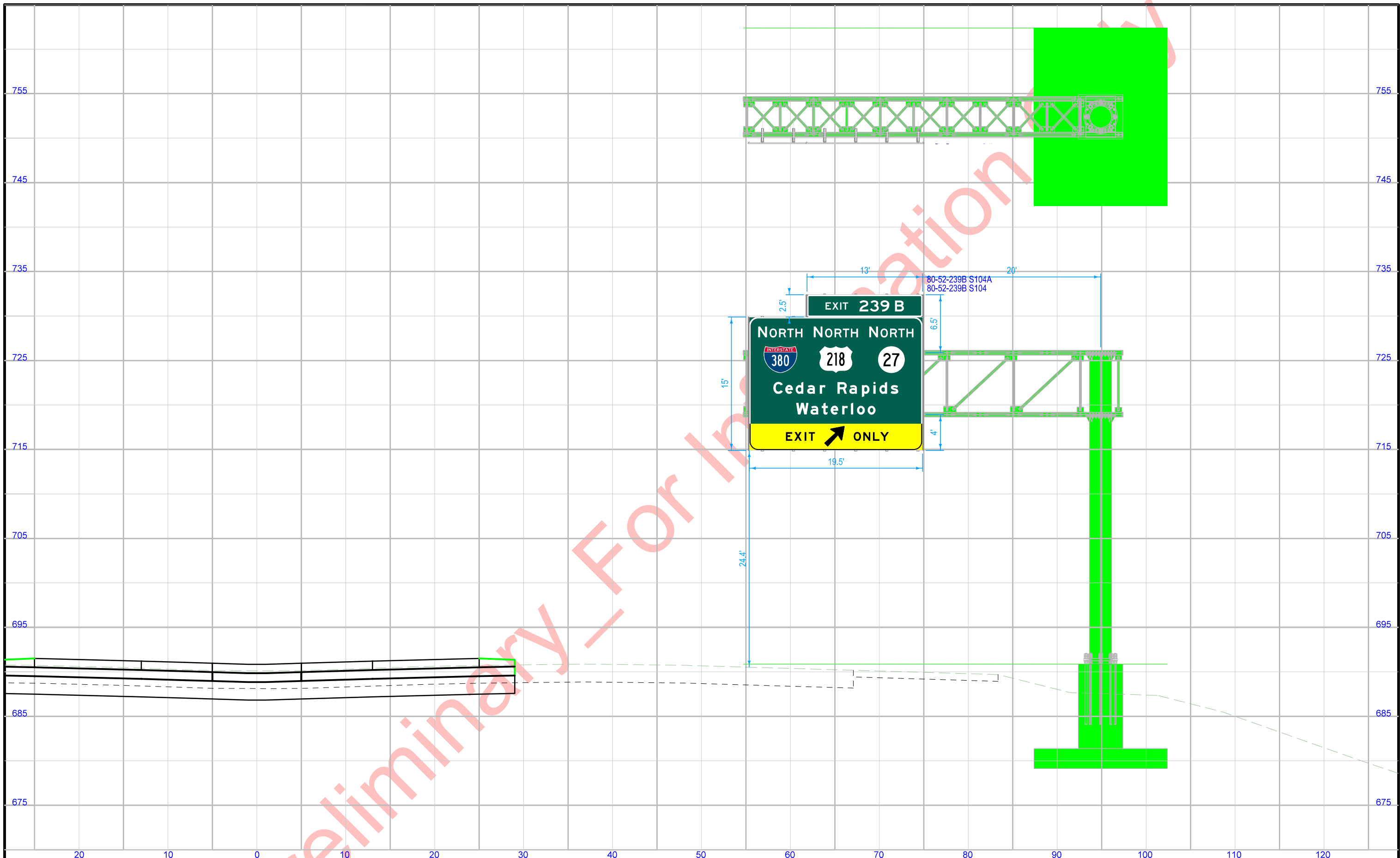

STA. 683+50\_2A (SUR080) VIEWED IN DIRECTION OF TRAVEL  
 Existing SCST 39.5' Cantilever

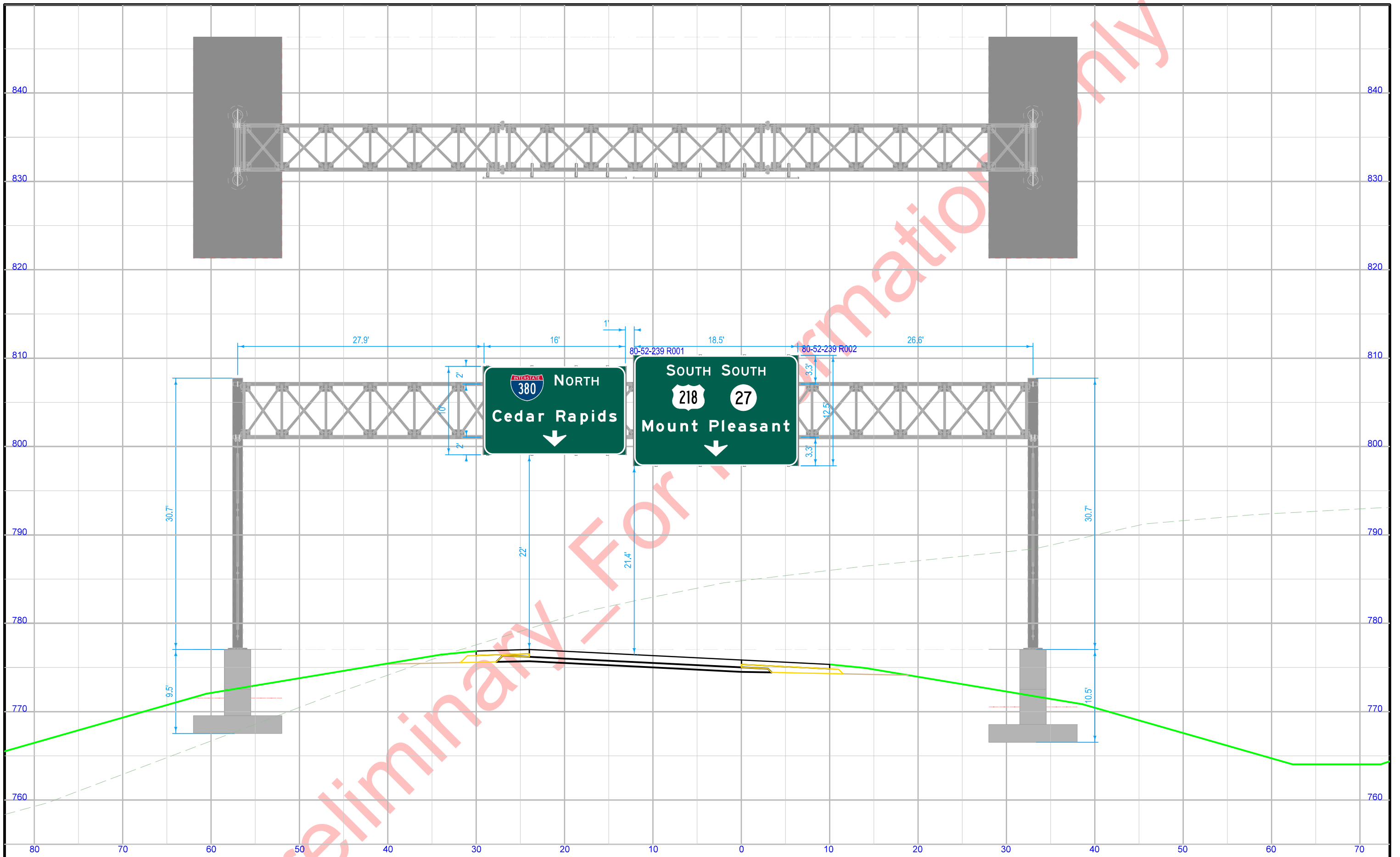

STA. 2530+00\_2A (ML380B) VIEWED IN DIRECTION OF TRAVEL  
 Existing SOST 90' Truss

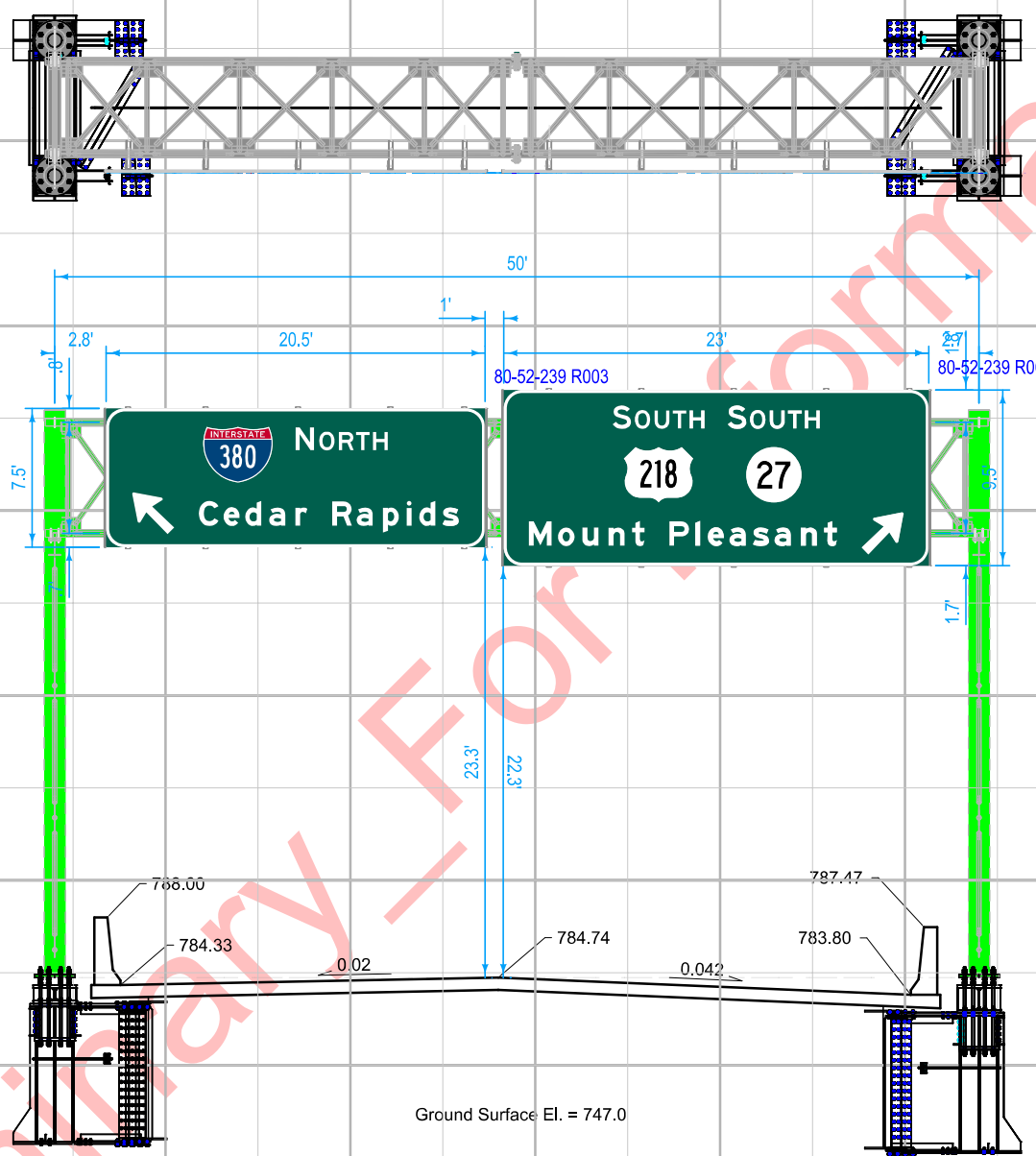

Sta. 2537+61.93\_2A (ML380B) VIEWED IN DIRECTION OF TRAVEL  
Existing 50' SOST Sign Truss

Sign Reinstalled to This Location

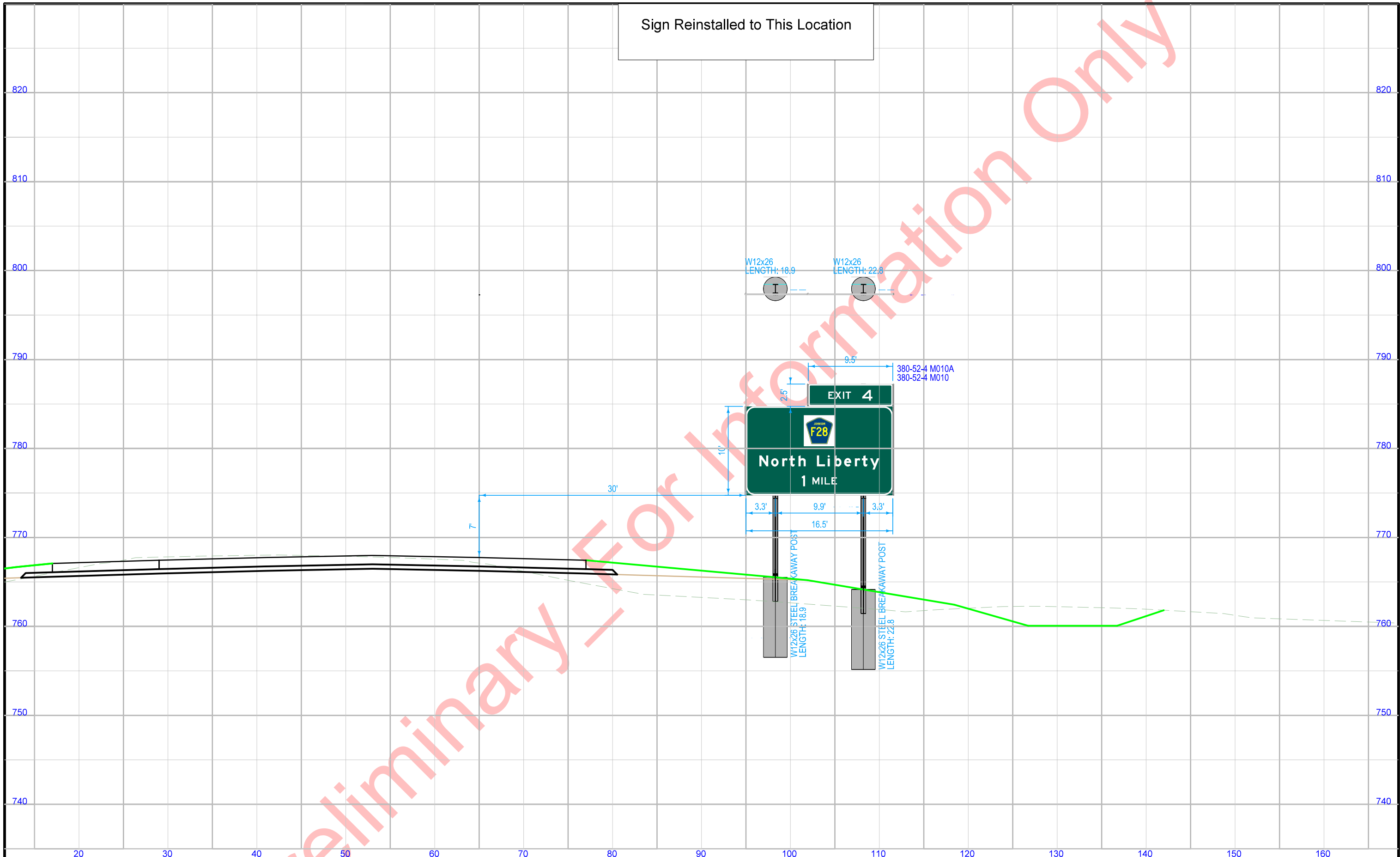

STA. 1310+00\_2A (ML380) VIEWED IN DIRECTION OF TRAVEL  
Proposed W12x26 Post and Foundation

Sign Shown for Design Purposes  
will be Installed in Future Stage (3D)

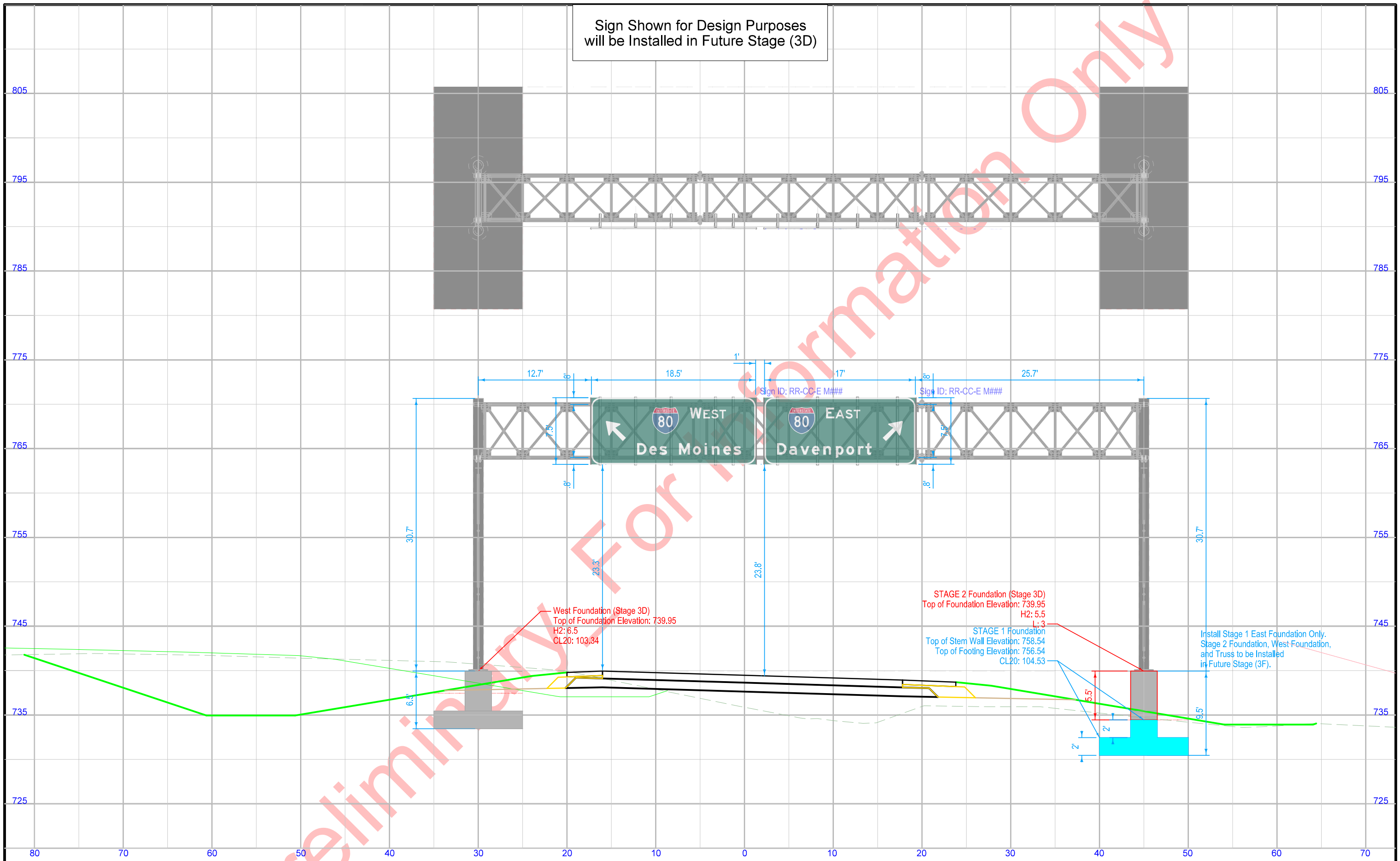

STA. 5579+50\_2B (ML380E) VIEWED IN DIRECTION OF TRAVEL  
Proposed SOST 75' Truss (East Foundation Only)

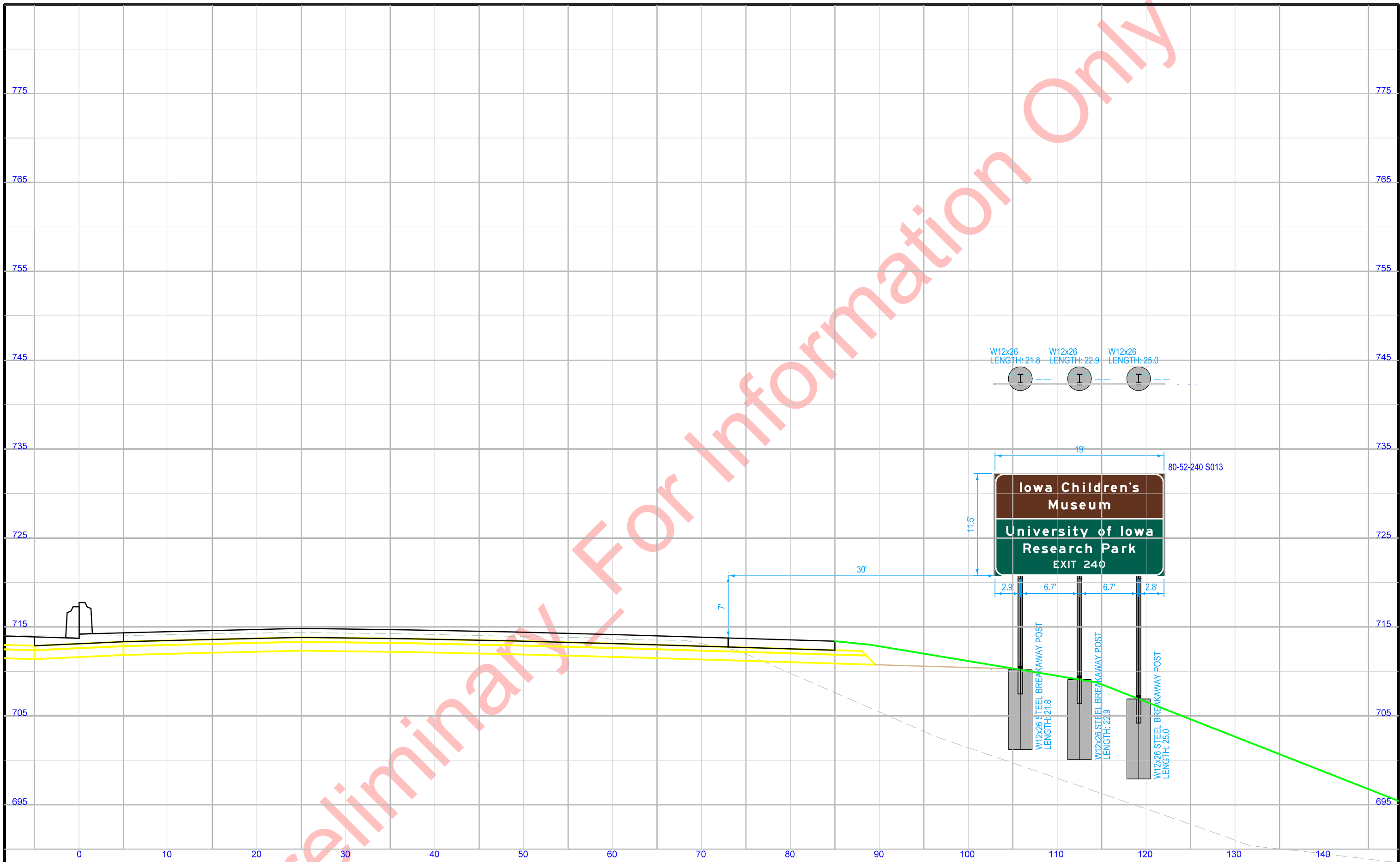

STA. 698+00\_2C (SUR080) VIEWED IN DIRECTION OF TRAVEL  
Proposed W12x26 Post and Foundation

Preliminary - For Information Only

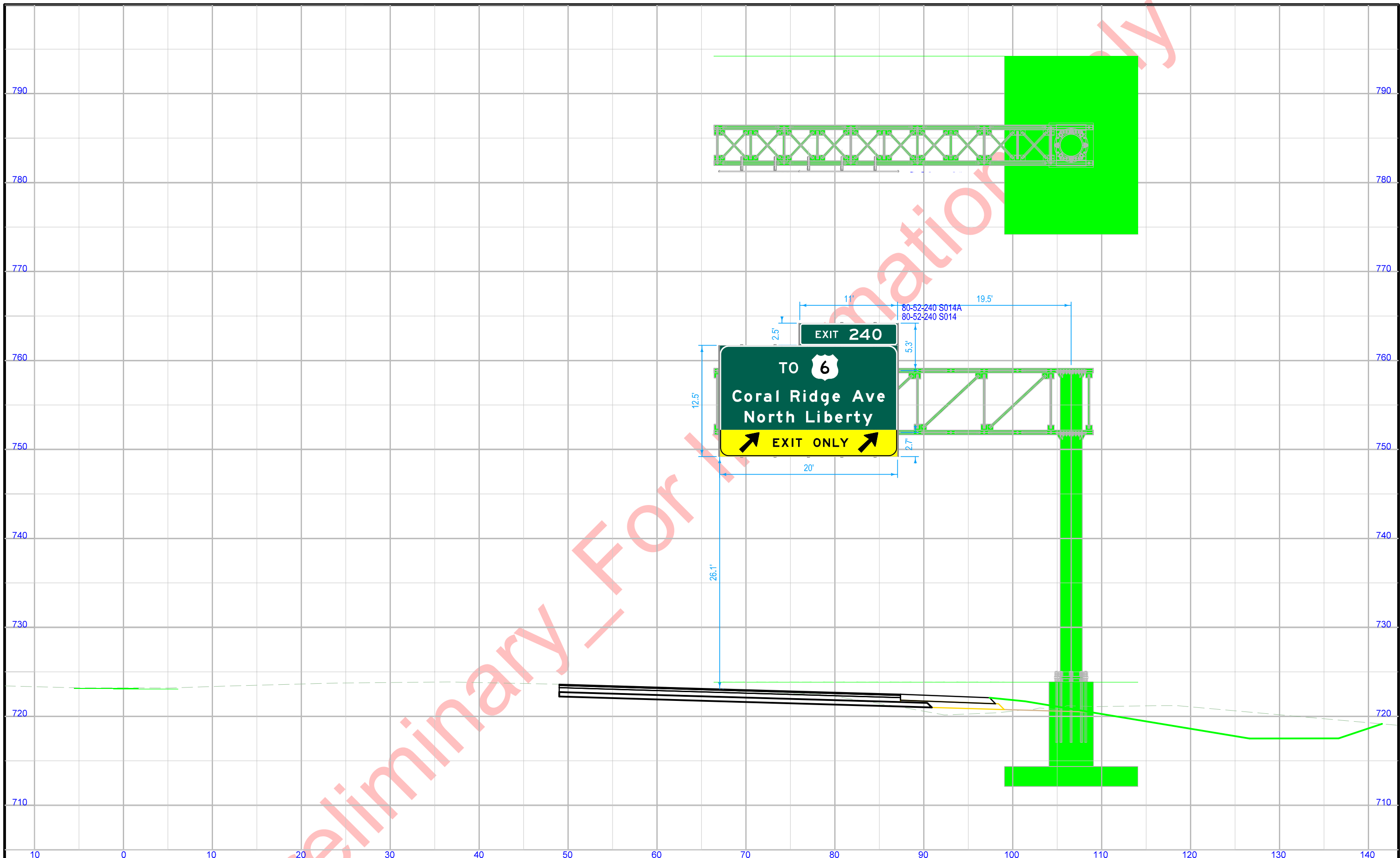

STA. 704+00\_2C (SUR080) VIEWED IN DIRECTION OF TRAVEL  
 Existing SCST 39.5' Cantilever

Exit Direction Sign  
Reinstalled to this location

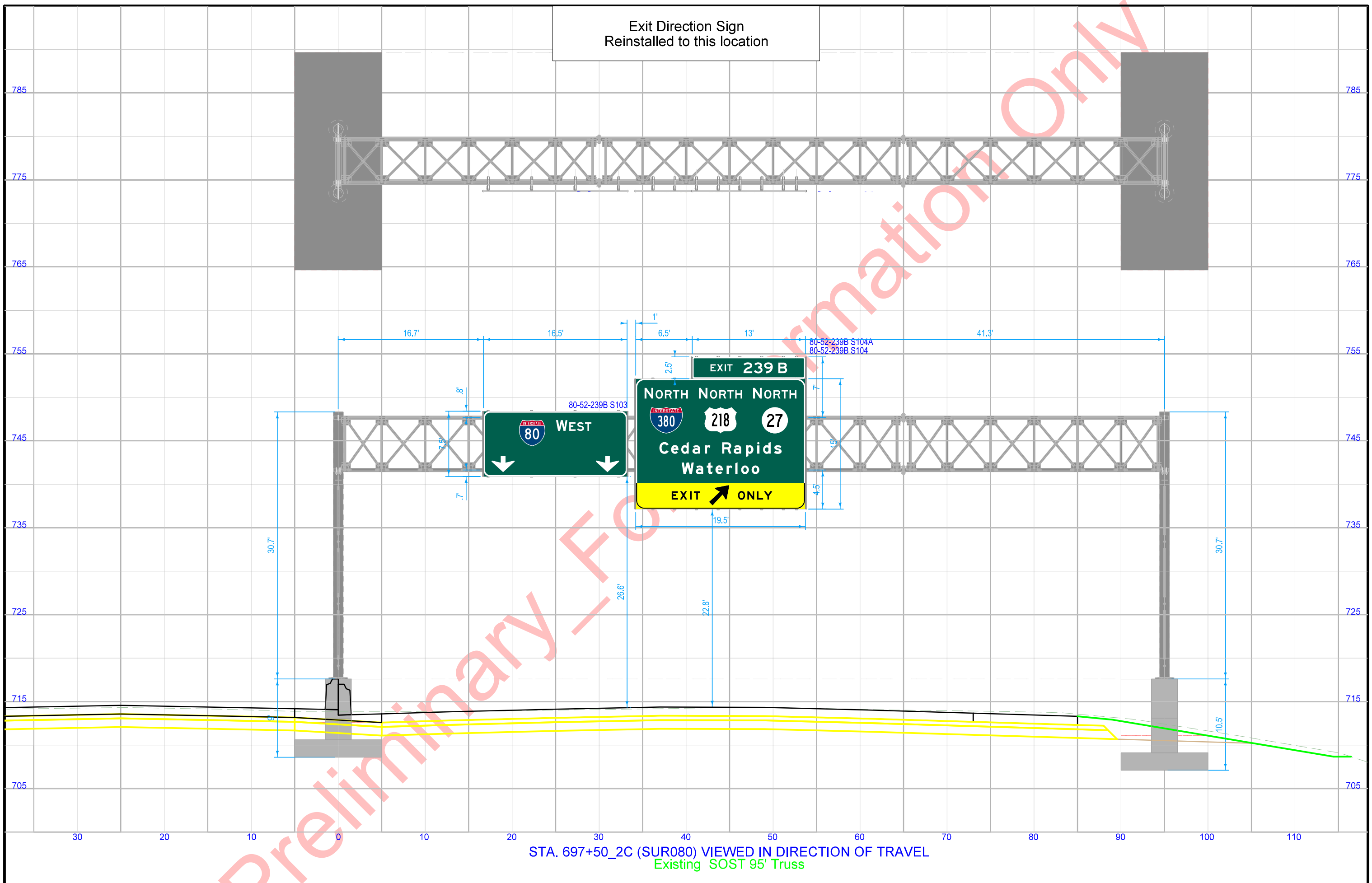



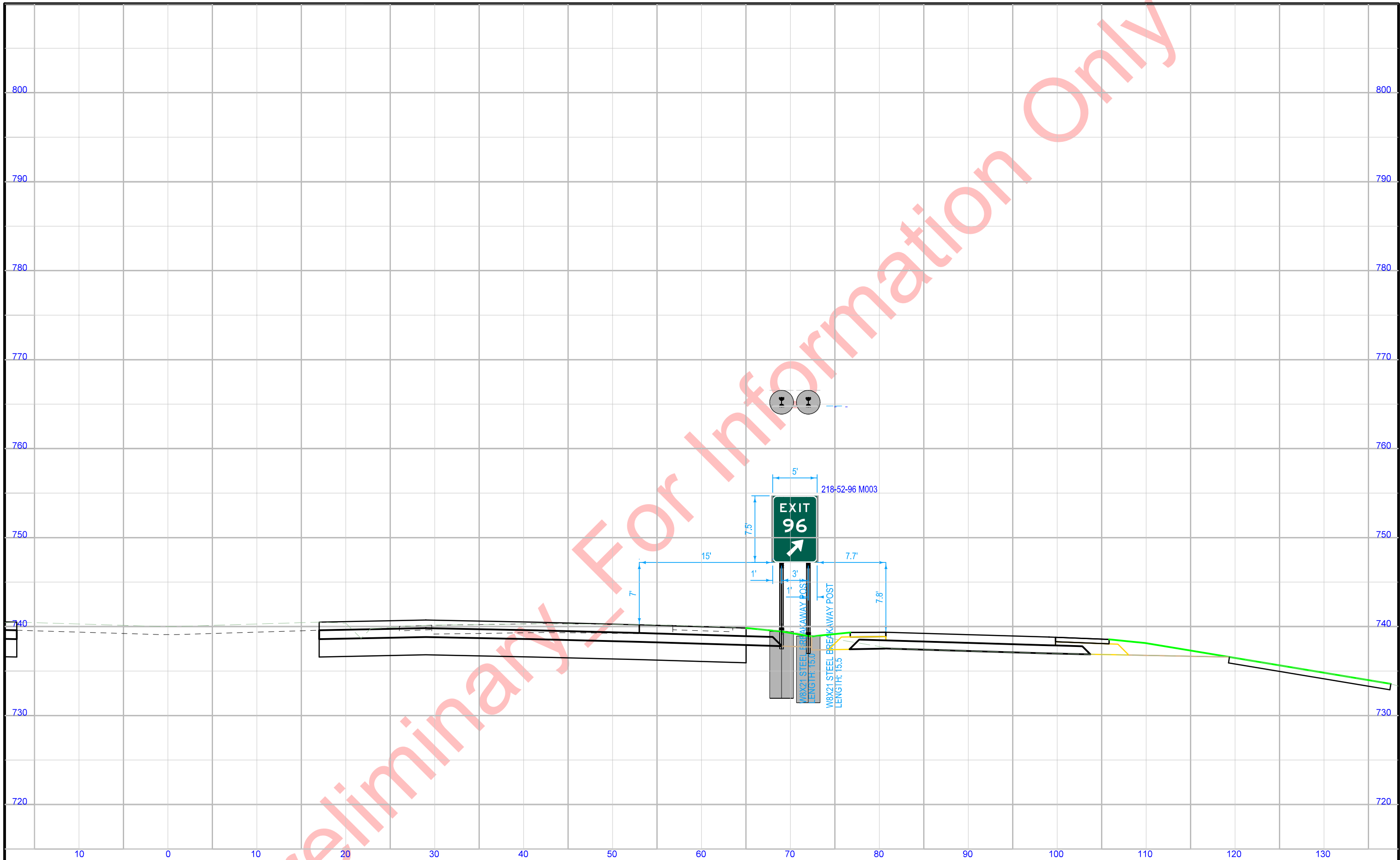

STA. 1136+50\_2C (ML380) VIEWED IN DIRECTION OF TRAVEL  
 Proposed W8x21 Post and Foundation

DMS Shown for Design Purposes  
will be Installed in Future Stage (3D)

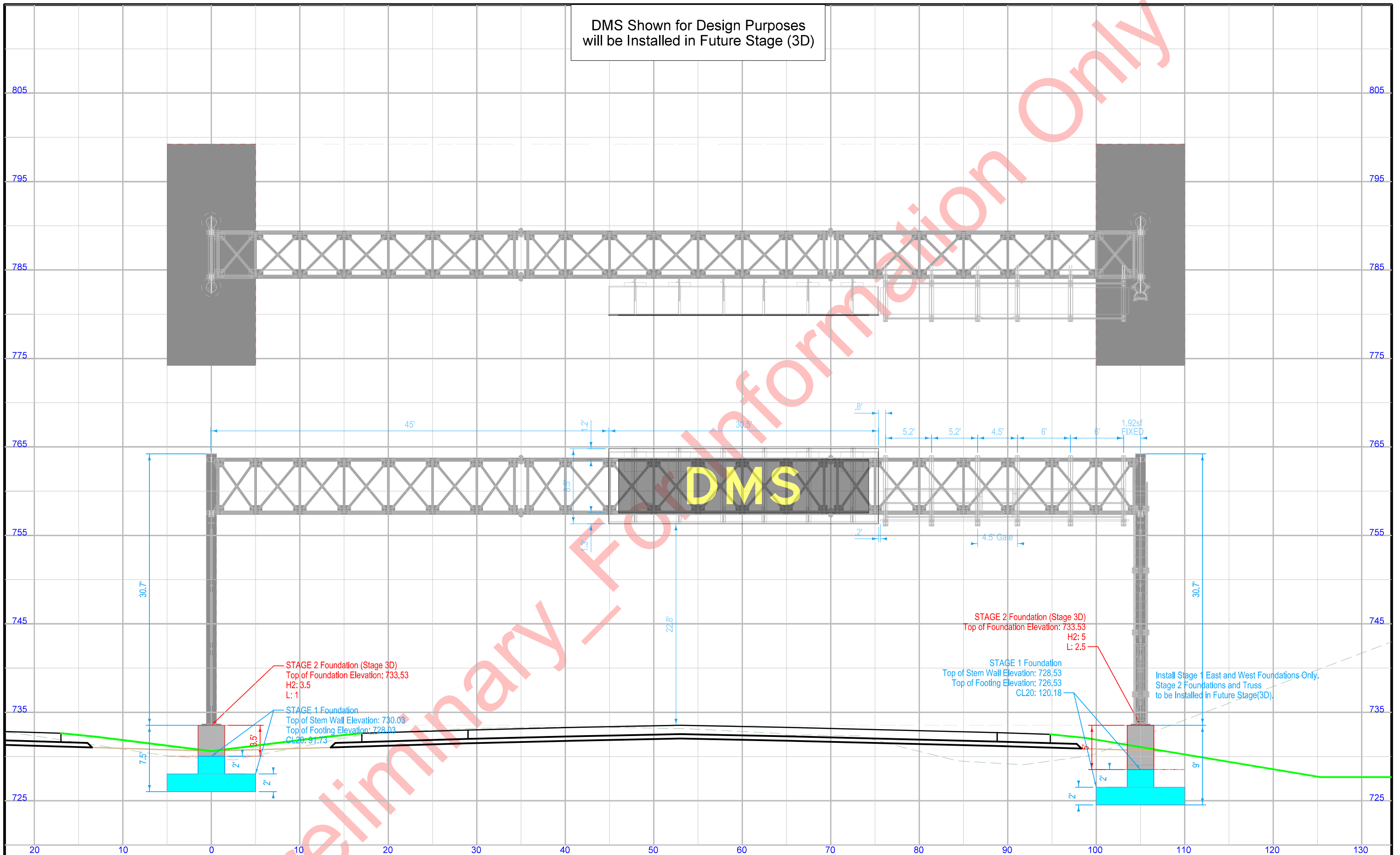

STA. 1218+00\_2C (ML380) VIEWED IN DIRECTION OF TRAVEL  
Proposed SOST 105' Truss (Stage 1 Foundation Only)

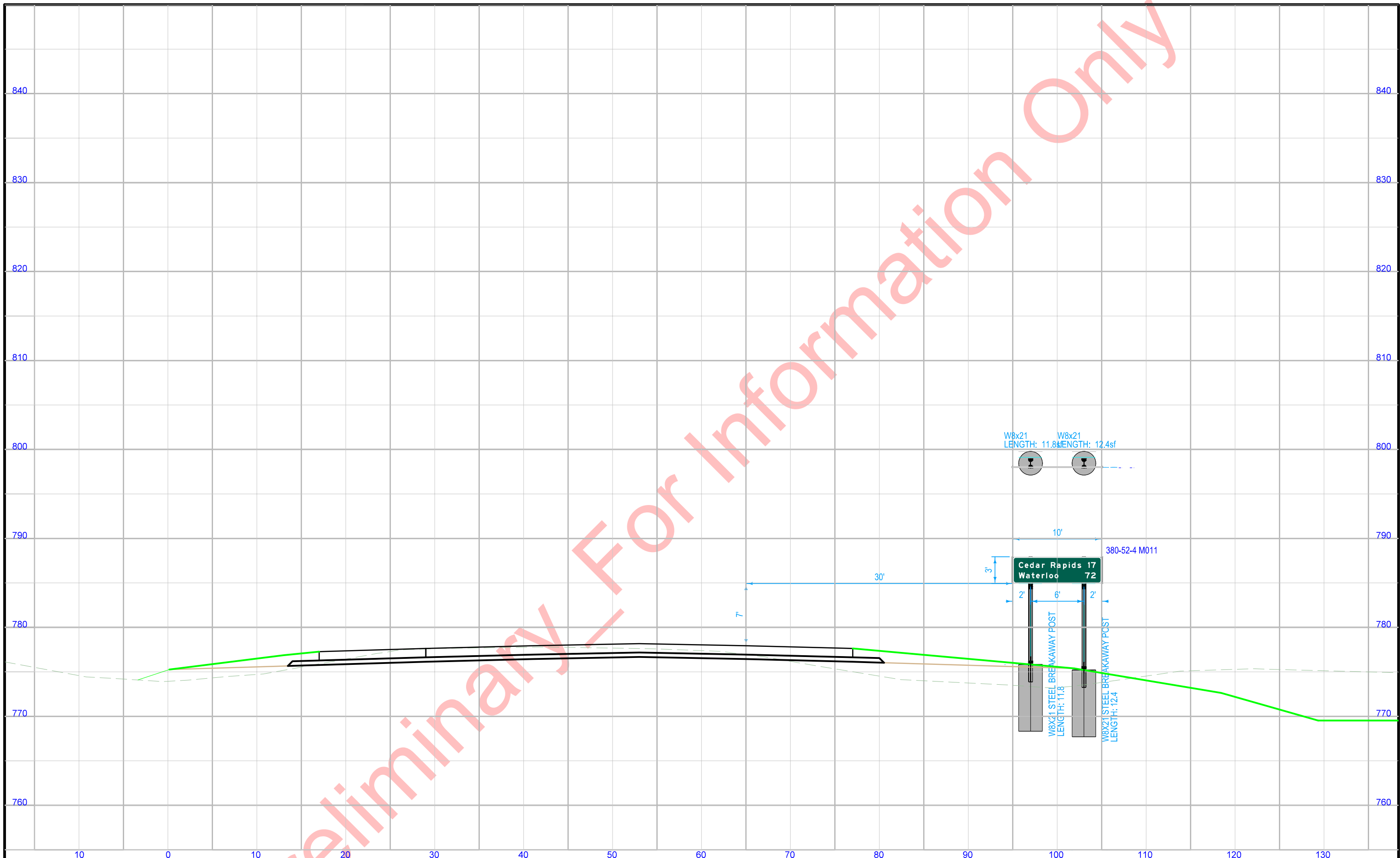

STA. 1325+00 (ML380) VIEWED IN DIRECTION OF TRAVEL (REINSTALLED)  
 Proposed W8x21 Post and Foundation

Sign Shown for Design Purposes  
will be Installed in Future Stage (3E)

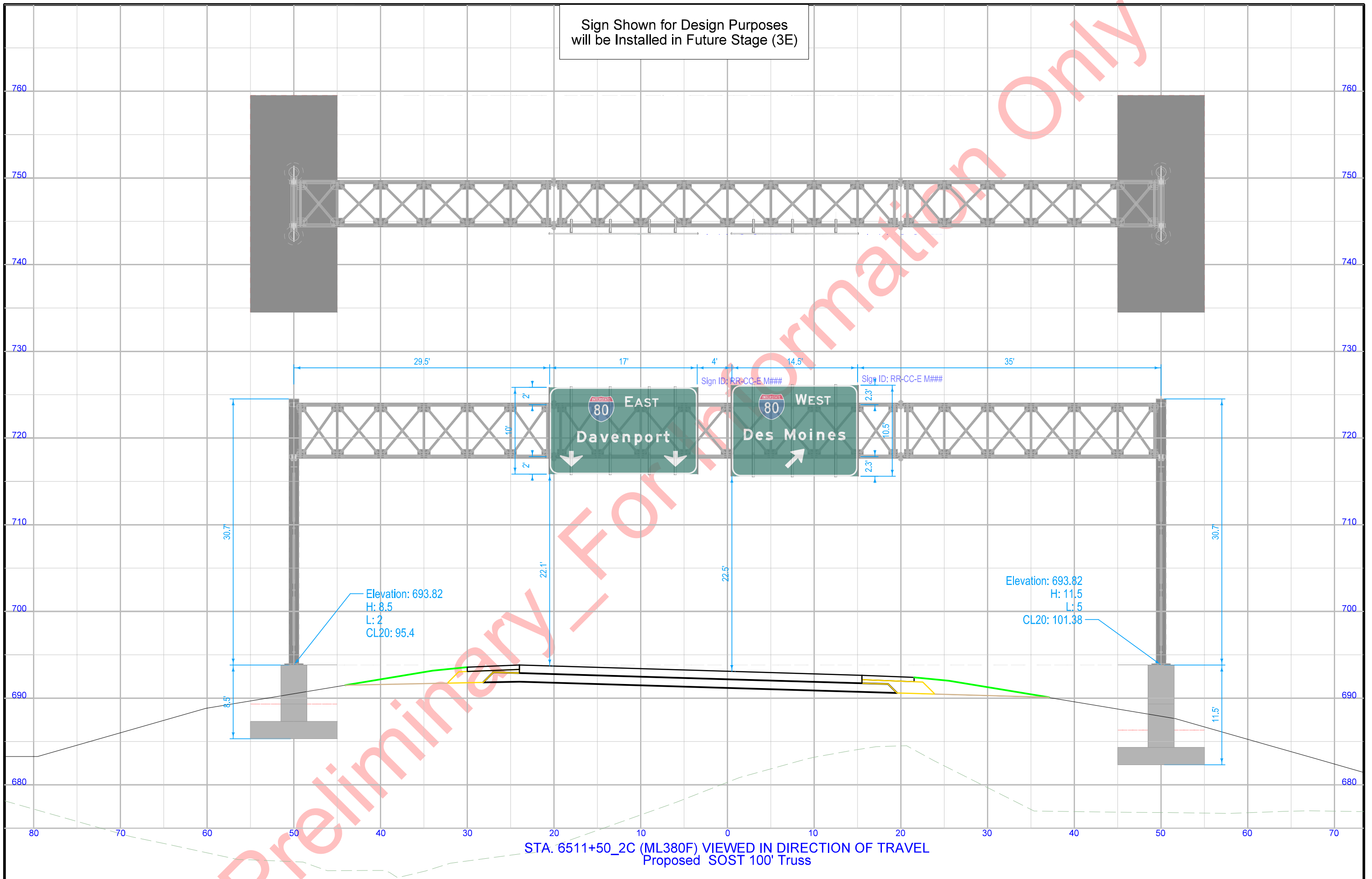

STA. 6511+50\_2C (ML380F) VIEWED IN DIRECTION OF TRAVEL  
Proposed SOST 100' Truss

I-80 West Pull Thru Previously installed (2C)  
Cedar Rapids/Waterloo installed this Stage

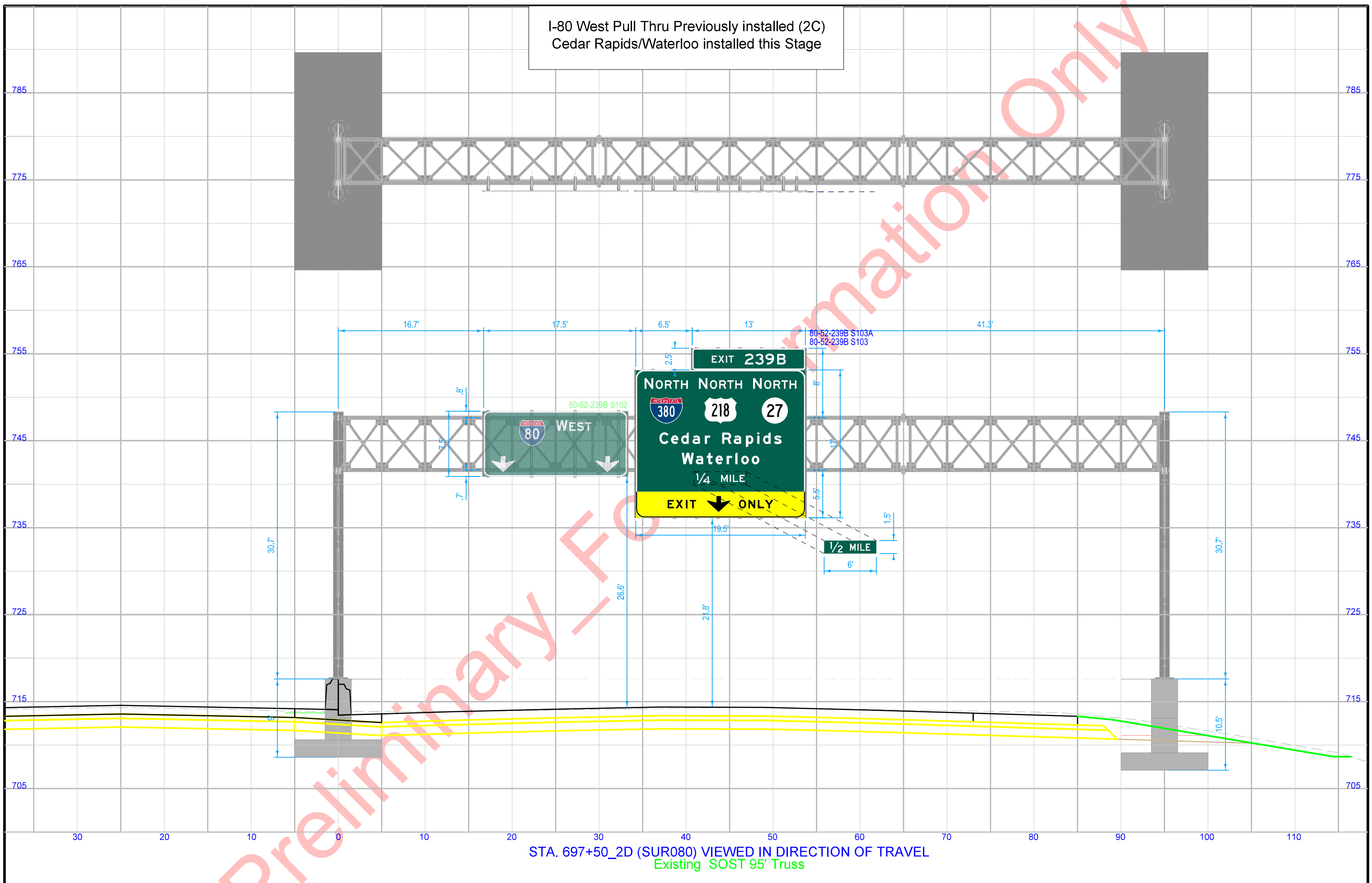

Sign Shown for Design Purposes  
will be Installed in Future Stage (3E)

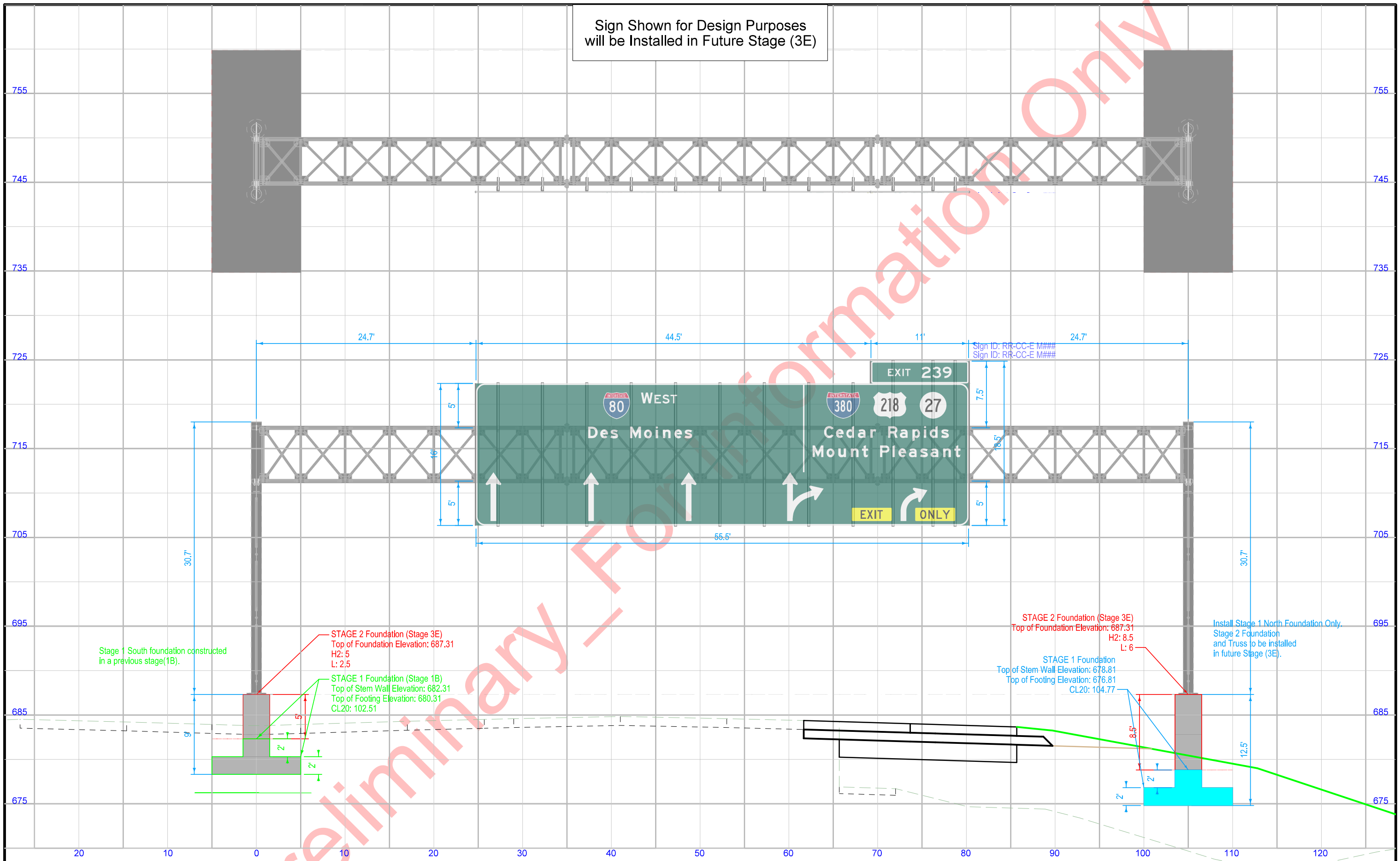

STA. 677+50\_2D (SUR080) VIEWED IN DIRECTION OF TRAVEL  
Proposed SOST 105' Truss (North Foundation Only)

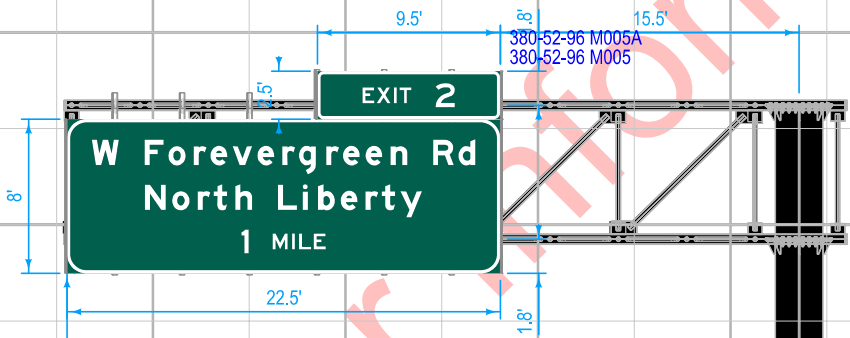
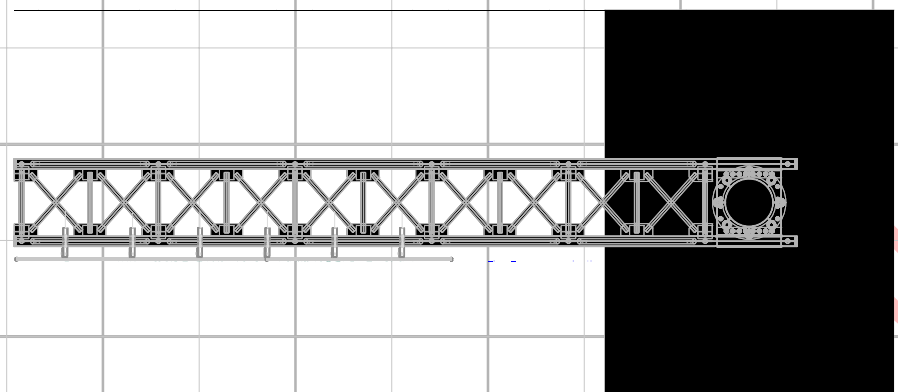

Elevation: 712.97  
 Excavation: 115.32

STA. 1192+50\_2D (ML380) VIEWED IN DIRECTION OF TRAVEL  
 Proposed SCST 38' Cantilever

Preliminary For Information Only

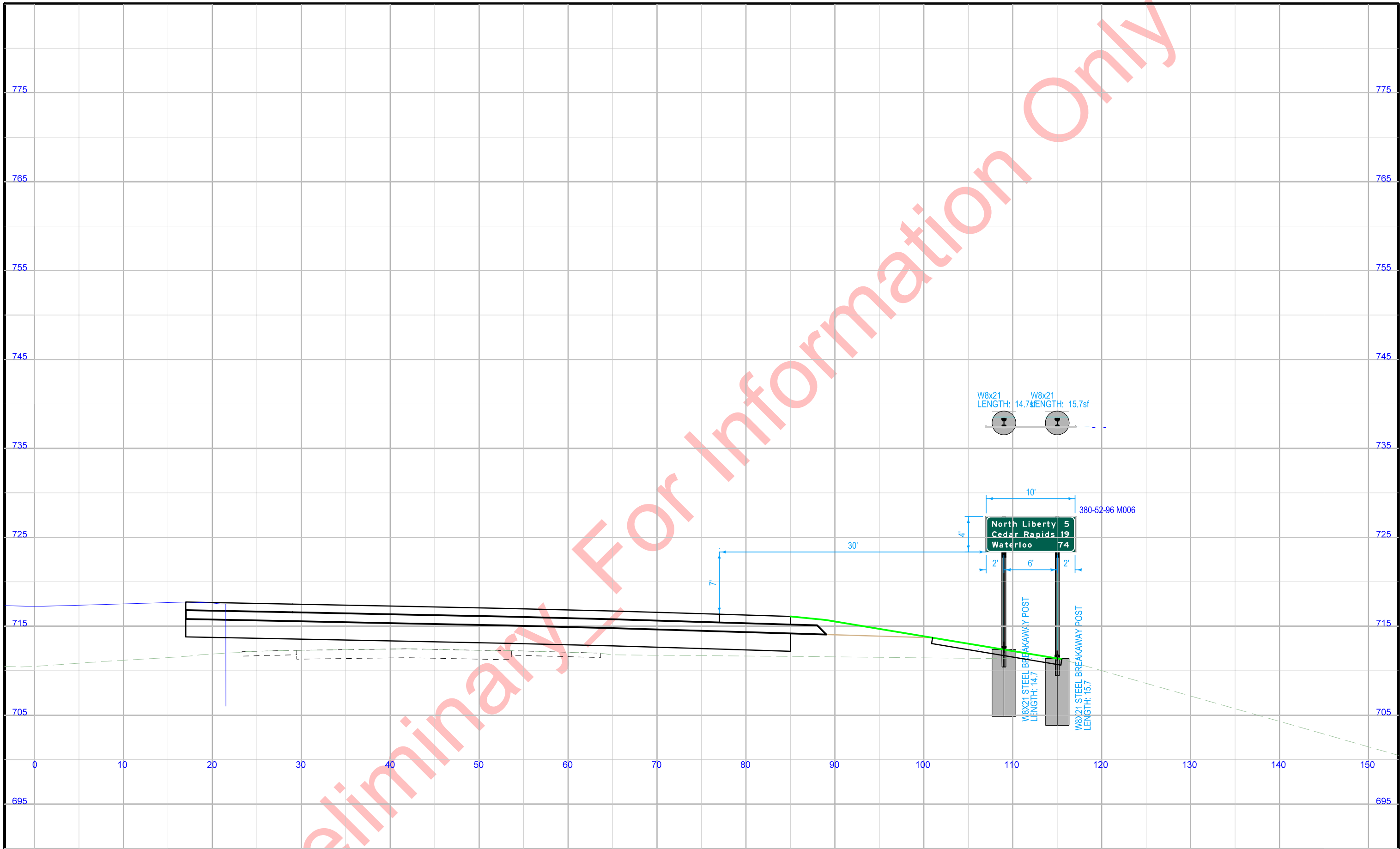

STA. 1203\_2D (ML380) VIEWED IN DIRECTION OF TRAVEL  
Proposed W8x21 Post and Foundation



Sign Reinstalled to This Location

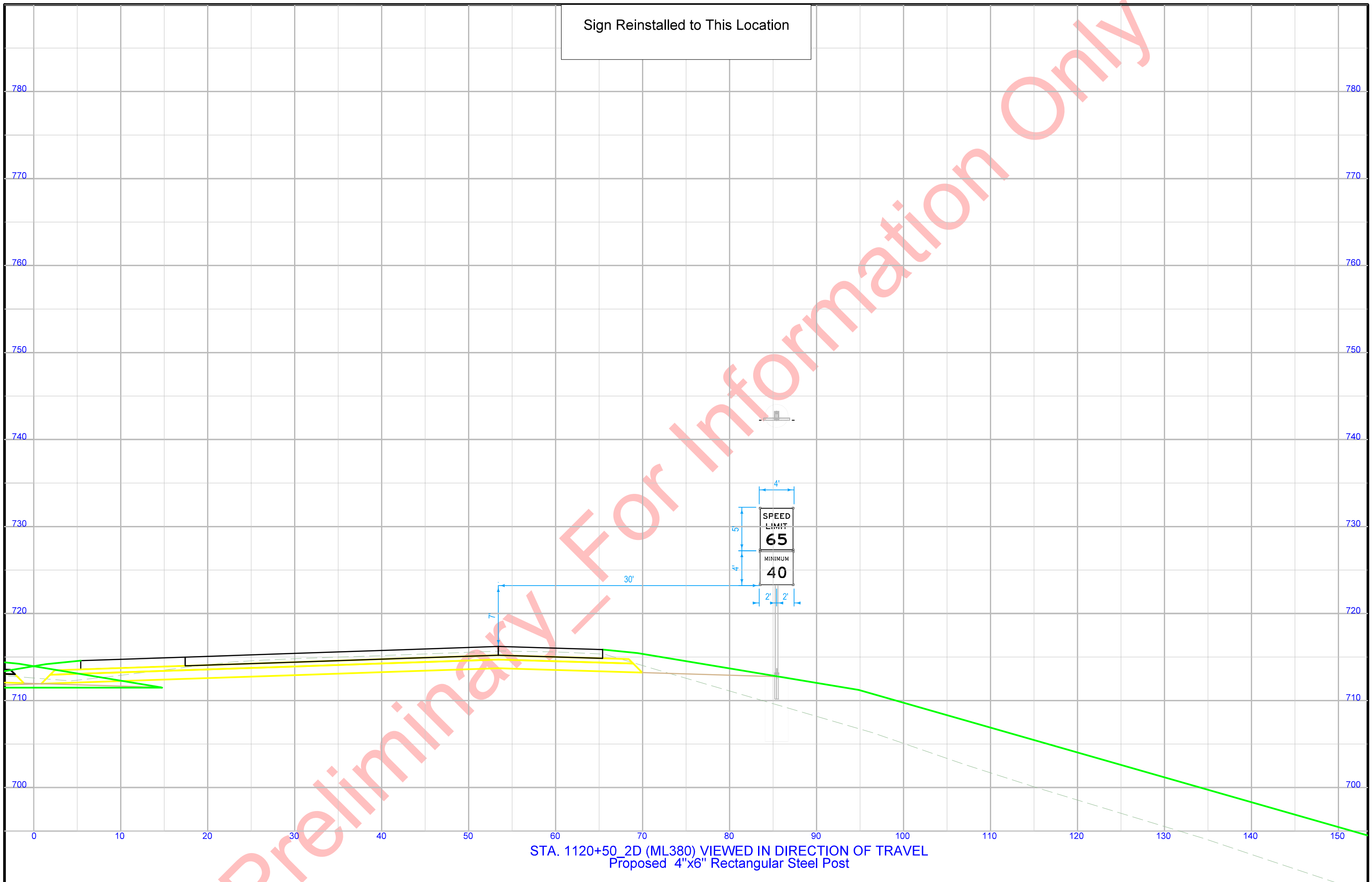

STA. 1120+50\_2D (ML380) VIEWED IN DIRECTION OF TRAVEL  
Proposed 4"x6" Rectangular Steel Post

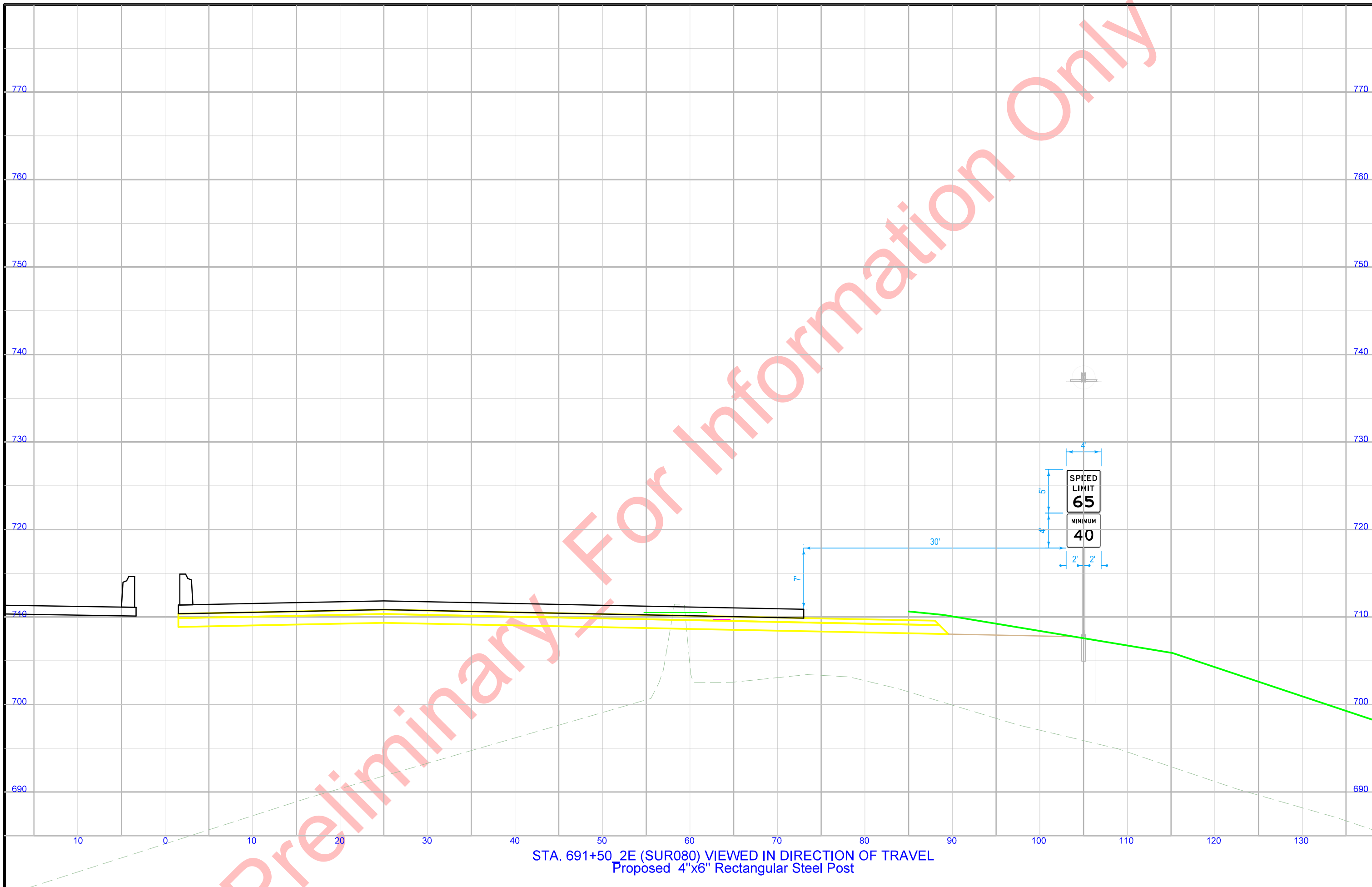

STA. 691+50\_2E (SUR080) VIEWED IN DIRECTION OF TRAVEL  
 Proposed 4"x6" Rectangular Steel Post

Sign Reinstalled to This Location

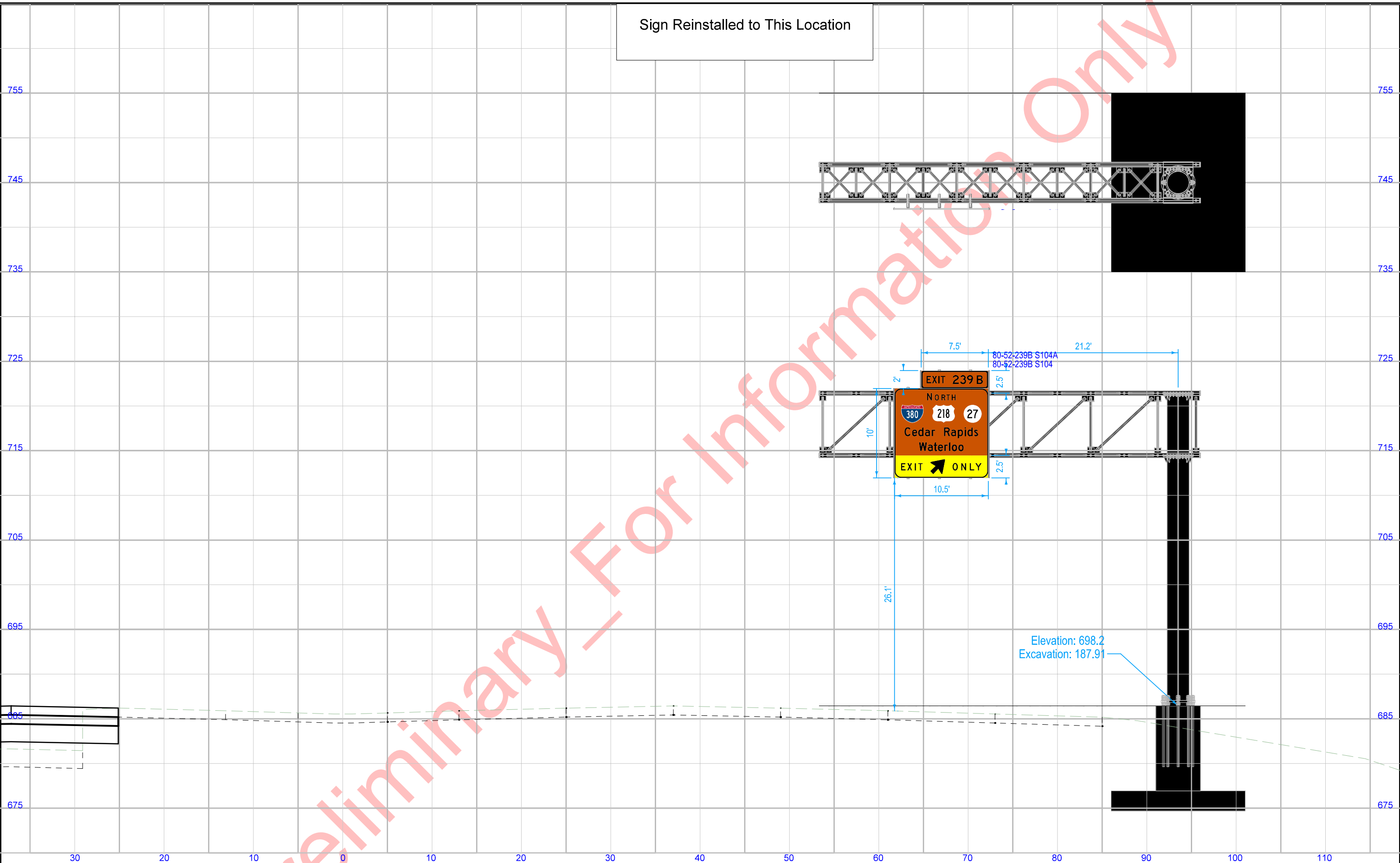

STA. 680+00\_2E (SUR080) VIEWED IN DIRECTION OF TRAVEL  
Proposed SCST 39.5' Cantilever

Sign Reinstalled to This Location

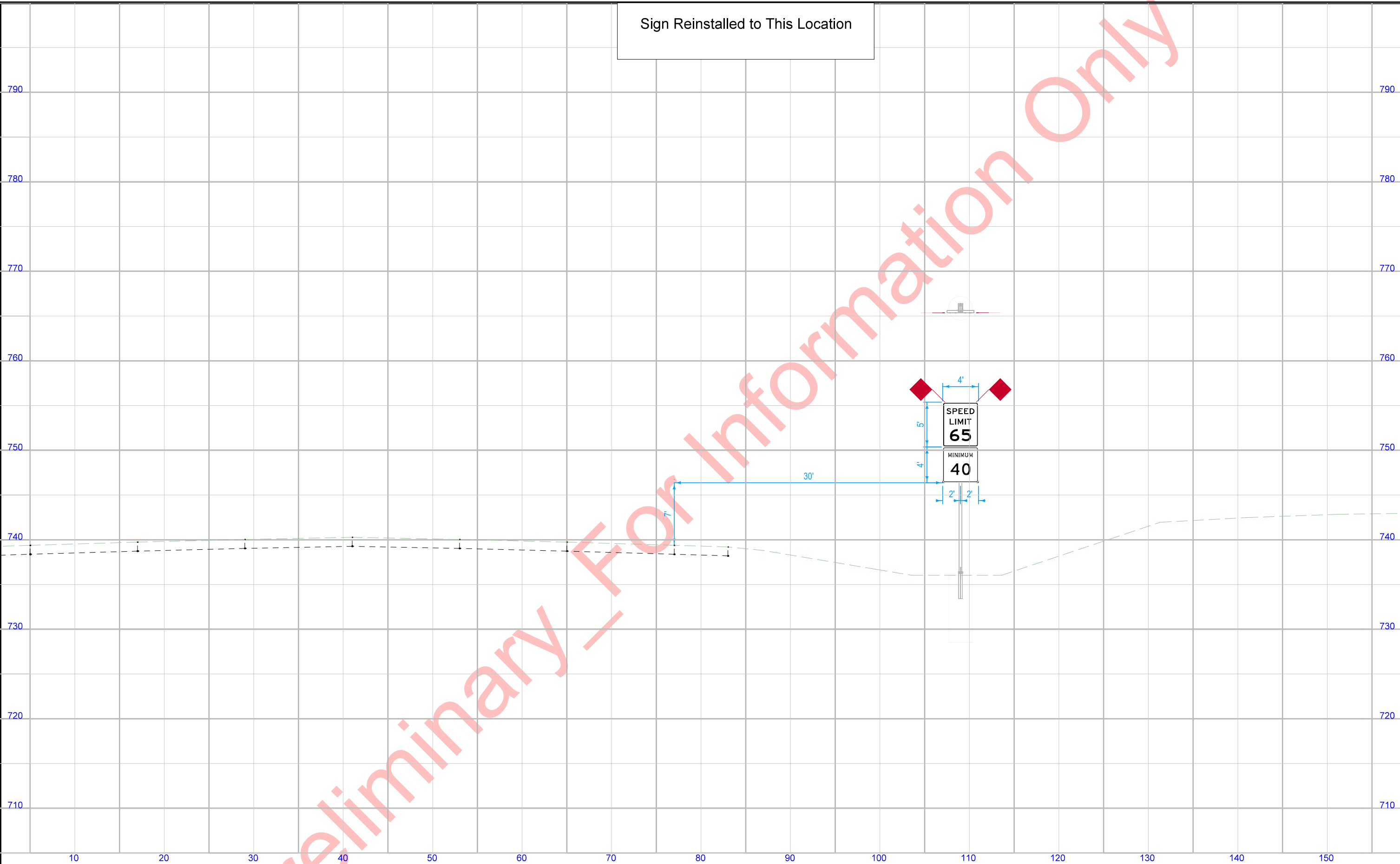

STA. 603+00\_2F (SUR080) VIEWED IN DIRECTION OF TRAVEL  
Proposed 4"x6" Rectangular Steel Post

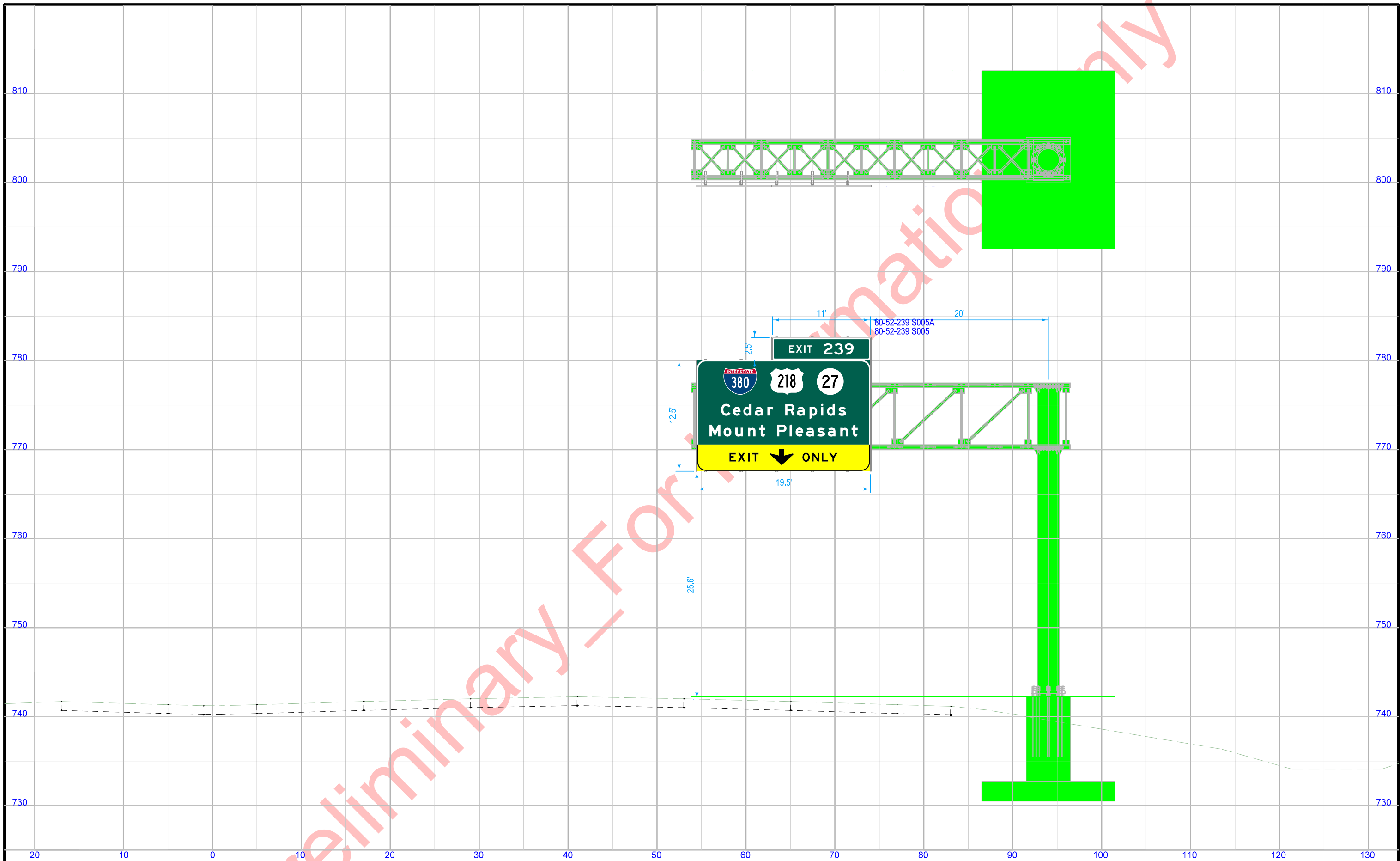

STA. 605+00\_2F (SUR080) VIEWED IN DIRECTION OF TRAVEL  
 Existing SCST 39.5' Cantilever

Sign Reinstalled to This Location

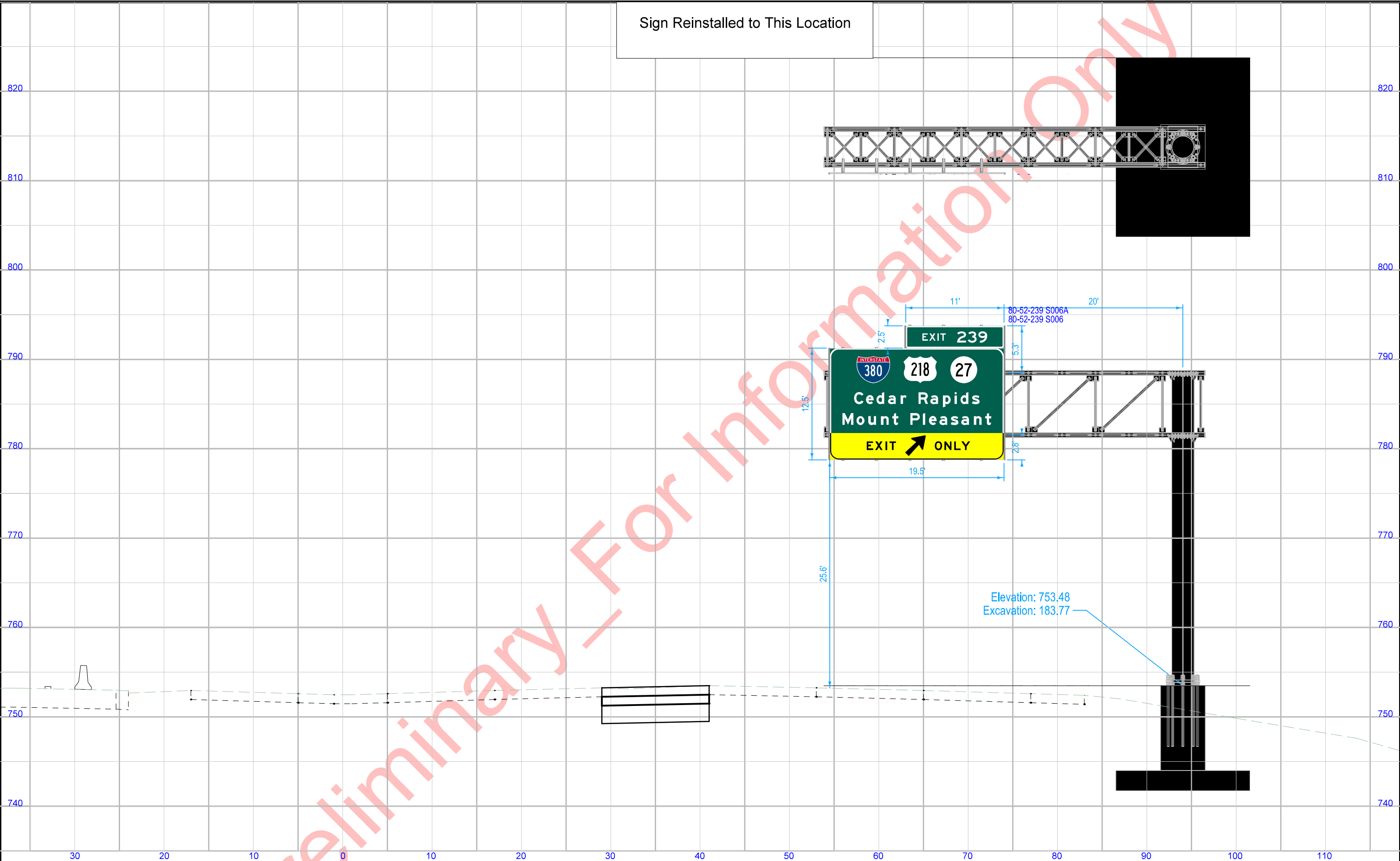

STA. 612+00\_2F (SUR080) VIEWED IN DIRECTION OF TRAVEL  
Proposed SCST 39.5' Cantilever

Sign Shown for Design Purposes  
will be Installed in Future Stage (3E)

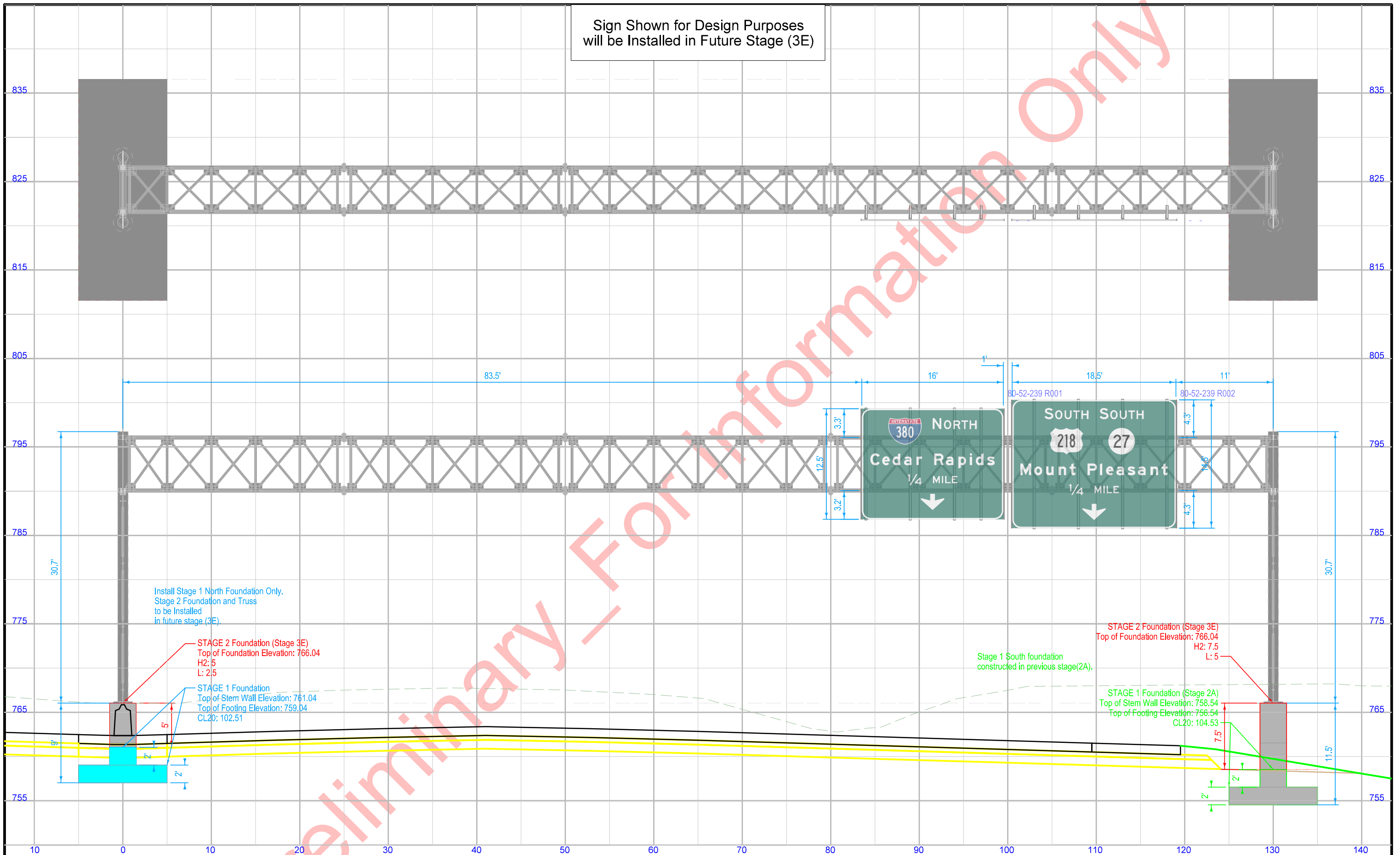

Install Stage 1 North Foundation Only.  
Stage 2 Foundation and Truss  
to be Installed  
in future stage (3E).

STAGE 2 Foundation (Stage 3E)  
Top of Foundation Elevation: 766.04  
H2: 5  
L: 2.5

STAGE 1 Foundation  
Top of Stem Wall Elevation: 761.04  
Top of Footing Elevation: 759.04  
CL20: 102.51

Stage 1 South foundation  
constructed in previous stage(2A).

STAGE 2 Foundation (Stage 3E)  
Top of Foundation Elevation: 766.04  
H2: 7.5  
L: 5

STAGE 1 Foundation (Stage 2A)  
Top of Stem Wall Elevation: 758.54  
Top of Footing Elevation: 756.54  
CL20: 104.53

STA. 620+00\_3A (SUR080) VIEWED IN DIRECTION OF TRAVEL  
Proposed SOST 130' Truss (North Foundation Only)

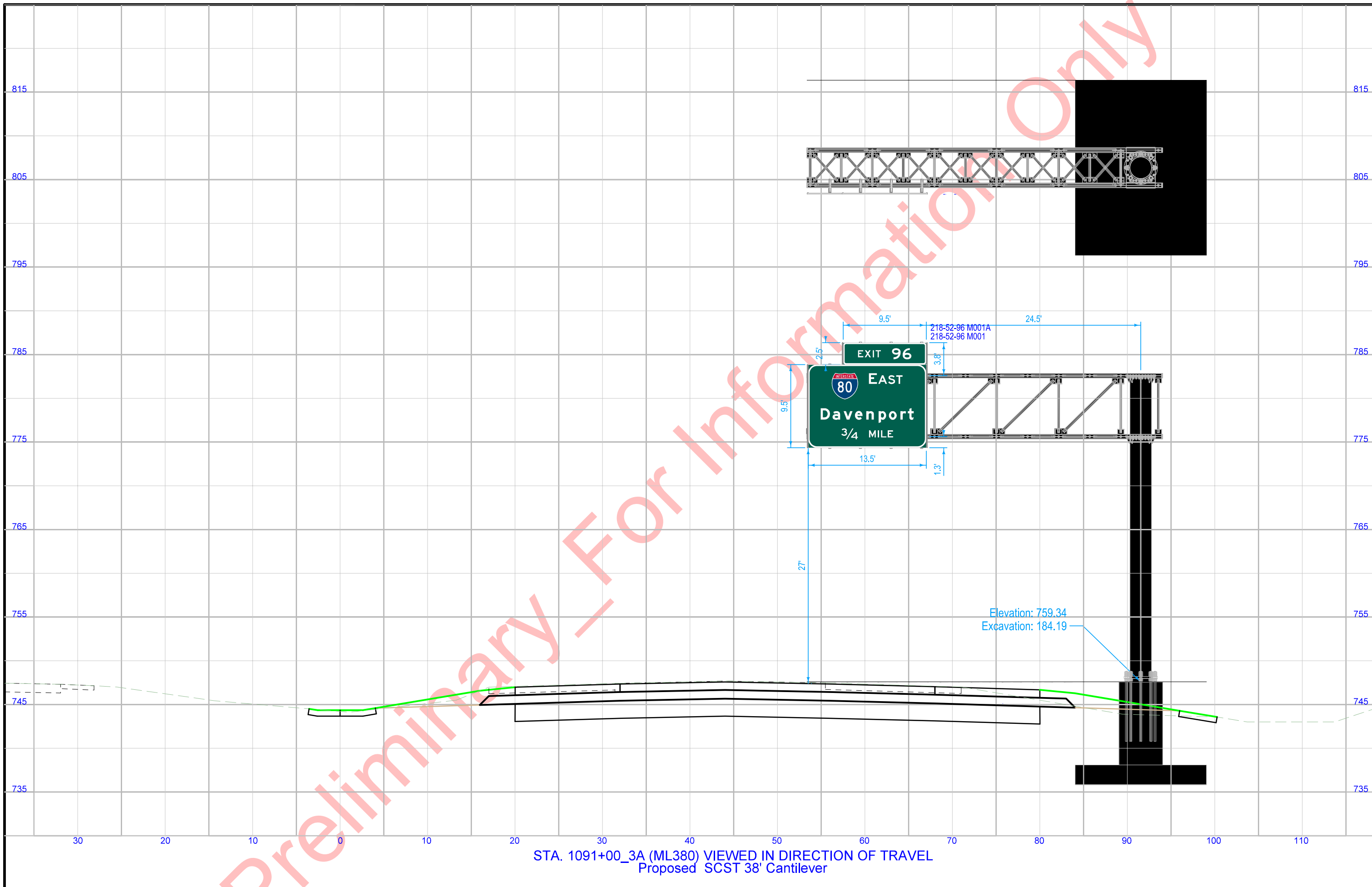

STA. 1091+00\_3A (ML380) VIEWED IN DIRECTION OF TRAVEL  
Proposed SCST 38' Cantilever



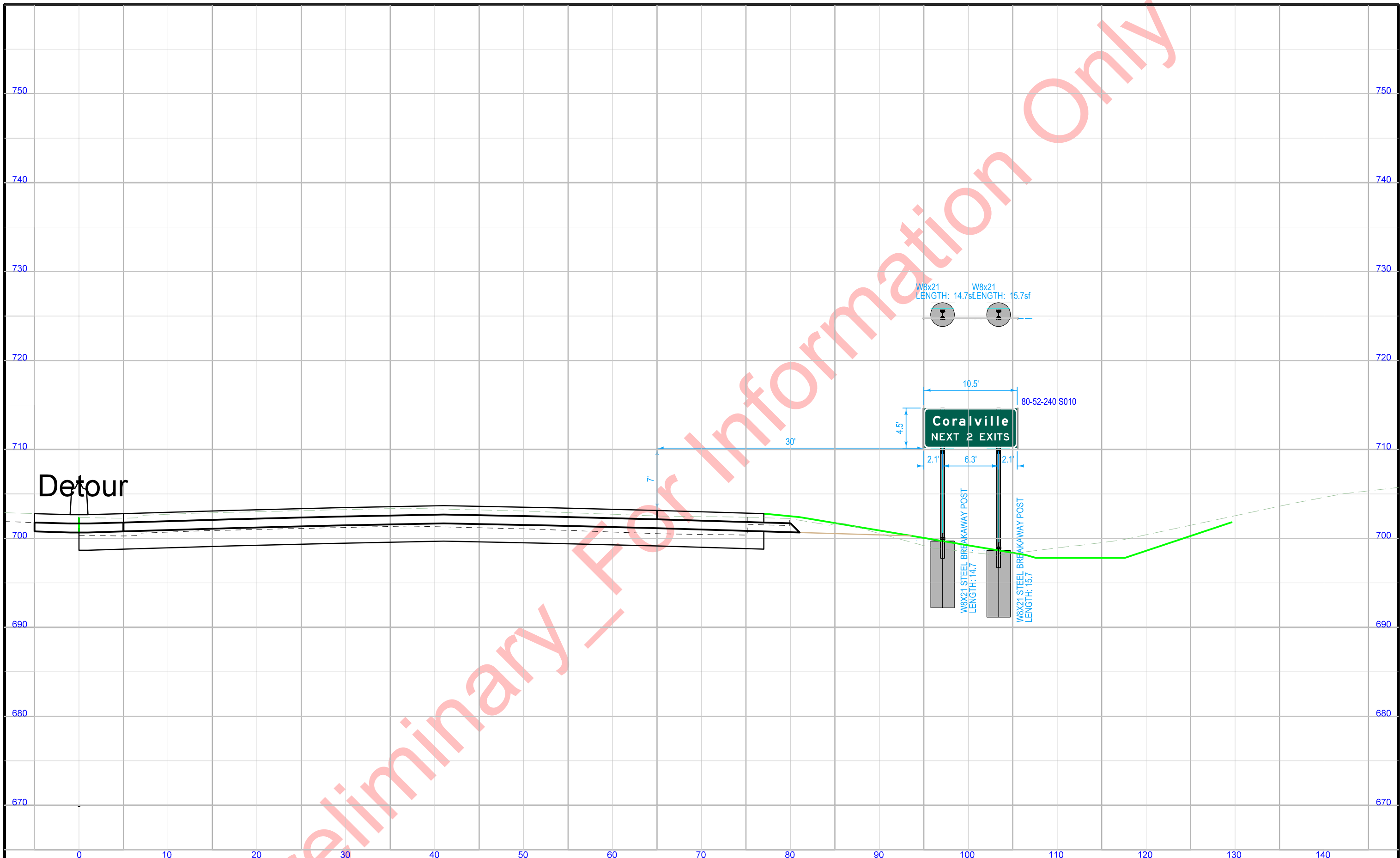

STA. 648+00\_3B (SUR080) VIEWED IN DIRECTION OF TRAVEL  
Proposed W8x21 Post and Foundation

Sign Reinstalled to This Location

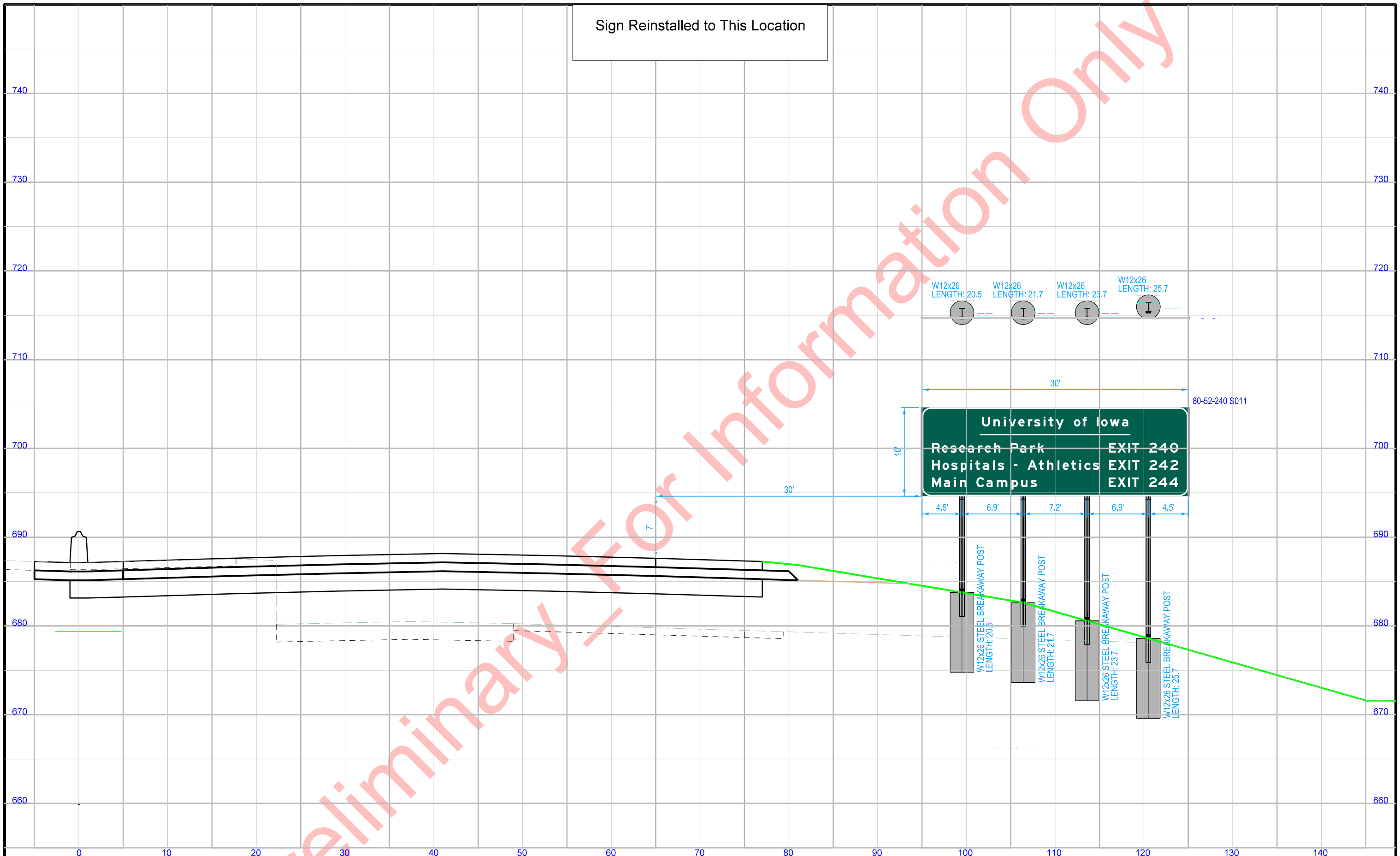

STA. 658+00\_3B (SUR080) VIEWED IN DIRECTION OF TRAVEL  
Proposed W12x26 Post and Foundation

Cedar Rapids/Waterloo installed this Stage  
Mount Pleasant/ Keokuk installed in  
future stage (3E)

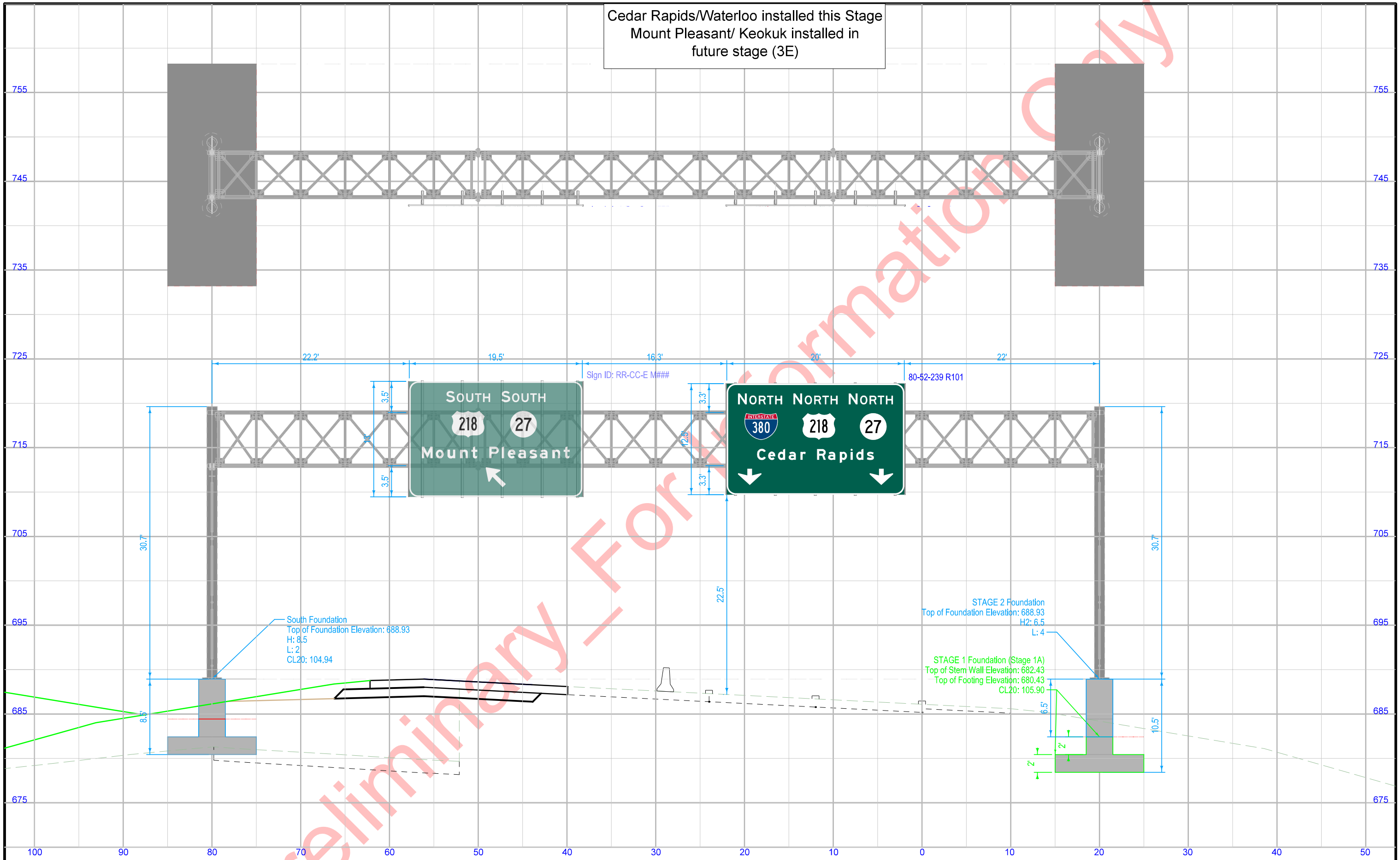

STA. 1558+75\_3C (ML380A) VIEWED IN DIRECTION OF TRAVEL  
Proposed SOST 100' Truss

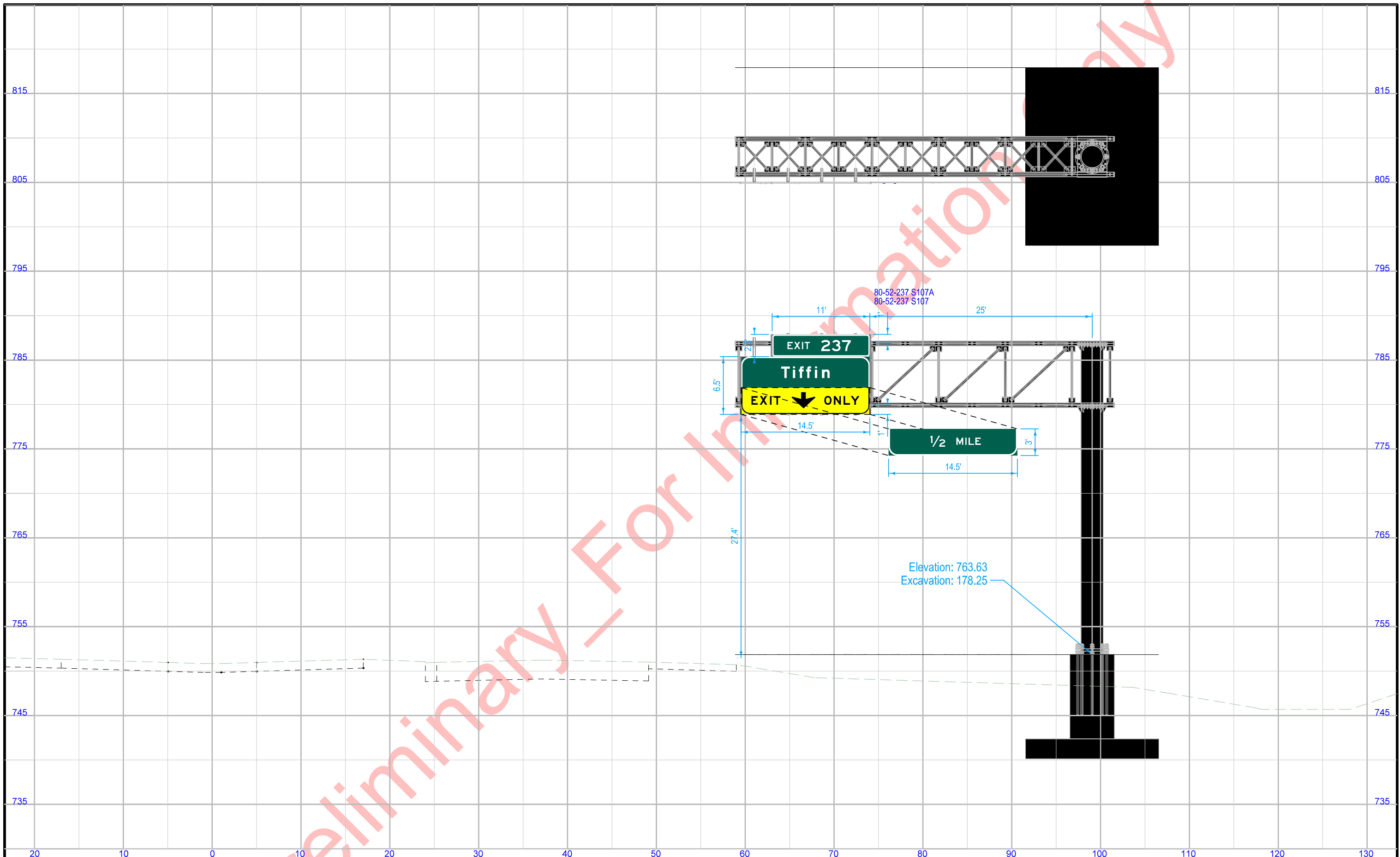

STA. 611+00\_3C (SUR080) VIEWED IN DIRECTION OF TRAVEL  
 Proposed SCST 39.5' Cantilever

Preliminary - For Information Only

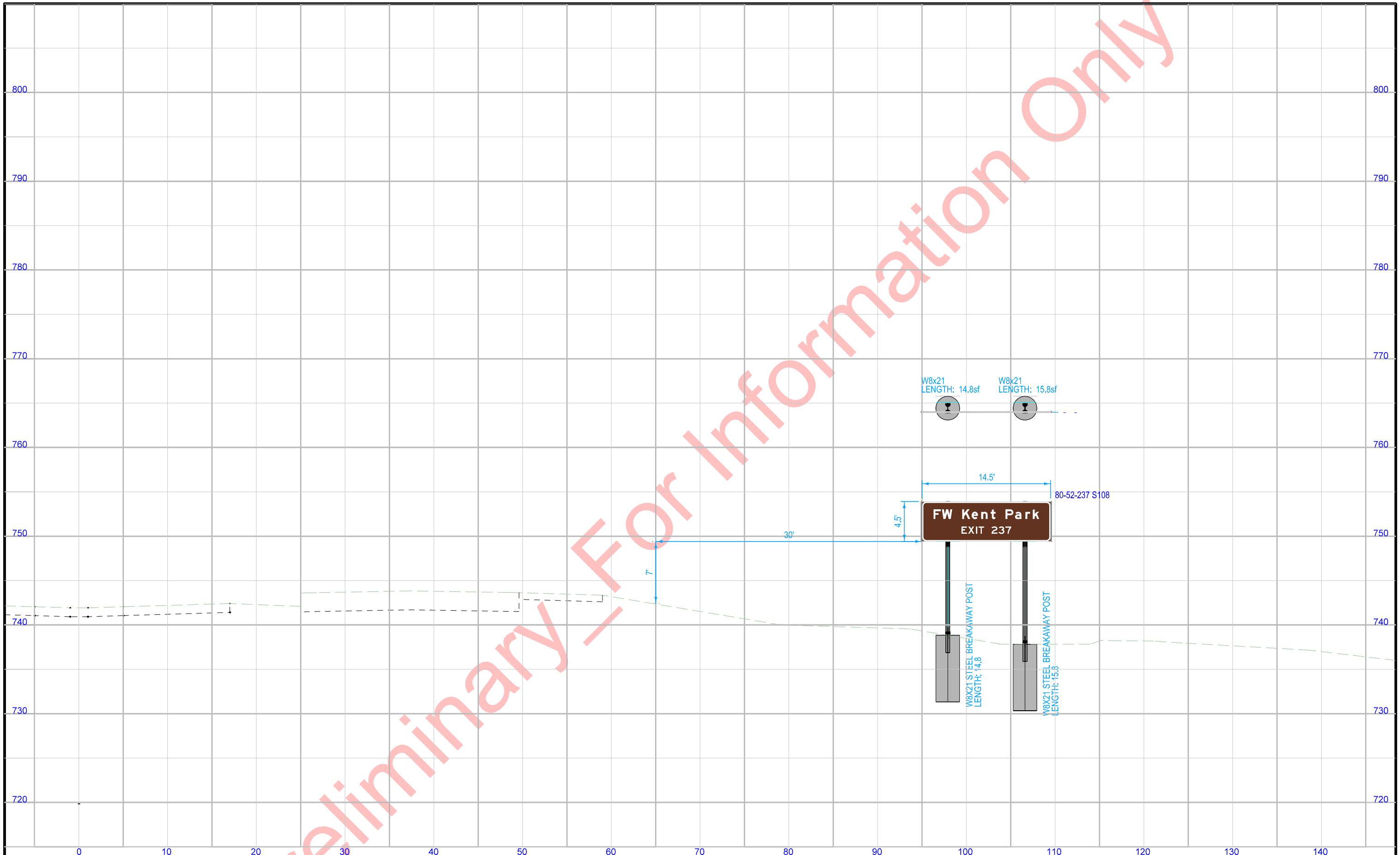

STA. 595+00\_3C (SUR080) VIEWED IN DIRECTION OF TRAVEL  
Proposed W8x21 Post and Foundation

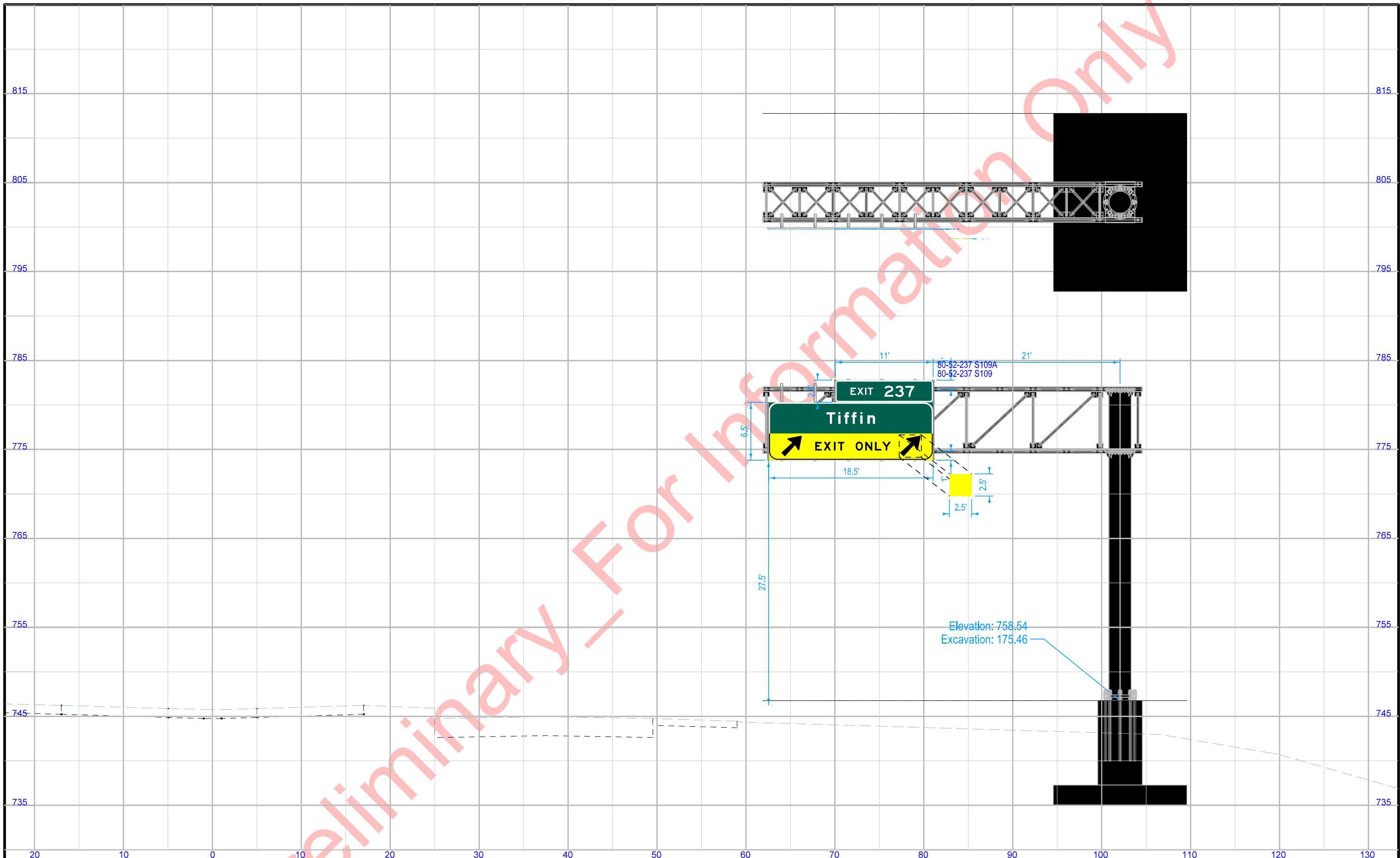

STA. 587+00\_3C (SUR080) VIEWED IN DIRECTION OF TRAVEL  
 Proposed SCST 39.5' Cantilever

Preliminary For Information Only

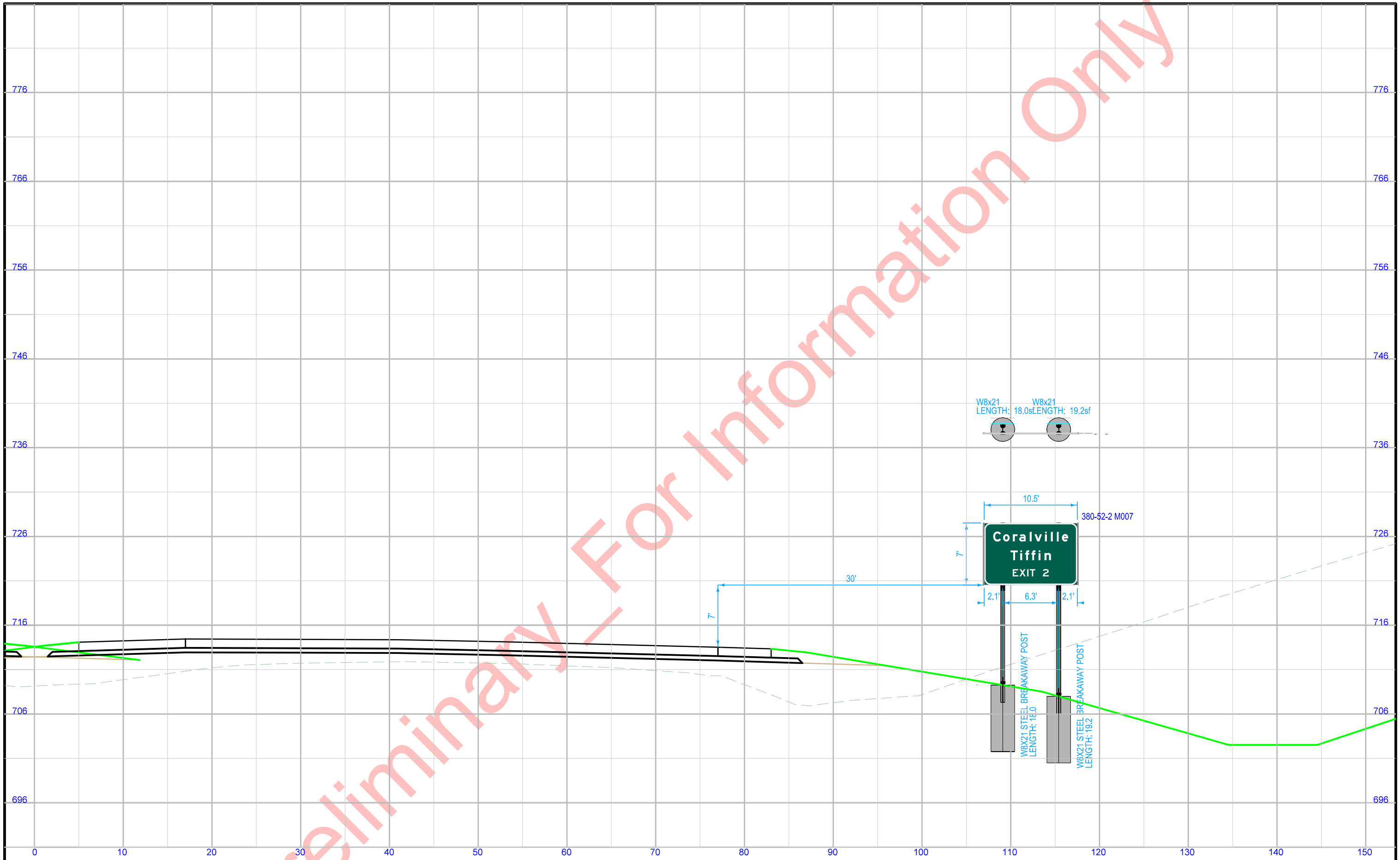

STA. 1210+00\_3C (ML380) VIEWED IN DIRECTION OF TRAVEL  
Proposed W8x21 Post and Foundation

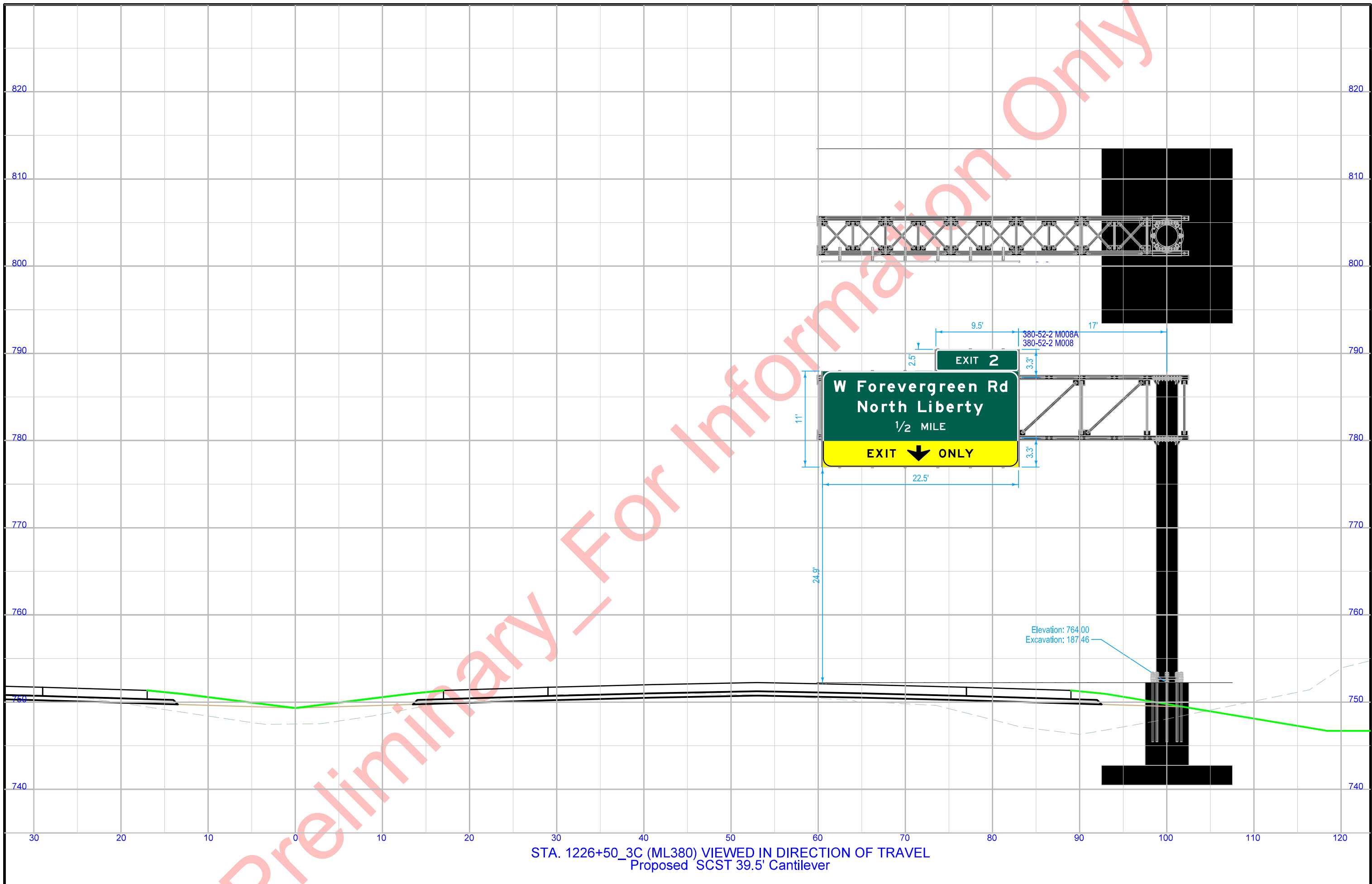



Preliminary For Information Only

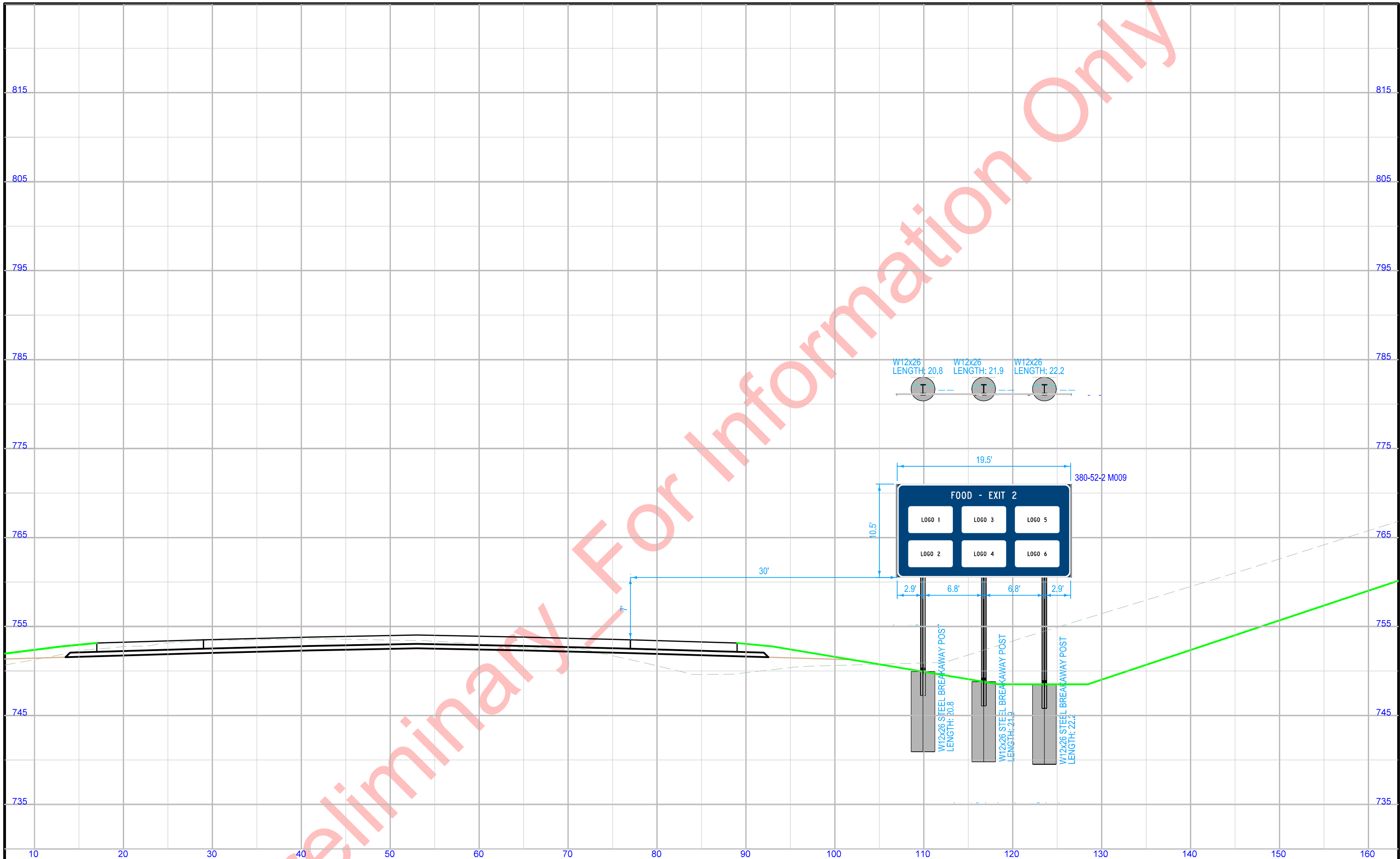

STA. 1234+50\_3C (ML380) VIEWED IN DIRECTION OF TRAVEL  
Proposed W12x26 Post and Foundation

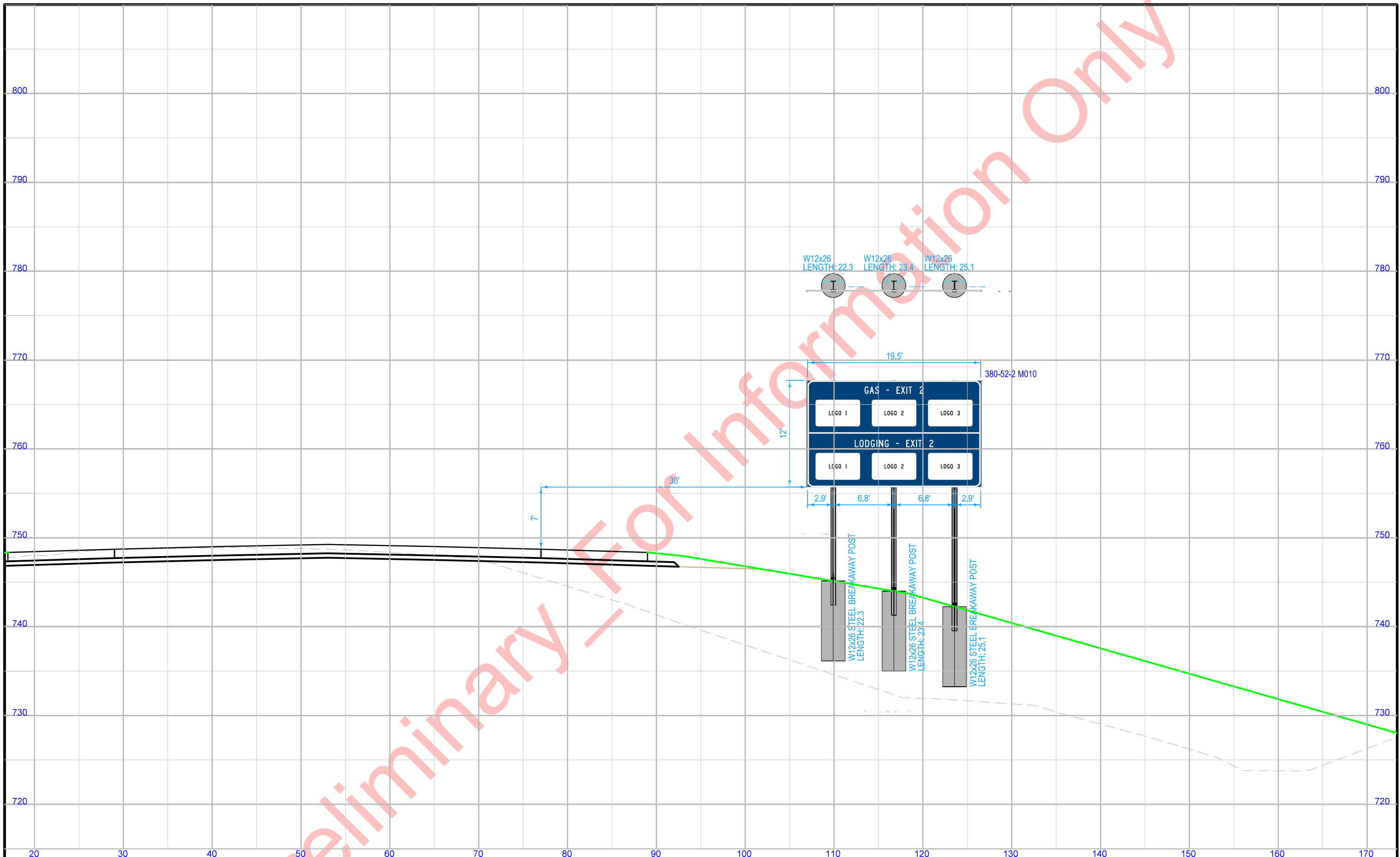

STA. 1242+50\_3C (ML380) VIEWED IN DIRECTION OF TRAVEL  
 Proposed W12x26 Post and Foundation

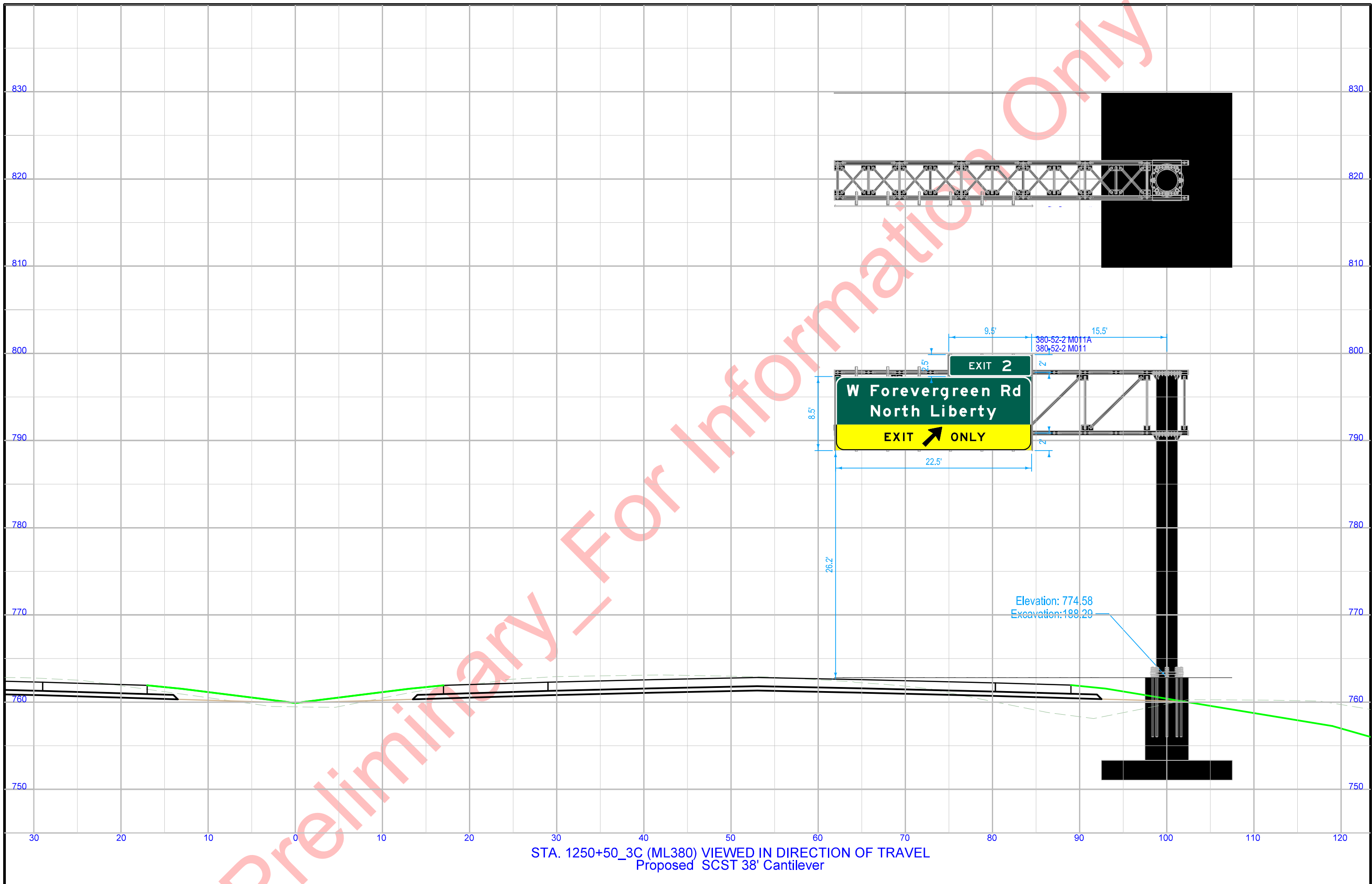

STA. 1250+50\_3C (ML380) VIEWED IN DIRECTION OF TRAVEL  
Proposed SCST 38' Cantilever

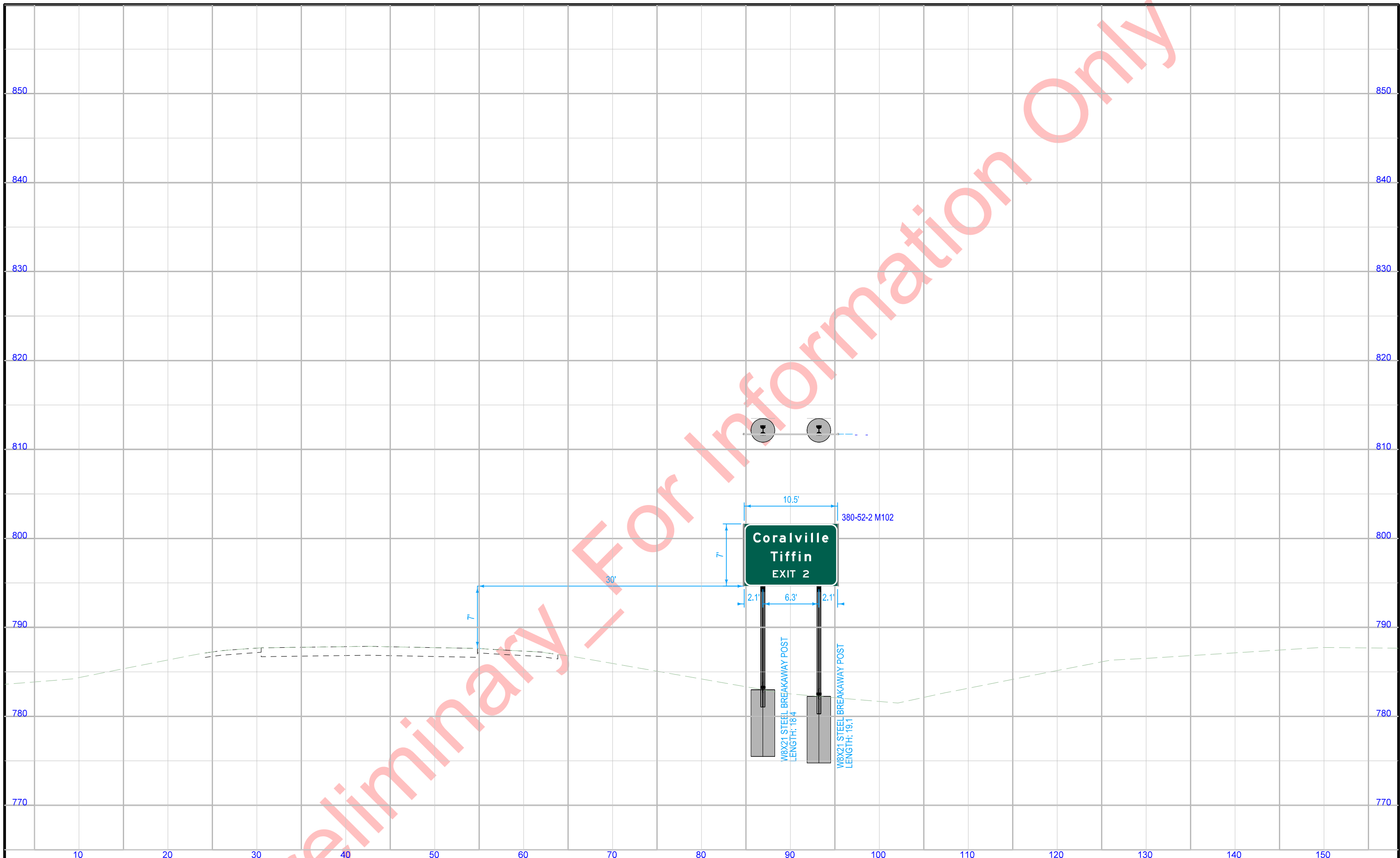

STA. 1337+50.3C (ML380) VIEWED IN DIRECTION OF TRAVEL  
Proposed W8x21 Post and Foundation

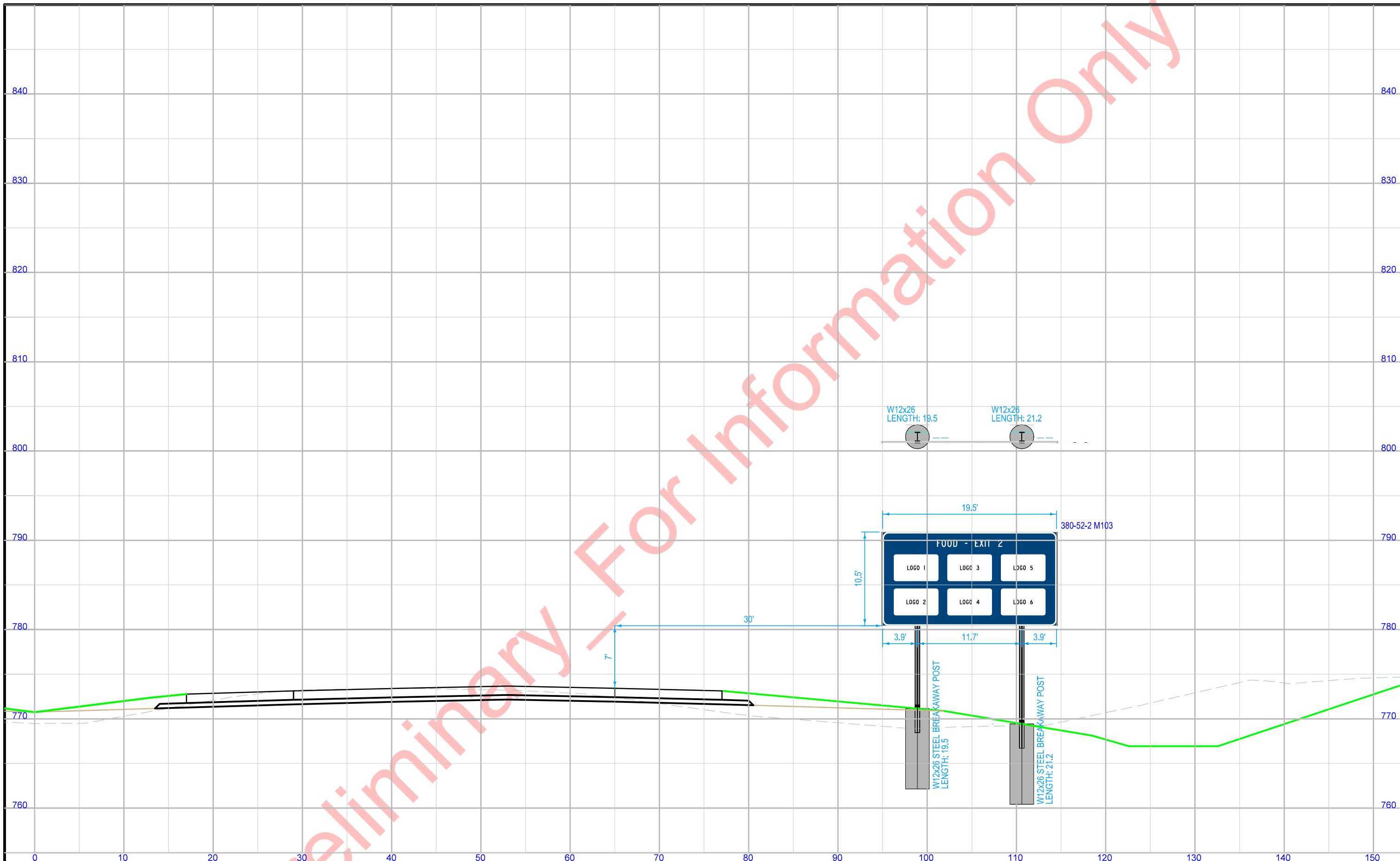

STA. 1318+50\_3C (ML380) VIEWED IN DIRECTION OF TRAVEL  
 Proposed W12x26 Post and Foundation

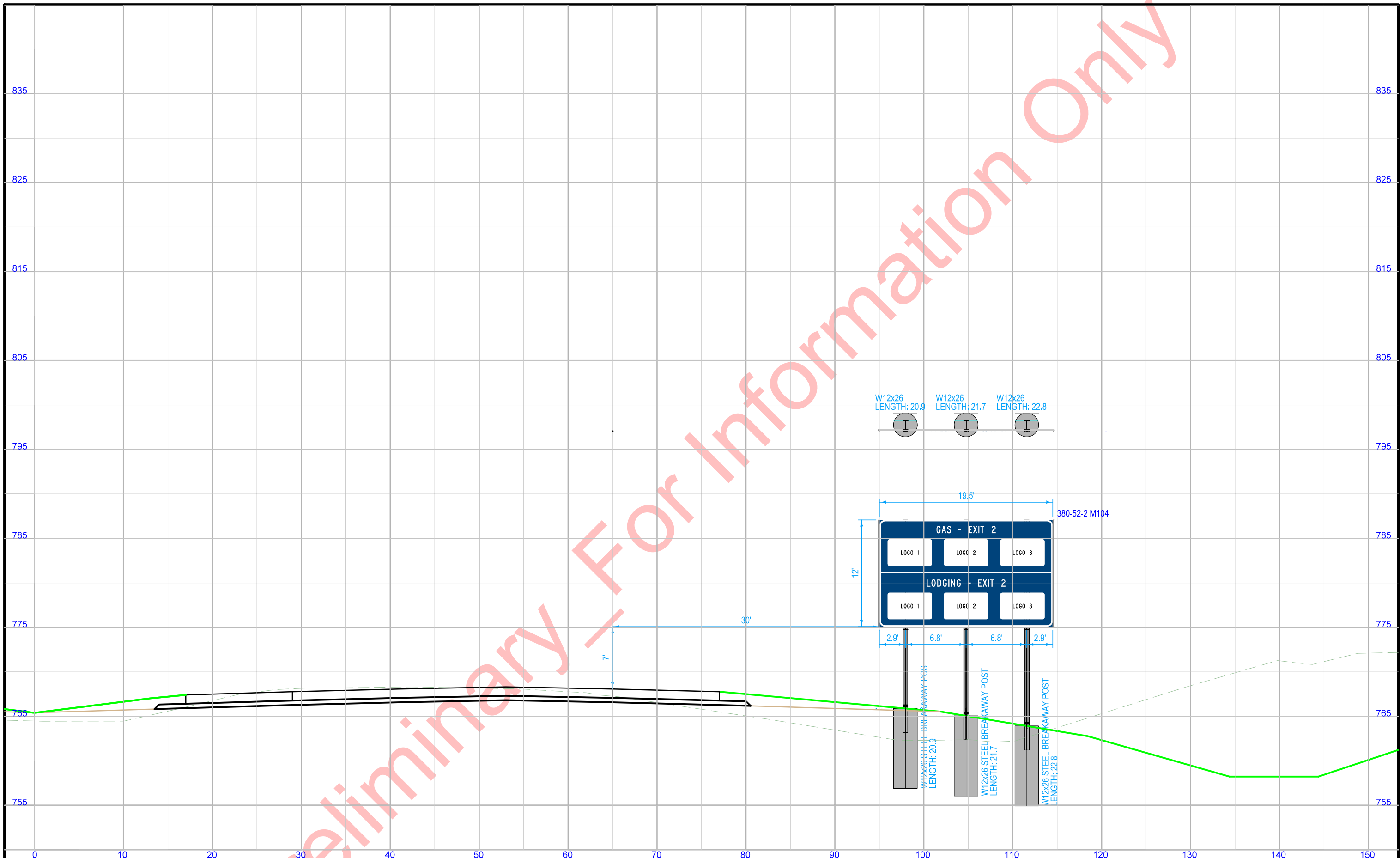

STA. 1310+50\_3C (ML380) VIEWED IN DIRECTION OF TRAVEL  
 Proposed W12x26 Post and Foundation

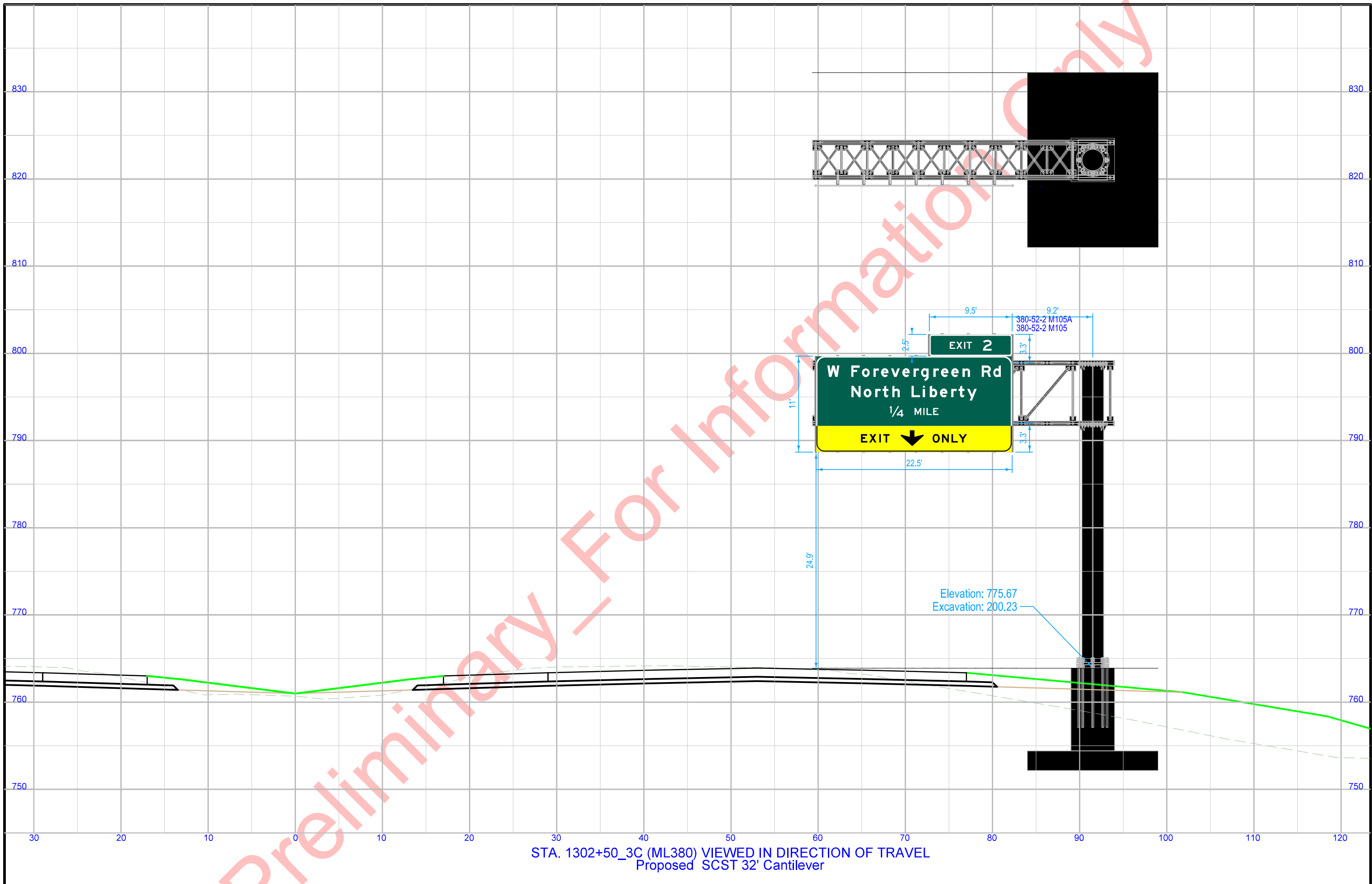

STA. 1302+50\_3C (ML380) VIEWED IN DIRECTION OF TRAVEL  
Proposed SCST 32' Cantilever

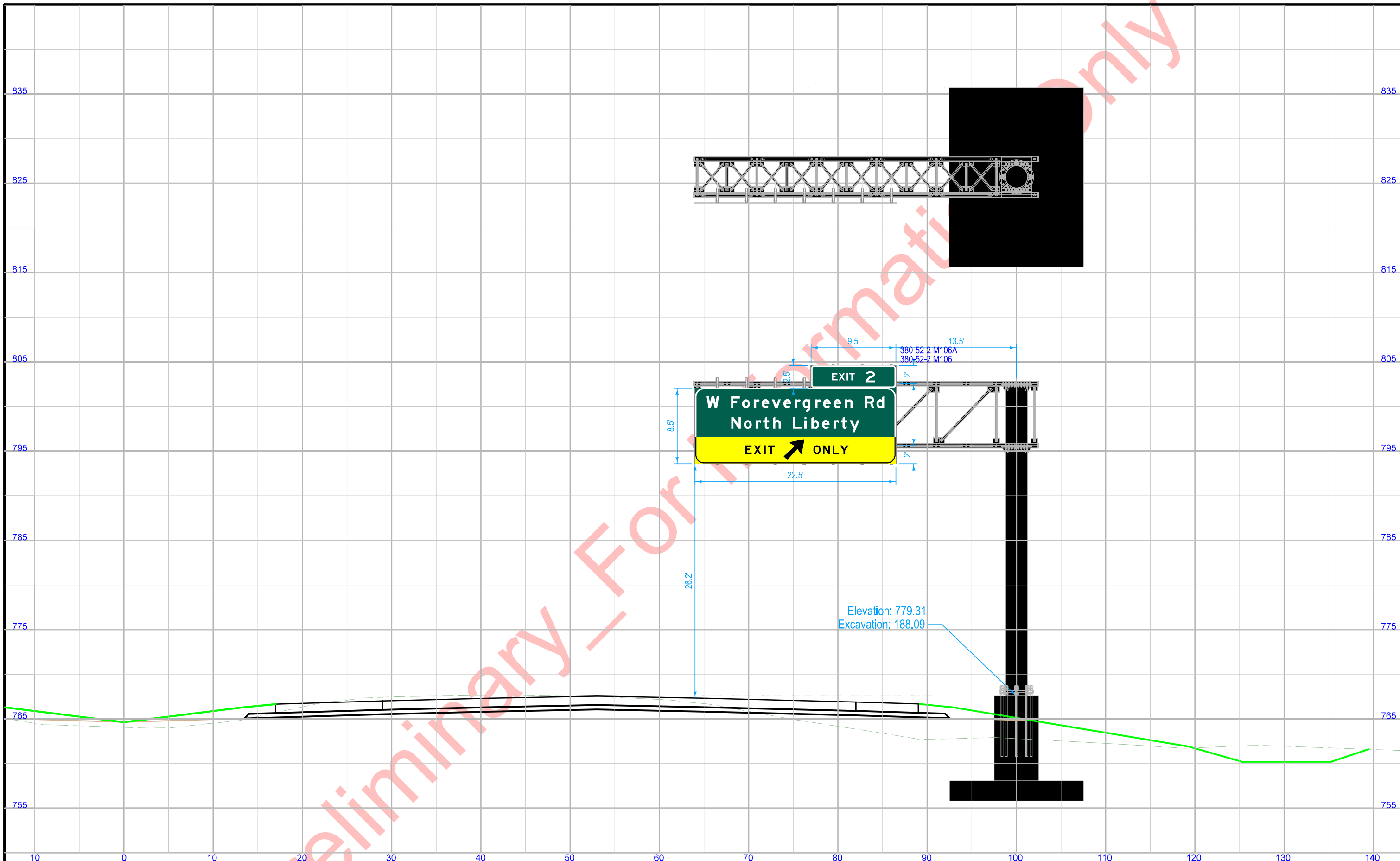

STA. 1292+50\_3C (ML380) VIEWED IN DIRECTION OF TRAVEL  
Proposed SCST 36' Cantilever



Preliminary - For Information Only

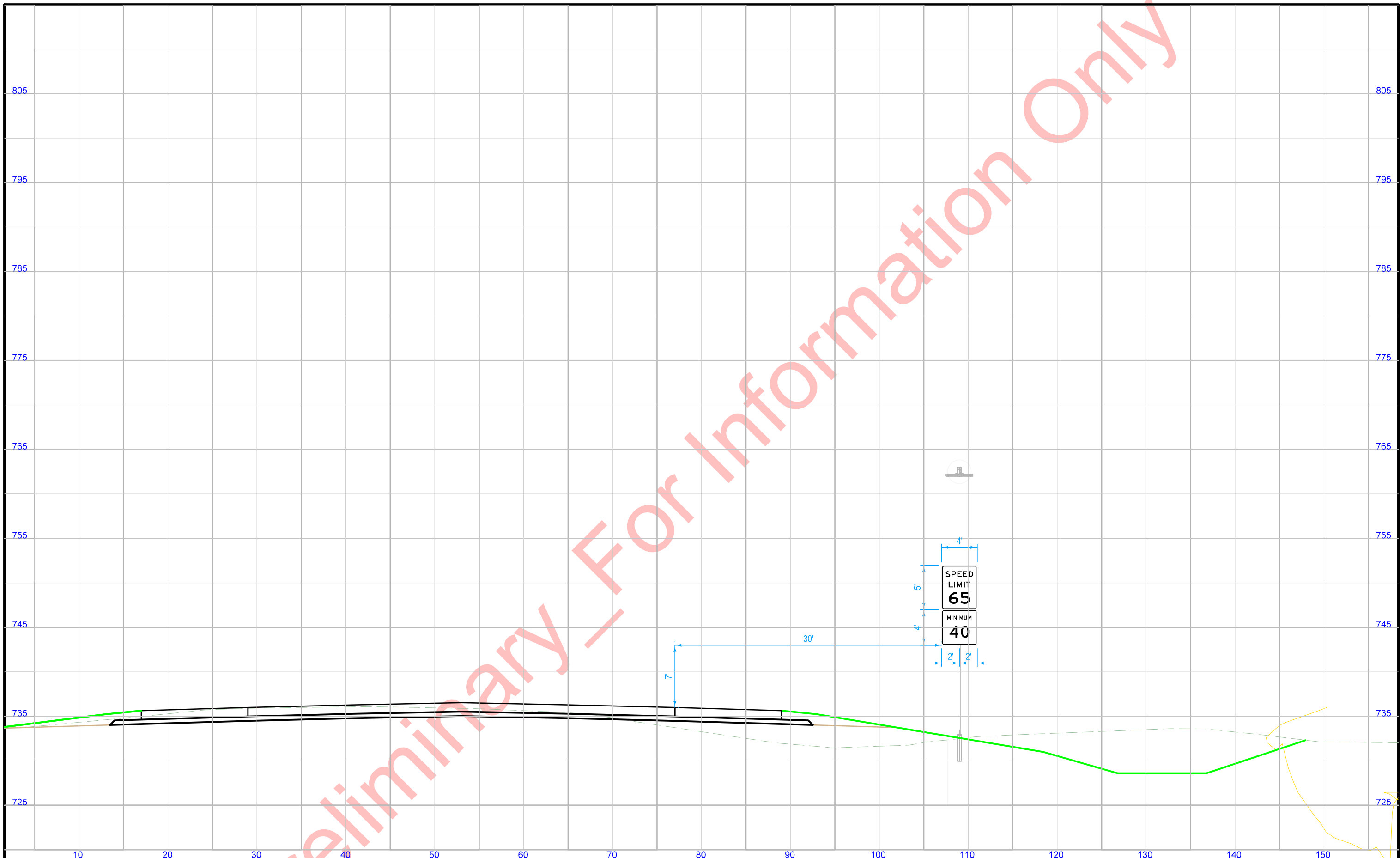

STA. 1219+00\_3C (ML030) VIEWED IN DIRECTION OF TRAVEL  
Proposed 4"x6" Rectangular Steel Post

Sign Shown for Design Purposes  
will be Installed in Future Stage (3D)

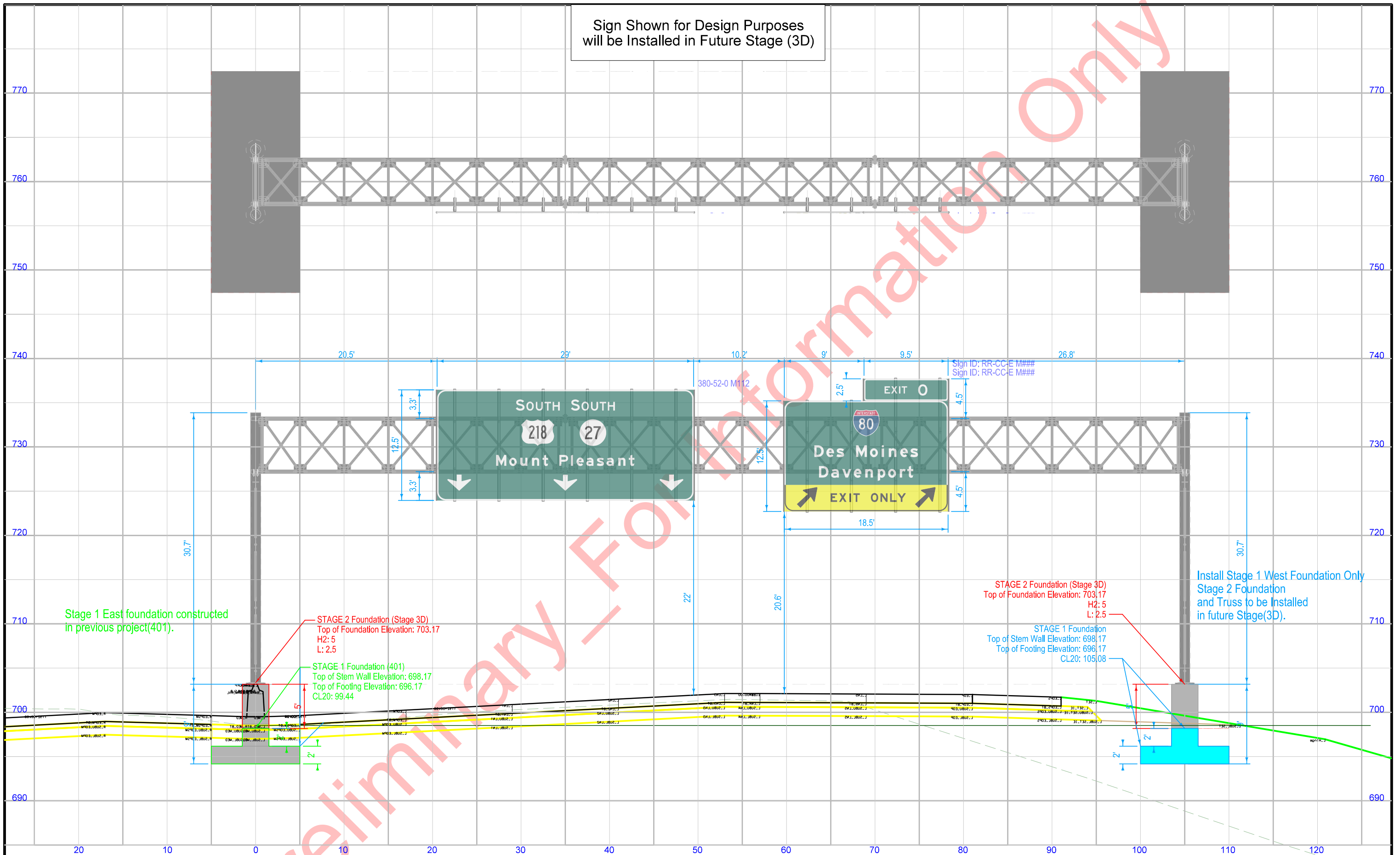

STA. 1192+00\_3C (ML380) VIEWED IN DIRECTION OF TRAVEL  
Proposed SOST 105' Truss (West Foundation Only)

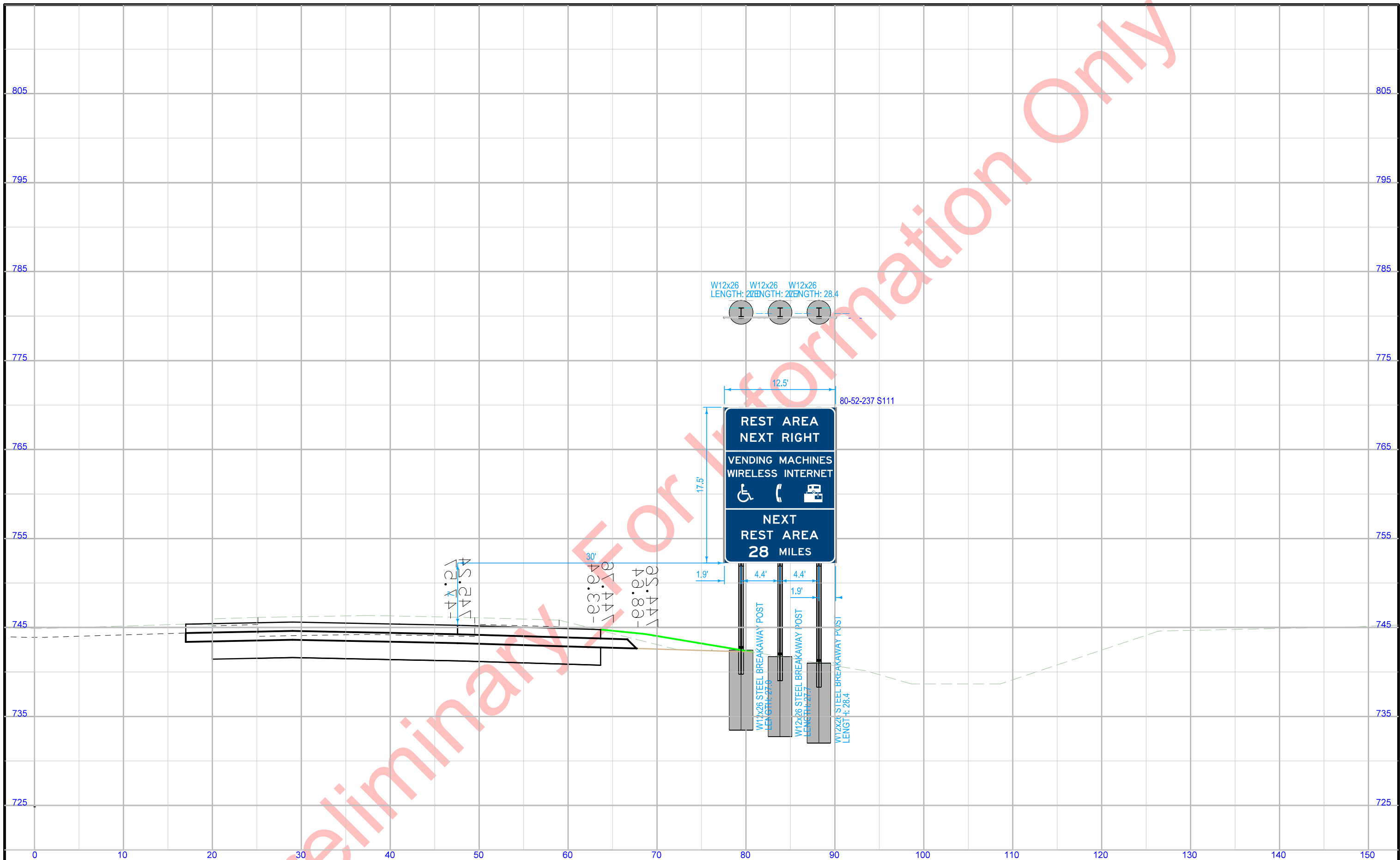

STA. 569+00 3D (SUR080) VIEWED IN DIRECTION OF TRAVEL  
Proposed W12x26 Post and Foundation

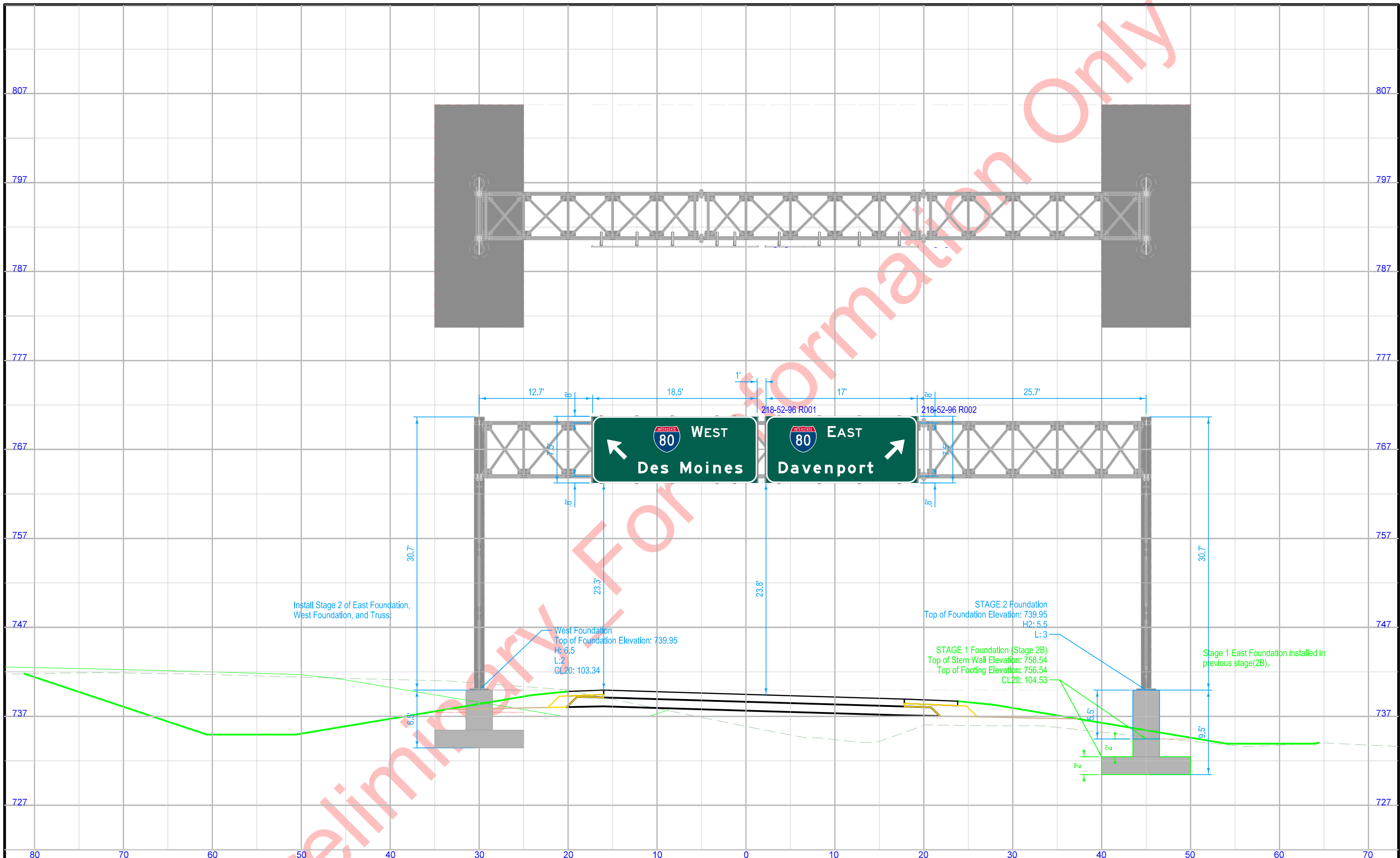

STA. 5579+50\_3D (ML380E) VIEWED IN DIRECTION OF TRAVEL  
Proposed SOST 75' Truss

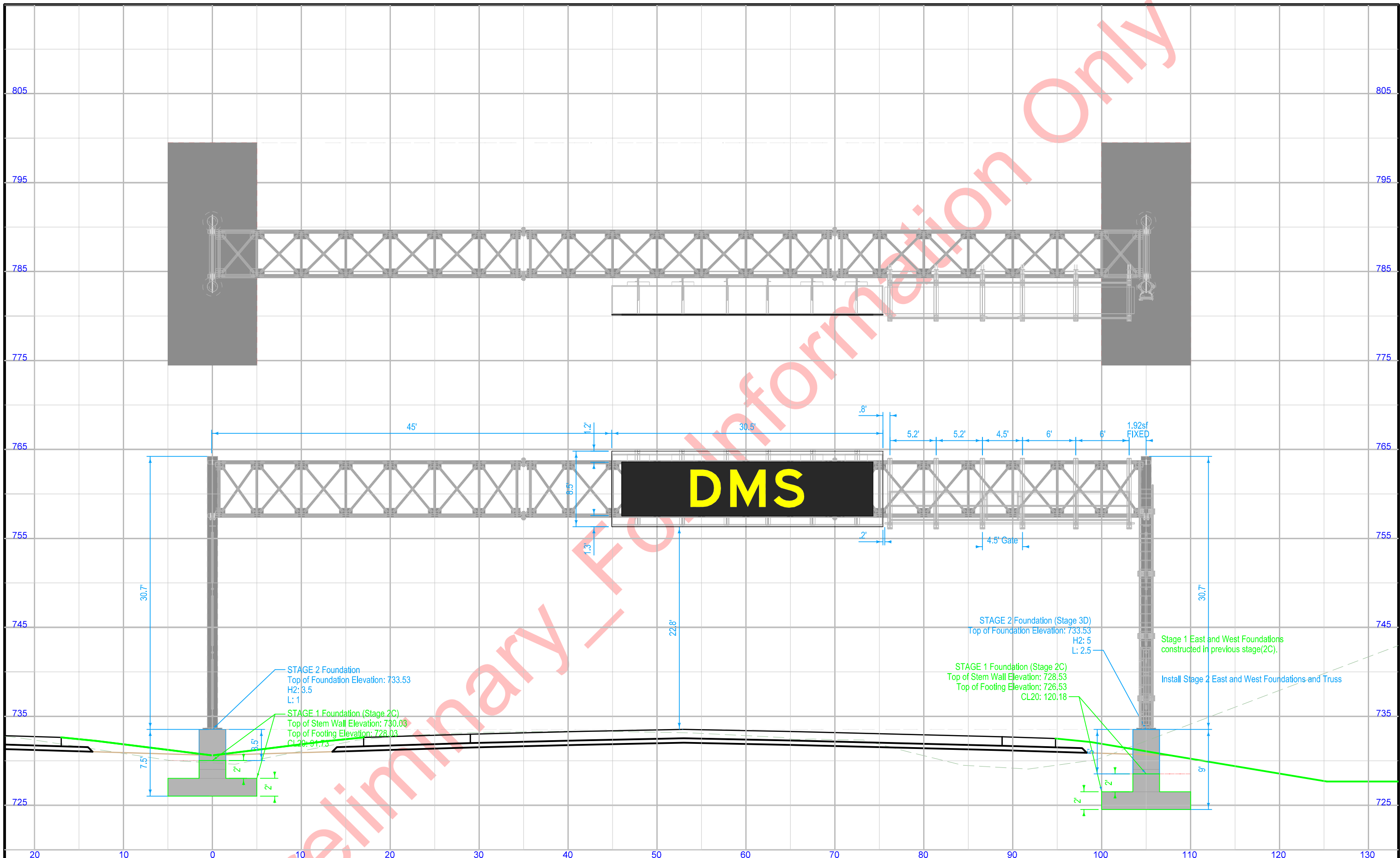

**DMS**

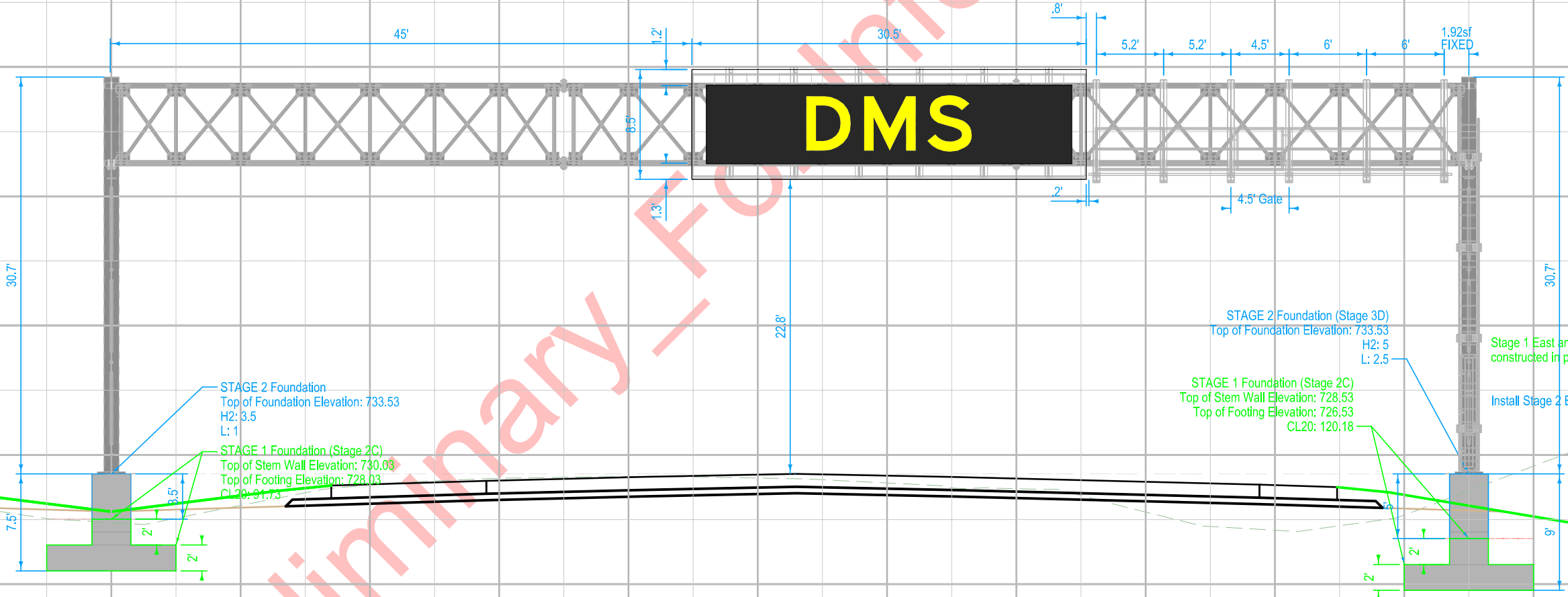

STAGE 2 Foundation  
 Top of Foundation Elevation: 733.53  
 H2: 3.5  
 L: 1

STAGE 1 Foundation (Stage 2C)  
 Top of Stem Wall Elevation: 730.03  
 Top of Footing Elevation: 728.03  
 CL20: 91.73

STAGE 2 Foundation (Stage 3D)  
 Top of Foundation Elevation: 733.53  
 H2: 5  
 L: 2.5

STAGE 1 Foundation (Stage 2C)  
 Top of Stem Wall Elevation: 728.53  
 Top of Footing Elevation: 726.53  
 CL20: 120.18

Stage 1 East and West Foundations  
 constructed in previous stage(2C).

Install Stage 2 East and West Foundations and Truss

STA. 1218+00\_3D (ML380) VIEWED IN DIRECTION OF TRAVEL  
 Proposed SOST 105' Truss

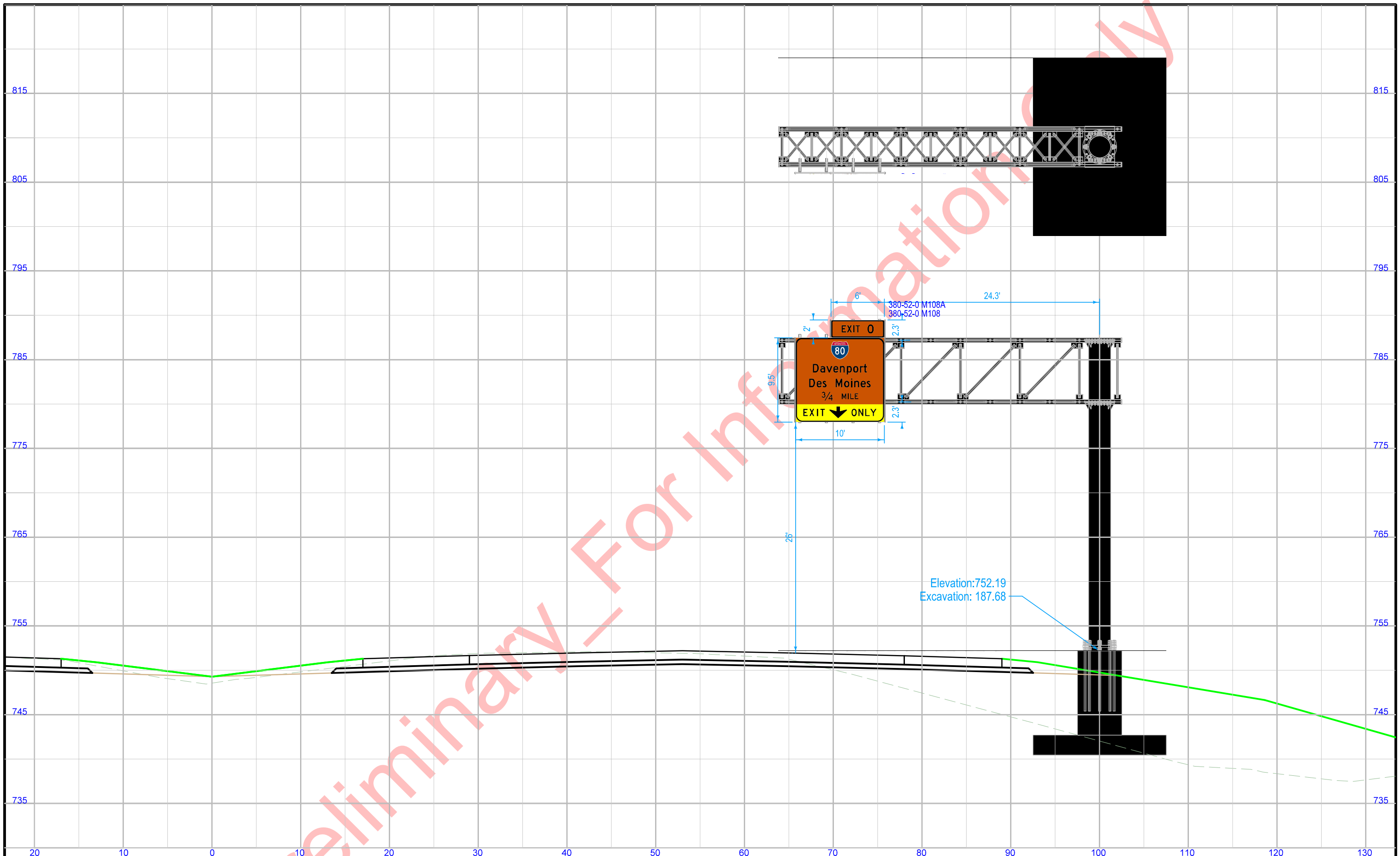

STA. 1245+50\_3E (ML380) VIEWED IN DIRECTION OF TRAVEL  
Proposed SCST 36' Cantilever

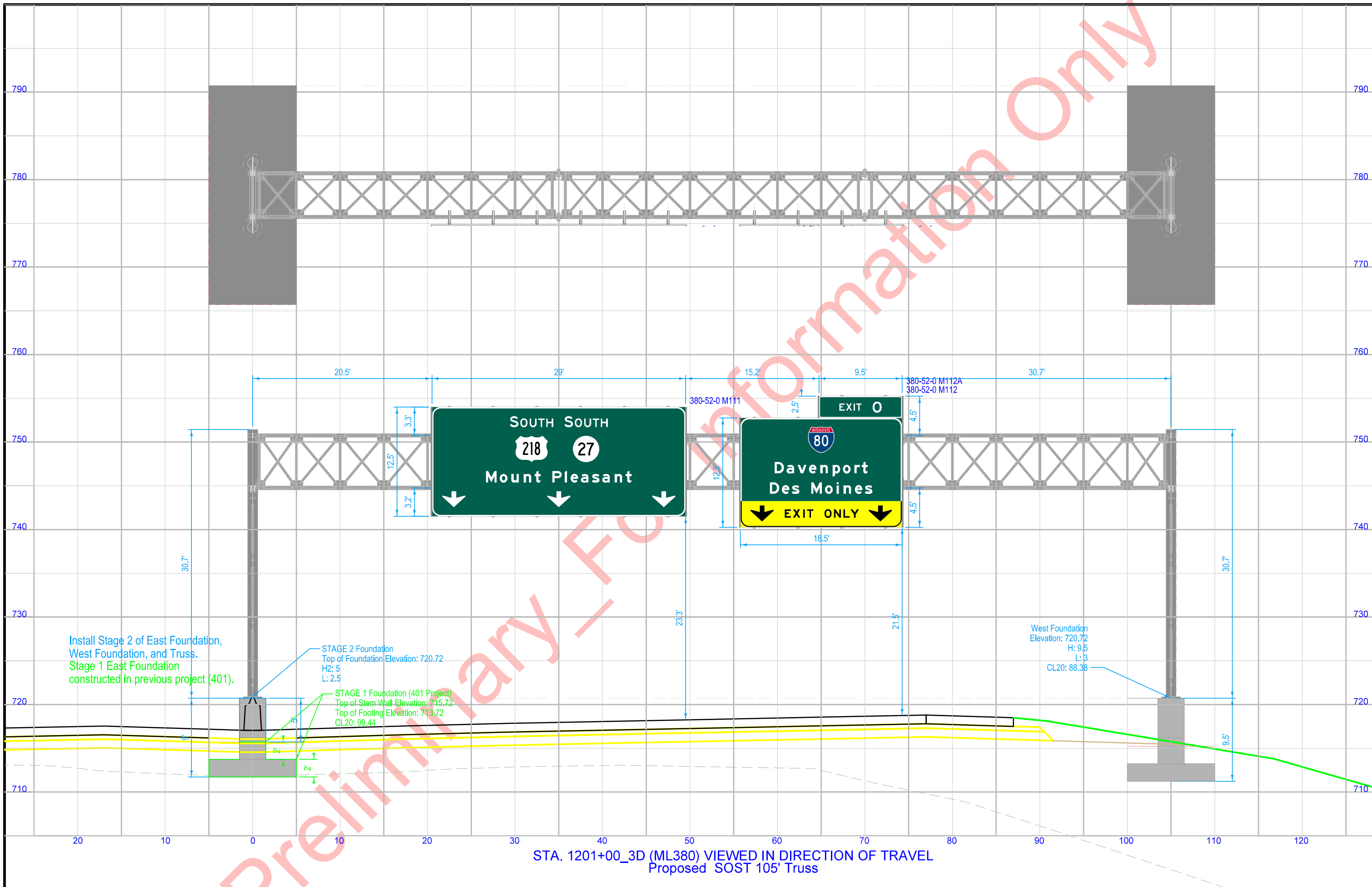

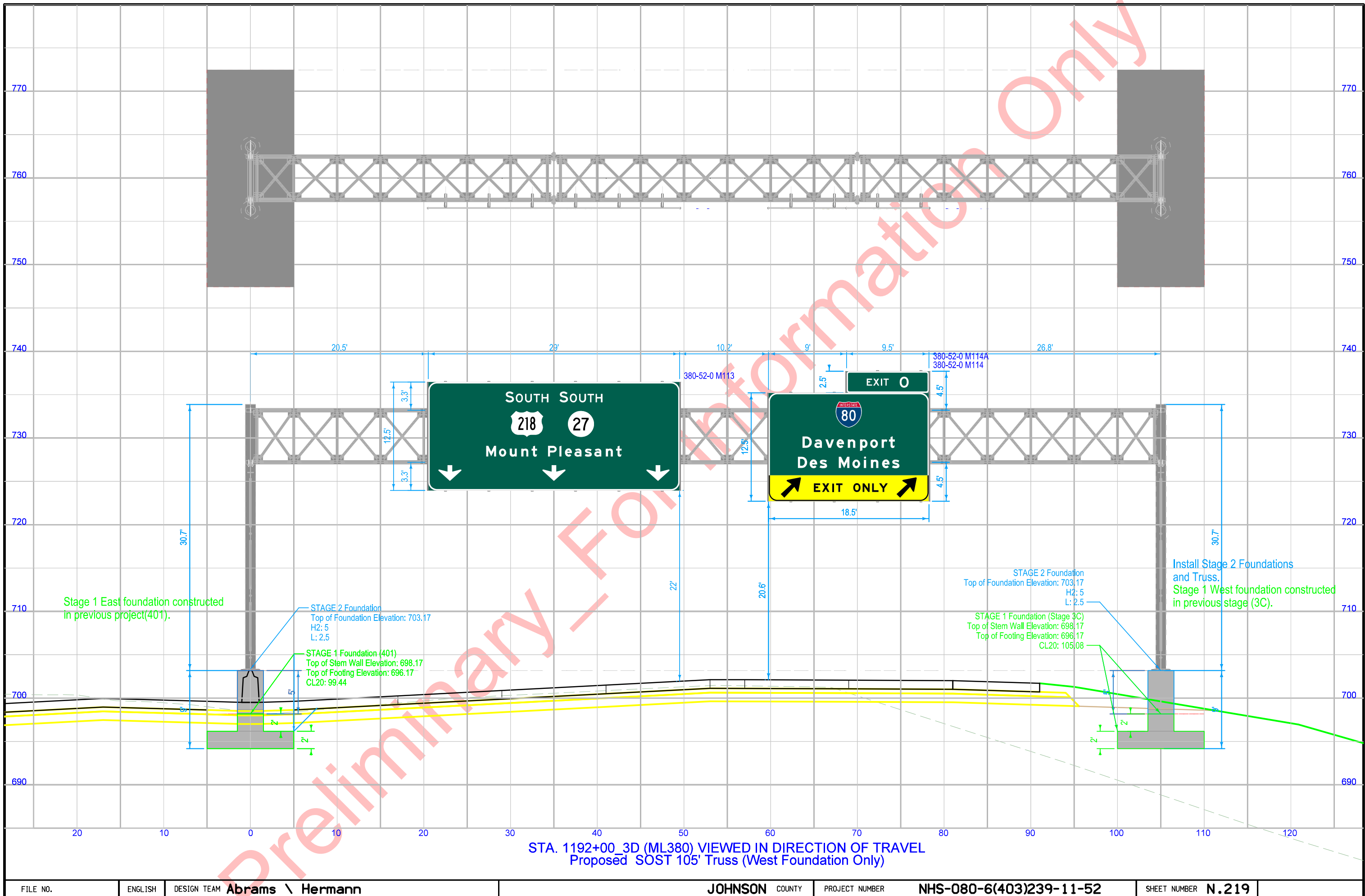

STA. 1192+00\_3D (ML380) VIEWED IN DIRECTION OF TRAVEL  
Proposed SOST 105' Truss (West Foundation Only)



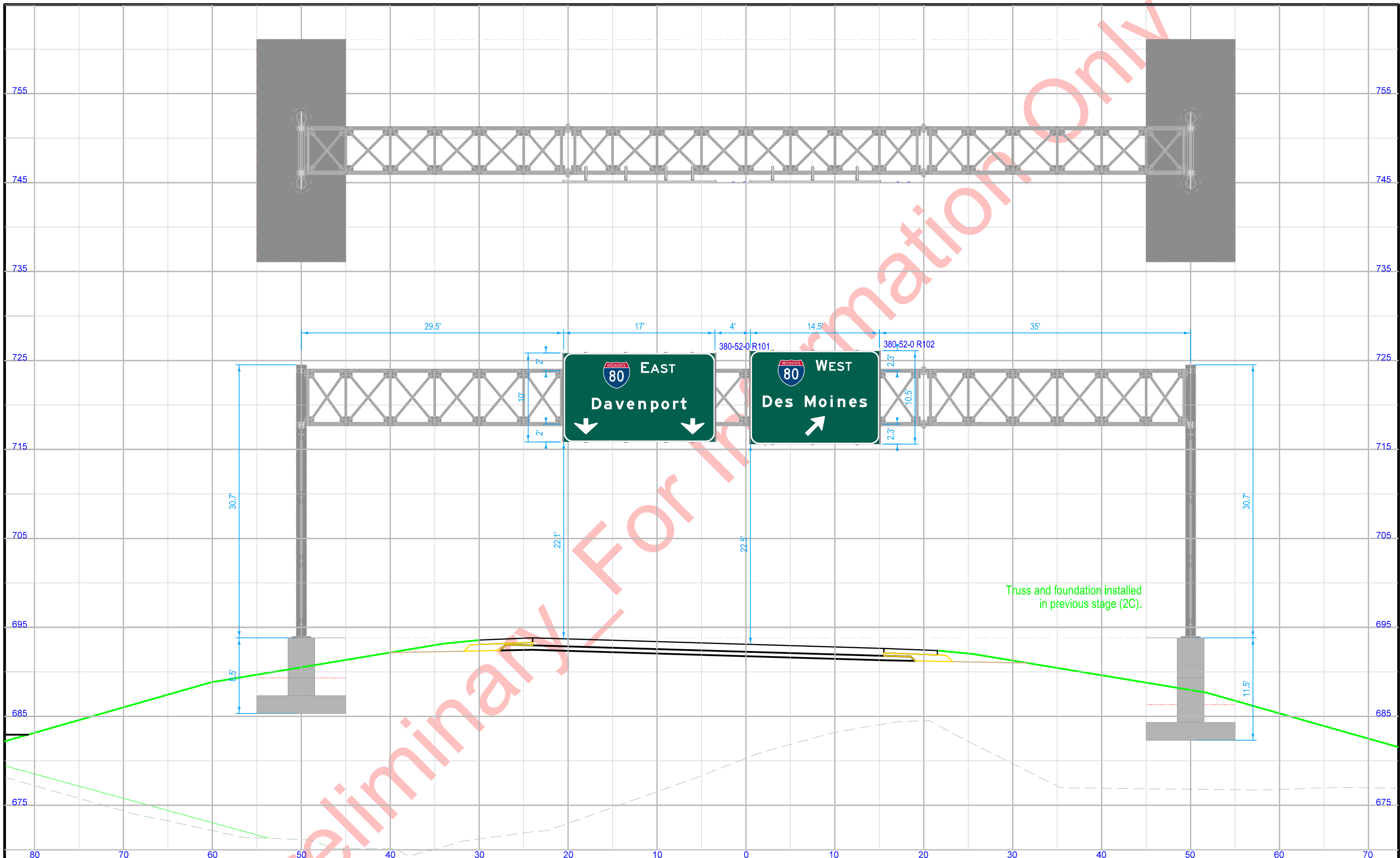

STA. 6511+50\_3D (ML380F) VIEWED IN DIRECTION OF TRAVEL  
 Existing SOST 100' Truss

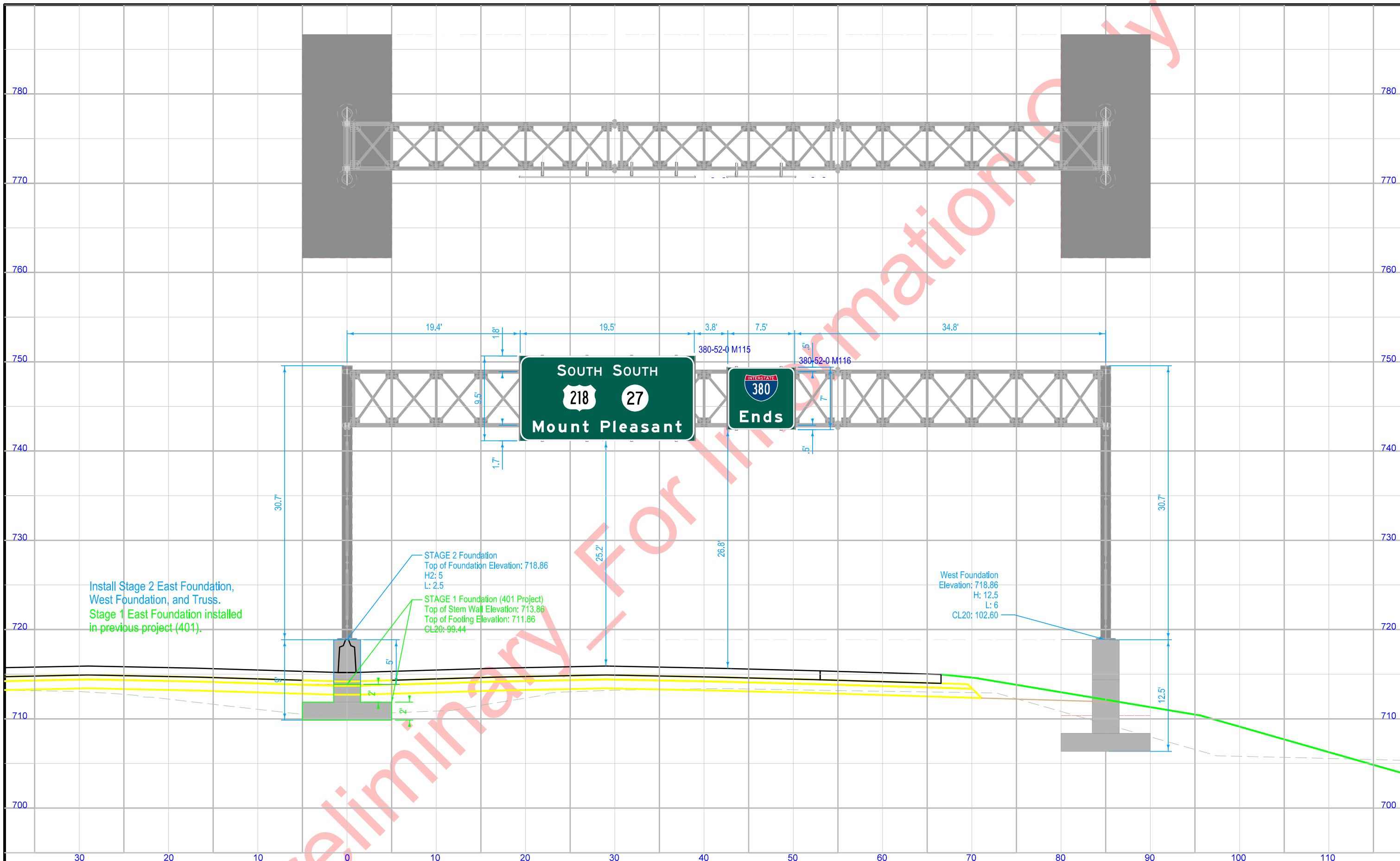

STA. 1173+00\_3D (ML380) VIEWED IN DIRECTION OF TRAVEL  
Proposed SOST 85' Truss

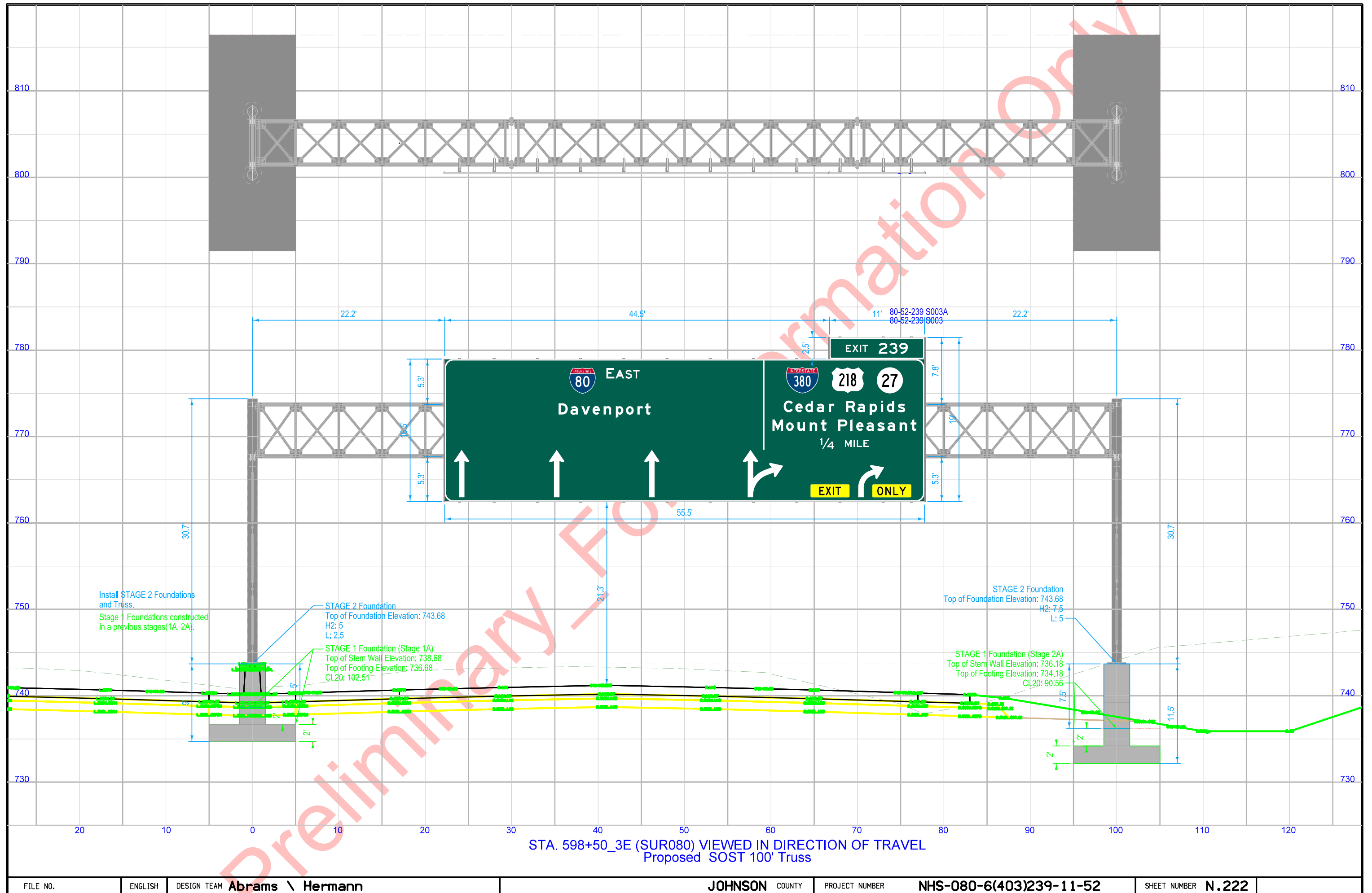

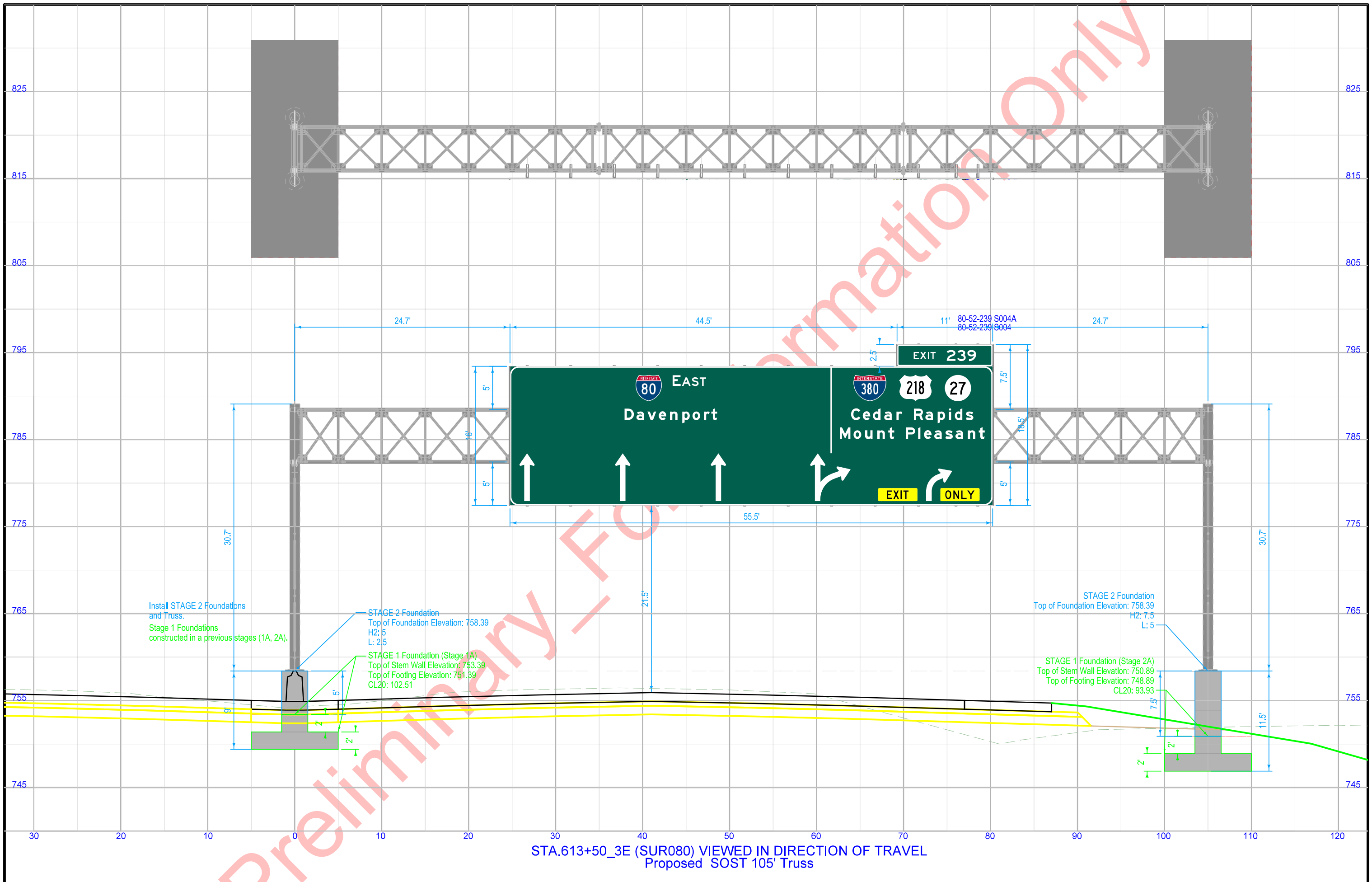

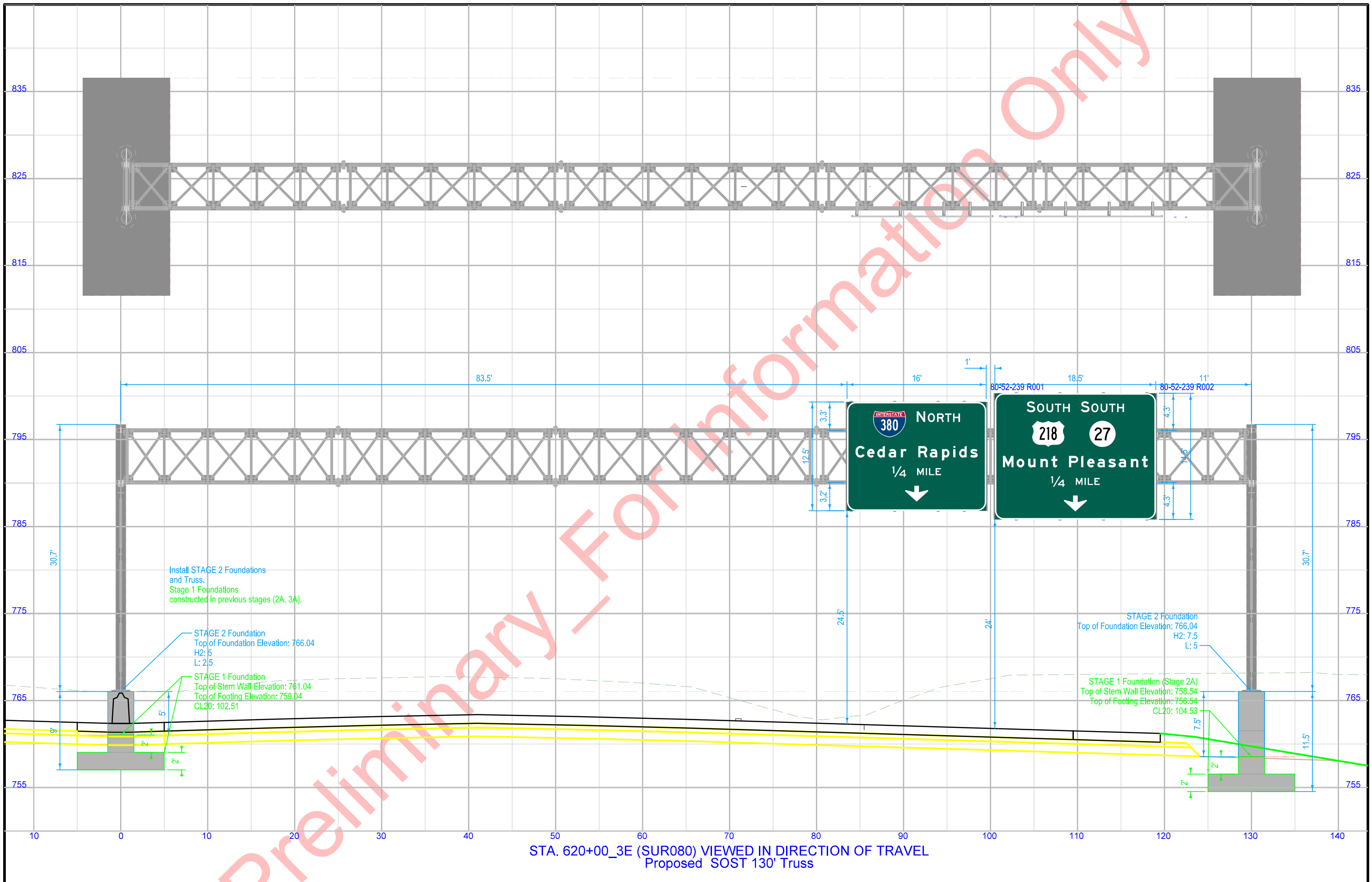

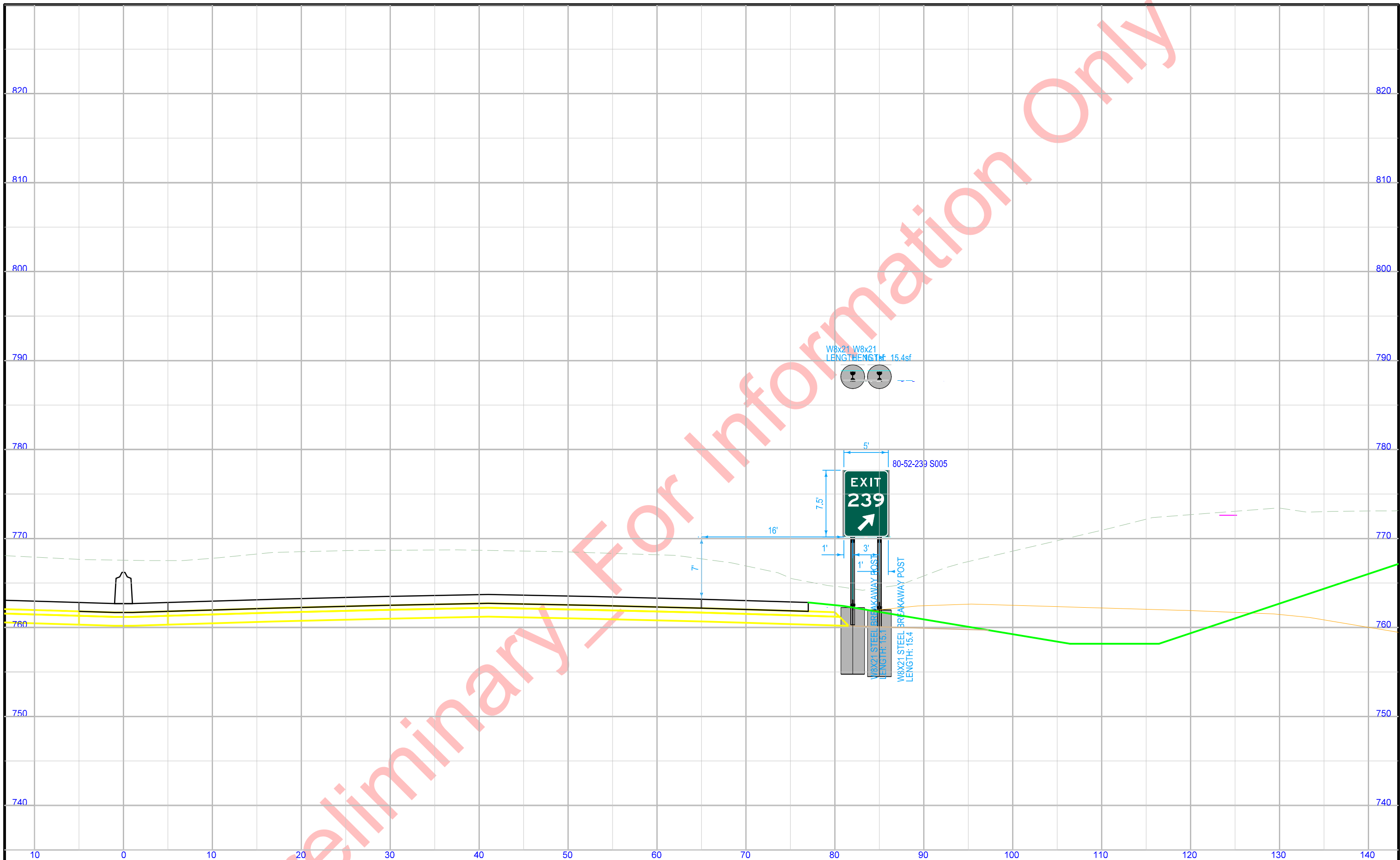

STA. 622+00\_3E (SUR080) VIEWED IN DIRECTION OF TRAVEL  
 Proposed W8x21 Post and Foundation

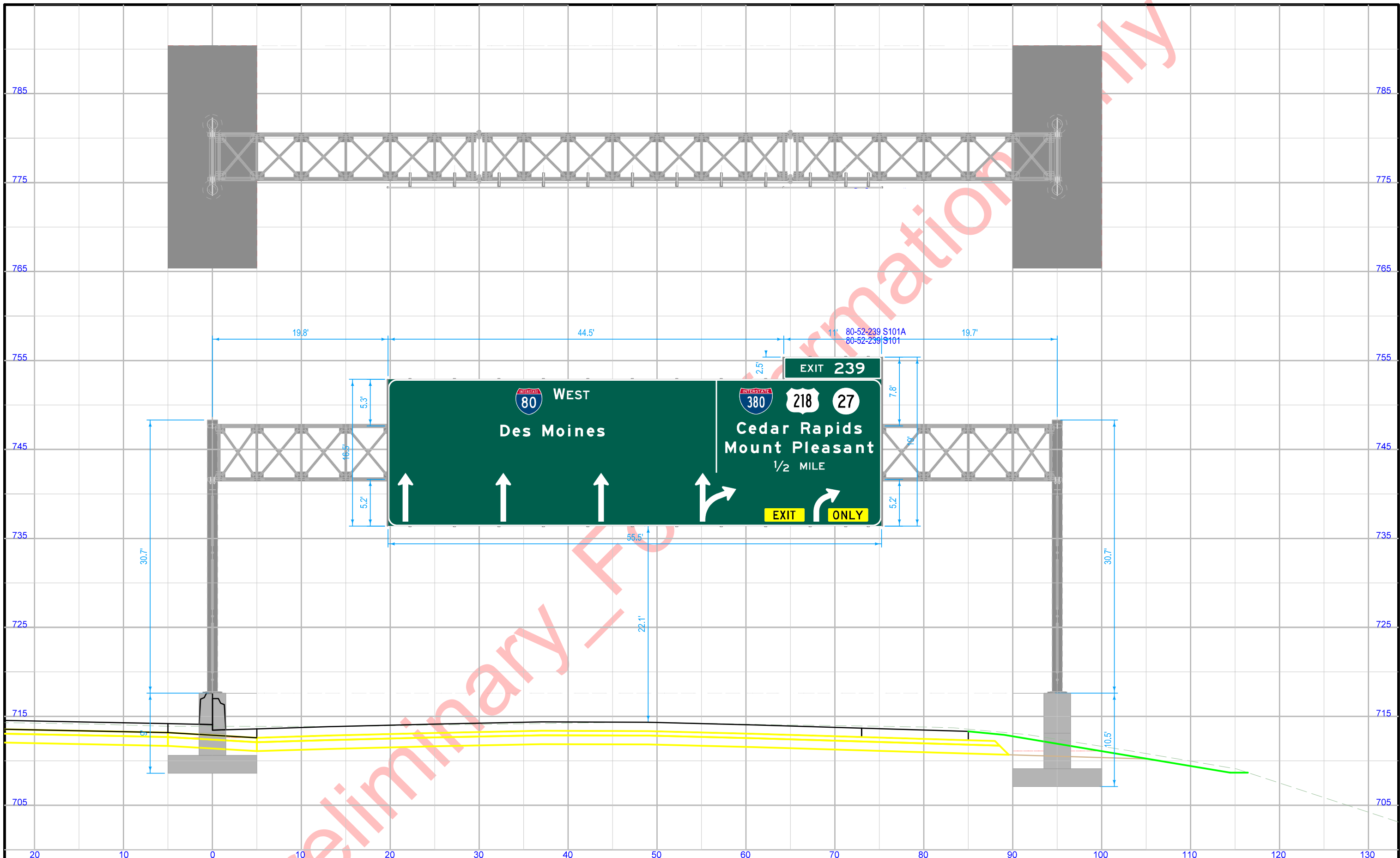

STA. 697+50\_3E (SUR080) VIEWED IN DIRECTION OF TRAVEL  
 Existing SOST 95' Truss

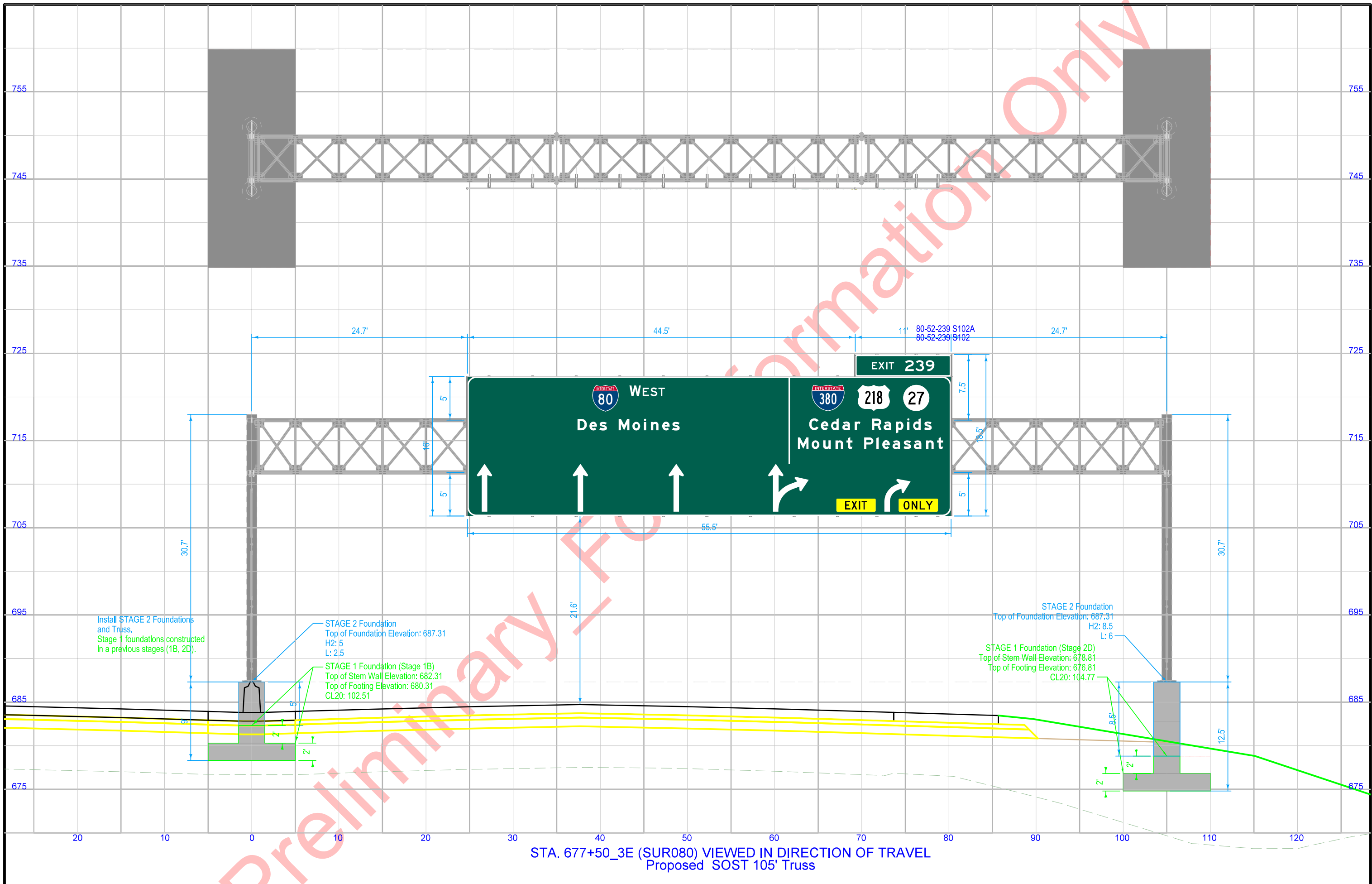



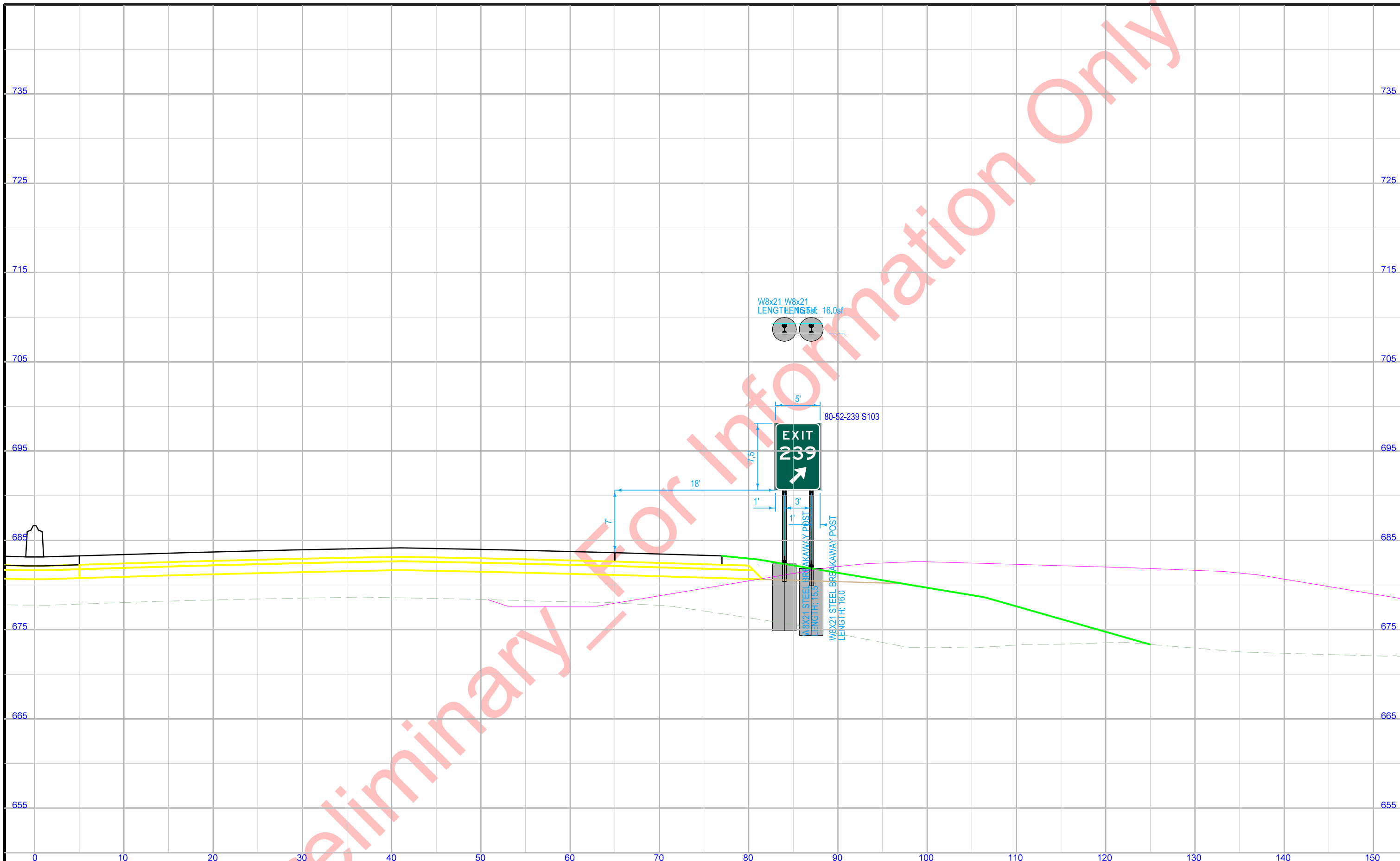

STA. 666+00\_3E (SUR080) VIEWED IN DIRECTION OF TRAVEL  
 Proposed W8x21 Post and Foundation

Cedar Rapids/Waterloo Previously installed (3C)  
Mount Pleasant/ Keokuk installed this Stage

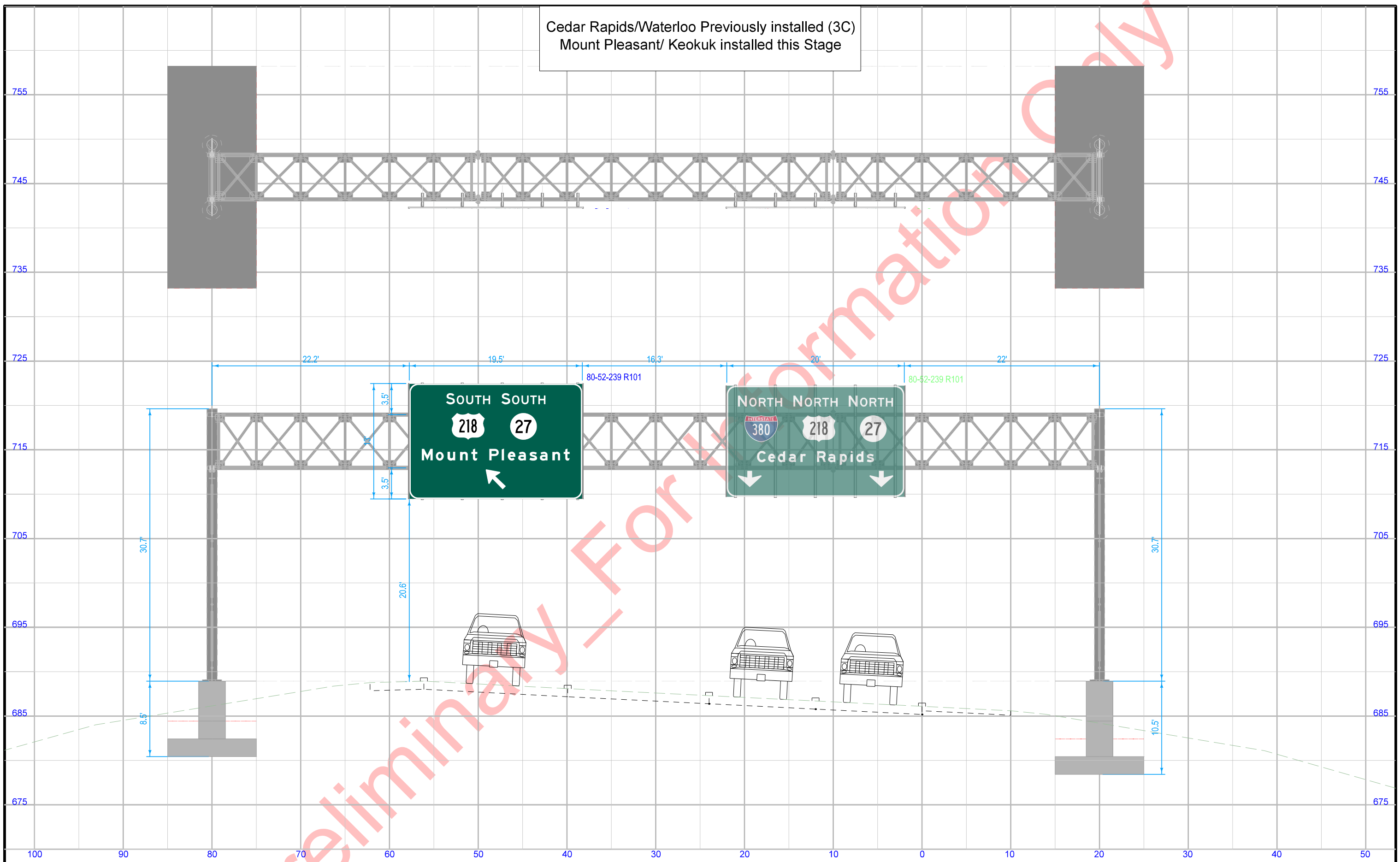

STA. 1558+75\_3E (ML380A) VIEWED IN DIRECTION OF TRAVEL  
Existing SOST 100' Truss

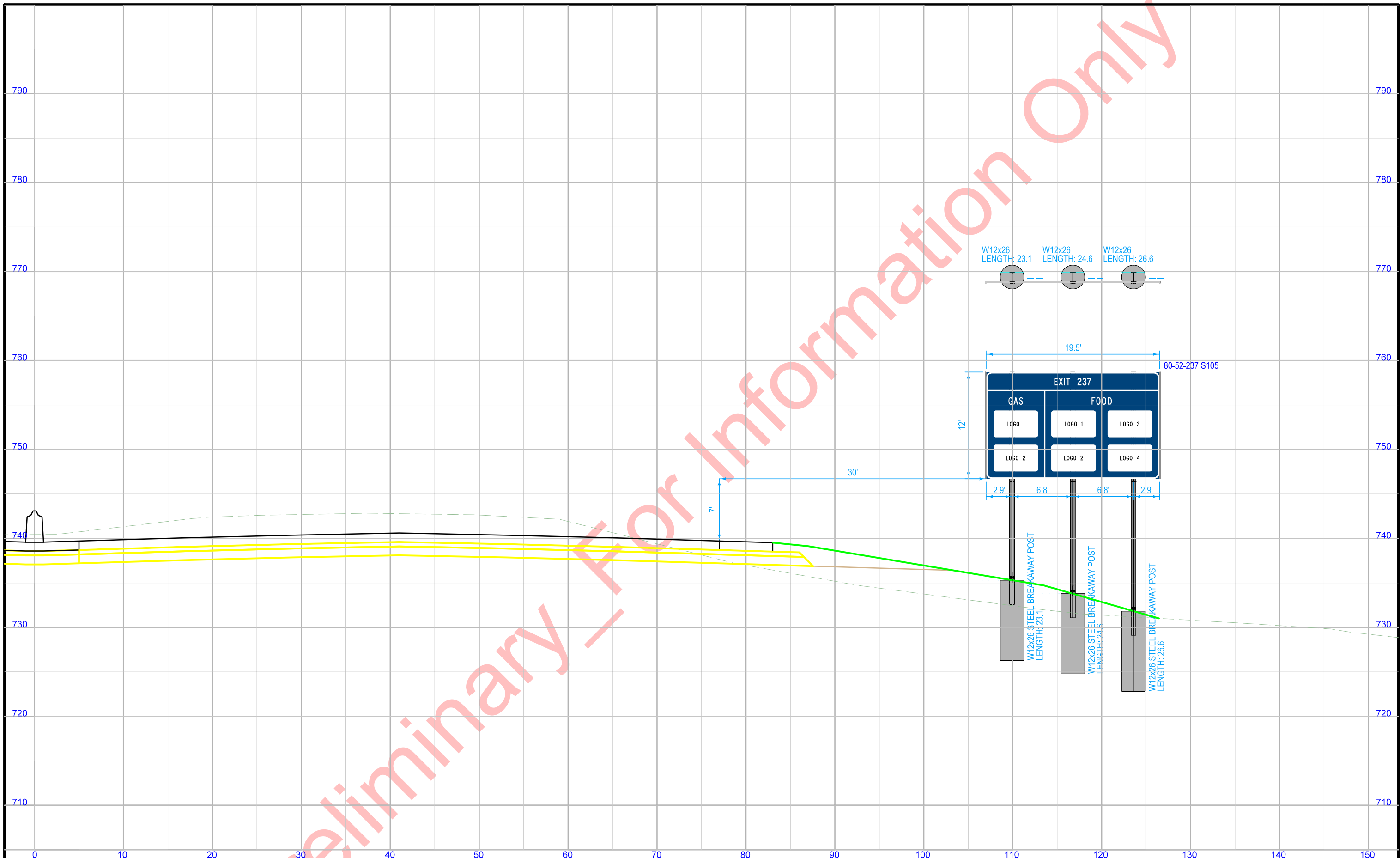

STA. 603+50\_3E (SUR080) VIEWED IN DIRECTION OF TRAVEL  
 Proposed W12x26 Post and Foundation

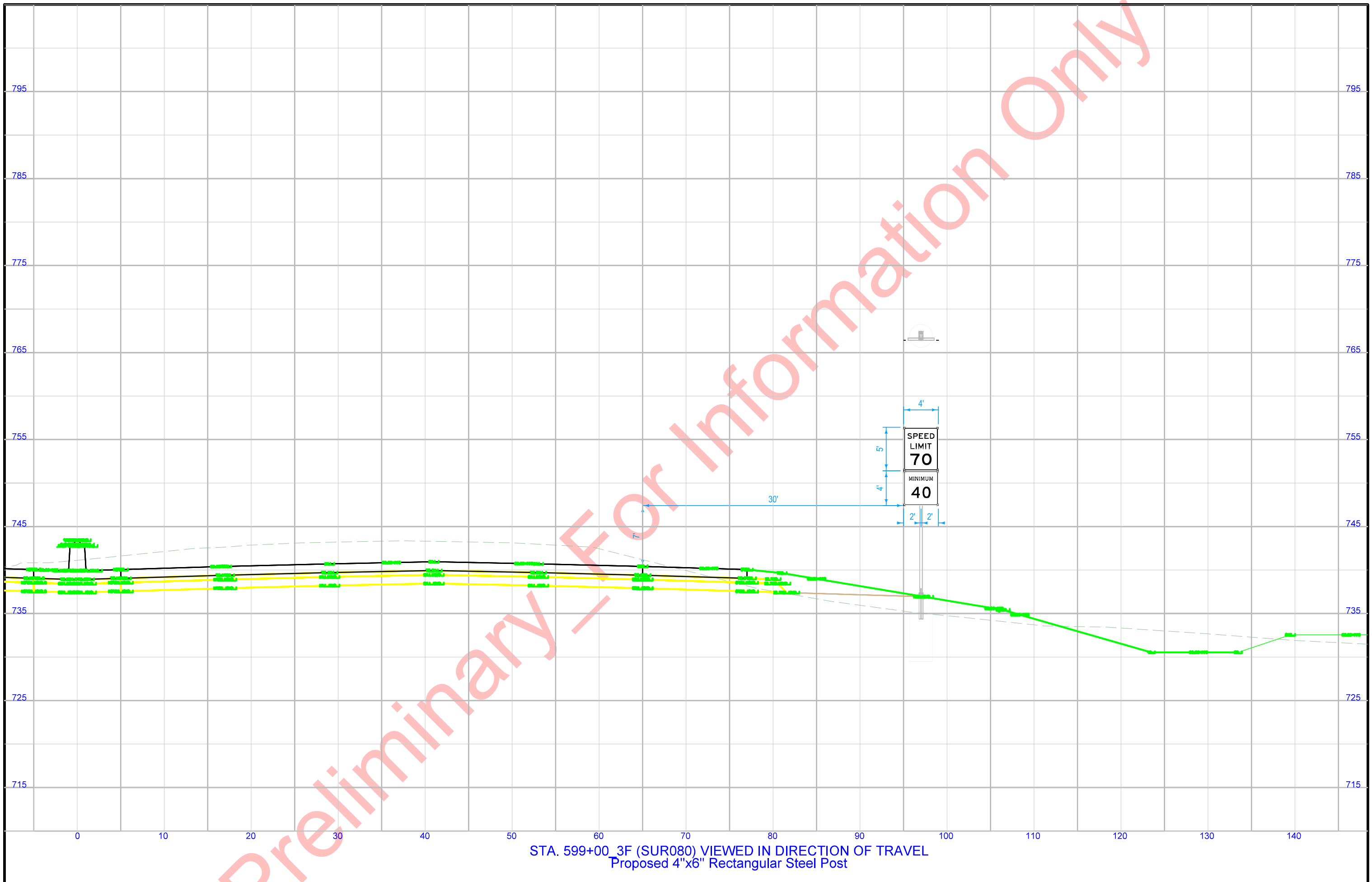

STA. 599+00\_3F (SUR080) VIEWED IN DIRECTION OF TRAVEL  
Proposed 4"x6" Rectangular Steel Post

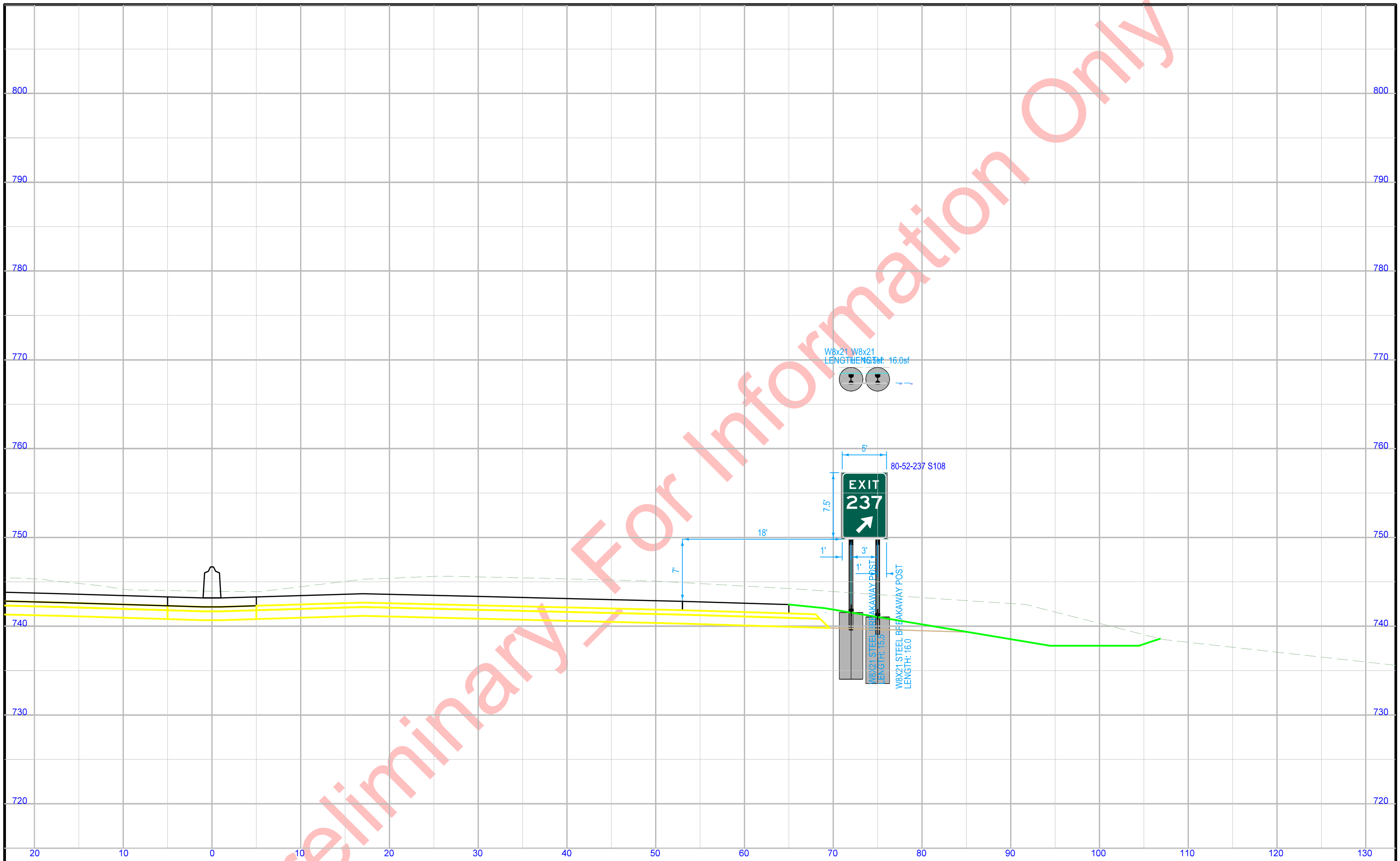

STA. 579+50.3E (SUR080) VIEWED IN DIRECTION OF TRAVEL  
 Proposed W8x21 Post and Foundation

Preliminary - For Information Only

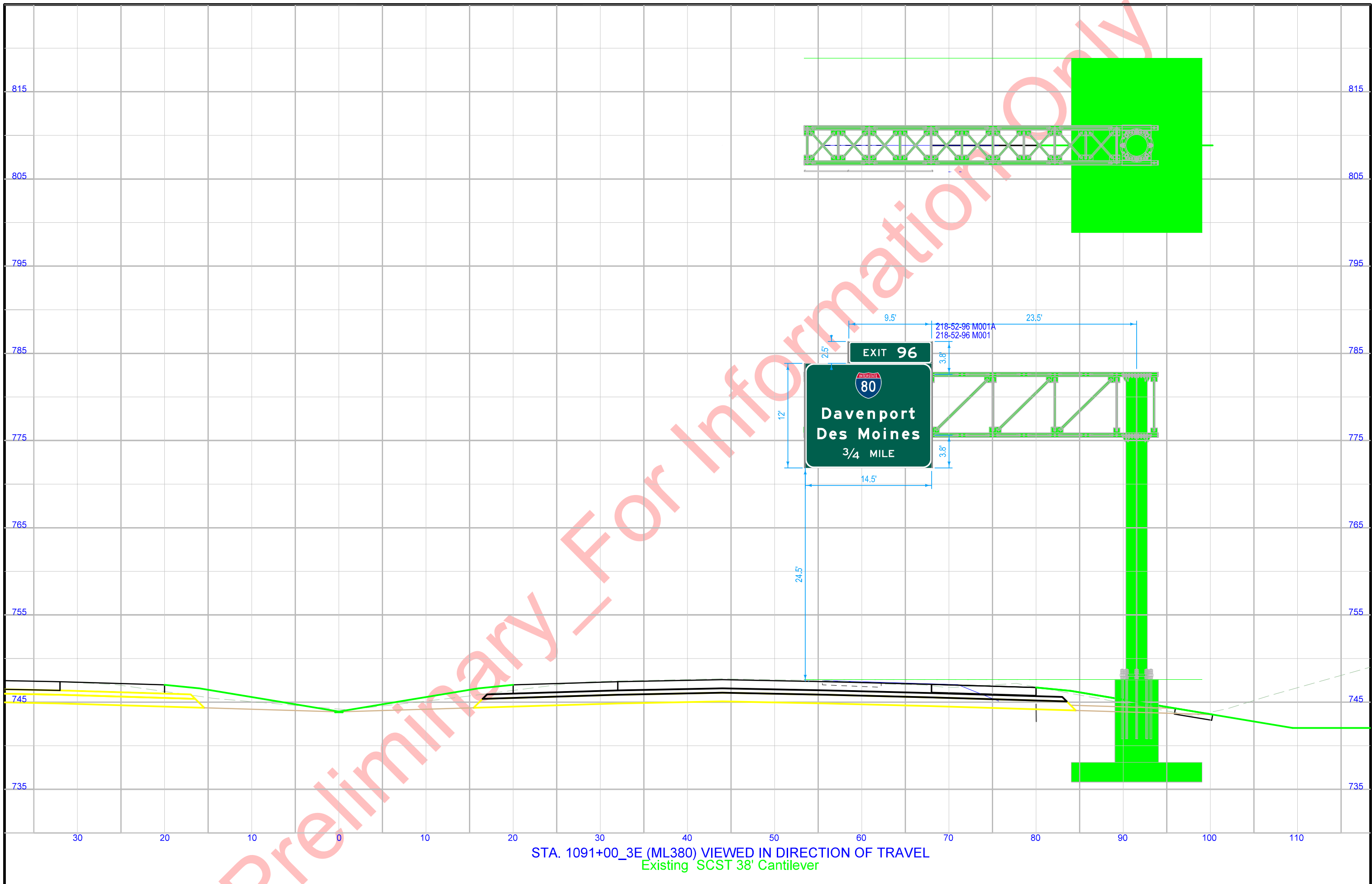

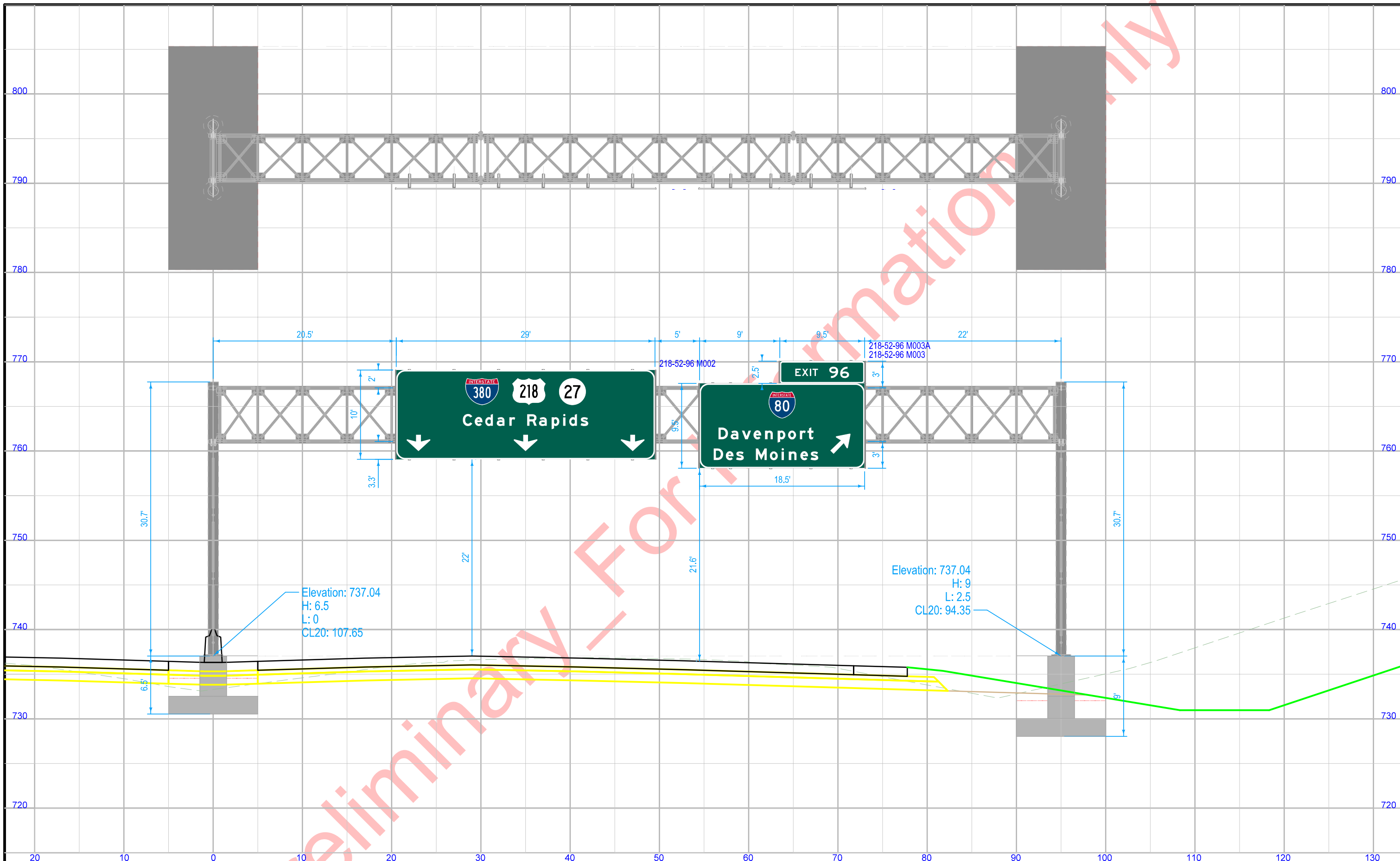

STA. 1131+50\_3E (ML380) VIEWED IN DIRECTION OF TRAVEL  
Proposed SOST 95' Truss

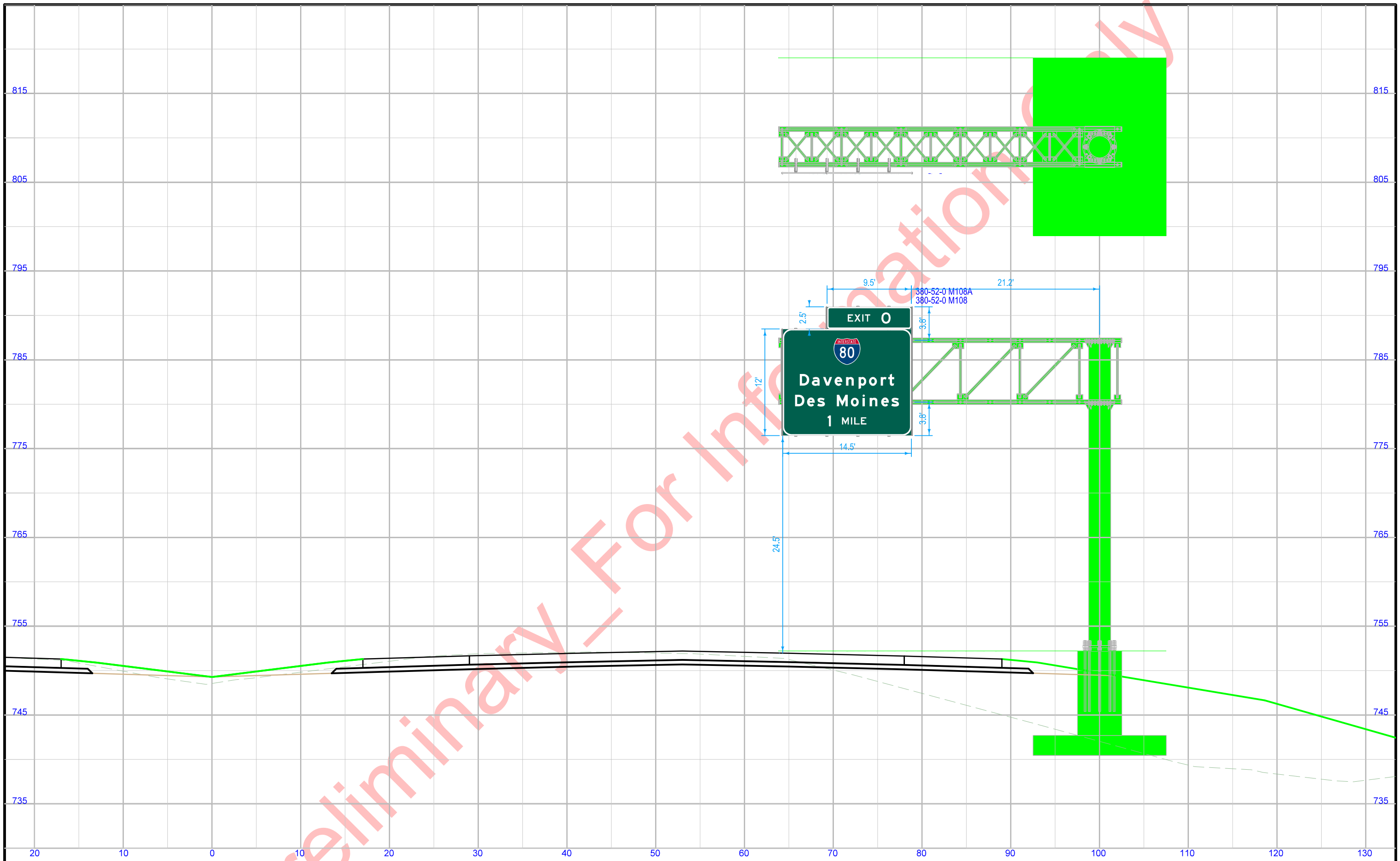

STA. 1245+50\_3E (ML380) VIEWED IN DIRECTION OF TRAVEL  
 Existing SCST 36' Cantilever



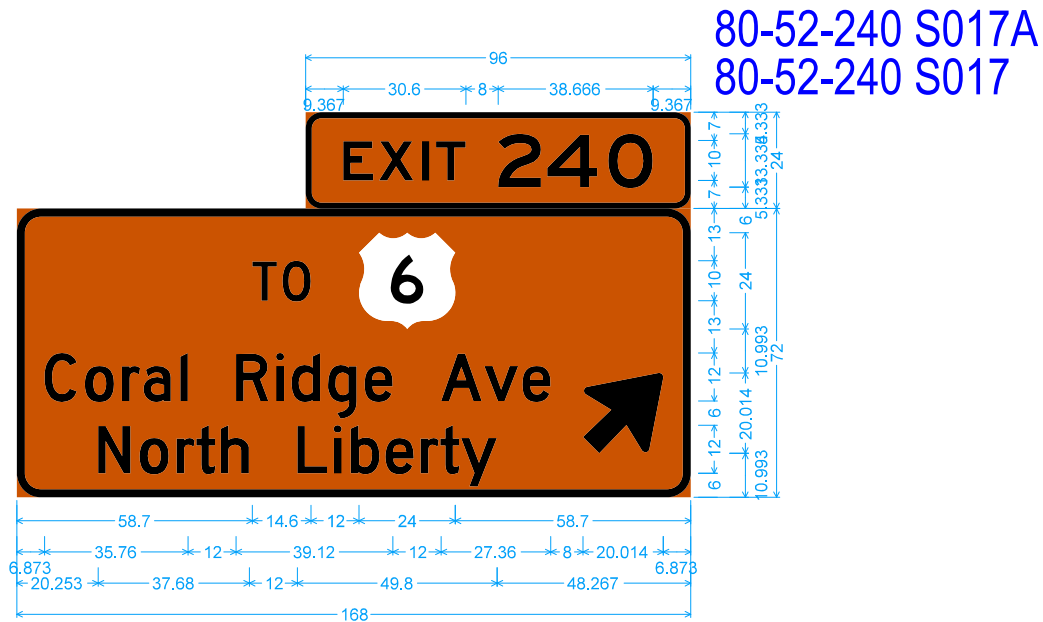

80-52-240 S017A  
80-52-240 S017

4.000" Radius, 1.500" Border, Black on Orange;  
[EXIT] E 2K; [240] E 2K;  
6.000" Radius, 2.000" Border, Black on Orange;  
[TO] D 2K; [Coral Ridge Ave] D 2K; [North Liberty] D 2K;  
Arrow I-E - 25.000" 45°;

SIGN DETAILS  
STAGE 1A

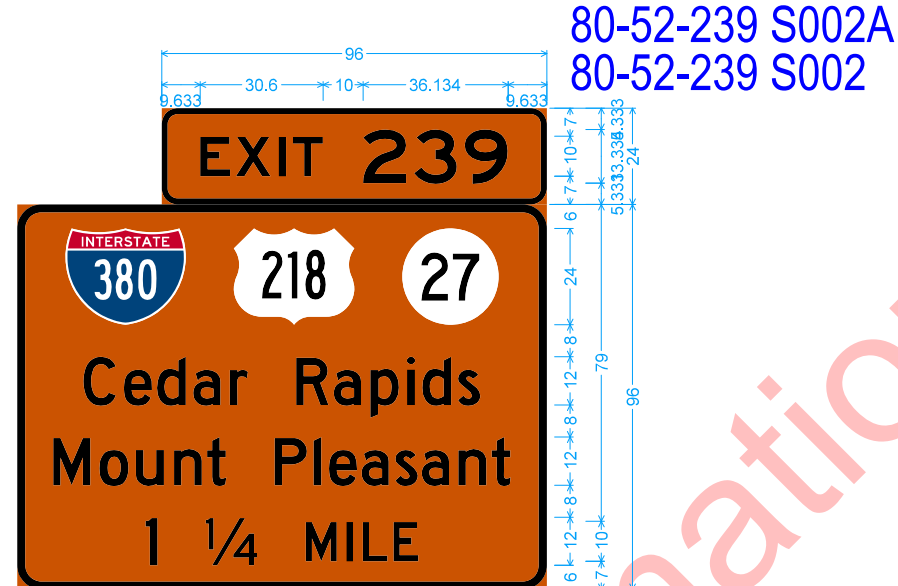

80-52-239 S002A  
80-52-239 S002

4.000" Radius, 1.500" Border, Black on Orange;  
[EXIT] E 2K; [239] E 2K;  
6.000" Radius, 2.000" Border, Black on Orange;  
State Highway 27 M1-5; [Cedar Rapids] D 2K;  
[Mount Pleasant] D 2K; [1] D 2K; [1/4] D 2K; [MILE] D 2K;



Identifier : topΦ;  
6.000" Radius, 1.500" Border, White on Green;  
[EXIT] E 2K 150) spacing;  
[239] E 2K;  
Arrow Custom - 29.250" 45°;

STA. 737+50 "1 MILE" OVERLAY

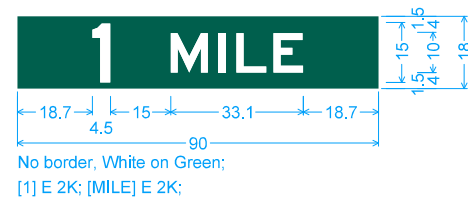

No border, White on Green;  
[1] E 2K; [MILE] E 2K;

STA. 704+99.54 "1/2 MILE" OVERLAY



No border, White on Green;  
[1/2] E 2K; [MILE] E 2K;

80-52-239B S105

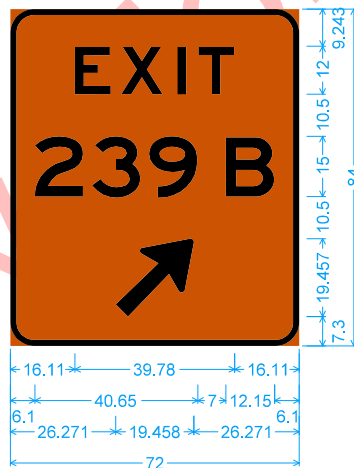

Identifier : topΦ;  
6.000" Radius, 1.500" Border, White on Green;  
[EXIT] E 2K 150) spacing;  
[239] E 2K; [B] E 2K;  
Arrow I-B - 25.000" 45°;

80-52-239A S106A  
80-52-239A S106

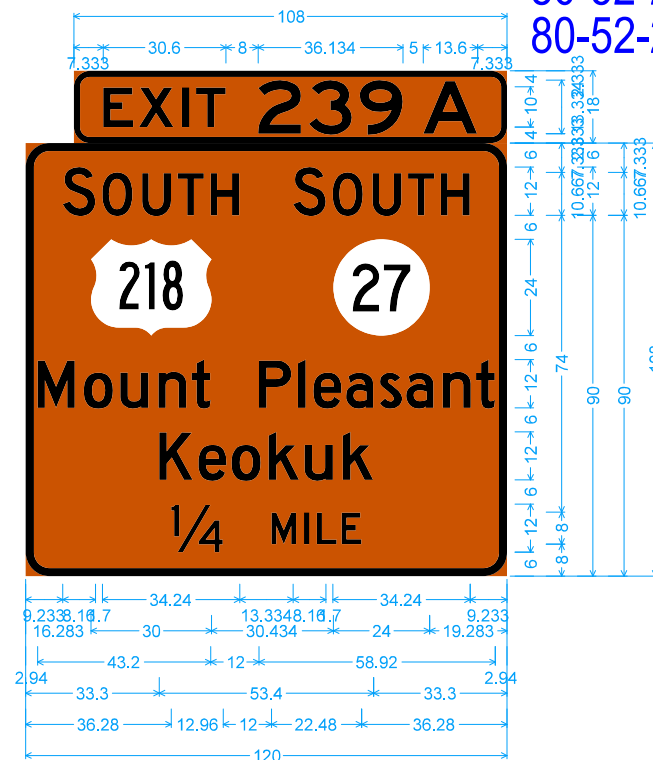

4.000" Radius, 1.500" Border, Black on Orange;  
[EXIT] E 2K; [239] E 2K; [A] E 2K;  
6.000" Radius, 2.000" Border, Black on Orange;  
[SOUTH] D 2K; [SOUTH] D 2K;  
State Highway 27 M1-5; [Mount Pleasant] D 2K;  
[Keokuk] D 2K; [1/4] D 2K; [MILE] D 2K;

SIGN DETAILS  
STAGE 2A

80-52-239B S104A  
80-52-239B S104

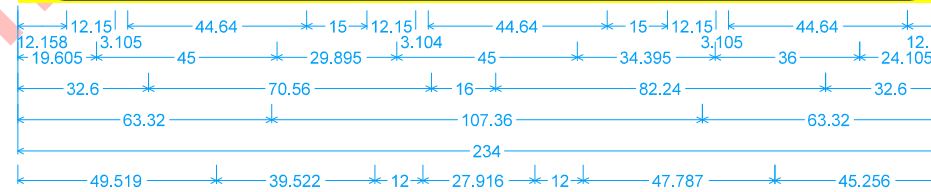
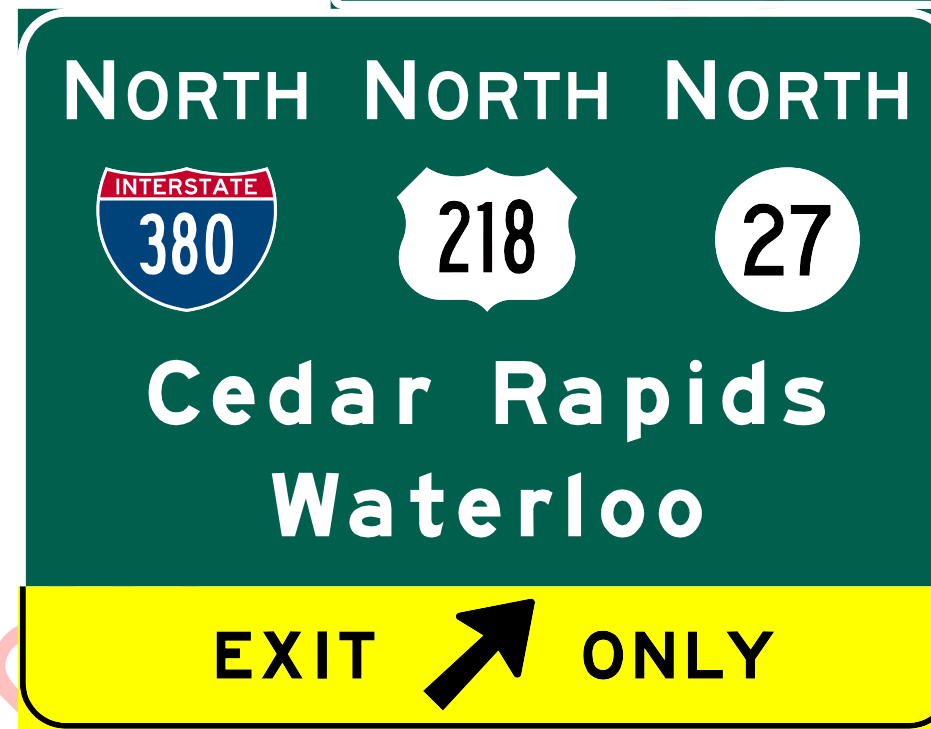
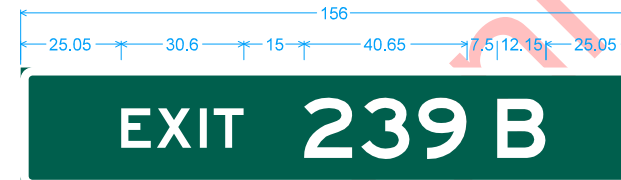

2.000" Border, White on Green;  
[EXIT] E 2K; [239] E 2K; [B] E 2K;  
12.000" Radius, 2.000" Border, White on Green;  
[NORTH] E 2K; [NORTH] E 2K; [NORTH] E 2K; State Highway 27 M1-5; [Cedar Rapids] E Mod 2K;  
[Waterloo] E Mod 2K;  
Identifier : E11-1dΦ;  
12.000" Radius, 1.500" Border, 0.500" Indent, Black on Yellow;  
[EXIT] E Mod 2K specified length; Arrow Custom - 35.625" 45°; [ONLY] E Mod 2K specified length;

80-52-239 S005A  
80-52-239 S005

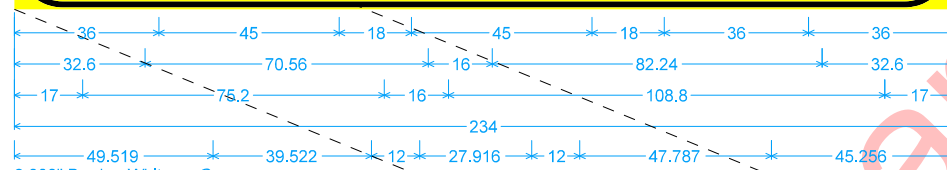
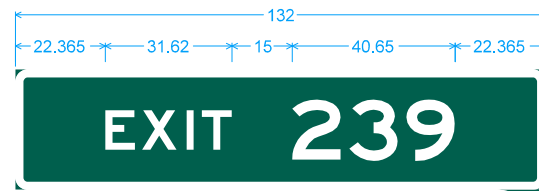

2.000" Border, White on Green;  
[EXIT] E 2K 120 spacing; [239] E 2K;  
12.000" Radius, 2.000" Border, White on Green;  
State Highway 27 M1-5; [Cedar Rapids] E Mod 2K; [Mount Pleasant] E Mod 2K;  
Identifier : E11-1dΦ;  
12.000" Radius, 1.500" Border, 0.500" Indent, Black on Yellow;  
[EXIT] E Mod 2K specified length; Arrow Custom - 35.625" 45°; [ONLY] E Mod 2K specified length;



12.000" Radius, 2.000" Border, White on Green;  
Arrow I-F - 35.000" 45°;

SIGN DETAILS  
STAGE 2A

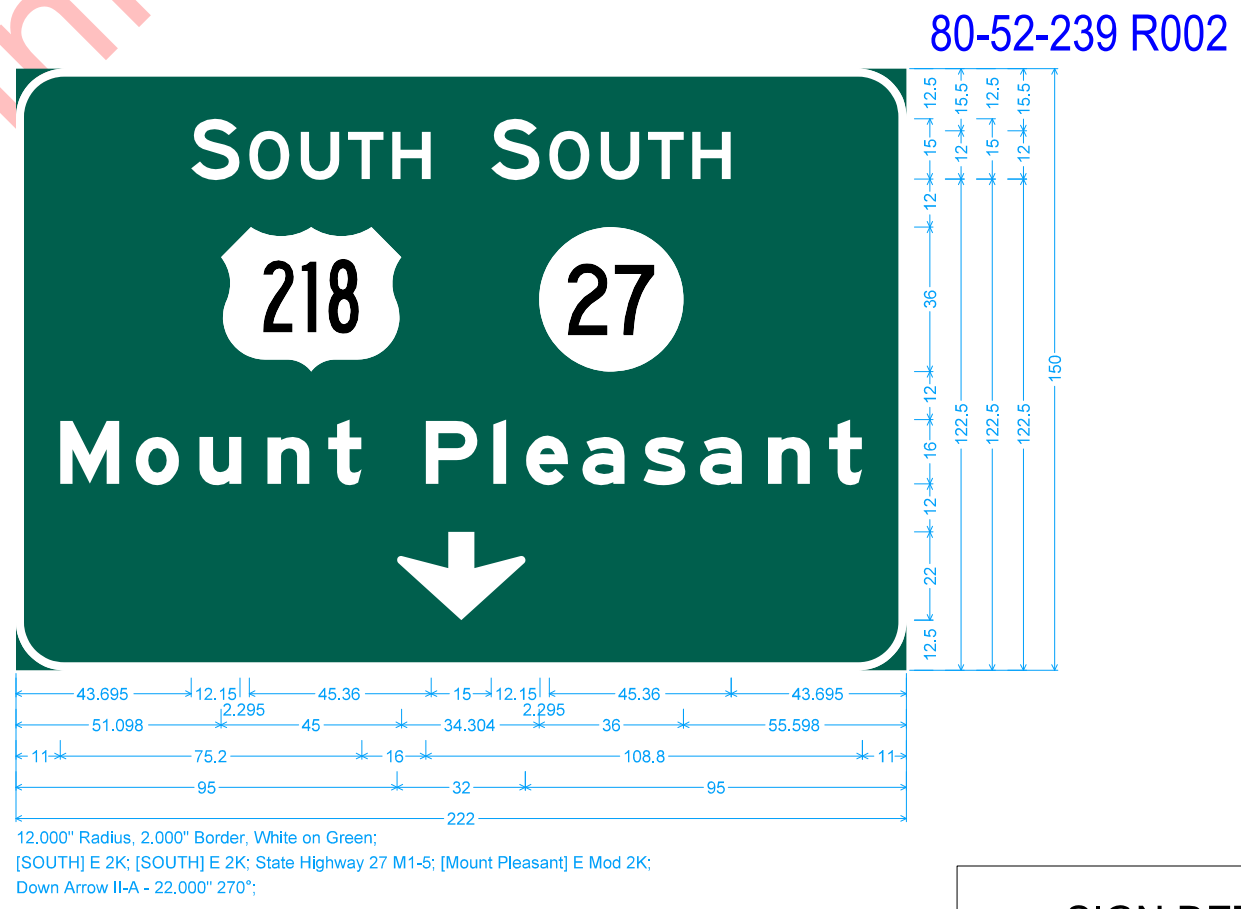
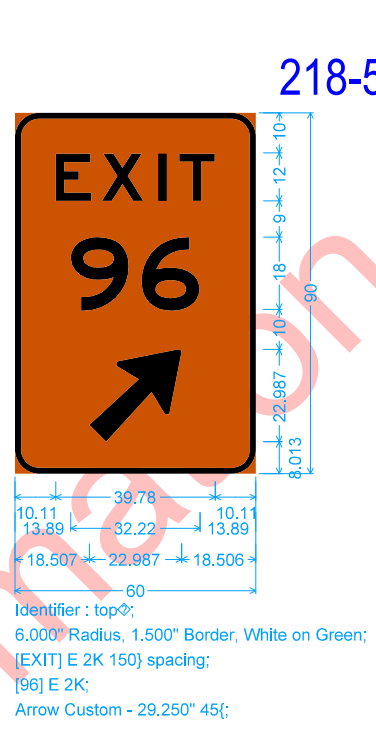
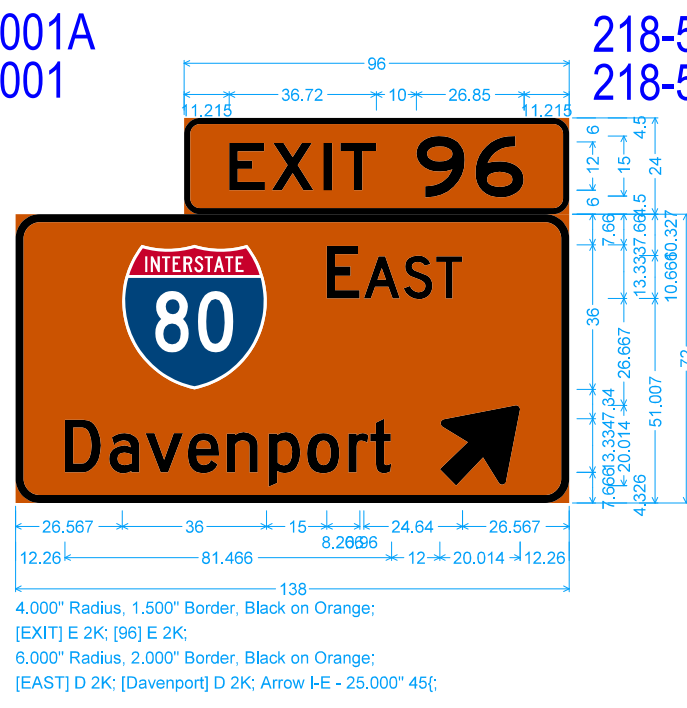
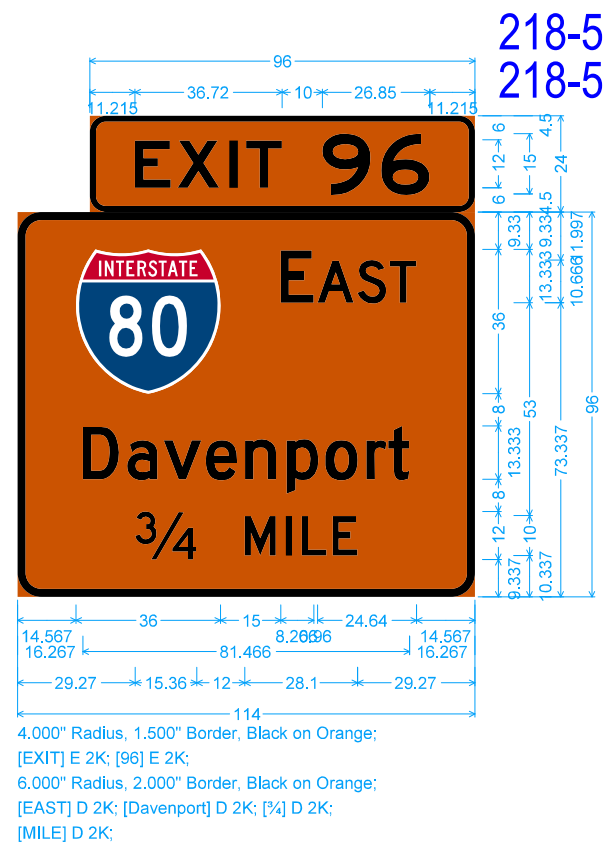

SIGN DETAILS  
STAGE 2A

80-52-239 R003

80-52-239 R004

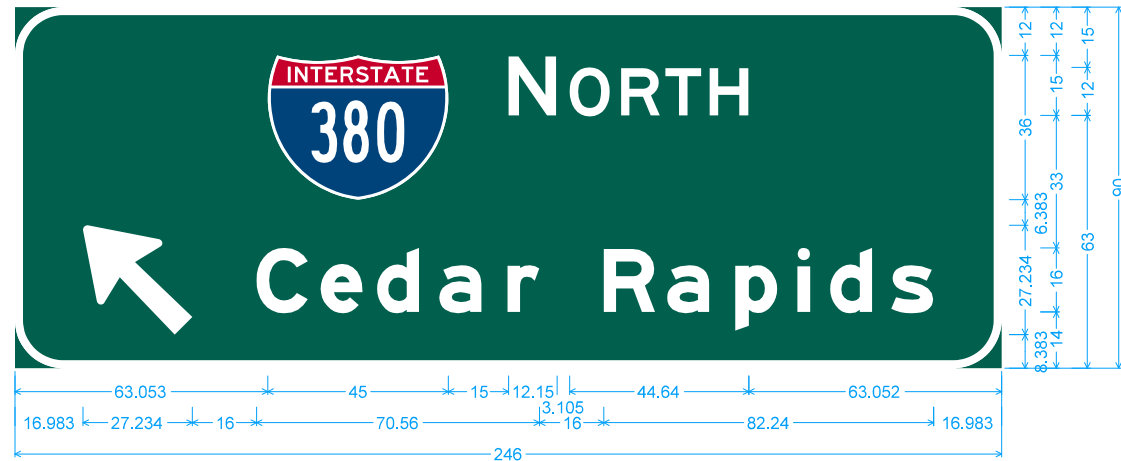

12.000" Radius, 2.000" Border, White on Green;  
 [NORTH] E 2K; Arrow I-F - 35.000" 135°; [Cedar Rapids] E Mod 2K;

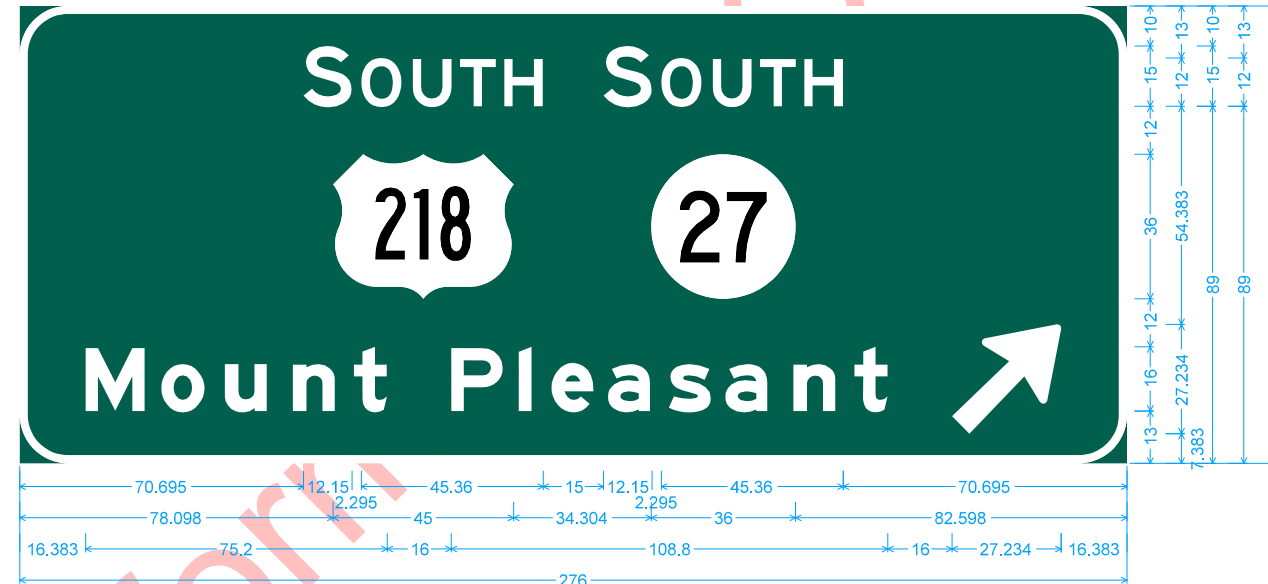

12.000" Radius, 2.000" Border, White on Green;  
 [SOUTH] E 2K; [SOUTH] E 2K; State Highway 27 M1-5; [Mount Pleasant] E Mod 2K; Arrow I-F - 35.000" 45°;

SIGN DETAILS  
 STAGE 2A

STA. 1080+00 "1" MILE OVERLAY

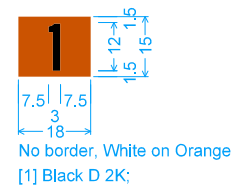

No border, White on Orange;  
 [1] Black D 2K;

SIGN DETAILS  
 STAGE 2B

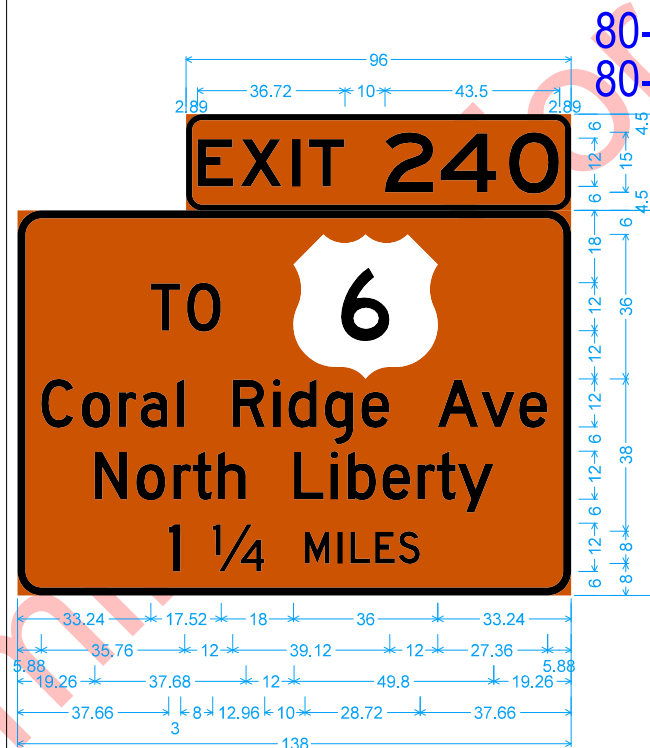

4.000" Radius, 1.500" Border, Black on Orange;  
 [EXIT] E 2K; [240] E 2K;  
 6.000" Radius, 2.000" Border, Black on Orange;  
 [TO] D 2K; [Coral Ridge Ave] D 2K; [North Liberty] D 2K;  
 [1] D 2K; [1/4] D 2K; [MILES] D 2K;

80-52-239 S007A  
 80-52-239 S007



12.000" Radius, 2.000" Border, White on Brown;  
 [Iowa Children's] E Mod 2K; [Museum] E Mod 2K;  
 12.000" Radius, 2.000" Border, White on Green;  
 [University of Iowa] E Mod 2K; [Research Park] E Mod 2K; [EXIT 240] E 2K;

80-52-240 S013

SIGN DETAILS  
 STAGE 2C



80-52-240 S014A  
80-52-240 S014

Identifier : E1-5P(2)\_132x30φ;  
4.000" Radius, 2.000" Border, White on Green;  
[EXIT] E 2K; [240] E 2K;  
12.000" Radius, 2.000" Border, White on Green;  
[TO] E 2K; [Coral Ridge Ave] E Mod 2K; [North Liberty] E Mod 2K;  
Identifier : E11-1e\_222x36φ;  
12.000" Radius, 1.500" Border, 0.500" Indent, Black on Yellow;  
Arrow Custom - 35.625" 45°; [EXIT] E Mod 2K specified length; [ONLY] E Mod 2K specified length;  
Arrow Custom - 35.625" 45°;

STA. 737+50 EXIT 239B-1 OVERLAY

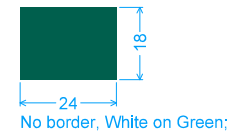

No border, White on Green;

STA. 704+99.54 "1 MILE" Cover Overlay



No border, White on Green;

80-52-239B S103

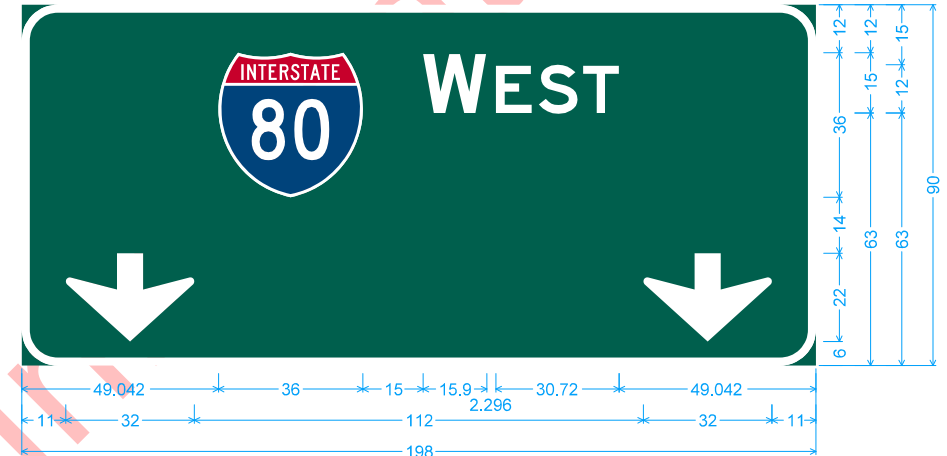

9.000" Radius, 2.000" Border, White on Green;  
[WEST] E 2K; Down Arrow II-A - 22.000" 270°; Down Arrow II-A - 22.000" 270°;

218-52-96 M003



Identifier : topφ;  
6.000" Radius, 1.500" Border, White on Green;  
[EXIT] E 2K 150° spacing;  
[96] E 2K;  
Arrow Custom - 29.250" 45°;

380-52-2 M007

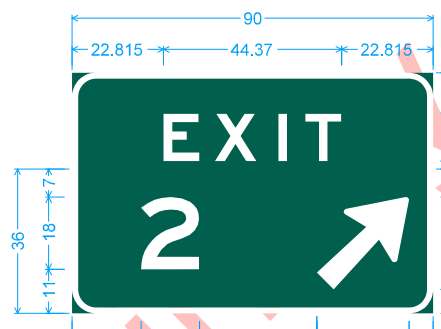

Identifier : topφ;  
6.000" Radius, 1.500" Border, White on Green;  
[EXIT] E 2K 225° spacing;  
Identifier : bottomφ;  
6.000" Radius, 1.500" Border, White on Green;  
[2] E 2K;  
Identifier : bottomφ;  
6.000" Radius, 1.500" Border, White on Green;  
Arrow Custom - 29.250" 45°;

380-52-4 M011

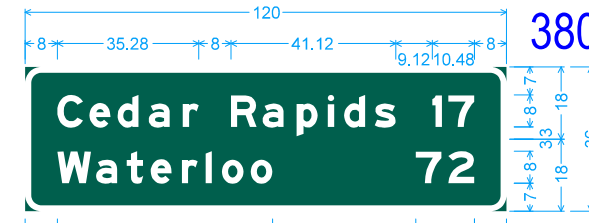

Identifier : Expressway Mileage 2 Line;  
4.000" Radius, 1.500" Border, White on Green;  
[Cedar Rapids] E Mod 2K; [17] E Mod 2K;  
4.000" Radius, 1.500" Border, White on Green;  
[Waterloo] E Mod 2K; [72] E Mod 2K;

SIGN DETAILS  
STAGE 2C

80-52-239B S103A  
80-52-239B S103

80-52-239B S104A  
80-52-239B S104

80-52-239B S105A  
80-52-239B S105

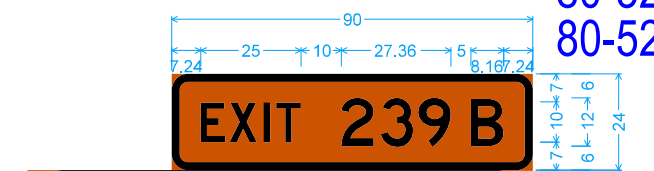
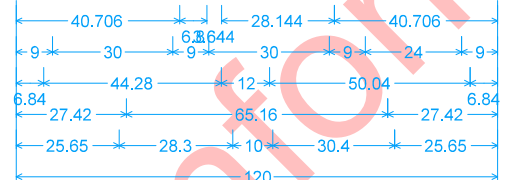
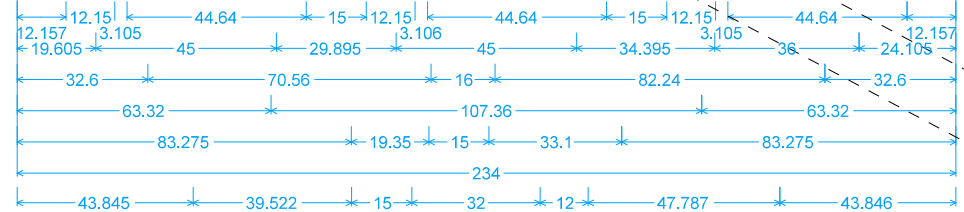
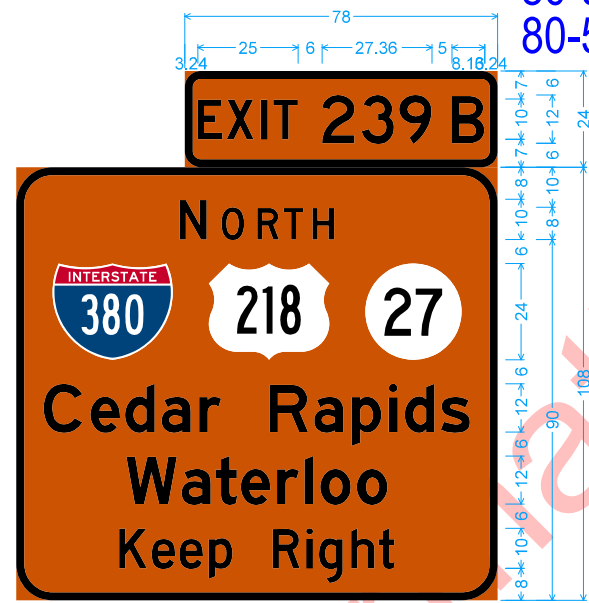
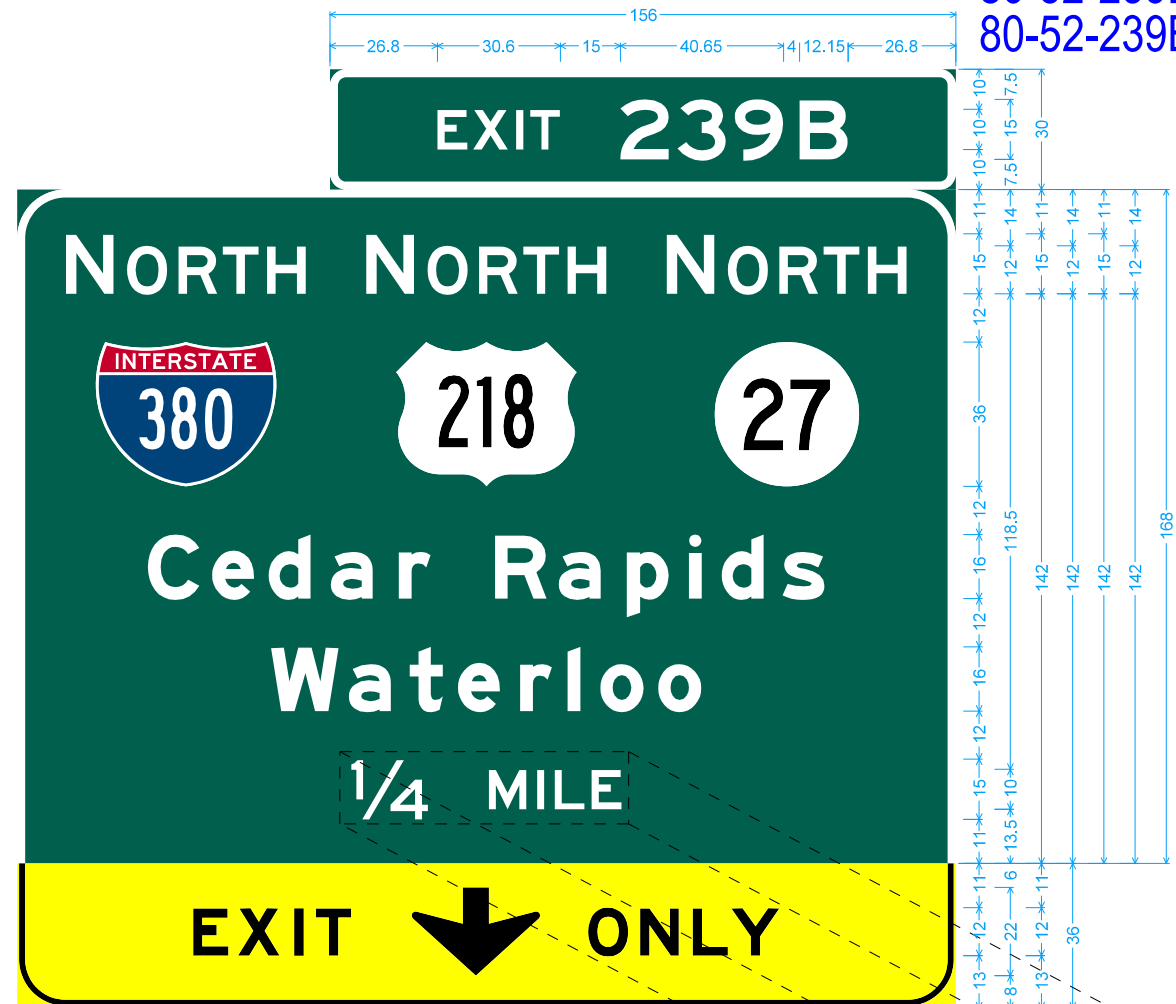

4.000" Radius, 2.000" Border, Black on Orange;  
[EXIT] D 2K; [239] D 2K 50) spacing; [B] D 2K;  
9.000" Radius, 2.000" Border, Black on Orange;  
[NORTH] D 2K 184) spacing; State Highway 27 M1-5;  
[Cedar Rapids] E 2K; [Waterloo] E 2K;  
[Keep Right] D 2K;

No border, White on Green;  
[1/2] D 2K; [MILE] D 2K;

4.000" Radius, 2.000" Border, White on Green;  
[EXIT] E 2K; [239] E 2K; [B] E 2K;  
12.000" Radius, 2.000" Border, White on Green;  
[NORTH] E 2K; [NORTH] E 2K; [NORTH] E 2K; State Highway 27 M1-5; [Cedar Rapids] E Mod 2K;  
[Waterloo] E Mod 2K; [1/4] E 2K; [MILE] E 2K;  
Identifier : E11-1Φ;  
12.000" Radius, 1.500" Border, 0.500" Indent, Black on Yellow;  
[EXIT] E Mod 2K specified length; Down Arrow Custom - 22.000" 270; [ONLY] E Mod 2K specified length;

9.000" Radius, 1.500" Border, Black on Orange;  
[EXIT] D 2K; [239] D 2K 50) spacing; [B] D 2K;  
9.000" Radius, 1.500" Border, Black on Orange;  
[NORTH] D 2K 184) spacing; State Highway 27 M1-5;  
[Cedar Rapids] D 2K; [Waterloo] D 2K;  
9.000" Radius, 1.500" Border, Black on Yellow;  
[EXIT] D 2K 200) spacing; Arrow I-E - 25.000" 45;  
[ONLY] D 2K 200) spacing;

SIGN DETAILS  
STAGE 2D

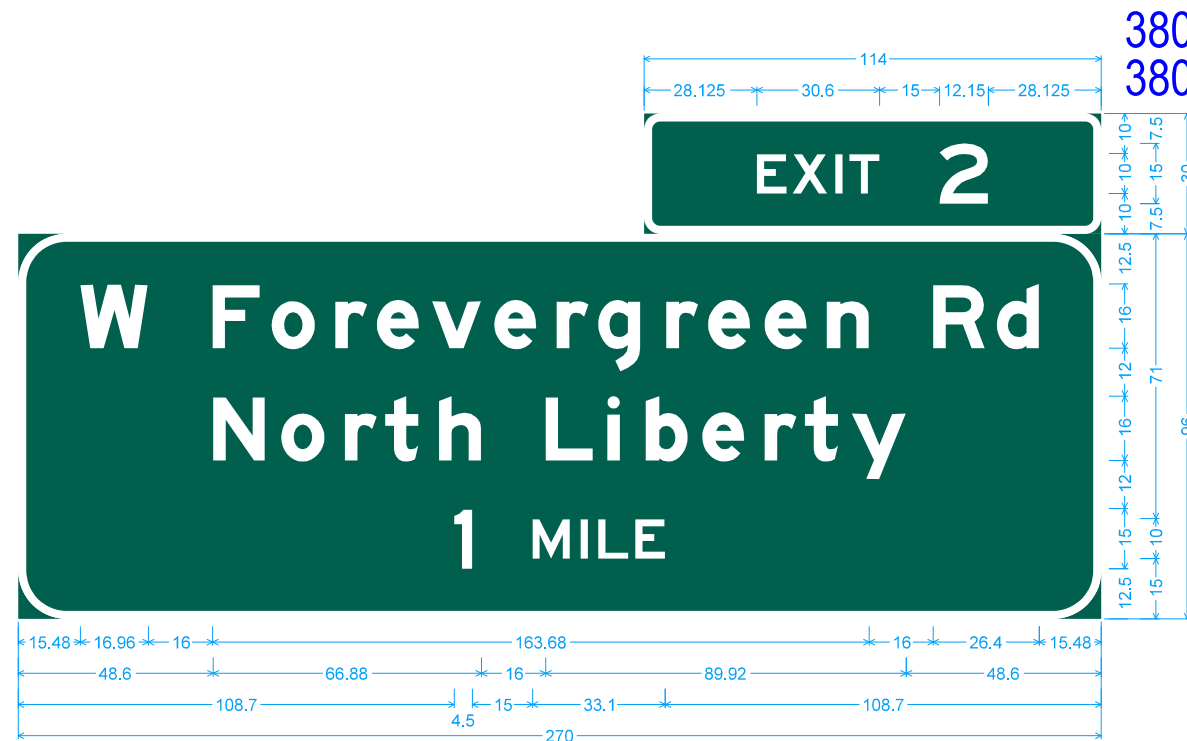

4.000" Radius, 2.000" Border, White on Green;  
 [EXIT] E 2K; [2] E 2K;  
 12.000" Radius, 2.000" Border, White on Green;  
 [W Forevergreen Rd] E Mod 2K; [North Liberty] E Mod 2K; [1] E 2K; [MILE] E 2K;



Identifier : Expressway Mileage 3 Line;  
 6.000" Radius, 1.500" Border, White on Green;  
 [North Liberty] E Mod 2K; [5] E Mod 2K;  
 6.000" Radius, 1.500" Border, White on Green;  
 [Cedar Rapids] E Mod 2K; [19] E Mod 2K;  
 6.000" Radius, 1.500" Border, White on Green;  
 [Waterloo] E Mod 2K; [74] E Mod 2K;

SIGN DETAILS  
STAGE 2D

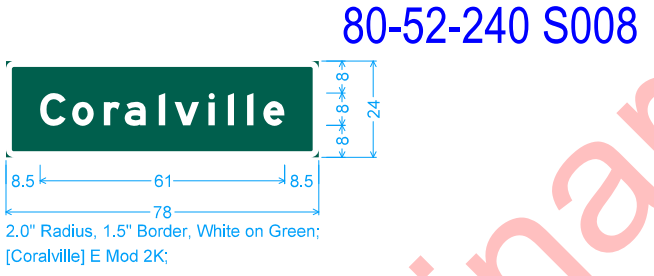

2.0" Radius, 1.5" Border, White on Green;  
 [Coralville] E Mod 2K;

STA. 1080+00 "1" MILE OVERLAY

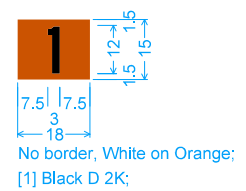

SIGN DETAILS  
STAGE 2E

80-52-239 S005A  
80-52-239 S005

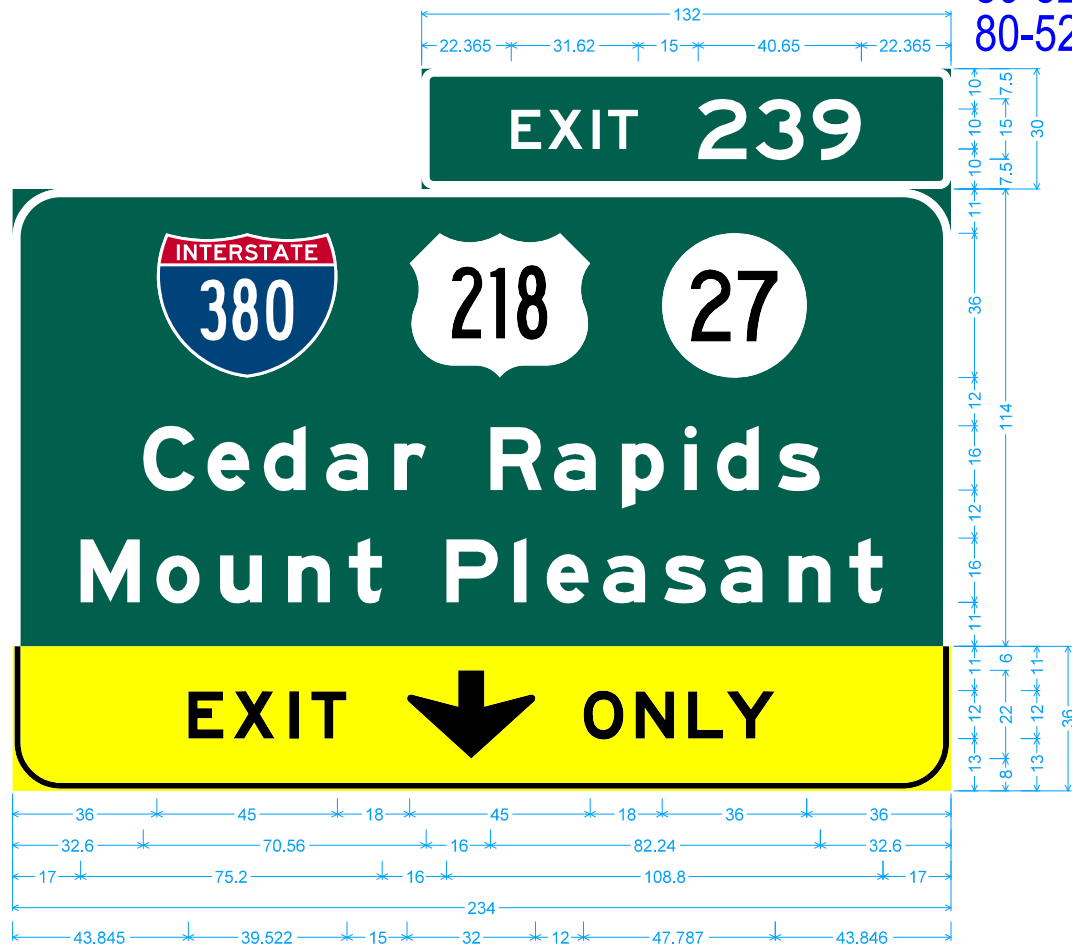

2,000" Border, White on Green;  
[EXIT] E 2K 120) spacing; [239] E 2K;  
12,000" Radius, 2,000" Border, White on Green;  
State Highway 27 M1-5; [Cedar Rapids] E Mod 2K; [Mount Pleasant] E Mod 2K;  
Identifier : E11-1φ;  
12,000" Radius, 1,500" Border, 0.500" Indent, Black on Yellow;  
[EXIT] E Mod 2K specified length; Down Arrow Custom - 22,000" 270; [ONLY] E Mod 2K specified length;

380-52-0B M110A  
380-52-0B M110

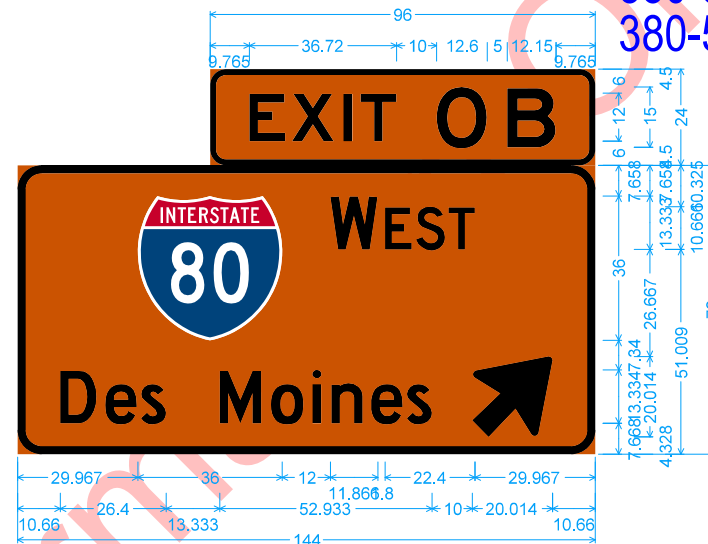

4,000" Radius, 1,500" Border, Black on Orange;  
[EXIT] E 2K; [O] E 2K; [B] E 2K;  
6,000" Radius, 2,000" Border, Black on Orange;  
[WEST] D 2K; [Des Moines] D 2K; Arrow I-E - 25,000" 45;

380-52-0A M112A  
380-52-0A M112

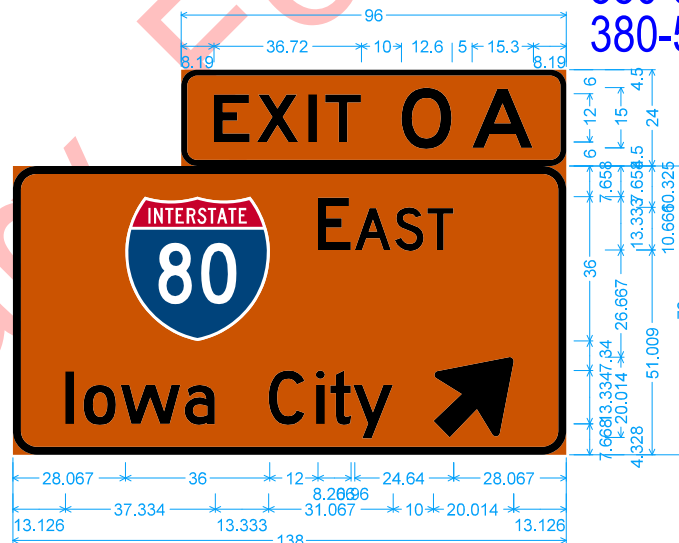

4,000" Radius, 1,500" Border, Black on Orange;  
[EXIT] E 2K; [O] E 2K; [A] E 2K;  
6,000" Radius, 2,000" Border, Black on Orange;  
[EAST] D 2K; [Iowa City] D 2K; Arrow I-E - 25,000" 45;

380-52-0A M113

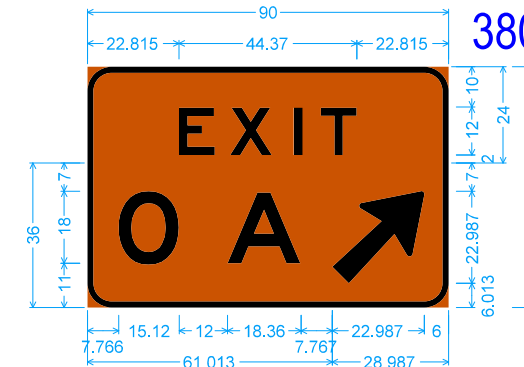

Identifier : topφ;  
6,000" Radius, 1,500" Border, Black on Orange;  
[EXIT] E 2K 225) spacing;  
Identifier : bottomφ;  
6,000" Radius, 1,500" Border, Black on Orange;  
[O] E 2K; [A] E 2K;  
Identifier : bottomφ;  
6,000" Radius, 1,500" Border, Black on Orange;  
Arrow Custom - 29,250" 45;

380-52-0B M111



Identifier : topφ;  
6,000" Radius, 1,500" Border, Black on Orange;  
[EXIT] E 2K 225) spacing;  
Identifier : bottomφ;  
6,000" Radius, 1,500" Border, Black on Orange;  
[O] E 2K; [B] E 2K;  
Identifier : bottomφ;  
6,000" Radius, 1,500" Border, Black on Orange;  
Arrow Custom - 29,250" 45;

SIGN DETAILS  
STAGE 2F



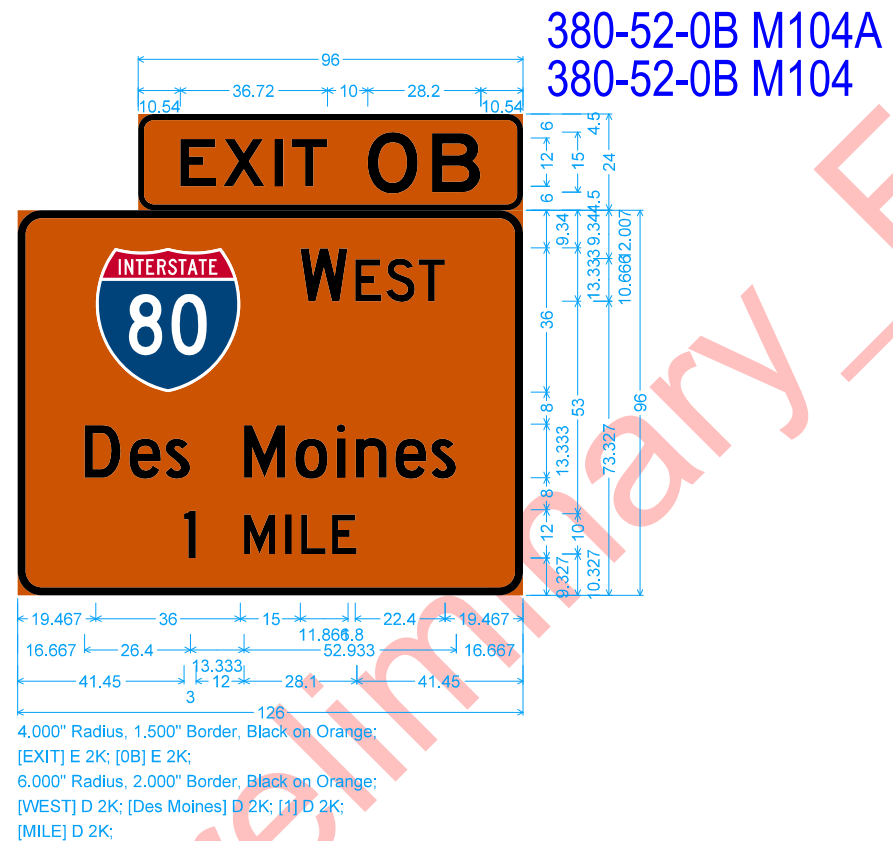
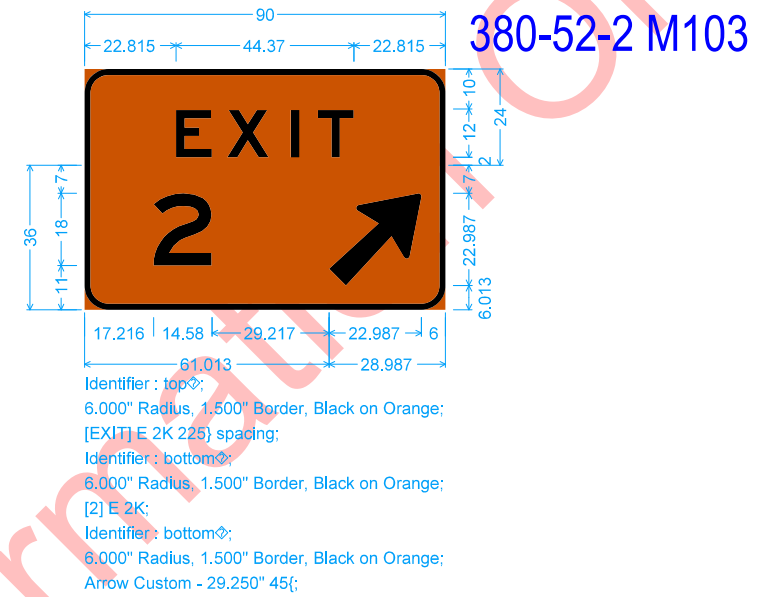
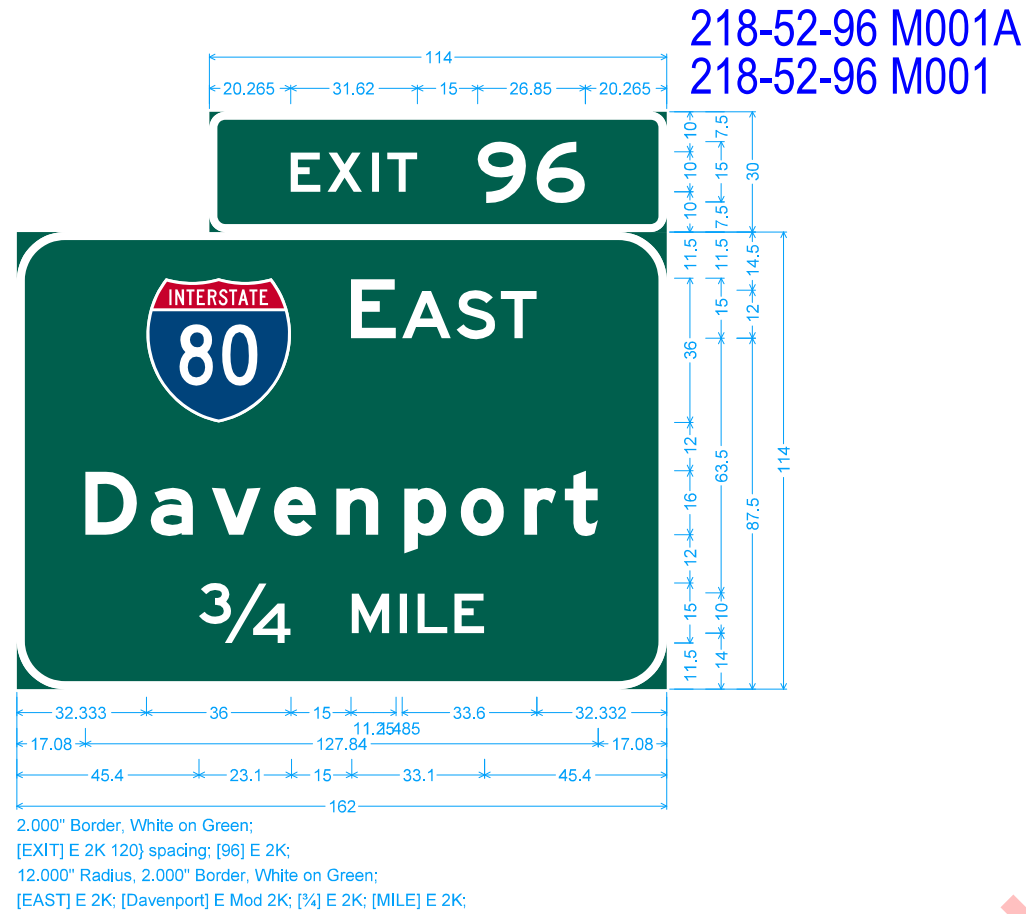

SIGN DETAILS  
STAGE 3A

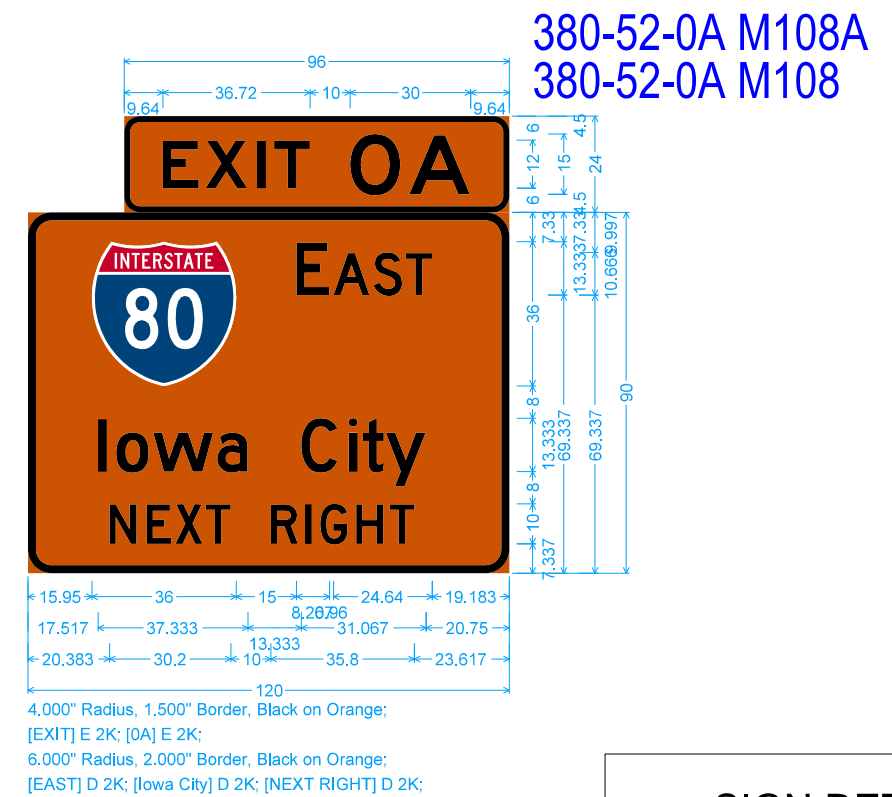
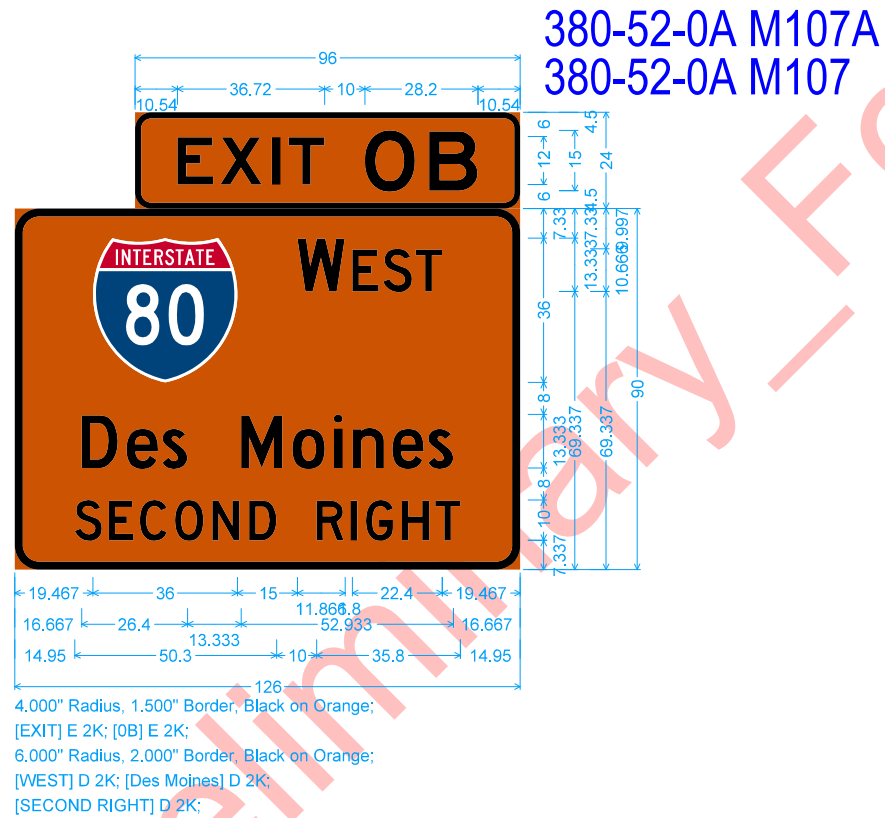
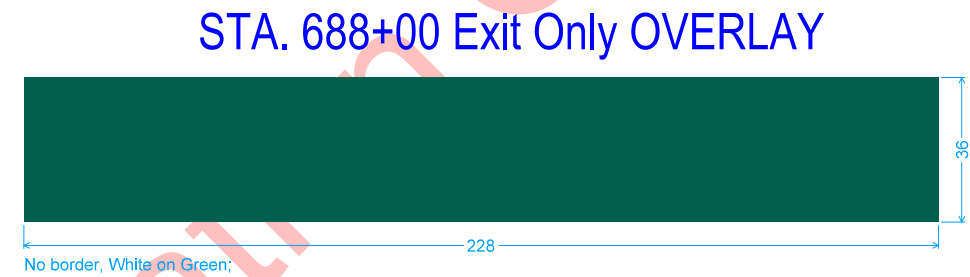

SIGN DETAILS  
STAGE 3B

80-52-237 S107A  
80-52-237 S107

80-52-239 R101

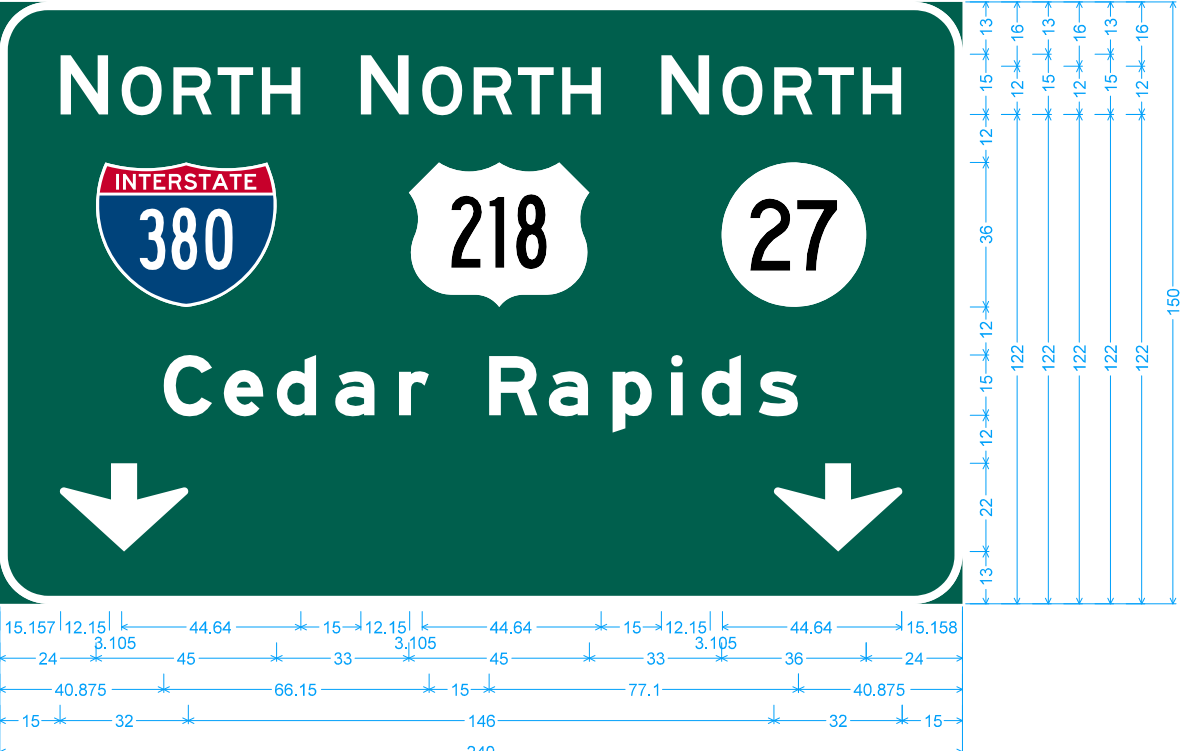

12.000" Radius, 2.000" Border, White on Green;  
[NORTH] E 2K; [NORTH] E 2K; [NORTH] E 2K; State Highway 27 M1-5; [Cedar Rapids] E Mod 2K;  
Down Arrow II-A - 22.000" 270; Down Arrow II-A - 22.000" 270;

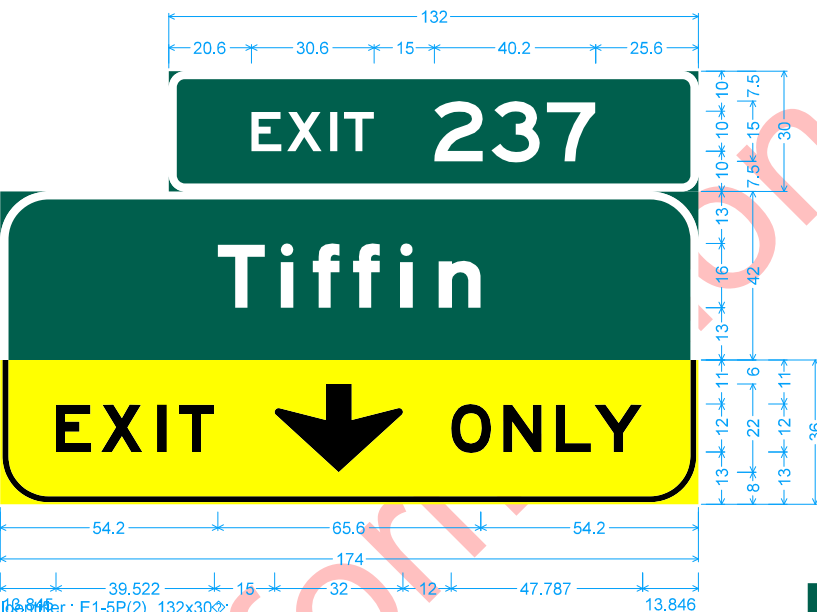

Identifier : E1-5P(2)\_132x30; 4.000" Radius, 2.000" Border, White on Green; [EXIT] E 2K; [237] E 2K; 12.000" Radius, 2.000" Border, White on Green; [Tiffin] E Mod 2K; Identifier : E11-1; 12.000" Radius, 1.500" Border, 0.500" Indent, Black on Yellow; [EXIT] E Mod 2K specified length; Down Arrow Custom - 22.000" 270; [ONLY] E Mod 2K specified length;

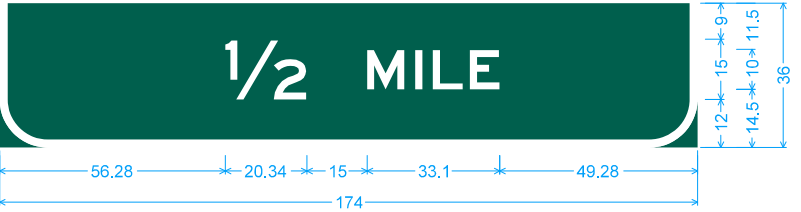

12.000" Radius, 2.000" Border, White on Green; [1/2] E 2K; [MILE] E 2K;

80-52-237 S109A  
80-52-237 S109

80-52-237 S108

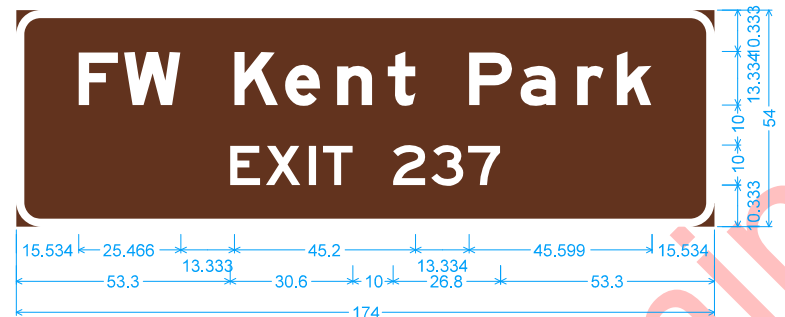

6.000" Radius, 2.000" Border, White on Brown; [FW Kent Park] E Mod 2K; [EXIT 237] E 2K;

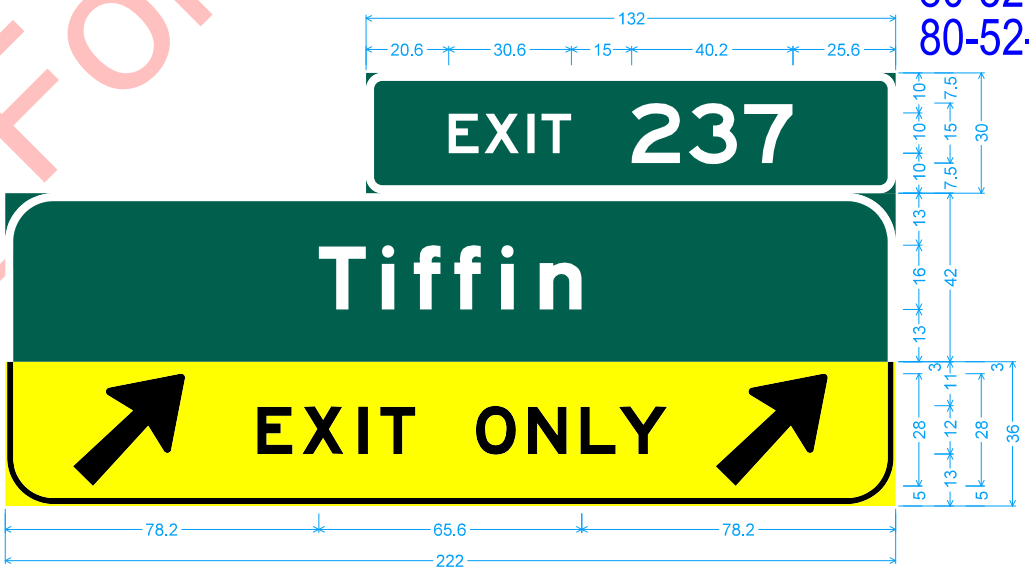

Identifier : E1-5P(2)\_132x30; 4.000" Radius, 2.000" Border, White on Green; [EXIT] E 2K; [237] E 2K; 12.000" Radius, 2.000" Border, White on Green; [Tiffin] E Mod 2K; Identifier : E11-1e; 12.000" Radius, 1.500" Border, 0.500" Indent, Black on Yellow; Arrow Custom - 35.625" 45; [EXIT] E Mod 2K specified length; [ONLY] E Mod 2K specified length; Arrow Custom - 35.625" 45;

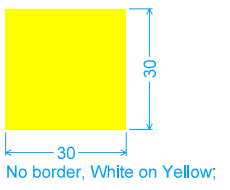

No border, White on Yellow;

SIGN DETAILS  
STAGE 3C

80-52-237 S111



Identifier : top☺;  
 6.000" Radius, 1.500" Border, White on Green;  
 [EXIT] E 2K 150) spacing;  
 [237] E 2K;  
 Arrow Custom - 29.250" 45{;

380-52-2 M007



9.000" Radius, 2.000" Border, White on Green;  
 [Coralville] E Mod 2K; [Tiffin] E Mod 2K; [EXIT 2] E 2K;

380-52-2 M008A  
 380-52-2 M008

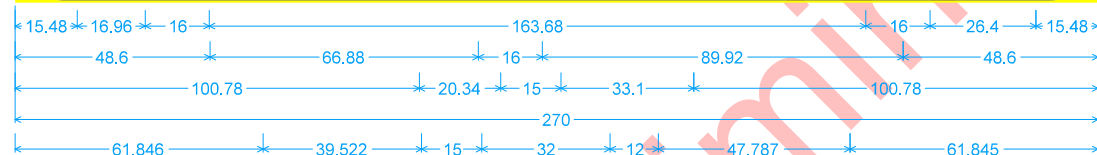
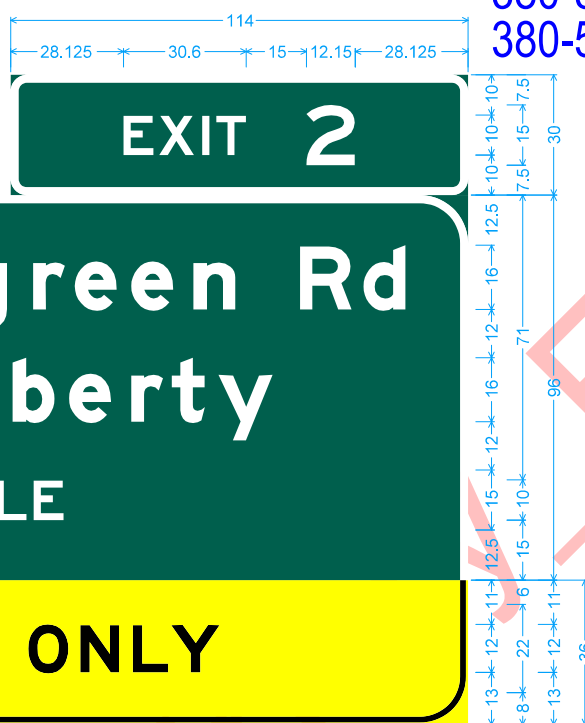

4.000" Radius, 2.000" Border, White on Green;  
 [EXIT] E 2K; [2] E 2K;  
 12.000" Radius, 2.000" Border, White on Green;  
 [W Forevergreen Rd] E Mod 2K; [North Liberty] E Mod 2K; [1/2] E 2K; [MILE] E 2K;  
 Identifier : E11-1☺;  
 12.000" Radius, 1.500" Border, 0.500" Indent, Black on Yellow;  
 [EXIT] E Mod 2K specified length; Down Arrow Custom - 22.000" 270{; [ONLY] E Mod 2K specified length;

380-52-2 M009

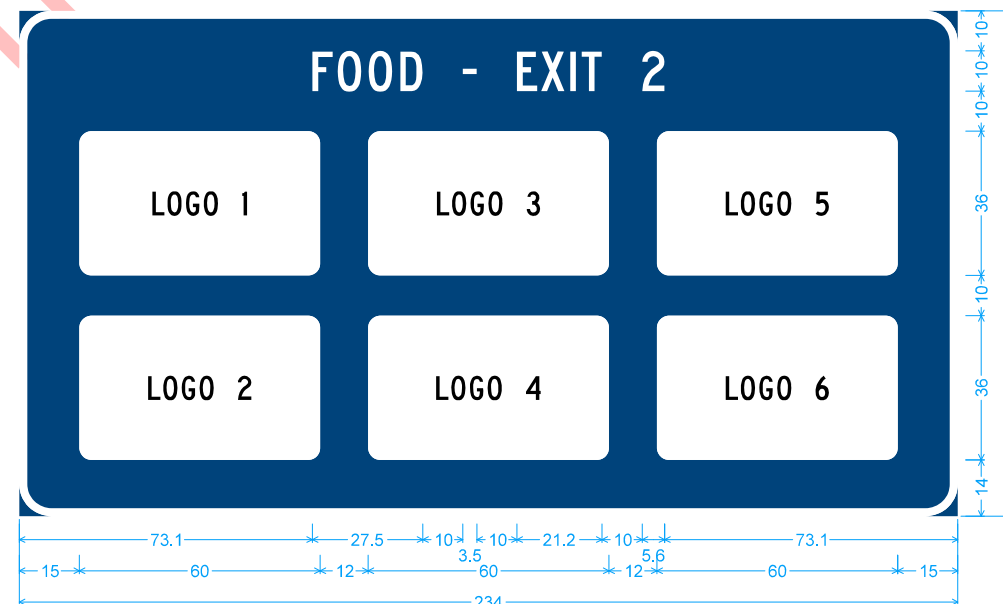

8.000" Radius, 2.000" Border, White on Blue;  
 [FOOD - EXIT 2] C 2K; Rounded Rectangle 3.000" Radius;  
 Rounded Rectangle 3.000" Radius;  
 Rounded Rectangle 3.000" Radius;  
 Rounded Rectangle 3.000" Radius;  
 Rounded Rectangle 3.000" Radius;

SIGN DETAILS  
 STAGE 3C

380-52-2 M010



8.000" Radius, 2.000" Border, White on Blue;  
 [GAS - EXIT 2] C 2K; Rounded Rectangle 3.000" Radius;  
 Rounded Rectangle 3.000" Radius;  
 Rounded Rectangle 3.000" Radius;  
 [LODGING - EXIT 2] C 2K; Rounded Rectangle 3.000" Radius;  
 Rounded Rectangle 3.000" Radius;  
 Rounded Rectangle 3.000" Radius;

380-52-2 M011A  
 380-52-2 M011

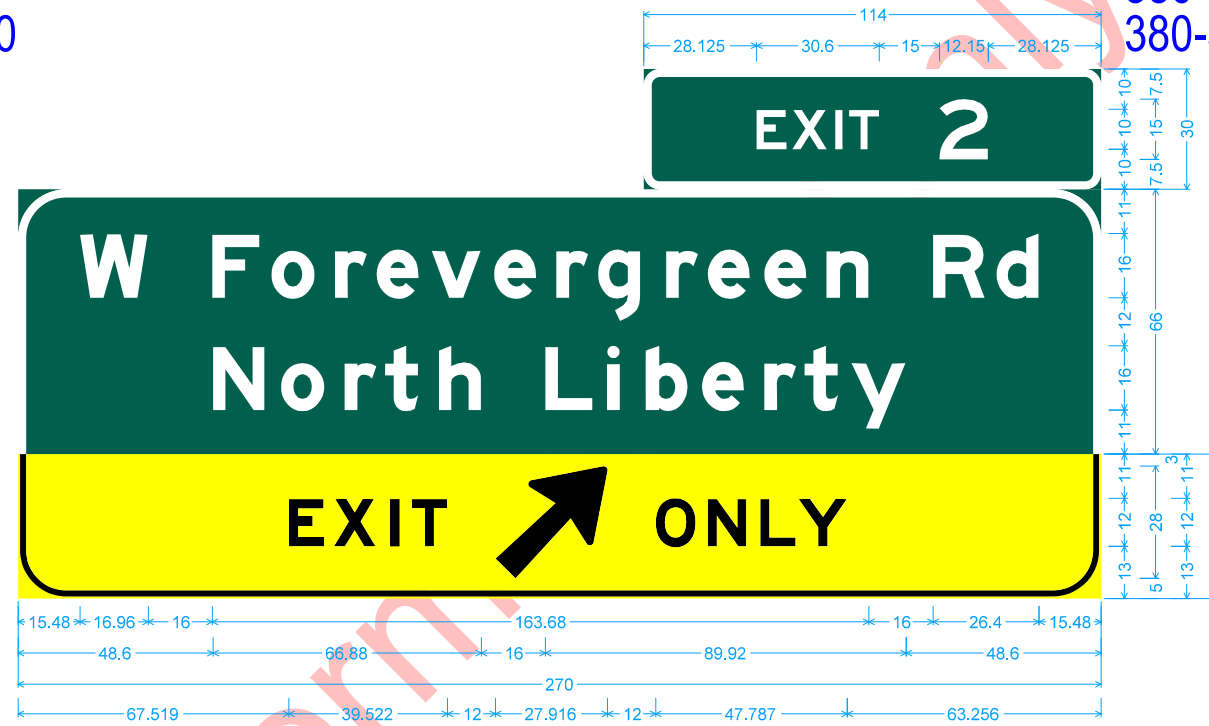

4.000" Radius, 2.000" Border, White on Green;  
 [EXIT] E 2K; [2] E 2K;  
 12.000" Radius, 2.000" Border, White on Green;  
 [W Forevergreen Rd] E Mod 2K; [North Liberty] E Mod 2K;  
 Identifier : E11-1d  
 12.000" Radius, 1.500" Border, 0.500" Indent, Black on Yellow;  
 [EXIT] E Mod 2K specified length; Arrow Custom - 35.625" 45°; [ONLY] E Mod 2K specified length;

380-52-2 M102

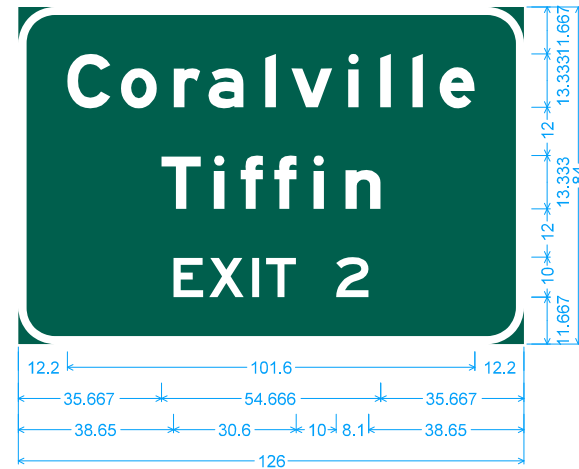

9.000" Radius, 2.000" Border, White on Green;  
 [Coralville] E Mod 2K; [Tiffin] E Mod 2K; [EXIT 2] E 2K;

380-52-2 M103

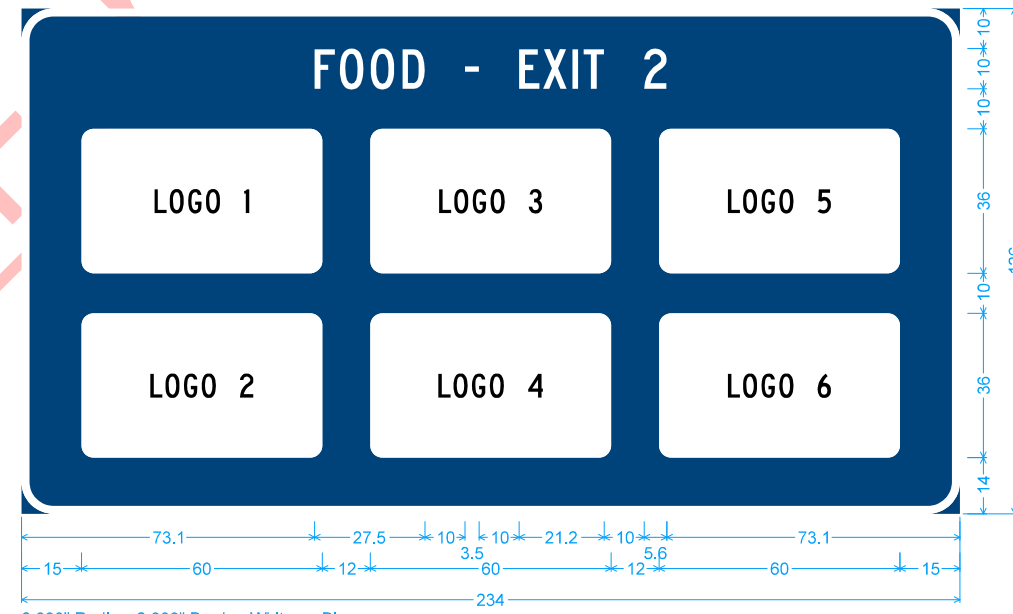

8.000" Radius, 2.000" Border, White on Blue;  
 [FOOD - EXIT 2] C 2K; Rounded Rectangle 3.000" Radius;  
 Rounded Rectangle 3.000" Radius;  
 Rounded Rectangle 3.000" Radius;  
 Rounded Rectangle 3.000" Radius;  
 Rounded Rectangle 3.000" Radius;

SIGN DETAILS  
 STAGE 3C

380-52-2 M104



8.000" Radius, 2.000" Border, White on Blue;  
 [GAS - EXIT 2] C 2K; Rounded Rectangle 3.000" Radius;  
 Rounded Rectangle 3.000" Radius;  
 [LODGING - EXIT 2] C 2K; Rounded Rectangle 3.000" Radius;  
 Rounded Rectangle 3.000" Radius;  
 Rounded Rectangle 3.000" Radius;

380-52-2 M105A  
380-52-2 M105

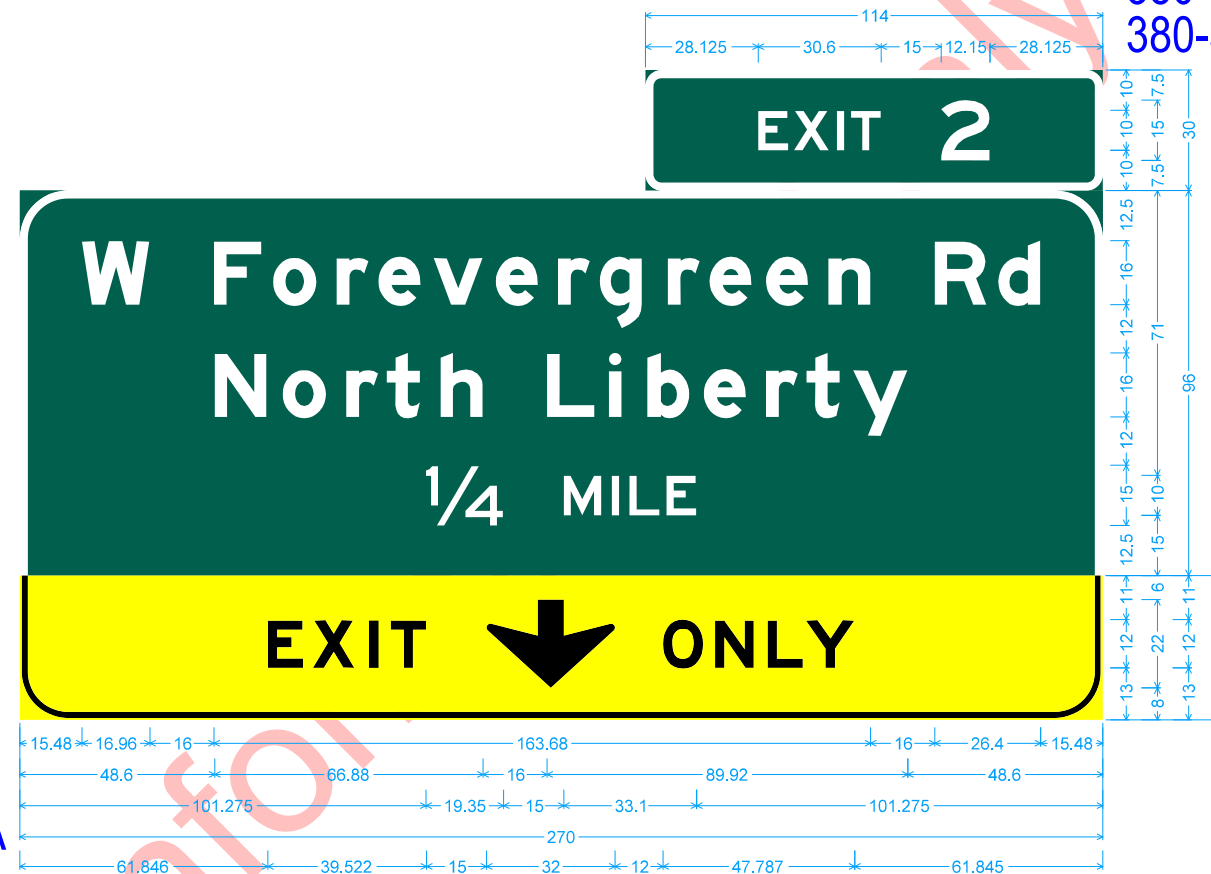

4.000" Radius, 2.000" Border, White on Green;  
 [EXIT] E 2K; [2] E 2K;  
 12.000" Radius, 2.000" Border, White on Green;  
 [W Forevergreen Rd] E Mod 2K; [North Liberty] E Mod 2K; [1/4] E 2K; [MILE] E 2K;  
 Identifier : E11-1d;  
 12.000" Radius, 1.500" Border, 0.500" Indent, Black on Yellow;  
 [EXIT] E Mod 2K specified length; Down Arrow Custom - 22.000" 270; [ONLY] E Mod 2K specified length;

380-52-2 M106A  
380-52-2 M106

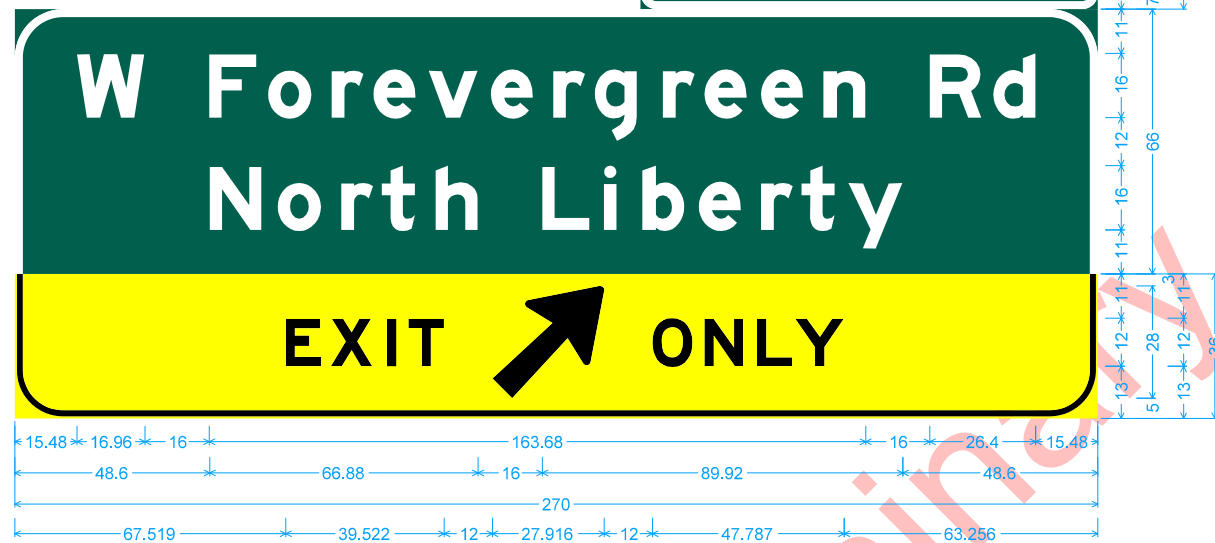
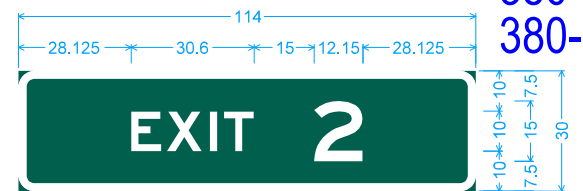

4.000" Radius, 2.000" Border, White on Green;  
 [EXIT] E 2K; [2] E 2K;  
 12.000" Radius, 2.000" Border, White on Green;  
 [W Forevergreen Rd] E Mod 2K; [North Liberty] E Mod 2K;  
 Identifier : E11-1d;  
 12.000" Radius, 1.500" Border, 0.500" Indent, Black on Yellow;  
 [EXIT] E Mod 2K specified length; Arrow Custom - 35.625" 45; [ONLY] E Mod 2K specified length;

380-52-2 M107



Identifier : top;  
 6.000" Radius, 1.500" Border, White on Green;  
 [EXIT] E 2K 225) spacing;  
 Identifier : bottom;  
 6.000" Radius, 1.500" Border, White on Green;  
 [2] E 2K;  
 Identifier : bottom;  
 6.000" Radius, 1.500" Border, White on Green;  
 Arrow Custom - 29.250" 45;

380-52-2 R004

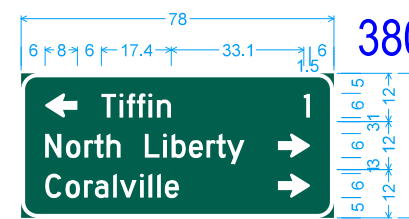

6 - 18.84 - 6 - 24.9 - 8 - 6  
 6 - 33.36 - 24.64 - 8 - 6  
 Identifier : Primary Project Destination 3 Line;  
 4.000" Radius, 1.000" Border, White on Green;  
 Arrow III-6S - 8.000" 180;  
 [Tiffin] D 2K; [1] D 2K;  
 4.000" Radius, 1.000" Border, White on Green;  
 [North Liberty] D 2K;  
 Arrow III-6S - 8.000" 0;  
 4.000" Radius, 1.000" Border, White on Green;  
 [Coralville] D 2K;  
 Arrow III-6S - 8.000" 0;

380-52-2 R104

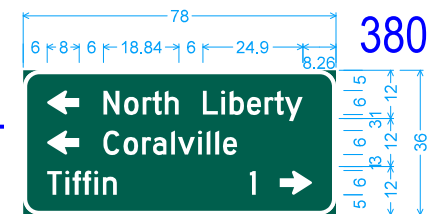

6 - 8 - 6 - 18.84 - 6 - 24.9 - 8 - 6  
 6 - 33.36 - 24.64 - 8 - 6  
 Identifier : Primary Project Destination 3 Line;  
 4.000" Radius, 1.000" Border, White on Green;  
 Arrow III-6S - 8.000" 180;  
 [North Liberty] D 2K;  
 4.000" Radius, 1.000" Border, White on Green;  
 Arrow III-6S - 8.000" 180;  
 [Coralville] D 2K;  
 [Tiffin] D 2K; [1] D 2K;  
 4.000" Radius, 1.000" Border, White on Green;  
 [Tiffin] D 2K; [1] D 2K;  
 Arrow III-6S - 8.000" 0;

SIGN DETAILS  
STAGE 3C

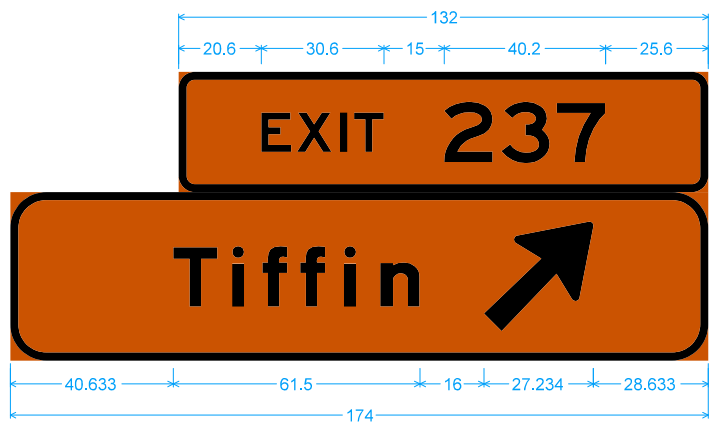

Identifier : E1-5P(2)\_132x30;  
 4.000" Radius, 2.000" Border, Black on Orange;  
 [EXIT] E 2K; [237] E 2K;  
 9.000" Radius, 2.000" Border, Black on Orange;  
 [Tiffin] E Mod 2K; Arrow I-F - 35.000" 45°;

80-52-237 S110A  
 80-52-237 S110



9.000" Radius, 2.000" Border, White on Blue;  
 [REST AREA] E 2K; [NEXT RIGHT] E 2K;  
 Identifier : D5-1a\_78x36;  
 9.000" Radius, 2.000" Border, White on Blue;  
 [VENDING MACHINES] E 2K 65) spacing;  
 [WIRELESS INTERNET] E 2K 65) spacing;  
 Handicapped Accessible Symbol; Symbol RM150; Symbol RM160;  
 9.000" Radius, 2.000" Border, White on Blue;  
 [NEXT] E 2K; [REST AREA] E 2K; [28] E 2K; [MILES] E 2K;

80-52-237 S111

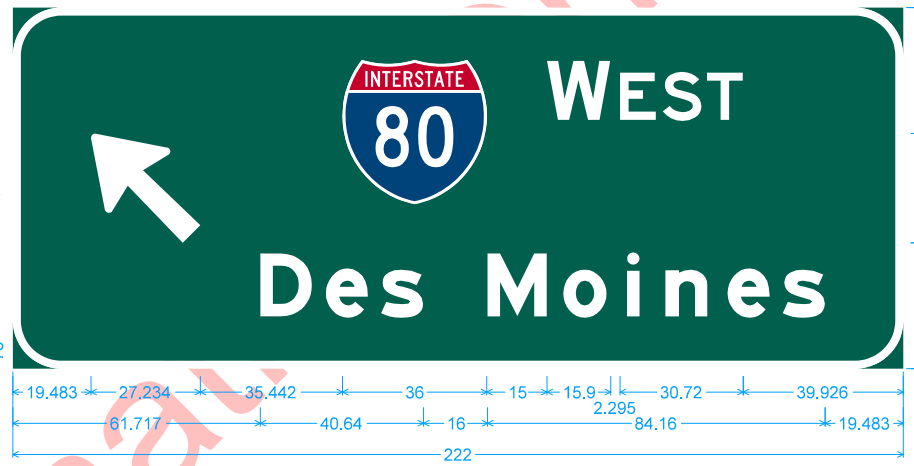

12.000" Radius, 2.000" Border, White on Green;  
 Arrow I-F - 35.000" 135°; [WEST] E 2K; [Des Moines] E Mod 2K;

218-52-96 R001

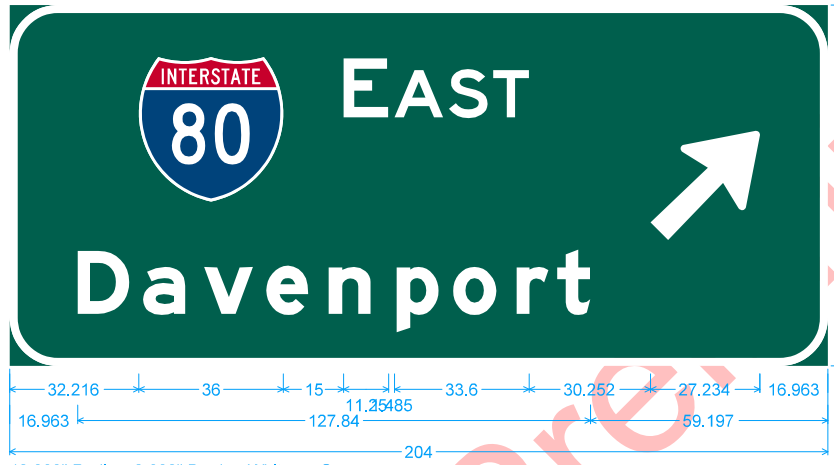

12.000" Radius, 2.000" Border, White on Green;  
 [EAST] E 2K; [Davenport] E Mod 2K; Arrow I-F - 35.000" 45°;

218-52-96 R002

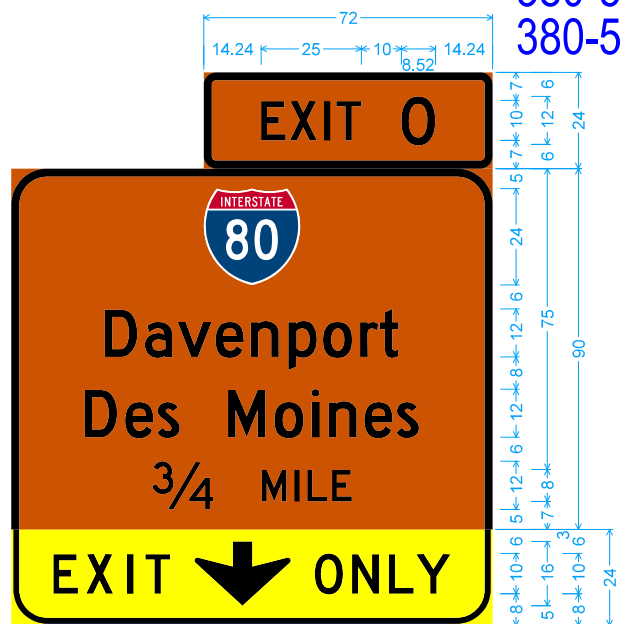

2.000" Radius, 2.000" Border, Black on Orange;  
 [EXIT] D 2K; [0] D 2K;  
 9.000" Radius, 2.000" Border, Black on Orange;  
 [Davenport] D 2K; [Des Moines] D 2K; [3/4] D 2K;  
 [MILE] D 2K;  
 Identifier : E11-1d;  
 9.000" Radius, 1.500" Border, 0.500" Indent, Black on Yellow;  
 [EXIT] D 2K 200) spacing;  
 Down Arrow II-B - 16.000" 270°; [ONLY] D 2K;

380-52-0 M108A  
 380-52-0 M108

SIGN DETAILS  
 STAGE 3D

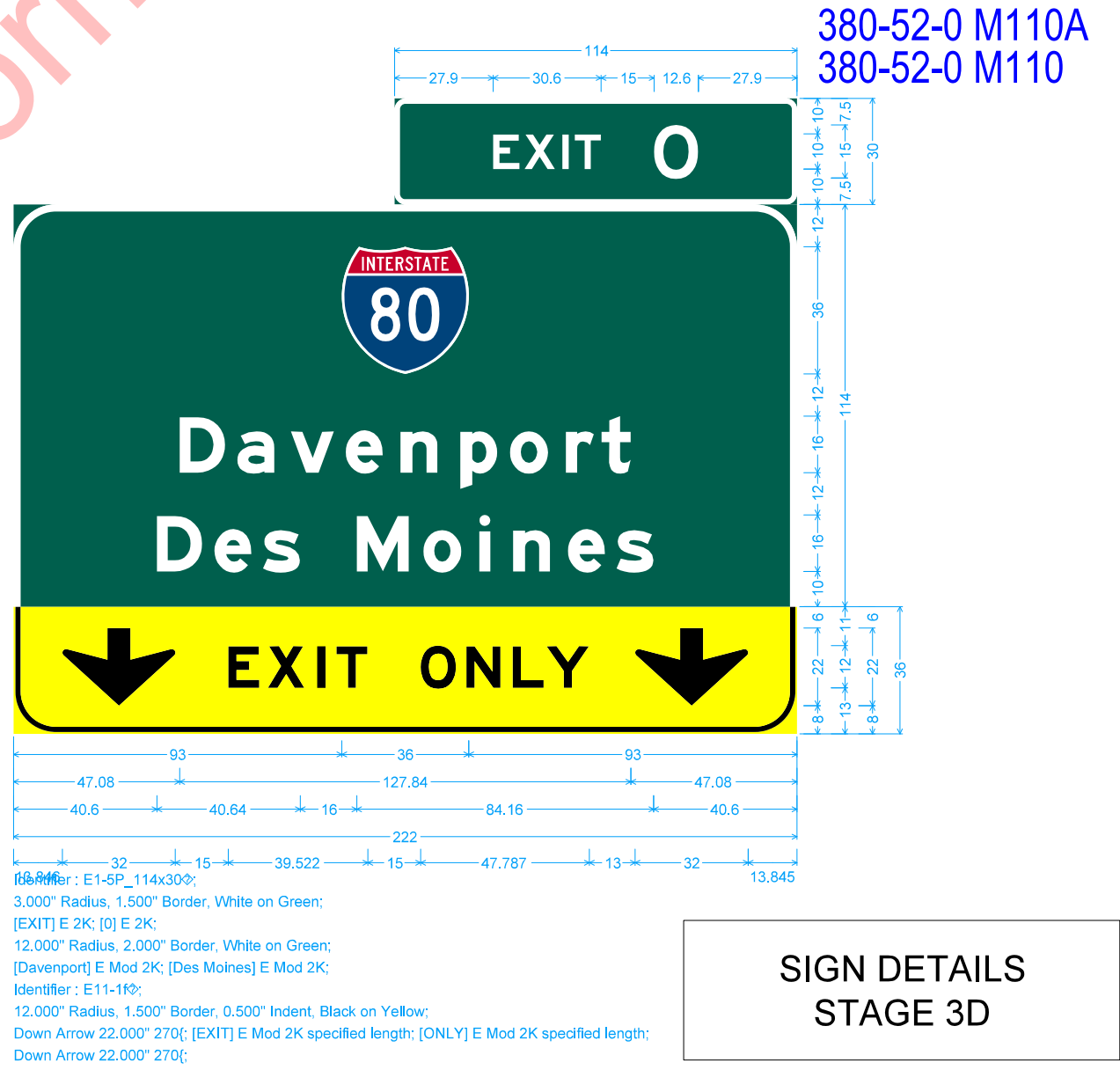
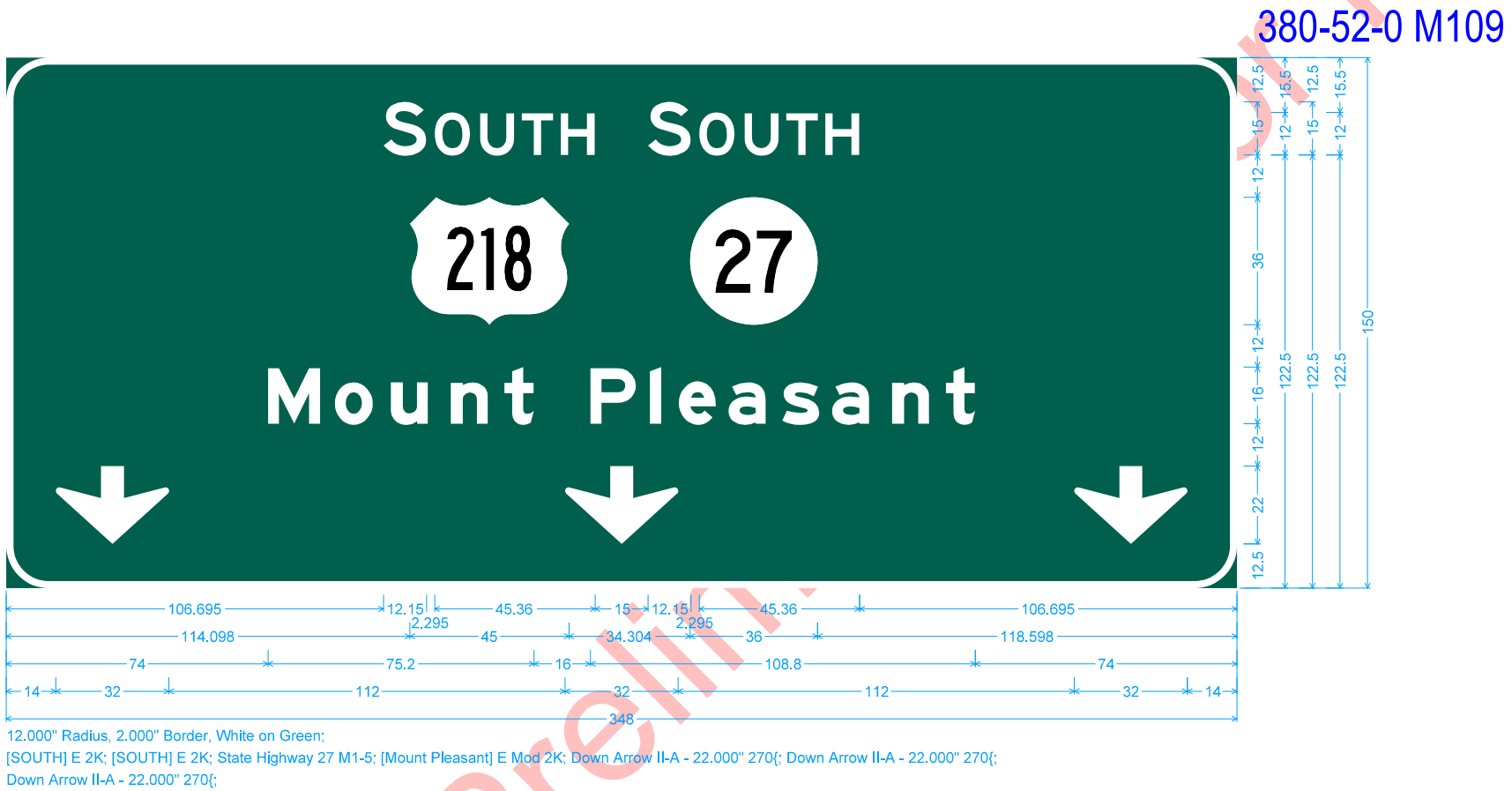
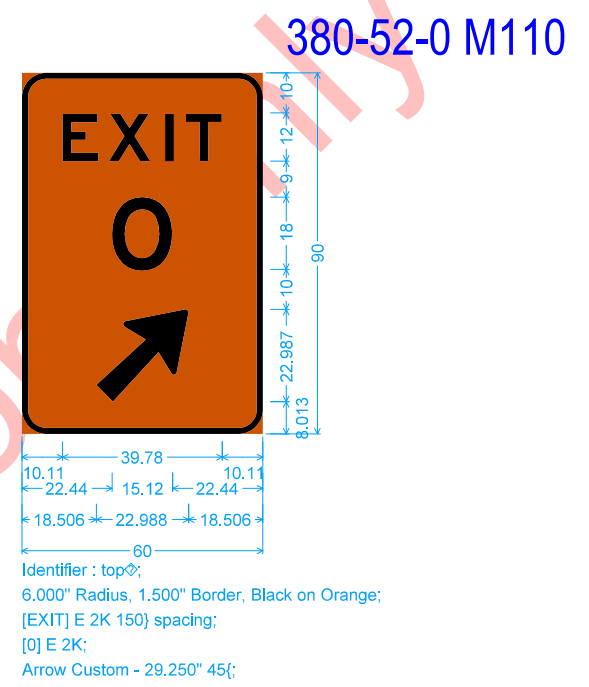
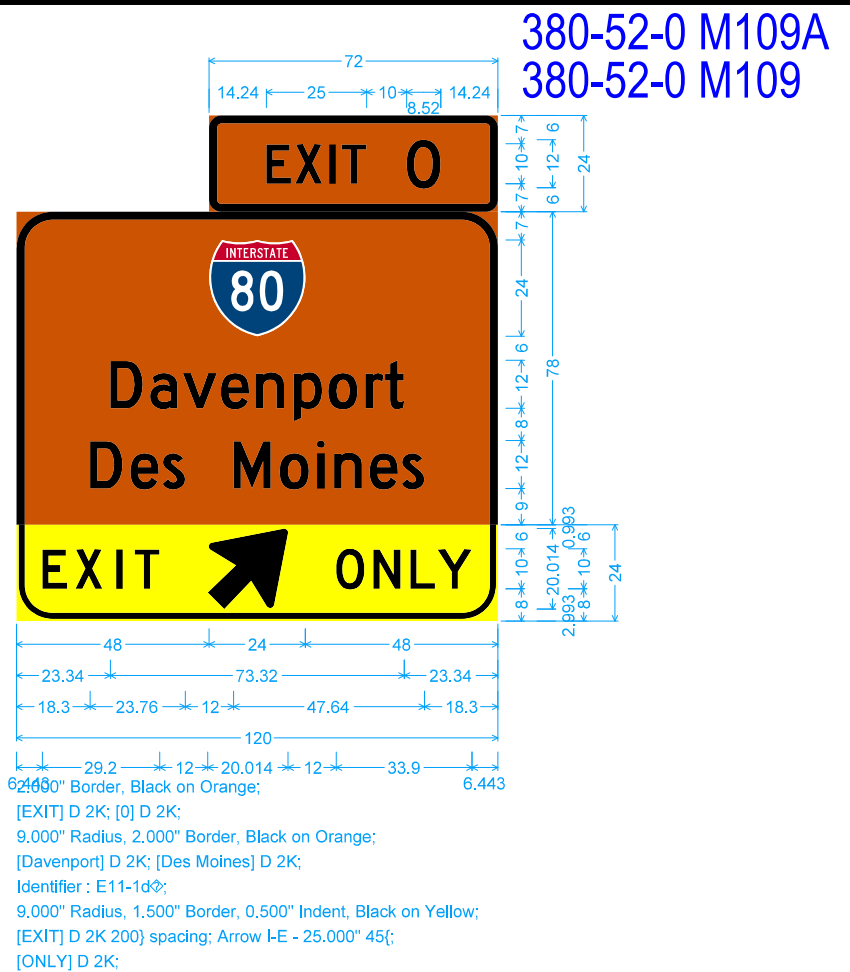

**SIGN DETAILS  
STAGE 3D**



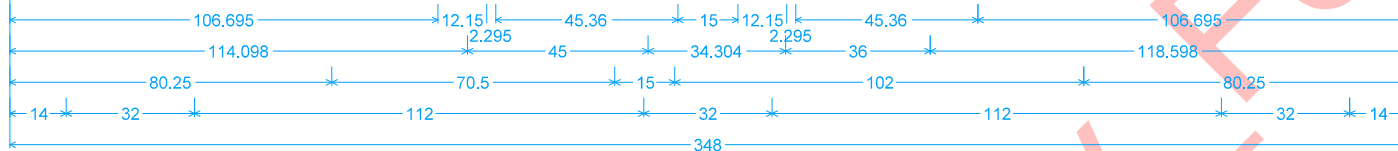
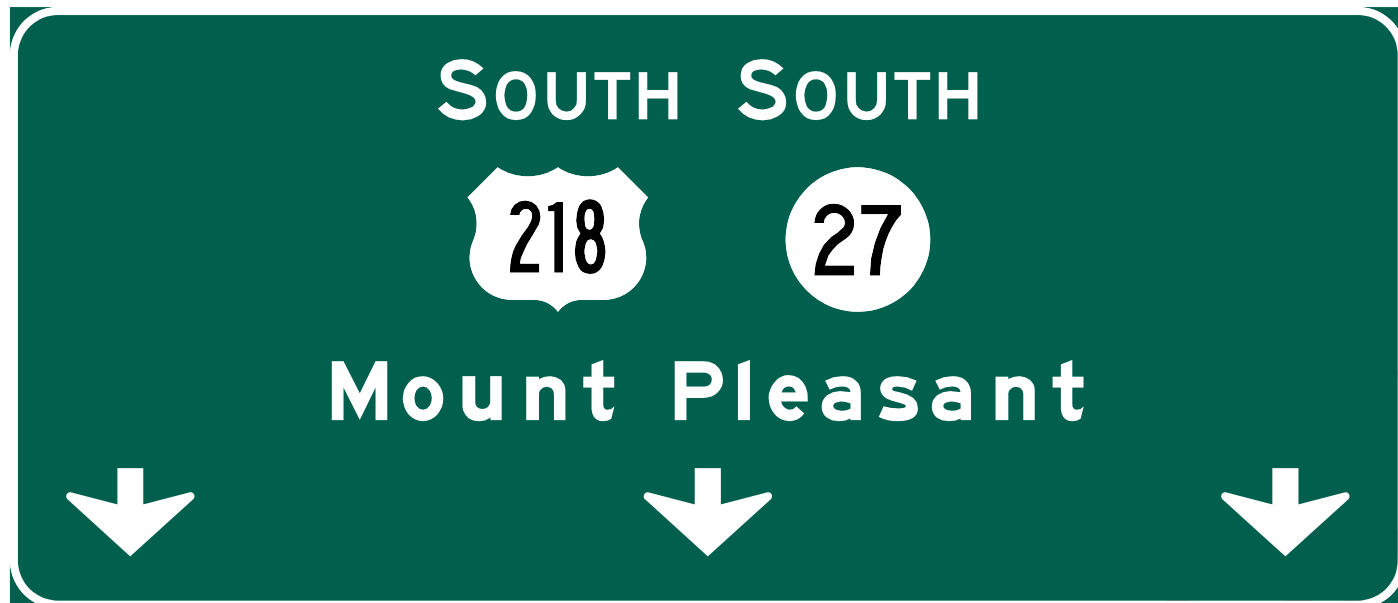

12.000" Radius, 2.000" Border, White on Green;  
 [SOUTH] E 2K; [SOUTH] E 2K; State Highway 27 M1-5; [Mount Pleasant] E Mod 2K; Down Arrow II-A - 22.000" 270; Down Arrow II-A - 22.000" 270;  
 Down Arrow II-A - 22.000" 270;

380-52-0 M113

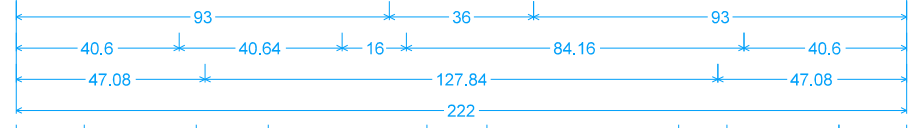

16.929 27.916 18 39.522 15 47.787 12 27.916 16.93  
 Identifier : E1-5P\_114x30  
 4.000" Radius, 2.000" Border, White on Green;  
 [EXIT] E 2K; [O] E 2K;  
 12.000" Radius, 2.000" Border, White on Green;  
 [Des Moines] E Mod 2K; [Davenport] E Mod 2K;  
 Identifier : E11-1e  
 12.000" Radius, 1.500" Border, 0.500" Indent, Black on Yellow;  
 Arrow Custom - 35.625" 45; [EXIT] E Mod 2K specified length; [ONLY] E Mod 2K specified length;  
 Arrow Custom - 35.625" 45;

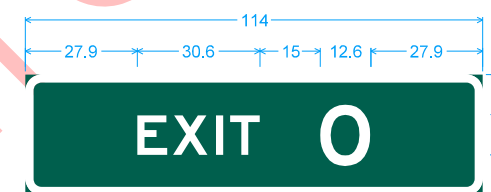

380-52-0 M114A  
 380-52-0 M114

SIGN DETAILS  
 STAGE 3D

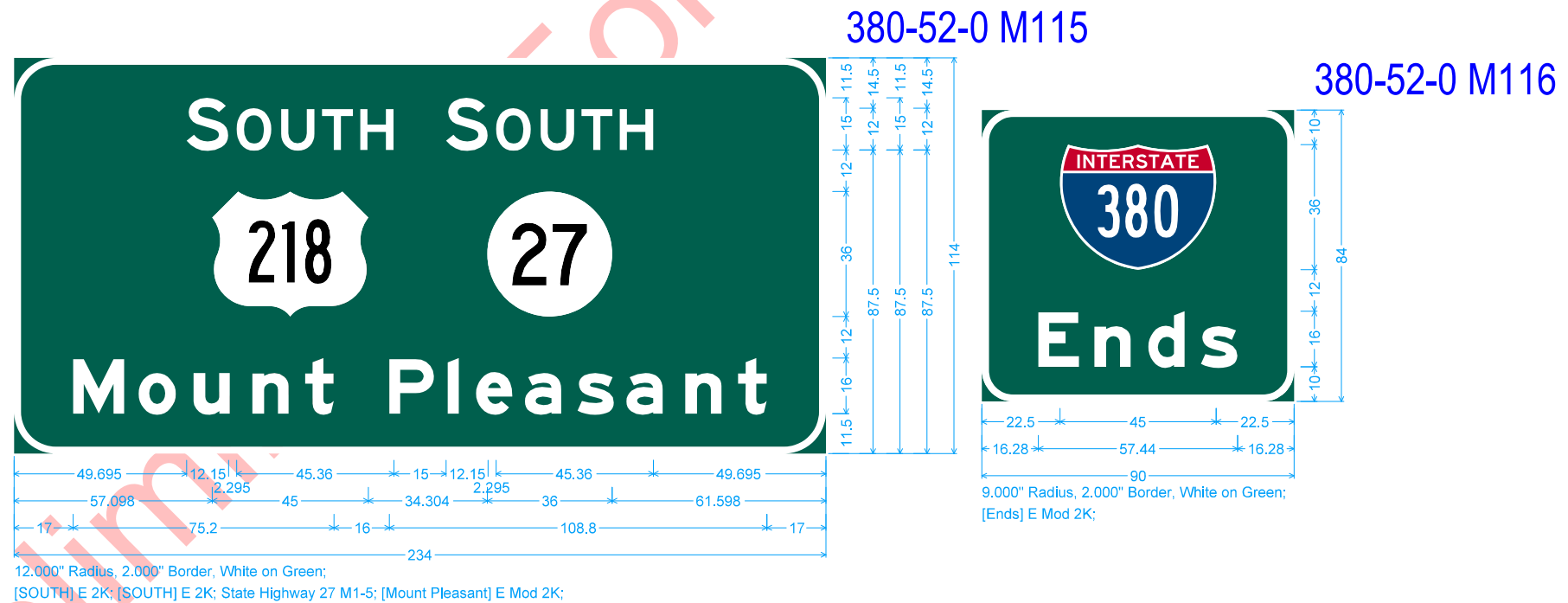
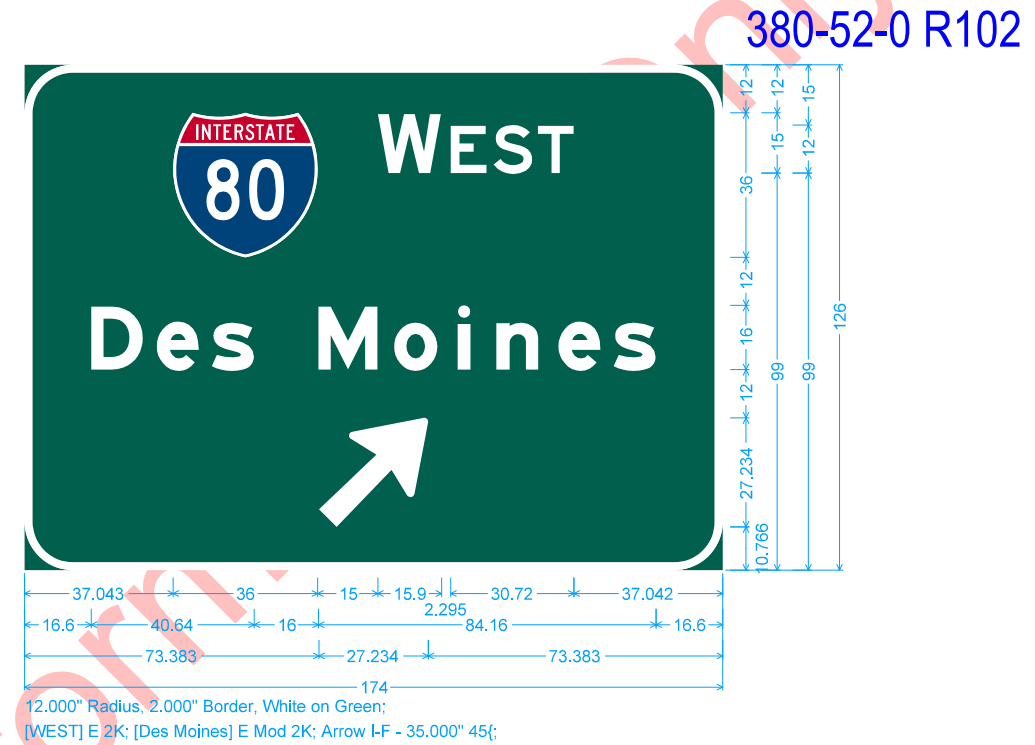
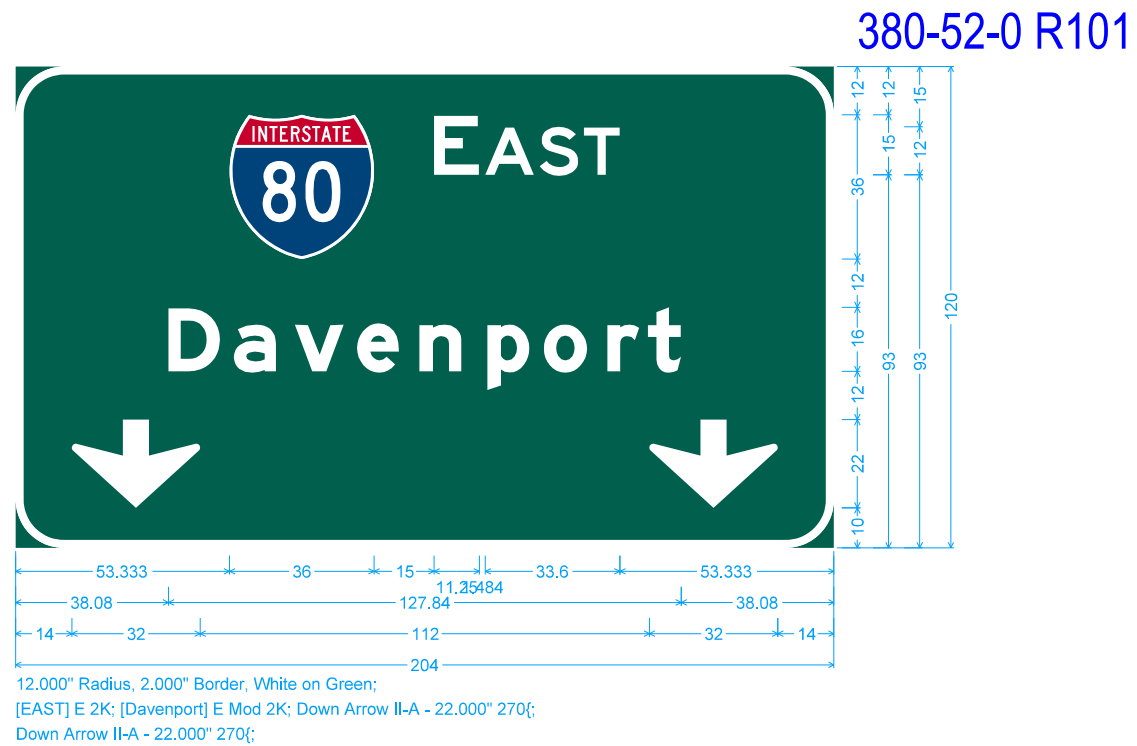

SIGN DETAILS  
 STAGE 3D

80-52-239 S003A  
80-52-239 S003

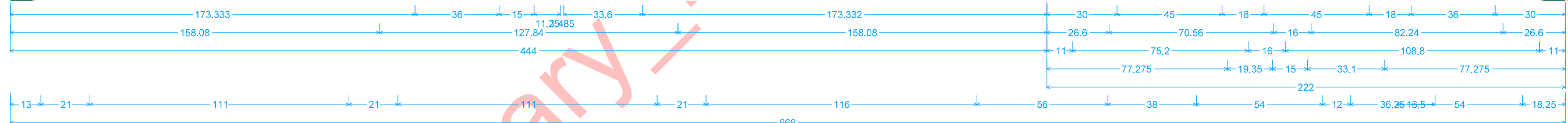
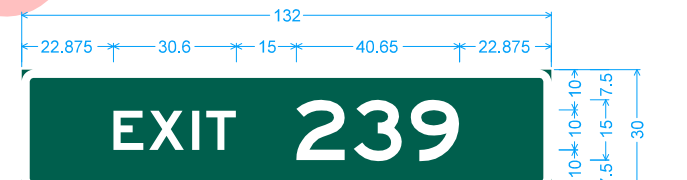
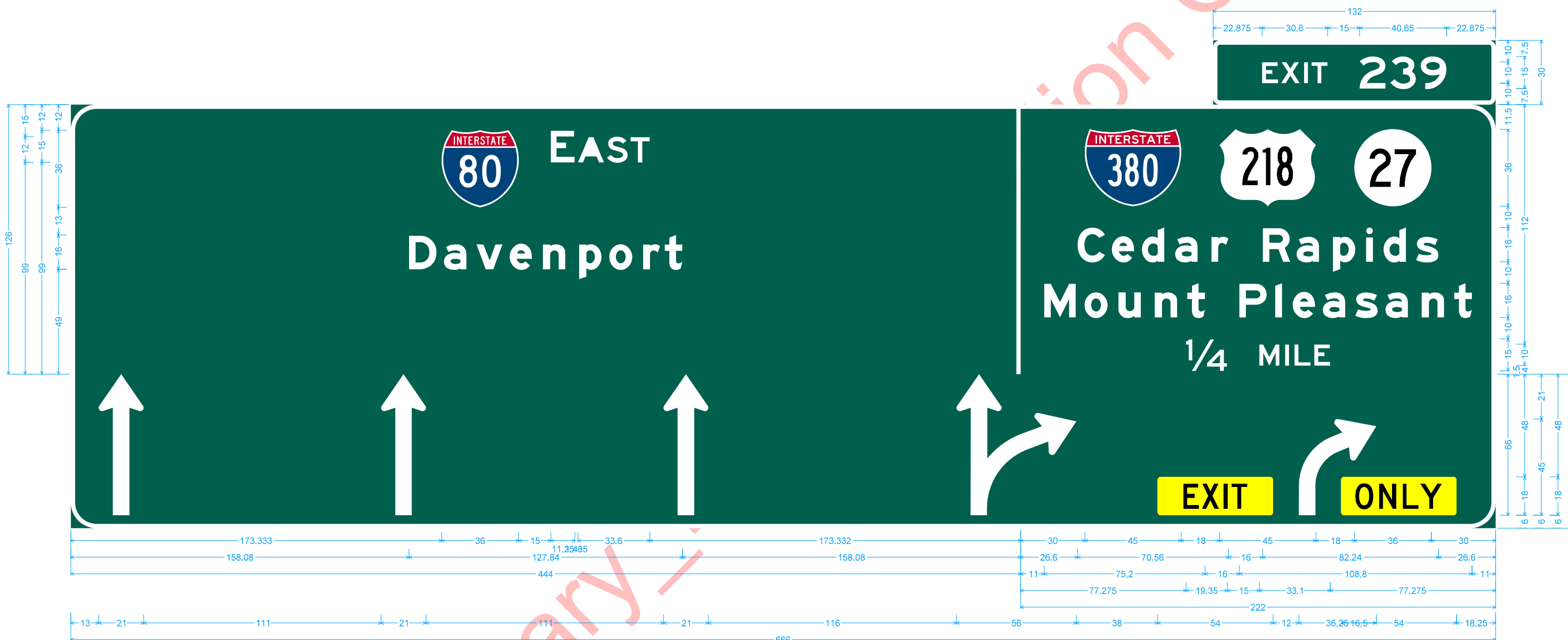

Identifier : E1-5P(2)\_132x300;  
 3.000" Radius, 2.000" Border, White on Green;  
 [EXIT] E 2K; [239] E 2K;  
 12.000" Radius, 2.000" Border, White on Green;  
 [EAST] E 2K; [Davenport] E Mod 2K;  
 12.000" Radius, 2.000" Border, White on Green;  
 State Highway 27 M1-5; [Cedar Rapids] E Mod 2K; [Mount Pleasant] E Mod 2K; [1/4 MILE] E 2K;  
 12.000" Radius, 2.000" Border, White on Green;  
 Standard Arrow Custom 66.000" X 21.000" 90{}; Standard Arrow Custom 66.000" X 21.000" 90{}; Standard Arrow Custom 66.000" X 21.000" 90{}; thru-right arrow; Rounded Rectangle 1.500" Radius Yellow;  
 right arrow; Rounded Rectangle 1.500" Radius Yellow;

SIGN DETAILS  
STAGE 3E

80-52-239 S004A  
80-52-239 S004

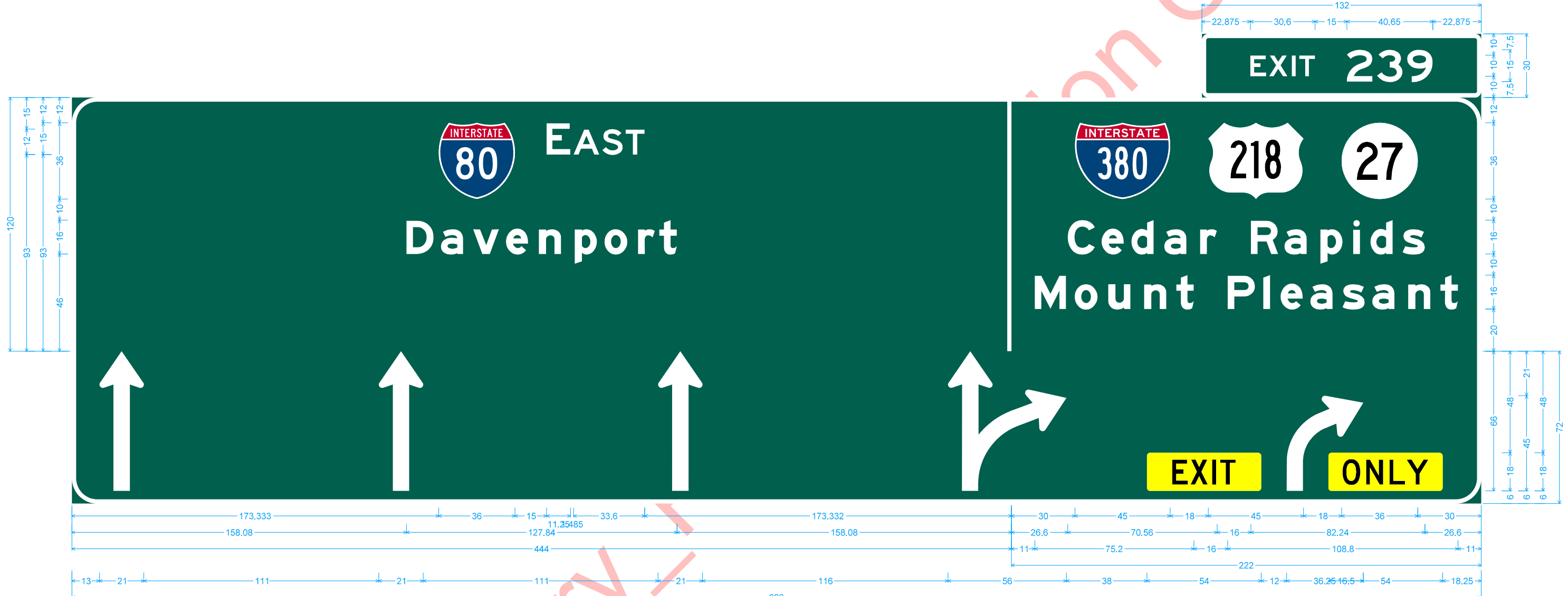

Identifier : E1-5P(2)\_132x300;  
 3.000" Radius, 2.000" Border, White on Green;  
 [EXIT] E 2K; [239] E 2K;  
 12.000" Radius, 2.000" Border, White on Green;  
 [EAST] E 2K; [Davenport] E Mod 2K;  
 12.000" Radius, 2.000" Border, White on Green;  
 State Highway 27 M1-5; [Cedar Rapids] E Mod 2K; [Mount Pleasant] E Mod 2K;  
 12.000" Radius, 2.000" Border, White on Green;  
 Standard Arrow Custom 66.000" X 21.000" 90{}; Standard Arrow Custom 66.000" X 21.000" 90{}; thru-right arrow; Rounded Rectangle 1.500" Radius Yellow;  
 right arrow; Rounded Rectangle 1.500" Radius Yellow;

SIGN DETAILS  
STAGE 3E

80-52-239 R001

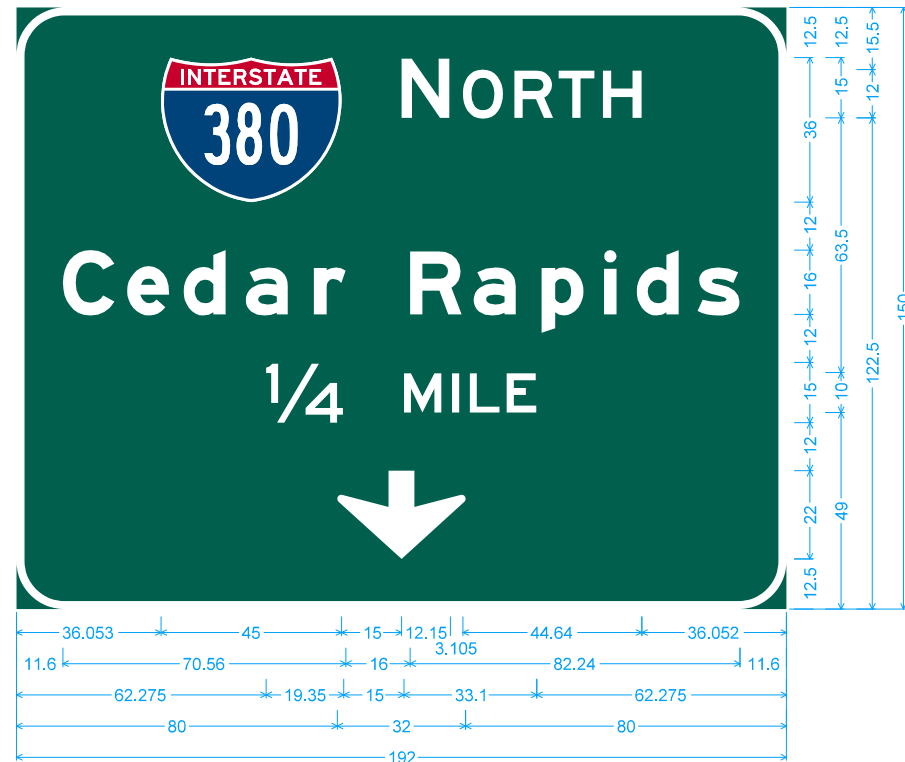

12.000" Radius, 2.000" Border, White on Green;  
 [NORTH] E 2K; [Cedar Rapids] E Mod 2K; [1/4] E 2K; [MILE] E 2K;  
 Down Arrow II-A - 22.000" 270;

80-52-239 R002

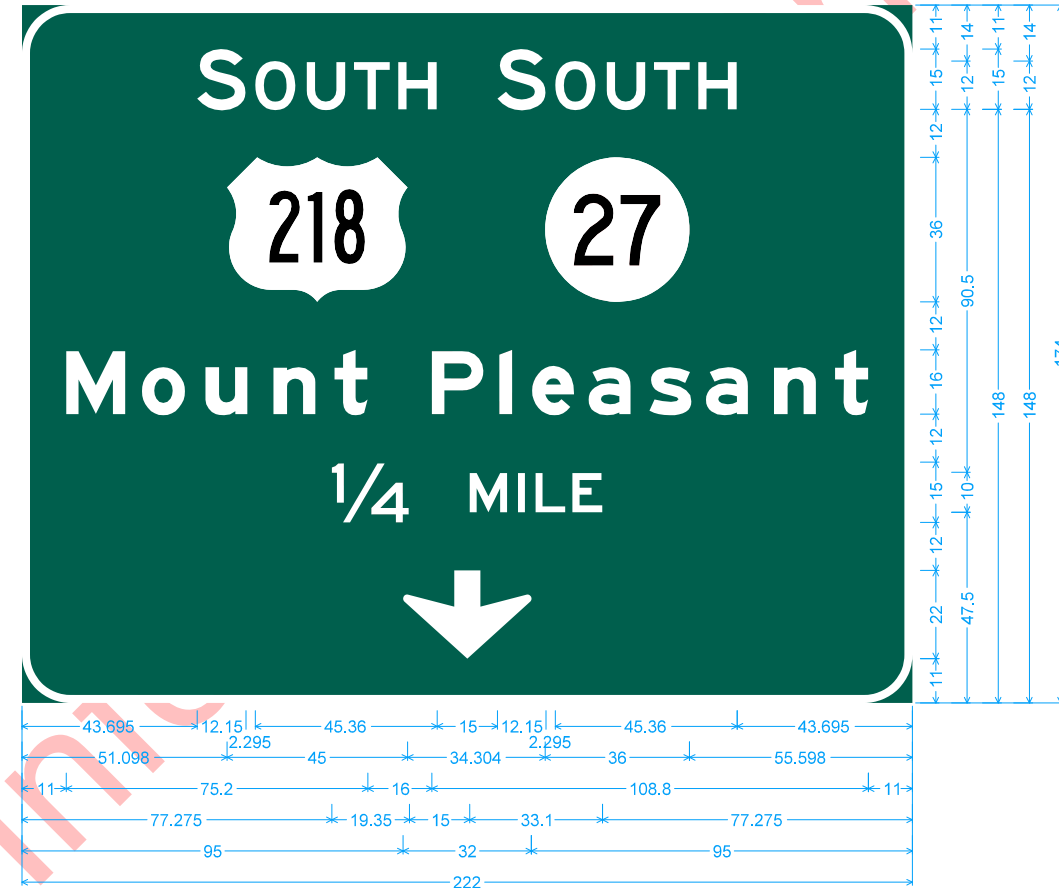

12.000" Radius, 2.000" Border, White on Green;  
 [SOUTH] E 2K; [SOUTH] E 2K; State Highway 27 M1-5; [Mount Pleasant] E Mod 2K; [1/4] E 2K;  
 [MILE] E 2K; Down Arrow II-A - 22.000" 270;

80-52-239 S005



Identifier : top;  
 6.000" Radius, 1.500" Border, White on Green;  
 [EXIT] E 2K 150} spacing;  
 [239] E 2K;  
 Arrow Custom - 29.250" 45;

80-52-239 S100A  
 80-52-239 S100

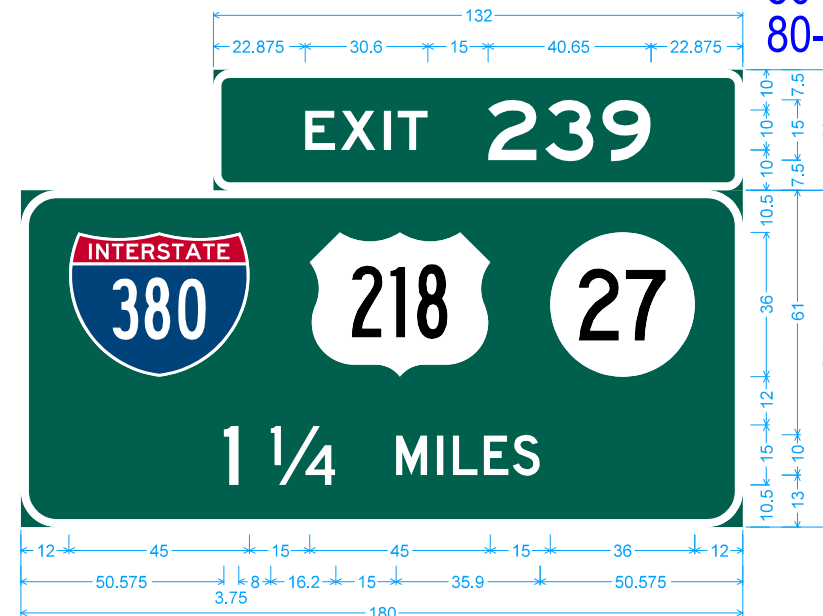

4.000" Radius, 2.000" Border, White on Green;  
 [EXIT] E 2K; [239] E 2K;  
 9.000" Radius, 2.000" Border, White on Green;  
 State Highway 27 M1-5; [1] D 2K; [1/4] D 2K; [MILES] D 2K;

SIGN DETAILS  
 STAGE 3E

80-52-239 S101A  
80-52-239 S101

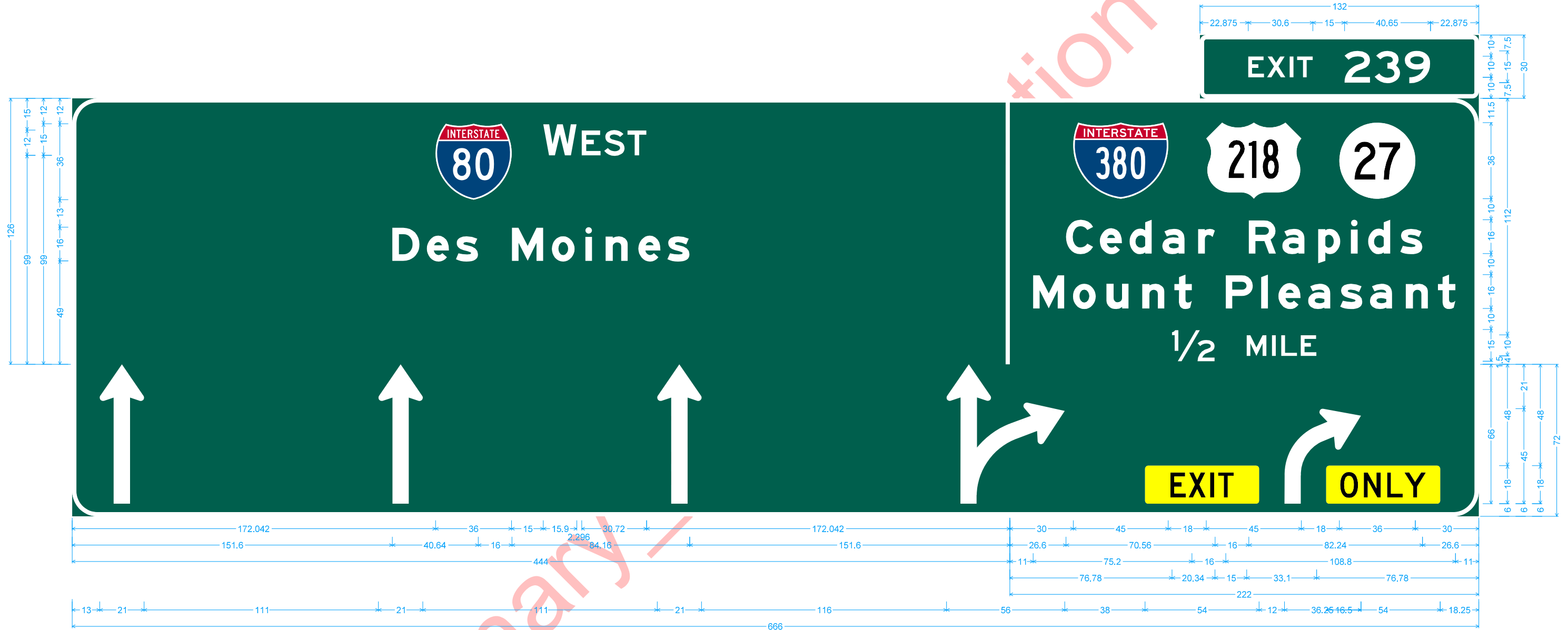

Identifier : E1-5P(2)\_132x30  
 3.000" Radius, 2.000" Border, White on Green;  
 [EXIT] E 2K; [239] E 2K;  
 12.000" Radius, 2.000" Border, White on Green;  
 [WEST] E 2K; [Des Moines] E Mod 2K;  
 12.000" Radius, 2.000" Border, White on Green;  
 State Highway 27 M1-5; [Cedar Rapids] E Mod 2K; [Mount Pleasant] E Mod 2K; [1/2 MILE] E 2K;  
 12.000" Radius, 2.000" Border, White on Green;  
 Standard Arrow Custom 66.000" X 21.000" 90°; Standard Arrow Custom 66.000" X 21.000" 90°; thru-right arrow; Rounded Rectangle 1.500" Radius Yellow;  
 right arrow; Rounded Rectangle 1.500" Radius Yellow;

SIGN DETAILS  
STAGE 3E

80-52-239 S102A  
80-52-239 S102

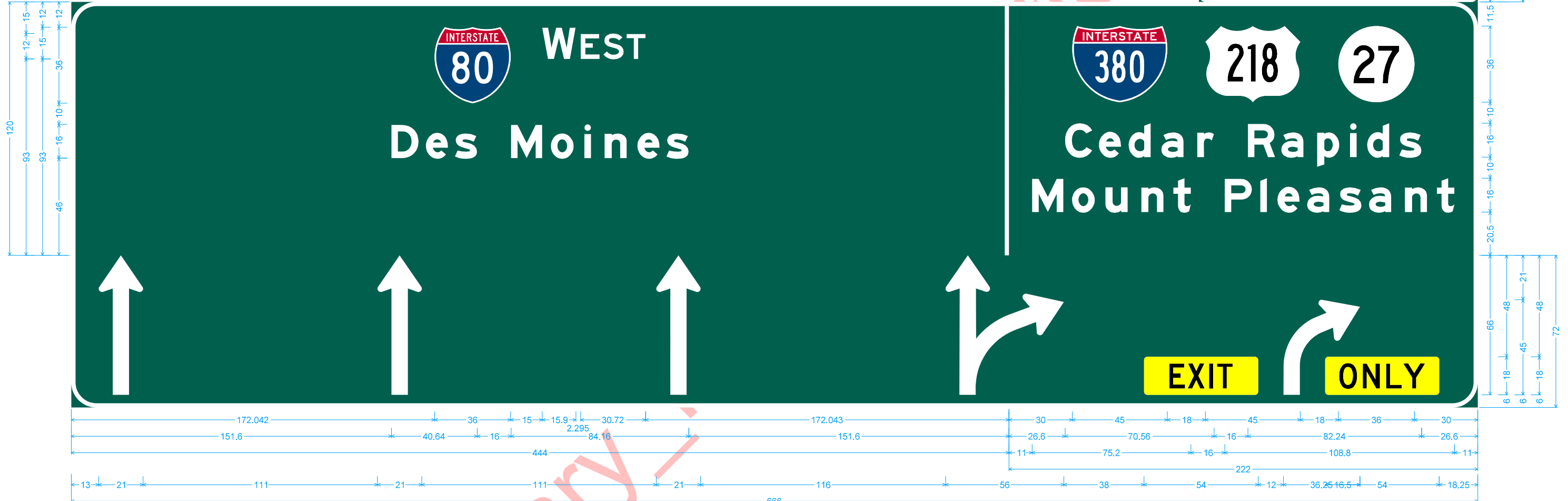
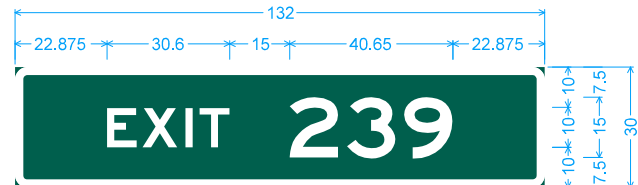

Identifier : E1-5P(2)\_132x30Φ;  
3.000" Radius, 2.000" Border, White on Green;  
[EXIT] E 2K; [239] E 2K;  
12.000" Radius, 2.000" Border, White on Green;  
[WEST] E 2K; [Des Moines] E Mod 2K;  
12.000" Radius, 2.000" Border, White on Green;  
State Highway 27 M1-5; [Cedar Rapids] E Mod 2K; [Mount Pleasant] E Mod 2K;  
12.000" Radius, 2.000" Border, White on Green;  
Standard Arrow Custom 66.000" X 21.000" 90°; Standard Arrow Custom 66.000" X 21.000" 90°; thru-right arrow; Rounded Rectangle 1.500" Radius Yellow;  
right arrow; Rounded Rectangle 1.500" Radius Yellow;

SIGN DETAILS  
STAGE 3E

80-52-239 S103



Identifier : topΦ;  
 6.000" Radius, 1.500" Border, White on Green;  
 [EXIT] E 2K 150) spacing;  
 [239] E 2K;  
 Arrow Custom - 29.250" 45{;

80-52-239 R101

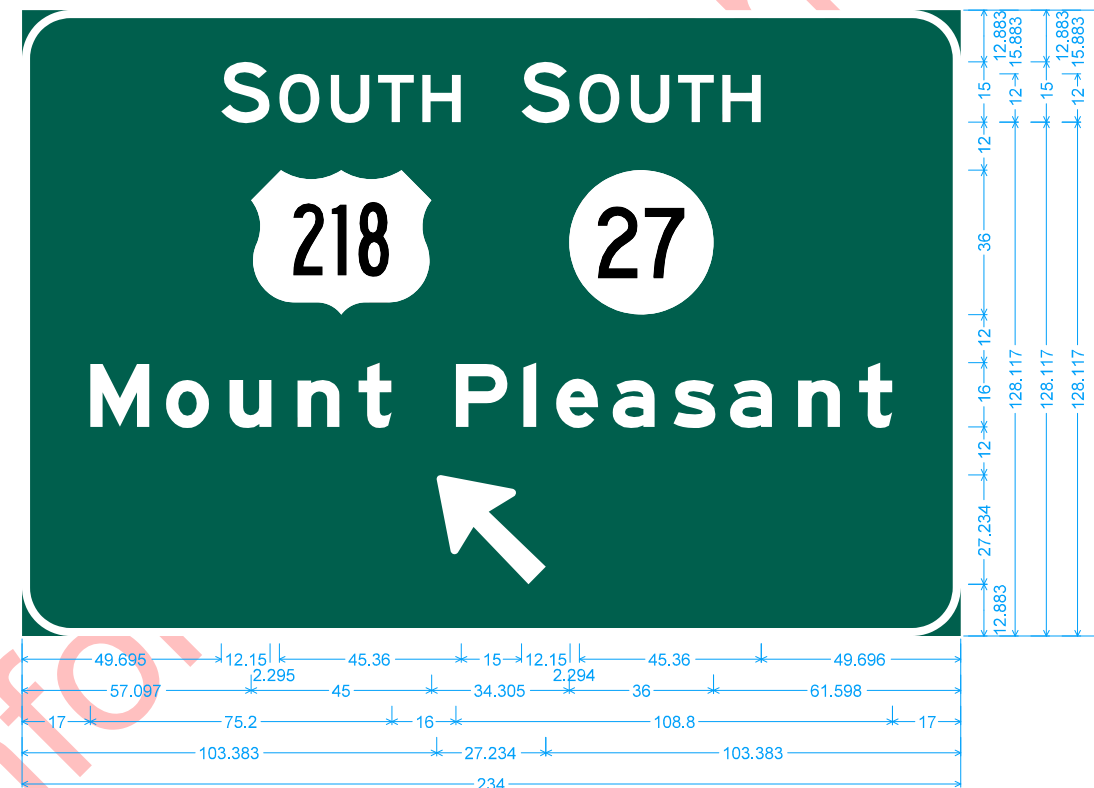

12.000" Radius, 2.000" Border, White on Green;  
 [SOUTH] E 2K; [SOUTH] E 2K; State Highway 27 M1-5; [Mount Pleasant] E Mod 2K;  
 Arrow I-F - 35.000" 135{;

80-52-237 S105

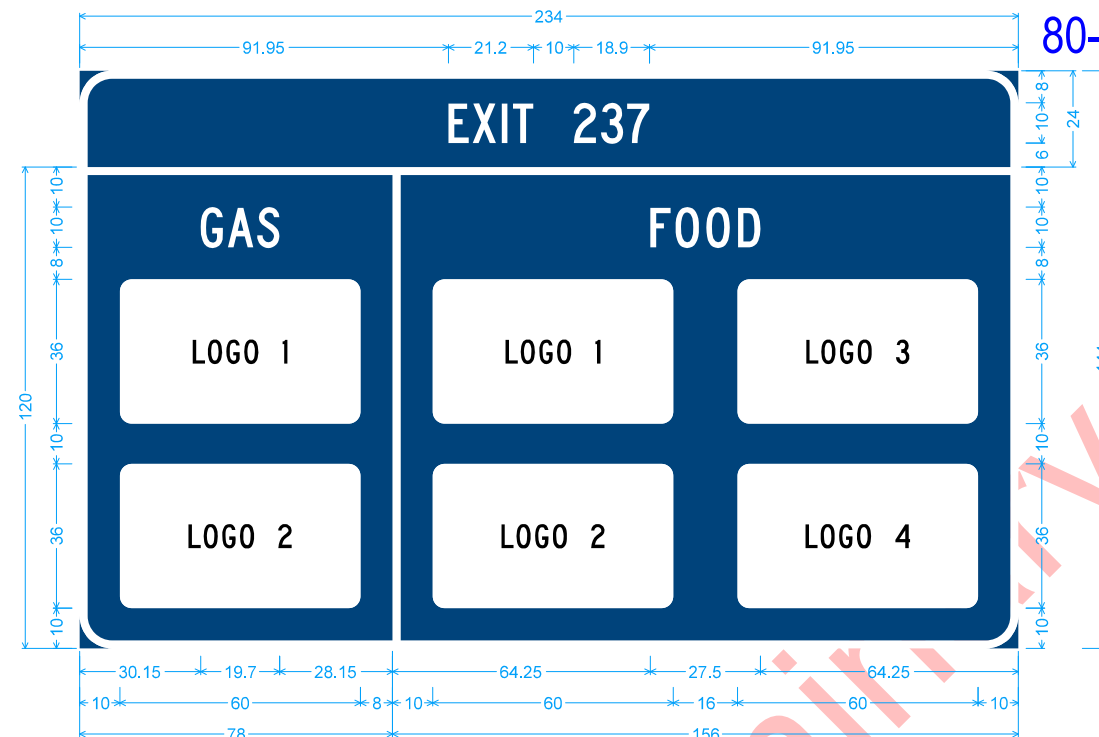

8.000" Radius, 2.000" Border, White on Blue;  
 [EXIT 237] C 2K;  
 8.000" Radius, 2.000" Border, White on Blue;  
 [GAS] C 2K; Rounded Rectangle 3.000" Radius;  
 Rounded Rectangle 3.000" Radius;  
 8.000" Radius, 2.000" Border, White on Blue;  
 [FOOD] C 2K; Rounded Rectangle 3.000" Radius;  
 Rounded Rectangle 3.000" Radius;  
 Rounded Rectangle 3.000" Radius;  
 Rounded Rectangle 3.000" Radius;

80-52-237 S108



Identifier : topΦ;  
 6.000" Radius, 1.500" Border, White on Green;  
 [EXIT] E 2K 150) spacing;  
 [237] E 2K;  
 Arrow Custom - 29.250" 45{;

SIGN DETAILS  
 STAGE 3E



218-52-96 M001A  
218-52-96 M001

218-52-96 M002

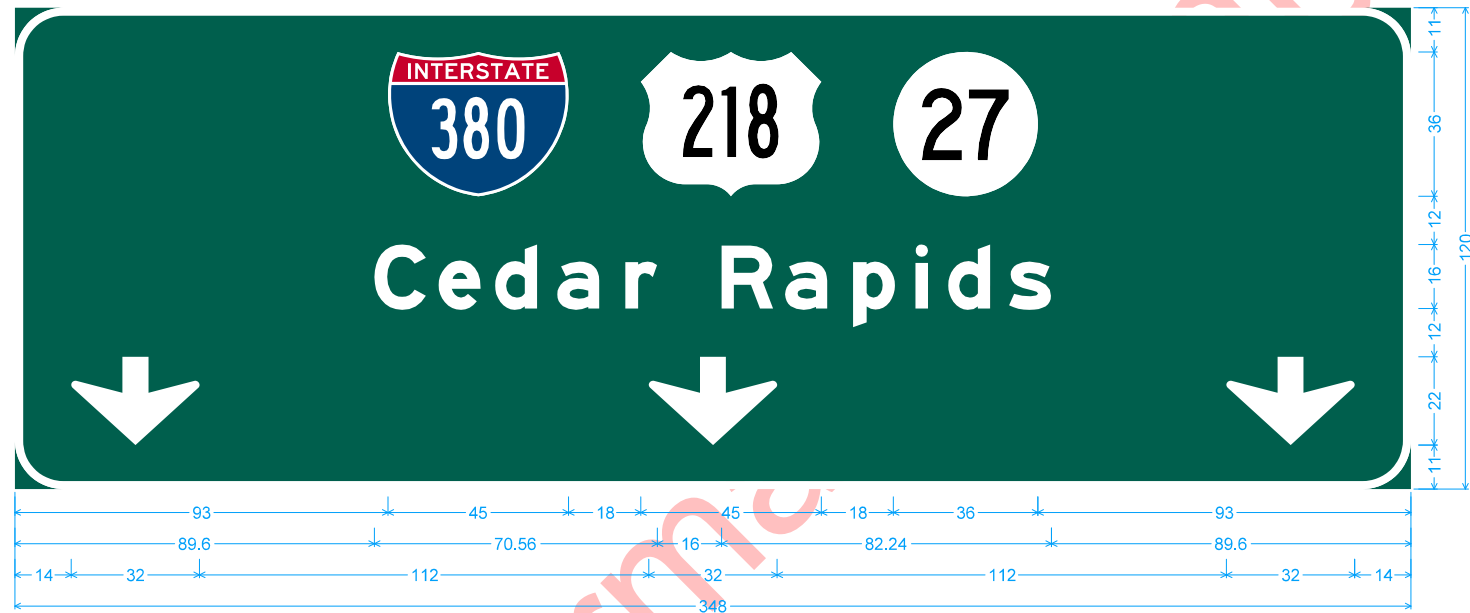
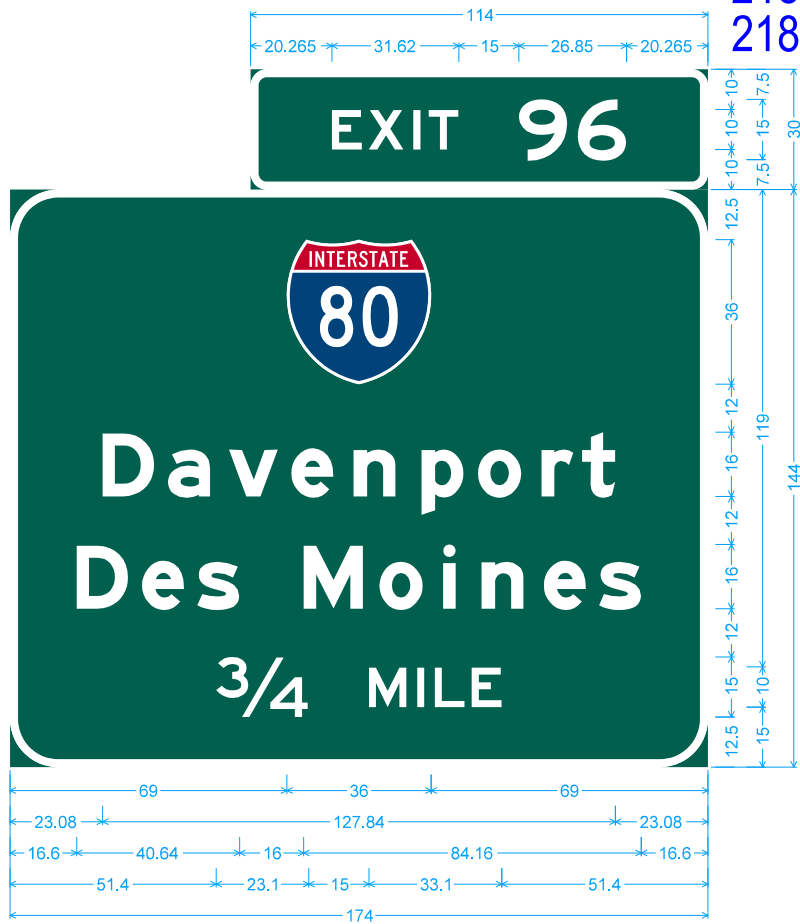

12.000" Radius, 2.000" Border, White on Green;  
State Highway 27 M1-5; [Cedar Rapids] E Mod 2K; Down Arrow II-A - 22.000" 270; Down Arrow II-A - 22.000" 270; Down Arrow II-A - 22.000" 270;

4.000" Radius, 2.000" Border, White on Green;  
[EXIT] E 2K 120 spacing; [96] E 2K;  
12.000" Radius, 2.000" Border, White on Green;  
[Davenport] E Mod 2K; [Des Moines] E Mod 2K; [3/4] E 2K; [MILE] E 2K;

218-52-96 M003A  
218-52-96 M003

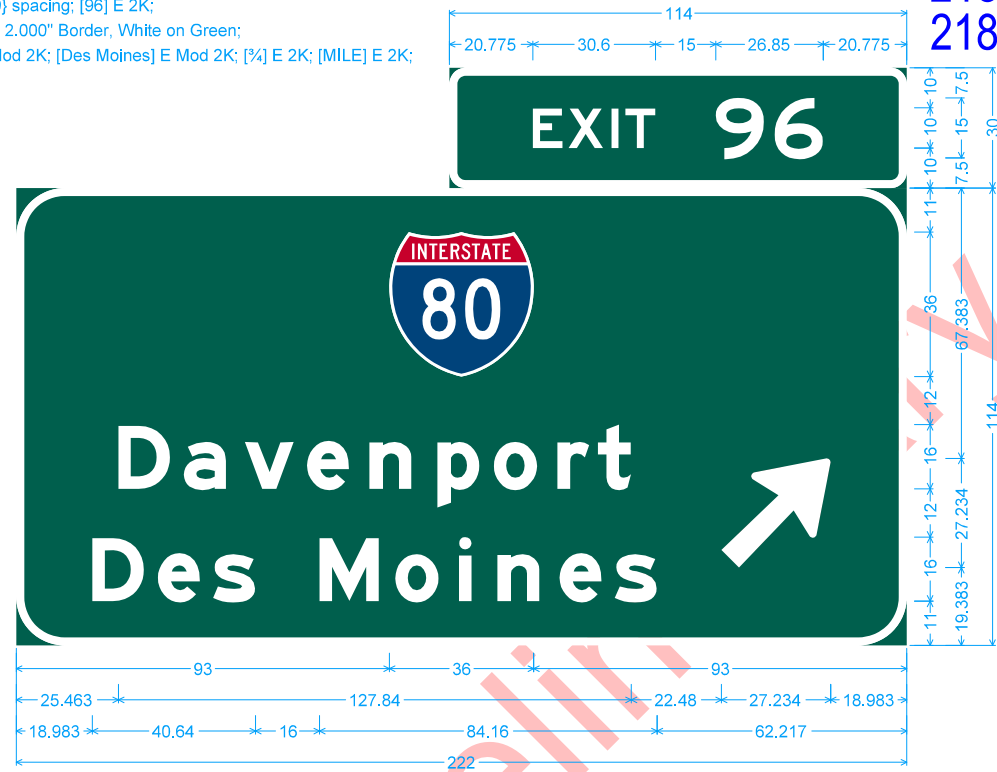

Identifier: E1-5P\_114x300;  
4.000" Radius, 2.000" Border, White on Green;  
[EXIT] E 2K; [96] E 2K;  
12.000" Radius, 2.000" Border, White on Green;  
[Davenport] E Mod 2K; [Des Moines] E Mod 2K; Arrow I-F - 35.000" 45;

380-52-0 M108A  
380-52-0 M108



4.000" Radius, 2.000" Border, White on Green;  
[EXIT] E 2K; [0] E 2K;  
12.000" Radius, 2.000" Border, White on Green;  
[Davenport] E Mod 2K; [Des Moines] E Mod 2K; [1] E 2K; [MILE] E 2K;

SIGN DETAILS  
STAGE 3E

STA. 1146+50 "Waterloo" OVERLAY

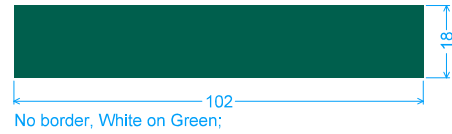

380-52-0 M113



Identifier : top<math>\phi</math>;  
 6.000" Radius, 1.500" Border, White on Green;  
 [EXIT] E 2K 150 spacing;  
 [O] E 2K;  
 Arrow Custom - 29.250" 45{;

Preliminary - For Information Only

SIGN DETAILS  
 STAGE 3E