

**DELAWARE/DUBUQUE CO.**  
**PCC PAVEMENT - GRADE AND NEW**  
**NHSX-020-9(203)--3H-28**  
 LETTING DATE  
 May 19, 2015

INDEX OF SHEETS	
No.	DESCRIPTION
<b>A Sheets</b>	<b>Title Sheets</b>
A.1	Title Sheet
A.2	Location Map Sheet
<b>B Sheets</b>	<b>Typical Cross Sections and Details</b>
B.1 - 12	Typical Cross Sections and Details
<b>C Sheets</b>	<b>Quantities and General Information</b>
C.1	Project Description
C.1 - 2	Estimated Project Quantities
C.3 - 5	Estimate Reference Information
C.6	Standard Road Plans
C.6	Index of Tabulations
C.7	Pollution Prevention Plan
C.8	General Notes
C.8 - 18	Tabulations
CS.1 - 2	Soils Tabulations
<b>D Sheets</b>	<b>Mainline Plan and Profile Sheets</b>
* D.1	Plan & Profile Legend & Symbol Information Sheet
* D.2 - 4	US 20
<b>E Sheets</b>	<b>Side Road Plan and Profile Sheets</b>
* E.1 - 8	330th Ave./332nd Ave.
* E.9	Industrial Parkway
* E.10 - 11	221st Street
* E.12	218th Street
* E.13	Field of Dreams Way
* E.14	330th Avenue - Channel
* E.15	320th Avenue/7th Street SW
<b>G Sheets</b>	<b>Survey Sheets</b>
G.1 - 3	Reference Ties and Bench Marks
G.4 - 6	Horizontal Control Tab. & Super for all Alignments
<b>J Sheets</b>	<b>Traffic Control and Staging Sheets</b>
J.1	Traffic Control Plan & Staging Notes
* J.2	Traffic Control & Staging Legend & Symbol Info. Sheet
* J.3	Staging Typical Section
* J.4 - 8	Staging and Traffic Control Sheets Stage 1
* J.9 - 13	Staging and Traffic Control Sheets Stage 2
* J.14	Staging and Traffic Control Sheet Stage 3
<b>K Sheets</b>	<b>Interchange Sheets</b>
* K.1 - 2	Interchange Layout Sheets
* K.3	330th Ave./332nd Ave. RAMP A Plan and Profile Sheets
* K.4	330th Ave./332nd Ave. RAMP B Plan and Profile Sheets
* K.5	330th Ave./332nd Ave. RAMP C Plan and Profile Sheets
* K.6	330th Ave./332nd Ave. RAMP D Plan and Profile Sheets
<b>L Sheets</b>	<b>Geometric, Staking and Jointing Sheets</b>
L.1 - 5	330th Avenue/Industrial Parkway and 221st Street
L.6 - 10	330th Avenue/Ramp B and Ramp D
L.11 - 15	332nd Avenue/Ramp A and Ramp C
L.16 - 19	332nd Avenue/218th Street and Field of Dreams Way
L.20 - 23	332nd Avenue and 12th Avenue SW
L.24 - 27	Industrial Parkway and (Old) 330th Avenue
L.28	(Old) 330th Avenue - Maintenance Turnaround
L.29	320th Avenue - Cul-de-sac
<b>M Sheets</b>	<b>Storm Sewer Sheets</b>
M.1	Storm Sewer Tabulations
M.2	Storm Sewer Legend & Symbol Information Sheet
M.3 - 9	Storm Sewer Plan and Profile Sheets
<b>P Sheets</b>	<b>Lighting Layout Sheets</b>
P.1	Lighting Tabulations
P.2	Lighting Layout Sheet
<b>Q Sheets</b>	<b>Soils Sheets</b>
* Q.1	Soils Legend & Symbol Information Sheet
* Q.2 - 24	Soils Sheets "Mainline or Side Road Name"
<b>T Sheets</b>	<b>Earthwork Quantity Sheets</b>
T.1 - 7	Earthwork Quantity Sheets

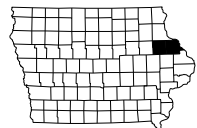

For Project Location Map  
Refer to Sheet A.2



## Highway Division

PLANS OF PROPOSED IMPROVEMENT ON THE

# PRIMARY ROAD SYSTEM DELAWARE/DUBUQUE COUNTIES PCC PAVEMENT - GRADE AND NEW

## U.S. 20 Interchange at 330th Avenue/332nd Avenue

SCALES: As Noted

Refer to the Proposal Form for list of applicable specifications.

Value Engineering Saves. Refer to Article 1105.15 of the Specifications.

MILEAGE SUMMARY			
			105-1
			09-27-94
Div.	Location	Lin. Ft.	Miles
1	US 20 Sta. 1039+98.04 to Sta. 1077+25.00	3726.96	
Total Length of Project		3726.96	0.706



DESIGN DATA RURAL			
2015	AADT	14,662	V.P.D.
2035	AADT	22,113	V.P.D.
20--	DHV	--	V.P.H.
	TRUCKS	25%	%
	Total		
	Design ESALs	--	

INDEX OF SEALS		
SHEET NO.	NAME	TYPE
A.1	Jeffrey A. Hillegonds	Primary Signature Block
CS.1	Roch S.V. Player	Geotechnical Design
P.1	Lane E. Ingram	Lighting Design

REVISIONS		TOTAL
		383
PROJECT IDENTIFICATION NUMBER		
10-31-020-010		
PROJECT NUMBER		
NHSX-020-9(203)--3H-28		
R.O.W. PROJECT NUMBER		
NHSN-020-8(48)--2R-28		
NHSN-020-9(202)--2R-31		

INDEX OF SHEETS	
No.	DESCRIPTION
<b>U Sheets</b>	<b>500 Series, Mod.Stds. and Detail Sheets</b>
* U.1 - 4	Water Main Relocation - Plan & Profiles Sheets
* U.5 - 8	Force Main Relocation - Plan & Profile Sheets
<b>V Sheets</b>	<b>Bridge and Culvert Situation Plans</b>
V.1	Bridge and Culvert Situation Plans
<b>W Sheets</b>	<b>Mainline Cross Sections</b>
W.1	Cross Sections Legend & Symbol Information Sheet
W.2 - 26	Mainline US 20 Cross Sections - Stage 1
W.27 - 48	Mainline US 20 Cross Sections - Stage 2
<b>X Sheets</b>	<b>Side Road Cross Sections</b>
X.1 - 44	Side Road 330th Ave./332nd Ave. Cross Sections
X.45 - 52	Side Road Industrial Parkway Cross Sections
X.53 - 83	Side Road 221st Street Cross Sections
X.84 - 99	Side Road 218th Street Cross Sections
X.100 - 110	Side Road Field of Dreams Way Cross Sections
X.111 - 116	Side Road 330th Avenue - Channel
<b>Y Sheets</b>	<b>Ramp Cross Sections</b>
Y.1 - 13	Ramp A Cross Sections
Y.14 - 28	Ramp B Cross Sections
Y.29 - 44	Ramp C Cross Sections
Y.45 - 60	Ramp D Cross Sections
	* Color Plan Sheets

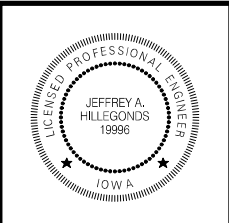

I hereby certify that this engineering document was prepared by me or under my direct personal supervision and that I am a duly licensed Professional Engineer under the laws of the State of Iowa.

*Jeffrey A. Hillegonds* 03/02/2015  
 Signature Date  
 Jeffrey A. Hillegonds  
 Printed or Typed Name

My license renewal date is December 31, 20 13.

Pages or sheets covered by this seal: A.1-A.2, B.1-B.12, C.1-C.18, D.1-D.4, E.1-E.15, G.1-G.6, J.1-J.14, K.1-K.6, L.1-L.29, M.1-M.9, T.1-T.7, U.1-U.8, W.1-W.48, X.1-X.116, and Y.1-Y.60

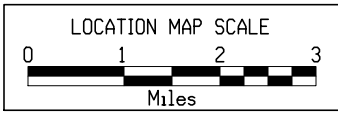
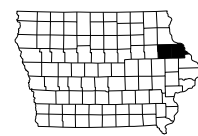
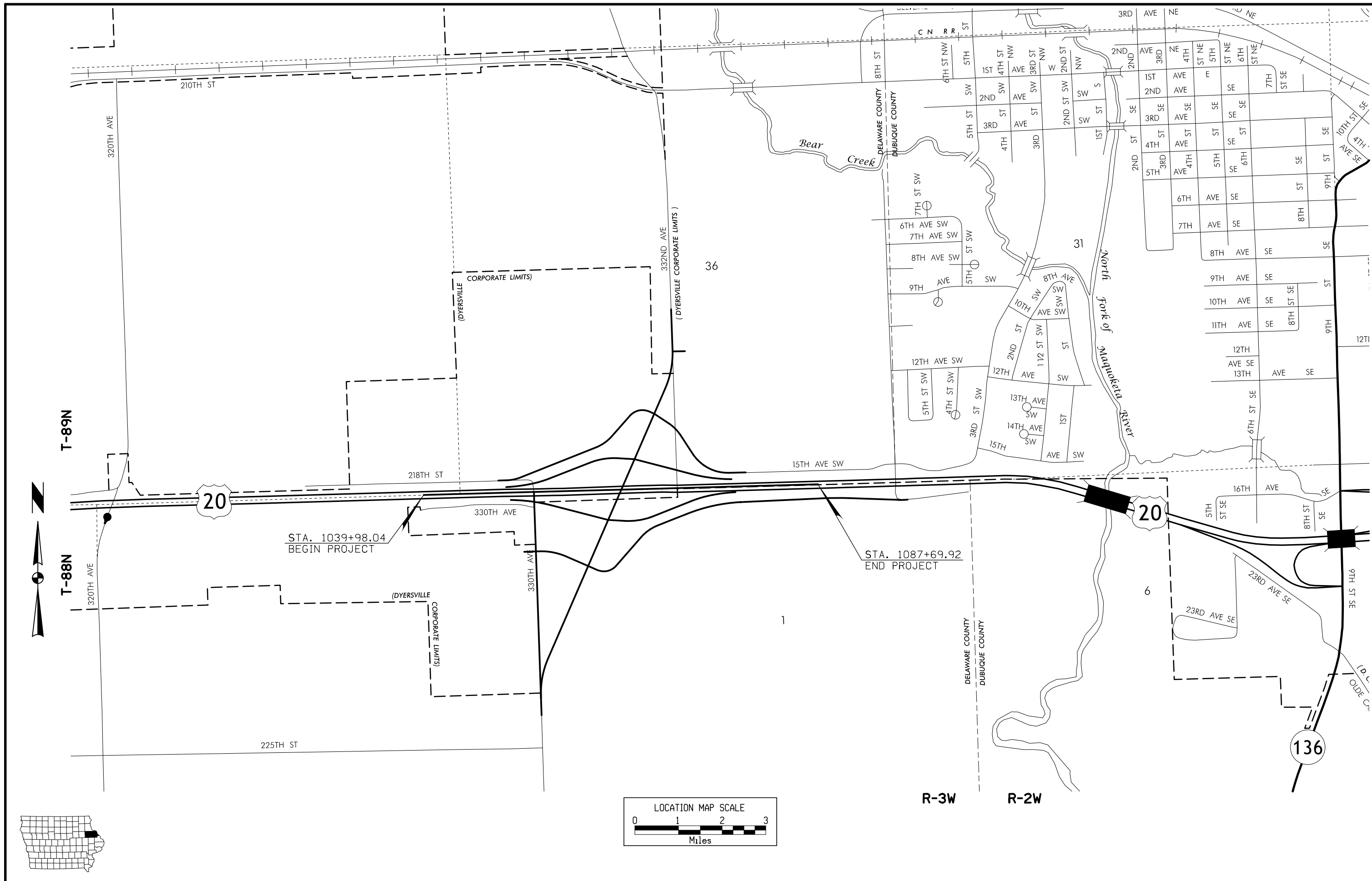



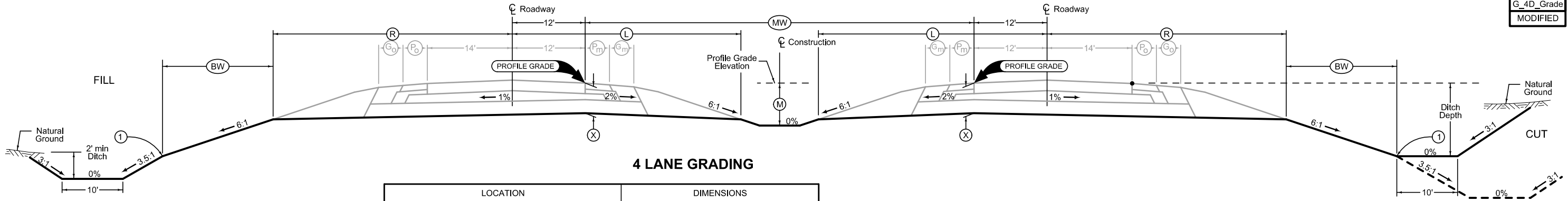

**4 LANE GRADING**

LOCATION		DIMENSIONS						
ROAD IDENTIFICATION	STATION TO STATION	L Feet	R Feet	X Inches	BW Feet	MW Feet	M Feet	
US 20	1039+98.04 - 1077+25.00	28.4	32.4	28.5	19.3	50	3	

Normal section shown may be modified appropriately in areas of superelevated curves or other locations specifically designated by the Engineer.

See Plan & Profile sheets and cross sections for additional details of ditches and backslopes.

① Refer to project plan and cross sections for specific location of foreslope change.

LOCATION		DIMENSIONS				
ROAD IDENTIFICATION	STATION TO STATION	L Feet	R Feet	X Inches	FS	
330TH AVENUE	11037+07.02 - 11059+90.41	27.6-47.6	27.6-47.6	21.5	4	
332ND AVENUE	11067+90.41 - 11082+51.85	27.6-47.6	27.6-47.6	21.5	4	
INDUSTRIAL PARKWAY	21046+49.14 - 21053+69.86	38.03	38.03	21.5	4	
221ST STREET	31053+93.86 - 31094+91.50	23.88	23.88	21.5	4	
FIELD OF DREAMS WAY	51074+02.60 - 51086+18.48	38.03	38.03	21.5	4	

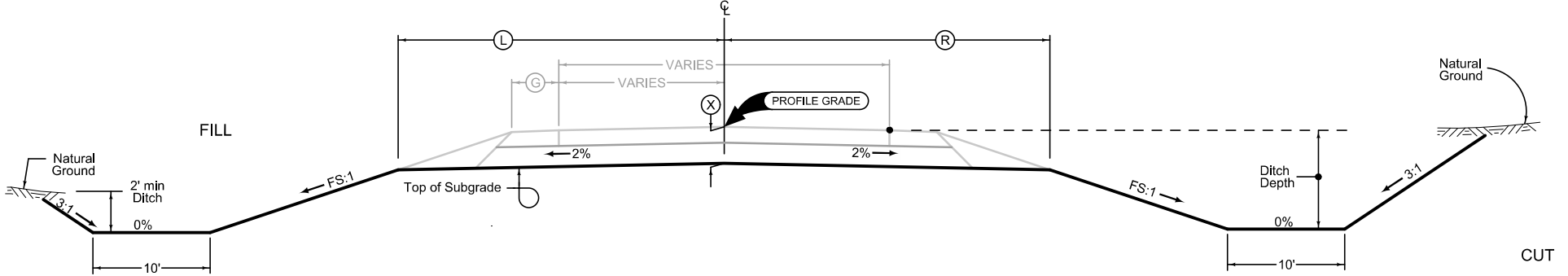

**2 LANE GRADING**

Normal section shown may be modified appropriately in areas of superelevated curves or other locations specifically designated by the Engineer.

See plan & profile sheets and cross sections for additional details of ditches and backslopes.

LOCATION		DIMENSIONS				
ROAD IDENTIFICATION	STATION TO STATION	L Feet	R Feet	X Inches	FS	
330TH AVENUE	11059+90.41 - 11061+83.26	27.6-47.6	27.6-47.6	21.5	4	
332ND AVENUE	11065+96.17 - 11067+90.41	27.6-47.6	27.6-47.6	21.5	4	

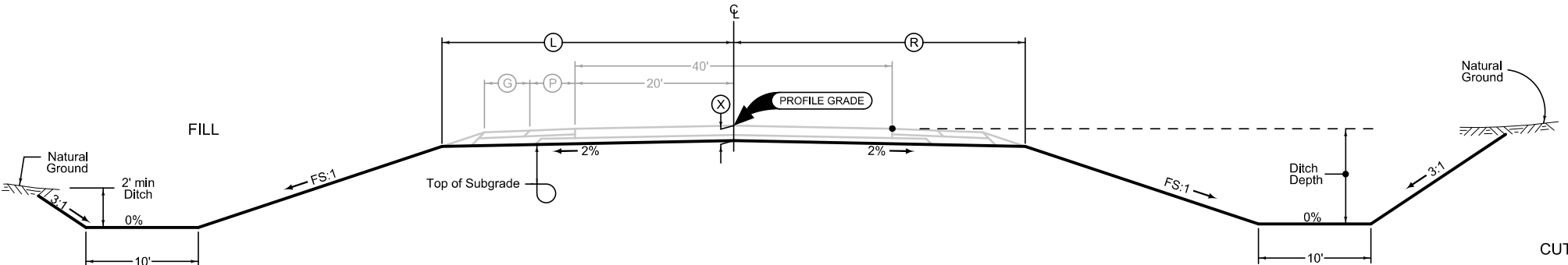

**2 LANE GRADING**

Normal section shown may be modified appropriately in areas of superelevated curves or other locations specifically designated by the Engineer.

See plan & profile sheets and cross sections for additional details of ditches and backslopes.

LOCATION				DIMENSIONS					
INTERCHANGE	RAMP	STATION TO STATION		(L) Feet	(R) Feet	(C) Feet	(X) Inches	(BW <sub>L</sub> ) Feet	(BW <sub>R</sub> ) Feet
330/332	A	2065+44.21	2067+42.61	33.49	31.21	16	21.5	17.14	16.94
330/332	A	2067+42.61	2069+22.61	33.49	VARIES	16	21.5	17.14	16.94
330/332	A	2069+22.61	2077+25.00	33.49	19.21	16	21.5	17.14	16.94
330/332	B	3050+50.00	3058+58.92	33.49	19.21	16	21.5	17.14	16.94
330/332	B	3058+58.92	3060+38.92	33.49	VARIES	16	21.5	17.14	16.94
330/332	B	3060+38.92	3062+35.32	33.49	31.21	16	21.5	17.14	16.94
330/332	C	4049+98.04	4065+85.11	33.49	19.21	16	21.5	17.14	16.94
330/332	D	5061+94.60	5077+69.92	33.49	19.21	16	21.5	17.14	16.94

G\_1R\_Grade  
04-15-14

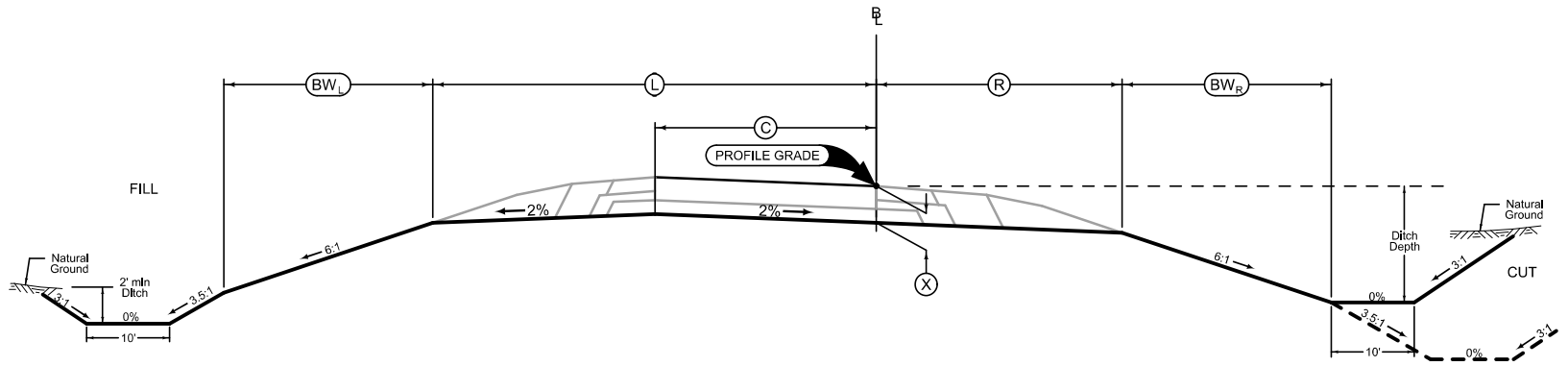

Section view is in direction of traffic.  
Normal sections shown may be appropriately modified for areas specifically designated by the Engineer such as intersections or superelevated curves.

RAMP GRADING

LOCATION			DIMENSIONS				
ROAD IDENTIFICATION	STATION TO STATION		(L) Feet	(R) Feet	FS	BS	(DW) Feet
218TH STREET	41053+46.33	41073+78.41	16	16	4	3	10

G\_2\_GradeGran  
04-17-12

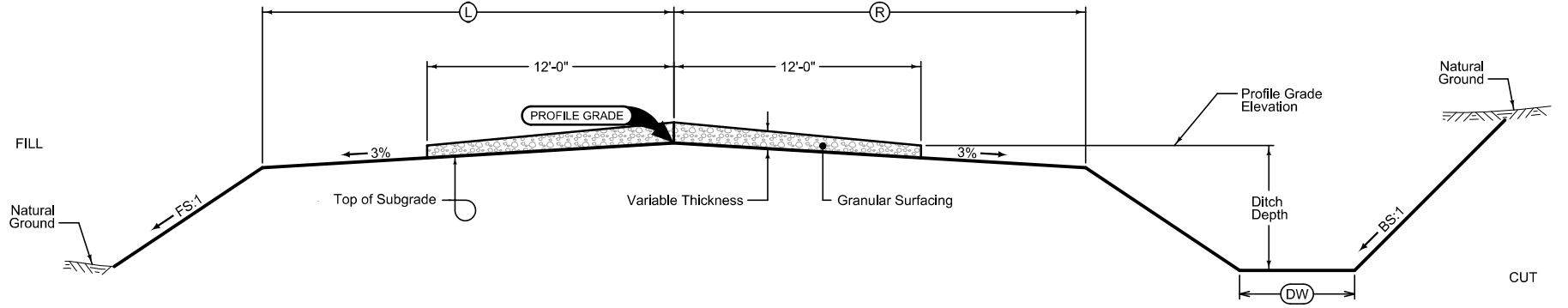

Normal section shown may be modified appropriately in areas of superelevated curves or other locations specifically designated by the Engineer.  
See plan & profile sheets and cross sections for additional details of ditches and backslopes.  
Place Granular Surfacing as follows:  
Grading design application rate is 2330 tons per mile.  
Paving design application rate is 0 tons per mile.

GRADING AND GRANULAR SURFACING

**Combination Shoulder**

Shoulder Jointing:  
Longitudinal joint: B

4_C_ 10-19-10				
Direction of Travel	BEGIN STATION	END STATION	(P) Feet	(G) Feet
BOTH	1039+98.04	1077+25.00	4	2

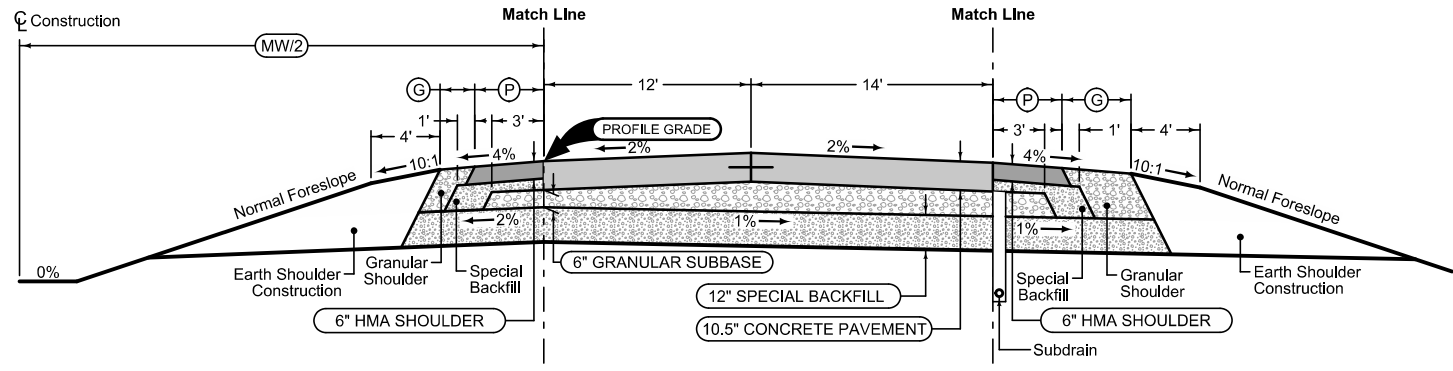

Section shown in the direction of traffic.

Mainline Jointing:  
Transverse joints: CD at 20' spacing  
Longitudinal joint: L-2

4DP_ 10-19-10				
Direction of Travel	BEGIN STATION	END STATION	(MW) Feet	
BOTH	1039+98.04	1077+25.00	50	

**Combination Shoulder**

Shoulder Jointing:  
Longitudinal joint: B

4_C_ 10-19-10				
Direction of Travel	BEGIN STATION	END STATION	(P) Feet	(G) Feet
BOTH	1039+98.04	1077+25.00	4	4

See Tab 100-24 for pavement quantities.  
See Tab 112-9 for shoulder quantities.

**US HIGHWAY 20**

**Granular Shoulder**

2_G_SR_10-19-10		(G)
STATION TO STATION		Feet
11037+07.02	11054+93.94	8
11072+86.66	11082+51.85	8

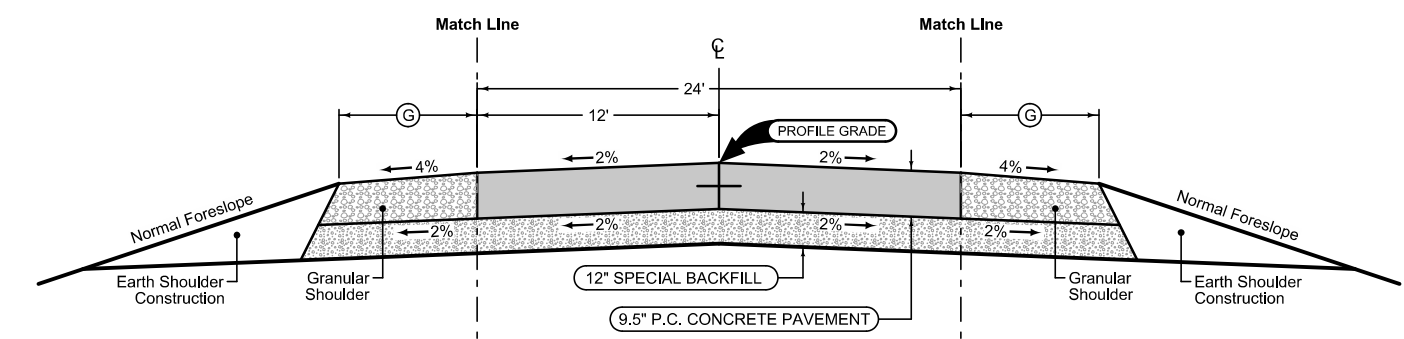

Mainline Jointing:  
 Transverse joints: CD at 20' spacing  
 Longitudinal joint: L-2

2P_MODIFIED		
STATION TO STATION		
11037+07.02	11054+93.94	
11072+86.66	11082+51.85	

**Granular Shoulder**

2_G_SR_10-19-10		(G)
STATION TO STATION		Feet
11037+07.02	11054+93.94	8
11072+94.73	11082+51.85	8

**Auxiliary Lane Granular Shoulder**

Longitudinal joint: L or KT  
 Transverse joint: Match Mainline

2_AuxLane_PCC_10-19-10		(AL)	(G)
STATION TO STATION		Feet	Feet
11072+86.66	11072+94.73	12	8

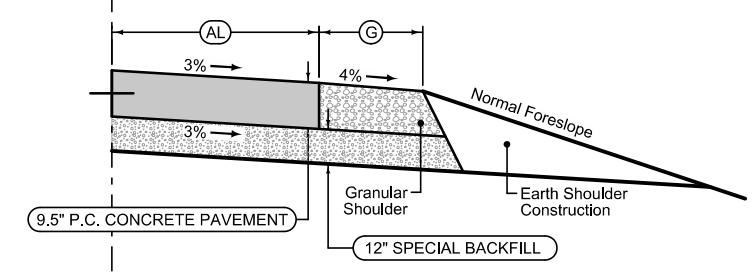

**Granular Shoulder**

2_G_SR_10-19-10		(G)
STATION TO STATION		Feet
11054+93.94	11059+90.41	8
11067+90.41	11068+31.27	8
11071+26.27	11072+86.66	8

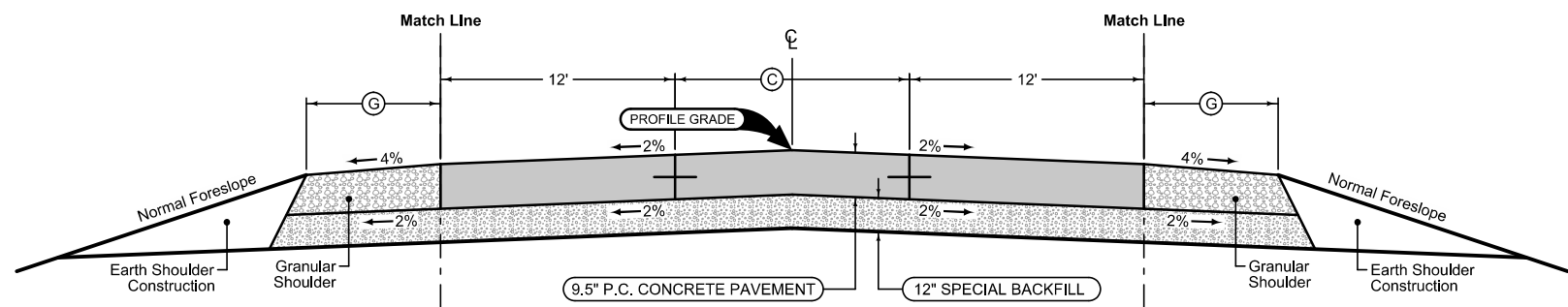

Mainline Jointing:  
 Transverse joints: CD at 20' spacing  
 Longitudinal joint: L-2

2P_TWLTL_MODIFIED		
STATION TO STATION		
11054+93.94	11058+53.94	0-16
11058+53.94	11059+90.41	16
11067+90.41	11069+26.66	16
11069+26.66	11072+86.66	0-16

**Granular Shoulder**

2_G_SR_10-19-10		(G)
STATION TO STATION		Feet
11054+93.94	11056+54.54	8
11059+49.54	11059+90.41	8
11067+90.41	11070+66.27	8

**Auxiliary Lane Granular Shoulder**

Longitudinal joint: L or KT  
 Transverse joint: Match Mainline

2_AuxLane_PCC_10-19-10		(AL)	(G)
STATION TO STATION		Feet	Feet
11056+54.54	11057+74.54	0-12	8
11057+74.54	11059+49.54	12	8
11070+66.27	11071+86.27	0-12	8
11071+86.27	11072+86.66	12	8

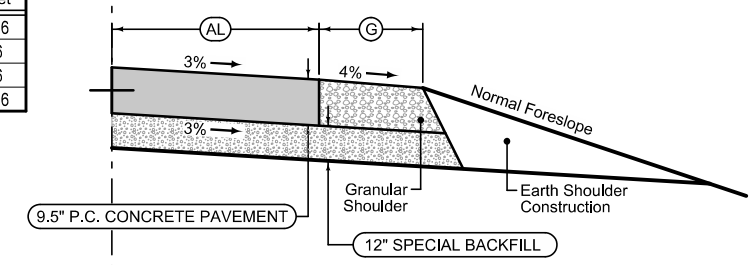
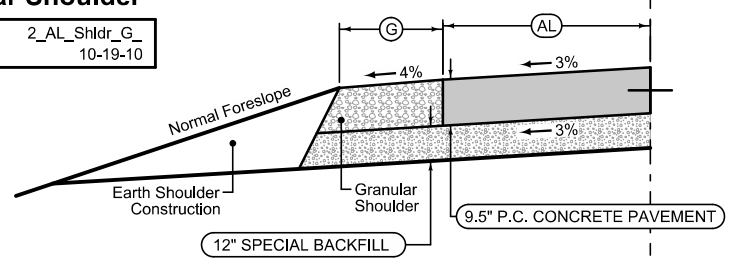

**Auxiliary Lane Granular Shoulder**

Longitudinal joint: L or KT  
 Transverse joint: Match Mainline

2_AuxLane_PCC_10-19-10		(AL)	(G)
STATION TO STATION		Feet	Feet
11068+31.27	11070+06.27	12	8
11070+06.27	11071+26.27	0-12	8

See Tab 100-24 for pavement quantities.  
 See Tab 112-9 for shoulder quantities.

**330TH / 332ND AVENUE**

**Combination Shoulder**

Shoulder Jointing:  
Longitudinal joint: B

STATION TO STATION		(P) Feet	(G) Feet
11059+90.41	11061+83.26	2	6
11065+96.17	11067+90.41	2	6

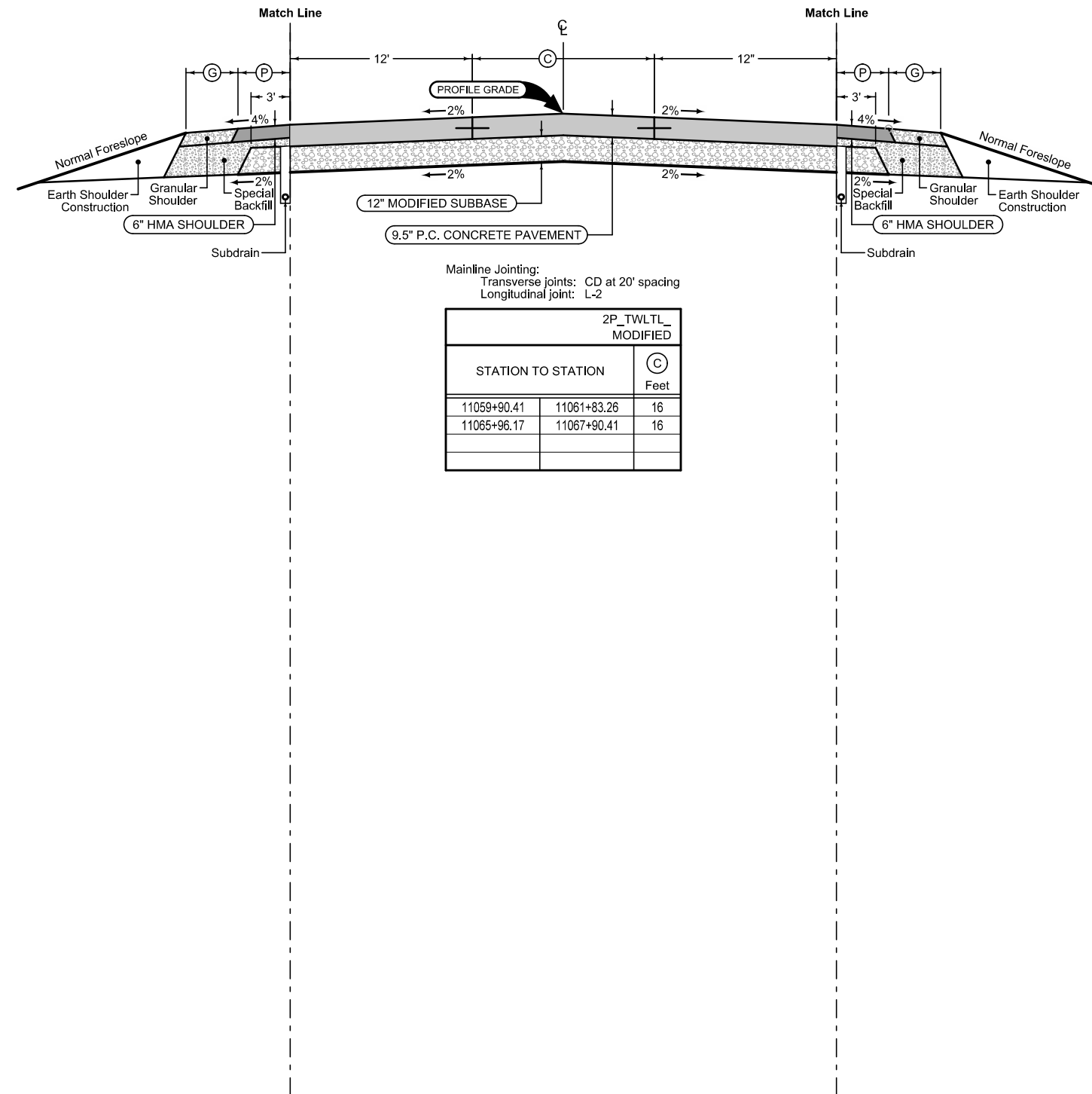

Mainline Jointing:  
Transverse joints: CD at 20' spacing  
Longitudinal joint: L-2

2P_TWLTL_MODIFIED		
STATION TO STATION		(C) Feet
11059+90.41	11061+83.26	16
11065+96.17	11067+90.41	16

**Combination Shoulder**

Shoulder Jointing:  
Longitudinal joint: B

STATION TO STATION		(P) Feet	(G) Feet
11059+90.41	11061+83.26	2	6
11065+96.17	11067+90.41	2	6

See Tab 100-24 for pavement quantities.  
See Tab 112-9 for shoulder quantities.

**330TH / 332ND AVENUE**



### Curbed Shoulder

Shoulder Jointing:  
 Longitudinal joint not required when distance from back of  
 curb to nearest joint is less than 15':

Single pour: L-2  
 Staged : KT-2  
 Transverse:C at 20' spacing

2_Curb_ MODIFIED				
ROAD IDENTIFICATION	STATION TO STATION		(P) Feet	Curb Type See PV-102
INDUSTRIAL PARKWAY	21046+49.14	21049+14.47	6.5	6" STANDARD CURB
FIELD OF DREAMS WAY	51074+71.95	51086+18.48	6.5	6" STANDARD CURB

### Curbed Shoulder

Shoulder Jointing:  
 Longitudinal joint not required when distance from back of  
 curb to nearest joint is less than 15':

Single pour: L-2  
 Staged : KT-2  
 Transverse:C at 20' spacing

2_Curb_ MODIFIED				
ROAD IDENTIFICATION	STATION TO STATION		(P) Feet	Curb Type See PV-102
INDUSTRIAL PARKWAY	21046+49.14	21053+61.86	6.5	6" STANDARD CURB
FIELD OF DREAMS WAY	51074+33.58	51086+18.48	6.5	6" STANDARD CURB

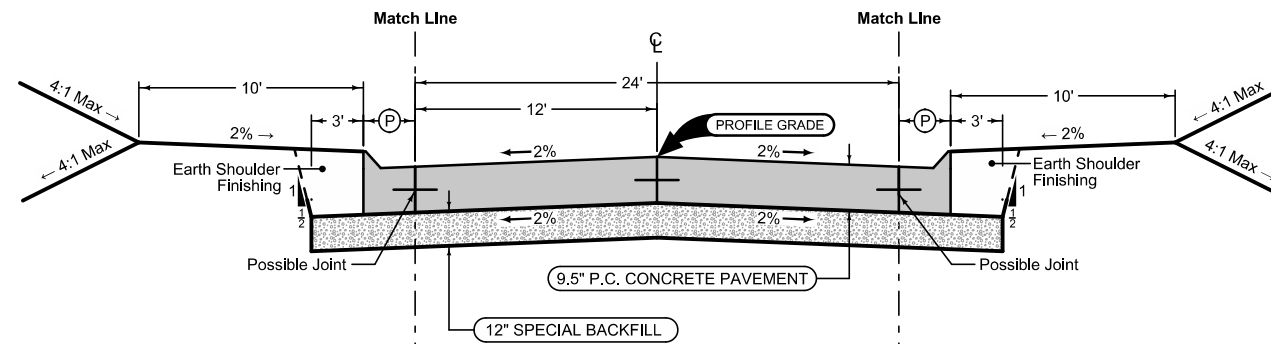

Mainline Jointing:  
 Transverse joints: CD at 20' spacing  
 Longitudinal joint: L-2

2P_ MODIFIED		
ROAD IDENTIFICATION	STATION TO STATION	
INDUSTRIAL PARKWAY	21046+48.14	21053+69.86
FIELD OF DREAMS WAY	51074+02.60	51086+18.48

### Granular Shoulder

2_G_SR_ MODIFIED			
ROAD IDENTIFICATION	STATION TO STATION		(G) Feet
INDUSTRIAL PARKWAY	21049+14.47	21053+69.86	8

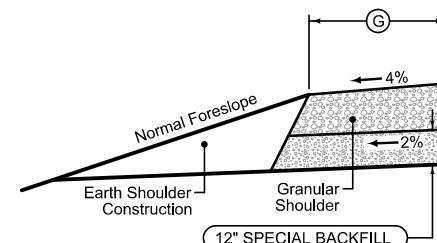

See Tab 100-24 for pavement quantities.  
 See Tab 112-9 for shoulder quantities.

## INDUSTRIAL PARKWAY & FIELD OF DREAMS WAY

**Granular Shoulder**

2_G_SR_		Ⓞ
10-19-10		
STATION TO STATION		Feet
31053+93.86	31094+91.50	4

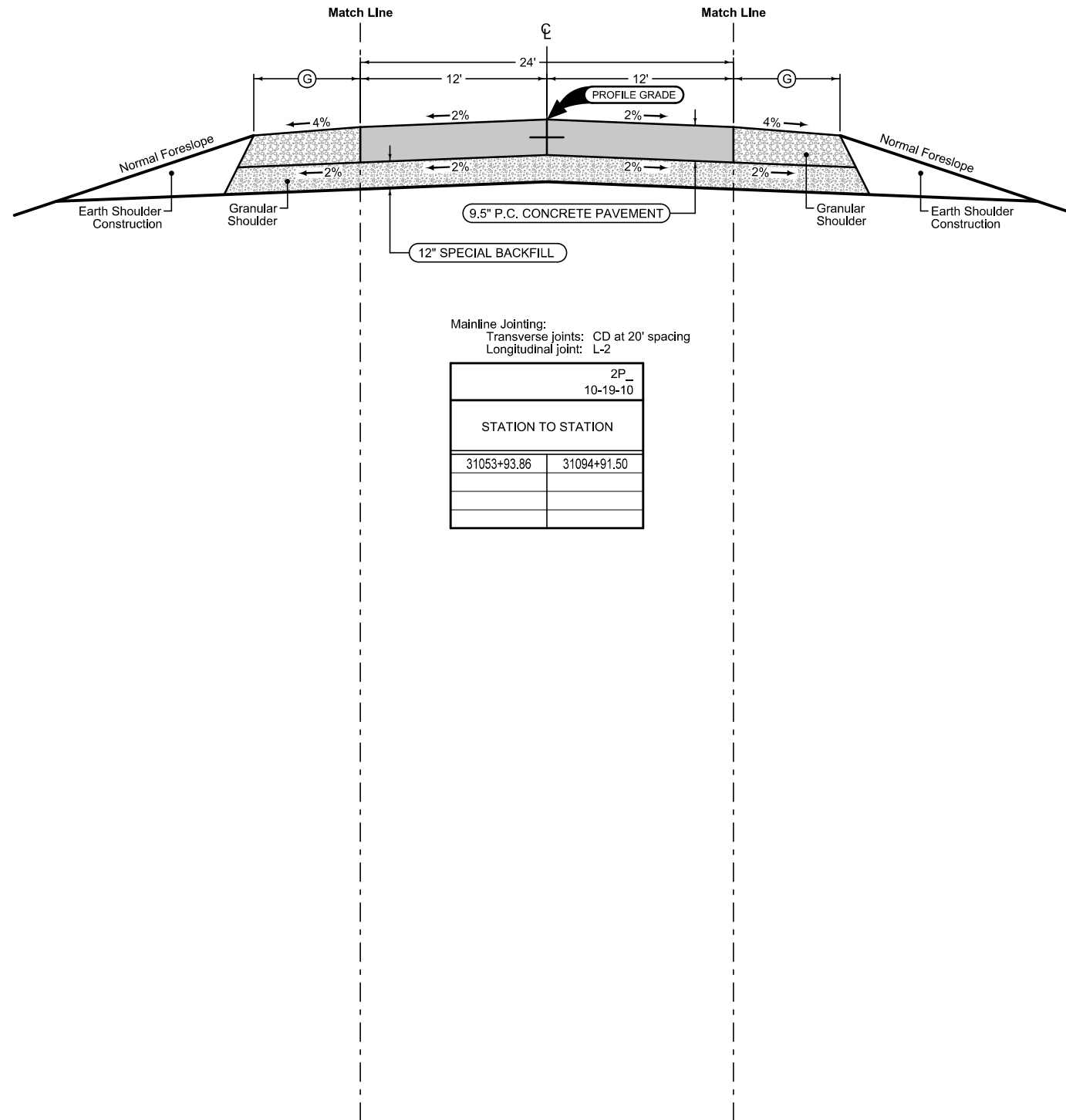

**Granular Shoulder**

2_G_SR_		Ⓞ
10-19-10		
STATION TO STATION		Feet
31053+93.86	31094+91.50	4

Mainline Jointing:  
 Transverse joints: CD at 20' spacing  
 Longitudinal joint: L-2

2P_	
10-19-10	
STATION TO STATION	
31053+93.86	31094+91.50

See Tab 100-24 for pavement quantities.  
 See Tab 112-9 for shoulder quantities.

**221ST STREET**

**Granular Shoulder**

1R_G_ 10-19-10		
BEGIN STATION	END STATION	(G) Feet
2065+44.21	2077+25.00	4
3050+50.00	3062+35.32	4
4049+98.04	4065+85.11	4
5061+94.60	5077+69.92	4

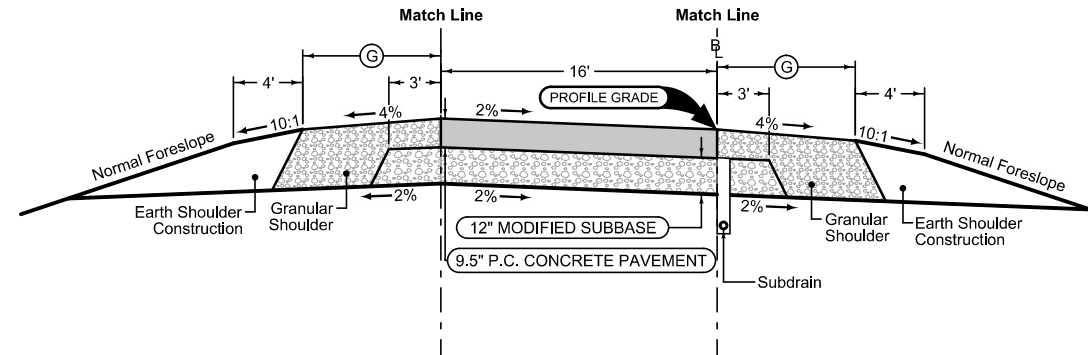

Section shown in the direction of traffic.

Ramp Jointing:  
Transverse joints: CD at 20' spacing.

1RP_ 10-19-10	
BEGIN STATION	END STATION
2065+44.21	2077+25.00
3050+50.00	3062+35.32
4049+98.04	4065+85.11
5061+94.60	5077+69.92

**Granular Shoulder**

1R_G_ 10-19-10		
BEGIN STATION	END STATION	(G) Feet
2069+22.61	2077+25.00	6
3050+50.00	3058+58.92	6
4049+98.04	4065+85.11	6
5061+94.60	5077+69.92	6

**Auxiliary Lane**

Longitudinal joint: L or KT  
Transverse joint: Match Mainline

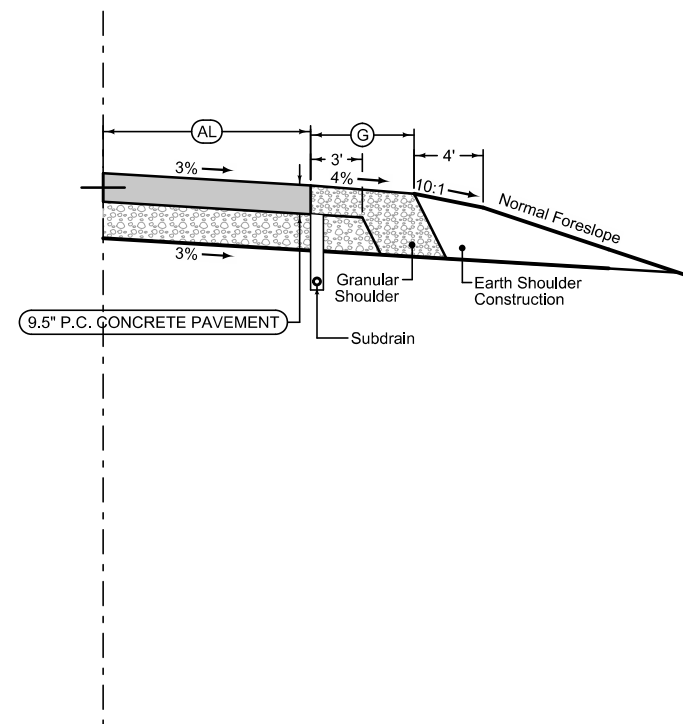

**Auxiliary Lane  
Granular Shoulder**

2_AuxLane_PCC_ 10-19-10		2_AL_Shldr_G_ 10-19-10	
STATION TO STATION	(AL) Feet	(G) Feet	(G) Feet
2065+44.21	2067+42.61	12	6
2067+42.61	2069+22.61	0-12	6
3058+58.92	3060+38.92	0-12	6
3060+38.92	3062+35.22	12	6

See Tab 100-24 for pavement quantities.  
See Tab 112-9 for shoulder quantities.

**RAMPS A, B, C, and D**

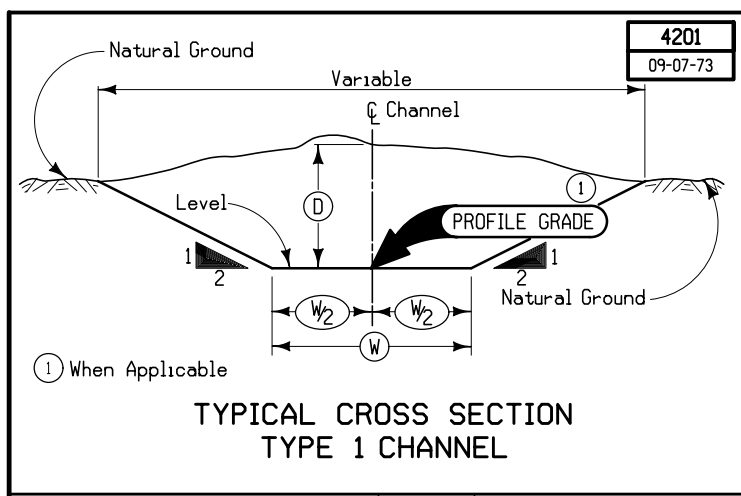

LOCATION		WIDTH	DEPTH (Average)
STATION	SIDE	(W)	(D)
2034+50 to 2045+25	BOTH	50ft	5ft

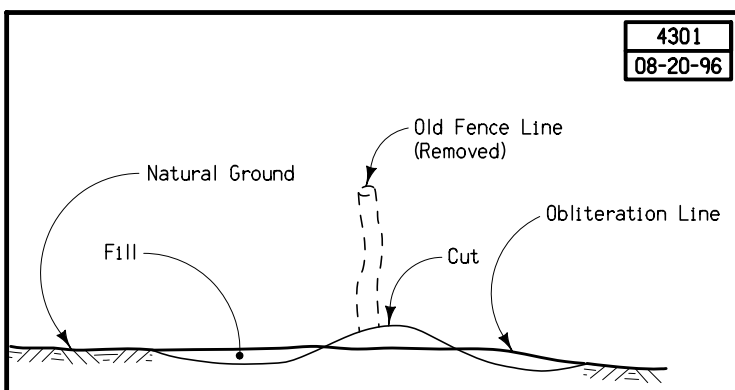

**TYPICAL DETAILS FOR  
OBLITERATION OF OLD FENCE RIDGE**

Notes:  
The work of obliterating or reshaping old fence ridges shall be done at the direction of the Engineer.

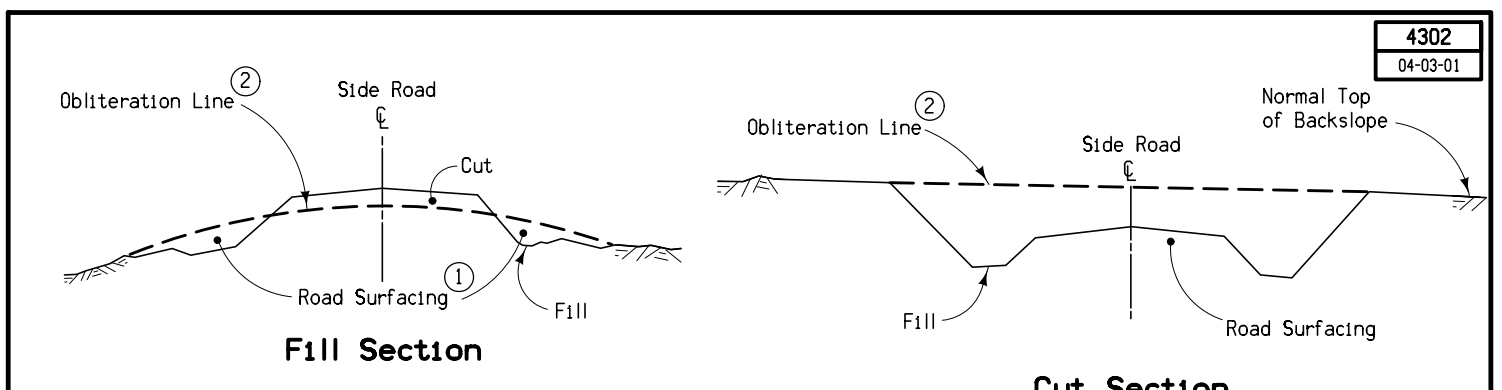

① Existing road surfacing (granular material) shall be placed as shown unless otherwise directed by the Engineer or provided for in the detail project plans.

② When specified, the upper 1' to be suitable for vegetation (grass or crops).

Note:  
The work of obliterating or reshaping old roadbeds shall be done at the direction of the Engineer.

**TYPICAL DETAILS FOR OBLITERATION EXISTING ROADBED**

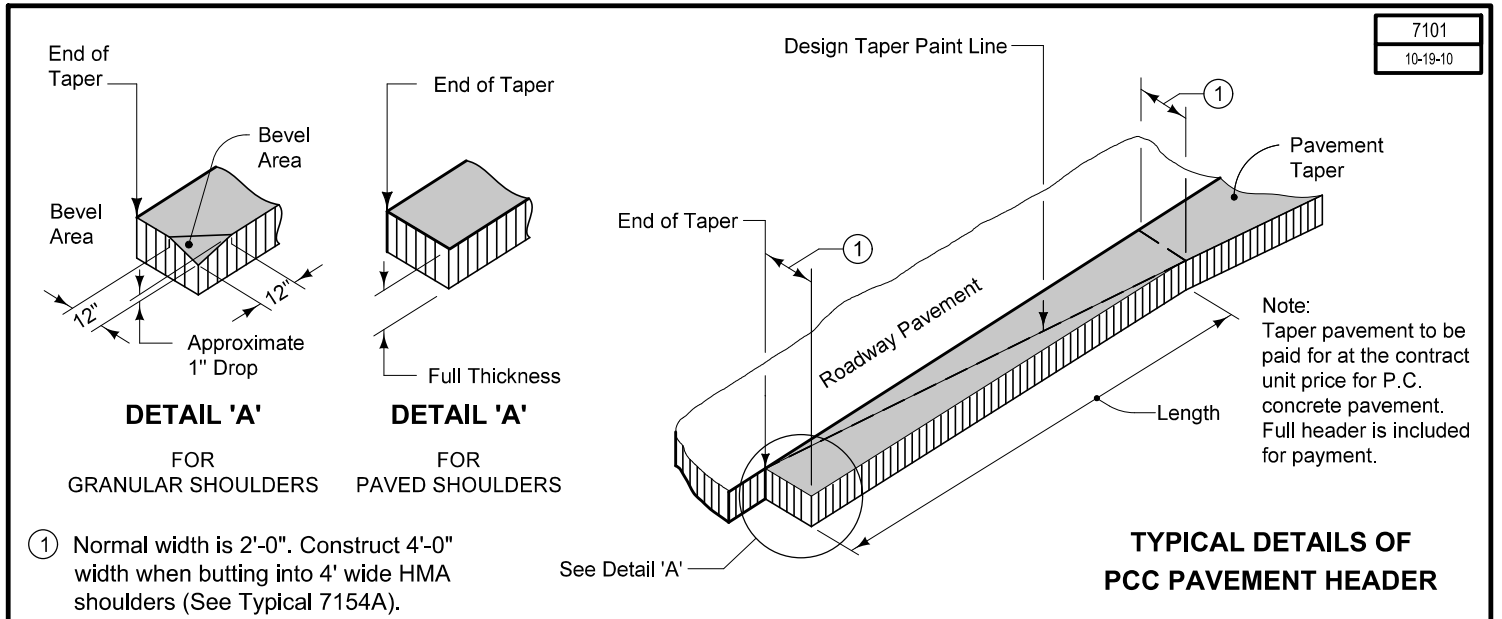
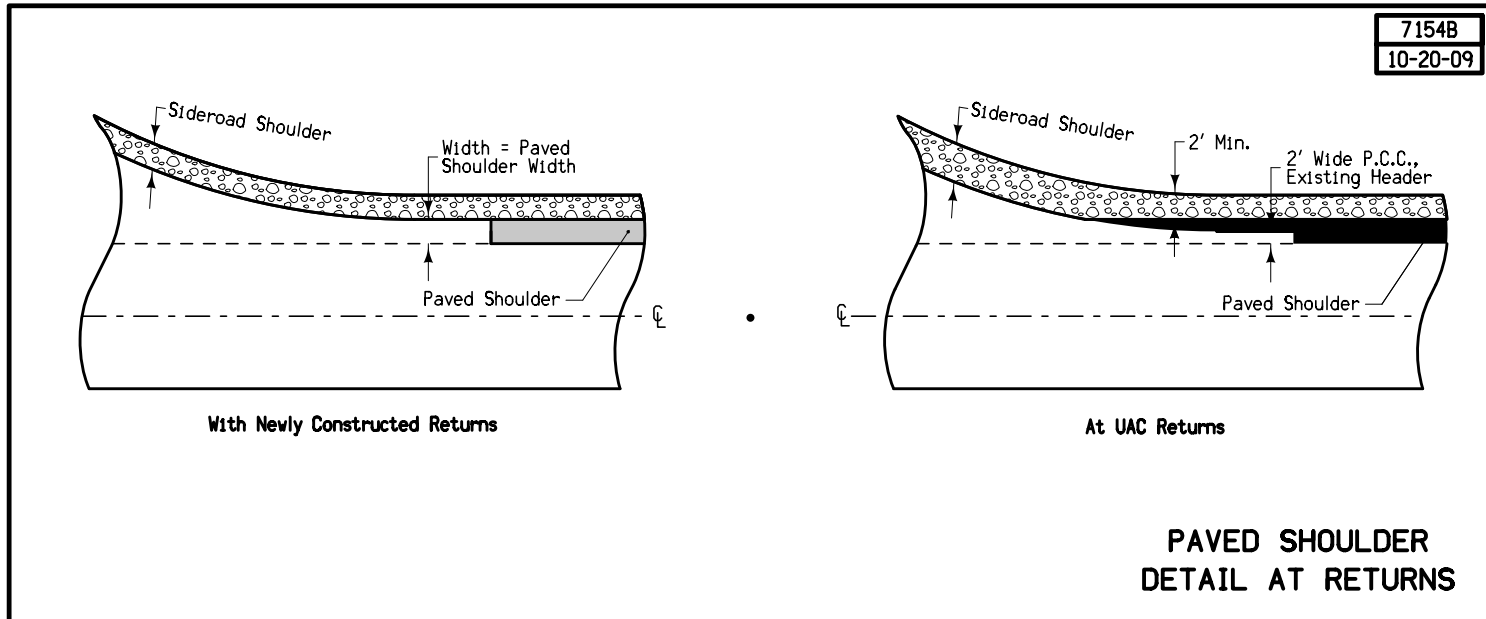
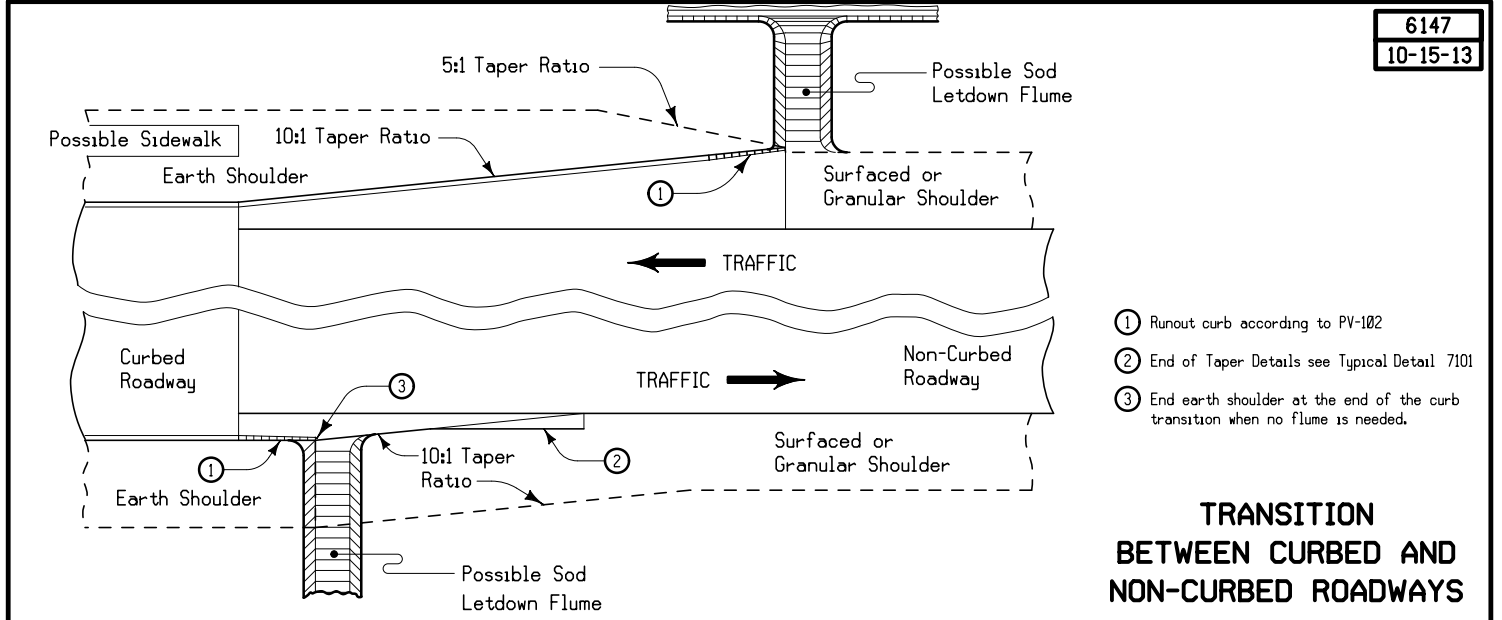
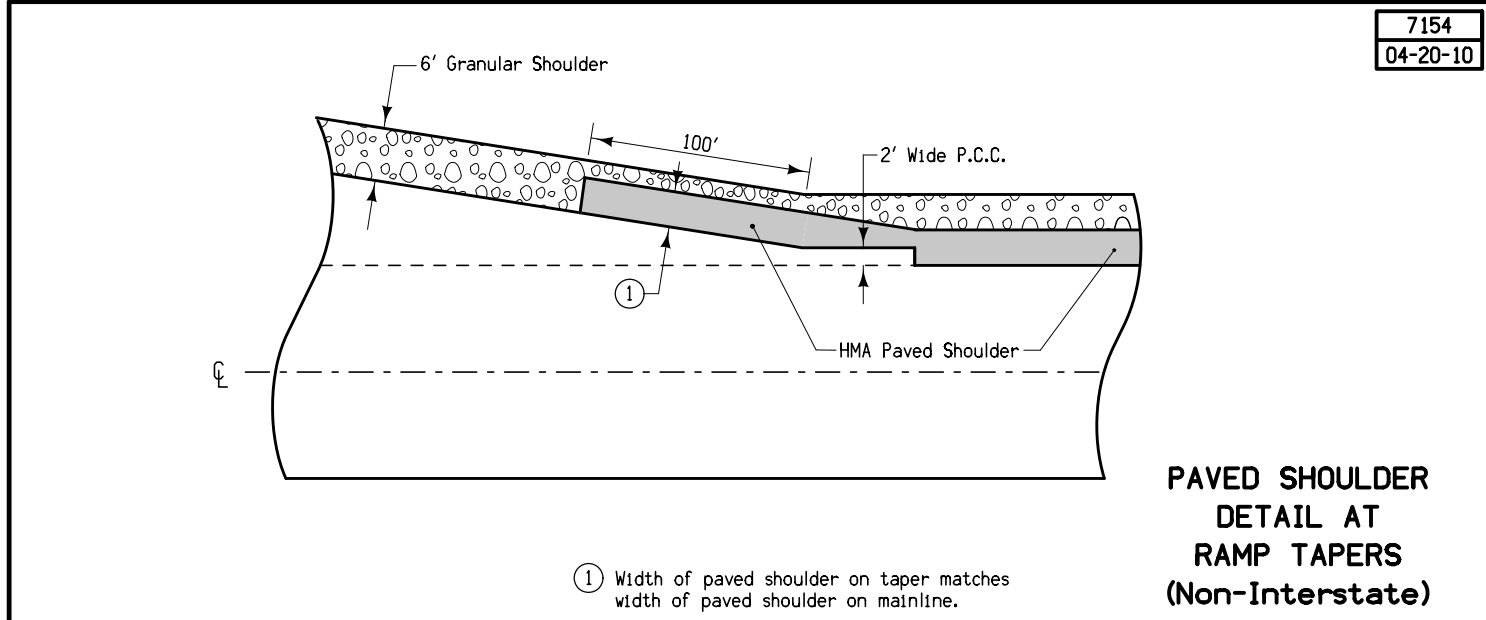

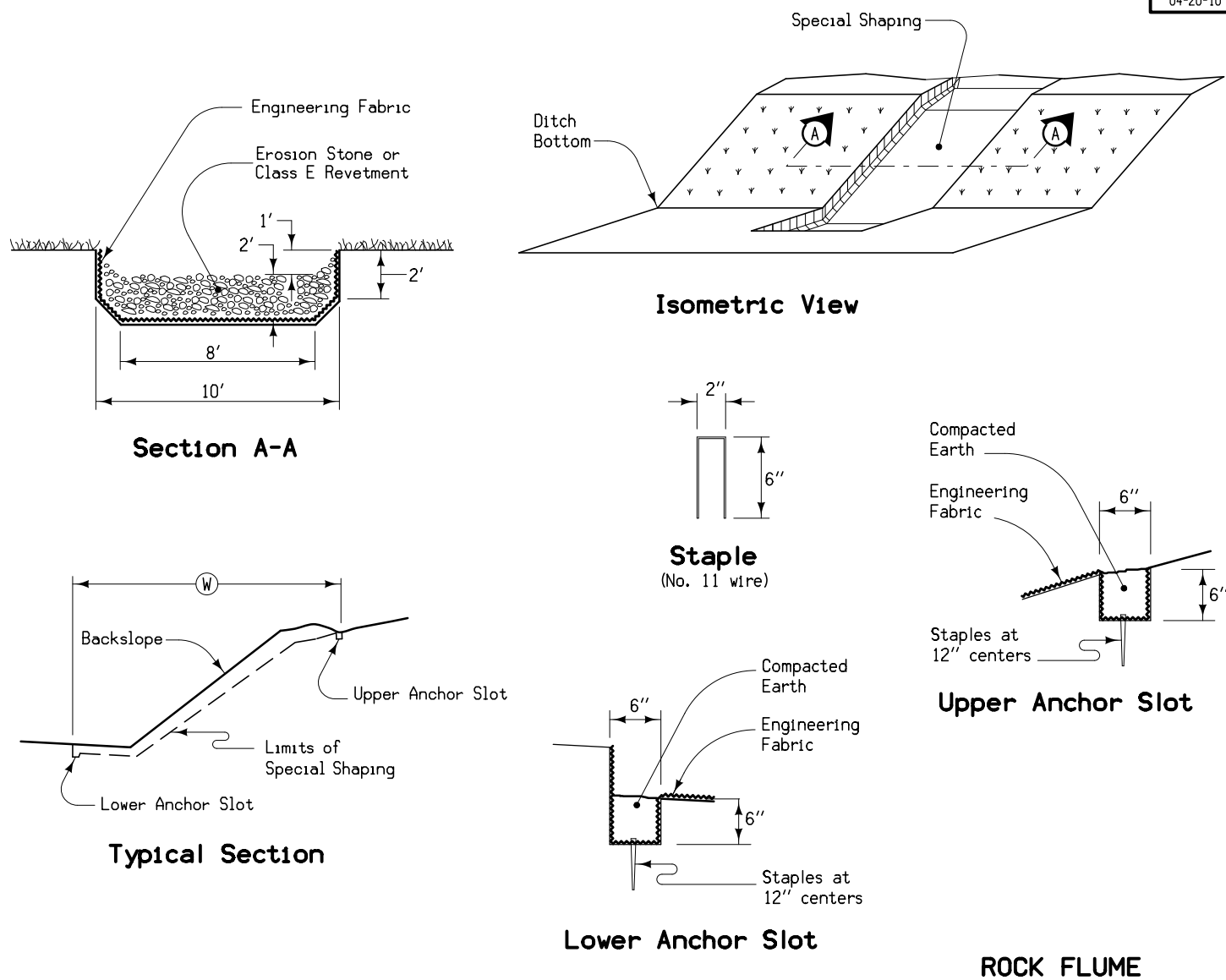

Refer to Tabulation 100-23 for additional information.

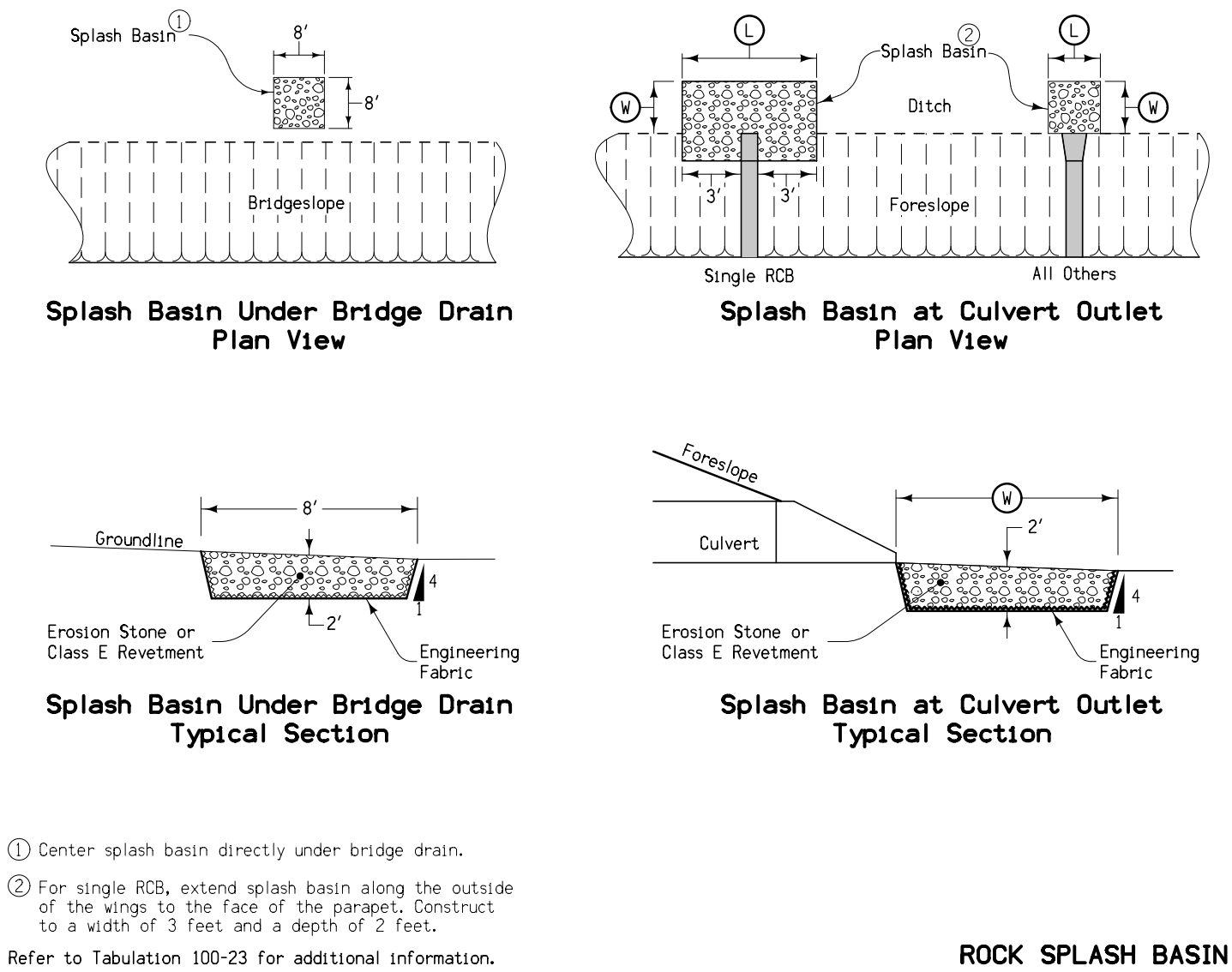



STAGE 1 / STAGE 2

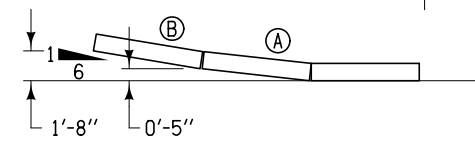
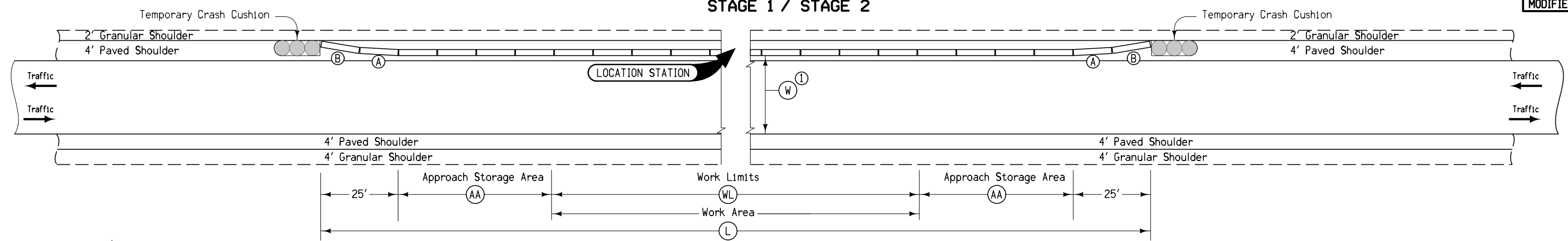

BARRIER OFFSETS FOR FLARE SECTIONS

Station	Side	AA	WL	L	Anchored X	W <sup>①</sup>	Remarks
		Feet	Feet	Feet		Ft-Inches	
1058+62.50	WB	50'	3575'	3725'		25'	Stage 1
1058+62.50	EB	50'	3575'	3725'		27'	Stage 2

① Where W is less than 14'-6", install restricted width signing as per Standard Road Plan TC-81.

TEMPORARY CONCRETE BARRIER LAYOUT for One-Way Traffic

STAGE 3

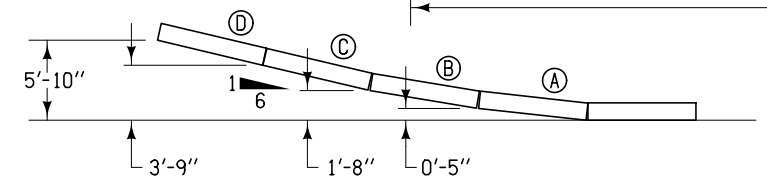
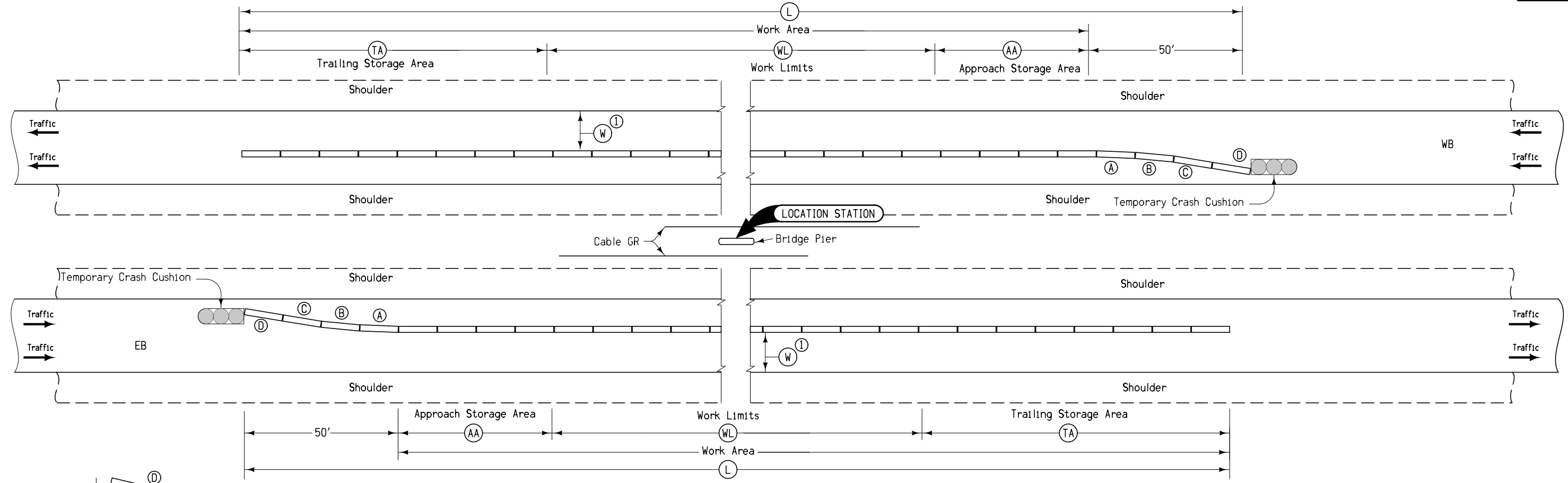

BARRIER OFFSETS FOR FLARE SECTIONS

Station	Side	AA	WL	TA	L	Anchored X	W <sup>①</sup>	Remarks
		Feet	Feet	Feet	Feet		Ft-Inches	
1063+89.71	EB	50'	650'	100'	850'		16'	
1063+89.71	WB	50'	650'	100'	850'		16'	

① Where W is less than 14'-6", install restricted width signing as per Standard Road Plan TC-81.

TEMPORARY CONCRETE BARRIER LAYOUT for One-Way Traffic

SELECT

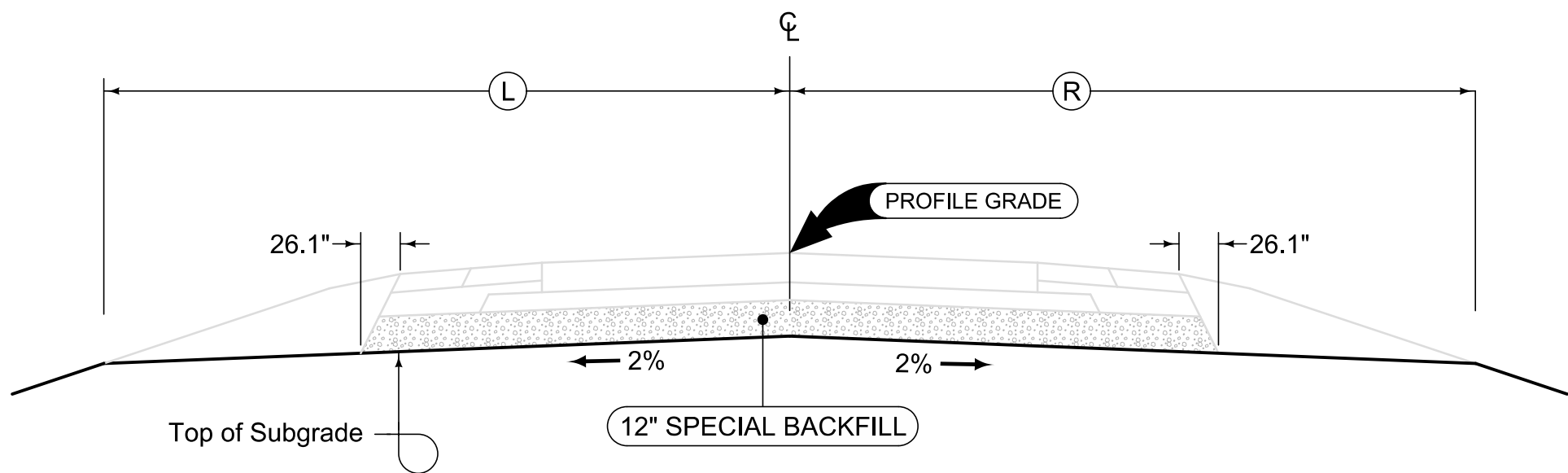
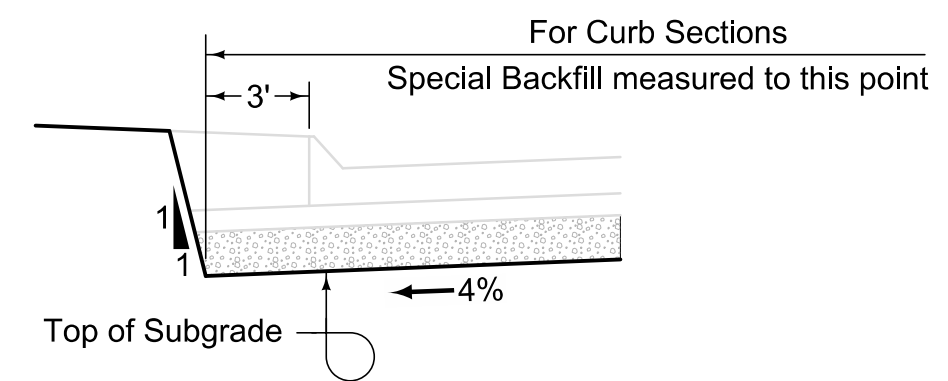
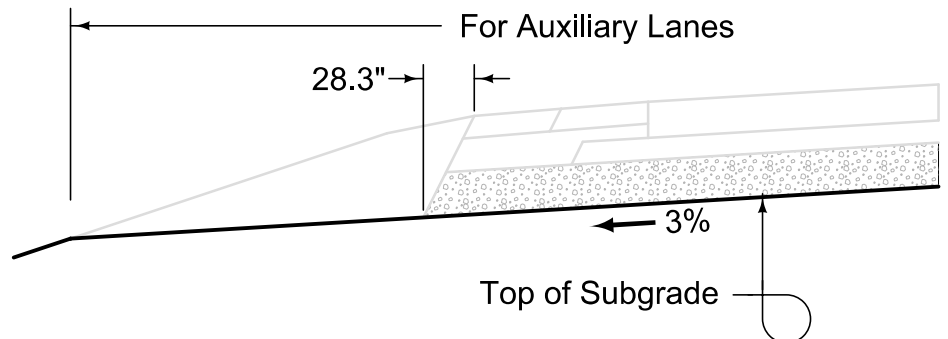

OPTION A - SPECIAL BACKFILL

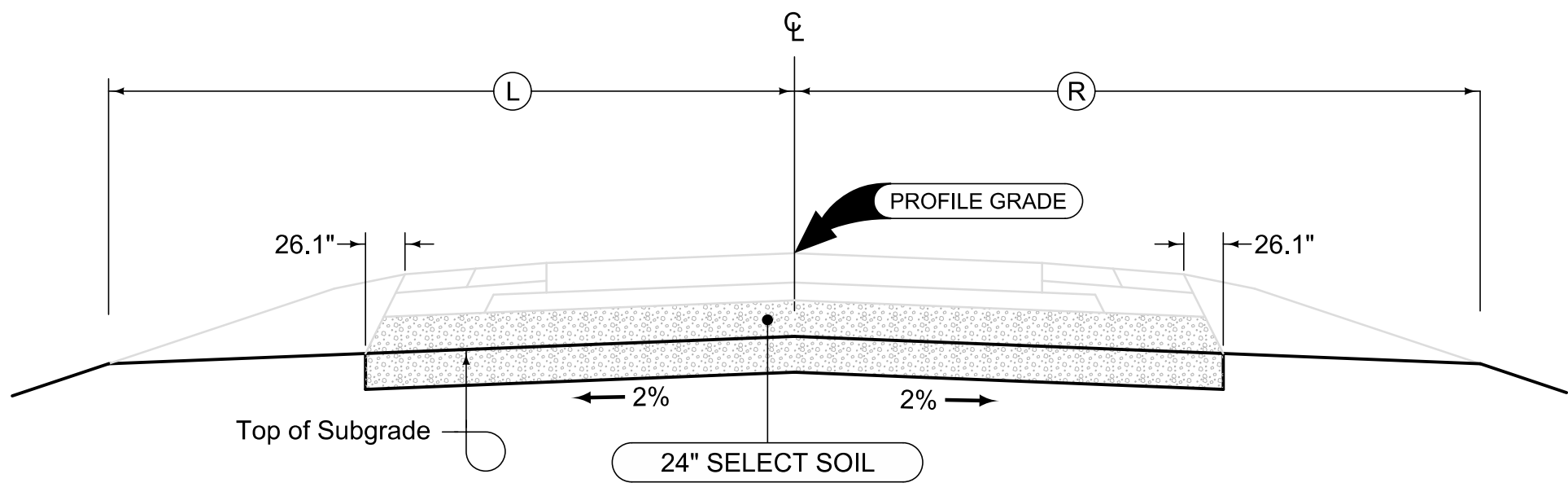
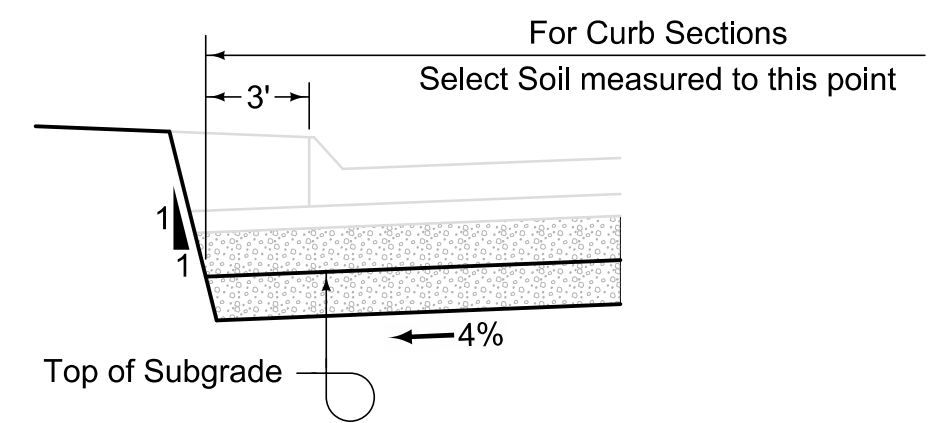
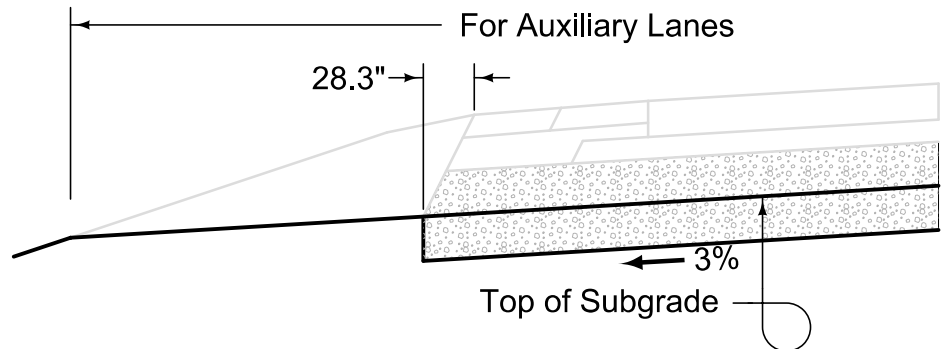

OPTION B - SELECT SOIL

SELECT TREATMENT  
OPTIONS



**ESTIMATED PROJECT QUANTITIES  
(UP TO A 5 DIVISION PROJECT)**

Division 1: Rural  
Division 2: 100% City of Dyersville Participation

Item No.	Item Code	Item	Unit	Quantities												
				Estimated					As Built							
				Division 1	Division 2	Division 3	Division 4	Division 5	Total	Division 1	Division 2	Division 3	Division 4	Division 5		
72	2518-6891810	PERMANENT ROAD CLOSURE, RURAL, SI-181	LF	102							102					
73	2518-6891820	PERMANENT ROAD CLOSURE, URBAN, SI-182	EACH	1							1					
74	2518-6910000	SAFETY CLOSURE	EACH	19							19					
75	2520-3350015	FIELD OFFICE	EACH	1							1					
76	2523-0000100	LIGHTING POLES	EACH	6							6					
77	2523-0000200	ELECTRICAL CIRCUITS	LF	1837							1837					
78	2523-0000310	HANDHOLES AND JUNCTION BOXES	EACH	12							12					
79	2523-0000400	CONTROL CABINET	EACH	1							1					
80	2526-8285000	CONSTRUCTION SURVEY	LS	1							1					
81	2527-9263109	PAINTED PAVEMENT MARKING, WATERBORNE OR SOLVENT-BASED	STA	845.64							845.64					
82	2527-9263131	WET RETROREFLECTIVE REMOVABLE TAPE MARKINGS	STA	181.28							181.28					
83	2527-9263137	PAINTED SYMBOLS AND LEGENDS, WATERBORNE OR SOLVENT-BASED	EACH	30							30					
84	2527-9263180	PAVEMENT MARKINGS REMOVED	STA	282.55							282.55					
85	2527-9263190	SYMBOLS AND LEGENDS REMOVED	EACH	16							16					
86	2528-8400048	TEMPORARY BARRIER RAIL, CONCRETE	LF	8210							8210					
87	2528-8400157	TEMPORARY FLOODLIGHTING LUMINAIRE	EACH	8							8					
88	2528-8445110	TRAFFIC CONTROL	LS	1							1					
89	2528-8445113	FLAGGERS	EACH	6							6					
90	2528-9109020	TEMPORARY LANE SEPARATOR SYSTEM	LF	2860							2860					
91	2533-4980005	MOBILIZATION	LS	1							1					
92	2551-0000130	TEMP CRASH CUSHION, SEVERE USE (SU)	EACH	8							8					
93	2552-0000300	TRENCH COMPACTION TESTING	LS							1						
94	2554-0114012	WATER MAIN, TRENCHED, PVC, 12 IN.	LF							2704						
95	2554-0134012	WATER MAIN WITH CASING PIPE, TRENCHED, PVC, 12 IN.	LF							162						
96	2554-0202200	FITTINGS BY COUNT, DUCTILE IRON, BEND, 12 IN., 11 1/4 DEGREE	EACH							3						
97	2554-0202200	FITTINGS BY COUNT, DUCTILE IRON, BEND, 12 IN., 22 1/2 DEGREE	EACH							3						
98	2554-0202200	FITTINGS BY COUNT, DUCTILE IRON, BEND, 12 IN., 90 DEGREE	EACH							1						
99	2554-0202200	FITTINGS BY COUNT, DUCTILE IRON, REDUCER, 12 IN. X 12 IN.	EACH							1						
100	2554-0202200	FITTINGS BY COUNT, DUCTILE IRON, TEE, 12 IN. X 12 IN.	EACH							1						
101	2554-0202200	FITTINGS BY COUNT, DUCTILE IRON, TEE, 12 IN. X 6 IN.	EACH							2						
102	2554-0207012	VALVE, GATE, DIP, 12 IN.	EACH							2						
103	2599-9999005	REMOVE AND REINSTALL EXISTING FIRE HYDRANT ASSEMBLY	EACH							3						
104	2599-9999009	REMOVAL OF EXISTING WATER MAIN AND FITTINGS	LF							2595						
105	2601-2634100	MULCHING	ACRE	64.5							64.5					
106	2601-2634105	MULCHING, BONDED FIBER MATRIX	ACRE	1							1					
107	2601-2636043	SEEDING AND FERTILIZING (RURAL)	ACRE	64.5							64.5					
108	2601-2636044	SEEDING AND FERTILIZING (URBAN)	ACRE	1							1					
109	2601-2639010	SODDING	SQ	3							3					
110	2601-2640350	SPECIAL DITCH CONTROL, WOOD EXCELSIOR MAT	SQ	1150.4							1150.4					
111	2601-2642100	STABILIZING CROP - SEEDING AND FERTILIZING	ACRE	64.5							64.5					
112	2601-2642120	STABILIZING CROP - SEEDING AND FERTILIZING (URBAN)	ACRE	1							1					
113	2601-2643110	WATERING FOR SOD, SPECIAL DITCH CONTROL, OR SLOPE PROTECTION	MGAL	251.9							251.9					
114	2601-2643300	MOBILIZATION FOR WATERING	EACH	3							3					
115	2601-2643412	TURF REINFORCEMENT MAT, TYPE 2	SQ	108.8							108.8					
116	2602-0000020	SILT FENCE	LF	66300							66300					
117	2602-0000030	SILT FENCE FOR DITCH CHECKS	LF	6621							6621					
118	2602-0000050	SILT BASINS	EACH	11							11					
119	2602-0000071	REMOVAL OF SILT FENCE OR SILT FENCE FOR DITCH CHECKS	LF	72921							72921					
120	2602-0000101	MAINTENANCE OF SILT FENCE OR SILT FENCE FOR DITCH CHECK	LF	72921							72921					
121	2602-0000312	PERIMETER AND SLOPE SEDIMENT CONTROL DEVICE, 12 IN. DIA.	LF	2000							2000					
122	2602-0000320	PERIMETER AND SLOPE SEDIMENT CONTROL DEVICE, 20 IN. DIA.	LF	2000							2000					
123	2602-0000350	REMOVAL OF PERIMETER AND SLOPE SEDIMENT CONTROL DEVICE	LF	4000							4000					
124	2602-0010010	MOBILIZATIONS, EROSION CONTROL	EACH	17							17					
125	2602-0010020	MOBILIZATIONS, EMERGENCY EROSION CONTROL	EACH	1							1					

**ESTIMATE REFERENCE INFORMATION**

Item No.	Item Code	Description
1	2101-0850001	CLEARING AND GRUBBING
2	2102-0425071	SPECIAL BACKFILL A. Refer to Tabs. 100-24, 112-8, and 112-9 in the C Sheets. B. Includes 1338.6 cu. yds. used for constructing the median crossovers at Sta. 1025+00.00 and 1084+00.00. C. Refer to Typical Sections in the B Sheets. D. Existing HMA and PCC from Pavement removal may be used on the project as special backfill.
3	2102-2624980	CONTRACTOR FURNISHED SELECT TREATMENT A. See Typical 'G 4D Grade' on Sheet B.1 and Tab. 100-24 and Tab. 112-9 in the C sheets for mainline grading locations. The quantity for CONTRACTOR FURNISH SELECT TREATMENT is based upon the volume of Special Backfill placed in accordance with Option A shown on Typical 'SELECT' in the B sheets. The contractor may place select soil as shown in Option B. Payment of CONTRACTOR FURNISH SELECT TREATMENT and EMBANKMENT-IN-PLACE, CONTRACTOR FURNISHED will be plan quantity and will not be adjusted based upon use of Option B.
4	2102-2625001	EMBANKMENT-IN-PLACE, CONTRACTOR FURNISHED A. Shrinkage will not be included in Embankment-in-Place, Contractor Furnished quantity.
5	2102-2710070	EXCAVATION, CLASS 10, ROADWAY AND BORROW A. Includes 220,423 cu. yds. of suitable material to be used in the roadway fill. Refer to Tab. 107-29 in the T sheets for locations and details. B. Includes 1,400 cu. yds. of unsuitable material to be used in the roadway fill. Refer to Tab. 112-8 in the C sheets for locations and details. D. Overhaul will not be measured or paid for, but shall be considered incidental to roadway excavation on this project.
6	2102-2710090	EXCAVATION, CLASS 10, WASTE A. Refer to Tab. 107-29 in the T sheets for locations and details.
7	2102-2712015	EXCAVATION, CLASS 12, BOULDERS OR ROCK FRAGMENTS A. Refer to Tab. 103-7 on Sheet CS.1. B. Dispose of excess material according to Article 1106.07 of the Standard Specifications.
8	2102-2712070	EXCAVATION, CLASS 12, ROADWAY AND BORROW A. Includes 61,411 cu. yds. of unsuitable material to be used in the roadway fill. B. Refer to Section 2107 of the Standard Specifications for Rock Fill placement details. C. Production blasting is allowed with approval from the Engineer and if used will be considered incidental to Class 12 Excavation. Refer to Standard Specification Section 2103. If production blasting is used, US 20 shall be closed to traffic in both directions during the blasting. The Contractor shall be responsible for any damages to adjacent structures caused by production blasting.
9	2102-5020010	OBLITERATE OLD ROADBED A. The work consists of obliterating 320th Avenue, 330th Avenue, 332nd Avenue, 221st Street, and 7th Street SW as shown on Typical 4302. B. Method of measurement will be in stations measured along centerline of old roadbed. C. Basis of payment will be the contract unit price for the number of stations of old roadbed obliterated. Payment is full compensation for construction as shown on Typical 4302. Excavation will not be paid separately. Pavement removal is bid separately.
10	2105-8425015	TOPSOIL, STRIP, SALVAGE AND SPREAD
11	2107-0875100	COMPACTION WITH MOISTURE CONTROL A. Refer to Tab. 103-6 on Sheet CS.1.
12	2111-8174100	GRANULAR SUBBASE A. Refer to Typical Sections in the B Sheets and Tab. 100-24 in the C Sheets.
13	2115-0100000	MODIFIED SUBBASE A. Refer to Typical Sections in the B Sheets and Tab. 100-24 and Tab. 112-9 in the C Sheets.
14	2121-7425010	GRANULAR SHOULDERS, TYPE A A. Includes 3888 tons for mainline shoulders, 4930 tons for ramps, and 5317.5 tons for sideroads. B. Refer to Tab. 112-9 in the C Sheets.
15	2122-5190105	PAVED SHOULDER, P.C. CONCRETE, 10.5 IN.
16	2122-5500060	PAVED SHOULDER, HOT MIX ASPHALT MIXTURE, 6 IN. A. Refer to Tab. 112-9 in the C Sheets.
17	2123-7450000	SHOULDER CONSTRUCTION, EARTH A. Includes 74.6 Sta. of 6 ft wide shoulders on mainline, 83.6 Sta. of 8 ft shoulders on mainline, and 86.1 Sta. of 8 ft wide shoulders on sideroads. B. Refer to Typical Sections in the B Sheets and Tab. 112-9 in the C Sheets. C. Requires 20348.3 cu. yds. of Class 10 for Earth Shoulder Fill. D. No payment for overhaul allowed for this material.
18	2123-7450020	SHOULDER FINISHING, EARTH A. Includes 33.1 stations of nominal 3 ft. wide shoulder. B. Material for the earth shoulders is included in the template quantities.
19	2301-1032095	STD/S-F PCC PAVEMENT, CLASS C, CLASS 2 DURABILITY, 9.5 IN.
20	2301-1034095	STD/S-F PCC PAVEMENT, CLASS C, CLASS 3I DURABILITY, 9.5 IN.
21	2301-1034105	STD/S-F PCC PAVEMENT, CLASS C, CLASS 3I DURABILITY, 10.5 IN. A. Refer to Typical Sections in the B Sheets.

**ESTIMATE REFERENCE INFORMATION**

Item No.	Item Code	Description
		B. Refer to Tab. 100-24 in the C Sheets. C. Pavement smoothness shall apply to these bid items. Refer to Sections 2316 and 2317 of the Standard Specifications.
22	2301-6911722	PORTLAND CEMENT CONCRETE PAVEMENT SAMPLES
23	2304-0100000	DETOUR PAVEMENT A. Refer to Tab. 112-8 in the C Sheets.
24	2312-8260051	GRANULAR SURFACING ON ROAD, CLASS A CRUSHED STONE A. See Typical 'G 2 GradeGran' for side road surfacing details B. Includes cul-de-sac at 320th Avenue. Refer to Sheet E.15 and Sheet L.29.
25	2315-8275025	SURFACING, DRIVEWAY, CLASS A CRUSHED STONE A. Refer to Tab. 102-3 in the C Sheets.
26	2401-6745650	REMOVAL OF EXISTING STRUCTURES A. Refer to Tab. 110-2 in the C Sheets.
27	2402-2720100	EXCAVATION, CLASS 20, FOR ROADWAY PIPE CULVERT A. Refer to Tab. 104-3 in the C Sheets.
28	2416-0100018	APRONS, CONCRETE, 18 IN. DIA.
29	2416-0100024	APRONS, CONCRETE, 24 IN. DIA.
30	2416-0100030	APRONS, CONCRETE, 30 IN. DIA.
31	2416-0100042	APRONS, CONCRETE, 42 IN. DIA.
32	2416-0101136	REMOVE AND REINSTALL CONCRETE PIPE APRONS GREATER THAN 36 IN. A. Refer to Tab. 104-3 in the C Sheets and Tab. 104-5B on Sheet M.1.
33	2416-1180024	CULVERT, CONCRETE ROADWAY PIPE, 24 IN. DIA.
34	2416-1180030	CULVERT, CONCRETE ROADWAY PIPE, 30 IN. DIA.
35	2416-1180042	CULVERT, CONCRETE ROADWAY PIPE, 42 IN. DIA.
36	2416-1240030	CULVERT, 3000D CONCRETE ROADWAY PIPE, 30 IN. DIA. A. Refer to Tab. 104-3 in the C Sheets.
37	2417-2307036	DRAIN, CORRUGATED METAL SLOTTED PIPE, 36 IN., W/6 IN. GRATE
38	2417-5895018	BEVELED PIPE AND GUARD, 18 INCH A. Refer to Tab. 112-8 in the C Sheets.
39	2422-0360018	APRONS, UNCLASSIFIED, 18 IN. DIA.
40	2422-0360024	APRONS, UNCLASSIFIED, 24 IN. DIA. A. Refer to Tabs. 102-3 and 104-3 in the C Sheets.
41	2422-1722018	CULVERT, UNCLASSIFIED ENTRANCE PIPE, 18 IN. DIA. A. Refer to Tab. 102-3 in the C Sheets.
42	2422-1723018	CULVERT, UNCLASSIFIED ROADWAY PIPE, 18 IN. DIA. A. Refer to Tab. 112-8 in the C Sheets.
43	2422-1723024	CULVERT, UNCLASSIFIED ROADWAY PIPE, 24 IN. DIA. A. Refer to Tab. 104-3 in the C Sheets.
44	2435-0140148	MANHOLE, STORM SEWER, SW-401, 48 IN.
45	2435-0140172	MANHOLE, STORM SEWER, SW-401, 72 IN.
46	2435-0250100	INTAKE, SW-501
47	2435-0250500	INTAKE, SW-505
48	2435-0251100	INTAKE, SW-511 A. Refer to Tab. 104-5B on Sheet M.1.
49	2435-0700010	INTAKE, SW-512, 30 IN. A. Refer to Tab. 104-3 in the C Sheets. Use SW-604 Type 4C Casting.
50	2435-0700010	CONNECTION TO EXISTING MANHOLE A. Refer to Sheet U.7 for location and details of connection to existing sanitary sewer manhole. B. Plugging of existing hole shall be considered incidental.
51	2502-8212034	SUBDRAIN, LONGITUDINAL, (SHOULDER) 4 IN. DIA.
52	2502-8221304	SUBDRAIN OUTLET, DR-304 A. Refer to Tab. 104-9 on Sheets CS.1 and CS.2.
53	2503-0114218	STORM SEWER GRAVITY MAIN, TRENCHED, RCP, 2000D (CLASS III), 18 IN.
54	2503-0114415	STORM SEWER GRAVITY MAIN, TRENCHED, RCP, 3000D (CLASS IV), 15 IN.
55	2503-0114418	STORM SEWER GRAVITY MAIN, TRENCHED, RCP, 3000D (CLASS IV), 18 IN. A. Refer to Tab. 104-5B on Sheet M.1.
56	2504-0150408	SANITARY SEWER FORCE MAIN, TRENCHED, PVC, 8 IN.
57	2504-0170408	SANITARY SEWER FORCE MAIN WITH CASING PIPE, TRENCHED, PVC, 8 IN. A. Refer to Sheets U.5 thru U.8. B. Requires installation of underground warning tape. To be buried 12" deep directly above the sanitary sewer force main for the entire length of pipe. Type: green, 6" wide, polyethylene, with detectable metallic core for ease of locating buried pipe. Printed wording shall read "Caution Buried Sewer Line Below".
58	2504-0230000	SEWAGE AIR RELEASE VALVE AND PIT A. Requires wastewater combination air release/vacuum valve from one of the following approved manufacturers:



**ESTIMATE REFERENCE INFORMATION**

Item No.	Item Code	Description
		ValMatic (Model 801A), APCO (Model 443), or A.R.I. (Model D-025, 2" nominal), or approved equal. B. Recommend 1" outlet, 2" inlet, and internal orifice greater than or equal to 1/8".
59	2504-0240036	REMOVE SANITARY SEWER PIPE LESS THAN OR EQUAL TO 36 IN. A. Refer to Tab. 110-14 in the C sheets.
60	2505-4008400	STEEL BEAM GUARDRAIL BARRIER TRANSITION SECTION
61	2505-4021010	STEEL BEAM GUARDRAIL END ANCHOR, BOLTED
62	2505-4021700	STEEL BEAM GUARDRAIL END TERMINAL A. Refer to Tabs. 108-8A and 107-23 in the C Sheets.
63	2505-6000111	HIGH TENSION CABLE GUARDRAIL
64	2505-6000121	HIGH TENSION CABLE GUARDRAIL, END ANCHOR A. Refer to Tabs. 108-9A and 107-24 in the C Sheets.
65	2507-3250005	ENGINEERING FABRIC A. Refer to Tab. 100-23 in the C Sheets. B. Engineering fabric shall be material as specified for embankment erosion control, Article 4196.01C. Material shall be measured in sq. yds. of actual area covered.
66	2507-8029000	EROSION STONE A. Refer to Tab. 100-23 in the C Sheets.
67	2510-6745850	REMOVAL OF PAVEMENT A. Refer to Tabs. 102-5 and 110-1 in the C Sheets.
68	2510-6750600	REMOVAL OF INTAKES AND UTILITY ACCESSES A. Refer to Tab. 110-15 in the C Sheets.
69	2512-1750006	CURB AND GUTTER, P.C. CONCRETE, AS PER PLAN A. Refer to Tab. 112-4 in the C Sheets and Sheet E.15.
70	2515-2475006	DRIVEWAY, P.C. CONCRETE, 6 IN. A. Refer to Tab. 102-3 in the C Sheets.
71	2515-6745600	REMOVAL OF PAVED DRIVEWAY A. Refer to Tab. 110-8 in the C Sheets. B. Requires 84 linear foot of full depth saw cut.
72	2518-6891810	PERMANENT ROAD CLOSURE, RURAL, SI-181
73	2518-6891820	PERMANENT ROAD CLOSURE, URBAN, SI-182 A. Refer to Tab. 102-4 in the C Sheets.
74	2518-6910000	SAFETY CLOSURE A. Refer to Tab. 108-13A in the C Sheets.
75	2520-3350015	FIELD OFFICE
76	2523-0000100	LIGHTING POLES
77	2523-0000200	ELECTRICAL CIRCUITS
78	2523-0000310	HANDHOLES AND JUNCTION BOXES
79	2523-0000400	CONTROL CABINET A. Refer to P Sheets.
80	2526-8285000	CONSTRUCTION SURVEY
81	2527-9263109	PAINTED PAVEMENT MARKING, WATERBORNE OR SOLVENT-BASED
82	2527-9263131	WET RETROREFLECTIVE REMOVABLE TAPE MARKINGS
83	2527-9263137	PAINTED SYMBOLS AND LEGENDS, WATERBORNE OR SOLVENT-BASED
84	2527-9263180	PAVEMENT MARKINGS REMOVED
85	2527-9263190	SYMBOLS AND LEGENDS REMOVED A. Refer to Tabs. 108-22 and 108-29 in the C Sheets and Sheet J.1.
86	2528-8400048	TEMPORARY BARRIER RAIL, CONCRETE A. Refer to Tab. 108-33 in the C Sheets and Sheet J.1.
87	2528-8400157	TEMPORARY FLOODLIGHTING LUMINAIRE A. Refer to Tab. 108-27 in the C Sheets.
88	2528-8445110	TRAFFIC CONTROL A. Refer to Traffic Control Plan on Sheet J.1.
89	2528-8445113	FLAGGERS A. Refer to Tab. 108-26A on Sheet J.1. Flaggers to be used at ramp terminals while EB and WB US 20 traffic shifted to the ramps.
90	2528-9109020	TEMPORARY LANE SEPARATOR SYSTEM A. Refer to Tab. 108-35 in the C Sheets and Sheet J.1.
91	2533-4980005	MOBILIZATION
92	2551-0000130	TEMP CRASH CUSHION, SEVERE USE (SU) A. Refer to Tab. 108-30 in the C Sheets and Sheet J.1.

**ESTIMATE REFERENCE INFORMATION**

Item No.	Item Code	Description
93	2552-0000300	TRENCH COMPACTION TESTING
94	2554-0114012	WATER MAIN, TRENCHED, PVC, 12 IN.
95	2554-0134012	WATER MAIN WITH CASING PIPE, TRENCHED, PVC, 12 IN.
96	2554-0202200	FITTINGS BY COUNT, DUCTILE IRON, BEND, 12 IN., 11 1/4 DEGREE
97	2554-0202200	FITTINGS BY COUNT, DUCTILE IRON, BEND, 12 IN., 22 1/2 DEGREE
98	2554-0202200	FITTINGS BY COUNT, DUCTILE IRON, BEND, 12 IN., 90 DEGREE
99	2554-0202200	FITTINGS BY COUNT, DUCTILE IRON, REDUCER, 12 IN. X 12 IN.
100	2554-0202200	FITTINGS BY COUNT, DUCTILE IRON, TEE, 12 IN. X 12 IN.
101	2554-0202200	FITTINGS BY COUNT, DUCTILE IRON, TEE, 12 IN. X 6 IN.
102	2554-0207012	VALVE, GATE, DIP, 12 IN. A. Refer to Sheets U.1 thru U.4. B. Requires installation of underground warning tape. To be buried 12" deep directly above the water main for the entire length of pipe. Type: blue, 6" wide, polyethylene, with detectable metallic core for ease of locating buried pipe. Printed wording shall read "Caution Buried Water Line Below".
103	2599-9999005	REMOVE AND REINSTALL EXISTING FIRE HYDRANT ASSEMBLY A. Refer to Sheets U.1 thru U.4. B. Method of Measurement: Each existing fire hydrant assembly removed and relocated to the new water main will be counted. C. Basis of Payment: Payment will be the contract unit price for each fire hydrant assembly removed and relocated. Payment is full compensation for the fire hydrant, barrel extensions sufficient to achieve proper bury depth of anchoring pipe and height of fire hydrant above finished grade, and components to connect the fire hydrant to the water main, including anchoring pipe, fittings, thrust blocks, pea gravel or porous backfill material, and fire hydrant gate valve.
104	2599-9999009	REMOVAL OF EXISTING WATER MAIN AND FITTINGS A. Refer to Sheets U.1 thru U.4. B. Method of Measurement: Measurement for each type and size of pipe removed will be in linear feet (meters) from end to end. C. Basis of Payment: Payment will be at the contract unit price per linear foot (meter) for each type and size of pipe. Payment is full compensation for removal, disposal, and capping (if specified) of pipe.
105	2601-2634100	MULCHING A. Perform mulching according to Article 2601.03, E, 2, of the Standard Specifications. Anchor mulch into the soil using mulch anchoring equipment with a minimum of two passes. B. Item is included for areas requiring reshaping and seedbed preparation. Use mulch that is Certified Noxious Weed Seed Free Mulch as certified by the Iowa Crop Improvement Association or adjacent states Crop Improvement Associations. C. Mulch Rate: 1 1/2 tons of dry cereal straw or native grass straw per acre.
106	2601-2634105	MULCHING, BONDED FIBER MATRIX A. A Bonded Fiber Matrix shall be applied as the mulch for all areas designated as "Stabilizing Crop - Seeding and Fertilizing (Urban)". B. The seed and fertilizer for the area to be covered shall be applied before the Bonded Fiber Matrix Hydraulic Mulch application. C. Application rate shall be a minimum of 3000 lbs per acre.
107	2601-2636043	SEEDING AND FERTILIZING (RURAL) A. Seed and fertilize all areas 8 foot adjacent to the shoulder mainline, medians, and side according to Article 2601.03, C, 3, of the Standard Specifications. B. Use ground driven equipment.
108	2601-2636044	SEEDING AND FERTILIZING (URBAN) A. For all areas designated by the Engineer. B. Prepare seedbed, fertilize, and seed according to Article 2601.03, C, 4, of the Standard Specifications. ☑ C. Use ground driven equipment.
109	2601-2639010	SODDING A. Refer to Sheet E.13 for location. B. To be used as a sod letdown flume at the east end of Field of Dreams Way per Road Design Detail 6147.
110	2601-2640350	SPECIAL DITCH CONTROL, WOOD EXCELSIOR MAT A. Refer to Tab. 100-22 in the C Sheets. Refer to Standard Road Plan EC-101. B. Prepare seedbed according to Article 2601.03, B, 4, and install according to Article 2601.03, H, 2, of the Standard Specifications.
111	2601-2642100	STABILIZING CROP - SEEDING AND FERTILIZING A. Item is included for disturbed rural areas as directed by the Engineer. B. Prepare seedbed according to Article 2601.03, B, 4, of the Standard Specifications. C. Seed and fertilize all disturbed areas according to Article 2601.03, C, 1, of the Standard Specifications. D. Seed mixture shall be: Oats 50 lbs. per acre Grain Rye 50 lbs. per acre *Canada wildrye (Elymus canadensis) 5 lbs. PLS. per acre *Big bluestem (Andropogon gerardii) 3 lbs. PLS. per acre *Little bluestem (Schizachyrium scoparium) 3 lbs. PLS. per acre Side-oats grama (Bouteloua curtipendula) 3 lbs. PLS. per acre Switchgrass (Panicum virgatum) 1 lbs. PLS. per acre Partridge Pea (Chamaecrista fasciculata) 2 lbs. PLS. per acre  *Note: Canada wildrye, Big bluestem and Little bluestem shall be debarbed or equal to facilitate the application of seed.

**ESTIMATE REFERENCE INFORMATION**

Item No.	Item Code	Description
		1. For stabilizing crop only, seed will not be required to be certified as Source Identified Class (Yellow Tag) Source G0-Iowa.
		2. Seed may be applied by broadcasting or with a Native Grass Drill.
		3. Broadcasted seed will require one complete rolling of the area seeded with a cultipacker with 24 hours after seeding and prior to mulching or hydromulching.
		4. Native Grass Drilled seed must meet Article 2601.03, A, 11, and be completed per Article 2601.03, C, 5 of the Standard Specifications prior to mulching or hydromulching.
		5. All seed shall be mixed off-site by a seed conditioner approved by the Iowa Crop Improvement or other state's Crop Improvement Association. Bags shall arrive on-site from seed conditioner sealed/unopened.
112	2601-2642120	<b>STABILIZING CROP - SEEDING AND FERTILIZING (URBAN)</b> A. Item is included for disturbed urban areas as directed by the Engineer. B. Seed and fertilize all disturbed areas according to Article 2601.03, C, 2, of the Standard Specifications.
113	2601-2643110	<b>WATERING FOR SOD, SPECIAL DITCH CONTROL, OR SLOPE PROTECTION</b> A. Estimate based on four waterings of the TRM at a rate of 50 gallons per square. B. The Contractor shall water the required areas no later than the day following placement of the TRM. If the Contractor fails to water by the second day following placement, a price adjustment will be assessed at a rate of \$200.00 per calendar day until the watering has been completed. C. Additional waterings will be required at intervals of 5 to 8 calendar days. Perform all waterings unless notified by the Engineer in writing at least 1 calendar day prior to the day the watering is to occur. If the Contractor fails to complete the watering before the 8th calendar day has elapsed, a price adjustment will be assessed at a rate of \$200.00 per calendar day, beginning on the 9th say, until the watering is completed.
114	2601-2643300	<b>MOBILIZATION FOR WATERING</b>
115	2601-2643412	<b>TURF REINFORCEMENT MAT, TYPE 2</b> A. Refer to Tab. 100-22 in the C Sheets. Refer to Standard Road Plan EC-101. B. Install according to Article 2601.03, H, 3, of the Standard Specifications. C. The seed and rate for the TRM application shall be as described in Table 2601.03-7: Ditches - Outside Shoulder Adjacent to Native Grass Seedings.
116	2602-0000020	<b>SILT FENCE</b> A. Refer to Tab. 100-17 in the C Sheets. B. The tabulation includes estimated locations for placement of "Silt Fence" to address erosion to be encountered during construction. C. Verify the specific locations with the Engineer prior to beginning placement. D. Bid item includes 25% additional quantity for field adjustments and replacements.
117	2602-0000030	<b>SILT FENCE FOR DITCH CHECKS</b> A. Refer to Tab 100-18 in the C Sheets. B. The tabulation includes estimated locations for placement of "Silt Fence for Ditch Checks" to address erosion to be encountered during construction. C. Verify the specific locations with the Engineer prior to beginning placement. D. Bid item includes 50% additional quantity for field adjustments and replacements.
118	2602-0000050	<b>SILT BASINS</b> A. Refer to Tab. 100-14 in the C Sheets for locations and details.
119	2602-0000071	<b>REMOVAL OF SILT FENCE OR SILT FENCE FOR DITCH CHECKS</b> A. This item is included for silt fence and silt fence for ditch check removal required for staging reasons, removal to allow for replacement (replacement to be paid separately), or for areas that have achieved 70% permanent growth.
120	2602-0000101	<b>MAINTENANCE OF SILT FENCE OR SILT FENCE FOR DITCH CHECK</b> A. This item is included for clean-out and repair of the silt fence and silt fence for ditch checks during the grading project.
121	2602-0000312	<b>PERIMETER AND SLOPE SEDIMENT CONTROL DEVICE, 12 IN. DIA.</b>
122	2602-0000320	<b>PERIMETER AND SLOPE SEDIMENT CONTROL DEVICE, 20 IN. DIA.</b> A. This item is included for temporary perimeter sediment control, inlet protection, and water velocity reduction on slopes or ditches at locations to be determined during construction. Verify specific locations with the Engineer prior to beginning placement. B. Perimeter and Slope Sediment Control Devices will be required to be constructed out of wood excelsior.
123	2602-0000350	<b>REMOVAL OF PERIMETER AND SLOPE SEDIMENT CONTROL DEVICE</b> A. This item is included for removal of Perimeter and Slope Sediment Control Devices. All material shall become the property of the Contractor and removed from the project within 24 hours.
124	2602-0010010	<b>MOBILIZATIONS, EROSION CONTROL</b>
125	2602-0010020	<b>MOBILIZATIONS, EMERGENCY EROSION CONTROL</b>

**STANDARD ROAD PLANS**

The following Standard Road Plans apply to construction work on this project.

Number	Date	Title
BA-200	10-18-11	Steel Beam Guardrail Components
BA-201	10-19-10	Steel Beam Guardrail Barrier Transition Section
BA-202	10-21-14	Steel Beam Guardrail Bolted End Anchor
BA-205	10-18-11	Steel Beam Guardrail End Terminal
BA-250	10-21-14	Steel Beam Guardrail Installation at Concrete Barrier or Bridge End Post
BA-351	04-20-10	High Tension Cable Guardrail
BA-401	04-16-13	Temporary Barrier Rail (Precast Concrete)
BA-500	04-20-10	Temporary Crash Cushions Sand Barrel
DR-101	04-21-15	Pipe Culvert (Bedding and Backfill)
DR-102	04-21-15	Pipe Culvert (Cover and Camber)
DR-103	04-21-15	Pipe Culvert (Installation Details)
DR-104	04-21-15	Depth of Cover Tables for Concrete and Corrugated Pipe
DR-121	04-21-15	Connected Pipe Joints
DR-122	04-21-15	Construction of Type "C" Concrete Adaptors for Pipe Culvert Connections
DR-141	04-21-15	Pipe Bends and Half Pipe
DR-201	04-21-15	Concrete Aprons
DR-203	04-21-15	Metal Pipe Aprons and Beveled Ends
DR-205	04-21-15	Concrete Apron with End Wall
DR-212	04-21-15	Beveled Pipe and Guard
DR-213	04-21-15	Pipe Apron Guard
DR-303	04-21-15	Subdrains (Longitudinal)
DR-304	04-21-15	Outlets for Longitudinal, Transverse and Backslope Subdrains
DR-401	04-21-15	Scour Protection for Bridge End Drain
DR-501	04-21-15	Corrugated Metal Type "A" Diaphragm
DR-502	04-21-15	Slotted Drain for Median Crossovers
DR-601	04-21-15	Reinforced Concrete Pipe Culvert
DR-611	04-21-15	Reinforced Concrete Pipe Culvert Letdown Structure
DR-621	04-21-15	Pipe Extension
DR-651	04-21-15	Unclassified Pipe Culvert
DR-652	04-21-15	Unclassified Letdown Structure Single Elbow
EC-101	04-21-15	Wood Excelsior Mat for Ditch Protection
EC-201	04-21-15	Silt Fence
EC-204	04-21-15	Perimeter and Slope Sediment Control Devices
EW-101	04-19-11	Embankment and Rebuilding Embankments
EW-102	10-21-14	Allowable Placement of Unsuitable Soil in Embankments
EW-103	10-15-13	Embankment Subgrade Treatment, Moisture Density Control and Special Compaction
EW-203	04-21-15	Bridge Berm Grading with Recoverable Slope (Non-Barnroof Section)
EW-301	04-19-11	Guardrail Grading
EW-302	10-15-13	Special Shaping for High Tension Cable Guardrail at Median Obstacles
EW-403	10-15-13	Temporary Erosion Control Measures
EW-501	10-15-13	Rural Entrance
EW-503	04-15-14	Side Road Grading
LI-101	10-21-14	Light Pole Location
LI-103	10-21-14	Conduit and Precast Handholes
LI-141	10-21-14	Electrical Installation (Roadway Ducts)
LI-142	04-21-15	Electrical Installation (Bases)
LI-152	10-21-14	Control Cabinet (Pad-Mounted)
LI-201	10-21-14	Light Pole Foundation
LI-211	10-21-14	Slip-Base for Light Poles
MI-210	10-15-13	PCC Driveways and Alleys
PM-110	04-16-13	Line Types
PM-111	04-21-15	Symbols and Legends
PM-120	10-21-14	Stop Lines and Islands
PM-310	04-16-13	Entrance and Exit Ramps
PM-520	04-19-11	Two-Lane Roadway with no Turn Lanes (Two-Way Stop Condition)
PM-521	04-19-11	Two-Lane Roadway with Right Turn Lanes
PM-550	04-19-11	Two-Lane Roadway with Two-Way Left Turn Lane
PV-101	04-21-15	Joints
PV-102	04-15-14	PCC Curb Details
PV-303	04-19-11	Superelevation Details Ramps
PV-410	10-18-11	Deceleration Taper for 16' Exit Ramp
PV-411	10-18-11	Acceleration Taper for 16' Entrance Ramp
PV-500	04-21-15	Median Crossover (50' Median)
SI-173	04-20-10	Object Markers
SI-181	10-18-11	Permanent Road Closure - Rural
SI-182	10-18-11	Permanent Road Closure - Urban
SI-211	10-19-10	Object Marker and Delineator Placement with Guardrail
SI-881	10-15-13	Special Signs for Workzones
SW-101	04-21-09	Trench Bedding and Backfill Zones
SW-102	04-21-09	Rigid Gravity Pipe Trench Bedding
SW-104	04-21-09	Pressure Pipe Trench Bedding
SW-202	04-21-09	Sewage Air Release Valve Pit
SW-211	10-16-12	Special Pipe Connections for Storm Sewer
SW-401	04-21-09	Circular Storm Sewer Manhole
SW-501	10-16-12	Single Grate Intake
SW-505	10-16-12	Double Grate Intake
SW-511	04-21-09	Rectangular Area Intake
SW-514	04-21-09	Boxouts for Grate Intakes
SW-602	04-21-15	Castings for Storm Sewer Manholes
SW-603	10-15-13	Castings for Grate Intakes
SW-604	10-20-09	Castings for Area Intakes
TC-1	04-16-13	Work Not Affecting Traffic (Two-Lane or Multi-Lane)
TC-61	04-21-15	Two-Lane, Two-way Operation
TC-202	04-21-15	Work Within 15 ft of Traveled Way
TC-251	04-17-12	Temporary Road Closure

**STANDARD ROAD PLANS**

The following Standard Road Plans apply to construction work on this project.

Number	Date	Title
TC-252	04-21-15	Routes Closed to Traffic
TC-402	04-21-15	Work Within 15 ft of Traveled Way
TC-417	04-16-13	Ramp Closure
TC-418	10-15-13	Lane Closure on Divided Highway
TC-421	10-21-14	Lane Closure with TBR
TC-451	04-21-15	Temporary Road Closure on Divided Highway
TC-454	10-16-12	Temporary Detour Using Ramps on Divided Highway
WM-101	04-21-09	Thrust Blocks
WM-102	04-21-09	Tracer System
WM-201	04-19-11	Fire Hydrant Assembly

**INDEX OF TABULATIONS**

Tabulation	Tabulation Title	Sheet No.
<b>C Sheets</b>		
100-1C	ESTIMATED PROJECT QUANTITIES (UP TO A 5 DIVISION PROJECT)	C.1 - C.2
100-1D	PROJECT DESCRIPTION	C.1
100-4A	ESTIMATE REFERENCE INFORMATION	C.3 - C.5
100-14	SILT BASINS	C.8
100-17	TABULATION OF SILT FENCES	C.14
100-18	TABULATION OF SILT FENCES FOR DITCH CHECKS	C.14
100-22	SPECIAL DITCH CONTROL AND SLOPE PROTECTION	C.8
100-23	ROCK DITCH CHECKS/DITCHES/FLUMES/SPLASH BASINS/SLOPE PROTECTION	C.8
100-24	PCC PAVEMENT	C.11
100-27	PAVEMENT SMOOTHNESS + PCC TEXTURE	C.11
102-3	ACCESS POINTS AND SAFETY RAMPS	C.12
102-4	LOCATIONS OF ROAD CLOSURE BARRICADES	C.15
102-5	EXISTING PAVEMENT	C.10
103-4	TABULATION OF SPREADING TOPSOIL	C.13
104-3	DRAINAGE STRUCTURE BY ROAD CONTRACTOR	C.9
104-9	LONGITUDINAL SUBDRAIN SHOULDER AND BACKSLOPE	C.9
105-4	STANDARD ROAD PLANS	C.6
107-23	GRADING FOR GUARDRAIL INSTALLATIONS	C.13
107-24	GRADING FOR HIGH TENSION CABLE GUARDRAIL INSTALLATIONS	C.13
108-8A	STEEL BEAM GUARDRAIL AT CONCRETE BARRIER OR BRIDGE RAIL END SECTION	C.13
108-9A	HIGH TENSION CABLE GUARDRAIL	C.13
108-13A	SAFETY CLOSURES	C.15
108-22	PAVEMENT MARKING LINE TYPES	C.16 - C.17
108-27	TEMPORARY FLOODLIGHTING LUMINAIRES	C.15
108-29	PAVEMENT MARKING SYMBOLS AND LEGENDS	C.18
108-30	CRASH CUSHIONS	C.15
108-33	TEMPORARY BARRIER RAIL	C.15
108-35	TEMPORARY LANE SEPARATOR SYSTEM	C.15
110-1	REMOVAL OF PAVEMENT	C.10
110-2	REMOVAL OF EXISTING STRUCTURES	C.10
110-8	REMOVAL OF CONCRETE DRIVES	C.10
110-12A	POLLUTION PREVENTION PLAN	C.7
110-14	SANITARY OR STORM SEWER ABANDONMENT OR REMOVAL	C.10
110-15	REMOVAL OF INTAKES AND UTILITY ACCESSES	C.10
111-25	INDEX OF TABULATIONS	C.6
112-4	CURBS AND RAISED ISLANDS	C.11
112-8	MEDIAN CROSSOVERS	C.15
112-9	SHOULDERS	C.12
213-3	SUBSOIL TILLAGE	C.8
213-4	TOPSOIL ON HAUL ROAD	C.8
232-10	EMERALD ASH BORER	C.8
252-1	TEMPORARY CROSSINGS AND DETOURS	C.8
253-1	MEDIAN CROSSOVER	C.8
254-1	INCIDENT MANAGEMENT	C.8
262-5	UTILITIES (POINT 25 PROJECT)	C.8
263-1	UTILITIES (SANITARY SEWER, WATER MAIN, AND APPURTENANCES)	C.8
<b>CS Sheets</b>		
103-6	EMBANKMENT WITH MOISTURE CONTROL	CS.1
103-7	SHRINKAGE DATA	CS.1
104-9	LONGITUDINAL SUBDRAIN SHOULDER AND BACKSLOPE	CS.1 - CS.2
107-31	PLOWING AND SHAPING	CS.1
<b>G Sheets</b>		
101-16	ALIGNMENT COORDINATES	G.4
101-17	SPIRAL OR CIRCULAR CURVE DATA	G.5
101-18	SUPERELEVATION DATA	G.6
<b>J Sheets</b>		
108-23A	TRAFFIC CONTROL PLAN	J.1
108-26A	STAGING NOTES	J.1
111-01	COORDINATED OPERATIONS	J.1
<b>M Sheets</b>		
104-5B	STORM SEWER	M.1
<b>P Sheets</b>		
100-1A	ESTIMATED LIGHTING QUANTITIES (1 DIVISION PROJECT)	P.1
100-4A	ESTIMATE REFERENCE INFORMATION	P.1
108-1	LIGHTING INSTALLATIONS	P.1
108-2	ELECTRICAL DUCTS	P.1
108-11A	HIGHWAY LIGHTING DATA	P.1
108-12	WIRE, CABLE AND CONNECTORS	P.1

**POLLUTION PREVENTION PLAN**

This Base Pollution Prevention Plan (PPP) includes information on Roles and Responsibilities, Project Site Description, Controls, Maintenance Procedures, Inspection Requirements, Non-Storm Water Controls, Potential Sources of Off Right-of-Way Pollution, and Definitions. This plan references other documents rather than repeating the information contained in the documents. A copy of this Base Pollution Prevention Plan, amended as needed per plan revisions or by contract modification, will be readily available for review.

All contractors shall conduct their operations in a manner that controls pollutants, minimizes erosion, and prevents sediments from entering waters of the state and leaving the highway right-of-way. The prime contractor shall be responsible for compliance and implementation of the PPP for their entire contract. This responsibility shall be further shared with subcontractors whose work is a source of potential pollution as defined in this PPP.

**I. ROLES AND RESPONSIBILITIES****A. Designer:**

1. Prepares Base PPP included in the project plan.
2. Prepares Notice of Intent (NOI) submitted to Iowa DNR.
3. Signature authority on the Base PPP and NOI.

**B. Contractor/Subcontractor:**

1. Affected contractors/subcontractors are co-permittees with the IDOT and will sign a certification statement adhering to the requirements of the NPDES permit and this PPP plan. All co-permittees are legally required under the Clean Water Act and the Iowa Administrative Code to ensure compliance with the terms and conditions of this PPP.
2. Submit a detailed schedule according to Article 2602 of the Specifications and any additional plan notes.
3. Install and maintain appropriate controls.
4. Supervise and implement good housekeeping practices.
5. Conduct joint required inspections of the site with inspection staff.
6. Signature authority on Co-Permittee Certification Statements and storm water inspection reports.

**C. RCE/Inspector:**

1. Update PPP whenever there is a change in design, construction, operation or maintenance, which has a significant effect on the discharge of pollutants from the project.
2. Maintain an up-to-date list that identifies contractors and subcontractors as co-permittees.
3. Make these plans available to the DNR upon their request.
4. Conduct joint required inspections of the site with the contractor/subcontractor.
5. Complete an inspection report after each inspection.
6. Signature authority on storm water inspection reports and Notice of Discontinuation (NOD).

**II. PROJECT SITE DESCRIPTION**

- A. This Pollution Prevention Plan (PPP) is for the construction of an interchange on US-20 at Dyersville with adjacent rural and urban side street and sideroad connections.
- B. This PPP covers approximately 120 acres with an estimated 88 acres being disturbed. The portion of the PPP covered by this contract has 65.5 acres disturbed.
- C. The PPP is located in an area of 1 soil association type, Dinsdale-Klinger. The estimated average SCS runoff curve number for this PPP after completion will be 65.0.
- D. Storm Water Site Map - Multiple sources of information comprise the base storm water site map including:
  1. Drainage patterns - Plan and Profile sheets and Situation plans.
  2. Proposed Slopes - Cross Sections.
  3. Areas of Soil Disturbance - construction limits shown on Plan and Profile sheets.
  4. Location of Structural Controls - Tabulations on C sheets.
  5. Locations of Non-structural Controls - Tabulations on C sheets.
  6. Locations of Stabilization Practices - generally within construction limits shown on Plan and Profile sheets.
  7. Surface Waters (including wetlands) - Plan and Profile sheets.
  8. Locations where storm water is discharged - Plan and Profile sheets.
- E. The base site map is amended by contract modifications and progress payments of completed erosion control work.
- F. Runoff from this work will flow into area ditches then into the N Fork of the Maquoketa River.

**III. CONTROLS**

- A. The contractor's work plan and sequence of operations specified in Article 2602.03 for accomplishment of storm water controls should clearly describe the intended sequence of major activities and for each activity define the control measure and the timing during the construction process that the measure will be implemented.
- B. Preserve vegetation in areas not needed for construction.
- C. Section 2601 and 2602 of the Standard Specifications define requirements to implement erosion and sediment control measures. Actual quantities used may vary from the Base PPP and amendment of the plan will be documented via fieldbook entries or by contract modification. Additional erosion and sediment control items may be required as determined by the inspector and/or contractor during storm water monitoring inspections. If the work involved is not applicable to any contract items, the work will be paid for according to Article 1109.03 paragraph B.
  1. EROSION AND SEDIMENT CONTROLS
    - a. Stabilization Practices
      - 1) Site plans will ensure that existing vegetation is preserved where attainable and disturbed portions of the site will be stabilized.
      - 2) Stabilization measures shall be initiated as soon as practicable in portions of the site where construction activities have temporarily or permanently ceased.
      - 3) Temporary stabilizing seeding shall be completed as the disturbed areas are constructed. If construction activity is not planned to occur in a disturbed area for at least 21 days, the area shall be stabilized by temporary seeding or mulching within 14 days. Other stabilizing methods shall be used outside the seeding time period.
      - 4) Stabilization measures to be used for this project are located in the Estimated Project Quantities (100-1A) and Estimate Reference Information (100-4A) located on the C sheets of the plan. Additional items may be found in the Inspector's Daily Reports (IDR) or Contract Modifications.
    - b. Structural Practices
      - 1) Structural practices will be implemented to divert flows from exposed soils and detain or otherwise limit runoff and the discharge of pollutants from exposed areas of the site.
      - 2) Structural items to be used for this project are located in the Estimated Project Quantities (100-1A) and Estimate Reference Information (100-4A) located on the C sheets of the plan, as well as all other item specific Tabulations. Typical drawings detailing construction of the devices to be used on this project can be found on the B sheets of the plan or are referenced in the Standard Road Plans Tabulation.
    - c. Storm Water Management
      - 1) Measures shall be installed during the construction process to control pollutants in storm water discharges that will occur after construction operations have been completed. The installation of these devices may be subject to Section 404 of the Clean Water Act.

**POLLUTION PREVENTION PLAN****2. OTHER CONTROLS**

- a. Contractor disposal of unused construction materials and construction material wastes shall comply with applicable state and local waste disposal, sanitary sewer, or septic system regulations. In the event of a conflict with other governmental laws, rules and regulations, the more restrictive laws, rules or regulations shall apply.
  - 1) Vehicle Entrances and Exits - Construct and maintain entrances and exits to prevent tracking of sediments onto roadways.
  - 2) Material Delivery, Storage and Use - Implement practices to prevent discharge of construction materials during delivery, storage, and use.
  - 3) Stockpile Management - Install controls to reduce or eliminate pollution of storm water from stockpiles of soil and paving.
  - 4) Waste Disposal - Do not discharge any materials, including building materials, into waters of the state, except as authorized by a Section 404 permit.
  - 5) Spill Prevention and Control - Implement procedures to contain and clean-up spills and prevent material discharges to the storm drain system and waters of the state.
  - 6) Concrete Residuals and Washout Wastes - Designate temporary concrete washout facilities for rinsing out concrete trucks. Provide directions to truck drivers where designated washout facilities are located.
  - 7) Vehicle and Equipment Cleaning - Employ washing practices that prevent contamination of surface and ground water from wash water.
  - 8) Vehicle and Equipment Fueling and Maintenance - Perform on site fueling and maintenance in accordance with all environment laws such as proper storage of onsite fuels and proper disposal of used engine oil or other fluids on site.
  - 9) Litter Management - Ensure employees properly dispose of litter.

**3. APPROVED STATE OR LOCAL PLANS**

During the course of this construction, it is possible that situations will arise where unknown materials will be encountered. When such situations are encountered, they will be handled according to all federal, state, and local regulations in effect at the time.

**IV. MAINTENANCE PROCEDURES**

The contractor is required to maintain all temporary erosion and sediment control measures in proper working order, including cleaning, repairing, or replacing them throughout the contract period. This shall begin when the features have lost 50% of their capacity.

**V. INSPECTION REQUIREMENTS**

- A. Inspections shall be made jointly by the contractor and the contracting authority at least once every seven calendar days. Storm water monitoring inspections will include:
  1. Date of the inspection.
  2. Summary of the scope of the inspection.
  3. Name and qualifications of the personnel making the inspection.
  4. Rainfall amount.
  5. Review erosion and sediment control measures within disturbed areas for the effectiveness in preventing impacts to receiving waters.
  6. Major observations related to the implementation of the PPP.
  7. Identify corrective actions required to maintain or modify erosion and sediment control measures.
- B. Include storm water monitoring inspection reports in the Amended PPP. Incorporate any additional erosion and sediment control measures determined as a result of the inspection. Immediately begin corrective actions on all deficiencies found and complete all actions within 3 calendar days of the inspection.

**VI. NON-STORM WATER DISCHARGES**

This includes subsurface drains (i.e. longitudinal and standard subdrains) and slope drains. The velocity of the discharge from these features may be controlled by the use of patio blocks, Class A stone, erosion stone or other appropriate materials.

**VII. POTENTIAL SOURCES OF OFF RIGHT-OF-WAY (ROW) POLLUTION**

Silts, sediment, and other forms of pollution may be transported onto highway right-of-way (ROW) as a result of a storm event. Potential sources of pollution located outside highway ROW are beyond the control of this PPP. Pollution within highway ROW will be conveyed and controlled per this PPP.

**VIII. DEFINITIONS**

- A. Base PPP - Initial Pollution Prevention Plan.
- B. Amended PPP - May include Plan Revisions or Contract Modifications for new items and fieldbook entries made by the inspector.
- C. IDR - Inspector's Daily Report - this contains the inspector's daily diary and item postings.
- D. Controls - Methods, practices, or measures to minimize or prevent erosion, control sedimentation, control storm water, or minimize contaminants from other types of waste or materials.
- E. Signature Authority - Representative from Designer, Contractor/Subcontractor, or RCE/Inspector authorized to sign various storm water documents.

**CERTIFICATION STATEMENT**

I certify under penalty of law that this document and all attachments were prepared under my direction or supervision in accordance with a system designed to assure that qualified personnel properly gathered and evaluated the information submitted. Based on my inquiry of the person or persons who manage the system, or those persons directly responsible for gathering the information, the information submitted is, to the best of my knowledge and belief, true, accurate, and complete. I am aware that there are significant penalties for submitting false information, including the possibility of fine and imprisonment for knowing violations.



Jeffrey A. Hillegonds  
Printed or Typed Name

**213-3**  
04-15-14

### SUBSOIL TILLAGE

All stockpile areas, haul roads, and areas used for equipment on this project require subsoil tillage to an average depth of 16 to 20 inches prior to placement of topsoil and/or stabilizing crop seeding. Complete this tillage at 3 foot maximum centers and at right angles to the finished slope.

Use tillage equipment equipped with an arrowhead type shoe that will provide lateral displacement and limit the movement of the subsoil to the surface. Obtain the Engineer's approval for the equipment. This work is incidental to other work on the project.

Following the subsoil tillage, the area is to remain in a "loosened" condition. Additional compaction or the operation of heavy equipment, other than required for topsoil placement and shaping, will not be allowed on areas which have received subsoil tillage.

**232-10**  
10-21-14

### EMERALD ASH BORER

Dispose of all wood material generated as a result of clearing and/or grubbing according to the Iowa Department of Agriculture and Land Stewardship's Emerald Ash Borer (EAB) Quarantine Order. For more information refer to [http://www.iowatrepeests.com/eab\\_regulations.html](http://www.iowatrepeests.com/eab_regulations.html).

**254-1**  
10-02-01

### INCIDENT MANAGEMENT

An incident management plan, provided by the District Office, will be discussed at the pre-construction conference.

**213-4**  
04-21-15

### TOPSOIL ON HAUL ROAD

Before placing a construction haul road, strip and stockpile 8 inches of topsoil from within the proposed haul road footprint. After the haul road has been removed, prepare the disturbed area according to Standard Note 213-3 and then place topsoil over the disturbed area to a minimum depth of 4 inches. This work is incidental to Mobilization and will not be paid for separately.

**252-1**  
10-16-12

### TEMPORARY CROSSINGS AND DETOURS

Blading, shaping, and other work in preparation for maintaining temporary crossings or detours is incidental to other work. Furnish and spread additional granular surfacing needed for temporary crossings or detours during construction at the contract price.

**262-5**  
10-18-05

### UTILITIES (POINT 25 PROJECT)

This is a POINT 25 project and is subject to the provisions of IAC 761-115.25.

**253-1**  
10-18-11

### MEDIAN CROSSOVER

The Contractor is prohibited from using any established or other type median crossover on this project unless specifically designated for the Contractor's use by this plan.

**263-1**  
10-18-11

### UTILITIES (SANITARY SEWER, WATER MAIN, AND APPURTENANCES)

For bedding and backfill purposes under Primary roads, use crushed rock or crushed gravel material complying with Article 4120.04 of the Standard Specifications for all bedding and backfill. Place and compact the material according to Article 2435.03, A and Article 2552.03, E (Class 1 materials) of the Standard Specifications. Gravels must be 100% crushed produced by crushing material retained on a 1.5 inch or larger screen.

**100-23**  
10-19-10

\* Design shown for mandatory locations is the minimum allowed.

### ROCK DITCH CHECKS/DITCHES/FLUMES/SPLASH BASINS/SLOPE PROTECTION

Refer to Typical 4401, 4402, 4403, 4404, and 4405

Location				Type						Material			Remarks	
Road Identification	Station	Side Lt./Rt.	Mandatory* Location (yes or no)	Rock Ditch Check	Rock Ditch	Rock Flume	Rock Splash Basin	Rock Slope Protection	L FT	W FT	Erosion Stone	Class E Revetment		Eng. Fabric
											TON	TON		SY
332nd Avenue	11083+24.76	Lt.	Yes				X		4.0	6.0	3.0		9.0	
Industrial Parkway	21047+76.00	Rt.	Yes				X		7.0	10.0	8.5		17.0	
Field of Dreams Way	51076+65.00	Lt.	Yes				X		4.0	6.0	3.0		9.0	

**100-22**  
08-01-08

### SPECIAL DITCH CONTROL AND SLOPE PROTECTION

Location				L FT	W FT	No. Squares	Remarks
No.	Begin Station	End Station	Side				
1	1050+00.00	1052+50.00	Lt.	250	16	40.0	Special Ditch Control
2	1053+50.00	1058+00.00	Rt.	450	16	72.0	Special Ditch Control
3	1154+50.00	1159+00.00	Rt.	450	16	72.0	Special Ditch Control
4	11054+50.00	11058+50.00	Lt.	400	16	64.0	Special Ditch Control
5	11074+75.00	11078+25.00	Lt.	350	16	56.0	Special Ditch Control
6	11074+75.00	11081+25.00	Rt.	650	16	104.0	Special Ditch Control
7	11079+00.00	11079+90.00	Lt.	90	16	14.4	Special Ditch Control
8	31065+00.00	31074+50.00	Rt.	950	16	152.0	Special Ditch Control
9	31065+00.00	31074+50.00	Lt.	950	16	152.0	Special Ditch Control
10	41056+00.00	41058+50.00	Rt.	250	16	40.0	Special Ditch Control
11	41061+75.00	41072+50.00	Rt.	1075	16	172.0	Special Ditch Control
12	41061+75.00	41073+00.00	Lt.	1125	16	180.0	Special Ditch Control
13	51077+25.00	51079+25.00	Lt.	200	16	32.0	Special Ditch Control
Total						1150.4	
14	11068+75.00	11072+50.00	Lt.	375	16	60.0	Turf Reinforcement Mat, Type 2
15	11069+20.00	11072+25.00	Rt.	305	16	48.8	Turf Reinforcement Mat, Type 2
Total						108.8	

**100-14**  
04-21-15

### SILT BASINS

Refer to EW-403

Location Station	Side	Each	Remarks
1042+27.00	LT	2	30" Culvert Under US 20
1042+27.00	RT	2	30" Culvert Under US 20
1082+05.00	RT	2	42" Culvert Under US 20
11081+00.00	RT	1	South End Culvert Under 12th Ave
41065+21.00	RT	2	24" Culvert Under 218th St
41065+21.00	LT	2	24" Culvert Under 218th St





**EXISTING PAVEMENT**

No.	Location					Year	Type	Project Number	Surface		Base		Subbase		Removal		Coarse Aggregate			Reinforcement	Remarks	
	County	Route	Dir. of Travel	Begin Milepost	End Milepost				Type	Depth	Type	Depth	Type	Depth	Type	Depth	Source	Type	Durability Class			
																						IN
1	Delaware	US-20	EB	283.02	293.15	2013	W	NHSX-020-8(49)--3H-28	HMA	1.5	HMA	1.5	HMA	3	SCR	1						
						2013		NHSX-020-8(49)--3H-28	HMA	1.5	HMA	1.5										
						1999		MP-20-6(701)283--76-28	MSS													
						1992		RP-20-8(34)--16-28	ACC	3												
						1978		FN-20-8(17)--21-28	ACC	1.5	TBB	1.5										
1964	FN-1072	ACC	4.5	ATB	8	SAS	6			WHITE QRY.	C.LST.											
		US-20	WB	282.71	293.16	1987		F-20-8(22)--20-28	PCC	10	CTB	4						WHITE QRY.	C.LST.	I		
2	DUBUQUE	US-20	EB	293.16	294.55	1987		F-20-9(66)--20-31	PCC	10	ECB	4							SUNDHEIM	C.LST.	I	
						2013	NHSX-020-8(49)--3H-28	HMA	1.5	HMA	1.5	SCR	1									
		US-20	WB	293.15	294.55	1988		NA	PCC	10	CTB			4								

**REMOVAL OF EXISTING STRUCTURES**

Location	Description	Remarks
1001+38.79, 133.18' Rt.	18" x 28.5' CMP	Remove
1001+41.82, 89.95' Rt.	24" x 78.4' Conc Pipe & Aprons	Remove
1001+71.21, 2.06' Lt.	18" x 115.3' Conc Pipe & Aprons	Remove
1001+90.74, 154.74' Rt.	15" x 30.2' CMP	Remove
1002+41.36, 106.27' Lt.	24" x 67.6' Conc Pipe & Aprons	Remove
1045+20.27, 166.69' Rt.	18" x 80.9' CMP & Aprons	Remove
1049+99.57, 8.14' Rt.	24" x 76.9' Conc Pipe & Aprons	Remove
1050+80.22, 166.66' Rt.	15" x 41.5' CMP	Remove
1052+36.37, 170.67' Lt.	24" x 42.4' Conc Pipe & Aprons	Remove
1052+37.39	30" x 163' Conc Pipe & Aprons	Remove
1052+61.94, 150.86' Rt.	36" x 63.4' CMP & Aprons	Remove
1053+65.20, 88.21' Lt.	24" x 72.4' Conc Pipe & Aprons	Remove
1053+84.55, 2.24' Rt.	18" x 115.4' Conc Pipe & Aprons	Remove
1056+50.38, 6.17' Rt.	24" x 83.7' Conc Pipe & Aprons	Remove
1067+50.33, 7.43' Rt.	24" x 78.3' Conc Pipe & Aprons	Remove
1070+09.22, 0.29' Lt.	18" x 103.1' Conc Pipe & Aprons	Remove
1070+69.89, 84.54' Rt.	24" x 52.4' CMP & Aprons	Remove
1075+99.78, 7.20' Rt.	24" x 76.7' Conc Pipe & Aprons	Remove
1096+25.05, 87.44' Lt.	24" x 185.7' Conc Pipe & Aprons	Remove
1096+45.57, 90.58' Rt.	24" x 146.8' Conc Pipe & Aprons	Remove
2042+29.04, 19.15' Rt.	24" x 36.9' CMP	Remove
2042+33.64, 18.59' Rt.	24" x 36.7' CMP	Remove
3002+21.98, 37.21' Lt.	18" x 49.6' CMP	Remove
3003+00.96, 210.86' Lt.	18" x 40.7' CMP & Aprons	Remove
3003+14.29, 36.38' Rt.	18" x 47.5' CMP	Remove
3003+14.72, 36.15' Lt.	18" x 90.8' CMP & Aprons	Remove
3011+86.26, 38.11' Rt.	15" x 30.7' CMP	Remove
3013+21.95, 23.69' Lt.	30" x 48.1' CMP	Remove
3013+48.10, 38.39' Rt.	24" x 26.8' CMP	Remove
3014+85.42, 37.72' Lt.	18" x 53.6' CMP	Remove
3015+78.44, 37.83' Lt.	18" x 89.0' CMP	Remove

**REMOVAL OF PAVEMENT**

\* Not a Bid Item

Begin Station	End Station	Side	Pavement Type	Area	Saw Cut*	Remarks
				SY	LF	
998+92.14	1005+62.41	Median	PCC	1168.3	938.0	Median crossing and left turn lanes at 320th Avenue
1020+31.00	1029+69.00	Median	Unk.	2695.0		Median crossover Installed for project
1040+00.00	1077+25.00	Left	HMA/PCC	10087.3	48.0	WB lanes
1040+00.00	1077+25.00	Right	PCC	9957.6	48.0	EB lanes
1049+86.91	1056+75.51	Median	PCC	1173.5		Median crossing and left turn lanes at 330th Avenue
1067+23.63	1073+03.16	Median	PCC	973.8		Median crossing and left turn lane at 332nd Avenue
1079+31.00	1088+69.00	Median	Unk.	2695.0		Median crossover Installed for project
1088+86.74	2+72.24	Median	PCC	2284.0	2006.5	Median Crossing and left turn lanes at 7th Street SW
1095+30.22	7+52.29	Left	HMA/PCC	2879.9	985.0	WB right turn lane at 7th Street SW and 7th Street SW
2045+39.07	2046+93.57	Both	PCC	867.2	75.0	330th Avenue at Industrial Parkway
2050+85.00	2052+85.00	Both	PCC	937.3	26.0	330th Avenue south of US 20
3000+50.00	3017+22.24	Both	HMA/PCC	5113.8	63.0	332nd Avenue north of US 20 to 12th Avenue SW
51086+06.67	51086+18.51	Both	PCC	31.7	24.0	Field of Dreams Way

**REMOVAL OF INTAKES AND UTILITY ACCESSES**

No.	Location/Description	Type	Remarks
MH 20	Sta. 1071+21.67 (US 20)	Utilities	
MH 21	Sta. 1075+21.27 (US 20)	Utilities	

**SANITARY OR STORM SEWER ABANDONMENT OR REMOVAL**

\* Not a bid item

Location/Description	Sanitary or Storm Sewer	Abandonment, Plug Only or Abandonment, Plug and Fill or Removal	Length of Pipe		Fill Material*	Remarks
			≤ 36 inch diameter	> 36 inch diameter	Flowable Mortar or CLSM	
			LF	LF	CY	
Sta. 2046+46.26 to Sta. 2046+93.57 (330th Ave)	Sanitary Sewer	Removal	118			Includes segment beneath Industrial Pkwy
Sta. 2046+93.57 to Sta. 2050+85.00 (330th Ave)	Sanitary Sewer	Abandonment, Plug Only			0.1	
Sta. 2050+85.00 to Sta. 2052+21.59 (330th Ave)	Sanitary Sewer	Removal	137			
Sta. 1053+54.09 to Sta. 1079+21.38 (US 20)	Sanitary Sewer	Removal	2570			

**REMOVAL OF CONCRETE DRIVES**

Location Station	Side	Area SY	Remarks
3014+84.42	Lt	119.4	
51086+50.44	Lt	28.3	

PCC PAVEMENT

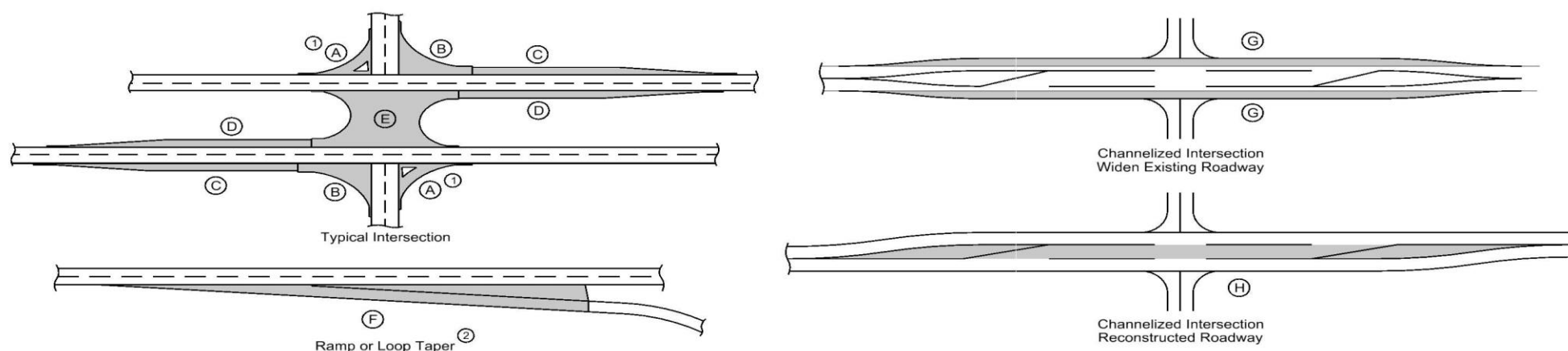

- ① Does not include island area or curb. Refer to tabulation 112-4 for quantities.
- ② Refer to PV-410, PV-411, PV-412, and PV-414.
- ③ Quantity includes Pavement Header.

Road Identification	Location Direction of Travel	Station to Station	Mainline			Area ③								Total Area By Pavement Thickness		Special Backfill CY	Modified Subbase CY	Granular Subbase SY	Remarks		
			Width	Length	Area	A	B	C	D	E	F	G	H	10.5 IN	9.5 IN						
			FT	FT	SY	SY	SY	SY	SY	SY	SY	SY	SY	SY	SY						
US 20	EB	1039+98.04	1044+50.00	26.0	452.0	1305.7										1305.7		435.2		1607.0	
US 20	EB	1044+50.00	1050+50.00	24.0	600.0	1600.0										2936.7		978.9		3337.1	
US 20	EB	1050+50.00	1075+39.92	26.0	2489.9	7193.1										7193.1		2397.7		8853.1	
US 20	EB	1075+39.92	1077+25.00	24.0	185.1	493.5										1394.9		629.5		2770.8	
US 20	WB	1039+98.04	1052+28.04	24.0	1230.0	3280.0										1394.9		1558.3		5273.4	
US 20	WB	1052+28.04	1077+25.00	26.0	2497.0	7213.4										4674.9		2850.0		10415.2	
RAMP A	WB	2065+44.21	2077+25.00	16.0	1180.8	2099.2										8550.1	2799.2		1193.1		
RAMP B	EB	3050+50.00	3062+35.32	16.0	1185.3	2107.2													1215.0		
RAMP C	WB	4049+98.04	4065+85.11	16.0	1587.1	2821.5													1471.1		
RAMP D	EB	5061+94.60	5077+69.92	16.0	1575.3	2800.6													1221.1		
330TH/332ND AVENUE	BOTH	11037+07.02	11054+93.81	24.0	1786.8	4764.8										4764.8	1588.3				
330TH/332ND AVENUE	NB	11054+93.81	11058+53.81	12-32	360.0	640.0															
330TH/332ND AVENUE	SB	11054+93.81	11058+19.56	12-21.3	325.8	579.8															
330TH/332ND AVENUE	SB	11058+19.56	11061+83.26	20.0	363.7	808.2															
330TH/332ND AVENUE	NB	11058+53.81	11061+83.26	20.0	329.4	732.1															
330TH/332ND AVENUE	SB	11065+96.17	11069+26.65	20.0	330.5	734.4															
330TH/332ND AVENUE	NB	11065+96.17	11069+60.85	20.0	364.7	810.4															
330TH/332ND AVENUE	SB	11069+26.65	11072+86.79	12-32	360.1	640.3															
330TH/332ND AVENUE	NB	11069+60.85	11072+86.79	12-21.3	325.9	589.2															
330TH/332ND AVENUE	BOTH	11072+86.79	11082+51.85	24.0	965.1	2573.5															
INDUSTRIAL PARKWAY	BOTH	21046+49.14	21053+69.86	37.0	720.7	2963.0															
221ST STREET	WB	31053+93.86	31094+91.50	12.0	4097.6	5463.5	66.0														
221ST STREET	EB	31053+93.86	31094+91.50	12.0	4097.6	5463.5															
FIELD OF DREAMS WAY	BOTH	51074+02.60	51086+14.71	37.0	1212.1	4983.1															
HAMMERHEAD AT OLD 330TH AVE						96.2															

CURBS AND RAISED ISLANDS

Refer to PV-20, PV-102, and 6000s Detail Series.

Point No.	Station	Offset	Island Interior Area ① SY	Curb and Gutter			Remarks
				Curb Type	Gutter Width FT	Length ① LF	
	1096+07.93	205.15 Lt		6" Standard PCC	6.5	194.0	

PAVEMENT SMOOTHNESS + PCC TEXTURE

Road Identification	Begin Station	End Station	Proposed Posted Speed			Remarks
			35 or less	40 - 45	over 45	
US 20 EB	1039+98.04	1077+25.00			65	Section 2316 of Standard Specifications
US 20 WB	1039+98.04	1077+25.00			65	Section 2316 of Standard Specifications
RAMP A	2065+44.21	2077+25.00			55	Section 2316 of Standard Specifications
RAMP B	3050+50.00	3062+35.32			55	Section 2316 of Standard Specifications
RAMP C	4049+98.04	4065+85.11			55	Section 2316 of Standard Specifications
RAMP D	5061+94.60	5077+69.92			55	Section 2316 of Standard Specifications

**SHOULDERS**

- ① Lane(s) to which the shoulder is adjacent.
- ② Bid Item
- ③ Applies only for Paved Shoulders constructed on project with existing granular shoulders.
- ④ Does not include shrink.

Calculations assume a HMA unit weight (lbs/cf) of 145, a Special Backfill unit weight (lbs/cf) of 140, and a Granular Shoulder unit weight (lbs/cf) of 140.

Road Identification	Direction Of Traffic	Location			Quantities																	Remarks				
		Station to Station	Side	P Width FT	G Width FT	L Length FT	Class 13 Excavation CY ②	Hot Mix Asphalt		Binder TONS	Paved Shoulder SY ②	Reinforced Paved Shoulder SY ②	Special Backfill				Modified Subbase CY ②	Granular Shoulder		Earth Shoulder Construction Alternates						
								TON	TON/STA				HMA Alternate		PCC Alternate			TON ②	TON/STA	STA ②	HMA CY ④		PCC CY ④			
													CY ②	CY/STA	CY ②	CY/STA										
US 20	EB	1039+98.04	1077+25.00	L	4.0	2.0	3727.0	574.2	15.4	34.5	1656.4							555.7	14.9	37.3	2559.2					
US 20	EB	1039+98.04	1045+79.51	R	4.0	4.0	581.5	89.6	15.4	5.4	1656.4							205.5	35.4	37.3	398.4					
US 20	EB	1045+79.51	1050+50.00	R		6.0	470.5											138.3	29.4	4.7	289.4					
US 20	EB	1050+50.00	1062+73.29	R	4.0	4.0	1223.3	188.5	15.4	11.3	543.7							432.4	35.4	12.2	838.2					
US 20	EB	1062+73.29	1064+51.57	R	15.0		178.3														1.8		10.5" PCC Paved Shld			
US 20	EB	1064+51.57	1075+39.92	R	4.0	4.0	1088.3	167.7	15.4	10.1	483.7							384.7	35.4	10.9	745.7					
US 20	EB	1077+69.92	1085+69.94	R		6.0	800.0											310.5	38.8	29.4	8.0	492.2				
US 20	EB	1085+69.94	1087+69.92	R	4 to 2	2 to 6	200.0	30.8	15.4	1.8	66.7							96.9	48.4	70.7	35.4	2.0	137.0			
US 20	WB	1039+98.04	1077+25.00	L	4.0	2.0	3727.0	574.2	15.4	34.5	1656.4							555.7	14.9	37.3	2559.2					
US 20	WB	1039+98.04	1041+97.94	R	2 to 4	6 to 2	199.9	30.8	15.4	1.8	66.6							70.7	35.4	2.0	137.0					
US 20	WB	1041+97.94	1049+98.04	R		6.0	800.1											310.6	38.8	29.4	8.0	492.2				
US 20	WB	1052+28.04	1063+27.86	R	4.0	4.0	1099.8	169.4	15.4	10.2	488.8							532.8	48.4	388.8	35.4	11.0	753.6			
US 20	WB	1063+27.86	1065+06.14	R	15.0		178.3														1.8		10.5" PCC Paved Shld			
US 20	WB	1065+06.14	1077+25.00	R	4.0	4.0	1218.9	187.8	15.4	11.3	541.7							590.5	48.4	430.9	35.4	12.2	835.1			
US 20	WB	1077+25.00	1081+95.22	R		6.0	470.2											182.5	38.8	138.2	29.4	4.7	289.3			
US 20	WB	1081+95.22	1083+25.00	R	4 to 2	2 to 6	129.8	20.0	15.4	1.2	43.3							62.9	48.4	45.9	35.4	1.3	88.9			
Ramp A	WB	2065+44.21	2077+25.00	R		6.0	1180.8													153.1	686.0	58.1	11.8		474.5	
Ramp A	WB	2065+44.21	2077+25.00	L		4.0	1180.8													153.1	413.3	35.0	11.8		494.2	
Ramp B	EB	3050+50.00	3062+35.22	R		6.0	1185.2													153.6	688.6	58.1	11.9		476.3	
Ramp B	EB	3050+50.00	3061+95.21	L		4.0	1145.2													148.5	400.8	35.0	11.5		479.3	
Ramp C	WB	4049+98.04	4065+85.11	R		6.0	1587.1													205.7	922.1	58.1	15.9		637.8	
Ramp C	WB	4052+26.70	4064+18.66	L		4.0	1192.0													154.5	417.2	35.0	11.9		498.9	
Ramp C	WB	4064+18.66	4065+85.11	L	2.0	2.0	166.5	13.6	8.2	0.8	37.0									21.6	36.8	22.1	1.7	69.7		
Ramp D	EB	5061+94.60	5077+69.92	R		6.0	1575.3													204.2	915.3	58.1	15.8		633.0	
Ramp D	EB	5061+94.60	5063+61.06	L	2.0	2.0	166.5	13.6	8.2	0.8	37.0									21.6	36.8	22.1	1.7	69.7		
Ramp D	EB	5063+61.06	5075+41.26	L		4.0	1180.2													153.0	413.1	35.0	11.8		493.9	
330th Avenue	NB	11037+07.02	11059+90.41	R		8.0	2283.4													775.5	34.0				699.4	
330th Avenue	NB	11059+90.41	11062+33.26	R	2.0	6.0	242.9	19.8	8.2	1.2	54.0									66.6	27.4					
330th Avenue	SB	11037+07.02	11059+90.41	L		8.0	2283.4													775.5	34.0				699.4	
330th Avenue	SB	11059+90.41	11062+13.26	L	2.0	6.0	222.9	18.2	8.2	1.1	49.5									61.2	27.4					
332nd Avenue	NB	11065+66.17	11067+90.41	R	2.0	6.0	224.2	18.3	8.2	1.1	49.8									61.5	27.4					
332nd Avenue	NB	11067+90.41	11080+50.00	R		8.0	1259.6														427.8	34.0				385.8
332nd Avenue	NB	11080+50.00	11081+38.31	R		8 to 2	88.3													30.0	34.0				27.0	
332nd Avenue	SB	11065+66.17	11067+90.41	L	2.0	6.0	244.2	19.9	8.2	1.2	54.3									67.0	27.4					
332nd Avenue	SB	11067+90.41	11081+95.52	L		8.0	1405.1													477.2	34.0				430.4	
332nd Avenue	SB	11081+95.52	11082+51.85	L		8 to 2	56.3													19.1	34.0				17.3	
Industrial Pkwy	WB	21049+14.47	21053+69.86	L		8.0	455.4													154.7	34.0				139.5	
221st Street	EB	31053+93.86	31094+91.50	R		4.0	4097.6													796.8	19.4				1350.7	
221st Street	WB	31053+93.86	31094+91.50	L		4.0	4097.6													796.8	19.4				1350.7	
Field of Dreams	EB	51086+40.40	51087+03.52	R		0 to 5	63.1													10.8	17.0				19.3	

**ACCESS POINTS AND SAFETY RAMPS**

Refer to Cross-Sections

Length of unclassified pipe calculated is based on using Reinforced Concrete Pipe.

- ① Refer to MI-210
- ② Refer to EW-501.
- ③ Refer to EW-501 or EW-502.

\*Predetermined for access point not constructed with this project.

Location		Type	Length of Opening ①			W FT	PR FT	SR FT	Pipe Culvert ③					Aprons No.	Driveway Surface Area		Driveway Surfacing Material TON	Remarks
Station	Side	A, B, C, Safety Ramp, or Predetermined*	Case 1 or 2	1 1/2" Dropped Curb LF	3" Dropped Curb LF				H FT	Size IN	Pipe Length LF	Lt. LF	Rt. LF		HMA SY	PCC SY		
11037+42.00	LT	C				20.0		20.0									13.000	
11037+42.00	RT	C				16.0		20.0									12.000	
11042+20.00	LT	B				45.0	50.0								798.9		40.000	
11078+88.00	LT	C				30.0		15.0										
11080+15.00	LT	C				20.0	10.0								75.9			
11080+86.00	LT	C				20.0		10.0									17.000	
31072+00.00	RT	C				15.0		3.0	18.0	62.0	30.7	43.5	2				20.000	
31089+60.00	RT	C				20.0		3.0	18.0	58.0	29.9	40.3	2				20.000	
41060+50.00	LT	C				20.0		15.0									16.000	
51086+50.00	LT	B				2-7	25.0								40.0			
60001+92.00	Rt	C				16.0		10.0	1.0	18.0	128.0	82.3	45.7	2			9.000	
60002+02.00	LT	C				16.0		10.0	1.0	18.0	109.0	42.3	66.7	2			7.000	

**107-23**  
10-18-11

### GRADING FOR GUARDRAIL INSTALLATIONS

Refer to EW-301

① Lane(s) to which the installation is adjacent.

No.	Direction of Traffic	Location			Dimensions (Feet)								Earthwork		Remarks		
		Station	Side	Foreslope at Guardrail	X1	Y1	X2	Y2	X3	Y3	X4	Y4	Z	Excavation Class 10		Embankment In Place	
																	CY
1	NB	11062+63.27	0	4	27.5	6.9							77.7	9.0	54.0		Earthwork included in template quantity
2	SB	11065+16.16	0	4	27.5	6.9							77.7	9.0	54.0		Earthwork included in template quantity

**107-24**  
10-15-13

### GRADING FOR HIGH TENSION CABLE GUARDRAIL INSTALLATIONS

Refer to Standard Road Plan EW-302

① Lane(s) to which the installation is adjacent.

No.	Direction of Traffic	Location			Dimensions			Protection Length (C <sub>A</sub> +C <sub>O</sub> +C <sub>T</sub> )	Earthwork: CY	Remarks
		Station	Side	Foreslope at Guardrail	C <sub>A</sub>	C <sub>O</sub>	C <sub>T</sub>			
1	EB	1061+19.38	M	252.3	36.0		288.3	0.0	Earthwork included in template quantity	
2	WB	1066+60.05	M	252.3	36.0		288.3	0.0	Earthwork included in template quantity	

**108-9A**  
04-20-10

### HIGH TENSION CABLE GUARDRAIL

Refer to BA-351.

① Lane(s) to which the installation is adjacent.

No.	Direction of Traffic	Location			Dimensions			Bid Items		Remarks
		Station	Side	Offset D <sub>0</sub>	Approach C <sub>A</sub>	Obstacle C <sub>O</sub>	Trailing C <sub>T</sub>	Protection Length (C <sub>A</sub> +C <sub>O</sub> +C <sub>T</sub> )	End Anchor	
1	EB	1061+19.38	M	8.0	252.3	36.0		288.3	2	
2	WB	1066+60.05	M	8.0	252.3	36.0		288.3	2	

**108-8A**  
10-21-14

### STEEL BEAM GUARDRAIL AT CONCRETE BARRIER OR BRIDGE RAIL END SECTION

Refer to BA-200, BA-201, BA-202, BA-205, BA-206, BA-210, BA-211, BA-250, SI-172, SI-173 and SI-211.

① Lane(s) to which the obstacle is adjacent.

No.	Direction of Traffic	Location			Layout Lengths BA-250				Long-Span System		Delineators and Object Markers				Bid Items					Remarks				
		Station	Side	Offset	VT1	VF	VT2	ET (37.5' or 50.0')	STATION	TYPE	SI-211	SI-172	Object Marker SI-173			Bolted End Anchor	Barrier Transition Section	Steel Beam Guardrail	End Terminal		Post Adapter			
													Type 1	Type 2	Type 3				Standard			Flared		
													White	OM2-2	OM3-L				OM3-R			BA-202	BA-201	BA-200
1	NB	11062+63.27	0	28.8	28.125		50.0			3														
2	SB	11065+16.16	0	28.8	28.125		50.0			3														

**103-4**  
04-19-11

### TABULATION OF SPREADING TOPSOIL

Perform this work according to Section 2105. Prior to placing topsoil on any cohesive soil, scarify the area to be covered to a minimum depth of 3 inches.

Appropriate adjustments have been made in the template quantities to reflect the placement of topsoil on foreslope, backslope and ditch bottom as detailed hereon.

Placement Description							Topsoil Excavation Available From			
Area	Quantity	Location		Side	Slope	Remarks	Amount Reserved	Station to Station		Remarks
No.	CY	Station to Station	L. or R.	B. or F.	IN		CY			
1	11773.0	1039+98.04	1077+25.00	L & R	B & F	11.3	11773.0		Mainline US 20 Stage 1	
2	7937.0	1039+98.04	1077+25.00	L & R	B & F	11.3	7937.0		Mainline US 20 Stage 2	
3	16133.0	11037+07.02	11082+51.85	L & R	B & F	11.3	16133.0		330th/332nd Avenue	
4	3862.0	21046+49.14	21053+69.86	L & R	B & F	11.3	3862.0		Industrial Parkway	
5	15012.0	31053+93.86	31094+91.50	L & R	B & F	11.3	15012.0		221st Street	
6	6843.0	41053+46.33	41073+78.41	L & R	B & F	11.3	6843.0		218th Street	
7	4127.0	51074+02.60	51086+18.48	L & R	B & F	11.3	4127.0		Field of Dreams Way	
8	4437.0	2065+44.21	2077+25.00	L & R	B & F	11.3	4437.0		Ramp A	
9	6801.0	3050+50.00	3062+35.32	L & R	B & F	11.3	6801.0		Ramp B	
10	4888.0	4052+26.70	4065+85.11	L & R	B & F	11.3	4888.0		Ramp C	
11	5715.0	5061+94.60	5075+41.26	L & R	B & F	11.3	5715.0		Ramp D	

100-18  
04-20-10

**TABULATION OF SILT FENCES  
FOR DITCH CHECKS**

Refer to EC-201

Location Station	Side	Length	Remarks
		LF	
Stage 1			
1054+50.00	RT	24.0	ML EB US-20
1055+25.00	RT	24.0	"
1056+00.00	RT	24.0	"
1056+75.00	RT	24.0	"
1057+50.00	RT	24.0	"
1057+90.00	RT	24.0	"
1058+10.00	RT	24.0	"
1058+20.00	RT	24.0	"
1059+70.00	RT	24.0	"
1061+20.00	RT	24.0	"
1064+50.00	RT	24.0	"
1067+40.00	RT	24.0	"
1067+60.00	RT	24.0	"
1068+15.00	RT	24.0	"
1071+60.00	RT	24.0	"
1071+80.00	RT	24.0	"
1077+25.00	RT	24.0	"
1078+75.00	RT	24.0	"
1080+25.00	RT	24.0	"
1081+75.00	RT	24.0	"
1082+20.00	RT	24.0	"
1084+90.00	RT	24.0	"
1087+65.00	RT	24.0	"
11038+00.00	LT	24.0	330TH AVENUE
11039+50.00	LT	24.0	"
11038+00.00	RT	24.0	"
11039+50.00	RT	24.0	"
11041+00.00	RT	24.0	"
11042+50.00	RT	24.0	"
11046+00.00	RT	24.0	"
11049+50.00	RT	24.0	"
11052+80.00	RT	24.0	"
11043+50.00	LT	24.0	"
11047+00.00	LT	24.0	"
11049+50.00	LT	24.0	"
11052+80.00	LT	24.0	"
11055+00.00	RT	24.0	"
11055+75.00	RT	24.0	"
11056+50.00	RT	24.0	"
11075+25.00	RT	24.0	"
11058+00.00	RT	24.0	"
11058+75.00	RT	24.0	"
11055+00.00	LT	24.0	"
11056+50.00	LT	24.0	"
11058+00.00	LT	24.0	"
21050+00.00	RT	24.0	INDUSTRIAL PRKWY
21052+00.00	RT	24.0	"
31055+00.00	RT	24.0	"
31057+00.00	RT	24.0	"
31077+00.00	RT	24.0	"
31080+00.00	RT	24.0	"
21050+00.00	LT	24.0	"
21052+00.00	LT	24.0	"
31055+00.00	LT	24.0	"
31057+00.00	LT	24.0	"
31077+00.00	LT	24.0	"
31080+00.00	LT	24.0	"
3052+50.00	LT	24.0	RAMP B
3053+00.00	LT	24.0	"
3053+25.00	LT	24.0	"
3055+00.00	RT	24.0	"
3057+75.00	RT	24.0	"
3058+00.00	RT	24.0	"
3057+90.00	LT	24.0	"
3058+20.00	LT	24.0	"
3059+70.00	LT	24.0	"
5063+50.00	RT	24.0	RAMP D
5065+00.00	RT	24.0	"
5067+00.00	RT	24.0	"
5070+00.00	RT	24.0	"
5070+75.00	RT	24.0	"
2071+50.00	RT	24.0	"
5071+50.00	RT	24.0	"
5072+25.00	RT	24.0	"
5073+75.00	RT	24.0	"
5066+30.00	LT	24.0	"
5069+10.00	LT	24.0	"
STAGE 2			

100-18  
04-20-10

**TABULATION OF SILT FENCES  
FOR DITCH CHECKS**

Refer to EC-201

Location Station	Side	Length	Remarks
		LF	
1058+50.00	LT	24.0	ML EB US-20
1060+10.00	LT	24.0	"
1061+50.00	LT	24.0	"
1059+90.00	LT	24.0	"
1065+50.00	LT	24.0	"
1067+50.00	LT	24.0	"
1072+85.00	LT	24.0	"
11069+00.00	LT	24.0	332ND AVENUE
11069+40.00	LT	24.0	"
11069+80.00	LT	24.0	"
11070+20.00	LT	24.0	"
11070+60.00	LT	24.0	"
11071+00.00	LT	24.0	"
11071+40.00	LT	24.0	"
11071+80.00	LT	24.0	"
11072+20.00	LT	24.0	"
11069+50.00	RT	24.0	"
11069+90.00	RT	24.0	"
11070+30.00	RT	24.0	"
77070+70.00	RT	24.0	"
11071+10.00	RT	24.0	"
11071+50.00	RT	24.0	"
11071+90.00	RT	24.0	"
11072+30.00	RT	24.0	"
11075+75.00	RT	24.0	"
11076+50.00	RT	24.0	"
11077+25.00	RT	24.0	"
11078+00.00	RT	24.0	"
11078+25.00	RT	24.0	"
11078+75.00	RT	24.0	"
11079+50.00	RT	24.0	"
11080+25.00	RT	24.0	"
11081+00.00	RT	24.0	"
11075+75.00	LT	24.0	"
11076+50.00	LT	24.0	"
11077+25.00	LT	24.0	"
11078+00.00	LT	24.0	"
11078+25.00	LT	24.0	"
41056+10.00	RT	23.0	218TH ST.
41056+50.00	RT	23.0	"
41063+00.00	RT	23.0	"
41063+75.00	RT	23.0	"
41064+50.00	RT	23.0	"
41067+00.00	RT	23.0	"
41067+75.00	RT	23.0	"
41068+50.00	RT	23.0	"
41069+25.00	RT	23.0	"
41070+00.00	RT	23.0	"
41070+75.00	RT	23.0	"
41071+50.00	RT	23.0	"
41072+25.00	RT	23.0	"
41056+10.00	RT	23.0	"
41056+50.00	LT	23.0	"
41063+00.00	LT	23.0	"
41063+75.00	LT	23.0	"
41064+50.00	LT	23.0	"
41067+00.00	LT	23.0	"
41067+75.00	LT	23.0	"
41068+50.00	LT	23.0	"
41069+25.00	LT	23.0	"
41070+00.00	LT	23.0	"
41070+75.00	LT	23.0	"
41071+50.00	LT	23.0	"
41072+25.00	LT	23.0	"
51076+00.00	RT	24.0	FIELD OF DREAMS WAY
51078+00.00	RT	24.0	"
51081+00.00	RT	24.0	"
51083+50.00	RT	24.0	"
51084+00.00	RT	24.0	"
51085+50.00	RT	24.0	"
51077+75.00	LT	24.0	"
51078+50.00	LT	24.0	"
51079+00.00	LT	24.0	"
1042+00.00	MED	34.0	ML US-20 MEDIAN
1042+50.00	MED	34.0	"
1046+10.00	MED	34.0	"
1049+75.00	MED	34.0	"
1050+00.00	MED	34.0	"
1055+00.00	MED	34.0	"
1056+50.00	MED	34.0	"

100-18  
04-20-10

**TABULATION OF SILT FENCES  
FOR DITCH CHECKS**

Refer to EC-201

Location Station	Side	Length	Remarks
		LF	
1058+00.00	MED	34.0	"
1059+50.00	MED	34.0	"
1060+00.00	MED	34.0	"
1074+00.00	MED	34.0	"
1075+50.00	MED	34.0	"
2067+00.00	RT	24.0	RAMP A
2067+75.00	RT	24.0	"
2068+50.00	RT	24.0	"
2069+25.00	RT	24.0	"
2070+00.00	RT	24.0	"
2067+00.00	LT	24.0	"
2068+50.00	LT	24.0	"
2070+00.00	LT	24.0	"
4056+75.00	RT	24.0	RAMP C
4058+00.00	RT	24.0	"
4060+50.00	RT	24.0	"
4061+25.00	RT	24.0	"
4062+00.00	RT	24.0	"
4062+75.00	RT	24.0	"
4063+50.00	RT	24.0	"
4053+50.00	LT	24.0	"
4057+00.00	LT	24.0	"
4064+50.00	LT	24.0	"

100-17  
04-20-10

**TABULATION OF SILT FENCES**

Refer to EC-201

Location			Length	Remarks
Begin Station	End Station	Side		
Stage 1				
1039+00.00	1080+00.00	Both	8200.0	ML EB US 20
3050+00.00	3062+25.00	Both	2450.0	WB Off Ramp B
5062+25.00	5077+50.00	Both	3050.0	WB On Ramp D
21046+50.00	21053+50.00	Both	1400.0	Industrial Parkway
31054+00.00	31095+00.00	Both	8200.0	221st St.
11037+00.00	11063+00.00	Both	5200.0	330th Ave.
Stage 2				
1039+00.00	1077+25.00	Both	7650.0	ML WB US 20
2065+75.00	2077+25.00	Both	2300.0	WB Off Ramp A
4050+00.00	4065+75.00	Both	3150.0	WB On Ramp C
11065+00.00	11084+00.00	Both	3800.0	332nd Ave.
41052+50.00	41073+50.00	Both	4200.0	218th St.
51074+00.00	51087+00.00	Both	2600.0	Field Of Dreams Way
1001+62.00	-	-	510.0	Cul-De-Sac
1096+10.00	-	-	330.0	7th St. SW

112-8  
04-15-14

### MEDIAN CROSSOVERS

Refer to PV-500 Series.

\* Not a bid item

Road Ident.	Location Station	Standard Road Plan	Detour Pavement	Special Backfill	Granular Shoulder	Embankment in Place	Class 10 Excavation	Class 13 Excavation	Removal of Pavement	Saw Cut*	18" Unclassified Roadway Pipe	36" CMP Slotted Drain/6" Grate	Beveled Pipe and Guard	Remarks
		No.	SY	CY	TON	CY	CY	CY	SY	LF	LF	LF	No.	
US 20	1025+00.00	PV-500	2695.0	669.3	275.0	1500.0	700.0				264.0	116.0	2	Class 10 Excavation includes 30% Shrink
US 20	1084+00.00	PV-500	2695.0	669.3	275.0	1500.0	700.0				264.0	116.0	2	Class 10 Excavation includes 30% Shrink

102-4  
10-18-11

### LOCATIONS OF ROAD CLOSURE BARRICADES

Refer to SI-181 and SI-182.

Location	W	SI-181	SI-182	Remarks
No. Station	LF	LF	No.	
1 1001+85.62	36.0	36		320th Avenue
2 1002+75.79	38.0	38		320th Avenue
3 1053+33.51	28.0	28		330th Avenue
4 1097+10.50	40.0		1	7th Street SW

108-30  
04-16-13

### CRASH CUSHIONS

\* Bid Item

① Lane(s) to which the installation is adjacent.

② Complete this section when using the Temporary Crash Cushion bid item and Earthwork is needed for Sand Barrel placement. Refer to BA-500

No.	Direction of Traffic	Location Station	Side	Obstacle Width FT	Crash Cushion (Select One)*					Sand Barrel Details ②					Earthwork*		Spare Parts Kit (Select One)*		Obstacle Description	Remarks
					Temporary	Temporary Redirective	Temporary Severe Use	Permanent	Permanent Severe Use	V	W	X	Y	Z	Excavation Class 10	Embankment in Place	Permanent	Permanent Severe Use		
										Length	Length	Length	Length	Length						
1	EB	1040+00.00	M	2.00															End of TBR	Stage 1
2	WB	1077+25.00	M	2.00															End of TBR	Stage 1
3	EB	1083+87.50	M	2.00															Temporary Barrier Rail (TC-61)	Stage 1
4	WB	1025+12.50	M	2.00															Temporary Barrier Rail (TC-61)	Stage 2
5	EB	1040+00.00	M	2.00															End of TBR	Stage 2
6	WB	1077+25.00	M	2.00															End of TBR	Stage 2
7	EB	1059+65.00	M	2.00															End of TBR	Stage 3
8	WB	1068+15.00	M	2.00															End of TBR	Stage 3

108-13A  
08-01-08

### SAFETY CLOSURES

Refer to Section 2518 of the Standard Specifications

Station	Closure Type		Remarks
	Road Qty.	Hazard Qty.	
1025+00.00	1		Stage 1 (Crossover)
1084+00.00	1		Stage 1 (Crossover)
2032+15.00	1		Stage 1 (330th Ave)
2045+90.00	1		Stage 1 & 2 (330th Ave)
2050+95.00	1		Stage 1 (330th Ave)
3000+70.00	1		Stage 1 (332nd Ave)
3014+30.00	1		Stage 1 (332nd Ave)
1025+00.00	1		Stage 2 (Crossover)
1050+50.00	1		Stage 2 & 3 (Ramp B)
1075+40.00	1		Stage 2 & 3 (Ramp D)
1084+00.00	1		Stage 2 (Crossover)
11054+44.00	1		Stage 2 & 3 (330th Ave)
11082+60.00	1		Stage 2 (332nd Ave)
61082+60.00	1		Stage 2 (12th Ave SW)
1052+00.00	1		Stage 3 (Ramp C)
1077+25.00	1		Stage 3 (Ramp A)
11073+10.50	1		Stage 3 (332nd Ave)
11060+95.00		1	Stage 3 (330th Ave)
11066+85.00		1	Stage 3 (332nd Ave)

108-33  
04-16-13

### TEMPORARY BARRIER RAIL

Refer to BA-400 and BA-401

\* Not a bid item. Anchorage requirements are based on TBR locations shown in the plans. TBR alignments that vary from what is shown in the plans may result in additional TBR sections requiring anchorage.

No.	Station to Station		Length LF	(Select One)		Anchored* (Y/N)	Remarks
				Steel BA-400	Concrete BA-401		
				1	1083+87.50		
2	1040+00.00	1077+25.00	3725.0	X	Yes	Stage 1 Shoulder	
3	1023+62.50	1025+12.50	150.0	X	No	Stage 2 Crossover	
4	1040+00.00	1077+25.00	3725.0	X	Yes	Stage 2 Shoulder	
5	1062+40.00	1064+70.00	230.0	X	Yes	Stage 3 Shoulder	
6	1063+08.00	1065+38.00	230.0	X	Yes	Stage 3 Shoulder	

108-27  
10-16-12

### TEMPORARY FLOODLIGHTING LUMINAIRES

No.	Location Station	Offset	Number Lumin.	Remarks
1	1024+15.00	30' RT	1	Stage 1
2	1025+85.00	30' LT	1	Stage 1
3	1082+25.00	30' LT	1	Stage 1
4	1084+85.00	30' RT	1	Stage 1
5	1024+15.00	30' LT	1	Stage 2
6	1026+75.00	30' RT	1	Stage 2
7	1083+15.00	30' RT	1	Stage 2
8	1084+85.00	30' LT	1	Stage 2

108-35  
04-17-12

### TEMPORARY LANE SEPARATOR SYSTEM

See TC-61

Station to Station		Length LF	Remarks
1024+05.00	1031+20.00	715	Stage 1 Crossover
1077+80.00	1084+95.00	715	Stage 1 Crossover
1024+05.00	1031+20.00	715	Stage 2 Crossover
1077+80.00	1084+95.00	715	Stage 2 Crossover

**PAVEMENT MARKING LINE TYPES**

See PM-110

\*\*\*MNY4 - Factor of 1.00 as value includes number of 4-inch passes to cover median nose area.

\*BCY4 - Place on the same side of the roadway to match existing markings near the project.  
\*\*NPY4 - For estimating purposes only. No Passing Zone Lines will be located in the field.

BCY4: Broken Centerline (Yellow) @ 0.25      DCY4: Double Centerline (Yellow) @ 2.00      NPY4: No Passing Zone Line (Yellow) @ 1.25      BLW4: Broken Lane Line (White) @ 0.25      ELW4: Edge Line Right (White) @ 1.00  
 ELY4: Edge Line Left (Yellow) @ 1.00      STW6: Standard Curb 6" (White) @ 3.03      CHW8: Channelizing Line (White) @ 2.00      CHY8: Channelizing Line (Yellow) @ 2.00      DCY4: Double Centerline (Yellow) @ 2.00  
 SLW4: Solid Lane Line (White) @ 1.00      DLW4: Dotted Line (White) @ 0.33      RLW4: Ramp Edge Line Right (White) @ 1.00      RLY4: Ramp Edge Line Left (Yellow) @ 1.00      SLW2: Stop Line (White) @ 6.00

Road ID	Station to Station		Dir. of Travel	Marking Type	Side			Length by Line Type (Unfactored)												Remarks			
					L	C	R	BCY4*	DCY4	NPY4**	BLW4	ELW4	ELY4	STW6	CHW8	CHY8	DCY4	SLW4	DLW4		RLW4	RLY4	SLW2
					STA	STA	STA	STA	STA	STA	STA	STA	STA	STA	STA	STA	STA	STA	STA		STA	STA	STA
<b>STAGE 1A</b>																							
IND. PRKWY	21046+49.00	21049+15.00		Waterborne/Solvent Paint	L										2.66								
"	21046+49.00	21053+62.00		Waterborne/Solvent Paint			R								7.13								
"				Waterborne/Solvent Paint																	0.76		
221ST ST.	31053+93.00	31094+92.00		Waterborne/Solvent Paint	L										40.99								
"	31053+93.00	31094+92.00		Waterborne/Solvent Paint			R								40.99								
"	31054+00.00	31060+00.00		Waterborne/Solvent Paint			C																
"	31060+00.00	31094+92.00		Waterborne/Solvent Paint			C		34.92		6.00											0.27	
				Waterborne/Solvent Paint																			
<b>330TH AVENU</b>																							
"	11037+00.00	11053+82.00		Waterborne/Solvent Paint	L										16.82								
"	11037+00.00	11053+82.00		Waterborne/Solvent Paint			R								16.82								
"	11037+00.00	11047+60.00		Waterborne/Solvent Paint			C		10.60														
"	11047+60.00	11053+60.00		Waterborne/Solvent Paint			C				6.00												
<b>STAGE 1C</b>																							
<b>REMOVE PAINT</b>																							
US-20	995+01.00	1025+00.00	EB	Removal of Paint			C					29.99											
"	1020+31.00	1025+00.00	EB	Removal of Paint			L							4.69									
"	1079+31.00	1084+00.00	EB	Removal of Paint			L							4.69									
"	1025+00.00	1029+69.00	WB	Removal of Paint			L							4.69									
"	1079+31.00	1113+99.00	WB	Removal of Paint			C					34.68											
<b>PAINT</b>																							
US-20	1002+51.00	1010+31.00	EB	Wet Retroreflective Removable Tape			R							7.80									
"	1010+31.00	1020+31.00	EB	Waterborne/Solvent Paint			R							10.00									
"	1029+69.00	1079+31.00	WB	Waterborne/Solvent Paint			C										49.62						
"	1020+31.00	1029+69.00	EB	Wet Retroreflective Removable Tape			R						9.38										
"	1020+31.00	1029+69.00	EB	Wet Retroreflective Removable Tape	L													9.38					
"	1079+31.00	1088+69.00	WB	Wet Retroreflective Removable Tape			R												9.38				
"	1079+31.00	1088+69.00	WB	Wet Retroreflective Removable Tape	L															9.38			
"	1088+69.00	1098+69.00	WB	Waterborne/Solvent Paint	L									10.00									
"	1098+69.00	1106+49.00	WB	Wet Retroreflective Removable Tape	L									7.80									
RAMP B	3050+50.00	3062+36.00	EB	Waterborne/Solvent Paint	L																11.86		
"	3060+38.00	3062+36.00	EB	Waterborne/Solvent Paint			C										1.98						
"	3044+50.00	3062+36.00	EB	Waterborne/Solvent Paint			R														17.86		
"				Waterborne/Solvent Paint																		0.86	
RAMP D	5061+94.00	5075+42.00	EB	Waterborne/Solvent Paint	L																	13.48	
"	5061+94.00	5087+70.00	EB	Waterborne/Solvent Paint			R														25.76		
<b>330TH BETW.</b>																							
"	11054+93.00	11059+91.00	SB	Waterborne/Solvent Paint			R								4.98								
"	11054+93.00	11059+91.00	NB	Waterborne/Solvent Paint			R								4.98								
"	11054+93.00	11059+91.00	SB	Waterborne/Solvent Paint	L																4.98		
"	11054+93.00	11059+91.00	NB	Waterborne/Solvent Paint	L																4.98		
"	11054+00.00	11055+00.00		Waterborne/Solvent Paint			C										1.00						
"	11057+75.00	11059+50.00	NB	Waterborne/Solvent Paint			R														1.75		
<b>STAGE 2</b>																							
<b>REMOVE PAINT</b>																							
US 20	1002+51.00	1010+31.00	EB	Removal of Removable Tape			R								7.80								
"	1010+31.00	1020+31.00	EB	Removal of Paint			R								10.00								
"	1029+69.00	1079+31.00	WB	Removal of Paint			C											49.62					
"	1020+31.00	1029+69.00	EB	Removal of Removable Tape			R											9.38					
"	1020+31.00	1029+69.00	EB	Removal of Removable Tape	L																9.38		
"	1079+31.00	1088+69.00	WB	Removal of Removable Tape			R														9.38		
"	1079+31.00	1088+69.00	WB	Removal of Removable Tape	L																9.38		
"	1088+69.00	1098+69.00	WB	Removal of Paint	L										10.00								
"	1098+69.00	1106+49.00	WB	Removal of Removable Tape	L										7.80								
<b>PAINT</b>																							
US-20	1002+51.00	1010+31.00	EB	Wet Retroreflective Removable Tape	L										7.80								
"	1010+31.00	1029+69.00	EB	Waterborne/Solvent Paint	L										19.38								
"	1020+31.00	1029+69.00	WB	Wet Retroreflective Removable Tape	L																9.38		
"	1020+31.00	1029+69.00	WB	Wet Retroreflective Removable Tape			R														9.38		
"	1029+69.00	1079+31.00	BOTH	Waterborne/Solvent Paint			C														49.62		
"	1079+31.00	1088+69.00	EB	Wet Retroreflective Removable Tape			R														9.38		
"	1079+31.00	1088+69.00	EB	Wet Retroreflective Removable Tape	L																9.38		
"	1088+69.00	1106+49.00	EB	Waterborne/Solvent Paint			C								17.80								
"	1098+69.00	1106+49.00	WB	Wet Retroreflective Removable Tape			R								7.80								
"	1088+69.00	1098+69.00	WB	Waterborne/Solvent Paint			R								10.00								





PAVEMENT MARKING SYMBOLS AND LEGENDS

Refer to PM-111

Road Identification	Location		↑	↶	↷	↘	↙	↕	↔	↗	↖	⊗	🚲	♿	♿	SCHOOL	XING	STOP	AHEAD	ONLY	BIKE	LANE	EXIT	Groove Cuts	Remarks		
	Station	Side																								STAW	RTAW
Stage 1C - Paint																											
EB US-20	0980+01.00	LT																									
EB US-20	0981+01.00	LT									1																
EB US-20	0990+01.00	LT									1																
EB US-20	0991+01.00	LT									1																
EB US-20	1117+99.00	RT																									
EB US-20	1118+99.00	RT																									
EB US-20	1127+99.00	RT																									
EB US-20	1128+99.00	RT																									
Stage 1C - Remove																											
EB US-20	0980+01.00	LT																									
EB US-20	0981+01.00	LT																									
EB US-20	0990+01.00	LT																									
EB US-20	0991+01.00	LT																									
EB US-20	1117+99.00	RT																									
EB US-20	1118+99.00	RT																									
EB US-20	1127+99.00	RT																									
EB US-20	1128+99.00	RT																									
Stage 2 - Paint																											
WB US-20	0980+01.00	RT																									
WB US-20	0981+01.00	RT																									
WB US-20	0990+01.00	RT																									
WB US-20	0991+01.00	RT																									
WB US-20	1117+99.00	LT																									
WB US-20	1118+99.00	LT																									
WB US-20	1127+99.00	LT																									
WB US-20	1128+99.00	LT																									
Stage 2 - Remove																											
WB US-20	0980+01.00	RT																									
WB US-20	0981+01.00	RT																									
WB US-20	0990+01.00	RT																									
WB US-20	0991+01.00	RT																									
WB US-20	1117+99.00	LT																									
WB US-20	1118+99.00	LT																									
WB US-20	1127+99.00	LT																									
WB US-20	1128+99.00	LT																									
Stage 3 - Paint																											
NB 330th Ave	11058+00.00	RT																									
NB 330th Ave	11059+00.00	RT																									
NB 332nd Ave	11072+00.00	RT																									
NB 332nd Ave	11073+00.00	RT																									
SB 330th Ave	11060+50.00	C																									
SB 330th Ave	11061+50.00	C																									
NB 332nd Ave	11066+00.00	C																									
NB 332nd Ave	11067+00.00	C																									
SB 332nd Ave	11069+00.00	RT																									
SB 332nd Ave	11070+00.00	RT																									
RAMP A	2066+00.00	RT																									
RAMP A	2067+00.00	RT																									
RAMP B	3060+50.00	RT																									
RAMP B	3061+50.00	RT																									

**LONGITUDINAL SUBDRAIN SHOULDER AND BACKSLOPE**

Refer to Soils Sheets

① Refer to EW-203, EW-204, or EW-211.  
\*Not a bid item

Line No.	Road or Lane Ident.	Location		Side	Longitudinal Subdrain (DR-303)							Subdrain Outlet		Porous* Backfill	Class "A" Crushed Stone	Remarks	
		Station to Station	Station to Station		Shoulder		Backslope		Bridge Berm ①			DR-303, DR-304, or DR-305	Station				Standard Road Plan and Type
					Size	Length	Size	Length	Size	Type	Length						
1	US 20 WBL	1040+00.00	1045+00.00	LT	36.0	4.0	540.0					1040+00.00	DR-304	41.7	0.2		
3	US 20 WBL	1045+00.00	1050+00.00	LT	36.0	4.0	540.0					1045+00.00	DR-304	41.7	0.2		
4	US 20 WBL	1050+00.00	1054+00.00	LT	36.0	4.0	440.0					1050+00.00	DR-304	34.0	0.2		
5	US 20 WBL	1054+00.00	1058+00.00	LT	36.0	4.0	440.0					1054+00.00	DR-304	34.0	0.2		
6	US 20 WBL	1058+00.00	1062+00.00	LT	24.0	4.0	440.0					1058+00.00	DR-304	20.4	0.2		
7	US 20 WBL	1062+00.00	1065+50.00	LT	24.0	4.0	390.0					1062+00.00	DR-304	18.1	0.2		
8	US 20 WBL	1065+50.00	1069+50.00	LT	36.0	4.0	440.0					1065+50.00	DR-304	34.0	0.2		
9	US 20 WBL	1069+50.00	1074+00.00	LT	36.0	4.0	490.0					1069+50.00	DR-304	37.8	0.2		
10	US 20 WBL	1074+00.00	1079+00.00	LT	36.0	4.0	540.0					1074+00.00	DR-304	41.7	0.2		
11	US 20 WBL	1079+00.00	1082+50.00	LT	36.0	4.0	390.0					1079+00.00	DR-304	30.1	0.2		
12	US 20 EBL	1040+00.00	1043+50.00	RT	42.0	4.0	390.0					1040+00.00	DR-304	36.1	0.2		
13	US 20 EBL	1043+50.00	1048+00.00	RT	42.0	4.0	490.0					1043+50.00	DR-304	45.4	0.2		
14	US 20 EBL	1048+00.00	1052+00.00	RT	36.0	4.0	440.0					1048+00.00	DR-304	34.0	0.2		
15	US 20 EBL	1052+00.00	1055+50.00	RT	36.0	4.0	390.0					1052+00.00	DR-304	30.1	0.2		
16	US 20 EBL	1055+50.00	1057+00.00	RT	36.0	4.0	190.0					1055+50.00	DR-304	14.7	0.2		
17	US 20 EBL	1057+00.00	1062+00.00	RT	24.0	4.0	540.0					1057+00.00	DR-304	25.0	0.2		
18	US 20 EBL	1062+00.00	1065+50.00	RT	24.0	4.0	390.0					1062+00.00	DR-304	18.1	0.2		
19	US 20 EBL	1065+50.00	1070+50.00	RT	36.0	4.0	540.0					1065+50.00	DR-304	41.7	0.2		
20	US 20 EBL	1070+50.00	1075+25.00	RT	36.0	4.0	515.0					1070+50.00	DR-304	39.7	0.2		
21	US 20 EBL	1077+70.00	1082+00.00	RT	42.0	4.0	470.0					1077+70.00	DR-304	43.5	0.2		
22	US 20 EBL	1082+00.00	1085+00.00	RT	42.0	4.0	340.0					1082+00.00	DR-304	31.5	0.2		
23	US 20 EBL	1085+00.00	1087+65.00	RT	42.0	4.0	305.0					1085+00.00	DR-304	28.2	0.2		
24	US 20 EBL	1087+75.00	1087+75.00	RT	48.0	4.0	20.0					1087+75.00	DR-304	2.2	0.2	OUTLET EXT. SEE NOTE 1	
25	330TH/332ND	11060+80.00	11062+25.00	RT	36.0	4.0	185.0					11060+80.00	DR-304	14.3	0.2		
26	330TH/332ND	11065+40.00	11067+50.00	RT	36.0	4.0	250.0					11065+40.00	DR-304	19.3	0.2		
27	330TH/332ND	11060+30.00	11062+25.00	LT	36.0	4.0	235.0					11060+30.00	DR-304	18.1	0.2		
28	330TH/332ND	11065+40.00	11067+20.00	LT	36.0	4.0	220.0					11065+40.00	DR-304	17.0	0.2		
29	RAMP A	2065+45.00	2069+25.00	LT	36.0	4.0	420.0					2065+45.00	DR-304	32.4	0.2		
30	RAMP A	2069+25.00	2074+00.00	LT	36.0	4.0	515.0					2069+25.00	DR-304	39.7	0.2		
31	RAMP A	2074+00.00	2077+25.00	LT	30.0	4.0	365.0					2074+00.00	DR-304	22.5	0.2		
32	RAMP B	3050+50.00	3055+00.00	RT	36.0	4.0	490.0					3050+50.00	DR-304	37.8	0.2		
33	RAMP B	3055+00.00	3058+58.00	RT	36.0	4.0	398.0					3055+00.00	DR-304	30.7	0.2		
34	RAMP B	3058+58.00	3062+25.00	RT	36.0	4.0	407.0					3058+58.00	DR-304	31.4	0.2		
35	RAMP C	4050+00.00	4055+00.00	LT	36.0	4.0	540.0					4050+00.00	DR-304	41.7	0.2		
36	RAMP C	4055+00.00	4060+00.00	LT	36.0	4.0	540.0					4055+00.00	DR-304	41.7	0.2		
37	RAMP C	4060+00.00	4064+50.00	RT	36.0	4.0	490.0					4060+00.00	DR-304	37.8	0.2		
38	RAMP C	4064+25.00	4065+85.00	LT	36.0	4.0	200.0					4064+25.00	DR-304	15.4	0.2		
39	RAMP D	5062+00.00	5064+00.00	RT	36.0	4.0	240.0					5062+00.00	DR-304	18.5	0.2		
40	RAMP D	5063+00.00	5066+00.00	LT	36.0	4.0	340.0					5063+00.00	DR-304	26.2	0.2		

**SHRINKAGE DATA**

Material	%	Remarks
TOPSOIL	40%	SHRINKAGE
CLASS 10	30%	SHRINKAGE
BROKEN/WEATHERED ROCK	0%	SWELL
ROCK	10%	SWELL
BOULDERS		200 CY (Est.) NOTE: BOULDER ESTIMATE IS FOR CLASS 12 BOULDER EXCAVATION IN THE OVERBURDEN SOIL ONLY AND IS A SEPARATE QUANTITY FROM CLASS 12 ROCK EXCAVATION.

**EMBANKMENT WITH MOISTURE CONTROL**

Moisture content shall be within the limits of minus 2 and plus 2 percentage points of Optimum Moisture Content for maximum density within the area described and listed below.

Moisture Control is required for all Class 10 fill placed in all locations and depths. Stability berms placed outside the normal foreslope template and topsoil will not require Moisture Control.

**PLOWING AND SHAPING**

Refer to Standard Road Plan EW-101

Station to Station	D	Remarks
	FT	
1048+00.00	1052+25.00	2.0 US 20 WBL
1077+25.00	1081+00.00	2.0 US 20 WBL
1048+00.00	1050+50.00	2.0 US 20 EBL
41054+00.00	41055+00.00	4.0 218TH
11037+07.02	11039+25.00	2.0 330TH/332ND
11079+25.00	11080+00.00	4.0 330TH/332ND
11080+00.00	11080+25.00	Varies (4.0ft to 2.0ft) 330TH/332ND
11080+25.00	11082+51.85	2.0 330TH/332ND

**SPECIAL ATTENTION (SLIVER FILL)**

Special attention should be given to Section 2107.03.C of the Standard Specifications on this project.

**GEOTECHNICAL DESIGN**

I hereby certify that this engineering document was prepared by me or under my direct personal supervision and that I am a duly licensed Professional Engineer under the laws of the State of Iowa.

 Signature: *R S V* Date: 3/2/2015

ROCH S. V. PLAYER  
Printed or Typed Name  
My license renewal date is December 31, 20 16

Pages or sheets covered by this seal: CS.1-CS.2, Q.1-Q.24

**LONGITUDINAL SUBDRAIN SHOULDER AND BACKSLOPE**

Refer to Soils Sheets

① Refer to EW-203, EW-204, or EW-211.  
\*Not a bid item

Line No.	Road or Lane Ident.	Location			Longitudinal Subdrain (DR-303)							Subdrain Outlet		Porous* Backfill	Class "A"* Crushed Stone	Remarks	
		Station to Station	Side	Depth D	Shoulder		Backslope		Bridge Berm ①			DR-303, DR-304, or DR-305	Station				Standard Road Plan and Type
					Size	Length	Size	Length	Size	Type	Length						
					IN	FT	IN	FT	IN		FT						
41	RAMP D	5066+00.00	5070+00.00	LT	24.0	4.0	440.0						5066+00.00	DR-304	20.4	0.2	
													5070+00.00	DR-304			
42	RAMP D	5070+00.00	5074+00.00	RT	24.0	4.0	440.0						5070+00.00	DR-304	20.4	0.2	
													5074+00.00	DR-304			
43	RAMP D	5074+00.00	5077+50.00	RT	36.0	4.0	390.0						5074+00.00	DR-304	30.1	0.2	
													5077+50.00	DR-304			
<b>Totals</b>						16775.0						83	1239.1	8.4			

NOTE: ALL LONGITUDINAL SUBDRAINS ARE TYPE 7A OR 7B (DEPENDING ON TYPE OF SHOULDER) WITH PCC UNLESS OTHERWISE NOTED IN REMARKS COLUMN.

NOTE: RECORDS INDICATE THAT LONGITUDINAL SUBDRAINS EXIST WITHIN THE PROJECT AREA. INSTALL EXTENSIONS ON OUTLETS TABULATED ABOVE AND MAKE OTHER ADJUSTMENTS AS NECESSARY, AS COORDINATED AND APPROVED BY THE ENGINEER.

NOTE: IF ADDITIONAL LONGITUDINAL SUBDRAINS AND/OR OUTLETS OTHER THAN THOSE TABBED ABOVE ARE ENCOUNTERED, THOSE EXISTING LONGITUDINAL SUBDRAINS AND OUTLETS SHALL REMAIN FUNCTIONAL (ESTABLISH A CLEAN CONTACT BETWEEN EXISTING TRENCH AND SPECIAL BACKFILL TREATMENT/SUBBASE) AND EXTENSIONS INSTALLED IF NECESSARY.

### SURVEY SYMBOLS

- SIGN SI Sign
- PIP Location of General Photo
- PIP Pipe Culvert
- TP TPD Telephone Pedestal
- ⊗ INB Storm Sewer Beehive Intake
- ⊕ MH Utility Access (Manhole)
- BB BB Billboard
- BLD Building or Foundation
- ⊙ MM Mile Marker Post
- x FW Wire Fence
- OUT Tile Outlet
- ⊕ IN Storm Sewer Intake
- LIN Miscellaneous Line
- LUM Luminaire
- ⊙ Flg FLG Flag Poles
- ⊙ WV WW Water Valve
- ⊙ X LC Approx. Lot Corner
- EB EB Electrical Box
- TVP TV Pedestal
- MIS Miscellaneous
- ⊕ PR Electric Riser Pole
- ⊕ FHD Fire Hydrants
- SIGN SL Speed Limit Sign
- # FCL Chain Link and Security Fence
- TDC Tree Deciduous
- SHR Shrub
- \* TEV Evergreen Tree
- TLNR Tree Line Right
- WH WHD Water Hydrant
- FWD Wood Fence
- ROC Rock Outcropping
- TLNL Tree Line Left
- CUL Culvert
- Til Tile Line
- LP L.P. Tank
- WEL Well
- EG Edge of Gravel Road
- EP Edge of Paved Roads (ML or SR)
- CU Back of Curb
- GU Gutter In Front of Curb
- CON Concrete or A/C Slab
- ENP Edge Paved Entrance & Park Lot
- ENT Centerline BL of Entrance
- SH Paved Shoulder
- ENU Edge Unpaved Entrance & Parking
- SNP Unpaved Shoulder
- D Centerline Draw or Stream (Down)
- DU Centerline Draw or Stream (Up)
- RIP Rip-Rap
- CP Control Point
- PRO Profile Shot
- SOP Size of Pipe or Culvert
- UE Utility Elevation
- BL Topo Breakline

### UTILITY LEGEND

- ALLIANT ENERGY  
Jason Hogan  
4902 North Biltmore  
Madison, WI 53707-1007  
608-458-4871  
jasonhogan@alliantenergy.com
- Maquoketa Valley Electric Cooperative  
Jeremy Richert  
P.O. Box 370  
Anamosa, IA 52205  
319-462-3541 : Ext 209  
jrichert@mvec.com
- Windstream Communications(Formerly Iowa Telecom)  
Dan Hogan  
107 East Fayette  
Manchester, IA 52057  
563-927-2623  
daniel.hogan@windstream.com
- City of Dyersville  
David Vorwald  
340 1st Avenue East  
Dyersville, IA 52040  
563-875-7724  
dvorwald@cityofdyersville.com
- Black Hills Energy  
Brad Fleming  
1815 Capital Avenue  
Omaha, NE 68102  
402-221-2714  
brad.fleming@blackhillscorp.com
- ICN  
Larry Klawitter  
400 East 1st Street / Grimes Office Building  
Des Moines, IA 50319  
515-725-4741  
larry.klawitter@iowa.gov
- Mediacom  
Bob Frazer  
207 West Pearl Street  
Decorah, IA 52101  
563-387-6119  
bfrazer@mediacomcc.com

### PLAN VIEW COLOR LEGEND OF PLAN AND PROFILE SHEETS

LINEWORK	Design Color No.	Description
Green	(2)	Existing Topographic Features and Labels
Blue	(1)	Proposed Alignment, Stationing, Tic Marks, and Alignment Annotation
Magenta	(5)	Existing Utilities

SHADING	Design Color No.	Description
Yellow	(4)	Highlight for Critical Notes or Features
Red	(3)	Delineates Restricted Areas
Lavender	(9)	Temporary Pavement Shading
Gray, Light	(48)	Proposed Pavement Shading
Gray, Med	(80)	Proposed Granular Shading
Gray, Dark	(112)	Proposed Grade and Pave Shading "In conjunction with a paving project"
Brown, Light	(236)	Grading Shading
Tan	(8)	Proposed Sidewalk Shading
Blue, Light	(230)	Proposed Sidewalk Landing Shading
Pink	(11)	Proposed Sidewalk Ramp Shading

### PROFILE VIEW COLOR LEGEND OF PLAN AND PROFILE SHEETS

LINEWORK	Design Color No.	Description
Green	(2)	Existing Ground Line Profile
Blue	(1)	Proposed Profile and Annotation
Magenta	(5)	Existing Utilities
Blue, Light	(230)	Proposed Ditch Grades, Left
Black	(0)	Proposed Ditch Grades, Median
Rust	(14)	Proposed Ditch Grades, Right

Reference Point

Station

Survey Line

Section Corner

Ground Line Intercept

Saw Cut

Guardrail

Trench Drain

HighTension Cable Guardrail

Sheet Pile

Pavement Removal

Clearing & Grubbing Area

### RIGHT-OF-WAY LEGEND

- ▲ Proposed Right-of-Way
- △ Existing Right of Way
- ▲ Existing and Proposed Right-of-Way
- ▲ Easement and Existing Right-of-Way
- Easement (Temporary)
- ⊕ Easement
- C/A Access Control
- Property Line

## PLAN AND PROFILE LEGEND AND SYMBOL INFORMATION SHEET

(COVERS SHEET SERIES D, E, F, & K)

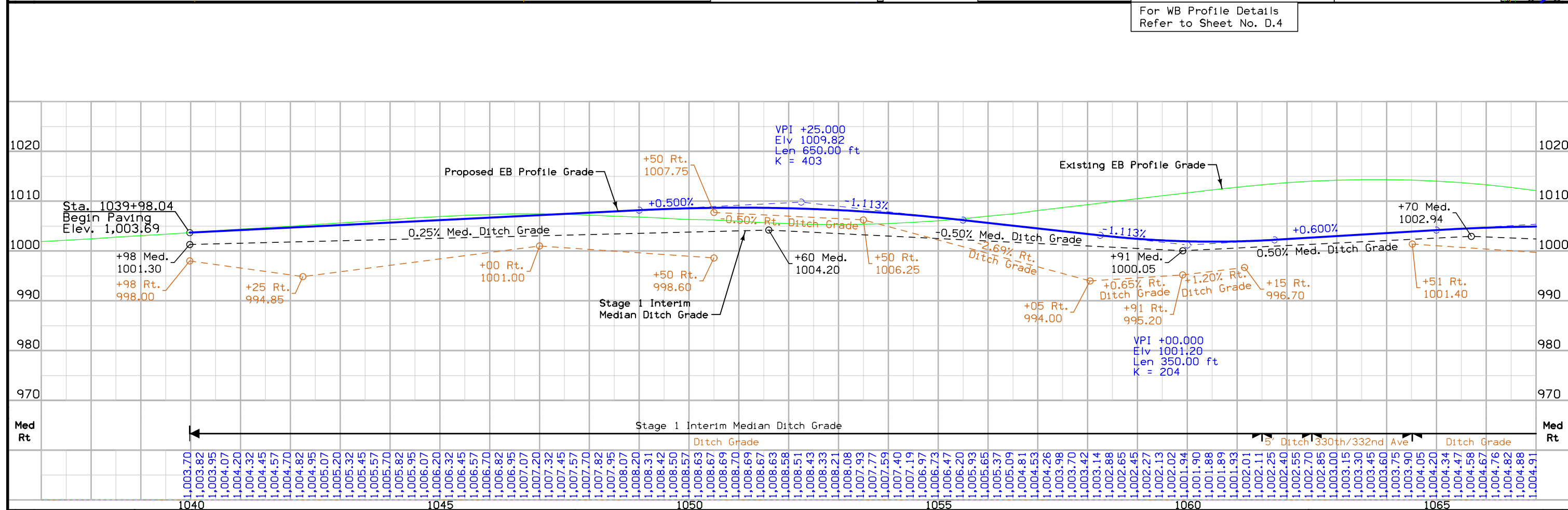
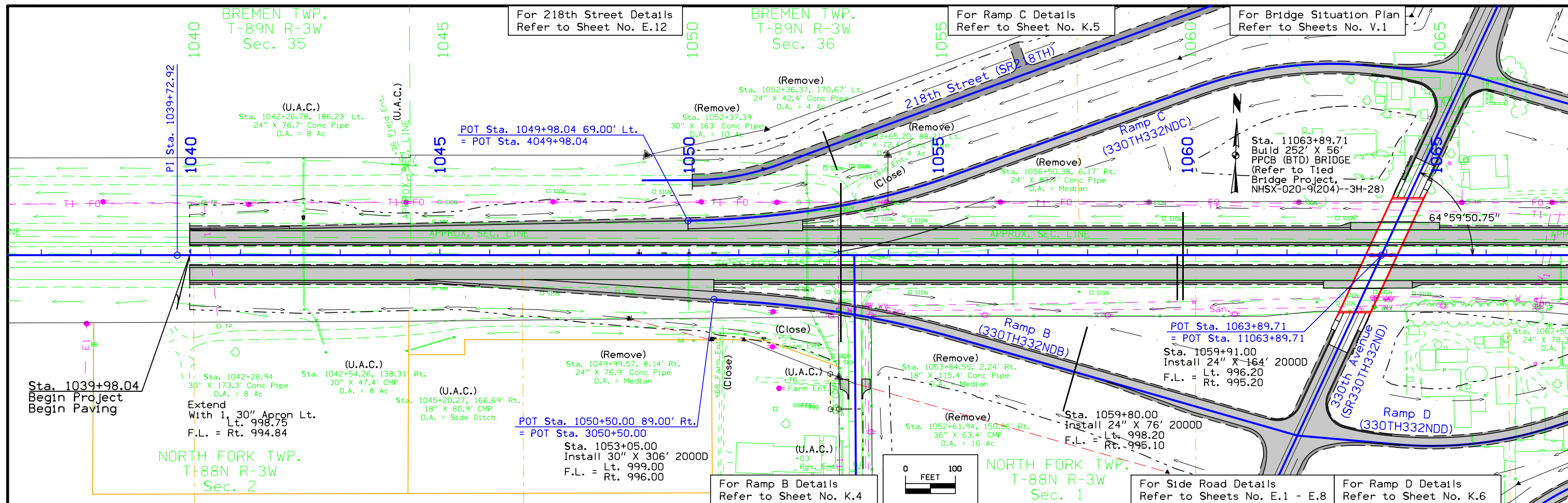



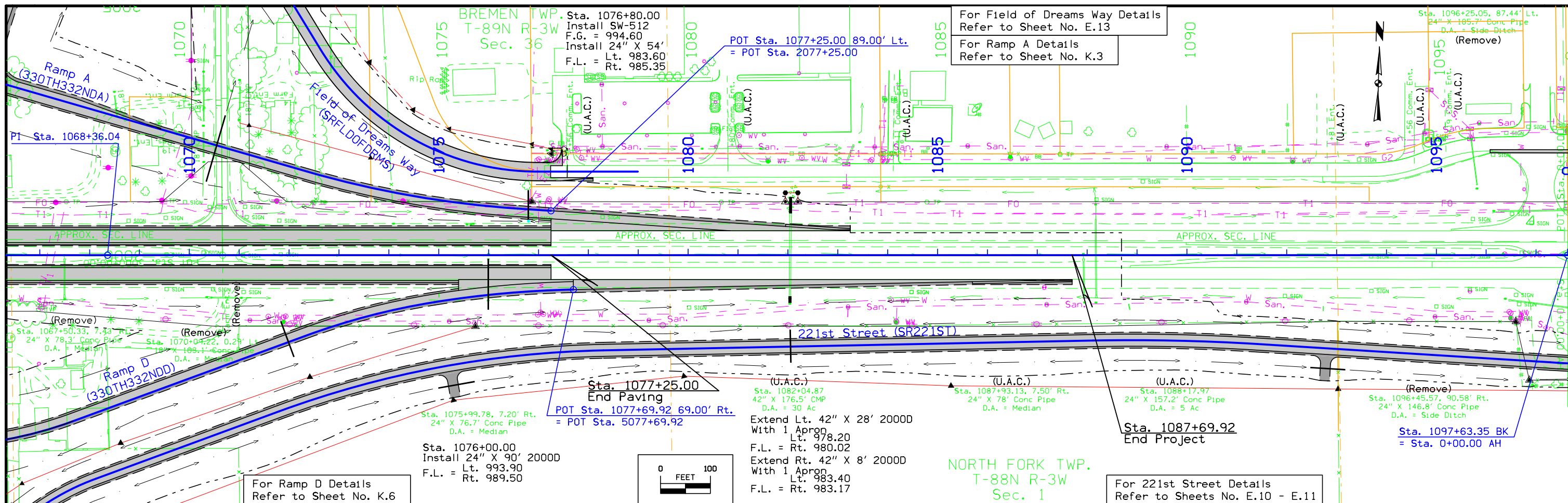

For Field of Dreams Way Details Refer to Sheet No. E.13  
 For Ramp A Details Refer to Sheet No. K.3

For Ramp D Details Refer to Sheet No. K.6

For 221st Street Details Refer to Sheets No. E.10 - E.11  
 For WB Profile Details Refer to Sheet No. D.4

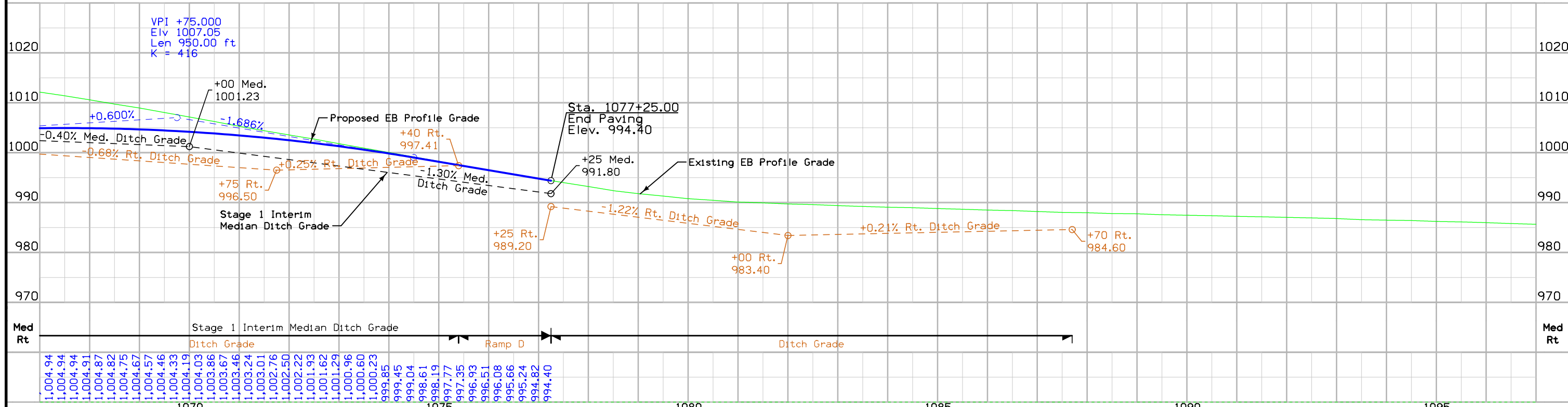

FILE NO.	ENGLISH	DESIGN TEAM	Stanley Consultants Inc.	DELAWARE/DUBUQUE COUNTY	PROJECT NUMBER	NHSX-020-9(203)--3H-28	SHEET NUMBER	D.3
----------	---------	-------------	--------------------------	-------------------------	----------------	------------------------	--------------	-----

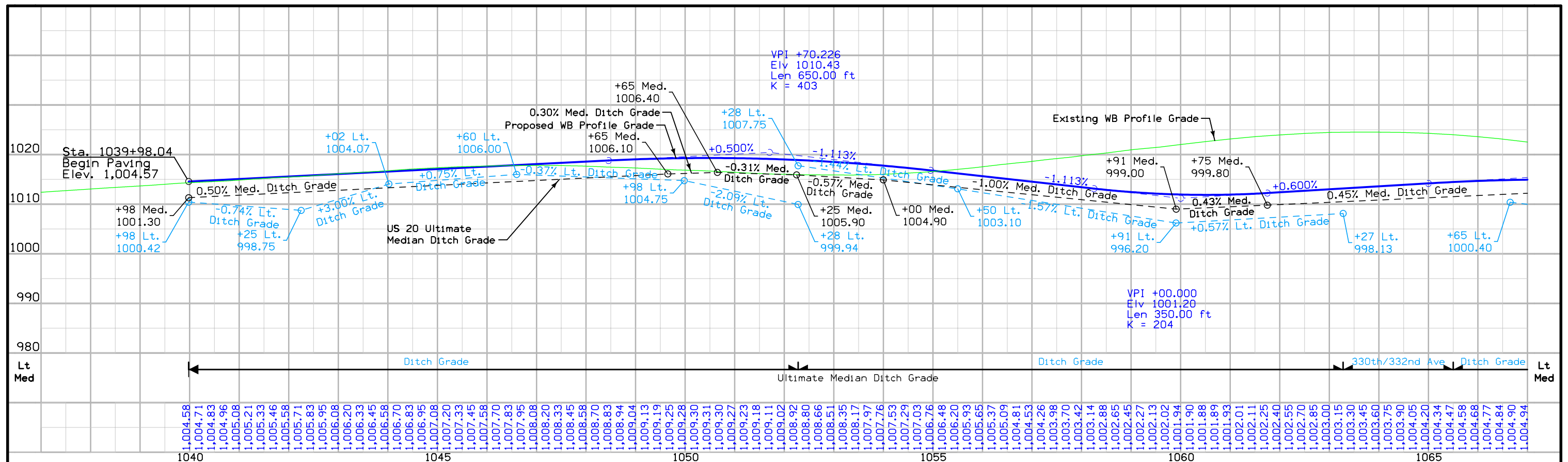

For Plan Details Refer to Sheets No. D.2 - D.3

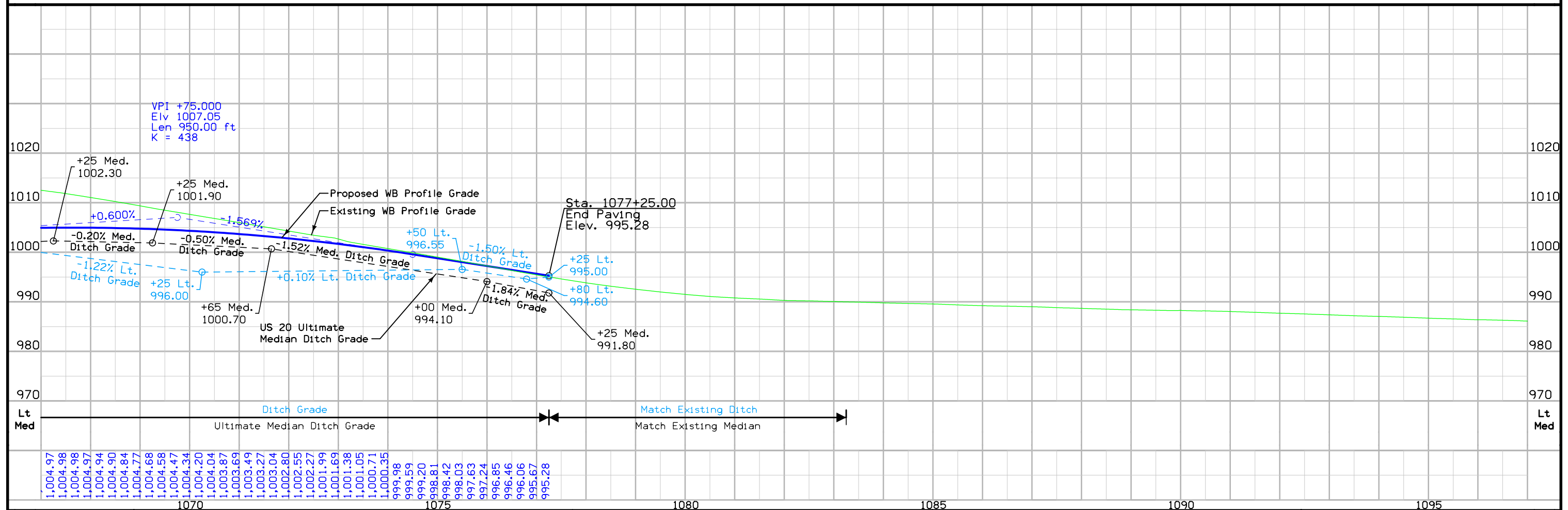



NORTH FORK TWP.  
T-88N R-3W  
Sec. 2

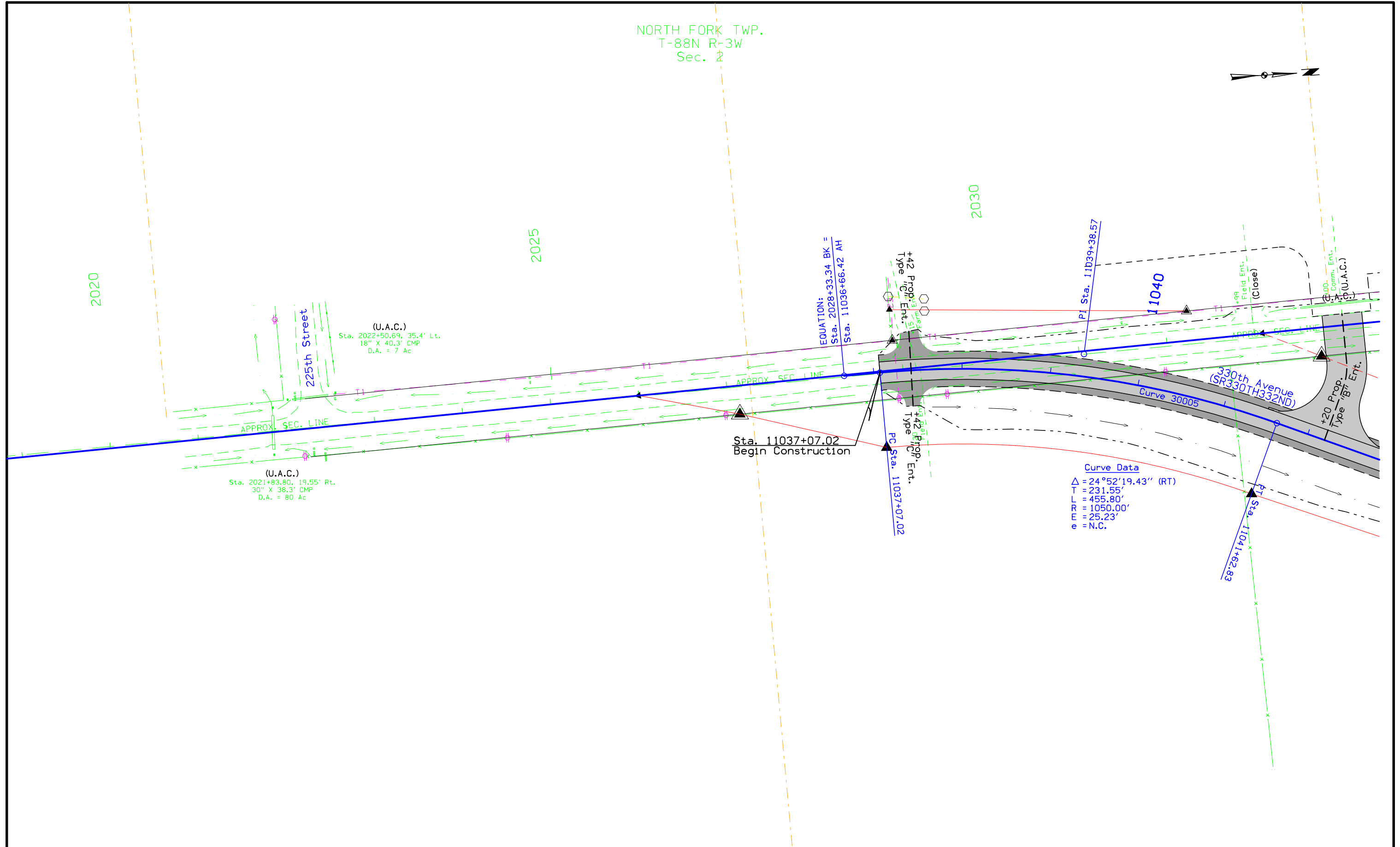

(U.A.C.)  
Sta. 2022+50.69, 35.4' Lt.  
18" X 40.3' CMP  
D.A. = 7 Ac

(U.A.C.)  
Sta. 2021+83.80, 19.55' Rt.  
30" X 38.3' CMP  
D.A. = 80 Ac

Sta. 11037+07.02  
Begin Construction

EQUATION:  
Sta. 2028+33.34 BK =  
Sta. 11036+66.42 AH

Curve Data  
 $\Delta = 24^\circ 52' 19.43''$  (RT)  
 $T = 231.55'$   
 $L = 455.80'$   
 $R = 1050.00'$   
 $E = 25.23'$   
 $e = N.C.$

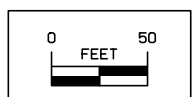

NORTH FORK TWP.  
T-88N R-3W  
Sec. 1

For Profile Details  
Refer to Sheet No. E.2

330th Avenue

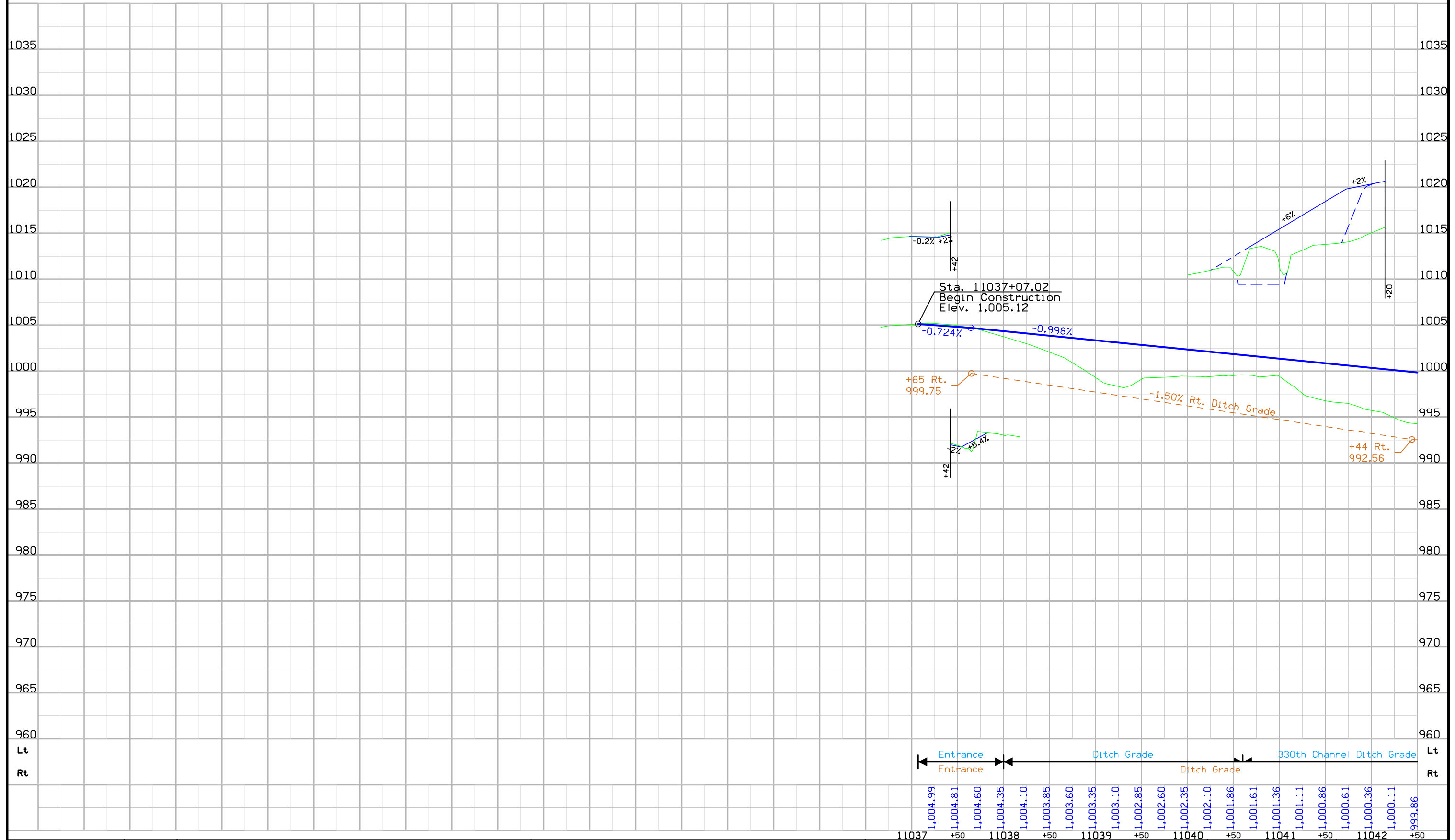

NORTH FORK TWP.  
T-88N R-3W  
Sec. 2

NORTH FORK TWP.  
T-88N R-3W  
Sec. 1

For Industrial Parkway Details  
Refer to Sheet No. E.9

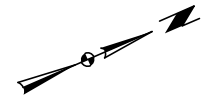

(Remove)  
Sta. 2042+29.04, 19.15' Rt.  
24" X 36.9' CMP  
D.A. = 90 Ac

POT Sta. 11053+81.86 (SR330TH332ND)  
= PI Sta. 21053+81.86 Lt. (SRINDPKWY)  
= PI Sta. 31053+81.86 Rt. (SR221ST)

Sta. 11052+95.00  
Install 42" X 106' 20000  
Skew = 5° Rt. Ahd.  
F.L. = Lt. 986.40  
Rt. 987.25

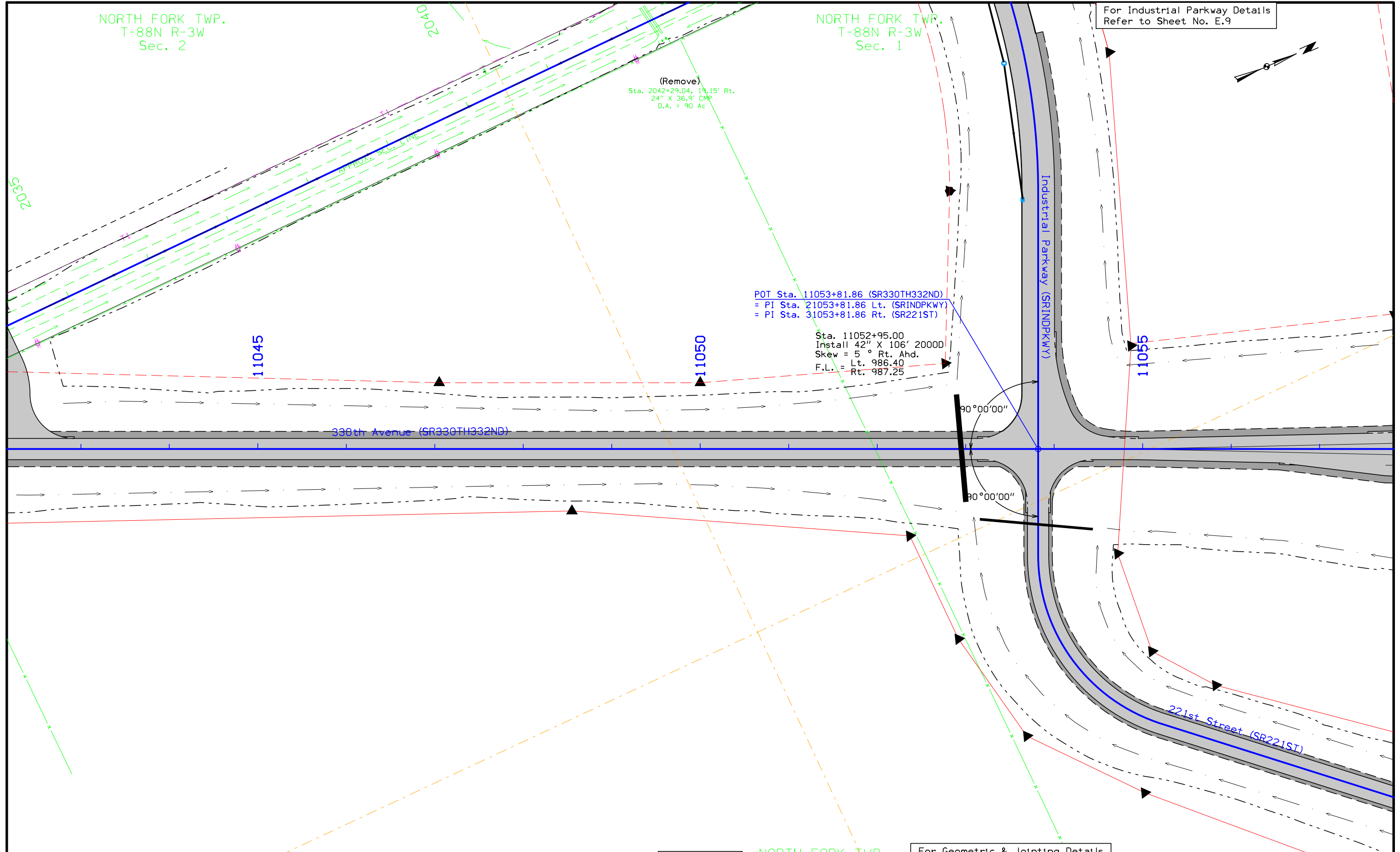

330th Avenue (SR330TH332ND)

Industrial Parkway (SRINDPKWY)

221st Street (SR221ST)

For Profile Details  
Refer to Sheet No. E.4

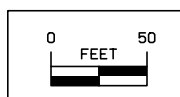

NORTH FORK TWP.  
T-88N R-3W  
Sec. 1

For Geometric & Jointing Details  
Refer to Sheets No. L.1 - L.5  
For 221st Street Details  
Refer to Sheets No. E.10 - E.11

330th Avenue

For Plan Details  
Refer to Sheet No. E.3

330th Avenue

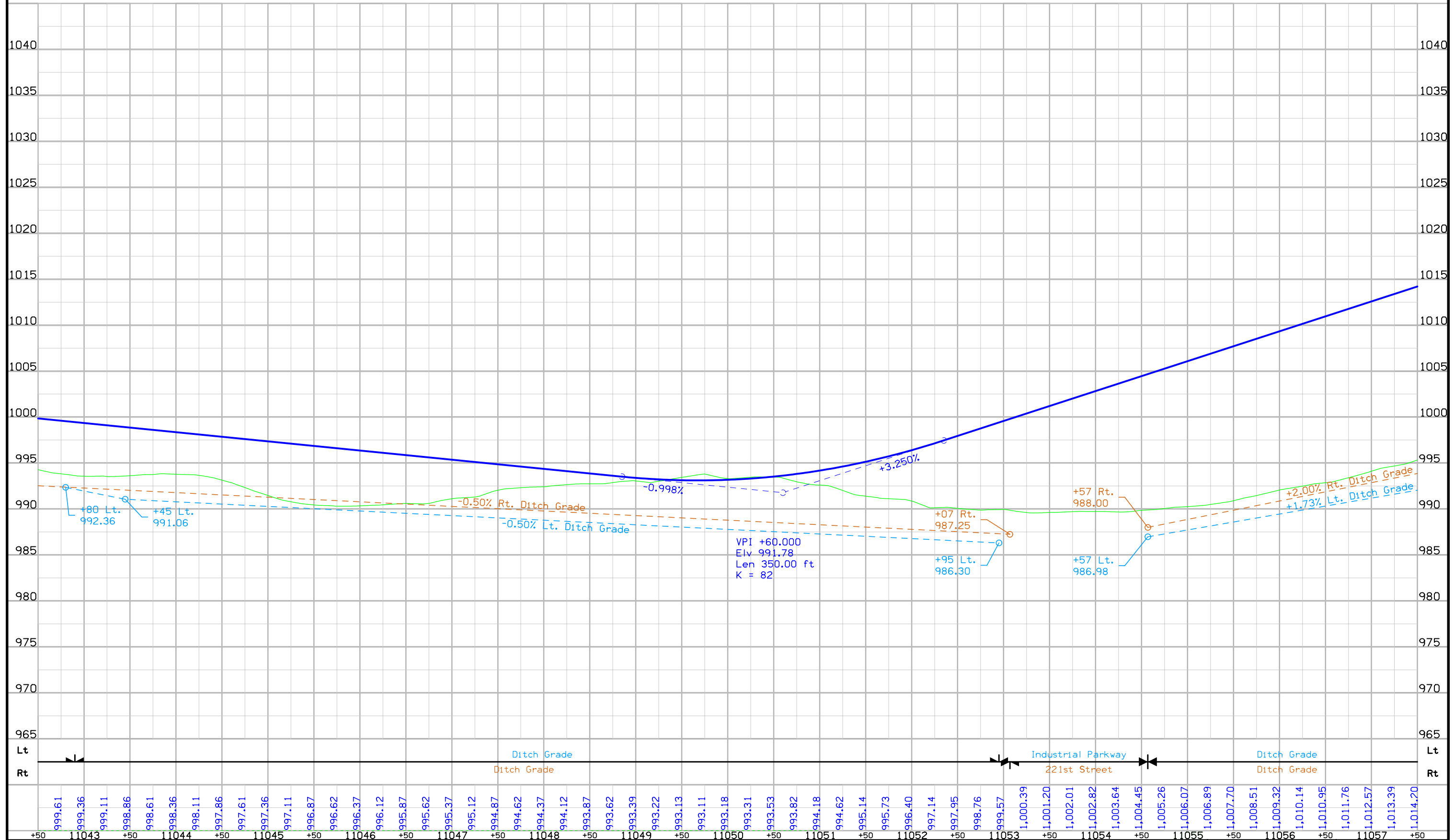

FILE NO.	ENGLISH	DESIGN TEAM	Stanley Consultants Inc.	DELAWARE/DUBUQUE COUNTY	PROJECT NUMBER	NHSX-020-9(203)--3H-28	SHEET NUMBER	E.4
----------	---------	-------------	--------------------------	-------------------------	----------------	------------------------	--------------	-----

NORTH FORK TWP.  
T-88N R-3W  
Sec. 1

BREMEN TWP.  
T-89N R-3W  
Sec. 36

For Ramp B Details  
Refer to Sheet No. K.4

For Bridge Situation Plan  
Refer to Sheets No. V.1

For Ramp C Details  
Refer to Sheet No. K.5

For 218th Street Details  
Refer to Sheet No. E.12

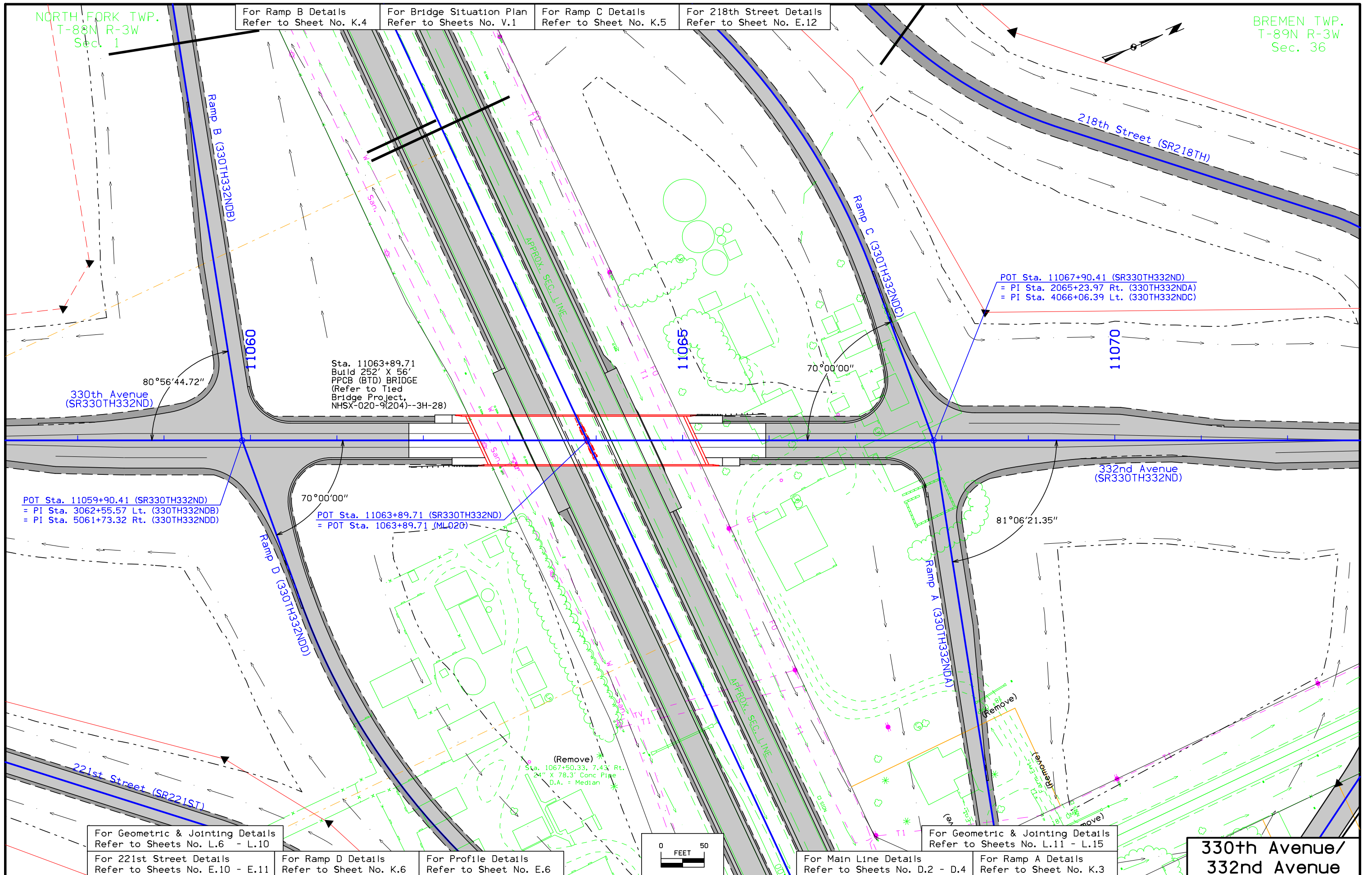

For Geometric & Jointing Details  
Refer to Sheets No. L.6 - L.10

For 221st Street Details  
Refer to Sheets No. E.10 - E.11

For Ramp D Details  
Refer to Sheet No. K.6

For Profile Details  
Refer to Sheet No. E.6

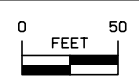

For Main Line Details  
Refer to Sheets No. D.2 - D.4

For Ramp A Details  
Refer to Sheet No. K.3

For Geometric & Jointing Details  
Refer to Sheets No. L.11 - L.15

**330th Avenue/  
332nd Avenue**

For Plan Details  
Refer to Sheet No. E.5

330th Avenue/  
332nd Avenue

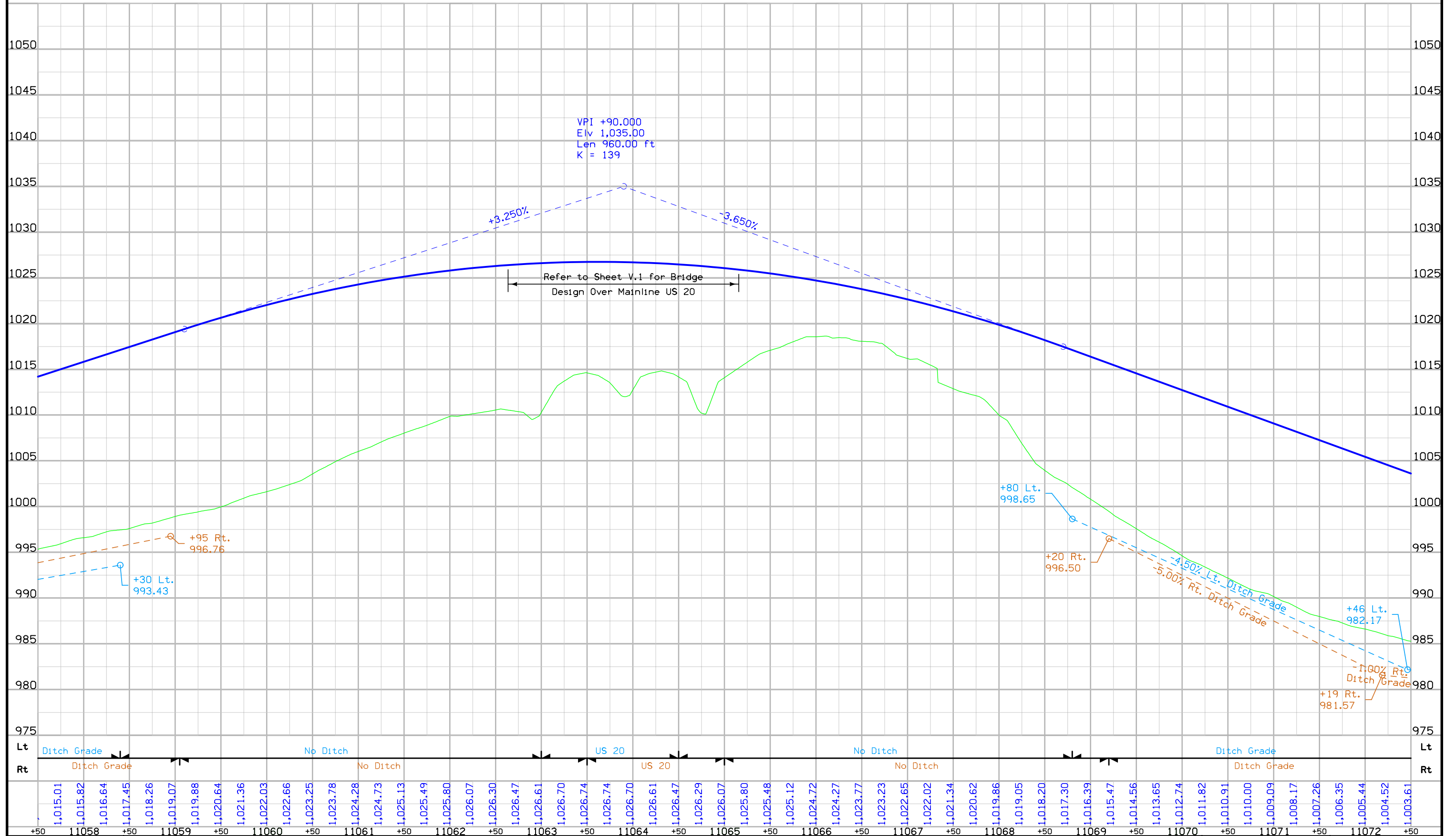

FILE NO.	ENGLISH	DESIGN TEAM	Stanley Consultants Inc.	DELAWARE/DUBUQUE COUNTY	PROJECT NUMBER	NHSX-020-9(203)--3H-28	SHEET NUMBER	E.6
----------	---------	-------------	--------------------------	-------------------------	----------------	------------------------	--------------	-----



For 218th Street Details  
Refer to Sheet No. E.12

BREMEN TWP.  
T-89N R-3W  
Sec. 36

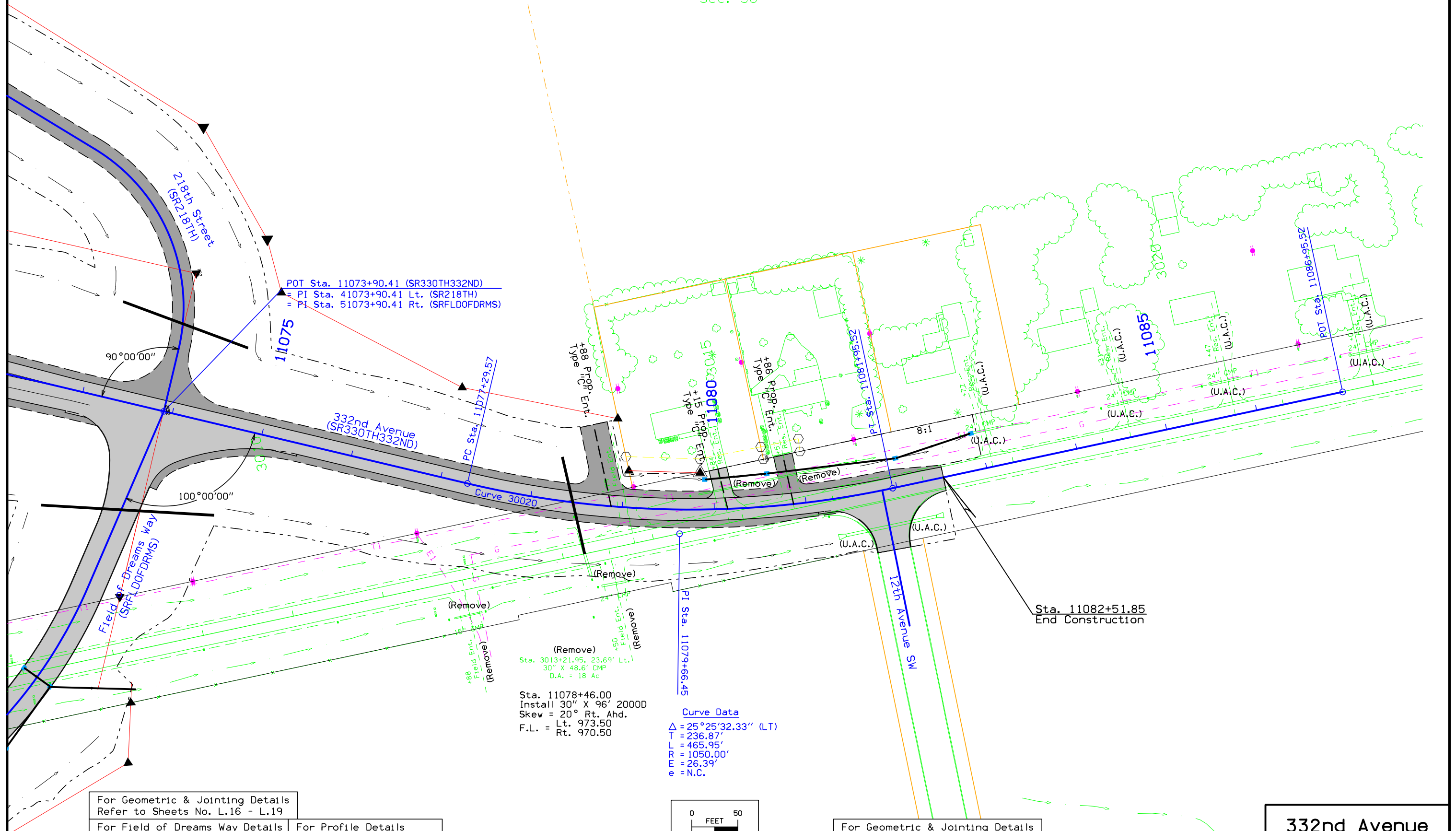

(Remove)  
Sta. 3013+21.95, 23.69' Lt.  
30' X 48.6' CMP  
D.A. = 18 Ac

Sta. 11078+46.00  
Install 30' X 96' 2000D  
Skew = 20° Rt. Ahd.  
Lt. 973.50  
Rt. 970.50

**Curve Data**  
Δ = 25°25'32.33" (LT)  
T = 236.87'  
L = 465.95'  
R = 1050.00'  
E = 26.39'  
e = N.C.

Sta. 11082+51.85  
End Construction

For Geometric & Jointing Details  
Refer to Sheets No. L.16 - L.19

For Field of Dreams Way Details  
Refer to Sheet No. E.13

For Profile Details  
Refer to Sheet No. E.8

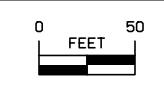

For Geometric & Jointing Details  
Refer to Sheets No. L.20 - L.23

**332nd Avenue**

For Plan Details  
Refer to Sheet No. E.7

# 332nd Avenue

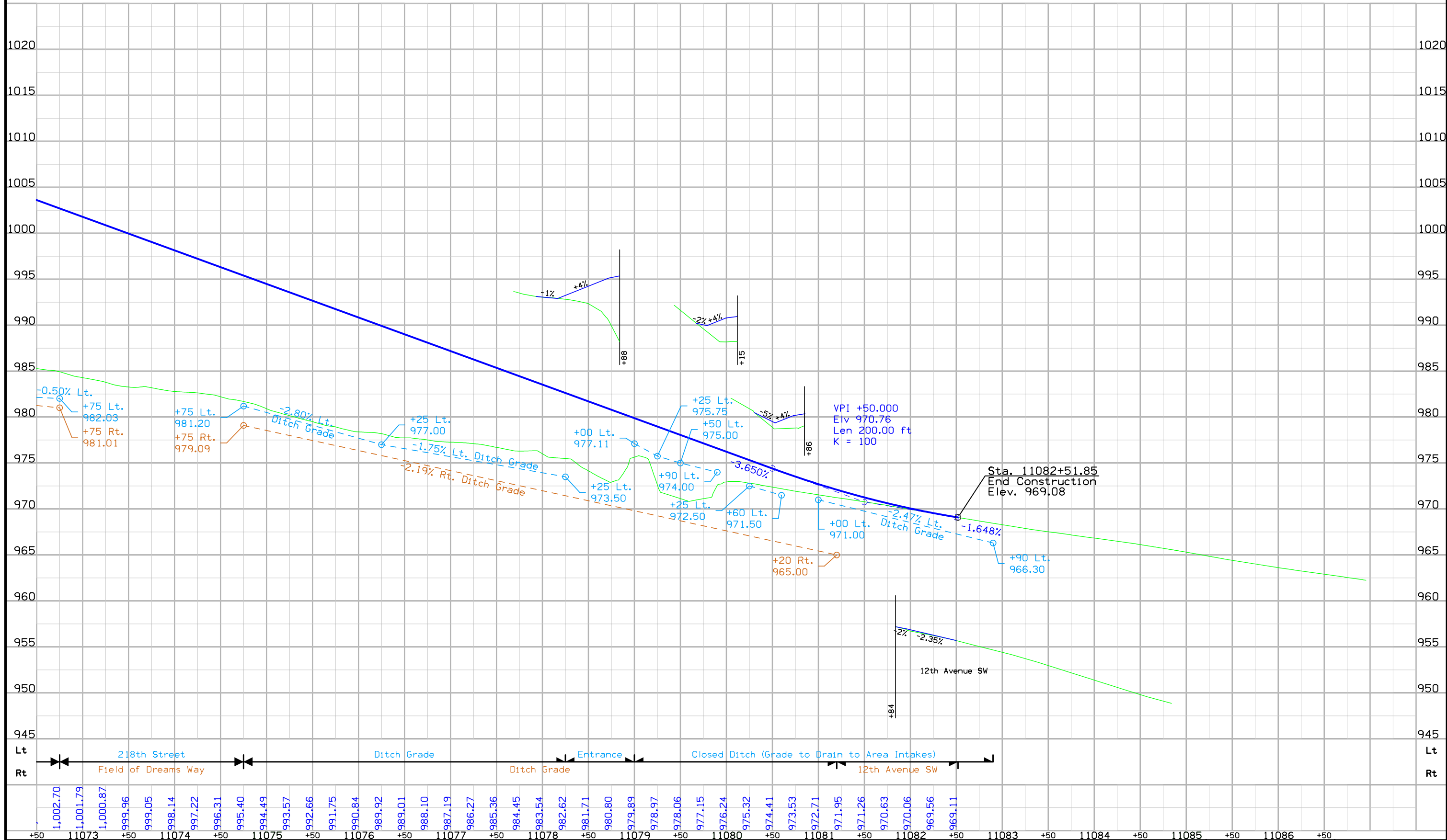

FILE NO.	ENGLISH	DESIGN TEAM	Stanley Consultants Inc.	DELAWARE/DUBUQUE COUNTY	PROJECT NUMBER	NHSX-020-9(203)--3H-28	SHEET NUMBER	E.8
----------	---------	-------------	--------------------------	-------------------------	----------------	------------------------	--------------	-----



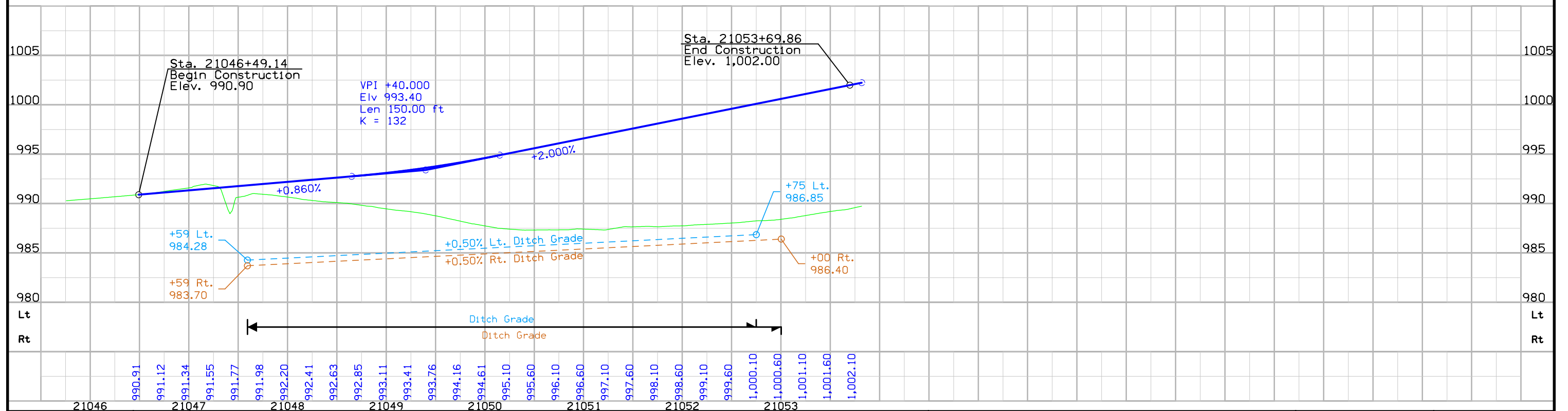
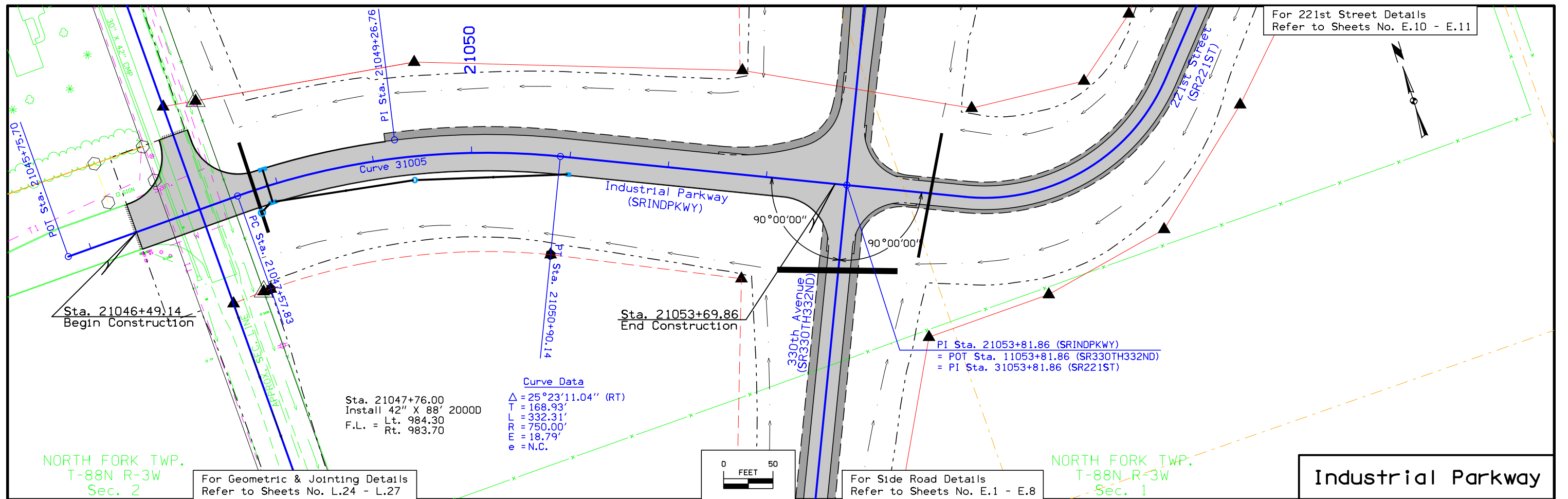

For Industrial Parkway Details Refer to Sheet No. E.9 | For Ramp B Details Refer to Sheet No. K.4 | For Side Road Details Refer to Sheets No. E.3 - E.6 | For Ramp D Details Refer to Sheet No. K.6 | For Main Line Details Refer to Sheets No. D.2 - D.4

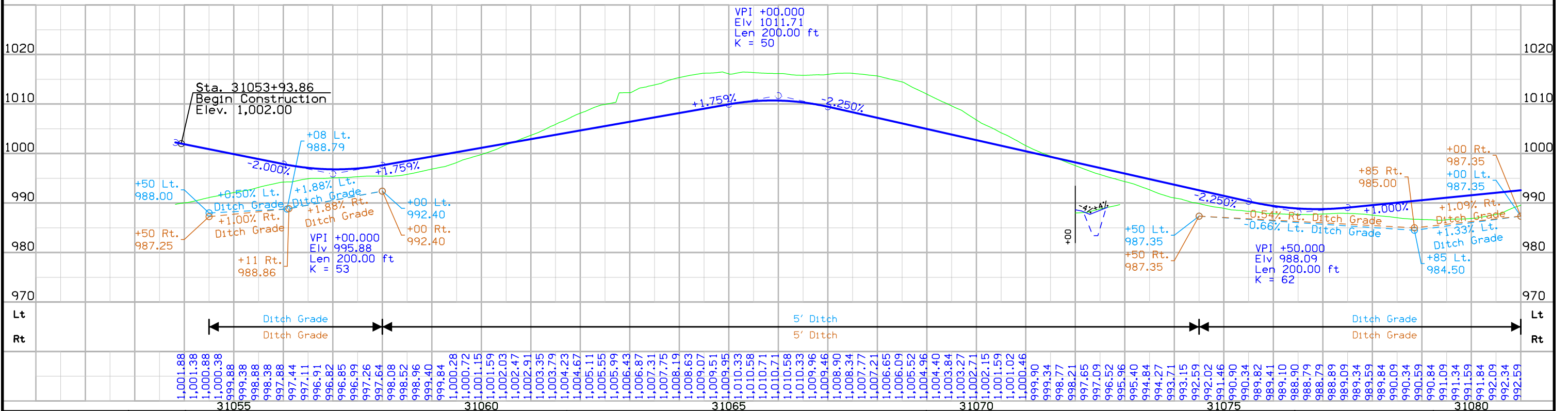
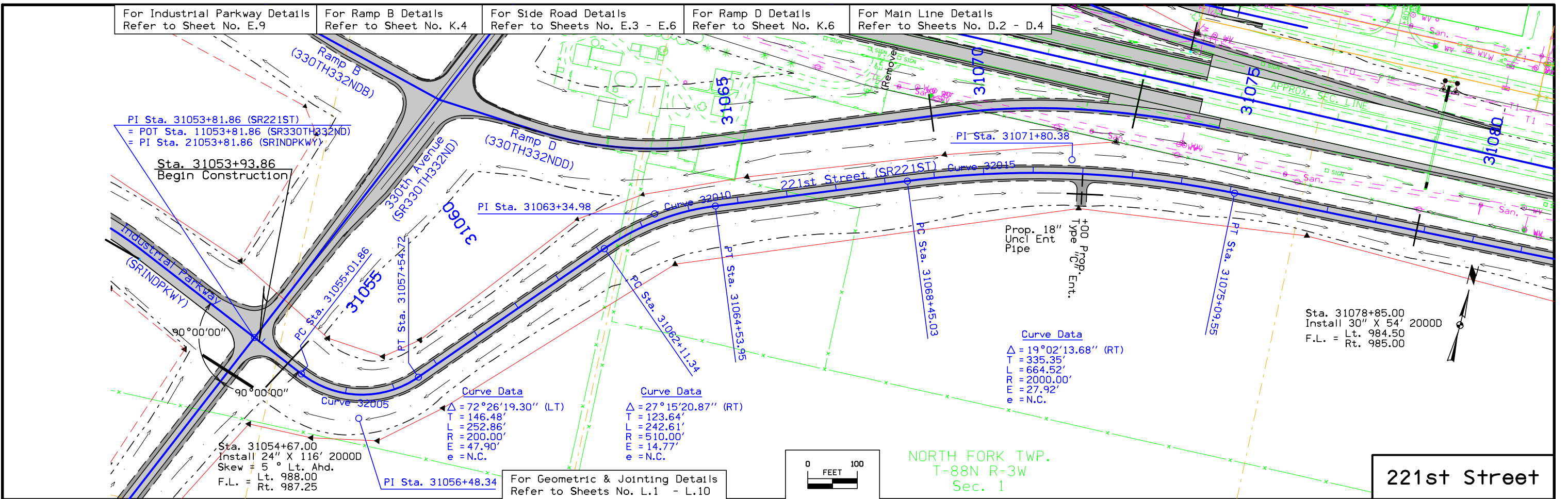

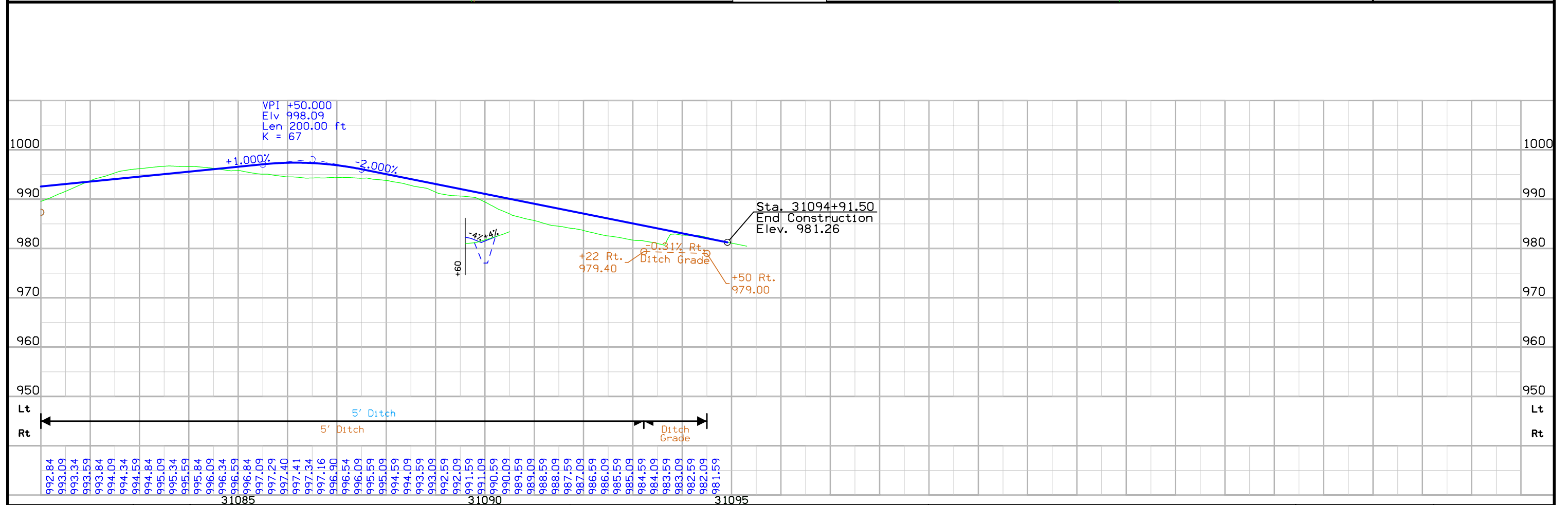
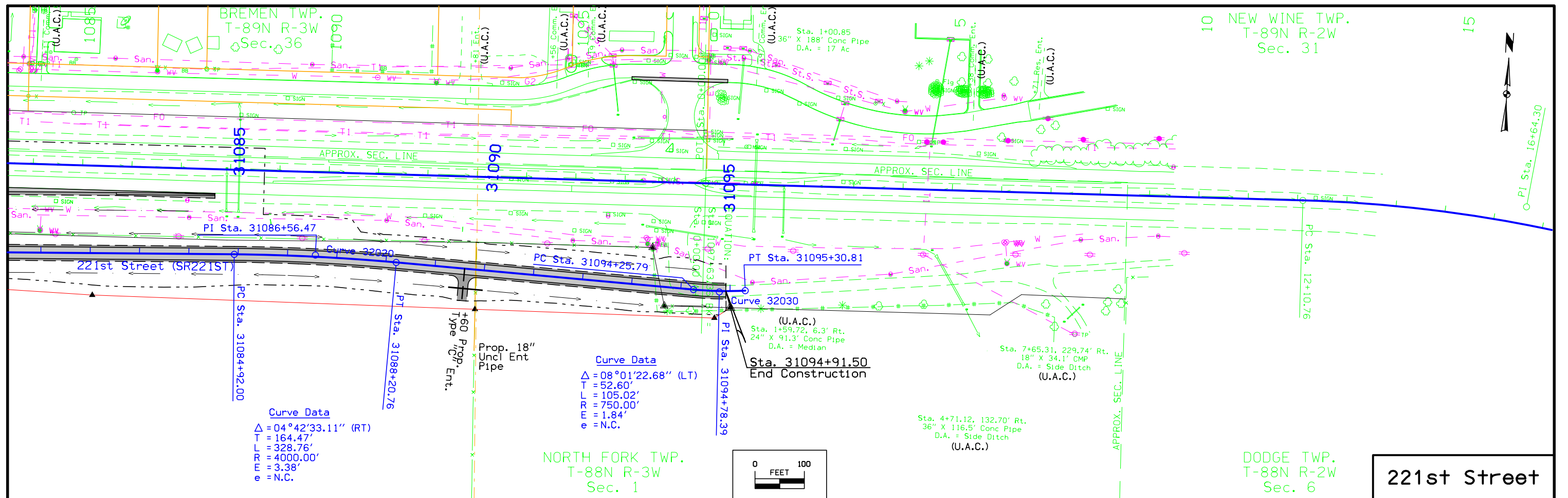



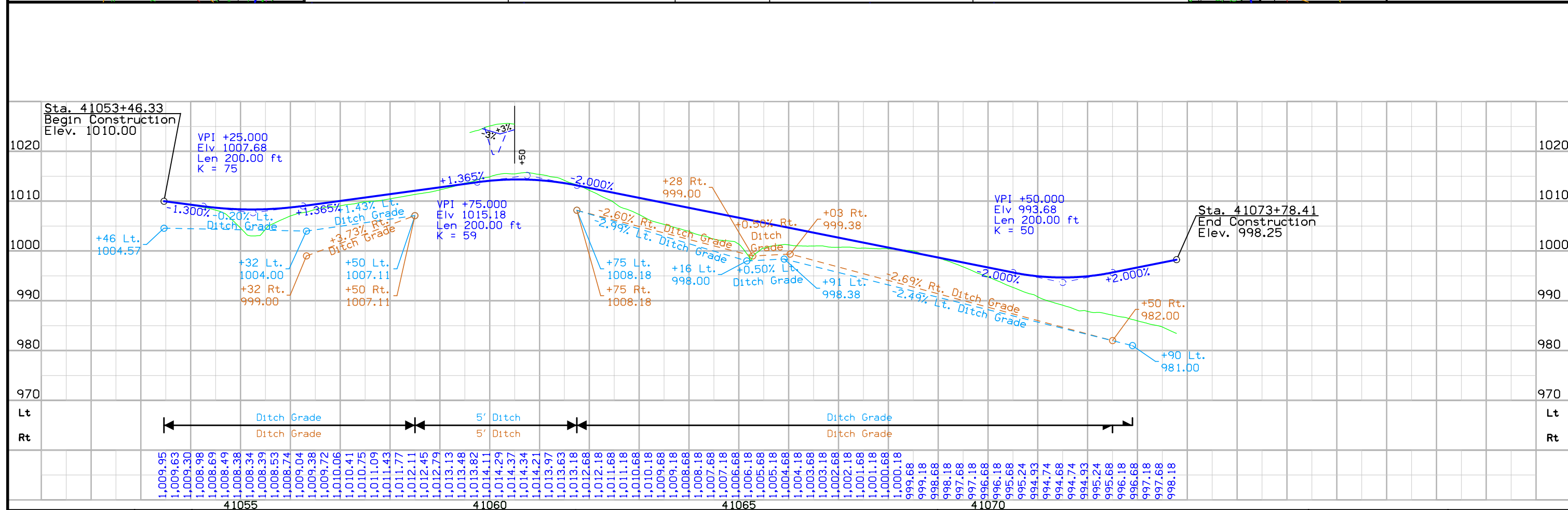
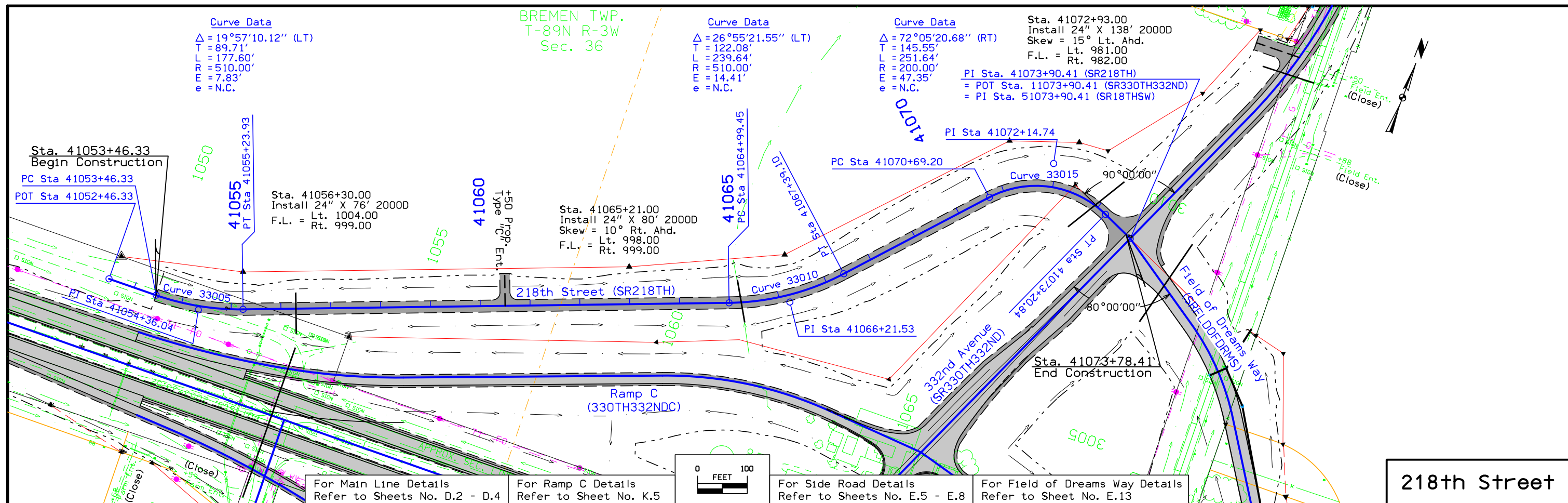

For Side Road Details Refer to Sheets No. E.7 - E.8 & E.12  
 For Geometric & Jointing Details Refer to Sheets No. L.16 - L.19

BREMEN TWP.  
 T-89N R-3W  
 Sec. 36

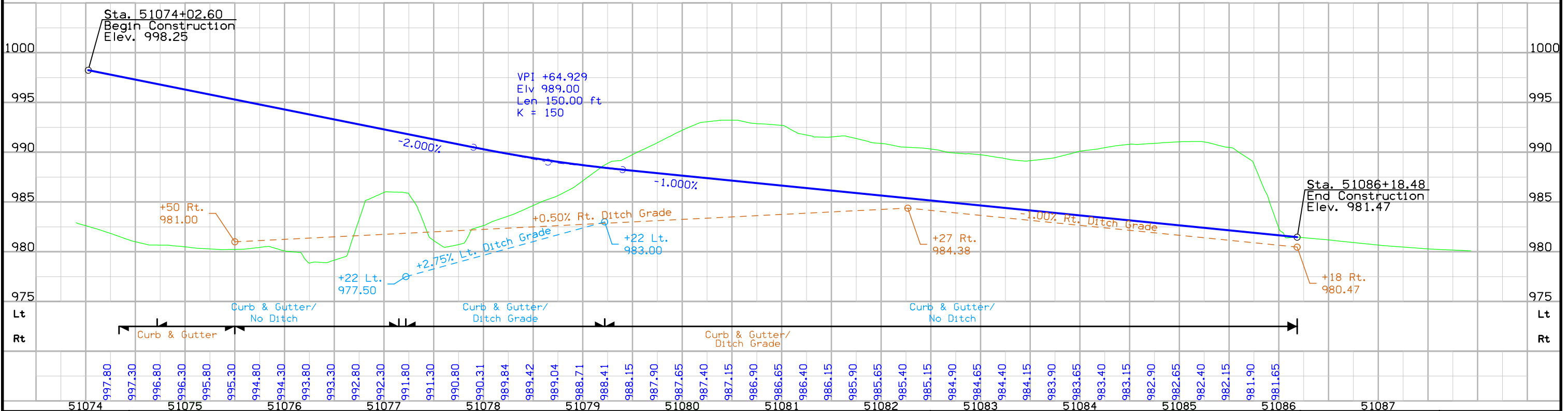
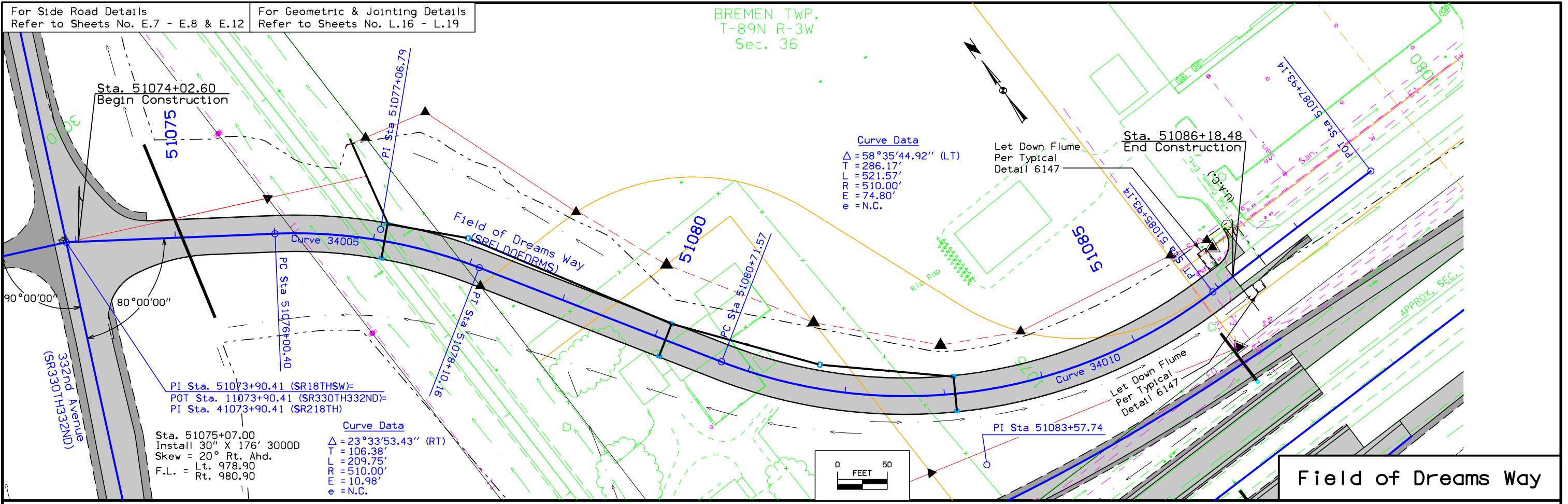

FILE NO.	ENGLISH	DESIGN TEAM	Stanley Consultants Inc.	DELAWARE/DUBUQUE COUNTY	PROJECT NUMBER	NHSX-020-9(203)--3H-28	SHEET NUMBER	E.13
----------	---------	-------------	--------------------------	-------------------------	----------------	------------------------	--------------	------

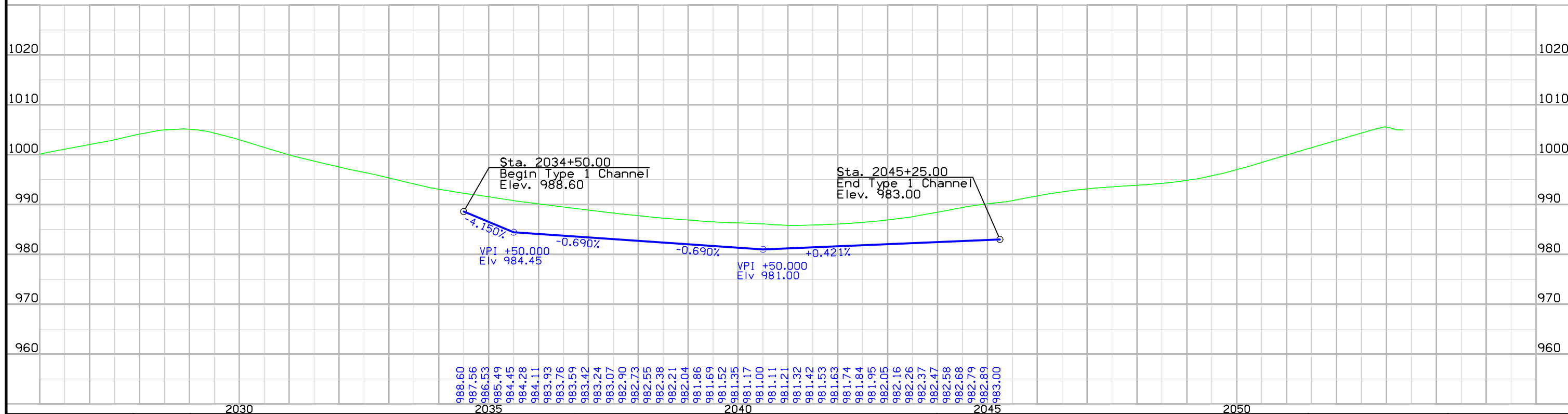
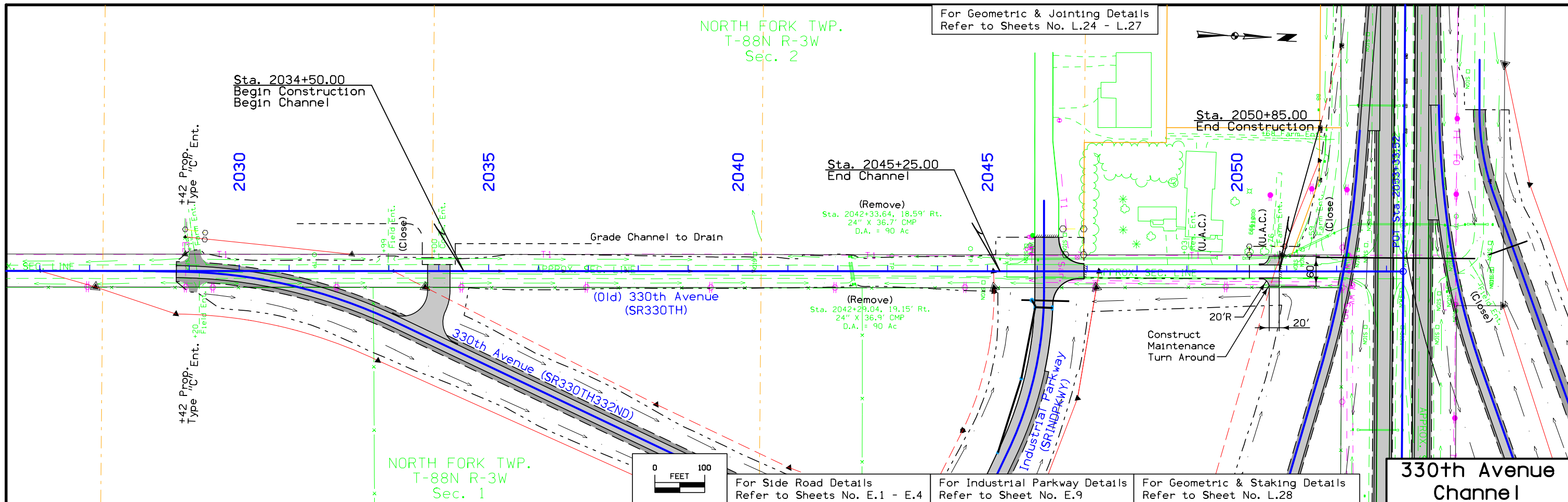

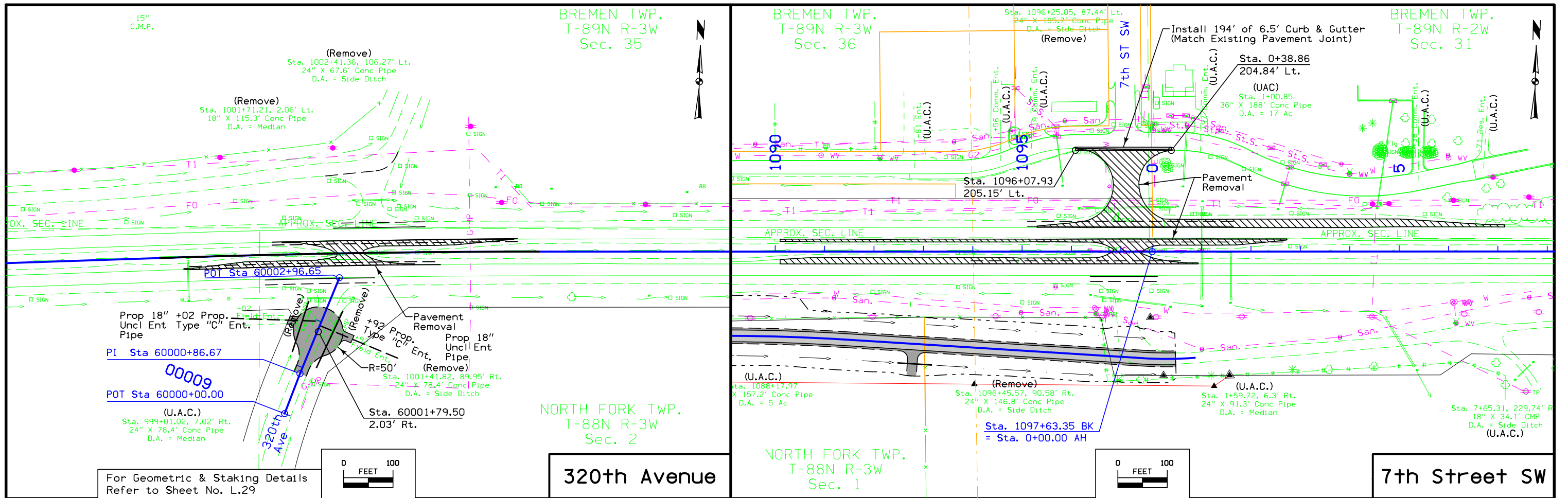

Lt Med Rt											Lt Med Rt



## Survey Information

### General Information

Measurement units for this survey are US survey feet. This survey is for proposed Dyersville Interchange between Co. Rd. X-47 and IA 136 in Dubuque County, Iowa. Project Datum was established using Opus and verified with multiple Iowa RTN observations. Horizontal Datum is a scaled Iowa North Coordinate System. This project is a Partial DTM field survey for the digital terrain model. It is anticipated aerial coverage will be added at a later. Full survey was not obtained on the Elenz property as anticipated. Access was not granted to our surveyors in the field and by the advice of the IDOT, we were not to survey this property.

### Vertical Control

Vertical datum for this survey is relative to NAVD88.

Vertical datum for this survey is NAVD88 as computed by OPUS using GEOID09. A 5hr and 13min static session was completed on point G10 (Opus\_1). The Reported peak-to-peak accuracy of the orthometric height was 0.063(m). A level run opening on G10, turning through all project benchmarks and closing on G10 was performed. All tolerances were accepted and was distributed proportionately among all turns.

Ia RTN orthometric height was checked against OPUS by averaging the first 5 wildcards collected on G10. The Pt Id's are as follows: 8605, 8244, 8243, 4015 and CHKG10. A difference of 0.0138 was found.

Vertical equations are as follows:

#### Datum Benchmark

BM # 508 this survey = Elev. 989.20  
= Proj. F-20-8(25)--20-28 BM # 40 = Elev. 1000.89

#### Datum Benchmark

BM NGS100 this survey = Elev. 966.46  
= NGS Monument NJ0503 = Elev. 966.54

### Horizontal Control

Measurement units for this survey are US survey feet. Iowa State Plane South coordinates were transformed to project ground coordinates by applying a combined scale factor (computed by OPUS) from held point G10 at the center of the project.

### Alignment Information

The horizontal alignment for this survey is a retrace of Delaware County Plans F-20-8(25)--20-28. Survey stationing was equated to the plan at found Sta. POT Sta 980+95.71 and found PC and PT points were held as shown below. Sideroad alignments were best fit from existing centerlines as surveyed.

Equations are as follows:

#### SUR020

POT Sta. 980+95.71 This Survey  
= POT Sta. 980+95.71 Delaware County Project No. F-20-8(25)--20-28

PC STA 998+44.58 this survey  
= PC STA 998+44.58 Delaware County Project No. F-20-8(25)--20-28

PT STA 1006+15.29 this survey  
= PT STA 1006+15.38 Delaware County Project No. F-20-8(25)--20-28

POT Sta. 1093+63.36 This Survey  
= POT Sta. 1093+63.45 Delaware County Project No. F-20-8(25)--20-28  
=POT Sta. 0+00.00 Dubuque County Project No. F-20-8(25)--20-28

PT STA 21+10.24 this survey  
= PT STA 21+10.19 Dubuque County Project No. F-20-8(25)--20-28

PC STA 39+25.99 this survey  
= PC STA 39+25.98 Dubuque County Project No. F-20-8(25)--20-28

#### SUR330TH

PI STA 2053+33.52 this survey  
=PI STA 2053+33.52 Delaware County Project No. F-20-8(25)--20-28

#### SUR332ND

PI STA 3000+00 this survey  
=PI STA 0+00 Delaware County Project No. F-20-8(25)--20-28

PI STA 3036+19.70 this survey  
=PI STA 36+19.70 Delaware County Project No. L-626

## VERTICAL CONTROL

Point	North	East	Elevation	Station	Offset	Feature	Description
500	3643593.871	5560469.981	990.003	9+74.56	112.434	BM	SET RR SPIKE IN POWER POLE
501	3643545.372	5559394.864	982.316	1096+61.88	131.692	BM	SET RR SPIKE IN POWER POLE
502	3643504.172	5558183.464	990.987	1084+49.81	139.948	BM	SET RR SPIKE IN POWER POLE
503	3643472.254	5556936.085	1010.698	1072+02.02	137.948	BM	SET RR SPIKE IN POWER POLE
504	3643697.915	5556279.339	1014.413	1065+51.65	-105.481	BM	SET RR SPIKE IN POWER POLE
505	3643656.520	5554753.227	1004.130	1050+24.98	-105.585	BM	SET RR SPIKE IN POWER POLE
506	3643624.519	5553553.476	1003.385	1038+24.80	-106.208	BM	SET RR SPIKE IN POWER POLE
507	3643580.260	5552322.792	997.857	1025+93.37	-95.418	BM	SET RR SPIKE IN POWER POLE
508	3643523.813	5551398.033	989.200	1016+67.42	-64.129	BM	FND PLUG IN CL HEADWALL
509	3643527.550	5550267.445	996.299	1005+37.68	-98.728	BM	SET RR SPIKE IN POWER POLE
510	3643548.939	5549105.599	1014.432	993+82.14	-180.052	BM	SET RR SPIKE IN POWER POLE
511	3642814.845	5555016.475	993.689	1052+65.25	742.935	BM	SET ARROW 2008 KENNEDY HYDRANT
512	3644251.179	5556715.912	983.661	1070+03.10	-646.674	BM	SET RR SPIKE IN POWER POLE
513	3645995.558	5556654.906	957.557	1069+89.53	-2392.067	BM	SET RR SPIKE IN POWER POLE



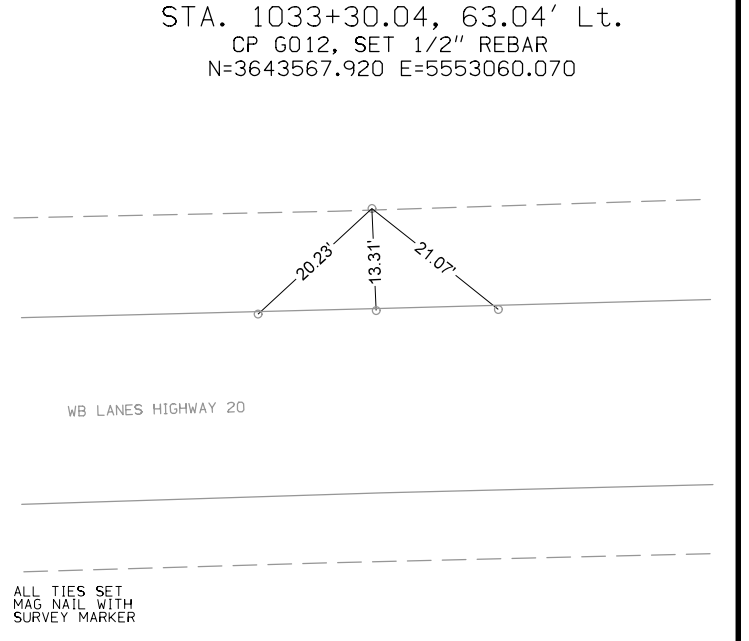
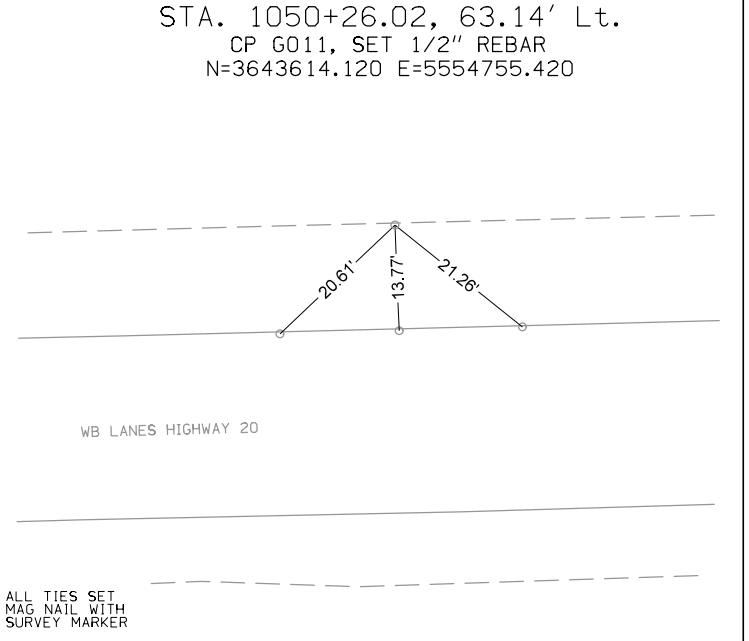
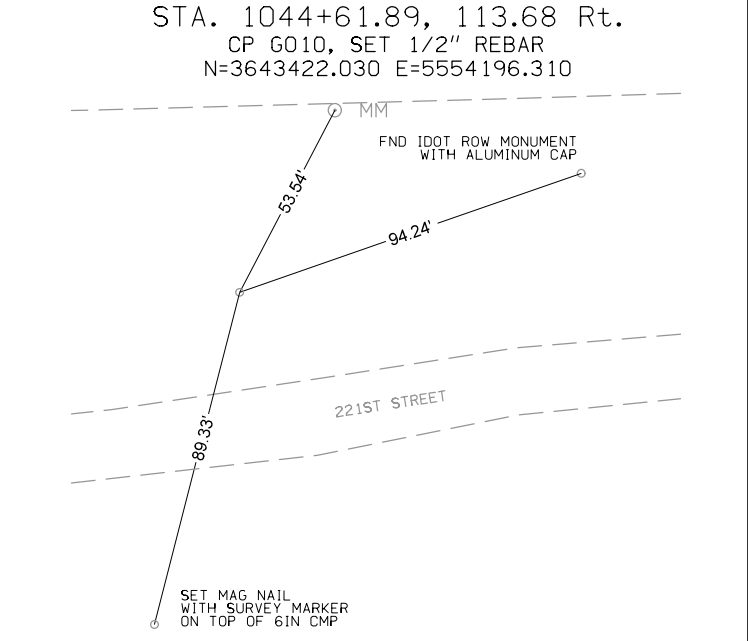
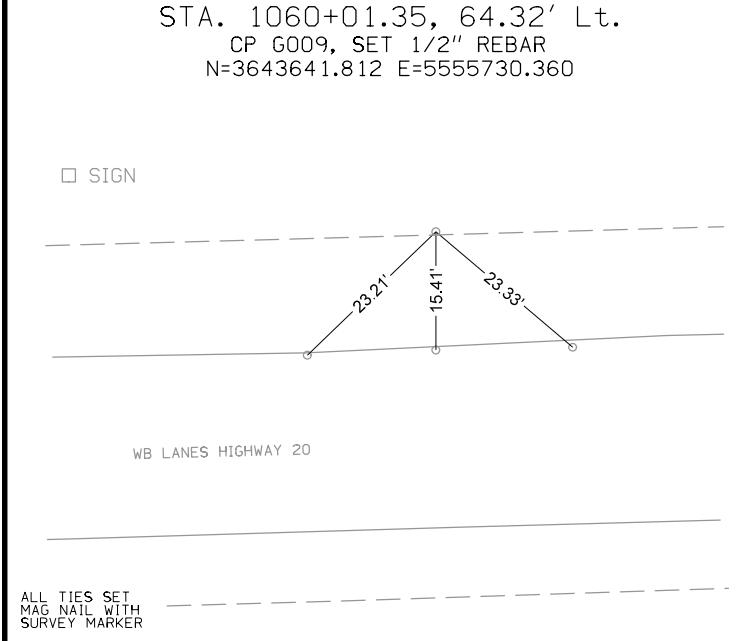
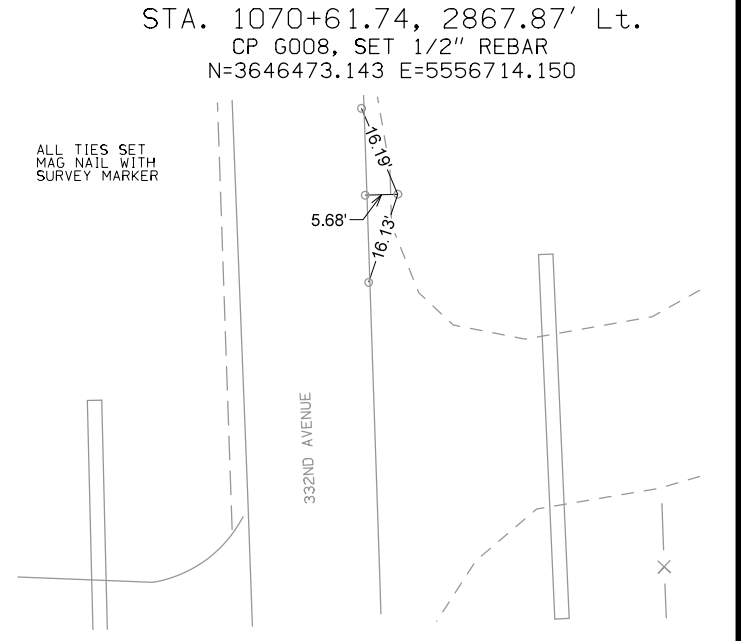
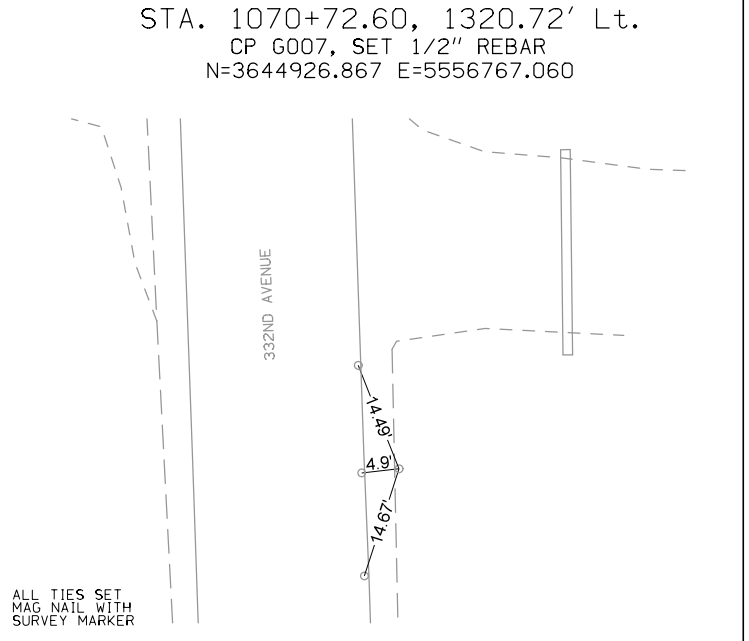
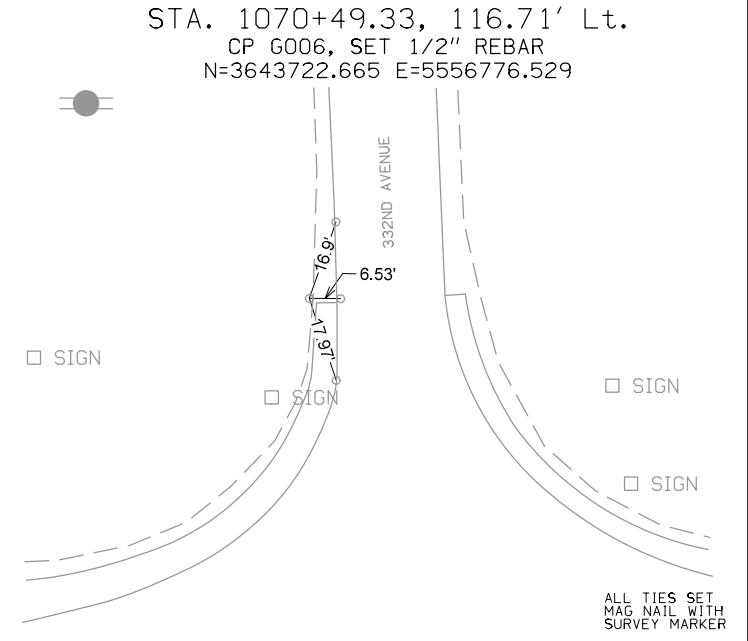
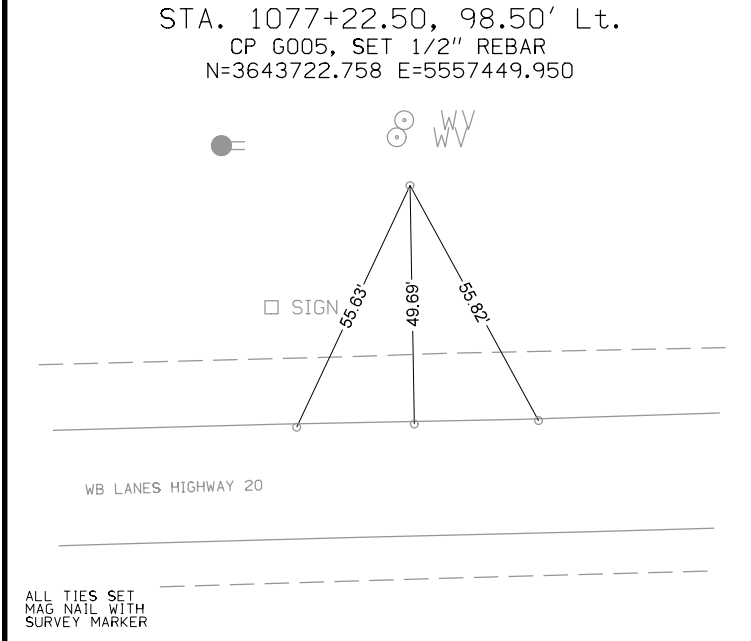
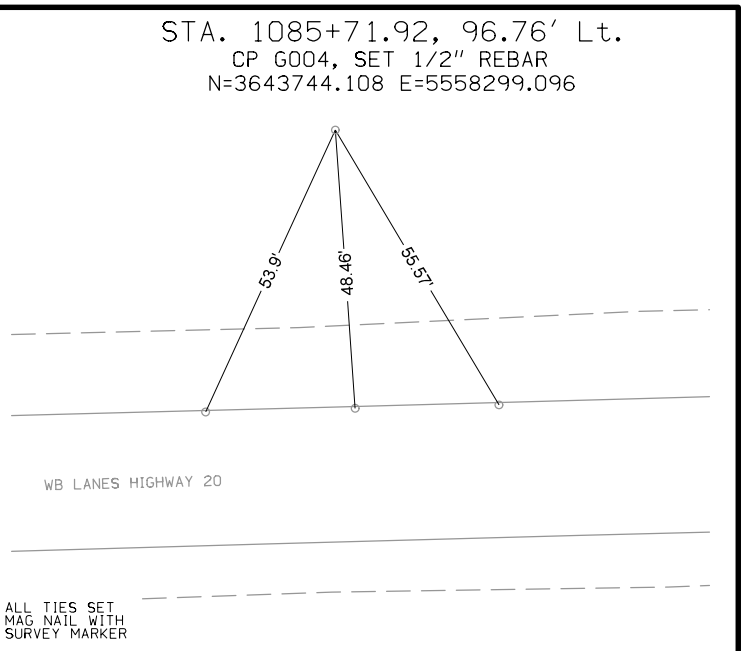
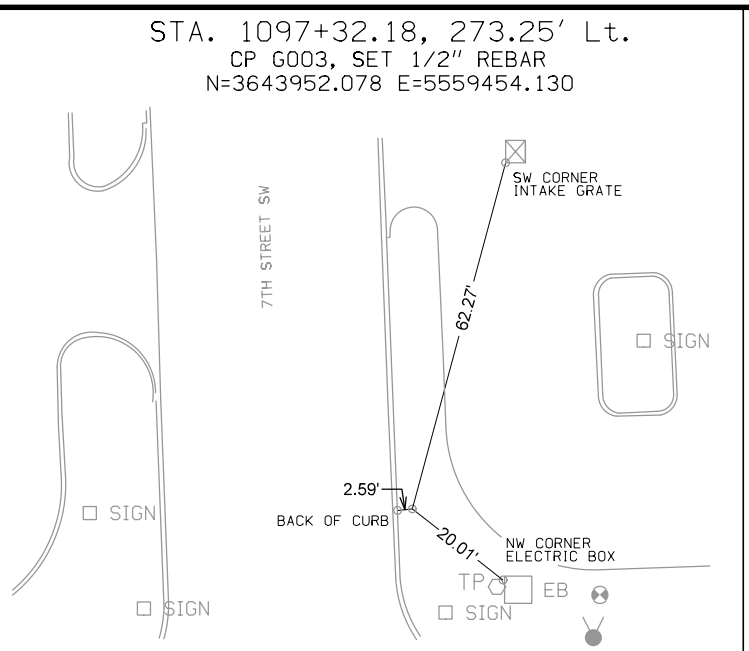
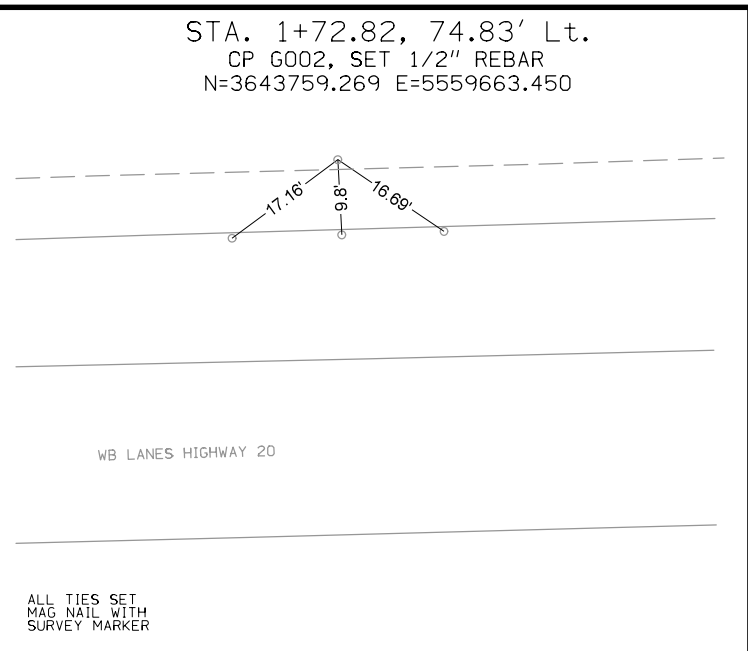
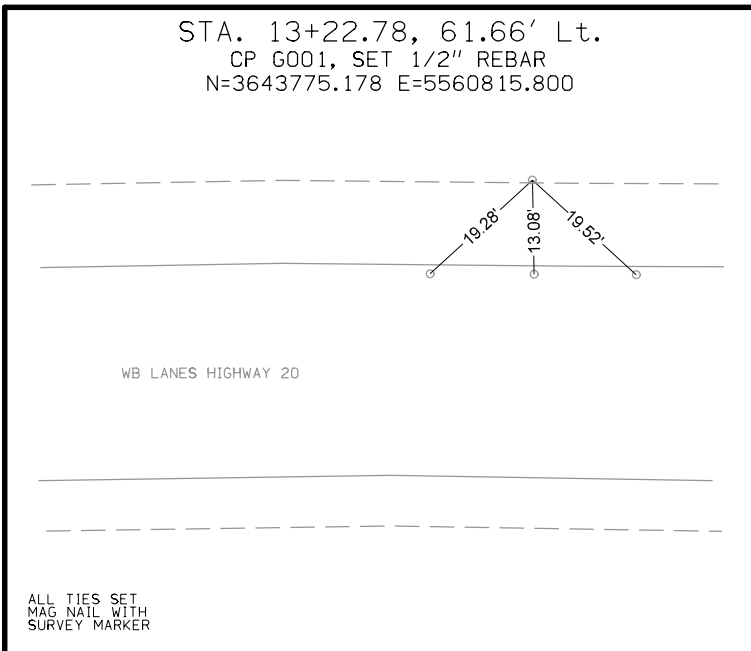

STA. 1021+89.66, 62.87' Lt.  
 CP G013, SET 1/2" REBAR  
 N=3643536.748 E=5551920.120

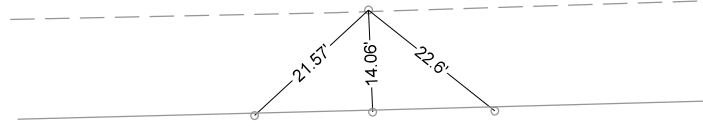

WB LANES HIGHWAY 20

ALL TIES SET  
 MAG NAIL WITH  
 SURVEY MARKER

STA. 1010+68.09, 63.58' Lt.  
 CP G014, SET 1/2" REBAR  
 N=3643506.977 E=5550798.940

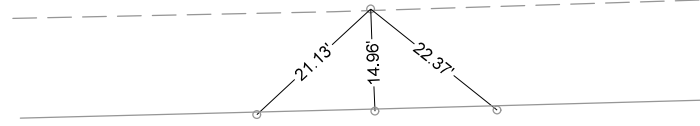

WB LANES HIGHWAY 20

ALL TIES SET  
 MAG NAIL WITH  
 SURVEY MARKER

STA. 999+94.25, 61.87' Lt.  
 CP G015, SET 1/2" REBAR  
 N=3643467.636 E=5549724.180

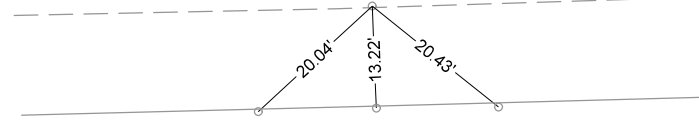

WB LANES HIGHWAY 20

ALL TIES SET  
 MAG NAIL WITH  
 SURVEY MARKER

STA. 988+88.23, 62.19' Lt.  
 CP G016, SET 1/2" REBAR  
 N=3643401.346 E=5548619.750

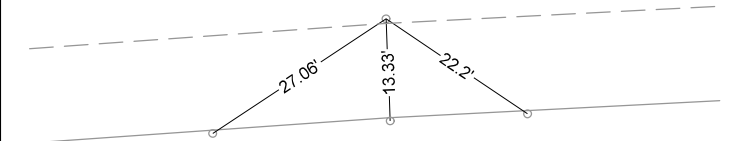

WB LANES HIGHWAY 20

ALL TIES SET  
 MAG NAIL WITH  
 SURVEY MARKER

STA. 1053+55.49, 818.93' Rt.  
 CP G017, SET 1/2" REBAR  
 N=3642741.330 E=5555108.748

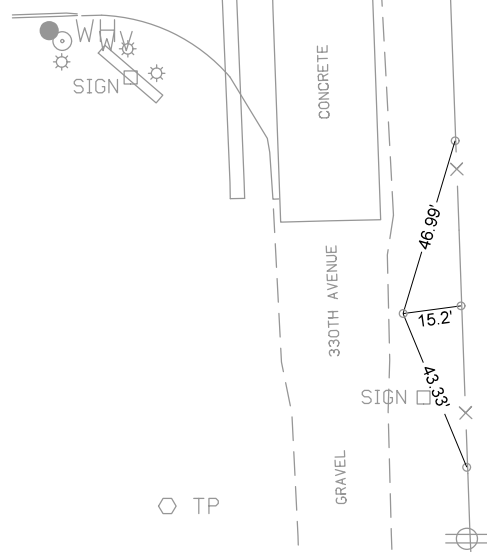

**ALIGNMENT COORDINATES**

101-16  
10-20-09

Name	Location	Point on Tangent			Begin Spiral			Begin Curve			Simple Curve PI or Master PI of SCS			End Curve			End Spiral		
		Station	Coordinates		Station	Coordinates		Station	Coordinates		Station	Coordinates		Station	Coordinates		Station	Coordinates	
			Y (Northing)	X (Easting)		Y (Northing)	X (Easting)		Y (Northing)	X (Easting)		Y (Northing)	X (Easting)		Y (Northing)	X (Easting)		Y (Northing)	X (Easting)
US20																			
20005								998+44.02	3,643,397.28	5,549,577.55	1002+27.78	3,643,420.56	5,549,960.61	1006+11.47	3,643,431.01	5,550,344.23			
20010		1039+72.92	3,643,522.50	5,553,704.43															
20015		1068+36.04	3,643,600.23	5,556,566.50															
20020		1097+63.35	3,643,679.77	5,559,492.73															
330th Ave./332th Ave.																			
30000		11036+66.42	3,641,060.60	5,555,148.90															
30005								11037+07.02	3,641,101.19	5,555,147.89	11039+38.57	3,641,332.67	5,555,142.13	11041+62.83	3,641,545.10	5,555,234.27			
30020								11077+29.57	3,644,817.34	5,556,653.46	11079+66.45	3,645,034.66	5,556,747.71	11081+95.52	3,645,271.39	5,556,739.53			
30025		11086+95.52	3,645,771.10	5,556,722.27															
Industrial Parkway																			
31000		21045+75.70	3,642,834.89	5,554,945.84															
31005								21047+57.83	3,642,841.05	5,555,127.87	21049+26.76	3,642,846.77	5,555,296.70	21050+90.14	3,642,779.56	5,555,451.68			
31010		21053+81.86	3,642,663.48	5,555,719.31															
221st St																			
32000		31053+81.86	3,642,663.48	5,555,719.31															
32005								31055+01.86	3,642,615.73	5,555,829.41	31056+48.34	3,642,557.45	5,555,963.79	31057+54.72	3,642,667.99	5,556,059.91			
32010								31062+11.34	3,643,012.56	5,556,359.53	31063+34.98	3,643,105.86	5,556,440.66	31064+53.95	3,643,151.65	5,556,555.51			
32015								31068+45.03	3,643,296.48	5,556,918.79	31071+80.38	3,643,420.68	5,557,230.30	31075+09.55	3,643,436.47	5,557,565.28			
32020								31084+92.00	3,643,482.73	5,558,546.63	31086+56.47	3,643,490.48	5,558,710.93	31088+20.76	3,643,484.71	5,558,875.30			
32030								31094+25.79	3,643,463.48	5,559,479.96	31094+78.39	3,643,461.64	5,559,532.52	31095+30.81	3,643,467.15	5,559,584.83			
32035		31095+30.81	3,643,467.15	5,559,584.83															
218th St																			
33000		41052+46.33	3,643,697.90	5,554,633.56															
33005								41053+46.33	3,643,700.98	5,554,733.52	41054+36.04	3,643,703.75	5,554,823.18	41055+23.93	3,643,736.94	5,554,906.52			
33010								41064+99.45	3,644,097.95	5,555,812.79	41066+21.53	3,644,143.13	5,555,926.20	41067+39.10	3,644,234.76	5,556,006.86			
33015								41070+69.20	3,644,482.53	5,556,224.98	41072+14.74	3,644,591.78	5,556,321.15	41073+20.84	3,644,533.87	5,556,454.68			
33020		41073+90.41	3,644,506.18	5,556,518.51															
Field of Dreams Way																			
34000		51073+90.41	3,644,506.18	5,556,518.51															
34005								51076+00.40	3,644,390.44	5,556,693.73	51077+06.79	3,644,331.81	5,556,782.49	51078+10.16	3,644,242.58	5,556,840.41			
34010								51080+71.57	3,644,023.31	5,556,982.74	51083+57.74	3,643,783.27	5,557,138.55	51085+93.14	3,643,791.19	5,557,424.62			
34015		51087+93.14	3,643,796.72	5,557,624.54															
Ramp A																			
35000		2065+23.97	3,643,955.72	5,556,279.77															
35005								2072+28.85	3,643,778.61	5,556,962.04	2074+44.28	3,643,724.48	5,557,170.55	2076+58.05	3,643,715.99	5,557,385.81			
35010		2077+25.00	3,643,713.36	5,557,452.71															
Ramp B																			
36005		3050+50.00	3,643,462.77	5,554,783.53															
36010								3051+19.79	3,643,460.02	5,554,853.27	3053+32.37	3,643,451.65	5,555,065.68	3055+43.36	3,643,398.81	5,555,271.59			
36015		3062+55.57	3,643,221.78	5,555,961.45															
Ramp C																			
37010								4049+98.04	3,643,619.31	5,554,727.30	4051+38.27	3,643,625.92	5,554,867.37	4052+78.04	3,643,652.01	5,555,005.15			
37020								4052+78.04	3,643,652.01	5,555,005.15	4054+08.90	3,643,676.35	5,555,133.72	4055+39.00	3,643,724.11	5,555,255.56			
37030								4060+59.43	3,643,914.02	5,555,740.10	4062+35.68	3,643,978.34	5,555,904.20	4064+06.39	3,643,967.75	5,556,080.13			
37035		4066+06.39	3,643,955.72	5,556,279.77															
Ramp D																			
38000		5061+73.32	3,643,221.78	5,555,961.45															
38005								5063+73.32	3,643,209.75	5,556,161.09	5065+52.02	3,643,199.01	5,556,339.46	5067+24.94	3,643,265.19	5,556,505.45			
38015								5072+20.85	3,643,448.84	5,556,966.10	5073+55.80	3,643,498.82	5,557,091.46	5074+89.92	3,643,523.93	5,557,224.05			
38025								5074+89.92	3,643,523.93	5,557,224.05	5076+30.15	3,643,550.02	5,557,361.83	5077+69.92	3,643,556.64	5,557,501.91			
330th Ave. Channel																			
39000		2013+33.52	3,639,561.64	5,555,199.11															
39005		2053+33.52	3,643,559.31	5,555,062.80															

**SPIRAL OR CIRCULAR CURVE DATA**

101-17  
04-19-11

Name	Location	Δ <sub>scs</sub>	Horizontal Alignment Data										Remarks			
			Spiral Data					Curve Data								
			θ <sub>s</sub>	L <sub>s</sub>	T <sub>s</sub>	E <sub>s</sub>	X <sub>c</sub>	Y <sub>c</sub>	L.T.	S.T.	Δ <sub>c</sub>	T	L	R	E	
US20																
20005											01° 55' 07.06" RT	383.76'	767.45'	22,918.32'	3.21'	
330th Ave./332th Ave.																
30005											24° 52' 19.43" RT	231.55'	455.80'	1,050.00'	25.23'	
30020											25° 25' 32.33" LT	236.87'	465.95'	1,050.00'	26.39'	
Industrial Parkway																
31005											25° 23' 11.04" RT	168.93'	332.31'	750.00'	18.79'	
221st St																
32005											72° 26' 19.30" LT	146.48'	252.86'	200.00'	47.90'	
32010											27° 15' 20.87" RT	123.64'	242.61'	510.00'	14.77'	
32015											19° 02' 13.68" RT	335.35'	664.52'	2,000.00'	27.92'	
32020											04° 42' 33.11" RT	164.47'	328.76'	4,000.00'	3.38'	
32030											08° 01' 22.68" LT	52.60'	105.02'	750.00'	1.84'	
218th St																
33005											19° 57' 10.12" LT	89.71'	177.60'	510.00'	7.83'	
33010											26° 55' 21.55" LT	122.08'	239.64'	510.00'	14.41'	
33015											72° 05' 20.68" RT	145.55'	251.64'	200.00'	47.35'	
Field of Dreams Way																
34005											23° 33' 53.43" RT	106.38'	209.75'	510.00'	10.98'	
34010											58° 35' 44.92" LT	286.17'	521.57'	510.00'	74.80'	
Ramp A																
35005											12° 17' 44.12" LT	215.43'	429.20'	2,000.00'	11.57'	
Ramp B																
36010											12° 08' 03.30" RT	212.58'	423.57'	2,000.00'	11.27'	
Ramp C																
37010											08° 01' 17.07" LT	140.23'	280.00'	2,000.00'	4.91'	
37020											10° 40' 47.54" LT	130.86'	260.96'	1,400.00'	6.10'	
37030											24° 50' 58.62" RT	176.25'	346.97'	800.00'	19.19'	
Ramp D																
38005											25° 10' 58.43" LT	178.70'	351.62'	800.00'	19.71'	
38015											11° 00' 43.17" RT	134.95'	269.07'	1,400.00'	6.49'	
38025											08° 01' 17.07" RT	140.23'	280.00'	2,000.00'	4.91'	

**SUPERELEVATION DATA**

See PV-300 Series

Road Identification	Circular Curve or Spiral Curve Name	Radius FT	Superelevation Data			Standard Road Plan	Section A-A	Section B-B	Section C-C	Section D-D	Section E-E	Section F-F	Case A	Case B	Case C	Case S	Case T	Case U	Remarks
			e	L	x														
			%	FT	FT														
RAMP A	35005	2000	5.4	168	62	PV-303	2071+73.25		2072+28.85	2072+79.25						2072+35.69	2072+35.69		
							2077+13.65		2076+58.05	2076+07.65						2076+51.21	2076+51.21		
RAMP B	36010	2000	5.4	168	62	PV-303	3050+64.19		3051+19.79	3051+70.19						3051+26.63	3051+26.63		
							3055+98.96		3055+43.36	3054+92.96						3055+36.52	3055+36.52		
RAMP C	37010	2000	5.4	168	62	PV-303	4049+42.44		4049+98.04	4050+48.44						4050+04.88	4050+04.88		
							4053+33.64		4052+78.04	4052+27.64						4052+71.20	4052+71.20		
RAMP C	37020	1400	6.0	186	62	PV-303	4052+09.84		4052+78.04	4053+33.84						4052+71.84	4052+71.84		
							4056+07.20		4055+39.00	4054+83.20						4055+45.20	4055+45.20		
RAMP C	37030	800	5.4	130	48	PV-303	4059+20.43	4059+68.43	4060+59.43	4060+98.43						4060+64.73	4060+64.73		
							4065+45.39	4064+97.39	4064+06.39	4063+67.39						4064+01.09	4064+01.09		
RAMP D	38005	800	5.4	130	48	PV-303	5062+34.32	5062+82.32	5063+73.32	5064+12.32						5063+78.62	5063+78.62		
							5068+63.94	5068+15.94	5067+24.94	5066+85.94						5067+19.64	5067+19.64		
RAMP D	38015	1400	6.0	186	62	PV-303	5071+52.65		5072+20.85	5072+76.65						5072+14.65	5072+14.65		
							5075+58.12		5074+89.92	5074+34.12						5074+96.12	5074+96.12		
RAMP D	38025	2000	5.4	168	62	PV-303	5074+34.32		5074+89.92	5075+40.32						5074+96.76	5074+96.76		
							5078+25.52		5077+69.92	5077+19.52						5077+63.08	5077+63.08		

# PARCEL CHECK LIST

04/15/13 13:48 HSL PRINT FOR N L CUVA PAGES: 1 - 4 GEN: 1

PARCEL CHECK BY PROJ UPDATED 04/15/13 13:48 PAGE: 1  
AND: 2

R2360003 PARCEL CHECK LIST BY PROJECT NUMBER  
COUNTY : DELAWARE PROJECT NO. :NHSN-020-8(48)--2R-28 PIN: 10-31-020010-00  
CONSTRUCTION NO.:NHSN-020-9(195)--2R-31 ASSIGNED TO: NLC

DESCRIPTION : Dyersville Interchange between 330th Aveand 332nd Ave

PARCEL	KEY	OWNER	TYPE	R/W W.D OR EASE.	BORROW W.D OR EASE.	HOUSE OR OTHER	COMMERCIAL	OCC ENVIRONMENTAL CONCERNS
0001	26643	GARY G. WESSELS LORI WESSELS	FEE DYERSVILLE CITY					
			FEE	10.82 WD ACRE				
			STATE OF IOWA					
				13.50 WD ACRE				
0002	26644	HERBERT P. RECKER MARY M. RECKER	FEE STATE OF IOWA					
			FEE	4.86 WD ACRE				
0003	26645	HERBERT P. RECKER MARY M. RECKER MICHAEL RECKER	FEE STATE OF IOWA					
			FEE	3,035.00 WD SQFT				
			CP1					
0003 A	26725	DYERSVILLE INDUSTRIES, INC	FEE DYERSVILLE CITY					
				0.13 WD ACRE				
0004	26646	LEON ELENZ	FEE DELAWARE COUNTY					
				19.62 WD ACRE				
			STATE OF IOWA					
				16.83 WD ACRE				
				10.76 EXCESS AC				
0004 A	26739	PHILIP WESTHOFF MONICA WESTHOFF	FEE DELAWARE COUNTY					
			FEE	1.22 WD ACRE				
0005	26647	GLADYS R. WESSELS	FEE STATE OF IOWA					
				0.69 WD ACRE				
0006	26648	PAUL E. CHRISTOFFER TAMMY L. CHRISTOFFER	FEE DELAWARE COUNTY					
			FEE	1,953.00 WD SQFT				
0007	26649	KAREN M. TEGELER DAVID D. TEGELER	FEE DELAWARE COUNTY					
			FEE	159.00 WD SQFT				

PARCEL CHECK LIST

04/15/13 13:48 HSL PRINT FOR N L CUVA PAGES: 1 - 4 GEN: 1

PARCEL CHECK BY PROJ UPDATED 04/15/13 13:48 PAGE: 3  
AND: 4

R2360003 PARCEL CHECK LIST BY PROJECT NUMBER  
COUNTY : DELAWARE PROJECT NO. :NHSN-020-8(48)--2R-28 PIN: 10-31-020010-00  
CONSTRUCTION NO.:NHSN-020-9(195)--2R-31 ASSIGNED TO: NLC  
DESCRIPTION : Dyersville Interchange between 330th Aveand 332nd Ave

PARCEL	KEY	OWNER	TYPE	R/W W.D OR EASE.	BORROW W.D OR EASE.	HOUSE OR OTHER	COMMERCIAL	OCC ENVIRONMENTAL CONCERNS
--------	-----	-------	------	------------------	---------------------	----------------	------------	----------------------------

0008	26650	KENNETH G. TUETKEN	FEE DYERSVILLE CITY	1.64	WD ACRE			
			STATE OF IOWA	0.62	WD ACRE			
0009	26651	BGPD LAND HOLDINGS, LLC	FEE DYERSVILLE CITY	2.00	WD ACRE			
0009	26651							
0010	26652	C&G PARTNERSHIP	FEE DYERSVILLE CITY	1.02	WD ACRE			

CITY of DYERSVILLE  
15.61 WARRANTY DEED ACRES

COUNTY of DELAWARE  
20.84 WARRANTY DEED ACRES  
2,112.00 WARRANTY DEED SQFT

STATE OF IOWA  
36.50 WARRANTY DEED ACRES  
3,035.00 WARRANTY DEED SQFT  
10.76 EXCESS ACRES

12 TOTAL PARCELS ON PROJECT

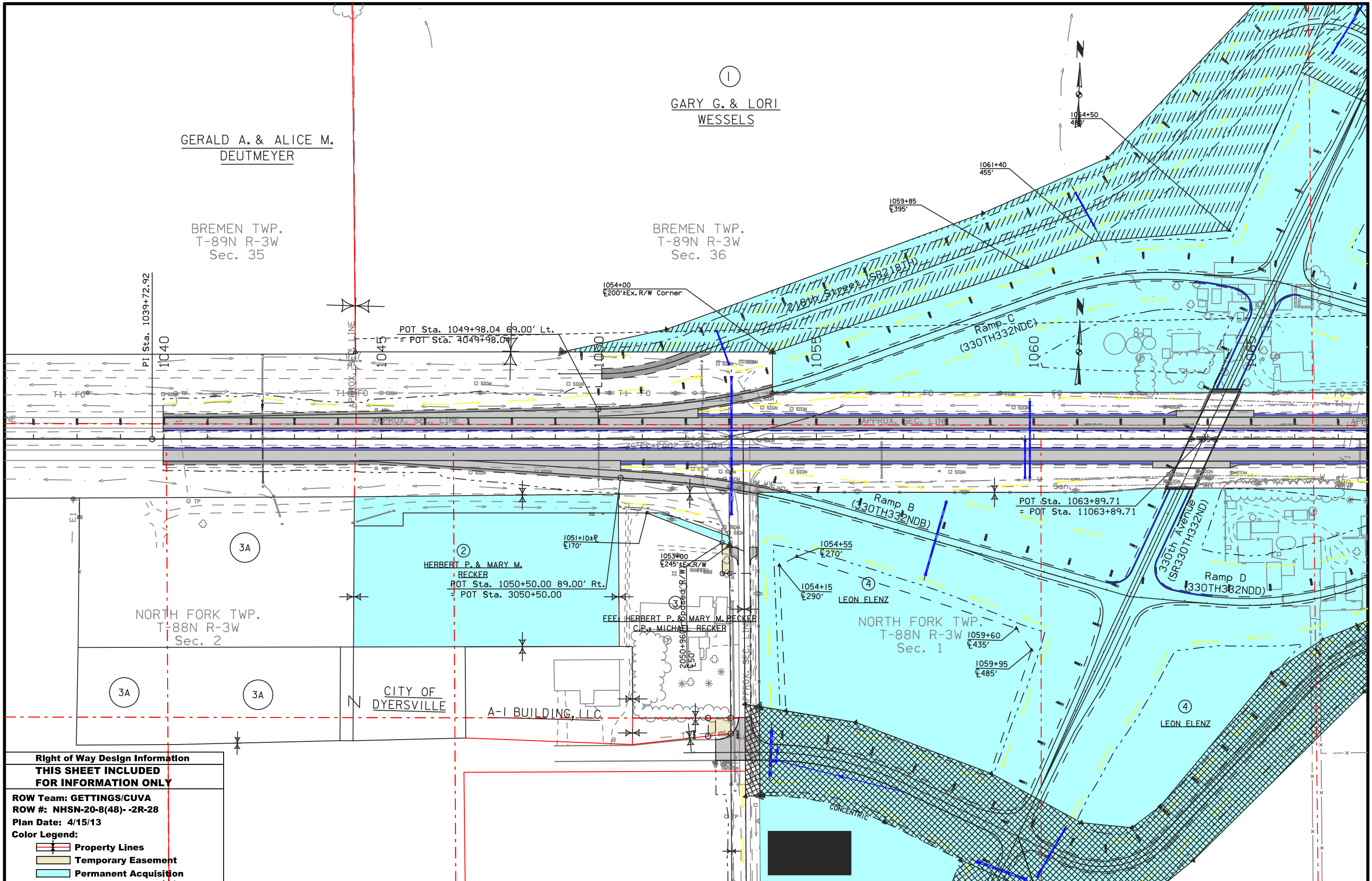

GERALD A. & ALICE M.  
DEUTMEYER

GARY G. & LORI  
WESFELS

BREMEN TWP.  
T-89N R-3W  
Sec. 35

BREMEN TWP.  
T-89N R-3W  
Sec. 36

PI Sta. 1039+72.92

1040

1045

POT Sta. 1049+98.04 69.00' Lt.  
= POT Sta. 1049+98.04

1054+00  
±200'±Ex. R/W Corner

1059+85  
±395'

1061+40  
455'

1064+50  
485'

1055

1060

Ramp C  
(330TH332NDC)

3A

HERBERT P. & MARY M.  
RECKER  
POT Sta. 1050+50.00 89.00' Rt.  
= POT Sta. 3050+50.00

1051+10±P  
±170'

1053+00  
±245'±Ex. R/W

1054+55  
±270'

1054+15  
±290'

LEON FLENZ

POT Sta. 1063+89.71  
= POT Sta. 11063+89.71

Ramp B  
(330TH332NDB)

330th Avenue  
(SR330TH332ND)

Ramp D  
(330TH332NDD)

NORTH FORK TWP.  
T-88N R-3W  
Sec. 2

HERBERT P. & MARY M. RECKER  
CIP MICHAEL RECKER

NORTH FORK TWP.  
T-88N R-3W  
Sec. 1

3A

3A

CITY OF  
DYERSVILLE

A-I BUILDING, LLC

LEON FLENZ

**Right of Way Design Information**  
**THIS SHEET INCLUDED**  
**FOR INFORMATION ONLY**

ROW Team: GETTINGS/CUVA  
ROW #: NHSN-20-8(48)-2R-28  
Plan Date: 4/15/13

- Color Legend:**
- Property Lines
  - Temporary Easement
  - Permanent Acquisition



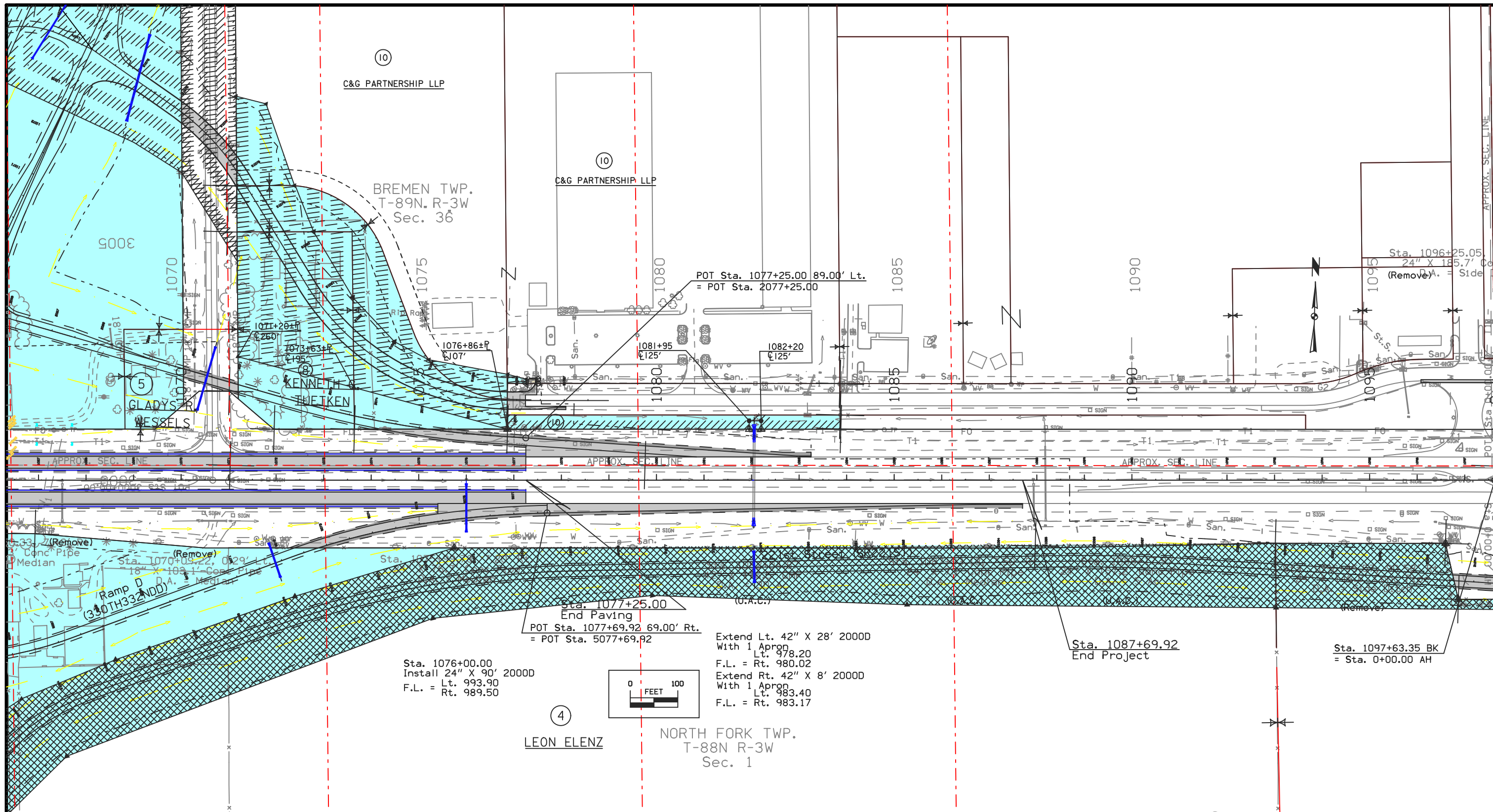

⑩  
C&G PARTNERSHIP LLP

BREMEN TWP.  
T-89N. R-3W  
Sec. 36

⑩  
C&G PARTNERSHIP LLP

⑤  
GLADYS R.  
WESSELS

⑧  
KENNETH  
THEIKEN

④  
LEON ELENZ

NORTH FORK TWP.  
T-88N R-3W  
Sec. 1

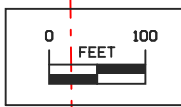

Sta. 1076+00.00  
Install 24" X 90' 2000D  
F.L. = Lt. 993.90  
Rt. 989.50

Sta. 1077+25.00  
End Paving  
POT Sta. 1077+69.92 69.00' Rt.  
= POT Sta. 5077+69.92

Extend Lt. 42" X 28' 2000D  
With 1 Apron  
Lt. 978.20  
F.L. = Rt. 980.02  
Extend Rt. 42" X 8' 2000D  
With 1 Apron  
Lt. 983.40  
F.L. = Rt. 983.17

Sta. 1087+69.92  
End Project

Sta. 1097+63.35 BK  
= Sta. 0+00.00 AH

POT Sta. 1077+25.00 89.00' Lt.  
= POT Sta. 2077+25.00

Sta. 1096+25.05  
24" X 185.7' Cd  
(Remove) A. = Side

<b>Right of Way Design Information</b>	
<b>THIS SHEET INCLUDED FOR INFORMATION ONLY</b>	
ROW Team: GETTINGS/CUVA	
ROW #: NHSN-20-8(48)-2R-28	
Plan Date: 4/15/13	
Color Legend:	
	Property Lines
	Temporary Easement
	Permanent Acquisition





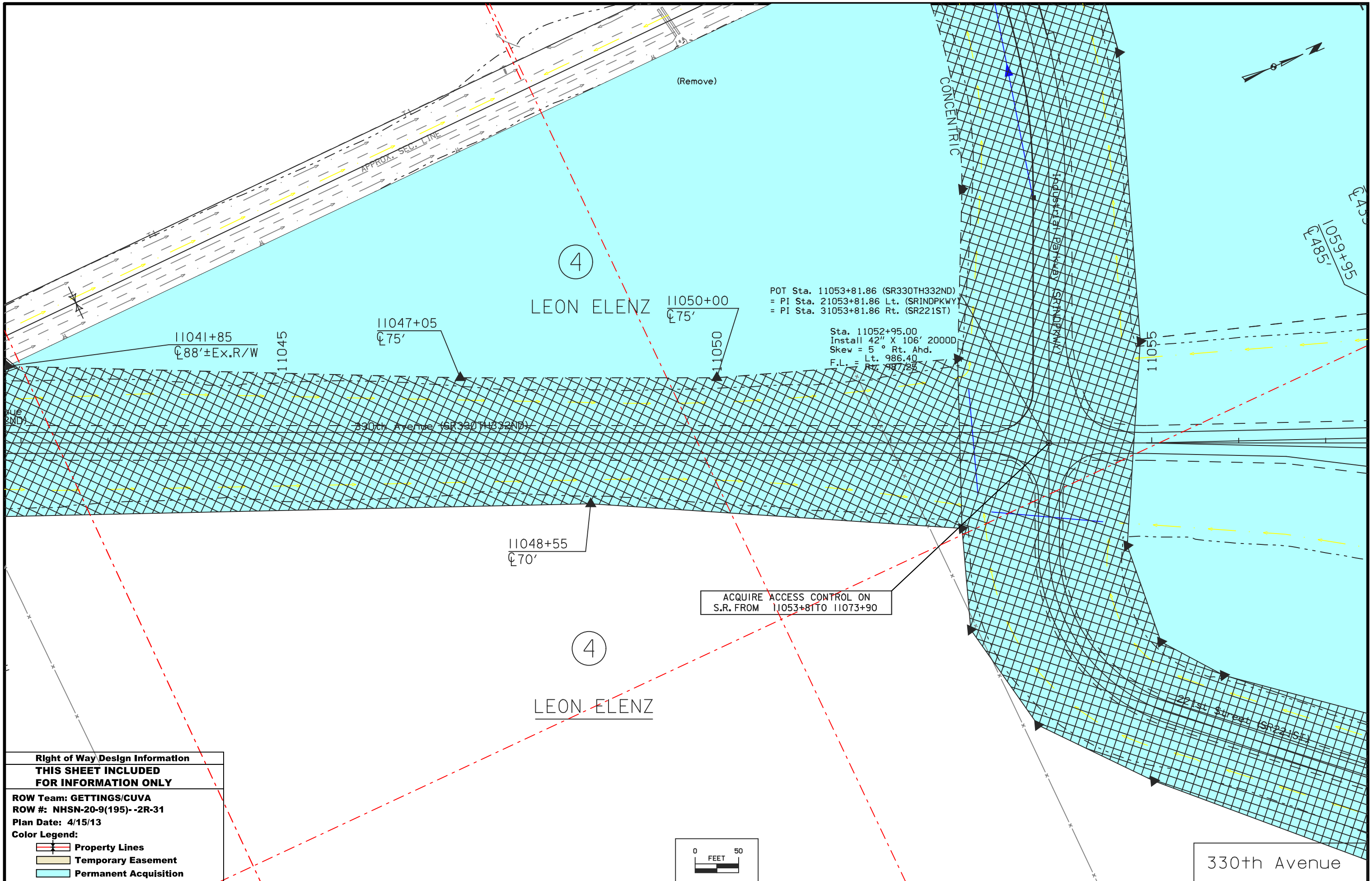

4

LEON ELENZ

4

LEON ELENZ

POT Sta. 11053+81.86 (SR330TH332ND)  
 = PI Sta. 21053+81.86 Lt. (SRINDPKWY)  
 = PI Sta. 31053+81.86 Rt. (SR221ST)

Sta. 11052+95.00  
 Install 42" X 106' 2000D  
 Skew = 5° Rt. Ahd.  
 F.L. = Lt. 986.40  
 Rt. 987.28

ACQUIRE ACCESS CONTROL ON  
 S.R. FROM 11053+81 TO 11073+90

11041+85  
 ±88'±Ex.R/W

11047+05  
 ±75'

11050+00  
 ±75'

11048+55  
 ±70'

11055

1059+95  
 ±485'

**Right of Way Design Information**  
**THIS SHEET INCLUDED**  
**FOR INFORMATION ONLY**

ROW Team: GETTINGS/CUVA  
 ROW #: NHSN-20-9(195)--2R-31  
 Plan Date: 4/15/13

- Color Legend:**
- Property Lines
  - Temporary Easement
  - Permanent Acquisition

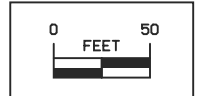

330th Avenue

**Right of Way Design Information**  
**THIS SHEET INCLUDED FOR INFORMATION ONLY**  
 ROW Team: GETTINGS/CUVA  
 ROW #: NHSN-20-9(195)-2R-31  
 Plan Date: 4/15/13  
 Color Legend:  
 - Property Lines  
 - Temporary Easement  
 - Permanent Acquisition

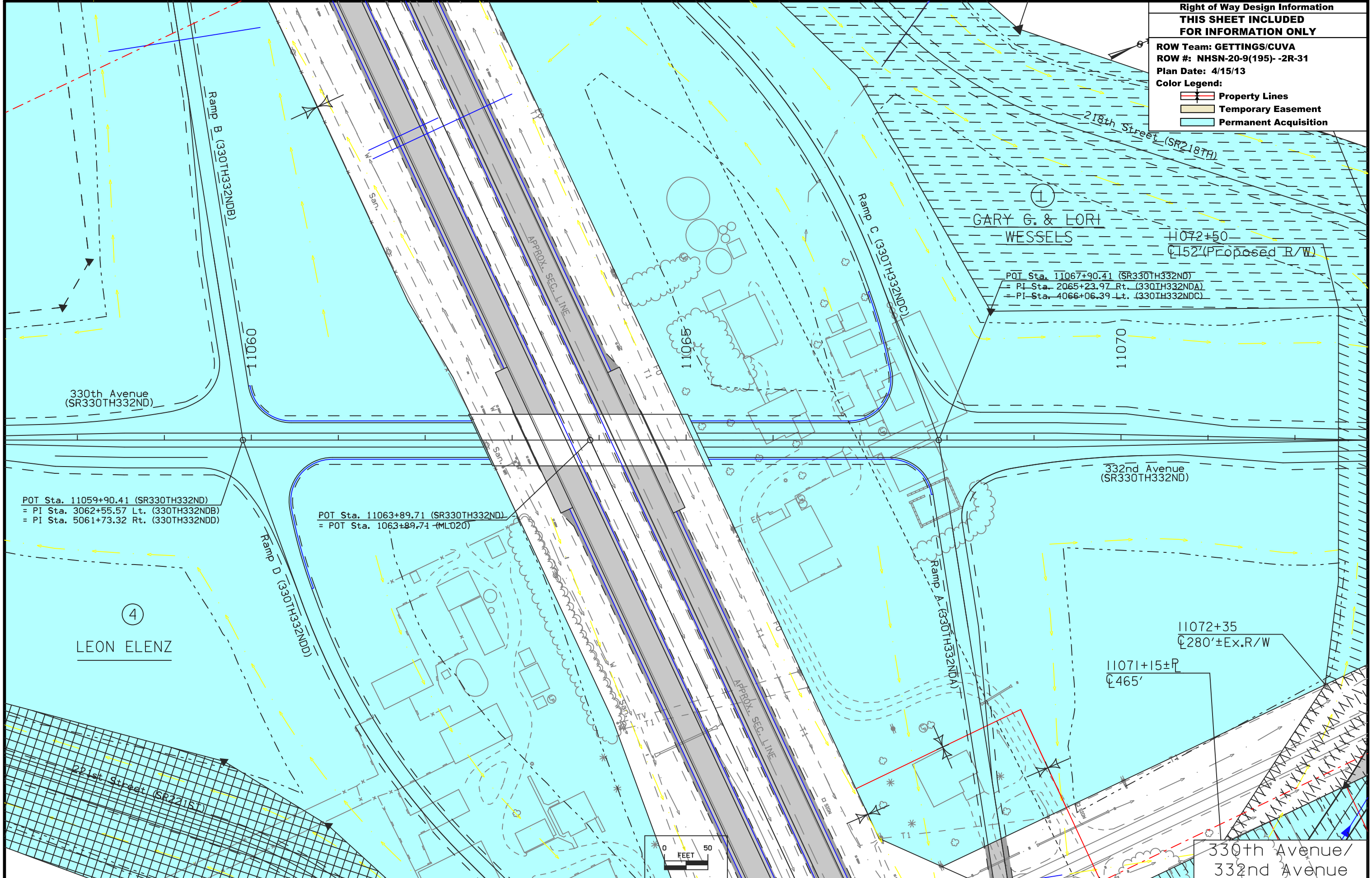



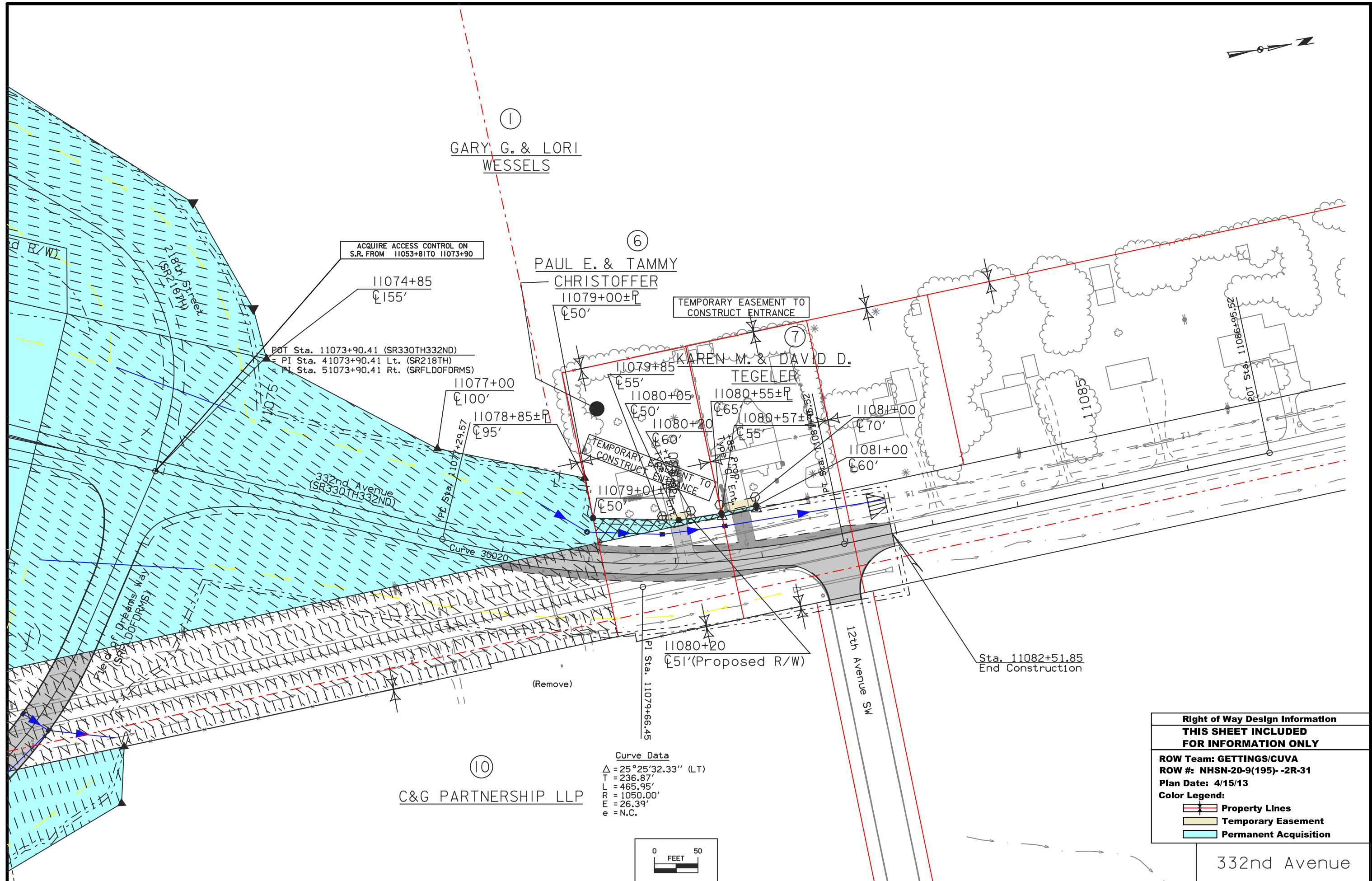

ACQUIRE ACCESS CONTROL ON S.R. FROM 11053+81 TO 11073+90

11074+85  
±155'

POT Sta. 11073+90.41 (SR330TH332ND)  
PI Sta. 41073+90.41 Lt. (SR218TH)  
PI Sta. 51073+90.41 Rt. (SRFLDOFDRMS)

332nd Avenue (SR330TH332ND)

Pt. Sta. 11077+29.57

Curve 36020'

Field of Dreams Way (SR FLDOFDRMS)

10  
C&G PARTNERSHIP LLP

1  
GARY G. & LORI WESSELES

6  
PAUL E. & TAMMY CHRISTOFFER

7  
KAREN M. & DAVID D. TEGELER

11077+00 ±100'

11078+85 ±95'

11079+00 ±50'

11079+85 ±55'

11080+05 ±50'

11080+20 ±60'

11080+55 ±65'

11080+57 ±55'

11081+00 ±70'

11081+00 ±60'

11079+00 ±50'

11080+20 ±51' (Proposed R/W)

PI Sta. 11079+66.45

12th Avenue SW

Sta. 11082+51.85 End Construction

(Remove)

TEMPORARY EASEMENT TO CONSTRUCT ENTRANCE

TEMPORARY EASEMENT TO CONSTRUCT ENTRANCE

Curve Data  
 $\Delta = 25^\circ 25' 32.33''$  (LT)  
 $T = 236.87'$   
 $L = 465.95'$   
 $R = 1050.00'$   
 $E = 26.39'$   
 $e = N.C.$

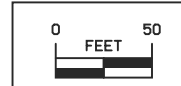

<b>Right of Way Design Information</b>	
<b>THIS SHEET INCLUDED FOR INFORMATION ONLY</b>	
ROW Team: GETTINGS/CUVA	
ROW #: NHSN-20-9(195)-2R-31	
Plan Date: 4/15/13	
Color Legend:	
	Property Lines
	Temporary Easement
	Permanent Acquisition

332nd Avenue

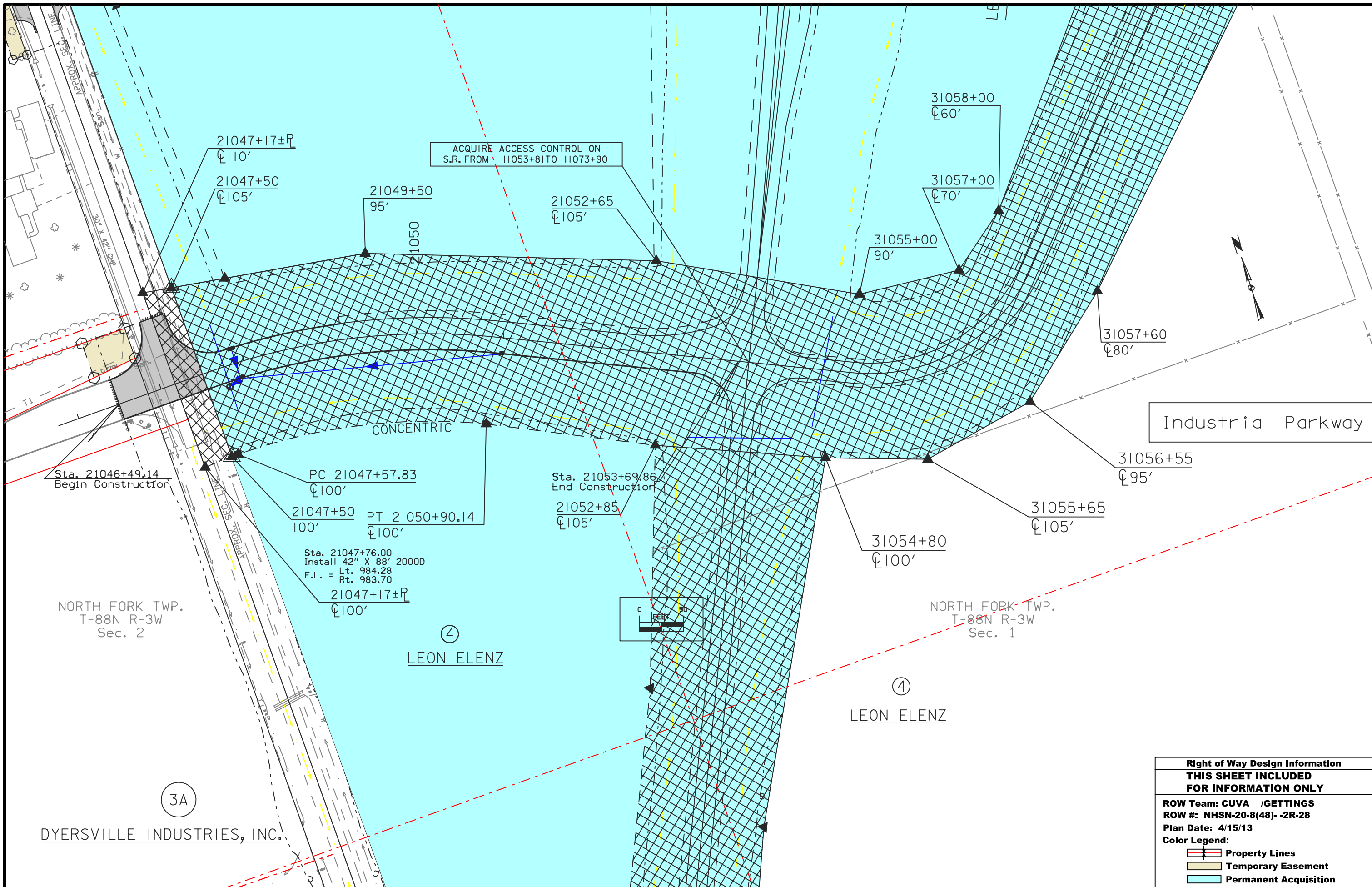

<b>Right of Way Design Information</b>	
<b>THIS SHEET INCLUDED FOR INFORMATION ONLY</b>	
ROW Team: CUVA /GETTINGS	
ROW #: NHSN-20-8(48)-2R-28	
Plan Date: 4/15/13	
Color Legend:	
	Property Lines
	Temporary Easement
	Permanent Acquisition



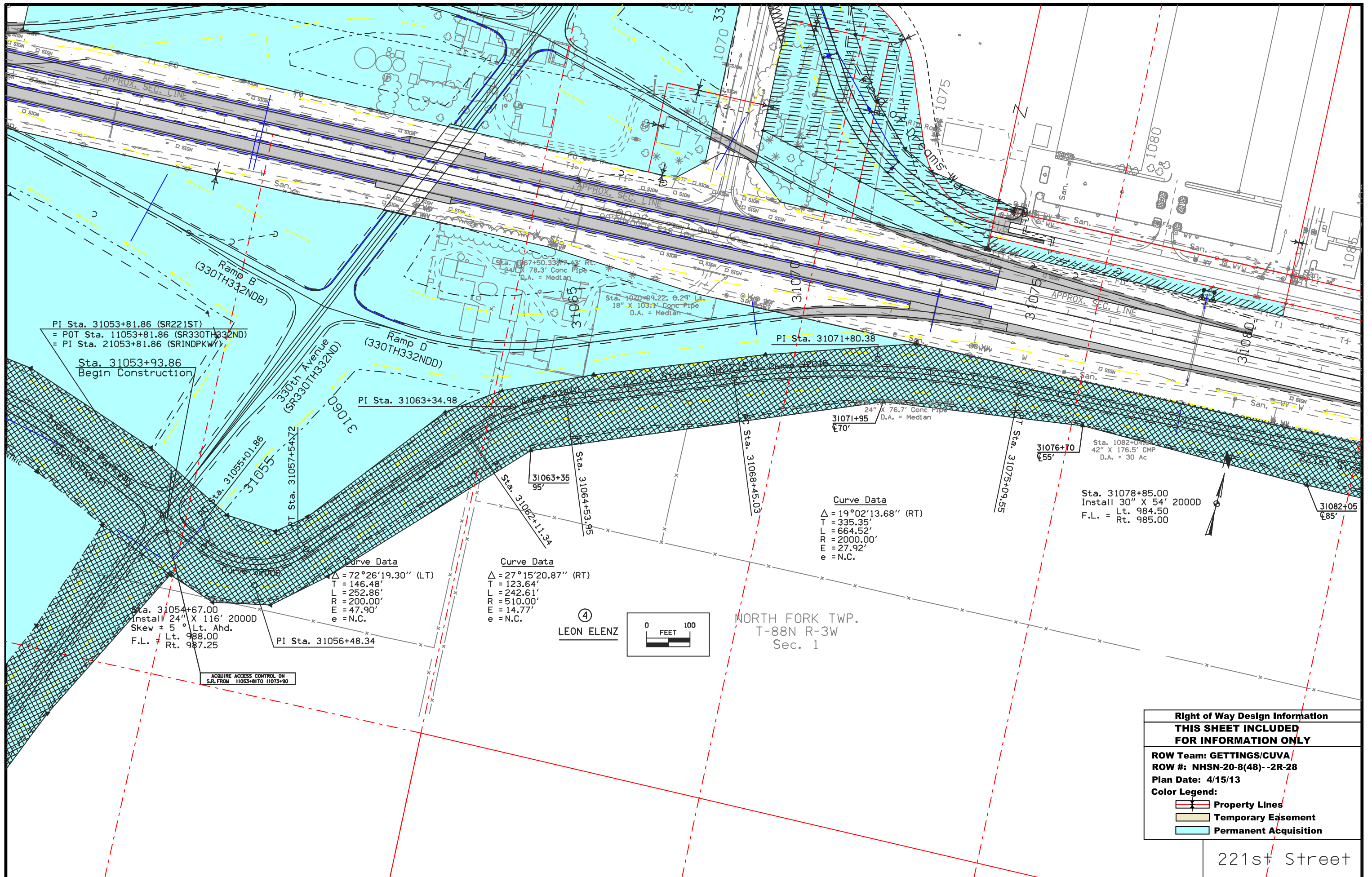

<b>Right of Way Design Information</b>	
<b>THIS SHEET INCLUDED FOR INFORMATION ONLY</b>	
ROW Team: <b>GETTINGS/CUVA</b>	
ROW #: <b>NHSN-20-8(48)-2R-28</b>	
Plan Date: <b>4/15/13</b>	
Color Legend:	
	Property Lines
	Temporary Easement
	Permanent Acquisition



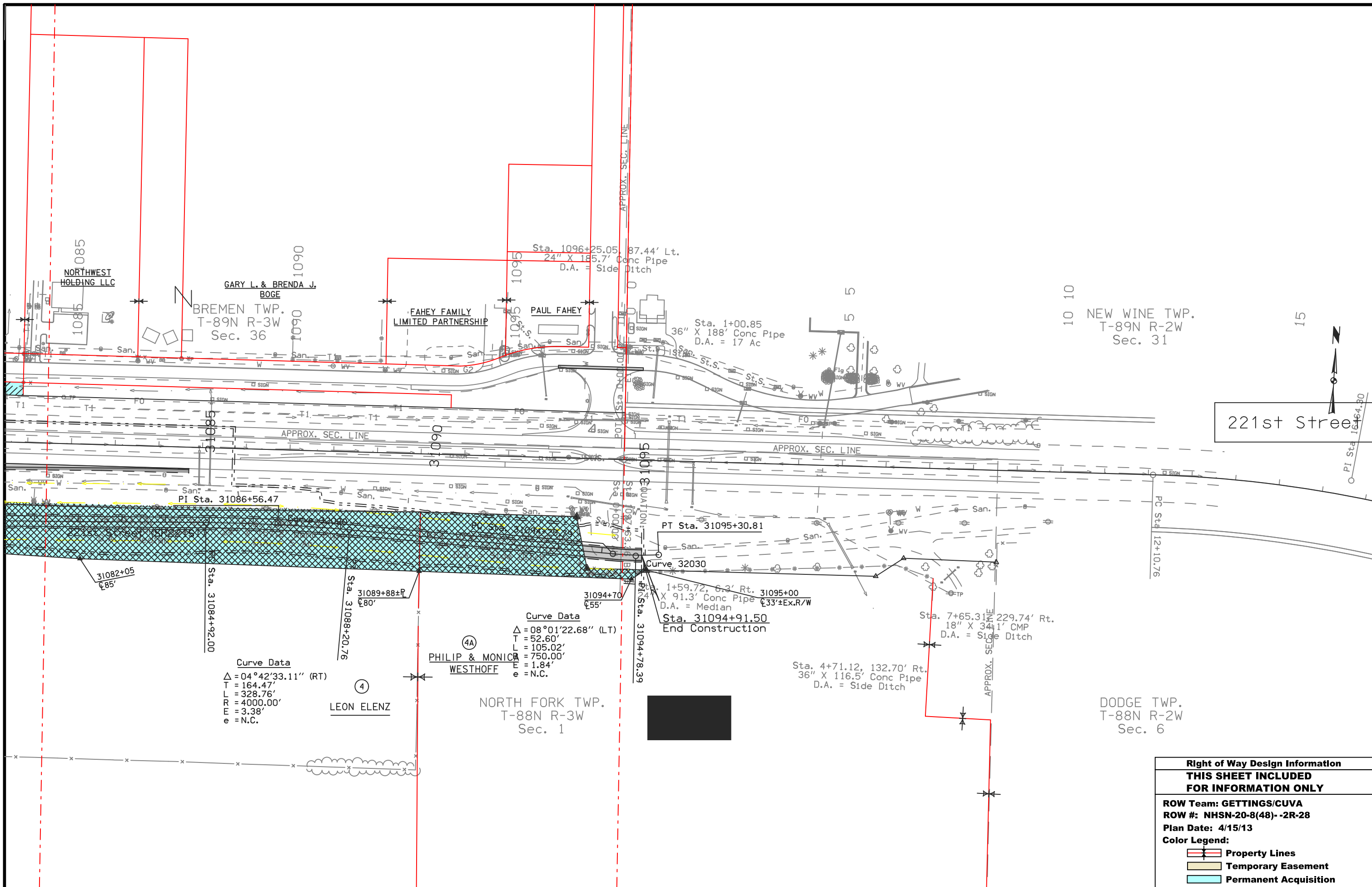

221st Street

<b>Right of Way Design Information</b>	
<b>THIS SHEET INCLUDED FOR INFORMATION ONLY</b>	
ROW Team: GETTINGS/CUVA	
ROW #: NHSN-20-8(48)-2R-28	
Plan Date: 4/15/13	
Color Legend:	
	Property Lines
	Temporary Easement
	Permanent Acquisition

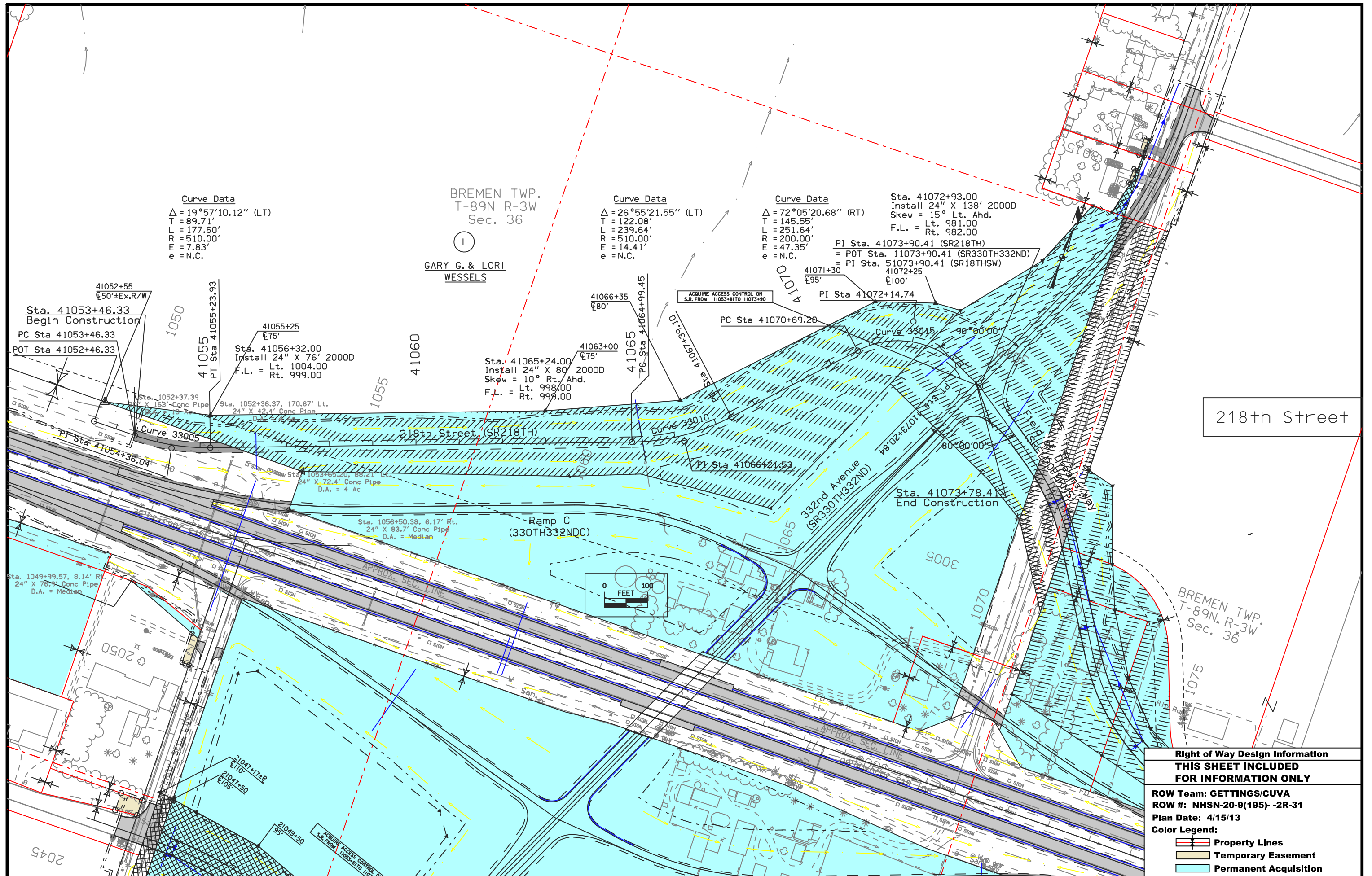

218th Street

<b>Right of Way Design Information</b>	
<b>THIS SHEET INCLUDED FOR INFORMATION ONLY</b>	
ROW Team: GETTINGS/CUVA	
ROW #: NHSN-20-9(195)-2R-31	
Plan Date: 4/15/13	
Color Legend:	
	Property Lines
	Temporary Easement
	Permanent Acquisition



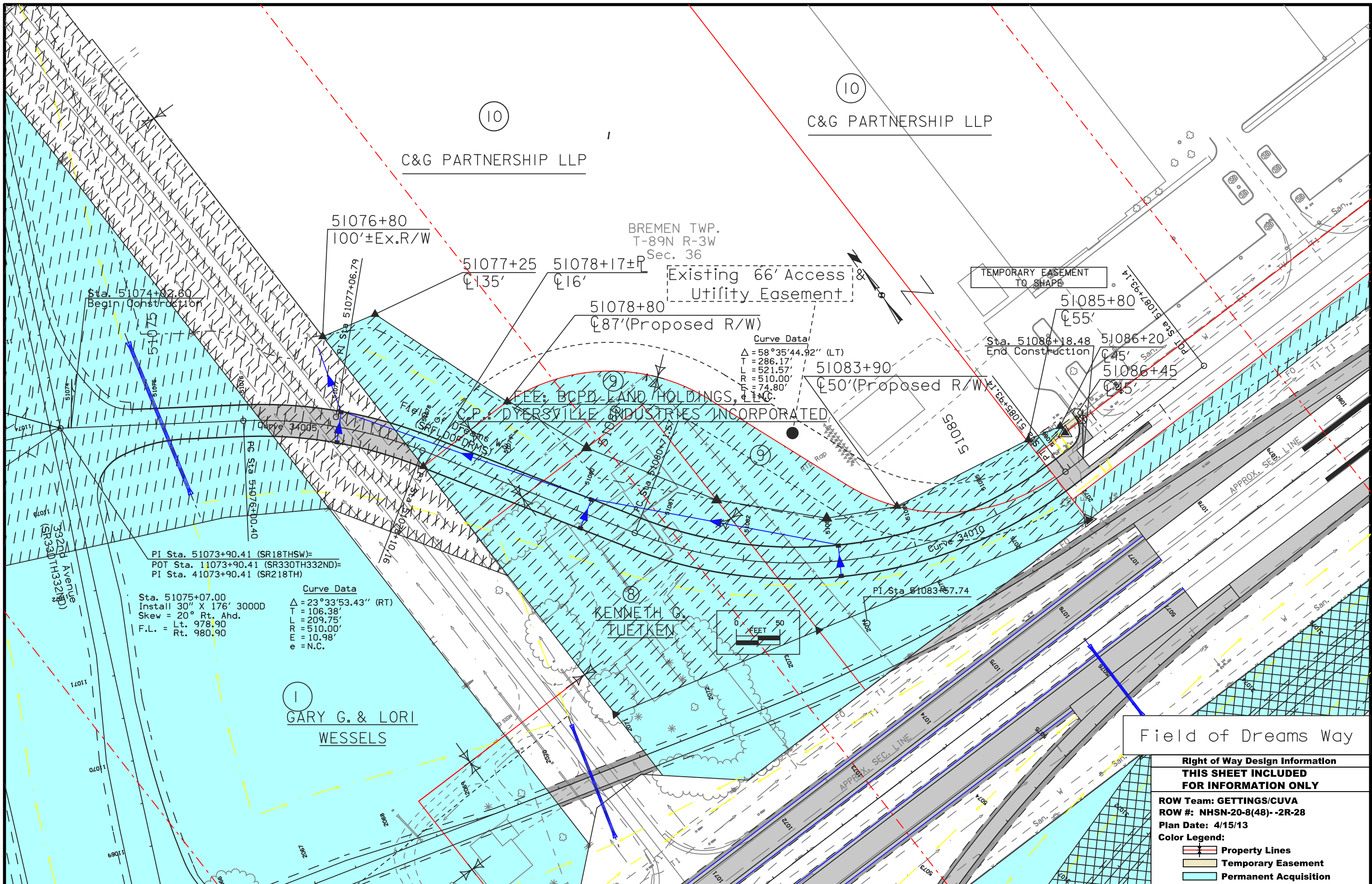

PI Sta. 51073+90.41 (SR18THSW)=  
 POT Sta. 51073+90.41 (SR330TH332ND)=  
 PI Sta. 41073+90.41 (SR218TH)

Sta. 51075+07.00  
 Install 30" X 176' 3000D  
 Skew = 20° Rt. Ahd.  
 F.L. = Lt. 978.90  
 Rt. 980.90

Curve Data  
 $\Delta = 23^\circ 33' 53.43''$  (RT)  
 T = 106.38'  
 L = 209.75'  
 R = 510.00'  
 E = 10.98'  
 e = N.C.

Curve Data  
 $\Delta = 58^\circ 35' 44.92''$  (LT)  
 T = 286.17'  
 L = 521.57'  
 R = 510.00'  
 E = 74.80'  
 e = N.C.

**Field of Dreams Way**

**Right of Way Design Information**  
**THIS SHEET INCLUDED**  
**FOR INFORMATION ONLY**



**ROW Team: GETTINGS/CUVA**  
**ROW #: NHSN-20-8(48)--2R-28**  
**Plan Date: 4/15/13**

**Color Legend:**  
**Property Lines**  
**Temporary Easement**  
**Permanent Acquisition**

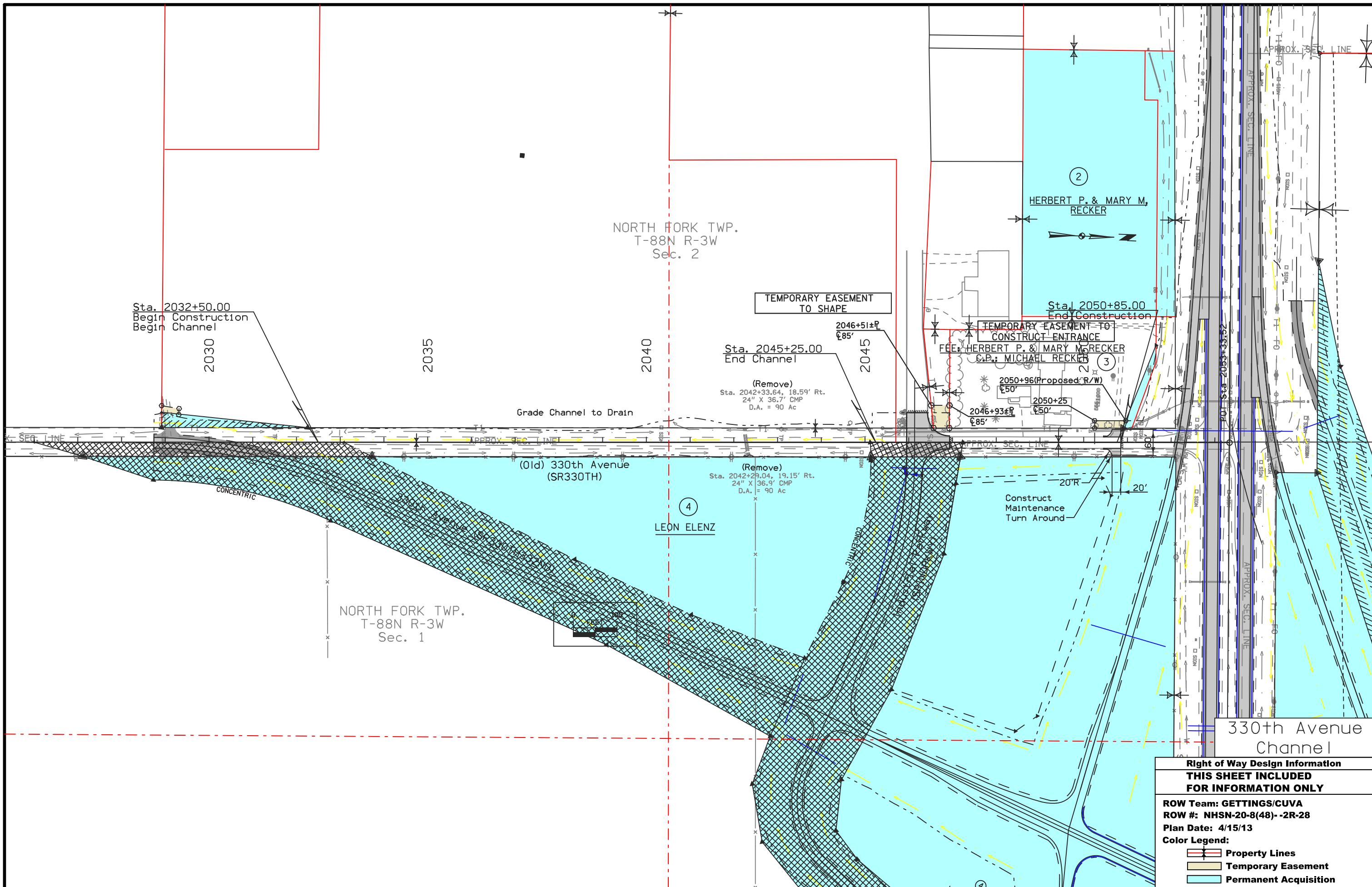



330th Avenue Channel

<b>Right of Way Design Information</b>	
<b>THIS SHEET INCLUDED FOR INFORMATION ONLY</b>	
ROW Team: GETTINGS/CUVA	
ROW #: NHSN-20-8(48)-2R-28	
Plan Date: 4/15/13	
Color Legend:	
	Property Lines
	Temporary Easement
	Permanent Acquisition

**TRAFFIC CONTROL PLAN**

US 20  
At all times, at least one lane of traffic shall be maintained on US 20 in each direction. During winter shutdown, November 20th - April 1st each year, two lanes of traffic shall be maintained on US 20 in each direction with the same profile in both directions.

Stage 1C/Stage 2  
Closure of US 20 will be allowed each day, Monday through Thursday, from 9:00 am to 2:30 pm for production blasting.

Stage 3  
For EB and WB traffic the Contractor will be allowed to close US 20 with use of the proposed 330th Ave./332 Ave. interchange ramps as a detour for placement of bridge beams. The ramps shall be paved before being used as a detour.

330th AVENUE  
330th Avenue will be closed at US 20 until the new interchange is open to traffic.

332nd AVENUE  
332nd Avenue will be closed at US 20 until the new interchange is open to traffic.

320th AVENUE  
320th Avenue will remain open until the new interchange is open to traffic. Once the interchange is open to traffic, 320th will be closed at US 20.

7th STREET SW  
7th Street SW will remain open until the new interchange is open to traffic. Once the interchange is open to traffic, 7th Street SW will be closed at US 20.

218th STREET  
218th St. will remain open to traffic at all times. Once the interchanged is open to traffic, the existing connection of 218th St. to US-20 will be closed at US-20.

**COORDINATED OPERATIONS**

Other work in progress during the same period of time will include the construction of the projects listed. Coordinate operations with those of other contractors working within the same area.

Project	Type of Work
MP-20-6(705)283--76-28	HMA Joint and Crack Sealing
NHSX-20-9(204)--3H-28	Bridge New PPCB
NHSN-000-S(726)--2R-00	Traffic Signs
NHSN-000-S(675)--2R-00	Traffic Signs
NHSN-20-8(48)-2R-28	Salvage & Removal, Parcel 8

**STAGING NOTES**

Stage 1A  
Traffic Control  
Close 330th Avenue south of the proposed southerly tie-in. Maintain access to existing Industrial Parkway via existing 330th Avenue to the north.

Construction  
Construct new 330th Avenue, between southerly tie-in and Industrial Parkway. Construct the extension of Industrial Parkway between existing 330th Avenue and 221st Street. Construct 221st Street, between new 330th Avenue and the US-20 Access to the east. Obliterate existing 330th Avenue south of Industrial Parkway to new tie-in and re-establish existing drainage.

Stage 1B  
Traffic Control  
EB and WB traffic shifted to outside lanes to construct median crossovers. Maintain one lane of traffic on US 20 in each direction. Move Industrial Parkway traffic to new construction (Industrial Parkway extension and 221st Street).

Construction  
Construct both median crossovers. Prior to winter shutdown, provide/maintain two lanes of traffic in both directions on US 20.

Stage 1C  
Traffic Control  
EB and WB traffic shifted to WB lanes utilizing new median crossovers, one lane in each direction. Closure of US 20 will be allowed each day, Monday through Thursday, from 9:00 am to 2:30 pm for production blasting. Close access to 330th Avenue and 332nd Avenue at US 20. Construct turnaround on 330th Avenue. Maintain access to existing Industrial Parkway via extension of Industrial Parkway and 221st Street. Maintain access to existing Field of Dreams Way via 7th Street SW.

Construction  
Reconstruct EB lanes of US 20. Construct Ramp B, Ramp D, and 330th Avenue between Industrial Parkway and Ramps B and D.

Stage 2  
Traffic Control  
EB and WB traffic shifted to newly constructed EB lanes utilizing median crossovers, one lane in each direction. Closure of US 20 will be allowed each day, Monday through Thursday, from 9:00 am to 2:30 pm for production blasting. Access to 330th Avenue and 332nd Avenue to remain closed at US 20. Maintain access to existing Industrial Parkway via extension of Industrial Parkway and 221st Street. Maintain access to existing Field of Dreams Way via 7th Street SW. Maintain access to existing 218th Street via US-20.

Construction  
Reconstruct WB lanes of US 20. Construct Ramp A, Ramp C, 332nd Avenue, Field of Dreams Way, and 218th Street. Remove 332nd Avenue between US 20 and Field of Dreams Way.

Stage 3  
Traffic Control  
EB and WB traffic shifted to outside lanes to remove median crossovers and construct median bridge pier. Maintain one lane of traffic on US 20 in each direction. Refer to Road Design Detail 8210 (Modified) on Sheet B.11. Maintain two lanes of traffic in each direction (Standard Road Plan TC-402) while constructing 330th/332nd bridge approach on both sides. For EB and WB traffic the Contractor will be allowed to close US 20 with use of the proposed 330th Ave./332 Ave. interchange ramps as a detour for placement of bridge beams. The ramps shall be paved before being used as a detour.









Maintain access to existing Industrial Parkway via extension of Industrial Parkway and 221st Street. Maintain access to new 218th St. via 332nd Avenue.

Construction  
Construct bridge approaches. Construct 330th Avenue/332nd Avenue bridge over US 20. Remove 7nd Street SW access at US 20. Remove 320th Street access at US 20 and construct turnaround. Remove access to 221st Street at US 20 opposite 7th Street SW. Remove access to 218th St. at US-20.

**CROSS SECTION VIEW COLOR LEGEND  
OF TRAFFIC CONTROL AND STAGING SHEETS**

SHADING	Design Color No.	
Green, Light	(225)	Existing Pavement Shading
Gray, Light	(48)	Previously Constructed Pavement Shading
Gray, Med	(80)	Previously Constructed Granular Surface Shading
Blue, Light	(230)	Proposed Pavement Shading
Lavender	(9)	Temporary Pavement Shading
Brown, Med	(237)	Future Proposed Pavement Shading

**CROSS SECTION VIEW PATTERN AND SYMBOL LEGEND  
OF TRAFFIC CONTROL AND STAGING SHEETS**

	Pavement Removal		Proposed Granular Shoulder
	Proposed Granular Subbase		Temporary Shoulder
	Proposed Special Backfill		Existing Shoulder Strengthening
	Temporary Barrier Rail		Permanent Barrier Rail
			Channelizing Device



















**PLAN VIEW COLOR LEGEND OF TRAFFIC CONTROL AND STAGING SHEETS**

LINEWORK	Design Color No.	
Green	(2)	Existing Topographic Features and Labels
Magenta	(5)	Pavement Marking Call Outs
Blue	(1)	Proposed Alignment, Stationing, Tic Marks, and Alignment Annotation
Yellow	(4)	Pavement Markings, Yellow
Off White	(254)	Pavement Markings, White

SHADING	Design Color No.	
Green, Light	(225)	Existing Pavement Shading
Gray, Light	(48)	Previously Constructed Pavement Shading
Gray, Med	(80)	Proposed Granular Surface Shading
Gray, Med	(80)	Previously Constructed Granular Surface Shading
Tan	(8)	Proposed Granular Surface Shading
Blue, Light	(230)	Proposed Pavement Shading
Lavender	(9)	Temporary Pavement Shading
Brown, Light	(236)	Proposed Grading Limits Shading
Pink, Dark	(13)	Proposed MSE or CIP Wall Shading
Red	(3)	Proposed Bridge Shading and Sign Trusses
Black w/Gray, Light Fill	(0,48)	Previously Constructed Structure

**PLAN VIEW PATTERN AND SYMBOL LEGEND  
OF TRAFFIC CONTROL AND STAGING SHEETS**

	Channelizing Device		Crash Cushion
	Drum		Traffic Signal
	Temporary Lane Separator		Flagger
	Tubular Marker		Temporary Floodlighting
	Channelizer Marker		Traffic Sign
	Concrete Barrier Marker		Type III Barricade
	Delineator		Type A Warning Light
	Temporary Barrier Rail		Direction of Traffic
	Pavement Removal		Safety Closure

NOTE: Device spacing according to Standard Road Plans unless specifically dimensioned.

**TRAFFIC CONTROL  
AND  
STAGING  
LEGEND AND SYMBOL  
INFORMATION SHEET**

**(COVERS SHEET SERIES J)**

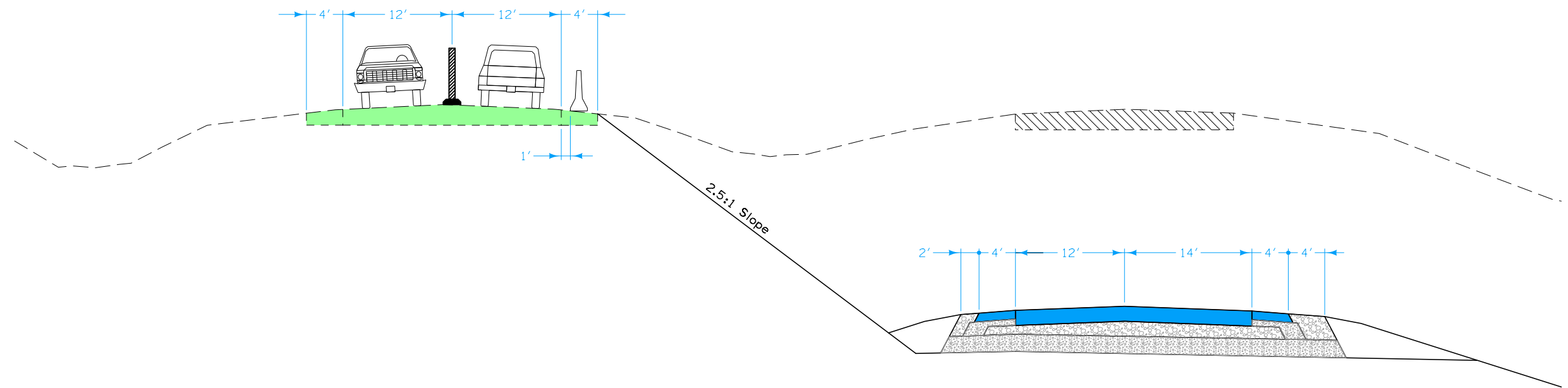

U.S. 20 - STAGE 1 - STA. 1062+00.00

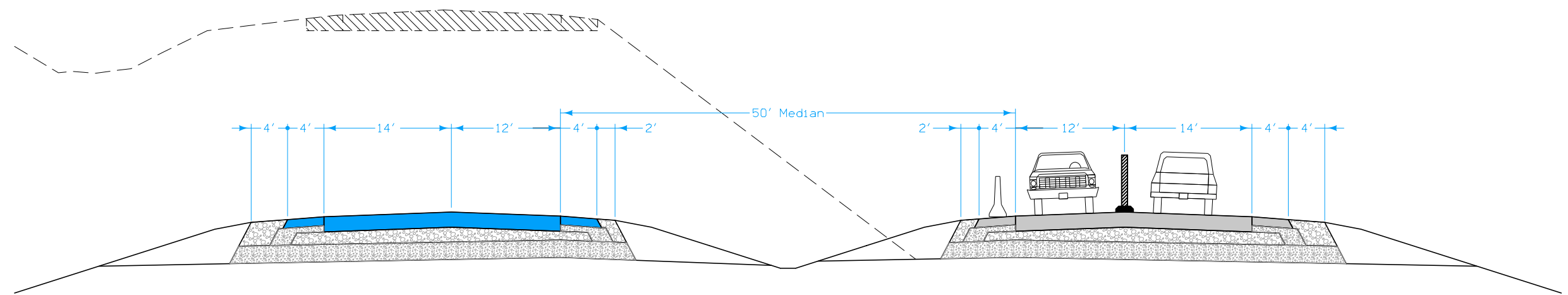

U.S. 20 - STAGE 2 - STA. 1062+00.00



BREMEN TWP.  
T-89N R-3W  
Sec. 35

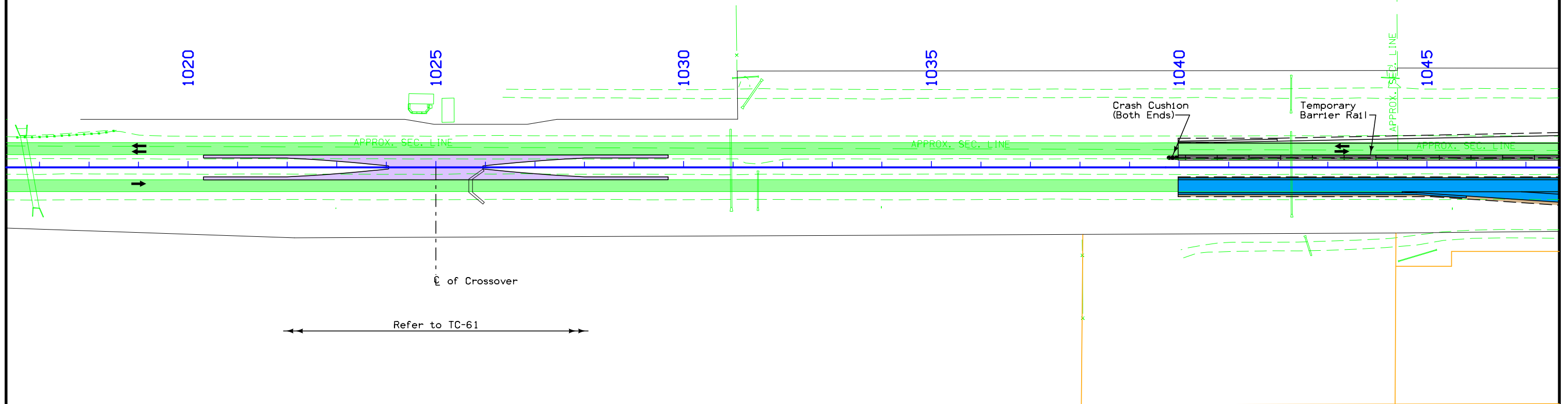

NORTH FORK TWP.  
T-88N R-3W  
Sec. 2

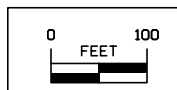

U.S. 20  
STAGE 1

BREMEN TWP.  
T-89N R-3W  
Sec. 36

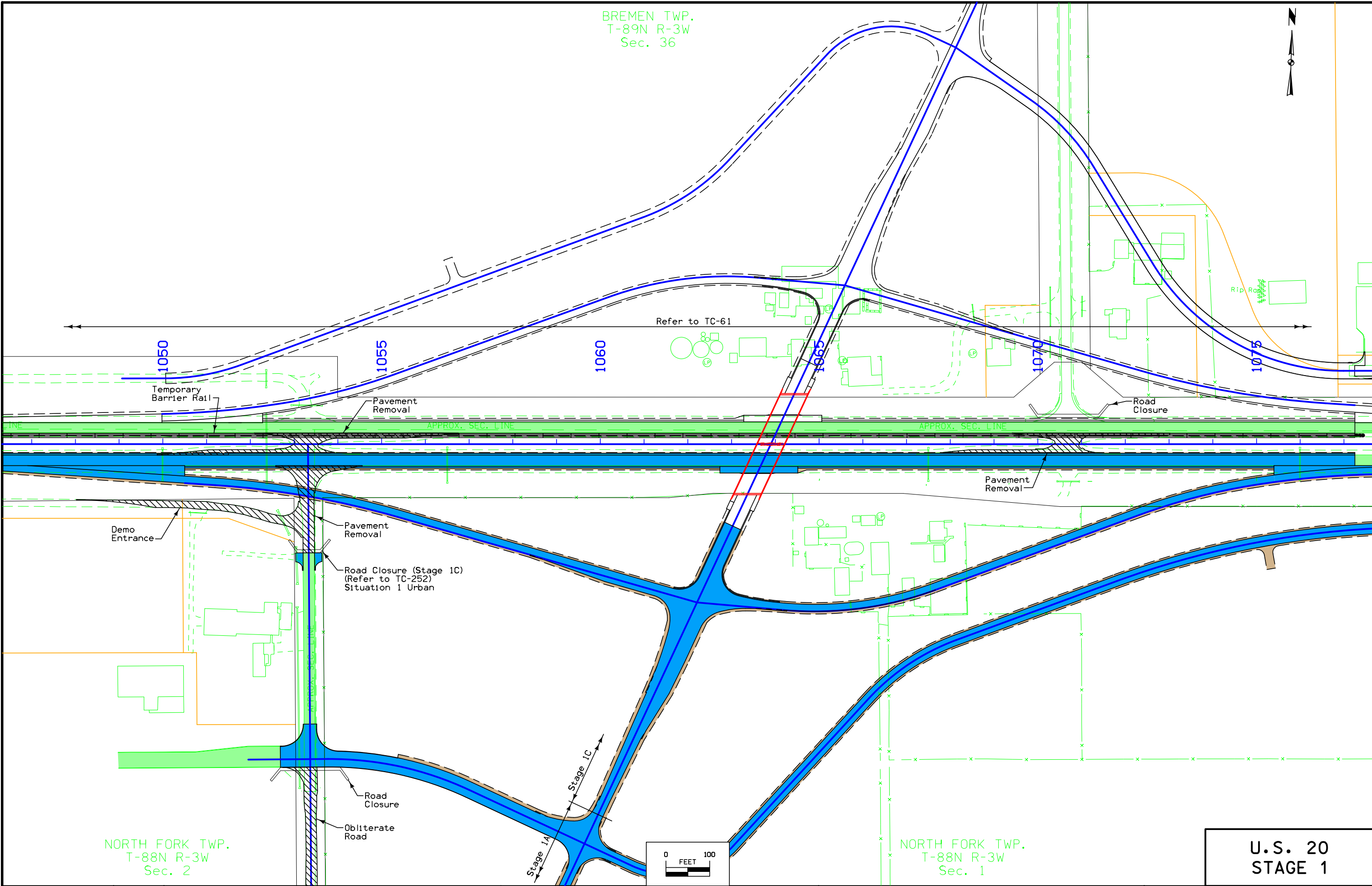

NORTH FORK TWP.  
T-88N R-3W  
Sec. 2

NORTH FORK TWP.  
T-88N R-3W  
Sec. 1

U.S. 20  
STAGE 1

BREMEN TWP.  
T-89N R-3W  
Sec. 36

NEW WINE TWP.  
T-89N R-2W  
Sec. 31



7th Street SW

APPROX. SEC. LINE

Refer to TC-418  
(Left Lane Closure with Access to 7th Street)

1080

1085

1090

1095

5

10

APPROX. SEC. LINE

APPROX. SEC. LINE

APPROX. SEC. LINE

APPROX. SEC. LINE

Crash Cushion  
Temporary Barrier Rail

℄ of Crossover

Refer to TC-61

NORTH FORK TWP.  
T-88N R-3W  
Sec. 1

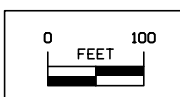

U.S. 20  
STAGE 1

NORTH FORK TWP.  
T-88N R-3W  
Sec. 2

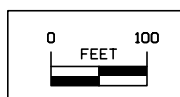
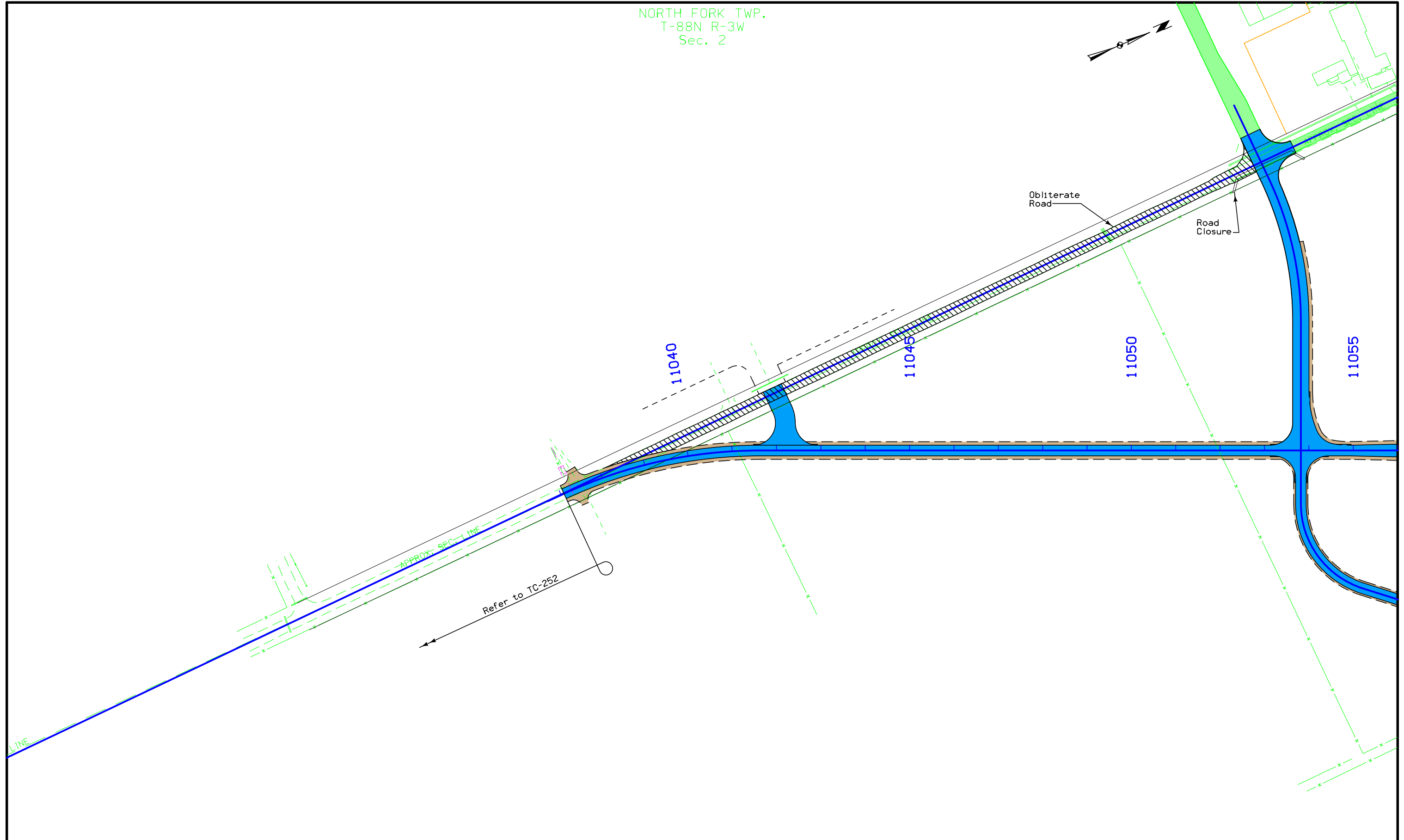
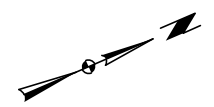

NORTH FORK TWP.  
T-88N R-3W  
Sec. 1

330th Ave  
STAGE 1

FILE NO.	ENGLISH	DESIGN TEAM	Stanley Consultants Inc.	DELAWARE/DUBUQUE COUNTY	PROJECT NUMBER	NHSX-020-9(203)--3H-28	SHEET NUMBER	J.7
----------	---------	-------------	--------------------------	-------------------------	----------------	------------------------	--------------	-----

BREMEN TWP.  
T-89N R-3W  
Sec. 36

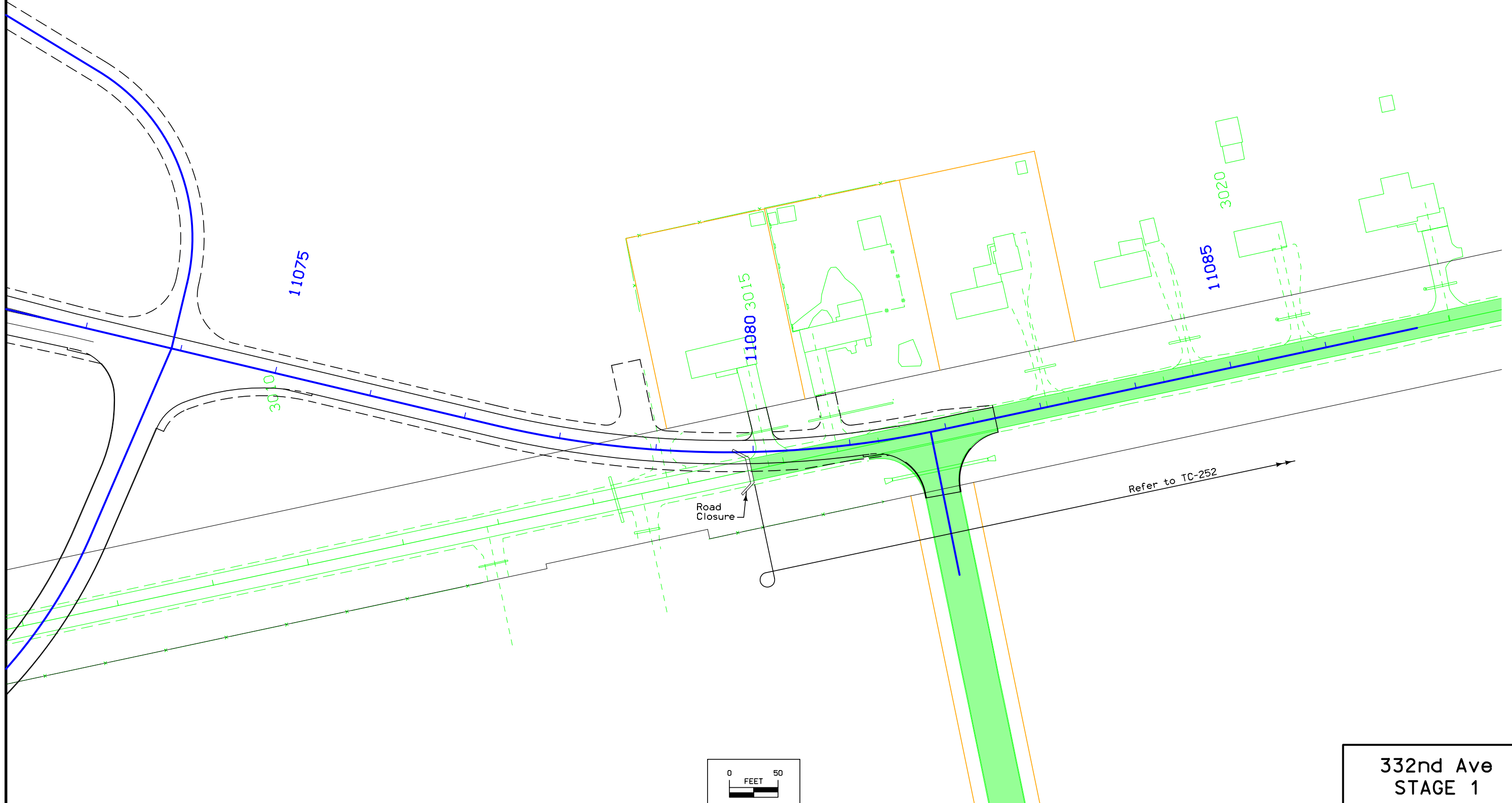

BREMEN TWP.  
T-89N R-3W  
Sec. 35

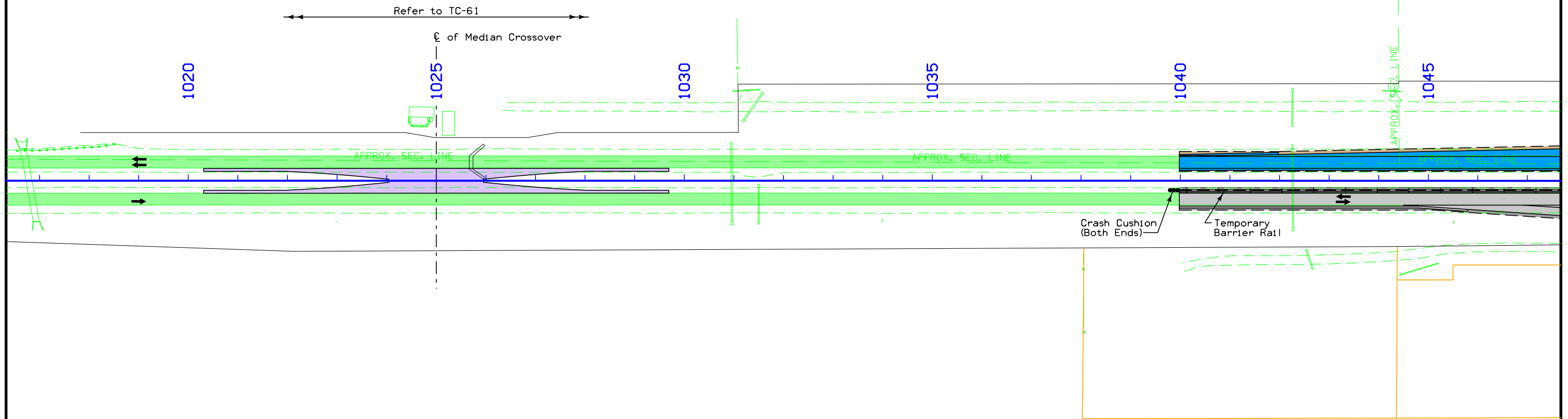

NORTH FORK TWP.  
T-88N R-3W  
Sec. 2

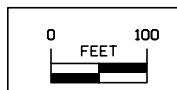

U.S. 20  
STAGE 2

BREMEN TWP.  
T-89N R-3W  
Sec. 36



Pavement Removal

Rip Road

Refer to TC-61

1050

1055

1060

1070

1075

Temporary Barrier Rail

Demo Entrance

APPROX. SEC. LINE

APPROX. SEC. LINE

Road Closure

Road Closure

NORTH FORK TWP.  
T-88N R-3W  
Sec. 2

NORTH FORK TWP.  
T-88N R-3W  
Sec. 1

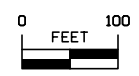

U.S. 20  
STAGE 2

FILE NO.

ENGLISH

DESIGN TEAM

Stanley Consultants Inc.

DELAWARE/DUBUQUE COUNTY

PROJECT NUMBER

NHSX-020-9(203)--3H-28

SHEET NUMBER

J.10

12:27:58 PM 3/13/2015

8725

c:\projects\datasource-1\common\d0319374\28020203j10.sht



BREMEN TWP.  
T-89N R-3W  
Sec. 36

NEW WINE TWP.  
T-89N R-2W  
Sec. 31



7th Street SW

APPROX. SEC. LINE

Refer to TC-418  
(Right Lane Closure with Access to 7th Street)

1080

1085

1090

1095

5

10

APPROX. SEC. LINE

APPROX. SEC. LINE

APPROX. SEC. LINE

APPROX. SEC. LINE

Crash Cushion  
Temporary Barrier Rail

℄ of Median Crossover

Refer to TC-61

NORTH FORK TWP.  
T-88N R-3W  
Sec. 1

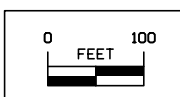

U.S. 20  
STAGE 2

NORTH FORK TWP.  
T-88N R-3W  
Sec. 2

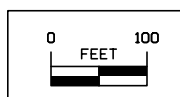
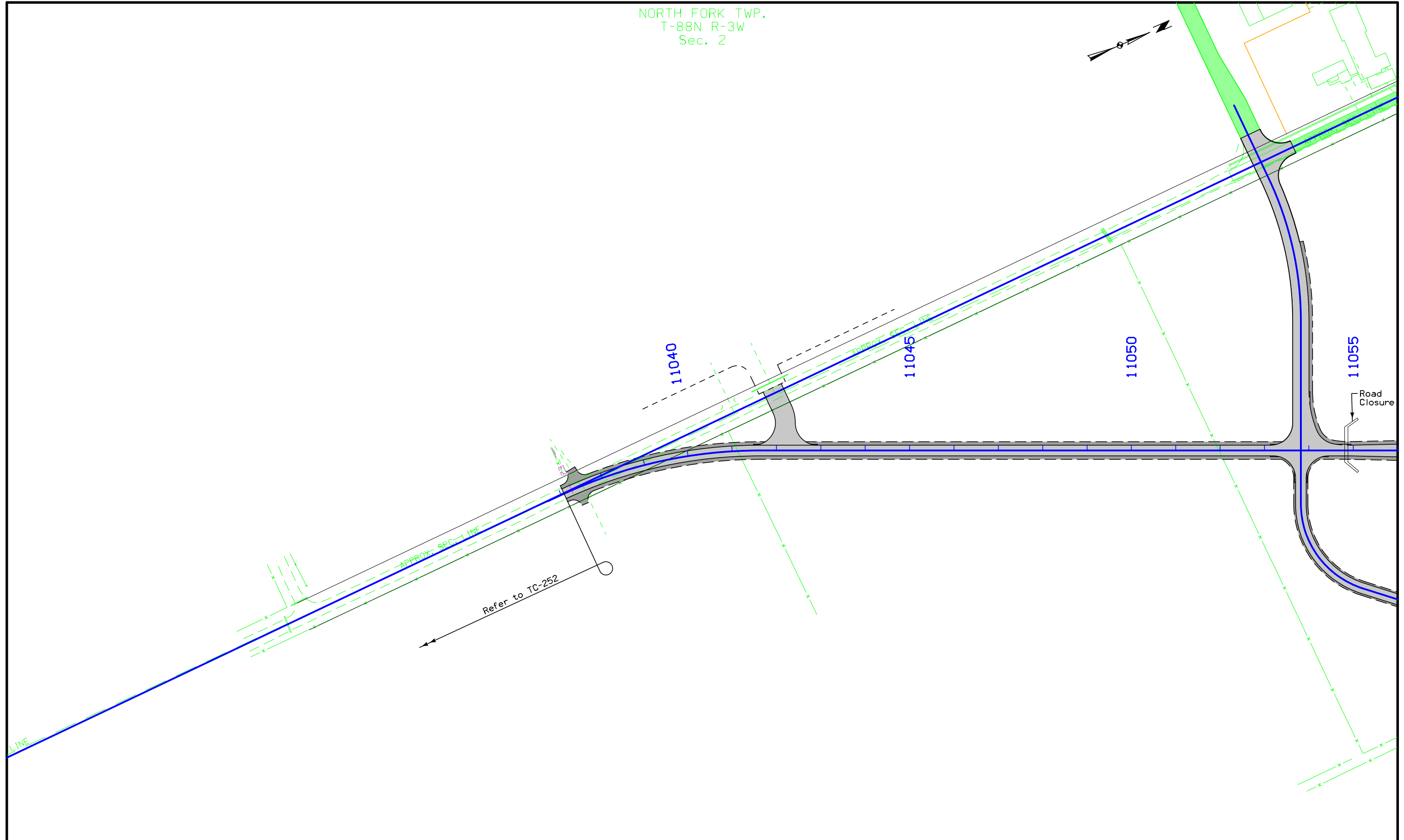
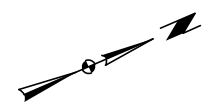

NORTH FORK TWP.  
T-88N R-3W  
Sec. 1

**330th Ave  
STAGE 2**

FILE NO.	ENGLISH	DESIGN TEAM <b>Stanley Consultants Inc.</b>	DELAWARE/DUBUQUE COUNTY	PROJECT NUMBER	<b>NHSX-020-9(203)--3H-28</b>	SHEET NUMBER	<b>J.12</b>
----------	---------	---	-------------------------	----------------	-------------------------------	--------------	-------------

BREMEN TWP.  
T-89N R-3W  
Sec. 36

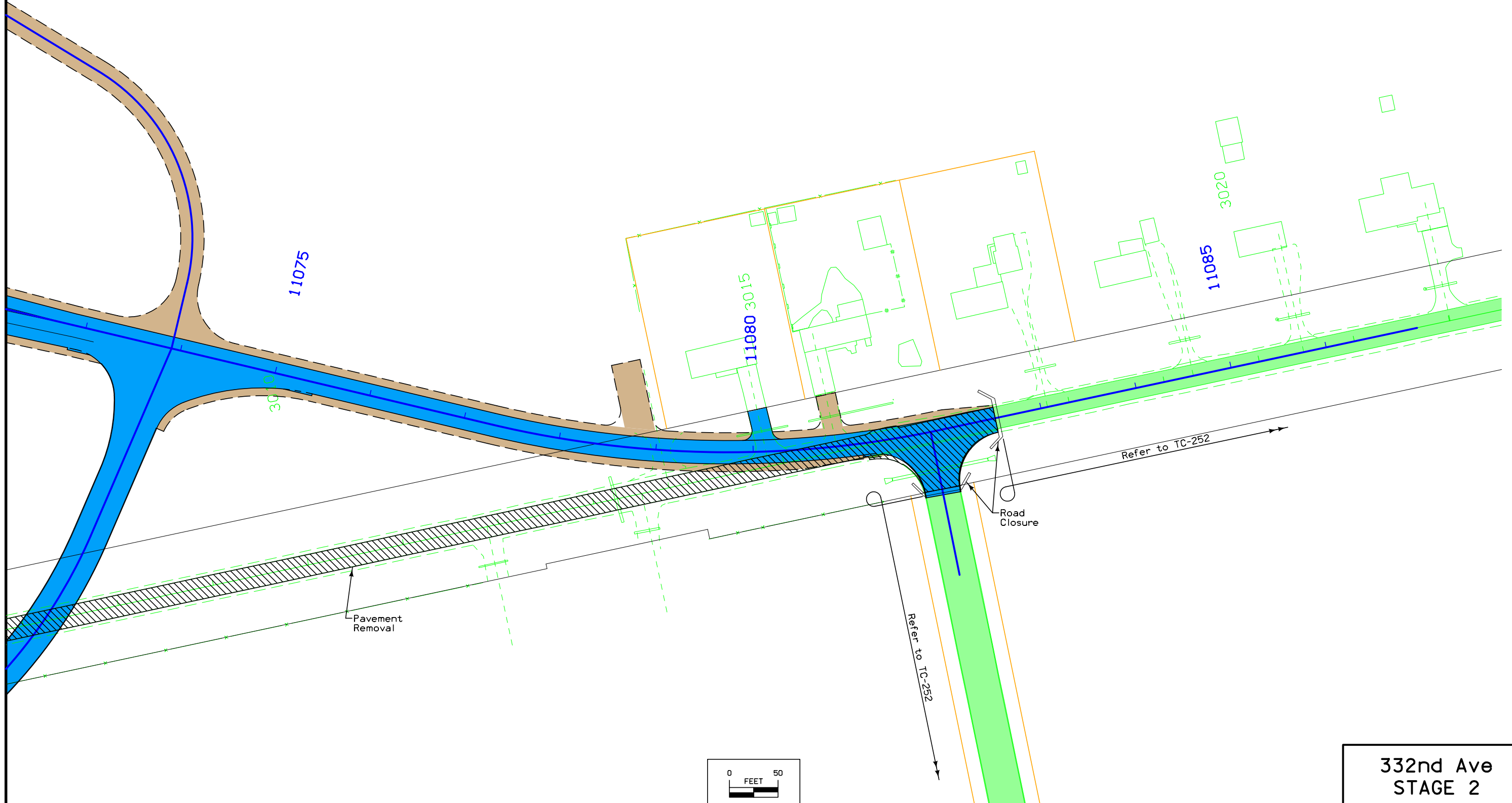

332nd Ave  
STAGE 2

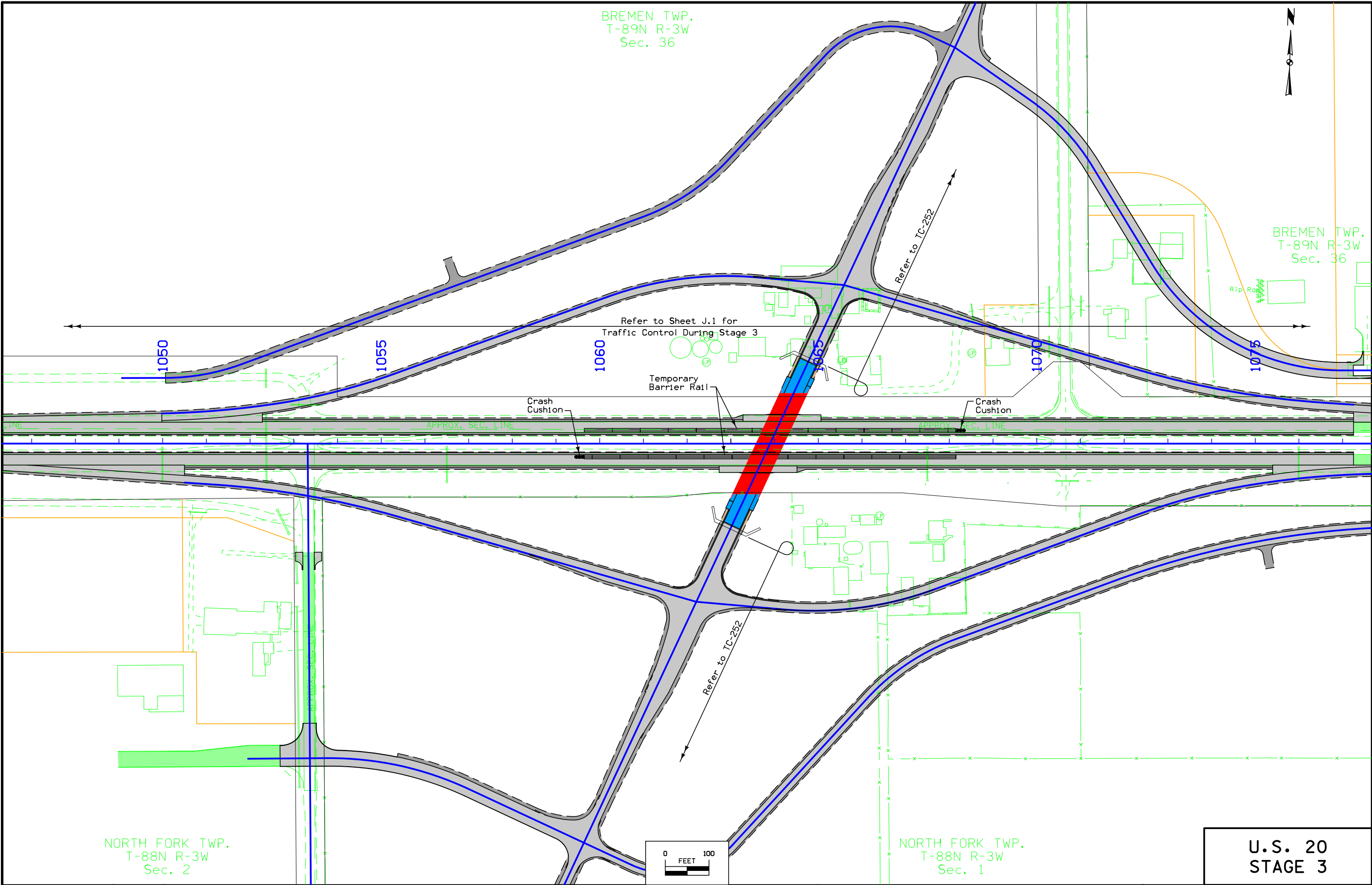

**U.S. 20  
STAGE 3**

DELAWARE/DUBUQUE COUNTY

PROJECT NUMBER

NHSX-020-9(203)--3H-28

SHEET NUMBER **J.14**

NORTH FORK TWP.  
T-88N R-3W  
Sec. 2

NORTH FORK TWP.  
T-88N R-3W  
Sec. 1

BREMEN TWP.  
T-89N R-3W  
Sec. 36

BREMEN TWP.  
T-89N R-3W  
Sec. 36

BREMEN TWP.  
T-89N R-3W  
Sec. 35

BREMEN TWP.  
T-89N R-3W  
Sec. 36

**Curve Data**  
 $\Delta = 24^\circ 50' 58.62''$  (RT)  
 $D = 07^\circ 09' 43.10''$   
 $R = 800.00'$   
 $T = 176.25'$   
 $L = 346.97'$   
 $E = 19.19'$   
 $e = 5.40\%$   
 $L = 130'$   
 $x = 48'$   
 $m = 39.0'$

**Curve Data**  
 $\Delta = 08^\circ 01' 17.07''$  (LT)  
 $D = 02^\circ 51' 53.24''$   
 $R = 2000.00'$   
 $T = 140.23'$   
 $L = 280.00'$   
 $E = 4.91'$   
 $e = 5.40\%$   
 $L = 168'$   
 $x = 62'$   
 $m = 50.4'$

**Curve Data**  
 $\Delta = 10^\circ 40' 47.54''$  (RT)  
 $D = 04^\circ 05' 33.20''$   
 $R = 1400.00'$   
 $T = 130.86'$   
 $L = 260.96'$   
 $E = 6.10'$   
 $e = 6.00\%$   
 $L = 186'$   
 $x = 62'$   
 $m = 55.8'$

**Curve Data**  
 $\Delta = 25^\circ 10' 58.43''$  (LT)  
 $D = 07^\circ 09' 43.10''$   
 $R = 800.00'$   
 $T = 178.70'$   
 $L = 351.62'$   
 $E = 19.71'$   
 $e = 5.40\%$   
 $L = 130'$   
 $x = 48'$   
 $m = 39.0'$

**Curve Data**  
 $\Delta = 12^\circ 08' 03.30''$  (RT)  
 $D = 02^\circ 51' 53.24''$   
 $R = 2000.00'$   
 $T = 212.58'$   
 $L = 423.57'$   
 $E = 11.27'$   
 $e = 5.40\%$   
 $L = 168'$   
 $x = 62'$   
 $m = 50.4'$

NORTH FORK TWP.  
T-88N R-3W  
Sec. 2

NORTH FORK TWP.  
T-88N R-3W  
Sec. 1

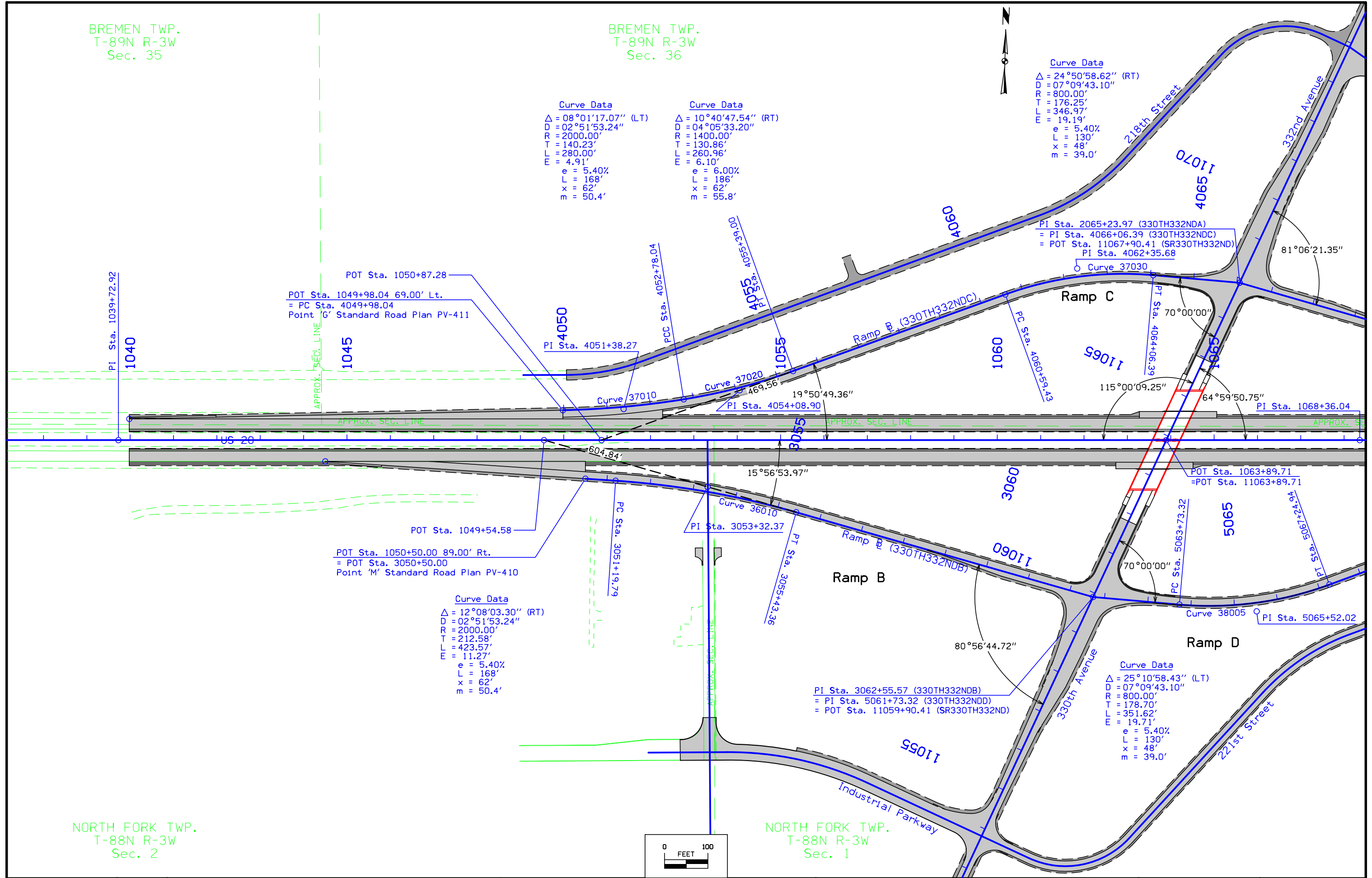



BREMEN TWP.  
T-89N R-3W  
Sec. 36



**Curve Data**  
 $\Delta = 24^\circ 50' 58.62''$  (RT)  
 $D = 07^\circ 09' 43.10''$   
 $R = 800.00'$   
 $T = 176.25'$   
 $L = 346.97'$   
 $E = 19.19'$   
 $e = 5.40\%$   
 $L = 130'$   
 $x = 48'$   
 $m = 39.0'$

**Curve Data**  
 $\Delta = 12^\circ 17' 44.12''$  (LT)  
 $D = 02^\circ 51' 53.24''$   
 $R = 2000.00'$   
 $T = 215.43'$   
 $L = 429.20'$   
 $E = 11.57'$   
 $e = 5.40\%$   
 $L = 168'$   
 $x = 62'$   
 $m = 50.4'$

PI Sta. 2065+23.97 (330TH332NDA)  
 = PI Sta. 4066+06.39 (330TH332NDC)  
 = POT Sta. 11067+90.41 (SR330TH332ND)  
 PI Sta. 4062+35.68

POT Sta. 1077+25.00 89.00' Lt.  
 = POT Sta. 2077+25.00  
 Point 'M' Standard Road Plan PV-410

POT Sta. 1063+89.71  
 = POT Sta. 11063+89.71

POT Sta. 1077+69.92 69.00' Rt.  
 = POT Sta. 5077+69.92  
 Point 'G' Standard Road Plan PV-411

**Curve Data**  
 $\Delta = 25^\circ 10' 58.43''$  (LT)  
 $D = 07^\circ 09' 43.10''$   
 $R = 800.00'$   
 $T = 178.70'$   
 $L = 351.62'$   
 $E = 19.71'$   
 $e = 5.40\%$   
 $L = 130'$   
 $x = 48'$   
 $m = 39.0'$

**Curve Data**  
 $\Delta = 11^\circ 00' 43.17''$  (RT)  
 $D = 04^\circ 05' 33.20''$   
 $R = 1400.00'$   
 $T = 134.95'$   
 $L = 269.07'$   
 $E = 6.49'$   
 $e = 6.00\%$   
 $L = 186'$   
 $x = 62'$   
 $m = 55.8'$

**Curve Data**  
 $\Delta = 08^\circ 01' 17.07''$  (RT)  
 $D = 02^\circ 51' 53.24''$   
 $R = 2000.00'$   
 $T = 140.23'$   
 $L = 280.00'$   
 $E = 4.91'$   
 $e = 5.40\%$   
 $L = 168'$   
 $x = 62'$   
 $m = 50.4'$

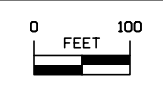

NORTH FORK TWP.  
T-88N R-3W  
Sec. 1

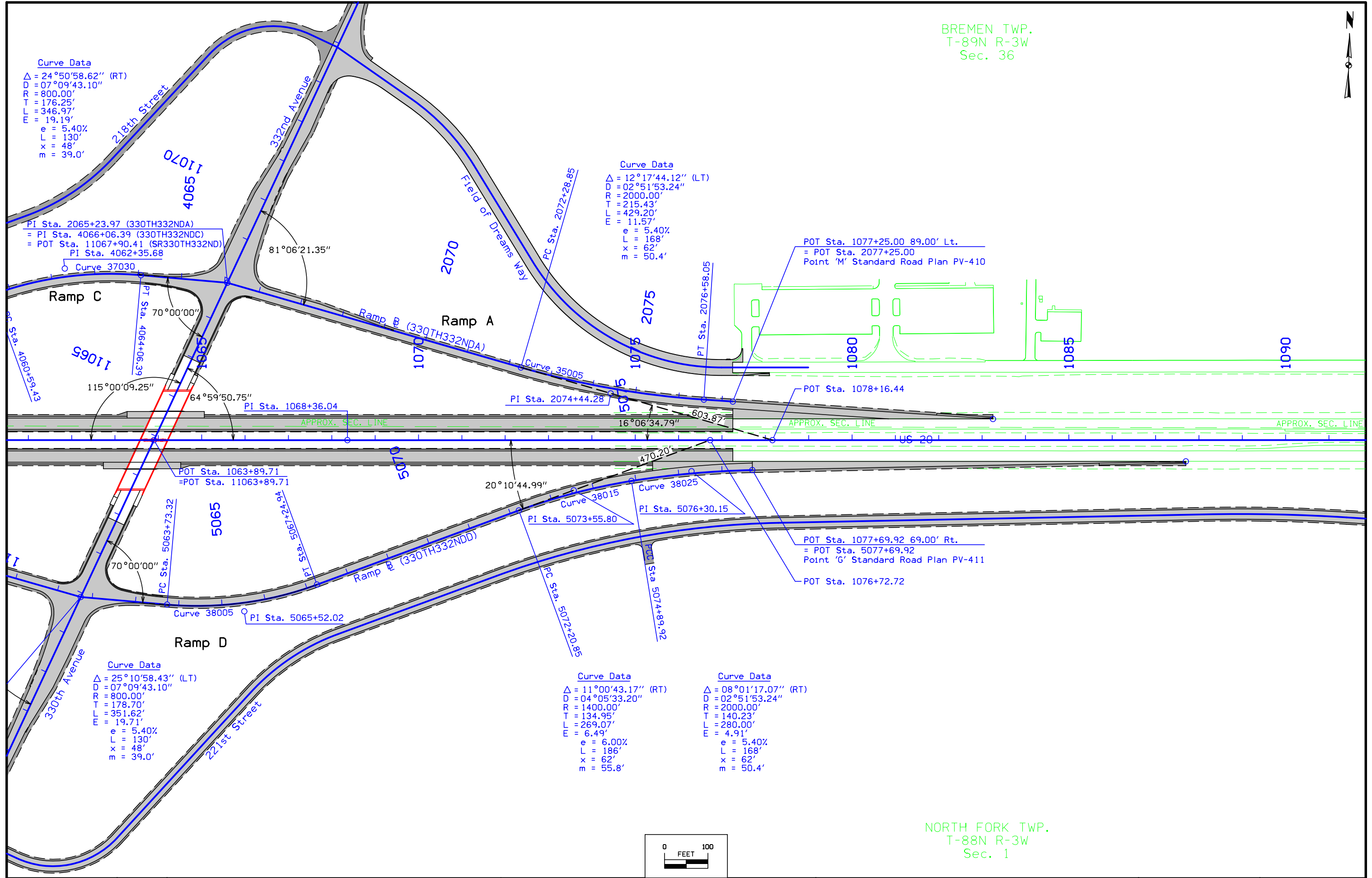





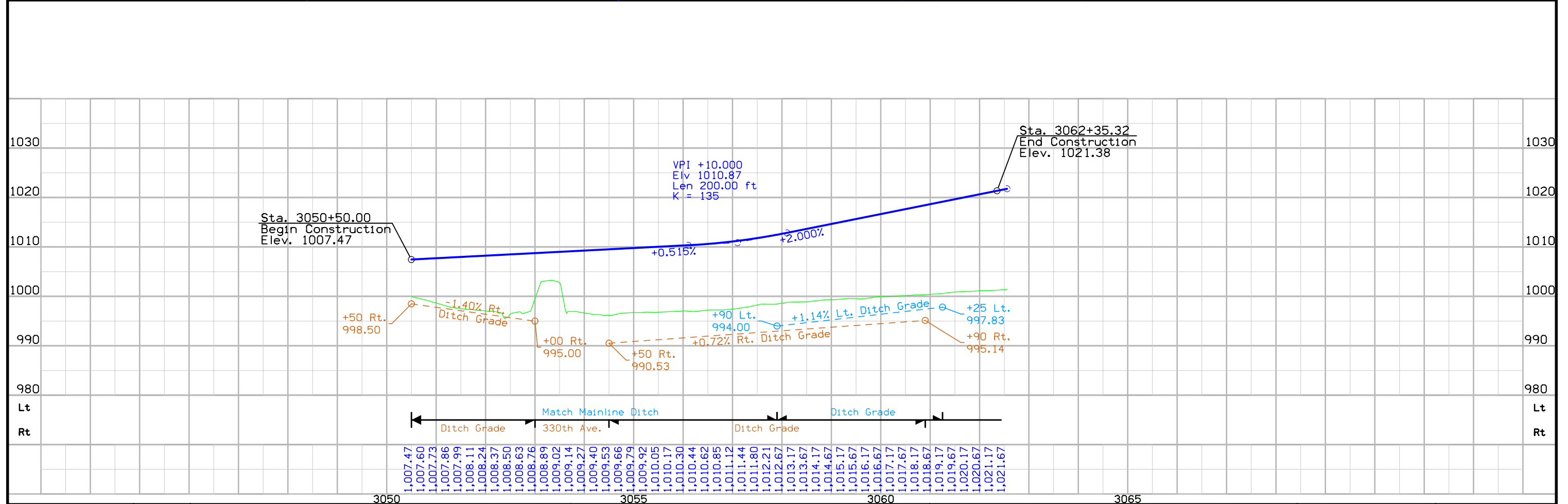
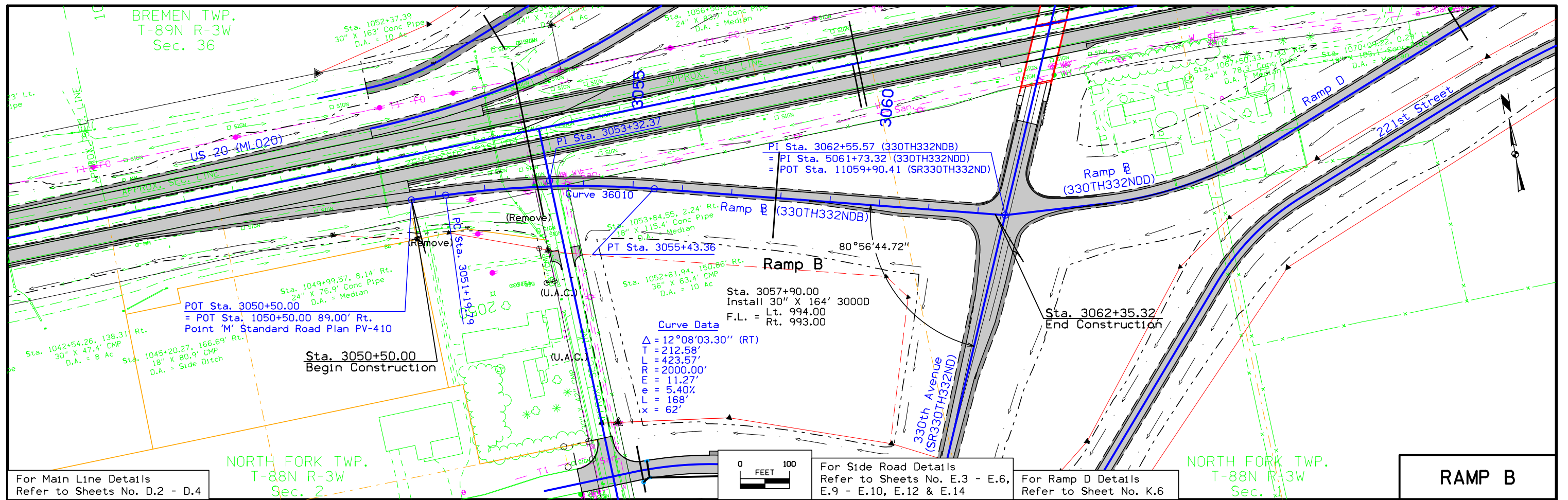

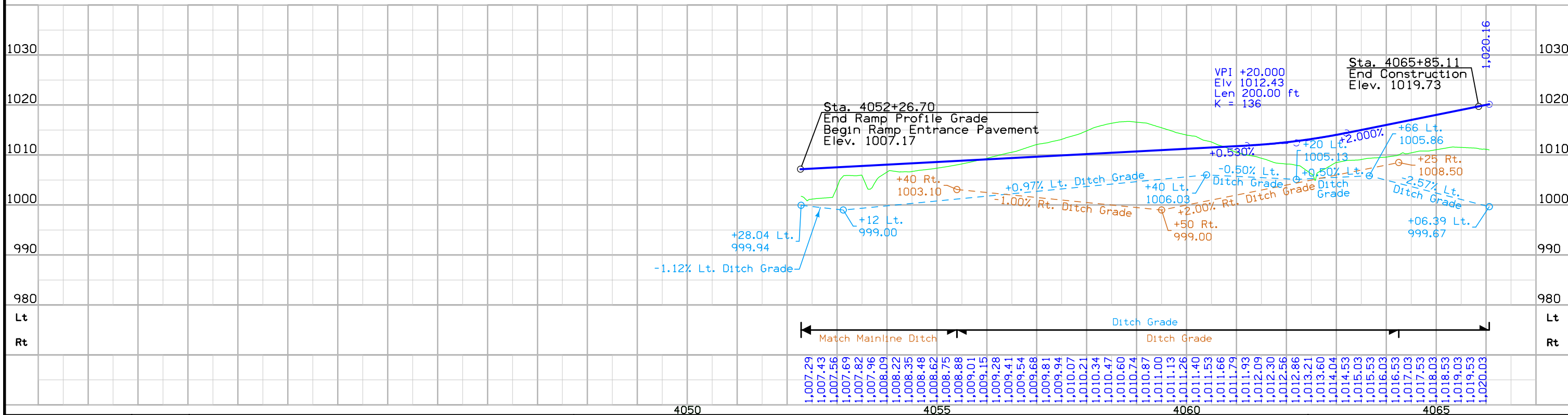
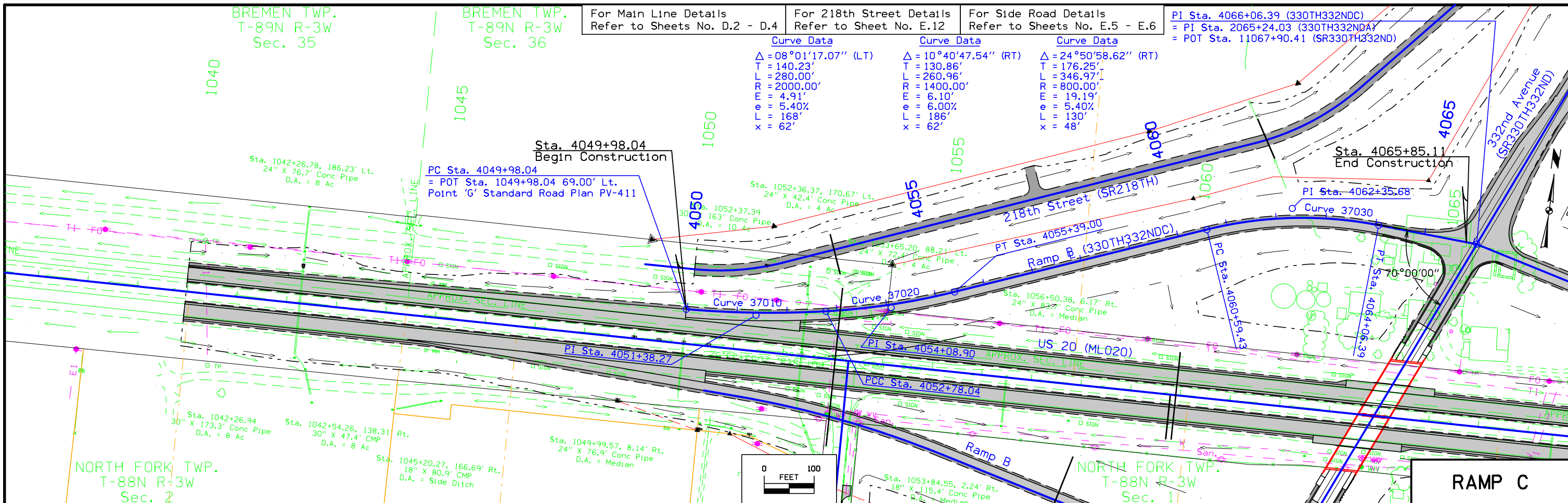



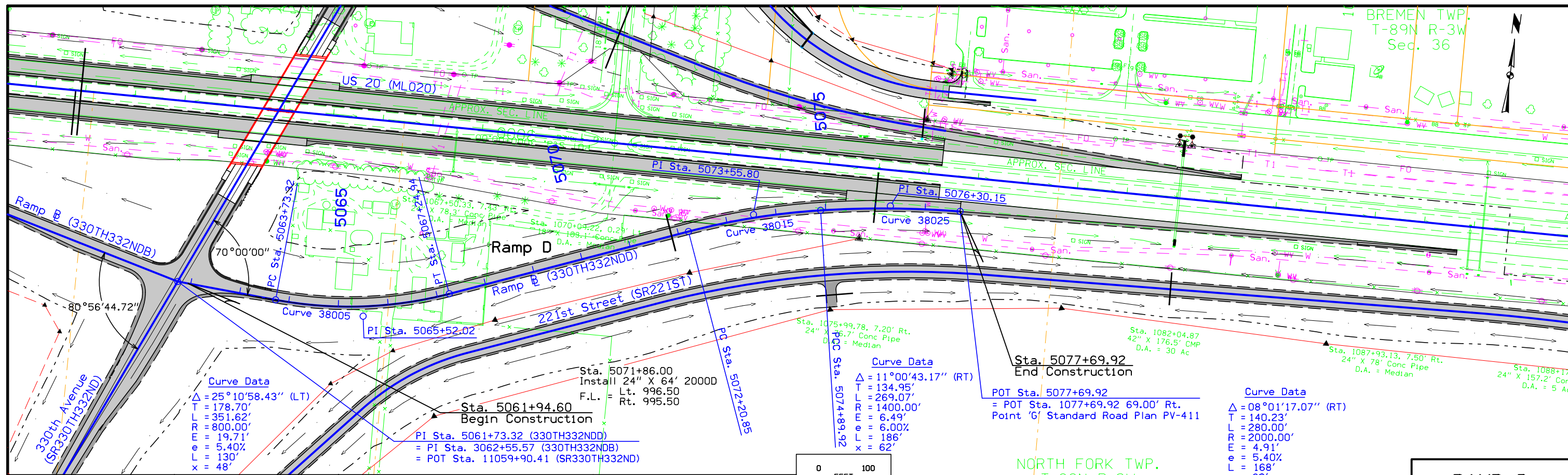

**RAMP D**

For Ramp B Details Refer to Sheet No. K.4  
 For Side Road Details Refer to Sheets No. E.3 - E.6  
 For 221st Street Details Refer to Sheets No. E.10 - E.11  
 For Main Line Details Refer to Sheets No. D.2 - D.4

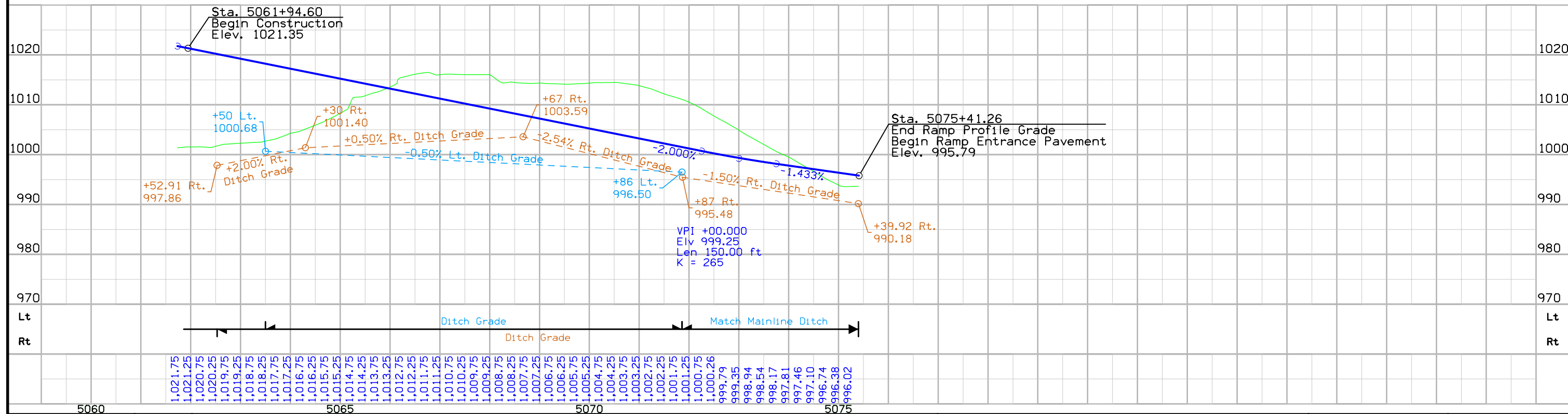

NORTH FORK TWP.  
T-88N R-3W  
Sec. 1

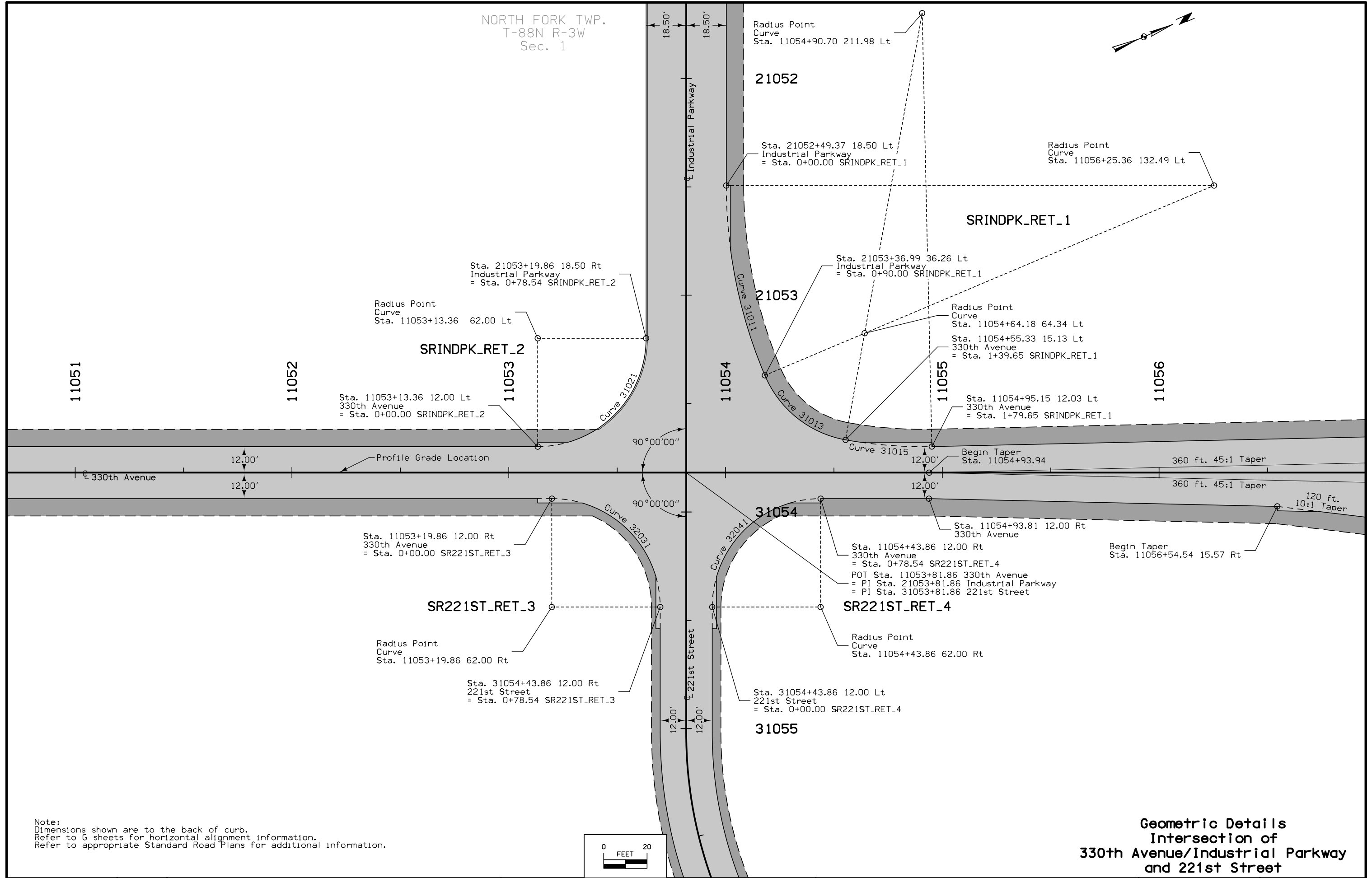

Note:  
Dimensions shown are to the back of curb.  
Refer to G sheets for horizontal alignment information.  
Refer to appropriate Standard Road Plans for additional information.

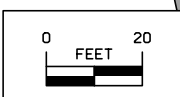

**Geometric Details**  
**Intersection of**  
**330th Avenue/Industrial Parkway**  
**and 221st Street**

FILE NO.	ENGLISH	DESIGN TEAM	<b>Stanley Consultants Inc.</b>	DELAWARE/DUBUQUE COUNTY	PROJECT NUMBER	<b>NHSX-020-9(203)--3H-28</b>	SHEET NUMBER	<b>L.1</b>
----------	---------	-------------	---------------------------------	-------------------------	----------------	-------------------------------	--------------	------------

NORTH FORK TWP.  
T-88N R-3W  
Sec. 1

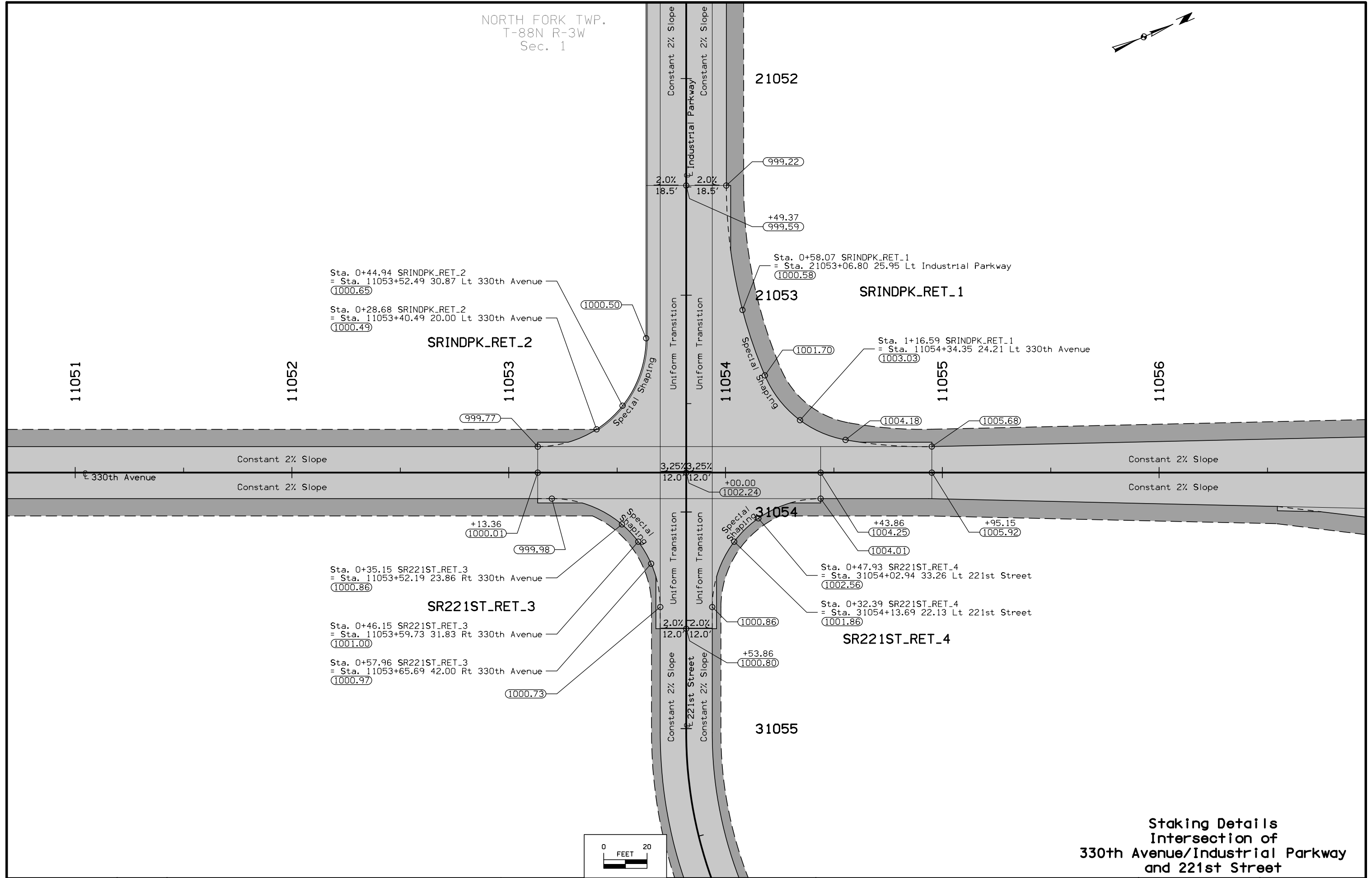
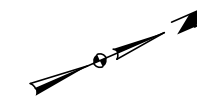

Staking Details  
Intersection of  
330th Avenue/Industrial Parkway  
and 221st Street

FILE NO.	ENGLISH	DESIGN TEAM	Stanley Consultants Inc.	DELAWARE/DUBUQUE COUNTY	PROJECT NUMBER	NHSX-020-9(203)--3H-28	SHEET NUMBER	L.2
----------	---------	-------------	--------------------------	-------------------------	----------------	------------------------	--------------	-----



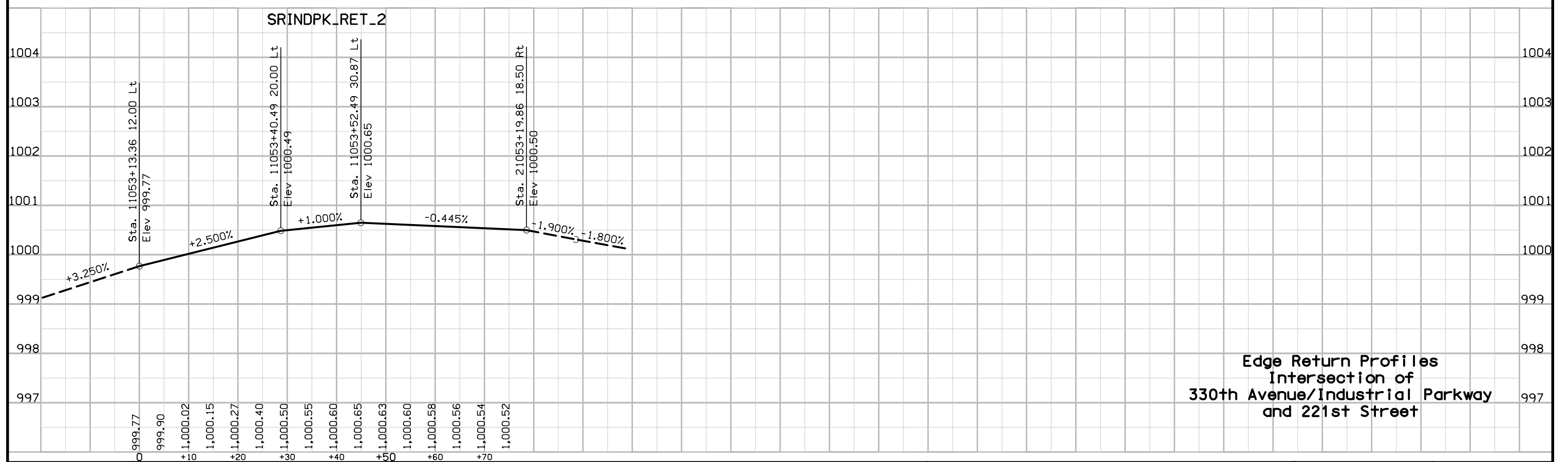
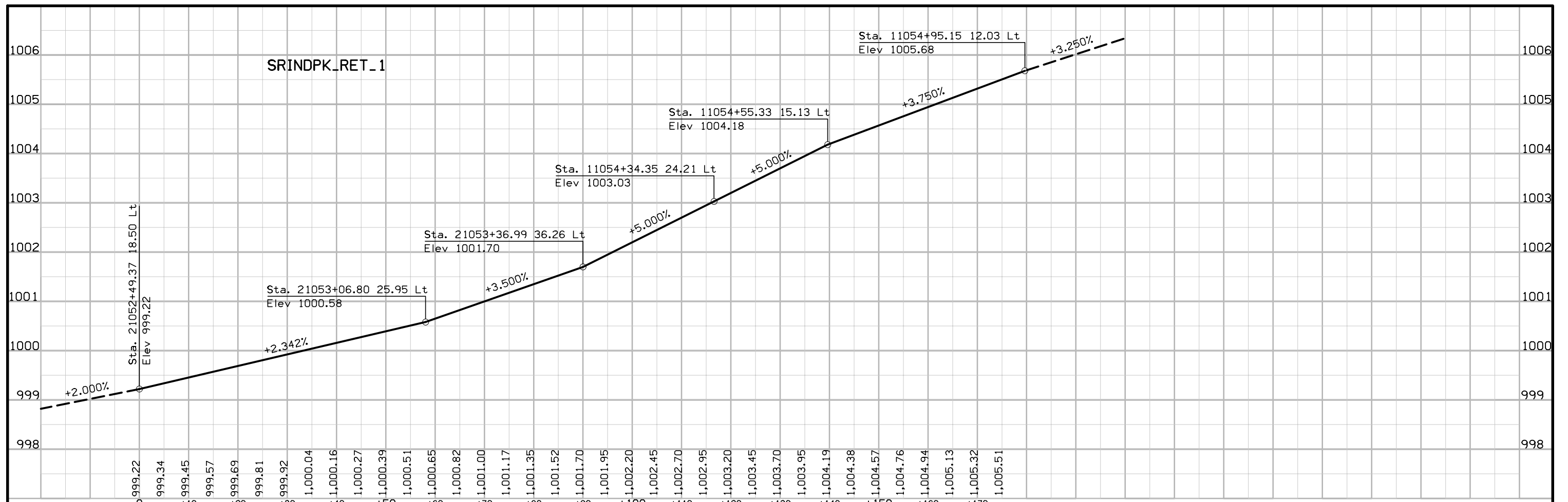

Edge Return Profiles  
 Intersection of  
 330th Avenue/Industrial Parkway  
 and 221st Street

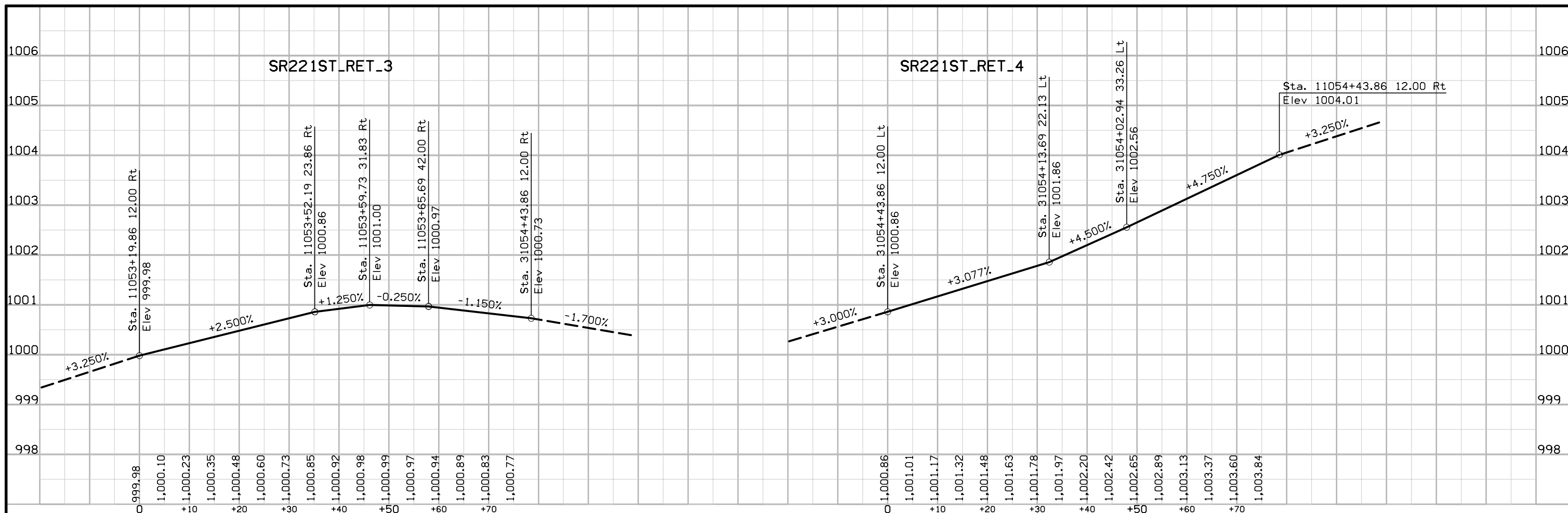

Edge Return Profiles  
 Intersection of  
 330th Avenue/Industrial Parkway  
 and 221st Street

NORTH FORK TWP.  
T-88N R-3W  
Sec. 1

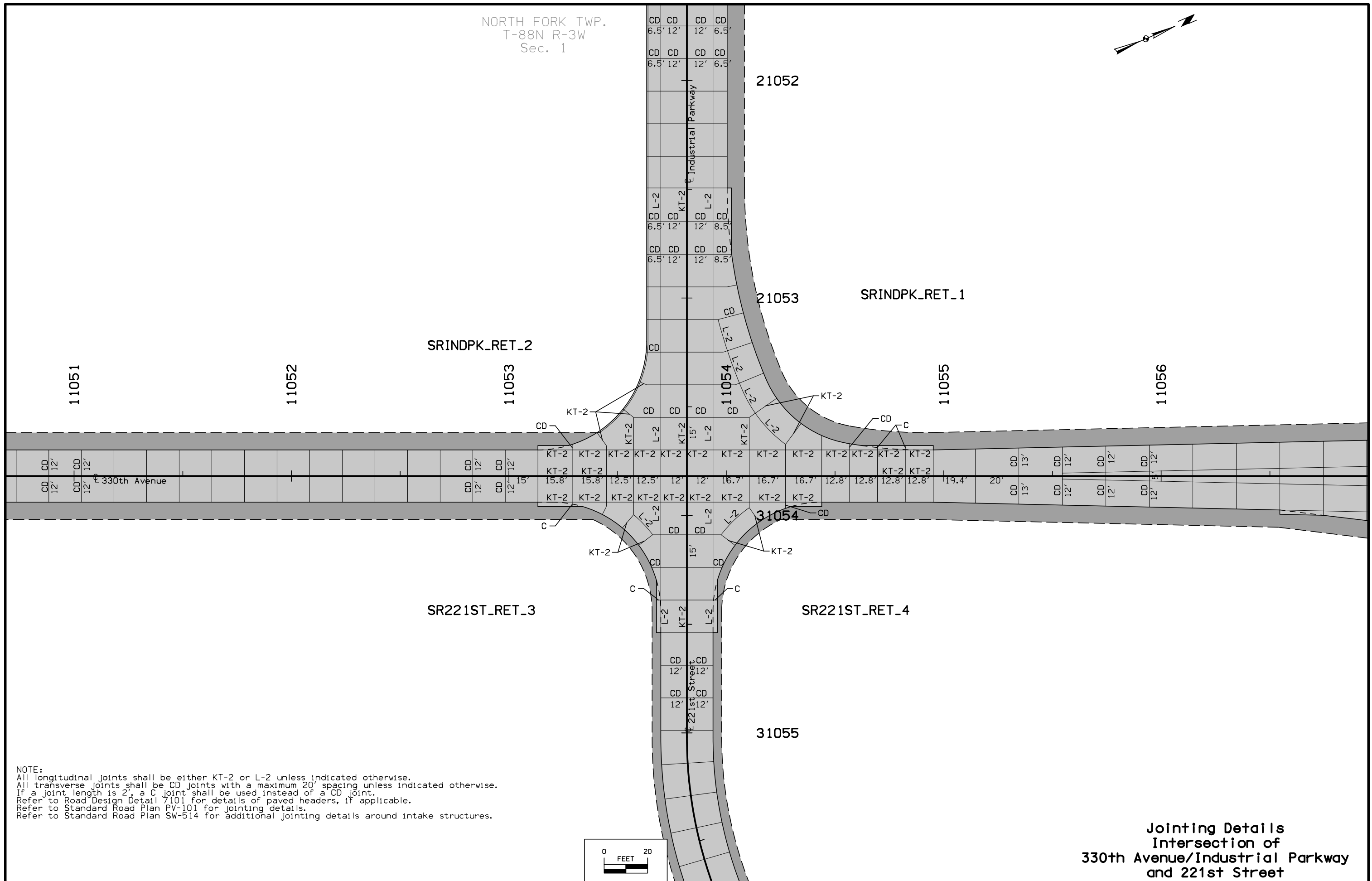

NOTE:  
All longitudinal joints shall be either KT-2 or L-2 unless indicated otherwise.  
All transverse joints shall be CD joints with a maximum 20' spacing unless indicated otherwise.  
If a joint length is 2', a C joint shall be used instead of a CD joint.  
Refer to Road Design Detail 7101 for details of paved headers, if applicable.  
Refer to Standard Road Plan PV-101 for jointing details.  
Refer to Standard Road Plan SW-514 for additional jointing details around intake structures.

Jointing Details  
Intersection of  
330th Avenue/Industrial Parkway  
and 221st Street

NORTH FORK TWP.  
T-88N R-3W  
Sec. 1

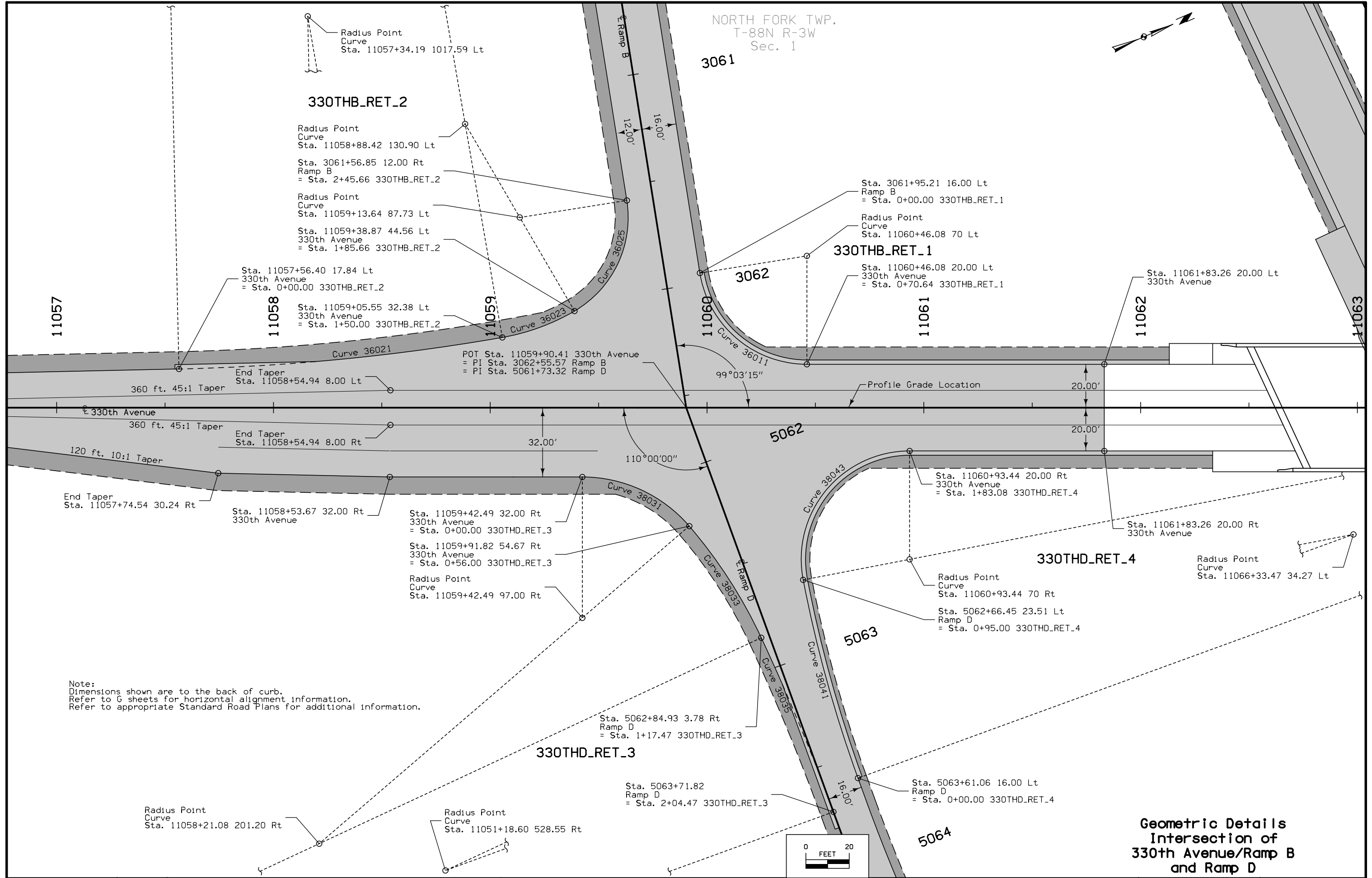

**330THB\_RET\_2**

Radius Point Curve  
Sta. 11057+34.19 1017.59 Lt

Radius Point Curve  
Sta. 11058+88.42 130.90 Lt

Sta. 3061+56.85 12.00 Rt  
Ramp B  
= Sta. 2+45.66 330THB\_RET\_2

Radius Point Curve  
Sta. 11059+13.64 87.73 Lt

Sta. 11059+38.87 44.56 Lt  
330th Avenue  
= Sta. 1+85.66 330THB\_RET\_2

**330THB\_RET\_1**

Sta. 3061+95.21 16.00 Lt  
Ramp B  
= Sta. 0+00.00 330THB\_RET\_1

Radius Point Curve  
Sta. 11060+46.08 70 Lt

Sta. 11060+46.08 20.00 Lt  
330th Avenue  
= Sta. 0+70.64 330THB\_RET\_1

**330THD\_RET\_4**

Sta. 11060+93.44 20.00 Rt  
330th Avenue  
= Sta. 1+83.08 330THD\_RET\_4

Radius Point Curve  
Sta. 11066+33.47 34.27 Lt

Sta. 11061+83.26 20.00 Lt  
330th Avenue

Radius Point Curve  
Sta. 11060+93.44 70 Rt

Sta. 5062+66.45 23.51 Lt  
Ramp D  
= Sta. 0+95.00 330THD\_RET\_4

**330THD\_RET\_3**

End Taper Sta. 11057+74.54 30.24 Rt

Sta. 11058+53.67 32.00 Rt  
330th Avenue

Sta. 11059+42.49 32.00 Rt  
330th Avenue  
= Sta. 0+00.00 330THD\_RET\_3

Sta. 11059+91.82 54.67 Rt  
330th Avenue  
= Sta. 0+56.00 330THD\_RET\_3

Radius Point Curve  
Sta. 11059+42.49 97.00 Rt

Radius Point Curve  
Sta. 11058+21.08 201.20 Rt

Radius Point Curve  
Sta. 11051+18.60 528.55 Rt

Note:  
Dimensions shown are to the back of curb.  
Refer to G sheets for horizontal alignment information.  
Refer to appropriate Standard Road Plans for additional information.

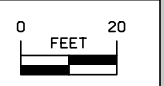

**Geometric Details  
Intersection of  
330th Avenue/Ramp B  
and Ramp D**

NORTH FORK TWP.  
T-88N R-3W  
Sec. 1

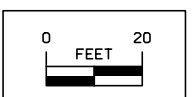
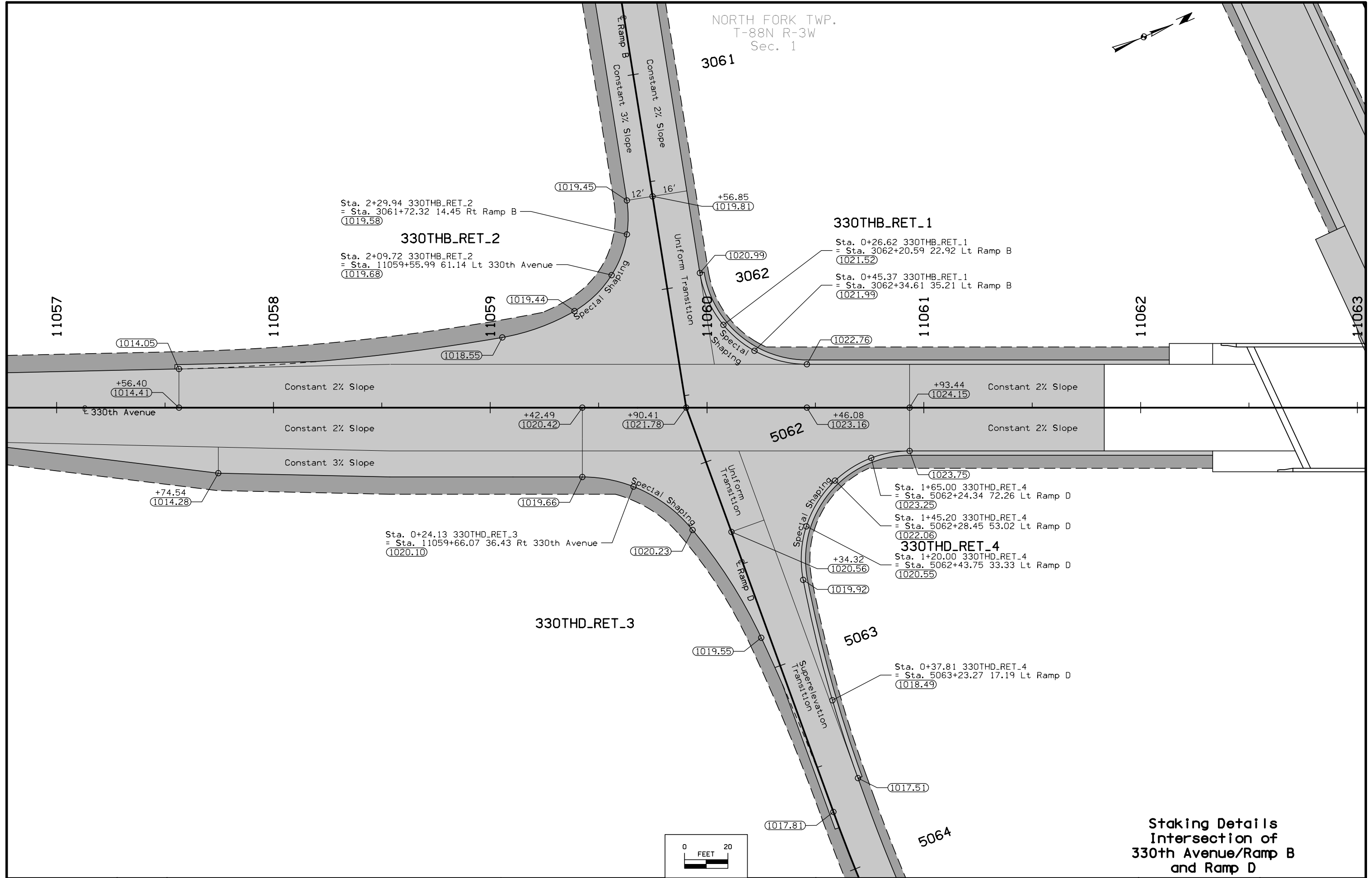
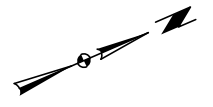

Staking Details  
Intersection of  
330th Avenue/Ramp B  
and Ramp D

FILE NO.	ENGLISH	DESIGN TEAM	Stanley Consultants Inc.	DELAWARE/DUBUQUE COUNTY	PROJECT NUMBER	NHSX-020-9(203)--3H-28	SHEET NUMBER	L.7
----------	---------	-------------	--------------------------	-------------------------	----------------	------------------------	--------------	-----



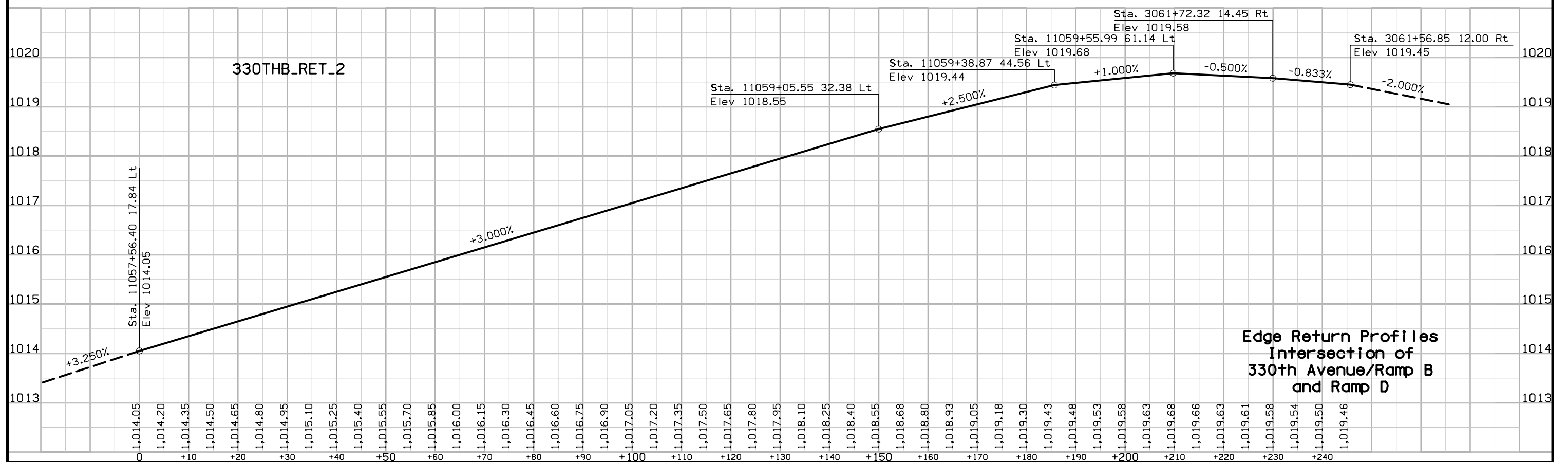

Edge Return Profiles  
Intersection of  
330th Avenue/Ramp B  
and Ramp D

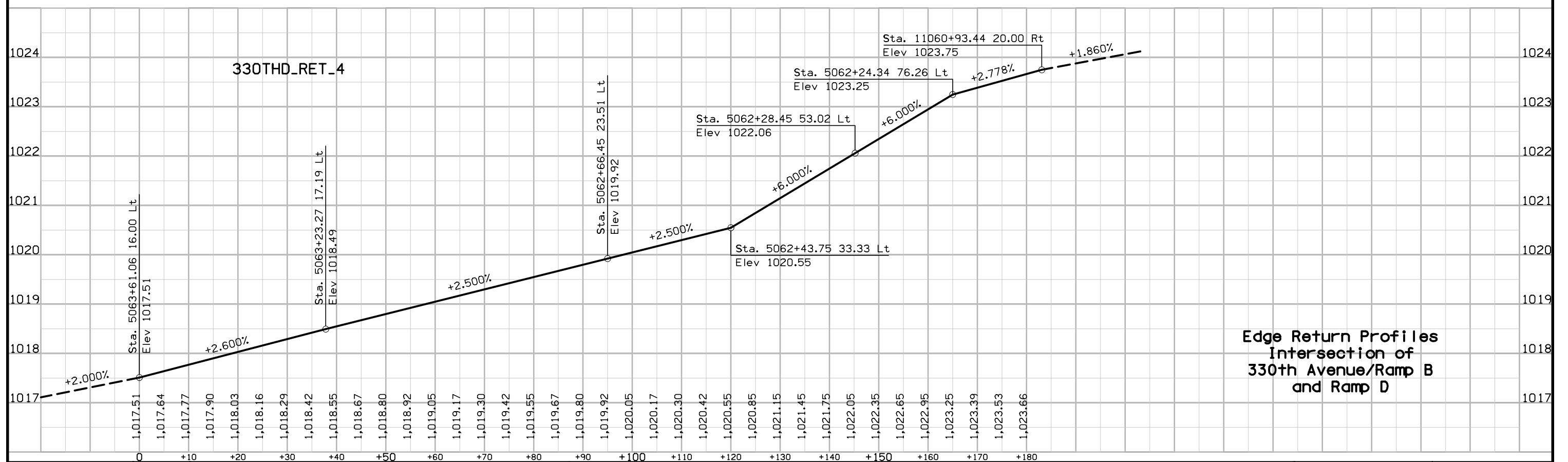
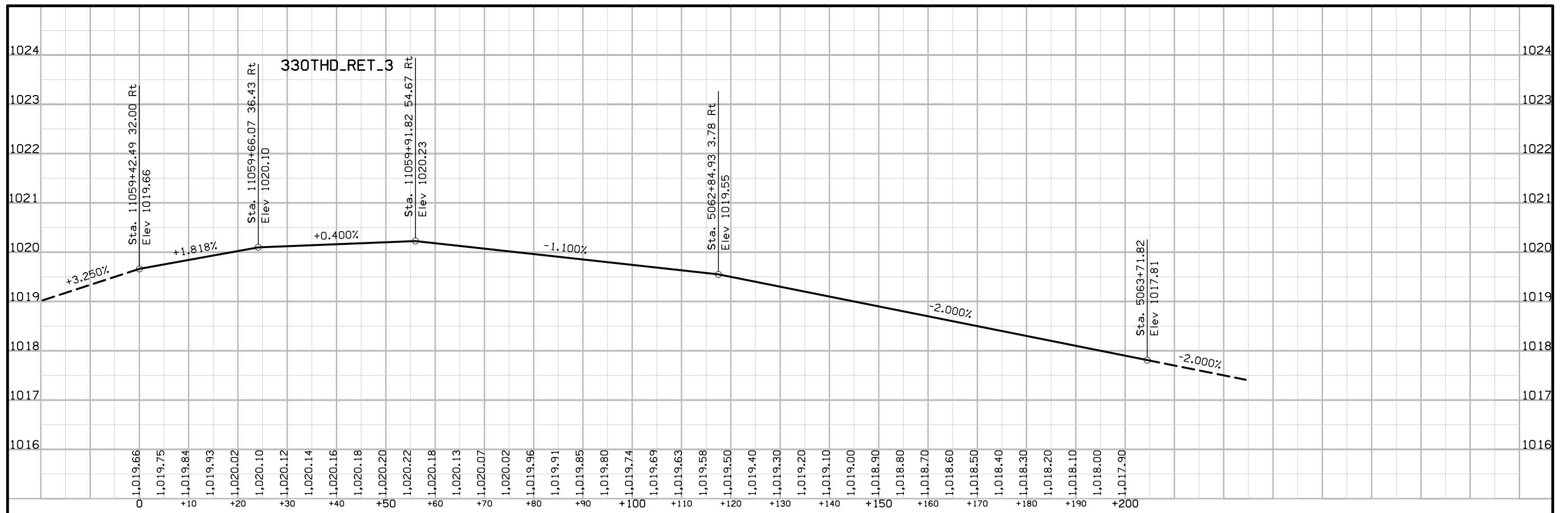

Edge Return Profiles  
Intersection of  
330th Avenue/Ramp B  
and Ramp D

NORTH FORK TWP.  
T-88N R-3W  
Sec. 1

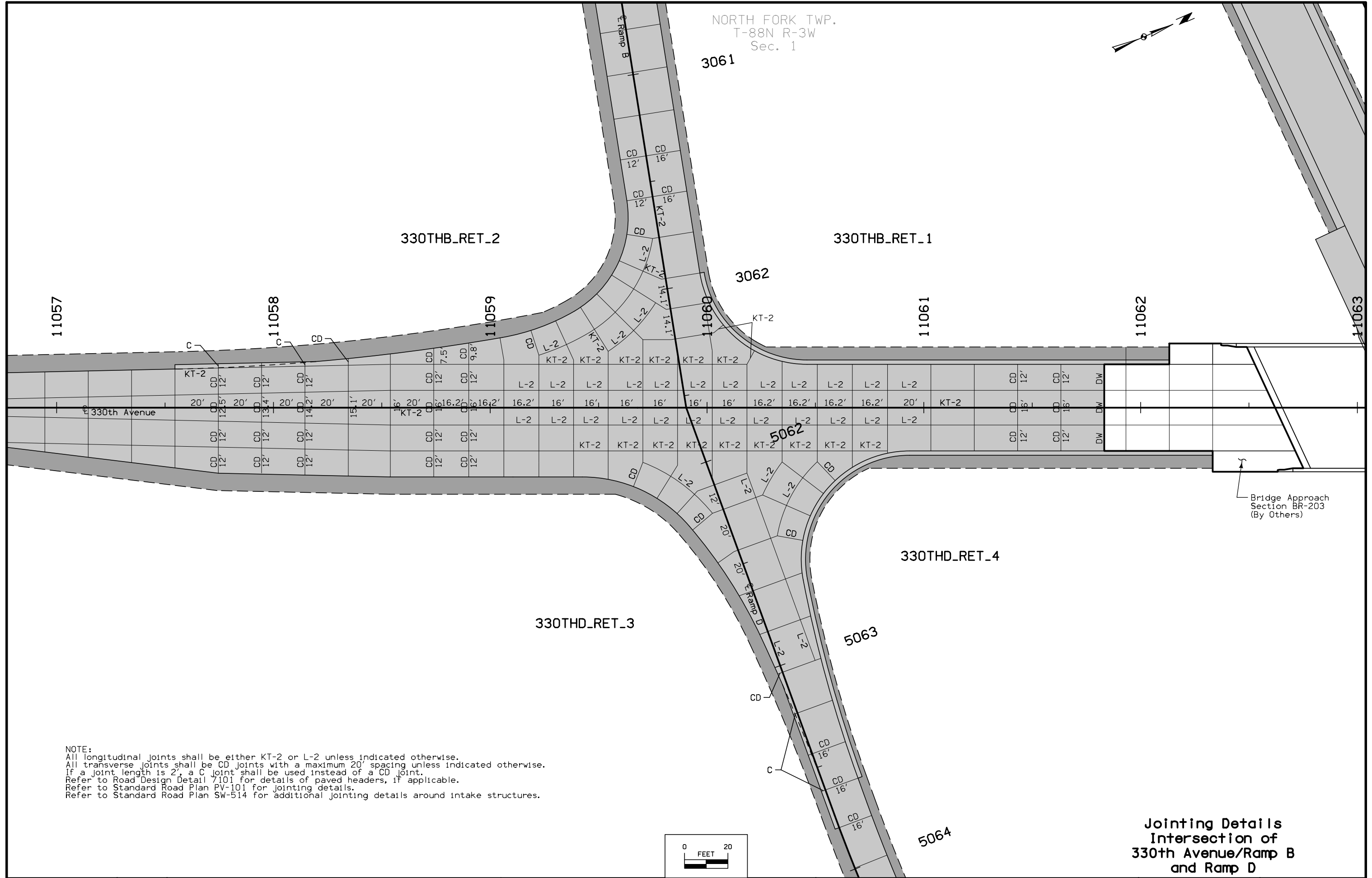
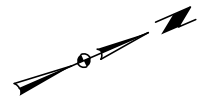

NOTE:  
All longitudinal joints shall be either KT-2 or L-2 unless indicated otherwise.  
All transverse joints shall be CD joints with a maximum 20' spacing unless indicated otherwise.  
If a joint length is 2', a C joint shall be used instead of a CD joint.  
Refer to Road Design Detail 7101 for details of paved headers, if applicable.  
Refer to Standard Road Plan PV-101 for jointing details.  
Refer to Standard Road Plan SW-514 for additional jointing details around intake structures.

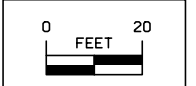

**Jointing Details  
Intersection of  
330th Avenue/Ramp B  
and Ramp D**

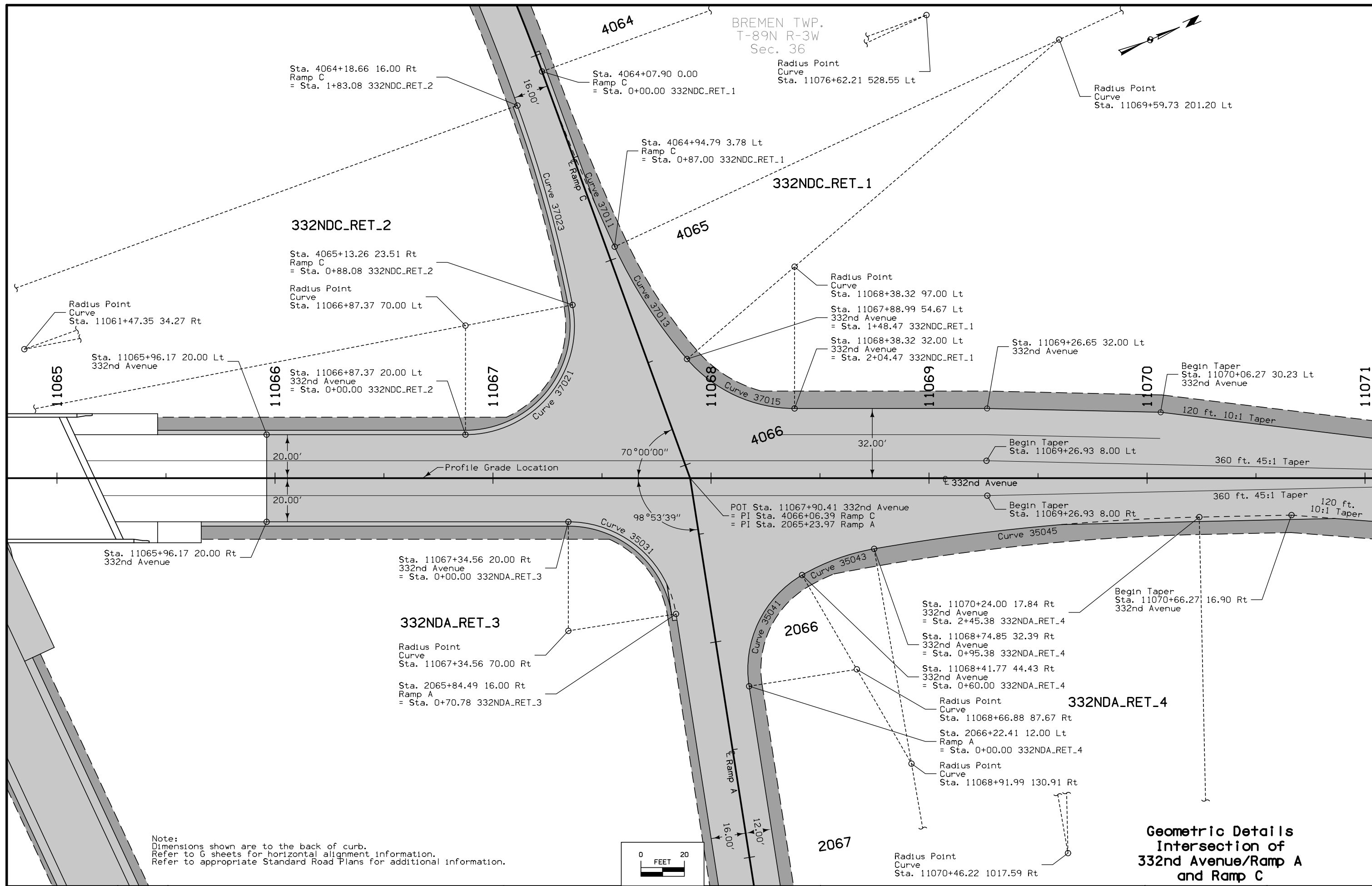

Note:  
 Dimensions shown are to the back of curb.  
 Refer to G sheets for horizontal alignment information.  
 Refer to appropriate Standard Road Plans for additional information.



**Geometric Details  
 Intersection of  
 332nd Avenue/Ramp A  
 and Ramp C**





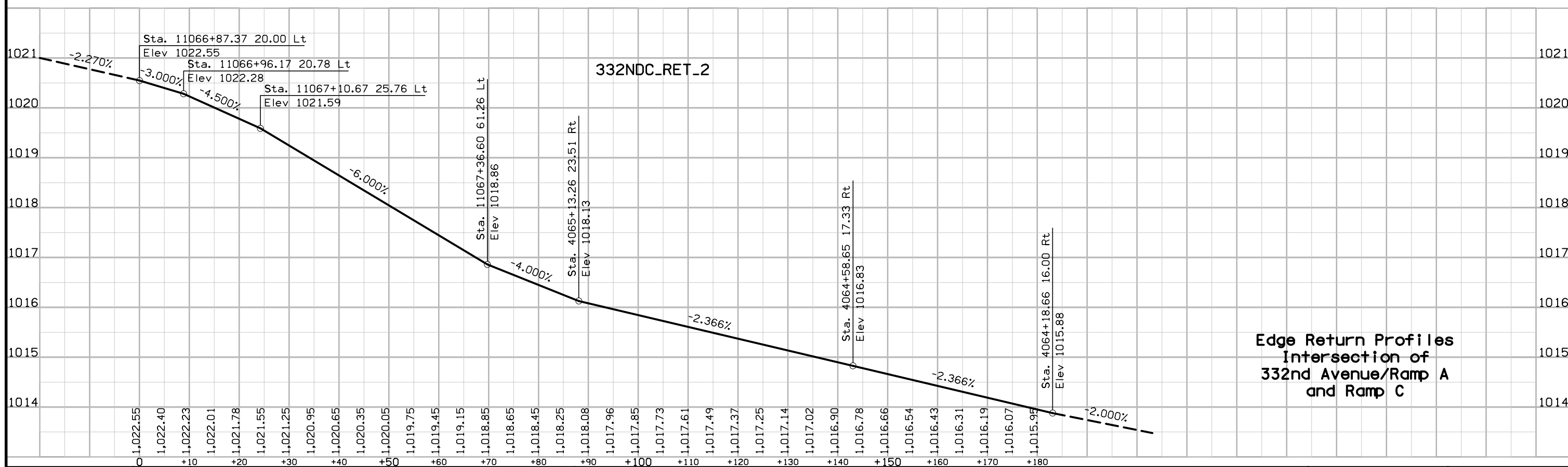
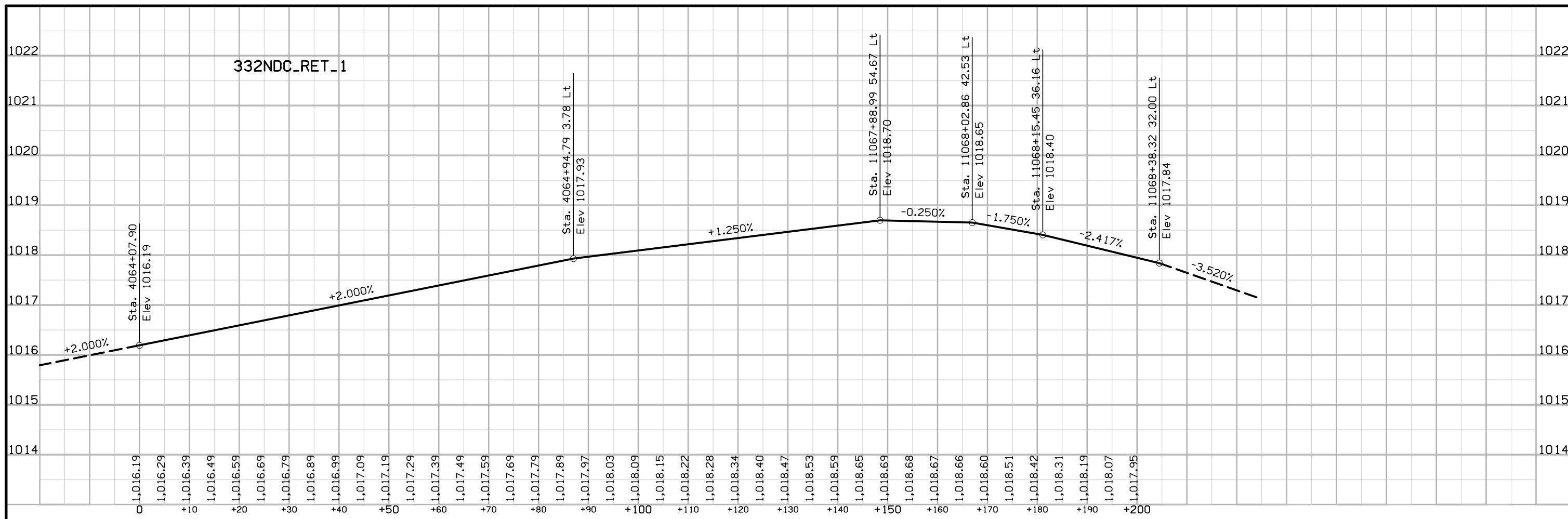

Edge Return Profiles  
Intersection of  
332nd Avenue/Ramp A  
and Ramp C

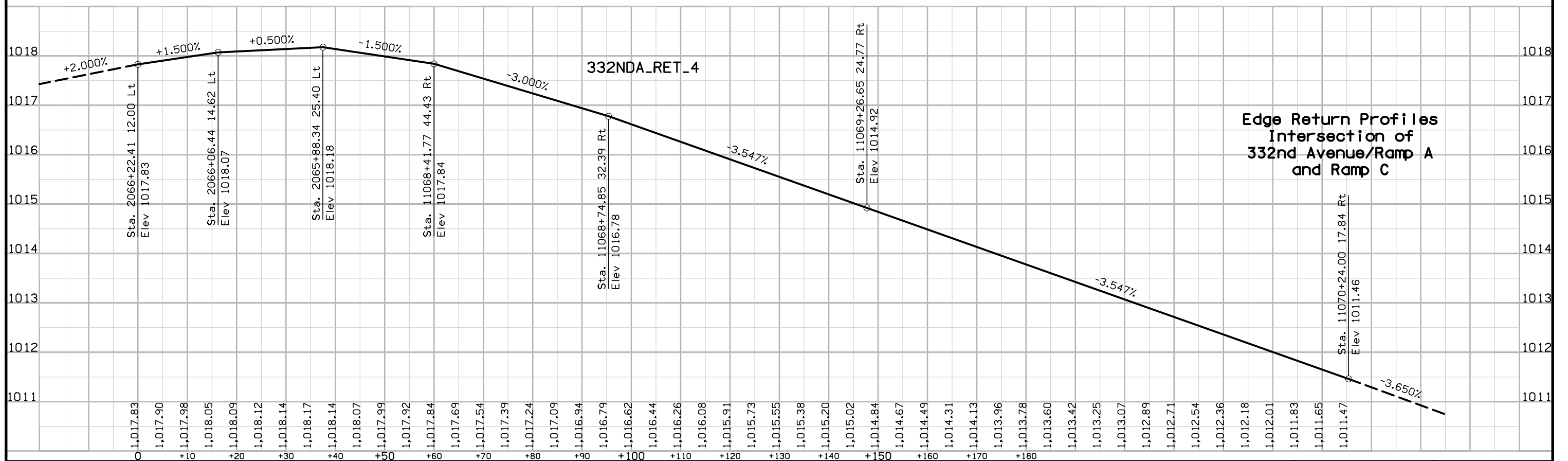
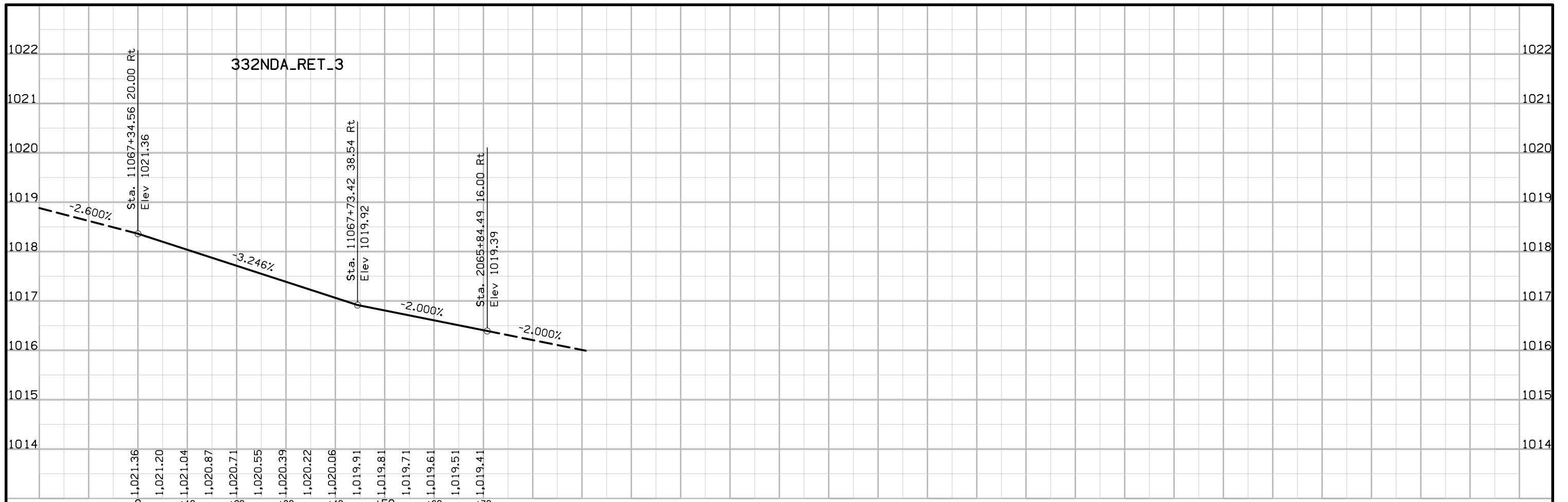

Edge Return Profiles  
Intersection of  
332nd Avenue/Ramp A  
and Ramp C

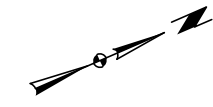

BREMEN TWP.  
T-89N R-3W  
Sec. 36

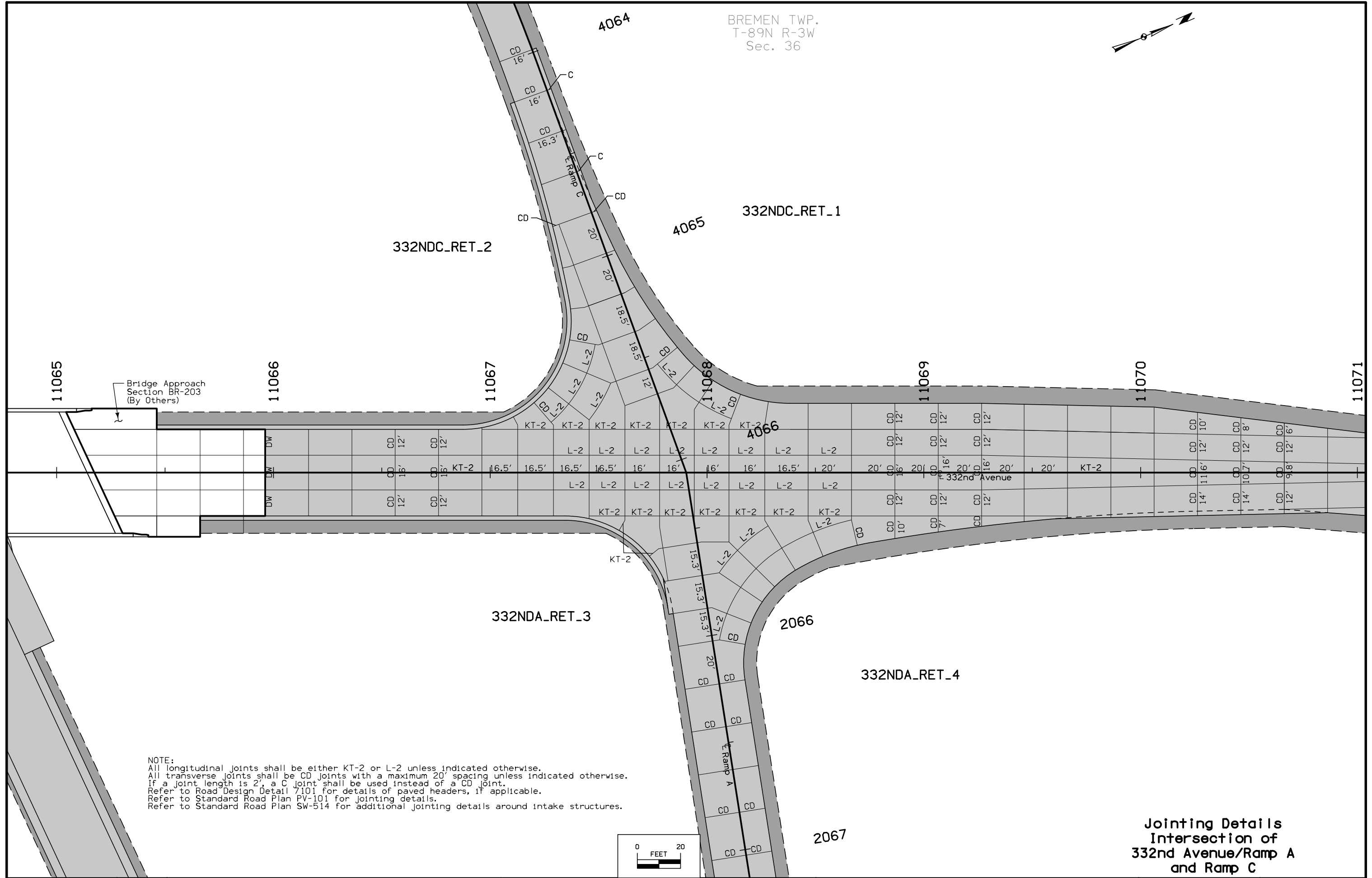

NOTE:  
All longitudinal joints shall be either KT-2 or L-2 unless indicated otherwise.  
All transverse joints shall be CD joints with a maximum 20' spacing unless indicated otherwise.  
If a joint length is 2', a C joint shall be used instead of a CD joint.  
Refer to Road Design Detail 7101 for details of paved headers, if applicable.  
Refer to Standard Road Plan PV-101 for jointing details.  
Refer to Standard Road Plan SW-514 for additional jointing details around intake structures.

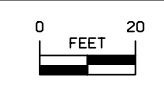

**Jointing Details  
Intersection of  
332nd Avenue/Ramp A  
and Ramp C**

BREMEN TWP.  
T-89N R-3W  
Sec. 36

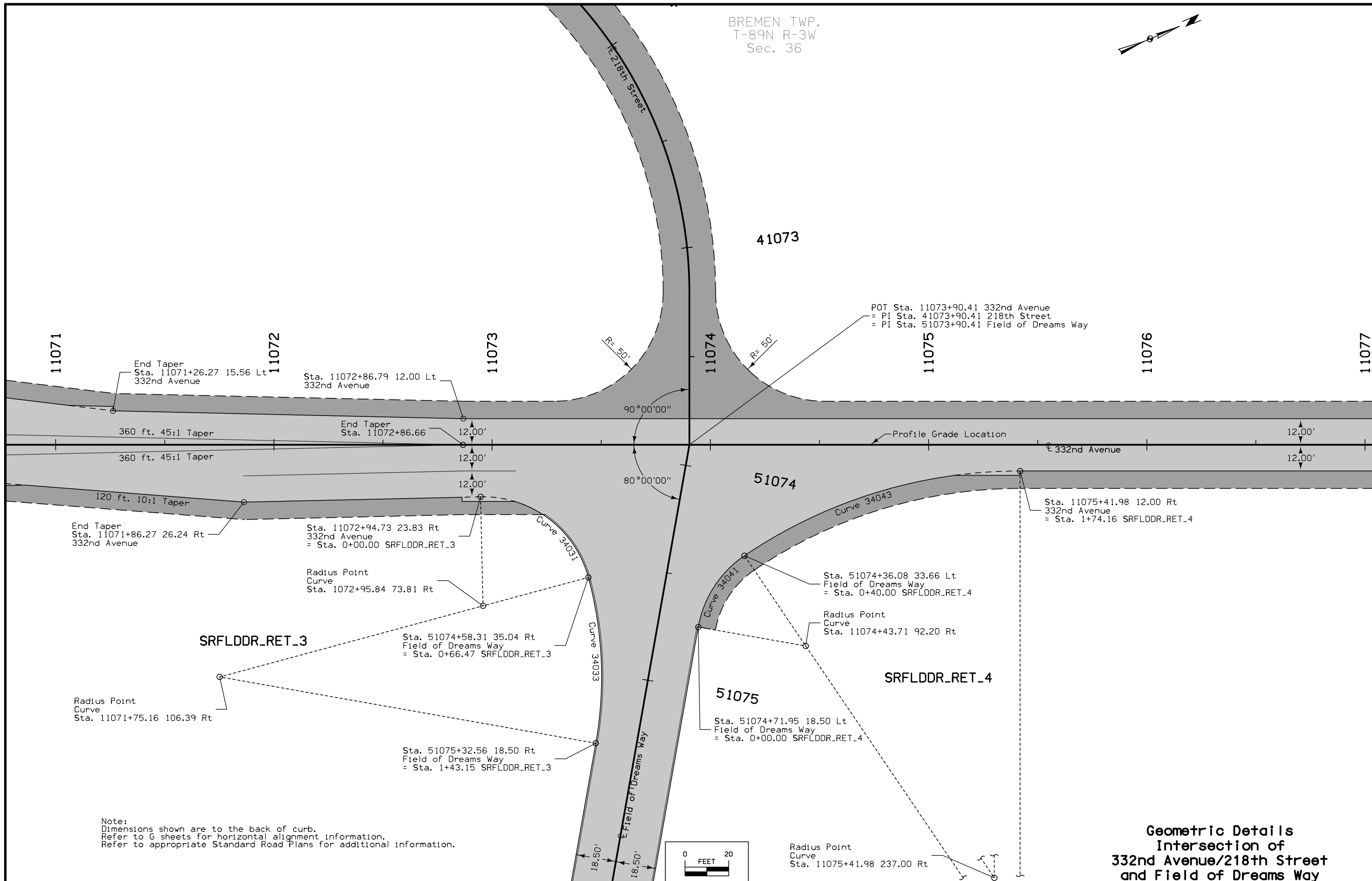
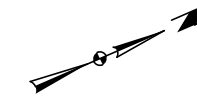

Note:  
Dimensions shown are to the back of curb.  
Refer to G sheets for horizontal alignment information.  
Refer to appropriate Standard Road Plans for additional information.

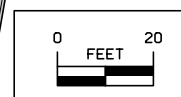

**Geometric Details  
Intersection of  
332nd Avenue/218th Street  
and Field of Dreams Way**

BREMEN TWP.  
T-89N R-3W  
Sec. 36

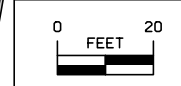
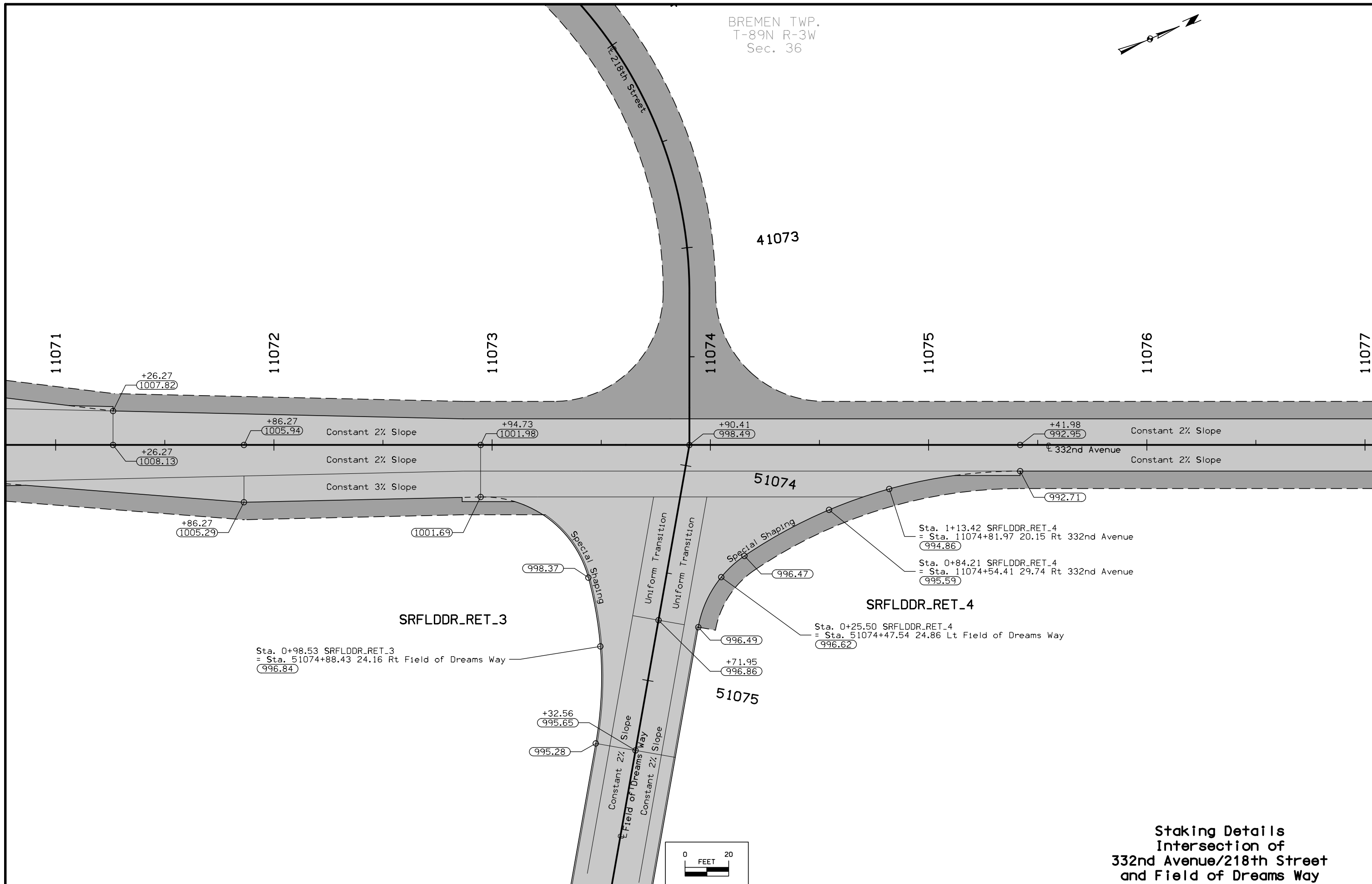
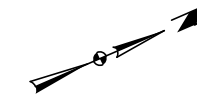

**Staking Details  
Intersection of  
332nd Avenue/218th Street  
and Field of Dreams Way**

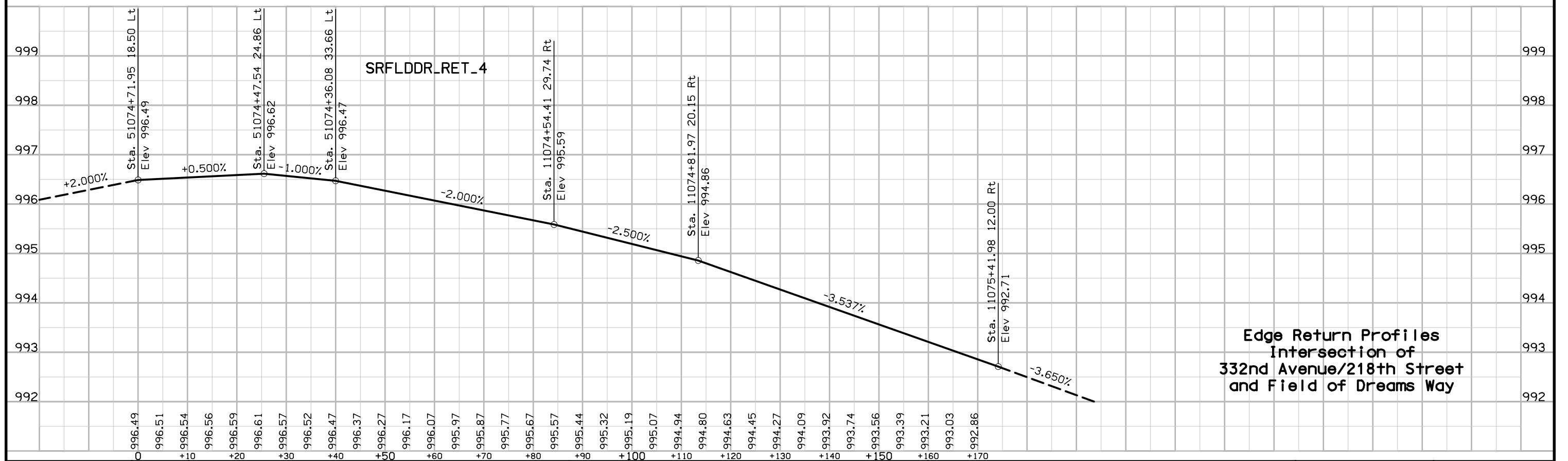
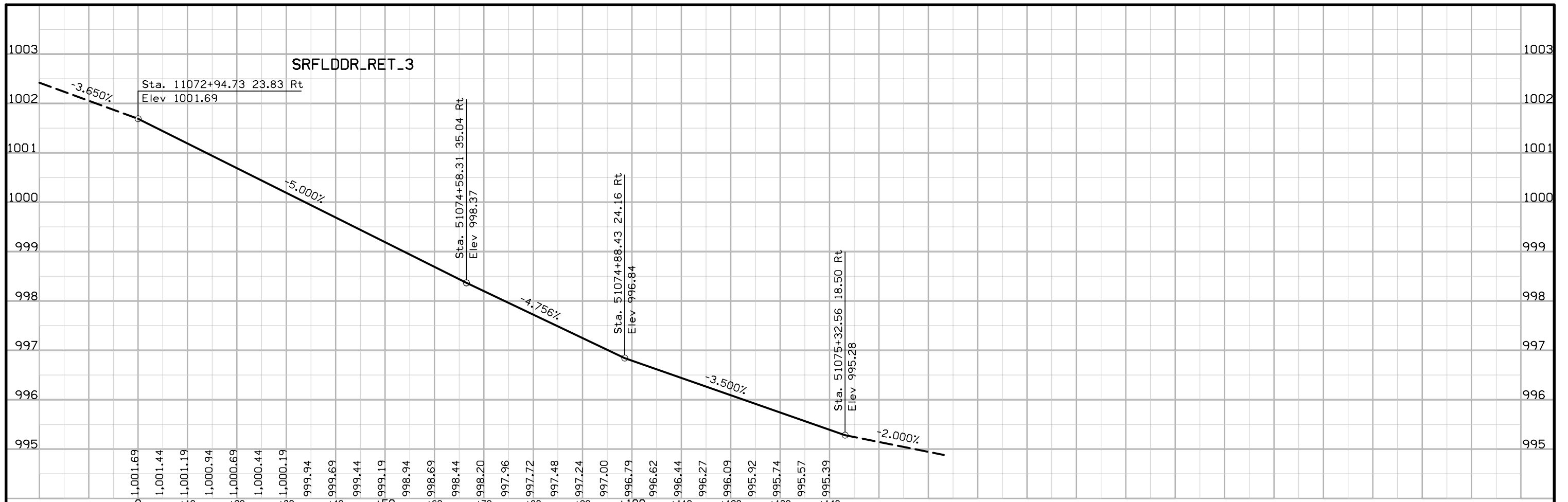

Edge Return Profiles  
 Intersection of  
 332nd Avenue/218th Street  
 and Field of Dreams Way



BREMEN TWP.  
T-89N R-3W  
Sec. 36

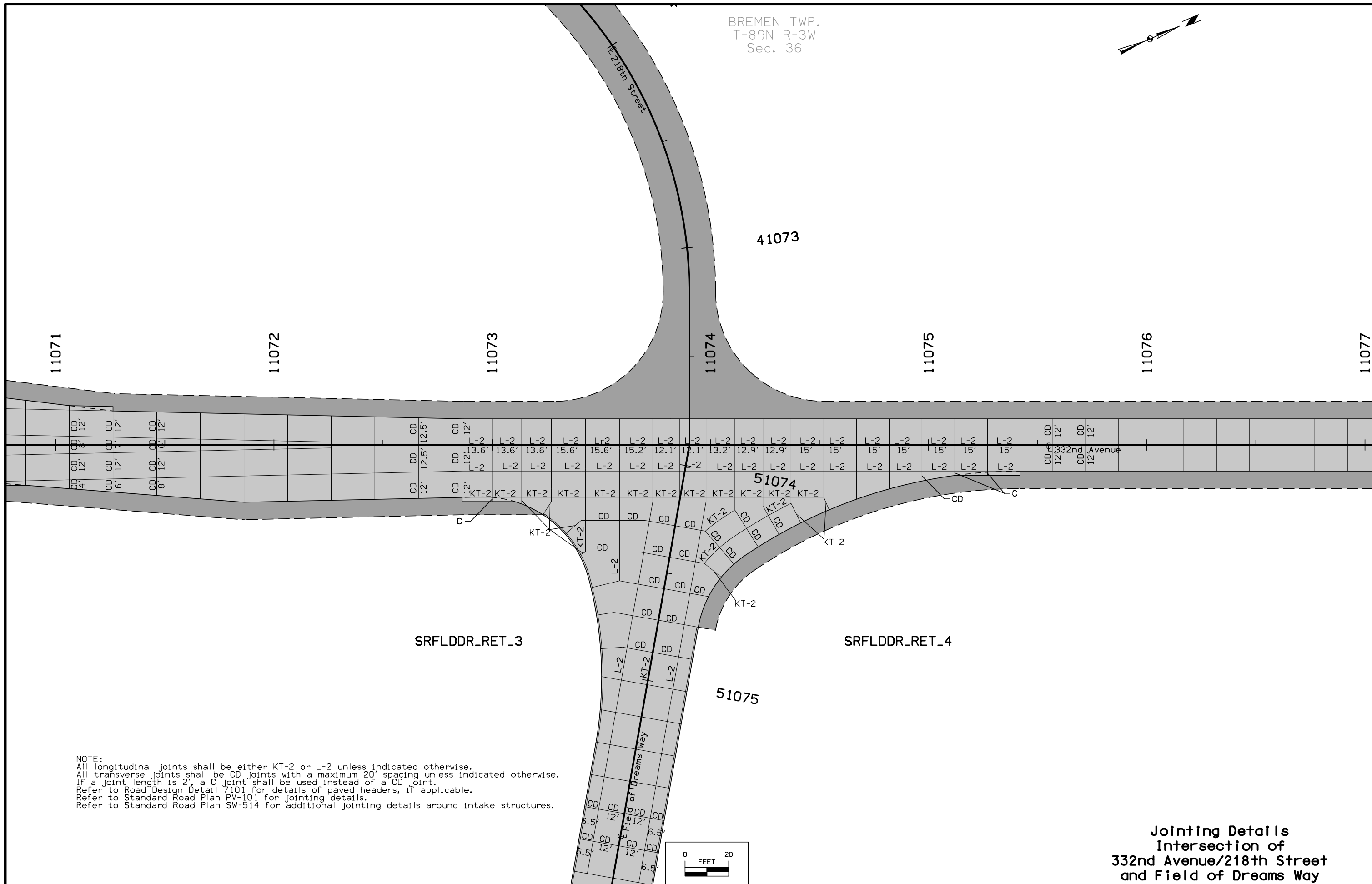
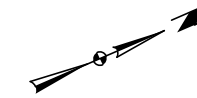

NOTE:  
All longitudinal joints shall be either KT-2 or L-2 unless indicated otherwise.  
All transverse joints shall be CD joints with a maximum 20' spacing unless indicated otherwise.  
If a joint length is 2', a C joint shall be used instead of a CD joint.  
Refer to Road Design Detail 7101 for details of paved headers, if applicable.  
Refer to Standard Road Plan PV-101 for jointing details.  
Refer to Standard Road Plan SW-514 for additional jointing details around intake structures.

Jointing Details  
Intersection of  
332nd Avenue/218th Street  
and Field of Dreams Way

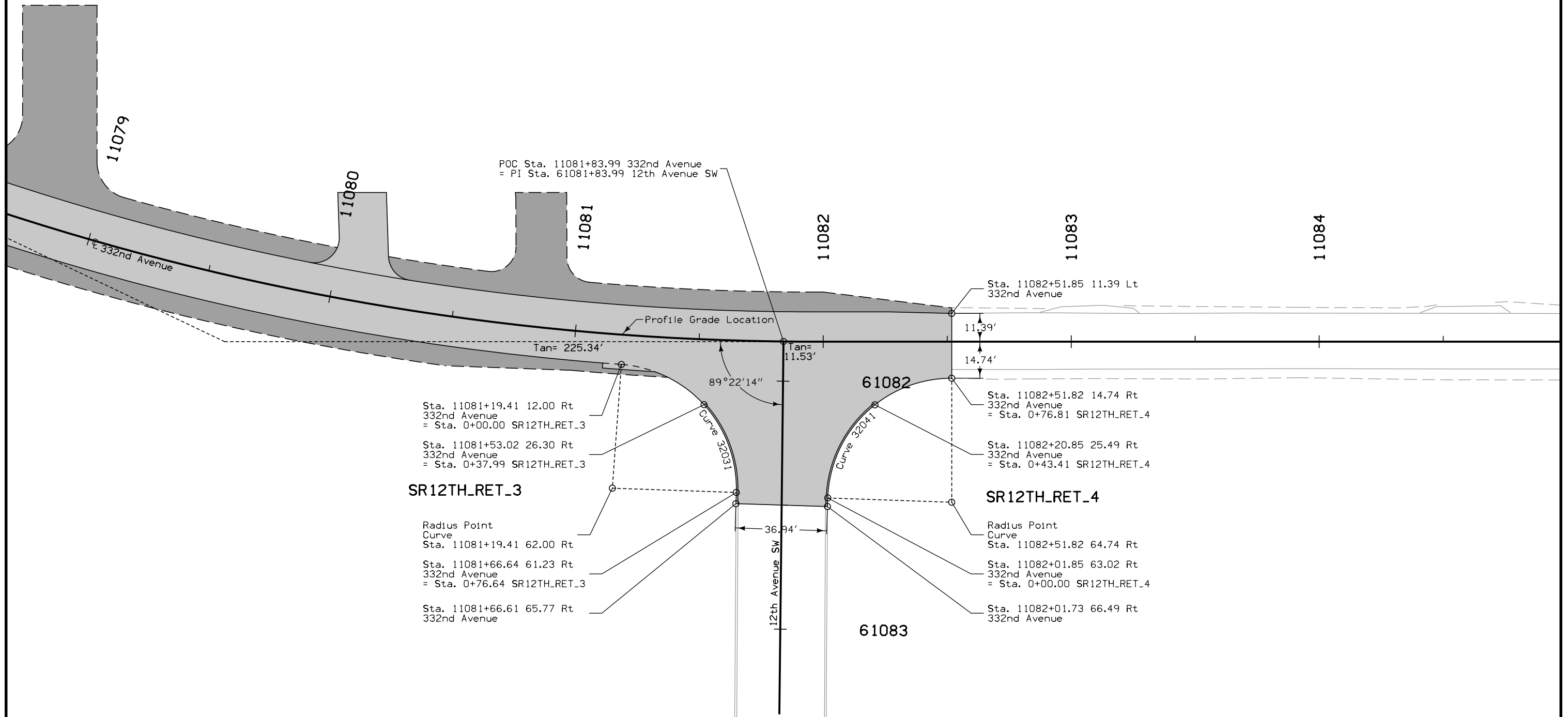
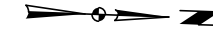

Note:  
Dimensions shown are to the back of curb.  
Refer to G sheets for horizontal alignment information.  
Refer to appropriate Standard Road Plans for additional information.



Geometric Details  
Intersection of  
332nd Avenue and 12th Avenue SW

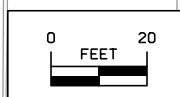
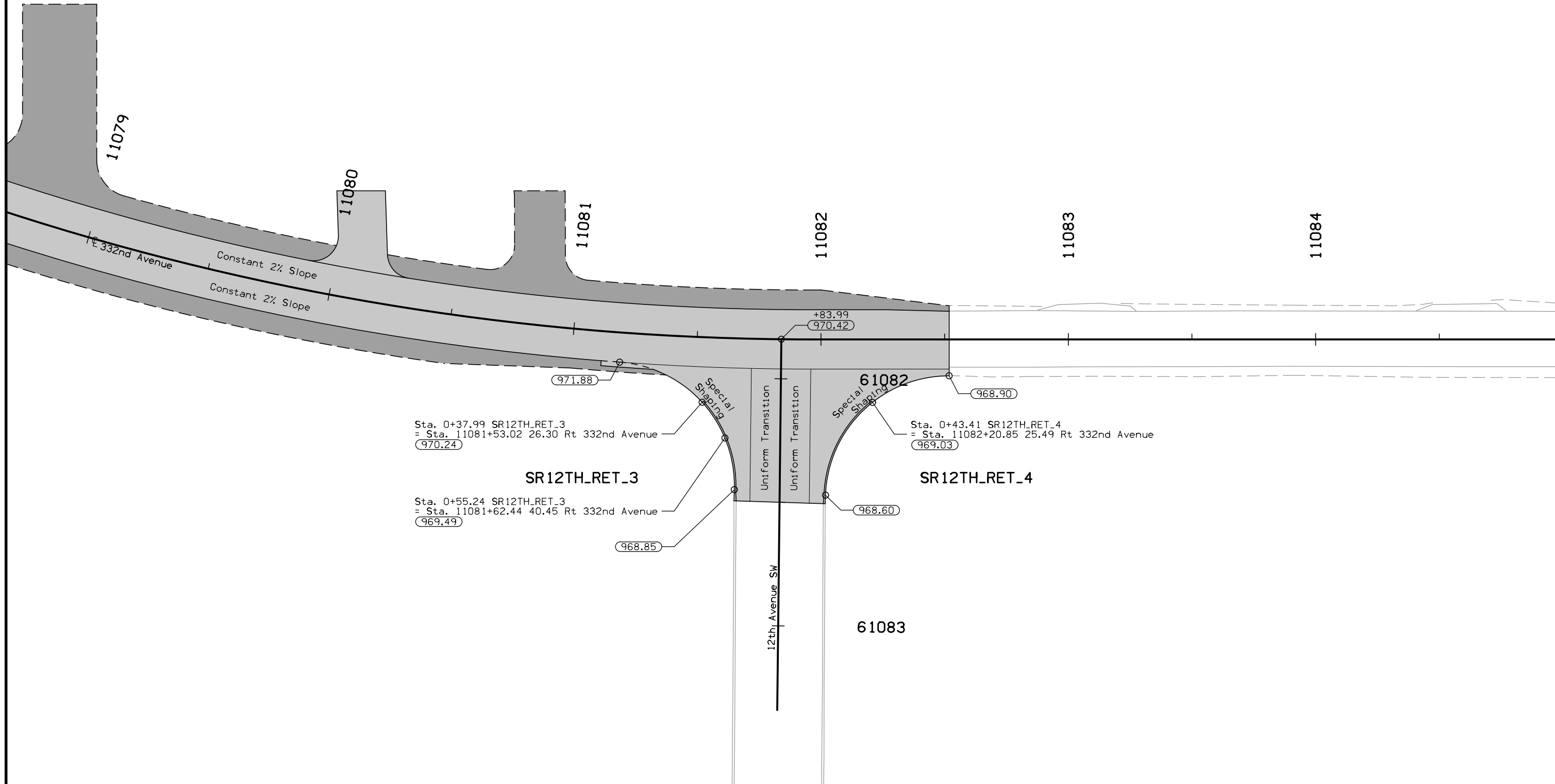
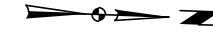

Staking Details  
Intersection of  
332nd Avenue and 12th Avenue SW

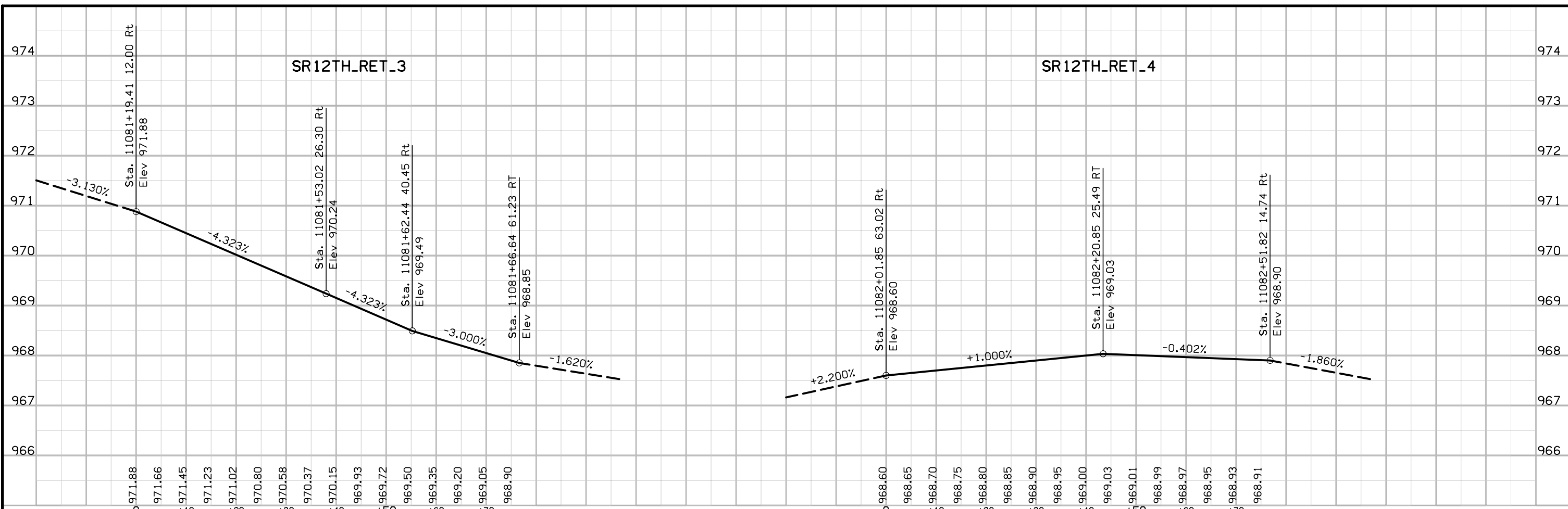

Edge Return Profiles  
 Intersection of  
 332nd Avenue and 12th Avenue SW

BREMEN TWP.  
T-89N R-3W  
Sec. 36

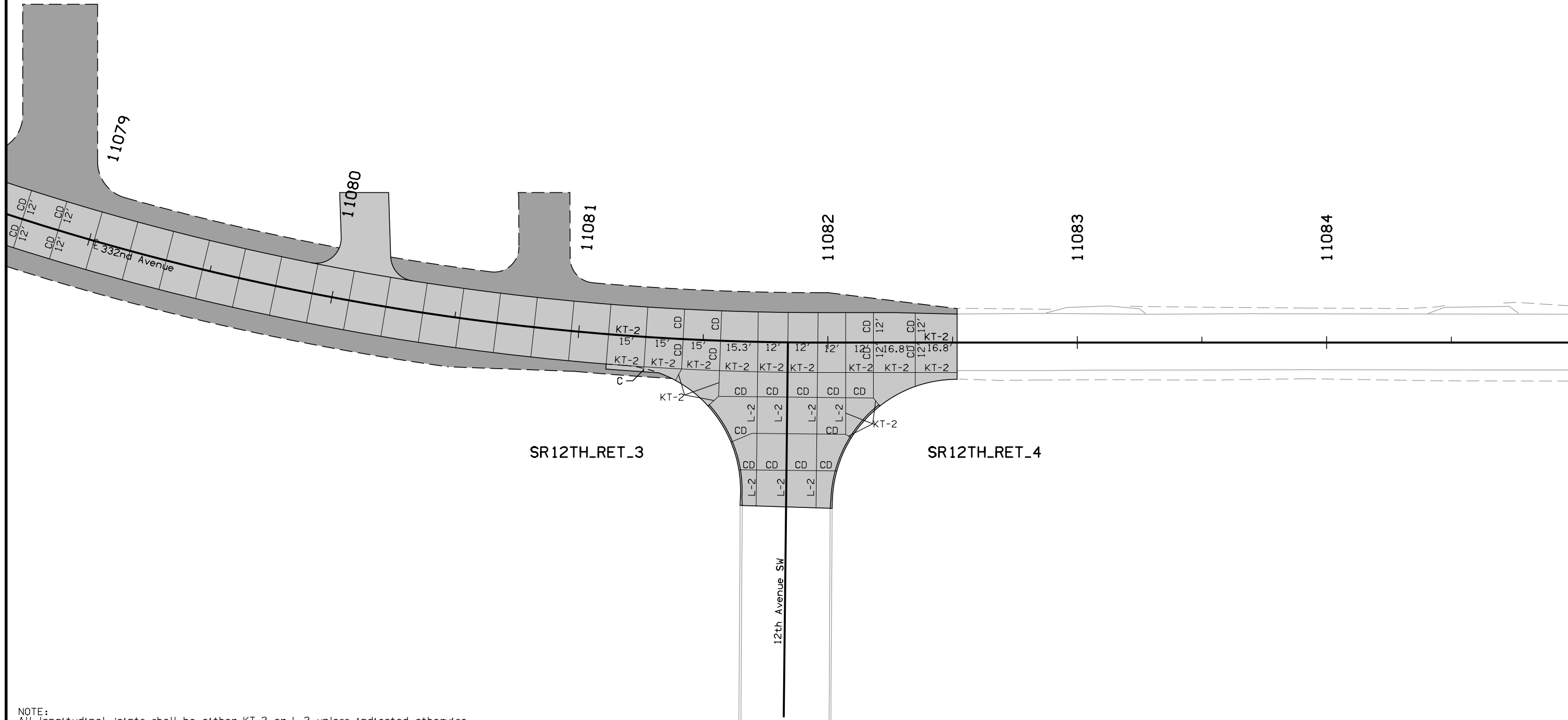
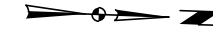

NOTE:  
All longitudinal joints shall be either KT-2 or L-2 unless indicated otherwise.  
All transverse joints shall be CD joints with a maximum 20' spacing unless indicated otherwise.  
If a joint length is 2', a C joint shall be used instead of a CD joint.  
Refer to Road Design Detail 7101 for details of paved headers, if applicable.  
Refer to Standard Road Plan PV-101 for jointing details.  
Refer to Standard Road Plan SW-514 for additional jointing details around intake structures.

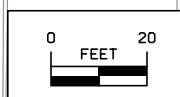

Jointing Details  
Intersection of  
332nd Avenue and 12th Avenue SW

FILE NO.	ENGLISH	DESIGN TEAM	Stanley Consultants Inc.	DELAWARE/DUBUQUE COUNTY	PROJECT NUMBER	NHSX-020-9(203)--3H-28	SHEET NUMBER	L.23
----------	---------	-------------	--------------------------	-------------------------	----------------	------------------------	--------------	------

NORTH FORK TWP.  
T-88N R-3W  
Sec. 2

NORTH FORK TWP.  
T-88N R-3W  
Sec. 1

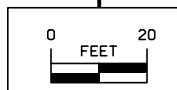
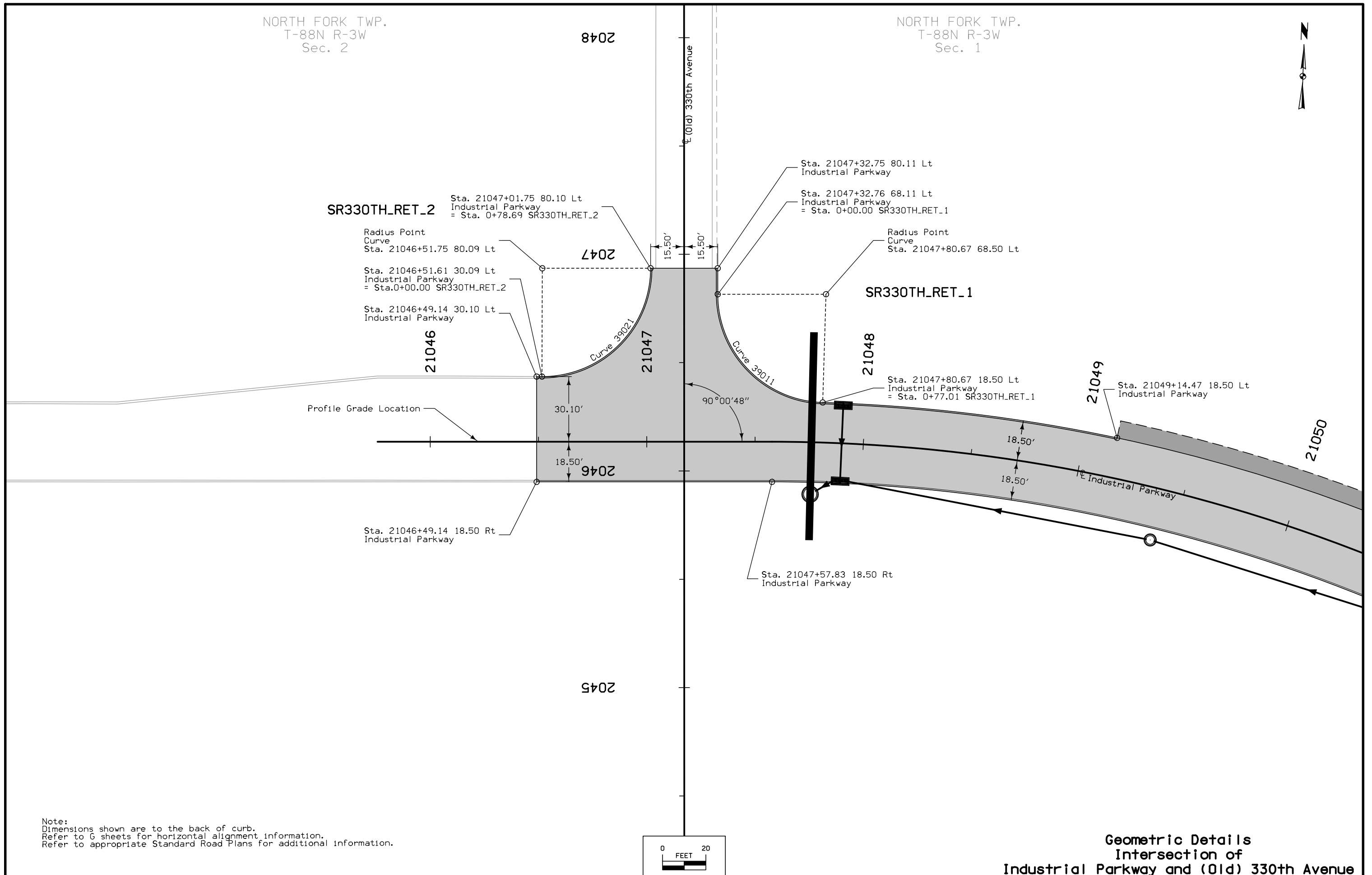

**Geometric Details  
Intersection of  
Industrial Parkway and (Old) 330th Avenue**

FILE NO.	ENGLISH	DESIGN TEAM <b>Stanley Consultants Inc.</b>	DELAWARE/DUBUQUE COUNTY	PROJECT NUMBER <b>NHSX-020-9(203)--3H-28</b>	SHEET NUMBER <b>L.24</b>
----------	---------	---	-------------------------	--	--------------------------



NORTH FORK TWP.  
T-88N R-3W  
Sec. 2

NORTH FORK TWP.  
T-88N R-3W  
Sec. 1



Sta. 0+64.48 SR330TH\_RET\_2  
= Sta. 21046+99.75 66.08 Lt Industrial Parkway  
(992.47)

Sta. 0+53.13 SR330TH\_RET\_2  
= Sta. 21046+95.37 55.63 Lt Industrial Parkway  
(992.02)

Sta. 0+36.22 SR330TH\_RET\_2  
= Sta. 21046+84.78 42.55 Lt Industrial Parkway  
(991.18)

Sta. 0+23.65 SR330TH\_RET\_2  
= Sta. 21046+74.41 35.51 Lt Industrial Parkway  
(990.74)

Sta. 0+27.99 SR330TH\_RET\_1  
= Sta. 21047+40.39 41.56 Lt Industrial Parkway  
(991.78)

Sta. 0+46.18 SR330TH\_RET\_1  
= Sta. 21047+52.62 28.22 Lt Industrial Parkway  
(991.60)

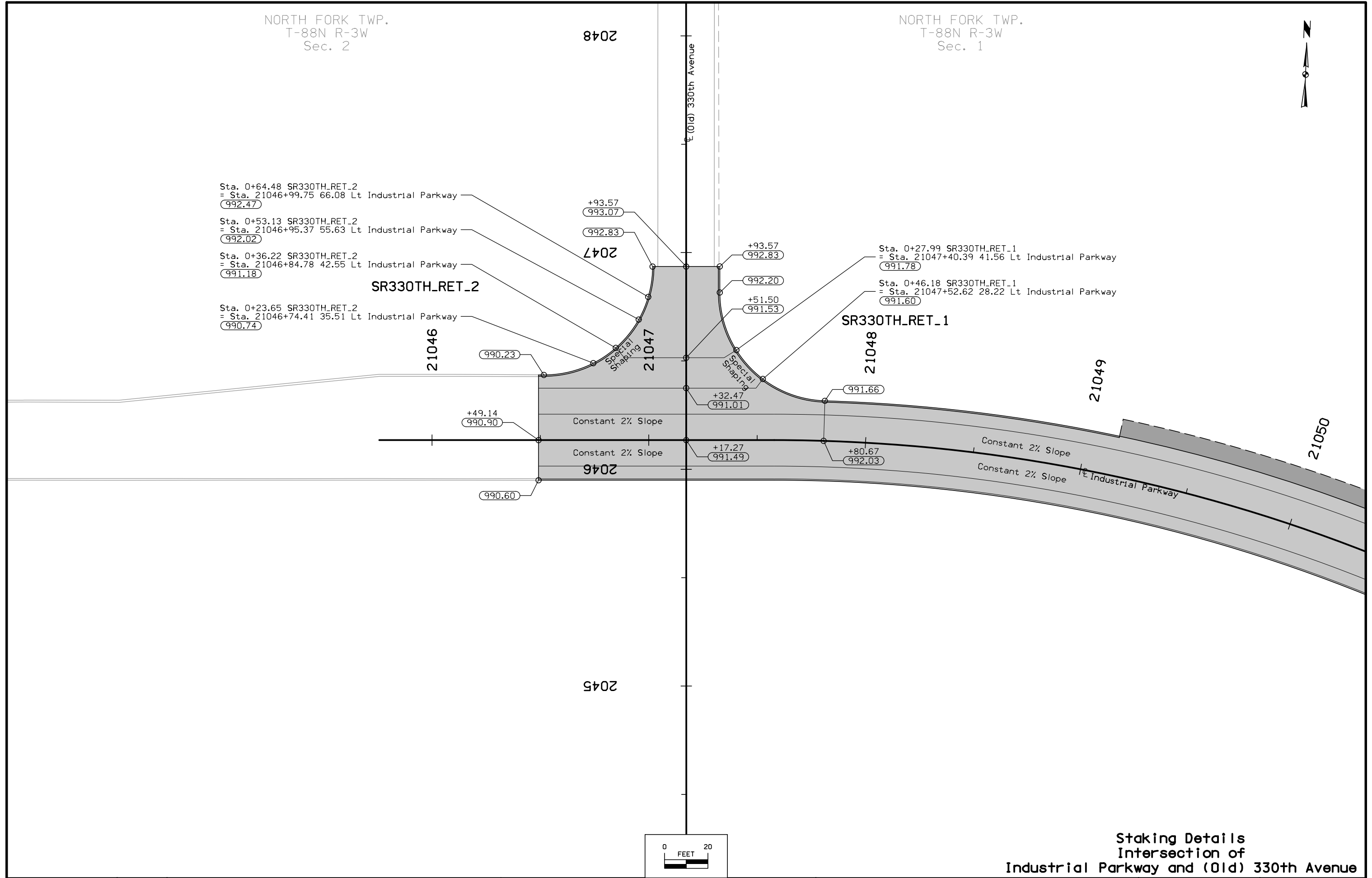

Staking Details  
Intersection of  
Industrial Parkway and (Old) 330th Avenue

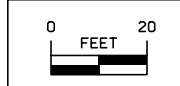

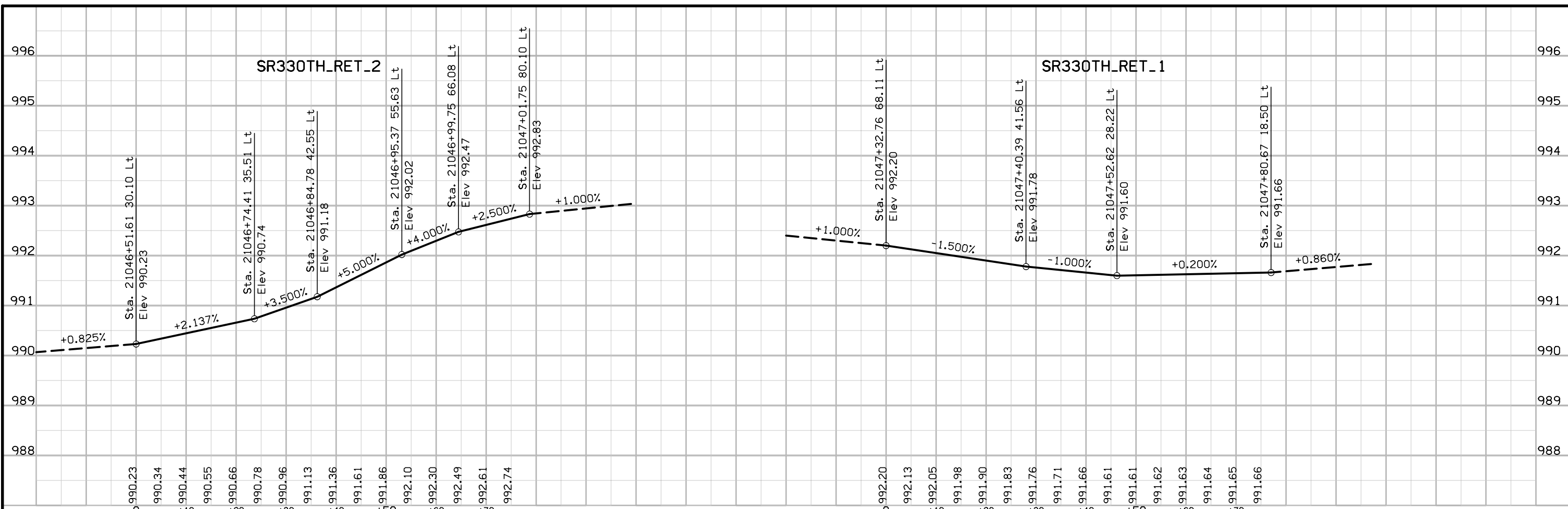

Edge Return Profiles  
Intersection of  
Industrial Parkway and (Old) 330th Avenue

NORTH FORK TWP.  
T-88N R-3W  
Sec. 2

NORTH FORK TWP.  
T-88N R-3W  
Sec. 1

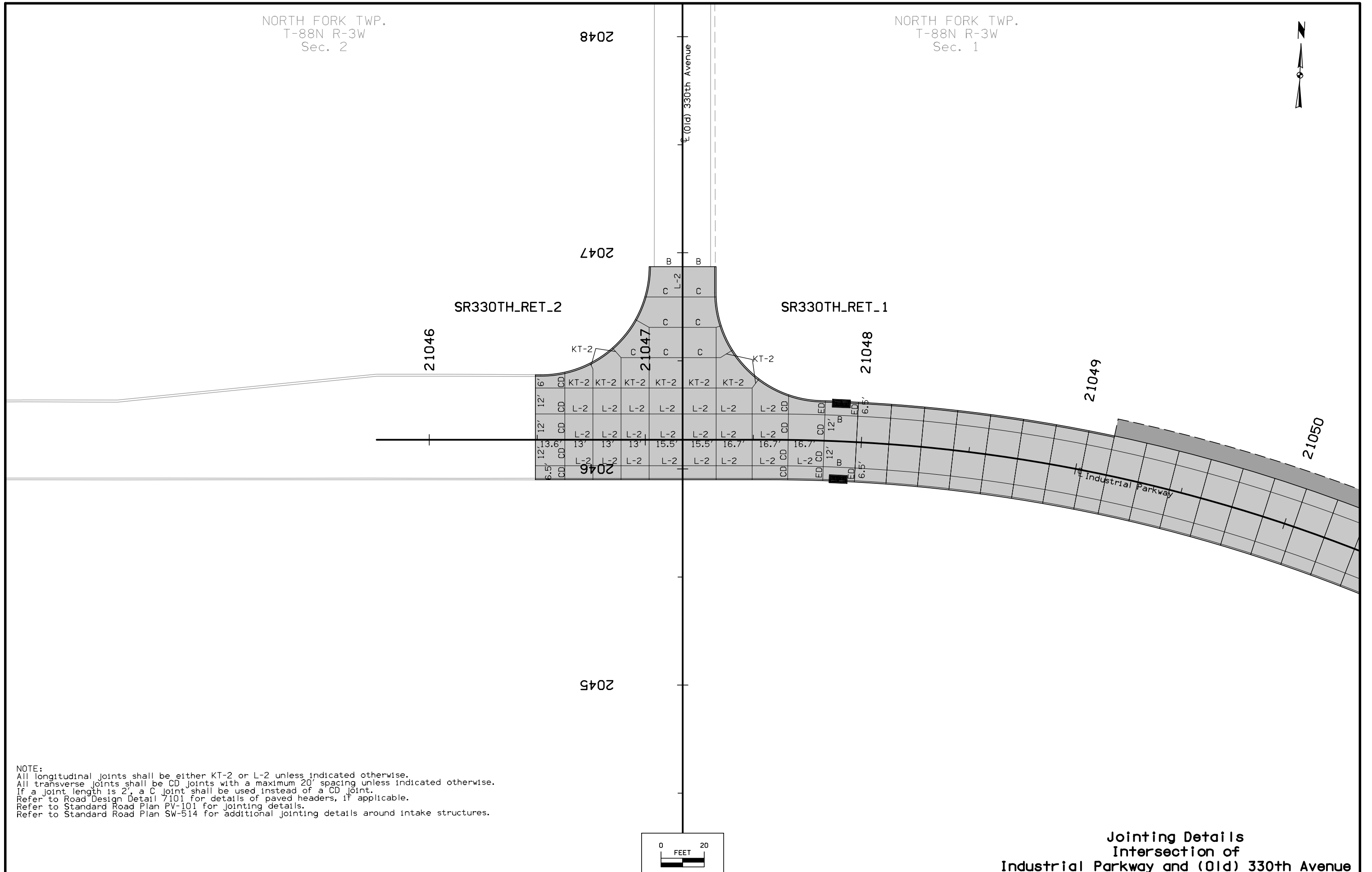

NOTE:  
 All longitudinal joints shall be either KT-2 or L-2 unless indicated otherwise.  
 All transverse joints shall be CD joints with a maximum 20' spacing unless indicated otherwise.  
 If a joint length is 2', a C joint shall be used instead of a CD joint.  
 Refer to Road Design Detail 7101 for details of paved headers, if applicable.  
 Refer to Standard Road Plan PV-101 for jointing details.  
 Refer to Standard Road Plan SW-514 for additional jointing details around intake structures.

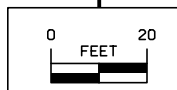

Jointing Details  
 Intersection of  
 Industrial Parkway and (Old) 330th Avenue

FILE NO.	ENGLISH	DESIGN TEAM <b>Stanley Consultants Inc.</b>	DELAWARE/DUBUQUE COUNTY	PROJECT NUMBER <b>NHSX-020-9(203)--3H-28</b>	SHEET NUMBER <b>L.27</b>
----------	---------	---	-------------------------	--	--------------------------

NORTH FORK TWP.  
T-88N R-3W  
Sec. 2

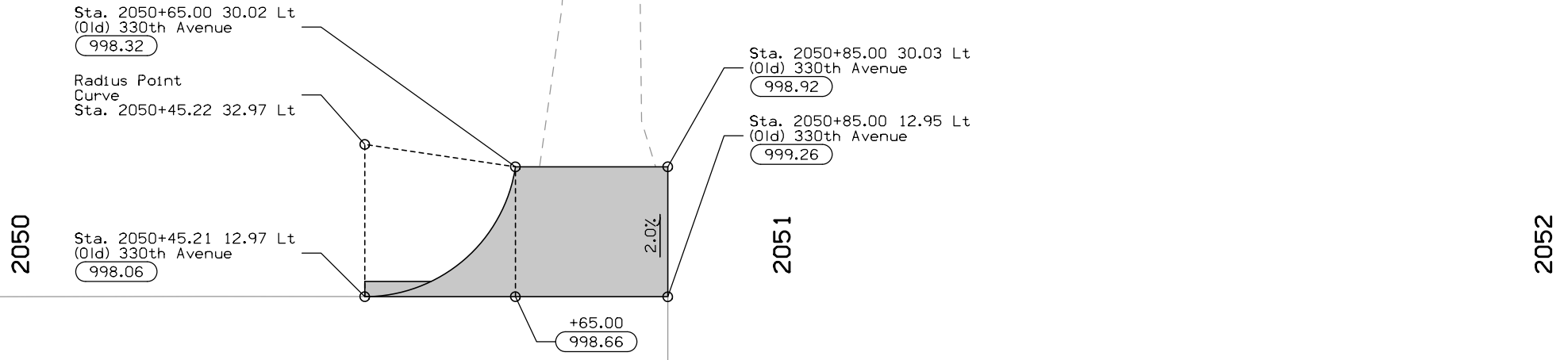
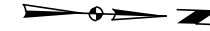

NORTH FORK TWP.  
T-88N R-3W  
Sec. 1

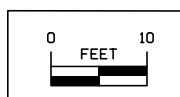
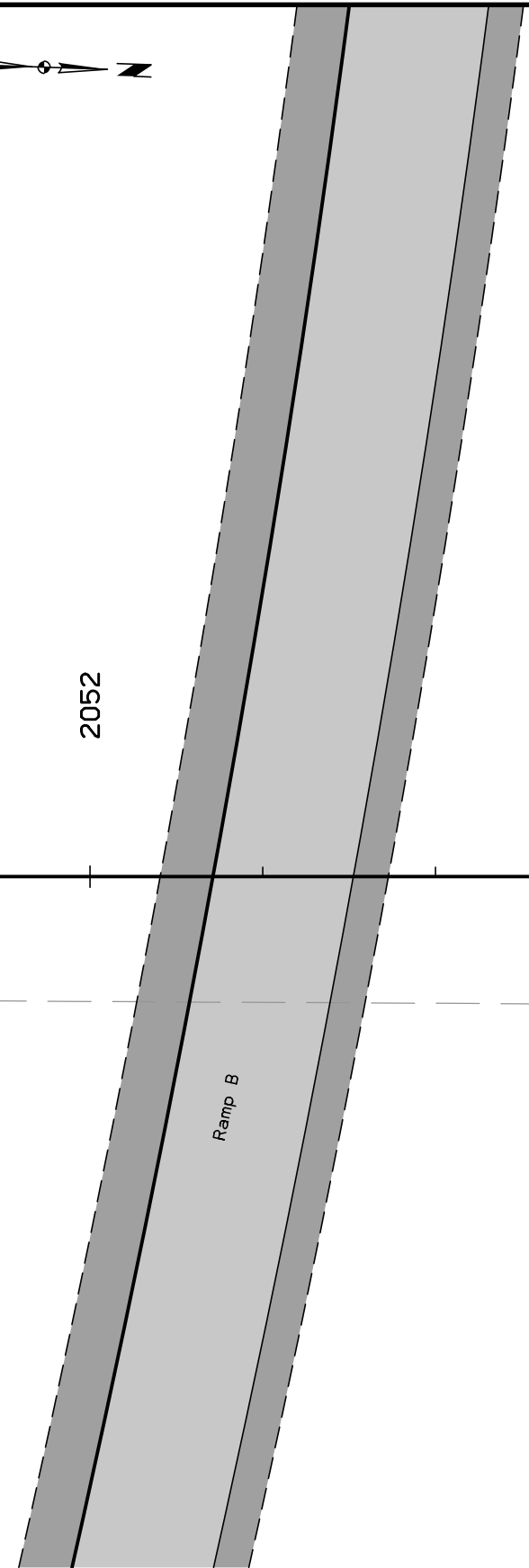
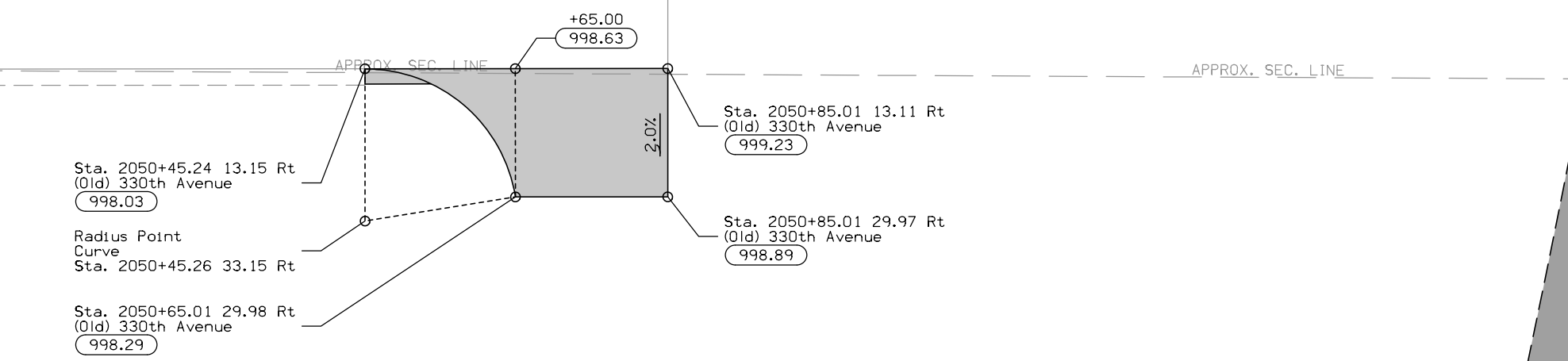

**Geometric/Staking Details  
(Old) 330th Avenue  
Maintenance Turnaround**

BREMEN TWP.  
T-89N R-3W  
Sec. 35

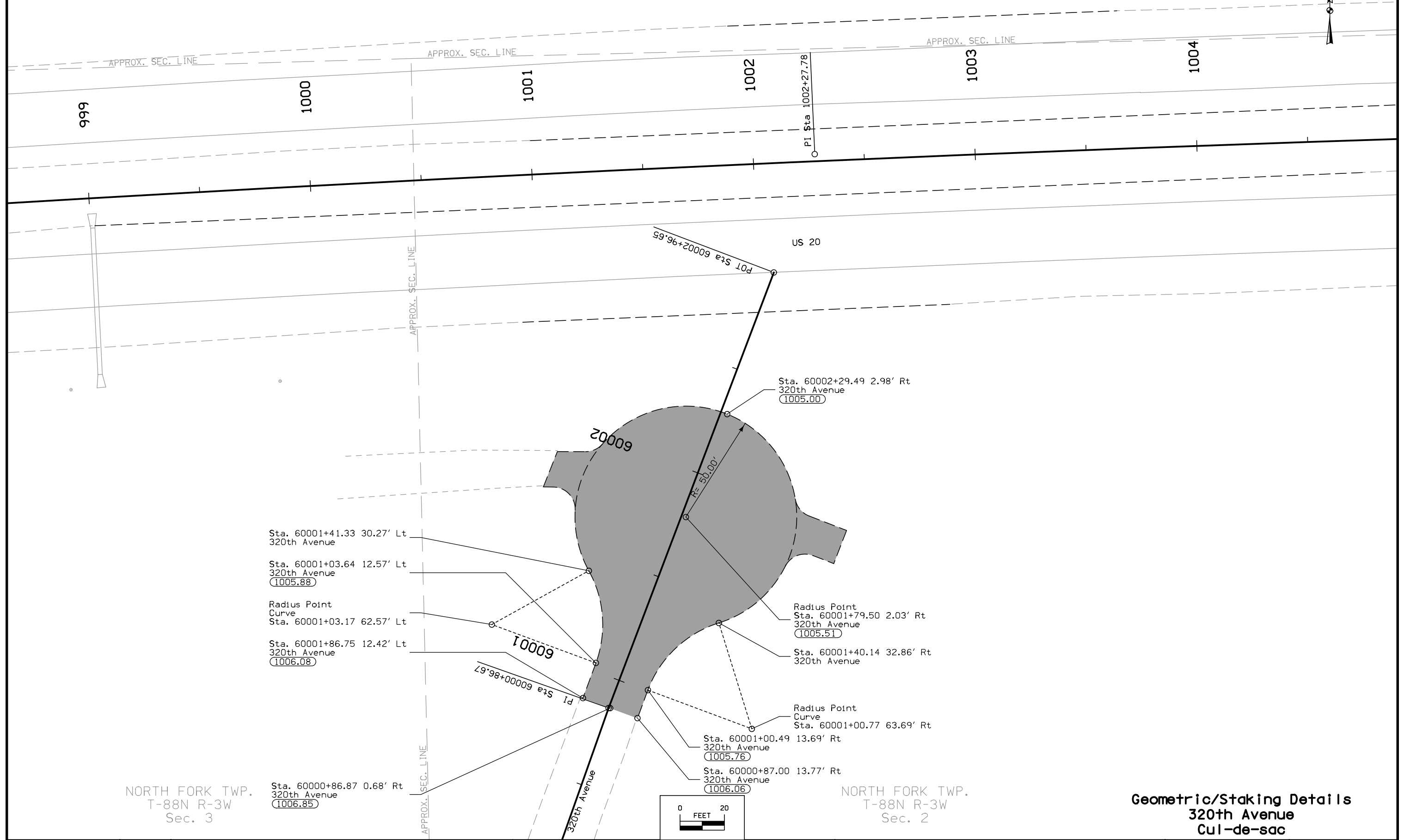

NORTH FORK TWP.  
T-88N R-3W  
Sec. 2

**Geometric/Staking Details**  
**320th Avenue**  
**Cul-de-sac**

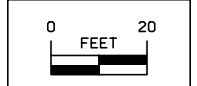





### SURVEY SYMBOLS

- SIGN SI Sign
- PLG Location of General Photo
- PIP Pipe Culvert
- TP TPD Telephone Pedestal
- ⊙ INB Storm Sewer Beehive Intake
- ⊕ MH Utility Access (Manhole)
- BB BB Billboard
- BLD Building or Foundation
- ⊙ MM Mile Marker Post
- x FW Wire Fence
- OUT Tile Outlet
- ⊕ IN Storm Sewer Intake
- LIN Miscellaneous Line
- LUM Luminaire
- ⊙ FLG Flag Poles
- WV Water Valve
- ⊙ X LC Approx. Lot Corner
- EB Electrical Box
- TVP TV Pedestal
- MIS Miscellaneous
- PR Electric Riser Pole
- ⚡ FHD Fire Hydrants
- SIGN SL Speed Limit Sign
- # FCL Chain Link and Security Fence
- ☺ TDC Tree Deciduous
- ⊕ SHR Shrub
- ✱ TEV Evergreen Tree
- TLNR Tree Line Right
- WH WHD Water Hydrant
- FWD Wood Fence
- ROC Rock Outcropping
- TLNL Tree Line Left
- CUL Culvert
- Title TIL Tile Line
- ⊕ LP L.P. Tank
- ⊕ WEL Well
- EG Edge of Gravel Road
- EP Edge of Paved Roads (ML or SR)
- CU Back of Curb
- GU Gutter In Front of Curb
- CON Concrete or A/C Slab
- ENP Edge Paved Entrance & Park Lot
- ENT Centerline BL of Entrance
- SH Paved Shoulder
- ENU Edge Unpaved Entrance & Parking
- SNP Unpaved Shoulder
- D Centerline Draw or Stream (Down)
- DU Centerline Draw or Stream (Up)
- ▲▲▲▲▲ RIP Rip-Rap
- CP Control Point
- PRO Profile Shot
- SOP Size of Pipe or Culvert
- UE Utility Elevation
- BL Topo Breakline

### UTILITY LEGEND

- E1 — ALLIANT ENERGY  
Jason Hogan  
4902 North Biltmore  
Madison, WI 53707-1007  
608-458-4871  
jasonhogan@alliantenergy.com
- E2 — Maquoketa Valley Electric Cooperative  
Jeremy Richert  
P.O. Box 370  
Anamosa, IA 52205  
319-462-3541 : Ext 209  
jrichert@mvec.com
- T1 — Windstream Communications(Formerly Iowa Telecom)  
Dan Hogan  
107 East Fayette  
Manchester, IA 52057  
563-927-2623  
daniel.hogan@windstream.com
- San. — City of Dyersville  
David Vorwald  
340 1st Avenue East  
Dyersville, IA 52040  
563-875-7724  
dvorwald@cityofdyersville.com
- G-HP — Black Hills Energy  
Brad Fleming  
1815 Capital Avenue  
Omaha, NE 68102  
402-221-2714  
brad.fleming@blackhillscorp.com
- FO — ICN  
Larry Klawitter  
400 East 1st Street / Grimes Office Building  
Des Moines, IA 50319  
515-725-4741  
larry.klawitter@iowa.gov
- TV — Mediacom  
Bob Frazer  
207 West Pearl Street  
Decorah, IA 52101  
563-387-6119  
bfrazer@mediacomcc.com

### PLAN VIEW COLOR LEGEND OF STORM SEWER SHEETS

LINEWORK	Design Color No.	Description
Gray, Dark	(112)	Existing Topographic Features, Utilities, and Labels
Black	(17)	Proposed Storm Sewer Details, Alignment, Stationing, Tic Marks, and Alignment Annotation
SHADING	Design Color No.	Description
Gray, Light	(48)	Proposed Pavement Shading

### PROFILE VIEW COLOR LEGEND OF STORM SEWER SHEETS

LINEWORK	Design Color No.	Description
Gray, Dark	(112)	Existing Ground Line Profile and Existing Utilities Information
Black	(17)	Proposed Pipes and Intakes

### PLAN VIEW LINE STYLE LEGEND OF STORM SEWER SHEETS

- ▶▶▶▶▶▶ Plug and Abandon Existing Pipe or Structure
- --- --- --- --- --- Removal of Existing Pipe or Structure
- Previously Constructed Pipe or Structure
- ▶ Direction of Pipe Flow

### PROFILE VIEW LINE STYLE LEGEND OF STORM SEWER SHEETS

- --- --- --- Existing Ground
- Proposed Ground
- Previously Constructed Pipe or Structure
- Proposed Pipe or Structure

Reference Point

Station

▲ Section Corner

--- --- --- --- Ground Line Intercept

//// //// //// //// Saw Cut

— — — — — Guardrail

▨ Clearing & Grubbing Area

▨ Pavement Removal

### RIGHT-OF-WAY LEGEND

- ▲ Proposed Right-of-Way
- ▲ Existing and Proposed Right-of-Way
- ▲ Easement and Existing Right-of-Way
- Borrow
- Easement (Temporary)
- Easement
- ✕ Excess
- A/C Access Control

## STORM SEWER LEGEND AND SYMBOL INFORMATION SHEET

(COVERS SHEET SERIES M)

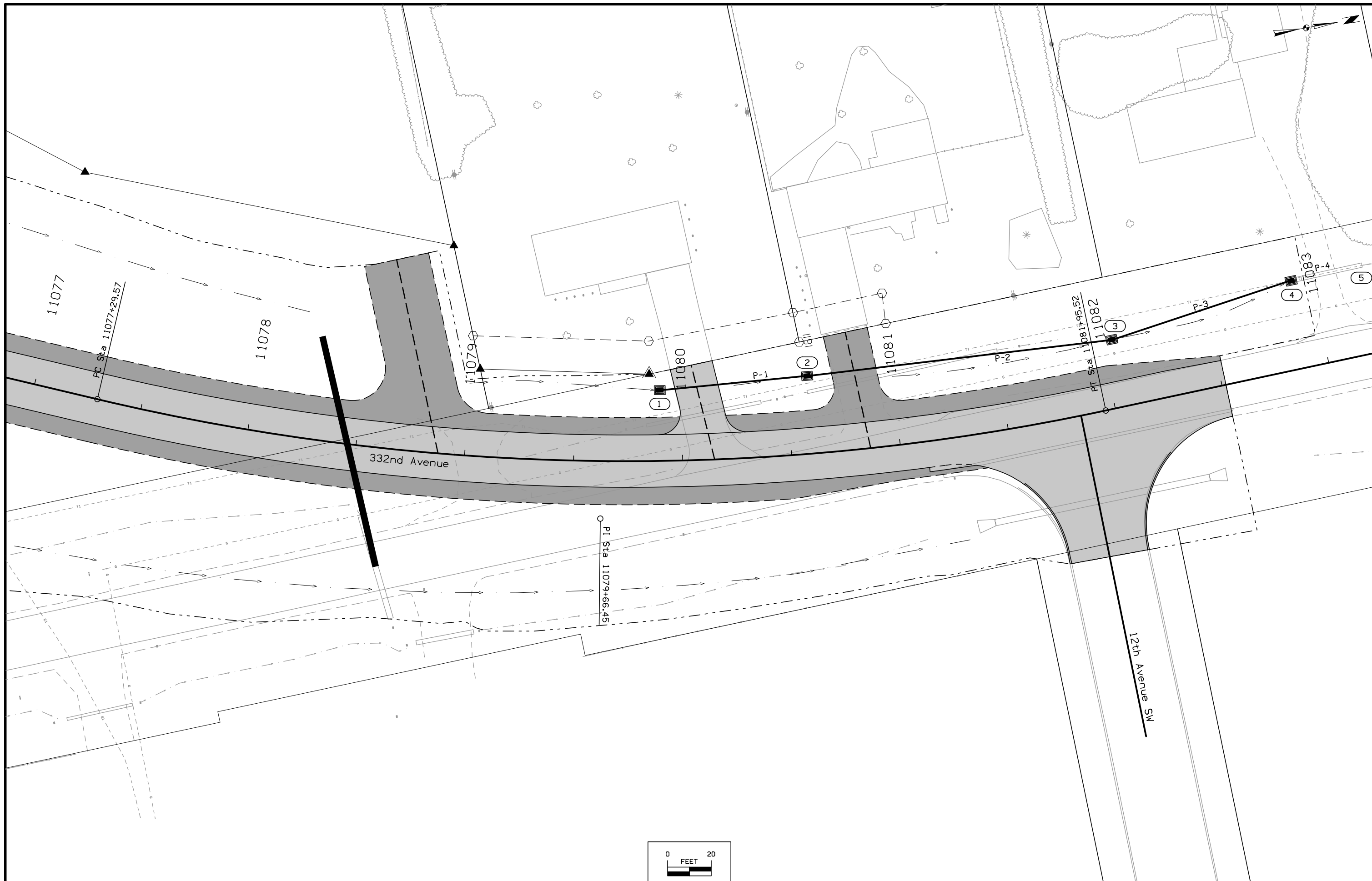

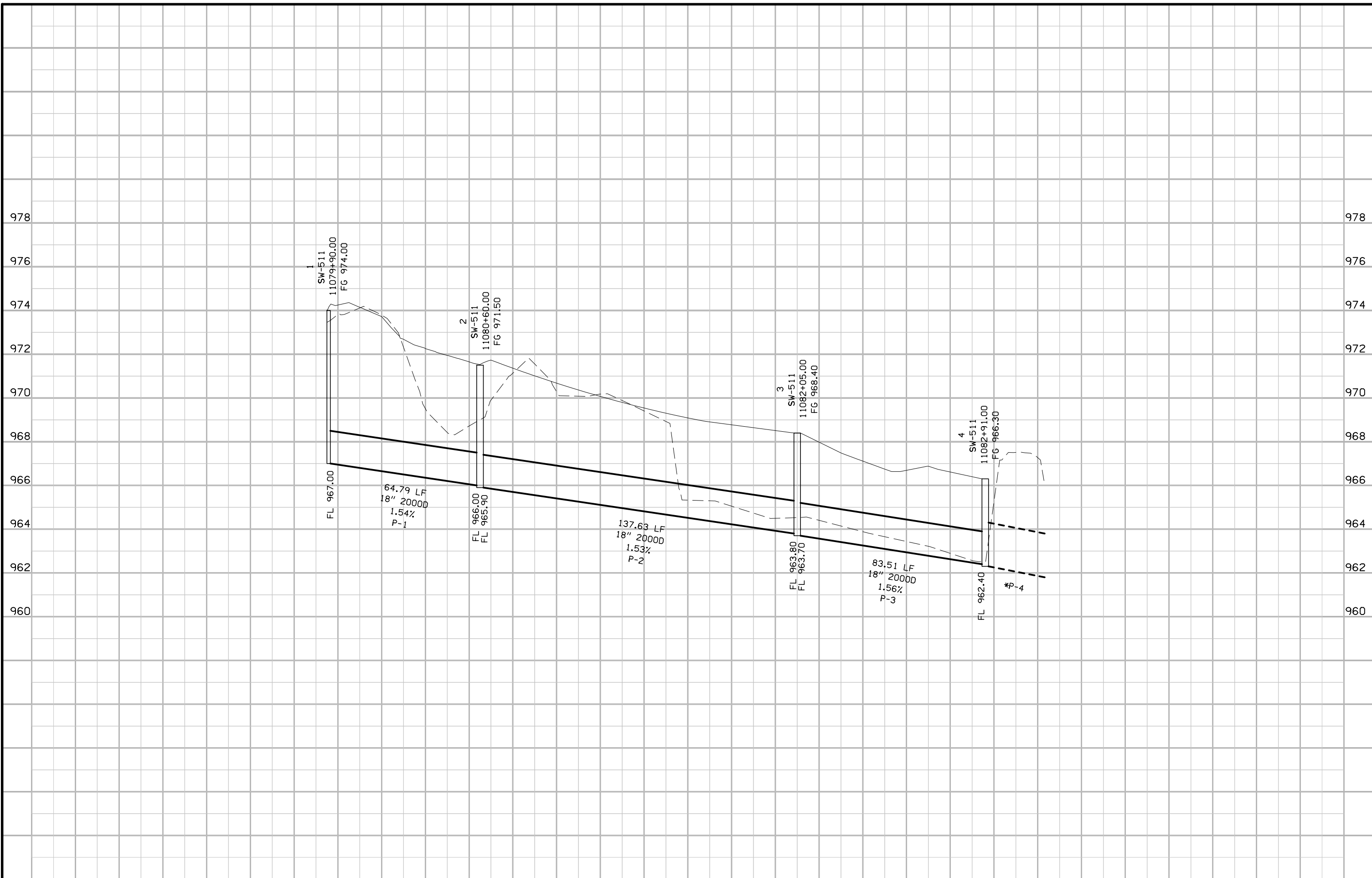

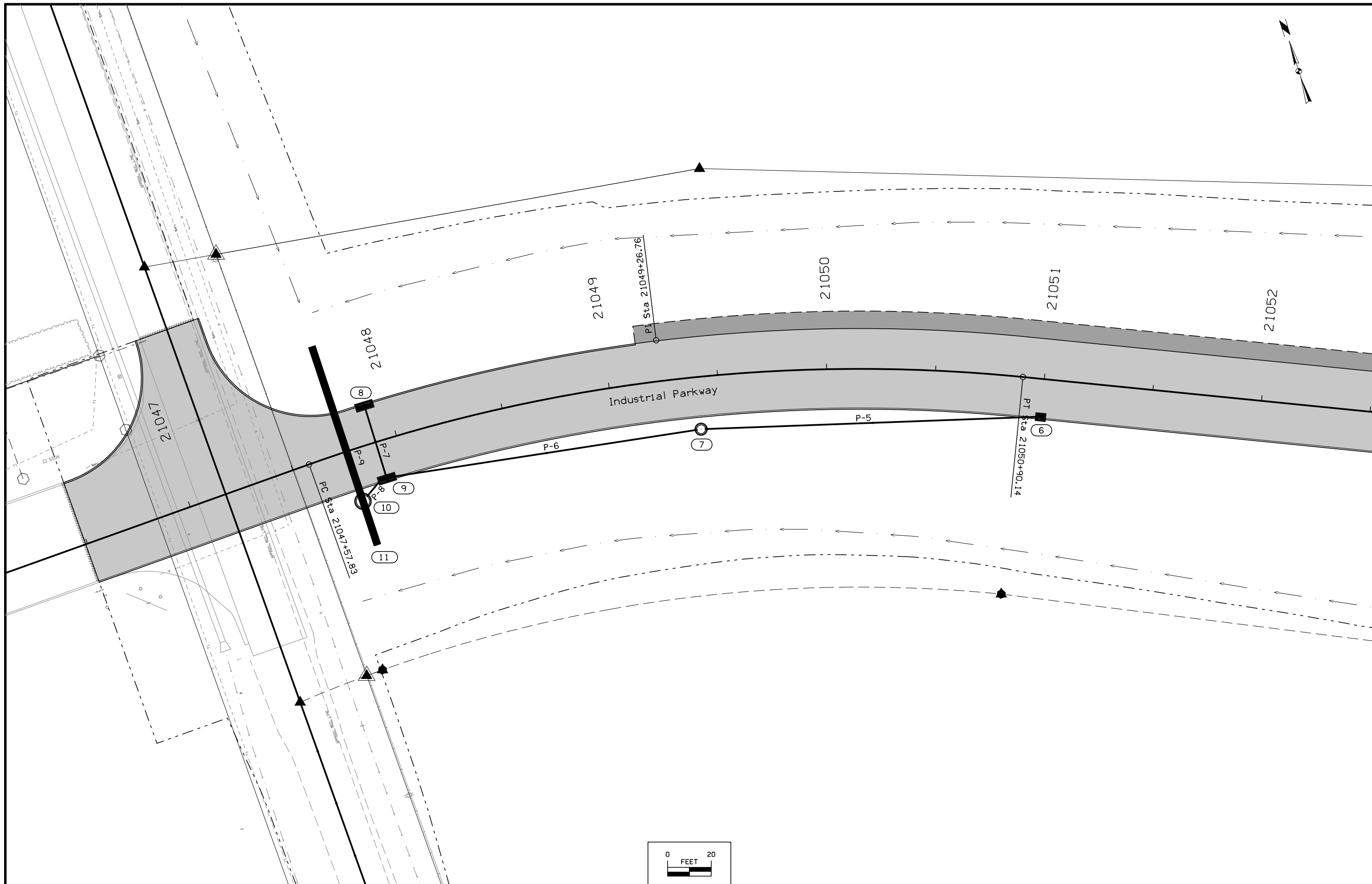

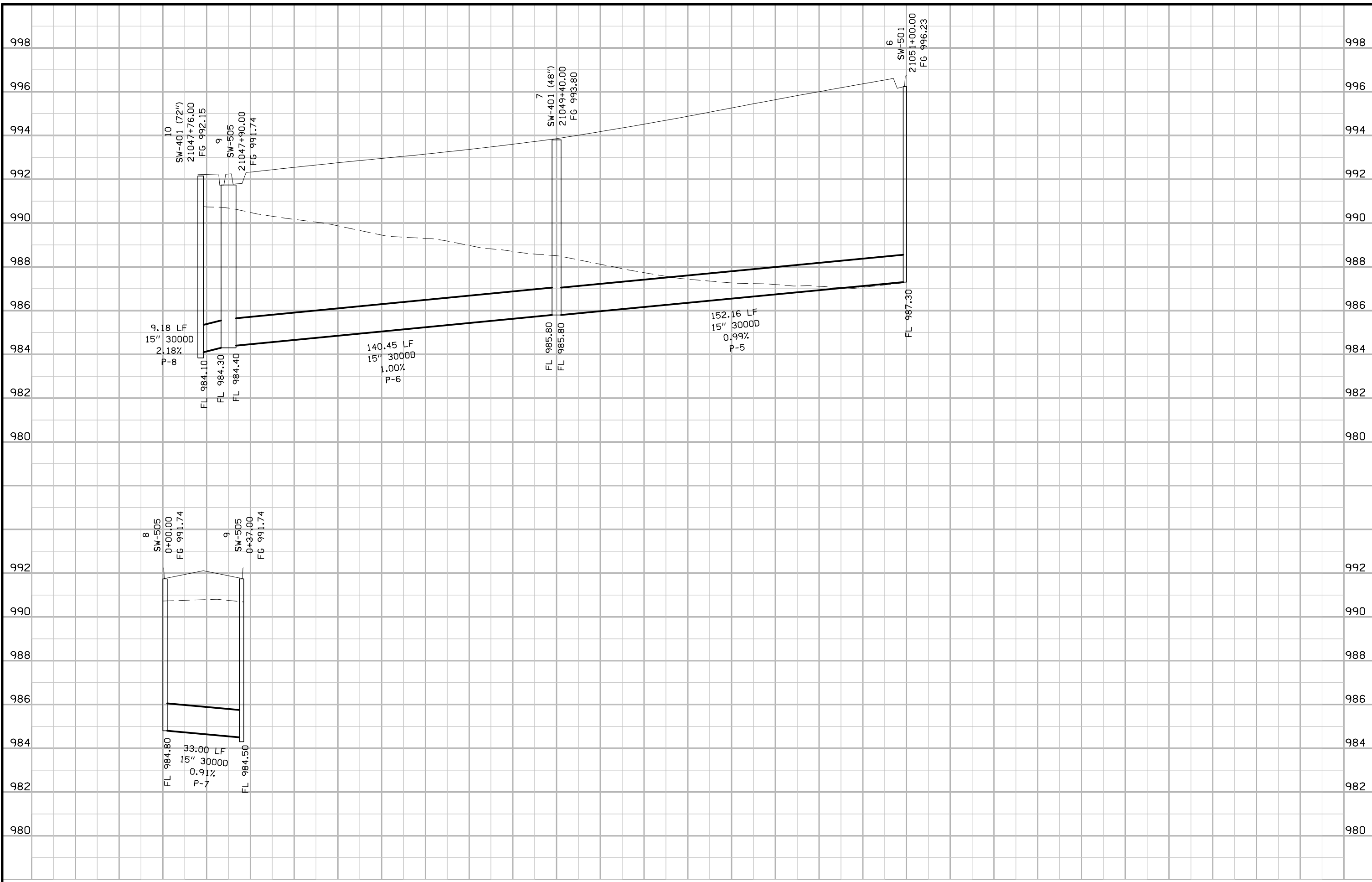

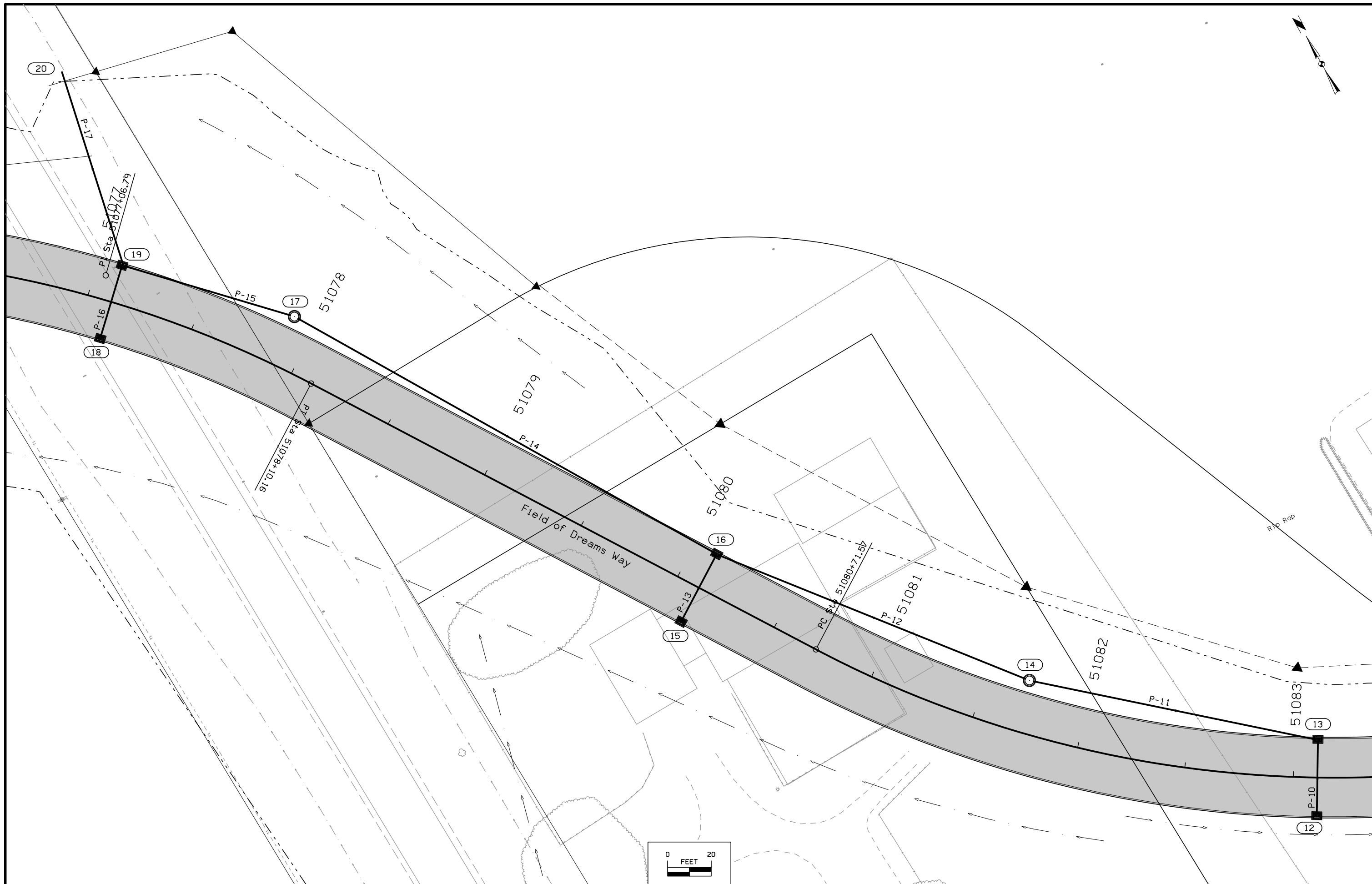



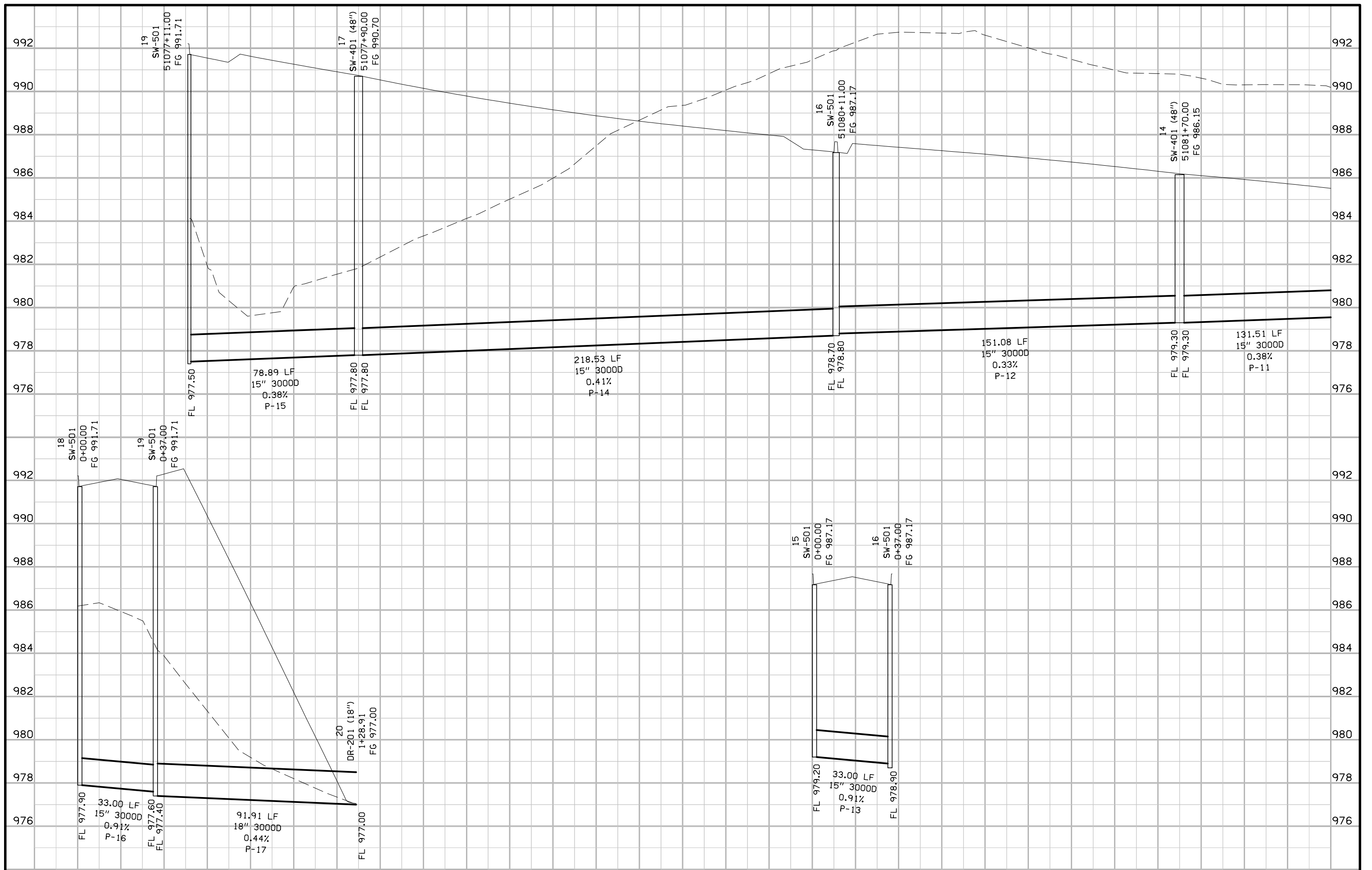

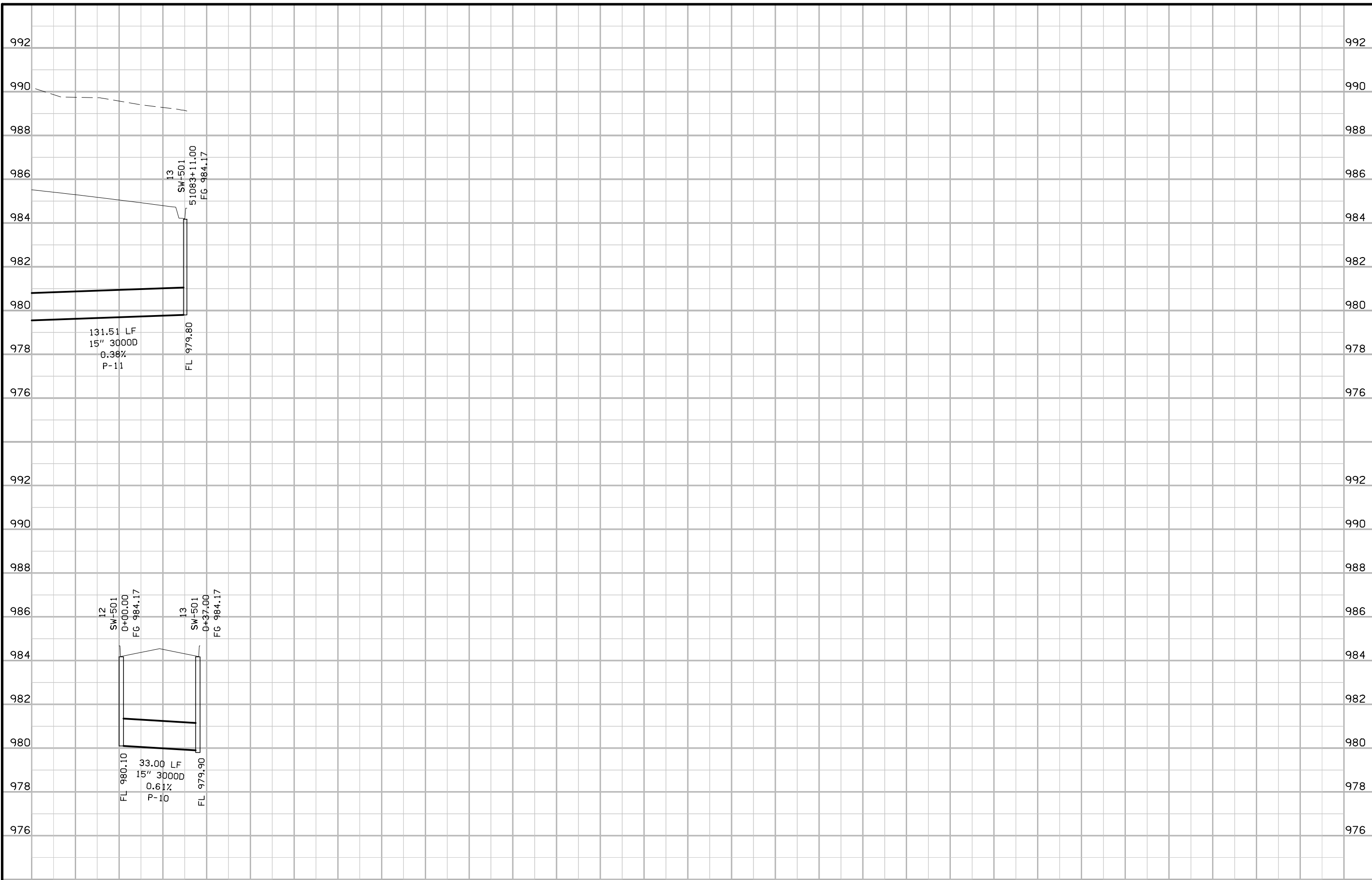

<b>108-11A</b> 08-01-08
<b>HIGHWAY LIGHTING DATA</b>
<p>ELECTRICAL SERVICE:            ALLIANT ENERGY WILL PROVIDE SECONDARY SERVICE (120/240 VOLTS SINGLE PHASE) TO THE CONTROL STATION. EXACT LOCATION OF THE CONTROL STATION SHALL BE DETERMINED BY THE ENGINEER AND APPROVED BY THE UTILITY COMPANY. IT SHALL BE THE CONTRACTOR'S RESPONSIBILITY TO MAKE THE NECESSARY CONTACTS WITH THE UTILITY COMPANY WITH REGARD TO CONNECTIONS TO THE SERVICE DROP.            CONTACT IS: NATE RUCKER, ALLIANT ENERGY, 563-587-4543, naterucker@alliantenergy.com</p> <p>ROADWAY LUMINAIRES:            HIGH-PRESSURE SODIUM, 250 WATT A.N.S.I./I.E.S. GLARE-CONTROL RATINGS SHALL BE FULL CUTOFF WITH APPROVED SOCKET POSITIONS AND REFRACTORS. ALL BALLASTS TO BE CONNECTED FOR 240 VOLTS.</p>

<b>108-1</b> 10-21-14					
<b>LIGHTING INSTALLATIONS</b>					
Location	LI-101			LI-201	Remarks
	Type	A	E FT	Type	
No.	Station				
D101	11069+40	1	6	10.0	A
D102	4064+75	1	6	10.0	A
D103	11066+65	1	6	10.0	A
D201	11061+00	1	6	10.0	A
D202	5063+00	1	6	10.0	A
D203	11058+40	1	6	10.0	A

<b>100-1A</b> 07-15-97					
<b>ESTIMATED LIGHTING QUANTITIES (1 DIVISION PROJECT)</b>					
Item No.	Item Code	Item	Unit	Total	As Built Qty.
1	2523-0000100	LIGHTING POLES	EACH	6	
2	2523-0000200	ELECTRICAL CIRCUITS	LF	1837	
3	2523-0000310	HANDHOLES AND JUNCTION BOXES	EACH	12	
4	2523-0000400	CONTROL CABINET	EACH	1	

<b>108-2</b> 08-01-08				
<b>ELECTRICAL DUCTS</b>				
Location	Conduit Type	Dia. IN	Length FT	Remarks
Utility Pole	Per Utility	-	35.0	Utilty Pole
Control Cabinet "D"	Rigid PVC	2.0	30.0	Riser
218th St.	Rigid PVC	2.0	51.0	Roadway Crossing
Station 4064+75	Rigid PVC	2.0	86.0	Roadway Crossing
Station 11069+40	Rigid PVC	2.0	48.0	Roadway Crossing
Station 11061+00	Rigid PVC	2.0	74.0	Roadway Crossing
Station 5063+00	Rigid PVC	2.0	48.0	Roadway Crossing
Station 3061+50	Rigid PVC	2.0	60.0	Roadway Crossing
Bridge	Rigid Steel	2.0	255.0	Exst Embedded
Circuit D-0	Plastic	2.0	381.0	Circuit Ducts
Circuit D-1	Plastic	2.0	334.0	Circuit Ducts
Circuit D-2	Plastic	2.0	690.0	Circuit Ducts

<b>100-4A</b> 10-29-02		
<b>ESTIMATE REFERENCE INFORMATION</b>		
Item No.	Item Code	Description
1	2523-0000100	BID TO INCLUDE ANSI S-50 VA-250 LAMPS. ALL LUMINAIRES TO BE TYPE II-M.
2	2523-0000200	BID TO INCLUDE 600 VOLT FUSES AT 5 AMPERES FOR LUMINAIRE SUPPLY (L-1, CONNECTORS) AND 20 AMPERES FOR TAP CIRCUIT PROTECTION (Y-1 CONNECTORS) LOCATED IN THE JUNCTION BOXES OR HANDHOLES. INCLUDED ARE (12) TYPE Y-1 CONNECTORS, (2) TYPE Y-3 CONNECTORS, (12) TYPE L-1 CONNECTORS, AND (14) TYPE L-2 CONNECTORS. L-2 CONNECTORS IN CIRCUITS WITH CONDUCTORS SIZES THAT DO NOT FIT STANDARD CONNECTOR TO BE SPLIT BOLT CONNECTORS WITH WATER PROOF COVERING. COIL 50 FEET OF EACH PHASE, NEUTRAL AND GROUND WIRE AT THE BASE OF THE SERVICE POLE FOR CONNECTION BY ALLIANT ENERGY. ELECTRICAL CIRCUIT LENGTH IS CALCULATED FROM PLAN DIMENSIONS AS THE LINEAR, ONE-WAY LENGTH OF BOTH NEW AND EXISTING EMBEDDED CONDUITS. NO ALLOWANCE HAS BEEN ADDED TO THIS QUANTITY. ALLOWANCES HAVE BEEN ADDED TO ALL WIRE AND CABLE QUANTITIES LISTED IN TAB 108-12.
3	2523-0000310	ALL HANDHOLES TO BE LI-103, TYPE 1.
4	2523-0000400	CONTROL CABINET PER LI-152.

<b>108-12</b> 10-21-14																		
<b>WIRE, CABLE AND CONNECTORS</b>																		
Circuit Number	Connectors						Phase Lines						Ground		Remarks			
	Type	Quan. No.	Type	Quan. No.	Type	Quan. No.	Quan. No.	Size A.W.G.	Quan. LF	Size A.W.G.	Quan. LF	Size A.W.G.	Quan. LF	Size A.W.G.		Quan. LF		
D-0					L-2	2								#2	990	#6	498	
D-1	Y-1	6			L-1	6	L-2	2	#10	445	#8	1182				#6	634	
D-2	Y-1	6	Y-3	2	L-1	6	L-2	10	#10	445			#6	3131		#6	1277	

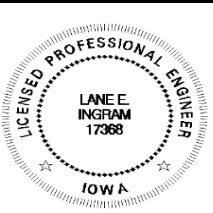
<b>LIGHTING DESIGN</b>	
	I hereby certify that this engineering document was prepared by me or under my direct personal supervision and that I am a duly licensed Professional Engineer under the laws of the State of Iowa.
	Signature: <i>[Signature]</i> Date: 3/2/2015
	Printed or Typed Name: Lane E. Ingram My license renewal date is December 31, 20 16
Pages or sheets covered by this seal: P.1-P.2	

BREMEN TWP.  
T-89N R-3W  
Sec. 36

BREMEN TWP.  
T-89N R-3W  
Sec. 36



CONTRACTOR TO LEAVE 50' COIL  
OF WIRE AT POLE BASE FOR  
INSTALLATION BY ALLIANT ENERGY

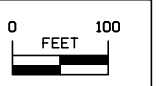
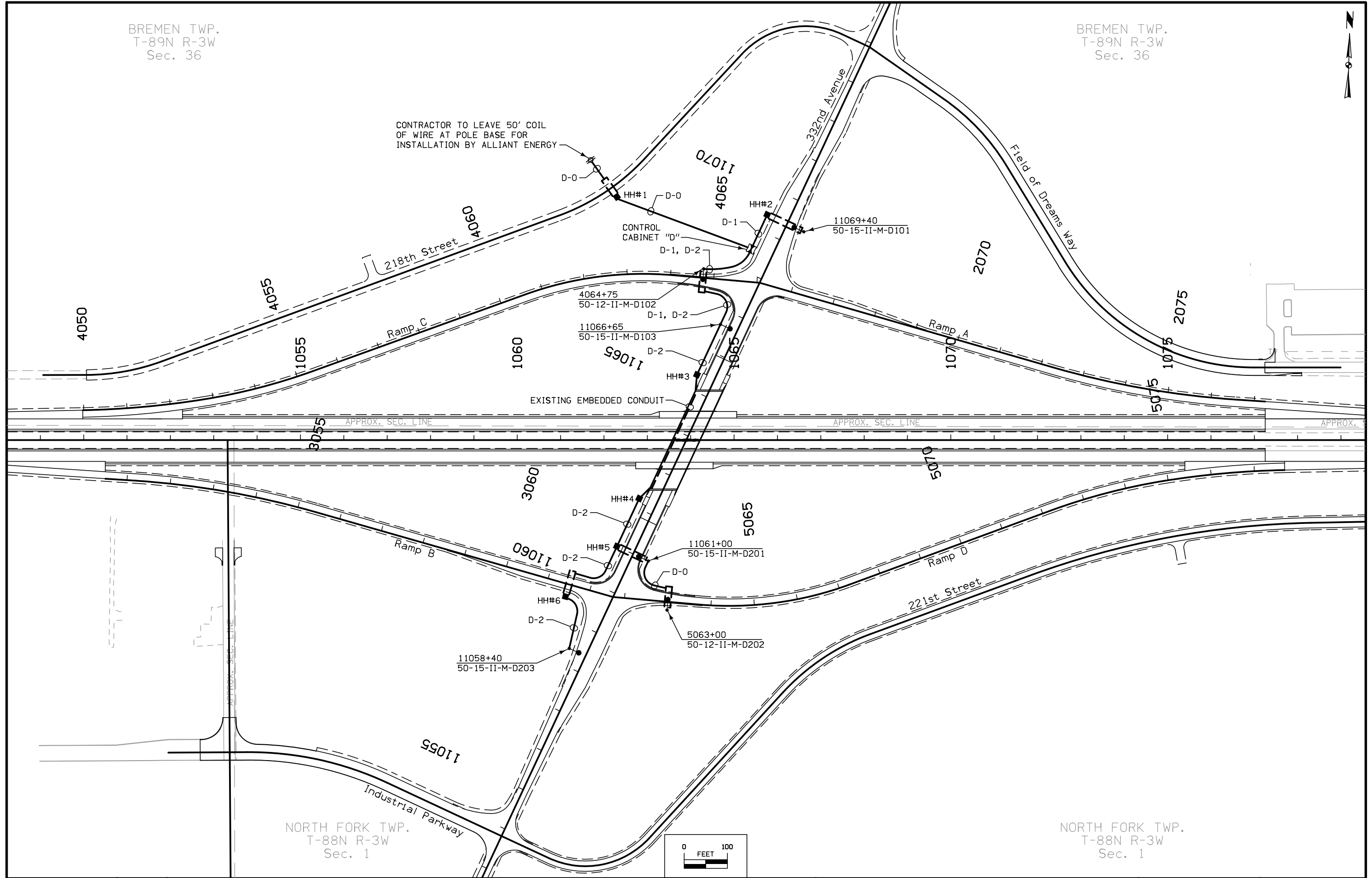

NORTH FORK TWP.  
T-88N R-3W  
Sec. 1

NORTH FORK TWP.  
T-88N R-3W  
Sec. 1

### SURVEY SYMBOLS

- SIGN SI Sign
- PLG Location of General Photo
- PIP Pipe Culvert
- TP TPD Telephone Pedestal
- ⊗ INB Storm Sewer Beehive Intake
- ⊕ MH Utility Access (Manhole)
- BB BB Billboard
- BLD Building or Foundation
- ⊙ MM Mile Marker Post
- x FW Wire Fence
- OUT Tile Outlet
- ⊗ IN Storm Sewer Intake
- LIN Miscellaneous Line
- LUM Luminaire
- ⊙ Flg FLG Flag Poles
- ⊙ WV WW Water Valve
- ⊙ LC Approx. Lot Corner
- EB Electrical Box
- TVP TV Pedestal
- MIS Miscellaneous
- PR Electric Riser Pole
- FHD Fire Hydrants
- SIGN SL Speed Limit Sign
- # FCL Chain Link and Security Fence
- TDC Tree Deciduous
- SHR Shrub
- TEV Evergreen Tree
- TLNR Tree Line Right
- WHD Water Hydrant
- FWD Wood Fence
- ROC Rock Outcropping
- TLNL Tree Line Left
- CUL Culvert
- TIL Tile Line
- LP L.P. Tank
- WEL Well
- EG Edge of Gravel Road
- EP Edge of Paved Roads (ML or SR)
- CU Back of Curb
- GU Gutter In Front of Curb
- CON Concrete or A/C Slab
- ENP Edge Paved Entrance & Park Lot
- ENT Centerline BL of Entrance
- SH Paved Shoulder
- ENU Edge Unpaved Entrance & Parking
- SNP Unpaved Shoulder
- D Centerline Draw or Stream (Down)
- DU Centerline Draw or Stream (Up)
- RIP Rip-Rap
- CP Control Point
- PRO Profile Shot
- SOP Size of Pipe or Culvert
- UE Utility Elevation
- BL Topo Breakline

### UTILITY LEGEND

- ALLIANT ENERGY  
Jason Hogan  
4902 North Biltmore  
Madison, WI 53707-1007  
608-458-4871  
jasonhogan@alliantenergy.com
- Maquoketa Valley Electric Cooperative  
Jeremy Richert  
P.O. Box 370  
Anamosa, IA 52205  
319-462-3541 : Ext 209  
jrichert@mvec.com
- Windstream Communications(Formerly Iowa Telecom)  
Dan Hogan  
107 East Fayette  
Manchester, IA 52057  
563-927-2623  
daniel.hogan@windstream.com
- City of Dyersville  
David Vorwald  
340 1st Avenue East  
Dyersville, IA 52040  
563-875-7724  
dvorwald@cityofdyersville.com
- Black Hills Energy  
Brad Fleming  
1815 Capital Avenue  
Omaha, NE 68102  
402-221-2714  
brad.fleming@blackhillscorp.com
- ICN  
Larry Klawitter  
400 East 1st Street / Grimes Office Building  
Des Moines, IA 50319  
515-725-4741  
larry.klawitter@iowa.gov
- Mediacom  
Bob Frazer  
207 West Pearl Street  
Decorah, IA 52101  
563-387-6119  
bfrazer@mediacomcc.com

### PLAN VIEW COLOR LEGEND OF SOILS SHEETS

LINEWORK	Design Color No.	
Green	(2)	Existing Topographic Features and Labels
Purple (Halo)	(15)	Backslope Drains
Blue	(1)	Proposed Alignment, Stationing, Tic Marks, and Alignment Annotation

SHADING	Design Color No.	
Brown, Light	(236)	Core Out

### PROFILE VIEW COLOR LEGEND OF SOILS SHEETS

LINEWORK	Design Color No.	
Blue	(1)	Proposed Alignment, Stationing, and Alignment Annotation
Green	(2)	Existing Ground Line Profile
Green, Med	(227)	Class 10 Topsoil
Green, M.Light	(226)	Unsuitable A Topsoil
Green, Light	(225)	Unsuitable B Topsoil
Green, V.Light	(224)	Unsuitable C Topsoil
Orange	(6)	Loam
Brown, Dark	(238)	Class 10
Brown, Med	(237)	Sand
Red	(3)	Unsuitable A
Pink, Dark	(13)	Unsuitable B
Pink	(11)	Unsuitable C
Red	(3)	Shale
Red	(3)	Waste
Gray, Light	(48)	Broken and Weathered Rock
Gray, Med	(80)	Rock
Gray, V.Dark	(128)	Boulders

### PATTERN AND SYMBOL LEGEND OF SOILS SHEETS

Soils Book No. Drilled by Braun Intertec  
Date(s) Drilled 2012-2014

H <sub>2</sub> O	Water		Treatment		Unsuitable A Topsoil
DRY	Dry		Sand Blanket		Unsuitable B Topsoil
	Sample		Soil Remediation Area		Unsuitable C Topsoil
	Plugged		Select Soil		Unsuitable A
M	Moisture		Select Sand		Unsuitable B
	Shelby		Shale		Unsuitable C
	Blow Count		Broken and Weathered Rock		Sandy Soil
	Dens. Core		Rock		Boulders
			Sandstone		

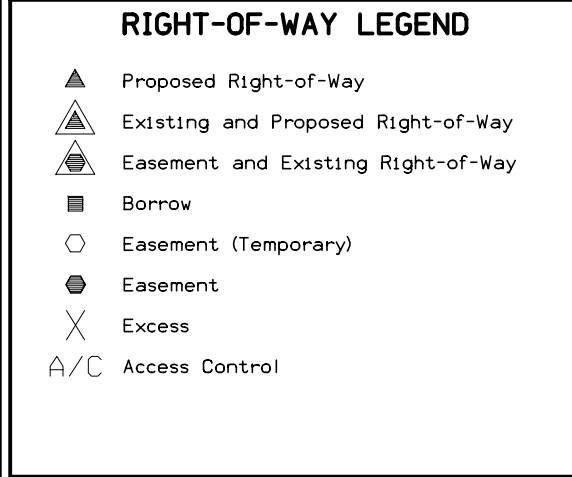
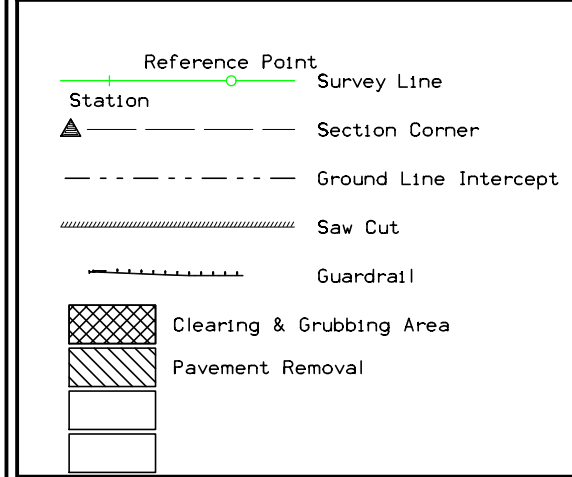

NOTE: Sounding and test boring data shown in the plans were accumulated for designing and estimating purposes. Their appearance on the plans does not constitute a guarantee that conditions other than those indicated will be encountered. Details and notes shown elsewhere shall be used for roadway and structure construction.

## SOILS LEGEND AND SYMBOL INFORMATION SHEET

(COVERS SHEET SERIES Q & R)

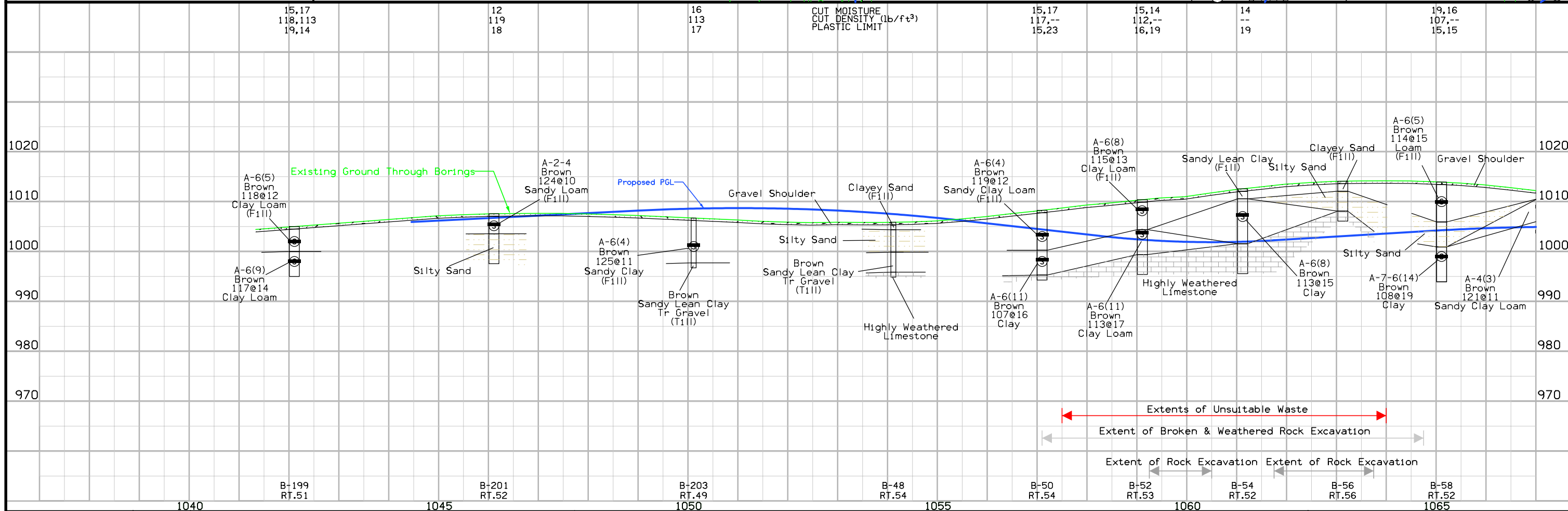
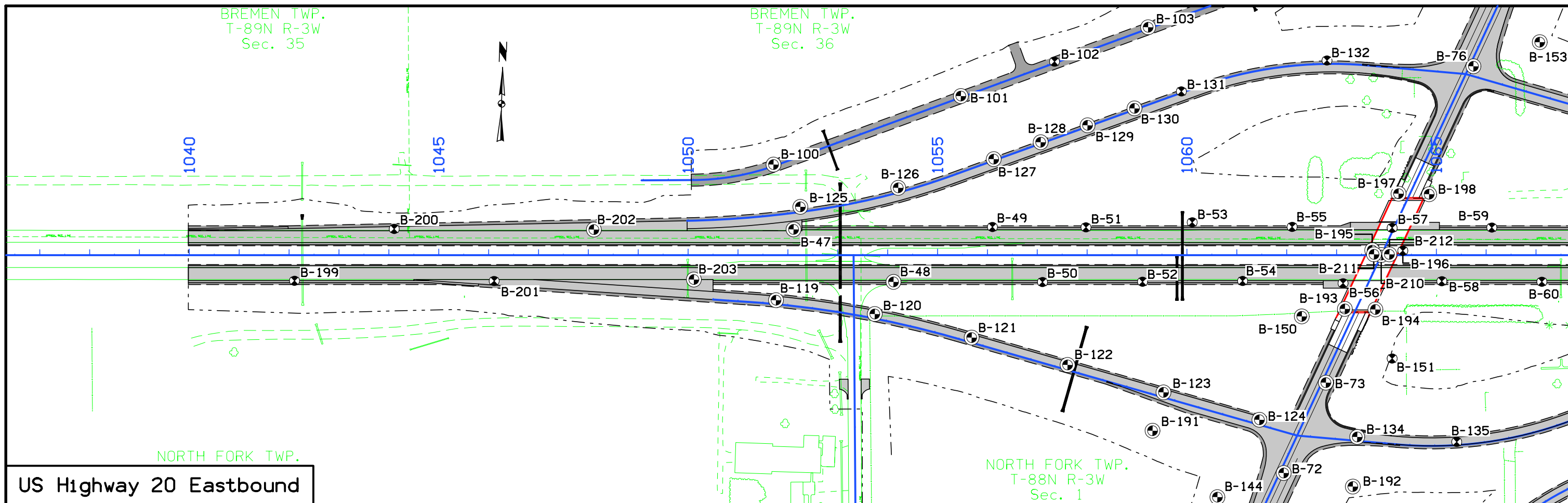



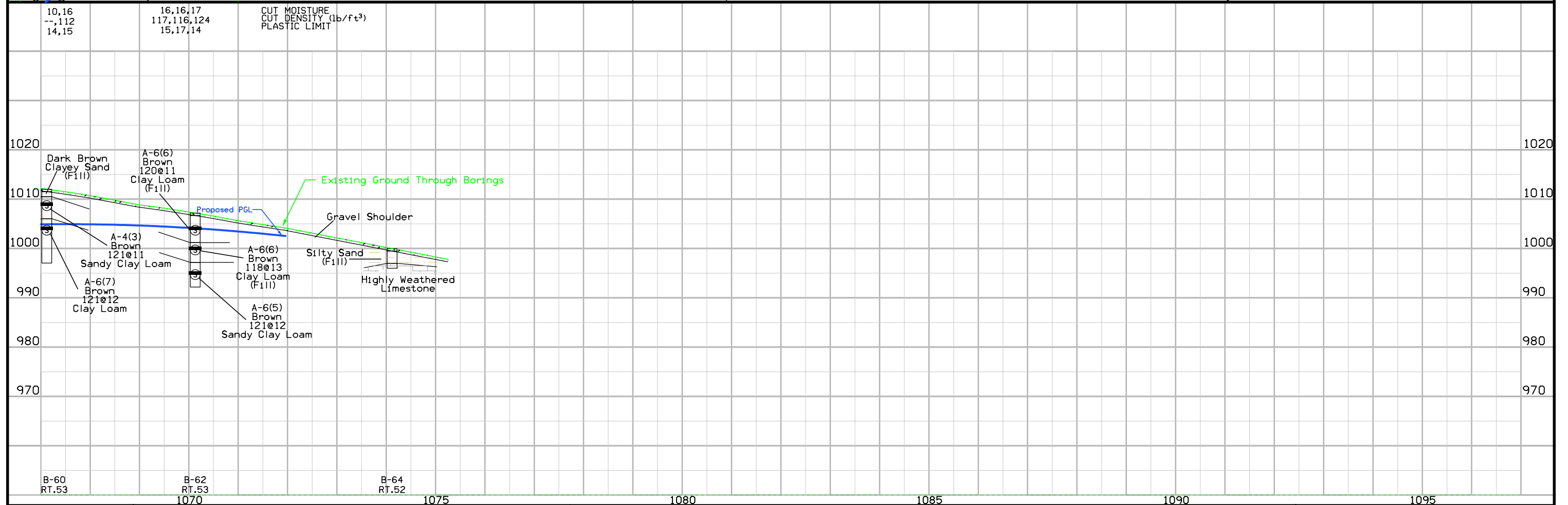
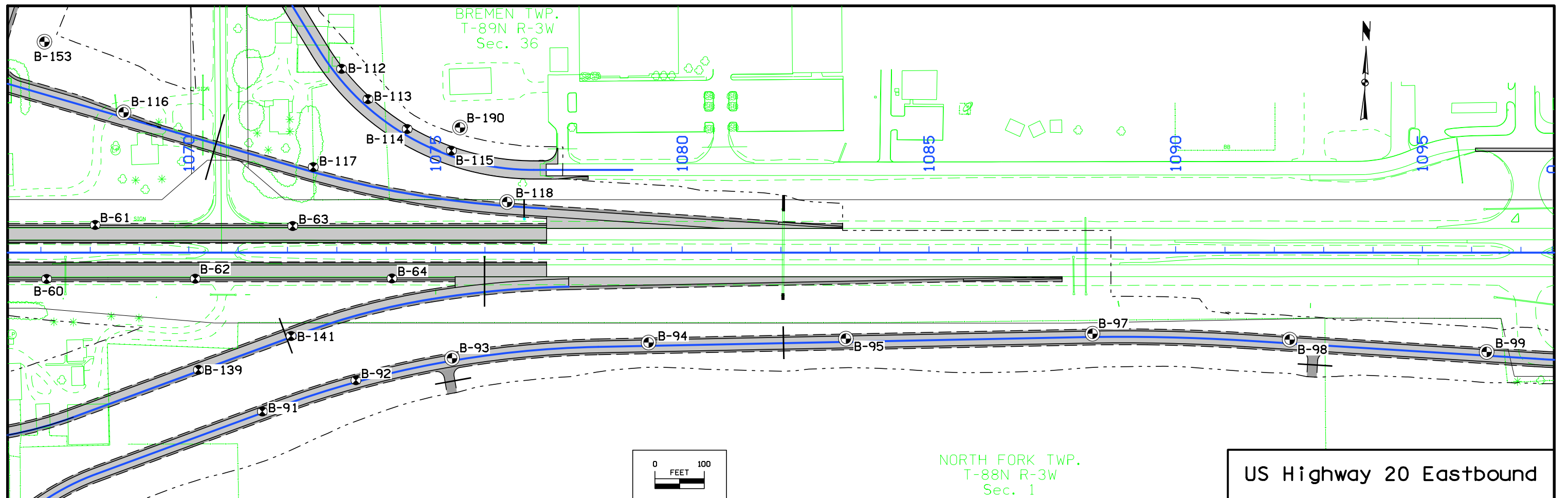

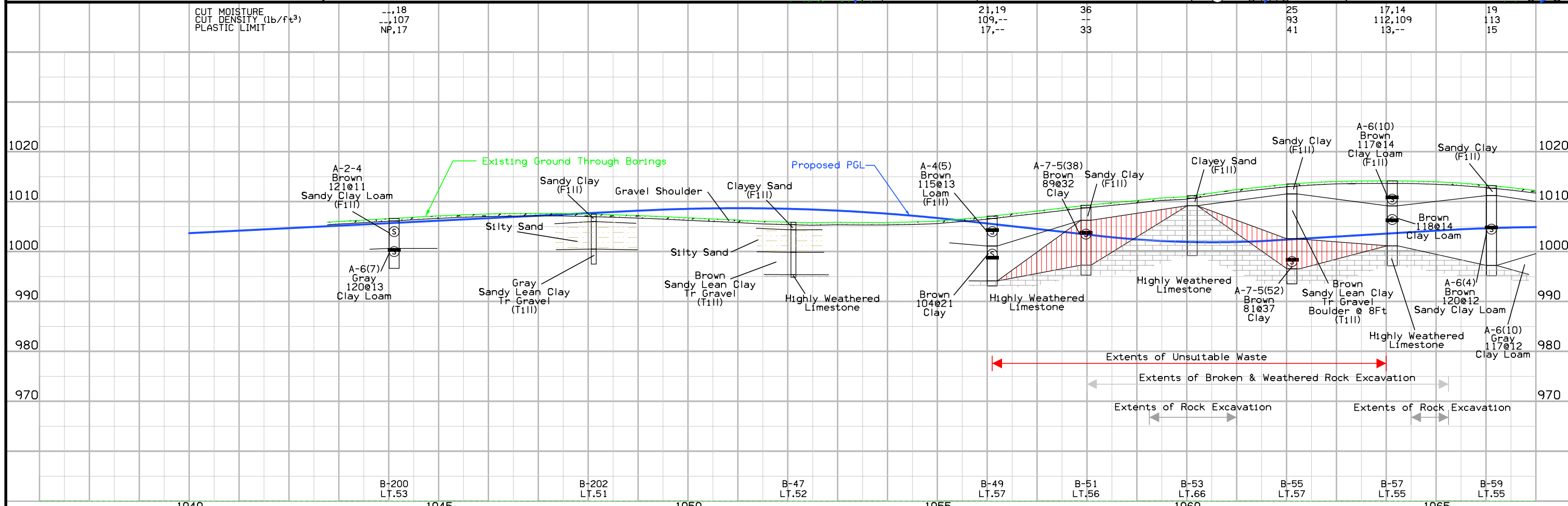
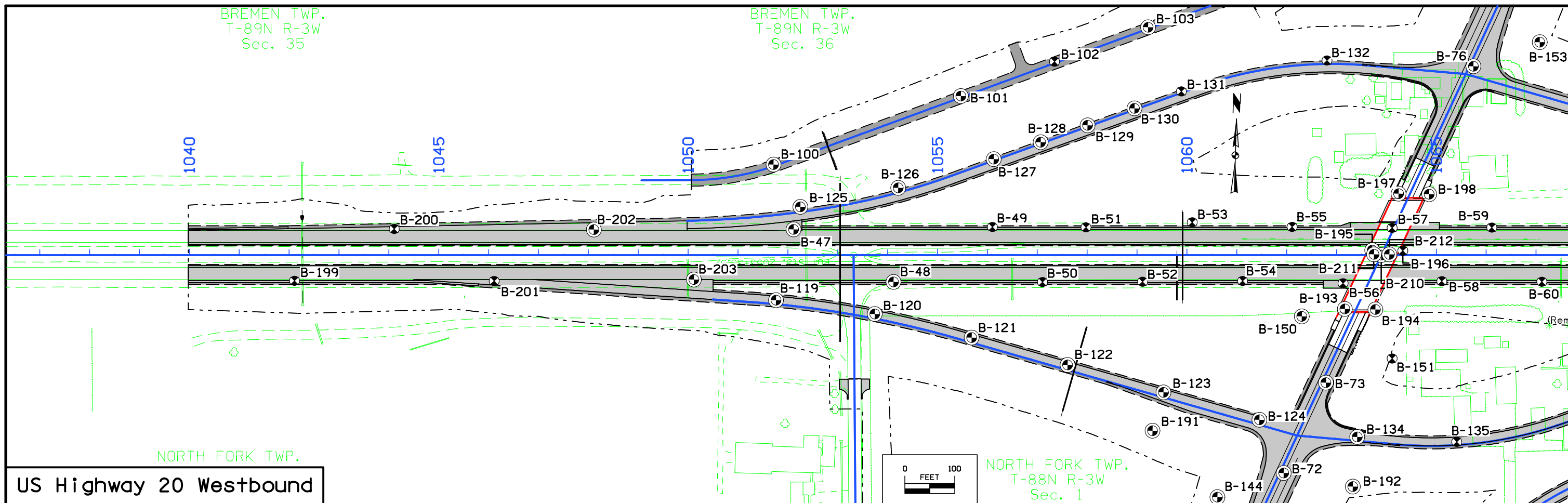

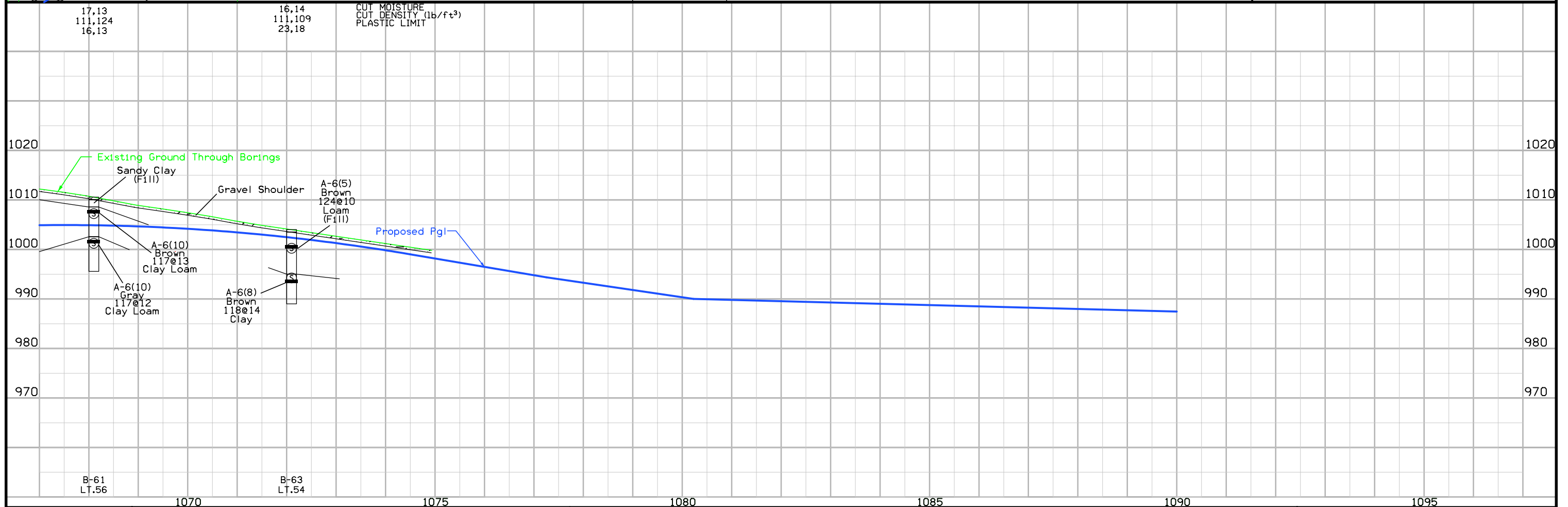
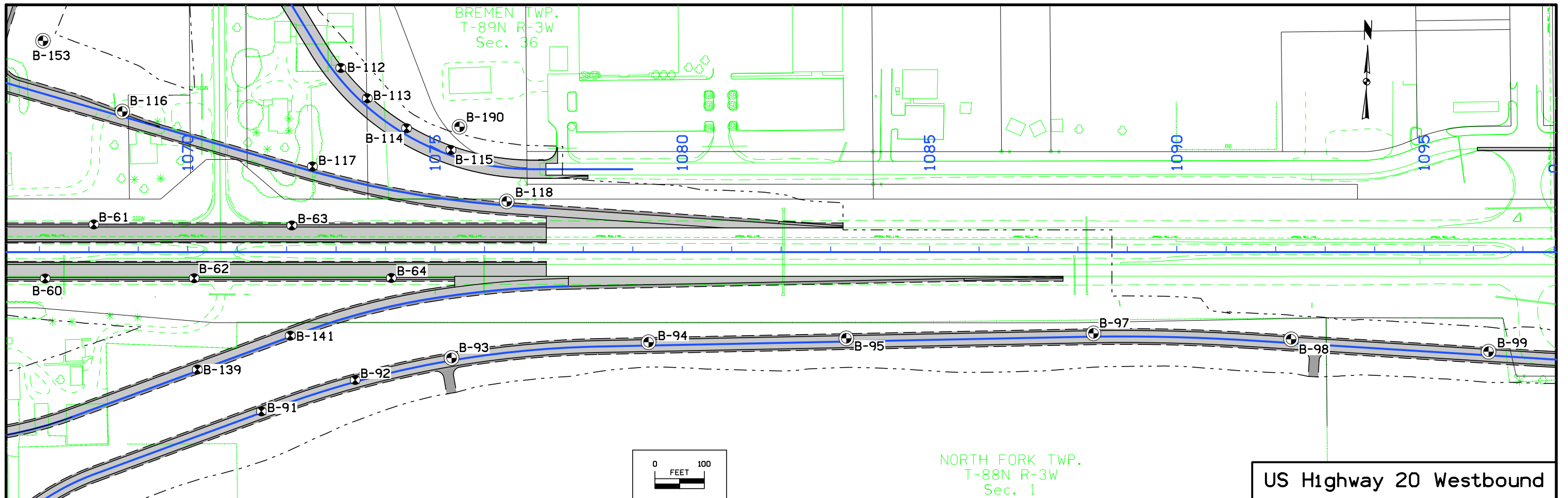

NORTH FORK TWP.  
T-88N R-3W  
Sec. 2

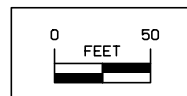
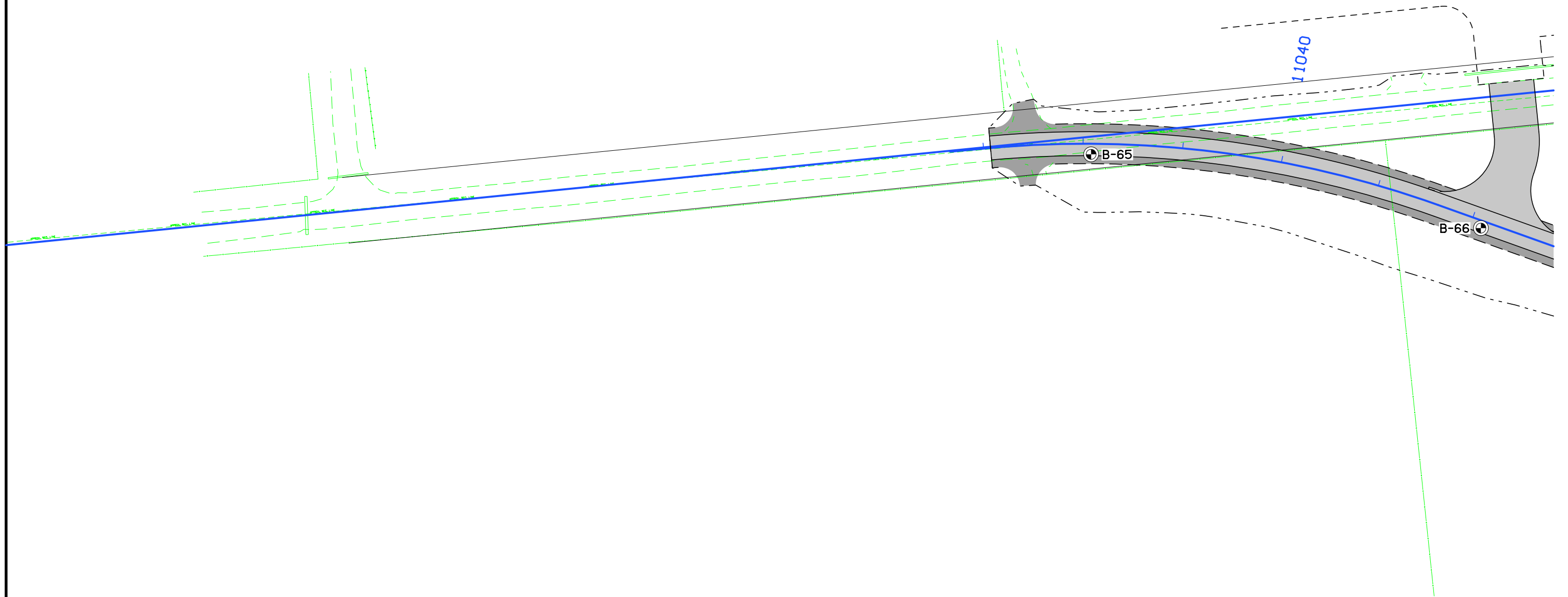

NORTH FORK TWP.  
T-88N R-3W  
Sec. 1

330th Avenue

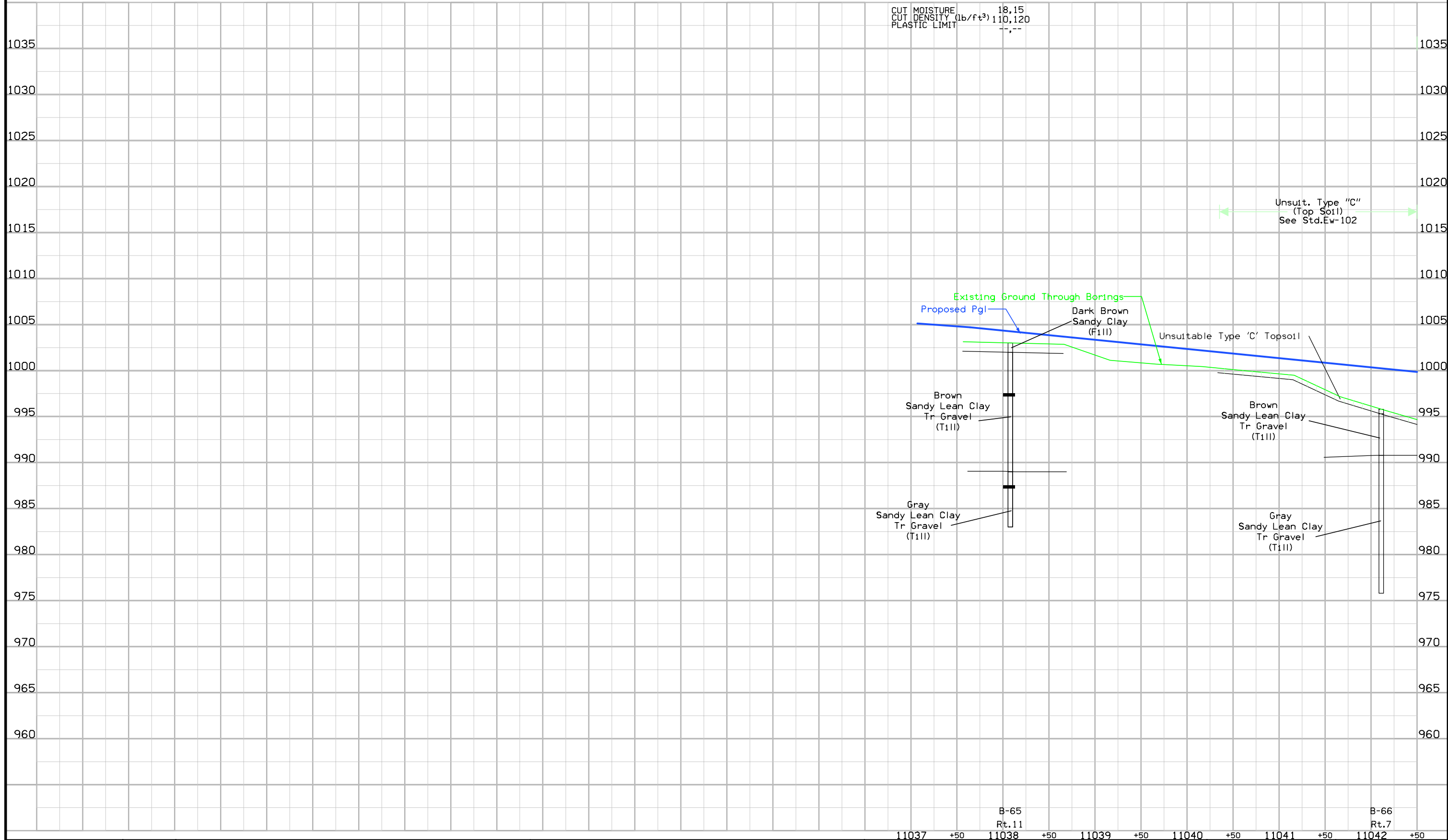

NORTH FORK TWP.  
T-88N R-3W  
Sec. 2

NORTH FORK TWP.  
T-88N R-3W  
Sec. 1

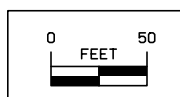
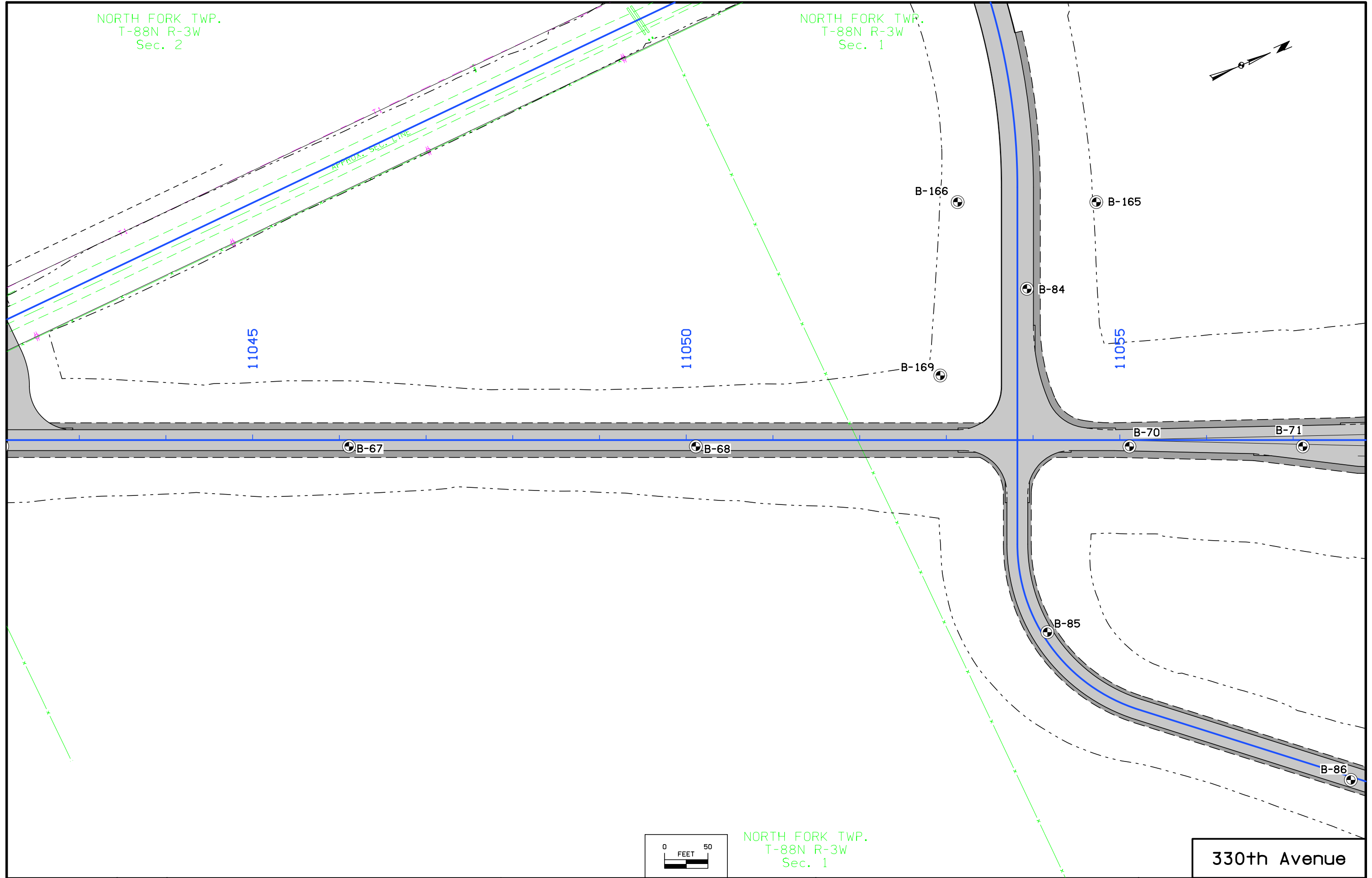
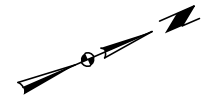

NORTH FORK TWP.  
T-88N R-3W  
Sec. 1

330th Avenue

FILE NO.	ENGLISH	DESIGN TEAM	Stanley Consultants Inc.\Braun Intertec	DELAWARE/DUBUQUE COUNTY	PROJECT NUMBER	NHSX-020-9(203)--3H-28	SHEET NUMBER	Q.8
----------	---------	-------------	---	-------------------------	----------------	------------------------	--------------	-----



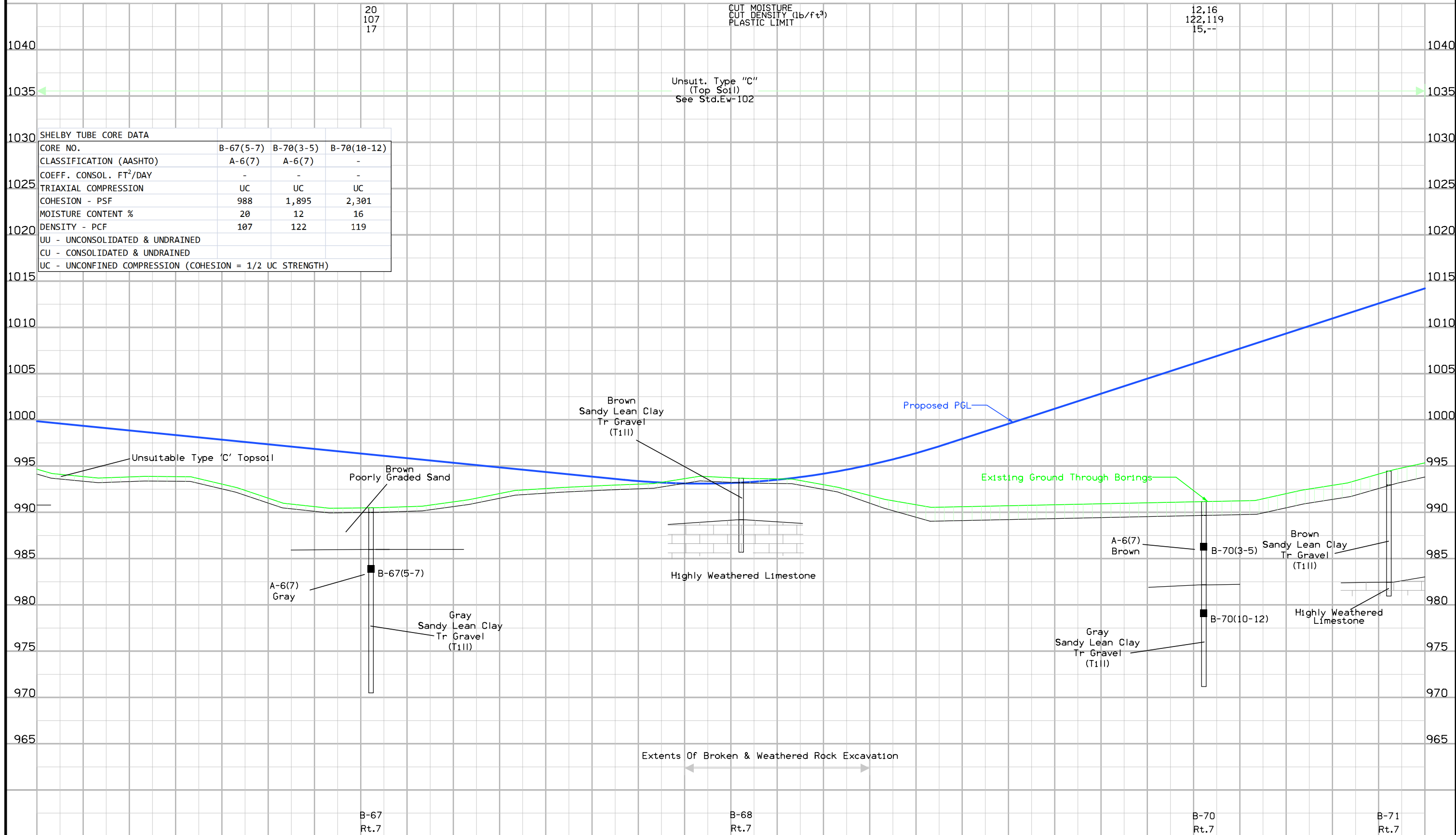

NORTH FORK TWP.  
T-88N R-3W  
Sec. 1

BREMEN TWP.  
T-89N R-3W  
Sec. 36

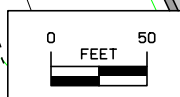
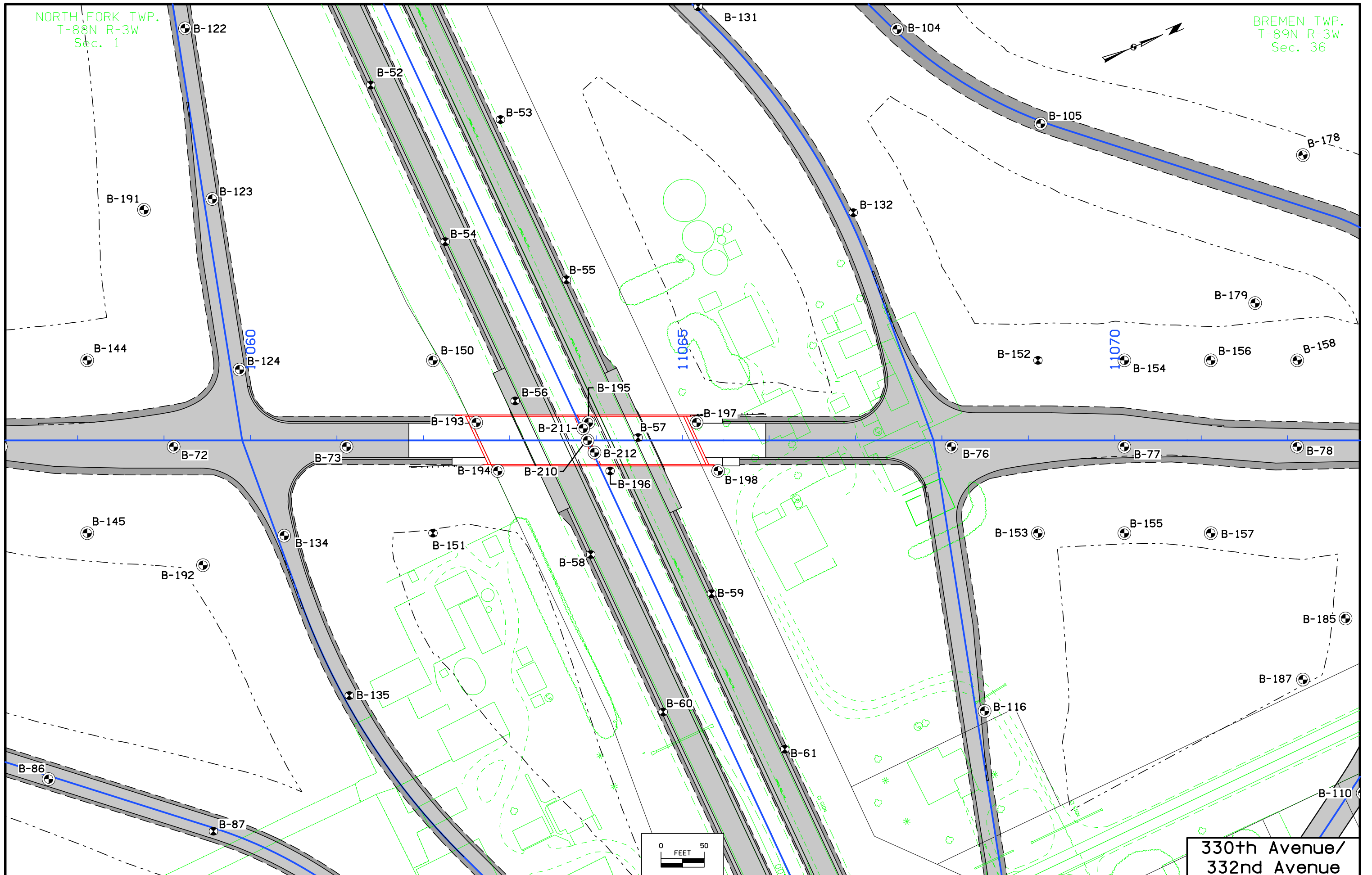
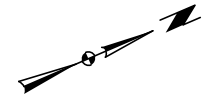

330th Avenue/  
332nd Avenue

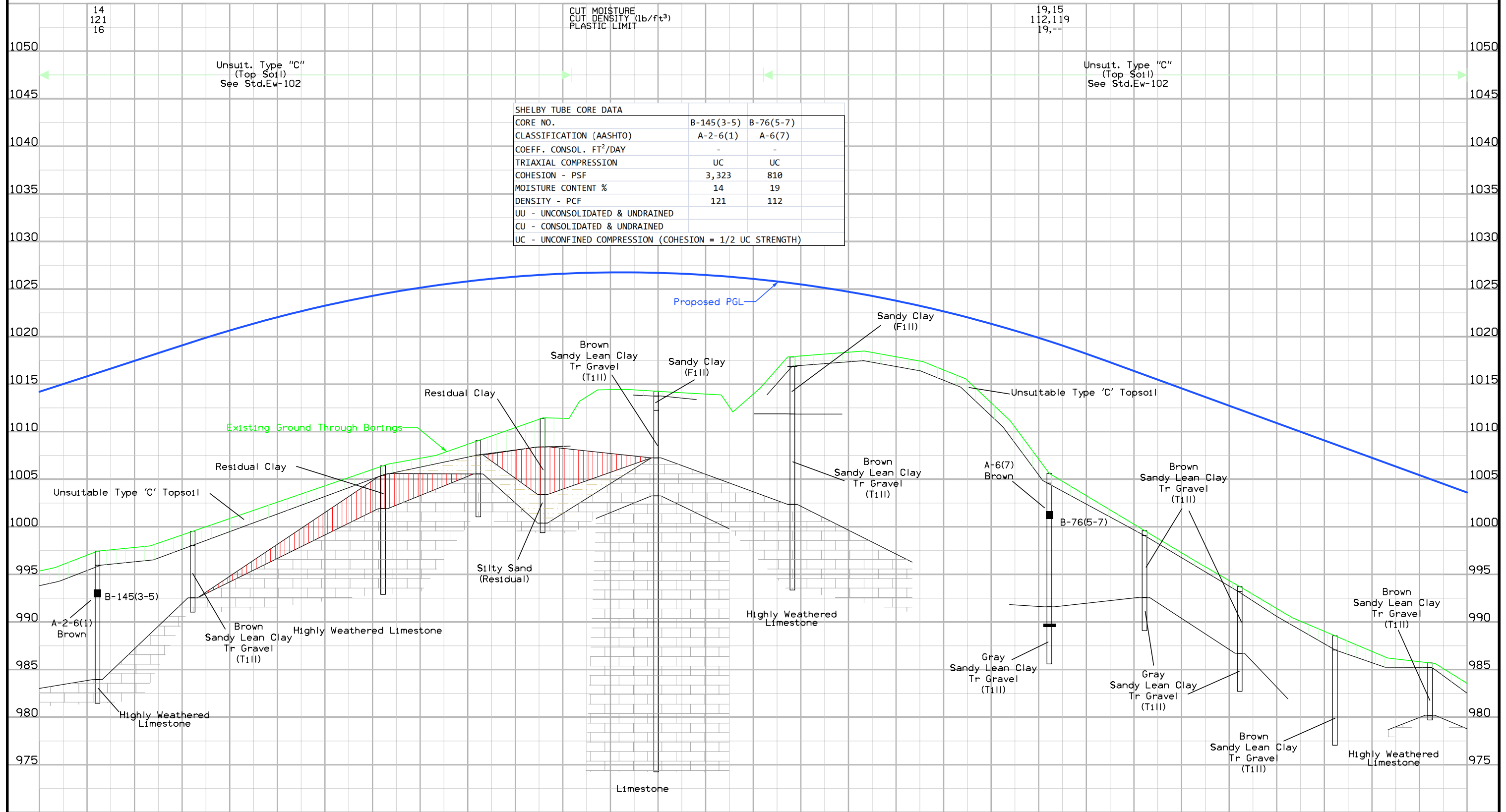

+50 11058 +50 11059 +50 11060 +50 11061 +50 11062 +50 11063 +50 11064 +50 11065 +50 11066 +50 11067 +50 11068 +50 11069 +50 11070 +50 11071 +50 11072 +50

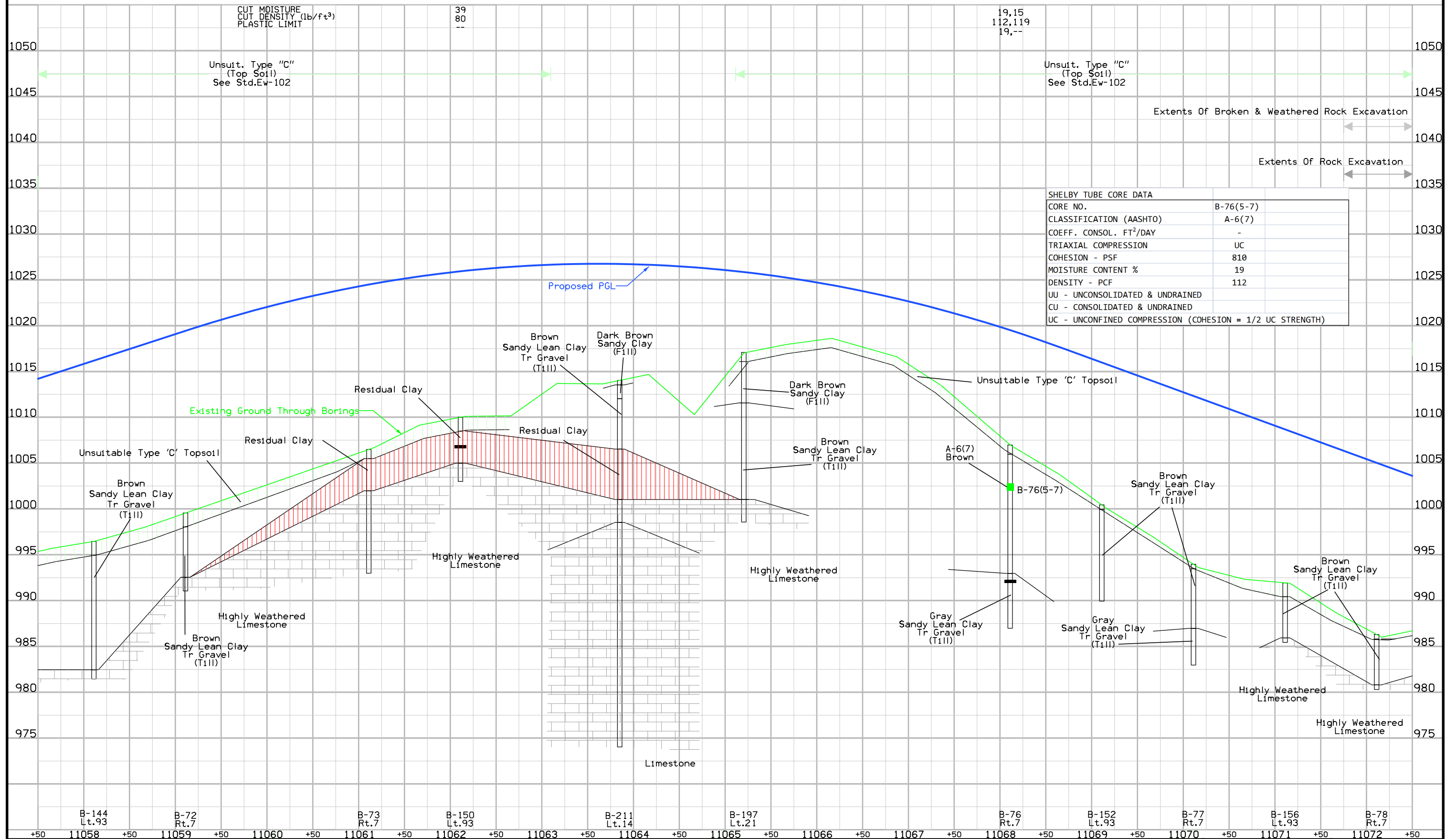

BREMEN TWP.  
T-89N R-3W  
Sec. 36

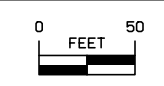
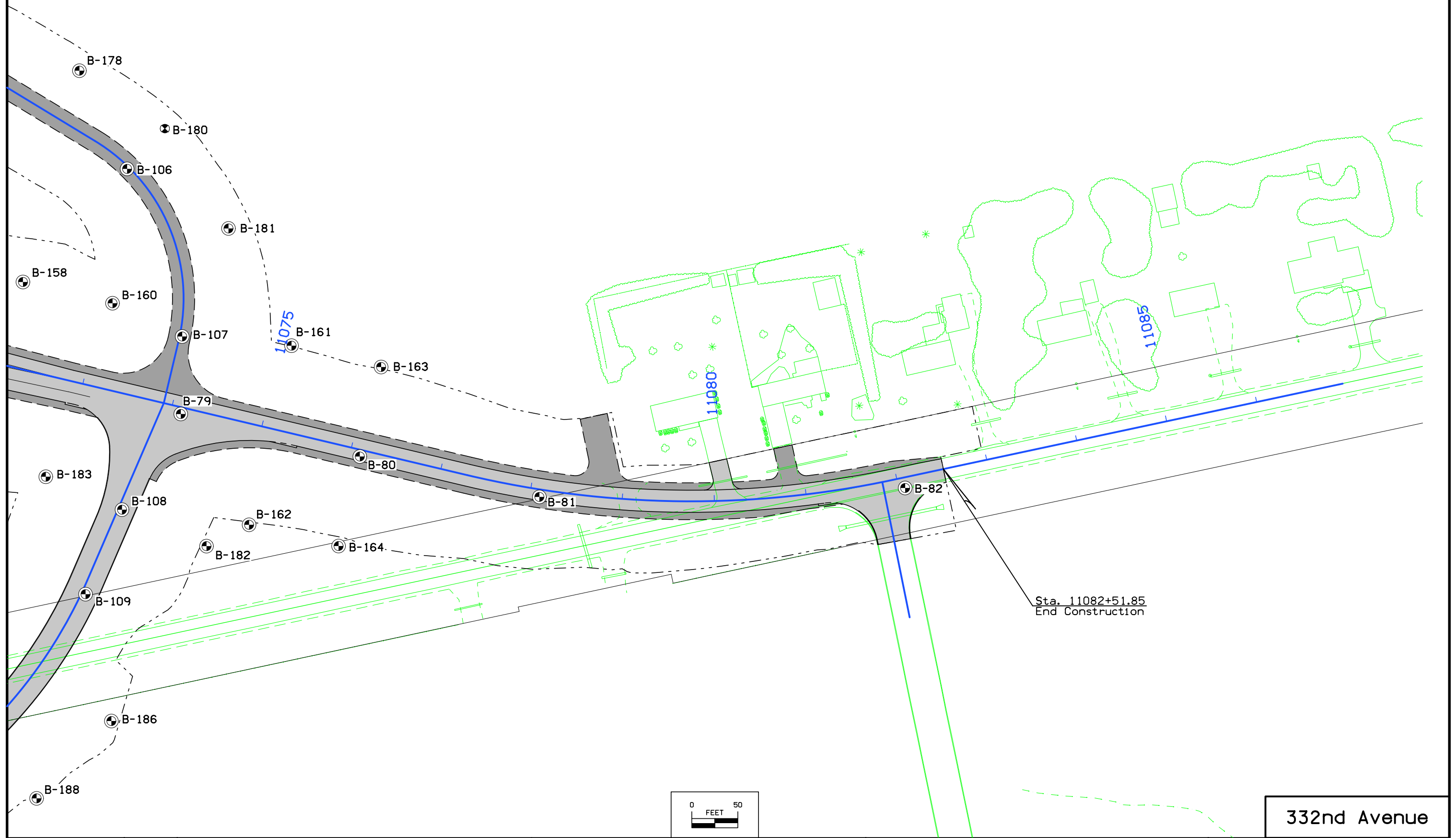

332nd Avenue

FILE NO.	ENGLISH	DESIGN TEAM	Stanley Consultants Inc.\Braun Intertec	DELAWARE/DUBUQUE COUNTY	PROJECT NUMBER	NHSX-020-9(203)--3H-28	SHEET NUMBER	Q.13
----------	---------	-------------	---	-------------------------	----------------	------------------------	--------------	------

1:02:19 PM 3/13/2015 8725 c:\projects\datasource-1\common\d0319374\28020203q13.sht

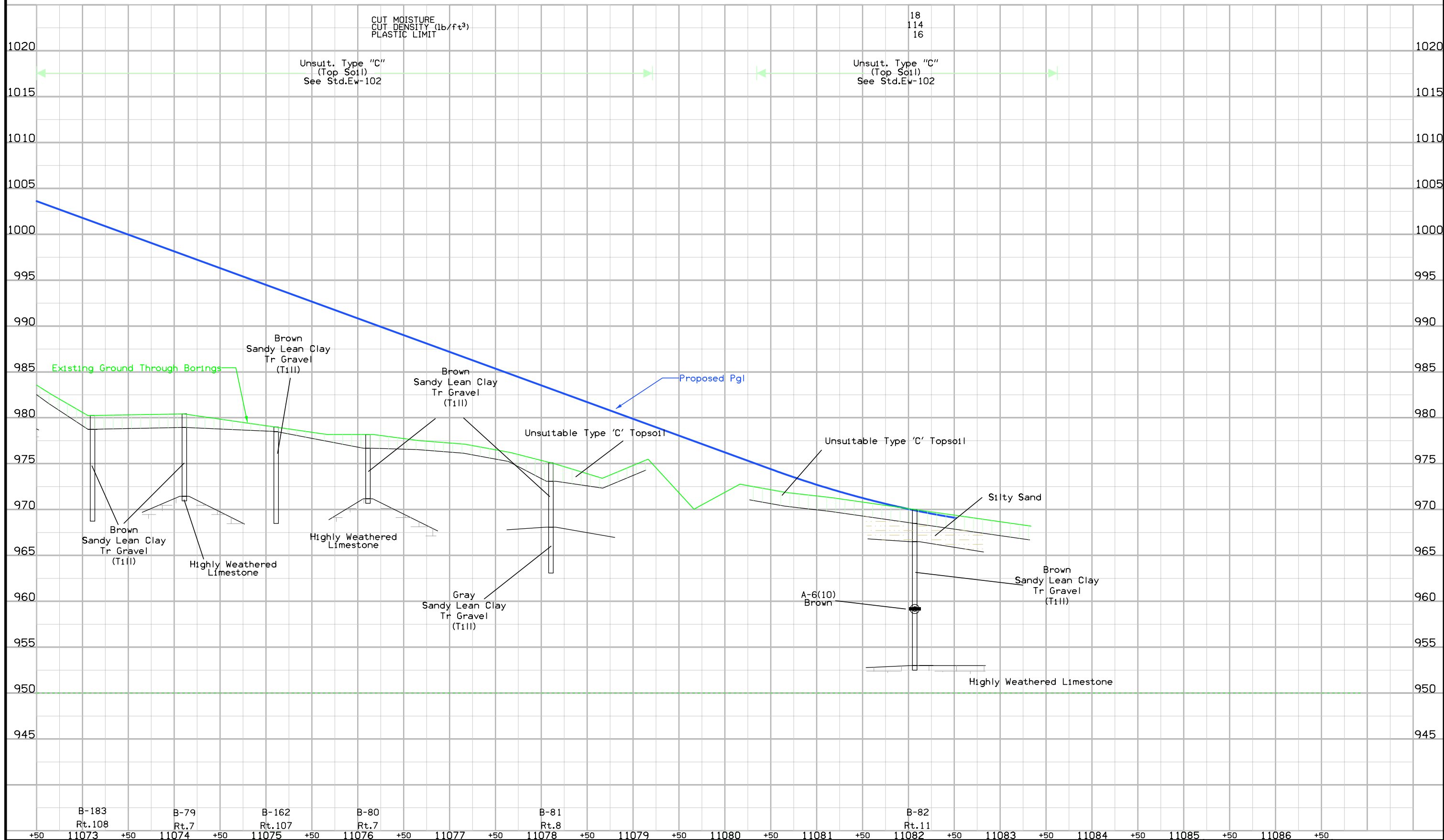



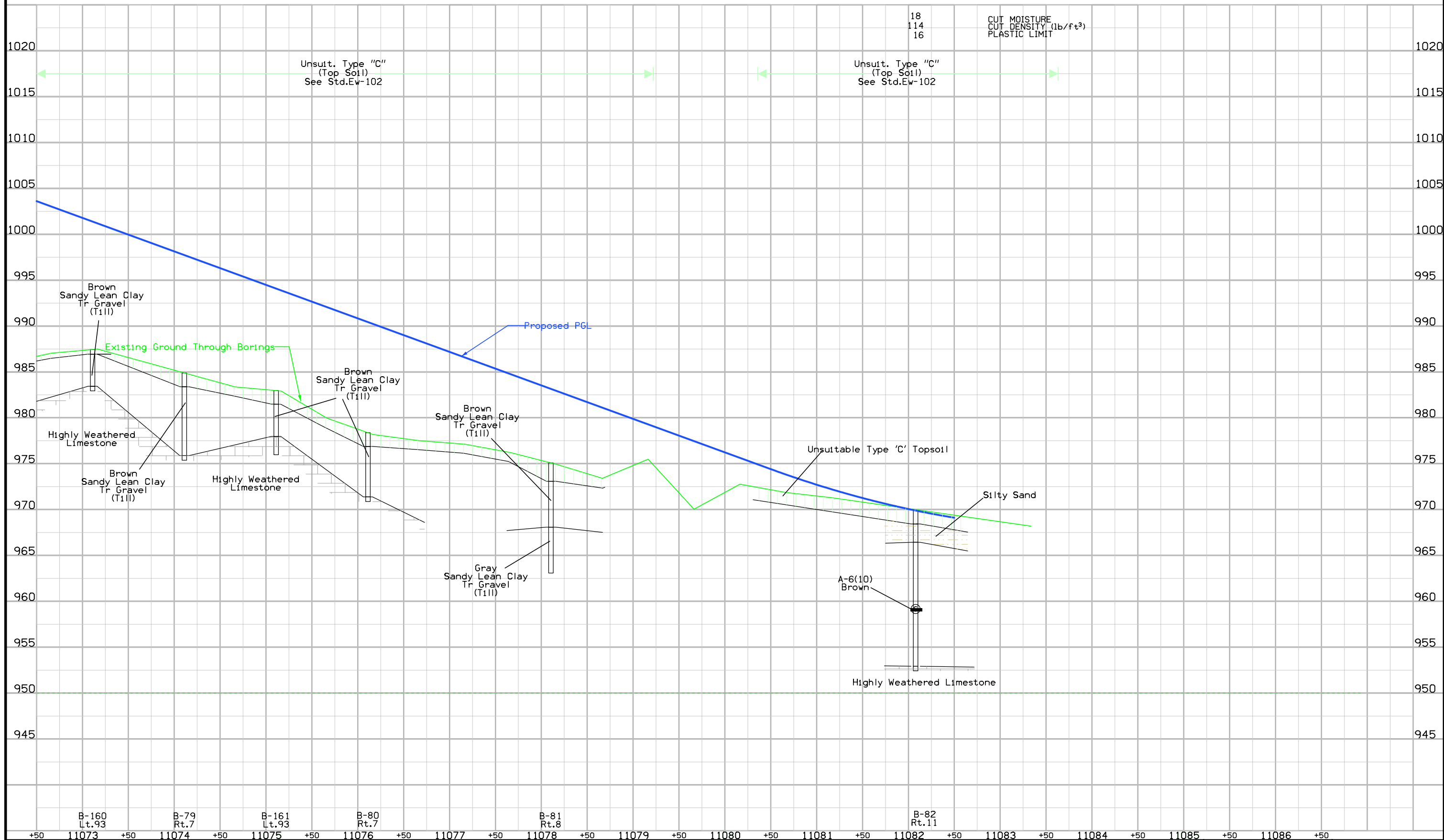

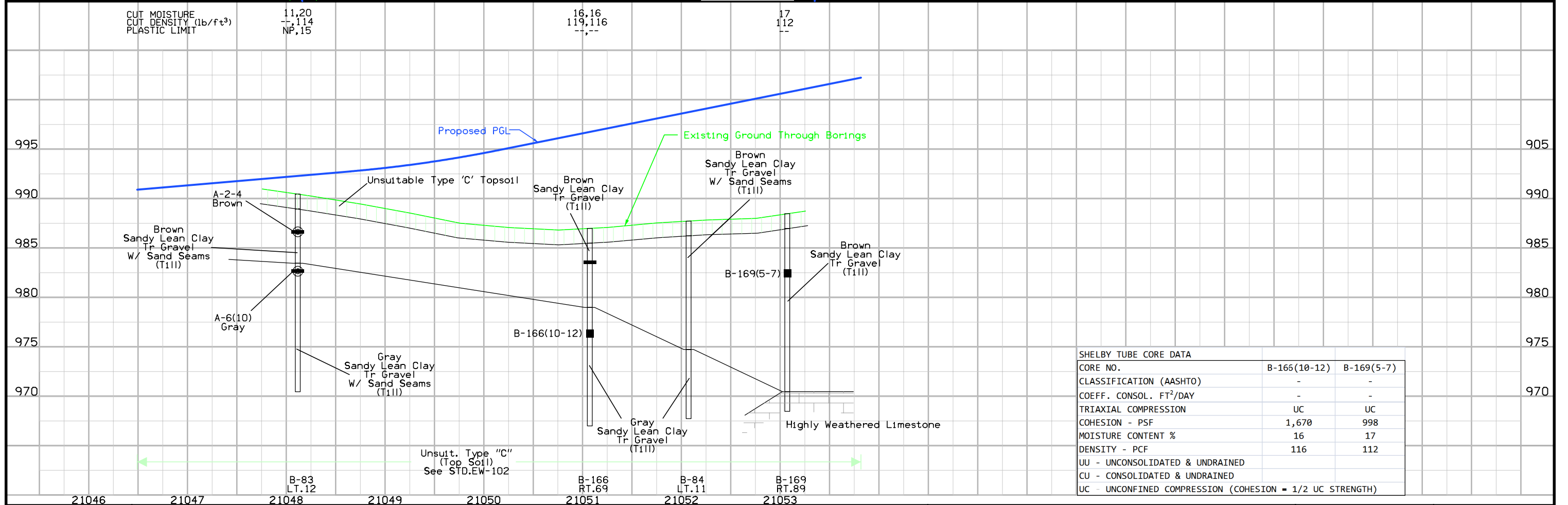
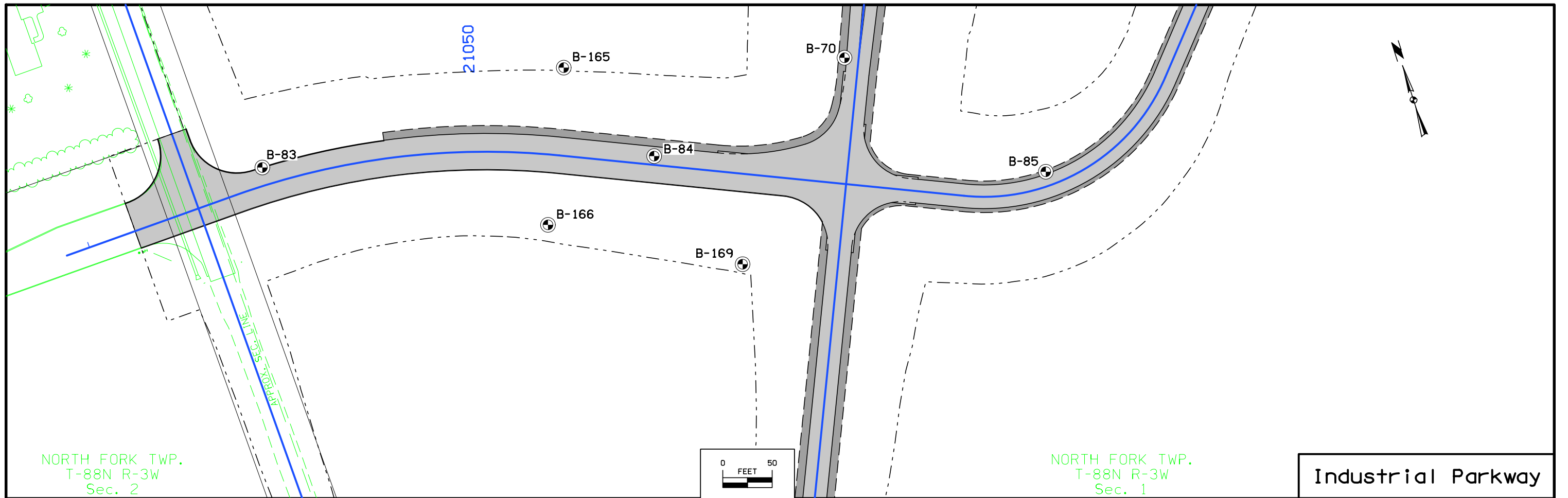

SHELBY TUBE CORE DATA		
CORE NO.	B-166(10-12)	B-169(5-7)
CLASSIFICATION (AASHTO)	-	-
COEFF. CONSOL. FT <sup>2</sup> /DAY	-	-
TRIAxIAL COMPRESSION	UC	UC
COHESION - PSF	1,670	998
MOISTURE CONTENT %	16	17
DENSITY - PCF	116	112
UU - UNCONSOLIDATED & UNDRAINED		
CU - CONSOLIDATED & UNDRAINED		
UC - UNCONFINED COMPRESSION (COHESION = 1/2 UC STRENGTH)		

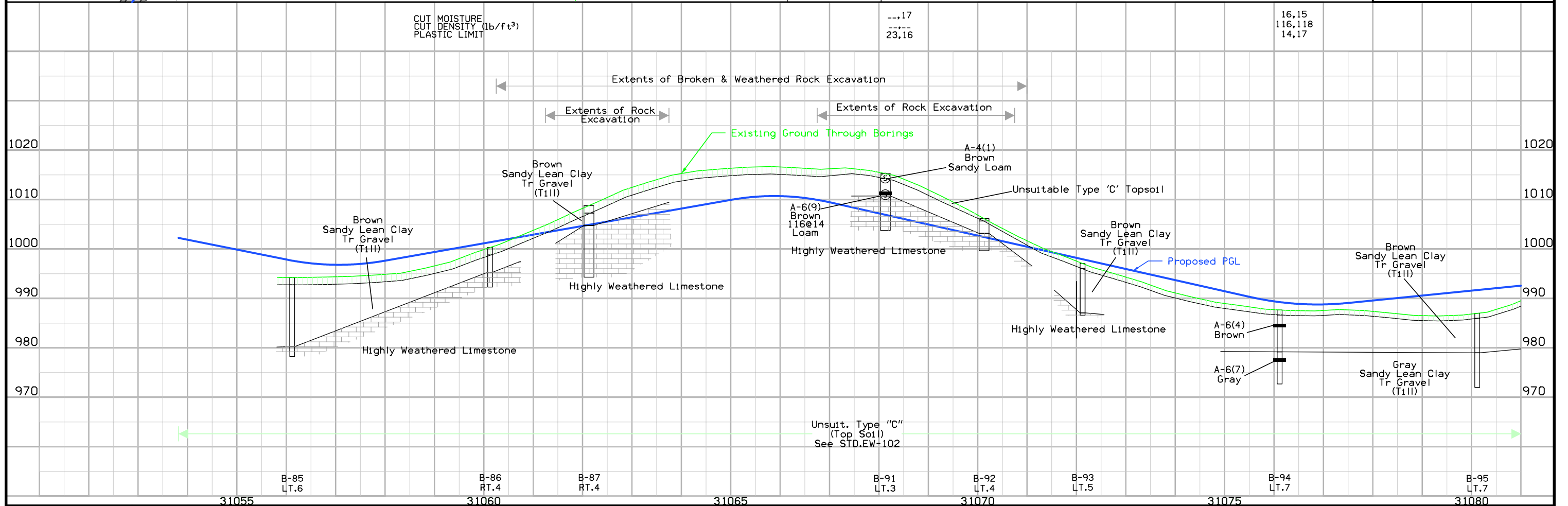
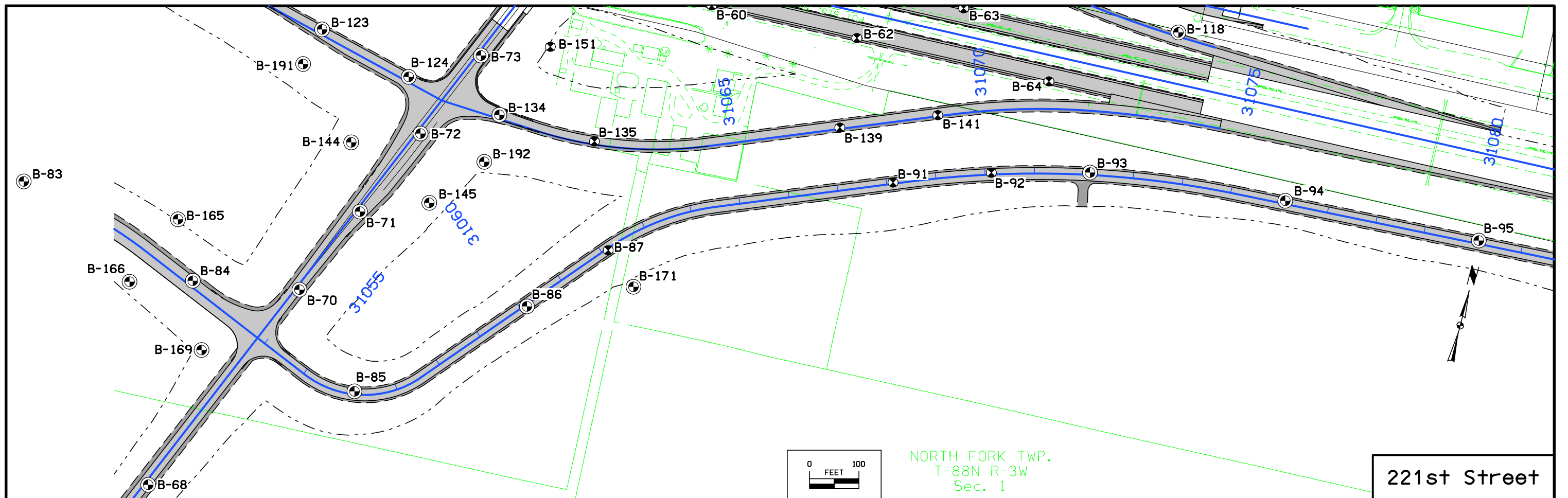

FILE NO.	ENGLISH	DESIGN TEAM	Stanley Consultants Inc.\Braun Intertec	DELAWARE/DUBUQUE COUNTY	PROJECT NUMBER	NHSX-020-9(203)--3H-28	SHEET NUMBER	Q.17
----------	---------	-------------	---	-------------------------	----------------	------------------------	--------------	------

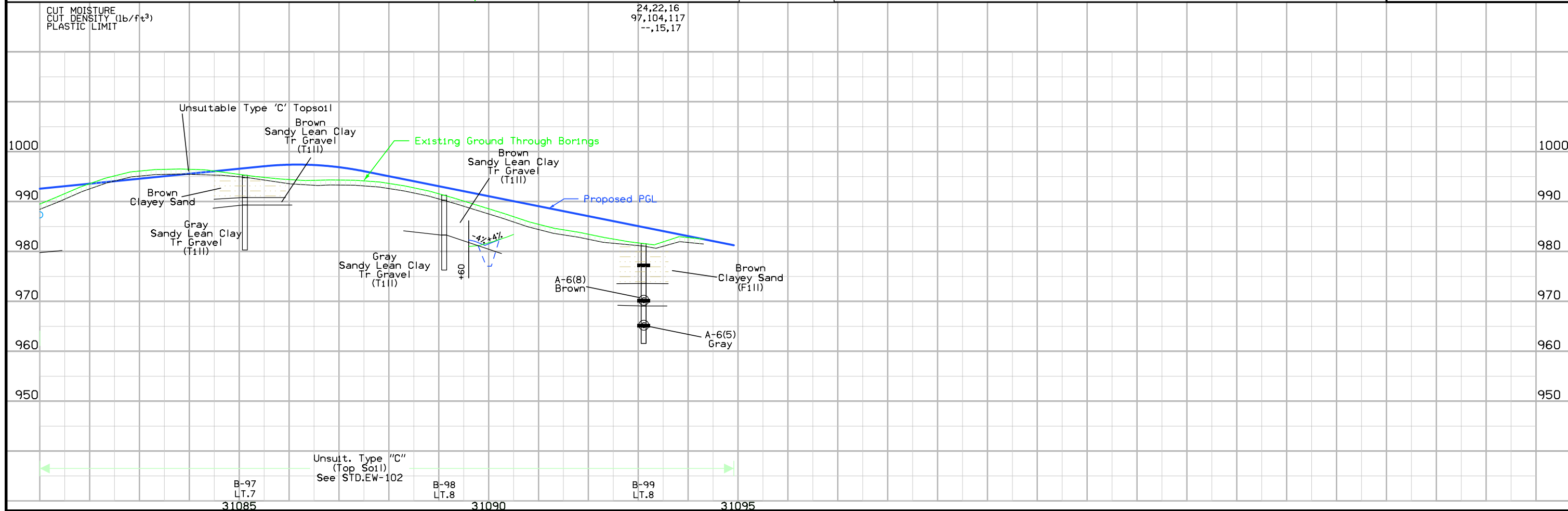
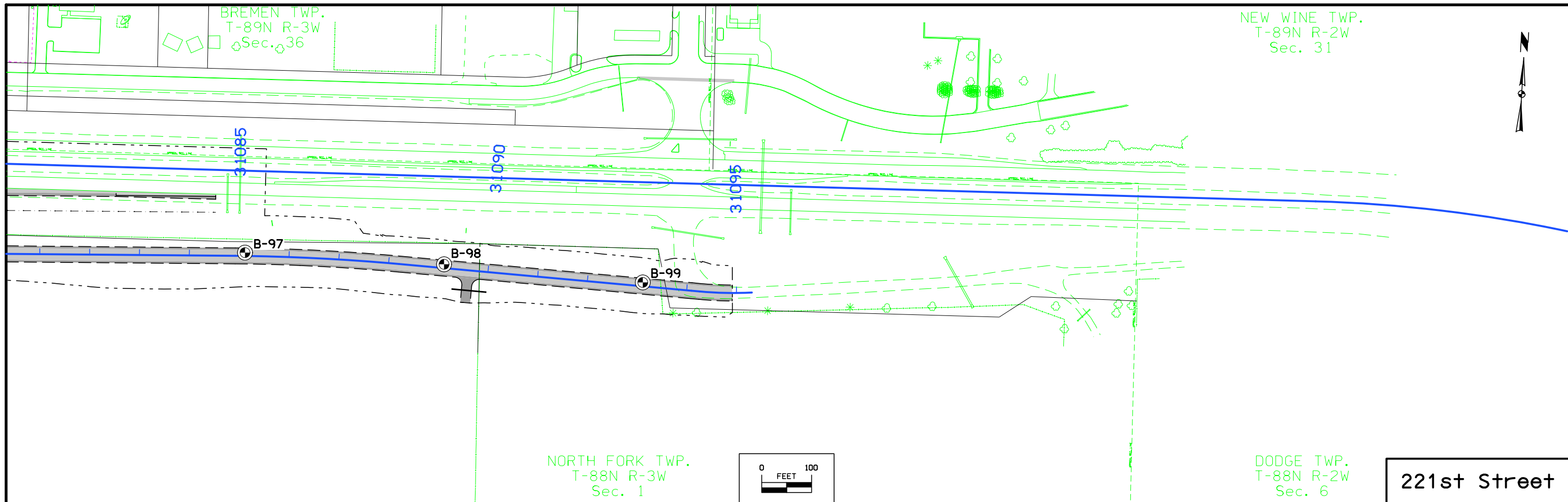

BREMEN TWP.  
T-89N R-3W  
Sec. 36

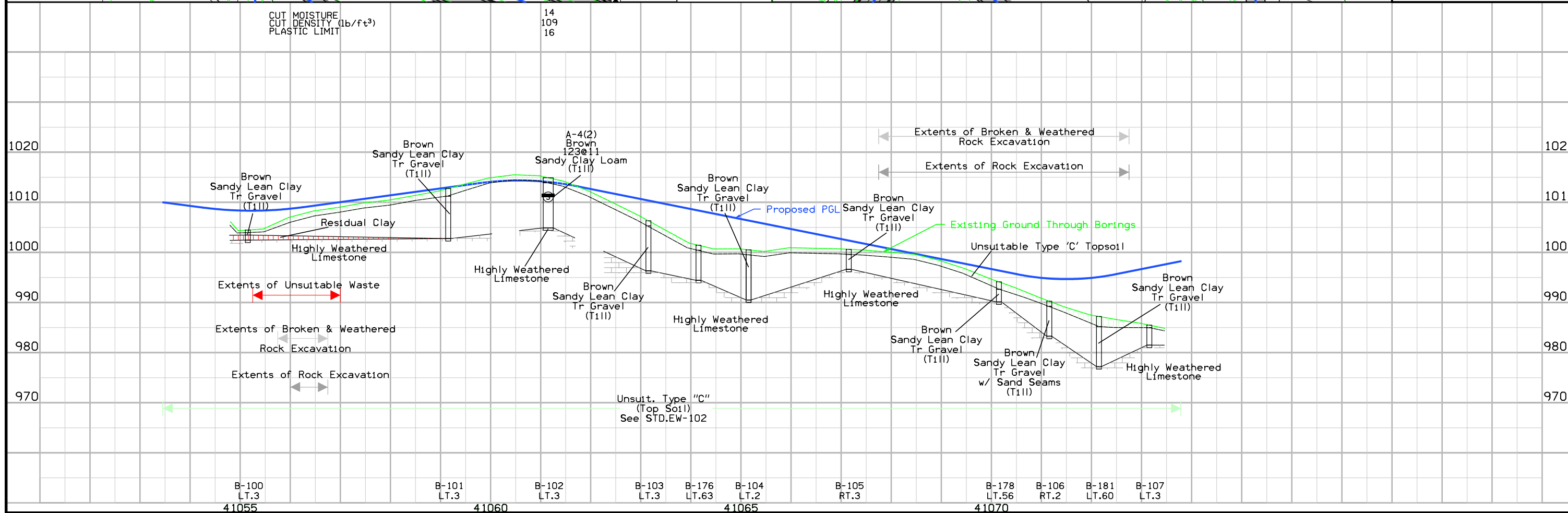
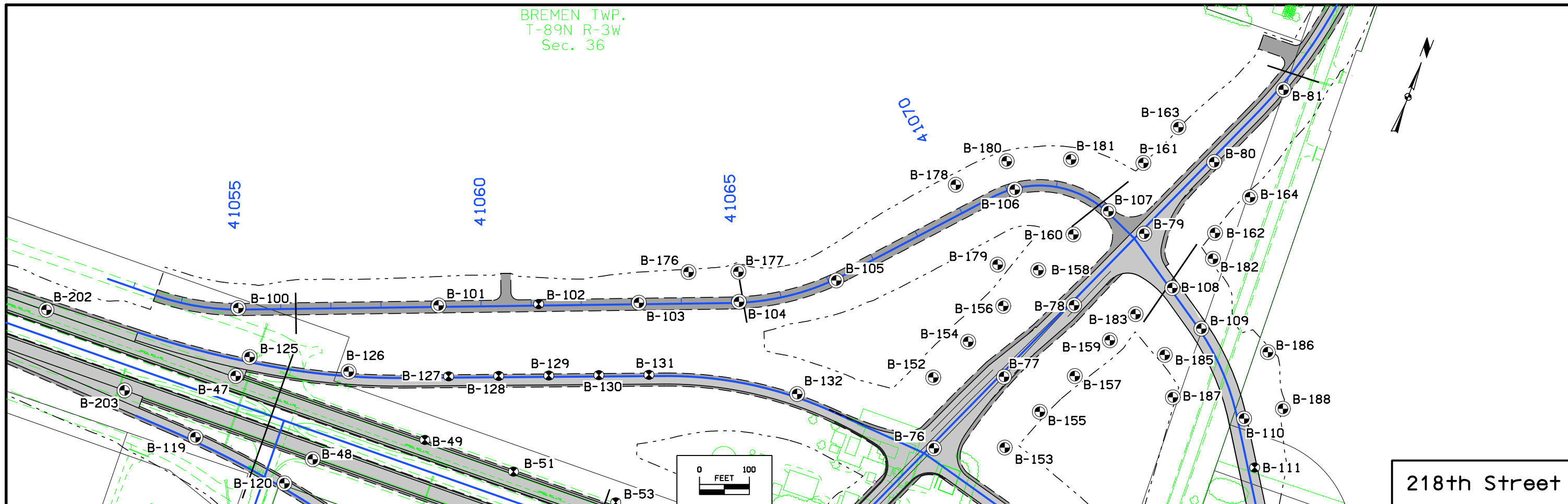



BREMEN TWP.  
T-89N R-3W  
Sec. 36

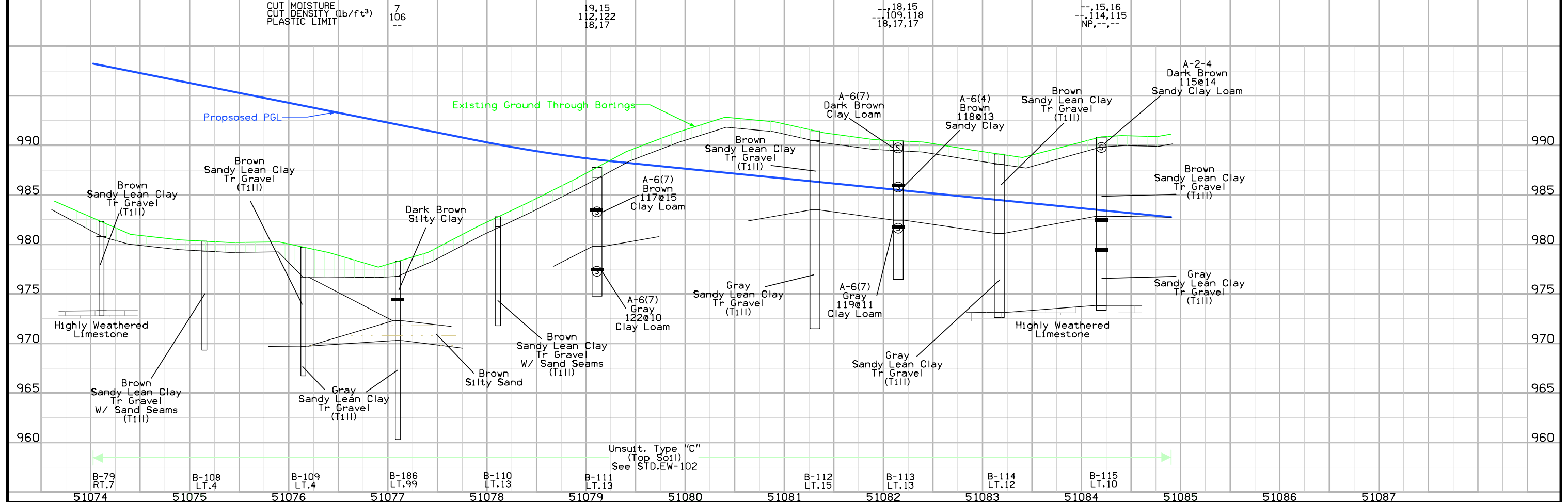
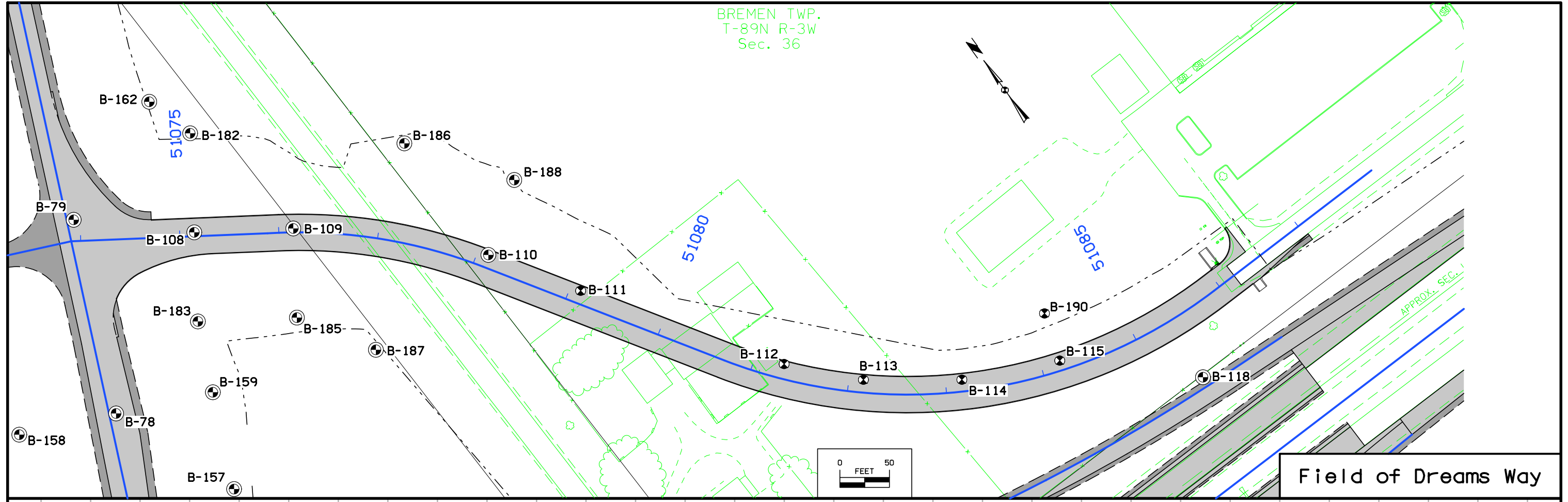

FILE NO.	ENGLISH	DESIGN TEAM	Stanley Consultants Inc.\Braun Intertec	DELAWARE/DUBUQUE COUNTY	PROJECT NUMBER	NHSX-020-9(203)--3H-28	SHEET NUMBER	Q.20
----------	---------	-------------	---	-------------------------	----------------	------------------------	--------------	------



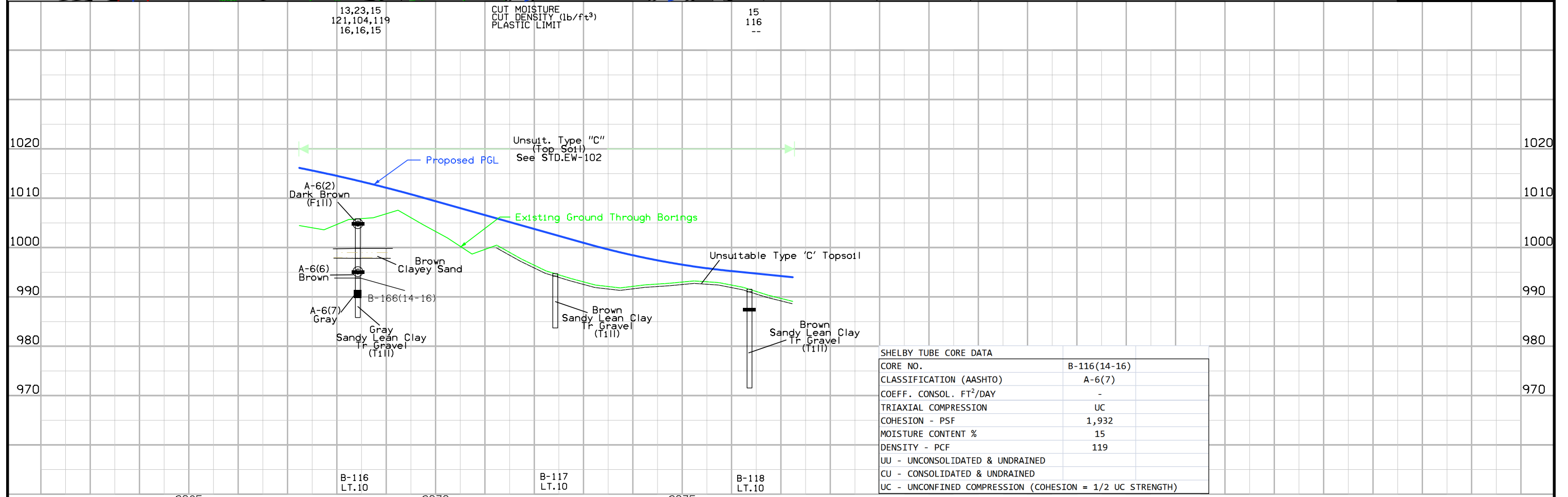
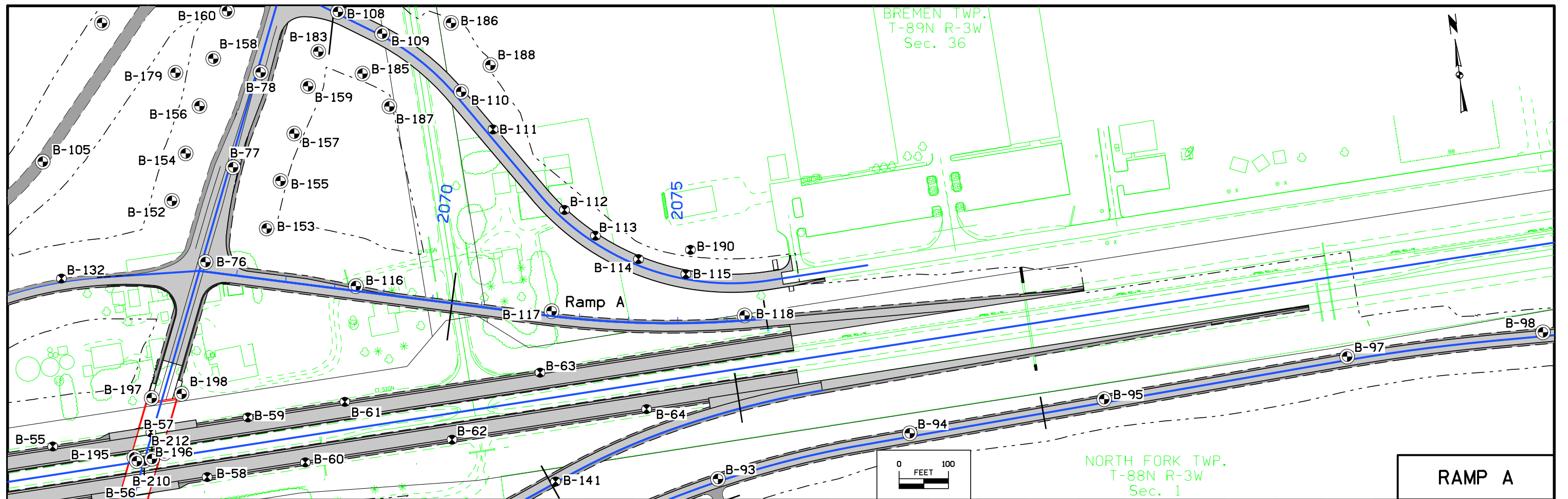

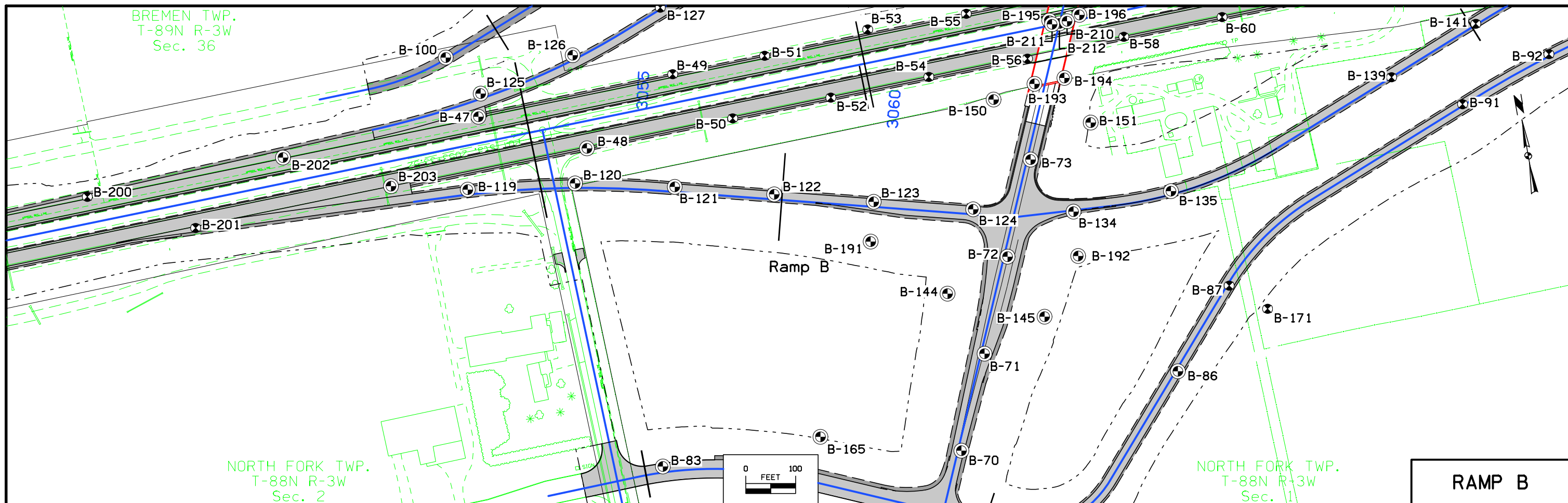

**RAMP B**

7,17	16	CUT MOISTURE	18
122,109	115	CUT DENSITY (lb/ft <sup>3</sup> )	113
---	--	PLASTIC LIMIT	16
			16
			105
			20

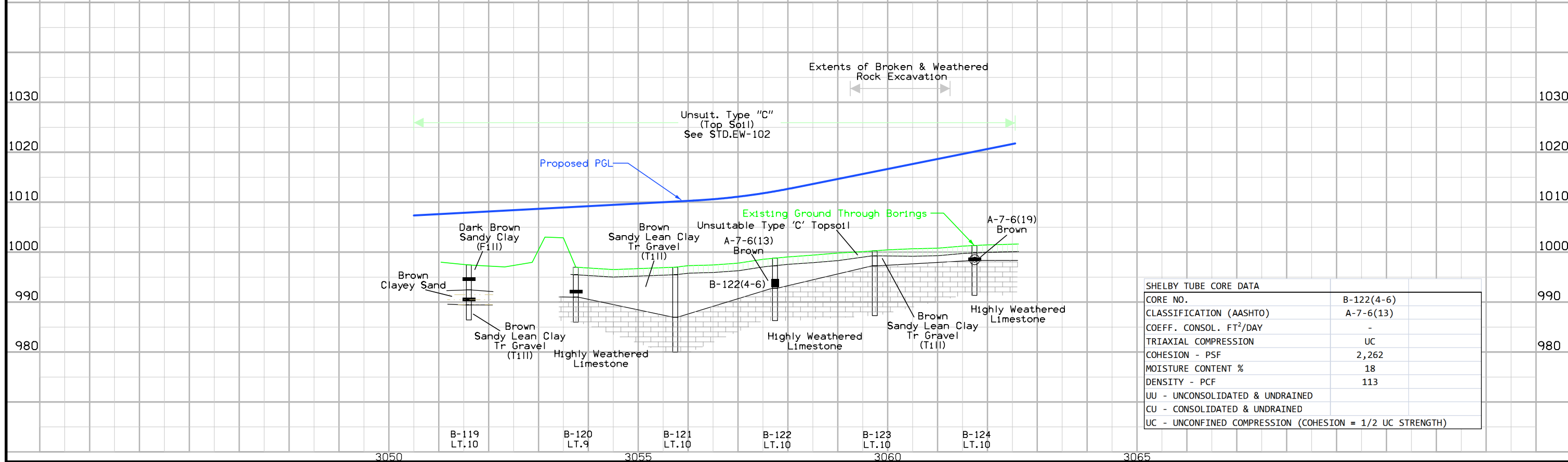

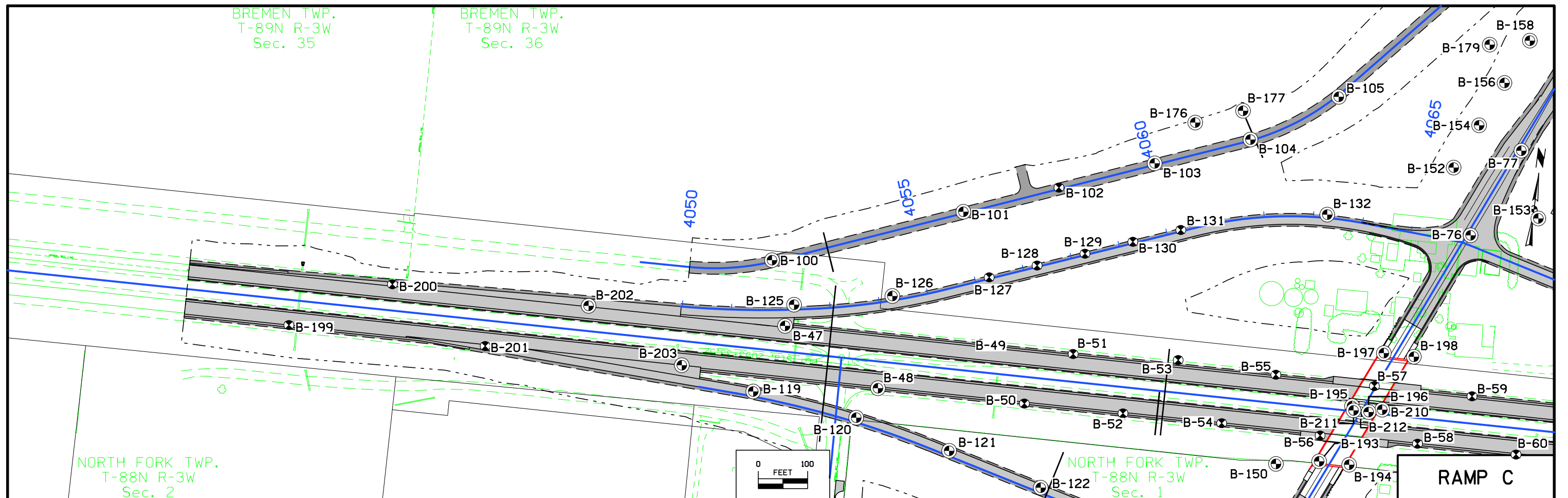

CUT MOISTURE	CUT DENSITY (lb/ft <sup>3</sup> )	PLASTIC LIMIT
--.32	--.96	20,--
--.30	--.96	NP,16
--.11	--.116	NP,13
11	124	13
16	108	--
--.7	--.96	19,13

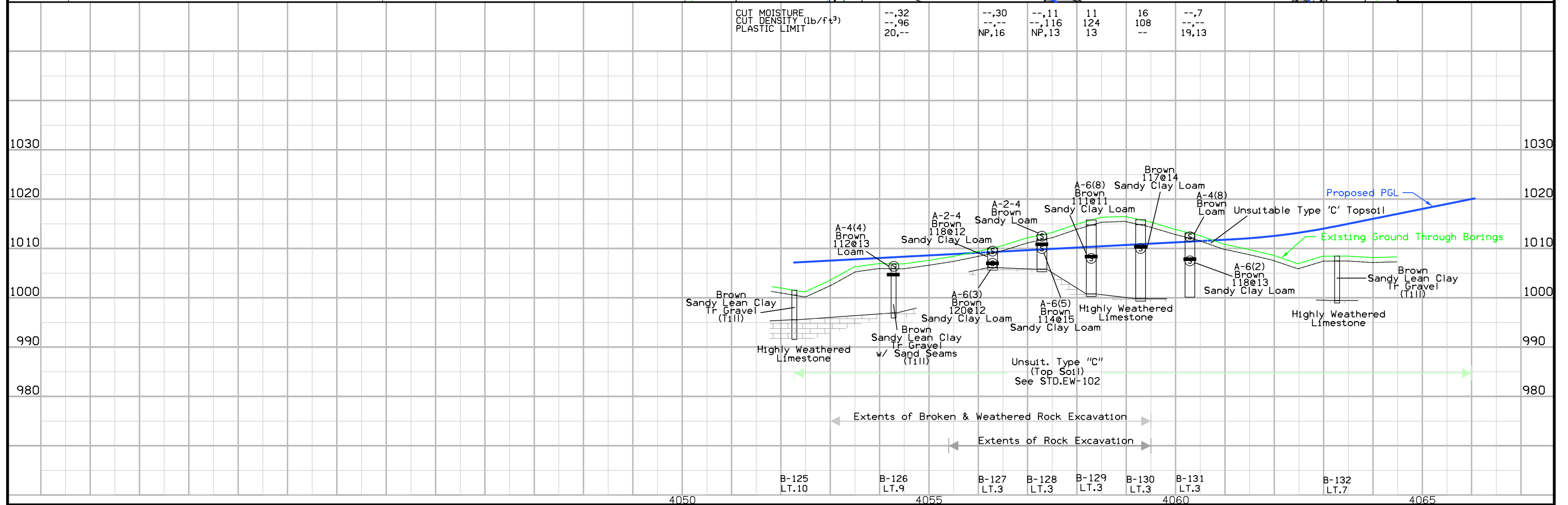



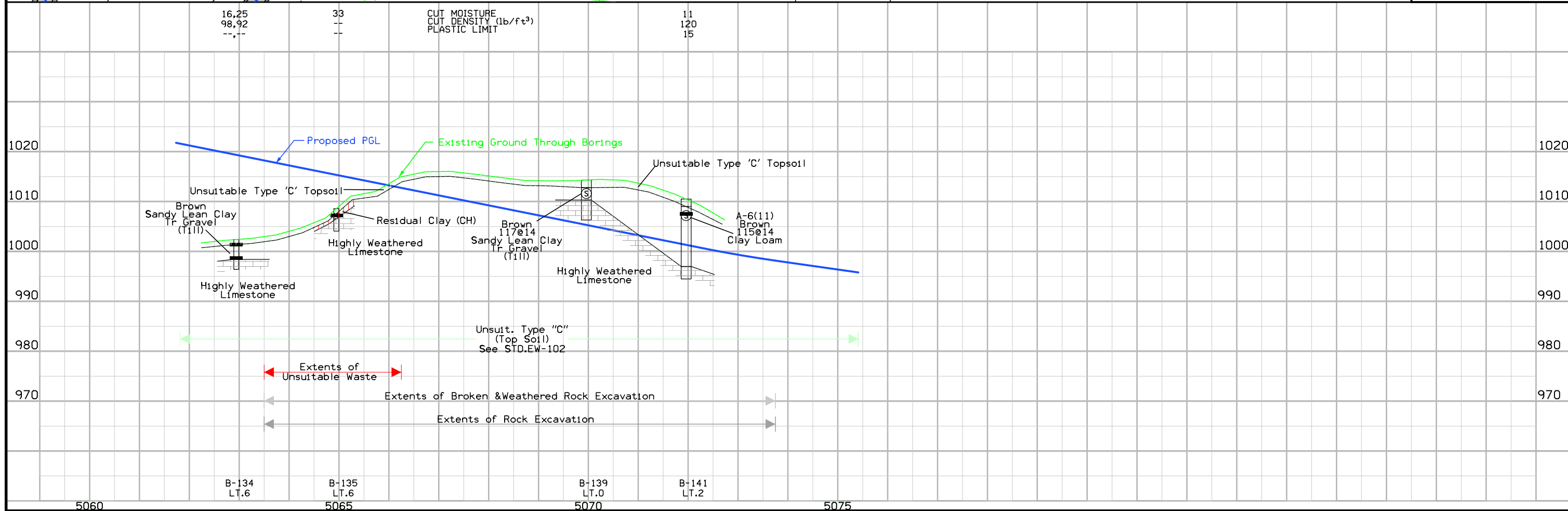
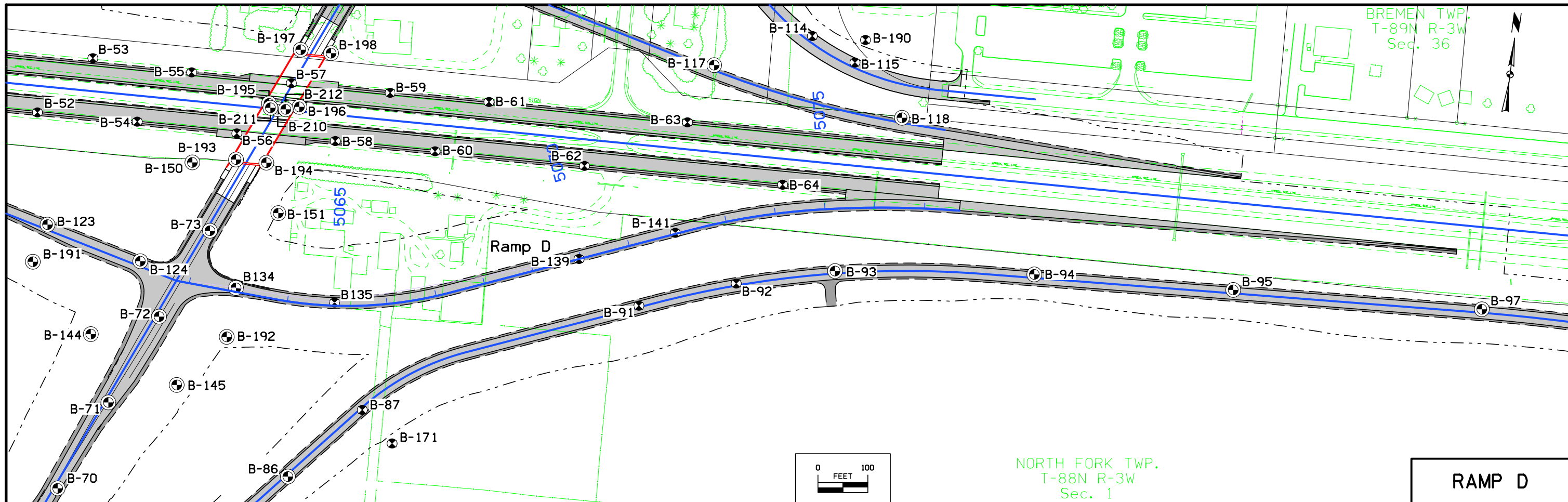

### TABULATION OF TEMPLATE QUANTITIES AND ADJUSTMENTS

Refer to Standard Road Plans EW-101 and EW-102.

STATION	TOTAL CUT	TOPSOIL TYPE C SAVED -C	TOPSOIL TYPE C SAVED WITH 40% SHRINK -C	BROKEN & WTHRD ROCK -C	HARD ROCK -C	HARD ROCK WITH 10% SWELL -C	CLASS 12 ROADWAY AND BORROW	CLASS 10 UNSUITABLE WASTE	CLASS 10 SUITABLE CUT	CLASS 10 SUITABLE -30% SHRINK	CLASS 10 ROADWAY AND BORROW	TOTAL FILL	APPROX. FILL VOLUME BELOW 3 FT	APPROX. FILL VOLUME BELOW 5 FT	STATION	TOTAL CUT	TOPSOIL TYPE C SAVED -C	TOPSOIL TYPE C SAVED WITH 40% SHRINK -C	BROKEN & WTHRD ROCK -C	HARD ROCK -C	HARD ROCK WITH 10% SWELL -C	CLASS 12 ROADWAY AND BORROW	CLASS 10 UNSUITABLE WASTE	CLASS 10 SUITABLE CUT	CLASS 10 SUITABLE -30% SHRINK	CLASS 10 ROADWAY AND BORROW	TOTAL FILL	APPROX. FILL VOLUME BELOW 3 FT	APPROX. FILL VOLUME BELOW 5 FT	
US 20 - Stg 1															1068+50.00	1,949	286	204												
1039+98.04	13	6	4						8	6	6	1			1069+00.00	1,819	280	200												
1040+00.00	326	125	89						201	155	155	29			1070+00.00	1,630	260	186												
1040+50.00	344	122	87						222	171	171	23			1071+00.00	1,525	176	126												
1041+00.00	361	122	87						239	184	184	15			1072+00.00	1,358	130	93												
1041+50.00	372	62	44						310	238	238	6			1073+00.00	1,096	174	124												
1042+00.00	400	90	64						310	238	238				1074+00.00	846	189	135												
1042+50.00	422	179	128						243	187	187	27			1075+00.00	623	186	133												
1043+00.00	430	174	124						257	198	198	51			1076+00.00	511	169	121												
1043+50.00	446	169	121						277	213	213	47			1077+00.00	421	136	97												
1044+00.00	461	169	121						291	224	224	34			1078+00.00	366	112	80												
1044+50.00	455	153	109						303	233	233	11			1079+00.00	337	99	71												
1045+00.00	466	167	119						299	230	230	17			1080+00.00	312	91	65												
1045+50.00	490	207	148						283	218	218	35			1081+00.00	479	197	141												
1046+00.00	490	223	159						268	206	206	56			1082+00.00	606	290	207												
1046+50.00	474	223	159						252	194	194	95			1083+00.00	523	260	186												
1047+00.00	454	223	159						232	178	178	126			1084+00.00	469	251	179												
1047+50.00	447	232	166						215	165	165	164			1085+00.00	220	123	88												
1048+00.00	782	316	226						465	358	358	547	85		1086+00.00	147	78	56												
1048+50.00	747	358	256						388	298	298	612	156		1087+00.00	127	34	24												
1049+00.00	672	350	250						322	248	248	643	190		1088+00.00	122	35	25												
1049+50.00	594	333	238						261	201	201	684	234		1089+00.00	122	35	25												
1050+00.00	547	354	253						193	148	148	770	328		1090+00.00	123	34	24												
1050+50.00	258	230	164						28	22	22	414			1091+00.00	143	69	49												
1051+00.00	4	3	2						1	1	1	4			1092+00.00	146	90	64												
1051+01.48	126	122	87						4	3	3	147			1093+00.00	152	98	70												
1051+50.00	125	116	83						9	7	7	178			1094+00.00	157	87	62												
1052+00.00	83	67	48						16	12	12	156			1095+00.00	163	90	64												
1052+50.00	51	11	8						40	31	31	94			1096+00.00	167	88	63												
1053+00.00	67	0	0						67	52	52	53			1097+00.00	170	84	60												
1053+50.00	132	56	40						76	58	58	112			1098+00.00	88	43	31												
1054+00.00	222	123	88						99	76	76	179			1099+00.00	94	43	31												
1054+50.00	297	108	77						189	145	145	156			1100+00.00	205	92	66												
1055+00.00	412	137	98						275	212	212	110			1101+00.00	238	101	72												
1055+50.00	563	189	135						374	288	288	67			1102+00.00	238	102	73												
1056+00.00	715	153	109						563	433	433	26			1103+00.00	215	108	77												
1056+50.00	923	160	114				1		763	587	587				1104+00.00	176	90	64												
1057+00.00	1,245	217	155				50		978	752	752				1105+00.00	139	64	46												
1057+50.00	1,593	230	164				133		1,230	946	946				1106+00.00	141	50	36												
1058+00.00	936	118	84				95		724	557	557				1107+00.00	142	34	24												
1058+25.00	1,028	122	87				118		786	605	605				1108+00.00	51	14	10												
1058+50.00	2,251	248	177				295		1,704	1,311	1,311				1109+00.00															
1059+00.00	2,503	253	181				357		1,864	1,434	1,434				1110+00.00															
1059+50.00	2,741	279	199				595		1,778	1,368	1,368				1111+00.00															
1060+00.00	2,890	295	211				802		1,732	1,332	1,332				1112+00.00															
1060+50.00	141	14	10				38		89	68	68				1113+00.00															
1060+52.41	2,792	287	205				752		1,753	1,348	1,348				1114+00.00															
1061+00.00	2,336	206	147				517		1,613	1,241	1,241				1115+00.00															
1061+50.00	908	57	41				121		730	562	562				1116+00.00															
1061+75.00	967	71	51				129		767	590	590				1117+00.00															
1062+00.00	1,985	176	126				332		1,468	1,129	1,129	22			1118+00.00															
1062+50.00	2,073	245	175				328		1,287	990	990	370			1119+00.00															
1063+00.00	2,132	295	211				253		1,380	1,062	1,062	688	239		1120+00.00															
1063+50.00	2,069	255	182				179		1,635	1,258	1,258	455			1121+00.00															
1064+00.00	2,063	232	166				118		1,712	1,317	1,317	114			1122+00.00															







### TABULATION OF TEMPLATE QUANTITIES AND ADJUSTMENTS

Refer to Standard Road Plans EW-101 and EW-102.

STATION	TOTAL CUT	TOPSOIL TYPE C SAVED -C	TOPSOIL TYPE C SAVED WITH 40% SHRINK -C	BROKEN & WTHRD ROCK -C	HARD ROCK -C	HARD ROCK WITH 10% SWELL -C	CLASS 12 ROADWAY AND BORROW	CLASS 10 UNSUITABLE WASTE	CLASS 10 SUITABLE CUT	CLASS 10 SUITABLE -30% SHRINK	CLASS 10 ROADWAY AND BORROW	TOTAL FILL	APPROX. FILL VOLUME BELOW 3 FT	APPROX. FILL VOLUME BELOW 5 FT	STATION	TOTAL CUT	TOPSOIL TYPE C SAVED -C	TOPSOIL TYPE C SAVED WITH 40% SHRINK -C	BROKEN & WTHRD ROCK -C	HARD ROCK -C	HARD ROCK WITH 10% SWELL -C	CLASS 12 ROADWAY AND BORROW	CLASS 10 UNSUITABLE WASTE	CLASS 10 SUITABLE CUT	CLASS 10 SUITABLE -30% SHRINK	CLASS 10 ROADWAY AND BORROW	TOTAL FILL	APPROX. FILL VOLUME BELOW 3 FT	APPROX. FILL VOLUME BELOW 5 FT
21047+50.00	53	43	31					10	8	8	24			31068+50.00	2,753	269	192	963	495	545	1,458		1,026	789	789				
21047+57.83	191	62	44					130	100	100	31			31069+00.00	2,430	262	187	846	422	464	1,268		901	693	693				
21047+76.00	81	22	16					58	45	45	4			31069+50.00	2,108	260	186	751	406	447	1,157		691	532	532				
21047+80.67	424	193	138					231	178	178	40			31070+00.00	1,764	258	184	579	336	370	915		591	455	455				
21048+00.00	961	490	350					471	362	362	212			31070+50.00	1,401	253	181	228	137	151	365		782	602	602				
21048+50.00	255	144	103					111	85	85	94			31071+00.00	1,078	251	179						827	636	636				
21048+65.00	553	335	239					219	168	168	275			31071+50.00	840	246	176						593	456	456				
21049+00.00	212	134	96					77	59	59	135			31072+00.00	629	230	164						399	307	307	13			
21049+14.47	478	323	231					155	119	119	399	65		31072+50.00	507	214	153						293	225	225	36			
21049+50.00	593	452	323					141	108	108	802	353		31073+00.00	465	210	150						255	196	196	66			
21050+00.00	163	136	97					27	21	21	303	174	63	31073+50.00	430	207	148						223	172	172	107			
21050+15.00	370	321	229					50	38	38	810	518	258	31074+00.00	400	203	145						197	152	152	130			
21050+50.00	425	375	268					50	38	38	1,074	751	454	31074+50.00	342	193	138						149	115	115	124			
21050+90.14	106	94	67					12	9	9	284	206	133	31075+00.00	55	35	25						20	15	15	21			
21051+00.00	542	484	346					57	44	44	1,559	1,177	807	31075+09.55	213	140	100						73	56	56	74			
21051+50.00	547	500	357					47	36	36	1,747	1,382	1,012	31075+50.00	237	161	115						76	58	58	60			
21052+00.00	428	400	286					28	22	22	1,560	1,185	819	31076+00.00	244	155	111						88	68	68	33			
21052+49.37	4	4	3								17	11	6	31076+50.00	215	122	87						93	72	72	14			
21052+50.00	327	309	221					18	14	14	1,361	962	592	31076+88.46	71	38	27						33	25	25	4			
21053+00.00	81	76	54					5	4	4	376	203	55	31077+00.00	333	169	121						163	125	125	17			
21053+19.86	41	41	29								299	12		31077+50.00	345	181	129						165	127	127	48			
21053+50.00	27	27	19								199	11		31078+00.00	331	190	136						141	108	108	120			
21053+69.86														31078+50.00	319	197	141						122	94	94	210			
Subtotal	7,448	5,407	3,862	0	0	0	0	2,042	1,571	1,571	11,678	7,010	4,199	31079+00.00	279	195	139						84	65	65	290			
221st Street														31079+50.00	231	185	132						46	35	35	345	41		
31053+93.86	8	8	6								59	23		31080+00.00	237	185	132						52	40	40	336	31		
31054+00.00	170	169	121								766	540	231	31080+50.00	295	193	138						102	78	78	235			
31054+43.86	39	39	28								154	126	82	31081+00.00	415	203	145						212	163	163	97			
31054+50.00	543	393	281					150	115	115	1,025	781	429	31081+50.00	649	216	154						434	334	334	17			
31055+00.00	29	18	13					11	8	8	30	20	7	31082+00.00	922	225	161						697	536	536				
31055+01.86	803	447	319					356	274	274	643	378	39	31082+50.00	1,055	228	163						827	636	636				
31055+50.00	927	448	320					479	368	368	404	105		31083+00.00	1,070	227	162						843	648	648				
31056+00.00	918	419	299					500	385	385	212			31083+50.00	1,021	225	161						796	612	612				
31056+50.00	801	378	270					423	325	325	116			31084+00.00	879	221	158						658	506	506				
31057+00.00	92	46	33					46	35	35	12			31084+50.00	578	181	129						398	306	306				
31057+06.41	559	295	211					263	202	202	79			31084+92.00	93	34	24						59	45	45	1			
31057+50.00	53	29	21					23	18	18	8			31085+00.00	507	209	149						299	230	230	73			
31057+54.72	459	281	201					177	136	136	103			31085+50.00	408	202	144						207	159	159	186			
31058+00.00	429	297	212					132	102	102	160			31086+00.00	123	66	47						57	44	44	83			
31058+50.00	409	294	210					115	88	88	176			31086+16.67	238	132	94						107	82	82	171			
31059+00.00	449	300	214					149	115	115	146			31086+50.00	379	197	141						181	139	139	200			
31059+50.00	526	312	223					214	165	165	94			31087+00.00	452	204	146						248	191	191	100			
31060+00.00	652	326	233	38				288	222	222	32			31087+50.00	514	210	150						304	234	234	38			
31060+50.00	904	344	246	144	12	13	156	404	311	311				31088+00.00	228	88	63						140	108	108	8			
31061+00.00	1,247	365	261	304	40	44	344	538	414	414				31088+20.76	326	125	89						201	155	155	12			
31061+50.00	1,568	391	279	773	73	80	846	333	256	256				31088+50.00	546	214	153						332	255	255	28			
31062+00.00	401	92	66	256	22	24	278	32	25	25				31089+00.00	531	213	152						318	245	245	35			
31062+11.34	1,521	321	229	771	69	76	840	360	277	277				31089+50.00	507	211	151						295	227	227	44			
31062+50.00	2,311	435	311	850	62	68	912	964	742	742				31090+00.00	417	204	146						213	164	164	109			
31063+00.00	2,571	431	308	950	113	124	1,063	1,078	829	829				31090+50.00	322	196	140						126	97	97	181			
31063+50.00	2,665	406	290	829	89	98	918	1,341	1,032	1,032				31091+00.00	292	192	137						100	77	77	204			
31064+00.00	2,679	398	284	491			491	1,790	1,377	1,377				31091+50.00	278	190	136						88	68	68	211			
31064+50.00	210	31	22	32			32	147	113	113				31092+00.00	282	190	136						92	71	71	210			
31064+53.95	2,359	365	261	388			388	1,605	1,235	1,235				31092+50.00	294	192	137						102	78	78	202			
31065+00.00	2,414	335	239	438			438	1,642	1,263	1,263				31093+00.00	312	193	138						119	92	92	183			
31065+50.00	1,788	207	148	362			362	1,219	938	938				31093+50.00	408	196	140						212	163	163	85			
31065+87.76	582	69	49	145			145	369	284	284				31094+00.00	256	99	71						156	120	120				
31066+00.00	2,405	276	197	710	8	9	718	1,411	1,085	1,085				31094+25.79	220	90	64						131	101	101				
31066+50.00	2,555	276	197	930	33																								



### TABULATION OF TEMPLATE QUANTITIES AND ADJUSTMENTS

Refer to Standard Road Plans EW-101 and EW-102.

STATION	TOTAL CUT	TOPSOIL TYPE C SAVED -C	TOPSOIL TYPE C SAVED WITH 40% SHRINK -C	BROKEN & WTHRD ROCK -C	HARD ROCK -C	HARD ROCK WITH 10% SWELL -C	CLASS 12 ROADWAY AND BORROW	CLASS 10 UNSUITABLE WASTE	CLASS 10 SUITABLE CUT	CLASS 10 SUITABLE -30% SHRINK	CLASS 10 ROADWAY AND BORROW	TOTAL FILL	APPROX. FILL VOLUME BELOW 3 FT	APPROX. FILL VOLUME BELOW 5 FT	STATION	TOTAL CUT	TOPSOIL TYPE C SAVED -C	TOPSOIL TYPE C SAVED WITH 40% SHRINK -C	BROKEN & WTHRD ROCK -C	HARD ROCK -C	HARD ROCK WITH 10% SWELL -C	CLASS 12 ROADWAY AND BORROW	CLASS 10 UNSUITABLE WASTE	CLASS 10 SUITABLE CUT	CLASS 10 SUITABLE -30% SHRINK	CLASS 10 ROADWAY AND BORROW	TOTAL FILL	APPROX. FILL VOLUME BELOW 3 FT	APPROX. FILL VOLUME BELOW 5 FT					
Ramp A															3058+00.00	218	125	89	3															
2065+44.21	6	6	4									42	3		3058+10.00	933	515	368	5															
2065+50.00	66	66	47									381	159		3058+50.00	220	118	84																
2065+84.49	42	42	30									228	133	18	3058+58.92	1,062	557	398	2															
2066+00.00	95	95	68									537	417	251	3059+00.00	1,235	582	416	95															
2066+22.41	322	203	145						119	92	92	1,041	928	724	3059+50.00	1,149	493	352	170															
2066+50.00	892	447	319						446	343	343	2,033	1,841	1,471	3060+00.00	889	391	279	128															
2067+00.00	456	221	158						235	181	181	981	881	696	3060+38.92	246	109	78	43															
2067+25.00	325	155	111						170	131	131	685	614	484	3060+50.00	1,036	473	338	215															
2067+42.61	137	64	46						72	55	55	283	253	198	3061+00.00	761	505	361	108															
2067+50.00	916	435	311						480	369	369	1,703	1,482	1,112	3061+50.00	57	57	41																
2068+00.00	934	430	307						504	388	388	1,376	1,126	756	3061+56.85	139	139	99																
2068+50.00	1,166	412	294						754	580	580	839	542	172	3061+95.21	7	7	5																
2069+00.00	683	181	129						502	386	386	164	10		3062+00.00	55	55	39																
2069+22.61	881	216	154						665	512	512	163			3062+35.32																			
2069+50.00	727	190	136						536	412	412	189	20		Subtotal	14,408	9,521	6,801	776	0	0	776	0	4,107	3,159	3,159	50,258	45,874	37,111					
2069+75.00	590	186	133						404	311	311	353	198	13																				
2070+00.00	766	316	226						450	346	346	728	421	51																				
2070+50.00	462	258	184						204	157	157	695	385	15																				
2071+00.00	356	237	169						119	92	92	761	457	87																				
2071+50.00	135	104	74						31	24	24	319	174	2																				
2071+73.25	139	120	86						19	15	15	428	267	69																				
2072+00.00	135	127	91						7	5	5	522	354	140																				
2072+28.85	91	90	64						1	1	1	401	279	122																				
2072+50.00	118	118	84									545	376	159																				
2072+79.25	79	78	56									370	249	95																				
2073+00.00	296	183	131									819	520	150																				
2073+50.00	421	195	139						112	86	86	819	520	150																				
2074+00.00	428	195	139						226	174	174	643	328																					
2074+50.00	465	176	126						234	180	180	438	105																					
2075+00.00	513	171	122						288	222	222	300																						
2075+50.00	498	158	113						342	263	263	233																						
2076+00.00	73	22	16						340	262	262	205																						
2076+07.65	386	119	85						51	39	39	30																						
2076+50.00	70	22	16						267	205	205	170																						
2076+58.05	312	111	79						48	37	37	32																						
2077+00.00	77	36	26						201	155	155	167																						
2077+13.65	39	27	19						41	32	32	53																						
2077+25.00									13	10	10	47																						
Subtotal	14,097	6,212	4,437	0	0	0	0	0	7,881	6,062	6,062	18,904	12,522	6,785																				
Ramp B																																		
3050+50.00	85	71	51						13	10	10	183	93																					
3050+64.19	225	188	134						37	28	28	518	297	32																				
3051+00.00	126	106	76						19	15	15	325	207	60																				
3051+19.79	186	164	117						22	17	17	552	377	153																				
3051+50.00	126	112	80						14	11	11	407	293	143																				
3051+70.19	197	171	122						26	20	20	657	494	273																				
3052+00.00	405	315	225						90	69	69	1,282	1,024	654																				
3052+50.00	566	357	255						209	161	161	1,226	963	593																				
3053+00.00	333	189	135						144	111	111	780	478	108																				
3053+50.00	164	162	116						1	1	1	1,195	929	559																				
3054+00.00	336	336	240									1,956	1,757	1,387																				
3054+50.00	305	305	218									1,780	1,617	1,299																				
3054+92.96	52	52	37									298																						

### TABULATION OF TEMPLATE QUANTITIES AND ADJUSTMENTS

Refer to Standard Road Plans EW-101 and EW-102.

STATION	TOTAL CUT	TOPSOIL TYPE C SAVED -C	TOPSOIL TYPE C SAVED WITH 40% SHRINK -C	BROKEN & WTHRD ROCK -C	HARD ROCK -C	HARD ROCK WITH 10% SWELL -C	CLASS 12 ROADWAY AND BORROW	CLASS 10 UNSUITABLE WASTE	CLASS 10 SUITABLE CUT	CLASS 10 SUITABLE -30% SHRINK	CLASS 10 ROADWAY AND BORROW	TOTAL FILL	APPROX. FILL VOLUME BELOW 3 FT	APPROX. FILL VOLUME BELOW 5 FT	STATION	TOTAL CUT	TOPSOIL TYPE C SAVED -C	TOPSOIL TYPE C SAVED WITH 40% SHRINK -C	BROKEN & WTHRD ROCK -C	HARD ROCK -C	HARD ROCK WITH 10% SWELL -C	CLASS 12 ROADWAY AND BORROW	CLASS 10 UNSUITABLE WASTE	CLASS 10 SUITABLE CUT	CLASS 10 SUITABLE -30% SHRINK	CLASS 10 ROADWAY AND BORROW	TOTAL FILL	APPROX. FILL VOLUME BELOW 3 FT	APPROX. FILL VOLUME BELOW 5 FT
Ramp C															5065+00.00	2,250	234	167	682	295	324	977	346	1,040	800	800	1,032	521	151
4052+26.70	5	3	2					2	2	2	8				5065+50.00	2,805	396	283	662	375	413	1,037	285	1,372	1,055	1,055	733	270	
4052+27.64	118	63	45					55	42	42	222	32			5066+00.00	2,958	375	268	438	455	500	893	240	1,691	1,301	1,301			
4052+50.00	181	78	56					103	79	79	319	74			5066+50.00	2,510	262	187	415	425	468	840	51	1,408	1,083	1,083			
4052+78.04	181	55	39	3			3	123	95	95	188	6			5066+85.94	1,026	101	72	181	168	185	349		576	443	443			
4053+00.00	301	42	30	11			11	248	191	191	119				5067+00.00	1,842	179	128	321	283	311	604		1,060	815	815			
4053+33.84	148	6	4	3			3	140	108	108	24				5067+24.94	1,851	178	127	358	308	339	666		1,007	775	775			
4053+50.00	564	116	83					448	345	345	172				5067+50.00	3,630	435	311	800	666	733	1,466		1,728	1,329	1,329			
4054+00.00	664	218	156					445	342	342	247				5068+00.00	1,122	164	117	297	218	240	515		443	341	341			
4054+50.00	470	160	114	2			2	308	237	237	136				5068+15.94	2,311	344	246	700	485	533	1,185		783	602	602			
4054+83.20	253	85	61	6	2	2	8	160	123	123	52				5068+50.00	924	139	99	295	220	242	515		271	208	208			
4055+00.00	659	216	154	11	3	3	14	431	332	332	83				5068+63.94	2,427	356	254	767	627	690	1,394		677	521	521			
4055+39.00	246	63	45	7	9	10	16	167	128	128	51				5069+00.00	3,572	498	356	928	1,140	1,254	2,068		1,006	774	774			
4055+50.00	1,301	293	209	76	86	95	162	847	652	652	194				5069+50.00	3,760	489	349	775	1,495	1,645	2,270		1,002	771	771			
4056+00.00	190	43	31	13	14	15	27	121	93	93					5070+00.00	3,809	463	331	723	1,142	1,256	1,865		1,482	1,140	1,140			
4056+07.20	1,283	265	189	92	124	136	216	804	618	618					5070+50.00	3,808	438	313	690	1,175	1,293	1,865		1,505	1,158	1,158			
4056+50.00	1,872	323	231	133	227	250	360	1,188	914	914					5071+00.00	3,693	346	247	680	1,212	1,333	1,892		1,456	1,120	1,120			
4057+00.00	2,304	337	241	136	250	275	386	1,580	1,215	1,215					5071+50.00	189	14	10	35	38	42	73		102	78	78			
4057+50.00	2,762	351	251	66	122	134	188	2,224	1,711	1,711					5071+52.65	3,116	248	177	408	379	417	787		2,081	1,601	1,601			
4058+00.00	3,276	364	260					2,912	2,240	2,240					5072+00.00	1,188	105	75	79	33	36	112		972	748	748			
4058+50.00	3,690	377	269	40	105	115	145	3,170	2,438	2,438					5072+20.85	219	20	14	15	6	7	21		178	137	137			
4059+00.00	1,575	157	112	32	82	90	114	1,305	1,004	1,004					5072+25.00	1,204	118	84	75	22	24	97		991	762	762			
4059+20.43	2,263	230	164	24	55	61	79	1,955	1,504	1,504					5072+50.00	1,093	118	84	71	12	13	83		894	688	688			
4059+50.00	1,348	143	102	1			1	1,204	926	926					5072+76.65	819	98	70	64	12	13	76		646	497	497			
4059+68.43	2,102	238	170					1,864	1,434	1,434					5073+00.00	1,412	202	144	192	65	71	257		955	735	735	9		
4060+00.00	2,733	358	256					2,375	1,827	1,827					5073+50.00	544	97	69	92	29	32	121		327	252	252	17		
4060+50.00	428	64	46					363	279	279					5073+75.00	458	92	66	54	4	4	58		308	237	237	30		
4060+59.43	1,479	260	186					1,219	938	938	12				5074+00.00	532	122	87	34			34		376	289	289	48		
4060+98.43	50	10	7					40	31	31	1				5074+34.12	215	55	39						160	123	123	21		
4061+00.00	579	118	84					462	355	355	9				5074+50.00	466	134	96	7			7		324	249	249	54		
4061+20.00	692	144	103					548	422	422	27				5074+89.92	101	34	24	4	4		4		64	49	49	15		
4061+50.00	917	267	191					649	499	499	274				5075+00.00	339	127	91	20			20		192	148	148	52		
4062+00.00	765	316	226					449	345	345	624	179			5075+40.32	7	3	2	1			1		3	2	2	1		
4062+50.00	612	309	221					302	232	232	754	288			5075+41.26														
4063+00.00	207	122	87					85	65	65	283	99			Subtotal	59,596	8,001	5,715	11,734	11,535	12,689	23,269	1,594	28,343	21,802	21,802	10,596	5,873	3,634
4063+20.00	310	181	129					129	99	99	429	153			Stage 1 Total	275,737	72,946	52,104	33,516	15,308	16,839	48,824	2,668	153,994	118,457	118,457	161,101	122,938	97,940
4063+50.00	185	104	74					81	62	62	263	100			Stage 2 Total	194,727	49,594	35,424	9,086	3,501	3,851	12,587	7,435	132,556	101,966	101,966	128,542	89,769	64,721
4063+67.39	355	196	140					159	122	122	511	204			Totals	470,464	122,539	87,528	42,602	18,809	20,690	61,411	10,103	286,550	220,423	220,423	289,643	212,707	162,661
4064+00.00	71	39	28					32	25	25	103	42																	
4064+06.39	14	7	5					7	5	5	17	3																	
4064+07.90	43	20	14					23	18	18	51																		
4064+18.66	19	20	14								104																		
4064+50.00	29	29	21								155																		
4064+97.39	2	1	1								8																		
4065+00.00	28	28	20								174																		
4065+45.39	3	3	2								19																		
4065+50.00	21	21	15								168																		
4065+85.11																													
Subtotal	37,298	6,843	4,888	656	1,078	1,186	1,734	0	28,727	22,098	22,098	5,801																	

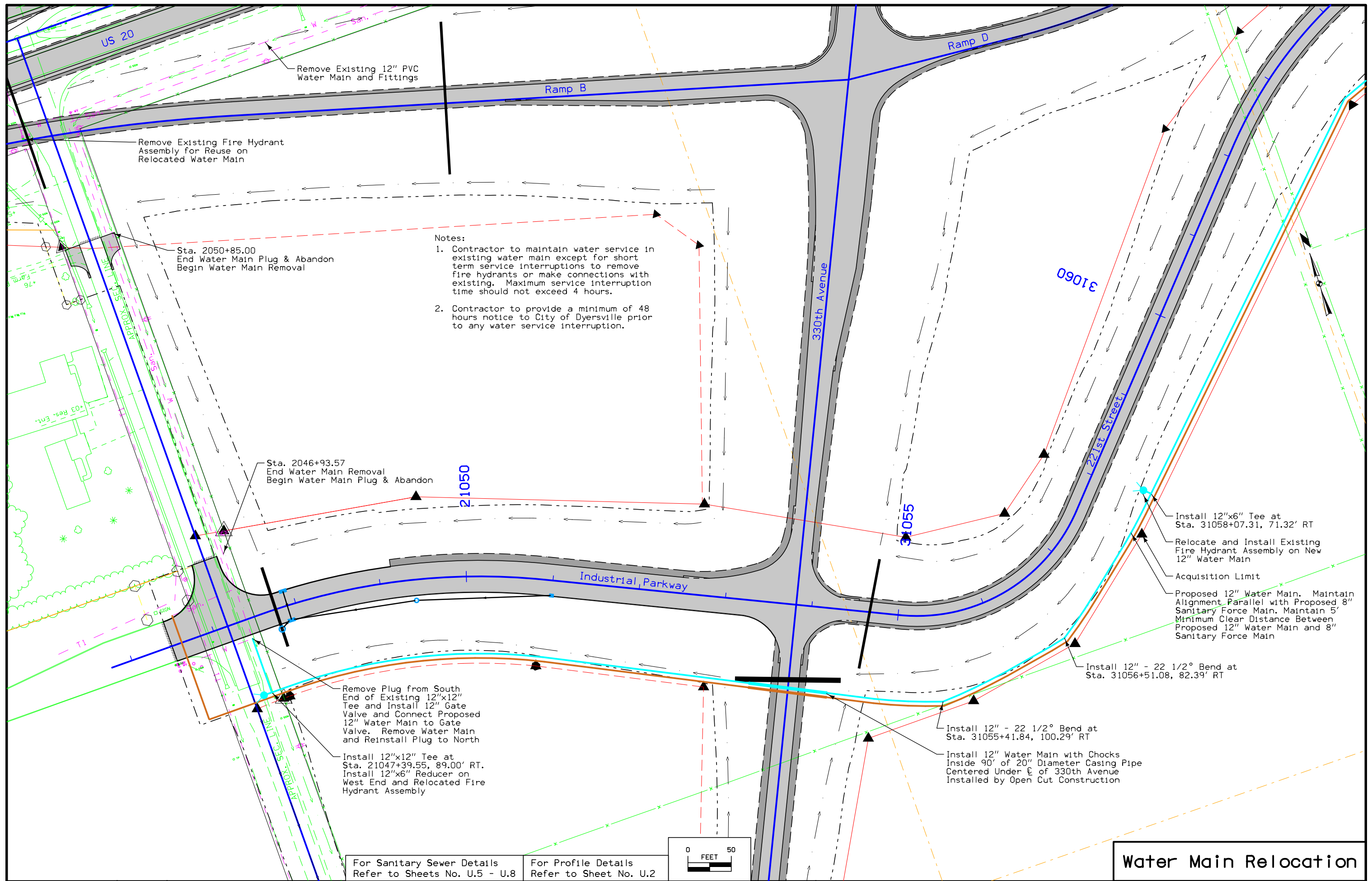

Remove Existing 12" PVC Water Main and Fittings

Remove Existing Fire Hydrant Assembly for Reuse on Relocated Water Main

Sta. 2050+85.00  
End Water Main Plug & Abandon  
Begin Water Main Removal

- Notes:
1. Contractor to maintain water service in existing water main except for short term service interruptions to remove fire hydrants or make connections with existing. Maximum service interruption time should not exceed 4 hours.
  2. Contractor to provide a minimum of 48 hours notice to City of Dyersville prior to any water service interruption.

Sta. 2046+93.57  
End Water Main Removal  
Begin Water Main Plug & Abandon

Remove Plug from South End of Existing 12"x12" Tee and Install 12" Gate Valve and Connect Proposed 12" Water Main to Gate Valve. Remove Water Main and Reinstall Plug to North

Install 12"x12" Tee at Sta. 21047+39.55, 89.00' RT. Install 12"x6" Reducer on West End and Relocated Fire Hydrant Assembly

Install 12"x6" Tee at Sta. 31058+07.31, 71.32' RT

Relocate and Install Existing Fire Hydrant Assembly on New 12" Water Main

Acquisition Limit

Proposed 12" Water Main. Maintain Alignment Parallel with Proposed 8" Sanitary Force Main. Maintain 5' Minimum Clear Distance Between Proposed 12" Water Main and 8" Sanitary Force Main

Install 12" - 22 1/2° Bend at Sta. 31056+51.08, 82.39' RT

Install 12" - 22 1/2° Bend at Sta. 31055+41.84, 100.29' RT

Install 12" Water Main with Chocks Inside 90' of 20" Diameter Casing Pipe Centered Under  $\bar{C}$  of 330th Avenue Installed by Open Cut Construction

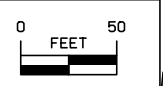

For Sanitary Sewer Details Refer to Sheets No. U.5 - U.8

For Profile Details Refer to Sheet No. U.2

# Water Main Relocation



For Plan Details  
Refer to Sheet No. U.1

# Water Main Relocation

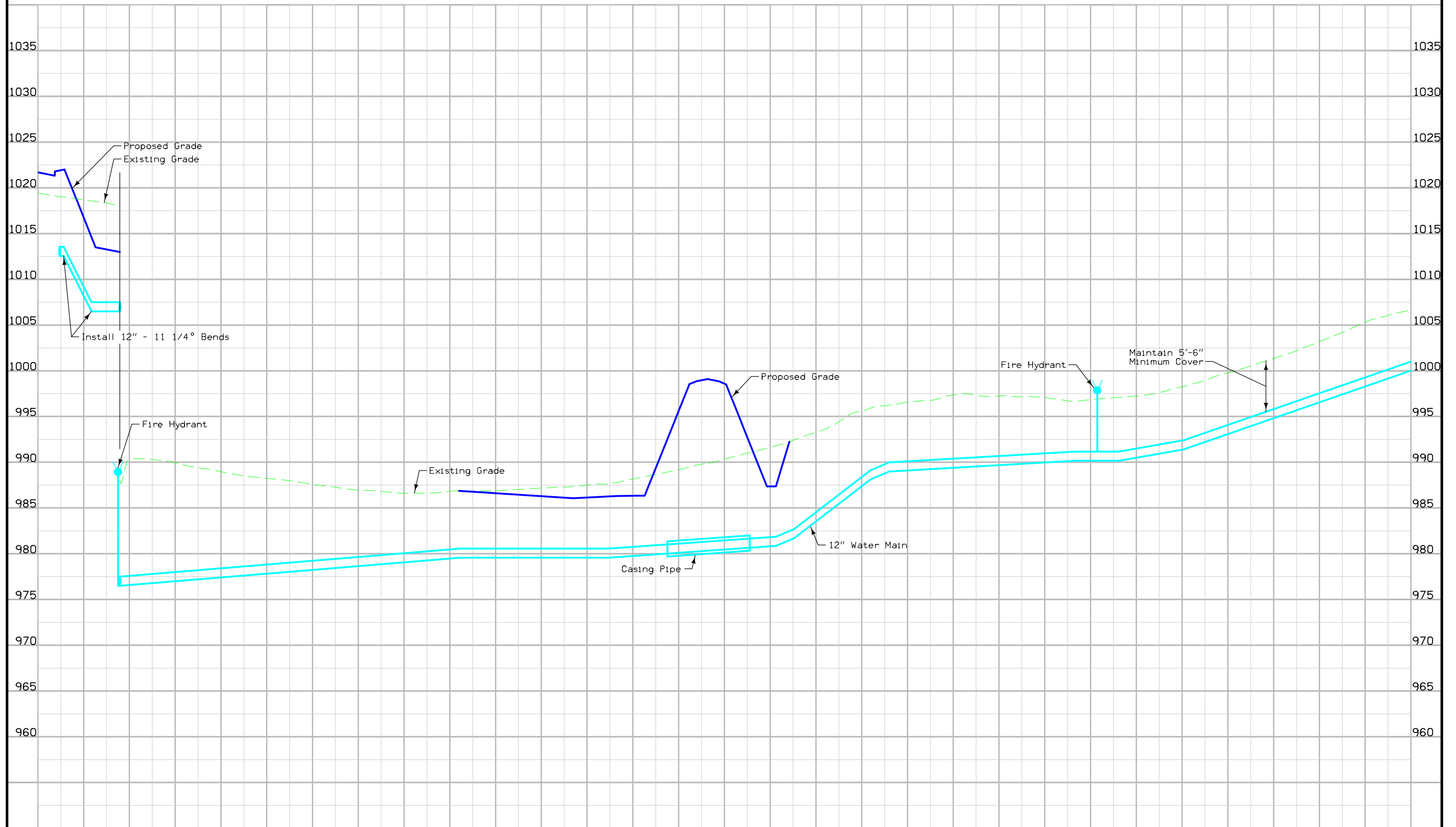

+50	21047	+50	21048	+50	21049	+50	21050	+50	21051	+50	21052	+50	21053	+50	31054	+50	31055	+50	31056	+50	31057	+50	31058	+50	31059	+50	31060	+50	31061	+50
FILE NO.	ENGLISH	DESIGN TEAM	Stanley Consultants Inc.										DELAWARE/DUBUQUE COUNTY	PROJECT NUMBER	NHSX-020-9(203)--3H-28					SHEET NUMBER	U.2									

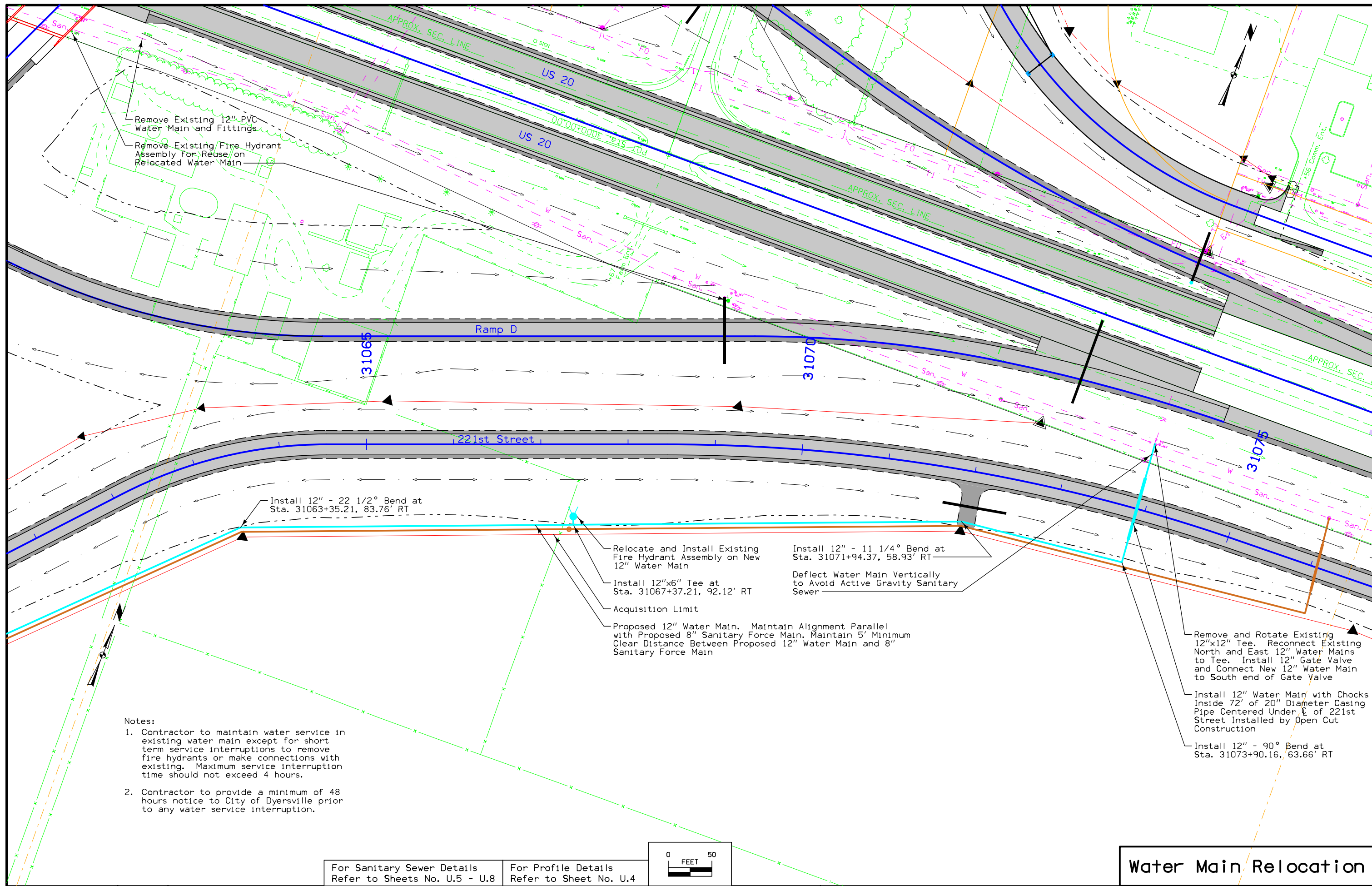

Remove Existing 12" PVC Water Main and Fittings  
 Remove Existing Fire Hydrant Assembly for Reuse on Relocated Water Main

Install 12" - 22 1/2° Bend at Sta. 31063+35.21, 83.76' RT

Relocate and Install Existing Fire Hydrant Assembly on New 12" Water Main

Install 12"x6" Tee at Sta. 31067+37.21, 92.12' RT

Acquisition Limit

Proposed 12" Water Main. Maintain Alignment Parallel with Proposed 8" Sanitary Force Main. Maintain 5' Minimum Clear Distance Between Proposed 12" Water Main and 8" Sanitary Force Main

Install 12" - 11 1/4° Bend at Sta. 31071+94.37, 58.93' RT

Deflect Water Main Vertically to Avoid Active Gravity Sanitary Sewer

Remove and Rotate Existing 12"x12" Tee. Reconnect Existing North and East 12" Water Mains to Tee. Install 12" Gate Valve and Connect New 12" Water Main to South end of Gate Valve

Install 12" Water Main with Chocks Inside 72' of 20" Diameter Casing Pipe Centered Under  $\frac{1}{2}$  of 221st Street Installed by Open Cut Construction

Install 12" - 90° Bend at Sta. 31073+90.16, 63.66' RT

- Notes:
- Contractor to maintain water service in existing water main except for short term service interruptions to remove fire hydrants or make connections with existing. Maximum service interruption time should not exceed 4 hours.
  - Contractor to provide a minimum of 48 hours notice to City of Dyersville prior to any water service interruption.

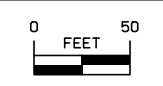

For Sanitary Sewer Details Refer to Sheets No. U.5 - U.8  
 For Profile Details Refer to Sheet No. U.4

### Water Main Relocation

For Plan Details  
Refer to Sheet No. U.3

# Water Main Relocation

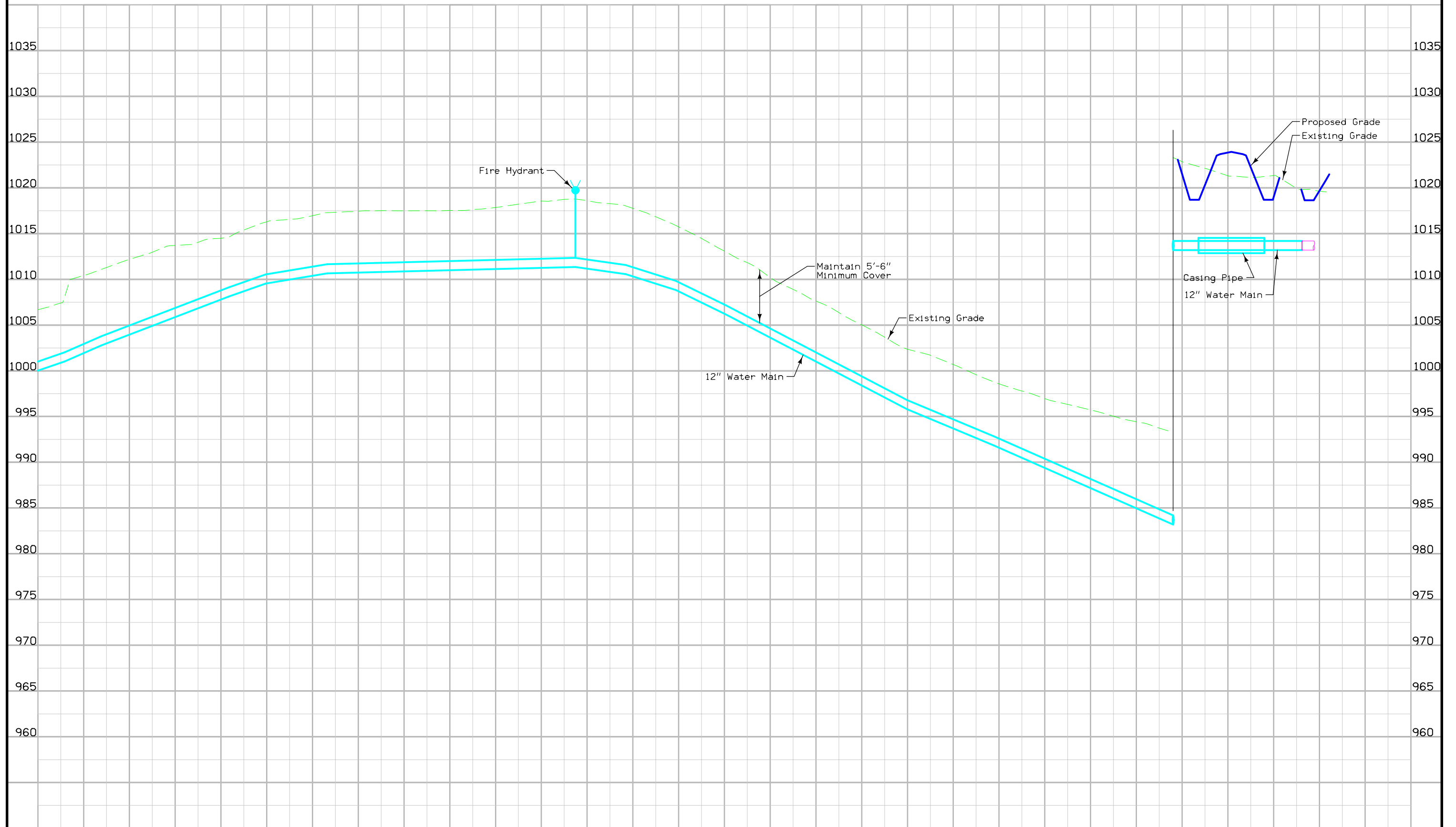

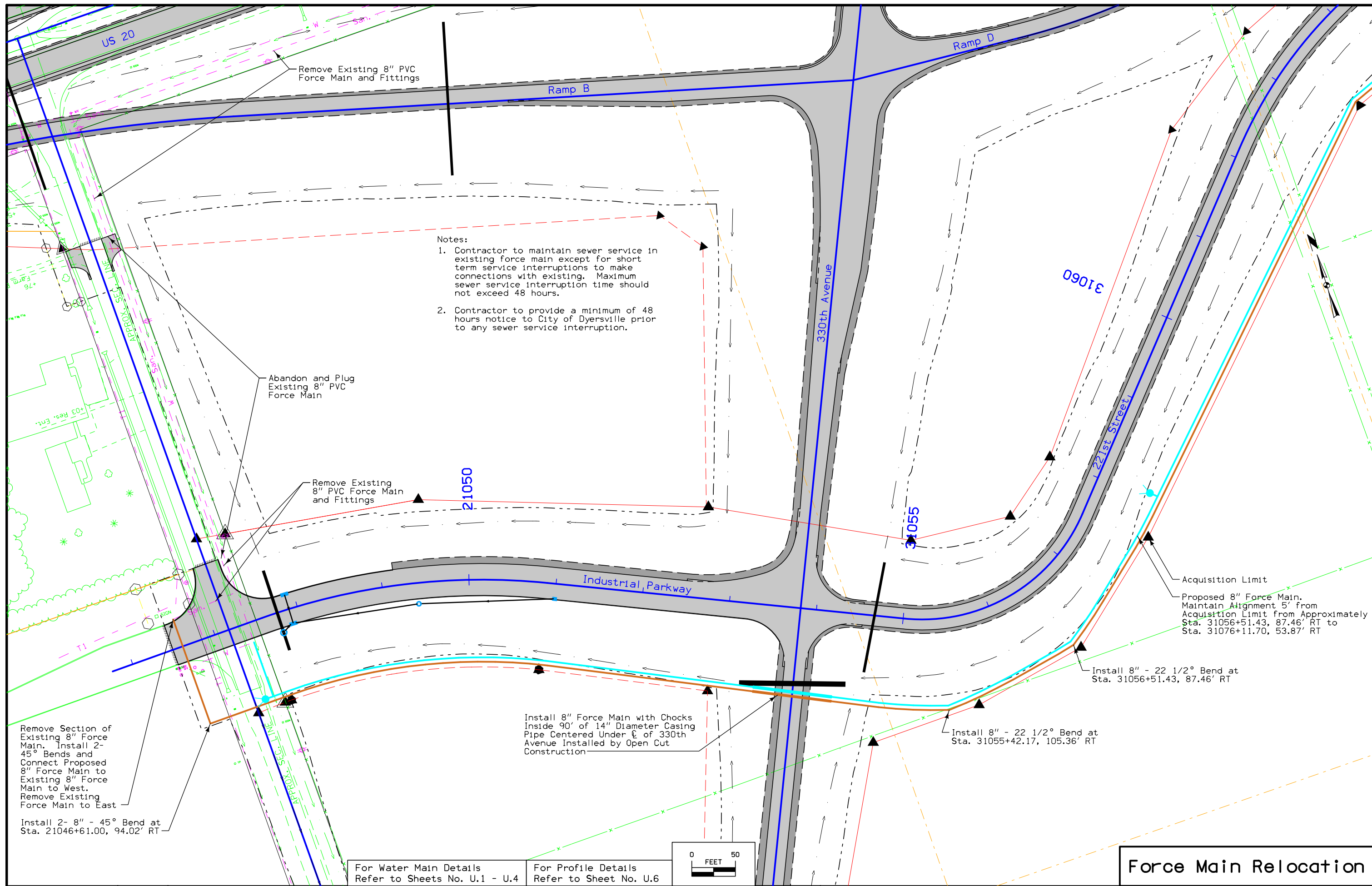

- Notes:
1. Contractor to maintain sewer service in existing force main except for short term service interruptions to make connections with existing. Maximum sewer service interruption time should not exceed 48 hours.
  2. Contractor to provide a minimum of 48 hours notice to City of Dyersville prior to any sewer service interruption.

Remove Section of Existing 8" Force Main. Install 2- 45° Bends and Connect Proposed 8" Force Main to Existing 8" Force Main to West. Remove Existing Force Main to East

Install 2- 8" - 45° Bend at Sta. 21046+61.00, 94.02' RT

Abandon and Plug Existing 8" PVC Force Main

Remove Existing 8" PVC Force Main and Fittings

Install 8" Force Main with Checks Inside 90' of 14" Diameter Casing Pipe Centered Under  $\epsilon$  of 330th Avenue Installed by Open Cut Construction

Install 8" - 22 1/2° Bend at Sta. 31055+42.17, 105.36' RT

Install 8" - 22 1/2° Bend at Sta. 31056+51.43, 87.46' RT

Acquisition Limit

Proposed 8" Force Main. Maintain Alignment 5' from Acquisition Limit from Approximately Sta. 31056+51.43, 87.46' RT to Sta. 31076+11.70, 53.87' RT

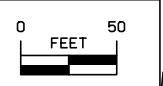

For Water Main Details Refer to Sheets No. U.1 - U.4

For Profile Details Refer to Sheet No. U.6

### Force Main Relocation

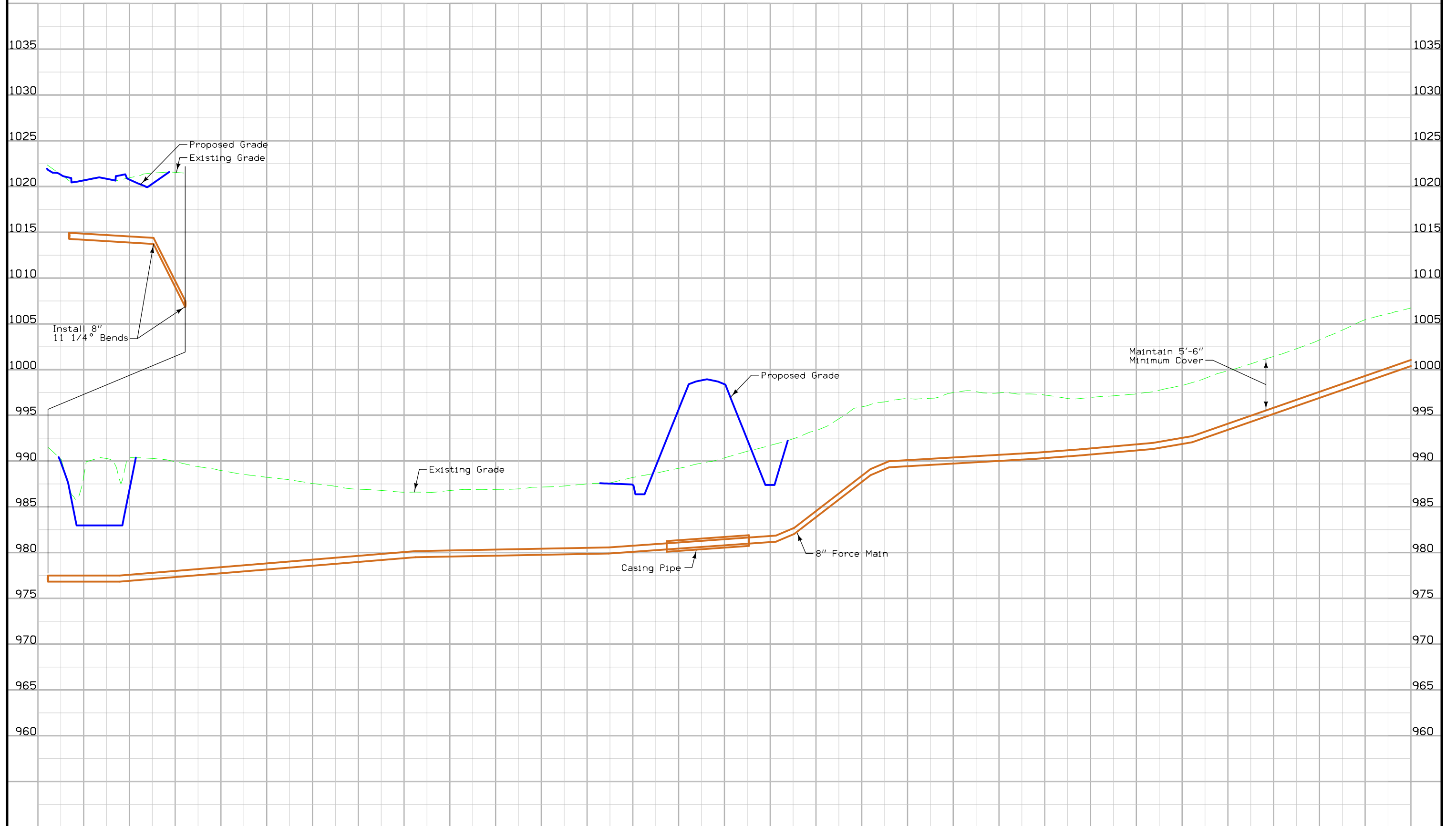

+50	21047	+50	21048	+50	21049	+50	21050	+50	21051	+50	21052	+50	21053	+50	31054	+50	31055	+50	31056	+50	31057	+50	31058	+50	31059	+50	31060	+50	31061	+50
FILE NO.	ENGLISH	DESIGN TEAM	Stanley Consultants Inc.										DELAWARE/DUBUQUE COUNTY	PROJECT NUMBER	NHSX-020-9(203)--3H-28					SHEET NUMBER	U.6									



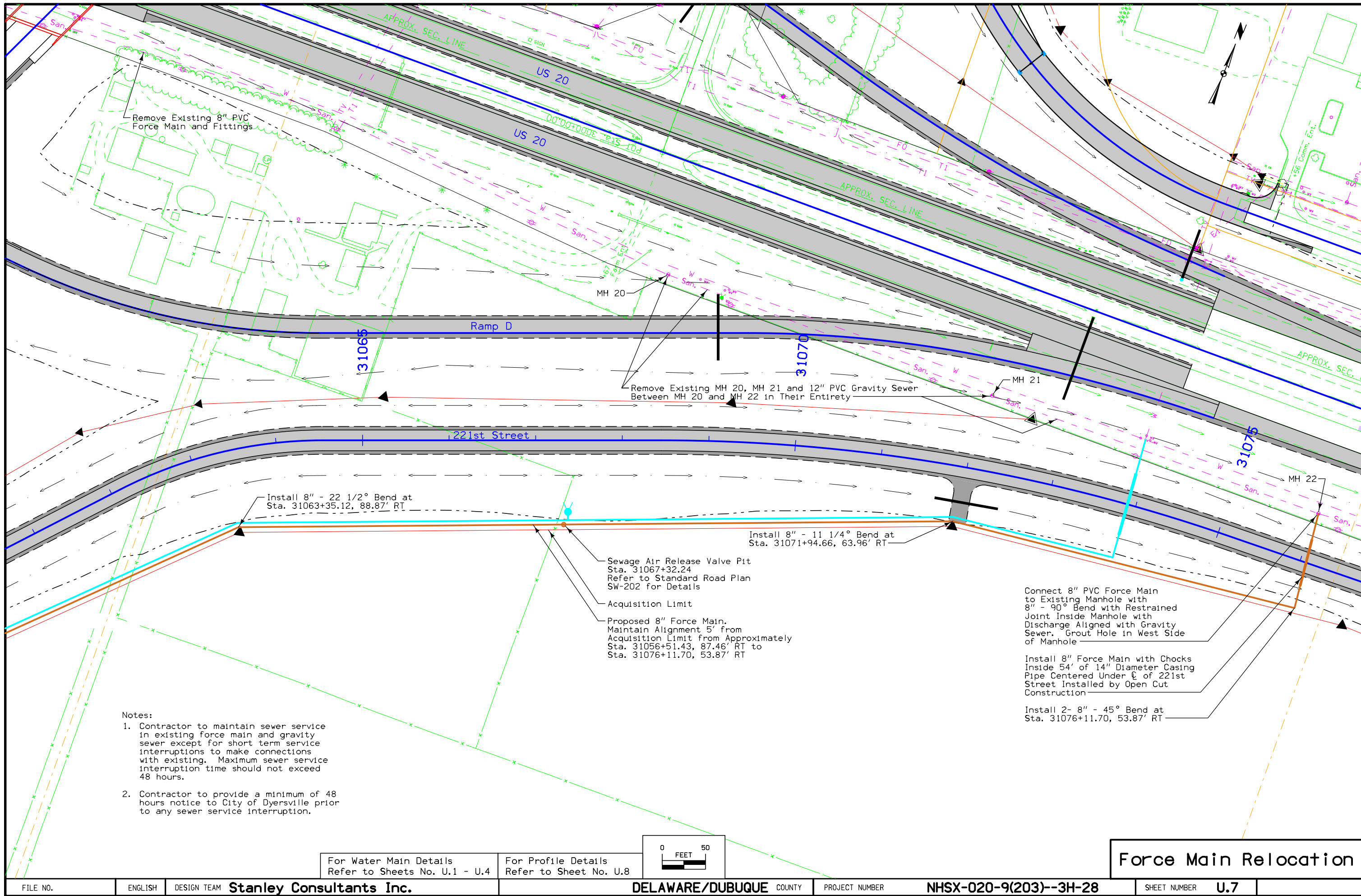

- Notes:
1. Contractor to maintain sewer service in existing force main and gravity sewer except for short term service interruptions to make connections with existing. Maximum sewer service interruption time should not exceed 48 hours.
  2. Contractor to provide a minimum of 48 hours notice to City of Dyersville prior to any sewer service interruption.

Install 8" - 22 1/2° Bend at Sta. 31063+35.12, 88.87' RT

Install 8" - 11 1/4° Bend at Sta. 31071+94.66, 63.96' RT

Sewage Air Release Valve Pit  
Sta. 31067+32.24  
Refer to Standard Road Plan SW-202 for Details

Acquisition Limit  
Proposed 8" Force Main.  
Maintain Alignment 5' from Acquisition Limit from Approximately Sta. 31056+51.43, 87.46' RT to Sta. 31076+11.70, 53.87' RT

Connect 8" PVC Force Main to Existing Manhole with 8" - 90° Bend with Restrained Joint Inside Manhole with Discharge Aligned with Gravity Sewer. Grout Hole in West Side of Manhole

Install 8" Force Main with Chocks Inside 54' of 14" Diameter Casing Pipe Centered Under  $\phi$  of 221st Street Installed by Open Cut Construction

Install 2- 8" - 45° Bend at Sta. 31076+11.70, 53.87' RT

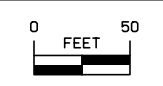

For Water Main Details Refer to Sheets No. U.1 - U.4

For Profile Details Refer to Sheet No. U.8

### Force Main Relocation



For Plan Details  
Refer to Sheet No. U.7

# Force Main Relocation

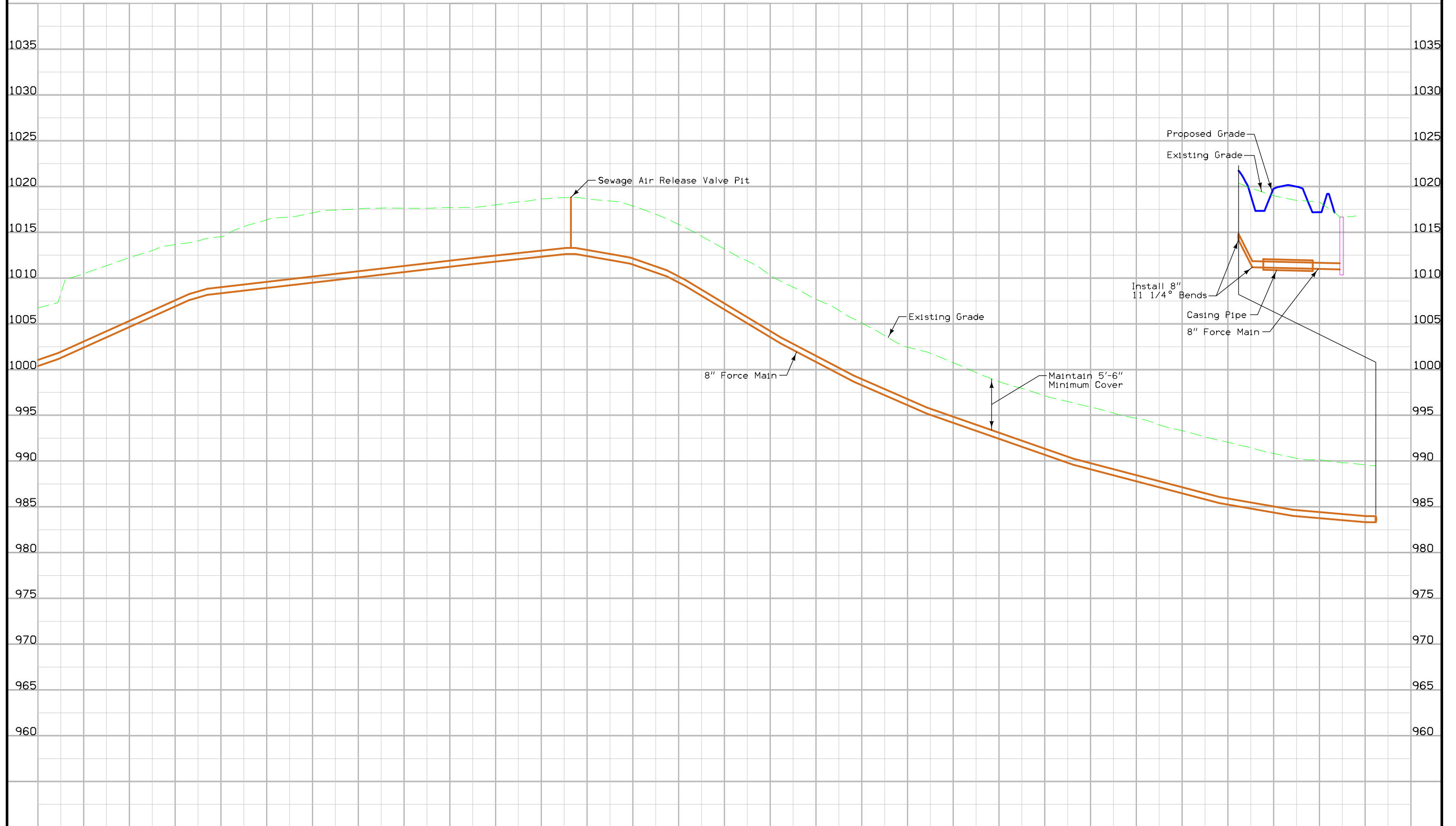

+50 31062	+50 31063	+50 31064	+50 31065	+50 31066	+50 31067	+50 31068	+50 31069	+50 31070	+50 31071	+50 31072	+50 31073	+50 31074	+50 31075	+50 31076	+50
FILE NO.	ENGLISH	DESIGN TEAM	Stanley Consultants Inc.			DELAWARE/DUBUQUE COUNTY			PROJECT NUMBER	NHSX-020-9(203)--3H-28		SHEET NUMBER	U.8		

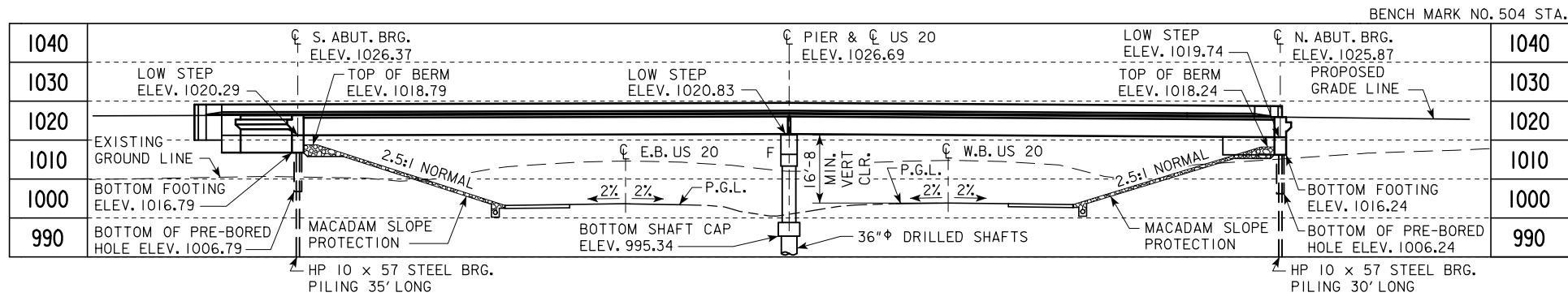

LONGITUDINAL SECTION ALONG 330TH/332ND AVENUE

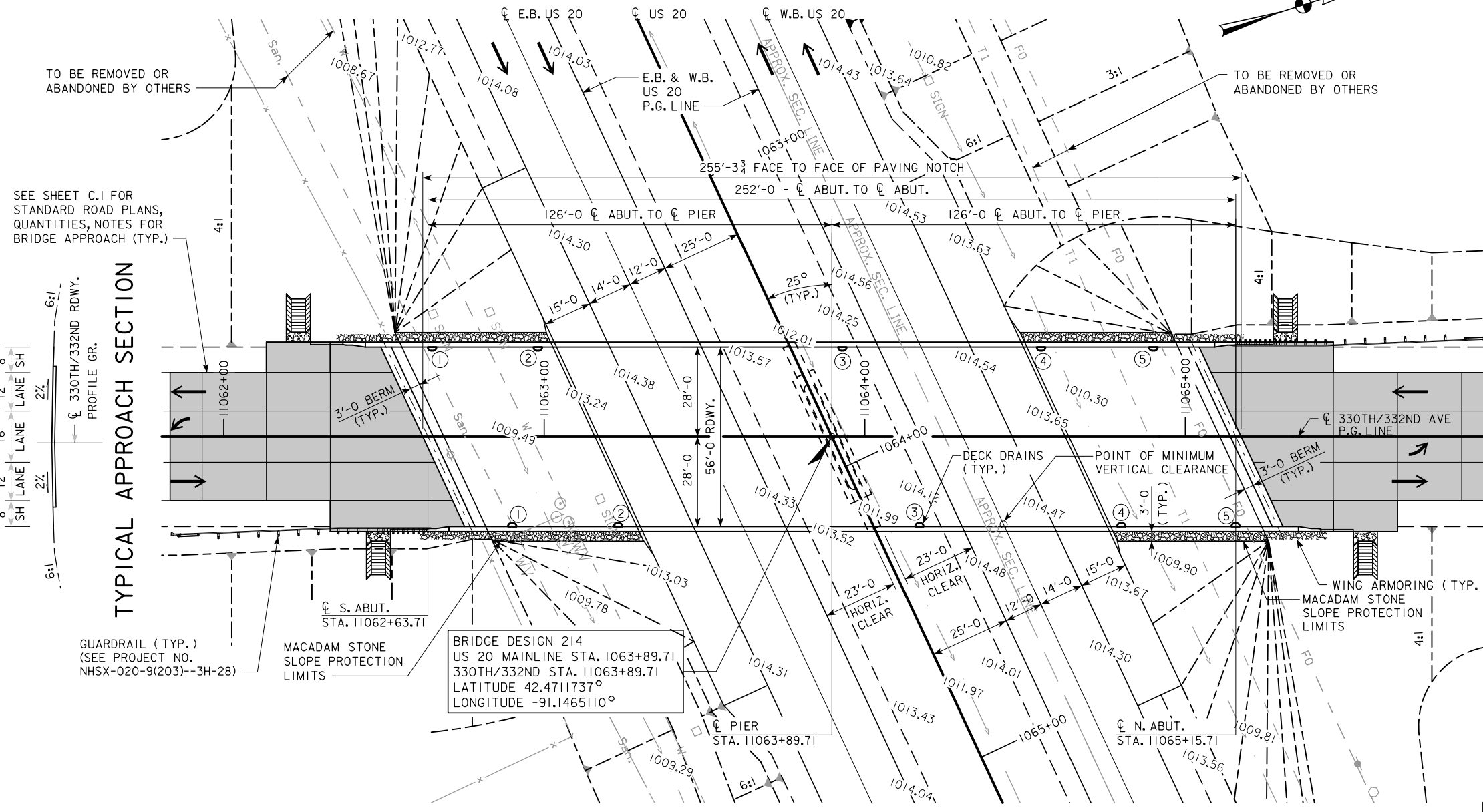
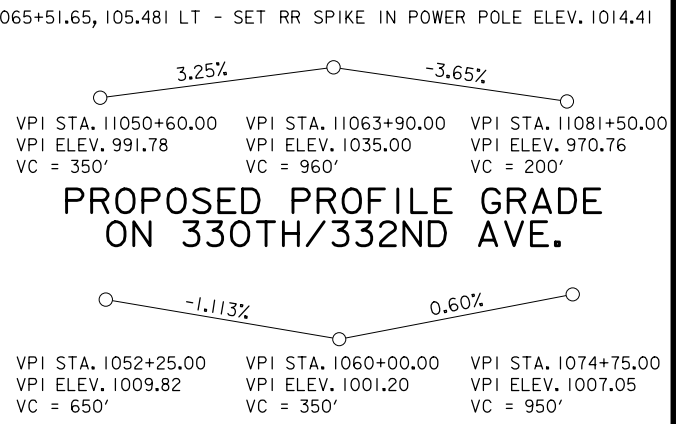

SEE SHEET C.1 FOR STANDARD ROAD PLANS, QUANTITIES, NOTES FOR BRIDGE APPROACH (TYP.)

TYPICAL APPROACH SECTION

BRIDGE DESIGN 214  
US 20 MAINLINE STA. 1063+89.71  
330TH/332ND STA. 11063+89.71  
LATITUDE 42.471173°  
LONGITUDE -91.1465110°

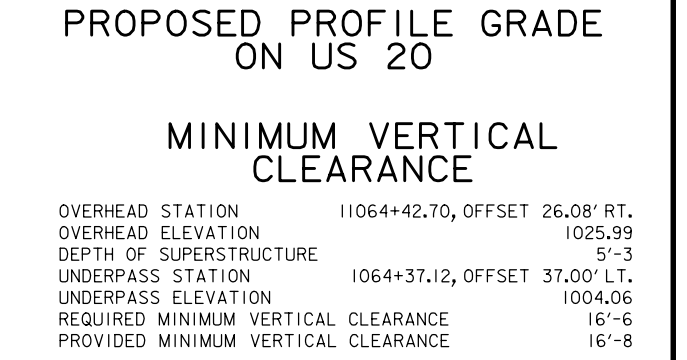

LOCATION  
330TH/332ND AVE OVER US 20  
T-88N R-3W SECTION 1  
NORTH FORK TWP.  
T-89N R-3W SECTION 36  
BREMEN TWP.  
DELAWARE COUNTY  
LATITUDE 42.471174°  
LONGITUDE -91.146511°  
FHWA NO. 700370

TRAFFIC ESTIMATE

2015 AADT	5420	V.P.D.
2035 AADT	9420	V.P.D.
2035 DHV	2355	V.P.H.
TRUCKS	25	%

NOTES:  
ALL UNITS ARE IN FEET UNLESS NOTED OTHERWISE.  
RECOVERABLE BERM SLOPE USING ROADWAY STANDARD EW-203 2-SPAN GRADING.  
SEE DESIGN SHEET NO. 4 FOR OVERALL SITE PLAN.  
PIER IS DESIGNED FOR VEHICULAR COLLISION FORCE.  
TOP OF BRIDGE DECK CROWN 0.03' BELOW PROFILE GRADE.  
SEE SHEET C.1 FOR BRIDGE APPROACH QUANTITIES AND DETAILS.

DECK DRAINS

	WEST	EAST
○	BARRIER RAIL	BARRIER RAIL
1	STA. 11062+65	STA. 11062+90
2	STA. 11062+98	STA. 11063+23
3	STA. 11063+93	STA. 11064+17
4	STA. 11064+55	STA. 11064+80
5	STA. 11064+90	STA. 11065+15

UTILITY LEGEND

— FO	FIBER OPTIC - ICN
— San.	SANITARY - CITY OF DYERSVILLE
— T1	TELEPHONE - MEDIACOM
— W	WATER - CITY OF DYERSVILLE

SITUATION PLAN

FOR INFORMATION ONLY

Refer to Tied Bridge New - PPCB Project,  
NHSX-020-9(204)--3H-28 for Bridge Plans

DESIGN FOR 25° SKEW (R.A.)  
**252'-0" x 56'-0" PRETENSIONED  
PRESTRESSED CONCRETE BEAM BRIDGE**  
126'-0" AND 126'-0" END SPANS  
**SITUATION PLAN**  
US 20 MAINLINE STA. 1063+89.71  
MARCH 2015  
**DELAWARE COUNTY**  
IOWA DEPARTMENT OF TRANSPORTATION - HIGHWAY DIVISION  
DESIGN SHEET NO. 3 OF 27 FILE NO. 30549 DESIGN NO. 214

**LINE STYLE LEGEND OF CROSS SECTION SHEETS (ROAD)**

- Existing Ground Line
- ===== Proposed Template
- ===== Proposed Topsoil Placement
- Additional Topsoil Removal
- Subgrade Treatment
- Granular Shoulder
- ===== Pavement
- Existing Pipe\R/CB
- ===== Proposed Pipe\R/CB
- ===== Proposed Dike
- ===== All Elements Associated with Proposed Entrances

**LINE STYLE LEGEND OF CROSS SECTION SHEETS (SOILS)**

- TS ----- Topsoil (Class 10)
- TS A ----- Topsoil (Type A Disposal)
- TS B ----- Topsoil (Type B Disposal)
- TS C ----- Topsoil (Type C Disposal)
- CL 10 ----- Class 10 Materials
- SEL L0 ----- Select Loams And Clay-Loams
- SEL SA ----- Select Sand
- UNS A ----- Unsuitable Type A Disposal
- UNS B ----- Unsuitable Type B Disposal
- UNS C ----- Unsuitable Type C Disposal
- SHALE ----- Shale
- WASTE ----- Waste
- B&W LS ----- Broken and Weathered Rock
- ROCK ----- Solid Rock
- BLDRS ----- Boulders

Note: All layer lines and descriptions identify layers above the line.

Note: Vertical or near vertical lines connecting soil layers at edges of cross sections are only for the purpose of calculating template quantities and do not depict soil stratification.

**SYMBOL LEGEND OF CROSS SECTION SHEETS**

- Existing ROW  
----- Existing Right-of-Way Limit
- Proposed ROW  
----- Proposed Right-of-Way Limit
- Temporary ROW  
----- Temporary Right-of-Way Limit

**CROSS SECTION  
LEGEND AND SYMBOL  
INFORMATION SHEET**

(COVERS SHEET SERIES W, X, Y, & Z)

# US 20 - Stage 1

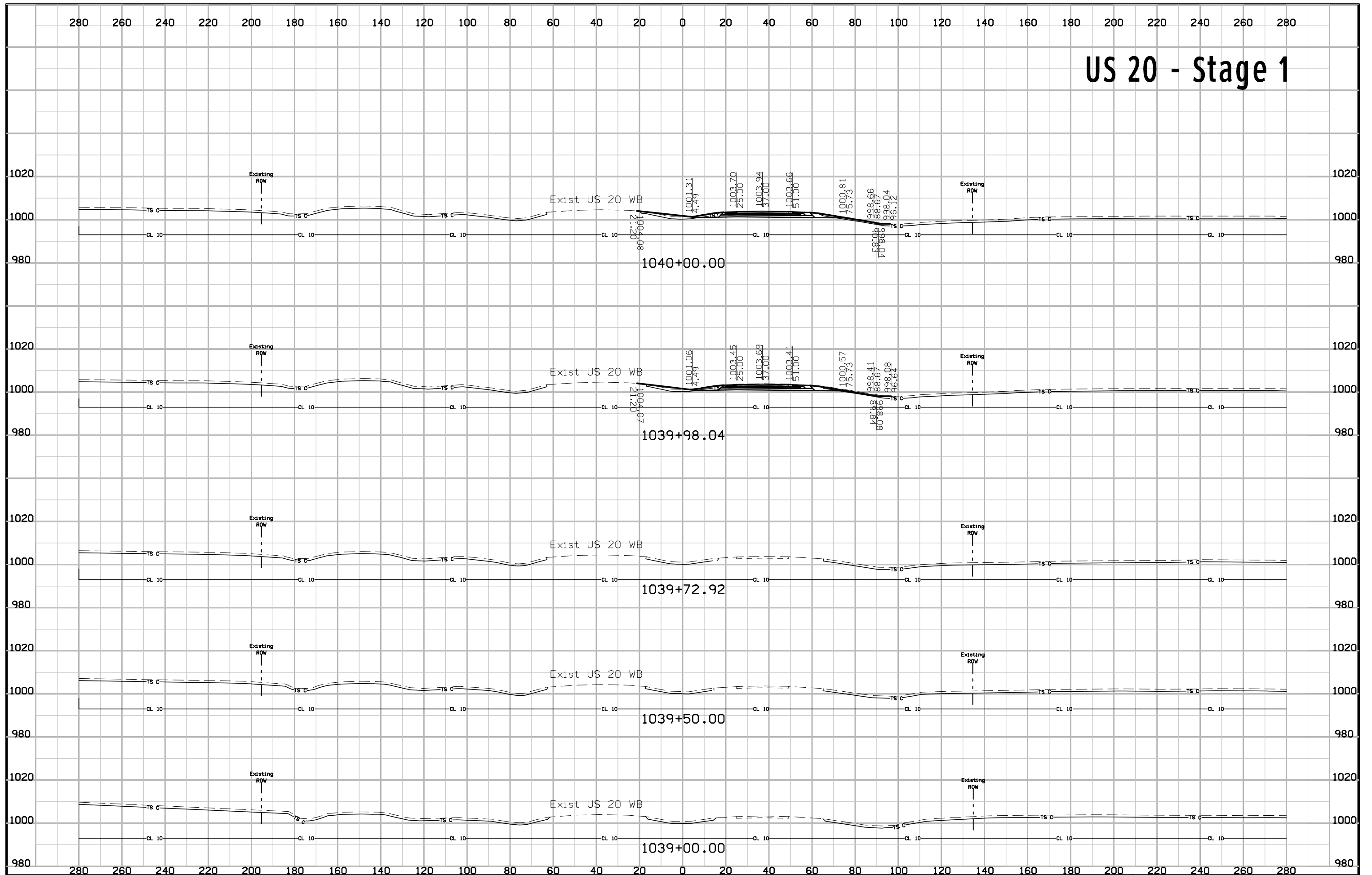

# US 20 - Stage 1

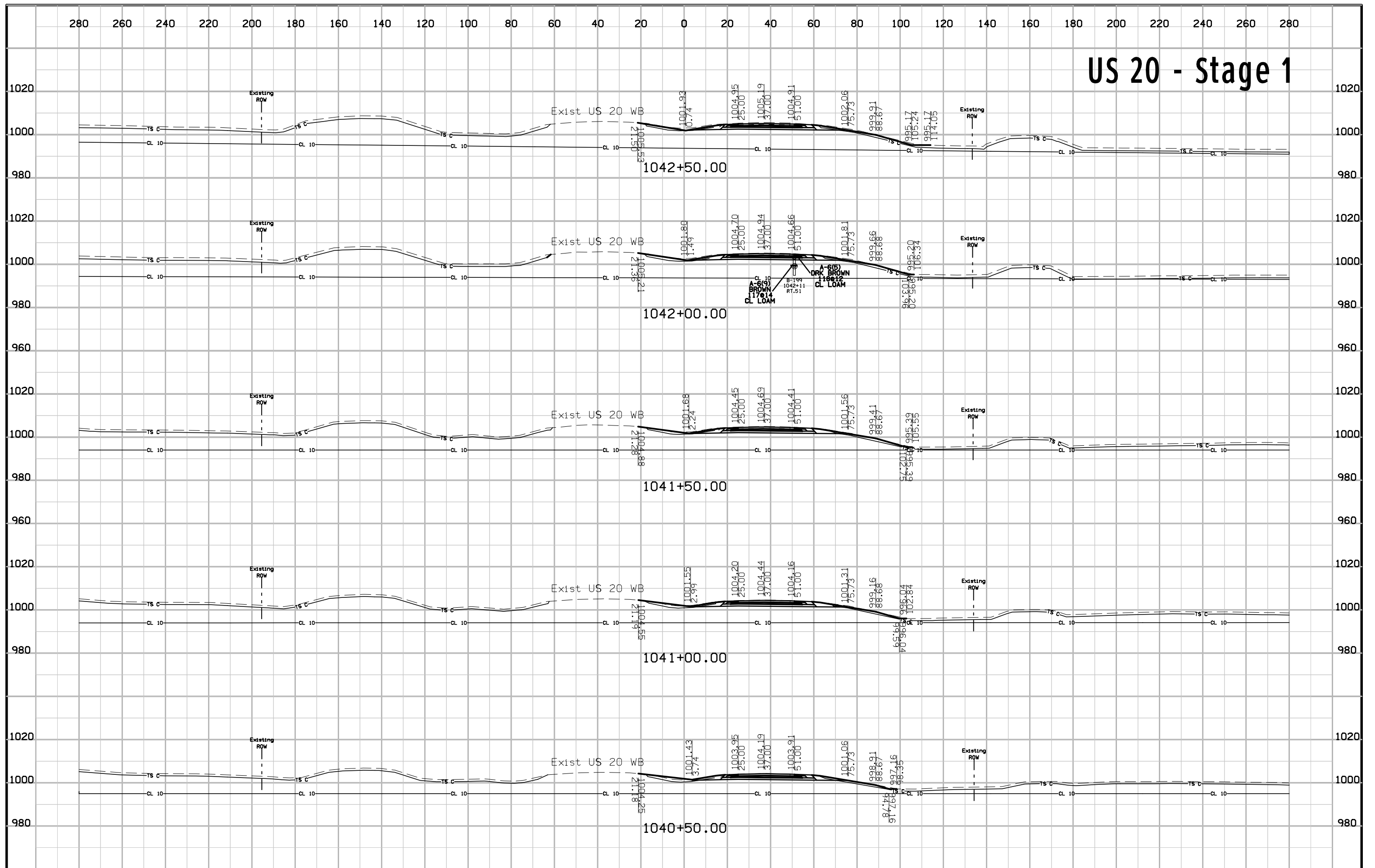

# US 20 - Stage 1

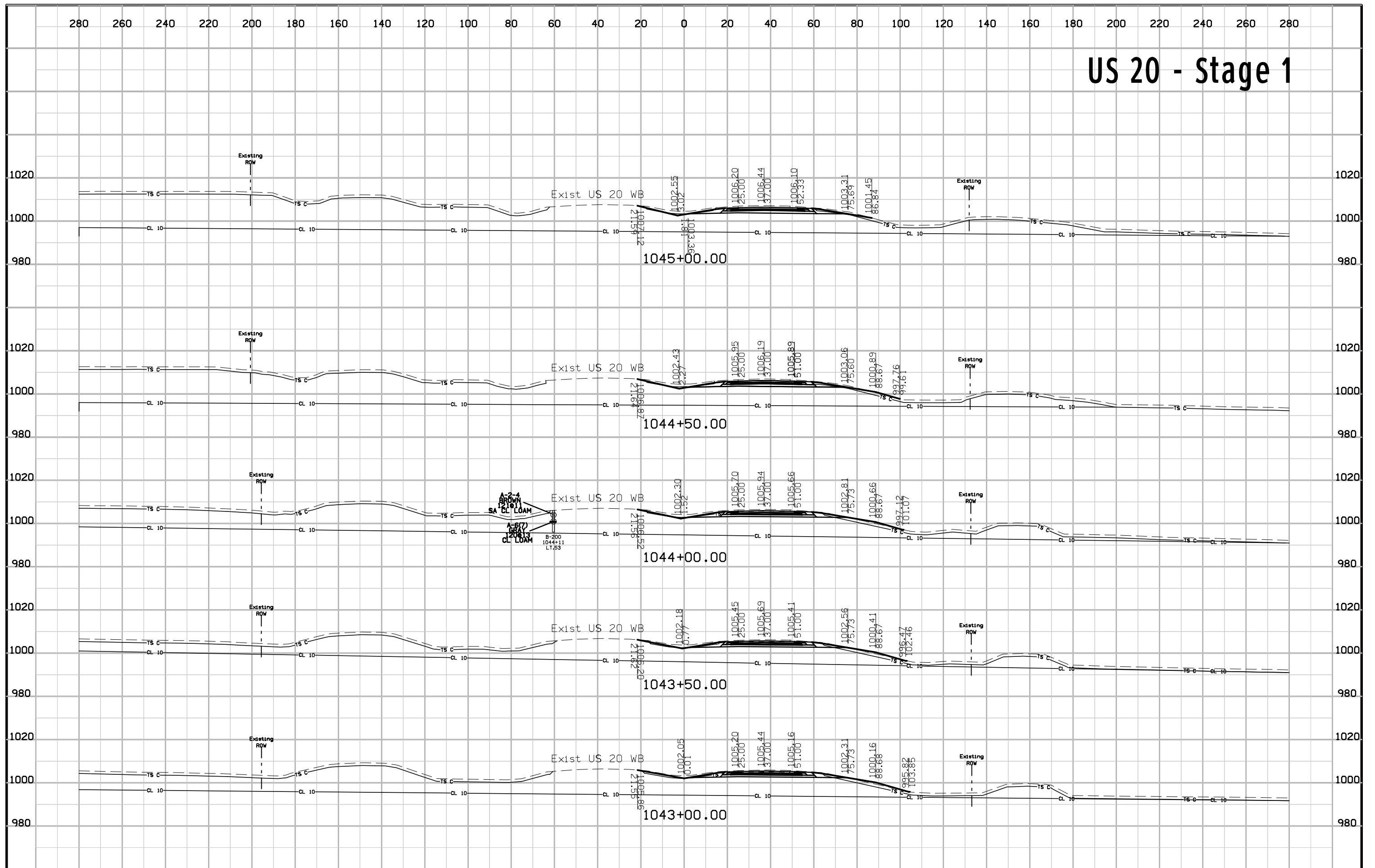



# US 20 - Stage 1

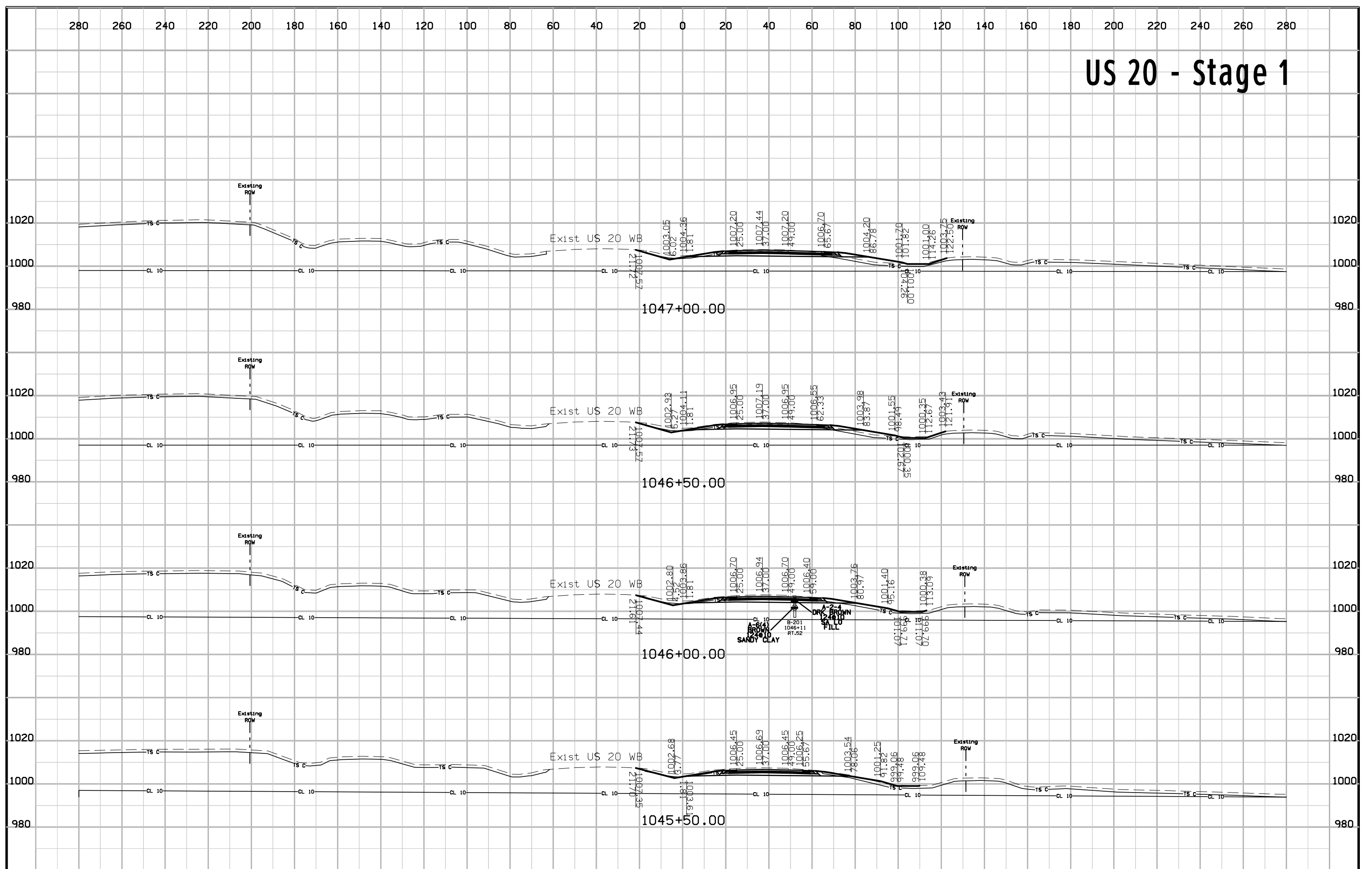

# US 20 - Stage 1

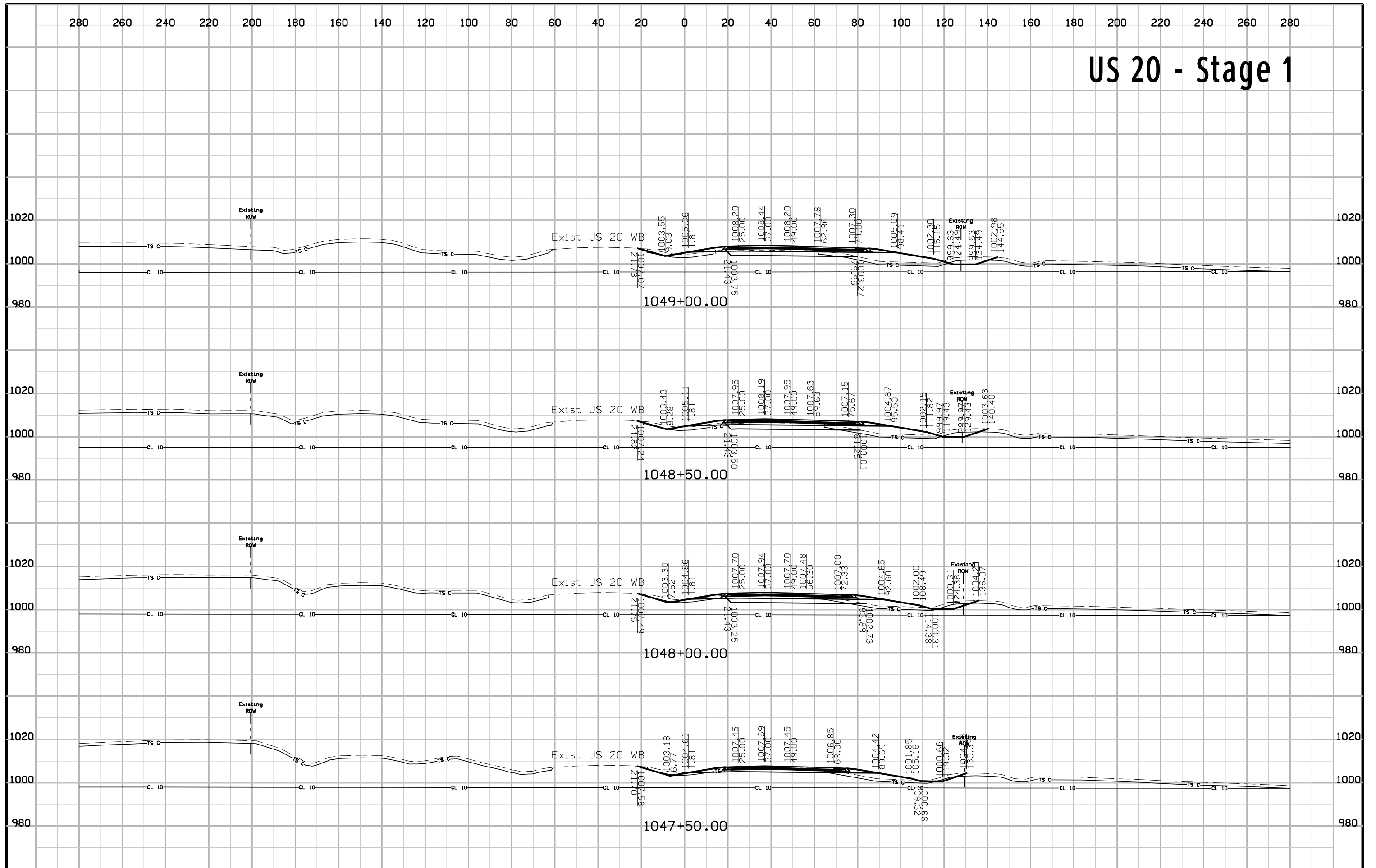

# US 20 - Stage 1

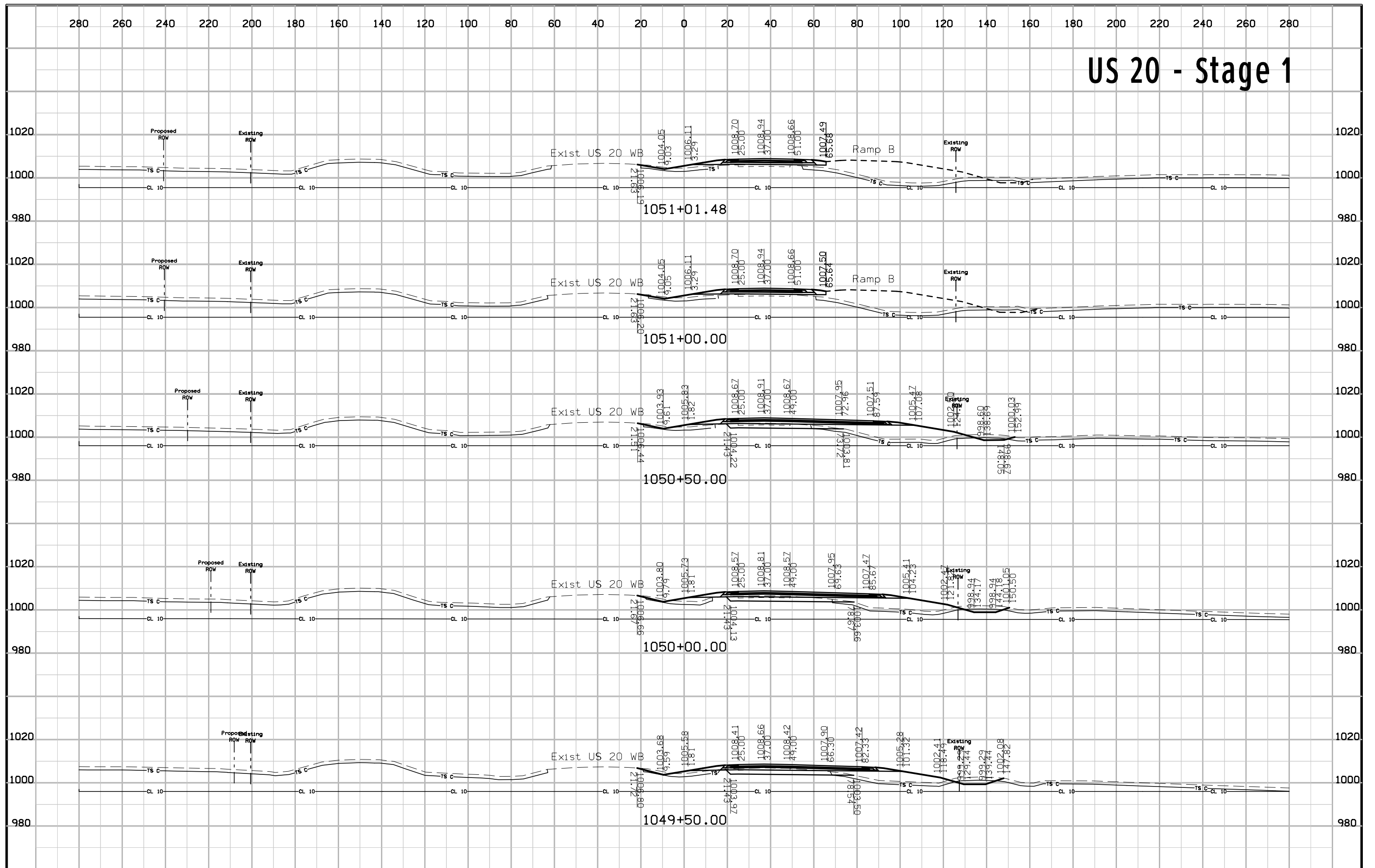

# US 20 - Stage 1

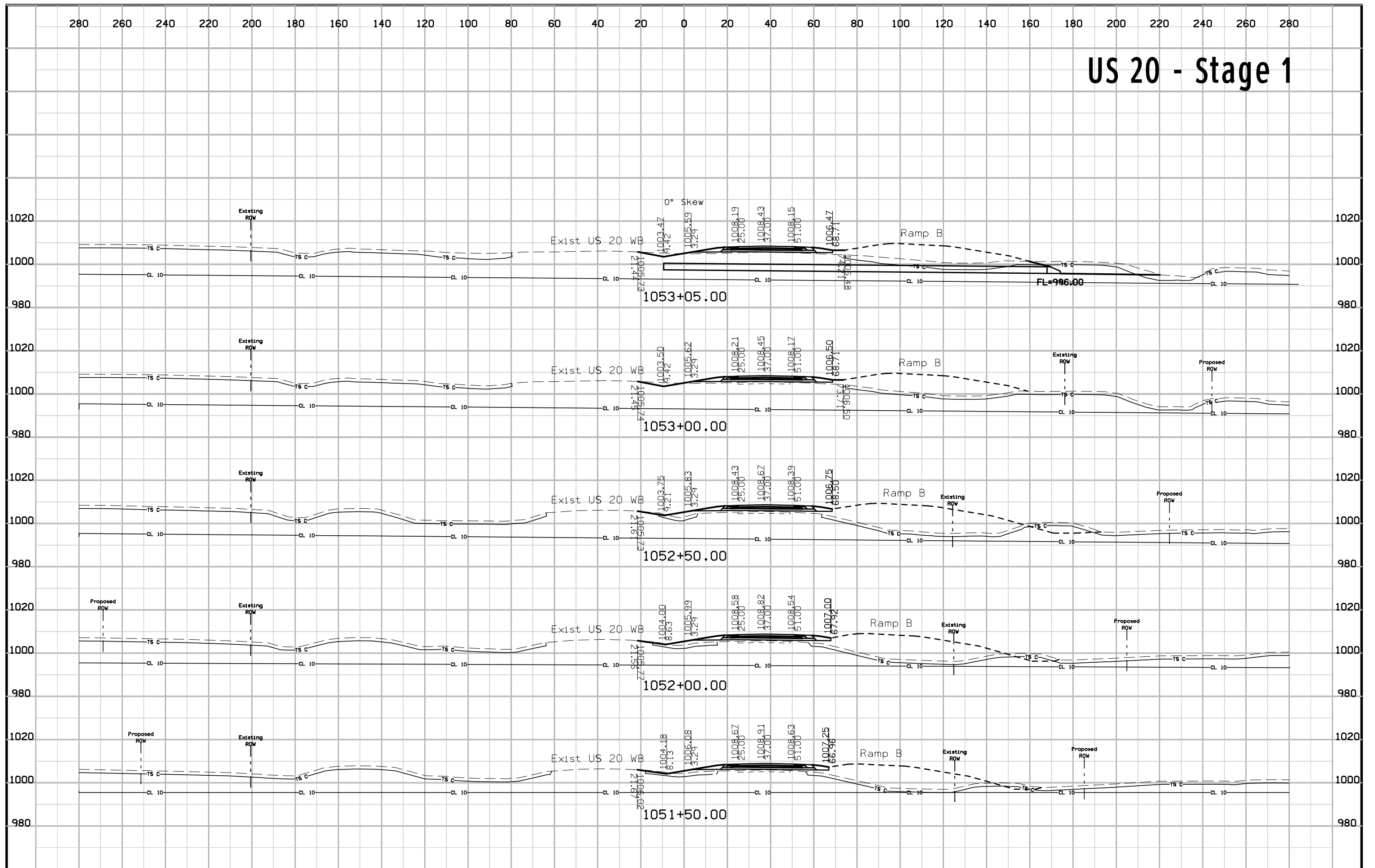

# US 20 - Stage 1

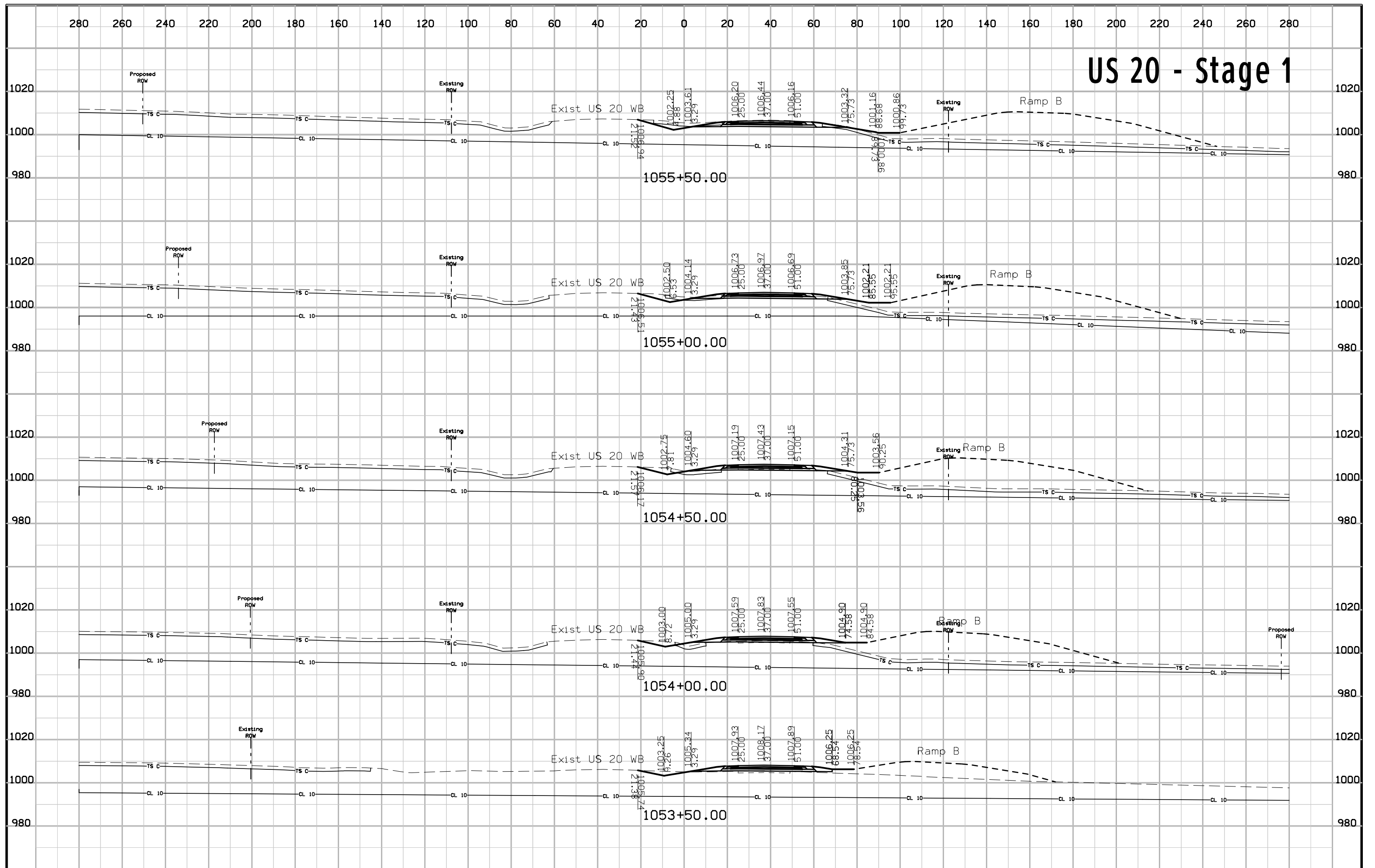

# US 20 - Stage 1

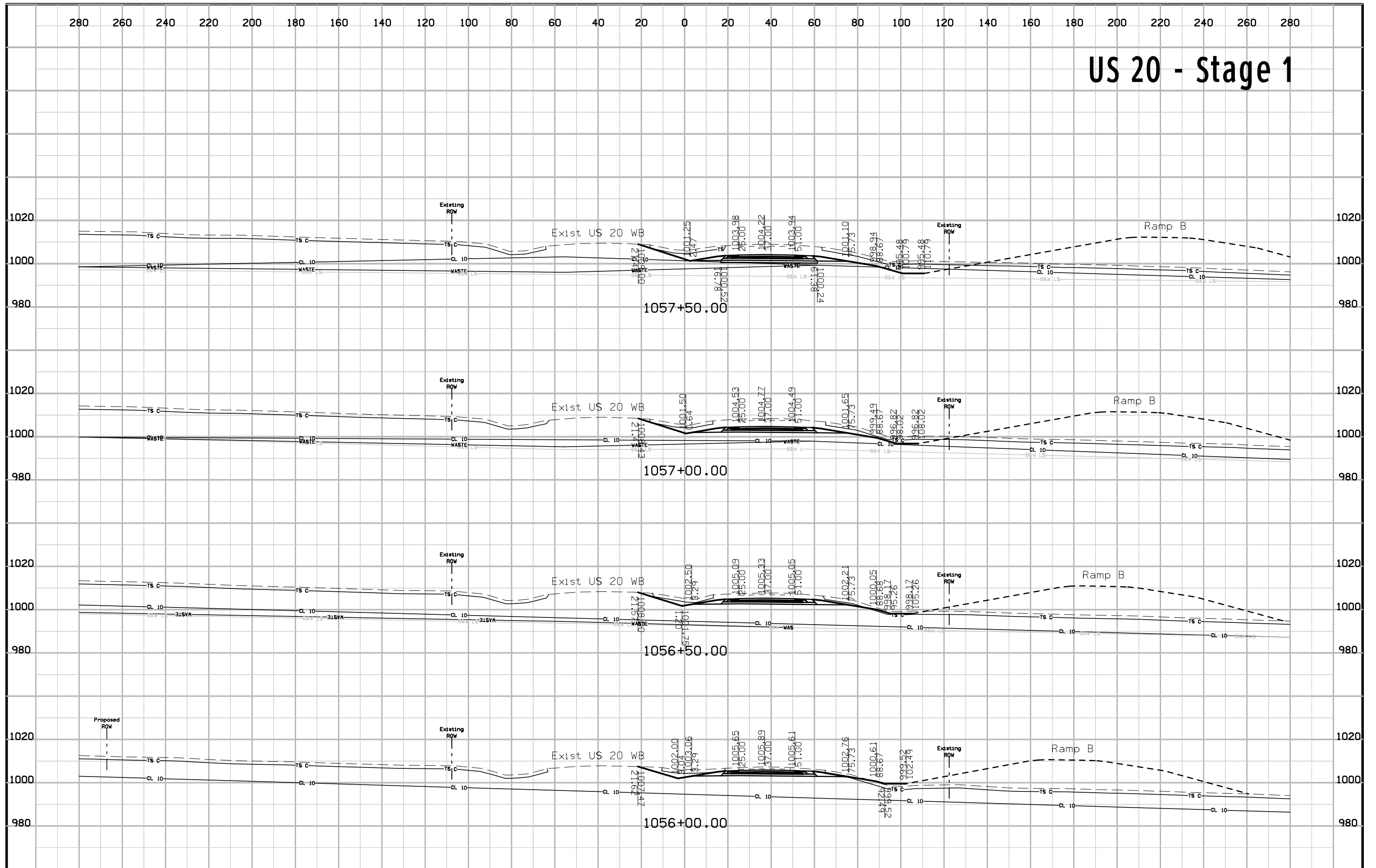



# US 20 - Stage 1

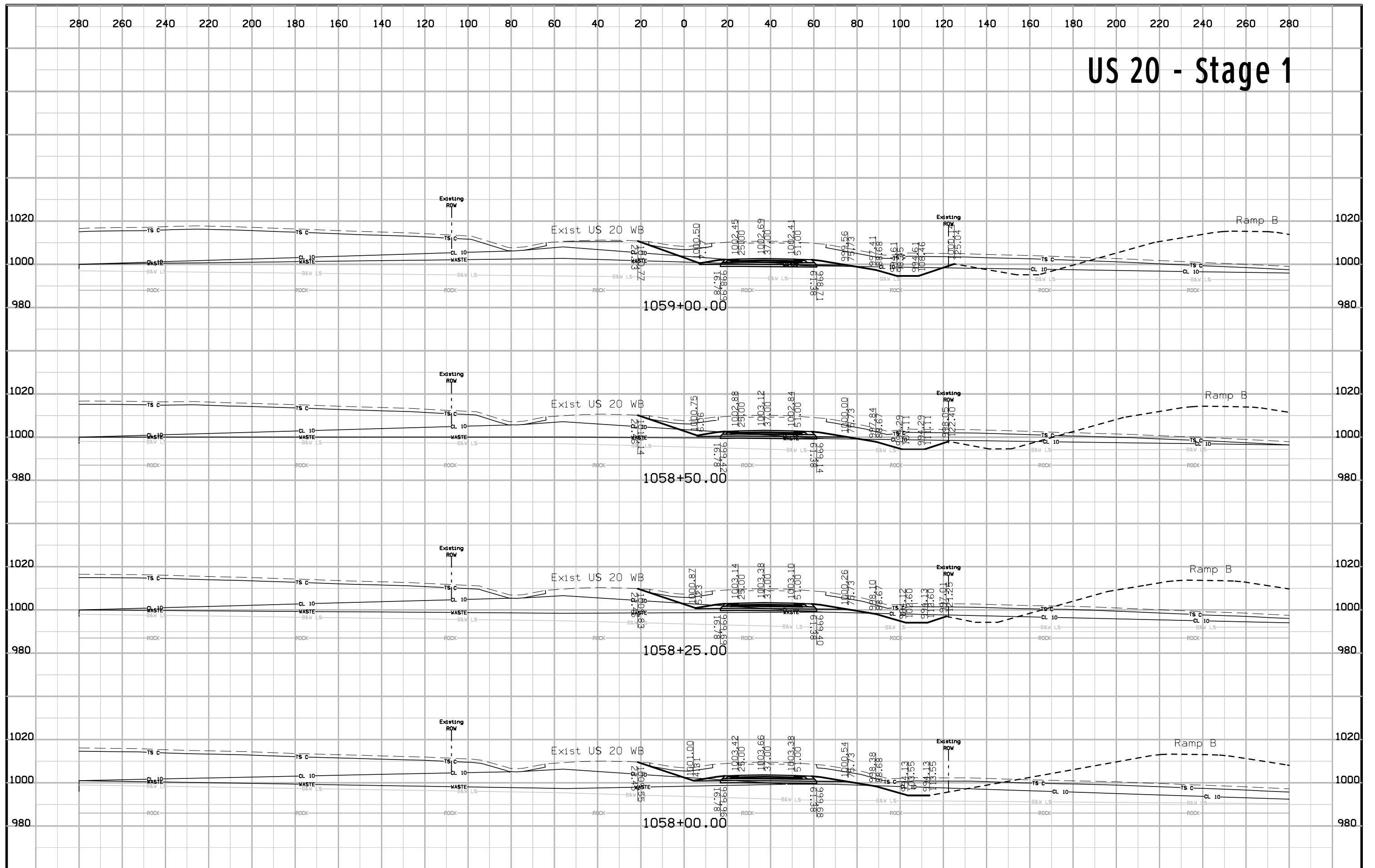

# US 20 - Stage 1

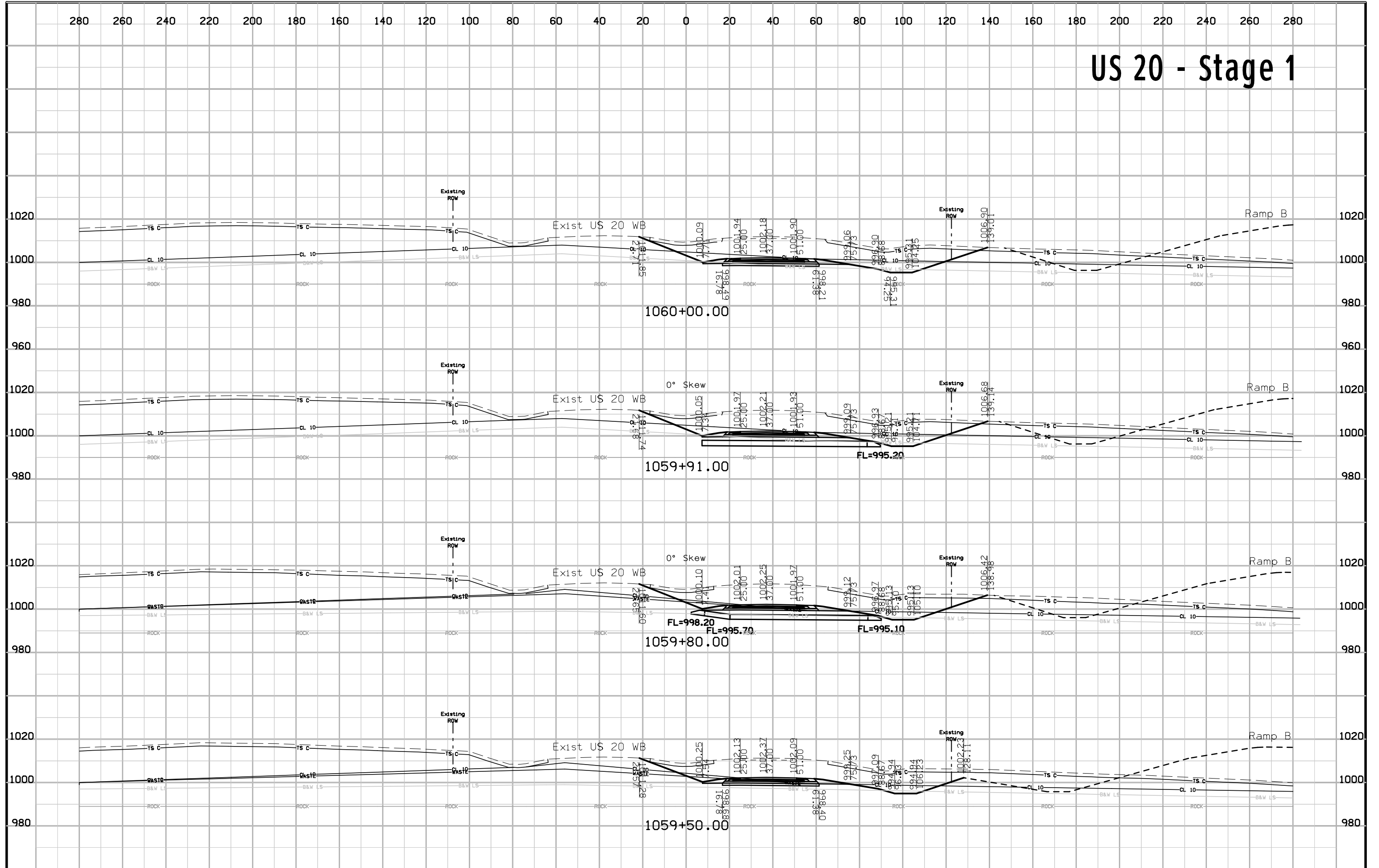

# US 20 - Stage 1

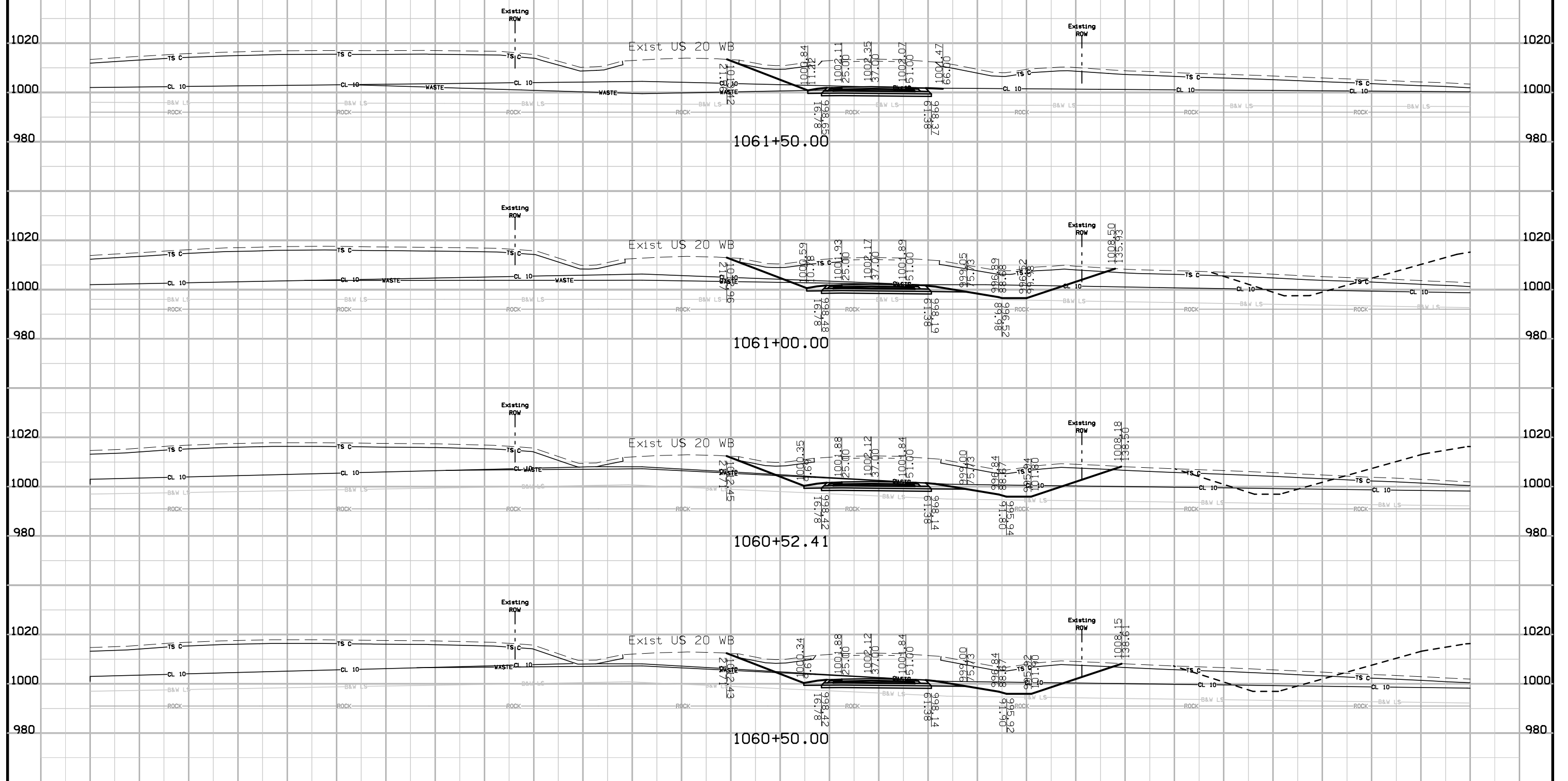

# US 20 - Stage 1

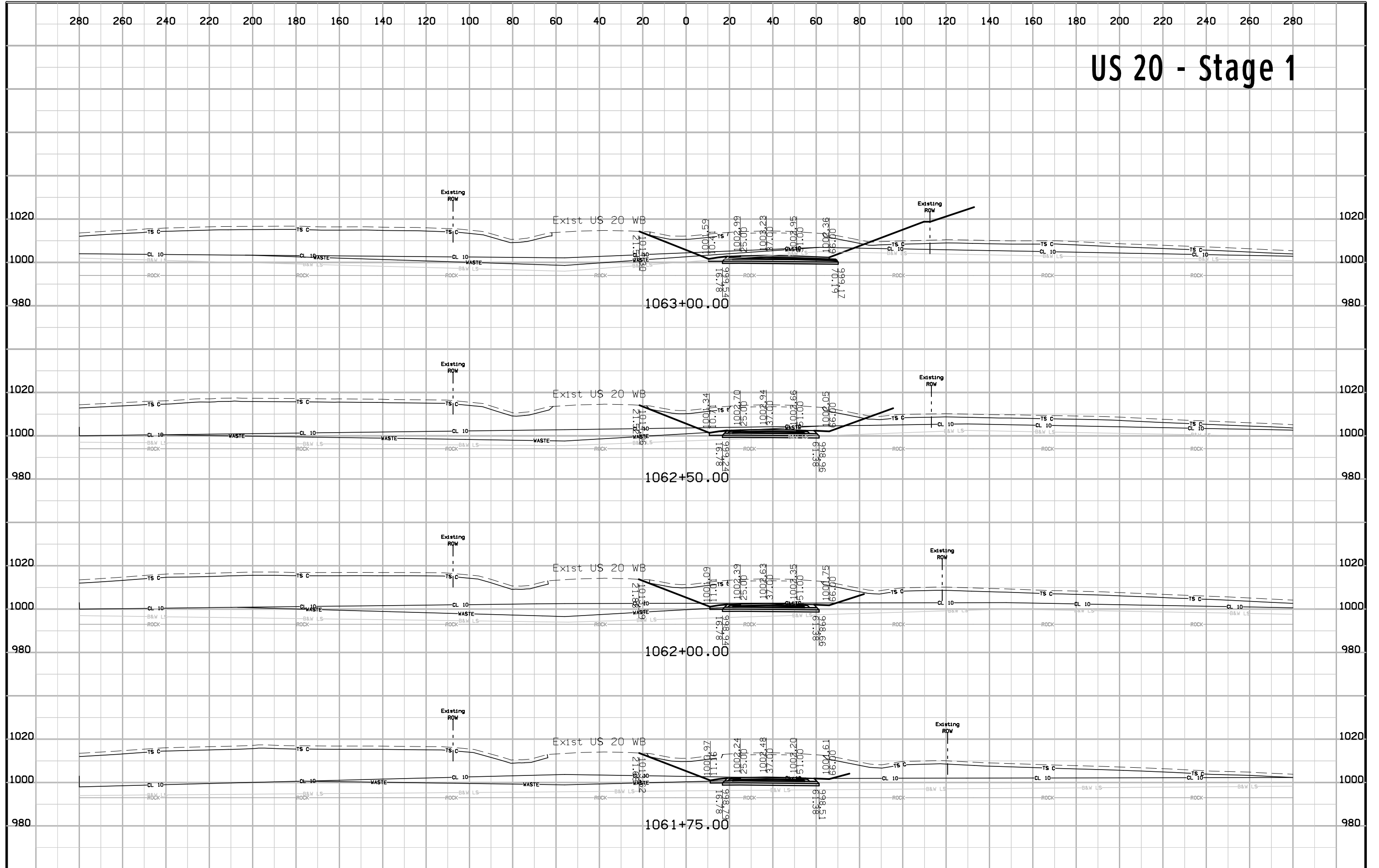

# US 20 - Stage 1

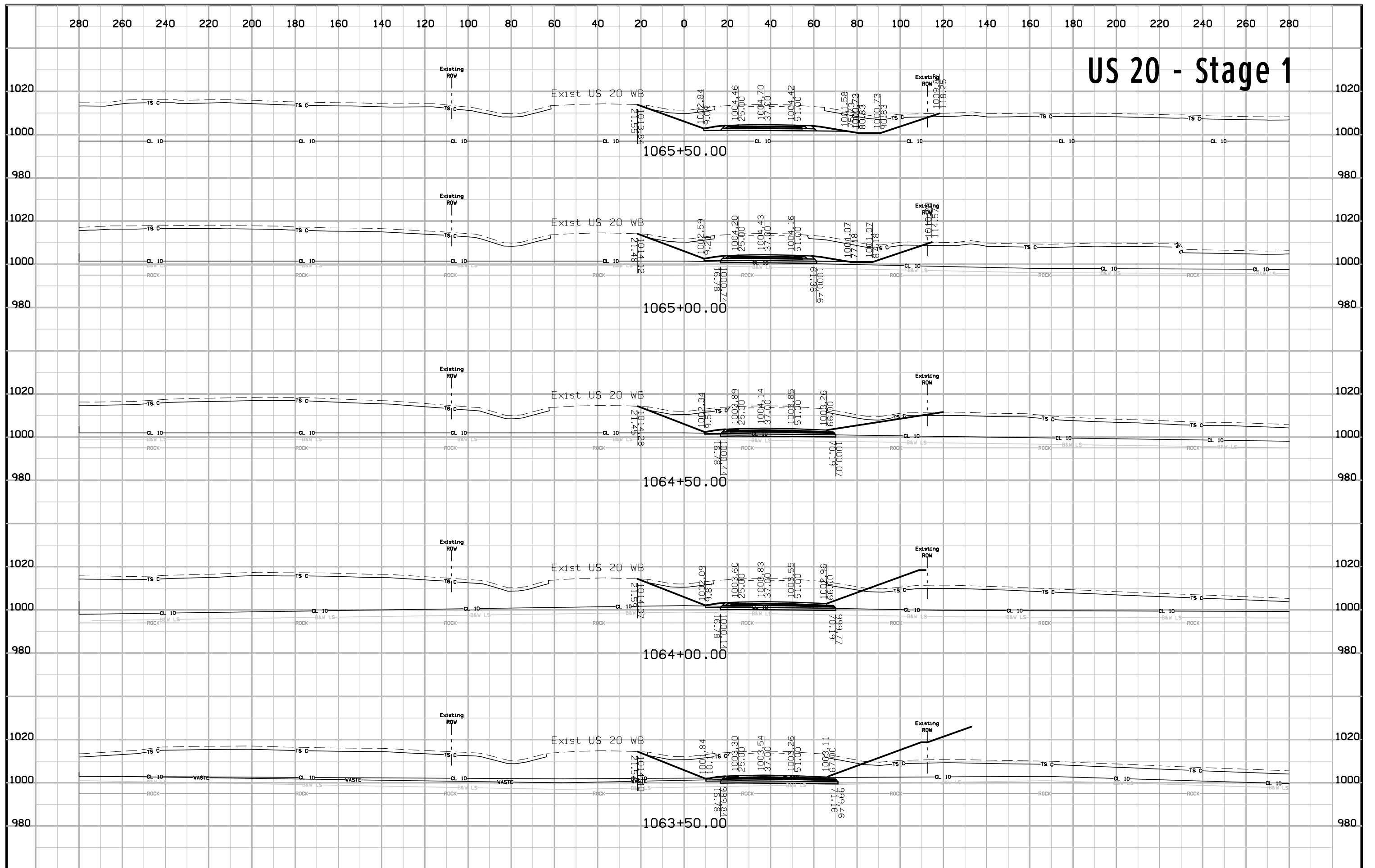

# US 20 - Stage 1

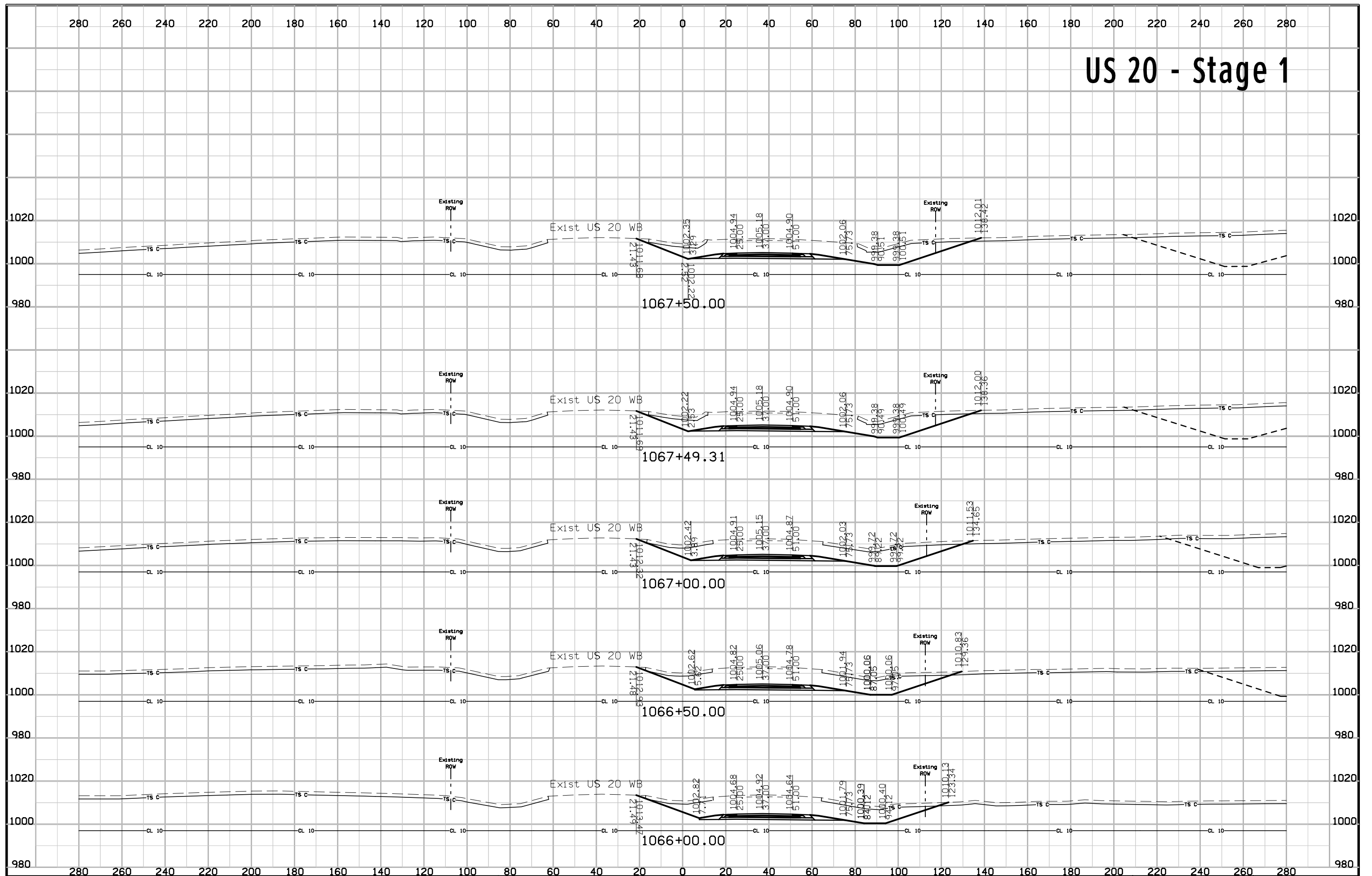



# US 20 - Stage 1

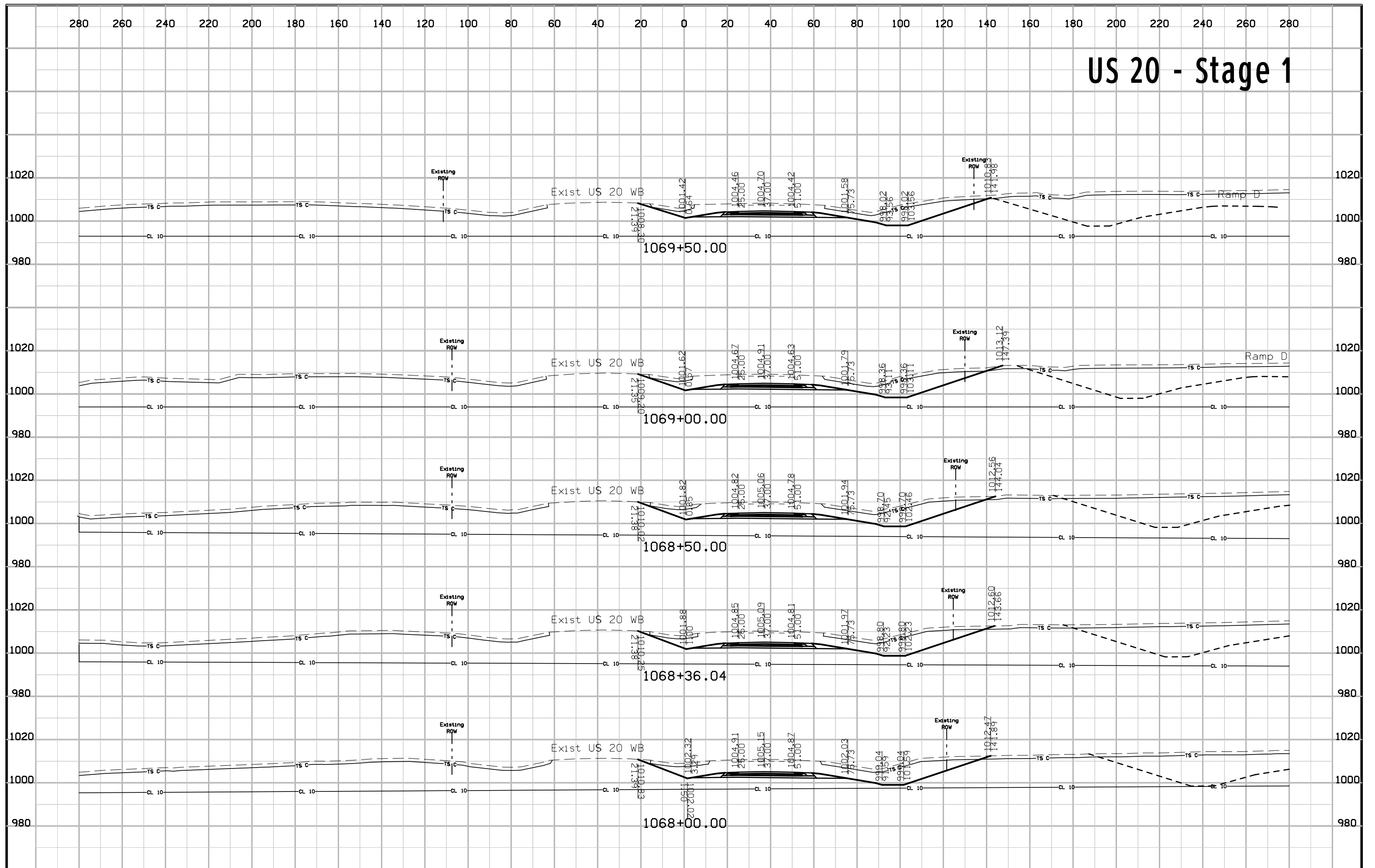

# US 20 - Stage 1

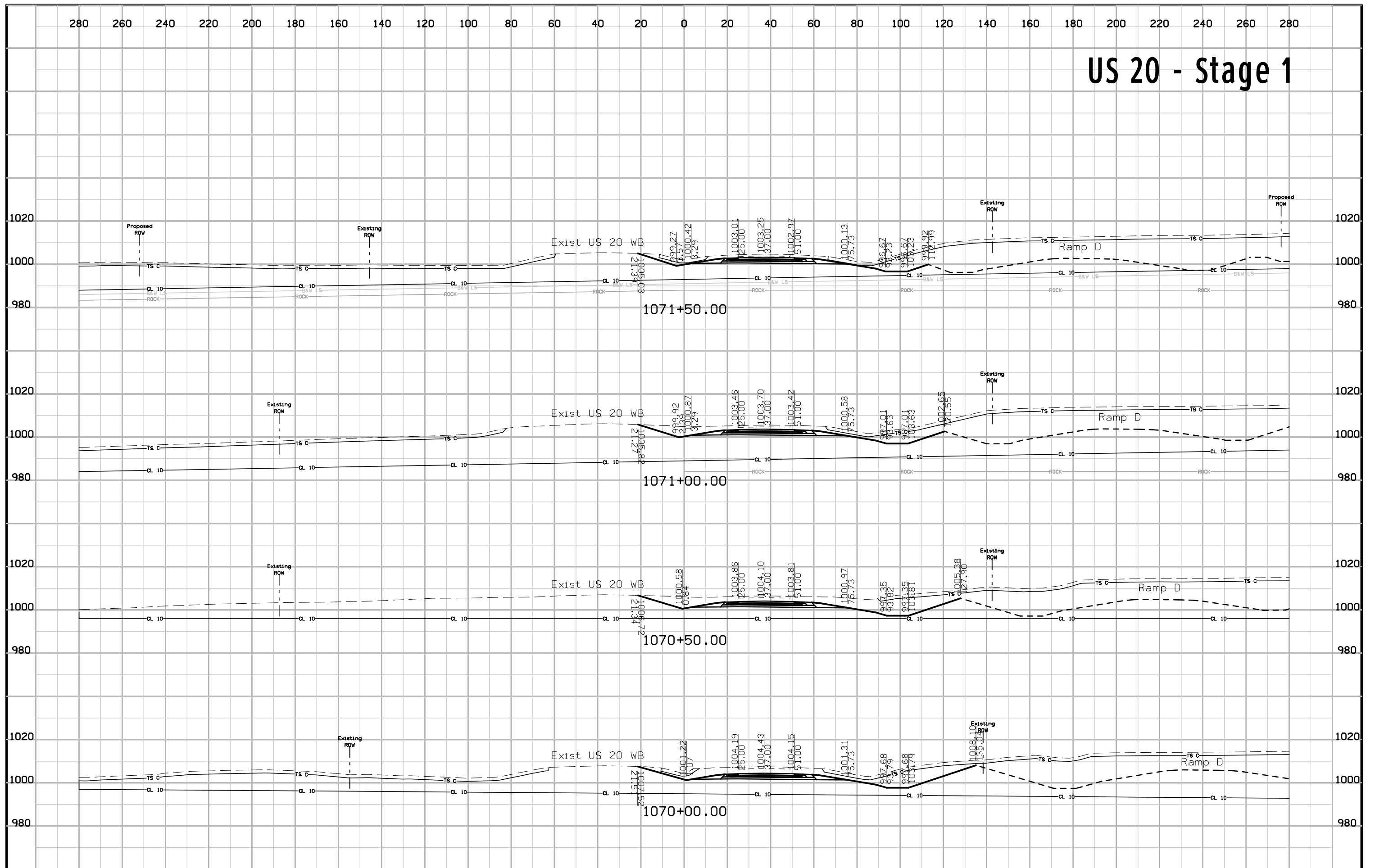

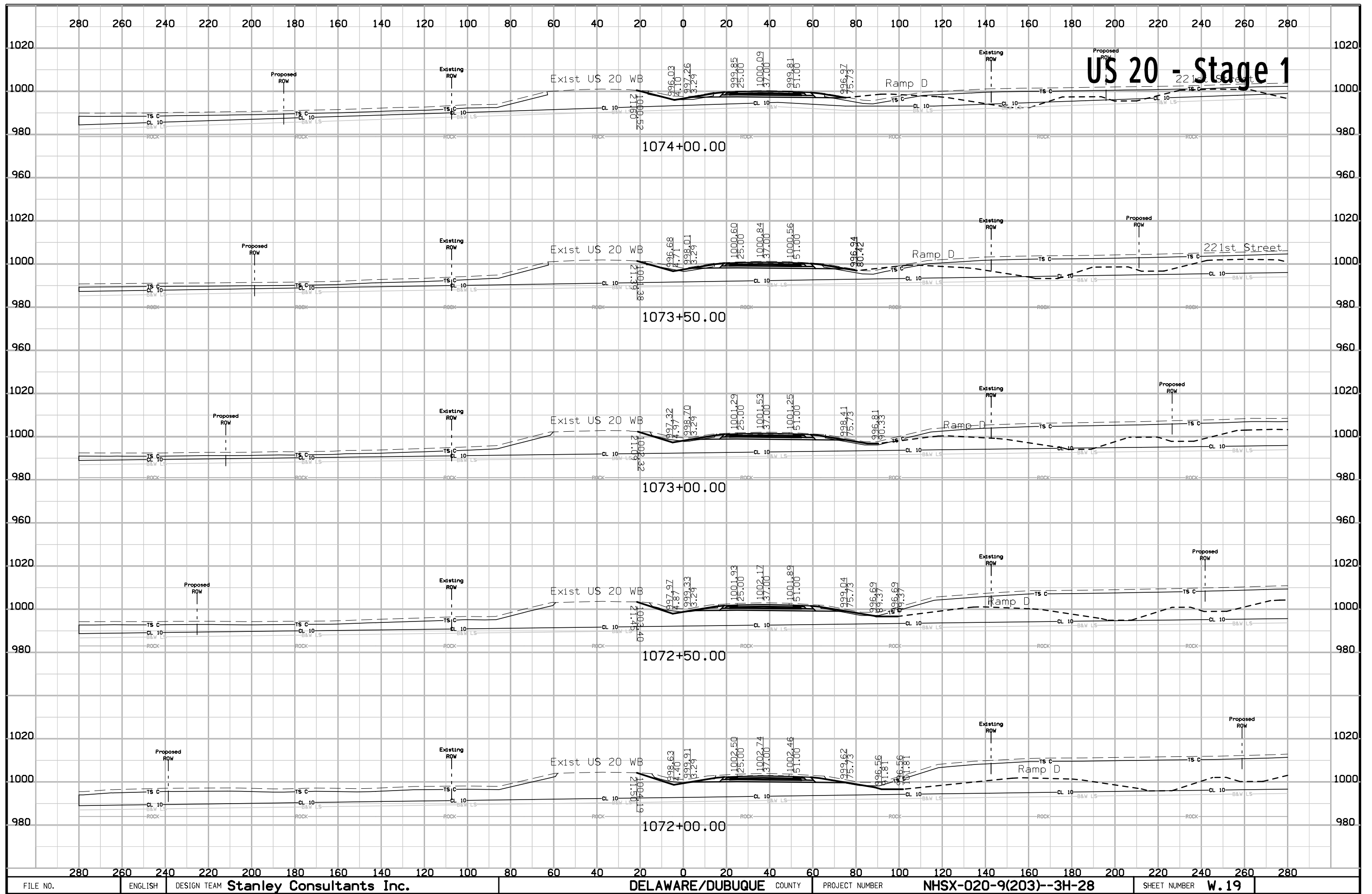

# US 20 - Stage 1



# US 20 - Stage 1

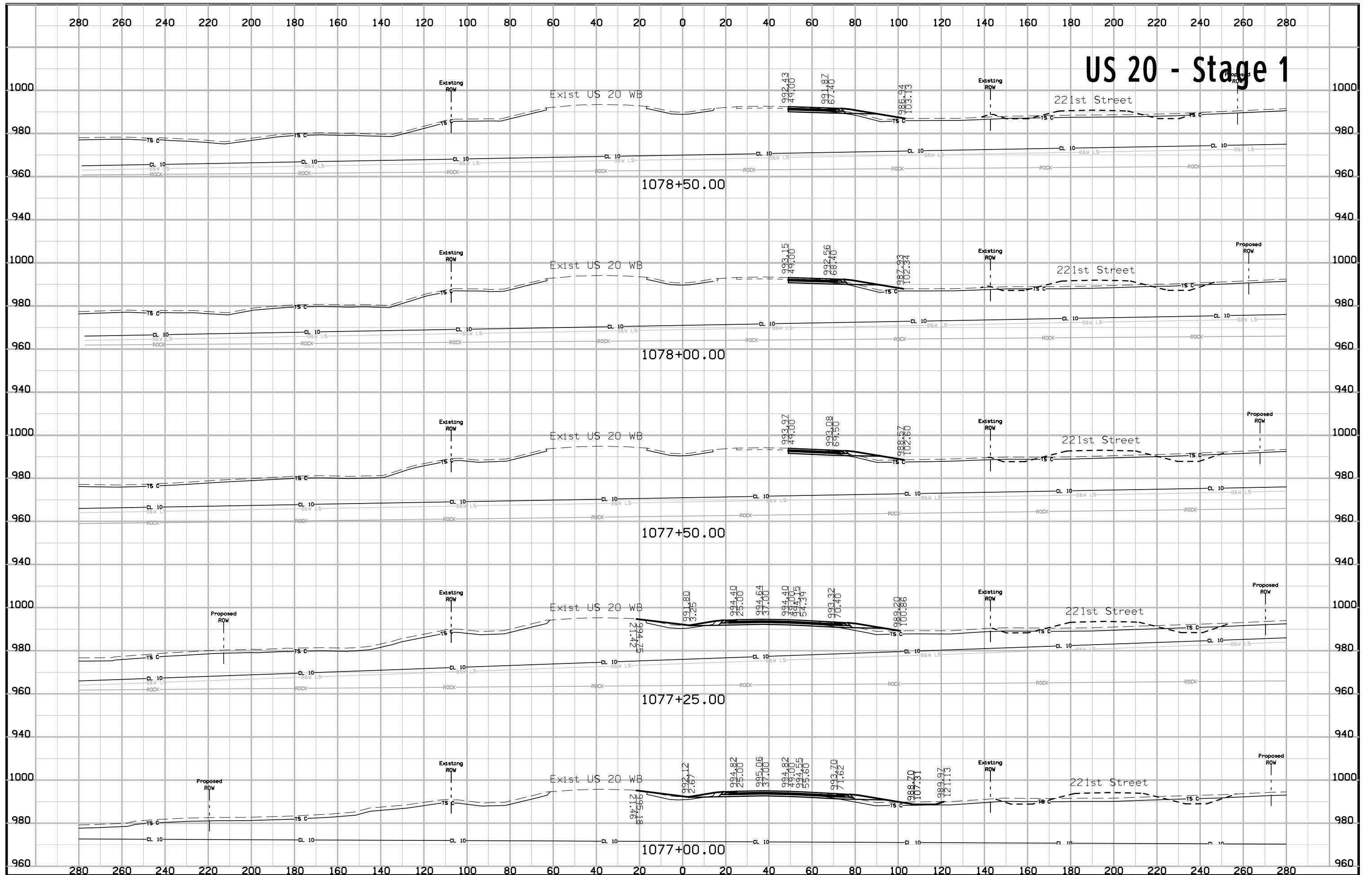

# US 20 - Stage 1

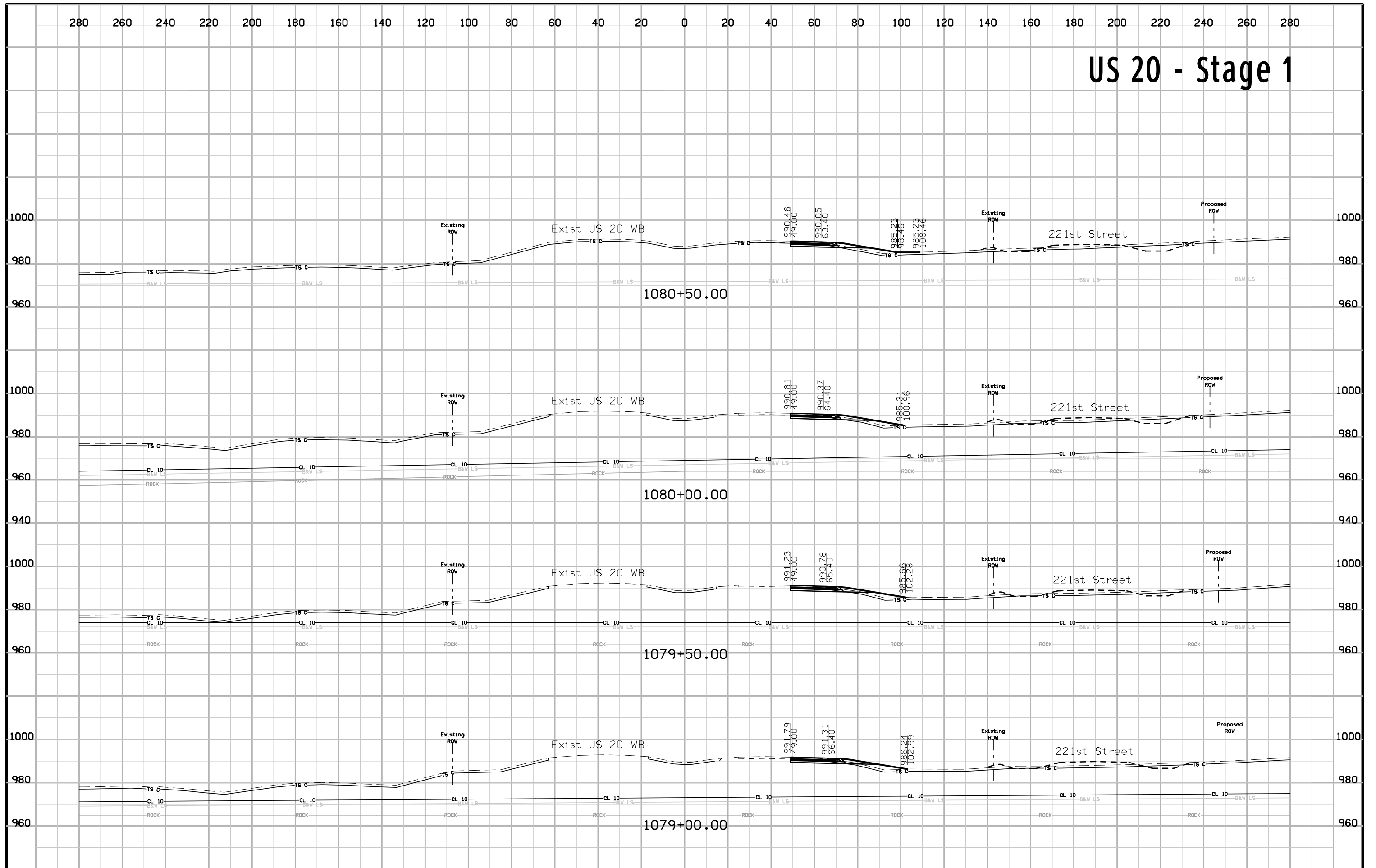

# US 20 - Stage 1

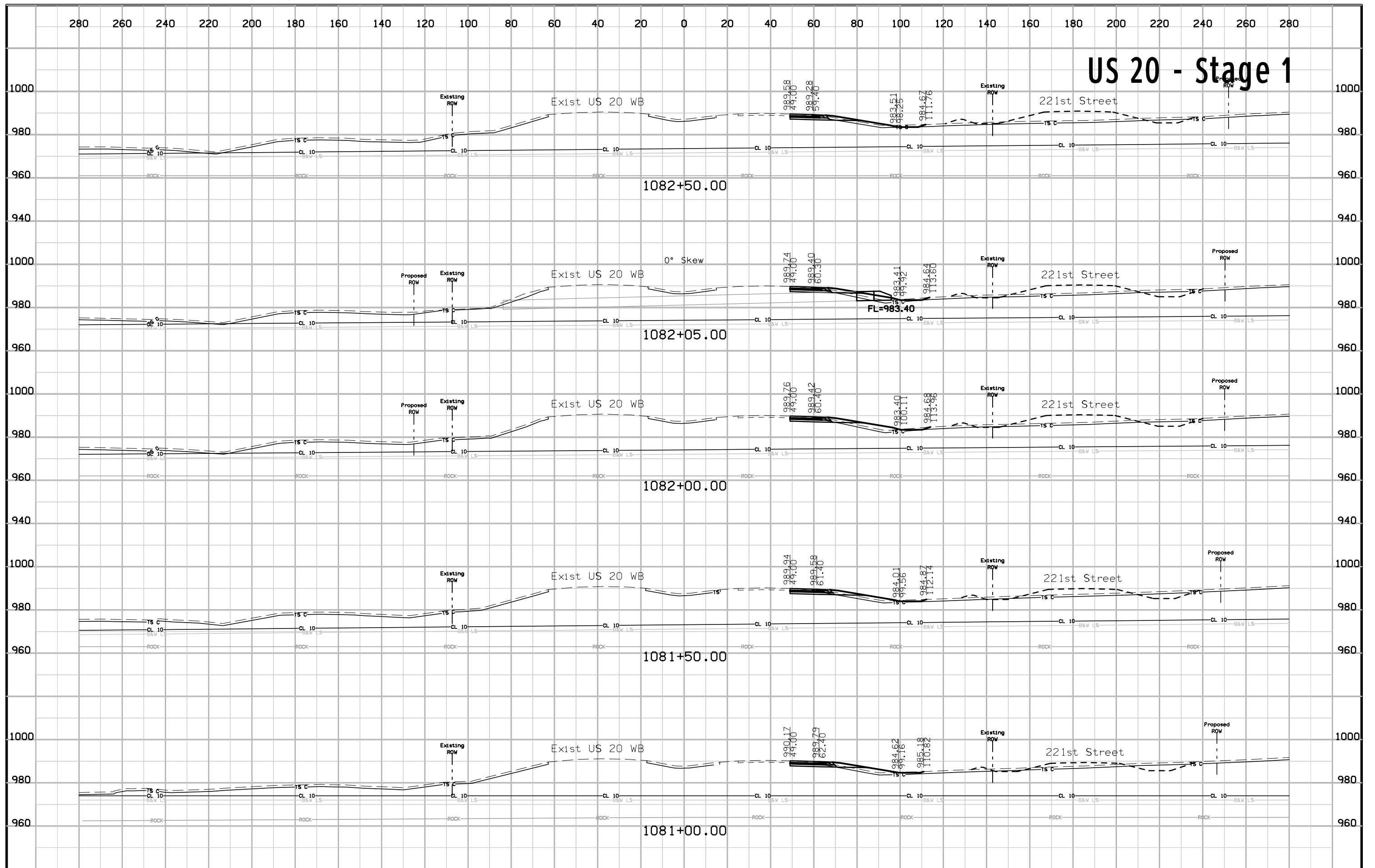



# US 20 - Stage 1

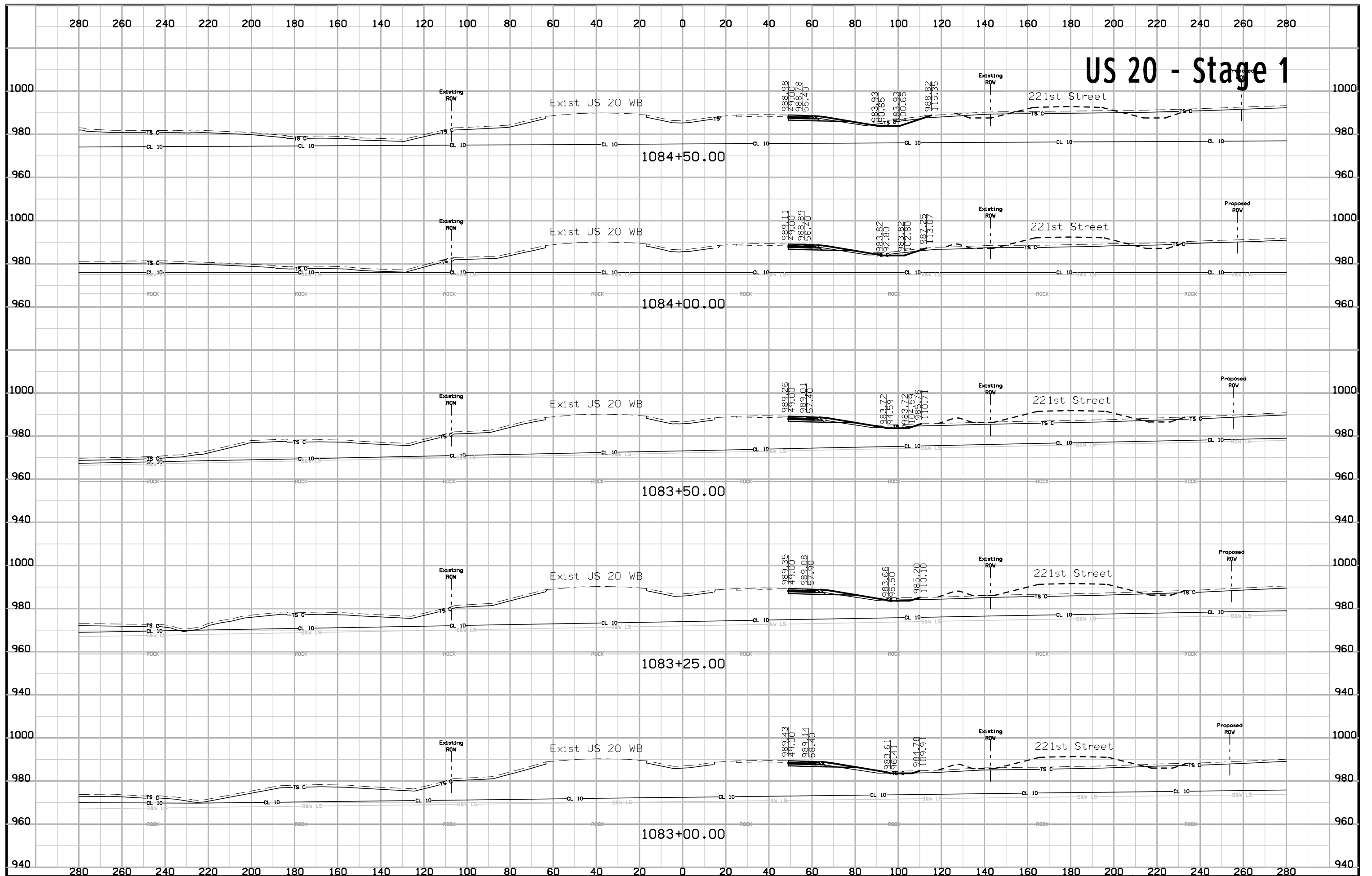

# US 20 - Stage 1

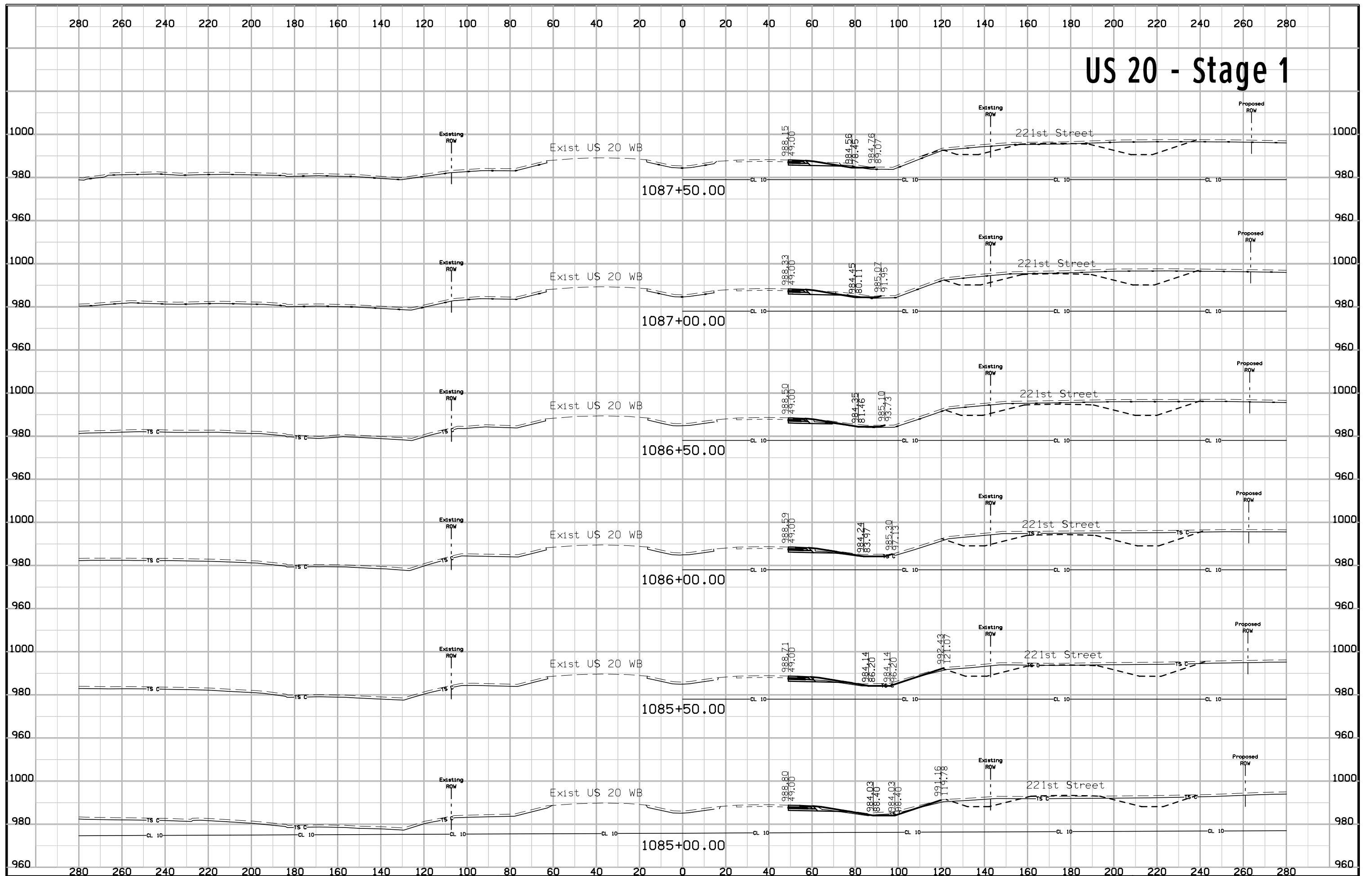

# US 20 - Stage 1

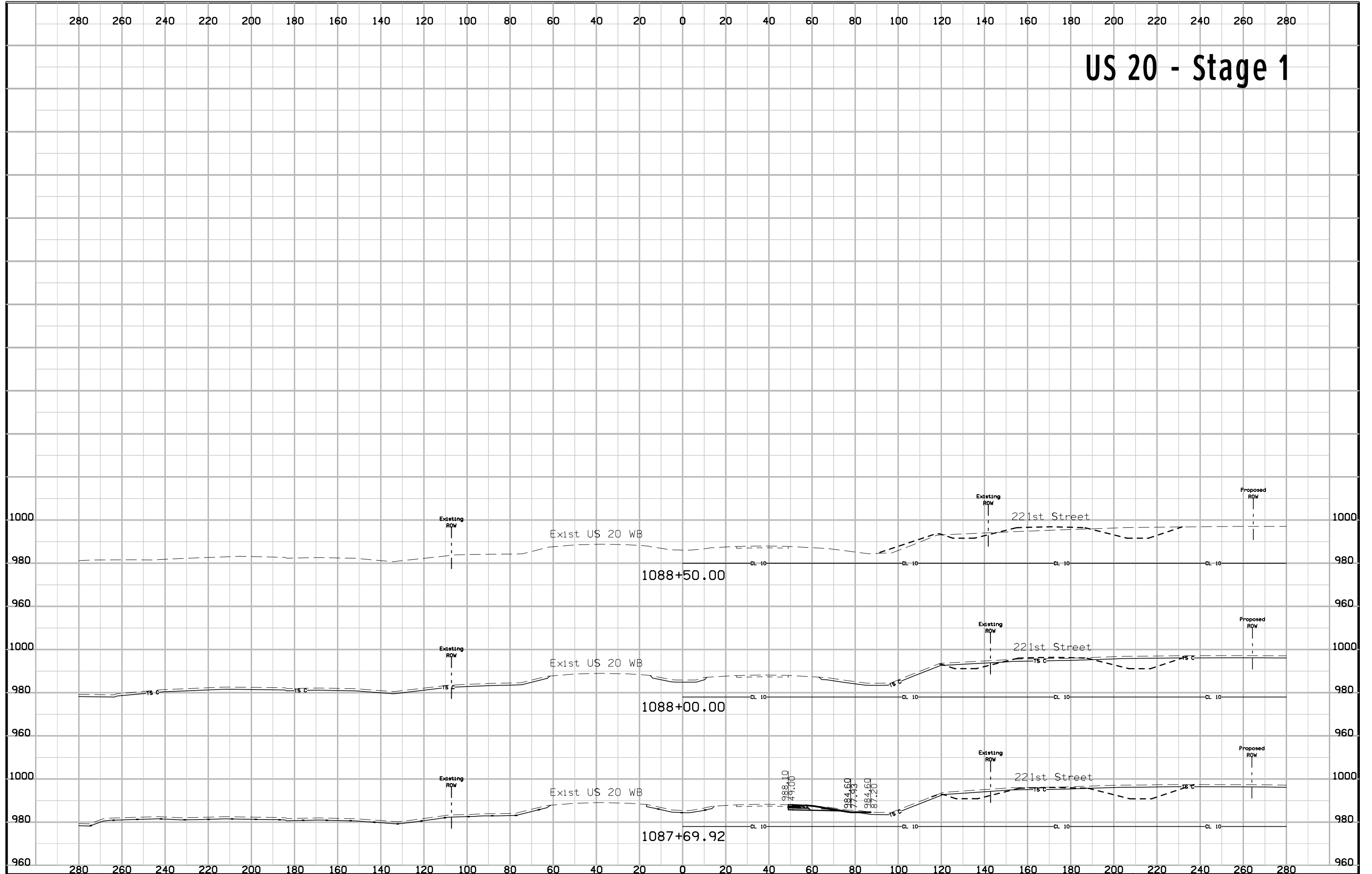

# US 20 - Stage 2

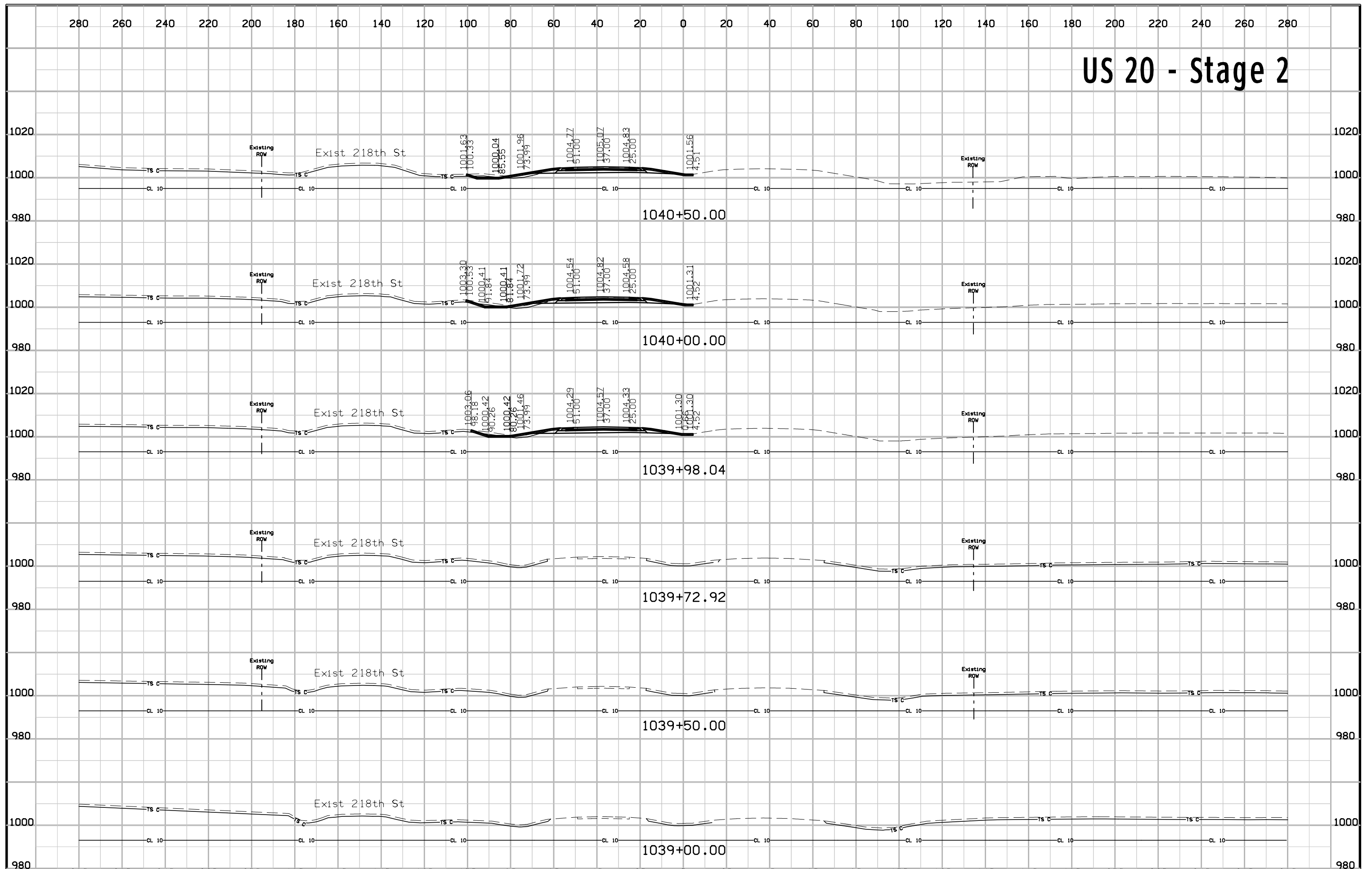

# US 20 - Stage 2

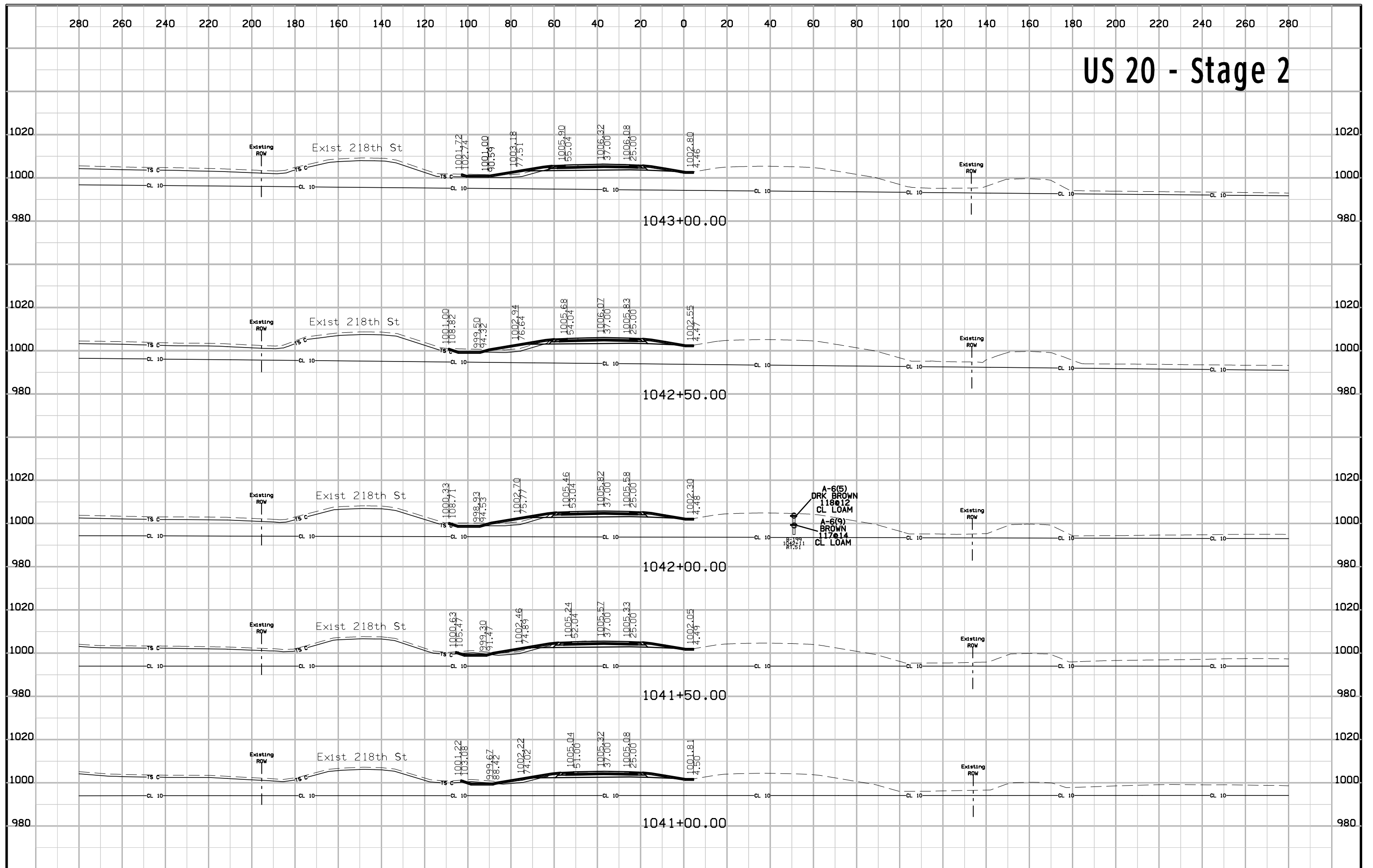

# US 20 - Stage 2

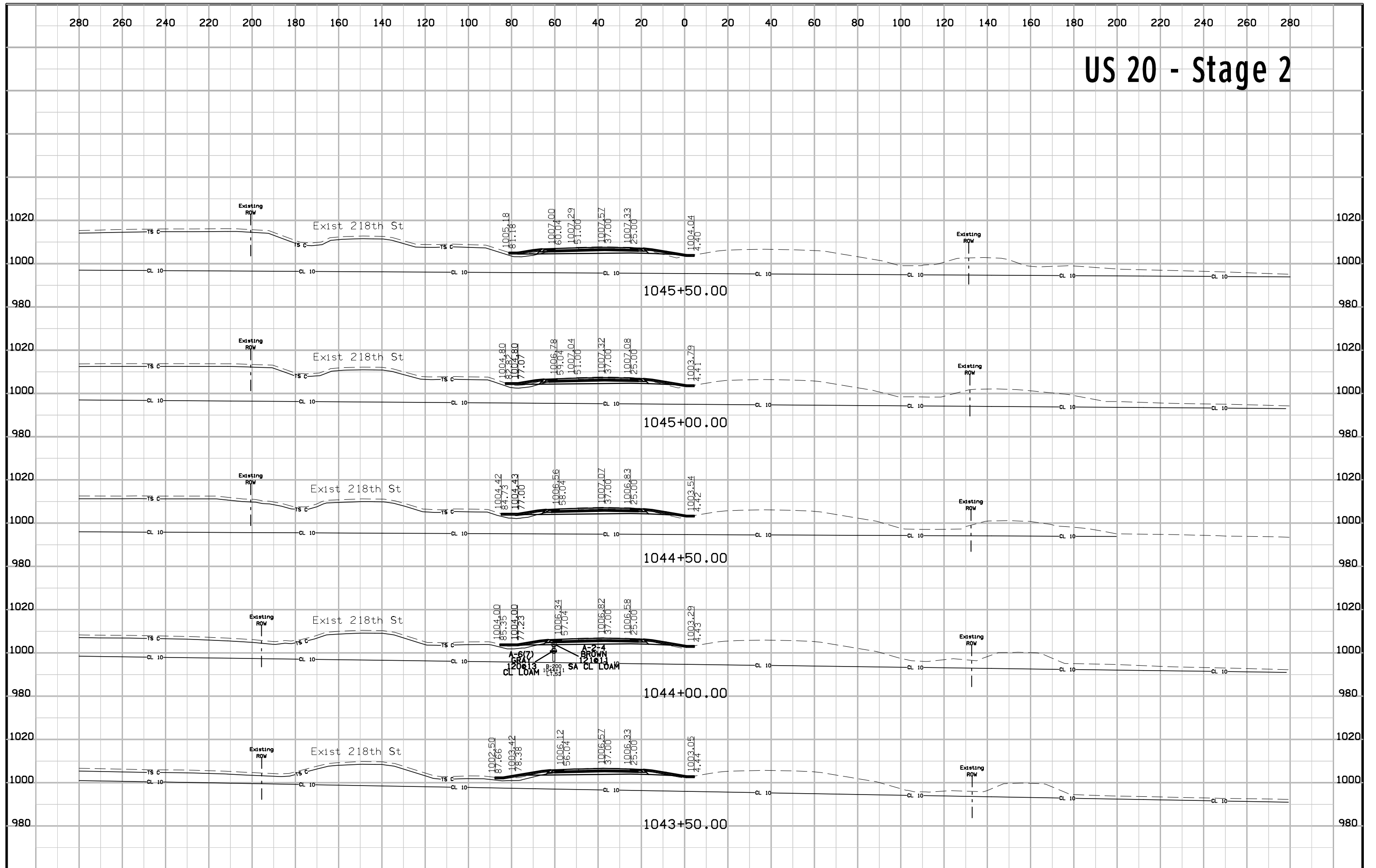

# US 20 - Stage 2

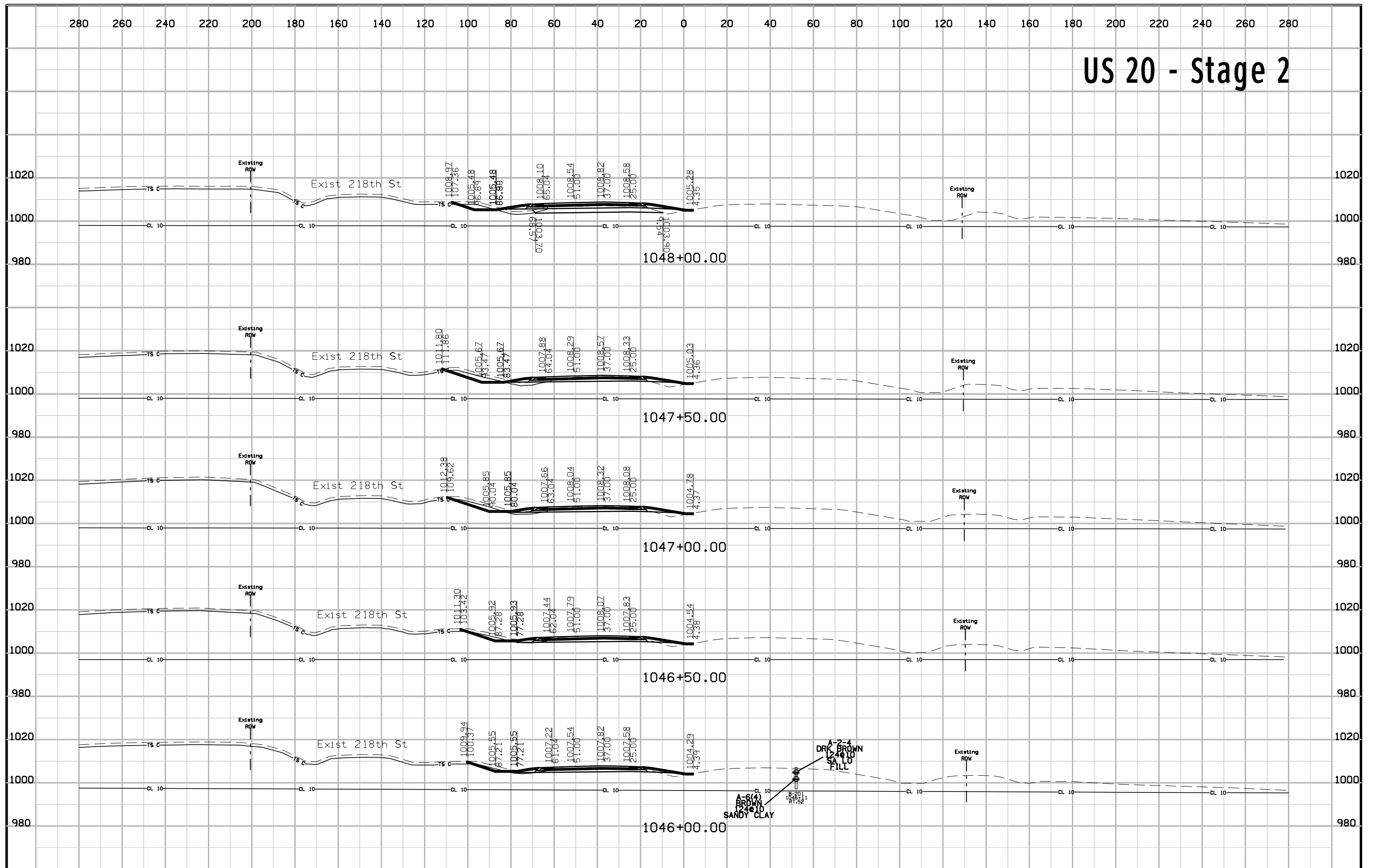



# US 20 - Stage 2

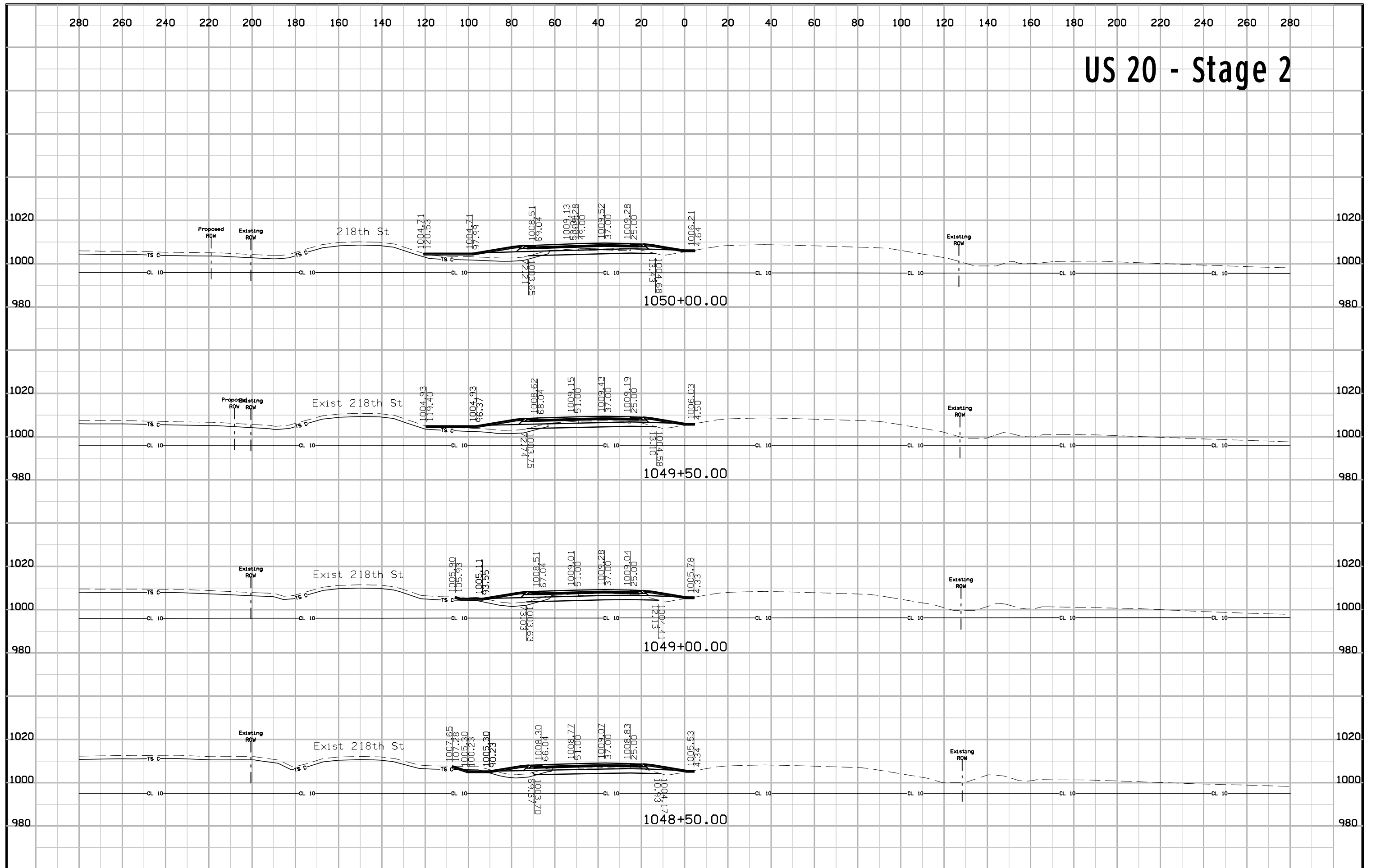

# US 20 - Stage 2

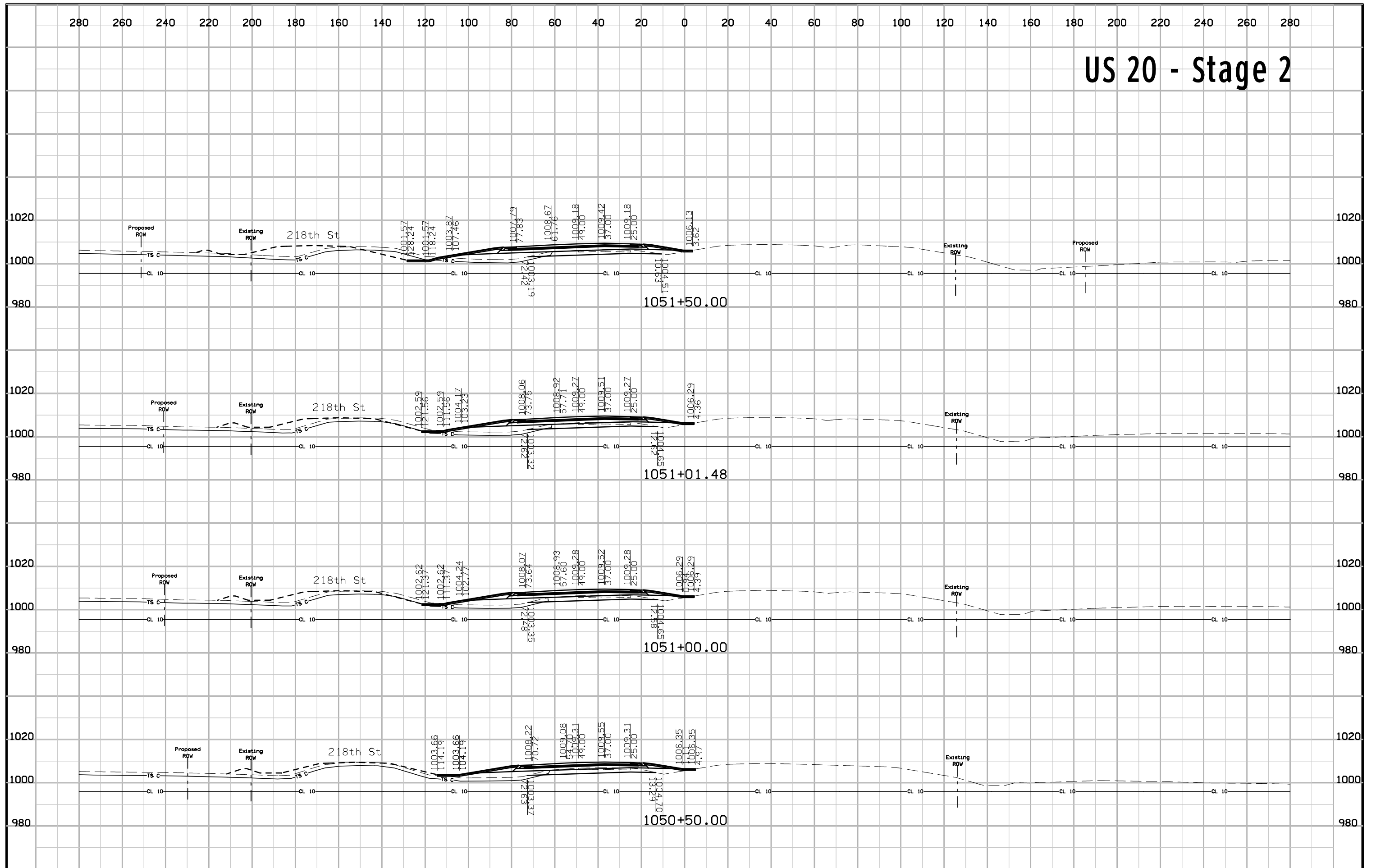

# US 20 - Stage 2

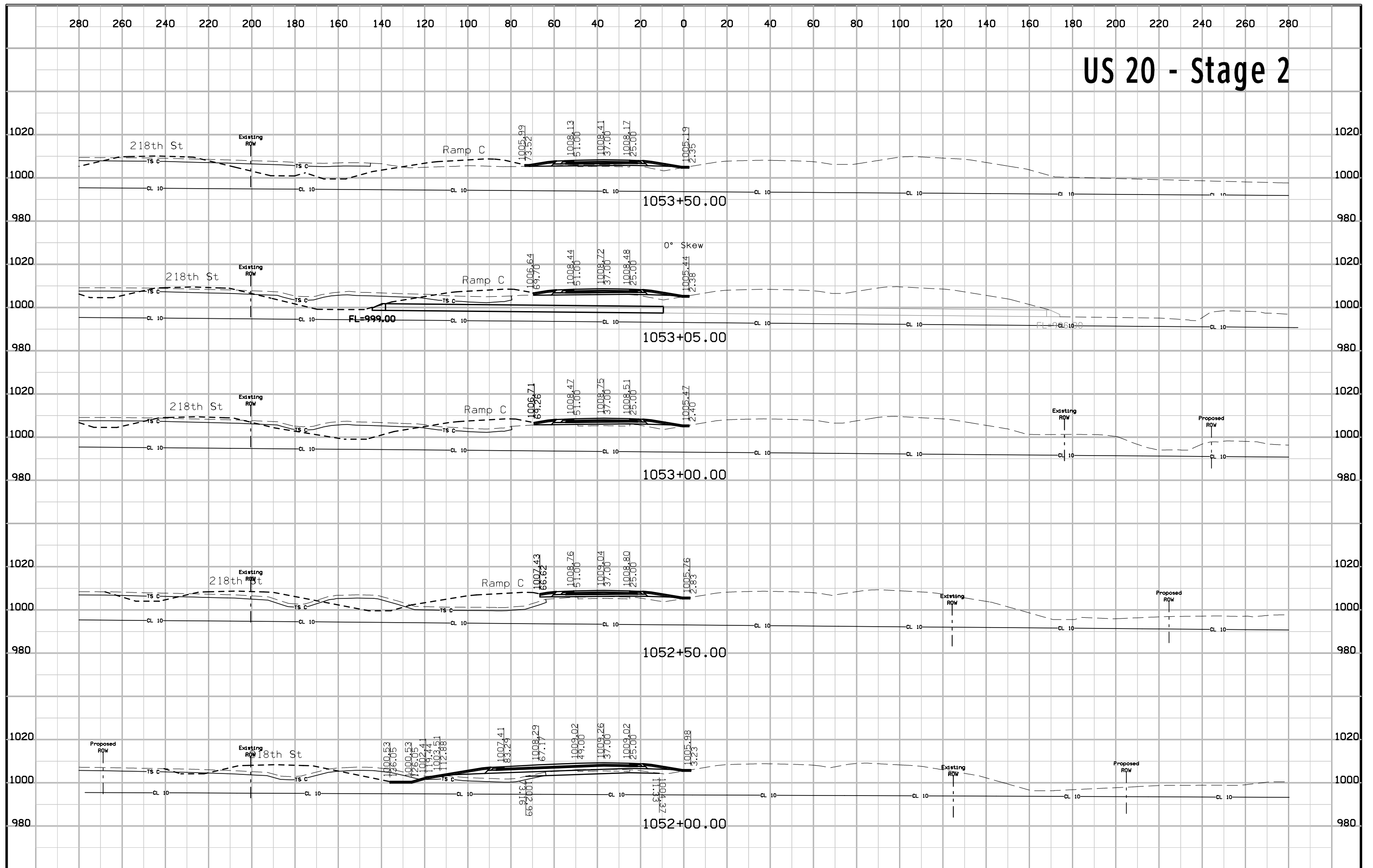

# US 20 - Stage 2

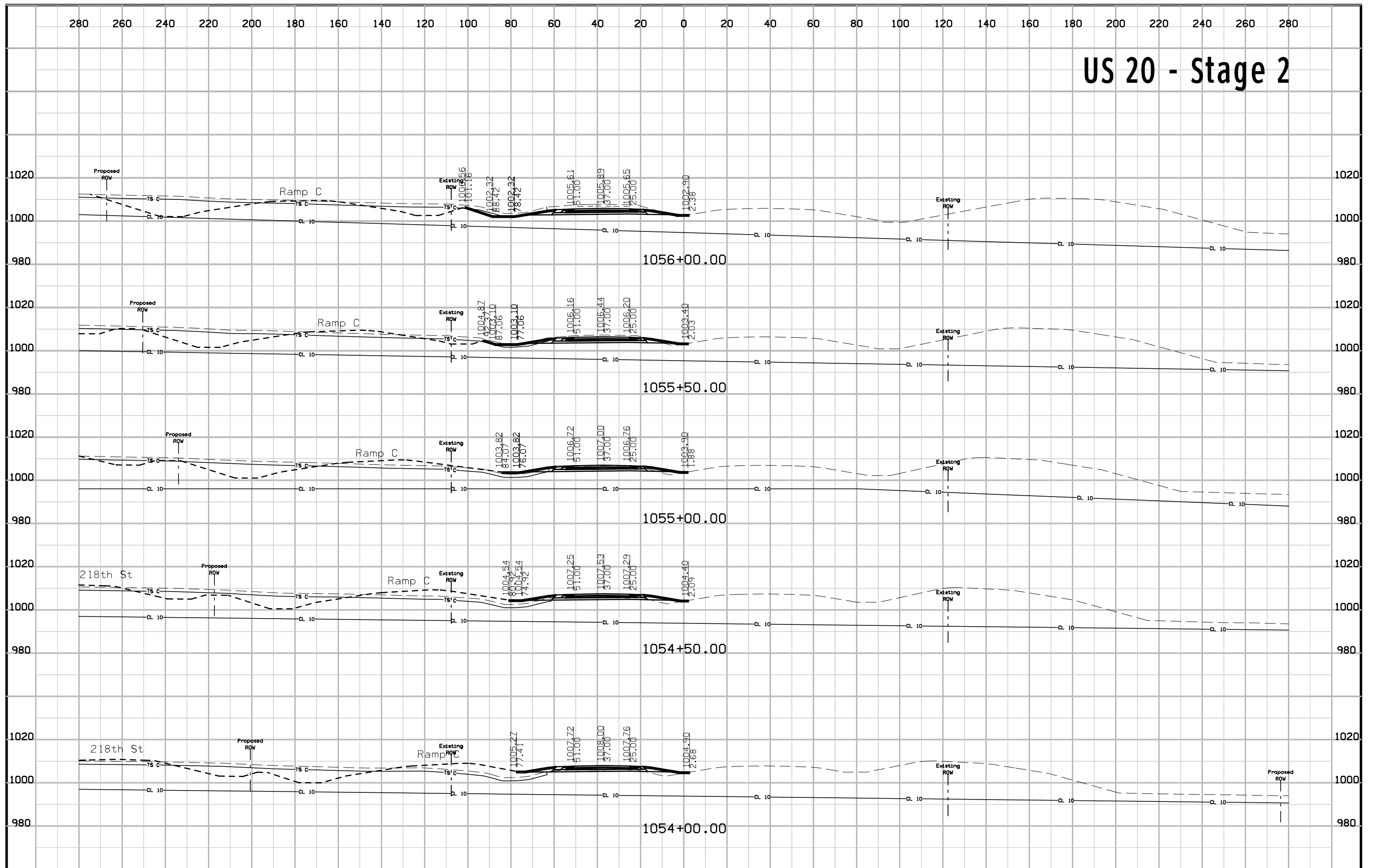

# US 20 - Stage 2

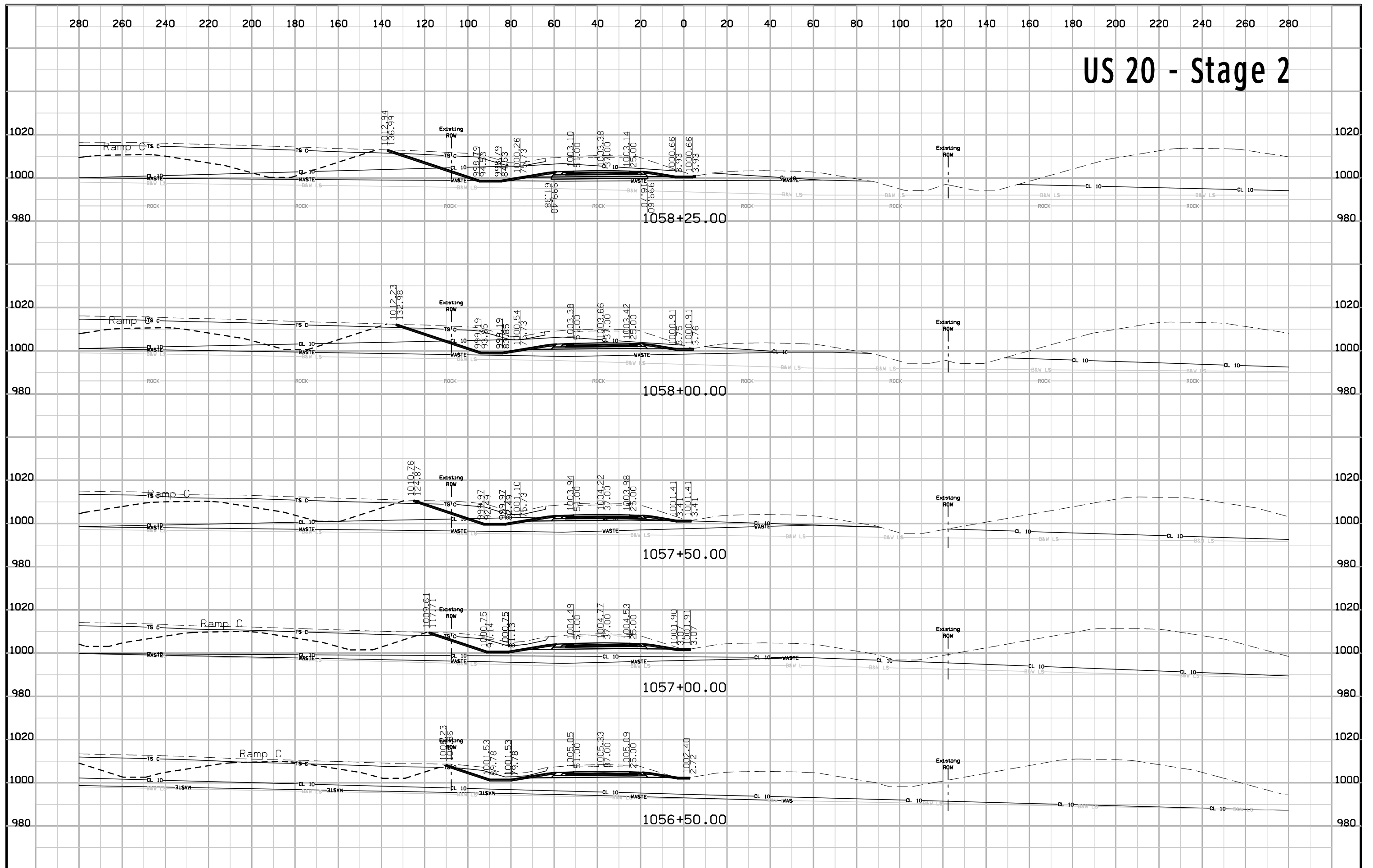

# US 20 - Stage 2

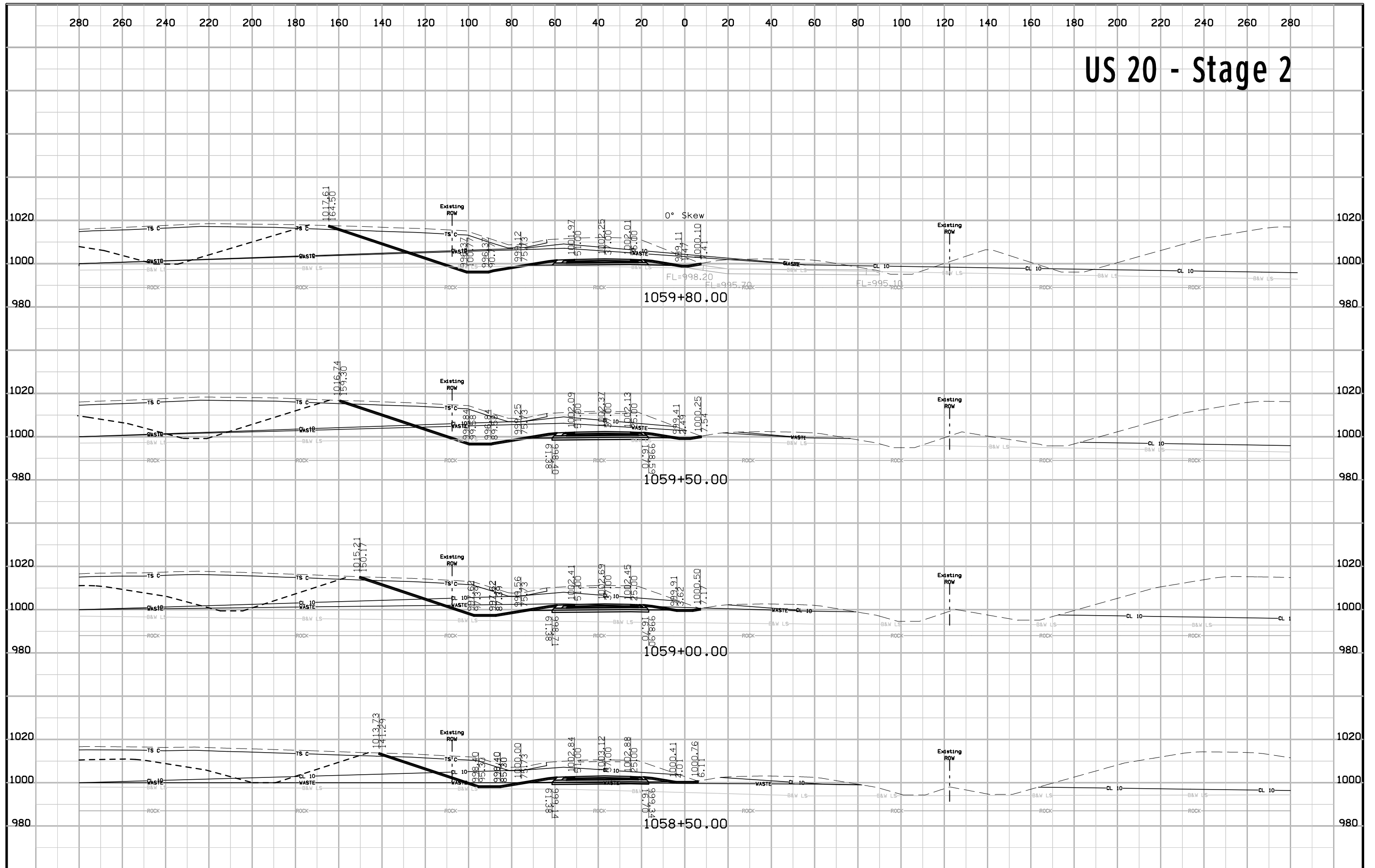

# US 20 - Stage 2

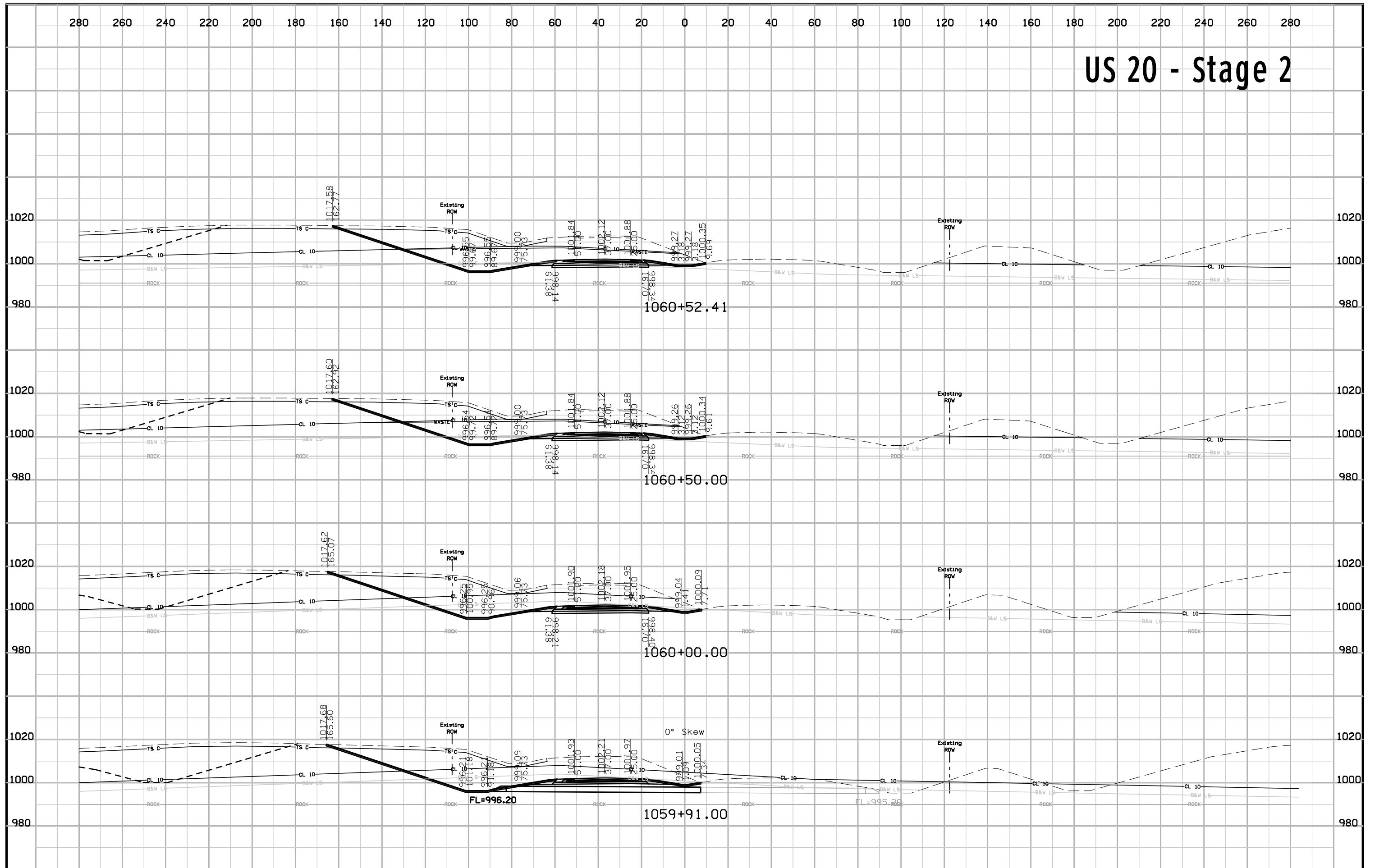



# US 20 - Stage 2

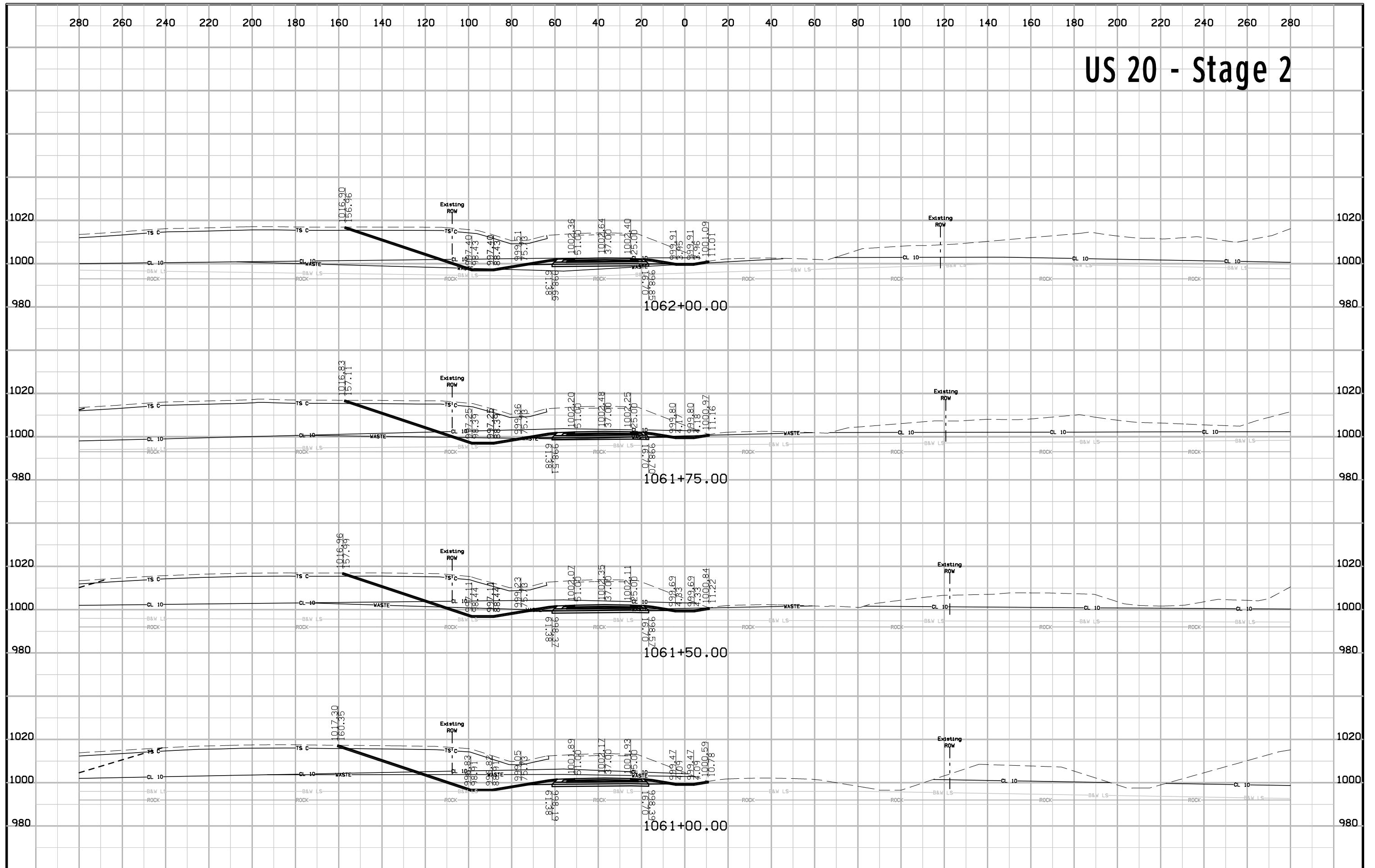

# US 20 - Stage 2

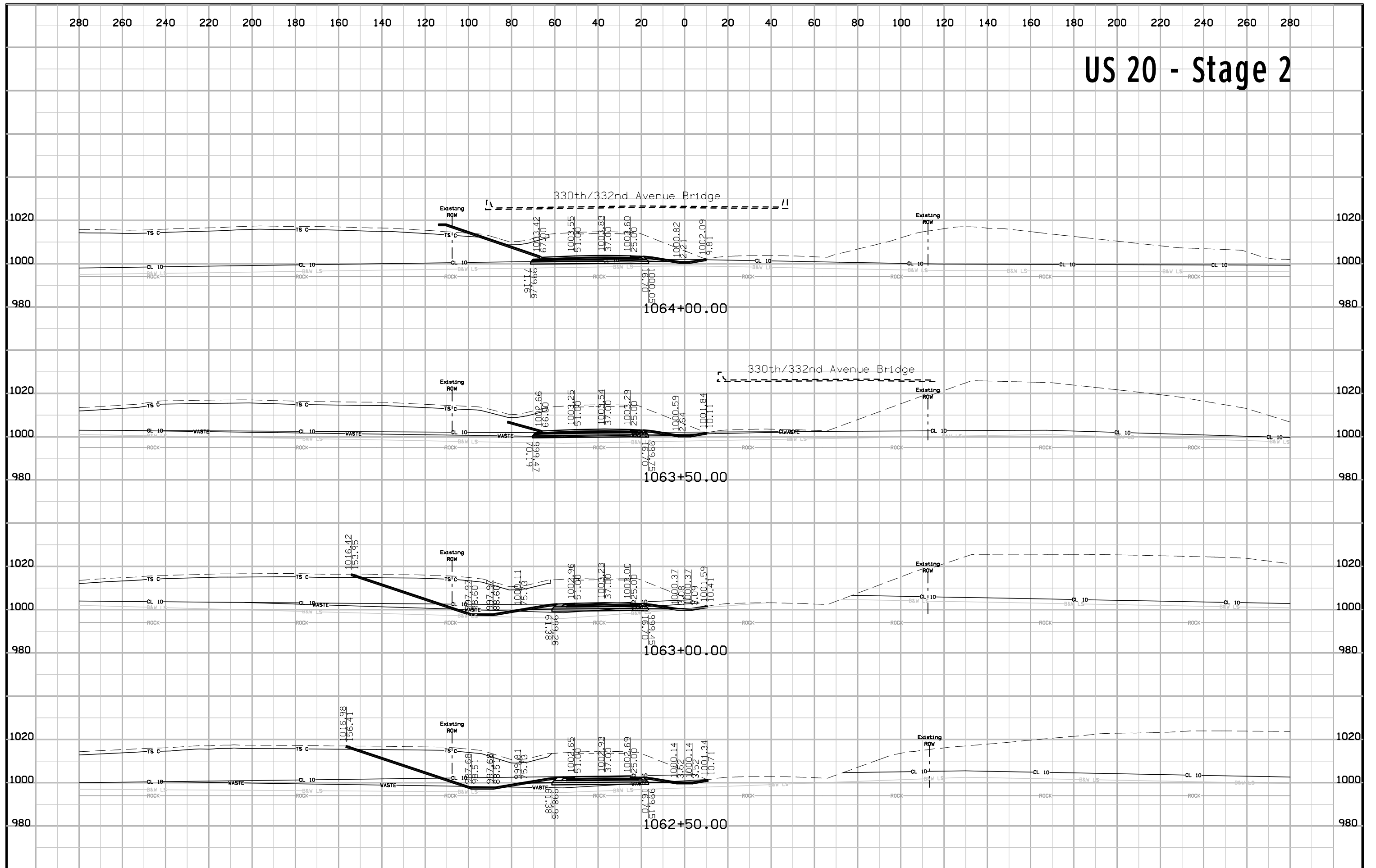

# US 20 - Stage 2

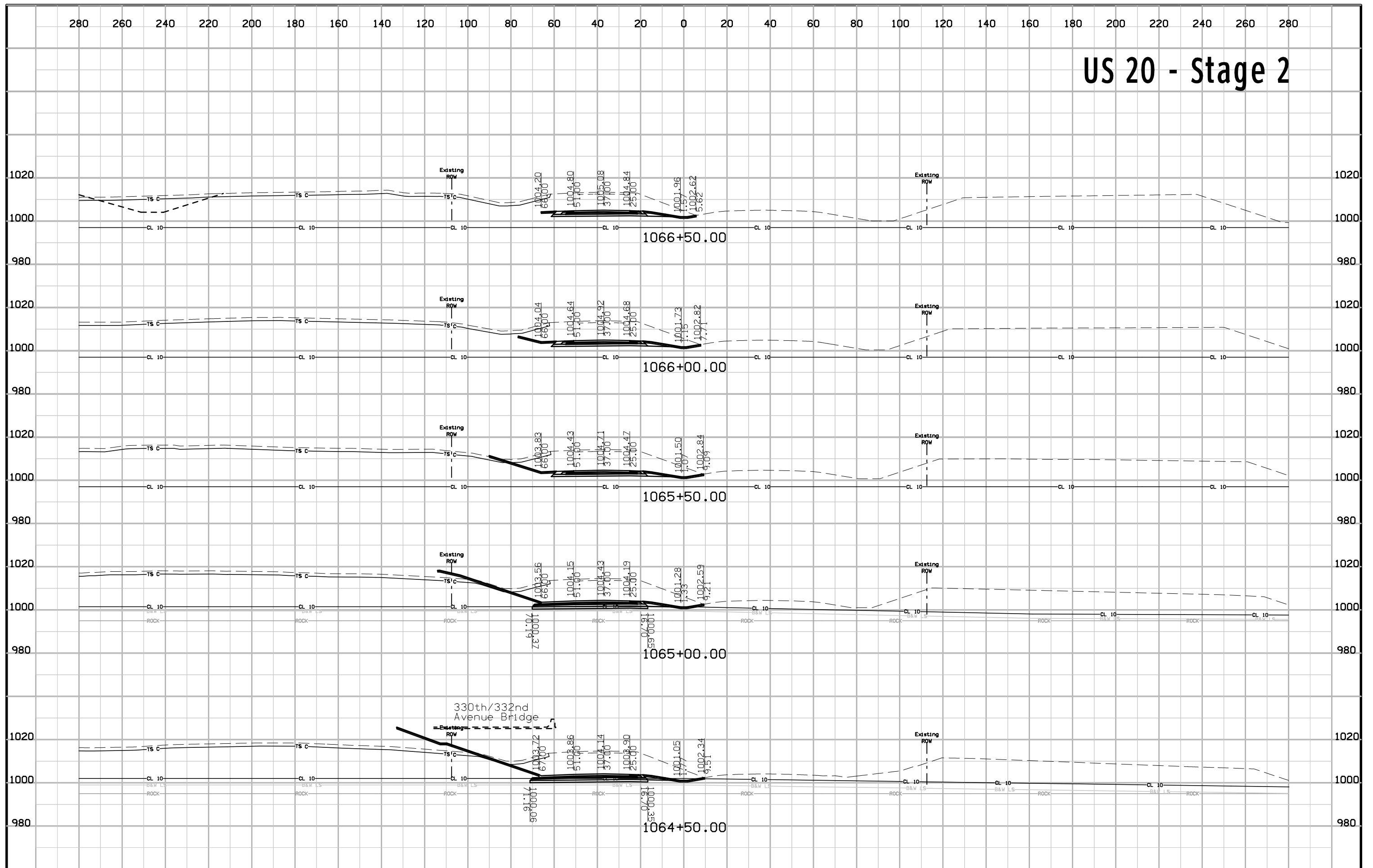

# US 20 - Stage 2

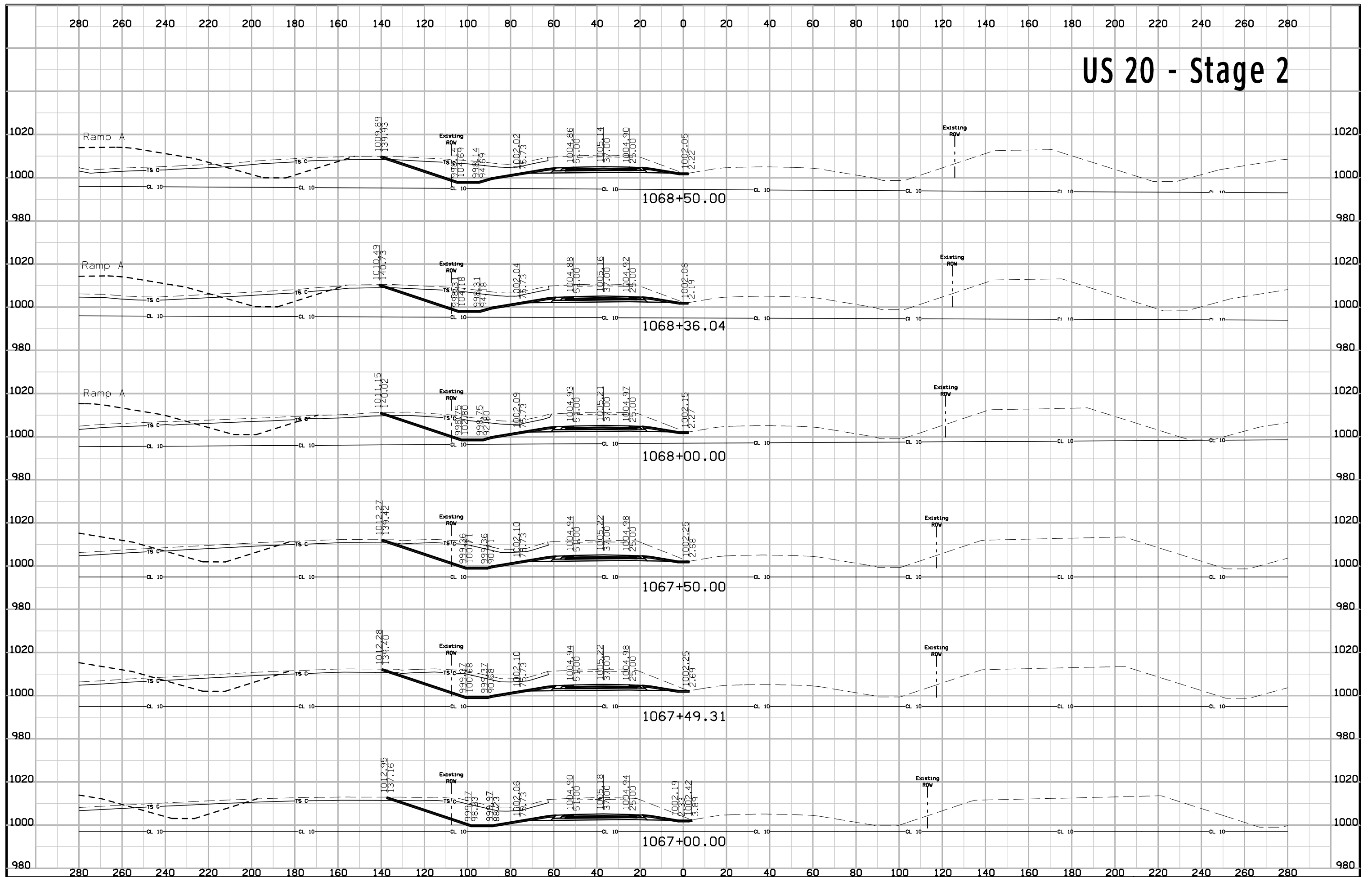

# US 20 - Stage 2

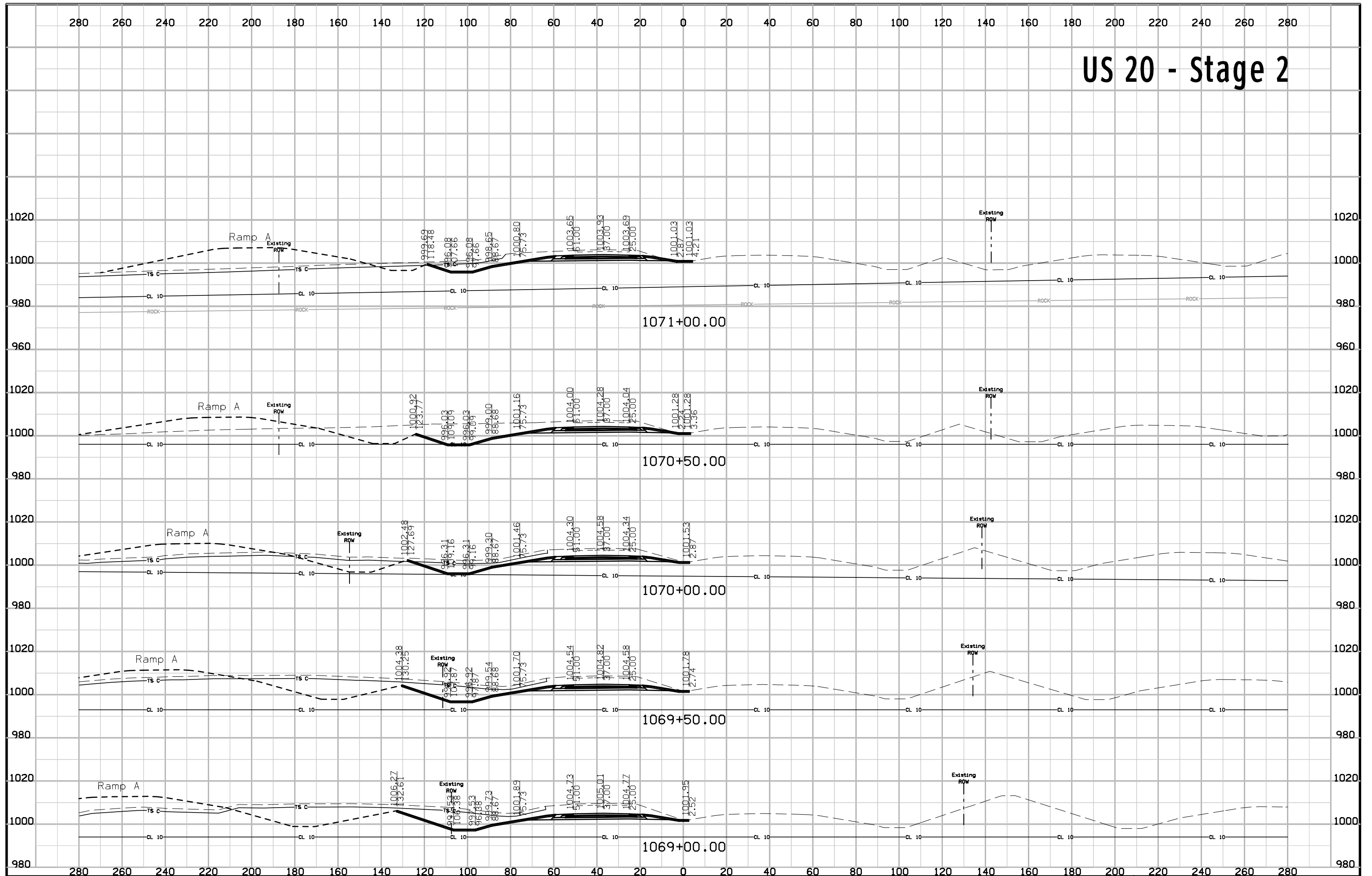

# US 20 - Stage 2

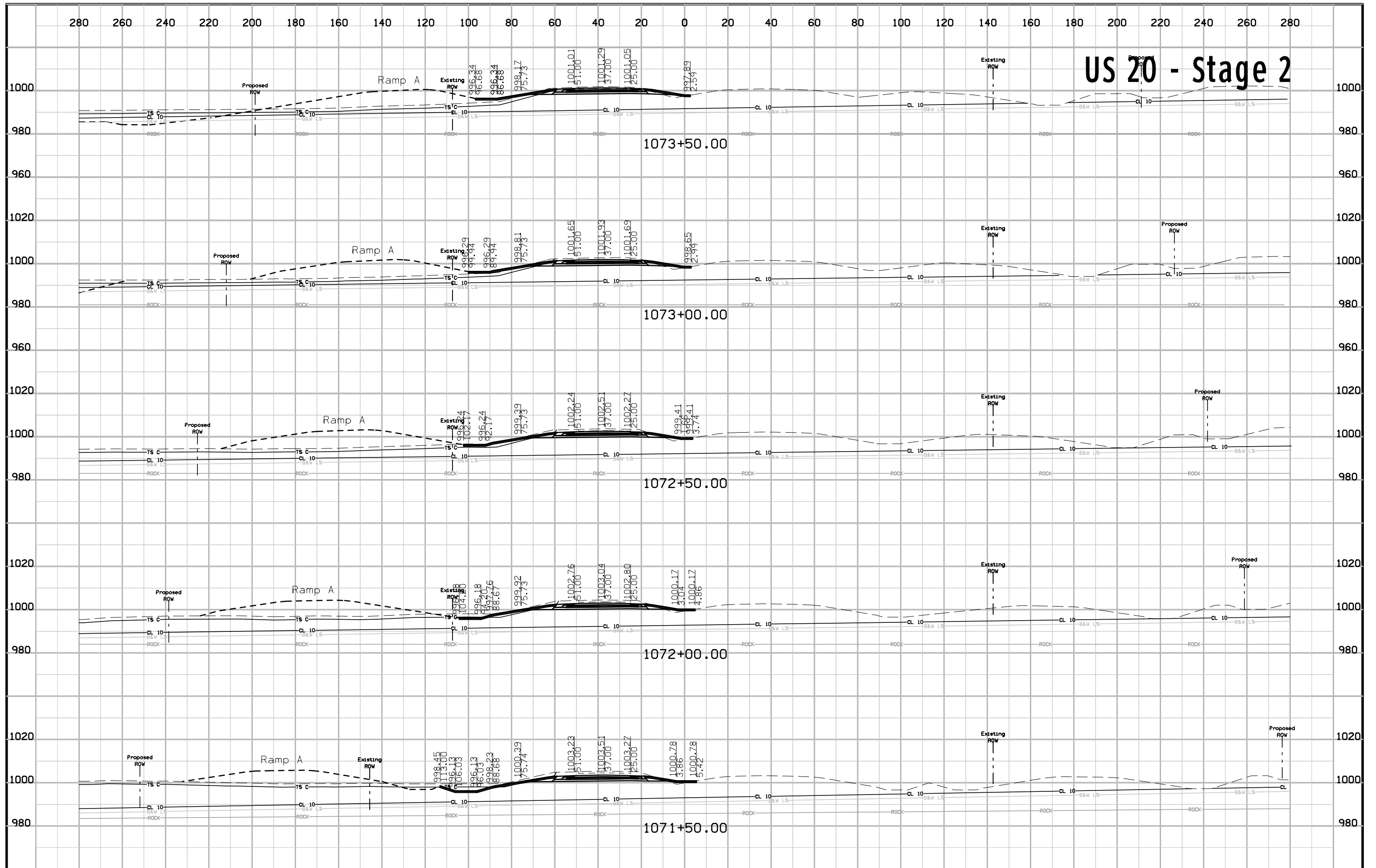

# US 20 - Stage 2

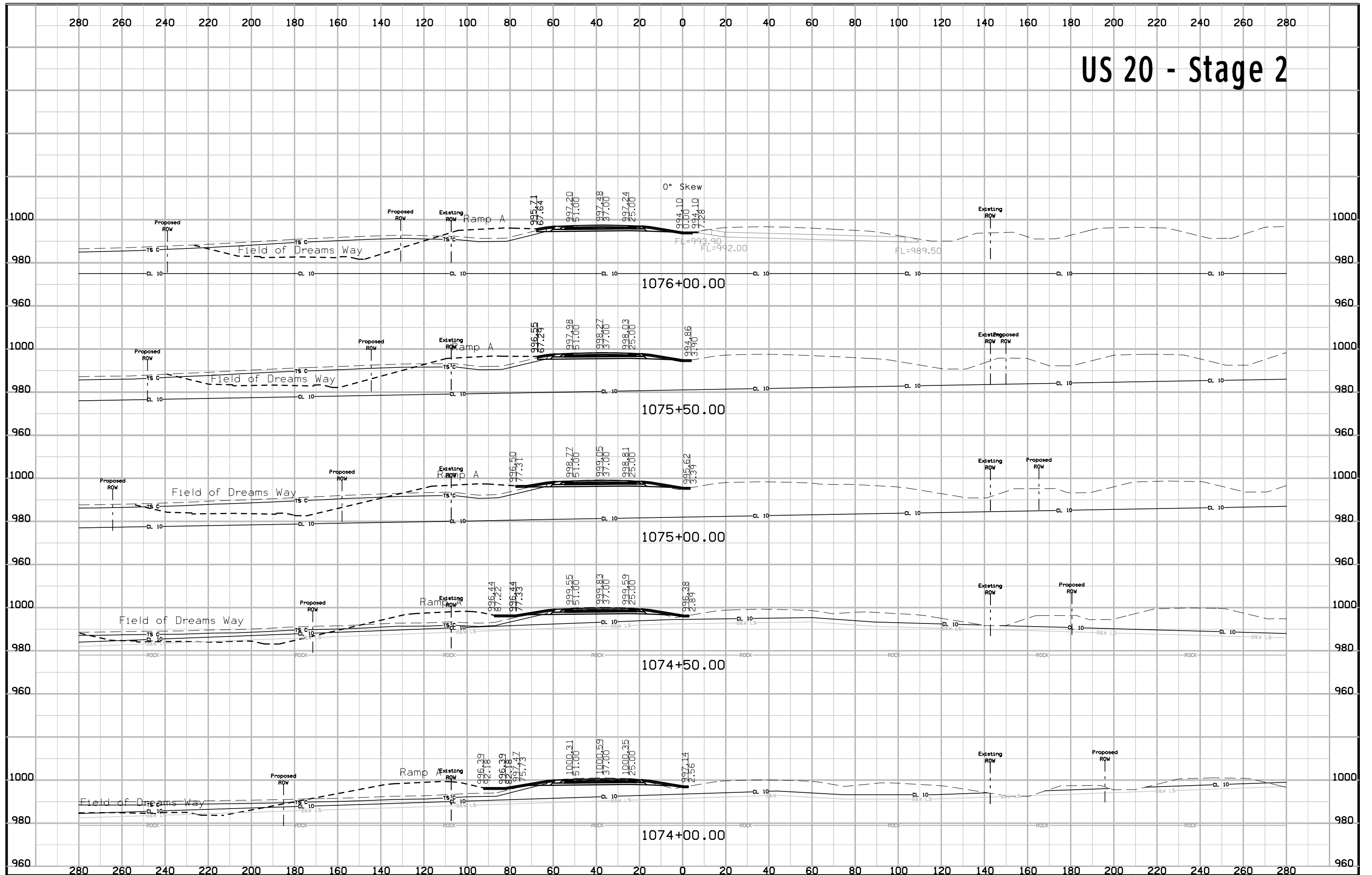



# US 20 - Stage 2

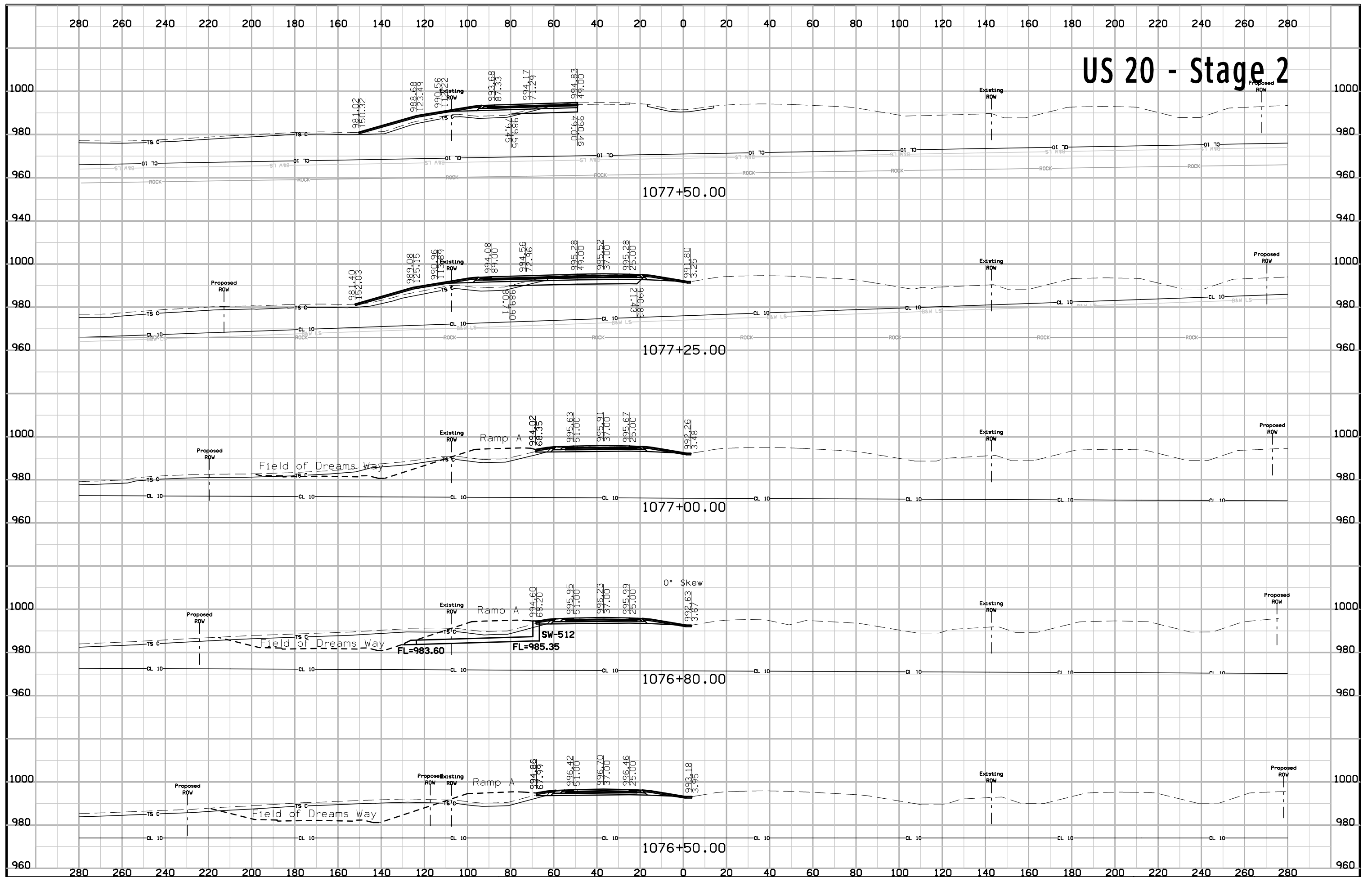

# US 20 - Stage 2

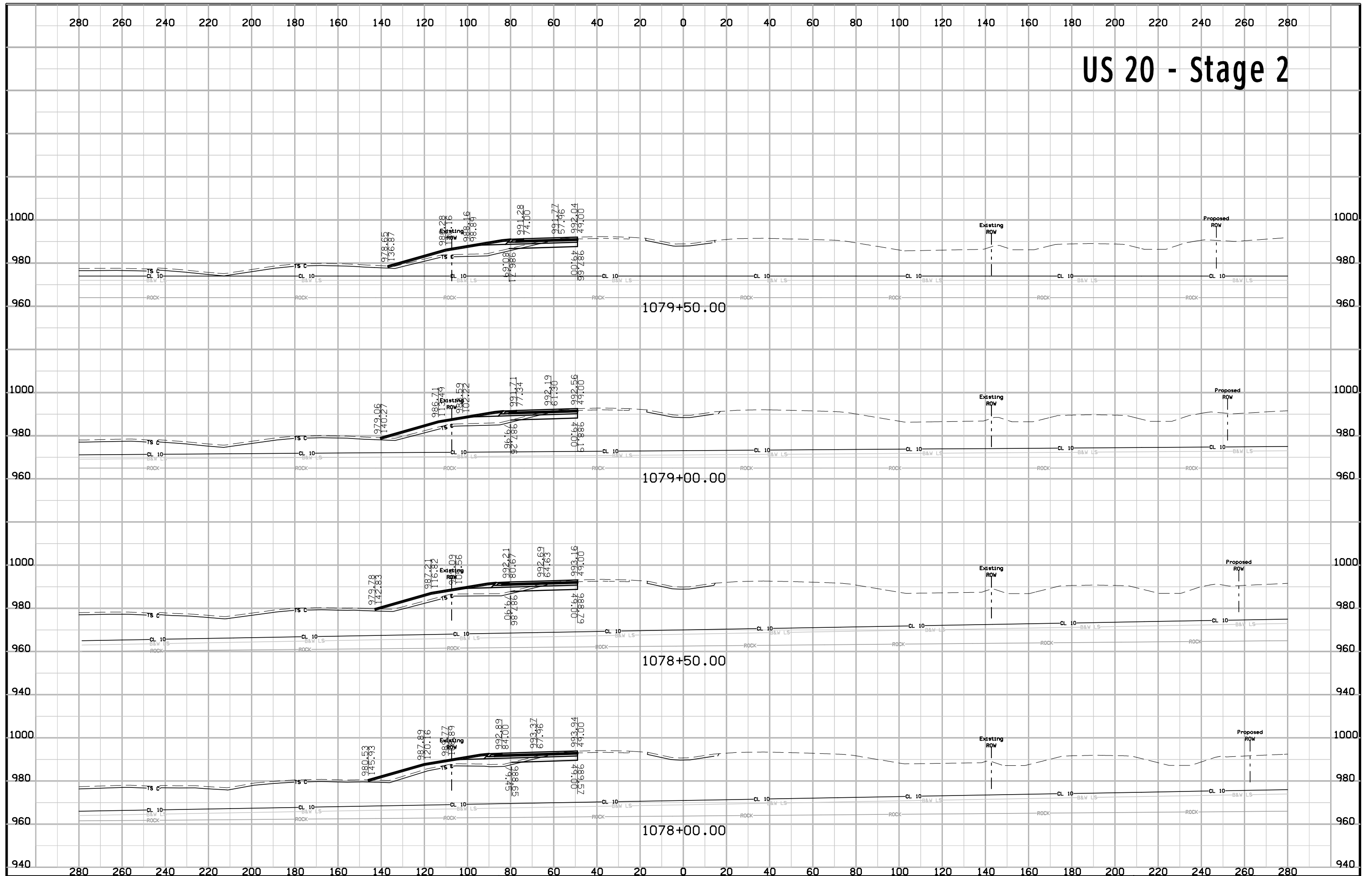



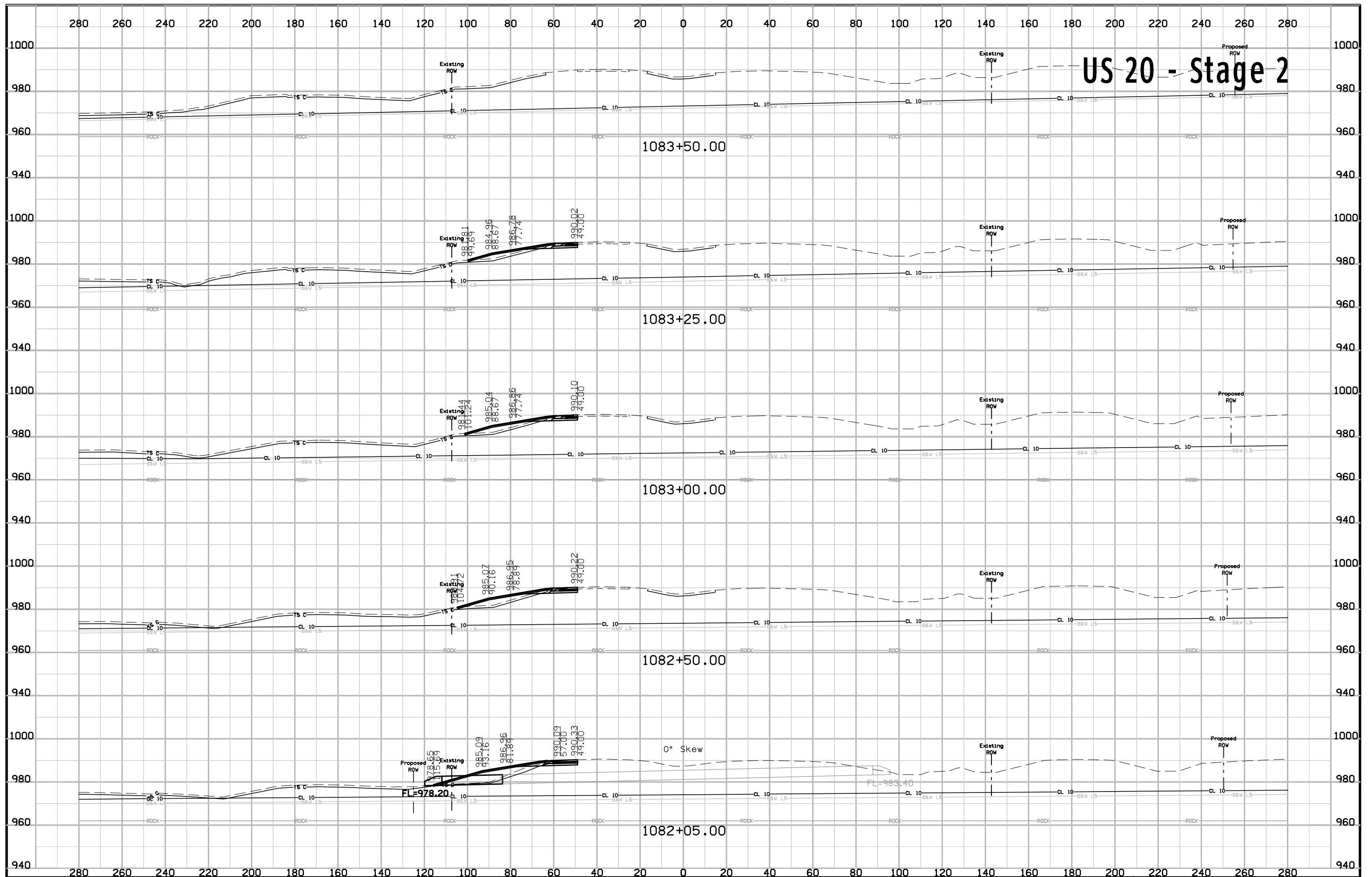

# 330th/332nd Avenue

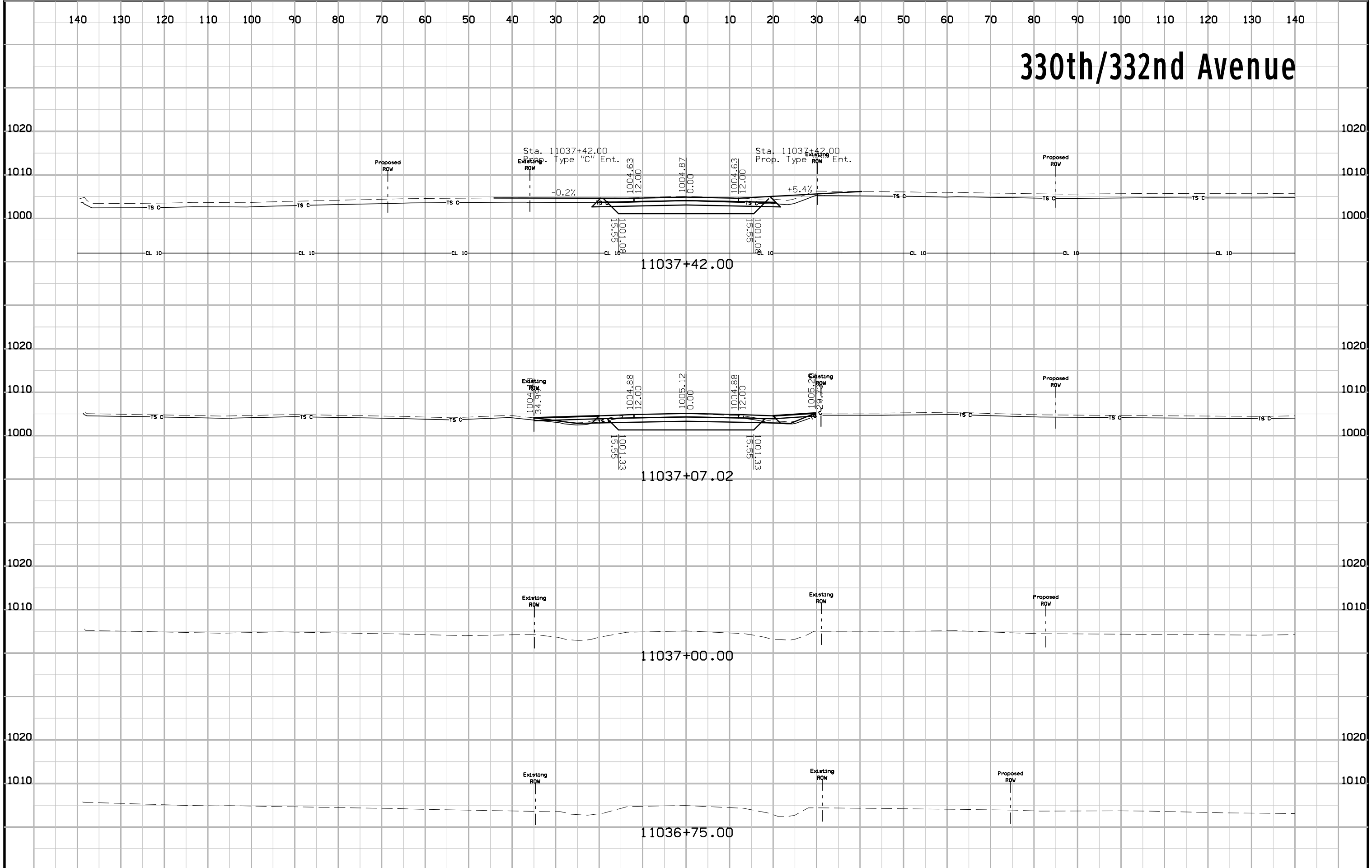

# 330th/332nd Avenue

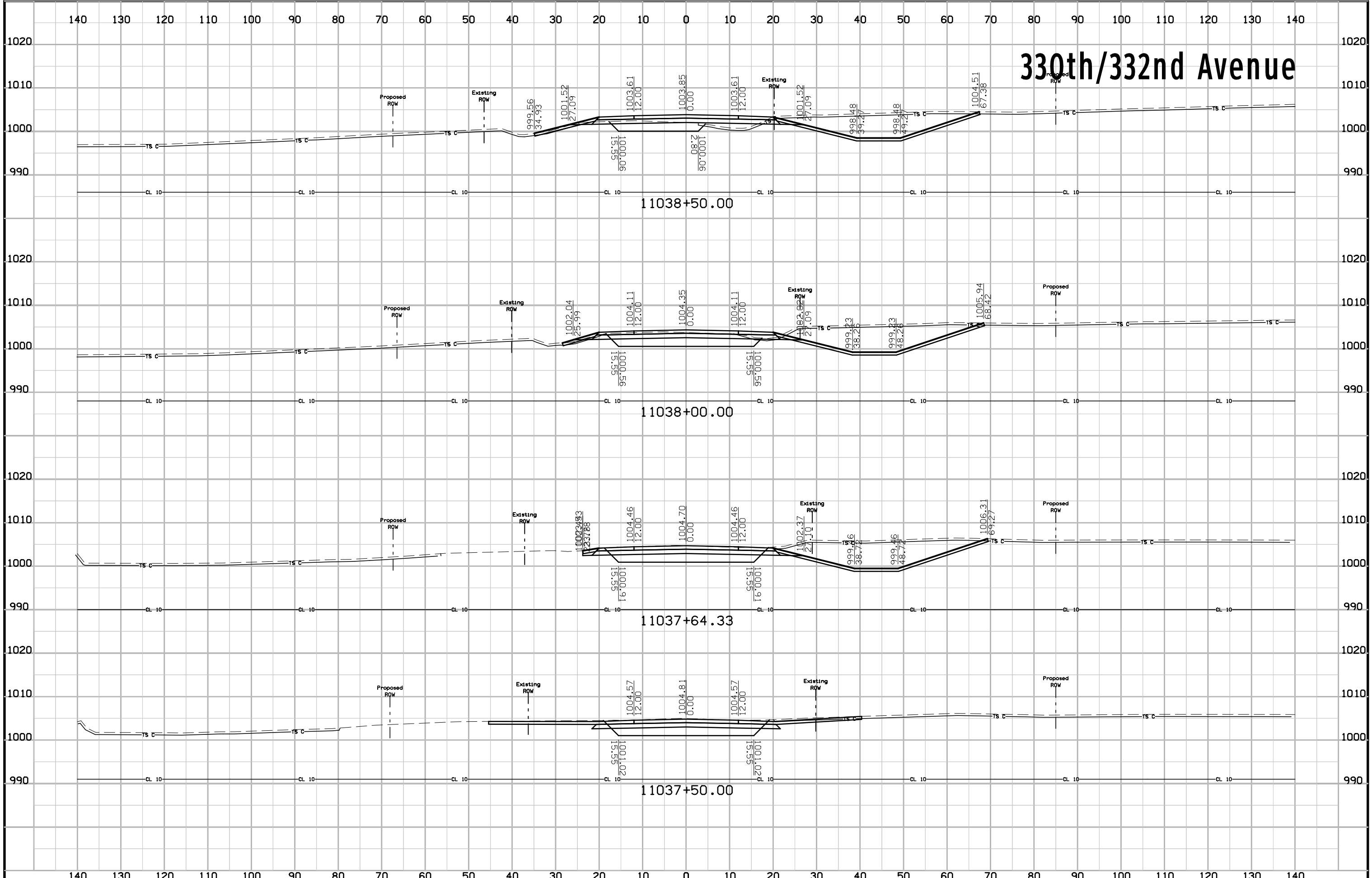

# 330th/332nd Avenue

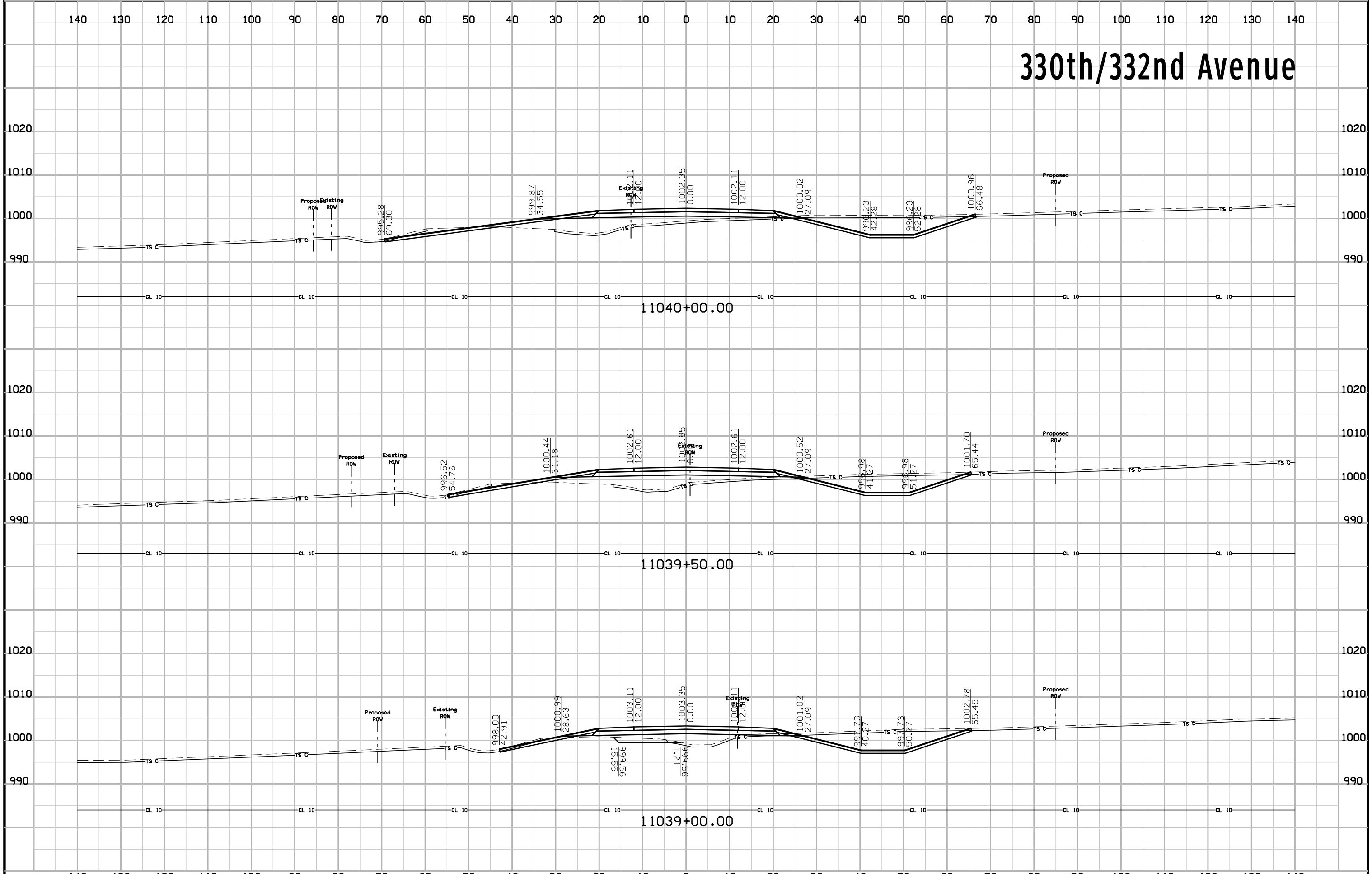



# 330th/332nd Avenue

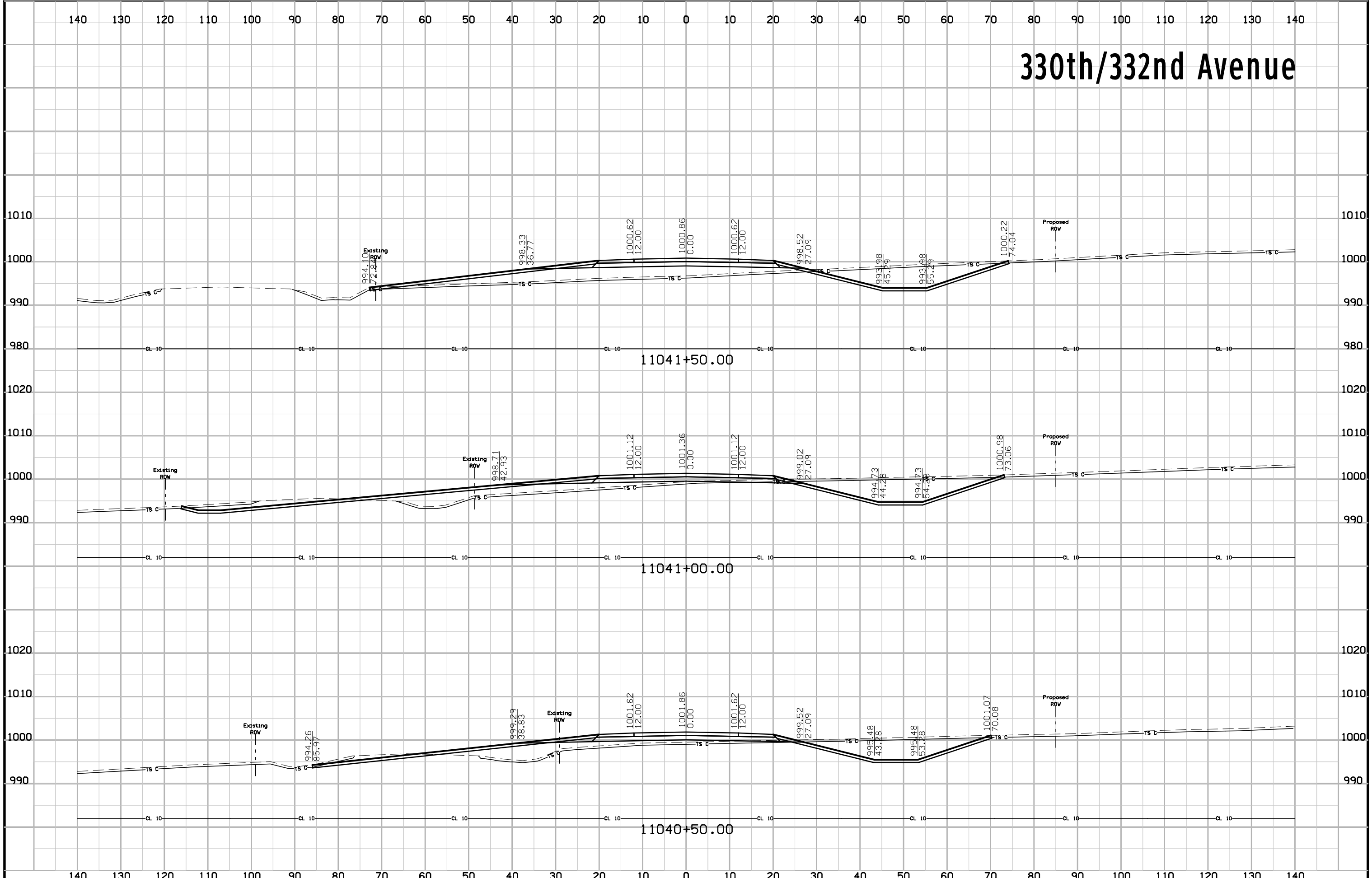

# 330th/332nd Avenue

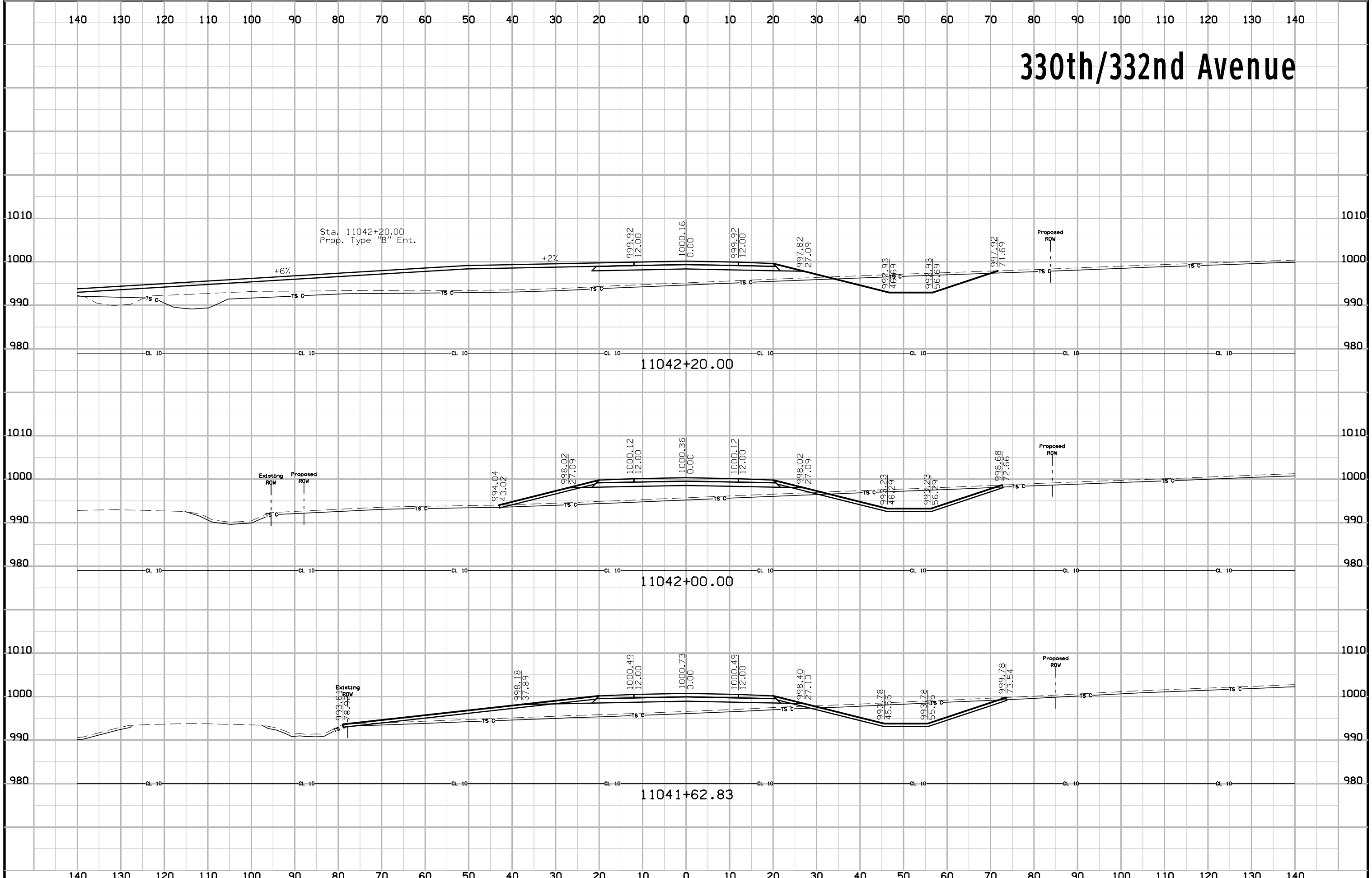

# 330th/332nd Avenue

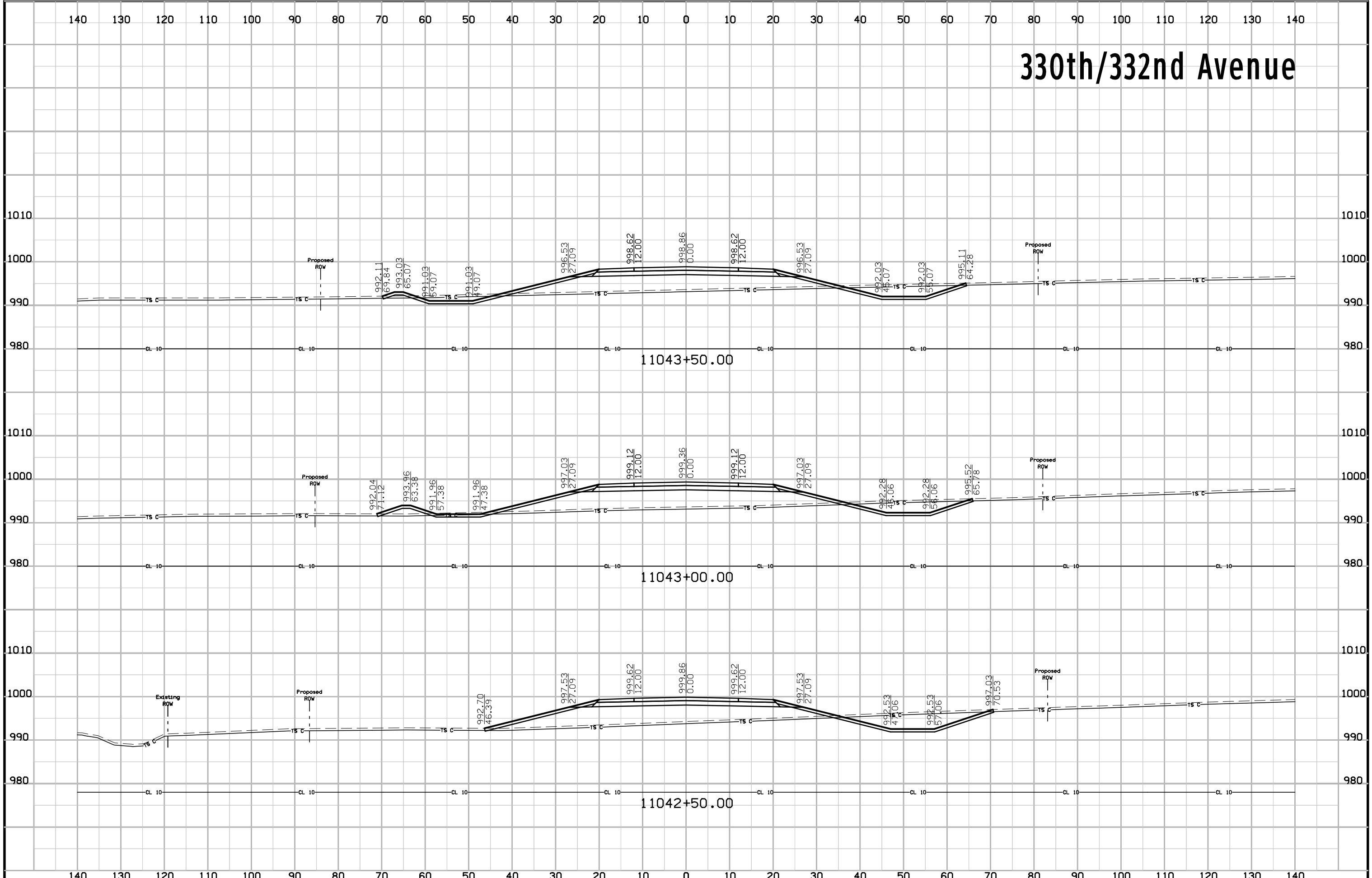

# 330th/332nd Avenue

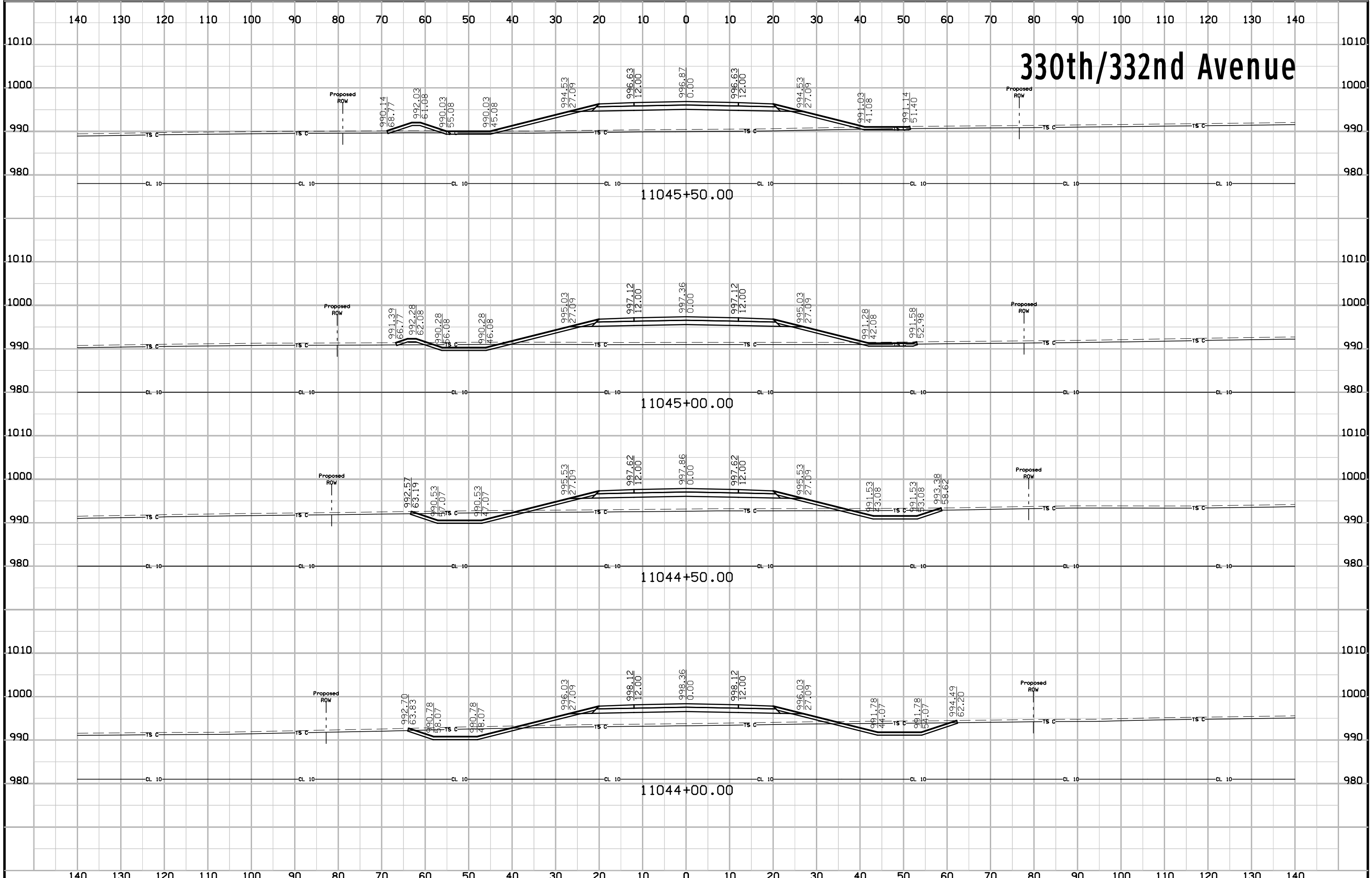

# 330th/332nd Avenue

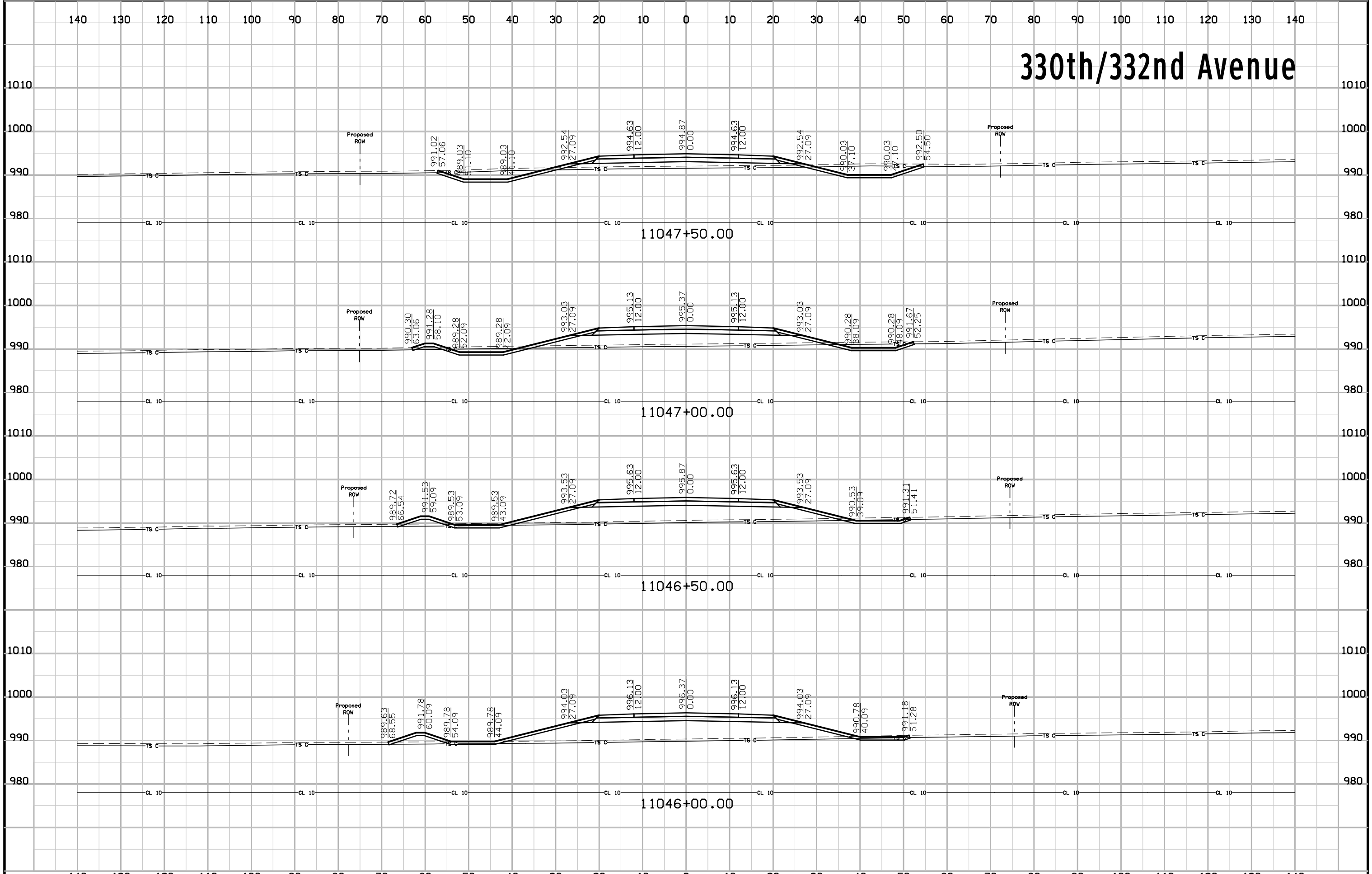

# 330th/332nd Avenue

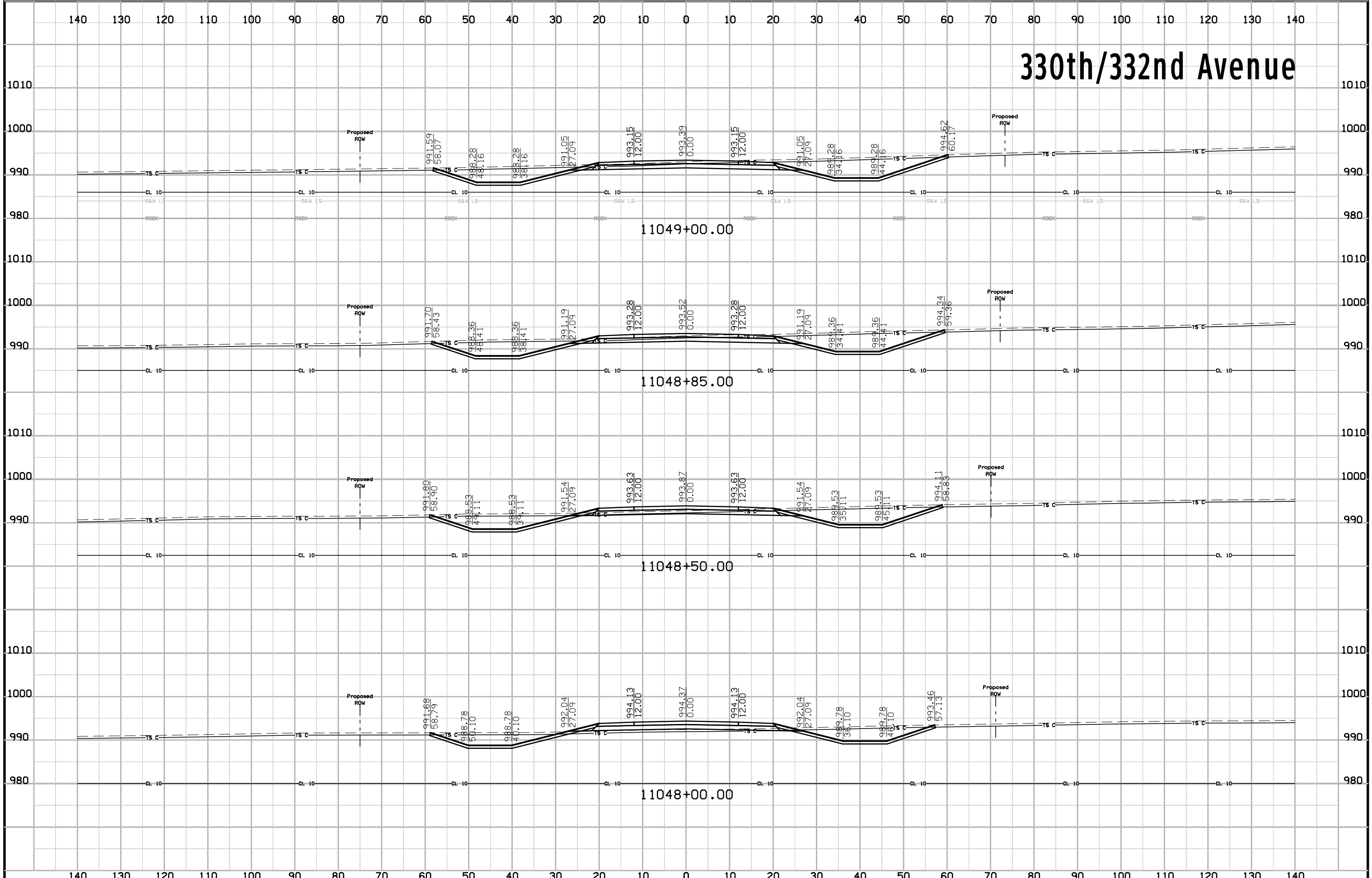

# 330th/332nd Avenue

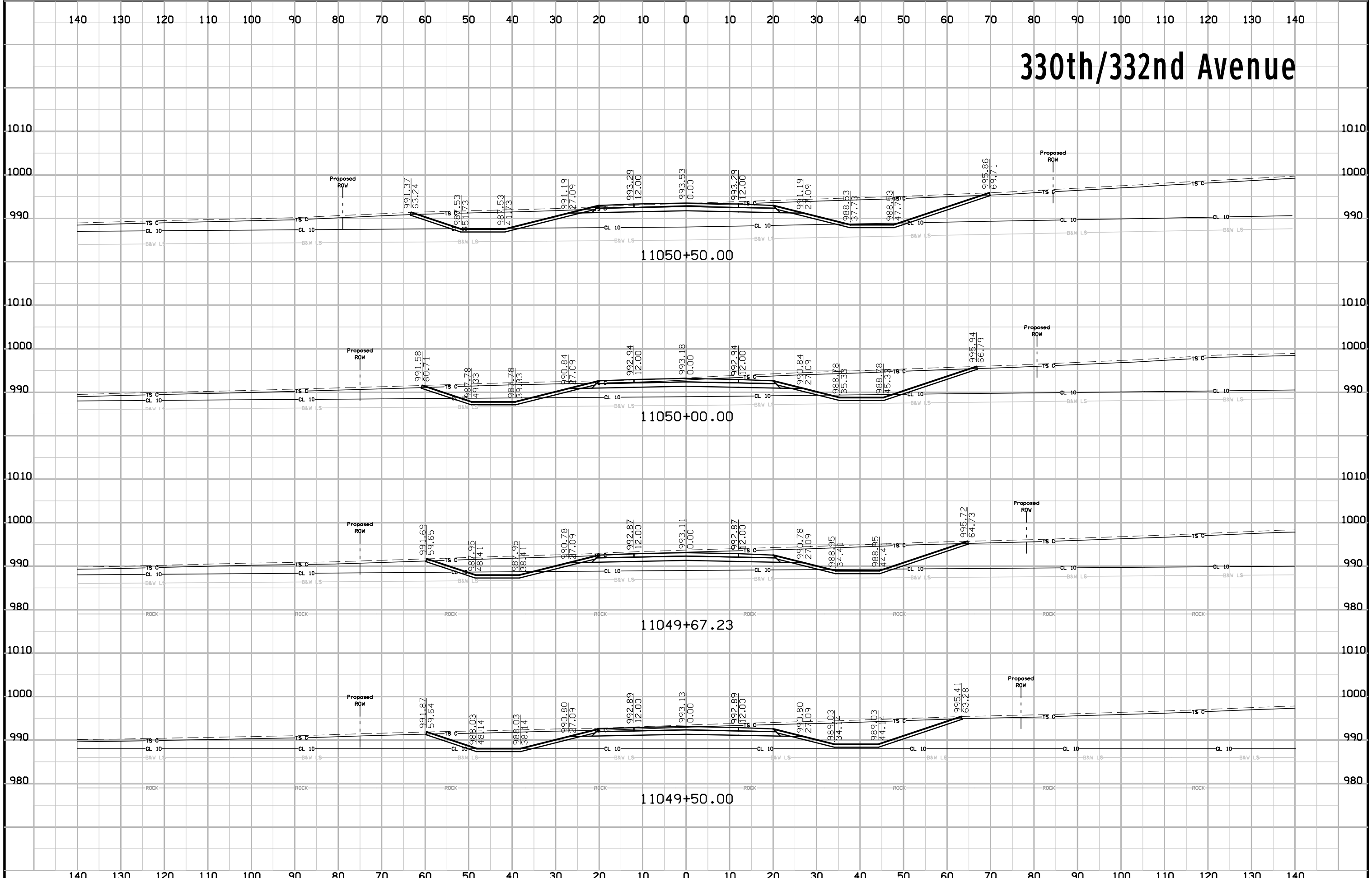



# 330th/332nd Avenue

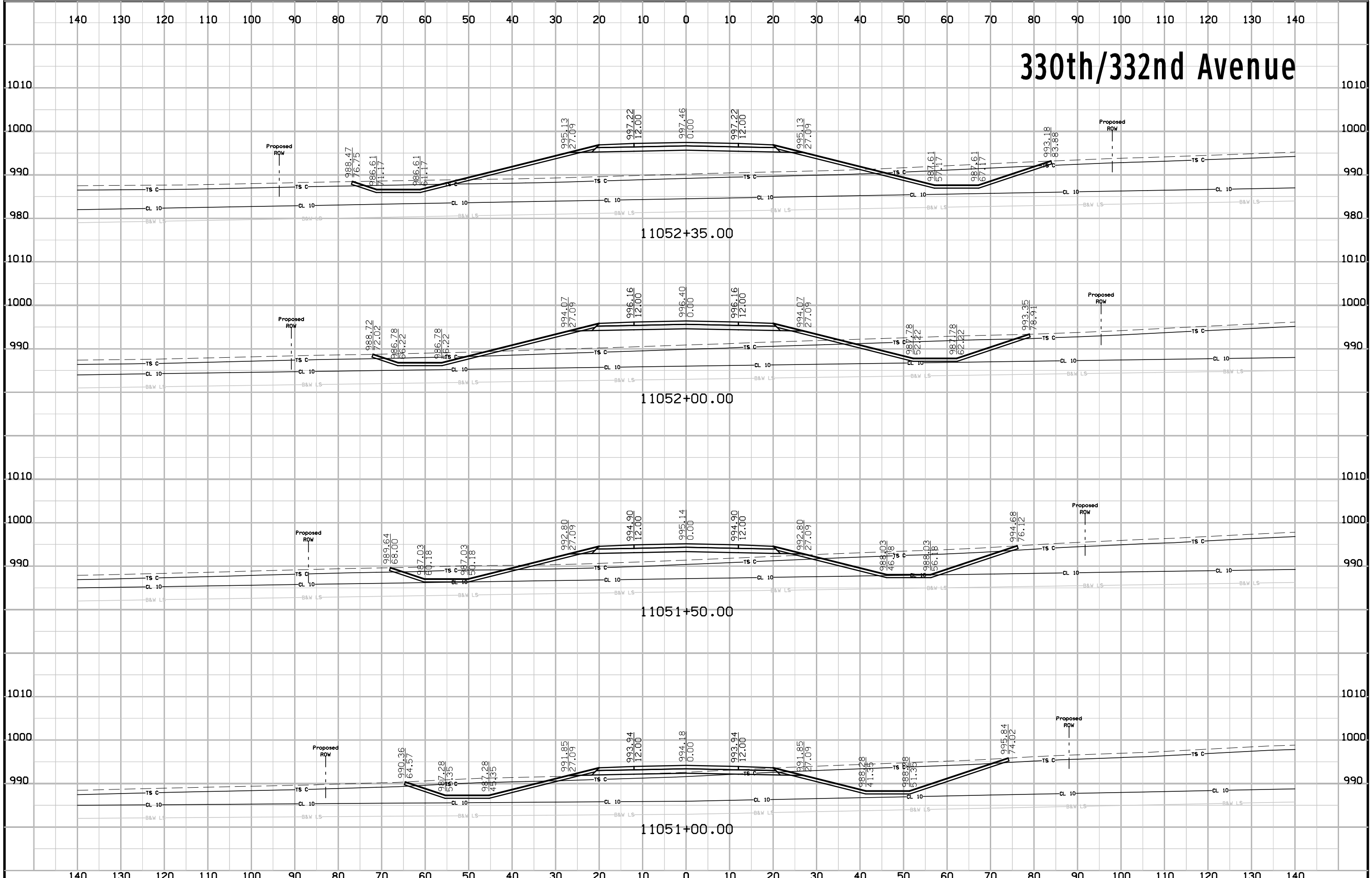

# 330th/332nd Avenue

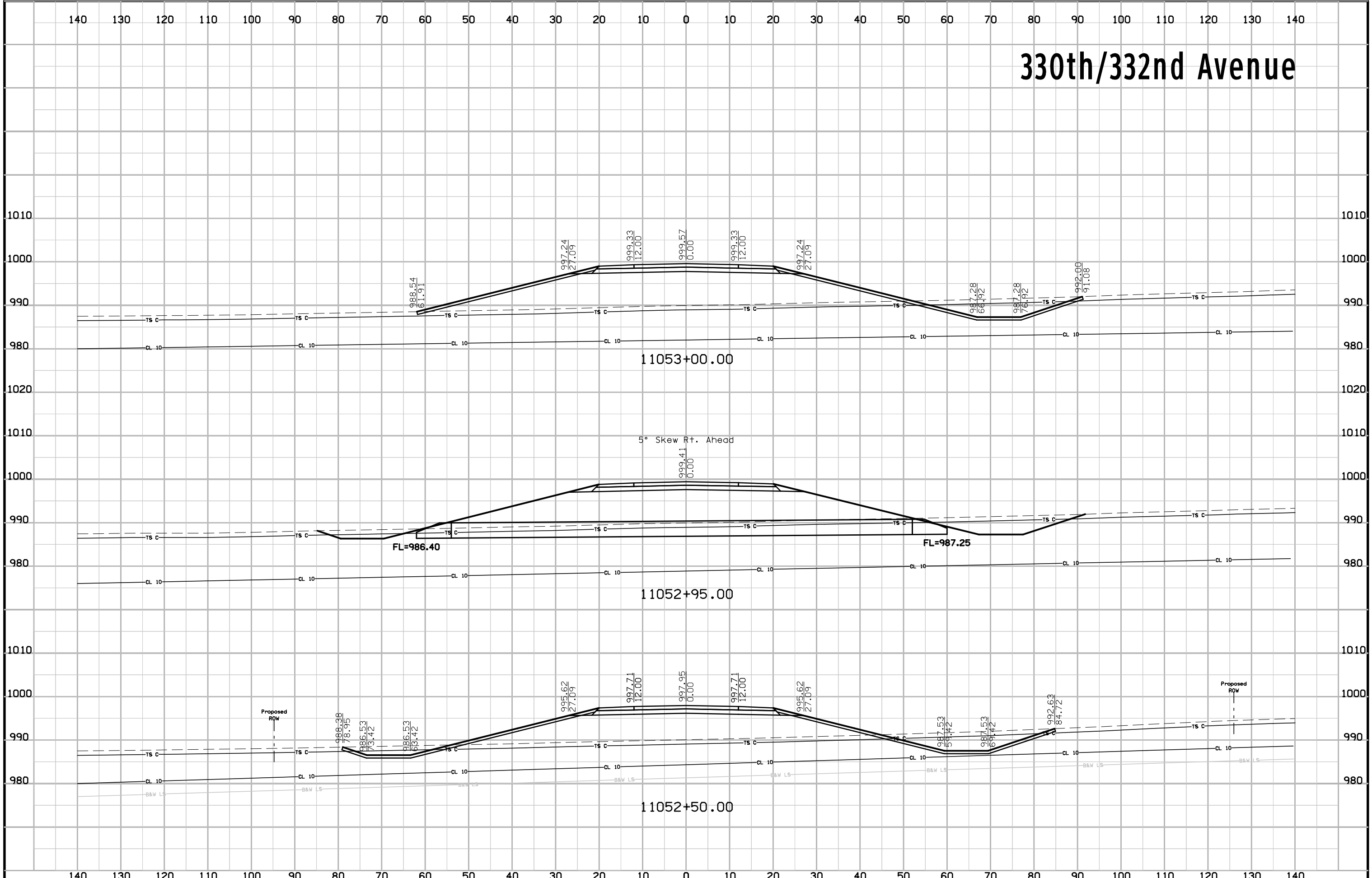

# 330th/332nd Avenue

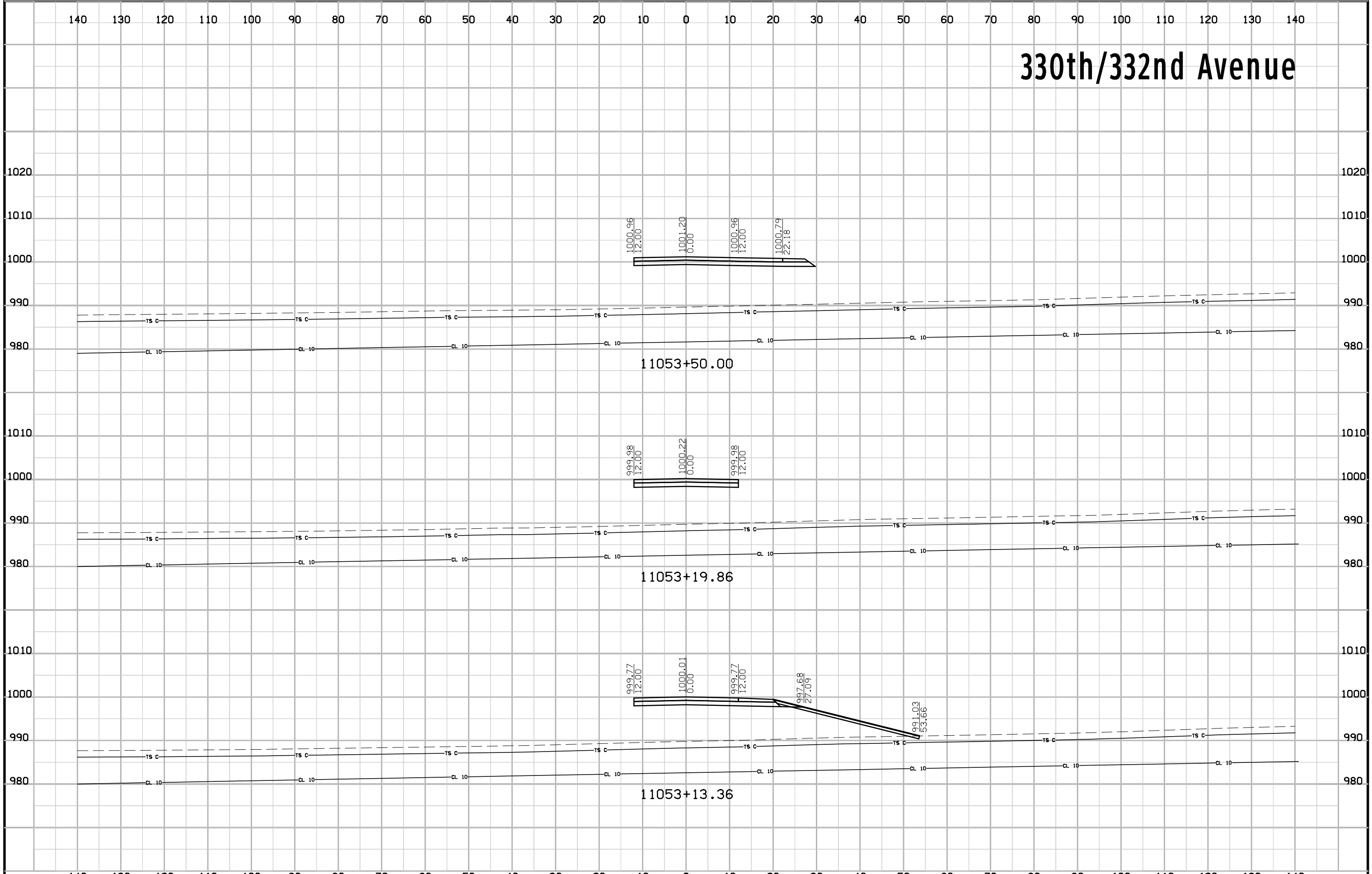

# 330th/332nd Avenue

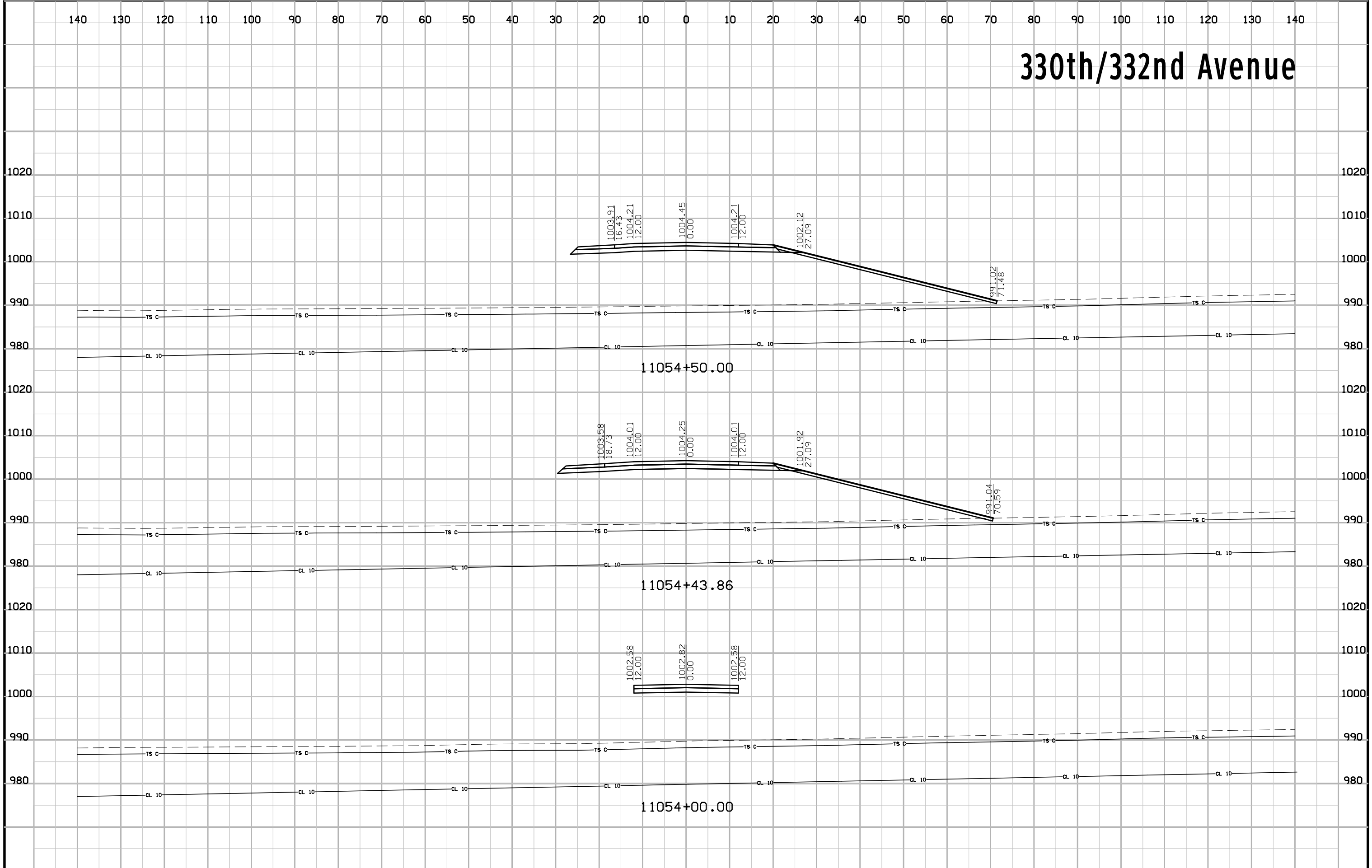

# 330th/332nd Avenue

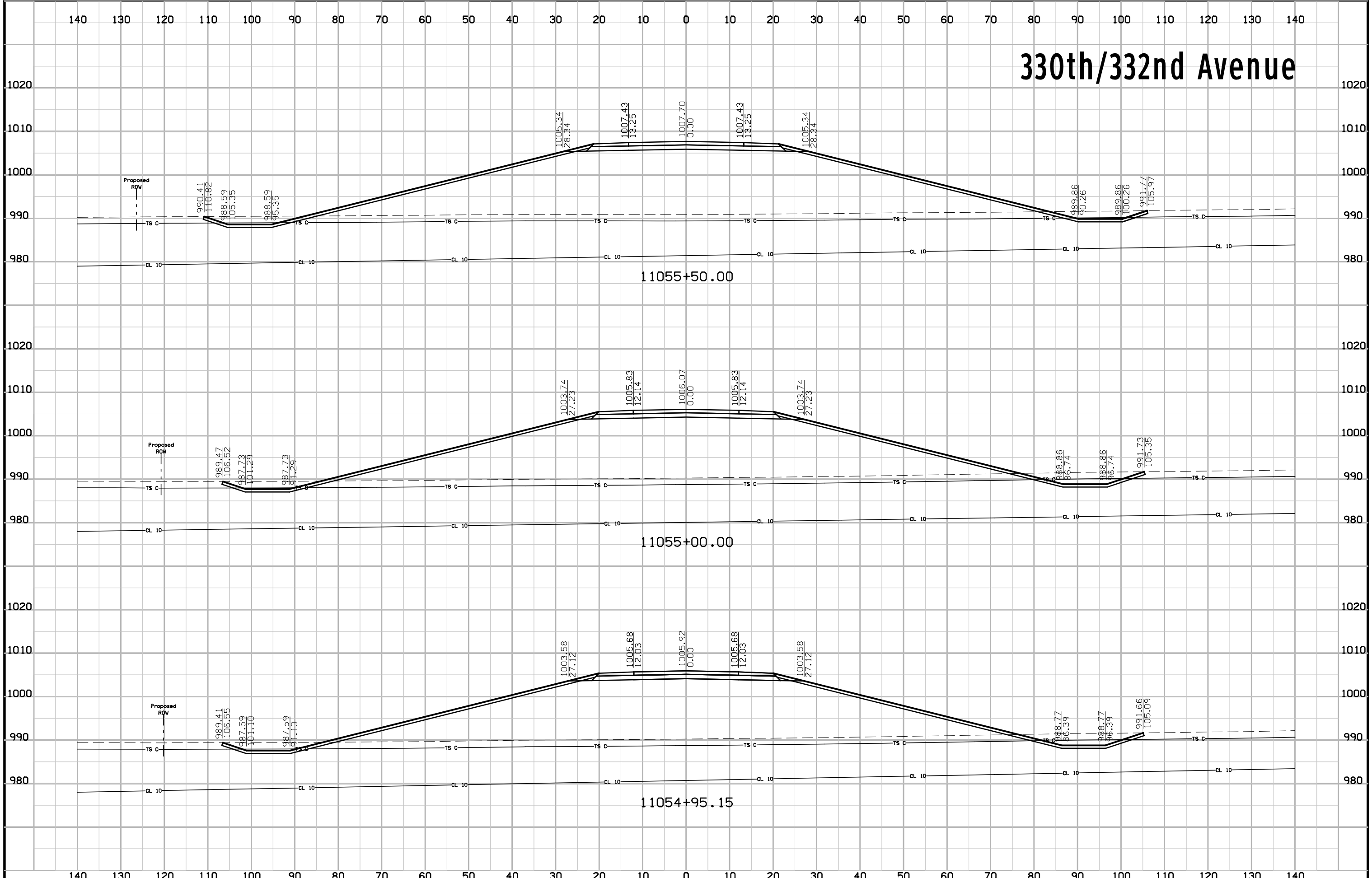

# 330th/332nd Avenue

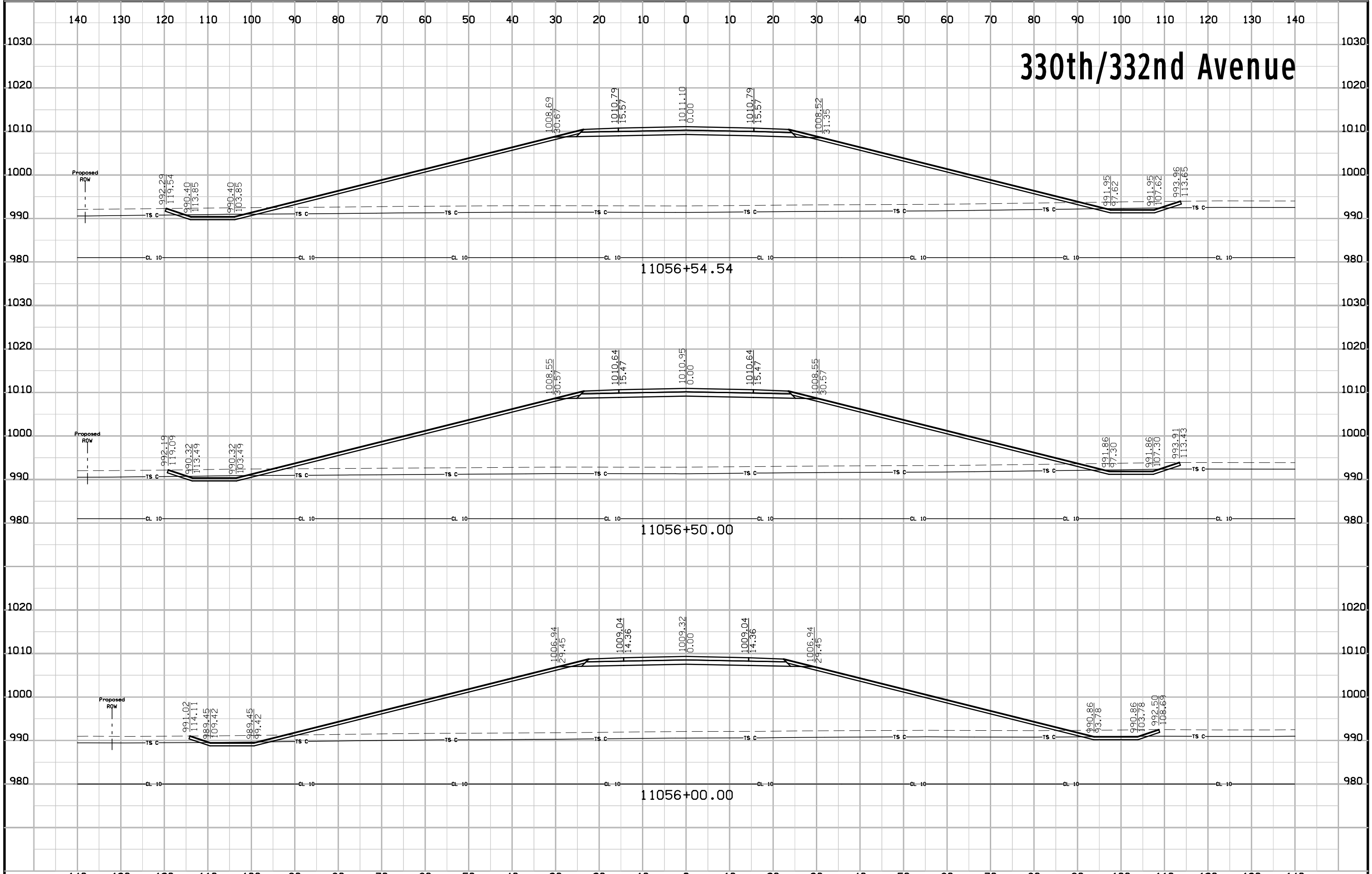

# 330th/332nd Avenue

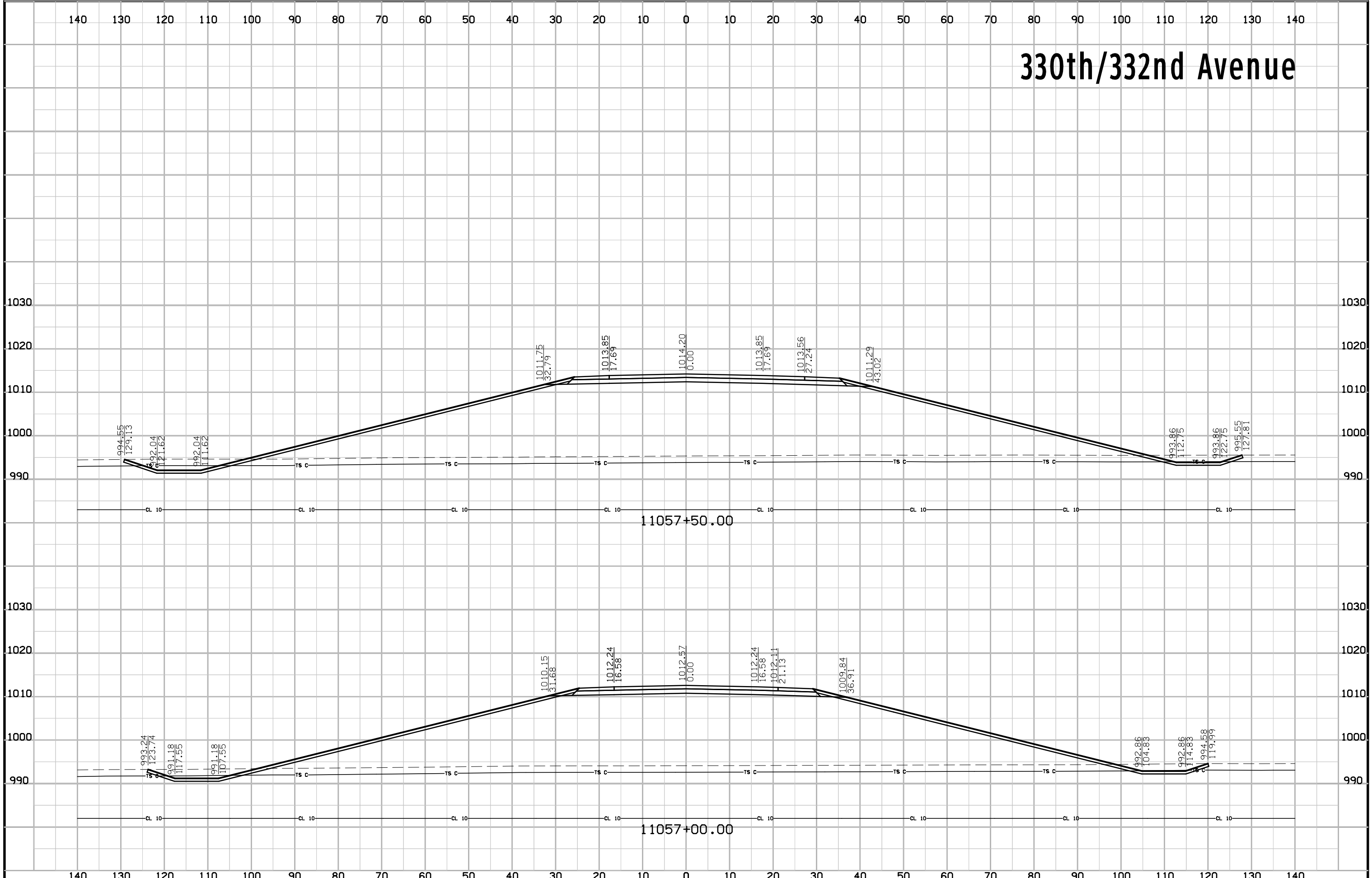



# 330th/332nd Avenue

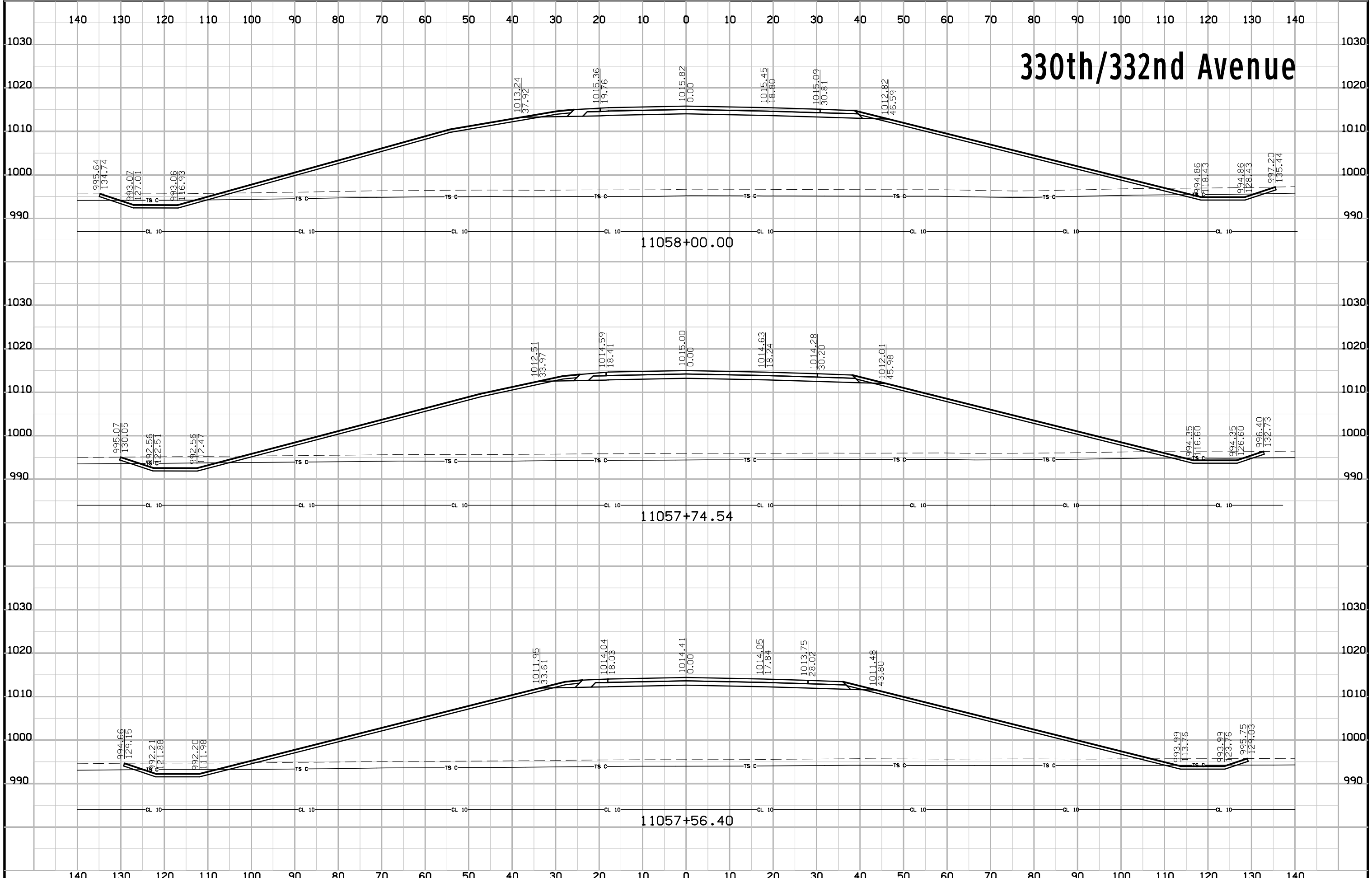

# 330th/332nd Avenue

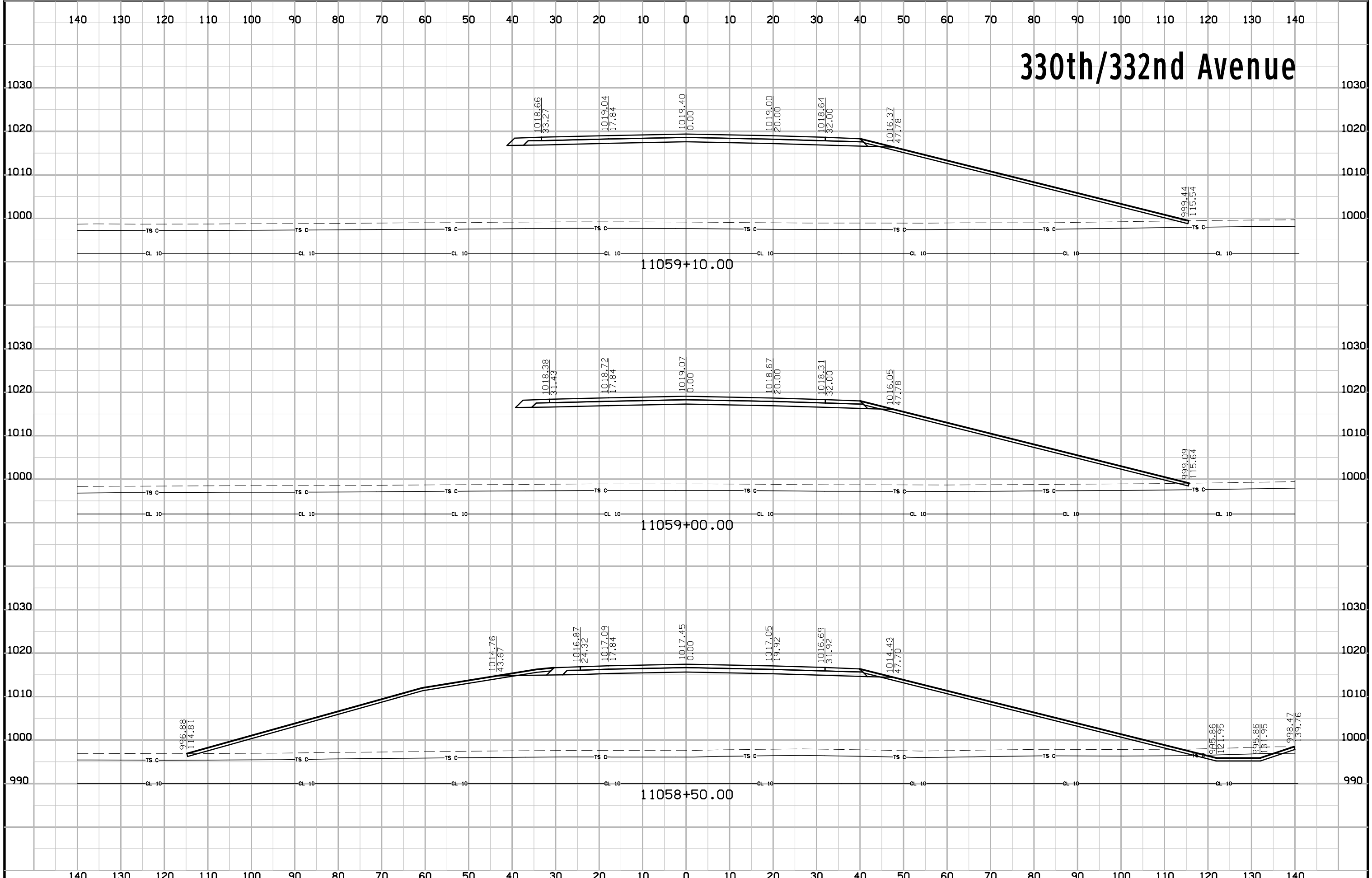

# 330th/332nd Avenue

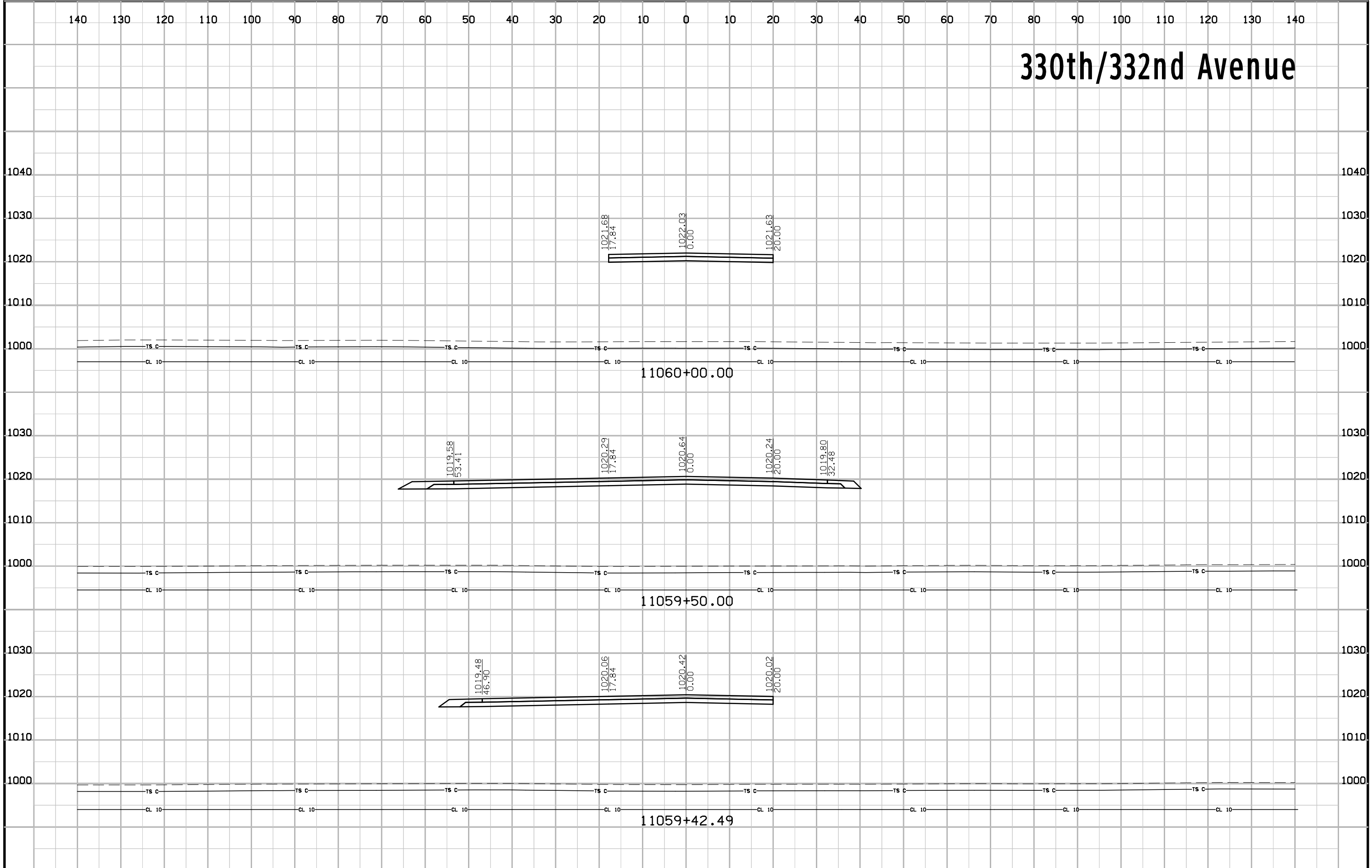

# 330th/332nd Avenue

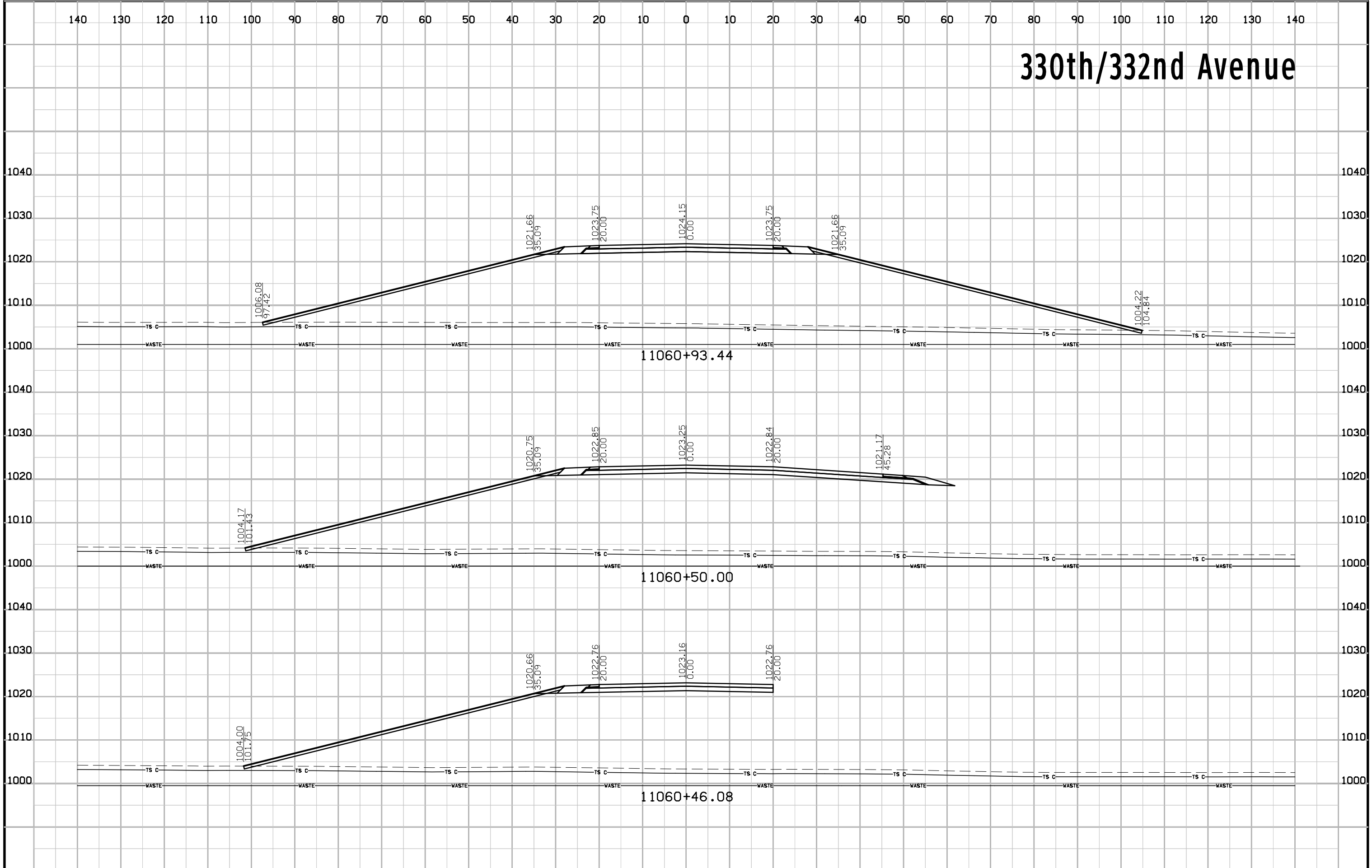

# 330th/332nd Avenue

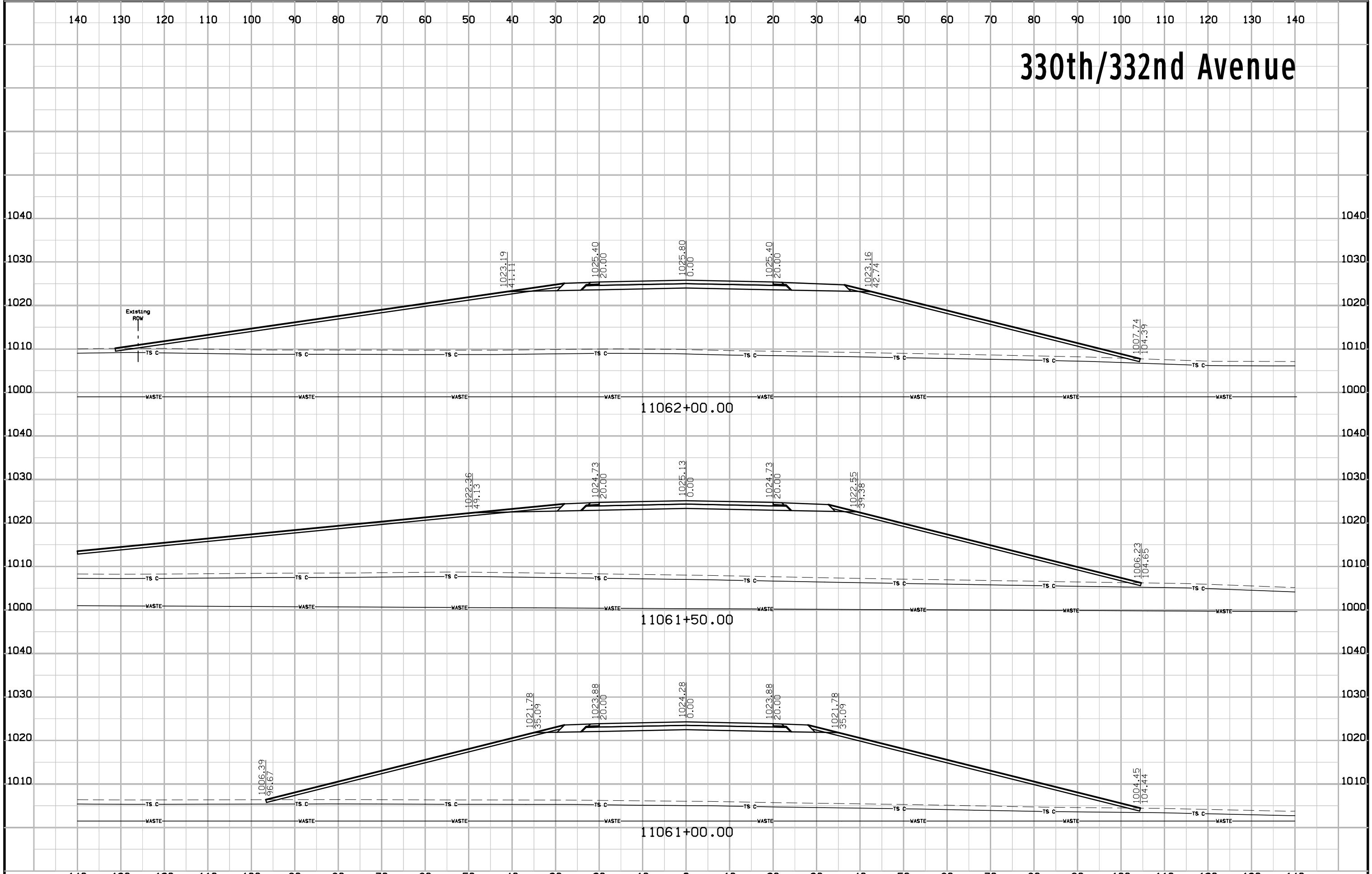

# 330th/332nd Avenue

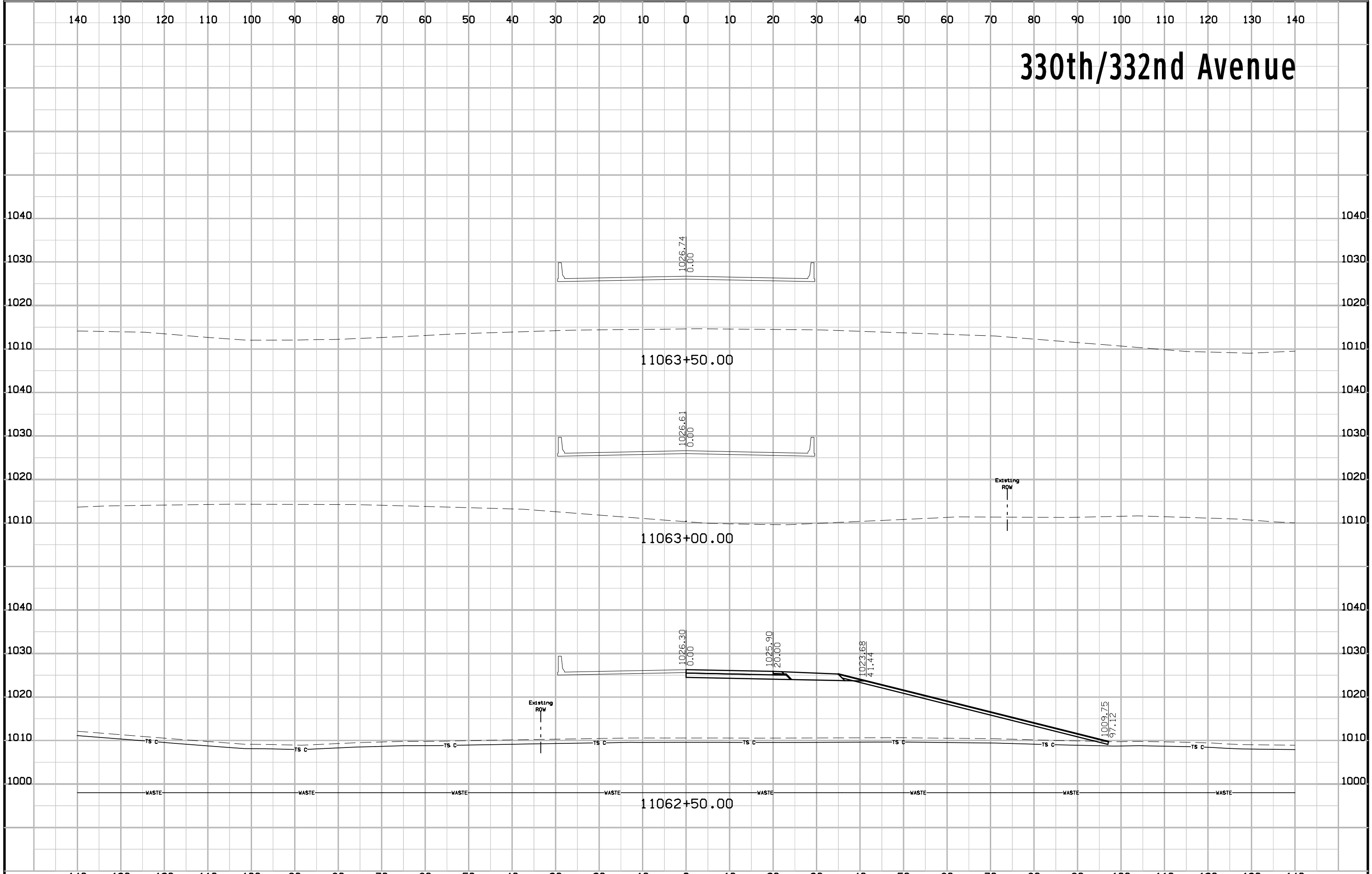

# 330th/332nd Avenue

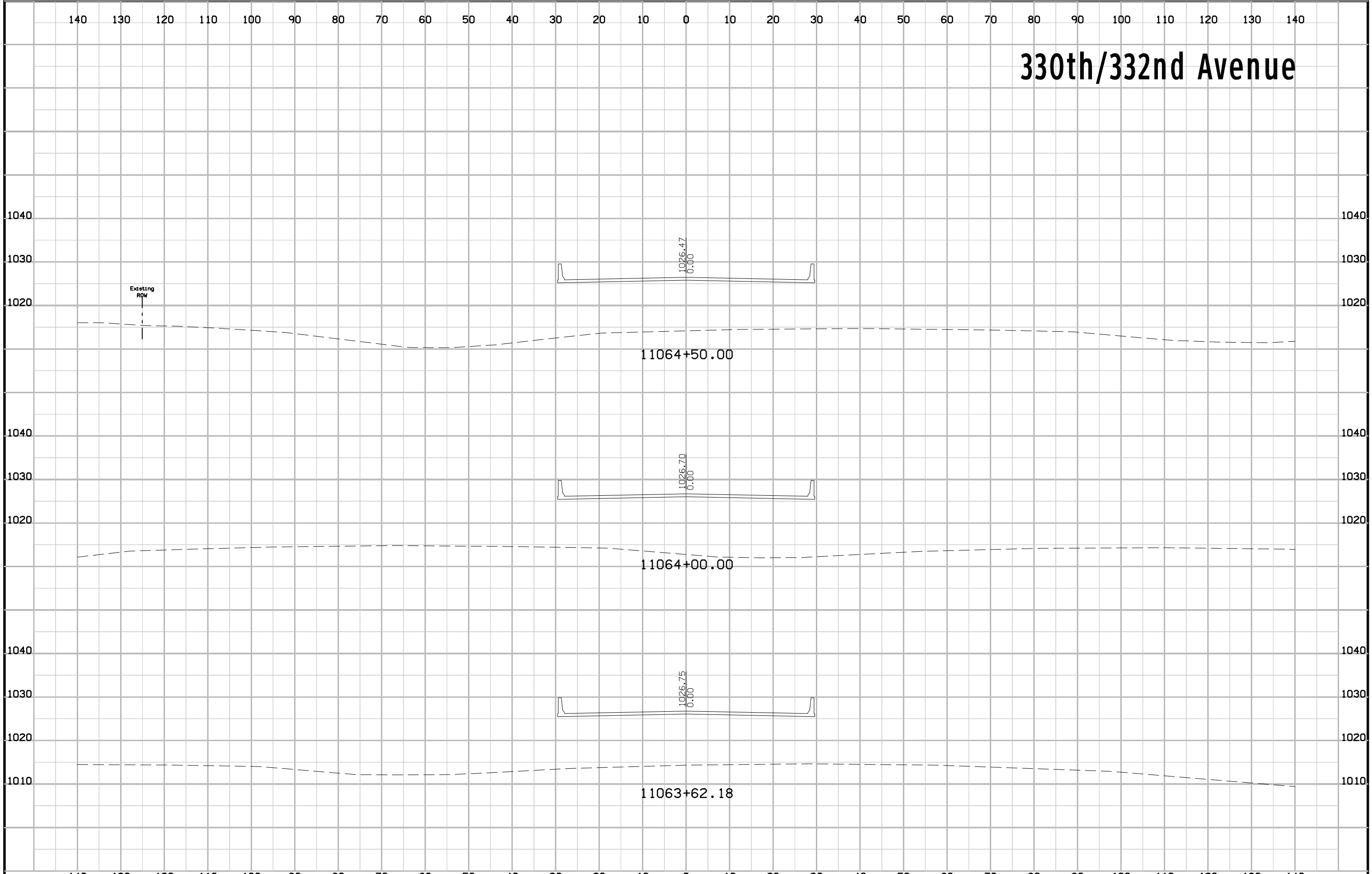



# 330th/332nd Avenue

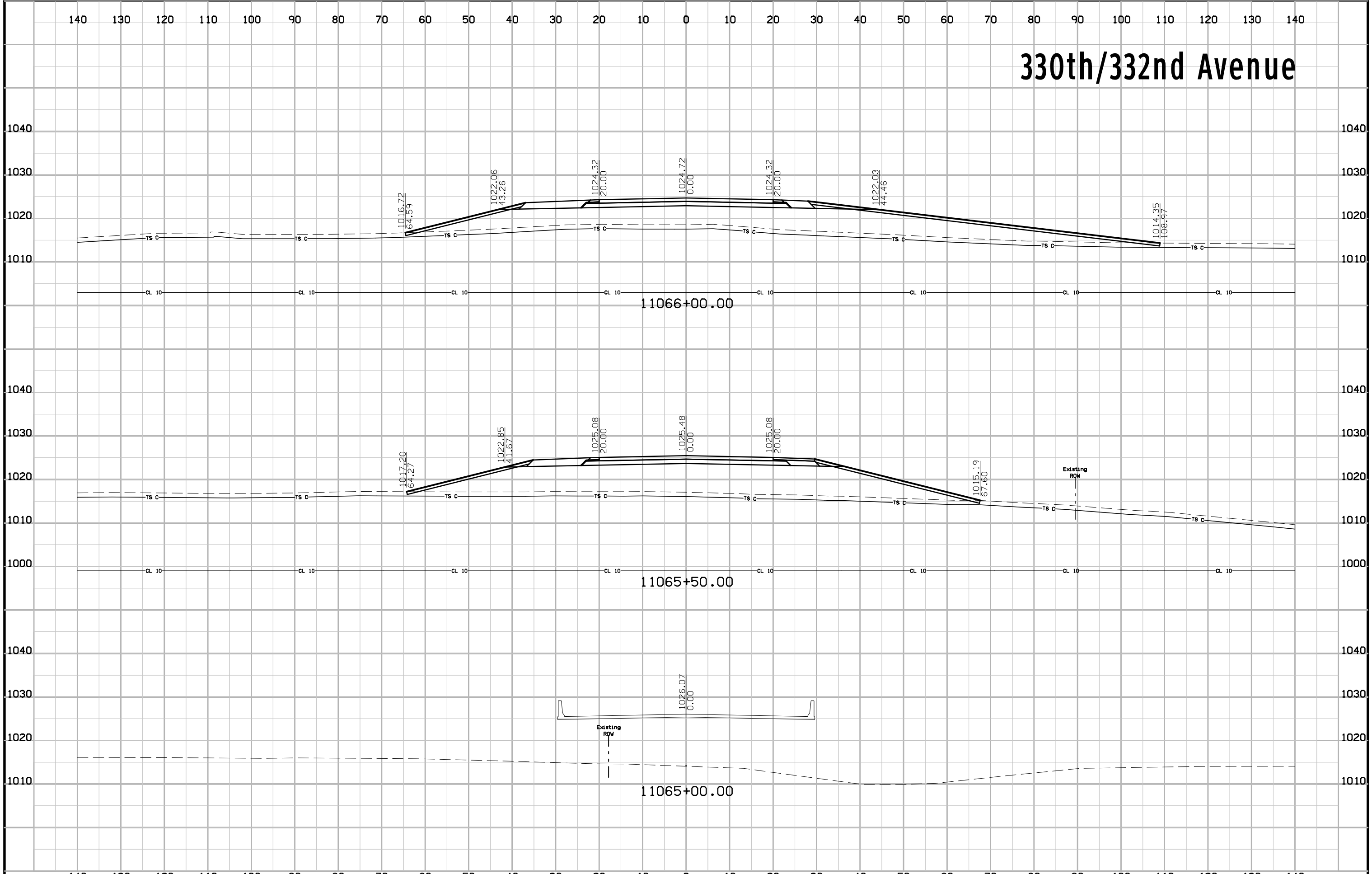

# 330th/332nd Avenue

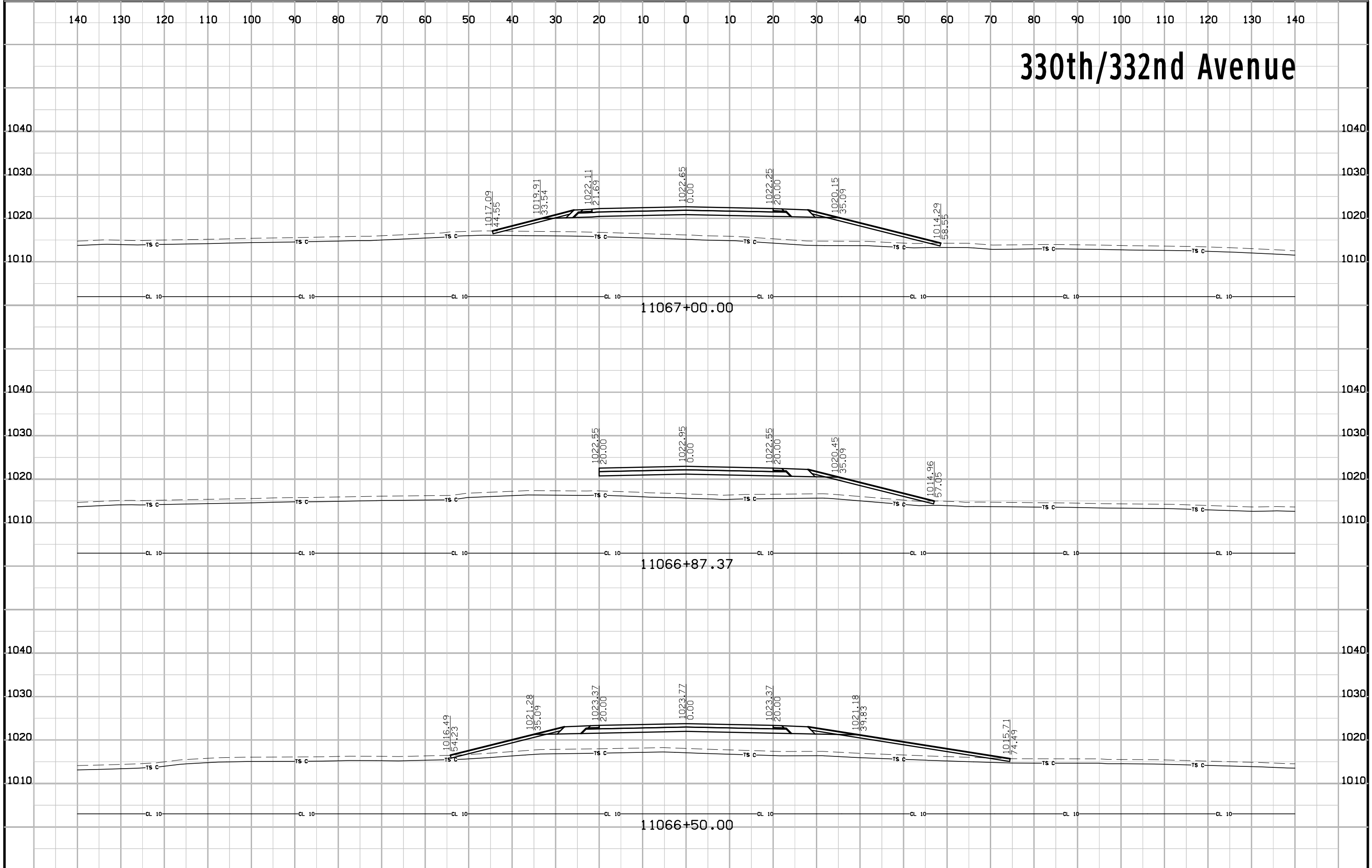

# 330th/332nd Avenue

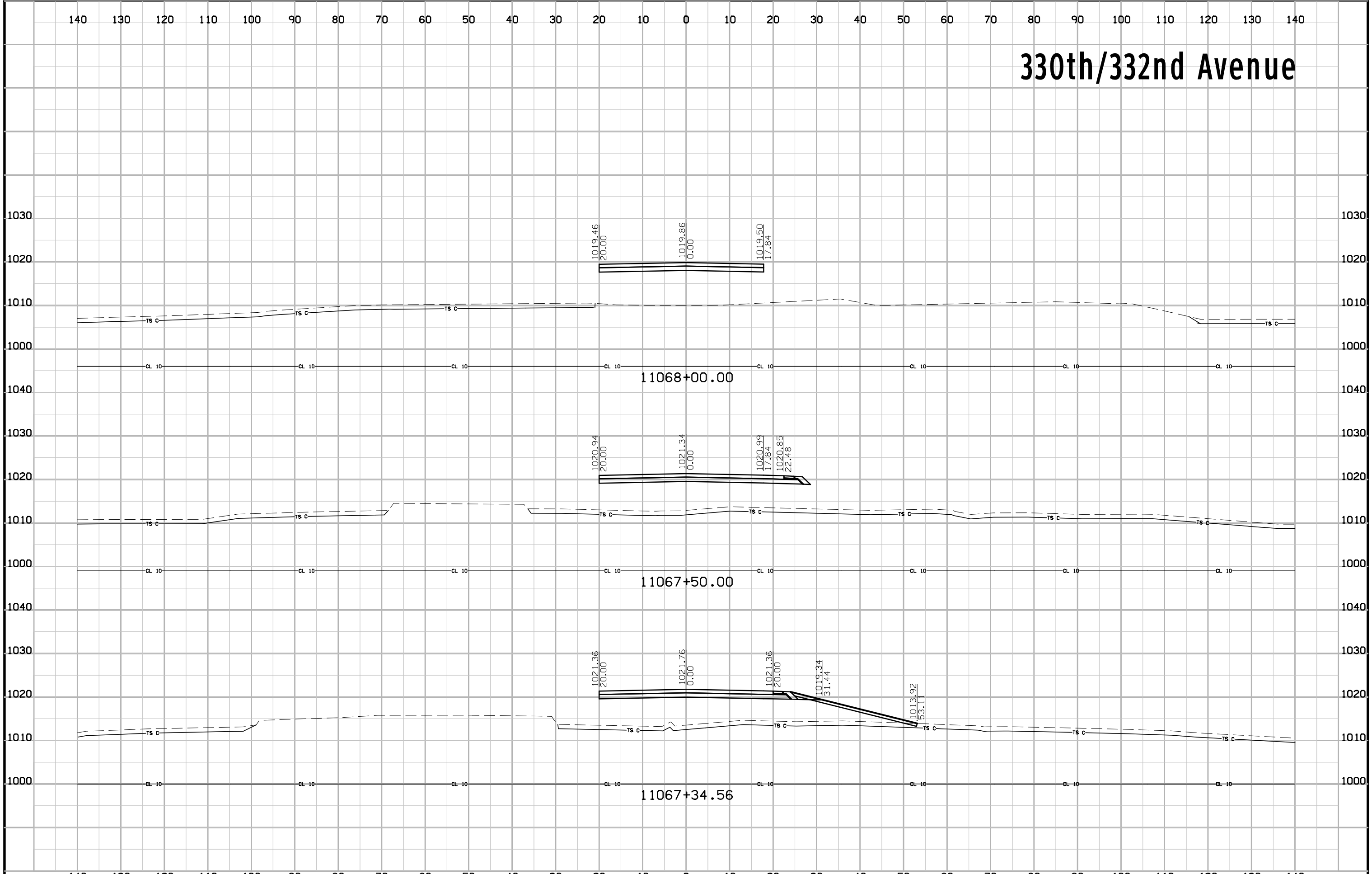

# 330th/332nd Avenue

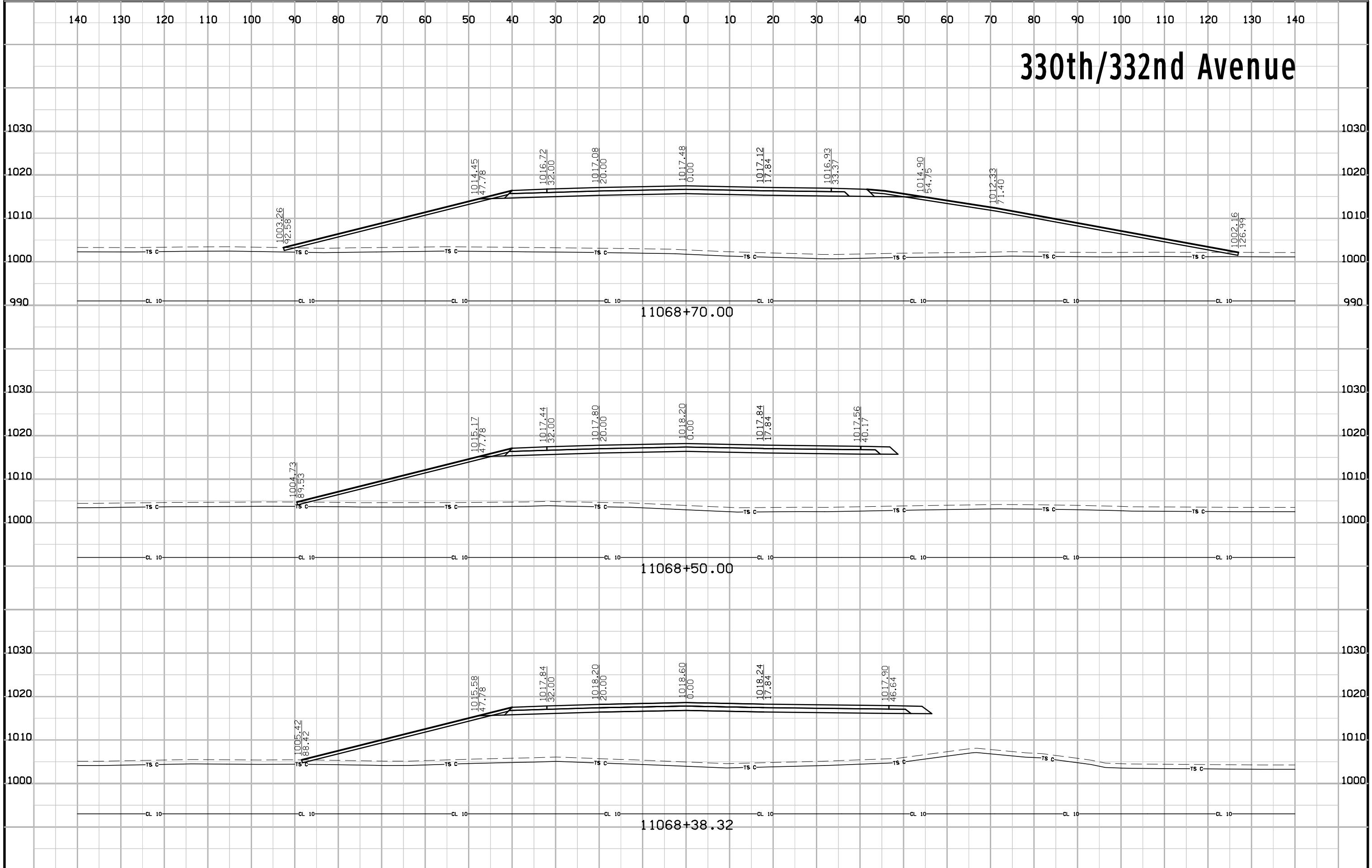

# 330th/332nd Avenue

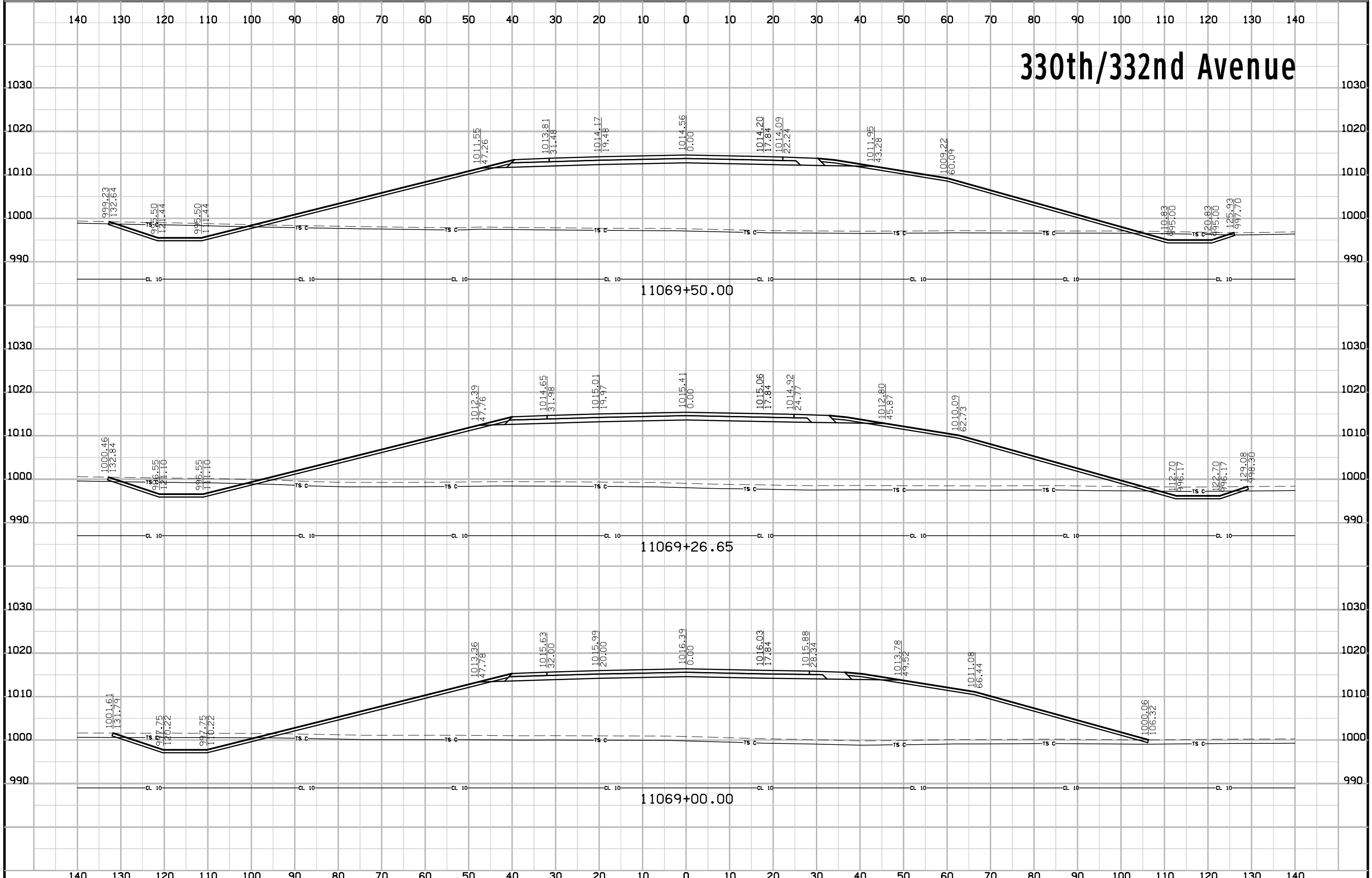

# 330th/332nd Avenue

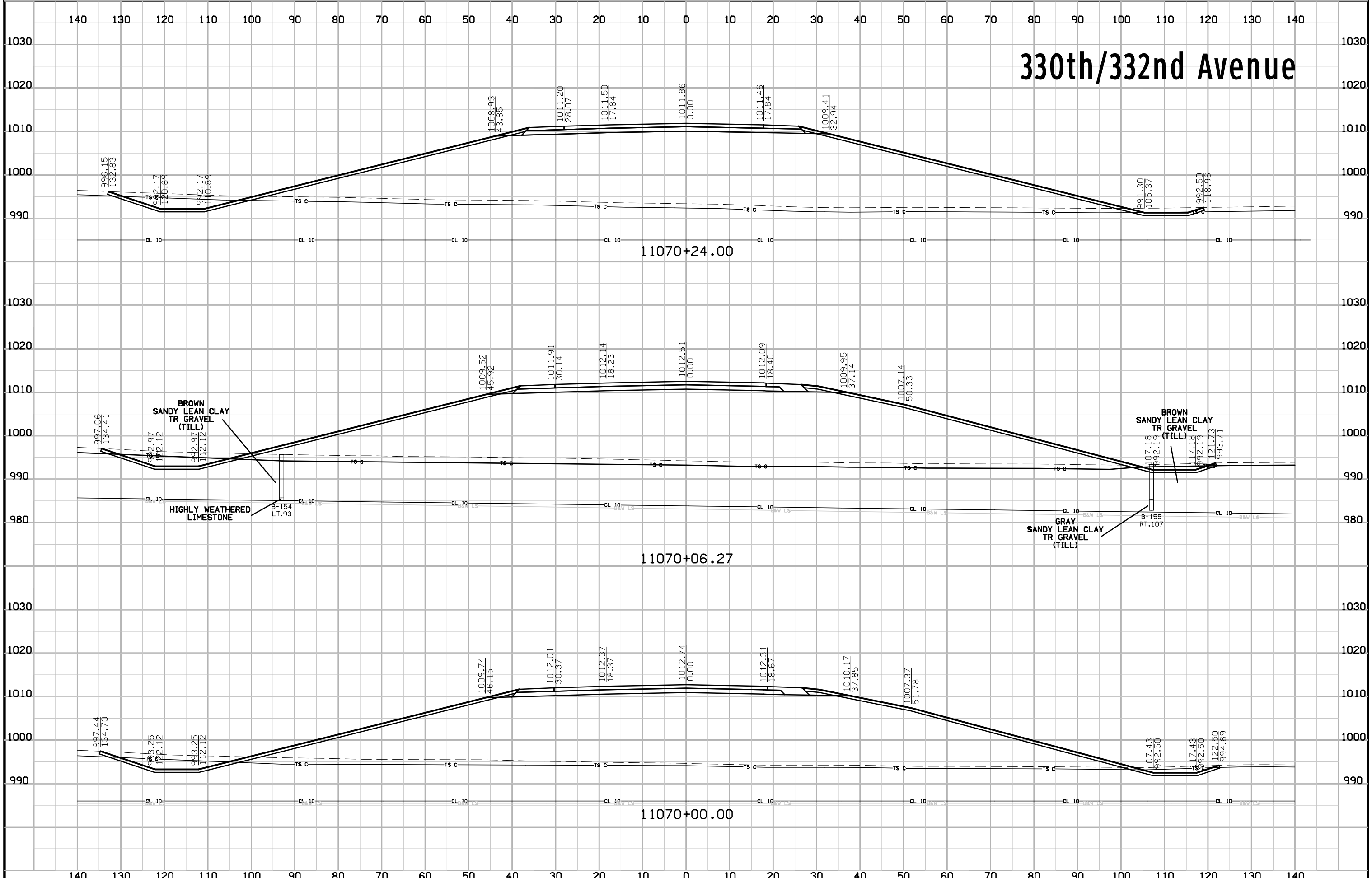

# 330th/332nd Avenue

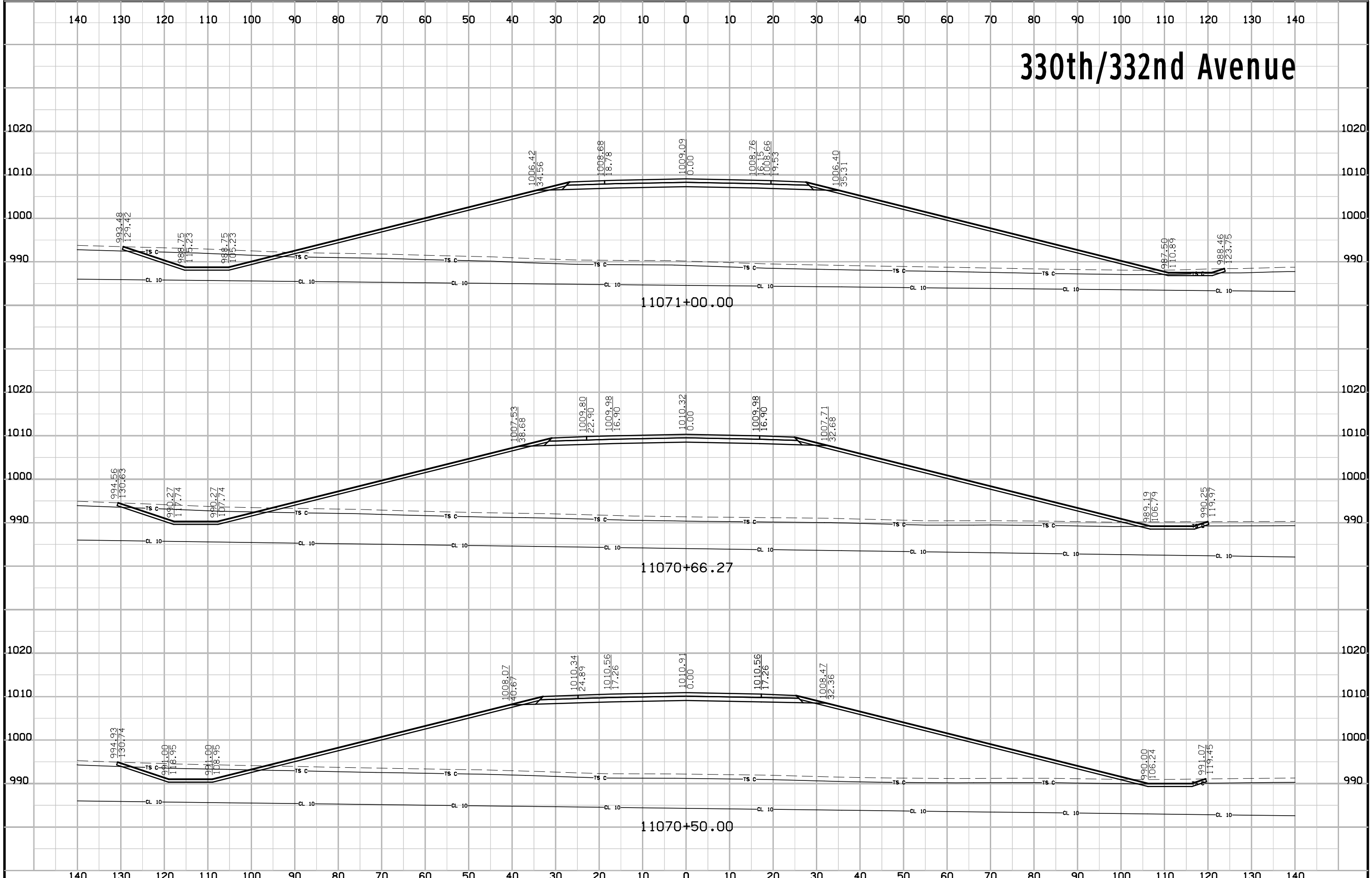

# 330th/332nd Avenue

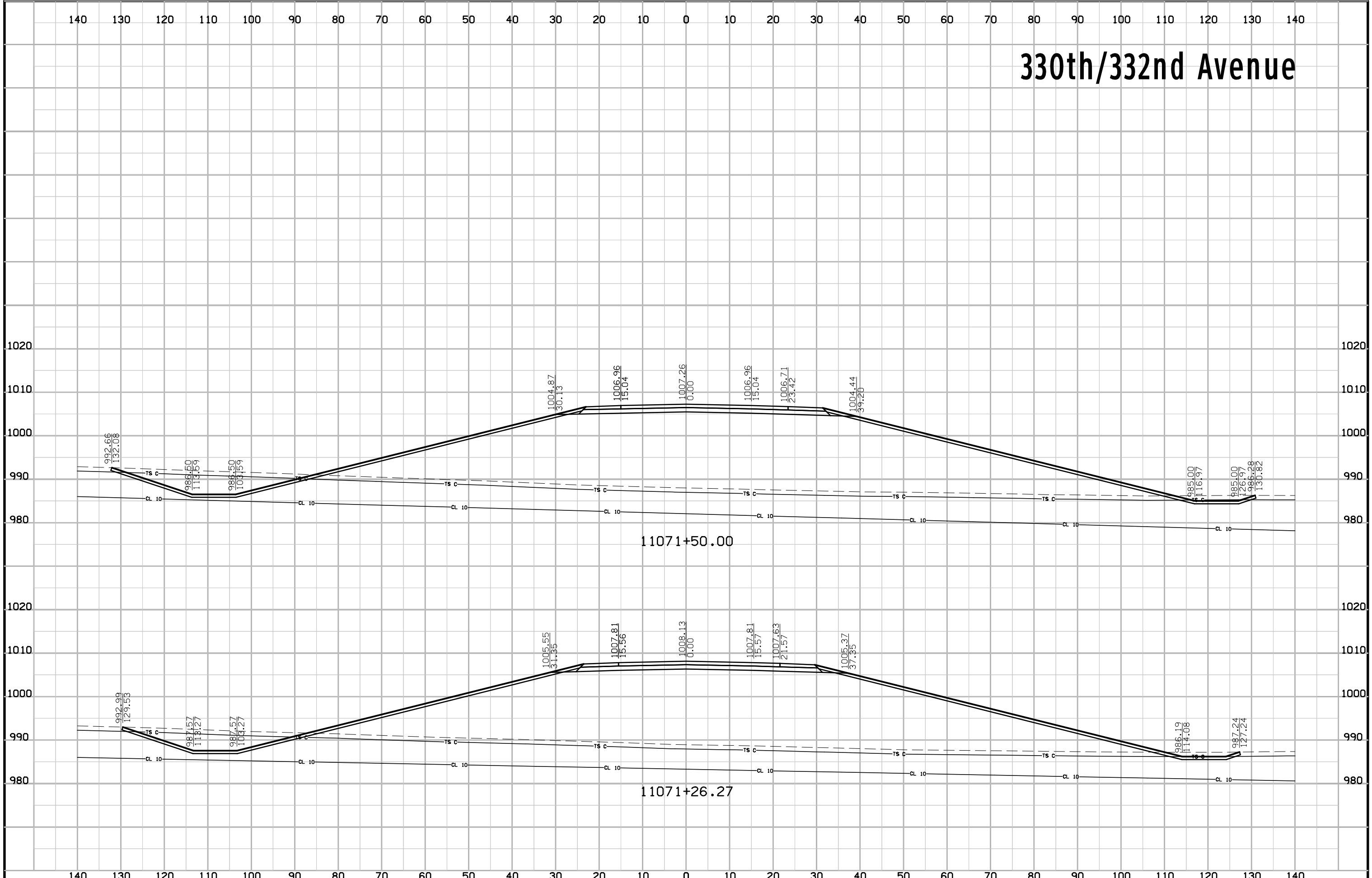



# 330th/332nd Avenue

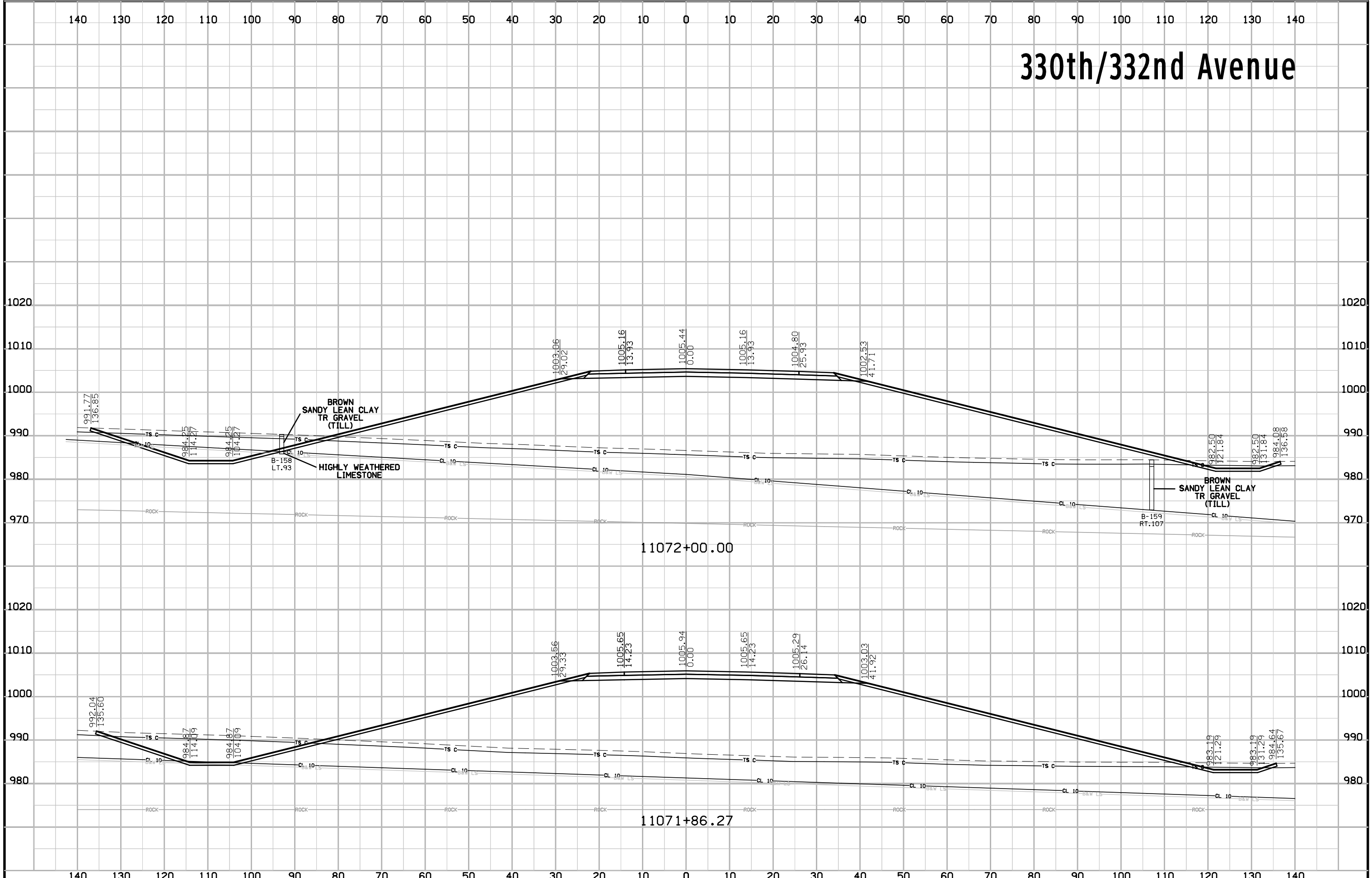

# 330th/332nd Avenue

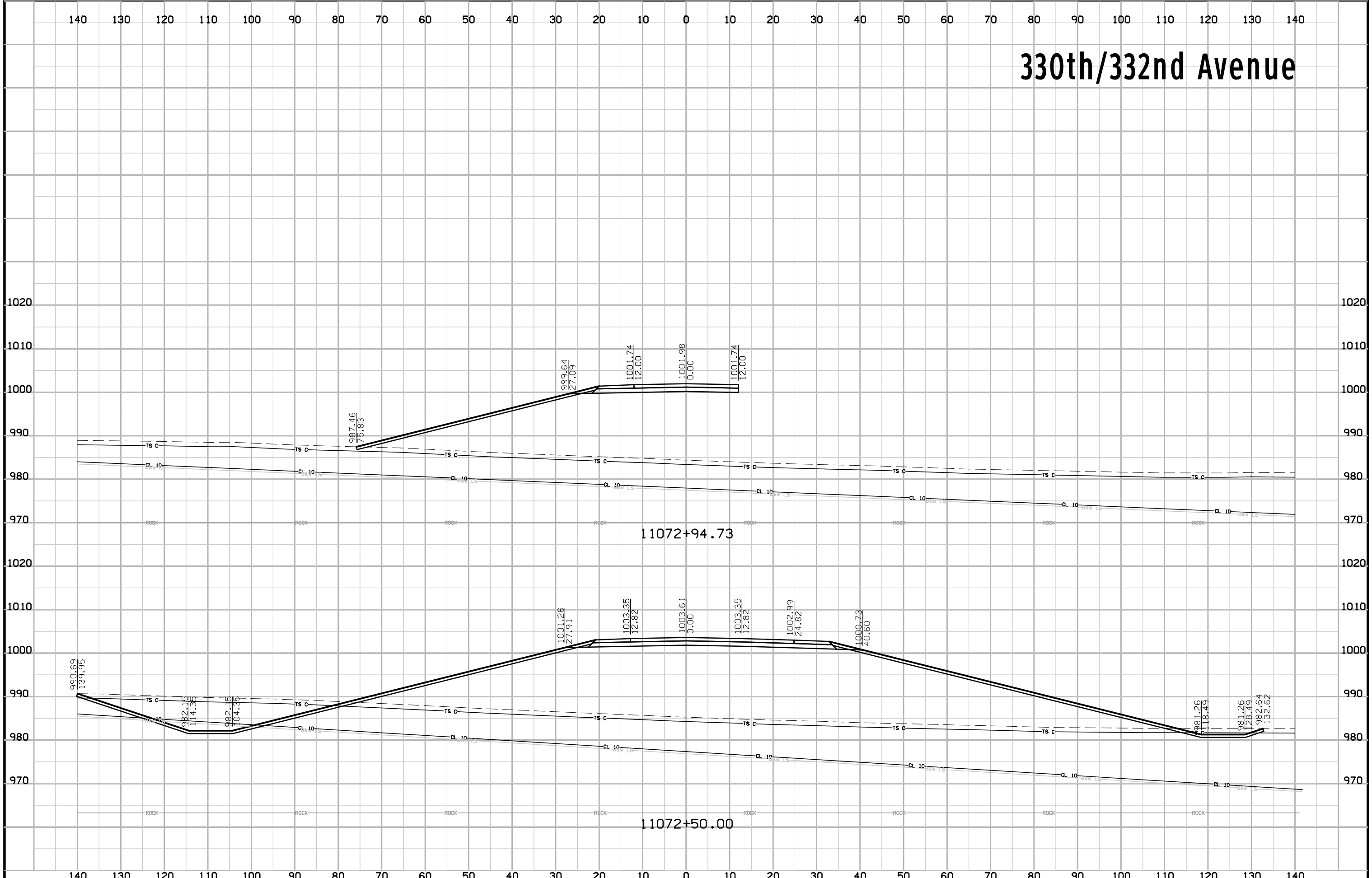

# 330th/332nd Avenue

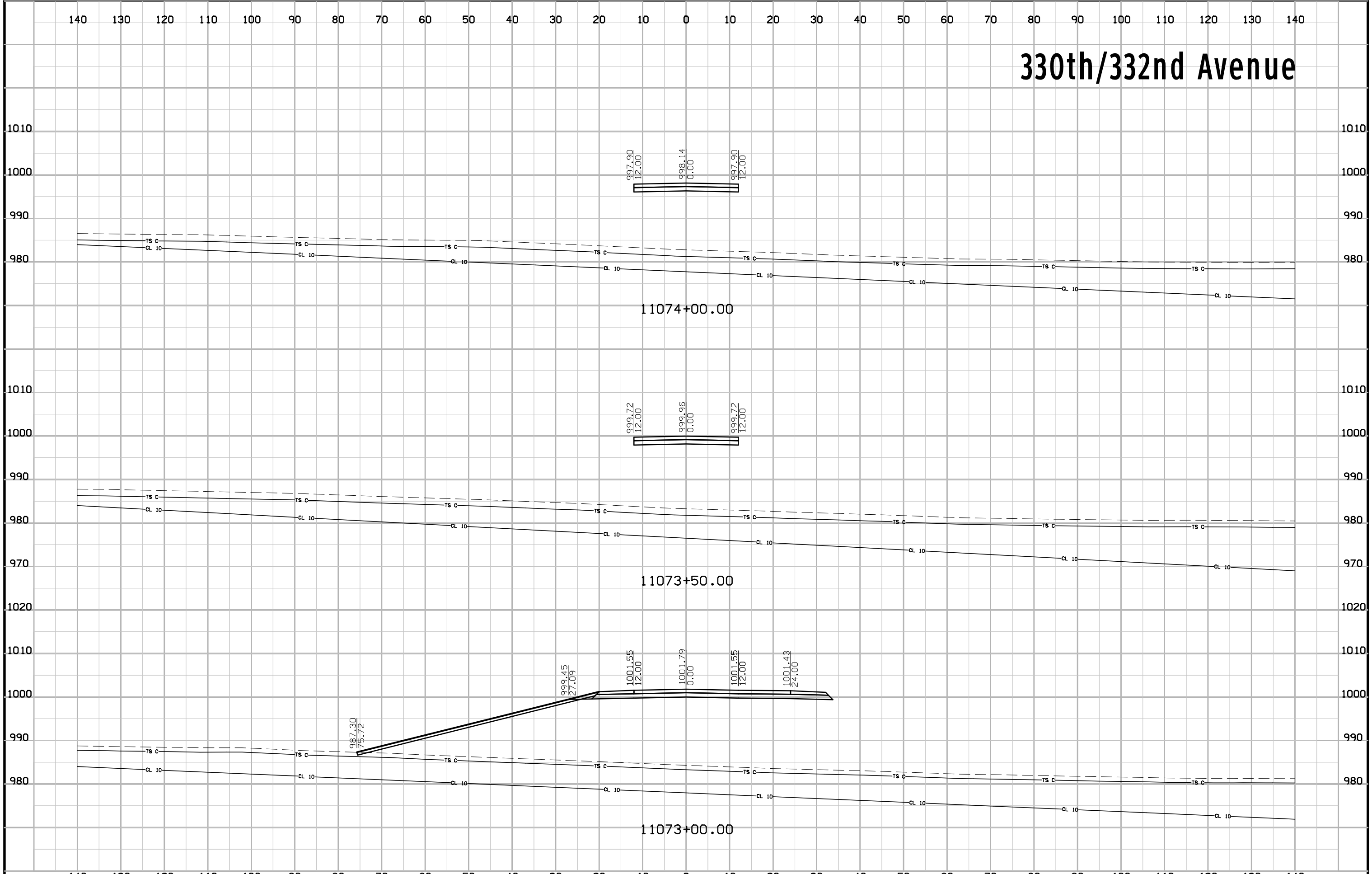

# 330th/332nd Avenue

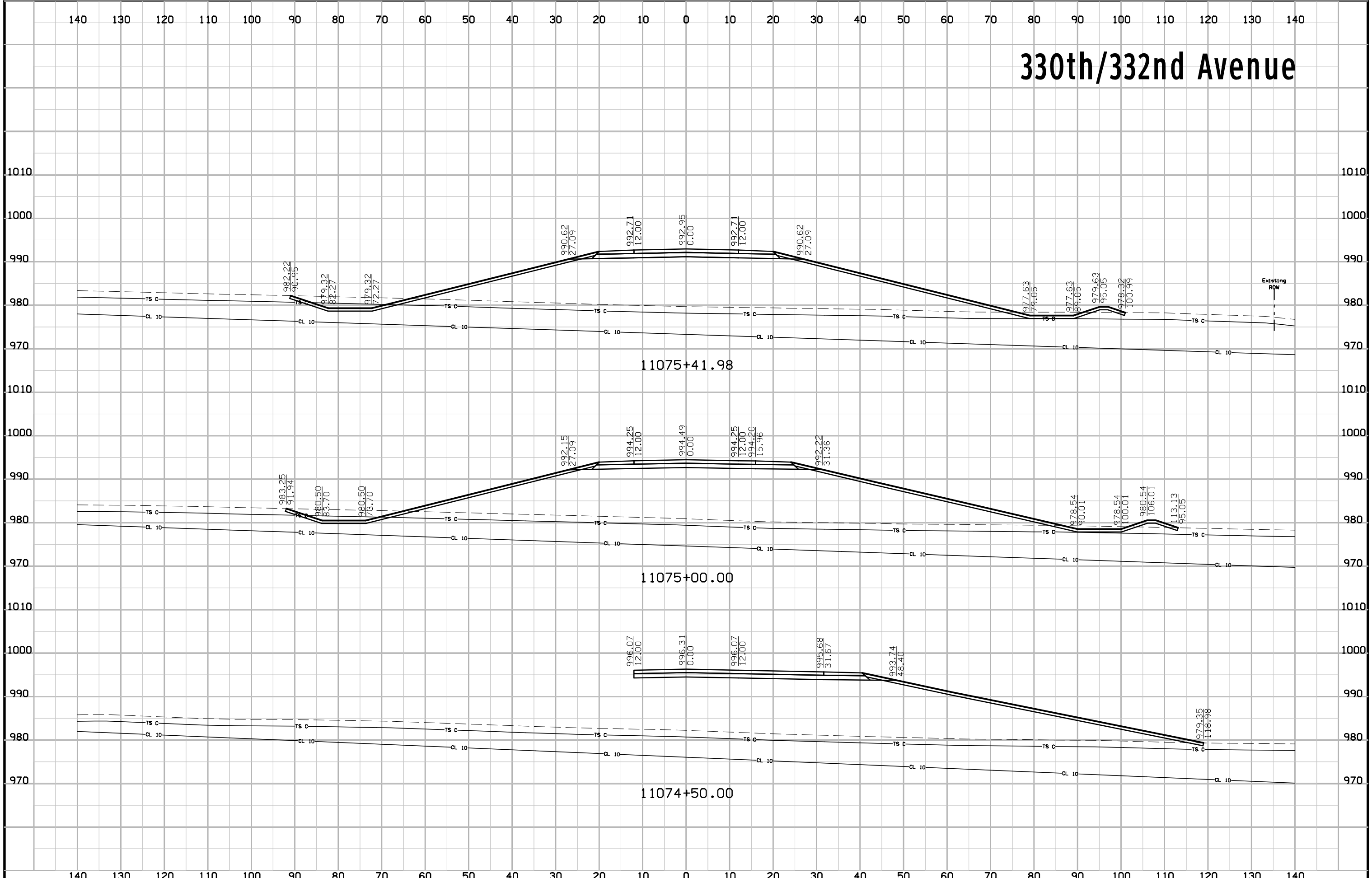

# 330th/332nd Avenue

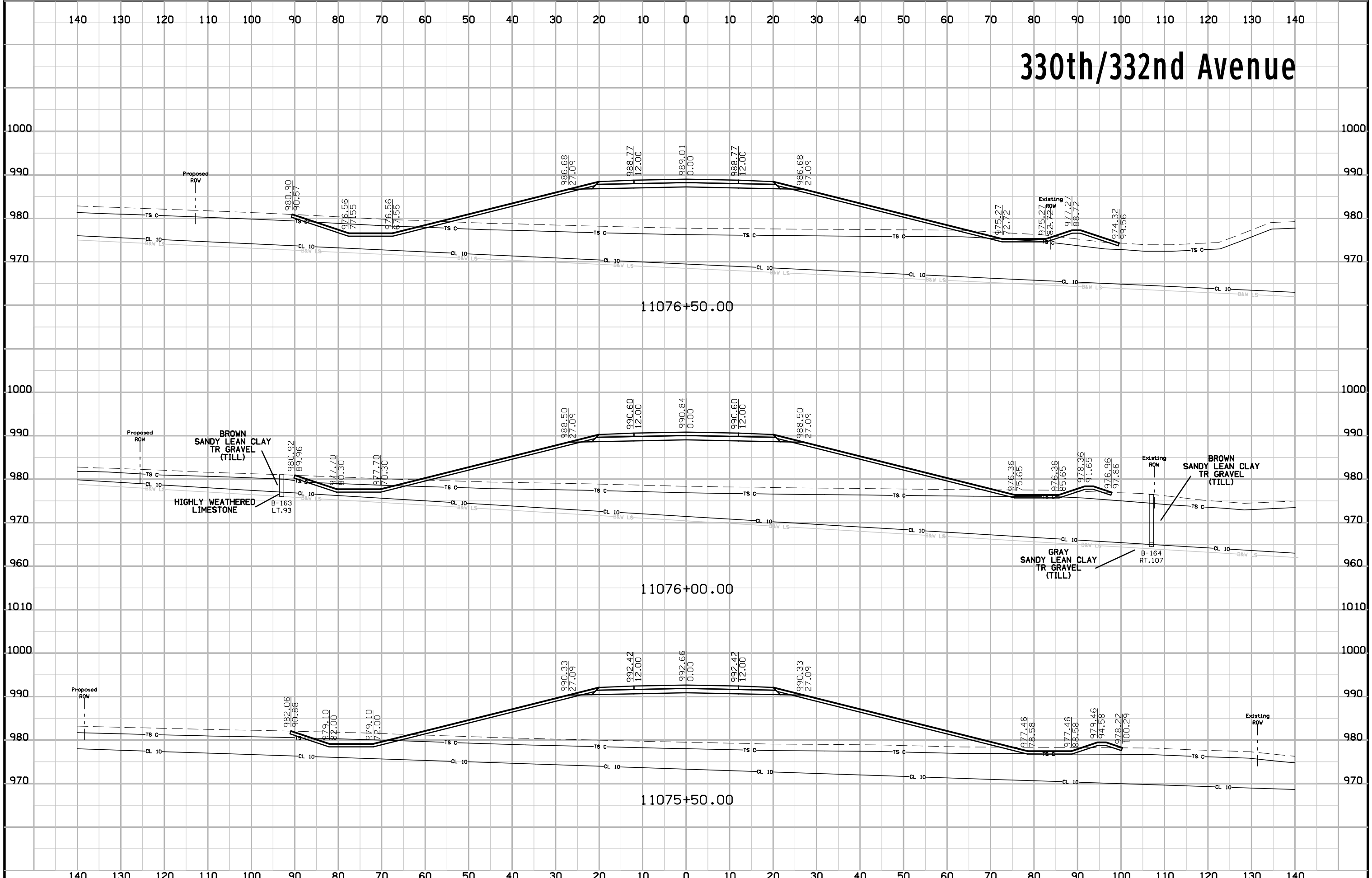

# 330th/332nd Avenue

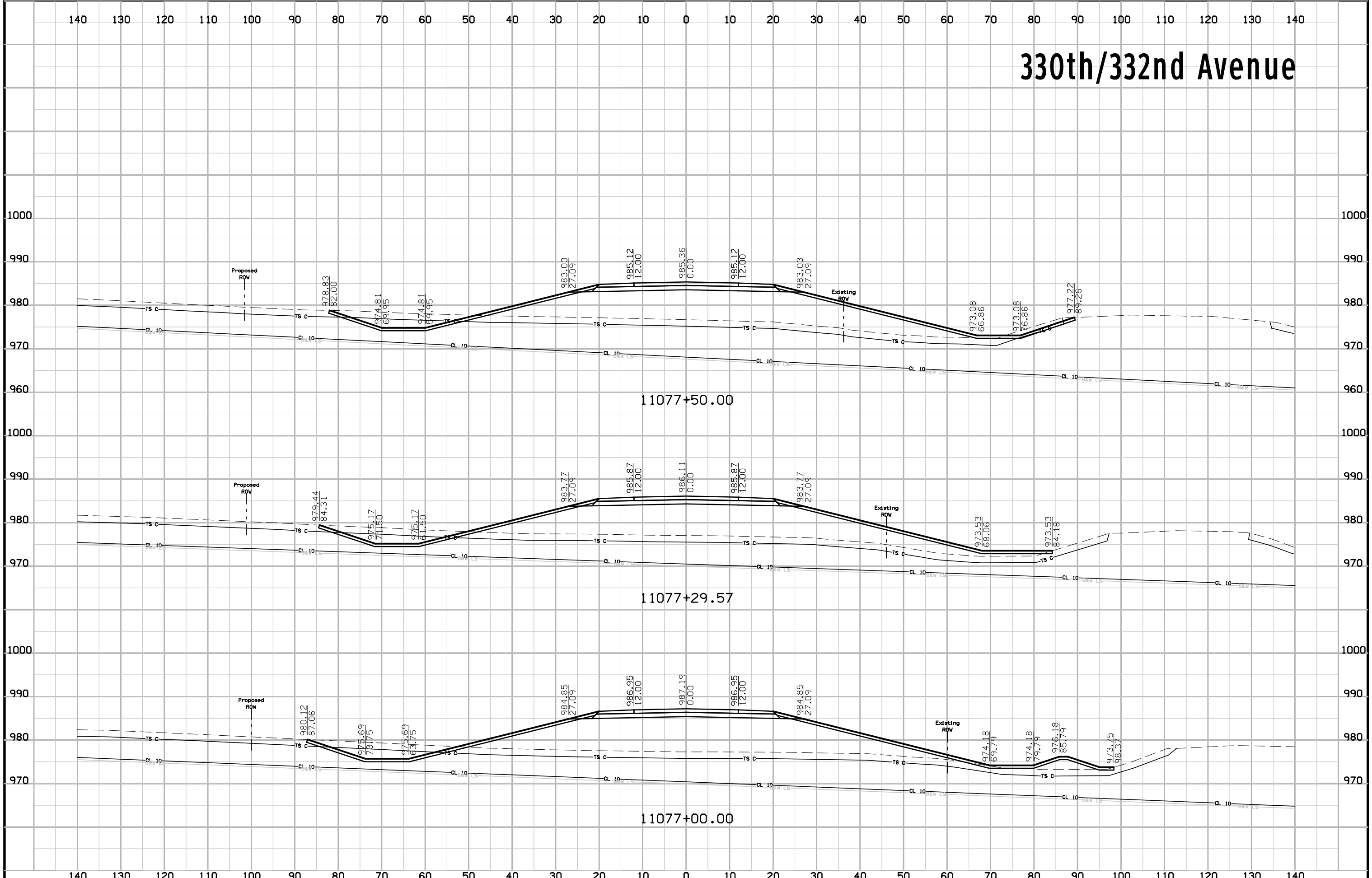

# 330th/332nd Avenue

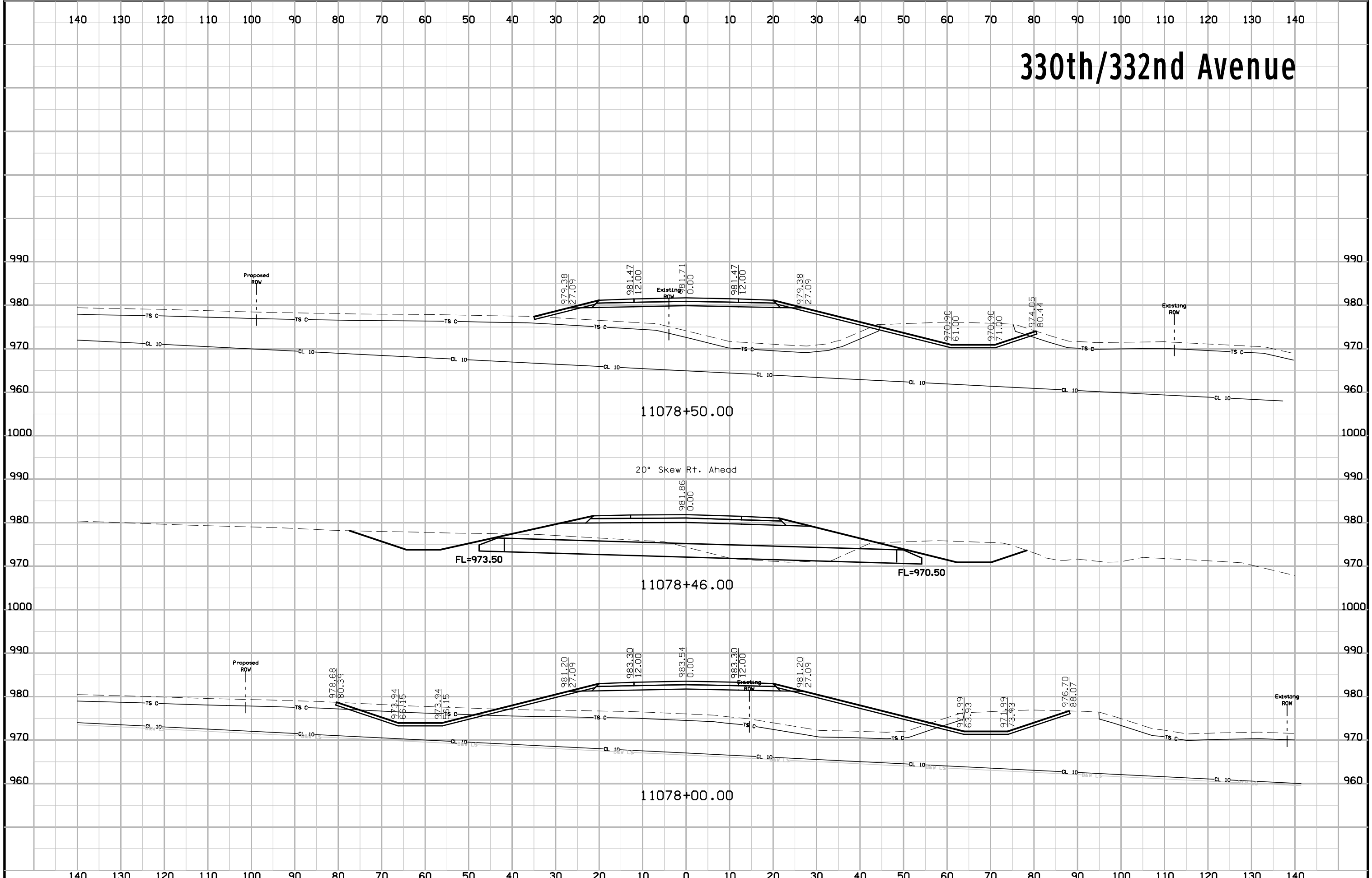

# 330th/332nd Avenue

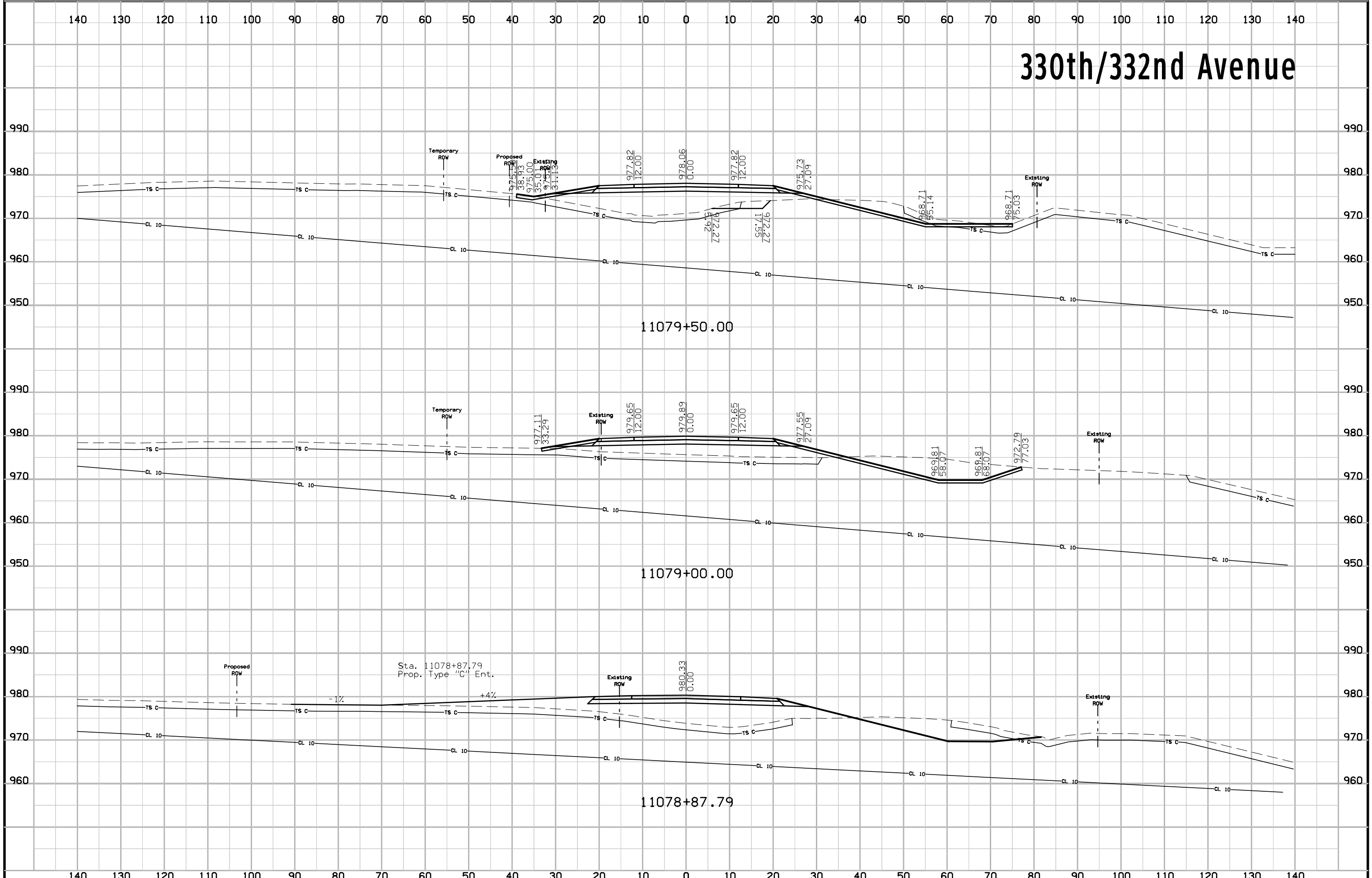



# 330th/332nd Avenue

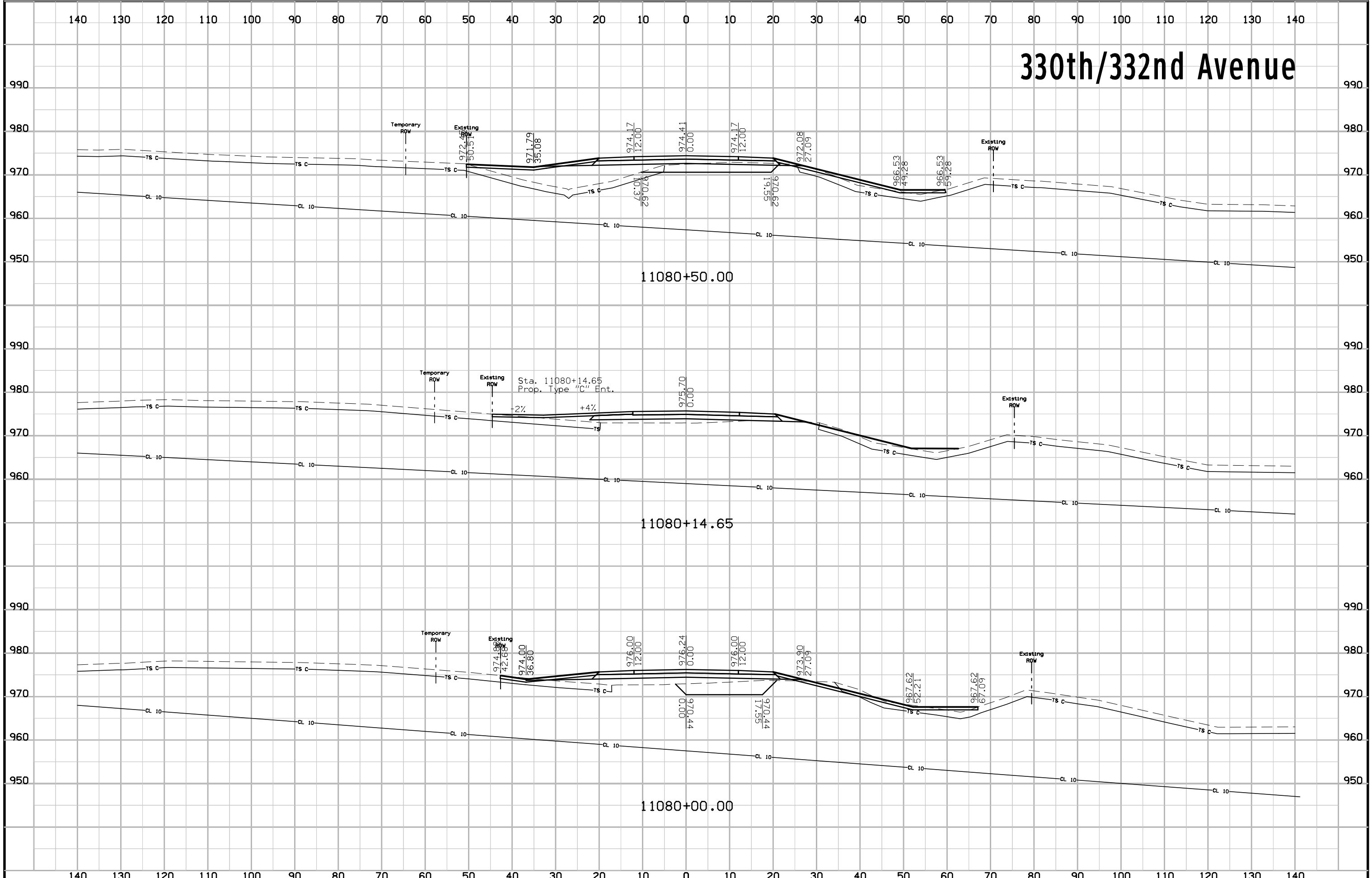

# 330th/332nd Avenue

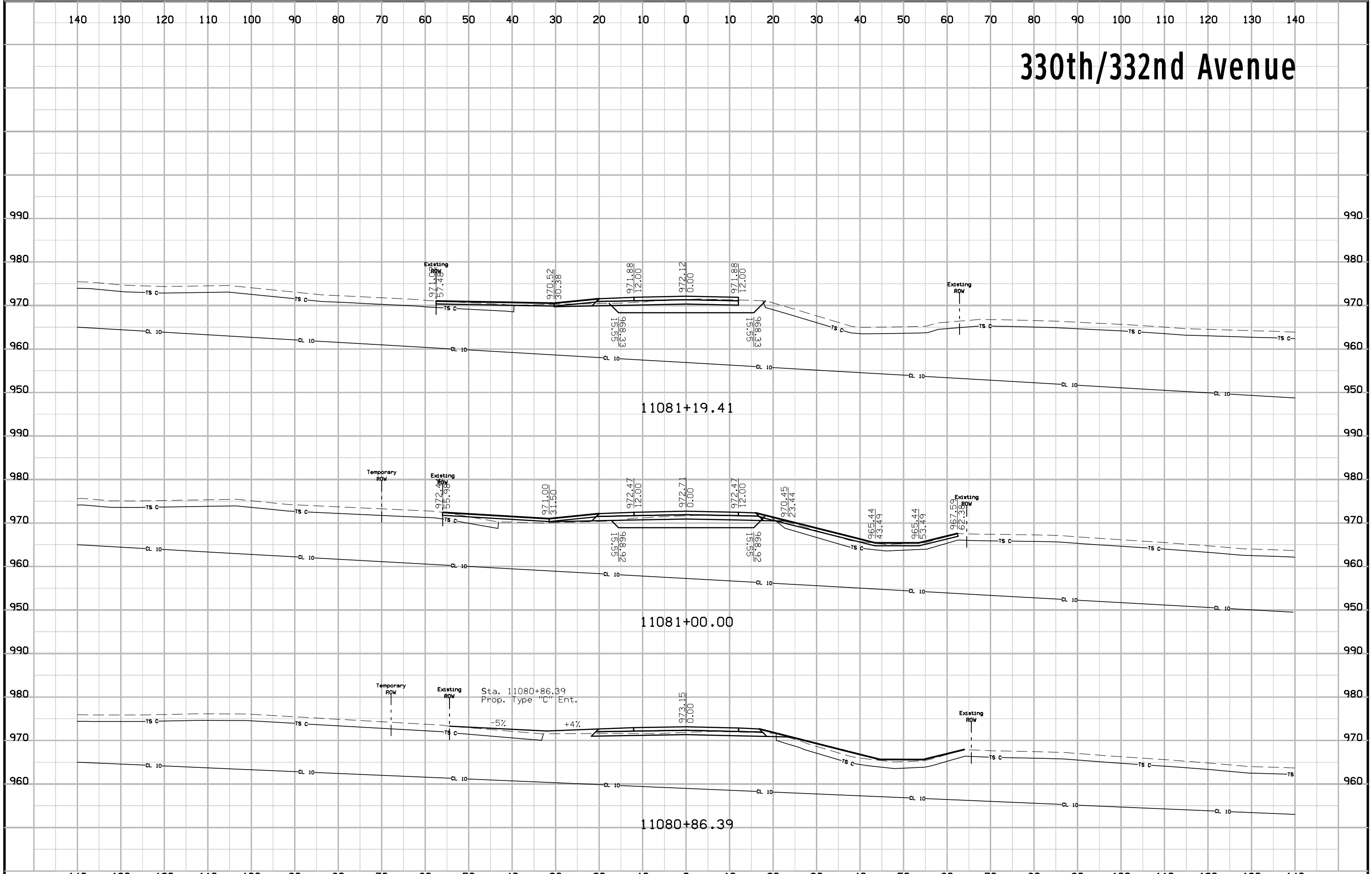

# 330th/332nd Avenue

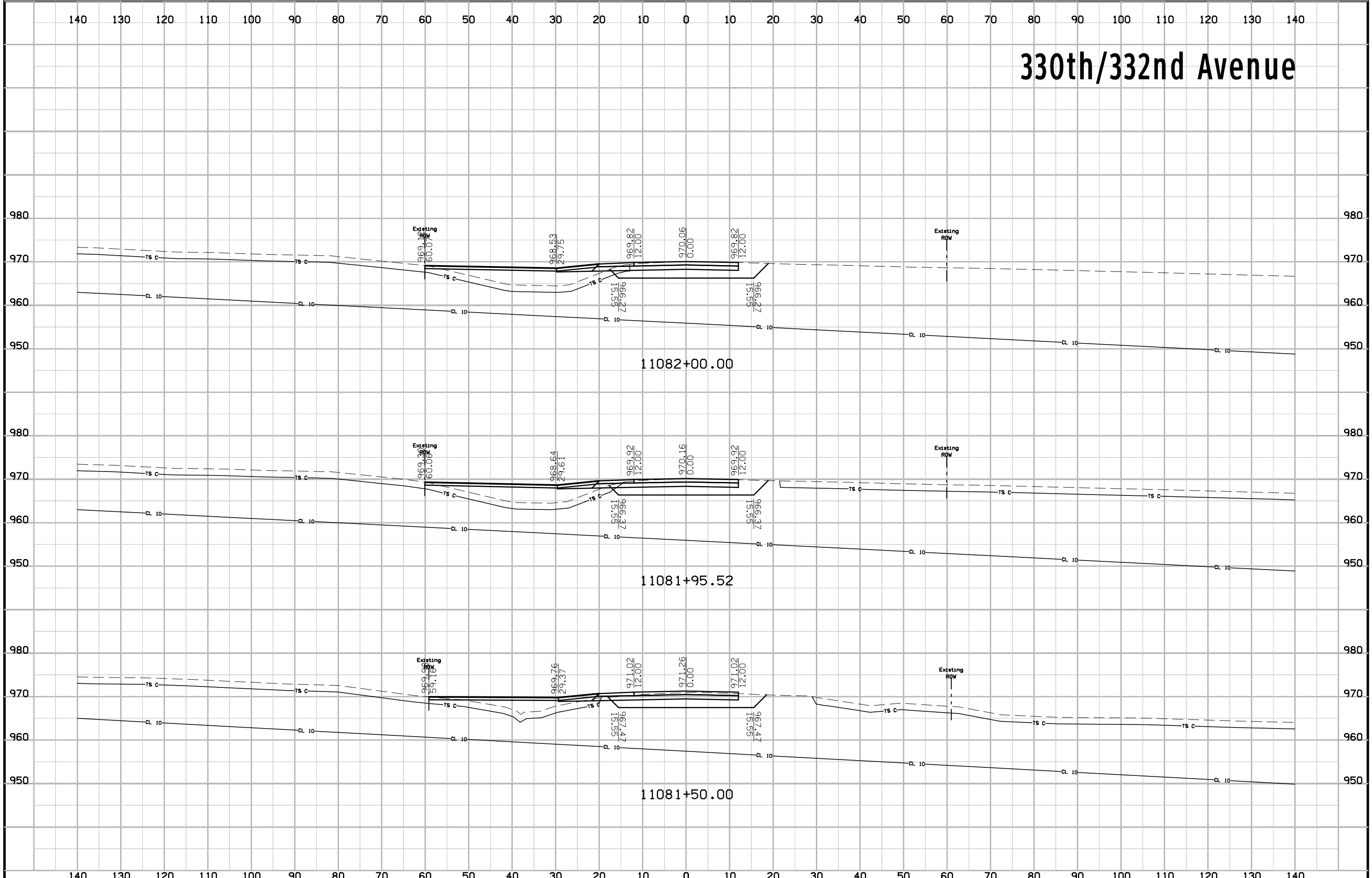



# Industrial Parkway

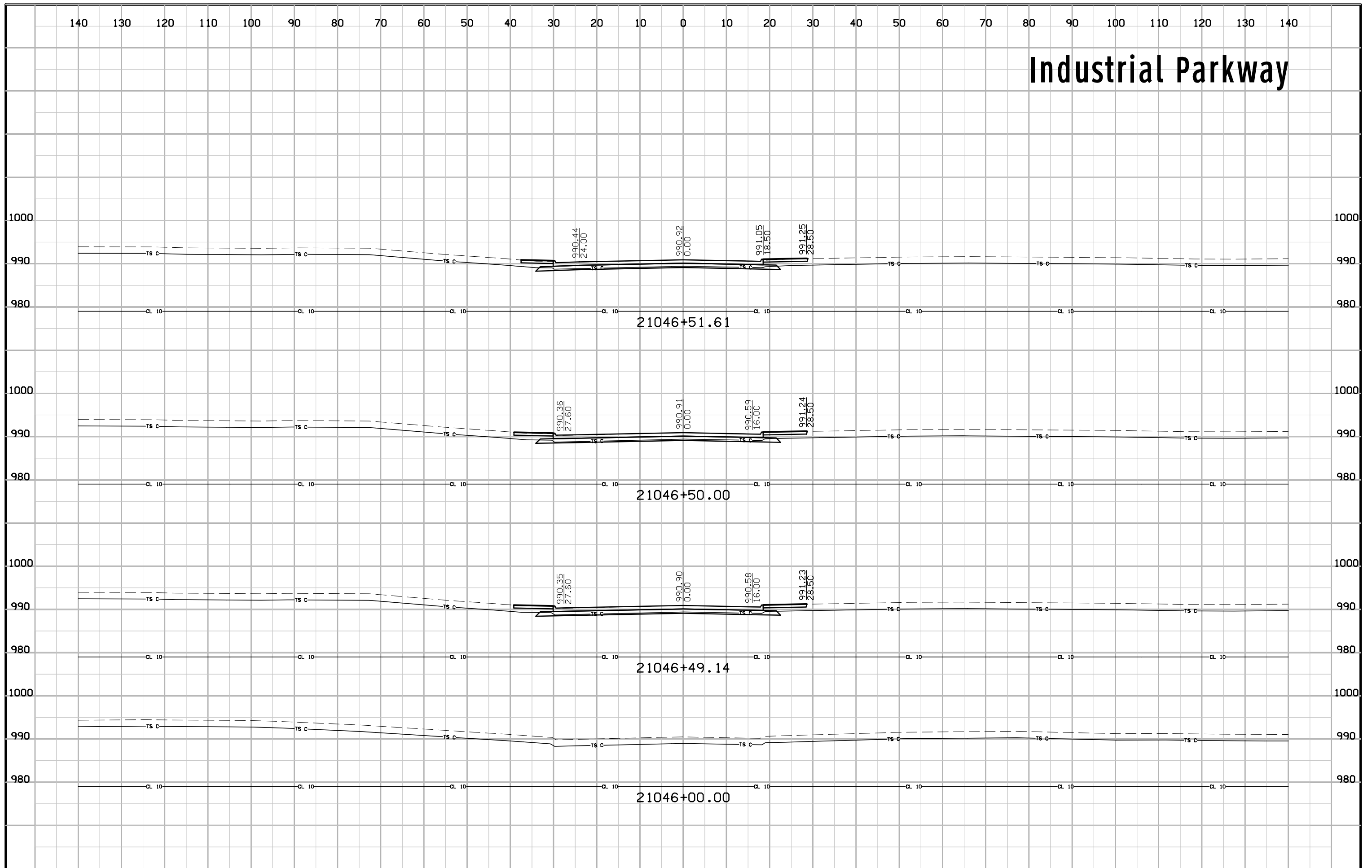

# Industrial Parkway

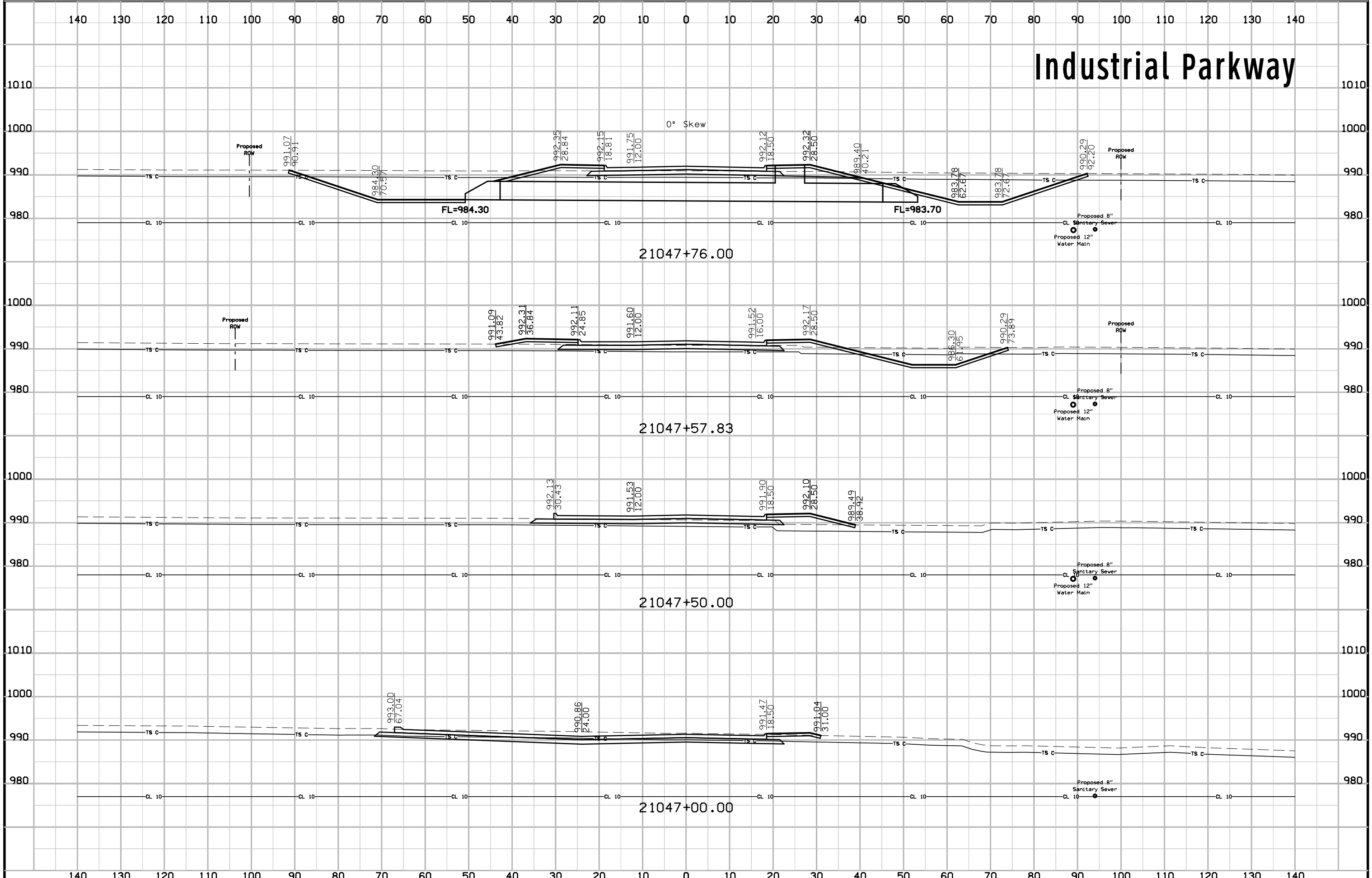

# Industrial Parkway

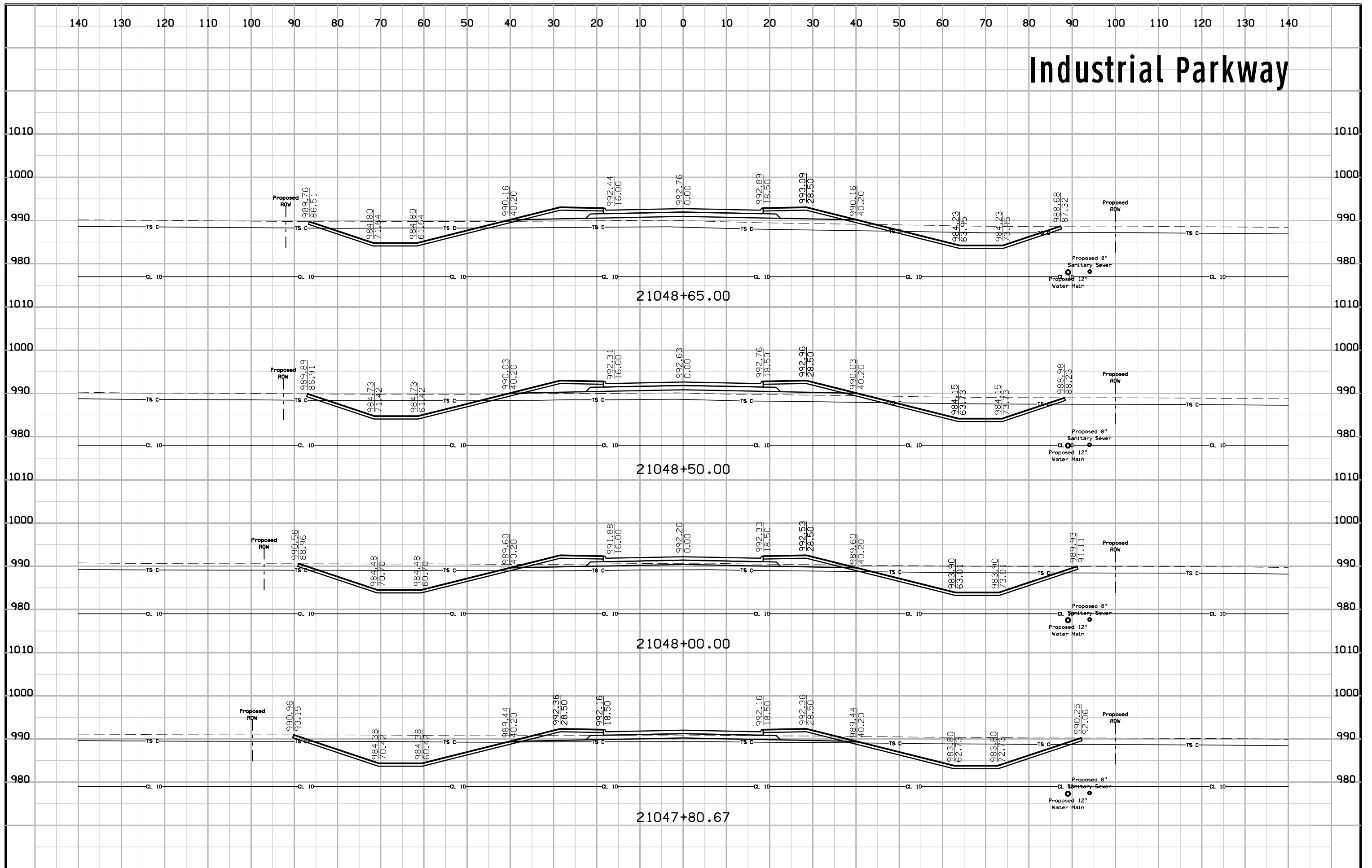

# Industrial Parkway

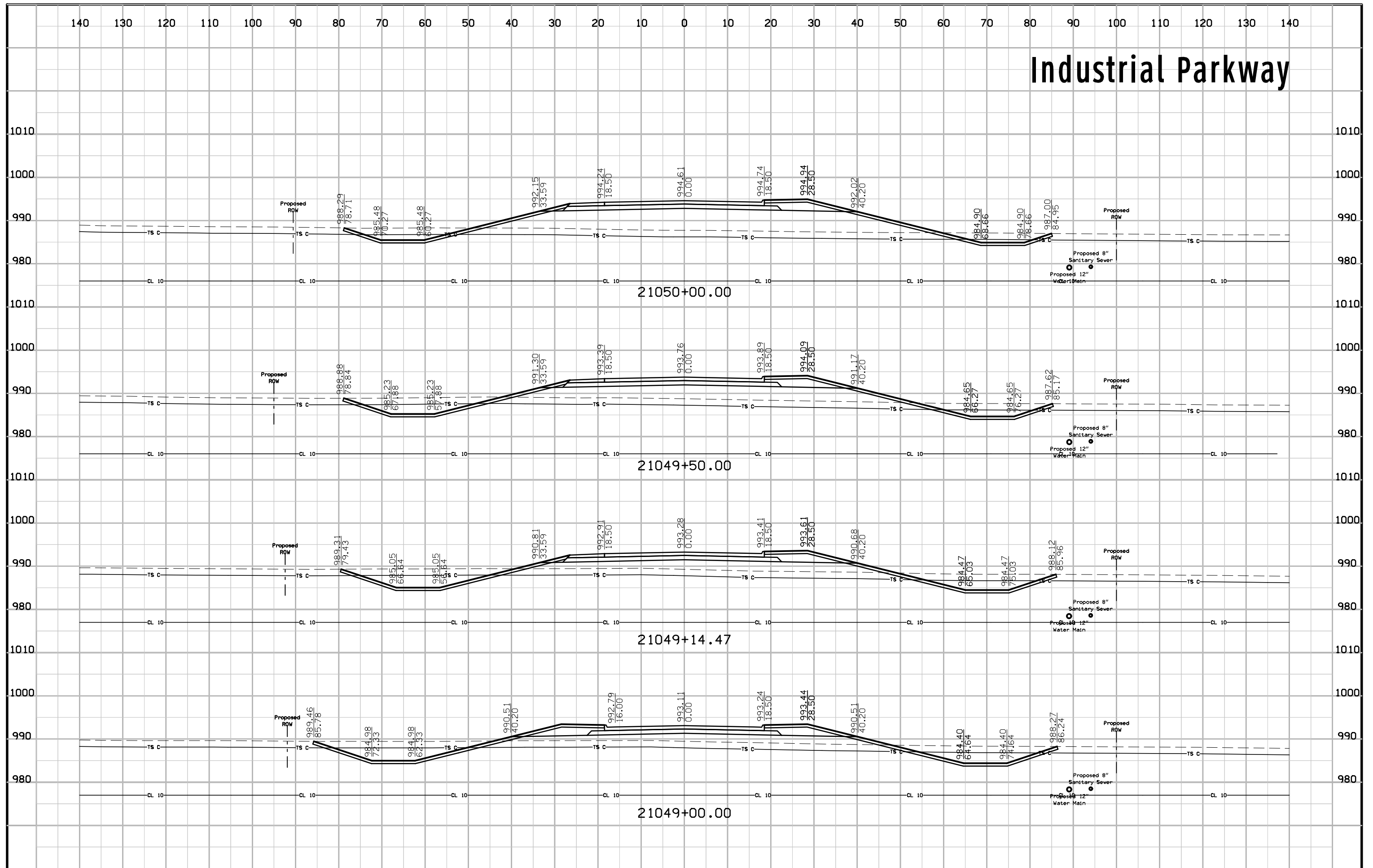



# Industrial Parkway

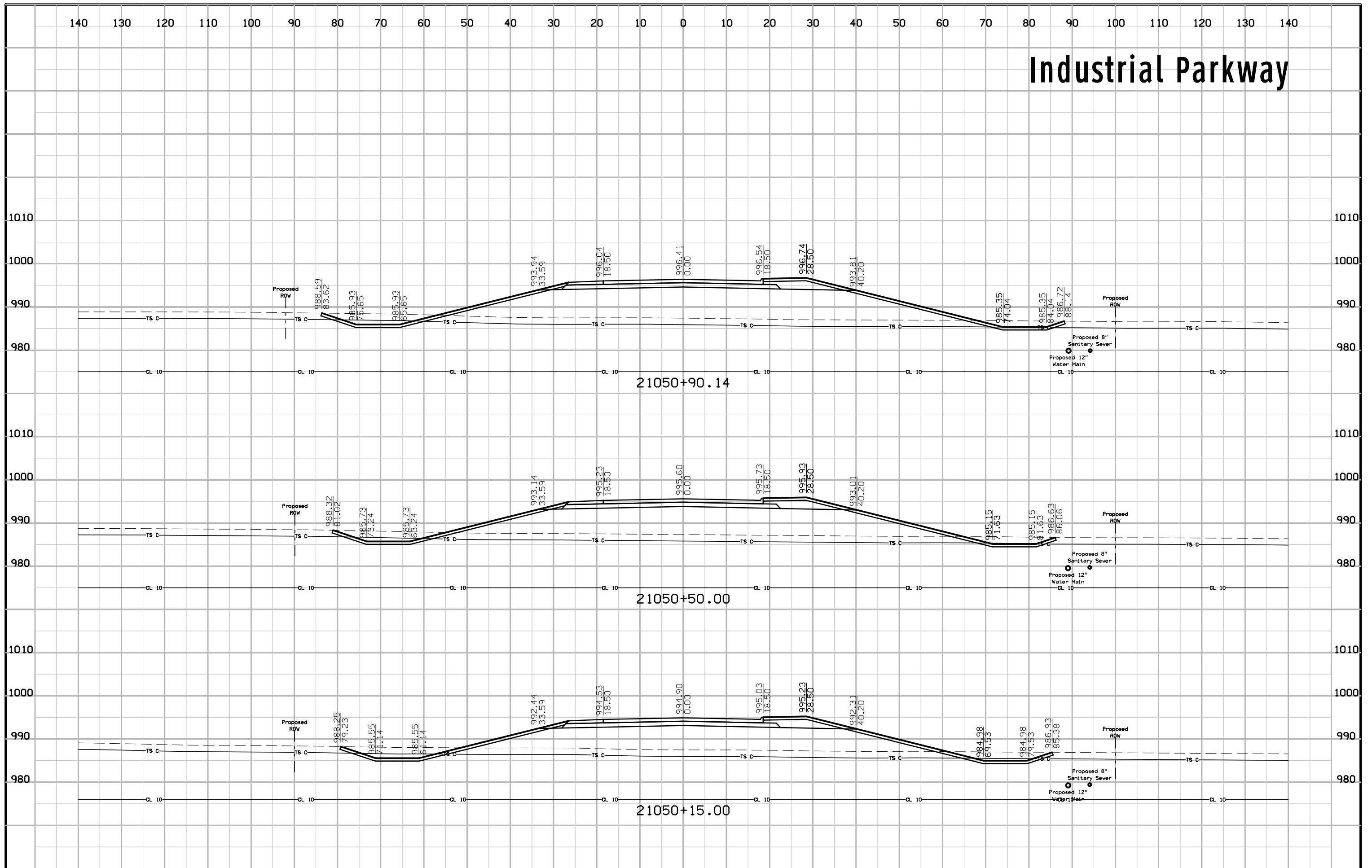

# Industrial Parkway

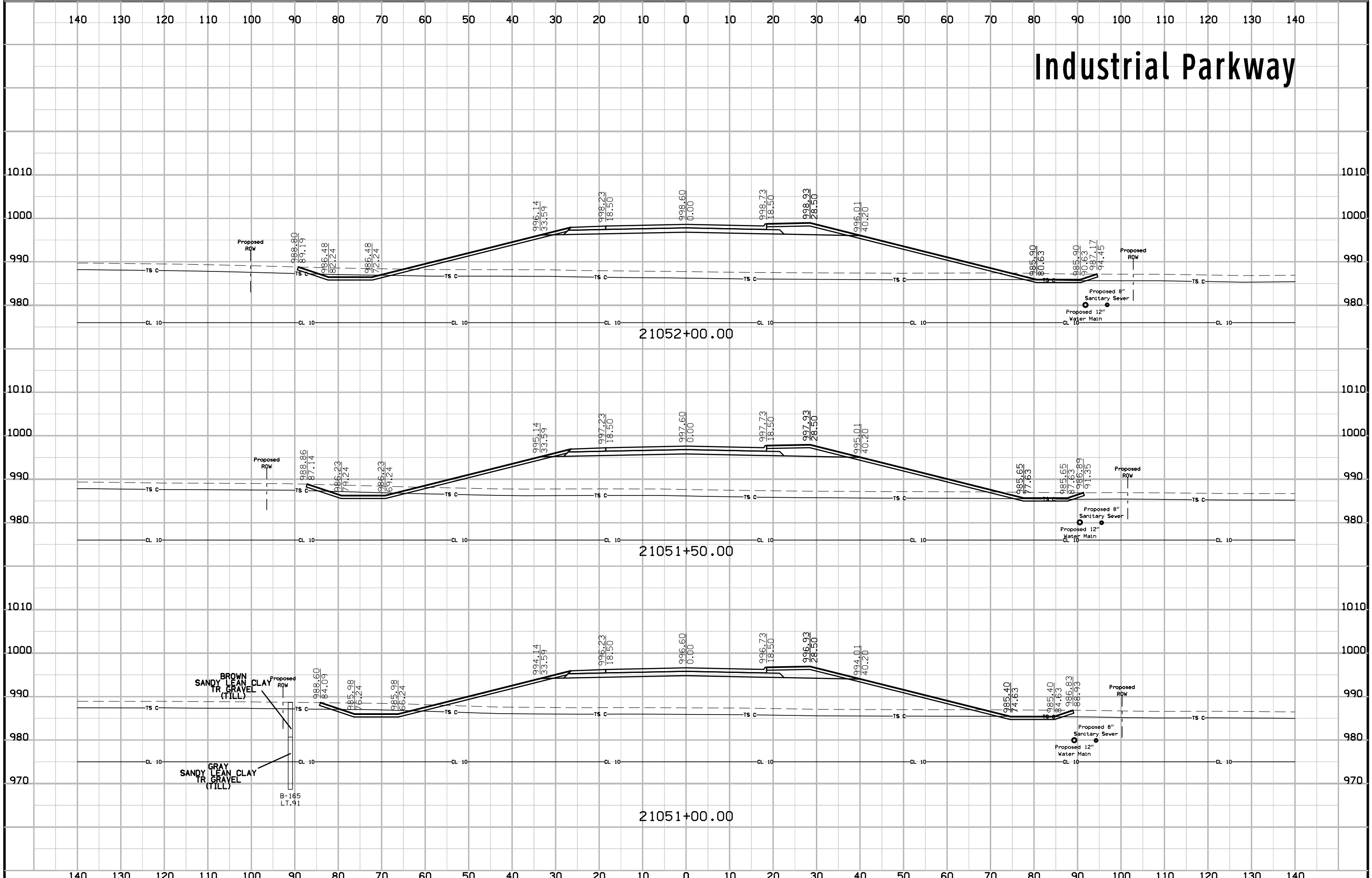

# Industrial Parkway

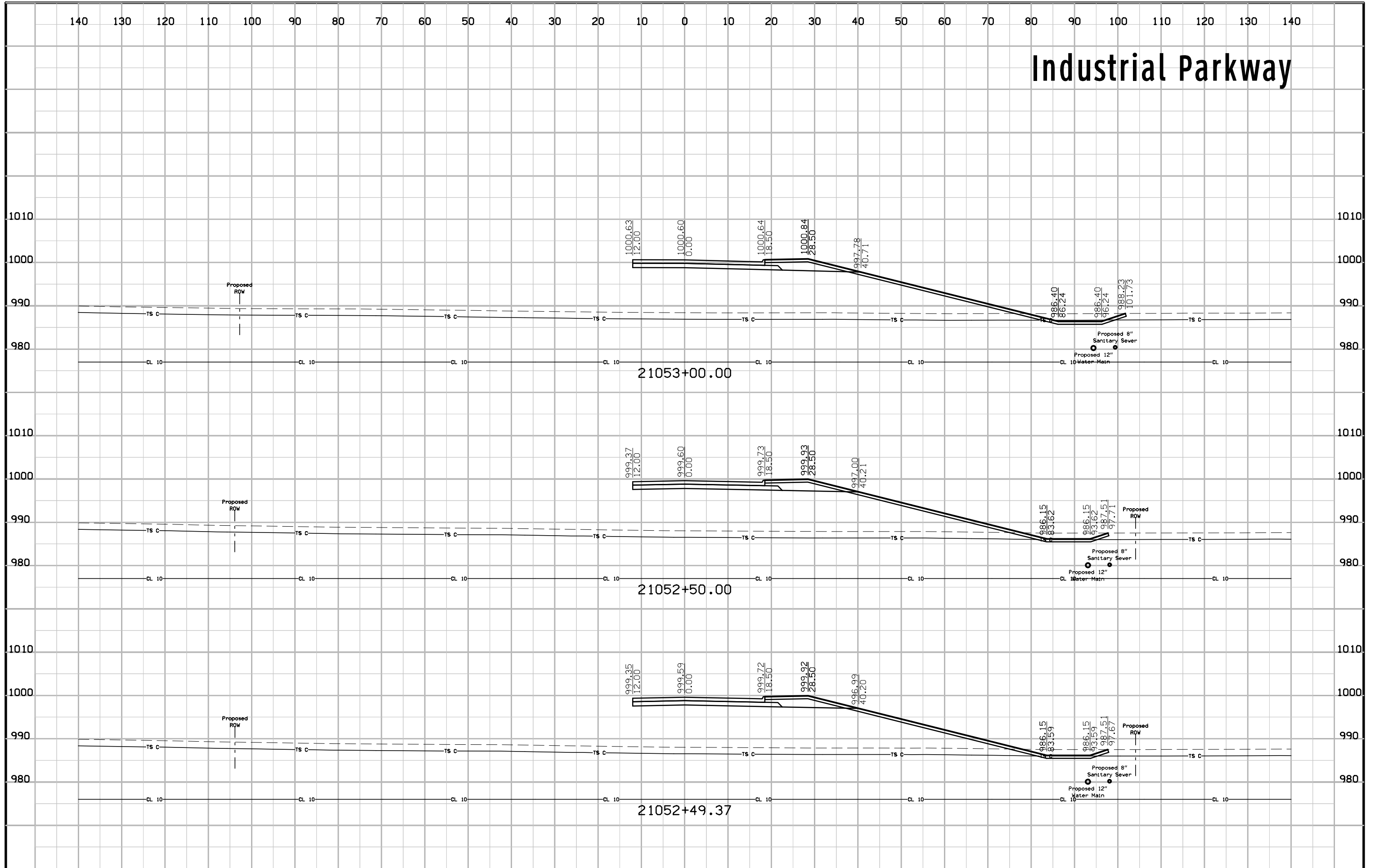

# Industrial Parkway

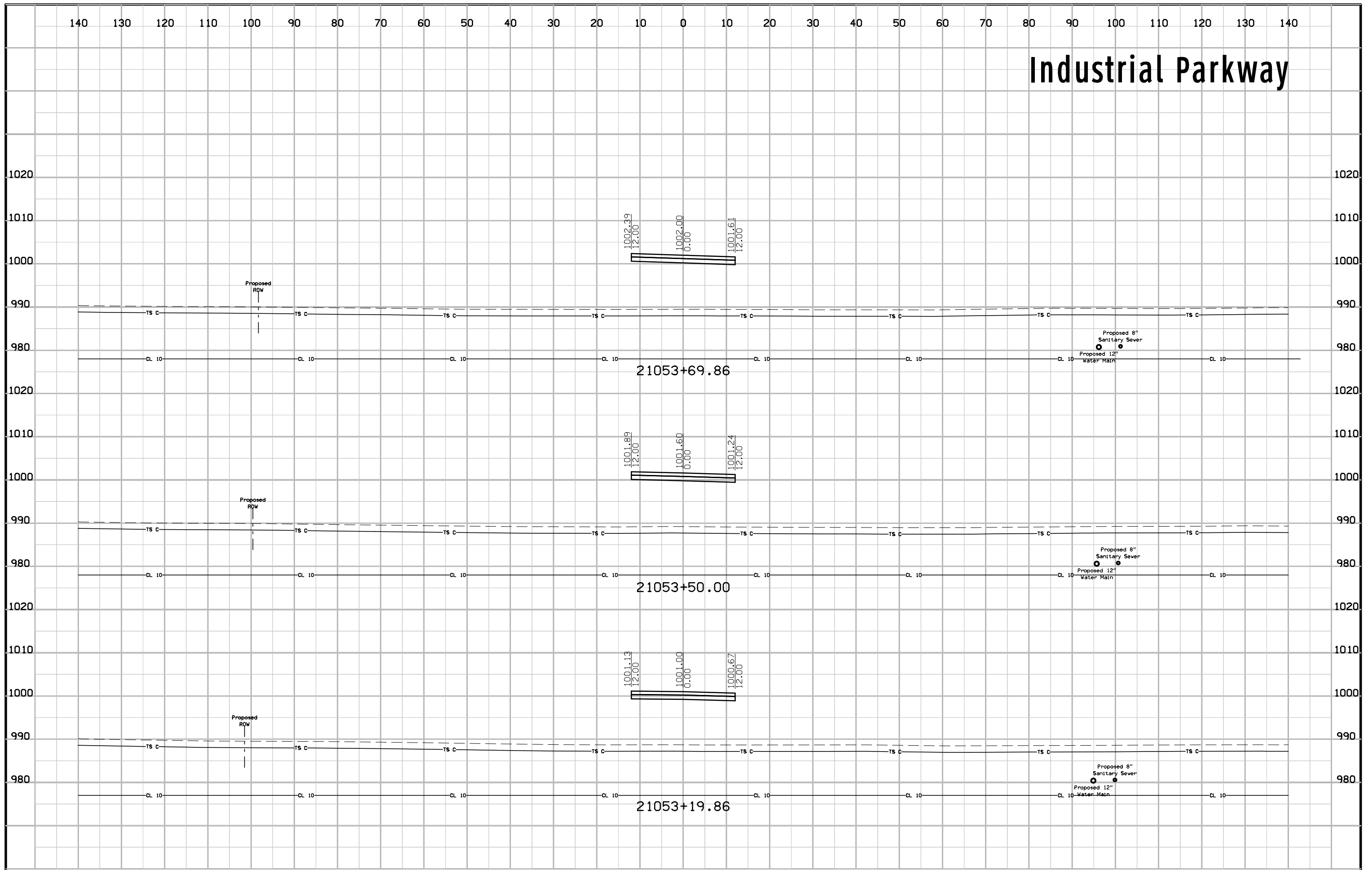

# 221st Street

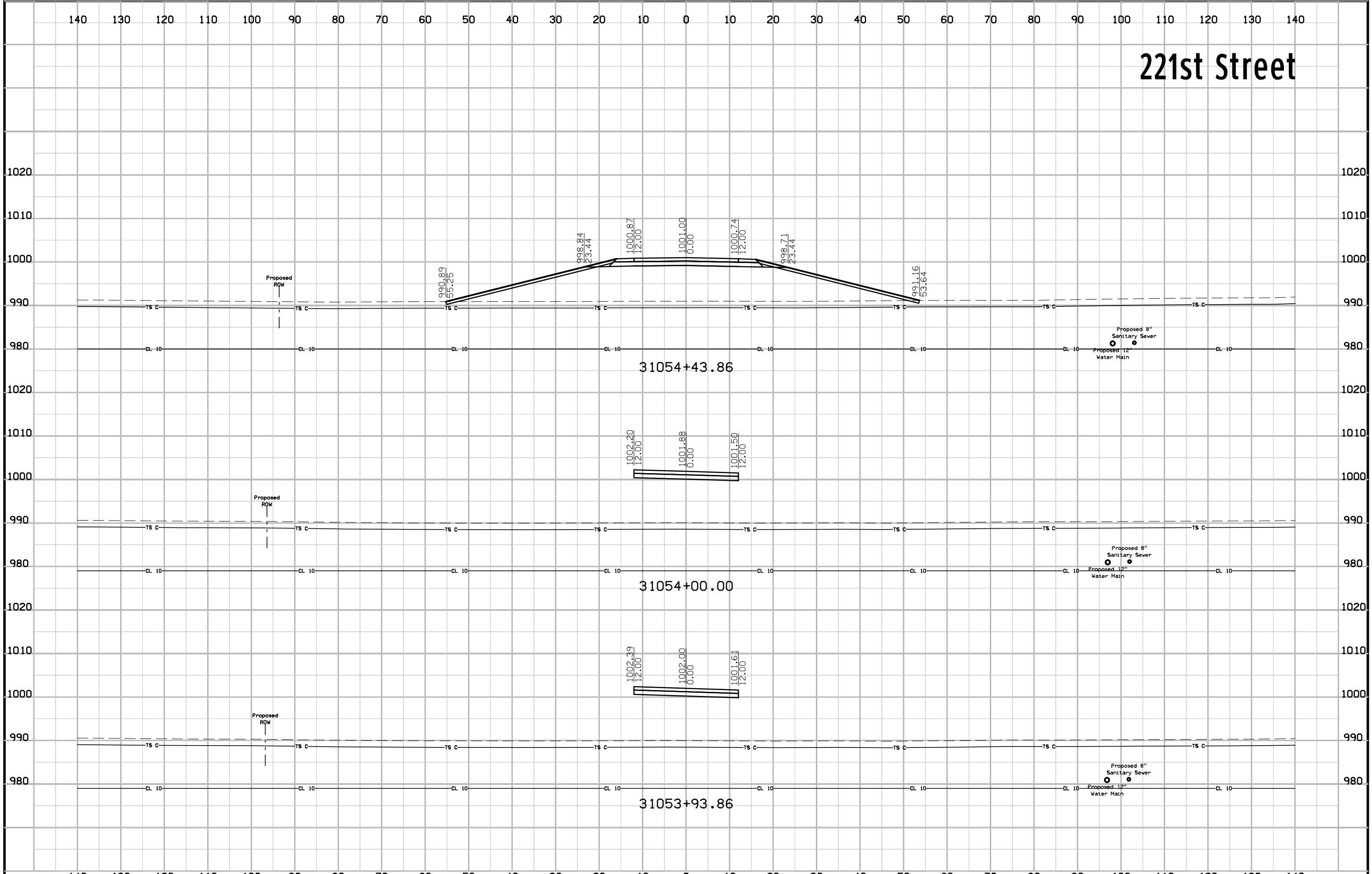

# 221st Street

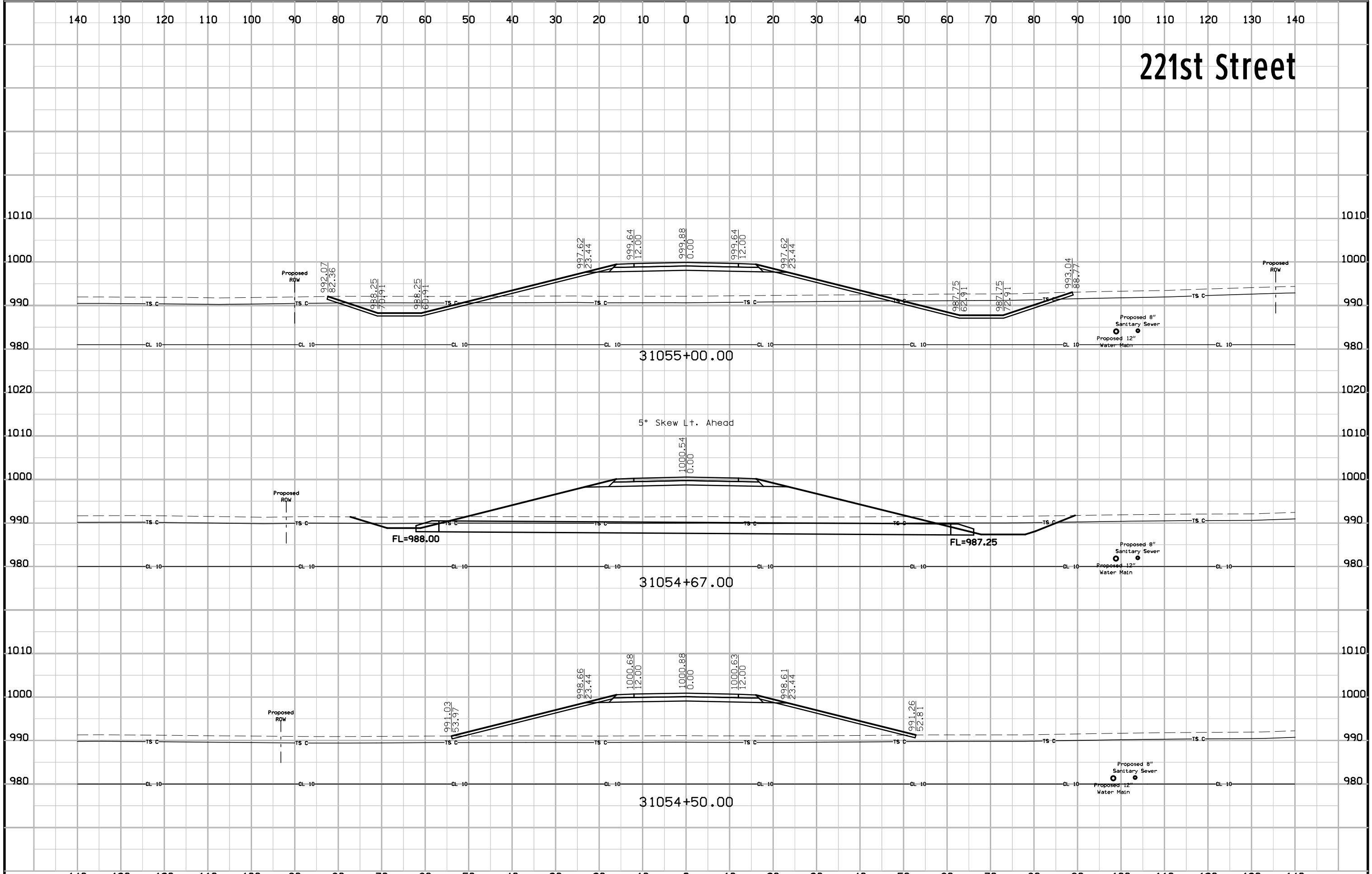



# 221st Street

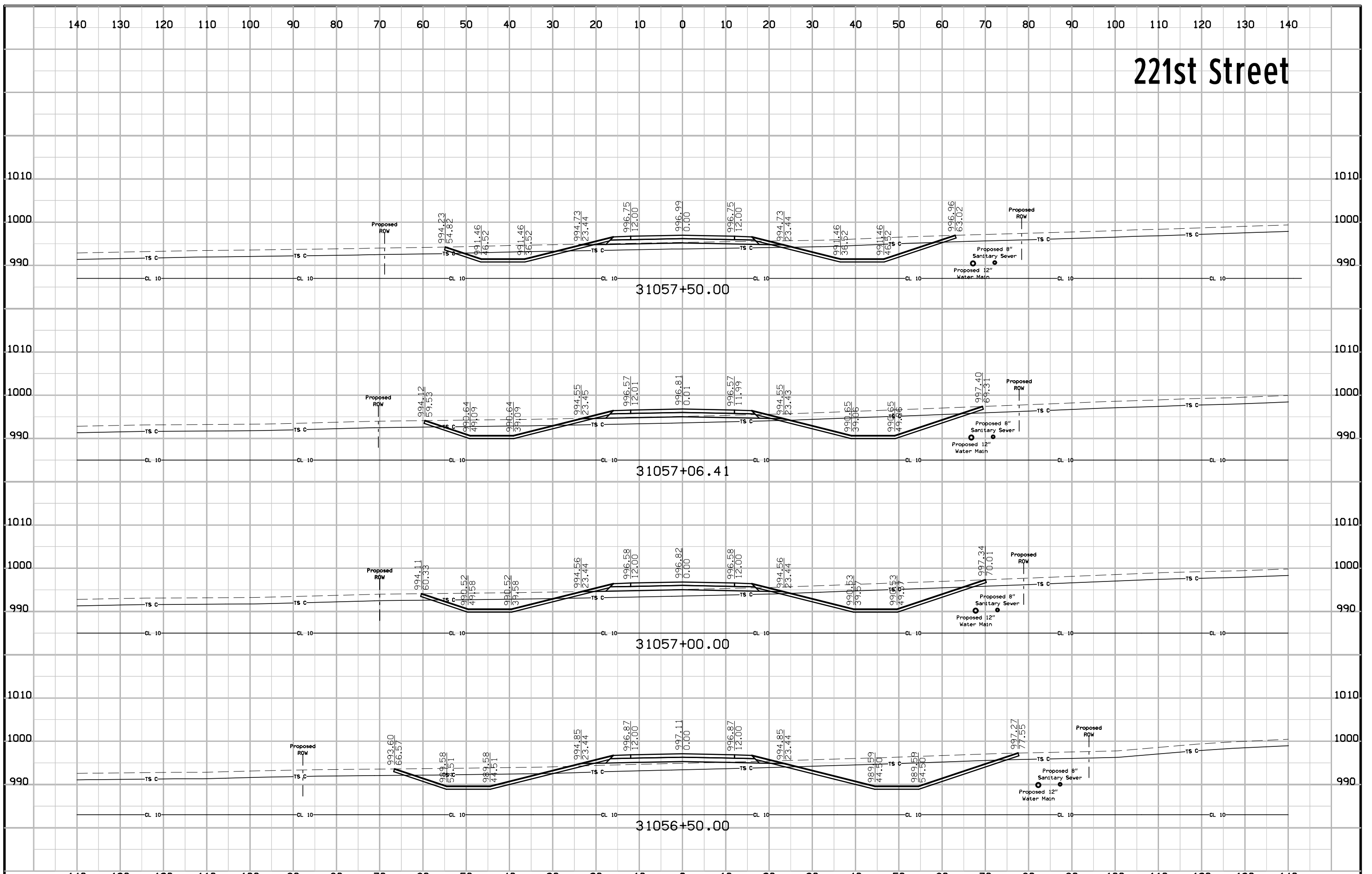



# 221st Street

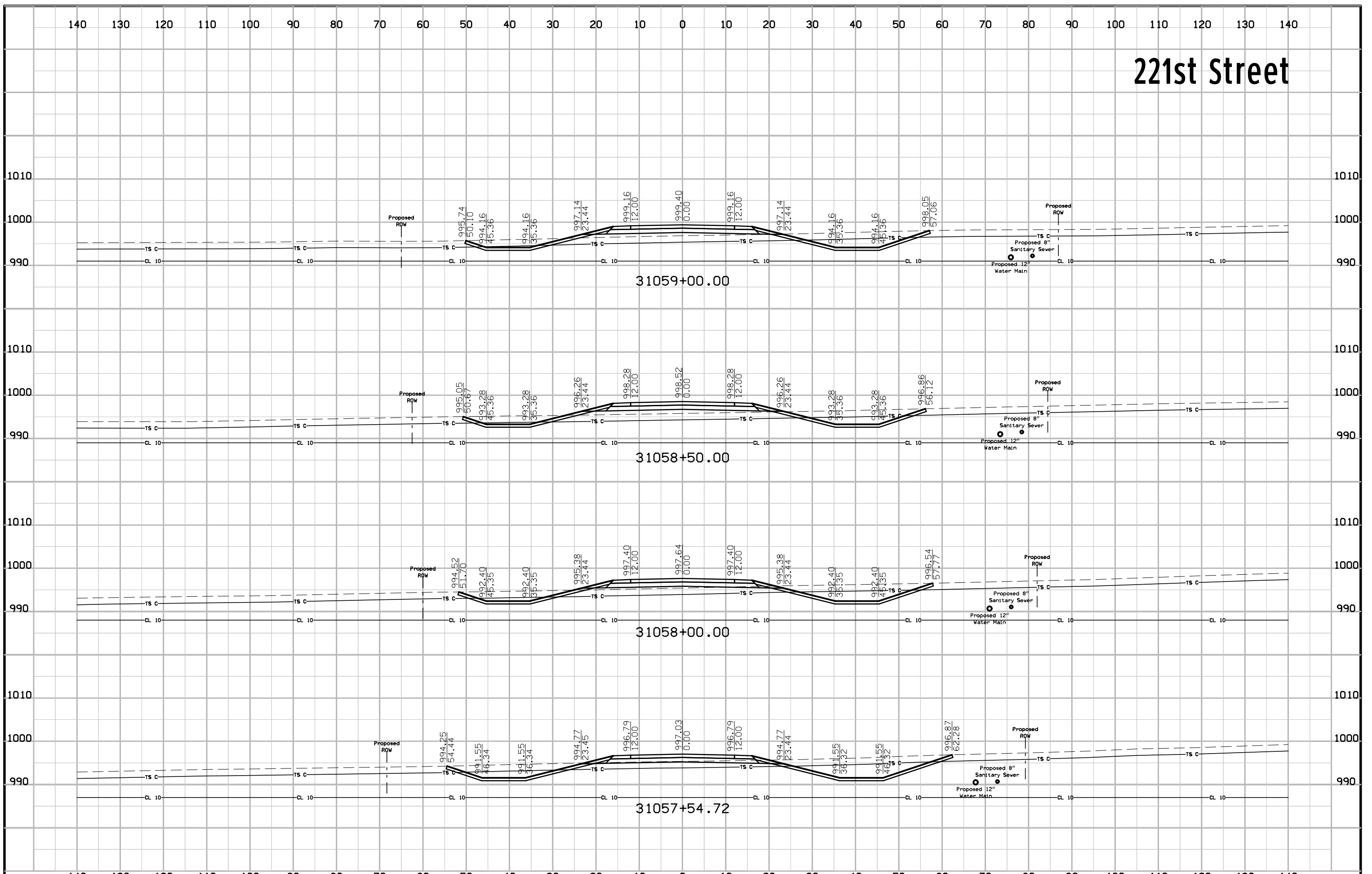

# 221st Street

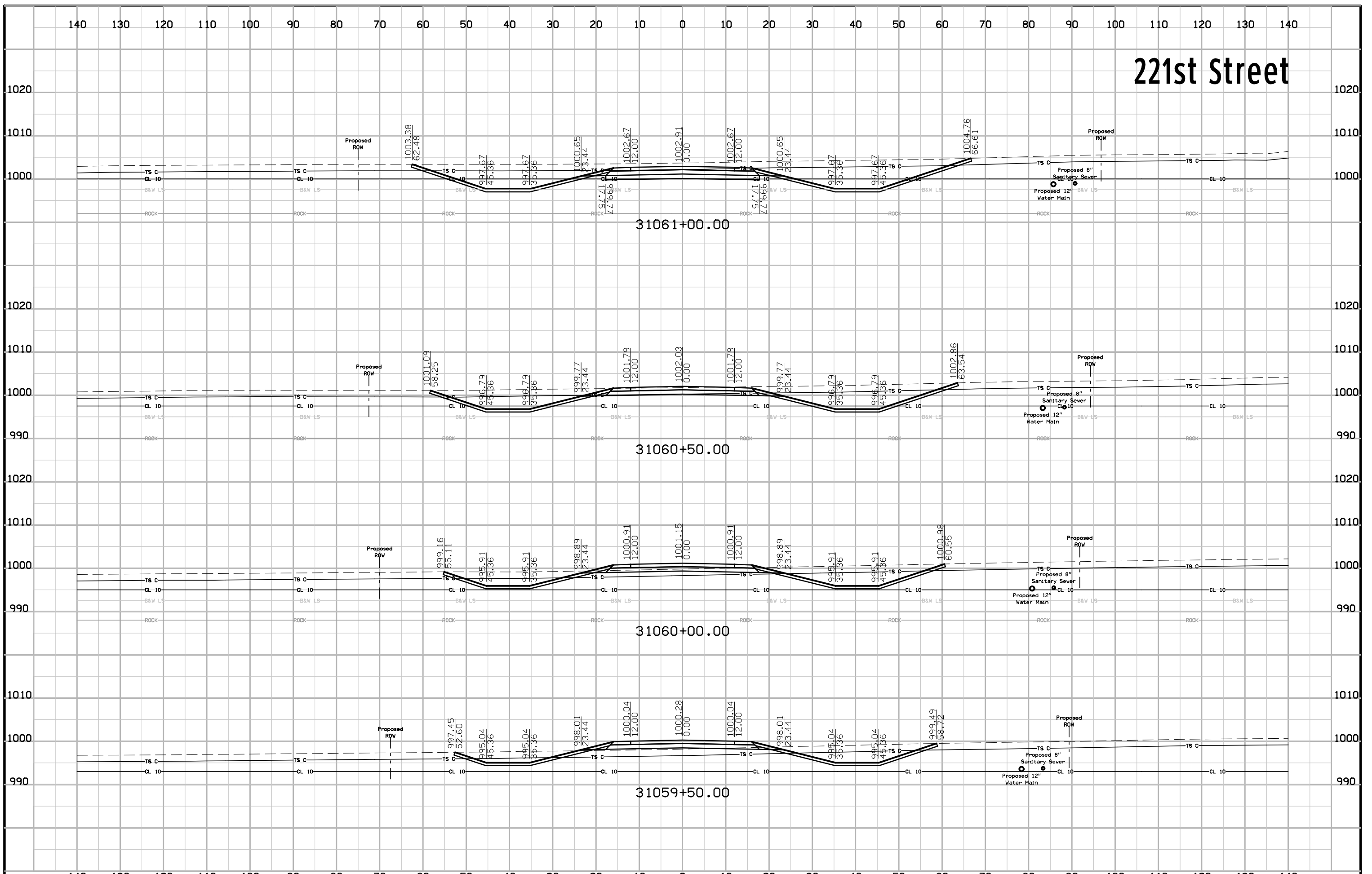

# 221st Street

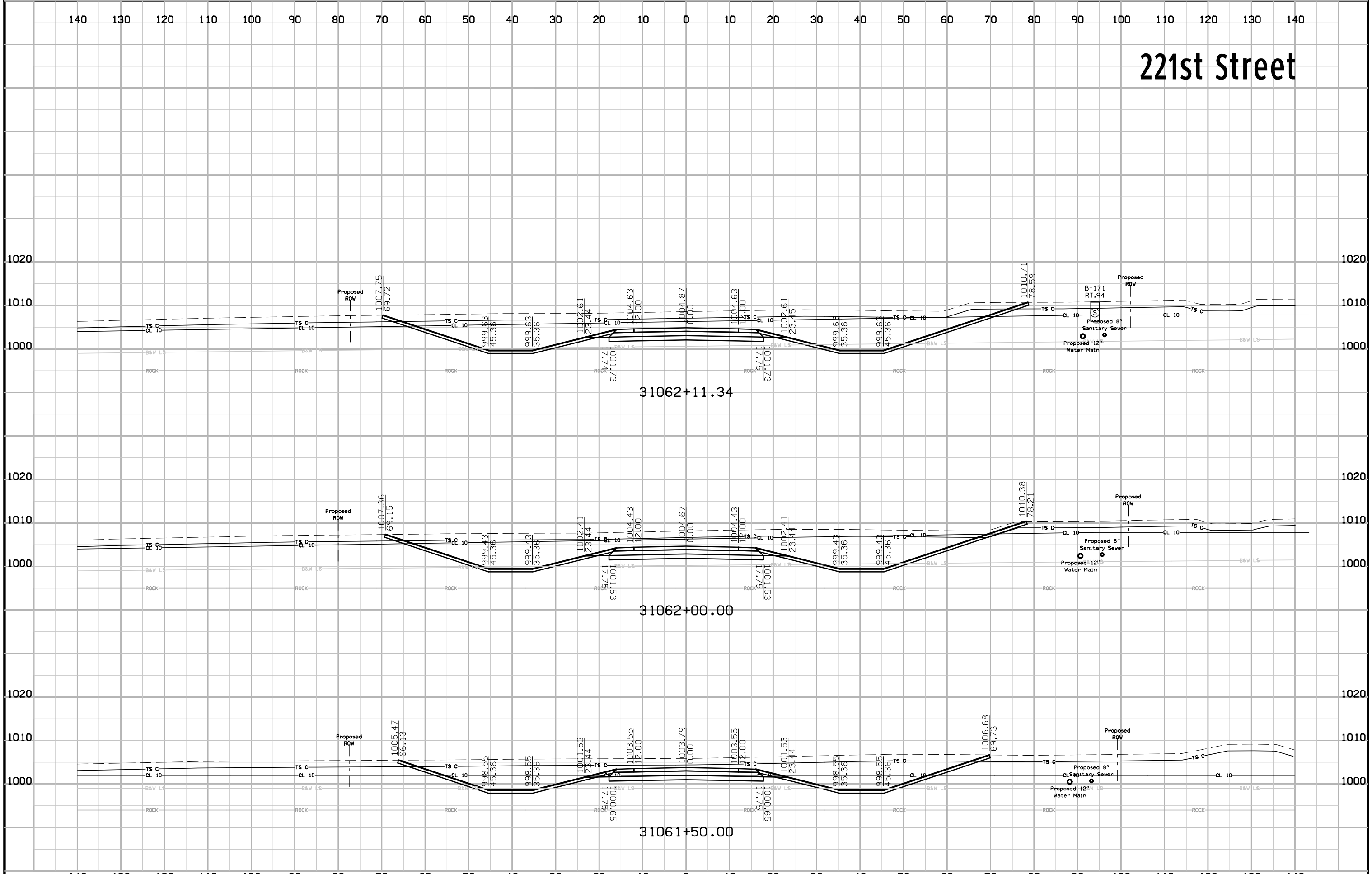

# 221st Street

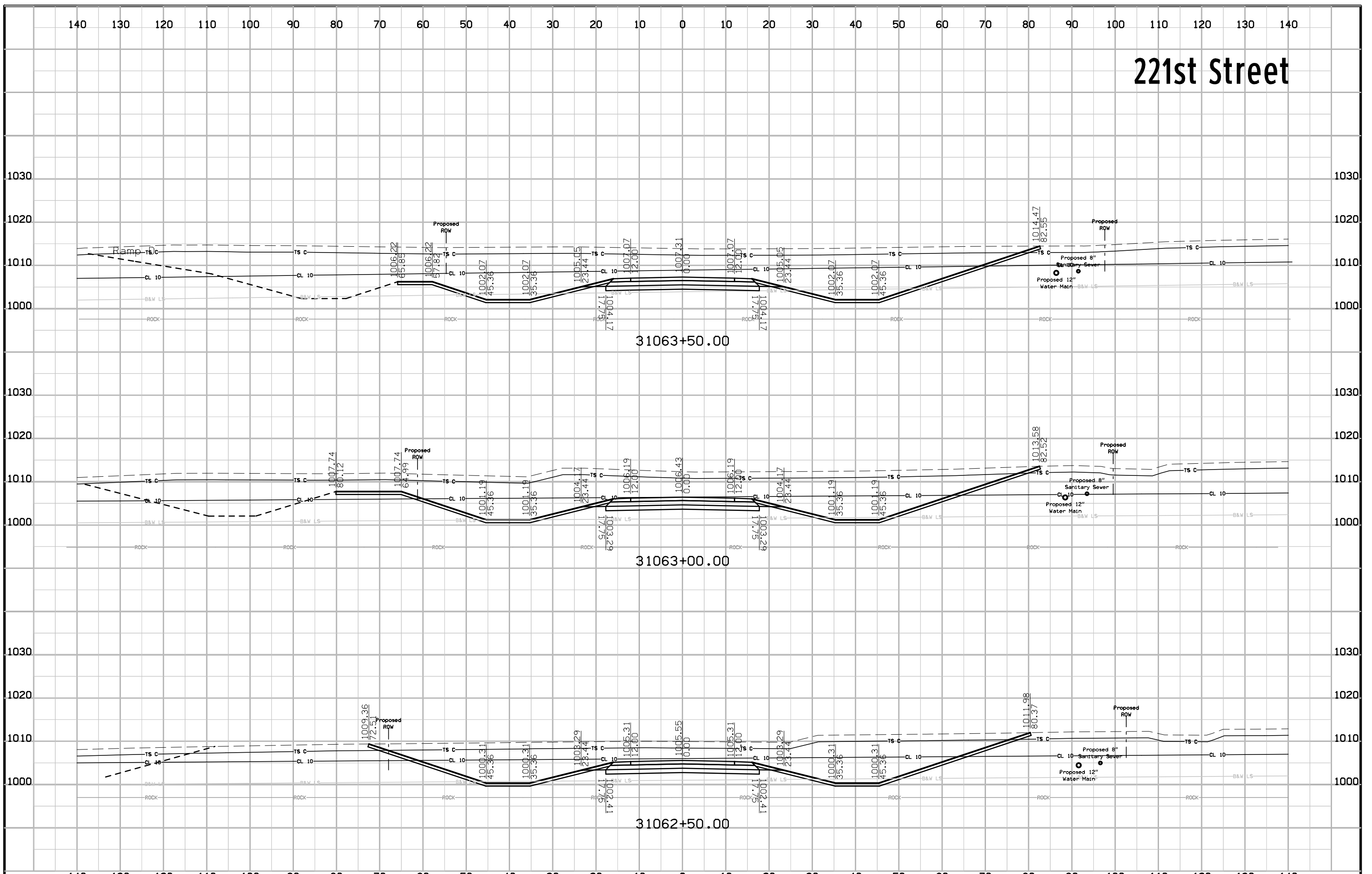

# 221st Street

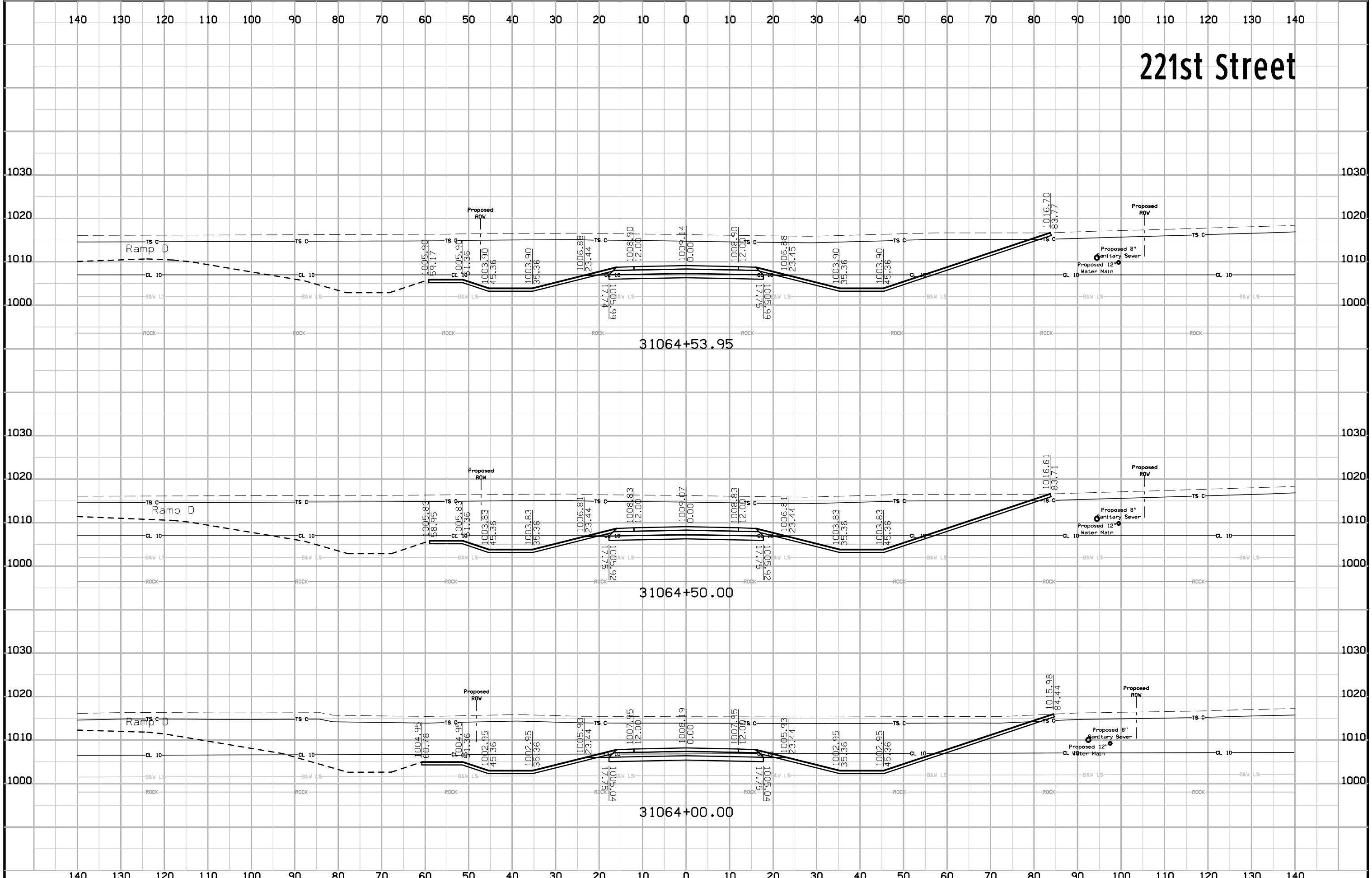

# 221st Street

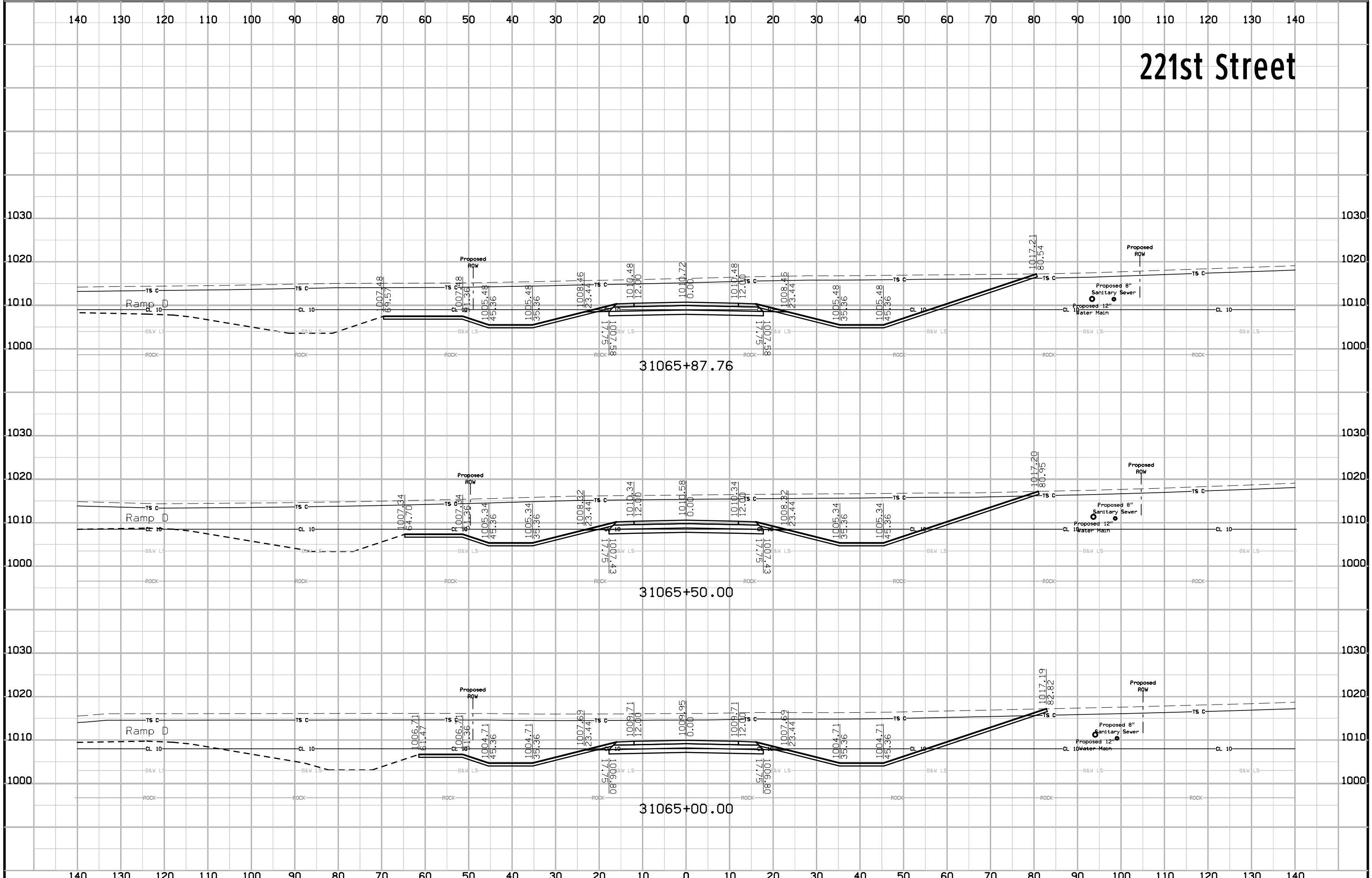

# 221st Street

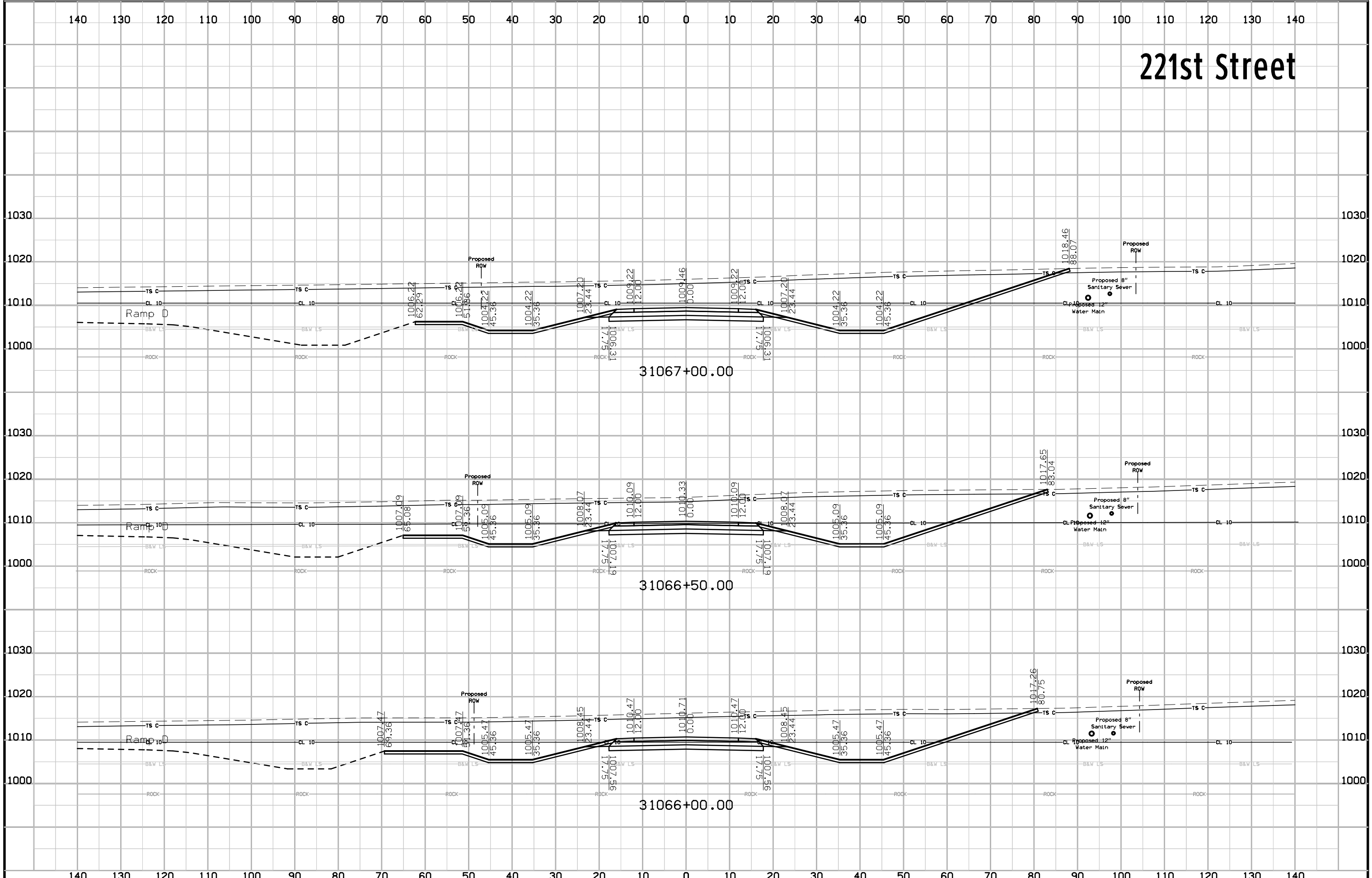

# 221st Street

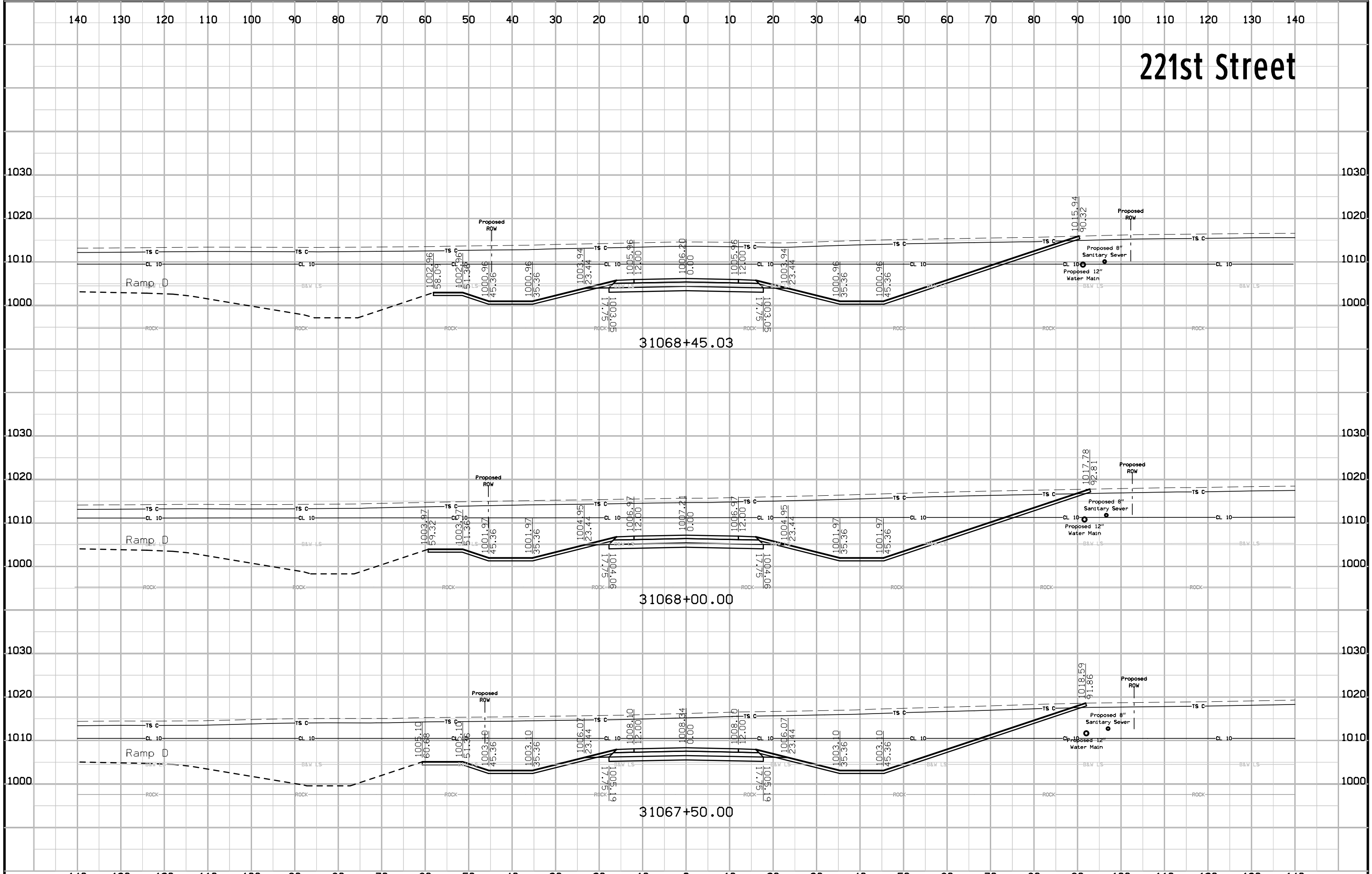



# 221st Street

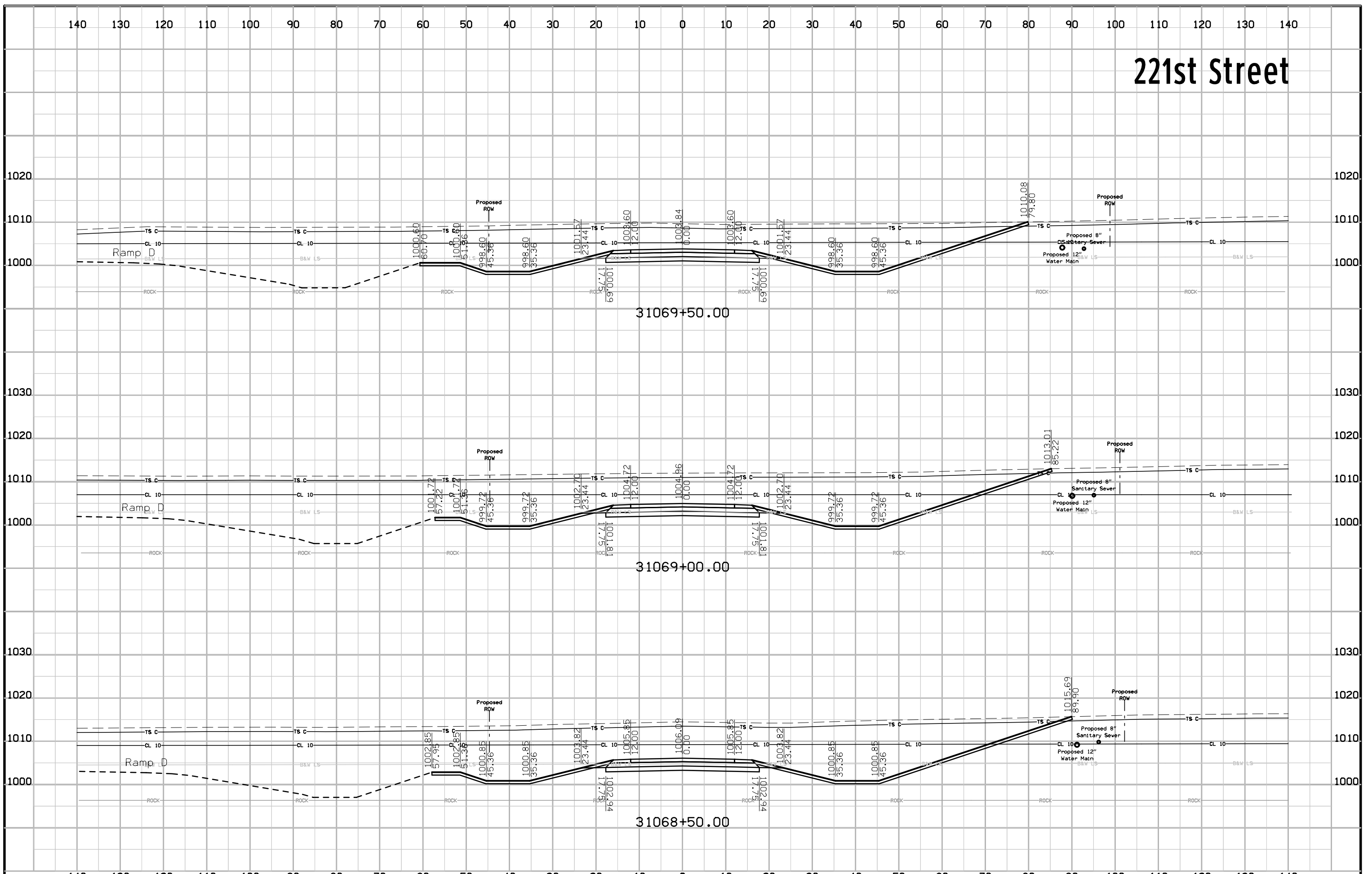

# 221st Street

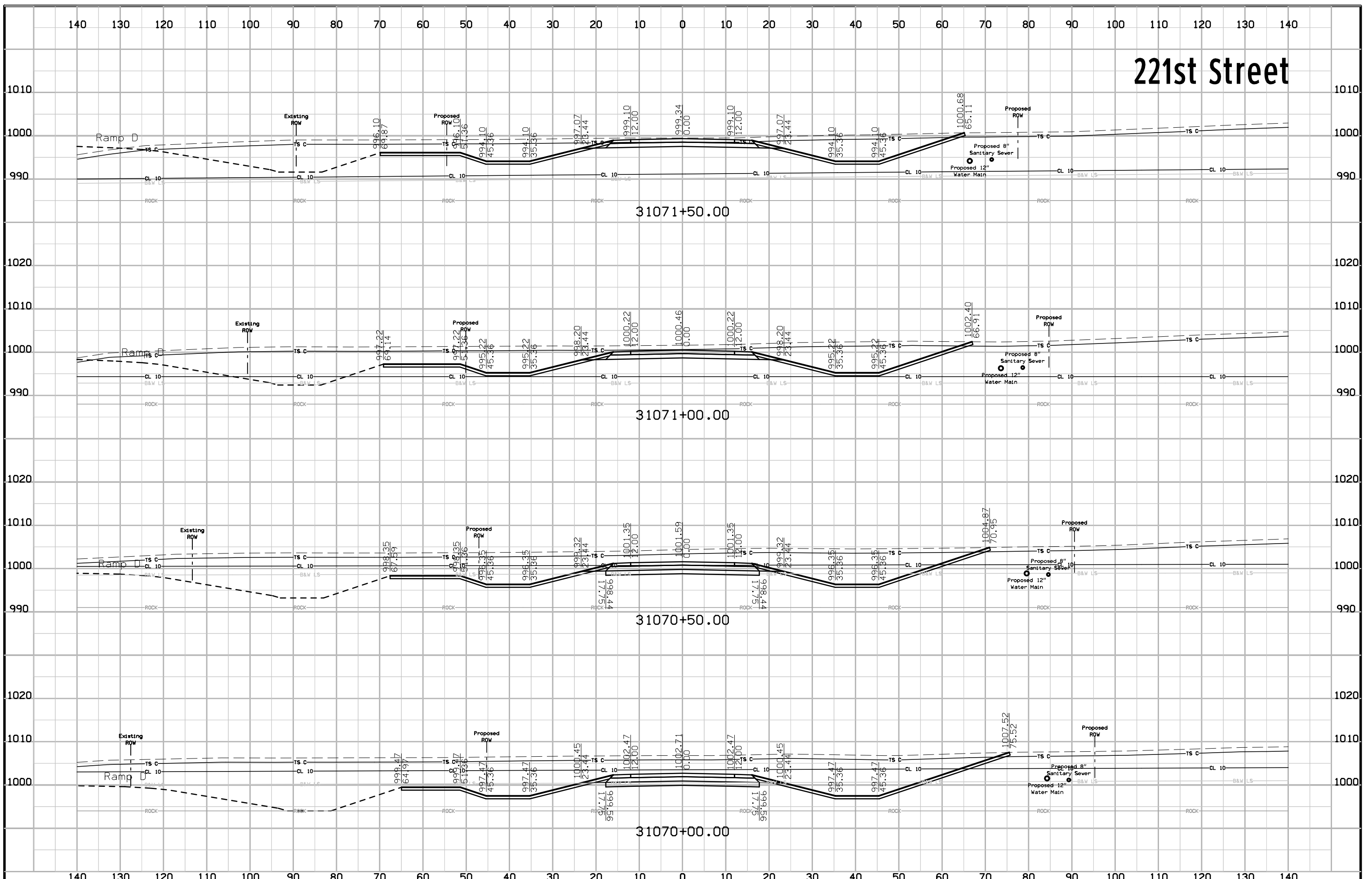

# 221st Street

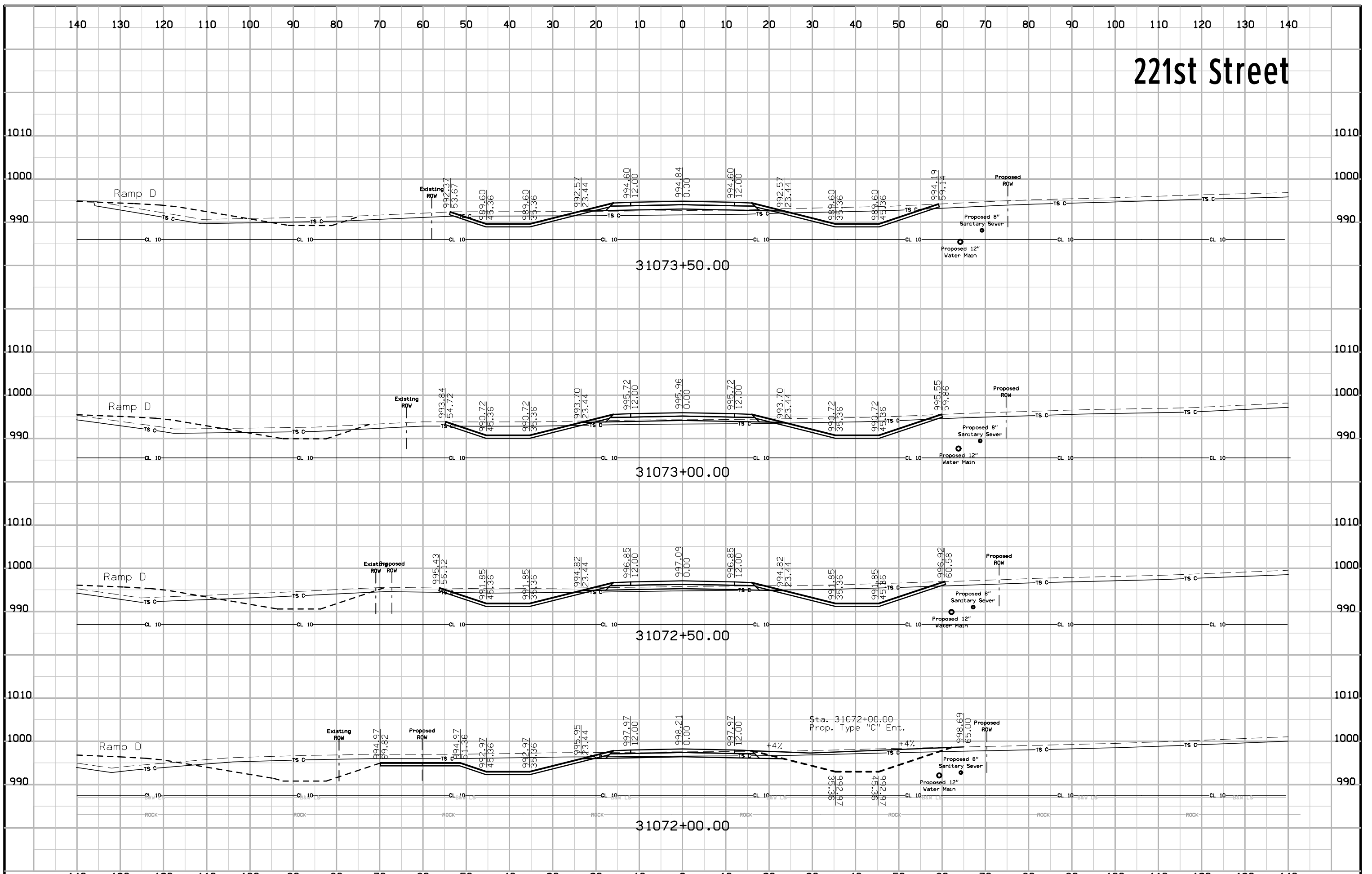

# 221st Street

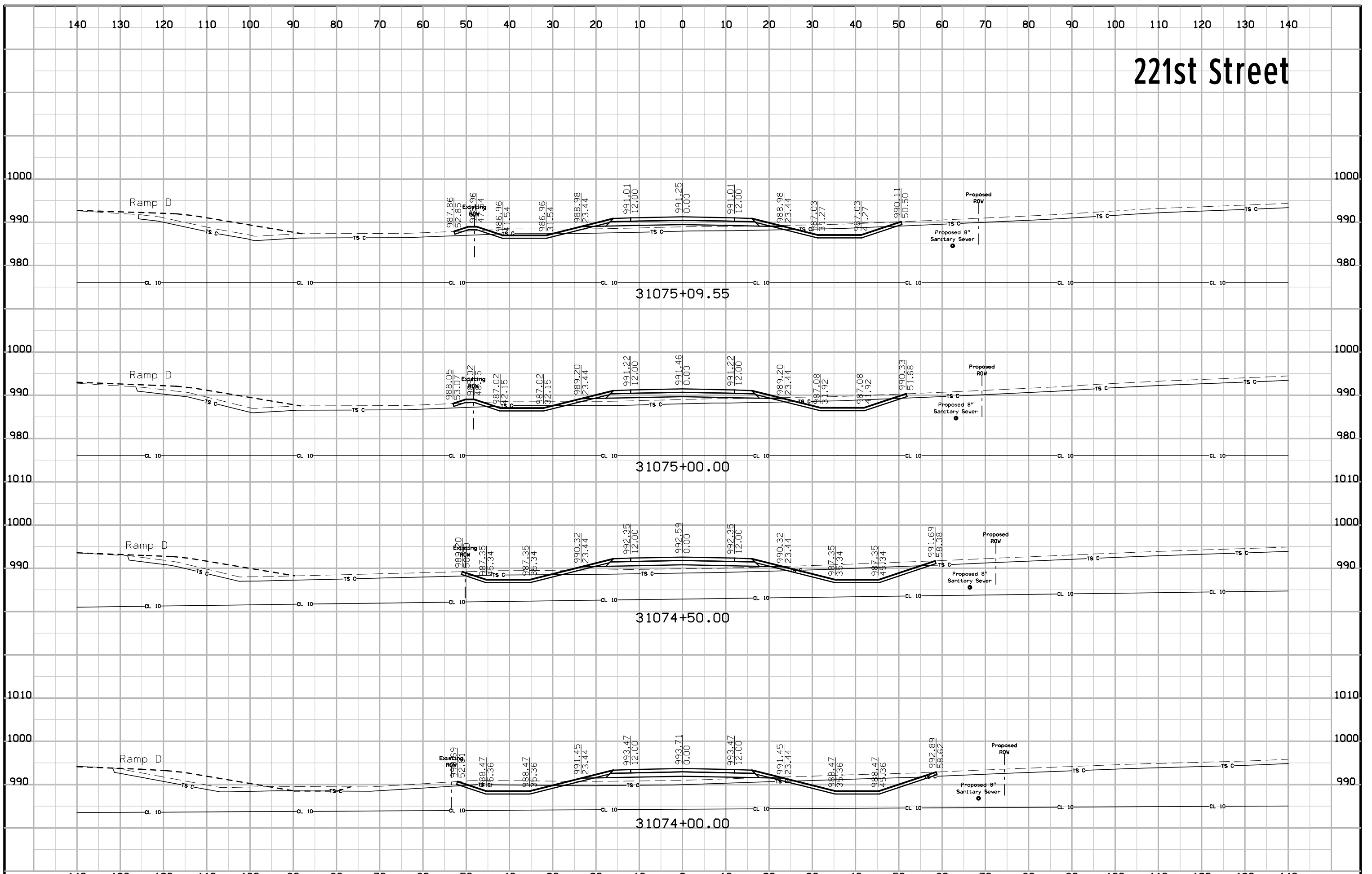

# 221st Street

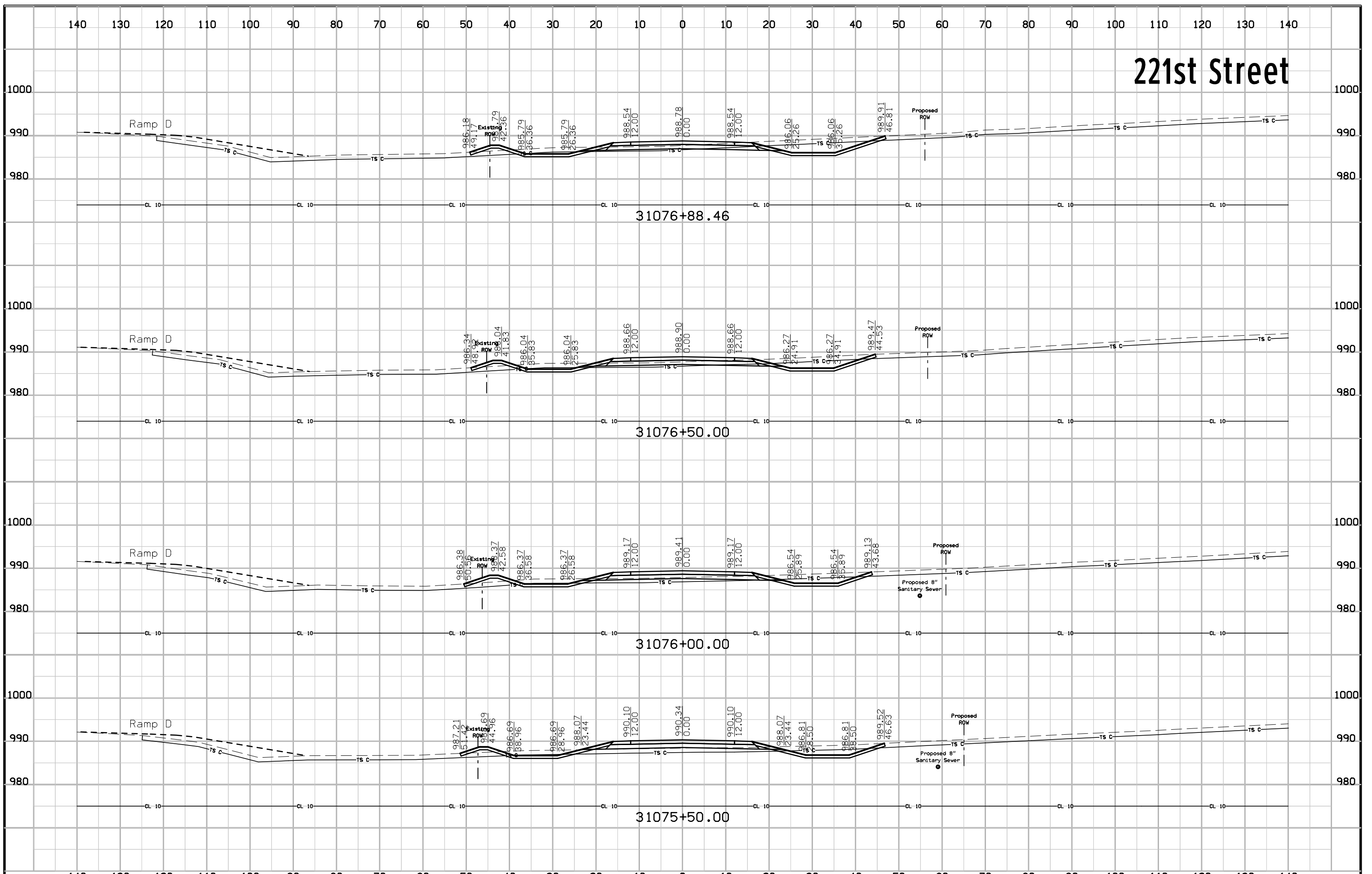

# 221st Street

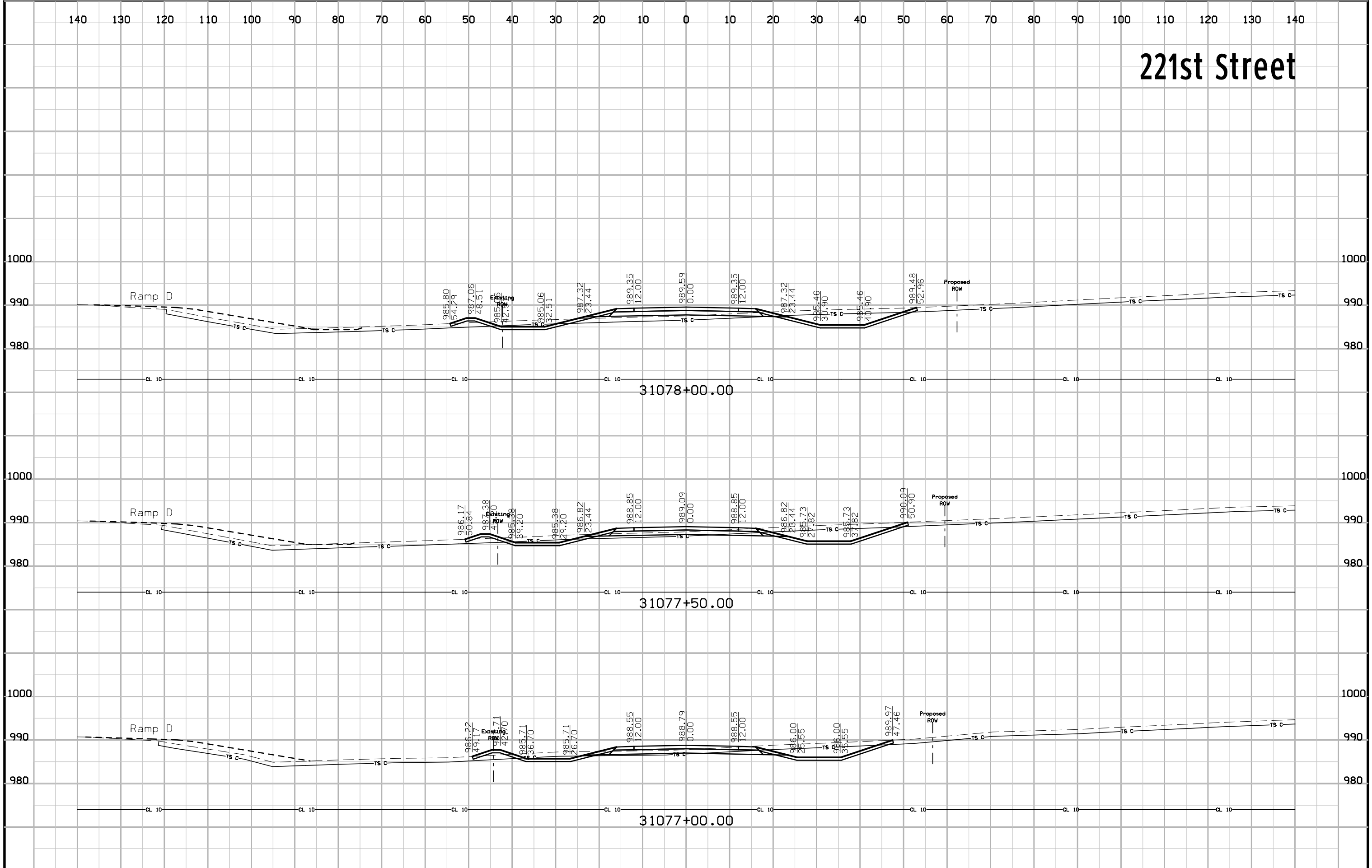

# 221st Street

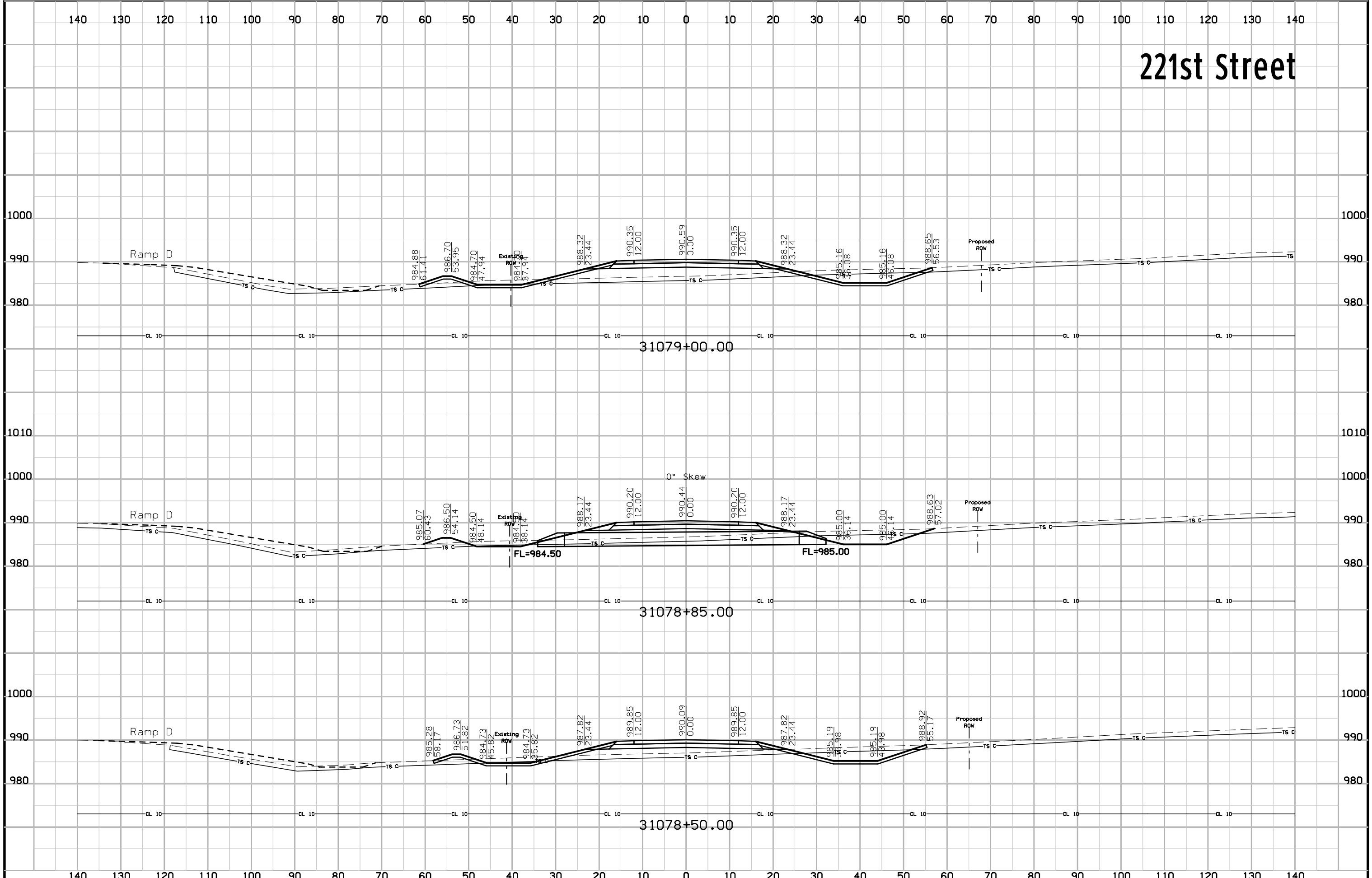

# 221st Street

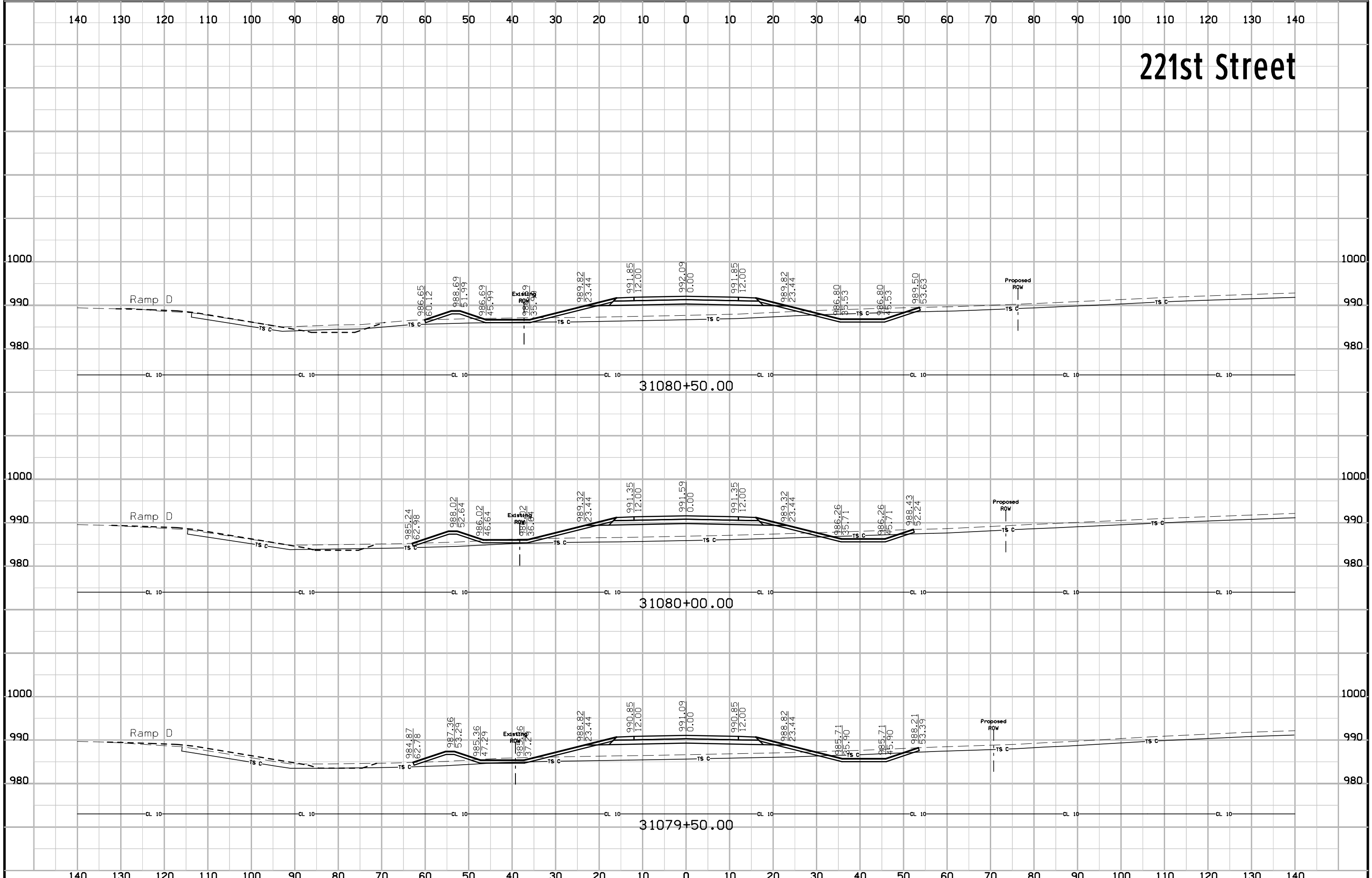



# 221st Street

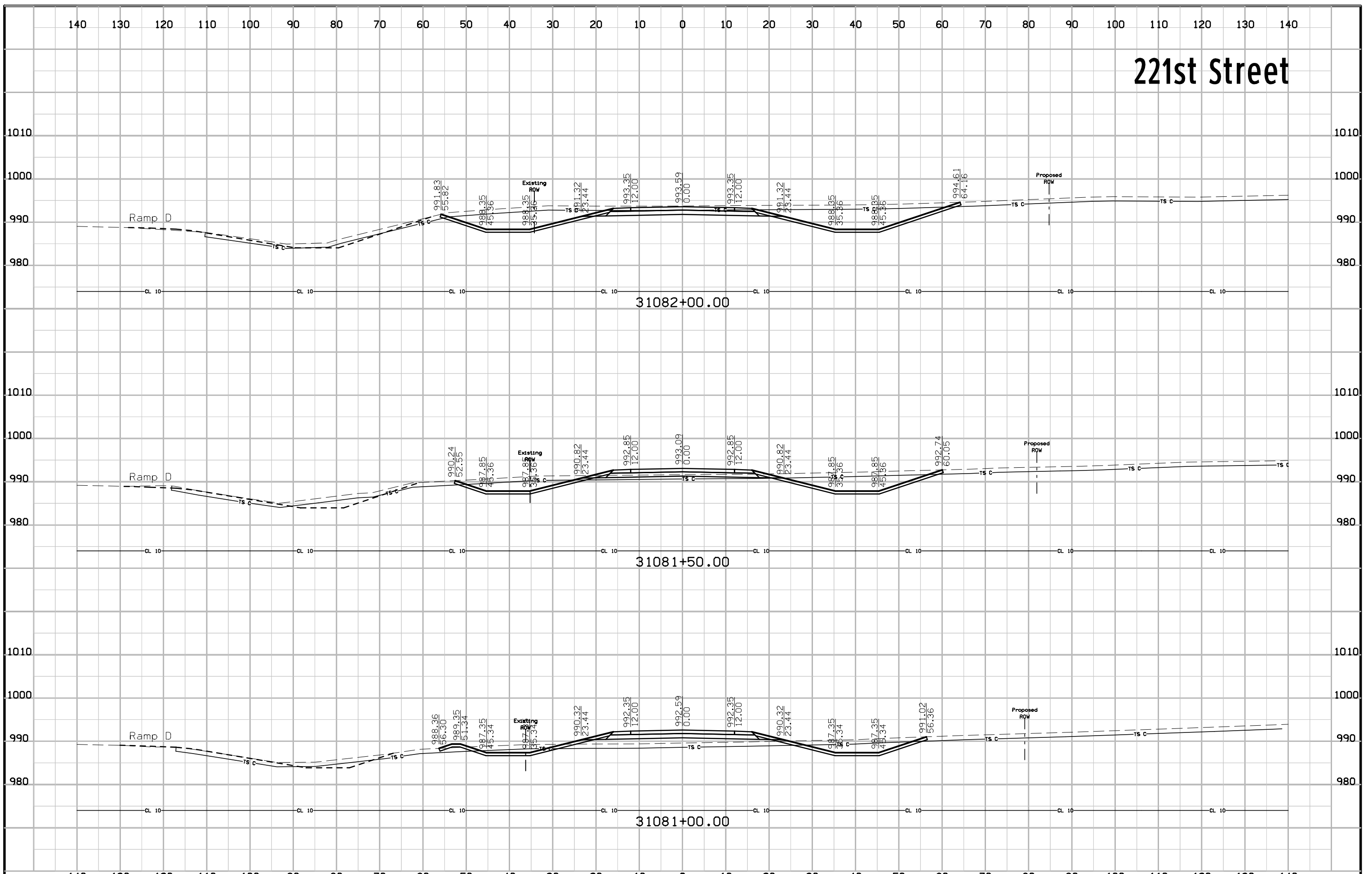

# 221st Street

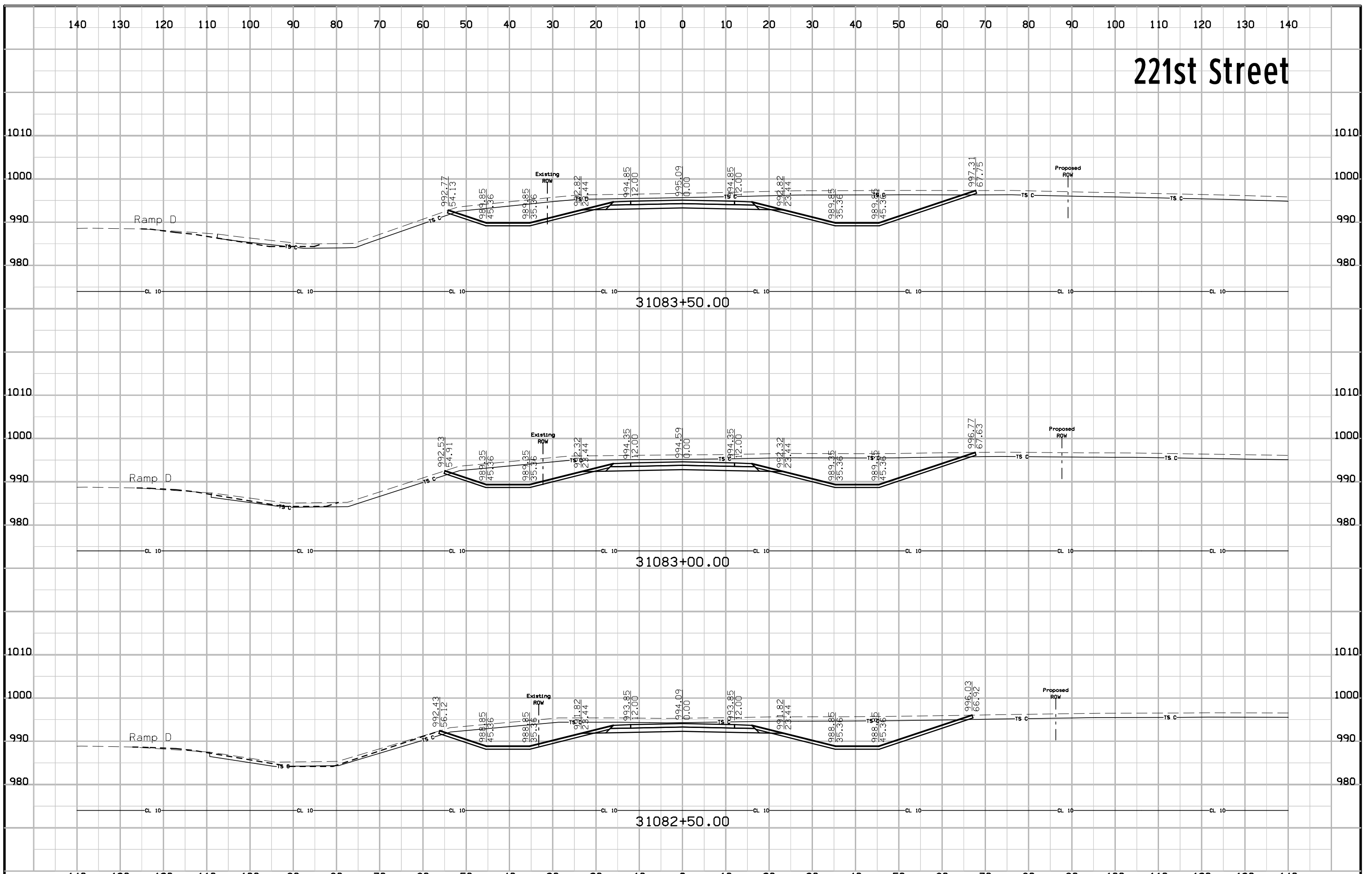

# 221st Street

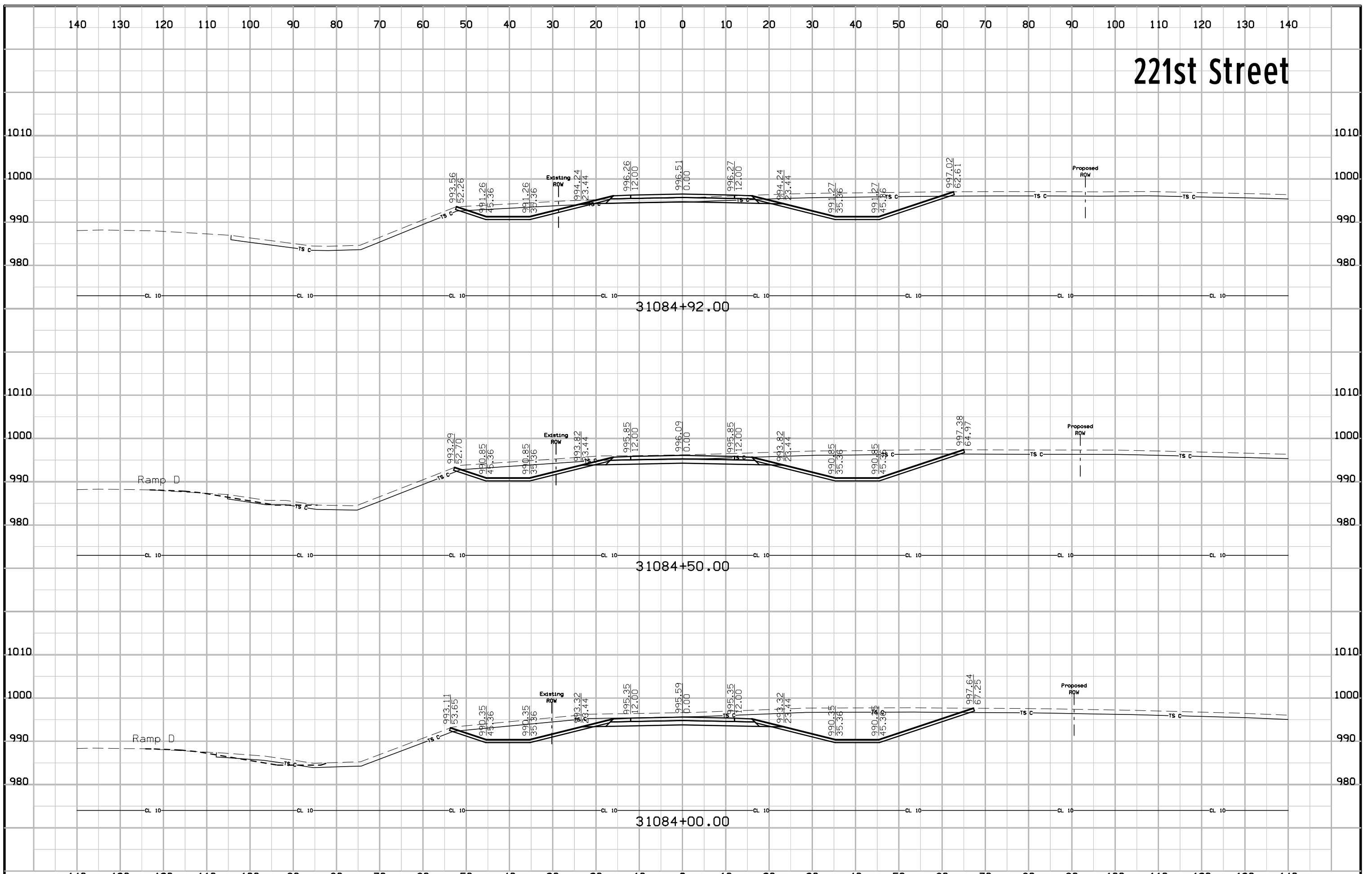

# 221st Street

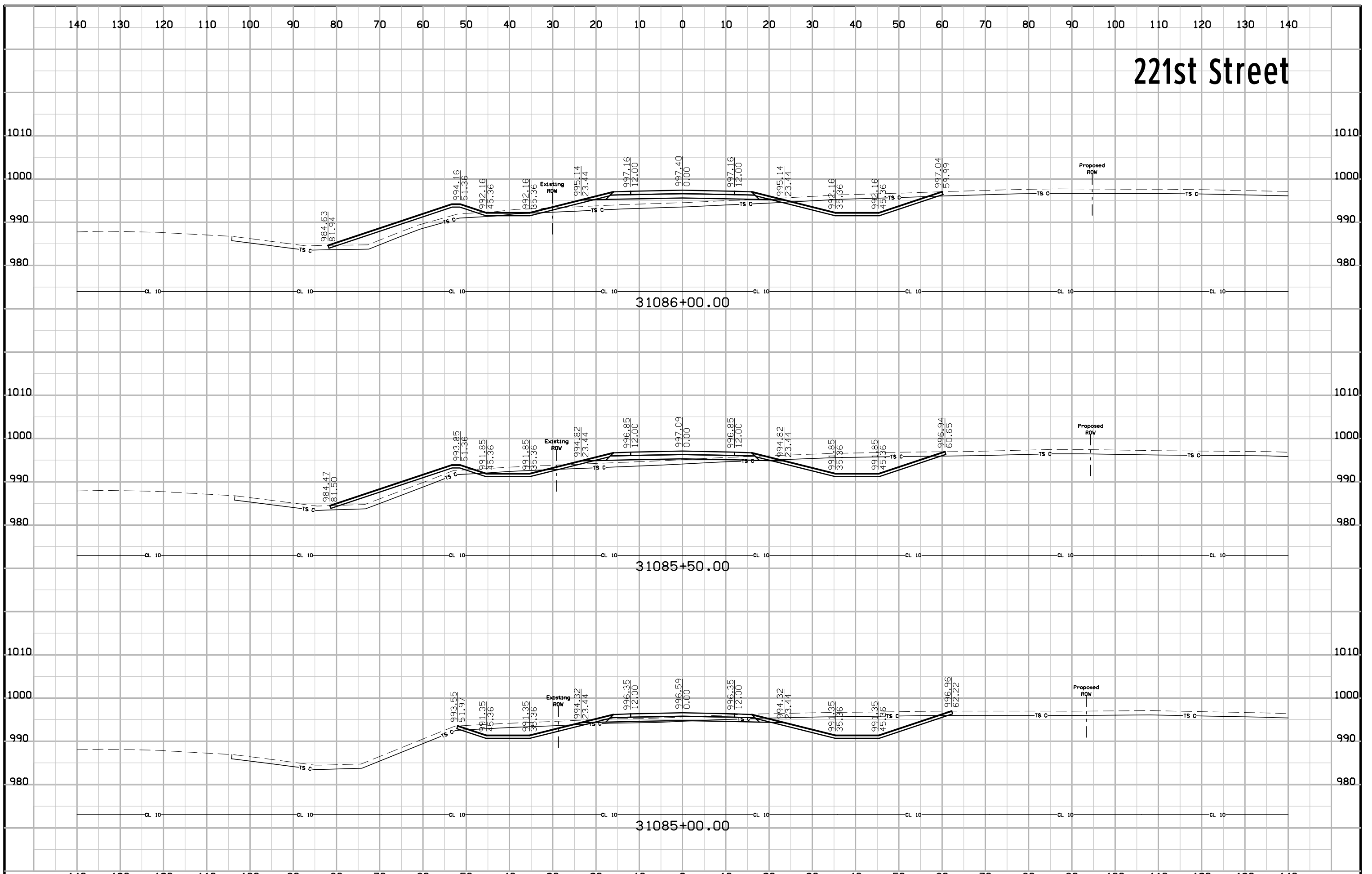

# 221st Street

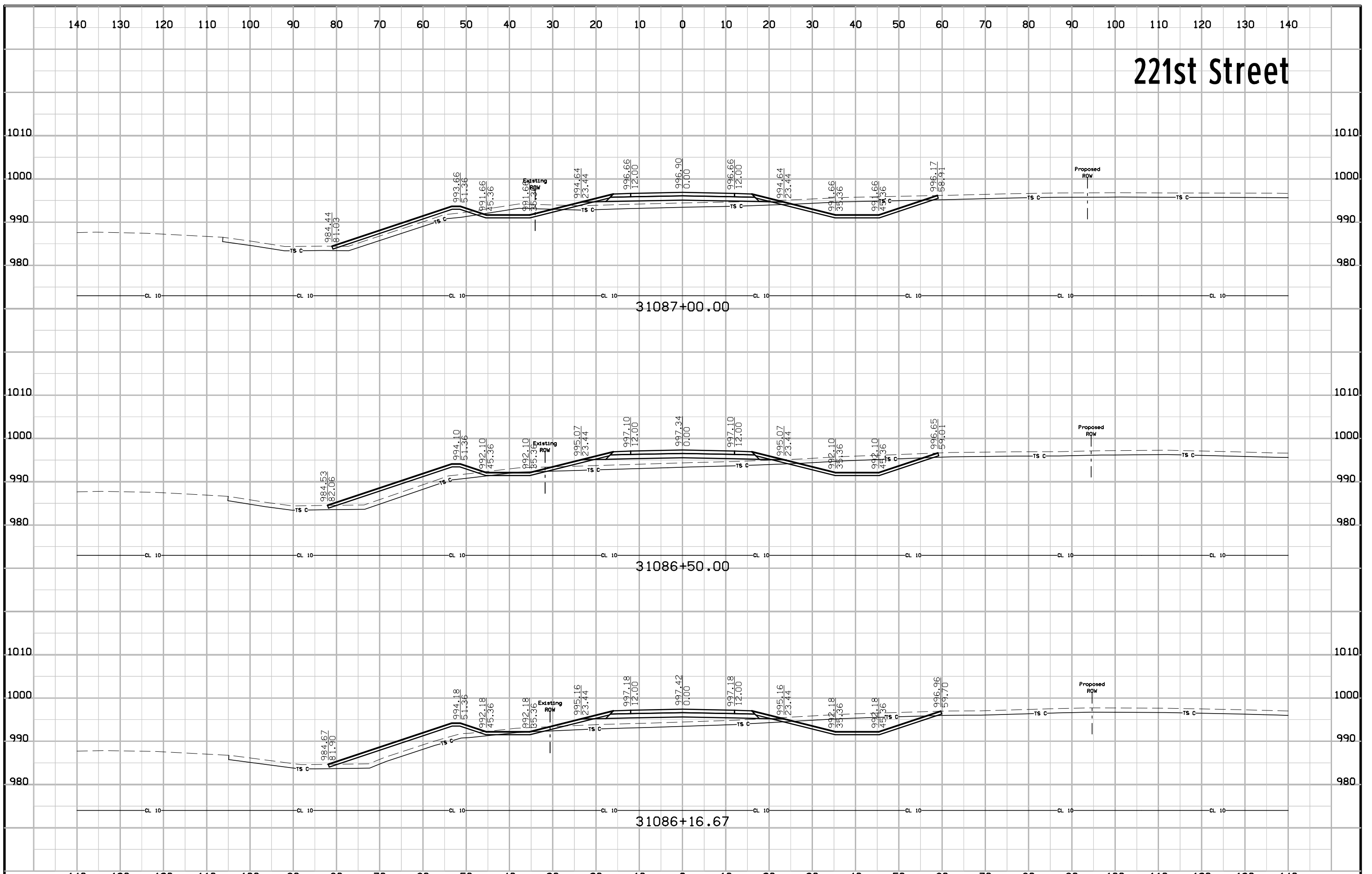

# 221st Street

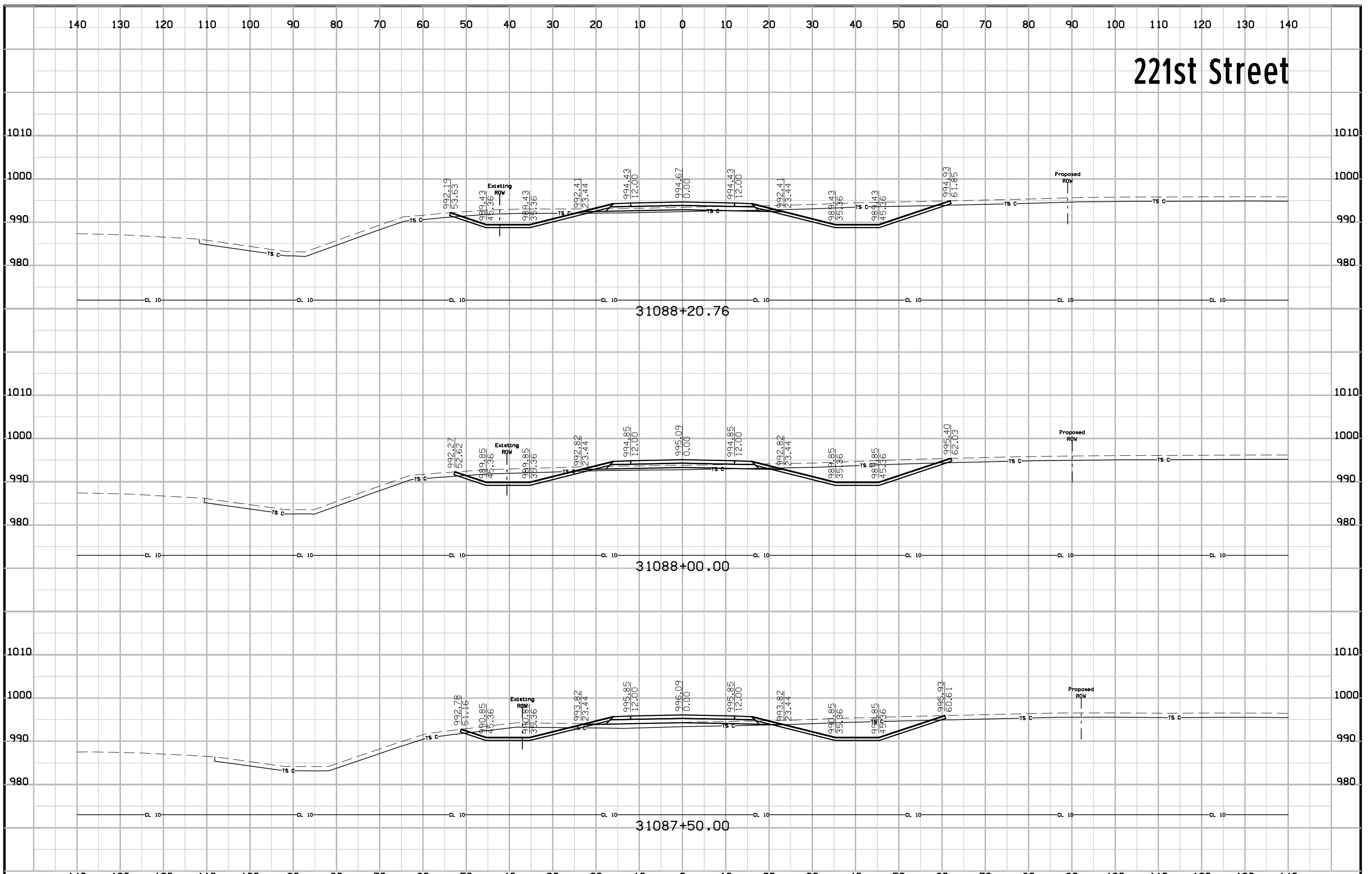

# 221st Street

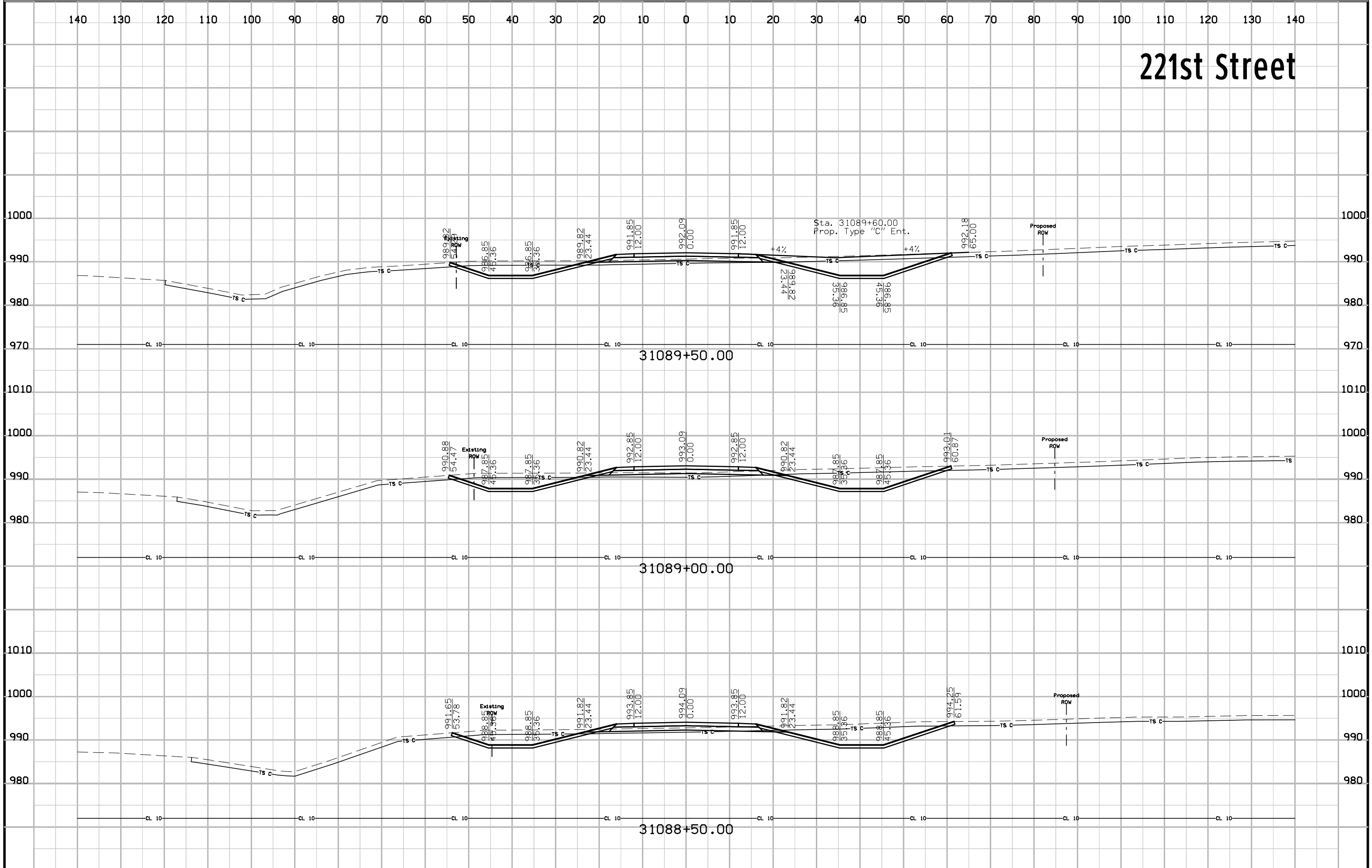

# 221st Street

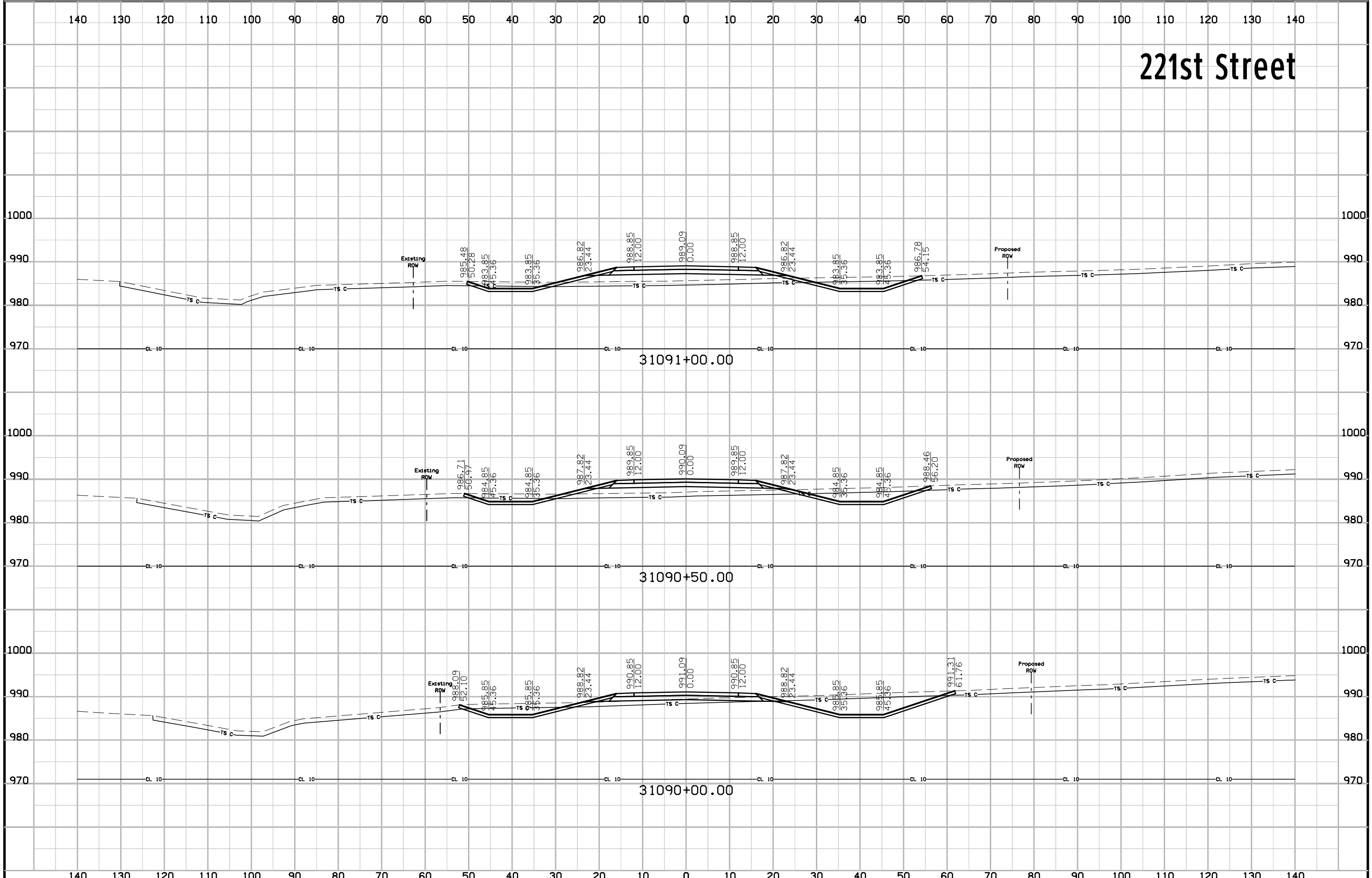



# 221st Street

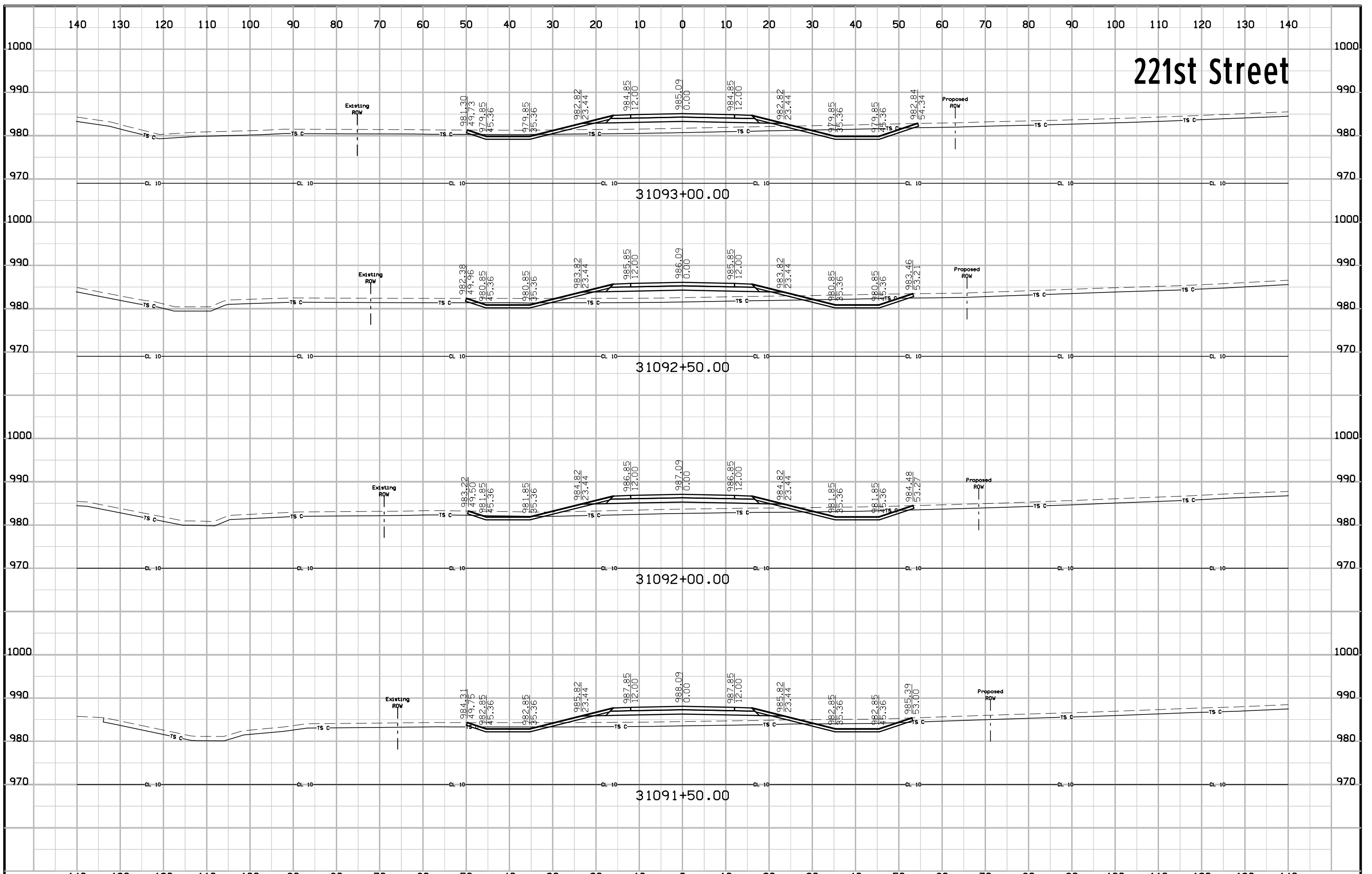

# 221st Street

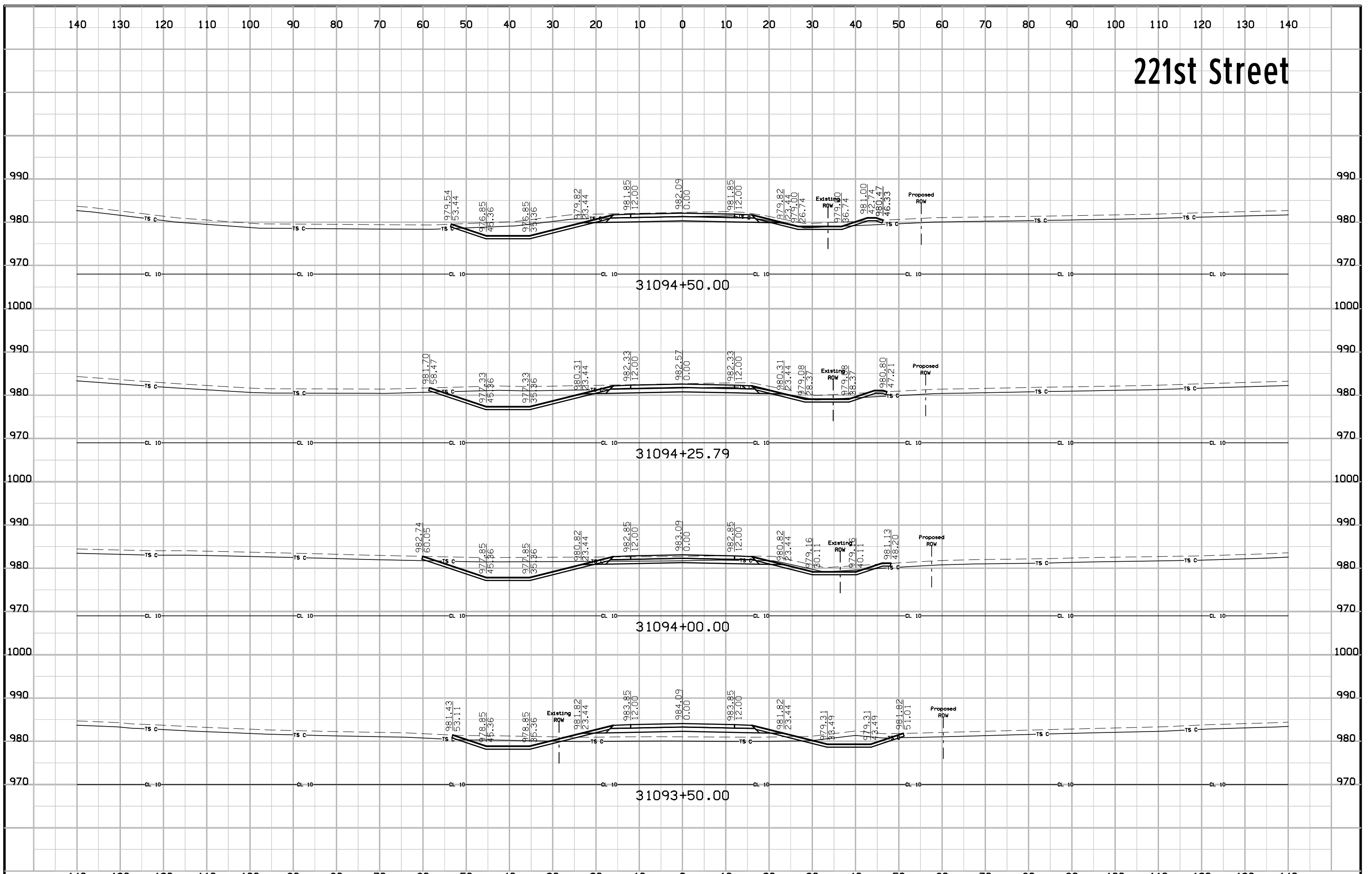



# 218th Street

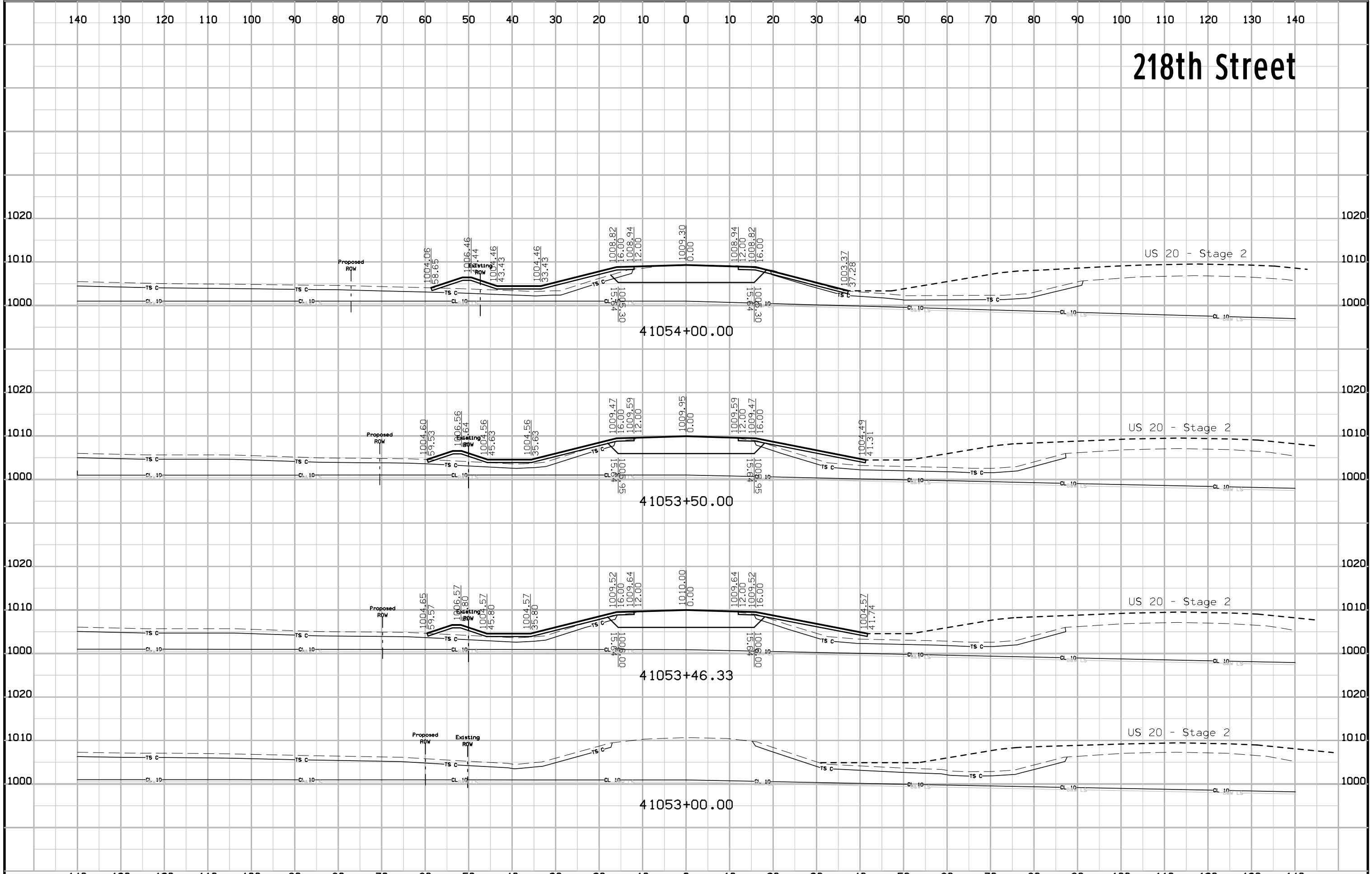

# 218th Street

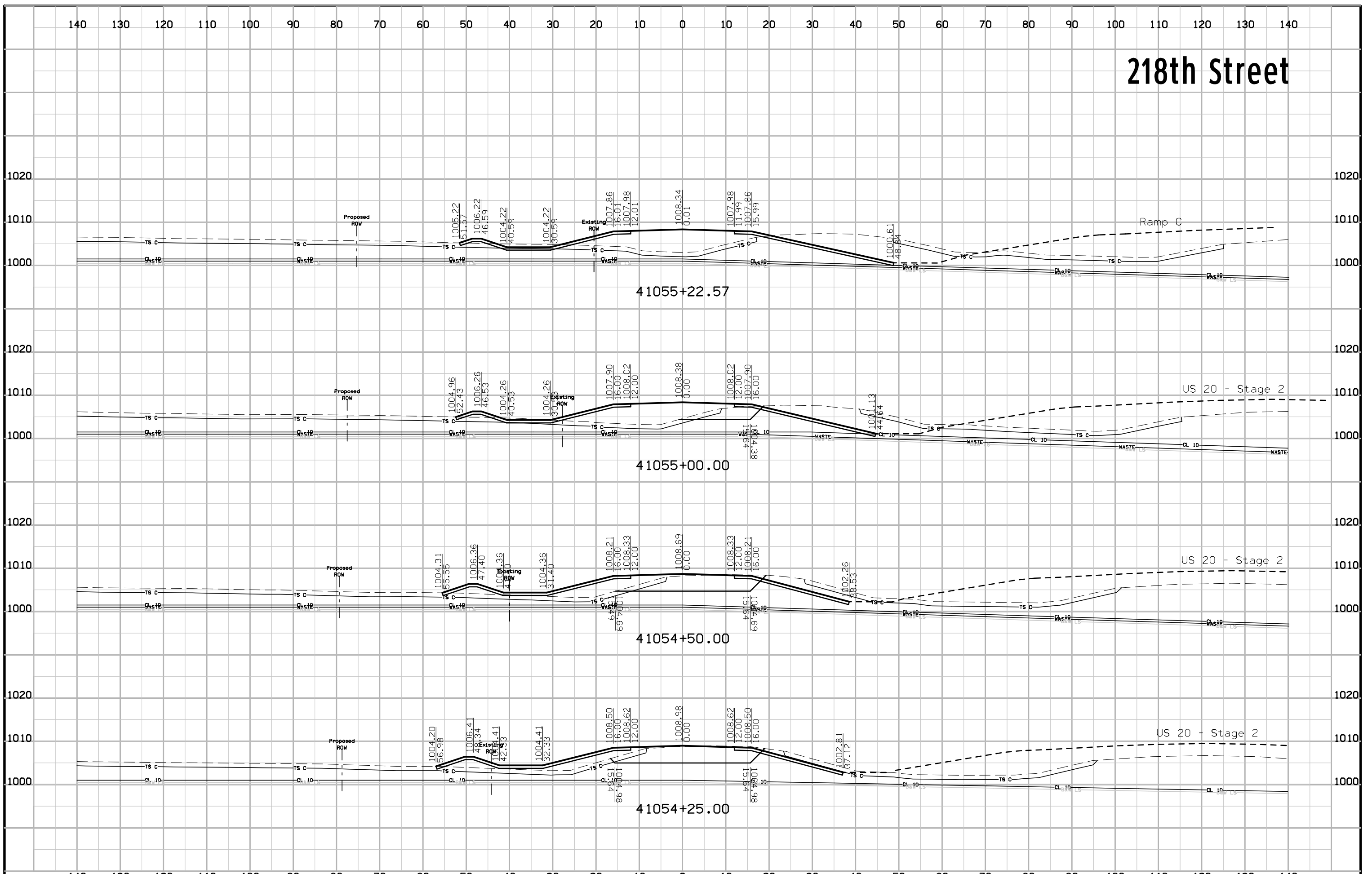

# 218th Street

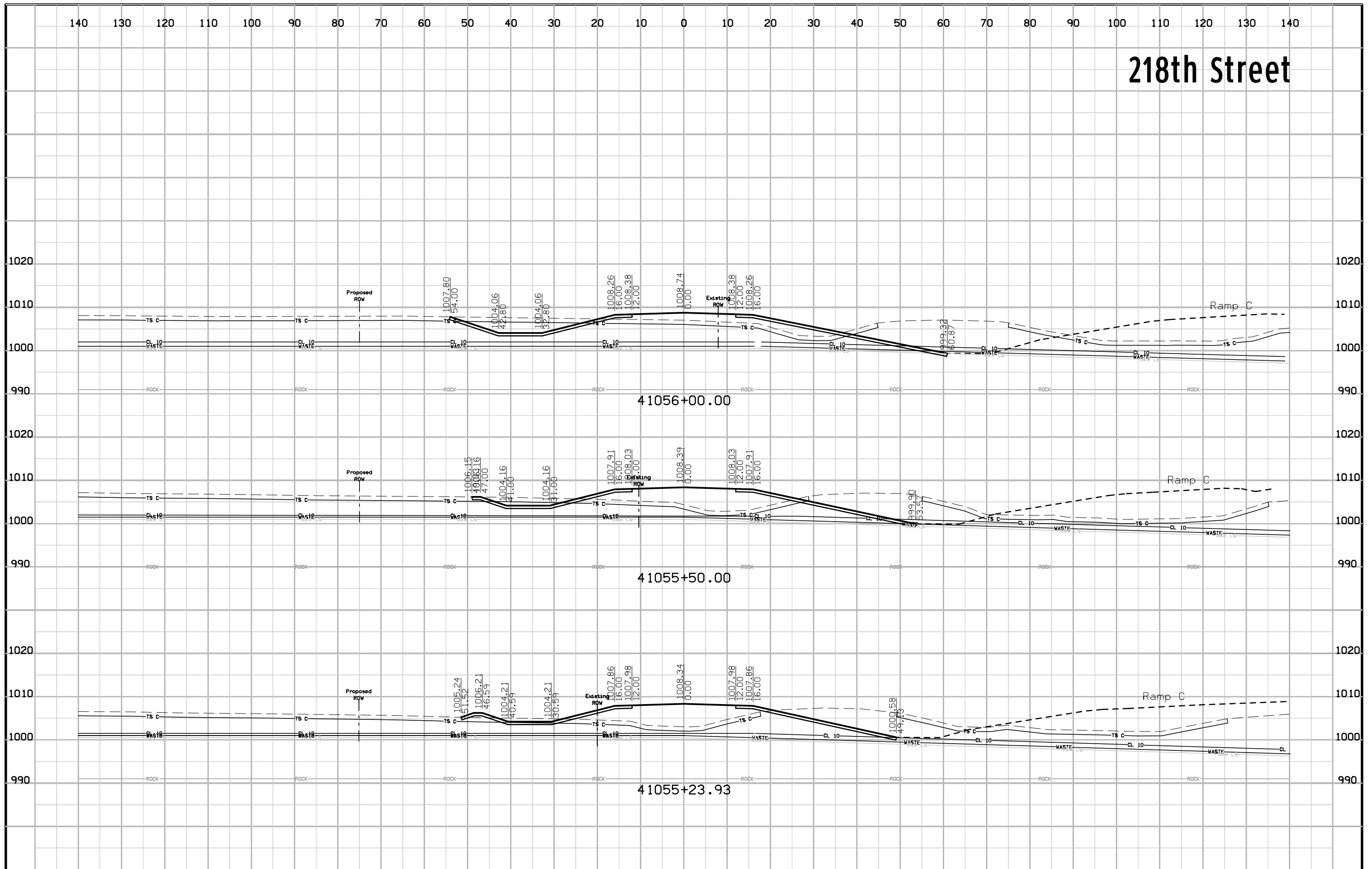

# 218th Street

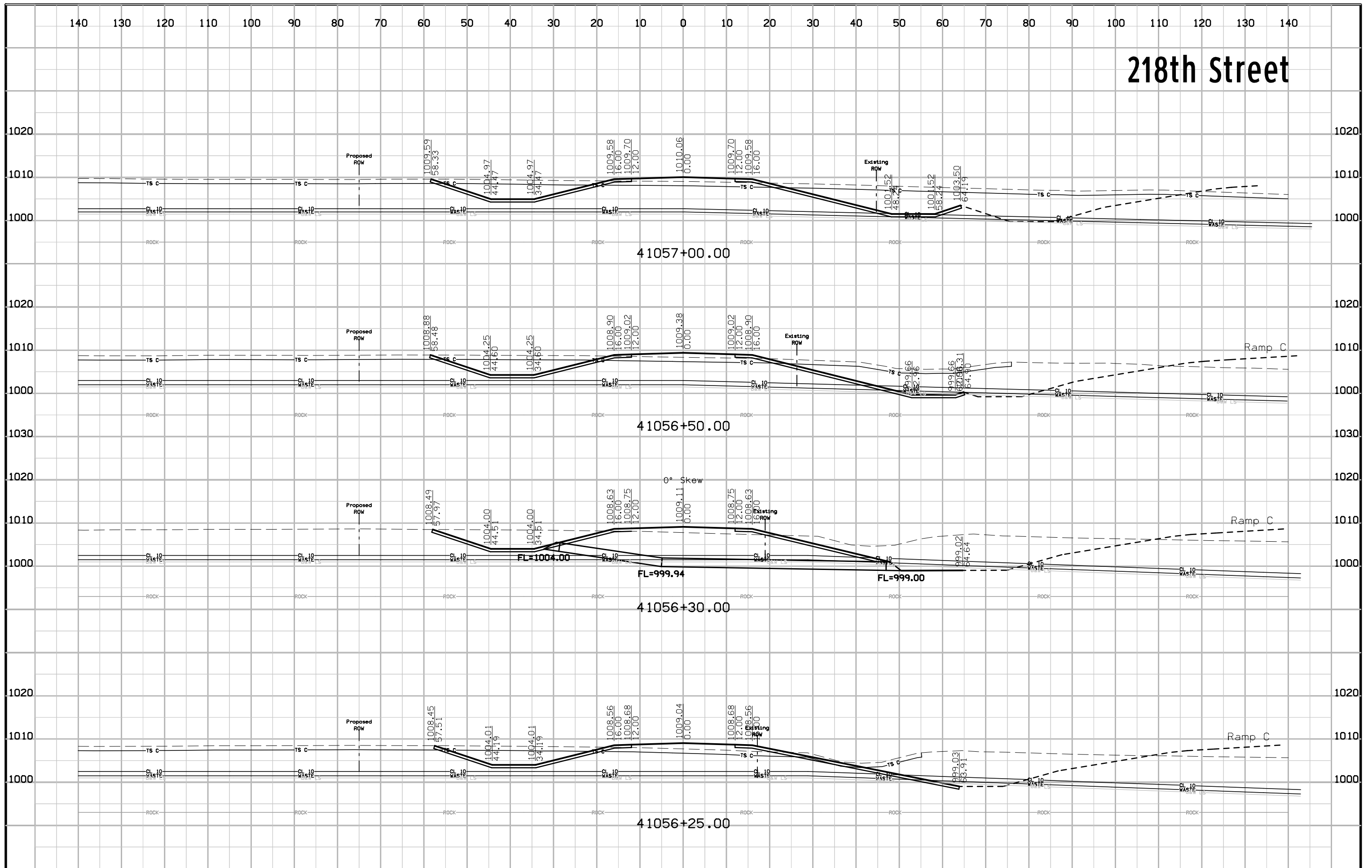

# 218th Street

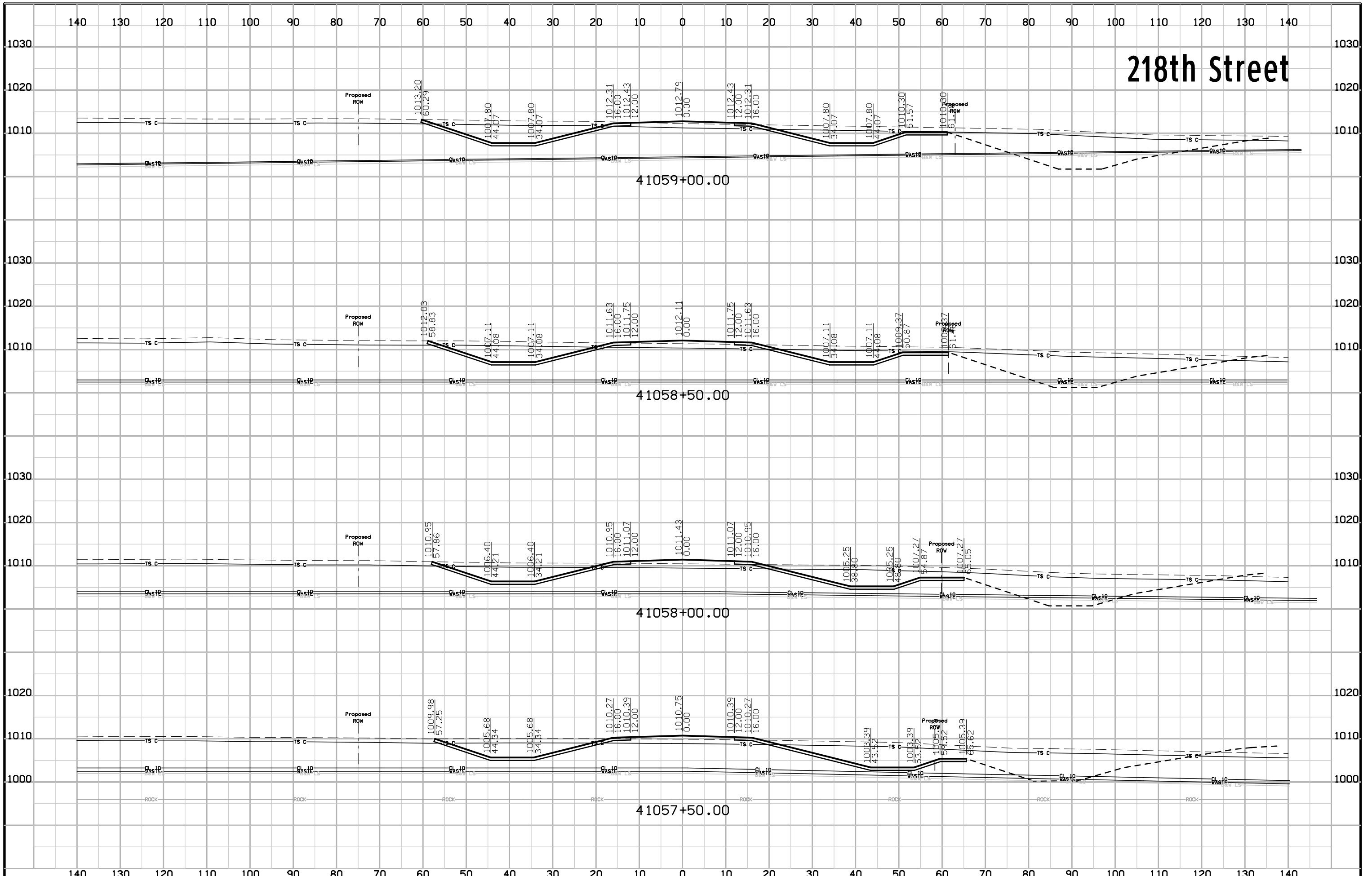



# 218th Street

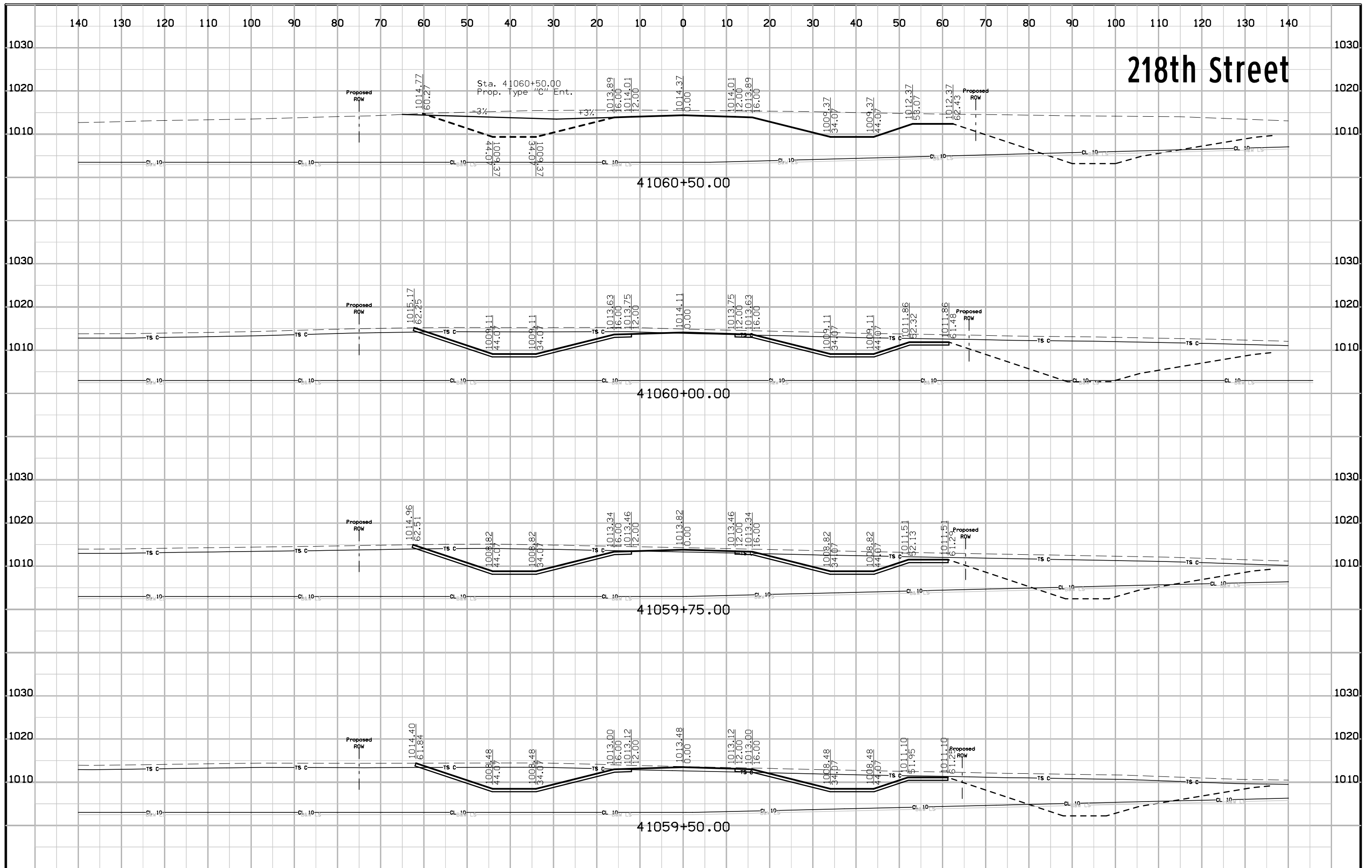

# 218th Street

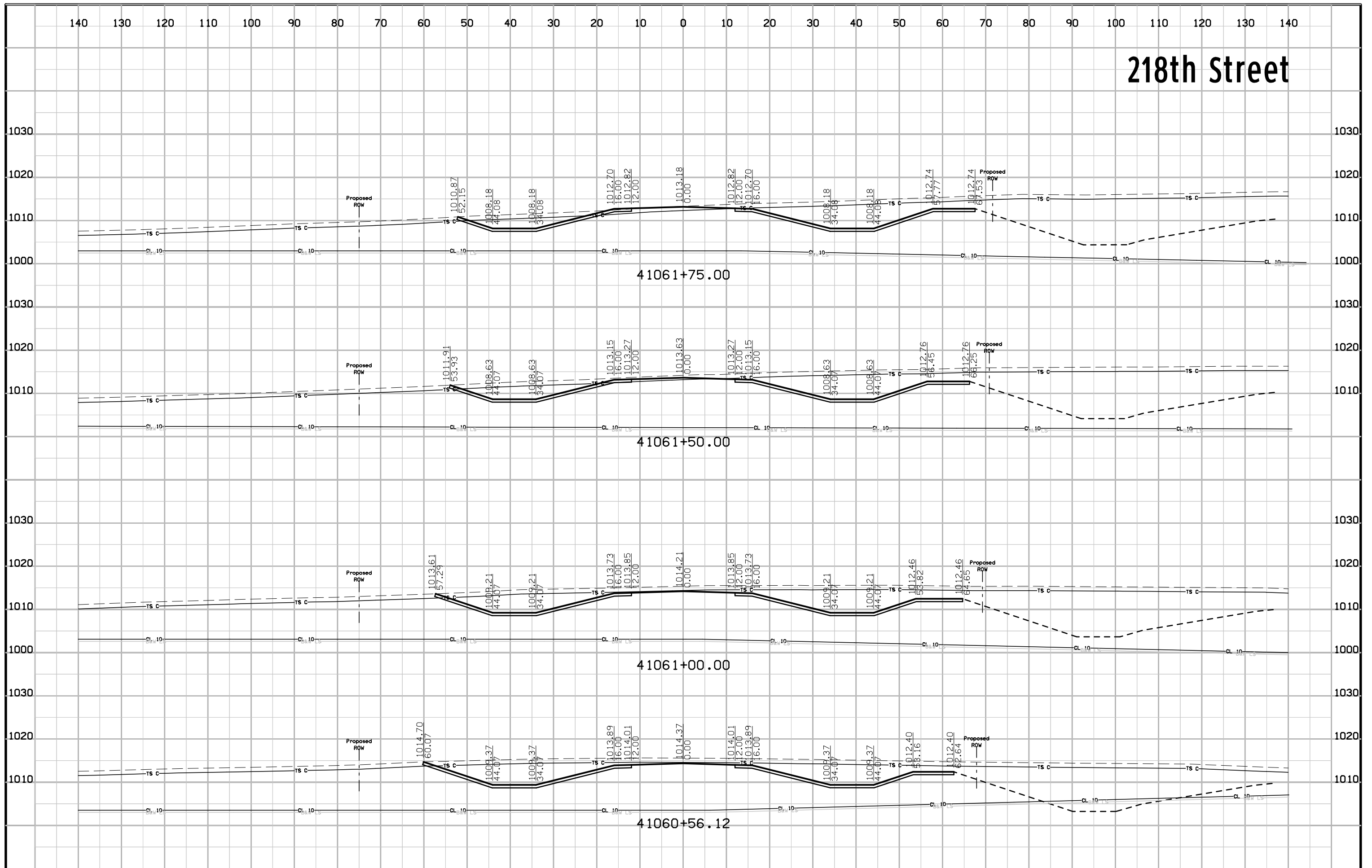

# 218th Street

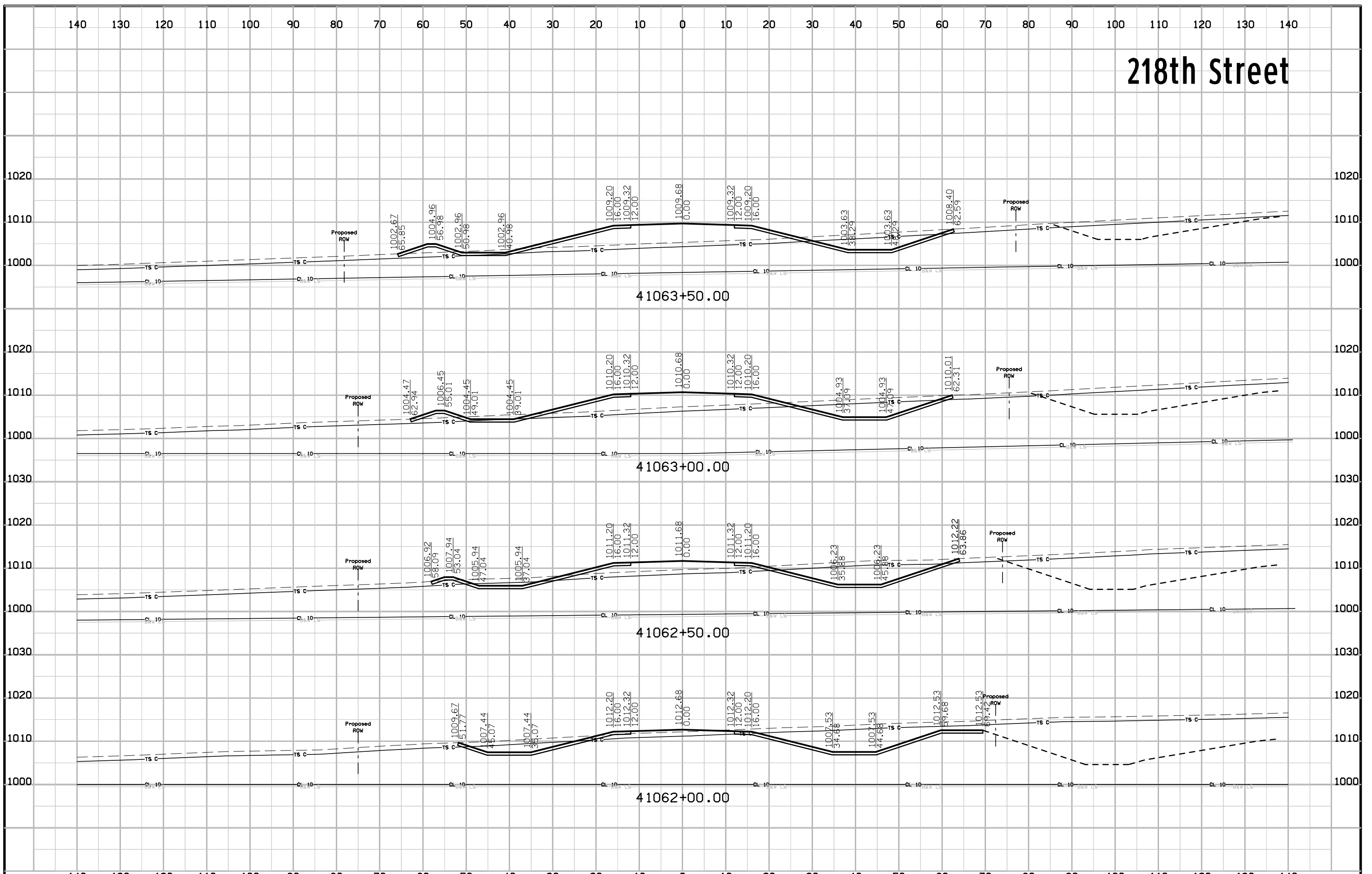

# 218th Street

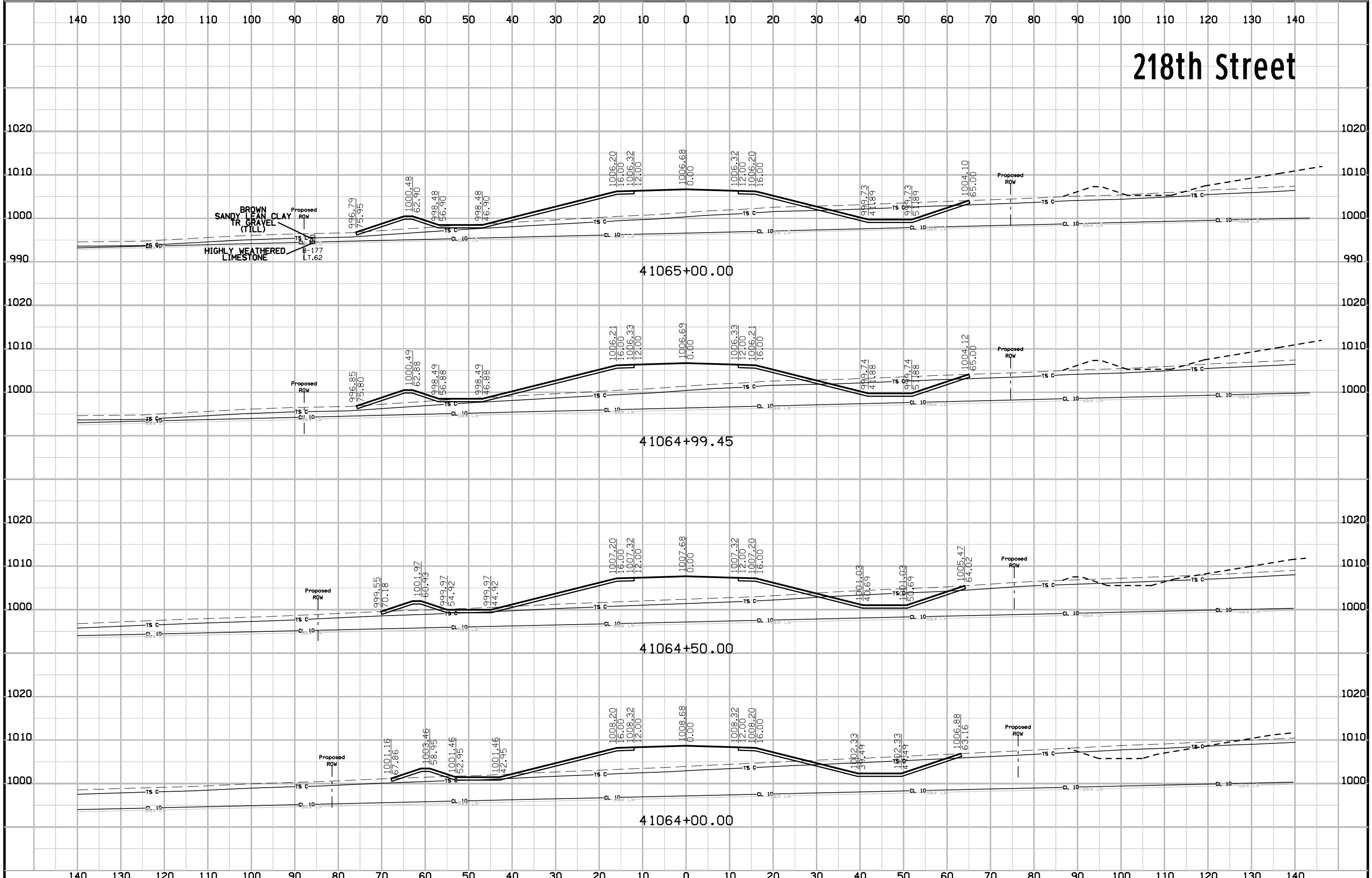

# 218th Street

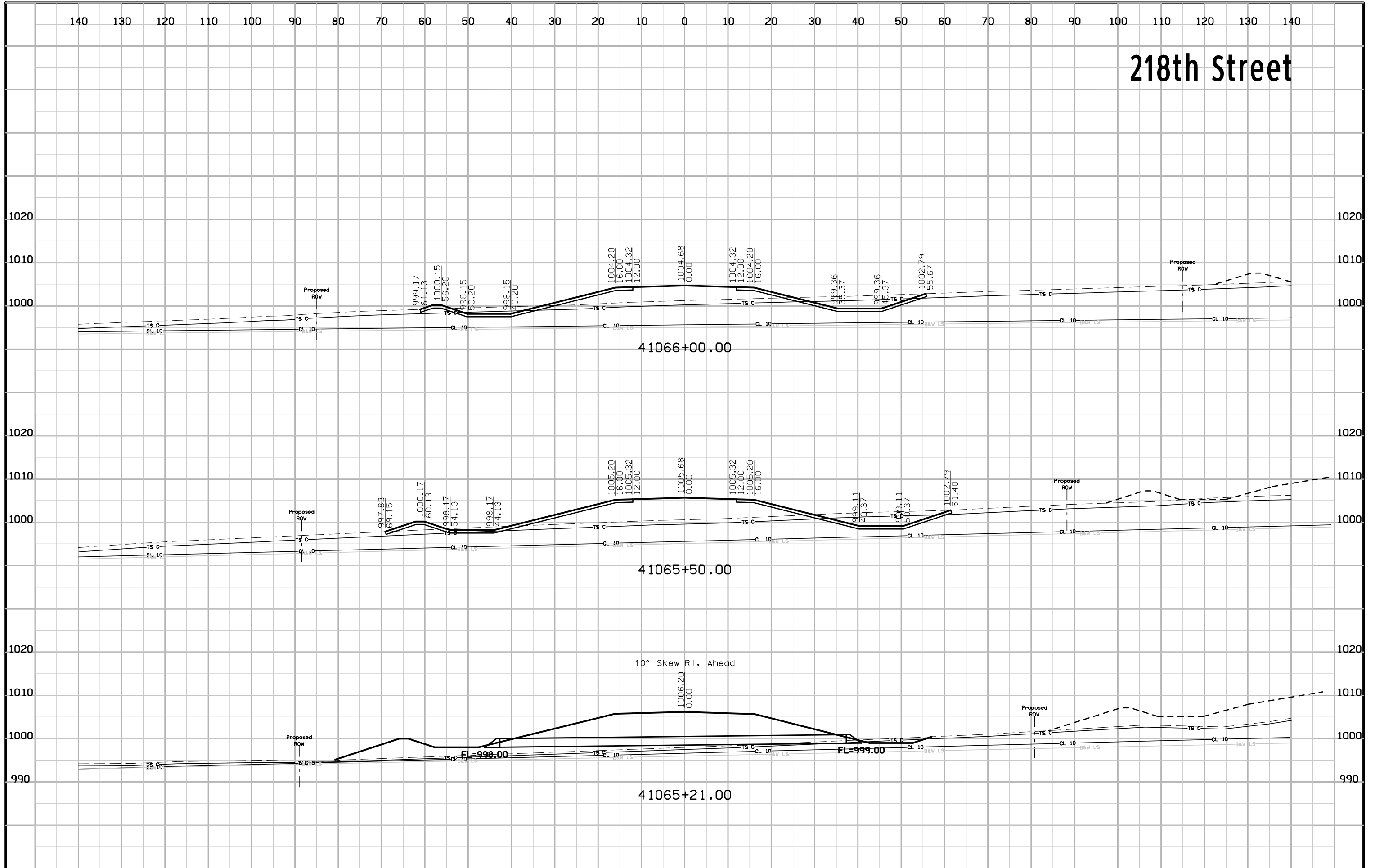

# 218th Street

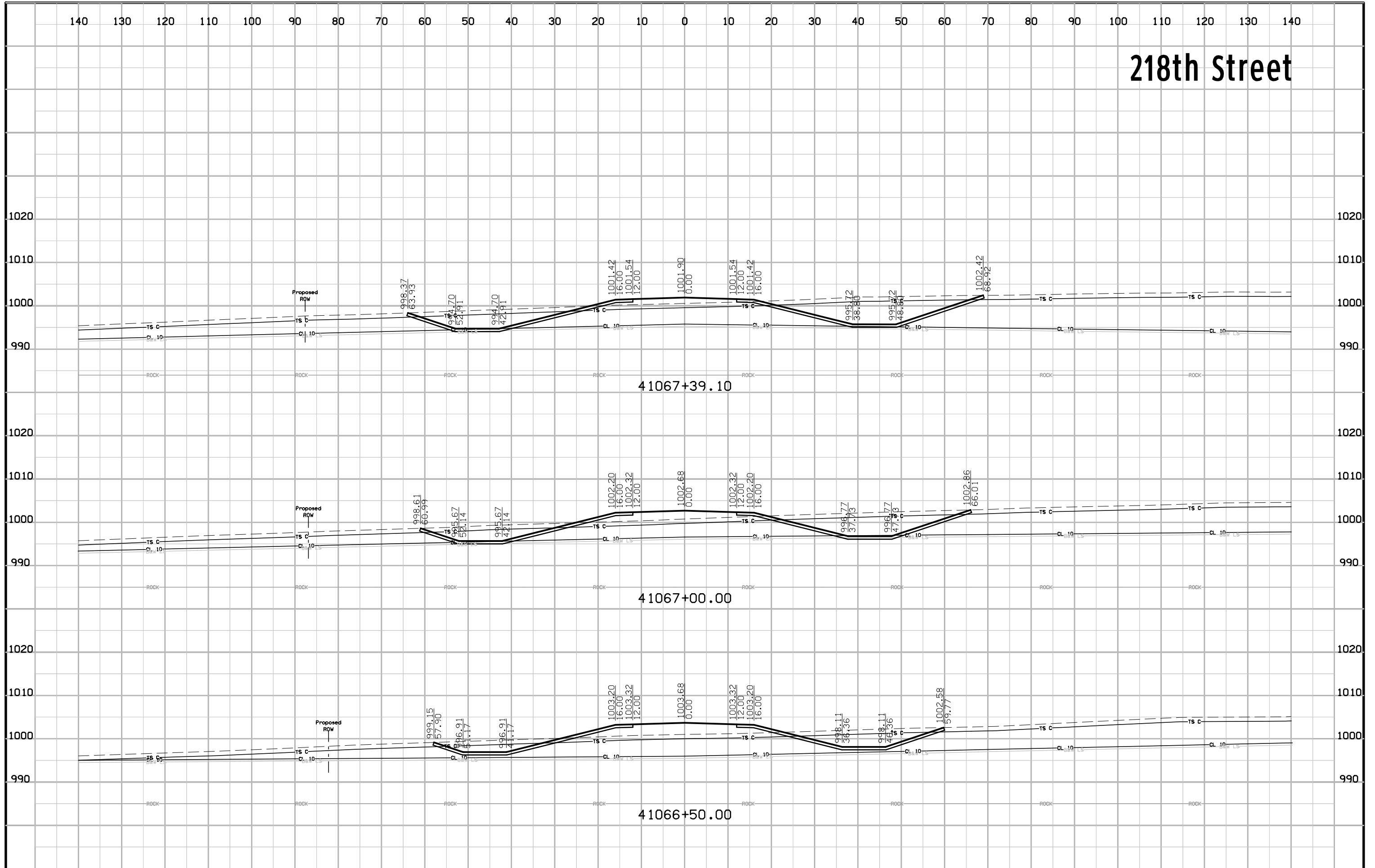

# 218th Street

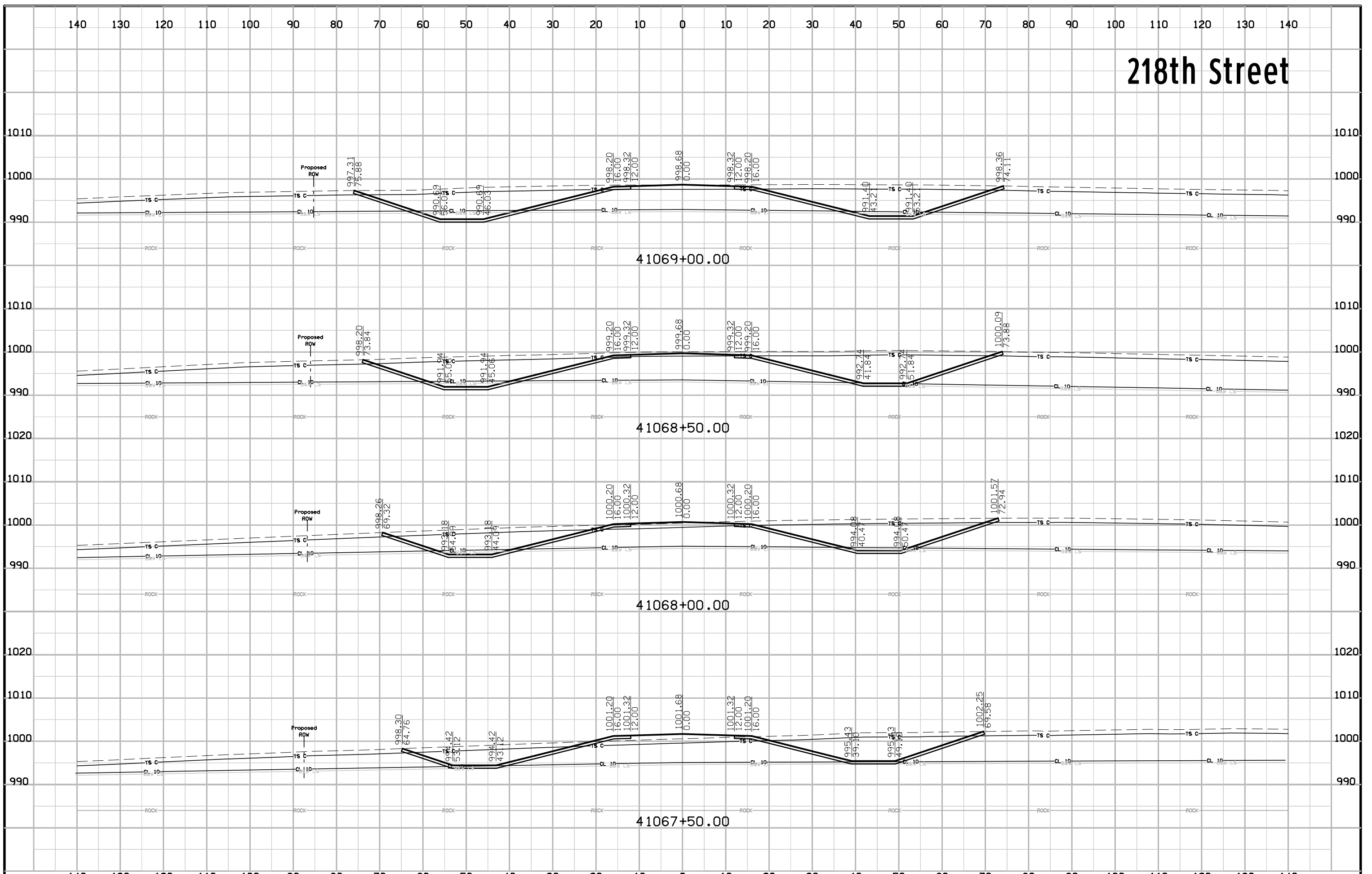

# 218th Street

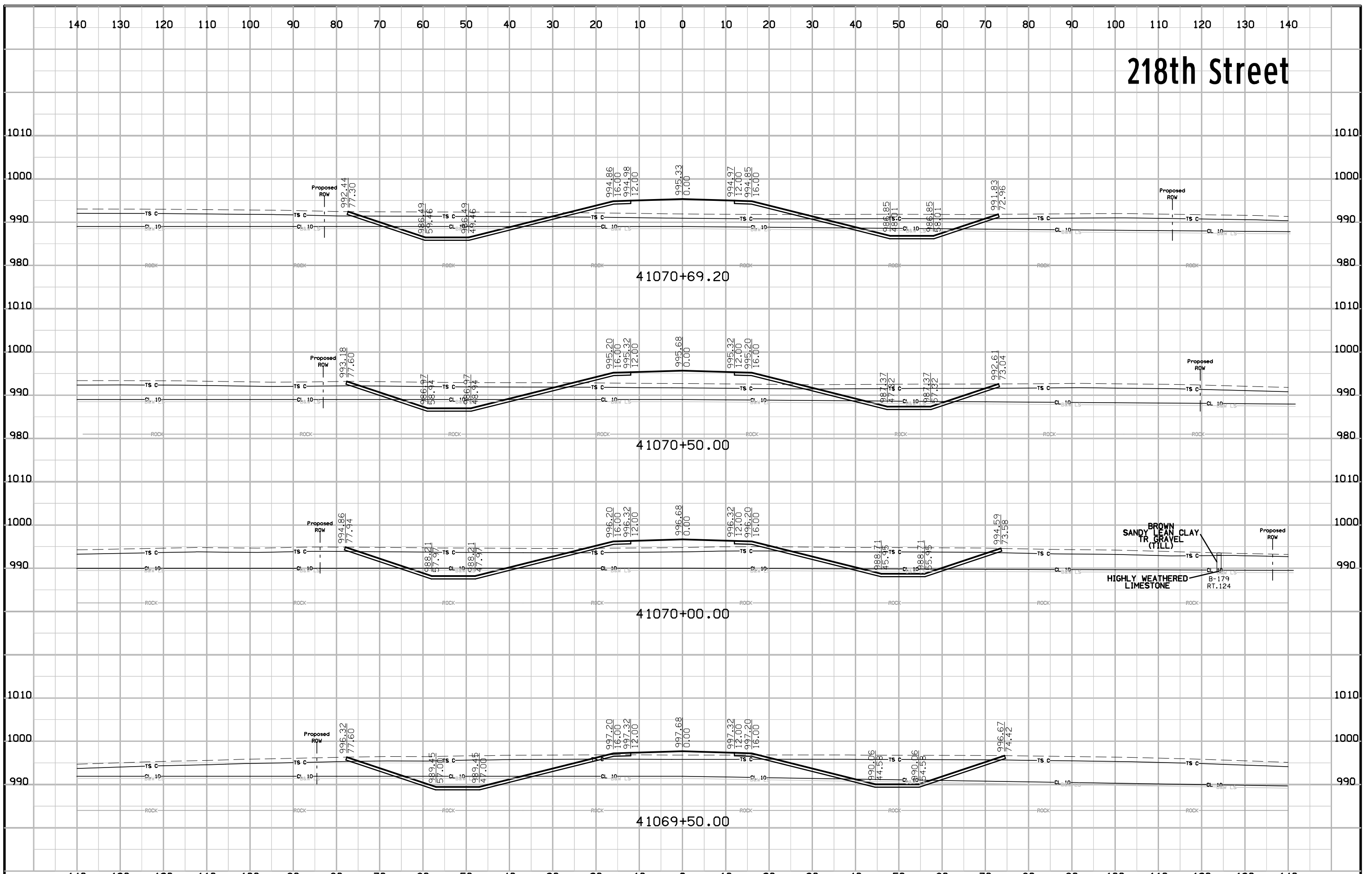



# 218th Street

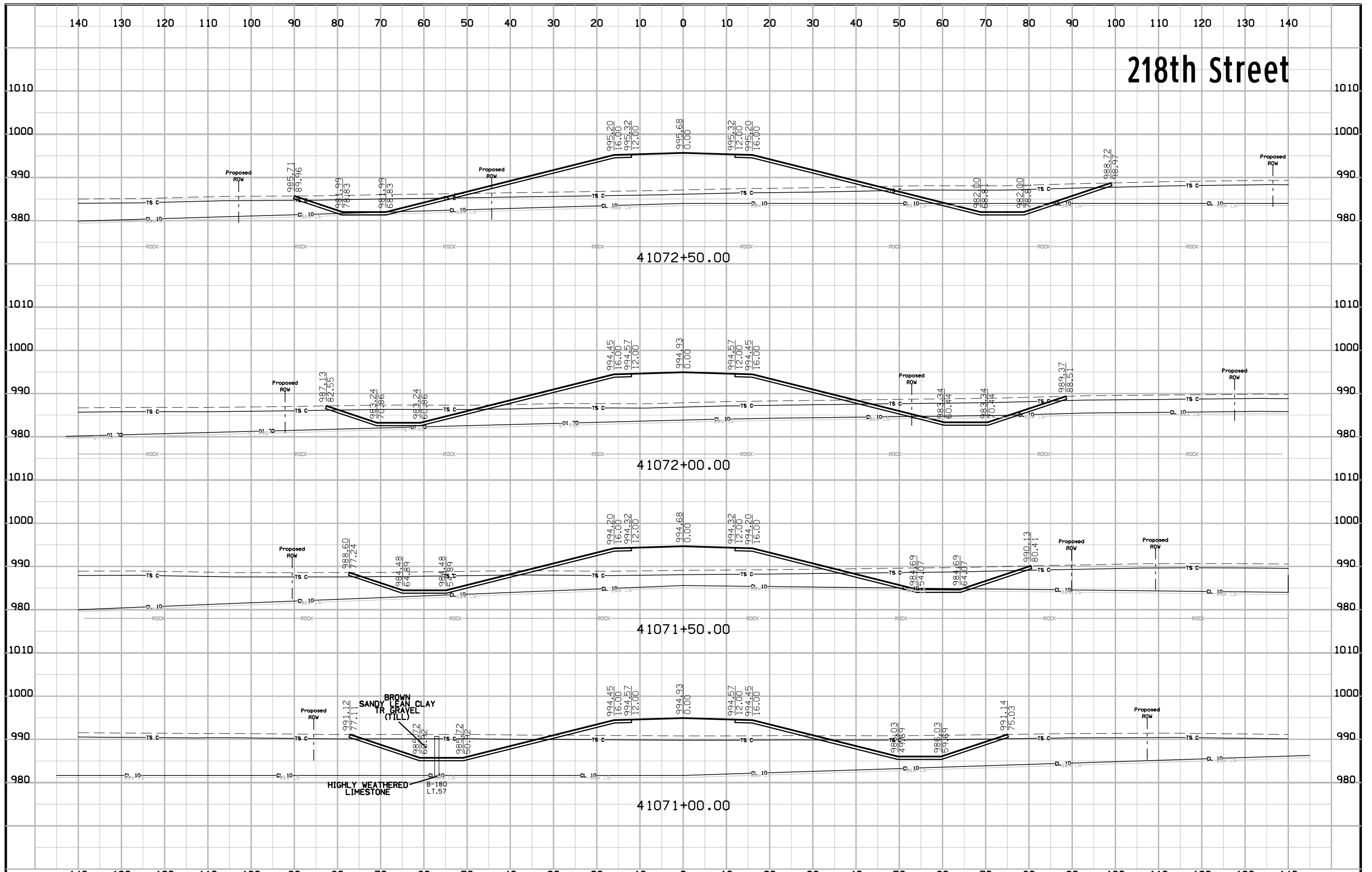



# 218th Street

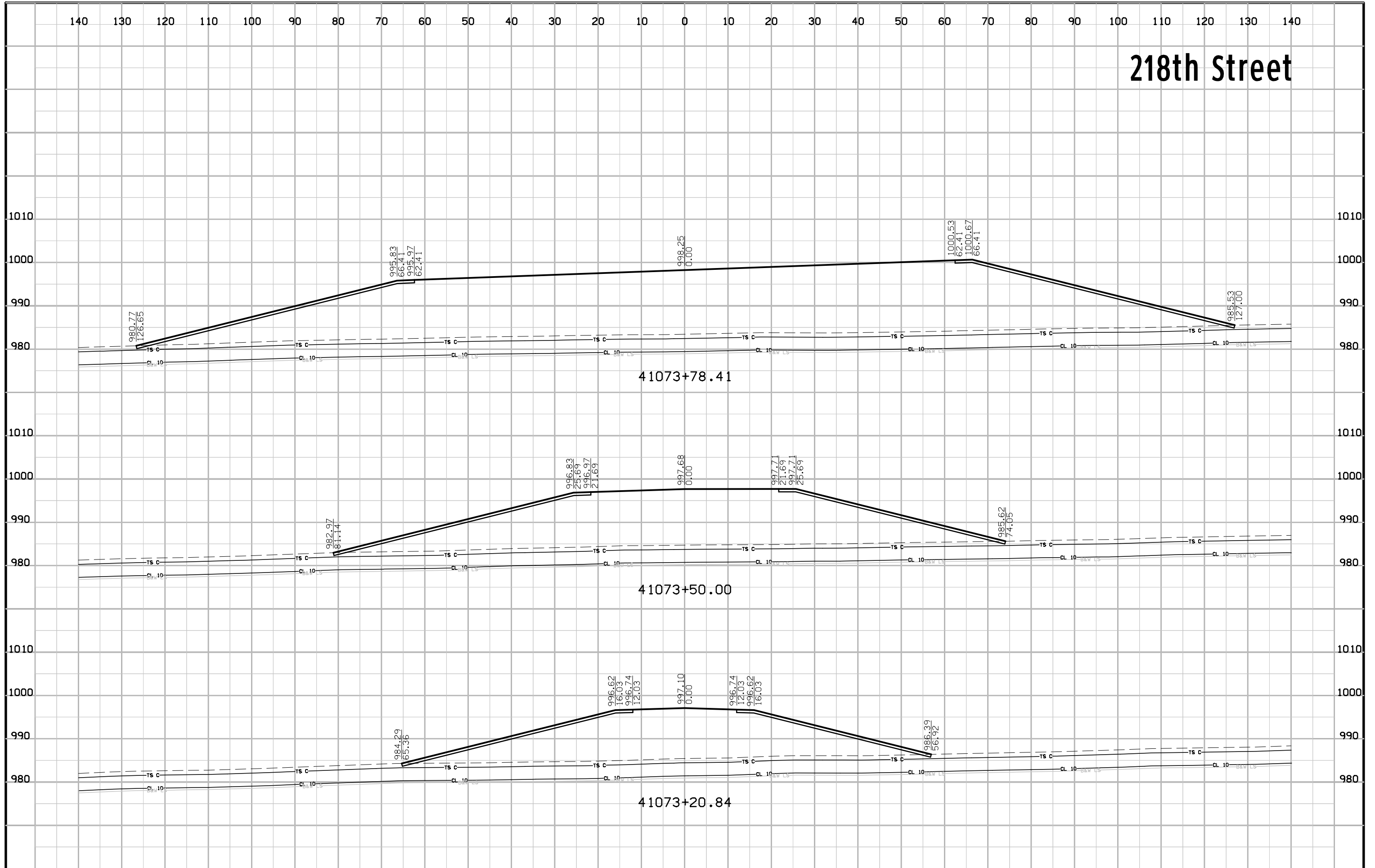

# Field of Dreams Way

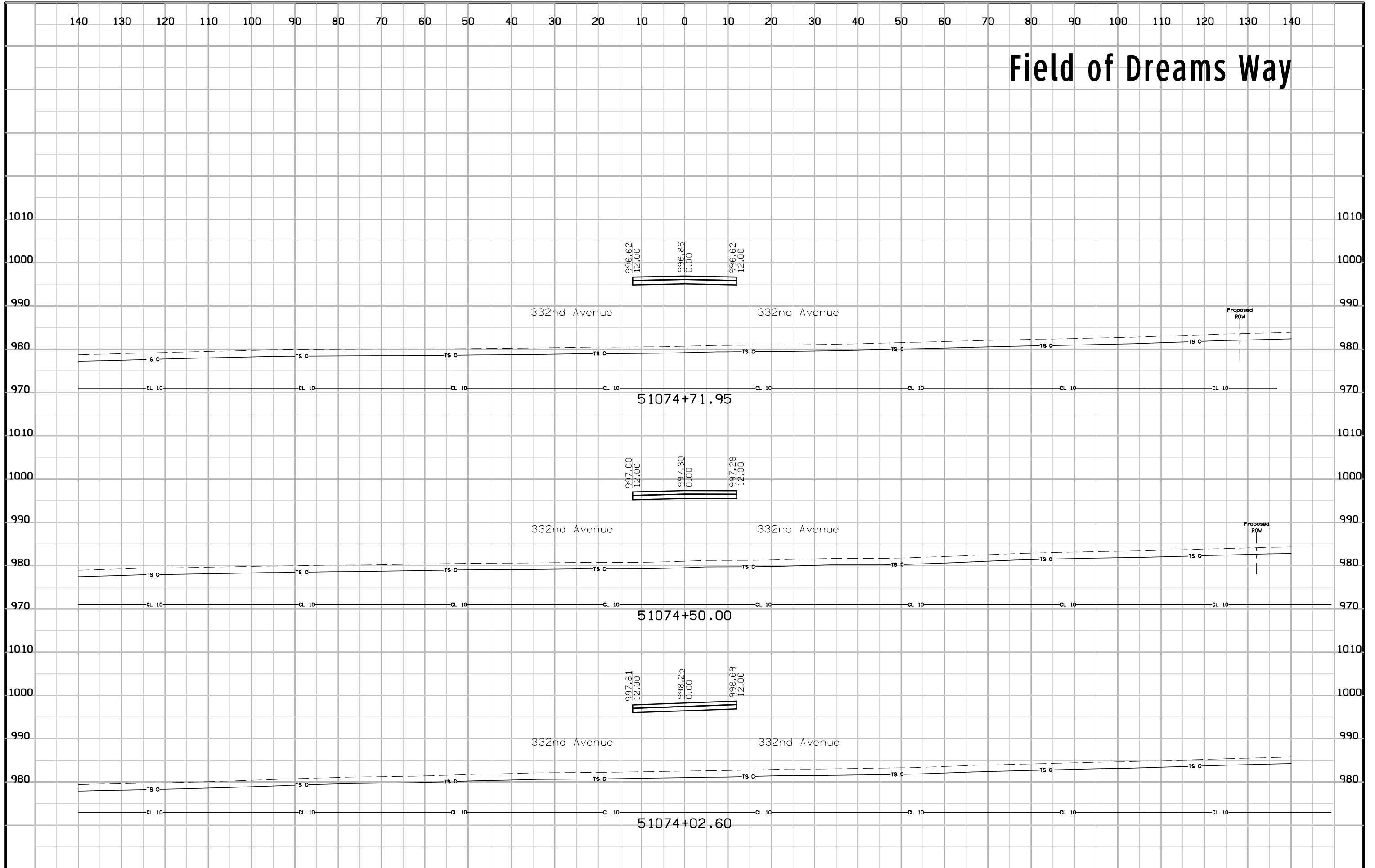

# Field of Dreams Way

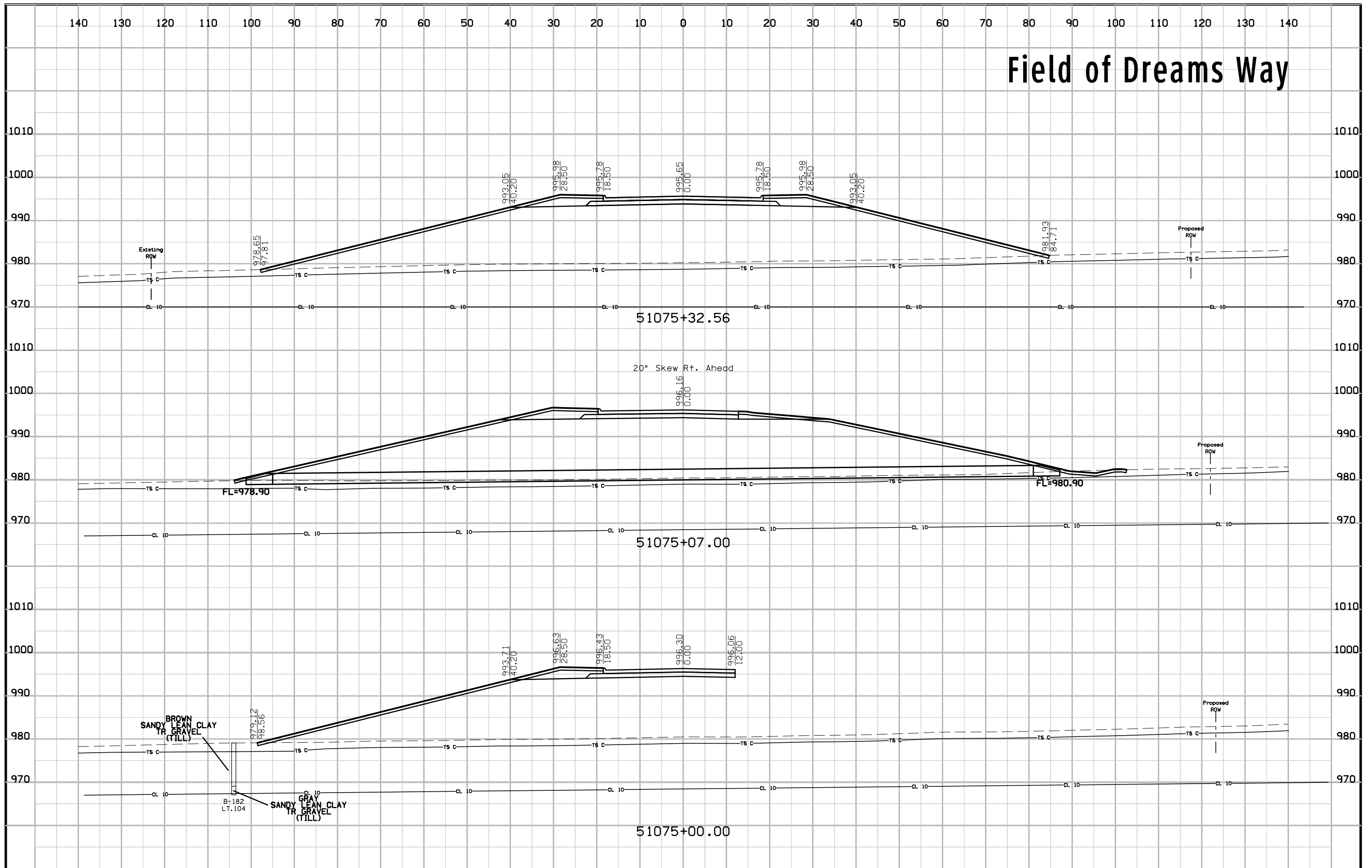

# Field of Dreams Way

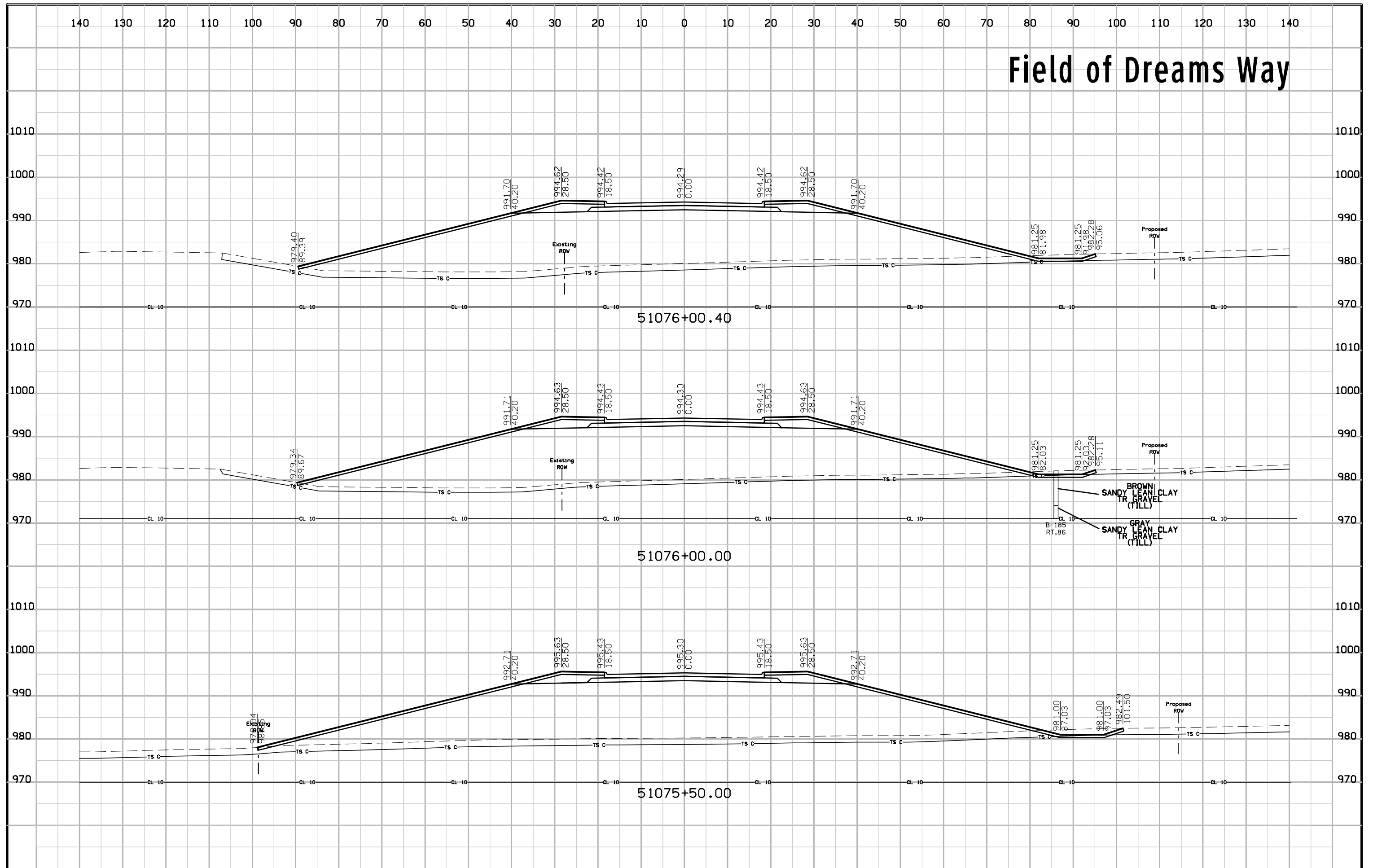

# Field of Dreams Way

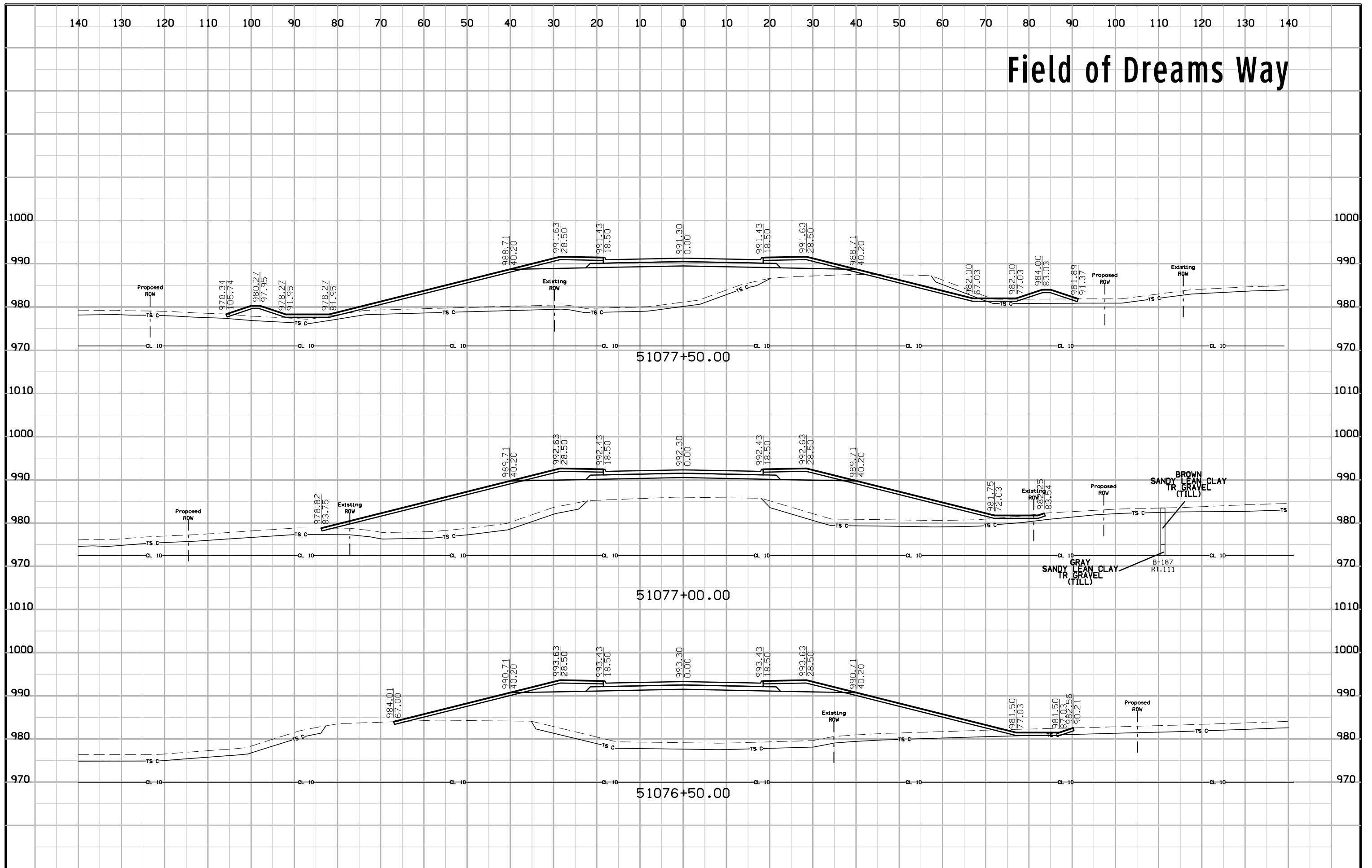

# Field of Dreams Way

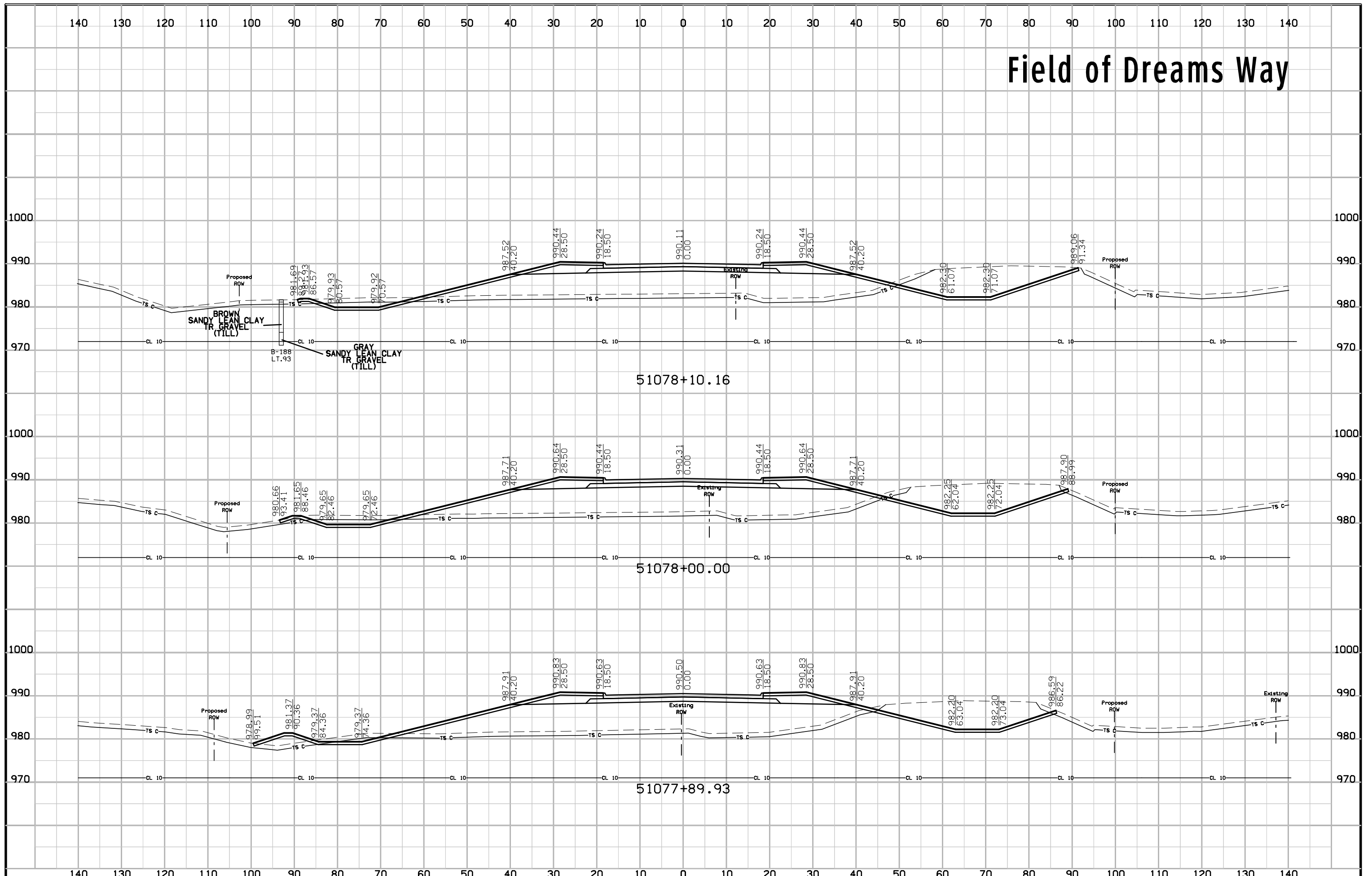



# Field of Dreams Way

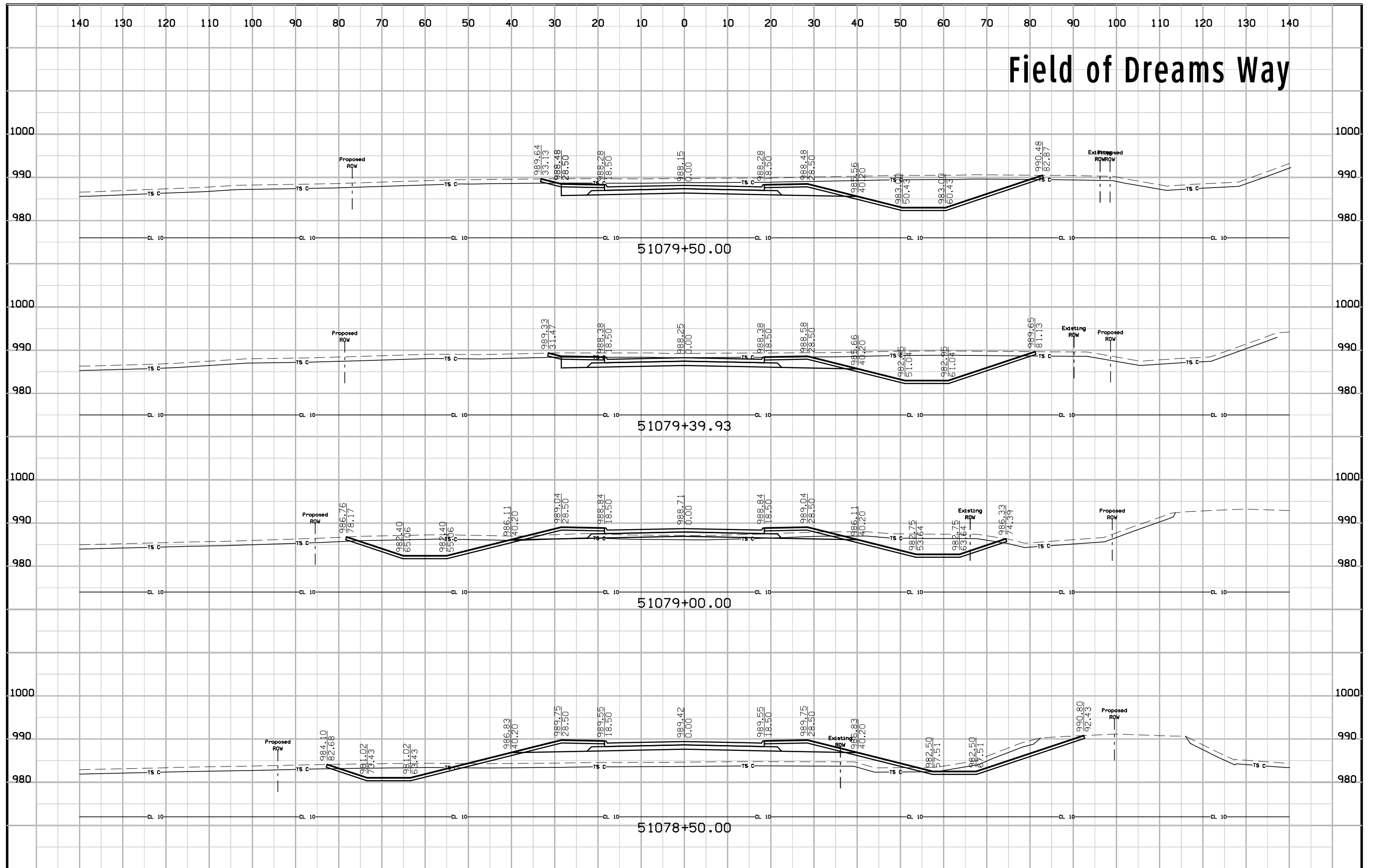

# Field of Dreams Way

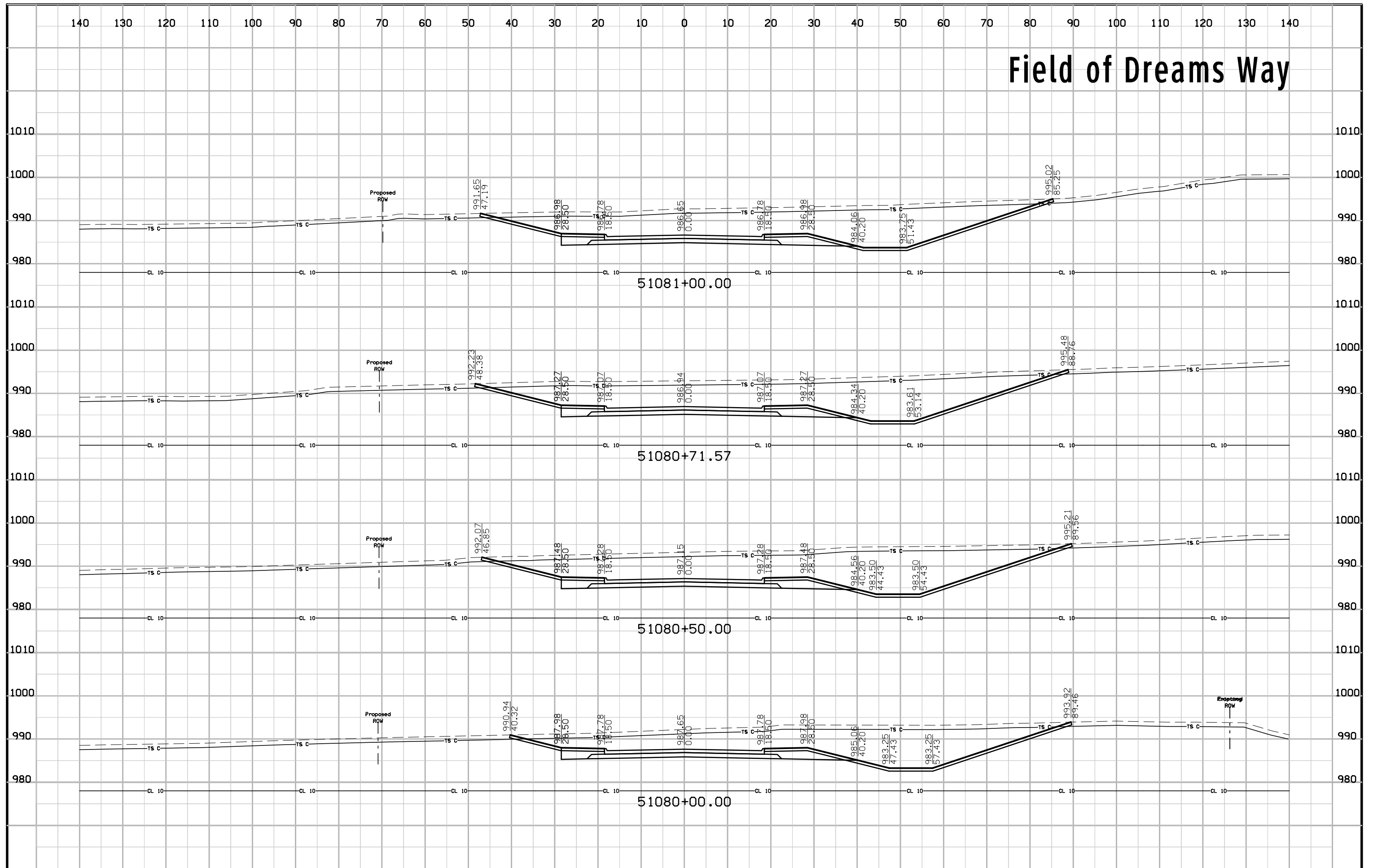

# Field of Dreams Way

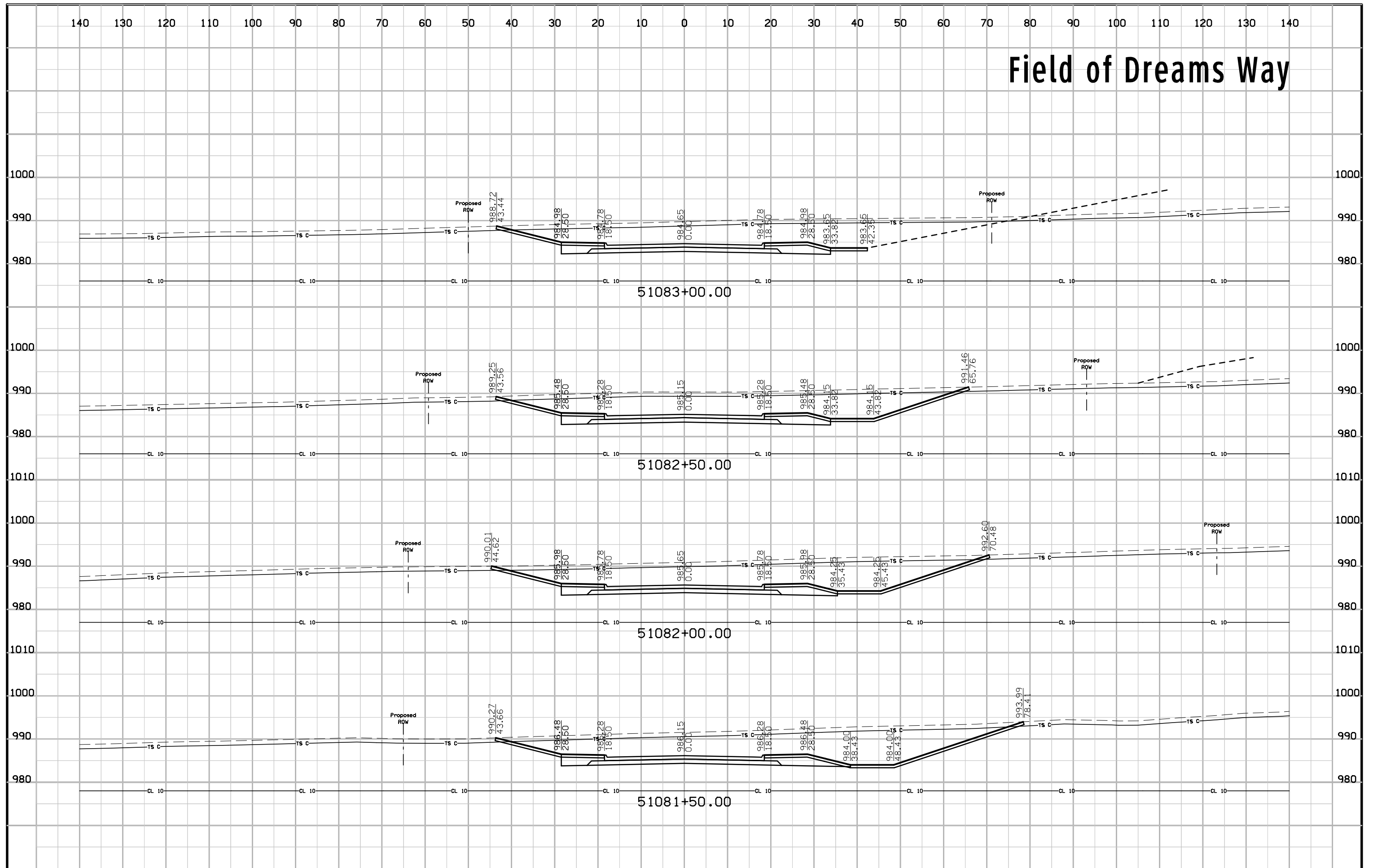

# Field of Dreams Way

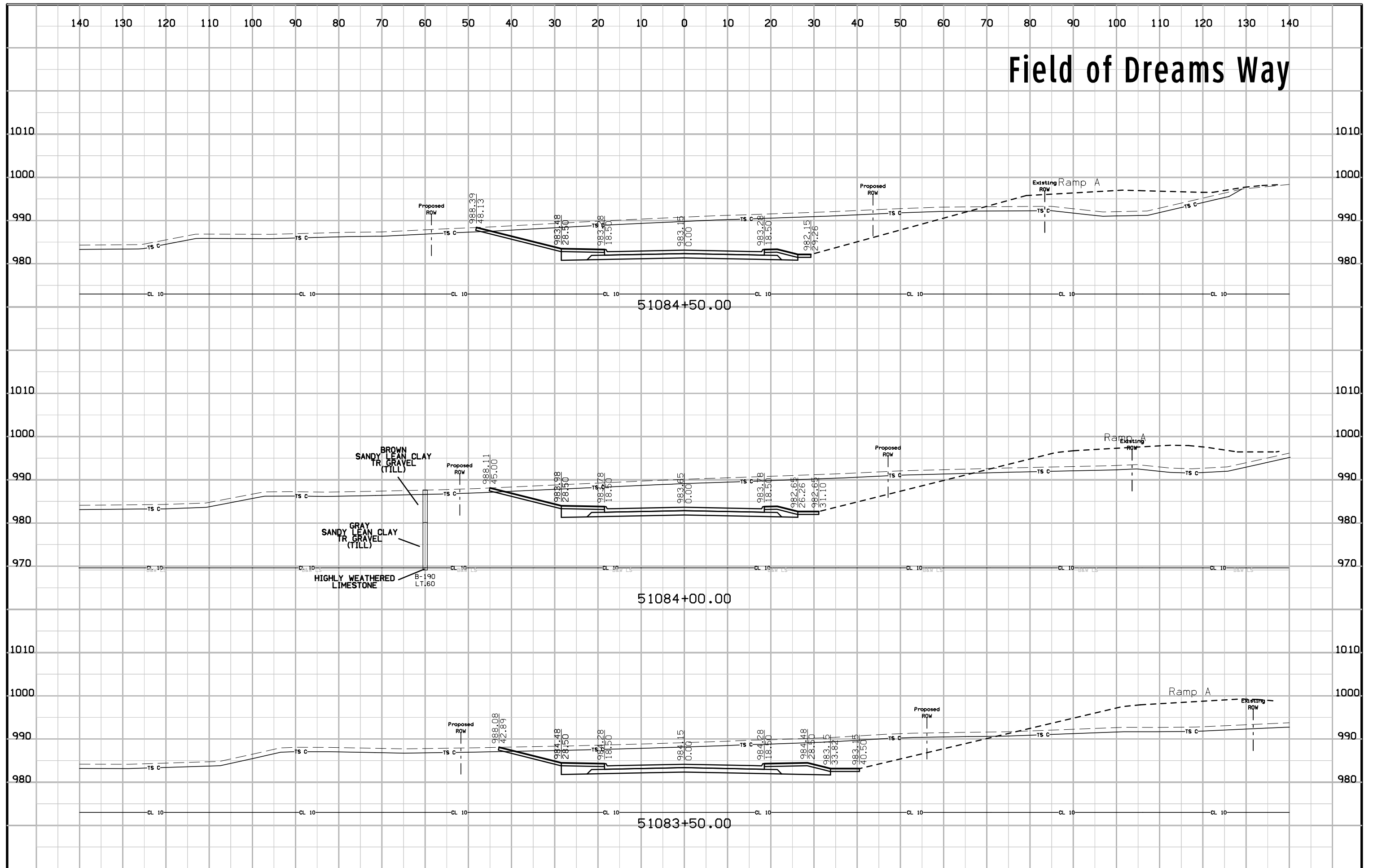

# Field of Dreams Way

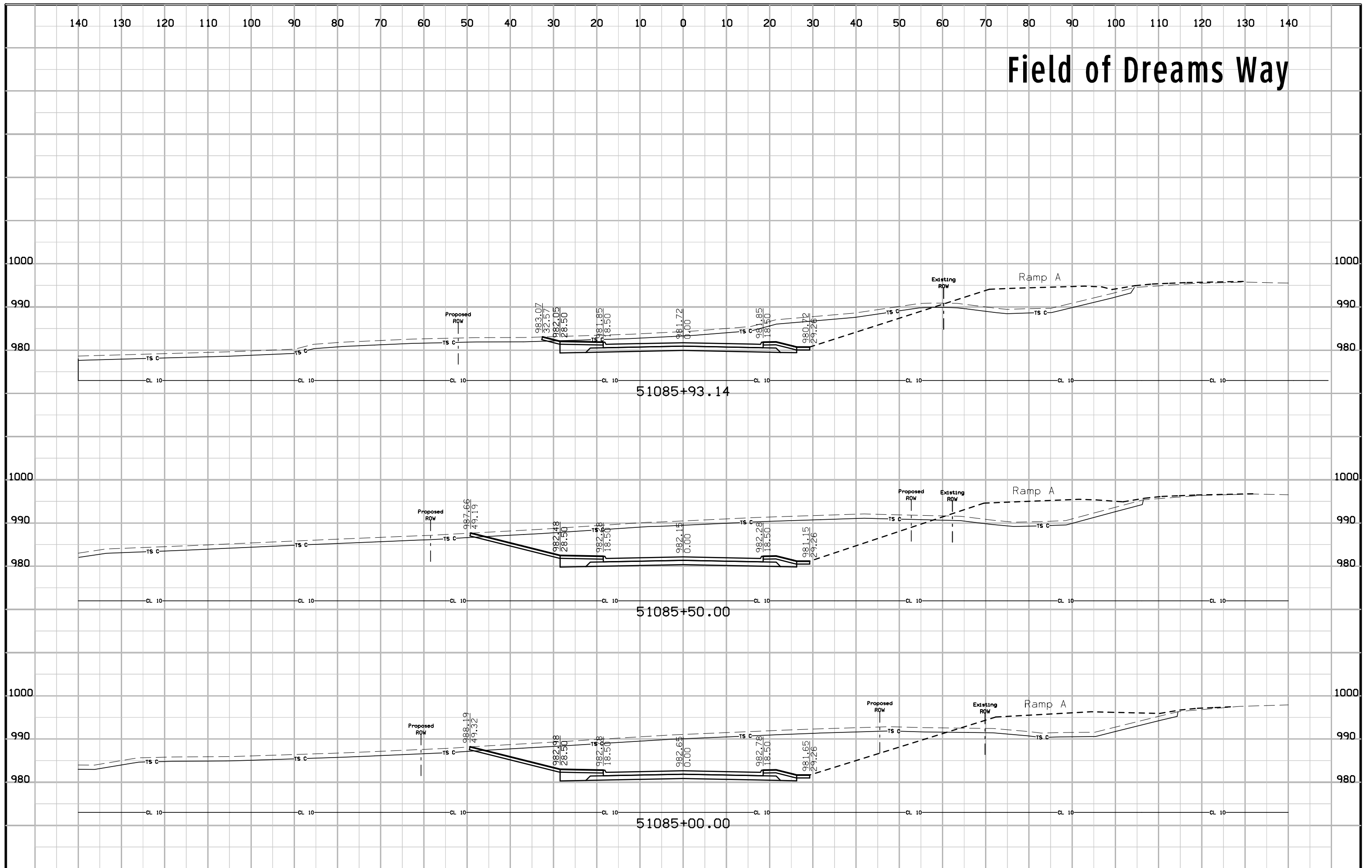

# Field of Dreams Way

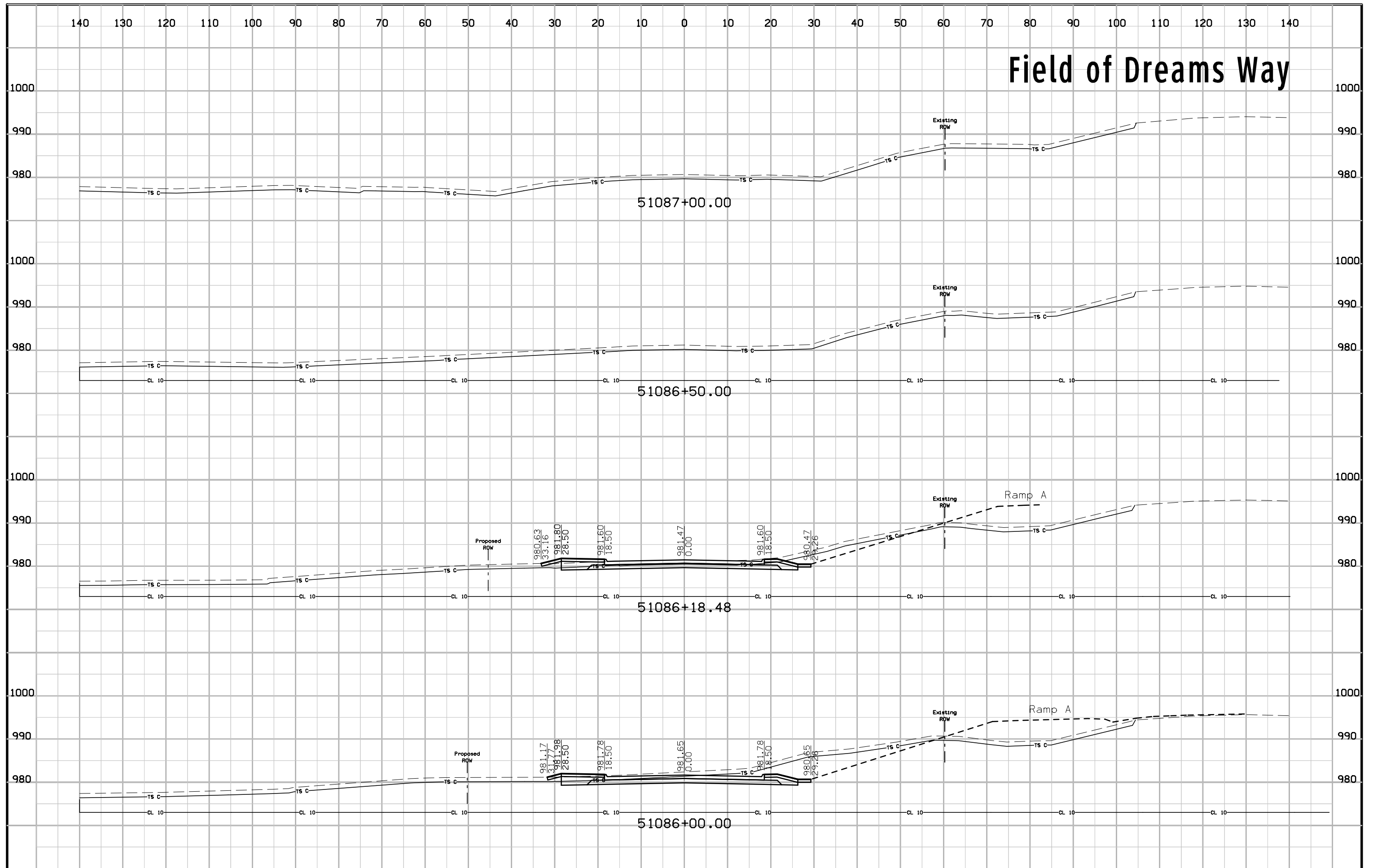

# Old 330th Channel

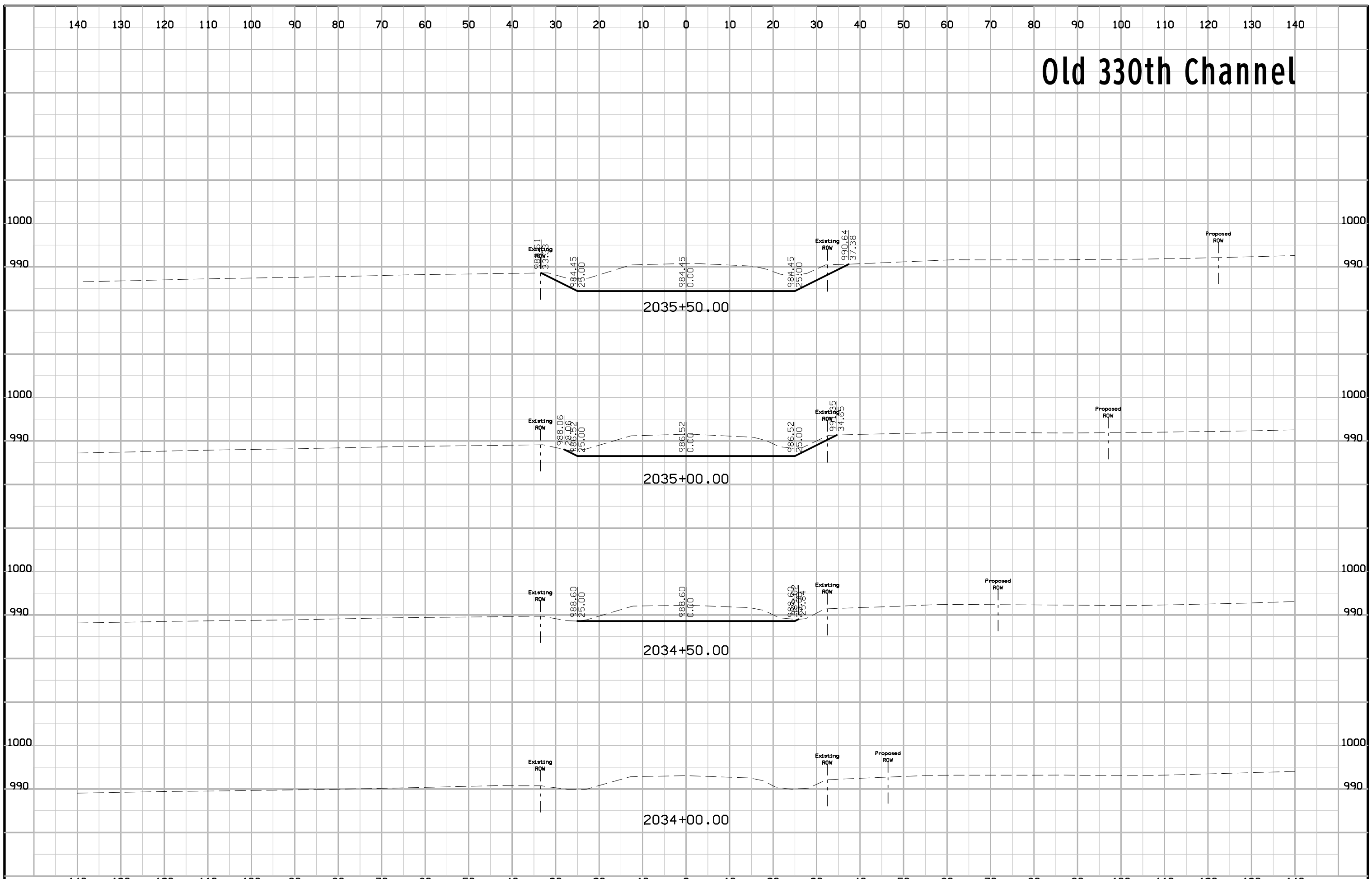

# Old 330th Channel

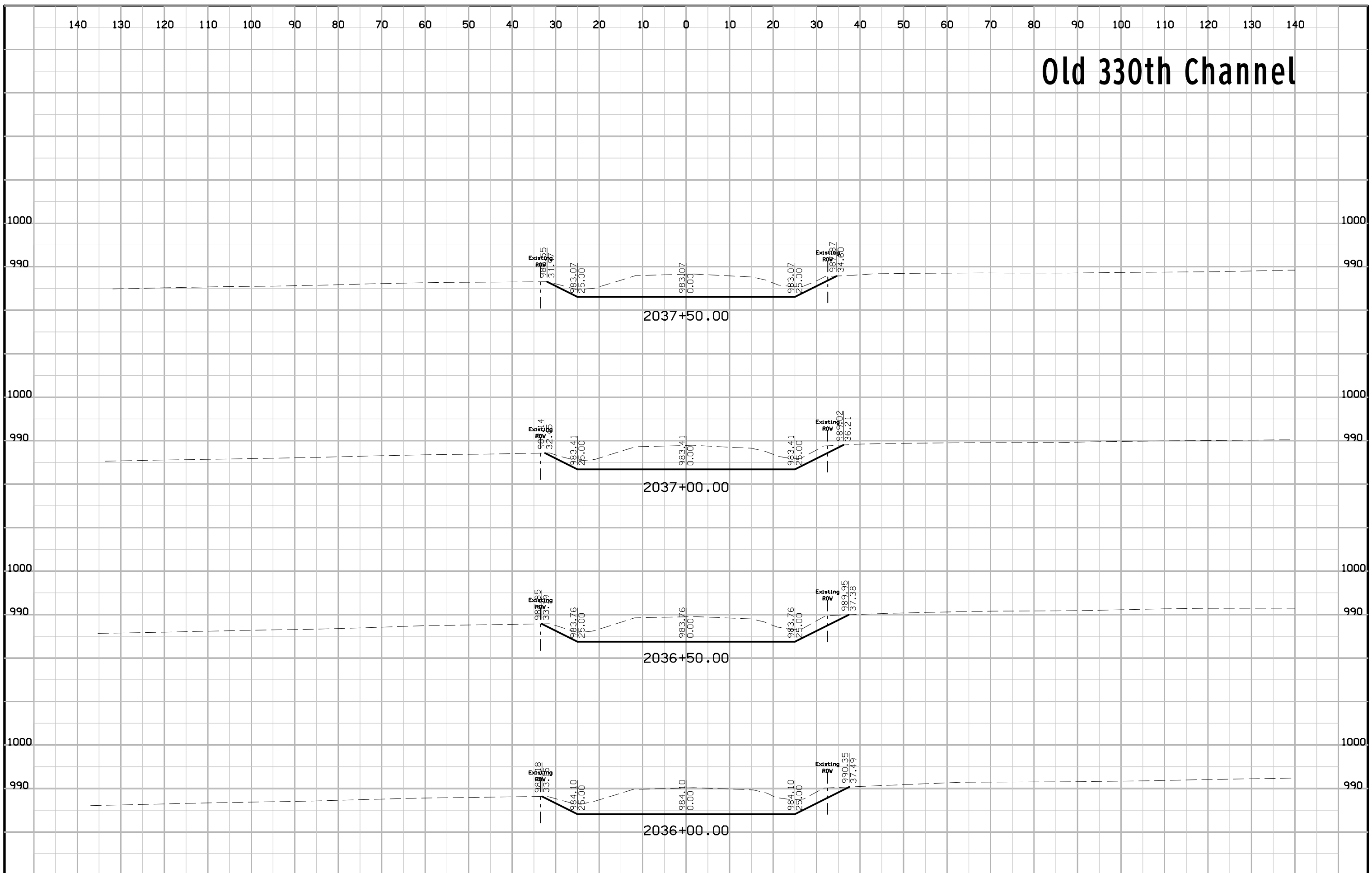



# Old 330th Channel

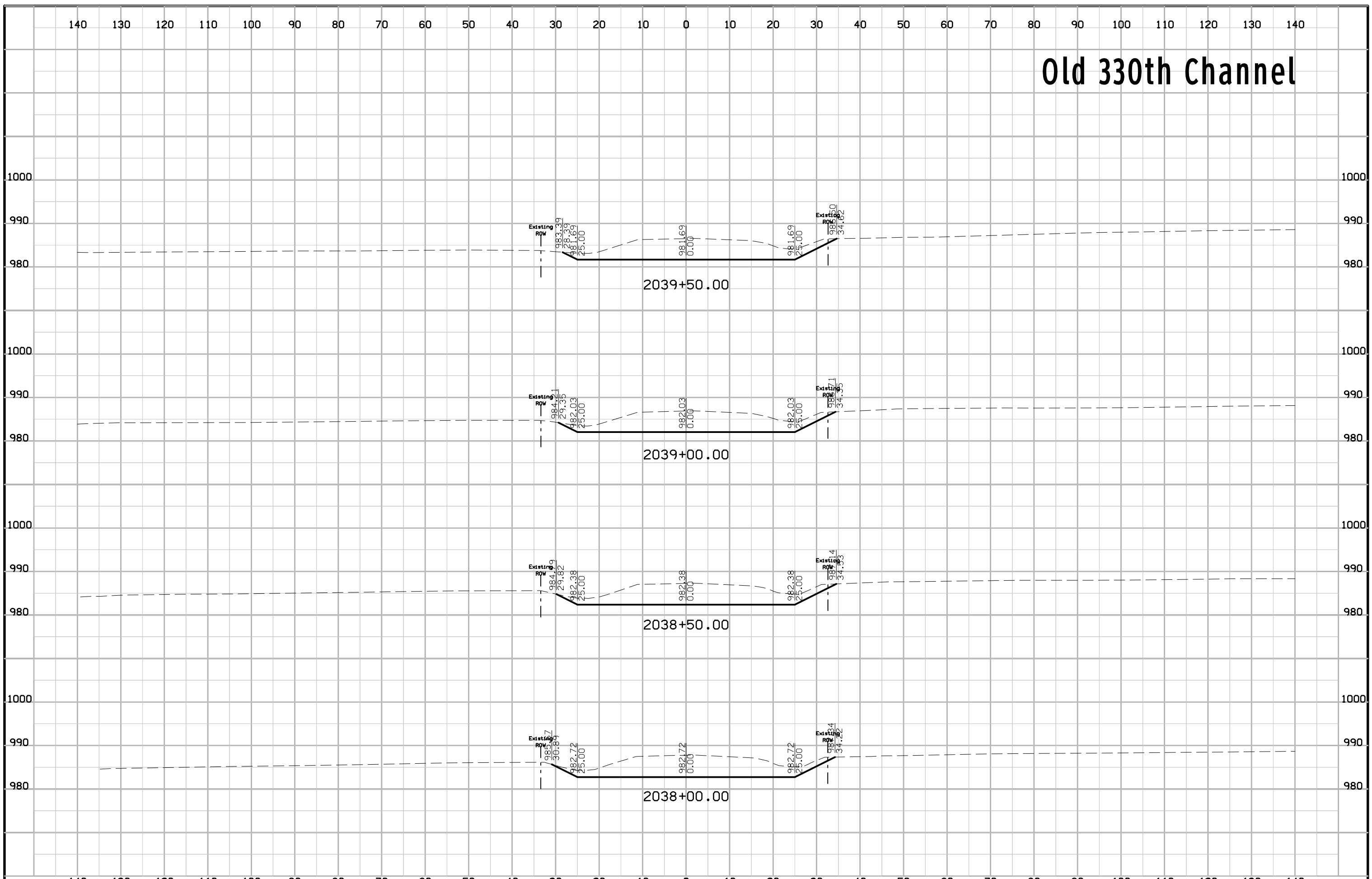

# Old 330th Channel

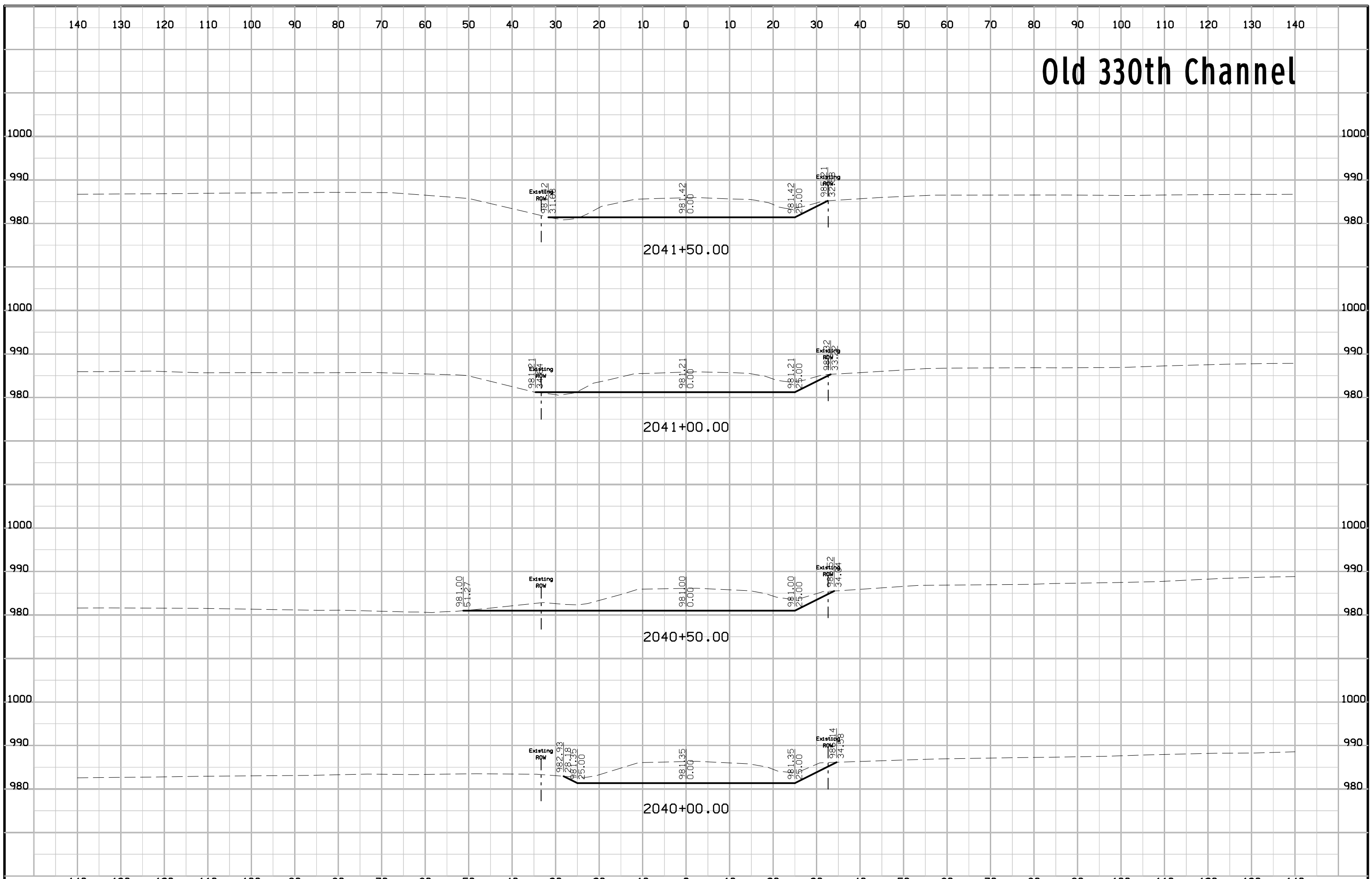

# Old 330th Channel

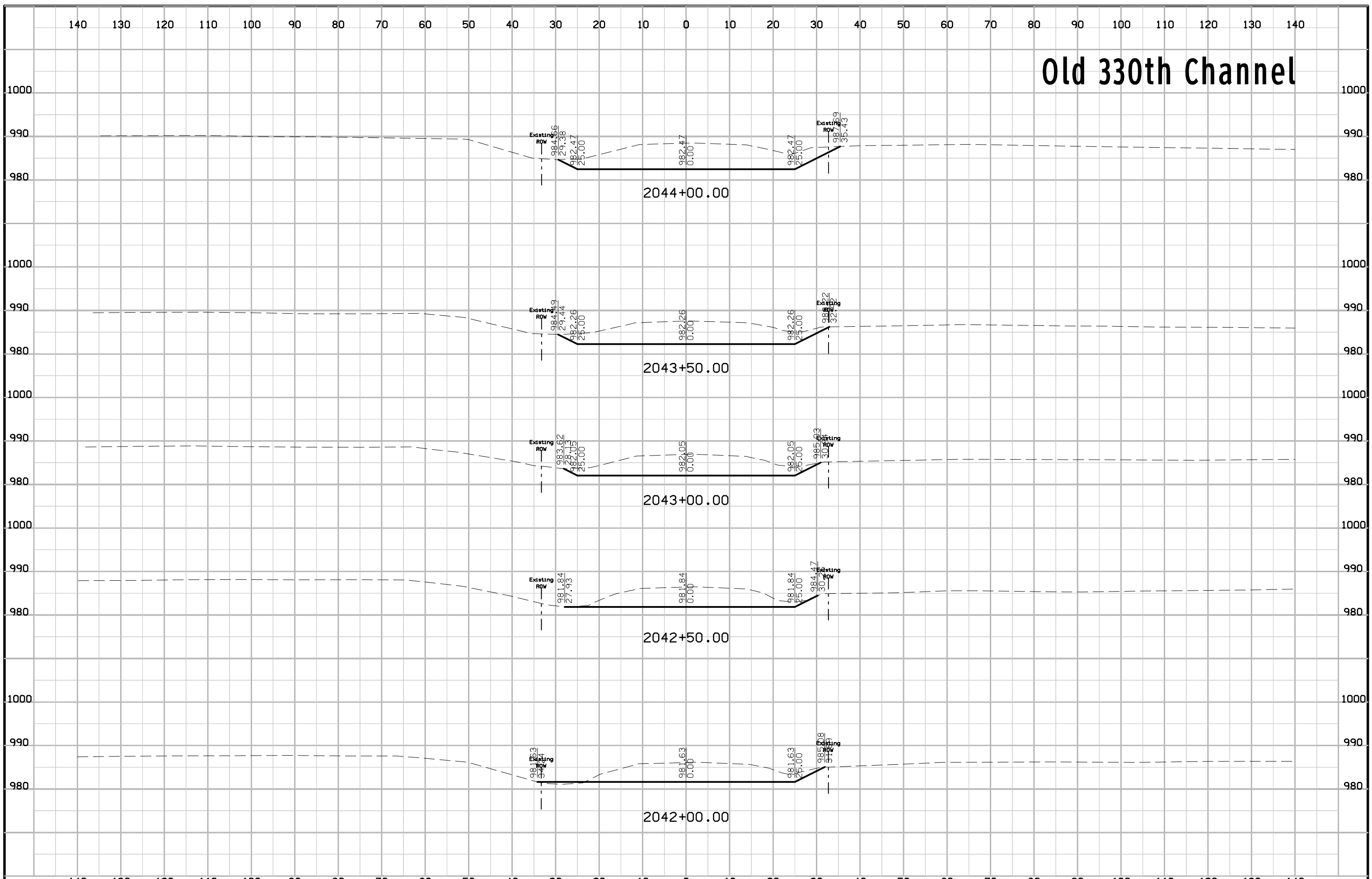

# Old 330th Channel

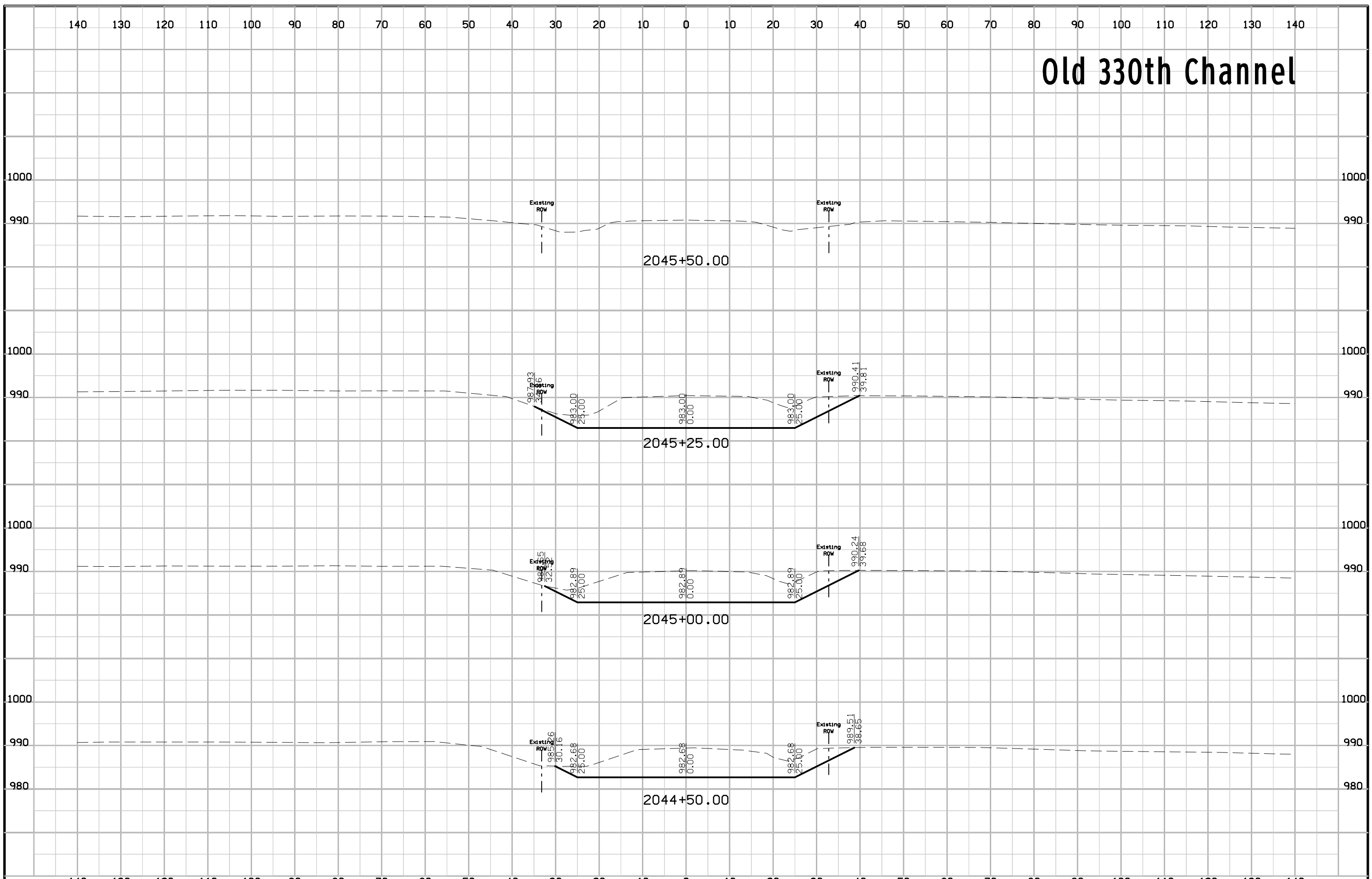

# Ramp A

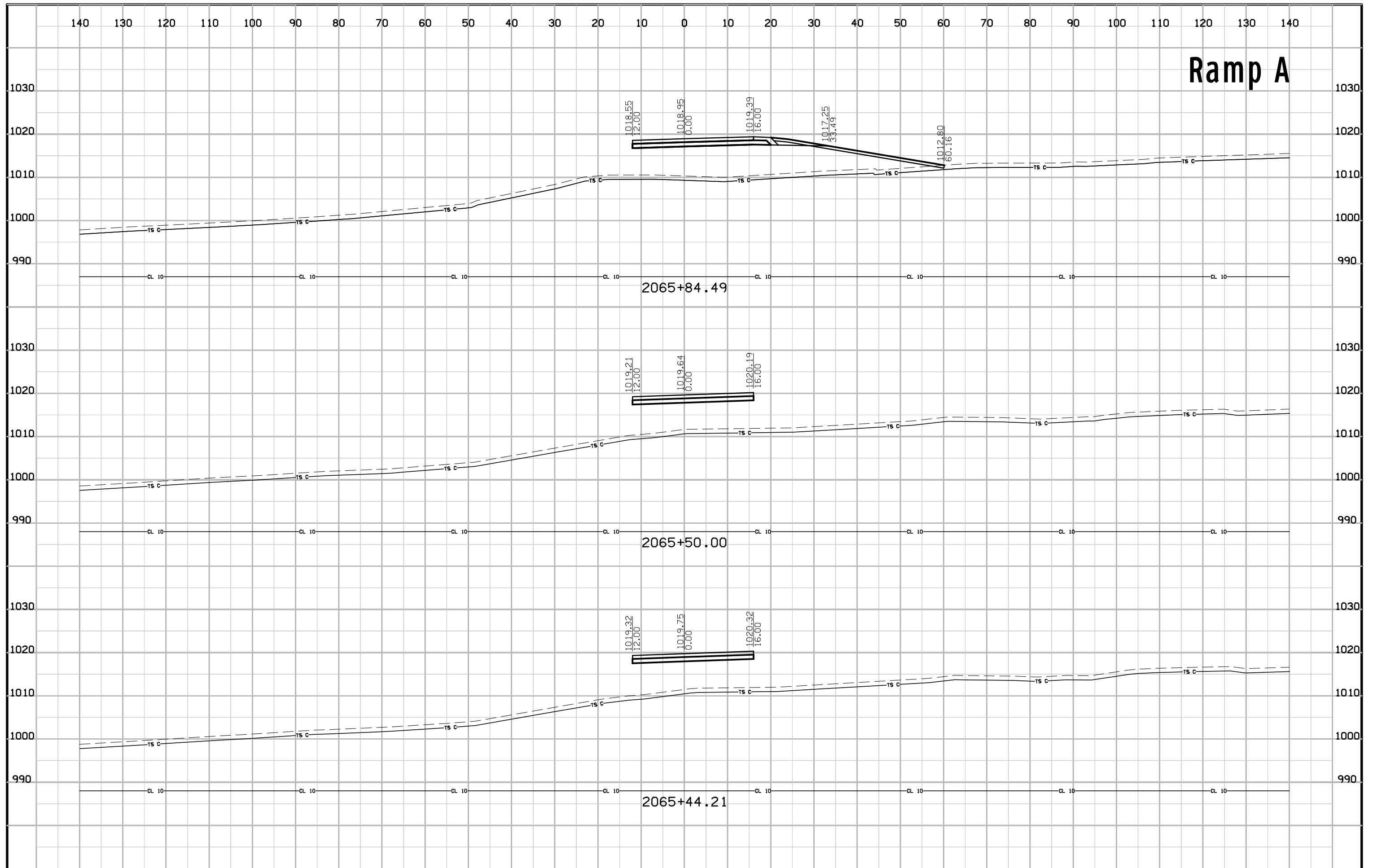

# Ramp A

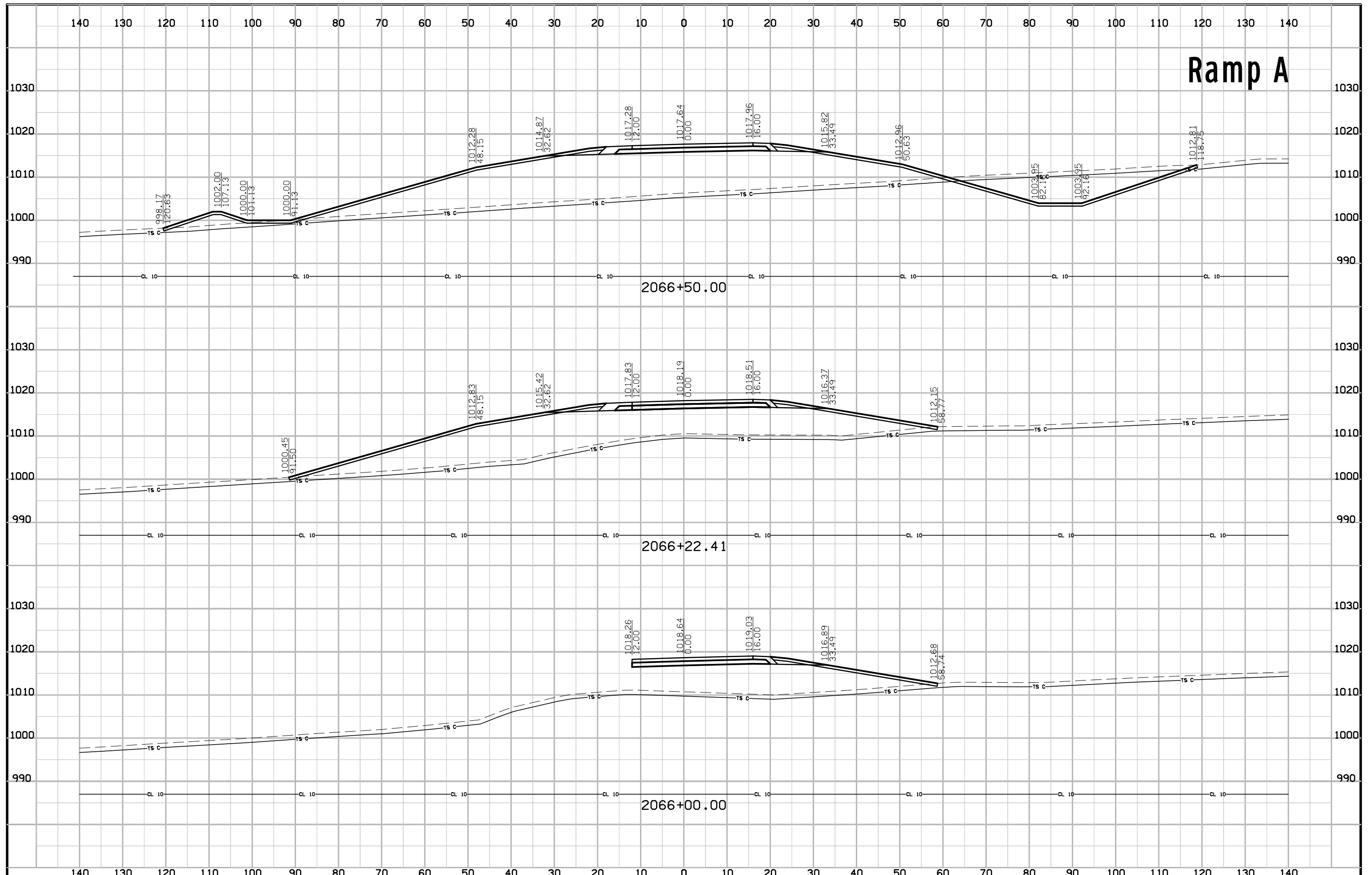

# Ramp A

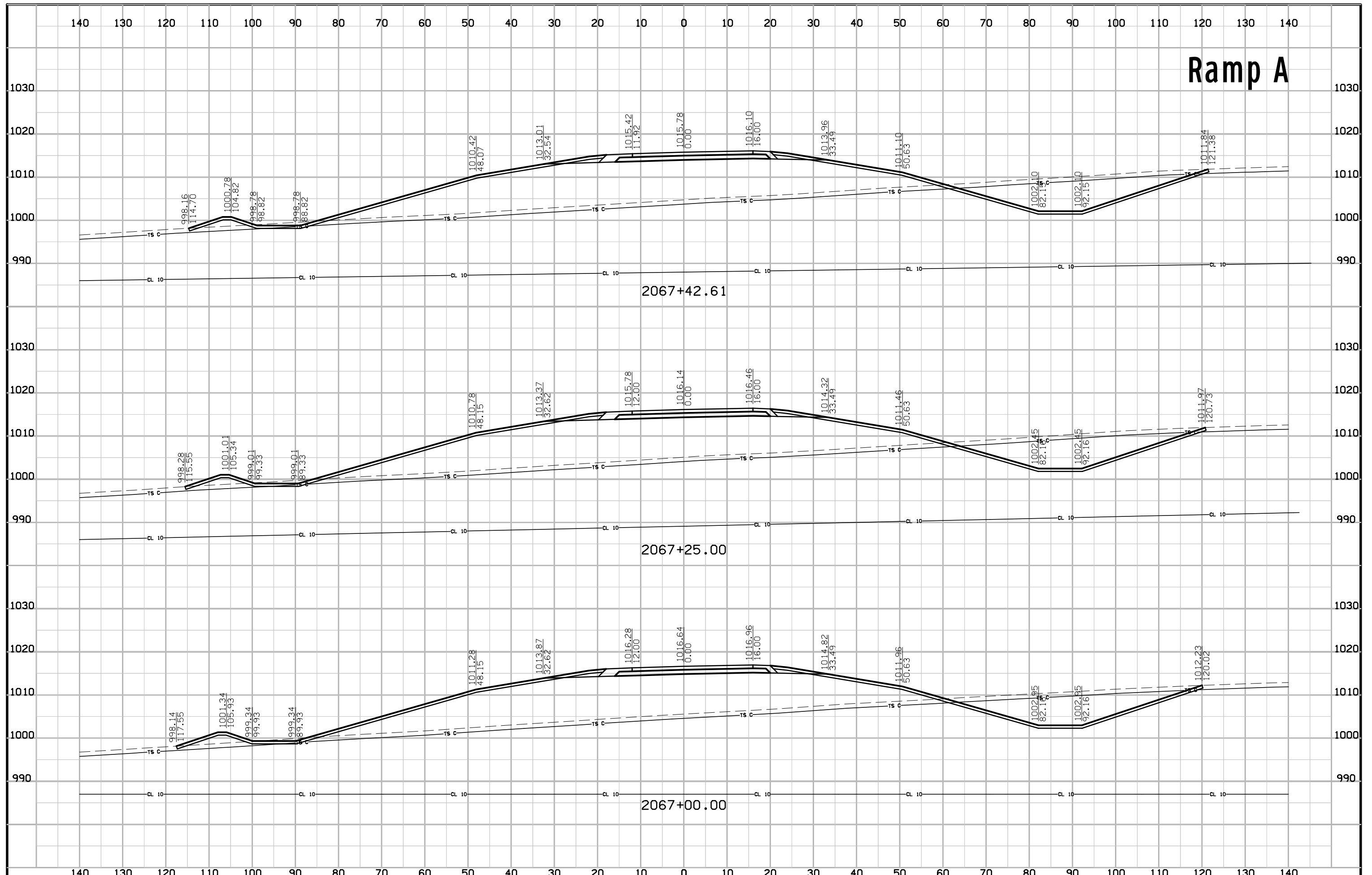

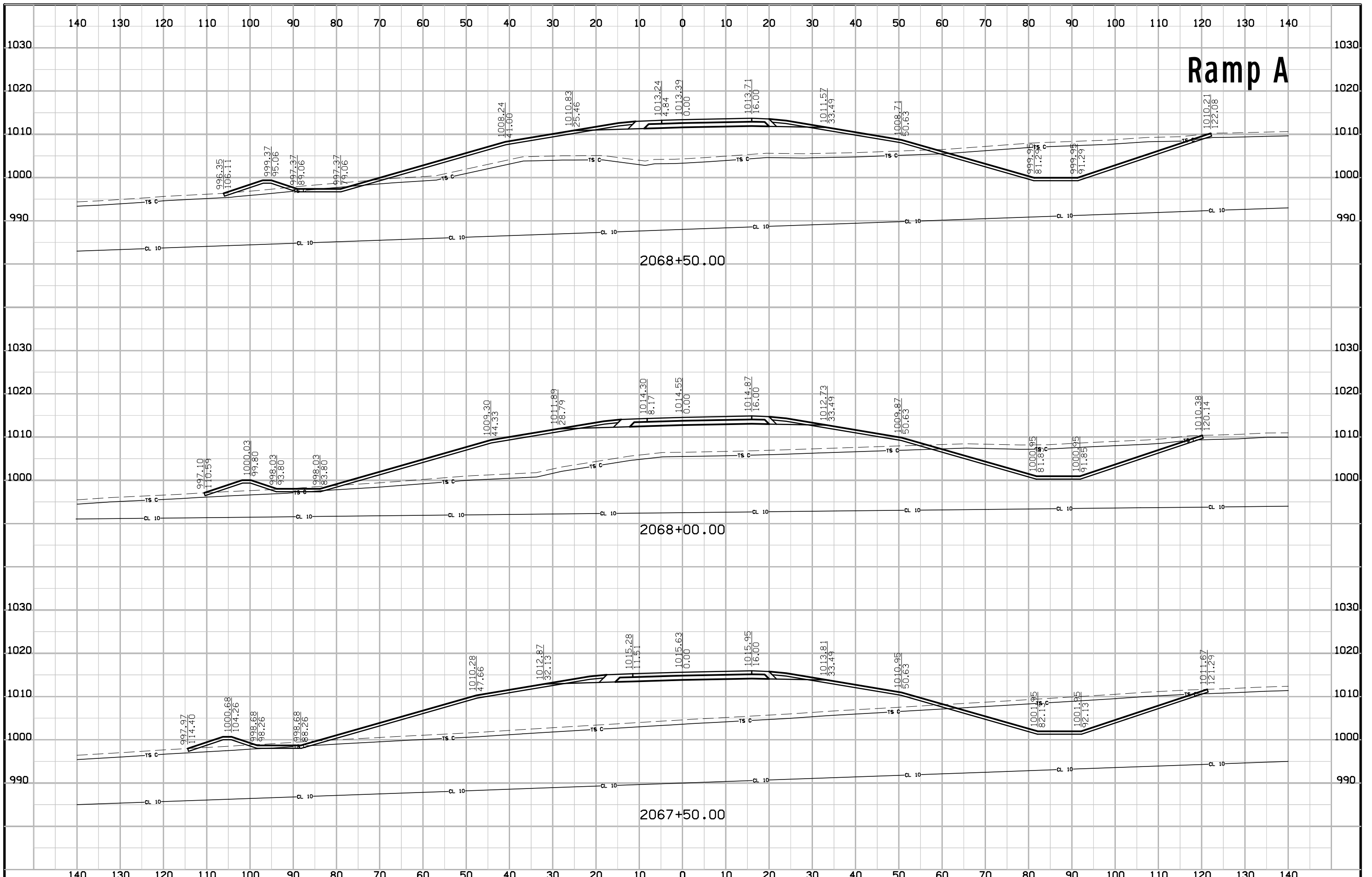



# Ramp A

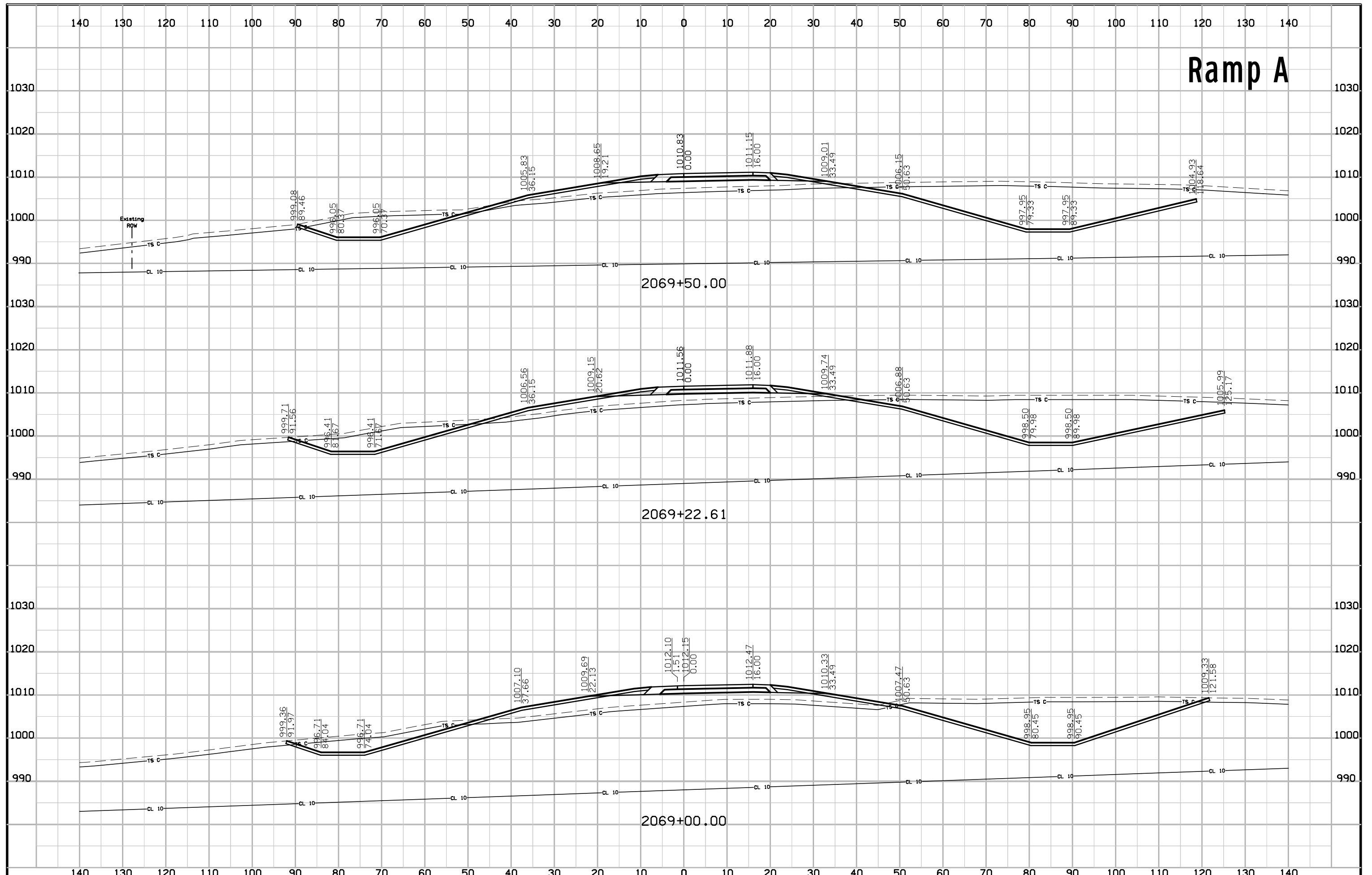

# Ramp A

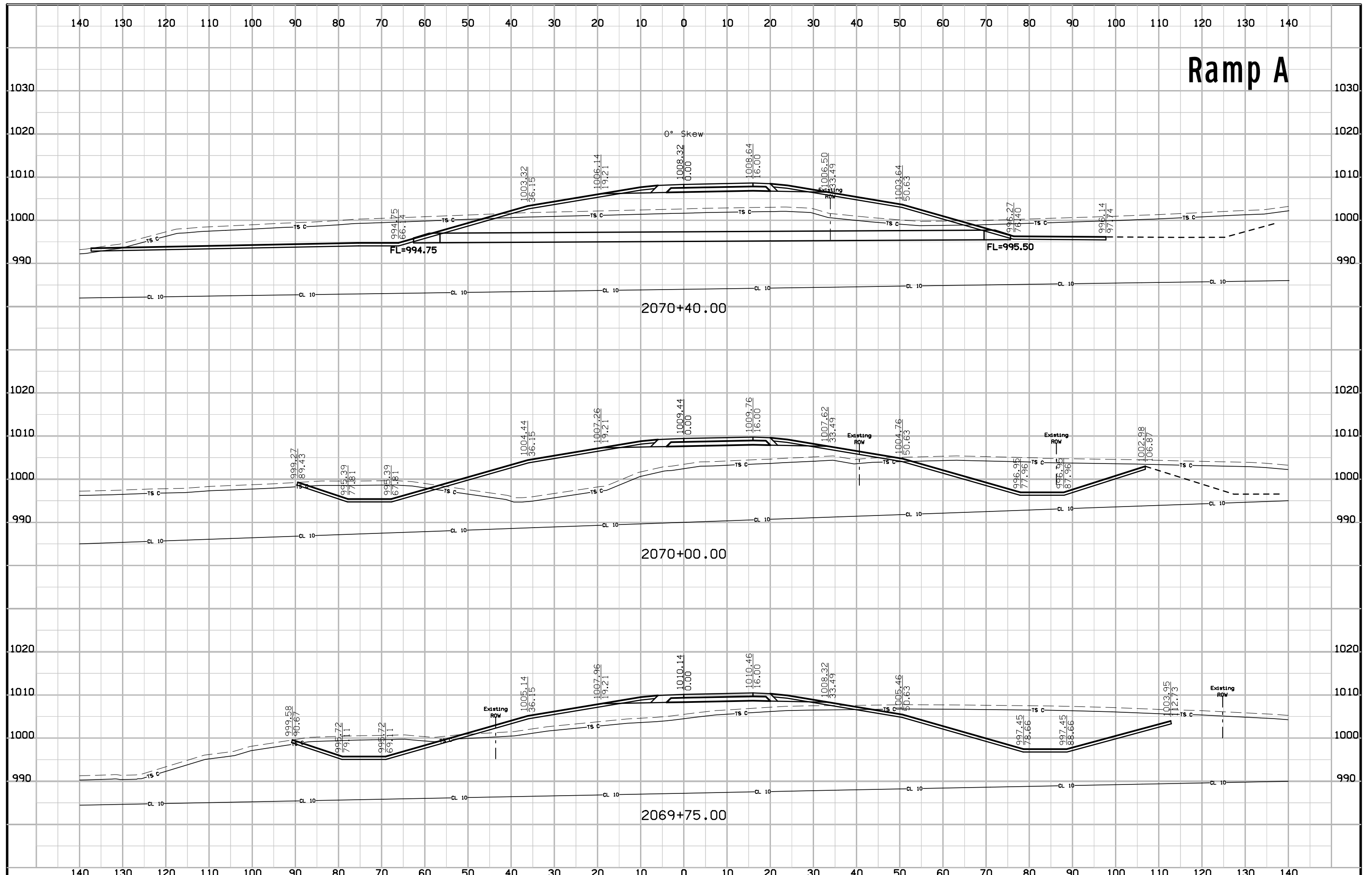



# Ramp A

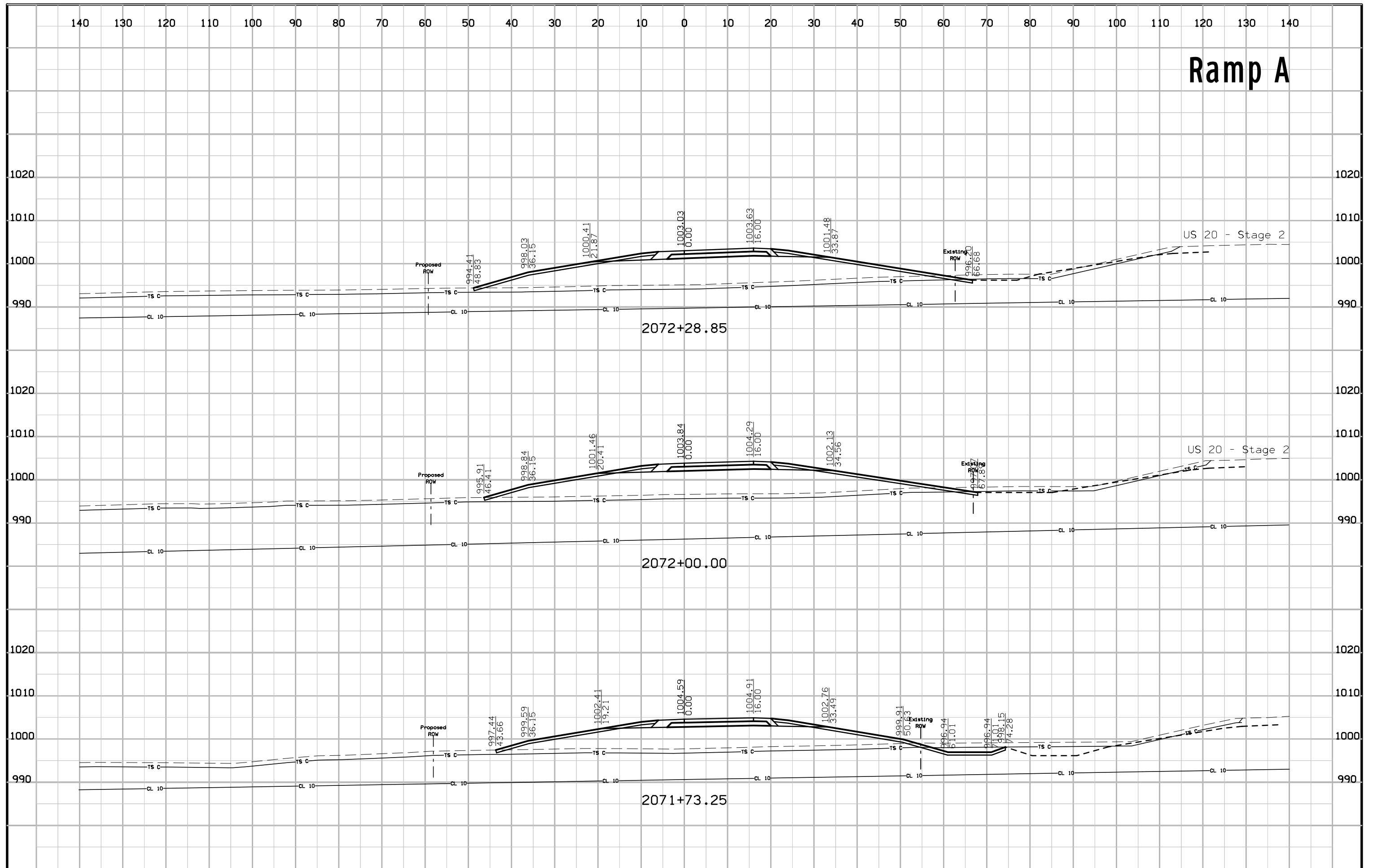

# Ramp A

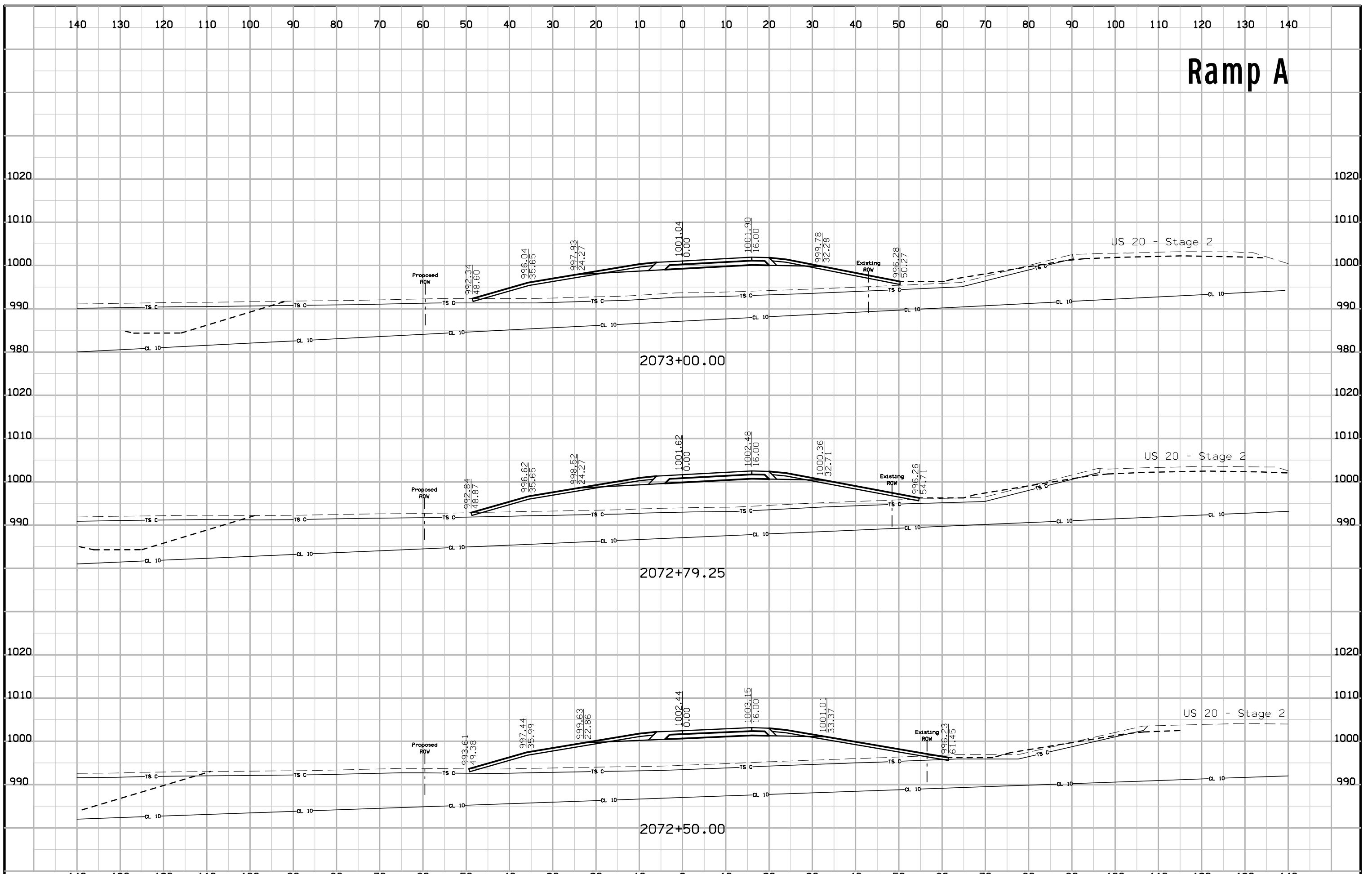

# Ramp A

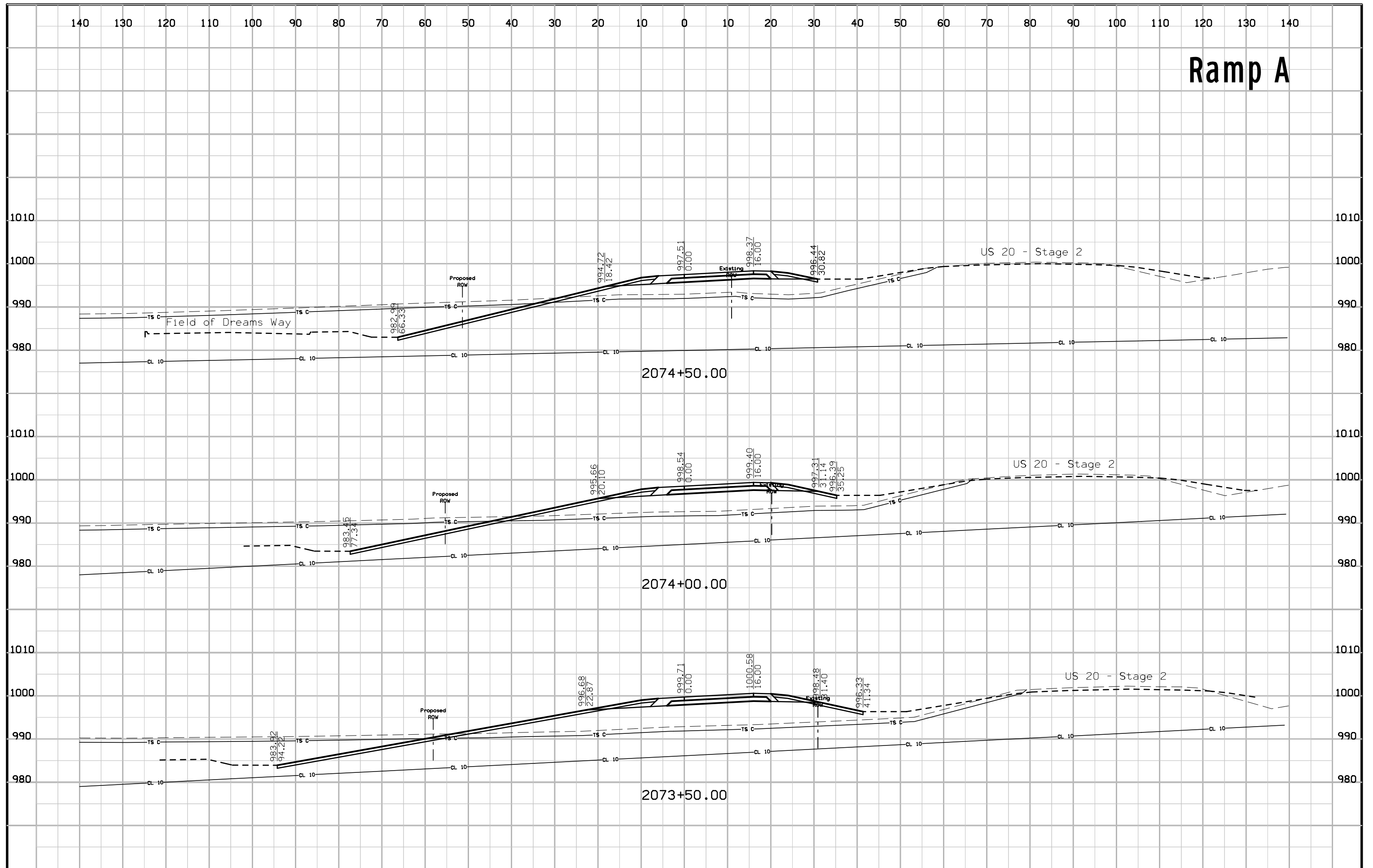

# Ramp A

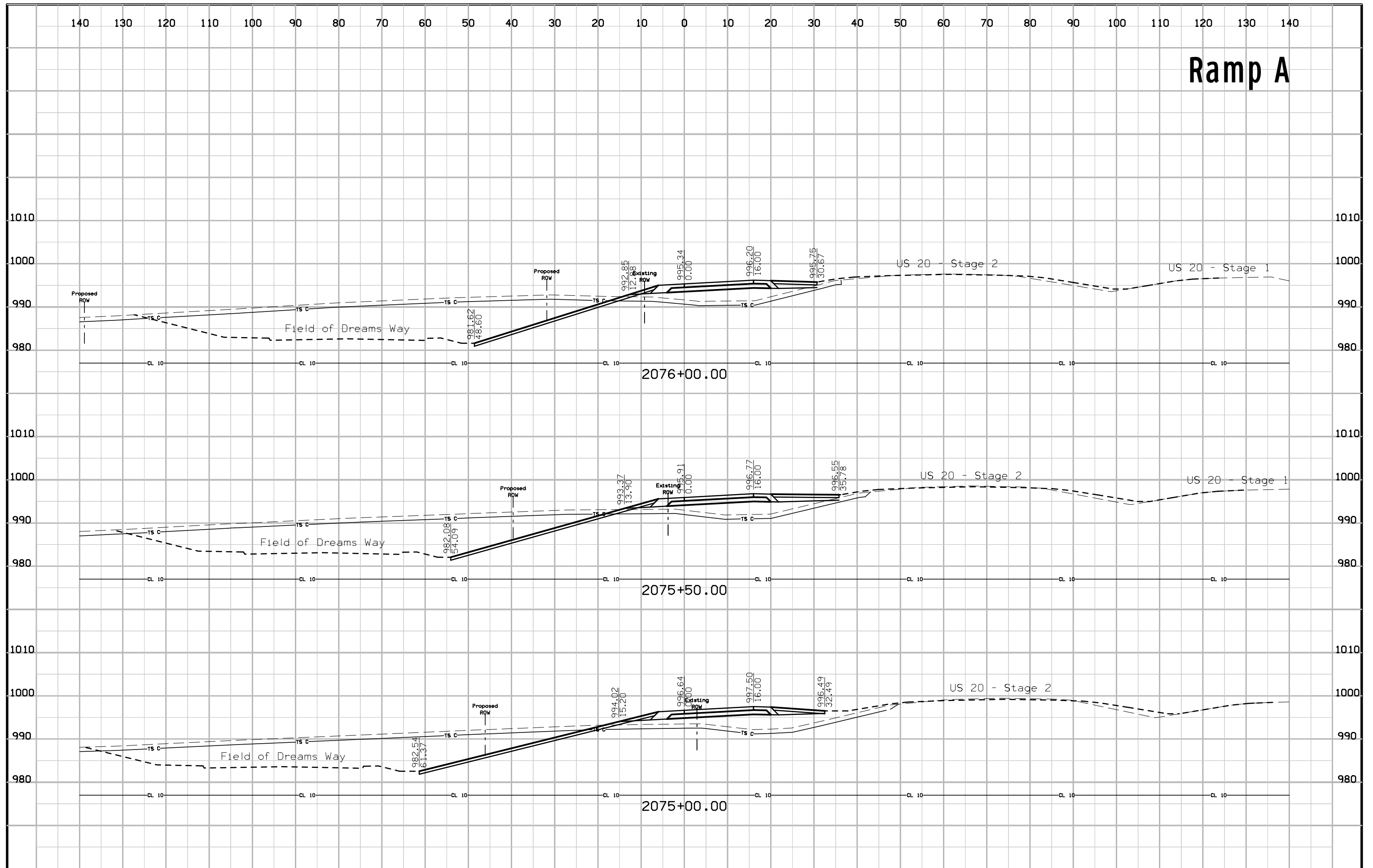







# Ramp B

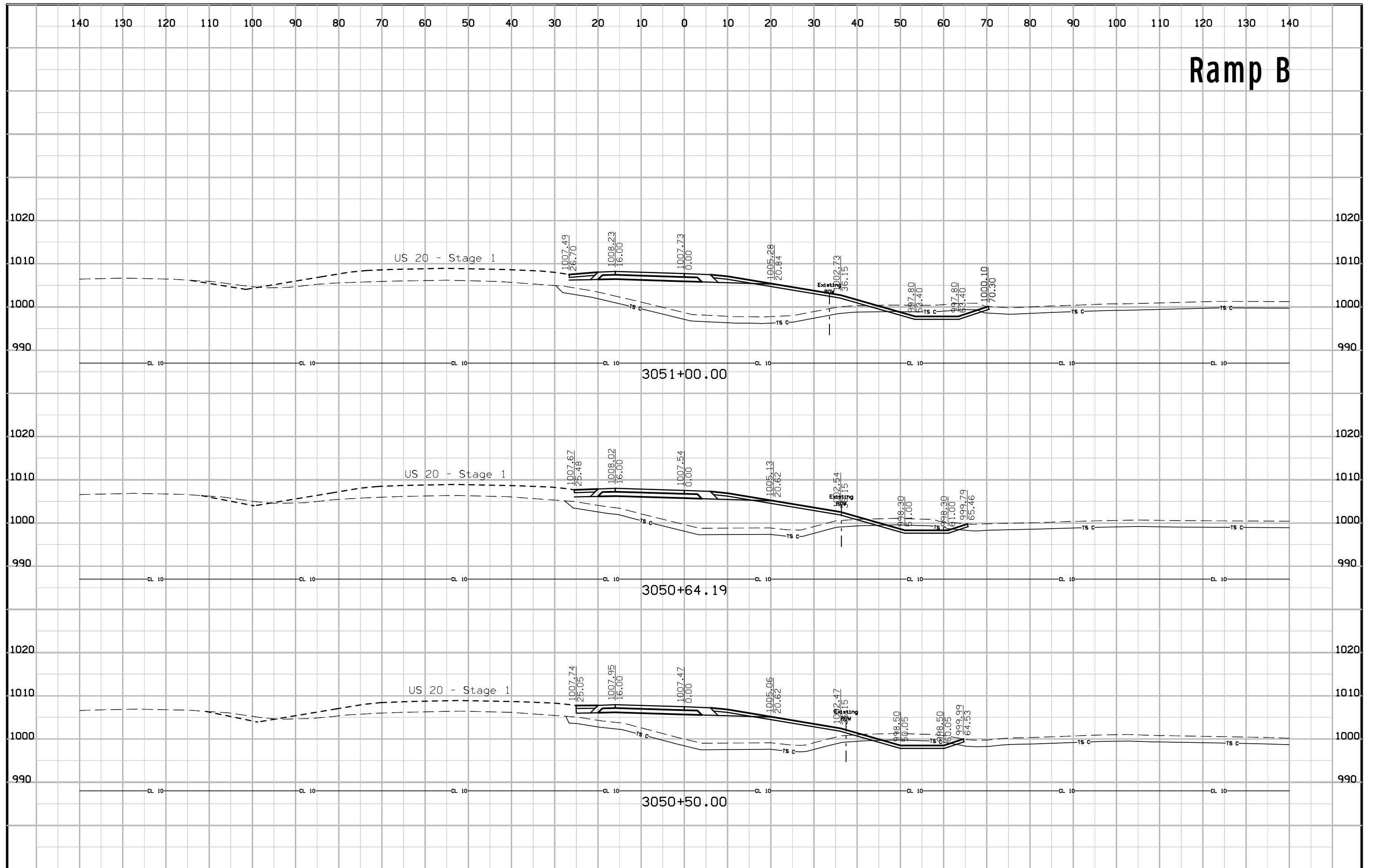

# Ramp B

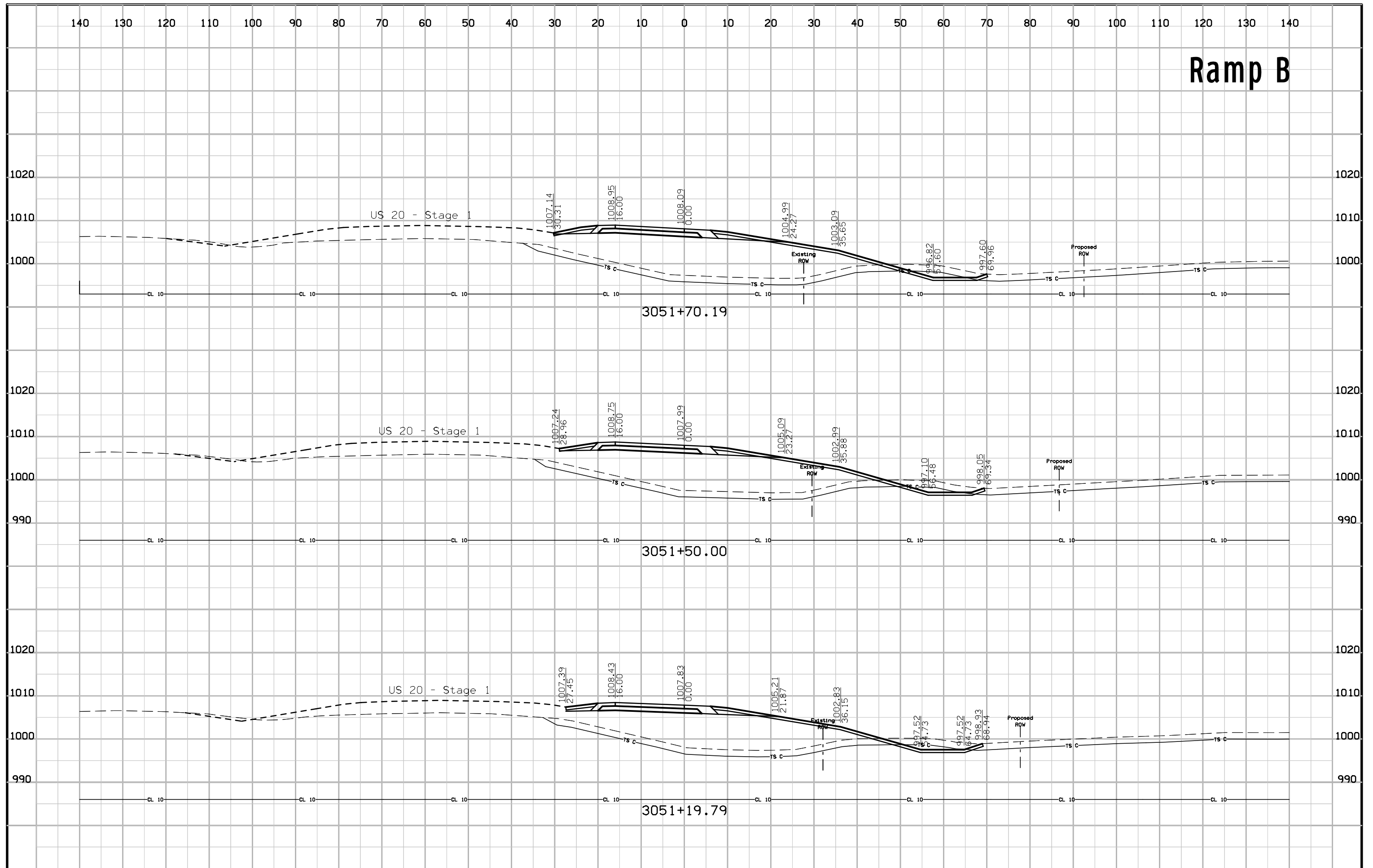

# Ramp B

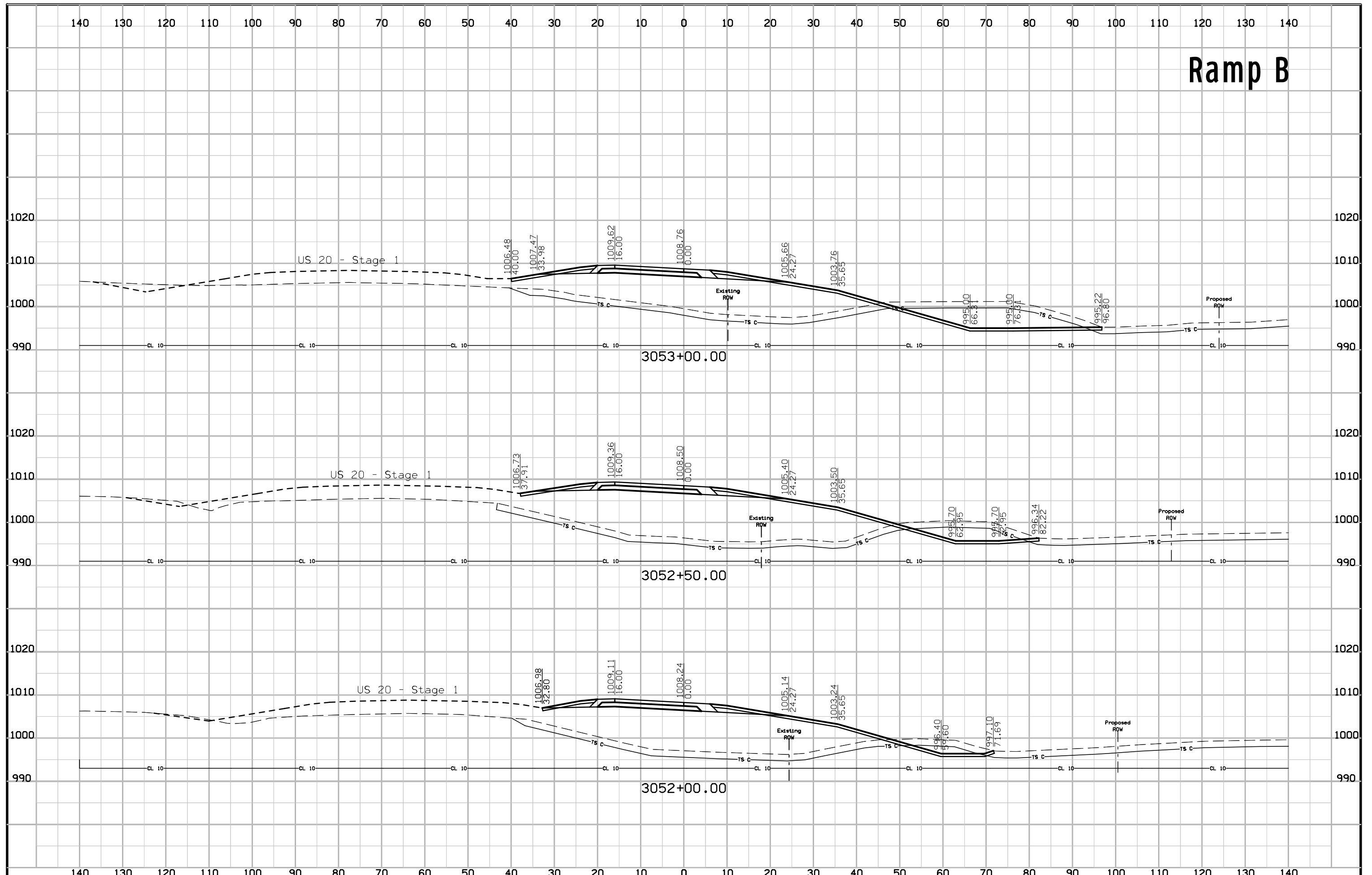

# Ramp B

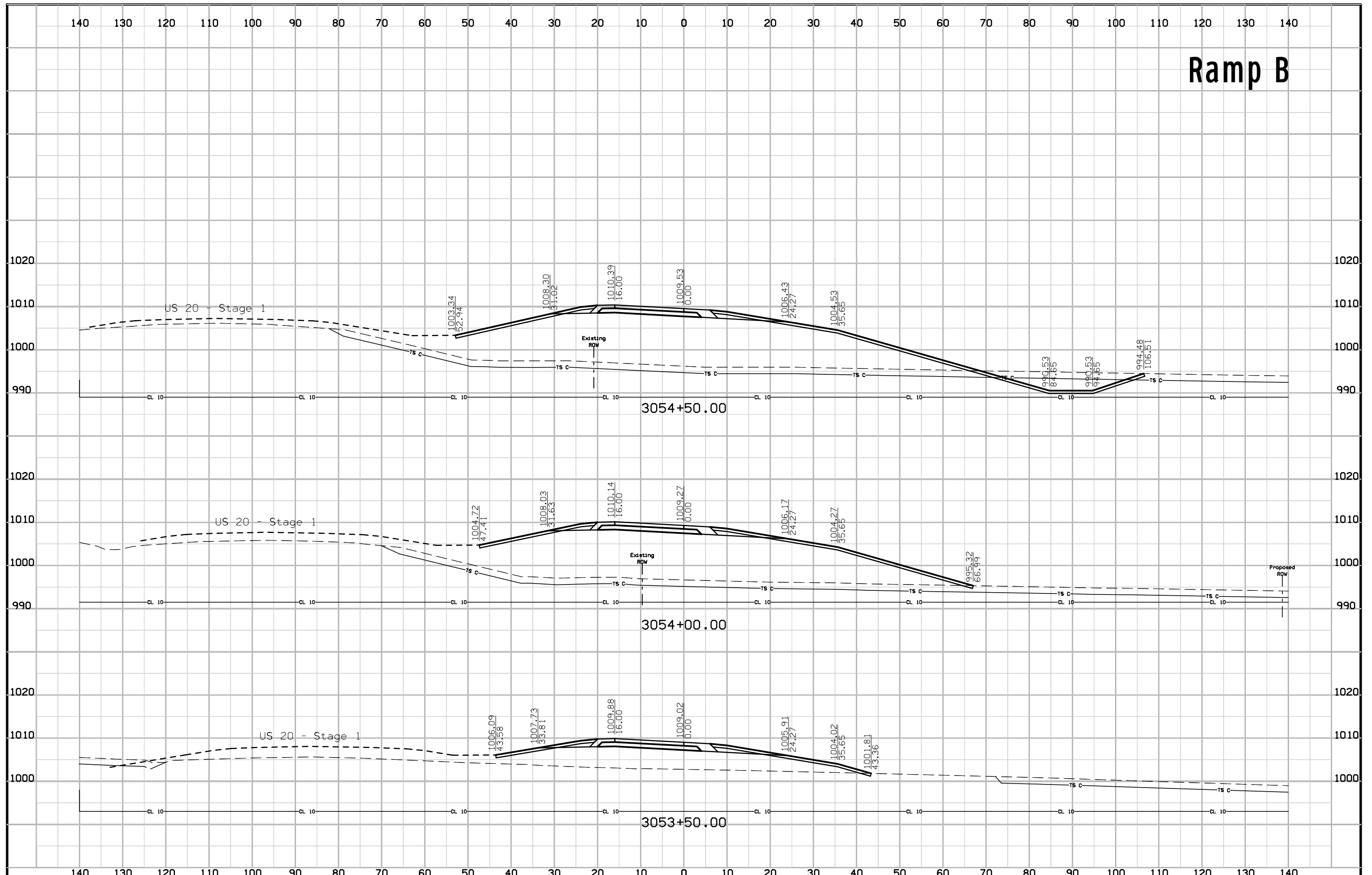

# Ramp B

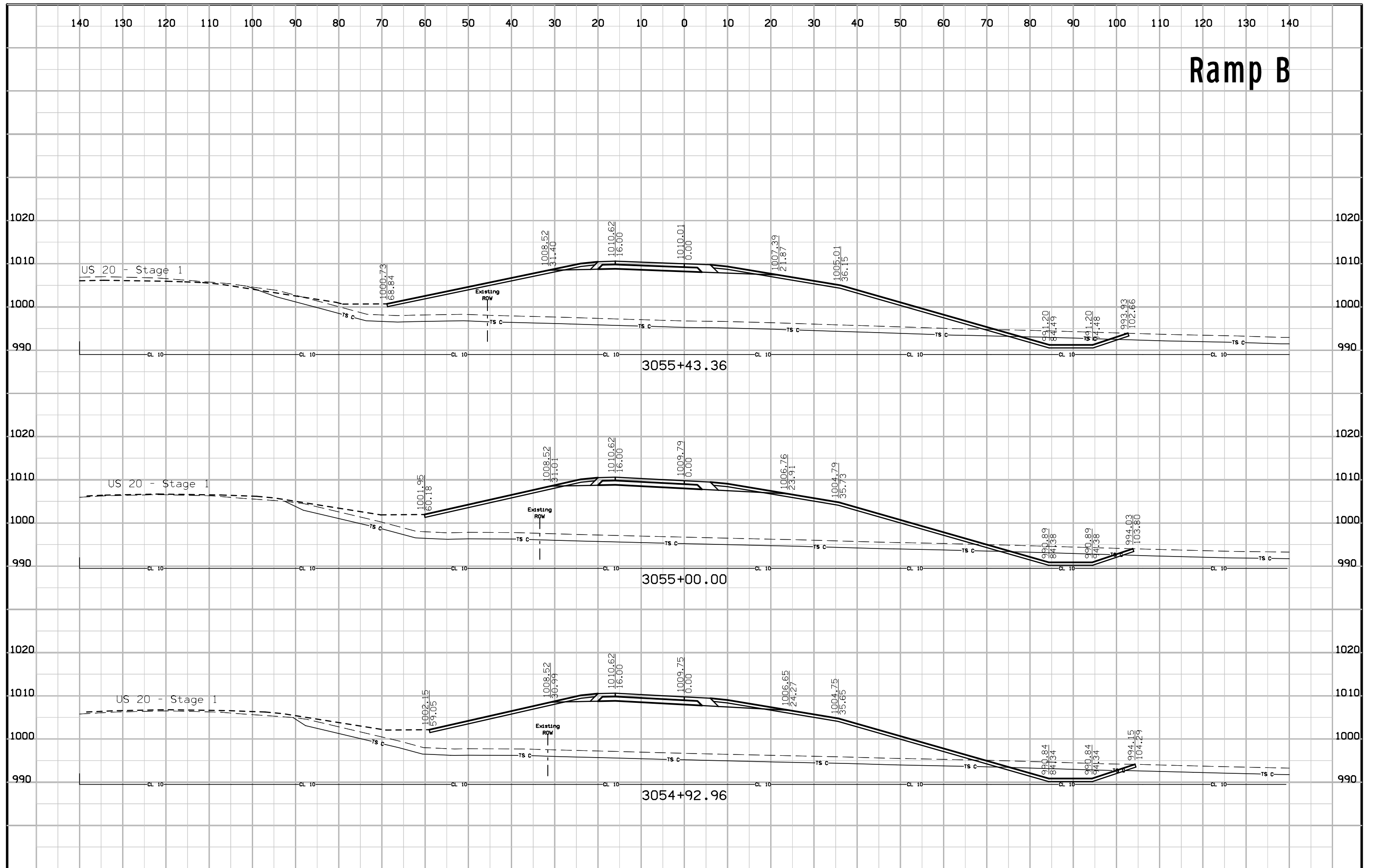

# Ramp B

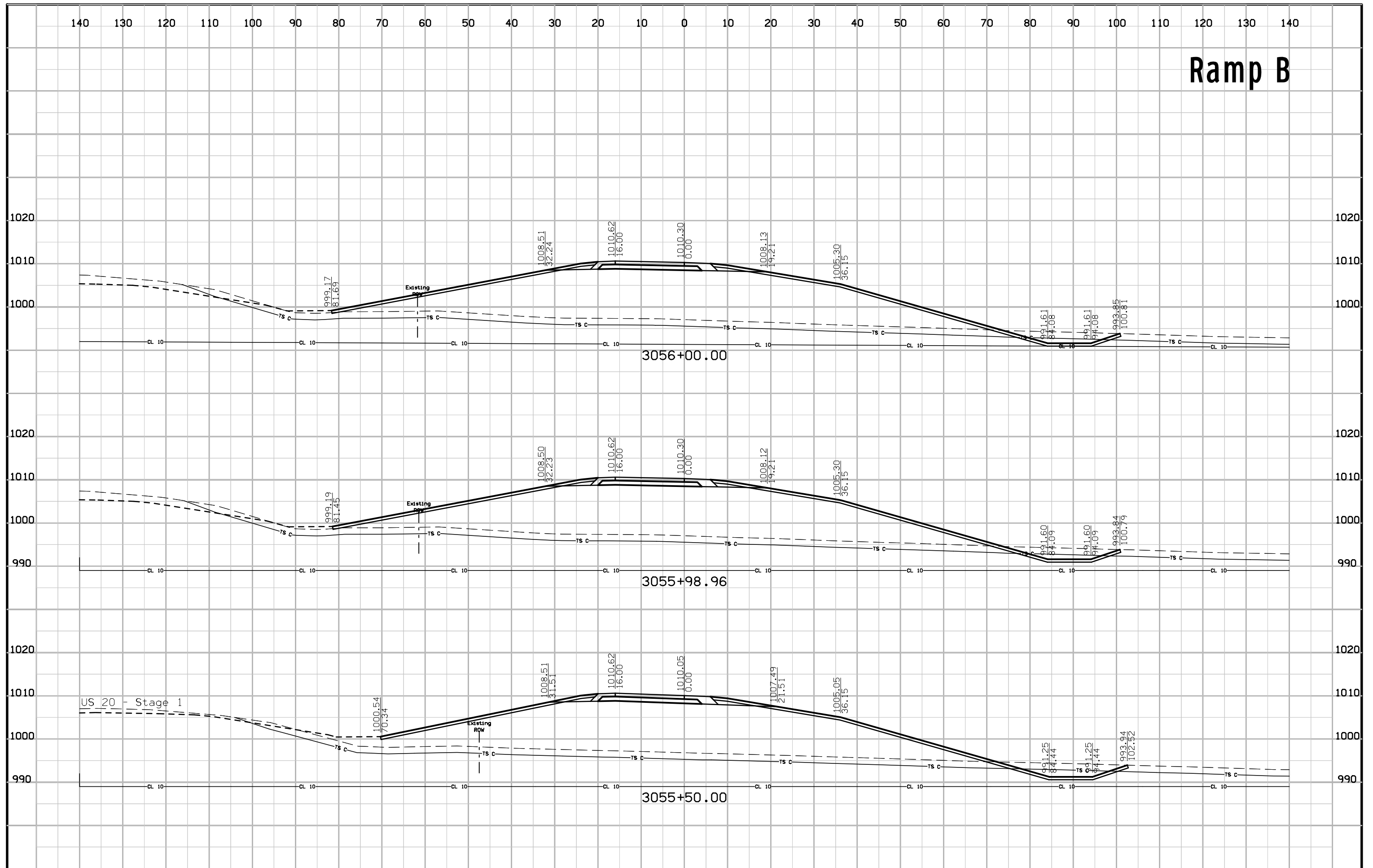

# Ramp B

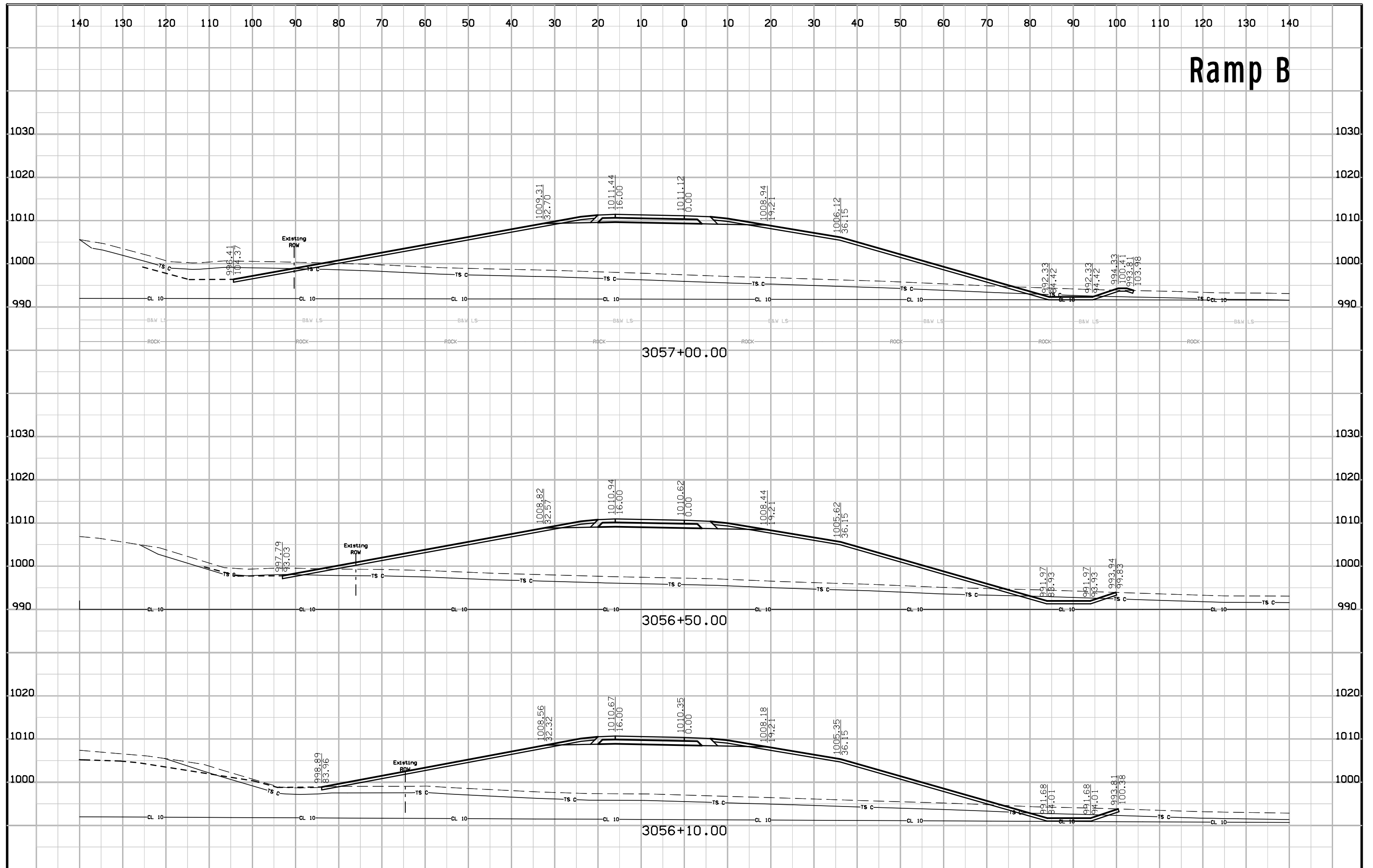



# Ramp B

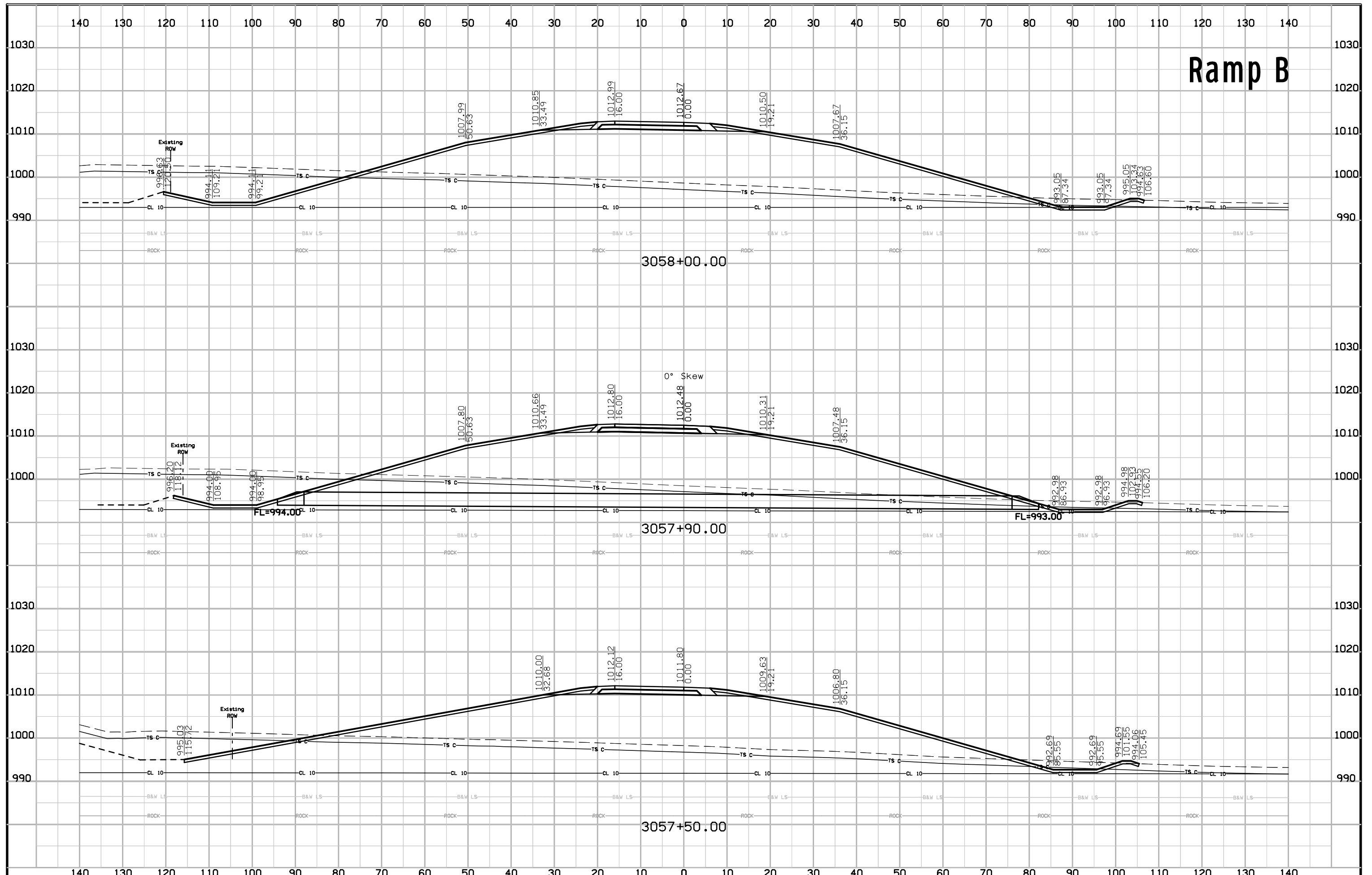

# Ramp B

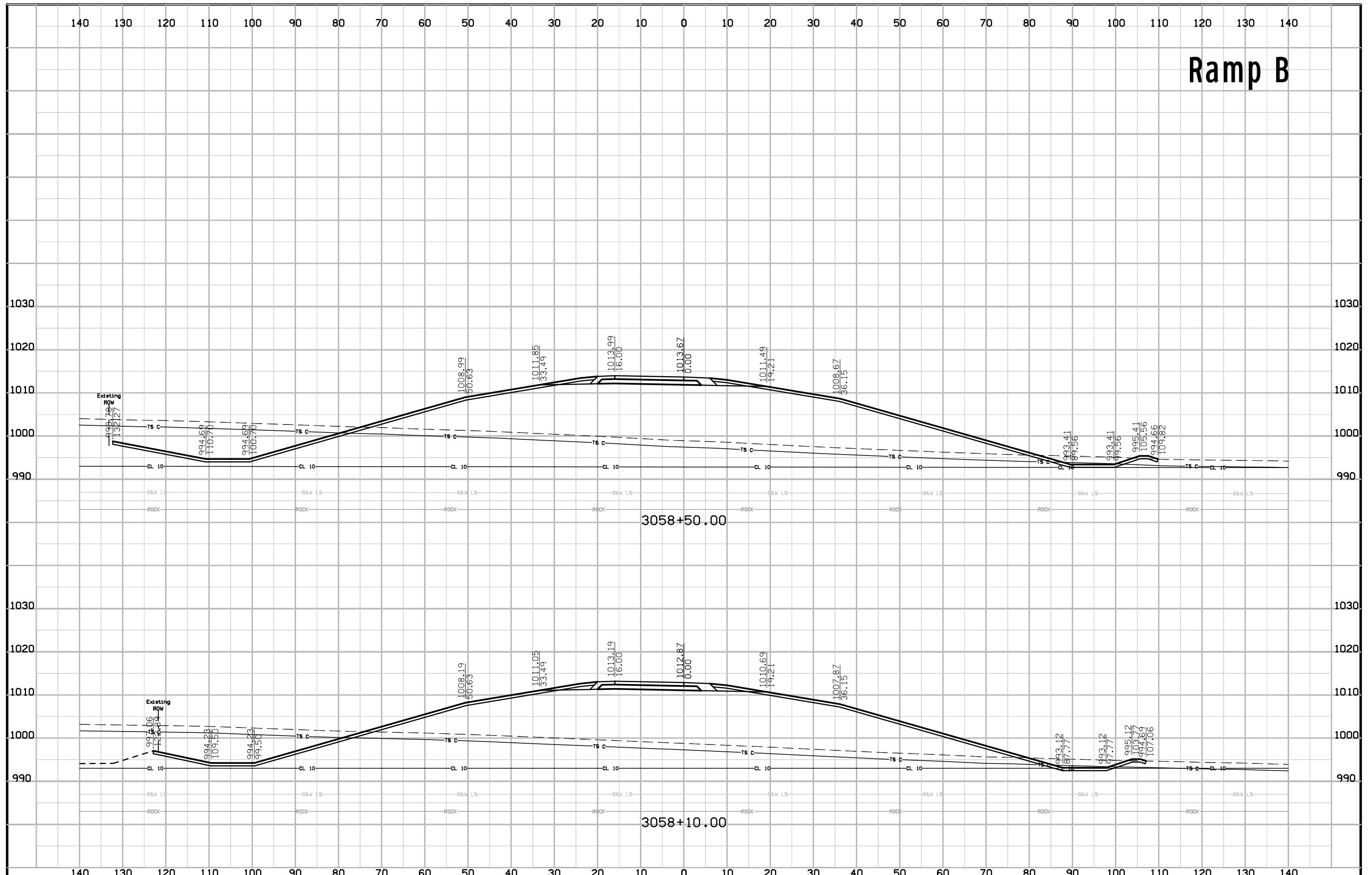

# Ramp B

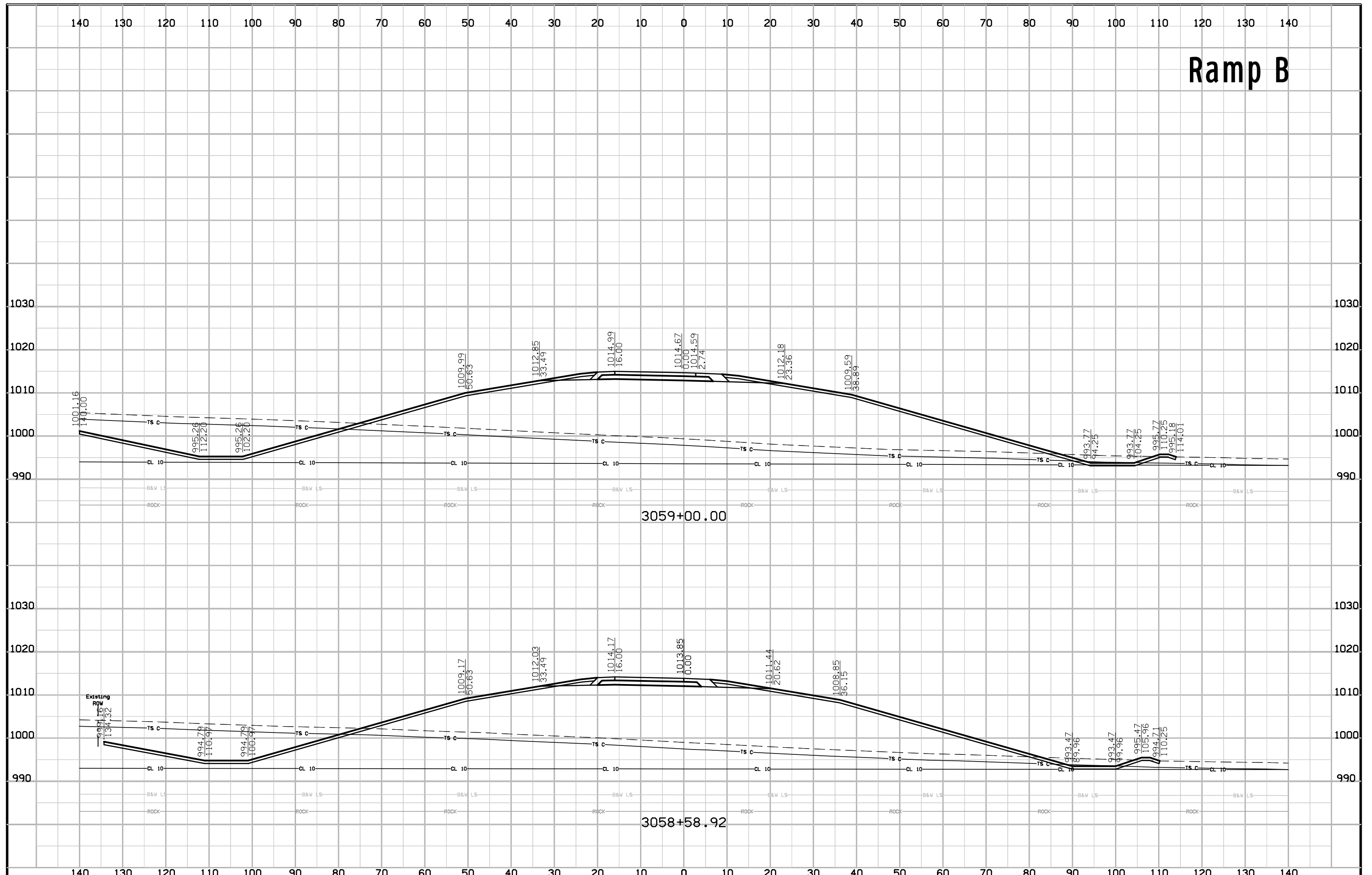

# Ramp B

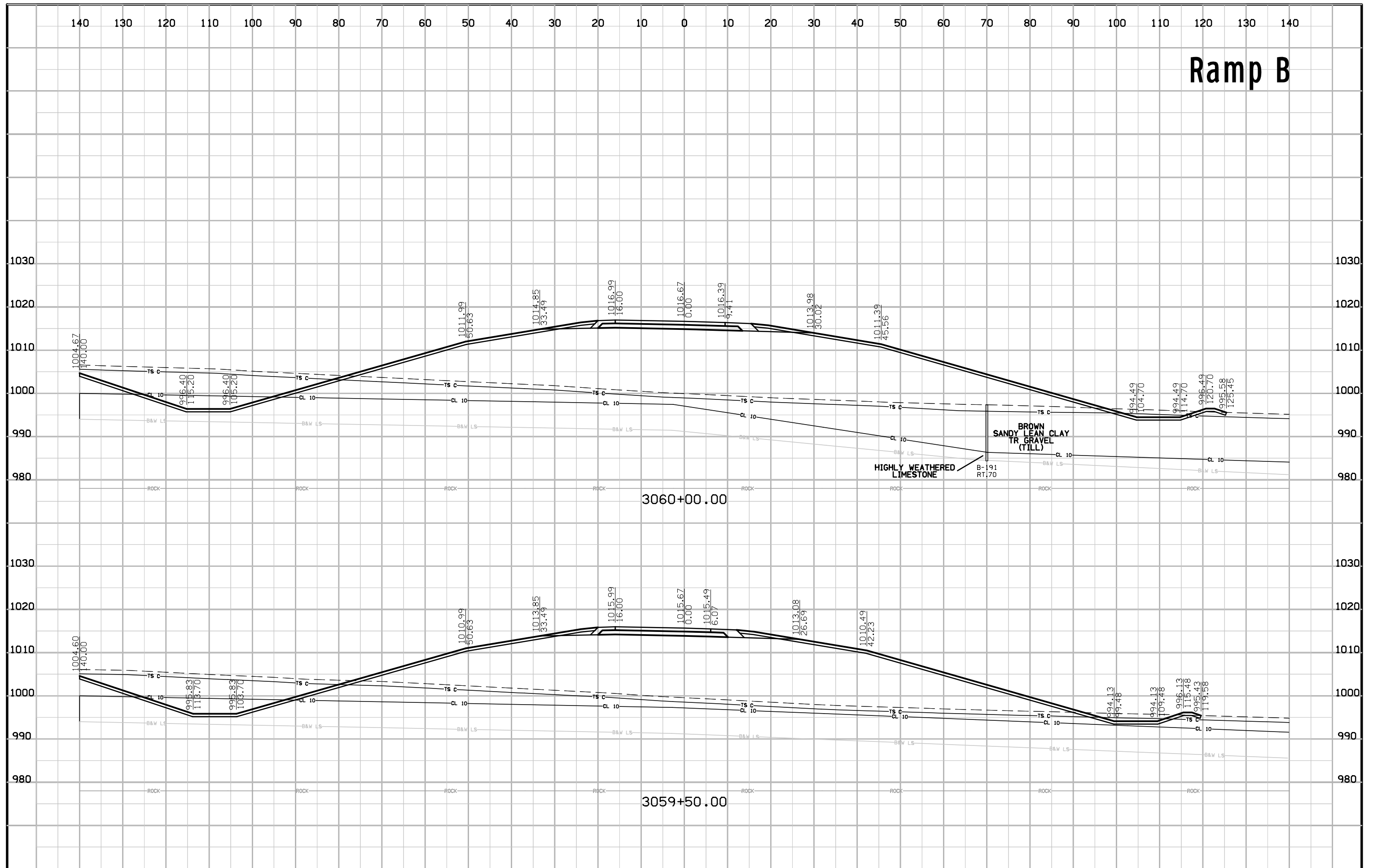

# Ramp B

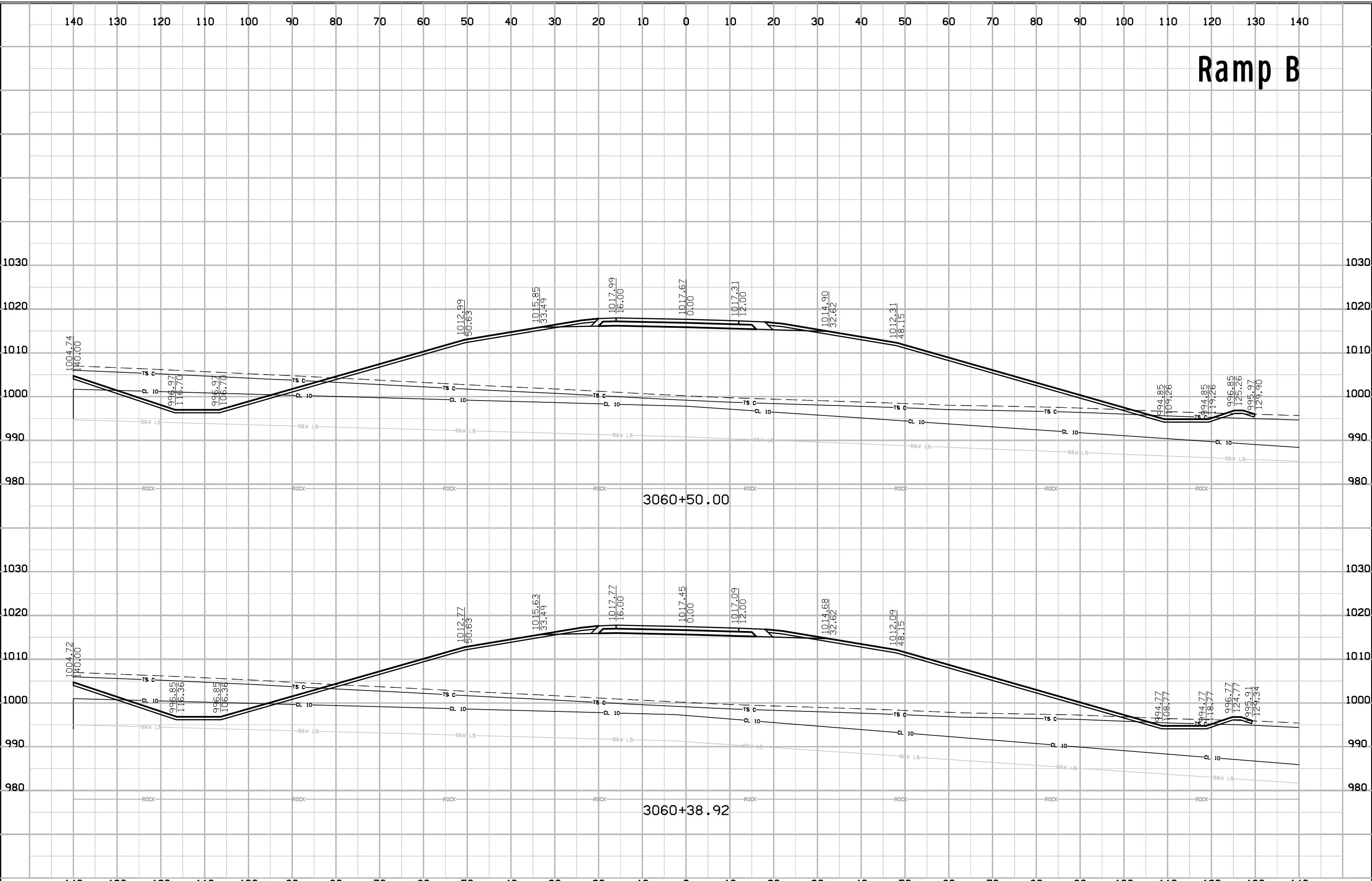

# Ramp B

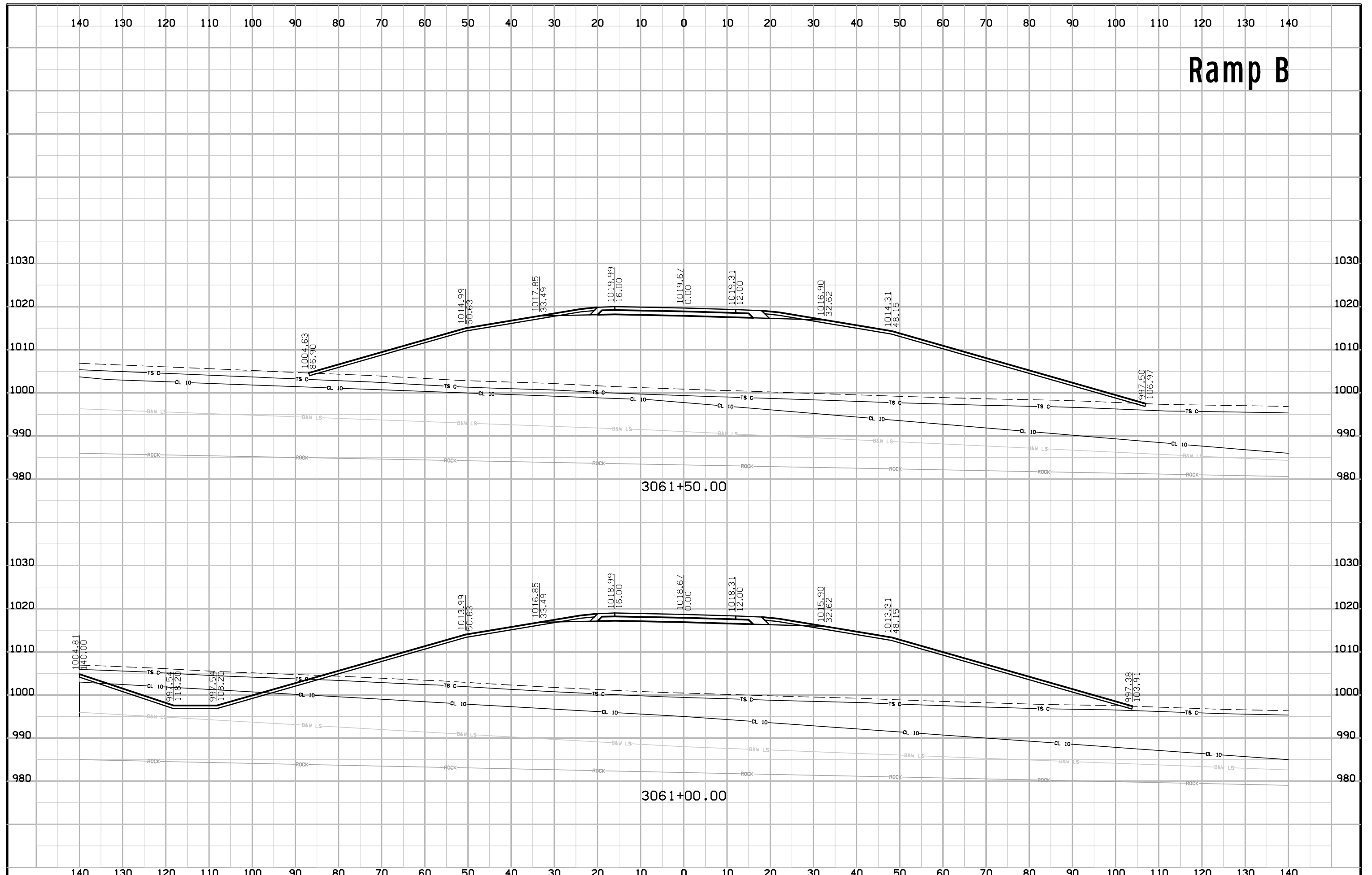

# Ramp B

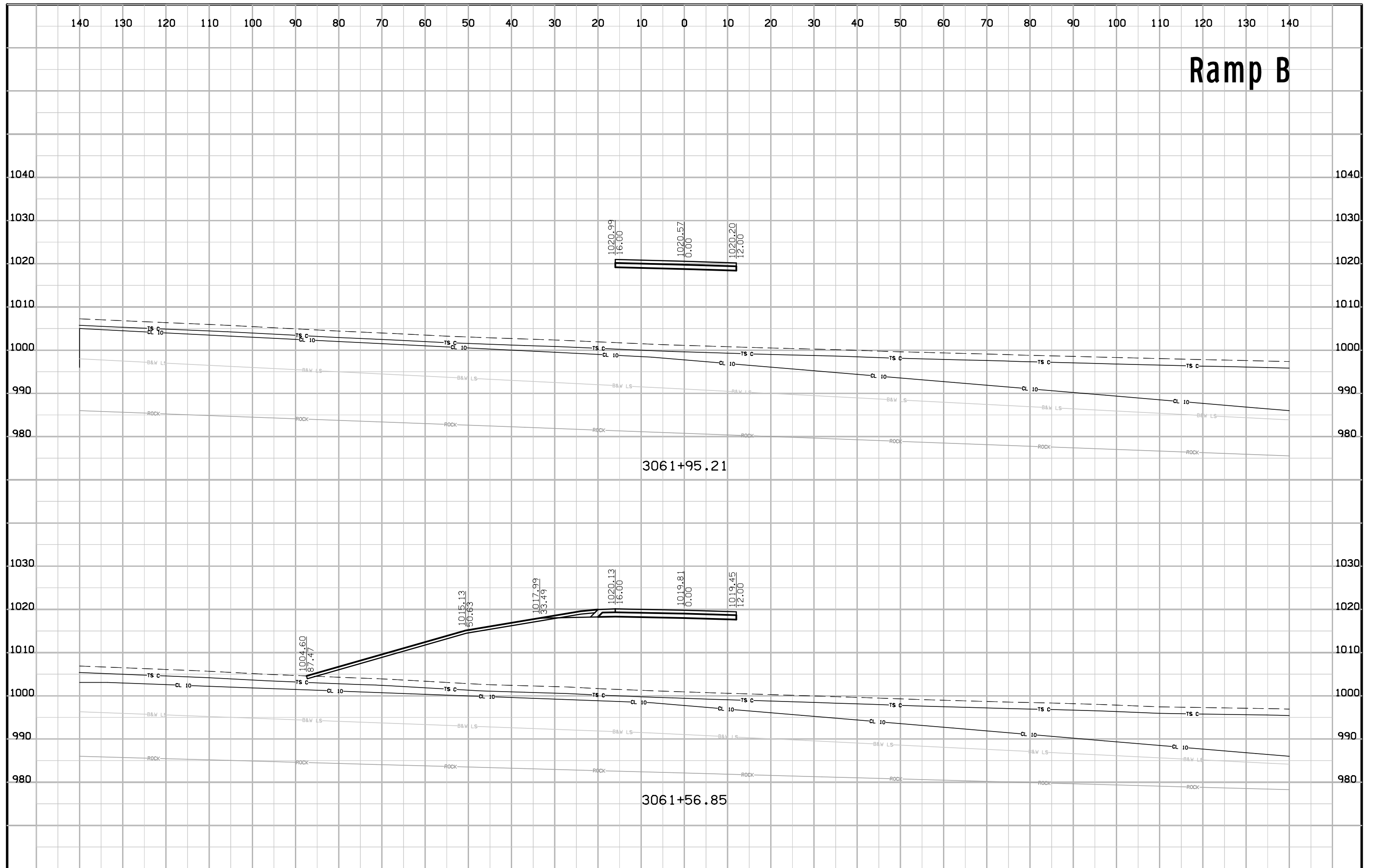

# Ramp B

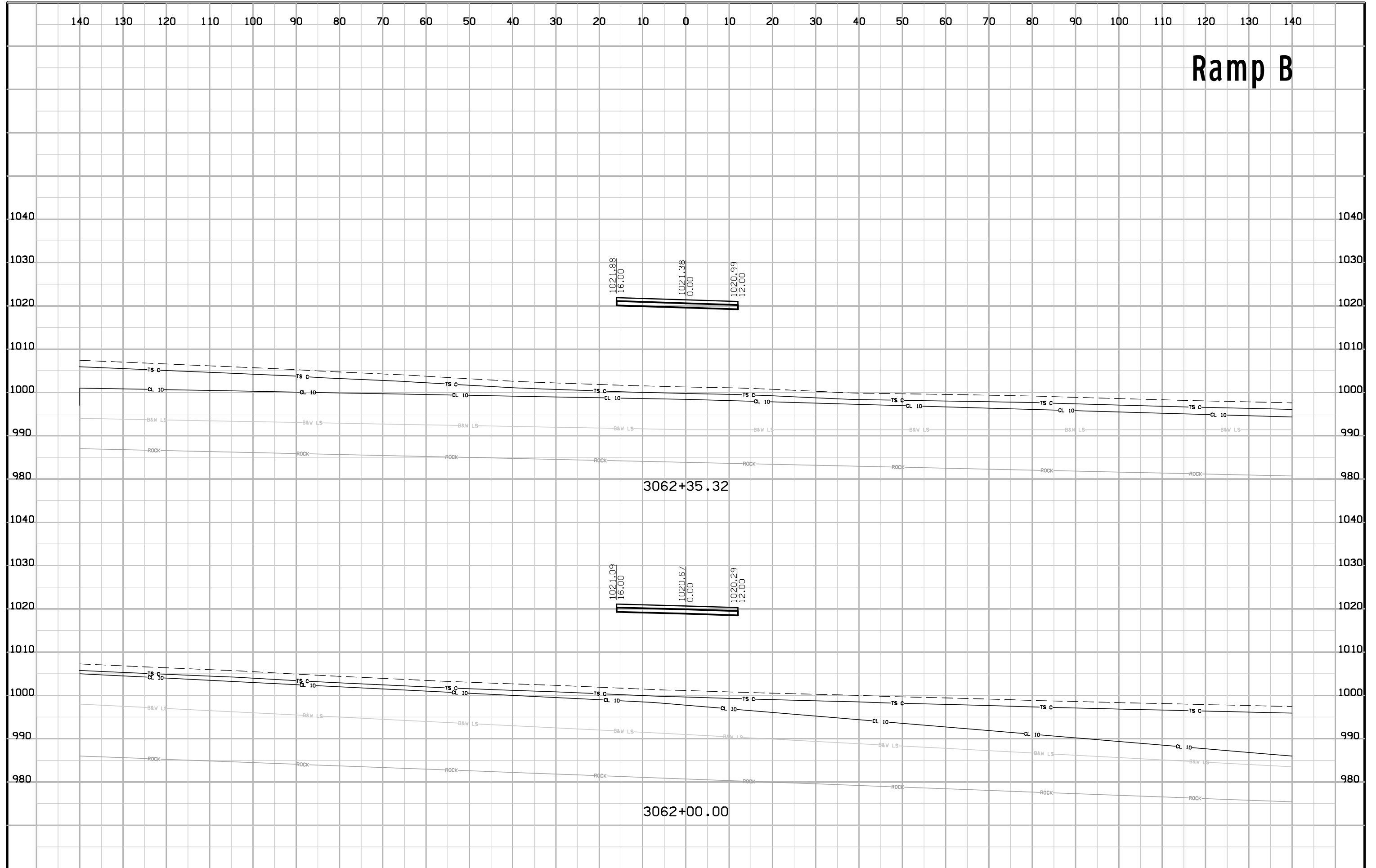



# Ramp C

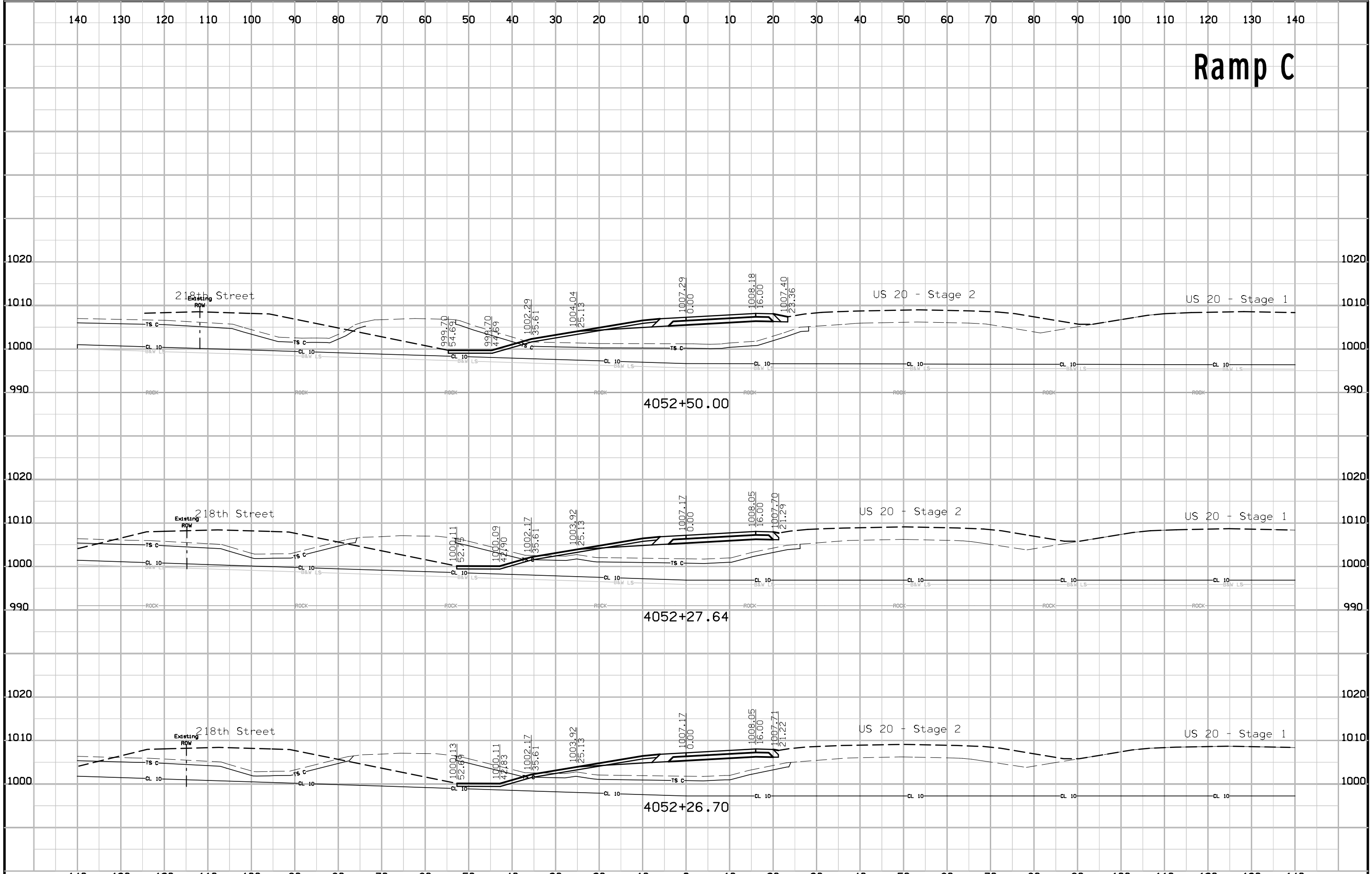

# Ramp C

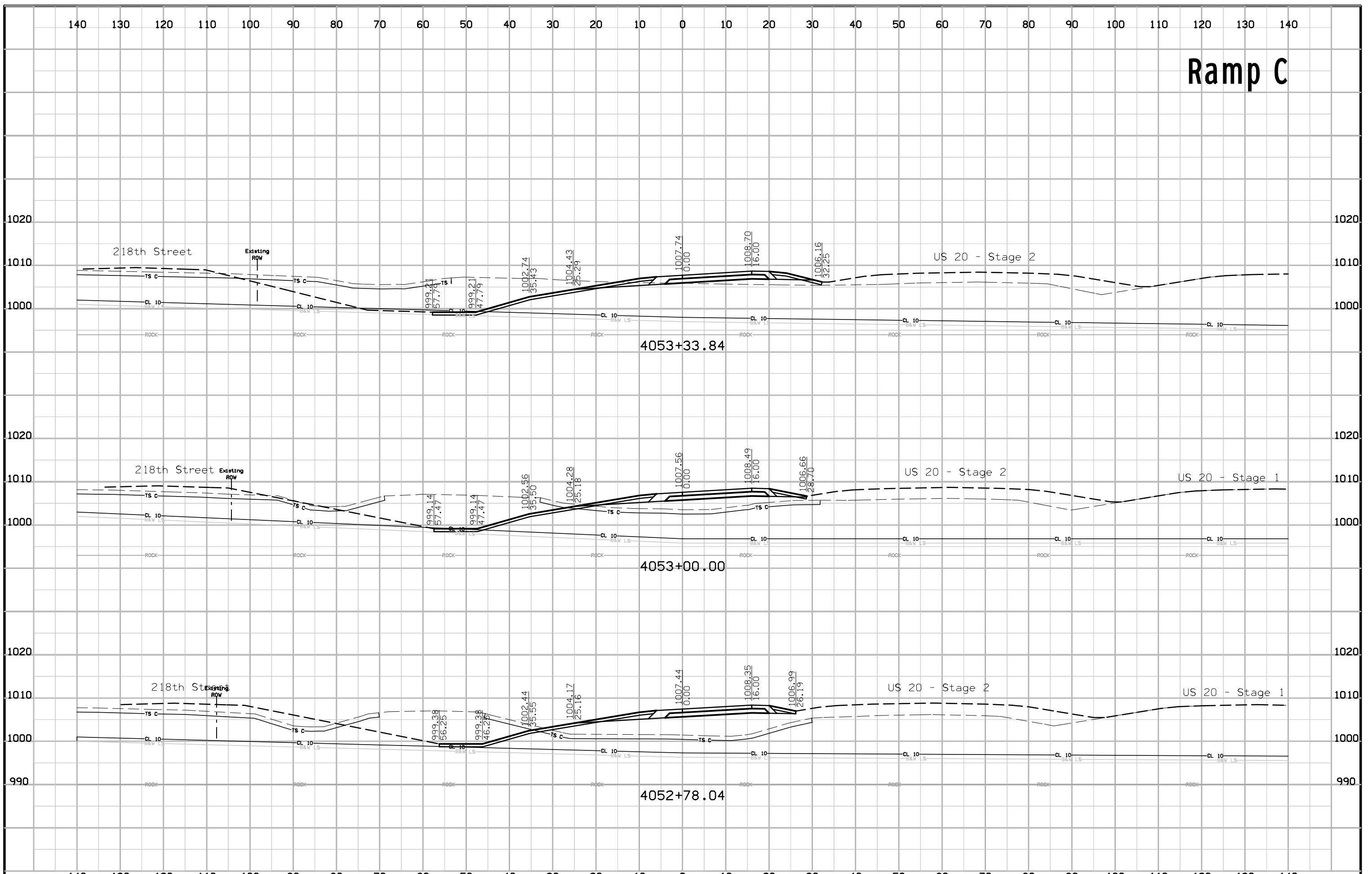

# Ramp C

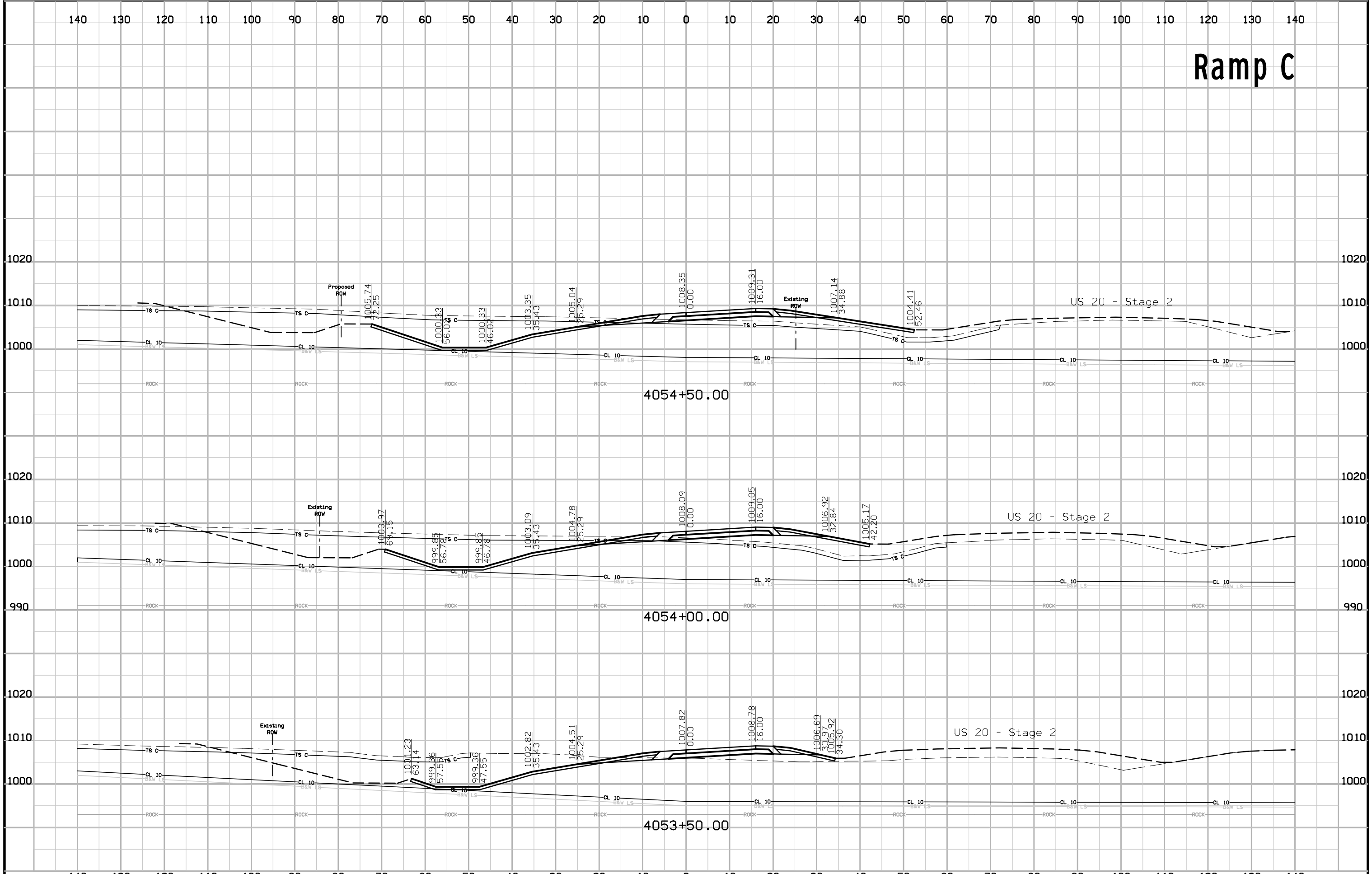

# Ramp C

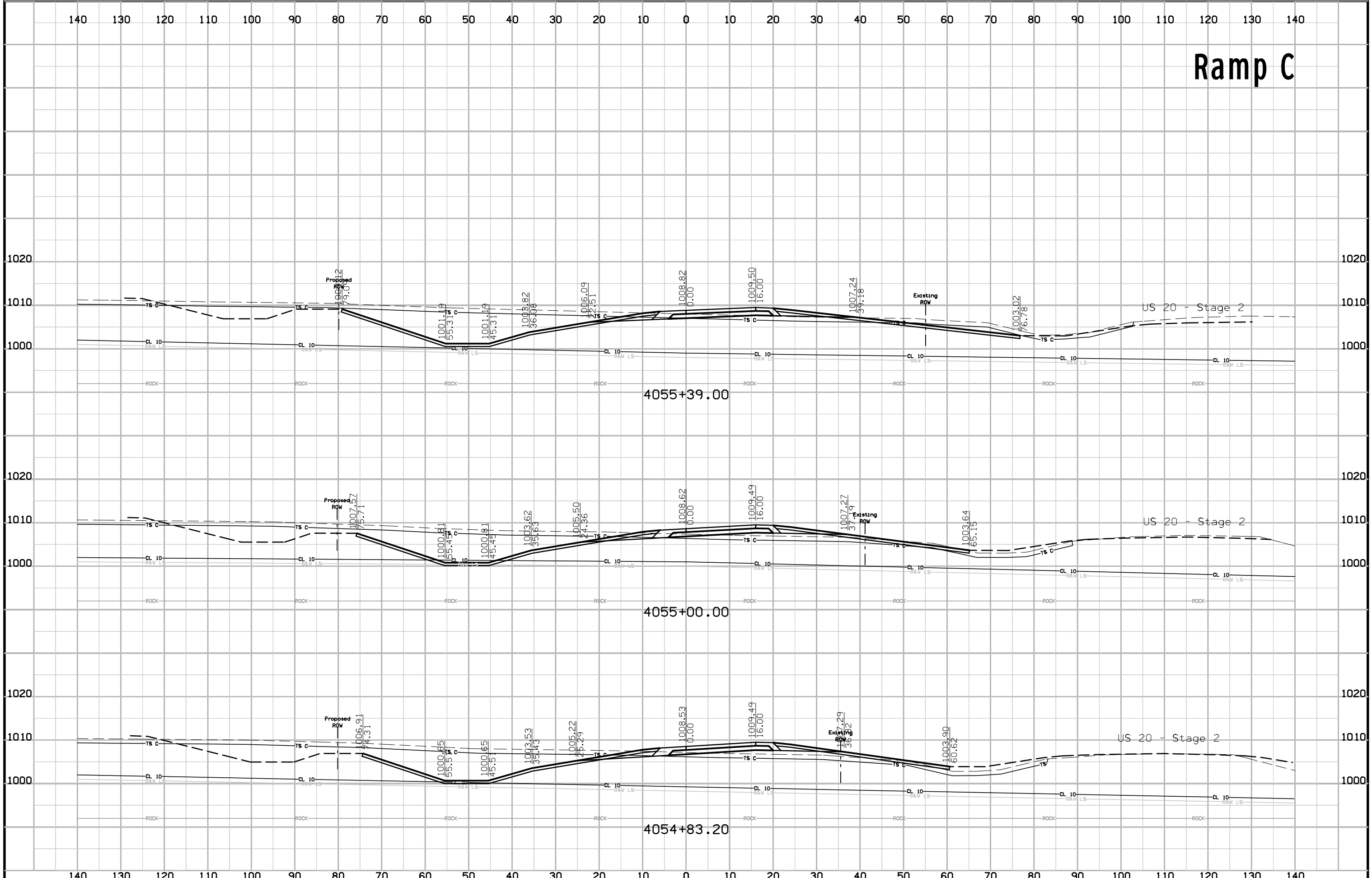

# Ramp C

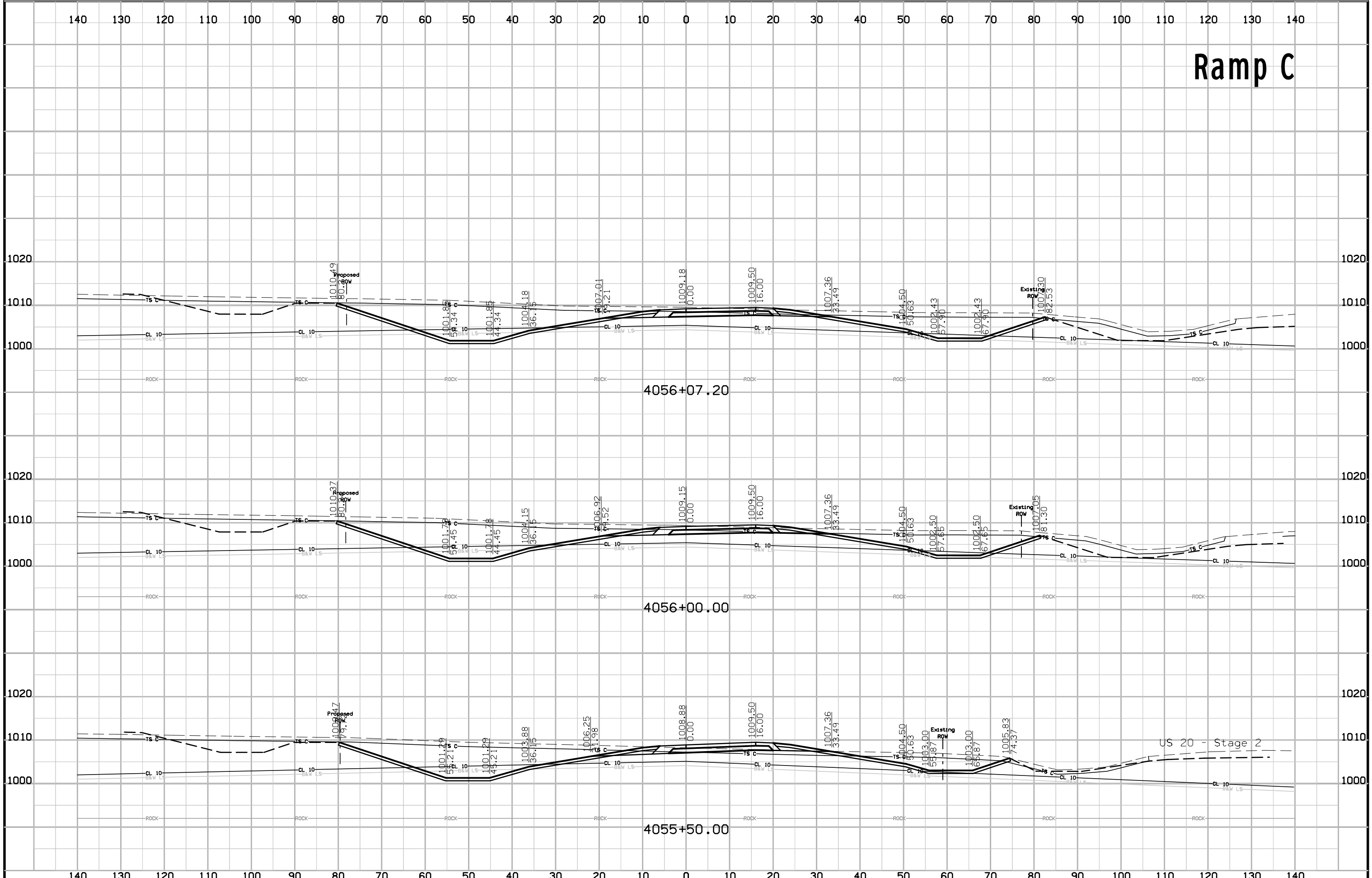

# Ramp C

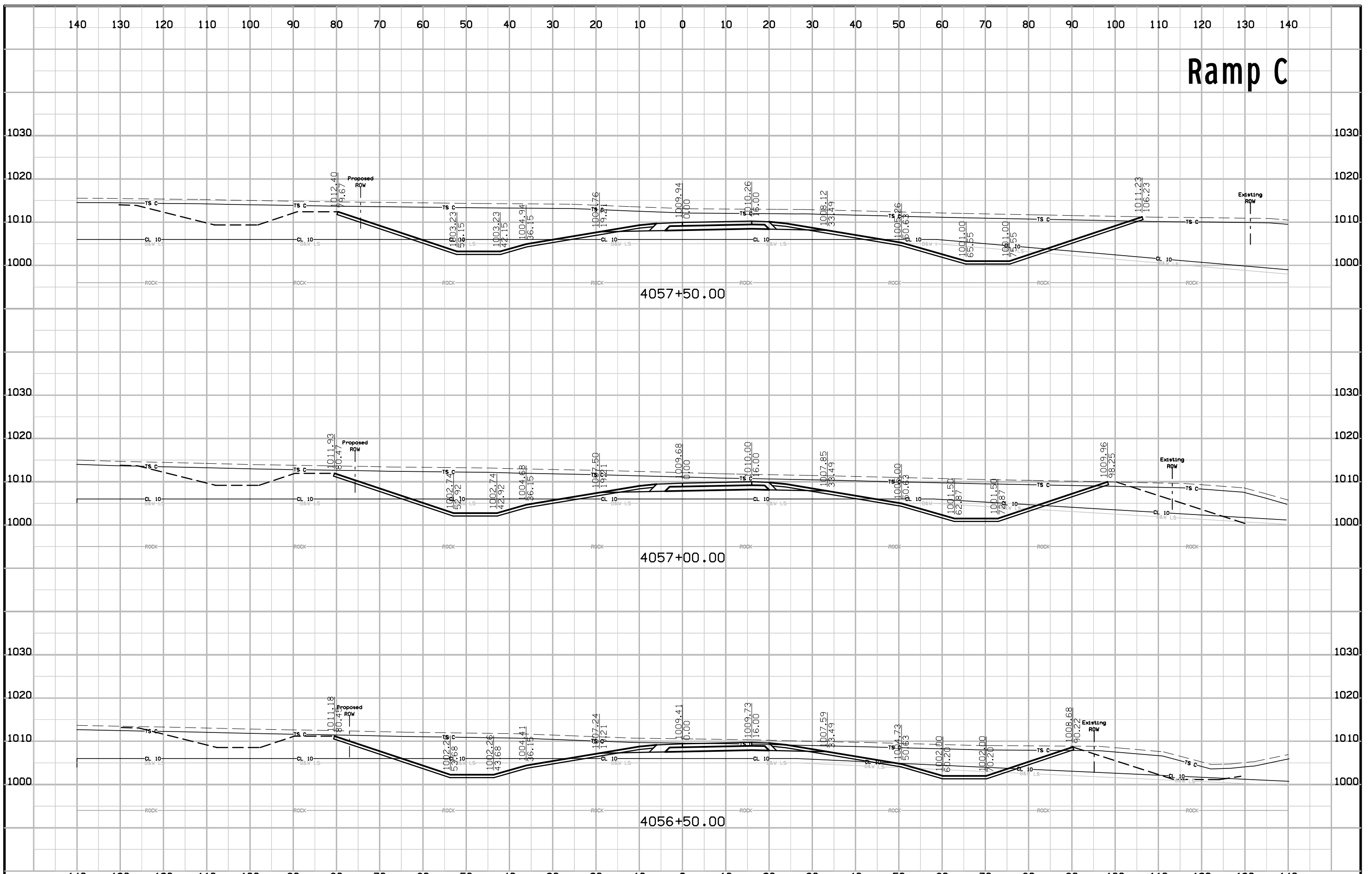

# Ramp C

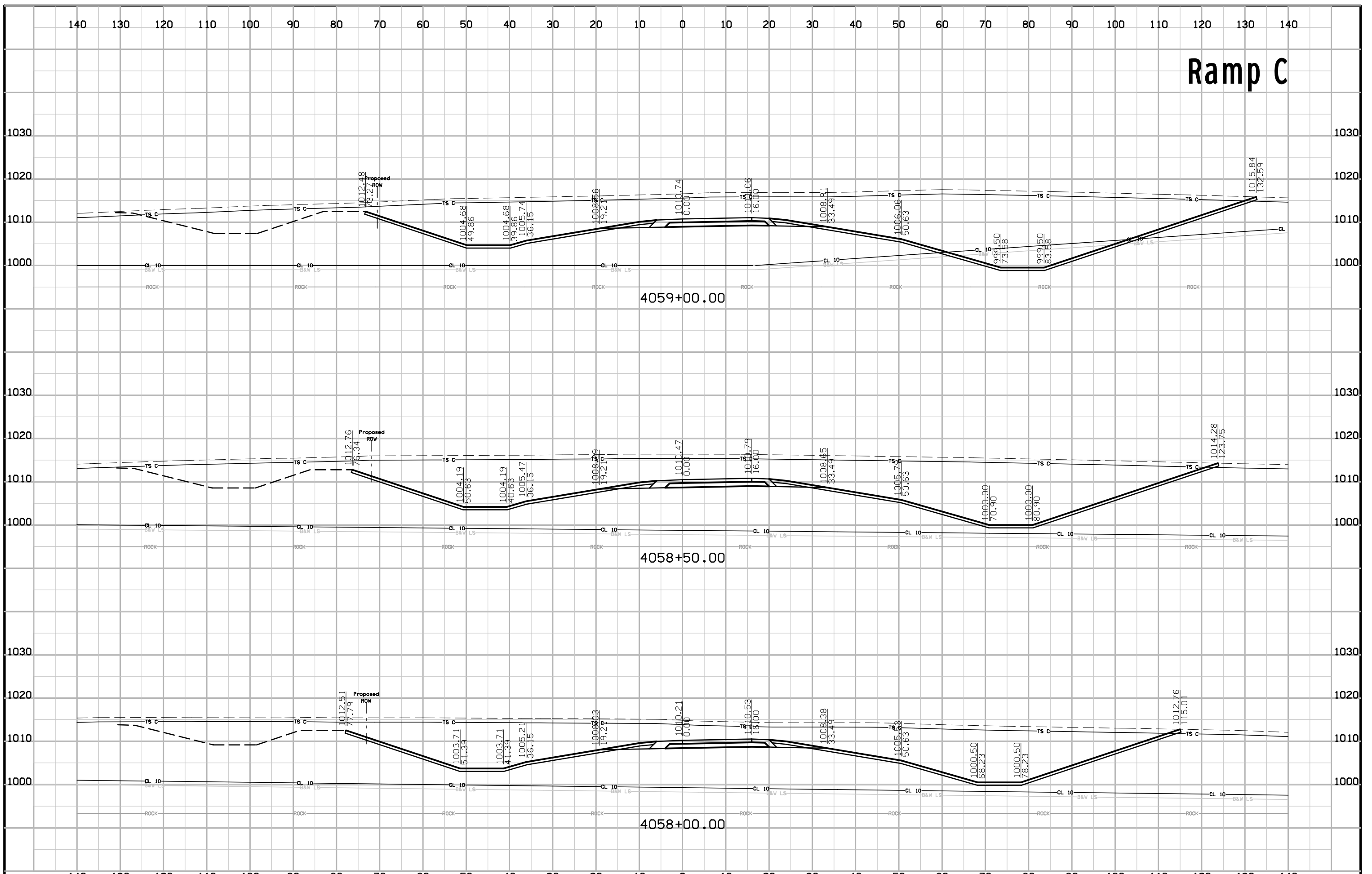

# Ramp C

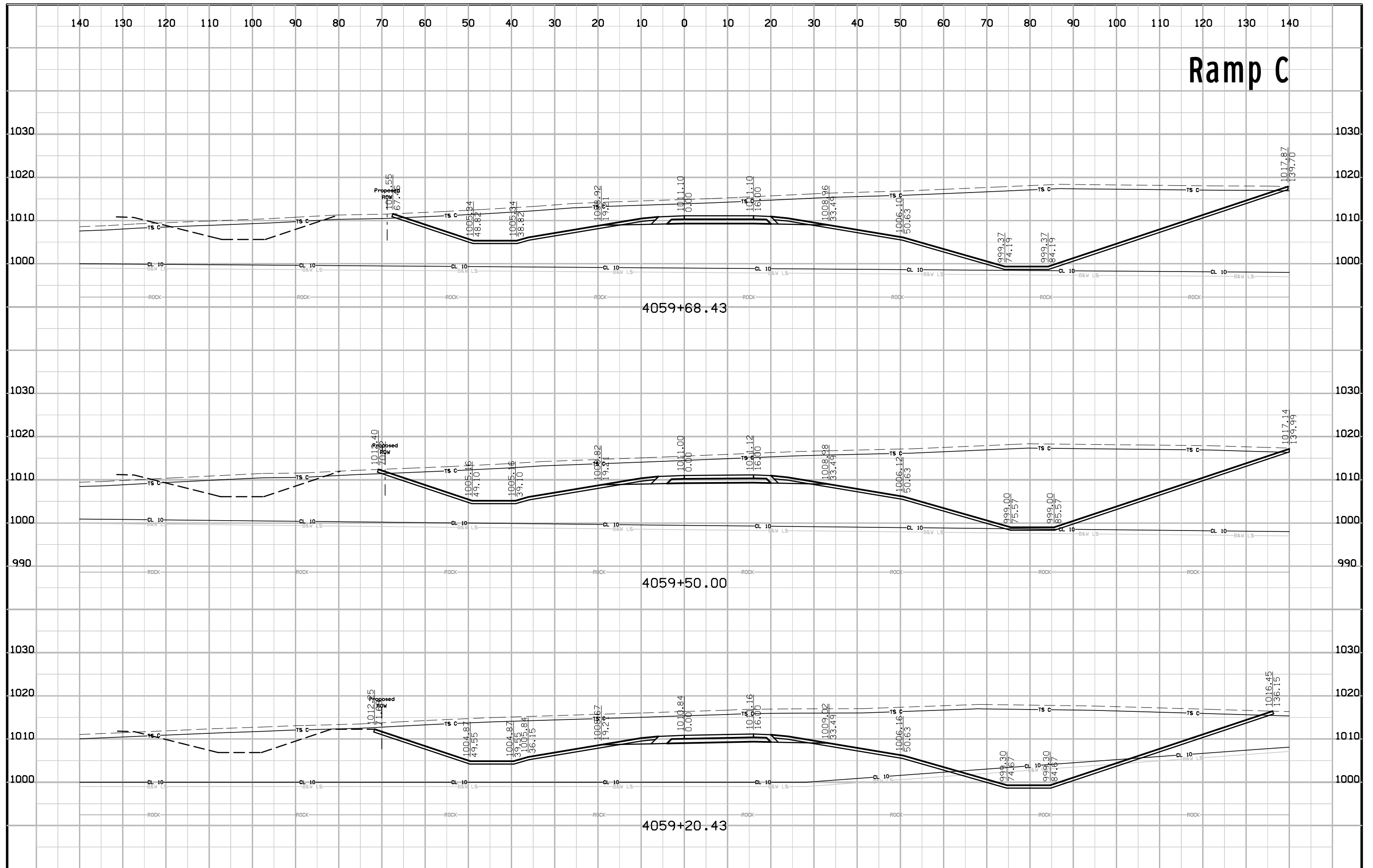

4059+68.43

4059+50.00

4059+20.43



# Ramp C

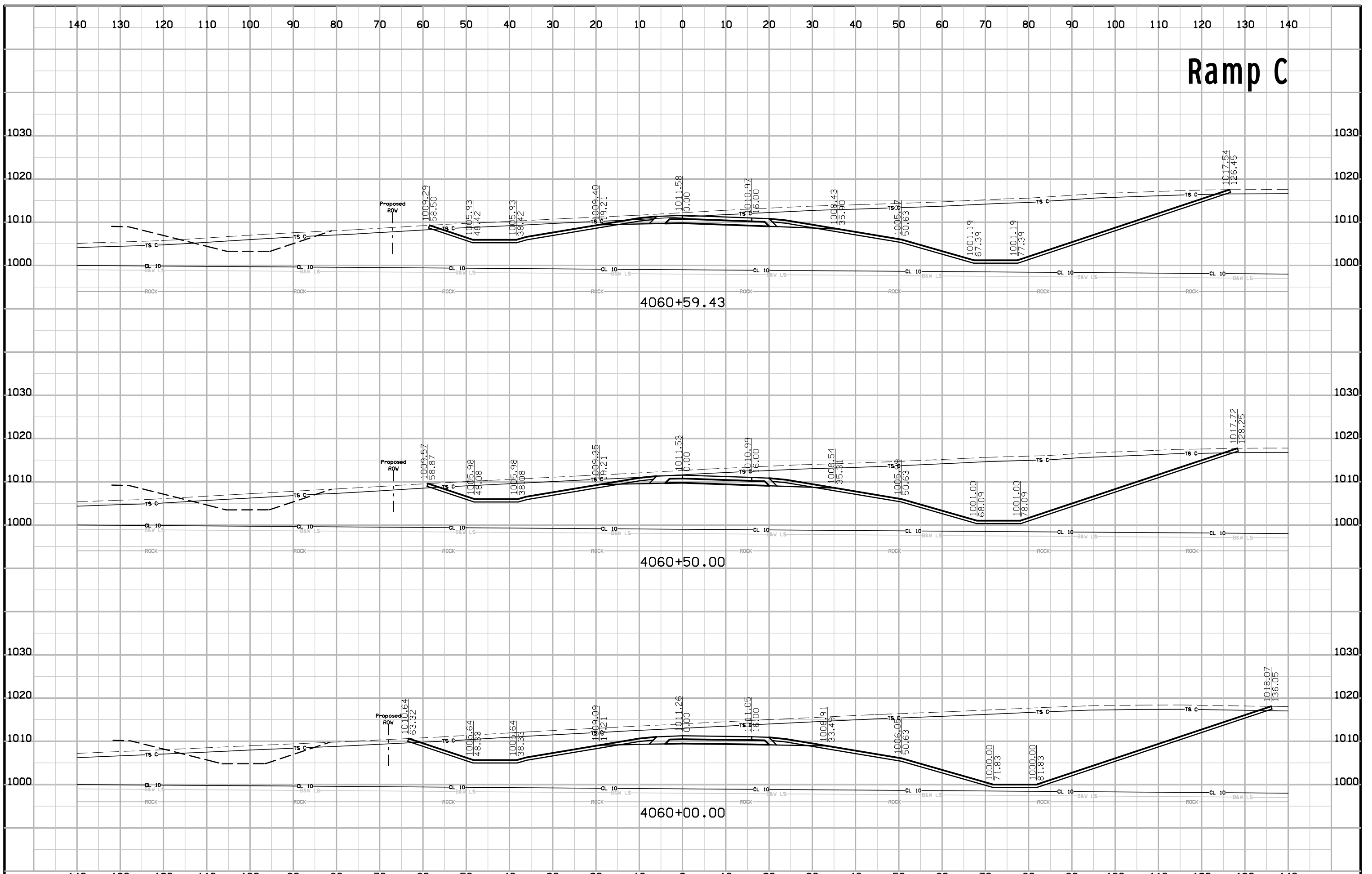

# Ramp C

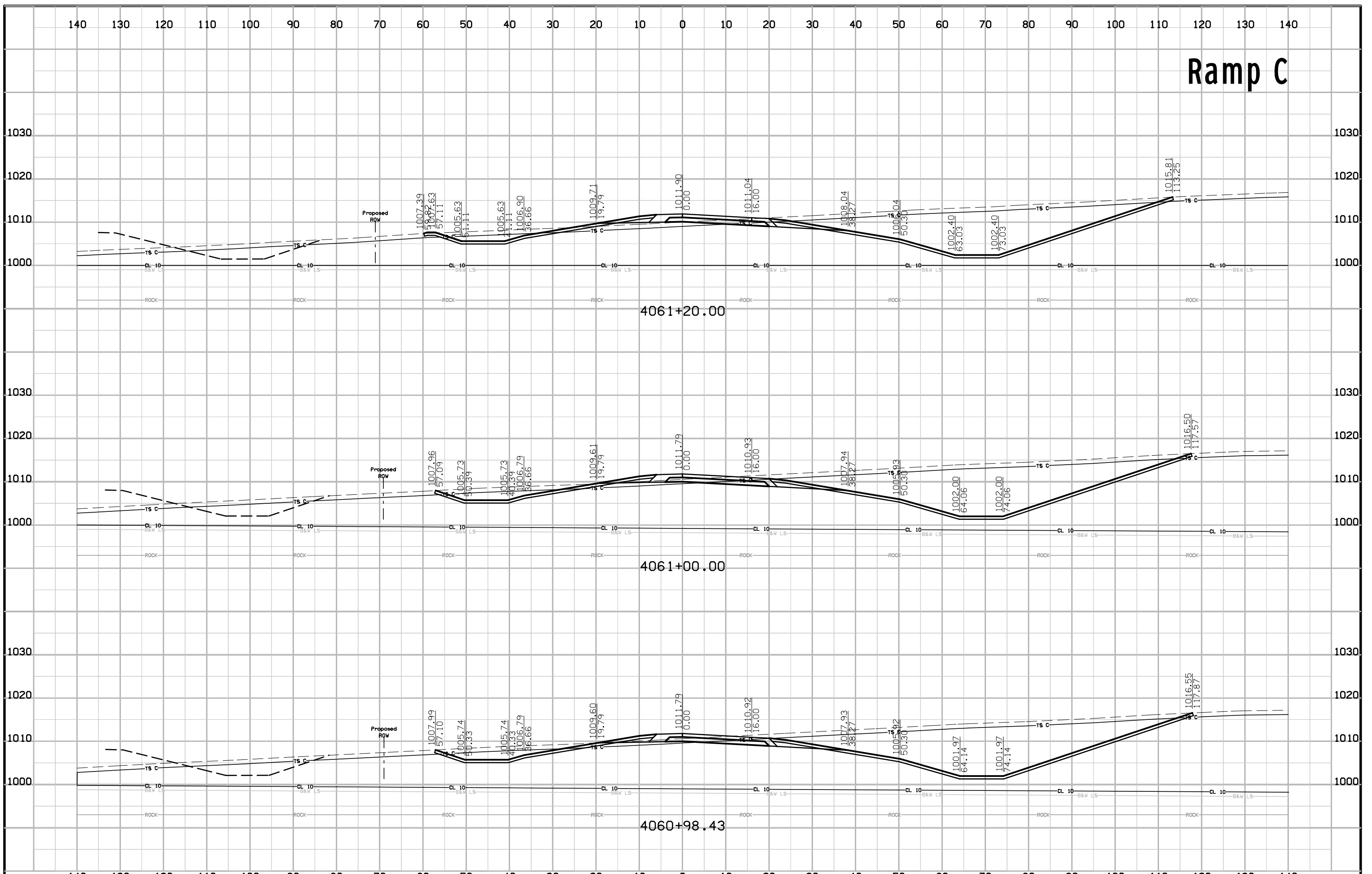

# Ramp C

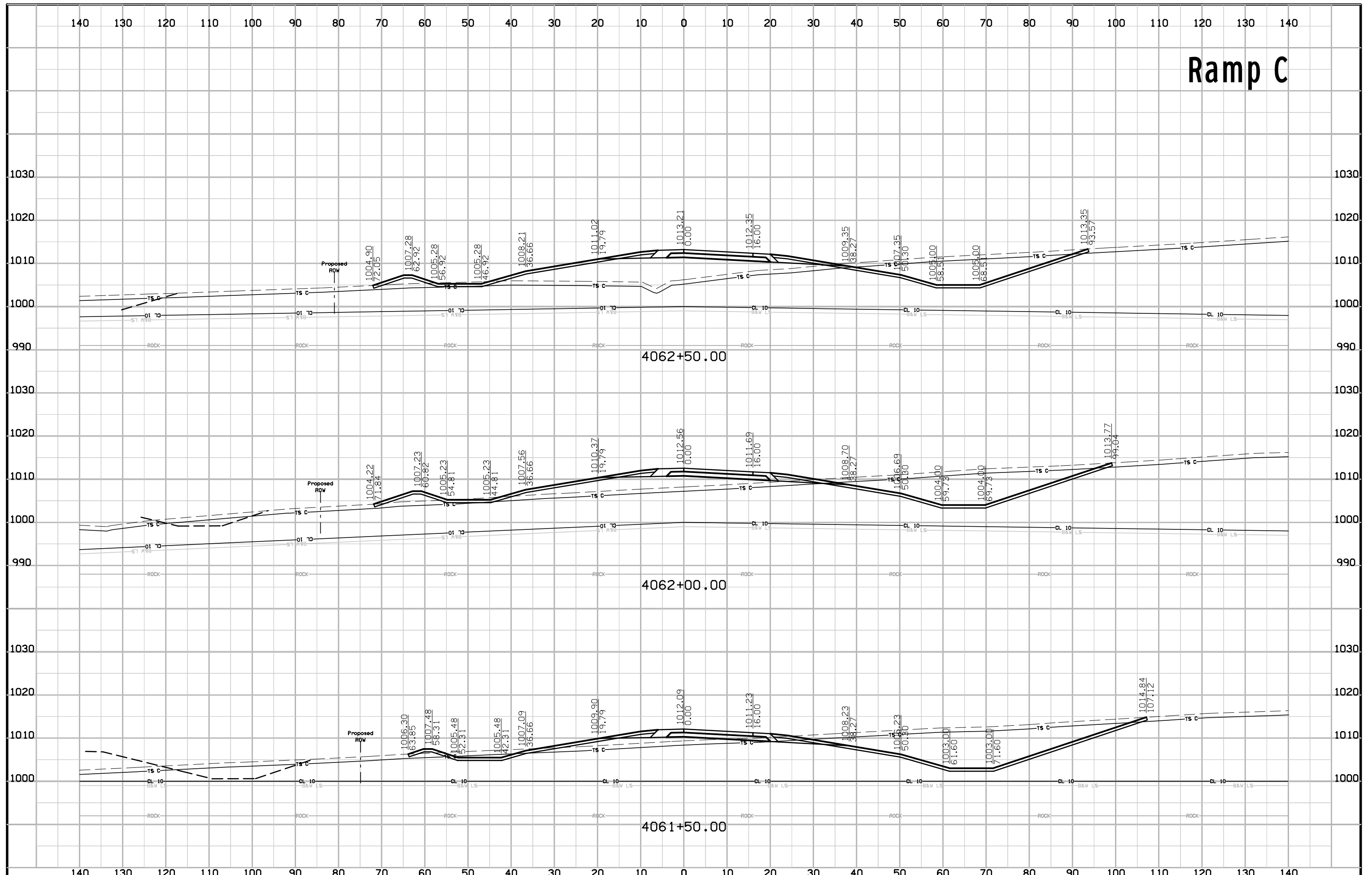

# Ramp C

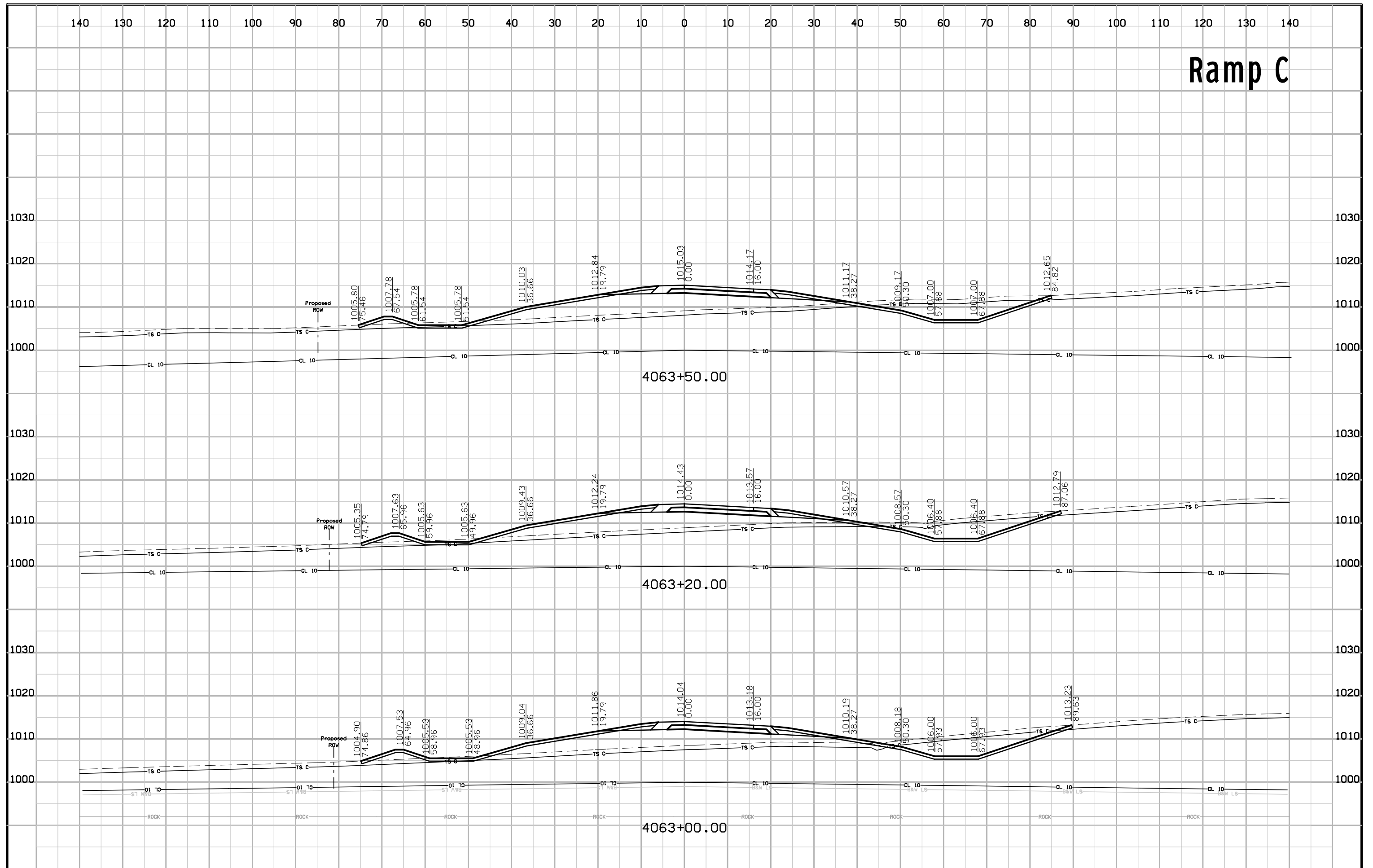

# Ramp C

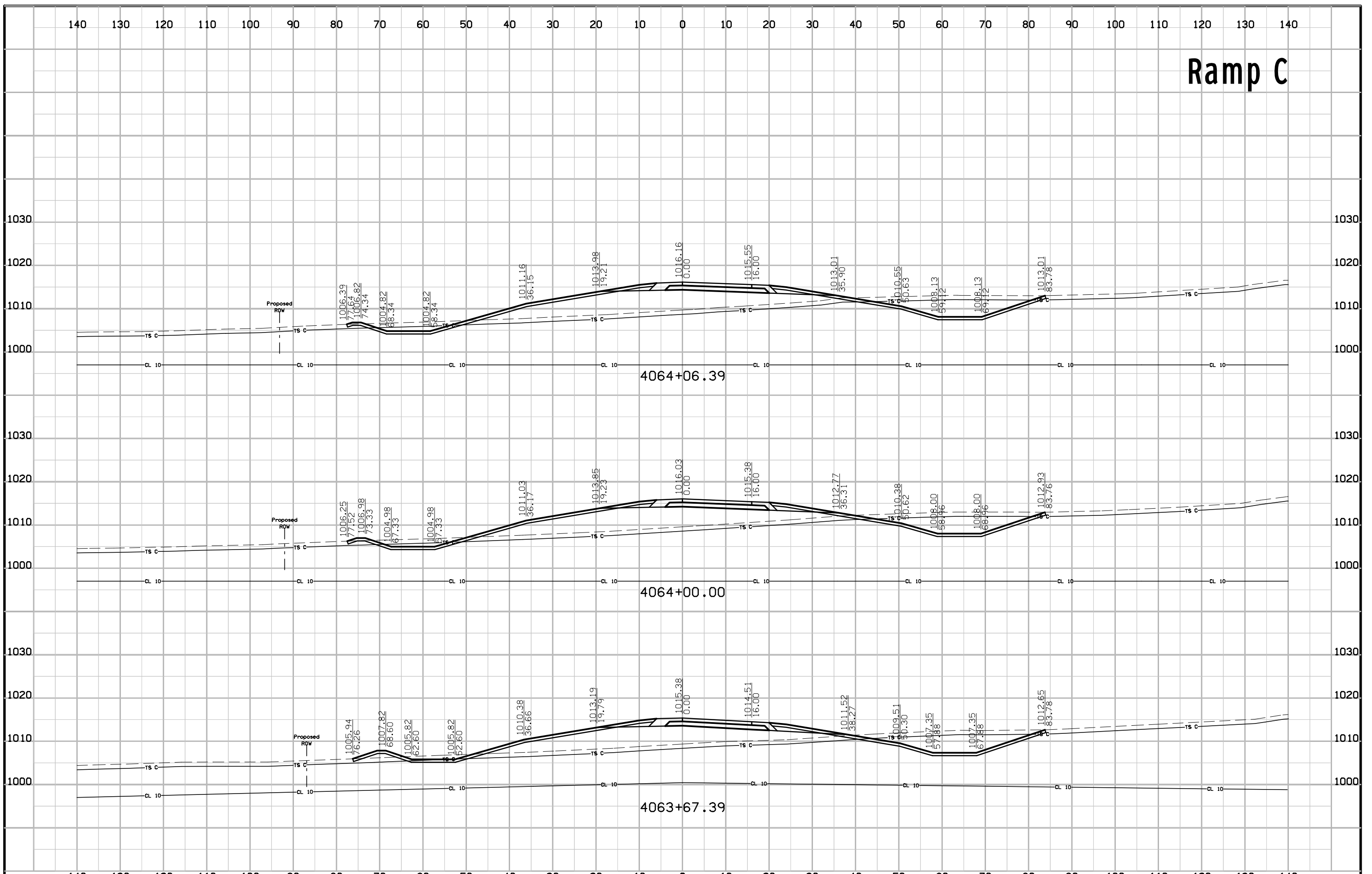

# Ramp C

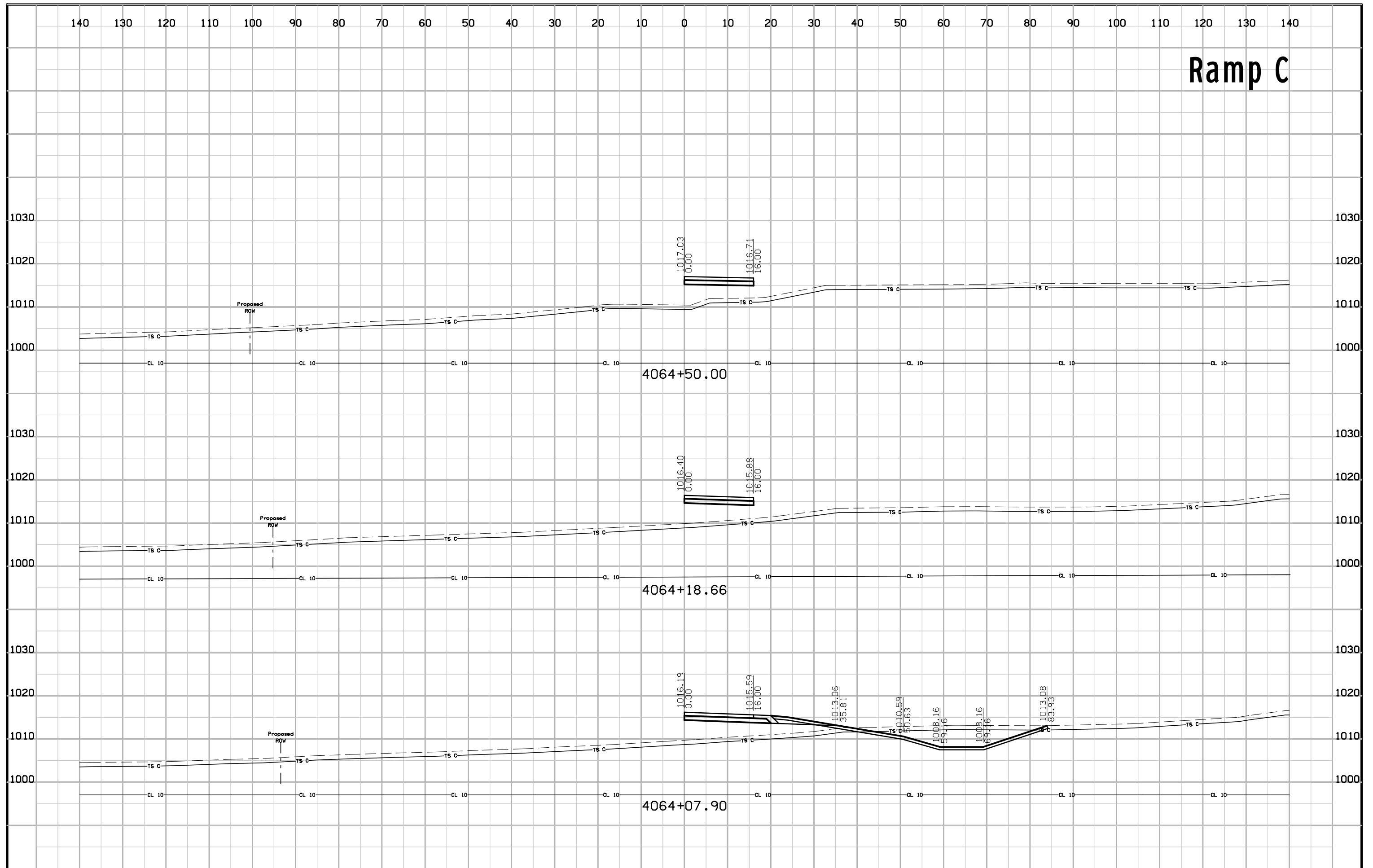

# Ramp C

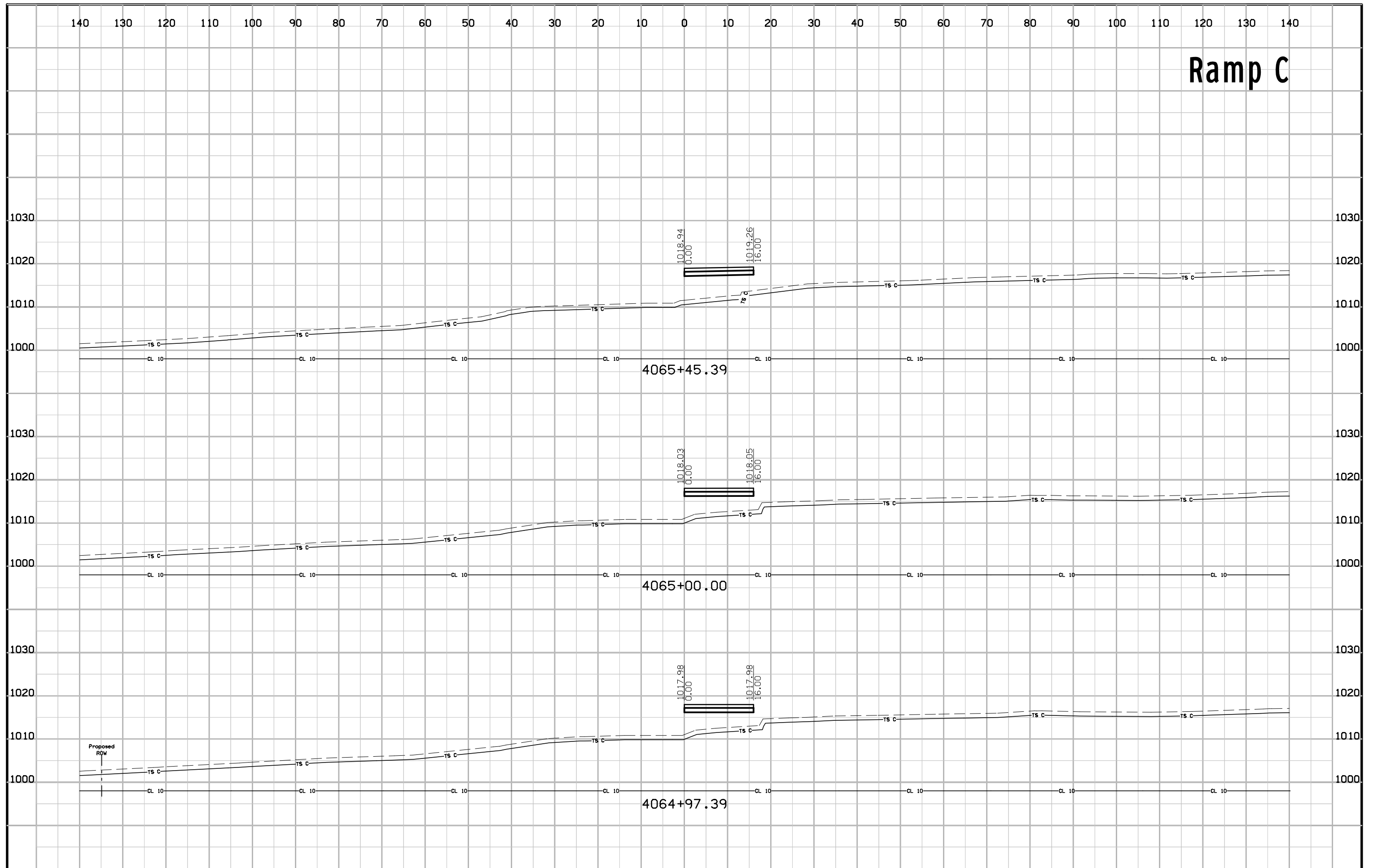

# Ramp C

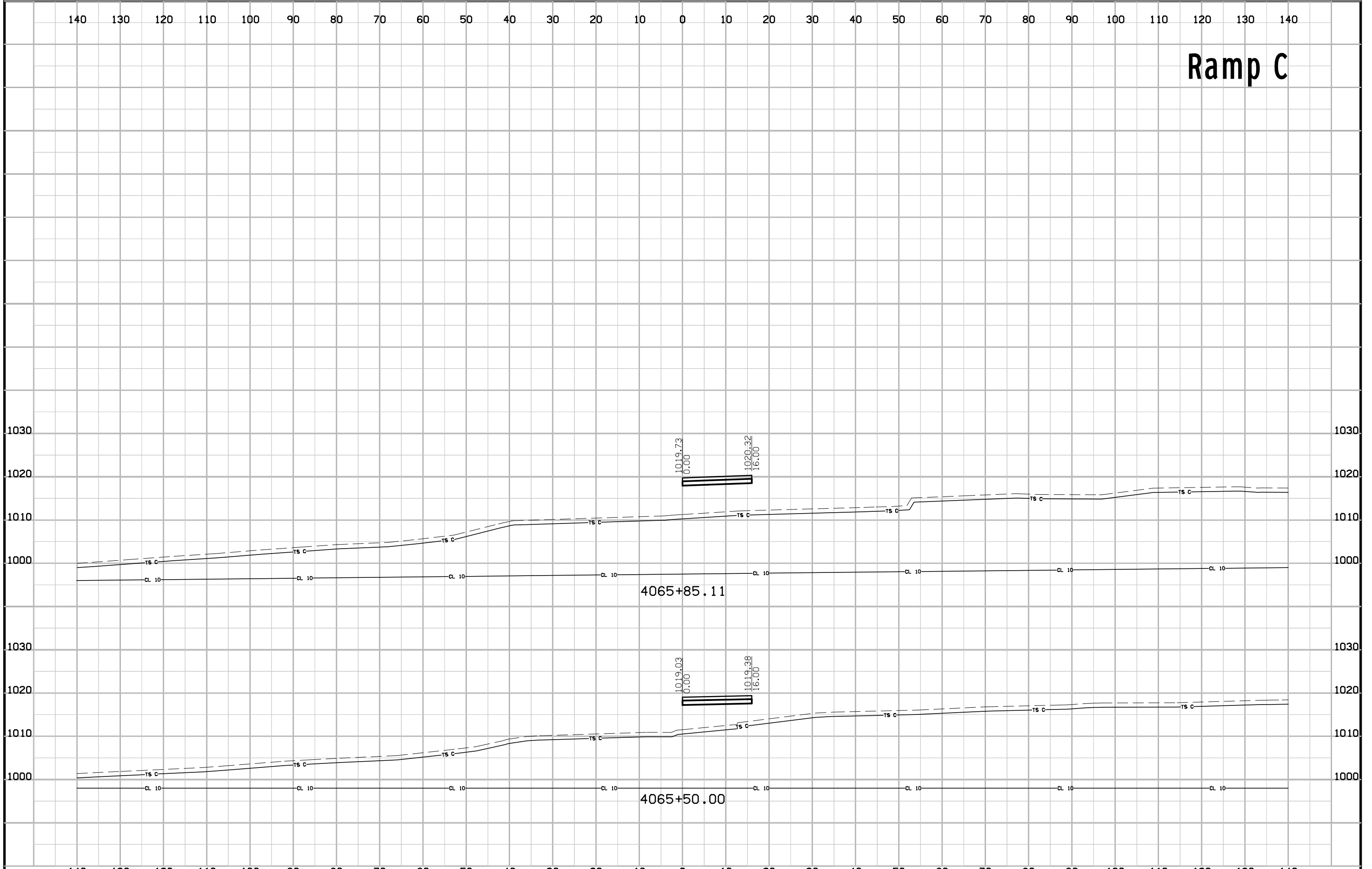



# Ramp D

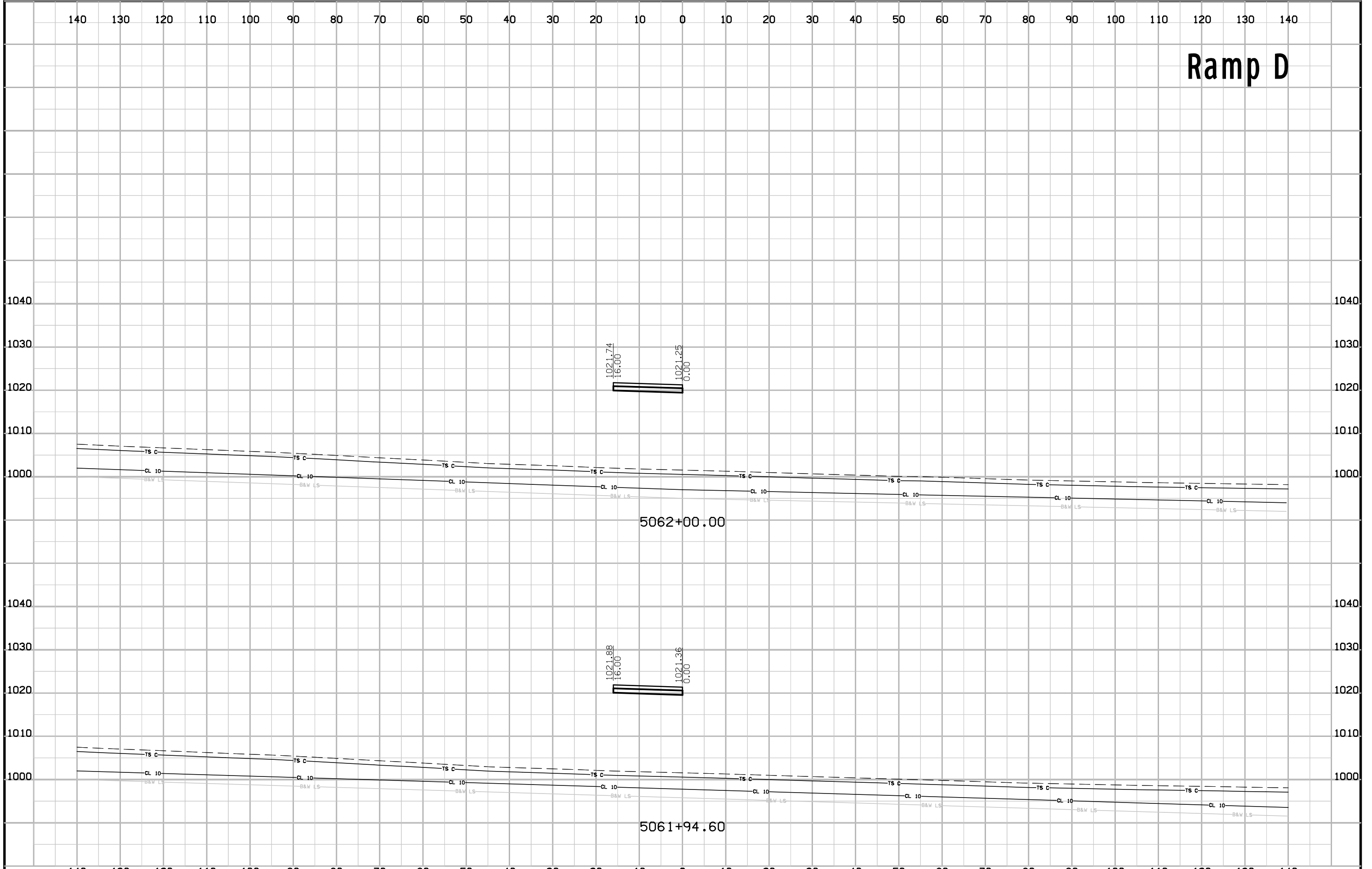

# Ramp D

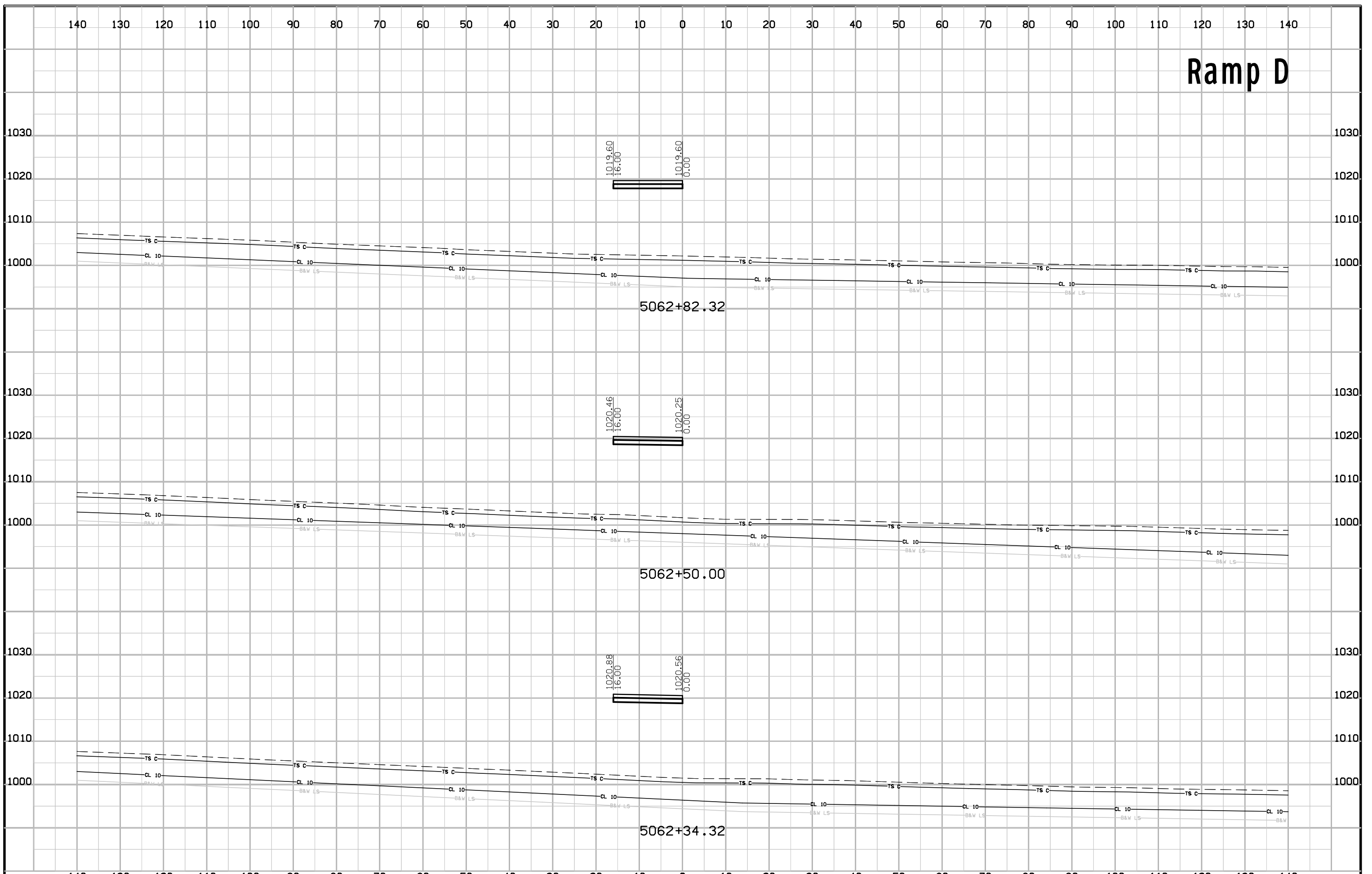

# Ramp D

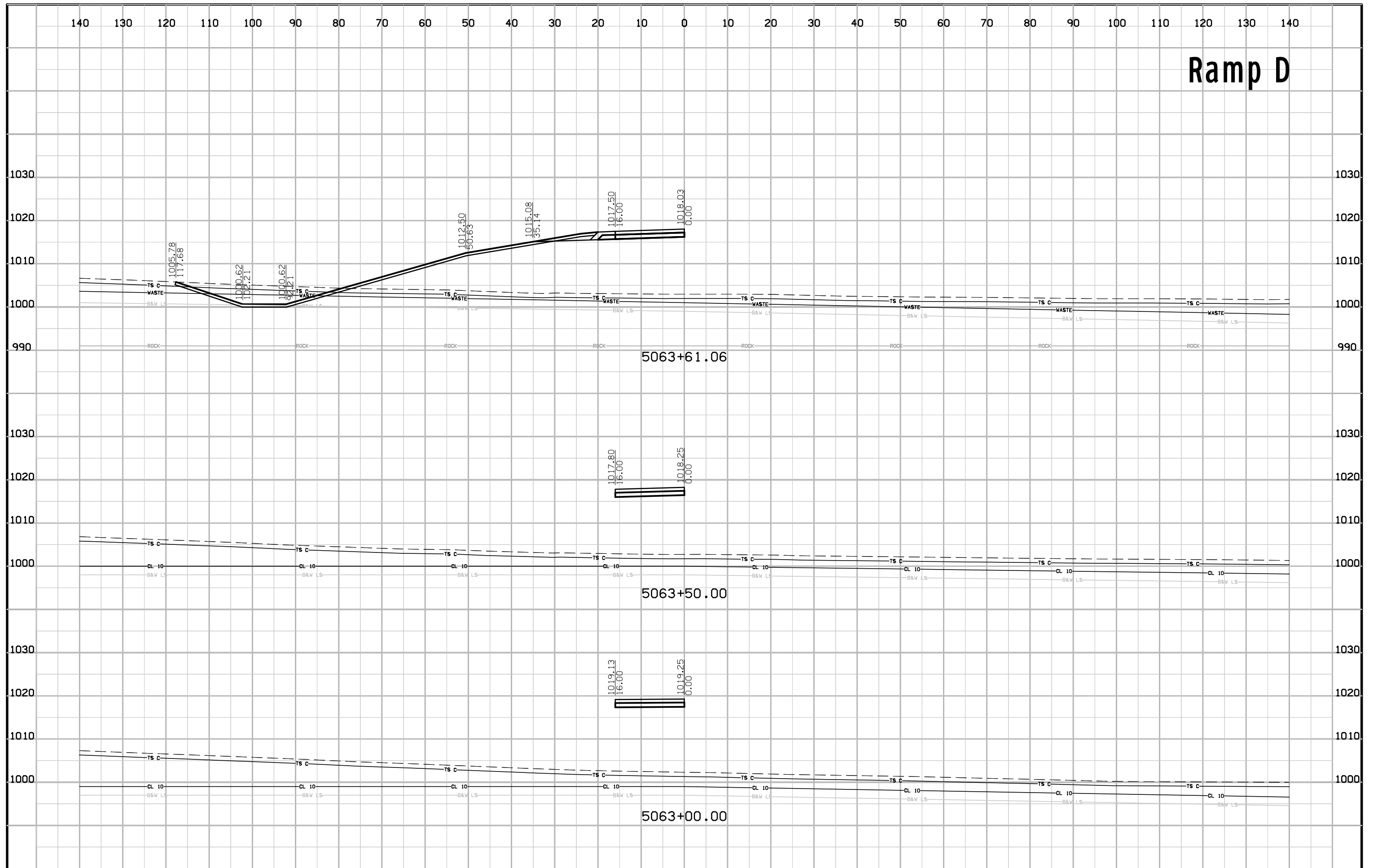

5063+61.06

5063+50.00

5063+00.00

# Ramp D

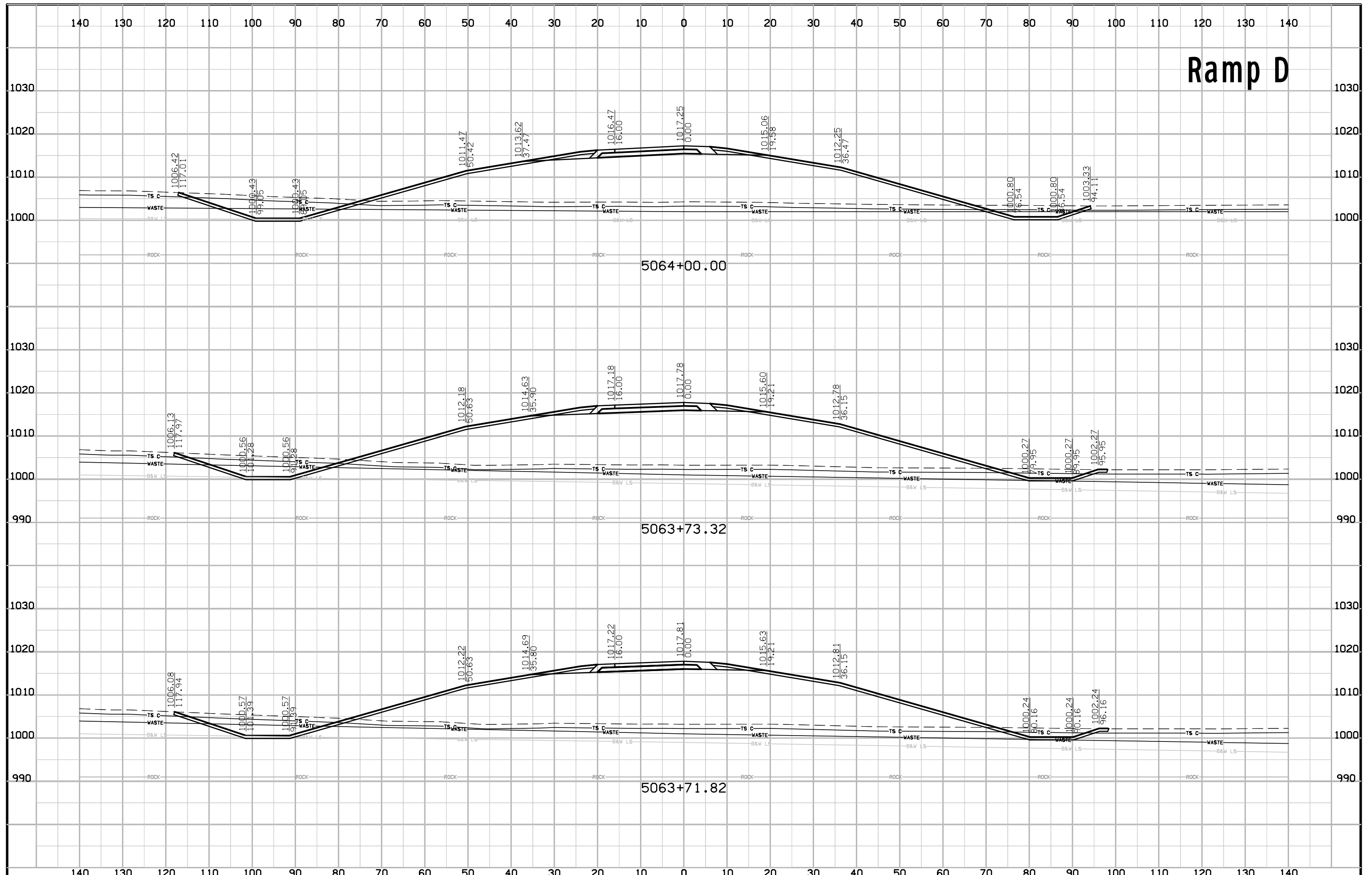

# Ramp D

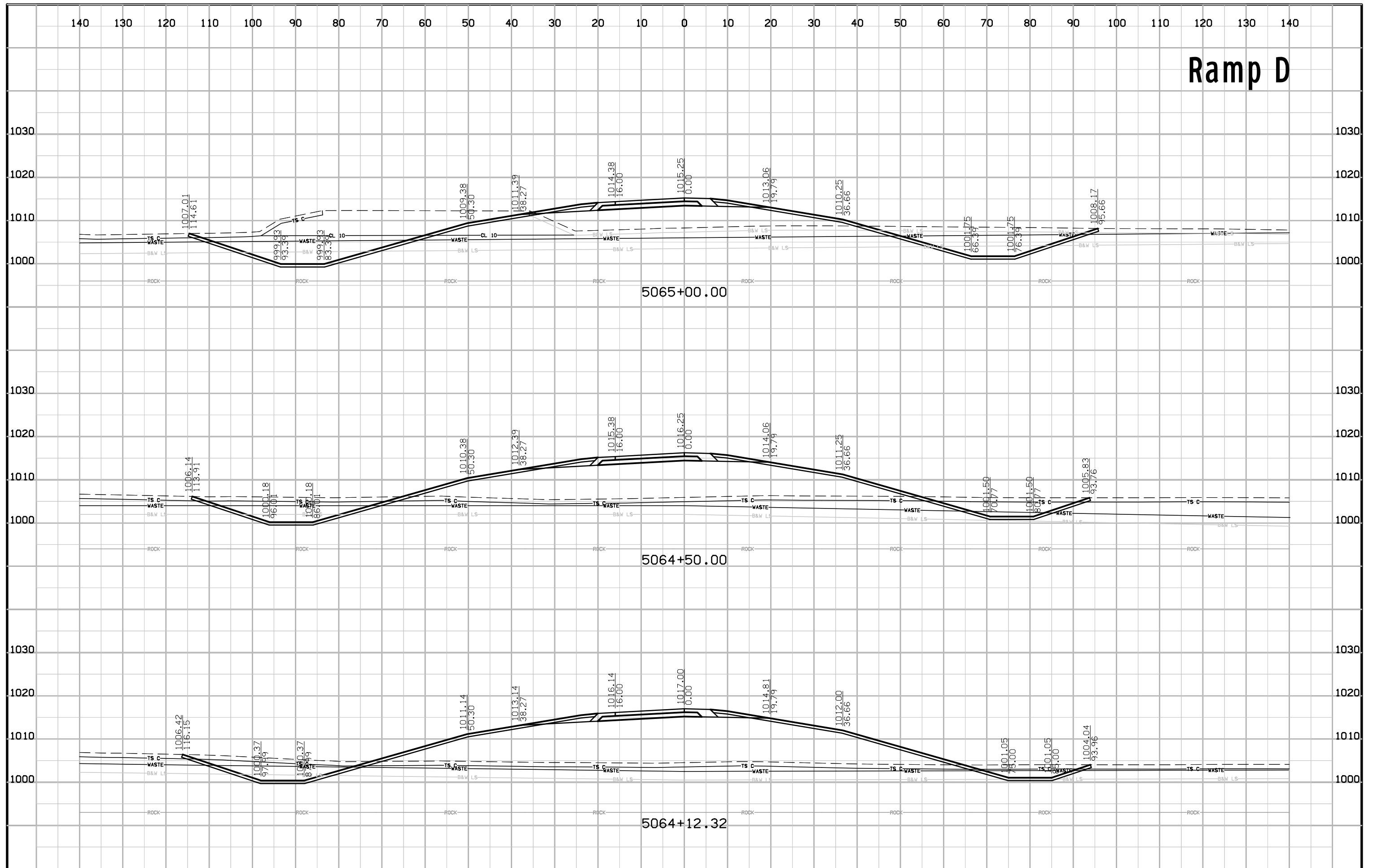

5065+00.00

5064+50.00

5064+12.32

# Ramp D

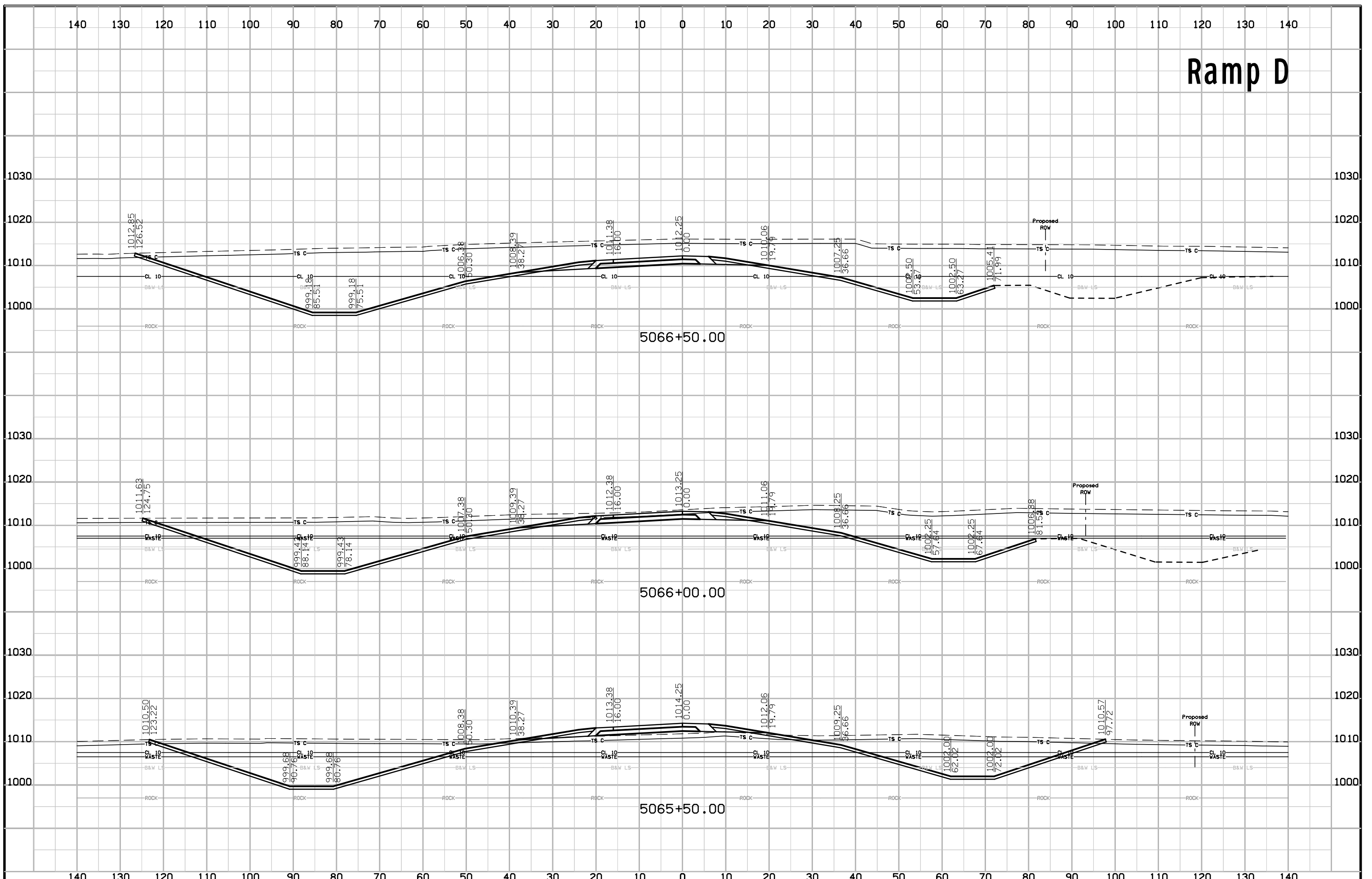

# Ramp D

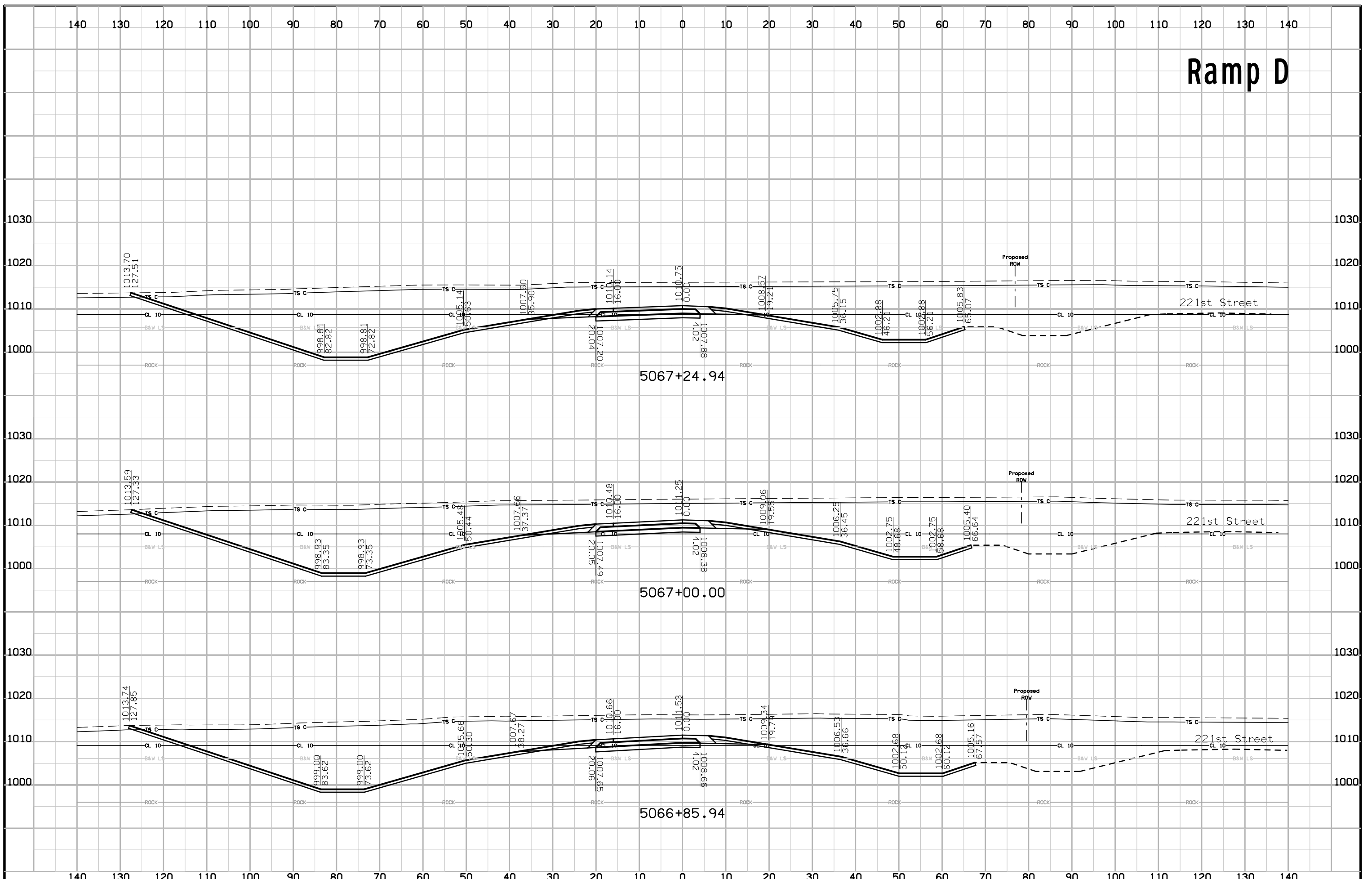

# Ramp D

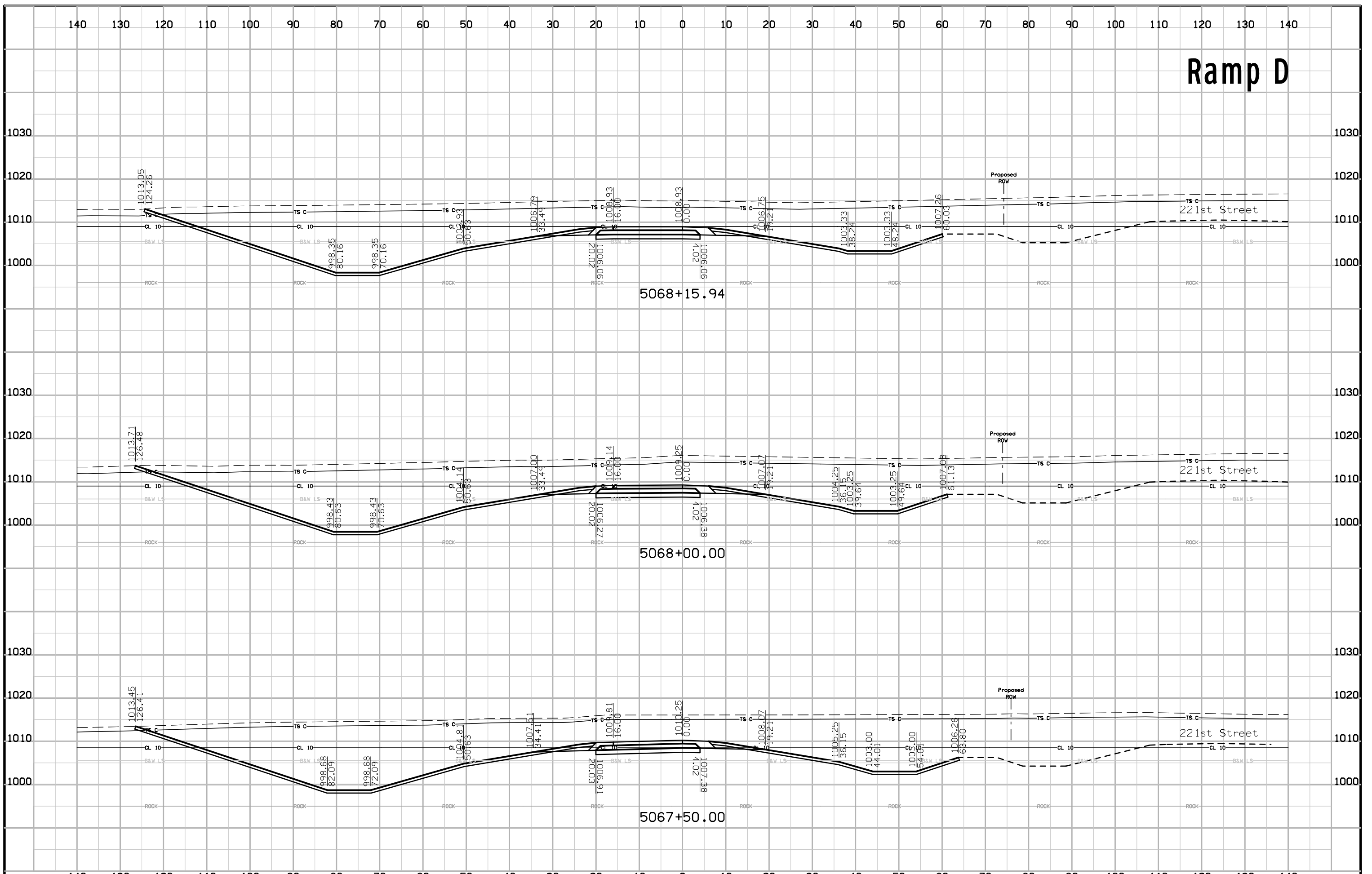



# Ramp D

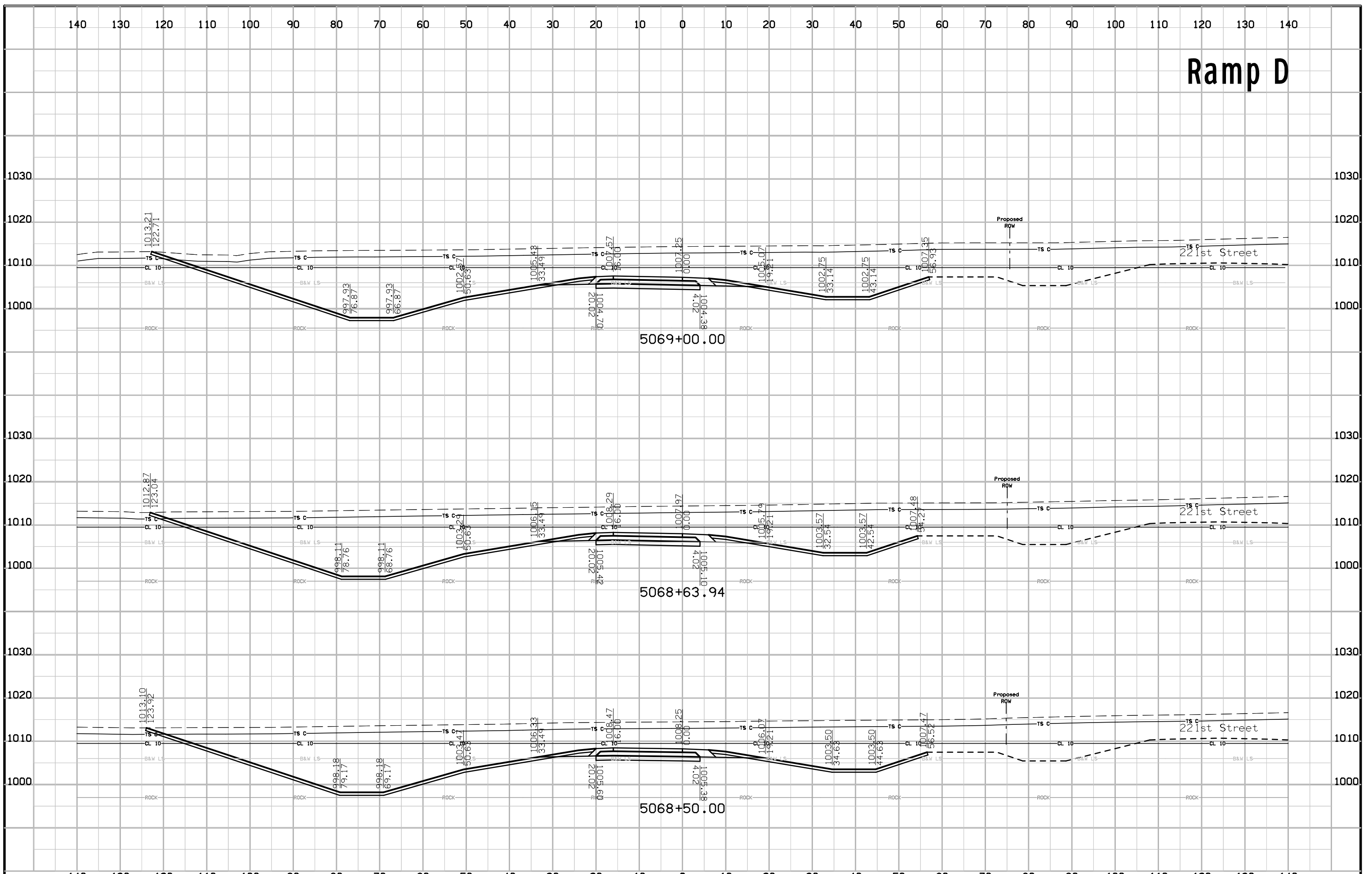

# Ramp D

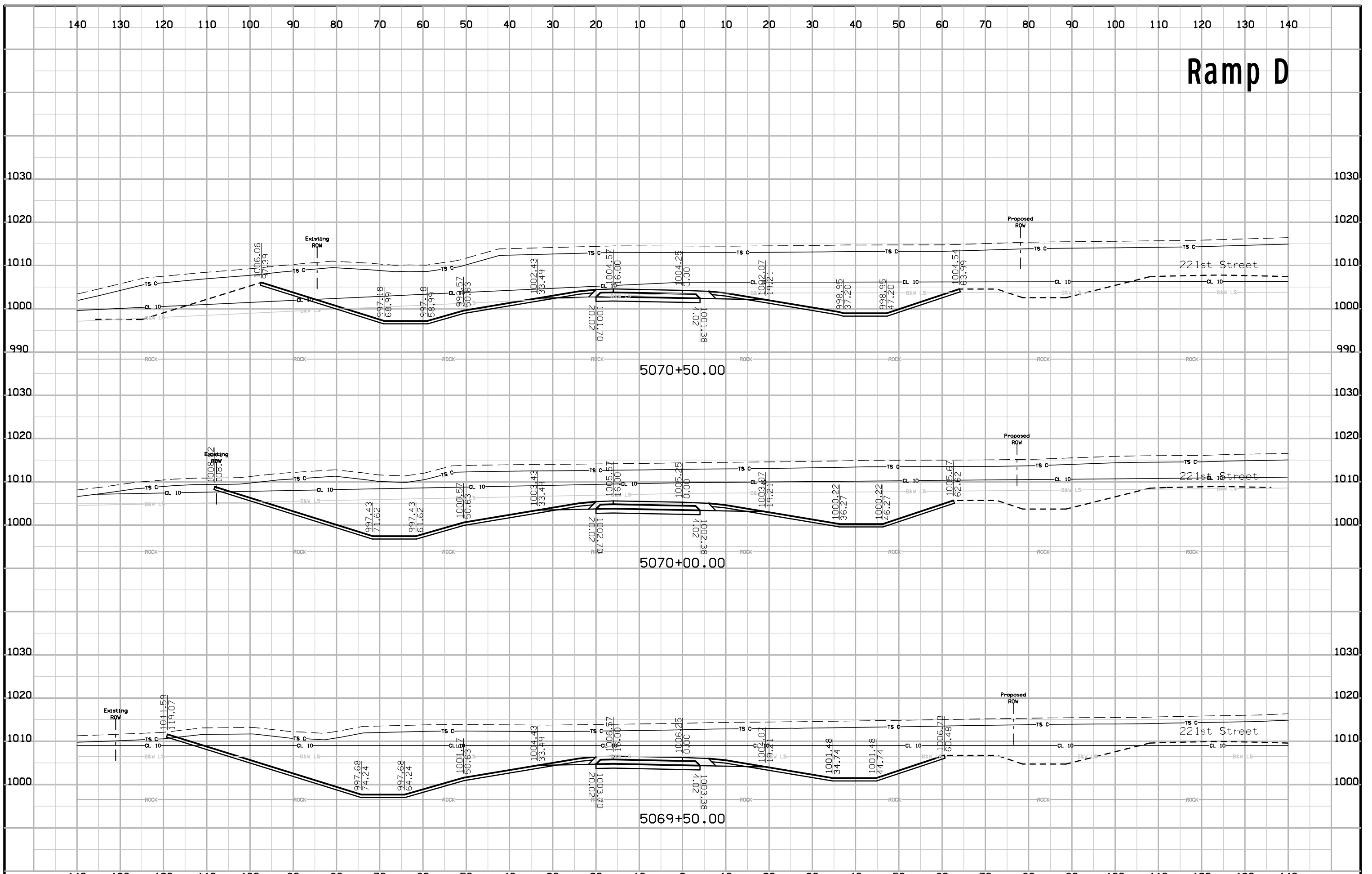

# Ramp D

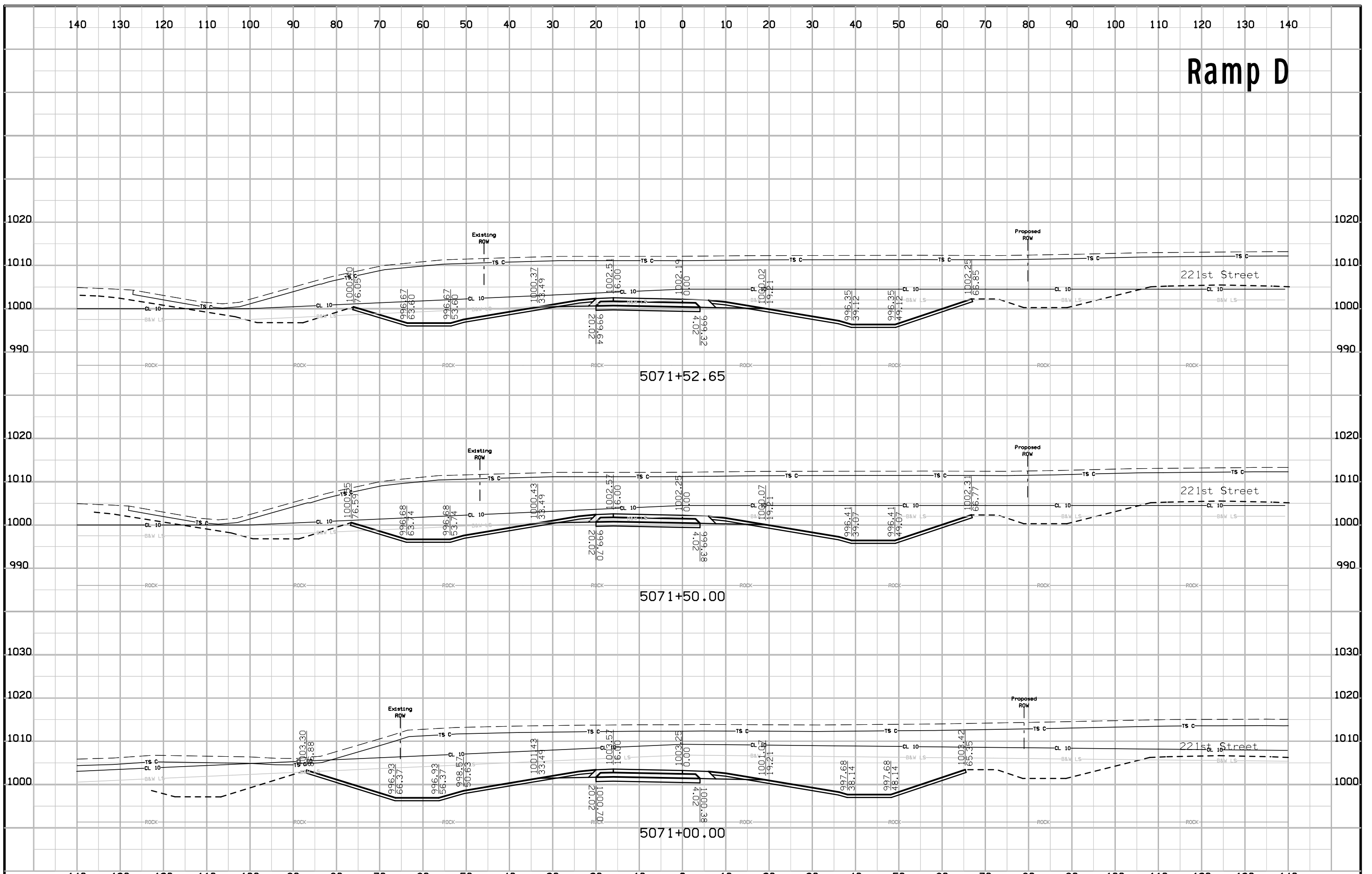

# Ramp D

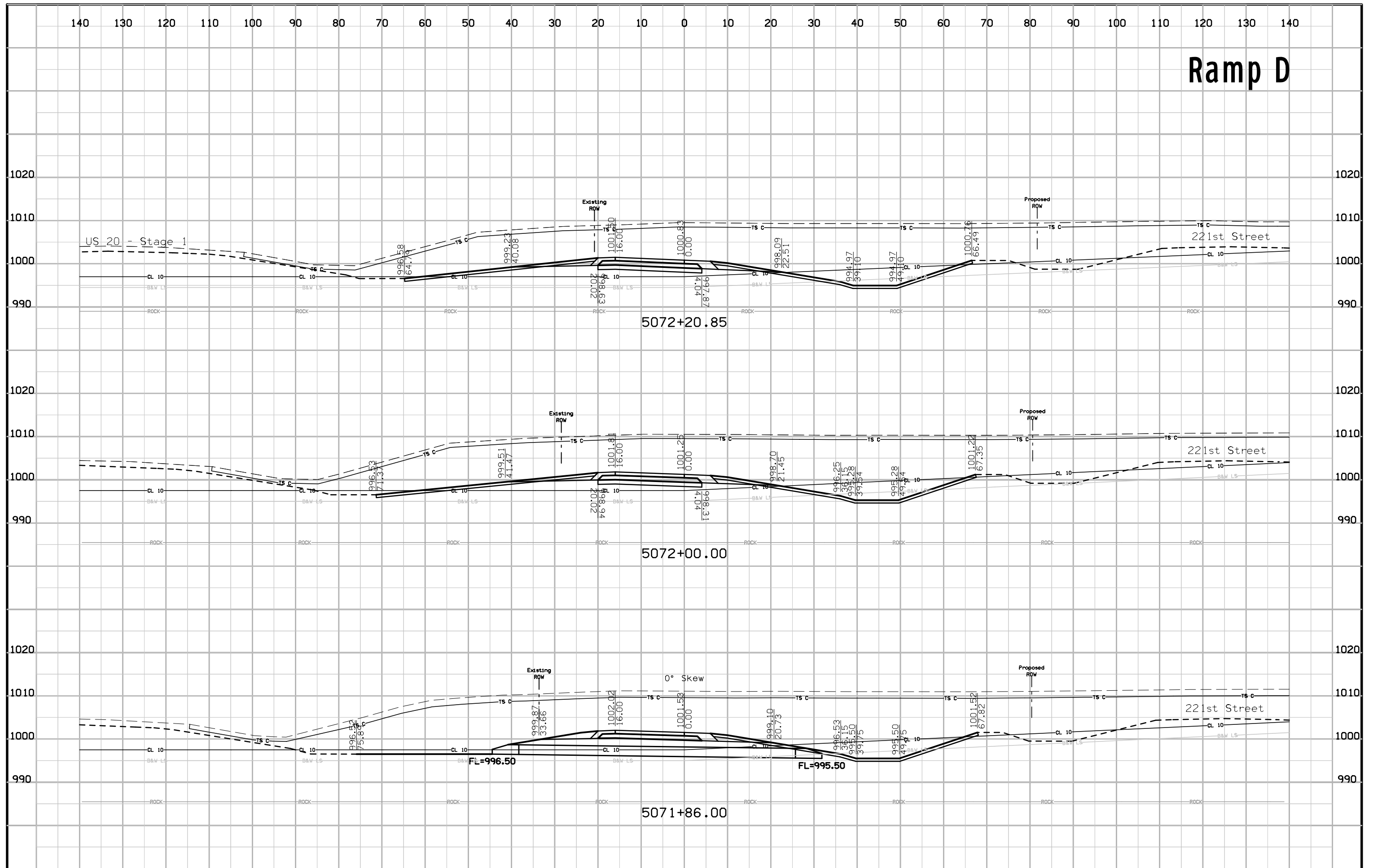

# Ramp D

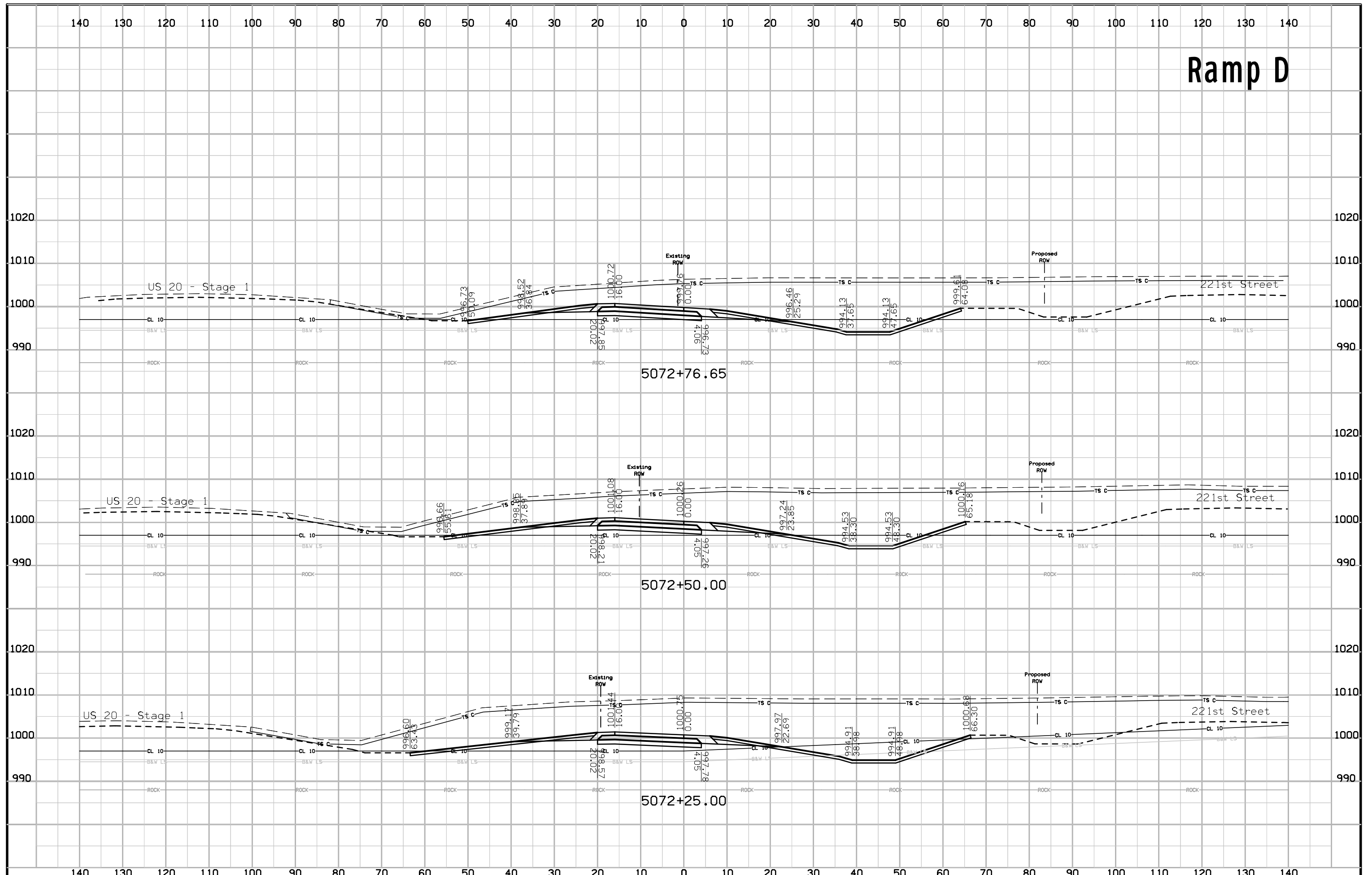

# Ramp D

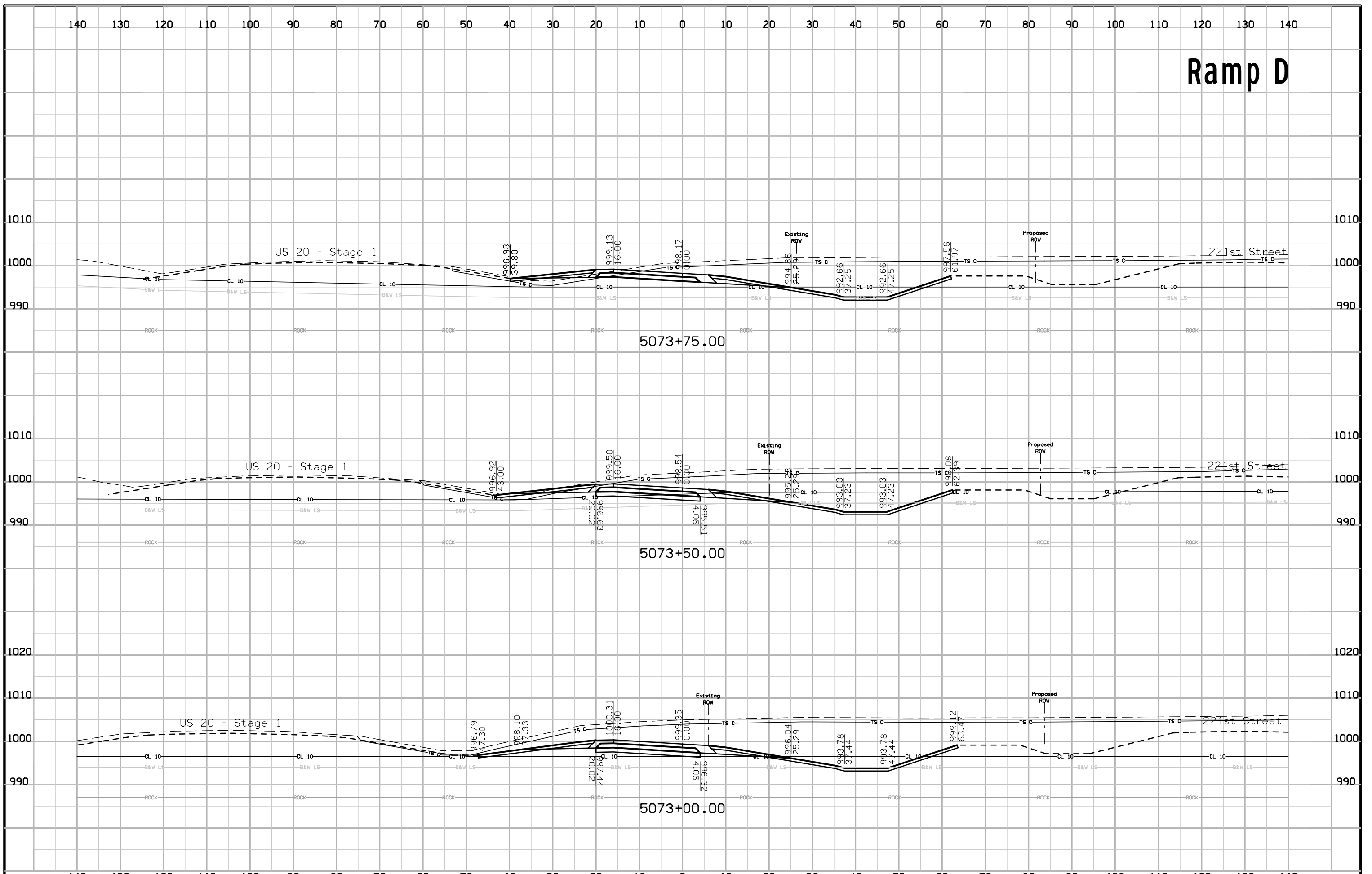

# Ramp D

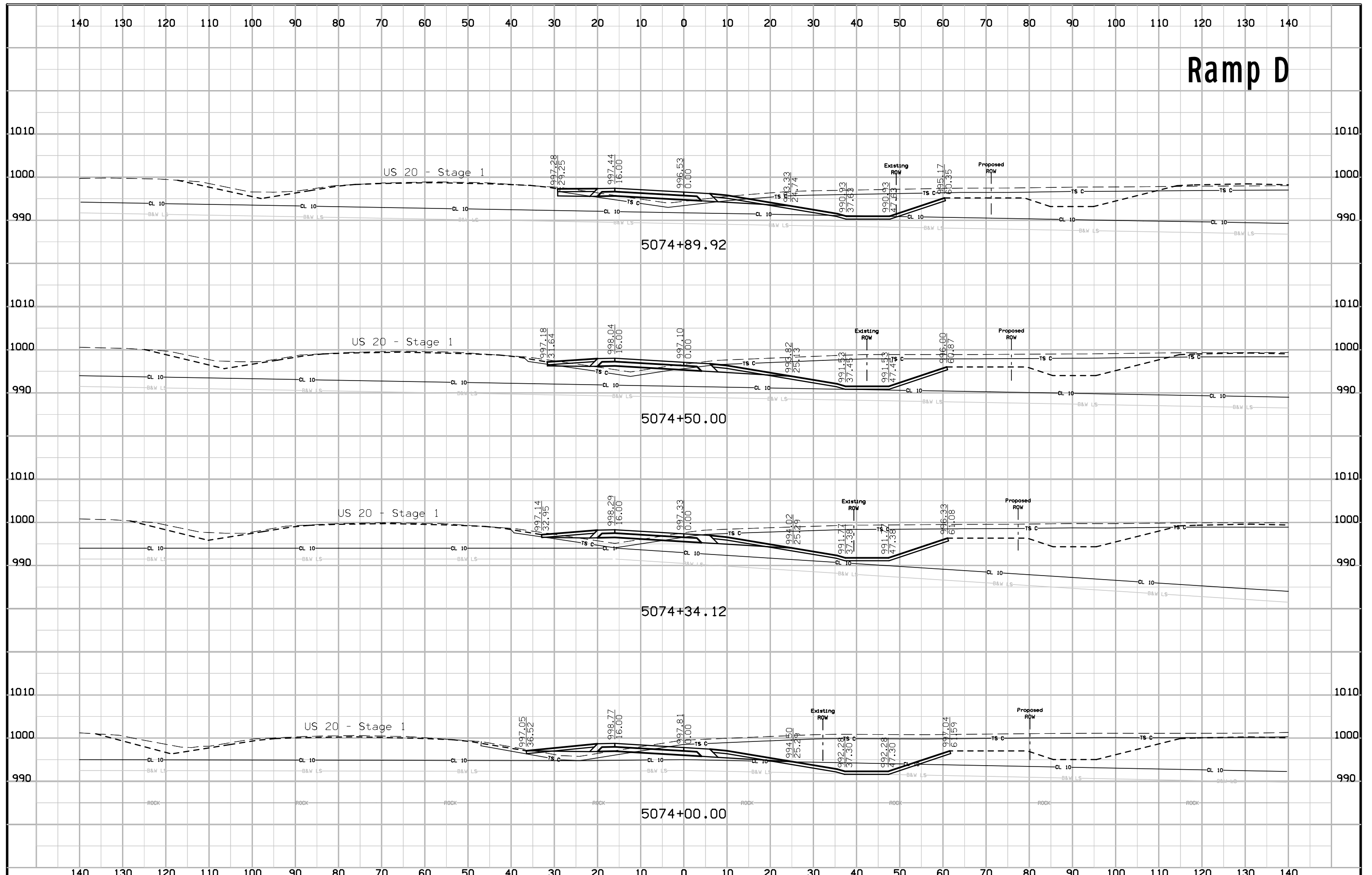

# Ramp D

