

PCC Pavement - Grade and New
 NHSX-030-4(119)-3H-08
 LETTING DATE
 3/16/2027

BOONE COUNTY



PLANS OF PROPOSED IMPROVEMENT ON THE
PRIMARY ROAD SYSTEM
BOONE COUNTY
 PCC Pavement - Grade and New
 Co Rd R27/Corporal
 Roger Snedden Dr
 Intersection in Boone
 SCALES: As Noted

Refer to the Proposal Form for list of applicable specifications.
 Value Engineering Saves. Refer to Article 1105.14 of the Specifications.



REVISIONS

TOTAL	..
PROJECT IDENTIFICATION NUMBER	25-08-030-010
PROJECT NUMBER	NHSX-030-4(119)-3H-08
R.O.W. PROJECT NUMBER	NHSN-030-4(120)-2R-08

INDEX OF SHEETS	
No.	DESCRIPTION
A Sheets	Title Sheets
A.1	Title Sheet
B Sheets	Typical Cross Sections and Details
B.1 - 5	Typical Cross Sections and Details
D Sheets	Mainline Plan and Profile Sheets
* D.1	Plan & Profile Legend & Symbol Information Sheet
* D.2 - 4	U.S. 30 Survey Alignment
* D.5 - 9	U.S. 30
E Sheets	Side Road Plan and Profile Sheets
* E.1 - 2	R-27/Snedden Dr. Survey Alignment
* E.3 - 4	Quill Ave/R-27
* E.5 - 6	Snedden Dr.
* E.7	Roundabout
F Sheets	Detour or Temporary Pavement Sheets
* F.1 - 2	Median Crossovers
W Sheets	Mainline Cross Sections
* W.1 - 31	US 30 Cross Sections
X Sheets	Side Road Cross Sections
* X.1 - 17	Quill Ave/R-27 Cross Sections
X.18 - 31	Snedden Dr Cross Sections
X.32 - 35	Roundabout Cross Section
	* Color Plan Sheets

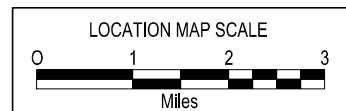
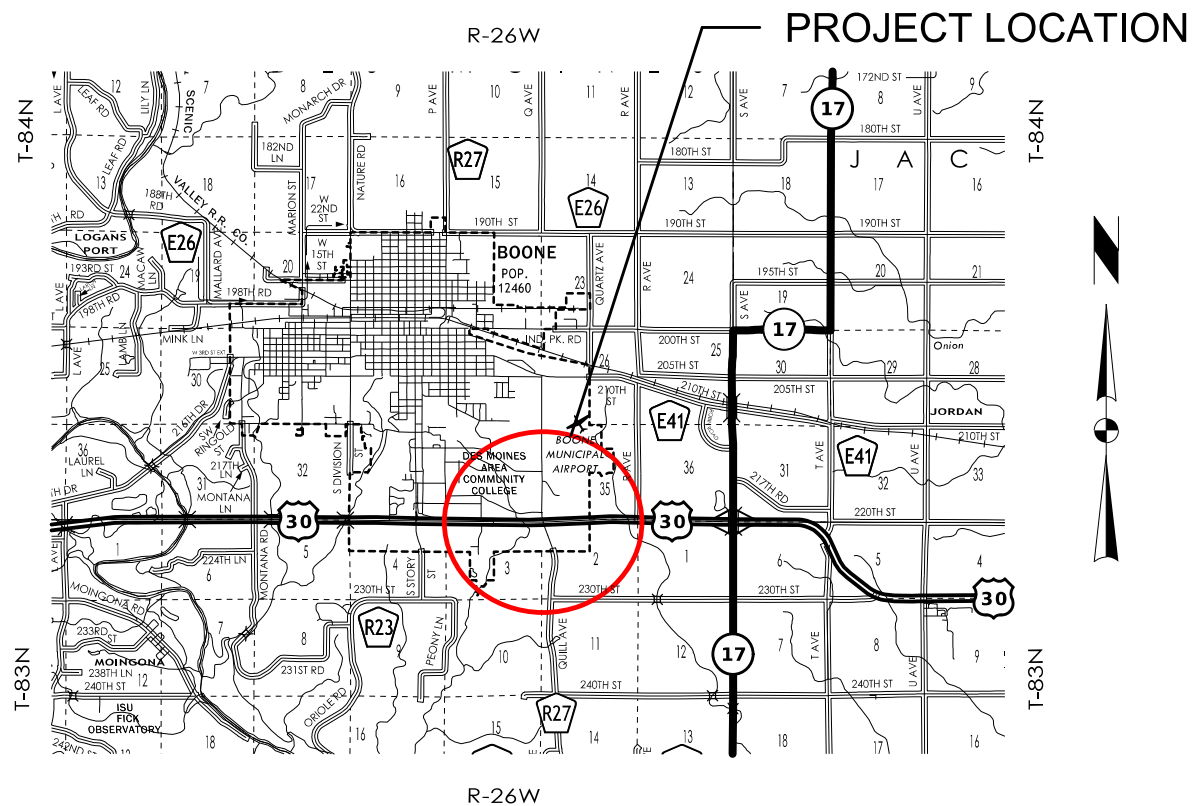

US 30 DESIGN DATA RURAL			
2019	AADT	12,066	V.P.D.
2047	AADT	14,325	V.P.D.
20	DHV	-	V.P.H.
	TRUCKS	8	%
	Total Design ESALS	-	

INDEX OF SEALS			
SHEET NO.	NAME	TYPE	BID QUANTITY SHEETS
A.1	X	Primary Signature Block	X
X	X	X	X

PRELIMINARY PLANS

Subject to change by final design.

D3 PLAN - 2/19/2025

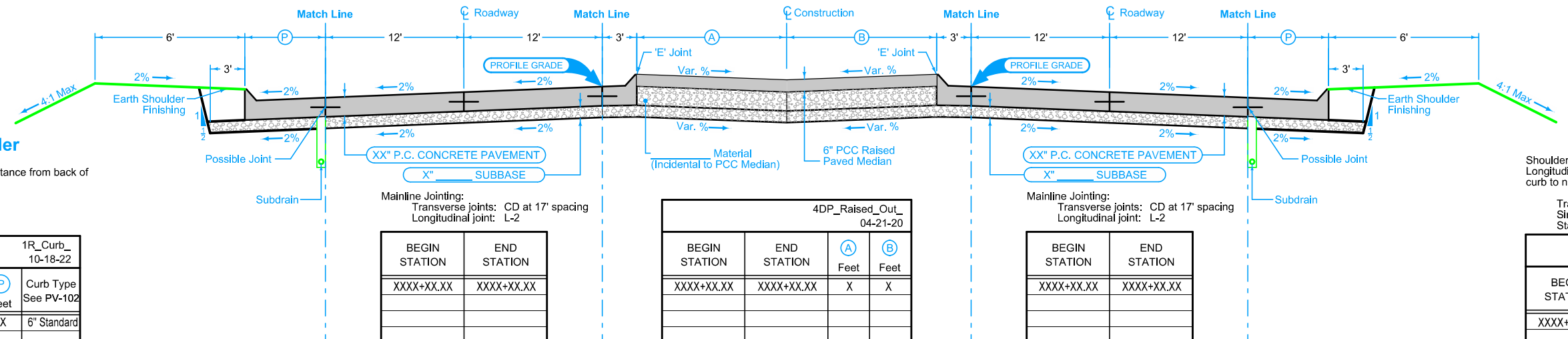

Curbed Shoulder

Shoulder jointing:
Longitudinal joint not required when distance from back of curb to nearest joint is less than 16':

Transverse: C at 15' spacing
Single pour: L-2
Staged: KT-2

1R_Curb_10-18-22			
BEGIN STATION	END STATION	(P) Feet	Curb Type See PV-102
XXXX+XX.XX	XXXX+XX.XX	X.X	6" Standard

Mainline Jointing:
Transverse joints: CD at 17' spacing
Longitudinal joint: L-2

BEGIN STATION	END STATION
XXXX+XX.XX	XXXX+XX.XX

4DP_Raised_Out_04-21-20			
BEGIN STATION	END STATION	(A) Feet	(B) Feet
XXXX+XX.XX	XXXX+XX.XX	X	X

Mainline Jointing:
Transverse joints: CD at 17' spacing
Longitudinal joint: L-2

BEGIN STATION	END STATION
XXXX+XX.XX	XXXX+XX.XX

Curbed Shoulder

Shoulder jointing:
Longitudinal joint not required when distance from back of curb to nearest joint is less than 16':

Transverse: C at 15' spacing
Single pour: L-2
Staged: KT-2

1R_Curb_10-18-22			
BEGIN STATION	END STATION	(P) Feet	Curb Type See PV-102
XXXX+XX.XX	XXXX+XX.XX	X	6" Standard

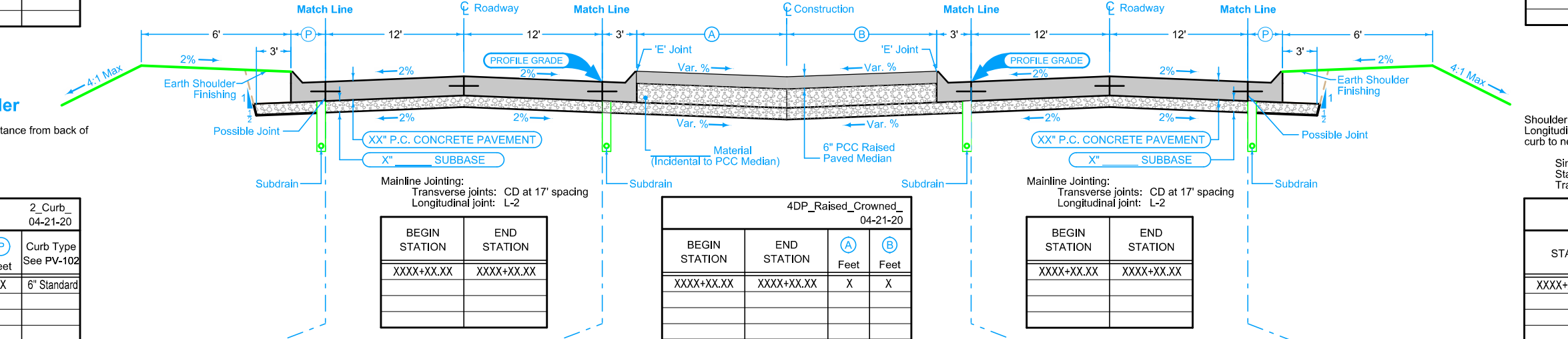

Curbed Shoulder

Shoulder Jointing:
Longitudinal joint not required when distance from back of curb to nearest joint is less than 15':

Single pour: L-2
Staged: KT-2
Transverse: C at 17' spacing

2_Curb_04-21-20			
STATION TO STATION	(P) Feet	Curb Type See PV-102	
XXXX+XX.XX	XXXX+XX.XX	X.X	6" Standard

Mainline Jointing:
Transverse joints: CD at 17' spacing
Longitudinal joint: L-2

BEGIN STATION	END STATION
XXXX+XX.XX	XXXX+XX.XX

4DP_Raised_Crowned_04-21-20			
BEGIN STATION	END STATION	(A) Feet	(B) Feet
XXXX+XX.XX	XXXX+XX.XX	X	X

Mainline Jointing:
Transverse joints: CD at 17' spacing
Longitudinal joint: L-2

BEGIN STATION	END STATION
XXXX+XX.XX	XXXX+XX.XX

Curbed Shoulder

Shoulder Jointing:
Longitudinal joint not required when distance from back of curb to nearest joint is less than 15':

Single pour: L-2
Staged: KT-2
Transverse: C at 17' spacing

2_Curb_04-21-20			
STATION TO STATION	(P) Feet	Curb Type See PV-102	
XXXX+XX.XX	XXXX+XX.XX	X.X	6" Standard

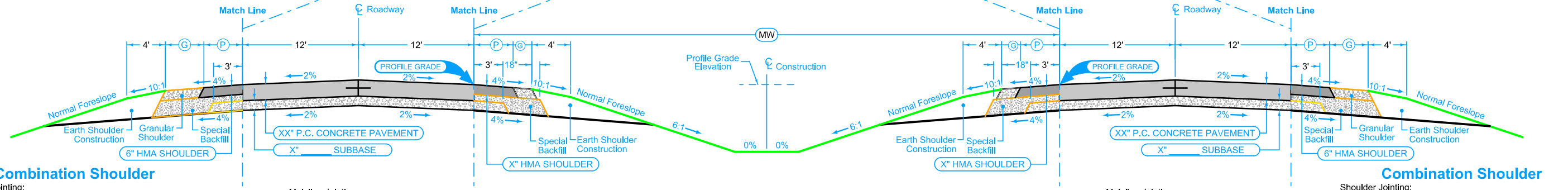

Combination Shoulder

Shoulder Jointing:
Longitudinal joint: B

Mainline Jointing:
Transverse joints: CD at 17' spacing
Longitudinal joint: L-2

4_C_04-21-20				
Direction of Travel	BEGIN STATION	END STATION	(P) Feet	(G) Feet
X	XXXX+XX.XX	XXXX+XX.XX	6	4

BEGIN STATION	END STATION
XXXX+XX.XX	XXXX+XX.XX

Combination Shoulder

Shoulder Jointing:
Longitudinal joint: B

4_C_04-21-20				
Direction of Travel	BEGIN STATION	END STATION	(P) Feet	(G) Feet
X	XXXX+XX.XX	XXXX+XX.XX	4	2

Combination Shoulder

Shoulder Jointing:
Longitudinal joint: B

4_C_04-21-20				
Direction of Travel	BEGIN STATION	END STATION	(P) Feet	(G) Feet
X	XXXX+XX.XX	XXXX+XX.XX	4	2

Mainline Jointing:
Transverse joints: CD at 17' spacing
Longitudinal joint: L-2

BEGIN STATION	END STATION
XXXX+XX.XX	XXXX+XX.XX

Combination Shoulder

Shoulder Jointing:
Longitudinal joint: B

4_C_04-21-20				
Direction of Travel	BEGIN STATION	END STATION	(P) Feet	(G) Feet
X	XXXX+XX.XX	XXXX+XX.XX	6	4

See Tab 100-24 or 100-25 for pavement quantities.
See Tab 112-9 for shoulder quantities.

Curbed Shoulder

Shoulder Jointing:
 Longitudinal joint not required when distance from back of curb to nearest joint is less than 15':

Single pour: L-2
 Staged : KT-2
 Transverse: CD refer to L sheets for spacing

2_Curb_04-21-20		
STATION TO STATION	(P) Feet	Curb Type See PV-102
	2.5	6" Standard
	2.5	6" Standard

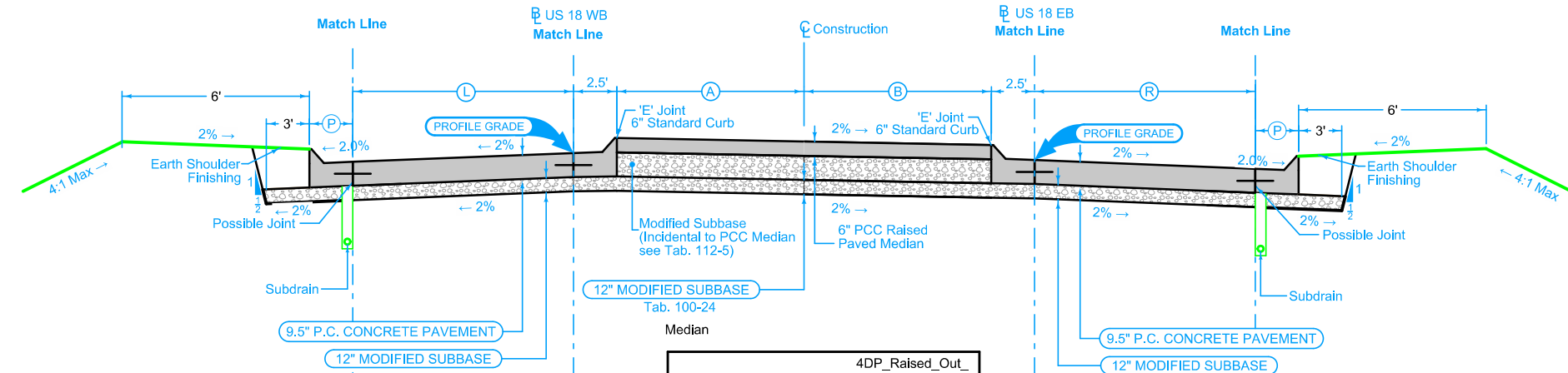

Mainline Jointing:
 Transverse joints: CD refer to L sheets for spacing
 Longitudinal joint: L-2

BEGIN STATION	END STATION	(L) Feet
		12
		Vari.
		Vari.

4DP_Raised_Out_04-21-20

BEGIN STATION	END STATION	(A) Feet	(B) Feet
		Vari.	Vari.
		Vari.	Vari.

Mainline Jointing:
 Transverse joints: CD refer to L sheets for spacing
 Longitudinal joint: L-2

BEGIN STATION	END STATION	(R) Feet
		12
		Vari.
		Vari.

Curbed Shoulder

Shoulder Jointing:
 Longitudinal joint not required when distance from back of curb to nearest joint is less than 15':

Single pour: L-2
 Staged : KT-2
 Transverse: CD refer to L sheets for spacing

2_Curb_04-21-20		
STATION TO STATION	(P) Feet	Curb Type See PV-102
	2.5	6" Standard
	2.5	6" Standard

Granular Shoulder

2_G_SR_04-21-20		
STATION TO STATION	(G) Feet	
	6	

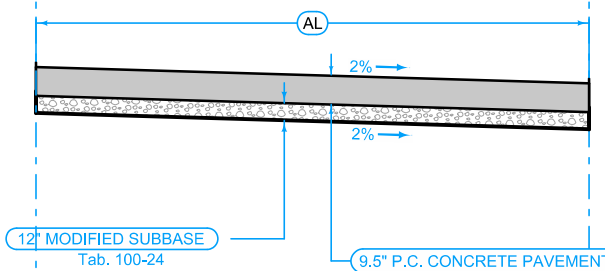
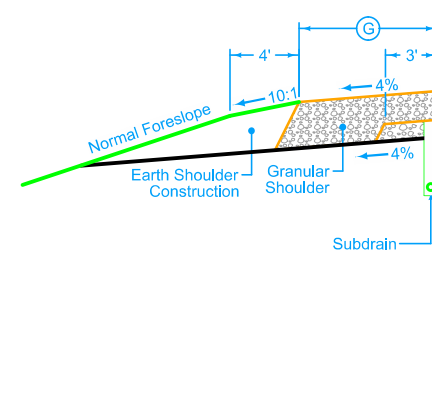

Median Jointing:
 Transverse joints: CD refer to L sheets for spacing
 Longitudinal joint: L-2

STATION TO STATION	(AL) Feet
	Vari
	Vari

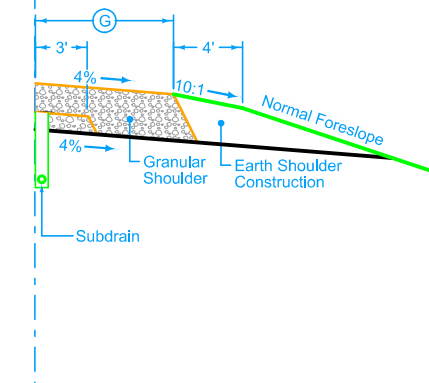

Granular Shoulder

2_G_SR_04-21-20		
STATION TO STATION	(G) Feet	
	6	

See Tab 100-24 or 100-25 for pavement quantities.
 See Tab 112-9 for shoulder quantities.

COUNTY ROAD R-27

Curbed Shoulder

Shoulder Jointing:
 Longitudinal joint not required when distance from back of curb to nearest joint is less than 15':

Single pour: L-2
 Staged : KT-2
 Transverse: CD refer to L sheets for spacing

2_Curb_04-21-20		
STATION TO STATION	(P) Feet	Curb Type See PV-102
	2.5	6" Standard
	2.5	6" Standard

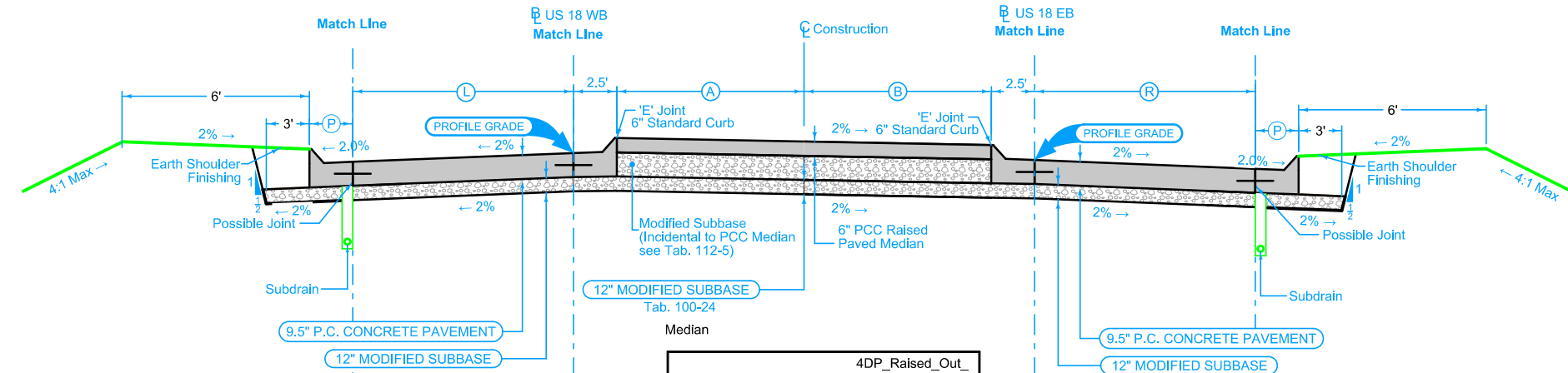

Mainline Jointing:
 Transverse joints: CD refer to L sheets for spacing
 Longitudinal joint: L-2

BEGIN STATION	END STATION	(L) Feet
		12
		Vari.
		Vari.

4DP_Raised_Out_04-21-20

BEGIN STATION	END STATION	(A) Feet	(B) Feet
		Vari.	Vari.
		Vari.	Vari.

Mainline Jointing:
 Transverse joints: CD refer to L sheets for spacing
 Longitudinal joint: L-2

BEGIN STATION	END STATION	(R) Feet
		12
		Vari.
		Vari.

Curbed Shoulder

Shoulder Jointing:
 Longitudinal joint not required when distance from back of curb to nearest joint is less than 15':

Single pour: L-2
 Staged : KT-2
 Transverse: CD refer to L sheets for spacing

2_Curb_04-21-20		
STATION TO STATION	(P) Feet	Curb Type See PV-102
	2.5	6" Standard
	2.5	6" Standard

Granular Shoulder

2_G_SR_04-21-20		
STATION TO STATION	(G) Feet	
	6	

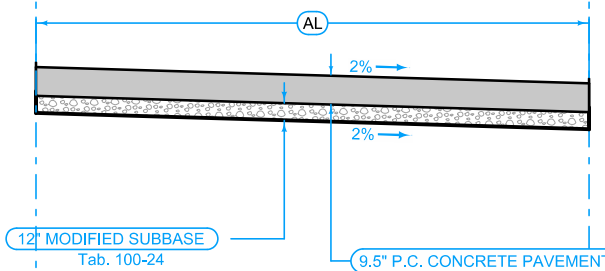
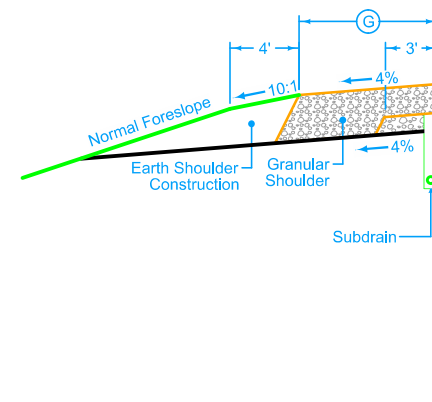

Median Jointing:
 Transverse joints: CD refer to L sheets for spacing
 Longitudinal joint: L-2

STATION TO STATION	(AL) Feet
	Vari
	Vari

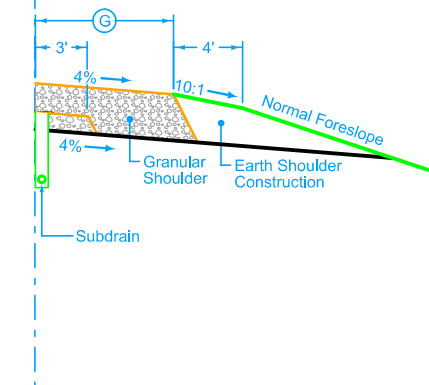

Granular Shoulder

2_G_SR_04-21-20		
STATION TO STATION	(G) Feet	
	10	

See Tab 100-24 or 100-25 for pavement quantities.
 See Tab 112-9 for shoulder quantities.

SNEDDEN DRIVE

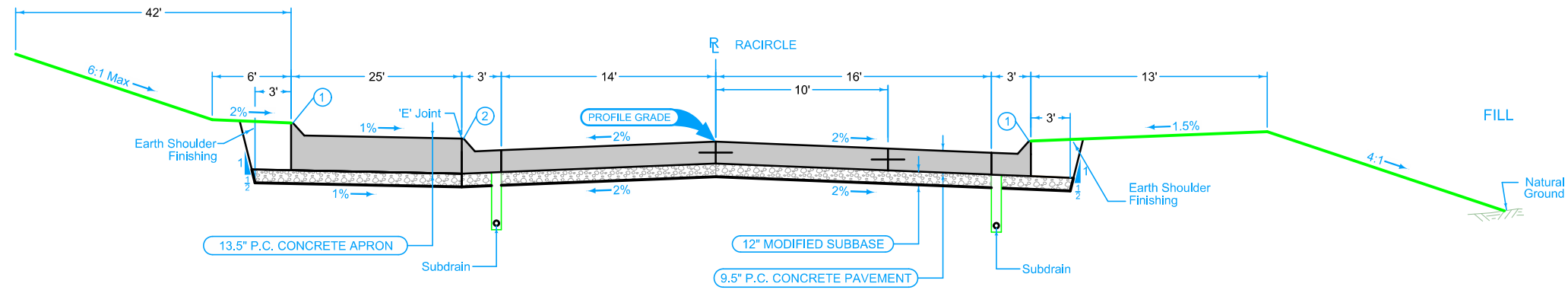

- ① 6" Standard Curb
- ② 4" Sloped Curb

Note: See 'L' Sheets for Jointing Layout

Mainline Jointing:
 Transverse joints: CD refer to L sheets for spacing
 Longitudinal joint: L-2

LOCATION			① Feet
ROAD IDENTIFICATION	STATION TO STATION		
RACIRCLE	XXXX+XX.XX	XXXX+XX.XX	X.X
RACIRCLE	XXXX+XX.XX	XXXX+XX.XX	X.X

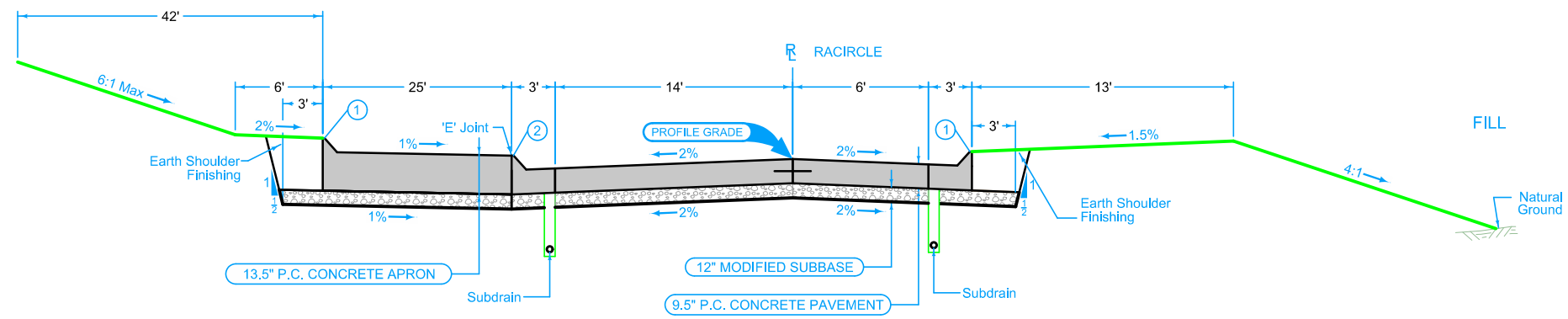

- ① 6" Standard Curb
- ② 4" Sloped Curb

Note: See 'L' Sheets for Jointing Layout

Mainline Jointing:
 Transverse joints: CD refer to L sheets for spacing
 Longitudinal joint: L-2

LOCATION			① Feet
ROAD IDENTIFICATION	STATION TO STATION		
RACIRCLE	XXXX+XX.XX	XXXX+XX.XX	X.X
RACIRCLE	XXXX+XX.XX	XXXX+XX.XX	X.X

See Tab 100-24 or 100-25 for pavement quantities.
 See Tab 112-9 for shoulder quantities.

Roundabout

6147
10-20-15

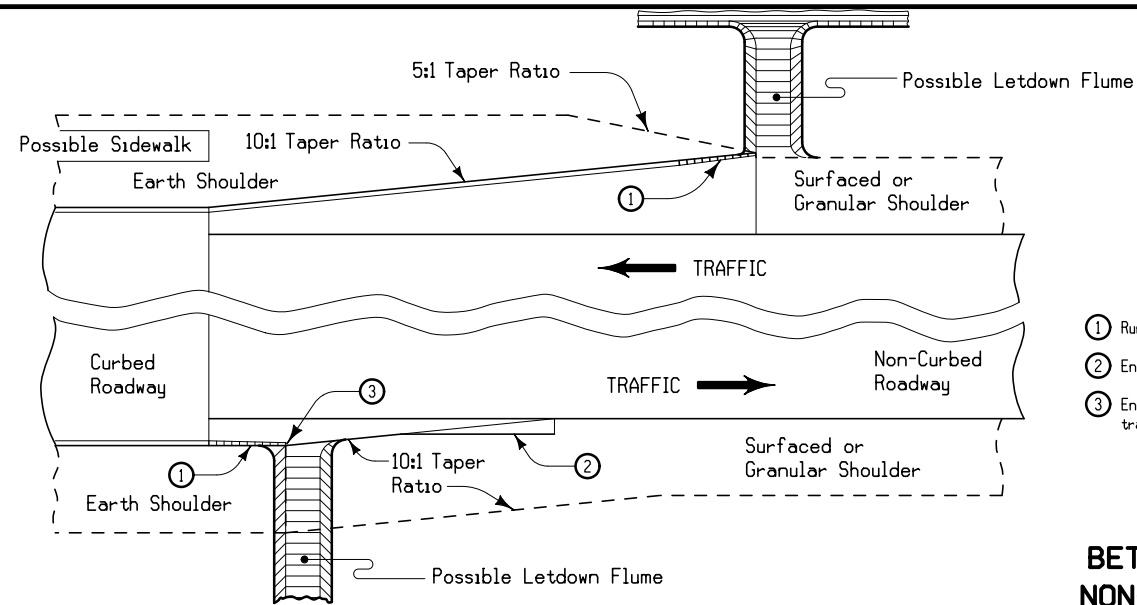

- ① Runout curb according to PV-102
- ② End of Taper Details see Typical Detail 7101
- ③ End earth shoulder at the end of the curb transition when no flume is needed.

**TRANSITION
BETWEEN CURBED AND
NON-CURBED ROADWAYS**

7101
10-19-10

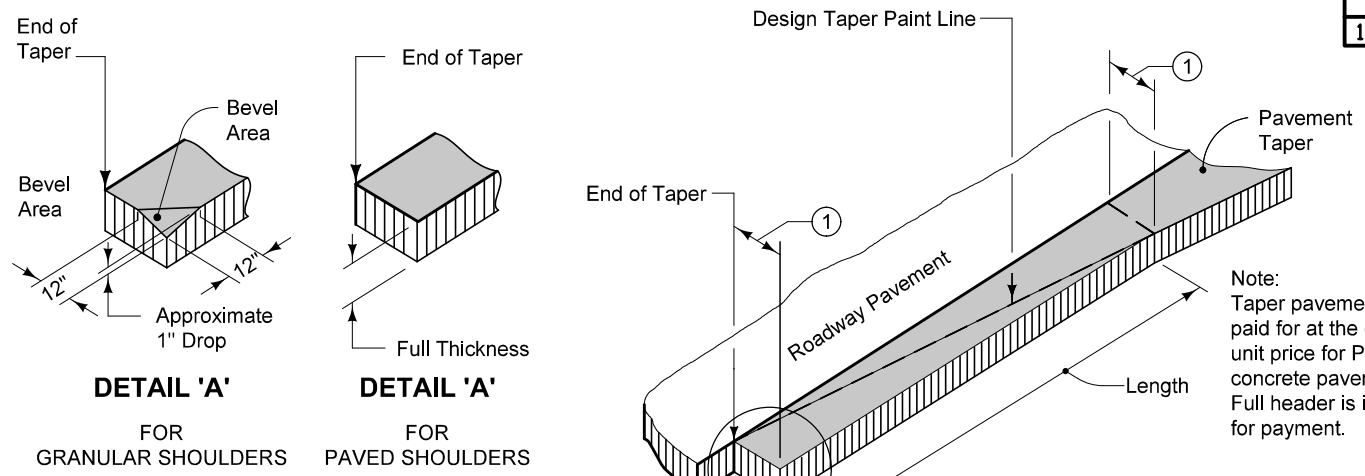

Note:
Taper pavement to be paid for at the contract unit price for P.C. concrete pavement. Full header is included for payment.

**TYPICAL DETAILS OF
PCC PAVEMENT HEADER**

- ① Normal width is 2'-0". Construct 4'-0" width when butting into 4' wide HMA shoulders (See Typical 7154A).

SURVEY SYMBOLS

- Interstate Highway Symbol
- U.S. Highway Symbol
- Iowa Highway Symbol
- County Road Highway Symbol
- Evergreen Tree
- Deciduous Tree
- Fruit Tree
- Shrub (Bushes)
- Timber
- Hedge
- Stump
- Swamp
- Rock Outcrop
- Broken Concrete
- Revetment (Rip Rap)
- Cemetery
- Grave
- Cave
- Sink Hole
- Board Fence
- Chain Link or Security Fence
- Wire Fence
- Terrace
- Earth Dam or Dike (Existing)
- Tile Outlet
- Edge of Water
- Existing Drainage
- Right of Way Rail or Lot Corner
- Concrete Monument
- Well
- Windmill
- Beehive Intake
- Existing Intake
- Existing Utility Access (Manhole)
- Fire Hydrant
- Water Hydrant (Rural)
- Septic Tank
- Cistern
- L.P. Gas Tank (No Footing)
- Underground Storage Tank
- Latrine
- Satellite TV Dish
- Water Hook Up
- Radio Tower
- Tower Anchor
- Guardrail (Beam or Cable)
- Guard Post (one or two)
- Guard Post (over two)
- Filler Pipe
- Gas Valve
- Water Valve
- Speed Limit Sign
- Mile Marker Post
- SIGN Sign
- Traffic Signal Control Box
- RRB Rail Road Signal Control Box
- Telephone Switch Box
- Electric Box

UTILITY LEGEND

- E1** **EL1D, Alliant Energy Elec - Quality D**
Billie Reid, Real Estate and ROW Representative II
200 1st St SE Cedar Rapids, IA, 52401
ph: 319-786-3703
billiereid@alliantenergy.com
- F05** **FO5D, Aureon - Quality D**
Jeff Klocko, OSP Engineer
7760 Office Plaza Drive South West Des Moines, IA, 50266
ph: 515-830-0445
jeff.klocko@aureon.com
- G** **GL1D, Black Hills Energy - Quality D**
Becky Reinhardt, Manager, Design Engineering
ph: 402-680-7221 cell: 402-680-7221
becky.reinhardt@blackhills.com
- F0** **FO1D, CenturyLink-Lumens - Quality D**
Steve Parker, Manager of Engineering & Construction
2103 E. University Ave, Des Moines, IA, 50317
ph: 515-265-0968 cell: 507-358-1978
Steven.Parker4@lumen.com
- T1** **TL1D, CenturyLink-Lumens - Quality D**
Steve Parker, Manager of Engineering & Construction
2103 E. University Ave, Des Moines, IA, 50317
ph: 515-265-0968 cell: 507-358-1978
Steven.Parker4@lumen.com
- W** **WL1D, City of Boone - Quality D**
John Rouse, Parks/Public Works Director
1410 8th St Boone, IA, 50036
ph: 515-432-4211
jrouse@city.boone.ia.us
- SAN** **SA1D, City of Boone - Quality D**
John Rouse, Parks/Public Works Director
1410 8th St Boone, IA, 50036
ph: 515-432-4211
jrouse@city.boone.ia.us
- F03** **FO3D, ICN Network - Quality D**
David Augspurger, Sr Telecom Specialist | OSP Lead
400 East 14th Street Des Moines, IA, 50319
ph: 515-725-4604 cell: 515-229-2013
david.augspurger@icn.state.ia.us
- F04** **FO4D, Jefferson Telephone Company - Quality D**
Duane Russell, CTO
105 W Harrison St Jefferson, IA, 50129
ph: 515-386-4141 cell: 515-386-4705
duane@jeffersontelecom.com
- G2** **GL2D, Northern Natural Gas - Quality D**
Jennifer Sweney, Right of Way Agent
1120 Centre Pointe Dr. Ste. 400 Mendota Heights, MN, 55120
ph: 651-456-1762 cell: 651-402-1776
jennifer.sweney@nngco.com
- F06** **FO6D, Ogden Telephone - Quality D**
Joel Munson, Operations Manager
202 W Walnut St Ogden, IA, 50212
ph: 515-275-2050 cell: 515-230-0625
jmunson@ogdentc.com
- F02** **FO2D, IOWA DOT - Quality D**
Jason Dale, ITS Maintenance Engineer
800 Lincoln Way Ames, IA, 50010
ph: 515-239-1995
Jason.Dale@iowadot.us
- PPA, Alliant Energy Elec**
Billie Reid, Real Estate and ROW Representative II
200 1st St SE Cedar Rapids, IA, 52401
ph: 319-786-3703
billiereid@alliantenergy.com
- PPB, Midland Power Coop**
Dan Kyle, VP of Operations
2005 S. Story St. Boone, IA, 50036
ph: 515-386-4111 cell: 515-370-1071
dkyle@midlandpower.coop

PLAN VIEW COLOR LEGEND OF PLAN AND PROFILE SHEETS

LINEWORK		Design Color No.	
Green	(2)		Existing Topographic Features and Labels
Blue	(1)		Proposed Alignment, Stationing, Tic Marks, and Alignment Annotation
Magenta	(5)		Existing Utilities
SHADING		Design Color No.	Transparency
Pink, Dark	(13)		Temporary Pavement Shading 50%
Yellow	(4)		Proposed Pavement Shading 50%
Orange	(6)		Proposed Granular Shading 50%
Orange	(70)		Proposed Shoulder Granular Shading 50%
Yellow	(68)		Proposed Shoulder Paved Full Depth Shading 50%
Yellow	(132)		Proposed Shoulder Paved Partial Depth Shading 50%
Brown, Light	(236)		Grading Shading 50%
Orange, Light	(134)		Proposed Granular Entrance Shading 50%
Yellow	(220)		Proposed Paved Entrance Shading 50%
Tan	(8)		Proposed Sidewalk Shading 50%
Blue, Light	(230)		Proposed Sidewalk Landing Shading 50%
Pink	(11)		Proposed Sidewalk Ramp Shading 50%
Red	(3)		Proposed Structure Shading 50%
Red	(3)		Delineates Restricted Areas 0%

PROFILE VIEW COLOR LEGEND OF PLAN AND PROFILE SHEETS

LINEWORK		Design Color No.	
Green	(10)		Existing Ground Line Profile
Blue	(1)		Proposed Profile and Annotation
Magenta	(5)		Existing Utilities
Blue, Light	(230)		Proposed Ditch Grades, Left
Black	(0)		Proposed Ditch Grades, Median
Rust	(14)		Proposed Ditch Grades, Right

- #### Reference Point
- Station
 - Section Corner
 - Ground Line Intercept
 - Saw Cut
 - Guardrail
 - Trench Drain
 - HighTension Cable Guardrail
 - Sheet Pile
 - Pavement Removal
 - Clearing & Grubbing Area

- #### RIGHT-OF-WAY LEGEND
- Proposed Right-of-Way Symbol
 - Proposed Right-of-Way Line
 - Existing Right of Way
 - Existing and Proposed Right-of-Way
 - Easement and Existing Right-of-Way
 - Easement (Temporary) Symbol
 - Easement (Temporary) Line
 - Easement
 - C/A Access Control
 - Property Line Symbol
 - Property Line

PLAN AND PROFILE LEGEND AND SYMBOL INFORMATION SHEET

(COVERS SHEET SERIES D, E, F, & K)

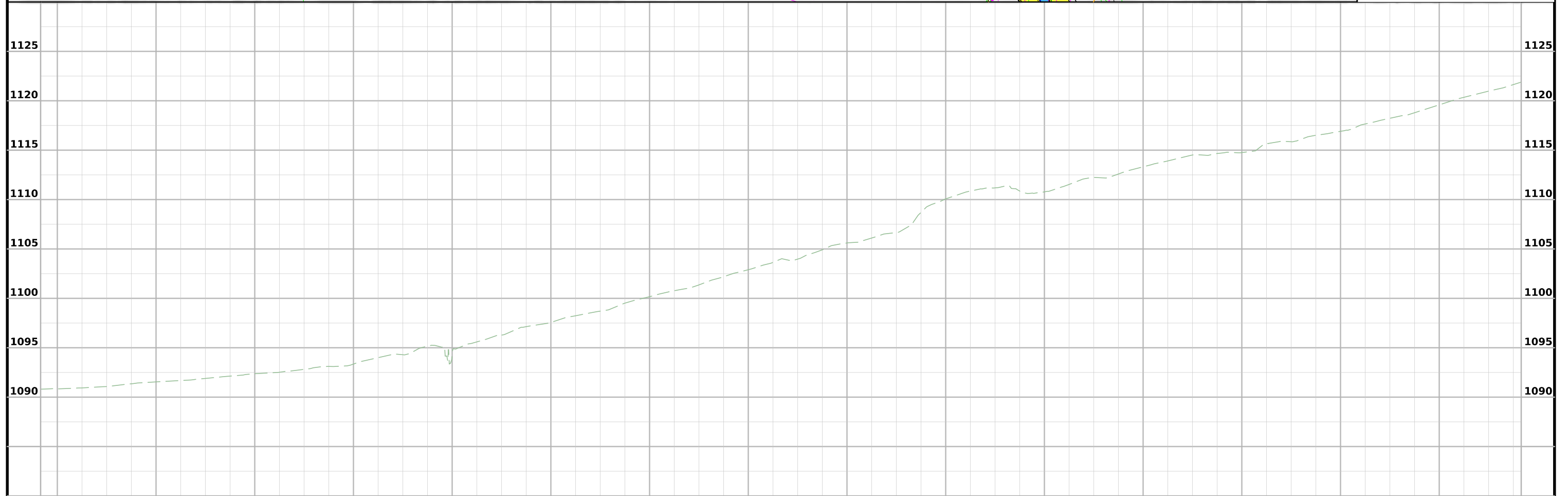
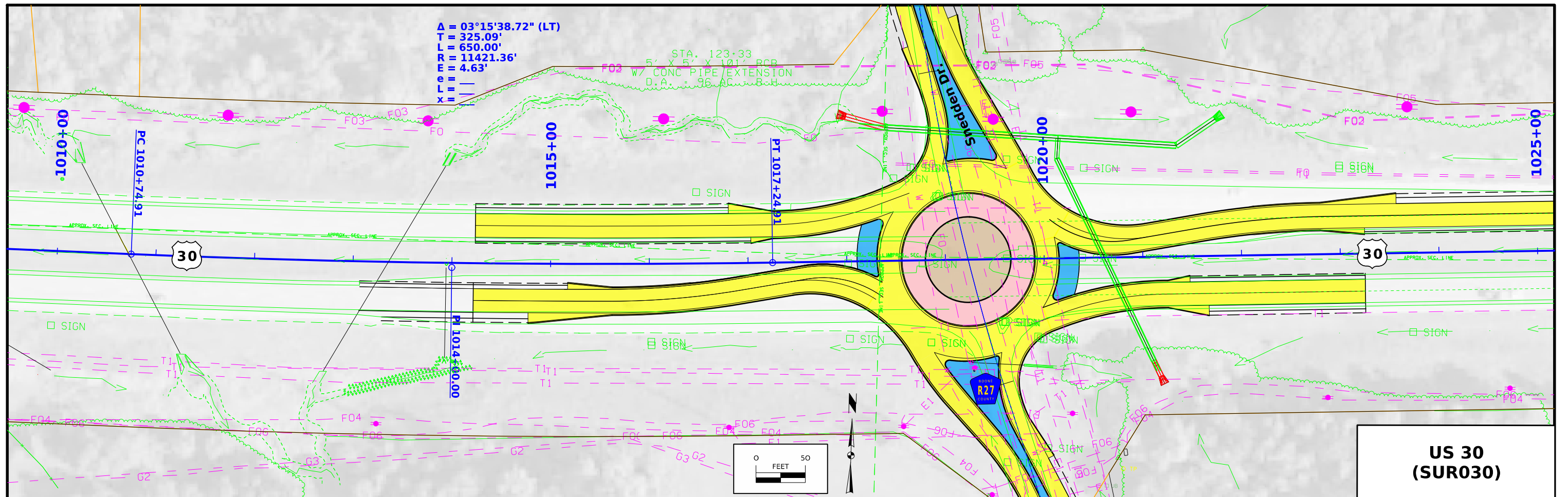

FILE NO. 98765	ENGLISH	DESIGN TEAM Strum\Prindle	BOONE COUNTY	PROJECT NUMBER NHSX-030-4(119)-3H-08	SHEET NUMBER D.2
----------------	---------	---------------------------	--------------	--------------------------------------	------------------

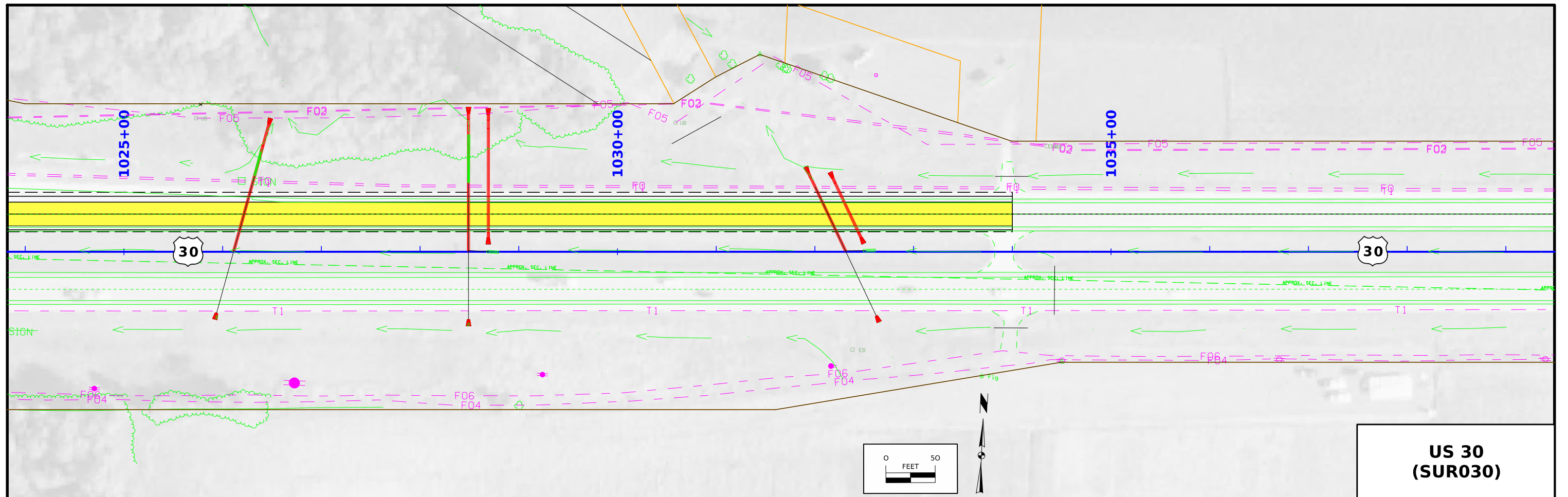

**US 30
(SUR030)**

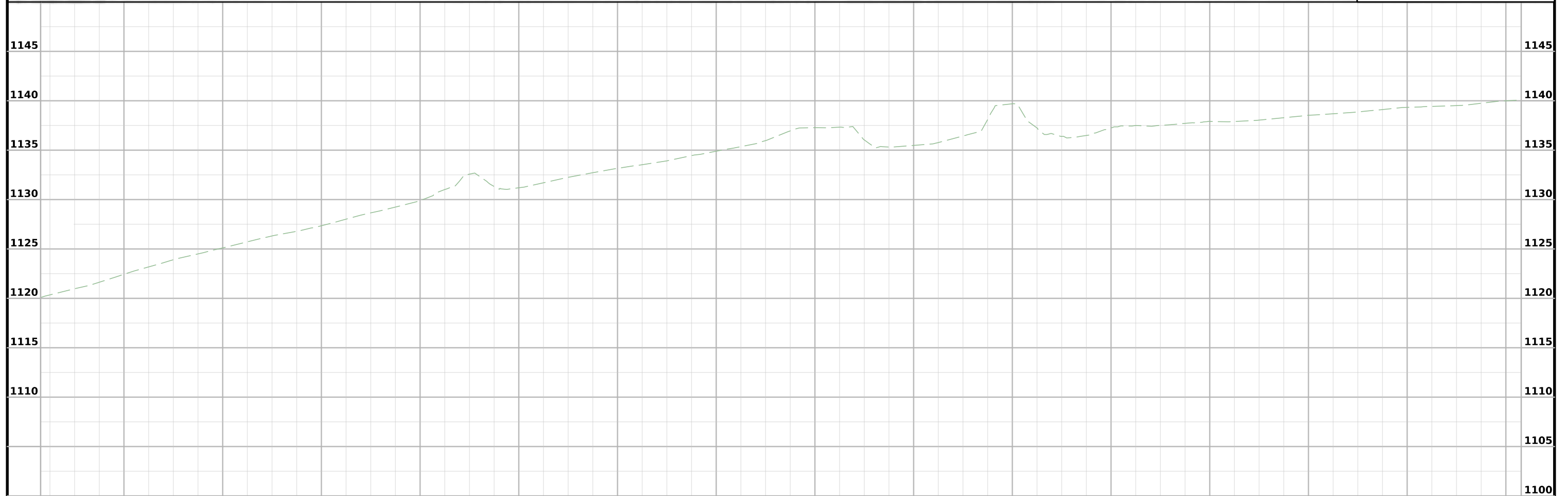

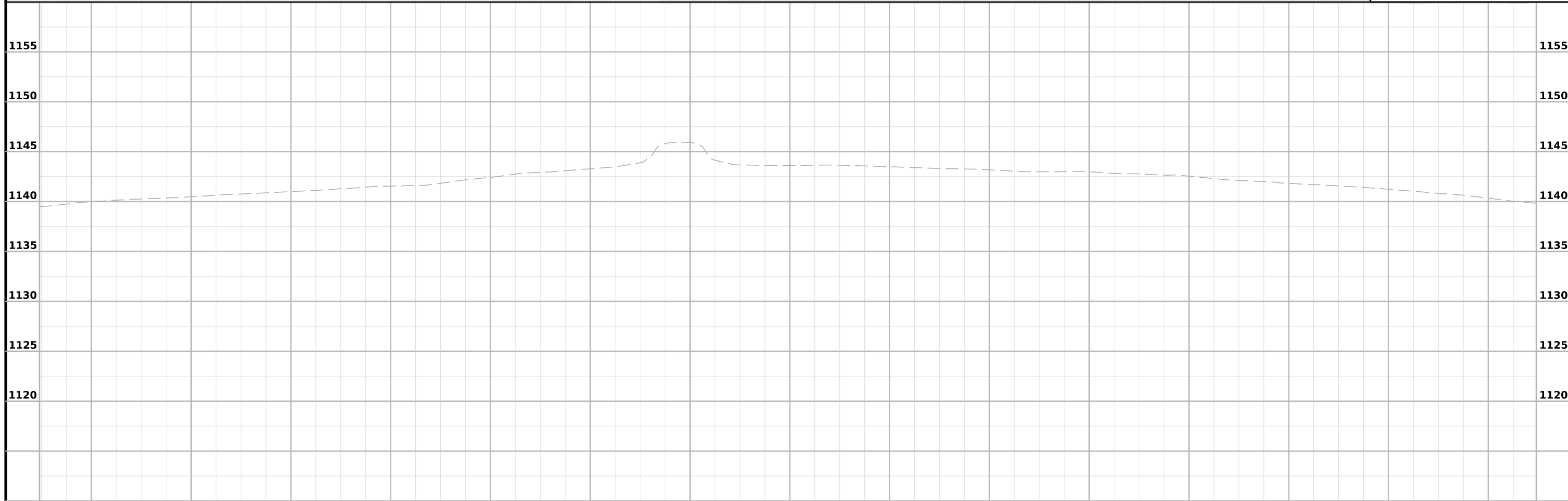
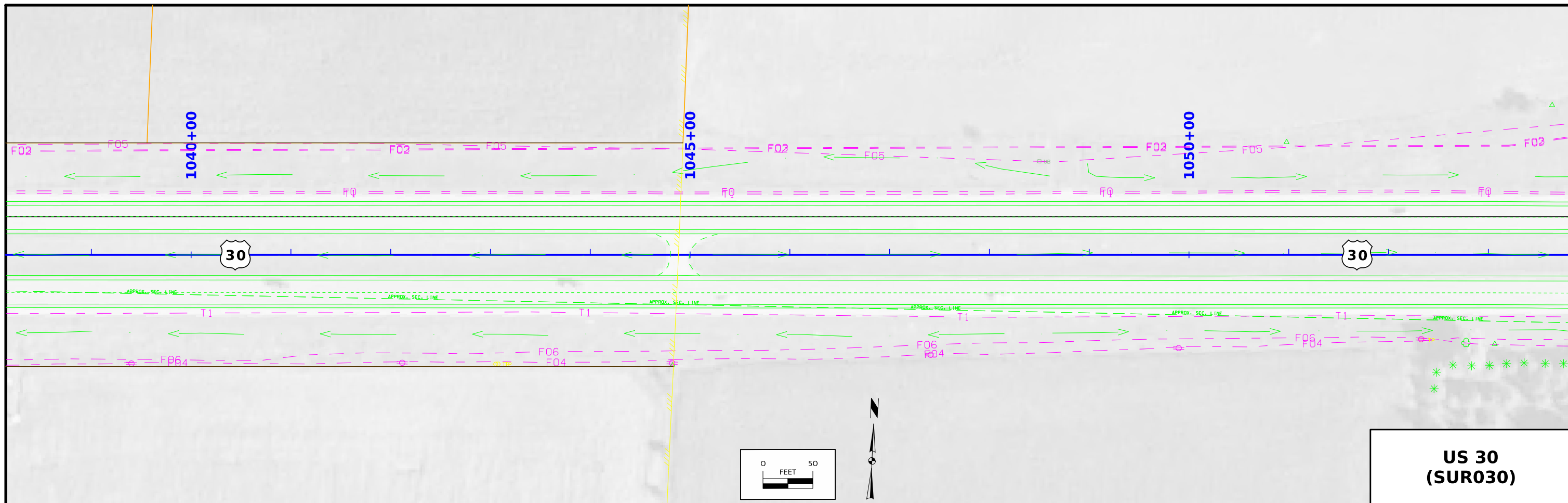

1039+00	1040+00	1041+00	1042+00	1043+00	1044+00	1045+00	1046+00	1047+00	1048+00	1049+00	1050+00	1051+00	1052+00	1053+00
FILE NO. 98765	ENGLISH	DESIGN TEAM Strum\Prindle	BOONE COUNTY			PROJECT NUMBER NHSX-030-4(119)-3H-08	SHEET NUMBER D.4							

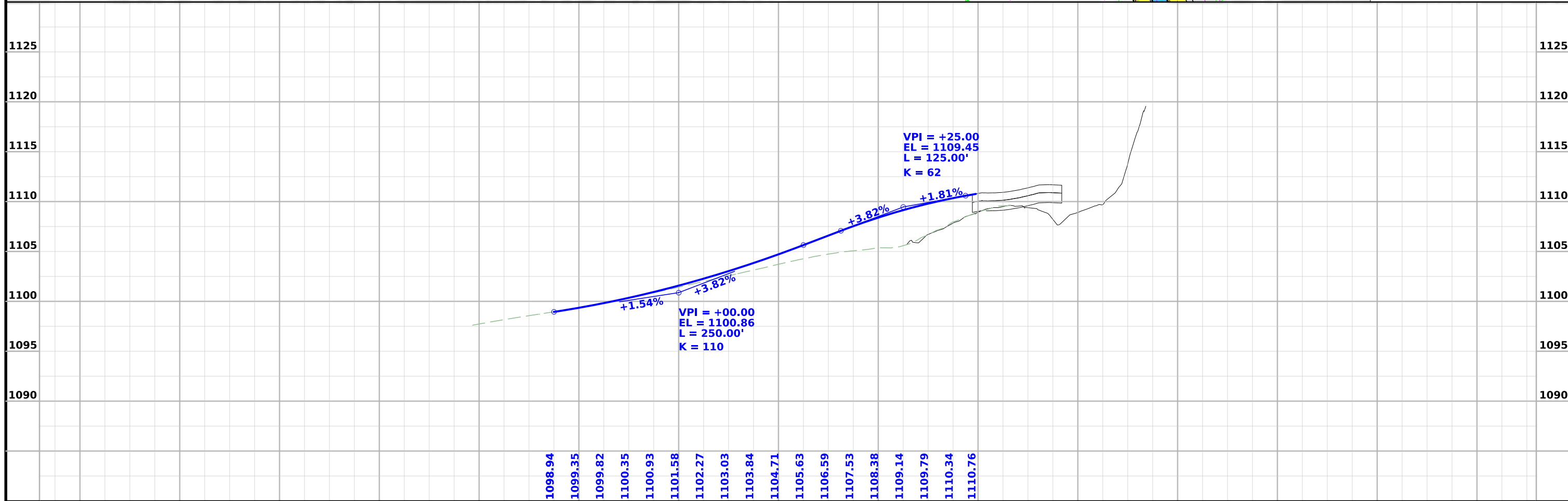
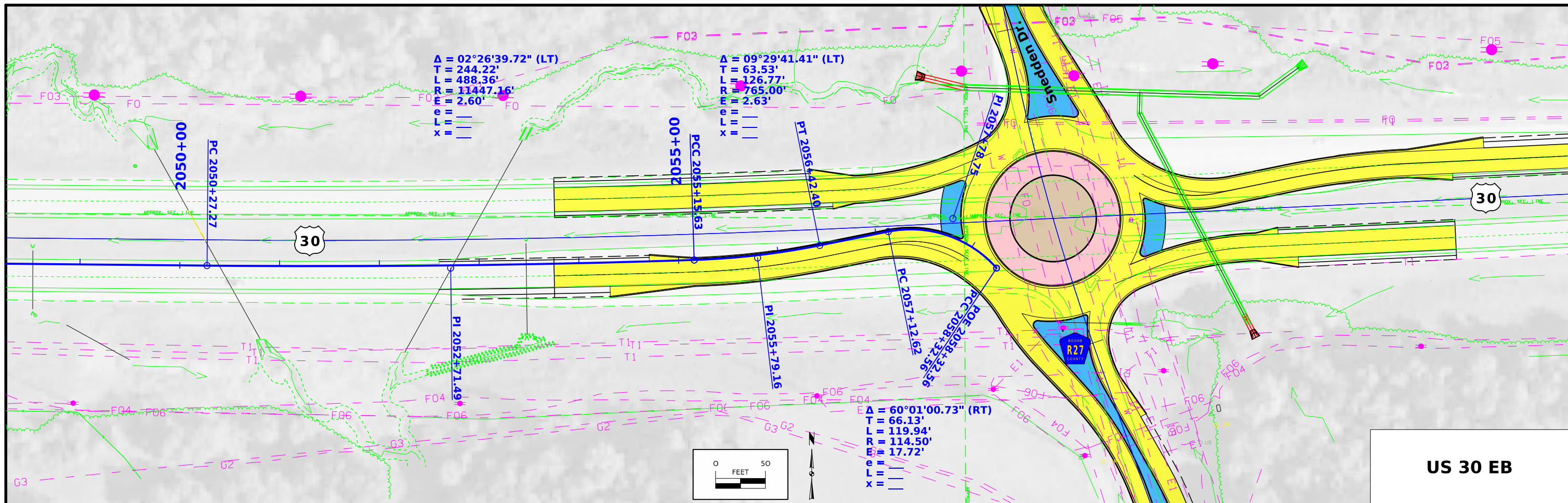

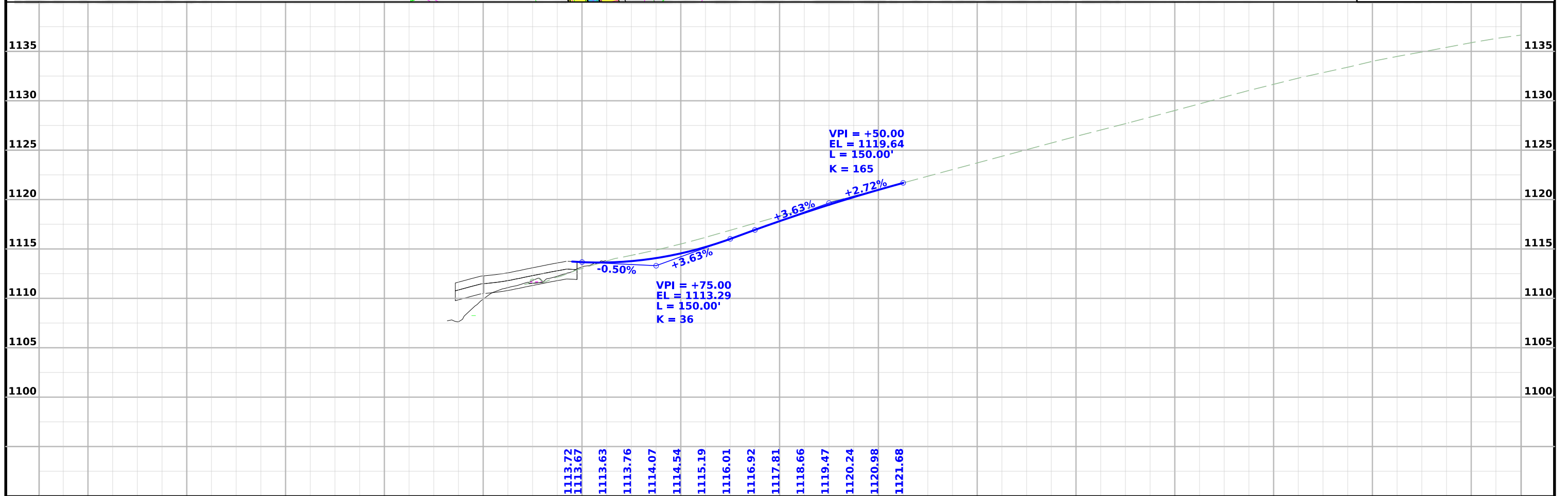
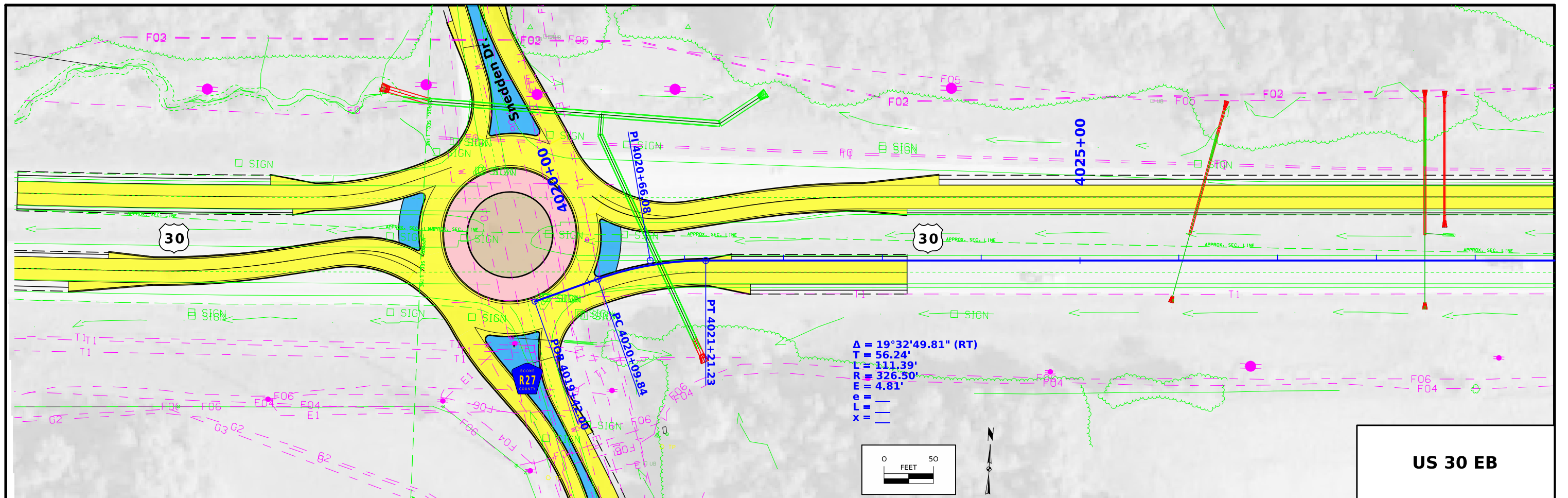

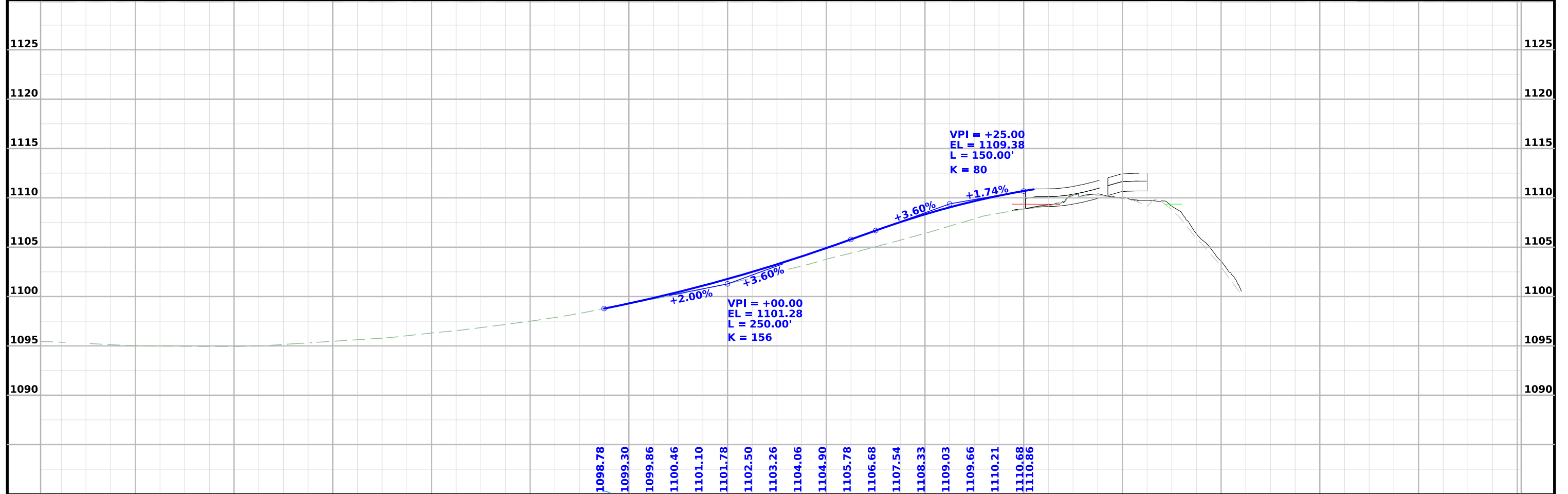
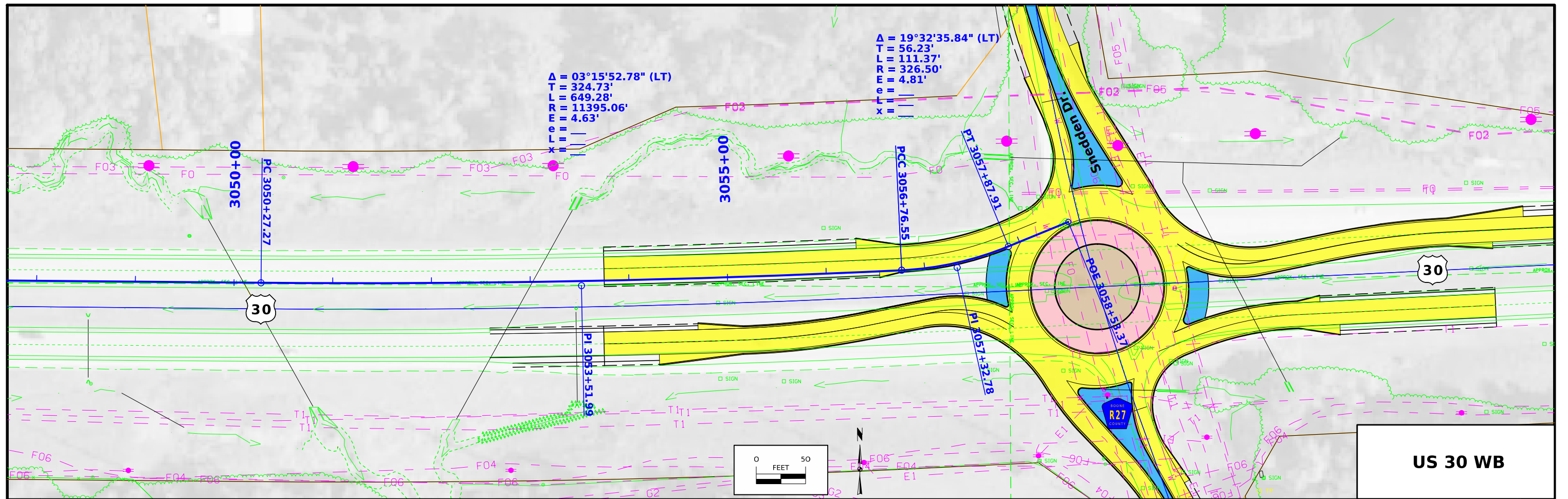

FILE NO. 98765	ENGLISH	DESIGN TEAM Strum\Prindle	BOONE COUNTY	PROJECT NUMBER NHSX-030-4(119)-3H-08	SHEET NUMBER D.7
----------------	---------	---------------------------	--------------	--------------------------------------	------------------

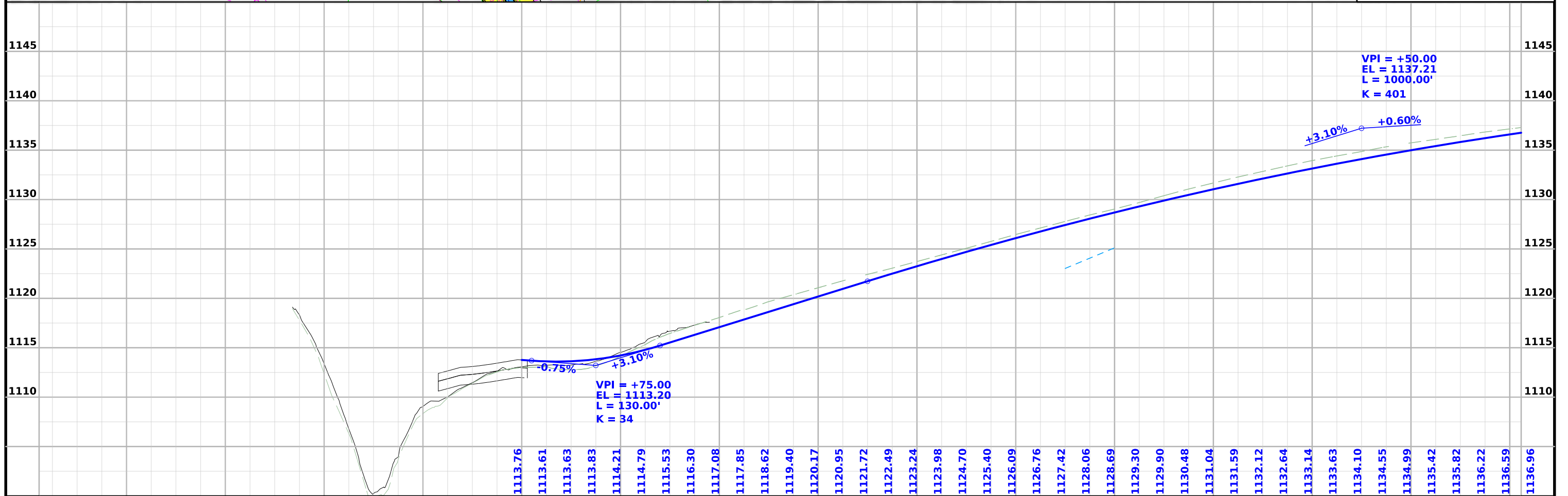
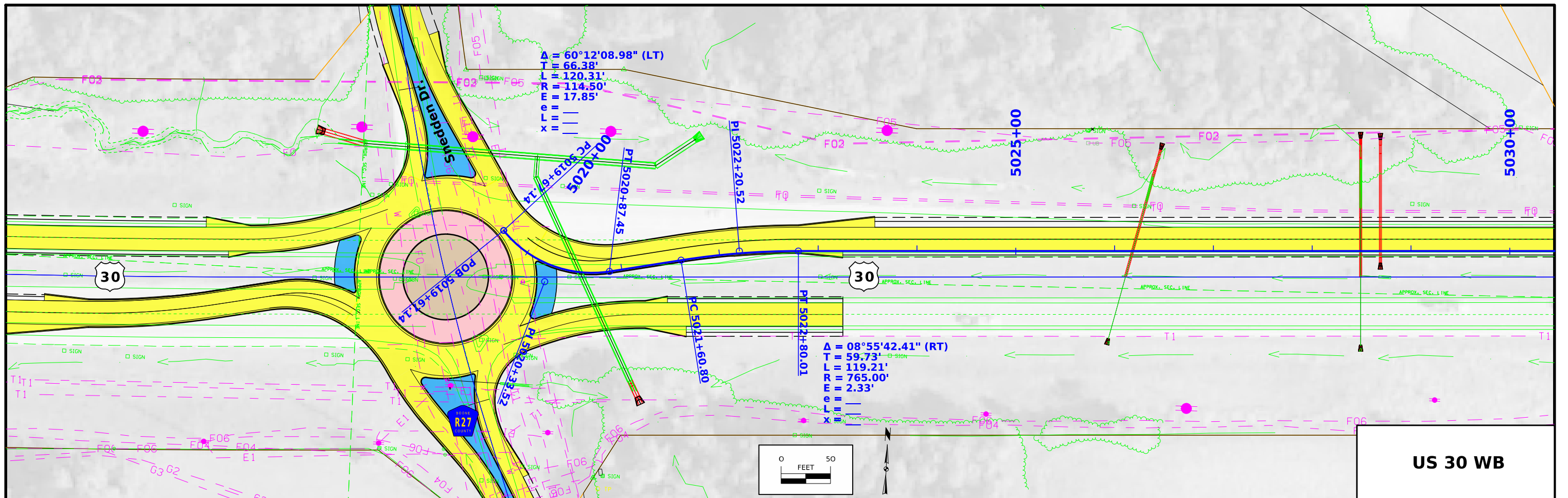

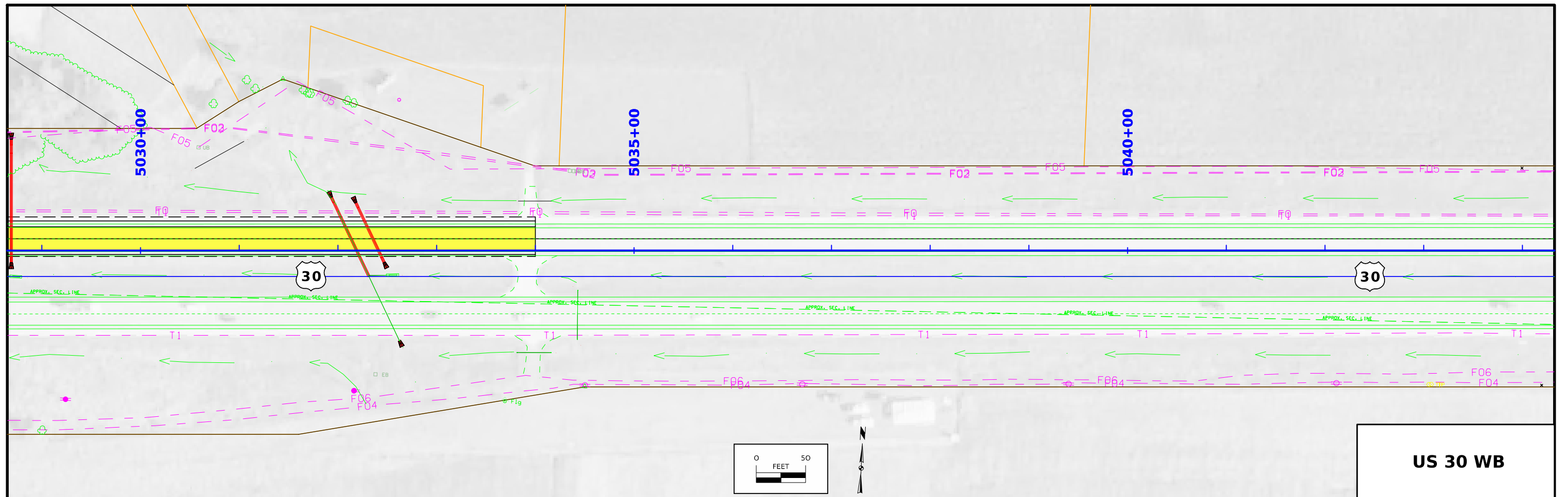

US 30 WB

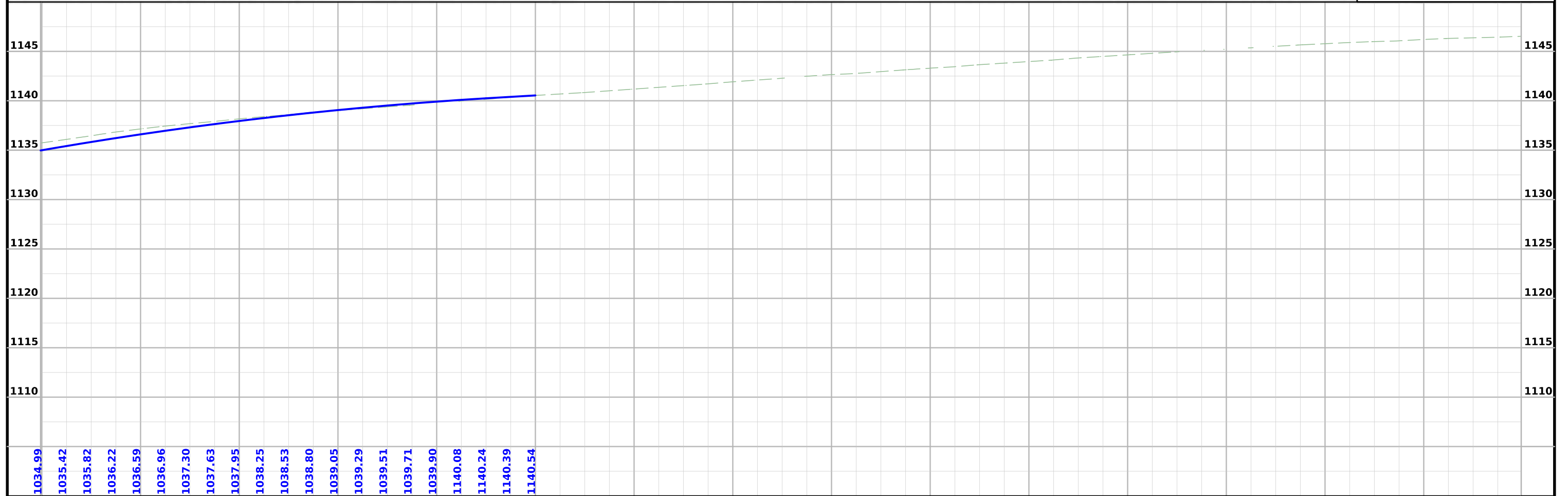

FILE NO. 98765	ENGLISH	DESIGN TEAM Strum\Prindle	BOONE COUNTY	PROJECT NUMBER NHSX-030-4(119)-3H-08	SHEET NUMBER D.9
-----------------------	---------	----------------------------------	---------------------	---	-------------------------

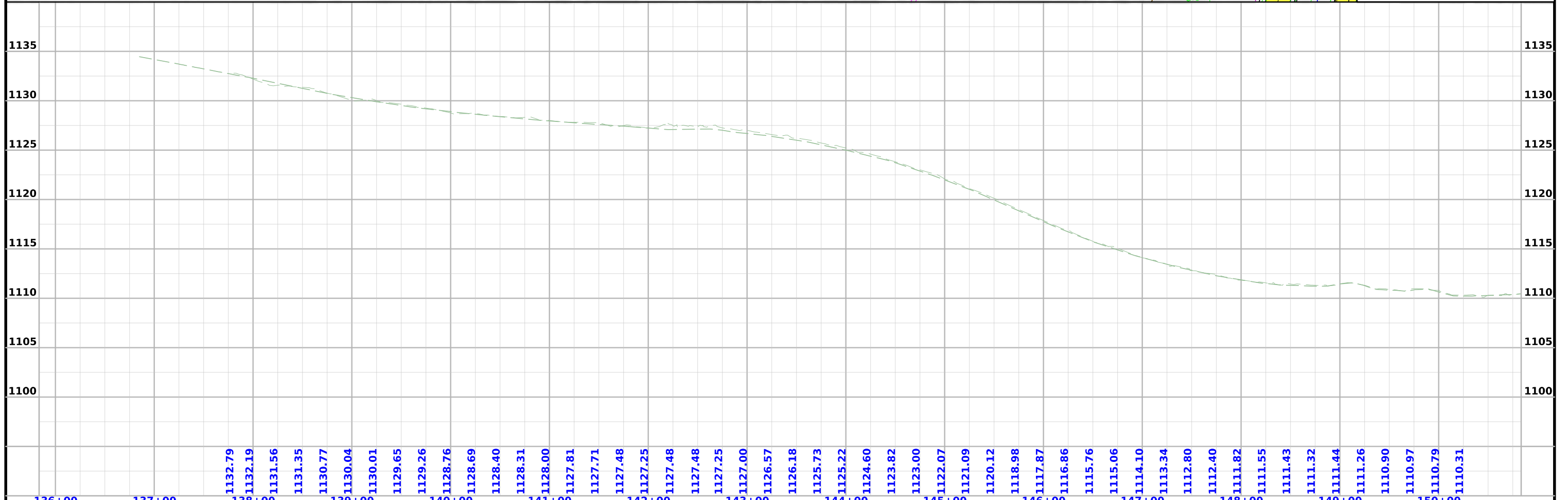
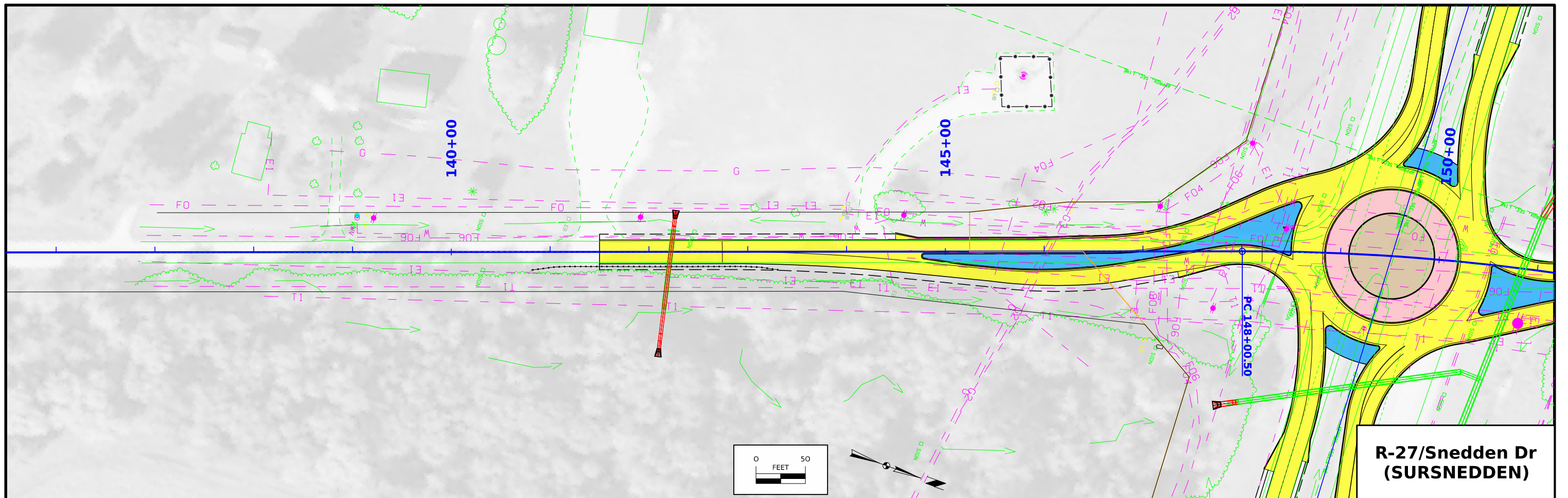

136+00	137+00	138+00	139+00	140+00	141+00	142+00	143+00	144+00	145+00	146+00	147+00	148+00	149+00	150+00																																	
1132.79	1132.19	1131.56	1131.35	1130.77	1130.04	1130.01	1129.65	1129.26	1128.76	1128.69	1128.40	1128.31	1128.00	1127.81	1127.71	1127.48	1127.25	1127.00	1126.57	1126.18	1125.73	1125.22	1124.60	1123.82	1123.00	1122.07	1121.09	1120.12	1118.98	1117.87	1116.86	1115.76	1115.06	1114.10	1113.34	1112.80	1112.40	1111.82	1111.55	1111.43	1111.32	1111.44	1111.26	1110.90	1110.97	1110.79	1110.31

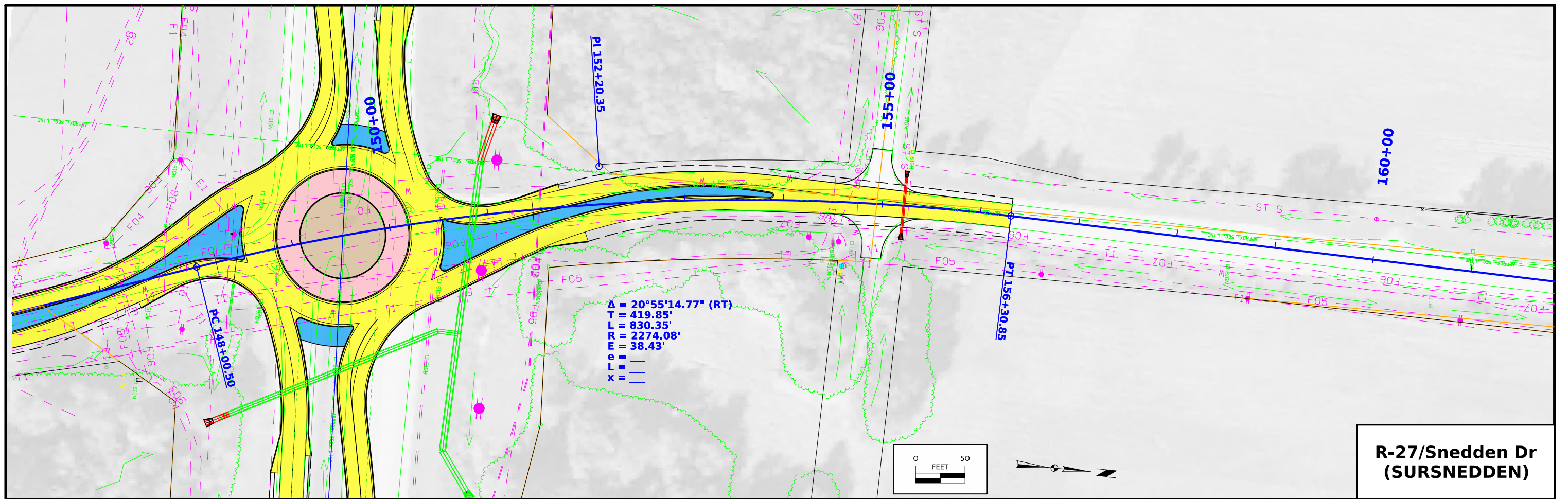

**R-27/Snedden Dr
(SURSNEDDEN)**

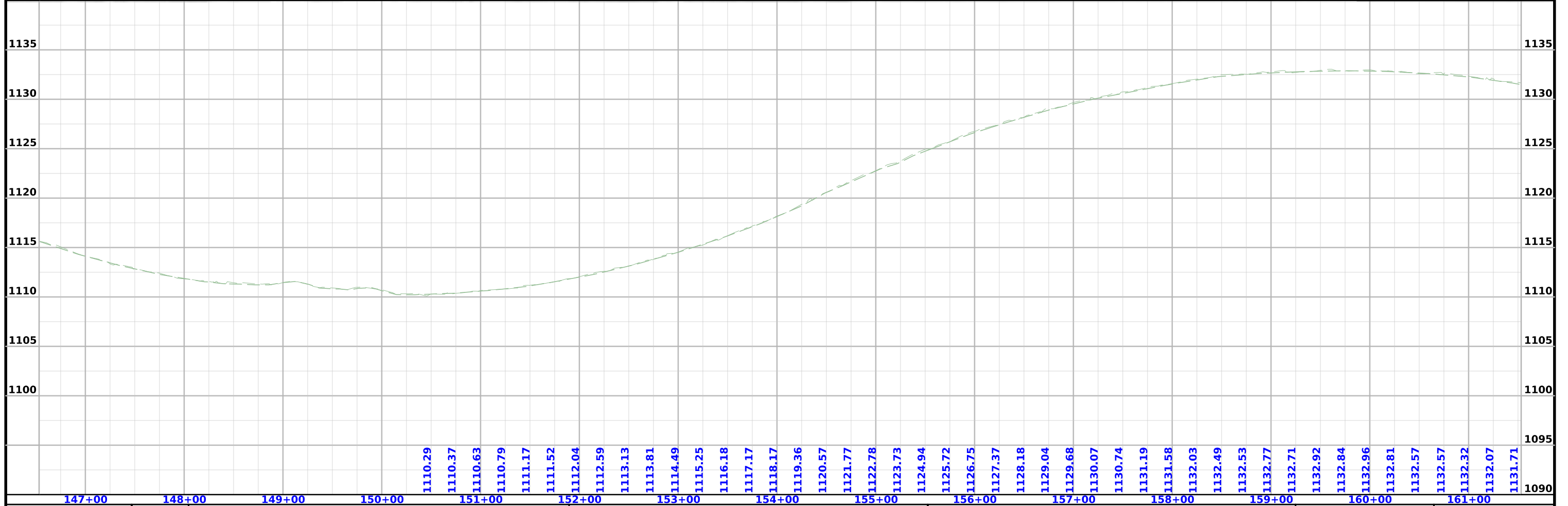

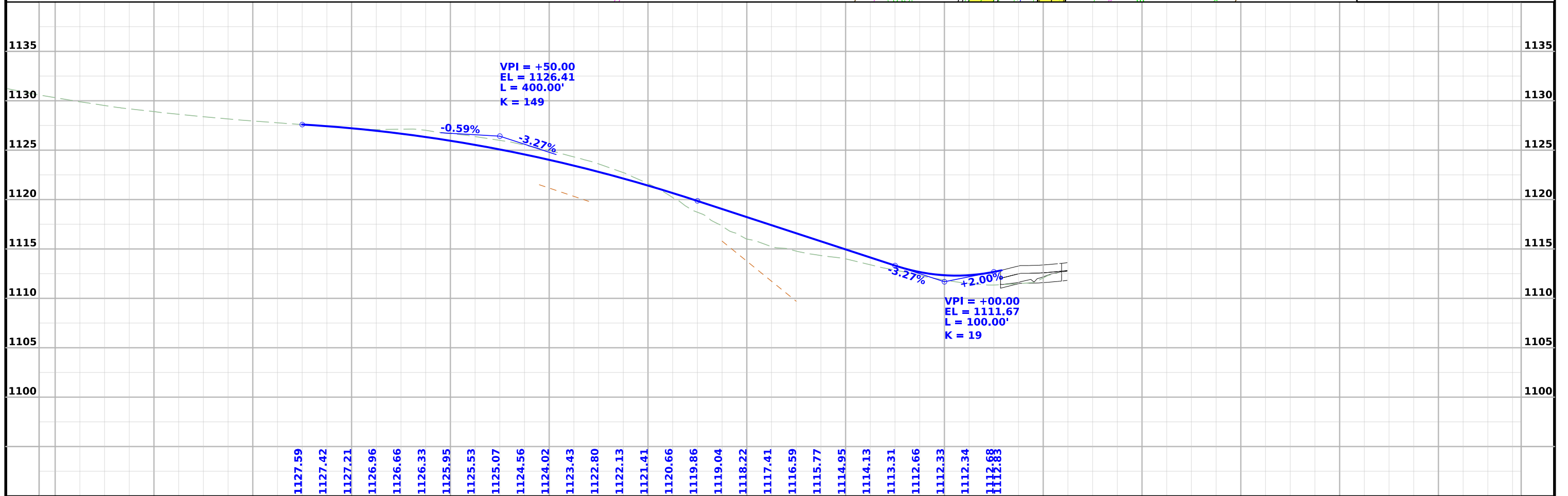
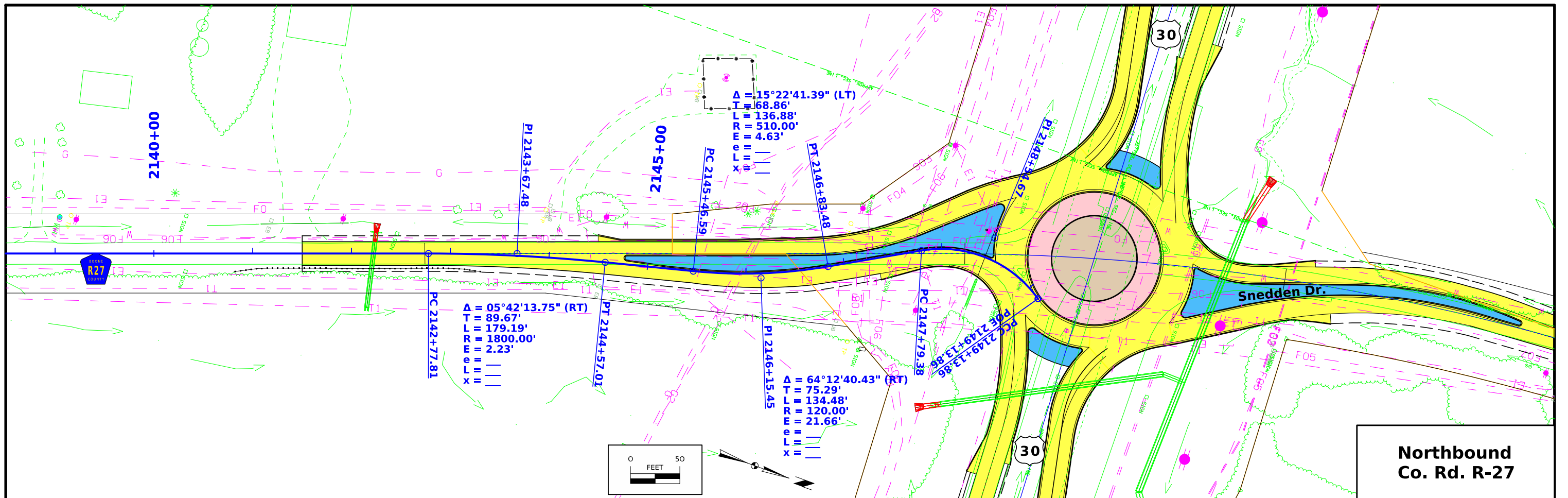

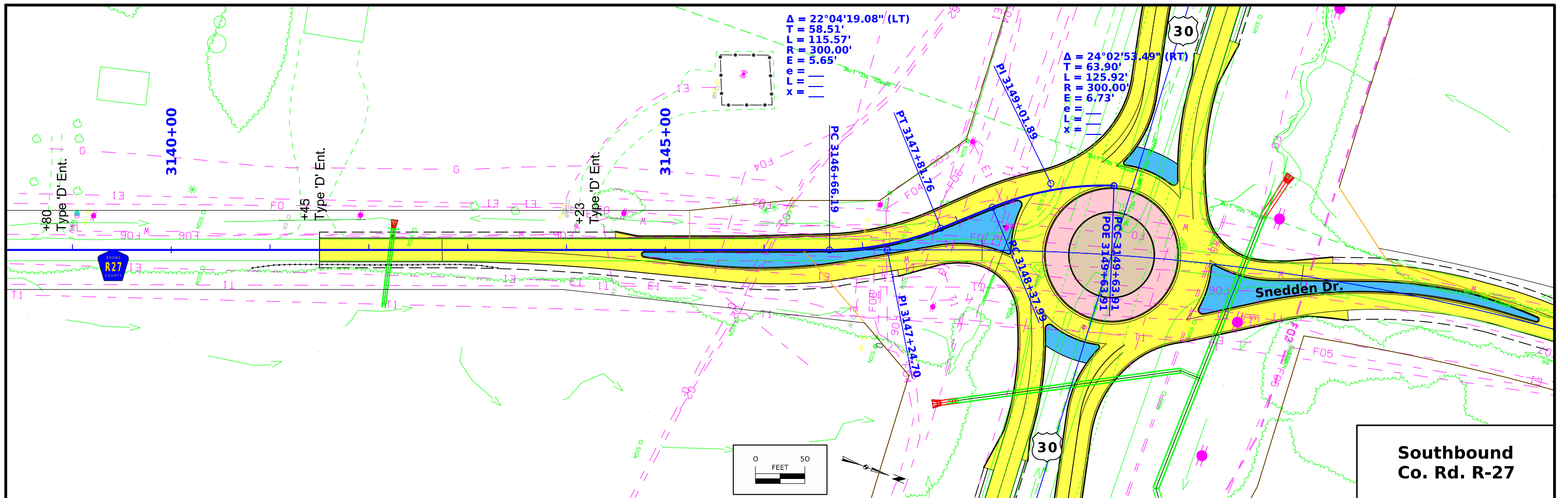

**Southbound
Co. Rd. R-27**

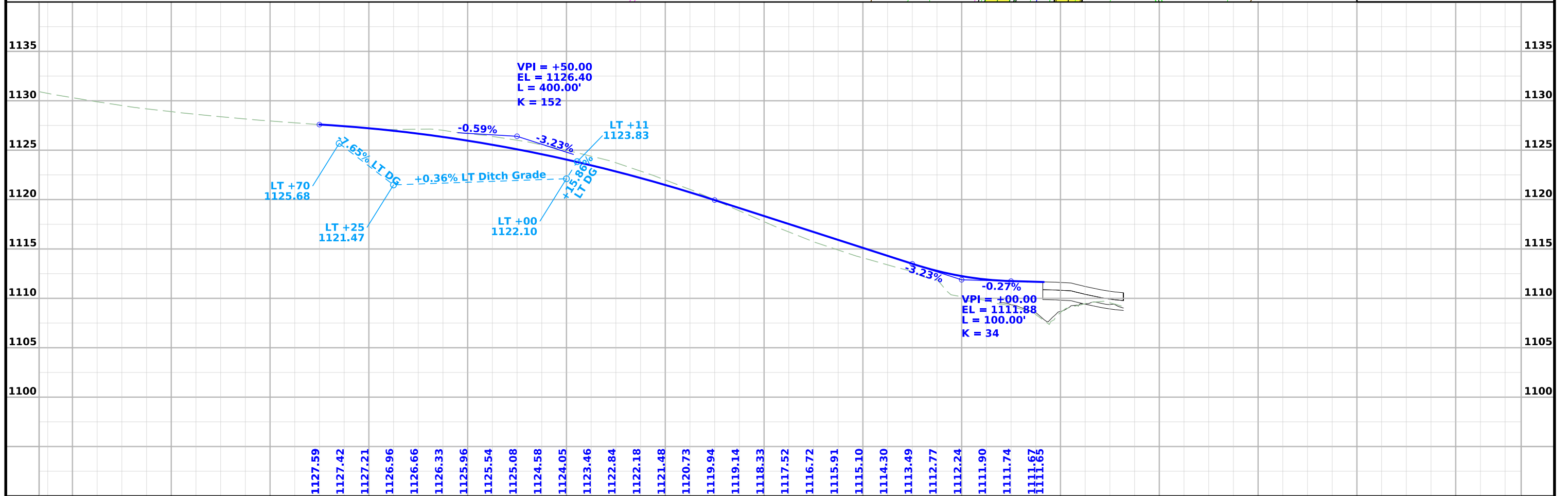

FILE NO. 98765	ENGLISH	DESIGN TEAM Strum\Prindle	BOONE COUNTY	PROJECT NUMBER NHSX-030-4(119)-3H-08	SHEET NUMBER E.4
----------------	---------	---------------------------	--------------	--------------------------------------	------------------

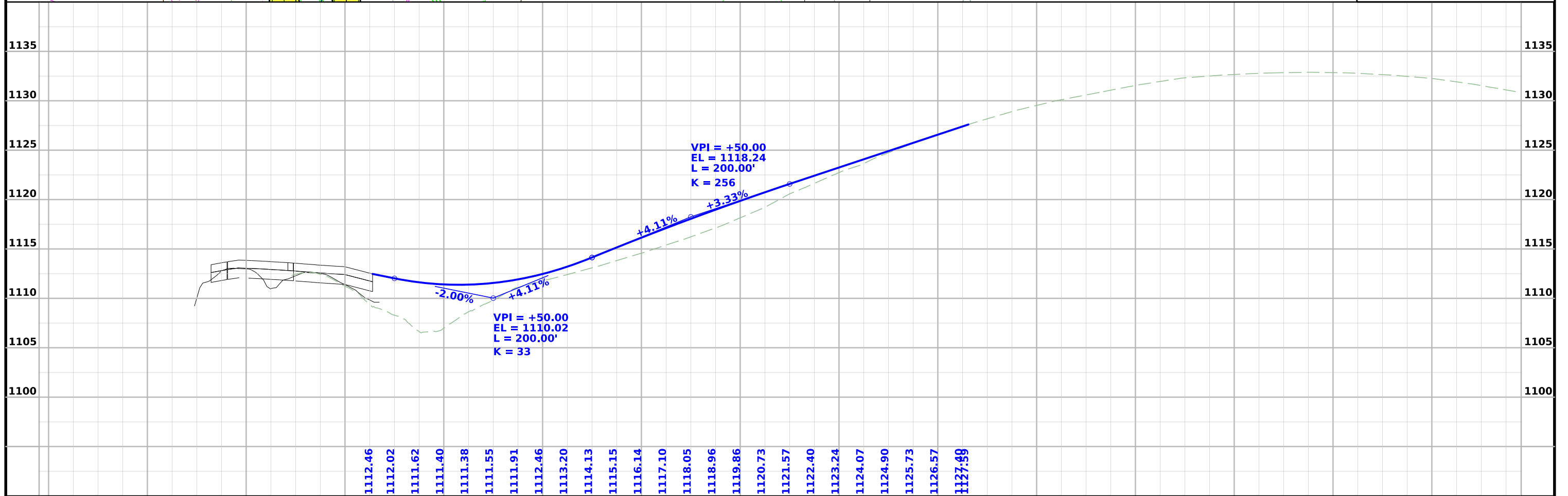
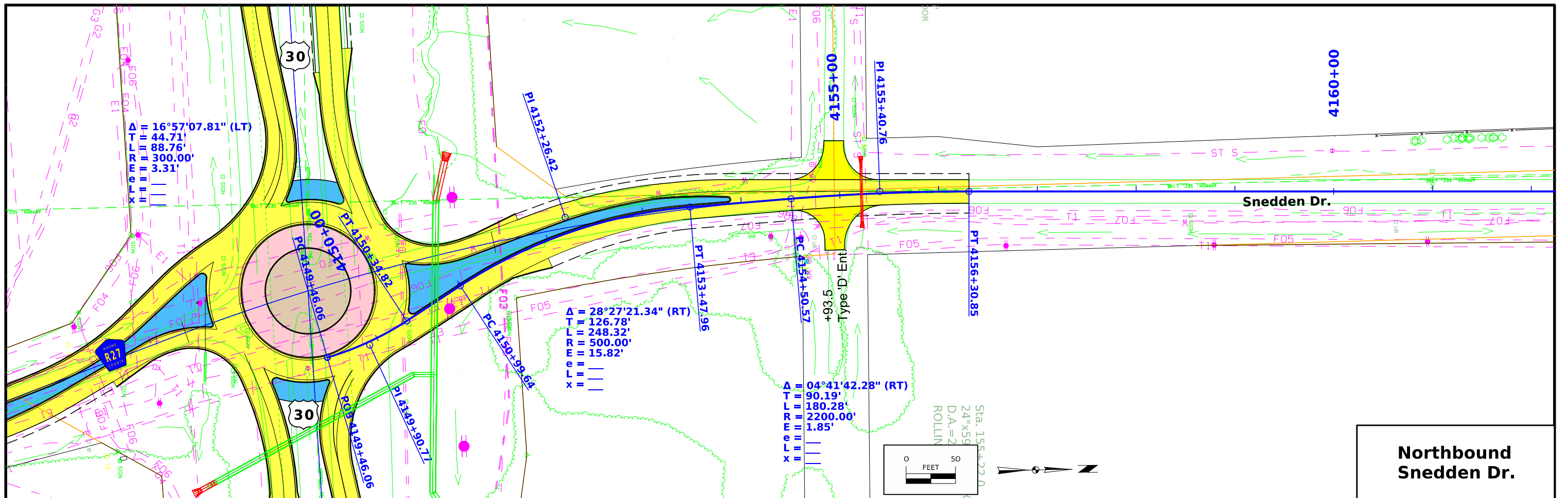

FILE NO. 98765	ENGLISH	DESIGN TEAM Strum\Prindle	BOONE COUNTY	PROJECT NUMBER NHSX-030-4(119)-3H-08	SHEET NUMBER E.5
----------------	---------	---------------------------	--------------	--------------------------------------	------------------

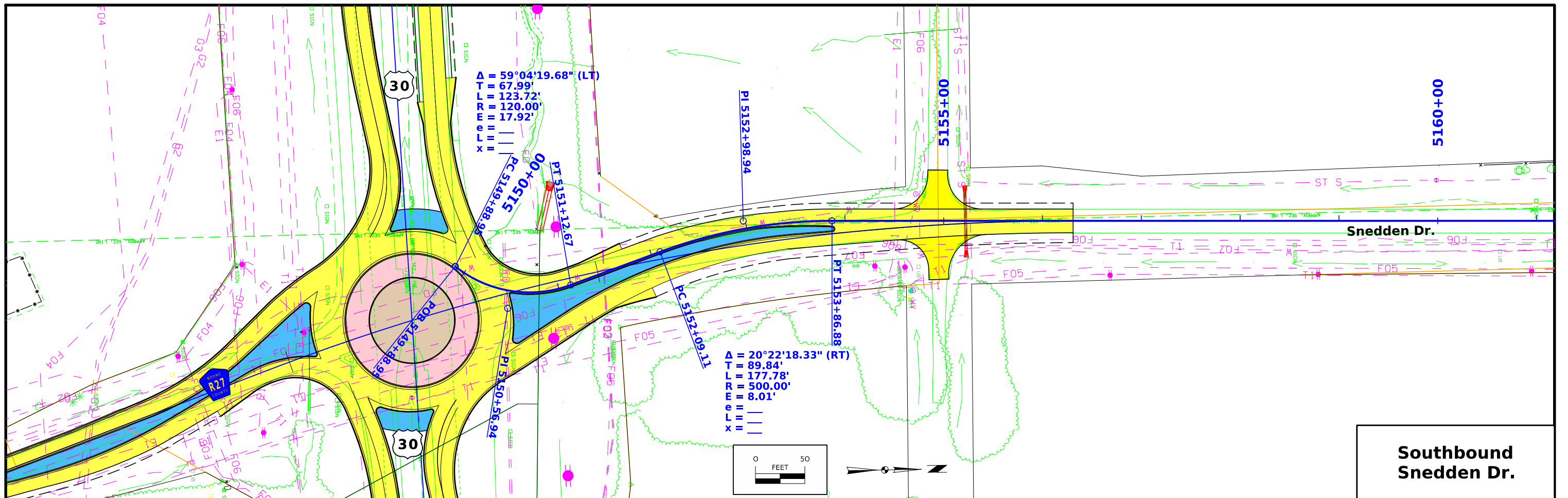

**Southbound
Snedden Dr.**

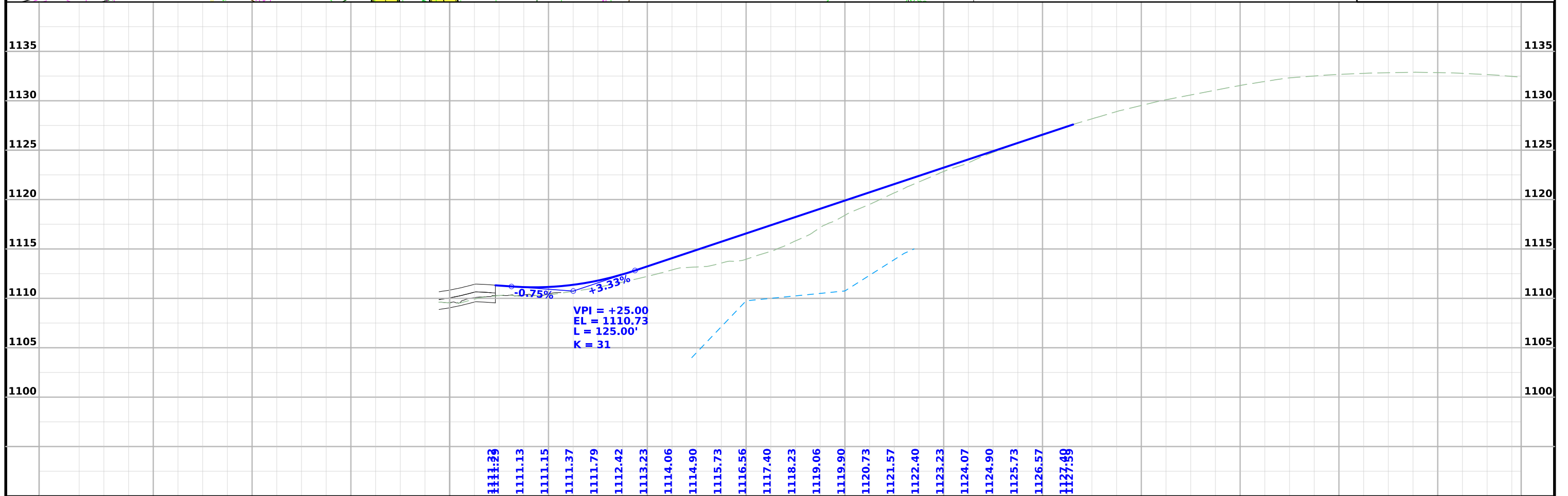

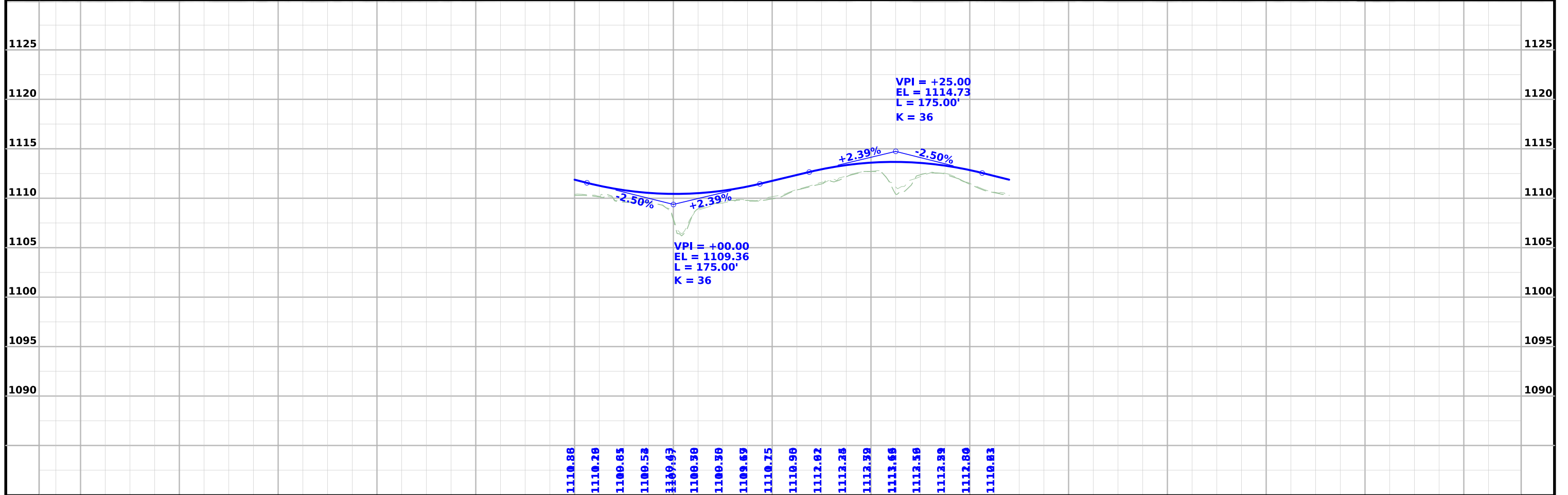
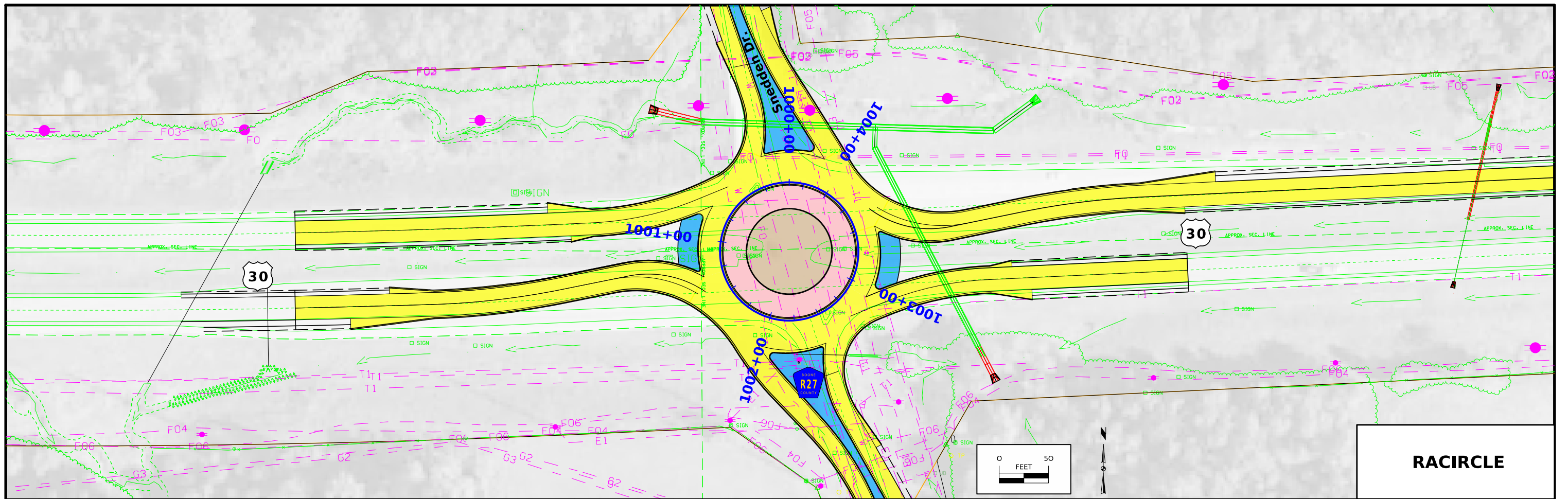

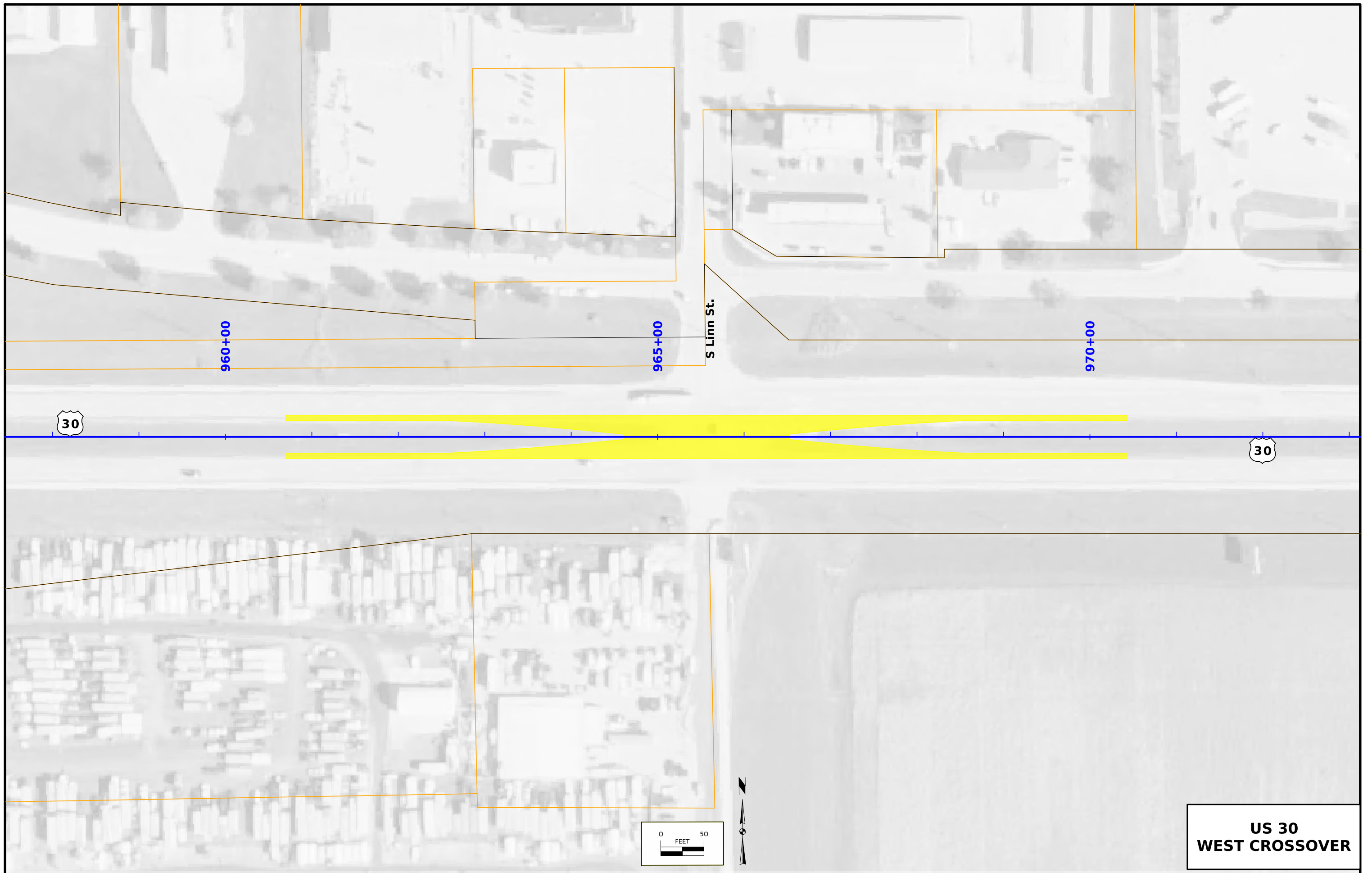

**US 30
WEST CROSSOVER**



R Ave.

30

30

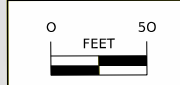

**US 30
EAST CROSSOVER**

US 30 EB Entrance

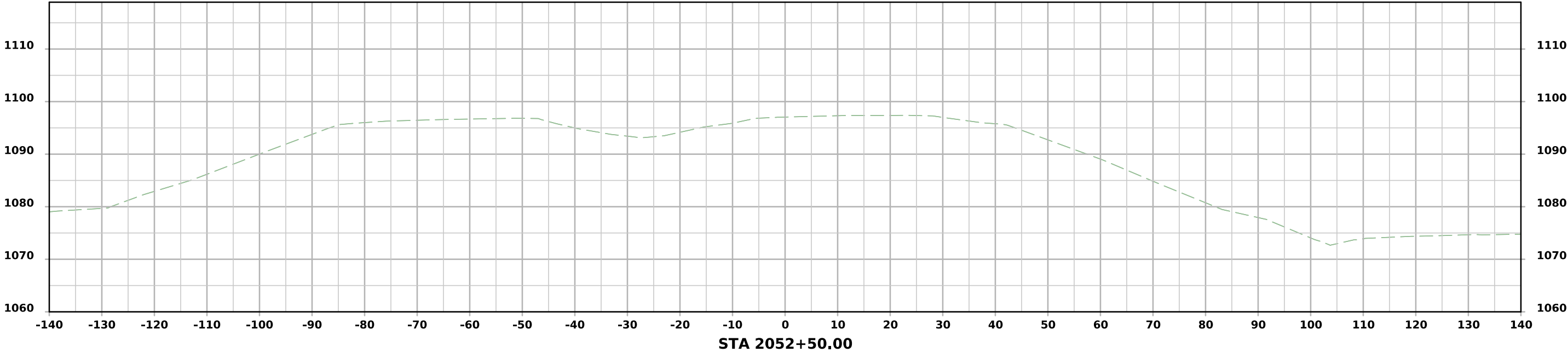
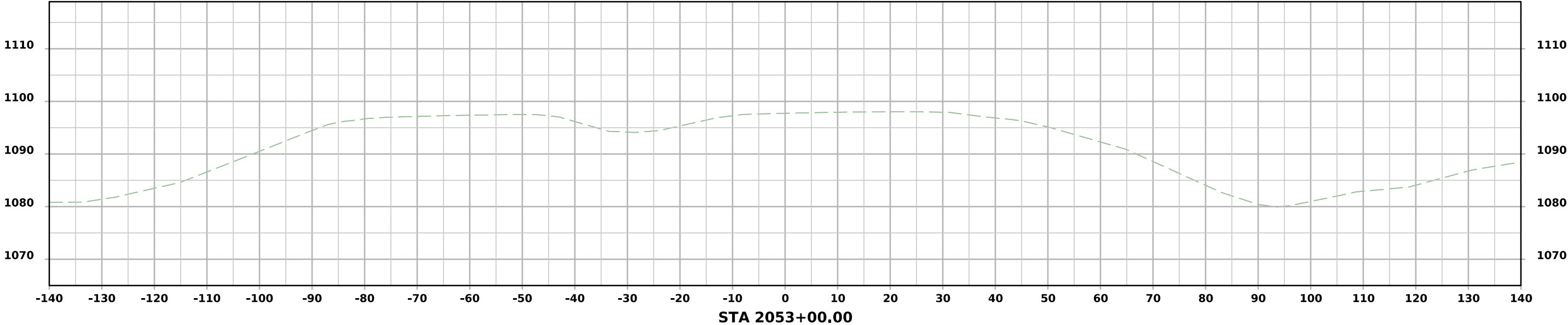

US 30 EB Entrance

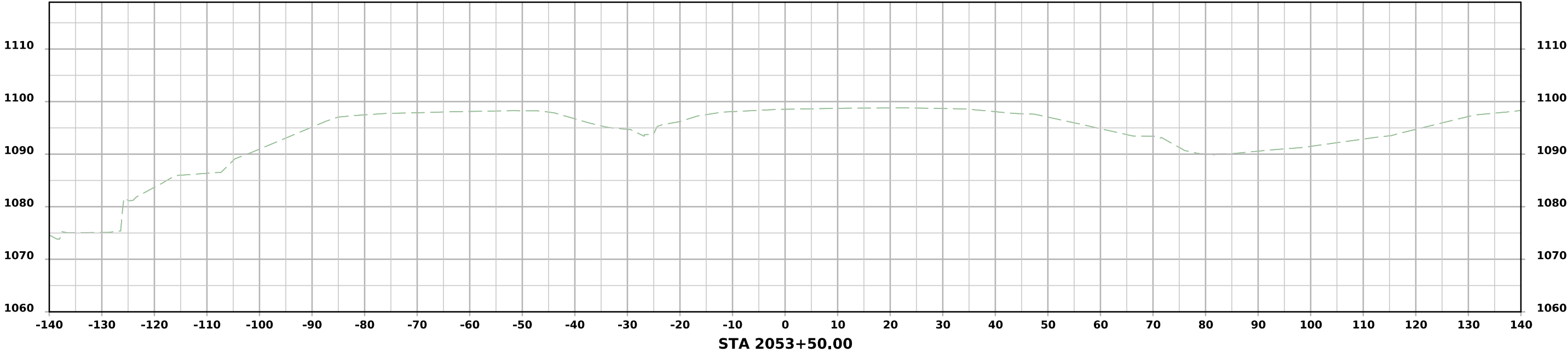
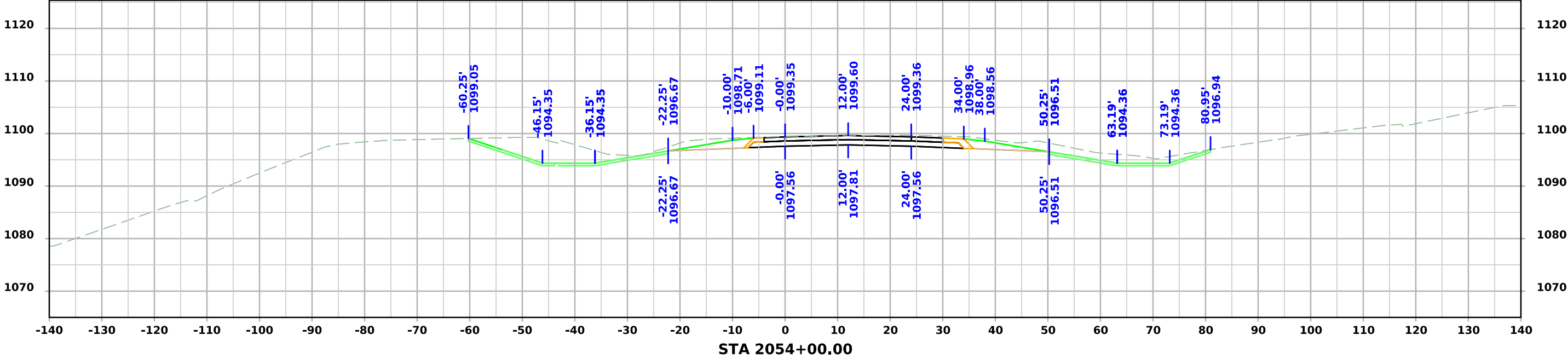

US 30 EB Entrance

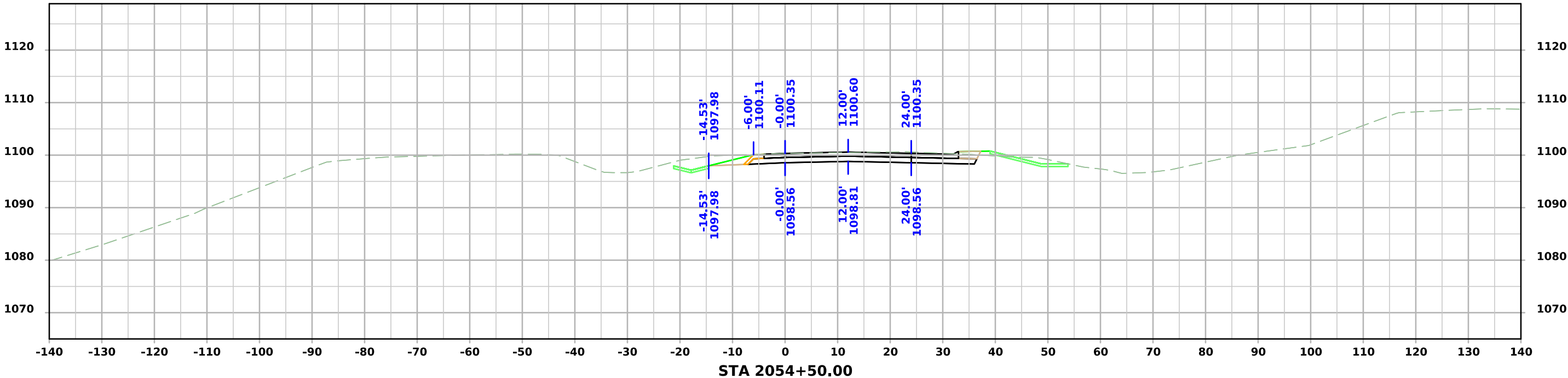
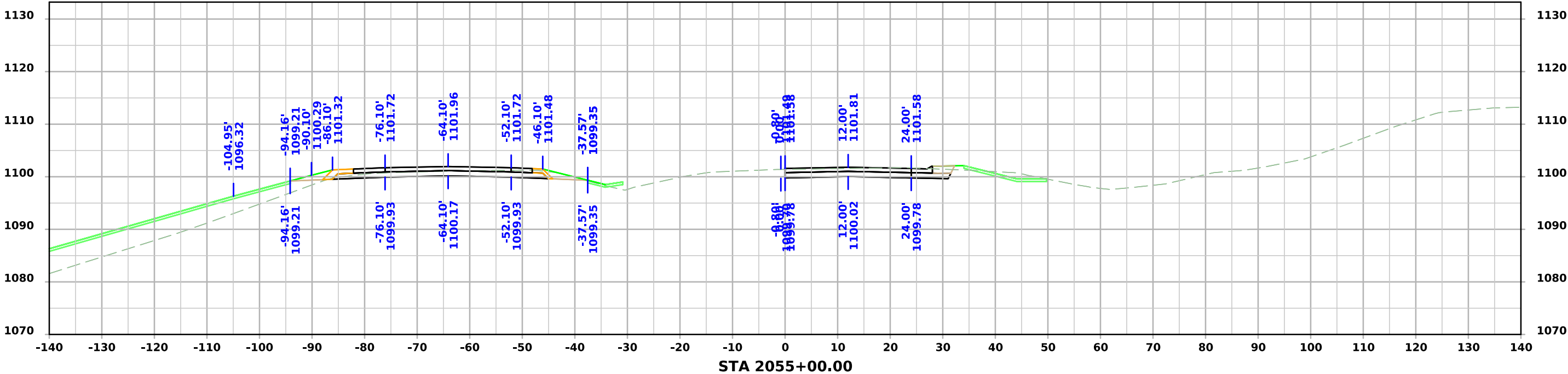

US 30 EB Entrance

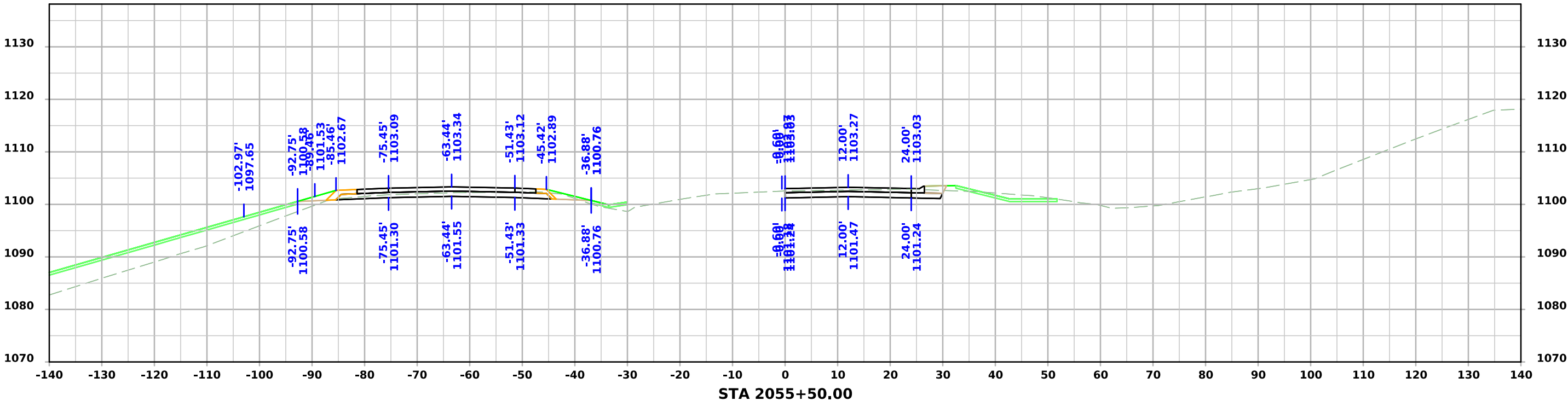
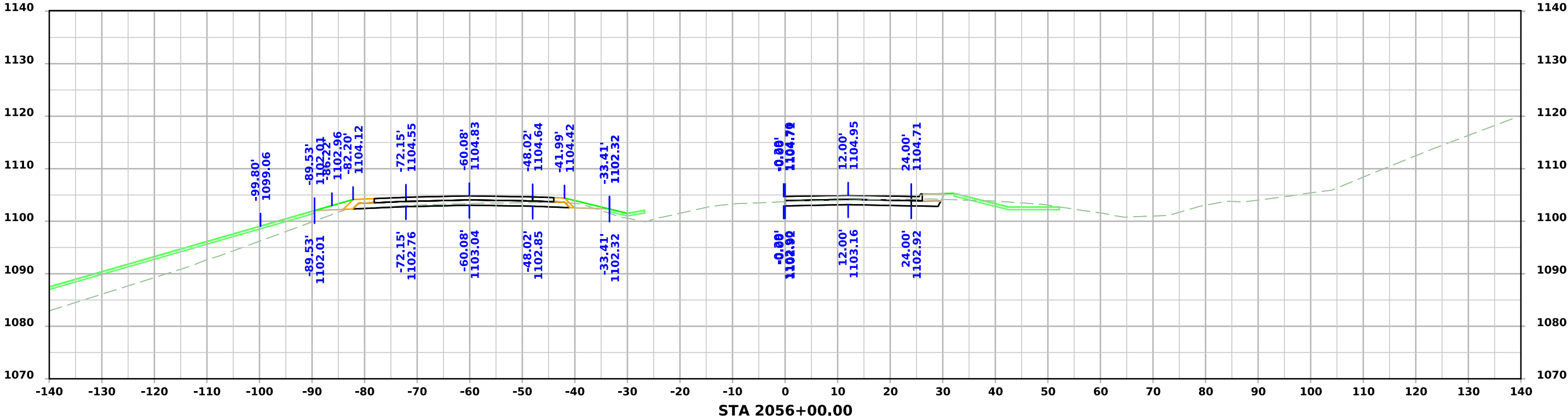

US 30 EB Entrance

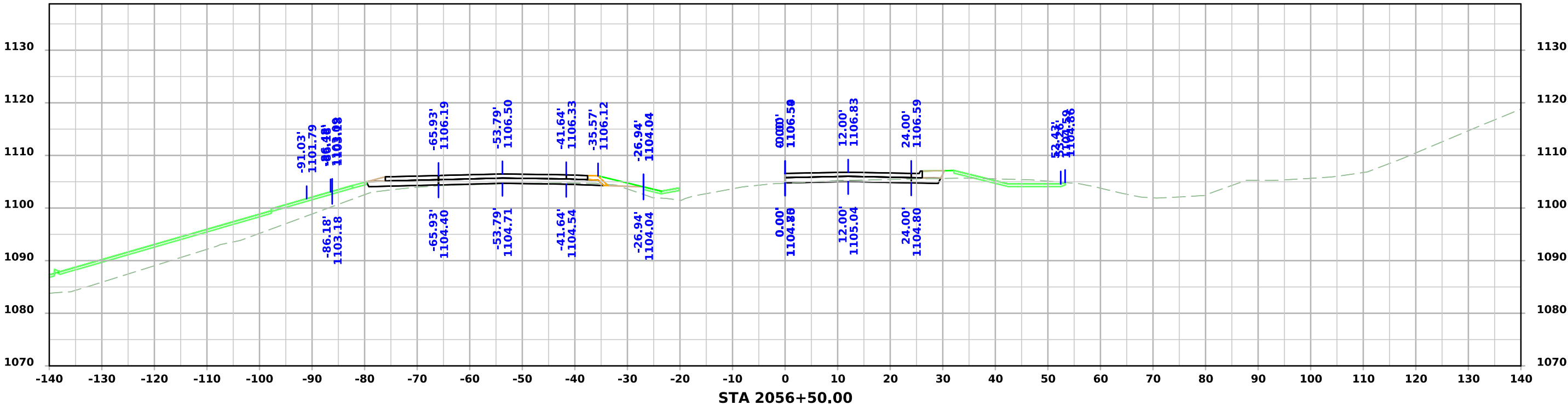
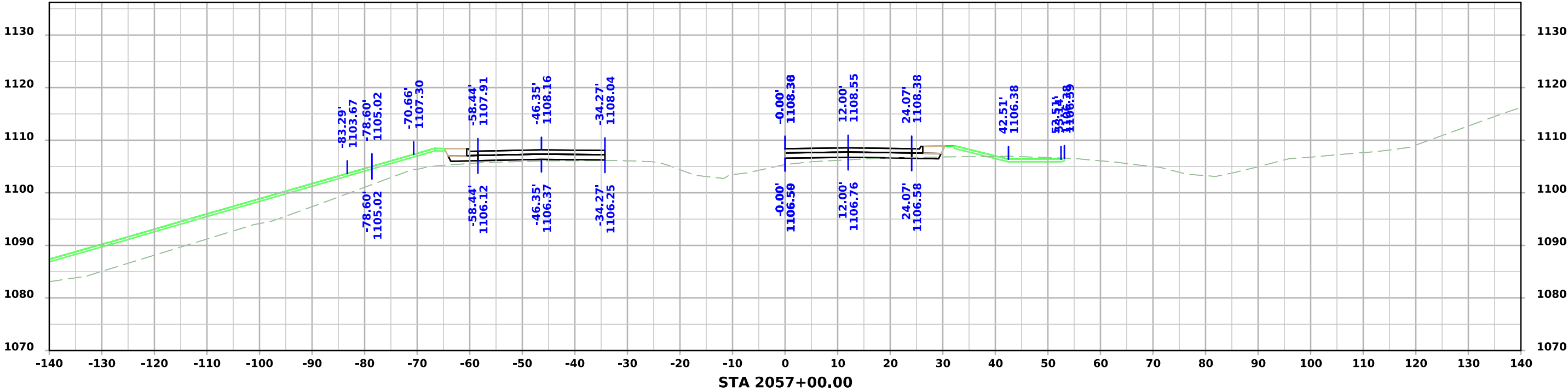

US 30 EB Entrance

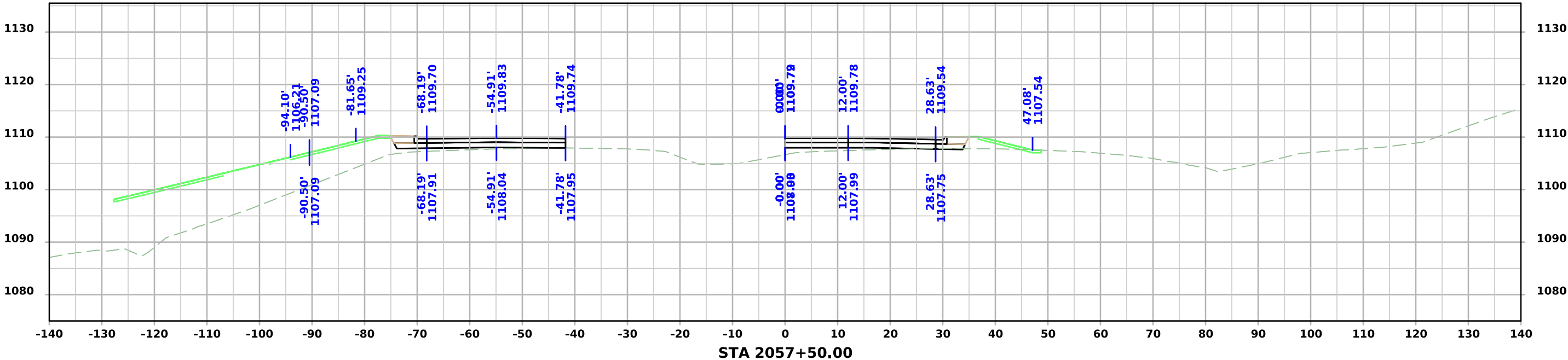
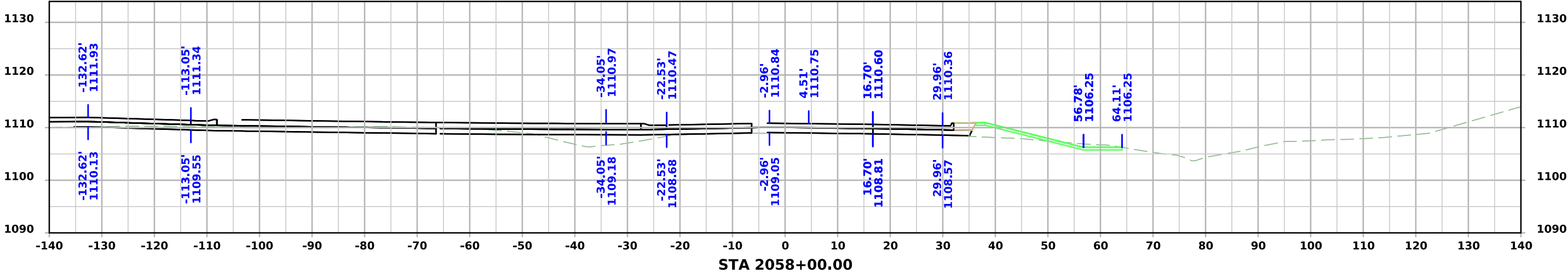

US 30 EB Entrance

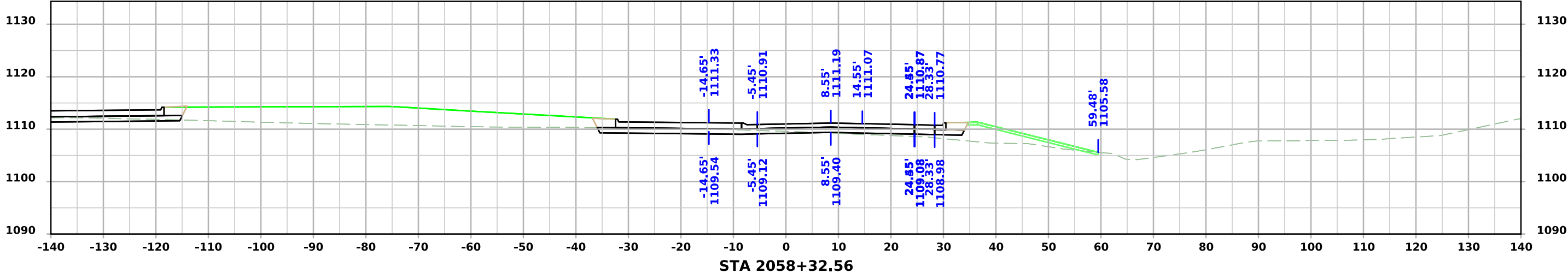

STA 2058+32.56

US 30 EB EXIT

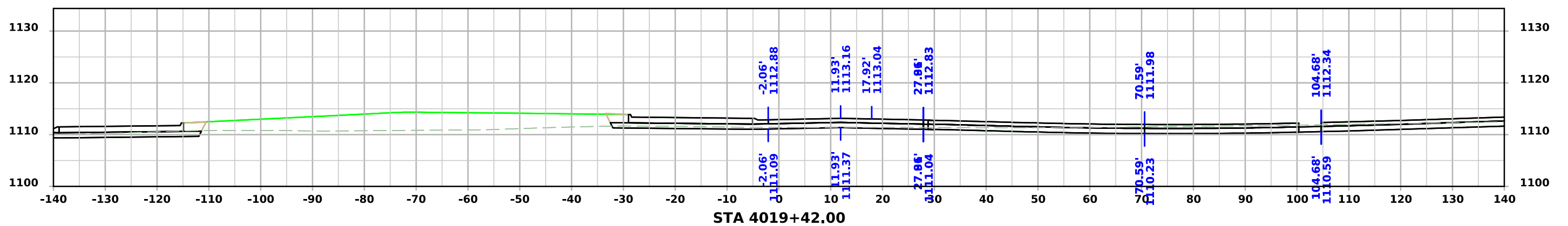
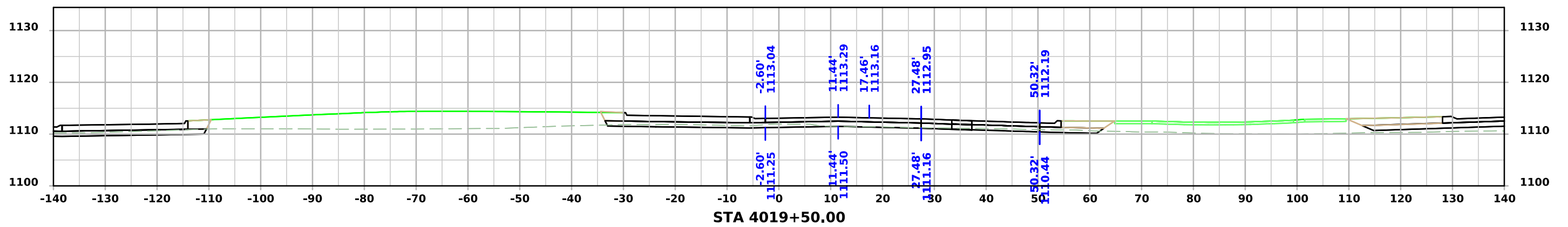
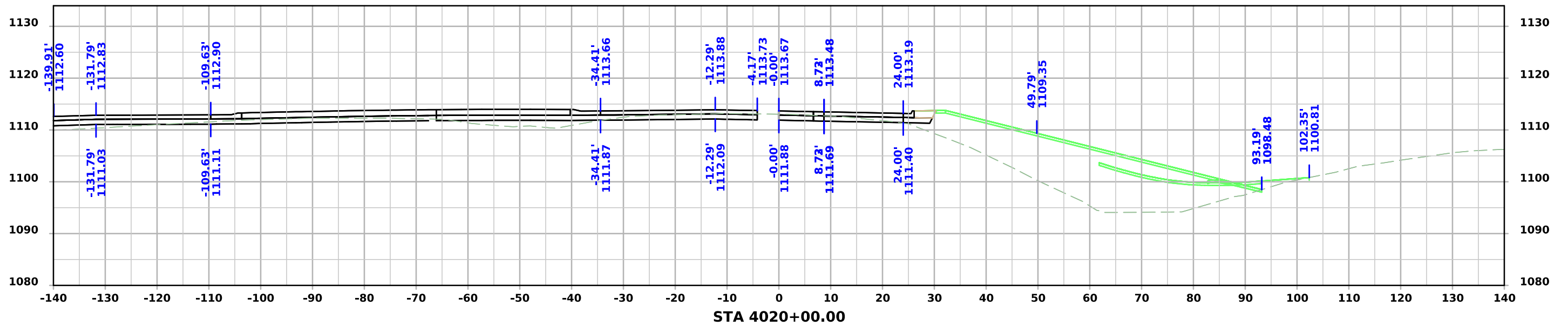

US 30 EB EXIT

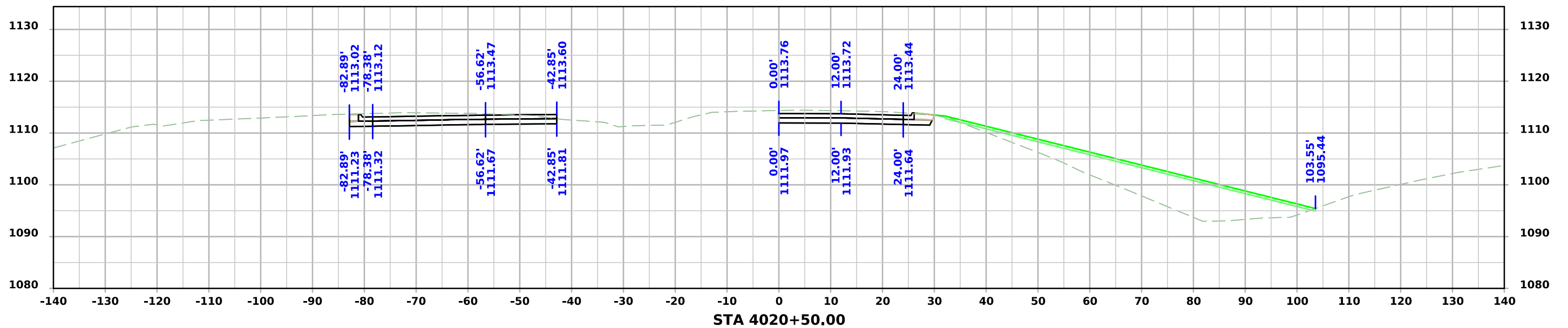
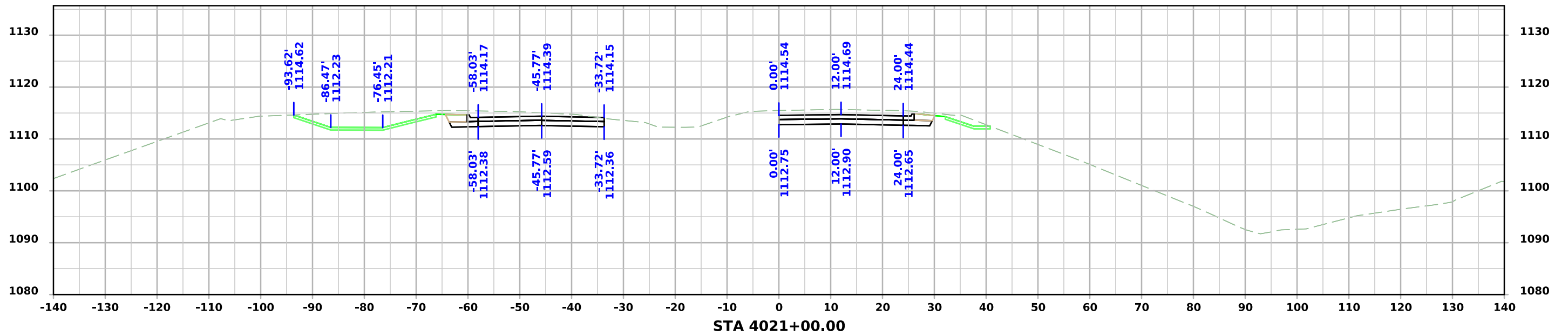

US 30 EB EXIT

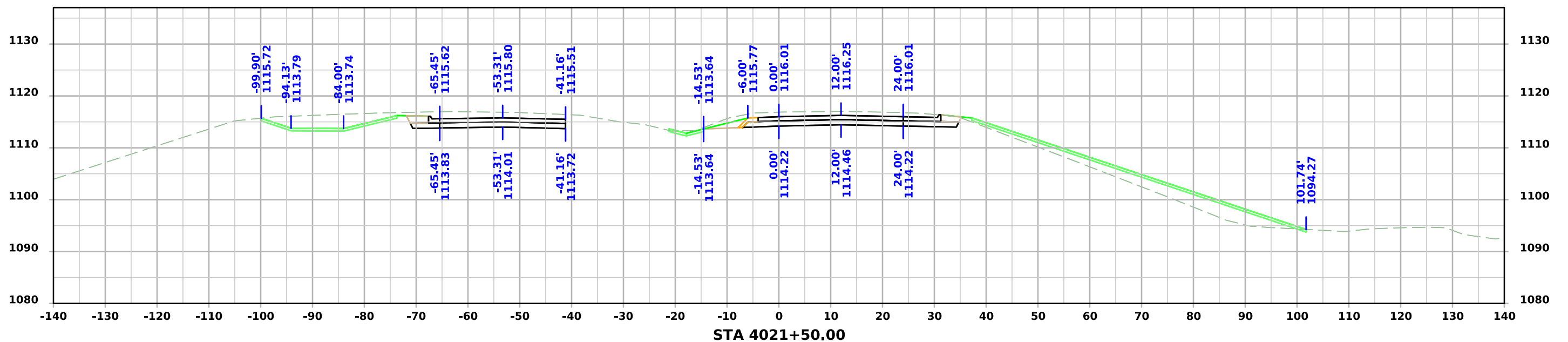
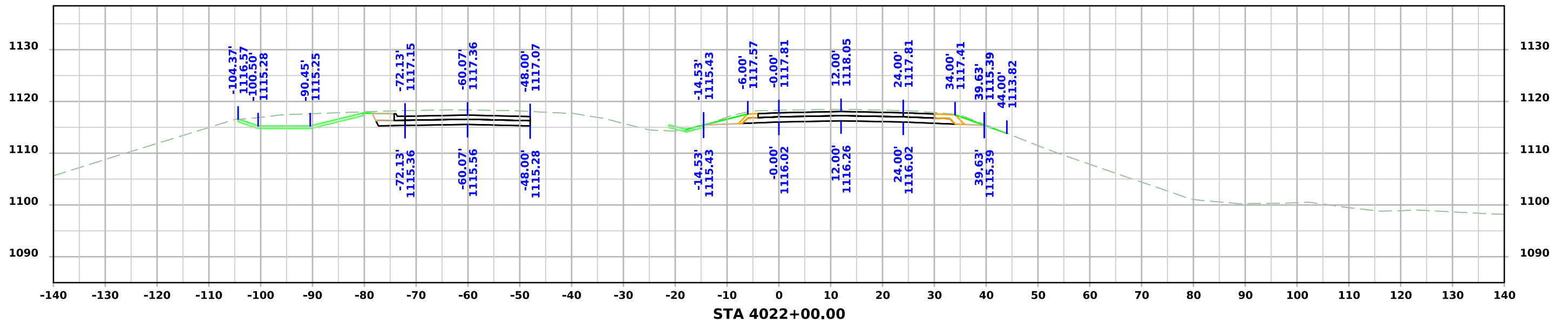

US 30 EB EXIT

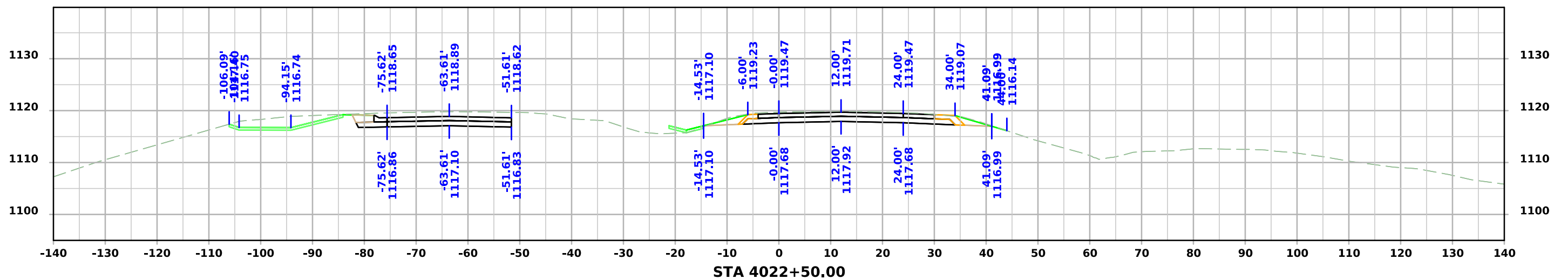
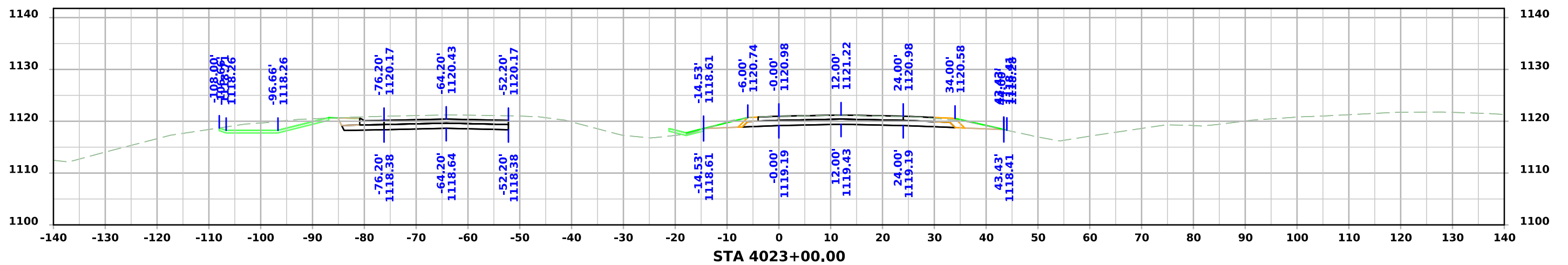
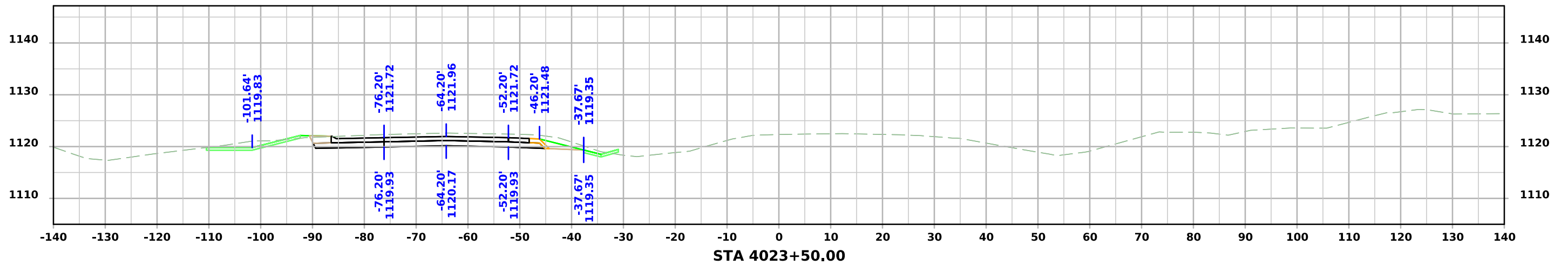

US 30 EB EXIT

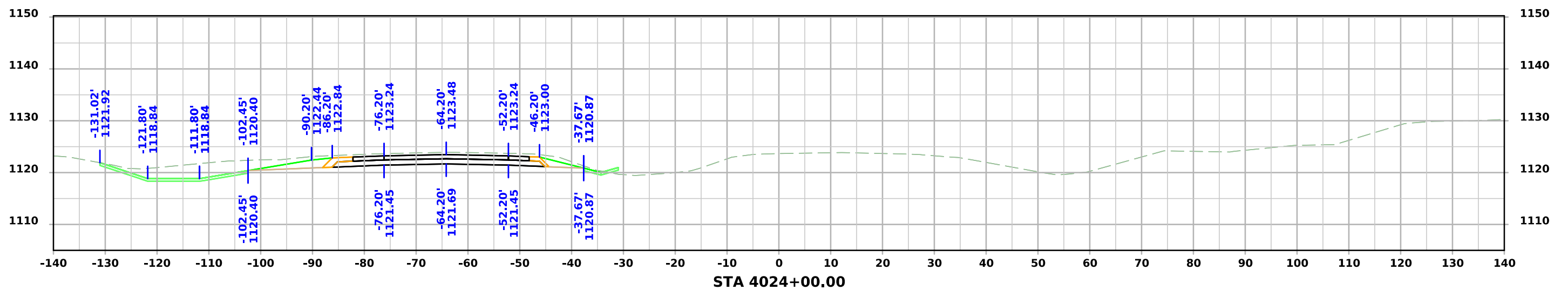

US 30 WB EXIT

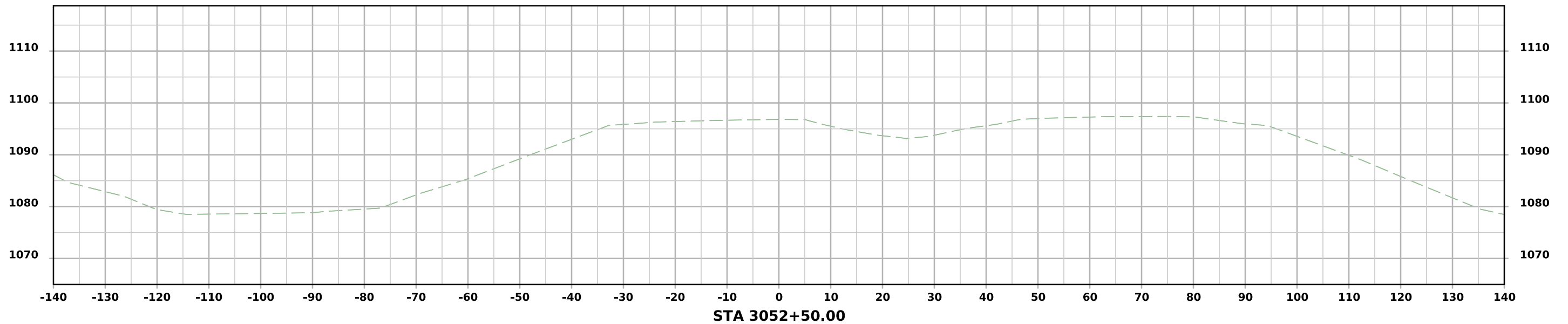
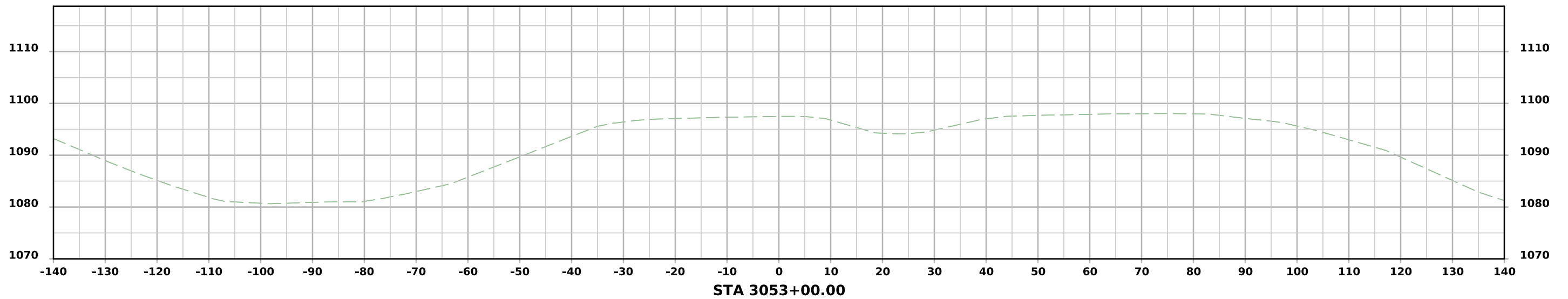

US 30 WB EXIT

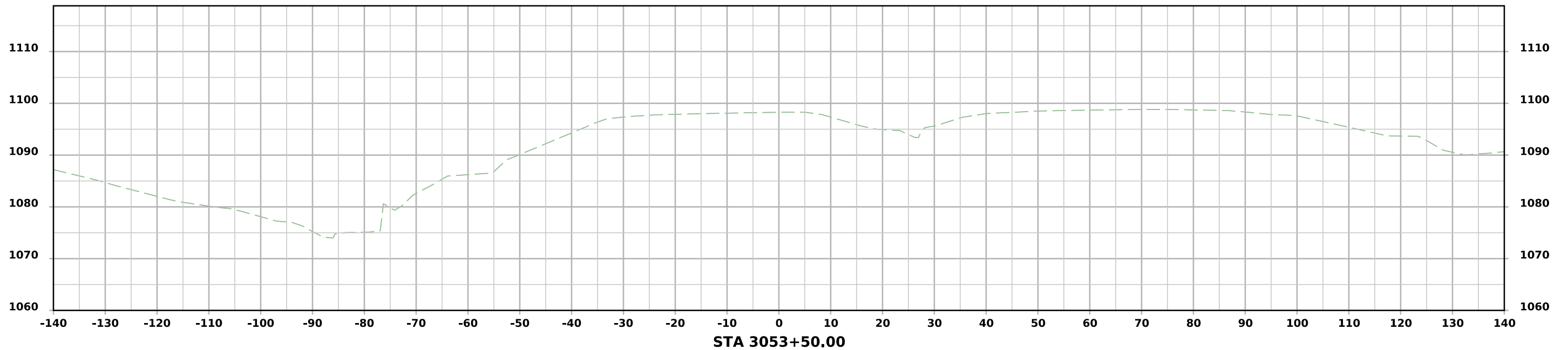
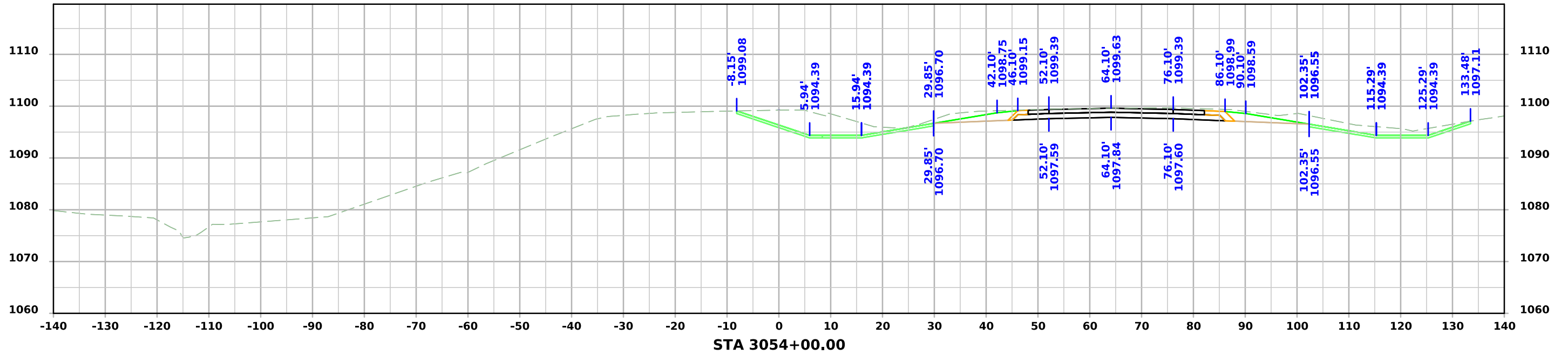

US 30 WB EXIT

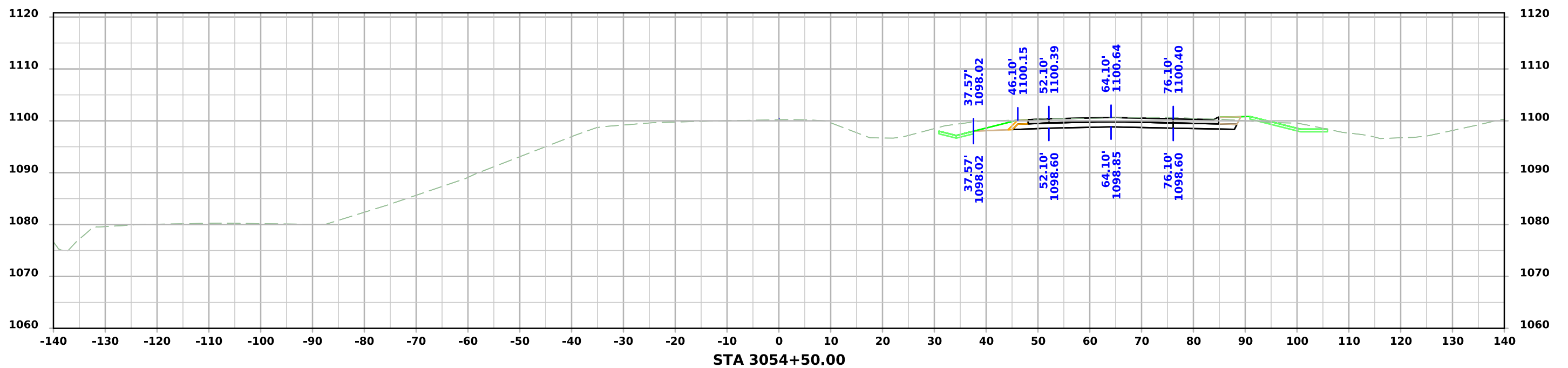
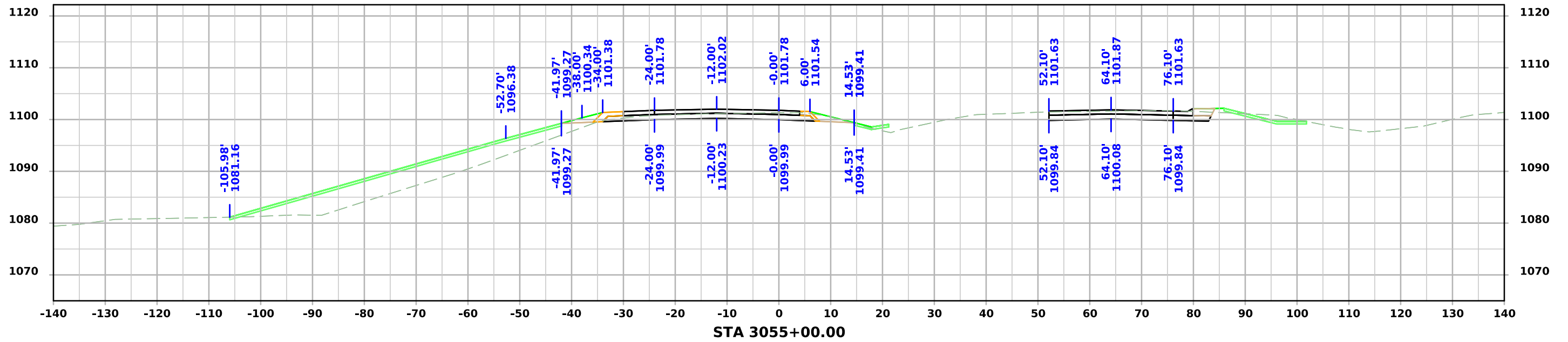

US 30 WB EXIT

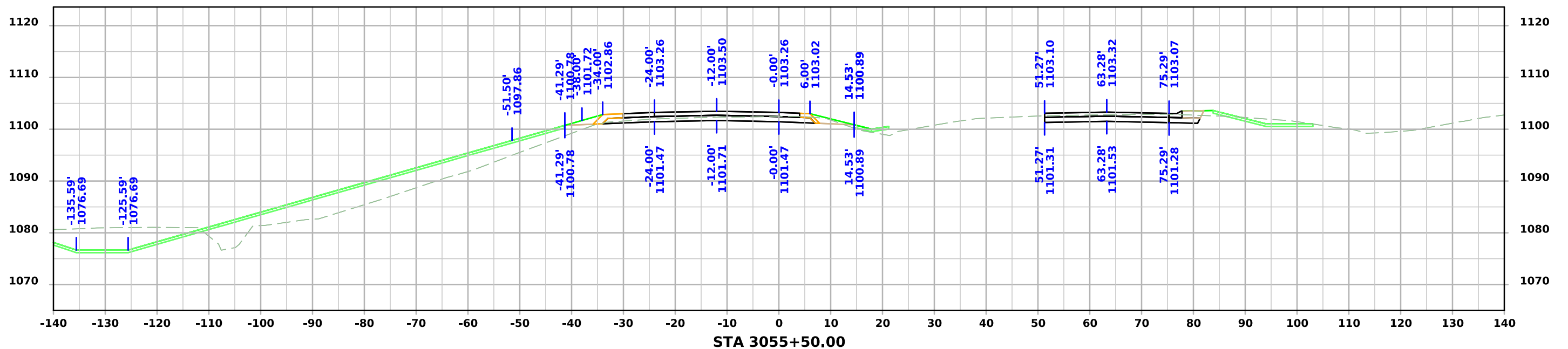
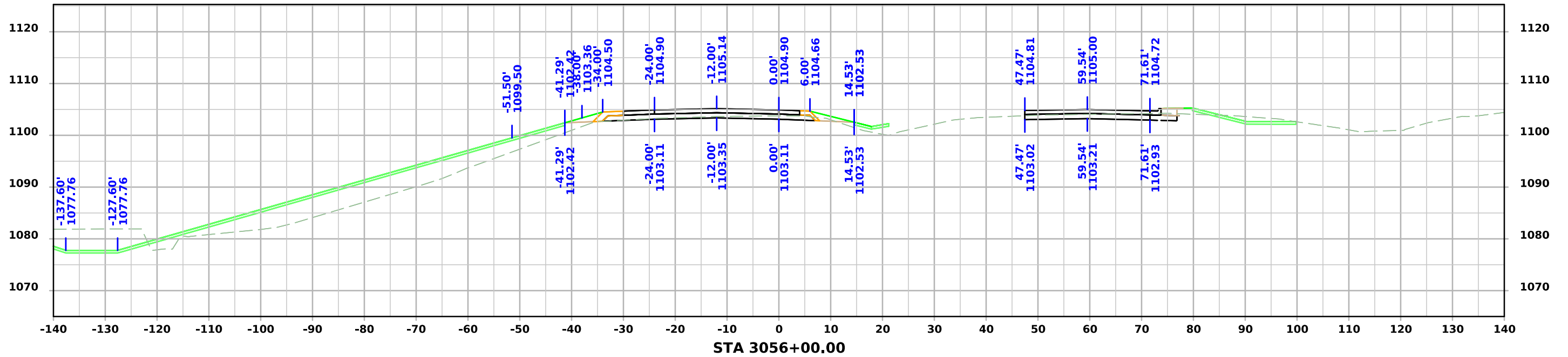

US 30 WB EXIT

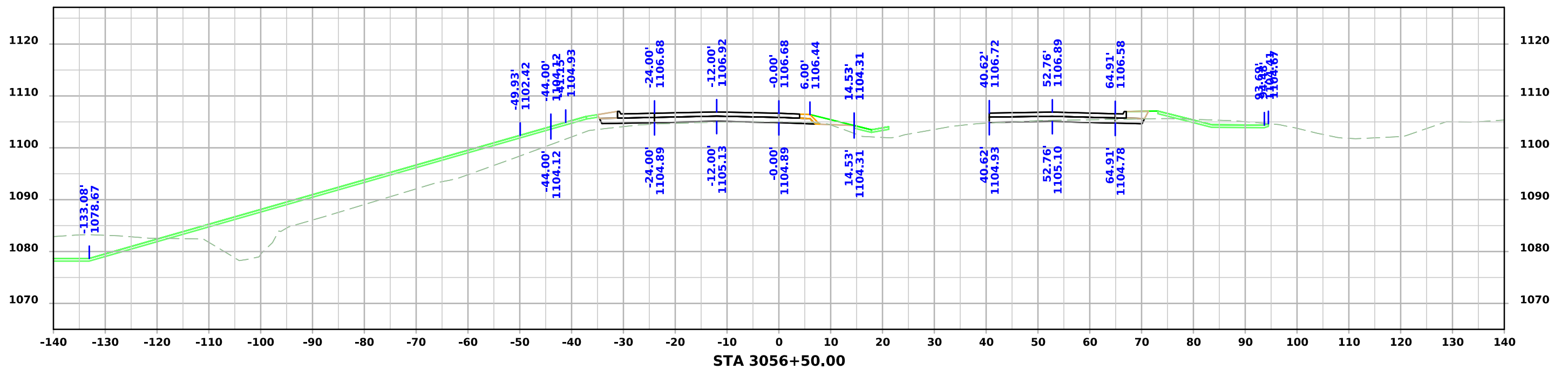
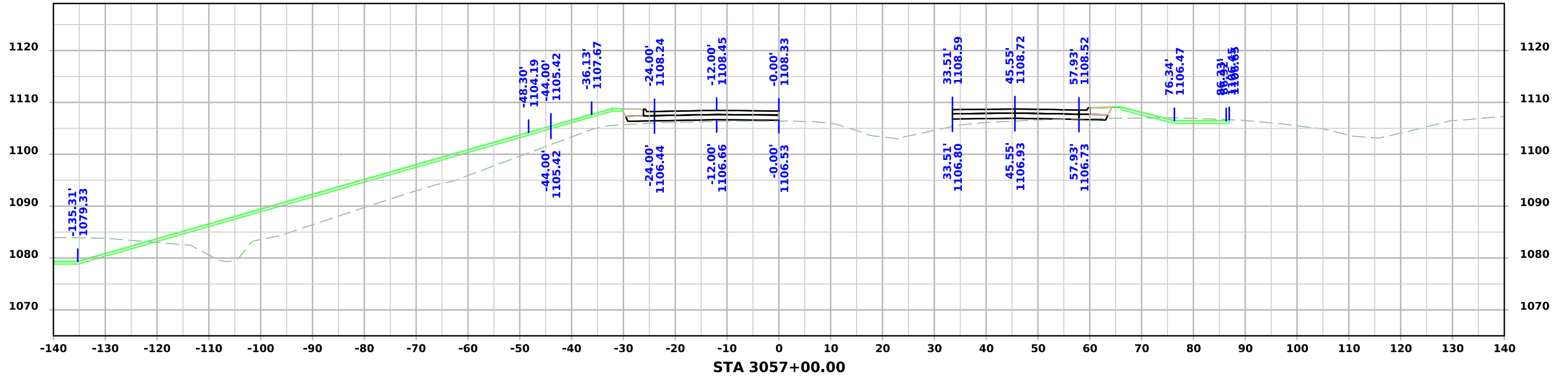

US 30 WB EXIT

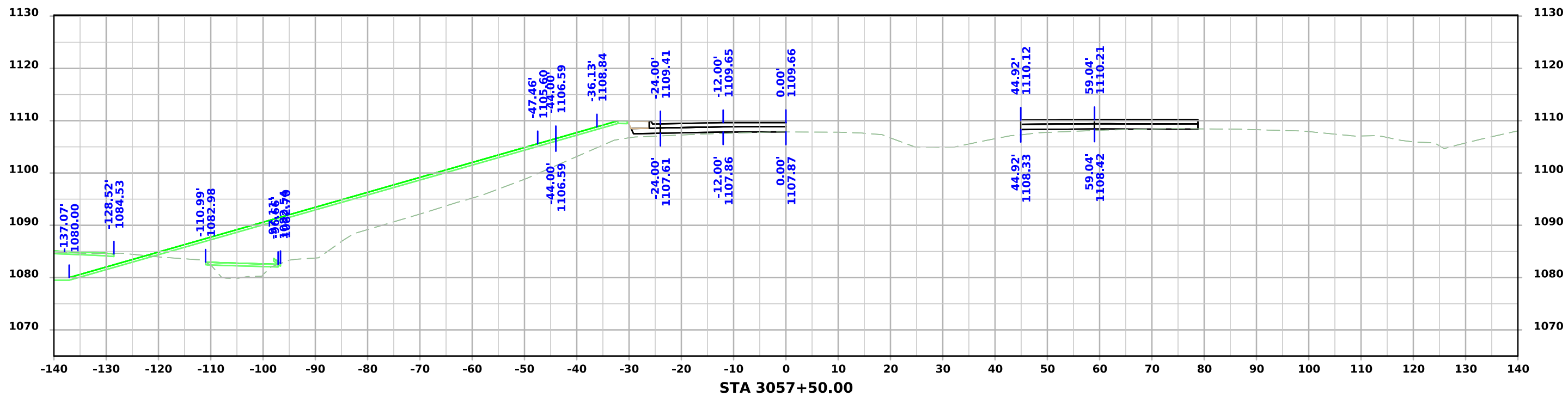
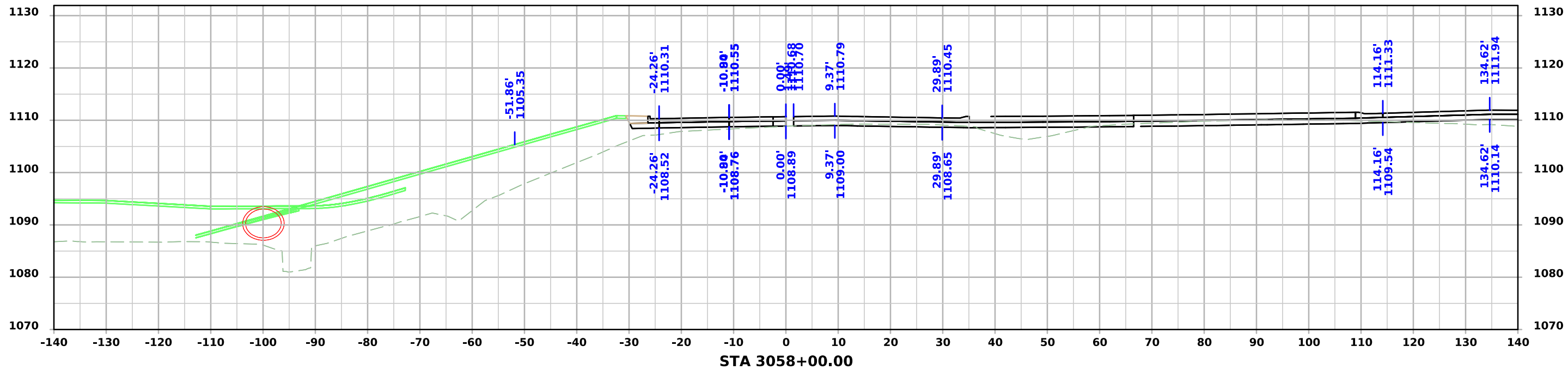

US 30 WB EXIT

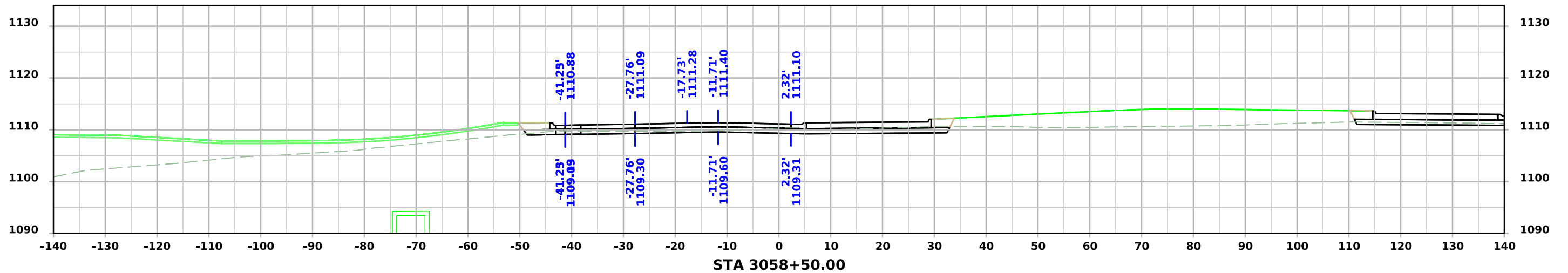

US 30 WB ENTRANCE

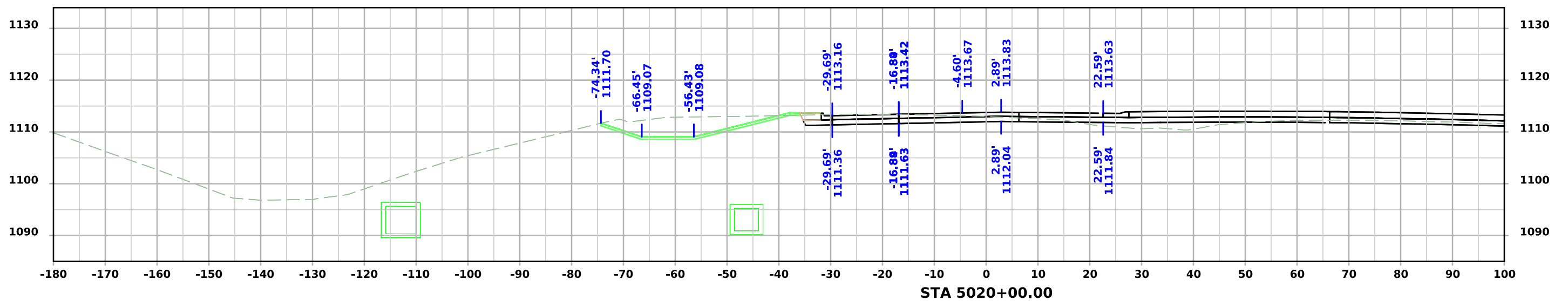
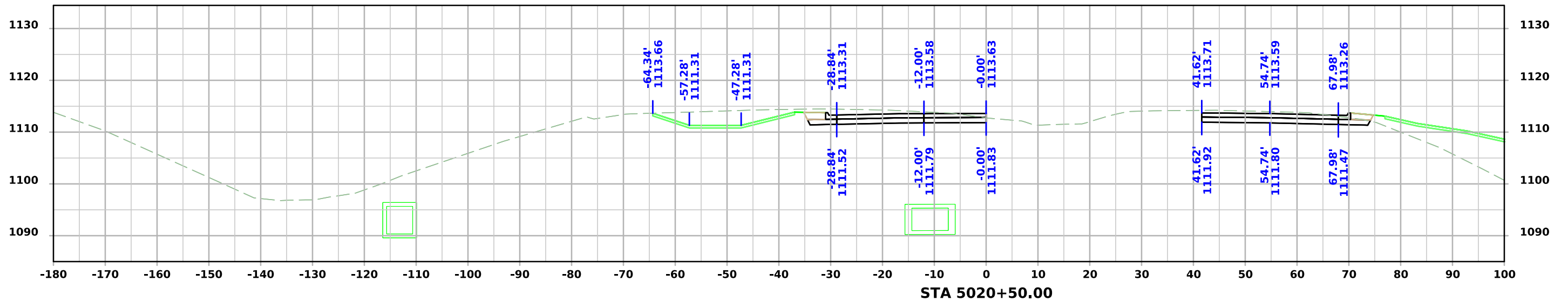

US 30 WB ENTRANCE

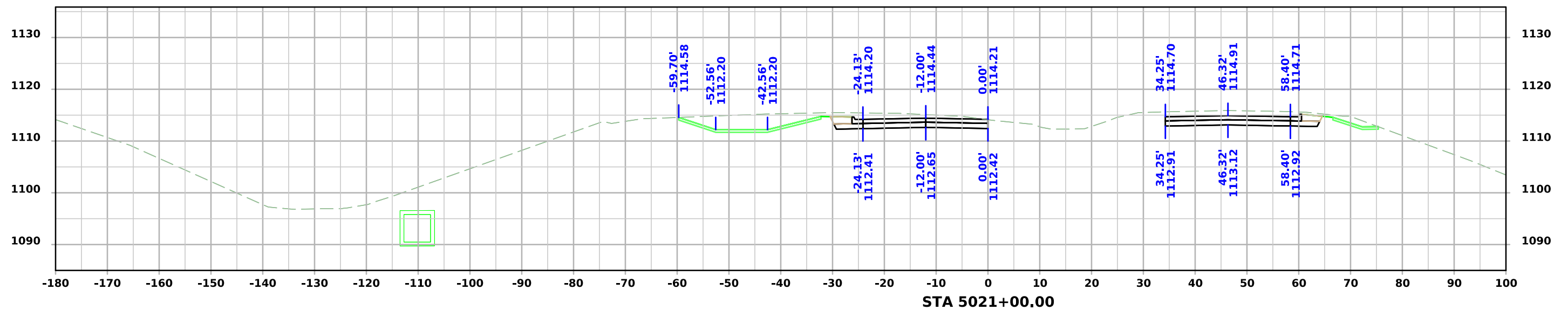
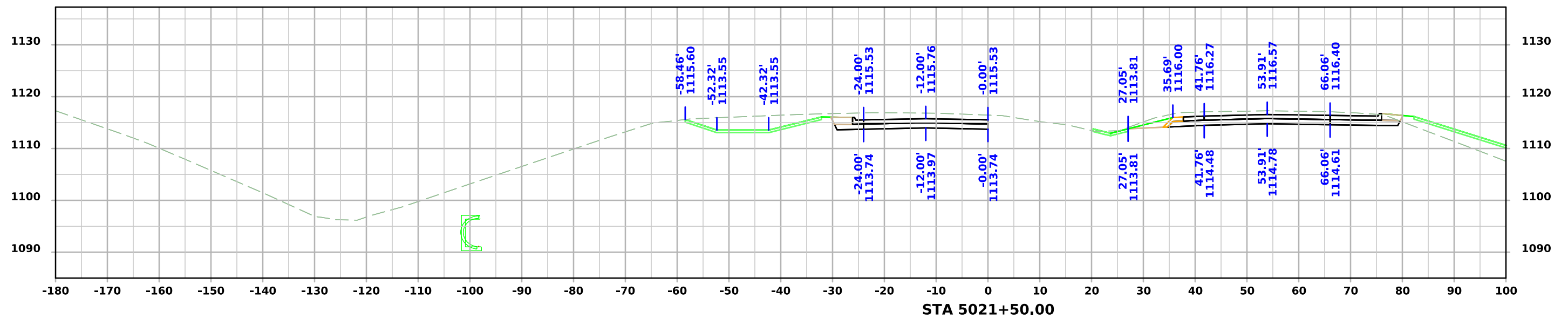

US 30 WB ENTRANCE

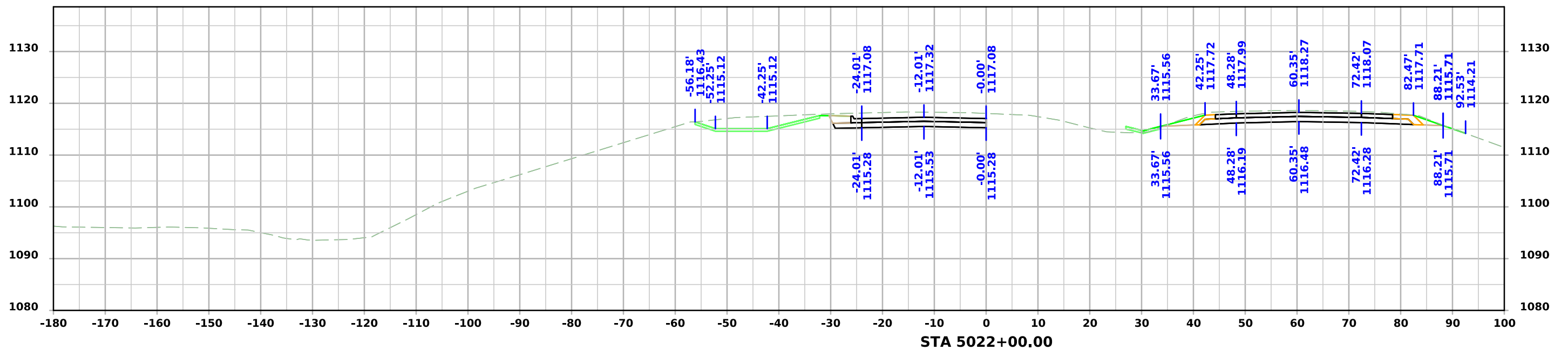
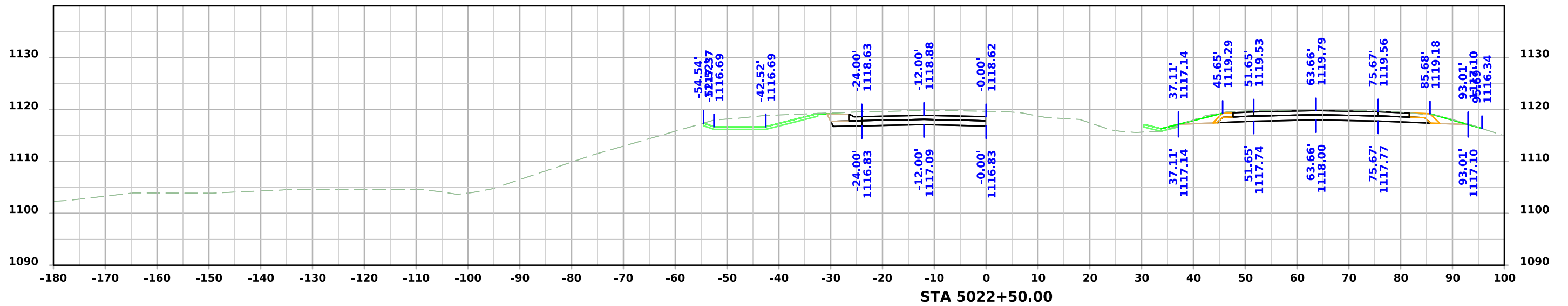

US 30 WB ENTRANCE

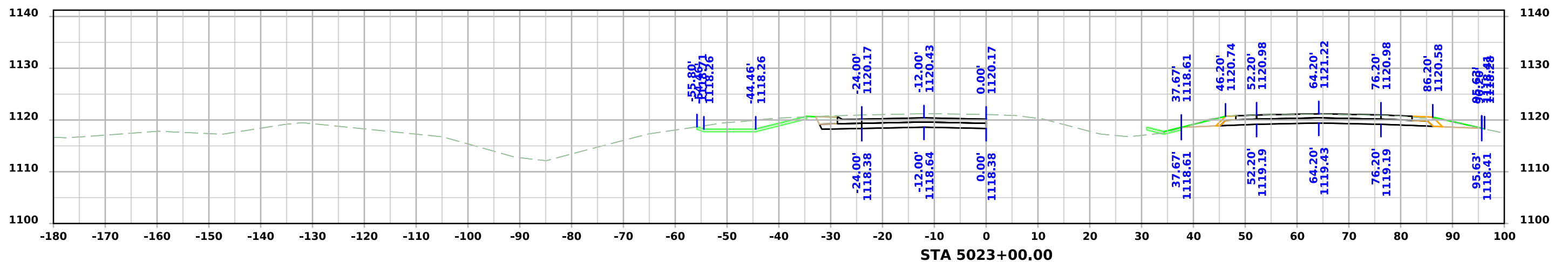
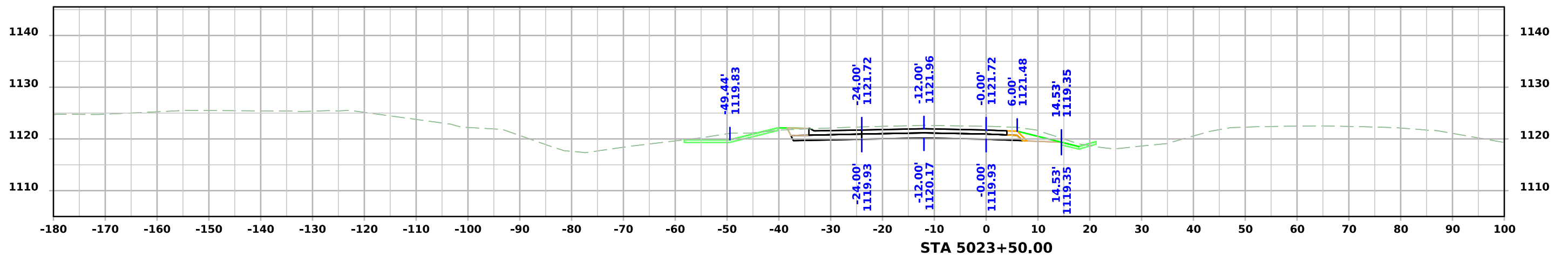
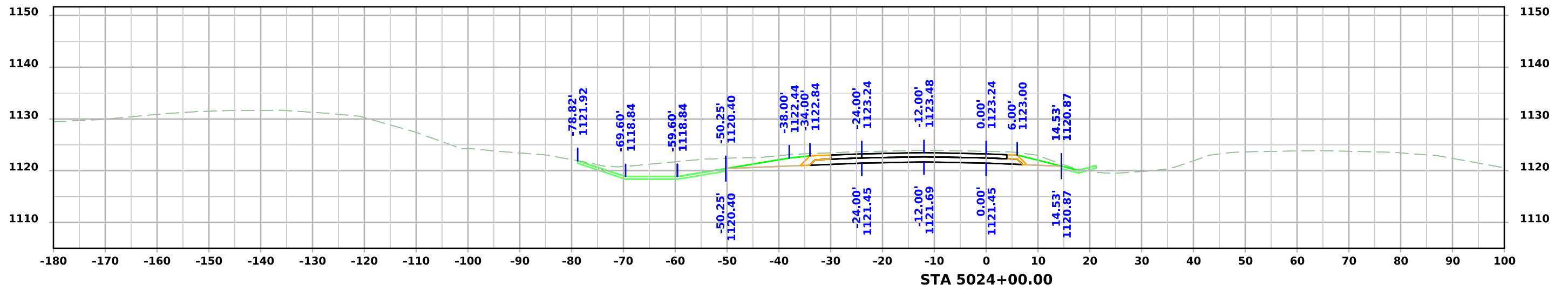

US 30 WB ENTRANCE

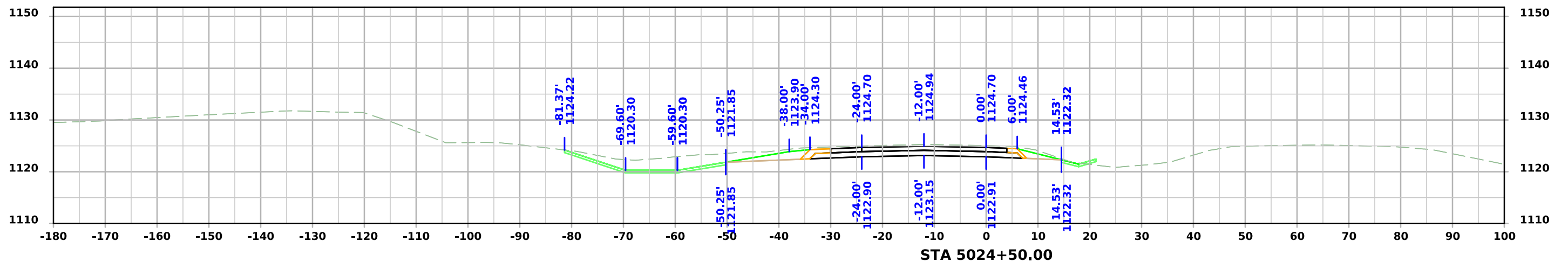
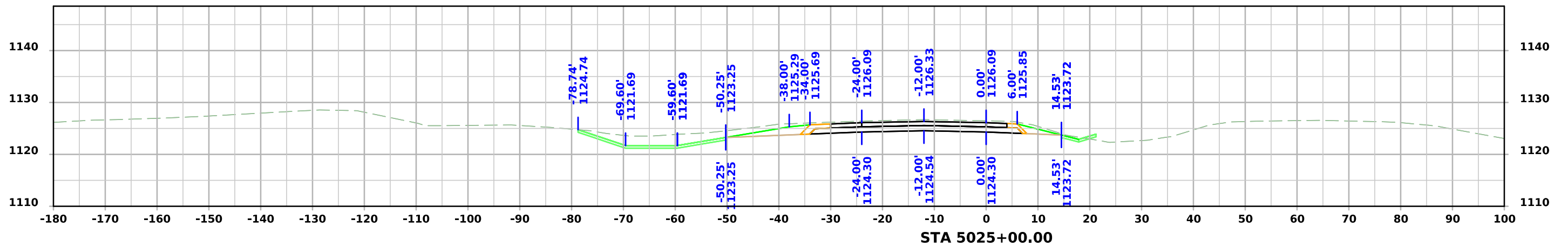
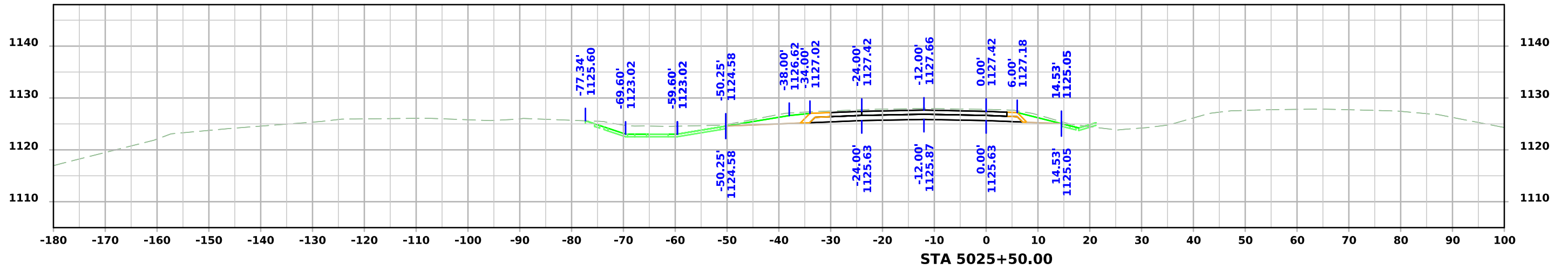

US 30 WB ENTRANCE

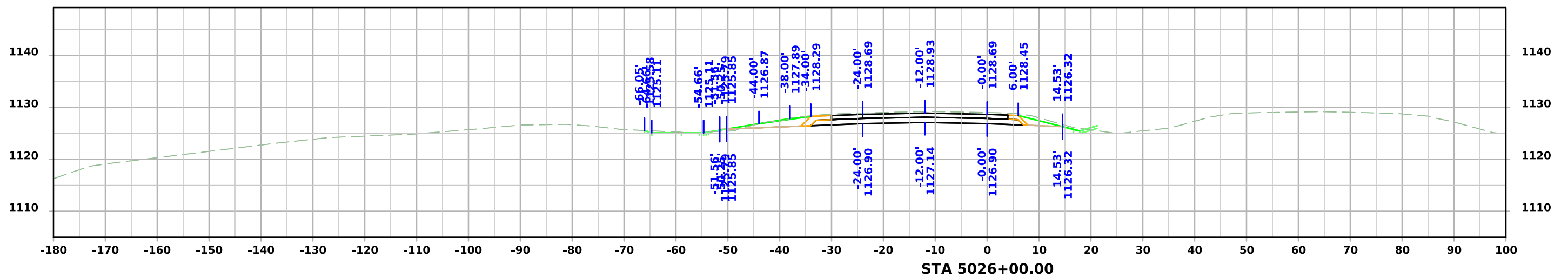
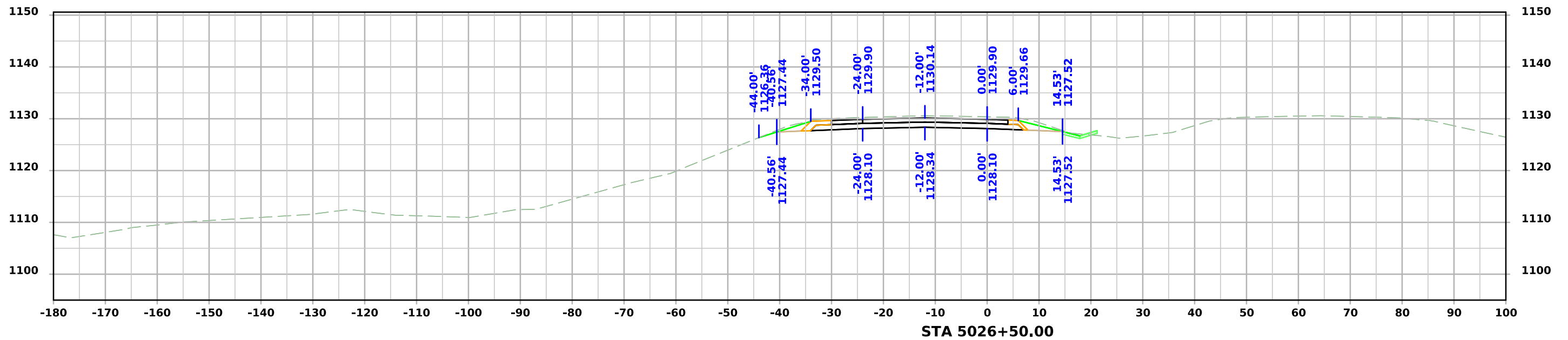

US 30 WB ENTRANCE

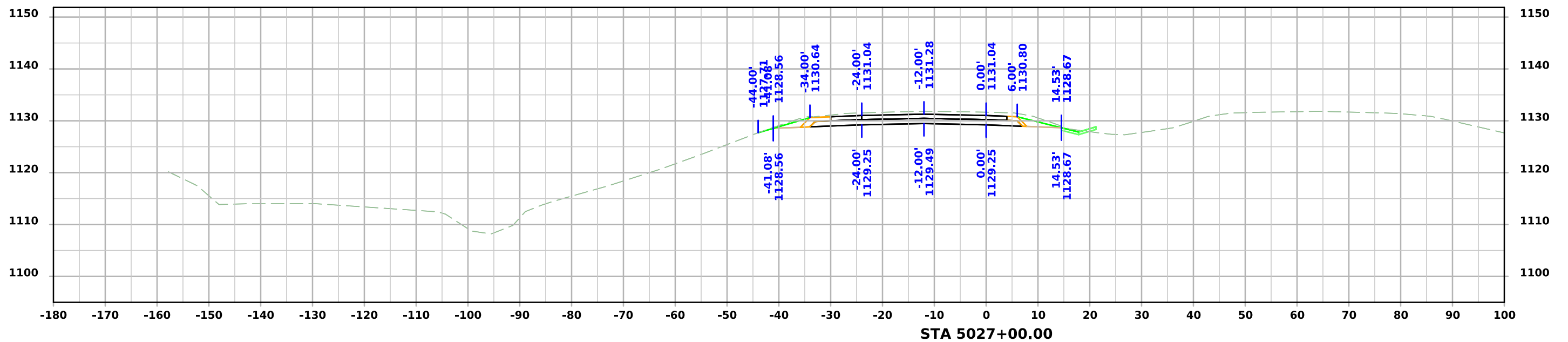
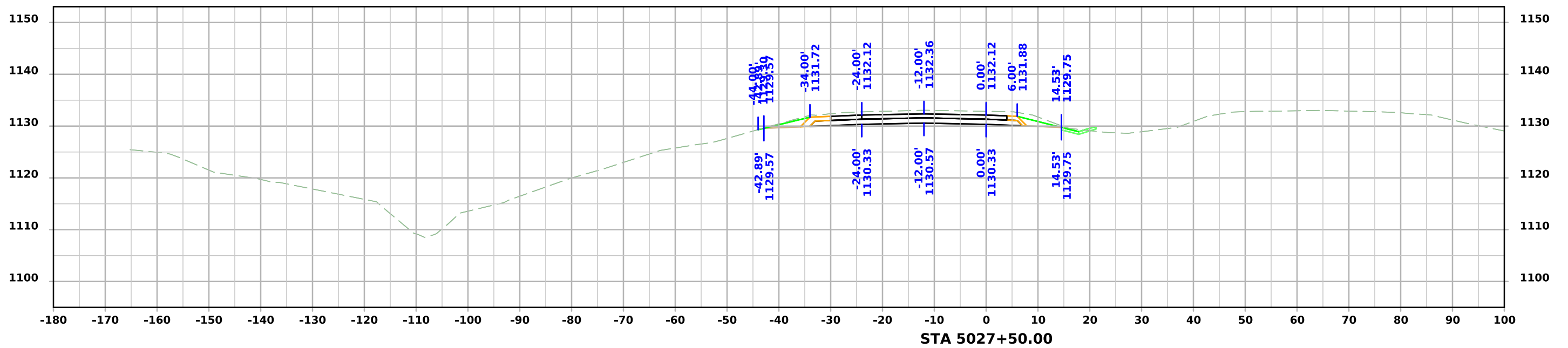

US 30 WB ENTRANCE

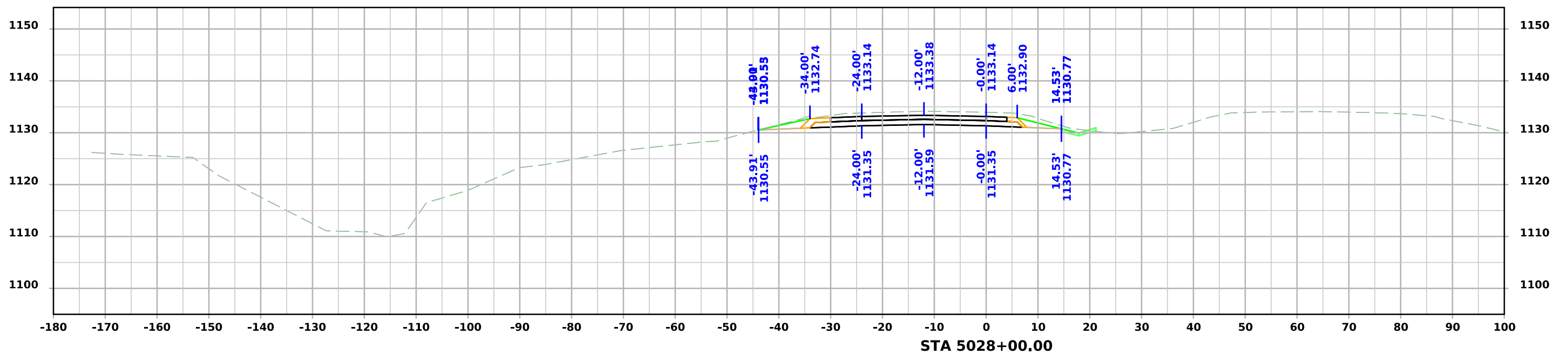
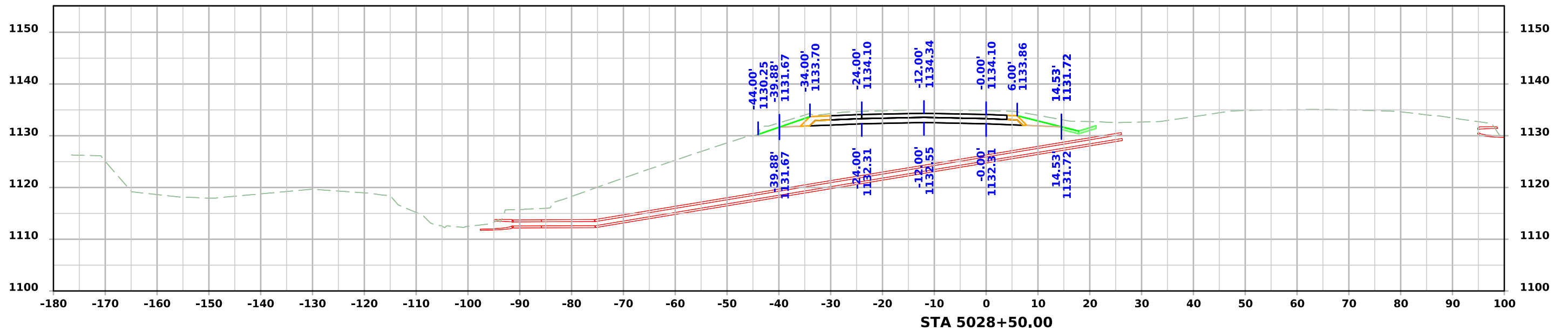

US 30 WB ENTRANCE

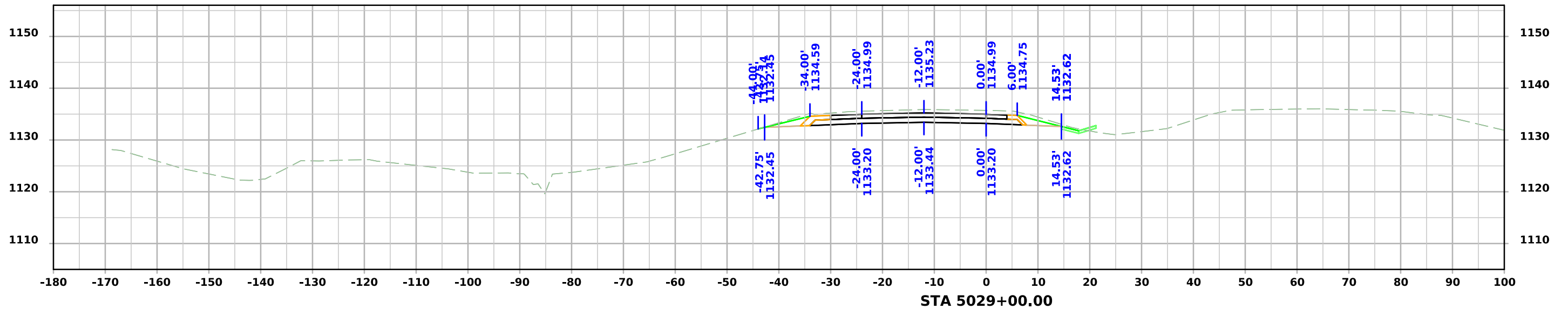
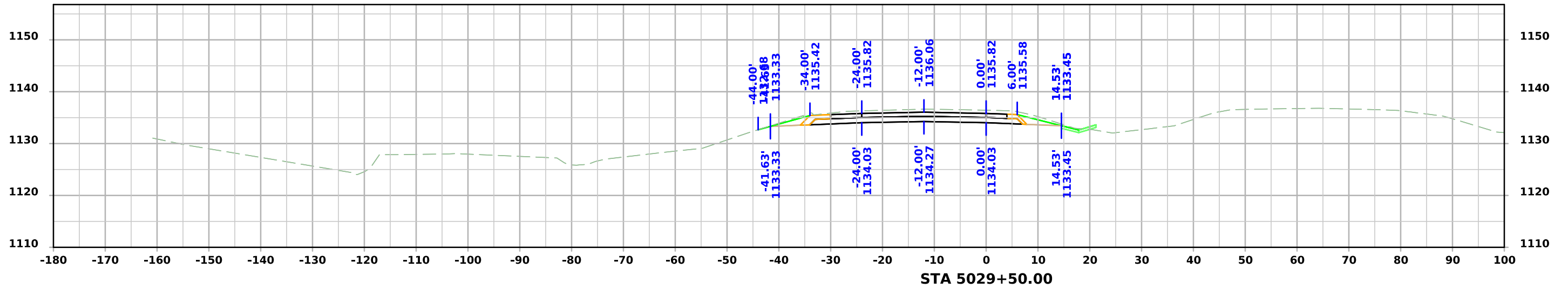
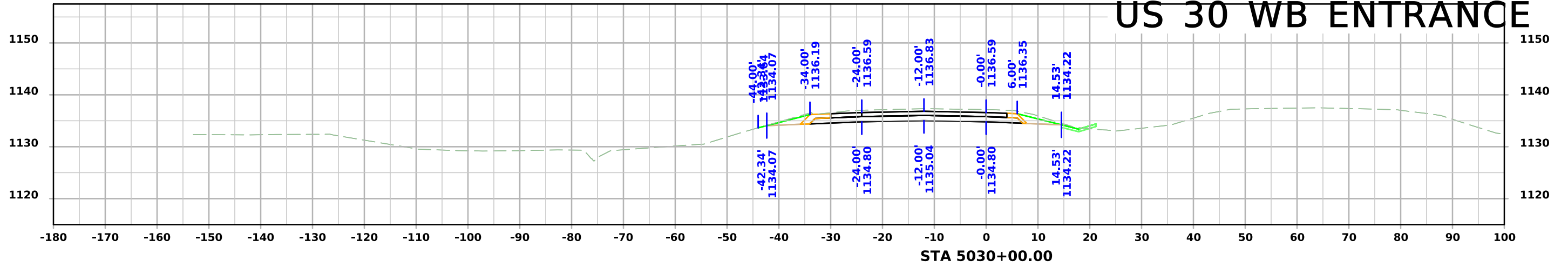

US 30 WB ENTRANCE

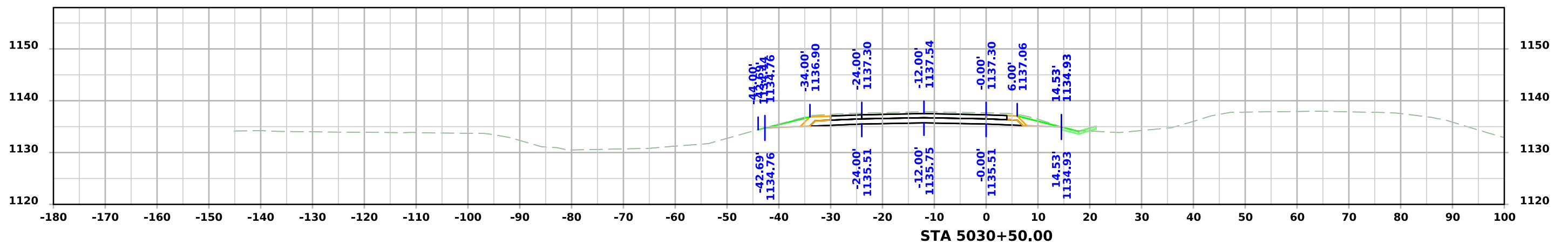
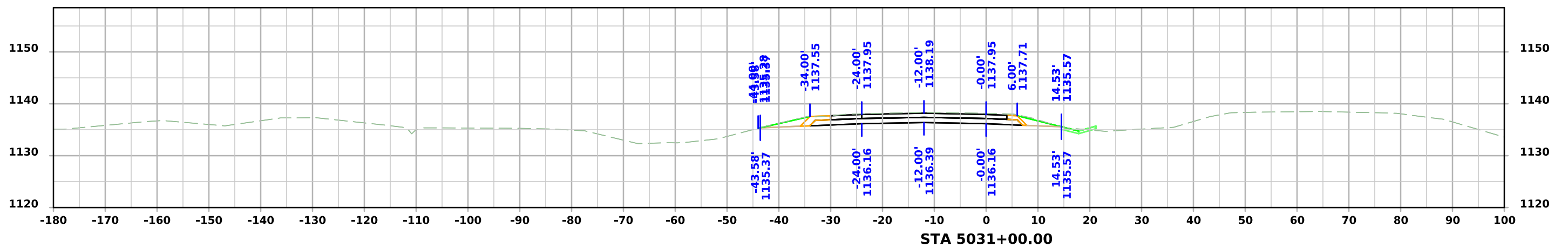
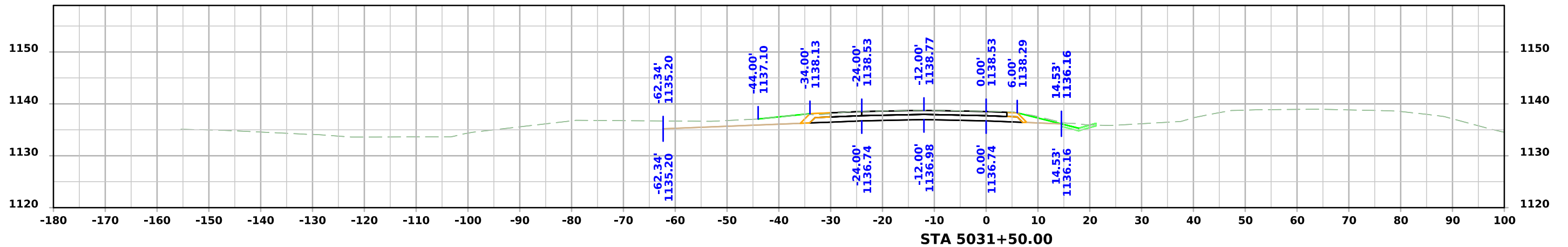

US 30 WB ENTRANCE

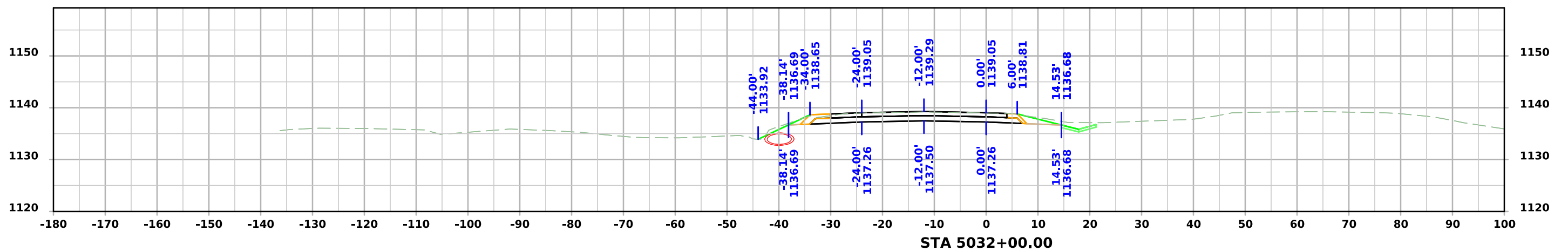
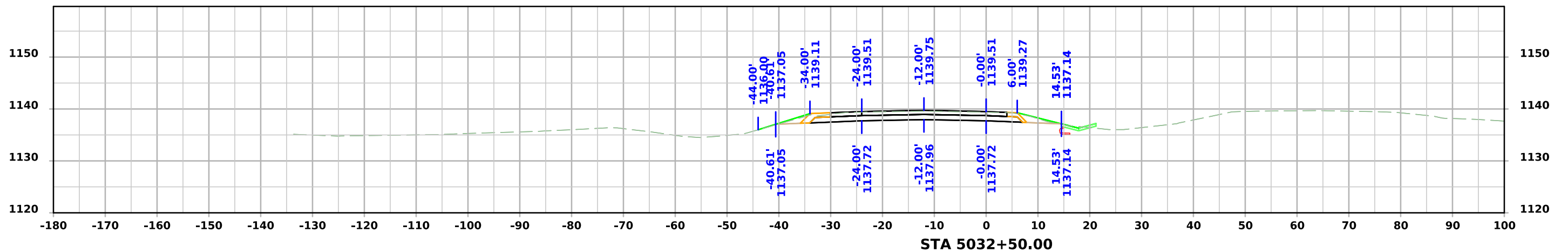
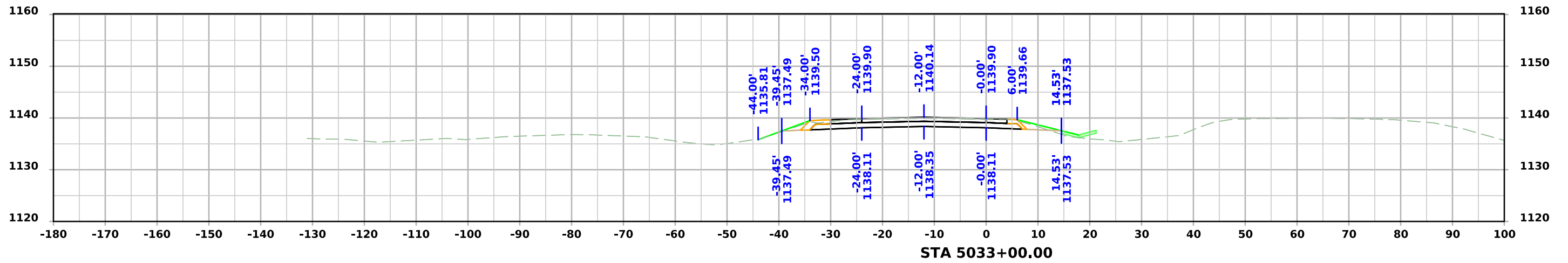

US 30 WB ENTRANCE

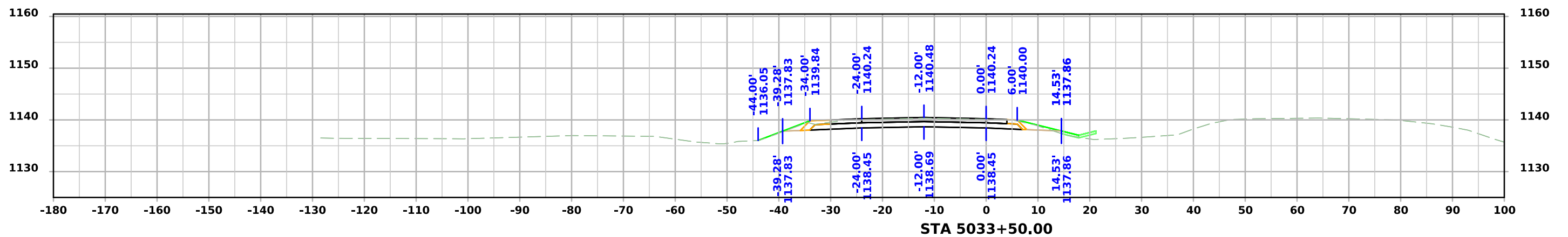
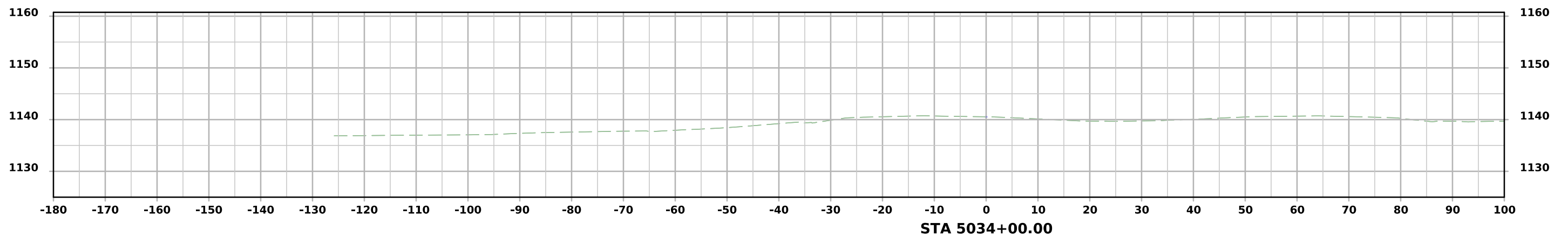
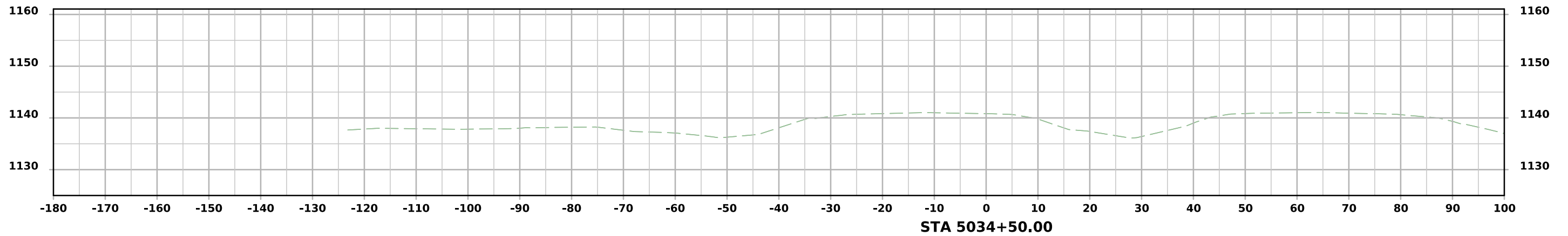

QUILL AVE NB ENTRANCE

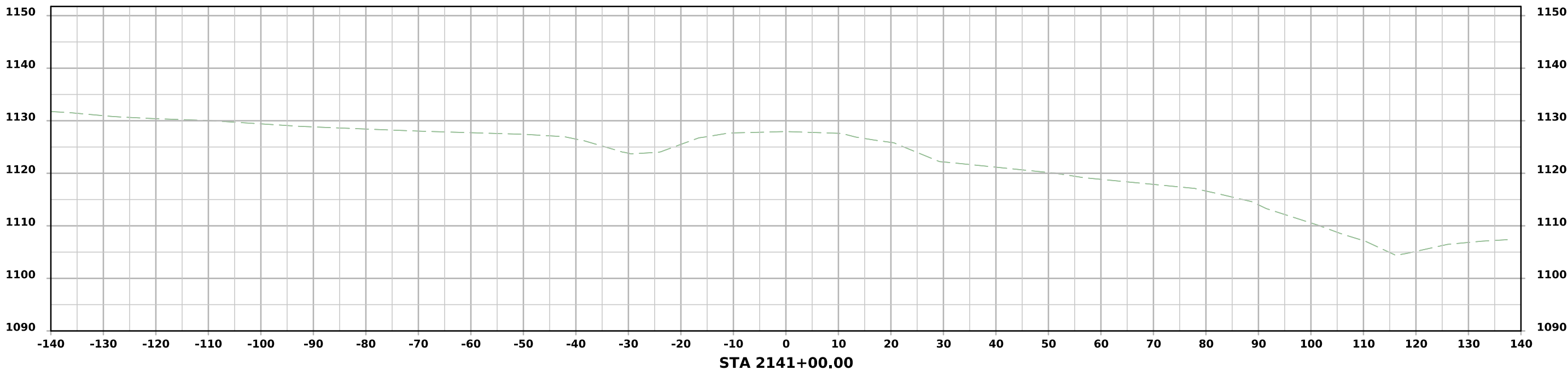
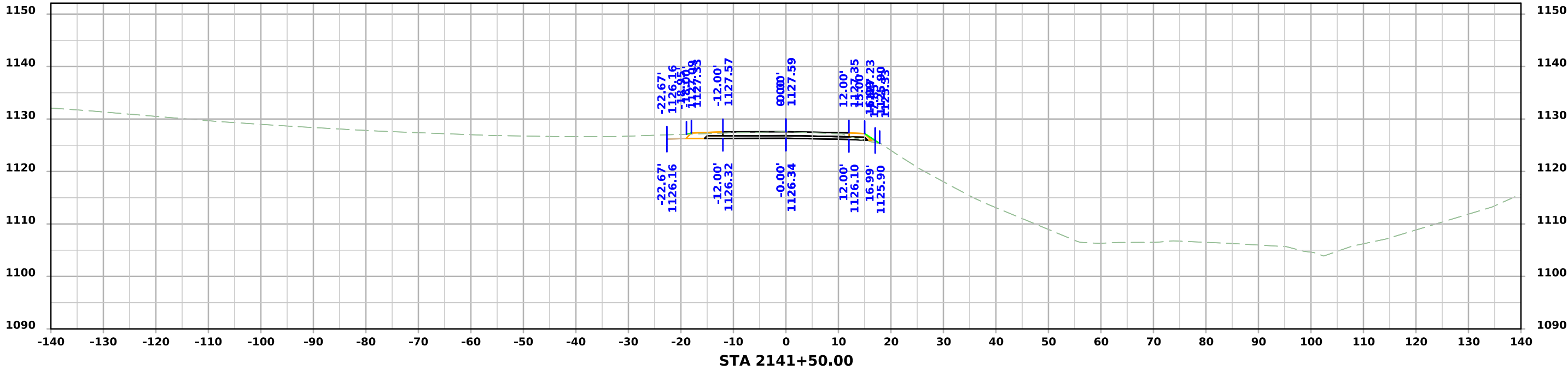

QUILL AVE NB ENTRANCE

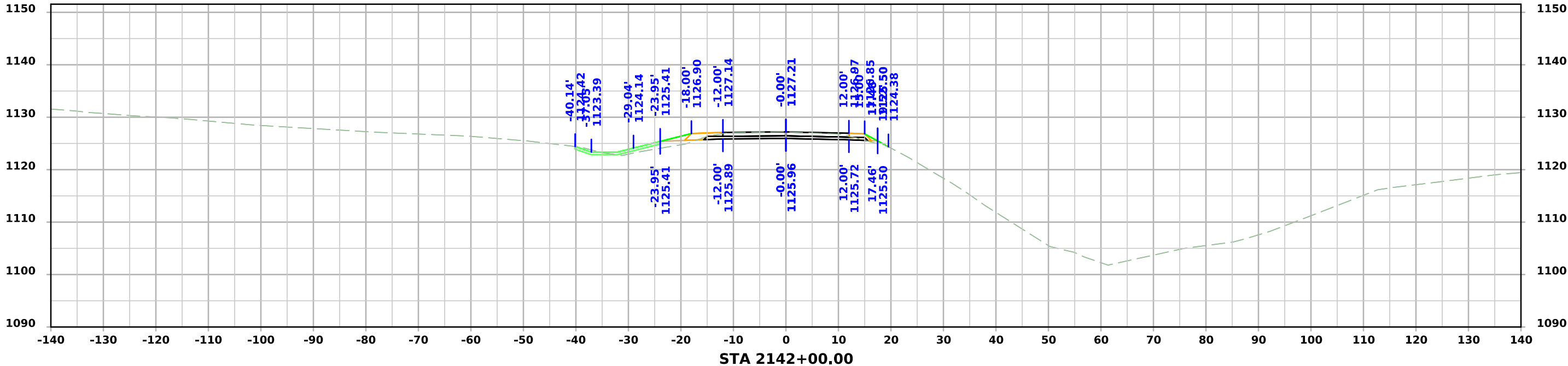
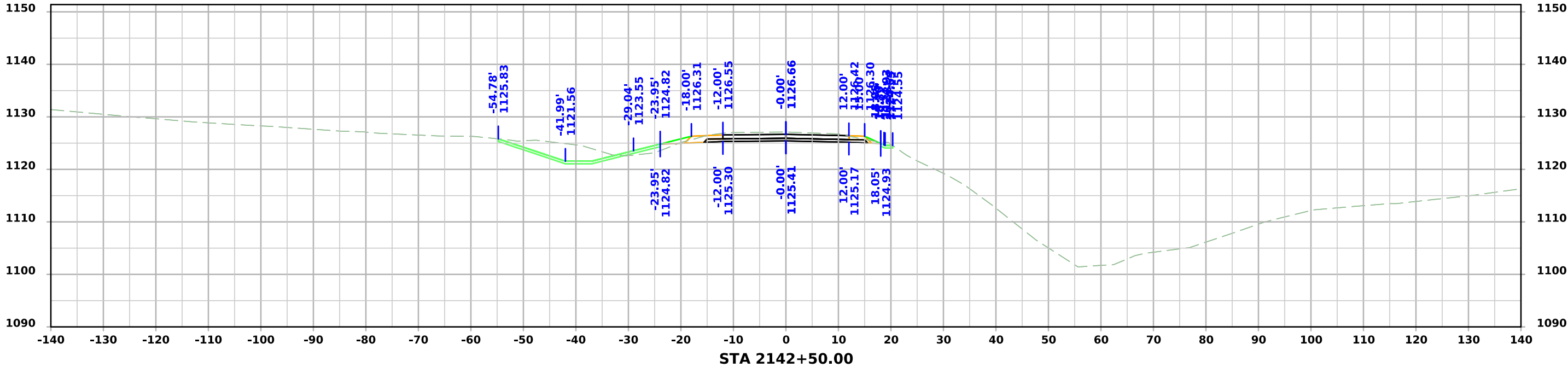

QUILL AVE NB ENTRANCE

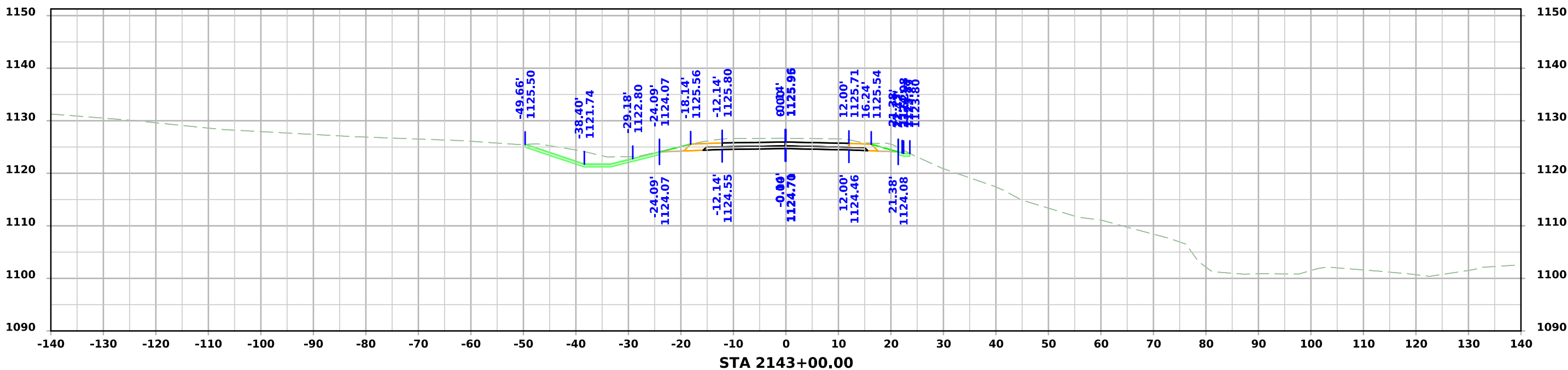
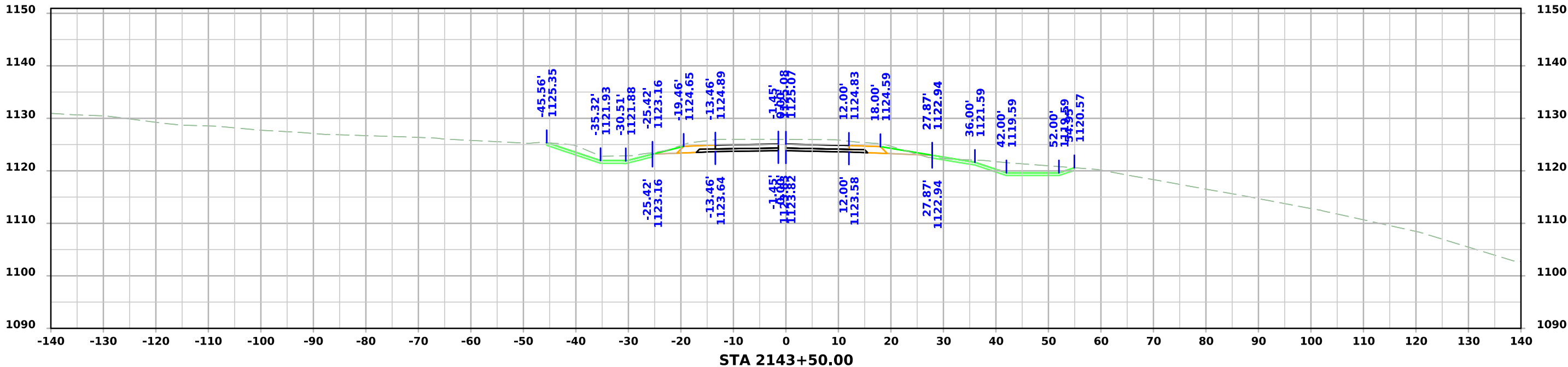

QUILL AVE NB ENTRANCE

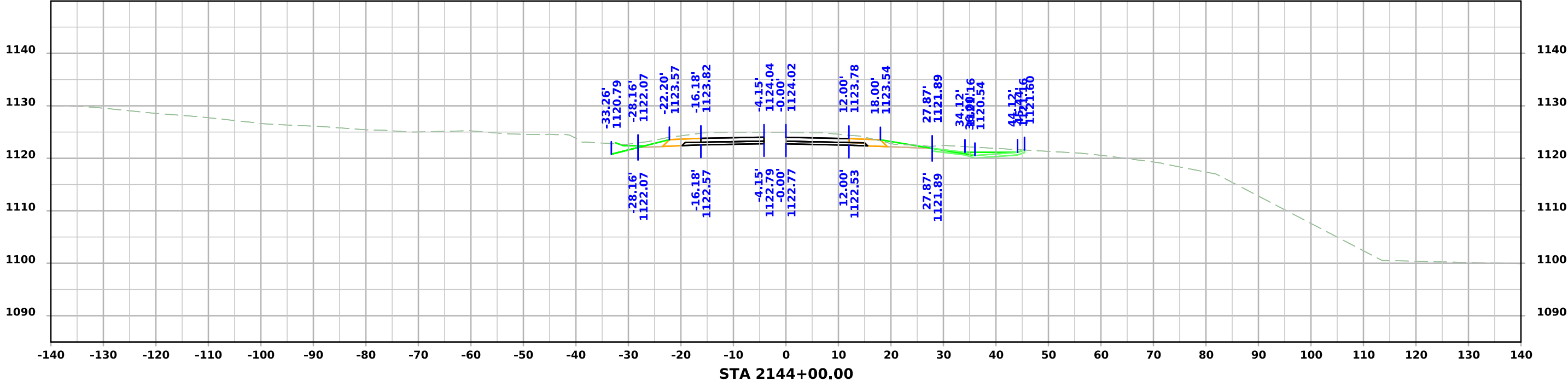
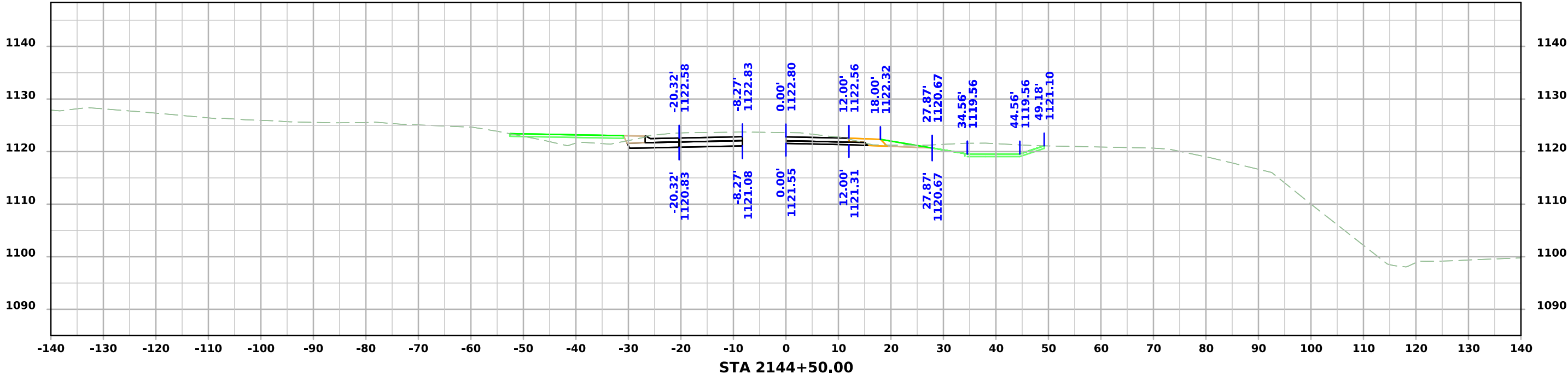

QUILL AVE NB ENTRANCE

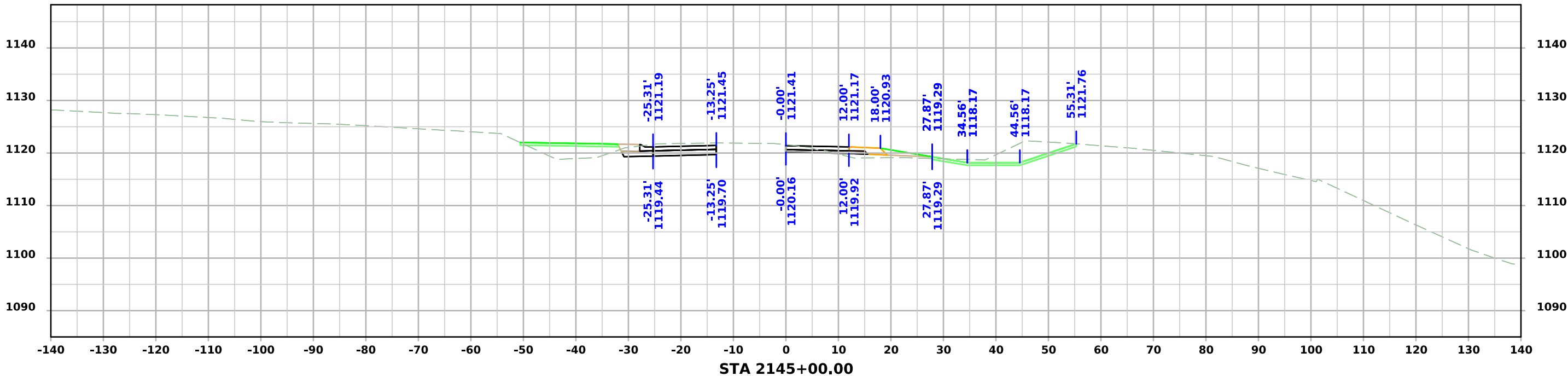
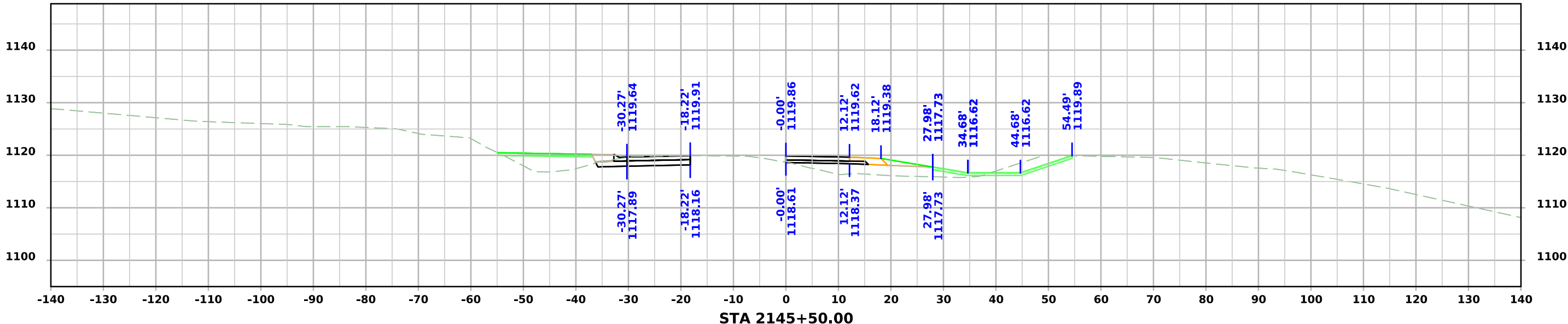

QUILL AVE NB ENTRANCE

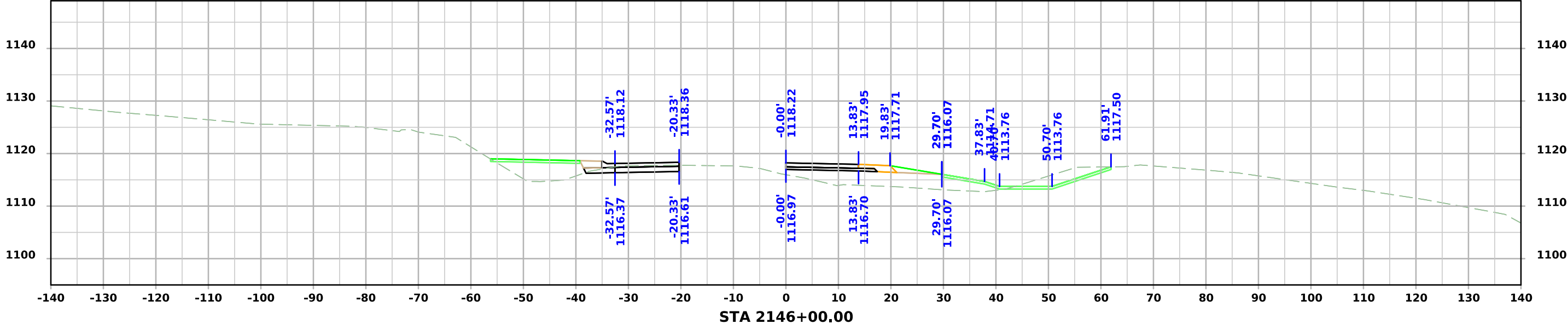
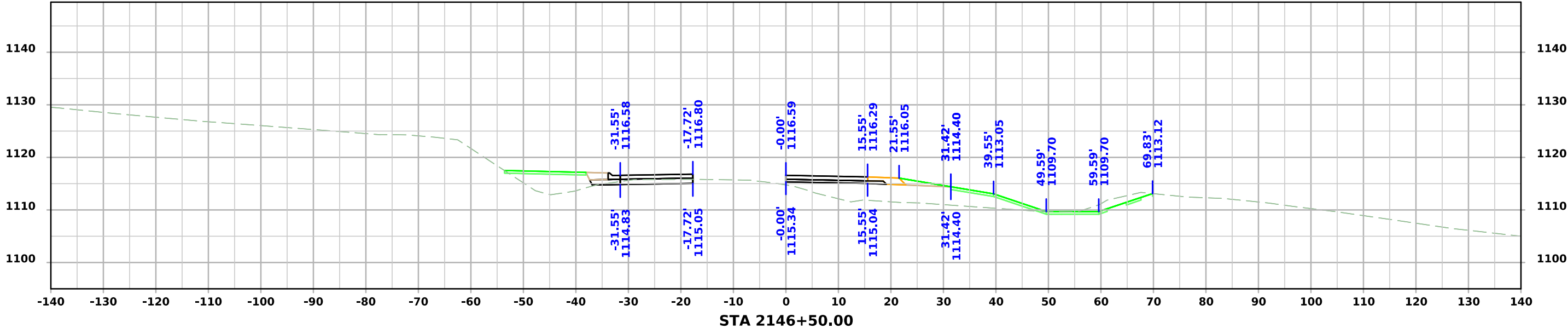

QUILL AVE NB ENTRANCE

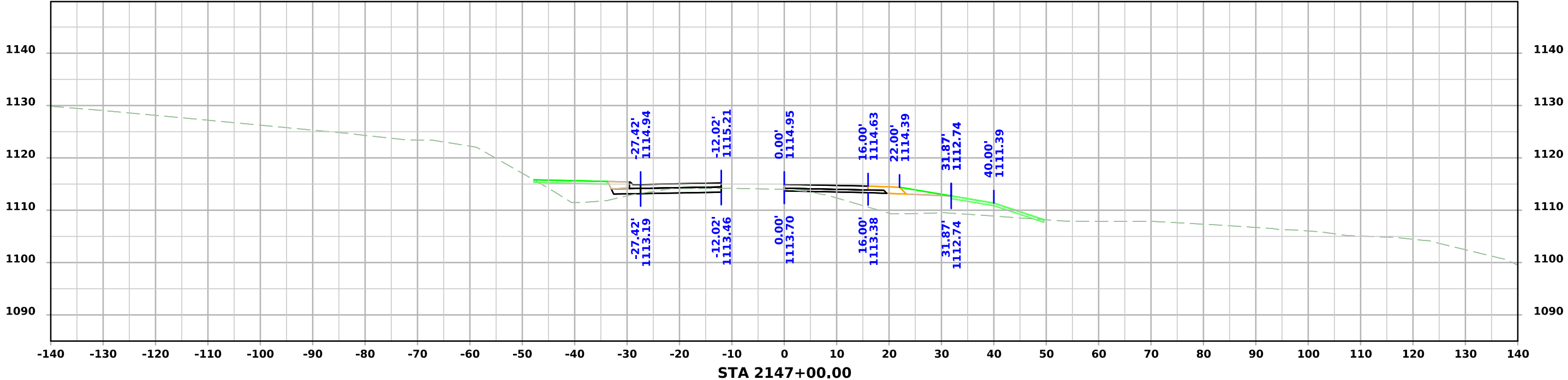
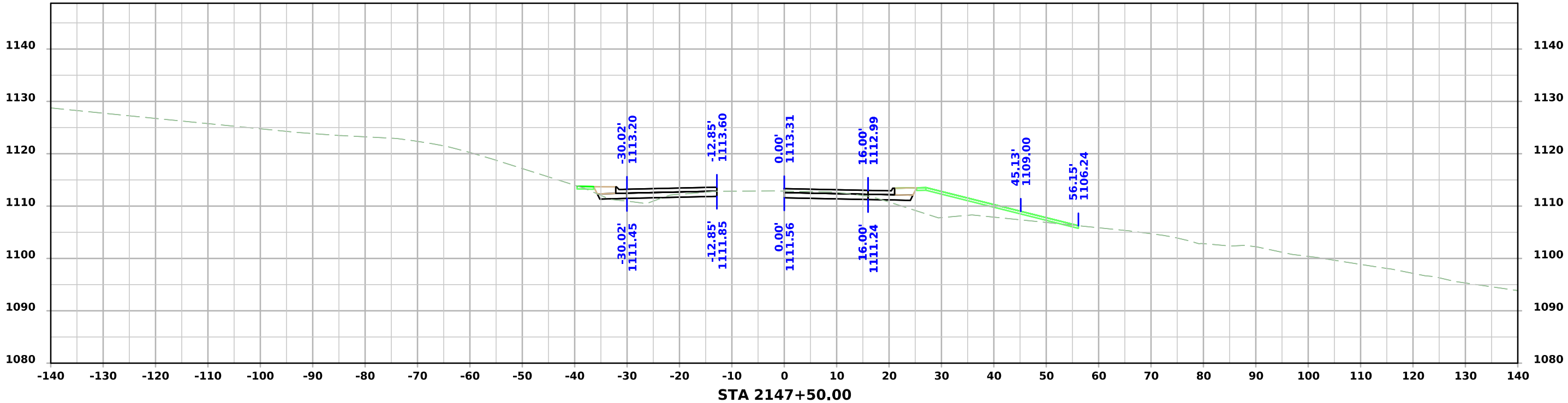

QUILL AVE NB ENTRANCE

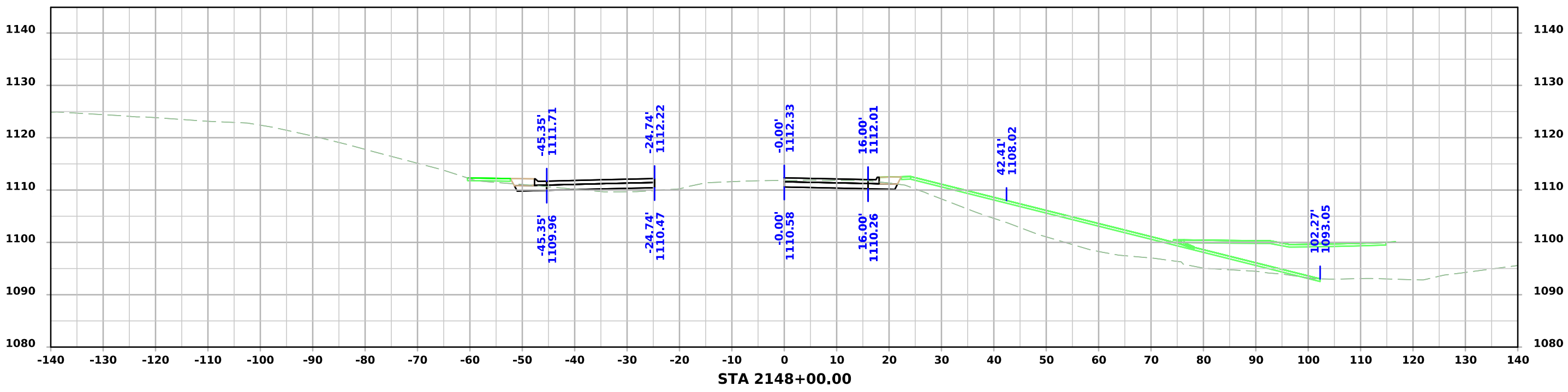
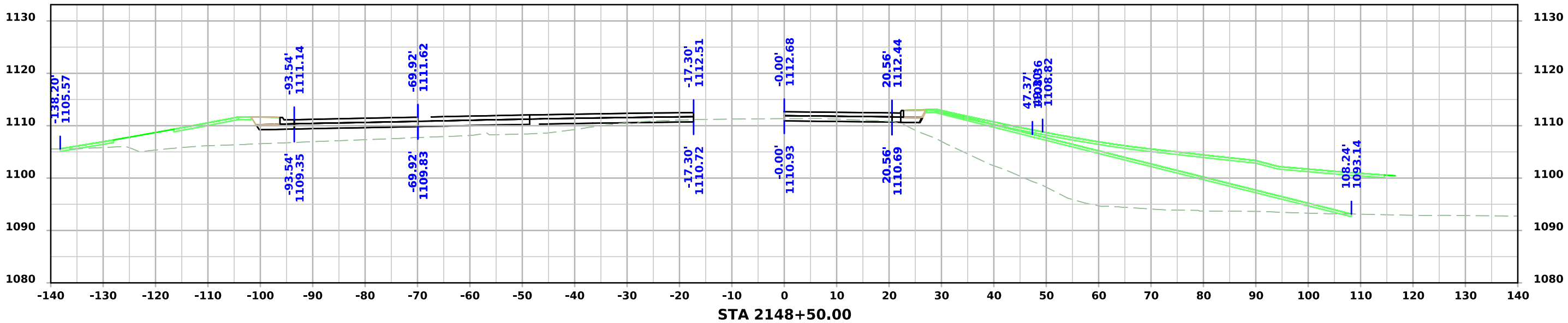

QUILL AVE NB ENTRANCE

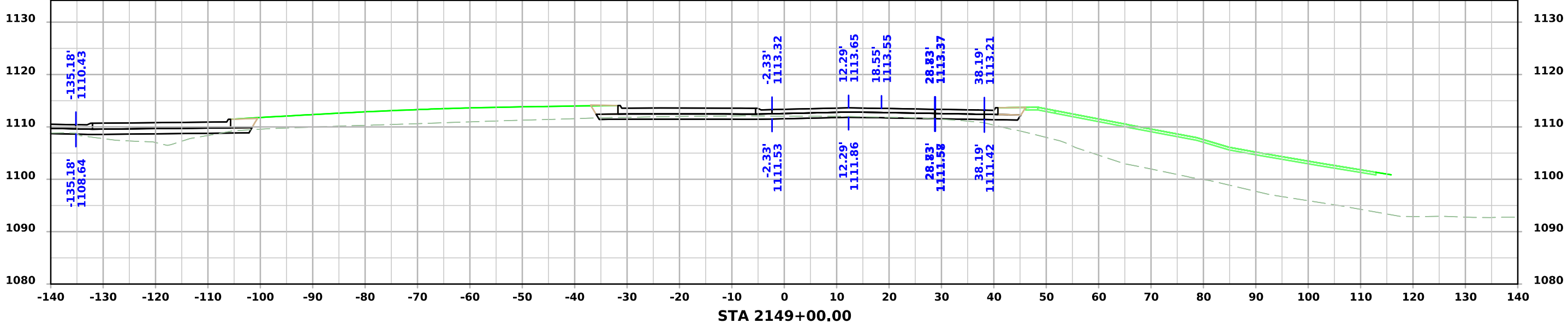

QUILL AVE SB EXIT

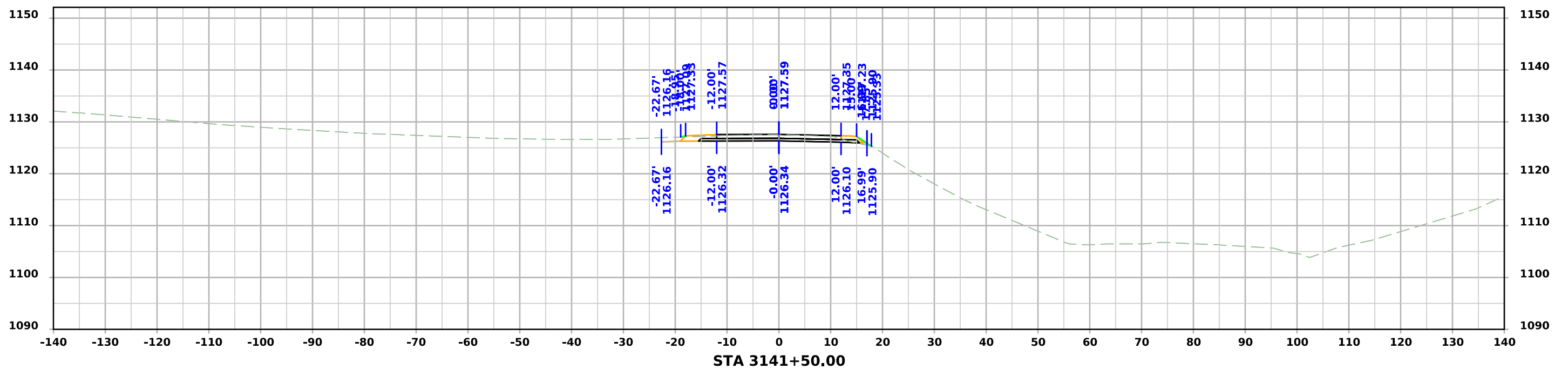
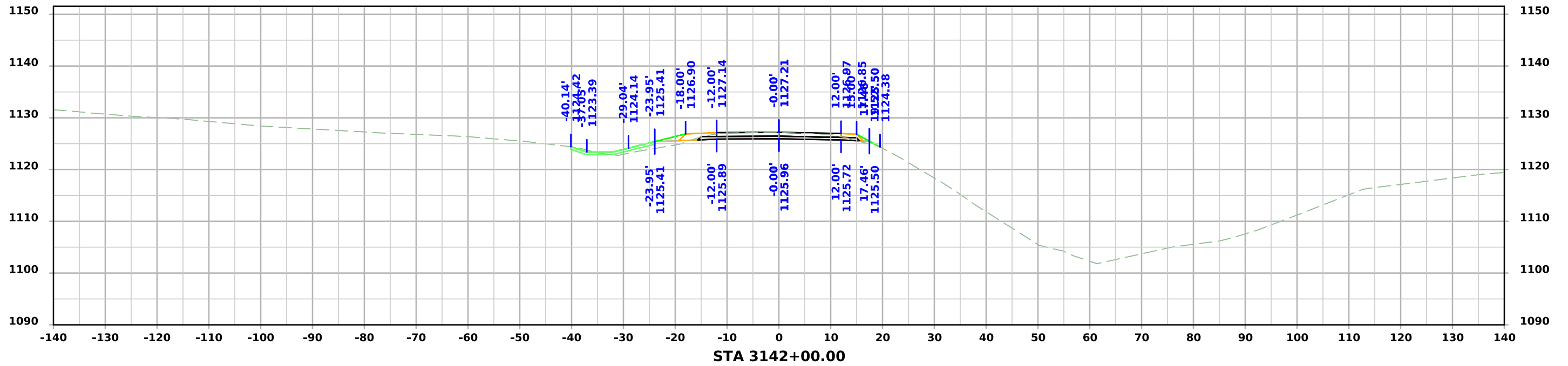

QUILL AVE SB EXIT

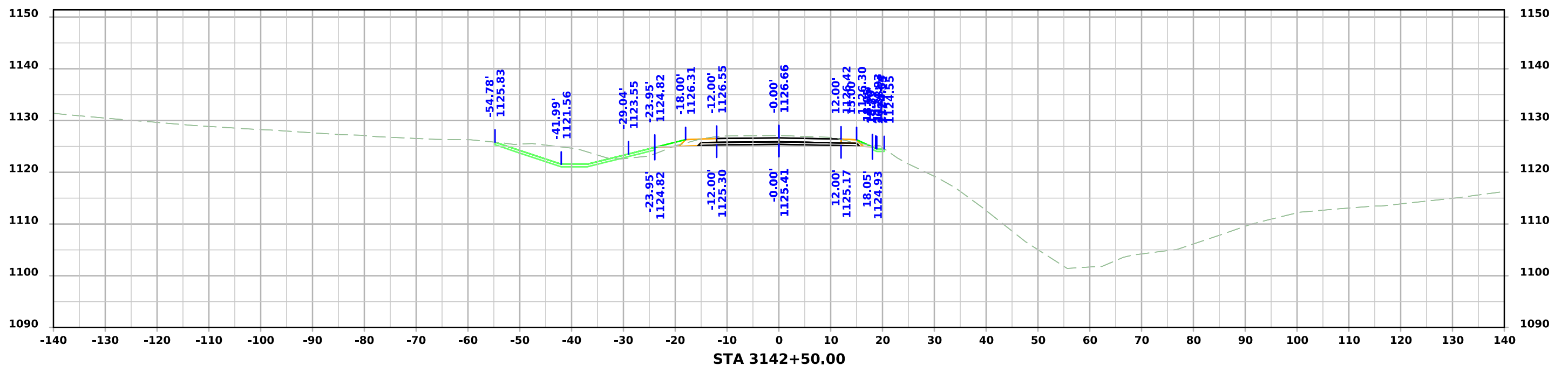
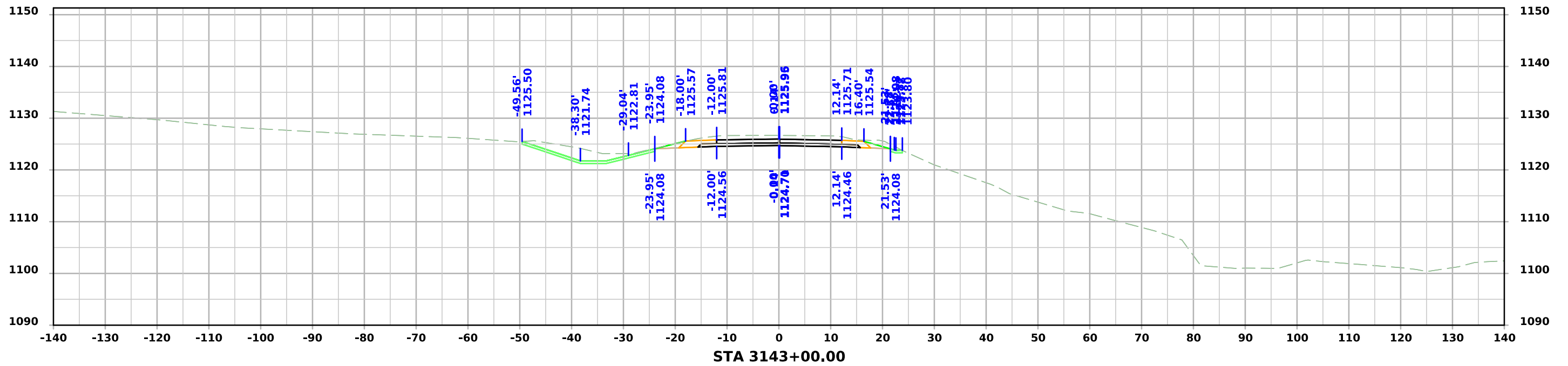

QUILL AVE SB EXIT

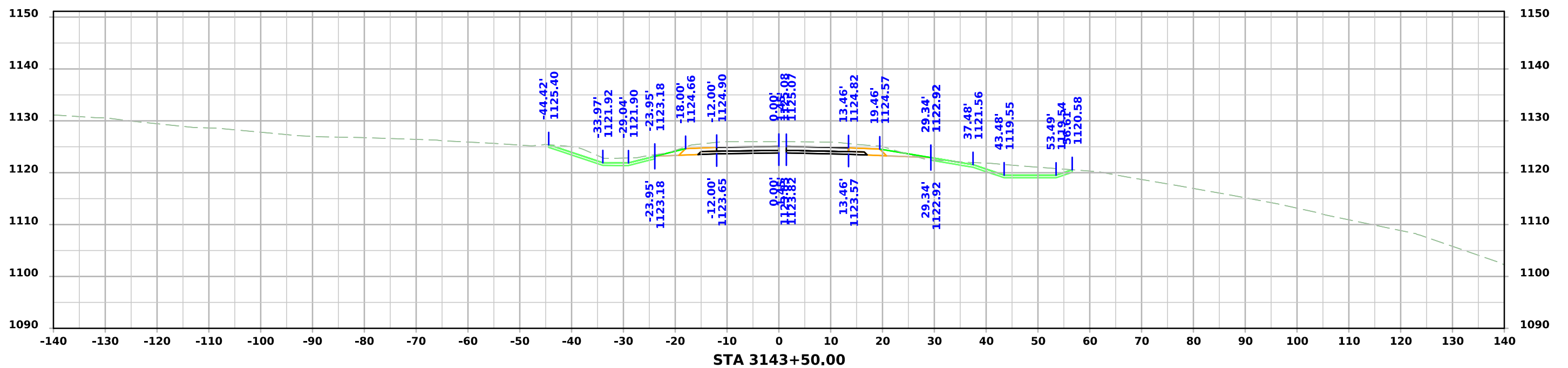
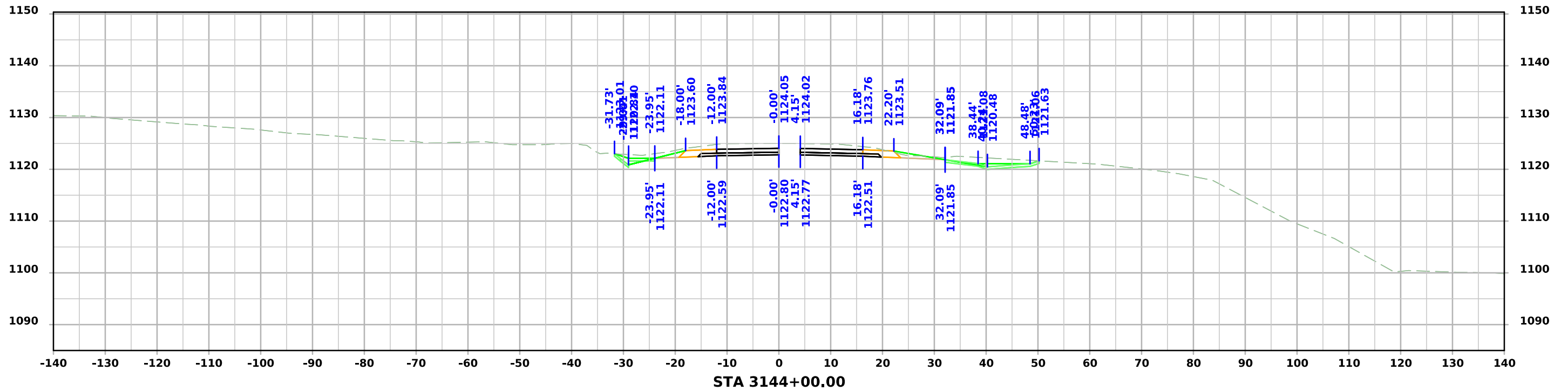

QUILL AVE SB EXIT

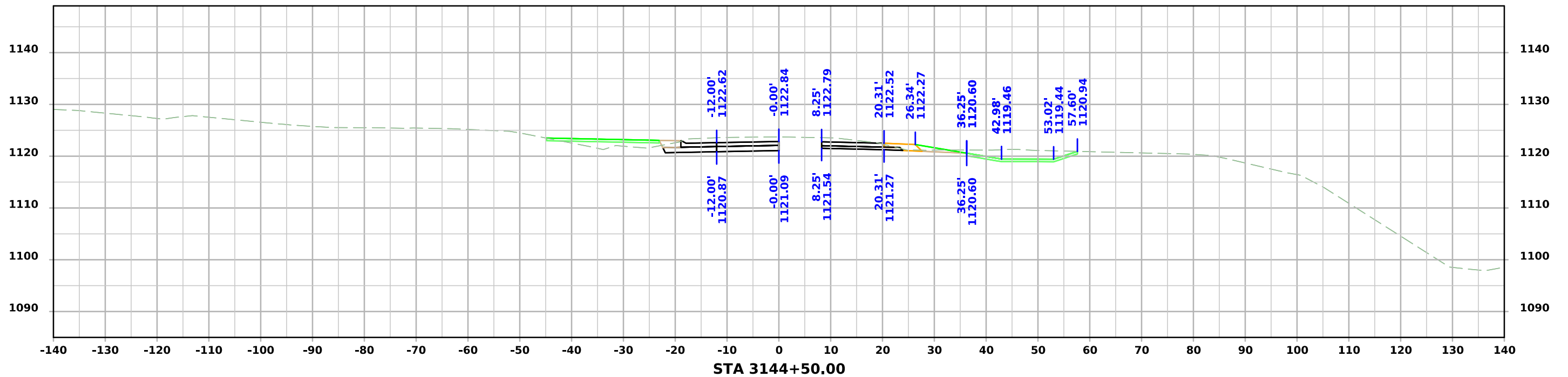
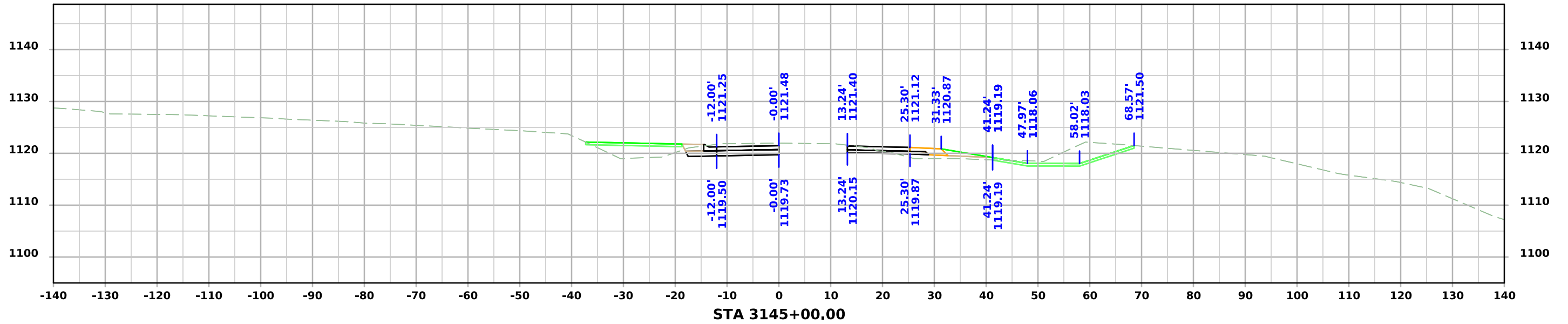

QUILL AVE SB EXIT

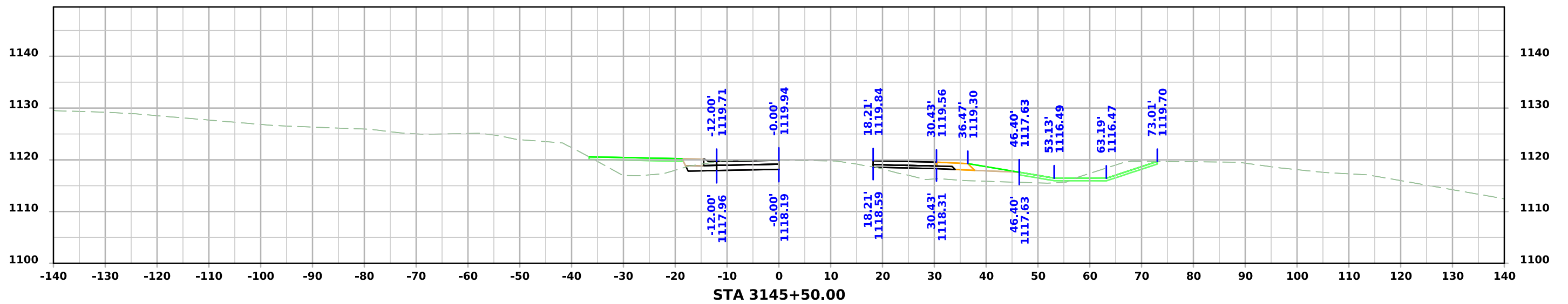
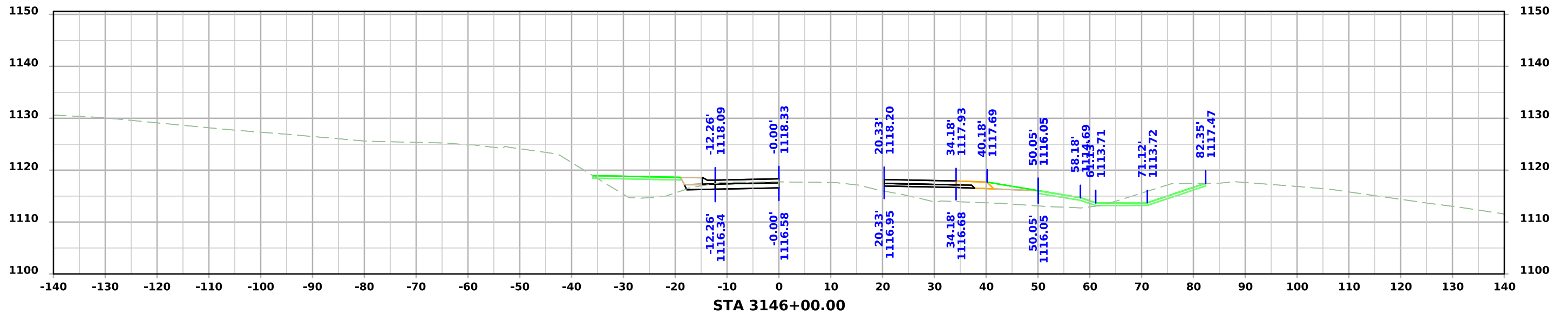

QUILL AVE SB EXIT

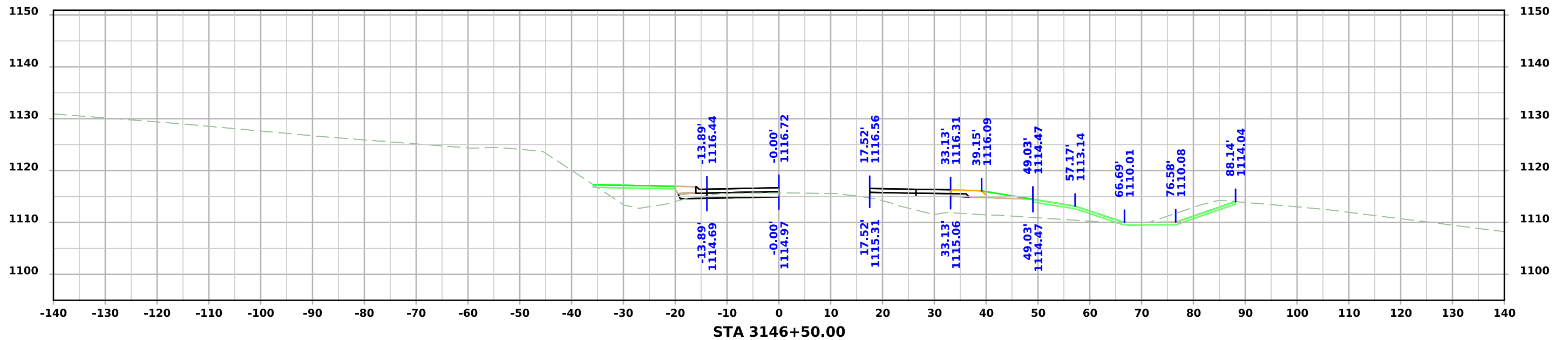
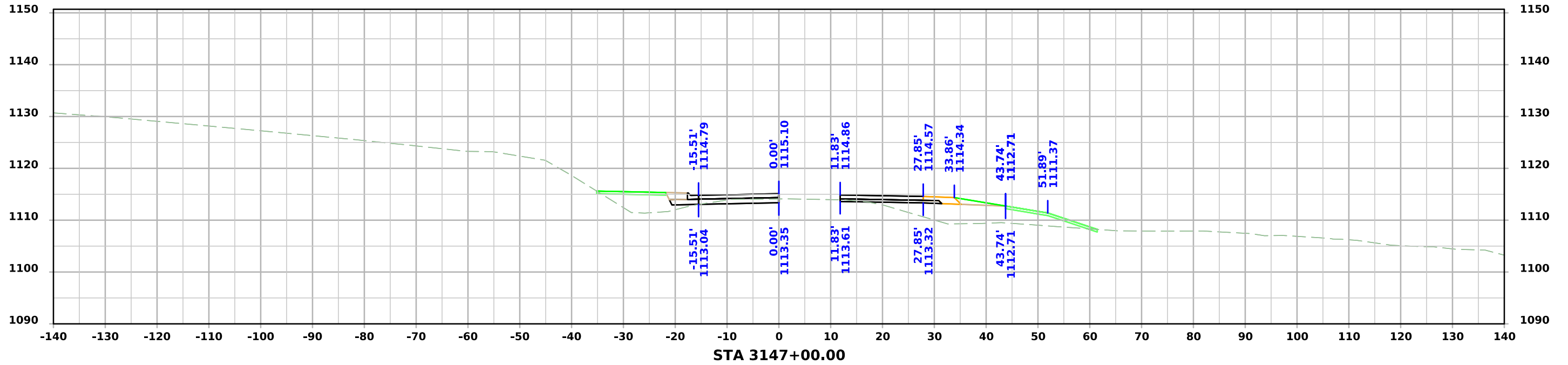

QUILL AVE SB EXIT

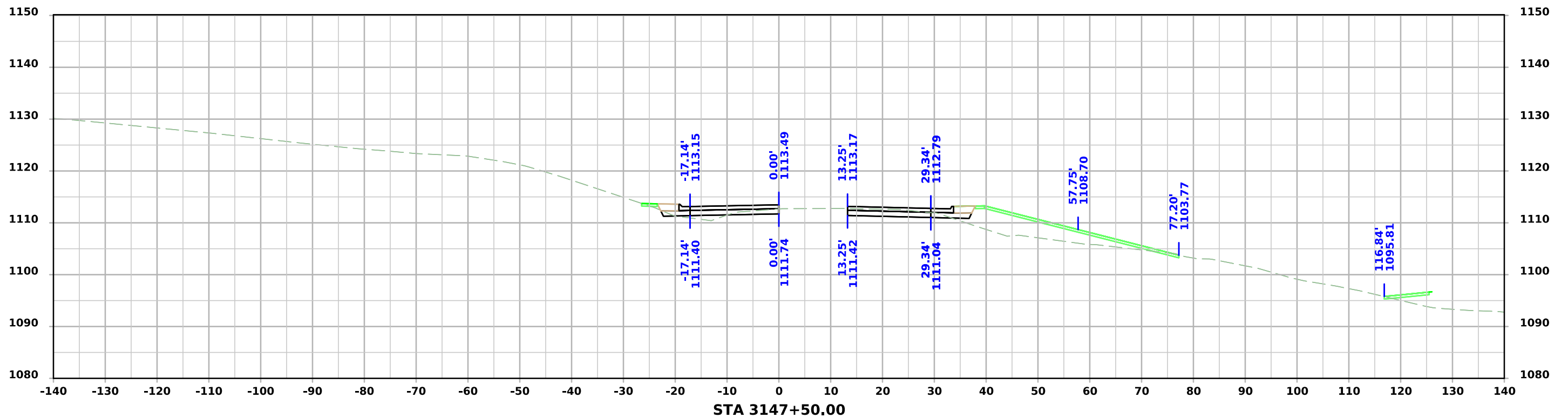
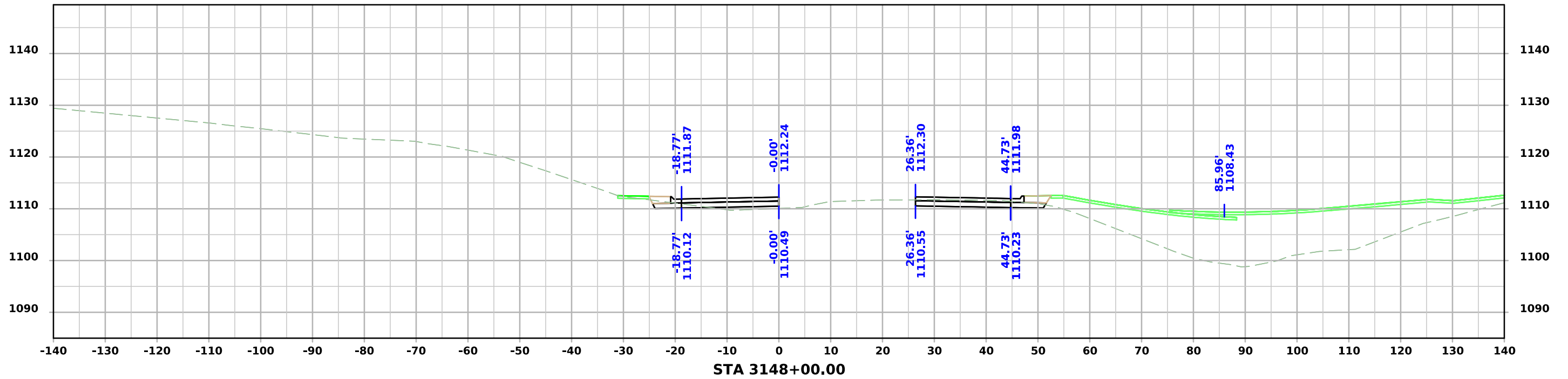

QUILL AVE SB EXIT

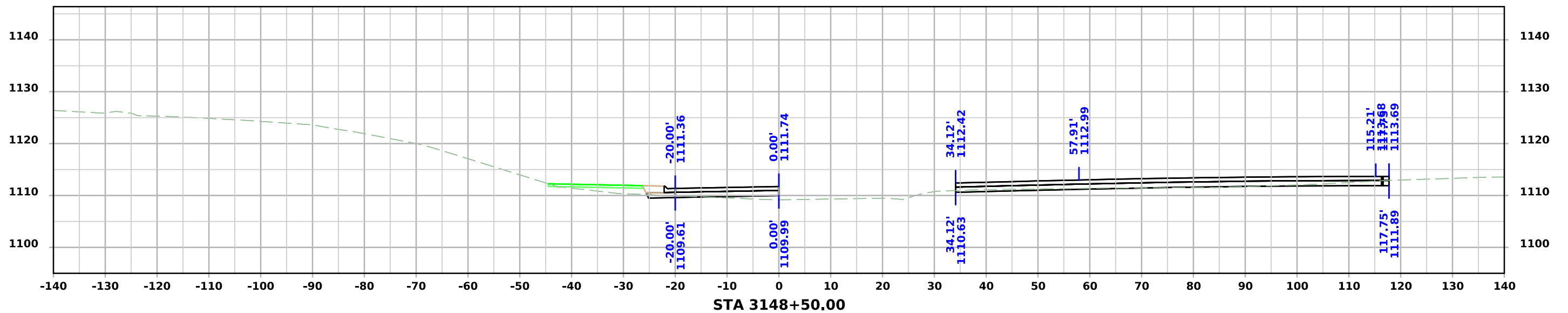
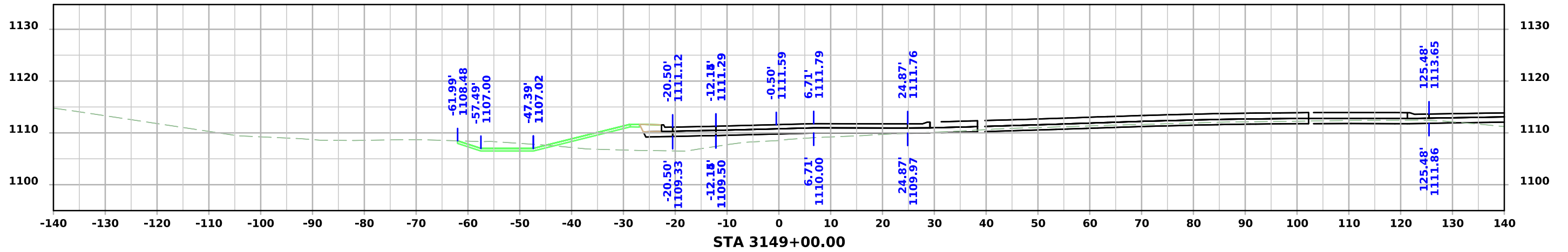
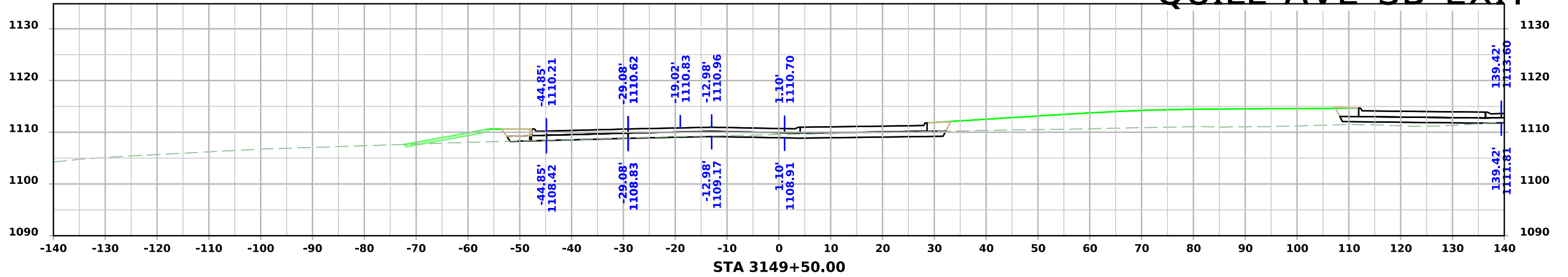

SNEDDEN DR NB EXIT

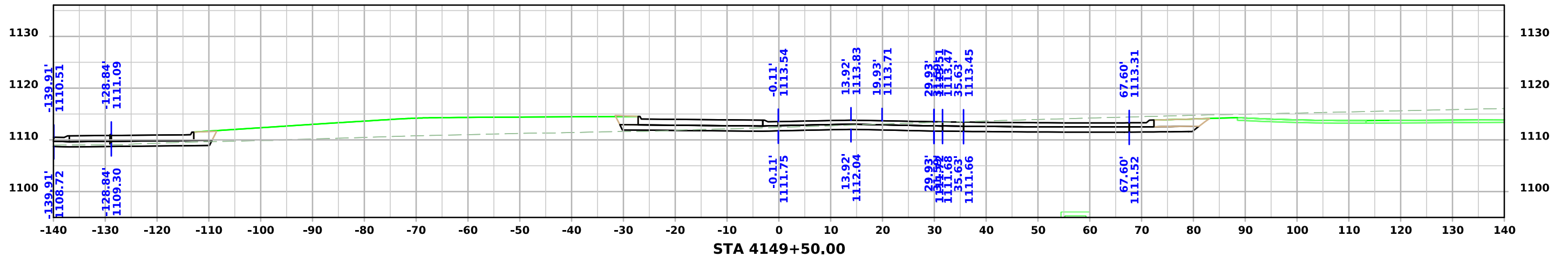
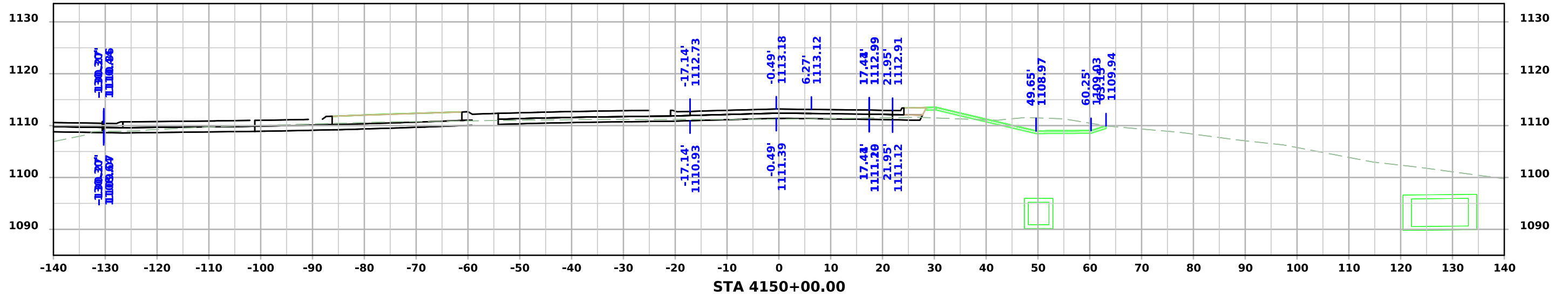
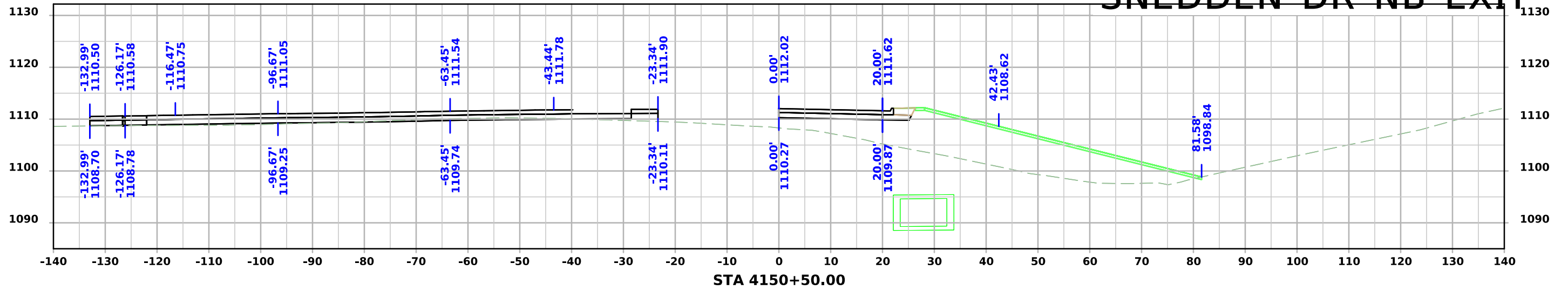

SNEDDEN DR NB EXIT

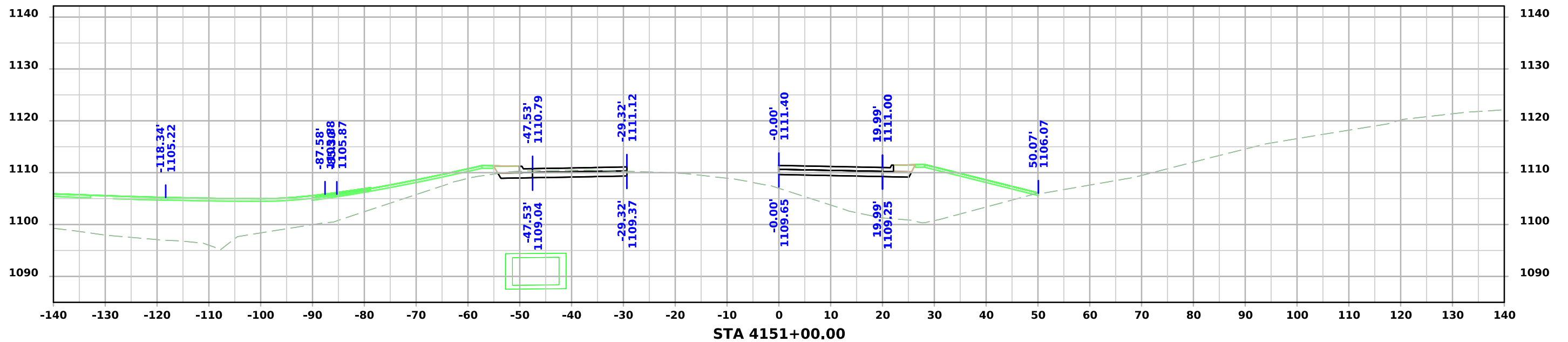
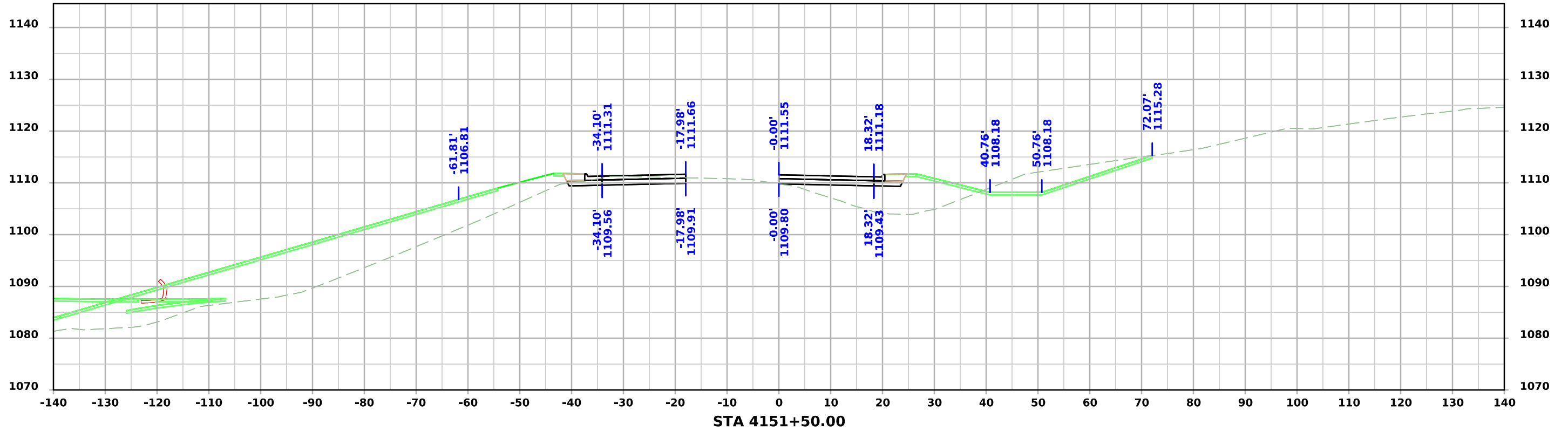

SNEDDEN DR NB EXIT

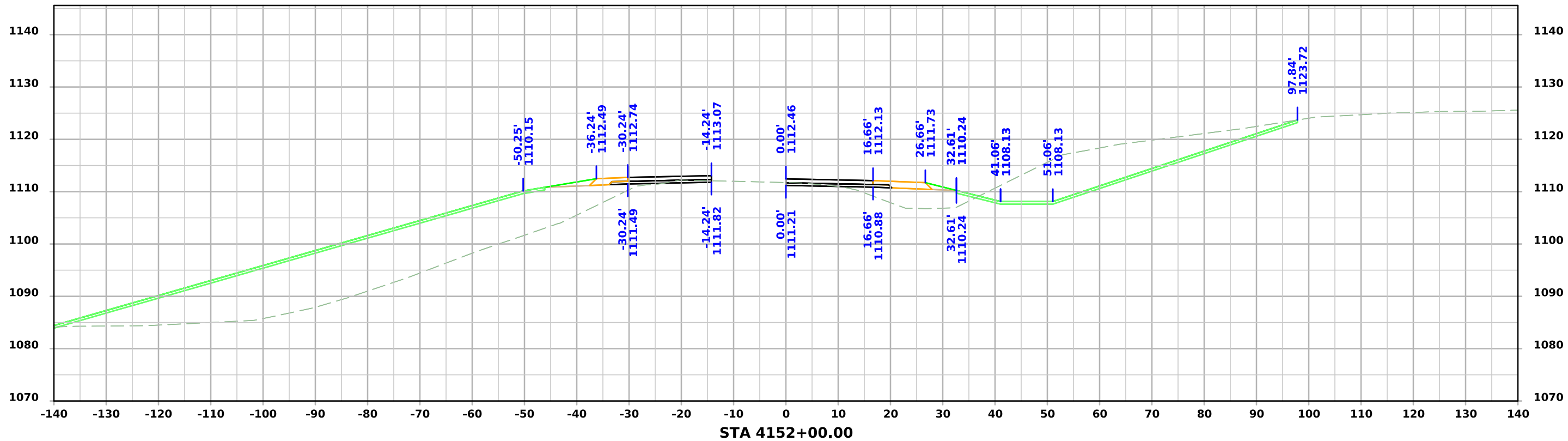
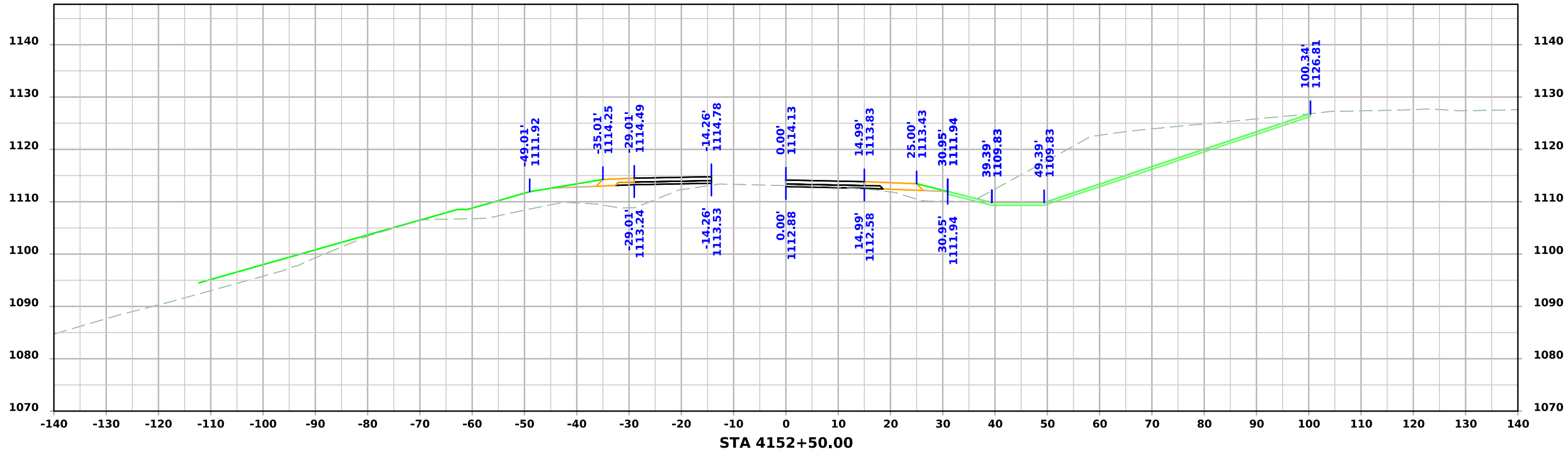

SNEDDEN DR NB EXIT

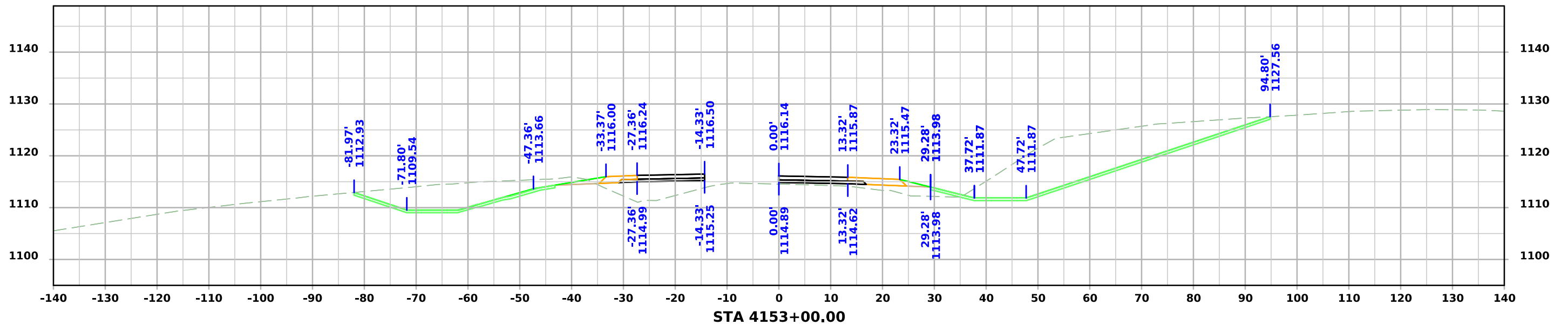
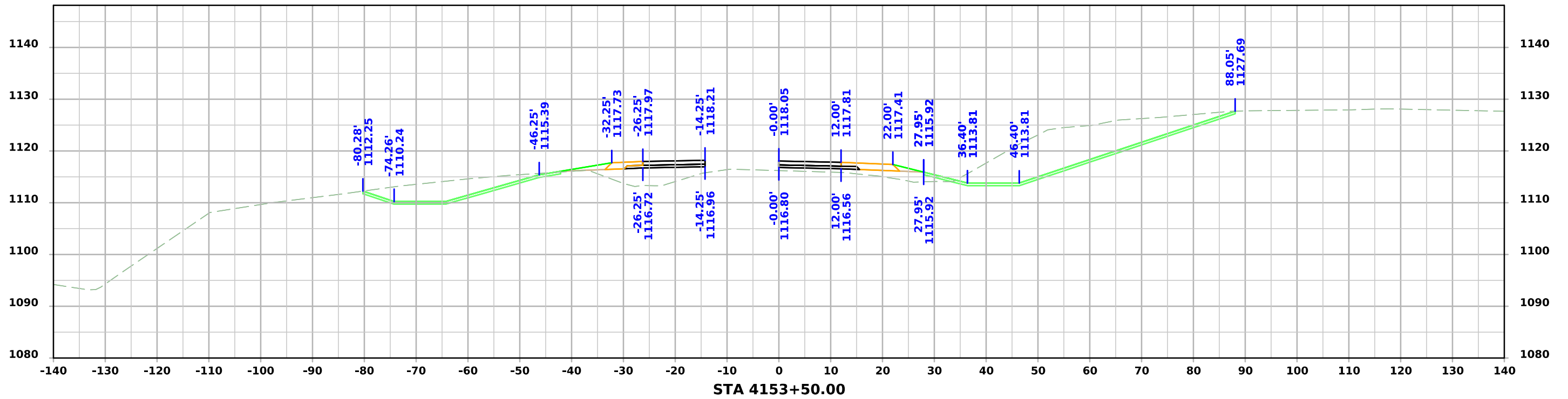

SNEDDEN DR NB EXIT

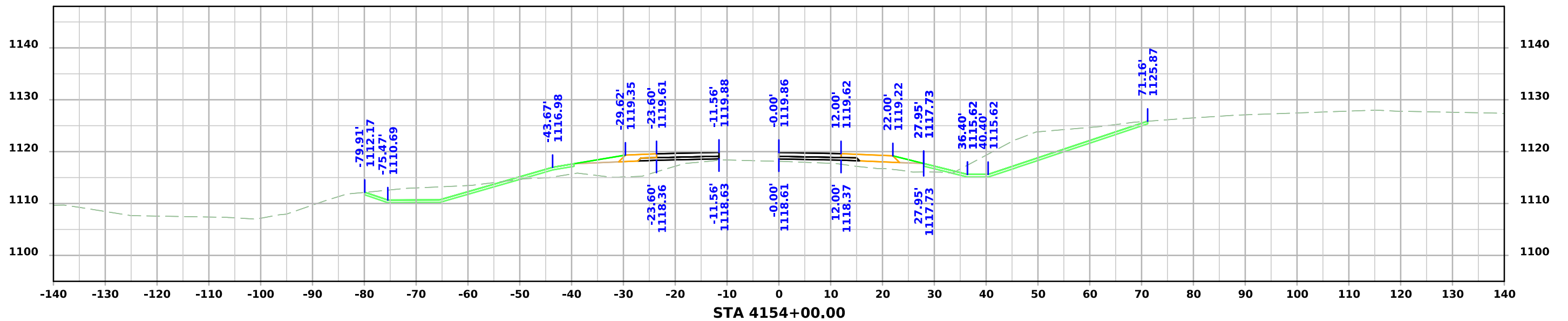
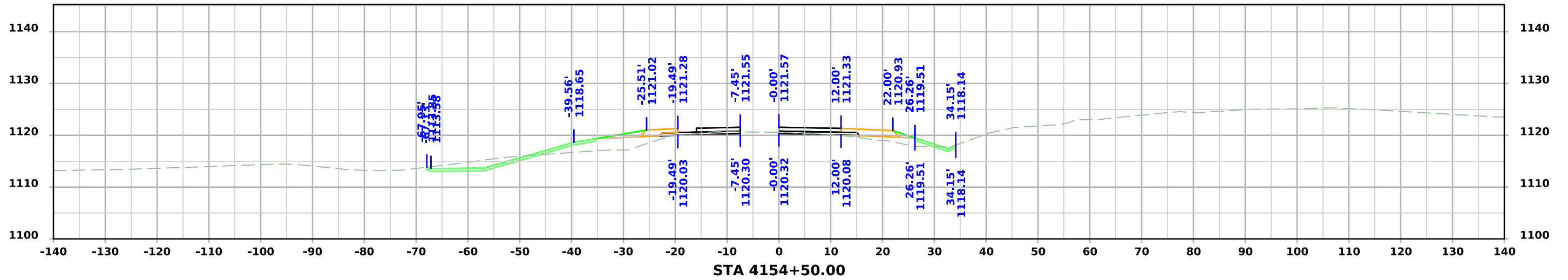
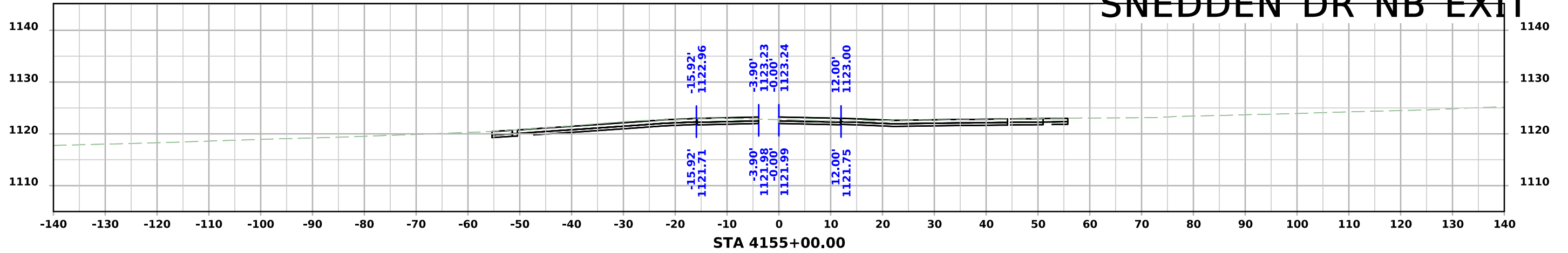

SNEDDEN DR NB EXIT

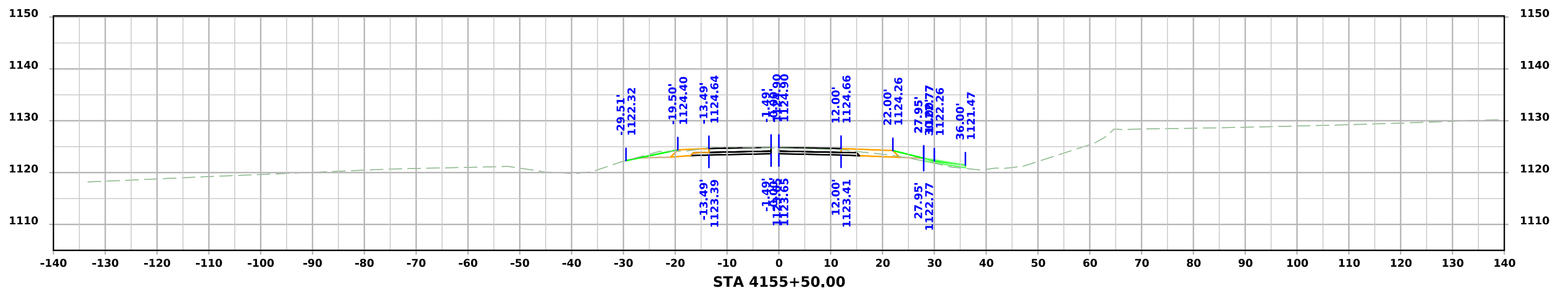
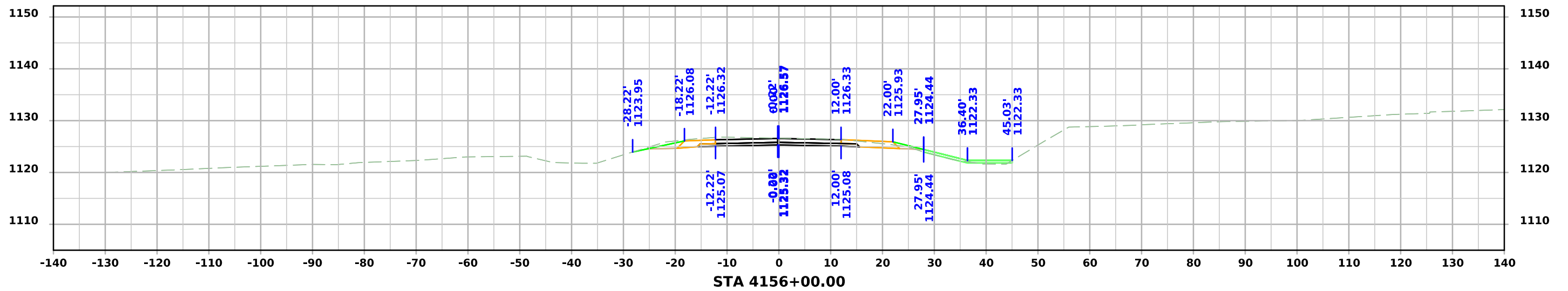
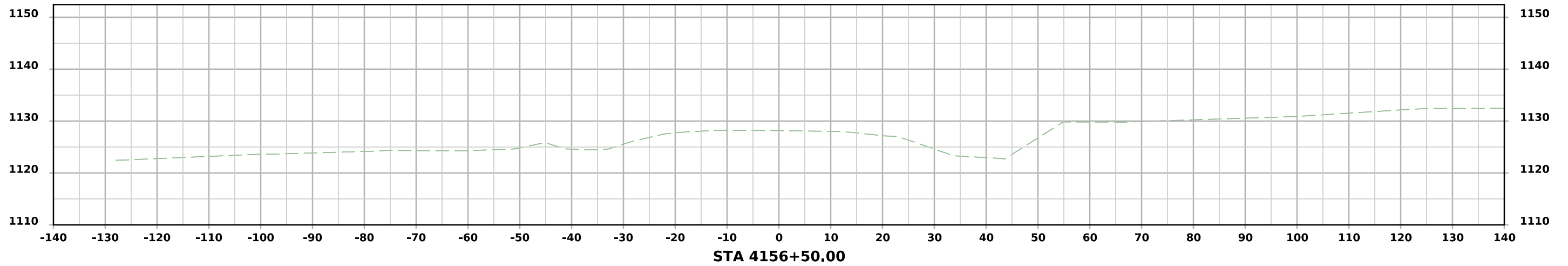

SNEDDEN DR NB EXIT

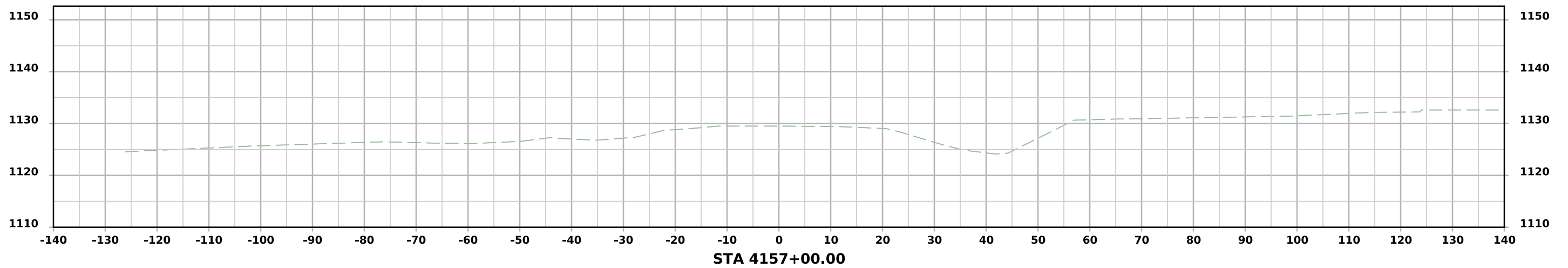

SNEDDEN DR SB ENTRANCE

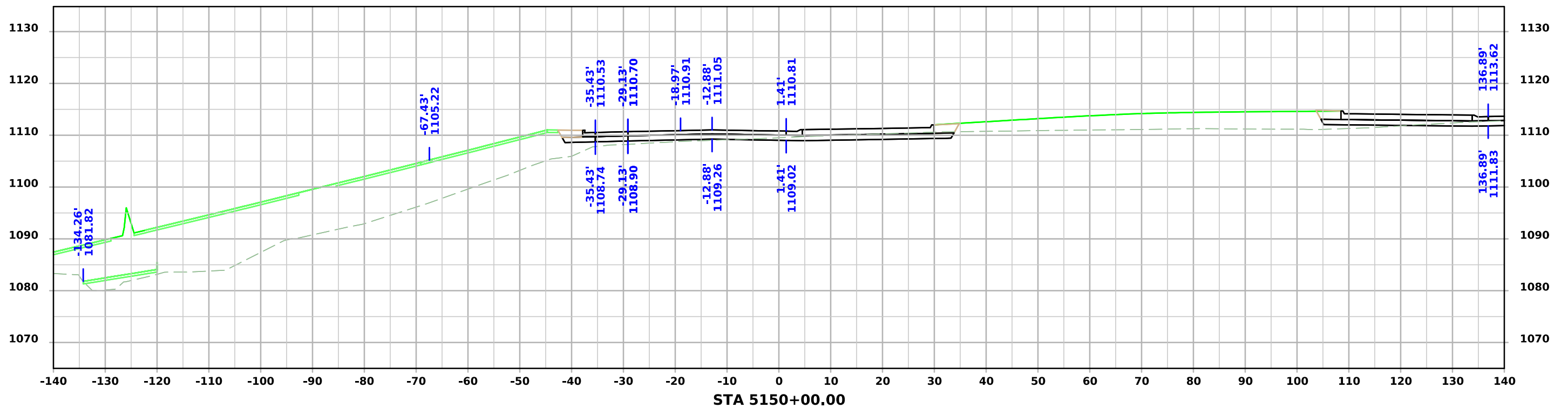
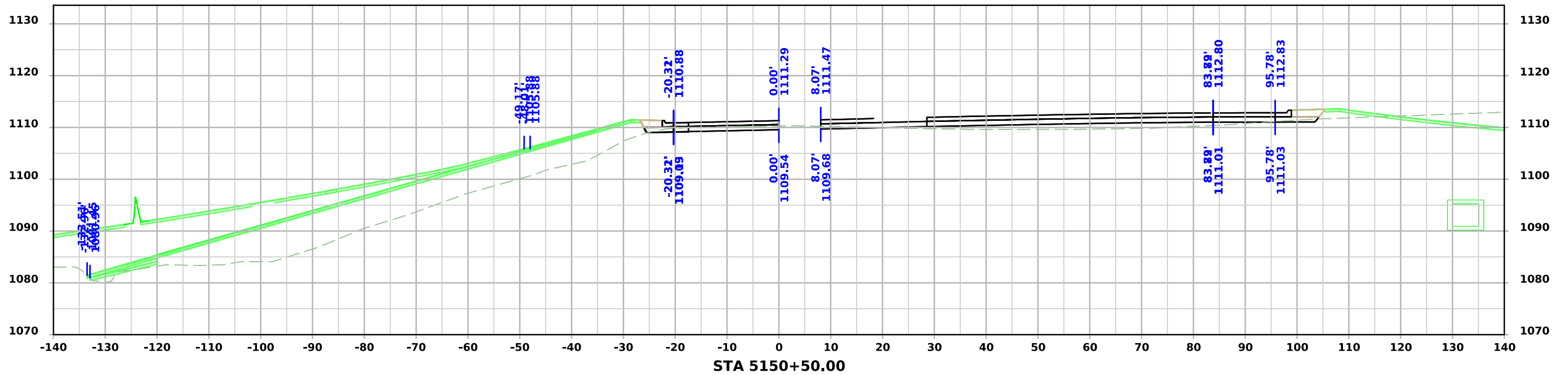

SNEDDEN DR SB ENTRANCE

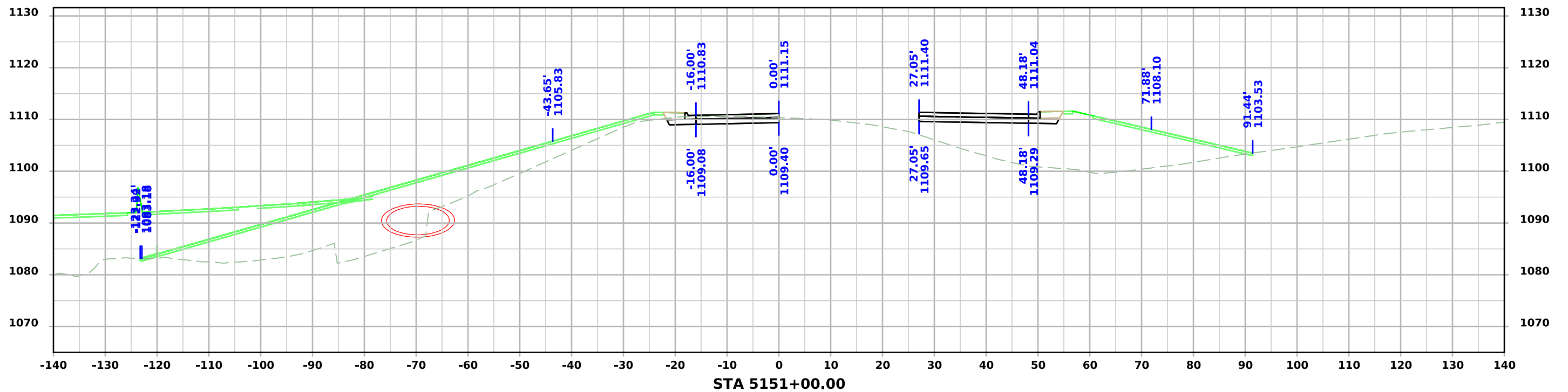
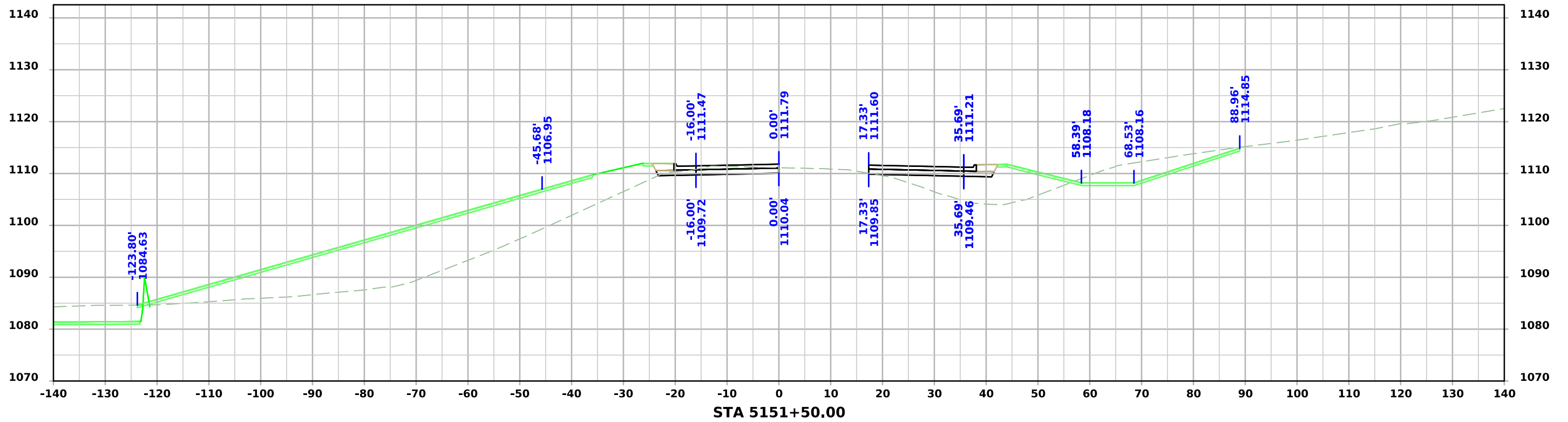

SNEDDEN DR SB ENTRANCE

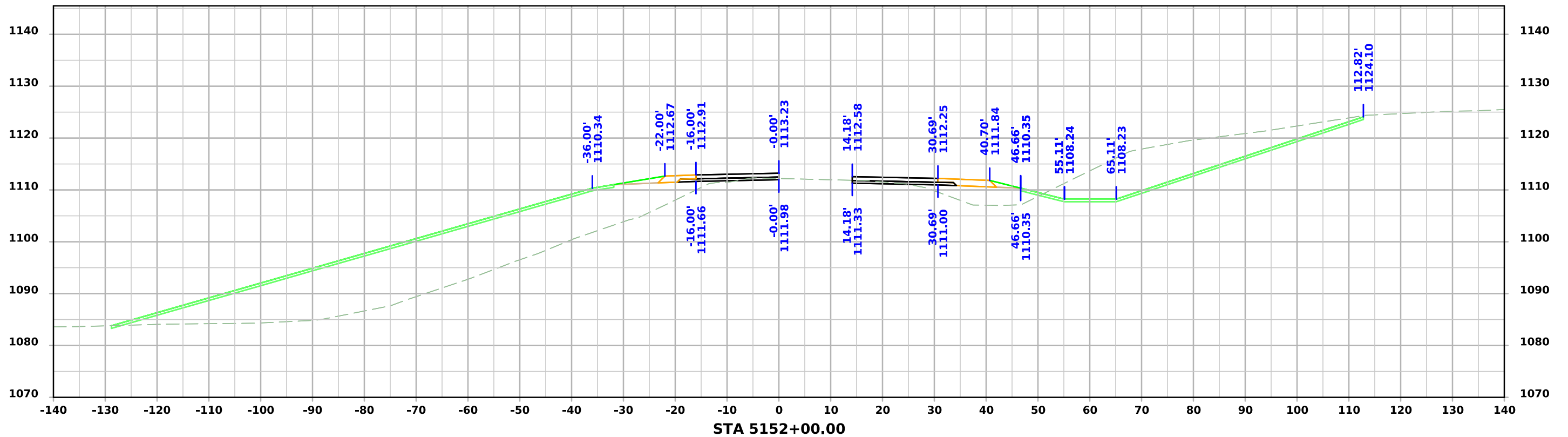
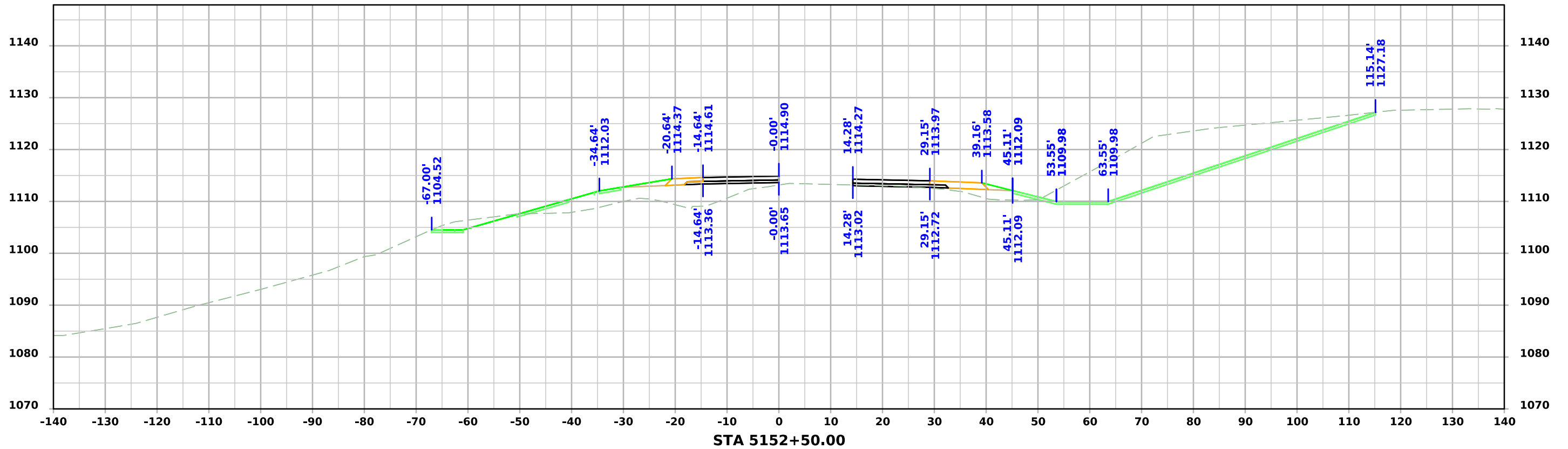

SNEDDEN DR SB ENTRANCE

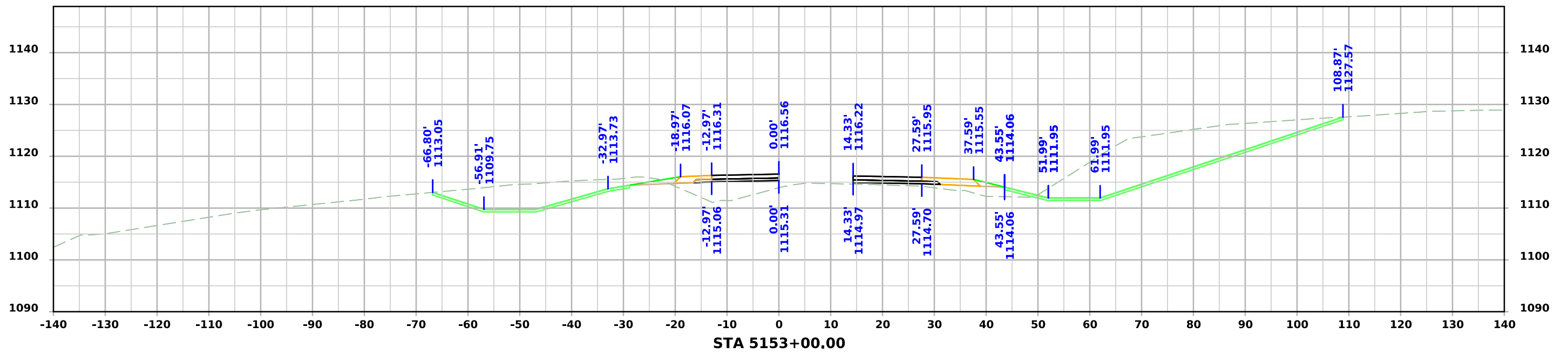
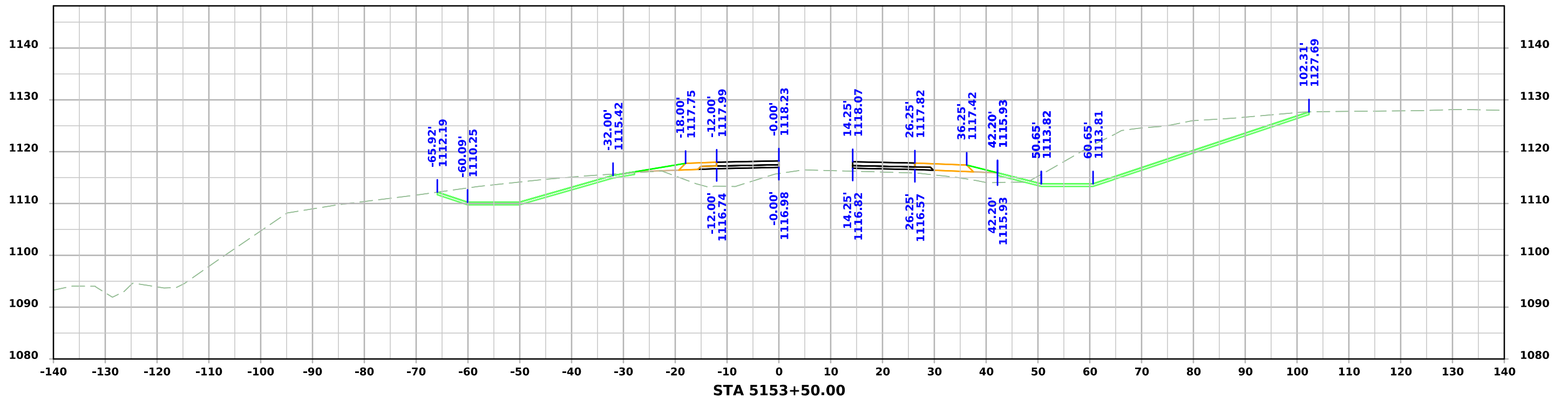

SNEDDEN DR SB ENTRANCE

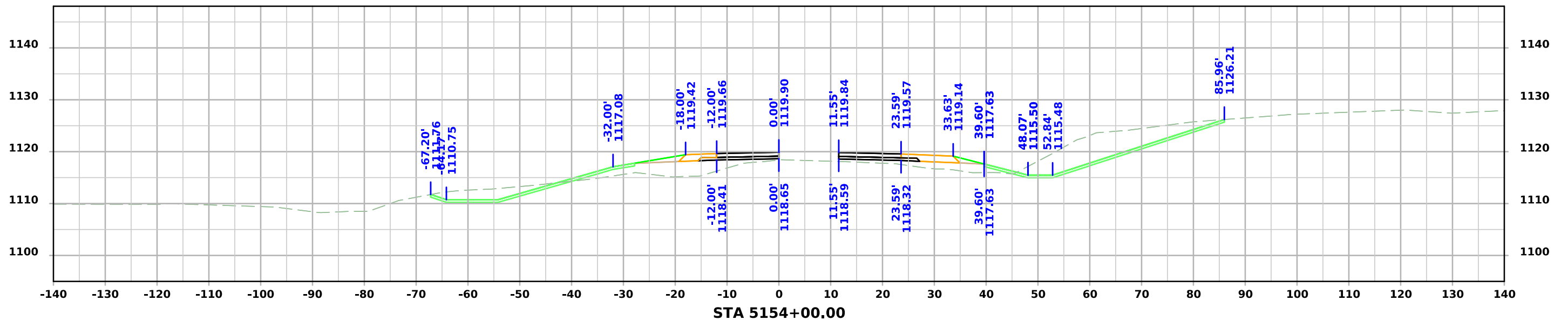
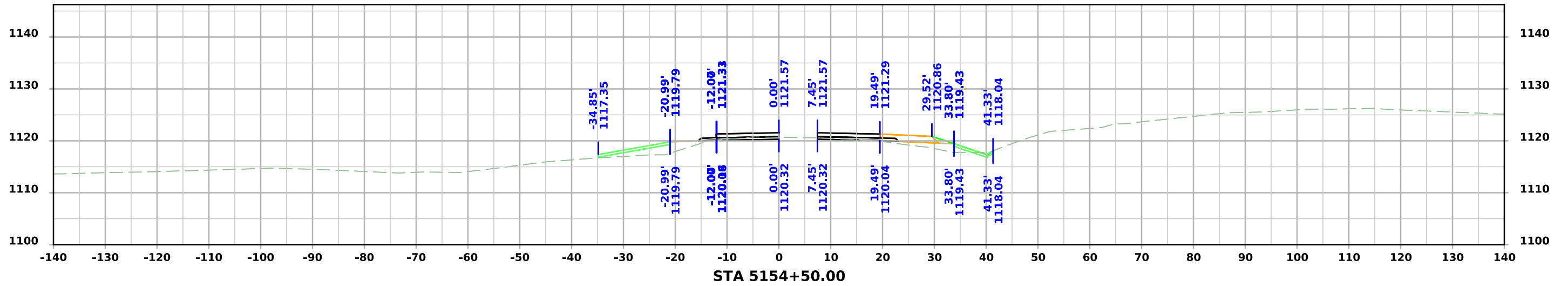
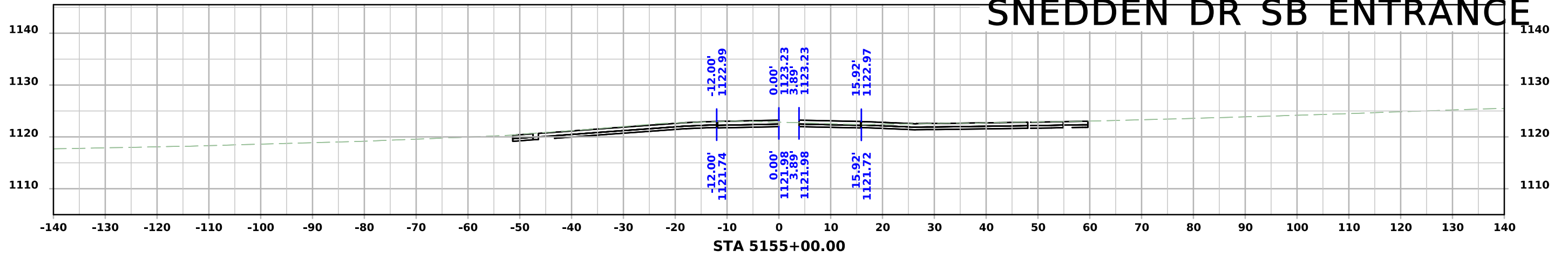

SNEDDEN DR SB ENTRANCE

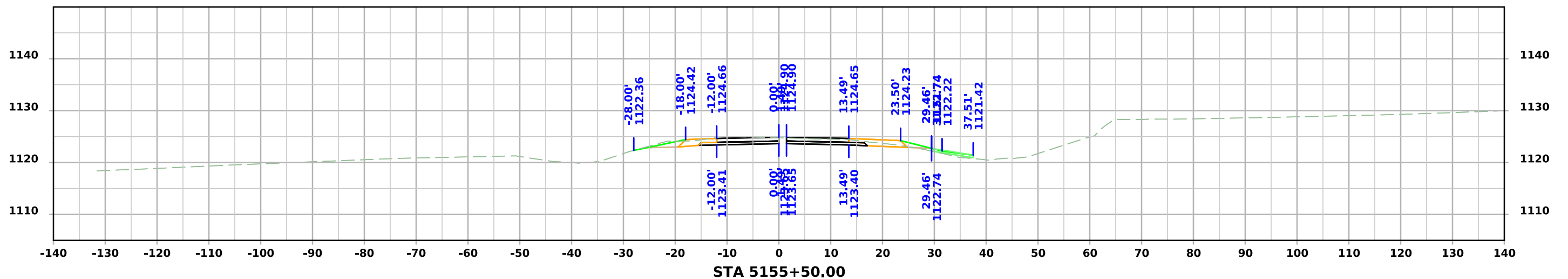
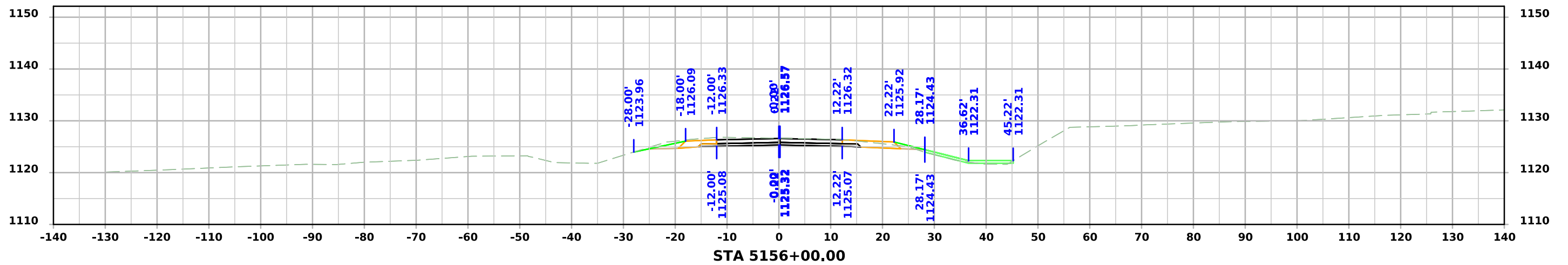
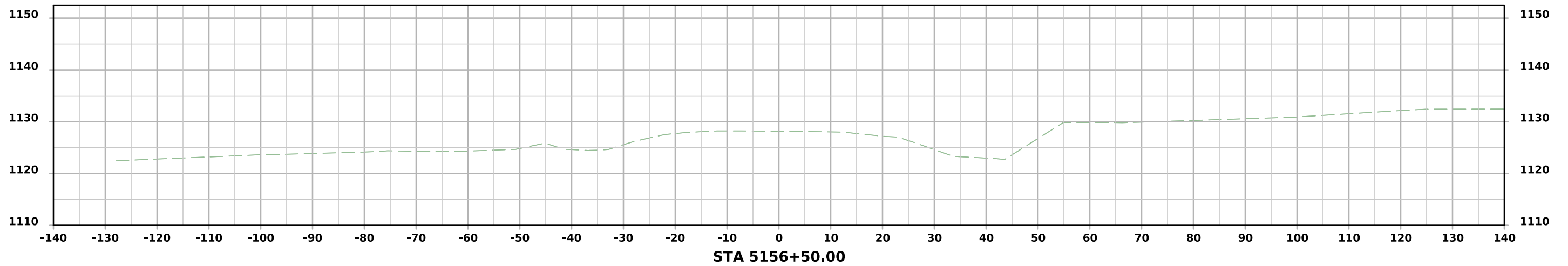

SNEDDEN DR SB ENTRANCE

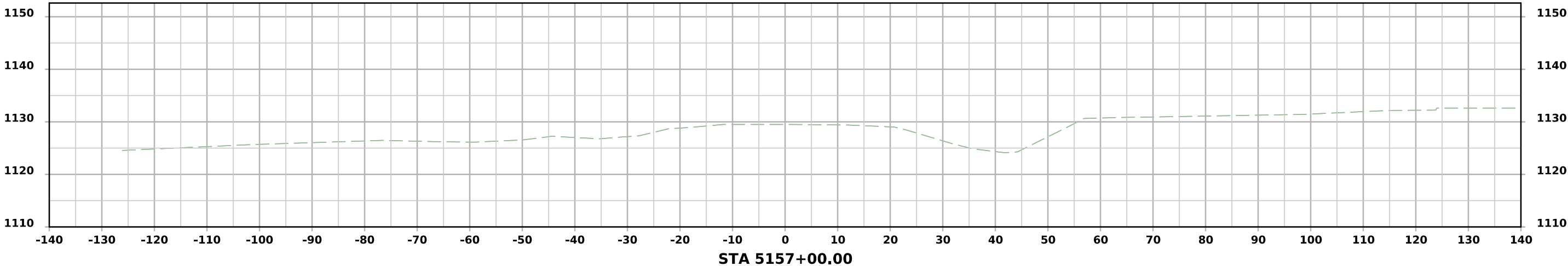

Roundabout

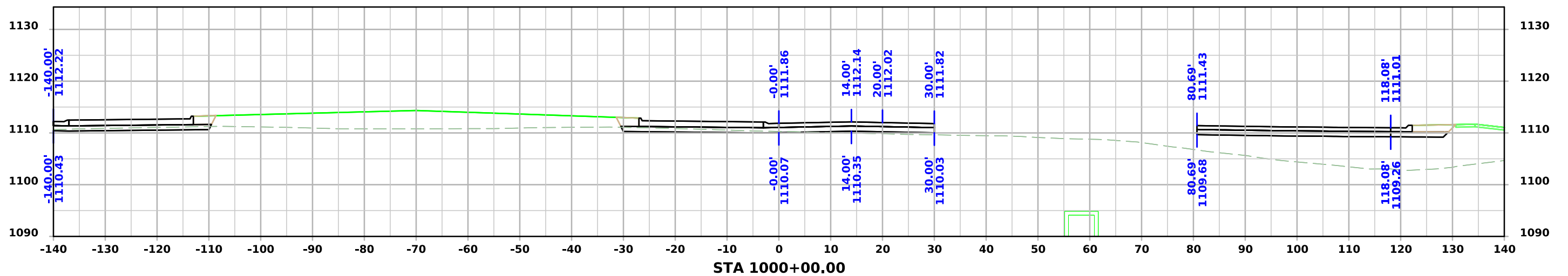
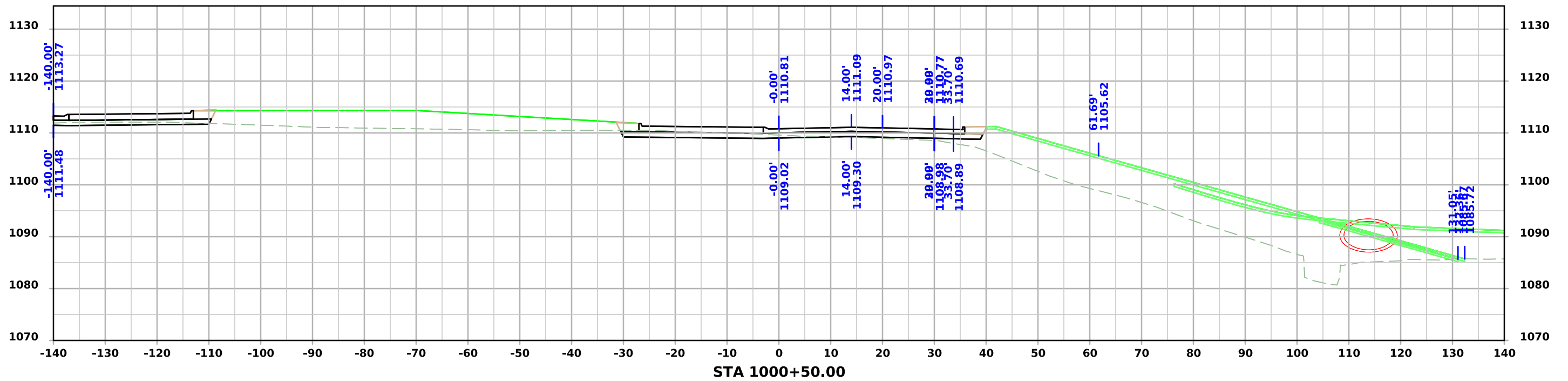

Roundabout

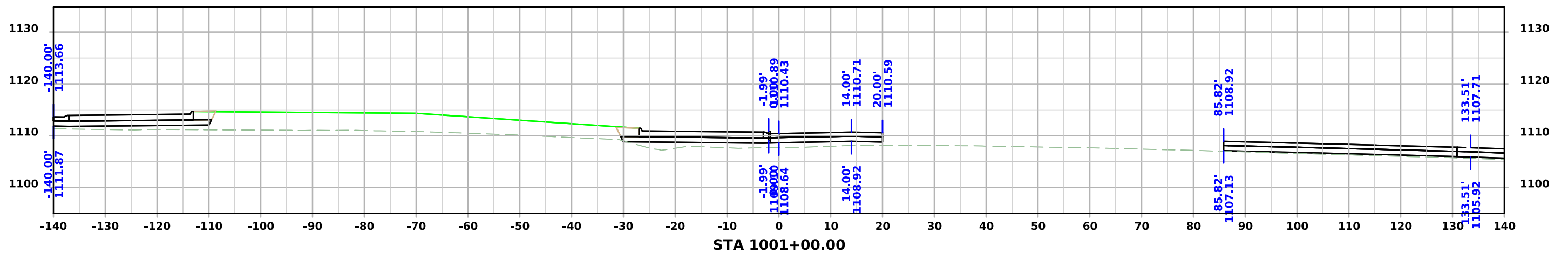
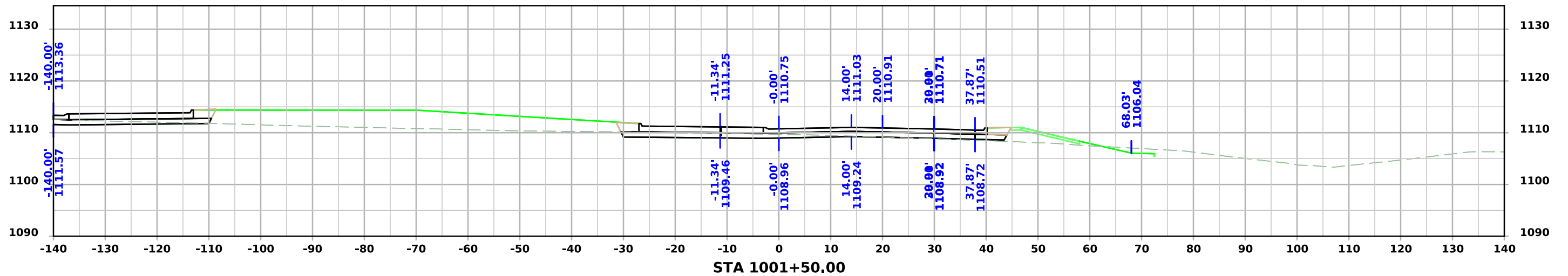
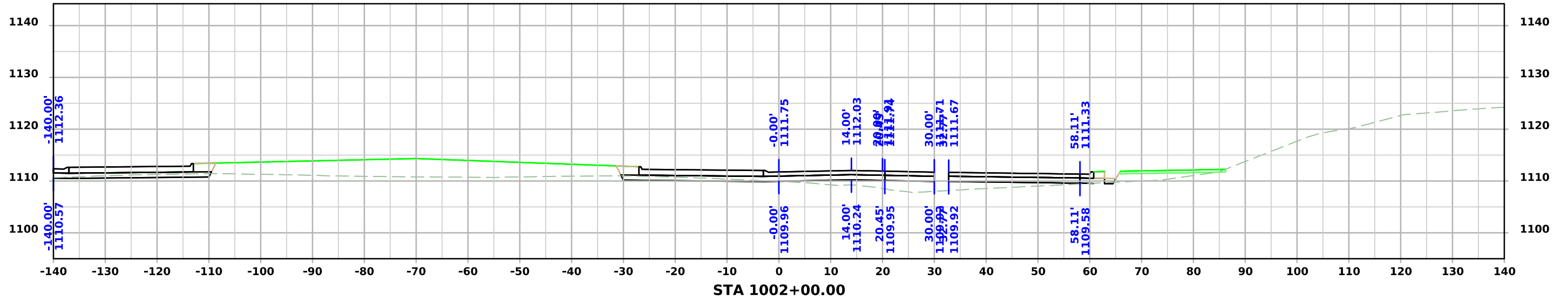

Roundabout

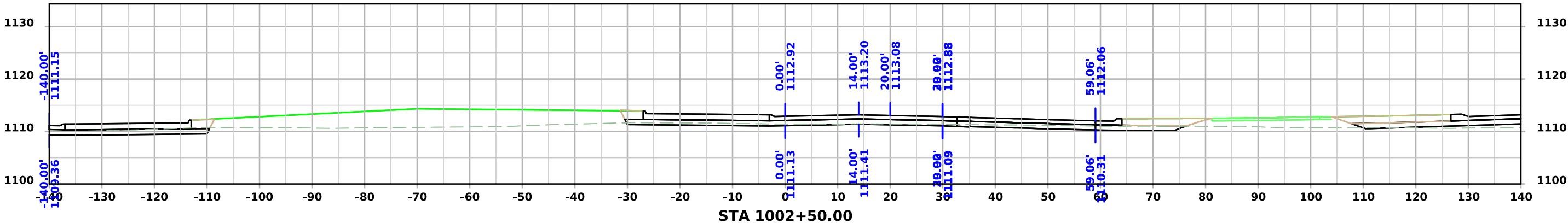
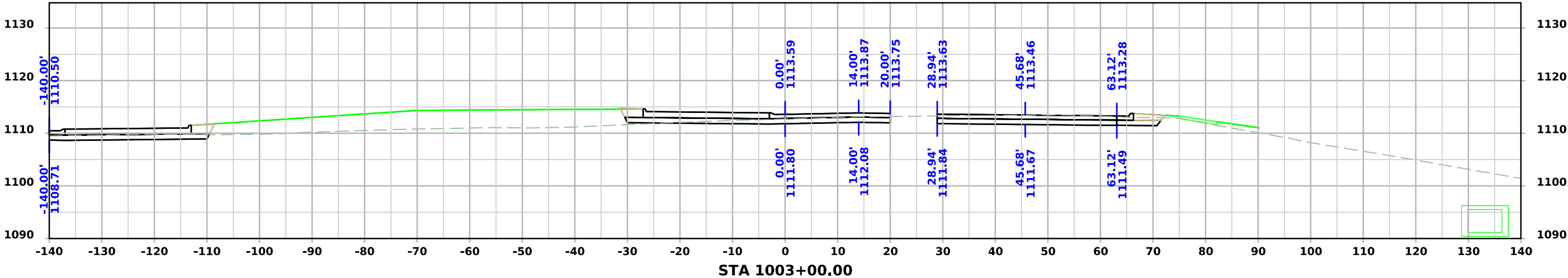
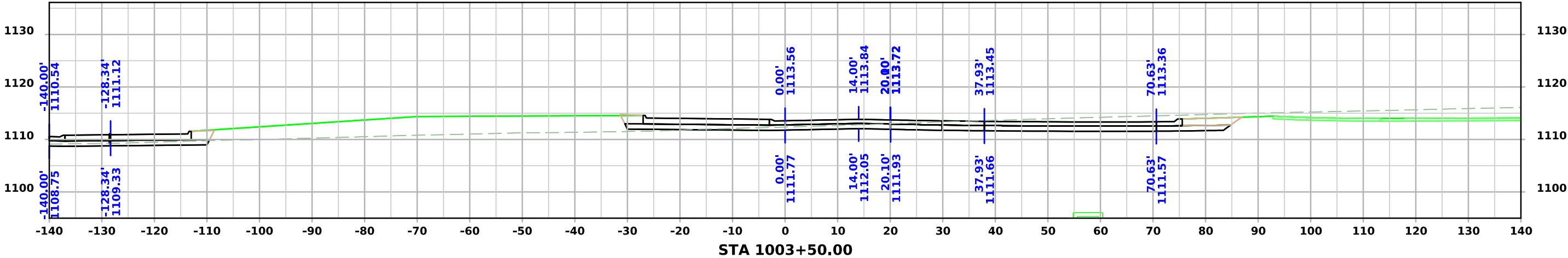

Roundabout

