

Price bid for "Bridge End Drain, DR-402" is full compensation for furnishing, installing, and constructing the Bridge End Drain as shown.

- ① Continue 4 inch sloped curb to edge of flume per section B-B. Refer to BR-201, BR-202, BR-203, or BR-204 for details of 4 inch curb.
- ② DI-1 and DI-2 distances measured from center of Bolt Pattern.
- ③ Extend rock flume to toe of backslope. If no backslope exists, extend rock flume a minimum of 4 feet beyond the toe of foreslope.

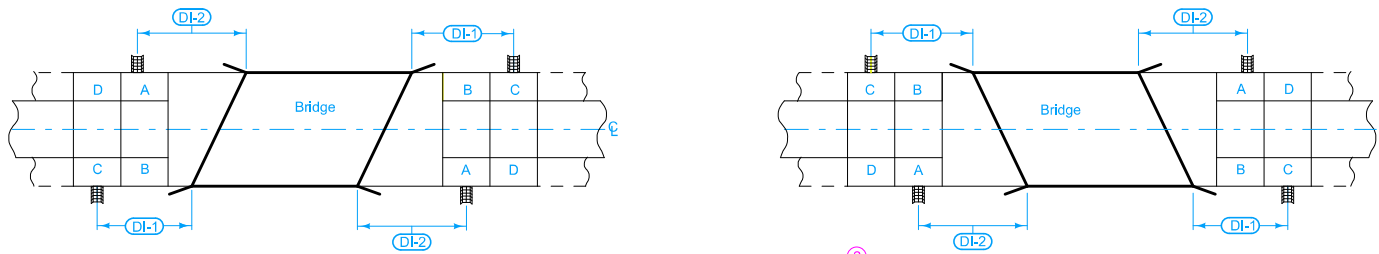

**PCC SHOULDER PANEL LOCATIONS
(Skewed Bridge)**

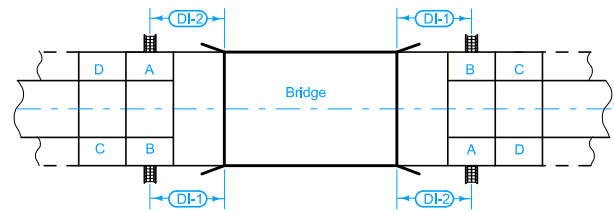

**PCC SHOULDER PANEL LOCATIONS
(Non-Skewed Bridge)**

Possible Contract Items:
 Paved Shoulder, Portland Cement Concrete (Paved Shoulder Panel for Bridge-End Drain)
 Bridge End Drain, DR-402

Incidental to Paved Shoulder:
 Modified Subbase
 Polymer Grid

Incidental to Bridge End Drain:
 Macadam Stone Base Material
 Erosion Stone
 Engineering Fabric
 Excavation, hauling, and disposing of material

Possible Tabulation:
 104-8A

IOWA DOT	REVISION
	4 04-17-18
	DR-402
STANDARD ROAD PLAN	SHEET 1 of 2
REVISIONS: Added a 3rd view on page 1 to show panel locations for non-skewed bridges.	

Brian Smith
 APPROVED BY DESIGN METHODS ENGINEER

ROCK FLUME FOR
BRIDGE END DRAIN

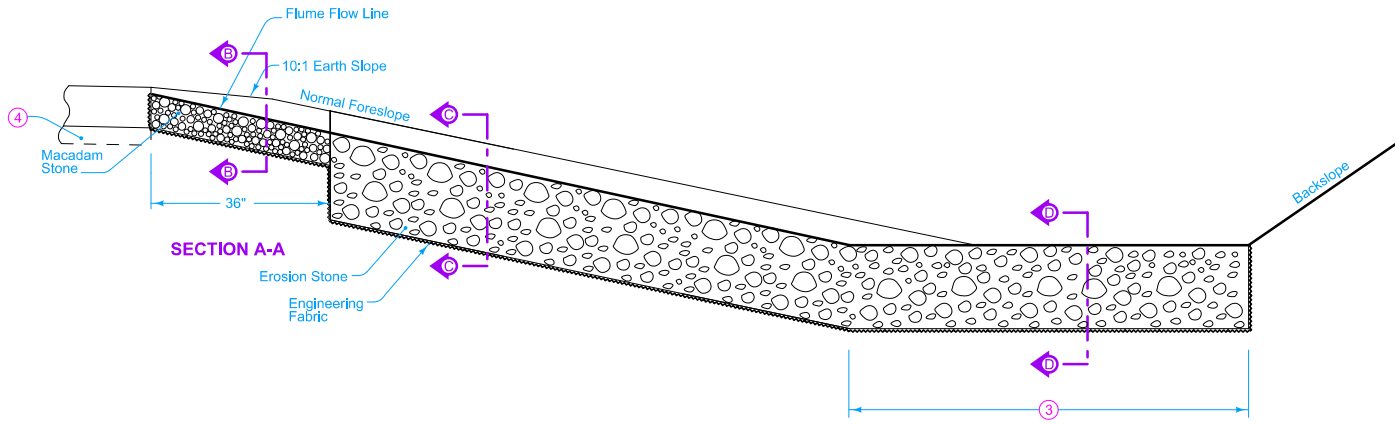

- ① Continue 4 inch sloped curb to edge of flume per section B-B. Refer to BR-201, BR-202, BR-203, or BR-204 for details of 4 inch curb.
- ③ Extend flume to toe of backslope. If no backslope exists, extend rock flume a minimum of 4 feet beyond the toe of foreslope.
- ④ Install modified subbase and polymer grid under PCC shoulder panels as shown in Section A-A on BR-201, BR-202, or BR-203, or BR-204.
- ⑤ Transitions from 2 inches at edge of pavement to 8 inches within 3 feet.
- ⑥ Transition the flume flow line depth from 8 inches at the toe of slope to 0 inches with an approximate transition rate of 2 inches per 1 foot horizontal.

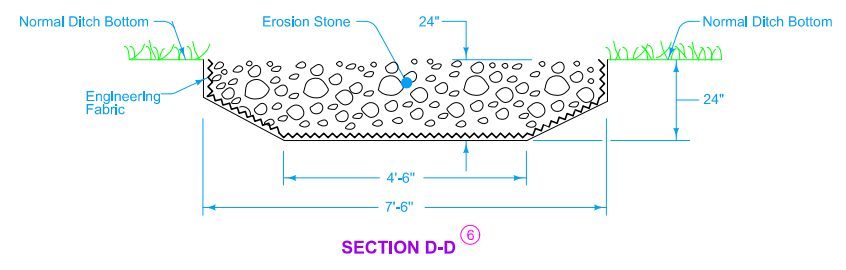
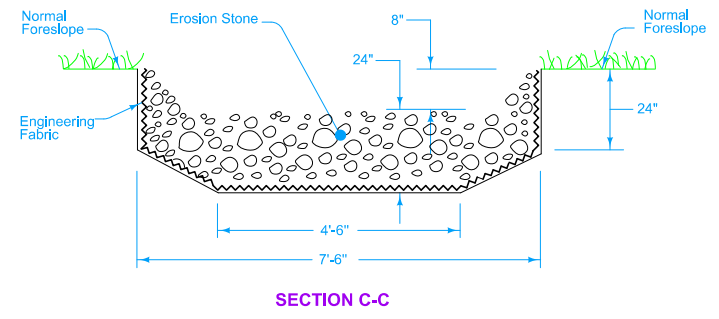
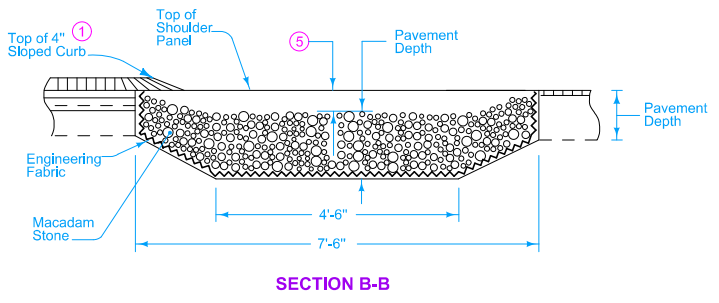

 STANDARD ROAD PLAN	REVISION 4 04-17-18
	DR-402
	SHEET 2 of 2
REVISIONS: Added a 3rd view on page 1 to show panel locations for non-skewed bridges.	
 APPROVED BY DESIGN METHODS ENGINEER	
ROCK FLUME FOR BRIDGE END DRAIN	