



**STANDARD SYMBOLS**

	Interstate Highway Symbol		Septic Tank
	U.S. Highway Symbol		Cistern
	Iowa Highway Symbol		L.P. Gas Tank (No Footing)
	County Road Highway Symbol		Underground Storage Tank
	Evergreen Tree		Latrine
	Deciduous Tree		Luminaire
	Fruit Tree		Traffic Signal
	Shrub (Bushes)		Traffic Signal with Luminaire
	Timber		Telephone Pedestal
	Hedge		TVP Television Pedestal
	Stump		Telephone Pole
	Swamp		Telephone Pole (Second Company)
	Rock Outcrop		Telephone Pole (Third Company)
	Broken Concrete		Telephone Pole (Fourth Company)
	Revetment (Rip Rap)		Telephone Pole (Fifth Company)
	Cemetery		Power Pole
	Grave		Power Pole (Second Company)
	Cave		Power Pole (Third Company)
	Sink Hole		Power Pole (Fourth Company)
	Board Fence		Power Pole (Fifth Company)
	Chain Link or Security Fence		Electrical Highline Tower (Metal or Concrete)
	Wire Fence		Telephone Riser Pole
	Terrace		Power Riser Pole
	Earth Dam or Dike (Existing)		Telegraph Pole
	Earth Dam or Dike (Proposed)		Satellite TV Dish
	Tile Outlet		Existing Water Line
	Edge of Water		Existing Water Line (Second Company)
	Existing Drainage		Existing Sanitary Sewer Line
	Proposed Drainage		Existing Telephone Line
	Right of Way Rail or Lot Corner		Existing Telephone Line (Second Company)
	Concrete Monument		Existing Fiber Optics Telephone Line
	Well		Existing Storm Sewer Line
	Windmill		Existing Gas Line
	Beehive Intake		Existing High Pressure Gas Line
	Existing Intake		Existing Gas Line (Second Company)
	Proposed Intake		Existing High Pressure Gas Line (Second Company)
	Existing Utility Access (Manhole)		Existing Power Line
	Proposed Utility Access (Manhole)		Existing Power Line (Second Company)
	Fire Hydrant		Cable Television Line
	Water Hydrant (Rural)		

	Guardrail (Beam or Cable)
	Guard Post (one or two)
	Guard Post (over two)
	Filler Pipe
	Gas Valve
	Water Valve
	Speed Limit Sign
	Mile Marker Post
	SIGN Sign
	Water Hook Up
	Radio Tower
	Tower Anchor
	Electric Box
	Traffic Signal Control Box
	Rail Road Signal Control Box
	Telephone Switch Box

**UTILITY LEGEND**

	City of Clinton Jason Craft P.O. Box 2958 Clinton, IA 52733-2958 Phone: (563) 244-3423		Mediacom Dennis Jarding 3900 26th Avenue Moline, IL 61265 Phone: (309) 743-4750
	Alliant Energy - Electric Jason Hogan 4902 North Biltmore Madison, WI 53707-1007 Phone: (608) 458-4871		Lightcore Kirk Thoeke 1151 Century Tel Drive Building A Wentzville, MO 63385 Phone: (636) 887-4752
	Alliant Energy - Gas Jason Hogan 4902 North Biltmore Madison, WI 53707-1007 Phone: (608) 458-4871		Sprint Gerry A. Crain 5600 North River Road, Suite 300 Rosemont, IL 60018 Phone: (847) 737-1279
	Iowa American Water Co. Charlie Jones 5201 Grand Avenue Davenport, IA 52807 Phone: (563) 468-9214		ITC Midwest Chad Levi 123 5th Street SE Suite 200 Cedar Rapids, IA 52401 Phone: (319) 297-6765
	Qwest Local Net Steven Parker 320 2nd Avenue Rochester, MN 55902 Phone: (507) 285-2335		PAETEC Mike Braughton 1719 Hawkeye Drive Hiawatha, IA 52233 Phone: (319) 361-3374

Where public utility fixtures are shown as existing on the plans or encountered within the construction area, it shall be the responsibility of the contractor to notify the owners of those utilities prior to the beginning of any construction. The contractor shall afford access to these facilities for necessary modification of services. Underground facilities, structures and utilities have been plotted from available surveys and records, and therefore their locations must be considered approximate only. It is possible there may be others, the existence of which presently not known or shown. It is the contractor's responsibility to determine their existence and exact location and to avoid damage thereto. No claims for additional compensation will be allowed to the contractor for any interference or delay caused by such work.

The contractor is required to utilize the utility one-call service at (800) 292-8989 at least 48 hours prior to excavating anywhere on the project.

The above utility companies are known to have facilities on the project.

Known utility conflicts are being resolved by each respective utility company. Utility conflicts discovered during construction will be addressed at the time of discovery.

**RIGHT OF WAY LEGEND**

	Proposed Right of Way
	Existing Right of Way
	Existing and Proposed Right of Way
	Easement and Existing Right of Way
	Borrow
	Easement (Temporary)
	Easement
	Excess
	Property Line
	Access Control

**SYMBOLS UNIQUE TO PROJECT**

	Proposed PCC Surface		Con. Brick Pavers
	Proposed HMA Surface		No-mow Fescue
	Pavement Removal		PCC Sidewalk (Typ.)
	Soil Boring		Detectable Warning Pavers
	Right of Way		Right of Way (I Sheets)
	Temporary Easement		Perennials
	Storm Sewer		Temporary Easement (I Sheets)
	SAN Sanitary Sewer		Heron Sculpture
	Proposed Storm S. Intake		Pedestrian Lights
	Proposed Storm S. Manhole		Roadway Lights
	Proposed San. S. Manhole		Evergreen Trees
	Slope Intercept Line (Refer to D Sheets and Cross Sections)		Pergola and Columns with Benches
	S-X Storm S. Structure Label		Columns without pergolas and benches
	P-X Storm S. Pipe Label		Understory Trees
	SAN MH X San S. Structure Label		Proposed Overstory Trees
	PP-X San S. Pipe Label		Hand Hole, RM-38
	SS-X San S. Service Label		Light Fixture Identification Number
	SI-X Proposed Sign Labels		
	Grade Elevation		

**CONVENTIONAL SIGNS**

	Survey Line
	Section Corner
	Proposed Profile Grade
	Railroad
	Field Tile
	Culverts
	Stream

**Legend And Symbol Information Sheet**

(Symbols are Typical Only, actual size may vary)

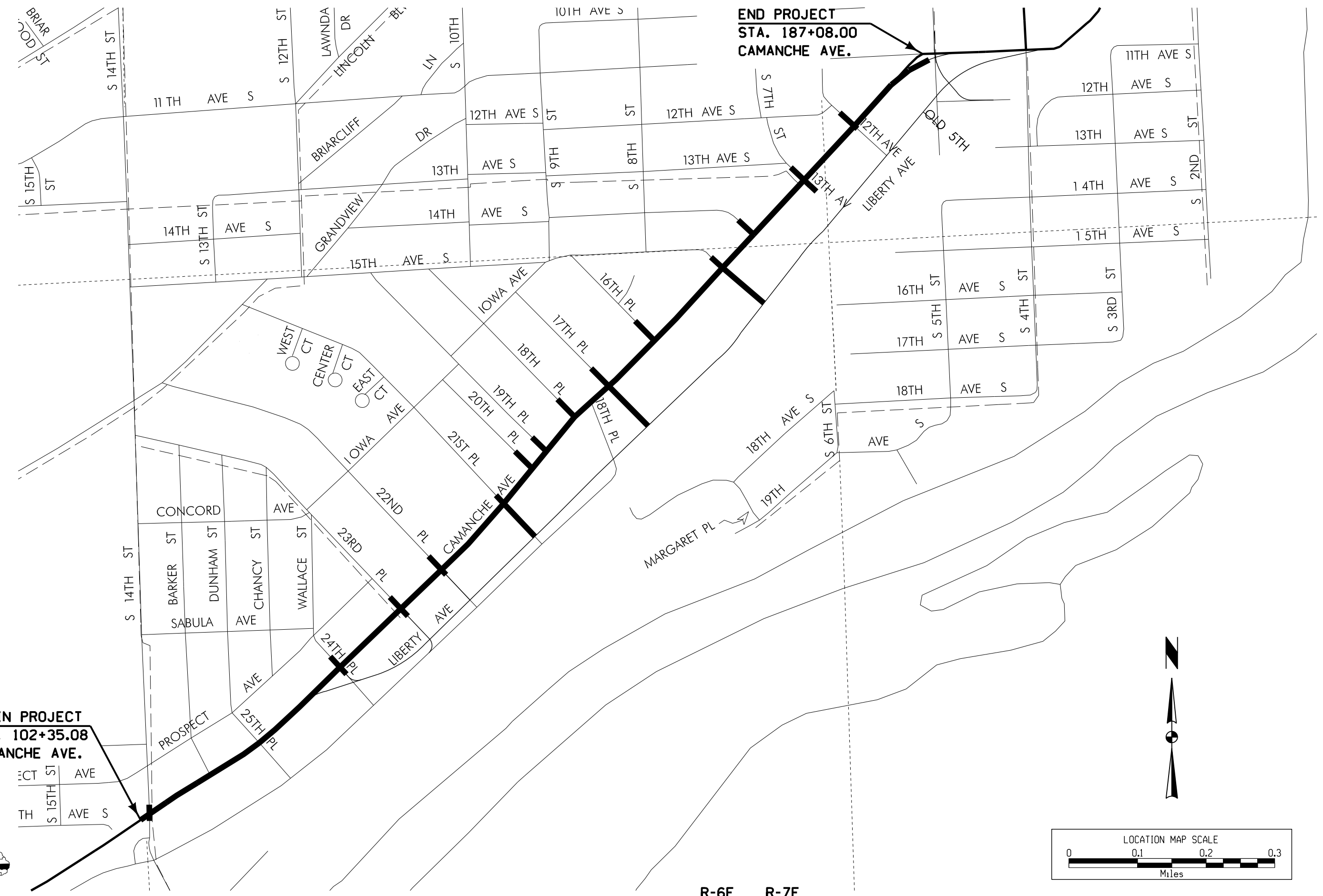

**END PROJECT  
STA. 187+08.00  
CAMANCHE AVE.**

**BEGIN PROJECT  
STA. 102+35.08  
CAMANCHE AVE.**

T-81N

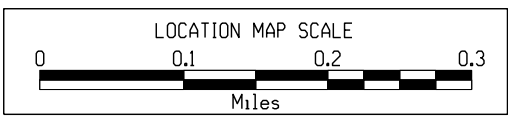
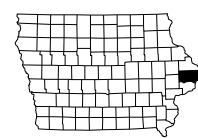

R-6E R-7E

LISTING OF PROJECT REVISIONS

111-23  
10-29-02

Date	Sheet No.	Description of Revisions

I hereby certify that these plans and specifications were prepared by me or under my direct supervision and that I am a duly registered Landscape Architect under the laws of the State of Iowa.



NICHOLAS H. STRENG \_\_\_\_\_ DATE  
 License Number: 553  
 My license renewal date is JUNE 30, 2013  
 Pages or sheets covered by this seal:  
 I

I hereby certify that this engineering document was prepared by me or under my direct personal supervision and that I am a duly licensed Professional Engineer under the laws of the State of Iowa.

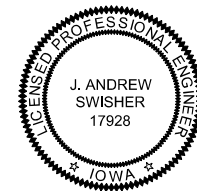

J. ANDREW SWISHER, P.E. \_\_\_\_\_ DATE  
 License Number: 17928  
 My license renewal date is DECEMBER 31, 2011  
 Pages or sheets covered by this seal:  
 N

I hereby certify that this engineering document was prepared by me or under my direct personal supervision and that I am a duly licensed Professional Engineer under the laws of the State of Iowa.



BRIAN F. GISI \_\_\_\_\_ DATE  
 License Number: 16017  
 My license renewal date is DECEMBER 31, 2011  
 Pages or sheets covered by this seal:  
 Q

I hereby certify that this engineering document was prepared by me or under my direct personal supervision and that I am a duly licensed Professional Engineer under the laws of the State of Iowa.

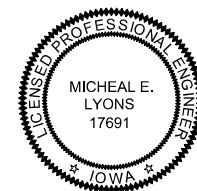

MICHEAL E. LYONS, P.E. \_\_\_\_\_ DATE  
 License Number: 17691  
 My license renewal date is DECEMBER 31, 2012  
 Pages or sheets covered by this seal:  
 F, J

I hereby certify that this engineering document was prepared by me or under my direct personal supervision and that I am a duly licensed Professional Engineer under the laws of the State of Iowa.

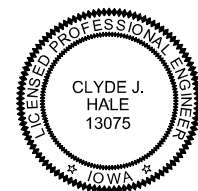

CLYDE J. HALE, P.E. \_\_\_\_\_ DATE  
 License Number: 13075  
 My license renewal date is DECEMBER 31, 2011  
 Pages or sheets covered by this seal:  
 P

I hereby certify that this engineering document was prepared by me or under my direct personal supervision and that I am a duly licensed Professional Engineer under the laws of the State of Iowa.

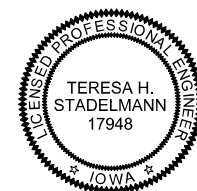

TERESA H. STADELMANN, P.E. \_\_\_\_\_ DATE  
 License Number: 17948  
 My license renewal date is DECEMBER 31, 2011  
 Pages or sheets covered by this seal:  
 M

I hereby certify that this engineering document was prepared by me or under my direct personal supervision and that I am a duly licensed Professional Engineer under the laws of the State of Iowa.



JON J. ESTREM, P.E. \_\_\_\_\_ DATE  
 License Number: 15645  
 My license renewal date is DECEMBER 31, 2012  
 Pages or sheets covered by this seal:  
 A, B, C, D, E, G, H, K, L, O, T, U, W, X

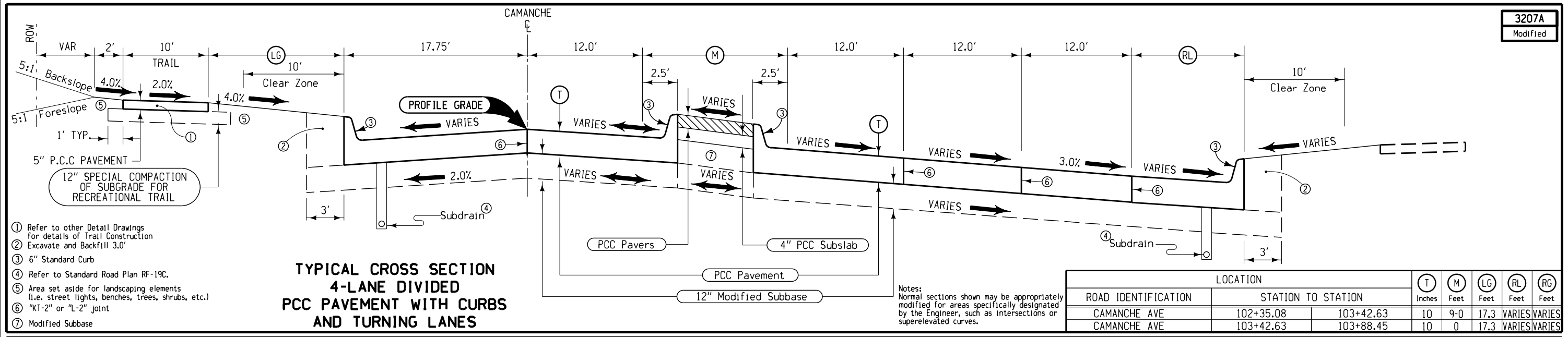

**TYPICAL CROSS SECTION  
4-LANE DIVIDED  
PCC PAVEMENT WITH CURBS  
AND TURNING LANES**

- ① Refer to other Detail Drawings for details of Trail Construction
- ② Excavate and Backfill 3.0'
- ③ 6" Standard Curb
- ④ Refer to Standard Road Plan RF-19C.
- ⑤ Area set aside for landscaping elements (i.e. street lights, benches, trees, shrubs, etc.)
- ⑥ "KT-2" or "L-2" joint
- ⑦ Modified Subbase

Notes:  
Normal sections shown may be appropriately modified for areas specifically designated by the Engineer, such as intersections or superelevated curves.

LOCATION		T	M	LG	RL	RG
ROAD IDENTIFICATION	STATION TO STATION	Inches	Feet	Feet	Feet	Feet
CAMANCHE AVE	102+35.08 103+42.63	10	9-0	17.3	VARIES	VARIES
CAMANCHE AVE	103+42.63 103+88.45	10	0	17.3	VARIES	VARIES

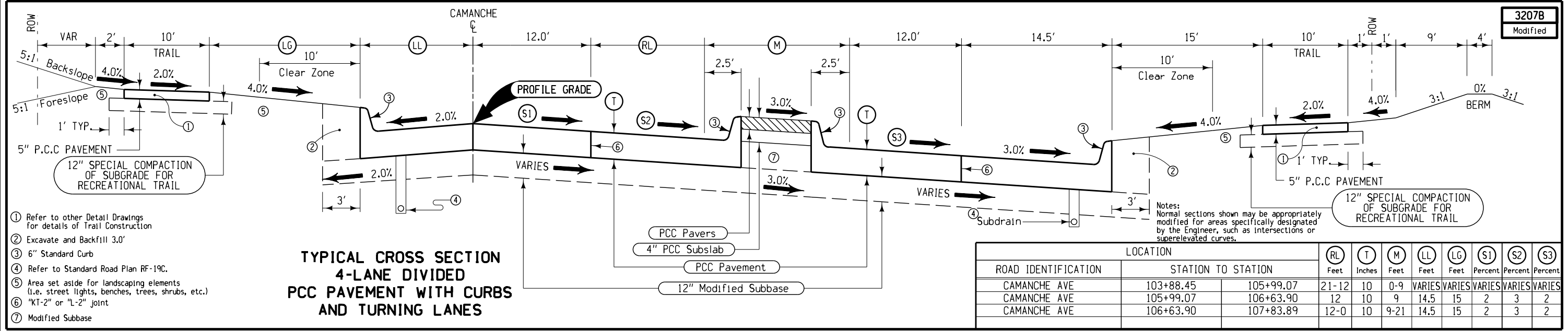

**TYPICAL CROSS SECTION  
4-LANE DIVIDED  
PCC PAVEMENT WITH CURBS  
AND TURNING LANES**

- ① Refer to other Detail Drawings for details of Trail Construction
- ② Excavate and Backfill 3.0'
- ③ 6" Standard Curb
- ④ Refer to Standard Road Plan RF-19C.
- ⑤ Area set aside for landscaping elements (i.e. street lights, benches, trees, shrubs, etc.)
- ⑥ "KT-2" or "L-2" joint
- ⑦ Modified Subbase

Notes:  
Normal sections shown may be appropriately modified for areas specifically designated by the Engineer, such as intersections or superelevated curves.

LOCATION		RL	T	M	LL	LG	S1	S2	S3
ROAD IDENTIFICATION	STATION TO STATION	Feet	Inches	Feet	Feet	Feet	Percent	Percent	Percent
CAMANCHE AVE	103+88.45 105+99.07	21-12	10	0-9	VARIES	VARIES	VARIES	VARIES	VARIES
CAMANCHE AVE	105+99.07 106+63.90	12	10	9	14.5	15	2	3	2
CAMANCHE AVE	106+63.90 107+83.89	12-0	10	9-21	14.5	15	2	3	2

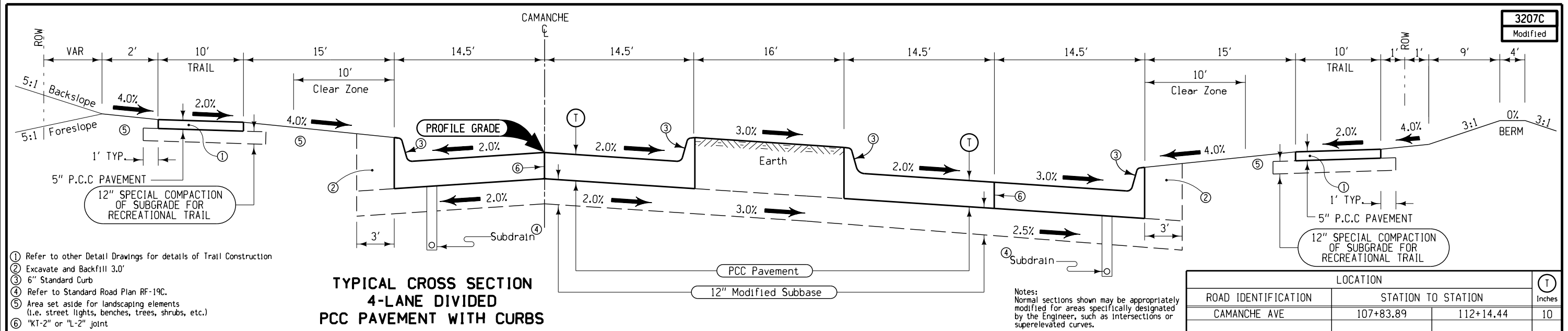

**TYPICAL CROSS SECTION  
4-LANE DIVIDED  
PCC PAVEMENT WITH CURBS**

- ① Refer to other Detail Drawings for details of Trail Construction
- ② Excavate and Backfill 3.0'
- ③ 6" Standard Curb
- ④ Refer to Standard Road Plan RF-19C.
- ⑤ Area set aside for landscaping elements (i.e. street lights, benches, trees, shrubs, etc.)
- ⑥ "KT-2" or "L-2" joint

Notes:  
Normal sections shown may be appropriately modified for areas specifically designated by the Engineer, such as intersections or superelevated curves.

LOCATION		T
ROAD IDENTIFICATION	STATION TO STATION	Inches
CAMANCHE AVE	107+83.89 112+14.44	10

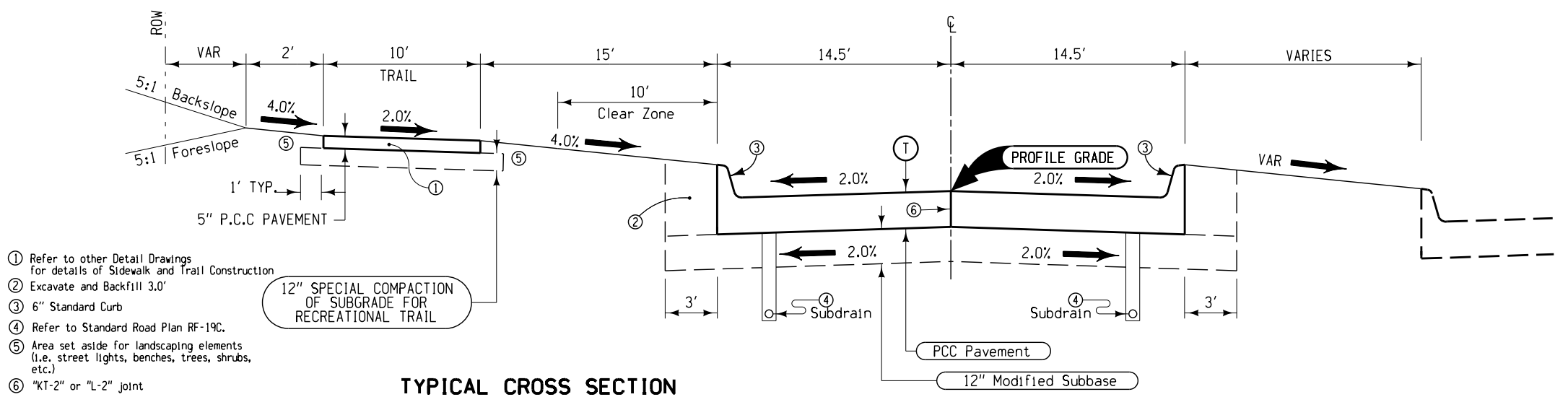

- ① Refer to other Detail Drawings for details of Sidewalk and Trail Construction
- ② Excavate and Backfill 3.0'
- ③ 6" Standard Curb
- ④ Refer to Standard Road Plan RF-19C.
- ⑤ Area set aside for landscaping elements (i.e. street lights, benches, trees, shrubs, etc.)
- ⑥ "KT-2" or "L-2" joint

12" SPECIAL COMPACTION OF SUBGRADE FOR RECREATIONAL TRAIL

**TYPICAL CROSS SECTION  
2-LANE PCC PAVEMENT WITH CURBS**

Notes:  
Normal sections shown may be appropriately modified for areas specifically designated by the Engineer, such as intersections or superelevated curves.

LOCATION		T
ROAD IDENTIFICATION	STATION TO STATION	Inches
CAMANCHE AVE (WB)	115+56.99 116+50.00	10

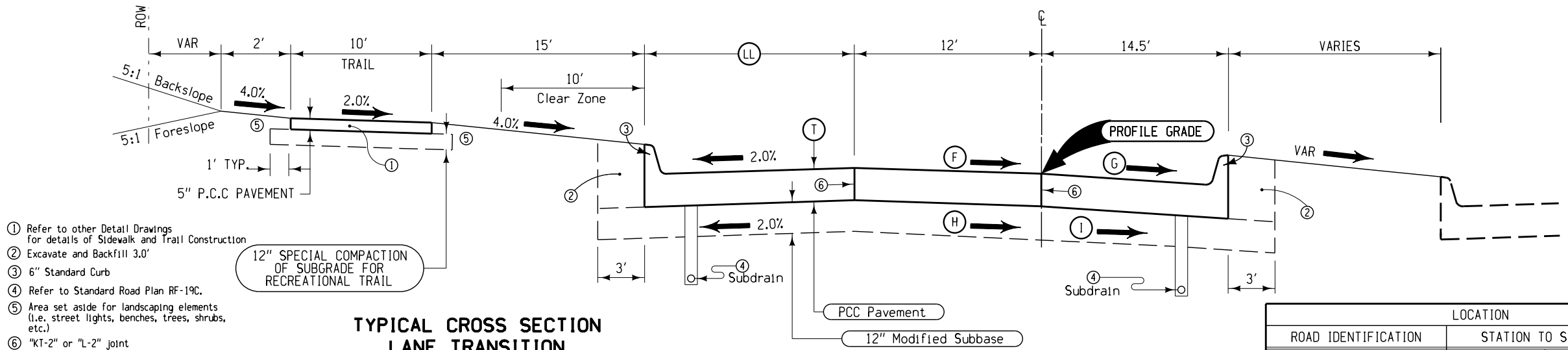

- ① Refer to other Detail Drawings for details of Sidewalk and Trail Construction
- ② Excavate and Backfill 3.0'
- ③ 6" Standard Curb
- ④ Refer to Standard Road Plan RF-19C.
- ⑤ Area set aside for landscaping elements (i.e. street lights, benches, trees, shrubs, etc.)
- ⑥ "KT-2" or "L-2" joint

12" SPECIAL COMPACTION OF SUBGRADE FOR RECREATIONAL TRAIL

**TYPICAL CROSS SECTION  
LANE TRANSITION  
PCC PAVEMENT WITH CURBS**

Notes:  
Normal sections shown may be appropriately modified for areas specifically designated by the Engineer, such as intersections or superelevated curves.

LOCATION		F	G	H	I	T	LL
ROAD IDENTIFICATION	STATION TO STATION	Percent	Percent	Percent	Percent	Inches	Feet
CAMANCHE AVE (WB)	116+50.00 118+00.00	-2	2	-2	2	10	2.5-8.5
CAMANCHE AVE (WB)	118+00.00 118+50.00	-2	2-3	-2	2-3	10	8.5-10.5
CAMANCHE AVE (WB)	118+50.00 119+50.00	-2 TO 2	3	-2 TO 2	3	10	10.5-14.5

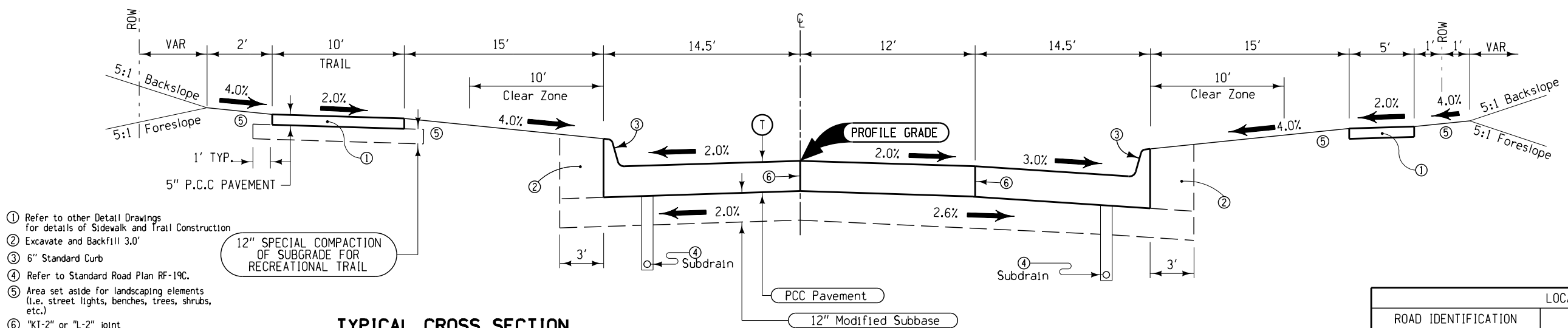

- ① Refer to other Detail Drawings for details of Sidewalk and Trail Construction
- ② Excavate and Backfill 3.0'
- ③ 6" Standard Curb
- ④ Refer to Standard Road Plan RF-19C.
- ⑤ Area set aside for landscaping elements (i.e. street lights, benches, trees, shrubs, etc.)
- ⑥ "KT-2" or "L-2" joint

12" SPECIAL COMPACTION OF SUBGRADE FOR RECREATIONAL TRAIL

**TYPICAL CROSS SECTION  
3-LANE PCC PAVEMENT WITH CURBS**

Notes:  
Normal sections shown may be appropriately modified for areas specifically designated by the Engineer, such as intersections or superelevated curves.

LOCATION		T
ROAD IDENTIFICATION	STATION TO STATION	Inches
CAMANCHE AVE (WB)	119+50.00 187+08.00	10

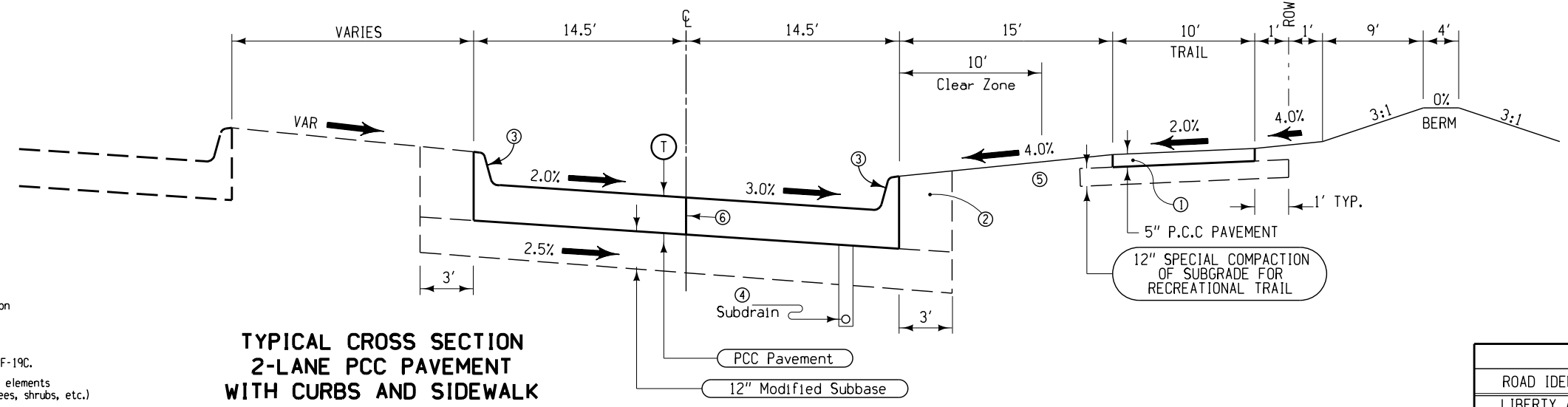

Notes:  
Normal sections shown may be appropriately modified for areas specifically designated by the Engineer, such as intersections or superelevated curves.

- ① Refer to other Detail Drawings for details of Trail Construction
- ② Excavate and Backfill 3.0'
- ③ 6" Standard Curb
- ④ Refer to Standard Road Plan RF-19C.
- ⑤ Area set aside for landscaping elements (i.e. street lights, benches, trees, shrubs, etc.)
- ⑥ "KT-2" or "L-2" joint

**TYPICAL CROSS SECTION  
2-LANE PCC PAVEMENT  
WITH CURBS AND SIDEWALK**

LOCATION		Inches
ROAD IDENTIFICATION	STATION TO STATION	
LIBERTY AVE (WB)	315+56.99 - 320+30.16	10

**TYPICAL CROSS SECTION  
3-LANE P.C.C.  
WITH 2.5' CURB SECTION  
(CONNECTOR STREETS)**

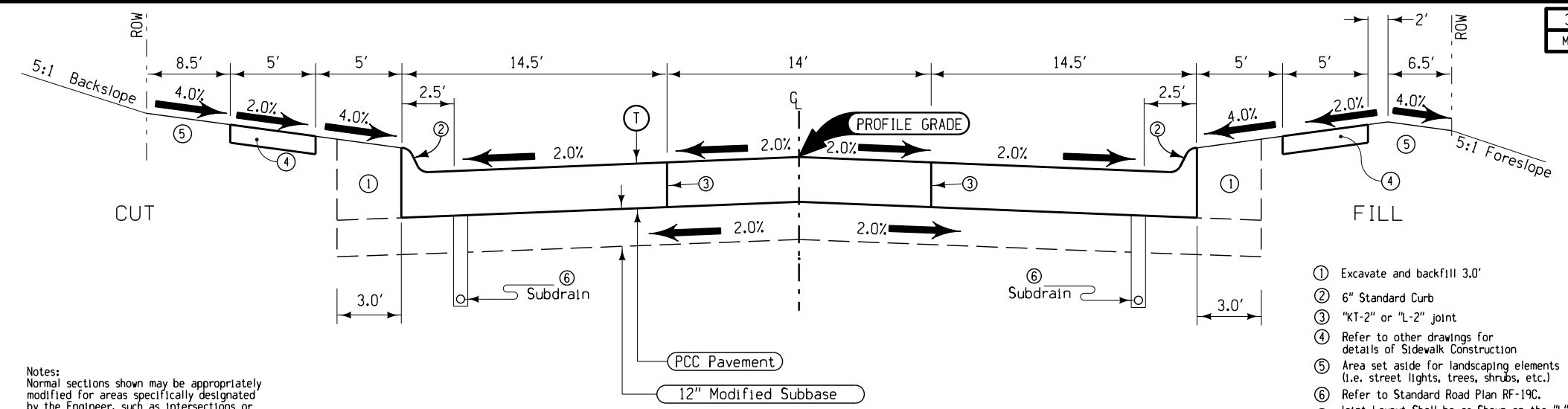

- ① Excavate and backfill 3.0'
- ② 6" Standard Curb
- ③ "KT-2" or "L-2" joint
- ④ Refer to other drawings for details of Sidewalk Construction
- ⑤ Area set aside for landscaping elements (i.e. street lights, trees, shrubs, etc.)
- ⑥ Refer to Standard Road Plan RF-19C.
- ⑦ Joint Layout Shall be as Shown on the "L" Sheets. Transverse Joints will be "CD"
- ⑧ See "L" and "W" Sheets for Additional Information

Notes:  
Normal sections shown may be appropriately modified for areas specifically designated by the Engineer, such as intersections or superelevated curves.

LOCATION		Inches
ROAD IDENTIFICATION	STATION TO STATION	
23RD PLACE	1398+75.00 - 1399+63.21	10
22ND PLACE	1498+75.00 - 1499+63.37	10
21ST PLACE	1597+10.00 - 1599+67.19	8
15TH AVENUE	2196+27.11 - 2199+63.26	8
13TH AVENUE	2398+75.00 - 2399+63.48	8
12TH AVENUE	2499+38.50 - 2499+63.48	8

**TYPICAL CROSS SECTION  
3-LANE P.C.C.  
WITH 2.5' CURB SECTION W/ TRAIL**

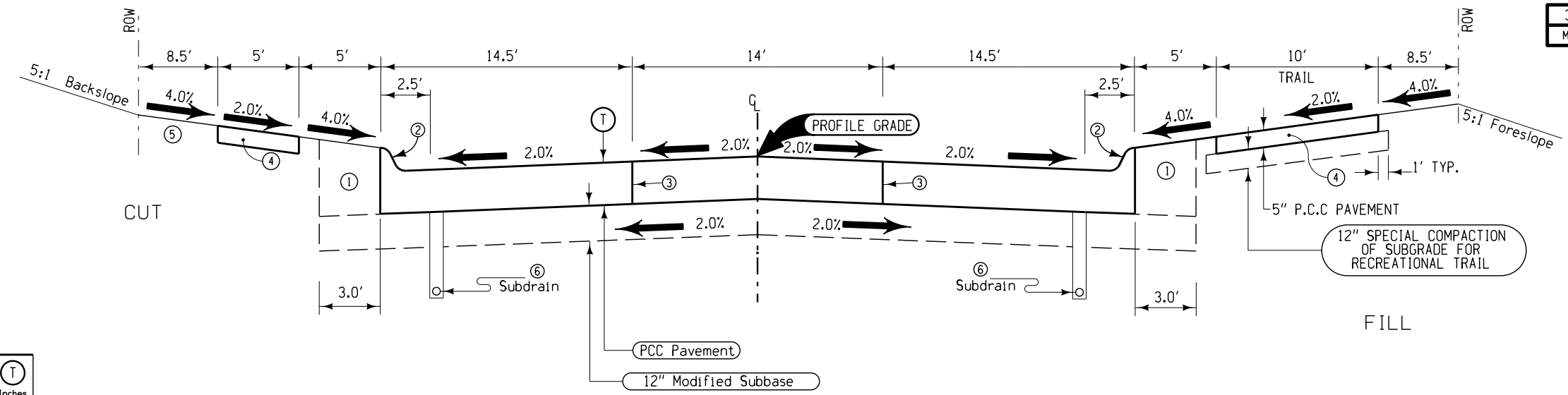

- ① Excavate and backfill 3.0'
- ② 6" Standard Curb
- ③ "KT-2" or "L-2" joint
- ④ Refer to other drawings for details of Sidewalk and Trail Construction
- ⑤ Area set aside for landscaping elements (i.e. street lights, trees, shrubs, etc.)
- ⑥ Refer to Standard Road Plan RF-19C.
- ⑦ Joint Layout Shall be as Shown on the "L" Sheets. Transverse Joints will be "CD"
- ⑧ See "L" and "W" Sheets for Additional Information

LOCATION		Inches
ROAD IDENTIFICATION	STATION TO STATION	
17TH PLACE	1996+14.67 - 1999+63.07	8

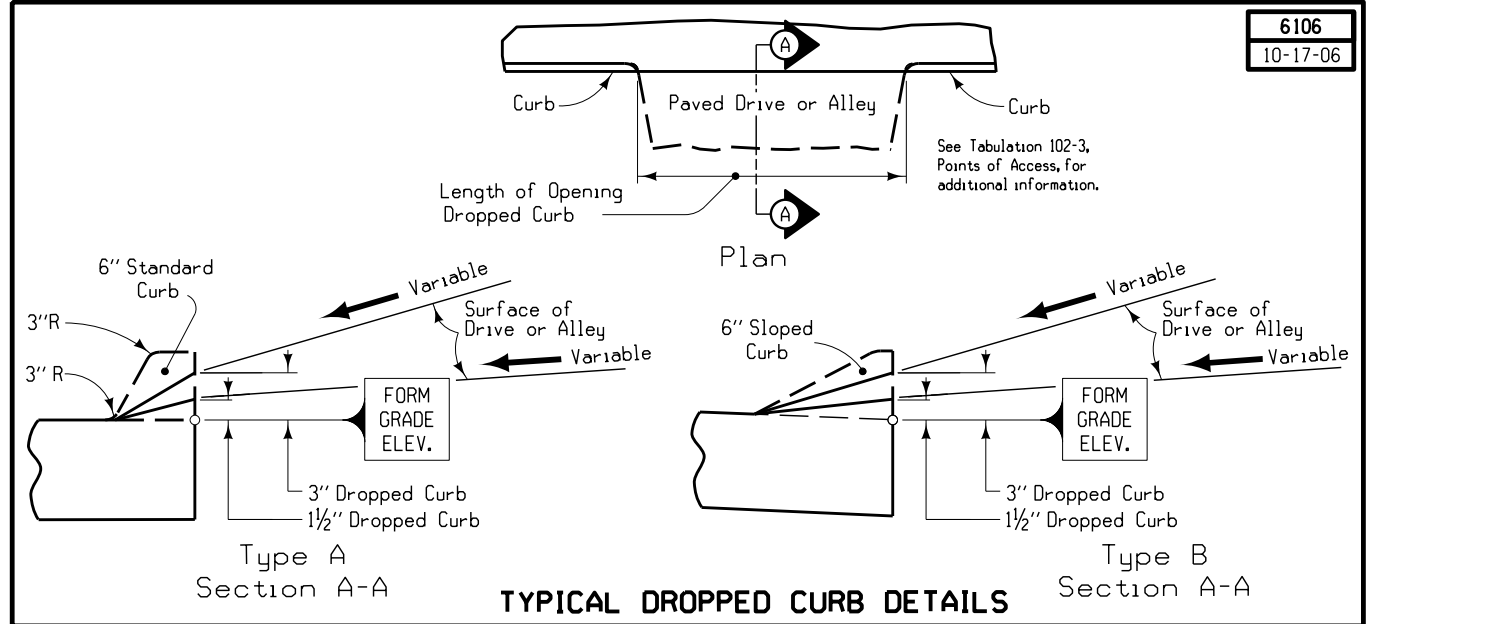
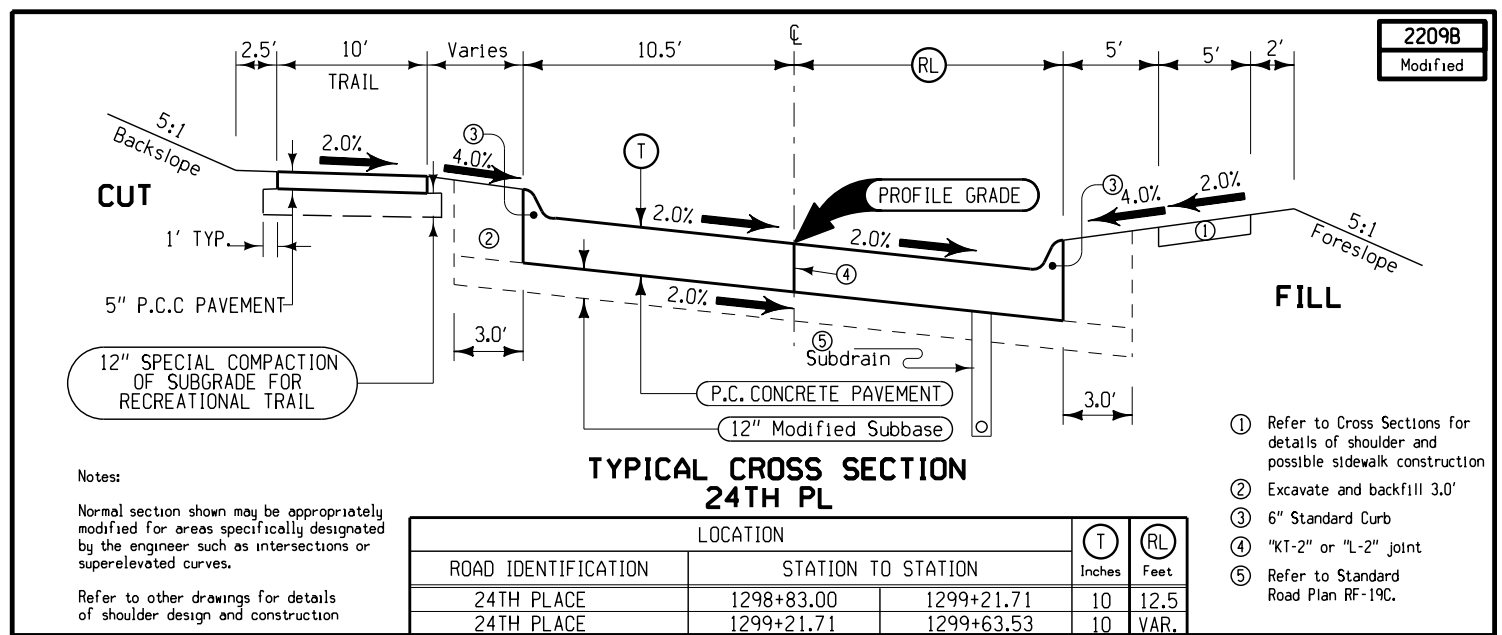
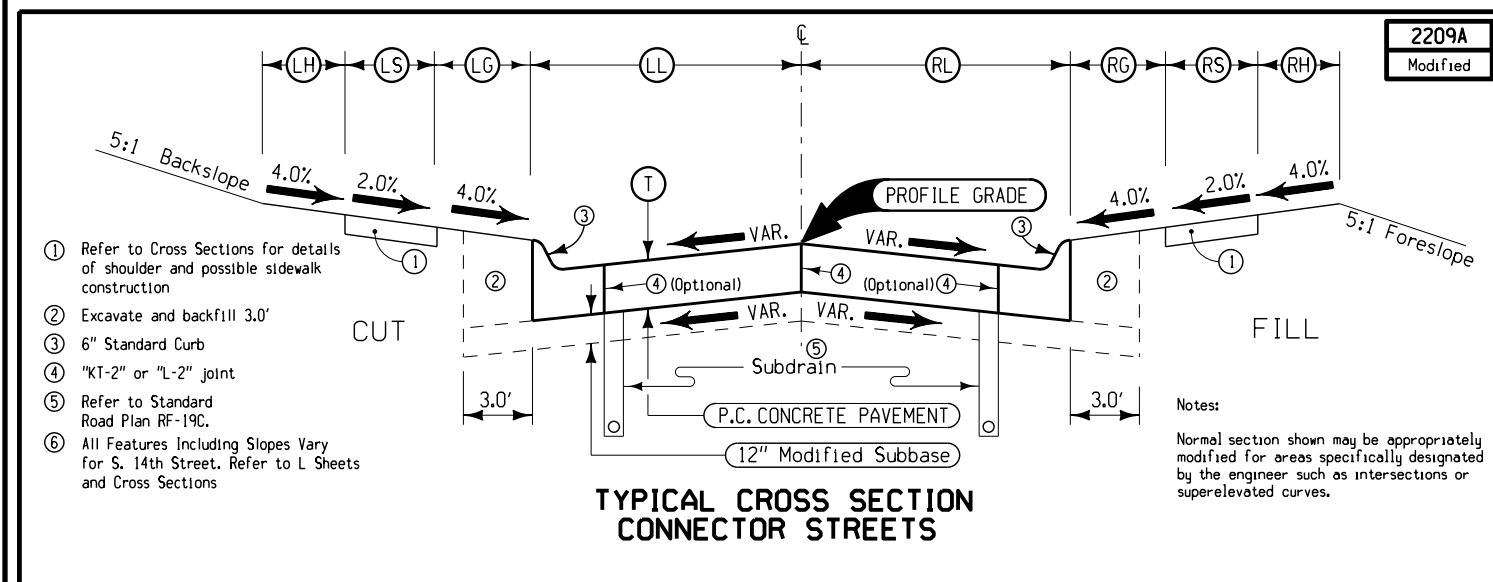
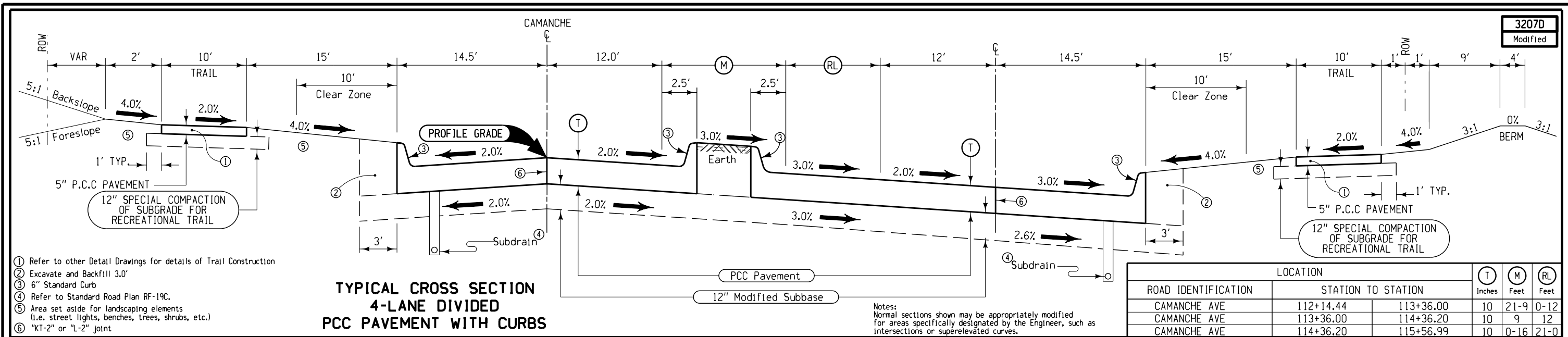



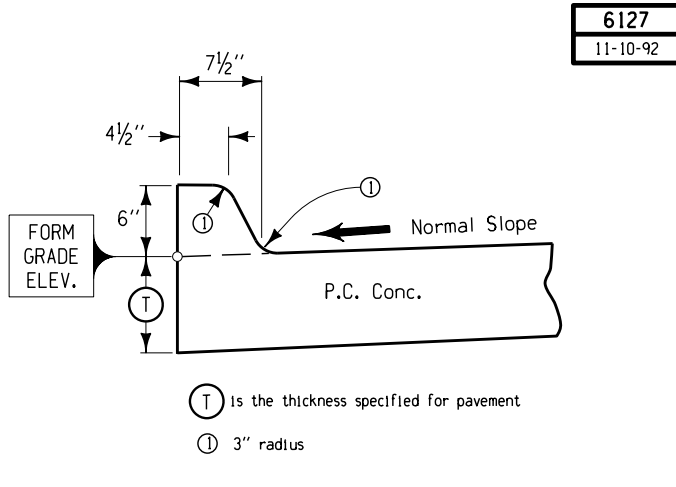

6127  
11-10-92

DETAILS OF INTEGRAL  
6" STANDARD CURB

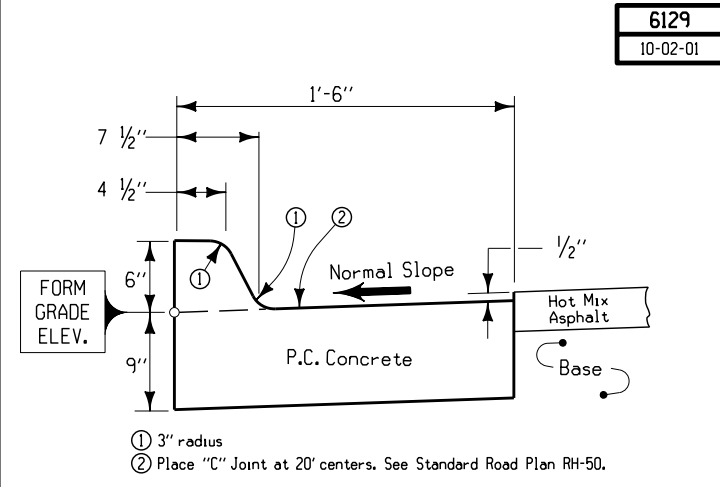

6129  
10-02-01

CURB AND GUTTER UNIT  
(STANDARD CURB - ADJACENT TO HMA)

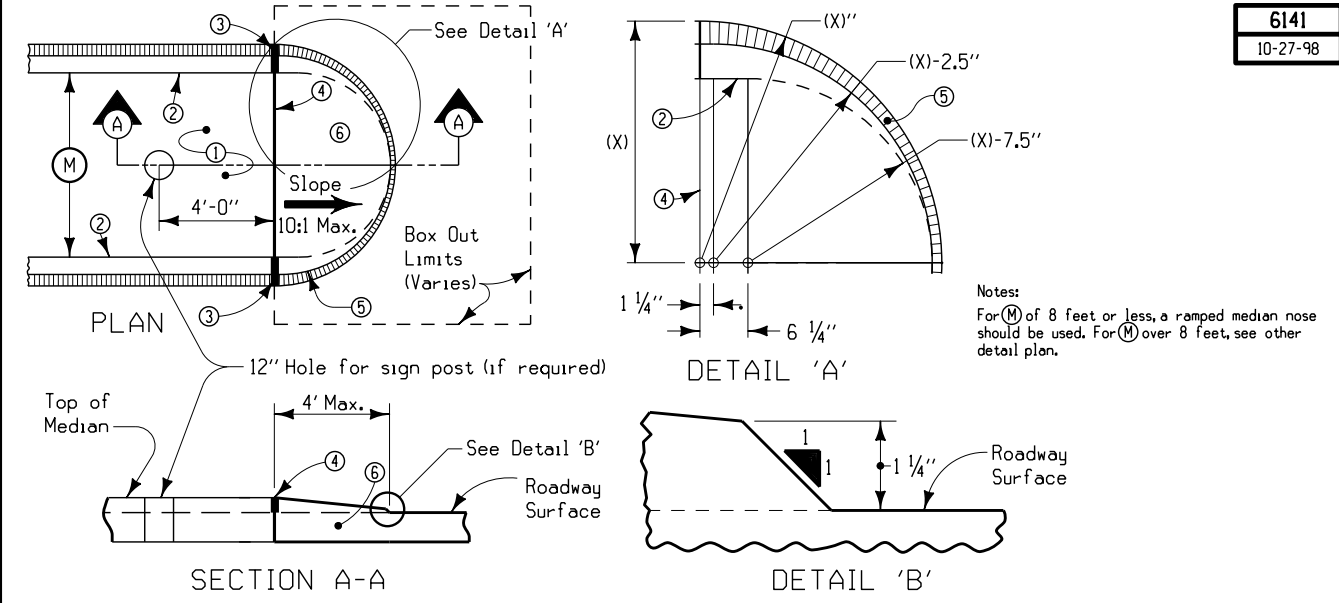

6141  
10-27-98

RAMPED MEDIAN NOSE  
(6" STANDARD CURB)

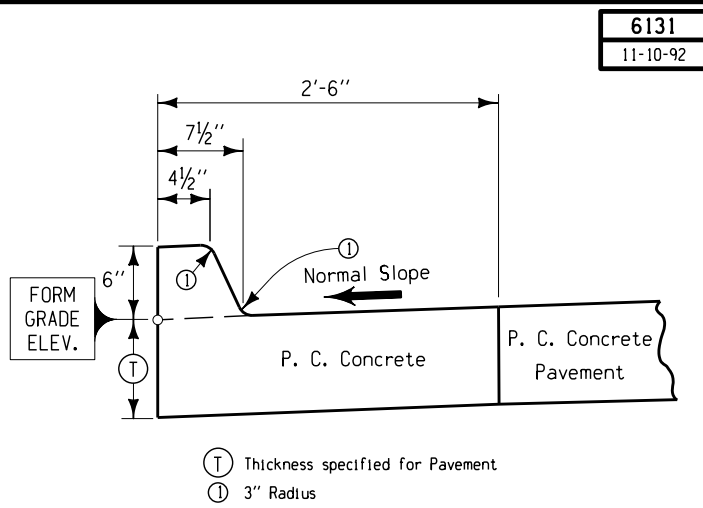

6131  
11-10-92

CURB AND GUTTER UNIT  
(STANDARD CURB - ADJACENT TO P.C.C.)

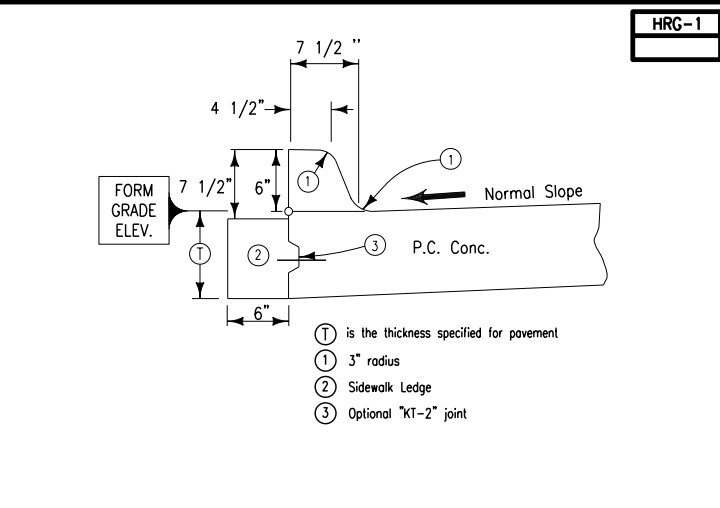

HRG-1

DETAILS OF INTEGRAL  
6" STANDARD CURB ADJACENT TO PCC PAVERS

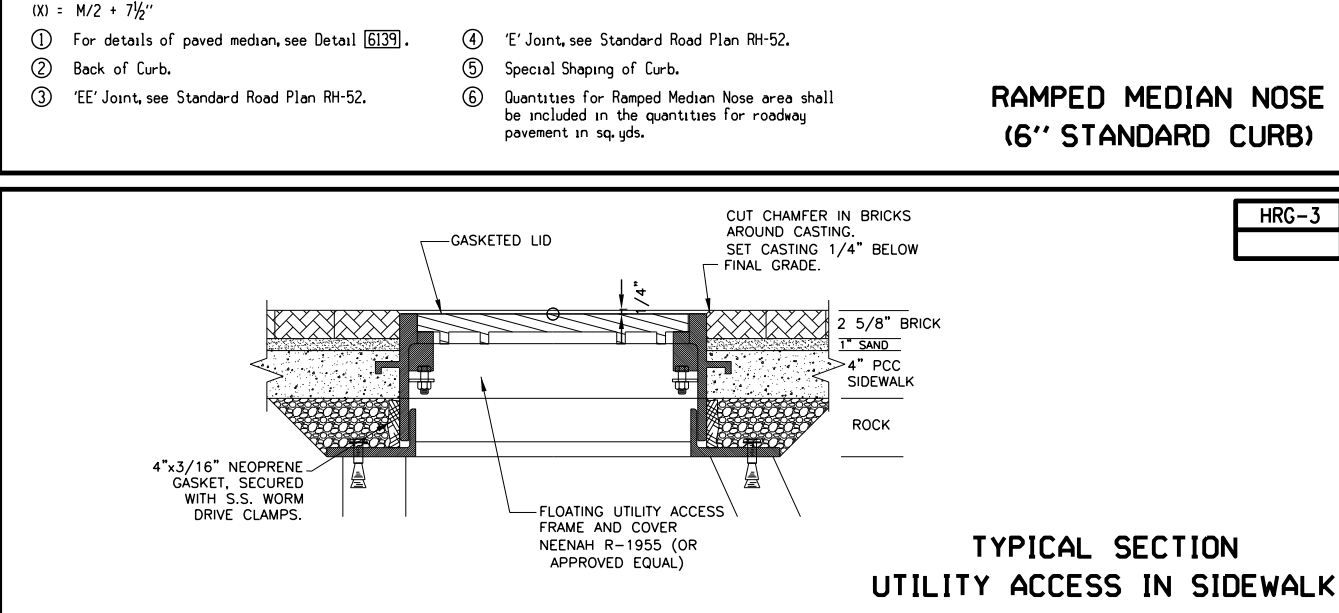

HRG-3

TYPICAL SECTION  
UTILITY ACCESS IN SIDEWALK

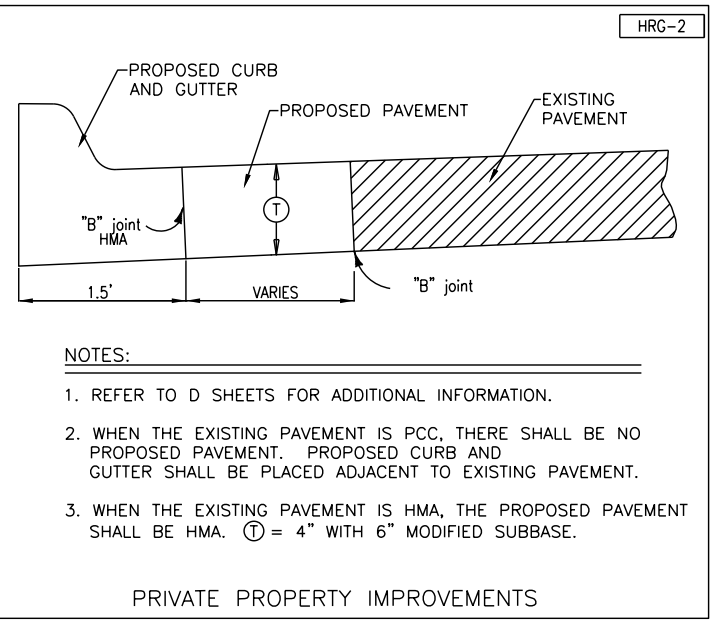

HRG-2

PRIVATE PROPERTY IMPROVEMENTS

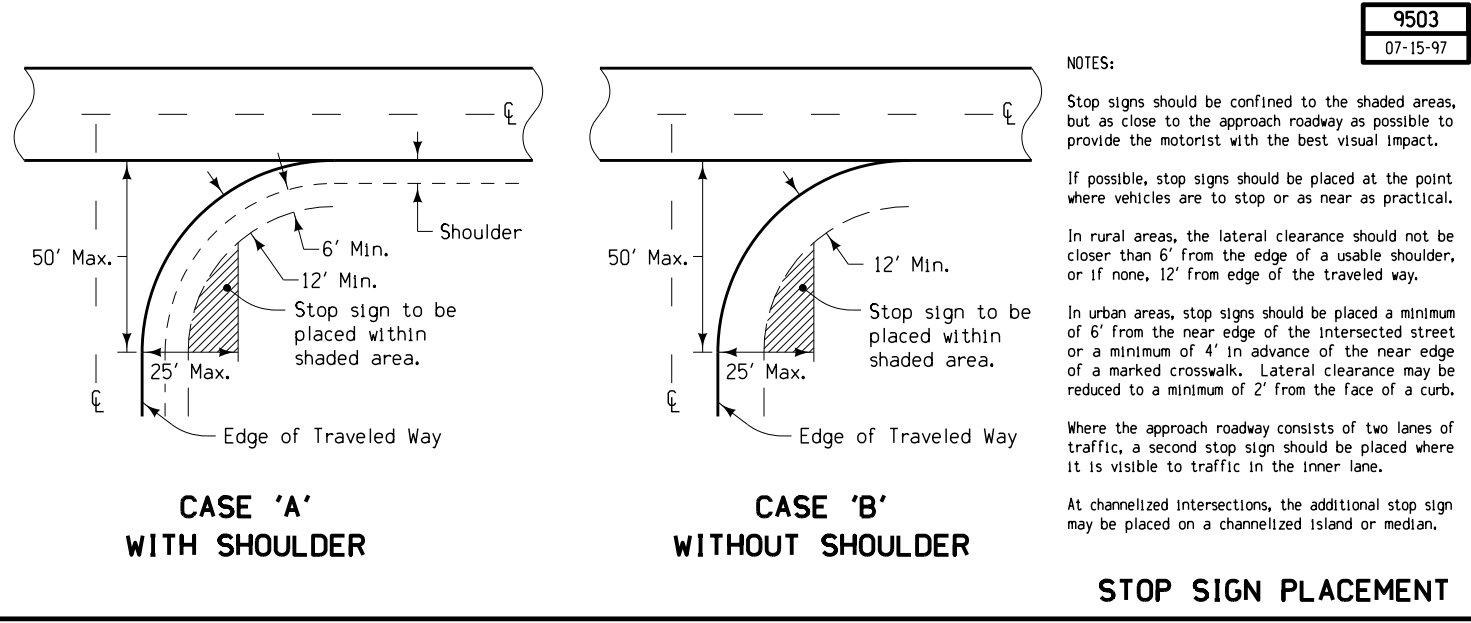

9503  
07-15-97

NOTES:  
 Stop signs should be confined to the shaded areas, but as close to the approach roadway as possible to provide the motorist with the best visual impact.  
 If possible, stop signs should be placed at the point where vehicles are to stop or as near as practical.  
 In rural areas, the lateral clearance should not be closer than 6' from the edge of a usable shoulder, or if none, 12' from edge of the traveled way.  
 In urban areas, stop signs should be placed a minimum of 6' from the near edge of the intersected street or a minimum of 4' in advance of the near edge of a marked crosswalk. Lateral clearance may be reduced to a minimum of 2' from the face of a curb.  
 Where the approach roadway consists of two lanes of traffic, a second stop sign should be placed where it is visible to traffic in the inner lane.  
 At channelized intersections, the additional stop sign may be placed on a channelized island or median.

CASE 'A'  
WITH SHOULDER  
 CASE 'B'  
WITHOUT SHOULDER  
 STOP SIGN PLACEMENT

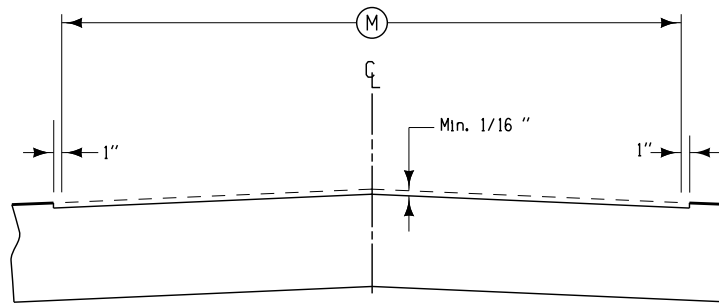

Details of Milling

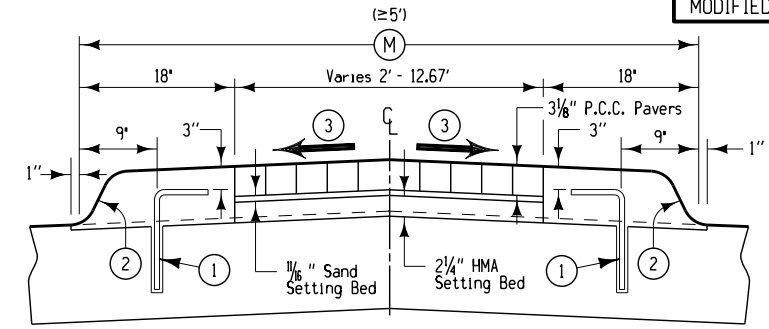

Details of Median Placement

DOWELED MEDIAN WITH STANDARD CURB

Notes:  
This section may be appropriately modified in areas specifically designated by the Engineer.  
Use 'C' joints in the doweled median and match the location of all transverse and longitudinal joints to the joints in the existing pavement.  
Place tie bars at 24" C-C longitudinal spacing between joints in existing pavement.  
Drill 3/8" holes for tie bars and epoxy to new pavement. See L Sheets for additional details. Epoxy material shall be as specified in Materials [M49]1.1, appendix C.

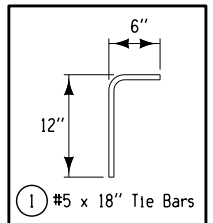

- ② 6" Standard Curb
- ③ Match Existing Pavement Slope.

**GENERAL NOTES**

- ALL RISERS TO BE OF EQUAL HEIGHT & ALL TREADS TO BE OF EQUAL LENGTH FOR ANY SET OF STAIRS. RISERS SHALL HAVE 1" BATTER. TREADS SHALL HAVE 1/4" PITCH.
- MIN. 2" COVER ON ALL STEEL.
- HANDRAIL MAY BE ATTACHED TO THE STEPS WITH THE OPTIONAL ANCHOR AS DETAILED.
- THIS DETAIL SHALL NOT BE USED ON STEPS REQUIRING MORE THAN 5 RISERS.

RISER (IN.)	TREAD (IN.)	SLOPE
4	16-18	4:1
5	14-16	3:1
6(MAX.)	12-14	2:1

STEEL SCHEDULE

BAR	SPACING (IN.)	REMARKS
K	24	TRANSVERSE STEP
L	12	LONGITUDINAL STEP
B	12	LUG

ALL STEEL TO BE NO. 4 BARS

OPTIONAL HANDRAIL ANCHOR: 2-3/8" APPROVED CALV. ANCHOR BOLTS MIN. 3" LENGTH

1/4" X 2 1/2" X 5" STEEL PLATE

DATE: 01-01-98

TYPE "A" CONCRETE STEPS WITH HANDRAIL

FIGURE: 9080J

SHEET 1 OF 1

ESTIMATED PROJECT QUANTITIES

Item No.	Item Code	Item	Unit	Quantities											
				Estimated					As Built						
				Div 1	Div 2	Div 3	0	0	Total	State 100%	City 100%	IM	0	0	
1	2101-0850002	CLEAR+GRUBB	UNIT	44						44					
2	2102-2710070	EXCAVATION, CL 10, RDWY+BORROW	CY	38329	6746					45075					
3	2105-8425005	TOPSOIL, FURN+SPREAD	CY	12717	1727					14444					
4	2107-0875100	COMPACTION W/MOISTURE CONTROL	CY	28388	4994					33382					
5	2115-0100000	MODIFIED SUBBASE	CY	18620	3214					21834					
6	2123-7450020	SHLD FINISH, EARTH	STA	140	38					178					
7	2201-0505100	BASE, STD/S-F PCC, 10"	SY	1509						1509					
8	2213-6745500	RMVL OF CURB	STA	0.6						0.6					
9	2301-1033080	STD/S-F PCC PAV'T, CL C CL 3, 8"	SY	2587	6830					9417					
10	2301-1033100	STD/S-F PCC PAV'T, CL C CL 3, 10"	SY	44948	1637					46585					
11	2301-4874006	MEDIAN, DOWELLED PCC	SY	98						98					
12	2301-6911722	PCC PAV'T SAMPLE	LS	1						1					
13	2303-0000100	HMA COMMERCIAL MIX (INCL ASPH BINDER)	TON	99						99					
14	2304-0101000	TEMPORARY PAV'T	SY	3894						3894					
15	2401-6745910	RMVL OF SIGN	EACH	32	2					34					
16	2401-6750001	REML	LS	1						1					
17	2401-7207020	RMVL OF CONC	CY	35.4						35.4					
18	2401-7207030	RMVL OF CONC	LS	1						1					
19	2416-0100030	APRON, CONC, 15"	EACH			1				1					
20	2435-0130148	MANHOLE, SAN SWR, SW-301, 48"	EACH		29					29					
21	2435-0130160	MANHOLE, SAN SWR, SW-301, 60"	EACH		7					7					
22	2435-0130172	MANHOLE, SAN SWR, SW-301, 72"	EACH		3					3					
23	2435-0140148	MANHOLE, STORM SWR, SW-401, 48"	EACH	3	1					4					
24	2435-0140160	MANHOLE, STORM SWR, SW-401, 60"	EACH		1					1					
25	2435-0140172	MANHOLE, STORM SWR, SW-401, 72"	EACH			5				5					
26	2435-0140184	MANHOLE, STORM SWR, SW-401, 84"	EACH			2				2					
27	2435-0140196	MANHOLE, STORM SWR, SW-401, 96"	EACH			9				9					
28	2435-0250100	INTAKE, SW-501	EACH	1						1					
29	2435-0250500	INTAKE, SW-505	EACH		17					17					
30	2435-0250600	INTAKE, SW-506	EACH		10					10					
31	2435-0250700	INTAKE, SW-507	EACH	9	9					18					
32	2435-0250800	INTAKE, SW-508	EACH	5	2					7					
33	2435-0250810	INTAKE, SW-508 MODIFIED	EACH	3	3					6					
34	2435-0250900	INTAKE, SW-509	EACH	40	9					49					
35	2435-0251000	INTAKE, SW-510	EACH	38						38					
36	2435-0251010	INTAKE, SW-510 MODIFIED	EACH	19		1				20					
37	2435-0251224	INTAKE, SW-512, 24 IN.	EACH	6						6					
38	2435-0251230	INTAKE, SW-512, 30 IN.	EACH	1						1					
39	2435-0251236	INTAKE, SW-512, 36 IN.	EACH	1						1					
40	2435-0251300	INTAKE, SW-513	EACH	0	10					10					
41	2435-0254500	INTAKE, SW-545	EACH	6	0					6					
42	2435-0600010	MANHOLE ADJUSTMENT, MINOR	EACH	1						1					
43	2435-0600110	INTAKE ADJUSTMENT, MINOR	EACH	3						3					
44	2435-0700010	CONNECTION TO EXISTING MANHOLE	EACH		3	2				5					
45	2435-0700020	CONNECTION TO EXISTING INTAKE	EACH	3	2	0				5					
46	2501-8400170	TEMP SHEET PILE+SHORING	LS	1						1					
47	2502-8212034	SUBDRAIN, LONGITUDINAL, (SHLD) 4"	LF	14817	3259					18076					
48	2502-8220193	SUBDRAIN OUTLET (RF-19C)	EACH	199	46					245					
49	2503-0111012	STORM SWR GRAVITY MAIN, TRENCHED, HDPE, 12"	LF	13						13					
50	2503-0111018	STORM SWR GRAVITY MAIN, TRENCHED, HDPE, 18"	LF	163						163					
51	2503-0114215	STORM SWR G-MAIN, TRENCHED, RCP 2000D, 15"	LF	2000	1112	347				3459					
52	2503-0114218	STORM SWR G-MAIN, TRENCHED, RCP 2000D, 18"	LF	1560	530	662				2752					
53	2503-0114221	STORM SWR G-MAIN, TRENCHED, RCP 2000D, 21"	LF	686	96	381				1163					
54	2503-0114224	STORM SWR G-MAIN, TRENCHED, RCP 2000D, 24"	LF	91	351	358				800					
55	2503-0114230	STORM SWR G-MAIN, TRENCHED, RCP 2000D, 30"	LF	94	468	1730				2292					
56	2503-0114236	STORM SWR G-MAIN, TRENCHED, RCP 2000D, 36"	LF	237	71	1257				1565					
57	2503-0114242	STORM SWR G-MAIN, TRENCHED, RCP 2000D, 42"	LF			1458				1458					
58	2503-0114248	STORM SWR G-MAIN, TRENCHED, RCP 2000D, 48"	LF		34	549				583					
59	2503-0116229	STORM SWR G-MAIN, TRENCHED, RCAP 2000D, 29X18"	LF	36						36					
60	2503-0116237	STORM SWR G-MAIN, TRENCHED, RCAP 2000D, 37X23"	LF	84						84					
61	2503-0116252	STORM SWR G-MAIN, TRENCHED, RCAP 2000D, 52X32"	LF			181				181					
62	2503-0116259	STORM SWR G-MAIN, TRENCHED, RCAP 2000D, 59X36"	LF			841				841					
63	2504-0114008	SAN SWR G-MAIN, TRENCHED, PVC, 8"	LF		101					101					
64	2504-0114010	SAN SWR G-MAIN, TRENCHED, PVC, 10"	LF		121					121					
65	2504-0114012	SAN SWR G-MAIN, TRENCHED, PVC, 12"	LF		3279					3279					
66	2504-0114015	SAN SWR G-MAIN, TRENCHED, PVC, 15"	LF		682					682					
67	2504-0114018	SAN SWR G-MAIN, TRENCHED, PVC, 18"	LF		1039					1039					
68	2504-0114024	SAN SWR G-MAIN, TRENCHED, PVC, 24"	LF		694					694					
69	2504-0114030	SAN SWR G-MAIN, TRENCHED, PVC, 30"	LF		1472					1472					
70	2504-0114036	SAN SWR G-MAIN, TRENCHED, PVC, 36"	LF		37					37					
71	2504-0116010	SAN SWR G-MAIN, TRENCHED, DIP, 10"	LF	31	6					37					
72	2504-0116012	SAN SWR G-MAIN, TRENCHED, DIP, 12"	LF		364					364					
73	2504-0116018	SAN SWR G-MAIN, TRENCHED, DIP, 18"	LF		581					581					
74	2504-0116024	SAN SWR G-MAIN, TRENCHED, DIP, 24"	LF		272					272					
75	2504-0116030	SAN SWR G-MAIN, TRENCHED, DIP, 30"	LF		208					208					
76	2504-0200406	SAN SWR SERVICE STUB, PVC, 6"	LF		1251					1251					
77	2504-0200408	SAN SWR SERVICE STUB, PVC, 8"	LF		1576					1576					
78	2504-0240036	RMV SAN SWR PIPE LE 36"	LF	12347	2506					14853					
79	2504-0240136	RMV SAN SWR PIPE GT 36"	LF	61	108					169					
80	2504-0240236	SAN SWR ABANDONMENT, FILL+PLUG, LE 36"	LF	3706						3706					
81	2506-4984000	FLOWABLE MORTAR	CY	171	384	1067				1622					

ESTIMATED PROJECT QUANTITIES

Item No.	Item Code	Item	Unit	Quantities											
				Estimated					As Built						
				Div 1	Div 2	Div 3	0	0	Total	State 100%	City 100%	IM	0	0	
82	2510-6745850	RMVL OF PAV'T	SY	52302	10756					63058					
83	2510-6750600	RMVL OF INTAKE+UTILITY ACCESS	EACH	102	56					158					
84	2511-0302500	RECREATIONAL TRAIL, PCC, 5"	SY	8203	420					8623					
85	2511-0310100	SPECIAL COMPACTION OF SUBGRADE/REC TRAIL	STA	77.4	3.9					81.3					
86	2511-6745900	RMVL OF SIDEWALK	SY	5466	1998					7464					
87	2511-7526004	SIDEWALK, PCC, 4"	SY	3375	1778					5153					
88	2512-1725156	CURB+GUTTER, PCC, 1.5'	LF	613						613					
89	2512-1725256	CURB+GUTTER, PCC, 2.5'	LF	1007						1007					
90	2515-2475007	DRIVEWAY, PCC, 7"	SY	5830	556					6386					
91	2515-6745600	RMVL OF PAVED DRIVEWAY	SY	3325	841					4166					
92	2518-6910000	SAFETY CLOSURE	EACH	39	0					39					
93	2520-3350015	FIELD OFFICE	EACH	1	0					1					
94	2523-0000100	LIGHTING UNIT	EACH	0	140					140					
95	2523-0000200	ELECTRICAL CIRCUIT	LF	0	19623					19623					
96	2523-0000310	HANDHOLE	EACH	0	32					32					
97	2523-0000400	LIGHTING CONTROL CABINET	EACH	0	4					4					
98	2523-6765009	RMV+REINSTALL LIGHT POLE+LUMINAIRE	EACH	0	6					6					
99	2524-6765010	RMV + REINSTALL SIGN	EACH	55	52					107					
100	2524-9325001	TYPE A SIGN, SHEET ALUM	SF	34	63					97					
101	2525-0000100	TRAFFIC SIGNALIZATION	LS	1	0					1					
102	2525-0000120	RMVL OF TRAFFIC SIGNALIZATION	LS	1	0					1					
103	2526-8285000	CONSTRUCTION SURVEY	LS	1	0					1					
104	2527-9263109	PAINTED PAV'T MARK, WATERBORNE/SOLVENT	STA	194.65	183.28					377.93					
105	2527-9263131	WET RETROREFLECTIVE REMOVABLE TAPE MARK	STA	80.91						80.91					
106	2527-9263137	PAINTED SYMBOL+LEGEND, WATERBORNE/SOLVNT	EACH	51	90					141					
107	2527-9263180	PAV'T MARK RMVD	STA	179.32						179.32					
108	2528-8400256	TEMPORARY TRAFFIC SIGNALS	EACH	3						3					
109	2528-8445110	TRAFFIC CONTROL	LS	1						1					
110	2528-8445113	FLAGGER	EACH	10						10					
111	2528-9109020	TEMP LANE SEPARATOR SYSTEM	LF	1990						1990					
112	2533-4980005	MOBILIZATION	LS	1						1					
113	2537-8900000	REMEDICATION OF PETRO CONTAMINATED SOIL	CY	8417						8417					
114	2537-8900100	SAMPLE+TEST-PETRO CONTAM (REMEDICATION)	EACH	60						60					
115	2537-8900500	AMENDED SOIL	CY		1715					1715					
116	2552-0000140	ROCK EXCAVATION	CY	606	4960	2649				8215					
117	2554-0203000	FITTINGS BY WEIGHT, DI	LB	495						495					
118	2599-9999001	SEED, NO-MOW FESCUE MIX	ACRE	1.1						1.1					
119	2599-9999005	CONCRETE COLUMNS	EACH		30					30					
120	2599-9999005	HERON SCULPTURE - INSTALL	EACH		1					1					
121	2599-9999005	INLET PROTECTION DEVICE	EACH	67	15					82					
122	2599-9999005	LIGHT ASSEMBLY, TYPE L3 (ATOP TRAFFIC SIGNAL)	EACH		4					4					
123	2599-9999005	LINCOLN HIGHWAY PLAQUES	EACH		14					14					
124	2599-9999005	PERENNIALS	EACH		1760					1760					
125	2599-9999005	PERGOLA BASE COLUMNS	EACH		12					12					
126	2599-9999005	PERGOLA BRIDGE BENCH	EACH		8					8					
127	2599-9999005	PERGOLAS	EACH		4					4					
128	2599-9999009	CERAMIC EPOXY SEWER LINING, 10"	LF		37					37					
129	2599-9999009	CERAMIC EPOXY SEWER LINING, 12"	LF		364					364					
130	2599-9999009	CERAMIC EPOXY SEWER LINING, 18"	LF		581					581					
131	2599-9999009	CERAMIC EPOXY SEWER LINING, 24"	LF		272					272					
132	2599-9999009	CERAMIC EPOXY SEWER LINING, 30"	LF		208					208					
133	2599-9999009	STEEL EDGING	LF		901					901					
134	2599-9999009	STEEL POSTS-TYPE A SIGNS, 2.25x2.25 IN., 12 GA	LF	645	390					1035					
135	2599-9999014	MOWSTRIP, PCC, 7-7/8"	SF		765					765					
136	2599-9999014	P.C. CONCRETE STEPS	CY	0.9						0.9					
137	2599-9999014	PCC PAVERS, 2-3/8 IN.	SF		2833					2833					
138	2599-9999014	PCC PAVERS, 3-1/8 IN.	SF	14629	11471					26100					
139	2599-9999014	PCC PAVERS, DETECTABLE WARNING, 3 IN.	SF	1228	160					1388					
140	2599-9999018	SIDEWALK, P.C. CONCRETE, 7-7/8 IN.	SY	1797	188					1985					
141	2599-9999018	SUBSLAB, PCC, 4 IN FOR PCC PAVERS	SY	1472	76					1548					
142	2599-9999018	SUBSLAB, PCC, 4.5 IN FOR PCC PAVERS	SY	205	119					324					
143	2601-2633100	MOWING	ACRE	20.8	2.5					23.3					
144	2601-2634100	MULCH	ACRE	3.4	0.7					4.1					
145	2601-2636044	SEED+FERTILIZE (URBAN)	ACRE	2.3	0.7					3					
146	2601-2639010	SOD	SQ	3058	244					3302					
147	2601-2642120	STABILIZE CROP - SEED+FERTILIZE (URBAN)	ACRE	2.3	0.7					3					
148	2601-2643110	WATER-SOD/SPEC DITCH CNTL/SLOPE PROTECT	MGAL	1835	146					1981					
149	2602-0000020	SILT FENCE	LF	7458	2577					10035					
150	2602-0000060	RMVL OF SILT FENCE	LF	7458	2577					10035					
151	2602-0000090	CLEAN-OUT OF SILT FENCE	LF	7458	2577					10035					
152	2611-0000200	TREES, AMUR MAPLE, F+I (WITH WARRANTY)	EACH		37					37					
153	2611-0000200	TREES, AUTUMN SERVICEBERRY, F+I (WITH WARRANTY)	EACH		12					12					
154	2611-0000200	TREES, AUTUMN BLAZE MAPLE, F+I (WITH WARRANTY)	EACH		101					103					
155	2611-0000200	TREES, SHADEMASTER HONEYLOCUST, F+I (WITH WARRANTY)	EACH		70					69					
156	2611-0000200	TREES, PRINCETON SENTRY GINKO, F+I (WITH WARRANTY)	EACH		66					65					
157	2611-0000200	TREES, RIVER BIRCH, F+I (WITH WARRANTY)	EACH		5					5					
158	2611-0000201	TREES, SPRING SNOW CRABAPPLE, F+I (WITH WARRANTY)	EACH		76					76					
159	2611-0000202	TREES, SWAMP WHITE OAK, F+I (WITH WARRANTY)	EACH		12					12					
160	2611-0000204	TREES, WHITE SPRUCE, F+I (WITH WARRANTY)	EACH		21					21					
161	2611-0000203	TREES, IVORY SILK JAPANESE TREE LILAC, F+I (WITH WARRANTY)	EACH		65					65					

**PROJECT DESCRIPTION**

This project involves complete removal, realignment, and reconstruction of Camanche Avenue (U.S. 30/67) from S. 14th Street to S. 5th Street. In general, the work involves 8" and 10" PCC Pavement, excavation, sidewalk, recreation trail, storm sewer, sanitary sewer, traffic signals, lighting, signs, PCC pavers, various streetscape structures, trees, shrubs, perennials, wildflower seeding & sodding.  
2422-172000

**ESTIMATE REFERENCE INFORMATION**

Item No.	Item Code	Description
1	2101-0850002	CLEARING AND GRUBBING A. Individual trees shall be marked by the Engineer prior to removal. B. Refer to Removals Tabulation 110-2B on the C Sheets. C. Refer to U Sheets for locations. D. Quantity includes: Trees: 2 at 3-6", 2 at 6"-9", 1 at 9"-12", 1 at 15"-18"; Shrubs: 8 at 3-6"
2	2102-2710070	EXCAVATION, CLASS 10, ROADWAY AND BORROW A. Refer to T Sheets for template quantities. B. The template quantities are based on bottom of Modified Subbase and do not include the topsoil volume. C. Bid quantity of 45,075 CY Class 10 based on estimated fill quantity in place. This quantity includes: 36,753 CY Excavation 45,075 CY Fill 11,042 CY Borrow to be furnished by Contractor. 2,720 CY Waste Quantities assume use of excess excavation will be utilized for fill regardless of construction stage. D. Overhaul will not be measured or paid for, but shall be considered incidental to roadway excavation on this project.
3	2105-8425005	TOPSOIL, FURNISH AND SPREAD A. Volume based on spreading 6 inches. B. Bid quantity includes volume plus 40% shrinkage. C. Topsoil shall be placed on all disturbed areas that are not paved. D. Topsoil shall be high quality soil consisting of the top 12 inches of field or pasture loam containing a good supply of humus and a high degree of fertility. Surface soils from sandy floodplains adjacent to rivers or streams, drained ponds, ditch bottoms, and eroded areas, or soils which are supporting growth of noxious weeds or other undesirable vegetation will not be accepted. Topsoil with 55% or more sand and/or 40% or more clay will not be allowed. Topsoil shall have a pH value from 6.0 to 7.5. It shall be free from hard clods, rocks and other debris larger than 2 inches. E. Overhaul will not be measured or paid for, but shall be considered incidental to roadway excavation. F. The quantity for which payment will be made will be the quantity shown in the contract documents. G. The contractor will be paid the contract unit price per cubic yard. This shall be considered full compensation for furnishing, transporting, and placing topsoil in accordance with the contract documents.
4	2107-0875100	COMPACTION WITH MOISTURE CONTROL A. Refer to Embankment with Moisture Control Tabulation 103-6 on the C Sheets. B. Item intended for fill placed beneath mainline paving. C. Refer to Moisture with Compaction Control developmental specification.
5	2115-0100000	MODIFIED SUBBASE A. Refer to B Sheets for Typical Sections.
6	2123-7450020	SHOULDER FINISHING, EARTH A. This item is for finishing the area of backfill between the curb and sidewalk/trail. B. Material for the earth shoulders is included in the template quantities.
7	2201-0505100	BASE, STANDARD OR SLIP FORM P.C. CONCRETE, 10 IN. A. Bid item intended for construction of crosswalks. Refer to I Sheets for detail. B. Refer to L Sheets for geometric staking and jointing details
8	2213-6745500	REMOVAL OF CURB A. Refer to C Sheets for Tabulation of Curb Removal 110-4.
9	2301-1033080	STANDARD OR SLIP FORM PORTLAND CEMENT CONCRETE PAVEMENT, CLASS C, CLASS 3 DURABILITY, 8 IN.
10	2301-1033100	STANDARD OR SLIP FORM PORTLAND CEMENT CONCRETE PAVEMENT, CLASS C, CLASS 3 DURABILITY, 10 IN. A. Refer to typical sections on B Sheets. B. Refer to L Sheets for geometric staking and jointing details C. Includes an estimated 24,547 linear feet of 6" integral standard curb.
11	2301-4874006	MEDIAN, DOWELLED, P.C. CONCRETE A. Refer to standard detail 6149 (Mod) on B Sheets. Refer to L Sheets for placement details. B. P.C.C. Pavers and associated setting beds paid separately.
12	2301-6911722	PCC PAVEMENT SAMPLES
13	2303-0000100	HMA COMMERCIAL MIX (INCLUDES ASPHALT BINDER), AS PER PLAN A. Refer to HMA Commercial Mix Tabulation HRG-5A on the C Sheets. B. Refer to D Sheets for plan locations. C. Bid quantity to be used for private property improvements
14	2304-0101000	TEMPORARY PAVEMENT A. Refer to Temporary Pavement Tabulation HRG-9A on the C Sheets. B. Refer to F Sheets for plan locations. C. Material shall be HMA 3M ESAL Intermediate 3/4 IN. mix.

**ESTIMATE REFERENCE INFORMATION**

Item No.	Item Code	Description
		D. Construction, measurement and payment shall be in accordance with Section 2304 of the Standard Specifications E. Any pavement removal required to place temporary pavement shall be measured and paid for as pavement removal. F. The contractor will be paid the contract unit price per square yard. This shall be considered full compensation for furnishing all tools, equipment, labor and materials necessary for placement, maintenance, and removal of temporary pavement including excavation and embankment.
15	2401-6745910	REMOVAL OF SIGN A. Refer to C Sheets for Removal of Signs Tabulation 110-2A. B. Includes removal and disposal of post, footing and hardware. Also includes delivery of sign face to City Maintenance Yard at the corner of S. 2nd Street and 12th Avenue S. C. The Removal of Signs will be measured for payment by actual count by the engineer, and the contractor shall be paid the contract unit price. D. The contractor will be paid the contract unit price per each. This shall be considered full compensation for furnishing all tools, equipment, labor and materials necessary for removing, backfilling and disposing of signs, posts, footings and hardware in accordance with the contract documents.
16	2401-6750001	REMOVALS, AS PER PLAN A. Refer to C Sheets for Removals Tabulation 110-2B. B. Refer to U Sheets.
17	2401-7207020	REMOVAL OF CONCRETE A. Intended for removal of concrete steps. B. Refer to C Sheets for Removal of Concrete Steps Tabulation HRG-3A. Refer to U Sheets for locations. C. Contractor will be paid the contract unit price for each cubic yard of concrete steps removed.
18	2401-7207030	REMOVAL OF CONCRETE A. Intended for removal of retaining walls and footings. B. Refer to C Sheets for Removals Tabulation 110-2B. C. The contractor will be paid the lump sum contract unit price. This shall be considered full compensation for furnishing all tools, equipment, labor and materials necessary to remove retaining walls and footings in accordance with the contract documents.
19	2416-0100015	APRONS, CONCRETE, 30 IN. DIA. A. Refer to M Sheets for Storm Sewer Tabulation 104-5B.
20	2435-0130148	MANHOLE, SANITARY SEWER, SW-301, 48"
21	2435-0130160	MANHOLE, SANITARY SEWER, SW-301, 60"
22	2435-0130172	MANHOLE, SANITARY SEWER, SW-301, 72" A. Refer to O Sheets for Sanitary Sewer plan and profiles and Sanitary Sewer tabulation
23	2435-0140148	MANHOLE, STORM SWR, SW-401, 48"
24	2435-0140160	MANHOLE, STORM SWR, SW-401, 60"
25	2435-0140172	MANHOLE, STORM SWR, SW-401, 72"
26	2435-0140184	MANHOLE, STORM SWR, SW-401, 84"
27	2435-0140196	MANHOLE, STORM SWR, SW-401, 96"
28	2435-0250100	INTAKE, SW-501
29	2435-0250500	INTAKE, SW-505
30	2435-0250600	INTAKE, SW-506
31	2435-0250700	INTAKE, SW-507
32	2435-0250800	INTAKE, SW-508
33	2435-0250810	INTAKE, SW-508 MODIFIED
34	2435-0250900	INTAKE, SW-509
35	2435-0251000	INTAKE, SW-510
36	2435-0251010	INTAKE, SW-510 MODIFIED
37	2435-0251224	INTAKE, SW-512, 24 IN.
38	2435-0251230	INTAKE, SW-512, 30 IN.
39	2435-0251236	INTAKE, SW-512, 36 IN.
40	2435-0251300	INTAKE, SW-513
41	2435-0254500	INTAKE, SW-545 A. For SW-501 and SW-512 items, refer to J Sheets for List of Intakes and Utility Accesses Tabulation HRG-12A. For all other structures, refer to M Sheets for Storm Sewer Tabulation 104-5B. B. All labor and materials required to connect existing storm sewer pipe to storm sewer manholes and intakes, where indicated on the plans, shall be considered incidental to the unit cost of the storm sewer structure. C. For structures located within PCC Paver Sections (sidewalk or street - as denoted in Tabulation 104-5B), utility access frame and cover to consist of Neenah R-1955 with 2 inch riser unit (adjusting ring) R-1979) or approved equal. D. Refer to B sheets for Utility Access in Sidewalk Detail.
42	2435-0600010	MANHOLE ADJUSTMENT, MINOR A. Refer to C Sheets for Manhole Adjustment Tabulation HRG-10A
43	2435-0600110	INTAKE ADJUSTMENT, MINOR A. Refer to Temporary Storm Sewer Notes on J Sheets.
44	2435-0700020	CONNECTION TO EXISTING INTAKE A. Refer to M Sheets for Storm Sewer Tabulation 104-5B and J Sheets for List of Intakes and Utility Accesses Tabulation HRG-12A. B. See M Sheets for storm sewer plan and profiles and J Sheets for Staging and Traffic Control Plans.
45	2501-8400170	TEMPORARY SHEET PILES AND SHORING A. Refer to J Sheets for location. B. Temporary shoring design is responsibility of the contractor. C. Item to be measured and paid the lump sum contract price. Payment is full compensation for all material, equipment, labor and performance of all work necessary to complete the work according to the contract documents.

**ESTIMATE REFERENCE INFORMATION**

Item No.	Item Code	Description
46	2502-8212034	SUBDRAIN, LONGITUDINAL, (SHOULDER) 4 IN. DIA.
47	2502-8220193	SUBDRAIN OUTLET (RF-19C) A. Quantities include 22 LF to be utilized for storm sewer connection. Refer to M Sheets for tabulation, location and details. For all other subdrain, refer to C Sheets for Tabulation 104-9. B. Includes approximately 1122 CY of porous backfill.
48	2503-0111012	STORM SEWER GRAVITY MAIN, TRENCHED, HIGH DENSITY POLYETHYLENE PIPE (HDPE), 12 IN.
49	2503-0111018	STORM SEWER GRAVITY MAIN, TRENCHED, HIGH DENSITY POLYETHYLENE PIPE (HDPE), 18 IN.
50	2503-0114215	STORM SEWER GRAVITY MAIN, TRENCHED, REINFORCED CONCRETE PIPE (RCP), 2000D (CLASS III), 15 IN.
51	2503-0114218	STORM SEWER GRAVITY MAIN, TRENCHED, REINFORCED CONCRETE PIPE (RCP), 2000D (CLASS III), 18 IN.
52	2503-0114221	STORM SEWER GRAVITY MAIN, TRENCHED, REINFORCED CONCRETE PIPE (RCP), 2000D (CLASS III), 21 IN.
53	2503-0114224	STORM SEWER GRAVITY MAIN, TRENCHED, REINFORCED CONCRETE PIPE (RCP), 2000D (CLASS III), 24 IN.
54	2503-0114230	STORM SEWER GRAVITY MAIN, TRENCHED, REINFORCED CONCRETE PIPE (RCP), 2000D (CLASS III), 30 IN.
55	2503-0114236	STORM SEWER GRAVITY MAIN, TRENCHED, REINFORCED CONCRETE PIPE (RCP), 2000D (CLASS III), 36 IN.
56	2503-0114242	STORM SEWER GRAVITY MAIN, TRENCHED, REINFORCED CONCRETE PIPE (RCP), 2000D (CLASS III), 42 IN.
57	2503-0114248	STORM SEWER GRAVITY MAIN, TRENCHED, REINFORCED CONCRETE PIPE (RCP), 2000D (CLASS III), 48 IN.
58	2503-0116229	STORM SEWER GRAVITY MAIN, TRENCHED, REINFORCED CONCRETE ARCH PIPE (RCAP), 2000D (CLASS A-III), 29 IN. X 18 IN.
59	2503-0116237	STORM SEWER GRAVITY MAIN, TRENCHED, REINFORCED CONCRETE ARCH PIPE (RCAP), 2000D (CLASS A-III), 37 IN. X 23 IN.
60	2503-0116252	STORM SEWER GRAVITY MAIN, TRENCHED, REINFORCED CONCRETE ARCH PIPE (RCAP), 2000D (CLASS A-III), 52 IN. X 32 IN.
61	2503-0116259	STORM SEWER GRAVITY MAIN, TRENCHED, REINFORCED CONCRETE ARCH PIPE (RCAP), 2000D (CLASS A-III), 59 IN. X 36 IN. A. For HDPE Pipe refer to J Sheets for Temporary Storm Pipe Tabulation HRG-13A. B. For RCP Pipe refer to M Sheets for Storm Sewer Tabulation 104-5B. C. Use Class R-2 pipe bedding unless otherwise noted. D. Includes 11,166 Tons Class A Crushed Stone for bedding and backfill under primary roads. Incidental to pipe. E. All storm sewer pipe shall have bell and spigot joints with an O-ring gasket joint (ASTM C443) incidental to pipe. F. All labor and materials including tee pipe sections necessary to connect to temporary storm sewer pipe included in item. G. Connections to existing pipe of similar material and size may use existing bell or spigot assuming they are in satisfactory condition. Connections to existing pipe of dissimilar size, material, or having damaged bell/spigot shall follow Standard Road Plan RF-2. All labor and material required for connection to existing pipe is incidental to pipe. Refer to M Sheet tabulation 104-5B (Modified) for locations.
62	2503-0200036	REMOVE STORM SEWER PIPE LESS THAN OR EQUAL TO 36 IN. A. Refer to J Sheets Tabulation HRG-13A for locations. B. Includes 340 Tons Class A Crushed Stone for sewer removal under primary roads. Incidental to pipe removal.
63	2504-0114008	SANITARY SEWER GRAVITY MAIN, TRENCHED, PVC, 8"
64	2504-0114010	SANITARY SEWER GRAVITY MAIN, TRENCHED, PVC, 10"
65	2504-0114012	SANITARY SEWER GRAVITY MAIN, TRENCHED, PVC, 12"
66	2504-0114015	SANITARY SEWER GRAVITY MAIN, TRENCHED, PVC, 15"
67	2504-0114018	SANITARY SEWER GRAVITY MAIN, TRENCHED, PVC, 18"
68	2504-0114024	SANITARY SEWER GRAVITY MAIN, TRENCHED, PVC, 24"
69	2504-0114030	SANITARY SEWER GRAVITY MAIN, TRENCHED, PVC, 30"
70	2504-0114036	SANITARY SEWER GRAVITY MAIN, TRENCHED, PVC, 36"
71	2504-0116010	SANITARY SEWER GRAVITY MAIN, TRENCHED, DIP, 10"
72	2504-0116012	SANITARY SEWER GRAVITY MAIN, TRENCHED, DIP, 12"
73	2504-0116018	SANITARY SEWER GRAVITY MAIN, TRENCHED, DIP, 18"
74	2504-0116024	SANITARY SEWER GRAVITY MAIN, TRENCHED, DIP, 24"
75	2504-0116030	SANITARY SEWER GRAVITY MAIN, TRENCHED, DIP, 30"
76	2504-0200406	SANITARY SEWER SERVICE STUB, PVC, 6 IN
77	2504-0200408	SANITARY SEWER SERVICE STUB, PVC, 8 IN A. Includes 7,072 Tons Class A Crushed Stone for bedding and backfill under primary roads. Incidental to pipe. B. Quantities include 14 LF 8" PVC, 25 LF 10" PVC, 19 LF 12" PVC and 31 LF 10" DIP to be utilized for storm sewer connections. Refer to M Sheets for tabulation, location and details. For all other pipe, refer to O Sheets for Sanitary Sewer Pipe Tabulation and Sanitary Sewer Services Tabulation. C. Refer to C Sheets for Contaminated Soil Sites Tabulation. If contaminated soils are encountered in areas not listed in the tabulation, contractor shall install ductile iron sanitary in these areas. Contractor shall place Nitrile gaskets at sanitary sewer pipe joints in contaminated soil locations and utilize ceramic epoxy sewer lining. If no contamination is encountered in areas calling for ductile iron sanitary, contractor shall install PVC sanitary with no Nitrile gaskets or epoxy sewer lining.
78	2504-0240036	REMOVE SANITARY SEWER PIPE LESS THAN OR EQUAL TO 36 IN.
79	2504-0240136	REMOVE SANITARY SEWER PIPE GREATER THAN 36 IN. A. Refer to Removal of Sewer tabulation HRG-2A on C Sheets. B. Includes 23150 tons Class A Crushed Stone for sewer removal under primary roads. Incidental to pipe removal.
80	2504-0240236	SANITARY SEWER ABANDONMENT, FILL AND PLUG, LESS THAN OR EQUAL TO 36 IN. DIA. A. Refer to Sanitary Sewer Abandonment Tabulation 110-9 on C Sheets and Temporary Storm Notes on J Sheets.
81	2506-4984000	FLOWABLE MORTAR A. Utilized for anti-seep collars on storm sewer (1397 CY) and sanitary sewer (225 CY). B. Refer to Contaminated Soil Sites Tabulation PCSS-2 on C Sheets for contaminated soil locations. C. See M Sheets for locations involving storm sewer. See O Sheets for locations involving sanitary sewer. D. Flowable mortar for abandonment of sewer pipes paid separately.
82	2510-6745850	REMOVAL OF PAVEMENT A. Refer to C Sheets for Removal of Pavement Tabulation 110-1. B. Depth of pavement shown is approximate. C. Includes removal and disposal of pavement. Includes an estimated 4263 linear feet of full depth saw cut.
83	2510-6750600	REMOVAL OF INTAKES AND UTILITY ACCESSES A. Refer to Removal of Sewer tabulation HRG-2A on C Sheets.

**ESTIMATE REFERENCE INFORMATION**

Item No.	Item Code	Description
		B. Includes removal of temporary structures. Refer to J Sheets Tabulation HRG-12A.
84	2511-0302500	RECREATIONAL TRAIL, PORTLAND CEMENT CONCRETE, 5 IN A. Refer to Typical Sections on B Sheets. B. Refer to D and E Sheets for location of recreational trail. C. Refer to L Sheets for geometric staking and jointing details.
85	2511-0310100	SPECIAL COMPACTION OF SUBGRADE FOR RECREATIONAL TRAIL A. Refer to B Sheets for Typical Sections. B. Refer to C Sheets for Special Compaction of Subgrade tabulation 103-1 C. Refer to Moisture and Density Testing for Special Compaction of Subgrade developmental specification. Revise specification so all references of "Special Compaction of Subgrade" are changed to "Special Compaction of Subgrade for Recreational Trail". Testing shall be performed at the same minimum frequencies.
86	2511-6745900	REMOVAL OF SIDEWALK A. Refer to C Sheets for Tabulation of Sidewalk Removal 110-05. B. Includes full depth saw cutting necessary to create a clean edge between existing and proposed sidewalks. C. Removal of sidewalks through driveways will be paid for as driveway removal. D. Refer to U Sheets for locations.
87	2511-7526004	SIDEWALK, P.C. CONCRETE, 4 IN. A. Refer to B Sheets for Typical Sidewalk Detail and Typical Sections. B. Refer to D and E Sheets for location of sidewalk.
88	2512-1725156	CURB AND GUTTER, P.C. CONCRETE, 1.5 FT
89	2512-1725256	CURB AND GUTTER, P.C. CONCRETE, 2.5 FT A. Refer to B Sheets for Typical Sections. B. Refer to C Sheets for Curb and Gutter Tabulation HRG-7A. C. Refer to D and E Sheets for locations.
90	2515-2475007	DRIVEWAY, P.C. CONCRETE, 7 IN. A. Refer to C Sheets for Points of Access Tabulation 102-3. B. Refer to D and E Sheets for locations. C. Item includes sidewalk within driveways.
91	2515-6745600	REMOVAL OF PAVED DRIVEWAY A. Refer to C Sheets for Removal of Concrete Drives Tabulation 110-8. B. Bid item includes full depth saw cutting of concrete necessary to create a clean edge between existing and proposed pavement.
92	2518-6910000	SAFETY CLOSURE A. Refer to C Sheets for Tabulation of Safety Closures 108-13a. B. Refer to J Sheets for construction sequence.
93	2520-3350015	FIELD OFFICE A. In addition to the specification requirements, the Contractor shall provide a high speed internet connection for the unit and shall pay all connection and disconnection costs. The Iowa Department of Transportation will pay the monthly service fees for the internet service at the completion of the project, provided the Contractor submits copies of monthly bills.
94	2523-0000100	LIGHTING POLES A. Refer to P Sheets for locations and details. B. Lighting unit types L1 and L2 C. Item includes luminaire, pole, mast arm, pole mounted decorative components, lamp, wiring connectors, wiring from connectors to luminaires, anchor bolts, ground rod, reinforced concrete foundation, and RM-37 junction box integral with the foundation as detailed on P sheets.
95	2523-0000200	ELECTRICAL CIRCUITS A. Item includes PVC Schedule 40 and 80 (as noted in the contract documents) conduit, grounding conductors, grounded conductors, and phase conductors between controllers, junction boxes and handholes.
96	2523-0000310	HANDHOLES AND JUNCTION BOXES A. As per IDOT Standard Road Plan RM-38.
97	2523-0000400	CONTROL CABINET A. Refer to P Sheets for Lighting Control Cabinet Details. B. Item includes meter socket, meter loop, base footing, installation of control cabinet, grounding, coordination with utility company, and all internal circuitry.
98	2523-6765009	RMV+REINSTALL LIGHT POLE+LUMINAIRE A. Item includes the removal and storage of existing lighting fixtures and poles and removal of the foundation. B. Lighting unit types L4 and L5. Refer to P sheets for locations and details. C. Includes new anchor bolts, ground rod, reinforced concrete foundation, RM-37 junction box integral with the foundation and removal of existing conduit and wiring. New conduit and wiring paid separately. D. Contractor will be paid the contract unit price for each pole/fixture relocated.
99	2524-6765010	REMOVE AND REINSTALL SIGN AS PER PLAN
100	2524-9325001	TYPE A SIGNS, SHEET ALUMINUM A. Refer to C Sheets for Summary of Materials for Signs Tabulation HRG-8A. Refer to K Sheets for signing plan. B. Contractor will be paid the contract unit price for each sign relocated. Posts to be paid separately.
101	2525-0000100	TRAFFIC SIGNALIZATION
102	2525-0000120	REMOVAL OF TRAFFIC SIGNALIZATION A. Refer to N Sheets for traffic signal details.

**ESTIMATE REFERENCE INFORMATION**

Item No.	Item Code	Description
		B. Refer to Special Provisions. C. Any components of an existing traffic signal installation removed by the contractor shall be delivered to the City of Clinton Maintenance Yard, located at the corner of S. 2nd Street and 12th Avenue S., unless otherwise directed by the Engineer. D. Removal of traffic signalization shall include removal of all hardware, conduit and footings to remove traffic signal complete.
103	2526-8285000	CONSTRUCTION SURVEY A. Refer to special provision. B. Includes staking of removal items as necessary. C. Includes staking of all streetscape and landscape items (see I Sheets).
104	2527-9263109	PAINTED PAVEMENT MARKING, WATERBORNE OR SOLVENT-BASED
105	2527-9263131	WET RETROREFLECTIVE REMOVABLE TAPE MARKINGS
106	2527-9263137	PAINTED SYMBOLS AND LEGENDS, WATERBORNE OR SOLVENT A. Refer to C Sheets for Tabulations 108-22 and 108-29. B. Refer to K Sheets for permanent pavement marking plan. C. Refer to J Sheets for construction sequence and temporary markings. D. Refer to Wet Retroreflective Removable Tape Markings supplemental specification.
107	2527-9263180	PAVEMENT MARKINGS REMOVED A. Refer to C Sheets for Tabulation of Pavement Markings Removals HRG-4A.
108	2528-8400256	TEMPORARY TRAFFIC SIGNALS A. Refer to J Sheets for traffic control and staging details. B. Refer to N Sheets for locations and details.
109	2528-8445110	TRAFFIC CONTROL A. Refer to J Sheets for traffic control and staging details. B. Item includes all special signing on J Sheets, including temporary advertising guide signs.
110	2528-8445112	FLAGGERS
111	2528-9109020	TEMPORARY LANE SEPARATOR SYSTEM A. Refer to J Sheets for traffic control and staging details. B. Refer to Temporary Lane Separator System developmental specification.
112	2533-4980005	MOBILIZATION
113	2537-8900000	REMEDIATION OF PETROLEUM CONTAMINATED SOIL
114	2537-8900100	SAMPLING AND TESTING FOR PETROLEUM CONTAMINATED SOIL A. Refer to Contaminated Soil Sites Tabulation PCSS-2 on C sheets. B. The Contractor shall have an Iowa Groundwater Professional, certified in accordance with 567 IAC Chapter 134, on site during excavation activities at the locations indicated in Tabulation PCSS-2. The Groundwater Professional shall monitor excavated material through soil vapor analysis and sampling. Samples shall be submitted to a laboratory accredited in accordance with 567 IAC Chapter 83 and analyzed for petroleum compounds using Iowa OA-1 and OA-2 testing procedures. Additional analyses may be added at the discretion of the Groundwater Professional and approved by the Engineer. C. The Groundwater Professional shall be available on an on-call basis during all other excavation activities. The Contractor shall cease operations in the immediate area upon encountering suspect contamination and contact the Groundwater Professional for field review and sampling. D. Compensation for oversight by the Groundwater Professional and sample analysis beyond petroleum compounds, shall be negotiated and paid for in accordance with Article 1109.03, B, of the Standard Specifications.
115	2537-8900500	AMENDED SOIL A. This item includes all labor, equipment and materials to furnish and install amended soil for shrub and perennial beds, complete. B. See special provision "Amended Soil" for requirements. C. At the contractor's discretion, amended soil can be mixed offsite and placed in a premixed fashion. D. See I sheets for tree and planting bed locations and installation details. E. Measurement and payment will be per cubic yard placed. F. Quantities are estimated to be 3.2 CY per tree and 12" depth for planting beds.
116	2552-0000140	ROCK EXCAVATION A. Refer to M Sheets and O Sheets for existing rock profile. B. Refer to Storm Sewer tabulation on M Sheets and Sanitary Sewer tabulation on O Sheets for rock excavation quantities required for storm sewer and sanitary sewer construction. C. Quantity includes 4763 CY for sanitary sewer, 3402 CY for storm sewer and 50 CY for roadway.
117	2554-0203000	FITTINGS BY WEIGHT, DUCTILE IRON A. Refer to M Sheets for Special Storm Sewer Connection Detail. B. Item includes restrained joints, pipe coupling to connect to existing pipe, bolts and nuts, polyethylene wrap on all joints and coupling and non-shrink grout that complies with IM 491.13 for grout.
118	2599-9999001	SEED, NO-MOW FESCUE MIX A. Furnish and install no-mow fescue seed mix at the following rates: Blue Fine Fescue 20% Azure Sheeps Fine Fescue 20% Ecostar Hard Fine Fescue 20% Boreal Creeping Red Fescue 20% LAMZ Chewings Fine Fescue 20% B. Application rate shall be 5 pounds/1,000 s.f. PLS C. Install in accordance with Iowa DOT specifications section 2601.04 - seeding. D. Fertilizer is incidental to the contract unit price E. Contractor shall be paid the contract unit price per acre. This shall be considered full compensation for all tools, equipment, labor and materials necessary to seed in accordance with the contract documents.

**ESTIMATE REFERENCE INFORMATION**

Item No.	Item Code	Description
119	2599-9999005	CONCRETE COLUMNS A. The contractor will be paid the contract unit price per each. This shall be considered full compensation for furnishing all tools, equipment, labor and materials necessary to construct bases in accordance with the contract documents. B. No uprights for Concrete Columns. C. Conduit and wire needed for LED lit landscaping structures shall be included in the unit price for this item. See details in P Sheets. D. LED lighting, and all items of pertinence to install said lighting for landscape structures as shown in the I-sheets and P-sheets shall be included in this item E. Refer to I sheets for locations and details. F. Refer to special provisions for Colored Sealer Coating For Structural Concrete. G. Colored sealer coating to be incidental to item.
120	2599-9999005	HERON SCULPTURE-INSTALL A. Great Blue Heron Sculpture will be furnished by the City of Clinton B. Item includes installation of Great Blue Heron Sculpture and any incidental hardware required for anchoring and leveling sculpture. C. Unit Price is per EACH sculpture installed D. Refer to I sheets for locations and details.
121	2599-9999005	INLET PROTECTION DEVICE A. Refer to C Sheets for Erosion Control Tabulation HRG-1A B. Use devices or filter socks, placed around or over the intake, that are capable of trapping or filtering sediment from runoff prior to entering the storm sewer. Do not allow device to completely plug intake or prevent inflow. C. Each device installed will be counted for payment. D. Payment will be made at the contract unit price for each device installed. This shall be considered full compensation for furnishing all tools, equipment, labor and materials necessary for placement, maintenance, clean-out, and removal of inlet protection device.
122	2599-9999005	LIGHT ASSEMBLY, TYPE L3 (ATOP TRAFFIC SIGNAL) A. Item for use on traffic signal poles. B. Item includes light fixture, lamp, and all other necessary appurtenances. C. Refer to P Sheets for lighting unit schedule and N Sheets for additional information. D. The light assemblies constructed will be counted for payment. E. The contractor will be paid the contract unit price per each. This shall be considered full compensation for furnishing all tools, equipment, labor and materials necessary to construct light assemblies in accordance with the contract documents.
123	2599-9999005	LINCOLN HIGHWAY PLAQUES A. Item includes fabricating and decorative bronze Lincoln Highway Plaques and any incidental hardware required for anchoring Lincoln Highway Plaques. B. Metal fabrication, casting, painting, and installation are included in the unit price. C. See special provisions. D. Unit Price is per EACH Lincoln Highway Plaque installed complete. E. Refer to I sheets for locations and details.
124	2599-9999005	PERENNIALS AND GRASSES, FURNISHED AND INSTALLED (WITH WARRANTY) A. Furnish and install plants. B. See I Sheets for locations and installation details. C. Plant unit prices will be for each warranted and installed plant. D. Refer to special provisions. E. Fertilizer, shredded hardwood mulch, and watering are incidental to the unit price. F. Method of Measurement and Basis of Payment: Contractor will be paid for each live and healthy plant.
125	2599-9999005	PERGOLA BASE COLUMNS A. The contractor will be paid the contract unit price per each. This shall be considered full compensation for furnishing all tools, equipment, labor and materials necessary to construct bases in accordance with the contract documents. B. Each Pergola Base Column includes a single upright. See details in P Sheets. C. Conduit and wire needed for LED lit landscaping structures shall be included in the unit price for this item. See details in P Sheets. D. LED lighting, and all items of pertinence to install said lighting for landscape structures as shown in the I-sheets and P-sheets shall be included in this item E. Refer to I sheets for locations and details. F. There are to be three (3) columns per each pergola location. G. Refer to special provisions for Colored Sealer Coating For Structural Concrete. H. Colored sealer coating to be incidental to item.
126	2599-9999005	PERGOLA BRIDGE BENCH A. This includes fabricating and installing Bridge Benches and any incidental hardware required for anchoring and leveling Bridge Benches. B. Unit Price is per EACH Bench fabricated and installed complete. C. There are to be two (2) pergola benches per pergola location. D. Sheet I sheets for locations and details.
127	2599-9999005	PERGOLAS A. Item includes fabricating and installing metal pergola structure and any incidental hardware required for anchoring and leveling pergolas to decorative concrete base. B. Metal fabrication, installation, and paint are included in the unit price. C. Unit Price is per EACH metal pergola structure installed complete. This shall be considered full compensation for furnishing all tools, equipment, labor and materials necessary to construct pergolas in accordance with the contract documents.

**ESTIMATE REFERENCE INFORMATION**

Item No.	Item Code	Description
		D. Refer to I sheets for locations and details.
128	2599-9999009	CERAMIC EPOXY SEWER LINING, 10"
129	2599-9999009	CERAMIC EPOXY SEWER LINING, 12"
130	2599-9999009	CERAMIC EPOXY SEWER LINING, 18"
131	2599-9999009	CERAMIC EPOXY SEWER LINING, 24"
132	2599-9999009	CERAMIC EPOXY SEWER LINING, 30"
		A. To be used for sanitary sewer in areas of contaminated soils. B. Refer to Tabulation of Contaminated Soils PCS-2 On C Sheets. C. Material shall contain at least 20% ceramic quartz pigment. D. Install according to manufacturer's installation instructions. E. Unit price shall be paid per LINEAL FOOT, installed complete. This shall be considered full compensation for furnishing all tools, equipment, labor and materials necessary for installation of lining.
133	2599-9999009	STEEL EDGING A. This item includes all labor, materials, and equipment to install steel landscape edging complete. B. Unit price shall be paid per LINEAL FOOT, installed complete. C. Refer to I sheets for details and location. D. Refer to special provisions.
134	2599-9999009	STEEL POSTS FOR TYPE A SIGNS, 2.25 IN X 2.25 IN., 12 GAUGE A. Refer to C Sheets for Summary of Materials for Signs Tabulation HRG-8A. B. Posts to be galvanized 12 gauge steel, 2.25 in. x 2.25 in. square telescoping tubing, with holes on 1-inch centers. Includes galvanized 12 gauge steel anchor base. Post to be installed as per manufacturer's specifications. C. Posts to conform to ASTM A570-92 and A-653 DES, G-90. D. Methods of Measurement and basis of payment to meet Article 2524.12C of the IDOT Specifications, amended as follows: "Steel posts for Type A and B Signs". Anchor bases to be incidental to posts.
135	2599-9999014	MOWSTRIP, P.C. CONCRETE, 7.875 IN A. Refer to I Sheets for details, location, and jointing of P.C.C. Mowstrip. B. The contractor will be paid the contract unit price per square foot. This shall be considered full compensation for furnishing all tools, equipment, labor and materials necessary to construct mowstrip in accordance with the contract documents. C. Reinforcing steel shall be incidental to the unit price for mowstrip D. Concrete shall meet the specifications for Sidewalk, P.C. Concrete, 4 IN. (Item 2511-7526004)
136	2599-9999014	P.C. CONCRETE STEPS A. Item intended for concrete steps located at Left Station 134+79.81. B. The contractor will be paid the contract unit price per cubic yard. This shall be considered full compensation for furnishing all tools, equipment, labor and materials necessary to construct the concrete steps in accordance with the contract documents. D. Refer to detail in B sheets for details.
137	2599-9999014	PCC PAVERS, 2-3/8 IN.
138	2599-9999014	PCC PAVERS, 3-1/8 IN.
139	2599-9999014	PCC PAVERS, DETECTABLE WARNING, 3 IN. A. Furnish and install pavers. B. See I Sheets for paver patterns, construction details and information. C. See Special Provisions. D. Refer to C Sheets for Tabulation 112-4 for Detectable Warning Pavers. E. PCC Pavers at roadway medians included as part of PCC Pavers 3-1/8 In. quantity. F. Cutting of PCC Pavers for fit, sand for joints and HMA setting beds are included in the unit price. G. In lieu of placing concrete pavers during the applicable construction stage, contractor may elect to install them at a later date. If the contractor chooses this option, the contractor shall place an HMA "cap" to fill the void where the concrete pavers are to be placed. The cost for the HMA "cap", its placement, removal and any additional traffic control shall be the contractor's responsibility. H. Payment will be made based on the area, in square feet, of PCC Pavers installed.
140	2599-9999018	SIDEWALK, P.C. CONCRETE, 7.875 IN. A. Finish, joints, and joint materials as shown in the I Sheets, shall be included in this item. B. See I Sheets for layout and staking information. C. The contractor will be paid the contract unit price per square yard. This shall be considered full compensation for furnishing all tools, equipment, labor and materials necessary to construct sidewalk in accordance with the contract documents. D. Concrete shall meet the specifications for Sidewalk, P.C. Concrete, 4 IN. (Item 2511-7526004)
141	2599-9999018	SUBSLAB, P.C. CONCRETE, 4 IN, FOR PCC PAVERS
142	2599-9999018	SUBSLAB, P.C. CONCRETE, 4.5 IN, FOR PCC PAVERS A. Refer to I Sheets for details, location and geometric staking of PCC Subslab for Pavers. B. The contractor will be paid the contract unit price per square yard. This shall be considered full compensation for furnishing all tools, equipment, labor and materials necessary to construct subslab in accordance with the contract documents. C. 4" subslab intended for 3-1/8" PCC Pavers and 3" Detectable Warning Pavers; 4.5" subslab intended for 2-5/8" PCC Pavers. D. Concrete shall meet the specifications for Sidewalk, P.C. Concrete, 4 IN. (Item 2511-7526004)
143	2601-2633100	MOWING A. Mowing consists of maintenance mowing at urban seeding and fertilizing (urban) areas (Item 2601-2636044) and at sodding areas (Item 2601-2639010) B. Contract quantity is for a total of two mowings
144	2601-2634100	MULCHING A. Refer to Erosion Control Details tabulation on C Sheets.

**ESTIMATE REFERENCE INFORMATION**

Item No.	Item Code	Description
		B. Apply 1 application prior to placing the seeding. C. Intended for Urban Seeding and No-Mow Fescue Seeding. 1) Mulch shall be premium finely shredded or ground hardwood chips graded to 1/4 to 1/2 inch diameter and max. 3 inch length. Green or freshly chipped or shredded mulch will be rejected. 2) Mulch to be free of weeds, chaff, diseases, or other foreign material.
145	2601-2636044	SEEDING AND FERTILIZING (URBAN) A. Use Standard Urban Mix (70% Bluegrass, 10% Perennial Rye, 20% Creeping Red Fescue) B. Item to be used from back of sidewalk to construction limits. C. Item includes general maintenance including mowing and watering of seeded areas through the date of project acceptance.
146	2601-2639010	SODDING A. The top 6 inches of the topsoil/sodbed shall be free of rock and debris and shall be suitable for the establishment of vegetation with the approval of the Engineer. B. See I Sheets for location of sodding. C. Item includes general maintenance including mowing of sodded areas through the date of project acceptance. D. Watering of sod will be paid separately.
147	2601-2642120	STABILIZING CROP - SEEDING AND FERTILIZING (URBAN) A. Use Standard Urban Mix (70% Bluegrass, 10% Perennial Rye, 20% Creeping Red Fescue) B. To be used in disturbed, unsodded and unseeded areas prior to winter shutdown.
148	2601-2643110	WATERING FOR SOD, SPECIAL DITCH CONTROL, OR SLOPE PROTECTION A. Watering for sod, special ditch control, or slope protection consists of watering at urban seeding and fertilizing (urban) areas - (Item 2601-2636044) and at sodding areas (Item 2601-2639010) B. Contract quantity is based on a total of six waterings at an application rate of 1 gallon per square foot at each watering. C. Quantity shall be adjusted for climatic conditions at time of urban seeding and fertilizing (urban) areas (Item 2601-2636044) and at sodding areas (Item 2601-2639010). D. Unit price is per 1000 gallons of water placed
149	2602-0000020	SILT FENCE
150	2602-0000060	REMOVAL OF SILT FENCE
151	2602-0000090	CLEAN-OUT OF SILT FENCE A. Refer to C Sheets for Erosion Control Tabulation HRG-1A B. Refer to J Sheets for locations. C. Refer to C Sheets for storm water pollution prevention plan sheets.
152	2611-0000200	TREES, AMUR MAPLE, FURNISHED AND INSTALLED (WITH WARRANTY)
153	2611-0000201	TREES, AUTUMN BRILLIANCE SERVICEBERRY, FURNISHED AND INSTALLED (WITH WARRANTY)
154	2611-0000200	TREES, AUTUMN BLAZE MAPLE, FURNISHED AND INSTALLED (WITH WARRANTY)
155	2611-0000200	TREES, SHADEMASTER HONEY LOCUST, FURNISHED AND INSTALLED (WITH WARRANTY)
156	2611-0000201	TREES, PRINCETON SENTRY GINKO, FURNISHED AND INSTALLED (WITH WARRANTY)
157	2611-0000200	TREES, RIVER BIRCH, FURNISHED AND INSTALLED (WITH WARRANTY)
158	2611-0000200	TREES, SPRING SNOW CRABAPPLE, FURNISHED AND INSTALLED (WITH WARRANTY)
159	2611-0000200	TREES, SWAMP OAK, FURNISHED AND INSTALLED (WITH WARRANTY)
160	2611-0000200	TREES, WHITE SPRUCE, FURNISHED AND INSTALLED (WITH WARRANTY)
161	2611-0000201	TREES, JAPANESE TREE LILAC, FURNISHED AND INSTALLED (WITH WARRANTY) A. Furnish and install plants. B. See I Sheets for locations and installation details. C. Plant unit prices will be for each warranted and installed plant. D. Fertilizer, shredded hardwood mulch, and watering are incidental to the unit price. E. Method of Measurement and Basis of Payment: Contractor will be paid for each live and healthy plant and in accordance with Schedule in 2611.05.

**PAVEMENT SMOOTHNESS + PCC TEXTURE**

Road Identification	Begin Station	End Station	Proposed Posted Speed			Remarks
			35 or less	40 - 45	over 45	
U.S. 30/67	102+35.08	103+46.12	X			
U.S. 30/67	103+56.28	104+90.34	X			
U.S. 30/67	105+00.85	122+74.50	X			
U.S. 30/67	123+51.51	129+19.13	X			
U.S. 30/67	129+94.61	133+61.52	X			
U.S. 30/67	134+36.36	140+55.39	X			
U.S. 30/67	141+38.64	152+75.31	X			
U.S. 30/67	153+54.32	165+43.50	X			
U.S. 30/67	166+18.51	174+59.80	X			
U.S. 30/67	175+37.86	180+32.30	X			
U.S. 30/67	181+07.30	187+08.00	X			
14TH STREET	1197+29.81	1199+02.00	X			
21ST PLACE	1597+10.00	1599+59.08	X			
17TH PLACE	1996+14.67	1999+52.99	X			
15TH AVENUE	2196+27.11	2199+52.76	X			



203-2  
10-18-11

### PLANS (COORDINATING OPERATIONS)

Coordinate operations with those of other contractors working within the same area. Other work in progress during the same period of time will include construction of the following projects:

Project	Type of Work
NHSN-30-9(129)--2R-23	HMA Resurfacing with Milling WBL US30 from Z24 E to US67 in Clinton
Unknown	HMA Resurfacing with Milling from N Jct US30 to W Jct IA136 in Clinton
BRFN-30-9(140)--39-23	Bridge Cleaning US30 Mississippi River Bridge
Unknown	PCC Patching from SCL Camanche NE to W Jct US30
BRFN-30-9(147)--39-23	Bridge Cleaning US30 Mississippi River Bridge

212-1  
10-18-11

### SOILS DESIGN

Sounding and test boring data shown on plans were accumulated for designing and estimating purposes. Their appearance on the plan does not constitute a guarantee that conditions other than those indicated will not be encountered.

213-1  
04-15-08

### WASTE (NON-DESIRABLE MATERIAL)

It shall be the contractor's responsibility to provide waste areas or disposal sites for excess material (excavated material or broken concrete) which is not desirable to be incorporated into the work involved on this project.

It shall be the contractor's responsibility to ensure that areas (including haul roads) selected for waste or disposal not impact 1) culturally sensitive sites or graves or 2) wetlands or "Waters of the U.S.", including streams or stream banks below the "ordinary high water mark", without an approved U.S. Army Corps of Engineers Section 404 Permit.

No payment for overhaul will be allowed for material hauled to these sites. No material shall be placed within the right-of-way, unless specifically stated in the plans.

213-3  
10-18-11

### SUBSOIL TILLAGE

All borrow areas, stockpile areas, haul roads, and areas used for equipment on this project require subsoil tillage to an average depth of 16 to 20 inches prior to placement of topsoil and/or stabilizing crop seeding. Complete this tillage at 3 foot maximum centers and at right angles to the finished slope.

Use tillage equipment equipped with an arrowhead type shoe that will provide lateral displacement and limit the movement of the subsoil to the surface. Obtain the Engineer's approval for the equipment. This work is incidental to other work on the project.

Following the subsoil tillage, the area is to remain in a "loosened" condition. Additional compaction or the operation of heavy equipment, other than required for topsoil placement and shaping, will not be allowed on areas which have received subsoil tillage.

252-1  
10-18-11

### DETOURS (INCIDENTAL)

Blading, shaping, and other work in preparation for maintaining temporary crossovers or detours is incidental to other work. Furnish and spread additional granular surfacing needed for temporary crossings or detours during construction at the contract price.

232-3B  
10-18-11

### EROSION CONTROL (URBAN SEEDING)

Following the completion of work in a disturbed area, place seed, fertilizer, and mulch as follows:

SEEDING MIXTURE: Seeding Rate: 4 lbs. per 1000 sq. ft.

Bluegrass, KY	70%
Fescue, Creeping Red	20%
Ryegrass, Perennial (Fineleaf-Derby Manhattan or equivalent)	10%

FERTILIZER:  
17 lbs. of 13-13-13 (or equivalent) commercial fertilizer per 1000 sq. ft.

MULCH:  
70 lbs. of dry cereal straw per 1000 sq. ft. Consolidate all mulch into the soil using a mulch stabilizer.

Preparing the seedbed and furnishing and applying seed, fertilizer, and mulch is incidental to mobilization. No extra compensation will be allowed.

232-6  
10-18-11

### EROSION CONTROL (SELECTIVE CLEARING)

Selective clearing will be required on this project. Do not remove any trees outside of the construction limits without the Engineer's approval.

232-8  
10-18-11

### EROSION CONTROL (DISTURBED AREAS)

Ensure the top 6 inches of the disturbed areas are free of rock and debris and are suitable for the establishment of vegetation, subject to the Engineer's approval.

232-10  
10-28-97

### EROSION CONTROL (EQUIPMENT FOR MAINTENANCE)

The contractor is expected to have materials, equipment, and labor available on a daily basis to install and maintain erosion control features on the project. This may involve seeding, silt fence, rock ditch checks, silt basins, or silt dikes.

254-1  
10-02-01

### INCIDENT MANAGEMENT

An incident management plan, provided by the District Office, will be discussed at the pre-construction conference.

262-5  
10-18-05

### UTILITIES (POINT 25 PROJECT)

This is a POINT 25 project and is subject to the provisions of IAC 761-115.25.

263-1  
10-18-11

### UTILITIES (SANITARY SEWER, WATER MAIN, AND APPURTENANCES)

For bedding and backfill purposes under Primary roads, use crushed rock or crushed gravel material complying with Article 4120.04 of the Standard Specifications for all bedding and backfill. Place and compact the material according to Article 2435.03, A and Article 2552.03, E (Class 1 materials) of the Standard Specifications. Gravels must be 100% crushed produced by crushing material retained on a 1.5 inch or larger screen.

111-25  
10-18-11

### INDEX OF TABULATIONS

Tabulation	Tabulation Title	Sheet No.
100-1C	ESTIMATED PROJECT QUANTITIES	C.1-C.2
100-1D	PROJECT DESCRIPTION	C.3
100-4A	ESTIMATE REFERENCE INFORMATION	C.3-C.6
100-26	INCIDENTAL ITEMS	C.6
100-27	PAVEMENT SMOOTHNESS + PCC TEXTURE	C.6
	STANDARD NOTES	C.7
100-17	TABULATION OF SILT FENCES	C.7
103-6	EMBANKMENT WITH MOISTURE CONTROL	C.7
103-7	SHRINKAGE DATA	C.7
100-24	TABULATION OF PAVEMENT	C.8
102-3	POINTS OF ACCESS (Modified)	C.9
103-4	TABULATION OF SPREADING TOPSOIL	C.10-C.11
104-9	LONGITUDINAL SUBDRAIN SHOULDER AND BACKSLOPE	C.12-C.13
105-4	STANDARD ROAD PLANS	C.14
108-13A	SAFETY CLOSURES	C.14
108-22	PAVEMENT MARKING LINE TYPES	C.15-C.17
108-29	PAVEMENT MARKING SYMBOLS AND LEGENDS	C.18-C.19
110-1	REMOVAL OF PAVEMENT	C.20-C.21
110-8	REMOVAL OF CONCRETE DRIVES	C.20
110-9	SANITARY SEWER ABANDONMENT (Modified)	C.21
110-5	SIDEWALK REMOVAL	C.21
110-4	CURB REMOVAL	C.21
110-12A	POLLUTION PREVENTION PLAN	C.22
113-2	SIDEWALK CLOSURES	C.23
HRG-1A	TABULATION OF EROSION CONTROL DETAILS	C.24-C.25
HRG-2A	REMOVAL OF SEWER	C.26-C.28
110-2A	REMOVALS BY OTHERS	C.28
110-2B	REMOVALS	C.29
110-2C	REMOVAL OF SIGNS	C.29
HRG-3A	REMOVAL OF CONCRETE STEPS	C.29
HRG-4A	TABULATION OF PAVEMENT MARKING REMOVALS	C.30
PCSS-2	CONTAMINATED SOIL SITES	C.30
HRG-5A	TABULATION OF HMA COMMERCIAL MIX	C.30
	HRG STANDARD NOTES	C.30
HRG-6A	SIDEWALK DETAILS	C.31-C.32
HRG-7A	TABULATION OF CURB & GUTTER	C.32
HRG-8A	SUMMARY OF MATERIALS FOR SIGNS	C.32-C.33
HRG-9A	TEMPORARY PAVEMENT	C.33
HRG-10A	MANHOLE ADJUSTMENT	C.33
HRG-11A	PEDESTRIAN CURB RAMPS	C.34

100-17  
04-20-10

### TABULATION OF SILT FENCES

Refer to EC-201

Begin Station	End Station	Side	Length		Remarks
			LF		
S 14TH ST.					
1197+29	1199+29	R	200.0		STAGE 1-A
CAMANCHE AVE.					
104+64	120+34	R	1570.0		STAGE 1-A
CAMANCHE AVE.					
100+46	102+34	R	242.0		STAGE 1-B
S 14TH ST.					
1196+82	1197+59	L	256.0		STAGE 1-B
CAMANCHE AVE.					
112+39	113+86	R	147.0		STAGE 2
124+59	129+20	R	490.0		STAGE 2
129+90	133+64	R	450.0		STAGE 2
134+37	135+07	R	125.0		STAGE 2
CAMANCHE AVE.					
123+46	124+90	R	172.0		STAGE 3
134+80	140+04	R	524.0		STAGE 3
141+79	152+25	R	1046.0		STAGE 3
154+06	165+25	R	1119.0		STAGE 3
166+51	174+00	R	749.0		STAGE 3
175+97	180+35	R	438.0		STAGE 3
181+06	187+08	R	602.0		STAGE 3
21ST PL.					
1597+10	1599+43	L	233.0		STAGE 3
1597+10	1599+61	R	251.0		STAGE 3
17TH PL.					
1996+15	1999+47	L	332.0		STAGE 3
1996+15	1999+44	R	329.0		STAGE 3
15TH PL.					
2196+23	2199+46	L	323.0		STAGE 3
2196+29	2199+45	R	316.0		STAGE 3
13TH PL.					
2398+50	2399+45	L	95.0		STAGE 3
2398+52	2399+46	R	94.0		STAGE 3

103-6  
04-19-11

### EMBANKMENT WITH MOISTURE CONTROL

Moisture content shall be within the limits of minus 2 and plus 3 percentage points of Optimum Moisture Content for maximum density within the area described and listed below.

Moisture Control is required for all Class-10 fill placed under pavement.

103-7  
08-01-08

### SHRINKAGE DATA

Material	%	Remarks
Entire Project	35%	
Topsoil	40%	



POINTS OF ACCESS (Modified)

- ① Refer to MI-210
- ② Refer to RL-8 for Type B or C. Type A per plan.

Refer to Cross-Sections

Station	Side	② Type A, B, or C	Length of Opening			① W FT	① ② PR FT	② SR FT	Pipe Culvert (RF-30A or RF-30B)					Aprons No.	Driveway Surface Area		Driveway Surfacing Material TON	Remarks
			① Case 1 or 2	1.5" Dropped Curb LF	3" Dropped Curb LF				② H FT	Size IN	Pipe Length LF	② Lt. LF	② Rt. LF		HMA SY	PCC SY		
CAMANCHE																		
111+35.0 RT	B		2	45.0		30.0										95.4		
111+35.9 LT	B		2	50.0		35.0										224.2		
112+69.4 LT	B		2	45.0		30.0										201.9		
114+44.7 LT	B		2	30.0		24.0										20.7		OFF OF PROPOSED 25TH PL. DRIVEWAY
114+64.5 LT	B		2	45.0		30.0										285.0		EXISTING 25TH PL.
114+76.1 LT	B		2	33.0		24.0										15.0		OFF OF PROPOSED 25TH PL. DRIVEWAY
116+00.9 LT	B		2	45.0		30.0										164.0		
117+18.7 LT	B		2	45.0		30.0										154.0		
118+65.3 LT	B		2	45.0		30.0										134.0		
119+79.5 LT	C		2	30.0		15.0										76.0		
120+28.8 LT	C		2	30.0		15.0										76.1		
120+77.9 LT	C		2	30.0		15.0										81.1		
121+31.7 LT	C		2	30.0		15.0										76.0		
121+85.4 LT	C		2	45.0		30.2										150.3		JOINT ENTRANCE
124+85.2 LT	C		2	56.0		40.8										177.0		JOINT ENTRANCE
125+98.0 LT	B		2	45.0		30.0										123.0		
126+56.5 RT	Predetermined		-	-		35.0												FUTURE DRIVEWAY
127+37.5 LT	C		2	40.0		25.0										104.2		JOINT ENTRANCE
128+61.5 LT	B		2	45.0		30.0										123.0		
135+85.3 LT	B		2	45.0		30.0										147.1		
136+64.5 LT	B		2	45.0		30.0										153.0		
137+80.1 RT	Predetermined		-	-		35.0												FUTURE DRIVEWAY
137+99.1 LT	B		2	45.0		30.0										159.2		
138+73.7 LT	C		2	30.0		15.0										82.0		
139+18.5 LT	C		2	30.0		15.0										82.0		
139+67.9 LT	C		2	30.0		15.0										79.9		
140+14.3 LT	C		2	30.0		15.0										82.4		
142+36.2 LT	B		2	45.0		30.0										162.1		
143+11.3 LT	C		2	30.0		15.0										78.0		
143+55.3 LT	B		2	39.0		24.0										118.4		
143+97.0 RT	B		2	50.0		35.0										152.8		JOINT ENTRANCE
149+68.6 RT	Predetermined		-	-		35.0												FUTURE DRIVEWAY
151+67.3 LT	B		2	45.0		30.0										138.6		
155+80.7 LT	B		2	45.0		30.0										164.3		
156+34.5 LT	B		2	45.0		30.0										136.0		JOINT ENTRANCE
157+99.1 RT	Predetermined		-	-		35.0												FUTURE DRIVEWAY
161+29.8 LT	B		2	45.0		30.0										138.3		
162+05.0 RT	Predetermined		-	-		35.0												FUTURE DRIVEWAY
162+49.0 LT	B		2	45.0		30.0										137.2		
163+51.9 LT	B		2	45.0		30.0										137.0		
164+43.7 LT	B		2	45.0		30.0										136.0		
166+42.4 LT	C		2	30.0		15.0										88.0		JOINT ENTRANCE
167+24.4 LT	C		2	30.0		15.0										88.0		
169+30.0 RT	Predetermined		-	-		35.0												FUTURE DRIVEWAY
171+13.6 LT	B		2	50.0		35.0										170.1		
171+79.7 LT	B		2	45.0		30.0										155.2		
173+51.5 LT	B		2	45.0		30.0										180.0		
178+59.6 LT	B		2	50.0		35.0										155.0		JOINT ENTRANCE
182+59.7 LT	B		2	28.0		20.0										98.1		EGRESS FLARE ONLY
183+08.0 RT	Predetermined		-	-		35.0												FUTURE DRIVEWAY
183+46.4 LT	B		2	32.0		24.0										97.0		INGRESS FLARE ONLY
184+14.8 LT	B		2	45.0		30.0										126.0		
185+50.8 LT	B		2	40.0		25.0										107.0		
24TH																		
1300+86.4 RT	B		2	42.0		35.0										46.0		
21ST																		
1598+04.3 LT	B		2	31.0		30.0										64.0		
1598+26.9 RT	B		2	40.0		35.0										112.2		
1601+04.4 RT	B		2	23.0		19.0										32.0		PARTIAL DRIVEWAY
1600+93.5 LT	B		2	39.0		24.0										63.3		
20TH																		
1701+28.4 LT	B		2	22.0		19.0										10.0		PARTIAL DRIVEWAY
17TH																		
1997+76.3 LT	Predetermined		-	-		35.0												FUTURE DRIVEWAY
1997+76.3 RT	Predetermined		-	-		35.0												FUTURE DRIVEWAY
2000+91.6 RT	B		2	31.0		24.0										37.1		
2000+81.0 LT	B		2	31.0		24.0										35.8		
16TH																		
2100+91.9 RT	B		2	40.0		31.0										33.8		
2100+91.9 LT	B		2	39.0		30.0										36.0		
15TH																		
2197+81.50 RT	Predetermined		-	-		35.0												FUTURE DRIVEWAY
2197+81.50 LT	Predetermined		-	-		35.0												FUTURE DRIVEWAY
2200+79.0 LT	B		2	26.0		22.2										18.6		PARTIAL DRIVEWAY
14TH																		
2301+12.7 RT	B		2	10.0		7.0										9.7		PARTIAL DRIVEWAY
12TH																		
2500+91.9 LT	B		2	41.0		31.0										58.0		

**TABULATION OF SPREADING TOPSOIL**

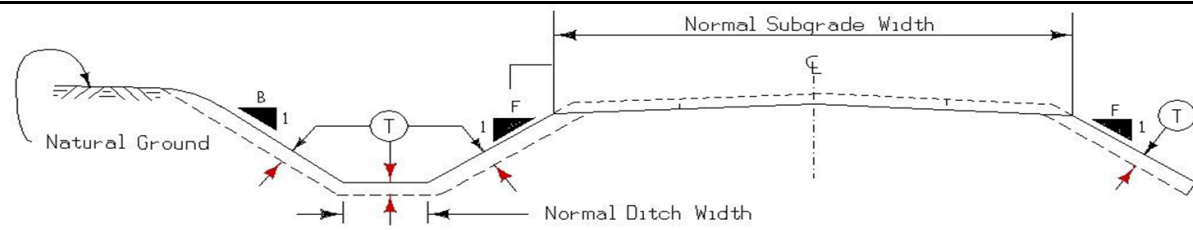

Perform this work according to Section 2105. Prior to placing topsoil on any cohesive soil, scarify the area to be covered to a minimum depth of 3 inches.

Appropriate adjustments have been made in the template quantities to reflect the placement of topsoil on foreslope, backslope and ditch bottom as detailed hereon.

Placement Description						Remarks	Topsoil Excavation Available From		Remarks
Area	Quantity	Location		Side	Slope		Amount Reserved	Station to Station	
No.	CY	Station to Station		L. or R.	B. or F.				
CAMANCHE AVE									
1	17.9	102+30.0	102+77.0	RT	F	6.0			CONTRACTORS SOURCE
2	54.0	102+34.0	103+42.0	LT	F	6.0			CONTRACTORS SOURCE
3	25.6	103+62.0	104+11.0	LT	F	6.0			CONTRACTORS SOURCE
4	8.6	104+36.0	104+88.0	RT	F	6.0			CONTRACTORS SOURCE
5	1679.4	105+03.0	120+27.0	RT	F	6.0			CONTRACTORS SOURCE
6	476.8	105+71.0	111+46.0	LT	F	6.0			CONTRACTORS SOURCE
7	31.0	108+11.0	108+91.0	RT	F	6.0			CONTRACTORS SOURCE
8	31.0	109+05.0	109+85.0	RT	F	6.0			CONTRACTORS SOURCE
9	31.1	109+99.0	110+79.0	RT	F	6.0			CONTRACTORS SOURCE
10	31.1	110+92.0	111+72.0	RT	F	6.0			CONTRACTORS SOURCE
11	274.3	111+61.0	114+47.0	LT	F	6.0			CONTRACTORS SOURCE
12	31.1	111+86.0	112+65.0	RT	F	6.0			CONTRACTORS SOURCE
13	31.1	112+79.0	113+59.0	RT	F	6.0			CONTRACTORS SOURCE
14	31.1	113+72.0	114+52.0	RT	F	6.0			CONTRACTORS SOURCE
15	31.1	114+66.0	115+45.0	RT	F	6.0			CONTRACTORS SOURCE
16	84.4	114+78.0	115+85.0	LT	F	6.0			CONTRACTORS SOURCE
17	32.0	115+59.0	116+39.0	RT	F	6.0			CONTRACTORS SOURCE
18	69.9	116+16.0	117+04.0	LT	F	6.0			CONTRACTORS SOURCE
19	37.6	116+53.0	117+33.0	RT	F	6.0			CONTRACTORS SOURCE
20	80.1	117+33.0	118+50.0	LT	F	6.0			CONTRACTORS SOURCE
21	43.4	117+47.0	118+27.0	RT	F	6.0			CONTRACTORS SOURCE
22	49.3	118+41.0	119+21.0	RT	F	6.0			CONTRACTORS SOURCE
23	56.3	118+80.0	119+72.0	LT	F	6.0			CONTRACTORS SOURCE
24	55.6	119+35.0	120+15.0	RT	F	6.0			CONTRACTORS SOURCE
25	22.0	119+87.0	120+21.0	LT	F	6.0			CONTRACTORS SOURCE
26	224.9	120+29.0	122+88.0	RT	F	6.0			CONTRACTORS SOURCE
27	21.7	120+36.0	120+70.0	LT	F	6.0			CONTRACTORS SOURCE
28	24.9	120+87.0	121+22.0	LT	F	6.0			CONTRACTORS SOURCE
29	22.0	121+37.0	121+70.0	LT	F	6.0			CONTRACTORS SOURCE
30	43.3	122+00.0	122+65.0	LT	F	6.0			CONTRACTORS SOURCE
31	65.0	123+61.0	124+65.0	LT	F	6.0			CONTRACTORS SOURCE
32	319.8	123+61.0	129+13.0	RT	F	6.0			CONTRACTORS SOURCE
33	44.2	125+06.0	125+83.0	LT	F	6.0			CONTRACTORS SOURCE
34	56.0	126+13.0	127+25.0	LT	F	6.0			CONTRACTORS SOURCE
35	57.9	127+50.0	128+46.0	LT	F	6.0			CONTRACTORS SOURCE
36	17.4	128+76.0	129+12.0	LT	F	6.0			CONTRACTORS SOURCE
37	170.6	130+03.0	133+55.0	LT	F	6.0			CONTRACTORS SOURCE
38	218.4	130+00.0	133+56.0	RT	F	6.0			CONTRACTORS SOURCE
39	70.0	134+46.0	135+70.0	LT	F	6.0			CONTRACTORS SOURCE
40	300.2	134+42.0	140+48.0	RT	F	6.0			CONTRACTORS SOURCE
41	34.1	136+00.0	136+49.0	LT	F	6.0			CONTRACTORS SOURCE
42	79.9	136+80.0	137+84.0	LT	F	6.0			CONTRACTORS SOURCE
43	40.9	138+14.0	138+66.0	LT	F	6.0			CONTRACTORS SOURCE
44	21.3	138+81.0	139+11.0	LT	F	6.0			CONTRACTORS SOURCE
45	27.7	139+26.0	139+60.0	LT	F	6.0			CONTRACTORS SOURCE
46	25.1	139+75.0	140+09.0	LT	F	6.0			CONTRACTORS SOURCE
47	13.8	140+35.0	140+48.0	LT	F	6.0			CONTRACTORS SOURCE
48	188.0	141+49.0	144+03.0	LT	F	6.0			CONTRACTORS SOURCE
49	939.2	141+51.0	152+70.0	RT	F	6.0			CONTRACTORS SOURCE
50	69.4	144+75.0	145+82.0	LT	F	6.0			CONTRACTORS SOURCE
51	190.2	146+65.0	149+27.0	LT	F	6.0			CONTRACTORS SOURCE
52	152.3	150+09.0	152+67.0	LT	F	6.0			CONTRACTORS SOURCE
53	0.0	153+62.0	157+63.0	LT	F	6.0			CONTRACTORS SOURCE
54	1275.1	153+61.0	165+38.0	RT	F	6.0			CONTRACTORS SOURCE
55	442.8	158+38.0	165+33.0	LT	F	6.0			CONTRACTORS SOURCE
56	217.6	166+26.0	168+90.0	LT	F	6.0			CONTRACTORS SOURCE
57	750.6	166+25.0	174+55.0	RT	F	6.0			CONTRACTORS SOURCE
58	315.5	169+69.0	174+51.0	LT	F	6.0			CONTRACTORS SOURCE
59	285.6	175+51.0	180+25.0	LT	F	6.0			CONTRACTORS SOURCE
60	364.3	175+42.0	180+26.0	RT	F	6.0			CONTRACTORS SOURCE
61	307.7	181+18.0	186+60.0	LT	F	6.0			CONTRACTORS SOURCE
62	314.9	181+13.0	187+08.0	RT	F	6.0			CONTRACTORS SOURCE
63	16.7	186+60.0	187+08.0	LT	F	6.0			CONTRACTORS SOURCE
S 14TH ST									
64	69.3	1197+21.0	1198+37.0	LT	F	6.0			CONTRACTORS SOURCE
65	176.2	1197+48.0	1199+17.0	RT	F	6.0			CONTRACTORS SOURCE
66	76.8	1200+84.0	1201+55.0	RT	F	6.0			CONTRACTORS SOURCE
67	76.1	1200+22.0	1201+64.0	LT	F	6.0			CONTRACTORS SOURCE
24TH PLACE									

TABULATION OF SPREADING TOPSOIL

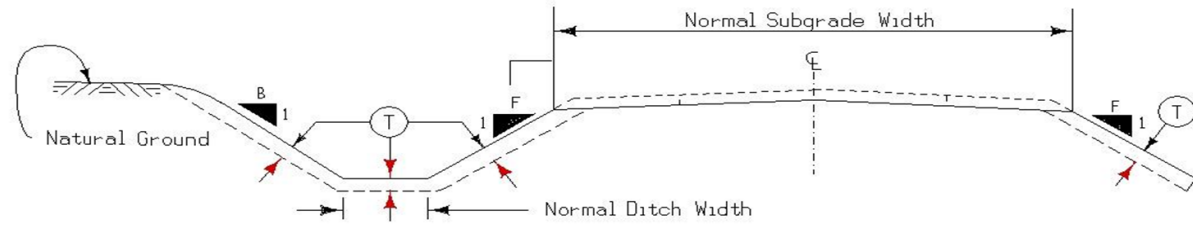

Perform this work according to Section 2105. Prior to placing topsoil on any cohesive soil, scarify the area to be covered to a minimum depth of 3 inches.

Appropriate adjustments have been made in the template quantities to reflect the placement of topsoil on foreslope, backslope and ditch bottom as detailed hereon.

Placement Description						Remarks	Topsoil Excavation Available From		Remarks
Area	Quantity	Location	Side	Slope	(T)		Amount Reserved	Station to Station	
No.	CY	Station to Station	L. or R.	B. or F.	IN		CY		
68	21.5	1298+83.0 1299+42.0	RT	F	6.0			CONTRACTORS SOURCE	
69	12.4	1300+51.0 1301+00.0	LT	F	6.0			CONTRACTORS SOURCE	
70	3.3	1300+53.0 1300+69.0	RT	F	6.0			CONTRACTORS SOURCE	
71	0.8	1300+93.0 1301+00.0	RT	F	6.0			CONTRACTORS SOURCE	
		23RD PLACE							
72	22.8	1398+75.0 1399+42.0	RT	F	6.0			CONTRACTORS SOURCE	
73	32.8	1398+75.0 1399+41.0	LT	F	6.0			CONTRACTORS SOURCE	
74	16.4	1400+50.0 1401+40.0	RT	F	6.0			CONTRACTORS SOURCE	
		22ND PLACE							
75	21.2	1498+75.0 1499+41.0	LT	F	6.0			CONTRACTORS SOURCE	
76	20.8	1498+75.0 1499+42.0	RT	F	6.0			CONTRACTORS SOURCE	
77	12.7	1500+41.0 1501+11.0	LT	F	6.0			CONTRACTORS SOURCE	
78	4.3	1501+17.0 1501+40.0	LT	F	6.0			CONTRACTORS SOURCE	
79	5.1	1500+41.0 1501+40.0	RT	F	6.0			CONTRACTORS SOURCE	
		21ST PLACE							
80	88.4	1597+10.0 1599+52.0	RT	F	6.0			CONTRACTORS SOURCE	
81	86.0	1597+10.0 1599+44.0	LT	F	6.0			CONTRACTORS SOURCE	
82	9.2	1600+59.0 1601+00.0	RT	F	6.0			CONTRACTORS SOURCE	
83	17.7	1600+53.0 1601+06.0	LT	F	6.0			CONTRACTORS SOURCE	
		20TH PLACE							
84	6.9	1700+40.0 1700+78.0	LT	F	6.0			CONTRACTORS SOURCE	
85	5.5	1700+50.0 1701+00.0	RT	F	6.0			CONTRACTORS SOURCE	
		19TH PLACE							
86	14.3	1800+58.0 1801+00.0	RT	F	6.0			CONTRACTORS SOURCE	
87	14.1	1800+58.0 1801+00.0	LT	F	6.0			CONTRACTORS SOURCE	
		18TH PLACE							
88	12.5	1900+51.0 1900+90.0	LT	F	6.0			CONTRACTORS SOURCE	
89	12.5	1900+51.0 1900+90.0	RT	F	6.0			CONTRACTORS SOURCE	
		17TH PLACE							
90	176.3	1996+15.0 1999+41.0	RT	F	6.0			CONTRACTORS SOURCE	
91	173.6	1996+15.0 1999+42.0	LT	F	6.0			CONTRACTORS SOURCE	
92	16.0	2000+52.0 2001+14.0	RT	F	6.0			CONTRACTORS SOURCE	
93	12.4	2000+52.0 2001+14.0	LT	F	6.0			CONTRACTORS SOURCE	
		16TH PLACE							
94	4.7	2100+42.0 2100+69.0	LT	F	6.0			CONTRACTORS SOURCE	
95	3.9	2100+42.0 2100+69.0	RT	F	6.0			CONTRACTORS SOURCE	
		15TH AVENUE							
96	138.7	2196+27.0 2199+41.0	RT	F	6.0			CONTRACTORS SOURCE	
97	139.3	2196+23.0 2199+42.0	LT	F	6.0			CONTRACTORS SOURCE	
98	1.0	2200+69.0 2200+90.0	RT	F	6.0			CONTRACTORS SOURCE	
99	1.9	2200+53.0 2200+90.0	RT	F	6.0			CONTRACTORS SOURCE	
		14TH AVENUE							
100	9.2	2300+52.0 2300+90.0	RT	F	6.0			CONTRACTORS SOURCE	
101	7.9	2300+51.0 2300+90.0	LT	F	6.0			CONTRACTORS SOURCE	
		13TH AVENUE							
102	24.9	2398+75.0 2399+42.0	RT	F	6.0			CONTRACTORS SOURCE	
103	21.7	2398+75.0 2399+42.0	LT	F	6.0			CONTRACTORS SOURCE	
104	5.1	2400+52.0 2400+90.0	LT	F	6.0			CONTRACTORS SOURCE	
105	4.9	2400+52.0 2400+90.0	RT	F	6.0			CONTRACTORS SOURCE	
		12TH AVENUE							
106	15.3	2500+42.0 2501+40.0	RT	F	6.0			CONTRACTORS SOURCE	
107	16.9	2500+42.0 2501+40.0	LT	F	6.0			CONTRACTORS SOURCE	

**LONGITUDINAL SUBDRAIN SHOULDER AND BACKSLOPE**

① Refer to RL-13 or RL-15.

Refer to Soils Sheets

\* Not a bid item

Line No.	Road or Lane Ident.	Location Station to Station		Side	Longitudinal Subdrain (RF-19C)							Subdrain Outlet			Porous* Backfill CY	Class "A"* Crushed Stone CY	Remarks	
					Depth D	Shoulder		Backslope		Bridge Berm ①			RF-19C, RF-19E, or RF-19F					
						Size	Length	Size	Length	Size	Type	Length	Station	Size				Standard Road Plan and Type
						IN	FT	IN	FT	IN		FT		IN				
1	CAM.	102+35	103+34	LT	24.0	4.0	102.0						103+34	6.0	RF-19C	6.3	TYPE 12 INSTALLATION, PLUG AT 102+35	
2	CAM.	105+00	106+56	RT	24.0	4.0	159.0						108+26	6.0	RF-19C	9.8	TYPE 12 INSTALLATION, PLUG AT 105+00	
3	CAM.	105+50	106+56	LT	24.0	4.0	109.0						106+63	6.0	RF-19C	6.7	TYPE 12 INSTALLATION, PLUG AT 105+50	
4	CAM.	106+61	108+26	RT	24.0	4.0	168.0						106+61, 108+26	6.0	RF-19C	10.4	TYPE 12 INSTALLATION	
5	CAM.	106+61	108+26	LT	24.0	4.0	168.0						106+61, 108+26	6.0	RF-19C	10.4	TYPE 12 INSTALLATION	
6	CAM.	108+32	110+26	RT	24.0	4.0	197.0						108+32, 110+26	6.0	RF-19C	12.2	TYPE 12 INSTALLATION	
7	CAM.	108+32	110+26	LT	24.0	4.0	197.0						108+32, 110+26	6.0	RF-19C	12.2	TYPE 12 INSTALLATION	
8	CAM.	110+32	112+37	RT	24.0	4.0	208.0						110+32, 112+37	6.0	RF-19C	12.8	TYPE 12 INSTALLATION	
9	CAM.	110+32	111+89	LT	24.0	4.0	160.0						110+32, 111+89	6.0	RF-19C	9.9	TYPE 12 INSTALLATION	
10	CAM.	111+95	113+79	LT	24.0	4.0	187.0						111+95, 113+79	6.0	RF-19C	11.5	TYPE 12 INSTALLATION	
11	CAM.	112+43	114+96	RT	24.0	4.0	256.0						112+43, 114+96	6.0	RF-19C	15.8	TYPE 12 INSTALLATION	
12	CAM.	113+85	115+17	LT	24.0	4.0	135.0						113+85, 115+17	6.0	RF-19C	8.3	TYPE 12 INSTALLATION	
13	CAM.	115+23	116+57	LT	24.0	4.0	137.0						115+23, 116+57	6.0	RF-19C	8.5	TYPE 12 INSTALLATION	
14	CAM.	116+00	116+57	RT	24.0	4.0	60.0						116+57	6.0	RF-19C	3.7	TYPE 12 INSTALLATION, PLUG AT 116+00	
15	CAM.	116+63	117+98	RT	24.0	4.0	138.0						116+63, 117+98	6.0	RF-19C	8.5	TYPE 12 INSTALLATION	
16	CAM.	116+63	117+99	LT	24.0	4.0	139.0						116+63, 117+99	6.0	RF-19C	8.6	TYPE 12 INSTALLATION	
17	CAM.	118+02	120+53	RT	24.0	4.0	254.0						118+02, 120+53	6.0	RF-19C	15.7	TYPE 12 INSTALLATION	
18	CAM.	118+05	120+53	LT	24.0	4.0	251.0						118+05, 120+53	6.0	RF-19C	15.5	TYPE 12 INSTALLATION	
19	CAM.	120+59	121+48	RT	24.0	4.0	92.0						120+59, 121+48	6.0	RF-19C	5.7	TYPE 12 INSTALLATION	
20	CAM.	120+59	121+48	LT	24.0	4.0	92.0						120+59, 121+48	6.0	RF-19C	5.7	TYPE 12 INSTALLATION	
21	CAM.	121+54	122+49	RT	24.0	4.0	98.0						121+54, 122+49	6.0	RF-19C	6.0	TYPE 12 INSTALLATION	
22	CAM.	121+54	122+48	LT	24.0	4.0	97.0						121+54, 122+48	6.0	RF-19C	6.0	TYPE 12 INSTALLATION	
23	CAM.	123+50	123+98	RT	24.0	4.0	51.0						123+98	6.0	RF-19C	3.1	TYPE 12 INSTALLATION, PLUG AT 123+50	
24	CAM.	123+50	123+98	LT	24.0	4.0	51.0						123+98	6.0	RF-19C	3.1	TYPE 12 INSTALLATION, PLUG AT 123+50	
25	CAM.	124+02	124+97	RT	24.0	4.0	98.0						124+02, 124+97	6.0	RF-19C	6.0	TYPE 12 INSTALLATION	
26	CAM.	124+02	125+19	LT	24.0	4.0	120.0						124+02, 125+19	6.0	RF-19C	7.4	TYPE 12 INSTALLATION	
27	CAM.	125+03	125+63	RT	24.0	4.0	63.0						125+03, 125+63	6.0	RF-19C	3.9	TYPE 12 INSTALLATION	
28	CAM.	125+25	125+63	LT	24.0	4.0	41.0						125+25, 125+63	6.0	RF-19C	2.5	TYPE 12 INSTALLATION	
29	CAM.	125+69	127+05	RT	24.0	4.0	139.0						125+69, 127+05	6.0	RF-19C	8.6	TYPE 12 INSTALLATION	
30	CAM.	125+69	127+05	LT	24.0	4.0	139.0						125+69, 127+05	6.0	RF-19C	8.6	TYPE 12 INSTALLATION	
31	CAM.	127+11	128+22	RT	24.0	4.0	114.0						127+11, 128+22	6.0	RF-19C	7.0	TYPE 12 INSTALLATION	
32	CAM.	127+11	128+22	LT	24.0	4.0	114.0						127+11, 128+22	6.0	RF-19C	7.0	TYPE 12 INSTALLATION	
33	CAM.	128+28	129+00	RT	24.0	4.0	75.0						128+28	6.0	RF-19C	4.6	TYPE 12 INSTALLATION, PLUG AT 129+00	
34	CAM.	128+28	129+00	LT	24.0	4.0	75.0						128+28	6.0	RF-19C	4.6	TYPE 12 INSTALLATION, PLUG AT 129+00	
35	CAM.	130+20	131+12	LT	24.0	4.0	95.0						130+20, 131+12	6.0	RF-19C	5.9	TYPE 12 INSTALLATION	
36	CAM.	130+23	131+12	RT	24.0	4.0	92.0						130+23, 131+12	6.0	RF-19C	5.7	TYPE 12 INSTALLATION	
37	CAM.	131+18	133+37	LT	24.0	4.0	222.0						131+18, 133+37	6.0	RF-19C	13.7	TYPE 12 INSTALLATION	
38	CAM.	131+18	133+34	RT	24.0	4.0	219.0						131+18, 133+34	6.0	RF-19C	13.5	TYPE 12 INSTALLATION	
39	CAM.	134+50	135+07	LT	24.0	4.0	60.0						134+50	6.0	RF-19C	3.7	TYPE 12 INSTALLATION, PLUG AT 134+50	
40	CAM.	134+50	135+07	RT	24.0	4.0	60.0						134+50	6.0	RF-19C	3.7	TYPE 12 INSTALLATION, PLUG AT 134+50	
41	CAM.	135+13	136+15	LT	24.0	4.0	105.0						135+13, 136+15	6.0	RF-19C	6.5	TYPE 12 INSTALLATION	
42	CAM.	135+13	136+15	RT	24.0	4.0	105.0						135+13, 136+15	6.0	RF-19C	6.5	TYPE 12 INSTALLATION	
43	CAM.	136+21	137+28	LT	24.0	4.0	110.0						136+21, 137+28	6.0	RF-19C	6.8	TYPE 12 INSTALLATION	
44	CAM.	136+21	137+29	RT	24.0	4.0	111.0						136+21, 137+29	6.0	RF-19C	6.9	TYPE 12 INSTALLATION	
45	CAM.	137+34	138+92	LT	24.0	4.0	161.0						137+34, 138+92	6.0	RF-19C	9.9	TYPE 12 INSTALLATION	
46	CAM.	137+35	138+92	RT	24.0	4.0	160.0						137+35, 138+92	6.0	RF-19C	9.9	TYPE 12 INSTALLATION	
47	CAM.	138+98	140+50	LT	24.0	4.0	155.0						138+98	6.0	RF-19C	9.6	TYPE 12 INSTALLATION, PLUG AT 140+50	
48	CAM.	138+98	140+50	RT	24.0	4.0	155.0						138+98	6.0	RF-19C	9.6	TYPE 12 INSTALLATION, PLUG AT 140+50	
49	CAM.	141+50	142+67	RT	24.0	4.0	120.0						142+67	6.0	RF-19C	7.4	TYPE 12 INSTALLATION, PLUG AT 141+50	
50	CAM.	141+69	142+66	LT	24.0	4.0	100.0						141+69, 142+66	6.0	RF-19C	6.2	TYPE 12 INSTALLATION	
51	CAM.	142+70	143+81	LT	24.0	4.0	114.0						142+70, 143+81	6.0	RF-19C	7.0	TYPE 12 INSTALLATION	
52	CAM.	142+73	143+82	RT	24.0	4.0	112.0						142+73, 143+82	6.0	RF-19C	6.9	TYPE 12 INSTALLATION	
53	CAM.	143+88	145+37	RT	24.0	4.0	152.0						143+88, 145+37	6.0	RF-19C	9.4	TYPE 12 INSTALLATION	
54	CAM.	145+43	146+00	LT	24.0	4.0	60.0						145+43	6.0	RF-19C	3.7	TYPE 12 INSTALLATION, PLUG AT 146+00	
55	CAM.	145+43	146+81	RT	24.0	4.0	141.0						145+43, 146+81	6.0	RF-19C	8.7	TYPE 12 INSTALLATION	
56	CAM.	146+87	149+06	RT	24.0	4.0	222.0						146+87, 149+06	6.0	RF-19C	13.7	TYPE 12 INSTALLATION	
57	CAM.	146+87	149+06	LT	24.0	4.0	222.0						146+87, 149+06	6.0	RF-19C	13.7	TYPE 12 INSTALLATION	
58	CAM.	149+12	150+27	RT	24.0	4.0	118.0						149+12, 150+27	6.0	RF-19C	7.3	TYPE 12 INSTALLATION	
59	CAM.	150+33	151+17	LT	24.0	4.0	87.0						150+33, 151+17	6.0	RF-19C	5.4	TYPE 12 INSTALLATION	
60	CAM.	150+33	151+17	RT	24.0	4.0	87.0						150+33, 151+17	6.0	RF-19C	5.4	TYPE 12 INSTALLATION	
61	CAM.	151+23	152+48	LT	24.0	4.0	128.0						151+23, 152+48	6.0	RF-19C	7.9	TYPE 12 INSTALLATION	
62	CAM.	151+23	152+48	RT	24.0	4.0	128.0						151+23, 152+48	6.0	RF-19C	7.9	TYPE 12 INSTALLATION	
63	CAM.	153+50	154+45	RT	24.0	4.0	98.0						154+45	6.0	RF-19C	6.0	TYPE 12 INSTALLATION, PLUG AT 153+50	
64	CAM.	153+81	154+42	LT	24.0	4.0	64.0						153+81, 154+42	6.0	RF-19C	4.0	TYPE 12 INSTALLATION	
65	CAM.	154+48	155+47	LT	24.0	4.0	102.0						154+48, 155+47	6.0	RF-19C	6.3	TYPE 12 INSTALLATION	
66	CAM.	154+49	155+47	RT	24.0	4.0	101.0						154+49, 155+47	6.0	RF-19C	6.2	TYPE 12 INSTALLATION	
67	CAM.	155+53	156+60	LT	24.0	4.0	110.0						155+53, 156+60	6.0	RF-19C	6.8	TYPE 12 INSTALLATION	
68	CAM.	155+53	156+60	RT	24.0	4.0	110.0						155+53, 156+60	6.0	RF-19C	6.8	TYPE 12 INSTALLATION	
69	CAM.	156+66	157+36	LT	24.0	4.0	73.0						156+66, 157+36	6.0	RF-19C	4.5	TYPE 12 INSTALLATION	
70	CAM.	156+66	159+02	RT	24.0	4.0	239.0						156+66, 159+02	6.0	RF-19C	14.8	TYPE 12 INSTALLATION	
71	CAM.	158+50	159+02	LT	24.0	4.0	55.0						159+02	6.0	RF-19C	3.4	TYPE 12 INSTALLATION, PLUG AT 158+50	
72	CAM.	159+08	160+32	RT	24.0	4.0	127.0						159+08, 160+32	6.0	RF-19C	7.8	TYPE 12 INSTALLATION	
73	CAM.	159+08	160+32	LT	24.0	4.0	127.0						159+08, 160+32	6.0	RF-19C	7.8	TYPE 12 INSTALLATION	
74	CAM.	160+38	161+62	RT	24.0	4.0	127.0						160+38, 161+62	6.0	RF-19C	7.8	TYPE 12 INSTALLATION	
75	CAM.	160+38	161+62	LT	24.0	4.0	127.0						160+38, 161+62	6.0	RF-19C	7.8	TYPE 12 INSTALLATION	
76	CAM.	161+68	162+78	RT	24.0	4.0	113.0						161+68, 162+78	6.0	RF-19C	7.0	TYPE 12 INSTALLATION	
77	CAM.	161+68	162+78	LT	24.0	4.0	113.0						161+68, 162+78	6.0	RF-19C	7.0	TYPE 12 INSTALLATION	
78	CAM.	162+84	164+09	RT	24.0	4.0	128.0						162+84, 164+09	6.0	RF-19C	7.9	TYPE 12 INSTALLATION	
79	CAM.	162+84	164+09	LT	24.0	4.0	128.0		</									

**LONGITUDINAL SUBDRAIN SHOULDER AND BACKSLOPE**

① Refer to RL-13 or RL-15.

Refer to Soils Sheets

\* Not a bid item

Line No.	Road or Lane Ident.	Location Station to Station		Side	Longitudinal Subdrain (RF-19C)							Subdrain Outlet			Porous* Backfill CY	Class "A"* Crushed Stone CY	Remarks
					Shoulder		Backslope		Bridge Berm ①			RF-19C, RF-19E, or RF-19F					
					Size	Length	Size	Length	Size	Type	Length	Station	Size	Standard Road Plan and Type			
					IN	FT	IN	FT	IN		FT		IN				
81	CAM.	164+18	165+50	LT	24.0	4.0	135.0						164+18	6.0	RF-19C	8.3	TYPE 12 INSTALLATION, PLUG AT 158+50
82	CAM.	166+67	168+64	RT	24.0	4.0	200.0						166+67, 168+64	6.0	RF-19C	12.3	TYPE 12 INSTALLATION
83	CAM.	166+67	168+64	LT	24.0	4.0	200.0						166+67, 168+64	6.0	RF-19C	12.3	TYPE 12 INSTALLATION
84	CAM.	168+70	170+54	RT	24.0	4.0	187.0						168+70, 170+54	6.0	RF-19C	11.5	TYPE 12 INSTALLATION
85	CAM.	169+95	170+57	LT	24.0	4.0	65.0						169+95, 170+57	6.0	RF-19C	4.0	TYPE 12 INSTALLATION
86	CAM.	170+60	172+47	RT	24.0	4.0	190.0						170+60, 172+47	6.0	RF-19C	11.7	TYPE 12 INSTALLATION
87	CAM.	170+60	171+42	LT	24.0	4.0	85.0						170+60, 171+42	6.0	RF-19C	5.2	TYPE 12 INSTALLATION
88	CAM.	171+46	172+46	LT	24.0	4.0	103.0						171+46, 172+46	6.0	RF-19C	6.4	TYPE 12 INSTALLATION
89	CAM.	172+50	174+34	LT	24.0	4.0	187.0						172+50, 174+34	6.0	RF-19C	11.5	TYPE 12 INSTALLATION
90	CAM.	172+53	174+34	RT	24.0	4.0	184.0						172+53, 174+34	6.0	RF-19C	11.4	TYPE 12 INSTALLATION
91	CAM.	175+50	176+57	RT	24.0	4.0	110.0						176+57	6.0	RF-19C	6.8	TYPE 12 INSTALLATION, PLUG AT 175+50
92	CAM.	175+66	176+57	LT	24.0	4.0	94.0						175+66, 176+57	6.0	RF-19C	5.8	TYPE 12 INSTALLATION
93	CAM.	176+63	177+87	RT	24.0	4.0	127.0						176+63, 177+87	6.0	RF-19C	7.8	TYPE 12 INSTALLATION
94	CAM.	176+63	177+87	LT	24.0	4.0	127.0						176+63, 177+87	6.0	RF-19C	7.8	TYPE 12 INSTALLATION
95	CAM.	177+93	179+02	RT	24.0	4.0	112.0						177+93, 179+02	6.0	RF-19C	6.9	TYPE 12 INSTALLATION
96	CAM.	177+93	179+02	LT	24.0	4.0	112.0						177+93, 179+02	6.0	RF-19C	6.9	TYPE 12 INSTALLATION
97	CAM.	179+08	180+05	RT	24.0	4.0	100.0						179+08, 180+05	6.0	RF-19C	6.2	TYPE 12 INSTALLATION
98	CAM.	179+08	180+07	LT	24.0	4.0	102.0						179+08, 180+07	6.0	RF-19C	6.3	TYPE 12 INSTALLATION
99	CAM.	181+00	182+21	RT	24.0	4.0	124.0						182+21	6.0	RF-19C	7.7	TYPE 12 INSTALLATION, PLUG AT 181+00
100	CAM.	181+00	182+20	LT	24.0	4.0	123.0						182+20	6.0	RF-19C	7.6	TYPE 12 INSTALLATION, PLUG AT 181+00
101	CAM.	182+27	183+83	RT	24.0	4.0	159.0						182+27, 183+83	6.0	RF-19C	9.8	TYPE 12 INSTALLATION
102	CAM.	182+26	183+84	LT	24.0	4.0	161.0						182+26, 183+84	6.0	RF-19C	9.9	TYPE 12 INSTALLATION
103	CAM.	183+89	184+90	RT	24.0	4.0	104.0						183+89, 184+90	6.0	RF-19C	6.4	TYPE 12 INSTALLATION
104	CAM.	183+88	184+90	LT	24.0	4.0	105.0						183+88, 184+90	6.0	RF-19C	6.5	TYPE 12 INSTALLATION
105	CAM.	184+96	186+17	RT	24.0	4.0	124.0						184+96, 186+17	6.0	RF-19C	7.7	TYPE 12 INSTALLATION
106	CAM.	184+96	186+17	LT	24.0	4.0	124.0						184+96, 186+17	6.0	RF-19C	7.7	TYPE 12 INSTALLATION
107	CAM.	186+23	187+12	RT	24.0	4.0	92.0						186+23, 187+12	6.0	RF-19C	5.7	TYPE 12 INSTALLATION
108	CAM.	186+23	187+08	LT	24.0	4.0	88.0						186+23	6.0	RF-19C	5.4	TYPE 12 INST., TIE-IN TO EXISTING AT 187+08
109	14TH ST	1197+30	1198+13	RT	24.0	4.0	86.0						1198+13	6.0	RF-19C	5.3	TYPE 12 INSTALLATION, PLUG AT 1197+30
110	14TH ST	1198+19	1199+04	RT	24.0	4.0	88.0						1198+19, 1199+04	6.0	RF-19C	5.4	TYPE 12 INSTALLATION
111	14TH ST	1200+49	1201+64	LT	24.0	4.0	118.0						1200+49	6.0	RF-19C	12.7	TYPE 12 INSTALLATION, PLUG AT 1201+64
112	LIB.	315+00	317+02	RT	24.0	4.0	205.0						315+00, 317+02	6.0	RF-19C	12.7	TYPE 12 INSTALLATION
113	LIB.	317+08	319+02	RT	24.0	4.0	197.0						317+08, 319+02	6.0	RF-19C	12.2	TYPE 12 INSTALLATION
114	LIB.	319+08	320+30	RT	24.0	4.0	125.0						319+08	6.0	RF-19C	7.7	TYPE 12 INSTALLATION, PLUG AT 320+30
115	24TH	1298+83	1299+50	RT	24.0	4.0	70.0									4.3	TIE TO EXIST. AT 1298+83, PLUG AT 1299+50
116	24TH	1300+60	1301+00	LT	24.0	4.0	43.0						1300+60	6.0	RF-19C	3.0	TYPE 12 INSTALLATION, PLUG AT 1301+00
117	24TH	1300+60	1301+00	RT	24.0	4.0	43.0						1300+60	6.0	RF-19C	2.7	TYPE 12 INSTALLATION, PLUG AT 1301+00
118	23RD	1398+75	1399+60	LT	24.0	4.0	88.0									5.4	TIE TO EXIST. AT 1398+75, PLUG AT 1399+60
119	23RD	1398+75	1399+60	RT	24.0	4.0	88.0									5.4	TIE TO EXIST. AT 1398+75, PLUG AT 1399+60
120	23RD	1400+65	1401+40	LT	24.0	4.0	78.0						1400+65	6.0	RF-19C	5.0	TYPE 12 INSTALLATION, PLUG AT 1401+40
121	23RD	1400+65	1401+40	RT	24.0	4.0	78.0						1400+65	6.0	RF-19C	4.8	TYPE 12 INSTALLATION, PLUG AT 1401+40
122	22ND	1498+75	1499+60	LT	24.0	4.0	88.0									5.4	TIE TO EXIST. AT 1498+75, PLUG AT 1499+60
123	22ND	1498+75	1499+60	RT	24.0	4.0	88.0									5.4	TIE TO EXIST. AT 1498+75, PLUG AT 1499+60
124	22ND	1500+65	1501+40	LT	24.0	4.0	78.0						1500+65	6.0	RF-19C	5.0	TYPE 12 INSTALLATION, PLUG AT 1501+40
125	22ND	1500+65	1501+40	RT	24.0	4.0	78.0						1500+65	6.0	RF-19C	4.8	TYPE 12 INSTALLATION, PLUG AT 1501+40
126	21ST	1597+10	1598+58	LT	24.0	4.0	151.0						1598+58	6.0	RF-19C	9.3	TYPE 12 INST., TIE-IN TO EXISTING AT 1597+10
127	21ST	1597+10	1598+58	RT	24.0	4.0	151.0						1598+58	6.0	RF-19C	9.3	TYPE 12 INST., TIE-IN TO EXISTING AT 1597+10
128	21ST	1598+62	1599+60	LT	24.0	4.0	101.0						1598+62	6.0	RF-19C	6.2	TYPE 12 INSTALLATION, PLUG AT 1599+60
129	21ST	1598+62	1599+60	RT	24.0	4.0	101.0						1598+62	6.0	RF-19C	6.2	TYPE 12 INSTALLATION, PLUG AT 1599+60
130	21ST	1600+69	1601+00	LT	24.0	4.0	34.0						1600+69	6.0	RF-19C	2.0	TYPE 12 INSTALLATION, PLUG AT 1601+00
131	21ST	1600+77	1601+00	RT	24.0	4.0	26.0						1600+77	6.0	RF-19C	1.6	TYPE 12 INSTALLATION, PLUG AT 1601+00
132	20TH	1700+68	1701+00	LT	24.0	4.0	35.0						1700+68	6.0	RF-19C	2.0	TYPE 12 INSTALLATION, PLUG AT 1701+00
133	20TH	1700+68	1701+00	RT	24.0	4.0	35.0						1700+68	6.0	RF-19C	2.2	TYPE 12 INSTALLATION, PLUG AT 1701+00
134	19TH	1800+72	1801+00	LT	24.0	4.0	31.0						1800+72	6.0	RF-19C	2.0	TYPE 12 INSTALLATION, PLUG AT 1801+00
135	19TH	1800+72	1801+00	RT	24.0	4.0	31.0						1800+72	6.0	RF-19C	1.9	TYPE 12 INSTALLATION, PLUG AT 1801+00
136	18TH	1900+64	1900+90	LT	24.0	4.0	29.0						1900+64	6.0	RF-19C	2.0	TYPE 12 INSTALLATION, PLUG AT 1900+90
137	18TH	1900+64	1900+90	RT	24.0	4.0	29.0						1900+64	6.0	RF-19C	1.8	TYPE 12 INSTALLATION, PLUG AT 1900+90
138	17TH	1996+10	1998+13	LT	24.0	4.0	206.0						1996+10, 1998+13	6.0	RF-19C	12.7	TYPE 12 INST., TIE TO EX. STRUC. AT 1996+10
139	17TH	1996+10	1998+13	RT	24.0	4.0	206.0						1996+10, 1998+13	6.0	RF-19C	12.7	TYPE 12 INST., TIE TO EX. STRUC. AT 1996+10
140	17TH	1998+17	1999+50	LT	24.0	4.0	136.0						1998+17	6.0	RF-19C	8.4	TYPE 12 INSTALLATION, PLUG AT 1999+50
141	17TH	1998+17	1999+50	RT	24.0	4.0	136.0						1998+17	6.0	RF-19C	8.4	TYPE 12 INSTALLATION, PLUG AT 1999+50
142	17TH	2000+59	2001+00	LT	24.0	4.0	44.0						2000+59	6.0	RF-19C	3.0	TYPE 12 INSTALLATION, PLUG AT 2001+00
143	17TH	2000+59	2001+00	RT	24.0	4.0	44.0						2000+59	6.0	RF-19C	2.7	TYPE 12 INSTALLATION, PLUG AT 2001+00
144	15TH	2196+37	2198+15	LT	24.0	4.0	181.0						2196+37, 2198+15	6.0	RF-19C	11.2	TYPE 12 INSTALLATION
145	15TH	2196+40	2198+15	RT	24.0	4.0	178.0						2196+40, 2198+15	6.0	RF-19C	11.0	TYPE 12 INSTALLATION
146	15TH	2198+19	2199+50	LT	24.0	4.0	134.0						2198+19, 2199+50	6.0	RF-19C	8.3	TYPE 12 INSTALLATION, PLUG AT 2199+50
147	15TH	2198+19	2199+50	RT	24.0	4.0	134.0						2198+19, 2199+50	6.0	RF-19C	8.3	TYPE 12 INSTALLATION, PLUG AT 2199+50
148	15TH	2200+59	2200+90	LT	24.0	4.0	34.0						2200+59	6.0	RF-19C	2.0	TYPE 12 INSTALLATION, PLUG AT 2200+90
149	15TH	2200+57	2200+90	RT	24.0	4.0	36.0						2200+62	6.0	RF-19C	1.9	TYPE 12 INSTALLATION, PLUG AT 2200+90
150	14TH	2300+66	2300+90	LT	24.0	4.0	27.0						2300+66	6.0	RF-19C	2.0	TYPE 12 INSTALLATION, PLUG AT 2300+90
151	14TH	2300+66	2300+90	RT	24.0	4.0	27.0						2300+66	6.0	RF-19C	1.7	TYPE 12 INSTALLATION, PLUG AT 2300+90
152	13TH	2398+75	2399+50	LT	24.0	4.0	78.0									4.8	TIE TO EXIST. AT 2398+75, PLUG AT 2399+50
153	13TH	2398+75	2399+50	RT	24.0	4.0	78.0									4.8	TIE TO EXIST. AT 2398+75, PLUG AT 2399+50
154	13TH	2400+63	2400+90	LT	24.0	4.0	30.0						2400+63	6.0	RF-19C	2.0	TYPE 12 INSTALLATION, PLUG AT 2400+90
155	13TH	2400+63	2400+90	RT	24.0	4.0	30.0						2400+63	6.0	RF-19C	1.9	TYPE 12 INSTALLATION, PLUG AT 2400+90
156	12TH	2500+64	2501+40	LT	24.0	4.0	79.0						2500+64	6.0	RF-19C	5.0	TYPE 12 INSTALLATION

**STANDARD ROAD PLANS**

The following Standard Road Plans apply to construction work on this project.

Number	Date	Title
BA-401	04-20-10	Temporary Barrier Rail (Precast Concrete)
EC-201	04-20-10	Silt Fence
EW-101	04-19-11	Embankment and Rebuilding Embankments
MI-210	10-18-11	PCC Driveways and Alleys
MI-220	10-18-11	Sidewalk with Detectable Warnings
PM-110	04-19-11	Line Types
PM-111	10-18-11	Symbols and Legends
PM-210	10-18-11	Separation In Two-Lane Roadway
PM-211	10-18-11	Separation In Four-Lane Roadway
PV-101	04-19-11	Joints
PV-102	04-19-11	PCC Curb Details
PV-103	04-19-11	Manhole Boxouts in PCC Pavement
PV-104	04-19-11	Ramped Median Nose
RF-2	10-18-11	Construction of Type "C" Concrete Adaptors for Pipe Culvert Connections
RF-3	10-18-11	Concrete Aprons
RF-13	10-18-11	Pipe Bends and Half Pipe
RF-14	10-18-11	Connected Pipe Joints
RF-19C	10-19-10	Subdrains (Longitudinal)
RF-21		
RF-26	10-18-11	Pipe Apron Guard
RF-31	03-28-95	Depth of Cover Tables for Concrete Pipe
RL-2A	10-18-05	Details of Embankment Subgrade Treatment, Moisture and Density Control & Special Compaction
RM-33	10-03-00	Electrical Installation Details (Roadway Ducts)
RM-34B	09-21-99	Electrical Installation Details (Transformer Base)
RM-38	04-27-99	Junction Box (Fiber Reinforced Concrete)
RM-39	10-18-11	Light Pole Footings
RM-40	09-21-99	Cable Splices and Connectors
RM-42	10-18-11	Precast Handhole
SI-101	04-21-09	Locations - Type 'A' Signs
SI-113	10-18-11	Support Structures - Steel Breakaway Posts
SI-114	10-18-11	Support Structures - Steel Breakaway Posts Rectangular Tube
SI-119	10-20-09	Support Structures - Mounting Brackets
SI-121	04-20-10	Fabrication - Sign Legend Components
SI-131	10-18-11	Installation - Type 'A' Signs
SI-171	10-20-09	Reference Posts
SI-182	10-18-11	Permanent Road Closure - Urban
SI-881	04-19-11	Special Signs for Workzones
SI-882	04-20-10	Special Signs for Restricted Width Traffic Control Zones
SW-101	04-21-09	Trench Bedding and Backfill Zones
SW-102	04-21-09	Rigid Gravity Pipe Trench Bedding
SW-105	10-20-09	Miscellaneous Pipe Bedding
SW-401	04-21-09	Circular Storm Sewer Manhole
SW-501	04-21-09	Single Grate Intake
SW-505	04-21-09	Double Grate Intake
SW-506	04-21-09	Double Grate Intake with Manhole
SW-507	10-20-09	Single Open-Throat Intake, Small Box
SW-508	10-20-09	Single Open-Throat Intake, Large Box
SW-509	10-18-11	Double Open-Throat Curb Intake, Small Box
SW-510	10-18-11	Double Open-Throat Curb Intake, Large Box
SW-512	10-20-09	Circular Area Intake
SW-513	04-21-09	Open-Sided Area Intake
SW-545	10-18-11	Single Open-Throat Curb Intake with Extended Opening
SW-602	10-20-09	Castings for Storm Sewer Manholes
SW-603	10-20-09	Castings for Grate Intakes
SW-604	10-20-09	Castings for Area Intakes
TC-1	10-18-11	Work Not Affecting Traffic (Two-Lane or Multi-Lane)
TC-81	04-20-10	Restricted Width Signing (Less Than 14.5 Feet)
TC-213	10-21-08	Lane Closure with Flaggers
TC-216	04-21-09	Lane Closure with Signals
TC-233	10-18-11	Pavement Marking Operations Two-Lane
TC-252	10-20-09	Road Closure
TC-253	04-20-10	Paved On-Site Detour
TC-273	04-20-10	Construction Site Entrance
TC-419	10-20-09	Lane Closure on Undivided Highway
TC-422	10-18-11	Closure of Two Adjacent Lanes on Divided Highway
TC-423	10-20-09	Closure of Two Adjacent Lanes on Undivided Highway
TC-429	10-20-09	Closure of Continuous Two-Way Left Turn Lane and Adjacent Lane

**SAFETY CLOSURES**

Refer to Section 2518 of the Standard Specifications

Station	Closure Type		Remarks
	Road Qty.	Hazard Qty.	
STAGE 1-A			
1197+30	1		S 14TH ST CLOSED
1199+86	1		S 14TH ST CLOSED
114+60	2		S 25TH PL CLOSED BOTH ENDS
120+46	1		END CONSTRUCTION CLOSED
STAGE 1-B			
1197+16	1		S 14TH ST CLOSED
1199+88	1		S 14TH ST CLOSED
100+47	1		EB CAMANCHE CLOSED
104+91	1		PROP. E CAMANCHE CLOSED
STAGE 2			
102+25	1		WB CAMANCHE CLOSED
1201+67	1		S 14TH ST CLOSED
F PROPECT AVE	1		S 14TH ST CLOSED
110+38	1		CAMANCHE CLOSED
129+56	2		S 23RD PL CLOSED
133+98	2		S 22ND PL CLOSED
STAGE 3			
110+05	1		BARKER ST CLOSED
110+27	1		PROP. WB CAMANCHE CLOSED
114+62	1		25T PL CLOSED
123+09	1		24TH PL CLOSED S TO LIBERT
140+96	2		21ST PL CLOSED S TO LIBERT
153+11	2		17TH PL CLOSED S TO LIBERT
165+81	2		15TH PL CLOSED S TO LIBERT
174+98	2		13TH AVE CLOSED S TO LIBERT
180+68	2		12TH AVE CLOSED S TO LIBERT
187+18	1		PROP. WB CAMANCHE CLOSED
STAGE 4			
154+43	1		WB CAMANCHE CLOSED
STAGE 5			
158+02	1		16TH PL CLOSED
165+80	1		15TH PL CLOSED
169+29	1		14TH AVE S CLOSED
175+00	1		13TH AVE CLOSED
180+70	1		12TH AVE CLOSED
187+18	1		WB CAMANCHE CLOSED
TOTAL	39		





PAVEMENT MARKING LINE TYPES

See PM Series

BCY4: Broken Centerline (Yellow) @ 0.25      DCY4: Double Centerline (Yellow) @ 2.00      NPY4: No Passing Zone Line (Yellow) @ 1.25      BLW4: Broken Lane Line (White) @ 0.25      ELW4: Edge Line Right (White) @ 1.00  
 ELY4: Edge Line Left (Yellow) @ 1.00      CHW8: Channelizing Line (White) @ 2.00      DLW4: Dotted Line (White) @ 0.33      SLW4: Solid Lane Line (White) @ 1.00      LDW8: Lane Drop (White) @ 0.50  
 SLW2: Stop Line (White) @ 6.00      CHY8: Channelizing Line (Yellow) @ 2.00

Road ID	Location		Dir. of Travel	Marking Type	Side			Length by Line Type (Unfactored)													Remarks		
	Station to Station	Station to Station			L	C	R	BCY4	DCY4	NPY4	BLW4	ELW4	ELY4	CHW8	DLW4	SLW4	LDW8	SLW2	CHY8				
								STA	STA	STA	STA	STA	STA	STA	STA	STA	STA	STA	STA	STA		STA	STA
17TH PL.	1996+06.0			Waterborne/Solvent Paint	X												0.14						
17TH PL.	1996+05.0	1996+62.0		Waterborne/Solvent Paint	X	X												0.27				Hatching Stripes	
17TH PL.	1996+05.0	1996+06.0		Waterborne/Solvent Paint	X	X												0.13					
17TH PL.	1996+05.0	1996+62.0		Waterborne/Solvent Paint	X	X												0.57					
17TH PL.	1996+06.0	1996+62.0		Waterborne/Solvent Paint	X													0.56					
17TH PL.	1996+62.0	1998+70.0		Waterborne/Solvent Paint	X						2.08												
17TH PL.	1996+62.0	1998+70.0		Waterborne/Solvent Paint	X					2.08													
17TH PL.	1996+62.0	1998+70.0		Waterborne/Solvent Paint		X																	
17TH PL.	1996+62.0	1998+70.0		Waterborne/Solvent Paint		X																	
17TH PL.	1998+70.0	1999+49.0		Waterborne/Solvent Paint	X						0.79												
17TH PL.	1998+89.0	1999+49.0		Waterborne/Solvent Paint		X									0.60								
17TH PL.	1999+49.0			Waterborne/Solvent Paint		X																	
17TH PL.	2000+43.0	2000+44.0		Waterborne/Solvent Paint	X																		
17TH PL.	2000+43.0	2001+15.0		Waterborne/Solvent Paint		X					0.72												
16TH PL.	2100+43.0	2100+44.0		Waterborne/Solvent Paint	X																		
16TH PL.	2100+44.0	2101+16.0		Waterborne/Solvent Paint		X					0.72												
15TH AVE.	2196+20.0			Waterborne/Solvent Paint	X																		
15TH AVE.	2196+17.0	2196+74.0		Waterborne/Solvent Paint	X	X																	
15TH AVE.	2196+17.0			Waterborne/Solvent Paint	X	X																	
15TH AVE.	2196+17.0	2196+74.0		Waterborne/Solvent Paint	X	X																	
15TH AVE.	2196+17.0	2196+74.0		Waterborne/Solvent Paint	X	X																	
15TH AVE.	2196+74.0	2198+69.0		Waterborne/Solvent Paint	X																		
15TH AVE.	2196+74.0	2198+69.0		Waterborne/Solvent Paint	X						1.95												
15TH AVE.	2196+74.0	2198+69.0		Waterborne/Solvent Paint		X					1.95												
15TH AVE.	2196+74.0	2198+69.0		Waterborne/Solvent Paint		X																	
15TH AVE.	2198+69.0	2199+49.0		Waterborne/Solvent Paint	X																		
15TH AVE.	2198+89.0	2199+49.0		Waterborne/Solvent Paint		X									0.60								
15TH AVE.	2199+49.0			Waterborne/Solvent Paint		X																	
15TH AVE.	2200+43.0	2200+44.0		Waterborne/Solvent Paint	X																		
15TH AVE.	2200+43.0	2201+11.0		Waterborne/Solvent Paint		X					0.68												
14TH AVE.	2300+43.0			Waterborne/Solvent Paint	X																		
13TH AVE.	2398+75.0	2399+49.0		Waterborne/Solvent Paint	X						0.74												
13TH AVE.	2398+92.0	2399+49.0		Waterborne/Solvent Paint		X									0.57								
13TH AVE.	2399+49.0			Waterborne/Solvent Paint		X																	
13TH AVE.	2400+43.0			Waterborne/Solvent Paint	X																		
13TH AVE.	2400+43.0	2401+10.0		Waterborne/Solvent Paint		X					0.67												
12TH AVE.	2498+71.0	2499+49.0		Waterborne/Solvent Paint	X						0.78												
12TH AVE.	2498+95.0	2499+49.0		Waterborne/Solvent Paint		X									0.54								
12TH AVE.	2499+49.0			Waterborne/Solvent Paint		X																	
12TH AVE.	2500+43.0	2500+44.0		Waterborne/Solvent Paint	X																		
12TH AVE.	2500+44.0	2501+61.0		Waterborne/Solvent Paint		X					1.17												
TEMPORARY																							
STAGE 1-A																							
CAMANCHE AVE.	WEST END	102+18.0		Retroreflective Removable		X																	
CAMANCHE AVE.	WEST END	103+15.0		Retroreflective Removable		X																	
CAMANCHE AVE.	WEST END	103+15.0		Retroreflective Removable		X																	
CAMANCHE AVE.	102+18.0	102+62.0		Retroreflective Removable	X																		
CAMANCHE AVE.	102+60.0	104+12.0		Waterborne/Solvent Paint	X						1.52												
CAMANCHE AVE.	102+65.0	103+15.0		Waterborne/Solvent Paint	X										0.50								
CAMANCHE AVE.	103+15.0	103+43.0		Waterborne/Solvent Paint		X					0.75											SW Return at S. 14th Street	
CAMANCHE AVE.	103+15.0			Waterborne/Solvent Paint	X																		
CAMANCHE AVE.	103+15.0			Waterborne/Solvent Paint		X																	
CAMANCHE AVE.	104+83.0	107+90.0		Waterborne/Solvent Paint		X					3.07												
CAMANCHE AVE.	105+26.0	109+67.0		Waterborne/Solvent Paint	X										4.41								
CAMANCHE AVE.	105+26.0			Waterborne/Solvent Paint	X																		
CAMANCHE AVE.	105+28.0	106+25.0		Waterborne/Solvent Paint	X																		
CAMANCHE AVE.	106+25.0	112+10.0		Waterborne/Solvent Paint	X																		
CAMANCHE AVE.	107+90.0	112+10.0		Waterborne/Solvent Paint	X						4.20												
CAMANCHE AVE.	109+66.0	112+10.0		Waterborne/Solvent Paint	X																		
CAMANCHE AVE.	109+66.0	114+40.0		Waterborne/Solvent Paint	X																		
CAMANCHE AVE.	114+87.0	118+50.0		Waterborne/Solvent Paint	X																		
14TH ST.	1196+88.0	1197+41.0		Waterborne/Solvent Paint		X																	
14TH ST.	1196+88.0	1198+81.0		Waterborne/Solvent Paint	X						0.53												
14TH ST.	1196+88.0	1199+15.0		Waterborne/Solvent Paint	X						1.93												
14TH ST.	1197+41.0	1199+15.0		Waterborne/Solvent Paint	X										2.27								
14TH ST.	1199+15.0			Waterborne/Solvent Paint	X																		
14TH ST.	1200+03.0	1200+80.0		Waterborne/Solvent Paint	X																		
14TH ST.	1200+97.0	NORTH END		Retroreflective Removable	X						0.77												
STAGE 1-B																							

PAVEMENT MARKING LINE TYPES

See PM Series

BCY4: Broken Centerline (Yellow) @ 0.25      DCY4: Double Centerline (Yellow) @ 2.00      NPY4: No Passing Zone Line (Yellow) @ 1.25      BLW4: Broken Lane Line (White) @ 0.25      ELW4: Edge Line Right (White) @ 1.00  
 ELY4: Edge Line Left (Yellow) @ 1.00      CHW8: Channelizing Line (White) @ 2.00      DLW4: Dotted Line (White) @ 0.33      SLW4: Solid Lane Line (White) @ 1.00      LDW8: Lane Drop (White) @ 0.50  
 SLW2: Stop Line (White) @ 6.00      CHY8: Channelizing Line (Yellow) @ 2.00

Location			Length by Line Type (Unfactored)																	Remarks		
Road ID	Station to Station	Dir. of Travel	Marking Type	Side			BCY4	DCY4	NPY4	BLW4	ELW4	ELY4	CHW8	DLW4	SLW4	LDW8	SLW2	CHY8				
				L	C	R	STA	STA	STA	STA	STA	STA	STA	STA	STA	STA	STA	STA	STA		STA	STA
CAMANCHE AVE.	100+66.0	102+35.0	Retroreflective Removable	X			1.69				1.69											
CAMANCHE AVE.	100+66.0	102+35.0	Retroreflective Removable		X																	
CAMANCHE AVE.	102+35.0	103+19.0	Waterborne/Solvent Paint	X			0.84															
CAMANCHE AVE.	102+35.0	103+19.0	Waterborne/Solvent Paint		X						0.84											
CAMANCHE AVE.	103+19.0		Waterborne/Solvent Paint	X	X												0.12					
CAMANCHE AVE.	105+39.0		Waterborne/Solvent Paint	X													0.12					
CAMANCHE AVE.	112+10.0	114+86.0	Waterborne/Solvent Paint	X							2.76											
14TH ST.	1196+45.0		Retroreflective Removable			X											0.12					ON BRIDGE
14TH ST.	1197+30.0	1199+10.0	Retroreflective Removable			X							1.80									
14TH ST.	1198+08.0	1199+15.0	Retroreflective Removable			X		1.07														
14TH ST.	1198+08.0	1199+15.0	Retroreflective Removable			X					1.07											
14TH ST.	1198+08.0		Retroreflective Removable			X											0.12					
14TH ST.	1199+15.0		Retroreflective Removable			X											0.16					
14TH ST.	1200+97.0	1201+86.0	Retroreflective Removable	X									0.89									
14TH ST.	1200+97.0	1201+86.0	Retroreflective Removable	X			0.89															
14TH ST.	1200+97.0		Retroreflective Removable	X													0.23					
STAGE 2																						
CAMANCHE AVE.	WEST END		Retroreflective Removable			X					6.33											NORTH LANE LINE SHIFT
CAMANCHE AVE.	WEST END		Retroreflective Removable			X							2.45									SOUTH LANE LINE SHIFT
CAMANCHE AVE.	WEST END		Retroreflective Removable			X						0.40										
CAMANCHE AVE.	100+10.0	103+42.0	Retroreflective Removable			X		3.32														
CAMANCHE AVE.	103+25.0	104+89.0	Retroreflective Removable			X					1.64											
CAMANCHE AVE.	103+42.0		Retroreflective Removable			X											0.14					
CAMANCHE AVE.	104+83.0	110+31.0	Retroreflective Removable			X		5.48														
CAMANCHE AVE.	104+83.0		Retroreflective Removable			X											0.14					
CAMANCHE AVE.	110+31.0	112+65.0	Waterborne/Solvent Paint			X					2.34											TEMPORARY CROSSOVER
CAMANCHE AVE.	110+31.0	113+36.0	Waterborne/Solvent Paint			X																TEMPORARY CROSSOVER
CAMANCHE AVE.	112+65.0	115+93.0	Waterborne/Solvent Paint	X								3.05										TEMPORARY CROSSOVER
CAMANCHE AVE.	113+36.0	115+77.0	Waterborne/Solvent Paint	X							2.41											TEMPORARY CROSSOVER
CAMANCHE AVE.	119+50.0	120+50.0	Waterborne/Solvent Paint	X							1.00											
STAGE 3																						
CAMANCHE AVE.	106+50.0	109+50.0	Retroreflective Removable			X						3.00										
CAMANCHE AVE.	107+78.0	114+14.0	Waterborne/Solvent Paint	X							6.36											
CAMANCHE AVE.	107+84.0	108+94.0	Retroreflective Removable			X						1.10										TEMPORARY CROSSOVER
CAMANCHE AVE.	107+86.0	108+81.0	Retroreflective Removable	X												0.95						TEMPORARY CROSSOVER
CAMANCHE AVE.	108+81.0	114+14.0	Waterborne/Solvent Paint	X											5.33							TEMPORARY CROSSOVER
CAMANCHE AVE.	108+94.0	114+14.0	Waterborne/Solvent Paint	X							5.20											TEMPORARY CROSSOVER
CAMANCHE AVE.	187+08.0	188+25.0	Retroreflective Removable			X					1.17											
STAGE 4																						
CAMANCHE AVE.	154+41.0	156+21.0	Waterborne/Solvent Paint			X					1.80											
CAMANCHE AVE.	154+41.0	159+31.0	Retroreflective Removable			X						4.90										TEMPORARY CROSSOVER
CAMANCHE AVE.	161+76.0	164+21.0	Waterborne/Solvent Paint	X									2.45									
CAMANCHE AVE.	169+11.0	171+56.0	Waterborne/Solvent Paint	X									2.45									
STAGE 5																						
15TH PL.	2197+50.0	2198+50.0	Retroreflective Removable			X					1.00											
13TH AVE.	2397+50.0	2398+50.0	Retroreflective Removable			X					1.00											
12TH AVE.	2497+50.0	2498+50.0	Retroreflective Removable			X					1.00											
CAMANCHE AVE.	187+08.0	188+43.0	Retroreflective Removable			X					1.35											
Length Subtotals																						
Temporary Tape							0.00	14.84	0.00	0.00	13.01	20.79	4.66	5.14	0.95	0.00	0.91	0.00	0.00	0.00	0.00	0.00
Temporary Striping							0.00	8.02	0.00	0.00	31.02	23.34	0.00	4.90	12.15	0.00	0.96	0.00	0.00	0.00	0.00	0.00
Permanent Striping							10.34	15.56	10.34	156.04	0.00	0.00	0.00	0.00	13.02	0.00	5.90	4.97	0.00	0.00	0.00	0.00
Quantity Factors																						
Temp Tape TOTALS							0.25	2.00	1.25	0.25	1.00	1.00	2.00	0.33	1.00	0.50	6.00	2.00	0.00	0.00	0.00	0.00
Temp Striping TOTALS							0.00	29.68	0.00	0.00	13.01	20.79	9.32	1.70	0.95	0.00	5.46	0.00	0.00	0.00	0.00	0.00
Perm Striping TOTALS							2.59	31.12	12.93	39.01	0.00	0.00	0.00	0.00	0.00	0.00	35.40	9.94	0.00	0.00	0.00	0.00
Total = 80.91 Stations																						
Total = 89.93 Stations																						
Total = 144.00 Stations																						
Total = 288.00 STA (Two applications)																						

PAVEMENT MARKING SYMBOLS AND LEGENDS

See PM Series

Road Identification	Location		↑ STAW	↻ RTAW	↶ LTAW	↗ CSRW	↖ CSLW	↕ CSTW	↘ CRLW	↑ FERW	↗ LLRW	↖ RLRW	X RR	♻️ BSLW	♿ WCSW	♿ WPSB	SCHOOL	XING	STOP	AHEAD	ONLY	BIKE	LANE	EXIT	Remarks	
	Station	Side																								
CAMANCHE AVE.	101+84.0	R		1																						
CAMANCHE AVE.	102+24.0	R																				1				
CAMANCHE AVE.	102+53	R			1																					
CAMANCHE AVE.	102+64	R		1																						
CAMANCHE AVE.	102+94	R																				1				
CAMANCHE AVE.	103+34	R			1																					
CAMANCHE AVE.	105+15	R			1																					
CAMANCHE AVE.	105+56	R																				1				
CAMANCHE AVE.	105+97	R			1																					
CAMANCHE AVE.	113+46.0	R			1																					
CAMANCHE AVE.	113+86.0	R																				1				
CAMANCHE AVE.	114+26.0	R			1																					
CAMANCHE AVE.	123+82	L				1																				
CAMANCHE AVE.	123+82	R	1				1																			
CAMANCHE AVE.	130+15	L				1																				
CAMANCHE AVE.	130+15	R	1				1																			
CAMANCHE AVE.	134+54	L				1																				
CAMANCHE AVE.	134+54	R	1				1																			
CAMANCHE AVE.	141+52	L				1																				
CAMANCHE AVE.	141+53	R	1				1																			
CAMANCHE AVE.	144+97	L				1																				
CAMANCHE AVE.	144+99	R	2																							
CAMANCHE AVE.	146+78	L				1																				
CAMANCHE AVE.	146+80	R	2																							
CAMANCHE AVE.	150+27	L				1																				
CAMANCHE AVE.	150+29	R	2																							
CAMANCHE AVE.	153+65	L				1																				
CAMANCHE AVE.	153+66	R	1				1																			
CAMANCHE AVE.	158+60	L				1																				
CAMANCHE AVE.	158+61	R	2																							
CAMANCHE AVE.	166+30	L				1																				
CAMANCHE AVE.	166+30	R	1				1																			
CAMANCHE AVE.	169+92	L				1																				
CAMANCHE AVE.	169+92	R	2																							
CAMANCHE AVE.	175+51	L				1																				
CAMANCHE AVE.	175+51	R	1				1																			
CAMANCHE AVE.	181+21	L				1																				
CAMANCHE AVE.	181+21	R	1				1																			
14TH ST.	1198+02	L			1																					
14TH ST.	1198+11	R		1																						
14TH ST.	1198+50	L																				1				
14TH ST.	1198+50	R																				1				
14TH ST.	1198+83	L			1																					
14TH ST.	1198+98	R		1																						
14TH ST.	1200+64	L			1																					
14TH ST.	1201+02	L																				1				
14TH ST.	1201+45	L			1																					
24TH PL.	1300+54	L				1																				
24TH PL.	1301+14	L				1																				
23RD PL.	1399+04	CL			1																					
23RD PL.	1399+05	R	1																							
23RD PL.	1399+23	CL																				1				
23RD PL.	1399+23	R																				1				
23RD PL.	1399+41	CL			1																					
23RD PL.	1399+43	R	1																							
23RD PL.	1400+58	L				1																				
23RD PL.	1401+28	L				1																				
22ND PL.	1498+97	CL			1																					
22ND PL.	1498+99	R	1																							
22ND PL.	1499+16	CL																				1				
22ND PL.	1499+16	R																				1				
22ND PL.	1499+34	CL			1																					
22ND PL.	1499+36	R	1																							
22ND PL.	1500+58	L				1																				
22ND PL.	1501+28	L				1																				
21ST PL.	1597+05	L			1																					
21ST PL.	1597+28	L																				1				
21ST PL.	1597+50	L				1																				
21ST PL.	1597+67	CL			1																					Part of TWLTL
21ST PL.	1597+83	CL			1																					Part of TWLTL
21ST PL.	1598+57	CL			1																					Part of TWLTL
21ST PL.	1598+72	CL			1																					Part of TWLTL
21ST PL.	1599+03	CL			1																					
21ST PL.	1599+06	R	1																							
21ST PL.	1599+23	CL																				1				
21ST PL.	1599+23	R																				1				

PAVEMENT MARKING SYMBOLS AND LEGENDS

See PM Series

Road Identification	Location		↑ STAW	↶ RTAW	↷ LTAW	↶↷ CSRW	↷↶ CSLW	↶↷↶ CSTW	↷↶↷ CRLW	↑ FERW	↗ LLRW	↖ RLRW	X RR	♻️ BLSW	♿ WCSW	♿ WPSB	SCHOOL	XING	STOP	AHEAD	ONLY	BIKE	LANE	EXIT	Remarks	
	Station	Side																								
21ST PL.	1599+41	CL			1																					
21ST PL.	1599+43	R	1																							
21ST PL.	1600+68	L				1																				
21ST PL.	1601+18	L				1																				
17TH PL.	1996+15	L			1																					
17TH PL.	1996+32	L																			1					
17TH PL.	1996+52	L			1																					
17TH PL.	1996+68	CL			1																					Part of TWLTL
17TH PL.	1996+84	CL			1																					Part of TWLTL
17TH PL.	1998+48	CL			1																					Part of TWLTL
17TH PL.	1998+64	CL			1																					Part of TWLTL
17TH PL.	1998+95	CL			1																					
17TH PL.	1998+97	R	1																							
17TH PL.	1999+14	CL																				1				
17TH PL.	1999+14	R																				1				
17TH PL.	1999+33	CL			1																					
17TH PL.	1999+34	R	1																							
17TH PL.	2000+61	L				1																				
17TH PL.	2001+10	L				1																				
16TH PL.	2100+59	L				1																				
16TH PL.	2101+10	L				1																				
15TH AVE.	2196+28	L			1																					
15TH AVE.	2196+43	L																			1					
15TH AVE.	2196+63	L			1																					
15TH AVE.	2196+79	CL			1																					Part of TWLTL
15TH AVE.	2196+95	CL			1																					Part of TWLTL
15TH AVE.	2198+49	CL			1																					Part of TWLTL
15TH AVE.	2198+65	CL			1																					Part of TWLTL
15TH AVE.	2198+99	CL			1																					
15TH AVE.	2199+01	R	1																							
15TH AVE.	2199+19	CL																				1				
15TH AVE.	2199+19	R																				1				
15TH AVE.	2199+37	CL			1																					
15TH AVE.	2199+39	R	1																							
15TH AVE.	2200+55	L				1																				
15TH AVE.	2201+06	L				1																				
13TH AVE.	2398+96	CL			1																					
13TH AVE.	2398+98	R	1																							
13TH AVE.	2399+15	CL																				1				
13TH AVE.	2399+15	R																				1				
13TH AVE.	2399+34	CL			1																					
13TH AVE.	2399+36	R	1																							
13TH AVE.	2400+59	L				1																				
13TH AVE.	2401+08	L				1																				
12TH AVE.	2499+01	CL			1																					
12TH AVE.	2499+03	R	1																							
12TH AVE.	2499+20	CL																				1				
12TH AVE.	2499+20	R																				1				
12TH AVE.	2499+38	CL			1																					
12TH AVE.	2499+40	R	1																							
12TH AVE.	2500+60	L				1																				
12TH AVE.	2501+22	L				1																				

**REMOVAL OF PAVEMENT**

Refer to Tabulation 102-5

\* Not a Bid Item

110-1  
08-01-08

Begin Station	End Station	Pavement Type	Area		Saw Cut* LF	Intakes and Utility Accesses No.	Remarks
			SY	LF			
CAMANCHE AVE.							
102+35.0	133+99.0	ACC/PCC	18272.2		90.0	39	W. END TO 22ND PL., APPR. 4" ACC ON 7" PCC; INCL. 199 SY MEDIAN
109+75.0	110+38.0	ACC/PCC	161.5		17.0	2	EXISTING BARKER ST. NORTH OF CAMANCHE AVE., ACC OVER 6" PCC (APPROX)
114+19.0	114+99.0	ACC/PCC	362.0		49.0	2	EXISTING 25TH PL. NORTH OF CAMANCHE AVE., ACC OVER 6" PCC (APPROX)
114+21.0	114+96.0	ACC/PCC	619.0		0.0	1	EXISTING 25TH PL. SOUTH OF CAMANCHE AVE., ACC OVER 6" PCC (APPROX)
119+09.0	122+63.0	PCC	711.3		273.0	3	EXISTING TRANSFER TO EB LIBERTY AVE., APPROX. 10" REINFORCED PCC
133+99.0	158+00.0	ACC/PCC	13216.6		0.0	39	22ND PL. TO 16TH PL., APPROX. 4" ACC OVER 11" PCC
158+00.0	183+62.0	ACC/PCC	14230.9		0.0	26	16TH PL. TO EAST END OF ORIG. PAV'T, APPROX. 4" ACC OVER 7" PCC
183+62.0	187+08.0	PCC	1598.7		41.0	5	TEMPORARY PAVEMENT AT EAST END, APPROX. 10" REINFORCED PCC
S. 14TH ST.							
1197+30.0	1199+61.0	PCC	1581.8		41.0	3	SOUTH OF CAMANCHE AVE., APPROX. 8" PCC - INCL CONNECTOR TO LIBERTY
1200+01.0	1201+45.0	PCC	622.5		79.0	3	NORTH OF CAMANCHE AVE., APPROX. 8" PCC
24TH PL.							
1298+83.0	1299+91.0	PCC	333.4		23.0	3	SOUTH OF CAMANCHE AVE., APPROX. 10" REINFORCED PCC
1300+39.0	1301+00.0	ACC	191.9		28.0	1	NORTH OF CAMANCHE AVE., APPROX. 6" ACC
23RD PL.							
1398+75.0	1399+90.0	PCC	428.6		43.0	0	SOUTH OF CAMANCHE AVE., APPROX. 8" REINFORCED PCC
1400+39.0	1401+40.0	PCC	355.2		140.0	3	NORTH OF CAMANCHE AVE., APPROX. 6" PCC
22ND PL.							
1498+35.0	1499+90.0	PCC	508.2		93.0	1	SOUTH OF CAMANCHE AVE., APPROX. 8" REINFORCED PCC
1500+40.0	1501+40.0	PCC	412.8		31.0	2	NORTH OF CAMANCHE AVE., APPROX. 6" PCC
21ST PL.							
1597+10.0	1597+85.0	PCC	302.4		43.0	0	SOUTH OF CAMANCHE AVE., APPROX. 8" REINFORCED PCC
1597+85.0	1600+05.0	HMA	652.9		0.0	0	SOUTH OF CAMANCHE AVE., APPROX. 2" HMA OVER 6" PCC
1600+45.0	1601+00.0	PCC	182.3		27.0	2	NORTH OF CAMANCHE AVE., APPROX. 6" PCC
20TH PL.							
1700+38.0	1701+00.0	ACC/PCC	155.6		19.0	2	NORTH OF CAMANCHE AVE., APPROX. 1" ACC OVER 6" PCC
19TH PL.							
1800+33.0	1801+00.0	ACC/PCC	189.2		27.0	2	NORTH OF CAMANCHE AVE., APPROX. 1" ACC OVER 6" PCC
18TH PL.							
1900+40.0	1900+90.0	PCC	169.0		27.0	2	NORTH OF CAMANCHE AVE., APPROX. 6" PCC
149+07.0	151+39.0	PCC	1336.9		0.0	0	SOUTH OF CAMANCHE AVE., APPROX. 7" REINFORCED PCC
17TH PL.							
2000+40.0	2001+14.0	ACC	232.5		41.0	2	NORTH OF CAMANCHE AVE., APPROX. 2" ACC OVER 6" PCC
16TH PL.							
2100+40.0	2100+80.0	ACC/PCC	142.7		31.0	3	NORTH OF CAMANCHE AVE., APPROX. 2" ACC OVER 6" PCC
15TH AVE. S.							
2200+42.0	2200+90.0	ACC/PCC	142.4		23.0	5	NORTH OF CAMANCHE AVE., APPROX. 2" ACC OVER 6" PCC
14TH AVE. S.							
2300+42.0	2300+90.0	PCC	183.2		32.0	3	NORTH OF CAMANCHE AVE., APPROX. 6" PCC
13TH AVE. S.							
2398+75.0	2399+93.0	PCC	566.3		43.0	1	SOUTH OF CAMANCHE AVE., APPROX. 8" REINFORCED PCC
2400+41.0	2400+90.0	ACC/PCC	211.6		35.0	5	NORTH OF CAMANCHE AVE., APPROX. 1" ACC OVER 6" PCC
12TH AVE. S.							
2499+38.0	2499+92.0	PCC	256.8		43.0	1	SOUTH OF CAMANCHE AVE., APPROX. 8" REINFORCED PCC
2500+40.0	2501+40.0	ACC	337.3		29.0	2	NORTH OF CAMANCHE AVE., APPROX. 1" ACC OVER 6" PCC
CAMANCHE AVE.							
117+34.0	118+50.0	ACC/PCC	32.4		122.0	0	NORTH OF CAMANCHE AVE., UNKNOWN PAV'T DEPTH, PARKING LOT
123+37.0	124+38.0	ACC/PCC	28.9		119.0	0	NORTH OF CAMANCHE AVE., UNKNOWN PAV'T DEPTH, PARKING LOT
125+67.0	126+32.0	ACC/PCC	11.6		76.0	0	NORTH OF CAMANCHE AVE., UNKNOWN PAV'T DEPTH, PARKING LOT
128+46.0	129+42.0	ACC/PCC	53.5		97.0	0	NORTH OF CAMANCHE AVE., UNKNOWN PAV'T DEPTH, PARKING LOT
138+71.0	140+62.0	PCC	869.6		301.0	0	SOUTH OF CAMANCHE AVE., UNKNOWN PAV'T DEPTH, PARKING LOT
140+35.0	140+71.0	ACC/PCC	9.6		57.0	0	NORTH OF CAMANCHE AVE., UNKNOWN PAV'T DEPTH, PARKING LOT
141+13.0	142+49.0	PCC	559.6		113.0	0	SOUTH OF CAMANCHE AVE., UNKNOWN PAV'T DEPTH, PARKING LOT
141+33.0	142+68.0	ACC/PCC	84.6		148.0	0	NORTH OF CAMANCHE AVE., UNKNOWN PAV'T DEPTH, PARKING LOT
142+49.0	145+08.0	ACC/PCC	1277.1		267.0	0	SOUTH OF CAMANCHE AVE., UNKNOWN PAV'T DEPTH, PARKING LOT
143+04.0	143+72.0	ACC/PCC	25.2		77.0	0	NORTH OF CAMANCHE AVE., UNKNOWN PAV'T DEPTH, PARKING LOT
144+59.0	145+94.0	ACC/PCC	37.5		0.0	0	NORTH OF CAMANCHE AVE., UNKNOWN PAV'T DEPTH, PARKING LOT
151+31.0	152+57.0	ACC/PCC	67.2		141.0	0	NORTH OF CAMANCHE AVE., UNKNOWN PAV'T DEPTH, PARKING LOT
153+37.0	154+39.0	ACC/PCC	27.9		99.0	0	NORTH OF CAMANCHE AVE., UNKNOWN PAV'T DEPTH, PARKING LOT
155+66.0	155+96.0	ACC/PCC	31.1		49.0	0	NORTH OF CAMANCHE AVE., UNKNOWN PAV'T DEPTH, PARKING LOT
156+20.0	156+78.0	ACC/PCC	26.4		68.0	0	NORTH OF CAMANCHE AVE., UNKNOWN PAV'T DEPTH, PARKING LOT
157+66.0	157+75.0	PCC	3.2		3.0	0	NORTH OF CAMANCHE AVE., UNKNOWN PAV'T DEPTH, PARKING LOT
160+36.0	161+15.0	ACC/PCC	21.8		113.0	0	NORTH OF CAMANCHE AVE., UNKNOWN PAV'T DEPTH, PARKING LOT
161+45.0	162+34.0	ACC/PCC	24.8		124.0	0	NORTH OF CAMANCHE AVE., UNKNOWN PAV'T DEPTH, PARKING LOT
162+64.0	163+37.0	ACC/PCC	28.4		105.0	0	NORTH OF CAMANCHE AVE., UNKNOWN PAV'T DEPTH, PARKING LOT
163+67.0	164+02.0	ACC/PCC	9.7		38.0	0	NORTH OF CAMANCHE AVE., UNKNOWN PAV'T DEPTH, PARKING LOT
164+08.0	165+61.0	ACC/PCC	52.7		195.0	0	NORTH OF CAMANCHE AVE., UNKNOWN PAV'T DEPTH, PARKING LOT
164+59.0	165+61.0	ACC	40.1		101.0	0	NORTH OF CAMANCHE AVE., UNKNOWN PAV'T DEPTH, PARKING LOT
182+50.0	182+70.0	PCC	21.2		39.0	0	NORTH OF CAMANCHE AVE., UNKNOWN PAV'T DEPTH, PARKING LOT
23RD PL.							
1400+62.0	1401+40.0	ACC/PCC	129.6		93.0	0	WEST OF 23RD PL., UNKNOWN PAV'T DEPTH, PARKING LOT
22ND PL.							
1498+38.0	1498+79.0	ACC/PCC	64.0		0.0	0	EAST OF 22ND PL., UNKNOWN PAV'T DEPTH, PARKING LOT
1500+64.0	1501+40.0	ACC/PCC	54.0		95.0	0	EAST OF 22ND PL., UNKNOWN PAV'T DEPTH, PARKING LOT
21ST PL.							
1599+94.0	1598+10.0	PCC	599.7		151.0	0	EAST OF 21ST PL., UNKNOWN PAV'T DEPTH, PARKING LOT
20TH PL.							
1700+86.1	1701+00.0	ACC/PCC	11.1		7.0	0	EAST OF 20TH PL., UNKNOWN PAV'T DEPTH, PARKING LOT
17TH PL.							

**REMOVAL OF CONCRETE DRIVES**

110-8  
08-01-08

Location		Area	Remarks
Station	Side	SY	
CAMANCHE AVE.			
105+19.62	RT	39.6	
106+21.79	RT	23.7	
106+84.30	RT	22.2	
107+29.46	RT	23.3	
107+86.40	RT	34.2	
108+86.58	RT	23.4	
109+41.81	RT	19.9	
109+91.03	LT	4.0	BARKER ST
110+17.86	LT	2.6	BARKER ST
110+23.26	RT	19.8	
110+79.68	LT	10.0	
111+28.38	LT	11.6	
111+53.74	LT	13.4	
111+91.03	LT	11.7	
113+26.17	LT	42.6	
113+27.83	LT	13.6	
113+62.45	LT	13.8	
115+19.01	LT	30.1	
116+78.87	LT	5.2	
117+18.74	LT	25.0	
117+61.30	LT	15.4	
118+17.27	LT	20.4	
118+79.80	LT	13.4	
118+93.04	RT	28.4	
119+78.13	LT	21.7	
120+29.22	LT	19.6	
120+76.58	LT	11.8	
121+31.21	LT	20.6	
121+77.20	LT	26.4	
121+95.06	LT	27.2	
122+43.33	LT	11.4	
123+92.19	LT	26.6	
124+56.10	RT	27.9	
124+72.34	LT	14.3	
125+00.06	LT	15.7	
125+61.91	RT	22.8	
125+94.52	LT	32.1	
126+91.46	RT	26.6	
127+42.64	LT	30.7	
127+76.33	RT	21.1	
128+61.50	LT	36.6	
128+80.64	RT	134.1	
130+39.06	RT	10.8	
130+85.96	RT	12.4	
131+74.87	RT	10.7	
132+18.73	RT	10.3	
133+30.70	RT	19.4	
134+98.42	RT	27.3	
135+70.81	RT	13.1	
135+85.30	LT	40.9	
136+12.96	RT	21.1	
136+68.07	RT	14.3	
136+83.87	LT	64.0	
137+17.36	RT	15.6	
137+67.36	RT	14.8	
137+99.08	LT	45.6	
138+19.15	RT	11.1	
138+68.59	RT	14.6	
138+73.56	LT	20.1	
139+17.85	RT	33.3	
139+18.49	LT	20.6	
139+66.86	LT	27.3	
140+15.41	RT	32.8	
140+20.38	LT	59.3	
141+47.61	RT	21.7	
141+63.95	LT	54.9	
142+29.99	RT	32.2	
142+36.16	LT	54.8	
143+13.39	LT	16.6	
143+31.74	RT	62.2	
143+76.90	LT	33.1	
144+29.21	RT	28.7	
146+04.19	RT	12.7	
146+44.37	RT	14.6	
146+99.03	RT	14.3	
147+73.98	RT	13.0	
148+58.07	RT	12.0	
149+11.32	RT	25.3	
149+75.04	RT	37.8	
151+84.46	LT	46.1	
153+90.53	LT	30.6	
154+90.72	LT	27.2	
155+86.06	LT	35.0	
156+44.68	LT	45.9	

**REMOVAL OF CONCRETE DRIVES**

110-8  
08-01-08

Location		Area	Remarks
Station	Side	SY	
159+73.28	LT	31.6	
161+07.16	LT	25.1	
161+36.05	RT	165.1	
162+77.14	LT	24.4	
163+73.75	LT	28.0	
164+47.66	LT	30.3	
165+30.04	LT	38.9	
166+42.77	LT	27.3	
167+21.58	LT	27.6	
168+66.82	RT	19.7	
169+38.13	RT	13.7	
169+72.99	RT	13.0	
170+17.17	RT	12.9	
170+75.27	RT	14.1	
171+13.35	LT	68.3	HMA
171+69.63	RT	15.8	
171+79.58	LT	54.3	
172+22.63	RT	8.1	
172+57.19	RT	26.7	
173+51.48	LT	81.6	
173+84.31	RT	15.6	
176+85.05	RT	15.1	
177+44.96	RT	14.2	
178+55.71	RT	13.2	
178+59.39	LT	55.4	
178+88.64	RT	13.8	
179+98.53	RT	12.7	
180+16.04	LT	16.7	
181+33.50	RT	31.9	
181+82.51	RT	23.9	
182+69.92	LT	25.3	
182+78.70	RT		

110-1  
08-01-08  
\* Not a Bid Item

### REMOVAL OF PAVEMENT

Refer to Tabulation 102-5

Begin Station	End Station	Pavement Type	Area	Saw Cut*	Intakes and Utility Accesses	Remarks
			SY	LF	No.	
2000+50.0	2000+68.0	PCC	4.8	19.0	0	EAST OF 17TH PL., UNKNOWN PAV'T DEPTH, PARKING LOT
16TH PL.						
2100+49.0	2100+77.0	PCC	13.9	28.0	0	WEST OF 16TH PL., UNKNOWN PAV'T DEPTH, PARKING LOT
2100+54.0	2100+77.0	PCC	13.3	33.0	0	EAST OF 16TH PL., UNKNOWN PAV'T DEPTH, PARKING LOT
15TH AVE. S.						
2200+57.0	2200+68.0	ACC	8.7	17.0	0	WEST OF 15TH AVE., UNKNOWN PAV'T DEPTH, PARKING LOT
TOTAL			62910.7	4263.0	163	

110-9  
10-18-11  
\* Not a bid item

### SANITARY SEWER ABANDONMENT (Modified)

0

Location Station	Location Station	Fill Material		Length	Size (In.)
		Flowable Mortar	Granular Backfill*		
		CY	TON		
104+57.2	10956.89	22.7		499.7	15
109+56.9	11460.43	22.9		503.5	15
114+60.4	11725.18	5.4		264.8	10
117+25.2	11880.81	3.1		155.6	10
118+80.8	12159.99	5.6		279.2	10
121+60.0	12307.15	3.0		147.2	10
123+07.2	12653.81	10.1		346.7	12
126+53.8	12954.1	8.7		300.3	12
129+54.1	13361.2	18.5		407.1	15
133+61.2	13399.4	1.1		38.2	12
133+99.4	13741.07	15.5		341.7	15
137+41.1	13926.73	27.3		185.7	27
139+26.7	14096.98	25.1		170.3	27
1198+36.5		14.8		66.0	15

110-5  
08-01-08

### SIDEWALK REMOVAL

Begin Station	End Station	Area	Remarks
		SY	
Camanche Ave.			
102+34.0	102+97.0	68.7	
102+69.0	103+51.0	87.6	
104+41.0	105+01.0	27.7	
105+37.0	106+13.0	32.2	
106+33.0	106+76.0	18.2	
106+94.0	107+21.0	11.5	
107+40.0	107+74.0	16.2	
108+02.0	108+78.0	32.8	
108+97.0	109+36.0	16.4	
109+48.0	110+15.0	28.0	
110+34.0	110+75.0	17.0	
110+59.0	111+48.0	40.7	
110+87.0	111+25.0	15.7	
111+34.0	111+85.0	20.3	
111+59.0	113+10.0	62.7	
111+95.0	113+21.0	50.7	
113+21.0	113+54.0	7.9	
113+45.0	114+43.0	36.8	
113+71.0	114+46.0	39.2	
114+80.0	115+00.0	7.8	
115+38.0	117+52.0	93.2	
117+56.0	118+05.0	21.4	
117+70.0	118+76.0	45.7	
118+29.0	118+72.0	19.1	
118+37.0	120+15.0	103.7	
118+87.0	119+75.0	39.0	
119+84.0	120+25.0	16.6	
120+33.0	120+70.0	15.0	
120+84.0	121+28.0	18.4	
121+36.0	121+89.0	17.2	
122+00.0	122+37.0	15.1	
122+50.0	122+95.0	18.1	
123+29.0	123+77.0	18.7	
123+64.0	124+40.0	33.9	
124+07.0	124+91.0	32.6	
124+72.0	125+49.0	33.2	
125+10.0	125+75.0	30.8	
125+75.0	126+76.0	43.9	
126+13.0	127+19.0	46.9	
127+07.0	127+64.0	24.4	
127+50.0	128+39.0	38.3	
127+89.0	128+57.0	29.4	
128+84.0	129+35.0	21.4	
129+04.0	129+42.0	26.7	
129+71.0	130+35.0	37.1	
129+74.0	133+81.0	261.9	
130+43.0	130+78.0	14.3	
130+94.0	131+68.0	32.0	
131+82.0	132+15.0	13.1	
132+23.0	133+19.0	41.3	
133+44.0	133+79.0	30.0	
134+17.0	134+82.0	28.8	
134+44.0	135+70.0	94.0	
135+15.0	135+64.0	21.7	

110-5  
08-01-08

### SIDEWALK REMOVAL

Begin Station	End Station	Area	Remarks
		SY	
135+78.0	136+00.0	9.6	
136+00.0	136+49.0	19.3	
136+25.0	136+60.0	15.2	
136+76.0	137+08.0	13.7	
137+18.0	137+81.0	27.9	
137+26.0	137+58.0	14.4	
137+76.0	138+12.0	16.3	
138+17.0	138+71.0	22.4	
138+26.0	138+58.0	13.9	
138+74.0	138+99.0	10.6	
138+79.0	139+13.0	15.0	
139+25.0	139+63.0	15.8	
139+37.0	139+97.0	25.7	
139+73.0	140+09.0	16.0	
140+34.0	140+74.0	19.2	
140+34.0	140+85.0	35.1	
141+13.0	141+34.0	9.4	
141+21.0	141+44.0	13.8	
141+60.0	142+10.0	21.9	
141+84.0	142+16.0	14.9	
142+48.0	142+93.0	19.4	
142+56.0	143+09.0	22.9	
143+21.0	143+57.0	15.0	
143+72.0	144+12.0	17.1	
143+94.0	144+25.0	13.1	
144+46.0	145+96.0	68.6	
144+57.0	146+05.0	60.8	
146+09.0	146+35.0	11.4	
146+43.0	149+51.0	142.6	
146+52.0	146+90.0	16.6	
147+07.0	147+67.0	26.7	
147+81.0	148+53.0	31.6	
148+65.0	148+97.0	13.2	
149+27.0	149+52.0	11.4	
149+87.0	151+53.0	69.8	
149+98.0	150+77.0	33.6	
151+26.0	161+16.0	426.9	
152+22.0	152+92.0	27.6	
153+29.0	153+72.0	17.2	
154+08.0	154+74.0	29.8	
155+04.0	156+17.0	33.6	
156+73.0	157+80.0	43.2	
158+20.0	159+55.0	67.0	
159+91.0	160+91.0	38.0	
161+22.0	162+62.0	57.6	
161+56.0	168+54.0	293.2	
162+92.0	163+56.0	27.6	
163+91.0	164+29.0	17.0	
164+66.0	165+12.0	22.6	
165+93.0	166+35.0	28.1	
166+49.0	167+19.0	37.3	
167+29.0	169+09.0	75.2	
168+80.0	169+30.0	21.3	
169+46.0	169+65.0	7.9	
169+51.0	170+90.0	56.9	

110-5  
08-01-08

### SIDEWALK REMOVAL

Begin Station	End Station	Area	Remarks
		SY	
169+81.0	170+10.0	12.7	
170+24.0	170+67.0	18.8	
170+85.0	171+61.0	35.2	
171+36.0	171+64.0	10.3	
171+79.0	172+41.0	23.6	
171+95.0	173+35.0	56.4	
172+74.0	173+75.0	45.9	
173+68.0	174+79.0	48.0	
173+94.0	174+77.0	41.4	
175+20.0	176+76.0	72.2	
175+22.0	178+37.0	122.6	
176+94.0	177+37.0	19.3	
177+53.0	178+81.0	46.9	
178+81.0	180+05.0	46.9	
178+97.0	179+91.0	42.7	
180+06.0	180+48.0	23.8	
180+27.0	180+51.0	11.0	
180+89.0	182+53.0	59.8	
180+91.0	181+15.0	15.8	
181+54.0	182+56.0	32.0	
182+89.0	183+35.0	17.6	
183+01.0	187+08.0	212.2	
183+59.0	185+21.0	94.2	
185+55.0	186+61.0	89.8	
S 14th St			
1197+49.0	1199+03.0	63.6	
1200+29.0	1201+64.0	58.1	
1200+60.0	1201+64.0	43.2	
25th Pl			
114+44.0	114+49.0	34.4	
114+33.0	114+48.0	56.9	
114+36.0	114+43.0	19.4	
24th Pl			
1298+83.0	1299+85.0	65.3	
1298+77.0	1299+90.0	138.0	
1300+47.0	1301+00.0	15.8	
23rd Pl			
1398+75.0	1399+79.0	58.0	
1398+75.0	1399+80.0	58.3	
1400+48.0	1401+40.0	55.3	
22nd Pl			
1498+75.0	1499+63.0	50.3	
1498+75.0	1499+84.0	66.1	
1500+48.0	1501+40.0	54.3	
21st Pl			
1597+75.0	1597+89.0	7.9	
1597+75.0	1597+96.0	11.5	
1598+50.0	1599+88.0	59.1	
1600+60.0	1601+06.0	18.6	
1600+66.0	1600+82.0	8.2	
20th Pl			
1700+51.0	1700+80.0	12.3	
1700+51.0	1700+86.0	24.2	
19th Pl			
1800+41.0	1801+00.0	30.3	

110-5  
08-01-08

### SIDEWALK REMOVAL

Begin Station	End Station	Area	Remarks
		SY	
1800+47.0	1801+00.0	28.2	
18th Pl			
1900+46.0	1900+90.0	28.2	
1900+48.0	1900+90.0	27.0	
148+94.0	150+77.0	226.3	CAMANCHE STA. (RT)
149+63.0	151+40.0	227.3	CAMANCHE STA. (RT)
17th Pl			
2000+48.0	2000+69.0	13.9	
2000+48.0	2000+68.0	12.9	
2000+90.0	2001+14.0	15.2	
2000+93.0	2001+14.0	13.3	
16th Pl			
2100+47.0	2101+16.0	15.7	
2100+48.0	2101+16.0	11.2	
15th Ave			
2200+51.0	2200+90.0	21.8	
2200+57.0	2200+90.0	17.9	
14th Ave			
2300+48.0	2300+90.0	28.0	
2300+48.0	2300+76.0	15.3	
13th Ave			
2398+75.0	2399+83.0	59.8	
2398+75.0	2399+83.0	59.8	
2400+48.0	2400+90.0	22.6	
2400+54.0	2400+90.0	19.3	
12th Ave			
2499+40.0	2499+81.0	22.8	
2499+40.0	2499+81.0	22.7	
2500+47.0	2501+40.0	47.9	
2500+49.0	2500+76.0	14.8	
2501+07.0	2501+40.0	17.0	
TOTAL		7463.8	

110-4  
08-01-08

### CURB REMOVAL

Begin Station	End Station	Side	Length	Remarks
			STA	
178+83.5	178+98.5	LT	0.2	Protect existing isla
1498+35.3	1498+79.0	R	0.4	22ND PL

**POLLUTION PREVENTION PLAN**

This Base Pollution Prevention Plan (PPP) includes information on Roles and Responsibilities, Project Site Description, Controls, Maintenance Procedures, Inspection Requirements, Non-Storm Water Controls, Potential Sources of Off Right-of-Way Pollution, and Definitions. This plan references other documents rather than repeating the information contained in the documents. A copy of this Base Pollution Prevention Plan, amended as needed per plan revisions or by contract modification, will be readily available for review.

All contractors shall conduct their operations in a manner that controls pollutants, minimizes erosion, and prevents sediments from entering waters of the state and leaving the highway right-of-way. The prime contractor shall be responsible for compliance and implementation of the PPP for their entire contract. This responsibility shall be further shared with subcontractors whose work is a source of potential pollution as defined in this PPP.

**I. ROLES AND RESPONSIBILITIES****A. Designer:**

1. Prepares Base PPP included in the project plan.
2. Prepares Notice of Intent (NOI) submitted to Iowa DNR.
3. Signature authority on the Base PPP and NOI.

**B. Contractor/Subcontractor:**

1. Affected contractors/subcontractors are co-permittees with the IDOT and will sign a certification statement adhering to the requirements of the NPDES permit and this PPP plan. All co-permittees are legally required under the Clean Water Act and the Iowa Administrative Code to ensure compliance with the terms and conditions of this PPP.
2. Submit a detailed schedule according to Article 2602 of the Specifications and any additional plan notes.
3. Install and maintain appropriate controls.
4. Supervise and implement good housekeeping practices.
5. Conduct joint required inspections of the site with inspection staff.
6. Signature authority on Co-Permittee Certification Statements and storm water inspection reports.

**C. RCE/Inspector:**

1. Update PPP whenever there is a change in design, construction, operation or maintenance, which has a significant effect on the discharge of pollutants from the project.
2. Maintain an up-to-date list that identifies contractors and subcontractors as co-permittees.
3. Make these plans available to the DNR upon their request.
4. Conduct joint required inspections of the site with the contractor/subcontractor.
5. Complete an inspection report after each inspection.
6. Signature authority on storm water inspection reports and Notice of Discontinuation (NOD).

**II. PROJECT SITE DESCRIPTION**

- This Pollution Prevention Plan (PPP) is for the reconstruction (grading, drainage, paving, and structures) of Interstate 29 south of the City of Sioux City, in Woodbury County. The project begins approximately 1.5 miles south of Singing Hills Boulevard and extends northerly approximately 4 miles. Reconstruction will include areas at interchanges with Singing Hills Boulevard and with US 20 / US 75, as well as along side roads of York Street and Singing Hills Boulevard.
- This PPP covers approximately 230 acres with an estimated 145 acres being disturbed. The portion of the PPP covered by this contract has 28.5 acres disturbed.
- The PPP is located in an area of one soil association (Luton-Onawa Salix). The estimated average SCS runoff curve number for this PPP after completion will be 86.
- Storm Water Site Map - Multiple sources of information comprise the base storm water site map including:
  1. Drainage patterns - Plan and Profile sheets and Situation plans.
  2. Proposed Slopes - Cross Sections.
  3. Areas of Soil Disturbance - construction limits shown on Plan and Profile sheets.
  4. Location of Structural Controls - Tabulations on C sheets.
  5. Locations of Non-structural Controls - Tabulations on C sheets.
  6. Locations of Stabilization Practices - generally within construction limits shown on Plan and Profile sheets.
  7. Surface Waters (including wetlands) - Plan and Profile sheets.
  8. Locations where storm water is discharged - Plan and Profile sheets.
- The base site map is amended by contract modifications and progress payments of completed erosion control work.
- Runoff from this work will flow into various storm sewers and unnamed ditches and waterways that flow into the Missouri River.

**III. CONTROLS**

- The contractor's work plan and sequence of operations specified in Article 2602.03 for accomplishment of storm water controls should clearly describe the intended sequence of major activities and for each activity define the control measure and the timing during the construction process that the measure will be implemented.
- Preserve vegetation in areas not needed for construction.
- Section 2601 and 2602 of the Standard Specifications define requirements to implement erosion and sediment control measures. Actual quantities used may vary from the Base PPP and amendment of the plan will be documented via fieldbook entries or by contract modification. Additional erosion and sediment control items may be required as determined by the inspector and/or contractor during storm water monitoring inspections. If the work involved is not applicable to any contract items, the work will be paid for according to Article 1109.03 paragraph B.
  - 1. EROSION AND SEDIMENT CONTROLS**
    - a. Stabilization Practices**
      - 1) Site plans will ensure that existing vegetation is preserved where attainable and disturbed portions of the site will be stabilized.
      - 2) Stabilization measures shall be initiated as soon as practicable in portions of the site where construction activities have temporarily or permanently ceased.
      - 3) Temporary stabilizing seeding shall be completed as the disturbed areas are constructed. If construction activity is not planned to occur in a disturbed area for at least 21 days, the area shall be stabilized by temporary seeding or mulching within 14 days. Other stabilizing methods shall be used outside the seeding time period.
      - 4) Stabilization measures to be used for this project are located in the Estimated Project Quantities (100-1A) and Estimate Reference Information (100-4A) located on the C sheets of the plan. Additional items may be found in the Inspector's Daily Reports (IDR) or Contract Modifications.
    - b. Structural Practices**
      - 1) Structural practices will be implemented to divert flows from exposed soils and detain or otherwise limit runoff and the discharge of pollutants from exposed areas of the site.

**POLLUTION PREVENTION PLAN**

- 2) Structural items to be used for this project are located in the Estimated Project Quantities (100-1A) and Estimate Reference Information (100-4A) located on the C sheets of the plan, as well as all other item specific Tabulations. Typical drawings detailing construction of the devices to be used on this project can be found on the B sheets of the plan or are referenced in the Standard Road Plans Tabulation.

**c. Storm Water Management**

- 1) Measures shall be installed during the construction process to control pollutants in storm water discharges that will occur after construction operations have been completed. The installation of these devices may be subject to Section 404 of the Clean Water Act.

**2. OTHER CONTROLS**

- a. Contractor disposal of unused construction materials and construction material wastes shall comply with applicable state and local waste disposal, sanitary sewer, or septic system regulations. In the event of a conflict with other governmental laws, rules and regulations, the more restrictive laws, rules or regulations shall apply.**
  - 1) Vehicle Entrances and Exits - Construct and maintain entrances and exits to prevent tracking of sediments onto roadways.
  - 2) Material Delivery, Storage and Use - Implement practices to prevent discharge of construction materials during delivery, storage, and use.
  - 3) Stockpile Management - Install controls to reduce or eliminate pollution of storm water from stockpiles of soil and paving.
  - 4) Waste Disposal - Do not discharge any materials, including building materials, into waters of the state, except as authorized by a Section 404 permit.
  - 5) Spill Prevention and Control - Implement procedures to contain and clean-up spills and prevent material discharges to the storm drain system and waters of the state.
  - 6) Concrete Residuals and Washout Wastes - Designate temporary concrete washout facilities for rinsing out concrete trucks. Provide directions to truck drivers where designated washout facilities are located.
  - 7) Vehicle and Equipment Cleaning - Employ washing practices that prevent contamination of surface and ground water from wash water.
  - 8) Vehicle and Equipment Fueling and Maintenance - Perform on site fueling and maintenance in accordance with all environment laws such as proper storage of onsite fuels and proper disposal of used engine oil or other fluids on site.
  - 9) Litter Management - Ensure employees properly dispose of litter.

**3. APPROVED STATE OR LOCAL PLANS**

During the course of this construction, it is possible that situations will arise where unknown materials will be encountered. When such situations are encountered, they will be handled according to all federal, state, and local regulations in effect at the time.

**IV. MAINTENANCE PROCEDURES**

The contractor is required to maintain all temporary erosion and sediment control measures in proper working order, including cleaning, repairing, or replacing them throughout the contract period. This shall begin when the features have lost 50% of their capacity.

**V. INSPECTION REQUIREMENTS**

- Inspections shall be made jointly by the contractor and the contracting authority at least once every seven calendar days and after each rain event that is 1/2" or greater. Storm water monitoring inspections will include:
  1. Date of the inspection.
  2. Summary of the scope of the inspection.
  3. Name and qualifications of the personnel making the inspection.
  4. Rainfall amount.
  5. Review erosion and sediment control measures within disturbed areas for the effectiveness in preventing impacts to receiving waters.
  6. Major observations related to the implementation of the PPP.
  7. Identify corrective actions required to maintain or modify erosion and sediment control measures.
- Include storm water monitoring inspection reports in the Amended PPP. Incorporate any additional erosion and sediment control measures determined as a result of the inspection. Immediately begin corrective actions on all deficiencies found and complete all actions within 3 calendar days of the inspection.

**VI. NON-STORM WATER DISCHARGES**

This includes subsurface drains (i.e. longitudinal and standard subdrains) and slope drains. The velocity of the discharge from these features may be controlled by the use of patio blocks, Class A stone, erosion stone or other appropriate materials.

**VII. POTENTIAL SOURCES OF OFF RIGHT-OF-WAY (ROW) POLLUTION**

Silts, sediment, and other forms of pollution may be transported onto highway right-of-way (ROW) as a result of a storm event. Potential sources of pollution located outside highway ROW are beyond the control of this PPP. Pollution within highway ROW will be conveyed and controlled per this PPP.

**VIII. DEFINITIONS**

- Base PPP - Initial Pollution Prevention Plan.
- Amended PPP - May include Plan Revisions or Contract Modifications for new items and fieldbook entries made by the inspector.
- IDR - Inspector's Daily Report - this contains the inspector's daily diary and item postings.
- Controls - Methods, practices, or measures to minimize or prevent erosion, control sedimentation, control storm water, or minimize contaminants from other types of waste or materials.
- Signature Authority - Representative from Designer, Contractor/Subcontractor, or RCE/Inspector authorized to sign various storm water documents.



### SIDEWALK CLOSURES

Refer to TC Plans.

\*Assumes 6 foot wide barricade.  
Closures may need to be removed and re-established.

Location	Side	Type III	Remarks
		Barricades* No.	
<b>STAGE 1A</b>			
SW CORNER S 17th ST/US 30		1	
SW CORNER PROSPECT AVE/S 14TH ST		1	
SE CORNER PROSPECT AVE/S 14TH ST		1	
SOUTH END OF S 14TH ST BRIDGE		1	PLACE AT END OF RETURN
STA. 100+50.00	RT	1	CAMANCHE AVENUE
STA. 114+35.00	RT	1	CAMANCHE AVENUE
STA. 117+50.00	LT	1	CAMANCHE AVENUE
STA. 320+50.00	RT	1	LIBERTY AVENUE
<b>STAGE 2</b>			
STA. 102+15.00	LT	1	CAMANCHE AVENUE
STA. 122+70.00 (OFFSET 170')	RT	1	CROSSING ON LIBERTY AVENUE
STA. 124+50.00	RT	1	CAMANCHE AVENUE
STA. 1397+02.00	LT	1	23RD PLACE/LIBERTY AVENUE
STA. 1397+35.00	LT	1	23RD PLACE
STA. 1397+35.00	RT	1	23RD PLACE
STA. 1497+18.00	LT	1	22ND PLACE
<b>STAGE 3</b>			
STA. 108+40.00	LT	1	CAMANCHE AVENUE
STA. 129+10.00	RT	1	CAMANCHE AVENUE
STA. 1597+00.00	LT	1	21ST AVENUE
STA. 1597+00.00	RT	1	21ST AVENUE
STA. 1996+07.00	LT	1	17TH PLACE
STA. 1996+07.00	RT	1	17TH PLACE
STA. 2196+15.00	LT	1	15TH PLACE
STA. 2196+15.00	RT	1	15TH PLACE
STA. 2398+55.00	LT	1	13TH AVENUE
STA. 2398+55.00	RT	1	13TH AVENUE
STA. 2499+20.00	LT	1	12TH AVENUE
STA. 2499+20.00	RT	1	12TH AVENUE
<b>STAGE 4</b>			
STA. 123+31.00 (OFFSET 100')	LT	1	24TH PLACE EAST SIDEWALK
STA. 1401+43.00	RT	1	23RD PLACE
STA. 1501+44.00	LT	1	22ND PLACE
STA. 1501+67.00	RT	1	22ND PLACE
STA. 1601+04.00	RT	1	21ST PLACE
STA. 1601+13.00	LT	1	21ST PLACE
STA. 1701+04.00	LT	1	20TH PLACE
STA. 1801+04.00	LT	1	19TH PLACE
STA. 1801+04.00	RT	1	19TH PLACE
STA. 1900+95.00	LT	1	18TH PLACE
STA. 1900+95.00	RT	1	18TH PLACE
STA. 2001+18.00	LT	1	17TH PLACE
STA. 2001+18.00	RT	1	17TH PLACE
<b>STAGE 5</b>			
STA. 134+32.00	LT	1	CAMANCHE AVENUE
STA. 2101+34.00	LT	1	16TH PLACE
STA. 2101+34.00	RT	1	16TH PLACE
STA. 2201+03.00	LT	1	15TH PLACE
STA. 2201+03.00	RT	1	15TH PALCE
STA. 2301+09.00	LT	1	14TH AVENUE
STA. 2301+09.00	RT	1	14TH AVENUE
STA. 2401+06.00	LT	1	13TH AVENUE
STA. 2401+06.00	RT	1	13TH AVENUE
STA. 2501+55.00	LT	1	12TH AVENUE
STA. 2501+55.00	RT	1	12TH AVENUE

TABULATION OF EROSION CONTROL DETAILS

HRG-1A

Location	Side (Rt/Lt)	Seeding and Fertilizing (Acres)	Mulching (Acres)	Inlet Protection Device (Each)	Bonded Fiber Matrix (Squares)	Sod (Squares)	Remarks
Station to Station							
CAMANCHE AVENUE							
102+30 102+77	RT	0.02	0.02				URBAN SEEDING
102+34 103+42	LT					21.4	
103+62 104+11	LT					10.2	
104+36 104+88	RT					3.5	
105+03 120+27	RT	1.07	1.07			219.7	NO-MOW FESCUE
105+71 111+46	LT					189.0	
108+11 108+91	RT					12.3	MEDIAN AREA
109+05 109+85	RT					12.3	MEDIAN AREA
109+99 110+79	RT					12.3	MEDIAN AREA
110+92 111+72	RT					12.4	MEDIAN AREA
111+61 114+47	LT					108.6	
111+86 112+65	RT					12.4	MEDIAN AREA
112+79 113+59	RT					12.4	MEDIAN AREA
113+72 114+52	RT					12.4	MEDIAN AREA
114+66 115+45	RT					12.4	MEDIAN AREA
114+78 115+85	LT					33.4	
115+59 116+39	RT					12.8	MEDIAN AREA
116+16 117+04	LT					27.7	
116+53 117+33	RT					14.9	MEDIAN AREA
117+33 118+50	LT					31.7	
117+47 118+27	RT					17.2	MEDIAN AREA
118+41 119+21	RT					19.6	MEDIAN AREA
118+80 119+72	LT					22.4	
119+35 120+15	RT					22.1	MEDIAN AREA
119+87 120+21	LT					8.7	
120+29 122+88	RT					89.2	WEST END GATEWAY
120+36 120+70	LT					8.6	
120+87 121+22	LT					9.9	
121+37 121+70	LT					8.7	
122+00 122+65	LT					17.2	
123+61 124+65	LT					25.7	
123+61 129+13	RT	0.11	0.11			78.9	URBAN SEEDING
125+06 125+83	LT					17.6	
126+13 127+25	LT					22.2	
127+50 128+46	LT					22.9	
128+76 129+12	LT					6.9	
130+03 133+55	LT					67.6	
130+00 133+56	RT	0.09	0.09			50.5	URBAN SEEDING
134+46 135+70	LT					27.7	
134+42 140+48	RT	0.08	0.08			87.0	URBAN SEEDING
136+00 136+49	LT					13.5	
136+80 137+84	LT					31.7	
138+14 138+66	LT					16.2	
138+81 139+11	LT					8.4	
139+26 139+60	LT					10.9	
139+75 140+09	LT					10.0	
140+35 140+48	LT					5.5	
141+49 144+03	LT					74.6	
141+51 152+70	RT	0.50	0.50			159.9	URBAN SEEDING
144+75 145+82	LT					27.5	
146+65 149+27	LT					75.3	
150+09 152+67	LT					60.4	
153+62 157+63	LT					98.2	
153+61 165+38	RT	0.79	0.79			169.1	URBAN SEEDING
158+38 165+33	LT					175.4	
166+26 168+90	LT					86.2	
166+25 174+55	RT	0.42	0.42			119.0	URBAN SEEDING
169+69 174+51	LT					125.1	
175+51 180+25	LT					113.3	
175+42 180+26	RT	0.18	0.18			69.0	URBAN SEEDING
181+18 186+60	LT					122.0	
181+13 187+08	RT	0.10	0.10			84.1	URBAN SEEDING
186+60 187+08	LT	0.02	0.02				URBAN SEEDING
S 14TH ST							
1197+21 1198+20	LT	0.10	0.10				URBAN SEEDING
1197+30 1198+42	RT	0.10	0.10				URBAN SEEDING
1197+48 1198+42	RT					5.1	
1198+42 1199+70	RT					5.5	URBAN SEEDING

TABULATION OF EROSION CONTROL DETAILS

HRG-1A

Location	Side (Rt/Lt)	Seeding and Fertilizing (Acres)	Mulching (Acres)	Inlet Protection Device (Each)	Bonded Fiber Matrix (Squares)	Sod (Squares)	Remarks
Station to Station							
1200+42 1201+64	LT					24.0	
1200+86 1201+64	RT					23.6	
24TH PLACE							
1298+83 1299+23	RT	0.01	0.01			1.3	URBAN SEEDING
1298+77 1299+23	LT					1.9	
1299+23 1299+53	LT					1.1	
1293+23 1299+73	RT	0.01	0.01			0.6	URBAN SEEDING
1300+51 1301+00	LT					3.8	
1300+53 1300+69	RT					1.0	
23RD PLACE							
1398+75 1399+41	RT	0.01	0.01			2.5	URBAN SEEDING
1398+75 1399+41	LT	0.01	0.01			2.5	URBAN SEEDING
1400+42 1401+40	LT					10.6	
1400+42 1401+40	RT						
1400+44 1401+40	RT						
22ND PLACE							
1498+75 1499+41	LT	0.01	0.01			2.5	URBAN SEEDING
1498+75 1499+42	RT	0.01	0.01			2.5	URBAN SEEDING
1500+41 1501+11	LT					3.9	
1501+15 1501+40	LT					1.3	
1500+41 1501+40	RT					0.2	
21ST PLACE							
1597+10 1599+52	RT	0.04	0.04			9.0	URBAN SEEDING
1597+10 1597+89	LT	0.03	0.03			2.9	URBAN SEEDING
1598+19 1599+44	LT	0.03	0.03			4.6	URBAN SEEDING
1600+51 1600+81	RT					1.8	
1600+47 1600+74	LT					2.2	
1600+98 1601+00	LT					0.4	
20TH PLACE							
1700+40 1700+82	LT					1.0	
1700+53 1700+82	LT					0.7	
1700+50 1701+00	RT					0.9	
19TH PLACE							
1800+41 1801+00	RT					5.1	
1800+41 1801+00	LT					5.7	
18TH PLACE							
1900+42 1900+90	LT					4.3	
1900+42 1900+90	RT					4.3	
17TH PLACE							
1996+15 1999+41	RT	0.09	0.09			24.3	URBAN SEEDING
1996+15 1999+42	LT	0.09	0.09			24.4	URBAN SEEDING
2000+52 2001+14	RT					4.9	
2000+52 2001+14	LT					3.8	
16TH PLACE							
2100+42 2100+69	LT					1.4	
2100+42 2100+69	RT					1.2	
15TH AVENUE							
2196+27 2199+41	RT	0.07	0.07			11.7	URBAN SEEDING
2196+23 2199+42	LT	0.07	0.07			11.8	URBAN SEEDING
2200+69 2200+90	RT					0.3	
2200+53 2200+90	RT					0.6	
14TH AVENUE							
2300+52 2300+90	RT					2.8	
2300+51 2300+90	LT					2.4	
13TH AVENUE							
2398+75 2399+42	RT	0.02	0.02			2.5	URBAN SEEDING
2398+75 2399+42	LT	0.01	0.01			2.5	URBAN SEEDING
2400+52 2400+90	LT					1.6	

TABULATION OF EROSION CONTROL DETAILS

HRG-1A

Location		Side (Rt/Lt)	Seeding and Fertilizing (Acres)	Mulching (Acres)	Inlet Protection Device (Each)	Bonded Fiber Matrix (Squares)	Sod (Squares)	Remarks
Station to Station								
2400+52	2400+90	RT					1.5	
12TH AVENUE								
2500+42	2501+40	RT					4.7	
2500+42	2501+40	LT					5.1	
CAMANCHE AVENUE								
120+34	OFF - 89	RT			1			STAGE 1-A
122+90	OFF - 173	RT			1			STAGE 1-A
S 14TH STREET								
1198+18	OFF - 26	RT			1			STAGE 1-B
CAMANCHE AVENUE								
106+57	OFF - 59	RT			1			STAGE 1-B
108+27	OFF - 59	RT			1			STAGE 1-B
110+27	OFF - 59	RT			1			STAGE 1-B
112+38	OFF - 59	RT			1			STAGE 1-B
114+97	OFF - 59	RT			1			STAGE 1-B
117+05	OFF - 63	RT			1			STAGE 1-B
119+00	OFF - 69	RT			1			STAGE 1-B
CAMANCHE AVENUE								
102+40	OFF - 71	RT			1			STAGE 2
103+37	OFF - 60	RT			1			STAGE 2
S 14TH STREET								
1198+09	OFF - 54	LT			1			STAGE 2
CAMANCHE AVENUE								
103+35	OFF - 17	LT			1			STAGE 3
106+60	OFF - 14	LT			1			STAGE 3
106+60	OFF - 26	RT			1			STAGE 3
108+29	OFF - 14	LT			1			STAGE 3
108+29	OFF - 14	RT			1			STAGE 3
110+16	OFF - 67	LT			1			STAGE 3, EXISTING INTAKE ON BARKER STREET
110+28	OFF - 14	RT			1			STAGE 3
110+28	OFF - 14	LT			1			STAGE 3
115+22	OFF - 14	RT			1			STAGE 3
116+60	OFF - 14	RT			1			STAGE 3
118+00	OFF - 14	RT			1			STAGE 3
120+55	OFF - 26	RT			1			STAGE 3
121+51	OFF - 26	RT			1			STAGE 3
122+52	OFF - 26	RT			1			STAGE 3
125+00	OFF - 26	RT			1			STAGE 3
125+65	OFF - 26	RT			1			STAGE 3
127+08	OFF - 26	RT			1			STAGE 3
128+25	OFF - 26	RT			1			STAGE 3
130+21	OFF - 26	RT			1			STAGE 3
131+15	OFF - 26	RT			1			STAGE 3
133+35	OFF - 26	RT			1			STAGE 3
S 14TH STREET								
1200+39	OFF - 20	RT			1			STAGE 3
1200+43	OFF - 26	LT			1			STAGE 3
1201+45	OFF - 20	RT			1			STAGE 3
CAMANCHE AVENUE								
124+00	OFF - 26	RT			1			STAGE 4
135+10	OFF - 26	RT			1			STAGE 4
136+17	OFF - 26	RT			1			STAGE 4
137+32	OFF - 26	RT			1			STAGE 4
138+95	OFF - 26	RT			1			STAGE 4
142+70	OFF - 26	RT			1			STAGE 4
143+85	OFF - 26	RT			1			STAGE 4
145+40	OFF - 26	RT			1			STAGE 4
146+83	OFF - 26	RT			1			STAGE 4
149+08	OFF - 26	RT			1			STAGE 4
150+29	OFF - 26	RT			1			STAGE 4
151+20	OFF - 26	RT			1			STAGE 4

TABULATION OF EROSION CONTROL DETAILS

HRG-1A

Location		Side (Rt/Lt)	Seeding and Fertilizing (Acres)	Mulching (Acres)	Inlet Protection Device (Each)	Bonded Fiber Matrix (Squares)	Sod (Squares)	Remarks
Station to Station								
152+50	OFF - 26	RT			1			STAGE 4
154+47	OFF - 26	RT			1			STAGE 4
155+50	OFF - 26	RT			1			STAGE 4
156+63	OFF - 26	RT			1			STAGE 4
159+05	OFF - 26	RT			1			STAGE 4
160+35	OFF - 26	RT			1			STAGE 4
161+65	OFF - 26	RT			1			STAGE 4
162+81	OFF - 26	RT			1			STAGE 4
164+12	OFF - 26	RT			1			STAGE 4
166+65	OFF - 26	RT			1			STAGE 4
168+67	OFF - 26	RT			1			STAGE 4
170+56	OFF - 26	RT			1			STAGE 4
172+50	OFF - 26	RT			1			STAGE 4
174+36	OFF - 26	RT			1			STAGE 4
176+60	OFF - 26	RT			1			STAGE 4
177+90	OFF - 26	RT			1			STAGE 4
179+05	OFF - 26	RT			1			STAGE 4
180+07	OFF - 26	RT			1			STAGE 4
182+24	OFF - 26	RT			1			STAGE 4
183+86	OFF - 26	RT			1			STAGE 4
184+93	OFF - 26	RT			1			STAGE 4
186+20	OFF - 26	RT			1			STAGE 4
187+15	OFF - 26	RT			1			STAGE 4
21ST PLACE								
1598+60	OFF - 21	LT			1			STAGE 4
1598+60	OFF - 21	RT			1			STAGE 4
17TH PLACE								
1996+08	OFF - 21	LT			1			STAGE 4
1996+08	OFF - 21	RT			1			STAGE 4
1998+15	OFF - 21	LT			1			STAGE 4
1998+15	OFF - 21	RT			1			STAGE 4
15TH PLACE								
2196+35	OFF - 21	LT			1			STAGE 4
2196+35	OFF - 21	RT			1			STAGE 4
2198+17	OFF - 21	LT			1			STAGE 4
2198+17	OFF - 21	RT			1			STAGE 4
TOTAL =			4.07	4.07	82	0	3302	

REMOVAL OF SEWER

HRG-2A

NUMBER	LOCATION (STATION)	DESCRIPTION	PIPE REMOVAL		GRANULAR BACKFILL (TONS)	NOTES
			≤36" (LF)	>36" (LF)		
	CAMANICHE AVE.					
RS-1	102+12.91, 100.5' RT	UTILITY ACCESS				(1)
RS-2	102+12.91, 100.5' RT - 102+43.27, 99.9' RT	30" RCP ?	31			
RS-3	102+79.27, 88.8' RT - 103+18.98, 62.7' RT	15" RCP ?	49		277.3	
RS-4	103+18.98, 62.7' RT	INTAKE				
RS-5	103+18.98, 62.7' RT - 103+81.90, 11.3' RT	21" RCP	80		332.0	
RS-6	103+81.90, 11.3' RT	INTAKE				
RS-7	103+81.90, 11.3' RT - 103+82.44, 14.8' LT	21" RCP	27		101.3	
RS-8	103+82.44, 14.8' LT	INTAKE				
RS-9	103+82.44, 14.8' LT - 104+25.54, 23.4' LT	21" RCP	45		176.5	
RS-10	104+25.54, 23.4' LT	UTILITY ACCESS				(1)
RS-11	104+57.18, 35.2' RT - 104+68.64, 75.5' RT	6" CLAY	42		114.3	
RS-12	104+57.18, 35.2' RT	UTILITY ACCESS				(1)
RS-13	104+57.18, 35.2' RT - 109+56.89, 10.1' LT	10" CLAY	500		3351.6	Fill, plug, and abandon
RS-14	108+33.65, 39.0' LT	INTAKE				
RS-15	108+33.65, 39.0' LT - 108+48.11, 35.6' LT	15" RCP	15			
RS-16	108+48.11, 35.6' LT	UTILITY ACCESS				(1)
RS-17	108+42.68, 19.6' RT - 108+48.11, 35.6' LT	15" RCP	56		69.2	
RS-18	108+42.68, 19.6' RT	INTAKE				
RS-19	108+48.11, 35.6' LT - 110+34.97, 53.4' LT	15" RCP	188			
RS-20	109+56.89, 10.1' LT	UTILITY ACCESS				(1)
RS-21	110+34.97, 53.4' LT	INTAKE				
RS-22	110+34.97, 53.4' LT - 110+41.18, 4.0' LT	15" RCP	50		4.5	
RS-23	110+41.18, 4.0' LT	INTAKE				
RS-24	109+56.89, 10.1' LT - 114+60.43, 15.2' LT	10" CLAY	500		288.7	
RS-25	114+60.43, 15.2' LT	UTILITY ACCESS				(1)
RS-26	114+60.43, 15.2' LT - 114+59.01, 60.2' LT	15" VCP	46		6.3	
RS-27	114+59.01, 60.2' LT	UTILITY ACCESS				(1)
RS-28	114+60.43, 15.2' LT - 114+60.21, 13.3' RT	15" VCP	29		90.4	
RS-29	114+60.21, 13.3' RT	UTILITY ACCESS				(1)
RS-30	114+25.97, 5.27' LT	INTAKE				
RS-31	114+25.97, 5.27' LT - 114+39.55, 9.3' RT	15" RCP	22		0.8	
RS-32	114+19.23, 55.5' LT	INTAKE				
RS-33	114+19.23, 55.5' LT - 114+89.08, 51.7' LT	18" RCP	69		36.4	
RS-34	114+89.08, 51.7' LT	INTAKE				
RS-35	114+89.08, 51.7' LT - 116+01.92, 51.8' LT	18" RCP	110			
RS-36	114+60.43, 15.2' LT - 117+25.18, 18.3' RT	10" VCP	264		102.2	
RS-37	116+01.92, 51.8' LT	INTAKE				
RS-38	116+01.92, 51.8' LT - 119+16.91, 51.5' LT	30" RCP	315			
RS-39	117+25.18, 18.3' RT	UTILITY ACCESS				(1)
RS-40	117+25.18, 18.3' RT - 118+80.81, 16.7' LT	10" CLAY	156		219.7	
RS-41	118+80.81, 16.7' LT	UTILITY ACCESS				(1)
RS-42	118+80.81, 16.7' LT - 118+92.15, 57.7' LT	8" VCP	43		12.2	
RS-43	118+45.18, 1.8' LT	INTAKE				
RS-44	118+45.18, 1.8' LT - 119+54.73, 24.6' RT	15" RCP	105		99.0	
RS-45	119+54.73, 24.6' RT	INTAKE				
RS-46	119+54.73, 24.6' RT - 120+34.54, 88.8' RT	18" RCP	100			
RS-47	120+34.54, 88.8' RT	INTAKE				
RS-48	119+16.91, 51.5' LT	INTAKE				
RS-49	119+16.68, 2.6' LT - 119+16.91, 51.5' LT	15" RCP	50		13.8	
RS-50	119+16.68, 2.6' LT	INTAKE				
RS-51	119+16.91, 51.5' LT - 122+77.36, 39.3' LT	30" RCP	361			
RS-52	118+80.81, 16.7' LT - 121+59.99, 4.3' LT	10" CLAY	279		477.4	
RS-53	121+59.99, 4.3' LT	UTILITY ACCESS				(1)
RS-54	121+59.99, 4.3' LT - 123+07.15, 4.5' LT	10" CLAY	148		444.4	
RS-55	123+07.15, 4.5' LT	UTILITY ACCESS				(1)
RS-56	123+07.15, 4.5' LT - 123+07.28, 32.7' LT	10" CLAY	28		43.4	
RS-57	123+07.28, 32.7' LT	UTILITY ACCESS				(1)
RS-58	123+07.28, 32.7' LT - 123+07.37, 38.4' LT	10" CLAY	6			
RS-59	122+60.94, 34.4' LT - 123+07.28, 32.7' LT	8" CLAY	47			
RS-60	123+07.28, 32.7' LT - 123+64.54, 32.7' LT	8" CLAY	58			
RS-61	123+07.15, 4.5' LT - 123+06.41, 17.8' RT	15" VCP	23		90.0	
RS-62	123+06.41, 17.8' RT	UTILITY ACCESS				(1)
RS-63	122+77.36, 39.3' LT - 122+95.86, 21.1' RT	(2) 21" RCP		61	113.3	
RS-64	122+77.36, 39.3' LT	INTAKE				
RS-65	122+95.86, 21.1' RT - 123+44.18, 36.6' LT	24" RCP	73		103.2	
RS-66	123+44.18, 36.6' LT	UTILITY ACCESS				(1)
RS-67	123+44.18, 36.6' LT - 123+48.00, 39.6' LT	15" RCP ?	5			
RS-68	123+48.00, 39.6' LT	INTAKE				
RS-69	123+44.18, 36.6' LT - 126+64.06, 36.3' LT	24" RCP	320			
RS-70	123+07.15, 4.5' LT - 126+53.81, 3.5' LT	12" CLAY	347		935.4	
RS-71	126+53.81, 3.5' LT	UTILITY ACCESS				(1)
RS-72	126+64.06, 36.3' LT	UTILITY ACCESS				(1)

REMOVAL OF SEWER

HRG-2A

NUMBER	LOCATION (STATION)	DESCRIPTION	PIPE REMOVAL		GRANULAR BACKFILL (TONS)	NOTES
			≤36" (LF)	>36" (LF)		
RS-73	126+64.06, 36.3' LT - 126+72.60, 7.7' RT	15" RCP	45		10.0	
RS-74	126+72.60, 7.7' RT	UTILITY ACCESS				(1)
RS-75	126+64.06, 36.3' LT - 129+21.41, 36.6' LT	15" RCP	258			
RS-76	126+53.81, 3.5' LT - 129+54.10, 3.3' LT	12" CLAY	301		831.2	
RS-77	129+21.41, 36.6' LT	UTILITY ACCESS				(1)
RS-78	129+54.10, 3.3' LT	UTILITY ACCESS				(1)
RS-79	129+54.10, 3.3' LT - 129+55.11, 27.0' LT	10" VCP	24		50.8	
RS-80	129+54.10, 3.3' LT - 133+61.20, 3.3' LT	12" VCP	408		1577.0	
RS-81	133+61.20, 3.3' LT	UTILITY ACCESS				(1)
RS-82	133+61.20, 3.3' LT - 133+99.40, 6.8' LT	12" VCP	39		174.0	
RS-83	133+99.40, 6.8' LT	UTILITY ACCESS				(1)
RS-84	133+99.40, 6.8' LT - 133+99.15, 27.0' LT	12" VCP	21			
RS-85	133+99.40, 6.8' LT - 149+74.48, 1.9' RT	20" VCP	32			
RS-86	149+74.48, 1.9' RT	UTILITY ACCESS				(1)
RS-87	133+46.50, 11.1' RT	INTAKE				
RS-88	133+46.50, 11.1' RT - 149+74.48, 1.9' RT	15" RCP	57		148.4	
RS-89	133+29.07, 38.5' LT	INTAKE				
RS-90	133+29.07, 38.5' LT - 133+99.40, 6.8' LT	15" RCP	78		66.3	
RS-91	133+99.40, 6.8' LT - 134+86.36, 53.8' LT	12" VCP	99		55.1	
RS-92	134+86.36, 53.8' LT	INTAKE				
RS-93	134+36.50, 8.2' LT - 134+37.28, 8.9' RT	15" RCP ?	18		49.1	
RS-94	134+37.28, 8.9' RT	INTAKE				
RS-95	133+99.40, 6.8' LT - 137+41.07, 15.8' LT	15" VCP	341		1122.9	
RS-96	135+65.20, 12.8' LT - 135+95.23, 42.0' LT	15" RCP ?	42		0.1	
RS-97	135+95.23, 42.0' LT	INTAKE				
RS-98	137+41.07, 15.8' LT	UTILITY ACCESS				(1)
RS-99	137+25.82, 44.7' LT	INTAKE				
RS-100	137+25.82, 44.7' LT - 137+28.81, 39.9' LT	15" RCP ?	7			
RS-101	137+28.81, 39.9' LT	UTILITY ACCESS				(1)
RS-102	137+28.81, 39.9' LT - 137+41.07, 15.8' LT	10" VCP	28			
RS-103	137+40.40, 4.9' RT - 137+41.07, 15.8' LT	10" VCP	20		0.5	
RS-104	137+40.40, 4.9' RT	INTAKE				
RS-105	137+41.07, 15.8' LT - 139+26.73, 15.2' LT	15" VCP	186		444.5	
RS-106	139+26.73, 15.2' LT	UTILITY ACCESS				(1)
RS-107	139+22.25, 46.5' LT - 139+26.73, 15.2' LT	10" VCP	32		5.5	
RS-108	139+26.73, 15.2' LT - 140+96.98, 9.2' LT	15" VCP	170		541.7	
RS-109	140+36.71, 11.6' LT - 140+37.90, 42.5' LT	15" RCP	31		6.8	
RS-110	140+37.90, 42.5' LT	INTAKE				
RS-111	140+96.98, 9.2' LT	UTILITY ACCESS				(1)
RS-112	140+96.98, 9.2' LT - 140+96.99, 26.1' LT	15" VCP	17		25.4	
RS-113	140+96.99, 26.1' LT	UTILITY ACCESS				(1)
RS-114	140+96.99, 26.1' LT - 141+38.43, 43.2' LT	10" VCP	45		58.4	
RS-115	141+38.43, 43.2' LT	INTAKE				
RS-116	140+96.99, 26.1' LT - 144+31.78, 26.3' LT	27" VCP	334		337.1	
RS-117	144+31.78, 26.3' LT	UTILITY ACCESS				(1)
RS-118	144+31.78, 26.3' LT - 144+70.65, 41.8' LT	10" VCP	42		76.5	
RS-119	144+70.65, 41.8' LT	INTAKE				
RS-120	144+31.78, 26.3' LT - 144+40.38, 6.5' RT	10" VCP	34		65.1	
RS-121	144+40.38, 6.5' RT	INTAKE				
RS-122	144+31.78, 26.3' LT - 146+18.94, 21.7' LT	28" VCP	187		308.0	
RS-123	146+18.94, 21.7' LT	UTILITY ACCESS				(1)
RS-124	146+18.94, 21.7' LT - 1800+27.10, 1.0' LT	12" VCP	6			
RS-125	146+18.94, 21.7' LT - 146+54.28, 37.6' LT	10" VCP	39		96.6	
RS-126	146+54.28, 37.6' LT	INTAKE				
RS-127	146+18.94, 21.7' LT - 146+19.70, 11.2' RT	10" VCP	33		84.7	
RS-128	146+19.70, 11.2' RT	INTAKE				
RS-129	146+18.94, 21.7' LT - 147+65.74, 22.9' LT	28" VCP	149			
RS-130	147+65.74, 22.9' LT	UTILITY ACCESS				(1)
RS-131	147+65.74, 22.9' LT - 149+69.31, 26.0' LT	28" VCP	206		506.7	
RS-132	149+69.31, 26.0' LT	UTILITY ACCESS				(1)
RS-133	149+69.31, 26.0' LT - 149+69.54, 27.0' LT	10" VCP	2			
RS-134	149+69.31, 26.0' LT - 150+88.03, 26.4' LT	28" VCP	120		517.2	
RS-135	150+88.03, 26.4' LT	UTILITY ACCESS				(1)
RS-136	150+88.03, 26.4' LT - 151+41.43, 27.3' LT	28" VCP	54			
RS-137	151+41.43, 27.3' LT	UTILITY ACCESS				(1)
RS-138	151+41.43, 27.3' LT - 151+44.33, 41.0' LT	15" VCP	15			
RS-139	151+44.33, 41.0' LT	INTAKE				
RS-140	151+12.14, 3.1' RT - 151+41.43, 27.3' LT	30" RCP	43		437.1	
RS-141	151+12.14, 3.1' RT	UTILITY ACCESS				(1)
RS-142						

REMOVAL OF SEWER							HRG-2A
NUMBER	LOCATION (STATION)	DESCRIPTION	PIPE REMOVAL		GRANULAR BACKFILL (TONS)	NOTES	
			≤36" (LF)	>36" (LF)			
RS-146	152+77.82, 41.7' LT - 153+09.86, 28.6' LT	15" VCP	35		44.1		
RS-147	152+77.82, 41.7' LT	INTAKE					
RS-148	153+09.86, 28.6' LT - 153+09.68, 31.0' LT	15" VCP	3				
RS-149	152+80.37, 7.7' RT - 153+09.86, 28.6' LT	15" VCP	47		168.0		
RS-150	152+80.37, 7.7' RT	INTAKE					
RS-151	153+09.86, 28.6' LT - 155+59.48, 29.2' LT	20" VCP	245		232.3		
RS-152	155+59.48, 29.2' LT	UTILITY ACCESS				(1)	
RS-153	156+09.76, 42.1' LT	INTAKE					
RS-154	156+09.02, 7.5' RT - 156+09.76, 42.1' LT	10" VCP	50		31.2		
RS-155	156+09.02, 7.5' RT	INTAKE					
RS-156	155+59.48, 29.2' LT - 157+89.18, 25.7' LT	20" VCP	235		87.2		
RS-157	157+89.18, 25.7' LT	UTILITY ACCESS				(1)	
RS-158	157+66.43, 40.5' LT - 157+89.18, 25.7' LT	10" VCP	28		21.8		
RS-159	157+66.43, 40.5' LT	INTAKE					
RS-160	157+89.18, 25.7' LT - 157+89.77, 27.0' LT	10" VCP	2				
RS-161	157+89.18, 25.7' LT - 157+94.59, 8.9' RT	12" VCP	35		53.6		
RS-162	157+94.59, 8.9' RT	INTAKE					
RS-163	2100+53.19, 14.6' RT - 158+53.58, 27.8' LT	12" VCP	46		16.1		
RS-164	158+53.58, 27.8' LT	UTILITY ACCESS				(1)	
RS-165	158+53.58, 27.8' LT - 161+80.29, 31.1' LT	12" VCP	326				
RS-166	161+80.29, 31.1' LT	UTILITY ACCESS				(1)	
RS-167	161+77.14, 44.0' LT - 161+80.29, 31.1' LT	10" VCP	14				
RS-168	161+77.14, 44.0' LT	INTAKE					
RS-169	161+76.74, 54.6' LT - 161+77.14, 44.0' LT	6" VCP	11			CUT & PLUG @ 161+77, 54' LT	
RS-170	161+80.29, 31.1' LT - 161+87.57, 5.3' RT	10" VCP	37		12.7		
RS-171	161+87.57, 5.3' RT	INTAKE					
RS-172	161+80.29, 31.1' LT - 165+79.04, 29.2' LT	12" VCP	399		79.0		
RS-173	165+09.18, 43.3' LT	INTAKE					
RS-174	165+05.44, 6.1' RT - 165+09.18, 43.3' LT	15" VCP	50		38.6		
RS-175	165+05.44, 6.1' RT	INTAKE					
RS-176	165+08.49, 6.1' RT	INTAKE					
RS-177	165+05.43, 50.1' RT - 165+05.44, 6.1' RT	8" CAST IRON	45		15.8		
RS-178	165+08.49, 6.1' RT - 165+16.35, 44.9' RT	6" CAST IRON	40		34.4		
RS-179	165+79.04, 29.2' LT	UTILITY ACCESS				(1)	
RS-180	2200+44.95, 25.9' LT - 2200+57.91, 11.3' LT	10" VCP	20		19.9		
RS-181	2200+44.95, 25.9' LT	INTAKE					
RS-182	165+79.04, 29.2' LT - 165+79.02, 31.0' LT	30" VCP	2				
RS-183	2200+43.06, 30.2' RT - 2200+57.59, 11.1' RT	10" VCP	24		23.2		
RS-184	2200+43.06, 30.2' RT	INTAKE					
RS-185	165+79.04, 29.2' LT - 165+81.27, 6.0' RT	12" RCP	36		62.8		
RS-186	165+81.27, 6.0' RT	INTAKE					
RS-187	165+79.32, 40.9' RT - 165+81.27, 6.0' RT	6" STEEL	35		55.4		
RS-188	165+81.27, 6.0' RT - 165+94.30, 40.6' RT	8" STEEL	37		41.6		
RS-189	165+79.04, 29.2' LT - 169+29.63, 29.9' LT	30" VCP	350		250.6		
RS-190	169+29.63, 29.9' LT	UTILITY ACCESS				(1)	
RS-191	169+29.63, 29.9' LT - 169+29.47, 31.0' LT	18" VCP	1				
RS-192	169+29.63, 29.9' LT - 2300+42.63, 36.8' RT	10" VCP	40		63.7		
RS-193	2300+42.63, 36.8' RT	INTAKE					
RS-194	169+29.63, 29.9' LT - 169+61.00, 6.7' RT	15" CMP	49		106.0		
RS-195	169+61.00, 6.7' RT	INTAKE					
RS-196	169+29.63, 29.9' LT - 174+66.26, 28.5' LT	36" VCP	537		236.6		
RS-197	174+66.26, 28.5' LT	UTILITY ACCESS				(1)	
RS-198	174+59.49, 41.6' LT - 174+66.26, 28.5' LT	10" VCP	15				
RS-199	174+59.49, 41.6' LT	INTAKE					
RS-200	174+66.26, 28.5' LT - 174+97.42, 6.2' LT	36" VCP	39		462.5		
RS-201	174+97.42, 6.2' LT	UTILITY ACCESS				(1)	
RS-202	174+97.42, 6.2' LT - 174+97.45, 15.9' RT	36" VCP	23				
RS-203	174+59.85, 7.4' RT - 174+97.42, 6.2' LT	10" VCP	40		73.0		
RS-204	174+97.42, 6.2' LT - 174+98.62, 26.4' LT	30" VCP	20				
RS-205	174+98.62, 26.4' LT	UTILITY ACCESS				(1)	
RS-206	174+98.62, 26.4' LT - 174+98.52, 29.0' LT	18" VCP	3				
RS-207	174+98.62, 26.4' LT - 177+96.83, 26.3' LT	20" VCP	299		382.1		
RS-208	177+96.83, 26.3' LT	UTILITY ACCESS				(1)	
RS-209	177+96.83, 26.3' LT - 180+68.20, 26.1' LT	20" VCP	272		157.6		
RS-210	180+68.20, 26.1' LT	UTILITY ACCESS				(1)	
RS-211	180+29.51, 8.6' RT - 180+68.20, 26.1' LT	10" VCP	52		85.2		
RS-212	180+29.51, 8.6' RT	INTAKE					
RS-213	180+68.20, 26.1' LT - 2500+40.65, 36.8' LT	10" VCP	38		39.8		
RS-214	2500+40.65, 36.8' LT	INTAKE					
RS-215	180+68.20, 26.1' LT - 180+68.17, 27.0' LT	12" VCP	1				
RS-218	182+40.00, 25.3' LT - 182+60.00, 25.3' LT	10" VCP	20			REMOVE AND REPLACE SECTION	
RS-219	183+70.05, 35.6' LT	INTAKE					
RS-220	183+70.05, 35.6' LT - 184+99.42, 29.3' LT	15" RCP	126				

REMOVAL OF SEWER							HRG-2A
NUMBER	LOCATION (STATION)	DESCRIPTION	PIPE REMOVAL		GRANULAR BACKFILL (TONS)	NOTES	
			≤36" (LF)	>36" (LF)			
RS-222	184+99.42, 29.3' LT	INTAKE					
RS-223	184+93.14, 11.3' RT - 184+99.42, 29.3' LT	24" RCP	42		52.9		
RS-224	184+93.14, 11.3' RT	INTAKE					
RS-225	184+93.14, 11.3' RT - 187+08.00, 28.5' RT	24" RCP	213		235.0		
	S. 14TH ST.						
RS-231	1197+41.61, 33.7' LT - 1197+46.34, 25.4' LT	15" RCP ?	10		5.7	CUT & PLUG @ 1197+42, 33' LT	
RS-232	1197+46.34, 25.4' LT	INTAKE					
RS-233	103+18.98, 62.7' RT - 1198+50.43, 58.7' LT	24" RCP ?	36		217.5		
RS-234	1198+30.40, 85.6' LT - 1198+50.43, 58.7' LT	30" RCP	34		177.6		
RS-235	1198+50.43, 58.7' LT	UTILITY ACCESS				(1)	
RS-236	1198+19.68, 40.2' LT - 1198+50.43, 58.7' LT	15" RCP	36		68.2		
RS-237	1198+19.68, 40.2' LT	INTAKE					
RS-238	1198+19.68, 40.2' LT - 1198+36.49, 24.1' RT	15" RCP	66		121.5		
RS-239	1198+36.49, 24.1' RT	INTAKE					
RS-240	104+25.54, 23.4' LT - 1200+78.61, 20.2' LT	21" RCP	69		212.0		
RS-241	1200+78.61, 20.2' LT	INTAKE					
RS-242	1200+78.61, 20.2' LT - 1200+79.77, 20.8' RT	15" RCP	41		60.3		
RS-243	1200+79.77, 20.8' RT	INTAKE					
	BARKER ST.						
RS-244	109+92.52, 71.2' LT	INTAKE					
RS-245	109+92.52, 71.2' LT - 110+17.42, 68.0' LT	15" RCP	26				
RS-246	110+17.42, 68.0' LT	INTAKE					
RS-247	110+17.42, 68.0' LT - 110+34.97, 53.4' LT	15" RCP	23				
	25TH PL.						
RS-248	114+60.21, 13.3' RT - 114+62.48, 110.5' RT	15" VCP	97		163.9	CUT & PLUG @ 114+62, 110' RT	
RS-249	114+39.55, 9.3' RT	INTAKE					
RS-250	114+39.55, 9.3' RT - 114+60.21, 13.3' RT	15" RCP ?	22				
RS-251	114+60.21, 13.3' RT - 114+97.65, 18.9' RT	15" RCP ?	39				
	24TH PL.						
RS-253	123+06.41, 17.8' RT - 1298+83.25, 12.2' LT	15" VCP	103		707.3	CUT & PLUG @ 1298+83, 12' LT	
RS-254	122+95.86, 21.1' RT - 1298+71.51, 25.5' LT	42" RCP		108	313.4		
RS-255	122+95.86, 21.1' RT	INTAKE					
RS-256	122+95.86, 21.1' RT - 123+33.91, 26.5' RT	24" RCP	37		127.8		
RS-257	123+33.91, 26.5' RT	INTAKE					
RS-258	122+77.36, 39.3' LT - 1300+58.72, 18.1' LT	15" RCP	27				
RS-259	1300+58.72, 18.1' LT	INTAKE					
RS-260	123+44.18, 36.6' LT - 1300+57.92, 14.6' RT	15" RCP	27				
RS-261	1300+57.92, 14.6' RT	INTAKE					
	23RD PL.						
RS-262	129+21.41, 36.6' LT - 1400+58.86, 22.0' LT	15" RCP	27				
RS-263	1400+58.86, 22.0' LT	UTILITY ACCESS				(1)	
RS-264	1400+58.86, 22.0' LT - 1400+62.19, 15.5' LT	15" RCP	8				
RS-265	1400+62.19, 15.5' LT	INTAKE					
RS-266	1400+58.86, 22.0' LT - 1400+63.04, 15.6' RT	15" RCP	38				
RS-267	1400+63.04, 15.6' RT	INTAKE					
	22ND PL.						
RS-268	1498+75.00, 0.8' RT - 1499+74.48, 1.9' RT	20" VCP	189				
RS-269	133+99.40, 6.8' LT - 1500+53.08, 30.4' LT	18" RCP	56		94.0		
RS-270	1500+53.08, 30.4' LT - 1500+61.47, 15.7' LT	15" RCP	17				
RS-271	1500+61.47, 15.7' LT	INTAKE					
RS-272	133+99.40, 6.8' LT - 1500+39.75, 20.4' RT	12" VCP	39		87.1		
RS-273	1500+39.75, 20.4' RT	UTILITY ACCESS				(1)	
RS-274	1500+39.75, 20.4' RT - 1500+60.01, 22.4' RT	15" RCP	21				
RS-275	1500+60.01, 22.4' RT	INTAKE					
	21ST PL.						
RS-276	140+96.99, 26.1' LT - 1600+68.85, 15.0' LT	10" VCP	39		81.6		
RS-277	1600+68.85, 15.0' LT	INTAKE					
RS-278	140+96.99, 26.1' LT - 1600+81.40, 8.6' RT	10" VCP	51		149.7		
RS-279	141+38.43, 43.2' LT - 1600+73.10, 14.7' RT	10" VCP	30				
RS-280	1600+73.10, 14.7' RT	INTAKE					
	20TH PL.						
RS-281	144+31.78, 26.3' LT - 1700+54.54, 11.5' LT	10" VCP	30		38.3		
RS-282	1700+54.54, 11.5' LT	UTILITY ACCESS				(1)	
RS-283	1700+54.54, 11.5' LT - 1700+58.89, 12.7' LT	10" VCP	5		4.6		
RS-284	1700+58.89, 12.7' LT	INTAKE					
RS-285	144+31.78, 26.3' LT - 1700+73.35, 23.5' RT	10" VCP	56				
	19TH PL.						
RS-286	146+18.94, 21.7' LT - 1800+53.35, 18.9' LT	10" VCP	37		115.6		
RS-287	1800+53.35, 18.9' LT	UTILITY ACCESS				(1)	
RS-288	1800+53.35, 18.9' LT - 1800+58.00, 13.6' LT	10" VCP	8				
RS-289	1800+58.00, 13.6' LT	INTAKE					
RS-290	146+18.94, 21.7' LT - 1800+57.26, 21.8' RT	10" VCP	42		122.9		
RS-291	1800+57.26, 21.8' RT	UTILITY ACCESS				(1)	

REMOVAL OF SEWER						HRG-2A
NUMBER	LOCATION (STATION)	DESCRIPTION	PIPE REMOVAL		GRANULAR BACKFILL (TONS)	NOTES
			≤36" (LF)	>36" (LF)		
RS-292	1800+57.26, 21.8' RT - 1800+66.60, 13.4' RT	10" VCP	13			
RS-293	1800+66.60, 13.4' RT 18TH PL.	INTAKE				
RS-294	149+69.31, 26.0' LT - 1900+56.70, 17.7' LT	10" VCP	37		130.5	
RS-295	1900+56.70, 17.7' LT	UTILITY ACCESS				(1)
RS-296	1900+56.70, 17.7' LT - 1900+63.37, 13.6' LT	15" VCP	8			
RS-297	1900+63.37, 13.6' LT	INTAKE				
RS-298	149+69.31, 26.0' LT - 1900+52.48, 18.4' RT	10" VCP	32		104.6	
RS-299	1900+52.48, 18.4' RT	UTILITY ACCESS				(1)
RS-300	1900+52.48, 18.4' RT - 1900+58.49, 14.0' RT	10" VCP	8			
RS-301	1900+58.49, 14.0' RT	INTAKE				
RS-302	1900+52.48, 18.4' RT - 1900+80.24, 18.4' RT	8" VCP ?	28			
RS-303	11+97.00, 0.6' RT - 151+12.14, 3.1' RT	30" RCP	275		484.6	
RS-304	11+97.00, 0.6' RT	UTILITY ACCESS				(1)
RS-305	10+53.42, 0.0' RT - 11+97.00, 0.6' RT 17TH PL.	30" RCP	144			
RS-306	153+09.86, 28.6' LT - 2000+59.33, 18.0' LT	15" VCP	35		70.3	
RS-307	2000+59.33, 18.0' LT	UTILITY ACCESS				(1)
RS-308	2000+59.33, 18.0' LT - 2000+63.51, 13.7' LT	10" VCP	6			
RS-309	2000+63.51, 13.7' LT	INTAKE				
RS-310	153+09.86, 28.6' LT - 2000+58.03, 18.4' RT	15" VCP	36		76.7	
RS-311	2000+58.03, 18.4' RT	INTAKE				
RS-312	2000+58.03, 18.4' RT - 2000+60.78, 13.4' RT	10" VCP	6			
RS-313	2000+60.78, 13.4' RT	INTAKE				
RS-352	1996+63.32, 28.5' RT - 1996+88.68, 13.6' LT	8" CLAY	50		64.6	
RS-353	1996+88.68, 13.6' LT	UTILITY ACCESS				(1)
RS-354	1996+88.68, 13.6' LT - 1997+14.19, 58.7' LT 16TH PL.	8" CLAY	52		18.7	
RS-314	157+89.18, 25.7' LT - 2100+53.95, 14.7' LT	10" VCP	29		39.1	
RS-315	2100+53.95, 14.7' LT	UTILITY ACCESS				(1)
RS-316	2100+53.95, 14.7' LT - 2100+59.10, 15.7' LT	10" VCP	6		3.1	
RS-317	2100+59.10, 15.7' LT	INTAKE				
RS-318	157+89.18, 25.7' LT - 2100+53.19, 14.6' RT	10" VCP	38		58.7	
RS-319	2100+53.19, 14.6' RT	UTILITY ACCESS				(1)
RS-320	2100+53.19, 14.6' RT - 2100+57.84, 15.6' RT	10" VCP	5		5.4	
RS-321	2100+57.84, 15.6' RT 15TH AVE. S.	INTAKE				
RS-322	165+79.04, 29.2' LT - 2200+57.91, 11.3' LT	10" VCP	31		91.5	
RS-323	2200+57.91, 11.3' LT	UTILITY ACCESS				(1)
RS-324	2200+57.91, 11.3' LT - 2200+63.22, 11.3' LT	10" VCP	6			
RS-325	2200+63.22, 11.3' LT	INTAKE				
RS-326	165+79.04, 29.2' LT - 2200+57.59, 11.1' RT	10" CMP	31		91.0	
RS-327	2200+57.59, 11.1' RT	UTILITY ACCESS				(1)
RS-328	2200+57.59, 11.1' RT - 2200+62.53, 12.0' RT	10" VCP	6			
RS-329	2200+62.53, 12.0' RT 14TH AVE. S.	INTAKE				
RS-330	169+29.63, 29.9' LT - 2300+63.22, 15.6' LT	10" VCP	37		52.2	
RS-331	2300+63.22, 15.6' LT	INTAKE				
RS-332	169+29.63, 29.9' LT - 2300+57.60, 13.2' RT	10" VCP	31		72.8	
RS-333	2300+57.60, 13.2' RT	UTILITY ACCESS				(1)
RS-334	2300+57.60, 13.2' RT - 2300+62.12, 15.8' RT	10" VCP	6		9.0	
RS-335	2300+62.12, 15.8' RT 13TH AVE. S.	INTAKE				
RS-336	174+98.62, 26.4' LT - 2400+55.30, 17.3' LT	10" VCP	34		63.0	
RS-337	2400+55.30, 17.3' LT	UTILITY ACCESS				(1)
RS-338	2400+55.30, 17.3' LT - 2400+60.54, 18.2' LT	10" VCP	6			
RS-339	2400+60.54, 18.2' LT	INTAKE				
RS-340	174+98.62, 26.4' LT - 2400+56.37, 17.1' RT	10" VCP	35		69.2	
RS-341	2400+56.37, 17.1' RT	UTILITY ACCESS				(1)
RS-342	2400+56.37, 17.1' RT - 2400+61.45, 18.4' RT	10" VCP	6			
RS-343	2400+61.45, 18.4' RT 12TH AVE. S.	INTAKE				
RS-344	180+68.20, 26.1' LT - 2500+53.91, 17.2' RT	10" VCP	34		93.5	
RS-345	2500+53.91, 17.2' RT	UTILITY ACCESS				(1)
RS-346	2500+53.91, 17.2' RT - 2500+59.05, 14.7' RT	10" VCP	6			
RS-347	2500+59.05, 14.7' RT	INTAKE				
RS-348	2500+53.77, 17.6' LT - 2500+53.91, 17.2' RT	10" VCP	35		57.1	
RS-349	2500+53.77, 17.6' LT	UTILITY ACCESS				(1)
RS-350	2500+53.77, 17.6' LT - 2500+60.24, 14.2' LT	10" VCP	8			
RS-351	2500+60.24, 14.2' LT	INTAKE				
	TOTAL	158 STRUCTURES	14853		23150.4	(1) = SEPARATE BID ITEM (2) = TWIN PIPES

REMOVALS BY OTHERS				110-2A MODIFIED
Number	Location	Description	Disposal	
	CAMANCHE AVE.			
RO-1	102+44, 76' RT	POWER POLE		
RO-2	102+57, 89' RT	LUMINA IRE		
RO-3	103+59, 26' LT	POWER POLE		
RO-4	103+75, 20' LT	LUMINA IRE		
RO-5	103+91, 44' LT	LUMINA IRE		
RO-6	103+95, 37' LT	FIRE HYDRANT		
RO-7	105+21, 32' LT	LUMINA IRE		
RO-8	105+75, 48' RT	FIRE HYDRANT		
RO-9	106+62, 39' LT	LUMINA IRE		
RO-10	108+19, 48' LT	LUMINA IRE		
RO-11	109+85, 54' LT	LUMINA IRE		
RO-12	111+42, 64' LT	LUMINA IRE		
RO-13	112+81, 83' RT	POWER POLE		
RO-14	113+01, 65' LT	LUMINA IRE		
RO-15	113+44, 8' LT	FIRE HYDRANT		
RO-16	113+82, 95' RT	POWER POLE		
RO-17	114+79, 59' LT	POWER POLE		
RO-18	115+87, 52' LT	LUMINA IRE		
RO-19	117+03, 1' LT	FIRE HYDRANT		
RO-20	117+29, 52' LT	LUMINA IRE		
RO-21	118+91, 52' LT	LUMINA IRE		
RO-22	120+40, 40' LT	LUMINA IRE		
RO-23	121+66, 40' LT	LUMINA IRE		
RO-24	123+29, 48' LT	POWER POLE		
RO-25	124+32, 41' LT	POWER POLE		
RO-26	124+38, 17' RT	LUMINA IRE		
RO-27	124+86, 41' LT	LUMINA IRE		
RO-28	126+81, 42' LT	LUMINA IRE		
RO-29	128+38, 41' LT	LUMINA IRE		
RO-30	129+87, 40' LT	LUMINA IRE		
RO-31	131+43, 40' LT	LUMINA IRE		
RO-32	133+03, 40' LT	LUMINA IRE		
RO-33	133+73, 32' RT	POWER POLE		
RO-34	134+32, 11' RT	FIRE HYDRANT		
RO-35	136+02, 50' LT	LUMINA IRE		
RO-36	137+23, 47' LT	LUMINA IRE		
RO-37	138+08, 7' RT	FIRE HYDRANT		
RO-38	138+33, 46' LT	POWER POLE		
RO-39	138+76, 36' RT	LUMINA IRE		
RO-40	139+80, 45' LT	LUMINA IRE		
RO-41	141+36, 46' LT	LUMINA IRE		
RO-42	142+60, 57' LT	LUMINA IRE		
RO-43	142+77, 46' LT	LUMINA IRE		
RO-44	144+17, 51' LT	LUMINA IRE		
RO-45	146+57, 14' RT	FIRE HYDRANT		
RO-46	147+02, 37' LT	LUMINA IRE		
RO-47	148+34, 41' LT	LUMINA IRE		
RO-48	149+32, 10' RT	POWER POLE		
RO-49	149+91, 51' LT	LUMINA IRE		
RO-50	151+25, 48' LT	POWER POLE		
RO-51	151+34, 18' RT	FIRE HYDRANT		
RO-52	151+36, 43' LT	POWER POLE		
RO-53	151+47, 35' RT	POWER POLE		
RO-54	152+59, 22' RT	POWER POLE		
RO-55	153+46, 44' LT	POWER POLE		
RO-56	153+72, 18' RT	POWER POLE		
RO-57	154+49, 24' RT	POWER POLE		
RO-58	154+54, 18' RT	POWER POLE		
RO-59	154+69, 45' LT	POWER POLE		
RO-60	154+97, 17' RT	POWER POLE		
RO-61	155+96, 8' RT	FIRE HYDRANT		
RO-62	156+13, 44' LT	POWER POLE		
RO-63	156+22, 17' RT	POWER POLE		
RO-64	156+25, 18' RT	POWER POLE		
RO-65	157+23, 42' LT	POWER POLE		
RO-66	157+50, 18' RT	POWER POLE		
RO-67	158+21, 20' RT	POWER POLE		
RO-68	158+31, 43' LT	POWER POLE		
RO-69	158+84, 18' RT	POWER POLE		
RO-70	159+48, 45' LT	POWER POLE		
RO-71	160+14, 21' RT	POWER POLE		
RO-72	160+46, 6' RT	FIRE HYDRANT		
RO-73	160+56, 46' LT	POWER POLE		

REMOVALS BY OTHERS				110-2A MODIFIED
Number	Location	Description	Disposal	
RO-74	160+77, 52' LT	LUMINA IRE		
RO-75	161+13, 23' RT	POWER POLE		
RO-76	161+65, 20' RT	POWER POLE		
RO-77	161+80, 46' LT	POWER POLE		
RO-78	161+86, 20' RT	POWER POLE		
RO-79	162+27, 54' LT	LUMINA IRE		
RO-80	163+01, 46' LT	POWER POLE		
RO-81	164+67, 45' LT	POWER POLE		
RO-82	164+87, 7' RT	FIRE HYDRANT		
RO-83	166+13, 44' RT	PP/LUMINA IRE		
RO-84	167+57, 44' LT	POWER POLE		
RO-85	168+95, 43' LT	POWER POLE		
RO-86	169+02, 9' RT	POWER POLE		
RO-87	169+57, 9' RT	FIRE HYDRANT		
RO-88	170+17, 54' RT	POWER POLE		
RO-89	171+38, 15' RT	LUMINA IRE		
RO-90	171+81, 8' RT	POWER POLE		
RO-91	173+29, 8' RT	POWER POLE		
RO-92	173+31, 43' LT	POWER POLE		
RO-93	174+59, 44' LT	POWER POLE		
RO-94	174+63, 9' RT	UTILITY POLE		
RO-95	175+32, 10' RT	FIRE HYDRANT		
RO-96	175+39, 44' LT	POWER POLE		
RO-97	176+33, 43' LT	LUMINA IRE		
RO-98	177+72, 42' LT	POWER POLE		
RO-99	178+99, 42' LT	LUMINA IRE		
RO-100	180+39, 41' LT	LUMINA IRE		
RO-101	181+72, 41' LT	LUMINA IRE		
RO-102	182+92, 41' LT	LUMINA IRE		
RO-103	184+42, 41' LT	LUMINA IRE		
RO-104	185+88, 43' LT	LUMINA IRE		
	14TH ST.			
RO-105	1198+11, 64' RT	POWER POLE		
RO-106	1198+16, 69' RT	POWER POLE		
RO-106A	1201+01, 32' RT	SIGN		
	22ND ST.			
RO-106B	1500+42, 40' RT	LUMINA IRE		
	21ST PL.			
RO-107	1597+82, 28' LT	POWER POLE		
RO-108	1298+72, 19' LT	POWER POLE		
RO-109	1599+59, 19' LT	POWER POLE		
RO-110	1599+59, 38' LT	LUMINA IRE		
RO-111	1600+69, 21' RT	FIRE HYDRANT		
RO-112	1600+82, 17' LT	POWER POLE		
	18TH PL.			
RO-113	1900+83, 15' LT	POWER POLE		
RO-114	151+18, 54' RT (ML STATIONING)	POWER POLE		
	17TH PL.			
RO-115	1997+85, 65' LT	POWER POLE		
RO-116	1998+81, 52' RT	POWER POLE		
	13TH AVE.			
RO-117	2400+72, 24' LT	POWER POLE		

**REMOVALS**

110-2B  
MODIFIED

**REMOVAL OF SIGNS**

110-2C  
MODIFIED

**REMOVAL OF CONCRETE STEPS**

HRG-3A

Number	Location	Description	Disposal
CAMANCHE AVE.			
R-1	102+97, 33' LT	SHRUB (4)	BY CONTRACTOR
R-2	103+47, 92' RT	TRAFFIC SIGNAL (3)	BY CONTRACTOR
R-3	103+95, 26' LT	TRAF. SIG. CONTR. (3)	BY CONTRACTOR
R-4	104+19, 24' LT	TRAFFIC SIGNAL (3)	BY CONTRACTOR
R-5	104+70, 54' RT	TRAFFIC SIGNAL (3)	BY CONTRACTOR
R-6	105+02, 38' LT	TRAFFIC SIGNAL (3)	BY CONTRACTOR
R-36	105+17, 62' LT	SIGN FOOTINGS (1)	BY CONTRACTOR
R-7	119+86, 47' LT TO 120+24, 47' LT	RETAINING WALL (1)	BY CONTRACTOR
R-8	144+94, 47' LT TO 145+91, 45' LT	RETAINING WALL (1)	BY CONTRACTOR
R-9	145+92, 12' RT	TRAFFIC SIGNAL (3)	BY CONTRACTOR
R-10	146+00, 46' LT	TRAFFIC SIGNAL (3)	BY CONTRACTOR
R-11	146+31, 12' RT	TRAFFIC SIGNAL (3)	BY CONTRACTOR
R-12	146+53, 39' LT	TRAFFIC SIGNAL (3)	BY CONTRACTOR
R-13	151+00, 57' LT	SHRUB (4)	BY CONTRACTOR
R-15	152+83, 53' LT	SHRUB (4)	BY CONTRACTOR
R-37	157+00, 20' RT	LIGHT POLE FOOTINGS (1)	BY CONTRACTOR
R-16	159+98, 46' LT	CONCRETE FOOTING (2)	BY CONTRACTOR
R-17	161+58, 12' RT TO 168+22, 12' RT	RETAINING WALL (1)	BY CONTRACTOR
R-18	167+70, 58' LT	SHRUB (4)	BY CONTRACTOR
R-19	169+62, 55' LT TO 170+91, 52' LT	RETAINING WALL (1)	BY CONTRACTOR
R-20	174+65, 44' LT	TRAFFIC SIGNAL (3)	BY CONTRACTOR
R-21	175+37, 43' LT	TRAFFIC SIGNAL (3)	BY CONTRACTOR
R-22	177+28, 48' LT TO 177+70, 48' LT	RETAINING WALL (1)	BY CONTRACTOR
14TH ST.			
R-23	1200+82, 24' LT TO 1201+61, 25' LT	RETAINING WALL (1)	BY CONTRACTOR
R-24	1200+87, 31' RT	TREE (4)	BY CONTRACTOR
21ST PL.			
R-25	1598+46, 23' LT	SHRUB (4)	BY CONTRACTOR
R-26	1598+67, 25' LT	TREE (4)	BY CONTRACTOR
R-27	1598+86, 25' LT	SHRUB (4)	BY CONTRACTOR
R-28	1598+99, 23' LT	TREE (4)	BY CONTRACTOR
R-29	1599+15, 24' LT	SHRUB (4)	BY CONTRACTOR
R-30	1599+28, 24' LT	TREE (4)	BY CONTRACTOR
R-31	1599+42, 24' LT	SHRUB (4)	BY CONTRACTOR
R-32	1599+55, 26' LT	TREE (4)	BY CONTRACTOR
19TH PL.			
R-33	1800+41, 29' LT TO 1800+54, 29' LT	RETAINING WALL (1)	BY CONTRACTOR
R-34	1800+77, 19' RT	TREE (4)	BY CONTRACTOR
NOTE			
(1)	RETAINING WALLS AND FOOTINGS		
(2)	REMOVALS AS PER PLAN		
(3)	REMOVAL OF TRAFFIC SIGNALIZATION		
(4)	CLEARING AND GRUBBING		

Location	Description	Disposal
CAMANCHE AVE.		
102+83, 74' RT	OBJECT MARKER	(1)
102+97, 76' RT	DIRECTION SIGN	(1)
107+80, 43' LT	DIRECTION SIGN	(1)
109+90, 57' LT	STOP	(1)
110+25, 58' LT	STREET SIGNS	(1)
114+37, 62' LT	STREET SIGNS + STOP	(1)
114+86, 9' RT	STOP	(1)
126+50, 3' RT	LEFT LANE MUST TURN LEFT	(1)
131+02, 20' LT	WRONG WAY	
131+03, 32' RT	WRONG WAY	
132+49, 46' LT	NO PARKING	(1)
132+49, 5' RT	NO PARKING	(1)
138+42, 46' LT	NO PARKING	(1)
138+42, 5' RT	NO PARKING	(1)
143+46, 46' LT	NO PARKING	(1)
143+46, 5' RT	NO PARKING	(1)
148+37, 46' LT	NO PARKING	(1)
148+37, 5' RT	NO PARKING	(1)
152+63, 46' LT	NO PARKING	(1)
152+63, 5' RT	NO PARKING	(1)
156+80, 46' LT	NO PARKING	(1)
156+80, 5' RT	NO PARKING	(1)
162+28, 46' LT	NO PARKING	(1)
162+28, 5' RT	NO PARKING	(1)
167+50, 46' LT	NO PARKING	(1)
167+50, 5' RT	NO PARKING	(1)
172+07, 46' LT	NO PARKING	(1)
172+07, 5' RT	NO PARKING	(1)
179+29, 46' LT	NO PARKING	(1)
179+29, 5' RT	NO PARKING	(1)
183+18, 46' LT	NO PARKING	(1)
183+18, 5' RT	NO PARKING	(1)
S. 14TH ST.		
1201+10	NO PARKING	(1)
24TH PL.		
1299+70, 26' RT	YIELD	(1)
TOTAL		
(1)	SIGNS SHALL BE REMOVED WITH CARE AND STOCKPILED.	

Number	LOCATION		VOLUME Cu. Yds.	REMARKS
	Station	Side		
CAMANCHE AVE.				
RST-1	107+49.10	LT	0.52	
RST-2	119+97.51	LT	0.74	
RST-3	122+12.37	LT	1.11	
RST-4	122+60.64	LT	1.11	
RST-5	144+87.39	LT	3.67	
RST-6	145+27.37	LT	1.11	
RST-7	145+65.68	LT	1.11	
RST-9	147+25.84	LT	1.56	
RST-10	147+66.17	LT	1.56	
RST-11	148+10.26	LT	1.56	
RST-12	148+58.71	LT	1.56	
RST-13	148+97.44	LT	1.56	
RST-14	150+23.00	LT	1.30	
RST-15	166+21.69	LT	1.56	
RST-16	166+55.68	LT	1.56	
RST-17	167+07.58	LT	1.11	
RST-18	168+28.21	LT	1.11	
RST-19	174+29.63	LT	1.56	
RST-20	174+81.13	LT	1.56	
RST-21	175+34.57	LT	1.11	
RST-22	176+15.09	LT	1.56	
RST-23	176+54.10	LT	1.56	
RST-24	176+94.71	LT	0.44	
RST-25	177+36.96	LT	0.44	
RST-26	181+11.82	LT	1.11	
RST-27	181+60.64	LT	1.11	
RST-28	181+97.55	LT	1.11	
TOTAL			35.37	

**TABULATION OF PAVEMENT MARKINGS REMOVALS**

HRG-4A

BCY4:Broken Center Line (Yellow)      NPY4:No-Passing Zone Line (Yellow)      ELW4:Edge Line Right (White)      DLW4:Dotted Line (White)      CHW8:Channelizing Line (White)      SLW2:Stop Line (White)      STY6:Yellow Curb      YLW2:Yield Line (White)  
 DCY4:Double Center Line (Yellow)      BLW4:Broken Lane Line (White)      ELY4:Edge Line Left (Yellow)      SLW4:Solid Lane Line (White)      CHY8:Channelizing Line (Yellow)      CBW6:Crosswalk Line (White)      STW6:White Curb      DDY4:Double Dotted Line (Yellow)

Location				Length (In Stations)																	Remarks		
Road Identification	Station to Station	Side		BCY4	DCY4	NPY4	BLW4	ELW4	ELY4														
		L	R																				
CAMANCHE AVE	118+32 TO 183+55	X	X				65.23																
CAMANCHE AVE	118+32 TO 183+55	X	X		65.23																		
CAMANCHE AVE	118+32 TO 183+55						65.23																
STAGE 1-A			X																				
CAMANCHE AVE	WEST END		X				2.45																FAR WESTERLY LANE SHIFT
CAMANCHE AVE	WEST END		X	3.00			2.00		3.00														RIGHT TURN LANE OPENING
CAMANCHE AVE	WEST END																						LANE SHIFT THROUGH TWLT LANE
CAMANCHE AVE	102+66 TO 103+88	X					1.22																
CAMANCHE AVE	104+87	X											0.13										
CAMANCHE AVE	104+95 TO 112+10	X		2.23			7.15																
CAMANCHE AVE	112+10 TO 114+33	X																					
S 14TH ST	1197+49 TO 1199+75	X		2.46			2.26																
S 14TH ST	1200+17 TO 1202+63	X																					
STAGE 1-B																							
CAMANCHE AVE	100+66 TO 102+66	X					2.00																
CAMANCHE AVE	104+94	X											0.22										
STAGE 2			X	2.15					2.15														
CAMANCHE AVE	WEST END			0.73																			WEST OF S 14TH ST, TWLT LANE
CAMANCHE AVE	113+61 TO 114+32	X																					
CAMANCHE AVE	114+10 TO 114+32	X		0.22																			
CAMANCHE AVE	114+68 TO 115+93	X					1.25																
STAGE 3																							
CAMANCHE AVE	111+43 TO 114+24	X					2.81																
STAGE 4																							
CAMANCHE AVE	161+76 TO 164+26	X					2.50																
	Length Subtotals			10.57	65.45	0	154.1	0	5.15	0	0	0	0.35	0	0	0	0	0	0	0	0	0	
	Quantity Factors			.25	2	1	.25	1	1	.33	1	2	2	6	1.5	3	3.5	3	3.5	1.71	.66		
	Totals			2.64	130.9	0	38.53	0	5.15	0	0	0	2.1	0	0	0	0	0	0	0	0	0	TOTAL = 179.32

1-HRG  
 Where public utility fixtures are shown as existing on the plans or encountered within the construction area, it shall be the responsibility of the contractor to notify the owner of those utilities prior to the beginning of any construction. The contractor shall afford access to these facilities for necessary modification of services. Underground facilities, structures and utilities have been plotted from available surveys and records, and therefore their locations must be considered approximate only. It is possible there may be others, the existence of which is presently not known or shown. It is the contractor's responsibility to determine their existence and exact location and to avoid damage thereto.

4-HRG  
 For bedding and backfill of all storm, sanitary, intakes or trenches from removals under Primary roads use material complying with Article 4120.04 (Class A Crushed Stone) of the Standard Specifications. Place and compact the material according to Article 2552.03, E (Class I materials). For intakes Place and compact material according to Article 2435.03A.

2-HRG  
 The Contractor shall replace land corners and permanent reference markers disturbed as a result of construction activities on this project.

3-HRG  
 The Contractor shall submit working drawings to the Design Consultant at the following address:  
 HR Green, Inc.  
 8710 Earhart Lane SW  
 Cedar Rapids, IA 52404  
 One copy of the entire submittal (Cover Letter and Drawings) shall be sent by the Contractor to the review office specified in 1105.03 of the Standards Specification, and to the Resident Construction Engineer, the District Materials Engineer and the City Engineer.

**CONTAMINATED SOIL SITES**

Line Number	Location		Side (LT/RT)	Excavation CY	Remarks
	Station	Station			
1	114+50	115+50	RT	1,211	Roadway, Storm, Sanitary
2	123+50	124+50	RT	445	Roadway, Storm, Sanitary
3	132+50	134+00	RT	1,111	Roadway, Storm, Sanitary
4	140+00	142+00	RT	596	Roadway, Storm, Sanitary
5	141+25	142+50	LT	147	Storm, Sanitary
6	155+00	159+00	RT	1,301	Roadway, Storm, Sanitary
7	155+00	160+50	LT	325	Roadway, Storm, Sanitary
8	164+00	165+50	LT	237	Roadway, Storm, Sanitary
9	169+50	171+00	LT	204	Storm, Sanitary
10	170+00	171+50	RT	965	Roadway, Storm, Sanitary
11	176+50	180+25	LT	214	Storm, Sanitary
12	177+00	180+00	RT	1,082	Roadway, Storm, Sanitary
13	183+00	186+50	LT	5	Storm
14	183+50	186+50	RT	579	Roadway, Storm

PCSS-2  
SPECIAL

**TABULATION OF HMA COMMERCIAL MIX**

STATION TO STATION	SIDE	AREA (SF)	THICKNESS (IN)	TONS	REMARKS
123+37.41	124+37.53	LT	236.6	7.0	10.0
125+66.97	125+83.00	LT	32.1	7.0	1.4
126+13.00	126+32.18	LT	38.4	7.0	1.6
128+76.49	129+24.77	LT	96.6	7.0	4.1
139+86.50	140+34.09	RT	789.3	7.0	33.4
140+21.85	140+69.69	LT	92.0	7.0	3.9
151+30.66	151+52.26	LT	43.2	7.0	1.8
151+82.26	152+57.17	LT	149.8	7.0	6.3
156+49.55	156+78.30	LT	57.2	7.0	2.4
157+66.46	157+74.77	LT	28.7	7.0	1.2
164+07.94	164+28.74	LT	41.6	7.0	1.8
164+58.74	165+48.23	LT	179.9	7.0	7.6
1300+57.39	1300+69.09	RT	23.5	7.0	1.0
1599+21.75	1599+52.53	LT	157.4	7.0	6.7
1600+63.26	1600+74.08	LT	21.6	7.0	0.9
2100+49.29	2100+76.92	LT	125.5	7.0	5.3
2100+53.81	2100+76.7	RT	119.0	9.0	6.5
2200+55.11	2200+72.58	LT	78.2	7.0	3.3
TOTAL			2,310.6		99.2

HRG-5A



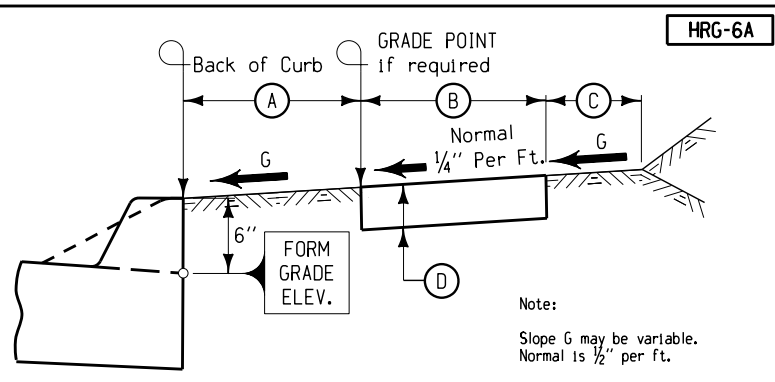

HRG-6A

**TYPICAL SIDEWALK DETAILS**  
(New construction only as shown on detail plans)

STATION TO STATION	SIDE	(A) Feet	(B) Feet	(C) Feet	NEW CONSTRUCTION Sq. Yds.	(D) Inch	
Camanche Ave.							
102+33.18	103+33.03	LT	17	10	2	110.9	5
103+69.56	104+11.42	LT	VAR.	10	2	46.5	5
105+42.36	111+20.61	RT	15	10	2	642.5	5
111+20.61	111+50.61	RT	15	10	2	33.3	5
111+50.61	120+26.48	RT	15	10	2	973.2	5
105+62.85	111+17.93	LT	15	10	2	616.8	5
107+49.10		LT	-	4	-	5.0	4
111+17.93	111+52.93	LT	15	10	2		7
111+52.93	112+53.97	LT	15	10	2	112.3	5
112+53.97	112+84.43	LT	15	10	2		7
112+84.43	114+47.16	LT	15	10	2	180.8	5
114+77.81	115+85.41	LT	15	10	2	119.6	5
115+85.41	116+16.34	LT	15	10	2		7
116+16.34	117+03.74	LT	15	10	2	97.1	5
117+03.74	117+33.74	LT	15	10	2		7
117+33.74	118+50.34	LT	15	10	2	129.6	5
118+50.34	118+80.34	LT	15	10	2		7
118+80.34	119+71.51	LT	15	10	2	101.3	5
119+71.51	119+86.51	LT	15	10	2		7
119+86.51	120+21.26	LT	15	10	2	38.6	5
119+99.97		LT	-	4	-	4.9	4
120+21.26	120+36.26	LT	15	10	2		7
120+36.26	120+71.47	LT	15	10	2	39.1	5
120+71.47	120+86.51	LT	15	10	2		7
120+86.51	121+21.69	LT	15	10	2	39.1	5
121+21.69	121+36.69	LT	15	10	2		7
121+36.69	121+70.30	LT	15	10	2	37.3	5
121+70.30	122+00.47	LT	15	10	2		7
122+00.47	122+58.50	LT	15	10	2	64.5	5
122+12.37		LT	-	4	-	8.3	4
122+60.64		LT	-	4	-	10.3	4
123+64.18	129+09.17	RT	15	5	2	302.8	4
123+64.73	124+64.84	LT	15	10	2	111.2	5
124+51.35		LT	-	4	-	7.9	4
124+64.84	125+05.67	LT	15	10	2		7
125+05.67	125+83.00	LT	15	10	2	85.9	5
125+17.51		LT	-	4	-	6.2	4
125+83.00	126+13.00	LT	15	10	2		7
126+13.00	127+25.04	LT	15	10	2	124.5	5
126+52.94		LT	-	4	-	3.6	4
127+04.10		LT	-	4	-	4.7	4
127+25.04	127+50.04	LT	15	10	2		7
127+50.04	128+46.44	LT	15	10	2	107.1	5
128+46.44	128+76.44	LT	15	10	2		7
128+76.44	129+02.55	LT	15	10	2	29.0	5
130+04.69	133+51.52	RT	15	5	2	192.7	4
130+09.51	133+44.86	LT	15	10	2	375.1	5
130+66.63		LT	-	19	-	17.6	4
134+44.05	134+82.33	LT	15	VAR.	2	14.2	5
134+46.32	140+45.45	RT	15	5	2	332.9	4
134+51.07	135+70.24	LT	15	10	2	132.4	5
135+45.19		LT	-	4	-	6.3	4
135+70.21	136+00.39	LT	15	10	2		7
136+00.39	136+49.41	LT	15	10	2	54.5	5
136+49.41	136+79.59	LT	15	10	2		7
136+79.59	137+84.00	LT	15	10	2	116.0	5
137+84.00	138+14.18	LT	15	10	2		7

**TYPICAL SIDEWALK DETAILS**  
(New construction only as shown on detail plans)

HRG-6A

STATION TO STATION	SIDE	(A) Feet	(B) Feet	(C) Feet	NEW CONSTRUCTION Sq. Yds.	(D) Inch	
138+14.18	138+66.16	LT	15	10	2	57.8	5
138+66.16	138+81.25	LT	15	10	2		7
138+81.25	139+10.97	LT	15	10	2	33.0	5
138+99.57		LT	-	4	-	8.8	4
139+10.97	139+26.06	LT	15	10	2		7
139+26.06	139+60.33	LT	15	10	2	38.1	5
139+60.33	139+75.42	LT	15	10	2		7
139+75.42	140+06.75	LT	15	10	2	34.8	5
139+94.34		LT	-	4	-	8.4	4
140+06.75	140+21.84	LT	15	10	2		7
140+21.84	140+42.33	LT	15	10	2	22.8	5
141+50.51	152+65.33	RT	15	5	2	619.3	4
141+53.06	142+21.16	LT	15	10	2	75.7	5
142+21.16	142+51.34	LT	15	10	2		7
142+51.34	143+03.83	LT	15	10	2	58.3	5
143+03.83	143+18.83	LT	15	10	2		7
143+18.83	143+43.28	LT	15	10	2	27.2	5
143+43.28	143+67.39	LT	15	10	2		7
143+67.39	143+99.52	LT	15	10	2	35.7	5
144+59.74	144+92.96	LT	15	VAR.	2	30.7	4
144+76.96	145+80.41	LT	15	10	2	114.9	5
145+27.37		LT	-	4	-	5.6	4
145+65.68		LT	-	4	-	5.1	4
146+67.66	149+25.14	LT	15	10	2	286.1	5
147+25.84		LT	-	4	-	4.4	4
148+10.26		LT	-	4	-	5.7	4
148+58.71		LT	-	4	-	6.1	4
148+97.44		LT	-	4	-	6.4	4
150+11.01	151+52.26	LT	15	10	2	156.9	5
150+72.23		LT	-	4	-	3.8	4
151+52.26	151+82.26	LT	15	10	2		7
151+82.26	152+60.85	LT	15	10	2	87.3	5
153+64.38	165+33.50	RT	15	5	2	649.5	4
153+68.04	155+65.66	LT	15	10	2	219.6	5
155+65.66	155+95.80	LT	15	10	2		7
155+95.80	156+19.55	LT	15	10	2	26.4	5
156+19.55	156+49.55	LT	15	10	2		7
156+49.55	157+61.32	LT	15	10	2	124.2	5
158+41.63	161+14.78	LT	15	10	2	303.5	5
161+14.78	161+44.78	LT	15	10	2		7
161+44.78	162+34.00	LT	15	10	2	99.1	5
162+34.00	162+64.00	LT	15	10	2		7
162+64.00	163+36.91	LT	15	10	2	81.0	5
163+36.91	163+66.91	LT	15	10	2		7
163+66.91	164+28.74	LT	15	10	2	68.7	5
164+28.74	164+58.74	LT	15	10	2		7
164+58.74	165+28.60	LT	15	10	2	77.6	5
166+21.69		LT	-	4	-	7.1	4
166+28.50	174+49.79	RT	15	5	2	456.3	4
166+33.19	166+35.86	LT	15	10	2	3.0	5
166+35.86	166+50.86	LT	15	10	2		7
166+50.86	167+16.93	LT	15	10	2	73.4	5
166+55.68		LT	-	4	-	6.9	4
167+07.58		LT	-	4	-	7.1	4
167+16.93	167+31.92	LT	15	10	2		7
167+31.92	168+90.35	LT	15	10	2	176.0	5
168+28.21		LT	-	10	-	6.6	4
169+70.56	170+95.48	LT	15	10	2	138.8	5
170+95.48	171+30.72	LT	15	10	2		7
171+30.72	171+64.70	LT	15	10	2	37.8	5
171+64.70	171+94.70	LT	15	10	2		7
171+94.70	173+36.49	LT	15	10	2	157.5	5
173+36.49	173+66.49	LT	15	10	2		7
173+66.49	174+45.29	LT	15	10	2	87.6	5
174+29.63		LT	-	4	-	6.6	4
175+47.87	180+22.41	LT	15	5	2	263.6	4
175+52.38	178+42.09	LT	15	10	2	321.9	5
175+81.12		LT	-	4	-	6.3	4
176+15.09		LT	-	4	-	6.3	4
176+54.10		LT	-	4	-	6.2	4
177+36.96		LT	-	4	-	5.2	4
178+42.09	178+77.09	LT	15	10	2		7
178+77.09	180+17.89	LT	15	10	2	156.4	5
181+17.29	187+08.00	RT	15	5	2	328.2	4

**TYPICAL SIDEWALK DETAILS**  
(New construction only as shown on detail plans)

HRG-6A

STATION TO STATION	SIDE	(A) Feet	(B) Feet	(C) Feet	NEW CONSTRUCTION Sq. Yds.	(D) Inch	
181+22.07	182+49.89	LT	15	10	2	142.0	5
181+60.64		LT	-	4	-	5.7	4
181+97.55		LT	-	4	-	5.7	4
182+49.89	182+69.89	LT	15	10	2		7
182+69.89	183+34.52	LT	15	10	2	71.8	5
183+34.52	183+58.52	LT	15	10	2		7
183+58.52	183+99.89	LT	15	10	2	46.0	5
183+99.89	184+29.89	LT	15	10	2		7
184+29.89	185+37.82	LT	15	10	2	119.9	5
185+37.82	185+61.82	LT	15	10	2		7
185+61.82	186+60.72	LT	15	10	2	109.9	5
S. 14th St.							
1197+49.08	1198+98.43	RT	VAR.	VAR.	8.5	79.4	4
1200+51.86	1201+64.32	LT	0	VAR.	4	73.8	4
1200+95.22	1201+64.02	RT	VAR.	VAR.	VAR.	49.7	4
25th Pl.							
114+40.00		LT	-	5	VAR.	14.7	4
114+40.00		LT	-	5	-		7
114+40.00		LT	-	5	VAR.	1.4	4
24th Pl.							
1298+83.00	1299+43.99	RT	VAR.	5	VAR.	33.9	4
1298+93.11	1299+50.00	LT	5	10	2	63.2	5
1300+53.46	1300+69.09	RT	5	5	2	8.7	4
1300+69.09	1301+04.09	RT	5	5	-		7
1301+04.09	1301+19.09	RT	5	5	VAR.	8.3	4
23rd Pl.							
1398+75.00	1399+44.97	LT	5	5	8.5	38.9	4
1398+75.00	1399+46.03	RT	5	5	8.5	39.5	4
1400+54.05	1401+40.00	RT	4	5.5	2	52.5	4
22nd Pl.							
1498+75.00	1499+45.26	LT	5	5	VAR.	39.0	4
1498+75.00	1499+45.86	RT	5	5	VAR.	39.4	4
1501+13.57		LT	-	6	-	3.3	4
1500+53.26	1501+40.00	LT	VAR.	5	2	48.2	4
1500+46.13	1501+15.06	RT	VAR.	VAR.	VAR.	54.2	4
21st Pl.							
1597+75.00	1597+89.25	LT	5	5	8.5	7.9	4
1597+75.00</							

**TYPICAL SIDEWALK DETAILS**

(New construction only as shown on detail plans)

HRG-6A

STATION TO STATION	SIDE	(A) Feet	(B) Feet	(C) Feet	NEW CONSTRUCTION Sq. Yds.	(D) Inch	
15th Ave.							
2196+22.77	2199+45.91	LT	5	5	8.5	179.5	4
2196+29.18	2199+45.05	RT	5	5	8.5	175.5	4
2200+52.73	2200+72.58	LT	-	7	2	15.4	4
2200+51.75	2200+90.01	LT	-	7	-		7
2200+51.35	2200+90.00	RT	-	7	VAR.	30.1	4
14th Ave.							
2300+51.46	2300+89.99	LT	6	6	VAR.	25.7	4
2300+53.54	2300+82.85	RT	6	5	VAR.	16.3	4
2300+82.85	2300+90.00	RT	6	5	-		7
13th Ave.							
2399+00.00	2399+45.31	LT	5	5	8.5	22.0	4
2399+00.00	2399+45.55	RT	5	5	8.5	22.0	4
2400+52.50	2400+90.00	LT	-	VAR.	VAR.	27.9	4
2400+52.63	2400+90.00	RT	-	VAR.	VAR.	27.7	4
12th Ave.							
2500+53.47	2500+73.44	LT	3	5	5	11.1	4
2500+73.44	2501+10.33	LT	3	5	-		7
2501+10.33	2501+40.00	LT	3	5	VAR.	16.5	4
2500+53.54	2501+40.00	RT	3	5	2	48.0	4
		TOTAL				13,777.0	

**TABULATION OF CURB & GUTTER**

HRG-7A

STATION TO STATION	SIDE	WIDTH LF	LENGTH LF	REMARKS
102+30.08	102+35.08	RT	2.5	5
117+33.74	118+50.34	LT	2.5	117
123+37.41	124+37.53	LT	1.5	100
125+66.97	125+83.00	LT	1.5	16
126+13.00	126+32.18	LT	1.5	19
128+76.49	129+24.77	LT	1.5	48
139+86.50	140+34.09	RT	1.5	48
140+21.85	140+69.69	LT	1.5	48
141+36.25	142+21.12	LT	2.5	85
142+51.39	142+67.62	LT	2.5	16
143+16.33	143+43.17	LT	2.5	27
151+30.66	151+52.26	LT	1.5	22
151+82.26	152+57.17	LT	1.5	75
153+41.62	154+39.10	LT	2.5	97
156+49.55	156+78.30	LT	1.5	29
157+66.46	157+74.77	LT	2.5	8
160+35.87	161+14.78	LT	2.5	79
161+44.78	162+34.00	LT	2.5	89
162+64.00	163+36.91	LT	2.5	73
163+66.91	164+01.92	LT	2.5	35
164+07.94	164+28.74	LT	1.5	21
164+58.74	165+48.23	LT	1.5	90
178+83.50	178+98.50	LT	1.5	15
178+85.49	178+96.49	LT	2.5	11
320+30.16	322+69.02	LT	2.5	245
1300+57.39	1300+69.09	RT	1.5	27
1498+35.34	1498+75.00	RT	2.5	40
1599+21.75	1599+52.53	LT	1.5	31
1600+63.26	1600+74.08	LT	1.5	11
1600+72.00	1600+74.76	RT	2.5	5
2000+49.68	2000+68.16	RT	2.5	19
2100+49.29	2100+76.92	LT	2.5	28
2100+53.81	2100+76.60	RT	2.5	23
2200+55.11	2200+68.02	LT	1.5	13

**SUMMARY OF MATERIALS FOR SIGNS**

HRG-8A

Road	Location (Station)	Offset	Code No.	Sign Message	Size (IN)	Sign Area (SF)	Steel Posts 2.25 IN x 2.25 IN LF
CAMANCHE AVE.	98+08	62' RT	W6-1	DIVIDED HIGHWAY (SYMBOL)		RELOCATE	30
CAMANCHE AVE.	100+59	17' RT	R4-7	KEEP RIGHT (SYMBOL)		RELOCATE	15
CAMANCHE AVE.	101+93	21' LT	W6-2	DIVIDED HIGHWAY ENDS (SYMBOL)		RELOCATE	30
CAMANCHE AVE.	101+95	17' RT	W6-2	DIVIDED HIGHWAY ENDS (SYMBOL)		RELOCATE	30
CAMANCHE AVE.	103+32	17' RT	R4-7	KEEP RIGHT (SYMBOL)	24x30	5	15
CAMANCHE AVE.	105+13	28' RT	R4-7	KEEP RIGHT (SYMBOL)		RELOCATE	15
CAMANCHE AVE.	109+95	106' LT	OM4-1	END OF ROADWAY MARKER (BARKER ST)		RELOCATE	15
CAMANCHE AVE.	110+02	106' LT	OM4-1	END OF ROADWAY MARKER (BARKER ST)		RELOCATE	15
CAMANCHE AVE.	110+09	107' LT	OM4-1	END OF ROADWAY MARKER (BARKER ST)		RELOCATE	15
CAMANCHE AVE.	114+40	177' LT	OM4-1	END OF ROADWAY MARKER (25TH PL)		RELOCATE	15
CAMANCHE AVE.	114+47	177' LT	OM4-1	END OF ROADWAY MARKER (25TH PL)		RELOCATE	15
CAMANCHE AVE.	114+51	96' LT	OM4-1	END OF ROADWAY MARKER (25TH PL)		RELOCATE	15
CAMANCHE AVE.	114+55	177' LT	OM4-1	END OF ROADWAY MARKER (25TH PL)		RELOCATE	15
CAMANCHE AVE.	114+59	96' LT	OM4-1	END OF ROADWAY MARKER (25TH PL)		RELOCATE	15
CAMANCHE AVE.	114+68	97' LT	OM4-1	END OF ROADWAY MARKER (25TH PL)		RELOCATE	15
CAMANCHE AVE.	117+87	27' LT	R2-1	SPEED LIMIT 35		RELOCATE	15
CAMANCHE AVE.	117+87	20' RT	R2-1	SPEED LIMIT 35	24x30	5	15
CAMANCHE AVE.	123+62	34' RT	D3-1	CAMANCHE AVE.	36x12	3	
CAMANCHE AVE.	123+62	34' RT	D3-1	24TH PL. (MOUNT WITH D3-1)	36x12	3	
CAMANCHE AVE.	126+29	22' LT	R2-1	SPEED LIMIT 35		RELOCATE	
CAMANCHE AVE.	130+05	38' RT	D3-1	CAMANCHE AVE.		RELOCATE	15
CAMANCHE AVE.	130+05	38' RT	D3-1	CAMANCHE AVE. (MOUNT WITH D3-1)		RELOCATE	
CAMANCHE AVE.	130+05	38' RT	D3-1	23RD PL. (MOUNT WITH D3-1)		RELOCATE	
CAMANCHE AVE.	134+52	35' RT	D3-1	CAMANCHE AVE.		RELOCATE	15
CAMANCHE AVE.	134+52	35' RT	D3-1	CAMANCHE AVE. (MOUNT WITH D3-1)		RELOCATE	
CAMANCHE AVE.	134+52	35' RT	D3-1	22ND PL. (MOUNT WITH D3-1)		RELOCATE	
CAMANCHE AVE.	136+32	22' LT	R2-1	SPEED LIMIT 35		RELOCATE	15
CAMANCHE AVE.	136+30	33' RT	R2-1	SPEED LIMIT 35		RELOCATE	15
CAMANCHE AVE.	139+41	19' LT	M1-4	HIGHWAY 30		RELOCATE	15
CAMANCHE AVE.	139+41	19' LT	M3-4	WEST (MOUNT WITH M1-4)		RELOCATE	
CAMANCHE AVE.	139+41	27' LT	M1-4	HIGHWAY 67		RELOCATE	15
CAMANCHE AVE.	139+41	27' LT	M3-1	SOUTH (MOUNT WITH M1-4)		RELOCATE	
CAMANCHE AVE.	139+58	38' RT	M1-4	HIGHWAY 30		RELOCATE	15
CAMANCHE AVE.	139+58	38' RT	M3-4	WEST (MOUNT WITH M1-4)		RELOCATE	
CAMANCHE AVE.	139+58	31' RT	M1-4	HIGHWAY 67		RELOCATE	15
CAMANCHE AVE.	139+58	31' RT	M3-1	SOUTH (MOUNT WITH M1-4)		RELOCATE	
CAMANCHE AVE.	141+44	36' RT	D3-1	CAMANCHE AVE.		RELOCATE	15
CAMANCHE AVE.	141+44	36' RT	D3-1	CAMANCHE AVE. (MOUNT WITH D3-1)		RELOCATE	
CAMANCHE AVE.	141+44	36' RT	D3-1	21ST PL. (MOUNT WITH D3-1)		RELOCATE	
CAMANCHE AVE.	144+55	29' RT	R6-1R	ONE WAY		RELOCATE	15
CAMANCHE AVE.	146+17	29' RT	R6-1R	ONE WAY		RELOCATE	15
CAMANCHE AVE.	149+61	29' RT	R6-1R	ONE WAY		RELOCATE	15
CAMANCHE AVE.	153+73	36' RT	D3-1	CAMANCHE AVE.	36x12	3	15
CAMANCHE AVE.	153+73	36' RT	D3-1	CAMANCHE AVE. (MOUNT WITH D3-1)	36x12	3	
CAMANCHE AVE.	153+73	36' RT	D3-1	17TH PL. (MOUNT WITH D3-1)	36x12	3	
CAMANCHE AVE.	155+26	22' LT	R2-1	SPEED LIMIT 35		RELOCATE	15
CAMANCHE AVE.	155+27	33' RT	R2-1	SPEED LIMIT 35		RELOCATE	15
CAMANCHE AVE.	158+02	30' RT	R6-1R	ONE WAY		RELOCATE	15
CAMANCHE AVE.	164+02	20' LT	M1-4	HIGHWAY 30		RELOCATE	15
CAMANCHE AVE.	164+02	20' LT	M3-4	WEST (MOUNT WITH M1-4)		RELOCATE	
CAMANCHE AVE.	164+02	24' LT	M1-4	HIGHWAY 67		RELOCATE	15
CAMANCHE AVE.	164+02	24' LT	M3-1	SOUTH (MOUNT WITH M1-4)		RELOCATE	
CAMANCHE AVE.	164+02	36' RT	M1-4	HIGHWAY 30		RELOCATE	15
CAMANCHE AVE.	164+02	36' RT	M3-4	WEST (MOUNT WITH M1-4)		RELOCATE	
CAMANCHE AVE.	164+02	31' RT	M1-4	HIGHWAY 67		RELOCATE	15
CAMANCHE AVE.	164+02	31' RT	M3-1	SOUTH (MOUNT WITH M1-4)		RELOCATE	
CAMANCHE AVE.	166+33	36' RT	D3-1	CAMANCHE AVE.	36x12	3	15
CAMANCHE AVE.	166+33	36' RT	D3-1	CAMANCHE AVE. (MOUNT WITH D3-1)	36x12	3	
CAMANCHE AVE.	166+33	36' RT	D3-1	15TH AVE. (MOUNT WITH D3-1)	36x12	3	
CAMANCHE AVE.	169+24	29' RT	R6-1R	ONE WAY		RELOCATE	15
CAMANCHE AVE.	173+07	19' LT	R2-1	SPEED LIMIT 35		RELOCATE	15
CAMANCHE AVE.	173+07	33' RT	R2-1	SPEED LIMIT 35		RELOCATE	15
CAMANCHE AVE.	175+50	37' RT	D3-1	CAMANCHE AVE.		RELOCATE	15
CAMANCHE AVE.	175+50	37' RT	D3-1	CAMANCHE AVE. (MOUNT WITH D3-1)		RELOCATE	
CAMANCHE AVE.	175+50	37' RT	D3-1	13TH AVE. (MOUNT WITH D3-1)		RELOCATE	
CAMANCHE AVE.	181+19	37' RT	D3-1	CAMANCHE AVE.		RELOCATE	15
CAMANCHE AVE.	181+19	37' RT	D3-1	CAMANCHE AVE. (MOUNT WITH D3-1)		RELOCATE	
CAMANCHE AVE.	181+19	37' RT	D3-1	12TH AVE. (MOUNT WITH D3-1)		RELOCATE	
S. 14TH ST.	1197+25	RT	R3-8B	LEFT ONLY, THROUGH ONLY, RIGHT ONLY	48x30	10	
S. 14TH ST.	1201+64	LT	R3-8B	LEFT ONLY, THROUGH/RIGHT	36x30	7.5	
24TH PL.	1300+50	21' LT	R6-1R	ONE WAY (MOUNT WITH R1-1)		RELOCATE	15
24TH PL.	1300+50	21' LT	R1-1	STOP		RELOCATE	

**SUMMARY OF MATERIALS FOR SIGNS**

HRG-8A

Road	Location (Station)	Offset	Code No.	Sign Message	Size (IN)	Sign Area (SF)	Steel Posts 2.25 IN x 2.25 IN
23RD PL.	1399+50	28' RT	R6-1R	ONE WAY (MOUNT WITH R1-1)		RELOCATE	15
23RD PL.	1399+50	28' RT	R6-1L	ONE WAY (MOUNT WITH R1-1)		RELOCATE	
23RD PL.	1399+50	28' RT	R1-1	STOP		RELOCATE	
23RD PL.	1400+49	36' LT	R6-1R	ONE WAY (MOUNT WITH R1-1)		RELOCATE	15
23RD PL.	1400+49	36' LT	R6-1L	ONE WAY (MOUNT WITH R1-1)		RELOCATE	
23RD PL.	1400+49	36' LT	R1-1	STOP		RELOCATE	
22ND PL.	1500+55	20' LT	R6-1R	ONE WAY (MOUNT WITH R1-1)		RELOCATE	15
22ND PL.	1500+55	20' LT	R6-1L	ONE WAY (MOUNT WITH R1-1)		RELOCATE	
22ND PL.	1500+55	20' LT	R1-1	STOP		RELOCATE	
22ND PL.	1499+49	27' RT	R6-1R	ONE WAY (MOUNT WITH R1-1)		RELOCATE	15
22ND PL.	1499+49	27' RT	R6-1L	ONE WAY (MOUNT WITH R1-1)		RELOCATE	
22ND PL.	1499+49	27' RT	R1-1	STOP		RELOCATE	
21ST PL.	1600+63	19' LT	R6-1R	ONE WAY (MOUNT WITH R1-1)		RELOCATE	15
21ST PL.	1600+63	19' LT	R6-1L	ONE WAY (MOUNT WITH R1-1)		RELOCATE	
21ST PL.	1600+63	19' LT	R1-1	STOP		RELOCATE	
21ST PL.	1599+57	26' RT	R6-1R	ONE WAY (MOUNT WITH R1-1)		RELOCATE	15
21ST PL.	1599+57	26' RT	R6-1L	ONE WAY (MOUNT WITH R1-1)		RELOCATE	
21ST PL.	1599+57	26' RT	R1-1	STOP		RELOCATE	
20TH PL.	1700+51	21' LT	R6-1R	ONE WAY (MOUNT WITH R1-1)		RELOCATE	15
20TH PL.	1700+51	21' LT	R1-1	STOP		RELOCATE	
19TH PL.	1800+48	20' LT	R6-1R	ONE WAY (MOUNT WITH R1-1)		RELOCATE	15
19TH PL.	1800+48	20' LT	R1-1	STOP		RELOCATE	
18TH PL.	1900+51	21' LT	R6-1R	ONE WAY (MOUNT WITH R1-1)		RELOCATE	15
18TH PL.	1900+51	21' LT	R1-1	STOP		RELOCATE	
17TH PL.	1995+32	13' LT	R6-1L	ONE WAY (MOUNT WITH R1-1)		RELOCATE	15
17TH PL.	1996+04	40' RT	D3-1	LIBERTY AVE.	36x12	3	15
17TH PL.	1996+04	40' RT	D3-1	17TH PL. (MOUNT WITH D3-1)	36x12	3	
17TH PL.	1996+07	24' LT	R6-1L	ONE WAY (MOUNT WITH R1-1)		RELOCATE	15
17TH PL.	1996+07	24' LT	R1-1	STOP		RELOCATE	
17TH PL.	2000+55	17' LT	R6-1R	ONE WAY (MOUNT WITH R1-1)		RELOCATE	15
17TH PL.	2000+55	17' LT	R6-1L	ONE WAY (MOUNT WITH R1-1)	36x12	3	
17TH PL.	2000+55	17' LT	R1-1	STOP		RELOCATE	
17TH PL.	1999+48	26' RT	R6-1R	ONE WAY (MOUNT WITH R1-1)		RELOCATE	15
17TH PL.	1999+48	26' RT	R6-1L	ONE WAY (MOUNT WITH R1-1)		RELOCATE	
17TH PL.	1999+48	26' RT	R1-1	STOP	30x30	6.25	
16TH PL.	2100+49	26' LT	R6-1R	ONE WAY (MOUNT WITH R1-1)		RELOCATE	15
16TH PL.	2100+49	26' LT	R1-1	STOP		RELOCATE	
15TH AVE.	2195+44	13' LT	R6-1L	ONE-WAY	36x12	3	15
15TH AVE.	2194+24	24' LT	R6-1L	ONE-WAY	36x12	3	15
15TH AVE.	2194+24	24' LT	R1-1	STOP (MOUNT WITH R6-1L)	30x30	6.25	
15TH AVE.	2194+25	40' RT	D3-1	LIBERTY AVE.	36x12	3	15
15TH AVE.	2194+25	40' RT	D3-1	15TH PL. (MOUNT WITH D3-1)	36x12	3	
15TH AVE.	2200+52	26' LT	R6-1R	ONE WAY (MOUNT WITH R1-1)		RELOCATE	15
15TH AVE.	2200+52	26' LT	R6-1L	ONE WAY (MOUNT WITH R1-1)	36x12	3	
15TH AVE.	2200+52	26' LT	R1-1	STOP		RELOCATE	
15TH AVE.	2199+49	26' RT	R6-1R	ONE WAY (MOUNT WITH R1-1)		RELOCATE	15
15TH AVE.	2199+49	26' RT	R6-1L	ONE WAY (MOUNT WITH R1-1)	36x12	3	
15TH AVE.	2199+49	26' RT	R1-1	STOP	30x30	6.25	
14TH AVE.	2300+54	21' LT	R6-1R	ONE WAY (MOUNT WITH R1-1)		RELOCATE	15
14TH AVE.	2300+54	21' LT	R1-1	STOP		RELOCATE	
13TH AVE.	2400+55	29' LT	R6-1R	ONE WAY (MOUNT WITH EXISTING STOP)		RELOCATE	15
13TH AVE.	2400+55	29' LT	R6-1L	ONE WAY (MOUNT WITH R1-1)		RELOCATE	
13TH AVE.	2400+55	29' LT	R1-1	STOP		RELOCATE	
13TH AVE.	2399+49	26' RT	R6-1R	ONE WAY (MOUNT WITH R1-1)		RELOCATE	15
13TH AVE.	2399+49	26' RT	R6-1L	ONE WAY (MOUNT WITH R1-1)		RELOCATE	
13TH AVE.	2399+49	26' RT	R1-1	STOP		RELOCATE	
12TH AVE.	2500+58	21' LT	R6-1R	ONE WAY (MOUNT WITH R1-1)		RELOCATE	15
12TH AVE.	2500+58	21' LT	R6-1L	ONE WAY (MOUNT WITH R1-1)		RELOCATE	
12TH AVE.	2500+58	21' LT	R1-1	STOP		RELOCATE	
12TH AVE.	2499+49	28' RT	R6-1R	ONE WAY (MOUNT WITH R1-1)		RELOCATE	15
12TH AVE.	2499+49	28' RT	R6-1L	ONE WAY (MOUNT WITH R1-1)		RELOCATE	
12TH AVE.	2499+49	28' RT	R1-1	STOP		RELOCATE	
TOTALS			131			97.25	1035

**TEMPORARY PAVEMENT**

HRG-9A

STATION TO STATION	SIDE	AREA SY	REMARKS
STAGE 1-A			
CAMANCHE AVE			
102+61	104+65	LT	261.5
102+78	103+88	RT	53.8
104+82	109+75	BOTH	429.8
S 14TH ST			
1197+21	1197+75	LT	33.8
1198+16	1198+92	LT	166.2
STAGE 1-B			
CAMANCHE AVE			
103+91	105+15	RT	470.6
STAGE 1-C			
CAMANCHE AVE			
103+28	103+72	RT	101.7
STAGE 2			
CAMANCHE AVE			
109+53	113+87	BOTH	478.5
STAGE 3			
CAMANCHE AVE			
107+78	110+56	LT	721.1
129+17	129+83	LT	146.7
133+56	134+28	LT	67.1
STAGE 4			
CAMANCHE AVE			
123+00	123+46	LT	116.7
129+27	129+88	LT	62.4
133+69	134+36	BOTH	82.9
140+66	141+33	BOTH	95
152+83	153+40	LT	64.8
155+40	159+31	BOTH	282.2
174+81	175+17	LT	60.2
STAGE 5			
CAMANCHE AVE			
165+52	166+08	LT	93.1
174+69	175+29	LT	52.8
180+39	180+98	LT	52.8
TOTAL			3,893.7

**MANHOLE ADJUSTMENT**

HRG-10A

No.	Location Station	Type of Fixture	Adjustment
1	181+22, 25.6' LT	SANITARY MANHOLE	+0.45'

**PEDESTRIAN CURB RAMPS**

HRG-11A

See MI-220.

Location	Side	Type	PCC Sidewalk Sq. Yds.	Detectable Warnings Sq. Ft.	Remarks
CAMANCHE AVE.					
102+81.66	88.5' RT	1-R	5.6	20	
103+20.42	74.9' RT	1-R	5.6	20	
103+51.33	17.7' LT	1-R	5.6	20	
103+51.17	60.2' RT	1-R	5.6	20	
104+95.89	17.0' LT	1-R	5.6	20	
104+95.48	59.5' RT	1-R	5.6	20	
105+05.47	35.3' LT	1-R	5.6	20	
105+48.02	36.2' LT	1-R	5.6	20	
122+77.41	19.8' LT	1-F MOD	5.6	20	
122+79.49	26.5' RT	1-F MOD	5.6	20	
123+48.92	18.3' LT	1-F MOD	3.3	12	
123+48.82	31.8' RT	1-F MOD	3.3	12	
129+20.30	18.9' LT	1-F MOD	3.3	12	
129+22.13	26.5' RT	1-F MOD	3.3	12	
129+93.60	19.9' LT	1-R	3.3	12	
129+91.61	26.5' RT	1-F MOD	3.3	12	
133+62.98	19.4' LT	1-F MOD	3.3	12	
133+64.52	26.5' RT	1-F MOD	3.3	12	
134+35.13	20.2' LT	1-F MOD	3.3	12	
134+33.35	26.5' RT	1-F MOD	3.3	12	
140+57.31	16.0' LT	1-F MOD	3.3	12	
140+58.37	26.5' RT	1-F MOD	3.3	12	
141+37.18	20.8' LT	1-F MOD	3.3	12	
141+35.65	26.5' RT	1-F MOD	3.3	12	
152+76.76	19.6' LT	1-F MOD	3.3	12	
152+78.30	26.5' RT	1-F MOD	3.3	12	
153+50.43	17.4' LT	1-F MOD	5.6	20	
153+49.32	26.5' RT	1-F MOD	5.6	20	
165+44.50	19.6' LT	1-F MOD	3.3	12	
165+46.50	26.5' RT	1-F MOD	3.3	12	
166+17.33	18.7' LT	1-F MOD	3.3	12	
166+15.50	26.5' RT	1-F MOD	3.3	12	
174+61.18	20.1' LT	1-F MOD	3.3	12	
174+62.79	26.5' RT	1-F MOD	3.3	12	
175+36.49	20.3' LT	1-F MOD	3.3	12	
175+34.85	26.5' RT	1-F MOD	3.3	12	
180+33.79	19.1' LT	1-F MOD	3.3	12	
180+35.29	26.5' RT	1-F MOD	3.3	12	
181+06.18	19.0' LT	1-F MOD	3.3	12	
181+04.29	26.5' RT	1-F MOD	3.3	12	
14TH ST.					
1198+90.92	32.0' LT	1-R	5.6	20	
1199+24.06	29.1' RT	1-R	5.6	20	
1200+32.25	27.4' LT	1-R	5.6	20	
1200+52.95	20.0' RT	1-R	5.6	20	
24TH ST.					
1299+58.29	10.5' LT	1-F MOD	3.3	12	
1299+58.20	26.7' RT	1-F MOD	3.3	12	
1300+35.84	20.0' LT	1-F MOD	5.6	20	
1300+35.74	17.5' RT	1-F MOD	5.6	20	
23RD PL.					
1399+56.32	21.5' LT	1-F MOD	3.3	12	
1399+56.32	21.5' RT	1-F MOD	3.3	12	
1400+35.54	20.2' LT	1-F MOD	5.6	20	
1400+36.09	20.8' RT	1-R	5.6	20	
22ND PL.					
1499+56.16	21.5' LT	1-F MOD	3.3	12	
1499+56.16	21.5' RT	1-F MOD	3.3	12	
1500+34.51	21.0' LT	1-F MOD	5.6	20	
1500+35.94	20.7' RT	1-F MOD	5.6	20	
21ST PL.					
1599+59.81	21.5' LT	1-F MOD	3.3	12	
1599+64.36	21.5' RT	1-F MOD	3.3	12	
1600+40.29	18.3' LT	1-F MOD	5.6	20	
1600+44.73	22.4' RT	1-F MOD	5.6	20	

**PEDESTRIAN CURB RAMPS**

HRG-11A

See MI-220.

Location	Side	Type	PCC Sidewalk Sq. Yds.	Detectable Warnings Sq. Ft.	Remarks
20TH PL.					
1700+33.79	17.0' LT	1-R	5.6	20	
1700+39.05	20.9' RT	1-R	5.6	20	
19TH PL.					
1800+34.11	16.2' LT	1-R	5.6	20	
1800+38.89	21.0' RT	1-R	5.6	20	
18TH PL.					
1900+35.79	18.2' LT	1-R	5.6	20	
1900+35.72	18.2' RT	1-R	5.6	20	
17TH PL.					
1999+56.44	21.5' LT	1-F MOD	3.3	12	
1999+55.57	21.5' RT	1-F MOD	3.3	12	
2000+36.18	18.9' LT	1-F MOD	5.6	20	
2000+35.46	18.1' RT	1-F MOD	5.6	20	
16TH PL.					
2100+35.55	20.3' LT	1-R	5.6	20	
2100+36.11	20.8' RT	1-R	5.6	20	
15TH AVE.					
2199+55.76	21.5' LT	1-F MOD	3.3	12	
2199+55.76	21.5' RT	1-F MOD	3.3	12	
2200+36.03	20.1' LT	1-F MOD	5.6	20	
2200+35.60	19.8' RT	1-F MOD	5.6	20	
14TH AVE.					
2300+35.77	20.5' LT	1-R	5.6	20	
2300+35.84	20.5' RT	1-R	5.6	20	
13TH AVE.					
2399+56.03	21.5' LT	1-F MOD	3.3	12	
2399+56.03	21.5' RT	1-F MOD	3.3	12	
2400+35.78	23.0' LT	1-F MOD	5.6	20	
2400+35.83	23.0' RT	1-F MOD	5.6	20	
12TH AVE.					
2499+56.02	21.5' LT	1-F MOD	3.3	12	
2499+56.02	21.5' RT	1-F MOD	3.3	12	
2500+35.79	19.5' LT	1-F MOD	5.6	20	
2500+35.82	19.5' RT	1-F MOD	5.6	20	
S. 4TH AVE.	SE Quadrant	1-F MOD	10.1	20	

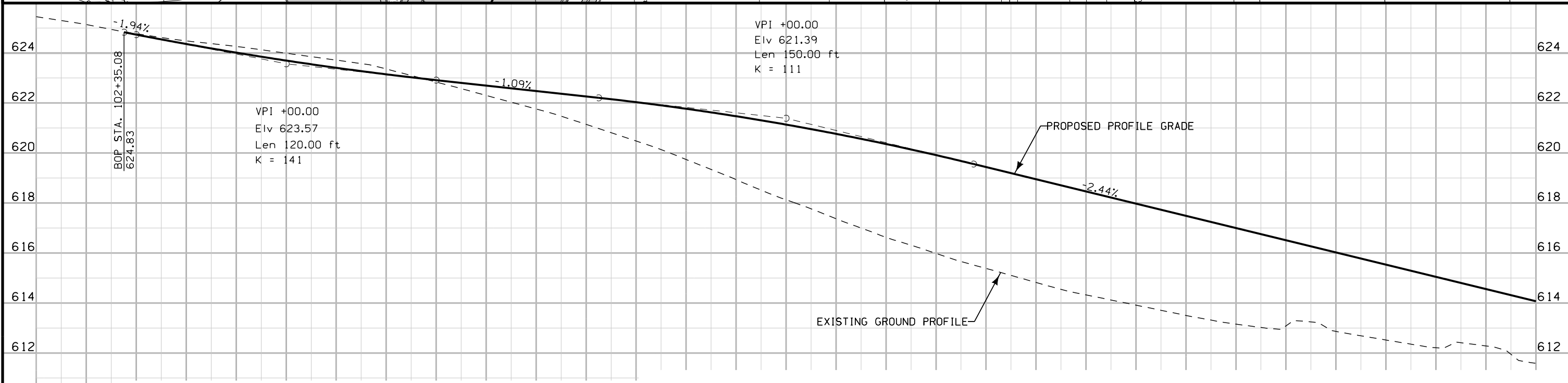
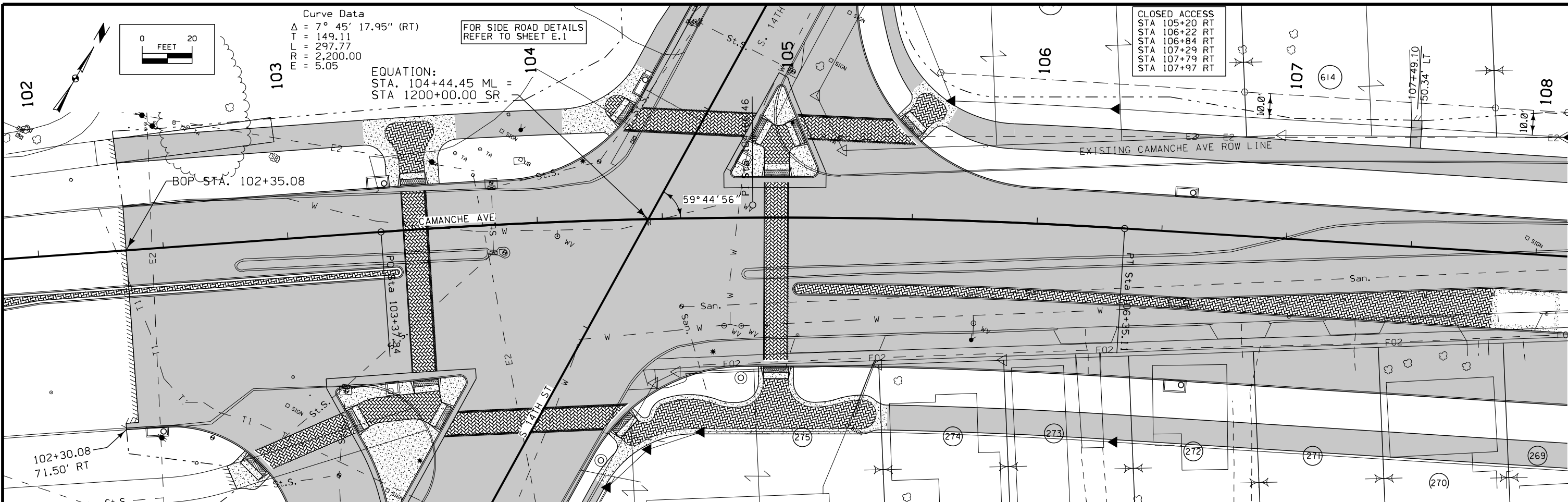

102	+20	+40	+60	+80	103	+20	+40	+60	+80	104	+20	+40	+60	+80	105	+20	+40	+60	+80	106	+20	+40	+60	+80	107	+20	+40	+60	+80	108
		624.73	624.36	624.01	623.70	623.41	623.15	622.92	622.70	622.48	622.26	622.03	621.77	621.47	621.14	620.77	620.36	619.92	619.44	618.95	618.46	617.97	617.49	617.00	616.51	616.02	615.53	615.05	614.56	614.07

$C = 258$      $F + 35\% = 7$      $\frac{C}{F} = \frac{251}{258}$     (STAGE 1B+1C)  
 $C$  FROM BORROW = 503     $F + 35\% = 1907$      $\frac{C}{F} = \frac{1404}{1907}$     (STAGE 2)  
 $C$  FROM BORROW = 6785     $F + 35\% = 6785$      $\frac{C}{F} = \frac{6785}{6785}$     (STAGE 1A)

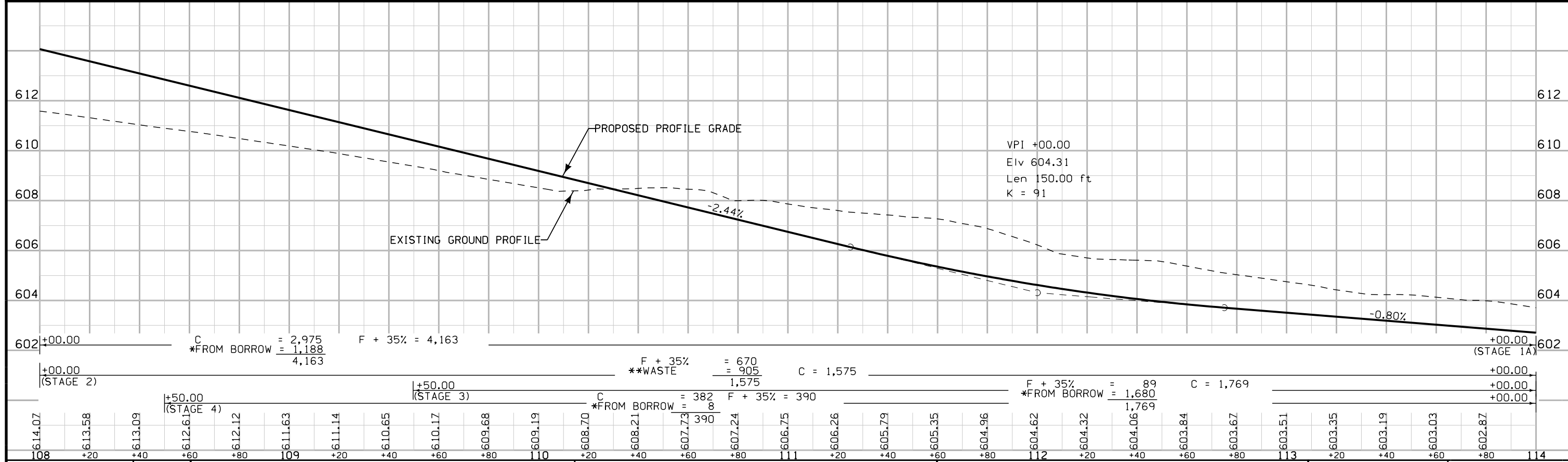
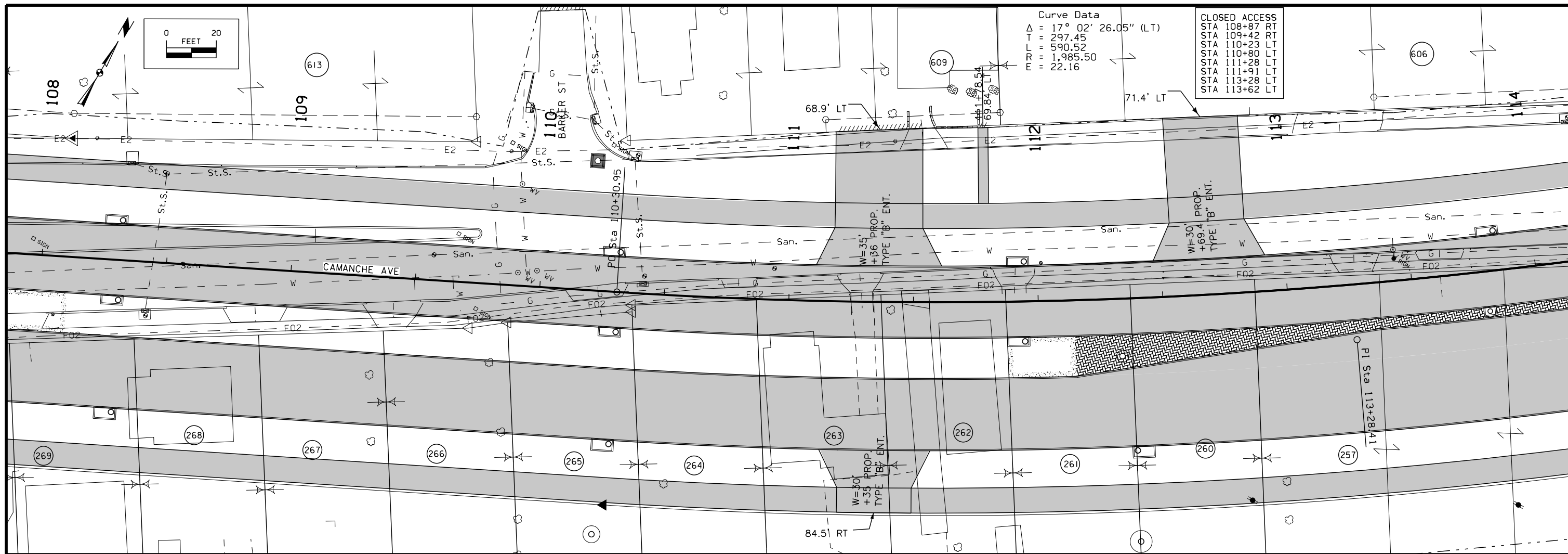

English	IOWA DOT	DESIGN TEAM	HR Green, Inc.	CLINTON COUNTY	PROJECT NUMBER	NHSX-030-9(134)--3H-23	SHEET NUMBER	D.2
---------	----------	-------------	----------------	----------------	----------------	------------------------	--------------	-----

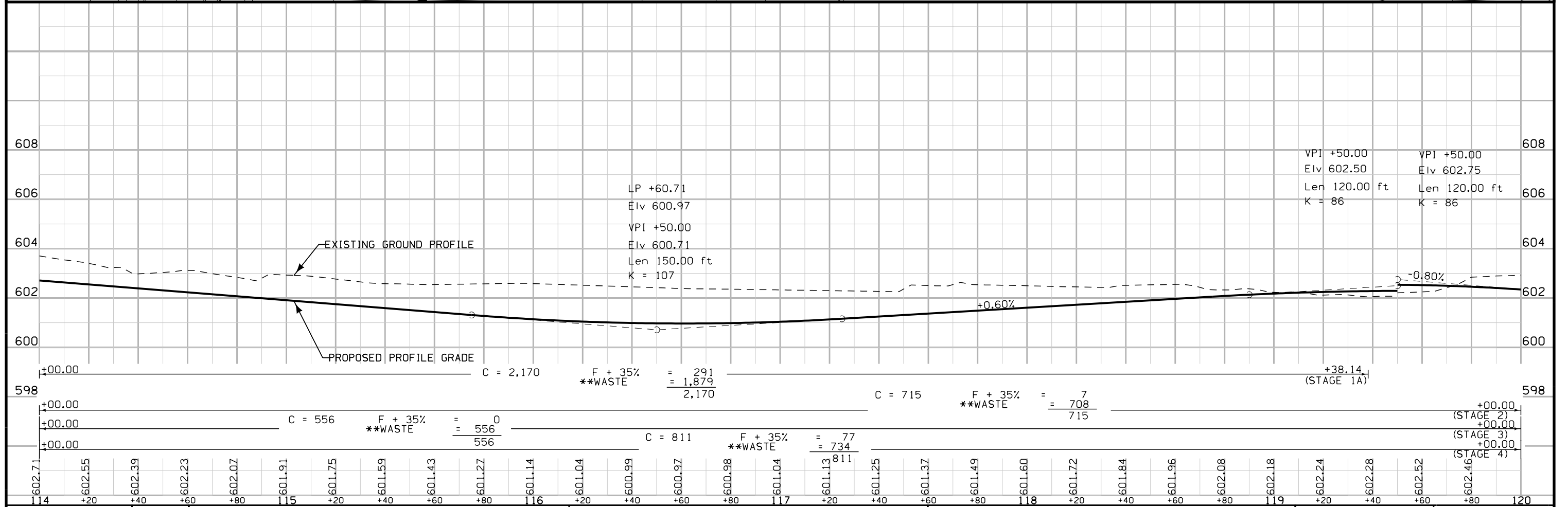
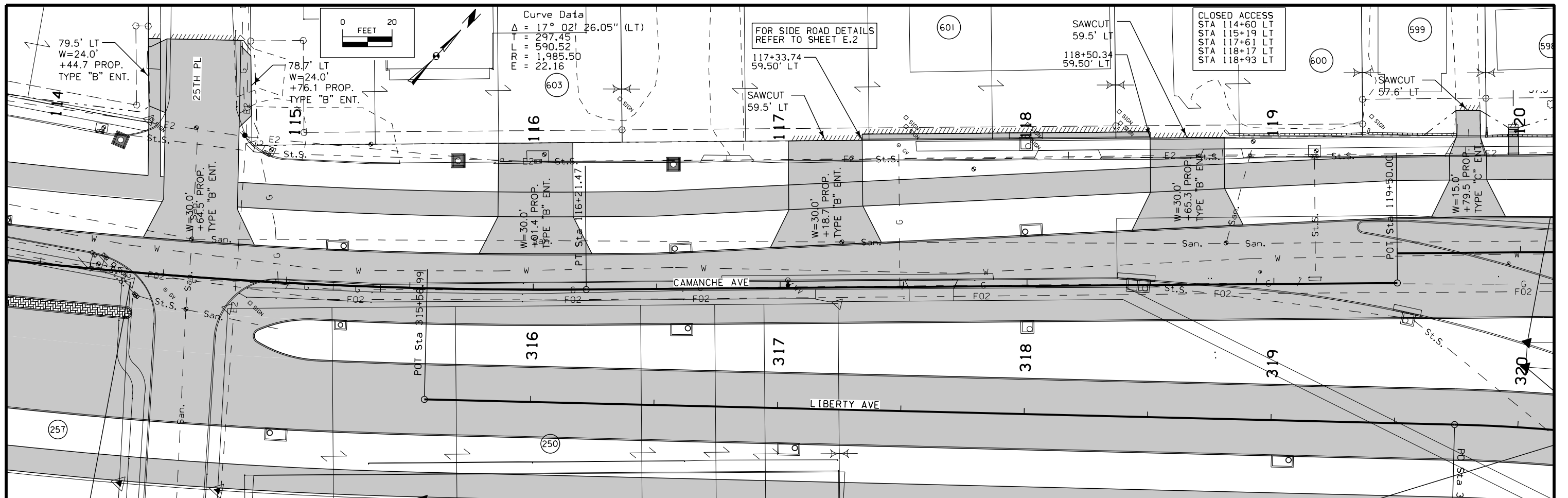

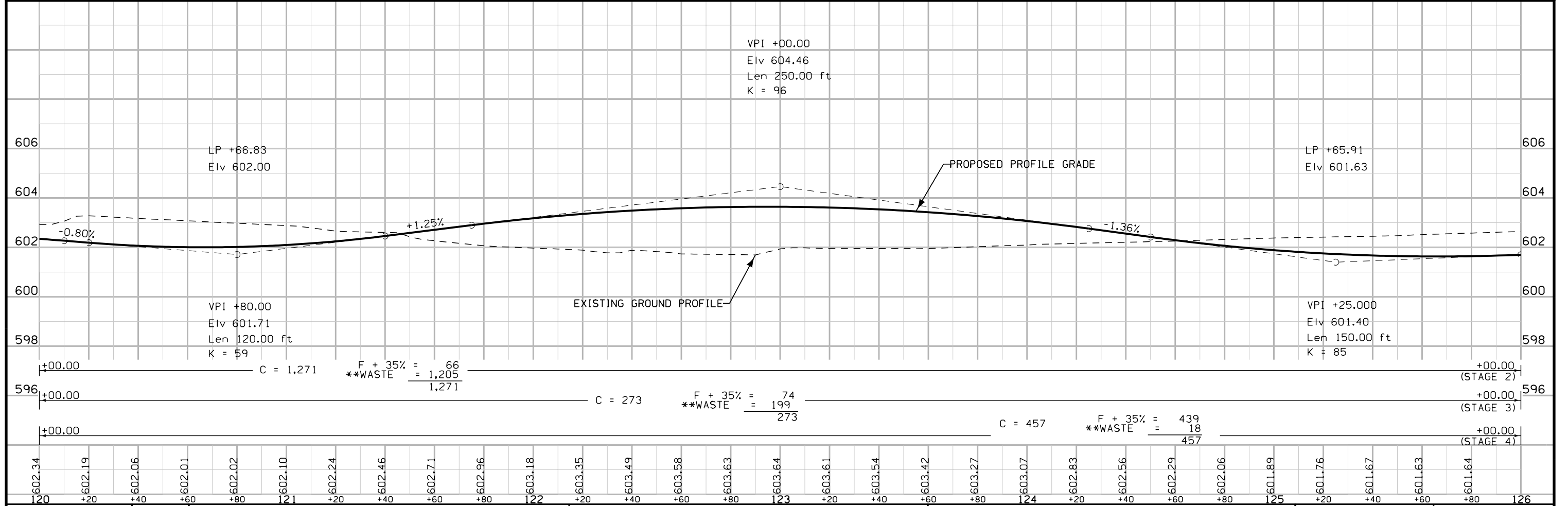
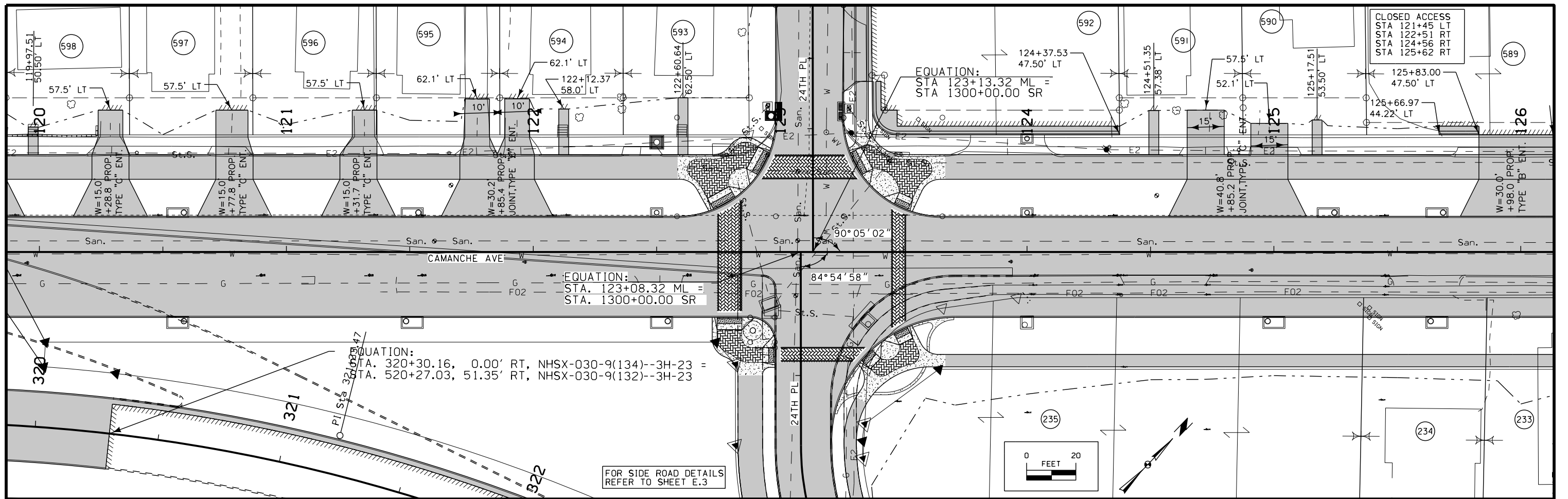



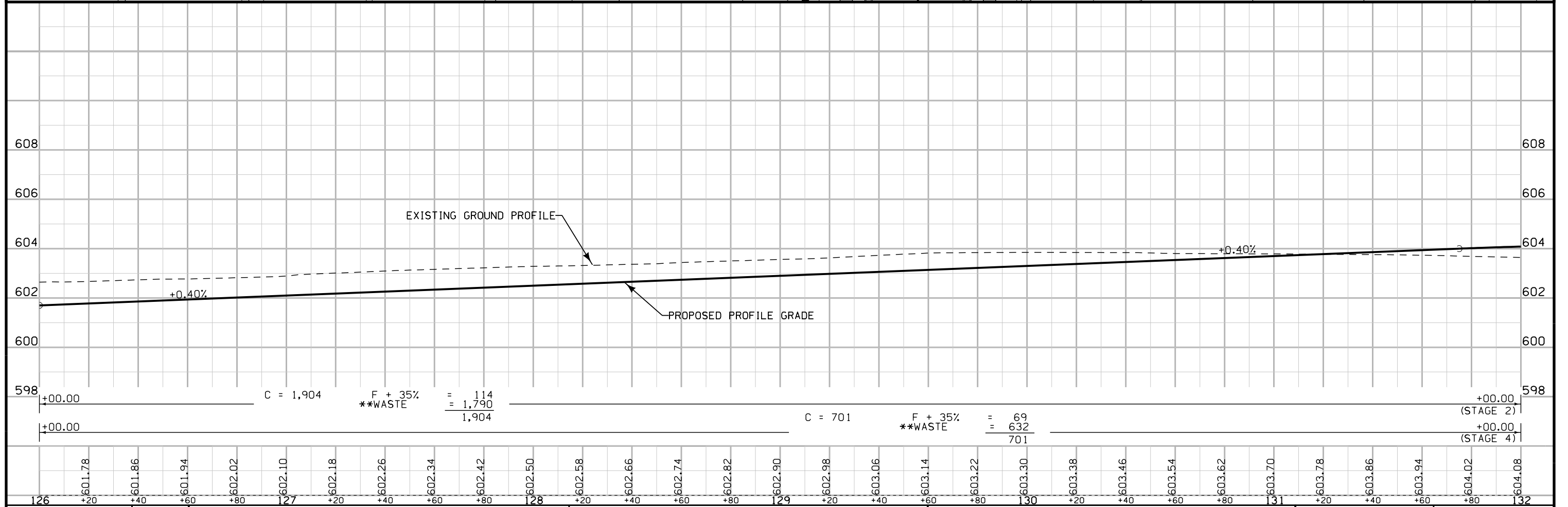
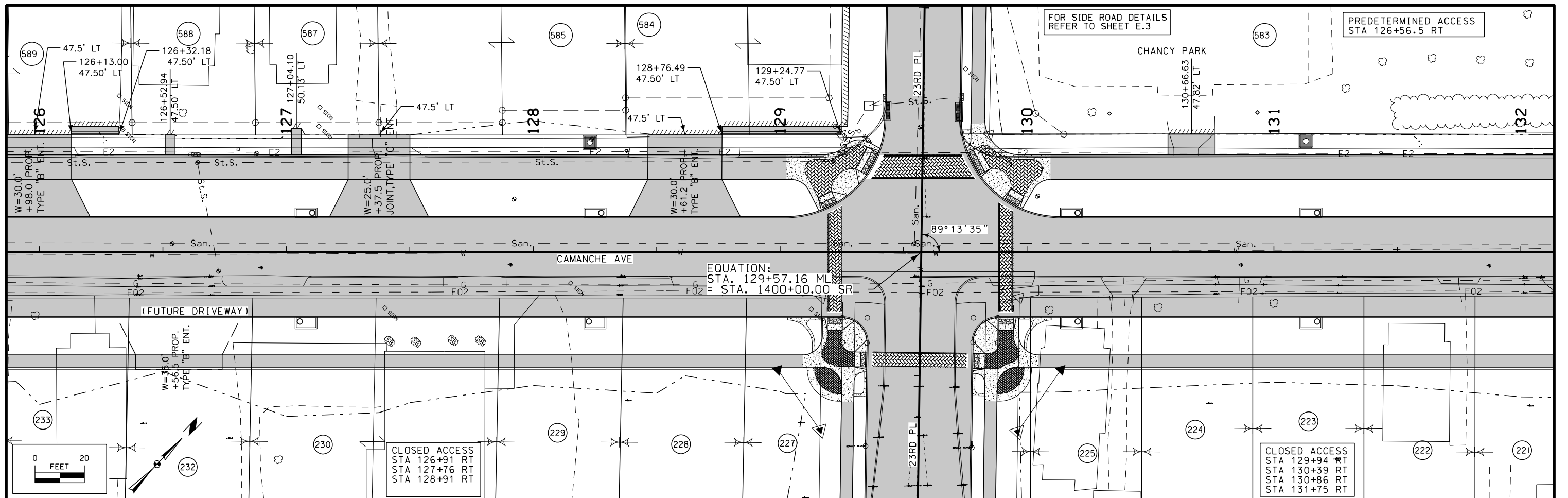

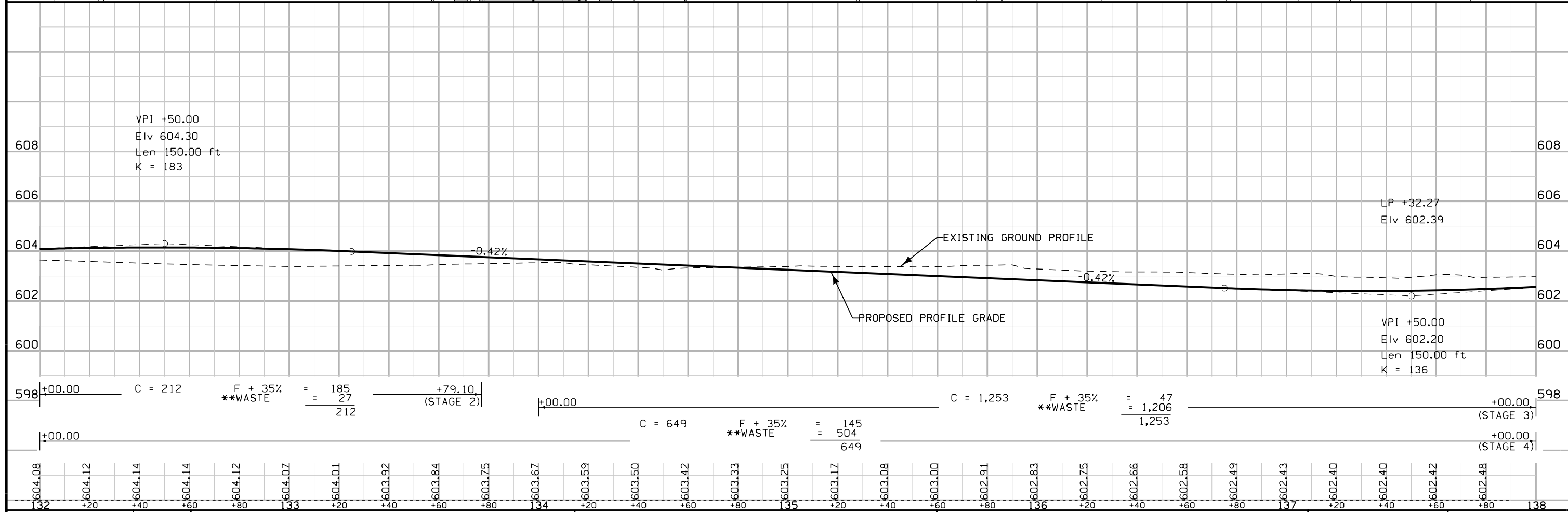
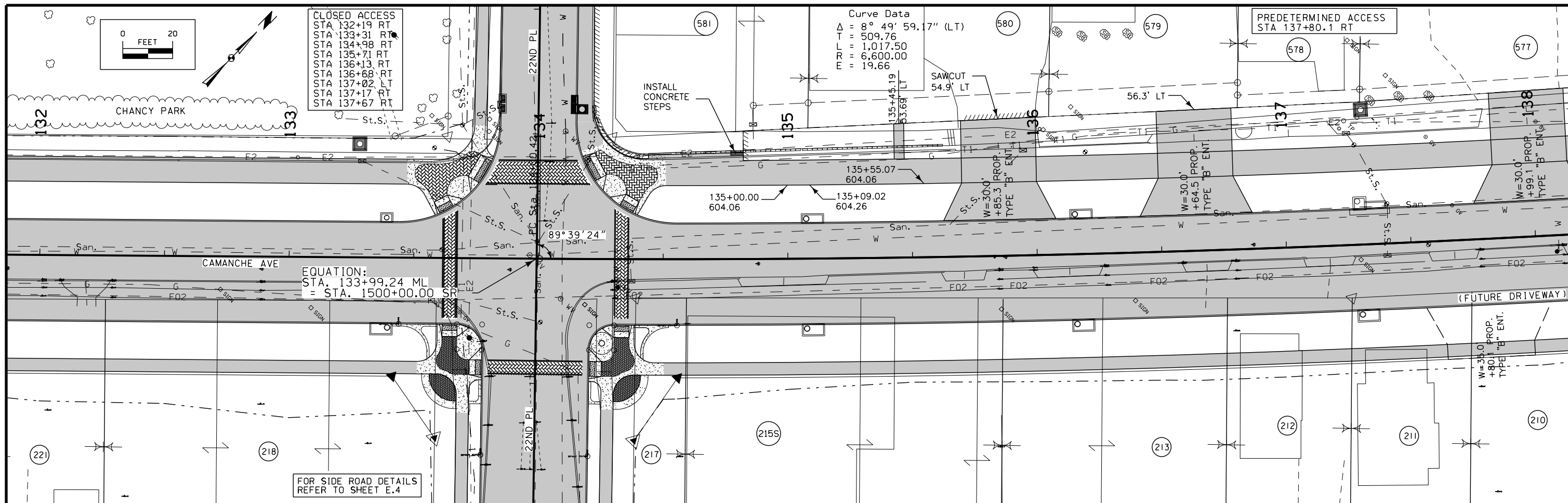

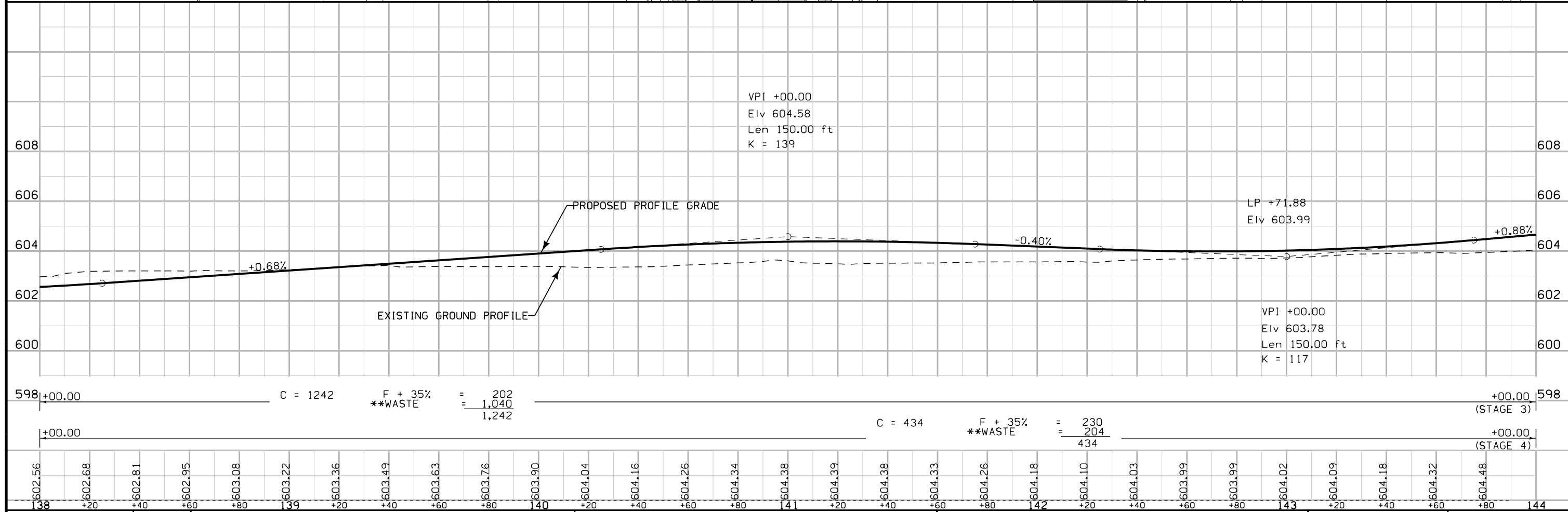
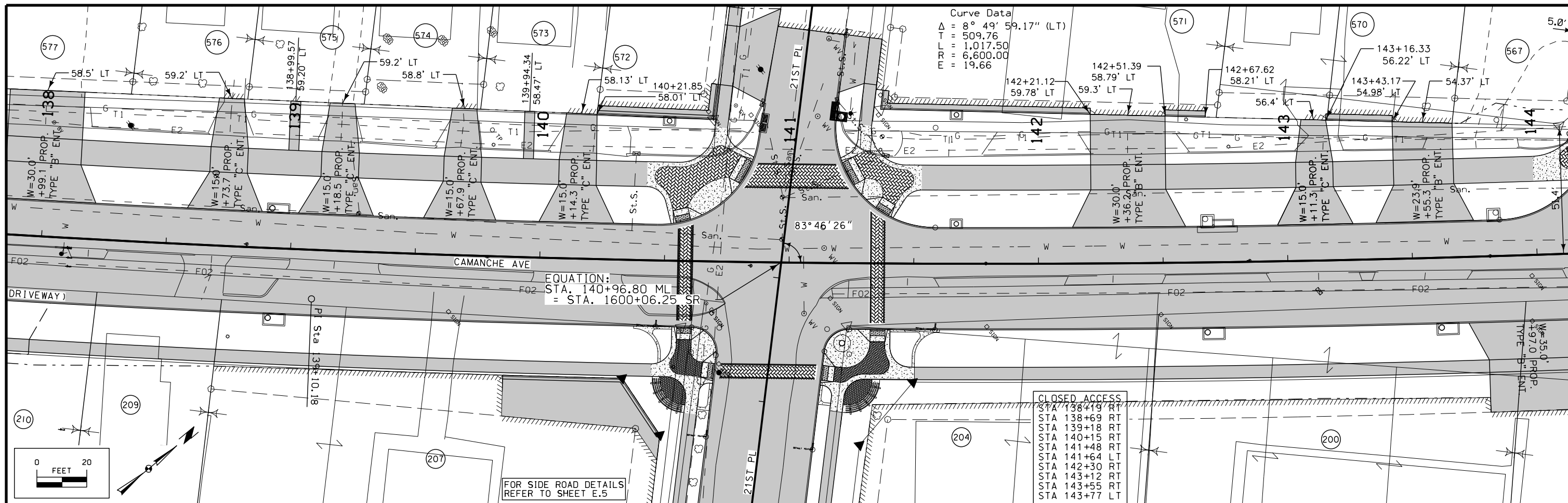

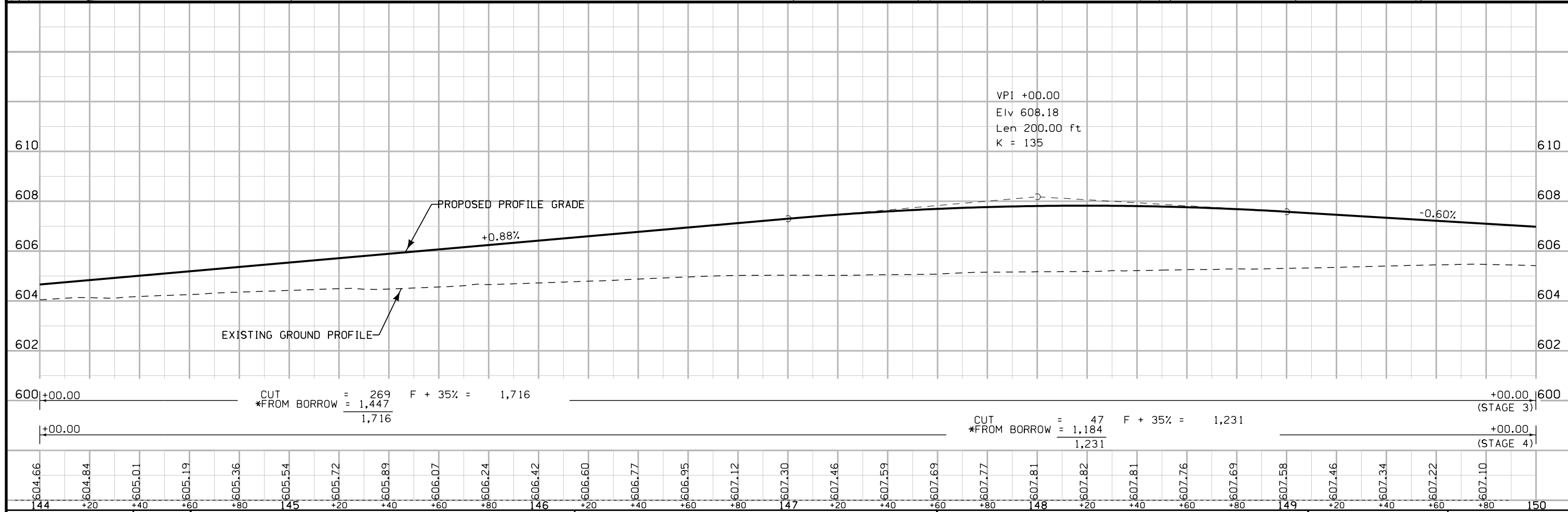
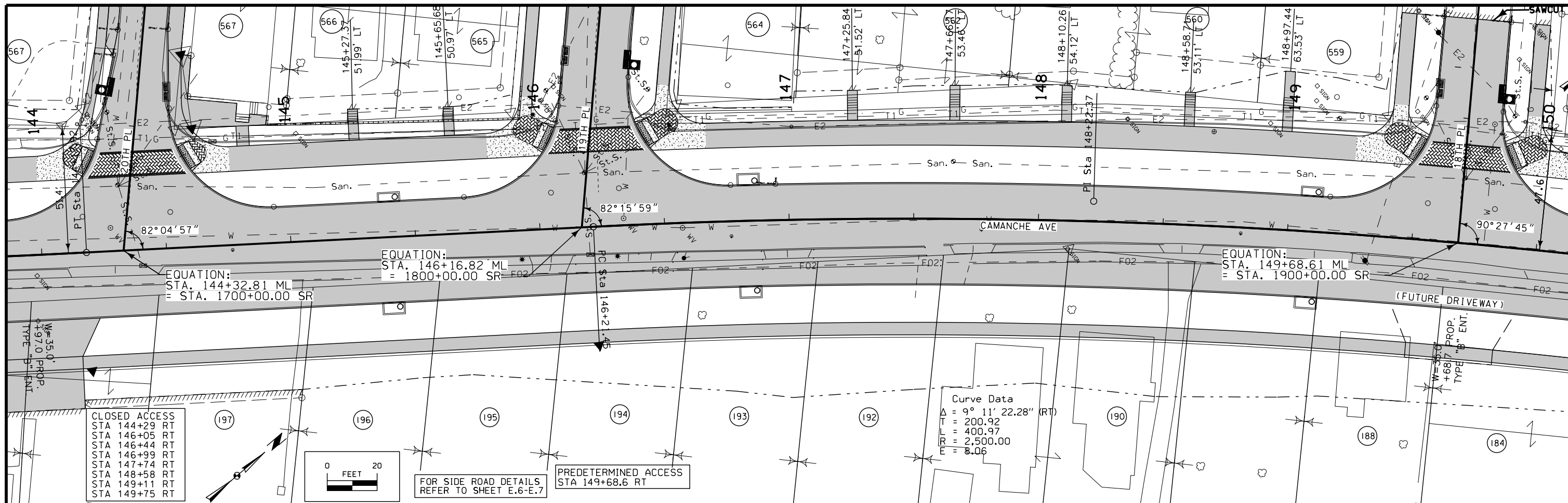

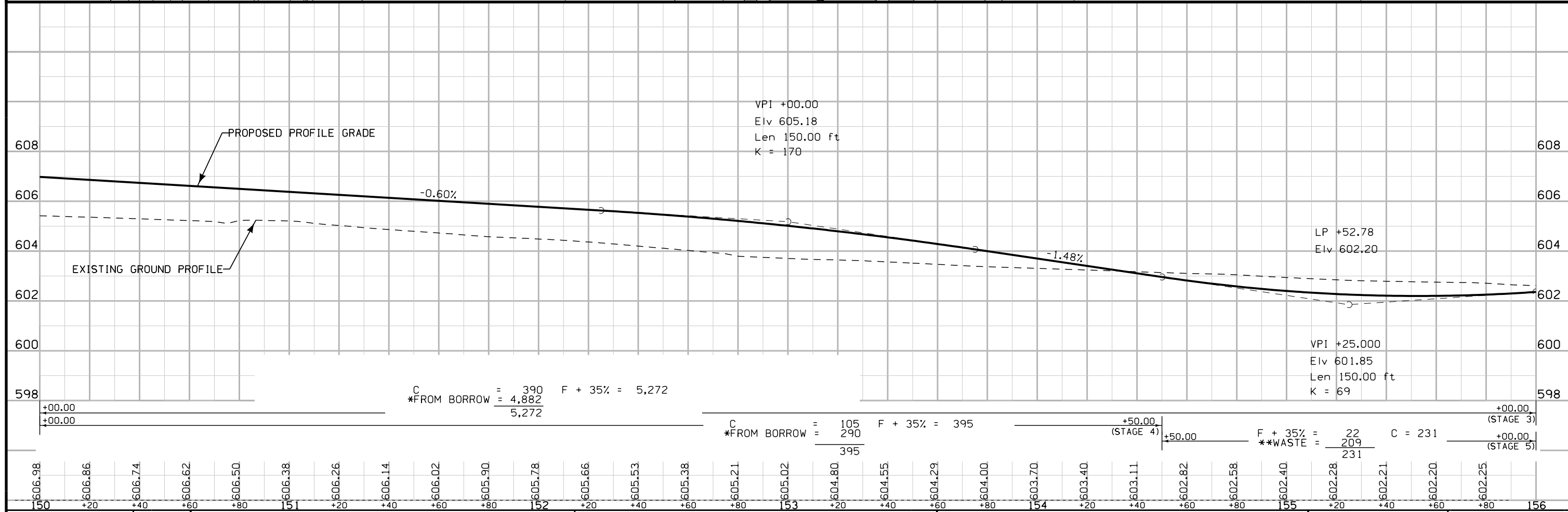
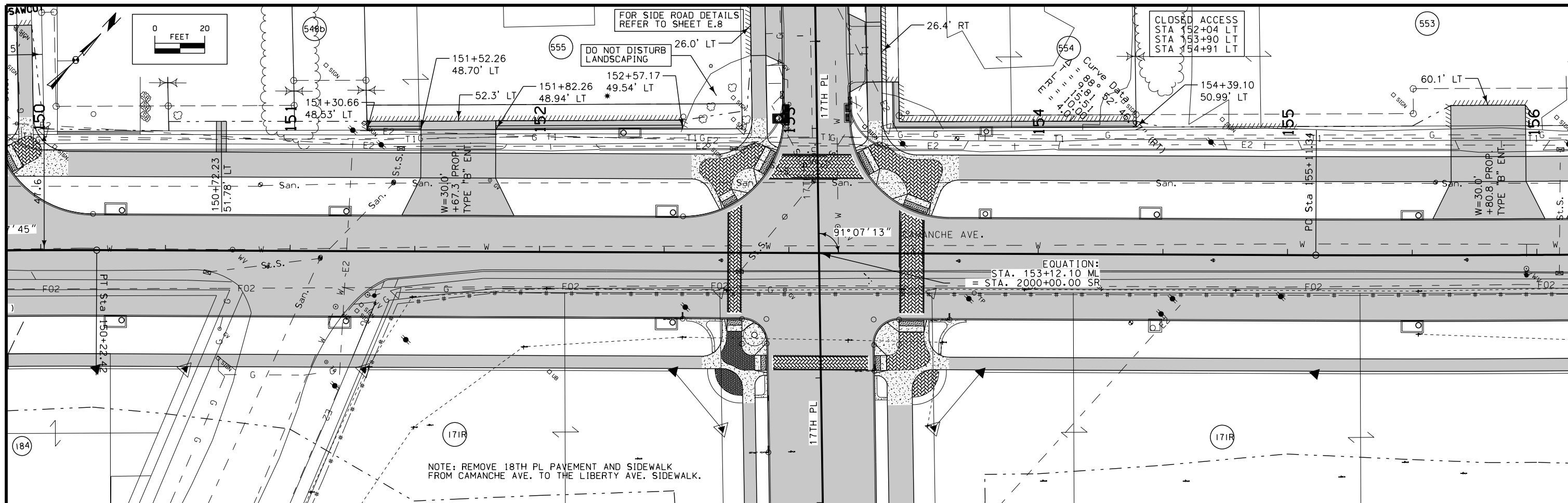

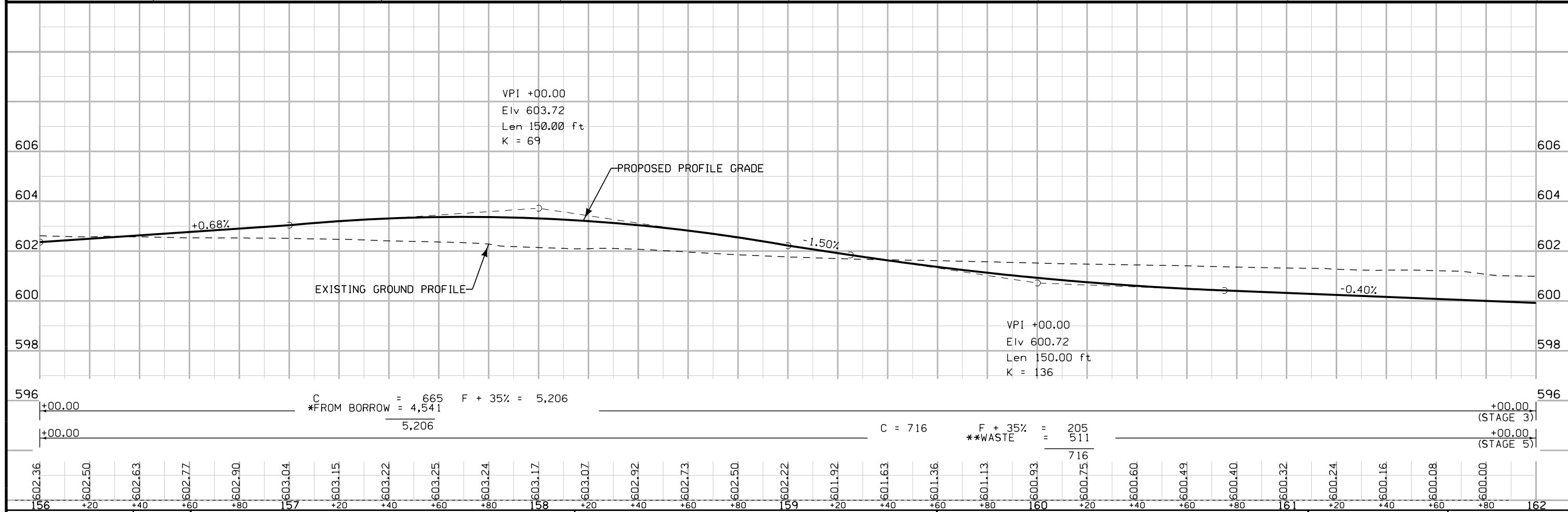
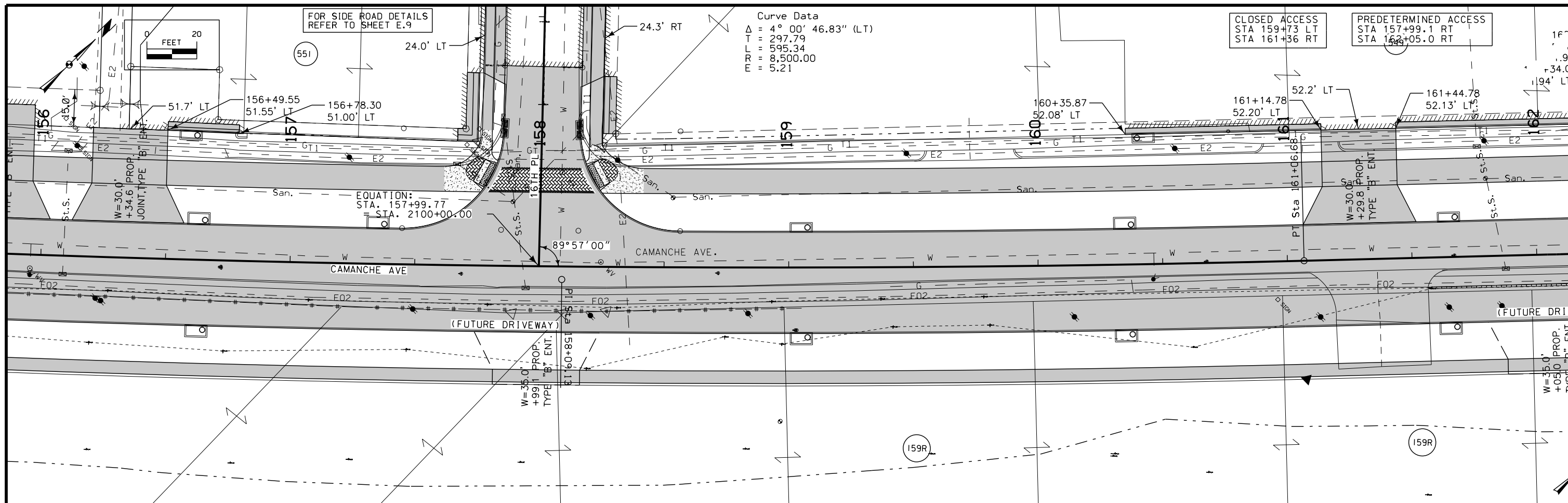



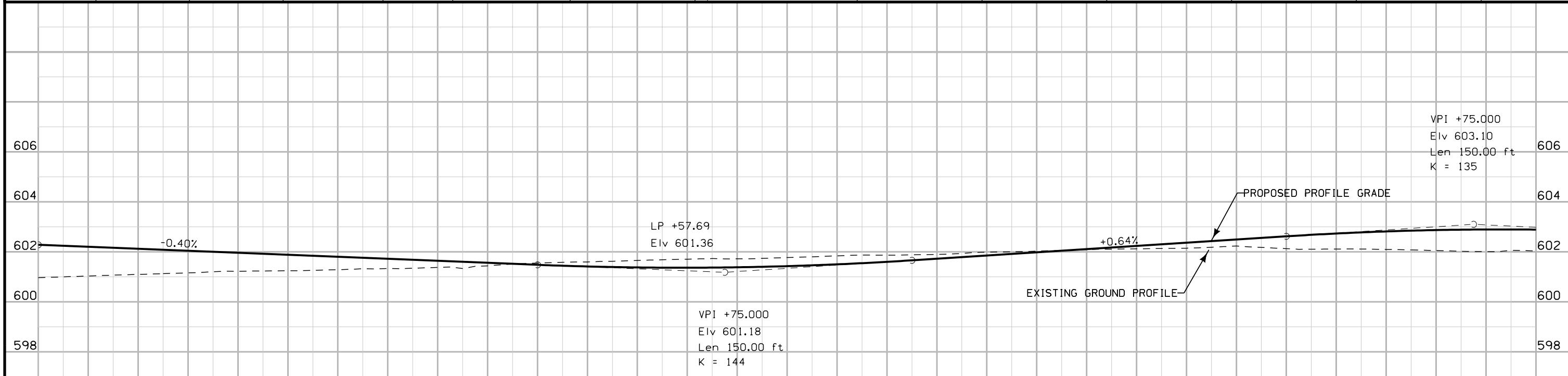
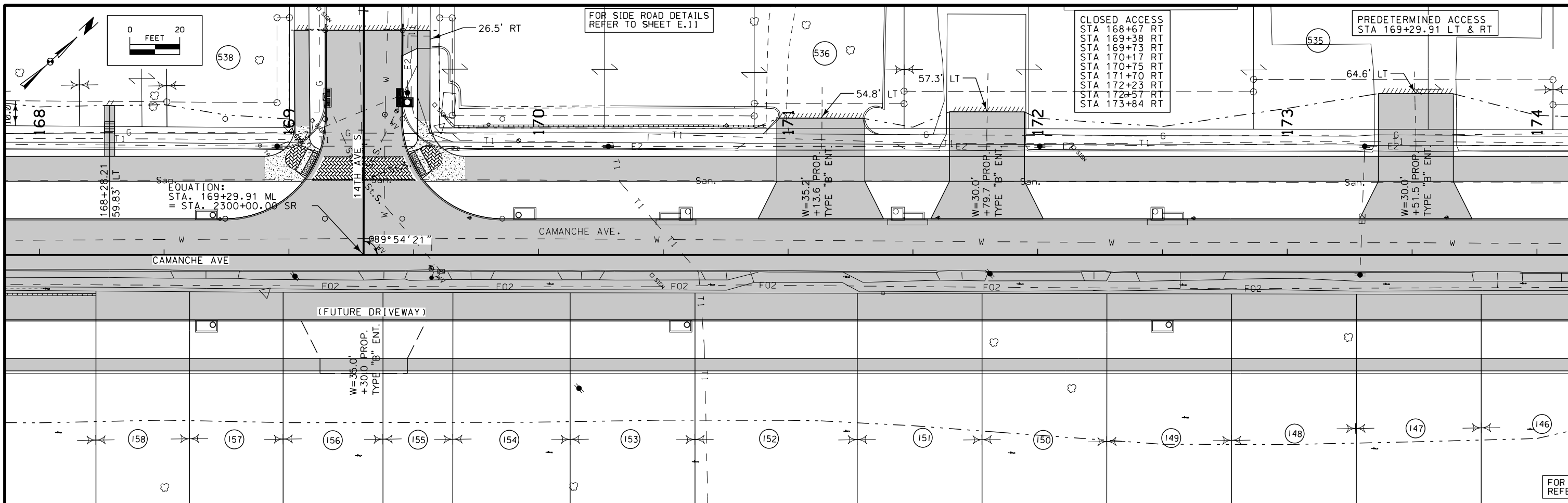

596	+00.00	C	= 822	F + 35% = 1,831		+00.00	596																							
		*FROM BORROW	= 1,009																											
			1,831																											
	+00.00		C = 452	F + 35% = 386		+00.00																								
			**WASTE = 66																											
				452																										
602.28	602.20	602.12	602.04	601.96	601.88	601.80	601.72	601.64	601.56	601.48	601.41	601.38	601.36	601.38	601.43	601.50	601.60	601.72	601.85	601.98	602.11	602.24	602.36	602.49	602.62	602.73	602.82	602.87	602.90	
168	+20	+40	+60	+80	169	+20	+40	+60	+80	170	+20	+40	+60	+80	171	+20	+40	+60	+80	172	+20	+40	+60	+80	173	+20	+40	+60	+80	174



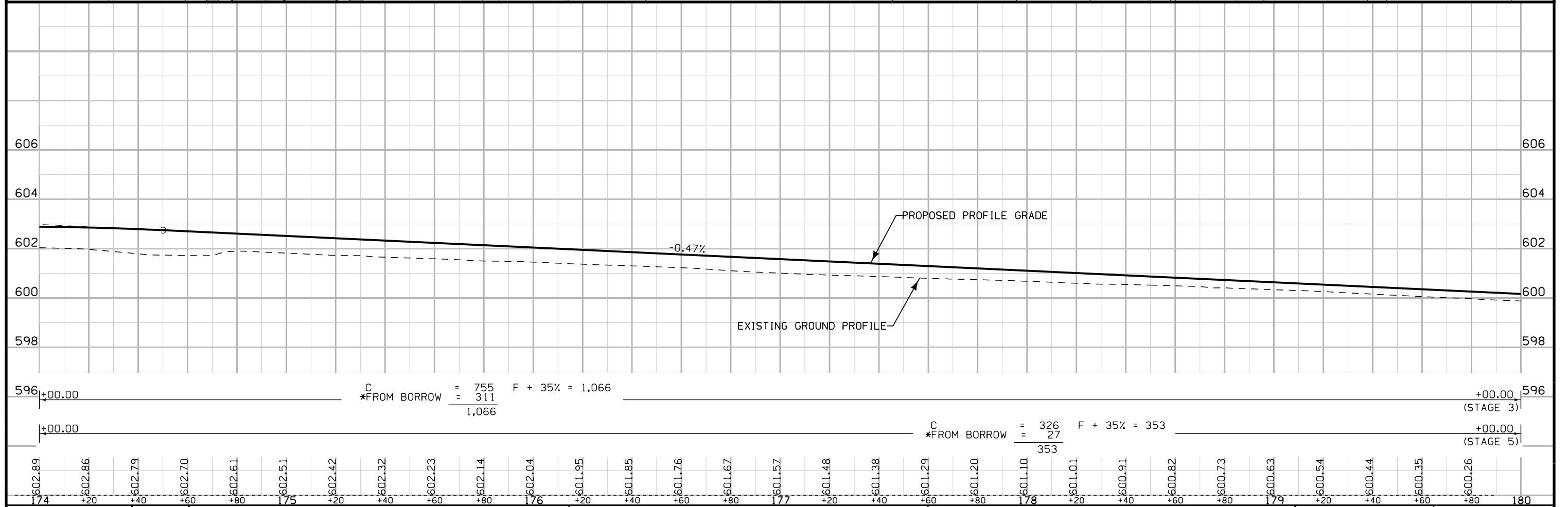
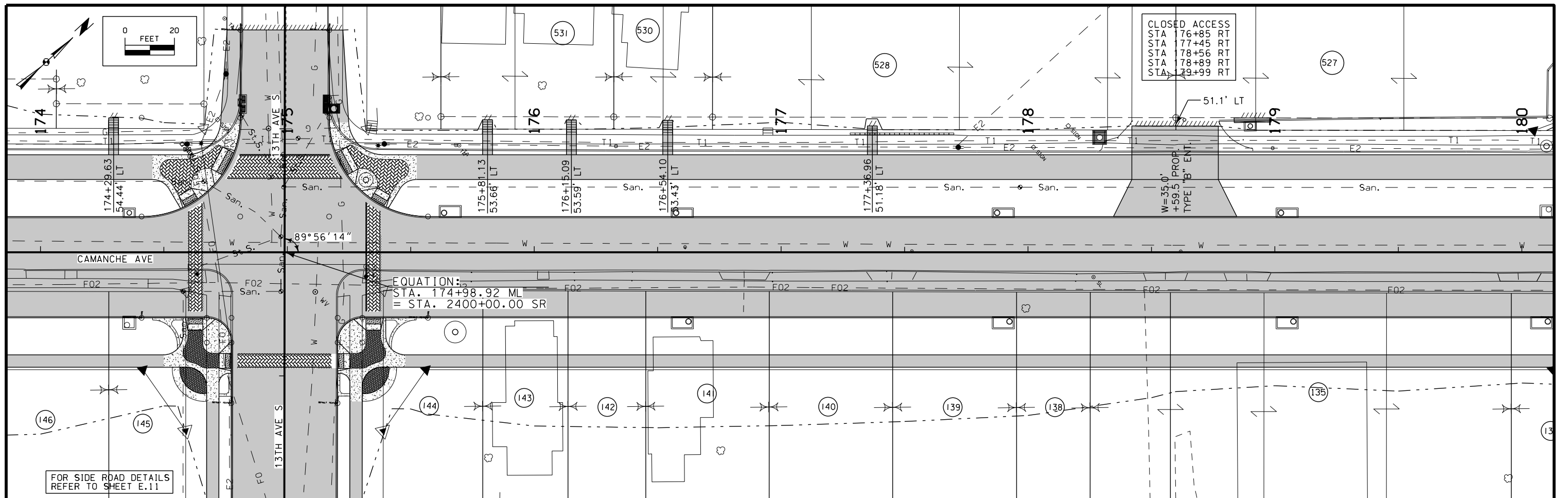

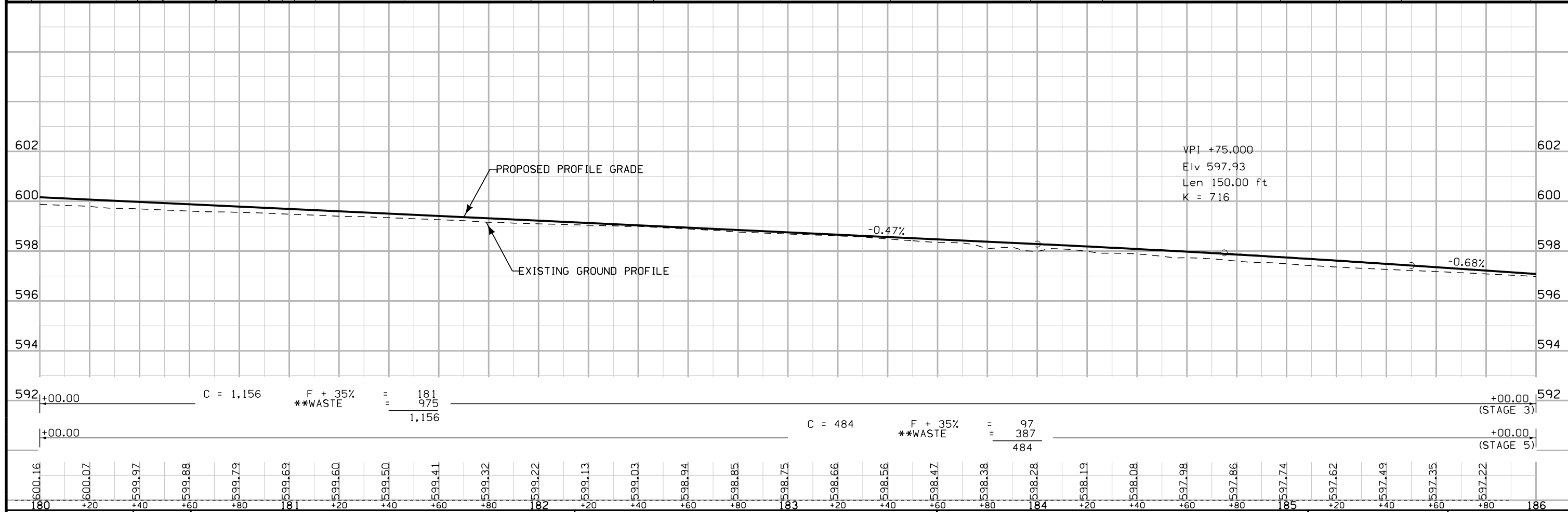
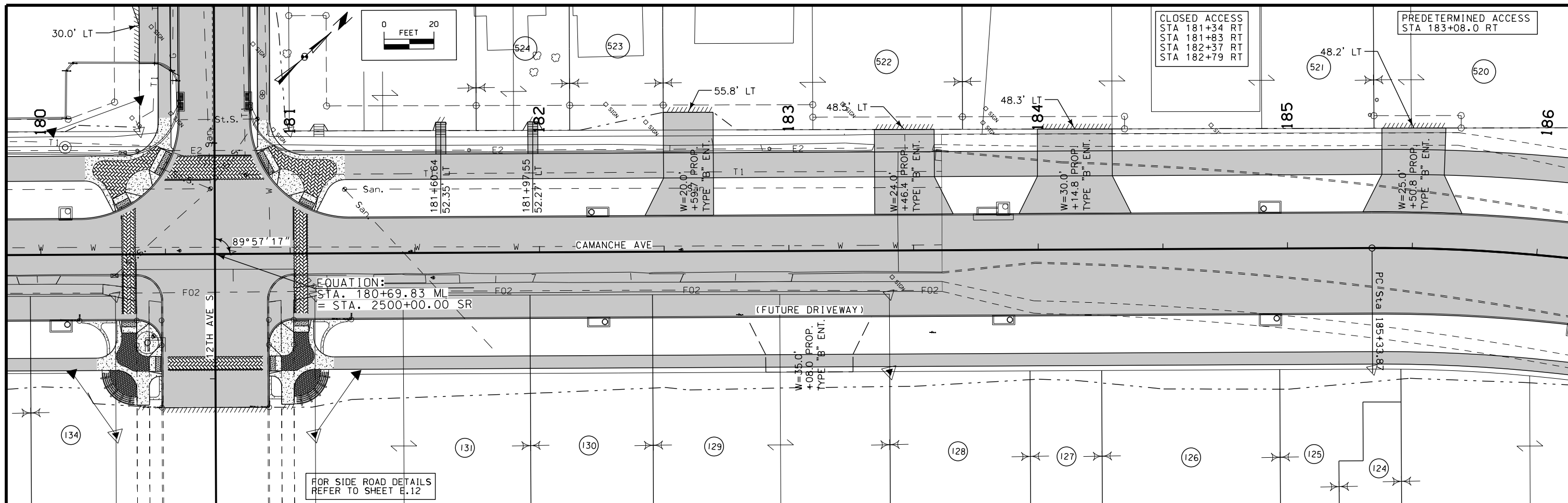

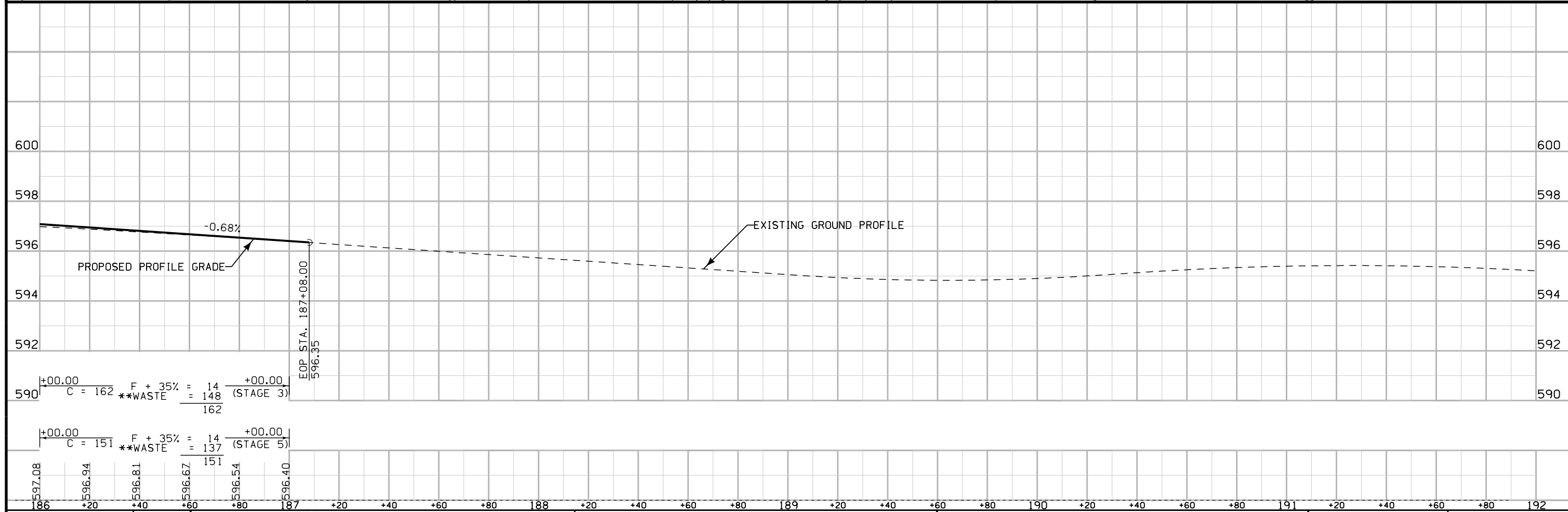
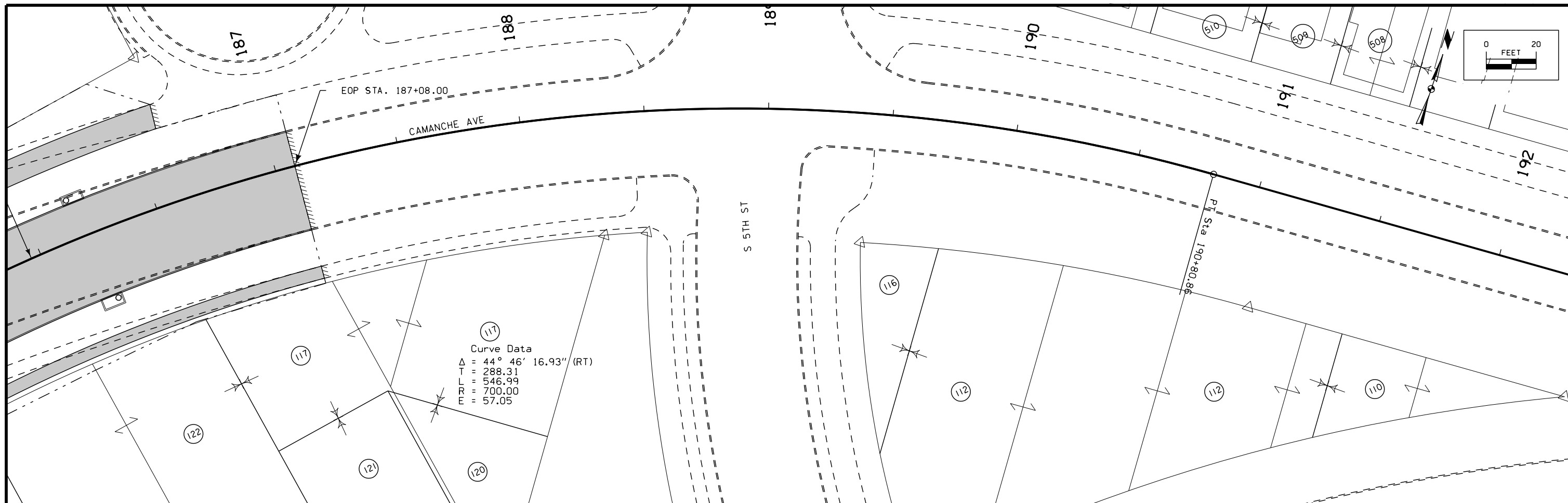

Curve Data  
 $\Delta = 26^\circ 35' 50.09''$  (RT)  
 T = 35.45  
 L = 69.63  
 R = 150.00  
 E = 4.13

EQUATION:  
 STA. 1200+00.00 SR  
 = STA. 104+44.45 ML

CLOSED ACCESS  
 STA 1198+10 LT  
 STA 1198+10 RT  
 STA 1200+45 LT

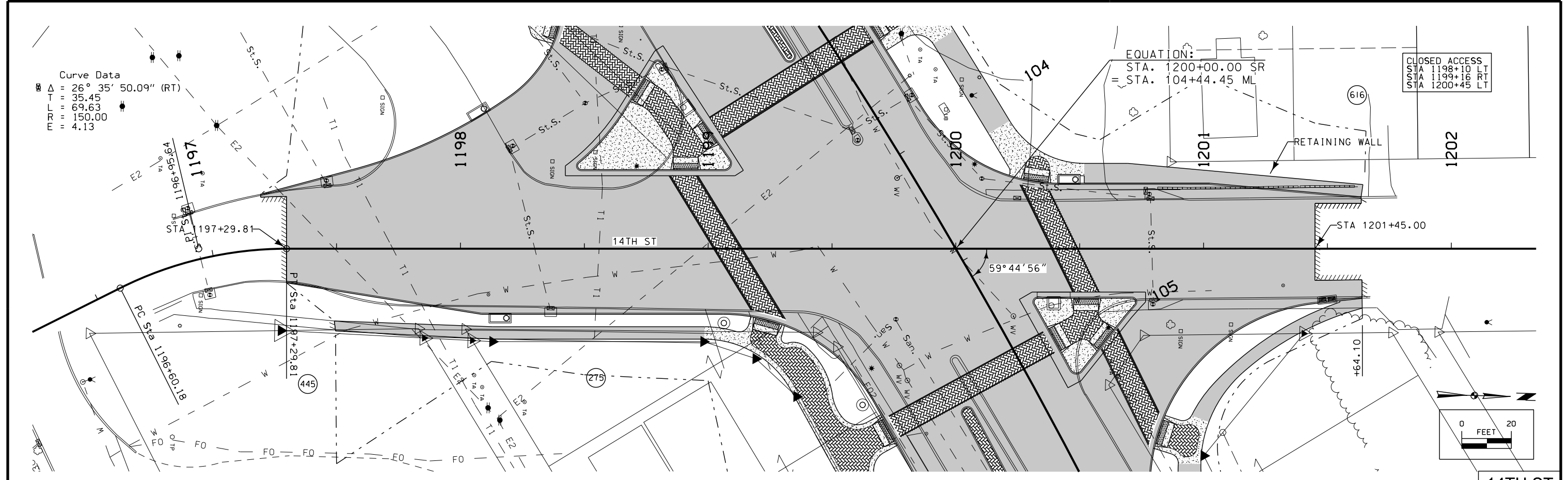

14TH ST

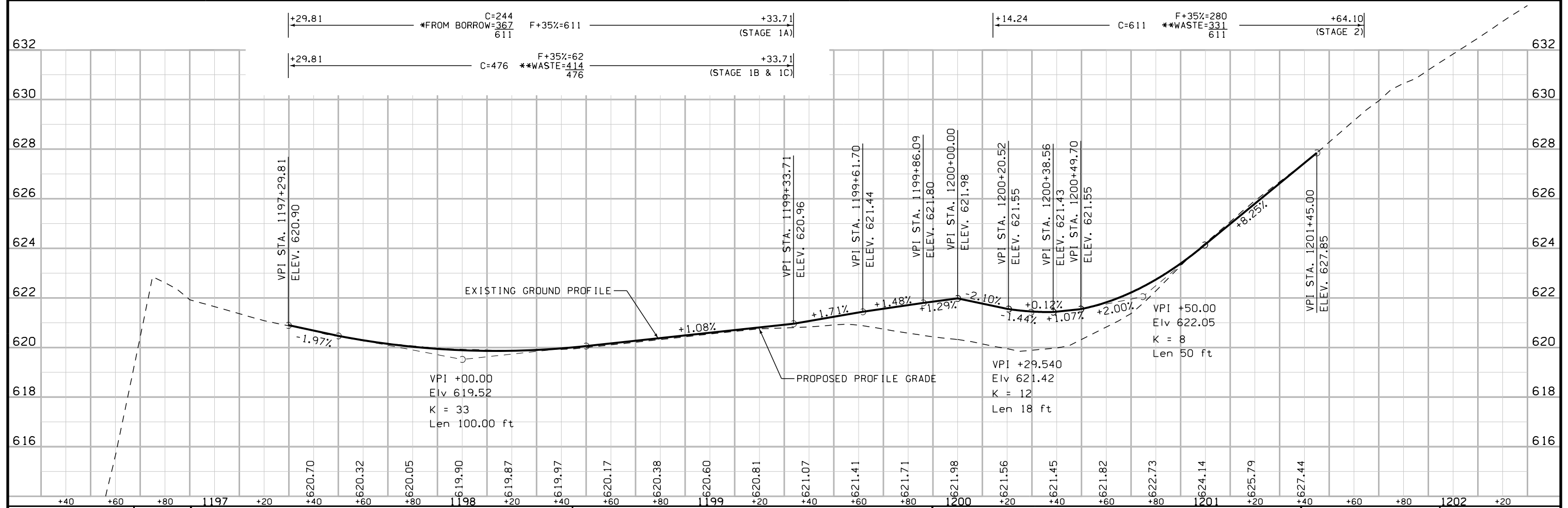

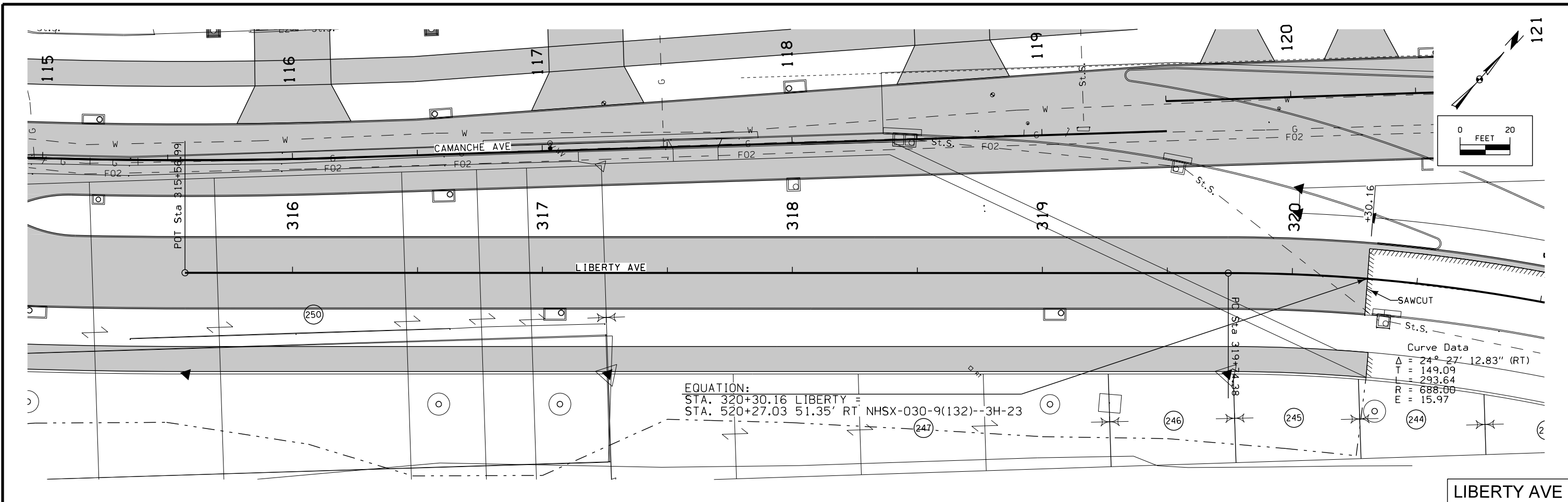

EQUATION:  
 STA. 320+30.16 LIBERTY =  
 STA. 520+27.03 51.35' RT NHSX-030-9(132)--3H-23

Curve Data  
 $\Delta = 24^\circ 27' 12.83''$  (RT)  
 $T = 149.09$   
 $L = 293.64$   
 $R = 688.00$   
 $E = 15.97$

LIBERTY AVE

+56.99 C=3979 F+35% = 438 \*\*WASTE=3541 3979 +30.16 (STAGE 1A)

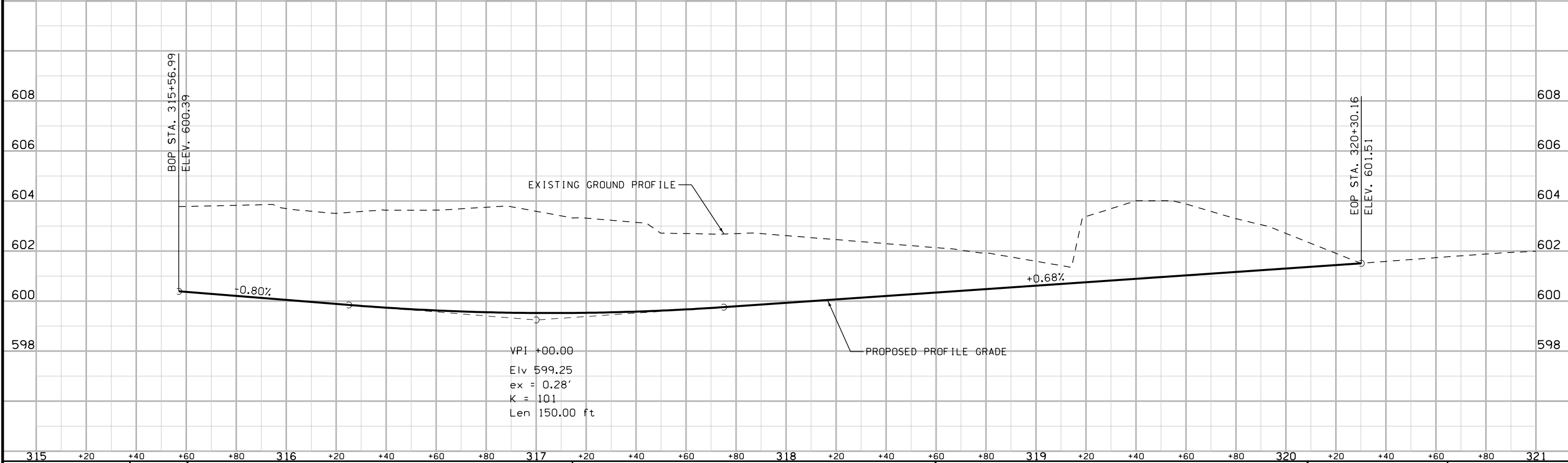

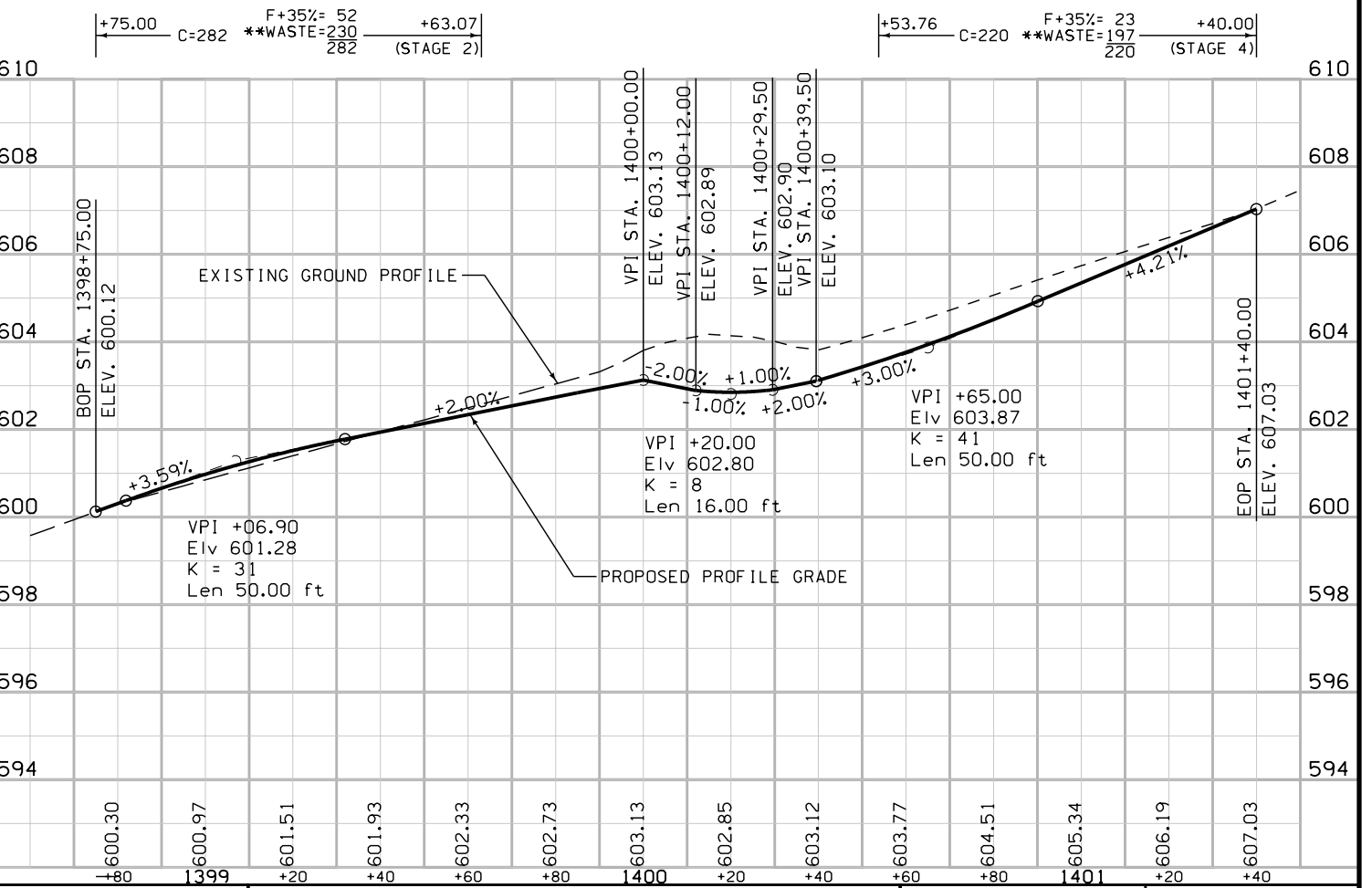
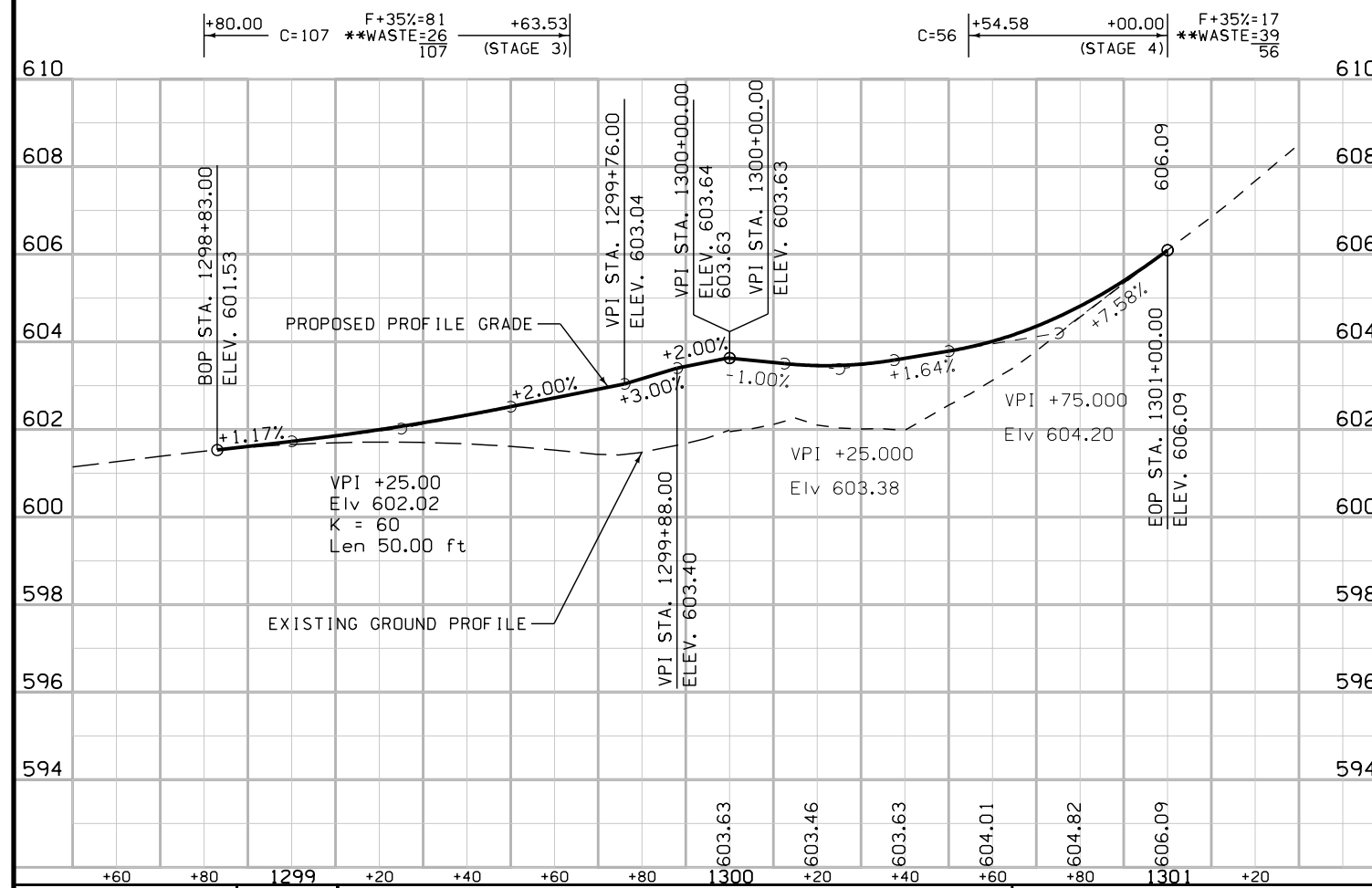
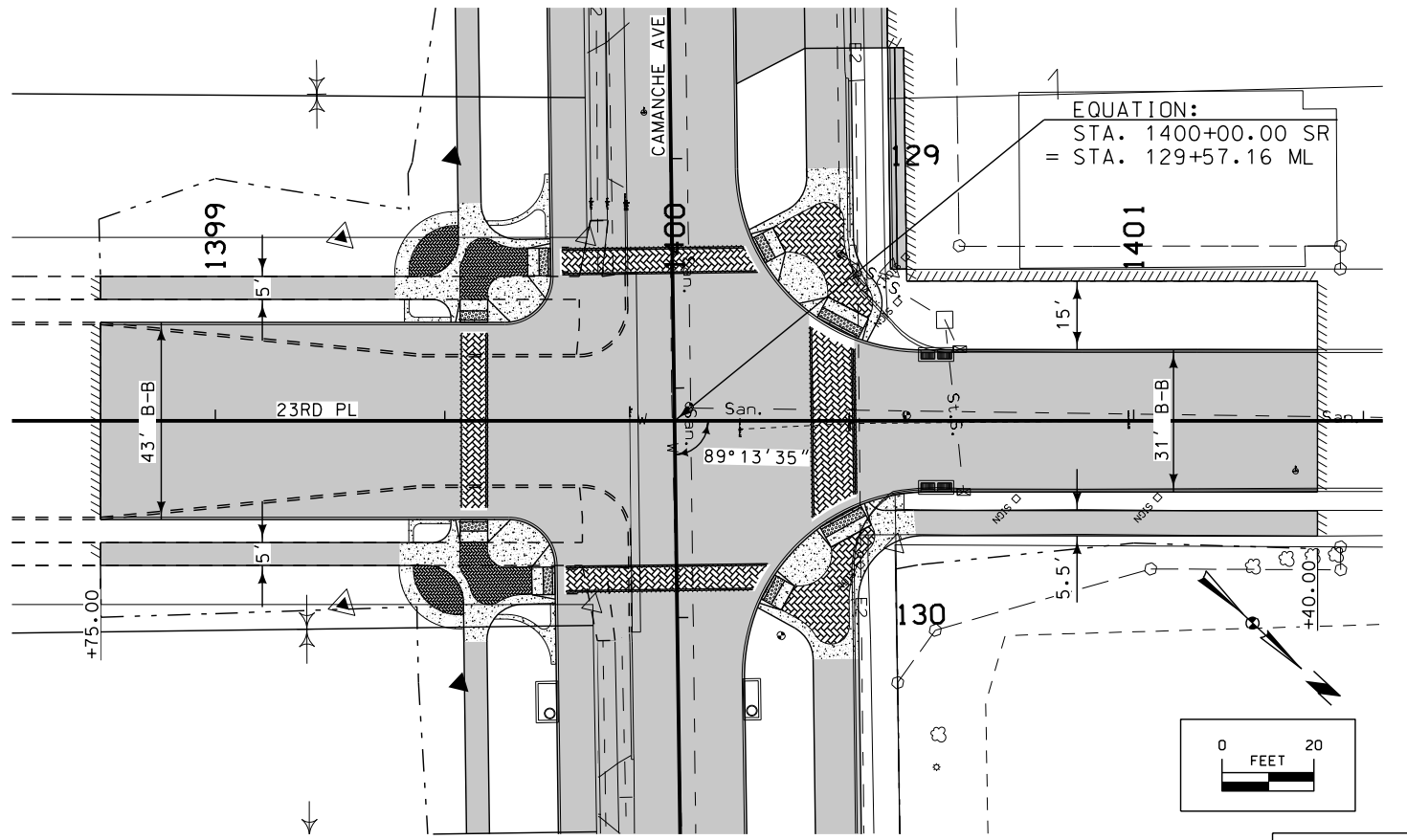
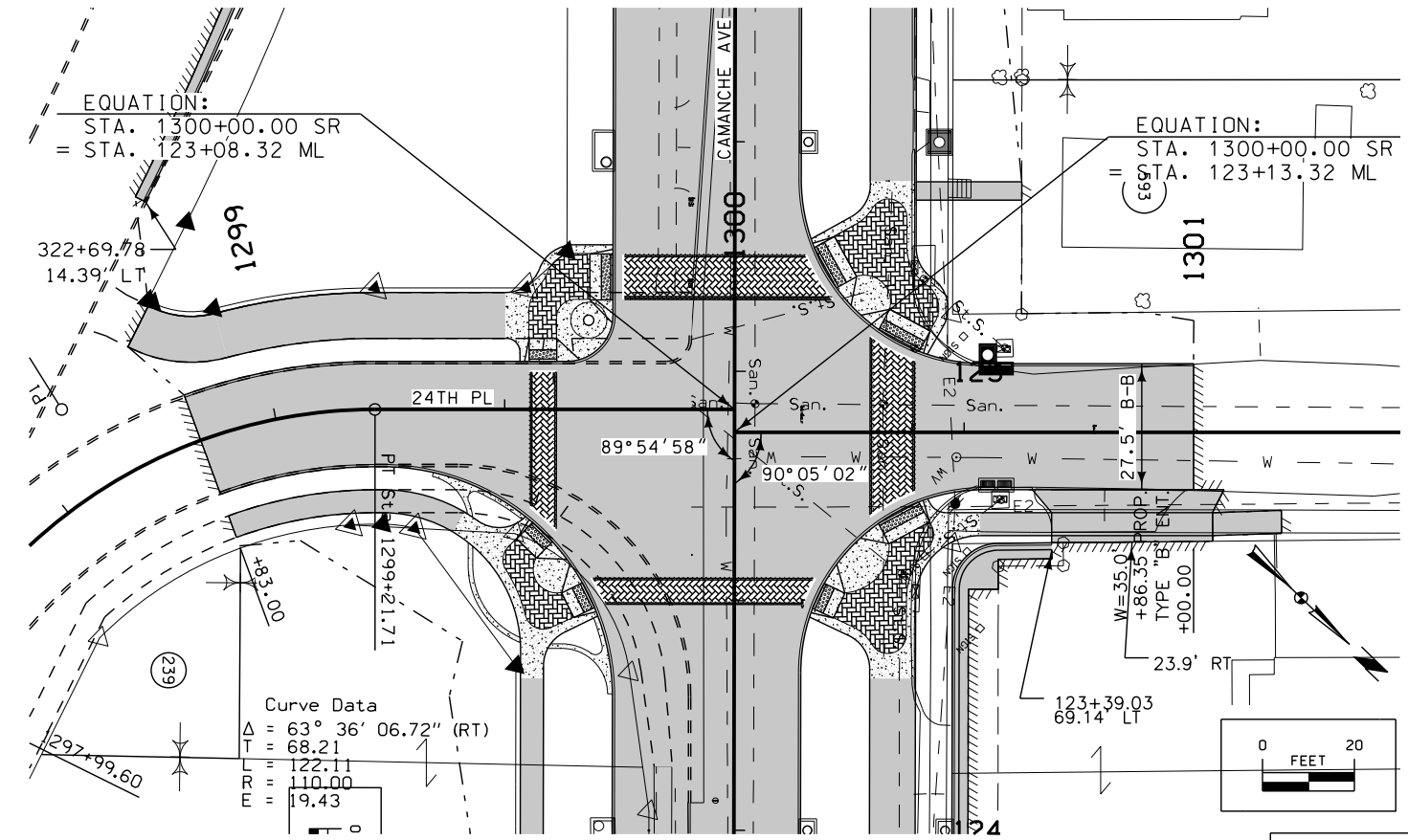

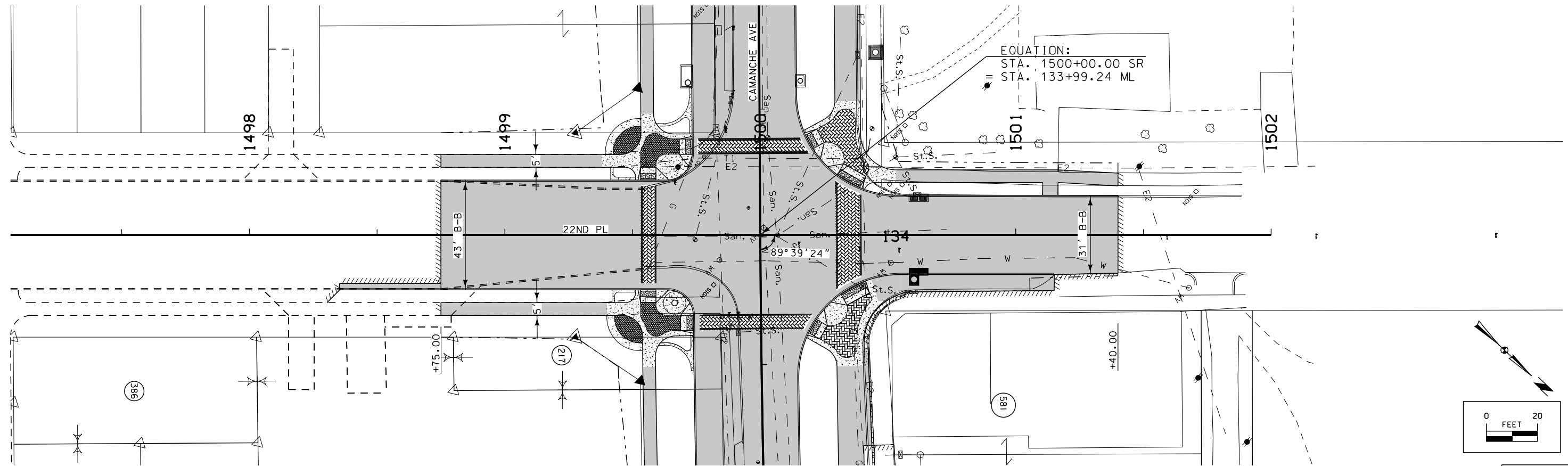

22ND PL

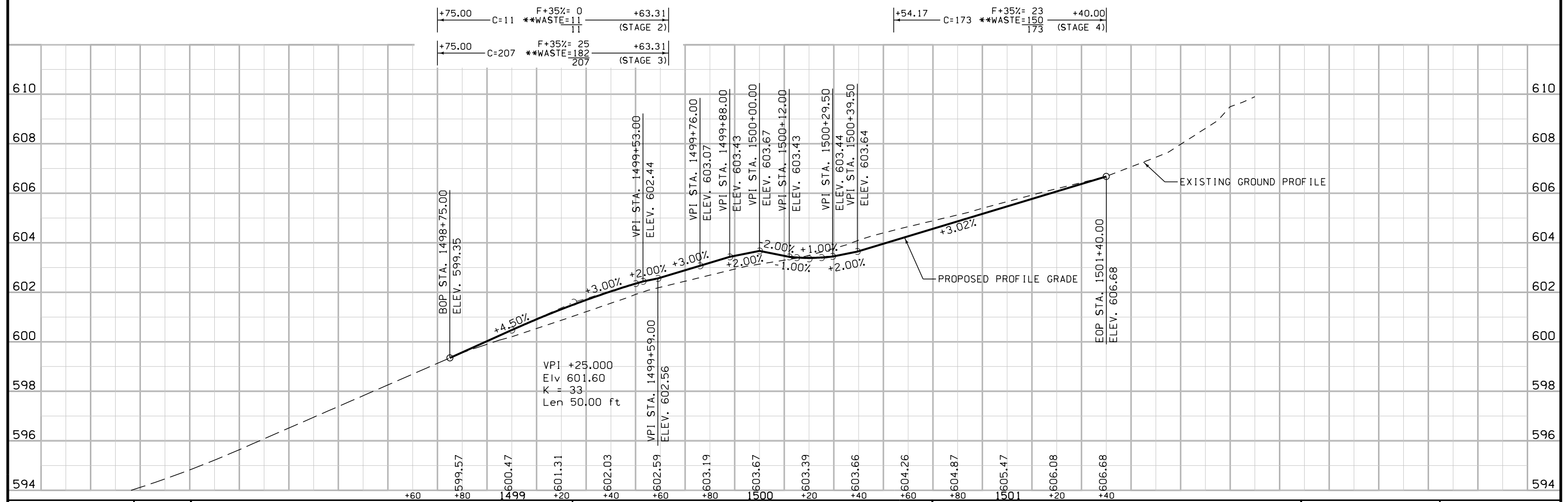

+75.00 C=11 F+35%= 0 \*\*WASTE=11 (STAGE 2)  
 +75.00 C=207 F+35%= 25 \*\*WASTE=182 (STAGE 3)  
 207

+54.17 C=173 F+35%= 23 \*\*WASTE=150 (STAGE 4)  
 173

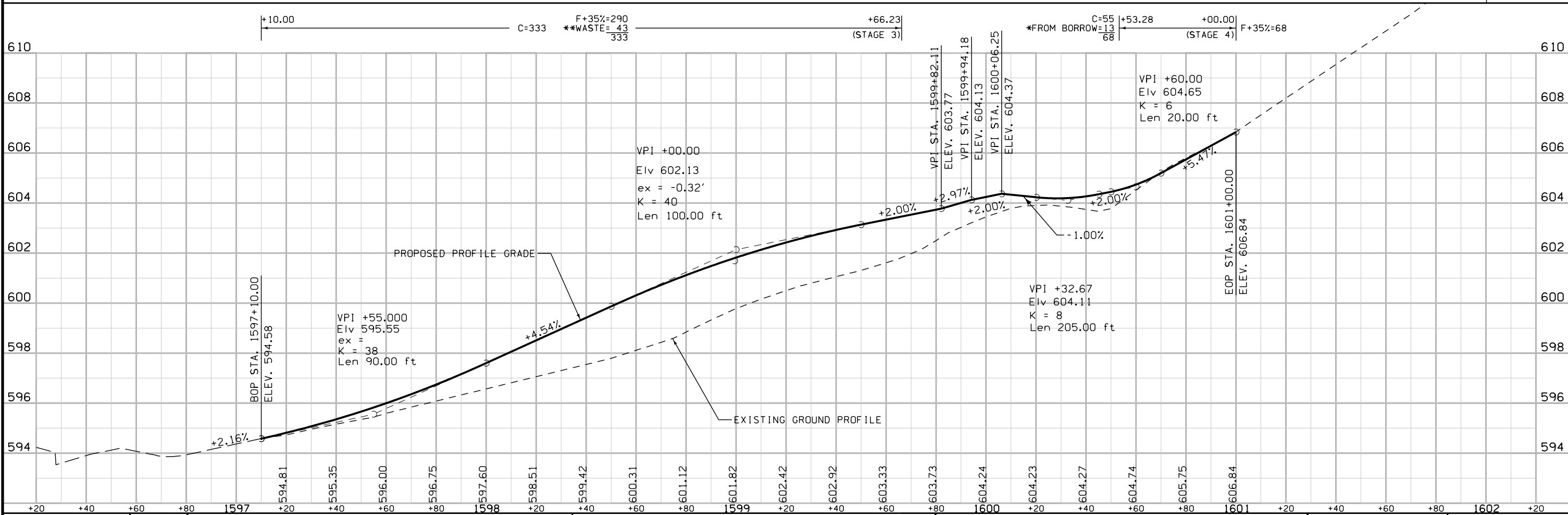
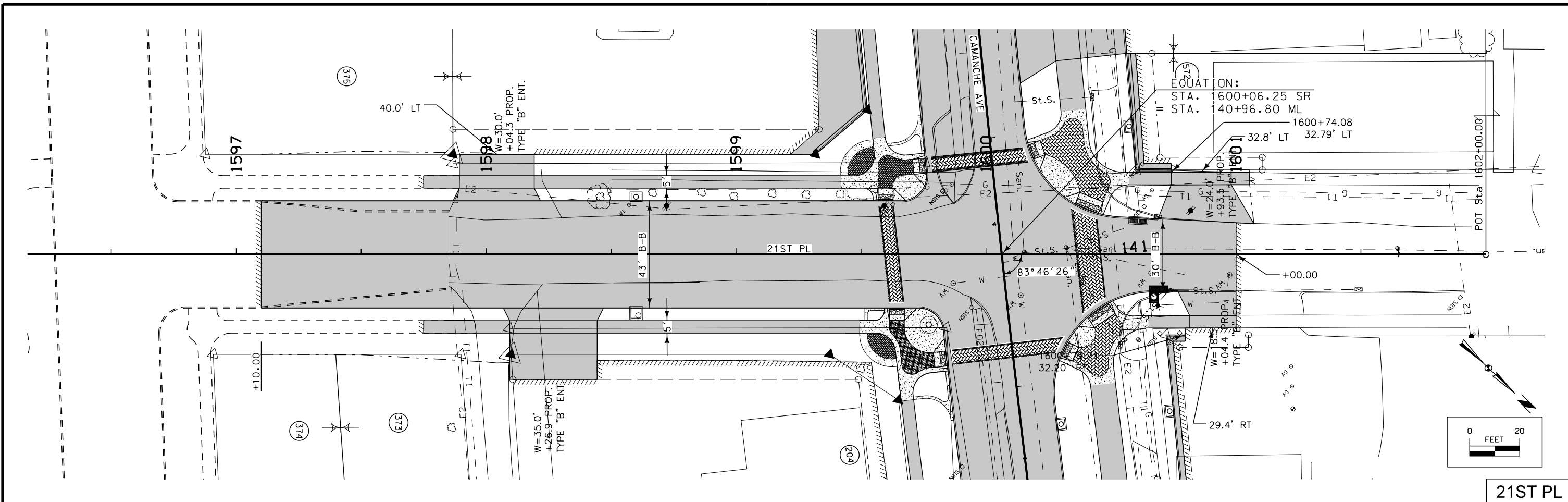



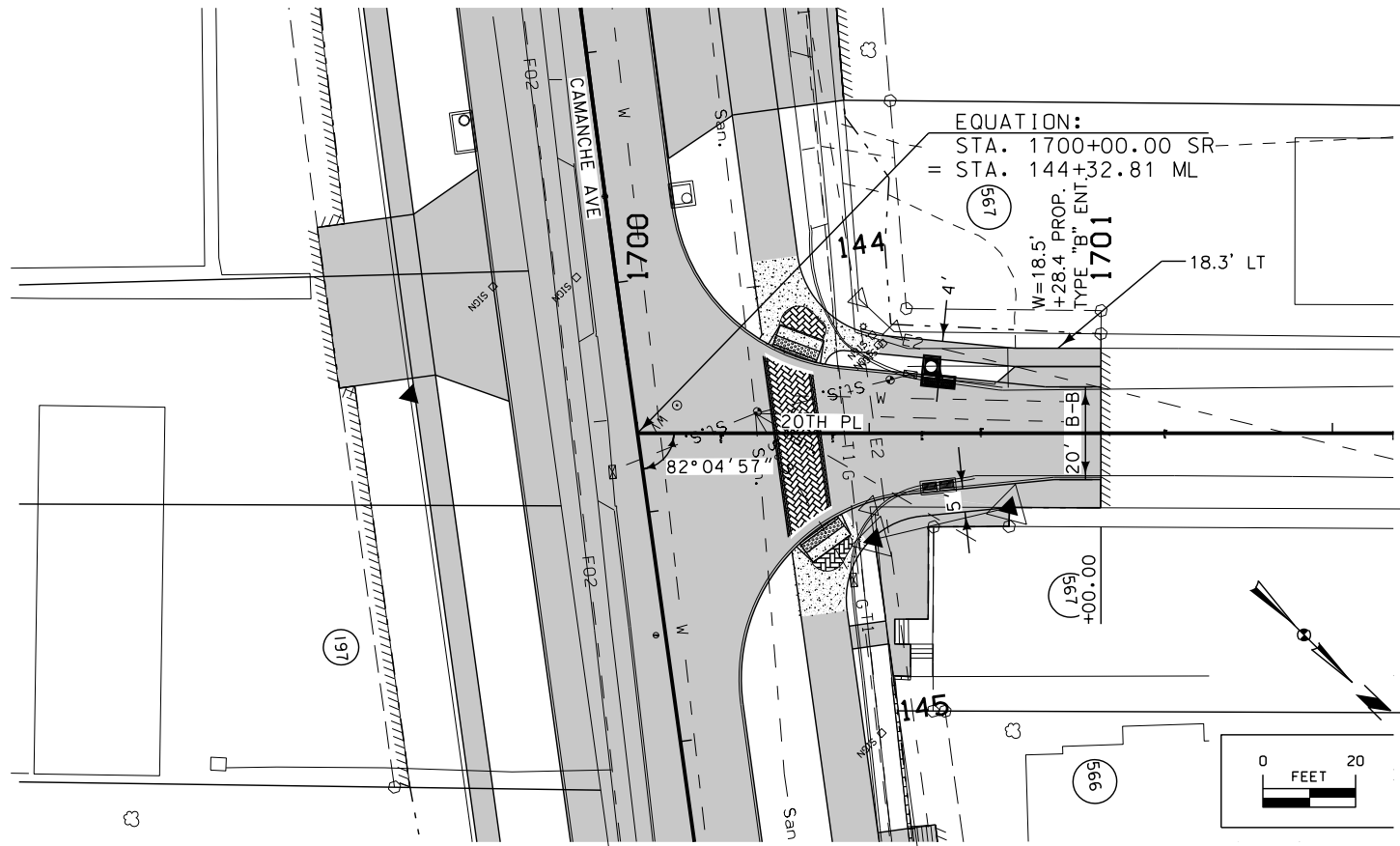

20TH PL

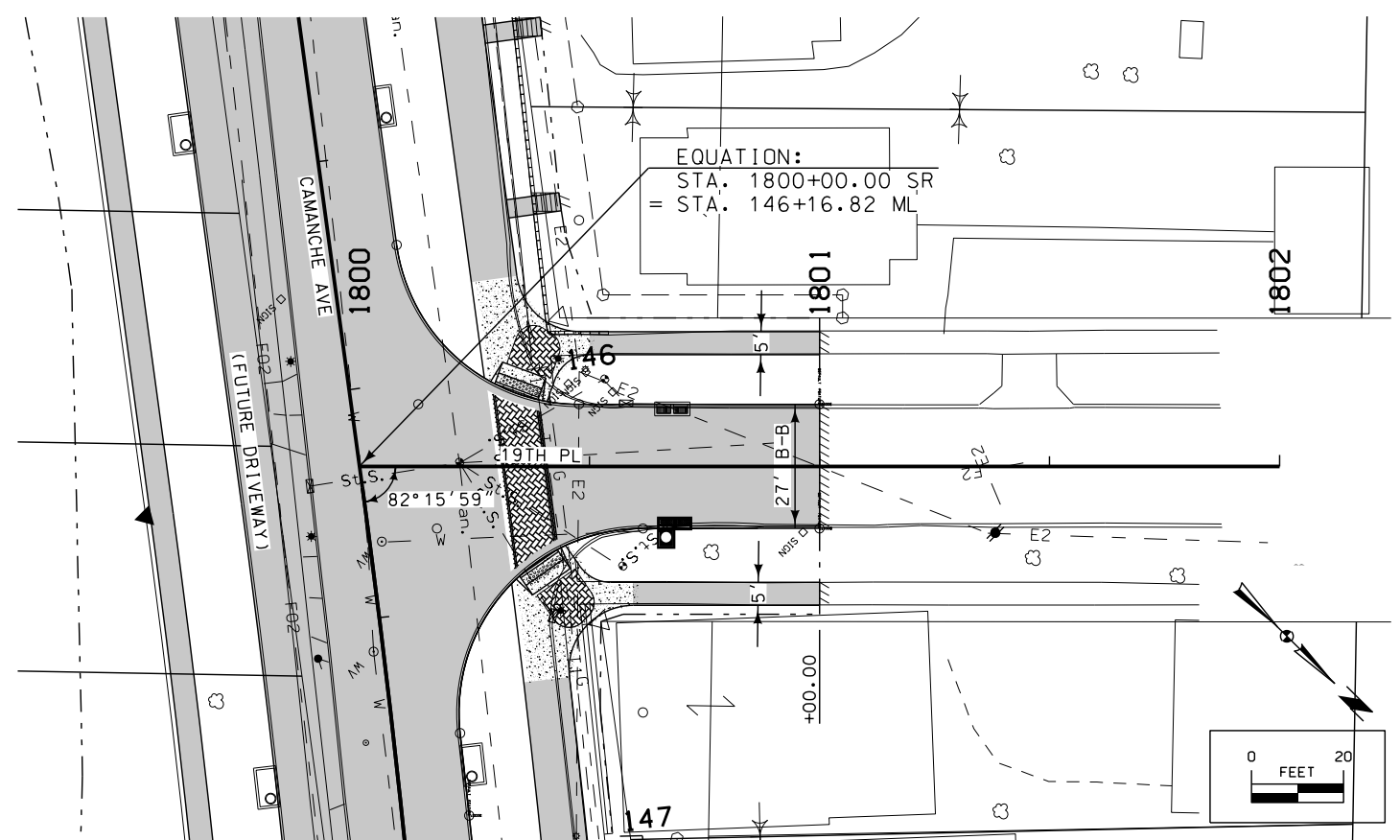

19TH PL

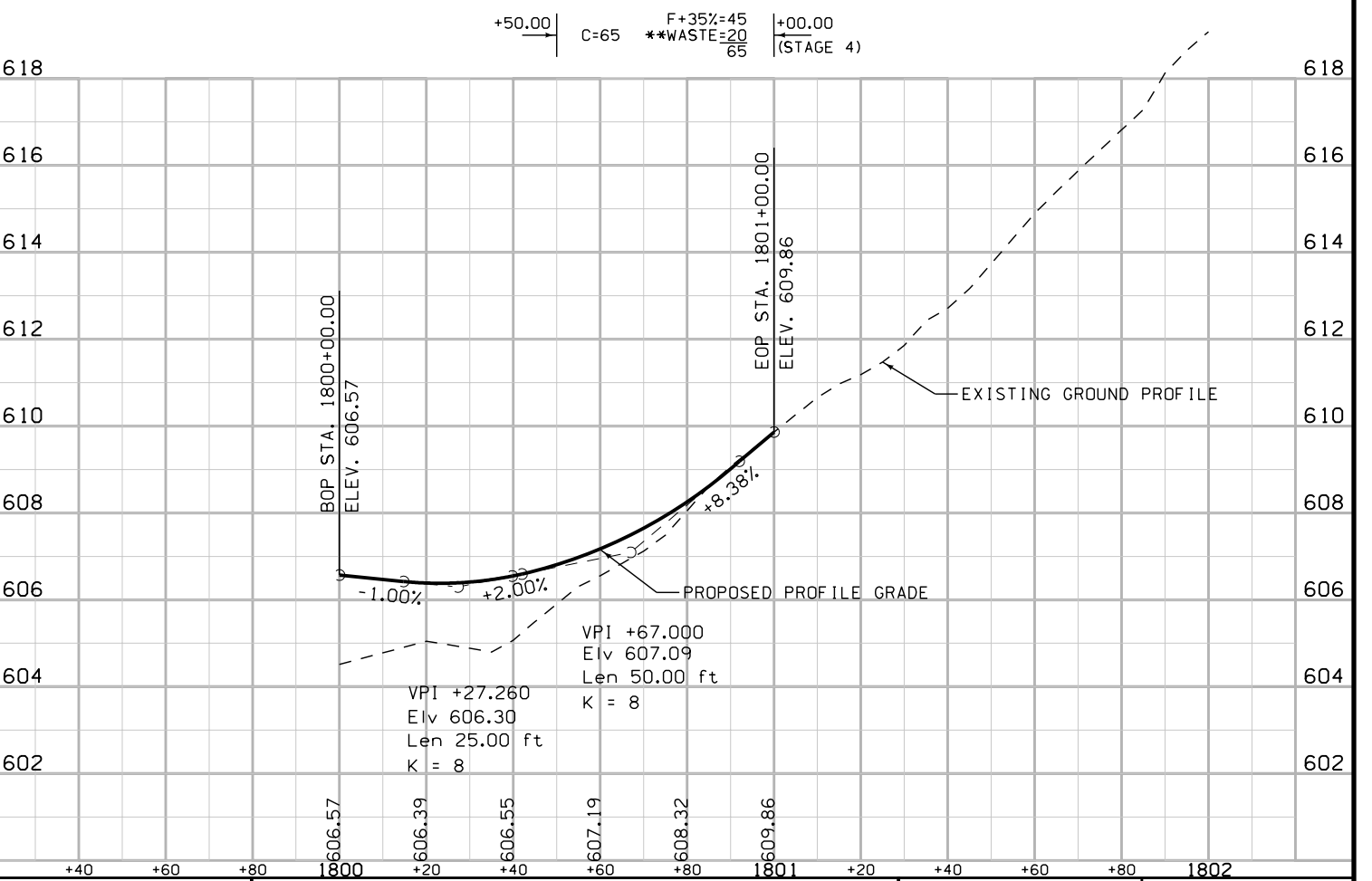
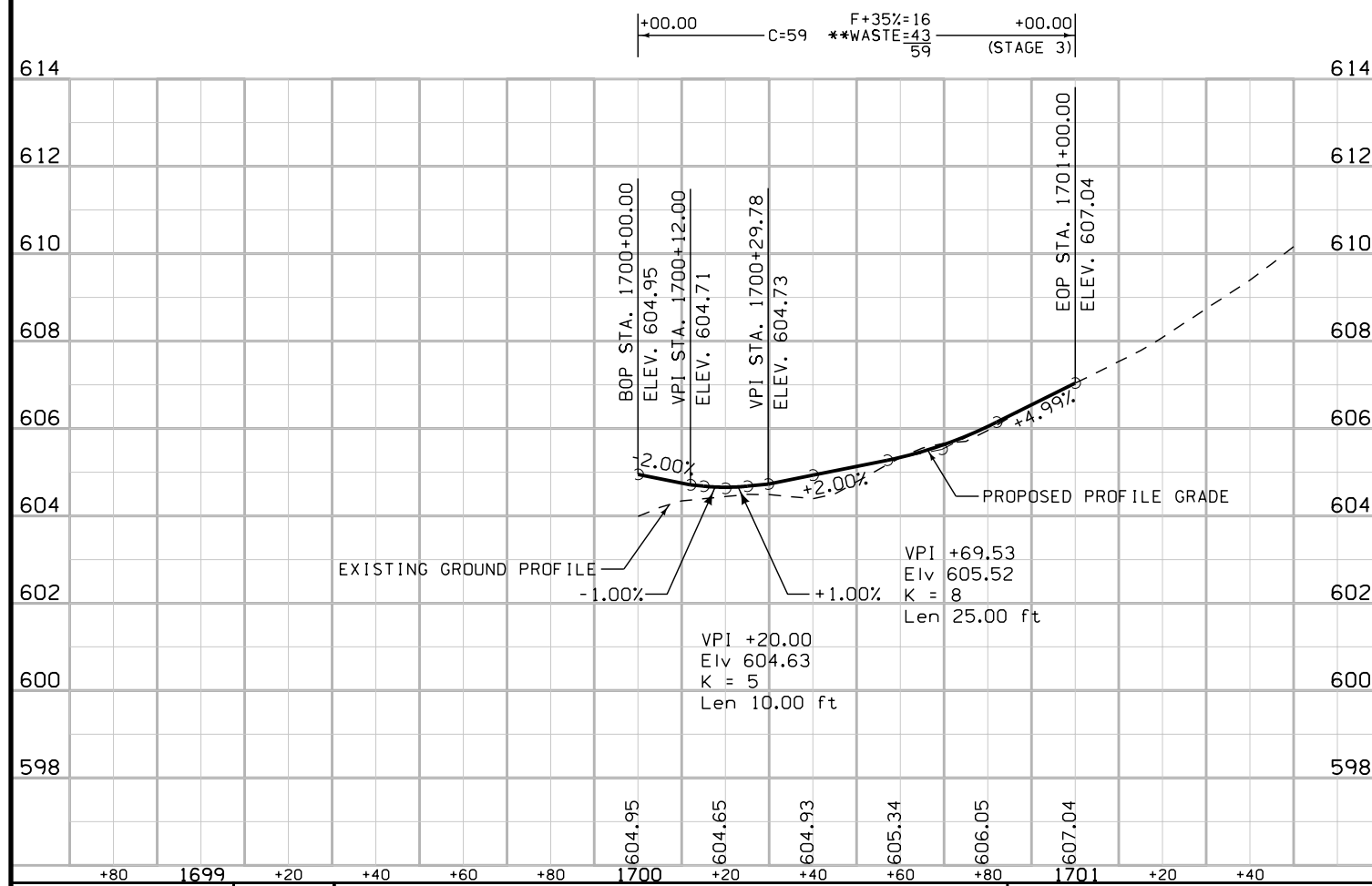

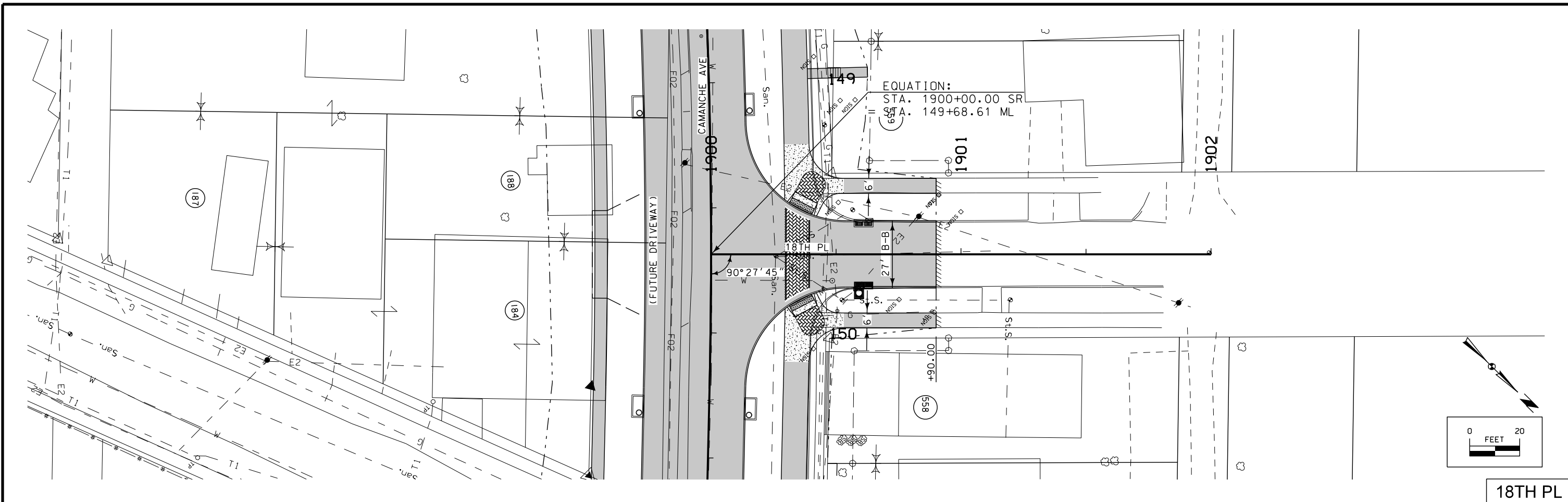

18TH PL

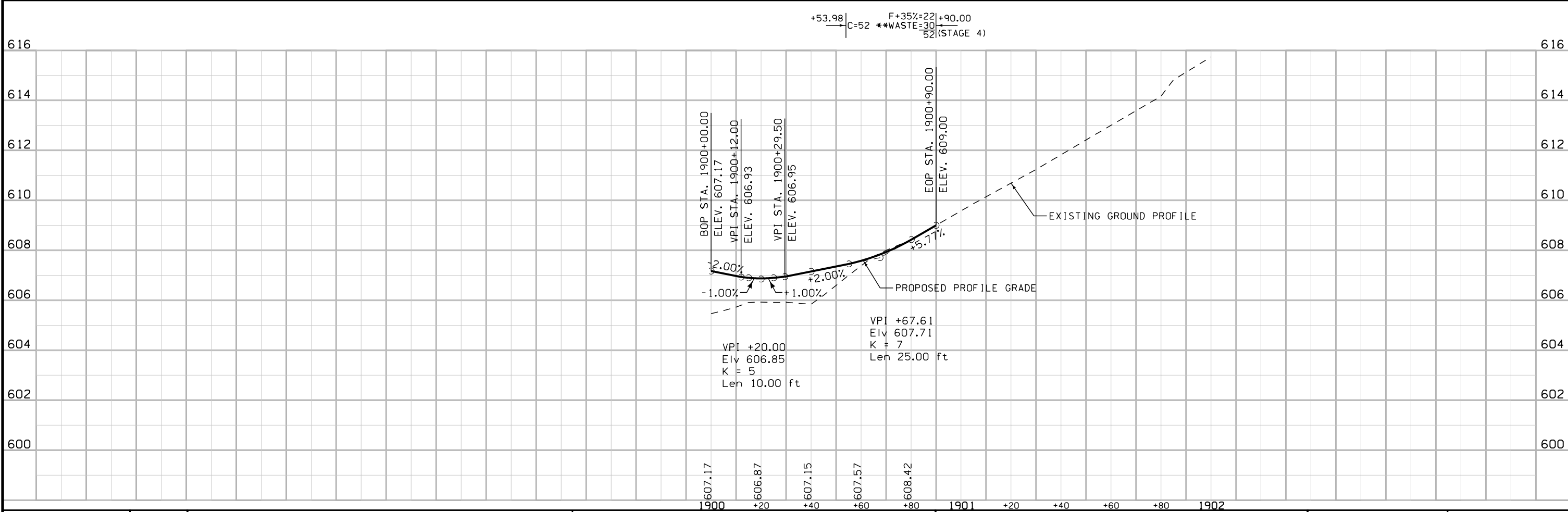

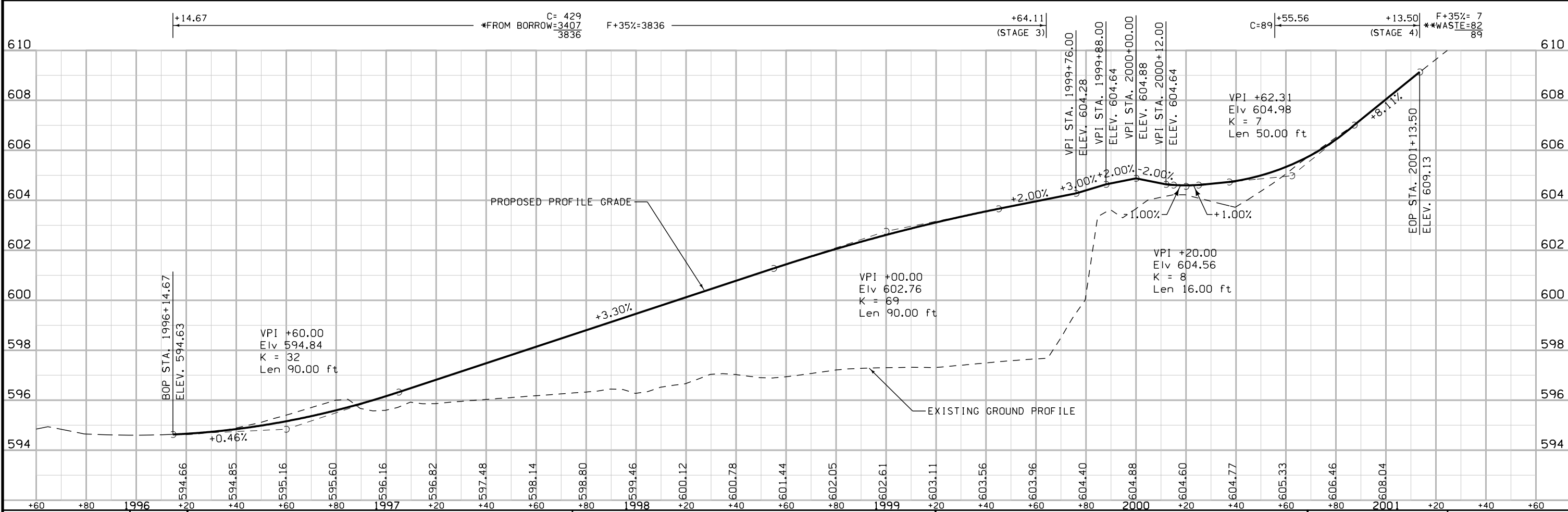
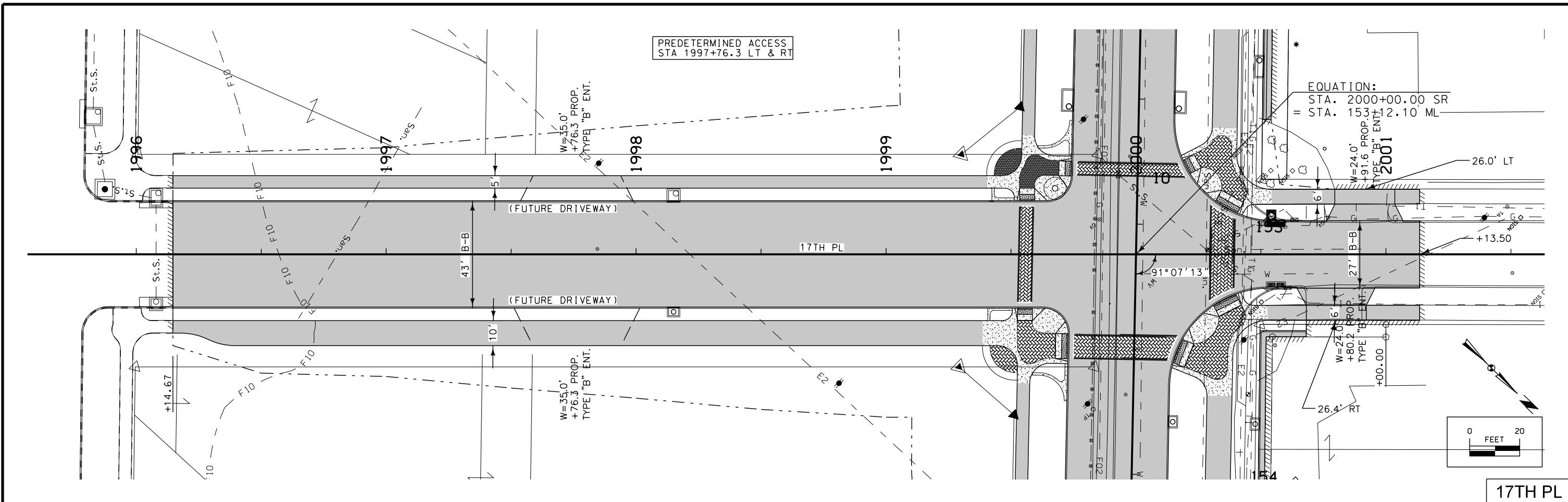

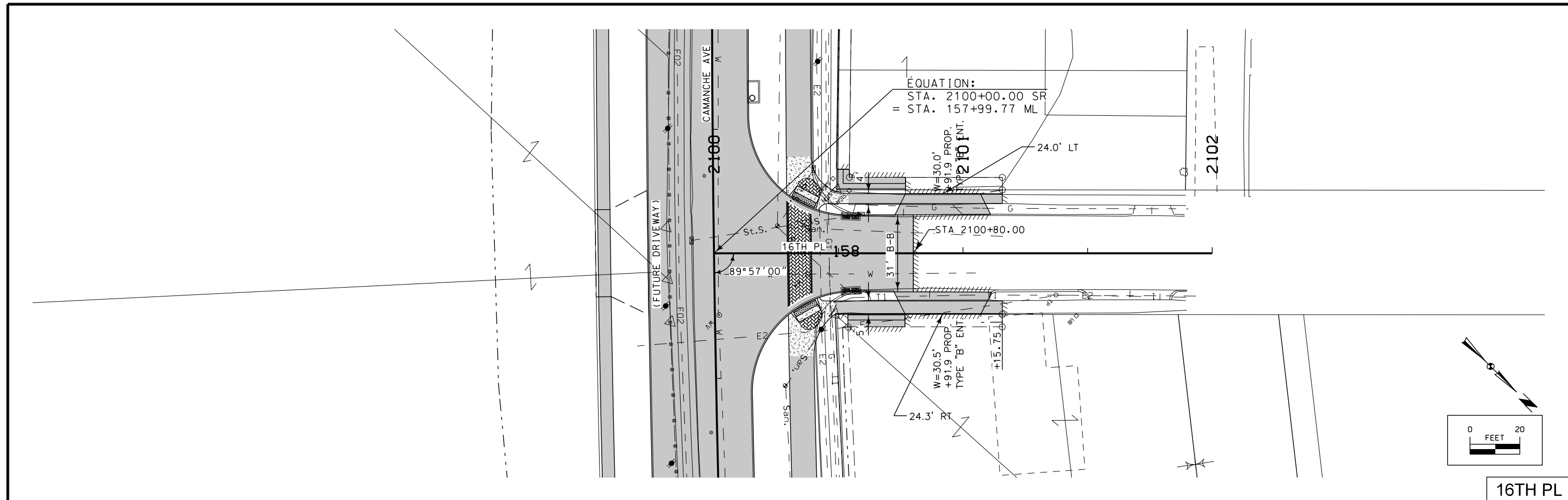

16TH PL

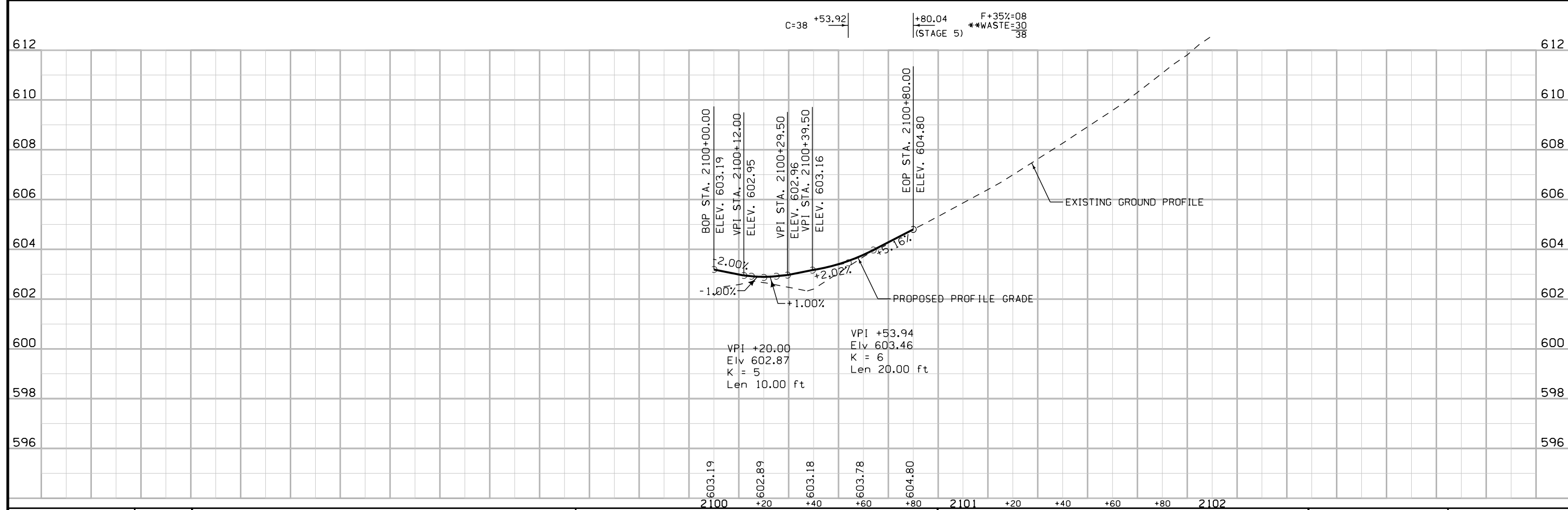



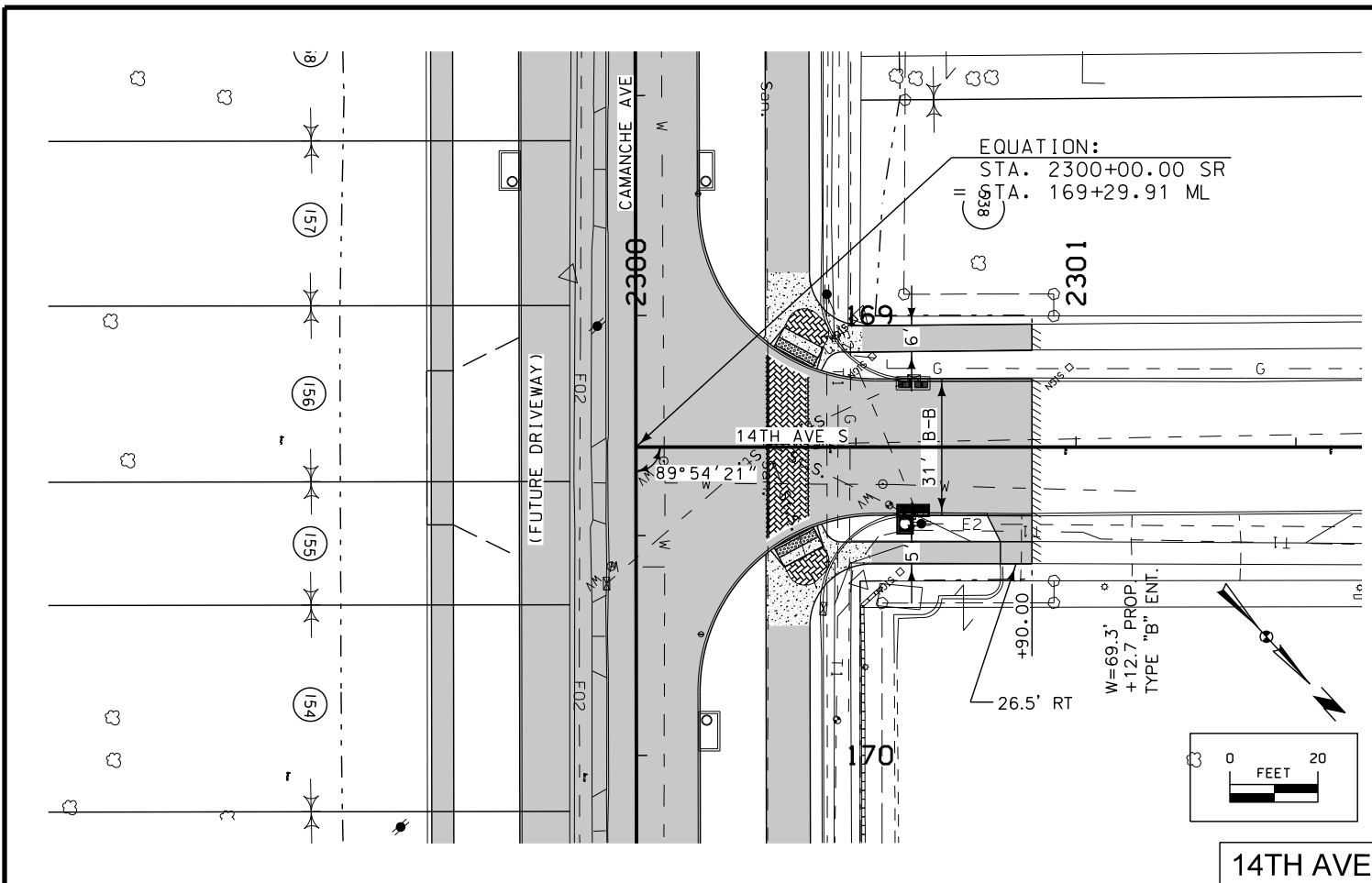

14TH AVE

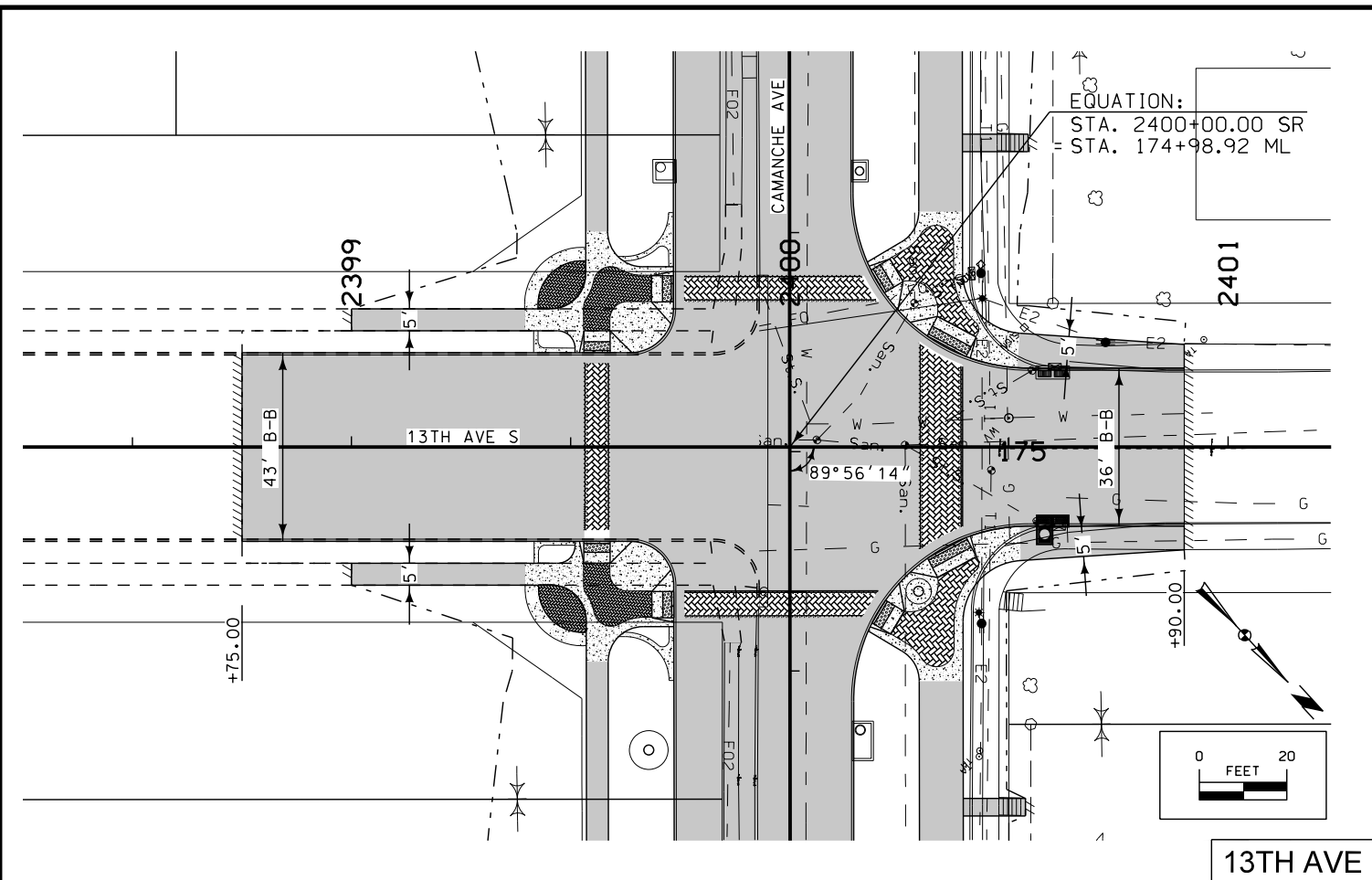

13TH AVE

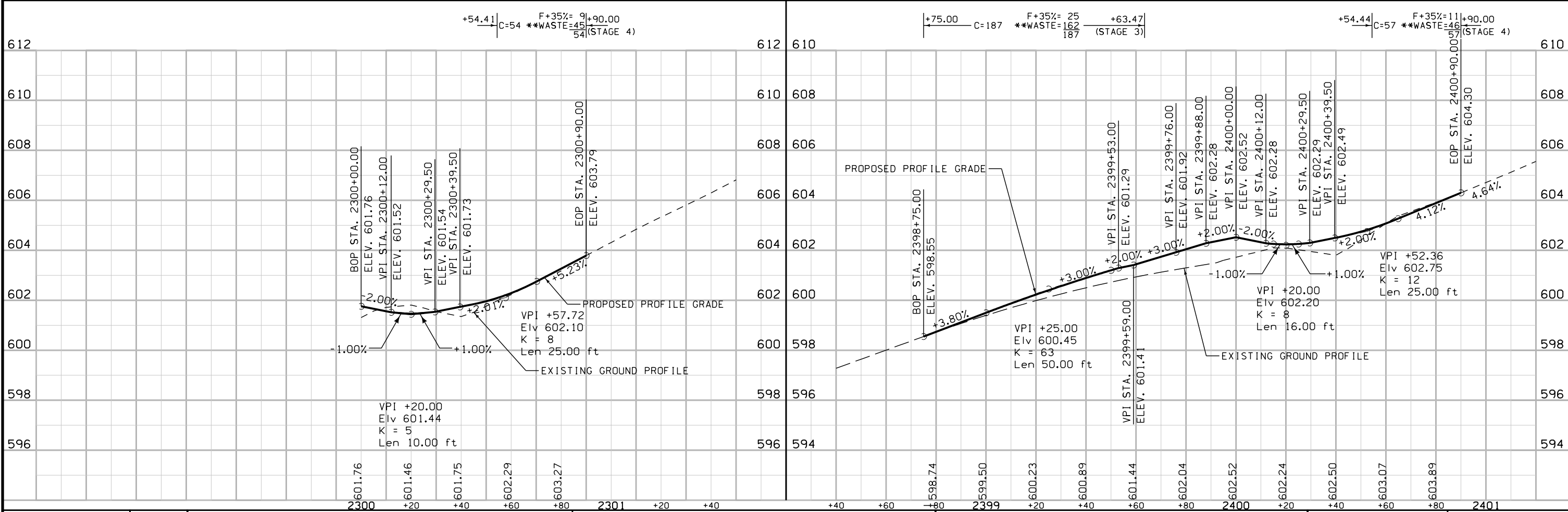

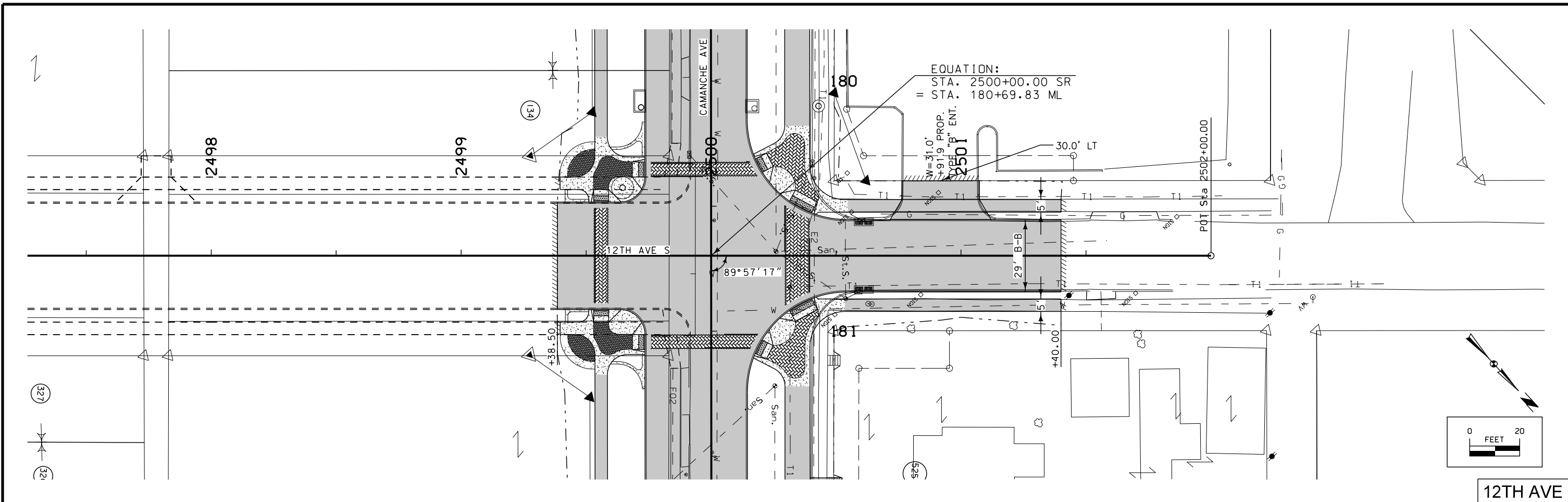

12TH AVE

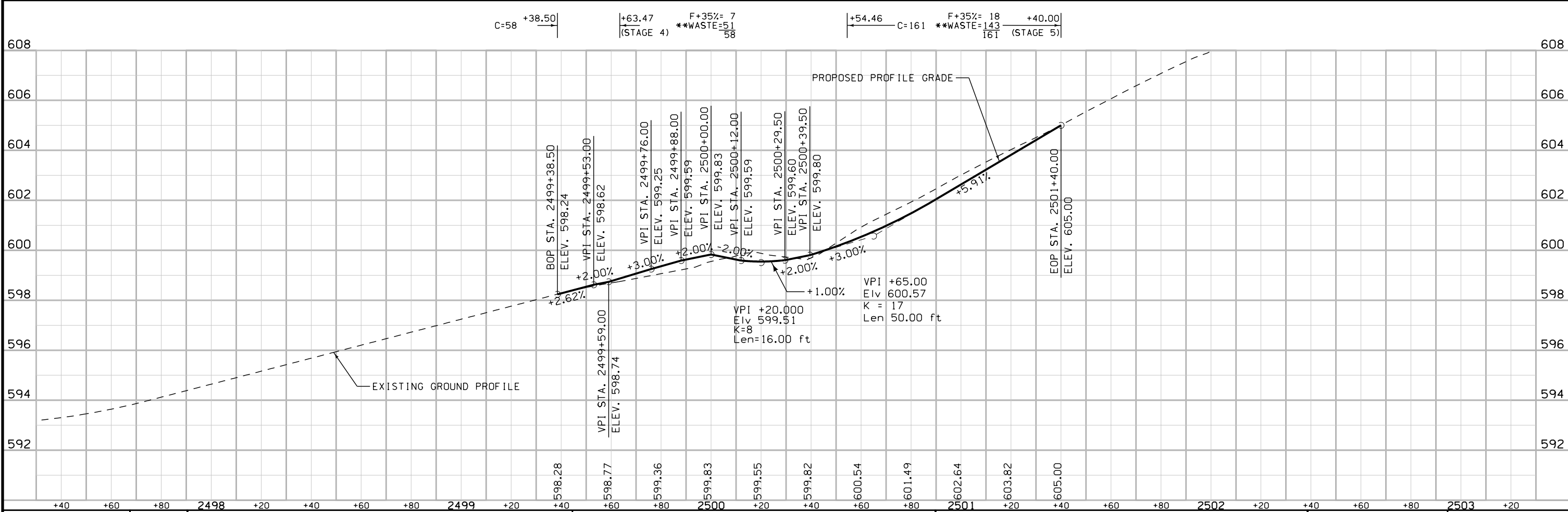

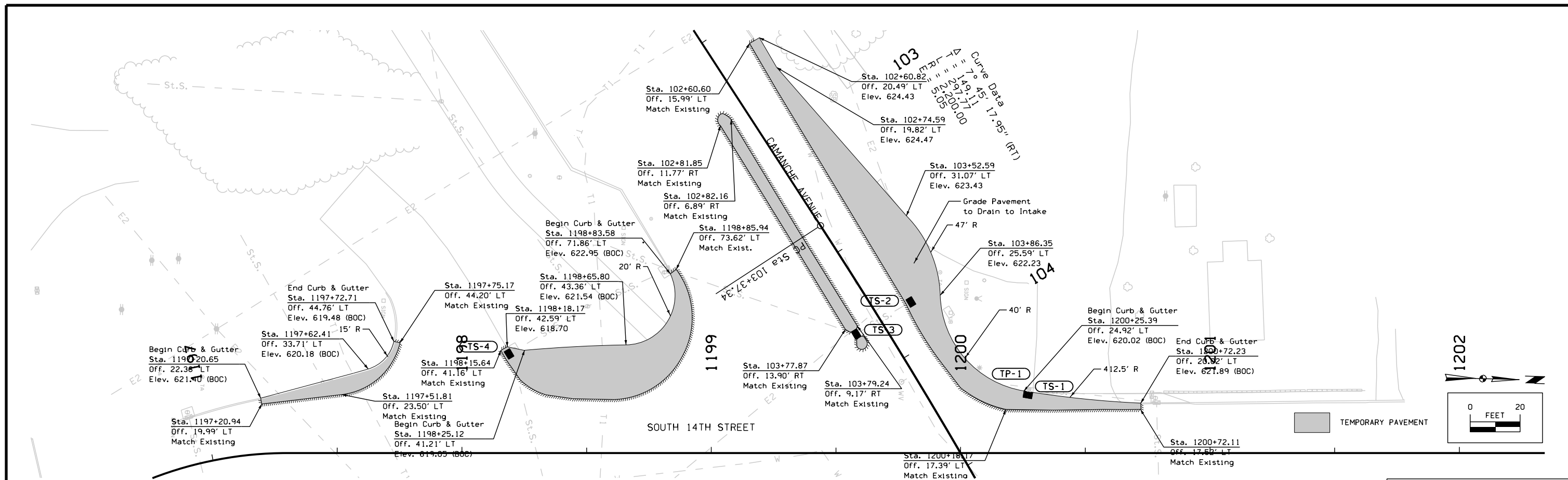

14TH ST - STAGE 1-A

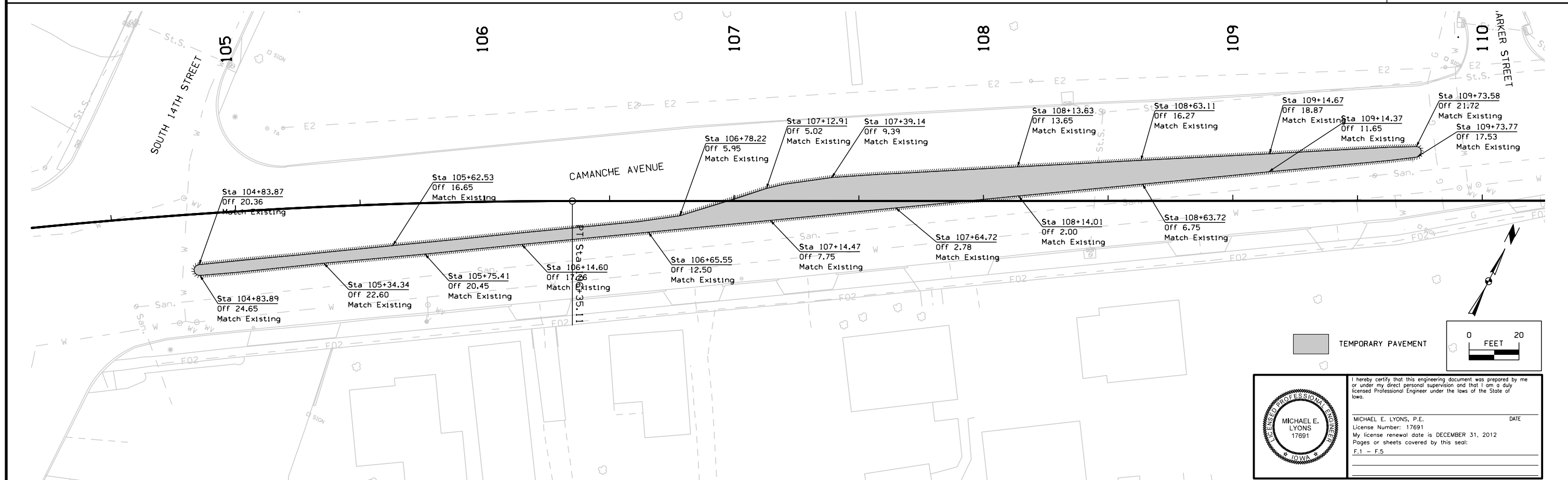

14TH ST - STAGE 1-A

	I hereby certify that this engineering document was prepared by me or under my direct personal supervision and that I am a duly licensed Professional Engineer under the laws of the State of Iowa.	
	MICHAEL E. LYONS, P.E. License Number: 17691 My license renewal date is DECEMBER 31, 2012 Pages or sheets covered by this seal: F.1 - F.5	DATE _____



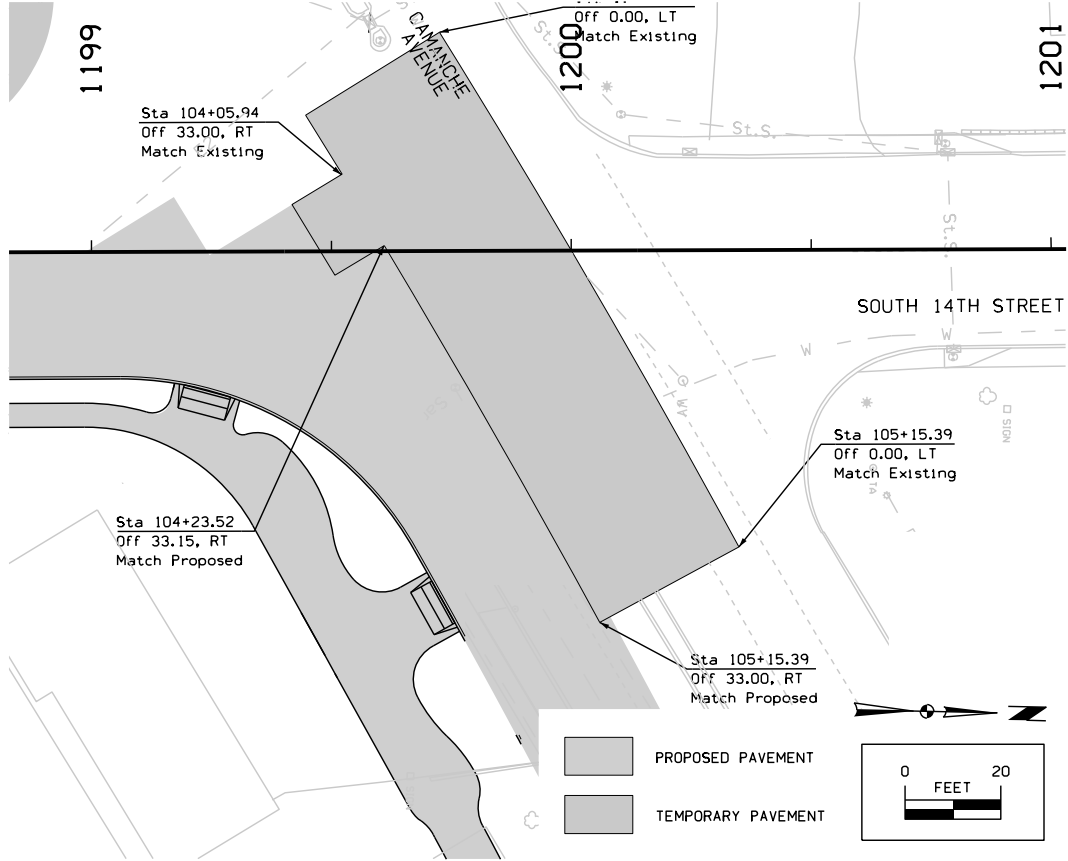

U.S. 30/67 - STAGE 1B

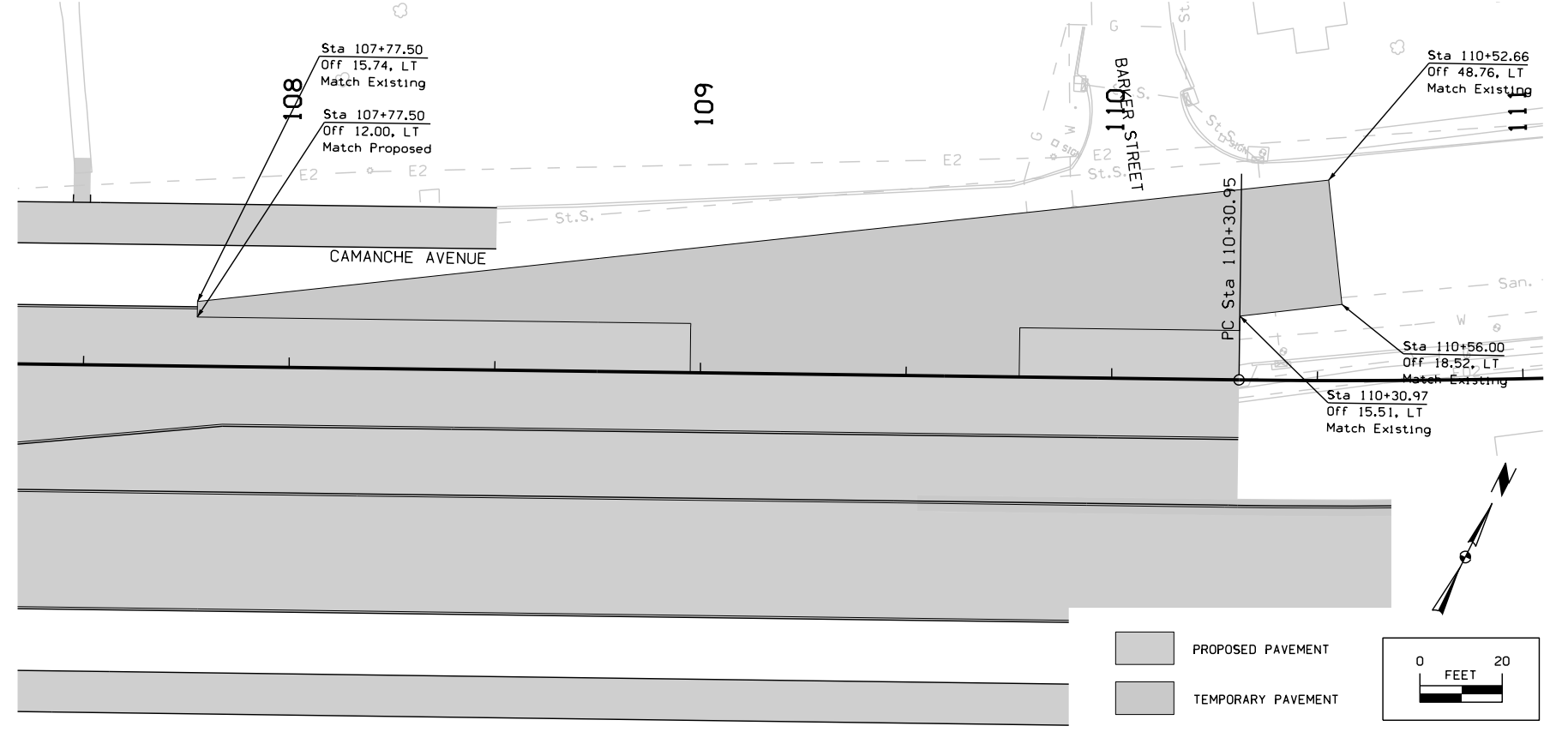

U.S. 30/67 - STAGE 1A

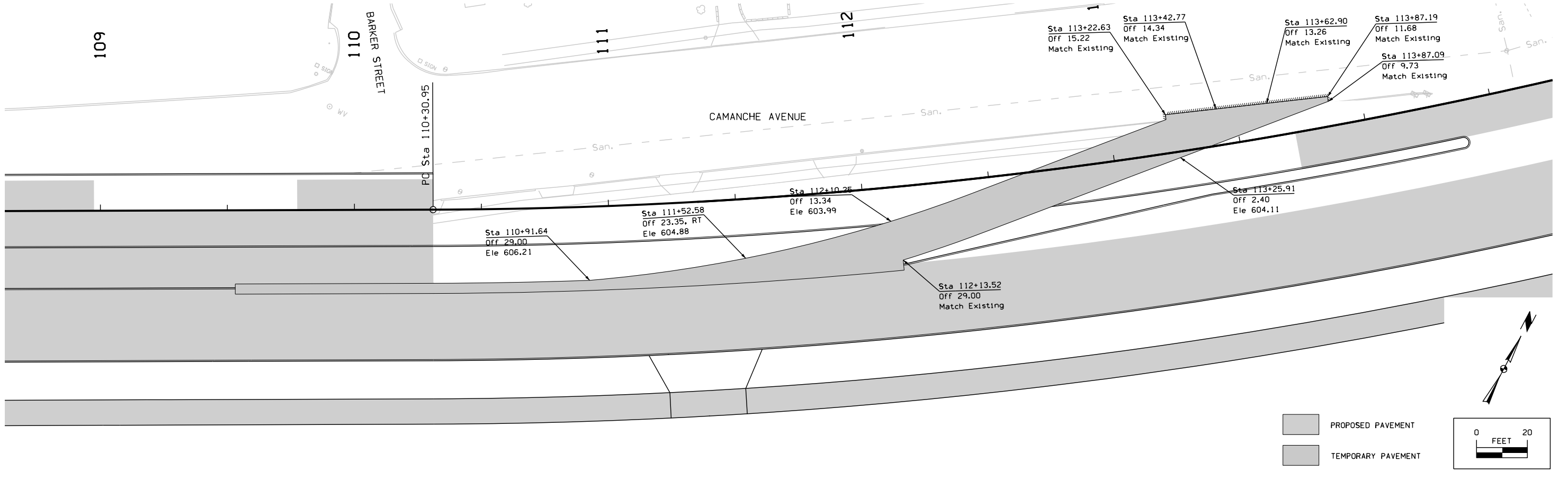

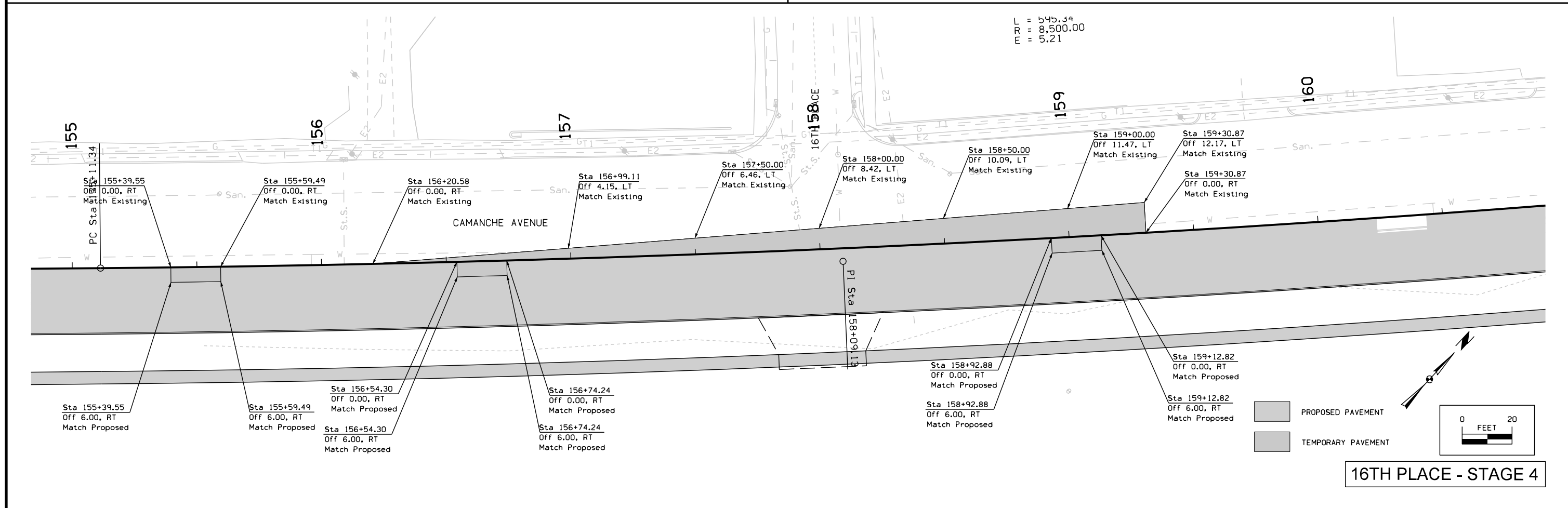
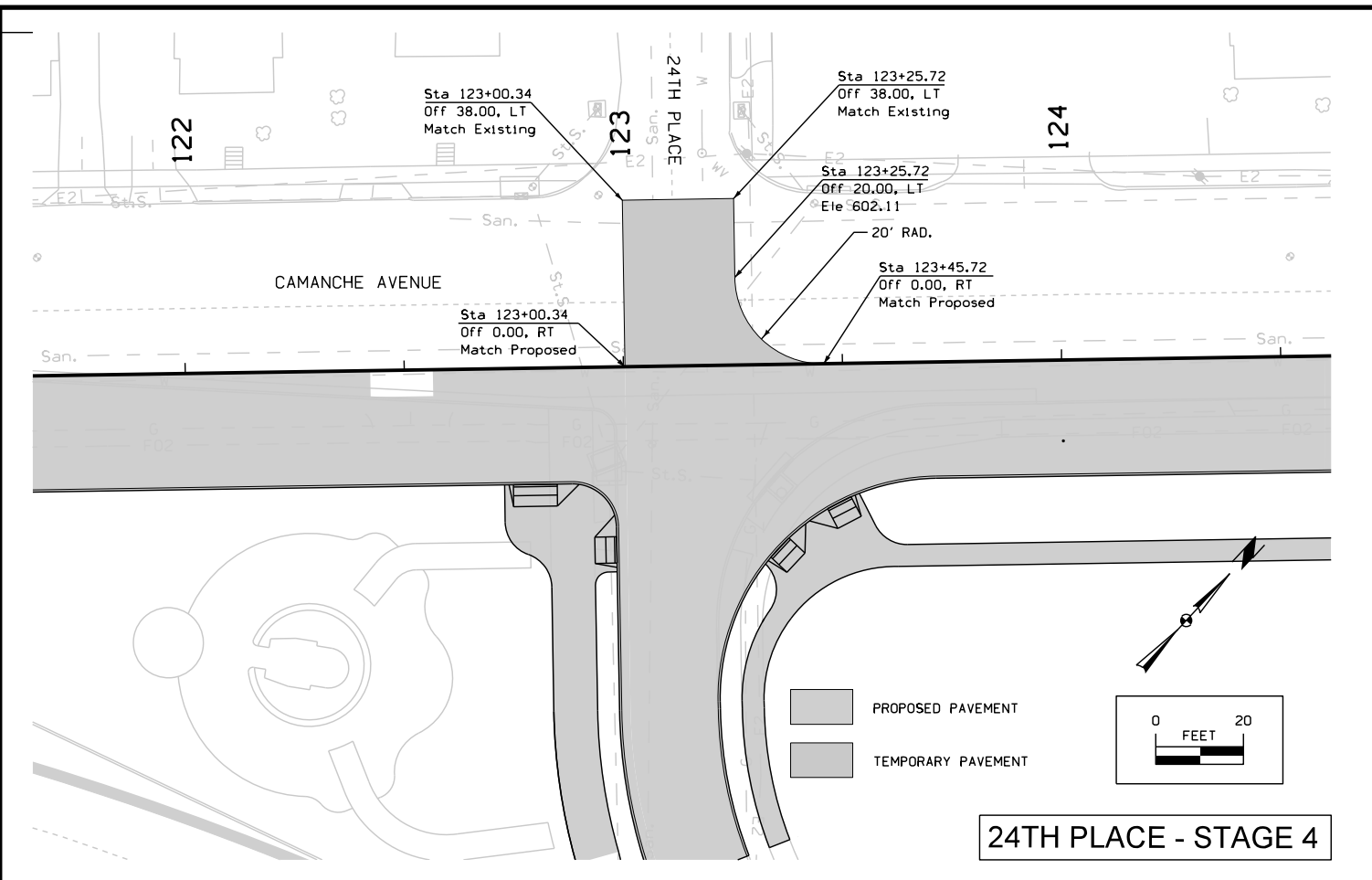
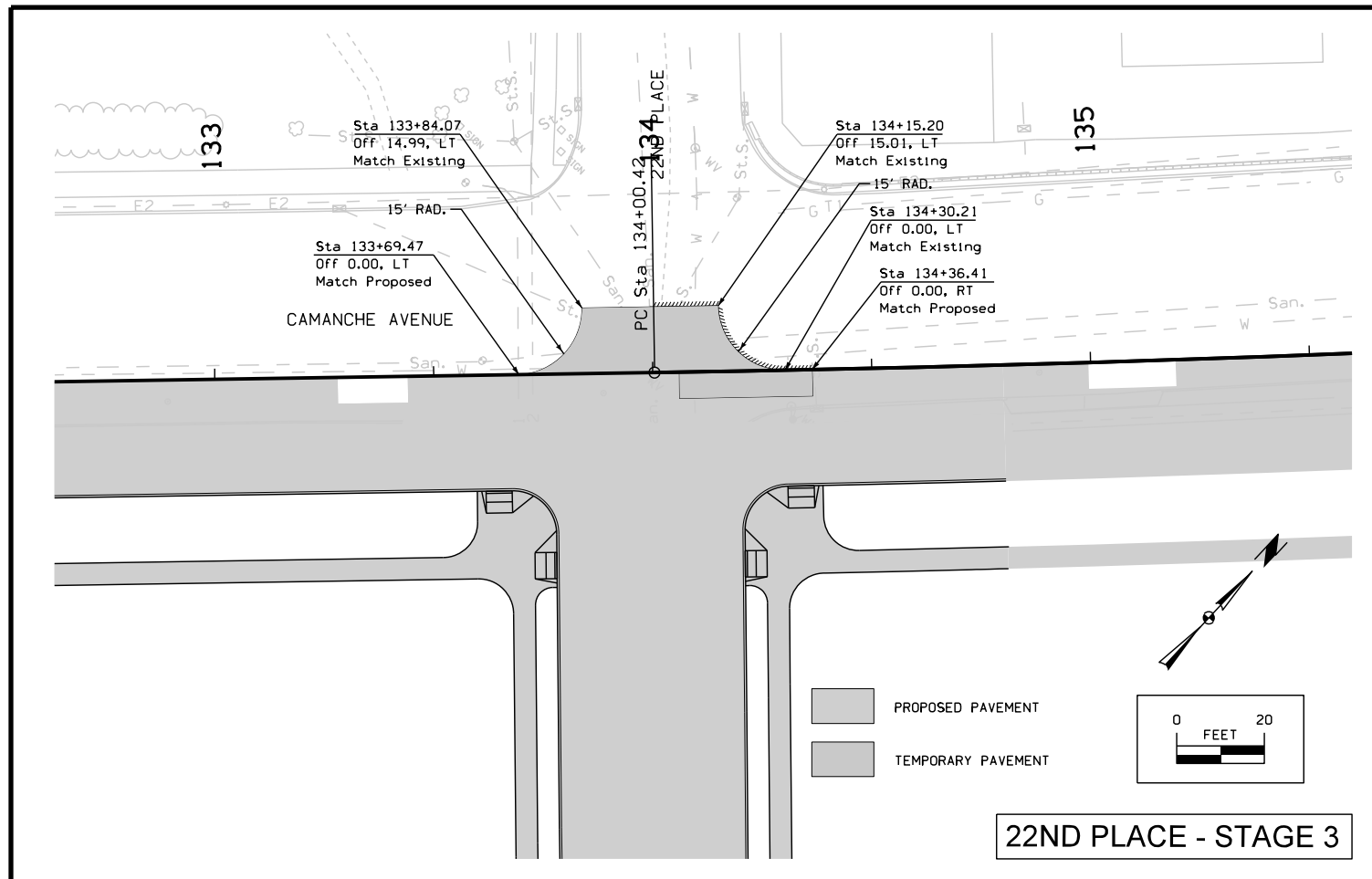

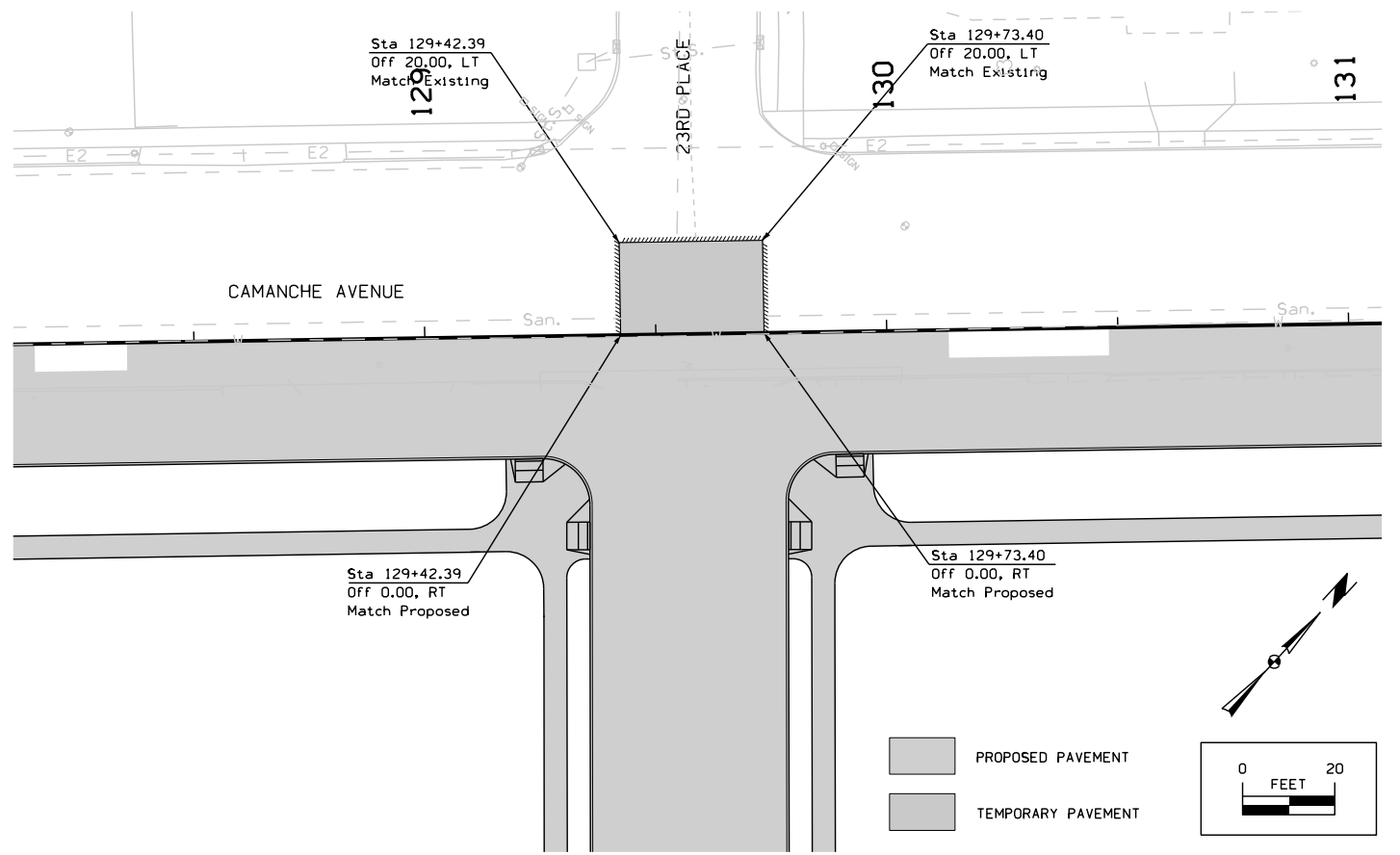

23RD PLACE - STAGE 3

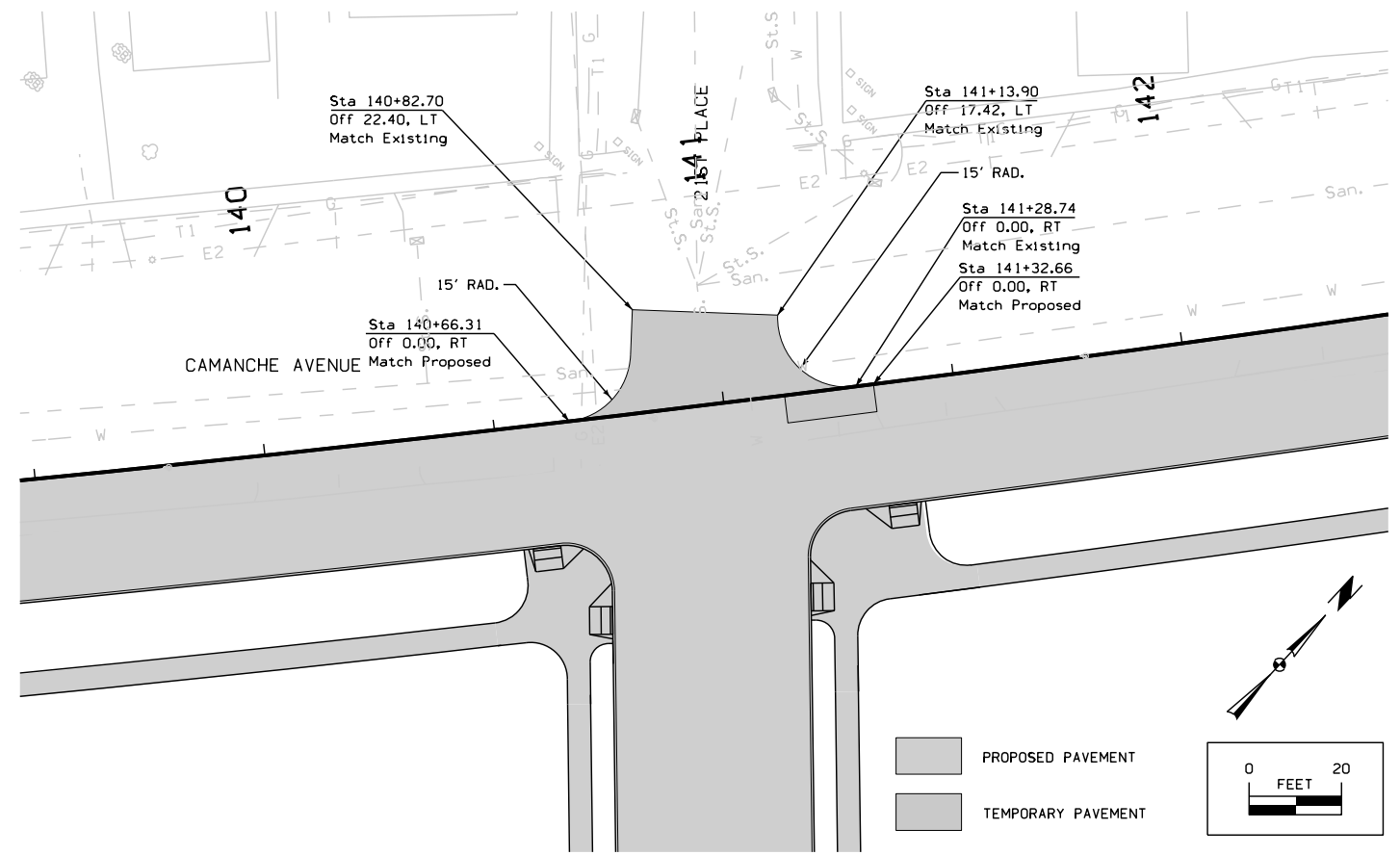

21ST PLACE - STAGE 4

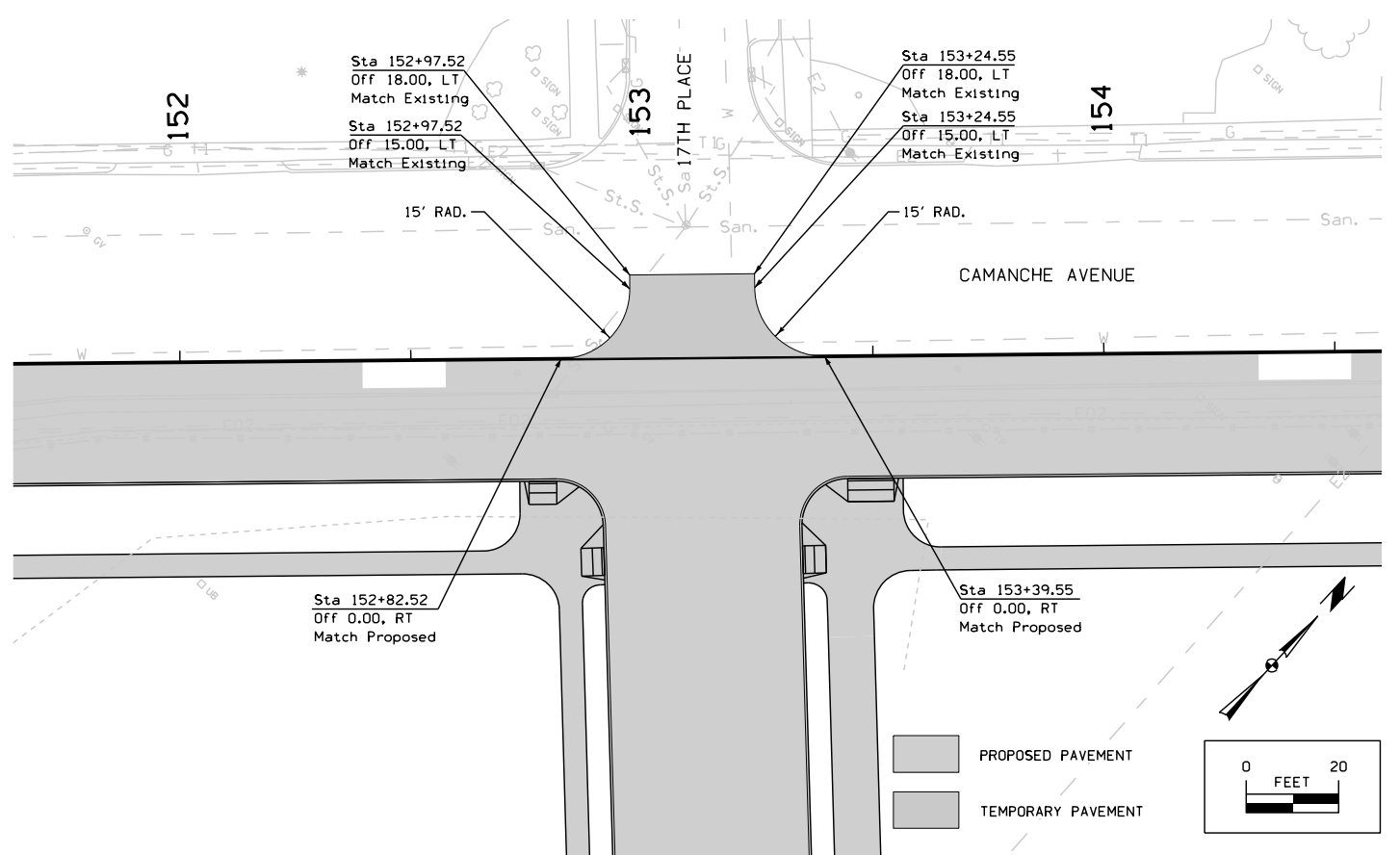

17TH PLACE - STAGE 4

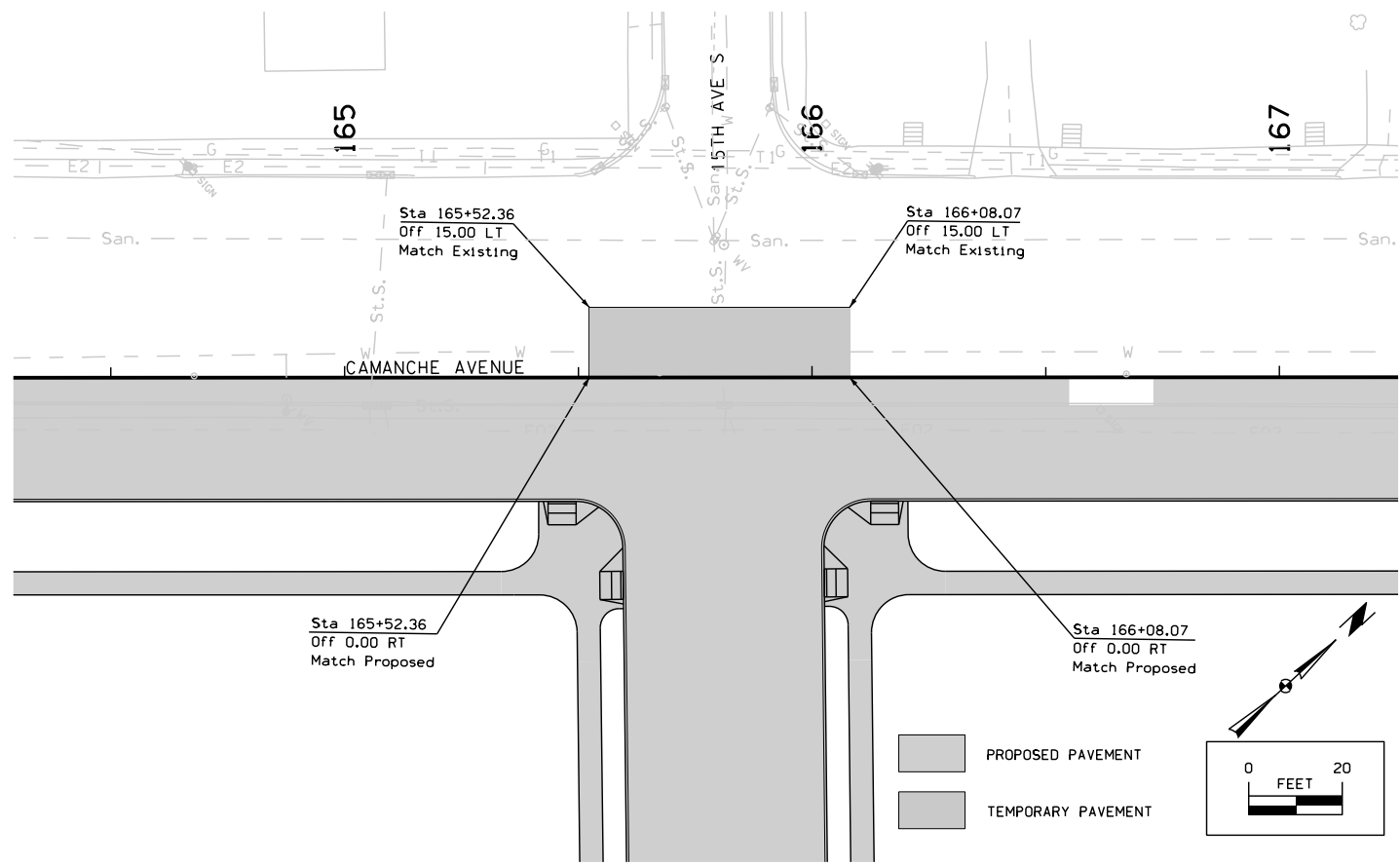

15TH PLACE - STAGE 5

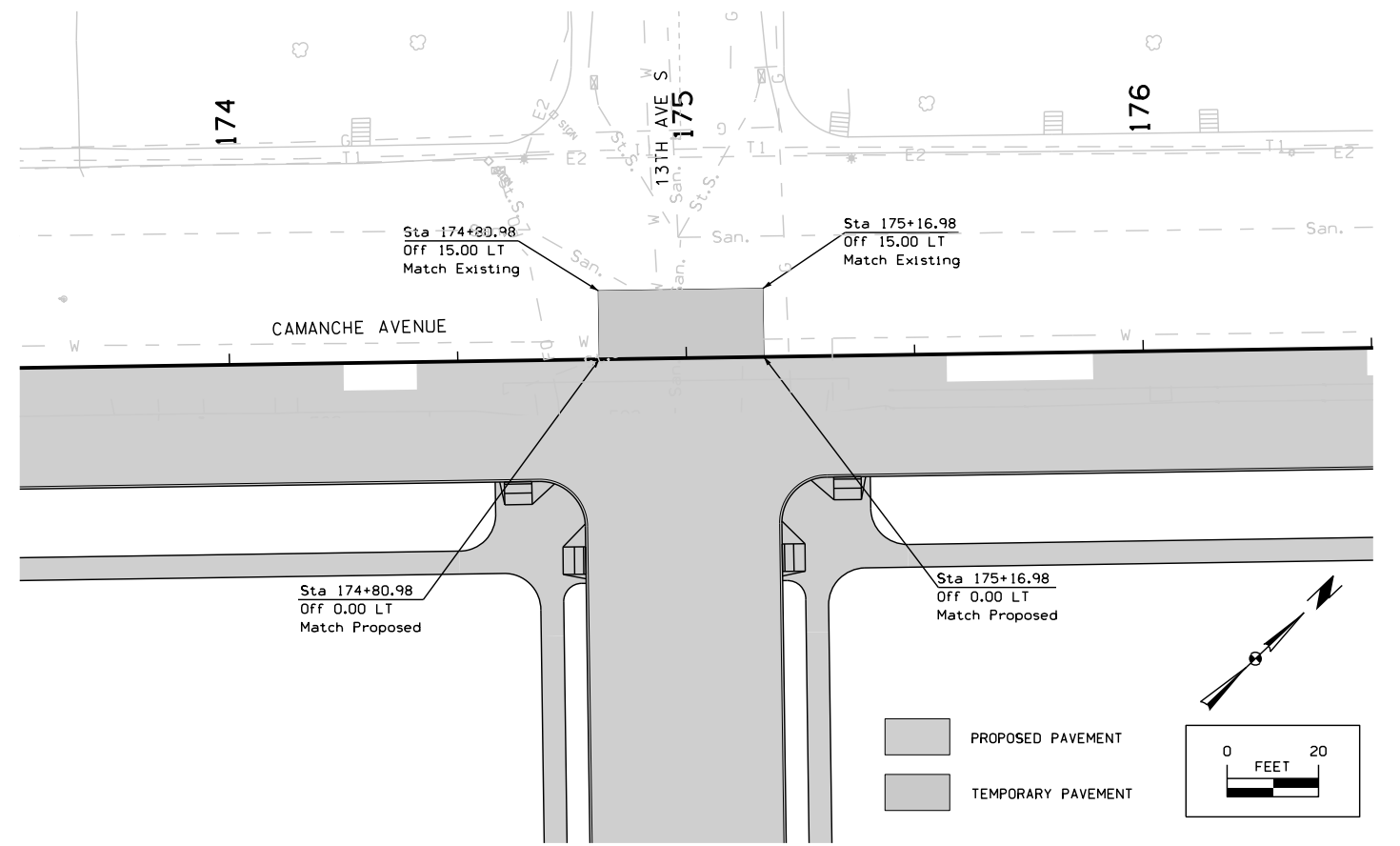

13TH AVENUE - STAGE 5

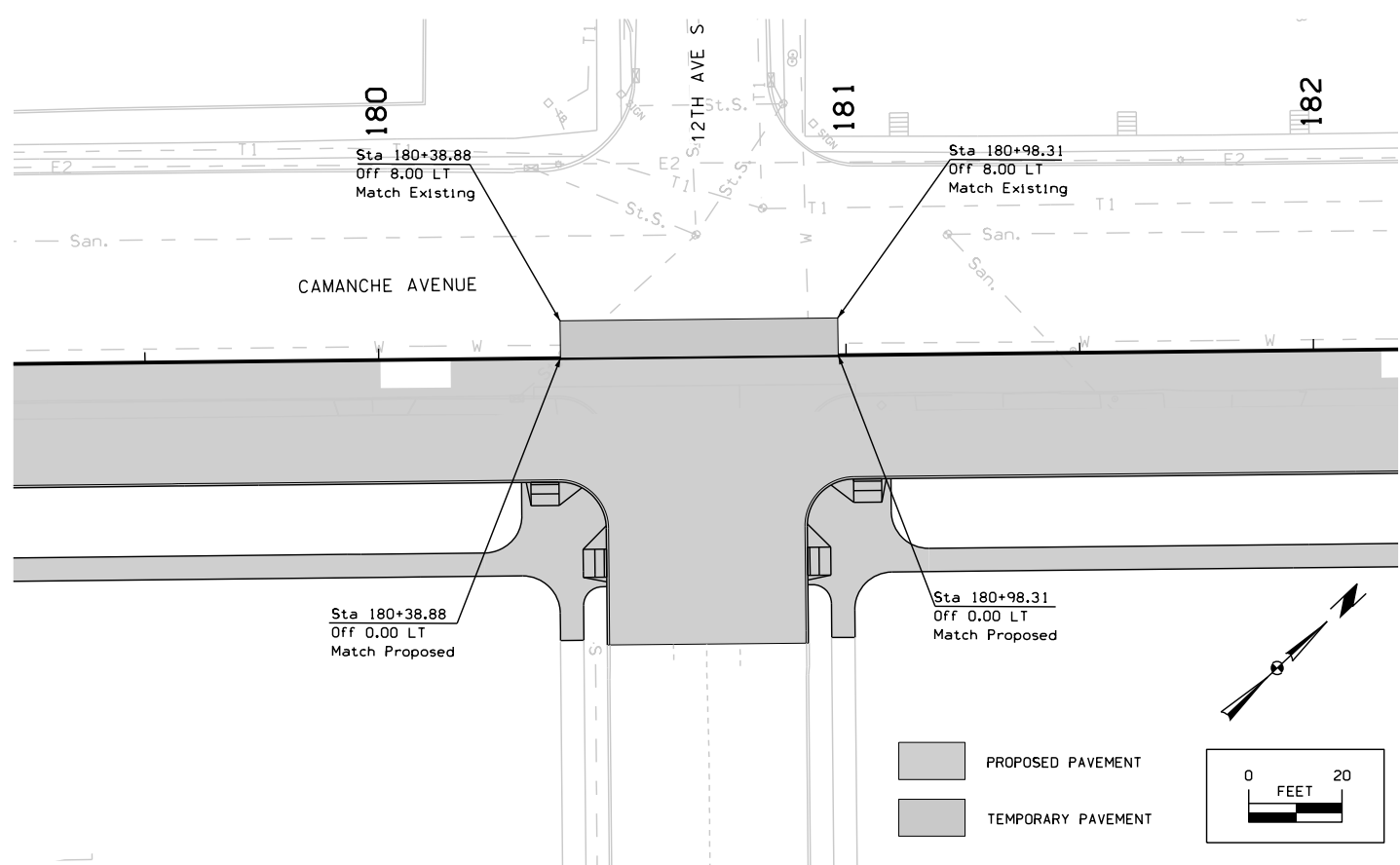

12TH AVENUE - STAGE 4

**VERTICAL DATUM**

Vertical control was obtained from conventional level runs from published points on the City of Clinton control network and adjusted to NAVD88 and published in U.S. Survey Feet.

**HORIZONTAL DATUM**

Horizontal control was obtained with G.P.S. static observations from the City of Clinton control network and adjusted to NAD83(86) State Plane Iowa North and published in U.S. Survey Feet.

**BENCHMARKS**

BENCHMARKS	ELEVATION
No. 515 Fnd. Eng. Benchmark at SE corner Tennis Court, Chancey Park	605.60
No. 516 Sta. 524+34.76, 284.47' Lt. Fnd. Cut "X" NW bolt sign base 40' +/- SW of Subway Bldg.	603.94
No. 517 Sta. 519+49.98, 51.29' Lt. Fnd. cut triangle W. corner retaining wall, 45' +/- SE of Snodgrass sign	604.68
No. 518 Fnd. "X" in bolt on Fire Hyd. S. side of Hwy 30, 80' +/- S. of Clinton Dry Cleaner	606.25
No. 501 "X" on top of NW mount bolt of Fire Hyd. 15' +/- N. of Liberty Ave. Between bldgs. #2532 & #2524	606.25
No. 502 Sta. 520+18.04, 351.97' Rt. "X" on bottom mount bolt Fire Hyd. 18' +/- N. of Liberty Ave. 345' +/- W. of 24th Place	594.82
No. 503 Sta. 528+56.85, 72.64' Rt. Set RR Spike N. side Pwr. Pole 20' +/- S. of Liberty Ave. 530' +/- W. of 22nd Place, House #2312	595.50
No. 504 Sta. 541+73.33, 43.65' Rt. "X" on top mount Fire Hyd. 15' +/- N. of Liberty Ave. 36' +/- E. of 21st Place, House #102	595.27
No. 505 Sta. 553+13.57, 19.77' Lt. "X" on top mount bolt Fire Hyd. 350' +/- E. of intersection of 18th Street & Liberty Ave. 48' +/- N. of N. edge conc. slab 270' +/- E. of CP #215	595.60
No. 506 Set RR spike W. side Pwr. Pole 200' +/- NW of CP #217, 240' +/- S. of Hwy. 30, open area between Hwy. 30 and Train Shop	597.07
No. 507 Sta. 570+36.64, 167.30' Rt. Ex. CP #218, Cut "X" in NE cor. conc. slab E. of RR shop Bldg. 36' +/- NW of "X" nails in W. face of Pwr. Pole	593.16
No. 508 Sta. 577+94.11, 53.67' Rt. Set RR spike S. side Pwr. Pole, 15' +/- S. of Liberty Ave., 3rd Pwr. Pole E. of S. 6th Street and Liberty Ave.	593.58
No. 509 Sta. 588+42.39, 116.51' Rt. Set RR spike S. side Pwr. Pole, 190' +/- E. of 12th Street at S. 5th Street, 27' +/- N. of 12th Street	595.74
No. 510 "X" on top mount bolt Fire Hyd. NE cor. 11th Street and S. 4th Street	598.33
No. 511 Sta. 587+59.75, 448.47' Lt. Set RR spike in NE face Pwr. Pole, 23' +/- S. of 11th Street, 110' +/- W. of 11th Street at Hwy. 30	603.99
No. 512 Sta. 573+59.75, 352.85' Lt. "X" in conc. wall, 30' +/- S. of Hwy. 30, 200' +/- W. of 13th Ave.	603.30
No. 513 Sta. 556+48.80, 508.36' Lt. Set RR spike S. side Pwr. Pole 160' +/- W. of 16th Place, 50' +/- N. of Hwy. 30	605.56
No. 514 Sta. 544+58.38, 433.10' Lt. Set RR spike S. side Pwr. Pole, 21' +/- W. of 20th Place, 30' +/- N. of Hwy. 30	606.15

**GPS CONTROL POINT #109**

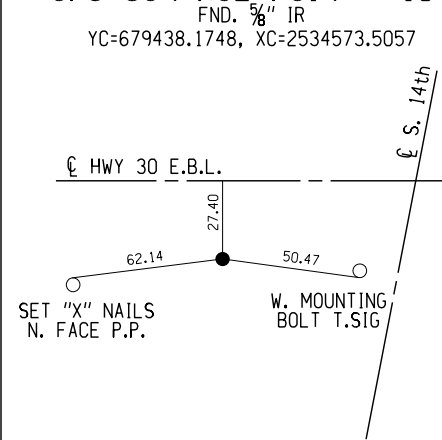

**GPS CONTROL POINT #111**

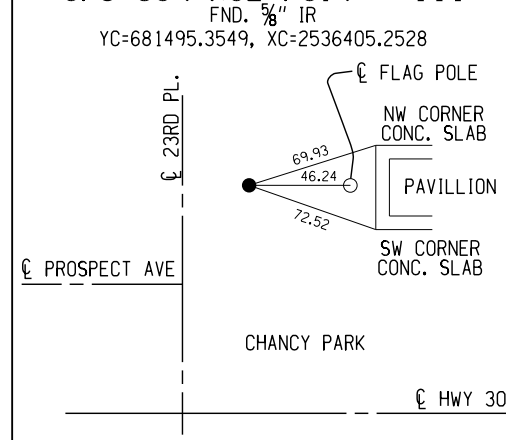

**GPS CONTROL POINT #114**

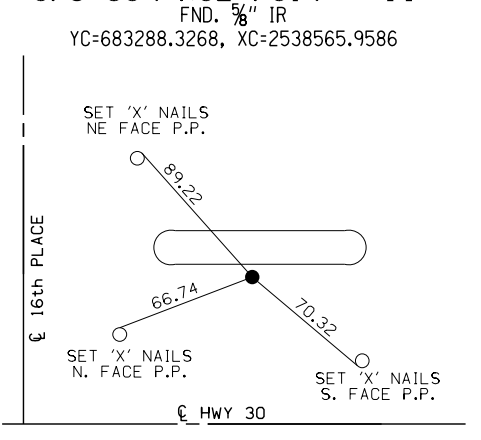

**GPS CONTROL POINT #112**

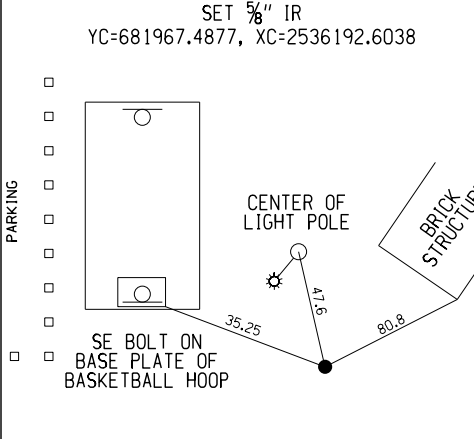

**GPS CONTROL POINT #116**

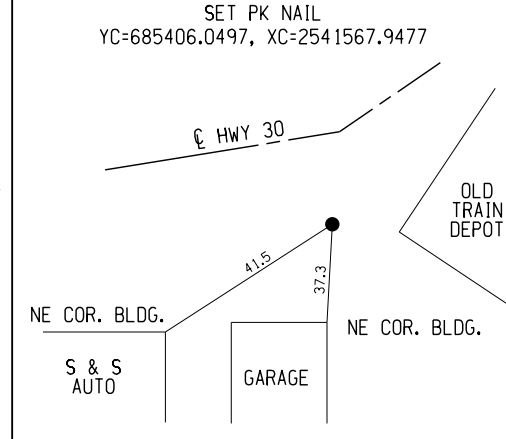

**CONTROL POINT # 206**

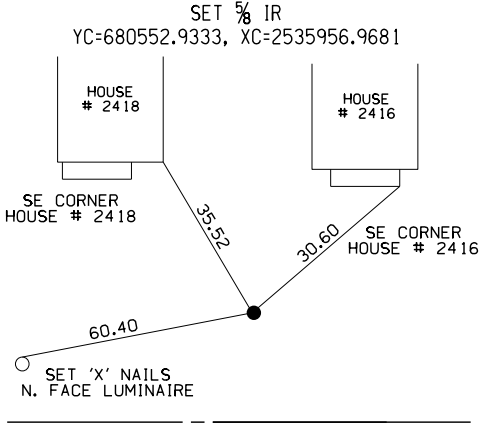

**CONTROL POINT # 208**

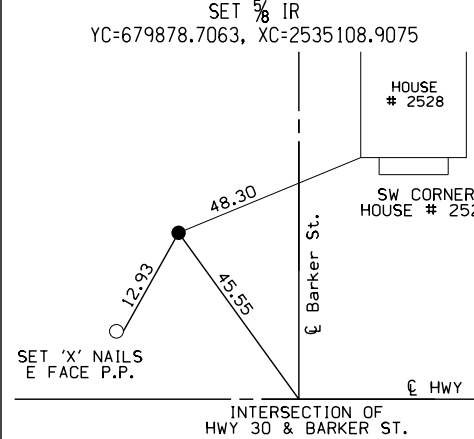

**CONTROL POINT # 209**

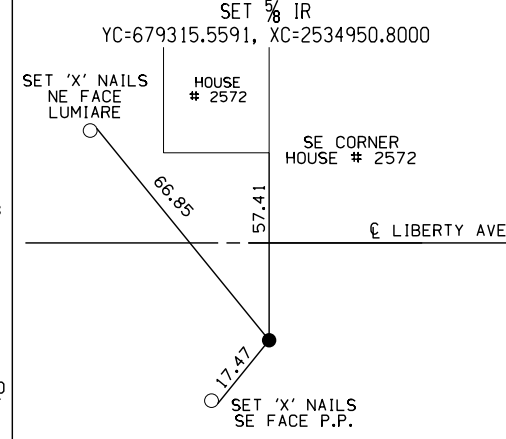

**CONTROL POINT # 210**

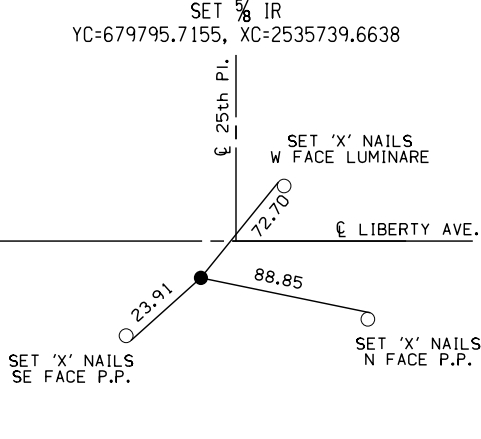

**CONTROL POINT # 211**

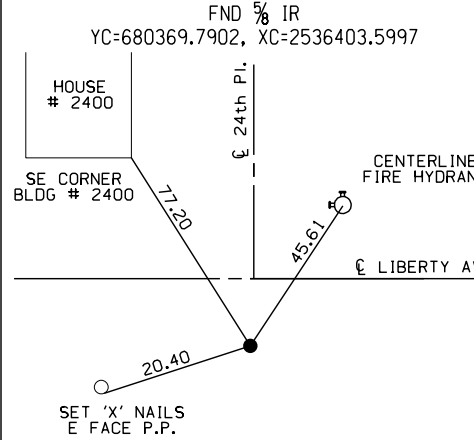

**DETAILS OF REFERENCE INFORMATION**  
All References are Plumb Distances unless otherwise noted.

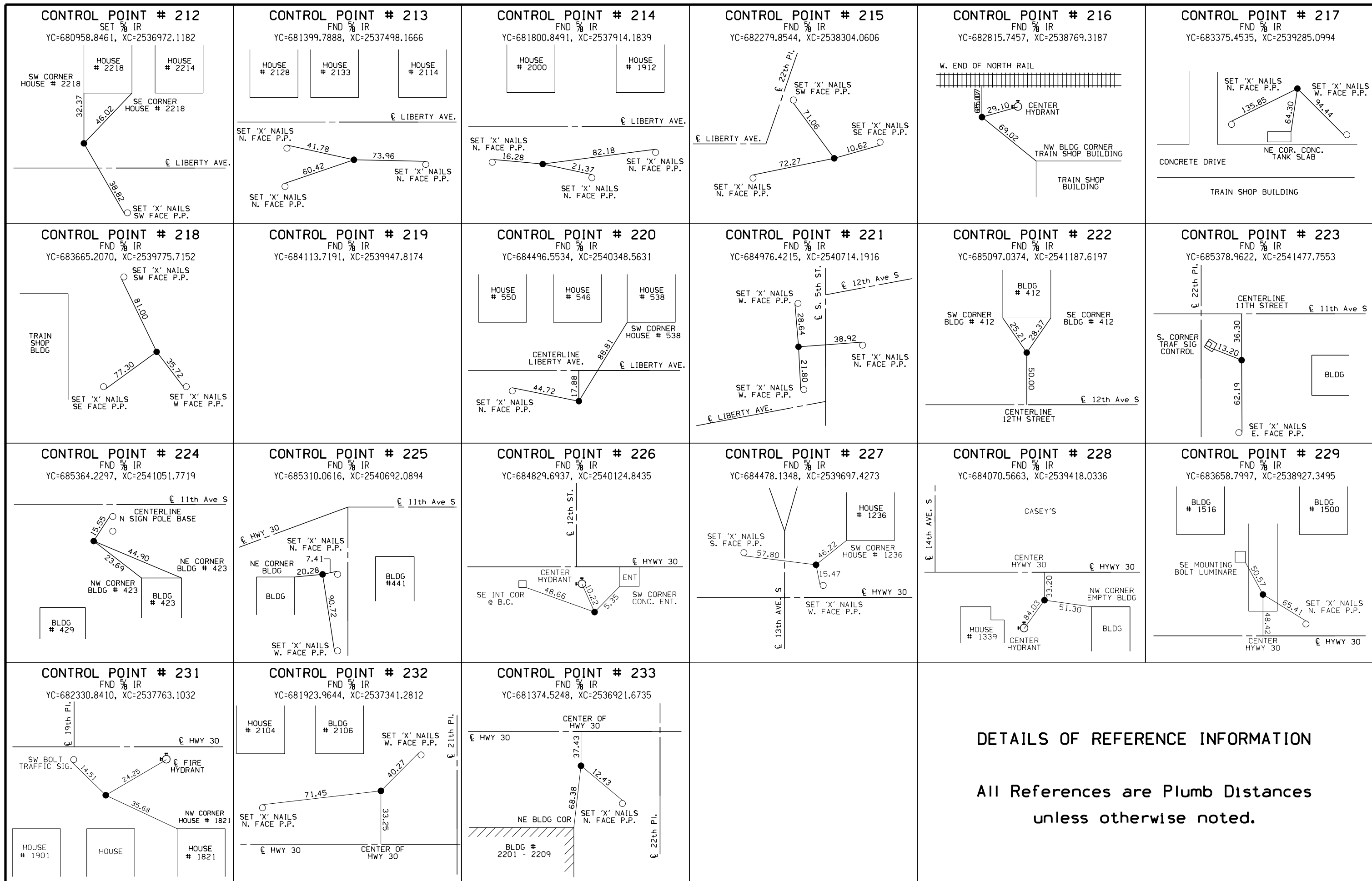

**DETAILS OF REFERENCE INFORMATION**  
 All References are Plumb Distances  
 unless otherwise noted.

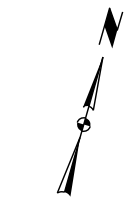

(N.T.S.)

STATION EQUATION  
 119+50.00 SEG. 2 (AH)  
 =12.00'LT. 119+50.00 SEG. 1 (BK)

STATION EQUATION:  
 119+50.00 SEG. 1 (BK)  
 =12.00'RT. 119+50.00 SEG. 2 (AH)

SEE PAGE G.04

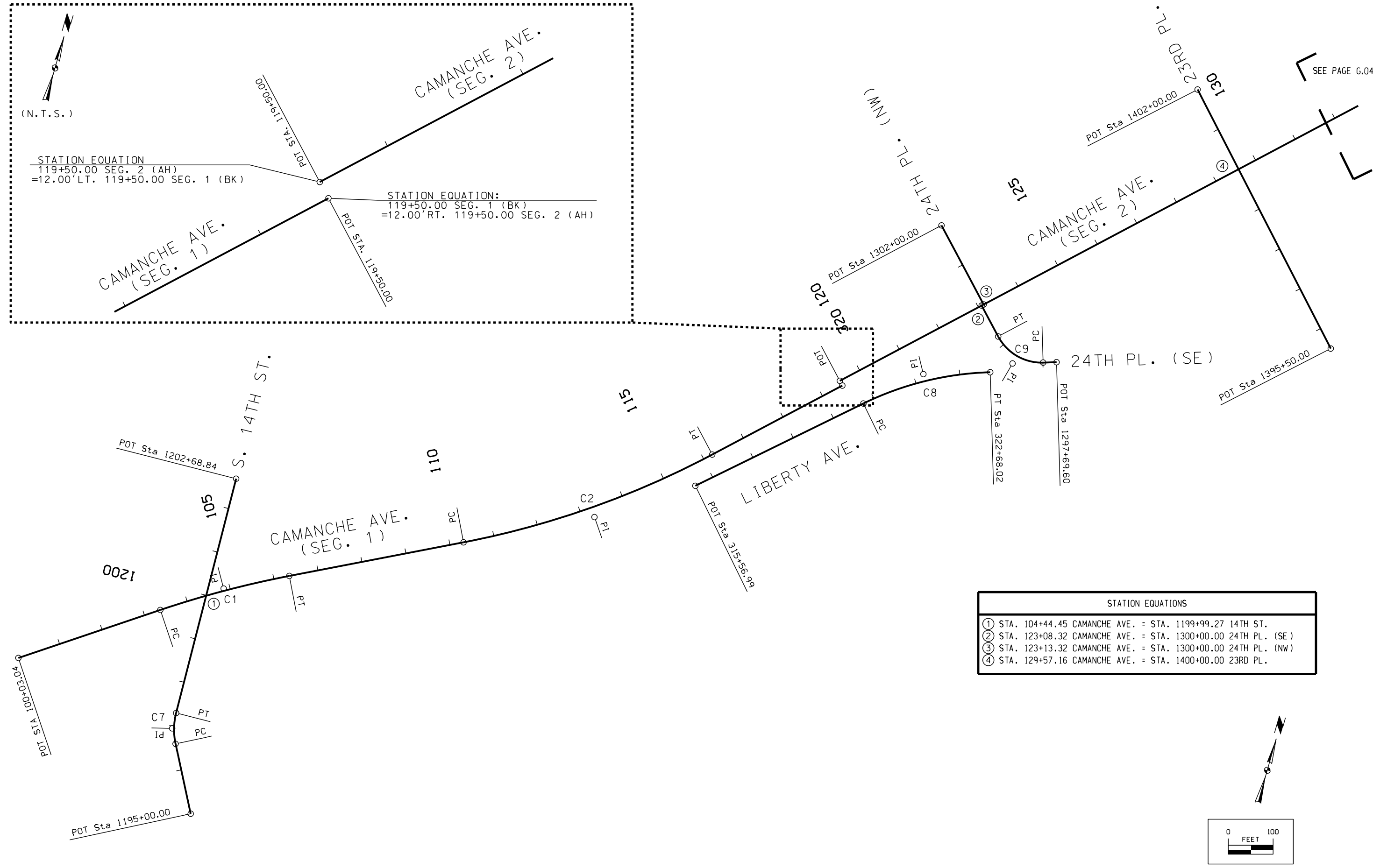

STATION EQUATIONS	
①	STA. 104+44.45 CAMANCHE AVE. = STA. 1199+99.27 14TH ST.
②	STA. 123+08.32 CAMANCHE AVE. = STA. 1300+00.00 24TH PL. (SE)
③	STA. 123+13.32 CAMANCHE AVE. = STA. 1300+00.00 24TH PL. (NW)
④	STA. 129+57.16 CAMANCHE AVE. = STA. 1400+00.00 23RD PL.

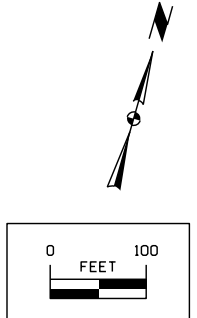

SEE PAGE G.05

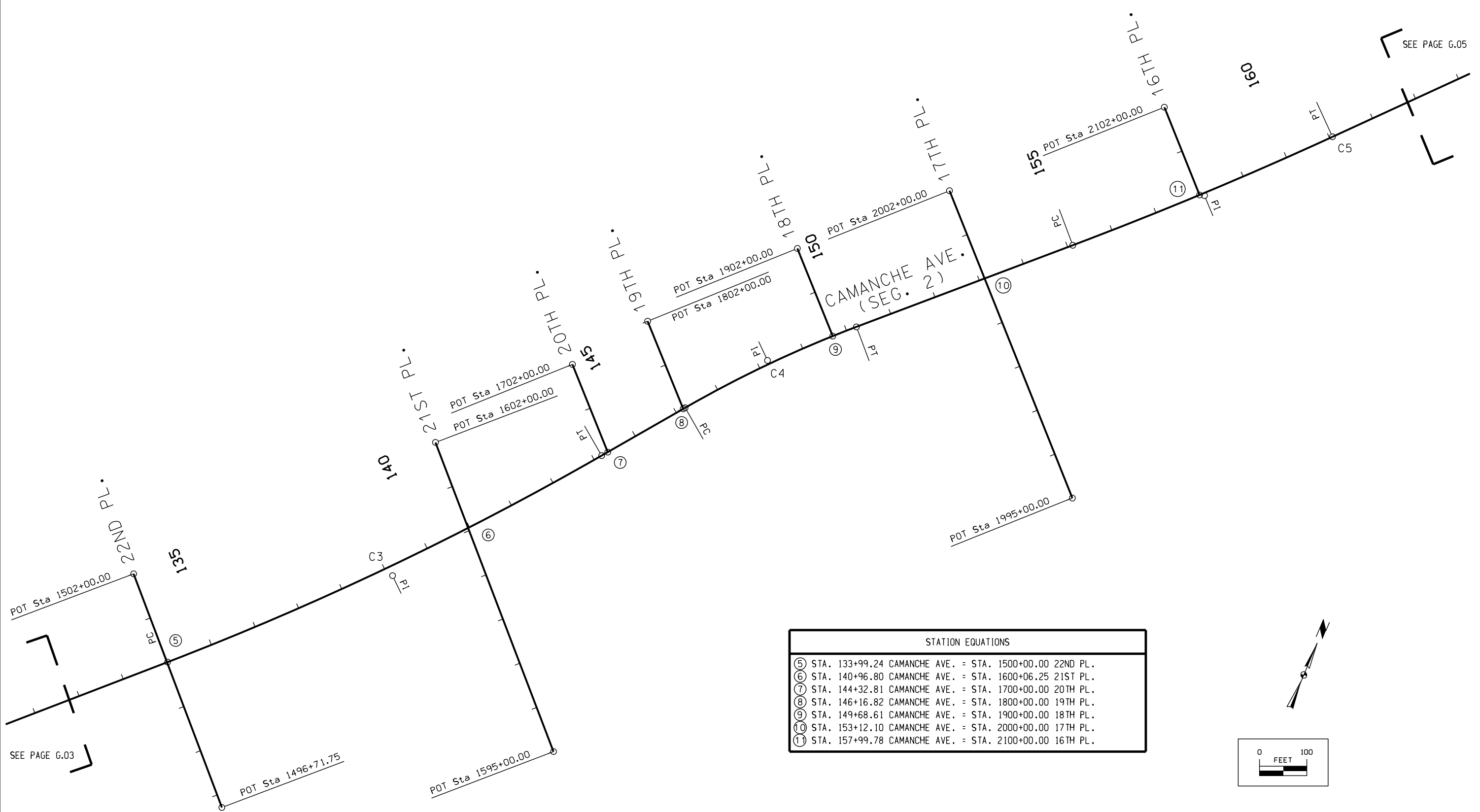

SEE PAGE G.03

STATION EQUATIONS	
⑤	STA. 133+99.24 CAMANCHE AVE. = STA. 1500+00.00 22ND PL.
⑥	STA. 140+96.80 CAMANCHE AVE. = STA. 1600+06.25 21ST PL.
⑦	STA. 144+32.81 CAMANCHE AVE. = STA. 1700+00.00 20TH PL.
⑧	STA. 146+16.82 CAMANCHE AVE. = STA. 1800+00.00 19TH PL.
⑨	STA. 149+68.61 CAMANCHE AVE. = STA. 1900+00.00 18TH PL.
⑩	STA. 153+12.10 CAMANCHE AVE. = STA. 2000+00.00 17TH PL.
⑪	STA. 157+99.78 CAMANCHE AVE. = STA. 2100+00.00 16TH PL.

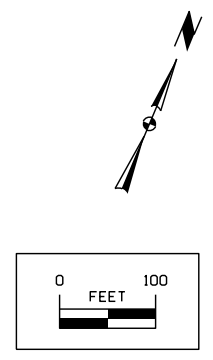



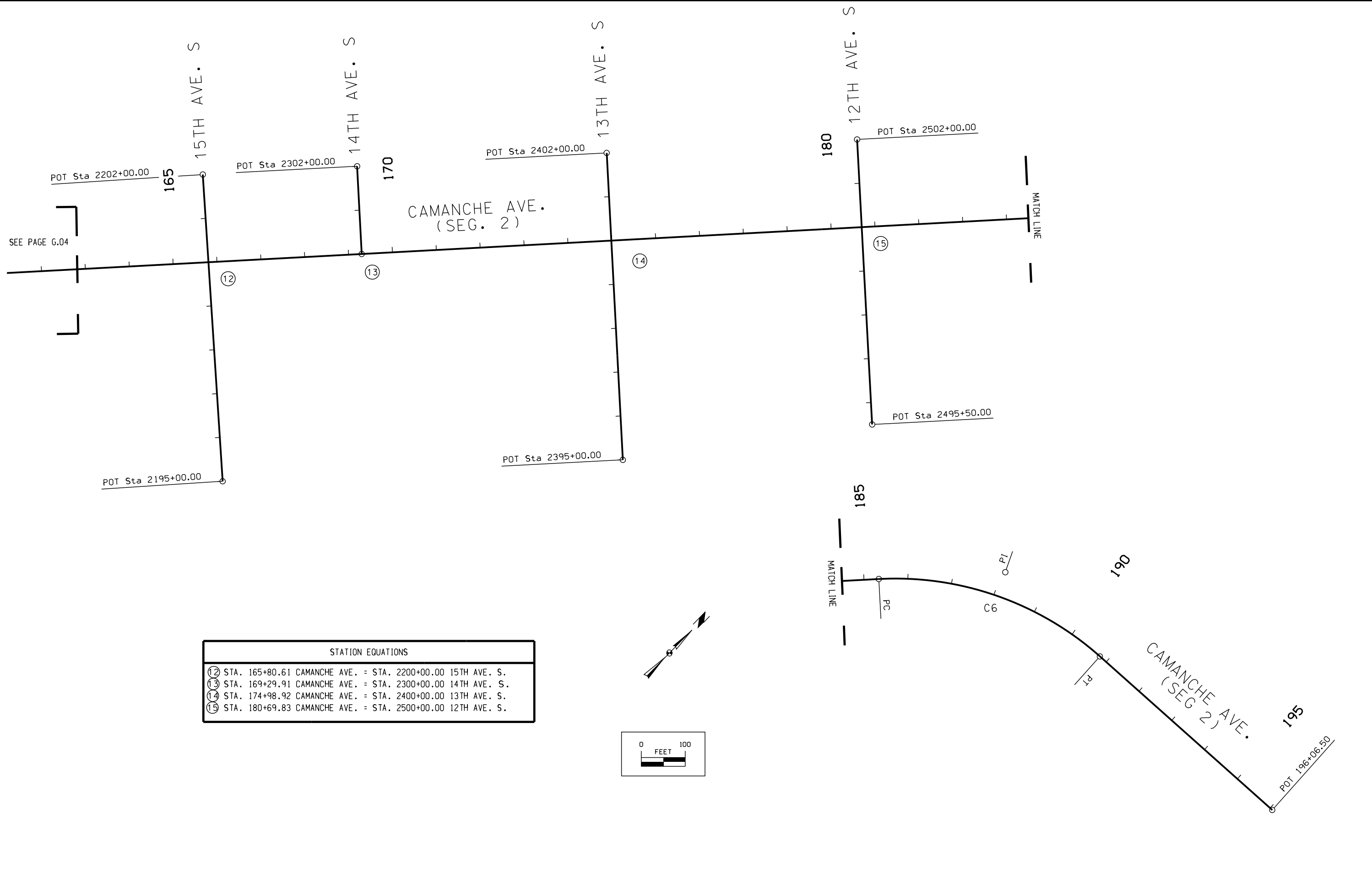

STATION EQUATIONS	
⑫	STA. 165+80.61 CAMANCHE AVE. = STA. 2200+00.00 15TH AVE. S.
⑬	STA. 169+29.91 CAMANCHE AVE. = STA. 2300+00.00 14TH AVE. S.
⑭	STA. 174+98.92 CAMANCHE AVE. = STA. 2400+00.00 13TH AVE. S.
⑮	STA. 180+69.83 CAMANCHE AVE. = STA. 2500+00.00 12TH AVE. S.

SEE PAGE G.04

CIRCULAR CURVE COORDINATE

101-10A  
10-29-02

No.	P.C.		P.I.			P.T.		
	Station	Coordinates	Station	Coordinates	Station	Coordinates	Station	Coordinates
CAMANCHE AVE. - SEGMENT 1								
			100+03.04	679,319.81	2,534,289.28			
C1	103+37.34	679,509.00	104+86.46	679,593.39	2,534,687.82	106+35.11	679,660.42	2,534,821.02
C2	110+30.95	679,838.35	113+28.41	679,972.06	2,535,440.32	116+21.47	680,177.76	2,535,655.18
			119+50.00	680,404.96	2,535,892.49			
CAMANCHE AVE. - SEGMENT 2								
			119+50.00	680,413.63	2,535,884.19			
C3	134+00.42	681,416.66	139+10.18	681,769.19	2,537,300.09	144+17.92	682,174.07	2,537,609.80
C4	146+21.45	682,335.73	148+22.37	682,495.31	2,537,855.53	150+22.42	682,633.35	2,538,001.52
C5	155+11.34	682,969.26	158+09.13	683,173.85	2,538,573.16	161+06.68	683,393.09	2,538,774.69
C6	185+33.87	685,180.01	188+22.18	685,392.27	2,540,612.42	190+80.86	685,405.54	2,540,900.43
			196+06.50	685,429.73	2,541,425.52			
14TH ST.								
			1195+00.00	679,089.84	2,534,753.82			
C7	1196+60.18	679,230.60	1196+95.64	679,261.90	2,534,662.24	1197+29.81	679,297.34	2,534,661.36
			1202+68.84	679,836.92	2,534,647.92			
LIBERTY AVE.								
			315+56.99	680,100.44	2,535,637.94			
C8	319+74.38	680,379.14	321+23.47	680,478.69	2,536,059.63	322+68.02	680,523.37	2,536,201.86
24TH PL. (SE)								
			1297+69.60	680,585.18	2,536,338.18			
C9	1297+99.60	680,576.19	1298+67.81	680,555.75	2,536,244.48	1299+21.71	680,604.94	2,536,197.24
			1300+00.00	680,672.14	2,536,132.72			
24TH PL. (NW)								
			1300+00.00	680,664.88	2,536,146.63			
			1302+00.00	680,809.14	2,536,008.11			
23RD PL.								
			1395+50.00	680,780.91	2,536,918.47			
			1402+00.00	681,256.45	2,536,475.35			
22ND PL.								
			1496+71.75	681,177.39	2,537,156.60			
			1502+00.00	681,561.14	2,536,793.58			
21ST PL.								
			1595+00.00	681,557.40	2,537,757.84			
			1602+00.00	682,064.12	2,537,274.90			
20TH PL.								
			1700+00.00	682,185.90	2,537,618.85			
			1702+00.00	682,328.14	2,537,478.25			
19TH PL.								
			1800+00.00	682,332.05	2,537,730.65			
			1802+00.00	682,473.84	2,537,589.59			
18TH PL.								
			1900+00.00	682,595.96	2,537,962.82			
			1902+00.00	682,738.18	2,537,822.20			
17TH PL.								
			1995+00.00	682,475.85	2,538,562.57			
			2002+00.00	682,974.98	2,538,071.79			

CIRCULAR CURVE AND SUPERELEVATION DATA

101-10B  
10-29-02

NO.	△	D	T	L	E	R	e	L	m	x
CAMANCHE AVE. - PART 1										
C1	7°45'17.95" RT	2°36'15.67"	149.11'	297.77'	5.05'	2,200.00'				
C2	17°02'26.05" LT	2°53'08.56"	297.45'	590.52'	22.16'	1,985.50'				
CAMANCHE AVE. - PART 2										
C3	8°49'59.17" LT	0°52'05.22"	509.76'	1,017.50'	19.66'	6,600.00'				
C4	9°11'22.28" RT	2°17'30.59"	200.92'	400.97'	8.06'	2,500.00'				
C5	4°00'46.83" LT	0°40'26.64"	297.79'	595.34'	5.21'	8,500.00'				
C6	44°46'16.93" RT	8°11'06.40"	288.31'	546.99'	57.05'	700.00'				
14TH ST.										
C7	26°35'50.09" RT	38°11'49.87"	35.45'	69.63'	4.13'	150.00'				
LIBERTY AVE.										
C8	24°27'12.83 RT	8°19'40.35"	149.09'	293.64'	15.97'	688.00'				
24TH PL. (SE)										
C9	63°36'06.72" RT	52°05'13.46"	68.21'	122.11'	19.43'	110.00'				



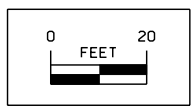
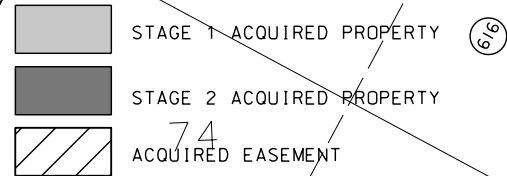

POINT #	STATION	OFFSET	NORTHING	EASTING	DESCRIPTION
19247	151+42.77	16.44 RT	682704.09	2538100.26	REBAR
19248	157+89.16	18.91 RT	683150.09	2538568.92	LS 10626
19250	158+09.91	18.56 RT	683165.13	2538583.30	LS 15524
90003	110+17.92	187.02 LT	679999.55	2535078.91	
90004	110+31.20	60.72 LT	679892.70	2535147.53	
90005	110+82.65	65.20 LT	679919.65	2535189.68	
90006	110+71.21	191.30 LT	680025.91	2535120.95	
150011	180+39.94	223.81 LT	684967.84	2539918.25	5/8IN IP 13480
150013	180+99.94	242.24 LT	685024.49	2539945.30	5/8IN IP SMOOTH BENT
150014	180+99.94	222.24 LT	685010.95	2539960.02	1/2IN BOLT BENT
150015	180+39.92	49.02 LT	684849.53	2540046.93	RR SPK
150016	178+59.90	49.34 LT	684717.22	2539924.87	5/8IN IP 13480
150035	174+66.22	50.06 LT	684427.87	2539657.91	X IN PCC
150037	174+06.44	50.16 LT	684383.93	2539617.38	X IN PCC
150061	165+60.35	181.77 LT	683850.10	2538947.90	5/8IN IP 9IN OUT
150062	165+61.14	51.31 LT	683762.39	2539044.47	BRASS DISK IN PCC
150083	134+26.84	169.51 LT	681556.94	2536833.20	X IN PCC
150089	123+36.69	173.96 LT	680806.70	2536043.20	3/4IN IP
150090	123+35.92	191.15 LT	680818.58	2536030.77	1/2IN IP
150096	114+71.09	197.33 LT	680230.44	2535417.44	1/2IN IP SLIGHTLY BENT
150103	140+86.02	385.04 RT	681666.63	2537695.29	1/2IN IP
150105	140+23.97	378.54 RT	681620.98	2537647.66	1/2IN IP 4705
150106	139+59.41	372.42 RT	681573.60	2537598.19	1/2IN IP 4705
150133	176+72.25	49.64 LT	684579.27	2539797.65	1/2IN IP
150142	191+83.43	47.14 LT	685457.35	2541000.73	3/4 GP
150143	191+50.14	46.94 LT	685455.62	2540967.48	1 GP
150144	190+83.46	47.49 LT	685453.10	2540900.84	1/2 IP 4705

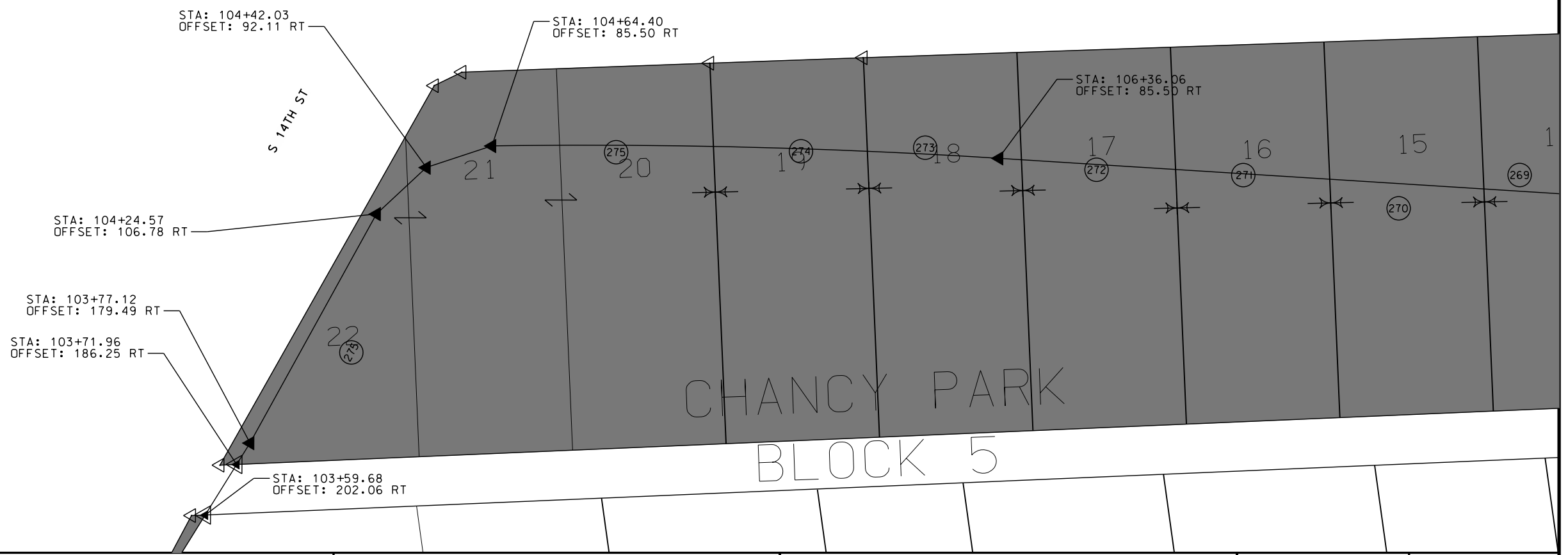
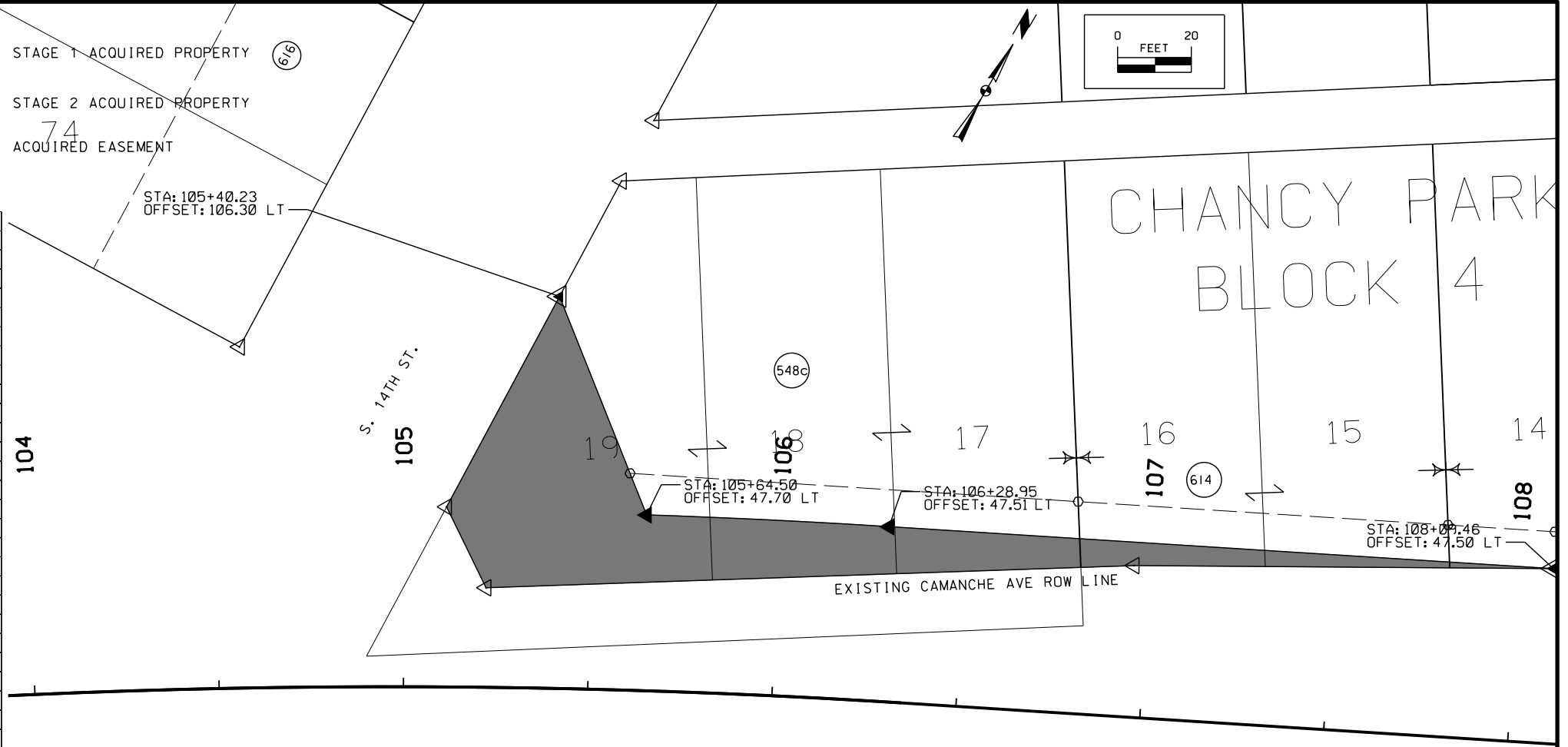



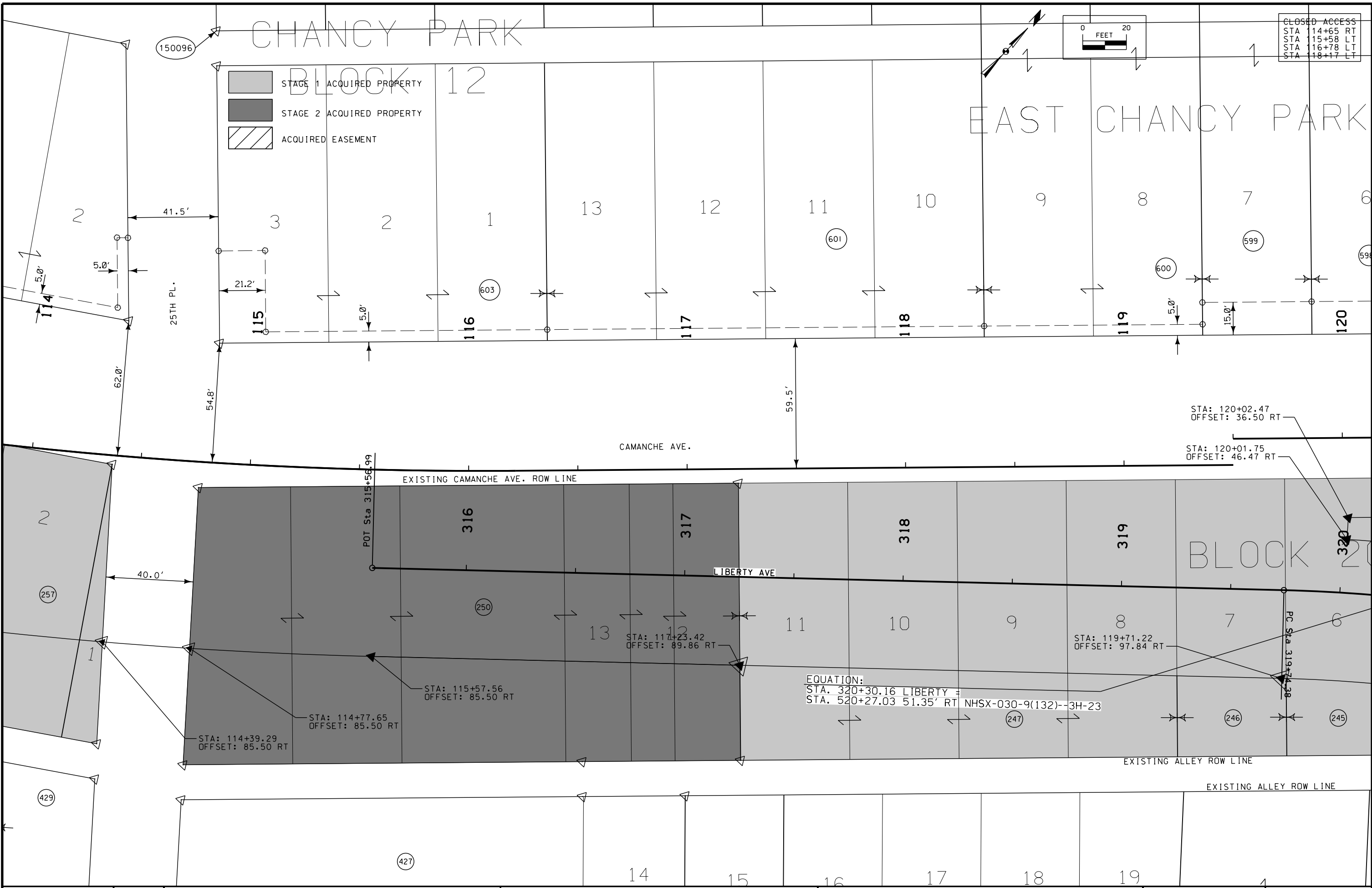

CLOSED ACCESS  
 STA 114+65 RT  
 STA 115+58 LT  
 STA 116+78 LT  
 STA 118+17 LT

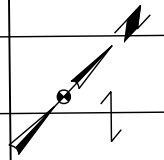
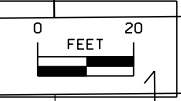

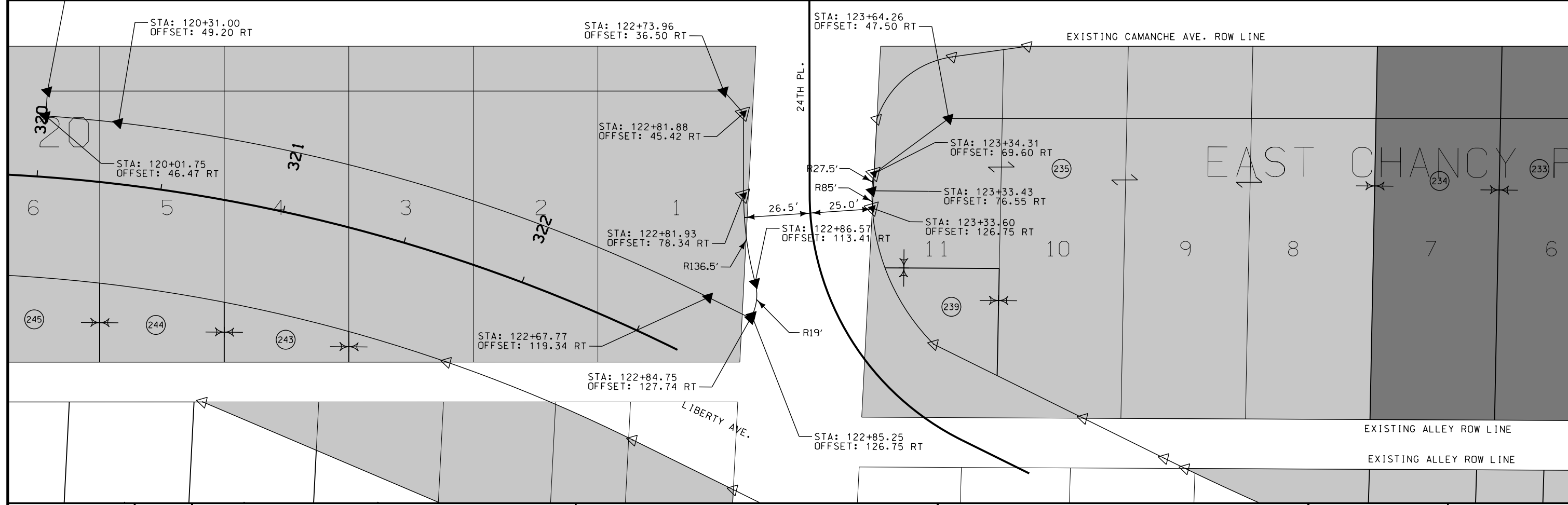
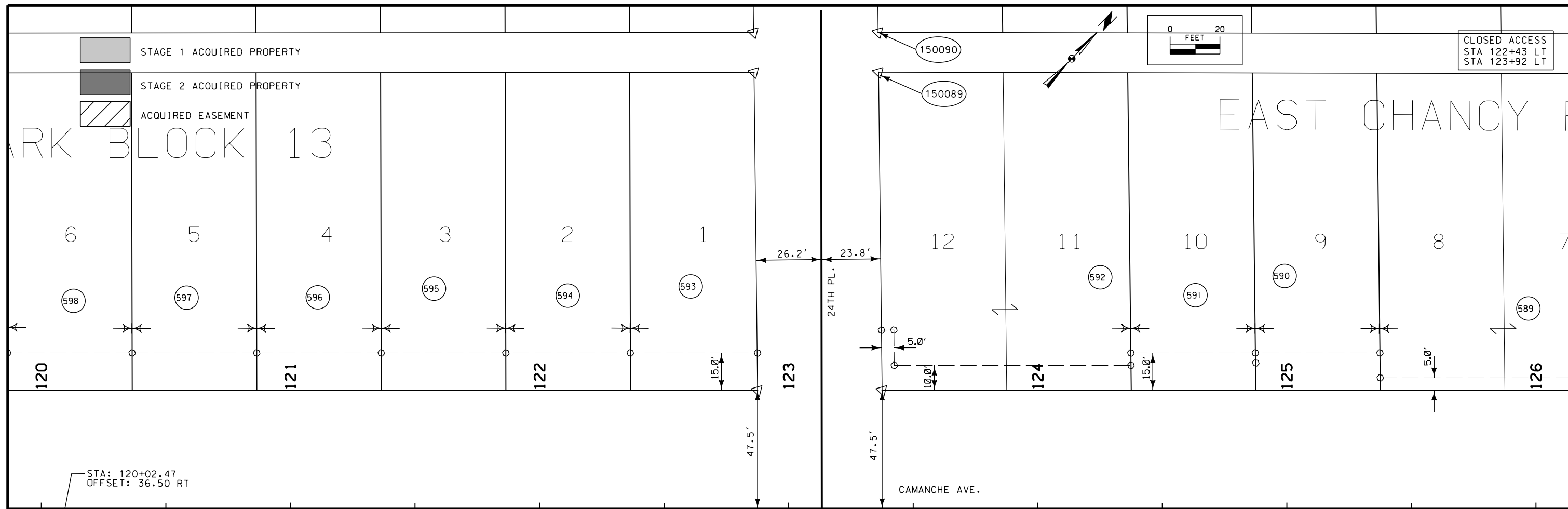

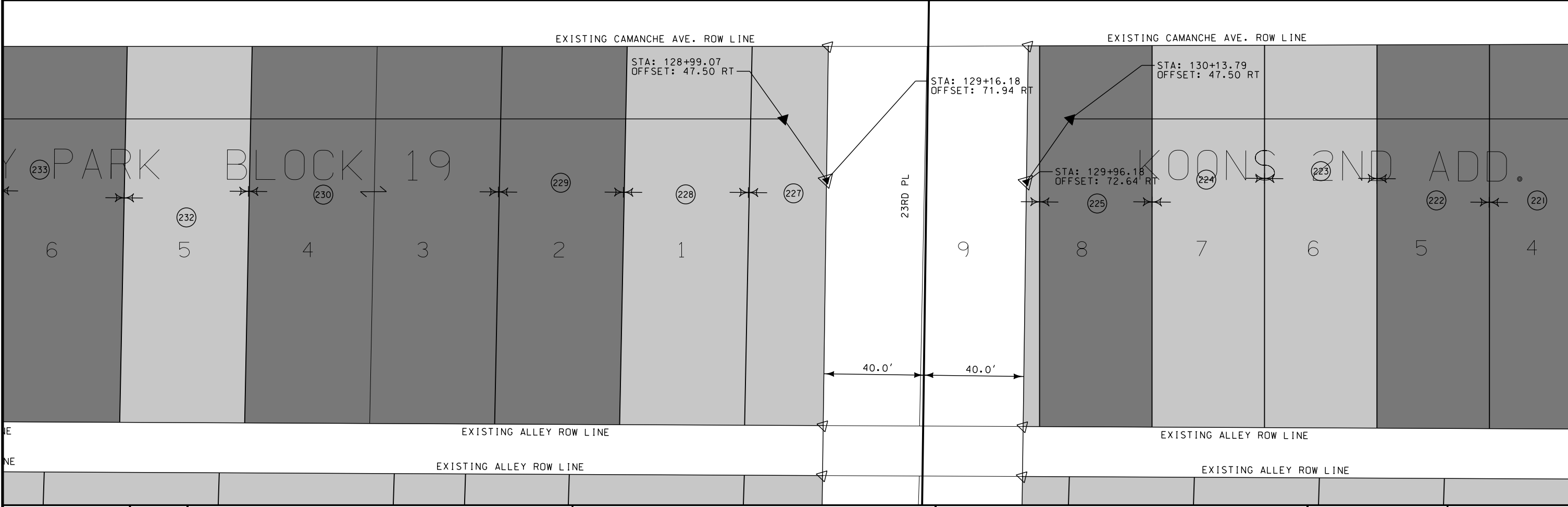
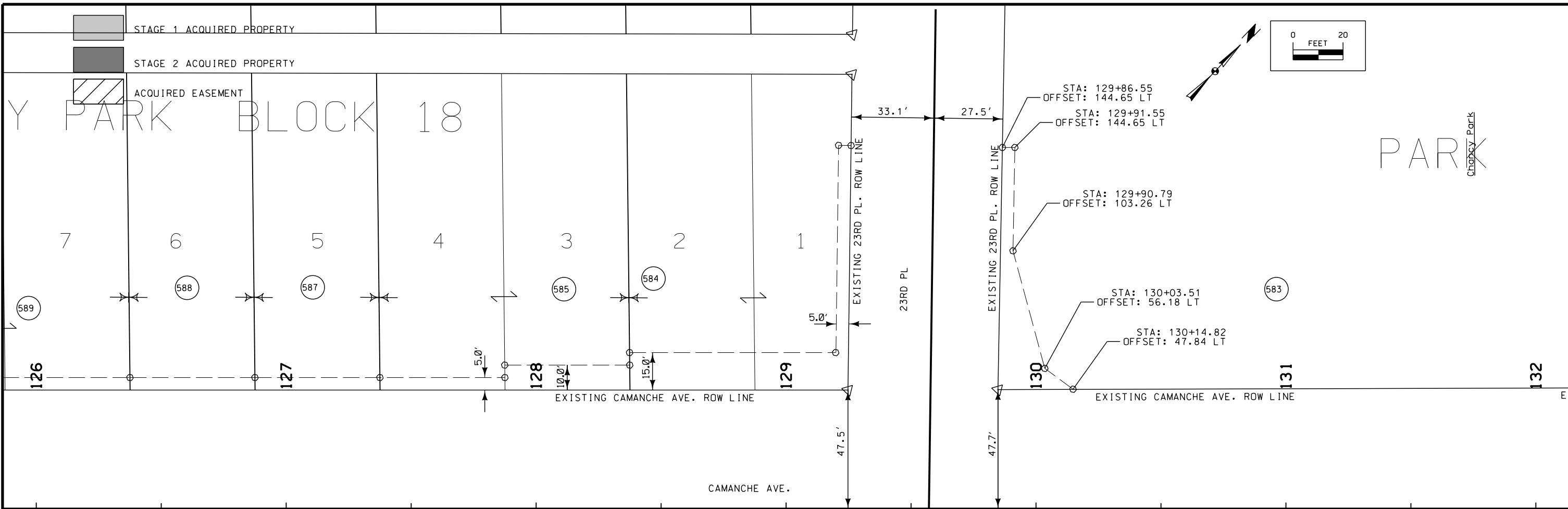



- STAGE 1 ACQUIRED PROPERTY
- STAGE 2 ACQUIRED PROPERTY
- ACQUIRED EASEMENT

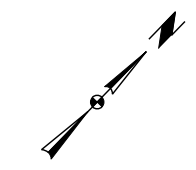
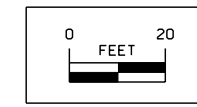



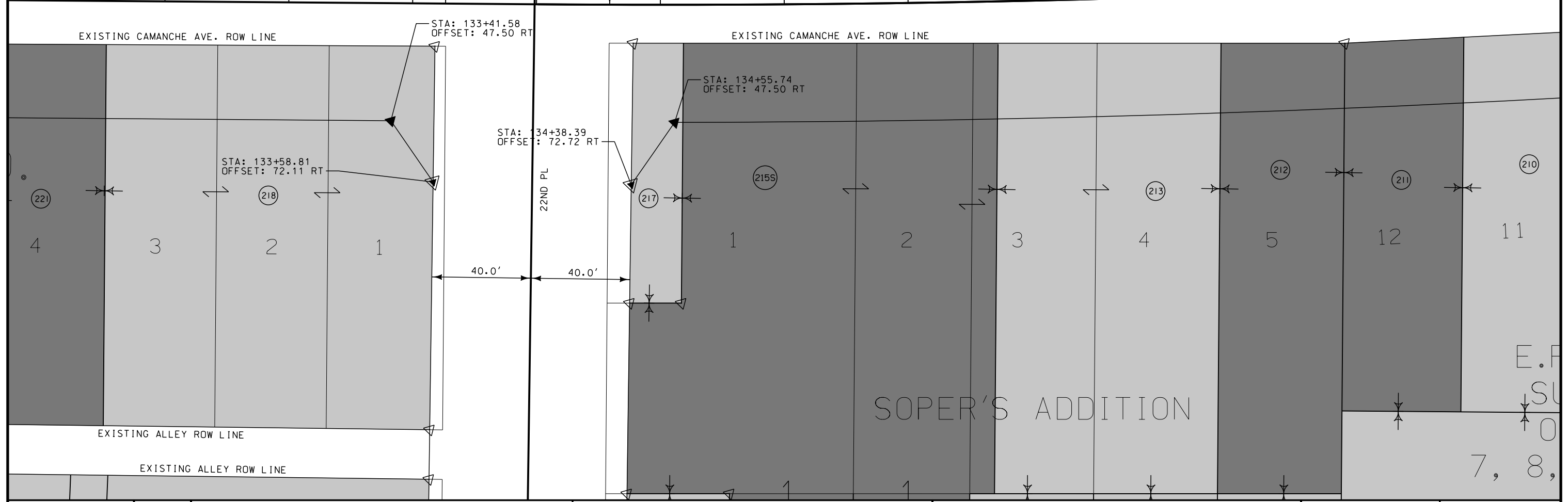
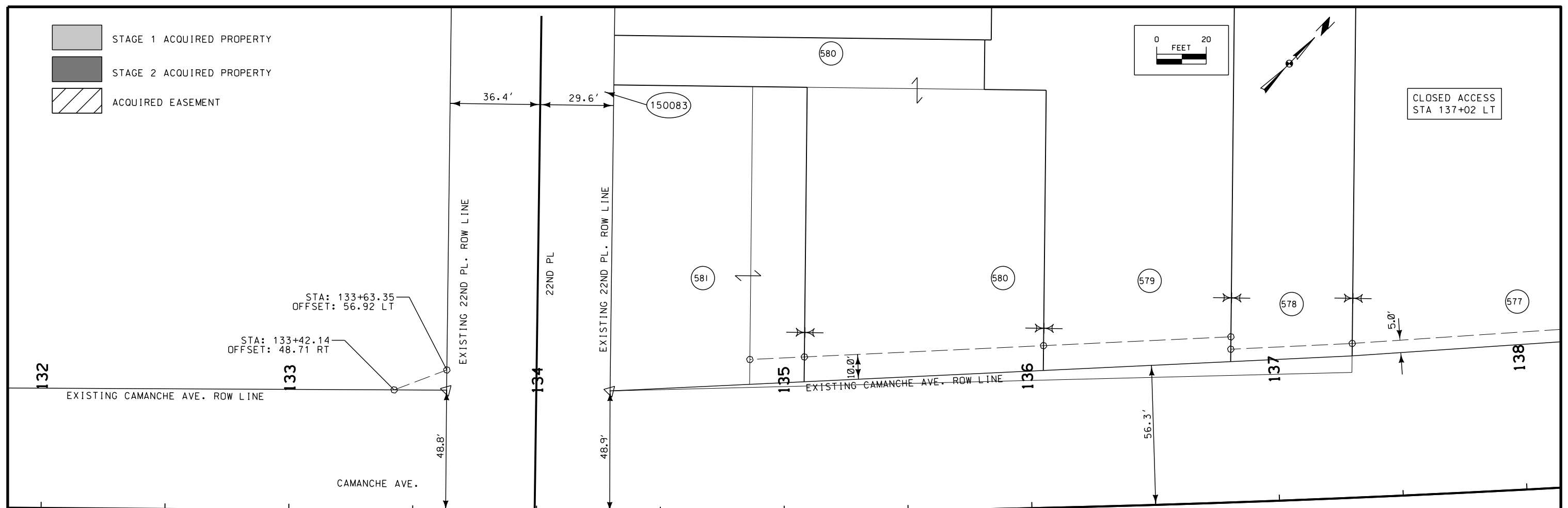

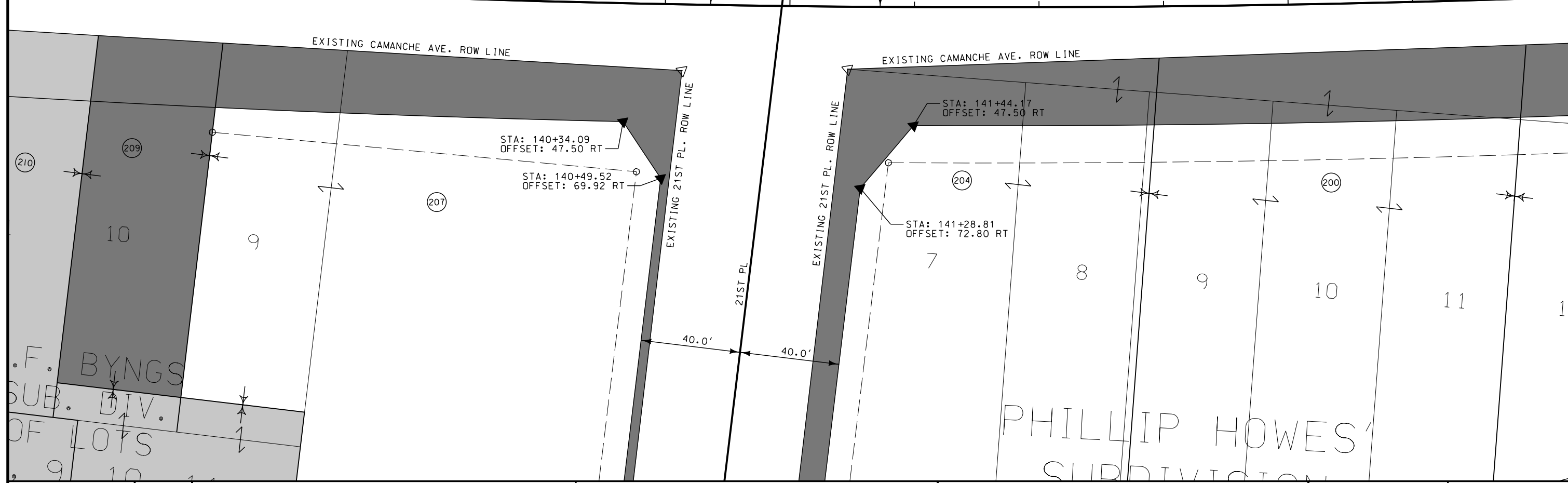
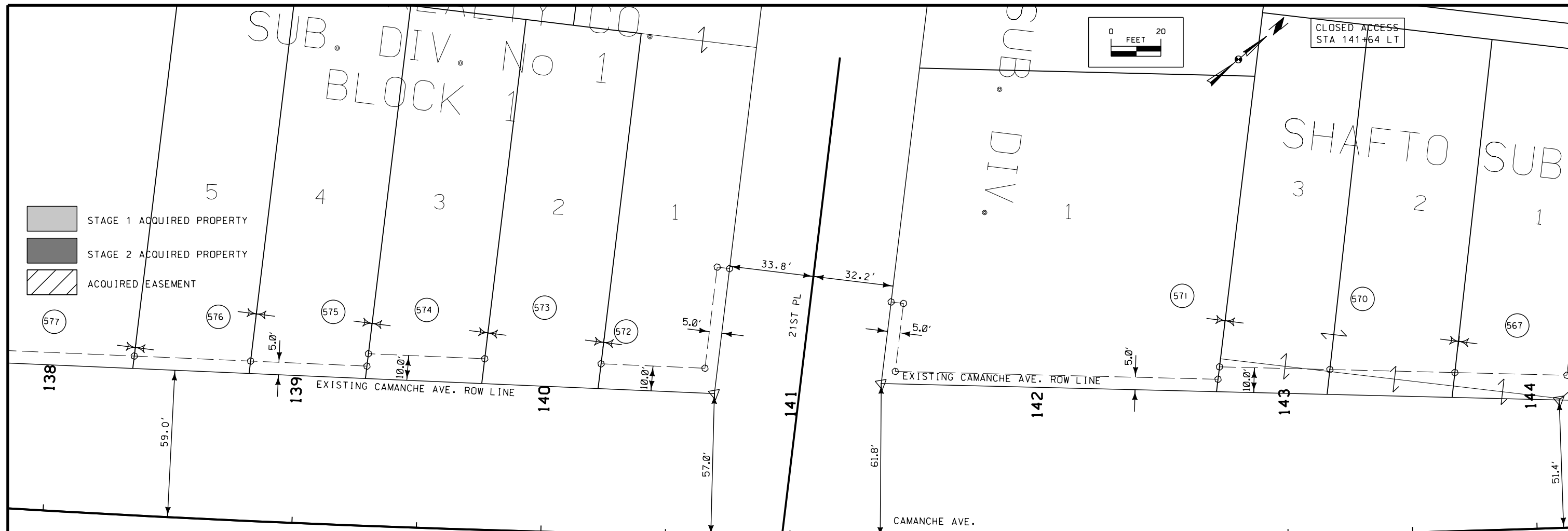
CLOSED ACCESS  
STA 137+02 LT

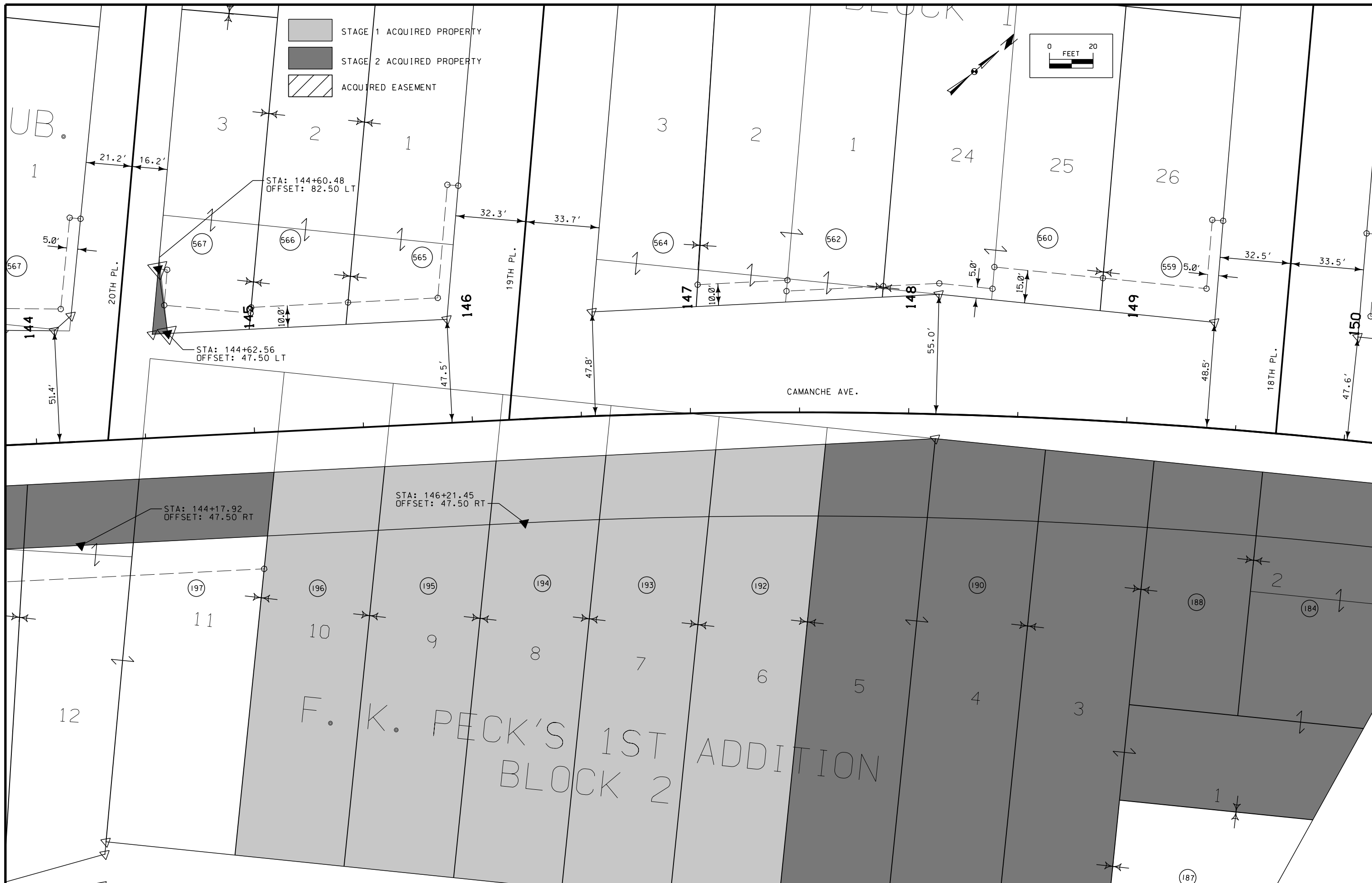

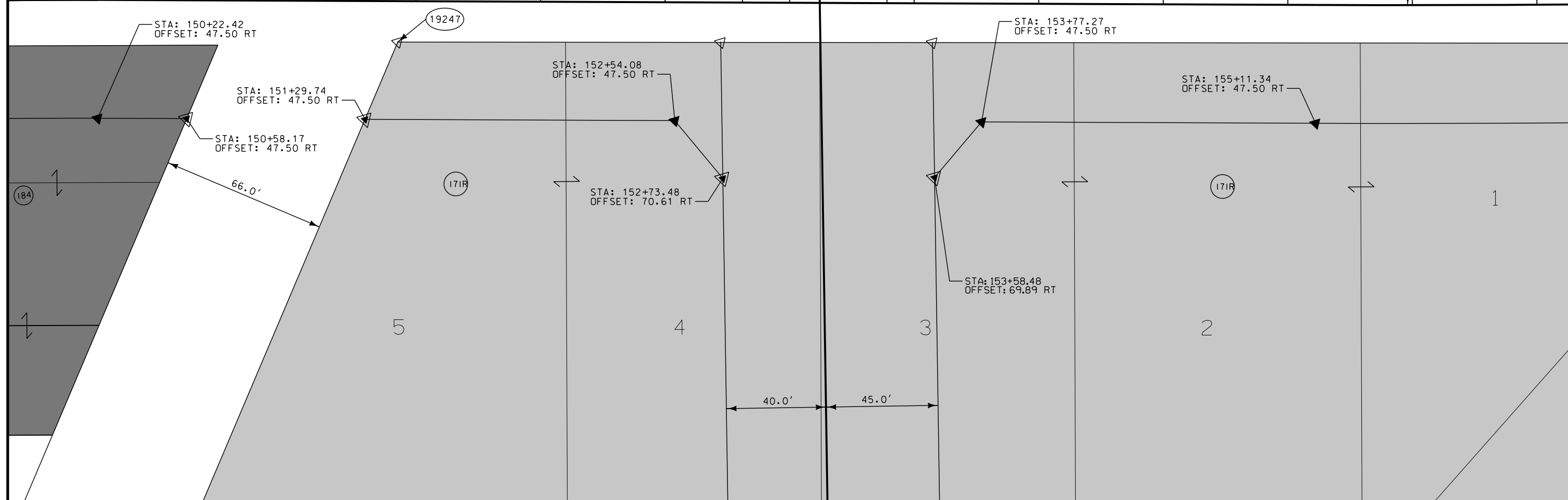
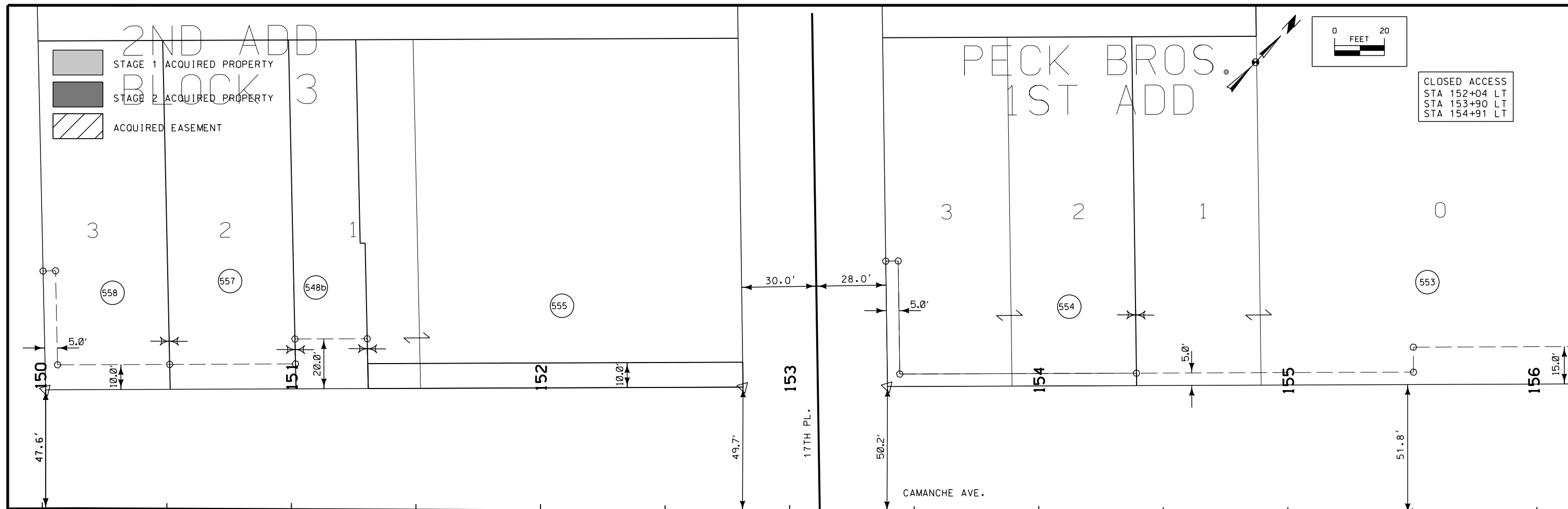





-  STAGE 1 ACQUIRED PROPERTY
-  STAGE 2 ACQUIRED PROPERTY
-  ACQUIRED EASEMENT

1ST ADD

BLOCK 1

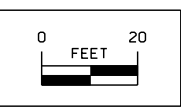

CLOSED ACCESS  
STA 159+73 LT  
STA 161+07 LT

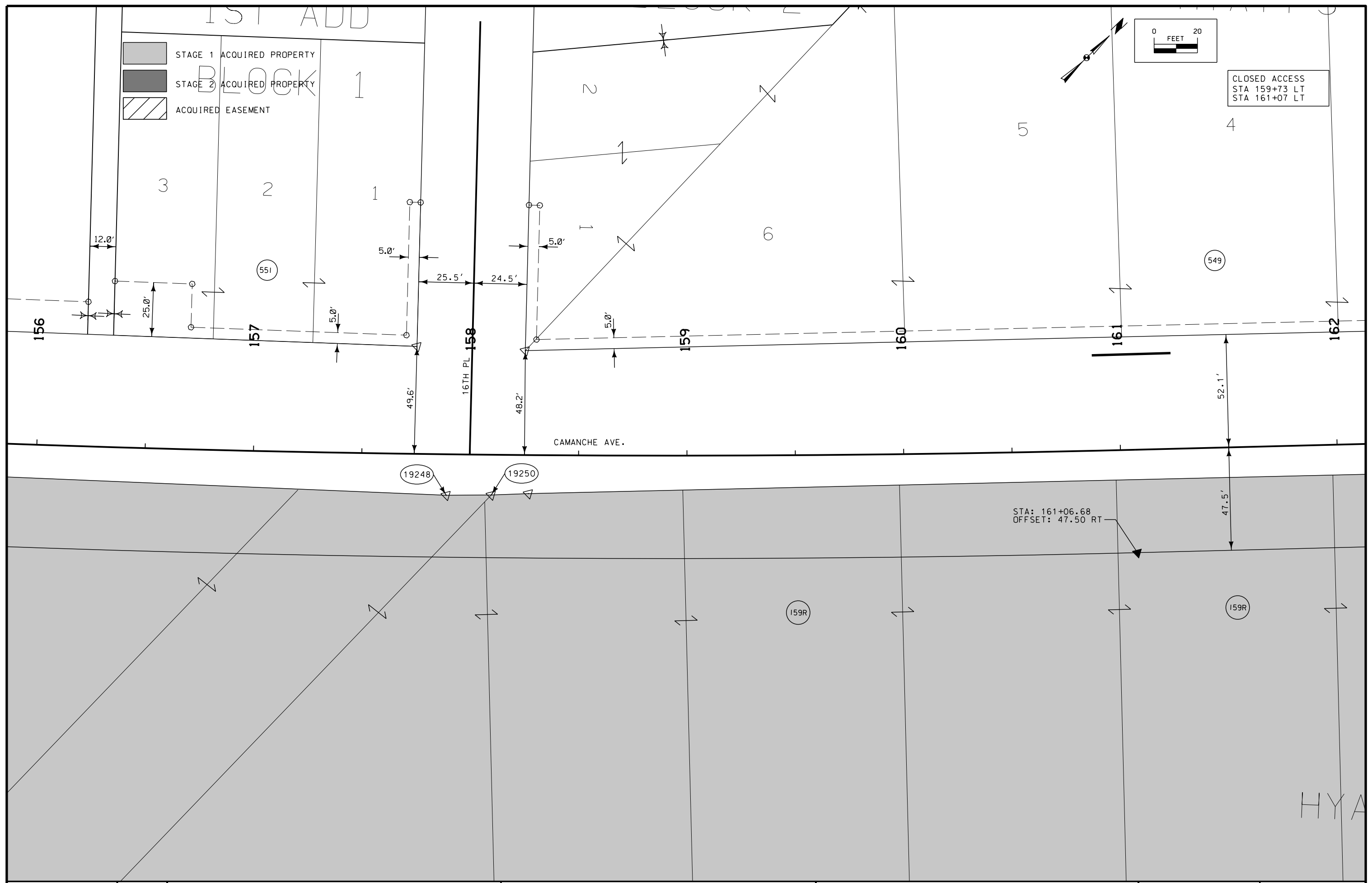

STA: 161+06.68  
OFFSET: 47.50 RT

HYA

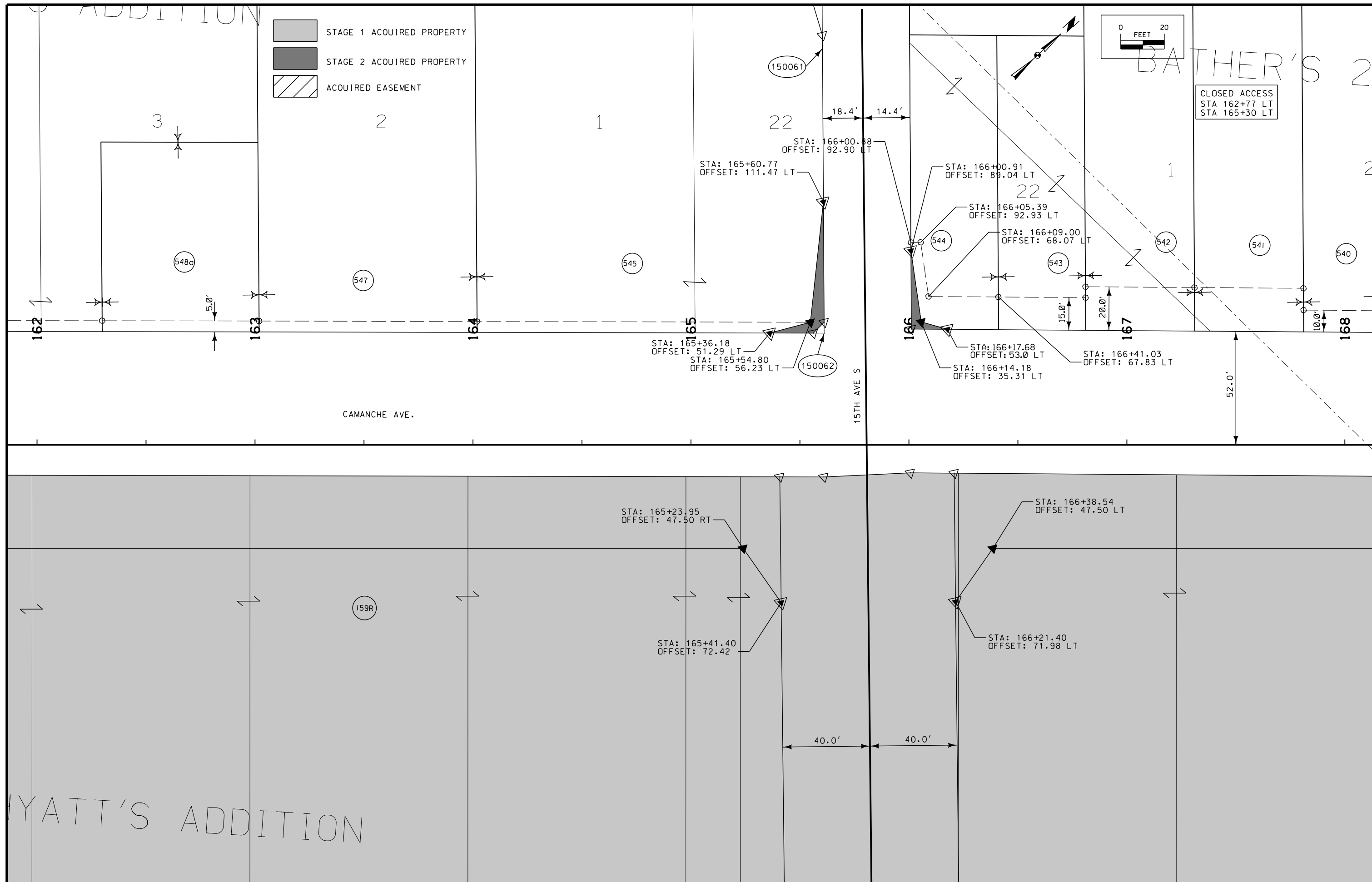

[Light Gray Box] STAGE 1 ACQUIRED PROPERTY  
 [Dark Gray Box] STAGE 2 ACQUIRED PROPERTY  
 [Hatched Box] ACQUIRED EASEMENT

2ND ADD

BATHER'S  
2ND ADD.

[North Arrow]  
 [Scale: 0 FEET 20]  
 BATHER'S  
5TH SUBDIV.

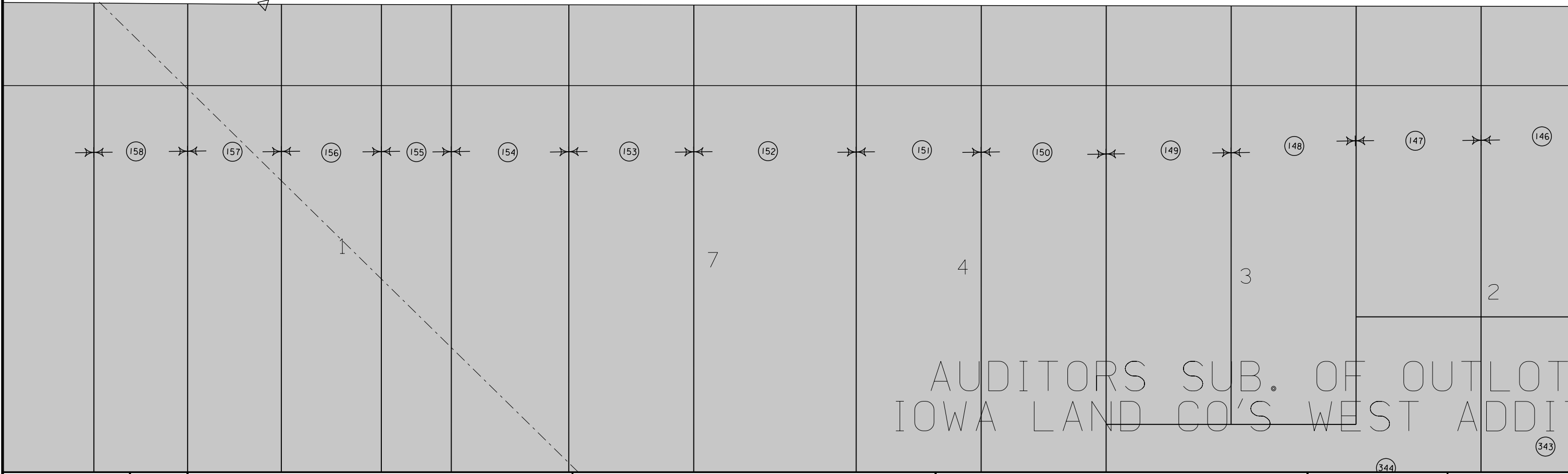
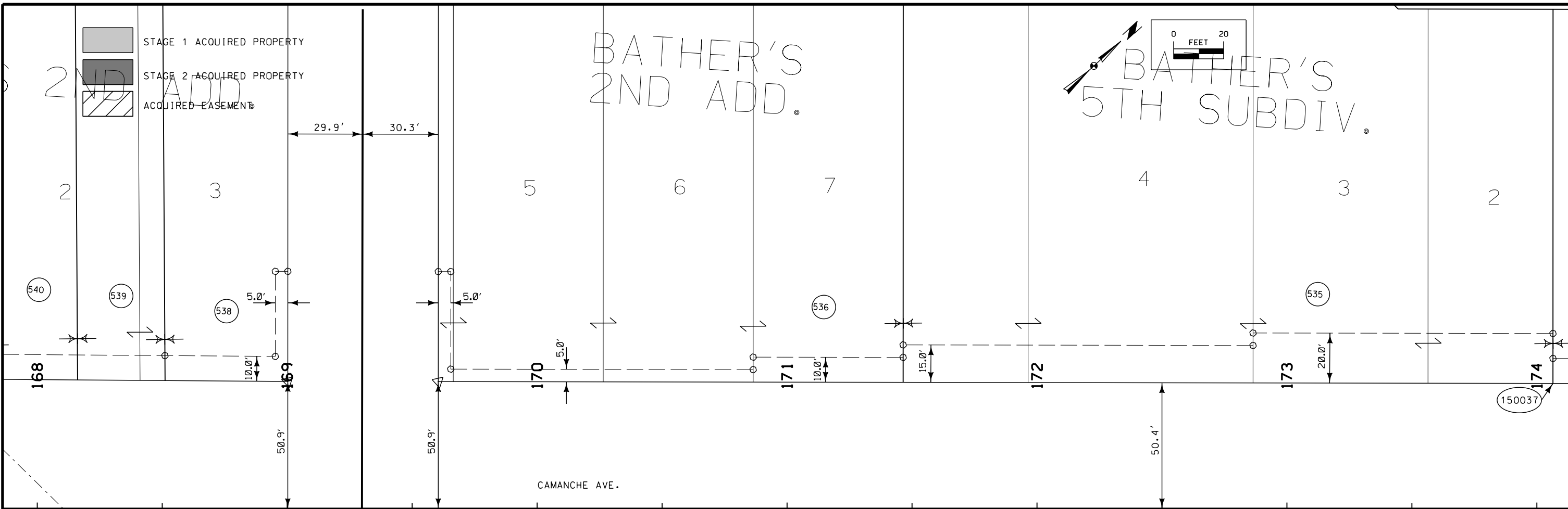

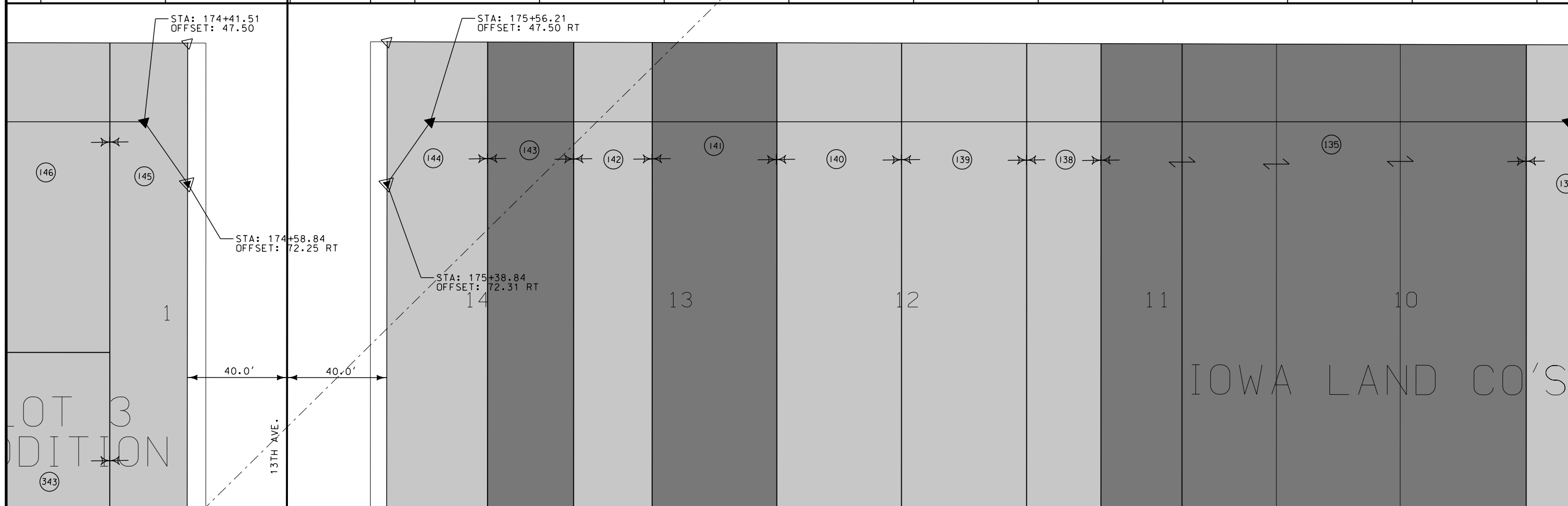
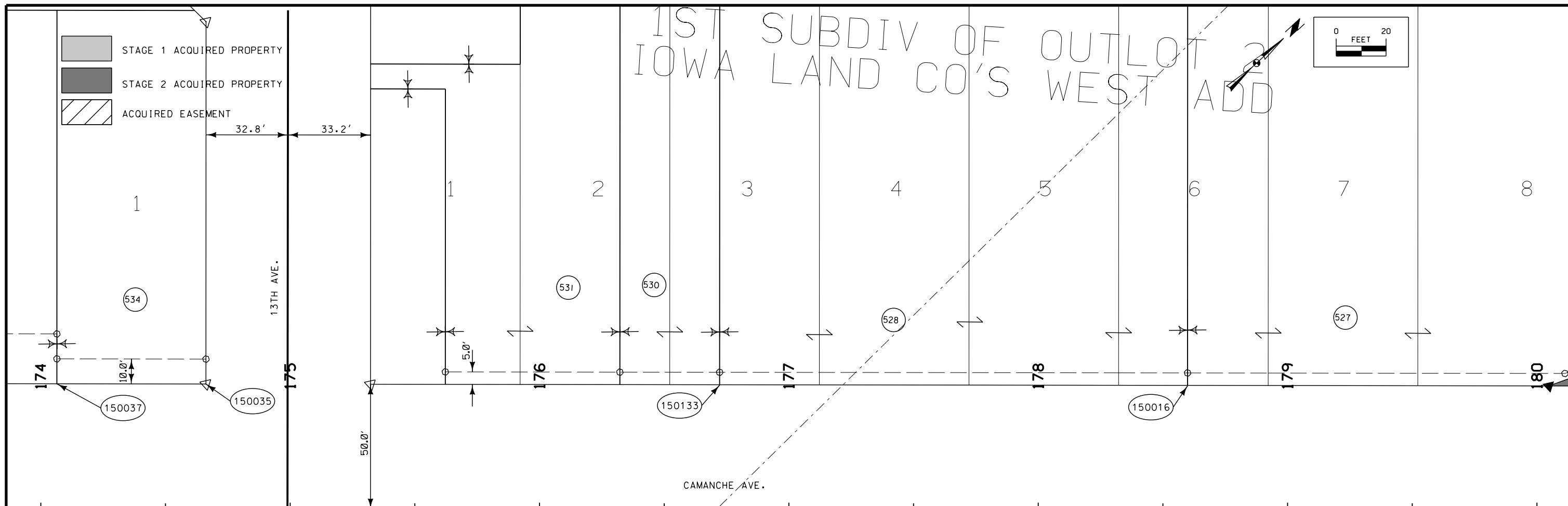



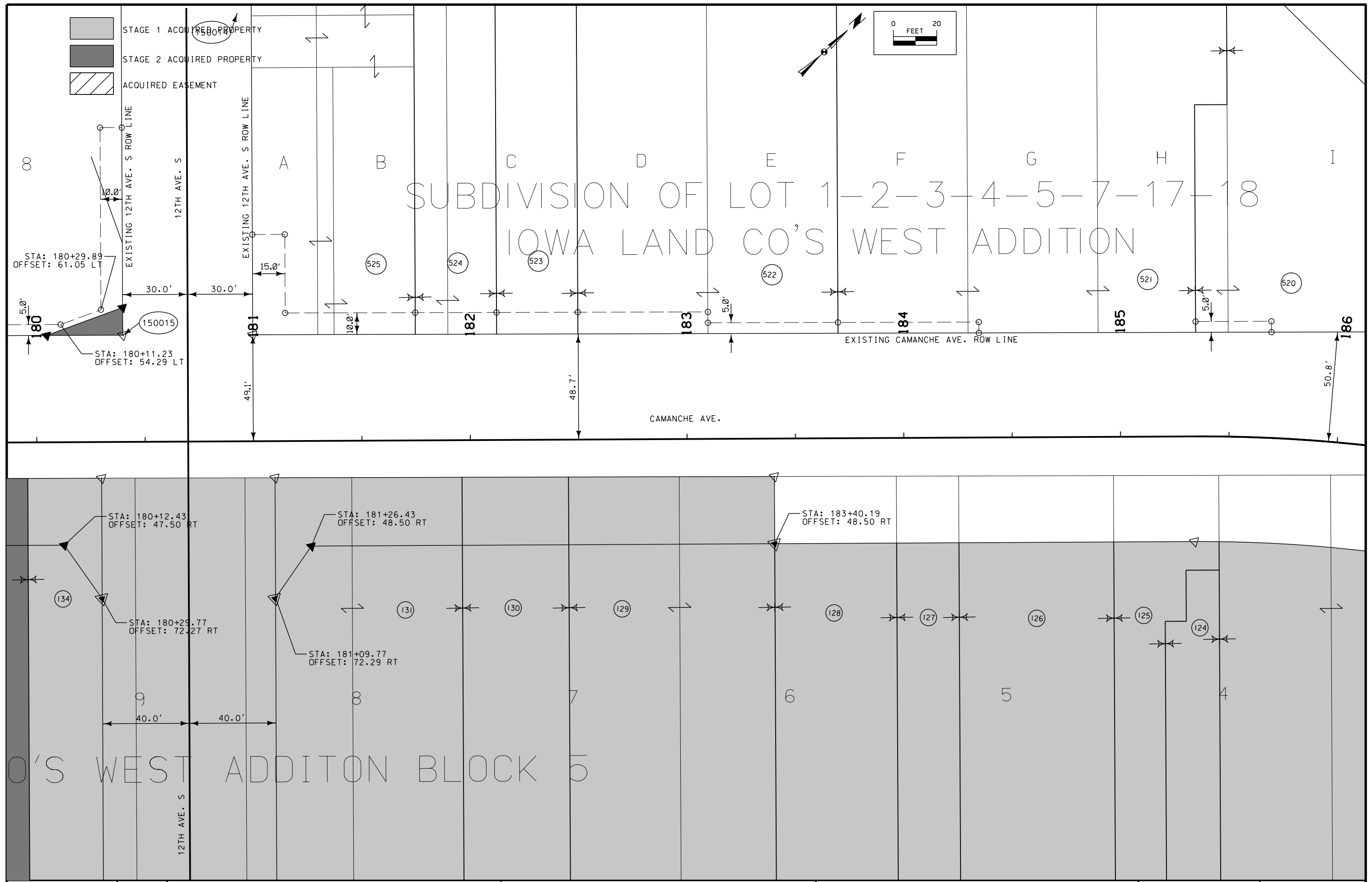



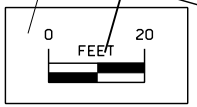

- STAGE 1 ACQUIRED PROPERTY
- STAGE 2 ACQUIRED PROPERTY
- ACQUIRED EASEMENT

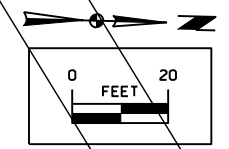
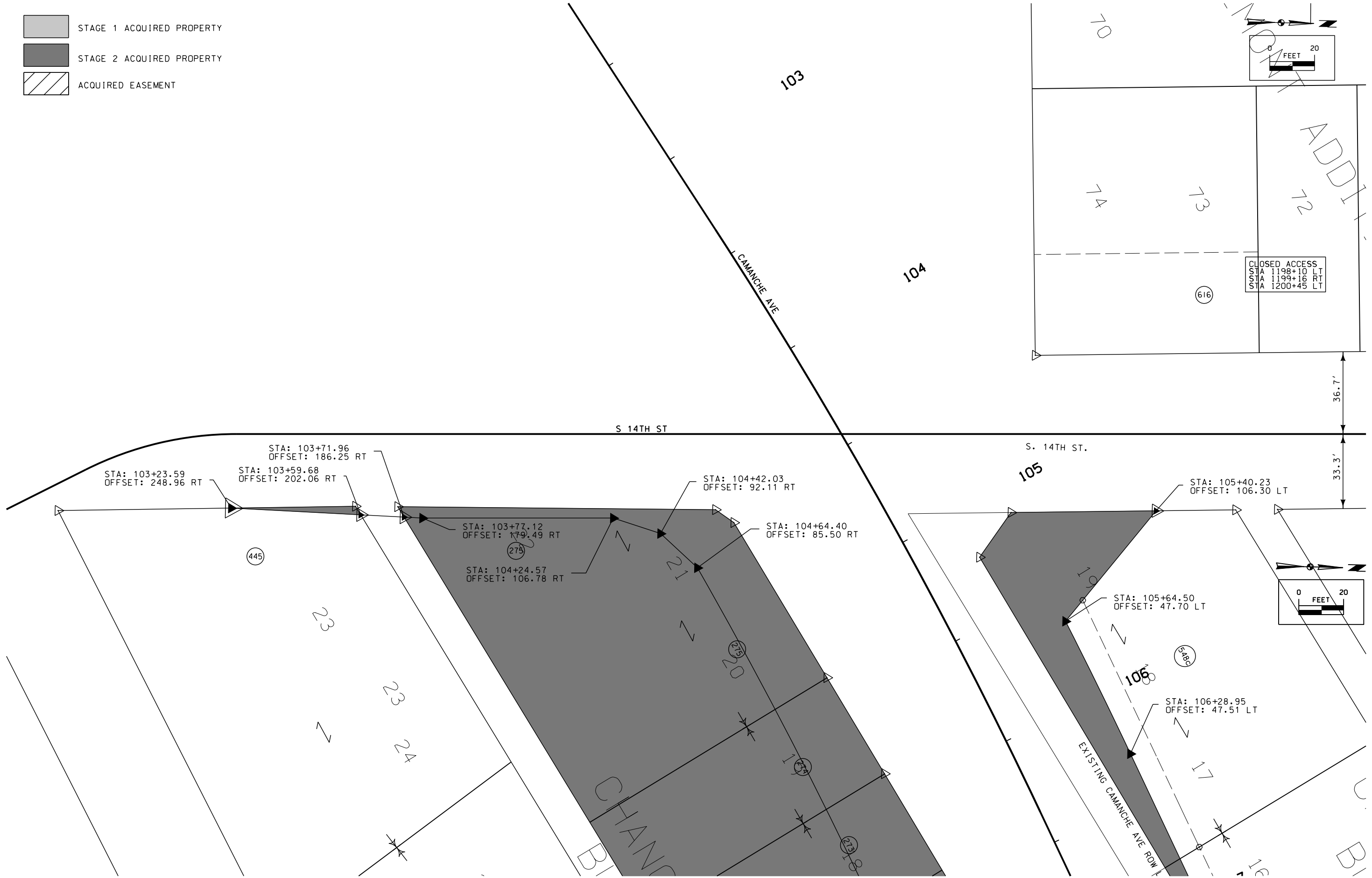
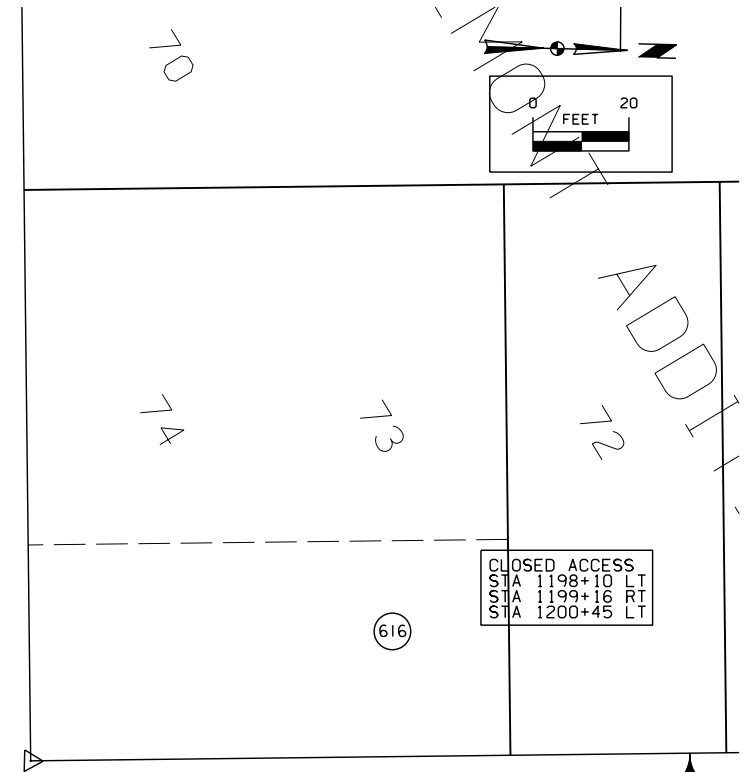

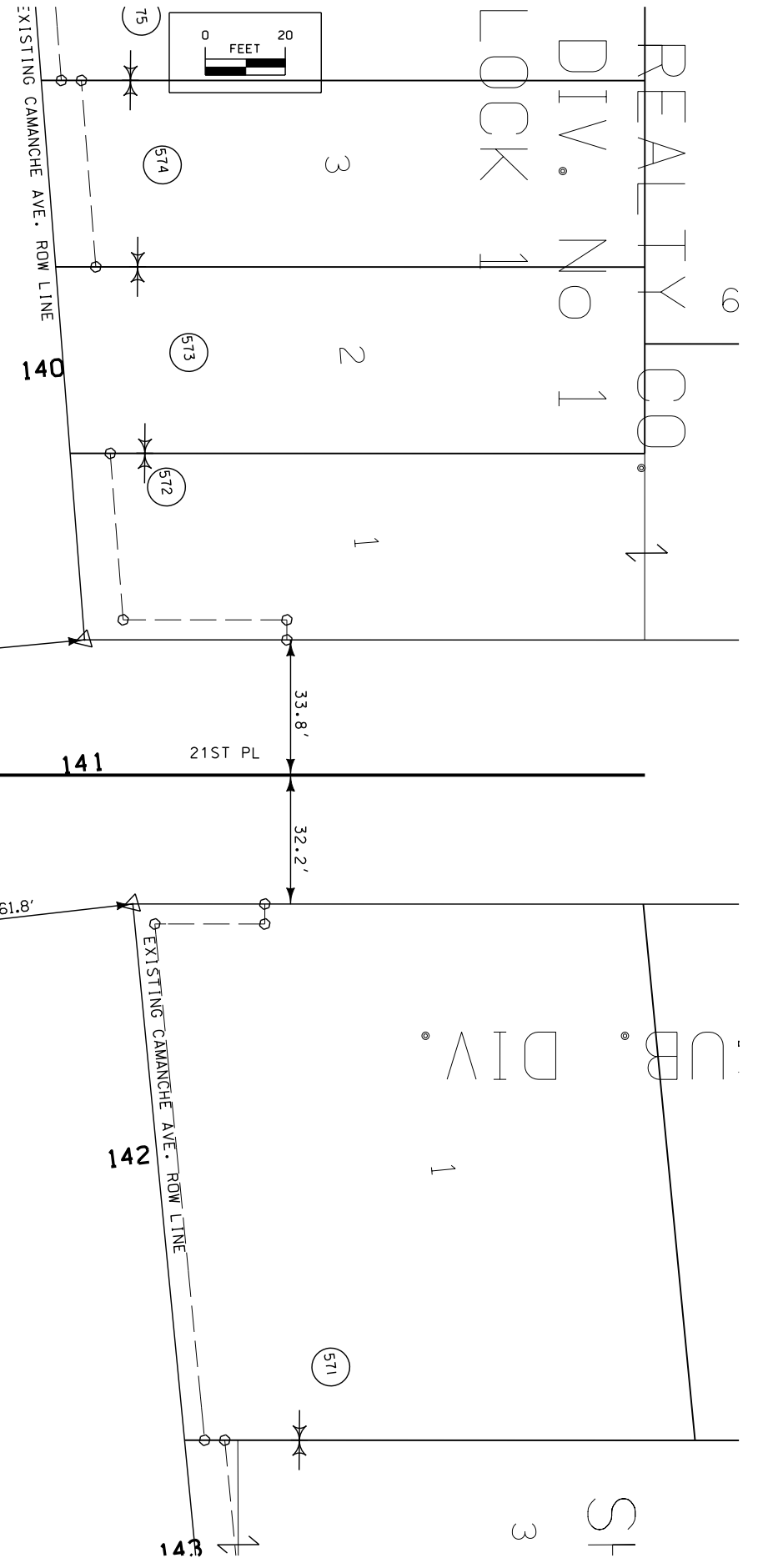
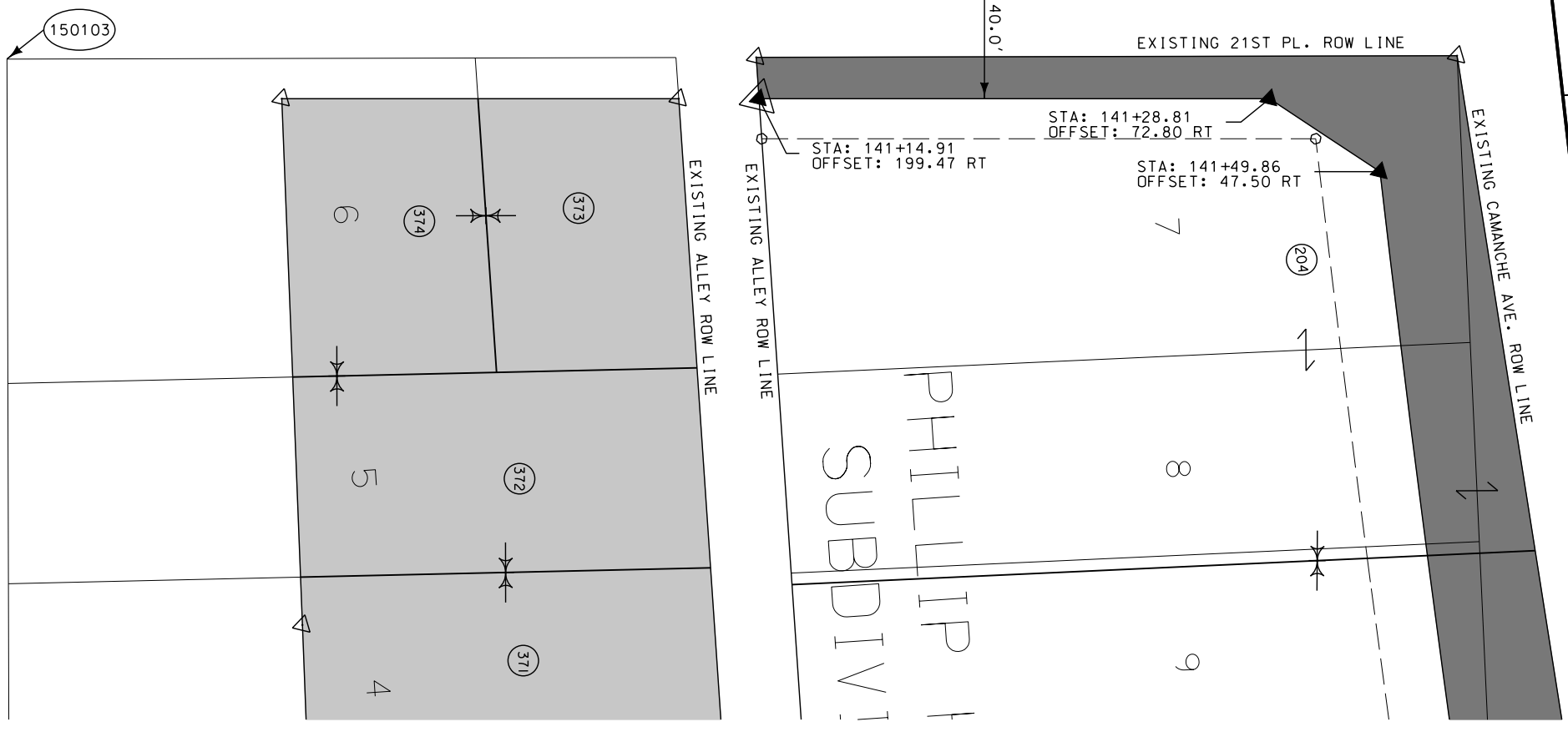
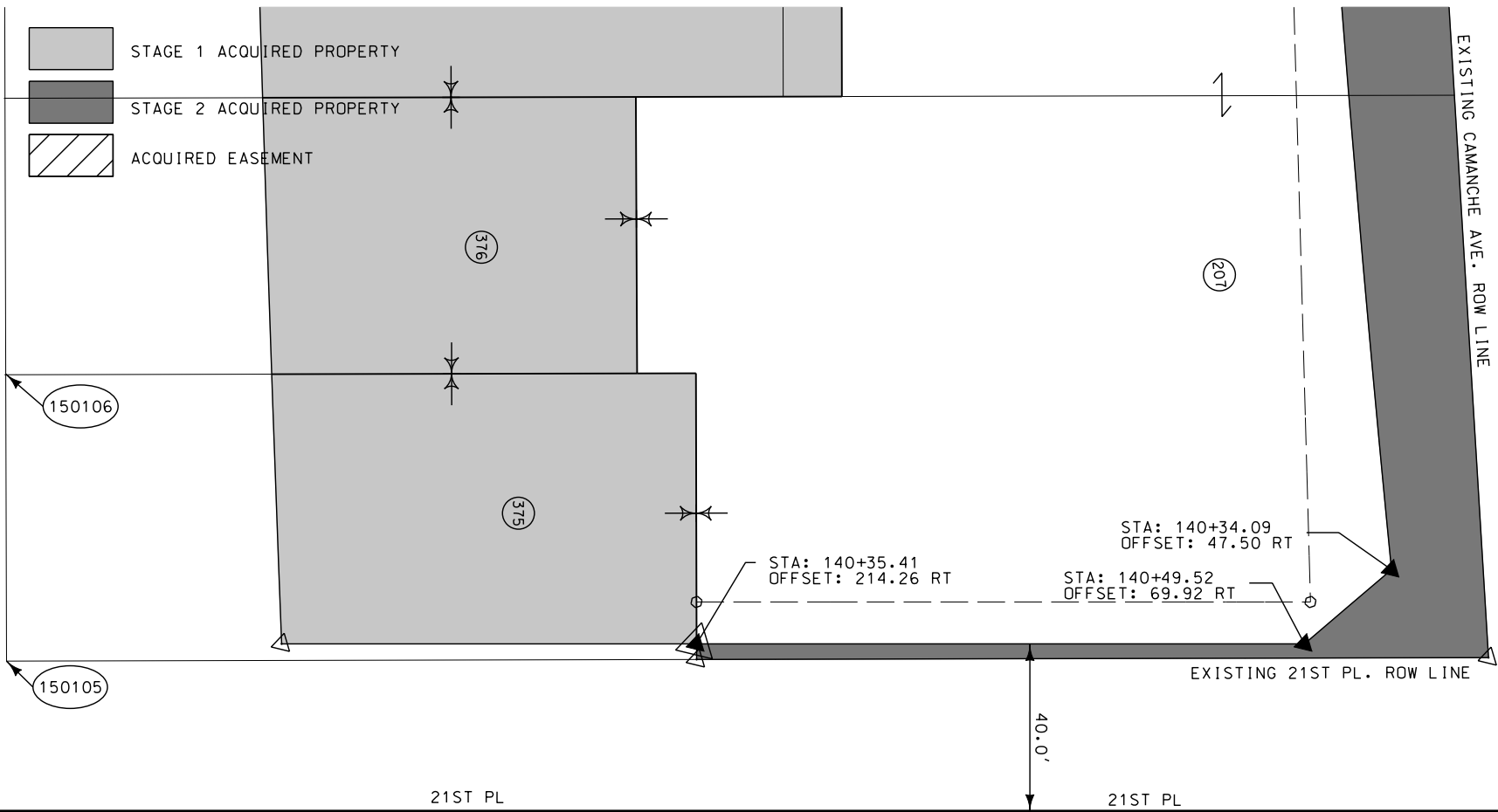



- STAGE 1 ACQUIRED PROPERTY
- STAGE 2 ACQUIRED PROPERTY
- ACQUIRED EASEMENT



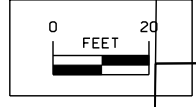
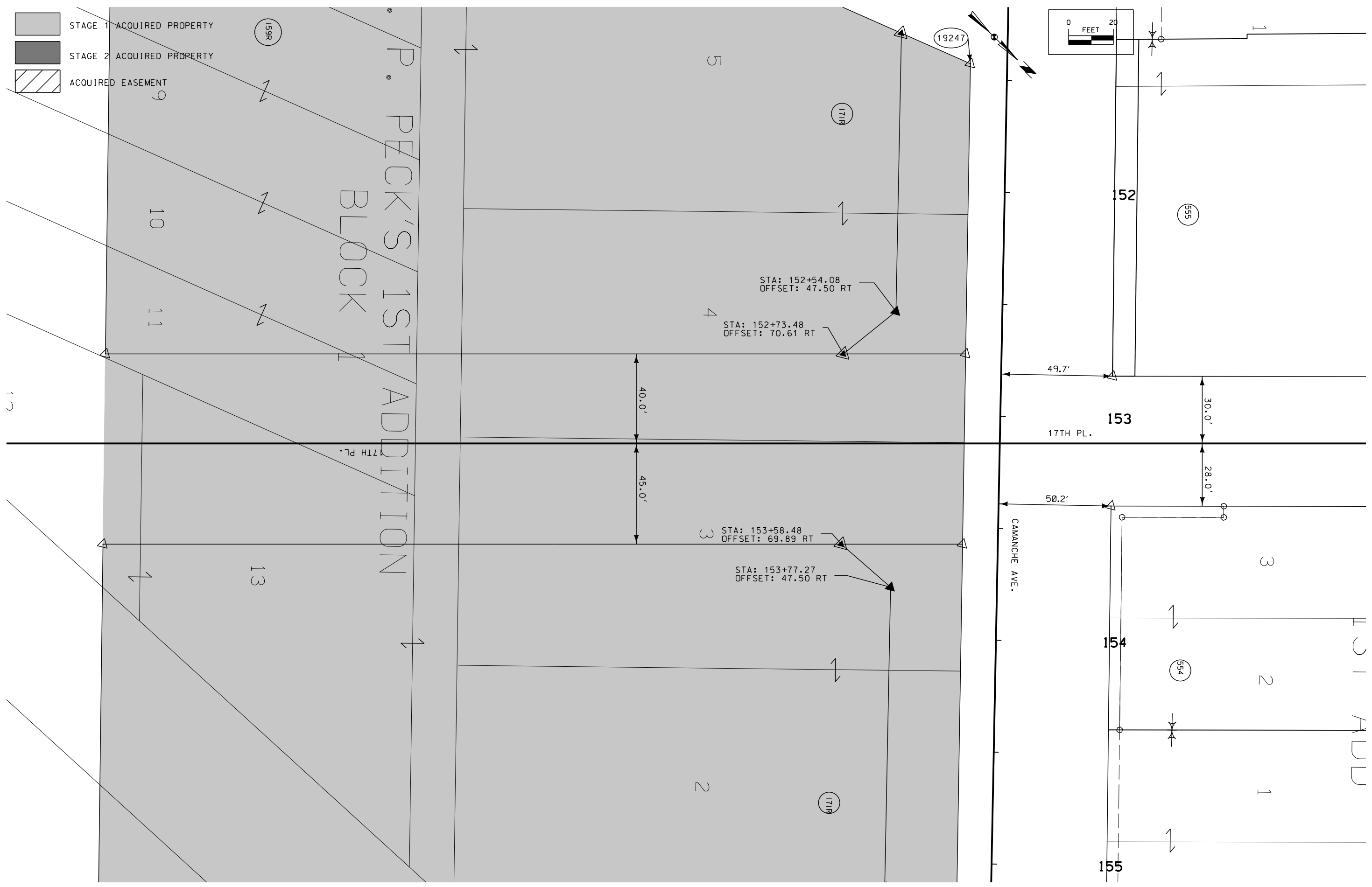

-  STAGE 1 ACQUIRED PROPERTY
-  STAGE 2 ACQUIRED PROPERTY
-  ACQUIRED EASEMENT



-  STAGE 1 ACQUIRED PROPERTY
-  STAGE 2 ACQUIRED PROPERTY
-  ACQUIRED EASEMENT

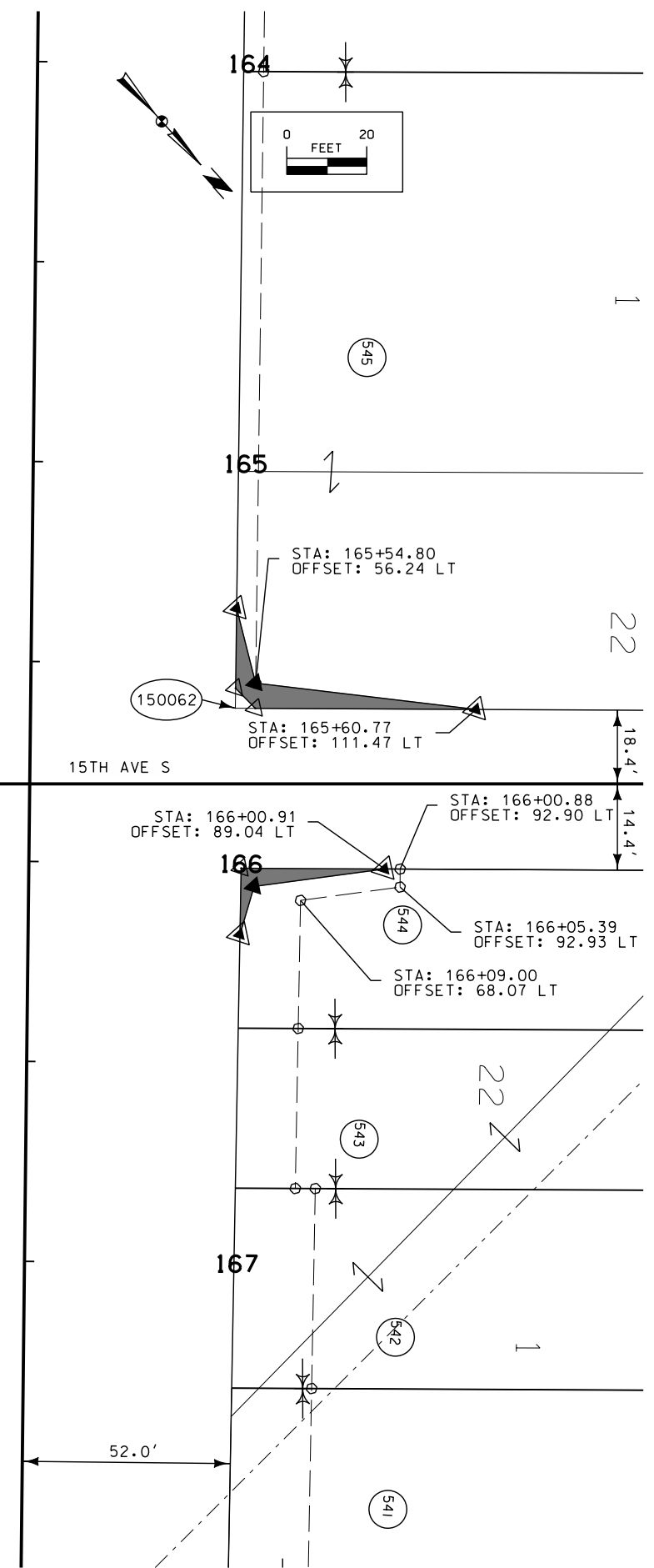
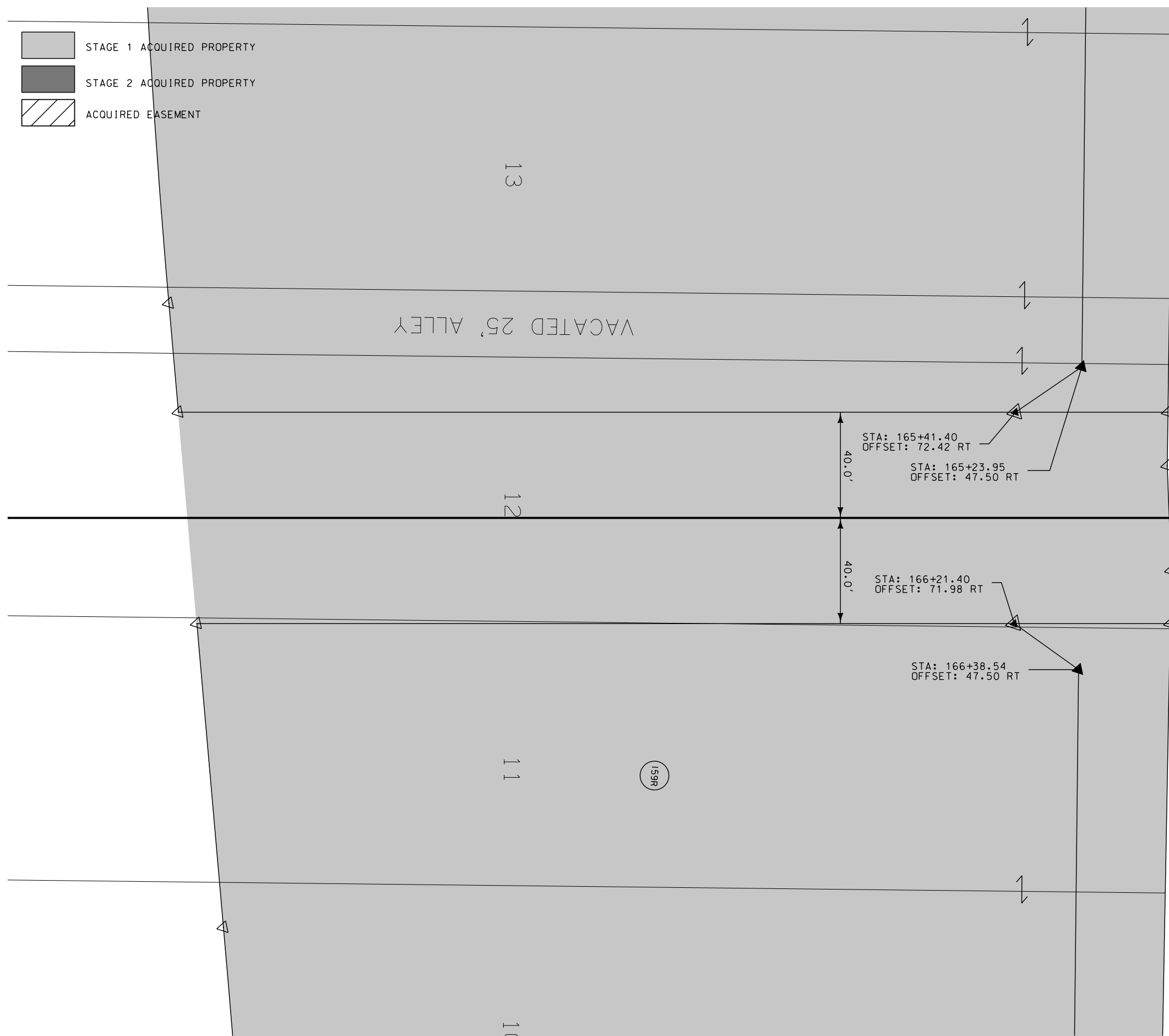

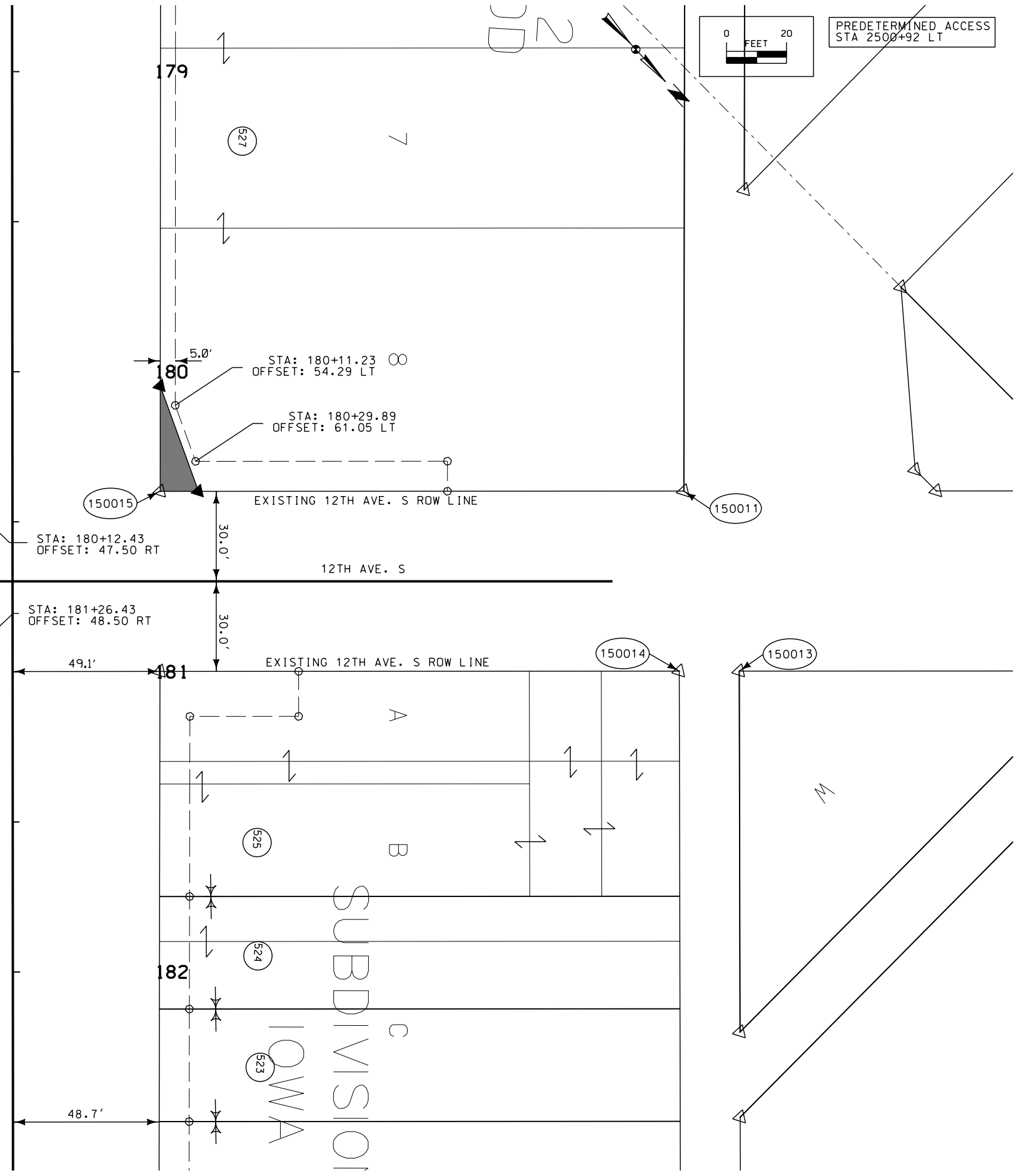
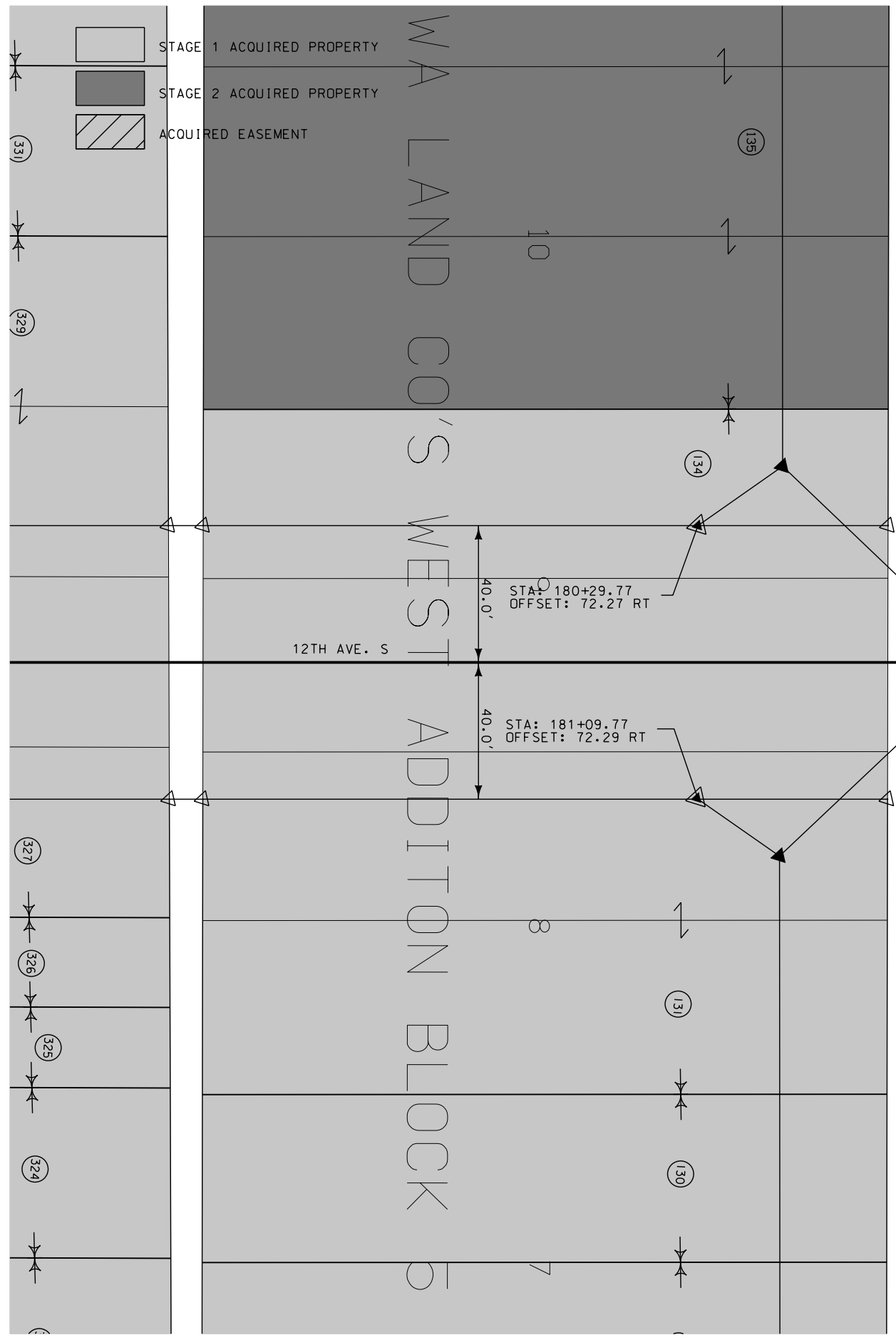

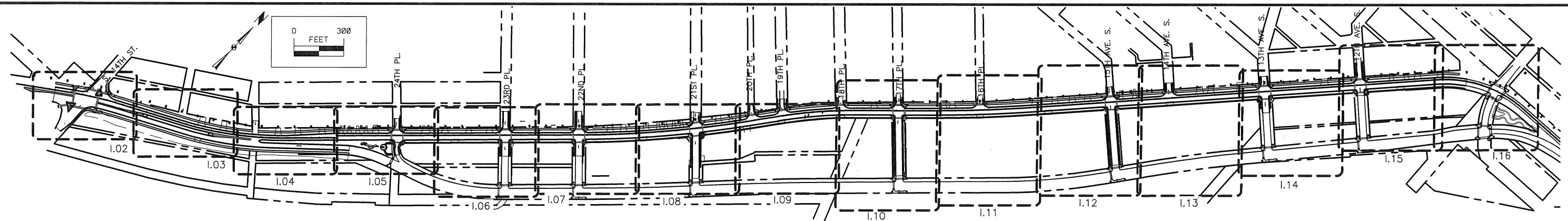

I SHEETS GRAPHIC LEGEND

	CONC. BRICK PAVERS		RIGHT OF WAY		PEDESTRIAN LIGHTS		PERGOLA AND COLUMNS WITH BENCHES
	NO-MOW FESCUE		PERENNIALS		ROADWAY LIGHTS		COLUMNS WITHOUT PERGOLAS AND BENCHES
	PCC SIDEWALK (TYP.)		TEMPORARY EASEMENT		EVERGREEN TREES		PROPOSED OVERSTORY TREES
	DETECTABLE WARNING PAVERS		HERON SCULPTURE		UNDERSTORY TREES		

LEGEND

	SOD
	IDOT PERMANENT SEED MIXTURE, URBAN AREAS
	NO-MOW FESCUE; SEE C-SHEETS FOR MIX

LEGEND

KEY	DESCRIPTION
EXP.	EXPANSION JOINT
CJ.	CONTROL JOINT
TYP.	TYPICAL
SIM.	SIMILAR
TS.	TOP OF SIDEWALK
BC	BACK OF CURB

SPECIAL REQUIREMENTS - MAINTENANCE

A. BEGIN MAINTENANCE IMMEDIATELY FOLLOWING INSTALLATION OF SOD AND CONTINUE FOR A PERIOD UNTIL SODDED AREAS ARE ESTABLISHED WITH SOD ROOTED IN PLACE. MAINTENANCE PERIOD SHALL BE A MINIMUM OF 14 DAYS.

B. MAINTENANCE OF SODDED AREAS SHALL INCLUDE WATERING, WEEDING, MOWING TO A 2 - 2 1/2 INCH HEIGHT AFTER HEIGHT HAS EXCEEDED 3 INCHES AND PRIOR TO 4 INCHES, AND REPLACEMENT AND INSTALLATION OF SOD AS ORIGINALLY SPECIFIED FOR SODDED AREAS FAILING TO SURVIVE. CLIPPINGS FROM MOWING WHICH MAT ON THE GRASS, ARE TO BE REMOVED.

GENERAL LAYOUT NOTES (APPLIES TO ALL I-SHEETS UNLESS NOTED)

- DIMENSIONS SHOWN ARE FROM BACK OF CURB UNLESS OTHERWISE NOTED ON DRAWINGS.
- SAWCUTS TO BE MADE AS SHOWN IN I-SHEETS OR OTHER SHEETS AND IDOT SPECS., UNLESS CONTRACTOR SUBMITS OTHERWISE, APPROVED BY ENGINEER. SEE I.47-I.58 FOR LANDING JOINTING PLAN. NO SAW CUT JOINT SHALL BE MORE THAN 7'-0" APART.
- PAVER FIELD SHALL BE SET IN PATTERN AS SHOWN ON I.43, UNLESS OTHERWISE NOTED. A SINGLE SOLDIER COURSE OF PAVERS SHALL SURROUND THE PERIMETER OF EACH PAVER CROSSWALK.
- CONTRACTOR TO VERIFY THAT PAVERS WILL FIT AREAS DESIGNATED IN DETAILS. PRIOR TO POURING CONCRETE, CONTRACTOR SHALL MOCK UP AND SUBMIT A 3'x6' SECTION OF PAVERS TO ENSURE CORRECT TOLERANCE FOR SPACERS AND JOINTS. CONTRACTOR TO PROVIDE SHOP DRAWINGS OF PAVER PATTERN LAYOUTS TO LANDSCAPE ARCHITECT FOR APPROVAL PRIOR TO INSTALLATION.
- ALL PLAZAS/LANDINGS TO BE GRADED AT 2% MAX. IN ALL DIRECTIONS, HAVE POSITIVE DRAINAGE, AND BE ADA ACCESSIBLE. SEE L-SHEETS FOR PLAZA/LANDING ELEVATIONS OF POINTS ON SHEETS I.32 & I.33. IF CONFLICTS ARISE, CONTRACTOR TO INFORM OWNER'S REPRESENTATIVE PROMPTLY FOR INSTRUCTIONS.

LANDSCAPE IMPROVEMENTS NOTES (APPLIES TO ALL I-SHEETS UNLESS NOTED)

- CONTRACTOR IS TO PRESERVE AND PROTECT EXISTING PLANT MATERIAL TO REMAIN. PLANT MATERIAL THAT IS DAMAGED SHALL BE REPLACED AT CONTRACTOR'S EXPENSE.
- ALL STREET TREES IN BOULEVARD TO BE LOCATED 12'-6" FROM BACK OF CURB. CENTER OF TREES TO BE IN-LINE WITH LIGHT BASES, UNLESS NOTED.
- OVERSTORY TREES ON BERM TO BE PLACED ALONG TOP OF BERM.
- BERM TO BE SEEDED WITH APPROVED NO-MOW TURF MIX, AS SHOWN IN PLANS.
- OVERSTORY STREET TREES TO BE ALIGNED ACROSS CAMANCHE/LIBERTY, UNLESS NOTED. CENTER OF OVERSTORY TREE TRUNK TO BE ALIGNED WITH CENTER OF LIGHT POSTS, UNLESS NOTED.
- SIDE STREET PLANTINGS: UNDERSTORY TREES TO BE ALIGNED ACROSS ALONG SIDE STREETS (12TH AVE. S., 13TH AVE. S., 15TH AVE. S., 17TH PL., 21ST PL., 22ND PL., AND 23RD PL.) UNLESS NOTED.
- BERM PLANTINGS: UNDERSTORY TREES AND EVERGREEN GROUPINGS SHALL GENERALLY BE CENTERED BETWEEN OVERSTORY TREES ALONG THE TOP OF BERM AS SHOWN IN PLANS.
- SEE I.17, I.18, AND I.19 FOR SOD AND SEED LIMITS.

SHEET INDEX	
NUMBER	DESCRIPTION
I.01	KEY PLAN
I.02	LAYOUT
I.03	LAYOUT
I.04	LAYOUT
I.05	LAYOUT
I.06	LAYOUT
I.07	LAYOUT
I.08	LAYOUT
I.09	LAYOUT
I.10	LAYOUT
I.11	LAYOUT
I.12	LAYOUT
I.13	LAYOUT
I.14	LAYOUT
I.15	LAYOUT
I.16	LAYOUT
I.17	SEEDING PLAN
I.18	SEEDING PLAN
I.19	SEEDING PLAN
I.20	FEATURE LAYOUTS
I.21	FEATURE LAYOUTS
I.22	FEATURE LAYOUTS
I.23	FEATURE LAYOUTS
I.24	FEATURE LAYOUTS
I.25	FEATURE LAYOUTS
I.26	FEATURE LAYOUTS
I.27	FEATURE LAYOUTS
I.28	FEATURE LAYOUTS
I.29	FEATURE LAYOUTS

NUMBER	DESCRIPTION
I.30	FEATURE LAYOUTS
I.31	FEATURE LAYOUTS
I.32	STATIONS AND OFFSETS
I.33	STATIONS AND OFFSETS
I.34	LANDSCAPE PLANS
I.35	LANDSCAPE PLANS
I.36	LANDSCAPE PLANS
I.37	LANDSCAPE PLANS
I.38	LANDSCAPE PLANS
I.39	LANDSCAPE PLANS
I.40	LANDSCAPE PLANS
I.41	LANDSCAPE PLANS
I.42	DETAILS
I.43	DETAILS
I.44	DETAILS
I.45	DETAILS
I.46	LANDSCAPE DETAILS
I.47	PAVEMENT JOINTING PLANS
I.48	PAVEMENT JOINTING PLANS
I.49	PAVEMENT JOINTING PLANS
I.50	PAVEMENT JOINTING PLANS
I.51	PAVEMENT JOINTING PLANS
I.52	PAVEMENT JOINTING PLANS
I.53	PAVEMENT JOINTING PLANS
I.54	PAVEMENT JOINTING PLANS
I.55	PAVEMENT JOINTING PLANS
I.56	PAVEMENT JOINTING PLANS
I.57	PAVEMENT JOINTING PLANS
I.58	PAVEMENT JOINTING PLANS

PLANT SCHEDULE						
QTY	KEY	BOTANICAL NAME	COMMON NAME	SIZE	COND	REMARKS
<b>DECIDUOUS TREES</b>						
12	AA	AMELANCHIER X GRANDIFLORA 'AUTUMN BRILLIANCE'	AUTUMN BRILLIANCE SERVICEBERRY	2" CAL.	B&B	SINGLE STEM, MATCHED
101	AF	ACER X FREEMANII 'JEFFERSRED'	'AUTUMN BLAZE' MAPLE	3" CAL.	B&B	MATCHED, CENTRAL LEADER
37	AG	ACER GINNALA	AMUR MAPLE	8" HGT.	B&B	CLUMP FORM
5	BN	BETULA NIGRA	RIVER BIRCH	2" CAL.	B&B	SINGLE STEM, MATCHED
64	GB	GINKGO BILOBA 'PRINCETON SENTRY'	PRINCETON SENTRY GINKGO	3" CAL.	B&B	CENTRAL LEADER
70	GT	GLEDDISIA TRIACANTHOS VAR. INERMIS 'SHADEMASTER'	SHADEMASTER THORNLESS HONEYLOCUST	3" CAL.	B&B	
73	MS	MALUS X 'SPRING SNOW'	'SPRING SNOW' CRABAPPLE	2" CAL.	B&B	CENTRAL LEADER
12	QB	QUERCUS BICOLOR	SWAMP WHITE OAK	3" CAL.	B&B	CENTRAL LEADER
65	SR	SYRINGA RETICULATA 'IVORY SILK'	IVORY SILK JAPANESE TREE LILAC	2" CAL.	B&B	MATCHED
<b>EVERGREEN TREES</b>						
21	PG	PICEA GLAUCA	WHITE SPRUCE	8' HGT	B&B	
<b>PERENNIALS AND GRASSES</b>						
127	CV	COREOPSIS VERTICILLATA 'MOONBEAM'	'MOONBEAM' COREOPSIS	1 GAL.	CONT.	SPACING 18" O.C.
554	HP	HEMEROCALLIS X 'PARDON ME'	'PARDON ME' DAYLILY	1 GAL.	CONT.	SPACING 18" O.C.
141	LM	LIRIOPE MUSCARI 'BIG BLUE'	'BIG BLUE' LILYTURF	6" POT	CONT.	SPACING 18" O.C.
323	PV	PANICUM VIRGATUM 'HEAVY METAL'	'HEAVY METAL' SWITCHGRASS	1 GAL.	CONT.	SPACING 36" O.C.
417	SH	SPOROBOLUS HETEROLEPIS	PRAIRIE DROPSEED	1 GAL.	CONT.	SPACING 24" O.C.
198	SN	SALVIA NEMOROSA 'MAY NIGHT'	'MAY NIGHT' SALVIA	1 GAL.	CONT.	SPACING 18" O.C.

MASTER PLANT SCHEDULE: ALL TREES AND SHRUBS ARE LISTED IN THE MASTER PLANT SCHEDULE. IF THERE IS A CONFLICT BETWEEN THE QUANTITIES SHOWN ON THE PLANTING PLAN DRAWINGS AND THE QUANTITIES SHOWN IN THE PLANT SCHEDULE, THE QUANTITIES SHOWN IN THE PLANTING PLAN DRAWINGS SHALL PREVAIL.

STATE OF IOWA  
NICHOLAS H. STRENG  
LANDSCAPE ARCHITECT  
No. 533

I hereby certify that these plans and specifications were prepared by me or under my direct personal supervision and that I am a duly registered Landscape Architect under the laws of the State of Iowa.

NICHOLAS H. STRENG, R.L.A., A.S.L.A. DATE 12.09.2011  
 License Number: 533  
 My license renewal date is June 30, 2013.  
 Pages or sheets covered by this seal:  
 I SHEETS







I SHEETS GRAPHIC LEGEND

	CONC. BRICK PAVERS		RIGHT OF WAY		PEDESTRIAN LIGHTS		PERGOLA AND COLUMNS WITH BENCHES
	NO-MOW FESCUE		PERENNIALS		ROADWAY LIGHTS		COLUMNS WITHOUT PERGOLAS AND BENCHES
	PCC SIDEWALK (TYP.)		TEMPORARY EASEMENT		EVERGREEN TREES		PROPOSED OVERSTORY TREES
	DETECTABLE WARNING PAVERS		HERON SCULPTURE		UNDERSTORY TREES		

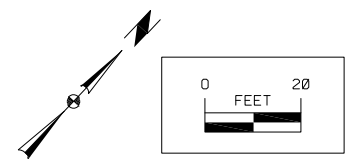

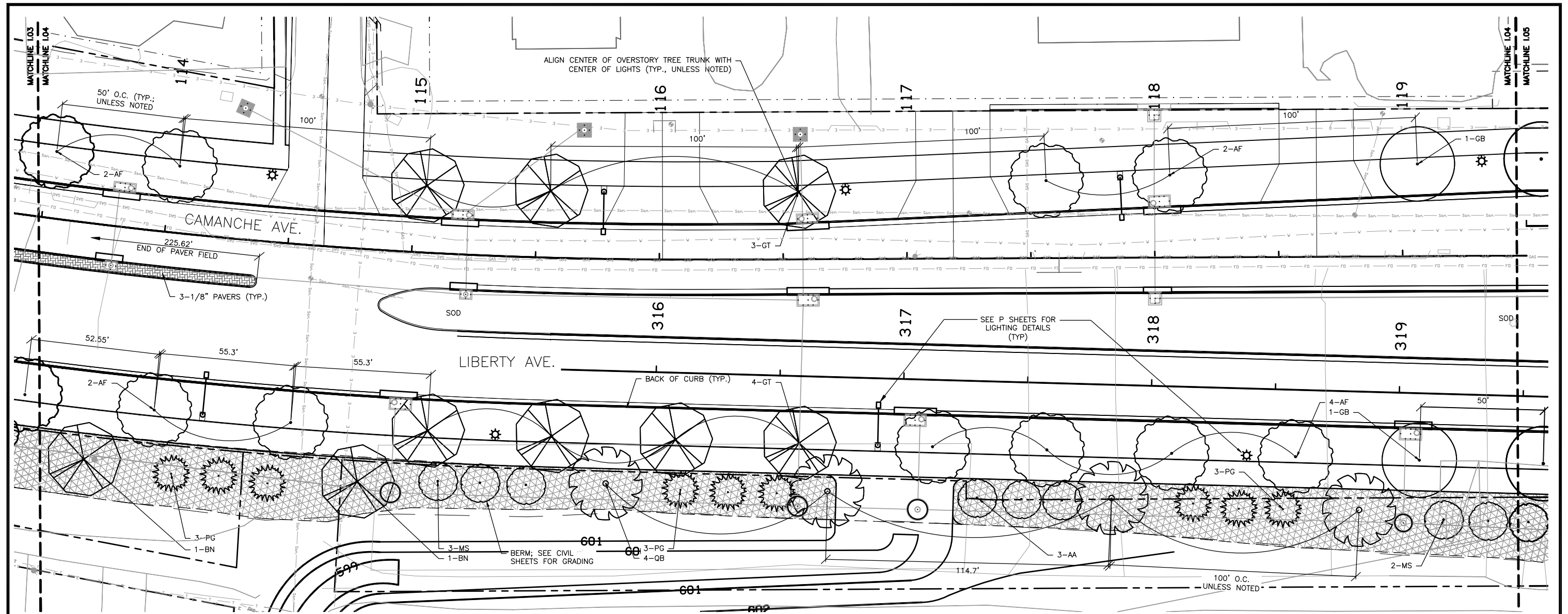

I SHEETS GRAPHIC LEGEND

	CONC. BRICK PAVERS		RIGHT OF WAY		PEDESTRIAN LIGHTS		PERGOLA AND COLUMNS WITH BENCHES
	NO-MOW FESCUE		PERENNIALS		ROADWAY LIGHTS		COLUMNS WITHOUT PERGOLAS AND BENCHES
	PCC SIDEWALK (TYP.)		TEMPORARY EASEMENT		EVERGREEN TREES		PROPOSED OVERSTORY TREES
	DETECTABLE WARNING PAVERS		HERON SCULPTURE		UNDERSTORY TREES		

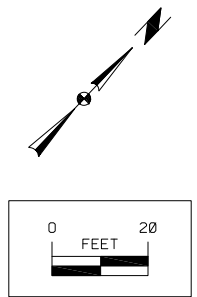



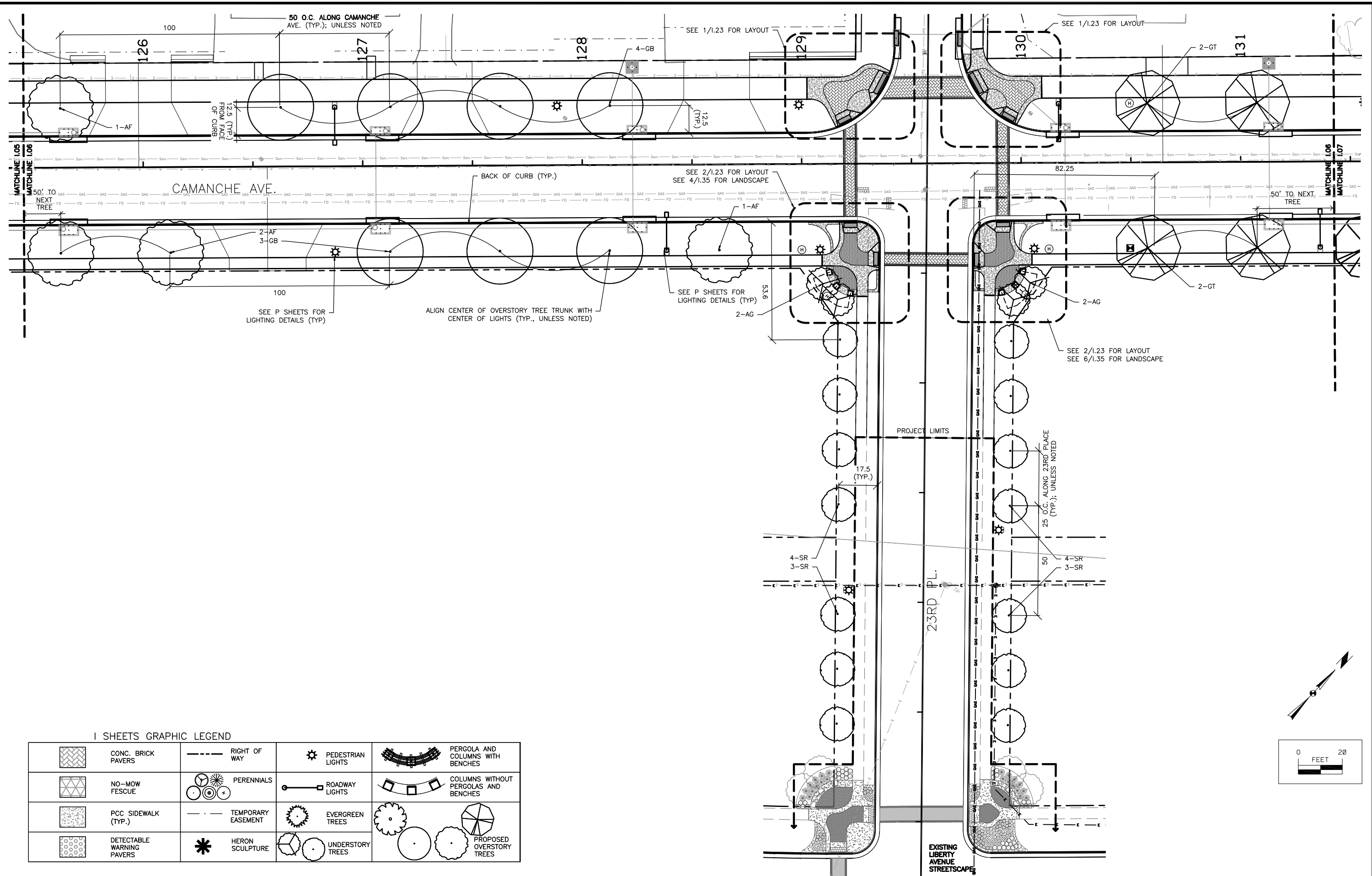

I SHEETS GRAPHIC LEGEND

	CONC. BRICK PAVERS		RIGHT OF WAY		PEDESTRIAN LIGHTS		PERGOLA AND COLUMNS WITH BENCHES
	NO-MOW FESCUE		PERENNIALS		ROADWAY LIGHTS		COLUMNS WITHOUT PERGOLAS AND BENCHES
	PCC SIDEWALK (TYP.)		TEMPORARY EASEMENT		EVERGREEN TREES		PROPOSED OVERSTORY TREES
	DETECTABLE WARNING PAVERS		HERON SCULPTURE		UNDERSTORY TREES		

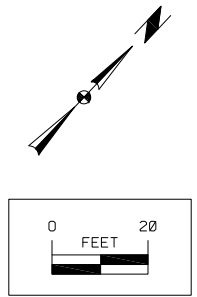

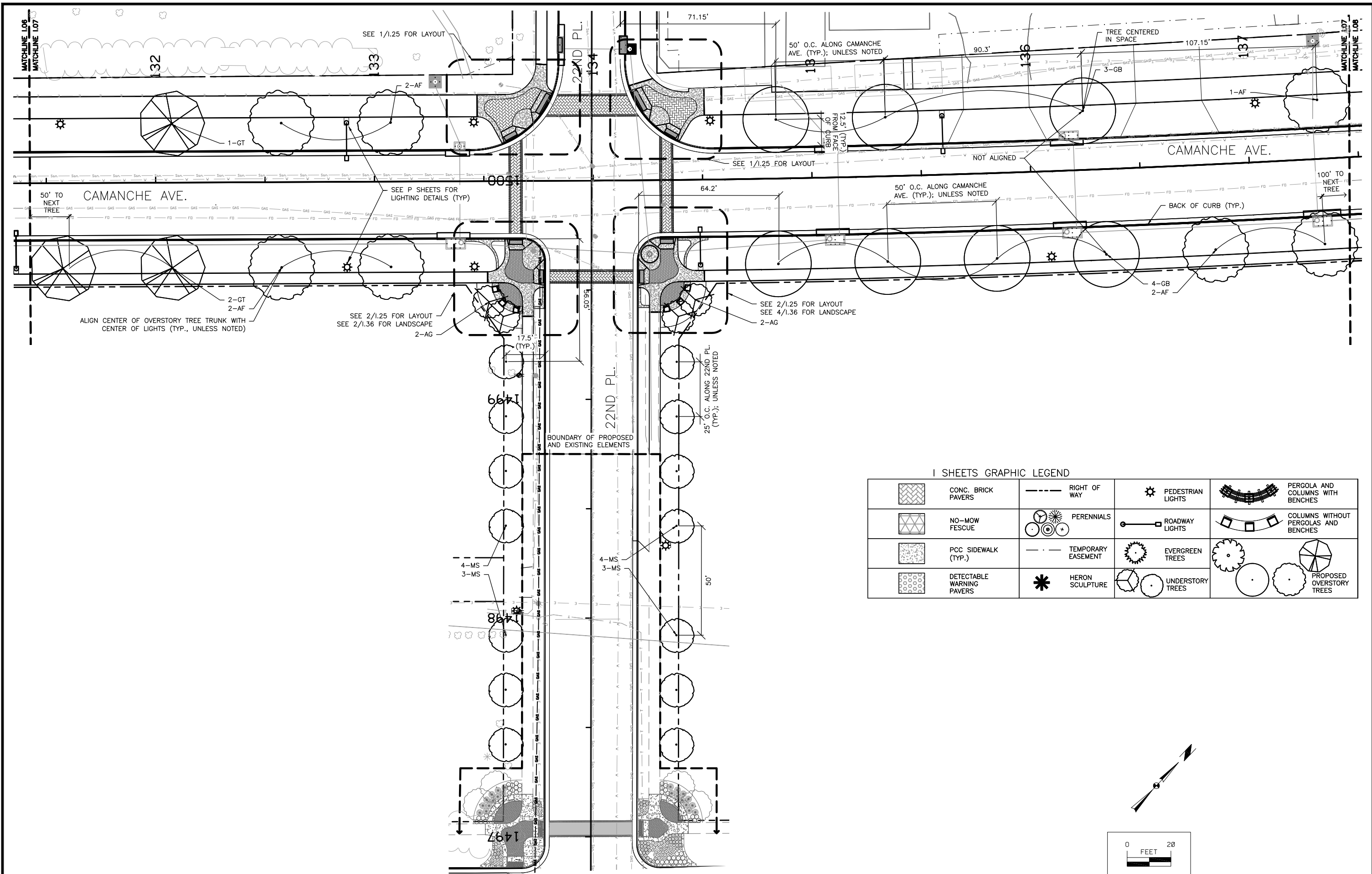

I SHEETS GRAPHIC LEGEND

	CONC. BRICK PAVERS		RIGHT OF WAY		PEDESTRIAN LIGHTS		PERGOLA AND COLUMNS WITH BENCHES
	NO-MOW FESCUE		PERENNIALS		ROADWAY LIGHTS		COLUMNS WITHOUT PERGOLAS AND BENCHES
	PCC SIDEWALK (TYP.)		TEMPORARY EASEMENT		EVERGREEN TREES		UNDERSTORY TREES
	DETECTABLE WARNING PAVERS		HERON SCULPTURE		PROPOSED OVERSTORY TREES		

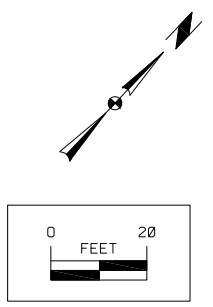

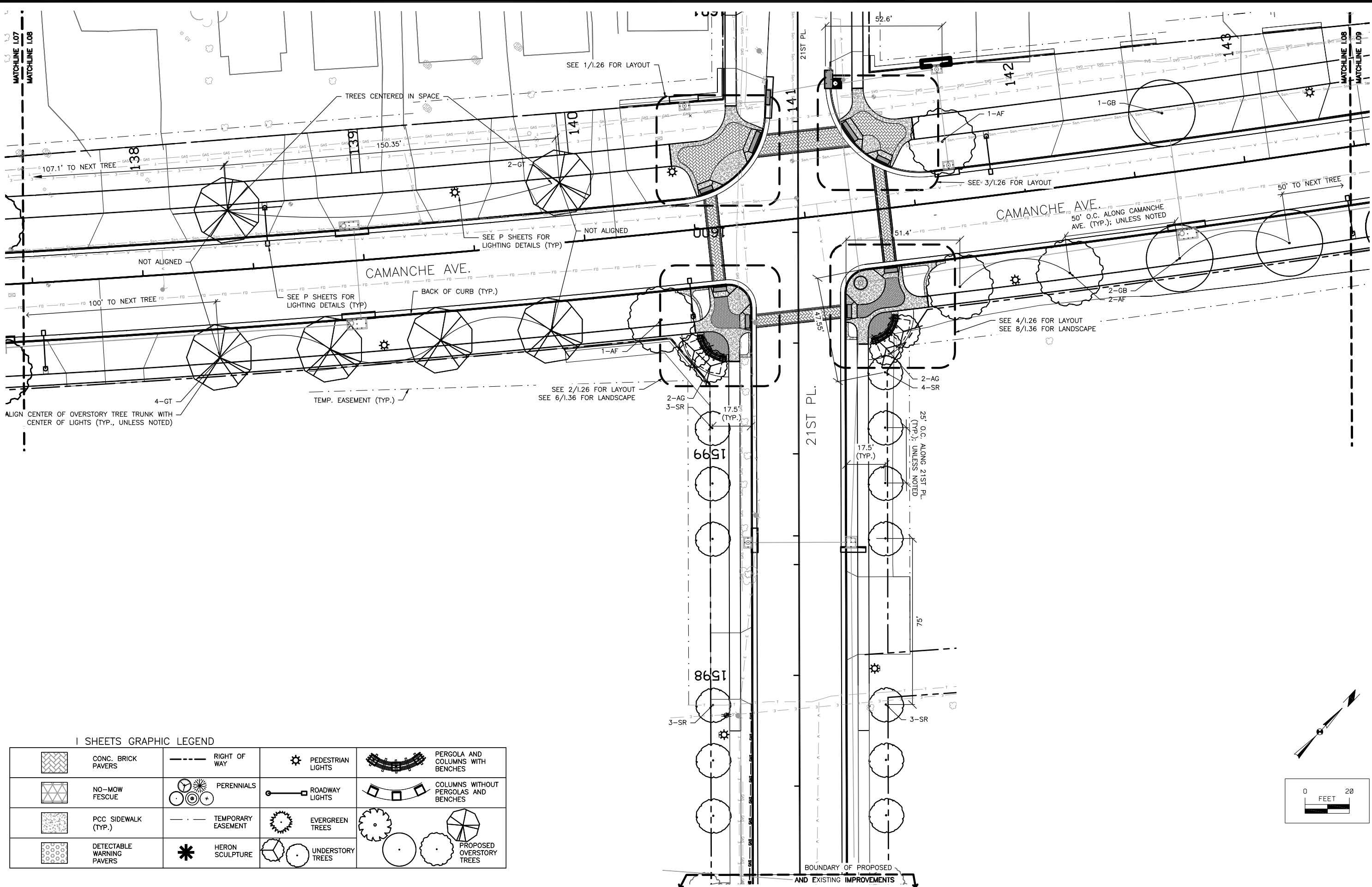

I SHEETS GRAPHIC LEGEND

	CONC. BRICK PAVERS		RIGHT OF WAY		PEDESTRIAN LIGHTS		PERGOLA AND COLUMNS WITH BENCHES
	NO-MOW FESCUE		PERENNIALS		ROADWAY LIGHTS		COLUMNS WITHOUT PERGOLAS AND BENCHES
	PCC SIDEWALK (TYP.)		TEMPORARY EASEMENT		EVERGREEN TREES		PROPOSED OVERSTORY TREES
	DETECTABLE WARNING PAVERS		HERON SCULPTURE		UNDERSTORY TREES		

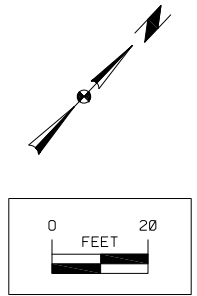

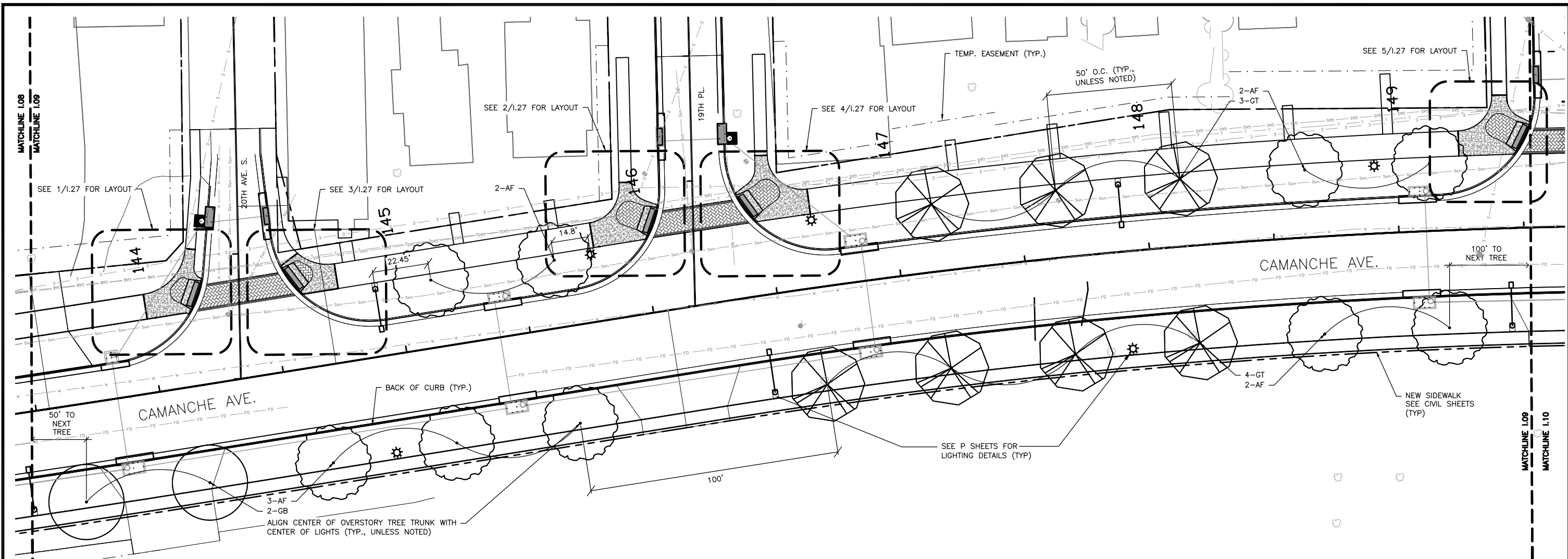

I SHEETS GRAPHIC LEGEND

	CONC. BRICK PAVERS		RIGHT OF WAY		PEDESTRIAN LIGHTS		PERGOLA AND COLUMNS WITH BENCHES
	NO-MOW FESCUE		PERENNIALS		ROADWAY LIGHTS		COLUMNS WITHOUT PERGOLAS AND BENCHES
	PCC SIDEWALK (TYP.)		TEMPORARY EASEMENT		EVERGREEN TREES		PROPOSED OVERSTORY TREES
	DETECTABLE WARNING PAVERS		HERON SCULPTURE		UNDERSTORY TREES		

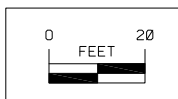
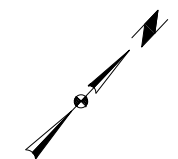





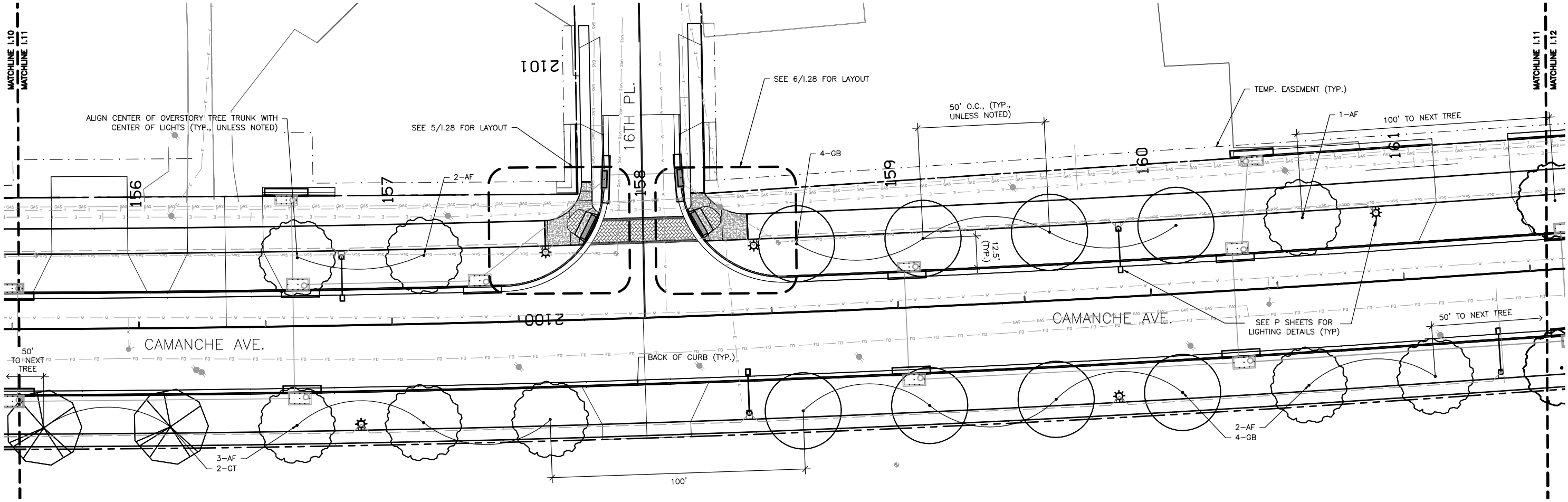

I SHEETS GRAPHIC LEGEND

	CONC. BRICK PAVERS		RIGHT OF WAY		PEDESTRIAN LIGHTS		PERGOLA AND COLUMNS WITH BENCHES
	NO-MOW FESCUE		PERENNIALS		ROADWAY LIGHTS		COLUMNS WITHOUT PERGOLAS AND BENCHES
	PCC SIDEWALK (TYP.)		TEMPORARY EASEMENT		EVERGREEN TREES		PROPOSED OVERSTORY TREES
	DETECTABLE WARNING PAVERS		HERON SCULPTURE		UNDERSTORY TREES		

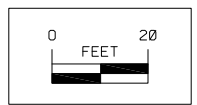
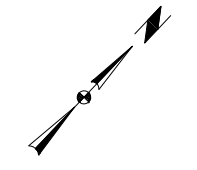

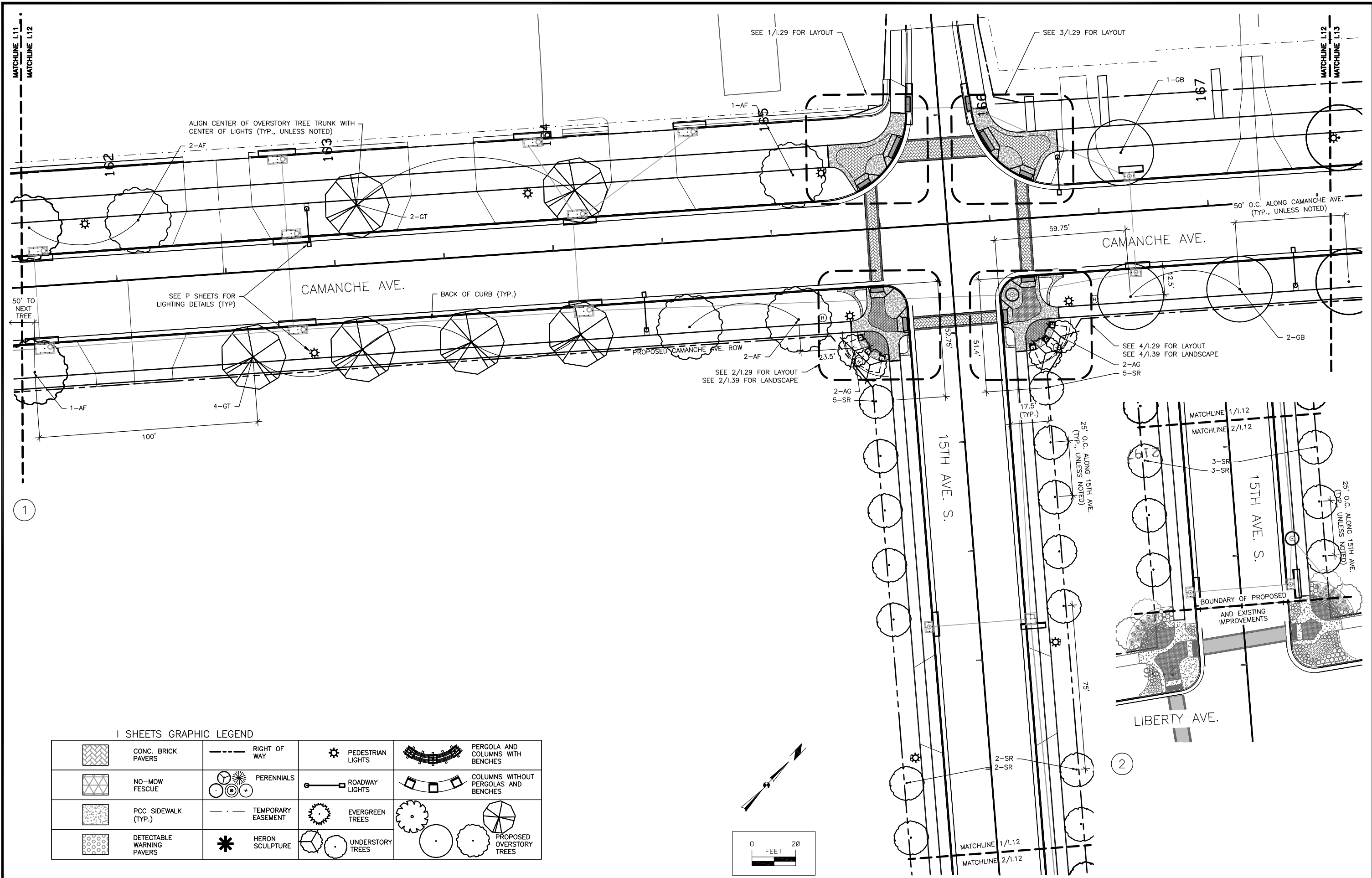

I SHEETS GRAPHIC LEGEND

	CONC. BRICK PAVERS		RIGHT OF WAY		PEDESTRIAN LIGHTS		PERGOLA AND COLUMNS WITH BENCHES
	NO-MOW FESCUE		PERENNIALS		ROADWAY LIGHTS		COLUMNS WITHOUT PERGOLAS AND BENCHES
	PCC SIDEWALK (TYP.)		TEMPORARY EASEMENT		EVERGREEN TREES		PROPOSED OVERSTORY TREES
	DETECTABLE WARNING PAVERS		HERON SCULPTURE		UNDERSTORY TREES		

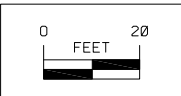
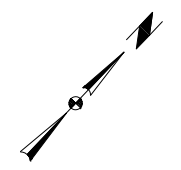

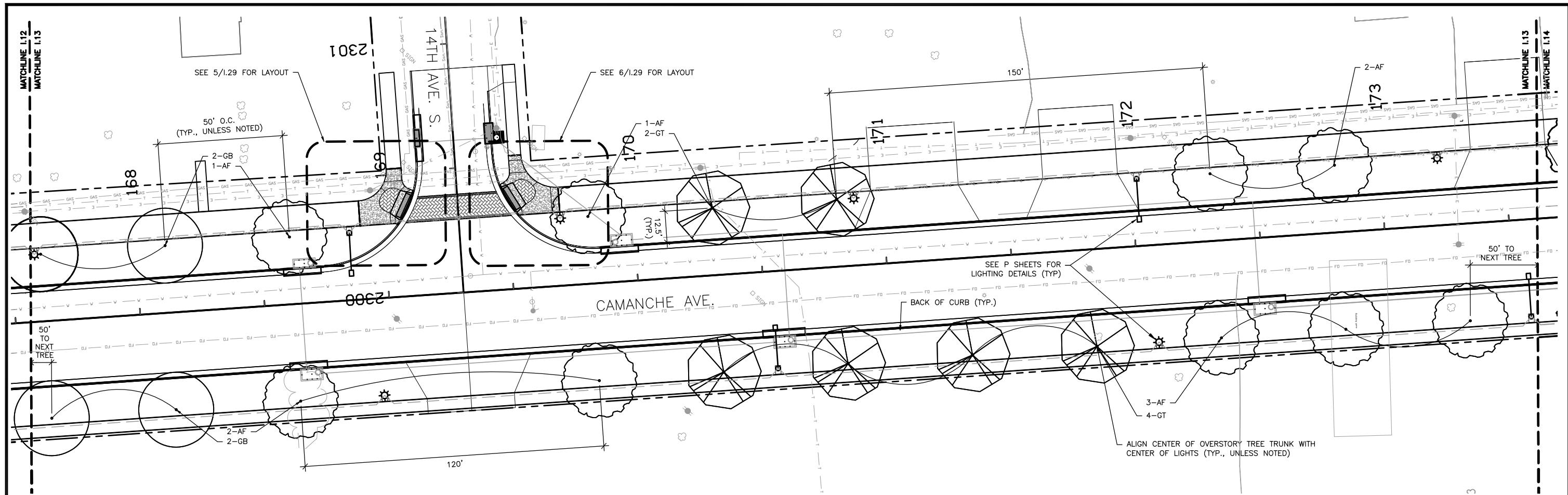

I SHEETS GRAPHIC LEGEND

	CONC. BRICK PAVERS		RIGHT OF WAY		PEDESTRIAN LIGHTS		PERGOLA AND COLUMNS WITH BENCHES
	NO-MOW FESCUE		PERENNIALS		ROADWAY LIGHTS		COLUMNS WITHOUT PERGOLAS AND BENCHES
	PCC SIDEWALK (TYP.)		TEMPORARY EASEMENT		EVERGREEN TREES		PROPOSED OVERSTORY TREES
	DETECTABLE WARNING PAVERS		HERON SCULPTURE		UNDERSTORY TREES		

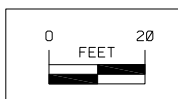
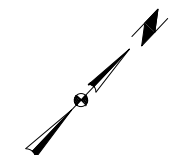



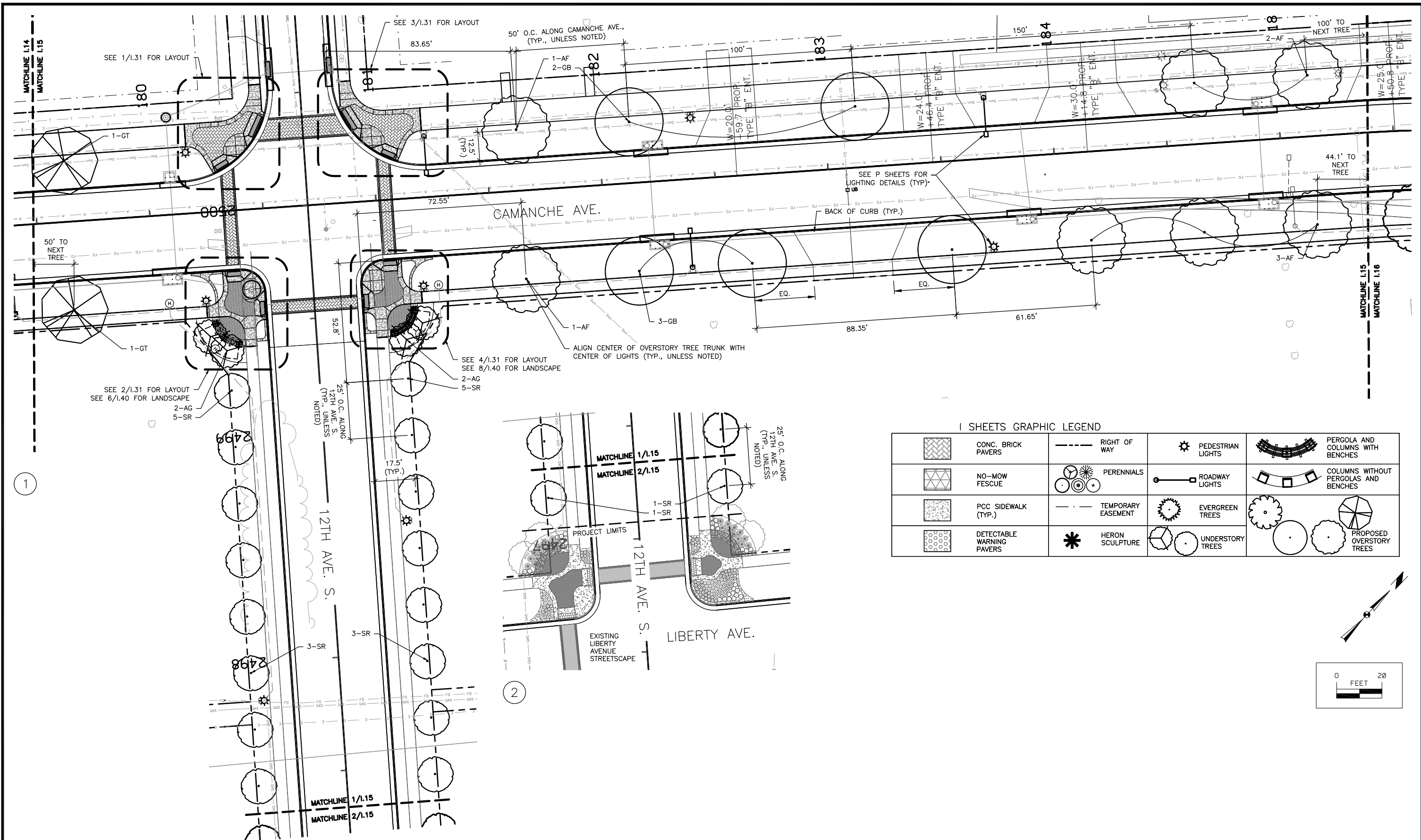

I SHEETS GRAPHIC LEGEND

	CONC. BRICK PAVERS		RIGHT OF WAY		PEDESTRIAN LIGHTS		PERGOLA AND COLUMNS WITH BENCHES
	NO-MOW FESCUE		PERENNIALS		ROADWAY LIGHTS		COLUMNS WITHOUT PERGOLAS AND BENCHES
	PCC SIDEWALK (TYP.)		TEMPORARY EASEMENT		EVERGREEN TREES		PROPOSED OVERSTORY TREES
	DETECTABLE WARNING PAVERS		HERON SCULPTURE		UNDERSTORY TREES		PROPOSED OVERSTORY TREES

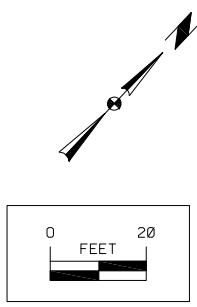



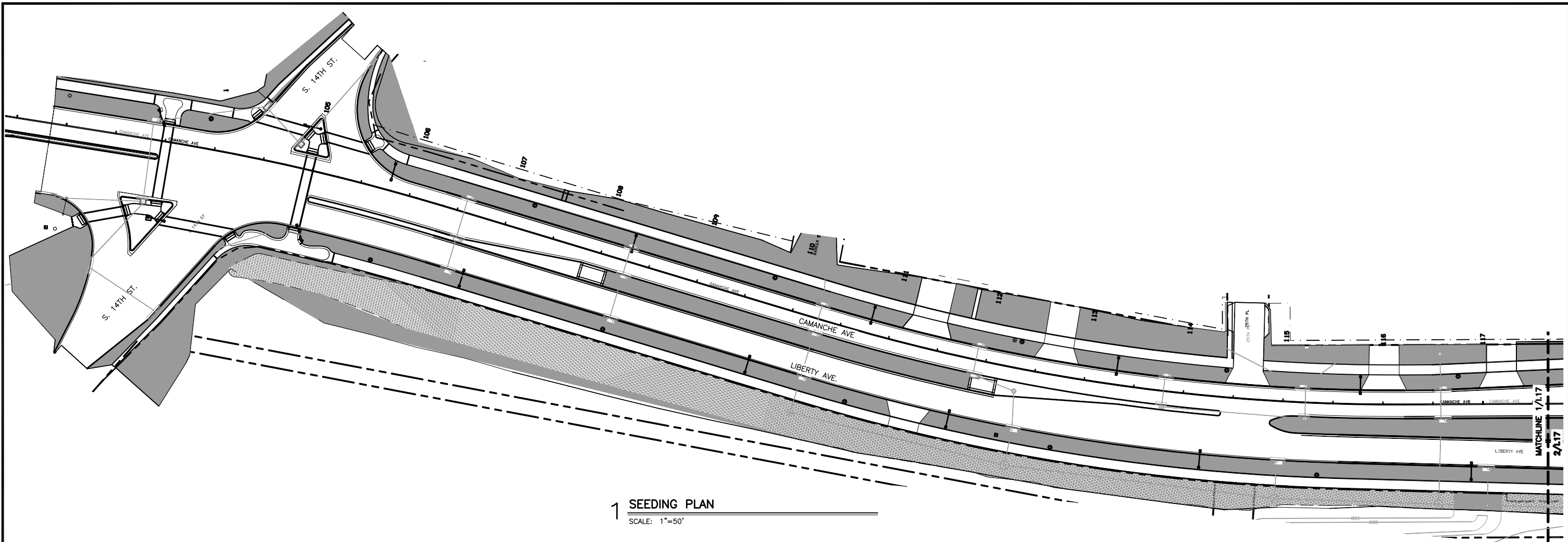

**1 SEEDING PLAN**  
SCALE: 1"=50'

LEGEND

	SOD
	DOT PERMANENT SEED MIXTURE, URBAN AREAS
	NO-MOW FESCUE; SEE C-SHEETS FOR MIX

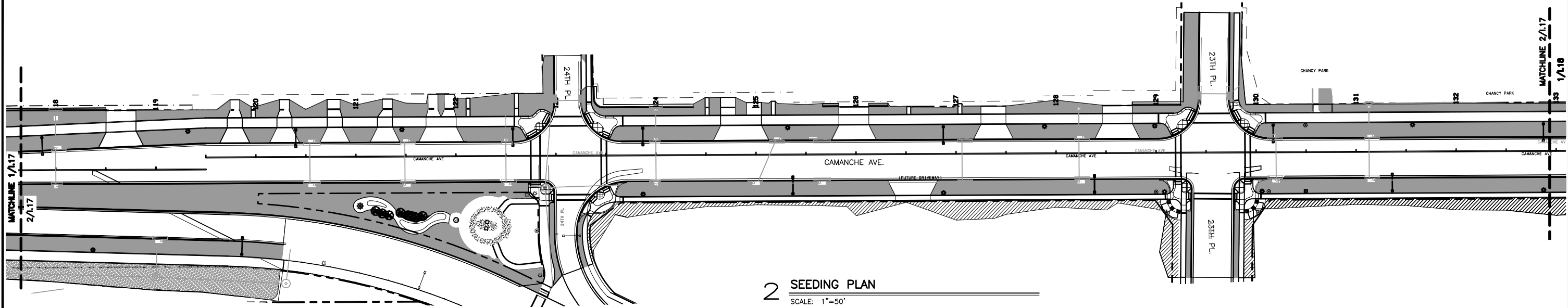
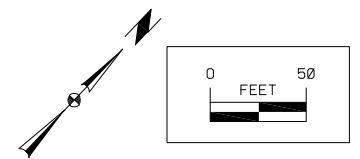

**2 SEEDING PLAN**  
SCALE: 1"=50'





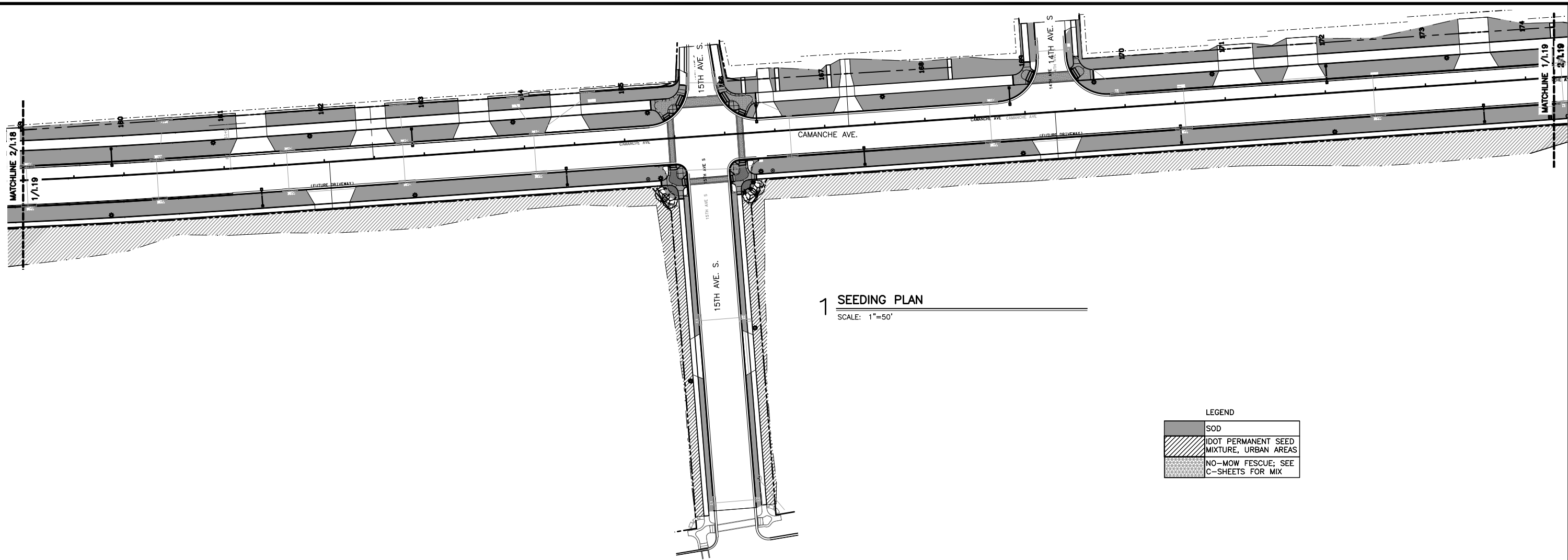

**1 SEEDING PLAN**  
SCALE: 1"=50'

LEGEND

	SOD
	IDOT PERMANENT SEED MIXTURE, URBAN AREAS
	NO-MOW FESCUE; SEE C-SHEETS FOR MIX

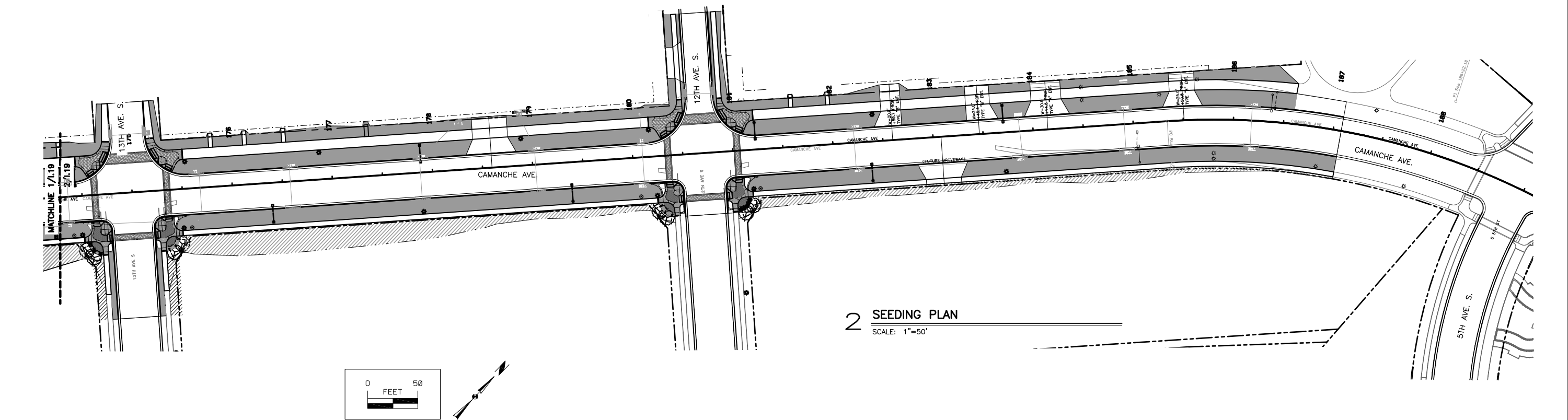

**2 SEEDING PLAN**  
SCALE: 1"=50'

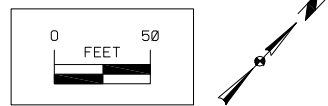

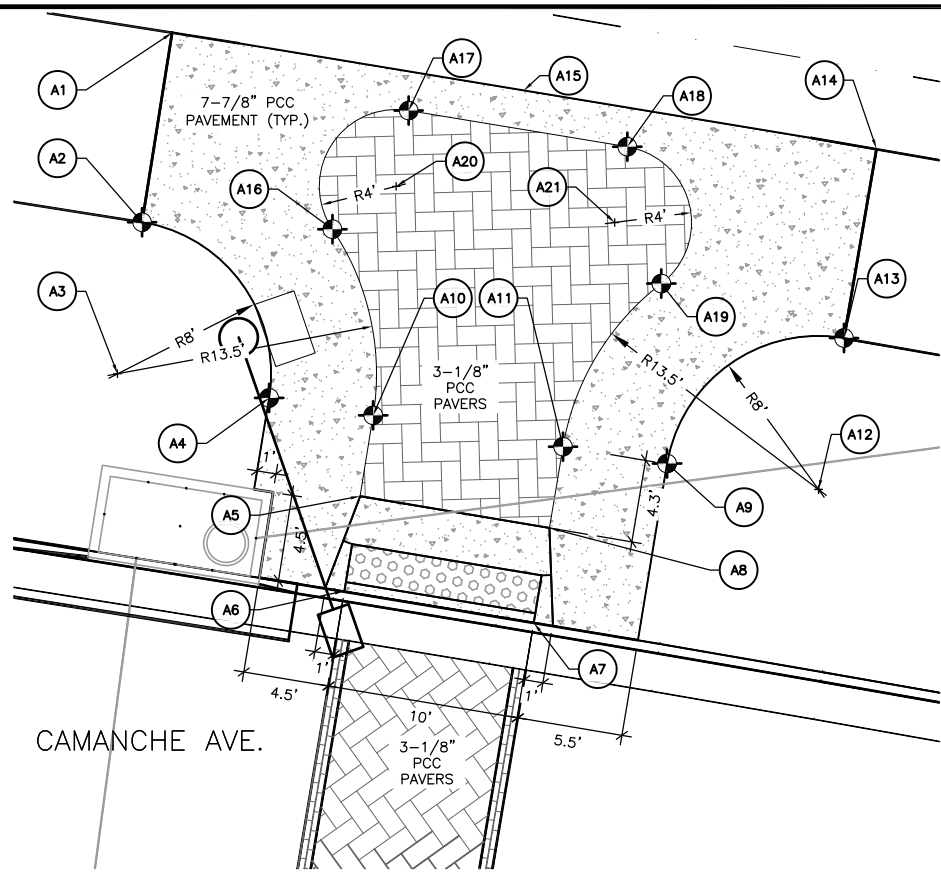

**1 PED. RAMP AT S. 14TH ST. LAYOUT**  
SCALE: 1"=5'

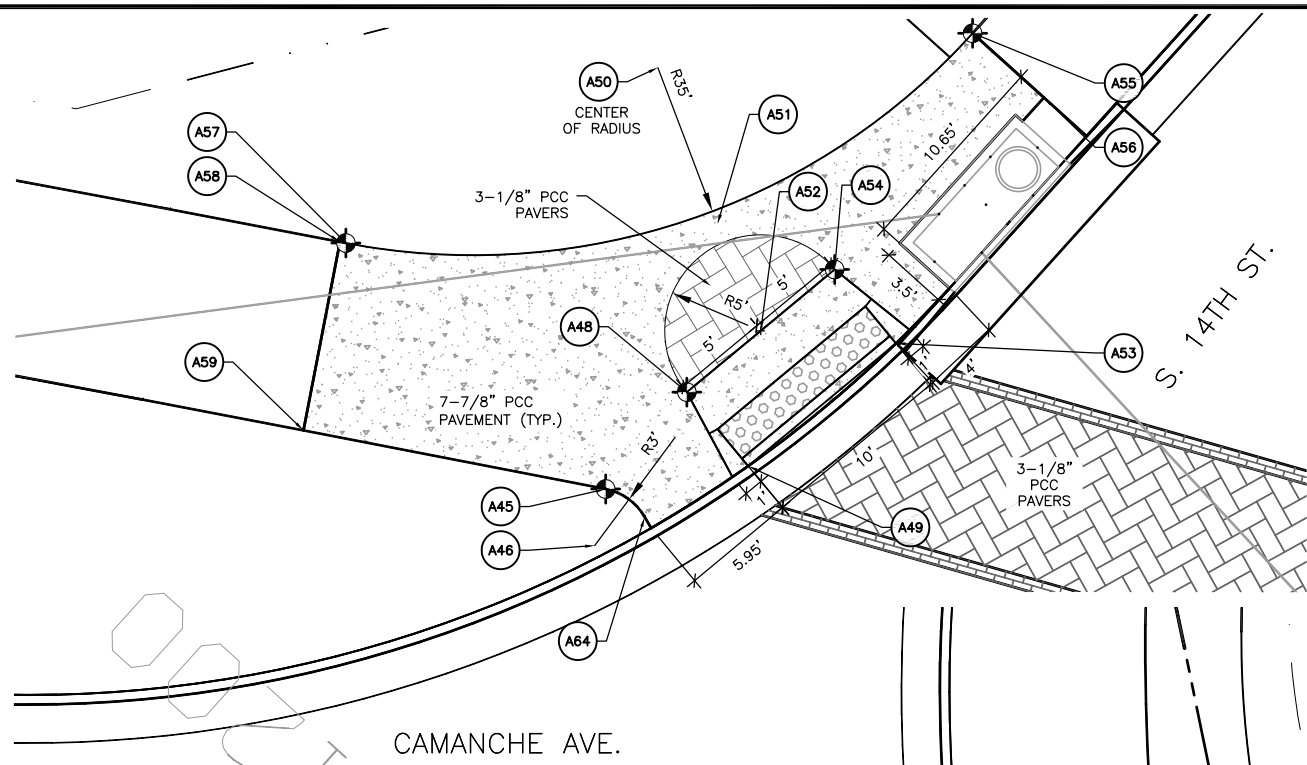

**3 NORTHWEST S. 14TH ST. LAYOUT**  
SCALE: 1"=5'

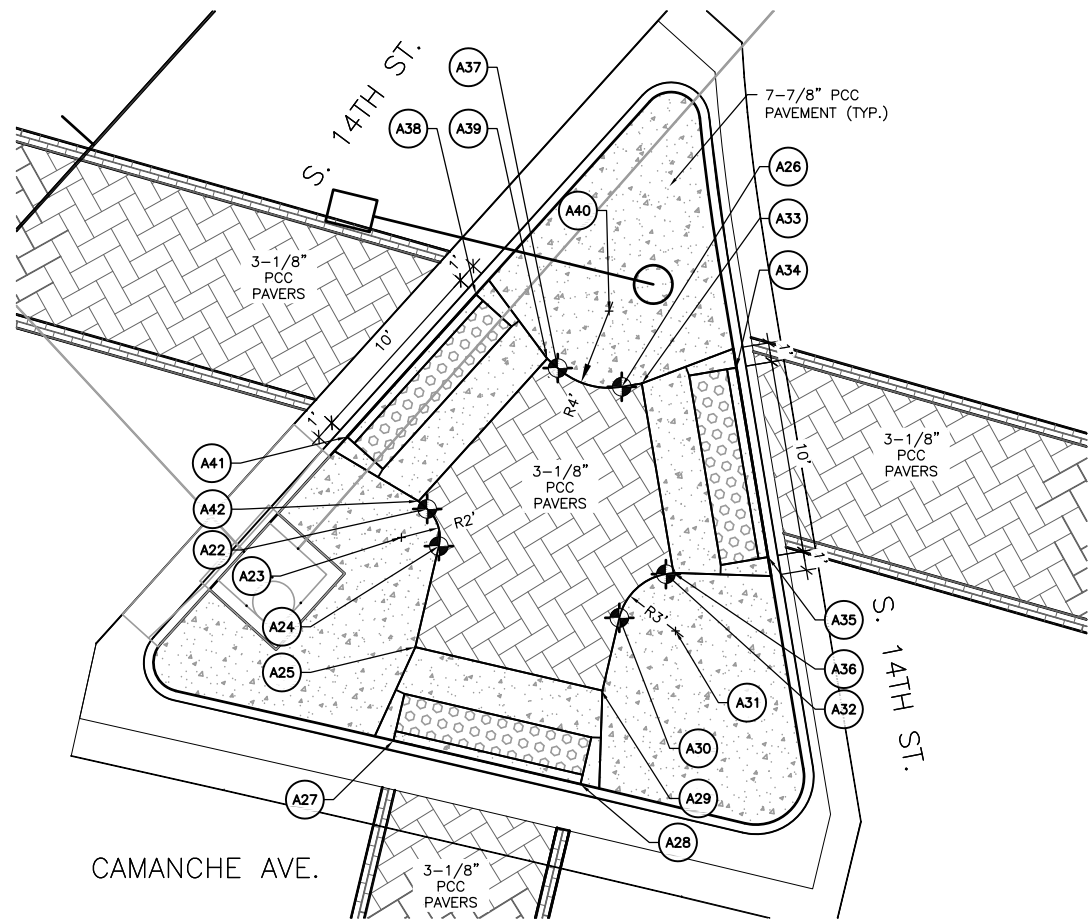

**2 NORTHERN ISLAND AT S. 14TH ST. LAYOUT**  
SCALE: 1"=5'

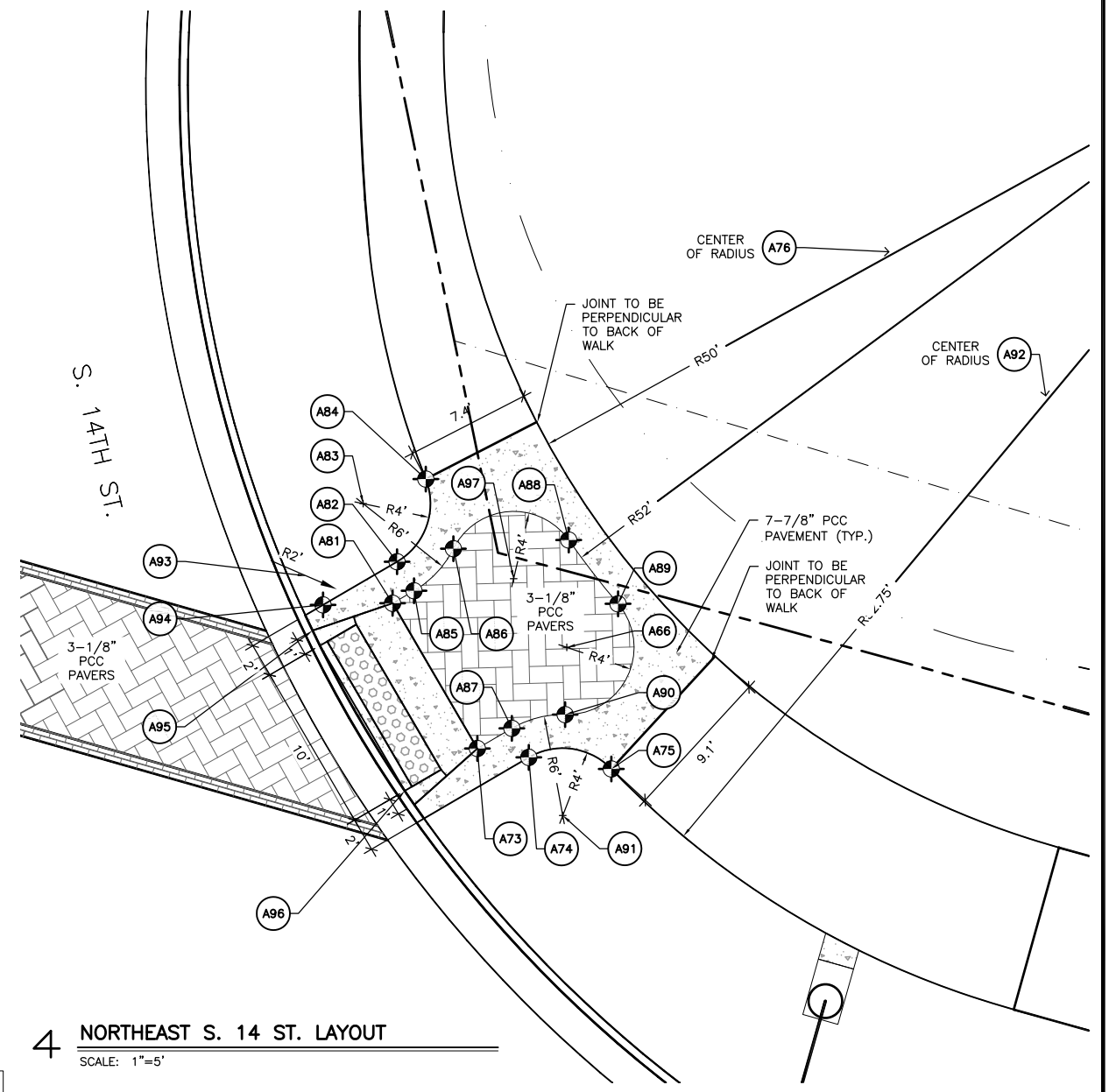

**4 NORTHEAST S. 14 ST. LAYOUT**  
SCALE: 1"=5'

◆ POINT OF TANGENCY (P.O.T.)  
NOTE: SEE 1.32 & 1.33 FOR STATIONS AND OFFSETS OF POINTS

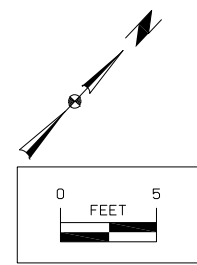

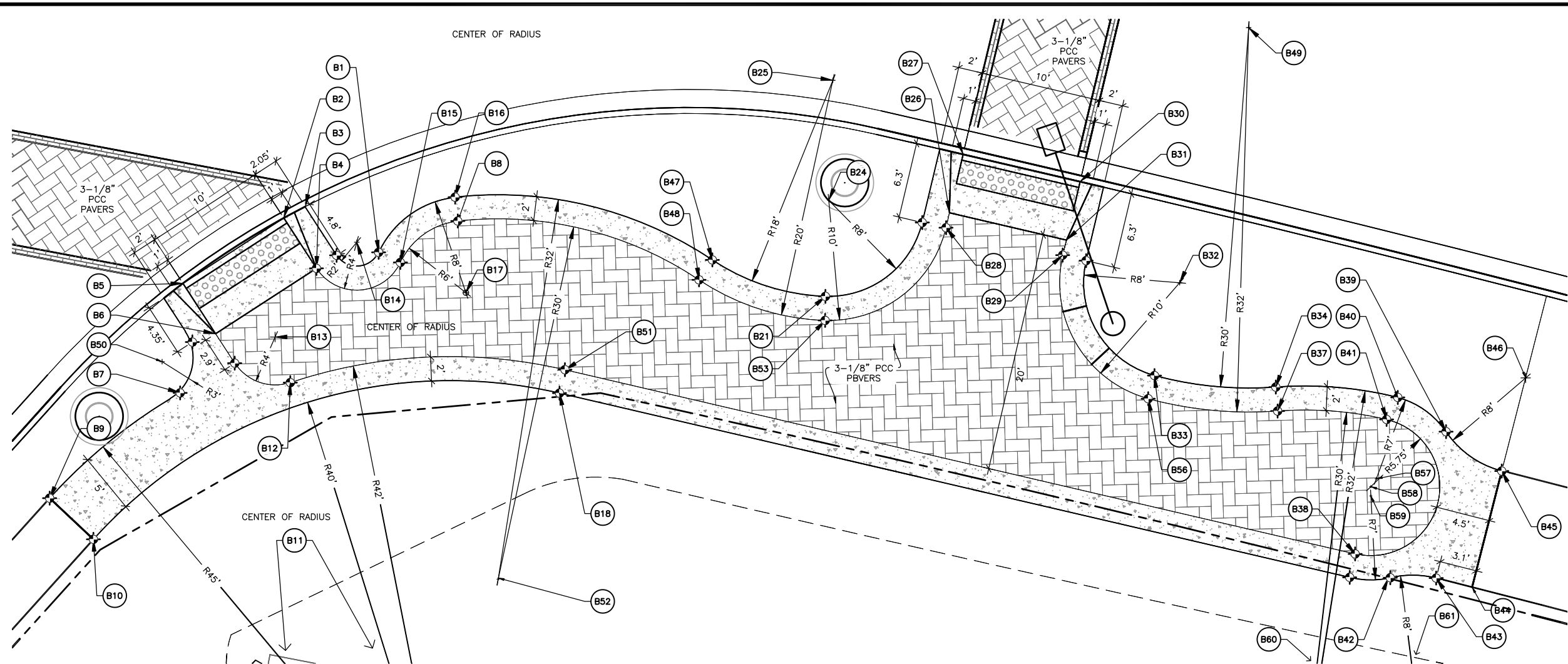

**1** SOUTHEAST S. 14TH ST. LAYOUT

SCALE: 1"=5'

**4** NOT USED

SCALE: 1/2"=1'

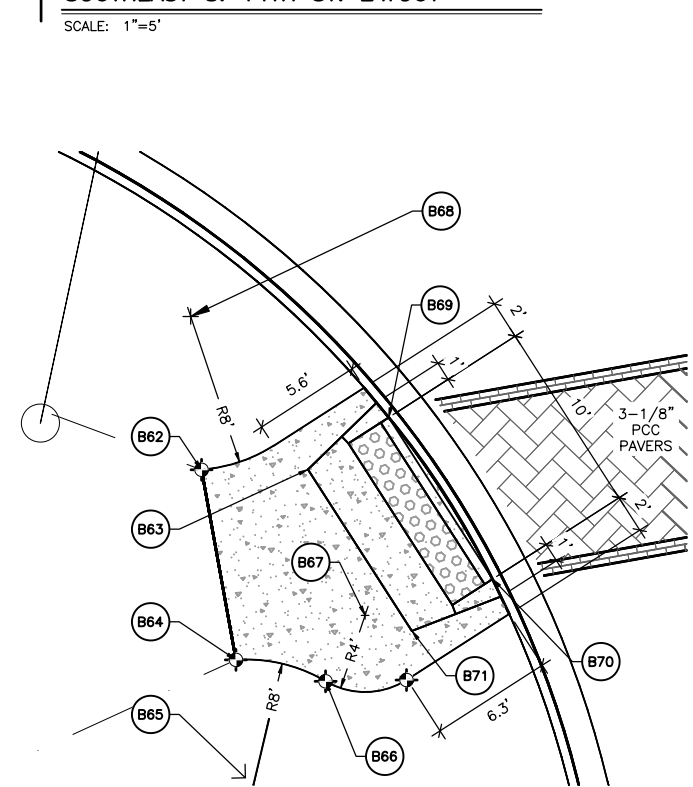

**2** SOUTHWEST S. 14TH ST. LAYOUT

SCALE: 1"=5'

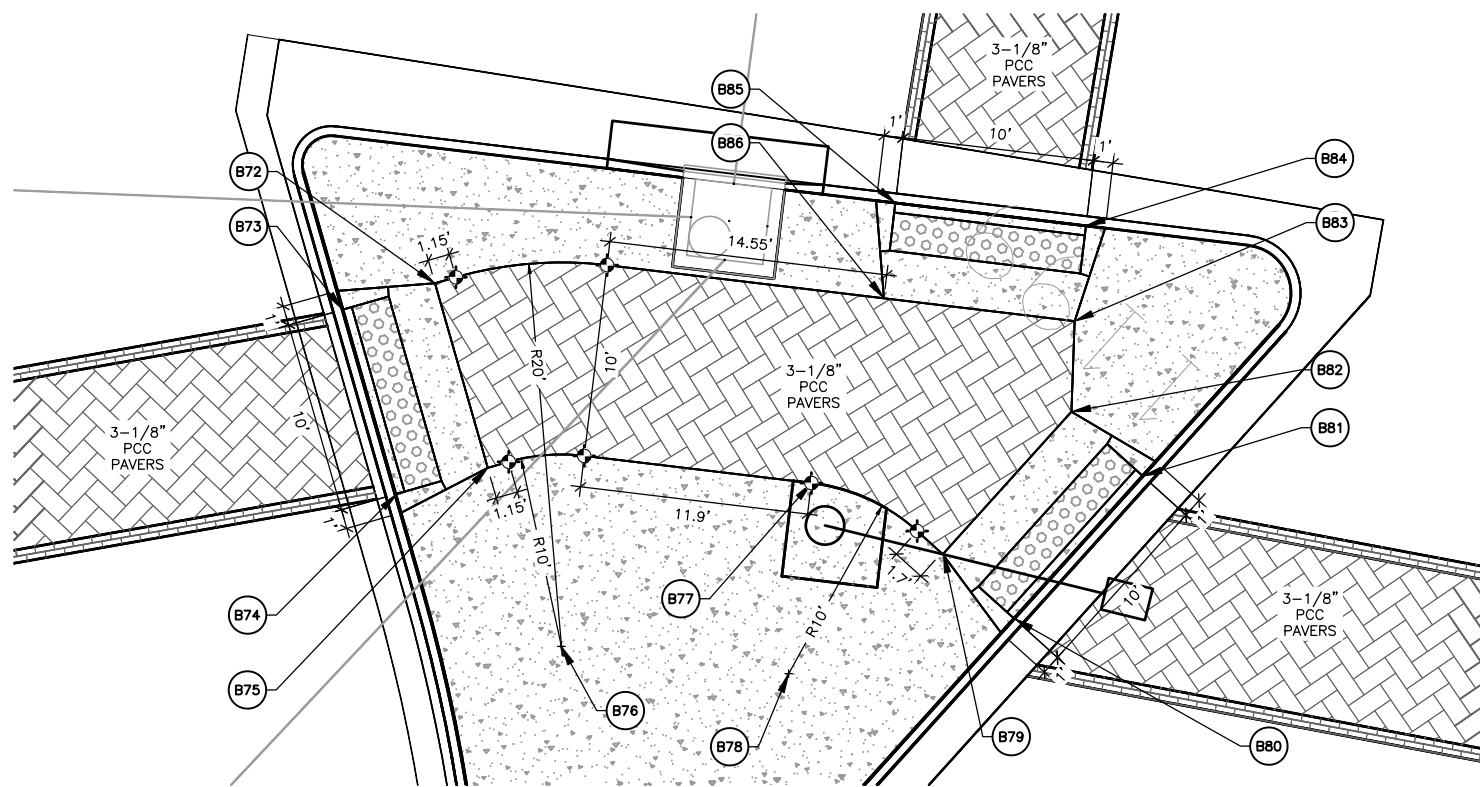

**3** SOUTHERN ISLAND AT S. 14TH ST. LAYOUT

SCALE: 1"=5'

◆ POINT OF TANGENCY (P.O.T.)  
NOTE: SEE I.32 & I.33 FOR STATIONS AND OFFSETS OF POINTS

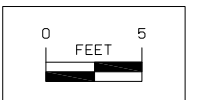
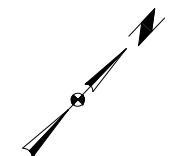

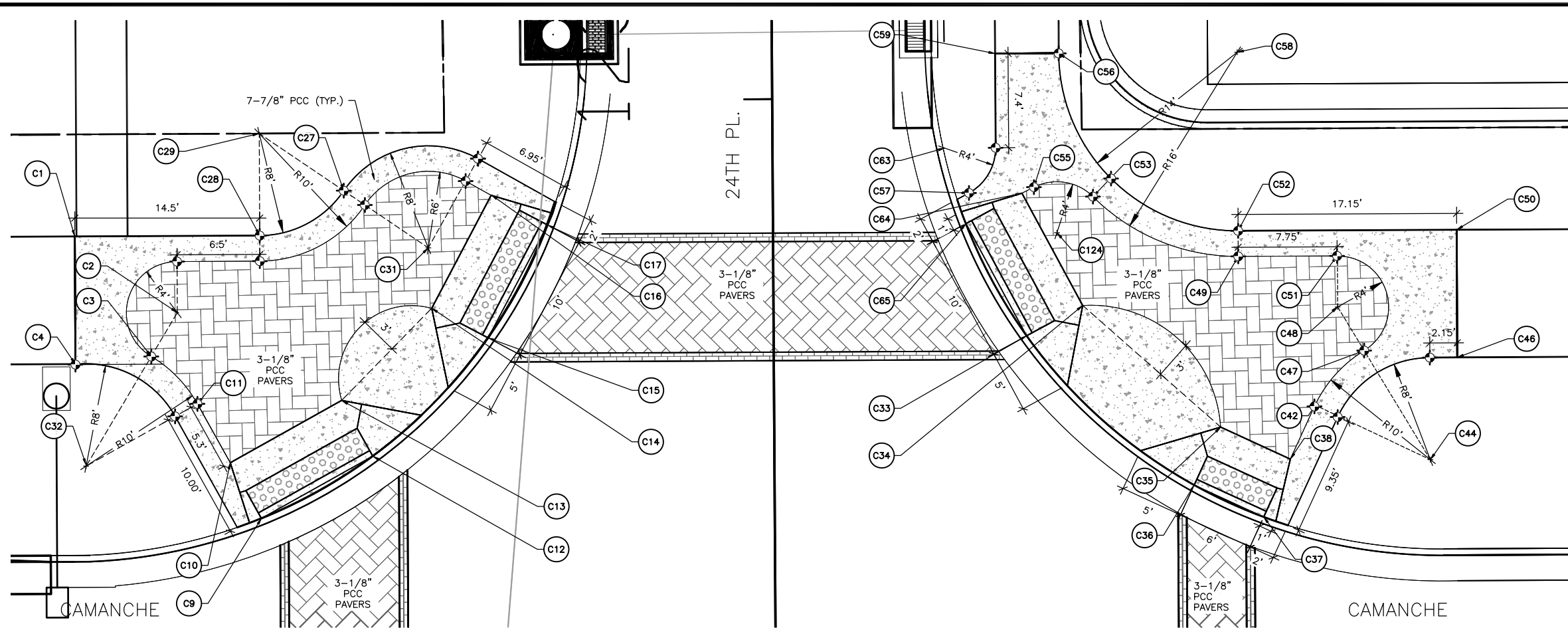

1 NORTHERN 24TH PL. LAYOUT

SCALE: 1"=5'

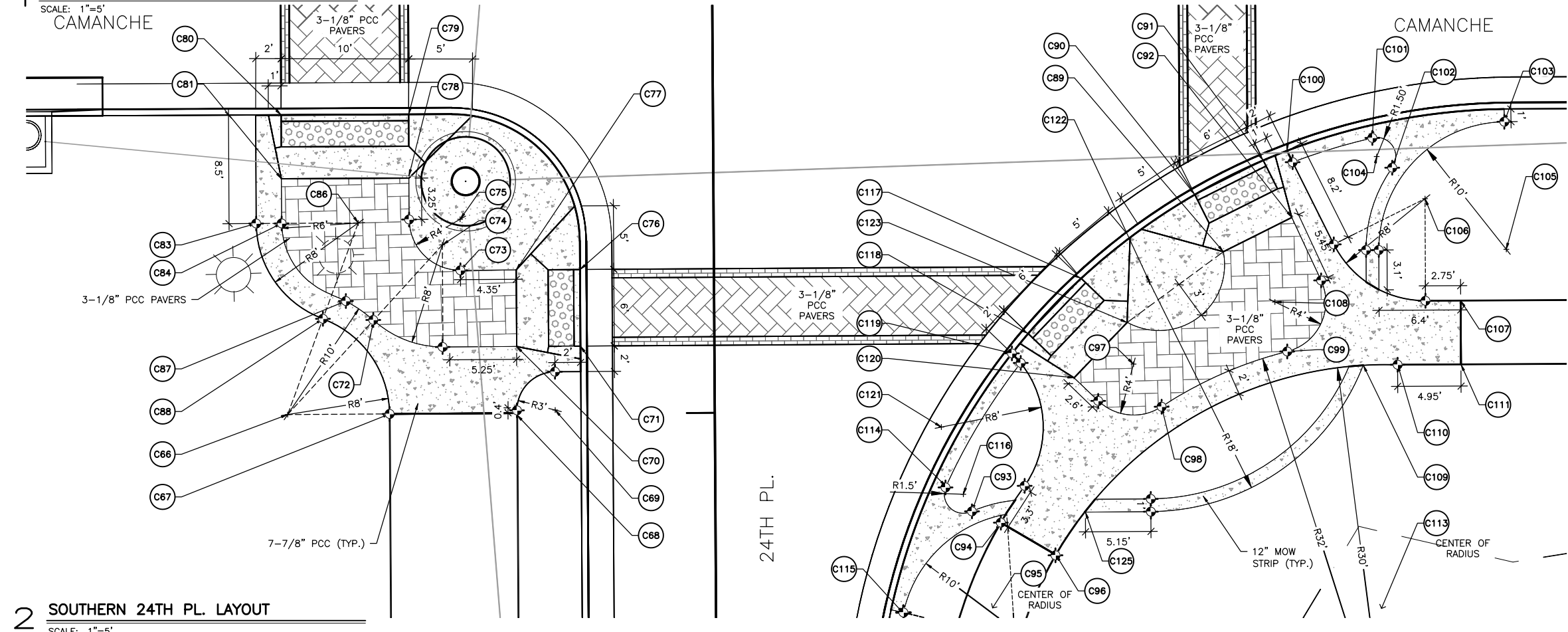

2 SOUTHERN 24TH PL. LAYOUT

SCALE: 1"=5'

◆ POINT OF TANGENCY (P.O.T.)  
 NOTE: SEE I.32 & I.33 FOR STATIONS AND OFFSETS OF POINTS

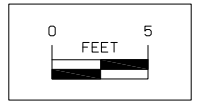
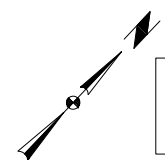
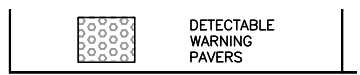



1 NOT USED  
SCALE: NTS

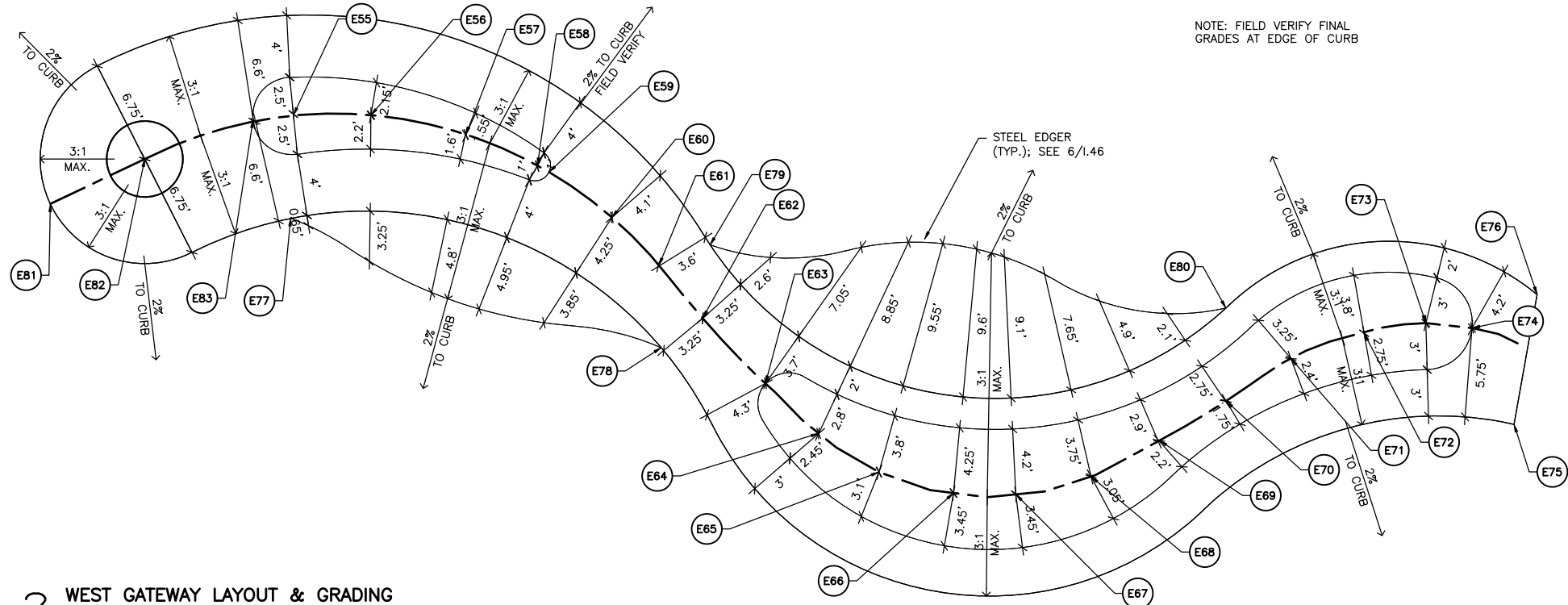

2 WEST GATEWAY LAYOUT & GRADING  
SCALE: 1"=5'

3 NOT USED  
SCALE: NTS

POINT OF TANGENCY (P.O.T.)  
NOTE: SEE I.32 & I.33 FOR STATIONS AND OFFSETS OF POINTS

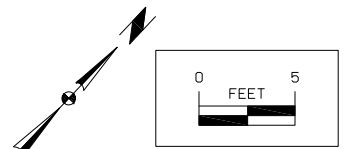

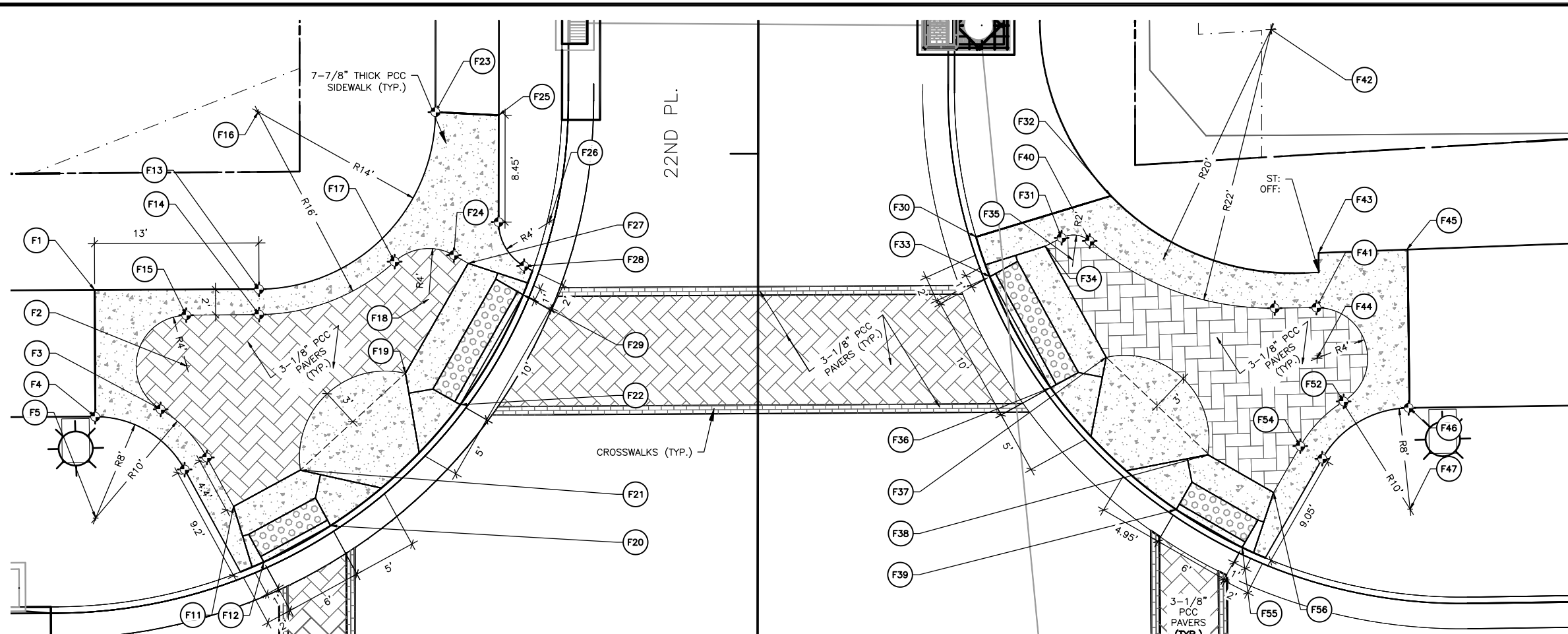

**1 NORTHERN 22ND PL. LAYOUT**

SCALE: 1"=5'

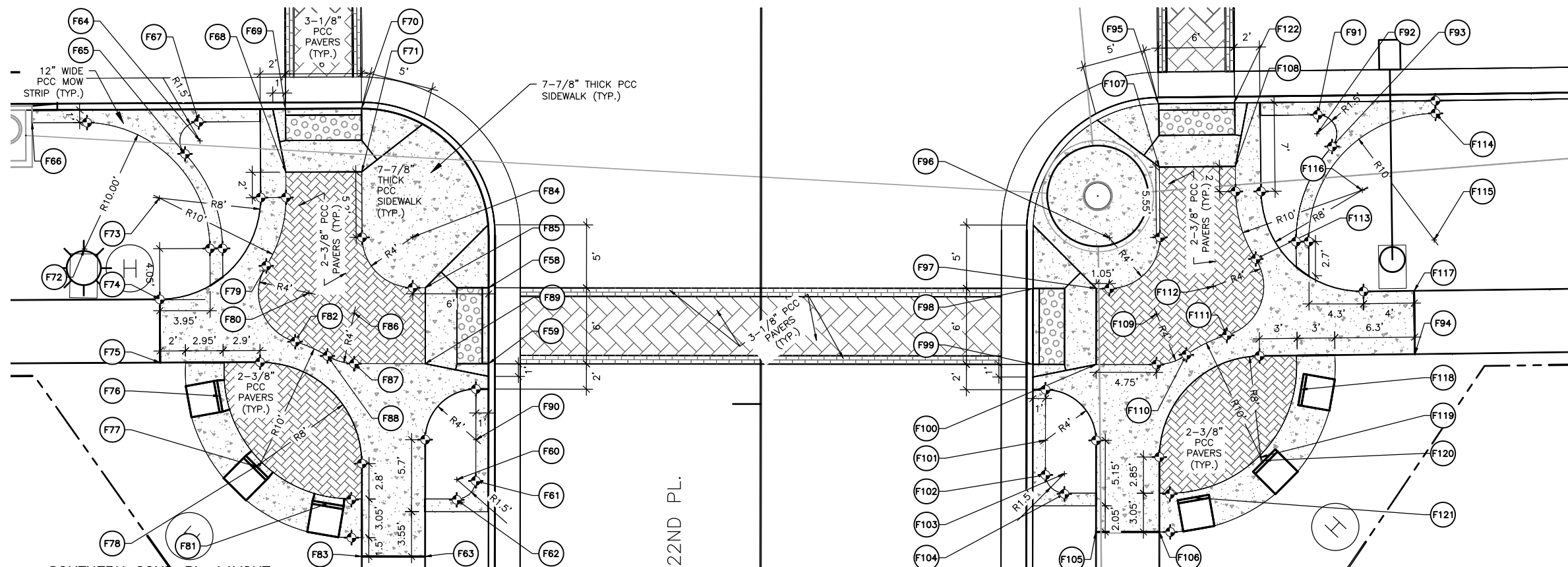

**2 SOUTHERN 22ND PL. LAYOUT**

SCALE: 1"=5'

◆ POINT OF TANGENCY (P.O.T.)

NOTE: SEE I.32 & I.33 FOR STATIONS AND OFFSETS OF POINTS

	PERGOLA AND COLUMNS WITH BENCHES
	COLUMNS WITHOUT PERGOLAS AND BENCHES
	DETECTABLE WARNING PAVERS

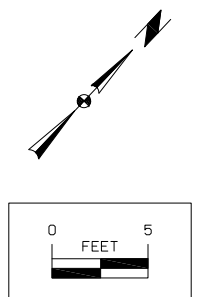



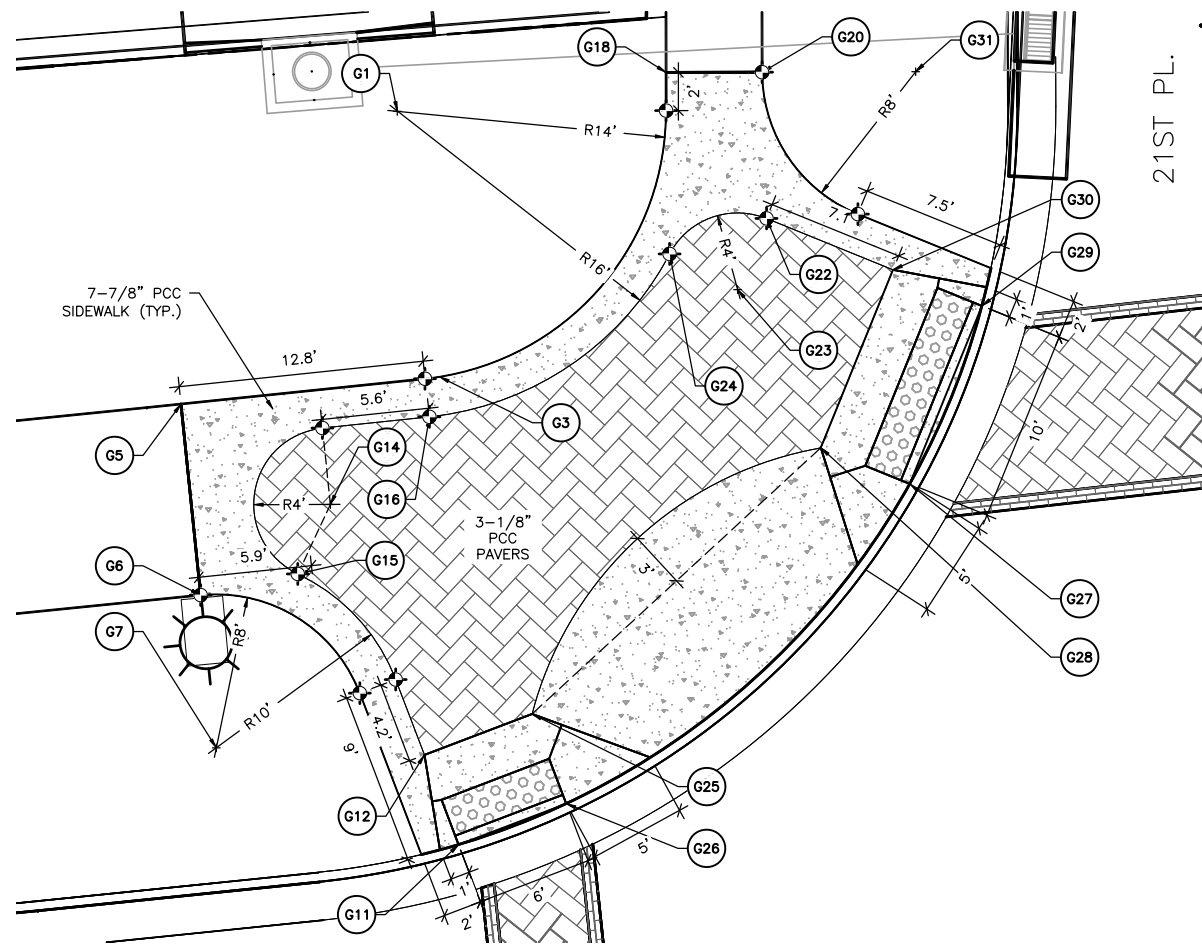

**1 NW 21ST PL. LAYOUT**  
SCALE: 1"=5'

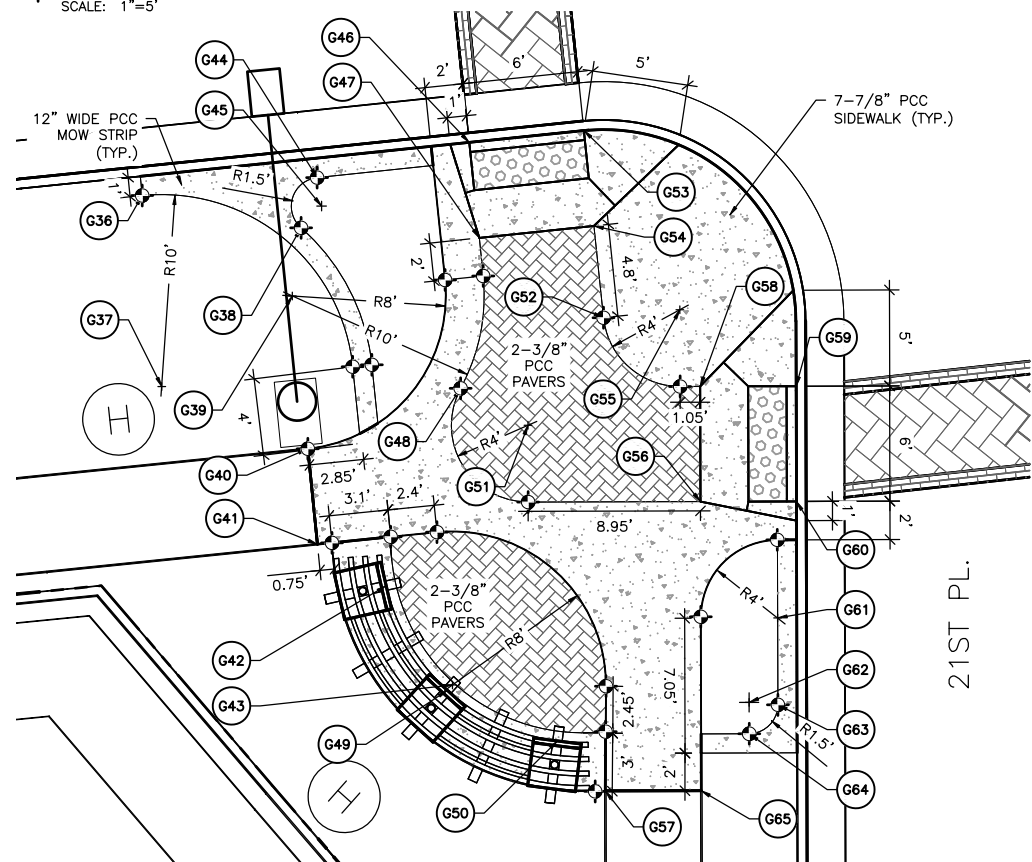

**2 SW 21ST PL. LAYOUT**  
SCALE: 1"=5'

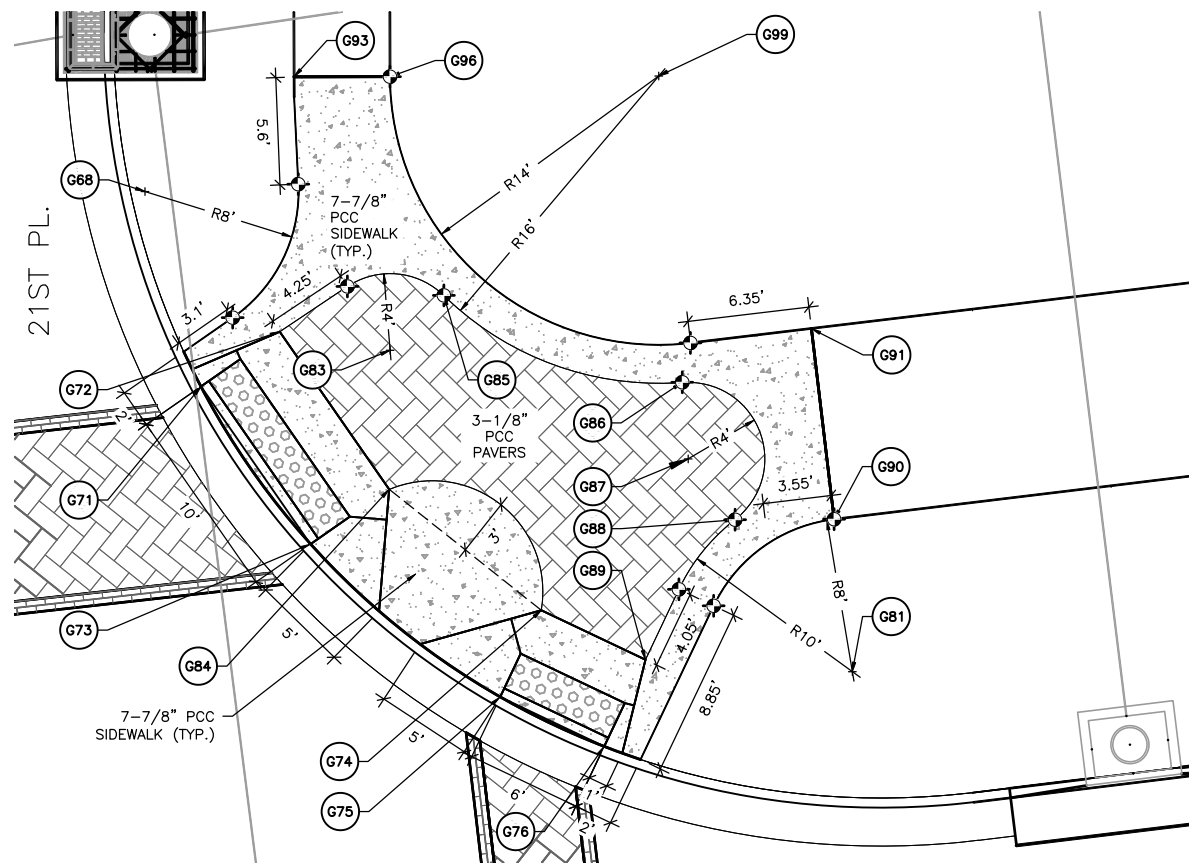

**3 NE 21ST PL. LAYOUT**  
SCALE: 1"=5'

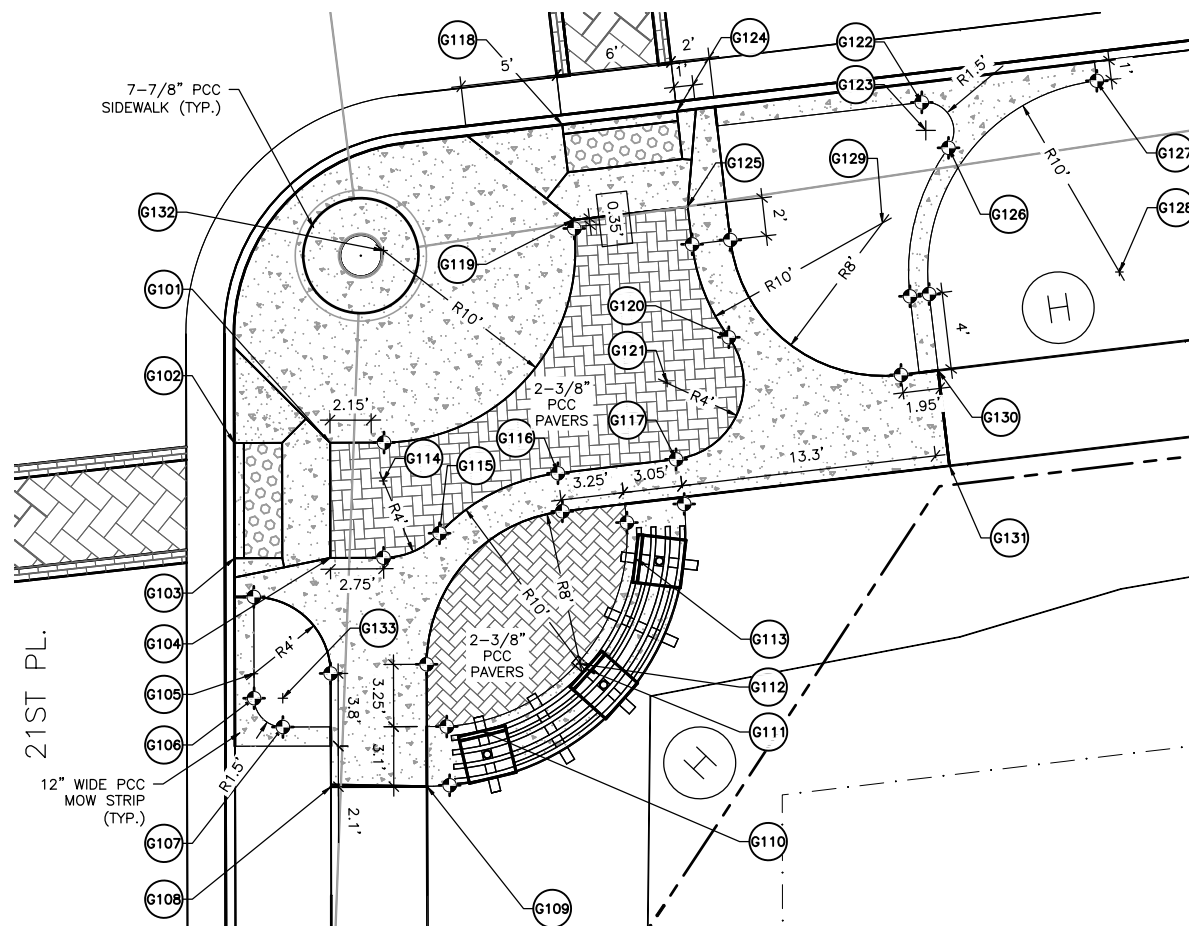

**4 SE 21ST PL. LAYOUT**  
SCALE: 1"=5'

◆ POINT OF TANGENCY (P.O.T.)  
NOTE: SEE I.32 & I.33 FOR STATIONS AND OFFSETS OF POINTS

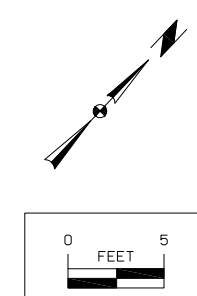
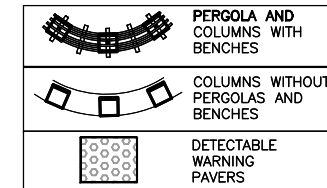

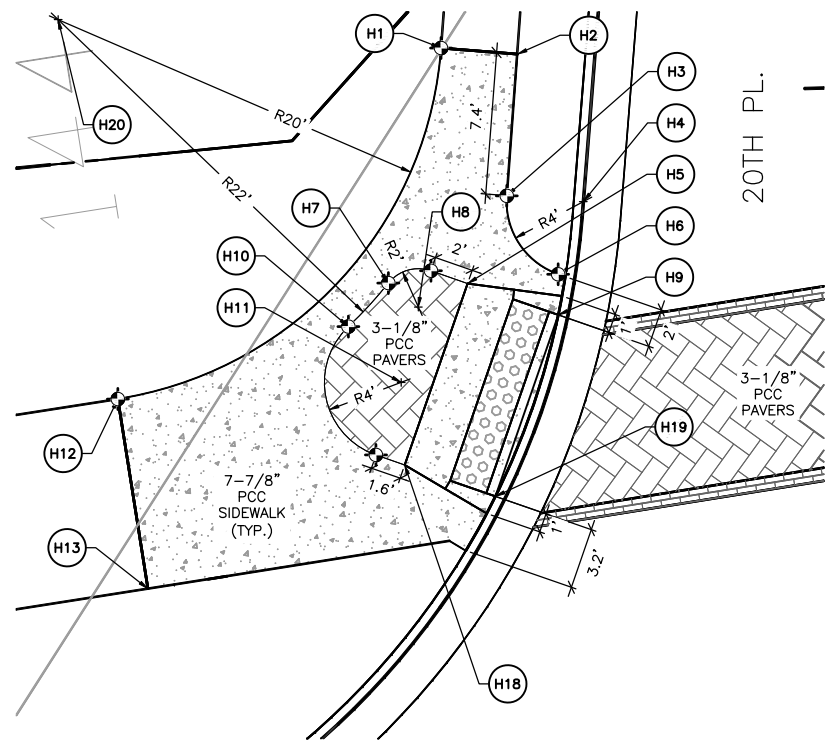

**1 NW 20TH PL. LAYOUT**  
SCALE: 1"=5'

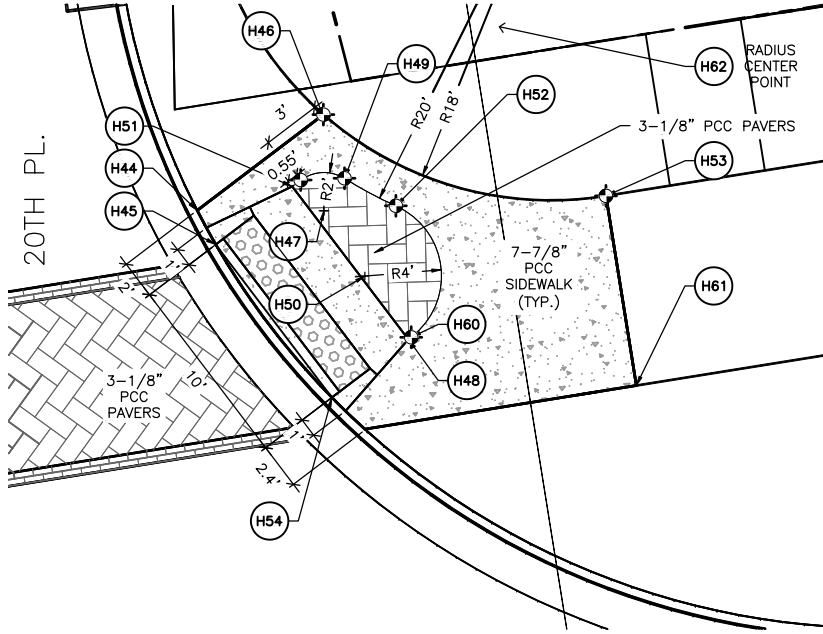

**3 NE 20TH PL. LAYOUT**  
SCALE: 1"=5'

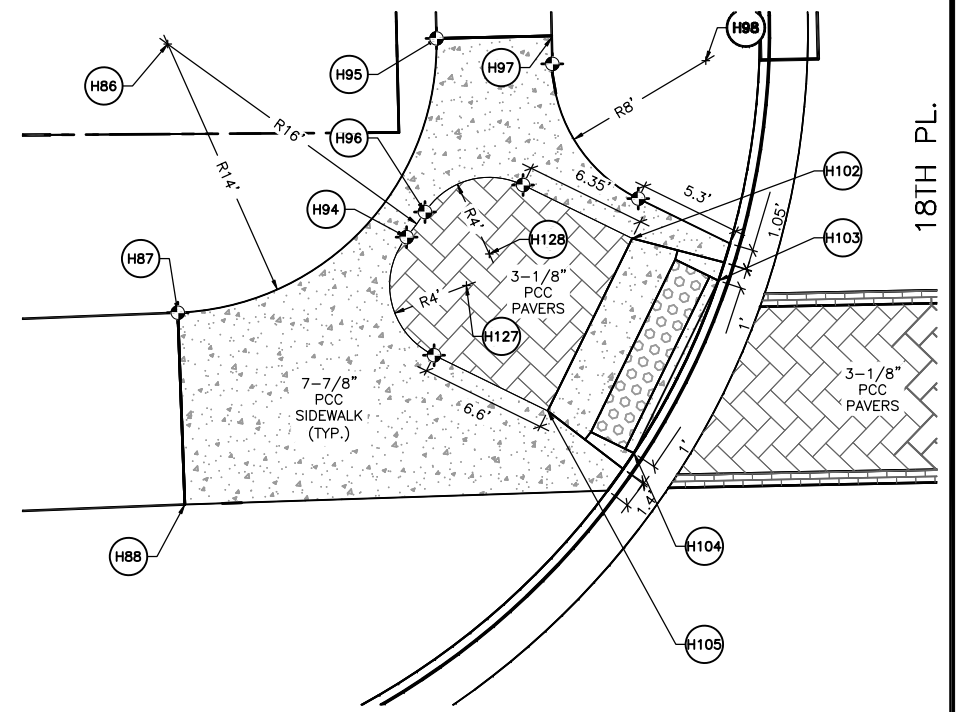

**5 NW 18TH PL. LAYOUT**  
SCALE: 1"=5'

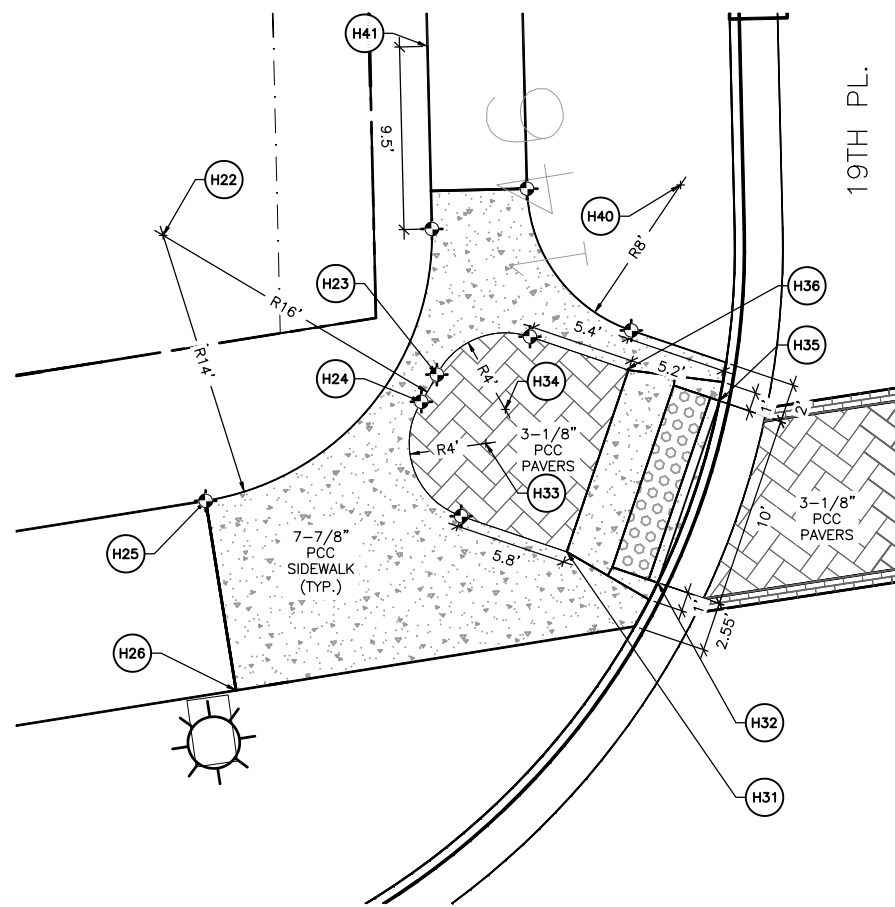

**2 NW 19TH PL. LAYOUT**  
SCALE: 1"=5'

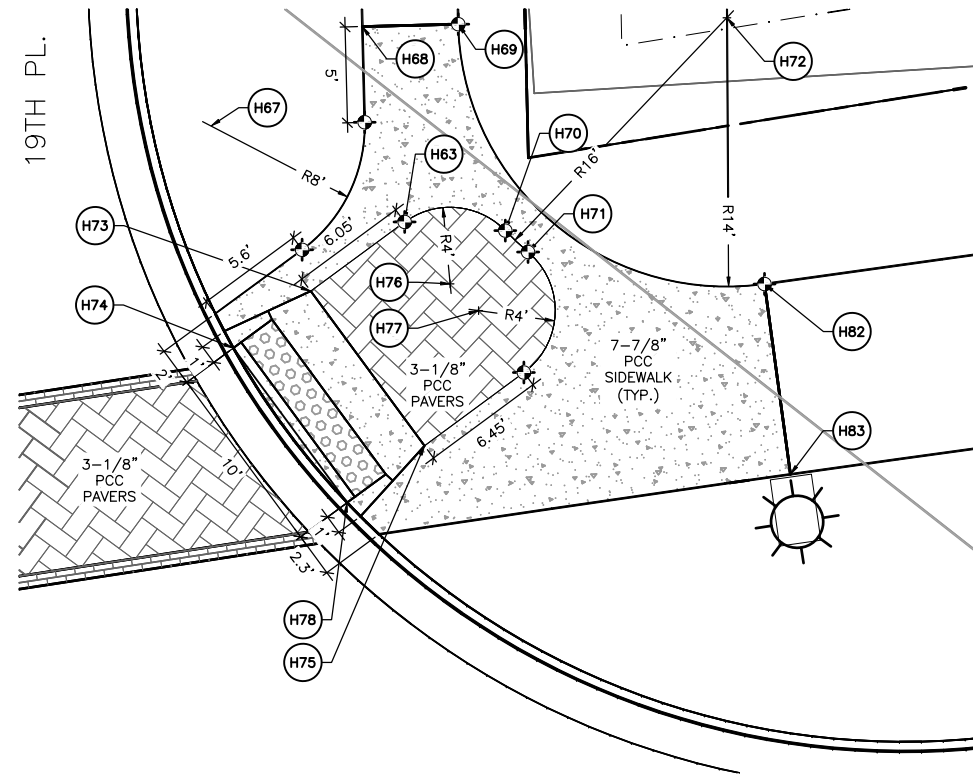

**4 NE 19TH PL. LAYOUT**  
SCALE: 1"=5'

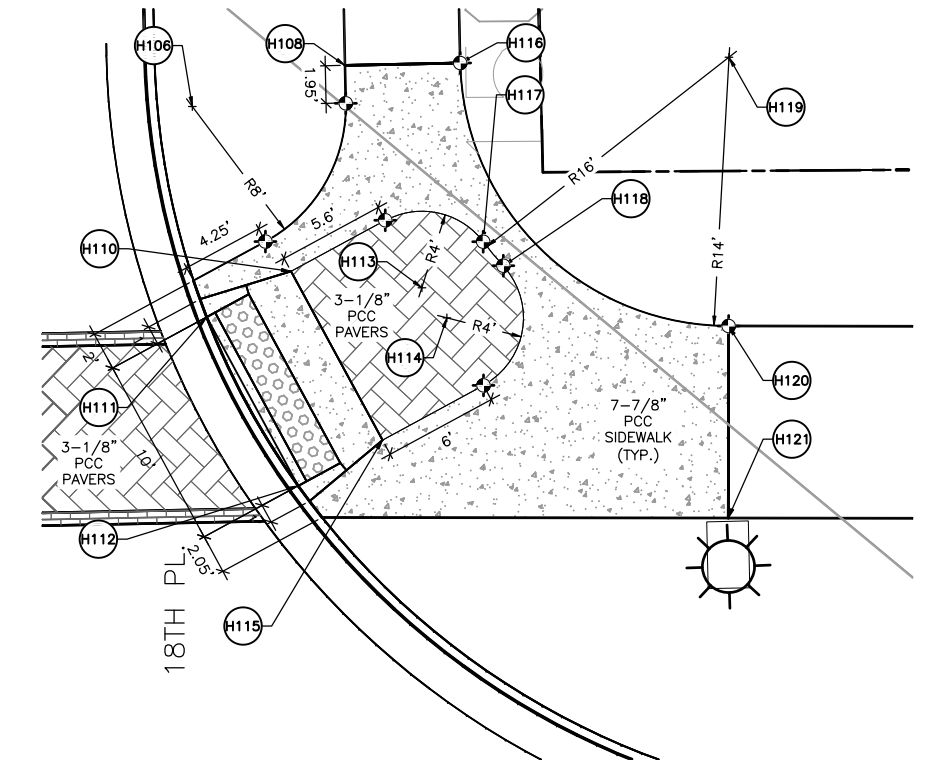

**6 NE 18TH PL. LAYOUT**  
SCALE: 1"=5'

◆ POINT OF TANGENCY (P.O.T.)  
NOTE: SEE I.32 & I.33 FOR STATIONS AND OFFSETS OF POINTS

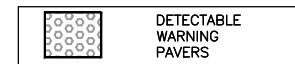
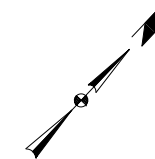
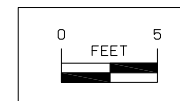

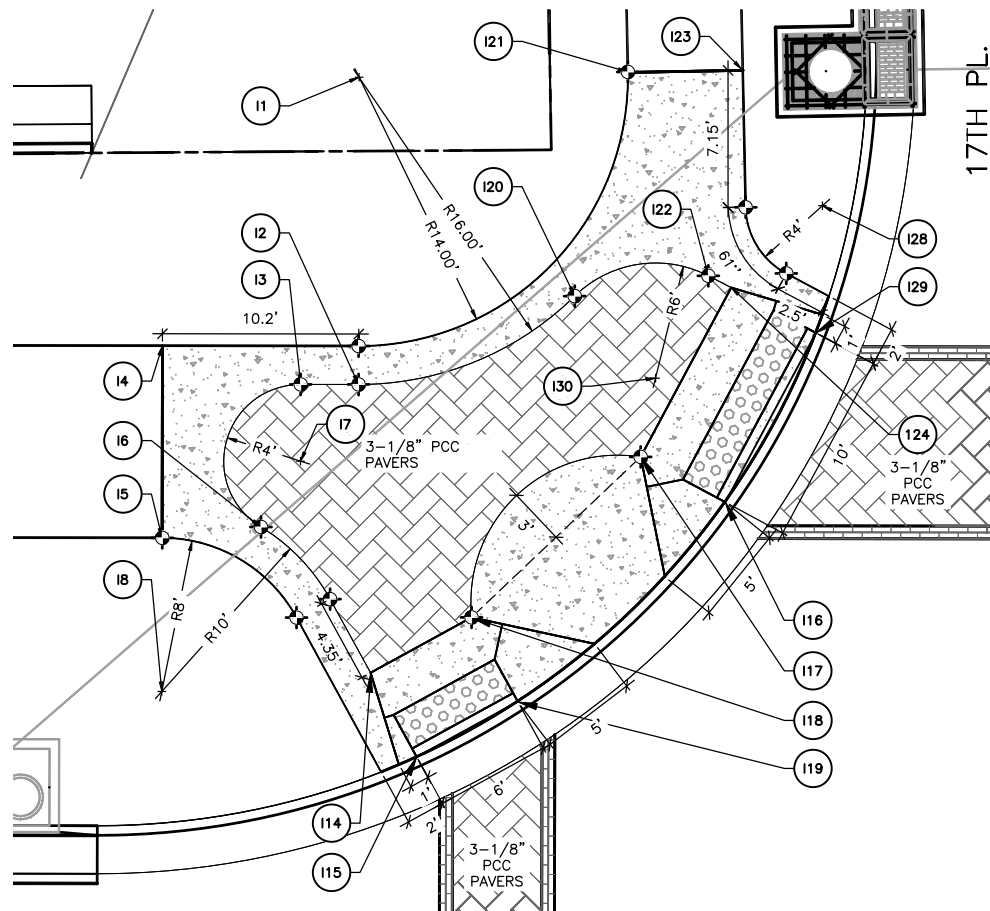

**1 NW 17TH PL. LAYOUT**  
SCALE: 1"=5'

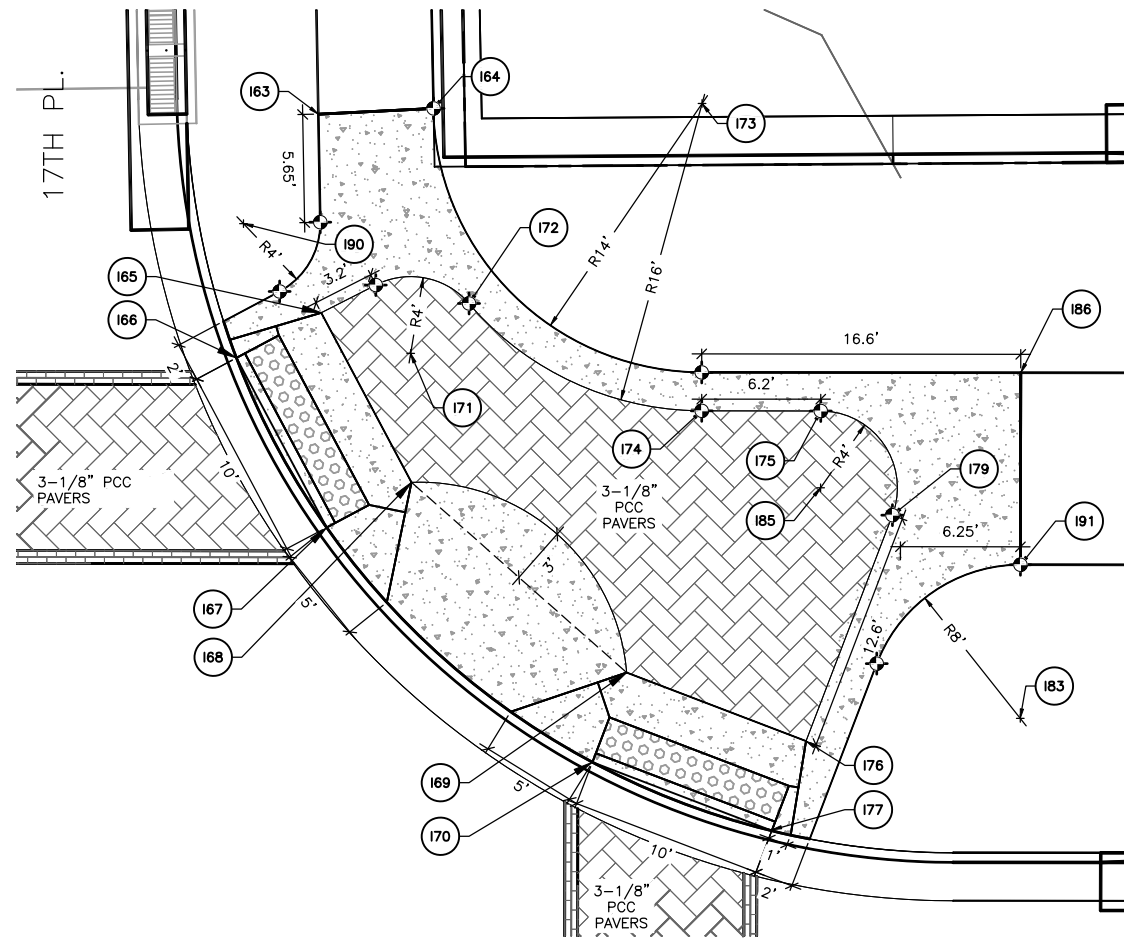

**3 NE 17TH PL. LAYOUT**  
SCALE: 1"=5'

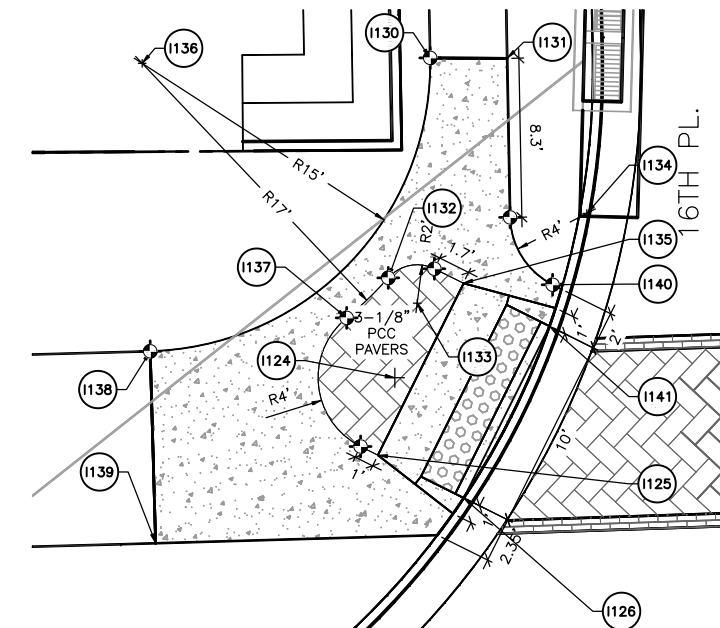

**5 NW 16TH PL. LAYOUT**  
SCALE: 1"=5'

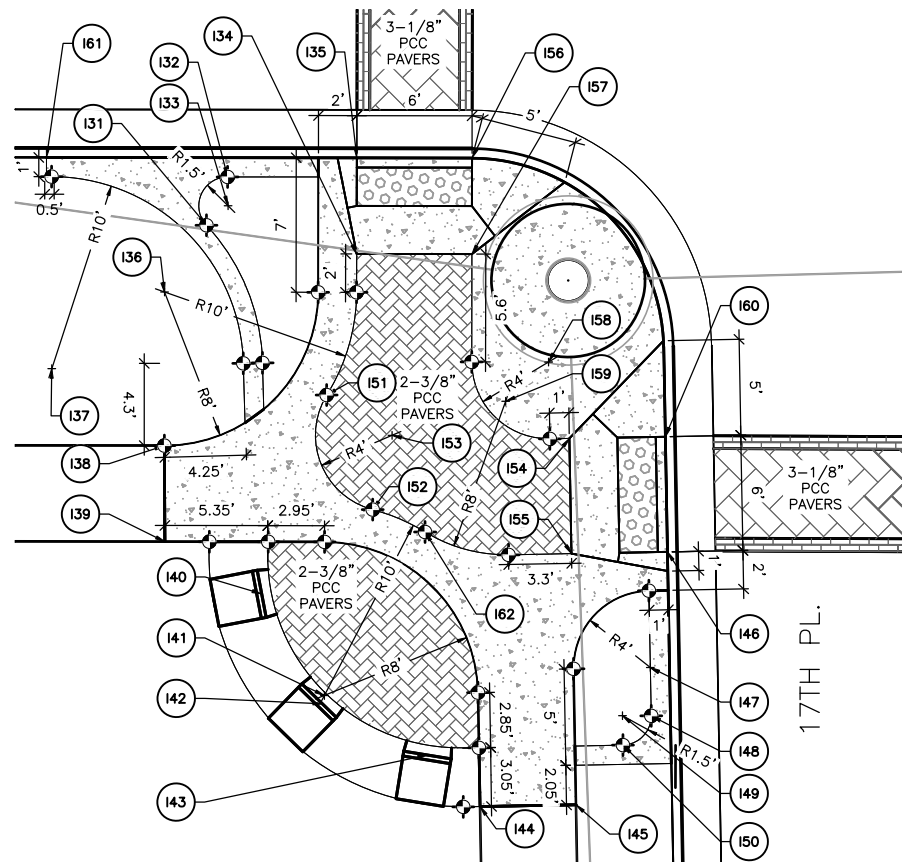

**2 SW 17TH PL. LAYOUT**  
SCALE: 1"=5'

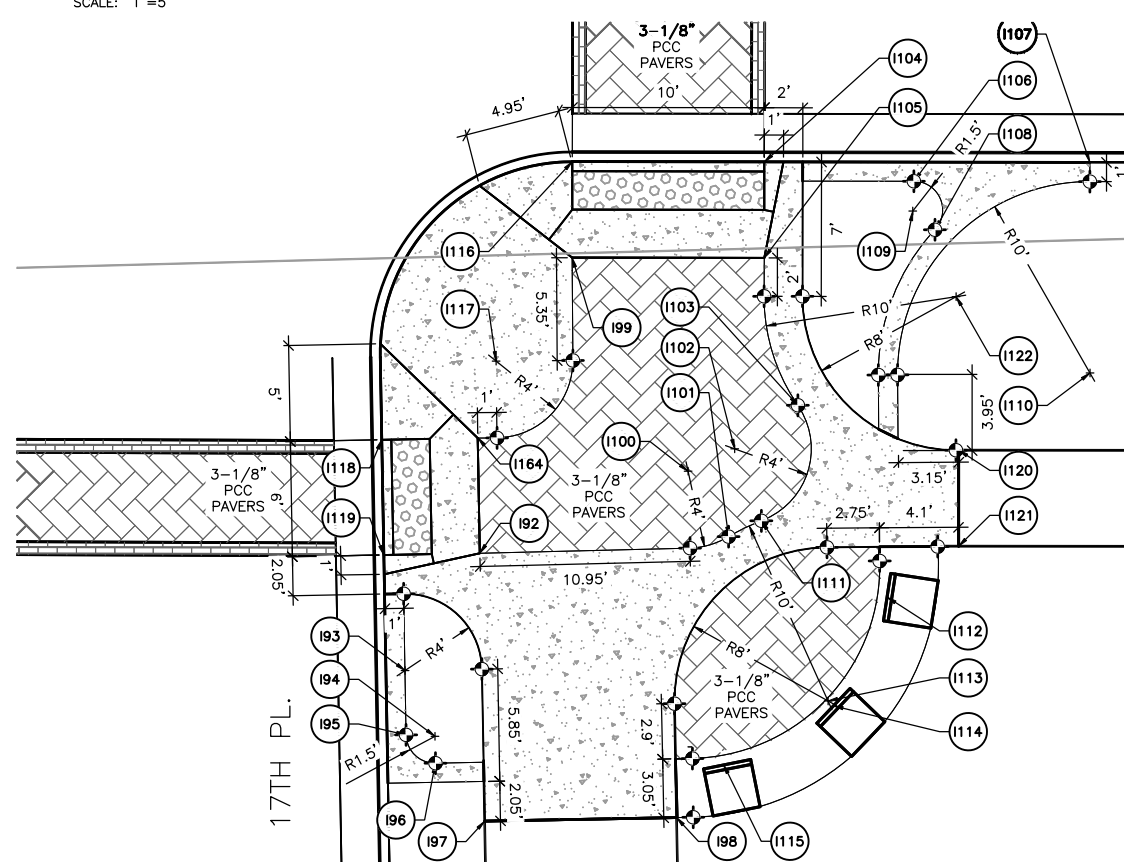

**4 SE 17TH PL. LAYOUT**  
SCALE: 1"=5'

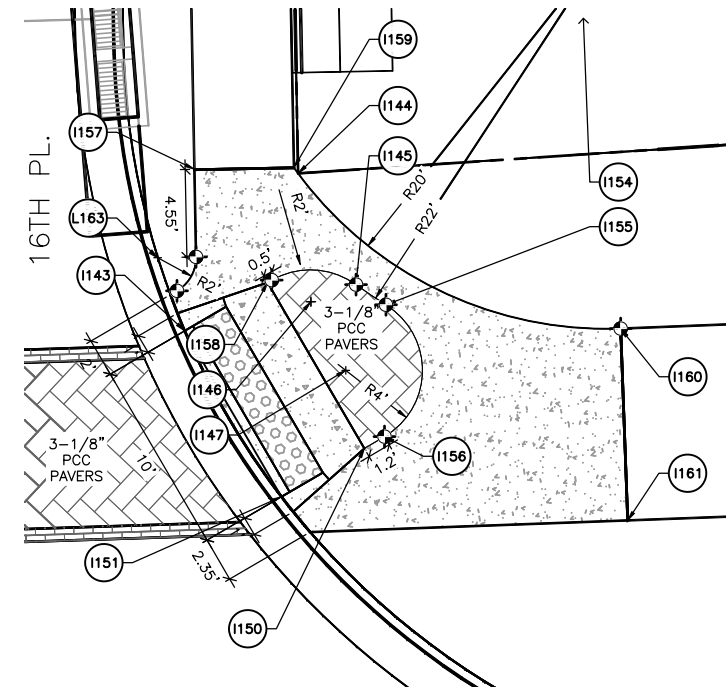

**6 NE 16TH PL. LAYOUT**  
SCALE: 1"=5'

◆ POINT OF TANGENCY (P.O.T.)  
NOTE: SEE I.32 & I.33 FOR STATIONS AND OFFSETS OF POINTS

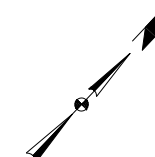
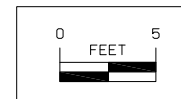
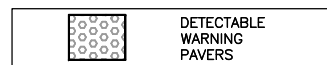





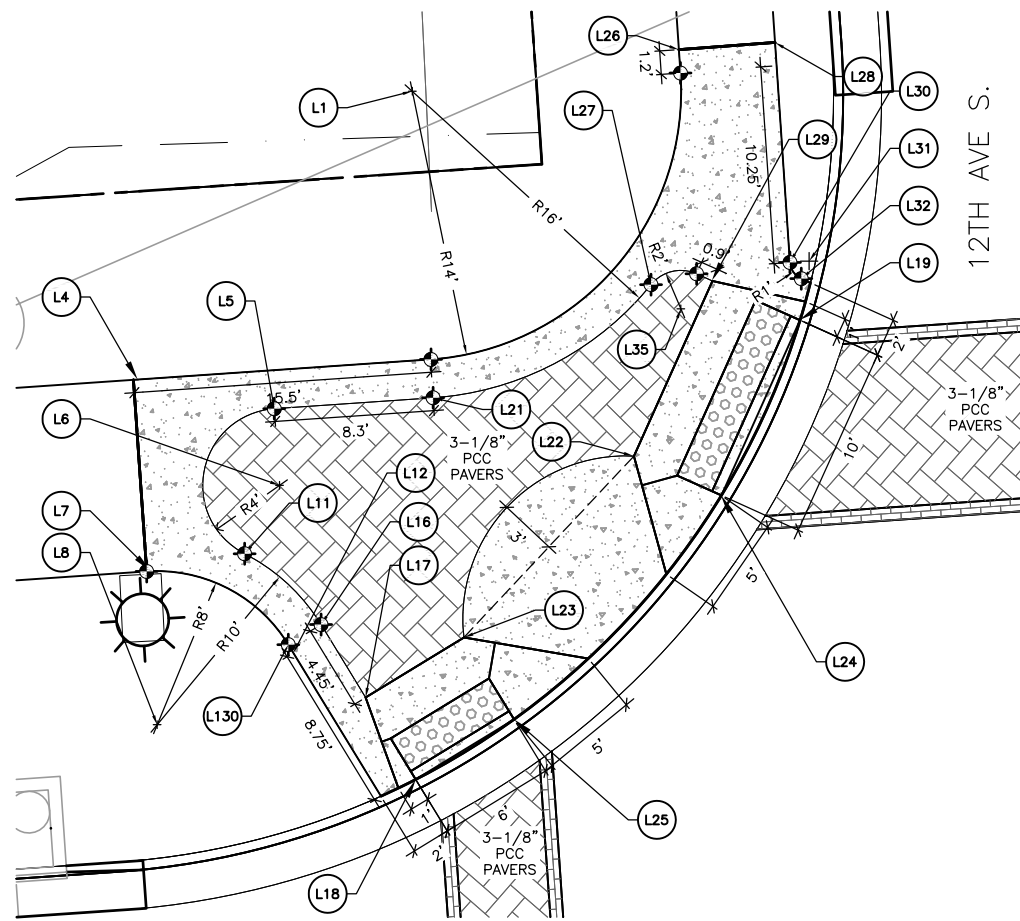

**1 NW 12TH AVE. S. LAYOUT**

SCALE: 1"=5'

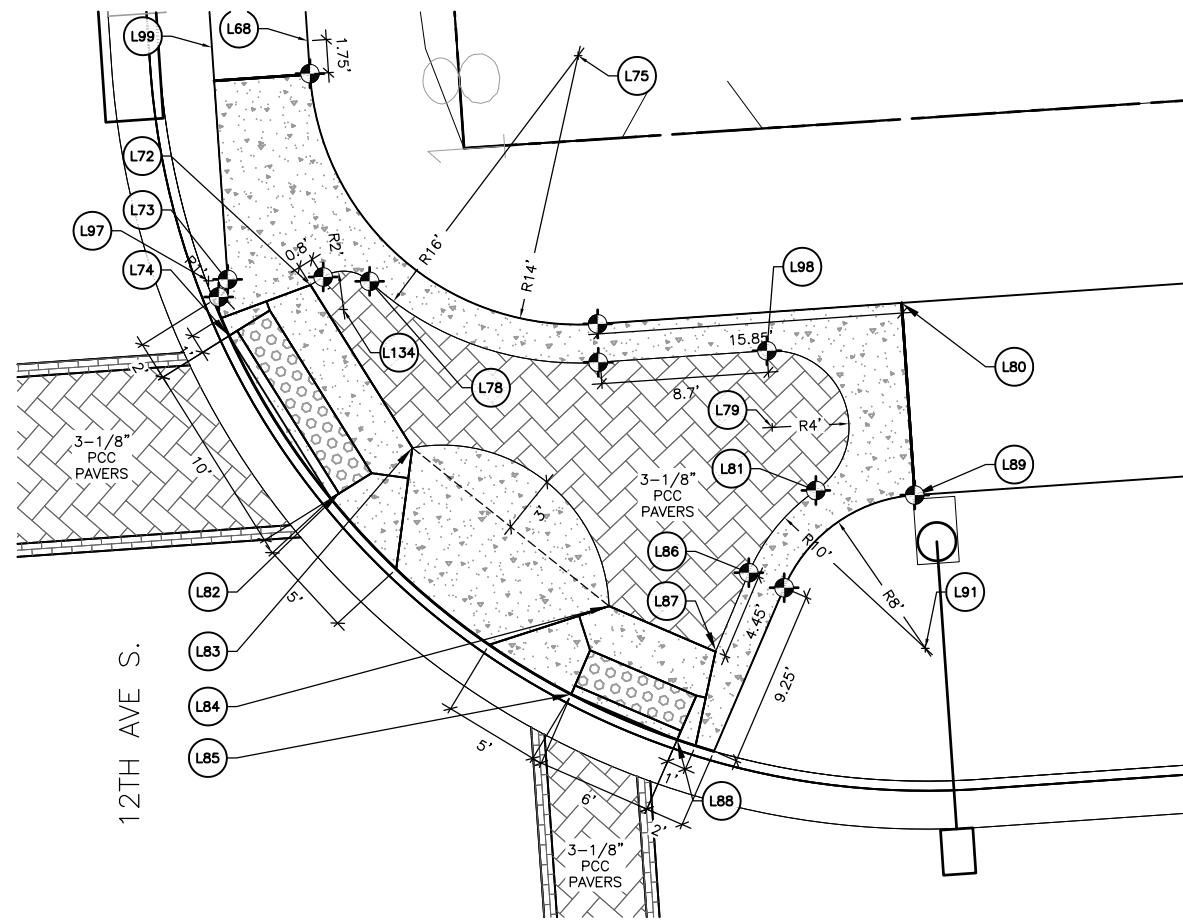

**3 NE 12TH AVE. S. LAYOUT**

SCALE: 1"=5'

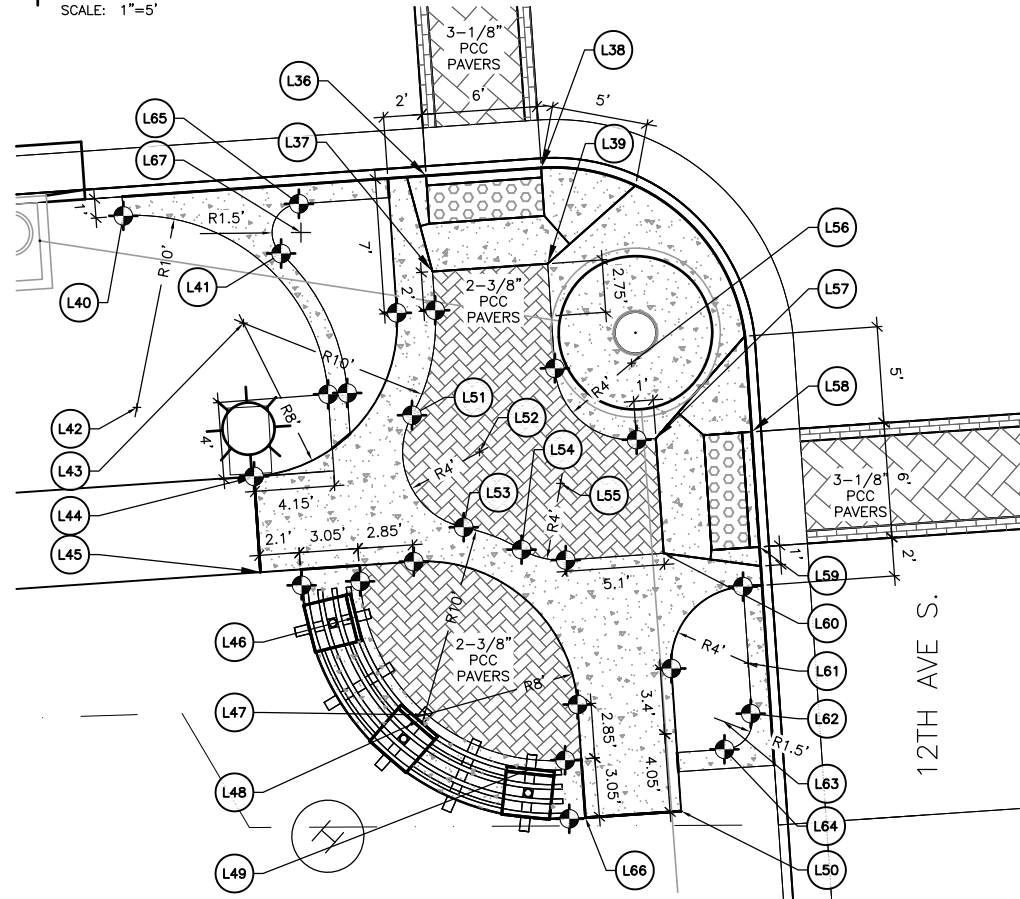

**2 SW 12TH AVE. S. LAYOUT**

SCALE: 1"=5'

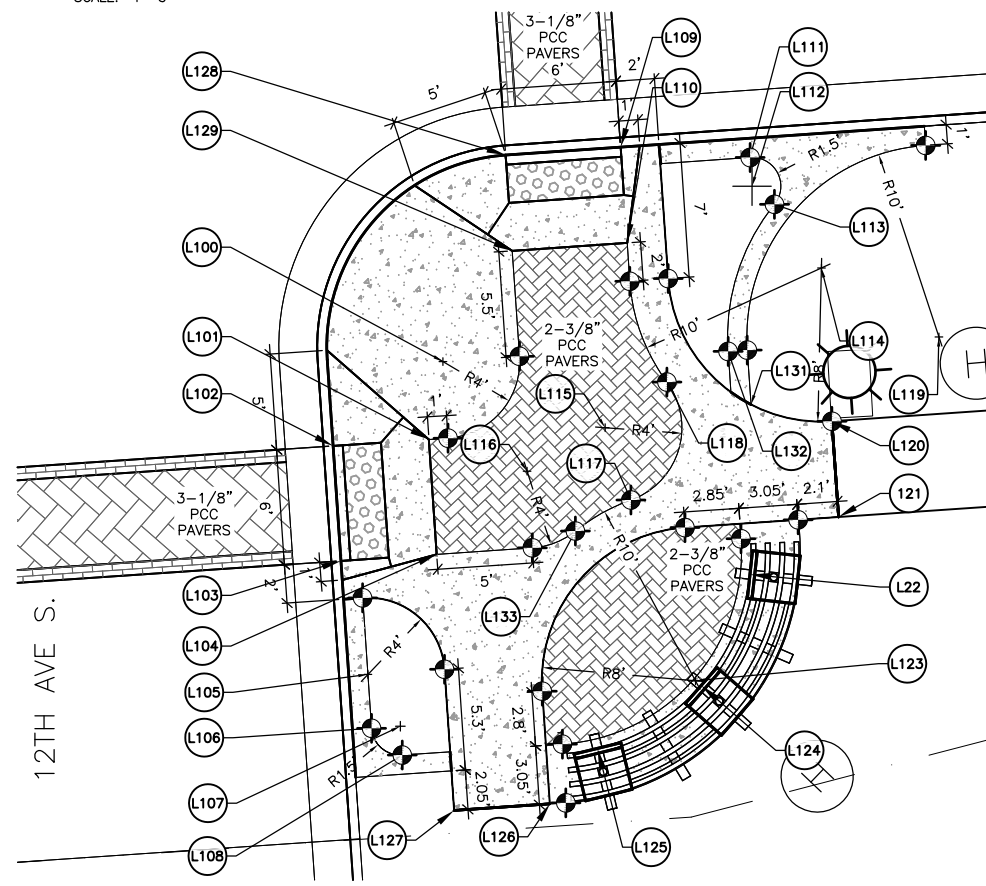

**4 SE 12TH AVE. S. LAYOUT**

SCALE: 1"=5'

◆ POINT OF TANGENCY (P.O.T.)  
 NOTE: SEE I.32 & I.33 FOR STATIONS AND OFFSETS OF POINTS

	PERGOLA AND COLUMNS WITH BENCHES
	COLUMNS WITHOUT PERGOLAS AND BENCHES
	DETECTABLE WARNING PAVERS

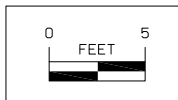
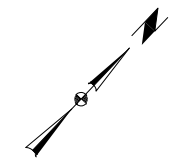

POINT	STA	OFF
A1	103+33.02	-45.099'
A2	103+33.02	-35.098'
A3	103+32.99	-27.111'
A4	103+40.95	-27.114'
A5	103+46.37	-22.814'
A6	103+46.36	-17.782'
A7	103+56.28	-17.782'
A8	103+56.27	-22.782'
A9	103+61.69	-27.114'
A10	103+46.37	-27.079'
A11	103+56.27	-27.079'
A12	103+69.60	-27.115'
A13	103+69.55	-35.115'
A14	103+69.54	-45.115'
A15	103+51.31	-45.000'
A16	103+42.78	-36.277'
A17	103+45.66	-43.011'
A18	103+56.98	-43.004'
A19	103+59.86	-36.272'
A20	103+45.65	-39.011'
A21	103+56.99	-39.004'
A22	104+89.93	-28.646'
A23	104+90.72	-27.854'
A24	104+90.94	-26.924'
A25	104+90.93	-21.532'
A26	104+98.23	-37.169'
A27	104+90.92	-16.532'
A28	105+00.84	-16.532'
A29	105+00.83	-21.532'
A30	105+00.82	-25.428'
A31	105+03.79	-25.437'
A32	105+02.64	-28.202'
A33	104+99.20	-37.582'
A34	105+03.72	-39.510'
A35	105+07.54	-30.296'
A36	105+03.00	-28.354'
A37	104+94.81	-37.359'
A38	104+89.88	-40.141'
A39	104+94.18	-37.716'
A40	104+96.71	-40.861'
A41	104+85.09	-31.406'
A42	104+89.40	-28.972'
A43	NOT USED	
A44	NOT USED	
A45	104+27.19	-35.144'
A46	104+27.21	-32.144'
A47	NOT USED	
A48	104+30.29	-40.925'
A49	104+34.11	-37.789'
A50	104+11.72	-80.099'
A51	104+30.12	-49.834'
A52	104+33.36	-44.819'
A53	104+40.25	-45.592'
A54	104+36.43	-48.717'
A55	104+40.87	-62.217'
A56	104+45.07	-59.695'
A57	104+11.72	-45.099'
A58	104+11.42	-45.099'
A59	104+11.41	-35.099'
A60	NOT USED	
A61	NOT USED	
A62	NOT USED	
A63	NOT USED	
A64	104+29.43	-34.094'
A65	NOT USED	
A66	105+58.52	-43.333'
A67	NOT USED	
A68	NOT USED	
A69	NOT USED	
A70	NOT USED	
A71	NOT USED	
A72	NOT USED	
A73	105+54.97	-36.198'
A74	105+58.01	-36.433'
A75	105+62.85	-37.022'
A76	105+89.29	-89.500'
A77	NOT USED	
A78	NOT USED	

A79	NOT USED	
A80	NOT USED	
A81	105+48.04	-43.287'
A82	105+47.69	-45.715'
A83	105+44.93	-48.557'
A84	105+48.10	-50.902'
A85	105+49.07	-44.295'
A86	105+50.68	-47.307'
A87	105+56.62	-37.844'
A88	105+57.04	-49.536'
A89	105+60.76	-46.617'
A90	105+59.43	-39.443'
A91	105+60.80	-33.607'
A92	105+89.29	-82.266'
A93	105+70.67	-33.078'
A94	105+44.14	-42.163'
A95	105+43.91	-40.500'
A96	105+51.48	-32.669'
A97	105+54.50	-46.482'

POINT	STA	OFF
B1	104+43.10	77.864'
B2	104+34.49	76.658'
B3	104+36.09	75.378'
B4	104+38.13	80.221'
B5	104+27.08	83.655'
B6	104+30.71	87.230'
B7	104+28.71	92.639'
B8	104+49.23	73.961'
B9	104+19.35	103.356'
B10	104+23.81	100.006'
B11	104+60.26	126.196'
B12	104+37.90	89.974'
B13	104+35.81	86.513'
B14	104+41.08	77.412'
B15	104+45.12	78.314'
B16	104+48.58	72.063'
B17	104+51.19	79.655'
B18	104+60.93	86.201'
B19	NOT USED	
B20	NOT USED	
B21	104+81.54	73.552'
B22	NOT USED	
B23	NOT USED	
B24	104+79.99	65.694'
B25	104+78.07	55.869'
B26	104+90.32	64.468'
B27	104+90.34	59.468'
B28	104+90.32	65.739'
B29	104+88.24	65.765'
B30	105+00.62	59.468'
B31	105+00.63	64.468'
B32	105+10.91	65.745'
B33	105+10.68	73.742'
B34	105+21.06	72.288'
B35	NOT USED	
B36	NOT USED	
B37	105+21.70	74.189'
B38	105+31.17	84.214'
B39	105+36.21	72.451'
B40	105+31.46	70.681'
B41	105+30.98	72.684'
B42	105+34.46	85.500'
B43	105+38.48	84.481'
B44	105+41.68	84.481'
B45	105+41.68	74.496'
B46	105+41.70	66.496'
B47	104+71.35	72.644'
B48	104+70.60	74.506'
B49	105+11.54	43.754'
B50	104+25.14	90.371'
B51	104+60.96	84.233'
B52	104+59.13	102.447'
B53	104+81.97	75.508'
B54	NOT USED	
B55	NOT USED	
B56	105+10.63	75.741'
B57	105+31.32	78.048'
B58	105+31.07	78.433'

B59	105+31.26	79.180'
B60	105+31.49	102.680'
B61	105+38.48	92.481'
B62	102+66.35	85.560'
B63	102+74.60	88.008'
B64	102+66.32	95.560'
B65	102+66.26	115.560'
B66	102+76.65	98.468'
B67	102+78.72	95.049'
B68	102+72.79	81.579'
B69	102+78.33	84.679'
B70	102+84.99	92.141'
B71	102+81.26	95.469'
B72	103+22.84	68.231'
B73	103+18.31	70.342'
B74	103+22.53	79.407'
B75	103+27.06	77.297'
B76	103+32.31	85.884'
B77	103+44.07	75.427'
B78	103+44.50	85.418'
B79	103+51.70	77.985'
B80	103+56.07	80.680'
B81	103+61.63	72.244'
B82	103+57.27	69.560'
B83	103+56.63	42.565'
B84	103+56.39	59.887'
B85	103+46.12	60.331'
B86	103+46.34	65.327'
B87	NOT USED	
B88	NOT USED	
B89	NOT USED	
B90	NOT USED	
B91	NOT USED	
B92	NOT USED	
B93	NOT USED	
B94	NOT USED	
B95	NOT USED	
B96	NOT USED	
B97	NOT USED	
B98	NOT USED	
B99	NOT USED	
B100	NOT USED	
B101	NOT USED	
B102	NOT USED	
B103	NOT USED	

B8	NOT USED	
B88	NOT USED	
B89	NOT USED	
B90	NOT USED	
B91	NOT USED	
B92	NOT USED	
B93	NOT USED	
B94	NOT USED	
B95	NOT USED	
B96	NOT USED	
B97	NOT USED	
B98	NOT USED	
B99	NOT USED	
B100	NOT USED	
B101	NOT USED	
B102	NOT USED	
B103	NOT USED	

POINT	STA	OFF
C1	122+58.50	-39.500'
C2	122+66.51	-33.500'
C3	122+64.45	-30.071'
C4	122+58.51	-29.460'
C5	NOT USED	
C6	NOT USED	
C7	NOT USED	
C8	NOT USED	
C9	122+73.03	-17.334'
C10	122+70.61	-21.712'
C11	122+68.05	-26.338'
C12	122+81.78	-22.173'
C13	122+79.36	-26.550'
C14	122+86.46	-33.747'
C15	122+90.88	-31.395'
C16	122+91.18	-42.602'
C17	122+95.58	-40.220'
C18	NOT USED	
C19	NOT USED	
C20	NOT USED	
C21	NOT USED	
C22	NOT USED	
C23	NOT USED	
C24	NOT USED	
C25	NOT USED	
C26	NOT USED	
C27	122+79.63	-42.977'
C28	122+73.00	-39.500'
C29	122+73.00	-47.500'
C30	NOT USED	
C31	122+86.22	-38.479'
C32	122+59.30	-21.500'

C33	123+33.11	-31.357'
C34	123+37.52	-33.716'
C35	123+48.31	-24.125'
C36	123+46.20	-19.597'
C37	123+51.64	-17.067'
C38	123+53.75	-21.595'
C39	NOT USED	
C40	NOT USED	
C41	NOT USED	
C42	123+55.71	-25.817'
C43	NOT USED	
C44	123+64.73	-21.500'
C45	NOT USED	
C46	123+66.88	-29.500'
C47	123+59.58	-30.072'
C48	123+57.52	-33.500'
C49	123+49.74	-37.500'
C50	123+66.88	-39.500'
C51	123+57.52	-37.500'
C52	123+49.74	-39.500'
C53	123+38.37	-42.240'
C54	123+84.64	37.046'
C55	123+33.74	-43.002'
C56	123+35.74	-53.480'
C57	123+28.63	-42.565'
C58	123+49.74	-53.500'
C59	123+30.74	-53.485'
C60	NOT USED	
C61	NOT USED	
C62	NOT USED	
C63	123+26.75	-46.098'
C64	123+32.84	-42.553'
C65	123+28.39	-40.173'
C66	122+74.89	49.983'
C67	122+82.89	49.971'
C68	122+92.88	46.500'
C69	122+95.88	49.732'
C70	122+92.87	44.737'
C71	122+97.88	44.729'
C72	122+81.67	42.629'
C73	122+88.50	38.743'
C74	122+87.09	36.745'
C75	122+88.49	34.743'
C76	122+97.87	38.729'
C77	122+92.87	38.737'
C78	122+84.49	31.500'
C79	122+84.49	26.500'
C80	122+74.49	26.500'
C81	122+74.49	31.500'
C82	NOT USED	
C83	122+72.50	35.000'
C84	122+74.50	35.000'
C85	NOT USED	
C86	122+80.50	34.997'
C87	122+79.50	41.109'
C88	122+77.69	42.490'
C89	123+48.35	37.581'
C90	123+46.13	33.090'
C91	123+51.51	30.431'
C92	123+53.72	34.922'
C93	123+28.46	57.855'
C94	123+30.78	58.719'
C95	123+31.86	67.935'
C96	123+35.09	61.258'
C97	123+41.26	46.351'
C98	123+43.44	49.701'
C99	123+53.32	45.419'
C100	123+53.37	29.685'
C101	123+60.07	28.719'
C102	123+61.62	31.060'
C103	123+70.42	27.503'
C104	123+60.40	30.181'
C105	123+70.53	37.502'
C106	123+64.18	33.500'
C107	123+66.93	41.500'
C108	123+52.36	41.534'
C109	123+59.27	46.530'
C110	123+61.96	46.500'
C111	123+66.93	46.500'

C112	NOT USED	
C113	123+60.97	76.623'
C114	123+26.72	55.377'
C115	123+24.33	61.353'
C116	123+27.86	56.481'
C117	123+37.18	39.612'
C118	123+33.00	43.920'
C119	123+31.72	45.466'
C120	123+36.59	47.398'
C121	123+26.15	51.209'
C122	123+42.53	39.919'
C123	123+40.77	43.090'
C124	123+35.53	-39.425'
C125	NOT USED	

POINT	STA	OFF
D1	129+02.55	-39.500'
D2	129+02.55	-39.500'
D3	129+04.43	-21.500'
D4	NOT USED	
D5	NOT USED	
D6	NOT USED	
D7	NOT USED	
D8	NOT USED	
D9	129+15.38	-21.982'
D10	129+17.62	-17.514'
D11	NOT USED	
D12	129+22.98	-20.209'
D13	12	

G131	141+50.51	46.501'
G132	141+22.71	31.945'
G133	141+14.90	54.511'

H75	146+49.20	-33.708'
H76	146+51.72	-41.852'
H77	146+52.96	-40.258'
H78	146+44.83	-31.375'
H79	NOT USED	
H80	NOT USED	
H81	NOT USED	
H82	146+67.67	-39.500'
H83	146+67.62	-29.500'
H84	NOT USED	
H85	NOT USED	
H86	149+25.14	-53.500'
H87	149+25.14	-39.500'
H88	149+25.14	-29.500'
H89	NOT USED	
H90	NOT USED	
H91	NOT USED	
H92	NOT USED	
H93	NOT USED	
H94	149+37.00	-43.009'
H95	149+38.85	-53.307'
H96	149+37.98	-44.290'
H97	149+44.72	-53.167'
H98	149+52.55	-51.735'
H99	NOT USED	
H100	NOT USED	
H101	NOT USED	
H102	149+48.54	-42.588'
H103	149+52.89	-40.267'
H104	149+48.32	-31.410'
H105	149+43.95	-33.738'
H106	149+83.67	-51.209'
H107	NOT USED	
H108	149+91.49	-53.248'
H109	NOT USED	
H110	149+88.61	-42.552'
H111	149+84.26	-40.227'
H112	149+88.84	-31.375'
H113	149+95.30	-41.621'
H114	149+96.57	-40.042'
H115	149+93.21	-33.708'
H116	149+97.37	-53.315'
H117	149+98.47	-43.994'
H118	149+99.48	-42.732'
H119	150+11.07	-53.526'
H120	150+11.01	-39.526'
H121	150+10.96	-29.527'
H122	NOT USED	
H123	NOT USED	
H124	NOT USED	
H125	NOT USED	
H126	NOT USED	
H127	149+39.97	-40.395'
H128	149+41.20	-41.998'
H129	NOT USED	

I23	152+91.07	-53.889'
I24	152+90.48	-42.574'
I25	NOT USED	
I26	NOT USED	
I27	NOT USED	
I28	152+95.22	-46.843'
I29	152+94.89	-40.219'
I30	152+86.54	-37.852'
I31	152+67.49	30.021'
I32	152+68.59	27.501'
I33	152+68.61	29.000'
I34	152+75.31	31.504'
I35	152+75.31	26.500'
I36	152+65.31	33.500'
I37	152+59.44	37.500'
I38	152+65.31	41.500'
I39	152+65.34	46.500'
I40	152+70.39	49.213'
I41	152+73.66	54.500'
I42	152+73.39	54.769'
I43	152+79.03	57.598'
I44	152+81.78	60.275'
I45	152+86.77	60.178'
I46	152+91.52	46.999'
I47	152+90.64	53.018'
I48	152+90.68	55.537'
I49	152+89.18	55.567'
I50	152+89.21	57.066'
I51	152+73.75	38.856'
I52	152+76.16	44.818'
I53	152+77.17	40.946'
I54	152+86.41	41.085'
I55	152+86.52	47.097'
I56	152+81.31	26.500'
I57	152+81.31	31.505'
I58	152+85.31	37.119'
I59	152+83.08	39.163'
I60	152+91.40	41.001'
I61	152+59.15	26.501'
I62	152+78.90	45.979'
I63	153+31.43	-52.921'
I64	153+37.43	-53.226'
I65	153+31.59	-42.574'
I66	153+27.18	-40.219'
I67	153+31.89	-31.397'
I68	153+36.30	-33.752'
I69	153+47.54	-23.863'
I70	153+45.76	-19.189'
I71	153+36.26	-40.464'
I72	153+39.29	-43.071'
I73	153+51.42	-53.500'
I74	153+51.42	-37.500'
I75	153+57.62	-37.500'
I76	153+56.88	-20.304'
I77	153+55.10	-15.631'
I78	NOT USED	
I79	153+61.36	-32.077'
I80	NOT USED	
I81	NOT USED	
I82	NOT USED	
I83	153+68.04	-21.500'
I84	NOT USED	
I85	153+57.62	-33.500'
I86	153+68.04	-39.500'
I87	NOT USED	
I88	NOT USED	
I89	NOT USED	
I90	153+27.54	-47.212'
I91	153+68.04	-29.500'
I92	153+39.53	46.902'
I93	153+35.64	53.014'
I94	153+37.20	56.336'
I95	153+35.70	56.365'
I96	153+37.23	57.836'
I97	153+39.80	60.850'
I98	153+49.80	60.655'
I99	153+44.32	31.500'
I100	153+50.37	42.611'
I101	153+52.49	46.019'

I102	153+52.80	41.446'
I103	153+56.09	39.175'
I104	153+54.32	26.500'
I105	153+54.32	31.500'
I106	153+62.11	27.500'
I107	153+71.28	27.500'
I108	153+63.21	30.020'
I109	153+62.06	29.050'
I110	153+71.29	37.471'
I111	153+54.19	45.194'
I112	153+60.74	49.155'
I113	153+57.68	54.567'
I114	153+57.96	54.824'
I115	153+52.43	57.872'
I116	153+44.32	26.500'
I117	153+40.37	36.890'
I118	153+34.41	41.001'
I119	153+34.53	46.999'
I120	153+64.47	41.500'
I121	153+64.47	46.500'
I122	153+64.32	33.500'
I123	NOT USED	
I124	157+74.06	-37.758'
I125	157+73.06	-33.755'
I126	157+77.48	-31.392'
I127	NOT USED	
I128	NOT USED	
I129	NOT USED	
I130	157+76.41	-54.349'
I131	157+80.44	-54.207'
I132	157+73.88	-42.966'
I133	157+75.35	-41.608'
I134	157+84.36	-46.012'
I135	157+77.81	-42.567'
I136	157+61.32	-54.500'
I137	157+71.64	-40.948'
I138	157+61.32	-39.500'
I139	157+61.32	-29.500'
I140	157+82.46	-42.352'
I141	157+82.23	-40.202'
I142	NOT USED	
I143	158+18.83	-40.202'
I144	158+25.05	-48.186'
I145	158+27.87	-42.291'
I146	158+25.48	-41.488'
I147	158+27.18	-37.853'
I148	NOT USED	
I149	NOT USED	
I150	158+28.00	-33.755'
I151	158+23.58	-31.392'
I152	NOT USED	
I153	NOT USED	
I154	158+41.74	-59.611'
I155	158+29.40	-41.185'
I156	158+29.08	-34.327'
I157	158+19.63	-48.591'
I158	158+23.25	-42.567'
I159	158+24.85	-48.507'
I160	158+41.63	-39.501'
I161	158+41.62	-29.500'
I162	158+41.62	-40.219'
I163	158+17.55	-44.058'
I164	153+39.41	40.902'

J15	165+39.45	-22.554'
J16	165+41.90	-18.158'
J17	165+58.04	-52.490'
J18	NOT USED	
J19	NOT USED	
J20	165+56.94	-40.903'
J21	165+53.35	-33.752'
J22	165+57.74	-31.317'
J23	165+44.69	-25.471'
J24	165+47.12	-21.102'
J25	165+65.01	-51.579'
J26	165+57.88	-42.668'
J27	165+58.06	-42.570'
J28	NOT USED	
J29	NOT USED	
J30	165+62.47	-40.216'
J31	165+35.80	-37.500'
J32	NOT USED	
J33	NOT USED	
J34	165+37.47	29.000'
J35	165+43.50	26.500'
J36	165+43.50	31.500'
J37	165+28.25	27.500'
J38	165+49.77	60.819'
J39	165+38.25	37.500'
J40	165+38.25	39.896'
J41	165+28.31	37.500'
J42	165+33.50	41.500'
J43	165+33.49	46.500'
J44	165+38.81	49.015'
J45	165+41.70	54.518'
J46	165+41.41	54.767'
J47	165+46.85	57.984'
J48	165+41.95	38.853'
J49	165+45.33	40.995'
J50	165+44.29	44.858'
J51	165+47.93	46.692'
J52	165+49.51	26.500'
J53	165+49.50	31.500'
J54	165+53.50	37.531'
J55	165+50.42	43.562'
J56	165+54.57	41.521'
J57	165+59.56	41.472'
J58	165+59.63	47.472'
J59	165+54.63	47.521'
J60	165+58.70	53.489'
J61	165+58.73	56.155'
J62	165+57.23	56.171'
J63	165+57.24	57.671'
J64	165+54.77	60.764'
J65	165+36.32	30.020'
J66	165+33.50	33.500'
J67	165+37.42	27.500'
J68	NOT USED	
J69	NOT USED	
J70	NOT USED	
J71	166+02.25	-42.692'
J72	165+97.64	-40.228'
J73	166+02.04	-42.578'
J74	NOT USED	
J75	166+04.63	-42.324'
J76	166+03.20	-40.927'
J77	166+02.34	-31.402'
J78	166+06.75	-38.391'
J79	166+16.85	-24.550'
J80	166+14.64	-20.071'
J81	166+16.08	-53.500'
J82	NOT USED	
J83	NOT USED	
J84	166+16.08	-37.500'
J85	166+20.03	-17.431'
J86	165+95.10	-51.526'
J87	166+22.23	-21.892'
J88	166+25.98	-33.500'
J89	166+25.98	-37.500'
J90	166+28.05	-30.075'
J91	166+33.19	-21.500'
J92	166+33.19	-39.500'
J93	166+33.19	-29.500'

J94	NOT USED	
J95	166+02.14	-52.184'
J96	NOT USED	
J97	166+02.56	41.000'
J98	166+02.62	47.000'
J99	166+07.62	46.940'
J100	166+03.69	52.982'
J101	166+03.72	55.970'
J102	166+05.22	55.946'
J103	166+05.24	57.454'
J104	166+12.51	31.500'
J105	166+12.51	26.500'
J106	166+07.77	60.478'
J107	166+12.77	60.409'
J108	166+16.74	41.075'
J109	166+17.87	44.911'
J110	166+20.10	38.911'
J111	166+18.51	31.500'
J112	166+25.40	27.500'
J113	166+25.40	29.000'
J114	166+25.40	29.000'
J115	166+26.50	30.036'
J116	166+28.51	33.500'
J117	166+24.56	40.458'
J118	166+34.56	37.500'
J119	166+28.51	41.500'
J120	166+28.51	46.500'
J121	166+23.89	49.153'
J122	166+20.71	54.500'
J123	166+20.99	54.764'
J124	166+15.39	57.696'
J125	166+08.51	36.934'
J126	166+12.89	42.883'
J127	166+07.56	40.924'
J128	166+15.13	46.202'
J129	NOT USED	
J130	169+02.64	-38.346'
J131	169+02.75	-33.753'
J132	NOT USED	
J133	NOT USED	
J134	NOT USED	
J135	169+07.16	-31.398'
J136	169+02.35	-51.501'
J137	169+08.35	-51.501'
J138	NOT USED	
J139	NOT USED	
J140	NOT USED	
J141	NOT USED	
J142	169+12.35	-46.763'
J143	169+04.07	-39.848'
J144	169+11.87	-40.219'
J145	169+07.46	-42.574'
J146	168+90.35	-51.500'
J147	168+90.35	-39.500'
J148	168+90.33	-29.500'
J149	NOT USED	
J150	168+99.91	-41.269'
J151	169+01.02	-42.437'
J152	169+58.87	-42.580'
J153	169+52.55	-42.574'
J154	169+48.14	-40.219'
J155	169+70.56	-53.500'
J156	169+60.08	-41.413'
J157	169+57.46	-38.391'
J158	169+57.26	-33.752'
J159	169+70.56	-39.500'
J160	169+70.56	-29.500'
J161	NOT USED	
J162	NOT USED	
J163	NOT USED	
J164	NOT USED	



- 1 NOT USED  
SCALE: NTS

---

- 2 NOT USED  
SCALE: NTS

---

- 4 NOT USED  
SCALE: NTS

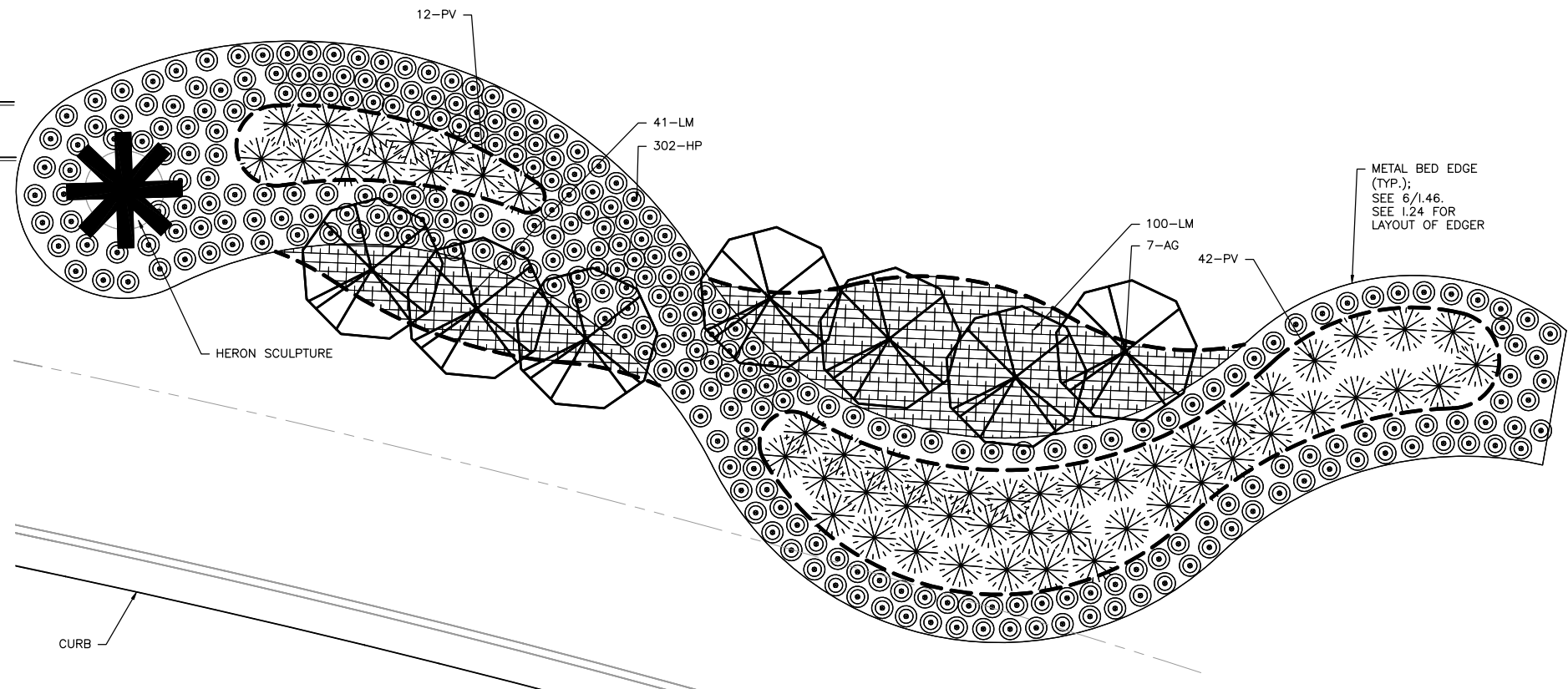

**3 WEST GATEWAY LANDSCAPE PLAN**  
SCALE: 1"=5'

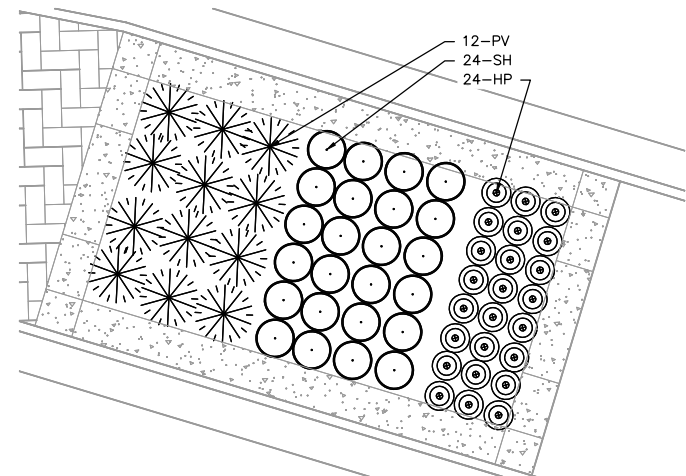

**5 WEST GATEWAY MEDIAN LANDSCAPE PLAN**  
SCALE: 1"=5'

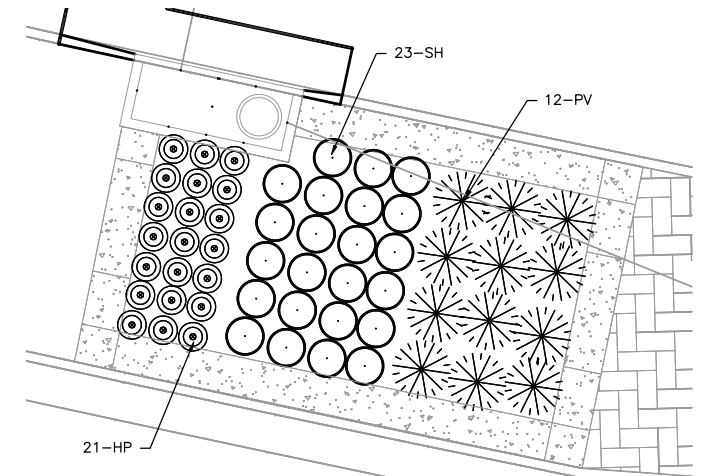

**6 25TH MEDIAN LANDSCAPE PLAN**  
SCALE: 1"=5'

NOTE:  
FINAL SHAPE OF METAL BED EDGE  
TO BE FIELD VERIFIED & APPROVED  
BY LANDSCAPE ARCHITECT

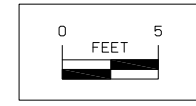

PRELIMINARY  
NOT FOR CONSTRUCTION

- 1 NOT USED  
SCALE: NTS
- 3 NOT USED  
SCALE: NTS
- 5 NOT USED  
SCALE: NTS
- 7 NOT USED  
SCALE: NTS

NOTE:  
FINAL SHAPE OF METAL BED EDGE  
TO BE FIELD VERIFIED & APPROVED  
BY LANDSCAPE ARCHITECT

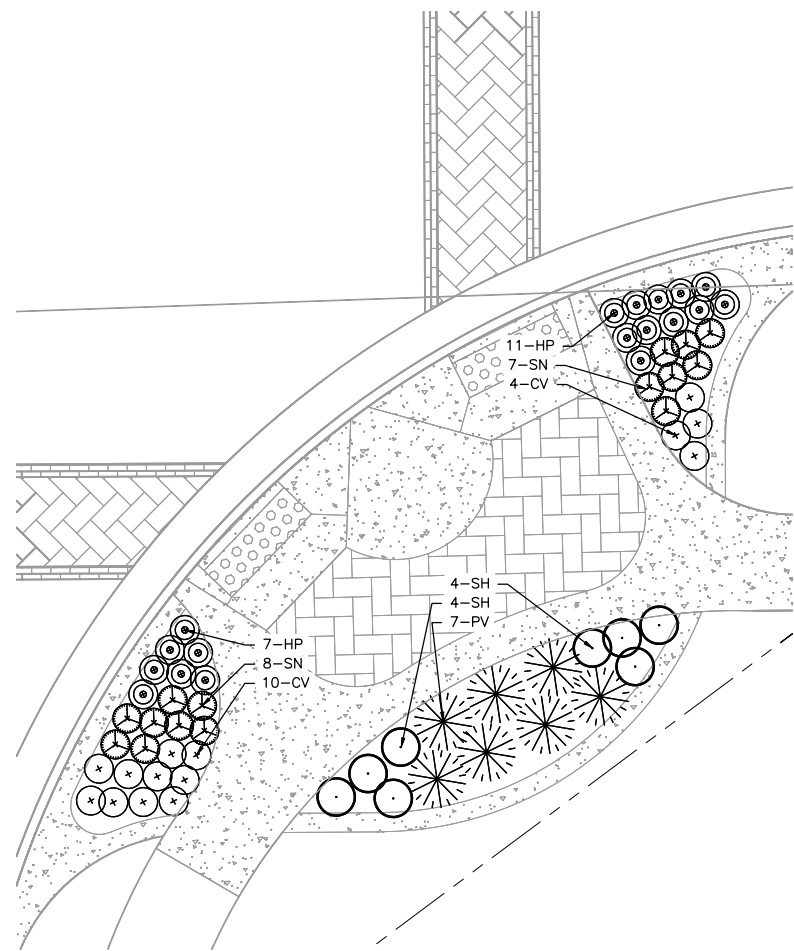

2 SE 24TH PL. LANDSCAPE PLAN  
SCALE: 1"=5'

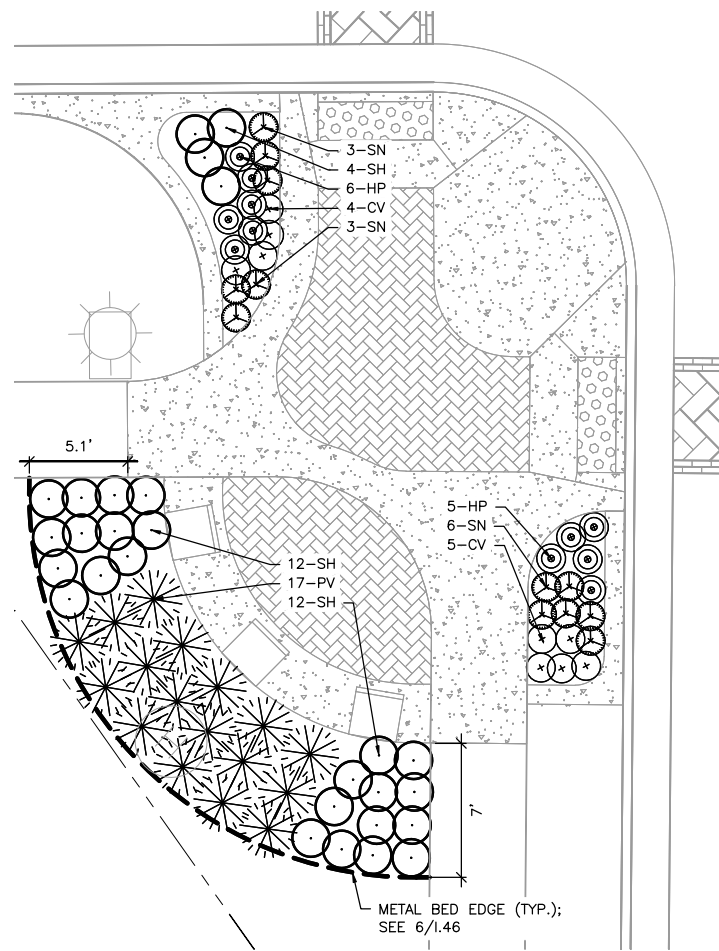

4 SW 23RD PL. LANDSCAPE PLAN  
SCALE: 1"=5'

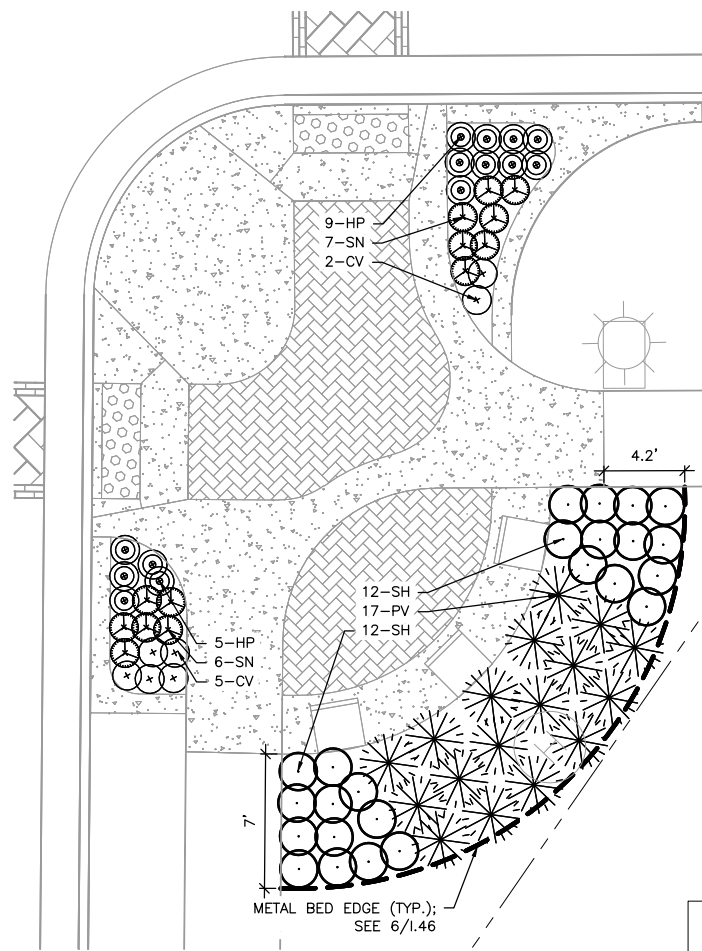

6 SE 23RD PL. LANDSCAPE PLAN  
SCALE: 1"=5'

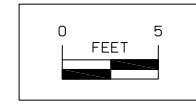

PRELIMINARY  
NOT FOR CONSTRUCTION

- 1 NOT USED  
SCALE: NTS
- 3 NOT USED  
SCALE: NTS
- 5 NOT USED  
SCALE: NTS
- 7 NOT USED  
SCALE: NTS

NOTE:  
FINAL SHAPE OF METAL BED EDGE  
TO BE FIELD VERIFIED & APPROVED  
BY LANDSCAPE ARCHITECT

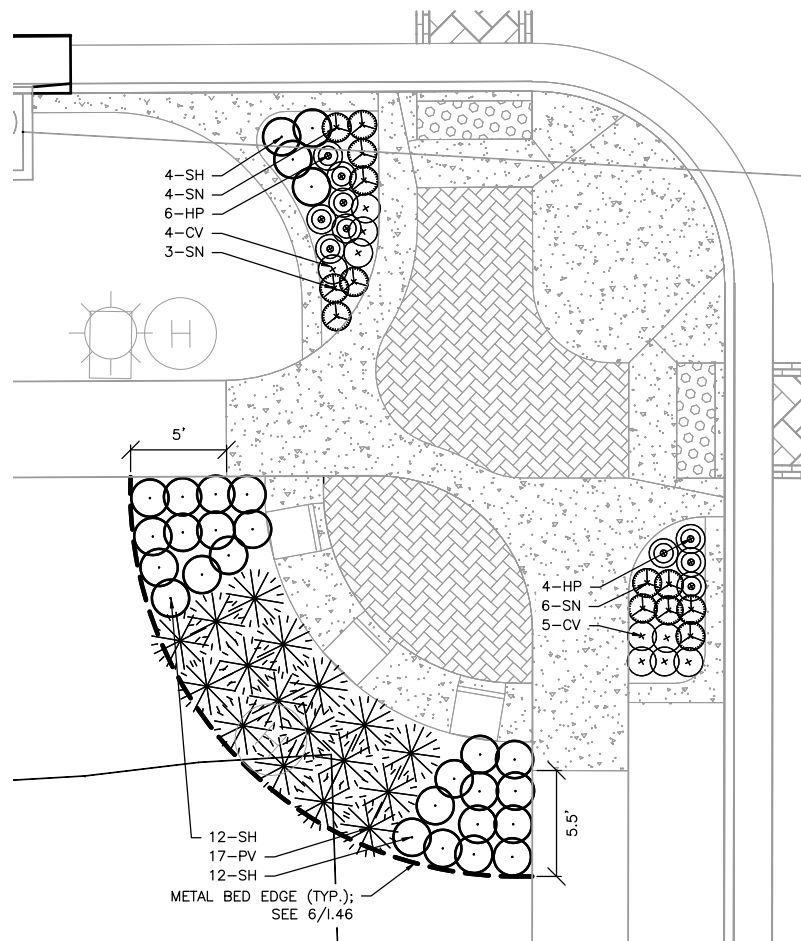
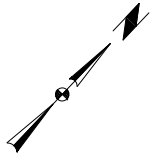
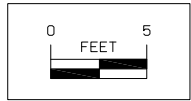

2 SW 22ND PL. LANDSCAPE PLAN  
SCALE: 1"=5'

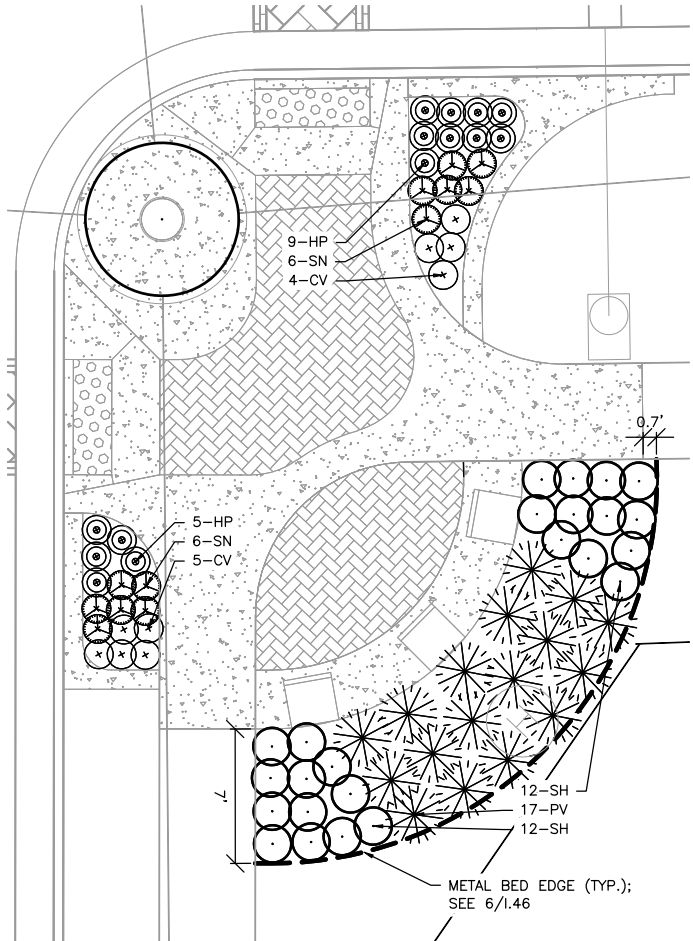

4 SE 22ND PL. LANDSCAPE PLAN  
SCALE: 1"=5'



6 SW 21ST PL. LANDSCAPE PLAN  
SCALE: 1"=5'

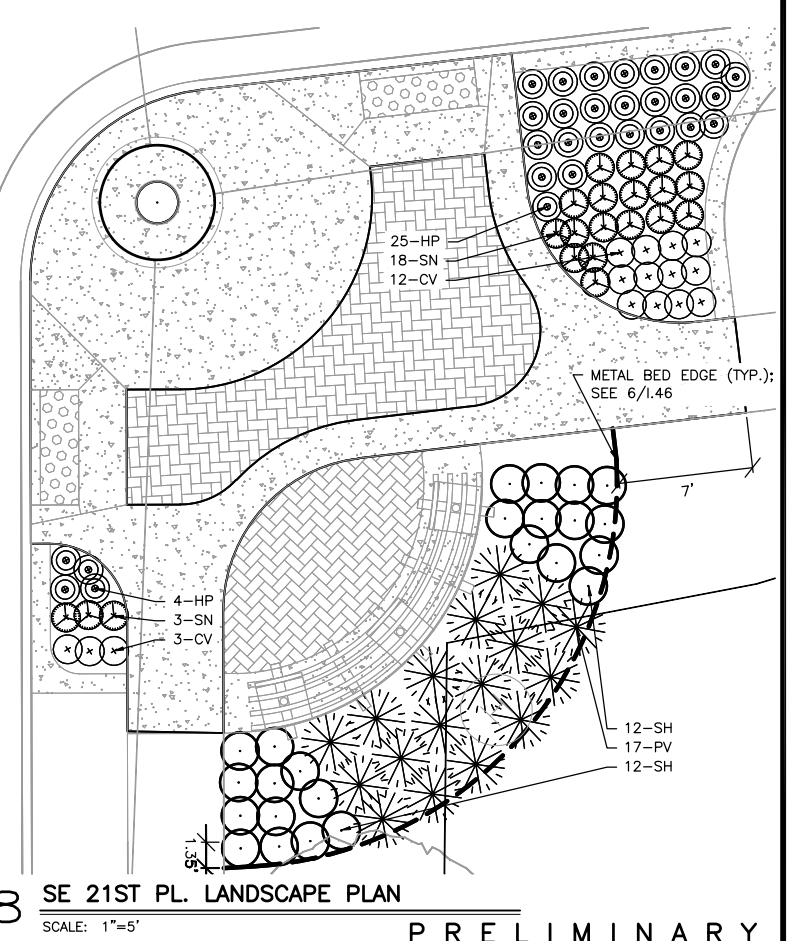

8 SE 21ST PL. LANDSCAPE PLAN  
SCALE: 1"=5'

PRELIMINARY  
NOT FOR CONSTRUCTION



**1** NW 20TH PL. LANDSCAPE PLAN  
SCALE: 1"=5'

**2** NE 20TH PL. LANDSCAPE PLAN  
SCALE: 1"=5'

**5** NW 18TH PL. LANDSCAPE PLAN  
SCALE: 1"=5'

**6** NE 18TH PL. LANDSCAPE PLAN  
SCALE: 1"=5'

**3** NW 19TH PL. LANDSCAPE PLAN  
SCALE: 1"=5'

**4** NE 19TH PL. LANDSCAPE PLAN  
SCALE: 1"=5'

DETAILS NO LONGER APPLICABLE

NOTE:  
FINAL SHAPE OF METAL BED EDGE  
TO BE FIELD VERIFIED & APPROVED  
BY LANDSCAPE ARCHITECT

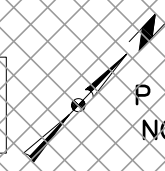

PRELIMINARY  
NOT FOR CONSTRUCTION

- 1 NOT USED  
SCALE: NTS

---

- 3 NOT USED  
SCALE: NTS

---

- 5 NOT USED  
SCALE: NTS

---

- 6 NOT USED  
SCALE: NTS

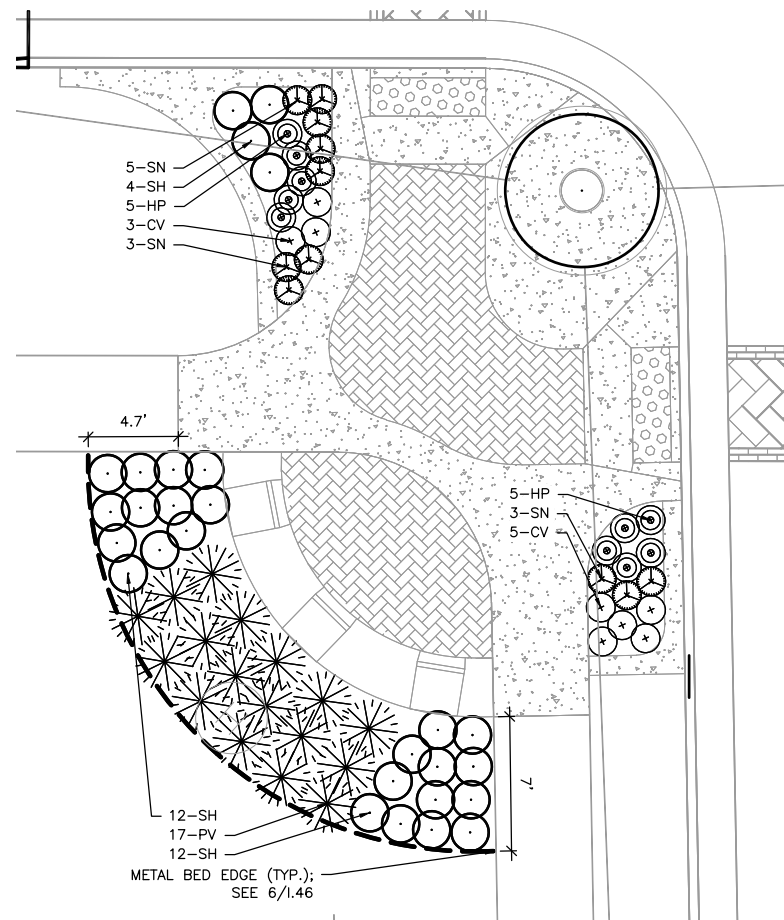

2 SW 17TH PL. LANDSCAPE PLAN  
SCALE: 1"=5'

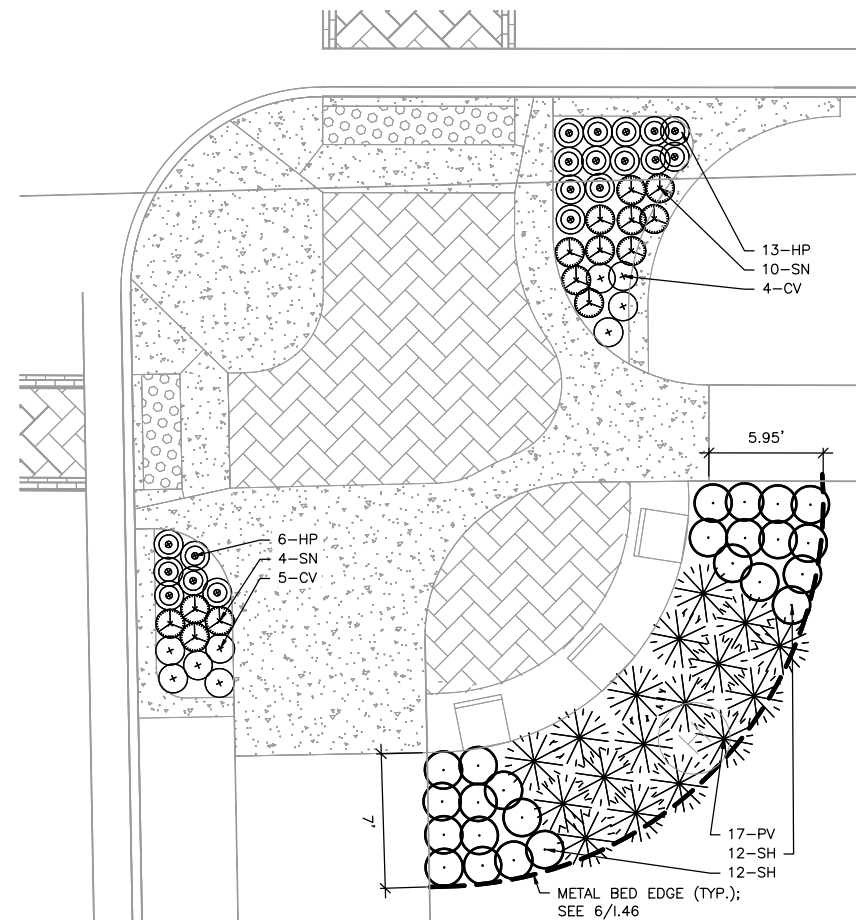

4 SE 17TH PL. LANDSCAPE PLAN  
SCALE: 1"=5'

NOTE:  
FINAL SHAPE OF METAL BED EDGE  
TO BE FIELD VERIFIED & APPROVED  
BY LANDSCAPE ARCHITECT

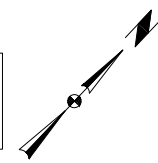
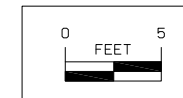

1 NOT USED  
SCALE: NTS

3 NOT USED  
SCALE: NTS

5 NOT USED  
SCALE: NTS

6 NOT USED  
SCALE: NTS



2 SW 15TH AVE. S. LANDSCAPE PLAN  
SCALE: 1"=5'

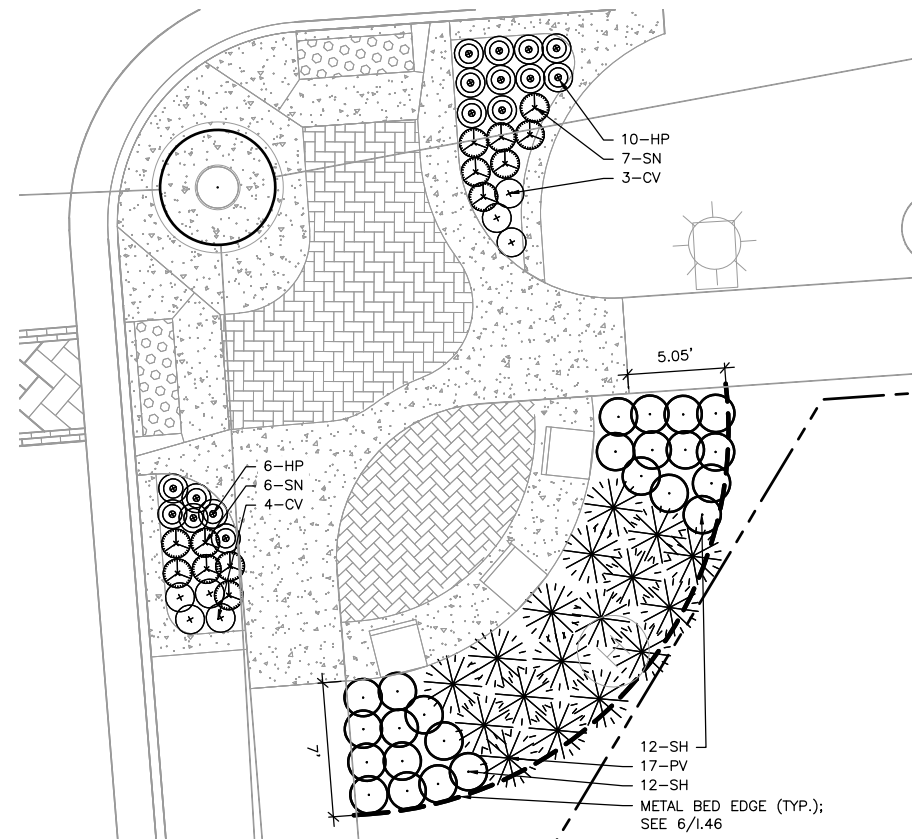

4 SE 15TH AVE. S. LANDSCAPE PLAN  
SCALE: 1"=5'

NOTE:  
FINAL SHAPE OF METAL BED EDGE  
TO BE FIELD VERIFIED & APPROVED  
BY LANDSCAPE ARCHITECT

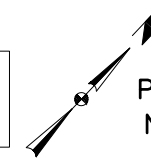
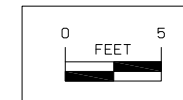

PRELIMINARY  
NOT FOR CONSTRUCTION

NOTE:  
FINAL SHAPE OF METAL BED EDGE  
TO BE FIELD VERIFIED & APPROVED  
BY LANDSCAPE ARCHITECT

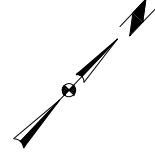
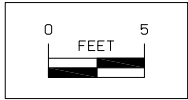

- 1 NOT USED  
SCALE: NTS
- 3 NOT USED  
SCALE: NTS
- 5 NOT USED  
SCALE: NTS
- 7 NOT USED  
SCALE: NTS

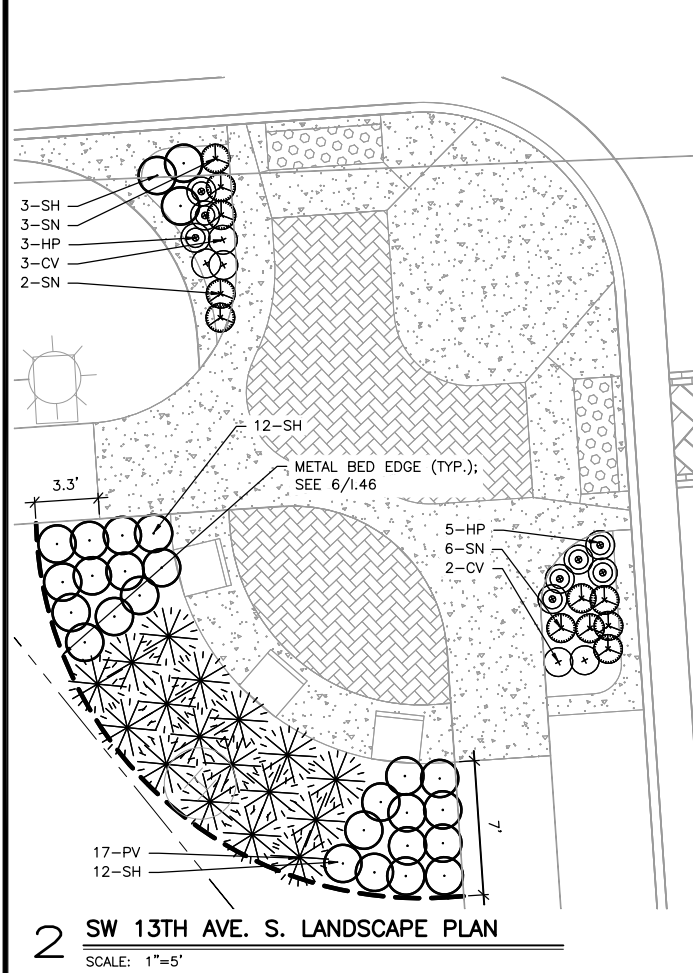

2 SW 13TH AVE. S. LANDSCAPE PLAN  
SCALE: 1"=5'



4 SE 13TH AVE. S. LANDSCAPE PLAN  
SCALE: 1"=5'

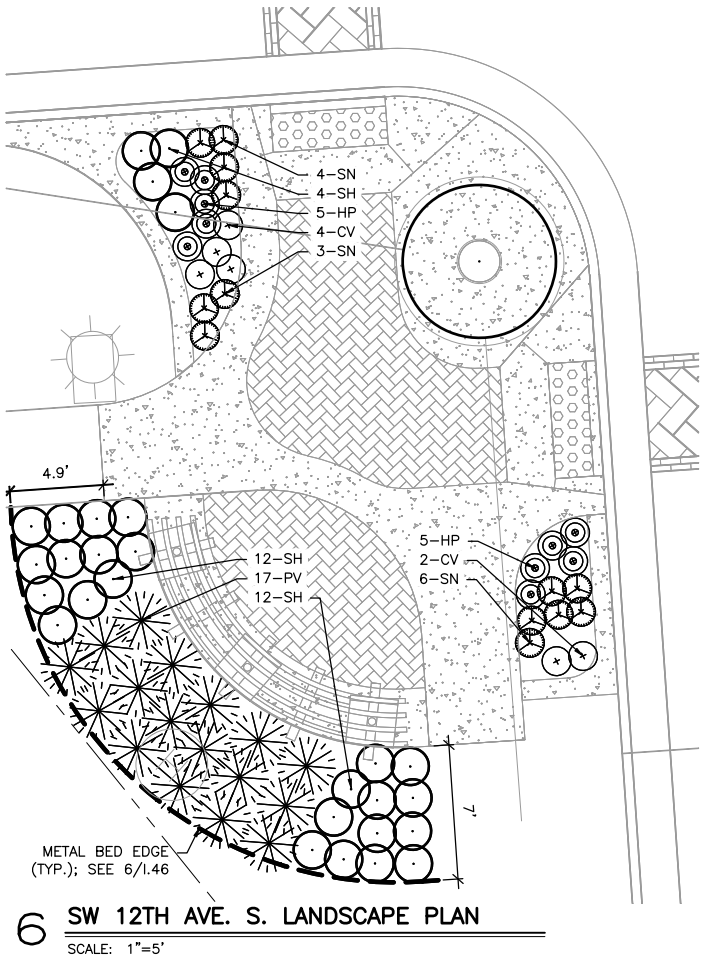

6 SW 12TH AVE. S. LANDSCAPE PLAN  
SCALE: 1"=5'

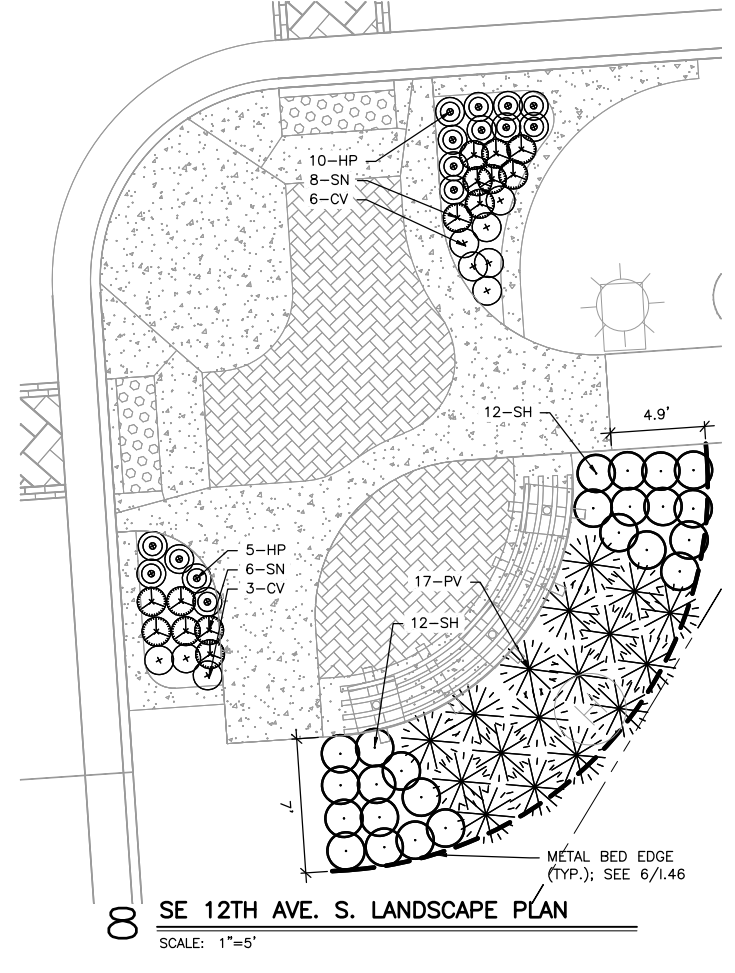

8 SE 12TH AVE. S. LANDSCAPE PLAN  
SCALE: 1"=5'

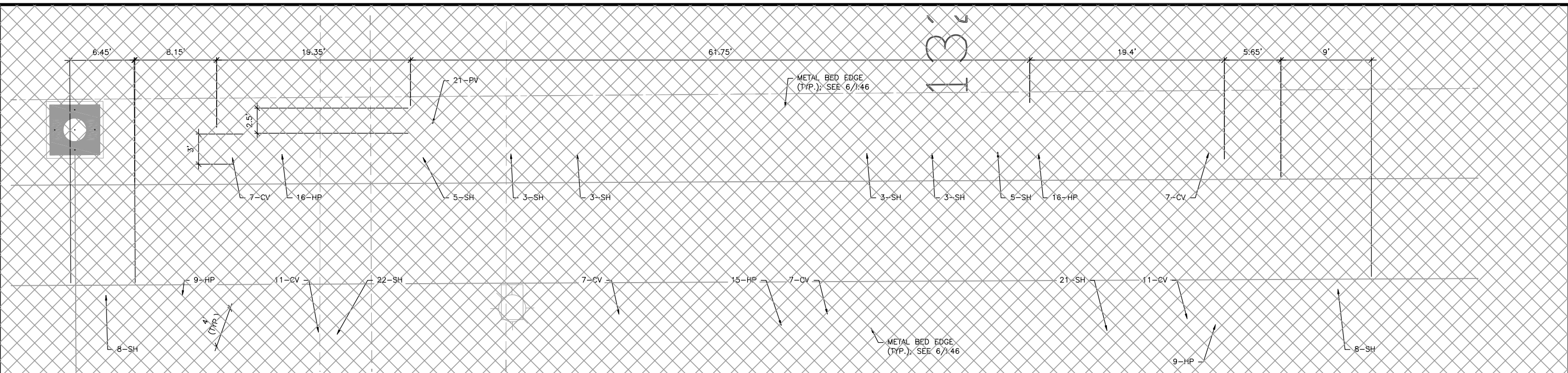

1 LANDING AT CHANCY PARK LANDSCAPE PLAN  
 SCALE: 1"=5'

NOTE:  
 FINAL SHAPE OF METAL BED EDGE  
 TO BE FIELD VERIFIED & APPROVED  
 BY LANDSCAPE ARCHITECT

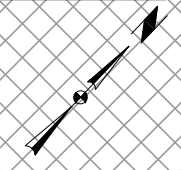
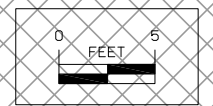

DETAILS NO LONGER APPLICABLE



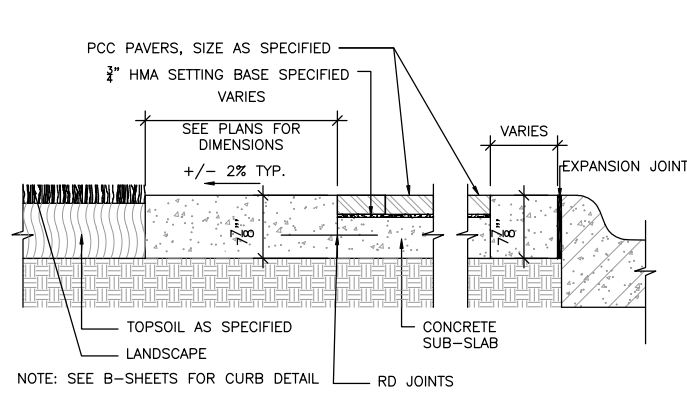

**1 TYP. SECTION: CONC. EDGING**  
 SCALE: NTS

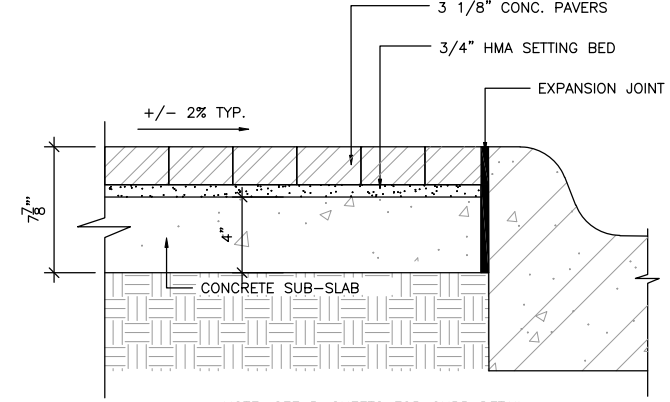

**5 TYP. SECTION: PAVERS ADJACENT TO CURB**  
 SCALE: NTS

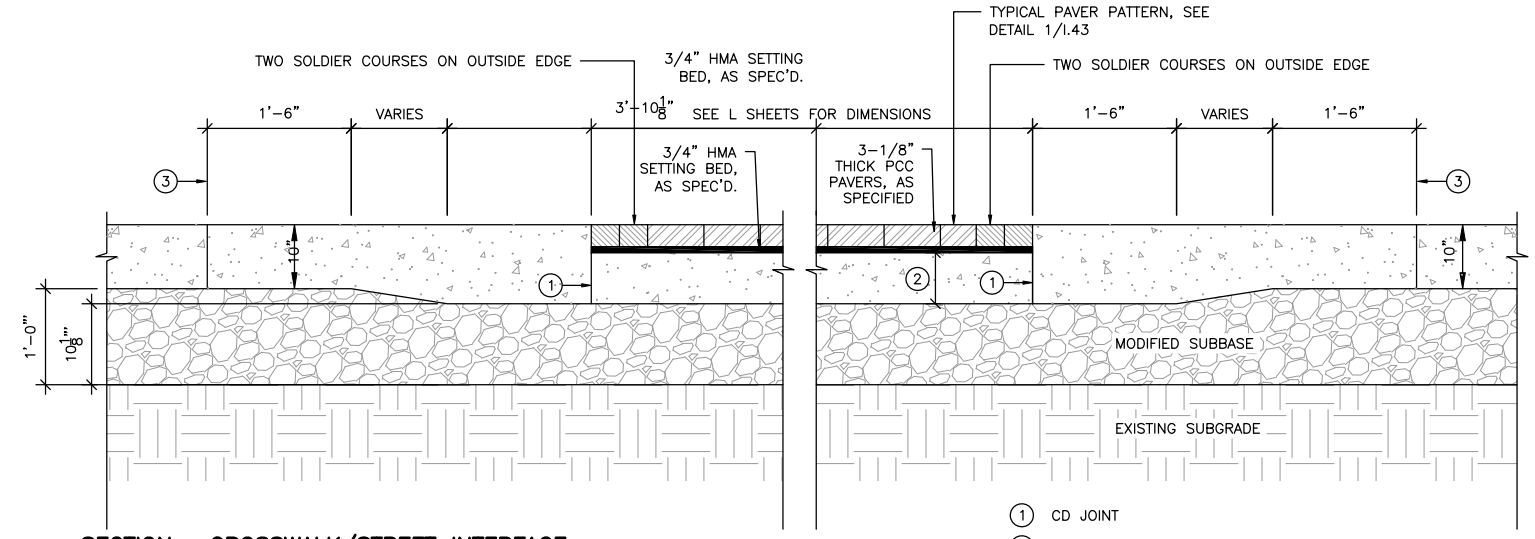

**8 SECTION: CROSSWALK/STREET INTERFACE**  
 SCALE: NTS

- ① CD JOINT
- ② STANDARD OR SLIPFORM P.C. CONCRETE BASE, 10 IN.
- ③ NEAREST CONSTRUCTION JOINT

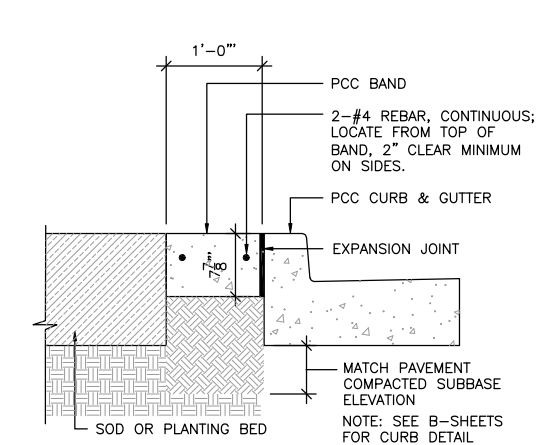

**2 CURB AND PCC BAND AT PLANTING AREAS**  
 SCALE: NTS

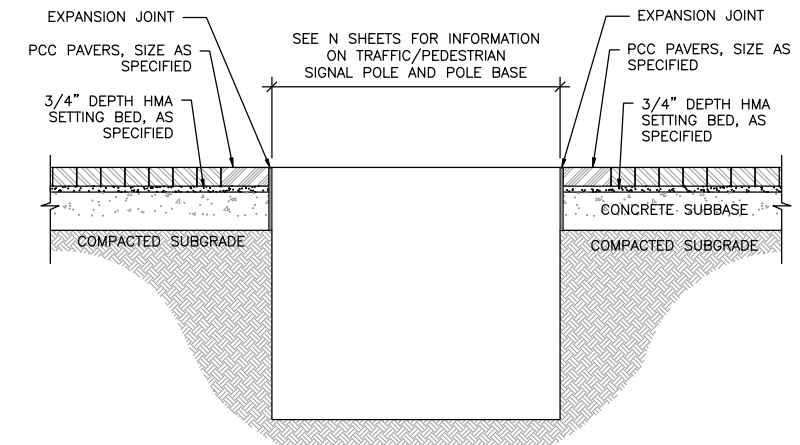

**6 TYP. SECTION: PCC PAVERS AT TRAFFIC SIGNAL**  
 SCALE: NTS

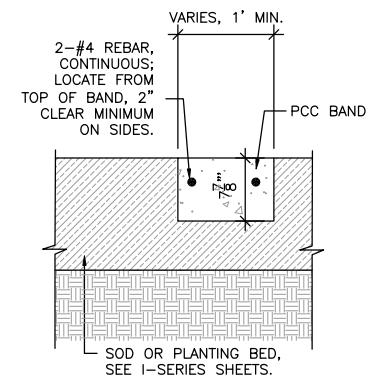

**3 TYP. SECTION: PCC MOW STRIP**  
 SCALE: NTS

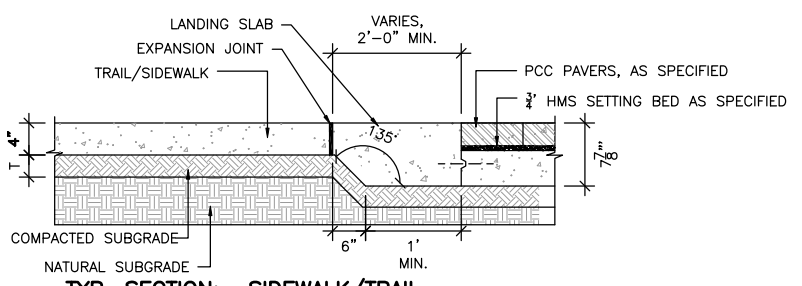

**4 TYP. SECTION: SIDEWALK/TRAIL TO LANDING TRANSITION AND PAVES EDGING**  
 SCALE: NTS

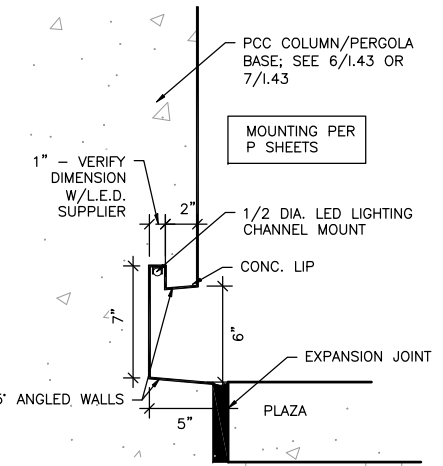

**7 TYPICAL LIGHT CHANNEL DETAIL**  
 SCALE: NTS

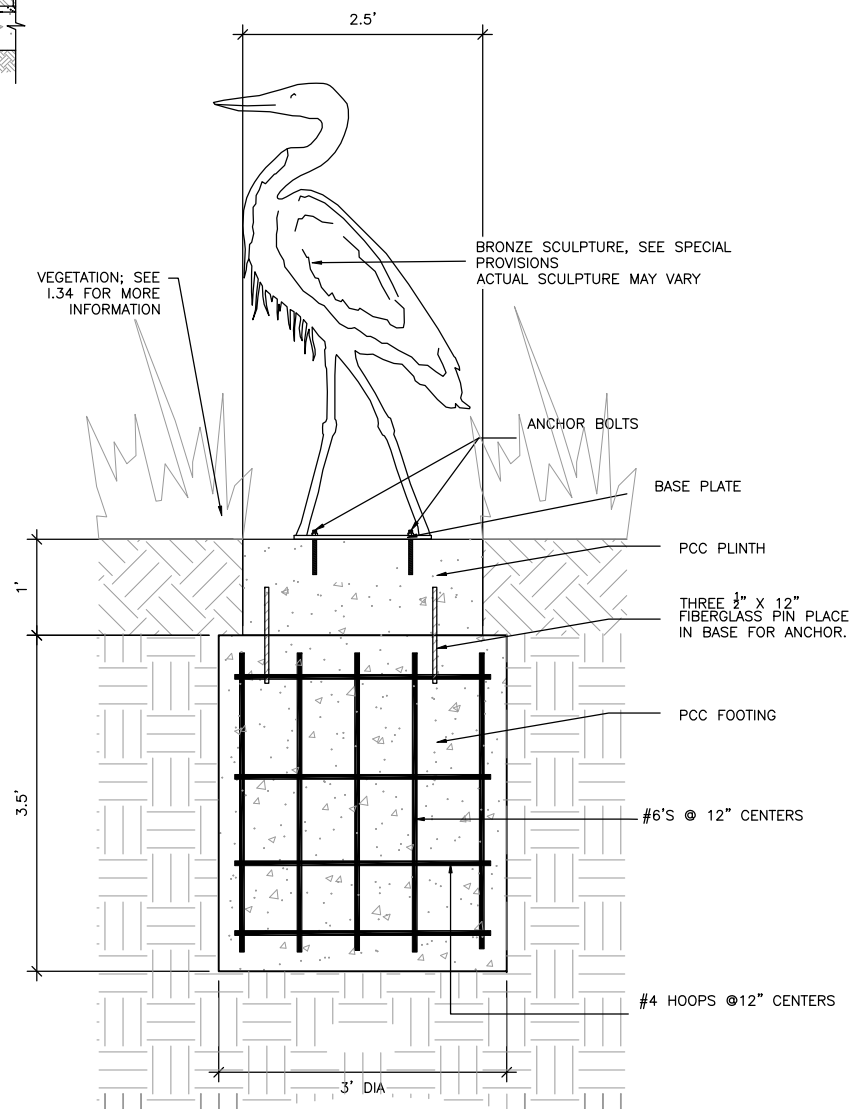

**9 HERON SCULPTURE SECTION**  
 SCALE: NTS

**10 NOT USED**  
 SCALE: NTS

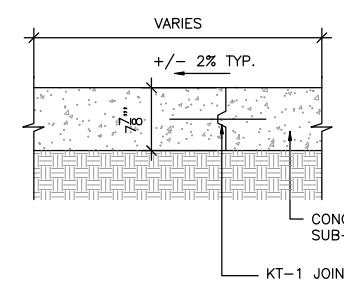

**11 TYP. SECTION: SIDEWALK SECTION**  
 SCALE: NTS

PAVER SCHEDULE					
LOCATION	PAVER SIZE	SUB-BASE DEPTH	SETTING BED DEPTH	MODIFIED SUBBASE	TOTAL
ROAD	3-1/8"	10"	3/4"	10 1/8"	1'-
BACK OF CURB ALONG TRAIL	3-1/8"	4"	3/4"		7-7/8"
BACK OF CURB	2-3/8"	4-3/4" (4.75")	3/4"		7-7/8"

NOTE: SEE 1.02-1.16 AND 1.20-1.31 FOR PAVES LOCATIONS AND SIZE

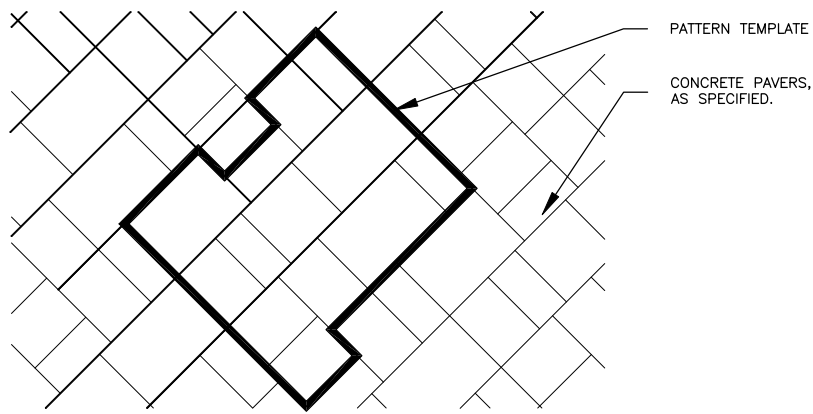

**1 TYP. PLAN: CONCRETE PAVER PATTERN**

SCALE: NTS

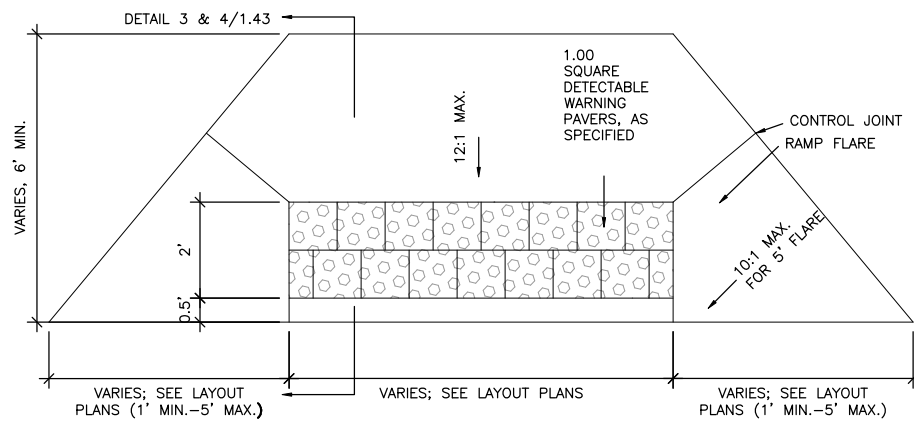

**2 ADA RAMP PLAN**

SCALE: 1"=2'

**3 NOT USED**

SCALE: NTS

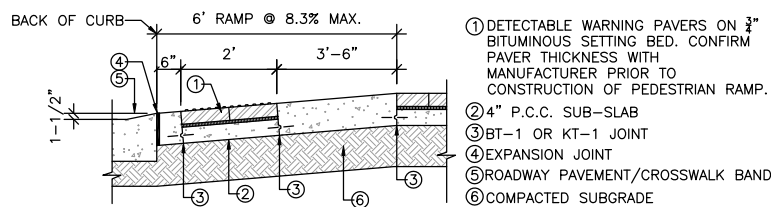

**4 ADA RAMP SECTION**

SCALE: NTS

**GENERAL NOTES**

- CONTRACTOR SHALL PROVIDE SHOP DRAWINGS FOR DESIGN OF THE AND CONCRETE COLUMNS, INCLUDING REINFORCEMENT, STRUCTURAL ELEMENTS, FABRICATION, FIT AND FINISH. SHOP DRAWINGS SHALL BE SIGNED BY A STRUCTURAL ENGINEER LICENSED IN THE STATE OF IOWA.
- CONTRACTOR TO PROVIDE COLOR SAMPLES FOR ALL PAINTED METAL WORK FOR APPROVAL. ALL METAL WORK SHALL HAVE EXTERIOR GRADE POWDER COAT FINISH WITH ZINC RICH PRIMER OR EQUIVALENT.
- SIZING FOR ALL METAL WORK FOR THE PERGOLAS IS FOR AESTHETIC REFERENCE ONLY. STRUCTURAL SIZING IS THE RESPONSIBILITY OF THE CONTRACTOR.
- ALL METAL/METAL AND METAL/CONCRETE CONNECTIONS SHALL BE HIDDEN OR MINIMIZED FROM VIEW FROM THE GROUND PLANE.
- PERGOLAS WILL BE PLACED AT THE INTERSECTIONS OF 21ST AVE. S., 17TH AVE. S., 15TH AVE. S., AND 12TH AVE. S.

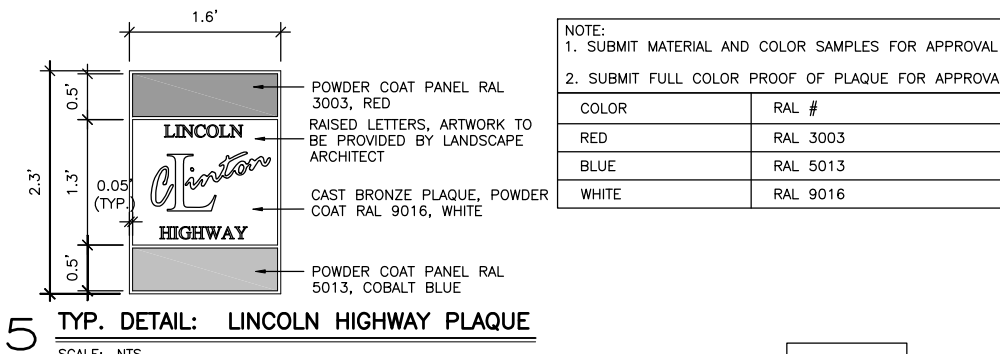

**5 TYP. DETAIL: LINCOLN HIGHWAY PLAQUE**

SCALE: NTS

NOTE:  
1. SUBMIT MATERIAL AND COLOR SAMPLES FOR APPROVAL  
2. SUBMIT FULL COLOR PROOF OF PLAQUE FOR APPROVAL

COLOR	RAL #
RED	RAL 3003
BLUE	RAL 5013
WHITE	RAL 9016

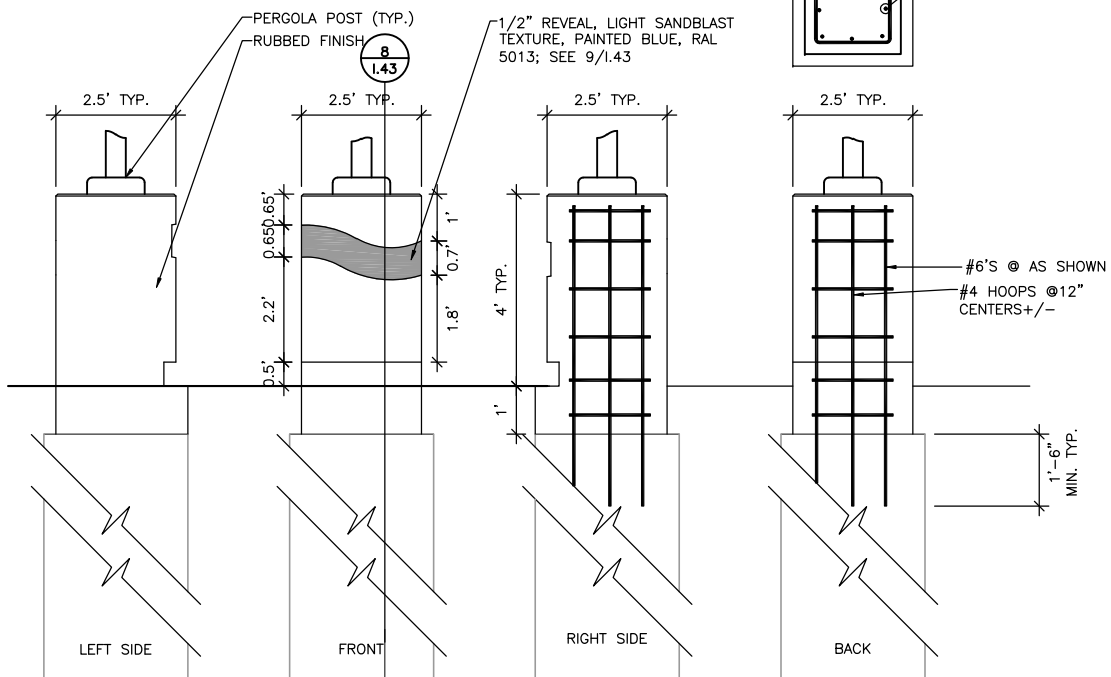

**6 TYP. ELEVATIONS: CONCRETE PERGOLA BASE**

SCALE: 1"=2'

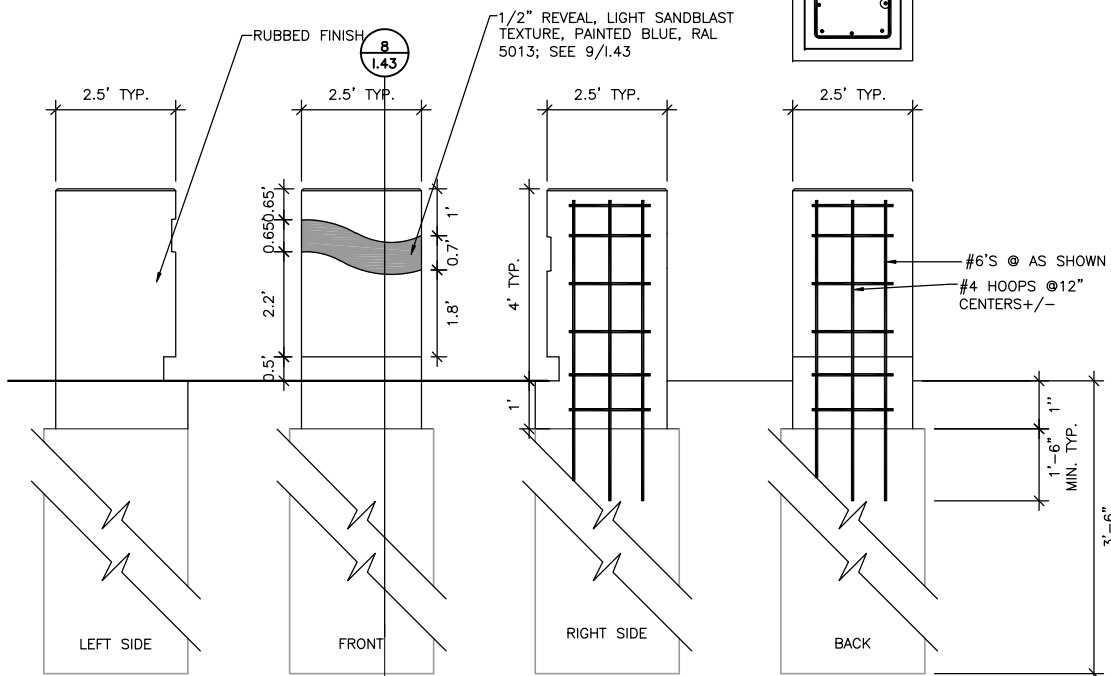

**7 TYP. ELEVATIONS: CONCRETE COLUMNS**

SCALE: 1"=2'

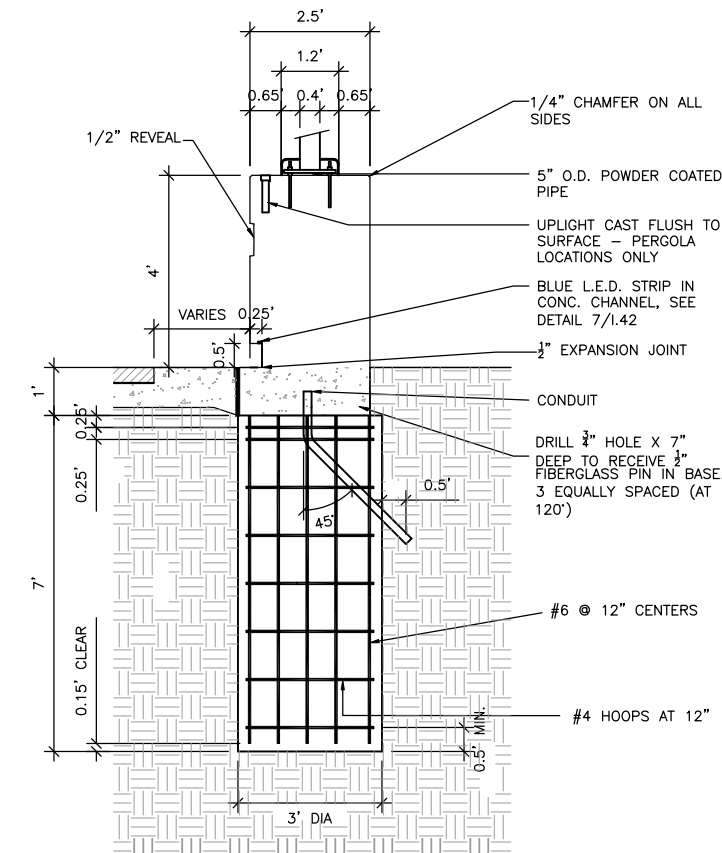

**8 TYP. SECTION: CONCRETE PERGOLA BASE**

SCALE: 1"=2'

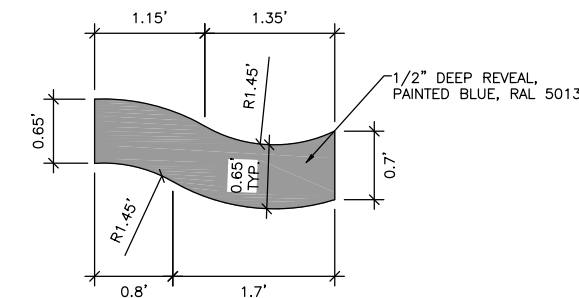

**9 TYP. DETAIL: CONCRETE COLUMN AND PERGOLA BASE REVEAL**

SCALE: 1"=1'

**10 NOT USED**

SCALE: NTS



- 1 **NOT USED**  
SCALE: NTS

---

- 2 **NOT USED**  
SCALE: NTS

---

- 3 **NOT USED**  
SCALE: NTS

---

- 4 **NOT USED**  
SCALE: NTS

---

- 5 **NOT USED**  
SCALE: NTS

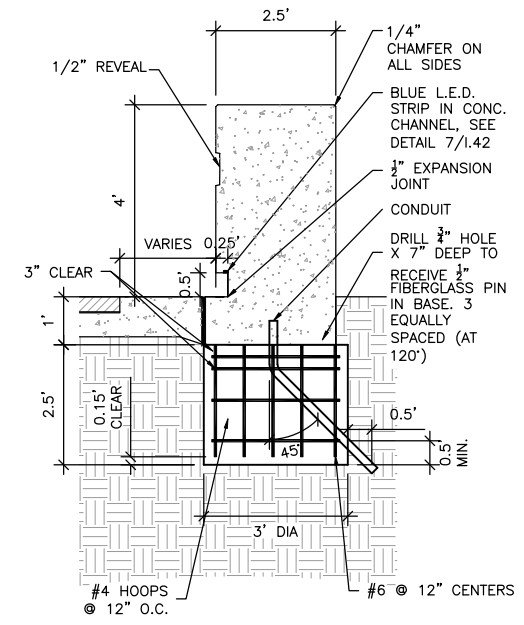

**6** TYP. SECTION:  
**CONCRETE BASE**  
SCALE: 1"=2'

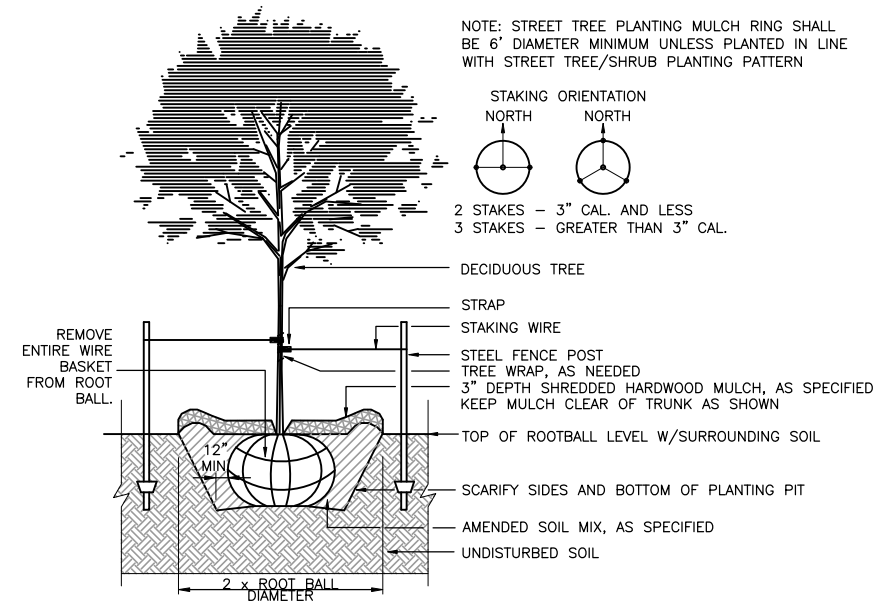

**1 TYPICAL TREE PLANTING DETAIL**

SCALE: NTS

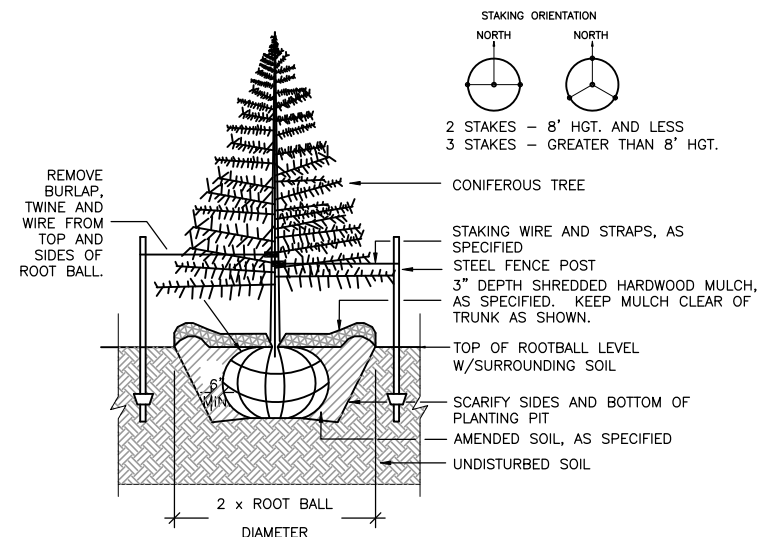

**2 TYPICAL EVERGREEN TREE PLANTING DETAIL**

SCALE: NTS

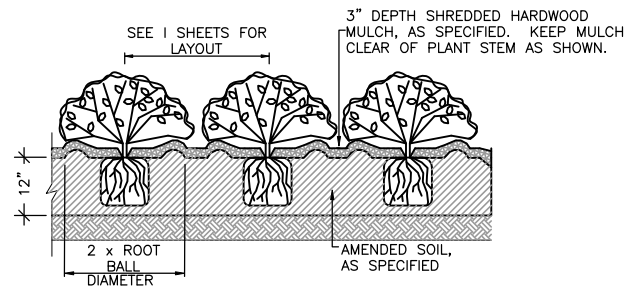

**3 TYPICAL SHRUB PLANTING DETAIL**

SCALE: NTS

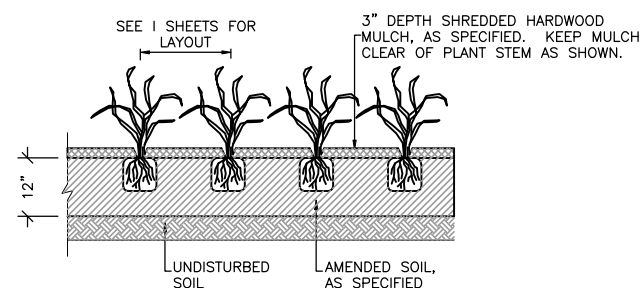

**4 TYPICAL PERENNIAL PLANTING DETAIL**

SCALE: NTS

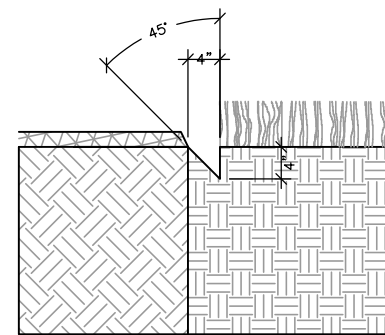

**5 TYPICAL SPADED EDGE DETAIL**

SCALE: NTS

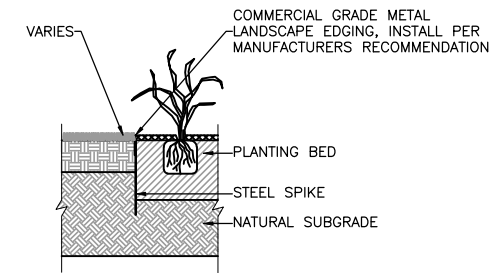

**6 TYPICAL METAL EDGE DETAIL**

SCALE: NTS

**TYPICAL DETAILS PLANTING**

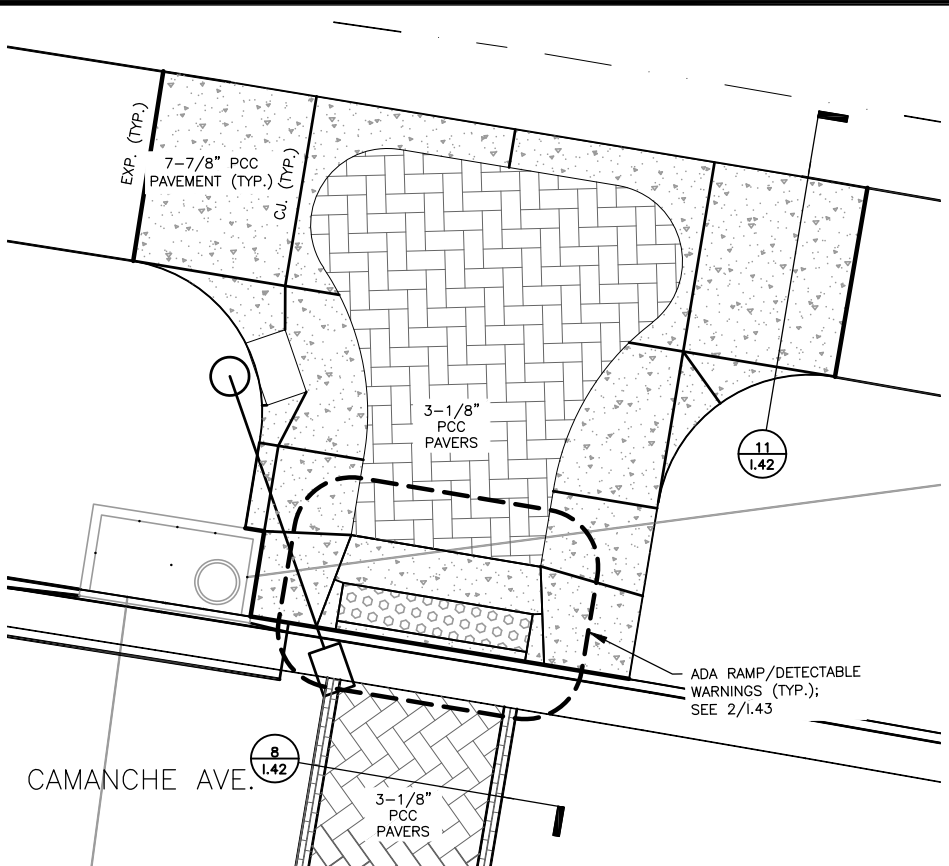
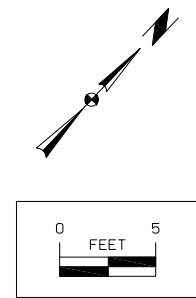

**1** PED. RAMP AT S. 14TH ST. JOINTING PLAN  
 SCALE: 1"=5'

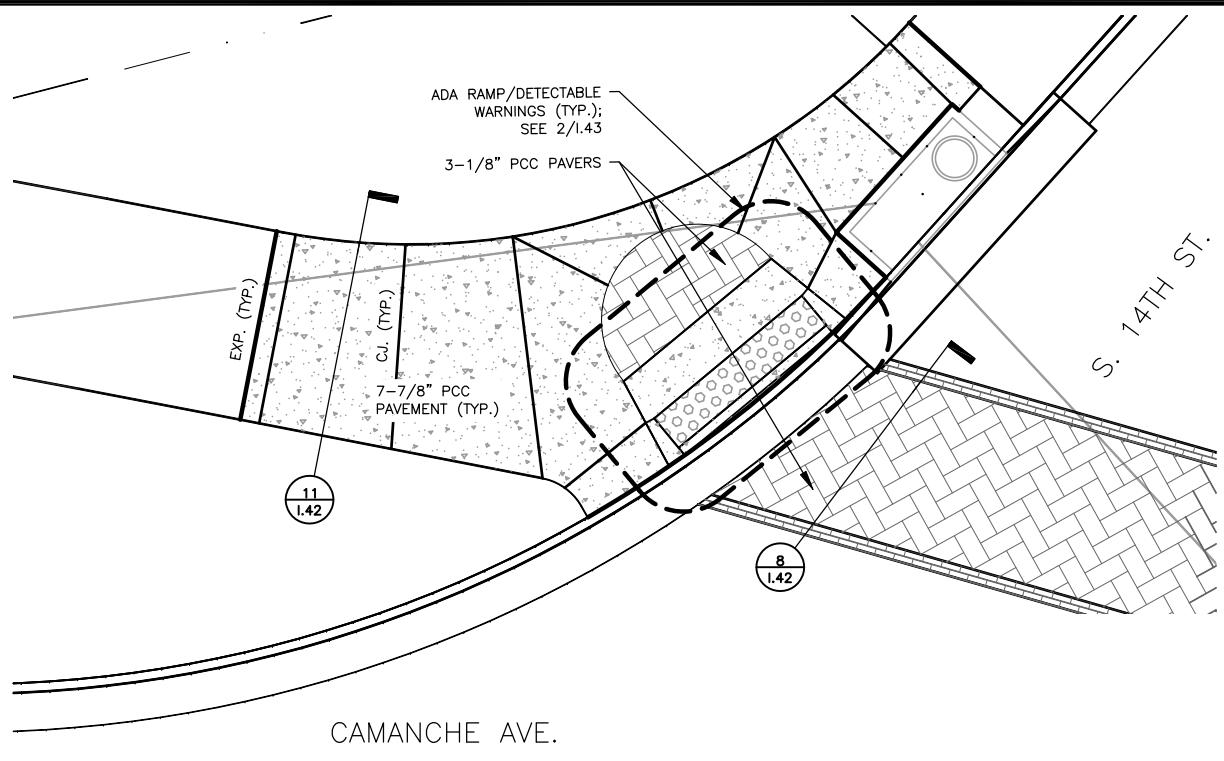

**3** SOUTHWEST S. 14TH ST. JOINTING PLAN  
 SCALE: 1"=5'

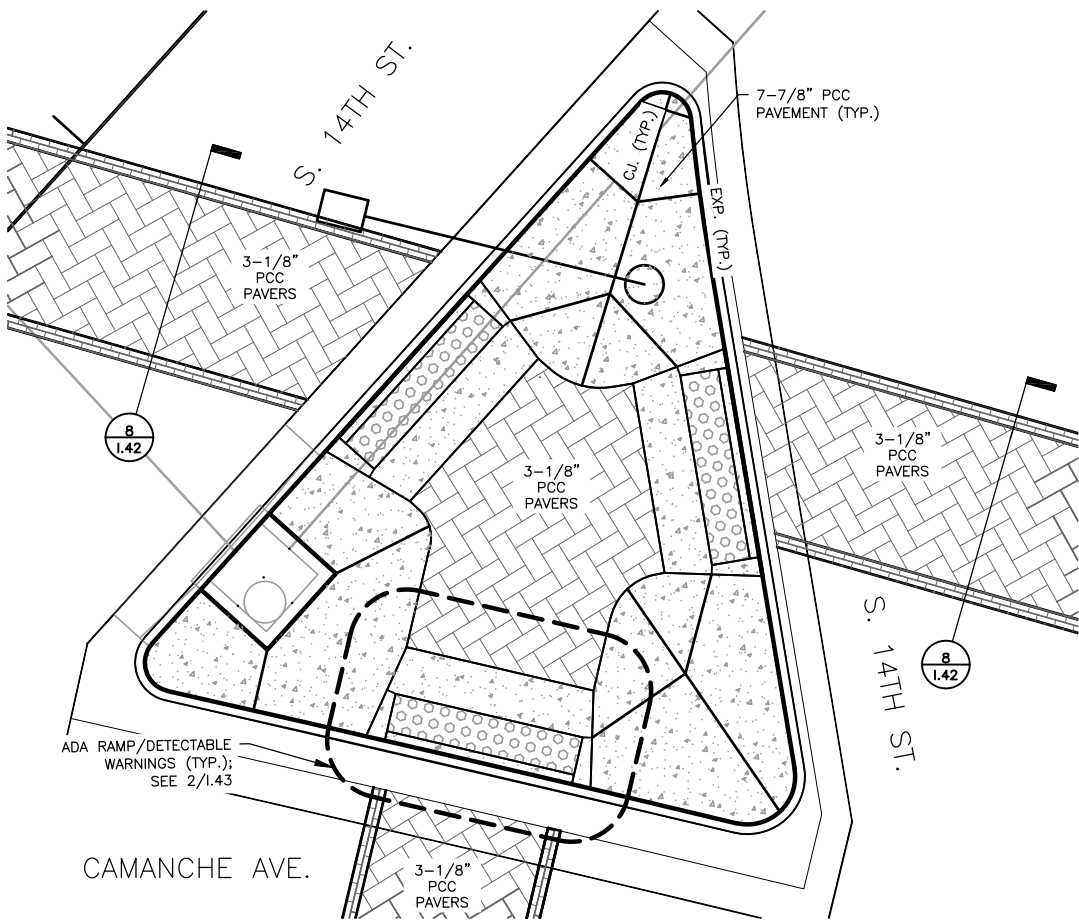

**2** NORTHERN ISLAND AT S. 14TH ST. JOINTING PLAN  
 SCALE: 1"=5'

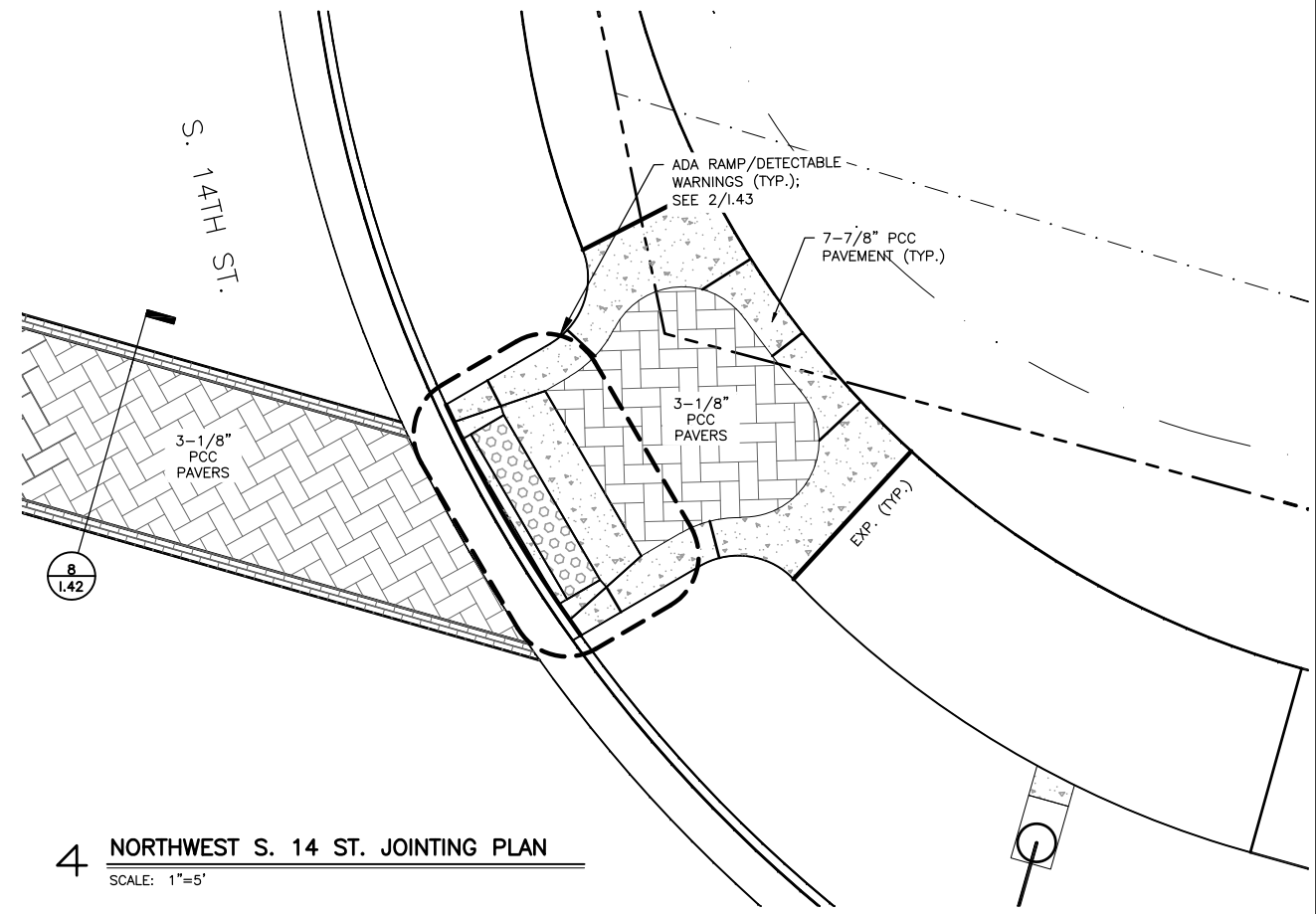

**4** NORTHWEST S. 14 ST. JOINTING PLAN  
 SCALE: 1"=5'

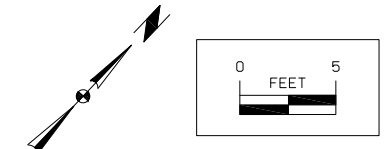
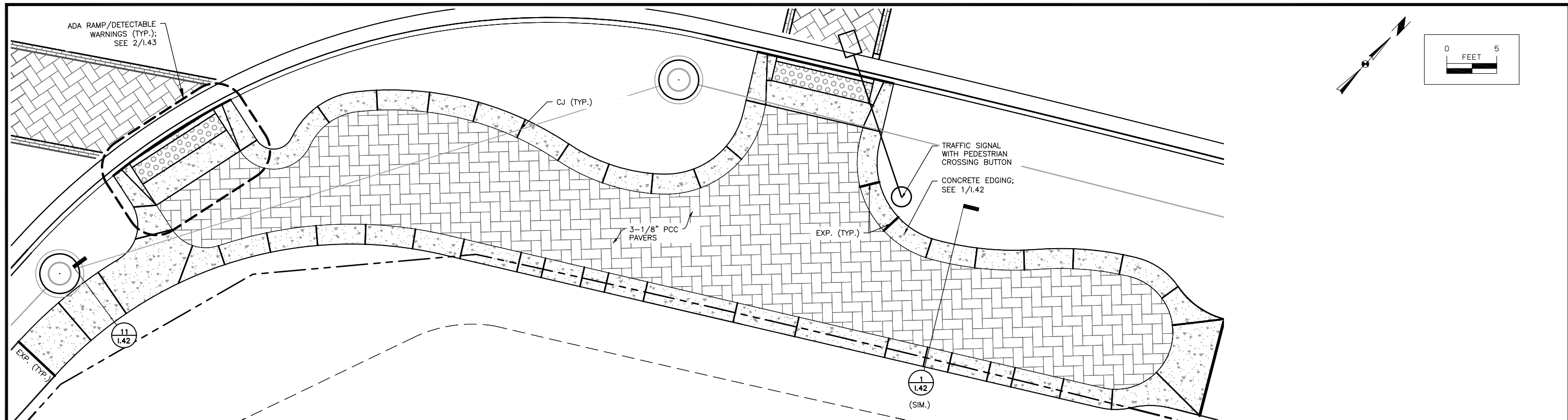

**1** SOUTHEAST S. 14TH ST. JOINTING PLAN  
SCALE: 1"=5'

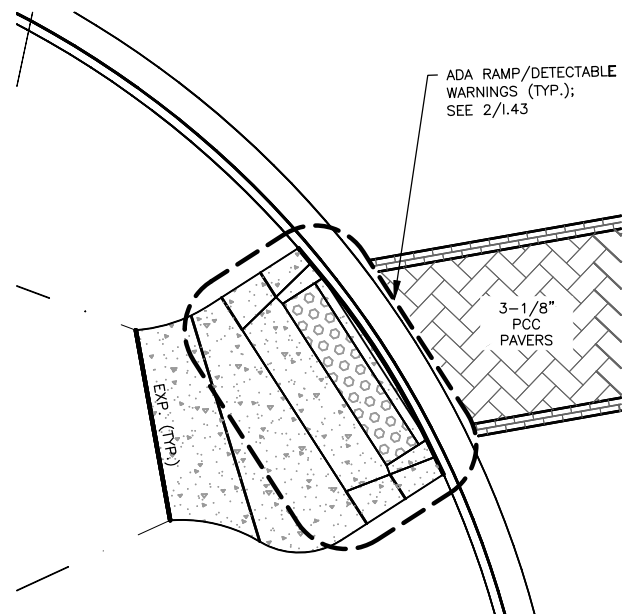

**2** SOUTHWEST S. 14TH ST. JOINTING PLAN  
SCALE: 1"=5'

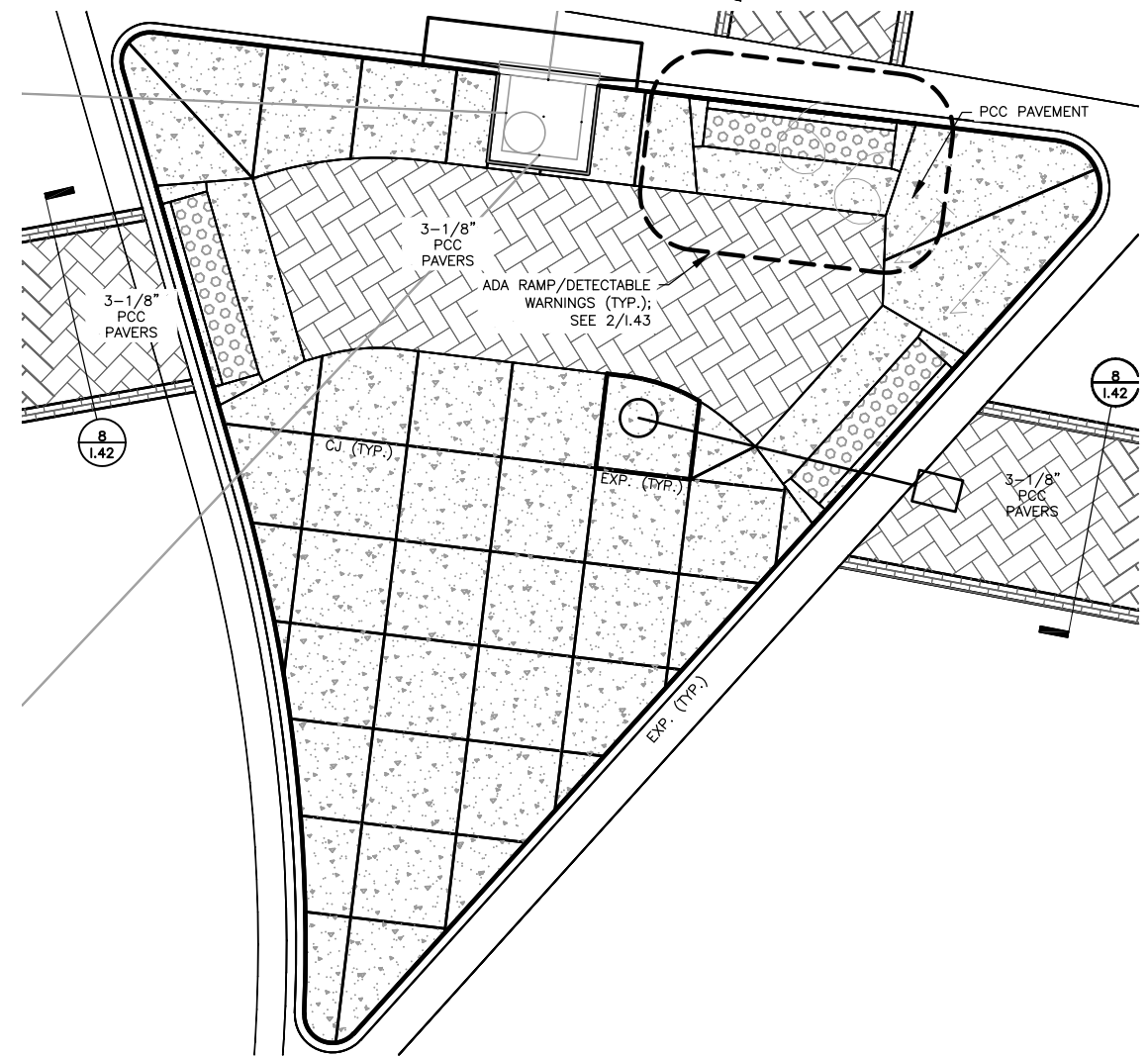

**3** SOUTHERN ISLAND AT S. 14TH ST. JOINTING PLAN  
SCALE: 1"=5'

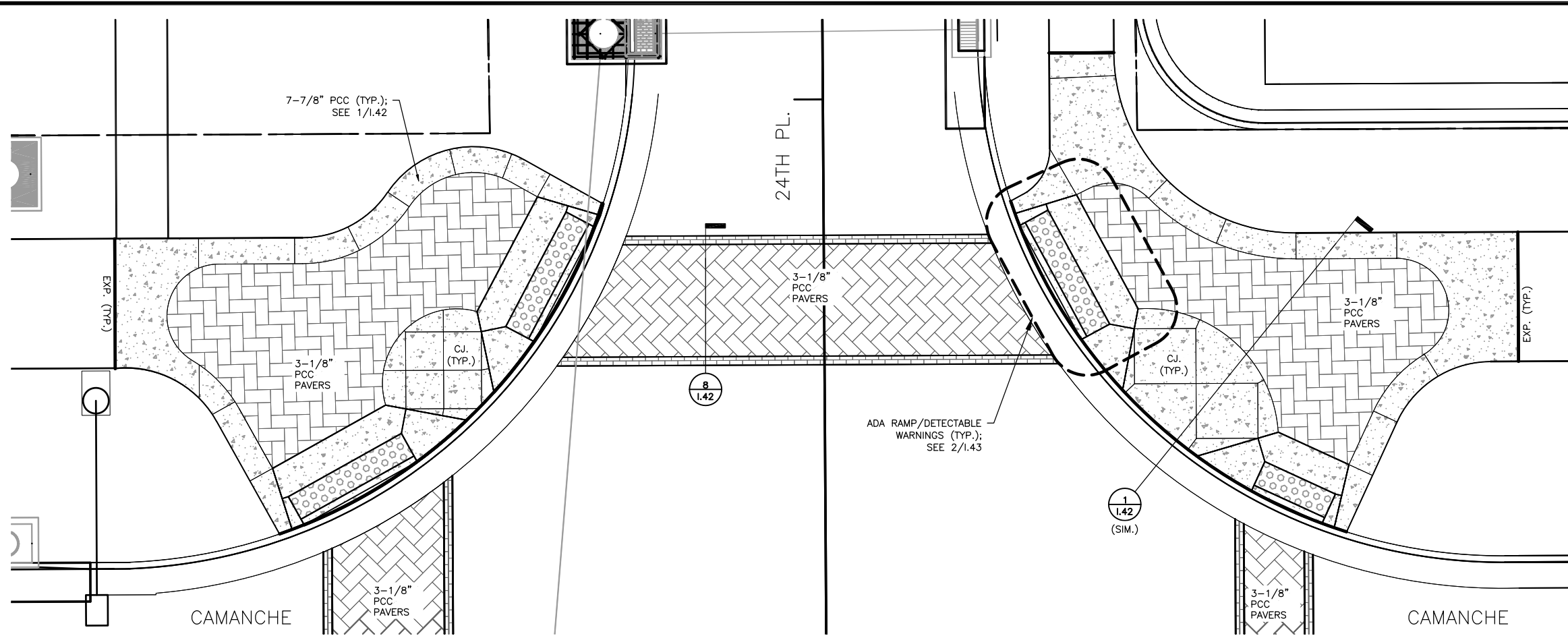

**1** NORTHERN 24TH PL. JOINTING PLAN  
SCALE: 1"=5'

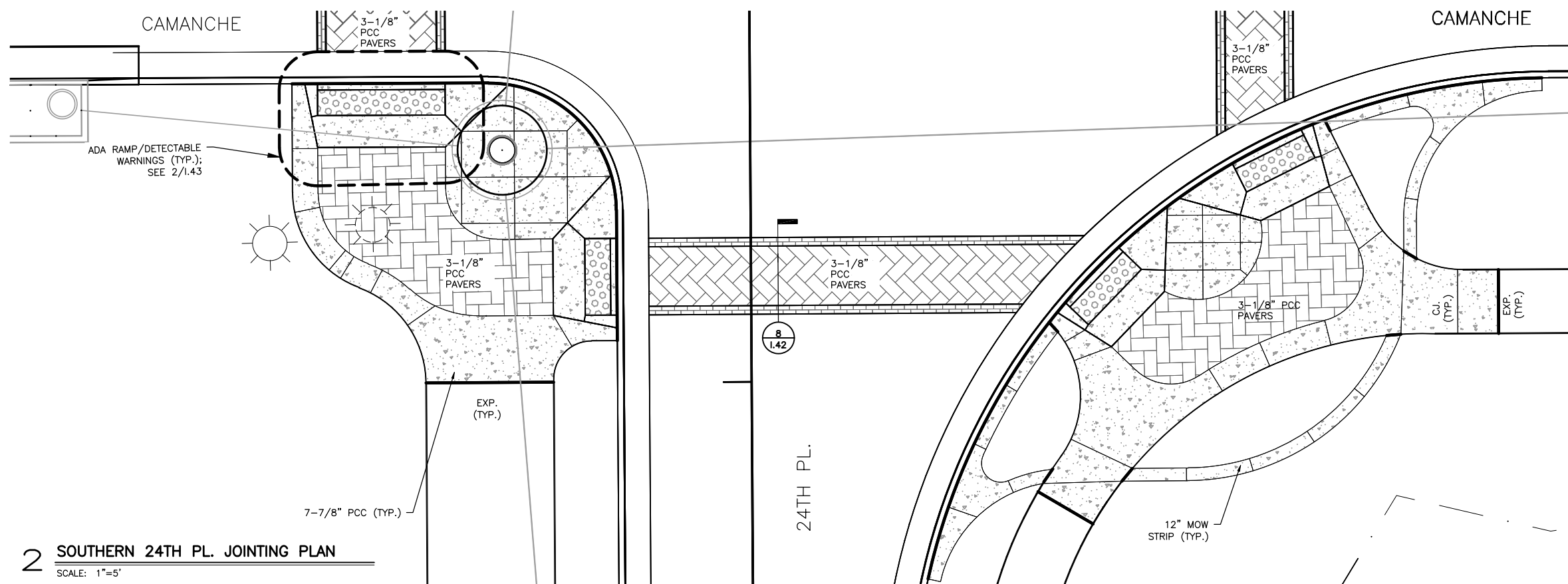

**2** SOUTHERN 24TH PL. JOINTING PLAN  
SCALE: 1"=5'

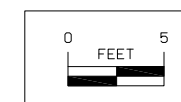
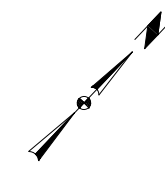



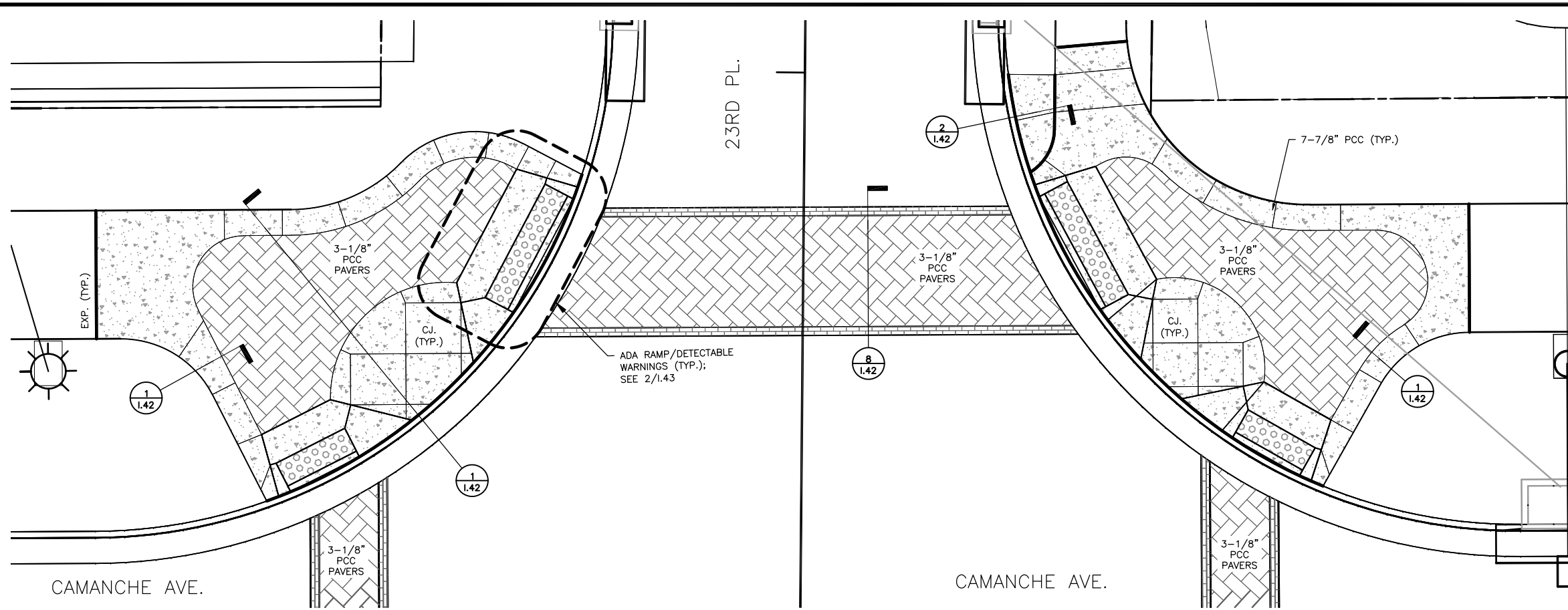

**1 NORTHERN 23RD PL. JOINTING PLAN**

SCALE: 1"=5'

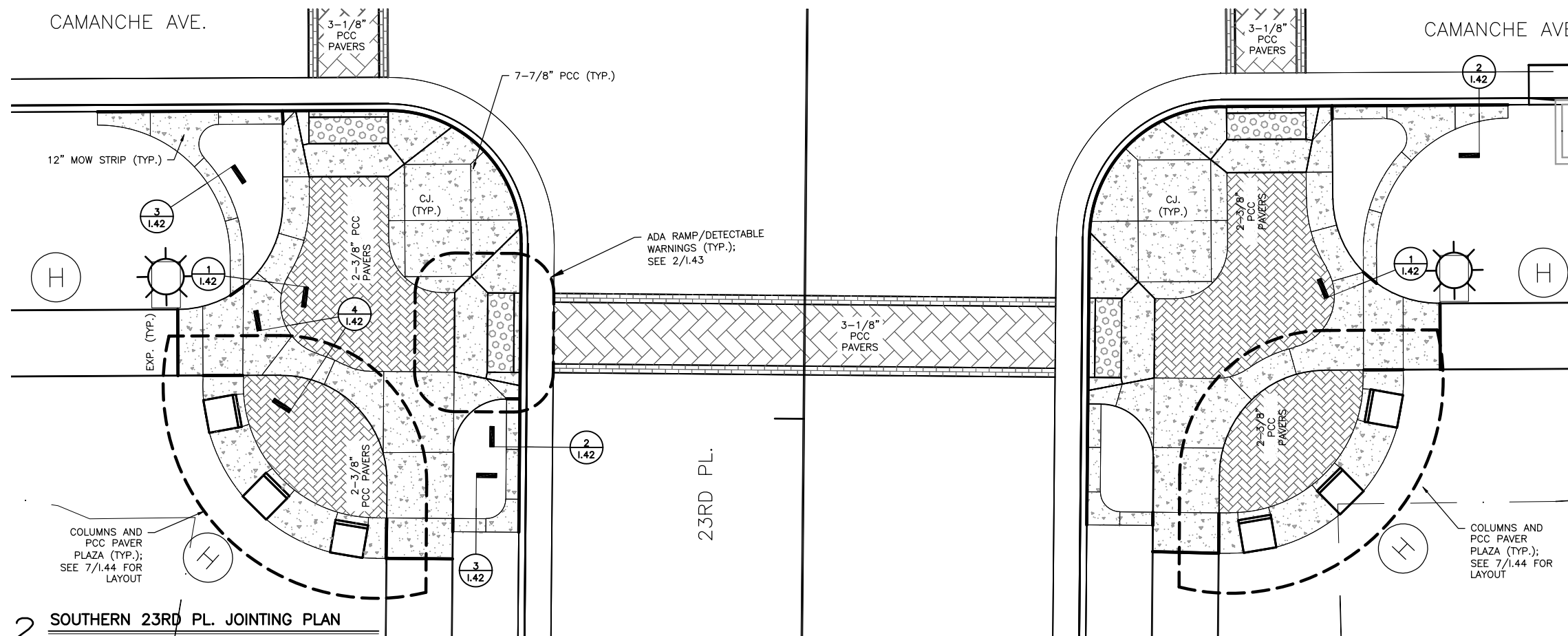

**2 SOUTHERN 23RD PL. JOINTING PLAN**

SCALE: 1"=5'

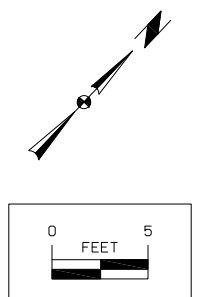

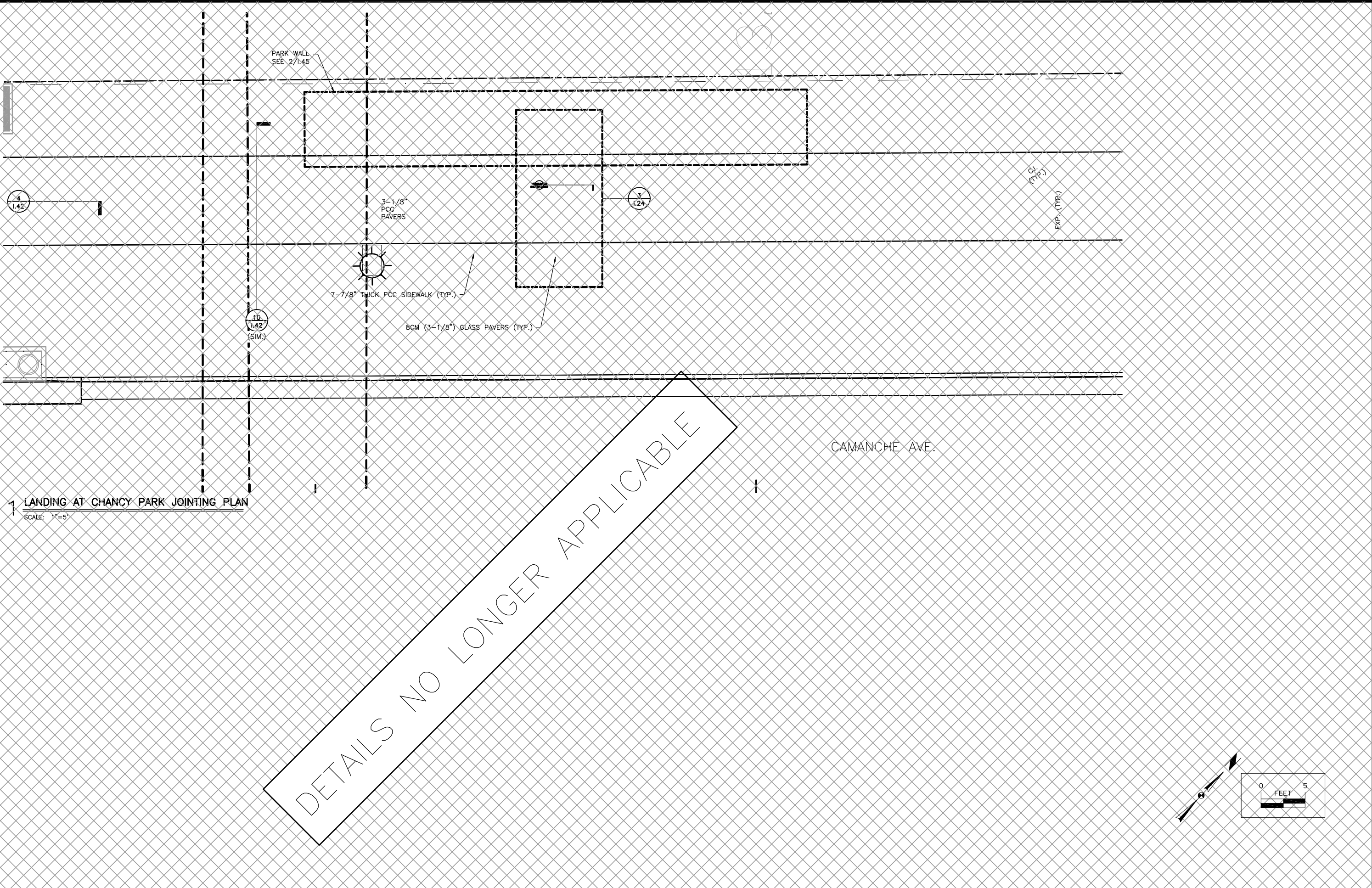

1 LANDING AT CHANCY PARK JOINTING PLAN  
 SCALE: 1"=5'

DETAILS NO LONGER APPLICABLE

CAMANCHE AVE.

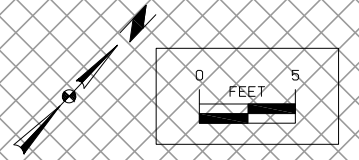

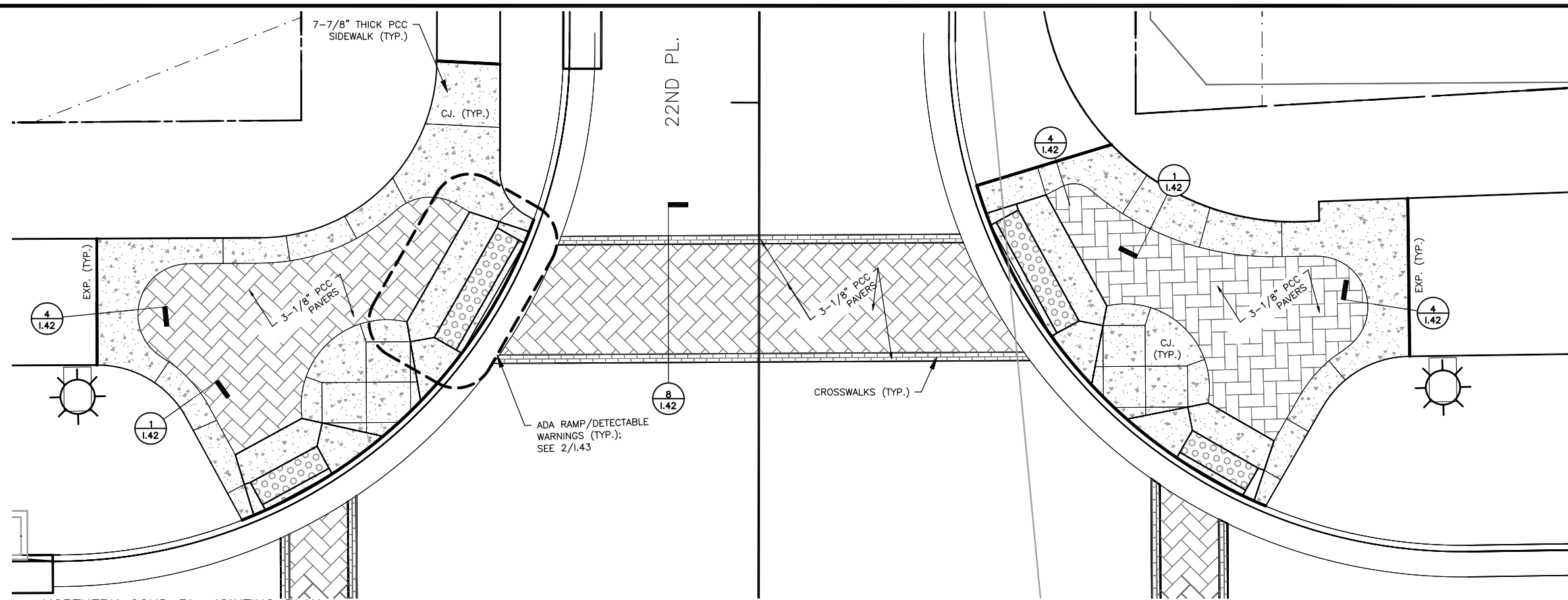

**1 NORTHERN 22ND PL. JOINTING PLAN**  
SCALE: 1"=5'

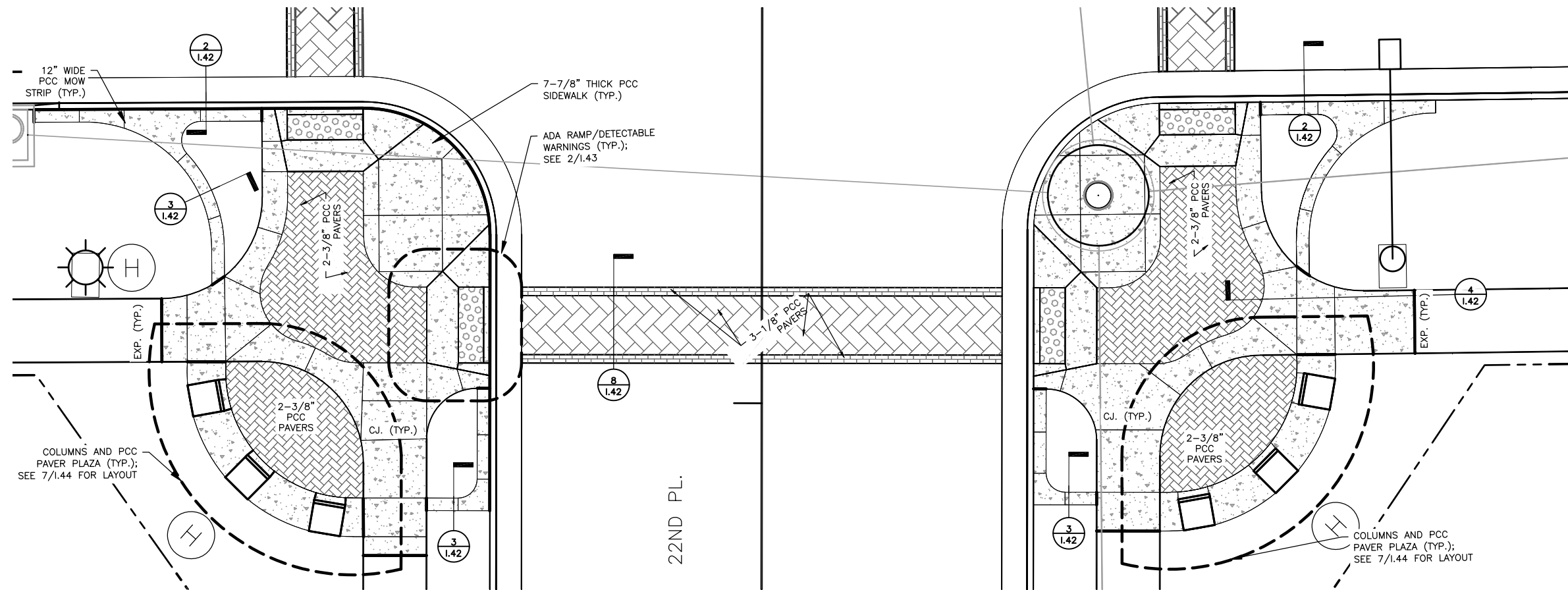

**2 SOUTHERN 22ND PL. JOINTING PLAN**  
SCALE: 1"=5'

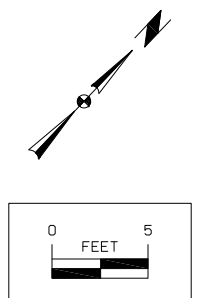

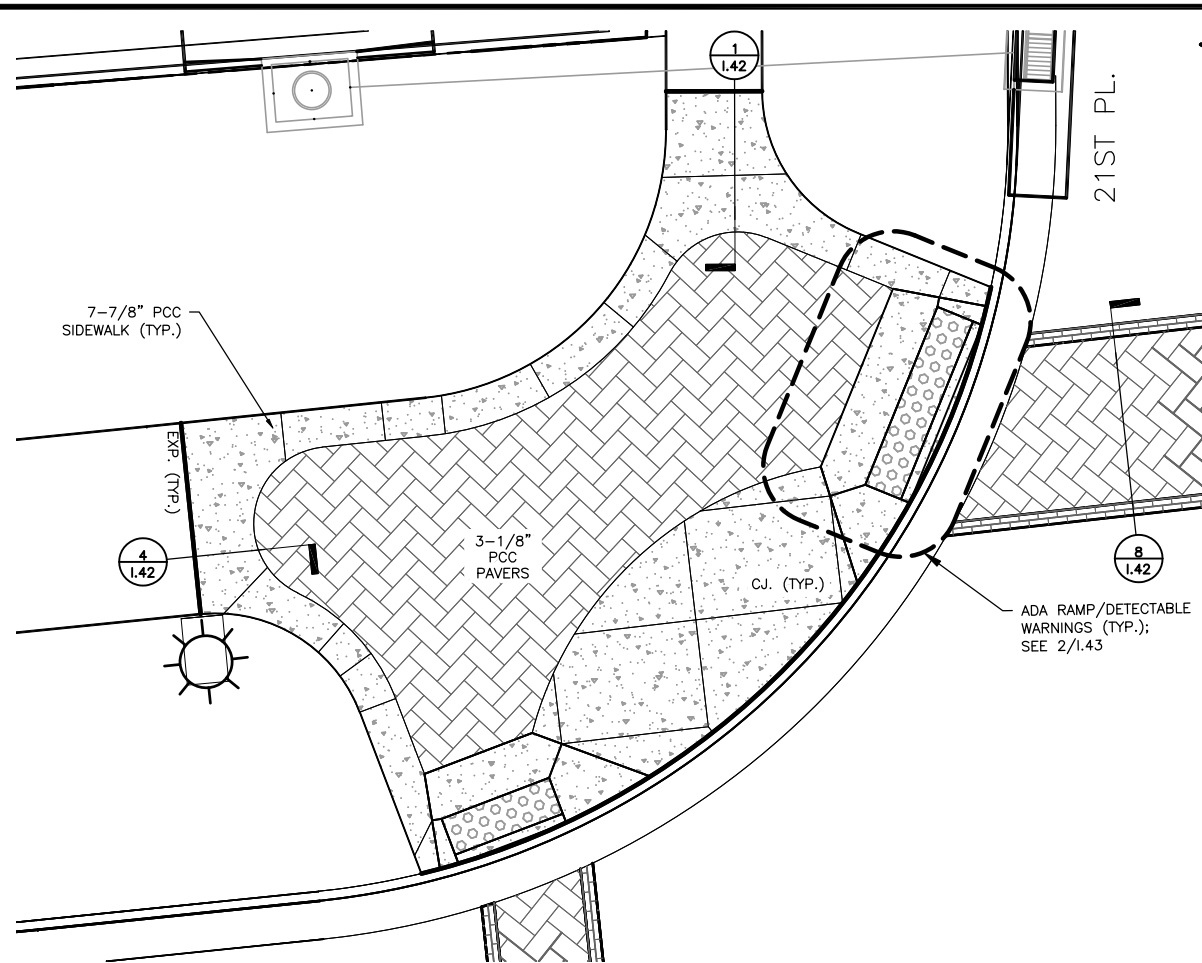

**1 NW 21ST PL. JOINTING PLAN**  
SCALE: 1"=5'

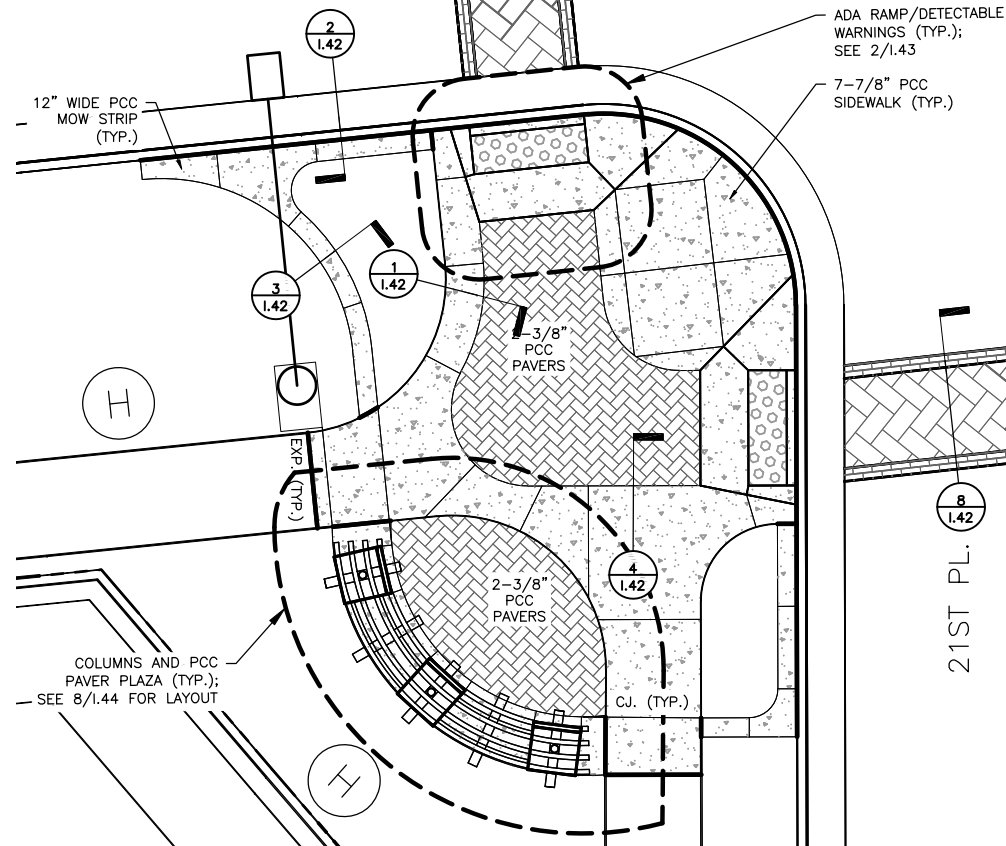

**2 SW 21ST PL. JOINTING PLAN**  
SCALE: 1"=5'

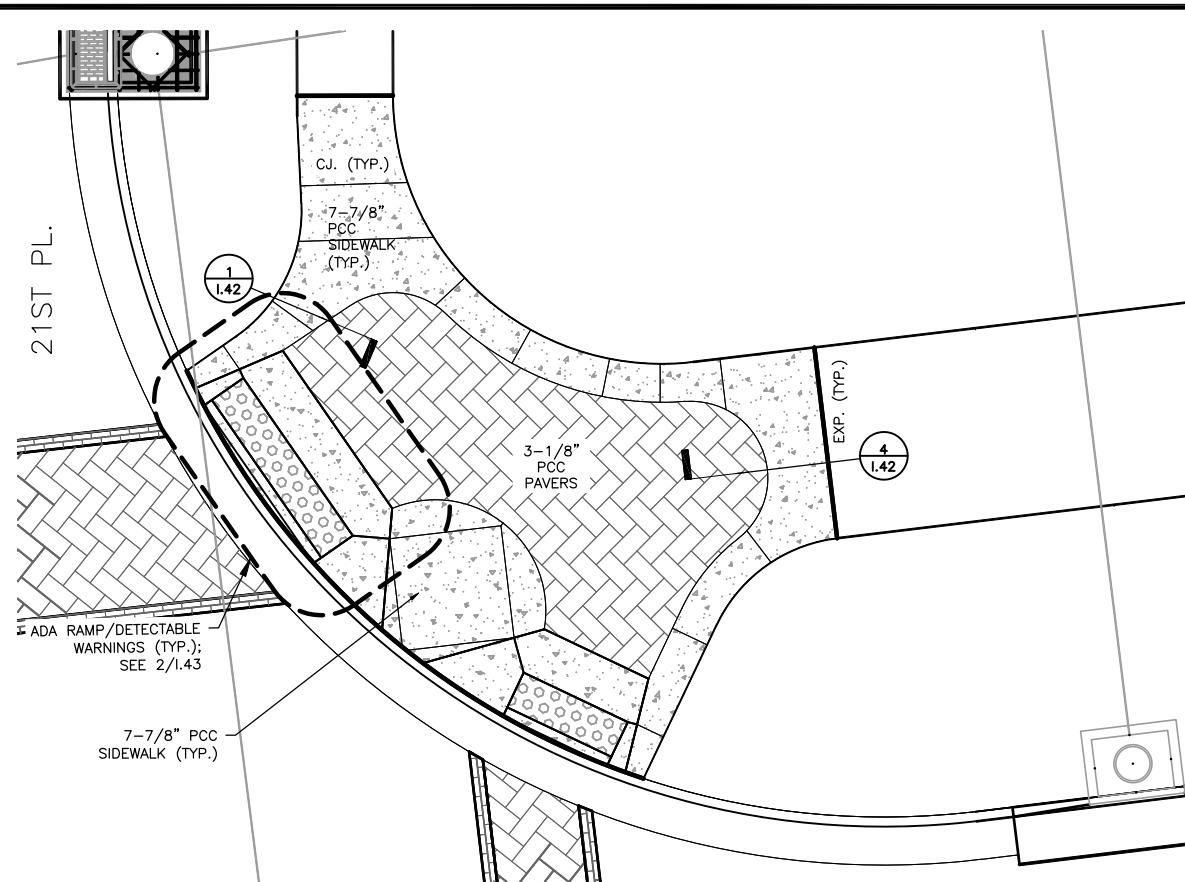

**3 NE 21ST PL. JOINTING PLAN**  
SCALE: 1"=5'

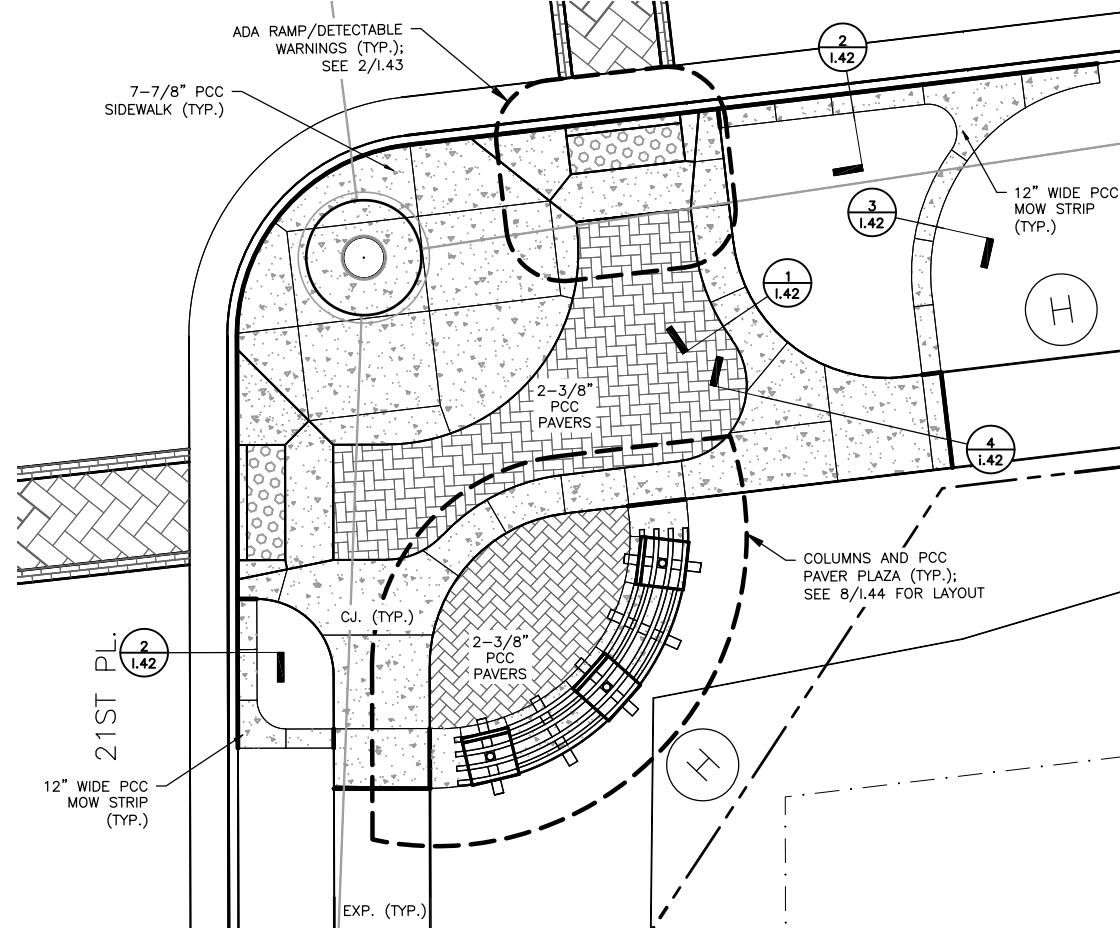

**4 SE 21ST PL. JOINTING PLAN**  
SCALE: 1"=5'

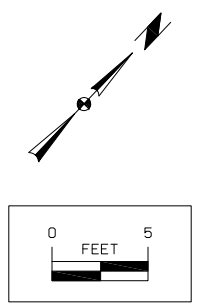

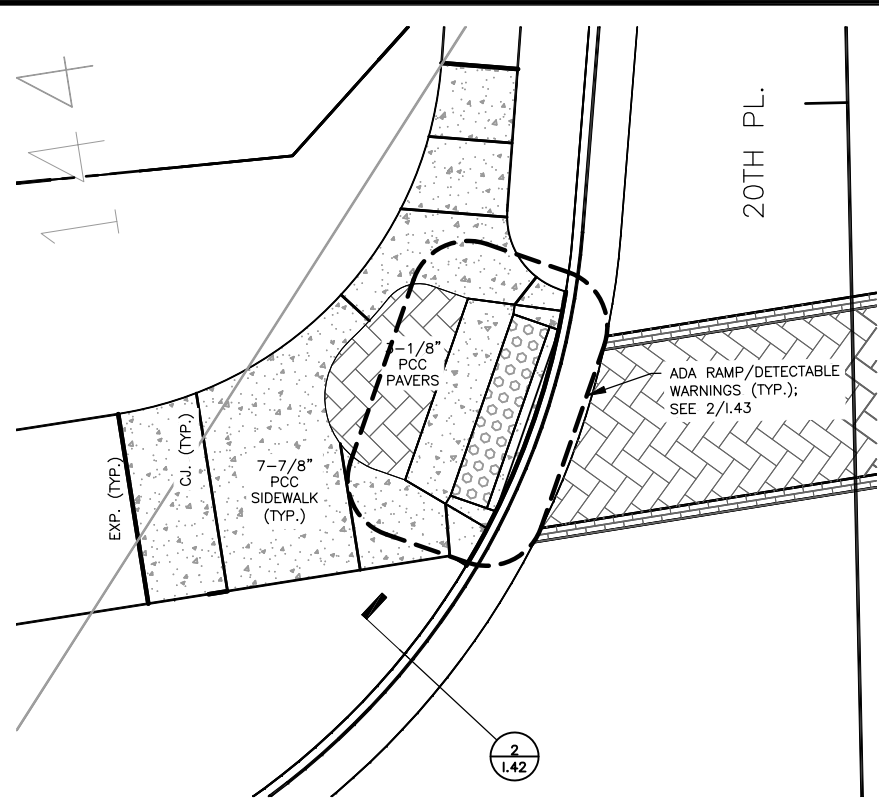

**1 NW 20TH PL. JOINTING PLAN**  
SCALE: 1"=5'

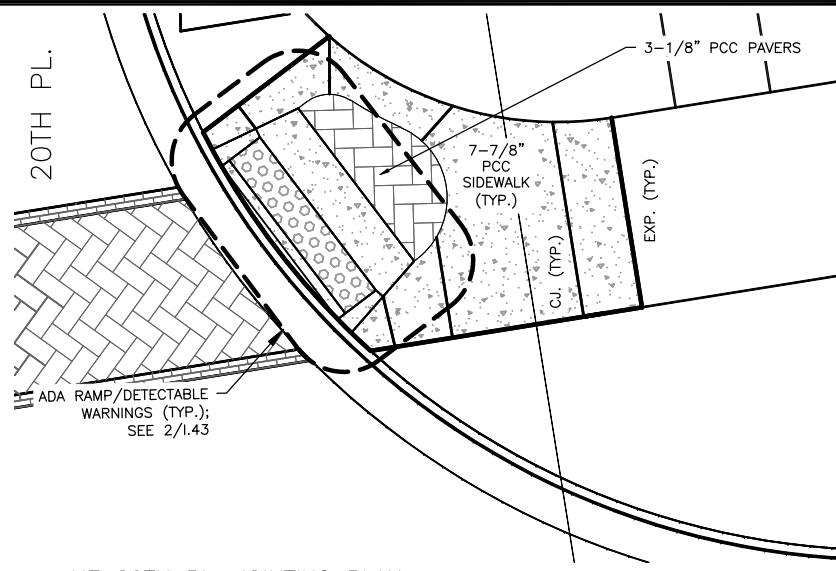

**3 NE 20TH PL. JOINTING PLAN**  
SCALE: 1"=5'

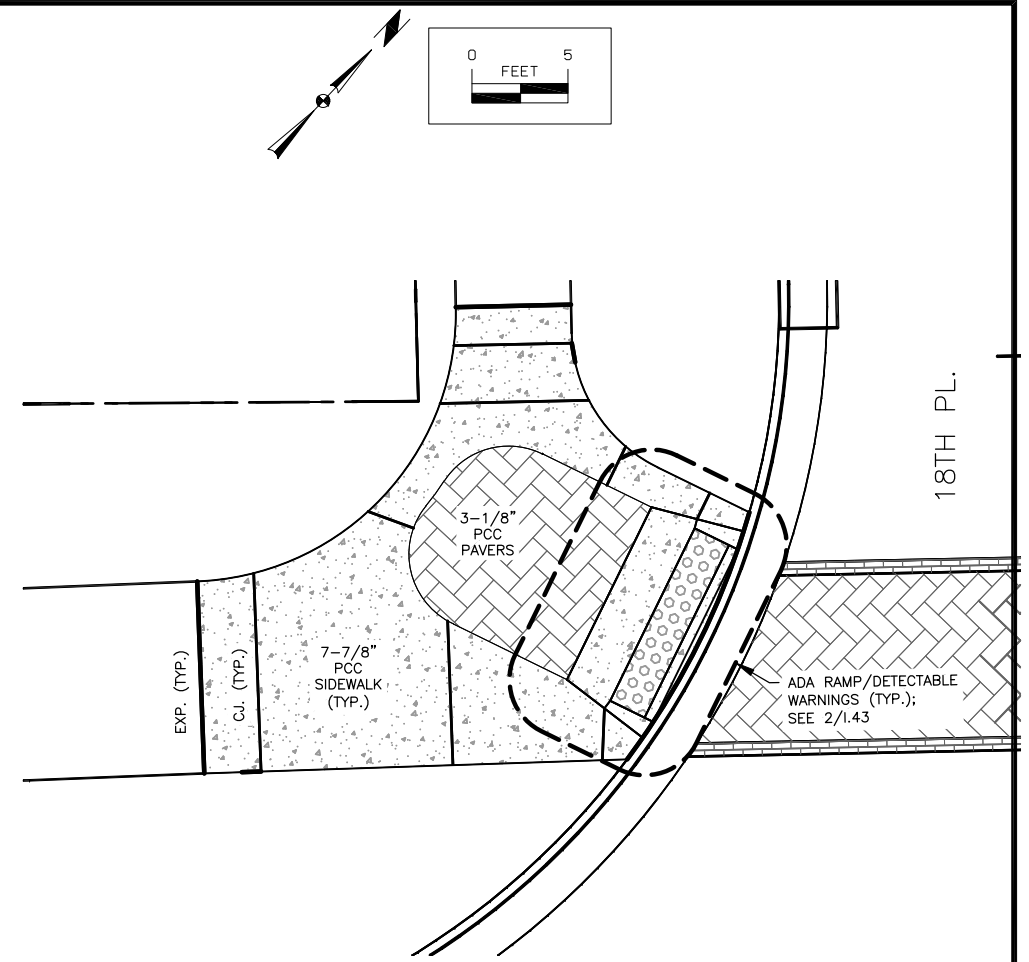

**5 NW 18TH PL. JOINTING PLAN**  
SCALE: 1"=5'

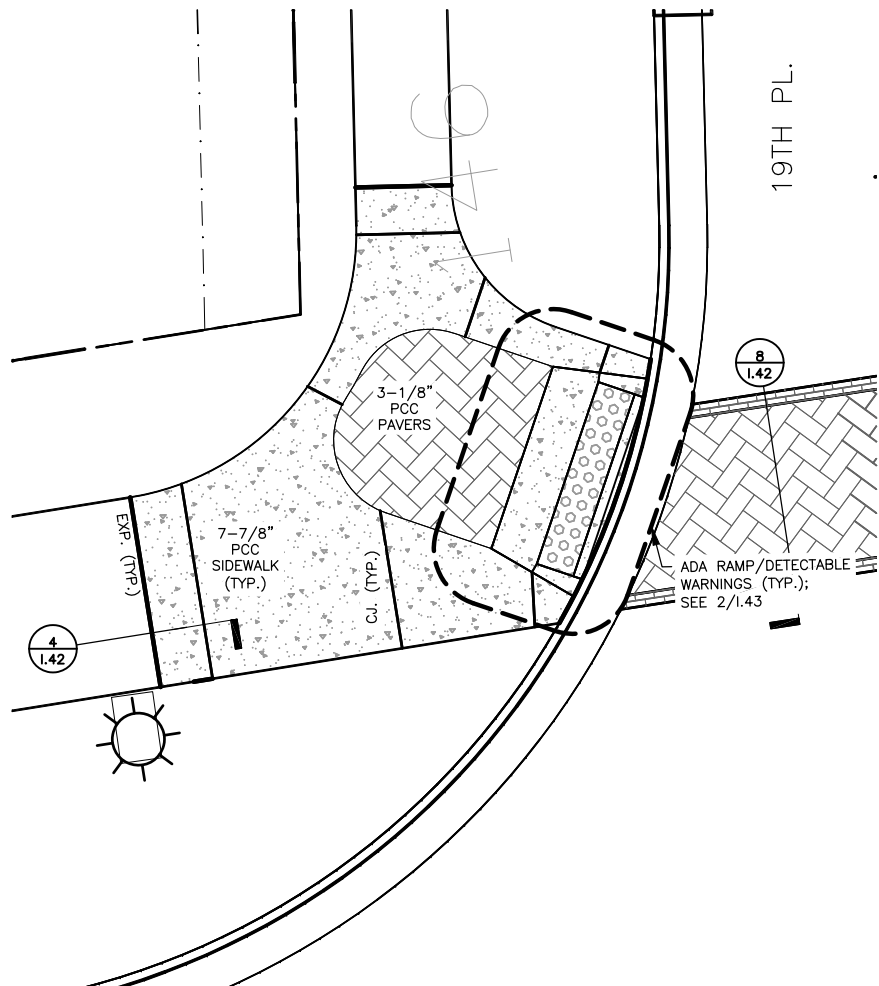

**2 NW 19TH PL. JOINTING PLAN**  
SCALE: 1"=5'

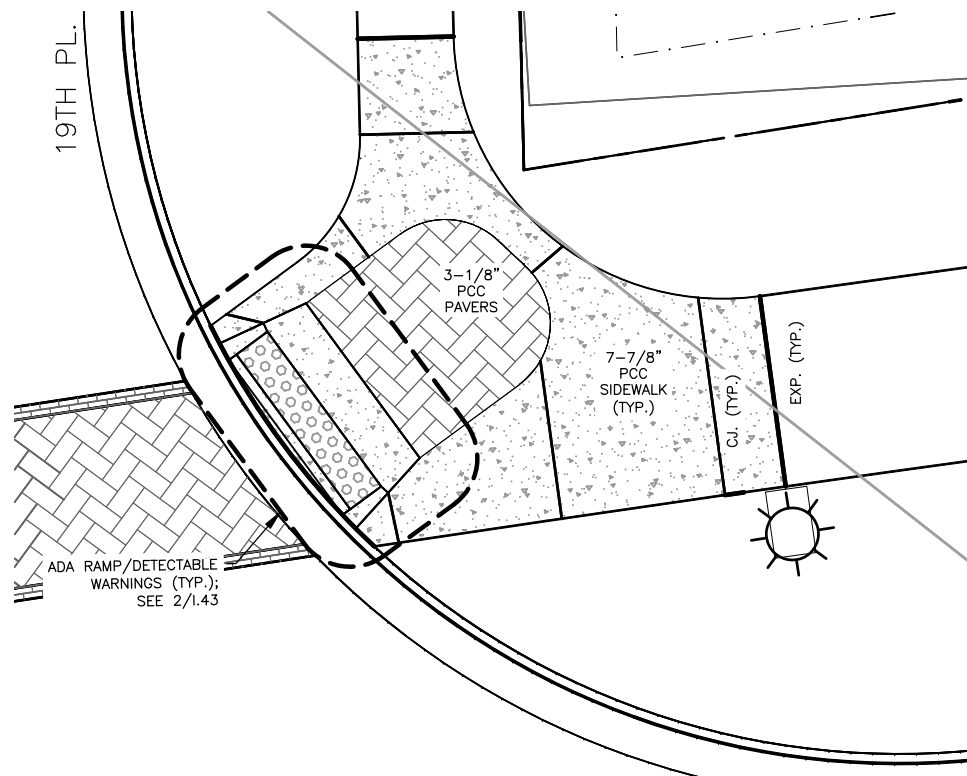

**4 NE 19TH PL. JOINTING PLAN**  
SCALE: 1"=5'

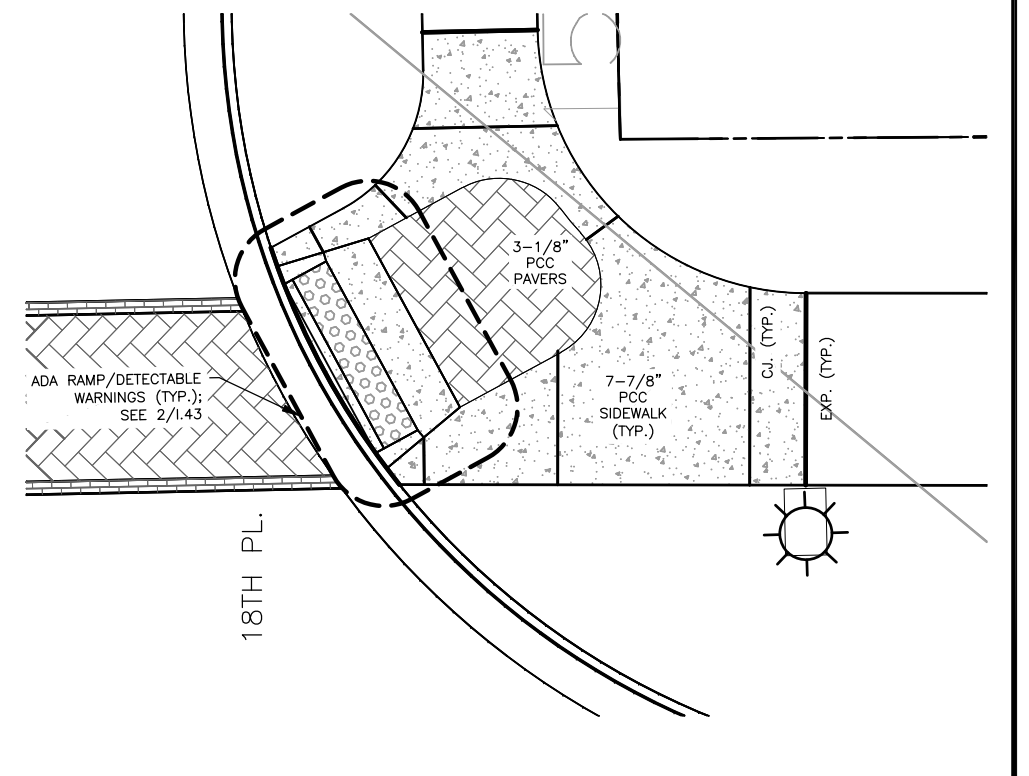

**6 NE 18TH PL. JOINTING PLAN**  
SCALE: 1"=5'

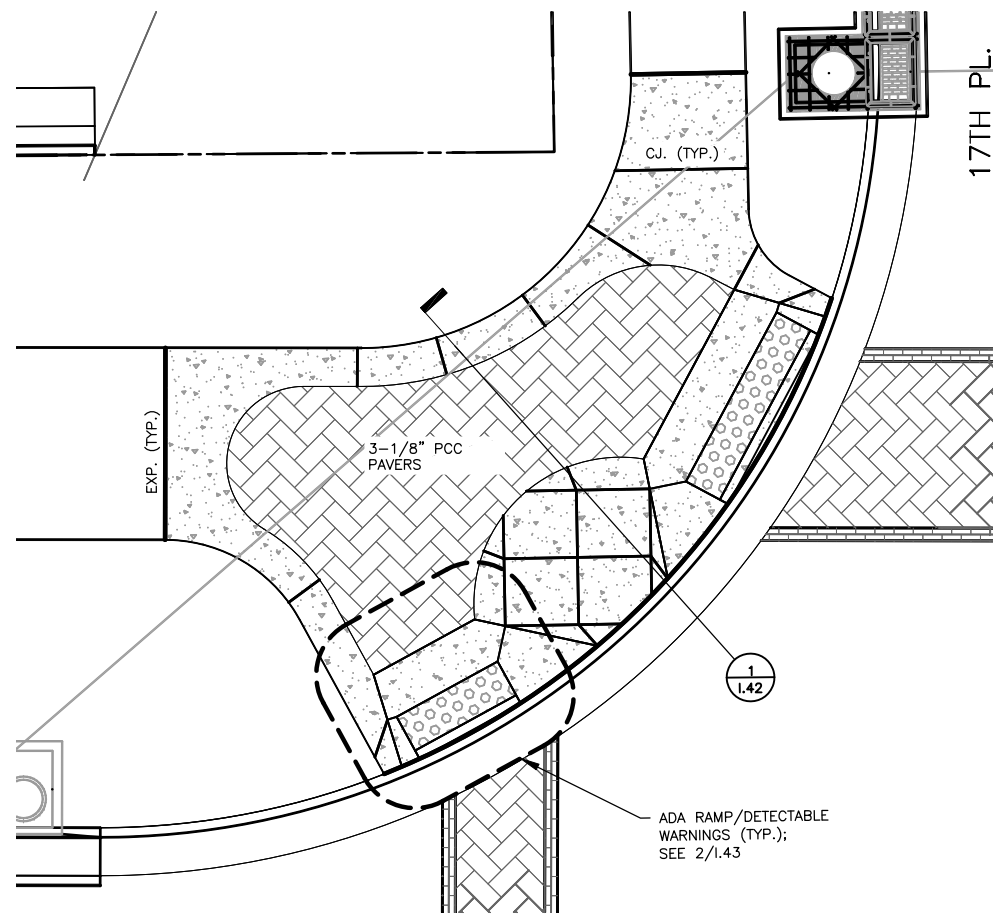

**1 NW 17TH PL. JOINTING PLAN**  
SCALE: 1"=5'

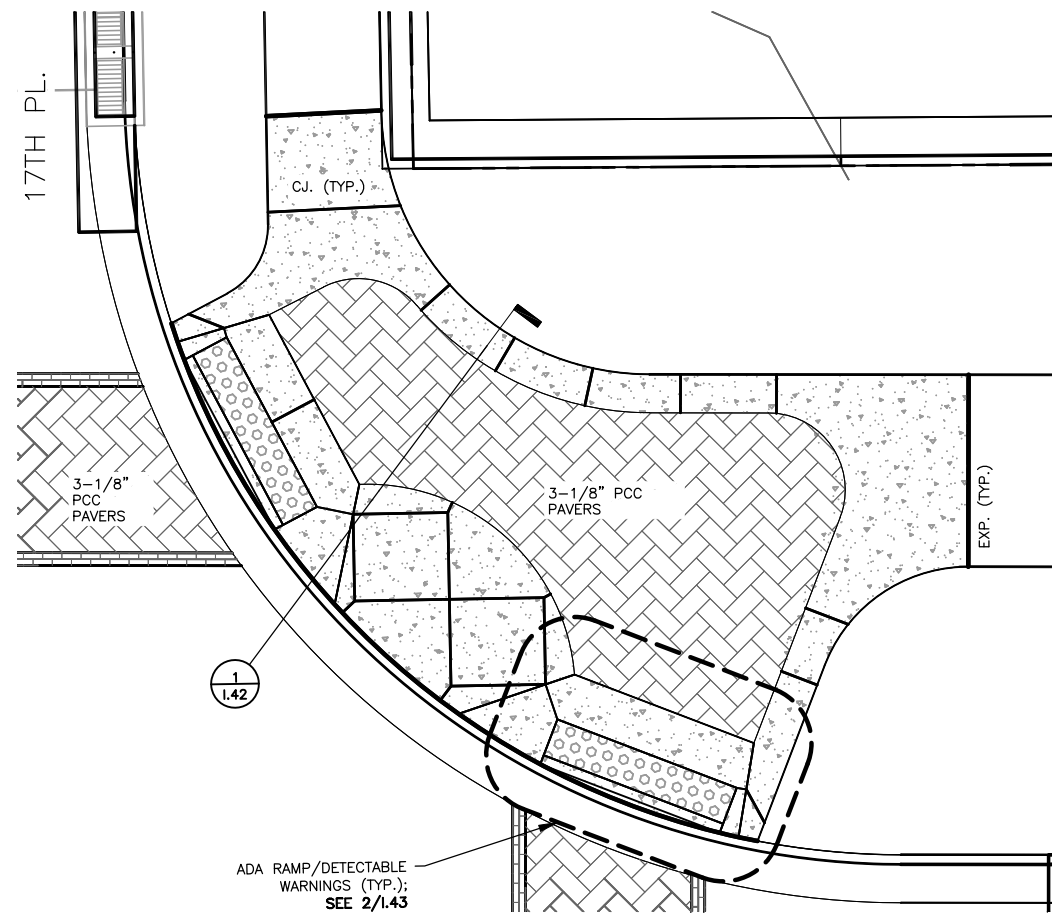

**3 NE 17TH PL. JOINTING PLAN**  
SCALE: 1"=5'

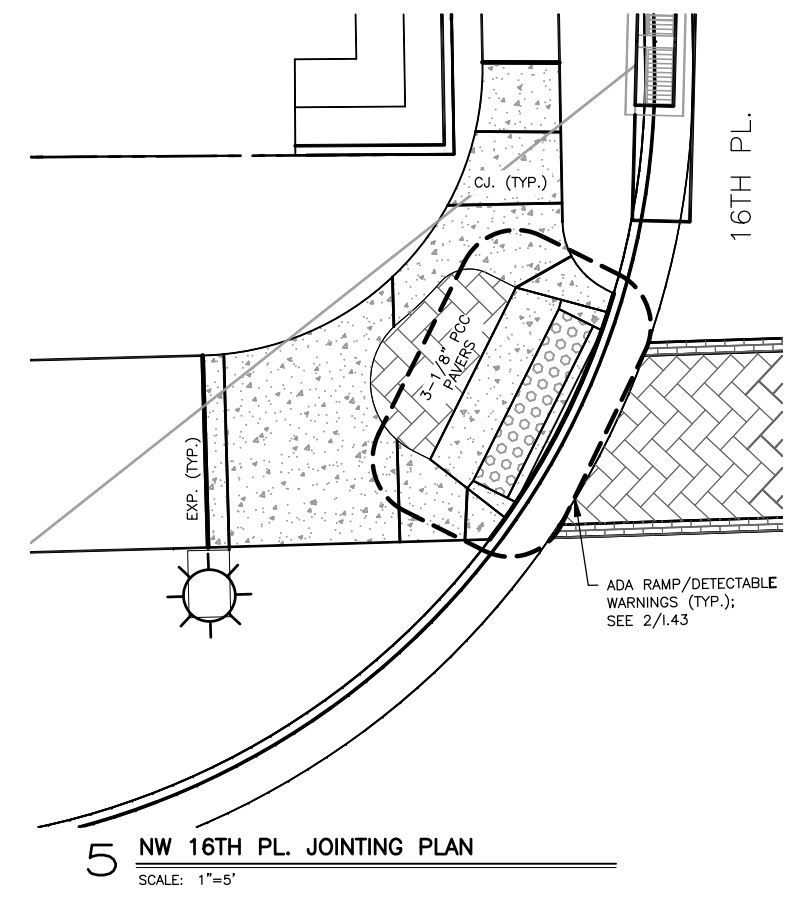

**5 NW 16TH PL. JOINTING PLAN**  
SCALE: 1"=5'

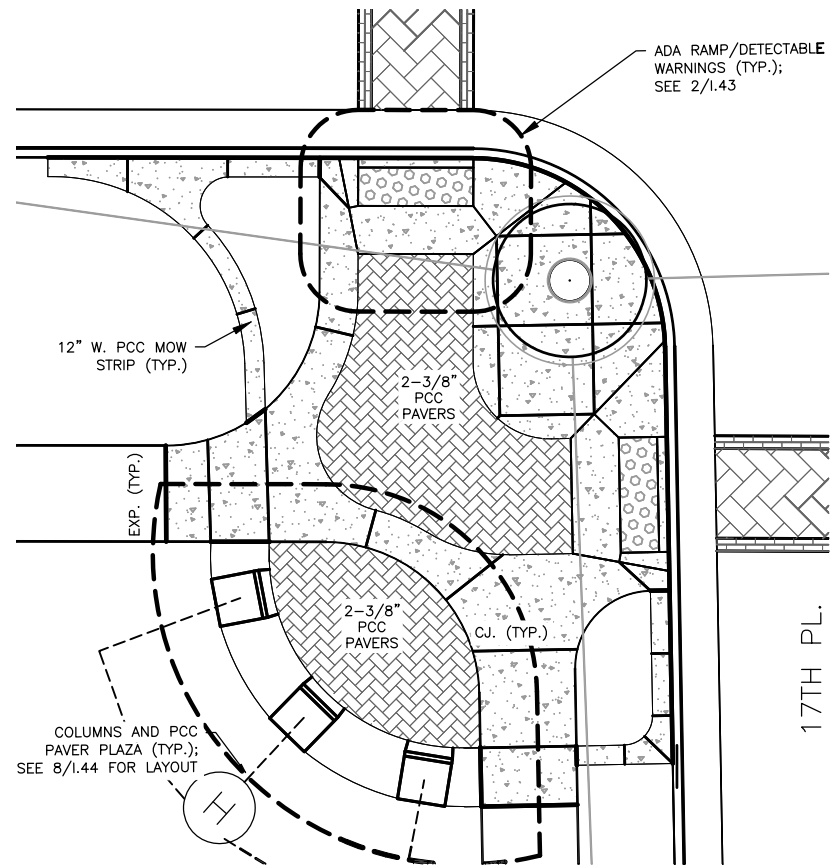

**2 SW 17TH PL. JOINTING PLAN**  
SCALE: 1"=5'

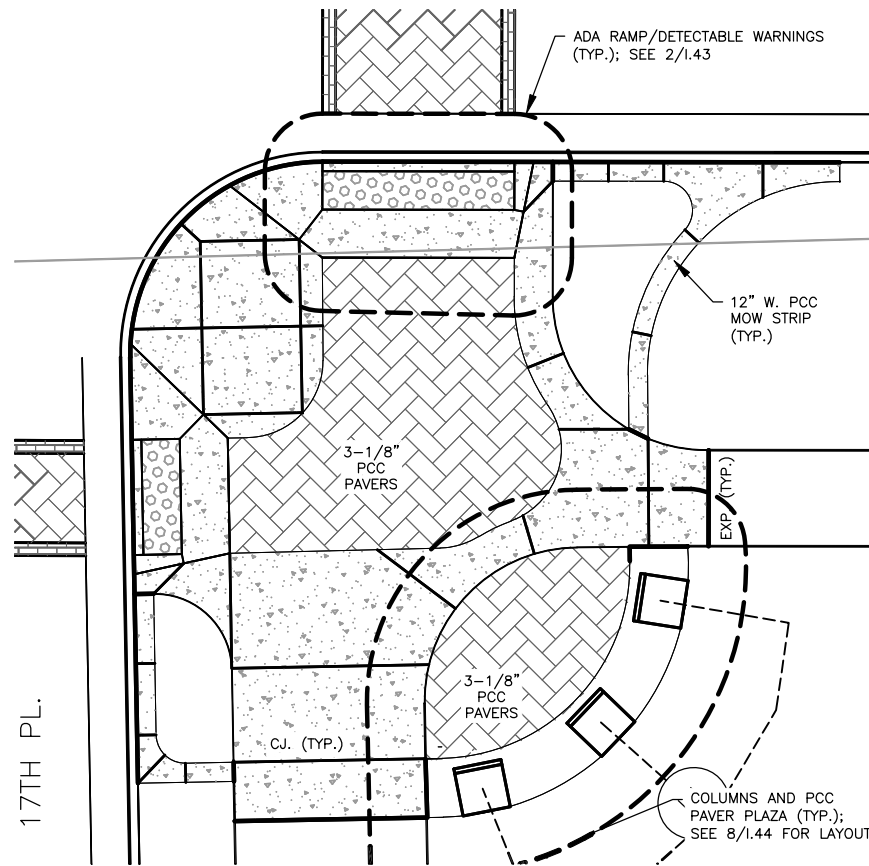

**4 SE 17TH PL. JOINTING PLAN**  
SCALE: 1"=5'

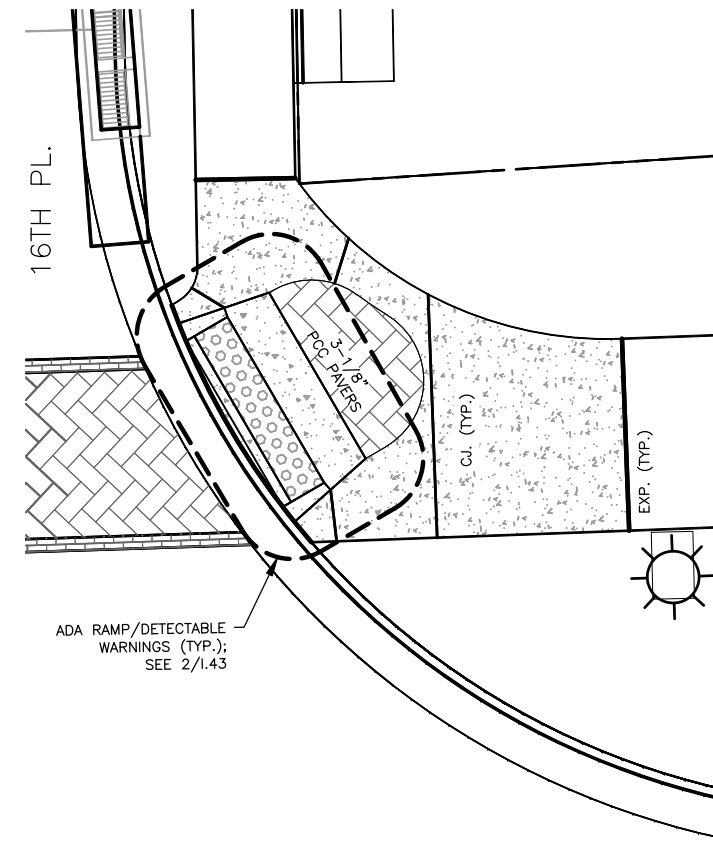

**6 NE 16TH PL. JOINTING PLAN**  
SCALE: 1"=5'

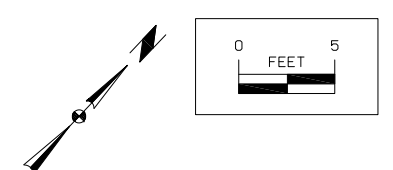

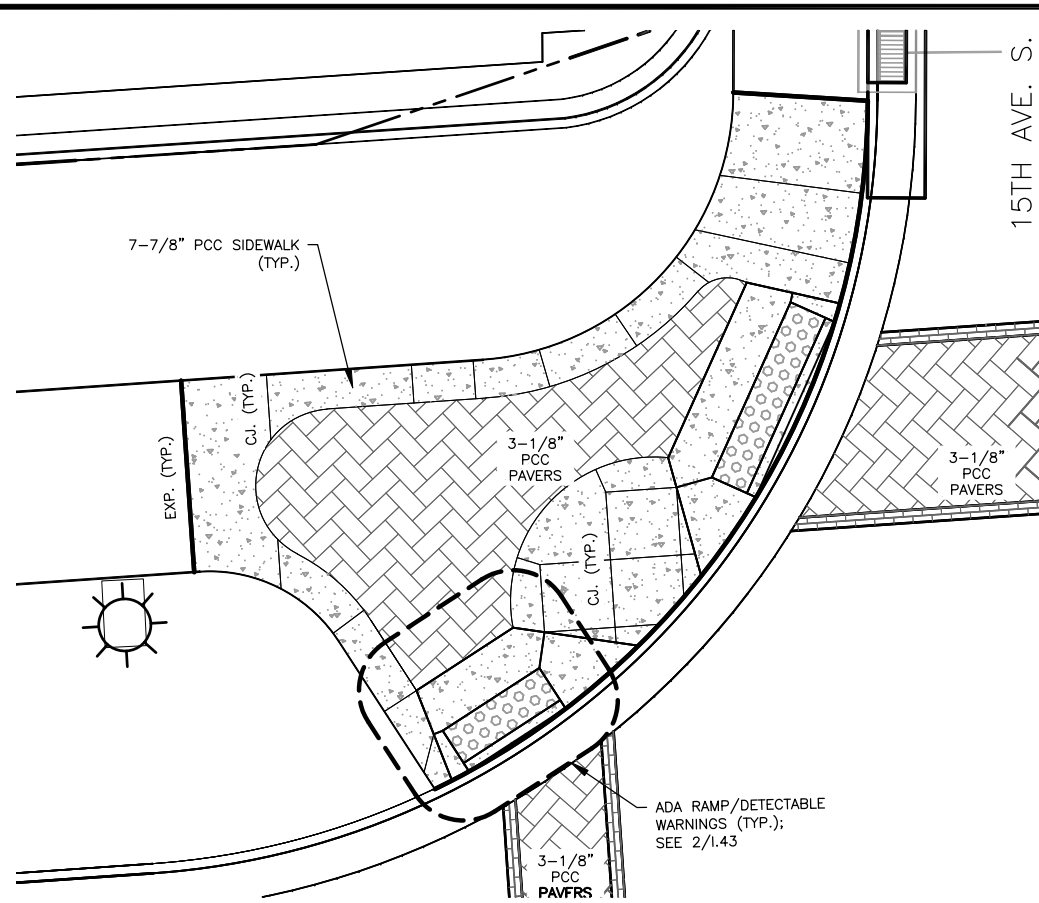

**1** NW 15TH AVE. S. JOINTING PLAN  
SCALE: 1"=5'

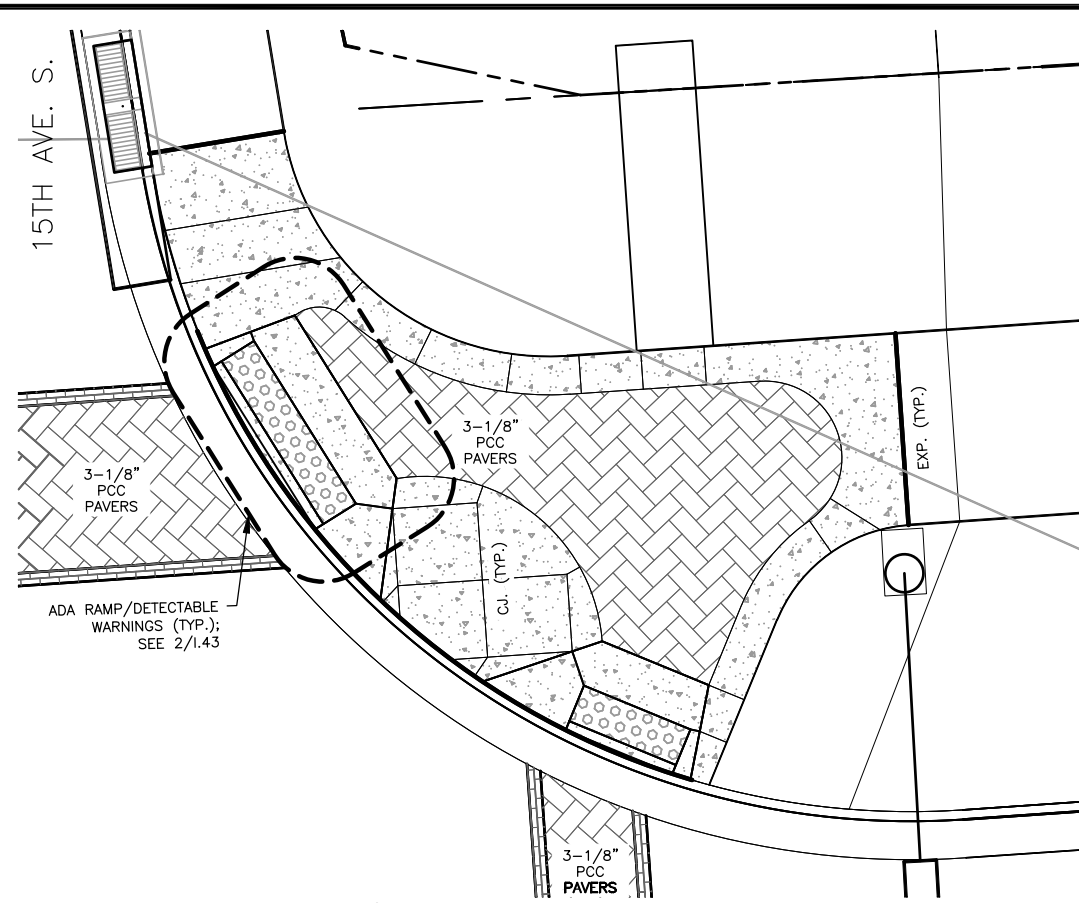

**3** NE 15TH AVE. S. JOINTING PLAN  
SCALE: 1"=5'

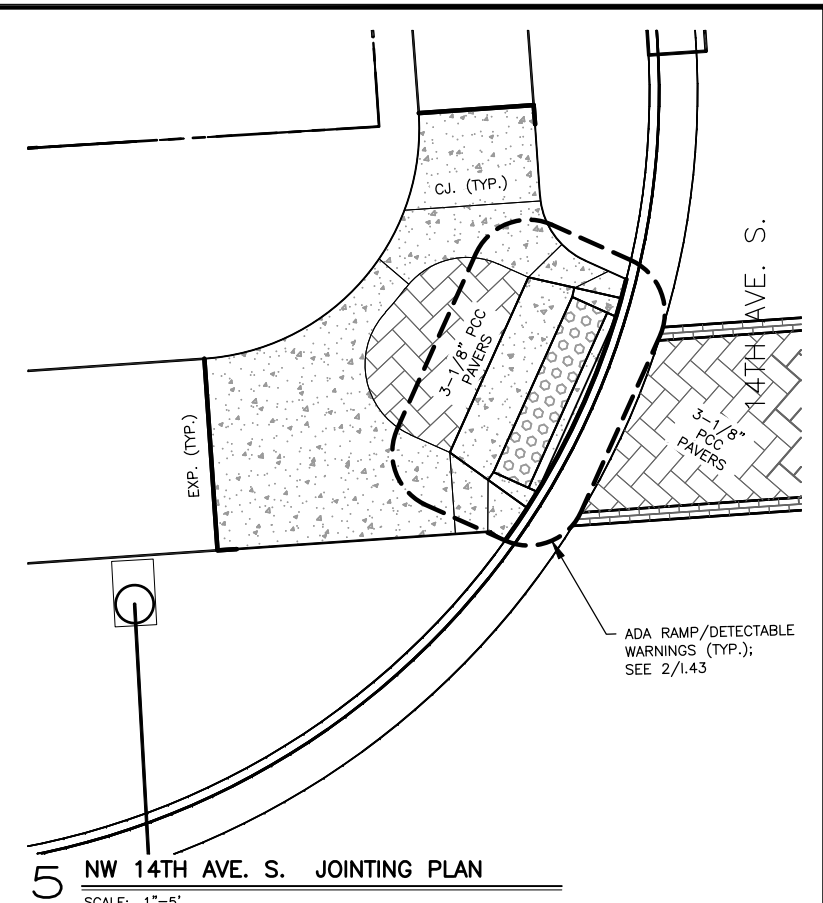

**5** NW 14TH AVE. S. JOINTING PLAN  
SCALE: 1"=5'

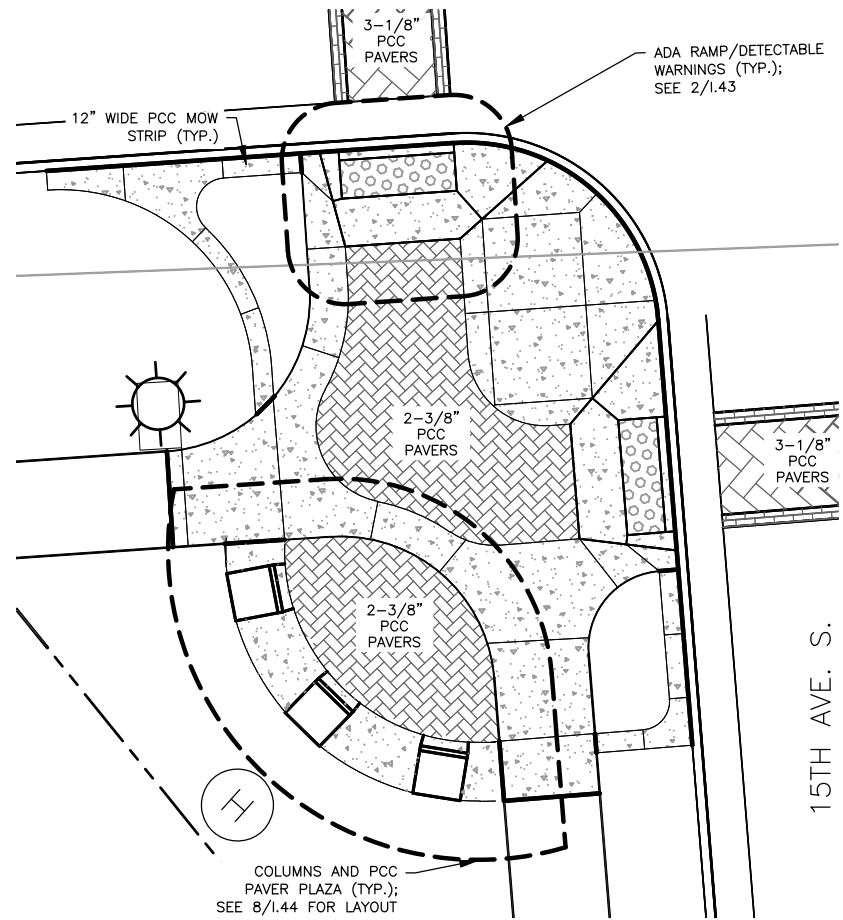

**2** SW 15TH AVE. S. JOINTING PLAN  
SCALE: 1"=5'

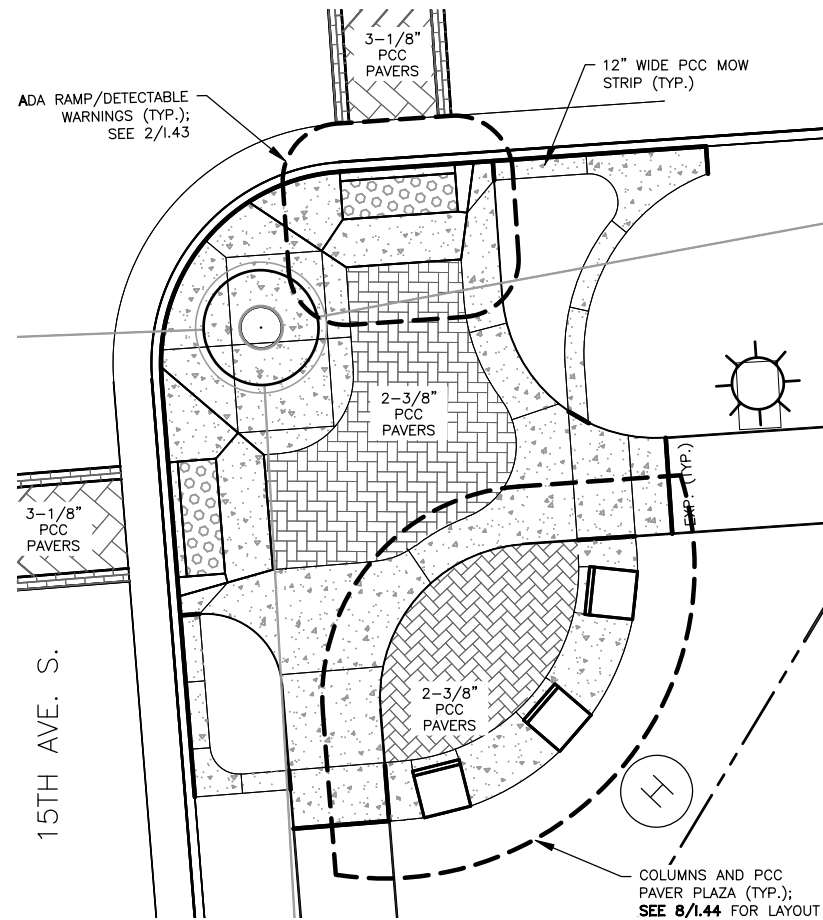

**4** SE 15TH AVE. S. JOINTING PLAN  
SCALE: 1"=5'

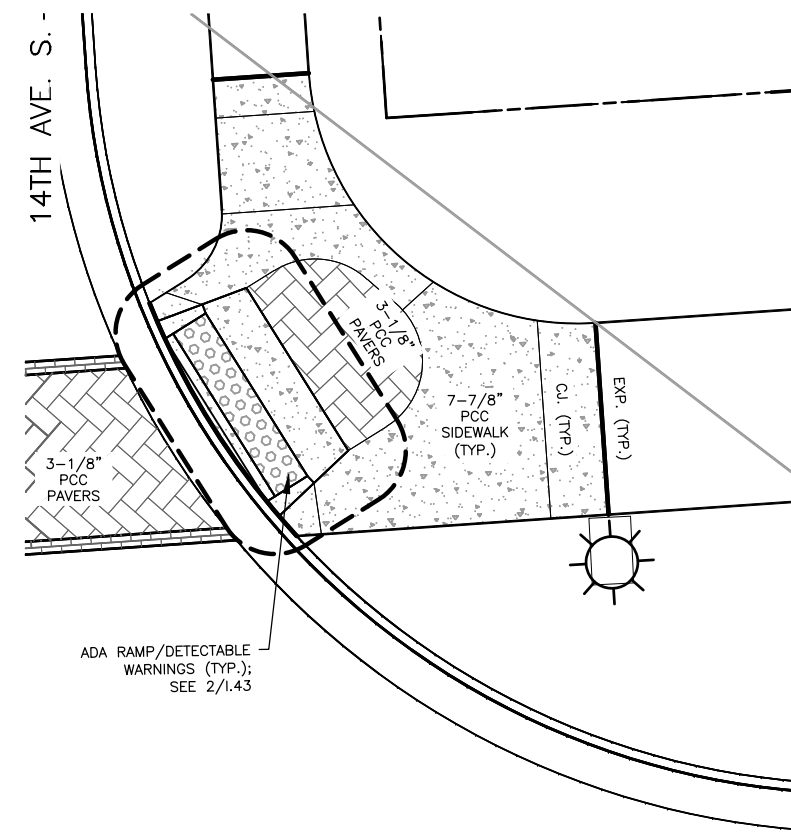

**6** NW 14TH AVE. S. JOINTING PLAN  
SCALE: 1"=5'

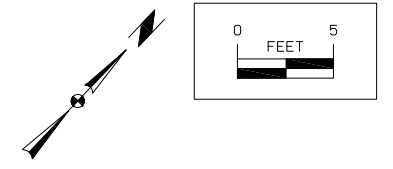

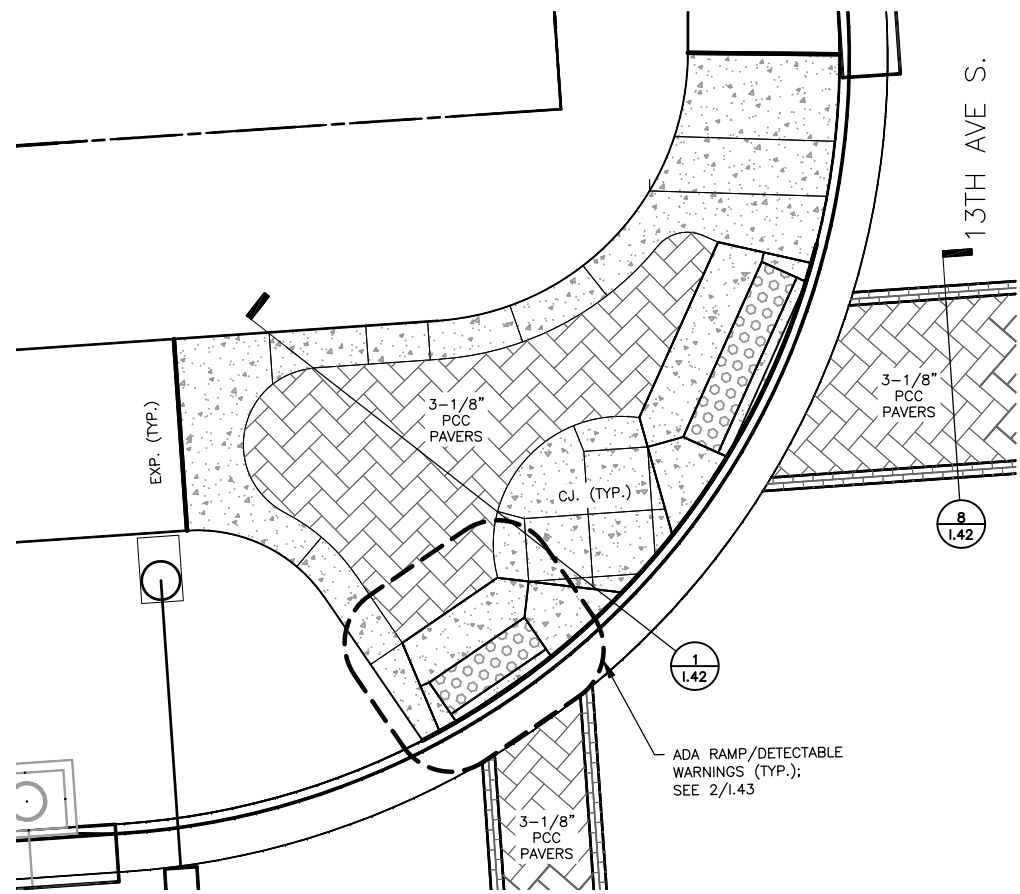

**1 NW 13TH AVE. S. JOINTING PLAN**  
SCALE: 1"=5'

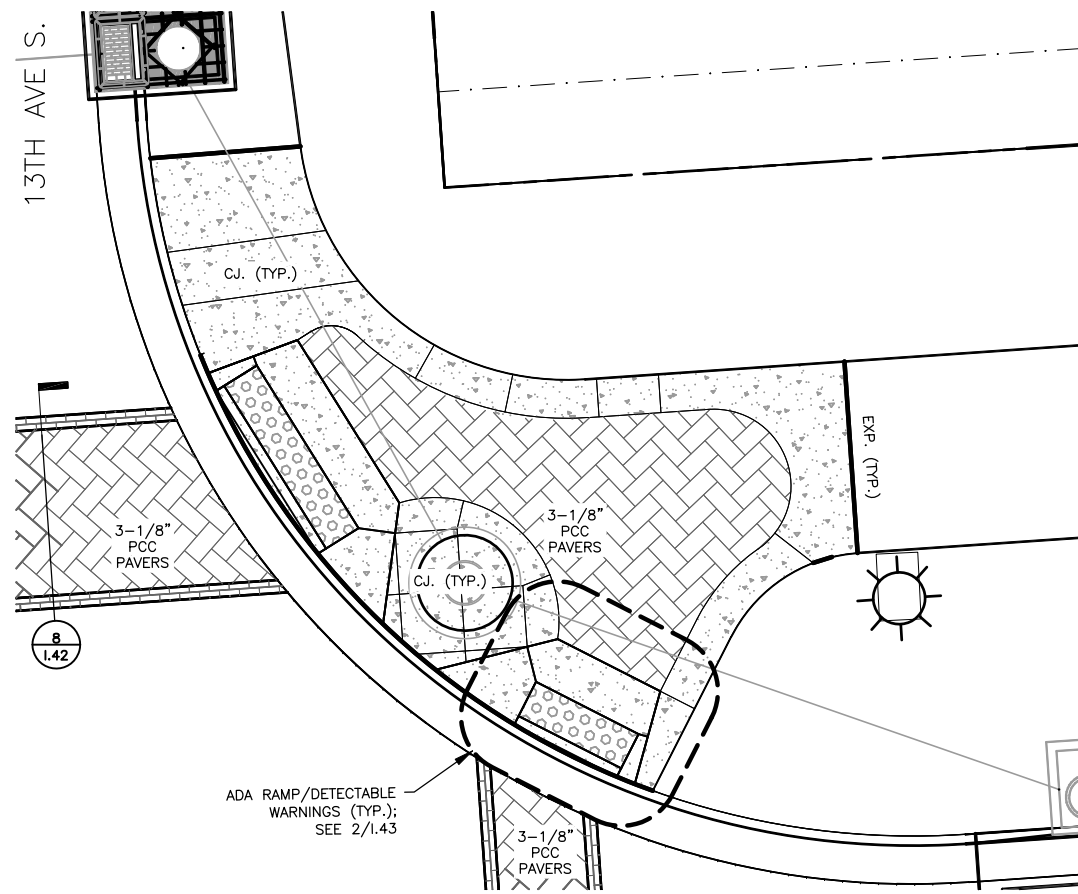

**3 NE 13TH AVE. S. JOINTING PLAN**  
SCALE: 1"=5'

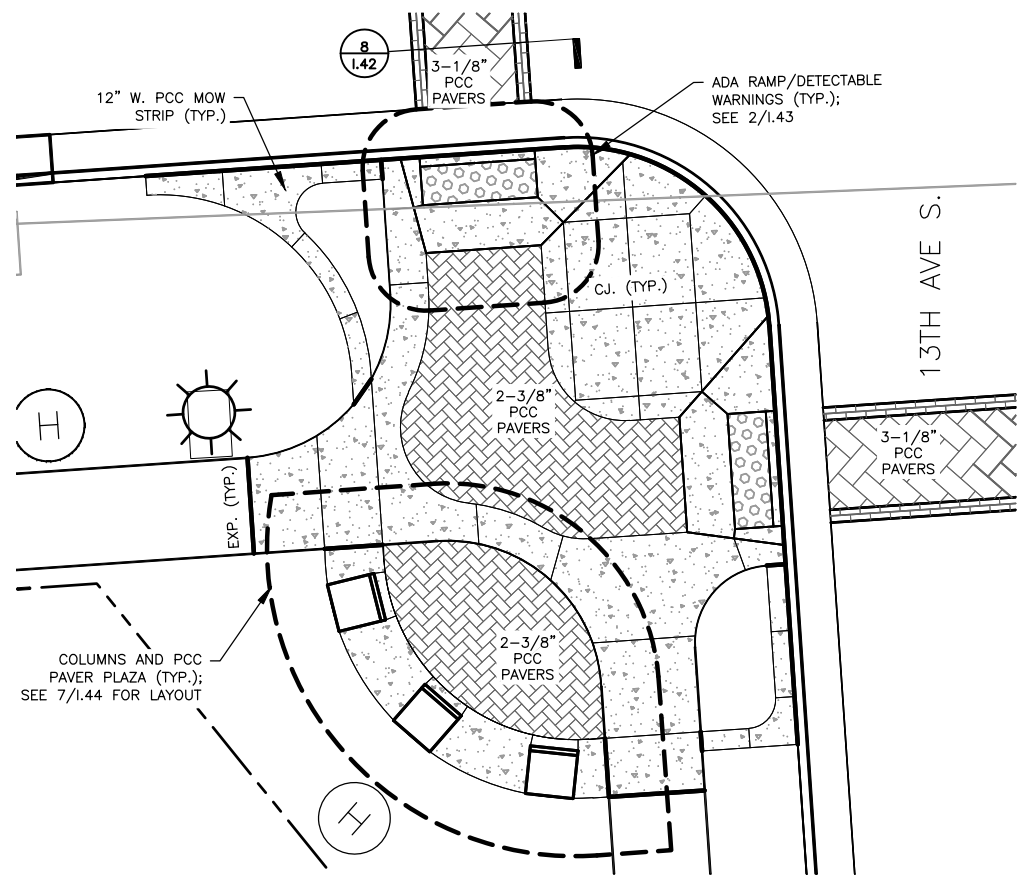

**2 SW 13TH AVE. S. JOINTING PLAN**  
SCALE: 1"=5'

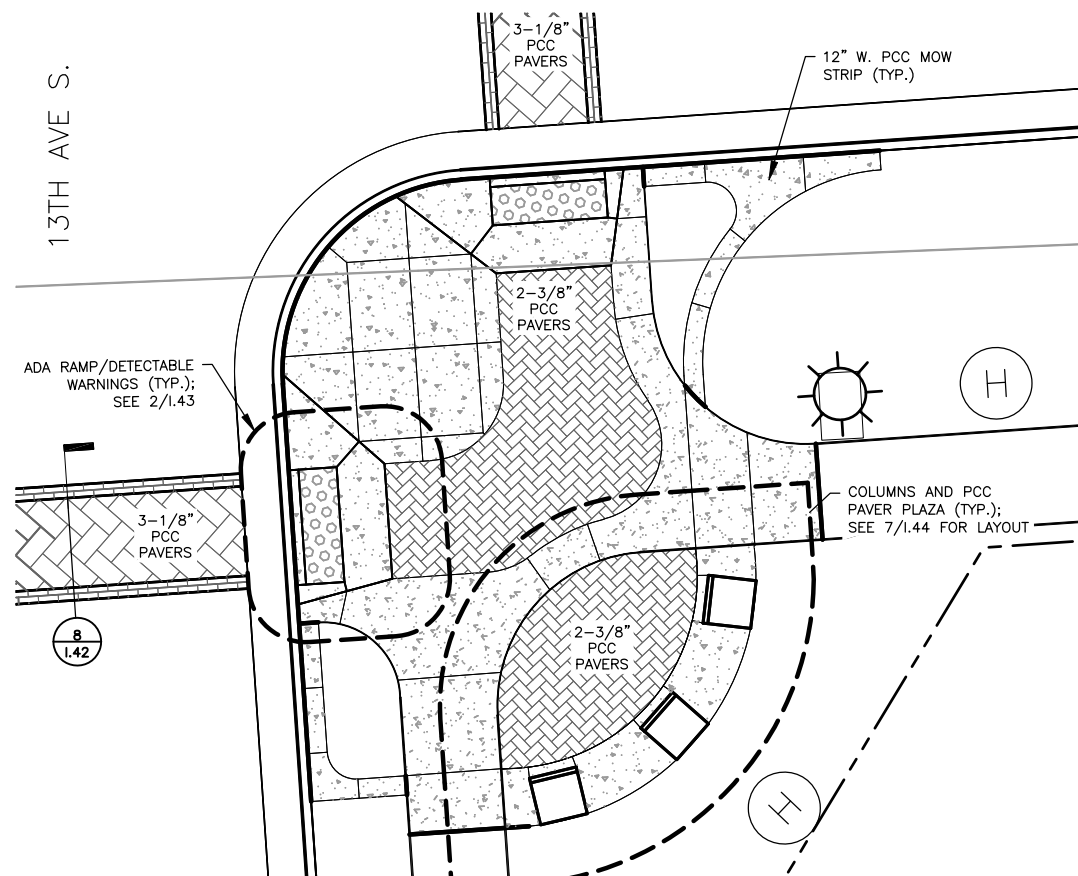

**4 SE 13TH AVE. S. JOINTING PLAN**  
SCALE: 1"=5'

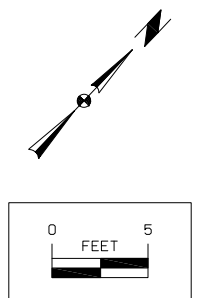





**STAGING NOTES**

108-26  
08-30-88

Traffic control on this project shall be in accordance with specific layouts shown on these plans and open to thru traffic during construction. In addition, traffic control shall be in accordance with Standard Road Plans TC-1, TC-81, TC-213, TC-216, TC-233, TC-252, TC-253, TC-273, TC-419, TC-422, TC-423, TC-429. For additional information refer to Part 6 of the Manual on Uniform Traffic Control Devices (MUTCD) and the current Standard Specifications.

The contractor shall employ sound practices of safety and traffic control. These methods and practices shall include, but not be limited to the following:

1. The contractor shall maintain access to commercial properties at all times during construction.
2. The contractor shall notify the engineer and owner(s) one (1) week prior to changes in traffic patterns during construction.
3. The channelizing device spacing shall not exceed a distance of 25 feet for taper channelization and 40 feet for tangent channelization unless specified on the staging and traffic control plan sheets.
4. The contractor shall place painted pavement markings and painted symbols and legends, as indicated by the staging and traffic control plan. The contractor shall also remove existing and temporary pavement markings and symbols and legends, as necessary, for the proposed traffic control plan.
5. Contractor shall erect all working signs on permanent 4" x 4" wood posts or alternative as approved by the engineer. Portable mountings for warning signs may be used for temporary installations of less than 3 days.
6. Special signs are shown in the plans to designate businesses. Business signs shall be 72" x 14" x 1/4". Signs shall have 6" Type C letters, unless otherwise noted. The background shall be orange. Sign lettering and symbols shall be black. The placement of these signs shall be determined by the engineer in the field.
7. Stages 1A, 1B, 1C, and 2 are considered separate construction sites to the remaining stage areas.
8. The contractor shall not begin Stage 4 work during the first construction season without prior authorization from the State.
9. The contractor shall construct the proposed sidewalk/trail on RT side from Sta. 104+25 to 120+27 in Stages 1A and 1B in order to have open to the general public as soon as possible.

**TABULATION OF SPECIAL EVENTS**

102-15  
10-29-02

Event	Location	Date
BRRRY SCURRY RIVERBOAT DAYS	THROUGHOUT CAMANCHE AVENUE	2/4/2012, 2/2/2013
AUTOS ON THE AVENUE/CORN ON THE CORNER	THROUGHOUT CAMANCHE AVENUE	June 2012, 2013
BALLONS IN JUNE NIGHT GLOW ON 5TH	THROUGHOUT CAMANCHE AVENUE	8/19/2012, 8/18/2013
	THROUGHOUT CAMANCHE AVENUE	6/28/2012, 6/27/2013

**STAGING NOTES**

108-26  
08-30-88

U. S. Highway 30/67 (Camanche Avenue) is a high volume roadway. Construction activities in this area will disrupt traffic on Camanche Avenue. Therefore, it is advisable to adopt a construction sequence that directs activities in an orderly manner to maintain most traffic patterns at all times.

Non-peak hours are determined to be 9 AM to 3 PM and 7 PM to 6 AM. Peak hours are determined to be 6 AM to 9 AM and 3 PM to 7 PM.

Due to the high traffic volumes on Camanche Avenue, the contractor is to perform work directly affecting traffic movement and flow such as staging changes on Camanche Avenue, temporary striping/signing, start-up of temporary signals, etc. during non-peak times.

It is not intended to confine the contractor's activities to the areas of suggested stages alone. It is understood that some of the various steps, though listed in numerical order may occur simultaneously. The contractor may conduct several operations concurrently, provided that traffic is maintained and that these operations do not conflict with the staging indicated herein.

It is recognized that as the various activities related to construction progress, certain situations may arise which will preclude adhering to the original construction sequence or which would readily lend themselves to more efficient staging operations. Should the contractor desire to deviate from the original plan, a written alternative plan shall be submitted to the engineer for approval.

**STAGE 1A - TRAFFIC OVERVIEW**

1. Close south side of Camanche Avenue from South 14th Street to 25th Place.
2. Close the east side of South 14th Street from Sta. 1197+30 to Sta. 1199+90.
3. Close south access to 25th Place.
4. Close west access on S 14th Street Sta. 1197+95, LT. Also close access at Liberty Avenue.
5. Restrict Camanche Avenue westbound traffic to one lane and shift the Camanche Avenue eastbound lanes northerly as shown on Sheets J.4 and J.5.
6. Refer to J.4 and J.5 for traffic control details. Refer to 108-22 and 108-29 in the C sheets for striping details.

**CONSTRUCTION SEQUENCE**

1. Construct temporary pavement as shown on J.4 and J.5. Refer to the F Sheets for additional information. Install curb and gutter along temporary pavement in areas shown on J.4, J.5 and F Sheets.
2. Remove existing intake tops and inserts on structures TS-1, TS-2, TS-3, TS-4. Construct Area Intake Grates (SW-604, Type 6) with concrete risers to elevations indicated on temporary storm sewer tabulations on J.3.
3. Remove existing pavement and install temporary shoring and temporary barrier rail as shown on J.4. Refer to tabulations in the C Sheets for location and quantity.
4. Construct 32 LF of P-306 (30" RCP) and plug.
5. Construct temporary storm sewer pipe TP-2. Refer to the storm sewer tabulations on J.3 for additional information.
6. Construct the south side of Camanche Avenue from Sta. 104+40 to Sta. 320+43 (Liberty Ave). Construction does not include 2.5' curb and gutter section left from Sta. 109+53 to Sta. 112+41.
7. Construct the east side of South 14th Street from Sta. 1197+30 to Sta. 1199+68.
8. Construct Liberty Avenue from Sta. 315+57 to Sta. 320+33.
9. Construct remaining storm sewer, pavement, drives and other related work on Liberty Avenue, south side of Camanche Avenue, and the east side of South 14th Street.
10. Contractor shall provide temporary drainage measures as necessary. Refer to J.3 for additional information on temporary drainage.
11. Remove pavement, sidewalk, etc. as necessary to build the above sections of roadway. Removals include portions of Camanche Avenue, Liberty, and South 14th Street.
12. Install and activate temporary traffic signal at the intersection of Camanche Avenue and South 14th Street as shown on the N Sheets.

**STAGING NOTES**

108-26  
08-30-88

13. Remove existing signals at the SE and SW corners of South 14th Street and Camanche Avenue.
14. Install and activate temporary traffic signals on the north end of the existing bridge on South 14th Street.

**STAGE 1B - TRAFFIC OVERVIEW**

1. Close south side of Camanche Avenue from Sta. 100+50 to Sta. 114+85.
2. Close the west side of South 14th Street from Sta. 1197+30 to Sta. 1199+90.
3. Restrict Camanche Avenue Eastbound and Westbound traffic to a two-lane, two-way operation from Sta. 100+08 to Sta. 114+85.
4. Shift South 14th Street traffic to the east side lanes and use a two-lane, two-way operation from the north side of the bridge to Prospect Avenue.
5. Refer to J.6 and J.7 for traffic control details. Refer to 108-22 and 108-29 in the C sheets for striping details.

**CONSTRUCTION SEQUENCE**

1. Construct temporary pavement at the intersection of Camanche Avenue and South 14th Street connecting proposed Stage 1-A pavement to the existing Camanche Avenue pavement. Construct under traffic. Refer to F sheets for additional information.
2. Construct temporary storm sewer pipe TP-3 to proposed storm sewer pipe P-303 and existing storm sewer. Refer to J.3 for additional information.
3. Construct remaining storm sewer, pavement, sidewalk and other related work on Camanche Avenue Eastbound and the west side of South 14th Street.
4. Contractor shall provide temporary drainage measures as necessary. Refer to J.3 for additional information on temporary drainage.
5. Remove pavement, sidewalk, etc. as necessary to build the above mentioned sections of roadway.

**STAGE 1C - TRAFFIC OVERVIEW**

1. Shift Eastbound traffic through Camanche Avenue and S. 14th Street and use newly constructed Camanche and Liberty Avenues.
2. Open up right turn lane for traffic traveling Eastbound on Camanche Avenue to South 14th Street.
3. Open two (2) lanes of traffic Westbound on existing Camanche Avenue.
4. Refer to J.8 and J.9 for traffic control details. Refer to 108-22 and 108-29 in the C Sheets for striping details.

**CONSTRUCTION SEQUENCE**

1. Construct portions of Camanch Avenue pavement from Sta. 100+52 to Sta. 104+23. This includes portions of the median area as shown on J.8.
2. Construct temporary pavement over a portion of P-303 constructed in Stage 1-B. Refer to F Sheets for additional information.
3. Remove pavement as necessary to build the above mentioned sections of roadway and median.

**STAGE 2 - TRAFFIC OVERVIEW**

1. Close South 14th Street north of Camanche Avenue.
2. Close the north side (Westbound) lanes of Camanche Avenue from Sta. 102+33 to Sta. 115+20.
3. Close Barker Street north of Camanche Avenue.
4. Close 25th Place north and south of Camanche Avenue.
5. Close 23rd Place south of Camanche Avenue.
6. Restrict Camanche Avenue traffic to a two-lane, two-way operation (using proposed pavement) from Sta. 100+03 to Liberty Avenue.
7. Refer to J.10 for traffic control details. Refer to tabulations 108-22 and 108-29 in the C Sheets for striping details.

**CONSTRUCTION SEQUENCE**

1. Construct temporary pavement crossover from Sta. 109+53 to Sta. 113+90.
2. Construct the north side (Westbound) of Camanche Avenue from Sta. 102+35 to Sta. 110+30. Construct temporary sanitary sewer connection from proposed manhole at Sta. 109+00 to existing manhole at Sta. 109+56. Fill existing sanitary sewer with flowable fill from existing manhole at Sta. 109+56 west to existing manhole at Sta. 104+57.
3. Construct the southern most westbound lane for Camanche Avenue from Sta. 113+72 to Sta. 122+56.
4. Construct the southern most westbound lane for Camanche Avenue from Sta. 124+60 to Sta. 133+78.

**STAGING NOTES**

108-26  
08-30-88

5. Construct the north side of South 14th Street from Sta. 1199+75 to Sta. 1201+64.
6. Construct 23rd Place south of Camanche Avenue.
7. Construct sanitary sewer from Manhole SS at Sta. 1499+46 at the Southwest corner of Camanche Avenue and 22nd Place. Make connection to existing manhole at Sta. 1497+86 on 22nd Place.
8. Construct storm sewer pipe P-409 and plug. Do not construct the southwest return or sidewalk area for Camanche Avenue and 22nd Place. This area will be constructed in Stage 3.
9. Construct storm sewer, pavement, drives, and other related work on Camanche Avenue Westbound and north side of South 14th Street.
10. Contractor shall provide temporary drainage measures as necessary. Refer to J.3 for additional information on temporary drainage.
11. Remove pavement, storm sewers, sidewalk, etc. as necessary to build the above mentioned sections of roadway.

**STAGE 3 - TRAFFIC OVERVIEW**

1. Close south side (existing eastbound lanes) of Camanche Avenue from Sta. 108+87 to Sta. 187+08.
2. Alternate closures at the following side streets south of Camanche Avenue to maintain access between Camanche Avenue and Liberty Avenue: 24th Place, 21st Place, 17th Place, 15th Place 13th Place, and 12th Avenue.
3. Restrict westbound traffic to two (2) lanes on Camanche Avenue from Sta. 114+50 to Sta. 187+08.
4. Use temporary pavement for connection at Sta. 110+31 for existing westbound traffic (two (2) lanes) onto newly constructed pavement.
5. Restrict eastbound traffic to one lane on Camanche Avenue from Sta. 109+53 to Sta. 112+29.

**CONSTRUCTION SEQUENCE**

1. Remove temporary traffic signals at the north and south ends of bridge on South 14th Street. Remove temporary traffic signal at South 14th Street and activate newly installed traffic signal.
2. Construct temporary pavement for temporary connection at Sta. 108+76 to existing pavement at Sta. 110+31 on Camanche Avenue.
3. Construct curb and gutter section and southern most westbound lanes (2) from Sta. 109+53 to Sta. 113+72.
4. Construct a single lane of westbound Camanche Avenue from Sta. 113+72 to west of 24th Place (Sta. 122+56).
5. Construct temporary pavement at 22nd Place for access north.
6. Construct the southern most westbound lanes (2) of Camanche Avenue from Sta. 133+78 to Sta. 187+08. Construct section from 12th Avenue to S. 5th Street first to allow two westbound lanes as soon as possible.
7. Construct 24th Place, 21st Place, 17th Place, 15th Place, 13th Avenue, and 12th Avenue south of Camanche Avenue. Alternate construction of side streets to maintain access between Camanche and Liberty Avenue. Maintain access for local residents and businesses within this area at all times during construction. Use existing pavement as parking for residents and businesses as necessary.
8. Construct storm sewer, sanitary sewer, sidewalk, pavement drives, and other related work on Camanche Avenue and above mentioned side roads. Construct temporary drainage structures as shown on J.11 and J.12. Refer to F Sheets for additional information. Contractor shall provide temporary drainage measures as necessary.
9. Remove pavement, storm sewers, sidewalk, etc. as necessary to build sections of roadway. Removals include portions of Camanche Avenue and the above mentioned side roads (Alternated).

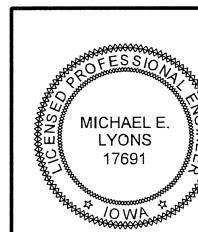

I hereby certify that this engineering document was prepared by me or under my direct personal supervision and that I am a duly licensed Professional Engineer under the laws of the State of Iowa.

*Michael E. Lyons* DATE

MICHAEL E. LYONS, P.E.  
License Number: 17691  
My license renewal date is DECEMBER 31, 2012  
Pages or sheets covered by this seal:  
J.1 - J.15

**STAGING NOTES**

108-26  
08-30-88

**STAGE 4 - TRAFFIC OVERVIEW**

1. Restrict westbound traffic to one lane on the newly constructed south lane of Camanche Avenue from Sta. 110+31 to Sta. 169+11.
2. Install temporary barrier rail from Sta. 110+31 to Sta. 154+40. Refer to C Sheets for temporary barrier rail tabulation.
3. Alternate closures at the following side streets south of Camanche Avenue to maintain access between Camanche Avenue and Liberty Avenue: 24th Place, 23rd Place, 22nd Place, 21st Place, and 17th Place.
4. Use temporary pavement to make connection with alternating closures at the following locations: 24th Place, 23rd Place, 22nd Place, 21st Place and 17th Place. Refer to F sheets for additional information.
5. Maintain access for local residents and businesses within this area at all times during construction. Use existing pavement as parking for residents and business as necessary.

**CONSTRUCTION SEQUENCE**

1. Construct the remaining pavement on Camanche Avenue from Sta. 108+50 to Sta. 154+50 as shown on J.13 and J.14.
2. Construct 25th Place, 24th Place, 23rd Place, 22nd Place, 21st Place, 20th Place, 19th Place, and 17th Place north of Camanche Avenue. Alternate construction of side streets to maintain access north of Camanche Avenue.
3. Construct storm sewer, sanitary sewer, sidewalk, pavement drives, and other related work on Camanche Avenue and the above mentioned side roads. Contractor shall provide temporary drainage measures as necessary.
4. Fill existing sanitary sewer with flowable fill and leave in place from manhole at Sta. 109+57 to southern most manhole at Sta. 140+97.18
5. Remove pavement, storm sewers, sidewalk, etc. as necessary to build the above sections of roadway. Removals include portions of Camanche Avenue and the above mentioned side roads.

**STAGE 5 - TRAFFIC OVERVIEW**

1. Alternate closures at the following side streets south of Camanche Avenue to maintain access between Camanche Avenue and Liberty Avenue: 16th Place, 15th Place, 14th Avenue, 13th Avenue, and 12th Avenue.
2. Restrict westbound traffic to one lane on the newly constructed south lane of Camanche Avenue from Sta. 154+50 to Sta. 187+08.
3. Install temporary barrier rail from Sta. 154+40 to Sta. 187+08. Refer to C Sheets for temporary barrier rail tabulation.
4. Use temporary pavement to make connection at 15th Place and 13th Avenue. Maintain access for local residents and businesses within this area at all times during construction. Use existing pavement as parking for residents and businesses as necessary.

**CONSTRUCTION SEQUENCE**

1. Construct the remaining pavement on Camanche Avenue from Sta. 154+50 to Sta. 187+08 as shown on J.15.
2. Construct 16th Place, 15th Place, 14th Avenue South, 13th Avenue, and 12th Avenue north of Camanche Avenue. Alternate construction of side streets to maintain access north of Camanche Avenue.
3. Construct storm sewer, sanitary sewer, sidewalk, pavement drives, and other related work on Camanche Avenue and the above mentioned side roads. Contractor shall provide temporary drainage measures as necessary.
4. Remove pavement, sanitary sewer, storm sewers, sidewalk, etc. as necessary to build the above sections of roadway. Removals include portions of Camanche Avenue and the above mentioned side roads.



TEMPORARY DETOUR FOR SOUTH 14TH STREET CONSTRUCTION  
(TO BE DONE BY CITY OF CLINTON DURING STAGE 2)  
NOT TO SCALE

**TEMPORARY INTAKES AND UTILITY ACCESSES**

HRG-11A

\* Included as part of bid item 'Intake Adjustment, Minor'.

\*\* For SW-545

Number	Location Station	Type or Standard Road Plan	Form Grade Elev.	Bottom Well Elev.	Extension Length* Ft.	Notes
TS-1	104+37.96	SW-501	620.00	615.11		TEMPORARY INTAKE, TYPE R GRATE
TS-2	103+82.46	SW-604	622.03			TYPE 6
TS-3	103+81.46	SW-604	621.90			TYPE 6
TS-4	103+12.34	SW-604	618.52			TYPE 6
TS-5	116+58.00	SW-512, CASE 1	600.04	596.04		24" RISER, SW-604 TYPE 3B
TS-6	121+49.00	SW-512, CASE 1	601.00	597.00		24" RISER, SW-604 TYPE 3B
TS-7	126+16.05	SW-512, CASE 1	600.83	596.60		24" RISER, SW-604 TYPE 3B
TS-8	137+30.00	SW-512, CASE 1	601.50	597.17		30" RISER, SW-604 TYPE 5
TS-9	142+68.00	SW-512, CASE 1	603.07	599.07		24" RISER, SW-604 TYPE 3B
TS-10	155+52.00	SW-512, CASE 1	601.27	597.23		24" RISER, SW-604 TYPE 3B
TS-11	162+79.04	SW-512, CASE 1	598.80	594.80		24" RISER, SW-604 TYPE 3B
TS-12	170+59.00	SW-512, CASE 2	600.43	594.15		36" RISER, SW-604 TYPE 4D

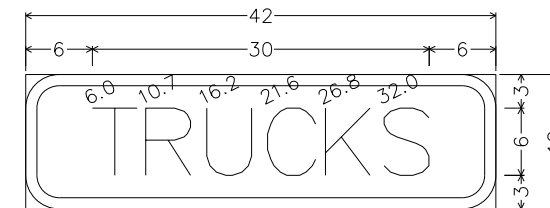

3.0" Radius, 1.0" Border, Black on Orange; [TRUCKS] D;

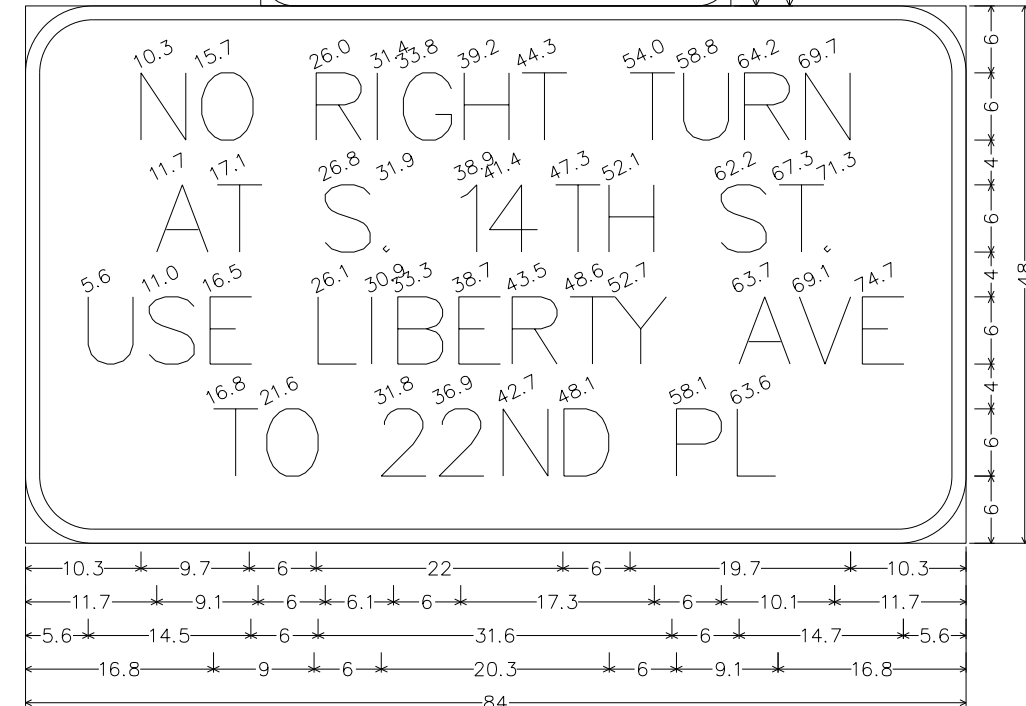

3.0" Radius, 1.0" Border, Black on Orange; [TRUCKS] D;  
6.0" Radius, 1.3" Border, Black on Orange; [NO RIGHT TURN] D; [AT S. 14TH ST.] D; [USE LIBERTY AVE] D; [TO 22ND PL] D;

**TEMPORARY STORM SEWER PIPE**

HRG-12A

Design Length, Slope, and Flowlines are calculated from inside wall to inside wall along  $\frac{1}{2}$  of pipe. An additional 6 feet length is added to Design Length to account for estimated length to center of structures.

Line Number	Intake/Utility Access No.		Pipe Diameter Inches	#Bid Length Feet	Slope %	Flow Lines		Notes
	From	To				Inlet Elevation	Outlet Elevation	
TP-1	TS-1	EXIST. 21" PIPE	18"	4.0	1.00	615.61	615.57	18-21 INCH 5 DEGREE TEE
TP-2	306	EXIST. STRUCTURE	12"	13.0	1.00	615.46	615.33	CONNECT TO EXIST. STRUCTURE, STA. 1198+36.49, 24.07' RT
TP-3	P-303	EXIST. 21" PIPE	18"	32.0	0.50	615.46	615.19	18-21 INCH TEE, 18-21 INCH 40 DEGREE TEE
TP-4	368	EXIST. STRUCTURE	18"	37.0	0.86	596.32	596.00	CONNECT TO EXIST. STRUCTURE, STA. 122+96.00, 22.00' RT
TP-5	382	EXIST. STRUCTURE	18"	60.0	0.93	596.56	596.00	CONNECT TO EXIST. STRUCTURE, STA. 123+35.00, 28.00' RT

Temporary Storm Sewer Notes:

TP-2 - Connect to existing intake at Sta. 1198+36.49, 24.07'. Remove top of existing intake, cut existing box if necessary to install a 6' concrete slab to cover top of existing box. Cover shall be drilled at the four corners and bolted down with 10" long stainless steel bolts. Cut hole in existing box for 12" pipe at the above elevation. Grout pipe and connect to proposed structure 306 by cutting hole in box at above elevation and grout. Field verify elevations to insure drainage from 306 to existing structure. Plug end of P-306 as per Standard Roadway Detail RF-21. During Stage 1B and completion of P-306, fill existing structure at Station 1198+36.49 with flowable fill and existing pipe underneath S 14th St. Remove 12" pipe and seal up hole with grout on proposed structure 306. All cost for TP-2 is included in the bid item 'Connection to Existing Intake'.

TP-4 and TP-5 - All work associated with the connection to existing structures is included in the bid item 'Connection to Existing Intake'.

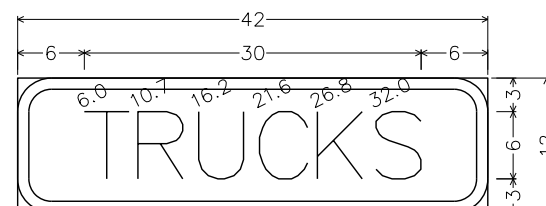

3.0" Radius, 1.0" Border, Black on Orange; [TRUCKS] D;

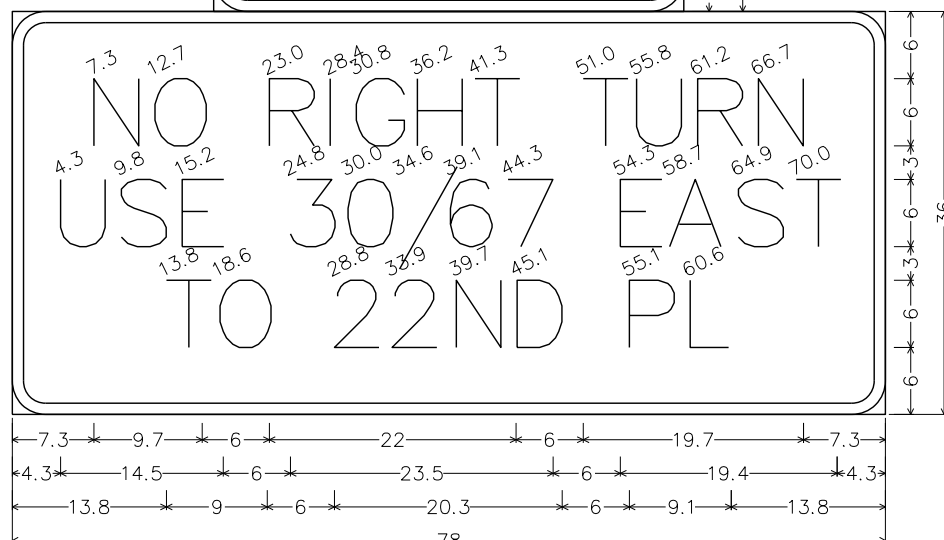

3.0" Radius, 1.0" Border, Black on Orange; [NO RIGHT TURN] D; [USE 30/67 EAST] D; [TO 22ND PL] D;

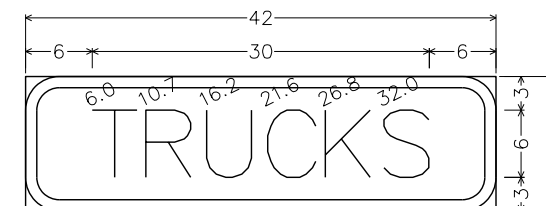

3.0" Radius, 1.0" Border, Black on Orange; [TRUCKS] D;

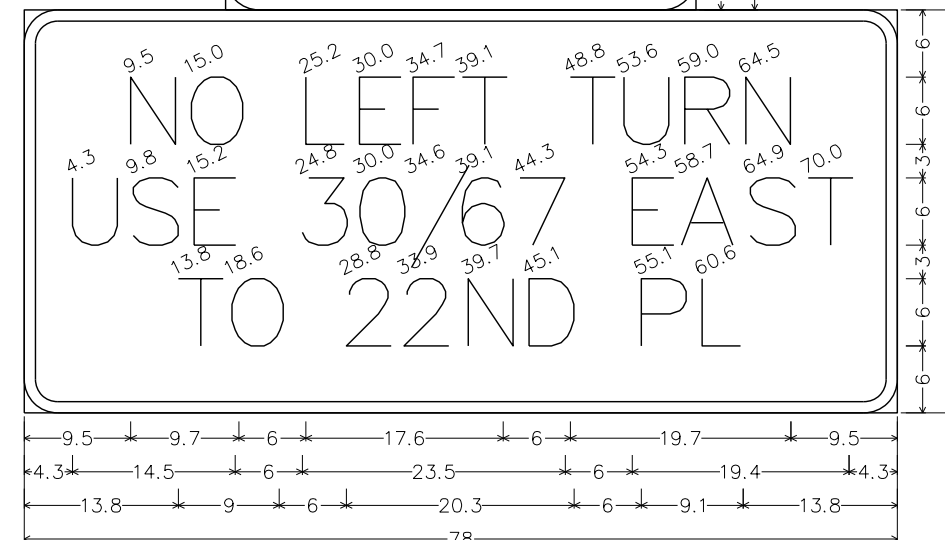

3.0" Radius, 1.0" Border, Black on Orange; [NO LEFT TURN] D; [USE 30/67 EAST] D; [TO 22ND PL] D;

REFER TO N-SHEETS FOR TRAFFIC SIGNAL DETAILS.

REFER TO TABULATIONS 108-22, 108-29 AND K-SHEETS FOR THE TEMPORARY AND PERMANENT PAVEMENT MARKING DETAILS AND LOCATIONS.

REFER TO TABULATIONS HRG-11A AND HRG-12A ON J SHEETS FOR TEMPORARY DRAINAGE INFORMATION AND LOCATIONS.

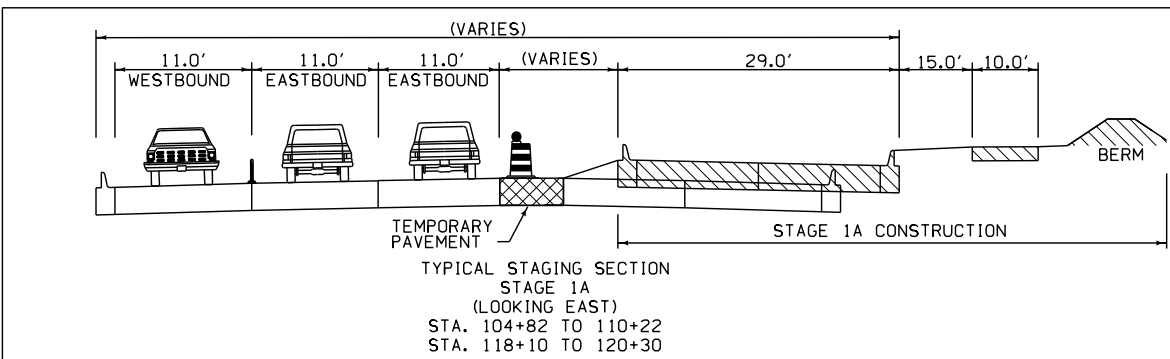
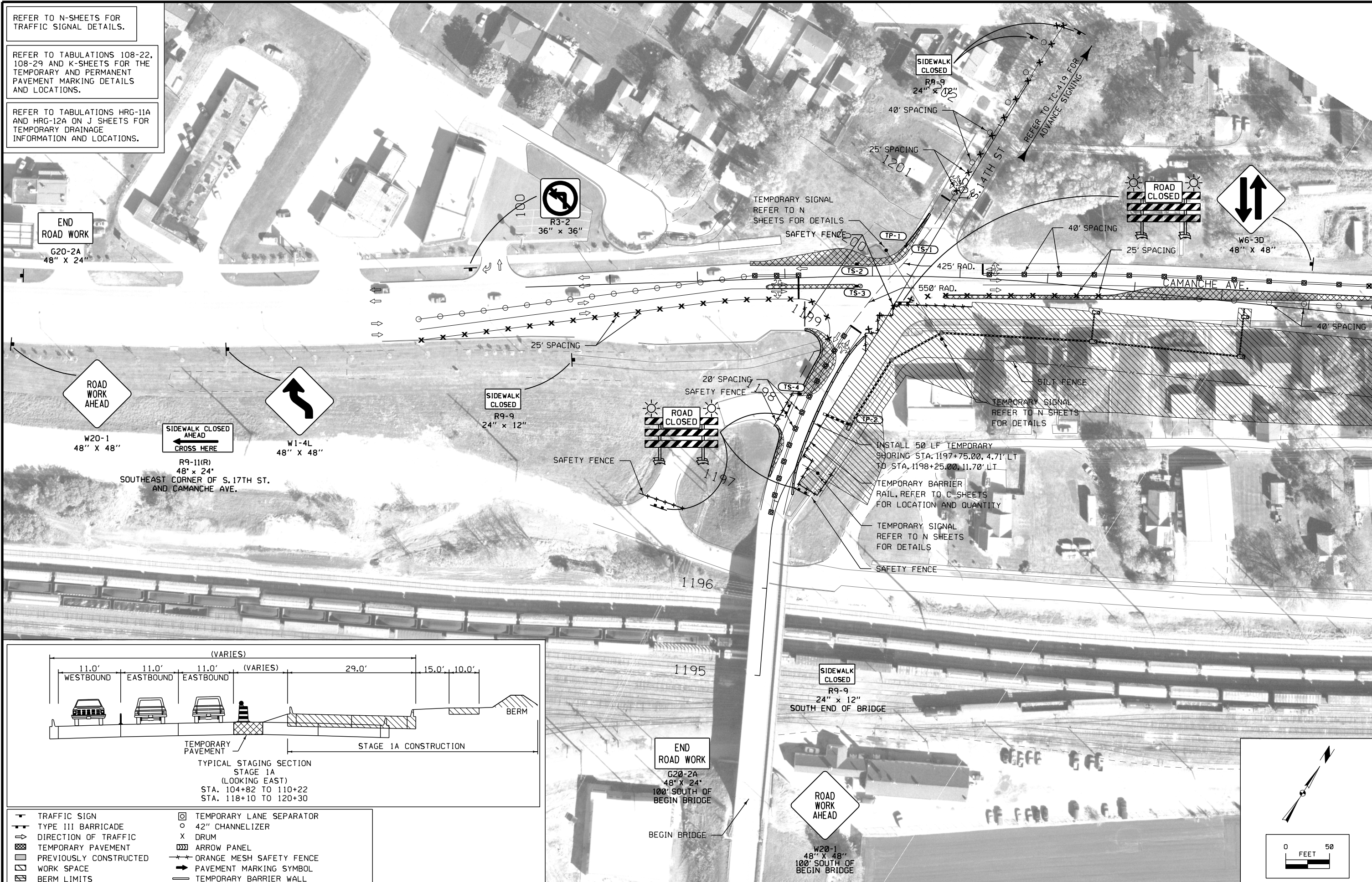

TRAFFIC SIGN	TEMPORARY LANE SEPARATOR
TYPE III BARRICADE	42" CHANNELIZER
DIRECTION OF TRAFFIC	DRUM
TEMPORARY PAVEMENT	ARROW PANEL
PREVIOUSLY CONSTRUCTED	ORANGE MESH SAFETY FENCE
WORK SPACE	PAVEMENT MARKING SYMBOL
BERM LIMITS	TEMPORARY BARRIER WALL

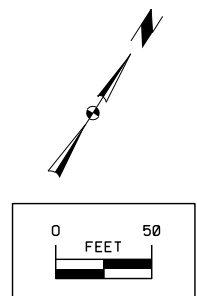

REFER TO N-SHEETS FOR TRAFFIC SIGNAL DETAILS.

REFER TO TABULATIONS 108-22, 108-29 AND K-SHEETS FOR THE TEMPORARY AND PERMANENT PAVEMENT MARKING DETAILS AND LOCATIONS.

REFER TO TABULATIONS HRG-11A AND HRG-12A ON J SHEETS FOR TEMPORARY DRAINAGE INFORMATION AND LOCATIONS.

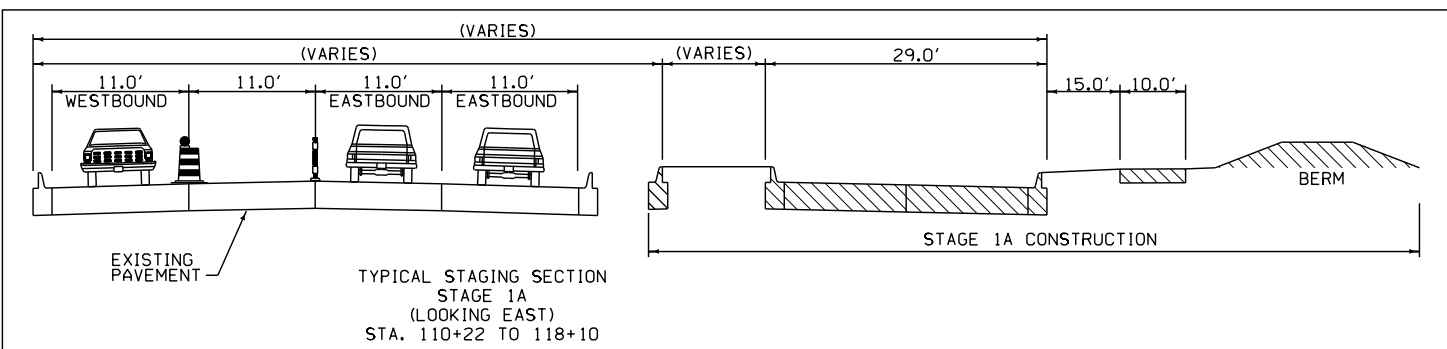
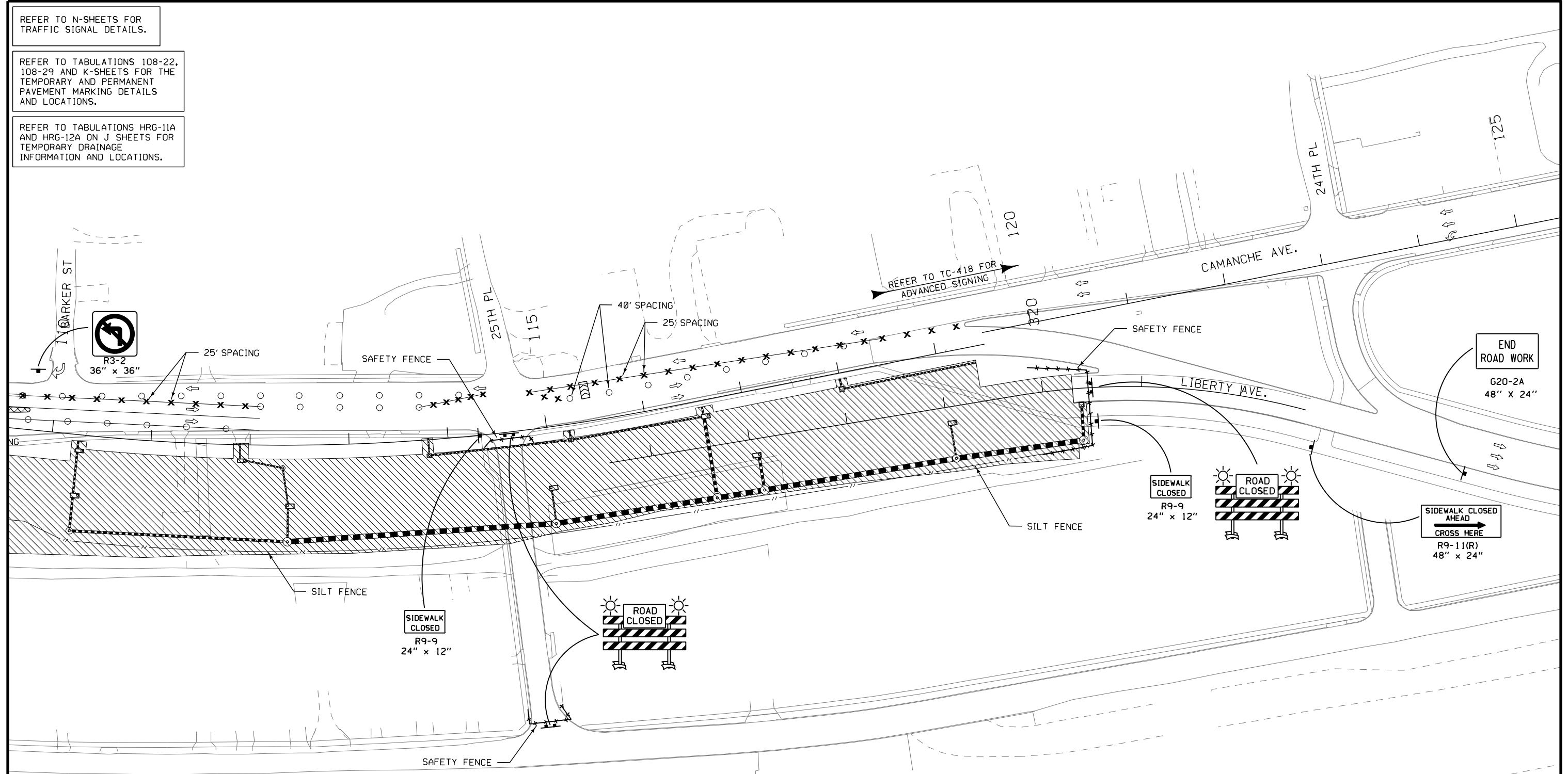

- |   |   |
|---|---|
| <ul style="list-style-type: none"> <li>— TRAFFIC SIGN</li> <li>— TYPE III BARRICADE</li> <li>— DIRECTION OF TRAFFIC</li> <li>— TEMPORARY PAVEMENT</li> <li>— PREVIOUSLY CONSTRUCTED</li> <li>— WORK SPACE</li> <li>— BERM LIMITS</li> </ul> | <ul style="list-style-type: none"> <li>□ TEMPORARY LANE SEPARATOR</li> <li>○ 42" CHANNELIZER</li> <li>× DRUM</li> <li>▨ ARROW PANEL</li> <li>— ORANGE MESH SAFETY FENCE</li> <li>— PAVEMENT MARKING SYMBOL</li> <li>— TEMPORARY BARRIER WALL</li> </ul> |
|---|---|

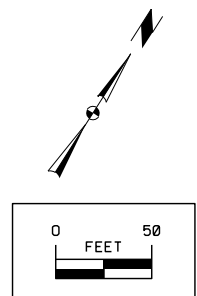

REFER TO N-SHEETS FOR TRAFFIC SIGNAL DETAILS.

REFER TO TABULATIONS 108-22, 108-29 AND K-SHEETS FOR THE TEMPORARY AND PERMANENT PAVEMENT MARKING DETAILS AND LOCATIONS.

REFER TO TABULATIONS HRG-11A AND HRG-12A ON J SHEETS FOR TEMPORARY DRAINAGE INFORMATION AND LOCATIONS.

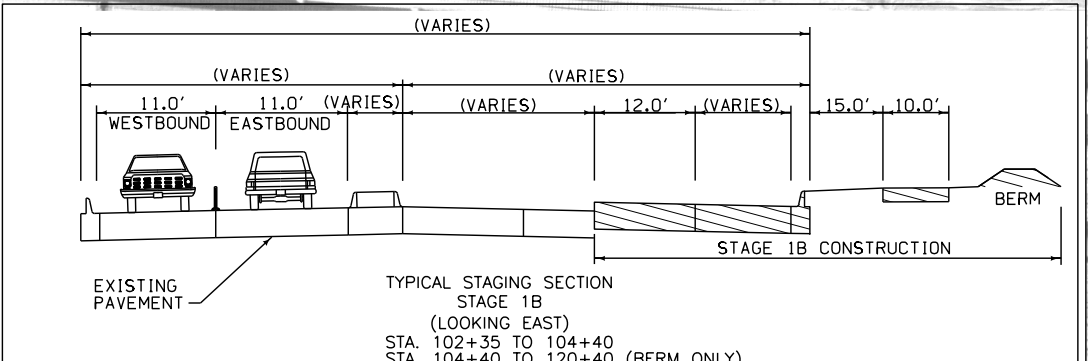
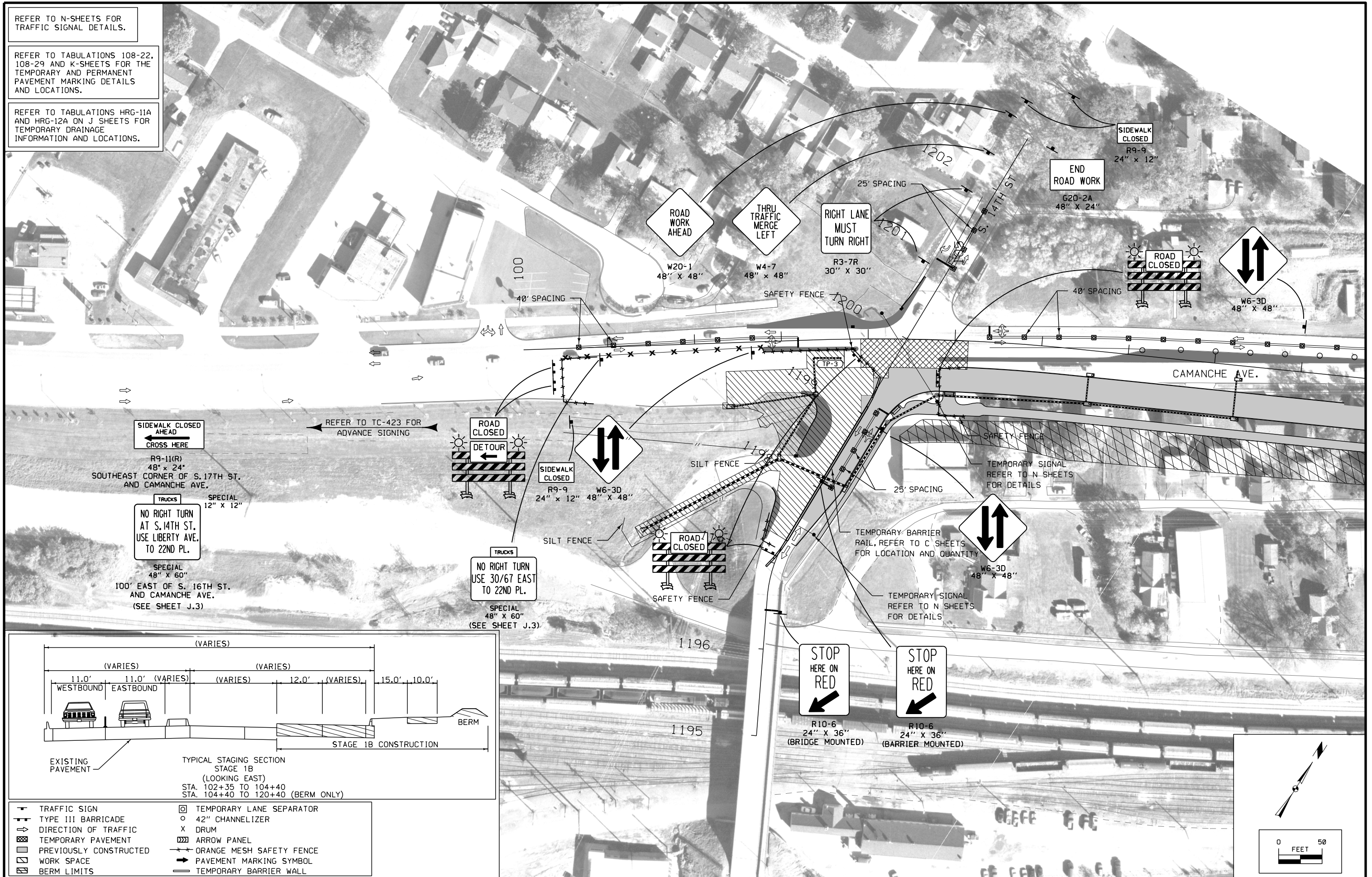

<ul style="list-style-type: none"> <li>TRAFFIC SIGN</li> <li>TYPE III BARRICADE</li> <li>DIRECTION OF TRAFFIC</li> <li>TEMPORARY PAVEMENT</li> <li>PREVIOUSLY CONSTRUCTED</li> <li>WORK SPACE</li> <li>BERM LIMITS</li> </ul>	<ul style="list-style-type: none"> <li>TEMPORARY LANE SEPARATOR</li> <li>42" CHANNELIZER</li> <li>DRUM</li> <li>ARROW PANEL</li> <li>ORANGE MESH SAFETY FENCE</li> <li>PAVEMENT MARKING SYMBOL</li> <li>TEMPORARY BARRIER WALL</li> </ul>
---	---

REFER TO N-SHEETS FOR TRAFFIC SIGNAL DETAILS.

REFER TO TABULATIONS 108-22, 108-29 AND K-SHEETS FOR THE TEMPORARY AND PERMANENT PAVEMENT MARKING DETAILS AND LOCATIONS.

REFER TO TABULATIONS HRG-11A AND HRG-12A ON J SHEETS FOR TEMPORARY DRAINAGE INFORMATION AND LOCATIONS.

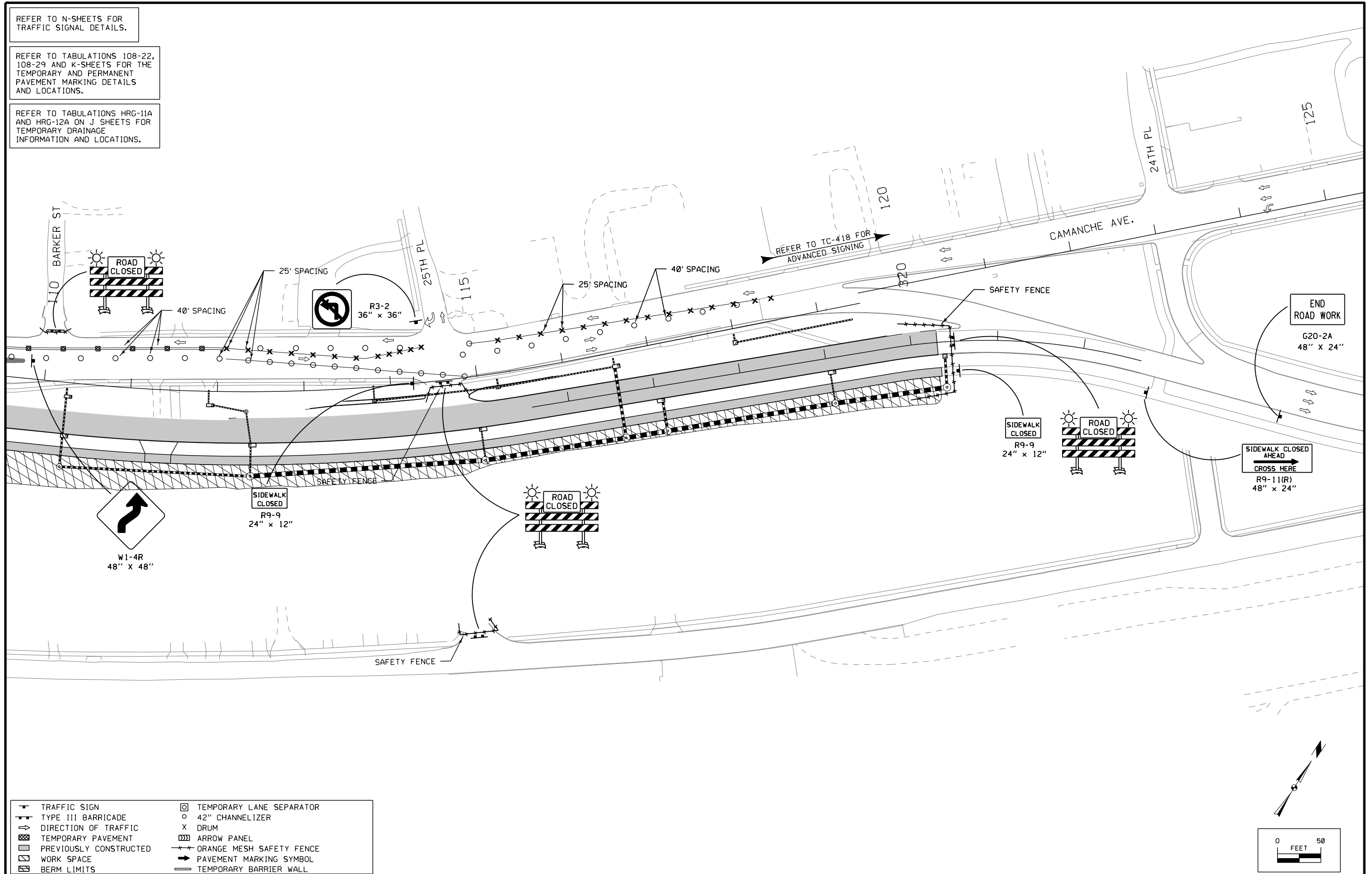

—	TRAFFIC SIGN	⊠	TEMPORARY LANE SEPARATOR
—	TYPE III BARRICADE	○	42" CHANNELIZER
→	DIRECTION OF TRAFFIC	x	DRUM
▨	TEMPORARY PAVEMENT	▨	ARROW PANEL
▨	PREVIOUSLY CONSTRUCTED	—x—x—	ORANGE MESH SAFETY FENCE
▨	WORK SPACE	→	PAVEMENT MARKING SYMBOL
▨	BERM LIMITS	—	TEMPORARY BARRIER WALL

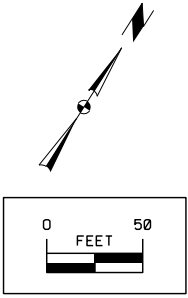



REFER TO N-SHEETS FOR TRAFFIC SIGNAL DETAILS.

REFER TO TABULATIONS 108-22, 108-29 AND K-SHEETS FOR THE TEMPORARY AND PERMANENT PAVEMENT MARKING DETAILS AND LOCATIONS.

REFER TO TABULATIONS HRG-11A AND HRG-12A ON J SHEETS FOR TEMPORARY DRAINAGE INFORMATION AND LOCATIONS.

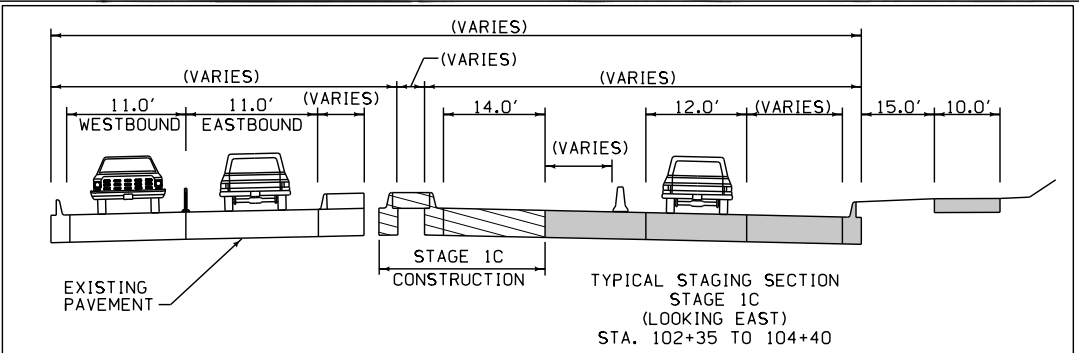
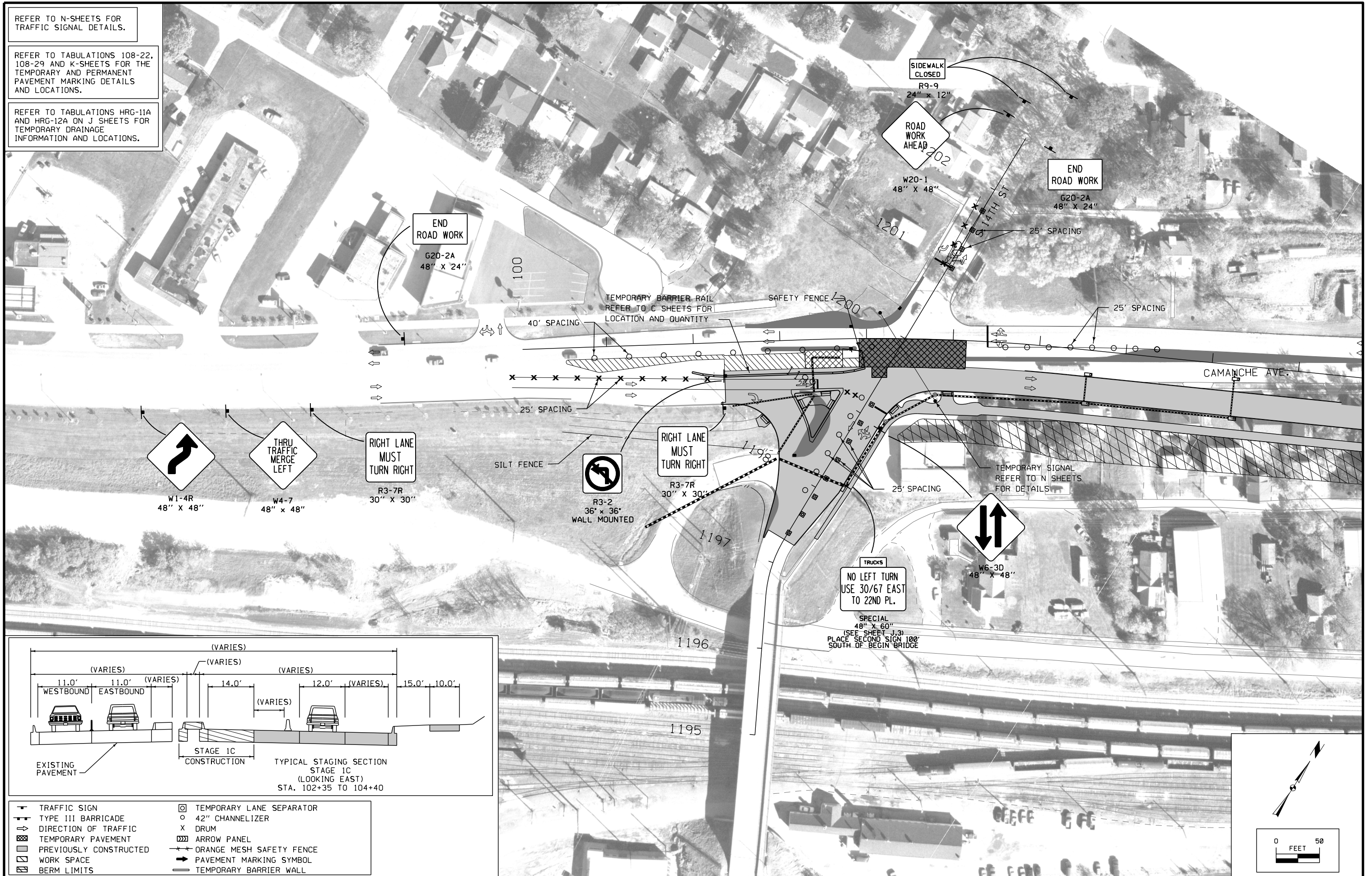

	TRAFFIC SIGN		TEMPORARY LANE SEPARATOR
	TYPE III BARRICADE		42" CHANNELIZER
	DIRECTION OF TRAFFIC		DRUM
	TEMPORARY PAVEMENT		ARROW PANEL
	PREVIOUSLY CONSTRUCTED		ORANGE MESH SAFETY FENCE
	WORK SPACE		PAVEMENT MARKING SYMBOL
	BERM LIMITS		TEMPORARY BARRIER WALL

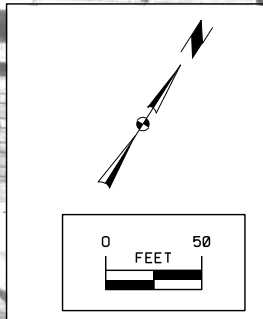

REFER TO N-SHEETS FOR TRAFFIC SIGNAL DETAILS.

REFER TO TABULATIONS 108-22, 108-29 AND K-SHEETS FOR THE TEMPORARY AND PERMANENT PAVEMENT MARKING DETAILS AND LOCATIONS.

REFER TO TABULATIONS HRG-11A AND HRG-12A ON J SHEETS FOR TEMPORARY DRAINAGE INFORMATION AND LOCATIONS.

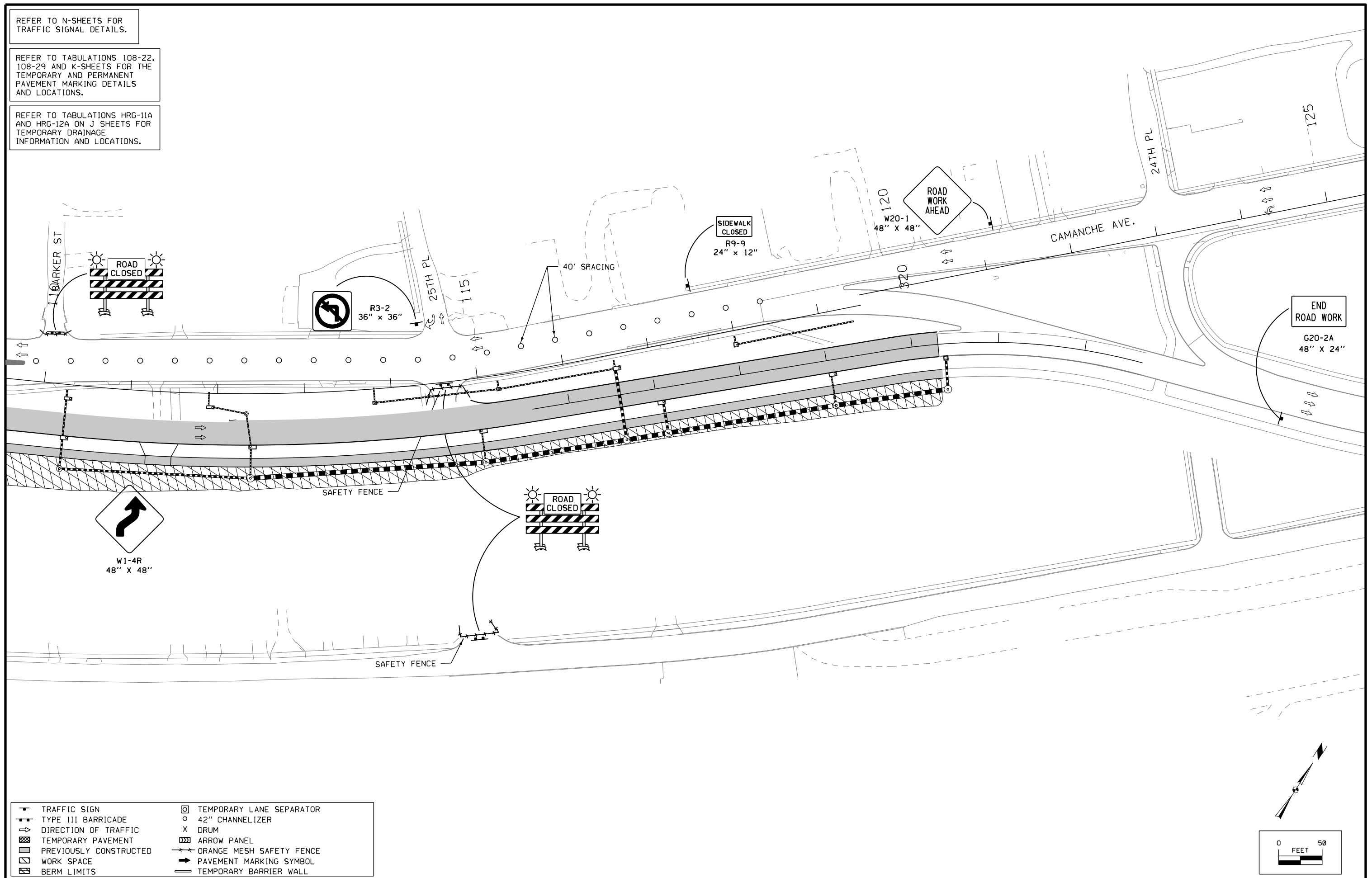

	TRAFFIC SIGN		TEMPORARY LANE SEPARATOR
	TYPE III BARRICADE		42" CHANNELIZER
	DIRECTION OF TRAFFIC		DRUM
	TEMPORARY PAVEMENT		ARROW PANEL
	PREVIOUSLY CONSTRUCTED		ORANGE MESH SAFETY FENCE
	WORK SPACE		PAVEMENT MARKING SYMBOL
	BERM LIMITS		TEMPORARY BARRIER WALL

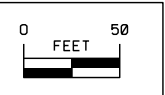
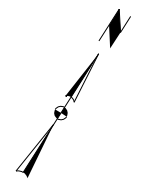

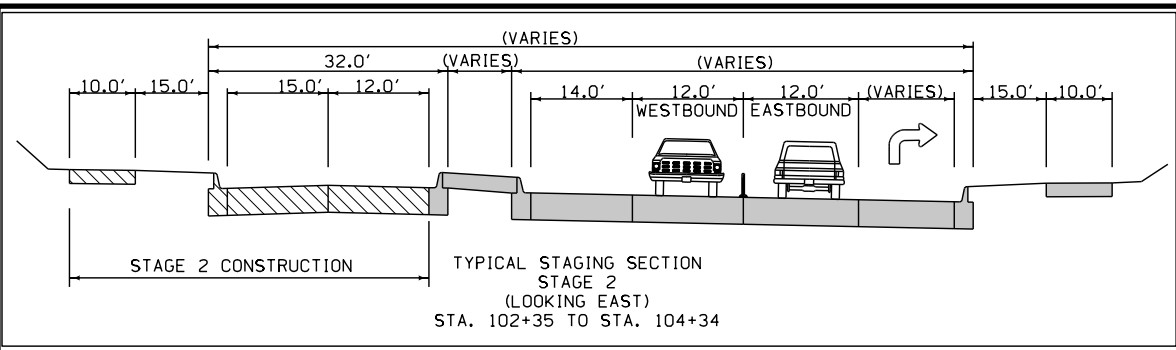

REFER TO N-SHEETS FOR TRAFFIC SIGNAL DETAILS.

REFER TO TABULATIONS 108-22, 108-29 AND K-SHEETS FOR THE TEMPORARY AND PERMANENT PAVEMENT MARKING DETAILS AND LOCATIONS.

REFER TO TABULATIONS HRG-11A AND HRG-12A ON J SHEETS FOR TEMPORARY DRAINAGE INFORMATION AND LOCATIONS.

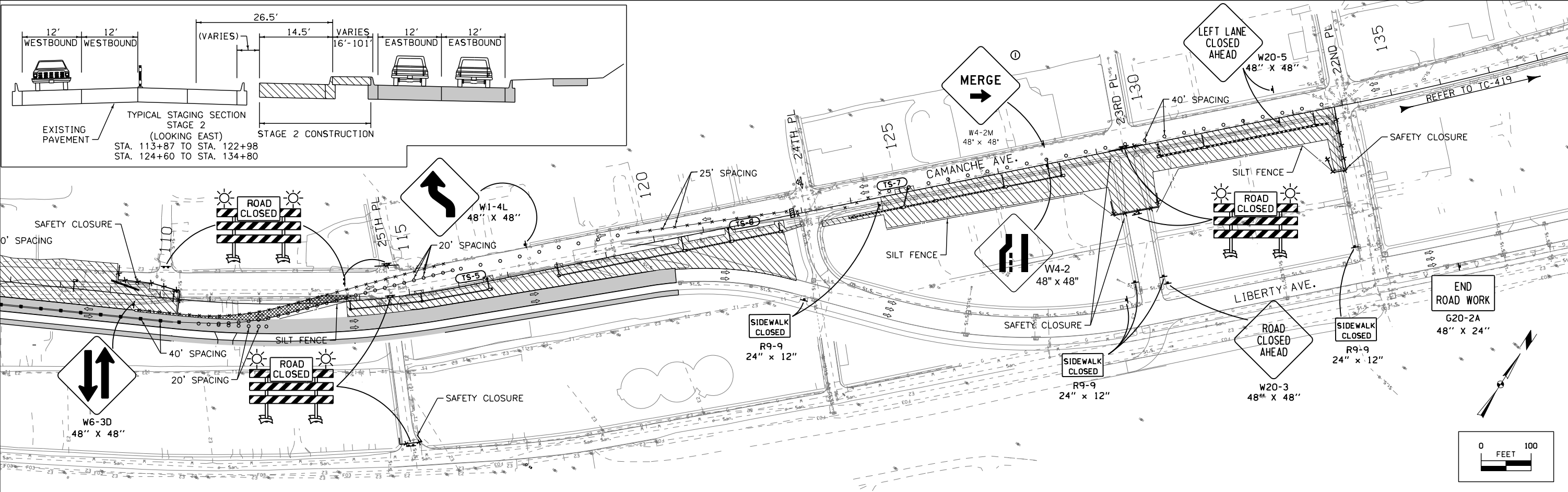
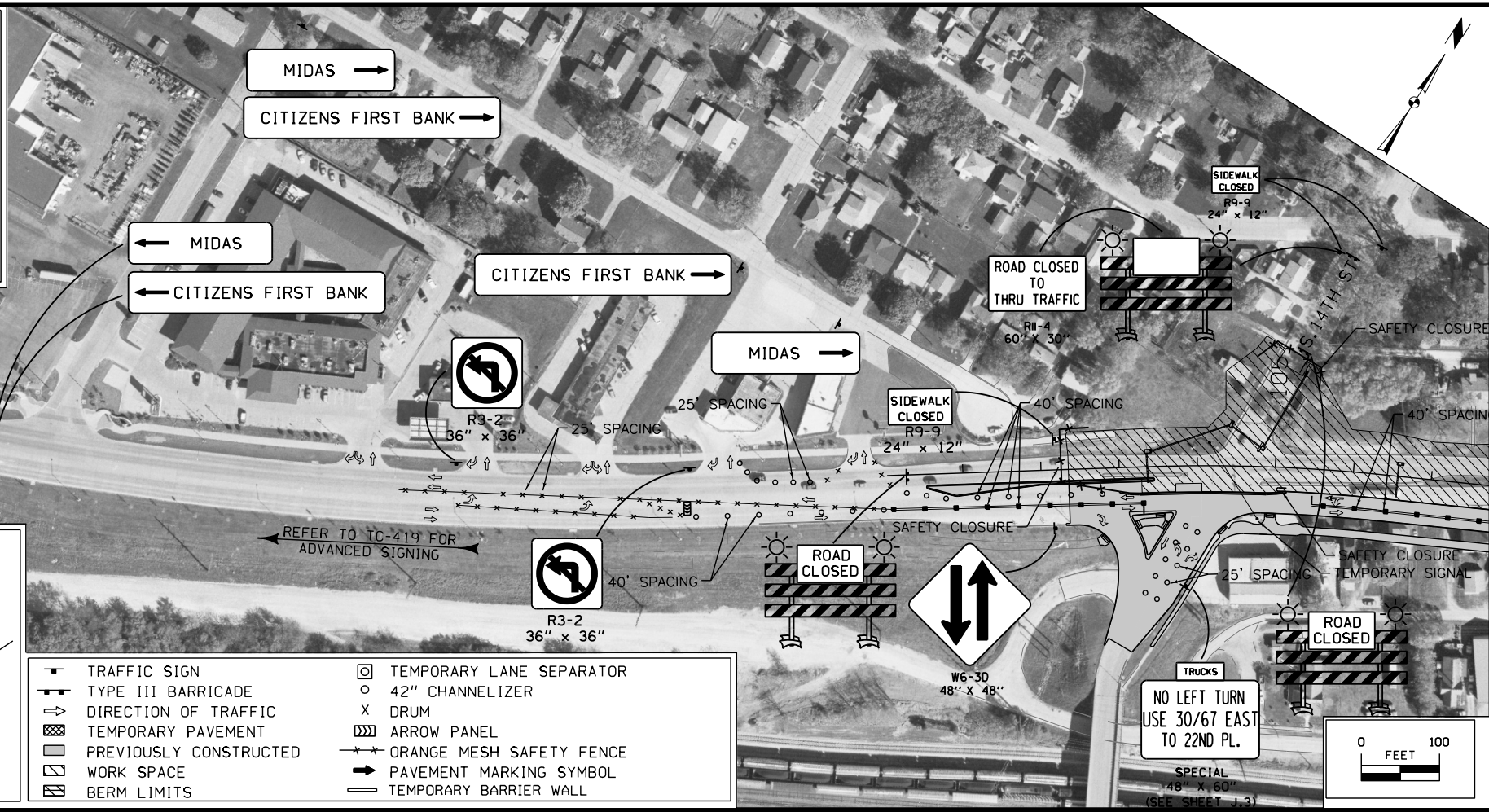
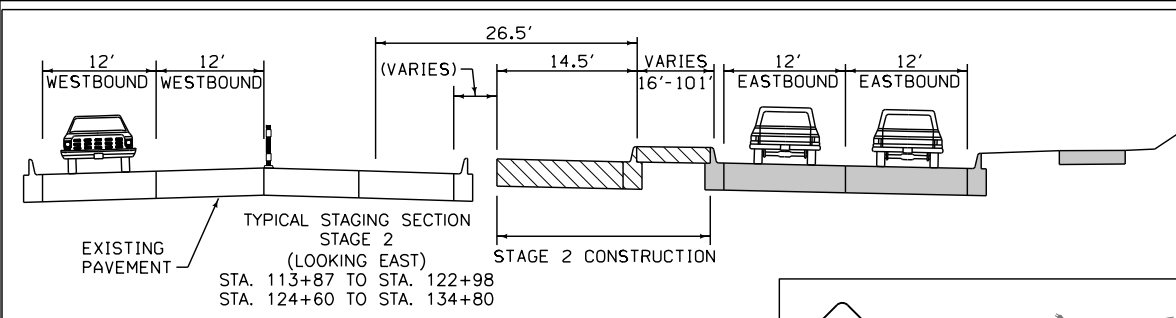
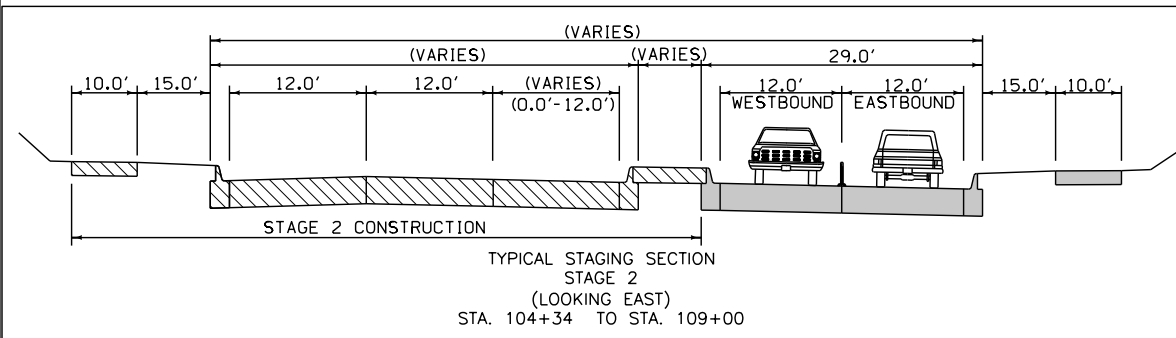

REFER TO N-SHEETS FOR TRAFFIC SIGNAL DETAILS.

REFER TO TABULATIONS HRG-11A AND HRG-12A ON J SHEETS FOR TEMPORARY DRAINAGE INFORMATION AND LOCATIONS.

REFER TO TABULATIONS 108-22, 108-29 AND K-SHEETS FOR THE TEMPORARY AND PERMANENT PAVEMENT MARKING DETAILS AND LOCATIONS.

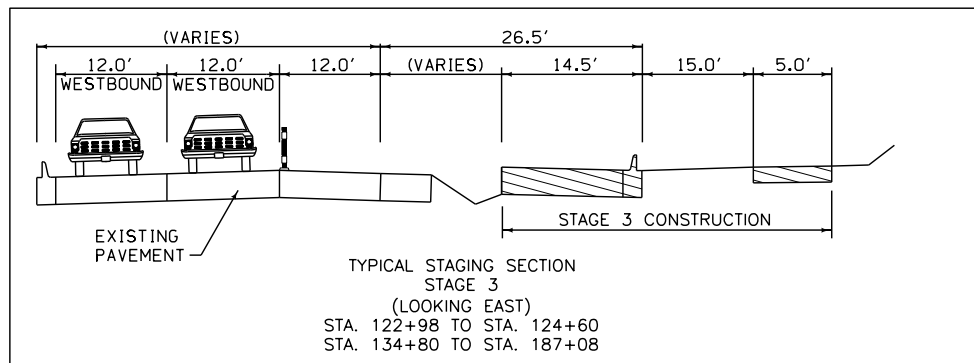
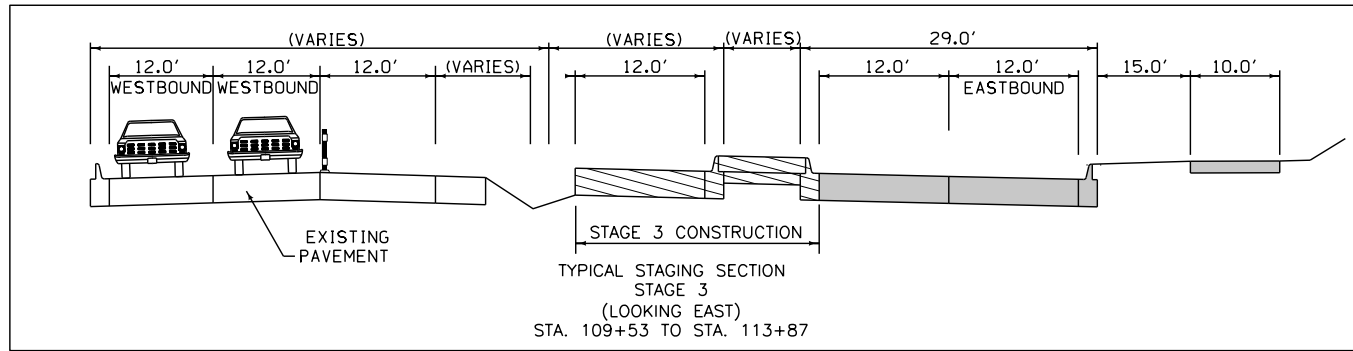

- |                        |                          |
|------------------------|--------------------------|
| TRAFFIC SIGN           | TEMPORARY LANE SEPARATOR |
| TYPE III BARRICADE     | 42" CHANNELIZER          |
| DIRECTION OF TRAFFIC   | DRUM                     |
| TEMPORARY PAVEMENT     | ARROW PANEL              |
| PREVIOUSLY CONSTRUCTED | ORANGE MESH SAFETY FENCE |
| WORK SPACE             | PAVEMENT MARKING SYMBOL  |
| BERM LIMITS            | TEMPORARY BARRIER WALL   |

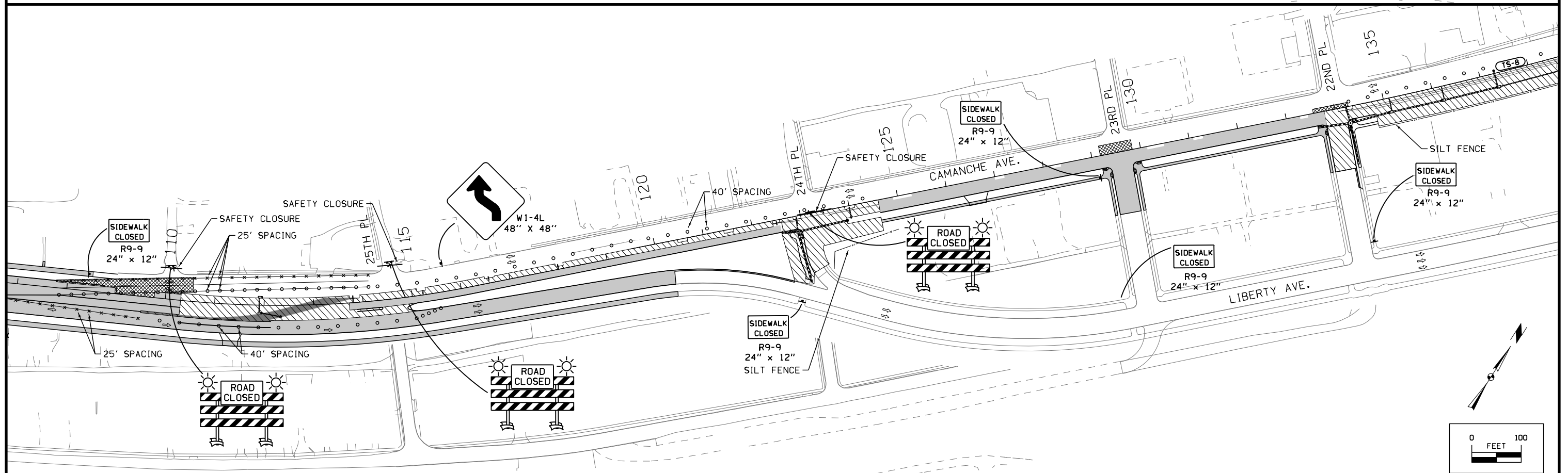
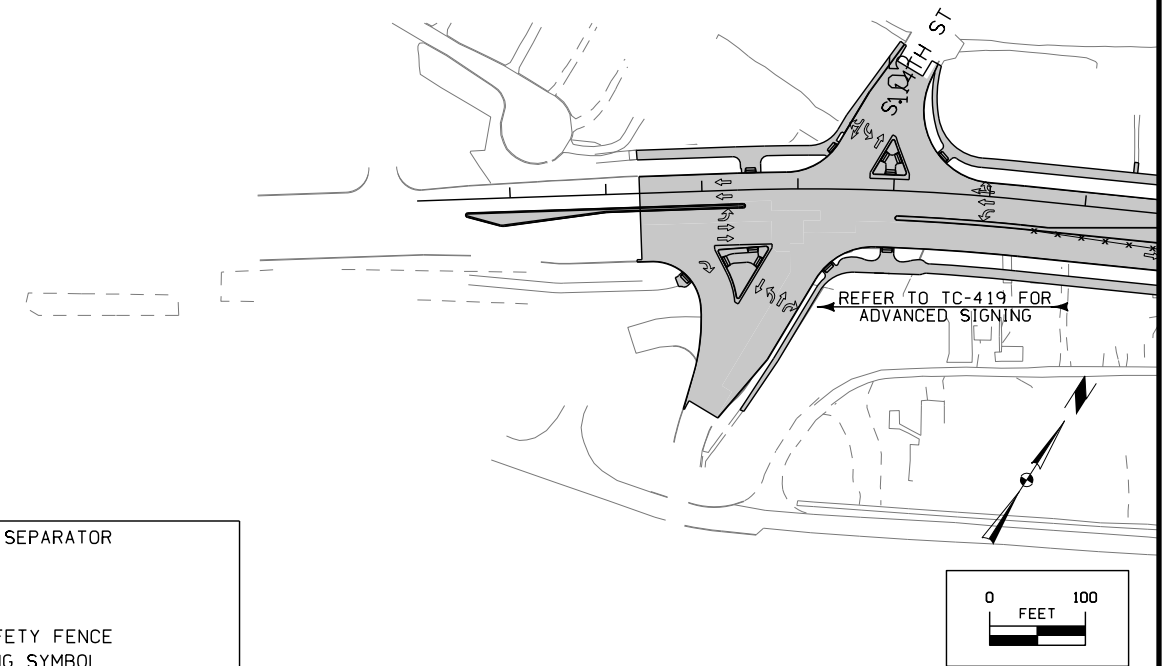

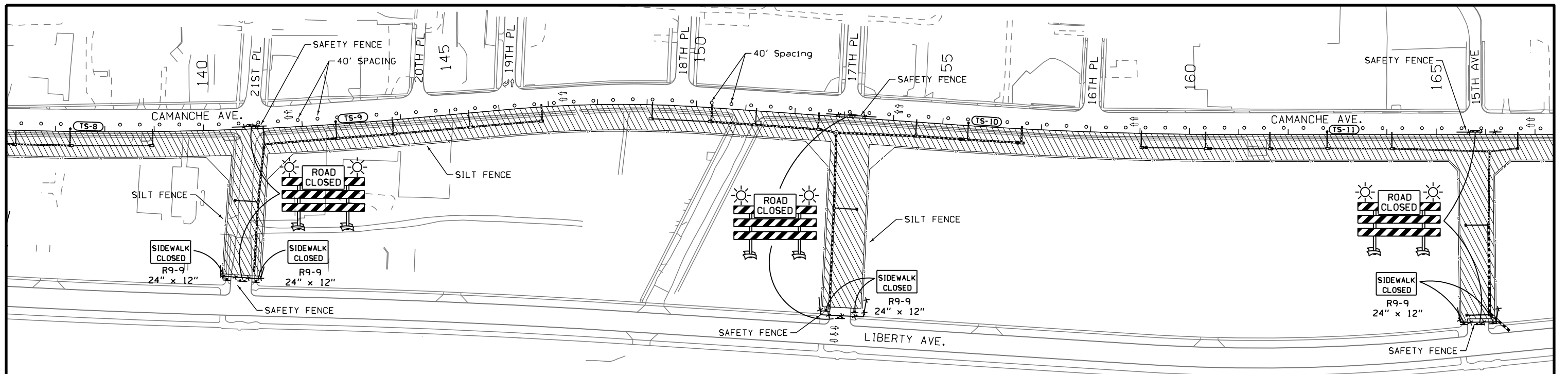

REFER TO N-SHEETS FOR TRAFFIC SIGNAL DETAILS.

REFER TO TABULATIONS 108-22, 108-29 AND K-SHEETS FOR THE TEMPORARY AND PERMANENT PAVEMENT MARKING DETAILS AND LOCATIONS.

REFER TO TABULATIONS HRG-11A AND HRG-12A ON J SHEETS FOR TEMPORARY DRAINAGE INFORMATION AND LOCATIONS.

TRAFFIC SIGN	TEMPORARY LANE SEPARATOR
TYPE III BARRICADE	42" CHANNELIZER
DIRECTION OF TRAFFIC	DRUM
TEMPORARY PAVEMENT	ARROW PANEL
PREVIOUSLY CONSTRUCTED	ORANGE MESH SAFETY FENCE
WORK SPACE	PAVEMENT MARKING SYMBOL
BERM LIMITS	TEMPORARY BARRIER WALL

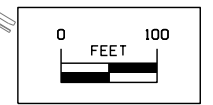
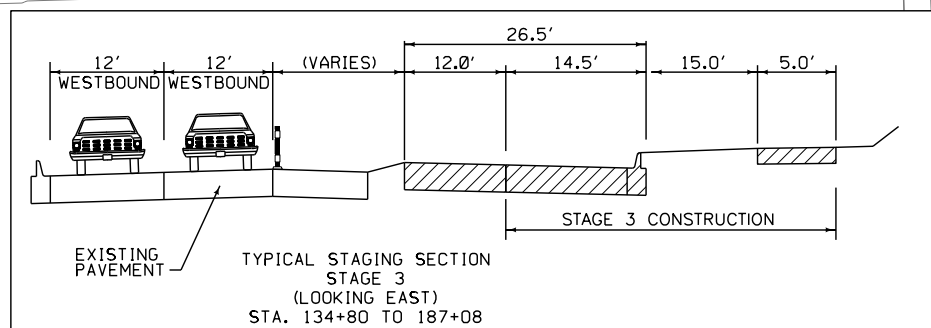
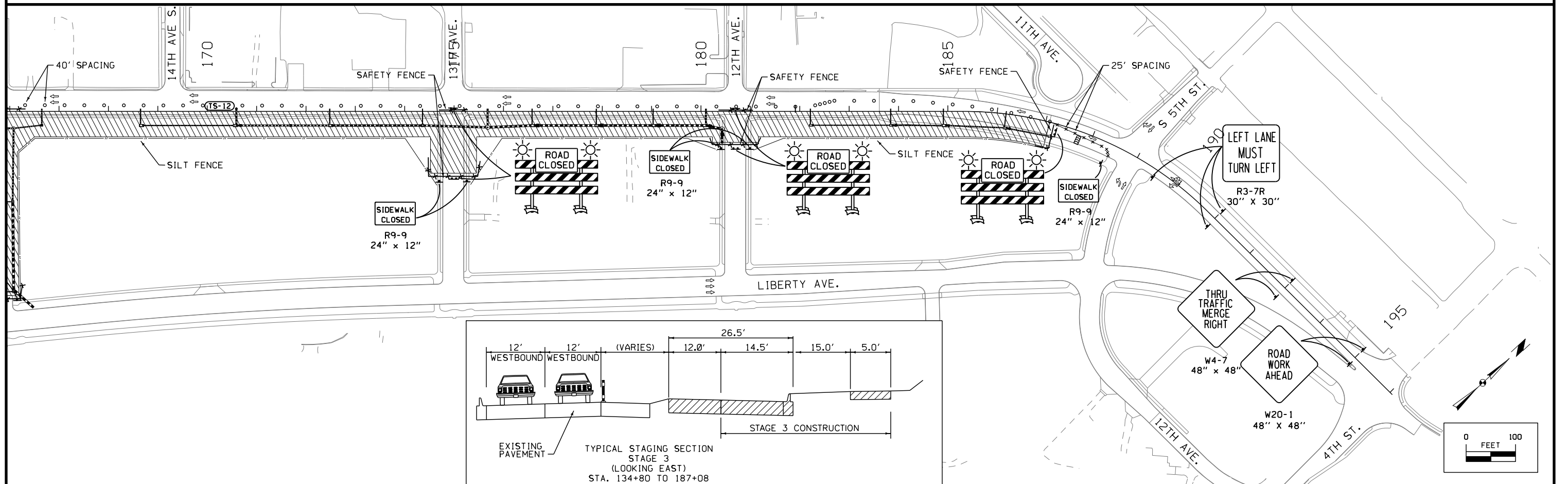
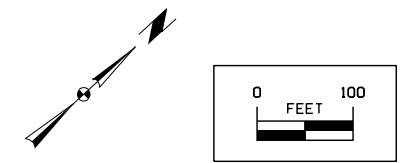

REFER TO N-SHEETS FOR TRAFFIC SIGNAL DETAILS.

REFER TO TABULATIONS HRG-11A AND HRG-12A ON J SHEETS FOR TEMPORARY DRAINAGE INFORMATION AND LOCATIONS.

REFER TO TABULATIONS 108-22, 108-29 AND K-SHEETS FOR THE TEMPORARY AND PERMANENT PAVEMENT MARKING DETAILS AND LOCATIONS.

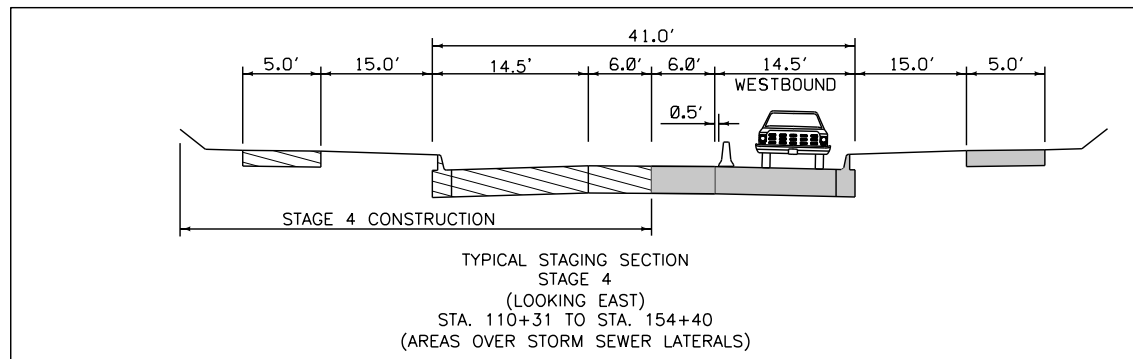
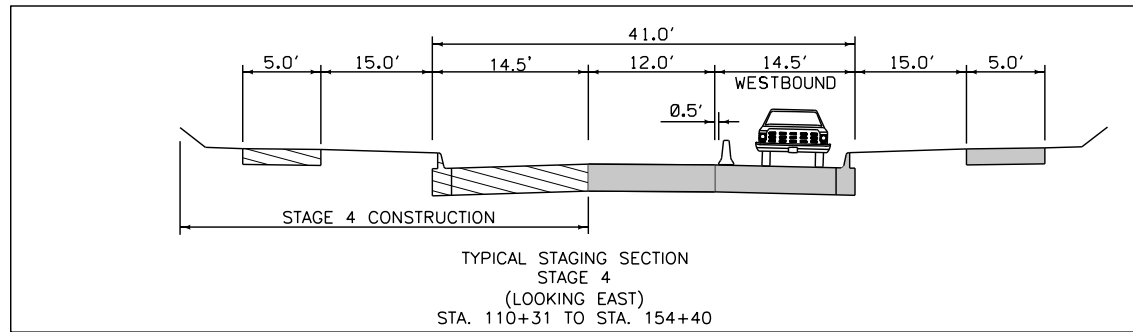

	TRAFFIC SIGN		TEMPORARY LANE SEPARATOR
	TYPE III BARRICADE		42" CHANNELIZER
	DIRECTION OF TRAFFIC		DRUM
	TEMPORARY PAVEMENT		ARROW PANEL
	PREVIOUSLY CONSTRUCTED		ORANGE MESH SAFETY FENCE
	WORK SPACE		PAVEMENT MARKING SYMBOL
	BERM LIMITS		TEMPORARY BARRIER WALL

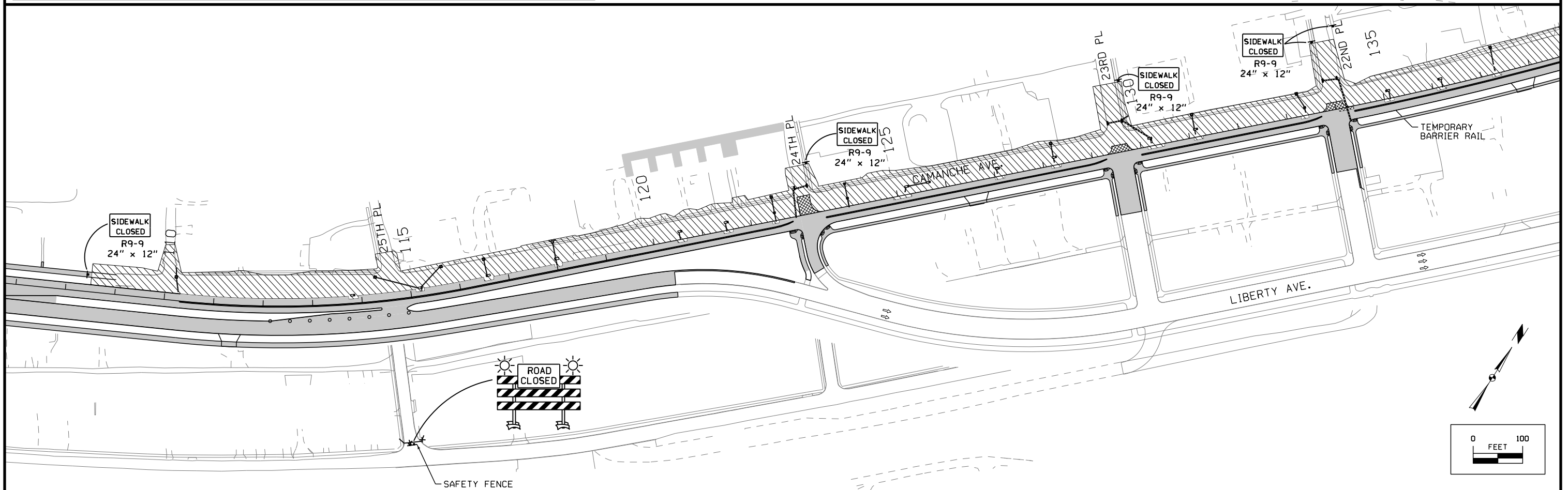
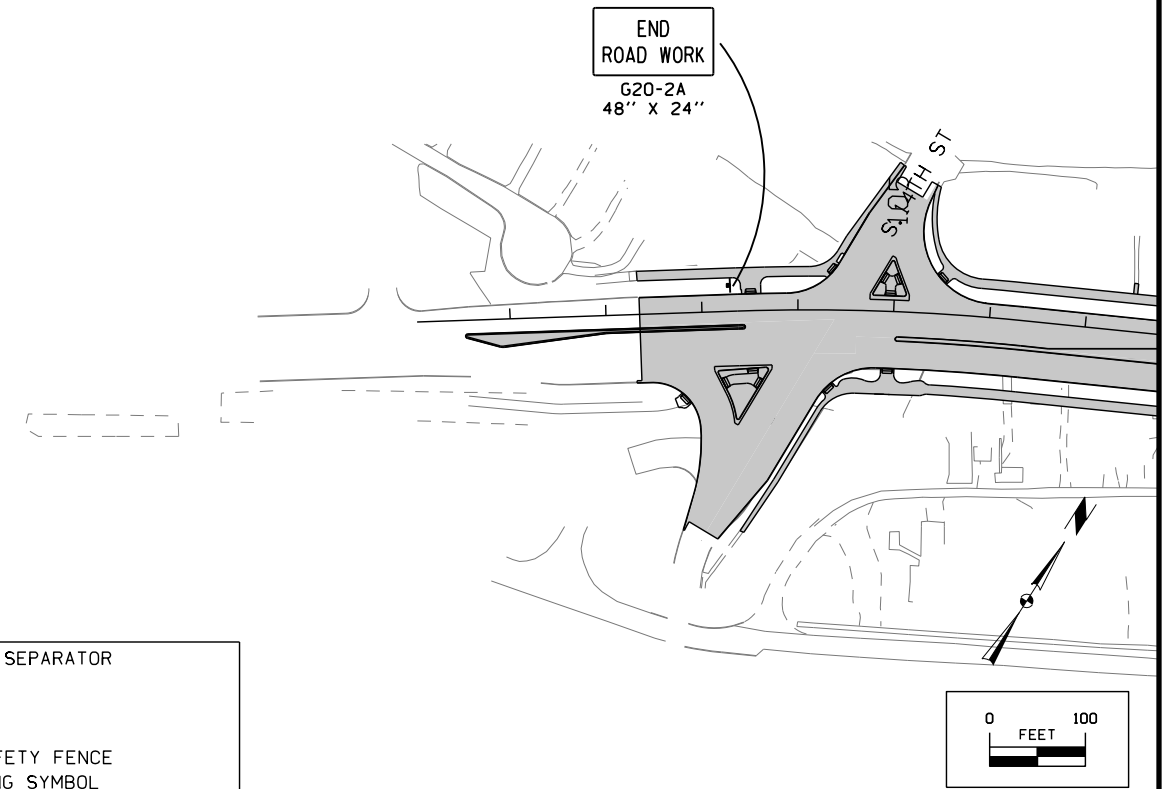

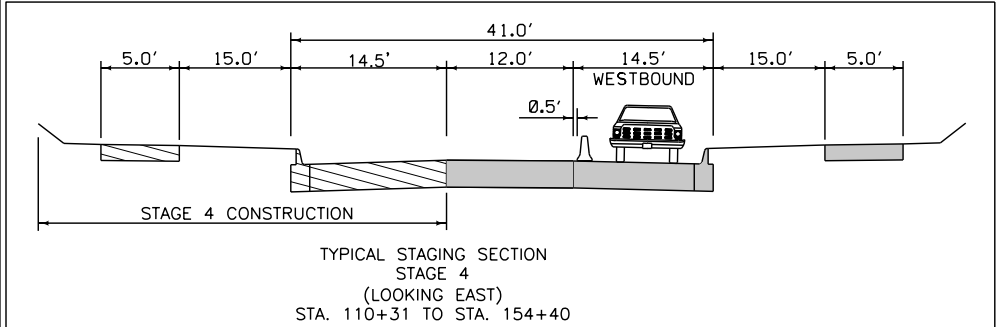
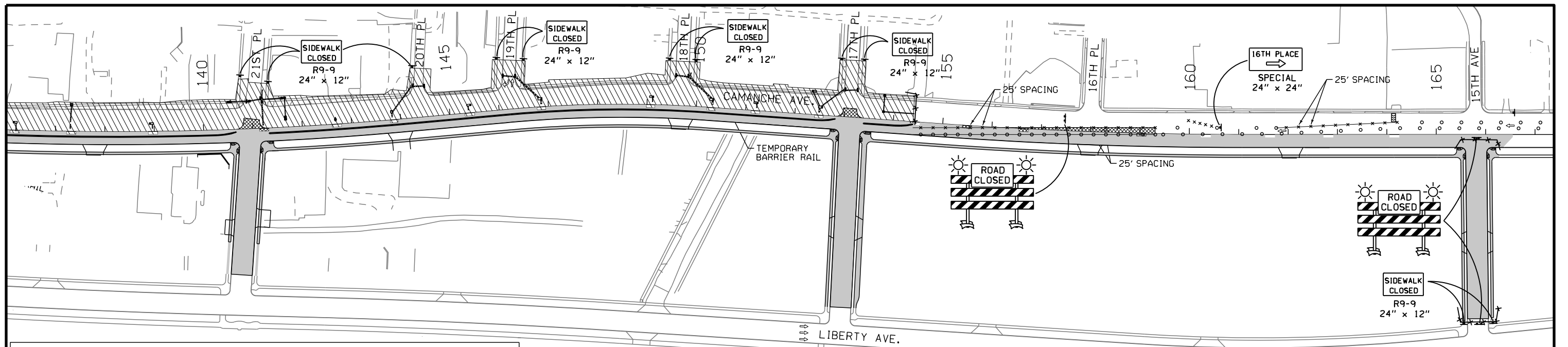

- |                        |                          |
|------------------------|--------------------------|
| TRAFFIC SIGN           | TEMPORARY LANE SEPARATOR |
| TYPE III BARRICADE     | 42" CHANNELIZER          |
| DIRECTION OF TRAFFIC   | DRUM                     |
| TEMPORARY PAVEMENT     | ARROW PANEL              |
| PREVIOUSLY CONSTRUCTED | ORANGE MESH SAFETY FENCE |
| WORK SPACE             | PAVEMENT MARKING SYMBOL  |
| BERM LIMITS            | TEMPORARY BARRIER WALL   |

REFER TO N-SHEETS FOR TRAFFIC SIGNAL DETAILS.

REFER TO TABULATIONS 108-22, 108-29 AND K-SHEETS FOR THE TEMPORARY AND PERMANENT PAVEMENT MARKING DETAILS AND LOCATIONS.

REFER TO TABULATIONS HRG-11A AND HRG-12A ON J SHEETS FOR TEMPORARY DRAINAGE INFORMATION AND LOCATIONS.

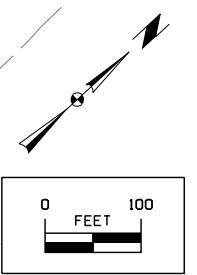
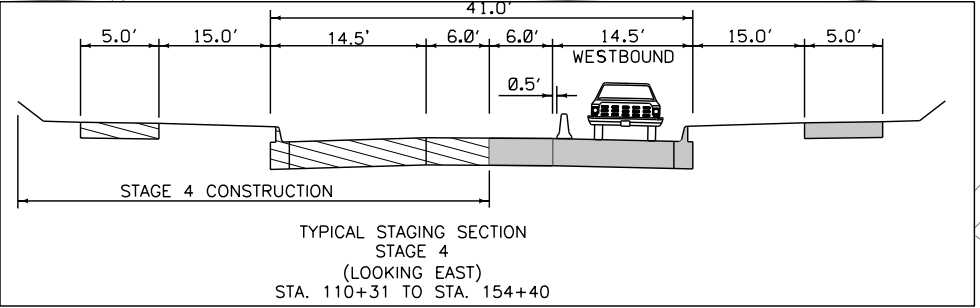
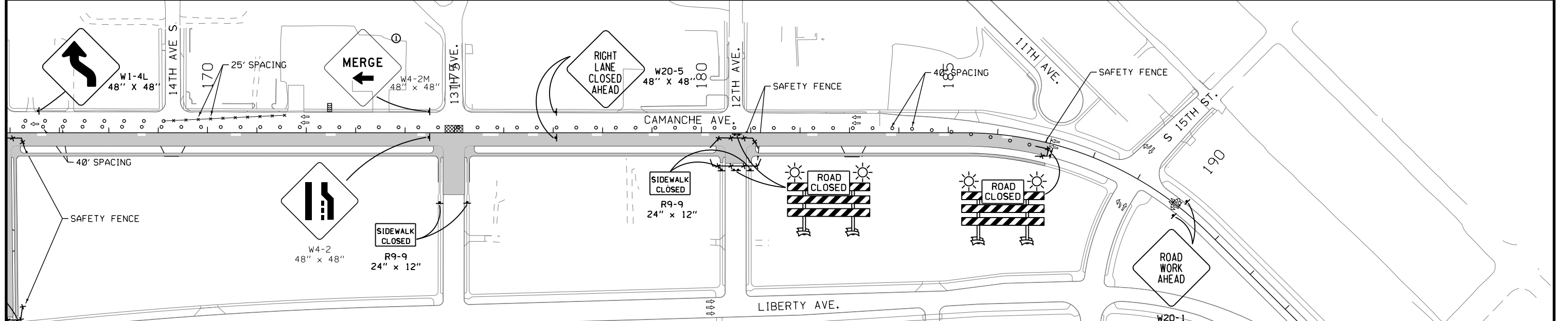
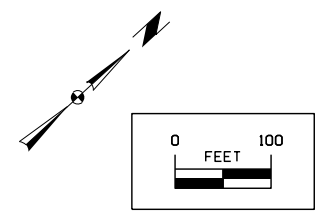

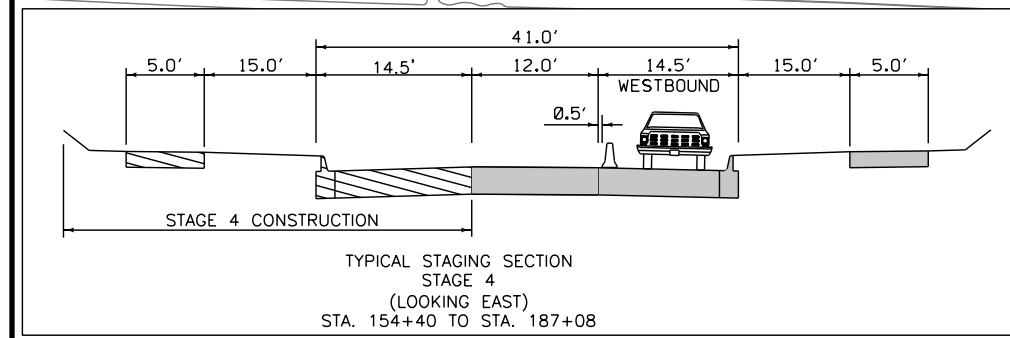
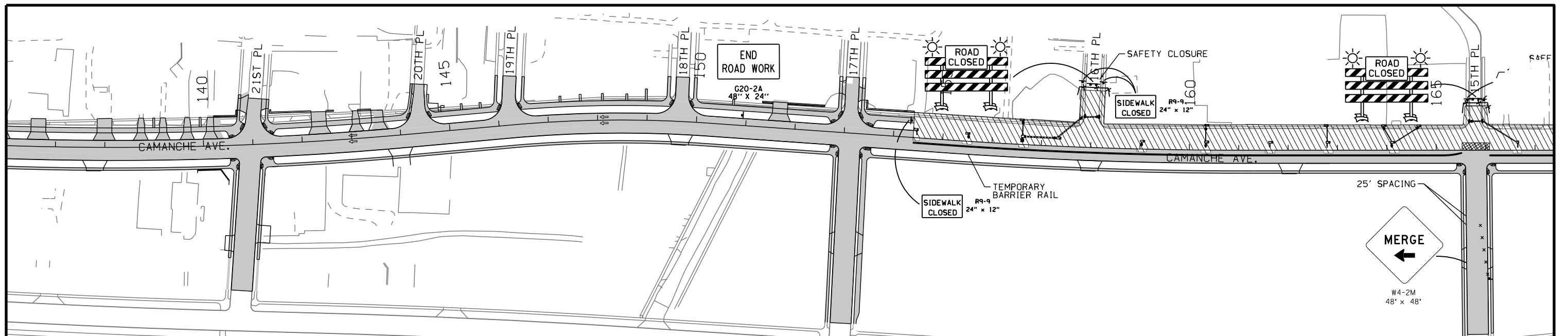

- |   |   |
|---|---|
| <ul style="list-style-type: none"> <li>TRAFFIC SIGN</li> <li>TYPE III BARRICADE</li> <li>DIRECTION OF TRAFFIC</li> <li>TEMPORARY PAVEMENT</li> <li>PREVIOUSLY CONSTRUCTED</li> <li>WORK SPACE</li> <li>BERM LIMITS</li> </ul> | <ul style="list-style-type: none"> <li>TEMPORARY LANE SEPARATOR</li> <li>42" CHANNELIZER</li> <li>DRUM</li> <li>ARROW PANEL</li> <li>ORANGE MESH SAFETY FENCE</li> <li>PAVEMENT MARKING SYMBOL</li> <li>TEMPORARY BARRIER WALL</li> </ul> |
|---|---|

REFER TO N-SHEETS FOR TRAFFIC SIGNAL DETAILS.

REFER TO TABULATIONS 108-22, 108-29 AND K-SHEETS FOR THE TEMPORARY AND PERMANENT PAVEMENT MARKING DETAILS AND LOCATIONS.

REFER TO TABULATIONS HRG-11A AND HRG-12A ON J SHEETS FOR TEMPORARY DRAINAGE INFORMATION AND LOCATIONS.

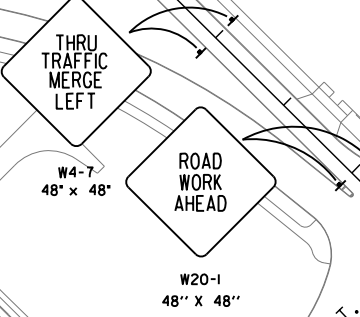
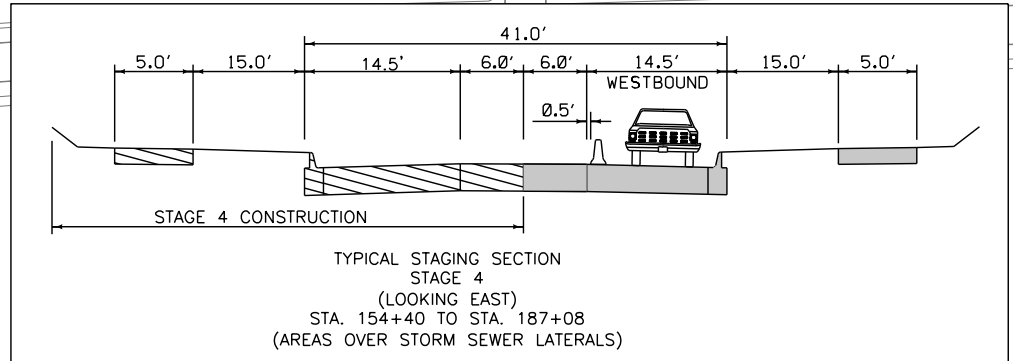
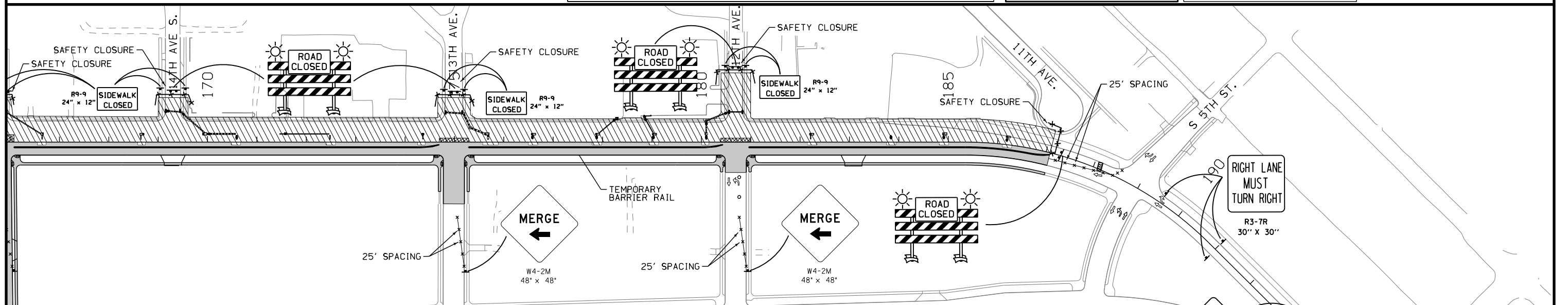
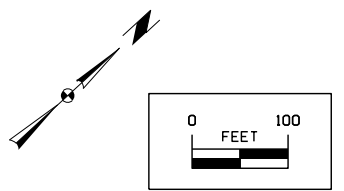



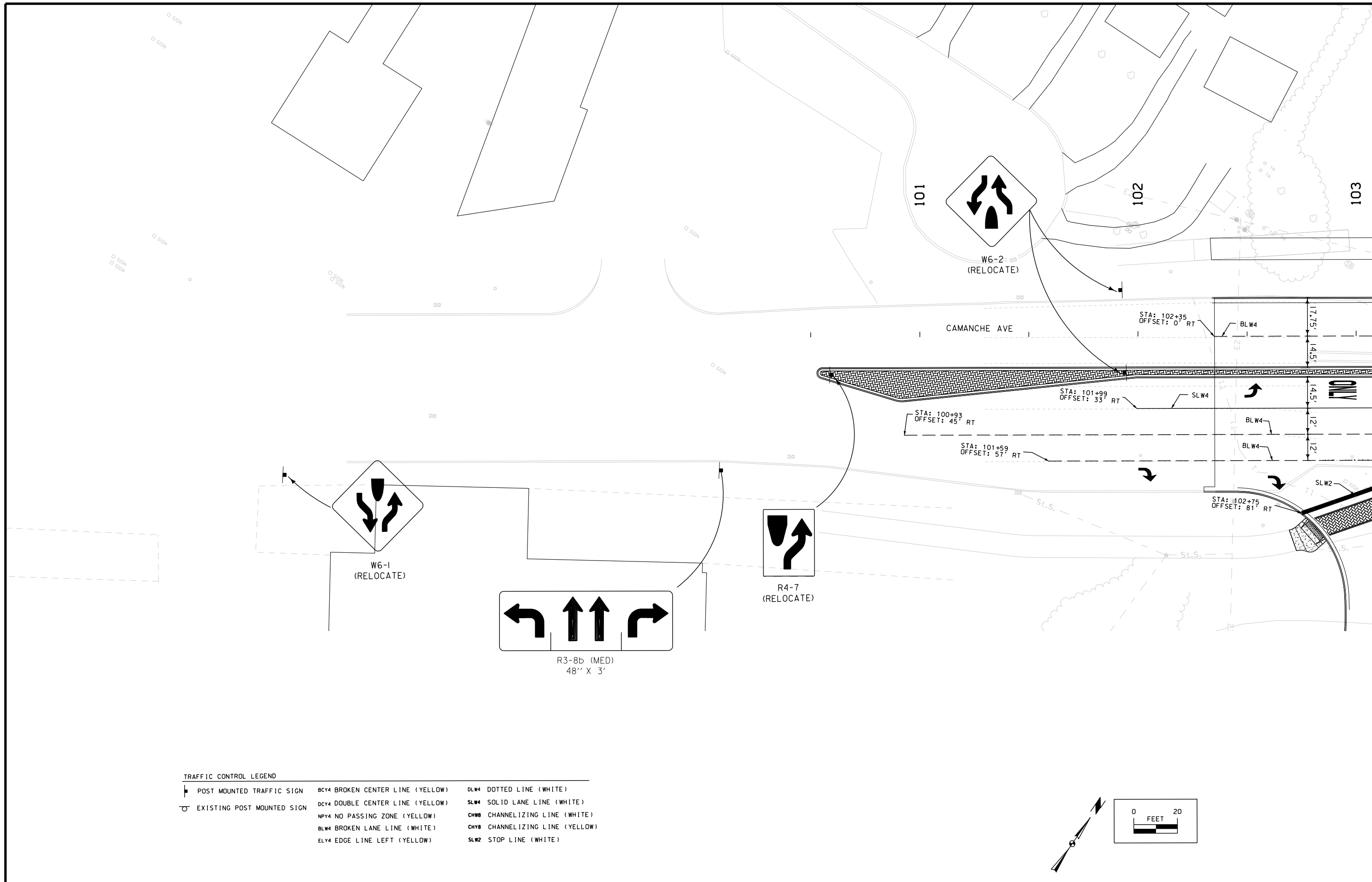

TRAFFIC CONTROL LEGEND

<ul style="list-style-type: none"> <li>▬ POST MOUNTED TRAFFIC SIGN</li> <li>◻ EXISTING POST MOUNTED SIGN</li> </ul>	<ul style="list-style-type: none"> <li>BCY4 BROKEN CENTER LINE (YELLOW)</li> <li>DCY4 DOUBLE CENTER LINE (YELLOW)</li> <li>NPY4 NO PASSING ZONE (YELLOW)</li> <li>BLW4 BROKEN LANE LINE (WHITE)</li> <li>ELY4 EDGE LINE LEFT (YELLOW)</li> </ul>	<ul style="list-style-type: none"> <li>DLW4 DOTTED LINE (WHITE)</li> <li>SLW4 SOLID LANE LINE (WHITE)</li> <li>CHW8 CHANNELIZING LINE (WHITE)</li> <li>CHY8 CHANNELIZING LINE (YELLOW)</li> <li>SLW2 STOP LINE (WHITE)</li> </ul>
---	--	---

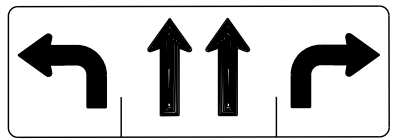

R3-8b (MED)  
48" X 3'

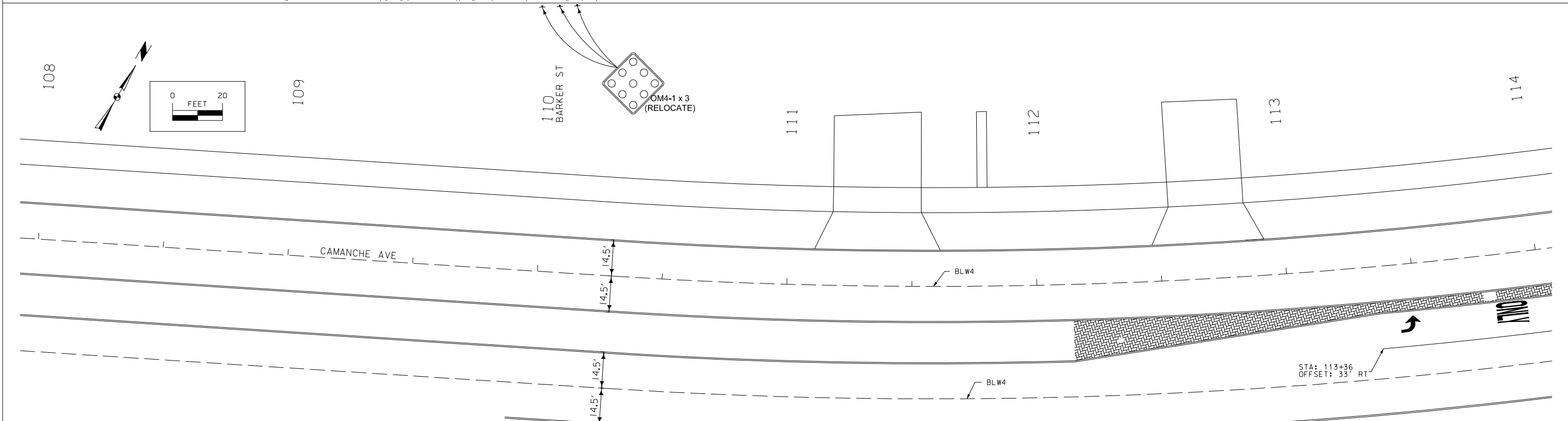
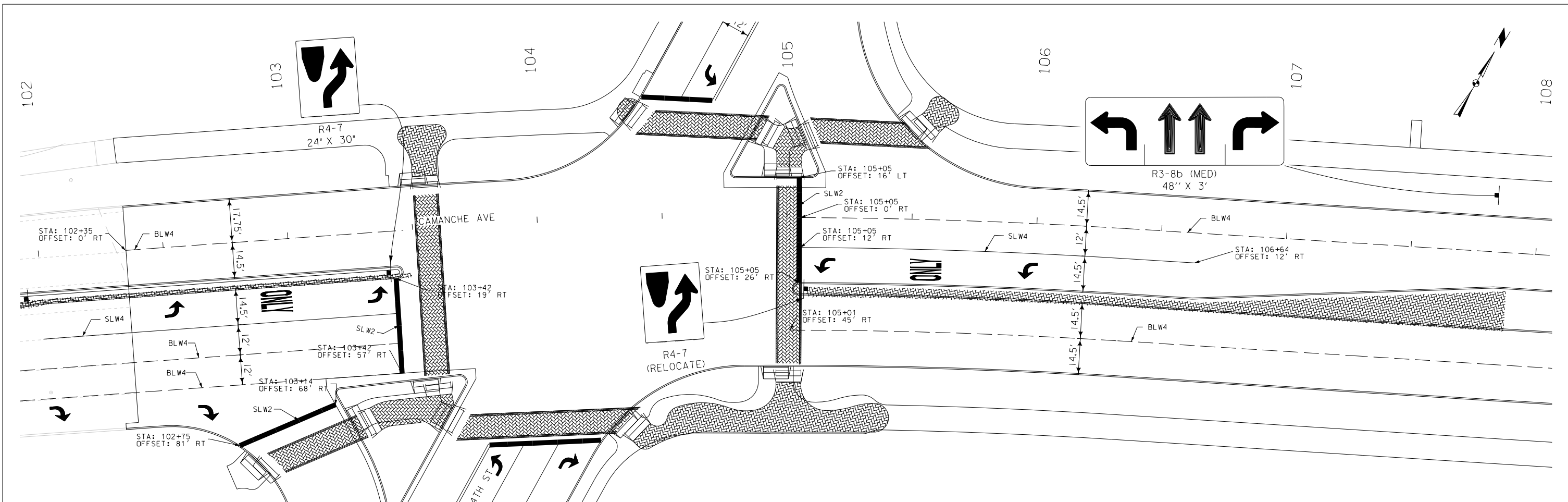

TRAFFIC CONTROL LEGEND

POST MOUNTED TRAFFIC SIGN	BCY4 BROKEN CENTER LINE (YELLOW)	DLW4 DOTTED LINE (WHITE)
EXISTING POST MOUNTED SIGN	DCY4 DOUBLE CENTER LINE (YELLOW)	SLW4 SOLID LANE LINE (WHITE)
	NPY4 NO PASSING ZONE (YELLOW)	CHW8 CHANNELIZING LINE (WHITE)
	BLW4 BROKEN LANE LINE (WHITE)	CHY8 CHANNELIZING LINE (YELLOW)
	ELV4 EDGE LINE LEFT (YELLOW)	SLW2 STOP LINE (WHITE)



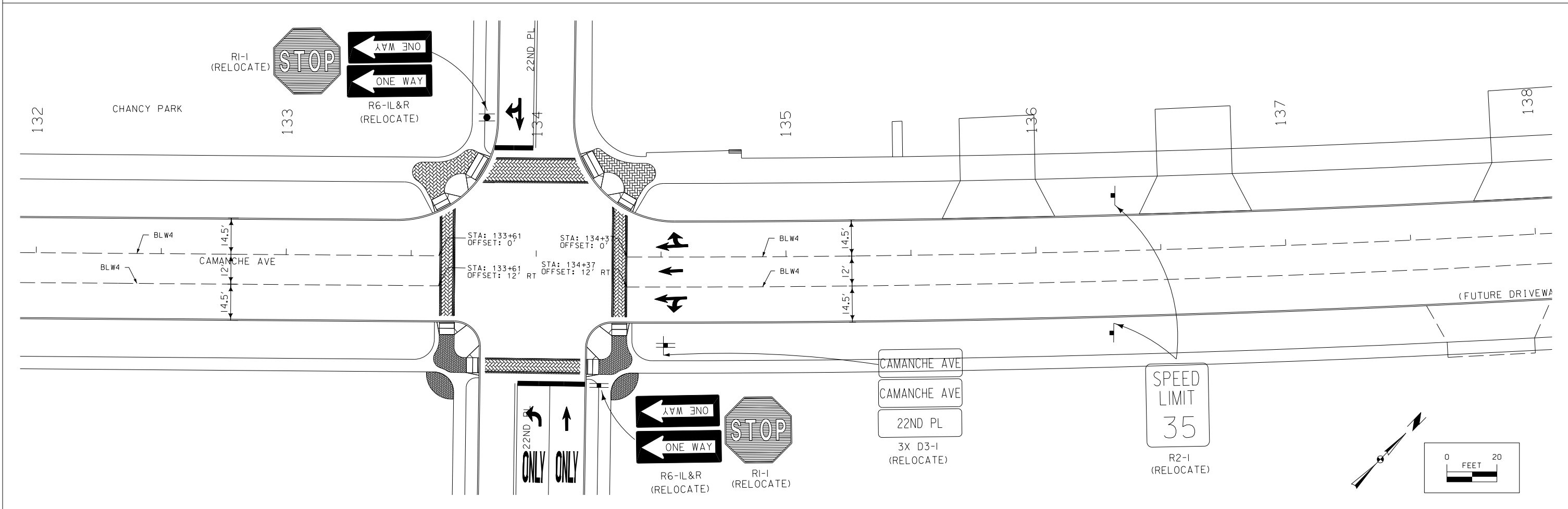
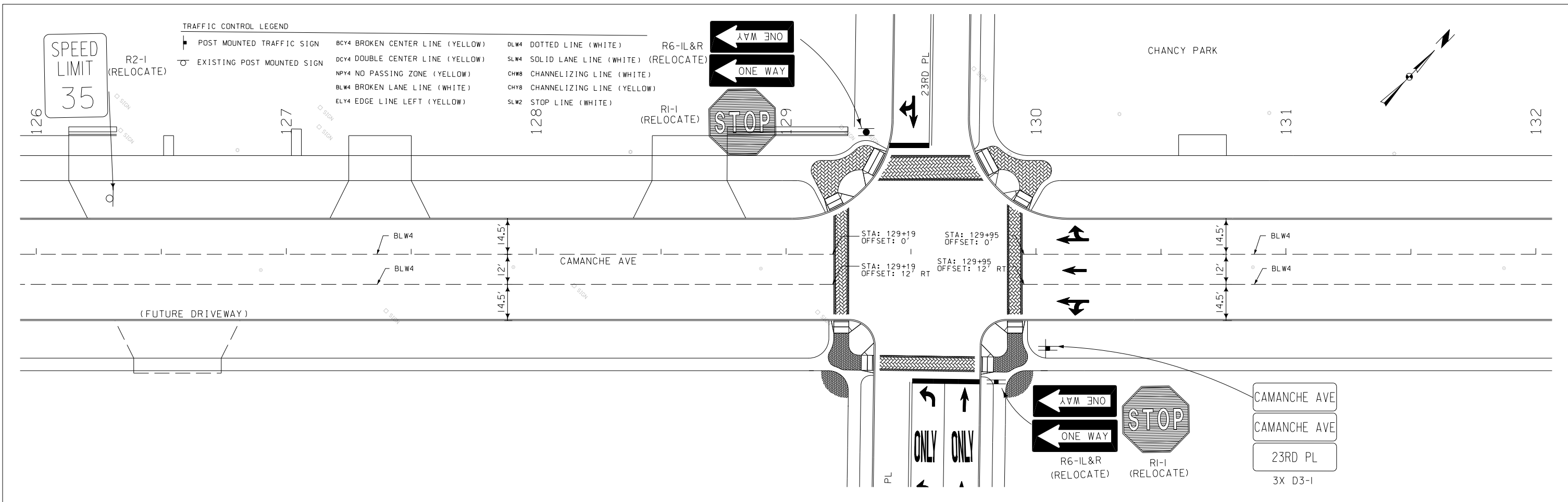

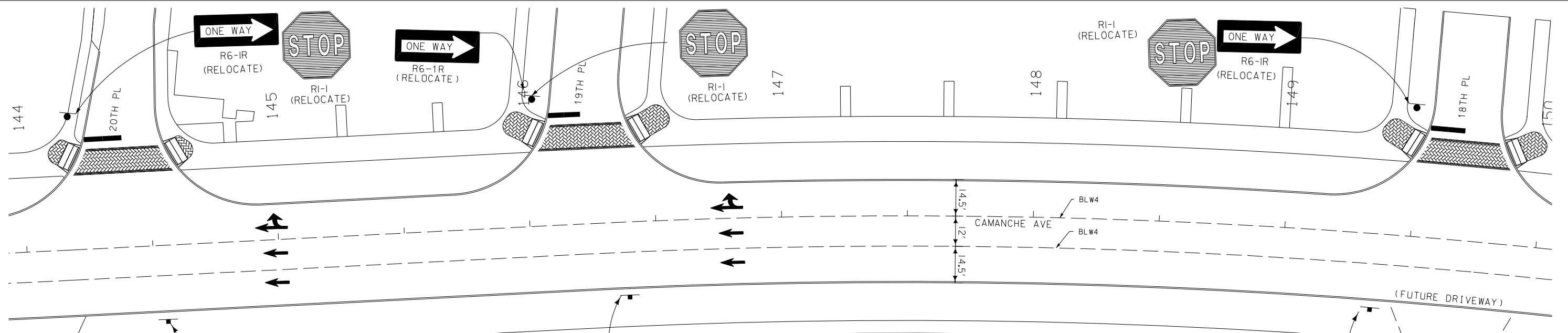
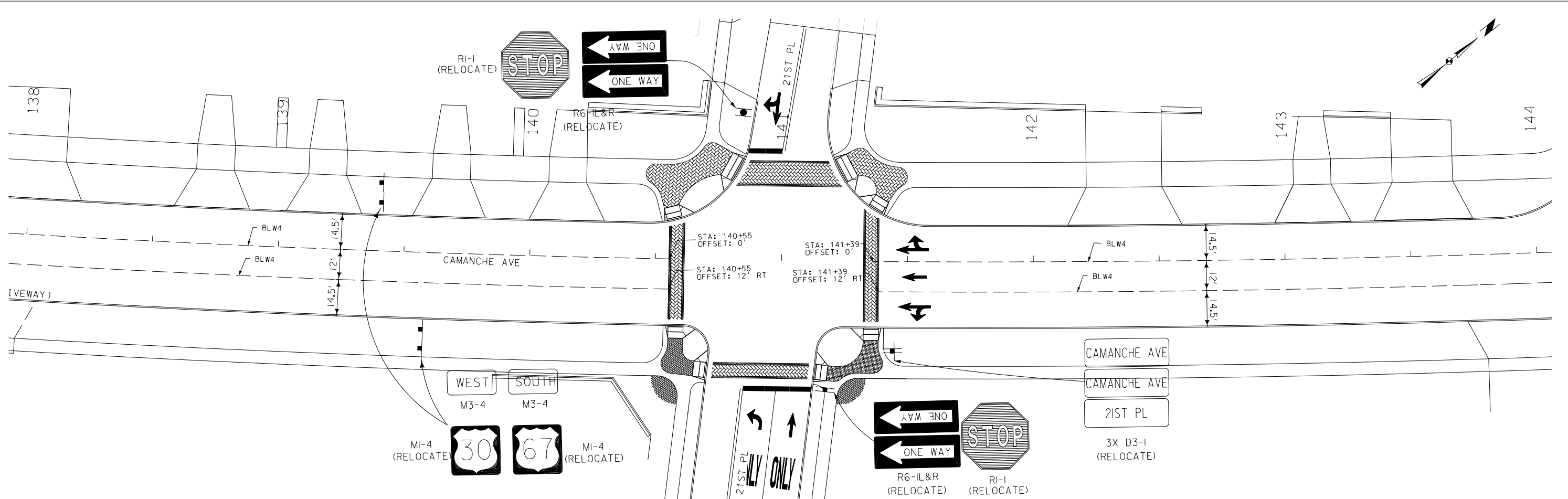

- DLW4 DOTTED LINE (WHITE)
- SLW4 SOLID LANE LINE (WHITE)
- CHW8 CHANNELIZING LINE (WHITE)
- CHY8 CHANNELIZING LINE (YELLOW)
- SLW2 STOP LINE (WHITE)

TRAFFIC CONTROL LEGEND

- POST MOUNTED TRAFFIC SIGN
- EXISTING POST MOUNTED SIGN
- BCY4 BROKEN CENTER LINE (YELLOW)
- DCY4 DOUBLE CENTER LINE (YELLOW)
- NPY4 NO PASSING ZONE (YELLOW)
- BLW4 BROKEN LANE LINE (WHITE)
- ELY4 EDGE LINE LEFT (YELLOW)
- DLW4 DOTTED LINE (WHITE)
- SLW4 SOLID LANE LINE (WHITE)
- CHW8 CHANNELIZING LINE (WHITE)
- CHY8 CHANNELIZING LINE (YELLOW)
- SLW2 STOP LINE (WHITE)

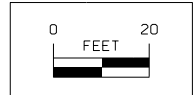

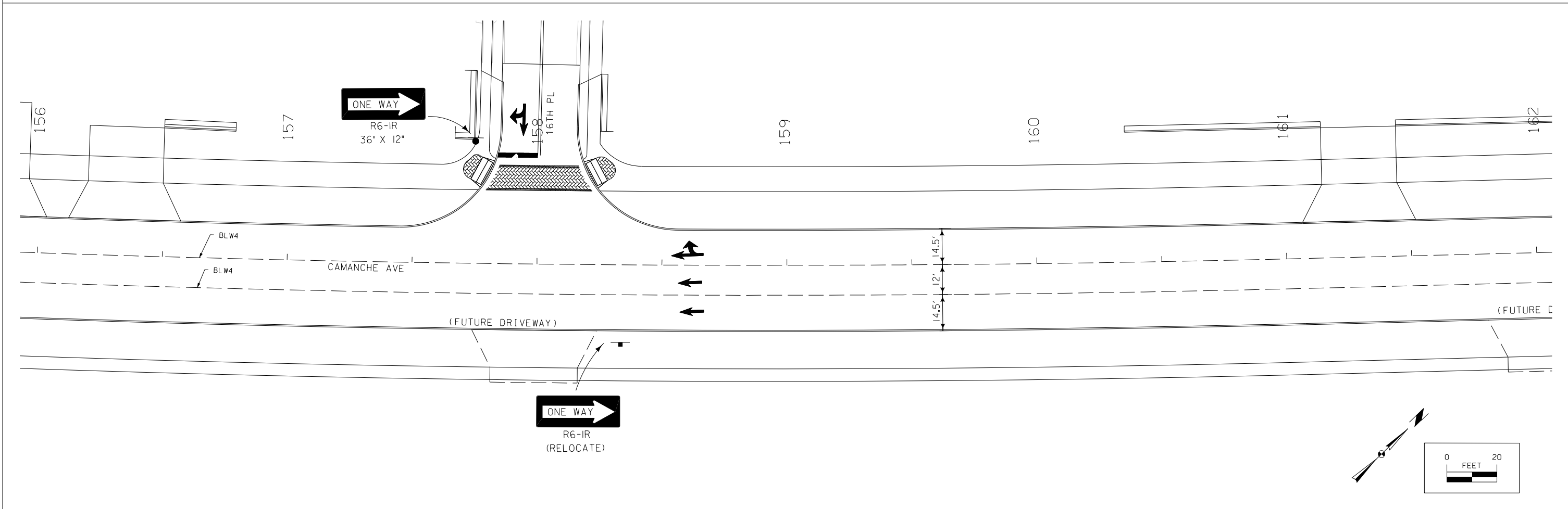
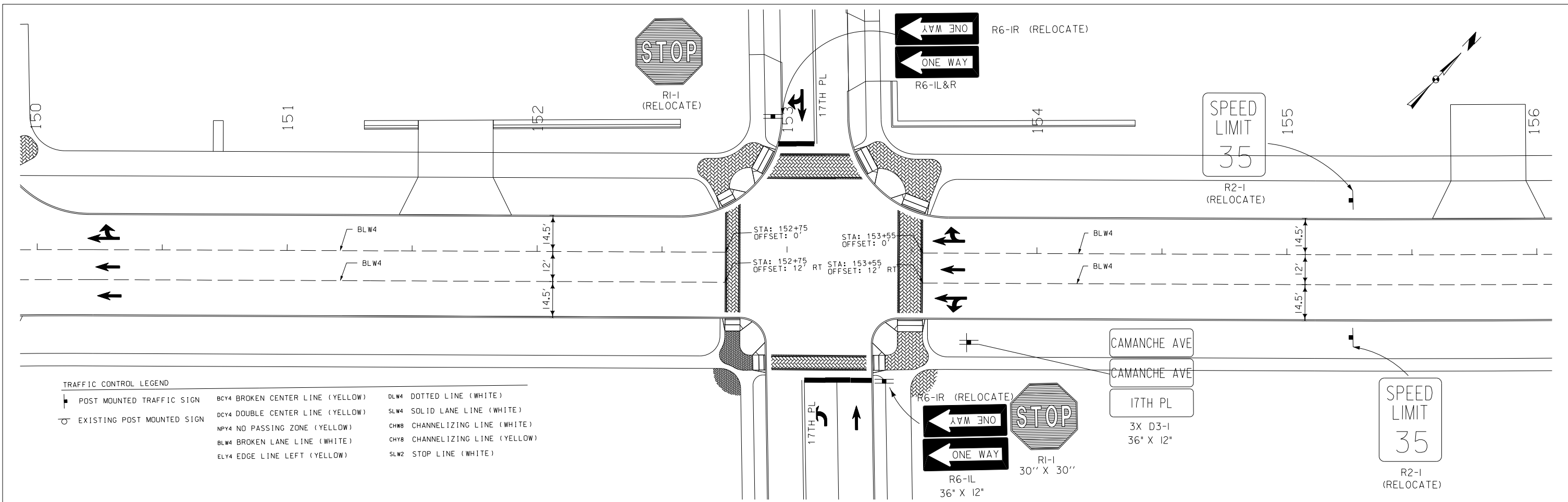

TRAFFIC CONTROL LEGEND

- POST MOUNTED TRAFFIC SIGN
- EXISTING POST MOUNTED SIGN
- BCY4 BROKEN CENTER LINE (YELLOW)
- DCY4 DOUBLE CENTER LINE (YELLOW)
- NPY4 NO PASSING ZONE (YELLOW)
- BLW4 BROKEN LANE LINE (WHITE)
- ELY4 EDGE LINE LEFT (YELLOW)
- DLW4 DOTTED LINE (WHITE)
- SLW4 SOLID LANE LINE (WHITE)
- CHW6 CHANNELIZING LINE (WHITE)
- CHY8 CHANNELIZING LINE (YELLOW)
- SLW2 STOP LINE (WHITE)

R6-IR (RELOCATE)  
R6-IL 36" X 12"

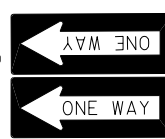

RI-1 (RELOCATE)

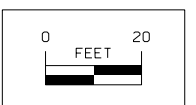
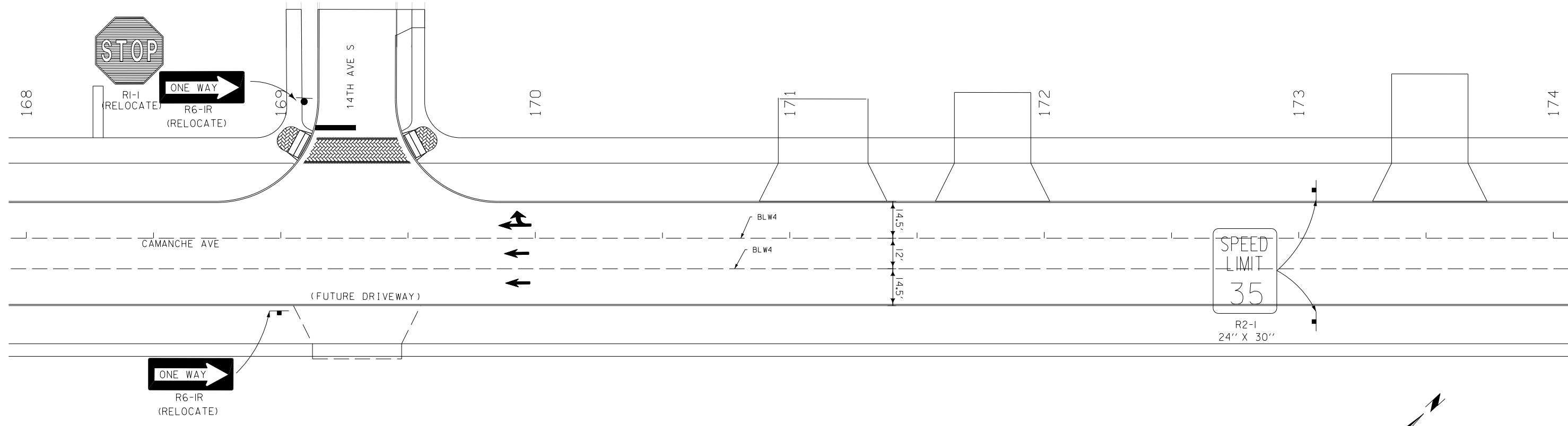
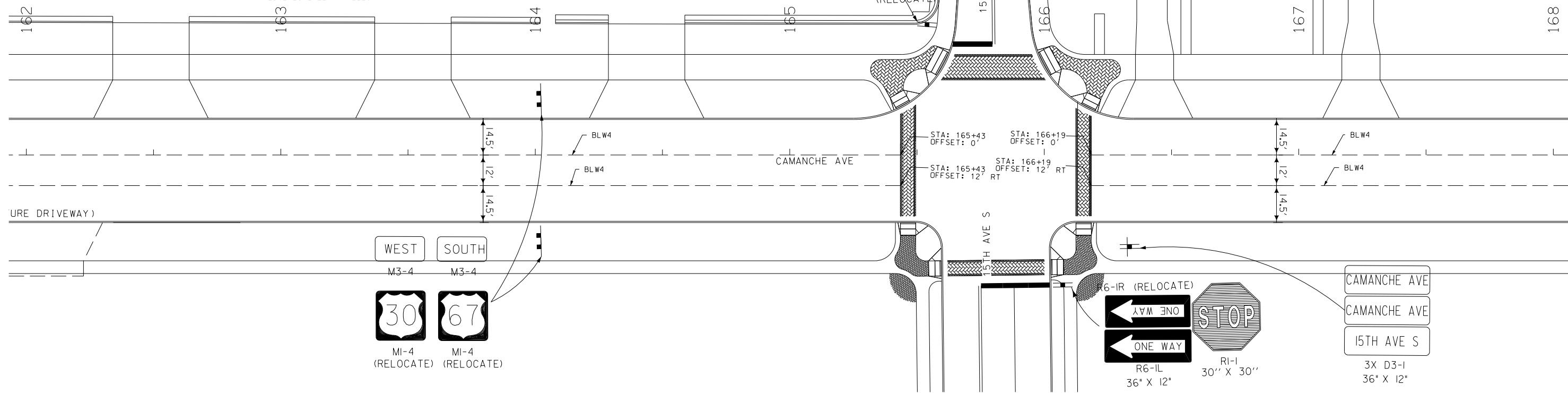

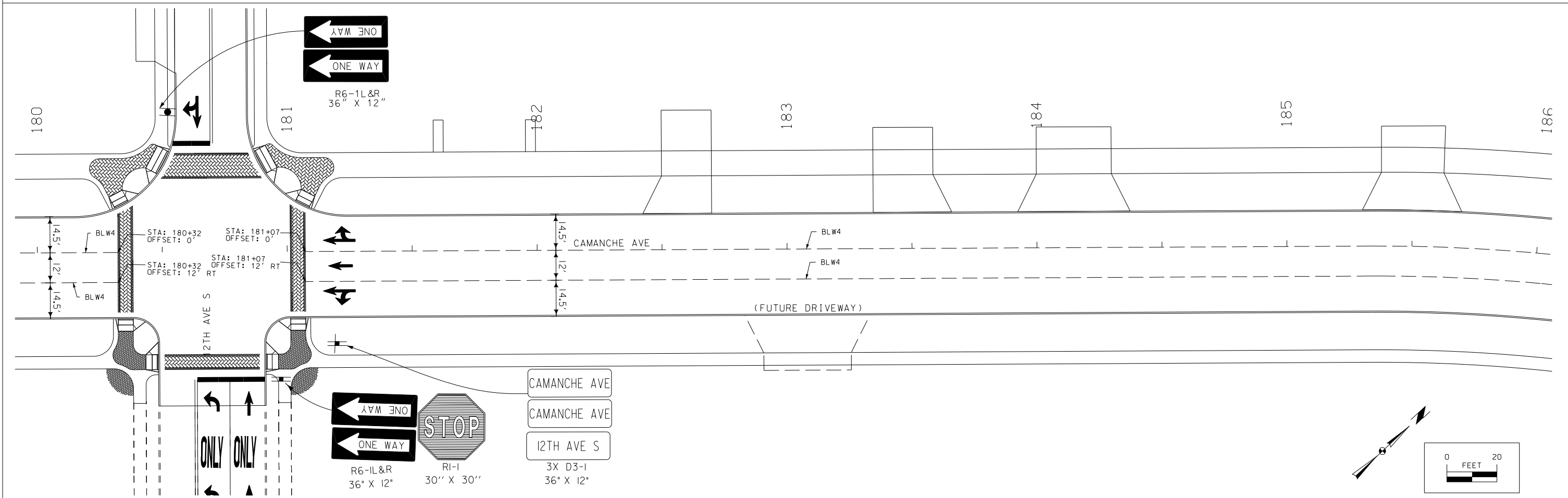
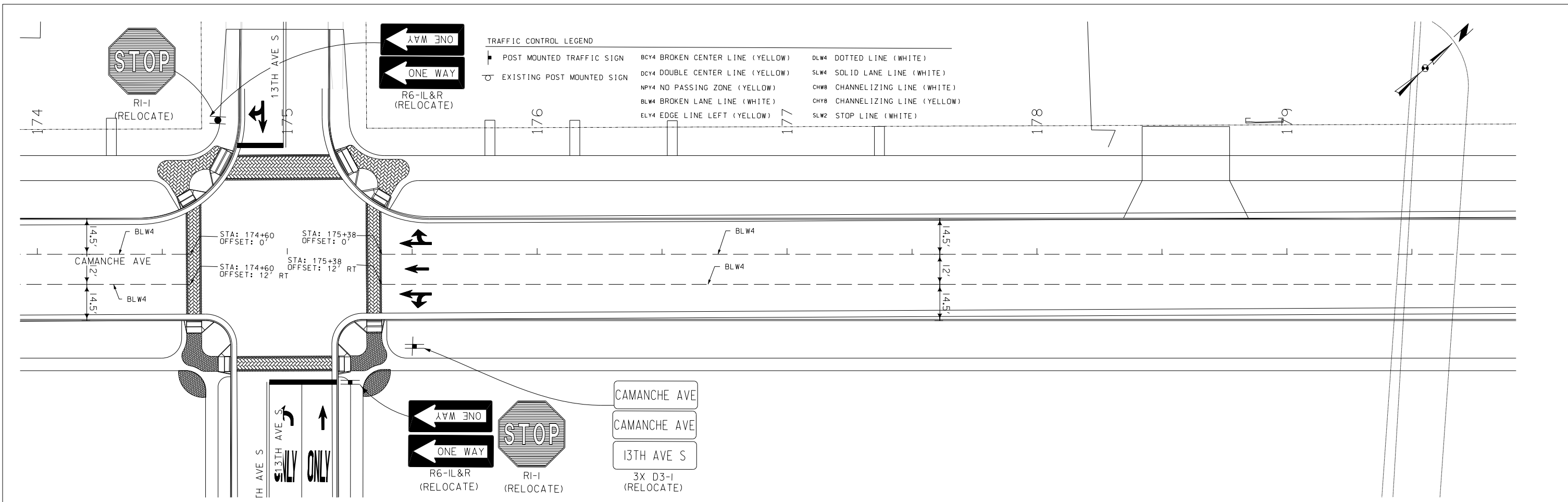



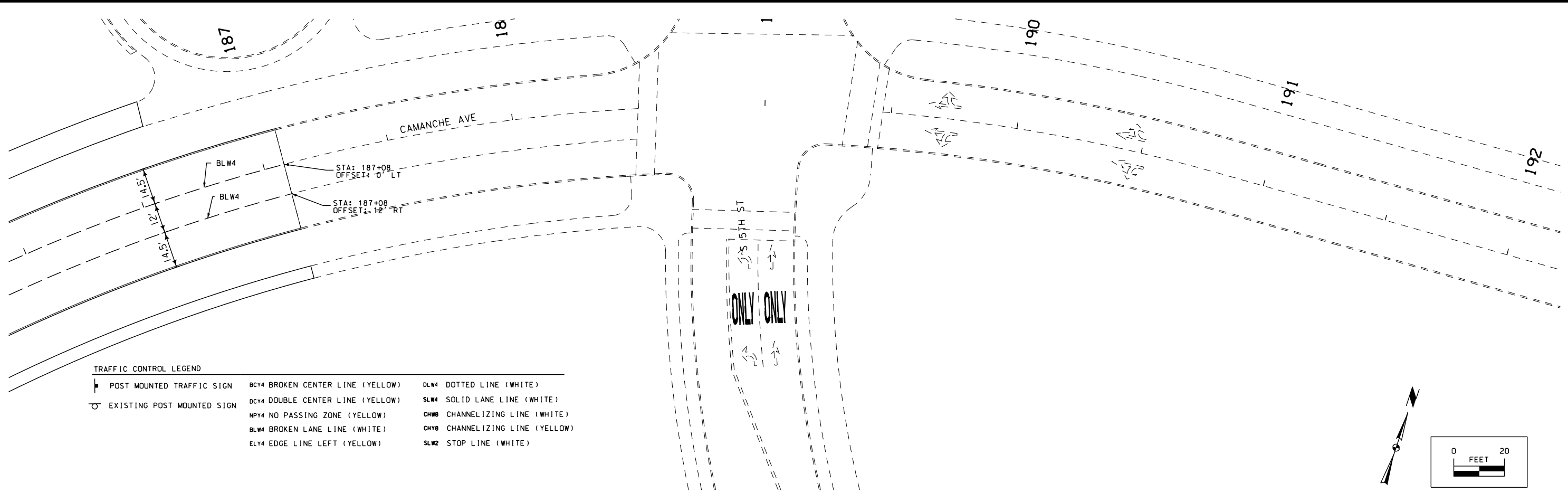

TRAFFIC CONTROL LEGEND

- |                            |                                  |                                 |
|----------------------------|----------------------------------|---------------------------------|
| POST MOUNTED TRAFFIC SIGN  | BCY4 BROKEN CENTER LINE (YELLOW) | DLW4 DOTTED LINE (WHITE)        |
| EXISTING POST MOUNTED SIGN | DCY4 DOUBLE CENTER LINE (YELLOW) | SLW4 SOLID LANE LINE (WHITE)    |
|                            | NPY4 NO PASSING ZONE (YELLOW)    | CHW8 CHANNELIZING LINE (WHITE)  |
|                            | BLW4 BROKEN LANE LINE (WHITE)    | CHY8 CHANNELIZING LINE (YELLOW) |
|                            | ELY4 EDGE LINE LEFT (YELLOW)     | SLW2 STOP LINE (WHITE)          |

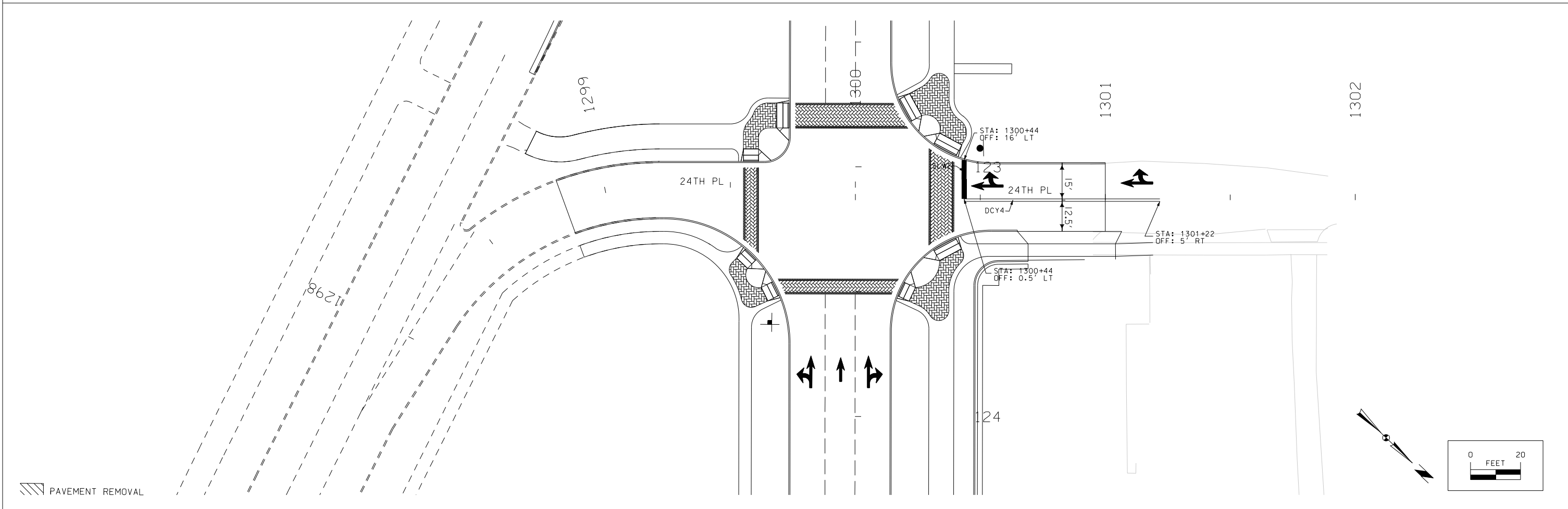
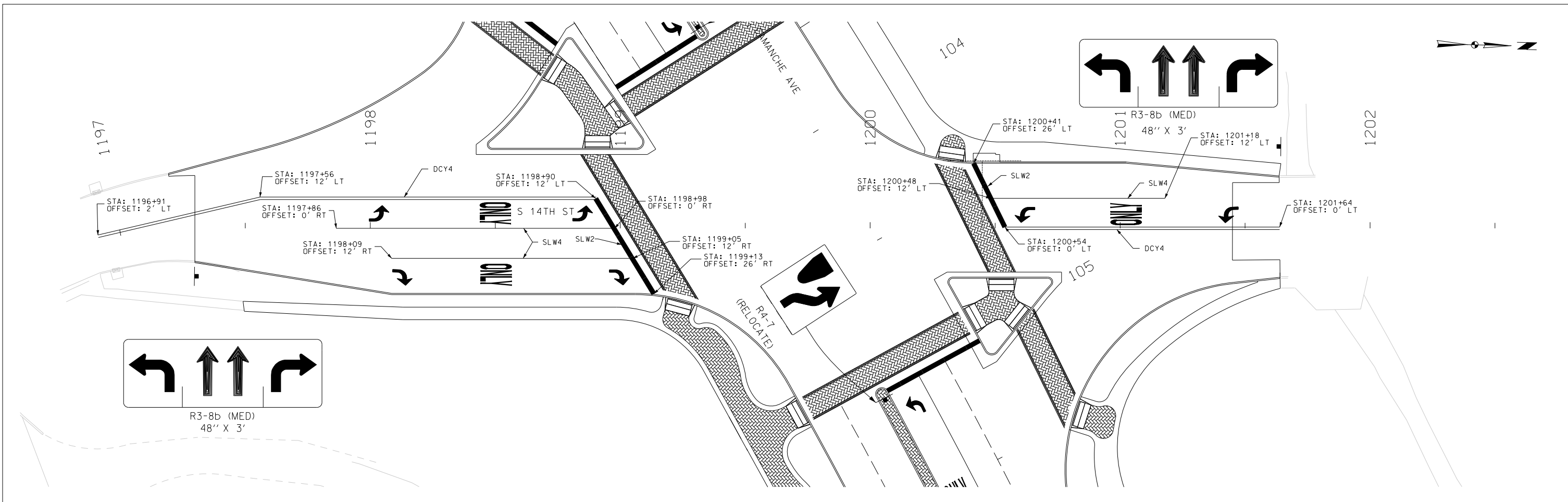

PAVEMENT REMOVAL

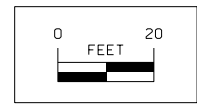

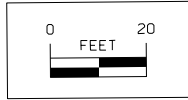
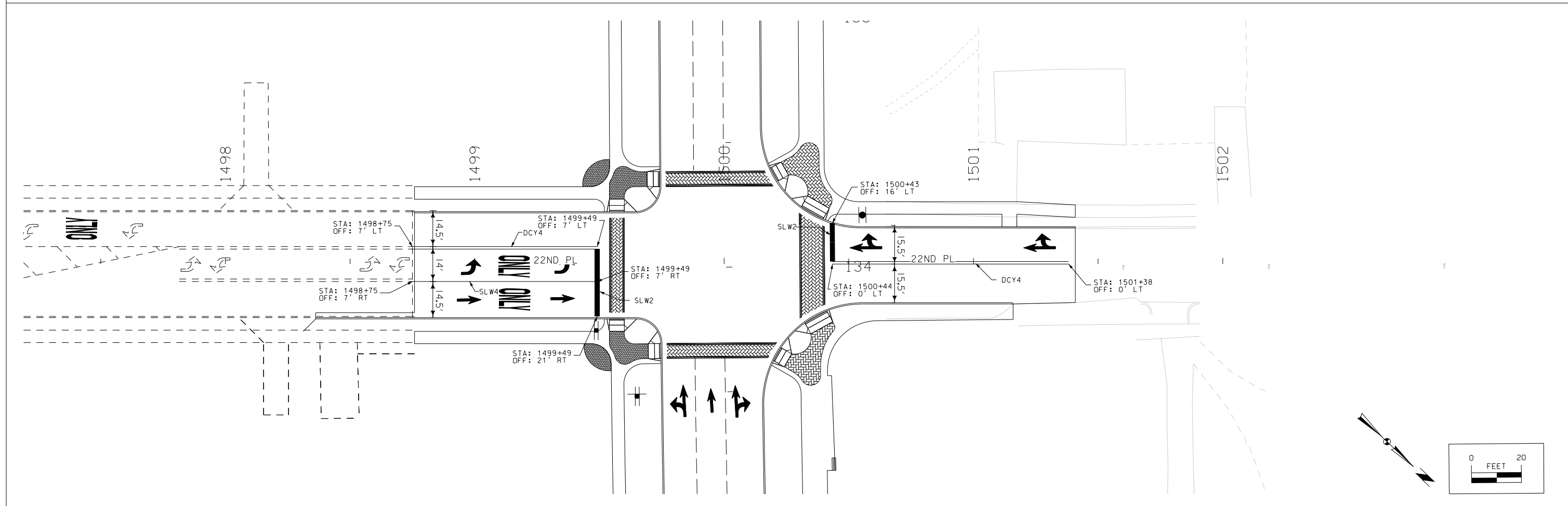
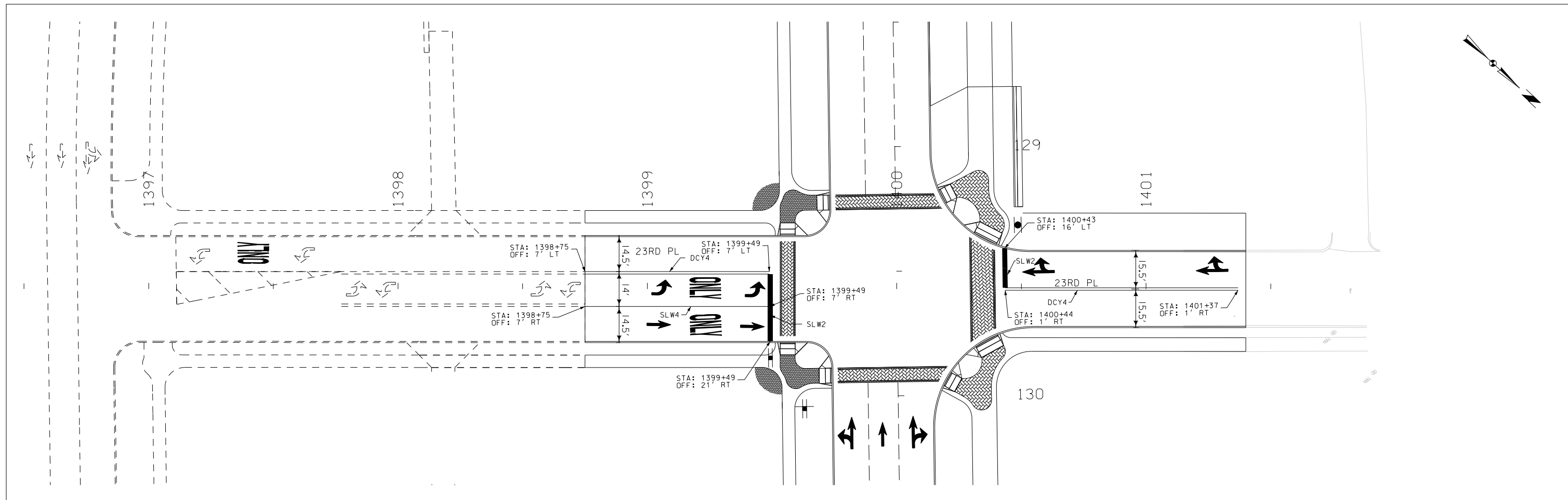

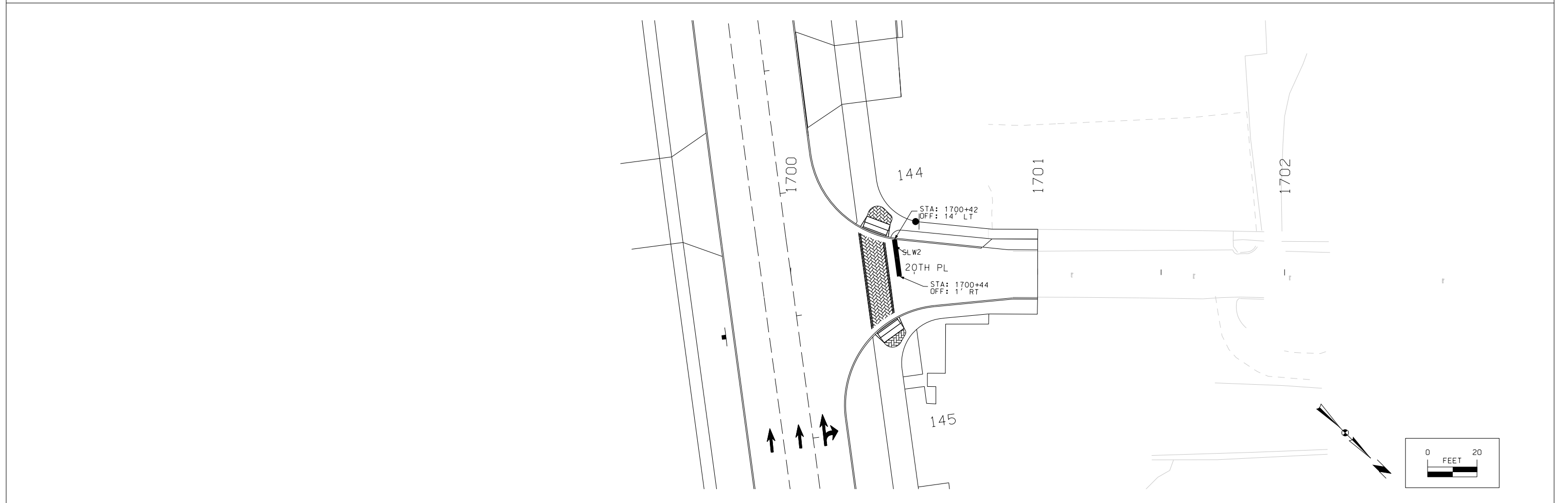
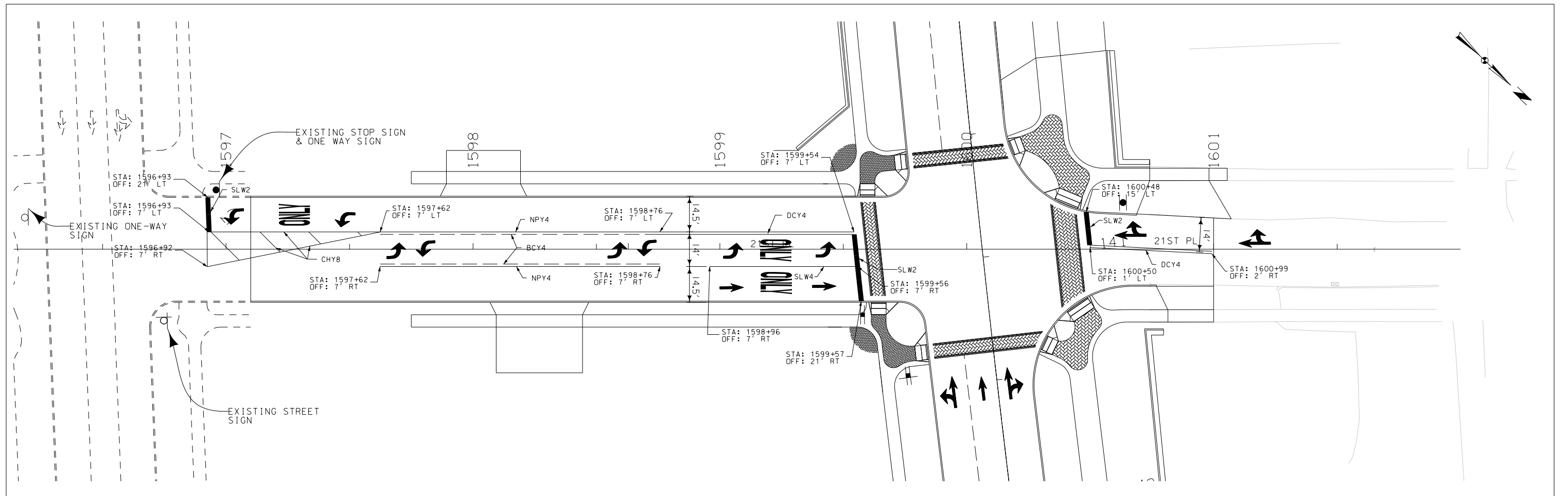

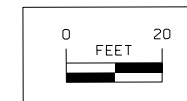
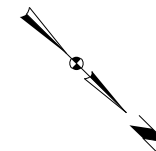
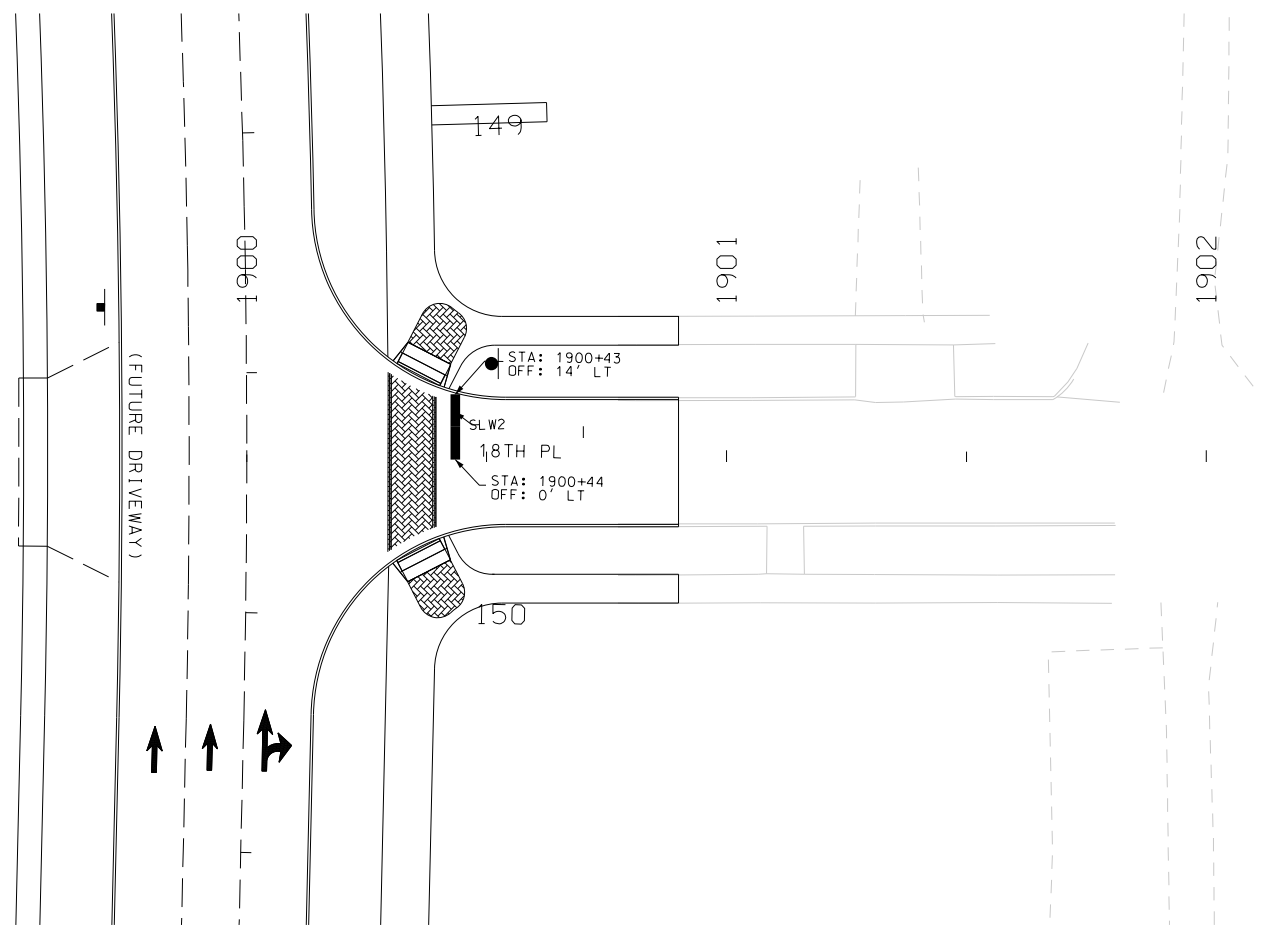
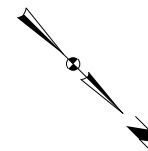
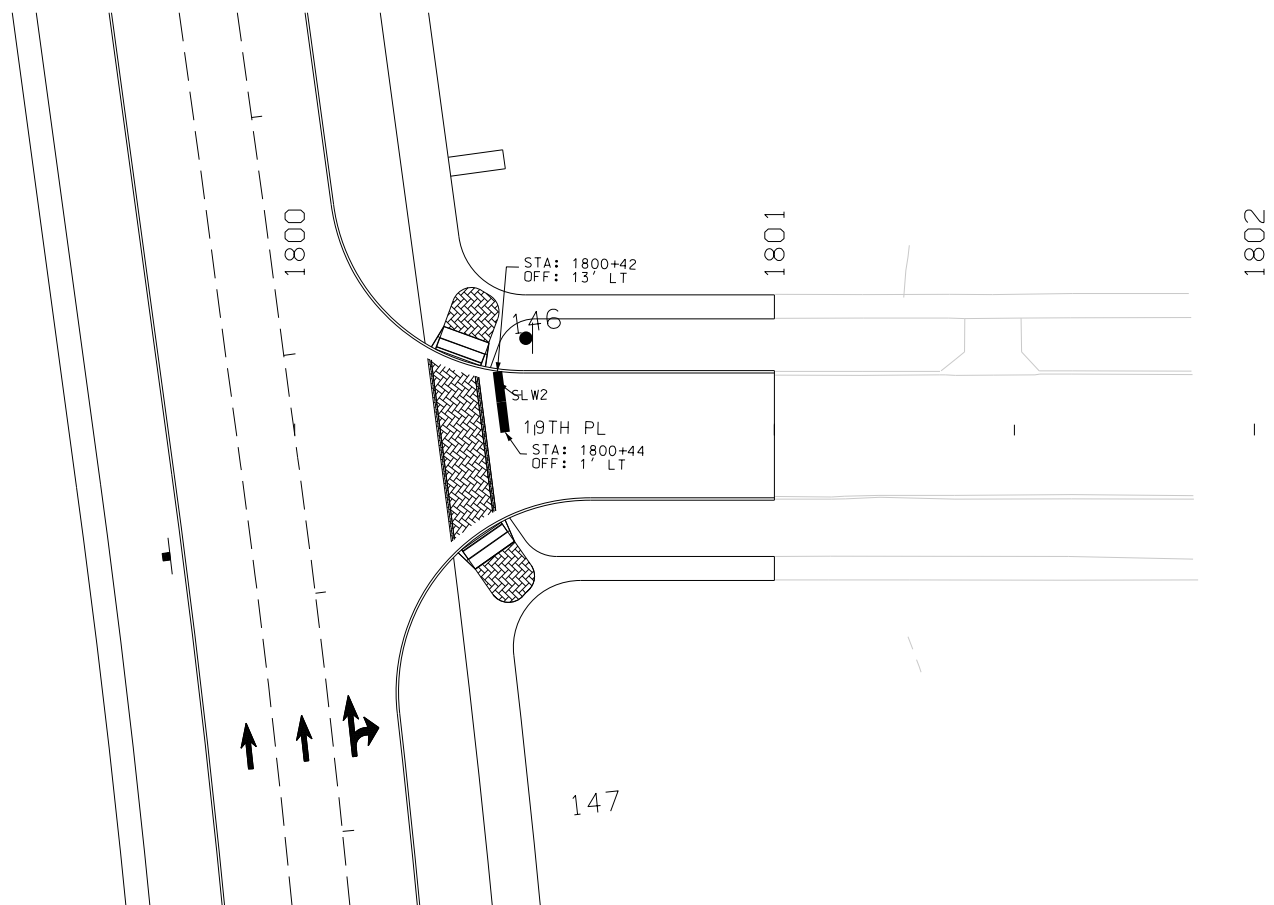

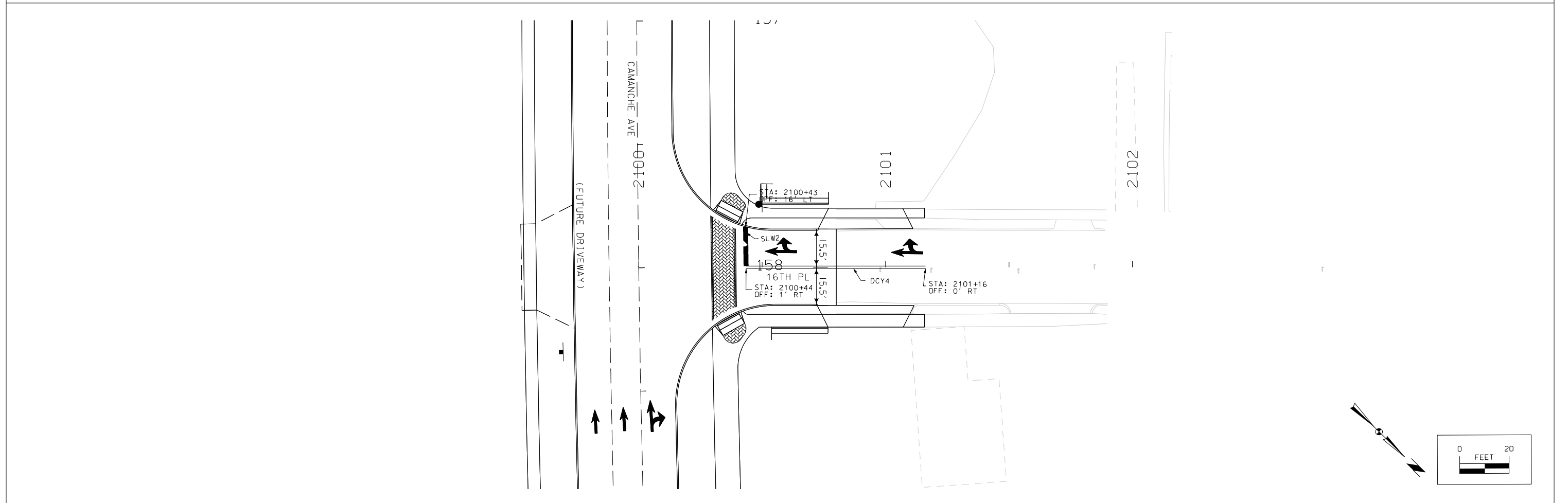
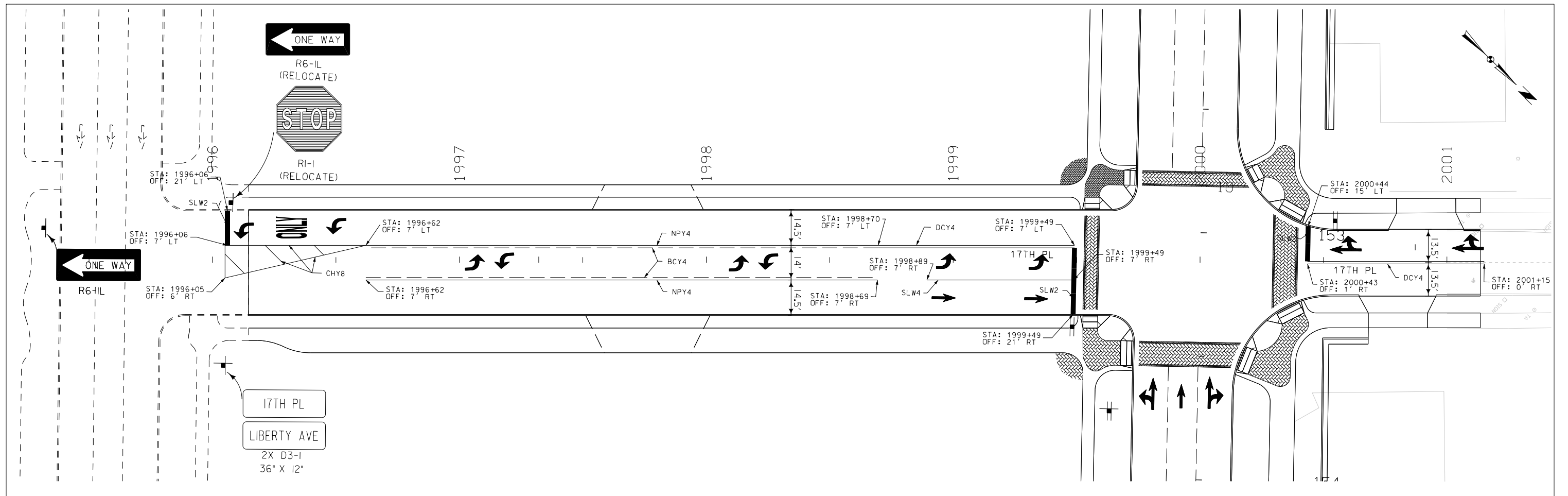

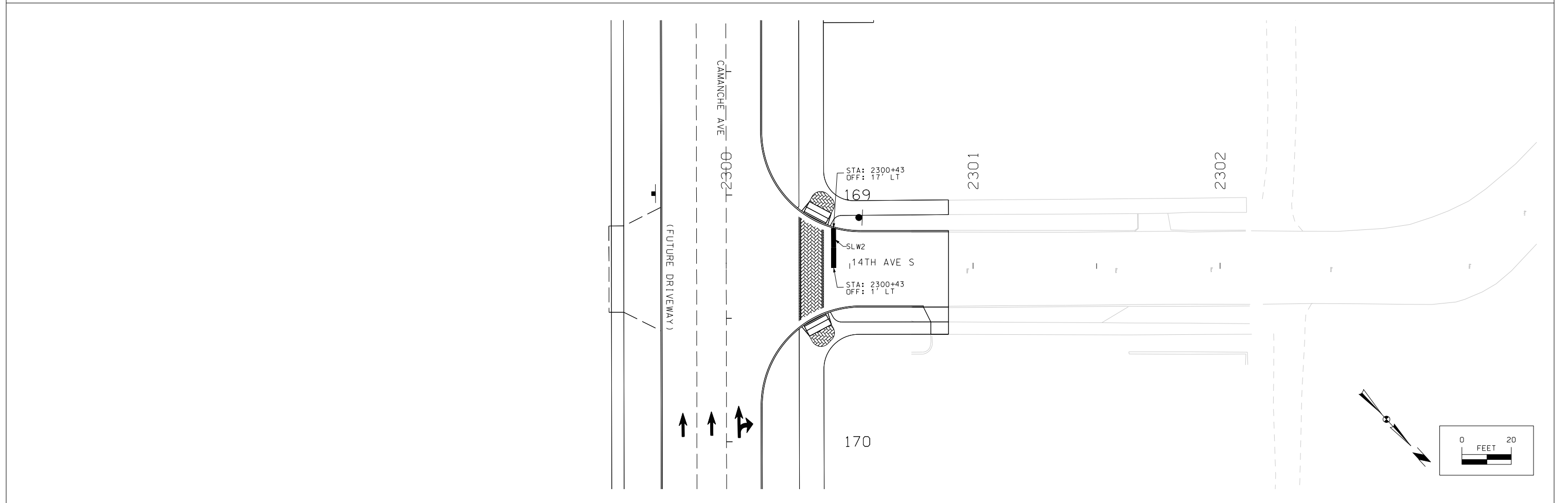
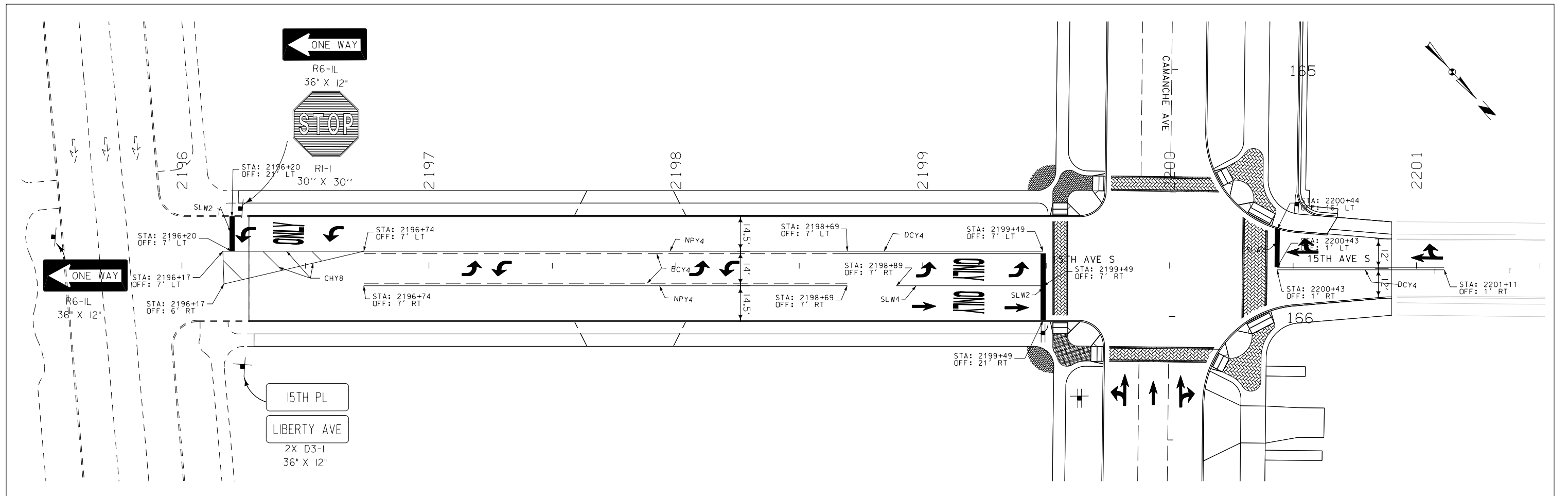

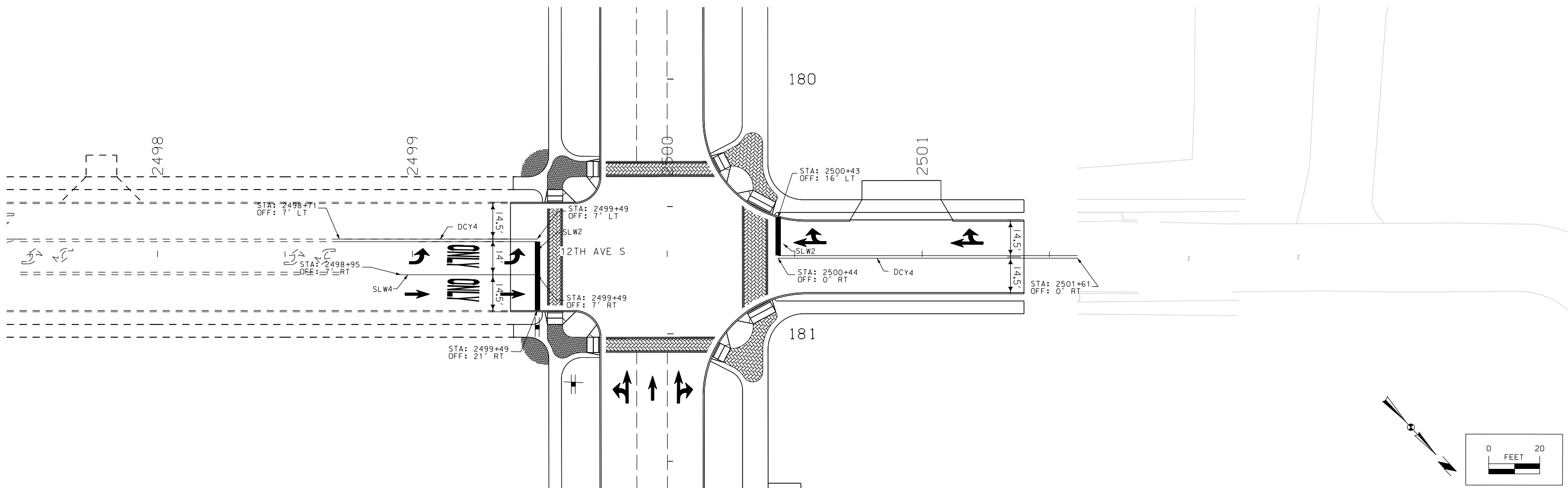
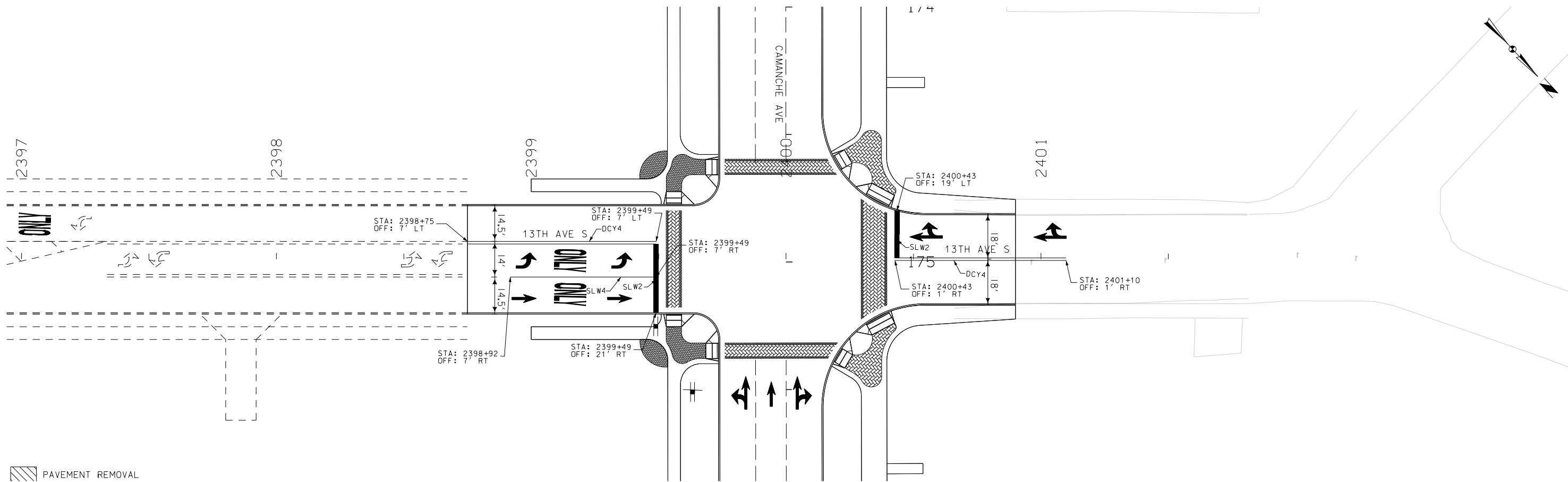



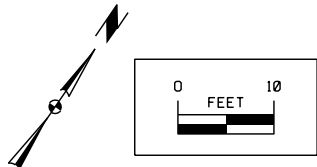

Point	Station	Offset	Elevation	Description
L100	100+55.10	16.47	N/A	CENTER OF 2' RADIUS
L101	100+54.53	18.35	625.37	FG END OF RADIUS/MATCH EXISTING
L102	100+55.13	14.50	625.94	FG END OF RADIUS/MATCH EXISTING
L103	100+88.94	28.80	625.26	FG END OF RADIUS/MATCH EXISTING
L104	100+92.79	29.17	625.24	FG END OF RADIUS/MATCH EXISTING
L105	100+91.80	19.38	N/A	CENTER OF 10' RADIUS
L106	101+99.43	18.50	625.48	END TAPER
L107	103+42.63	18.50	623.12	FG END OF RADIUS
L108	103+42.63	14.50	623.12	FG END OF RADIUS
L109	103+42.63	16.50	N/A	CENTER OF 2' RADIUS

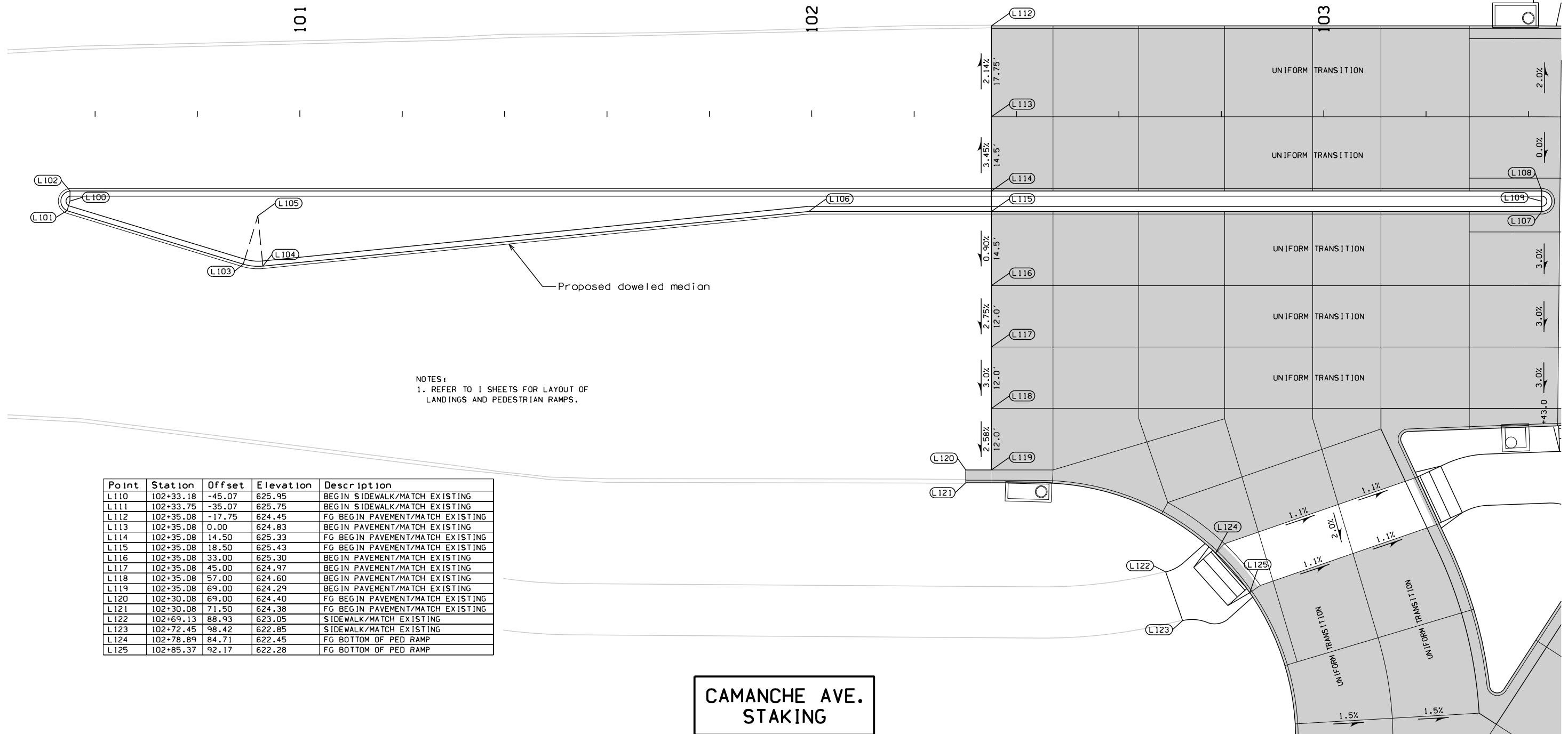

NOTES:  
1. REFER TO I SHEETS FOR LAYOUT OF LANDINGS AND PEDESTRIAN RAMPS.

Point	Station	Offset	Elevation	Description
L110	102+33.18	-45.07	625.95	BEGIN SIDEWALK/MATCH EXISTING
L111	102+33.75	-35.07	625.75	BEGIN SIDEWALK/MATCH EXISTING
L112	102+35.08	-17.75	624.45	FG BEGIN PAVEMENT/MATCH EXISTING
L113	102+35.08	0.00	624.83	BEGIN PAVEMENT/MATCH EXISTING
L114	102+35.08	14.50	625.33	FG BEGIN PAVEMENT/MATCH EXISTING
L115	102+35.08	18.50	625.43	FG BEGIN PAVEMENT/MATCH EXISTING
L116	102+35.08	33.00	625.30	BEGIN PAVEMENT/MATCH EXISTING
L117	102+35.08	45.00	624.97	BEGIN PAVEMENT/MATCH EXISTING
L118	102+35.08	57.00	624.60	BEGIN PAVEMENT/MATCH EXISTING
L119	102+35.08	69.00	624.29	BEGIN PAVEMENT/MATCH EXISTING
L120	102+30.08	69.00	624.40	FG BEGIN PAVEMENT/MATCH EXISTING
L121	102+30.08	71.50	624.38	FG BEGIN PAVEMENT/MATCH EXISTING
L122	102+69.13	88.93	623.05	SIDEWALK/MATCH EXISTING
L123	102+72.45	98.42	622.85	SIDEWALK/MATCH EXISTING
L124	102+78.89	84.71	622.45	FG BOTTOM OF PED RAMP
L125	102+85.37	92.17	622.28	FG BOTTOM OF PED RAMP

**CAMANCHE AVE.  
STAKING**



R3

Point	Station	Offset	Elevation	Description
L200	1197+20.65	-22.36	620.90	FG BEGIN PAVEMENT/MATCH EXISTING
L201	1197+29.81	-21.13	620.61	BEGIN PAVEMENT/MATCH EXISTING
L202	1197+29.81	-12.00	620.76	BEGIN PAVEMENT/MATCH EXISTING
L203	1197+29.81	0.00	620.90	BEGIN PAVEMENT/MATCH EXISTING
L204	1197+29.81	12.00	620.87	BEGIN PAVEMENT/MATCH EXISTING
L205	1197+29.81	13.75	620.78	FG BEGIN PAVEMENT/MATCH EXISTING
L206	1198+08.56	26.50	619.85	FG END TAPER
L207	104+18.88	94.41	620.13	FG END OF RADIUS
L208	104+27.08	83.69	620.21	FG BOTTOM OF PED RAMP
L209	104+34.50	76.69	620.24	FG BOTTOM OF PED RAMP
L210	104+46.17	68.81	620.21	FG MIDPOINT RADIUS
L211	103+69.54	-45.06	623.90	SIDEWALK
L212	103+69.56	-35.08	623.60	SIDEWALK
L213	103+33.03	-45.08	624.33	SIDEWALK
L214	103+33.03	-35.08	624.03	SIDEWALK
L215	103+46.37	-17.75	623.22	FG BOTTOM OF PED RAMP
L216	103+56.28	-17.75	623.10	FG BOTTOM OF PED RAMP
L217	103+88.46	-17.75	622.75	FG END OF RADIUS
L218	103+65.17	59.51	621.49	FG END OF RADIUS
L219	103+67.47	63.33	621.19	FG END OF RADIUS
L220	103+65.30	62.00	621.34	CENTER OF 2.5' RADIUS
L221	103+56.39	59.92	621.66	FG BOTTOM OF PED RAMP
L222	103+46.12	60.37	621.82	FG BOTTOM OF PED RAMP
L223	103+16.48	61.50	622.29	FG END OF RADIUS
L224	103+15.17	63.63	622.16	FG END OF RADIUS
L225	103+16.53	63.00	622.20	CENTER OF 1.5' RADIUS
L226	103+18.31	70.37	621.80	FG BOTTOM OF PED RAMP
L227	103+22.53	79.44	621.32	FG BOTTOM OF PED RAMP
L228	103+24.74	84.17	621.06	FG END OF RADIUS
L229	103+29.65	97.41	620.35	FG MIDPOINT OF RADIUS
L230	103+32.41	111.25	619.87	FG END OF RADIUS
L231	103+35.16	111.90	619.88	FG END OF RADIUS
L232	103+33.90	111.08	619.89	CENTER OF 1.5' RADIUS
L233	103+56.07	80.71	620.72	FG BOTTOM OF PED RAMP
L234	103+61.63	72.27	620.95	FG BOTTOM OF PED RAMP
L235	102+44.51	71.53	623.72	FG END OF RADIUS
L236	102+79.17	85.50	622.45	FG MIDPOINT OF RADIUS
L237	102+94.47	119.59	621.05	FG END OF RADIUS
L238	102+44.50	121.52	N/A	CENTER OF 50' RADIUS
L239	102+92.73	154.82	619.87	FG MIDPOINT OF RADIUS
L240	102+84.81	189.19	620.03	FG END OF RADIUS
L241	103+32.04	228.84	621.36	BEGIN SIDEWALK/MATCH EXISTING
L242	103+35.69	230.62	621.42	BEGIN SIDEWALK/MATCH EXISTING
L243	103+71.59	176.31	620.04	SIDEWALK
L244	103+76.21	178.96	620.14	SIDEWALK
L245	104+19.36	103.38	620.75	SIDEWALK
L246	104+23.81	106.04	620.85	SIDEWALK

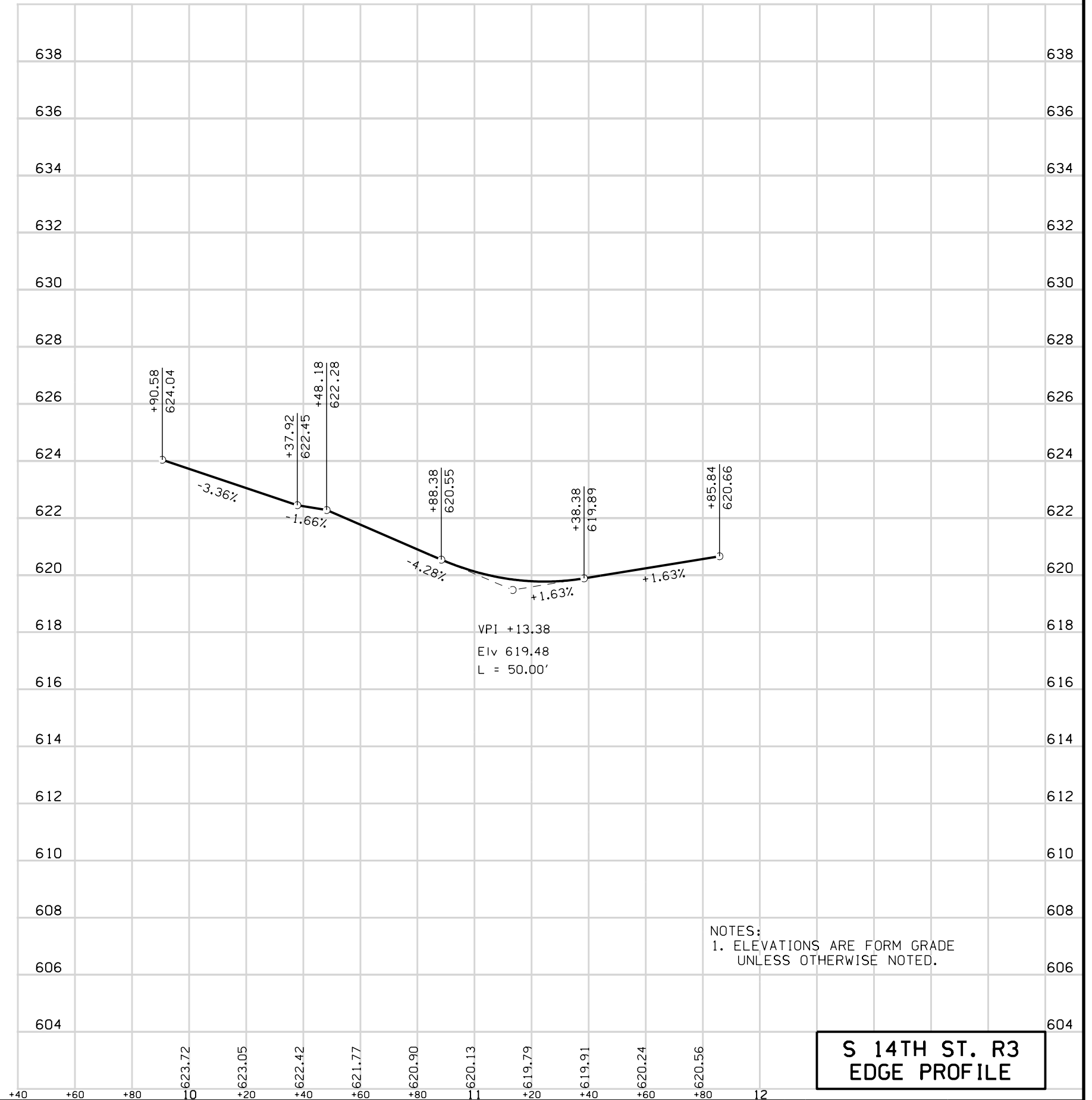

NOTES:  
1. ELEVATIONS ARE FORM GRADE  
UNLESS OTHERWISE NOTED.

**S 14TH ST. R3  
EDGE PROFILE**

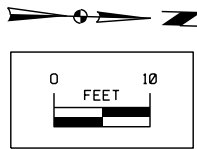

- NOTES:
1. ALL LONGITUDINAL JOINTS WILL BE "KT-2" OR "L-2" UNLESS OTHERWISE NOTED.
  2. ALL TRANSVERSE JOINTS WILL BE "CD" UNLESS OTHERWISE NOTED.

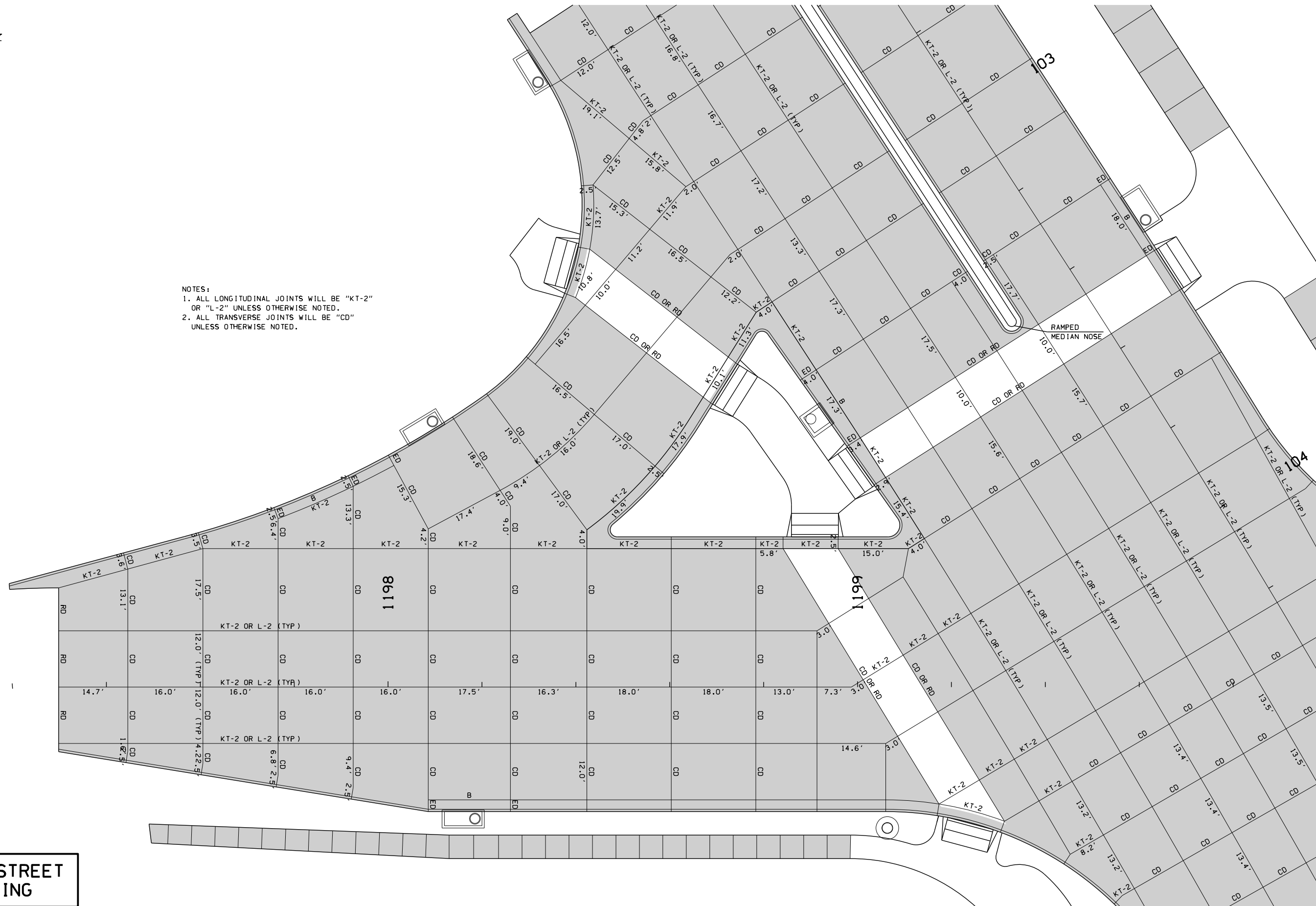

**S 14TH STREET  
JOINTING**

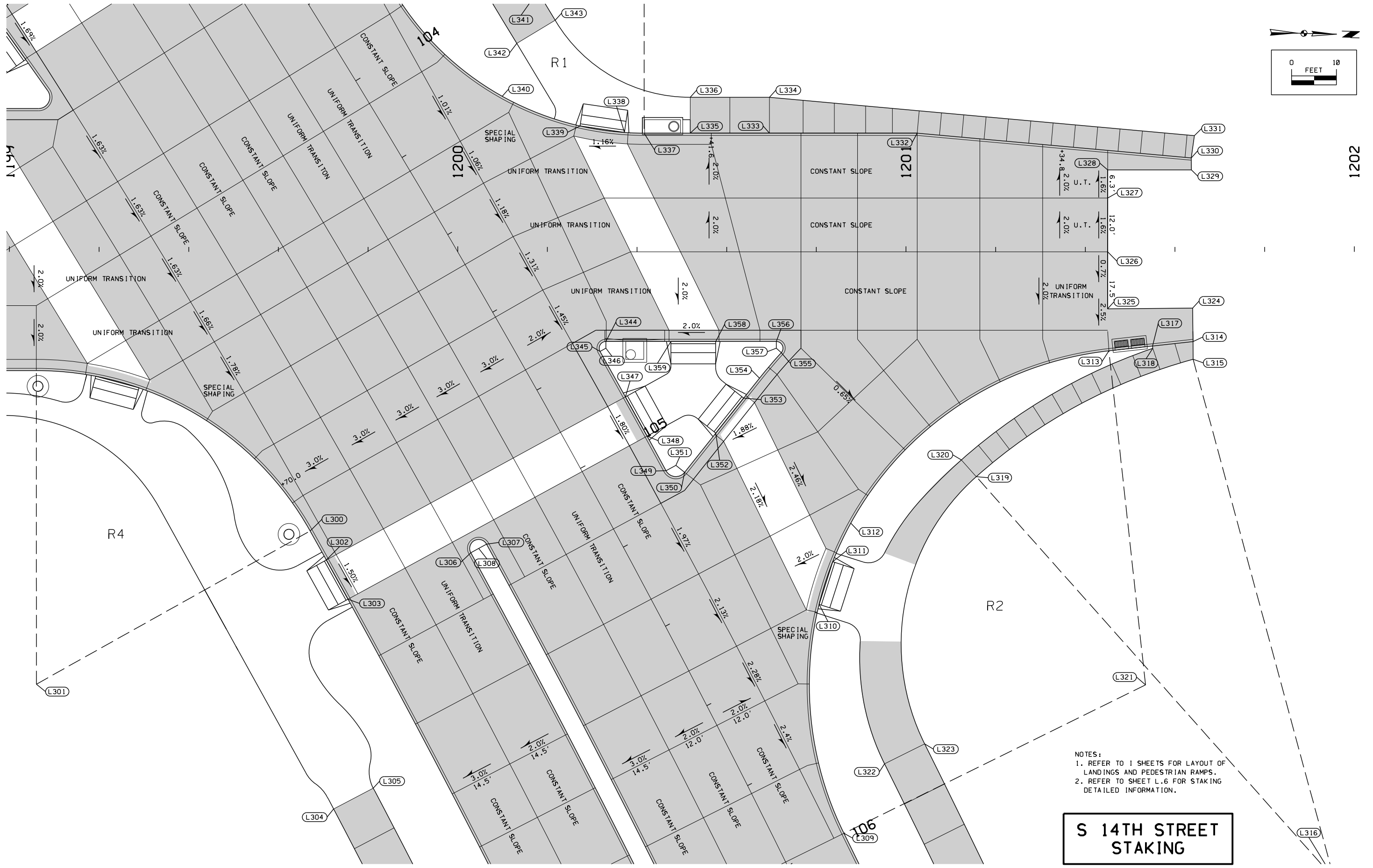
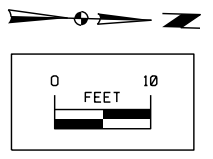

NOTES:  
 1. REFER TO 1 SHEETS FOR LAYOUT OF LANDINGS AND PEDESTRIAN RAMPS.  
 2. REFER TO SHEET L.6 FOR STAKING DETAILED INFORMATION.

**S 14TH STREET STAKING**

Point	Station	Offset	Elevation	Description
L300	104+82.71	59.50	619.71	FG END OF RADIUS
L301	104+82.71	129.50	N/A	CENTER OF 70' RADIUS
L302	104+90.34	59.50	619.62	FG BOTTOM OF PED RAMP
L303	105+00.62	59.50	619.47	FG BOTTOM OF PED RAMP
L304	105+41.68	84.51	620.10	SIDEWALK
L305	105+41.69	74.53	619.90	SIDEWALK
L306	105+04.77	30.50	620.17	FG END OF RADIUS
L307	105+04.78	26.50	620.29	FG END OF RADIUS
L308	105+04.77	28.50	N/A	CENTER OF 2' RADIUS
L309	105+99.07	-14.50	618.68	FG END OF RADIUS
L310	105+51.49	-32.63	620.10	FG BOTTOM OF PED RAMP
L311	105+44.56	-39.74	620.30	FG BOTTOM OF PED RAMP
L312	105+38.94	-47.31	620.80	FG MIDPOINT OF RADIUS
L313	1201+45.26	22.09	627.61	FG END OF RADIUS
L314	1201+64.02	20.04	629.10	FG END PAVEMENT/MATCH EXISTING
L315	1201+64.06	23.99	629.65	END SIDEWALK/MATCH EXISTING
L316	106+54.59	-108.75	N/A	CENTER OF 120' RADIUS
L317	1201+54.99	21.03	628.88	SIDEWALK
L318	1201+55.04	21.52	628.88	SIDEWALK
L319	105+42.67	-76.91	624.43	SIDEWALK/END OF RADIUS
L320	105+37.98	-75.70	624.33	SIDEWALK
L321	105+99.07	-89.50	N/A	CENTER OF 75' RADIUS
L322	105+89.29	-29.50	620.18	SIDEWALK
L323	105+89.29	-39.50	619.39	SIDEWALK
L324	1201+64.00	12.72	629.44	END PAVEMENT/MATCH EXISTING
L325	1201+45.00	12.72	627.82	END PAVEMENT/MATCH EXISTING
L326	1201+45.00	0.00	627.85	END PAVEMENT/MATCH EXISTING
L327	1201+45.00	-12.00	627.66	END PAVEMENT/MATCH EXISTING
L328	1201+45.00	-18.29	627.56	END PAVEMENT/MATCH EXISTING
L329	1201+63.66	-18.29	629.08	END PAVEMENT/MATCH EXISTING
L330	1201+63.63	-20.97	629.17	FG END PAVEMENT/MATCH EXISTING
L331	1201+64.32	-25.93	629.55	END SIDEWALK/MATCH EXISTING
L332	104+71.92	-102.06	623.81	FG END TAPER
L333	1200+69.53	-26.50	622.16	SIDEWALK
L334	1200+69.53	-34.50	622.32	SIDEWALK
L335	1200+51.86	-26.50	621.57	SIDEWALK
L336	1200+51.86	-34.50	621.73	SIDEWALK
L337	104+42.55	-49.27	621.11	FG END OF RADIUS
L338	104+40.26	-45.55	621.20	FG BOTTOM OF PED RAMP
L339	104+34.11	-37.76	621.40	FG BOTTOM OF PED RAMP
L340	104+19.74	-26.20	622.26	FG MIDPOINT OF RADIUS
L341	103+88.45	-82.76	N/A	CENTER OF 65' RADIUS
L342	104+11.42	-35.07	622.62	SIDEWALK
L343	104+11.42	-45.06	622.85	SIDEWALK
L344	104+78.09	-18.73	621.19	FG END OF RADIUS
L345	104+79.39	-16.50	621.18	FG END OF RADIUS
L346	104+79.39	-18.00	621.17	CENTER OF 1.5' RADIUS
L347	104+90.92	-16.50	621.02	FG BOTTOM OF PED RAMP
L348	105+00.85	-16.50	620.88	FG BOTTOM OF PED RAMP
L349	105+09.58	-16.50	620.75	FG END OF RADIUS
L350	105+11.86	-19.97	620.78	FG END OF RADIUS
L351	105+09.58	-19.00	620.80	CENTER OF 1.5' RADIUS
L352	105+07.55	-30.26	621.07	FG BOTTOM OF PED RAMP
L353	105+03.72	-39.48	621.32	FG BOTTOM OF PED RAMP
L354	105+01.57	-44.70	621.46	FG END OF RADIUS
L355	104+98.98	-51.69	621.78	FG END OF RADIUS
L356	104+96.31	-51.93	621.85	FG END OF RADIUS
L357	104+97.59	-51.20	621.78	CENTER OF 2.5' RADIUS
L358	104+89.89	-40.11	621.35	FG BOTTOM OF PED RAMP
L359	104+85.10	-31.38	621.15	FG BOTTOM OF PED RAMP

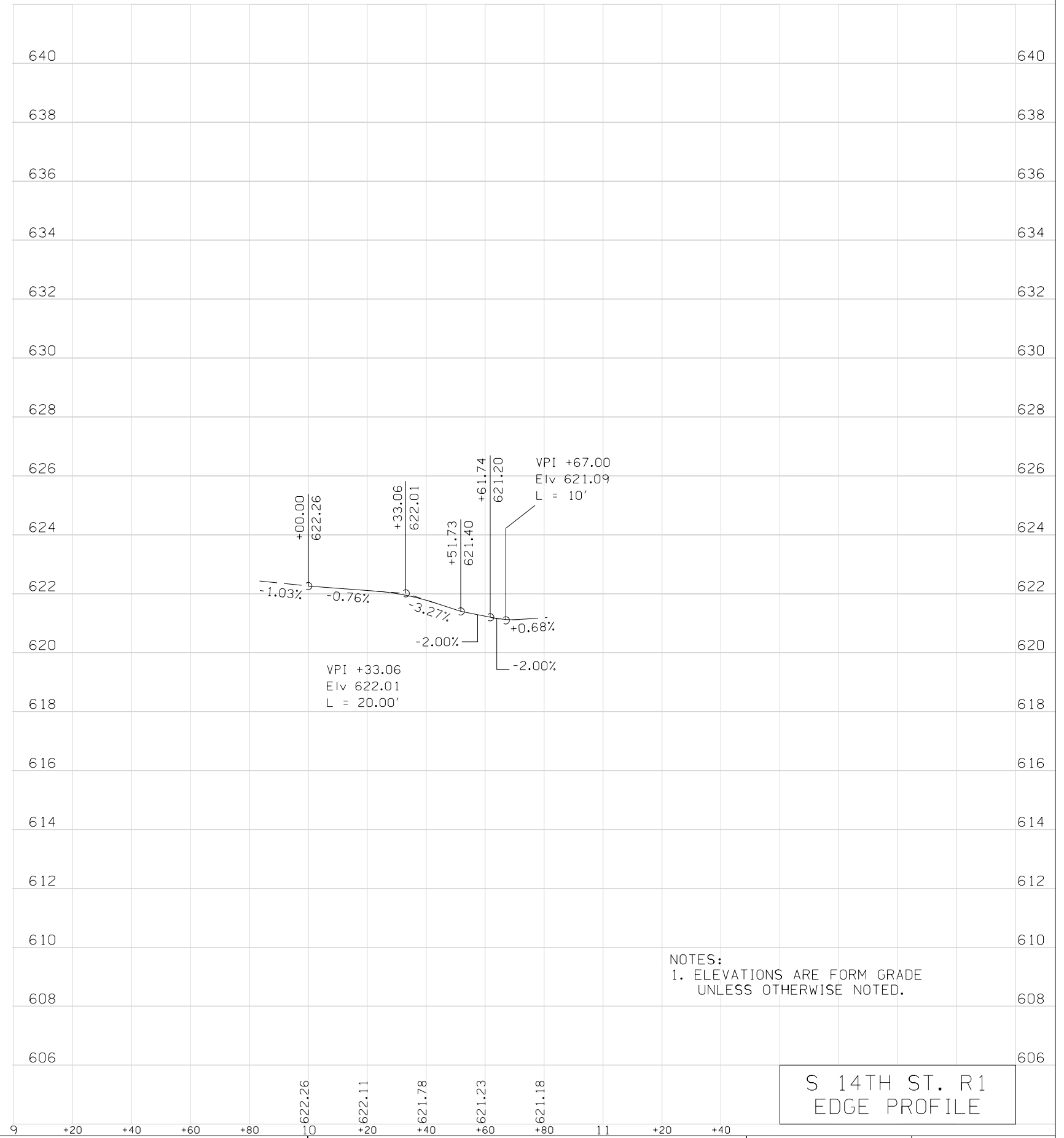

NOTES:  
1. ELEVATIONS ARE FORM GRADE  
UNLESS OTHERWISE NOTED.

S 14TH ST. R1  
EDGE PROFILE

R2

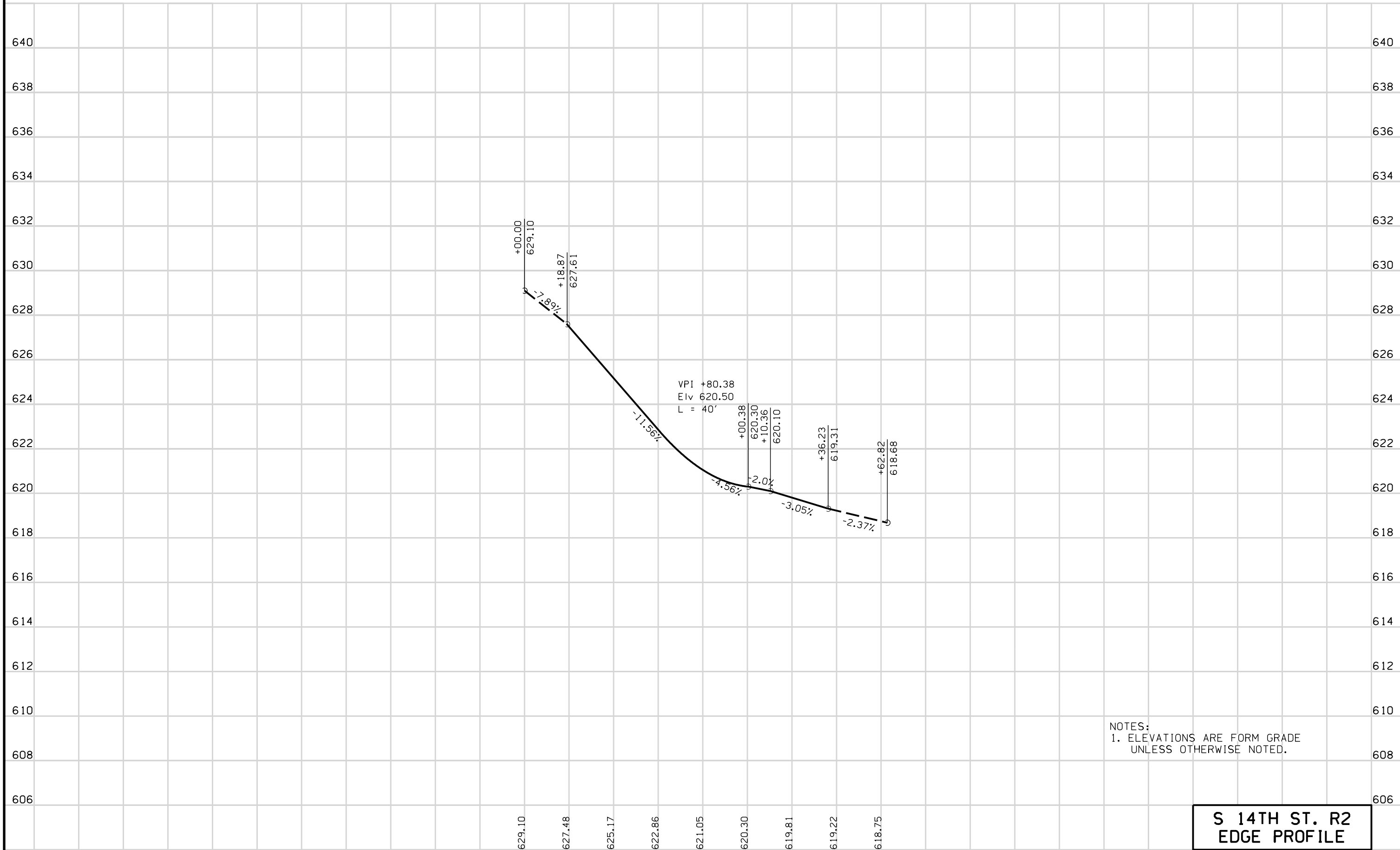

NOTES:  
1. ELEVATIONS ARE FORM GRADE  
UNLESS OTHERWISE NOTED.

**S 14TH ST. R2  
EDGE PROFILE**

R4

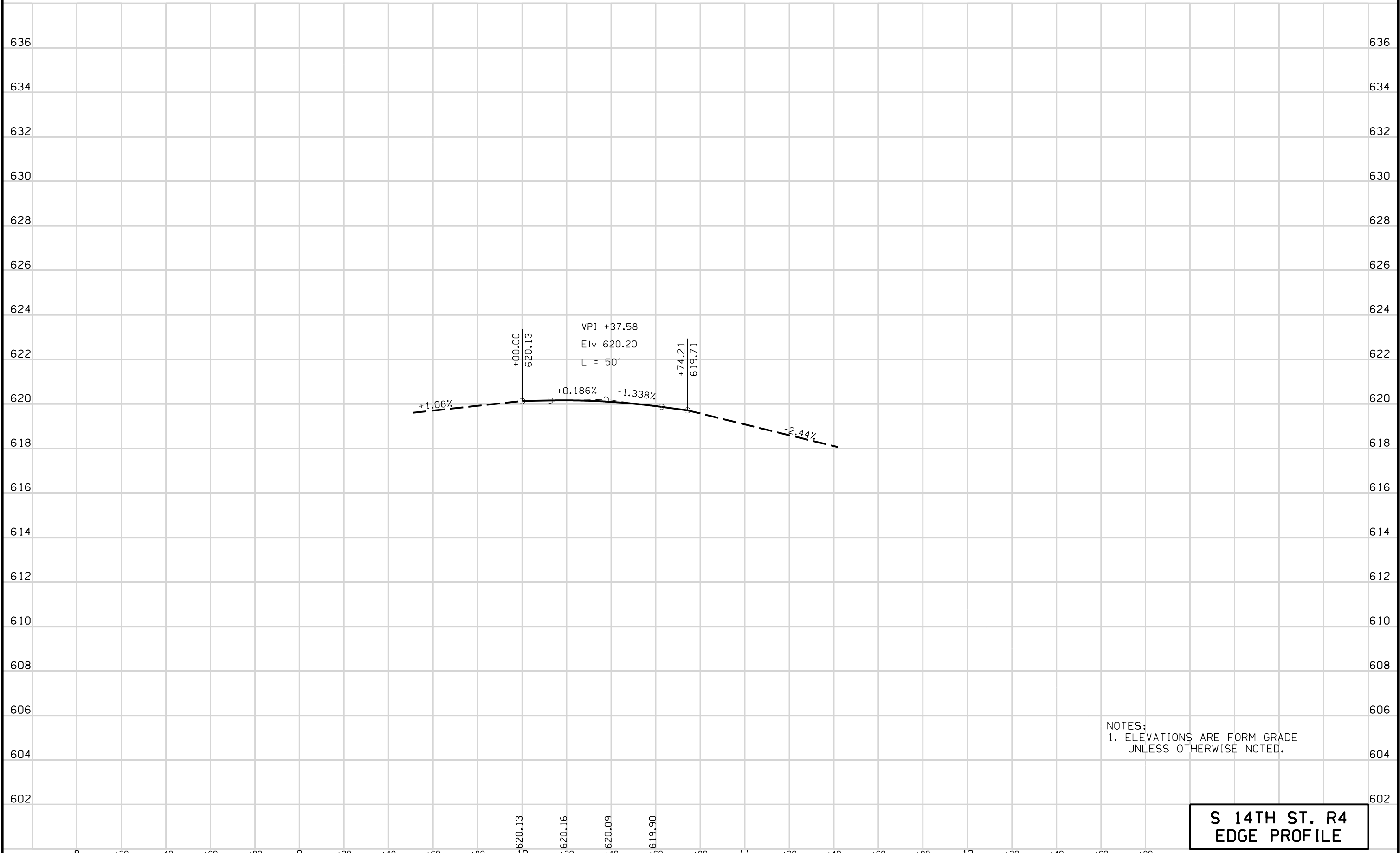

NOTES:  
 1. ELEVATIONS ARE FORM GRADE  
 UNLESS OTHERWISE NOTED.

**S 14TH ST. R4  
 EDGE PROFILE**



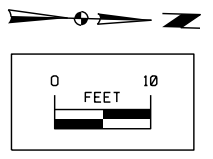

NOTES:  
 1. ALL LONGITUDINAL JOINTS WILL BE "KT-2"  
 OR "L-2" UNLESS OTHERWISE NOTED.  
 2. ALL TRANSVERSE JOINTS WILL BE "CD"  
 UNLESS OTHERWISE NOTED.

**S 14TH STREET  
 JOINTING**

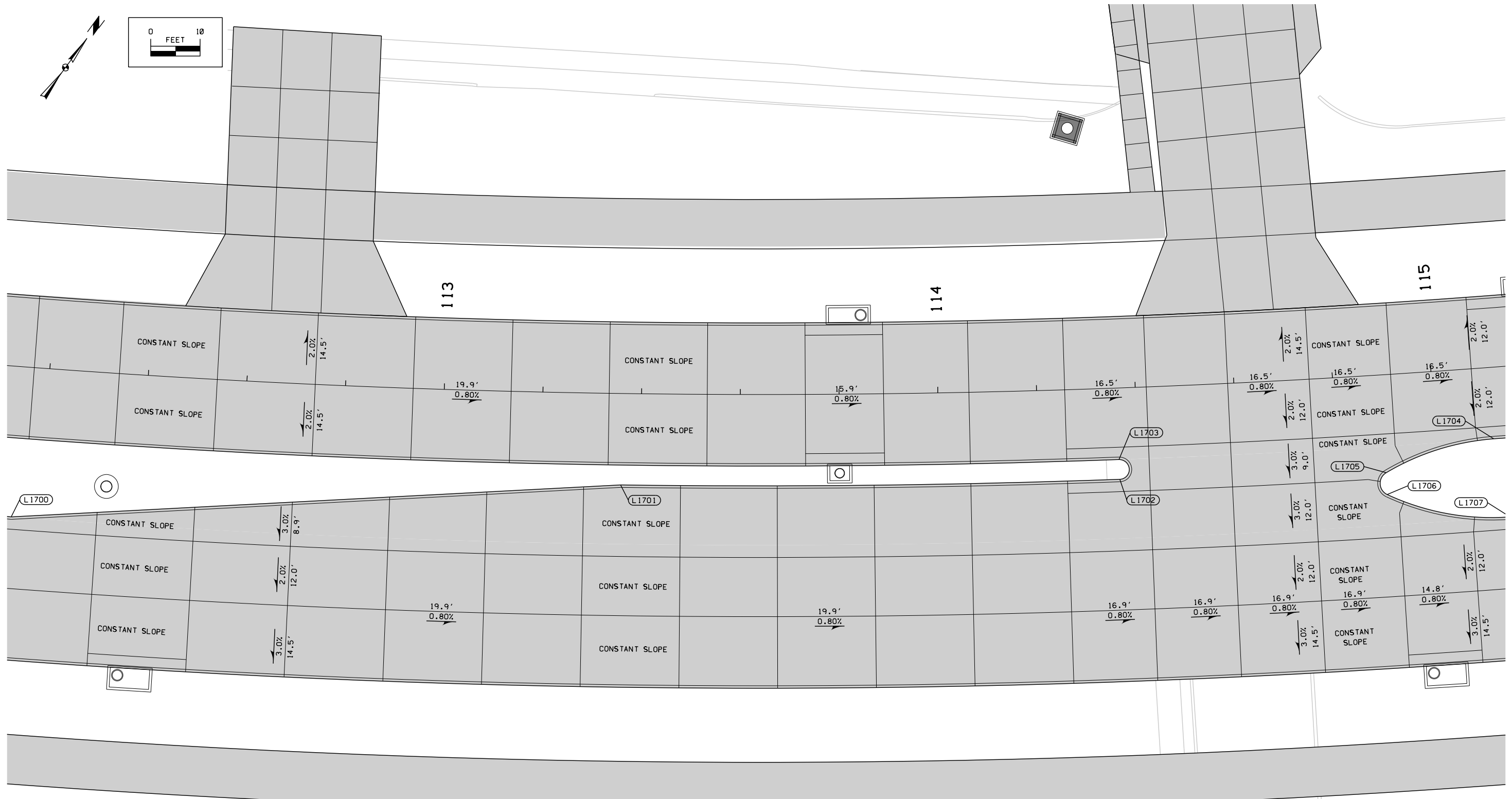
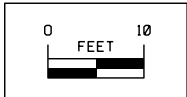
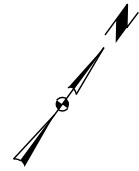

Point	Station	Offset	Elevation	Description
L1700	112+14.44	30.5	603.62	FG BEGIN TAPER
L1701	113+36.00	18.5	603.31	FG END TAPER
L1702	114+36.20	18.5	602.13	FG END OF RADIUS
L1703	114+36.20	14.5	602.01	FG END OF RADIUS
L1704	115+11.67	14.5	601.53	FG END OF RADIUS
L1705	114+89.65	19.84	601.59	FG BEGINNING OF RADIUS
L1706	114+89.59	24.27	601.50	FG BEGINNING OF RADIUS
L1707	115+13.74	30.5	601.03	FG END OF RADIUS

**CAMANCHE AVE.  
STAKING**



Point	Station	Offset	Elevation	Description
L448	1299+21.71	12.50	601.77	FG END OF RADIUS
L449	1299+02.35	12.50	601.51	FG MIDPOINT OF RADIUS
L450	1298+83.00	12.50	601.28	FG END OF RADIUS/MATCH EXISTING
L451	1298+83.00	0.00	601.53	END PAVEMENT/MATCH EXISTING
L452	1298+83.00	-10.50	601.74	FG END OF RADIUS/MATCH EXISTING
L453	1299+02.36	-10.50	601.97	FG MIDPOINT OF RADIUS
L454	1299+21.71	-10.50	602.23	FG END OF RADIUS
L455	122+97.87	36.49	602.92	FG END OF RADIUS
L456	122+94.94	29.43	602.97	FG MIDPOINT OF RADIUS
L457	122+87.87	26.50	602.98	FG END OF RADIUS
L458	122+87.88	36.50	N/A	CENTER OF 10' RADIUS
L459	1298+93.11	-15.50	602.45	END SIDEWALK/MATCH EXISTING
L460	1298+93.11	-25.50	602.65	END SIDEWALK/MATCH EXISTING
L461	1299+21.71	-15.50	602.93	SIDEWALK/END OF RADIUS
L462	1299+21.71	-25.50	603.13	SIDEWALK/END OF RADIUS
L463	1299+50.00	-15.50	603.33	SIDEWALK
L464	1299+50.00	-25.50	603.53	SIDEWALK
L465	122+97.89	44.73	602.84	FG BOTTOM OF PED RAMP
L466	122+97.88	38.74	602.90	FG BOTTOM OF PED RAMP
L467	122+84.49	26.50	602.97	FG BOTTOM OF PED RAMP
L468	122+74.50	26.50	602.95	FG BOTTOM OF PED RAMP

Point	Station	Offset	Elevation	Description
L400	122+58.50	-39.50	604.58	SIDEWALK
L401	122+58.50	-29.50	604.38	SIDEWALK
L402	122+73.03	-17.33	603.32	FG BOTTOM OF PED RAMP
L403	122+81.78	-22.18	603.35	FG BOTTOM OF PED RAMP
L404	122+90.88	-31.39	603.38	FG BOTTOM OF PED RAMP
L405	122+95.58	-40.22	603.40	FG BOTTOM OF PED RAMP
L406	122+58.23	-14.50	603.29	FG END OF RADIUS
L407	122+86.54	-26.24	603.36	FG MIDPOINT OF RADIUS
L408	122+98.23	-54.56	603.63	FG END OF RADIUS
L409	122+58.24	-54.50	N/A	CENTER OF 40' RADIUS
L410	1301+00.00	-15.00	605.63	FG BEGIN PAVEMENT/MATCH EXISTING
L411	1301+00.00	0.00	606.10	BEGIN PAVEMENT/MATCH EXISTING
L469	122+62.54	-62.50	603.57	SIDEWALK/MATCH EXISTING
L470	122+62.64	-62.50	603.58	SIDEWALK/MATCH EXISTING

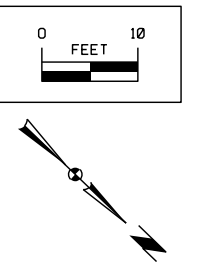

Point	Station	Offset	Elevation	Description
L430	123+66.93	41.50	603.68	SIDEWALK
L431	123+66.93	46.50	603.78	SIDEWALK
L432	123+51.51	30.43	602.68	FG BOTTOM OF PED RAMP
L433	123+46.13	33.09	602.62	FG BOTTOM OF PED RAMP
L434	123+37.18	39.61	602.45	FG BOTTOM OF PED RAMP
L435	123+33.01	43.92	602.35	FG BOTTOM OF PED RAMP
L436	123+30.78	58.72	602.77	END OF RADIUS
L437	123+35.09	61.26	602.87	SIDEWALK
L438	123+25.94	76.55	602.50	END OF RADIUS
L439	1299+21.70	17.50	602.47	END OF RADIUS
L440	123+30.93	76.56	602.70	END OF RADIUS
L441	1299+21.71	22.50	602.57	END OF RADIUS
L442	1298+83.00	17.50	601.98	END SIDEWALK/MATCH EXISTING
L443	1298+83.00	22.50	602.08	END SIDEWALK/MATCH EXISTING
L444	123+70.93	26.50	602.67	FG END OF RADIUS
L445	123+35.55	41.18	602.38	FG MIDPOINT OF RADIUS
L446	123+20.93	76.57	601.80	FG END OF RADIUS
L447	123+70.93	76.50	N/A	CENTER OF 50' RADIUS

Point	Station	Offset	Elevation	Description
L412	1300+99.99	12.73	605.40	FG BEGIN PAVEMENT/MATCH EXISTING
L413	1301+06.56	12.50	606.16	FG END TAPER/MATCH EXISTING
L414	123+25.74	-54.44	603.62	FG END OF RADIUS
L415	123+37.48	-26.20	603.30	FG MIDPOINT OF RADIUS
L416	123+65.73	-14.50	603.09	FG END OF RADIUS
L417	123+65.74	-54.50	N/A	CENTER OF 40' RADIUS
L418	1301+00.00	16.98	607.58	BEGIN SIDEWALK/MATCH EXISTING
L419	1301+00.00	21.96	607.64	BEGIN SIDEWALK/MATCH EXISTING
L420	1301+04.09	17.50	606.89	SIDEWALK
L421	1301+04.09	17.50	606.83	SIDEWALK
L422	123+30.74	-53.49	604.32	SIDEWALK
L423	123+35.74	-53.48	604.42	SIDEWALK
L424	123+28.39	-40.17	603.47	FG BOTTOM OF PED RAMP
L425	123+33.11	-31.36	603.37	FG BOTTOM OF PED RAMP
L426	123+46.20	-19.59	603.19	FG BOTTOM OF PED RAMP
L427	123+51.64	-17.06	603.16	FG BOTTOM OF PED RAMP
L428	123+66.88	-29.50	604.18	SIDEWALK
L429	123+66.88	-39.50	604.38	SIDEWALK
L471	123+37.41	-57.39	603.18	FG END OF RADIUS
L472	123+47.41	-47.50	602.62	FG END OF RADIUS
L473	123+47.41	-57.50	603.03	CENTER OF 10' RADIUS/MATCH EXISTING

NOTES:  
1. REFER TO 1 SHEETS FOR LAYOUT OF LANDINGS AND PEDESTRIAN RAMPS.

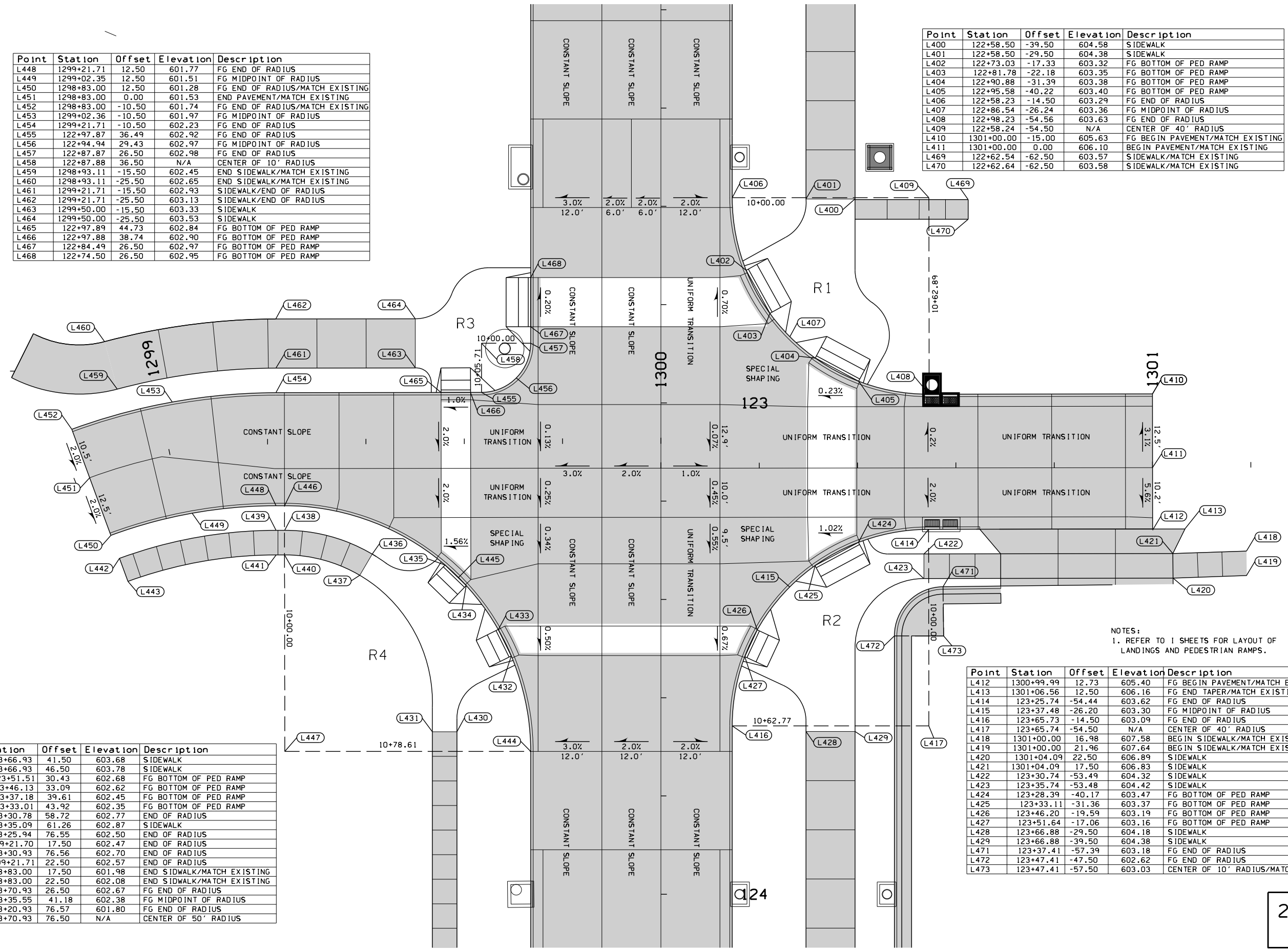

**24TH PLACE STAKING**

R1

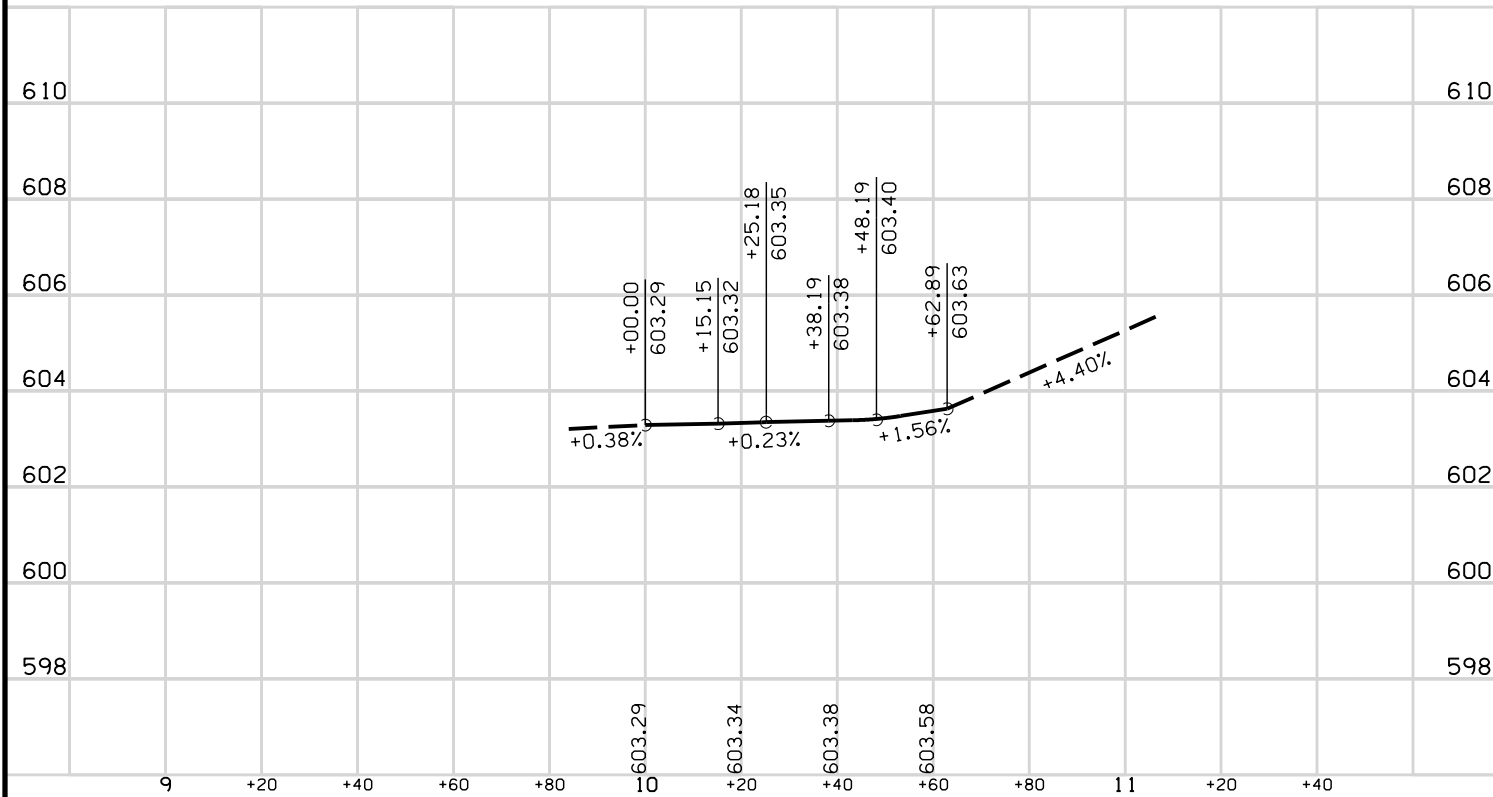

R2

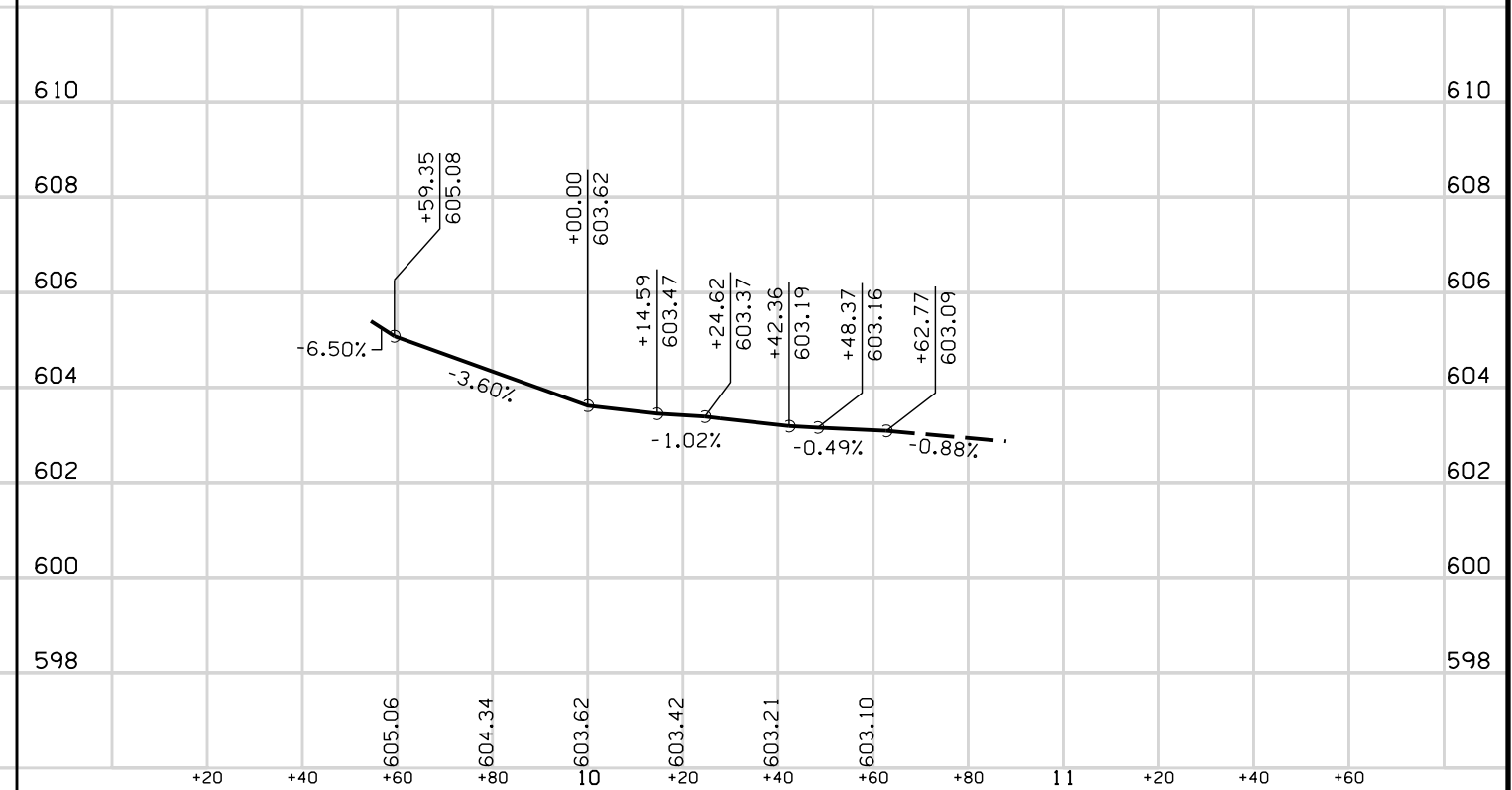

R3

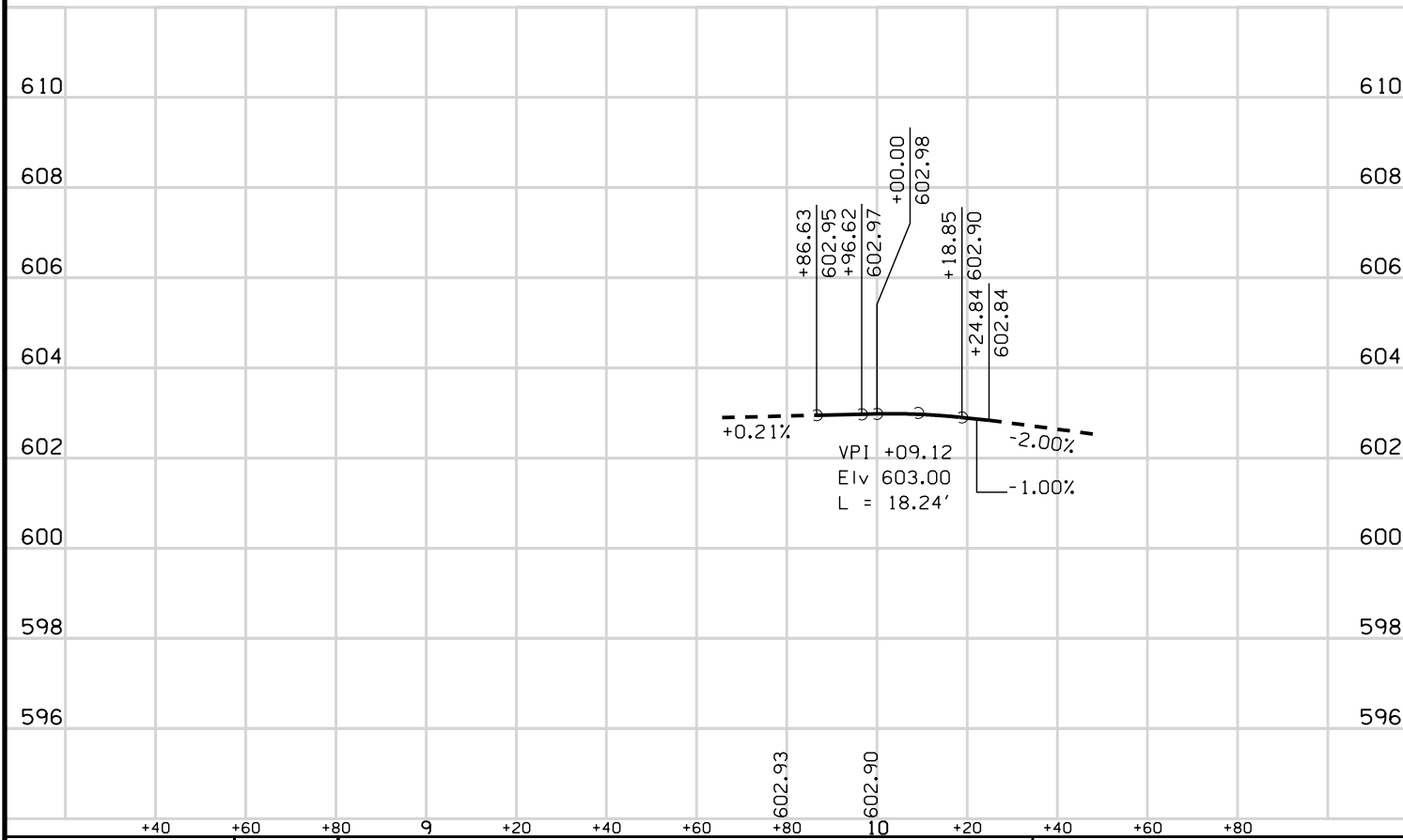

R4

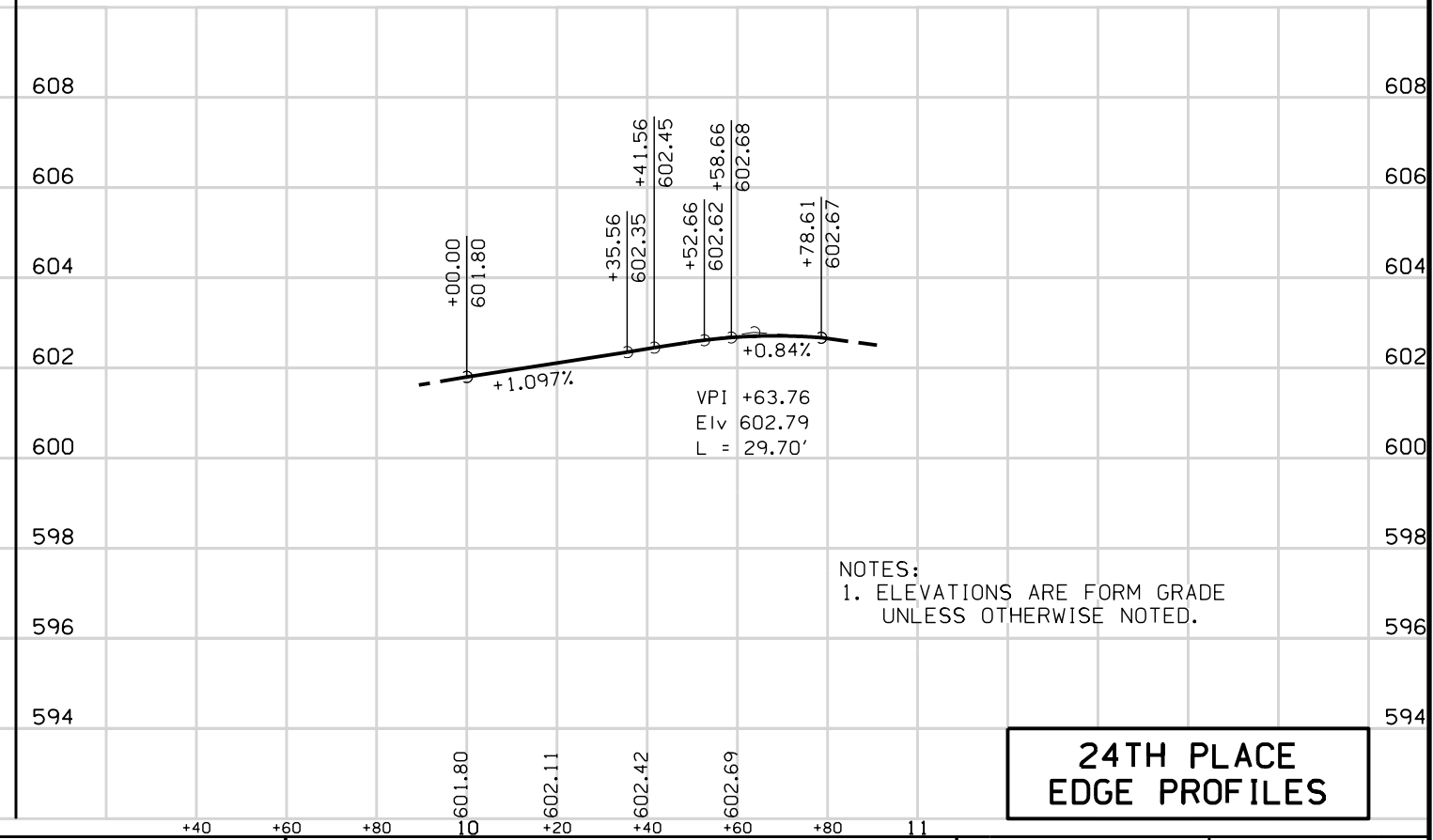

NOTES:  
 1. ELEVATIONS ARE FORM GRADE  
 UNLESS OTHERWISE NOTED.

24TH PLACE  
 EDGE PROFILES

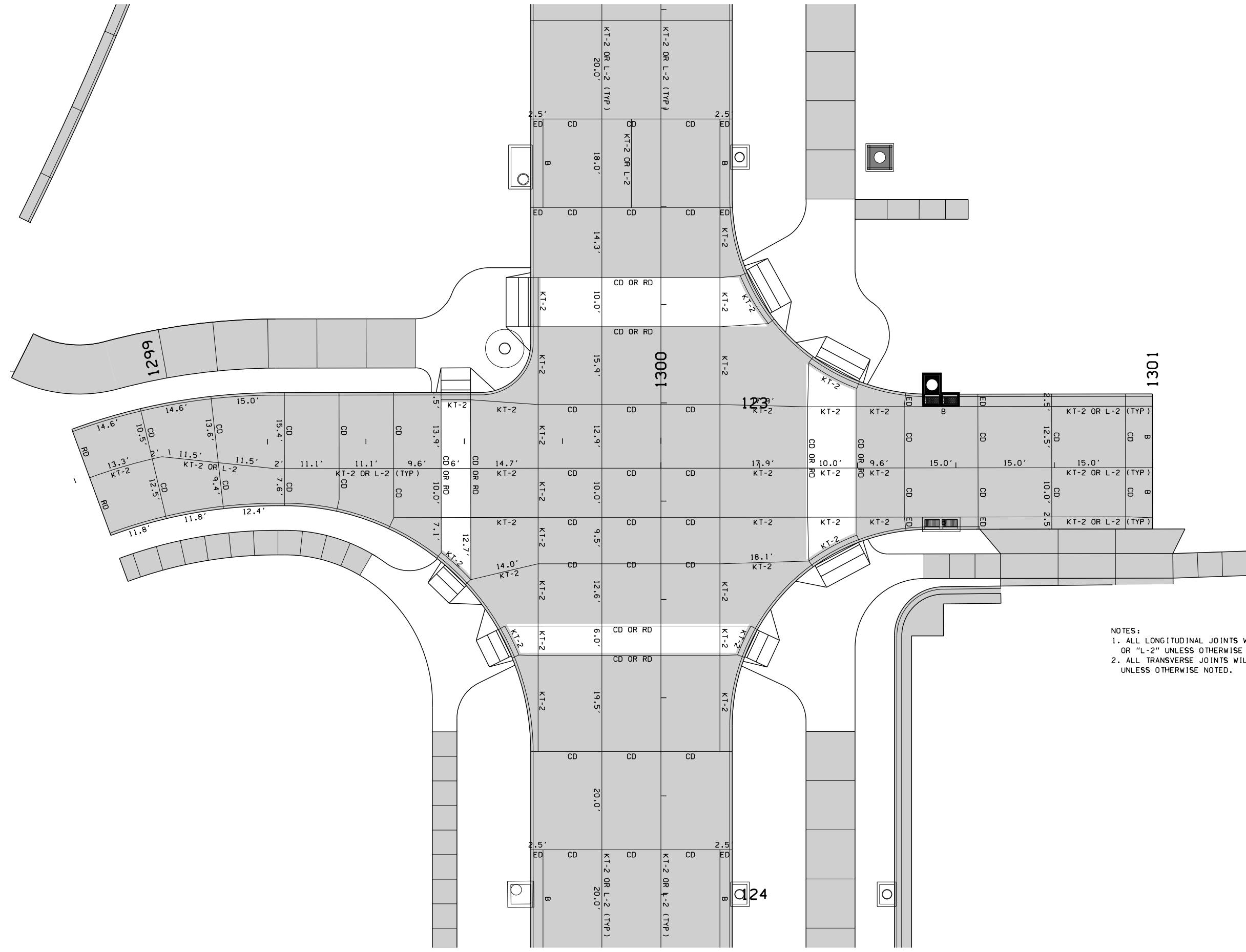
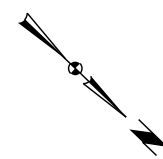
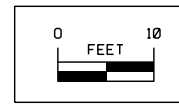

NOTES:  
 1. ALL LONGITUDINAL JOINTS WILL BE "KT-2"  
 OR "L-2" UNLESS OTHERWISE NOTED.  
 2. ALL TRANSVERSE JOINTS WILL BE "CD"  
 UNLESS OTHERWISE NOTED.

**24TH PLACE  
 JOINTING**

Point	Station	Offset	Elevation	Description
L542	1398+75.00	-26.50	600.39	BEGIN SIDEWALK/MATCH EXISTING
L543	1398+75.00	-31.50	600.49	BEGIN SIDEWALK/MATCH EXISTING
L544	1399+39.18	-26.50	602.35	SIDEWALK
L545	1399+39.17	-31.50	602.45	SIDEWALK
L546	129+09.17	41.50	603.36	SIDEWALK
L547	129+09.16	46.50	603.46	SIDEWALK
L548	129+19.13	26.50	602.30	FG BOTTOM OF PED RAMP
L549	129+25.13	26.50	602.32	FG BOTTOM OF PED RAMP
L550	129+35.11	40.38	602.19	FG BOTTOM OF PED RAMP
L551	129+35.04	46.38	602.07	FG BOTTOM OF PED RAMP
L552	1398+75.00	7.00	599.98	BEGIN PAVEMENT/MATCH EXISTING
L553	1398+75.00	-7.00	599.98	BEGIN PAVEMENT/MATCH EXISTING
L554	1398+75.00	-21.50	599.69	FG BEGIN PAVEMENT/MATCH EXISTING
L555	129+35.16	36.63	602.22	FG END OF RADIUS
L556	129+32.28	29.48	602.27	FG MIDPOINT OF RADIUS
L557	129+25.16	26.50	602.32	FG END OF RADIUS
L558	129+25.16	36.50	N/A	CENTER OF 10' RADIUS

Point	Station	Offset	Elevation	Description
L500	129+02.55	-39.50	603.90	SIDEWALK
L501	129+02.55	-29.50	603.70	SIDEWALK
L502	129+17.62	-17.51	602.67	FG BOTTOM OF PED RAMP
L503	129+22.98	-20.21	602.68	FG BOTTOM OF PED RAMP
L504	129+35.04	-31.40	602.73	FG BOTTOM OF PED RAMP
L505	129+39.75	-40.22	602.89	FG BOTTOM OF PED RAMP
L506	129+02.38	-14.50	602.62	FG END OF RADIUS
L507	129+30.48	-26.03	602.72	FG MIDPOINT OF RADIUS
L508	129+42.39	-53.96	603.25	FG END OF RADIUS
L509	129+02.39	-54.50	N/A	CENTER OF 40' RADIUS
L510	1401+40.00	-15.50	606.72	FG BEGIN PAVEMENT/MATCH EXISTING
L511	1401+40.00	0.00	607.22	BEGIN PAVEMENT/MATCH EXISTING

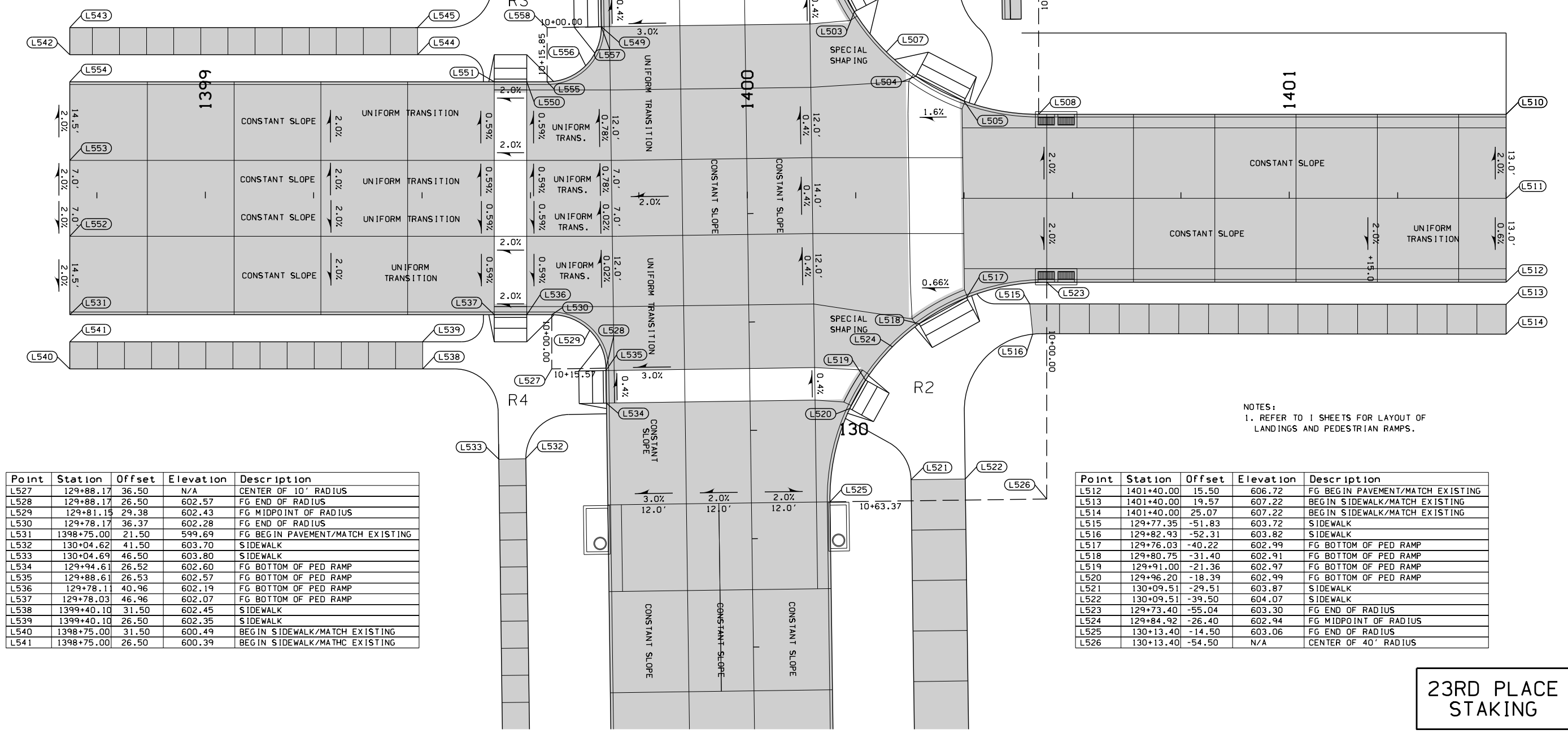
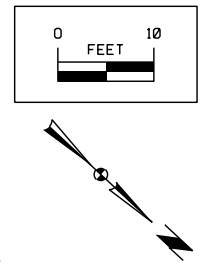

Point	Station	Offset	Elevation	Description
L527	129+88.17	36.50	N/A	CENTER OF 10' RADIUS
L528	129+88.17	26.50	602.57	FG END OF RADIUS
L529	129+81.15	29.38	602.43	FG MIDPOINT OF RADIUS
L530	129+78.17	36.37	602.28	FG END OF RADIUS
L531	1398+75.00	21.50	599.69	FG BEGIN PAVEMENT/MATCH EXISTING
L532	130+04.62	41.50	603.70	SIDEWALK
L533	130+04.69	46.50	603.80	SIDEWALK
L534	129+94.61	26.52	602.60	FG BOTTOM OF PED RAMP
L535	129+88.61	26.53	602.57	FG BOTTOM OF PED RAMP
L536	129+78.11	40.96	602.19	FG BOTTOM OF PED RAMP
L537	129+78.03	46.96	602.07	FG BOTTOM OF PED RAMP
L538	1399+40.10	31.50	602.45	SIDEWALK
L539	1399+40.10	26.50	602.35	SIDEWALK
L540	1398+75.00	31.50	600.49	BEGIN SIDEWALK/MATCH EXISTING
L541	1398+75.00	26.50	600.39	BEGIN SIDEWALK/MATCH EXISTING

Point	Station	Offset	Elevation	Description
L512	1401+40.00	15.50	606.72	FG BEGIN PAVEMENT/MATCH EXISTING
L513	1401+40.00	19.57	607.22	BEGIN SIDEWALK/MATCH EXISTING
L514	1401+40.00	25.07	607.22	BEGIN SIDEWALK/MATCH EXISTING
L515	129+77.35	-51.83	603.72	SIDEWALK
L516	129+82.93	-52.31	603.82	SIDEWALK
L517	129+76.03	-40.22	602.99	FG BOTTOM OF PED RAMP
L518	129+80.75	-31.40	602.91	FG BOTTOM OF PED RAMP
L519	129+91.00	-21.36	602.97	FG BOTTOM OF PED RAMP
L520	129+96.20	-18.39	602.99	FG BOTTOM OF PED RAMP
L521	130+09.51	-29.51	603.87	SIDEWALK
L522	130+09.51	-39.50	604.07	SIDEWALK
L523	129+73.40	-55.04	603.30	FG END OF RADIUS
L524	129+84.92	-26.40	602.94	FG MIDPOINT OF RADIUS
L525	130+13.40	-14.50	603.06	FG END OF RADIUS
L526	130+13.40	-54.50	N/A	CENTER OF 40' RADIUS

NOTES:  
1. REFER TO I SHEETS FOR LAYOUT OF LANDINGS AND PEDESTRIAN RAMPS.

**23RD PLACE STAKING**

R1

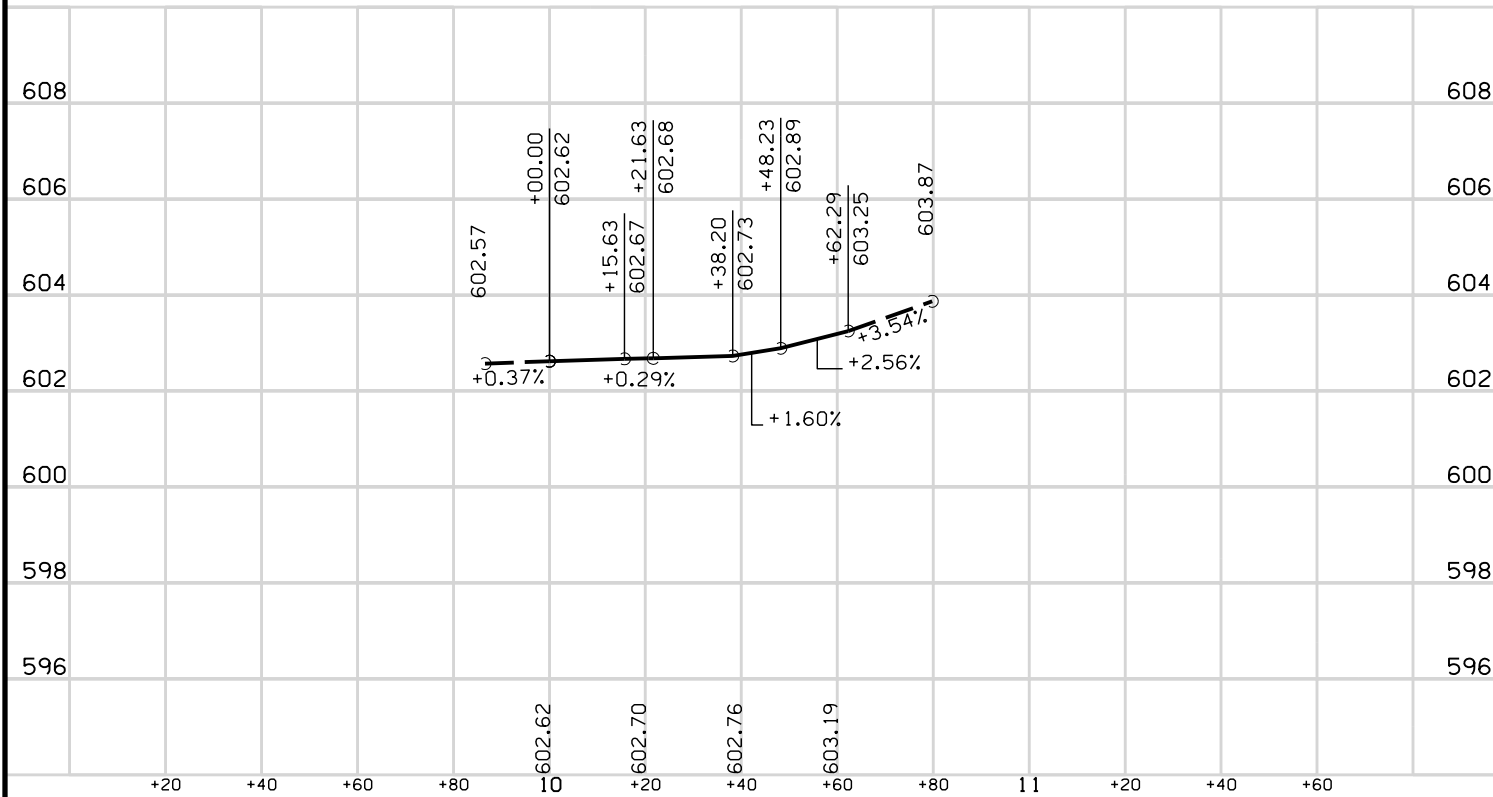

R2

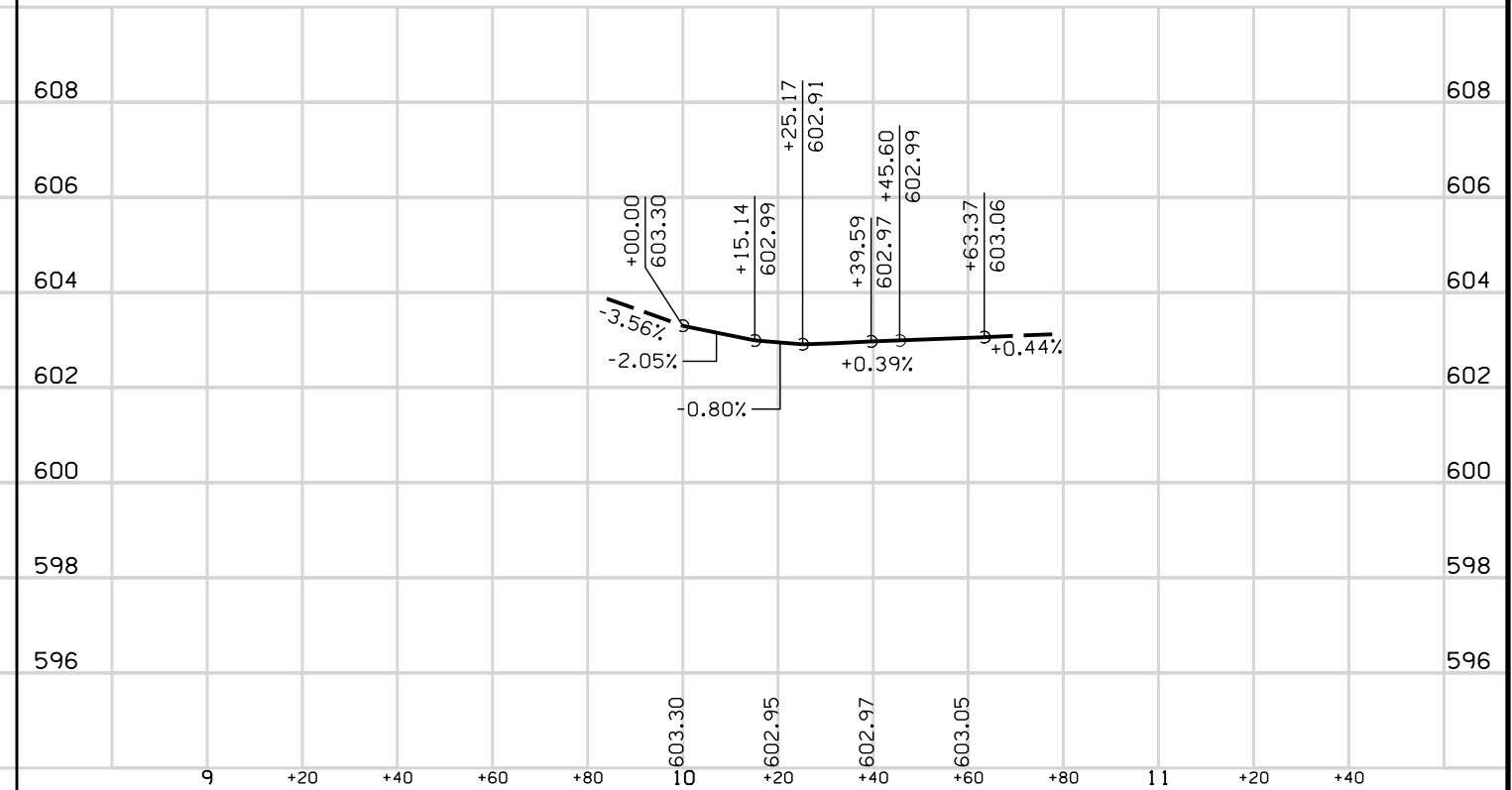

R3

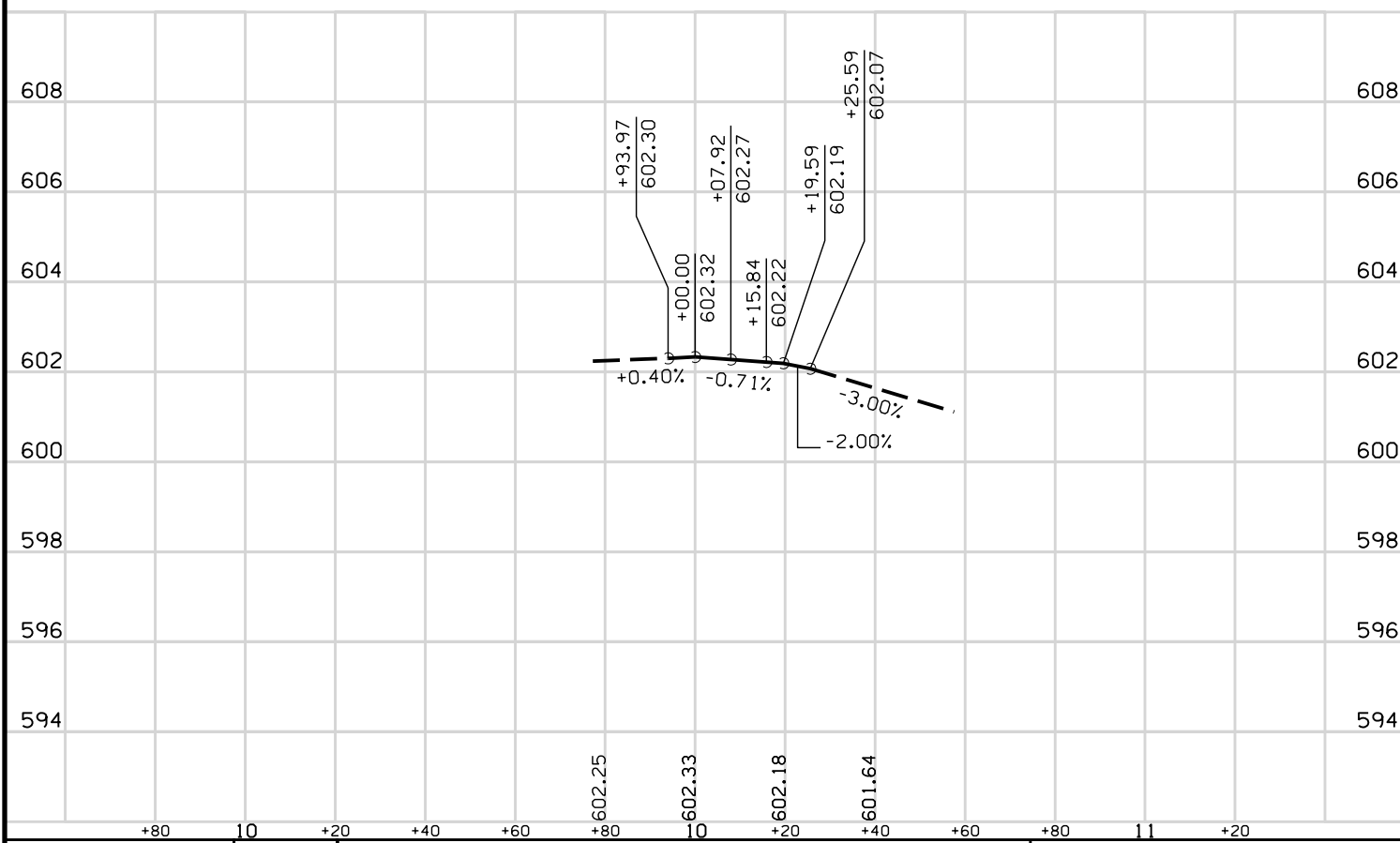

R4

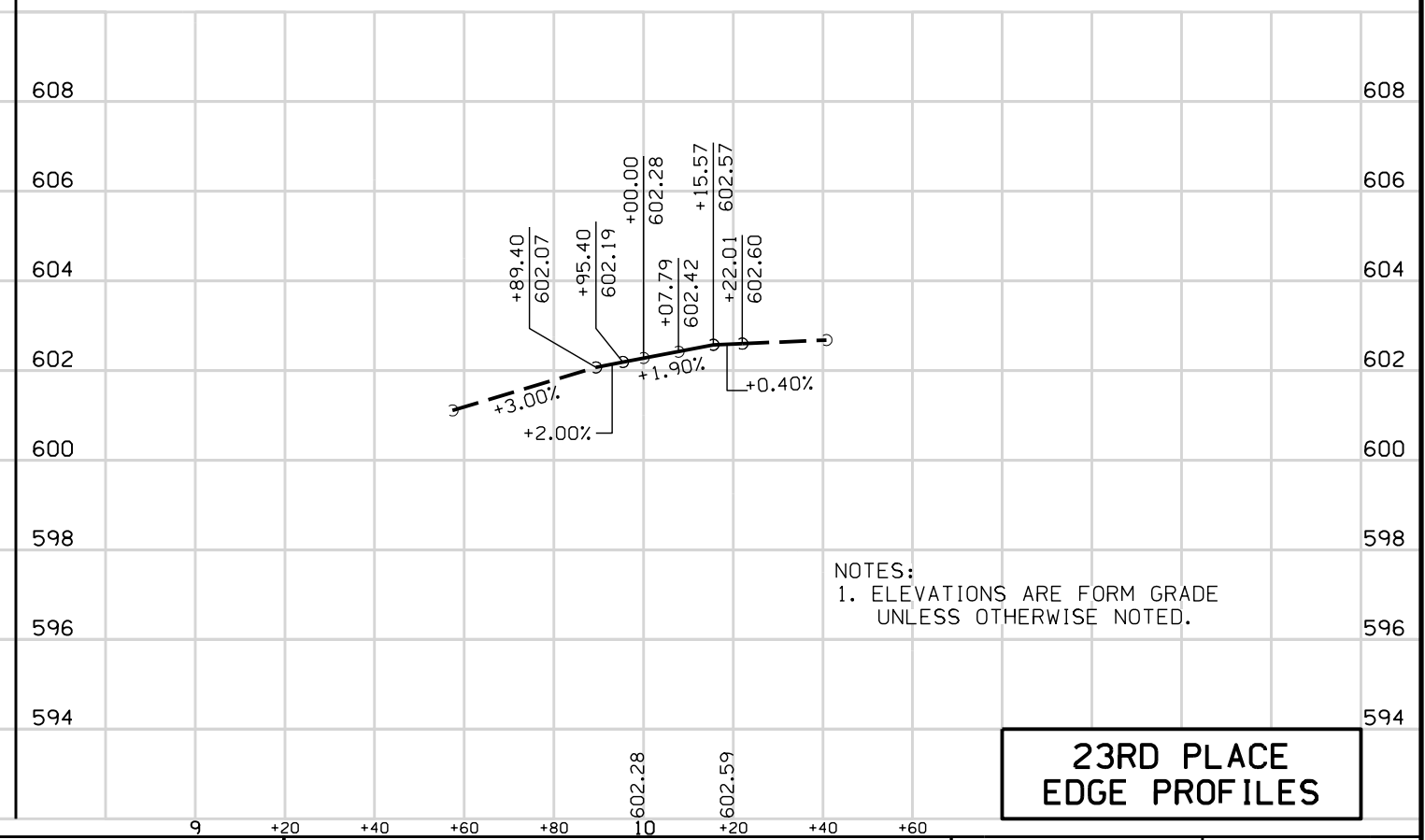

NOTES:  
1. ELEVATIONS ARE FORM GRADE  
UNLESS OTHERWISE NOTED.

**23RD PLACE  
EDGE PROFILES**





Point	Station	Offset	Elevation	Description
L655	1498+75.00	-7.00	599.21	BEGIN PAVEMENT/MATCH EXISTING
L656	1498+75.00	-21.50	598.92	FG BEGIN PAVEMENT/MATCH EXISTING
L657	133+77.52	36.56	602.59	FG END OF RADIUS
L658	133+74.62	29.45	602.86	FG MIDPOINT OF RADIUS
L659	133+67.52	26.50	603.13	FG END OF RADIUS
L660	133+67.52	36.50	N/A	CENTER OF 10' RADIUS
L661	1498+75.00	-26.50	599.62	BEGIN SIDEWALK/MATCH EXISTING
L662	1498+75.00	-31.50	599.72	BEGIN SIDEWALK/MATCH EXISTING
L663	1499+37.92	-26.50	602.36	SIDEWALK
L664	1499+37.93	-31.50	602.46	SIDEWALK
L665	133+51.52	46.50	604.30	SIDEWALK
L666	133+51.52	41.50	604.20	SIDEWALK
L667	1499+53.16	-21.50	602.33	FG BOTTOM OF PED RAMP
L668	1499+59.16	-21.50	602.45	FG BOTTOM OF PED RAMP
L669	133+67.52	26.50	603.13	FG BOTTOM OF PED RAMP
L670	133+61.52	26.50	603.16	FG BOTTOM OF PED RAMP

Point	Station	Offset	Elevation	Description
L600	133+47.08	-29.50	604.46	SIDEWALK
L601	133+47.08	-39.50	604.66	SIDEWALK
L602	133+60.34	-17.96	603.54	FG BOTTOM OF PED RAMP
L603	133+65.62	-20.80	603.48	FG BOTTOM OF PED RAMP
L604	133+75.92	-30.30	603.41	FG BOTTOM OF PED RAMP
L605	133+80.93	-38.96	603.50	FG BOTTOM OF PED RAMP
L606	133+79.06	-53.39	604.45	SIDEWALK
L607	133+74.06	-53.42	604.65	SIDEWALK
L608	1501+16.57	-20.50	606.36	SIDEWALK
L609	1501+16.57	-25.50	606.46	SIDEWALK
L610	1501+40.00	-19.21	606.93	BEGIN SIDEWALK/MATCH EXISTING
L611	1501+40.00	-24.22	607.05	BEGIN SIDEWALK/MATCH EXISTING
L612	1501+16.57	-15.50	606.16	SIDEWALK
L613	1501+10.57	-15.50	605.98	SIDEWALK
L614	133+44.07	-14.50	603.61	FG END OF RADIUS
L615	133+72.27	-26.13	603.40	FG MIDPOINT OF RADIUS
L616	133+84.07	-54.26	603.94	FG END OF RADIUS
L617	133+44.07	-54.50	N/A	CENTER OF 40' RADIUS
L618	1501+40.00	-15.50	606.28	FG BEGIN PAVEMENT/MATCH EXISTING

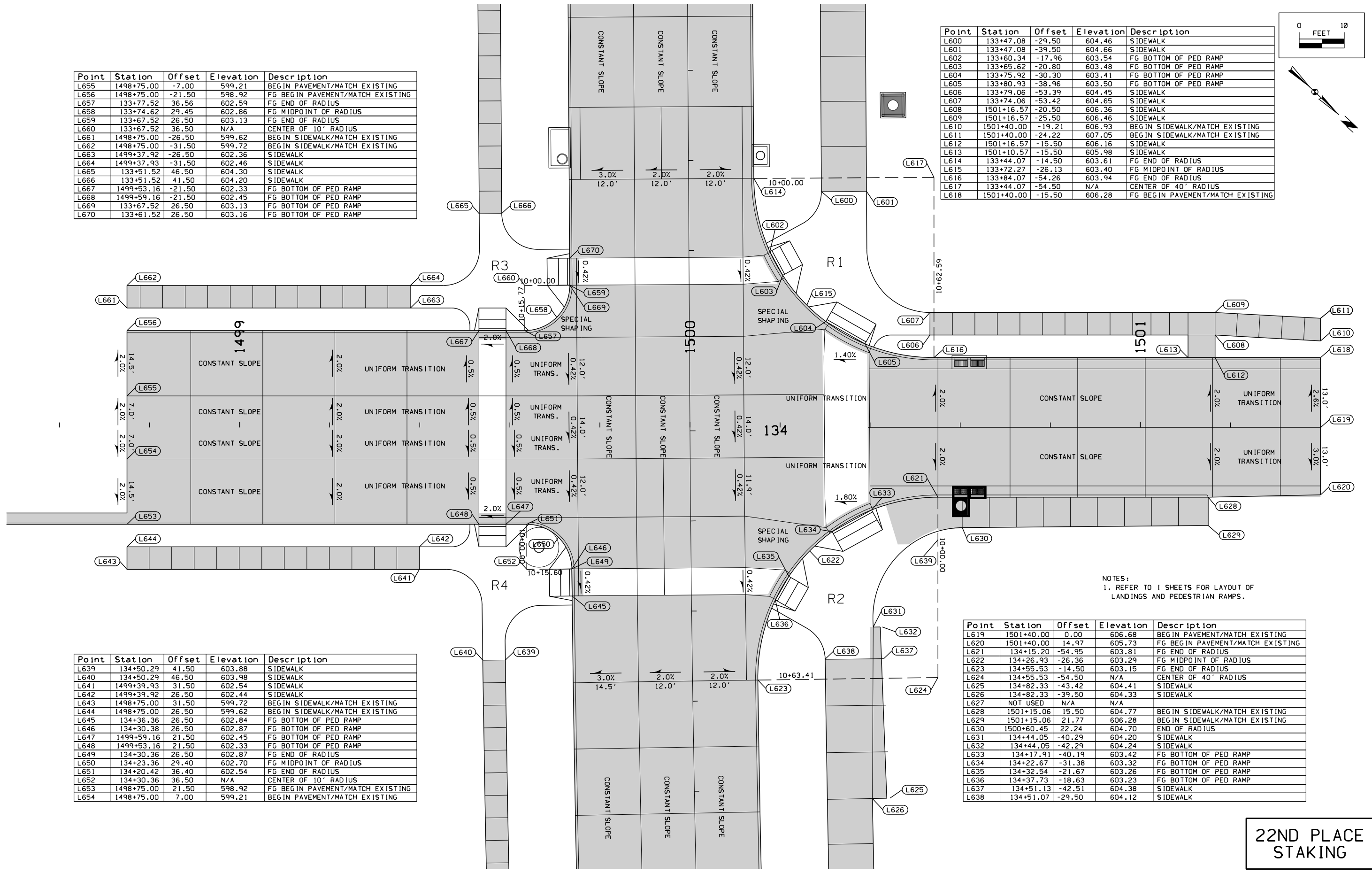
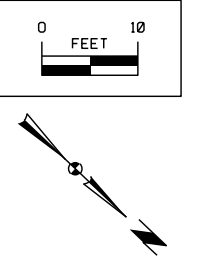

Point	Station	Offset	Elevation	Description
L639	134+50.29	41.50	603.88	SIDEWALK
L640	134+50.29	46.50	603.98	SIDEWALK
L641	1499+39.93	31.50	602.54	SIDEWALK
L642	1499+39.92	26.50	602.44	SIDEWALK
L643	1498+75.00	31.50	599.72	BEGIN SIDEWALK/MATCH EXISTING
L644	1498+75.00	26.50	599.62	BEGIN SIDEWALK/MATCH EXISTING
L645	134+36.36	26.50	602.84	FG BOTTOM OF PED RAMP
L646	134+30.38	26.50	602.87	FG BOTTOM OF PED RAMP
L647	1499+59.16	21.50	602.45	FG BOTTOM OF PED RAMP
L648	1499+53.16	21.50	602.33	FG BOTTOM OF PED RAMP
L649	134+30.36	26.50	602.87	FG END OF RADIUS
L650	134+23.36	29.40	602.70	FG MIDPOINT OF RADIUS
L651	134+20.42	36.40	602.54	FG END OF RADIUS
L652	134+30.36	36.50	N/A	CENTER OF 10' RADIUS
L653	1498+75.00	21.50	598.92	FG BEGIN PAVEMENT/MATCH EXISTING
L654	1498+75.00	7.00	599.21	BEGIN PAVEMENT/MATCH EXISTING

Point	Station	Offset	Elevation	Description
L619	1501+40.00	0.00	606.68	BEGIN PAVEMENT/MATCH EXISTING
L620	1501+40.00	14.97	605.73	FG BEGIN PAVEMENT/MATCH EXISTING
L621	134+15.20	-54.95	603.81	FG END OF RADIUS
L622	134+26.93	-26.36	603.29	FG MIDPOINT OF RADIUS
L623	134+55.53	-14.50	603.15	FG END OF RADIUS
L624	134+55.53	-54.50	N/A	CENTER OF 40' RADIUS
L625	134+82.33	-43.42	604.41	SIDEWALK
L626	134+82.33	-39.50	604.33	SIDEWALK
L627	NOT USED	N/A	N/A	SIDEWALK
L628	1501+15.06	15.50	604.77	BEGIN SIDEWALK/MATCH EXISTING
L629	1501+15.06	21.77	606.28	BEGIN SIDEWALK/MATCH EXISTING
L630	1500+60.45	22.24	604.70	END OF RADIUS
L631	134+44.05	-40.29	604.20	SIDEWALK
L632	134+44.05	-42.29	604.24	SIDEWALK
L633	134+17.91	-40.19	603.42	FG BOTTOM OF PED RAMP
L634	134+22.67	-31.38	603.32	FG BOTTOM OF PED RAMP
L635	134+32.54	-21.67	603.26	FG BOTTOM OF PED RAMP
L636	134+37.73	-18.63	603.23	FG BOTTOM OF PED RAMP
L637	134+51.13	-42.51	604.38	SIDEWALK
L638	134+51.07	-29.50	604.12	SIDEWALK

NOTES:  
1. REFER TO 1 SHEETS FOR LAYOUT OF LANDINGS AND PEDESTRIAN RAMPS.

**22ND PLACE STAKING**

R1

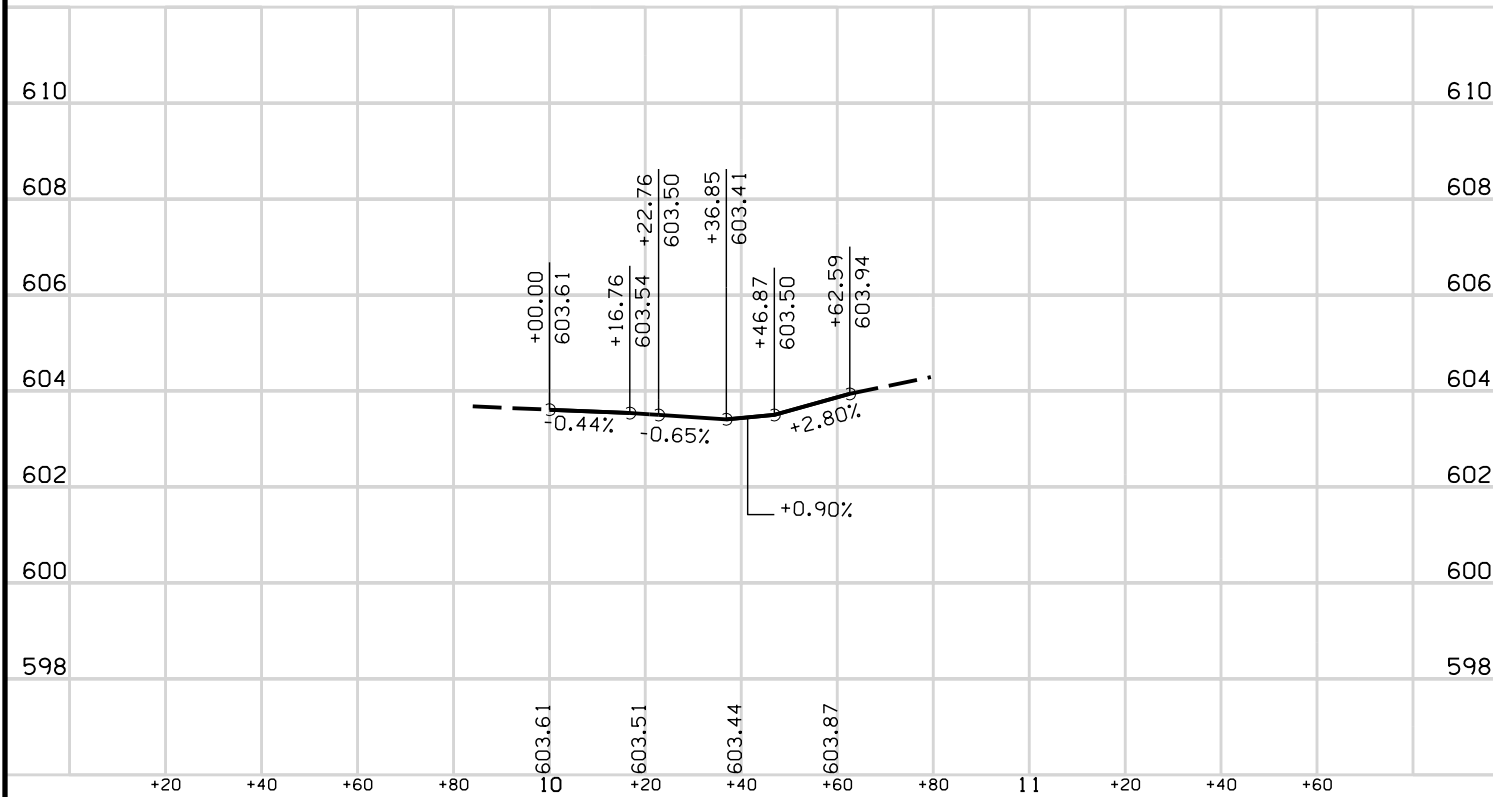

R2

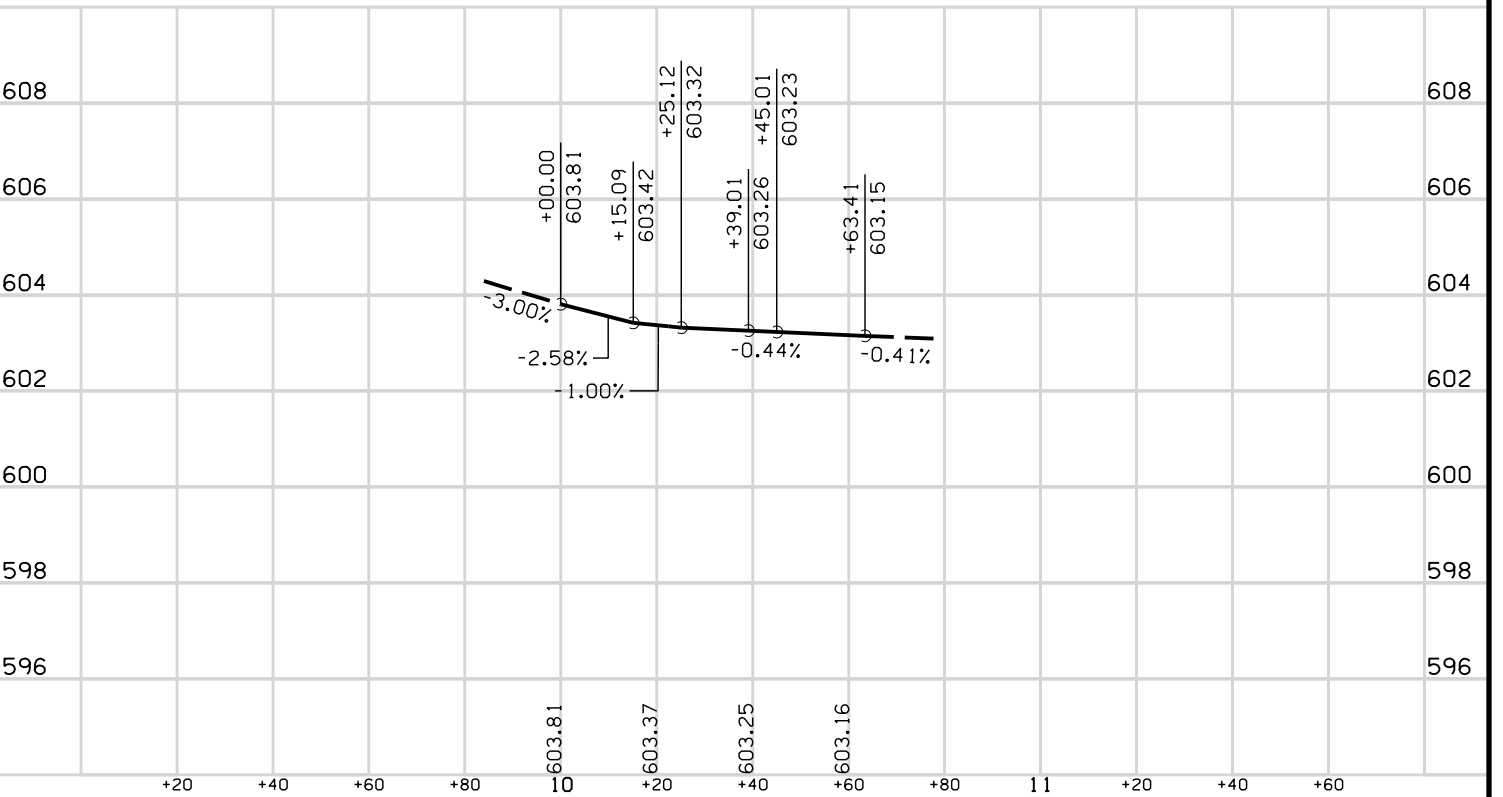

R3

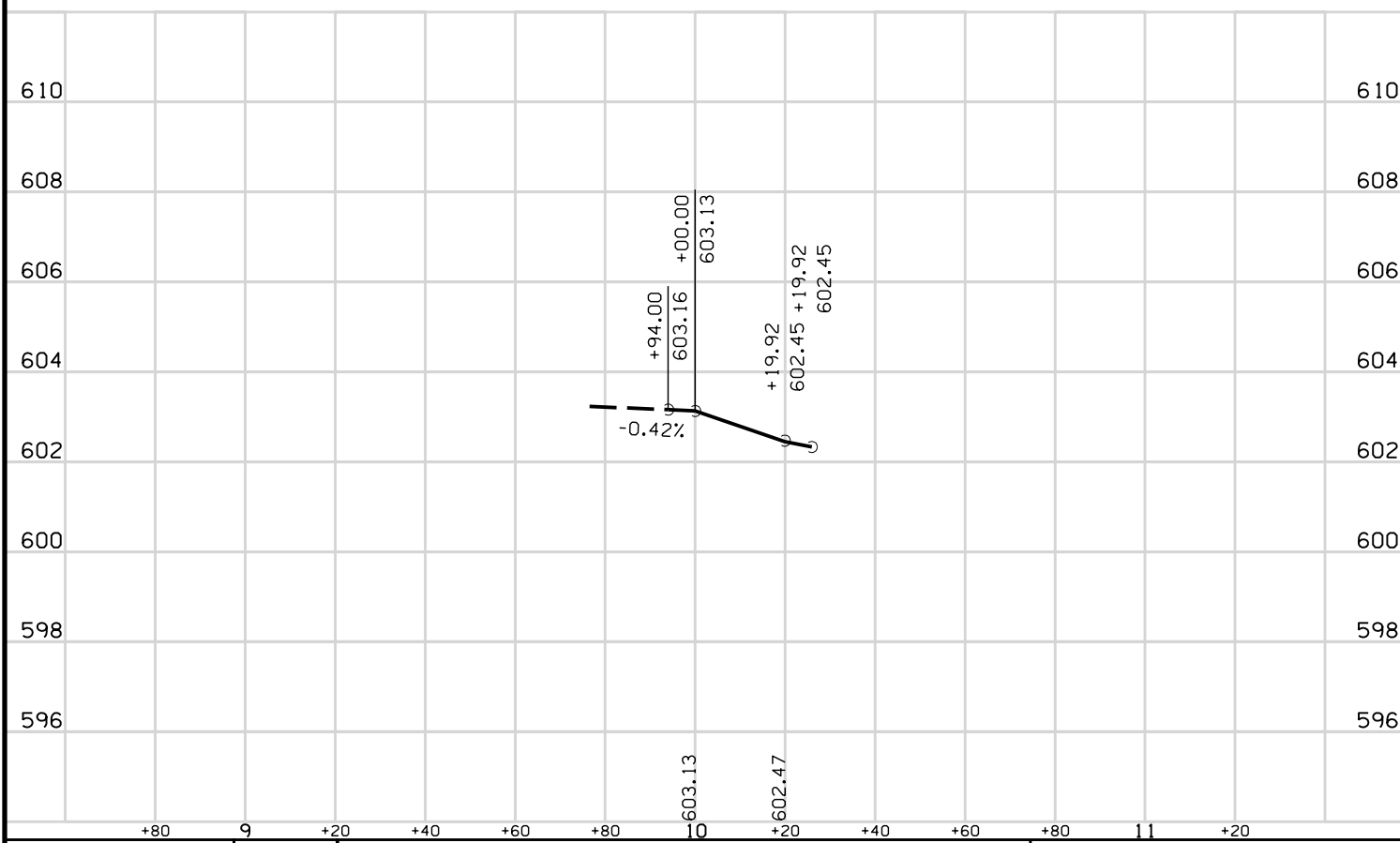

R4

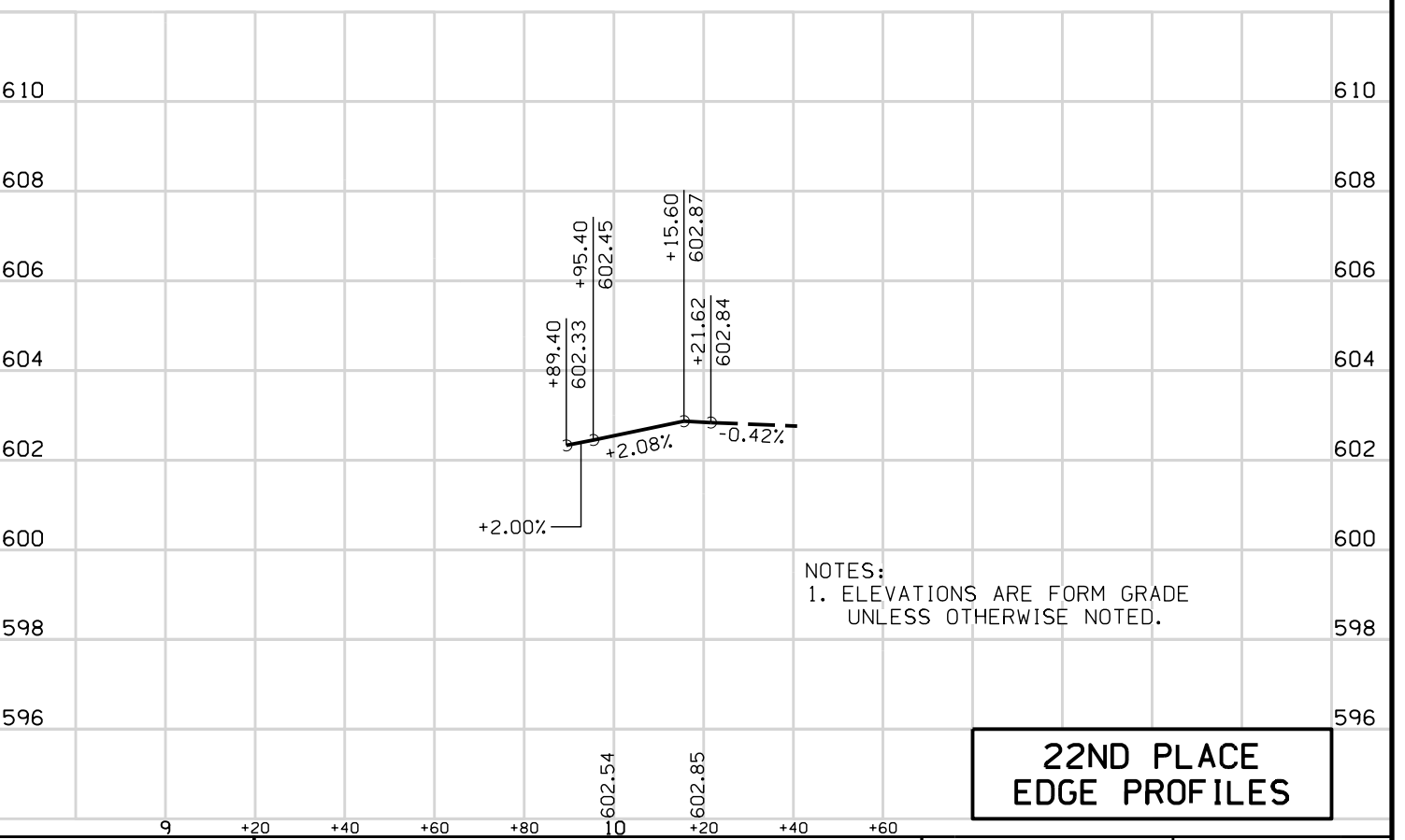

NOTES:  
1. ELEVATIONS ARE FORM GRADE  
UNLESS OTHERWISE NOTED.

**22ND PLACE  
EDGE PROFILES**



Point	Station	Offset	Elevation	Description
L743	1599+56.82	-21.50	603.04	FG BOTTOM OF PED RAMP
L744	1599+62.83	-21.50	603.16	FG BOTTOM OF PED RAMP
L745	140+61.37	26.50	603.59	FG BOTTOM OF PED RAMP
L746	140+55.39	26.50	603.57	FG BOTTOM OF PED RAMP
L747	1599+41.78	-26.50	603.30	SIDEWALK
L748	1599+41.78	-31.50	602.64	SIDEWALK
L749	140+45.44	46.50	604.72	SIDEWALK
L750	140+45.45	41.50	604.62	SIDEWALK
L751	140+71.26	37.53	603.23	FG END OF RADIUS
L752	140+68.76	29.81	603.41	FG MIDPOINT OF RADIUS
L753	140+61.37	26.50	603.59	FG END OF RADIUS
L754	140+61.37	36.50	N/A	CENTER OF 10' RADIUS

Point	Station	Offset	Elevation	Description
L700	140+42.33	-39.50	605.14	SIDEWALK
L701	140+42.33	-29.50	604.94	SIDEWALK
L702	140+74.46	-53.54	605.04	SIDEWALK
L703	140+69.44	-54.05	605.14	SIDEWALK
L704	1601+05.50	-27.79	605.19	BEGIN SIDEWALK/MATCH EXISTING
L705	1601+05.50	-32.79	605.19	BEGIN SIDEWALK/MATCH EXISTING
L706	140+54.40	-15.19	603.95	FG BOTTOM OF PED RAMP
L707	140+60.22	-16.73	603.99	FG BOTTOM OF PED RAMP
L708	140+79.84	-31.39	604.14	FG BOTTOM OF PED RAMP
L709	140+84.61	-40.20	604.20	FG BOTTOM OF PED RAMP
L710	140+46.98	-14.50	603.91	FG END OF RADIUS
L711	140+73.15	-24.11	604.08	FG MIDPOINT OF RADIUS
L712	140+86.82	-48.37	604.32	FG END OF RADIUS
L713	140+46.98	-54.50	N/A	CENTER OF 40' RADIUS
L714	1601+00.00	-12.68	607.09	BEGIN PAVEMENT/MATCH EXISTING

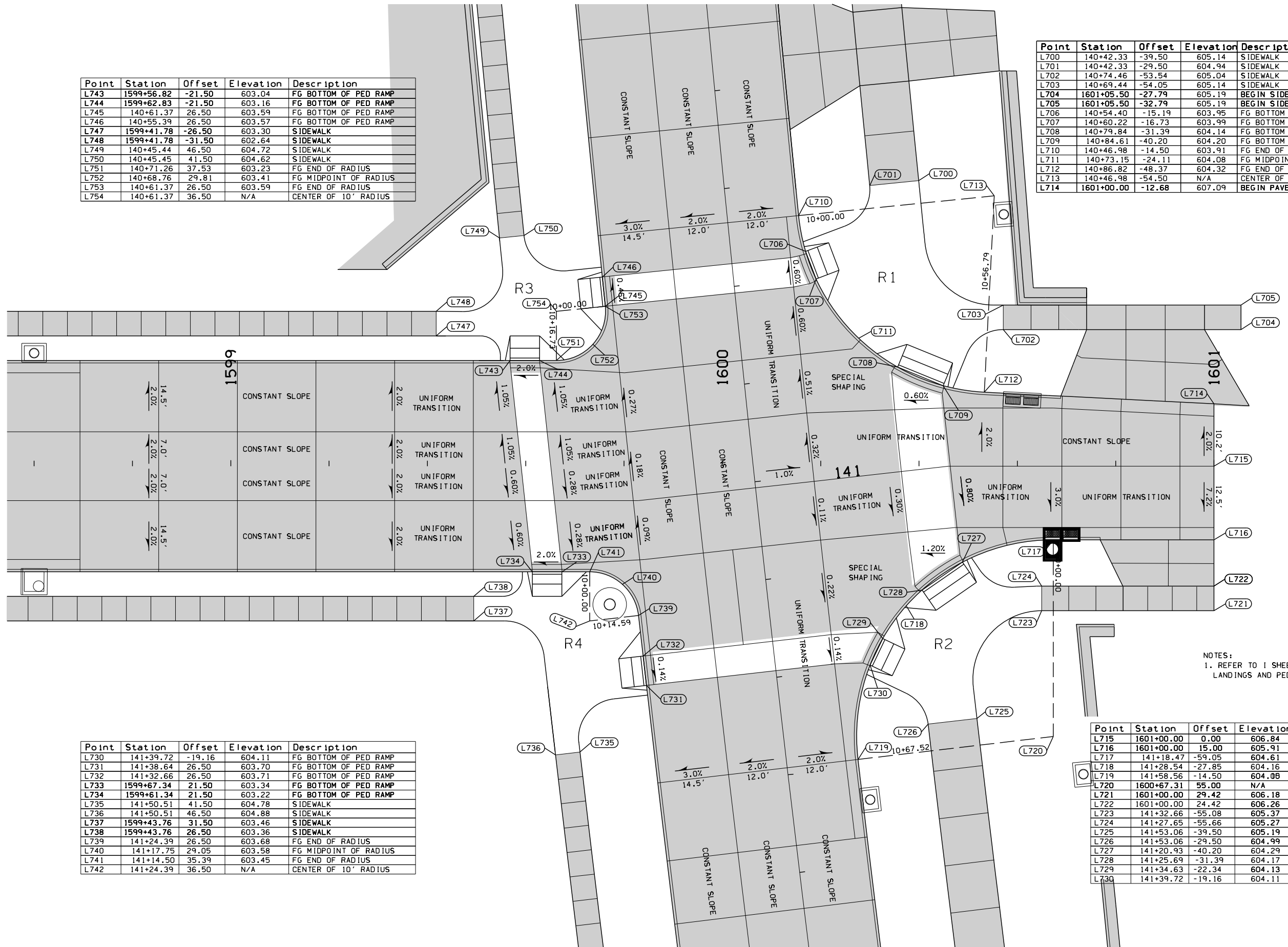
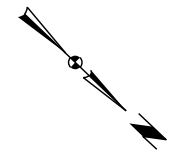
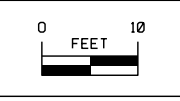

NOTES:  
1. REFER TO I SHEETS FOR LAYOUT OF LANDINGS AND PEDESTRIAN RAMPS.

Point	Station	Offset	Elevation	Description
L730	141+39.72	-19.16	604.11	FG BOTTOM OF PED RAMP
L731	141+38.64	26.50	603.70	FG BOTTOM OF PED RAMP
L732	141+32.66	26.50	603.71	FG BOTTOM OF PED RAMP
L733	1599+67.34	21.50	603.34	FG BOTTOM OF PED RAMP
L734	1599+61.34	21.50	603.22	FG BOTTOM OF PED RAMP
L735	141+50.51	41.50	604.78	SIDEWALK
L736	141+50.51	46.50	604.88	SIDEWALK
L737	1599+43.76	31.50	603.46	SIDEWALK
L738	1599+43.76	26.50	603.36	SIDEWALK
L739	141+24.39	26.50	603.68	FG END OF RADIUS
L740	141+17.75	29.05	603.58	FG MIDPOINT OF RADIUS
L741	141+14.50	35.39	603.45	FG END OF RADIUS
L742	141+24.39	36.50	N/A	CENTER OF 10' RADIUS

Point	Station	Offset	Elevation	Description
L715	1601+00.00	0.00	606.84	BEGIN PAVEMENT/MATCH EXISTING
L716	1601+00.00	15.00	605.91	BEGIN PAVEMENT/MATCH EXISTING
L717	141+18.47	-59.05	604.61	FG END OF RADIUS
L718	141+28.54	-27.85	604.16	FG MIDPOINT OF RADIUS
L719	141+58.56	-14.50	604.08	FG END OF RADIUS
L720	1600+67.31	55.00	N/A	CENTER OF 40' RADIUS
L721	1601+00.00	29.42	606.18	BEGIN SIDEWALK/MATCH EXISTING
L722	1601+00.00	24.42	606.26	BEGIN SIDEWALK/MATCH EXISTING
L723	141+32.66	-55.08	605.37	SIDEWALK
L724	141+27.65	-55.66	605.27	SIDEWALK
L725	141+53.06	-39.50	605.19	SIDEWALK
L726	141+53.06	-29.50	604.99	SIDEWALK
L727	141+20.93	-40.20	604.29	FG BOTTOM OF PED RAMP
L728	141+25.69	-31.39	604.17	FG BOTTOM OF PED RAMP
L729	141+34.63	-22.34	604.13	FG BOTTOM OF PED RAMP
L730	141+39.72	-19.16	604.11	FG BOTTOM OF PED RAMP

**21ST PLACE STAKING**

R1

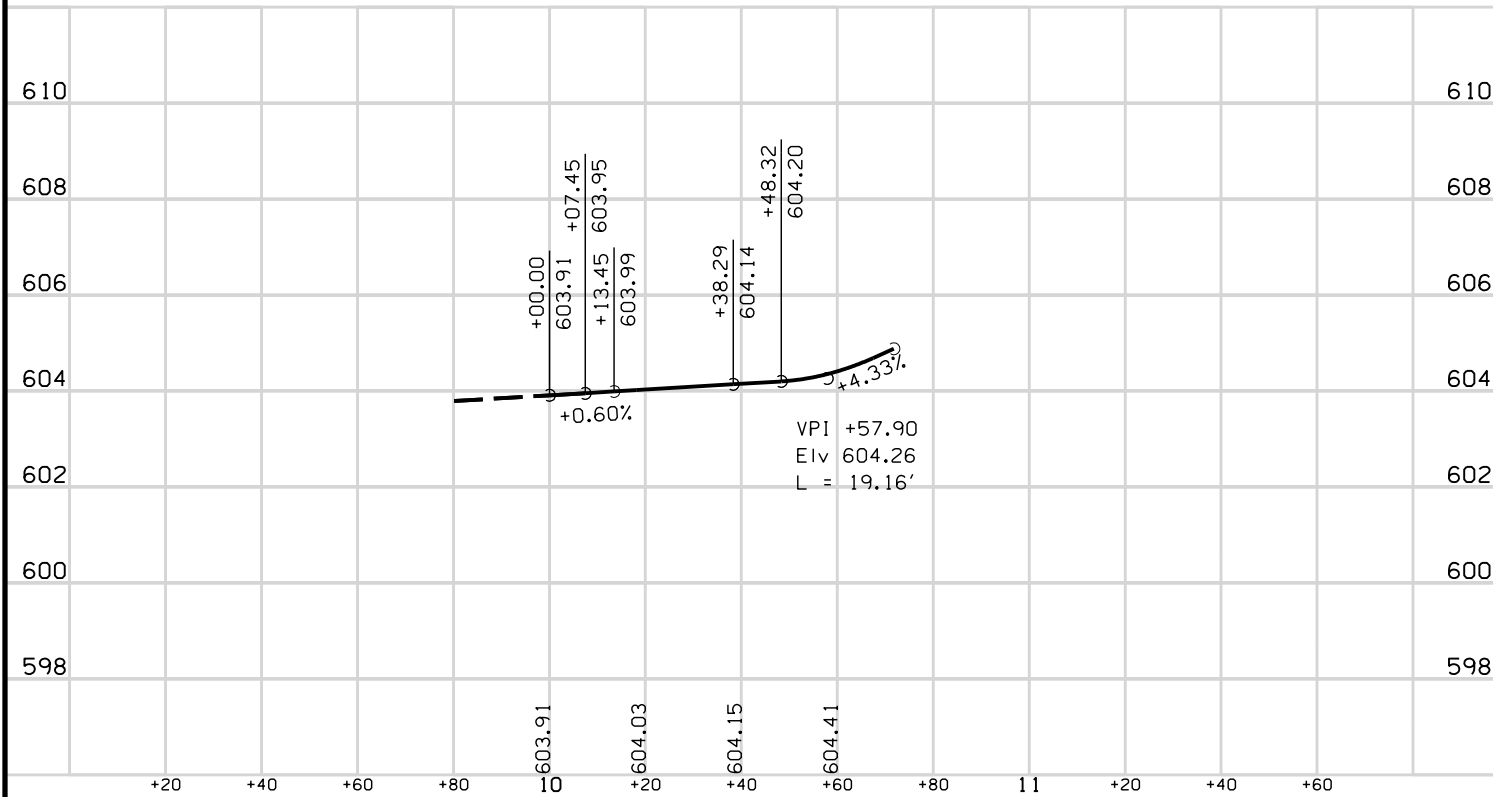

R2

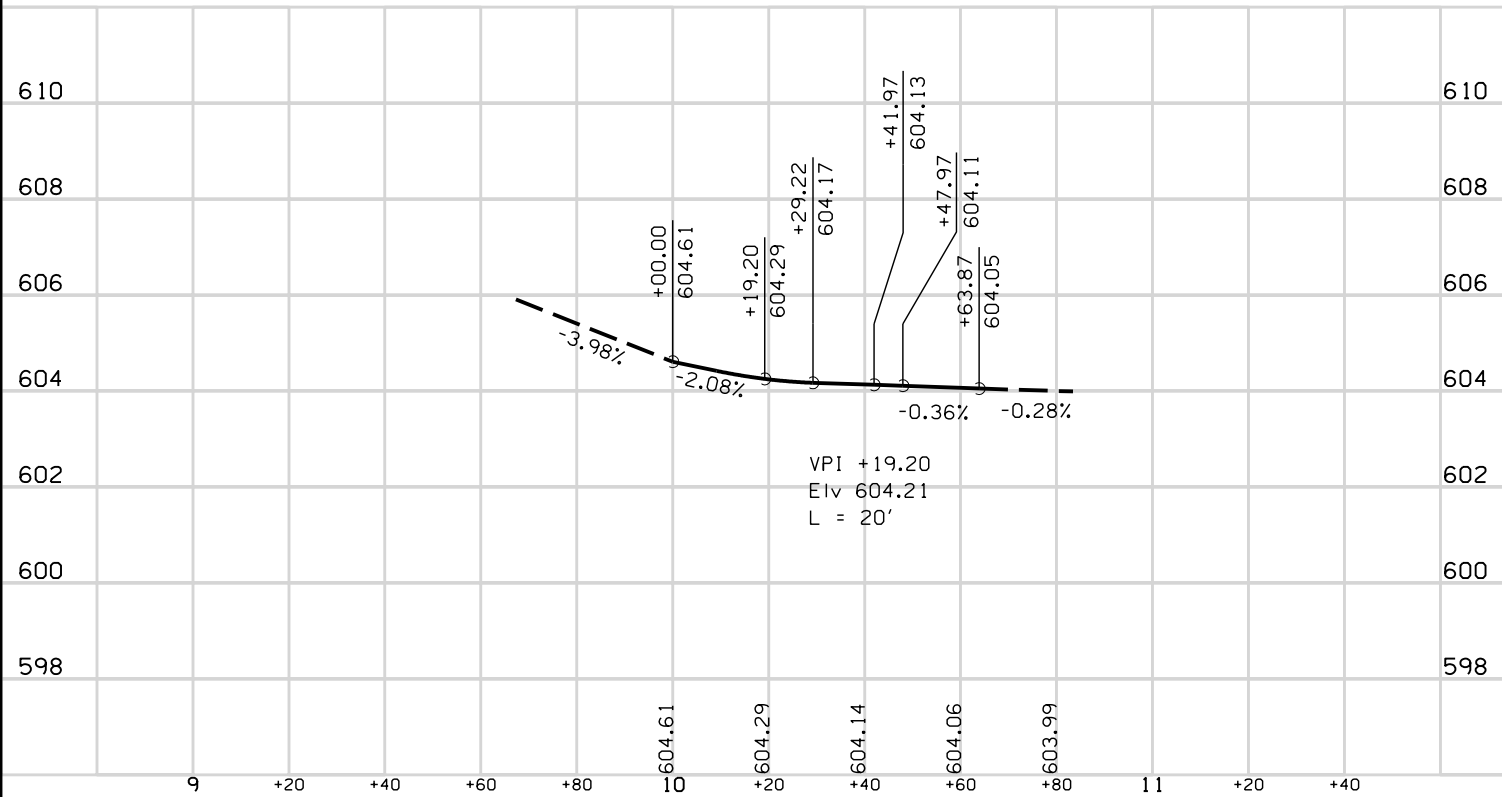

R3

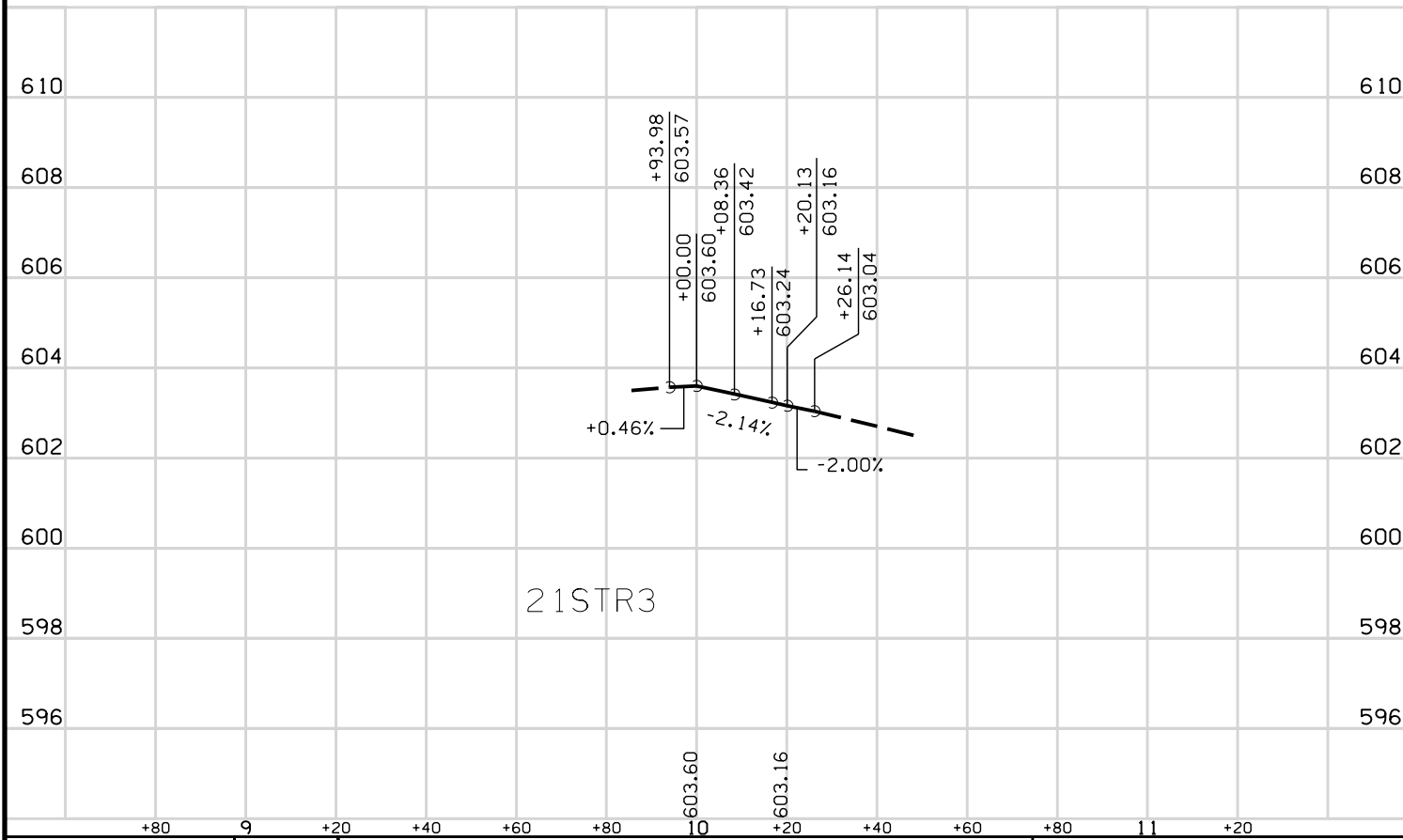

R4

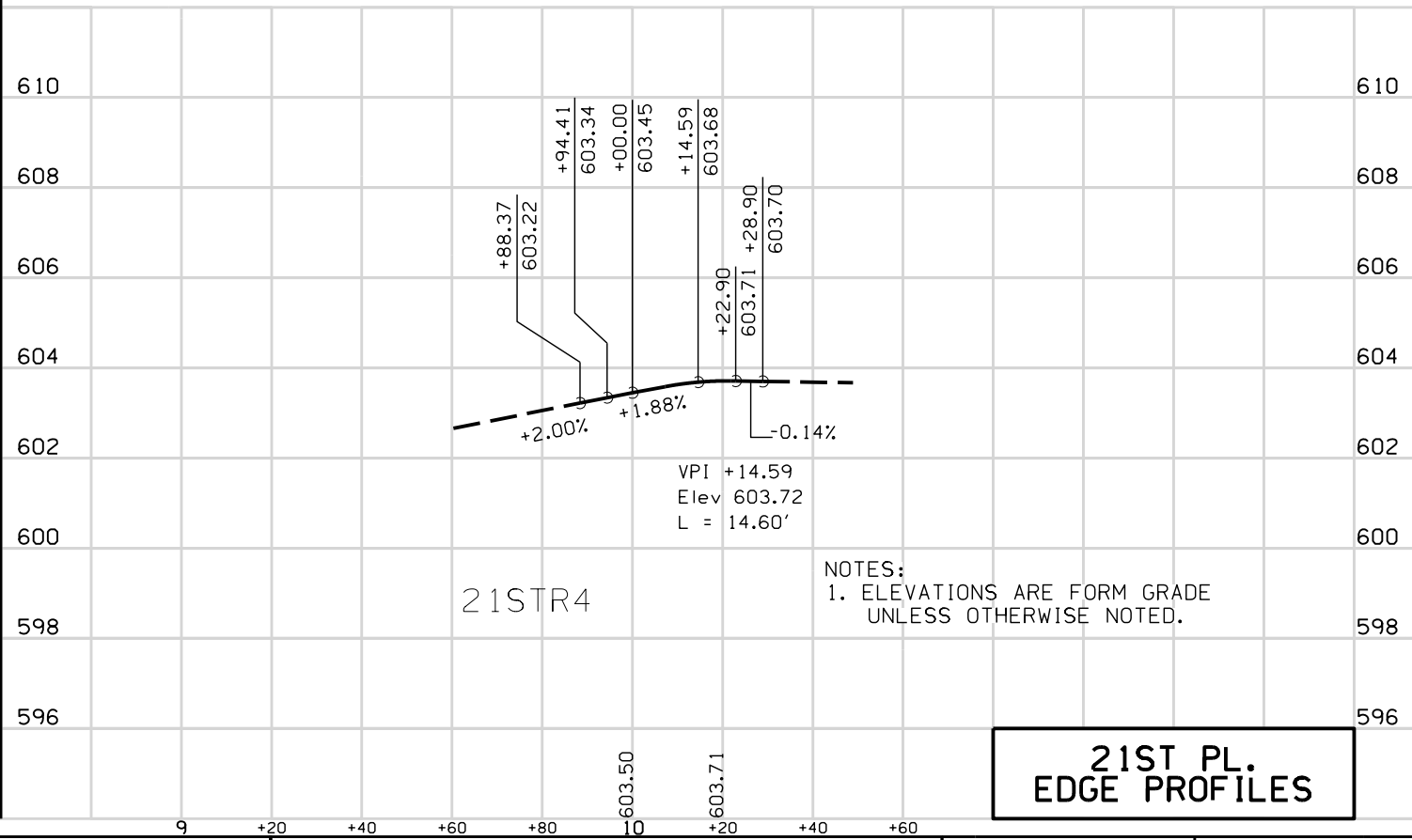

21ST PL. EDGE PROFILES

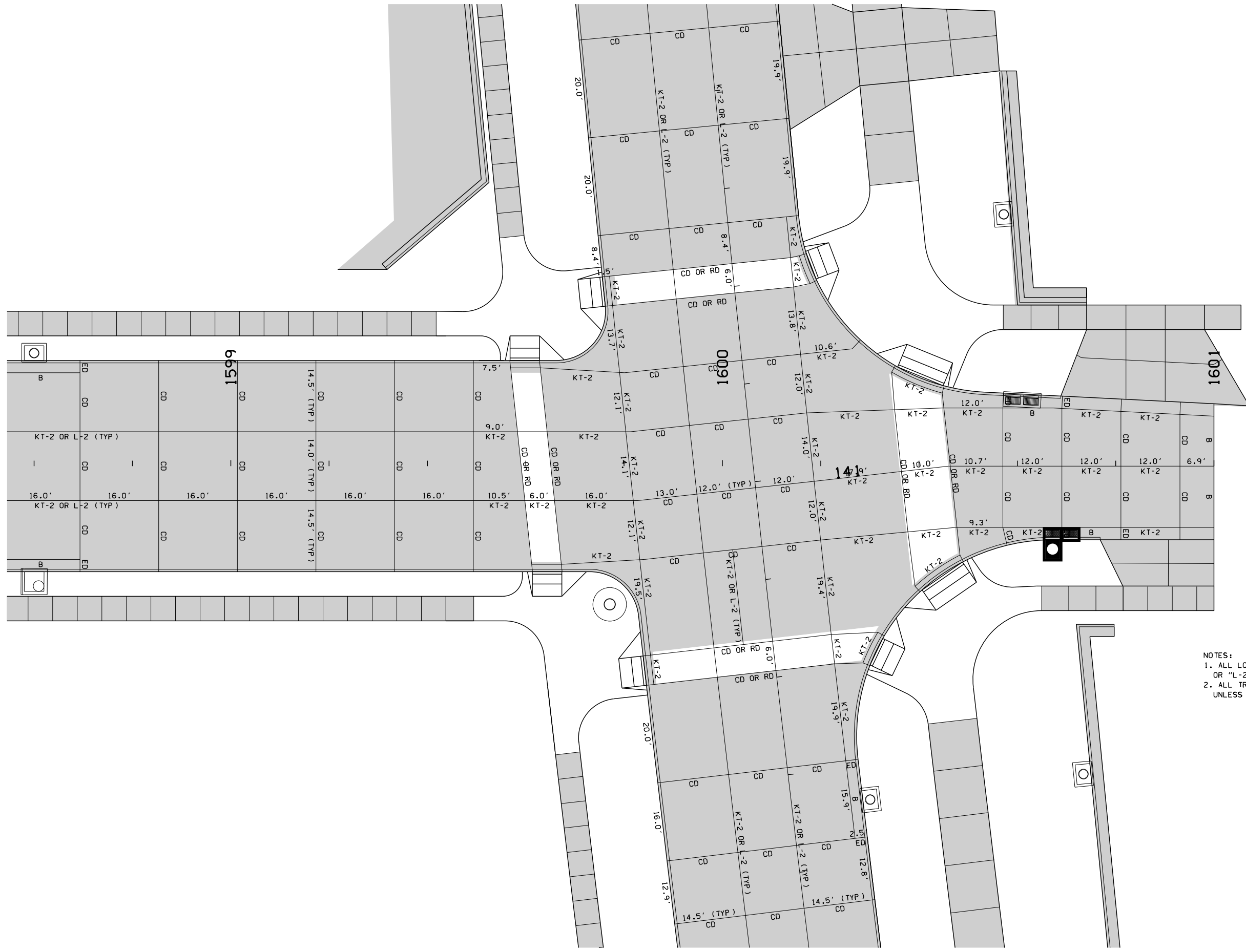
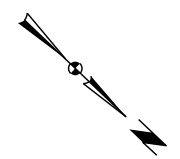
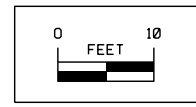

NOTES:  
 1. ALL LONGITUDINAL JOINTS WILL BE "KT-2" OR "L-2" UNLESS OTHERWISE NOTED.  
 2. ALL TRANSVERSE JOINTS WILL BE "CD" UNLESS OTHERWISE NOTED.

**21ST PLACE  
 JOINTING**

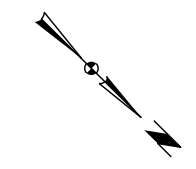
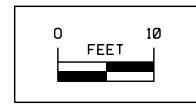

Point	Station	Offset	Elevation	Description
L800	143+99.51	-39.50	605.23	SIDEWALK
L801	143+99.52	-29.50	605.03	SIDEWALK
L802	144+18.24	-31.41	604.57	FG BOTTOM OF PED RAMP
L803	144+22.97	-40.22	604.66	FG BOTTOM OF PED RAMP
L804	144+23.00	-53.99	605.58	SIDEWALK
L805	144+19.14	-54.91	605.67	SIDEWALK
L806	1700+81.50	-14.39	606.41	SIDEWALK
L807	1700+81.50	-18.34	606.49	SIDEWALK
L808	1701+00.00	-14.38	607.40	BEGIN SIDEWALK/MATCH EXISTING
L809	1701+00.00	-18.34	607.48	BEGIN SIDEWALK/MATCH EXISTING
L810	143+85.37	-14.50	604.24	FG END OF RADIUS
L811	144+10.26	-23.07	604.47	FG MIDPOINT OF RADIUS
L812	144+24.51	-45.15	604.70	FG END OF RADIUS
L813	1700+88.00	-10.00	606.10	FG BEGIN TAPER
L814	1701+00.00	-10.00	606.73	FG BEGIN PAVEMENT/MATCH EXISTING
L815	1701+00.00	0.00	607.04	BEGIN PAVEMENT/MATCH EXISTING
L816	1701+00.00	10.00	606.76	FG BEGIN PAVEMENT/MATCH EXISTING
L817	1700+89.94	10.00	606.29	FG BEGIN TAPER
L818	144+53.88	-56.04	605.13	FG END OF RADIUS
L819	144+65.03	-26.77	604.88	FG MIDPOINT OF RADIUS
L820	144+93.85	-14.50	605.20	FG END OF RADIUS
L821	144+93.85	-54.50	N/A	CENTER OF 40' RADIUS
L822	1700+72.81	11.71	606.02	SIDEWALK
L823	1700+72.81	17.77	606.16	SIDEWALK
L824	1700+62.51	17.77	605.82	SIDEWALK
L825	144+63.10	-46.01	605.43	SIDEWALK
L826	144+55.81	-42.13	604.89	SIDEWALK
L827	144+76.96	-39.50	606.14	SIDEWALK
L828	144+76.96	-29.50	605.94	SIDEWALK
L829	144+56.49	-40.22	604.85	FG BOTTOM OF PED RAMP
L830	144+61.20	-31.40	604.82	FG BOTTOM OF PED RAMP
L831	144+76.96	-57.50	N/A	CENTER OF 18' RADIUS
L832	144+58.97	-58.19	605.80	END OF RADIUS
L833	143+85.37	-54.50	N/A	CENTER OF 40' RADIUS
L834	1701+00.00	10.00	607.35	BEGIN SIDEWALK/MATCH EXISTING
L835	144+81.19	-56.62	605.99	SIDE OF EXISTING STAIR STRUCTURE
L836	144+86.05	-52.12	606.47	SIDE OF EXISTING STAIR STRUCTURE
L837	144+92.96	-51.14	606.73	EDGE OF EXISTING WALKWAY

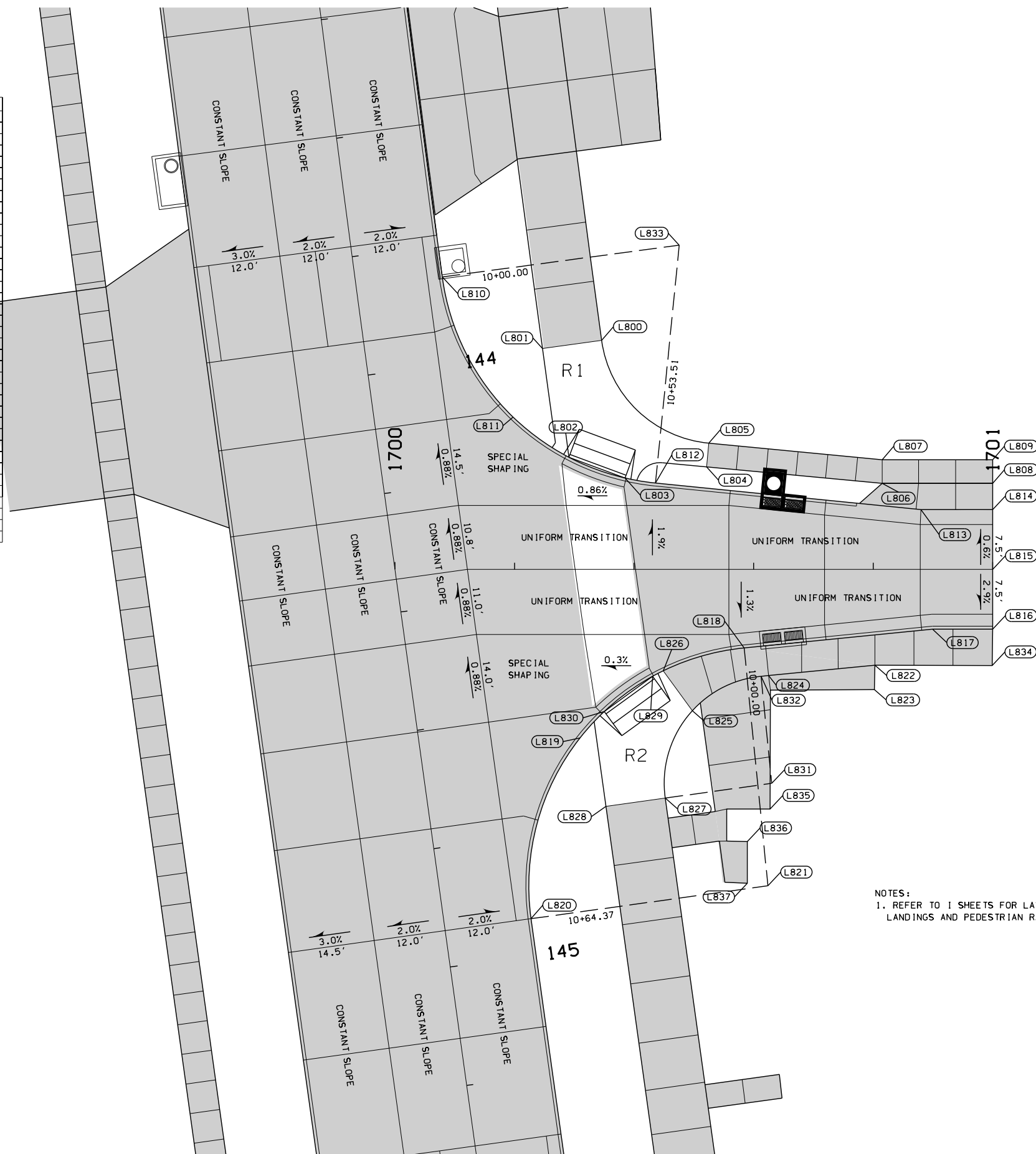

NOTES:  
 1. REFER TO 1 SHEETS FOR LAYOUT OF LANDINGS AND PEDESTRIAN RAMPS.

**20TH PLACE STAKING**



R1

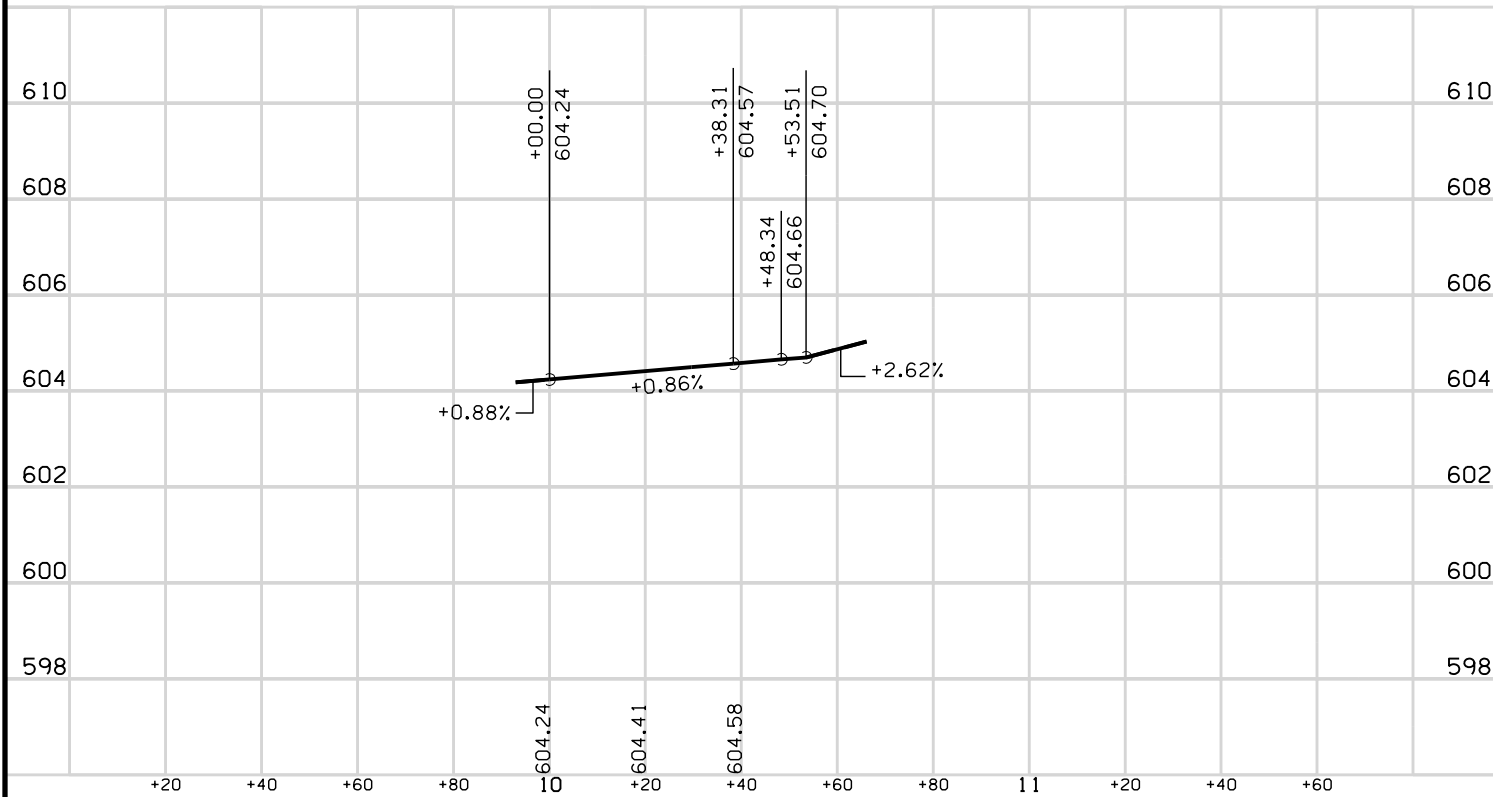

R2

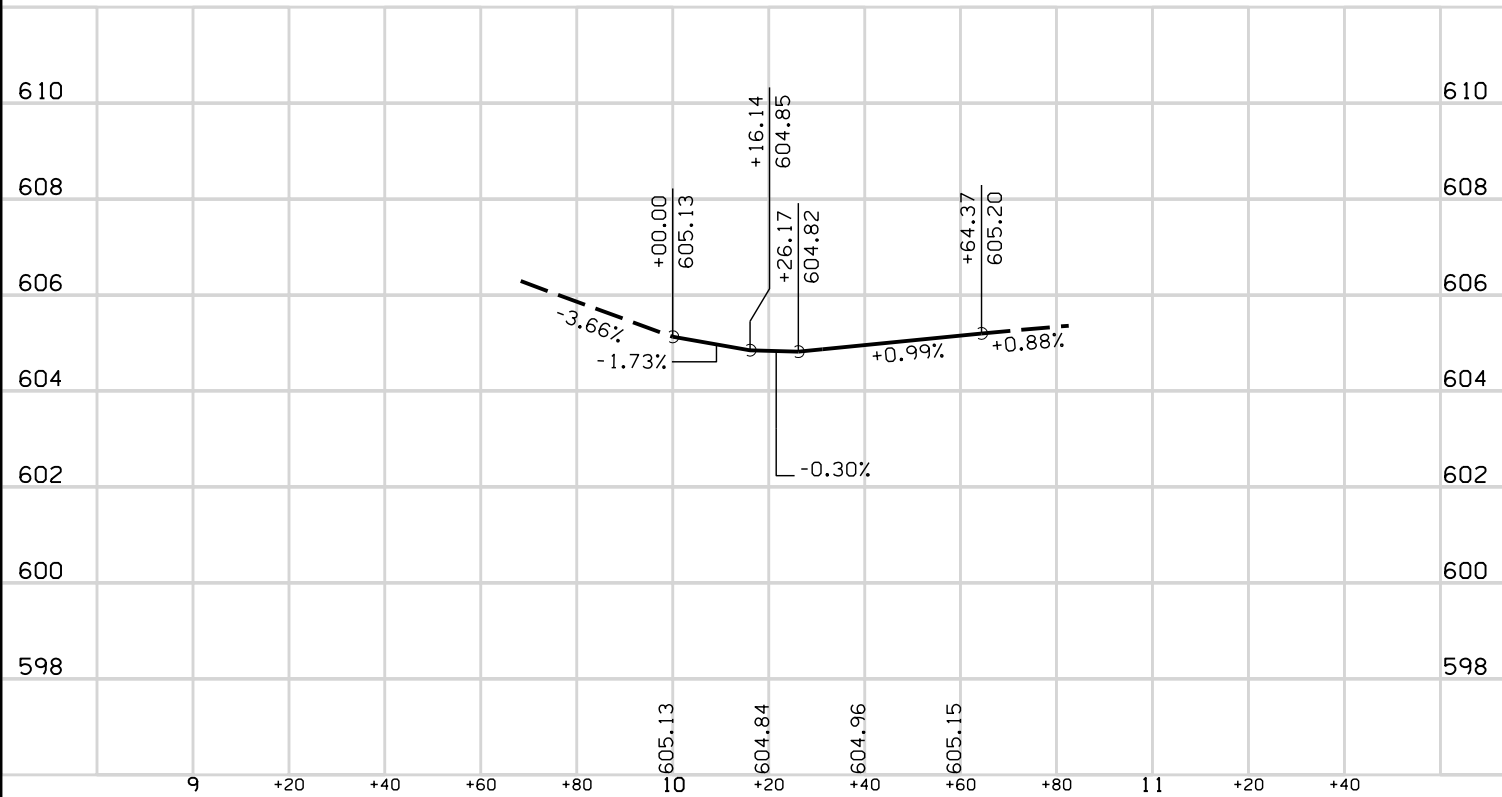

NOTES:  
1. ELEVATIONS ARE FORM GRADE  
UNLESS OTHERWISE NOTED.

**20TH PL.  
EDGE PROFILES**

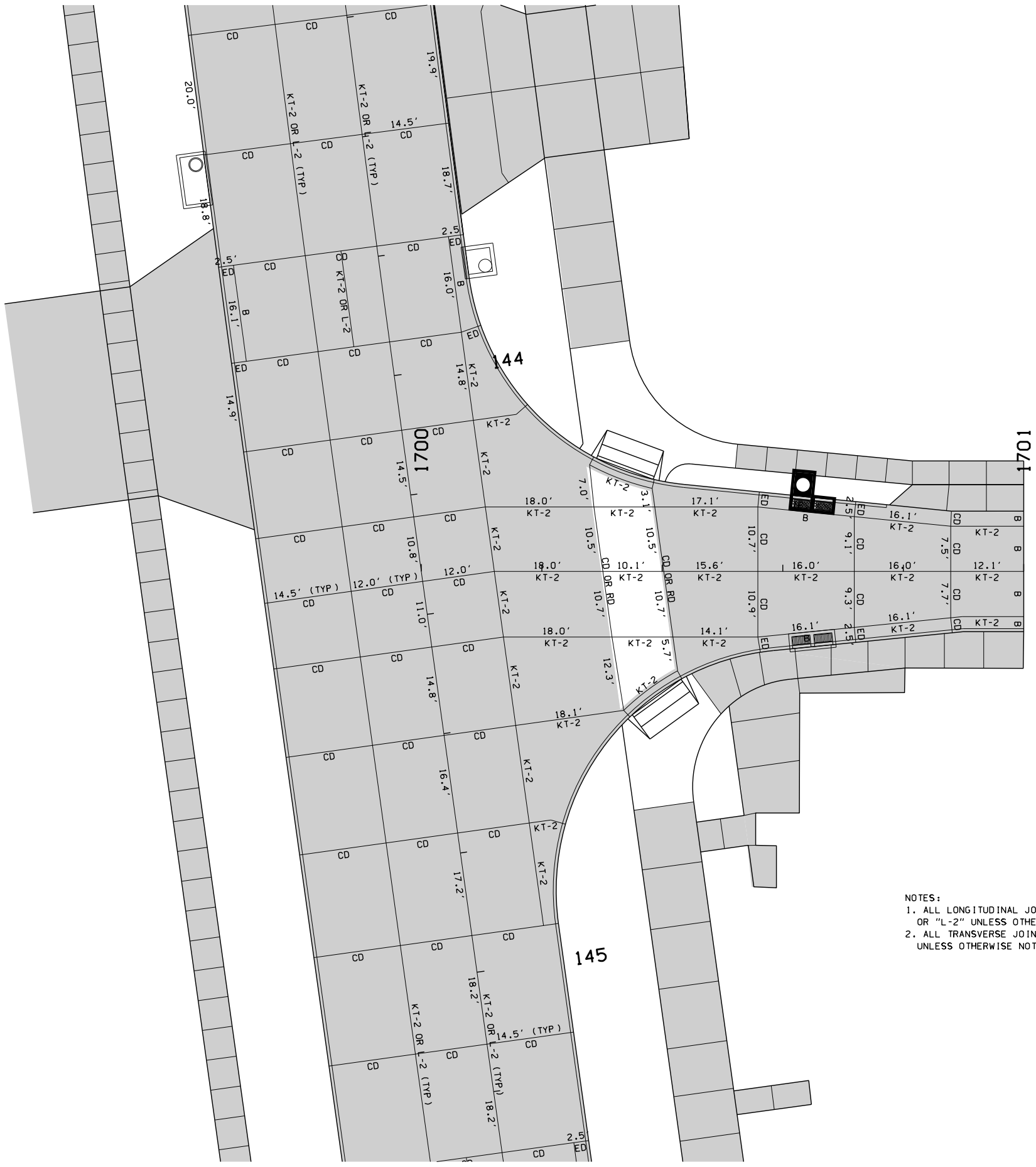
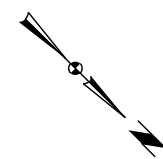
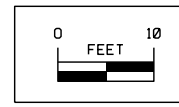

- NOTES:
1. ALL LONGITUDINAL JOINTS WILL BE "KT-2" OR "L-2" UNLESS OTHERWISE NOTED.
  2. ALL TRANSVERSE JOINTS WILL BE "CD" UNLESS OTHERWISE NOTED.

20TH PLACE  
JOINTING

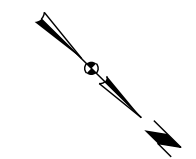
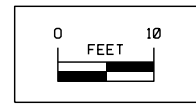

Point	Station	Offset	Elevation	Description
L900	145+80.42	-39.50	606.97	SIDEWALK
L901	145+80.42	-29.50	606.77	SIDEWALK
L902	146+03.00	-31.56	606.21	FG BOTTOM OF PED RAMP
L903	146+07.66	-40.40	606.30	FG BOTTOM OF PED RAMP
L904	145+95.57	-61.04	607.69	SIDEWALK
L905	146+00.53	-60.37	607.59	SIDEWALK
L906	1801+00.00	-24.26	610.23	BEGIN SIDEWALK/MATCH EXISTING
L907	1801+00.00	-29.26	610.33	BEGIN SIDEWALK/MATCH EXISTING
L908	145+70.23	-14.50	605.87	FG END OF RADIUS
L909	145+96.54	-24.37	606.12	FG MIDPOINT OF RADIUS
L910	146+09.86	-49.12	606.46	FG END OF RADIUS
L911	145+70.23	-54.50	N/A	CENTER OF 40' RADIUS
L912	1801+00.00	-13.50	609.30	FG BEGIN PAVEMENT/MATCH EXISTING
L913	1801+00.00	0.00	609.86	BEGIN PAVEMENT/MATCH EXISTING
L914	1801+00.00	13.50	609.66	FG BEGIN PAVEMENT/MATCH EXISTING
L915	146+38.09	-59.31	607.00	FG END OF RADIUS
L916	146+47.42	-28.03	606.42	FG MIDPOINT OF RADIUS
L917	146+76.92	-14.50	606.84	FG END OF RADIUS
L918	146+76.92	-54.50	N/A	CENTER OF 40' RADIUS
L919	1801+00.00	30.23	610.73	BEGIN SIDEWALK/MATCH EXISTING
L920	1801+00.00	25.23	610.63	BEGIN SIDEWALK/MATCH EXISTING
L921	146+54.07	-55.18	607.59	SIDEWALK
L922	146+49.21	-55.78	607.49	SIDEWALK
L923	146+67.67	-39.50	607.86	SIDEWALK
L924	146+67.62	-29.50	607.66	SIDEWALK
L925	146+40.25	-40.23	606.47	FG BOTTOM OF PED RAMP
L926	146+44.83	-31.37	606.37	FG BOTTOM OF PED RAMP

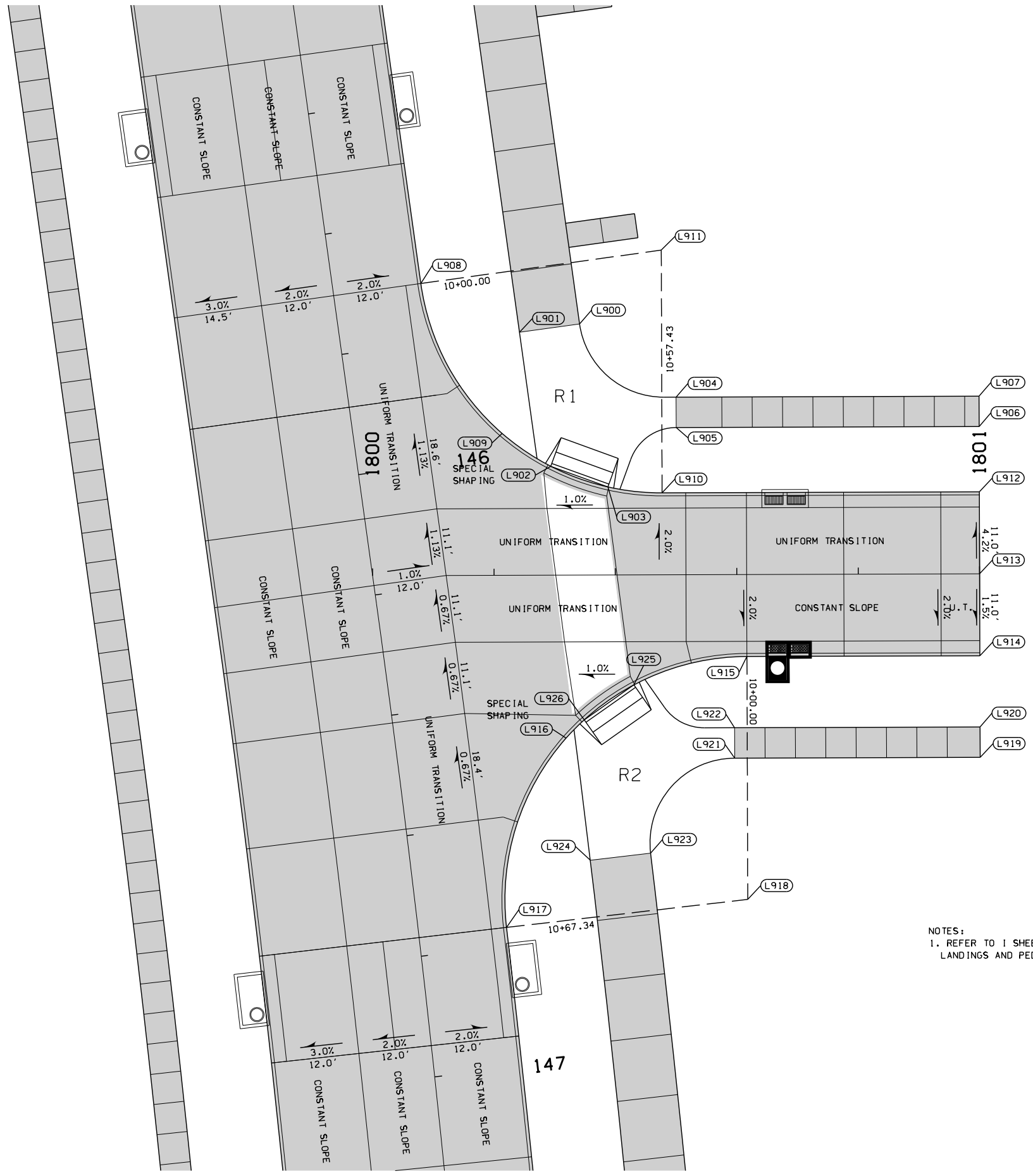

NOTES:  
 1. REFER TO I SHEETS FOR LAYOUT OF LANDINGS AND PEDESTRIAN RAMPS.

**19TH PLACE STAKING**

R1

R2

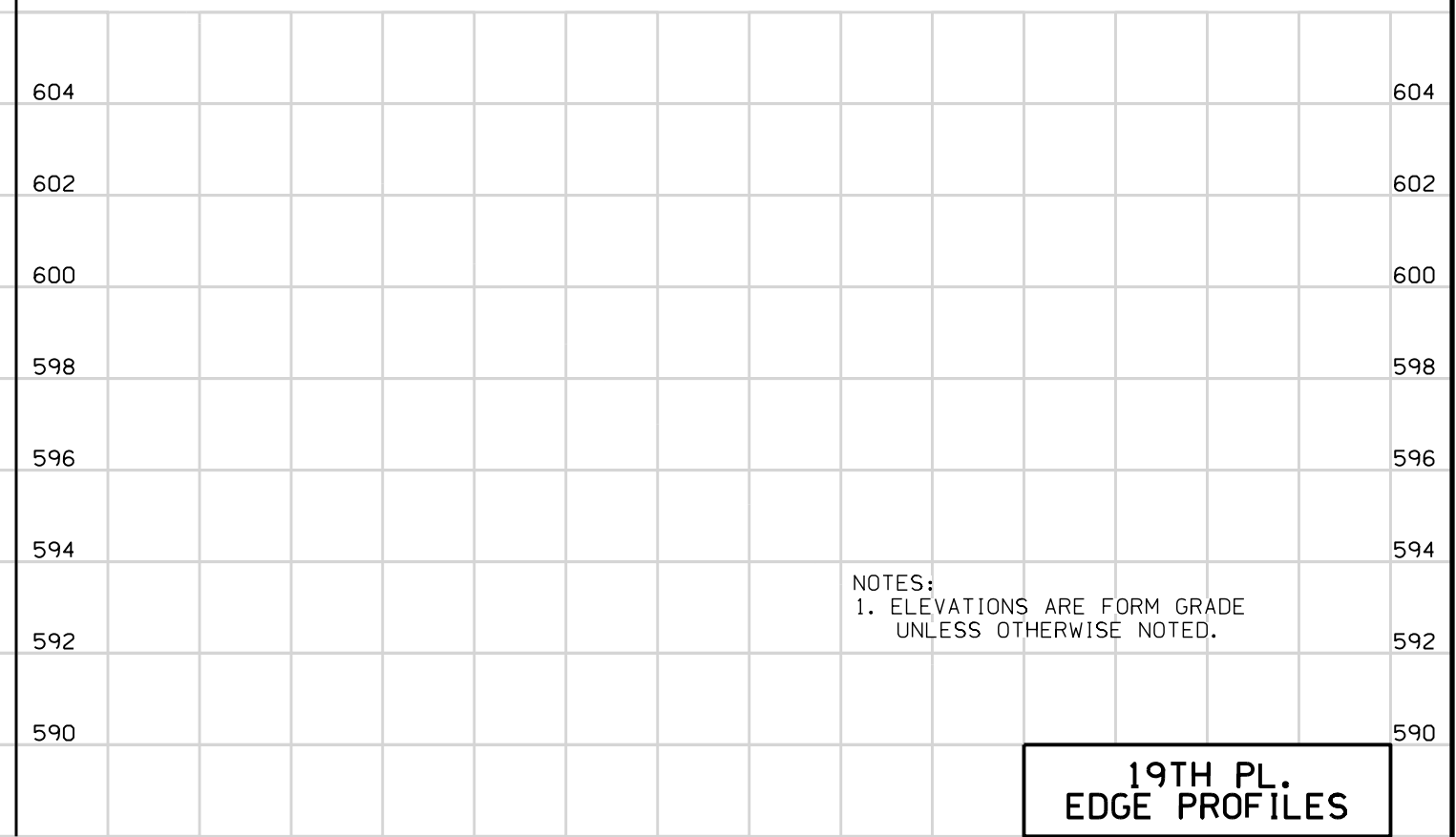
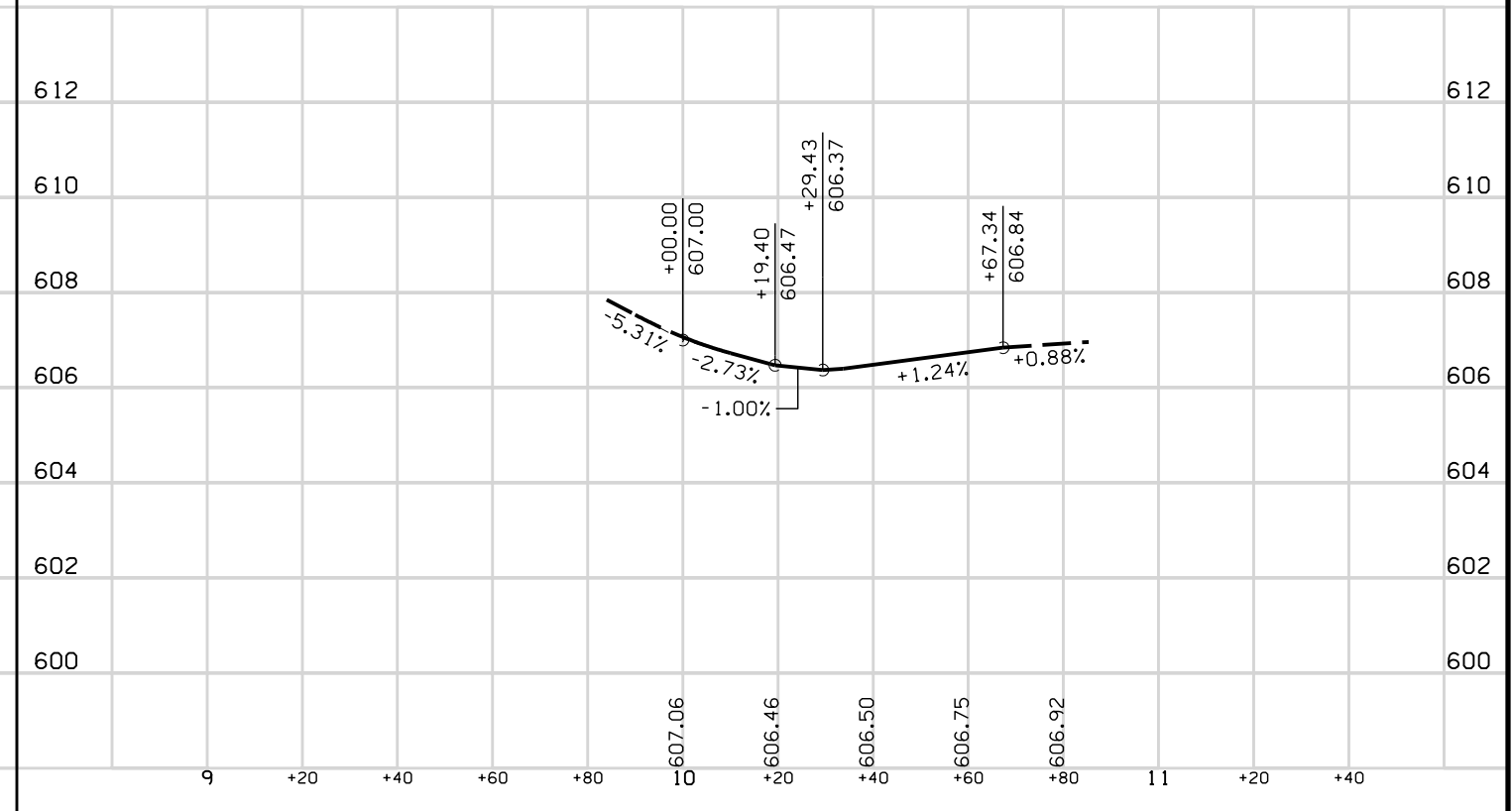
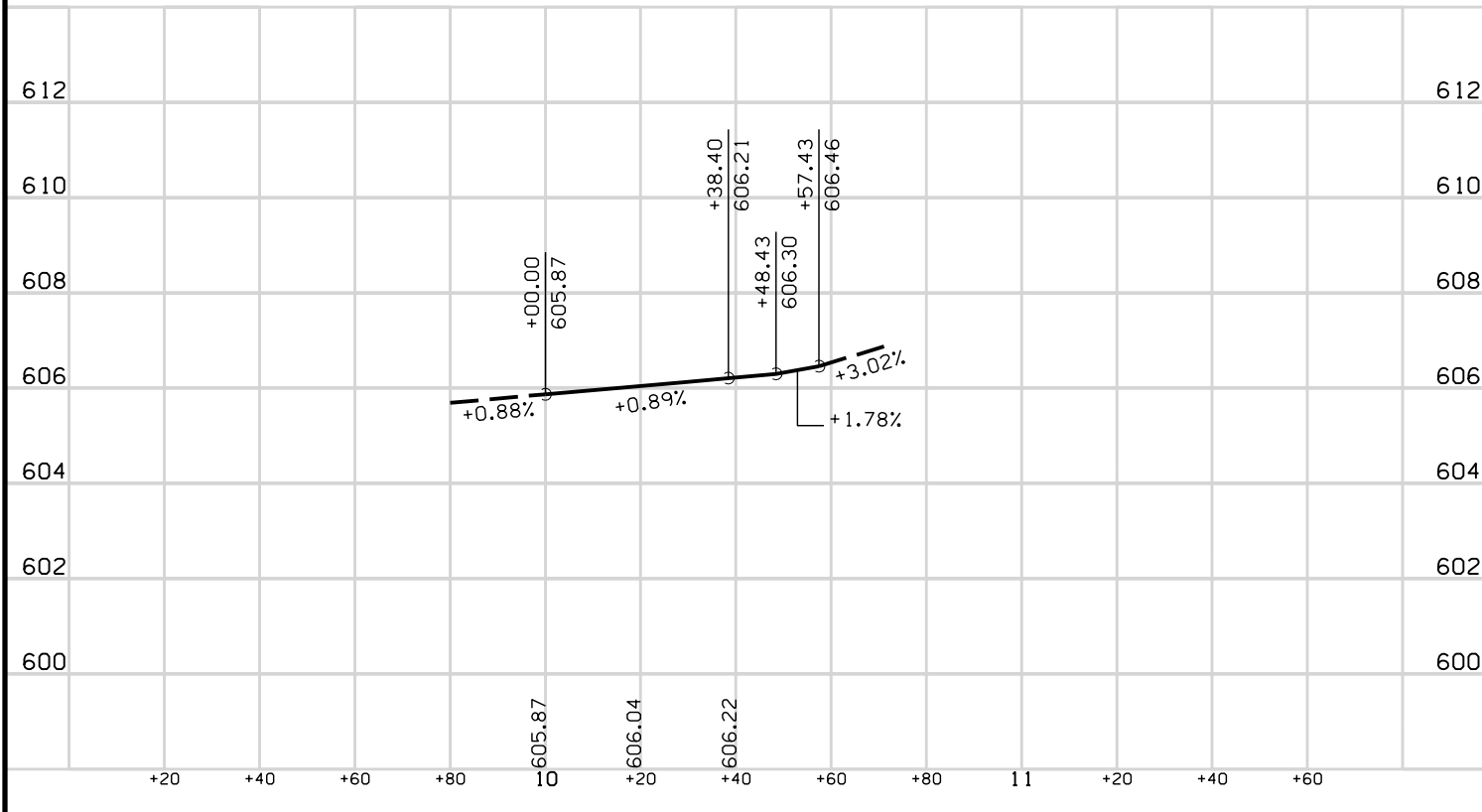

NOTES:  
1. ELEVATIONS ARE FORM GRADE  
UNLESS OTHERWISE NOTED.

19TH PL.  
EDGE PROFILES

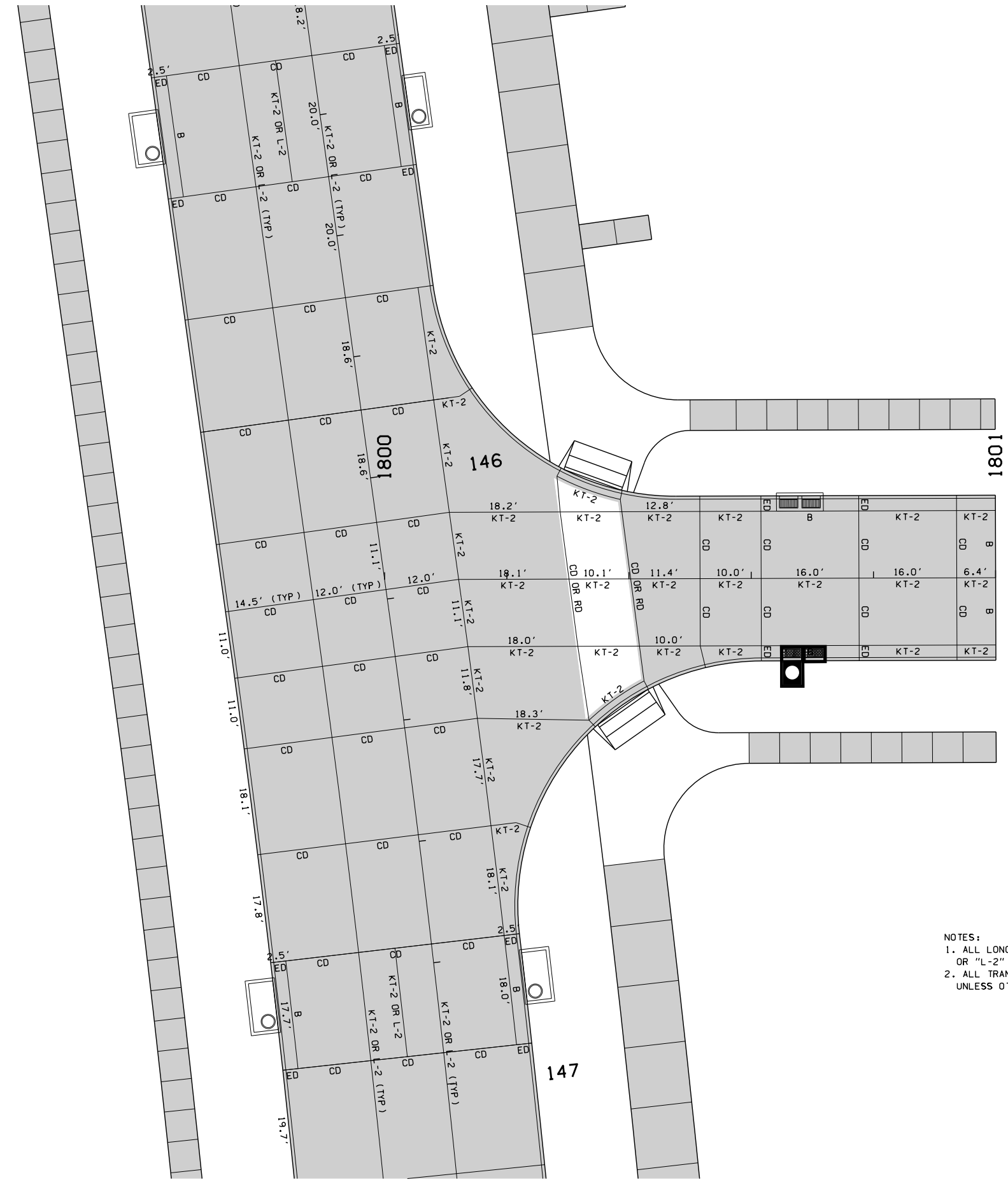
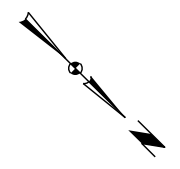
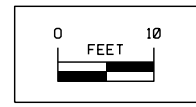

- NOTES:
1. ALL LONGITUDINAL JOINTS WILL BE "KT-2" OR "L-2" UNLESS OTHERWISE NOTED.
  2. ALL TRANSVERSE JOINTS WILL BE "CD" UNLESS OTHERWISE NOTED.

**19TH PLACE  
JOINTING**

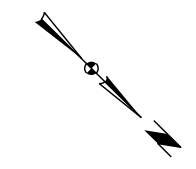
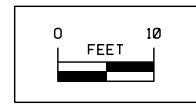

Point	Station	Offset	Elevation	Description
L1000	149+25.14	-39.50	608.38	SIDEWALK
L1001	149+25.14	-29.50	608.18	SIDEWALK
L1002	149+48.32	-31.41	606.96	FG BOTTOM OF PED RAMP
L1003	149+52.89	-40.27	606.98	FG BOTTOM OF PED RAMP
L1004	149+44.73	-53.24	608.07	SIDEWALK
L1005	149+38.85	-53.30	608.19	SIDEWALK
L1006	1900+90.00	-24.35	609.35	BEGIN SIDEWALK/MATCH EXISTING
L1007	1900+90.00	-30.35	609.47	BEGIN SIDEWALK/MATCH EXISTING
L1008	149+16.21	-14.50	607.19	FG END OF RADIUS
L1009	149+43.92	-26.09	607.00	FG MIDPOINT OF RADIUS
L1010	149+55.35	-54.01	607.23	FG END OF RADIUS
L1011	149+16.21	-54.50	N/A	CENTER OF 40' RADIUS
L1012	1900+90.00	-13.50	608.42	FG BEGIN PAVEMENT/MATCH EXISTING
L1013	1900+90.00	0.00	609.00	BEGIN PAVEMENT/MATCH EXISTING
L1014	1900+90.00	13.50	608.68	FG BEGIN PAVEMENT/MATCH EXISTING
L1015	149+81.78	-53.94	607.23	FG END OF RADIUS
L1016	149+93.24	-26.07	606.75	FG MIDPOINT OF RADIUS
L1017	150+20.91	-14.50	606.56	FG END OF RADIUS
L1018	150+20.93	-54.50	N/A	CENTER OF 40' RADIUS
L1019	1900+90.00	29.41	609.69	BEGIN SIDEWALK/MATCH EXISTING
L1020	1900+90.00	23.41	609.57	BEGIN SIDEWALK/MATCH EXISTING
L1021	149+97.37	-53.30	608.22	SIDEWALK
L1022	149+91.49	-53.23	608.10	SIDEWALK
L1023	149+84.26	-40.23	606.91	FG BOTTOM OF PED RAMP
L1024	149+88.84	-31.37	606.79	FG BOTTOM OF PED RAMP
L1025	150+11.01	-39.53	607.48	SIDEWALK
L1026	150+10.96	-29.53	607.28	SIDEWALK

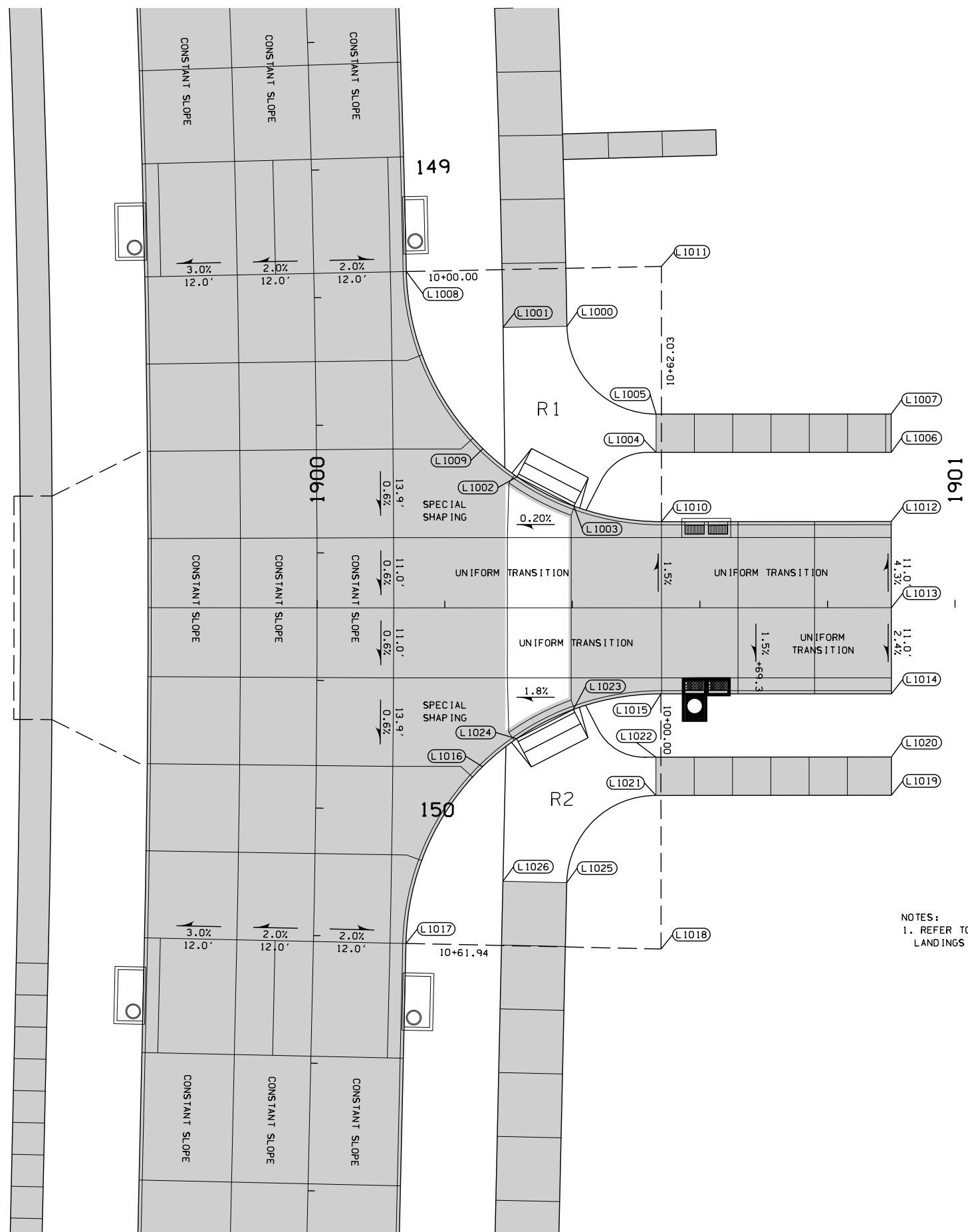

NOTES:  
 1. REFER TO I SHEETS FOR LAYOUT OF LANDINGS AND PEDESTRIAN RAMPS.

18TH PLACE  
 STAKING

R1

R2

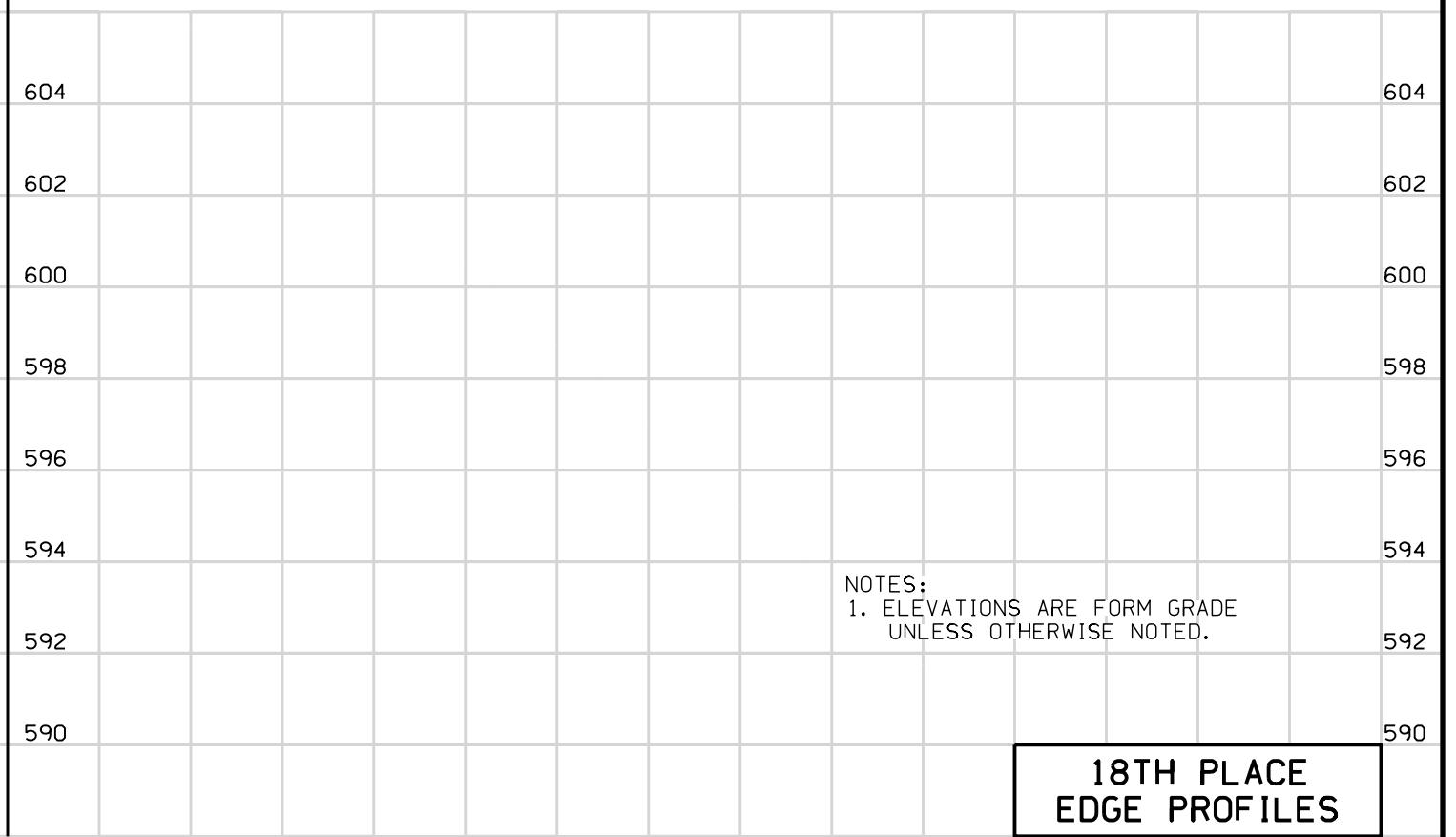
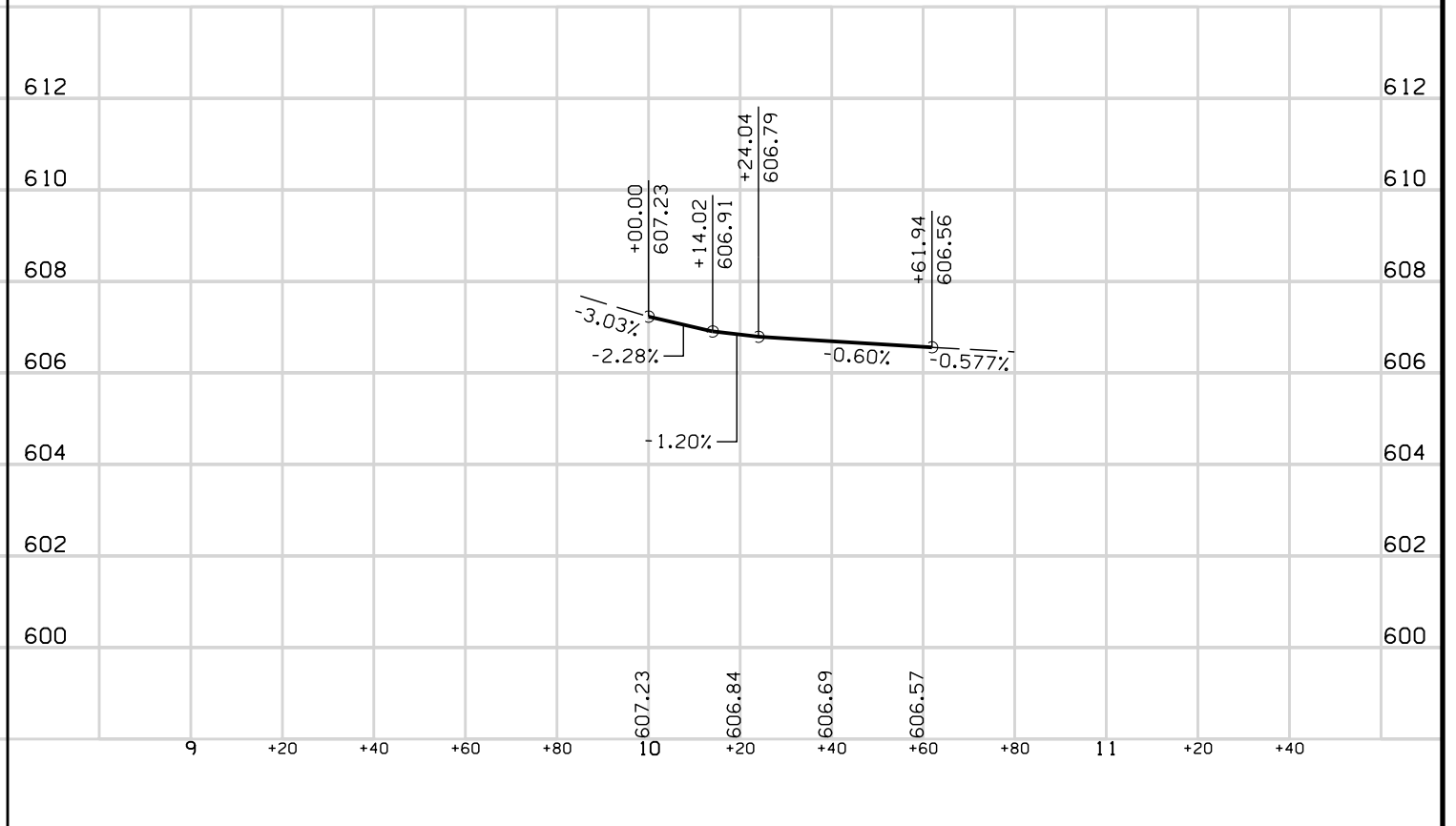
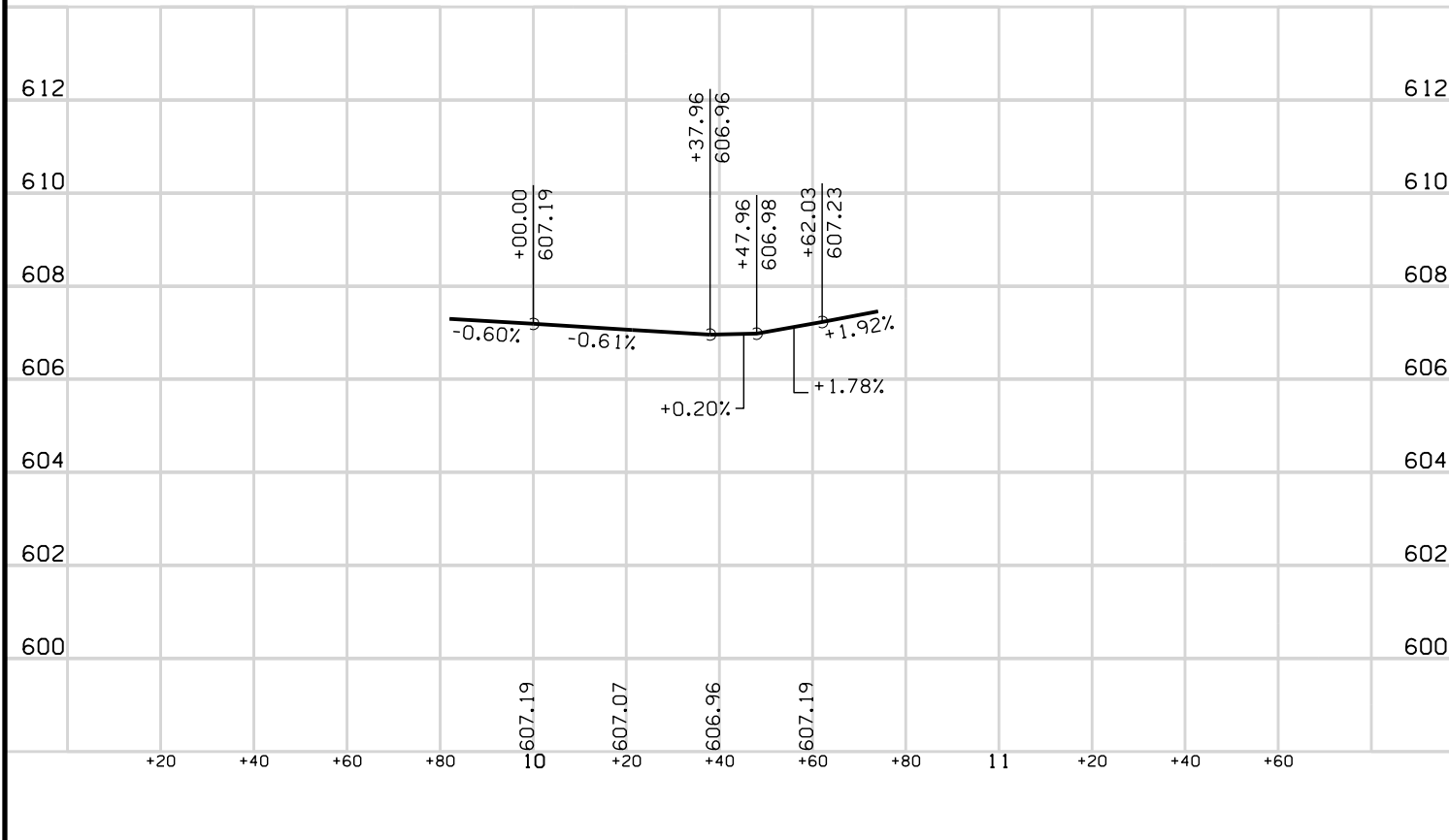

NOTES:  
1. ELEVATIONS ARE FORM GRADE  
UNLESS OTHERWISE NOTED.

**18TH PLACE  
EDGE PROFILES**

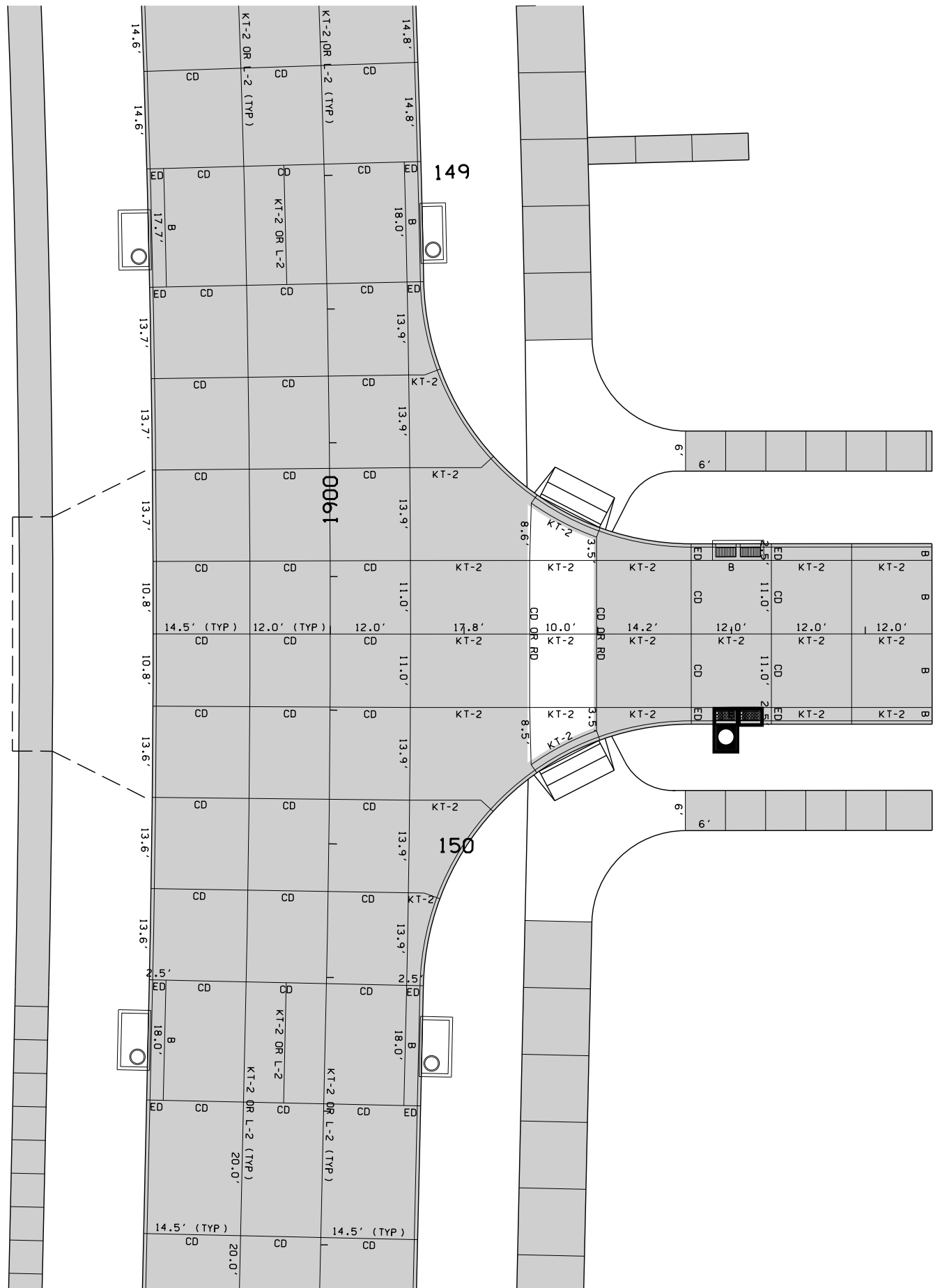
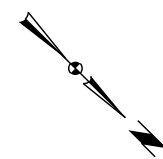
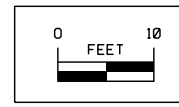

1901

- NOTES:
1. ALL LONGITUDINAL JOINTS WILL BE "KT-2" OR "L-2" UNLESS OTHERWISE NOTED.
  2. ALL TRANSVERSE JOINTS WILL BE "CD" UNLESS OTHERWISE NOTED.

**18TH PLACE  
JOINTING**



Point	Station	Offset	Elevation	Description
L1143	1999+40.33	-26.50	603.99	SIDEWALK
L1144	1999+40.33	-31.50	604.09	SIDEWALK
L1145	1999+53.41	-21.50	603.72	FG BOTTOM OF PED RAMP
L1146	1999+59.41	-21.50	603.83	FG BOTTOM OF PED RAMP
L1147	152+81.31	26.50	604.52	FG BOTTOM OF PED RAMP
L1148	152+75.31	26.50	604.58	FG BOTTOM OF PED RAMP
L1149	152+65.31	41.50	605.77	SIDEWALK
L1150	152+65.34	46.50	605.87	SIDEWALK
L1151	152+91.31	36.30	604.99	FG END OF RADIUS
L1152	152+88.31	29.36	604.25	FG MIDPOINT OF RADIUS
L1153	152+81.31	26.50	604.52	FG END OF RADIUS
L1154	152+81.31	36.50	N/A	CENTER OF 10' RADIUS

Point	Station	Offset	Elevation	Description
L1100	152+60.85	-39.50	606.27	SIDEWALK
L1101	152+60.86	-29.50	606.07	SIDEWALK
L1102	152+74.13	-18.11	604.97	FG BOTTOM OF PED RAMP
L1103	152+79.39	-21.00	604.92	FG BOTTOM OF PED RAMP
L1104	152+90.18	-31.40	604.87	FG BOTTOM OF PED RAMP
L1105	152+94.89	-40.22	604.91	FG BOTTOM OF PED RAMP
L1106	152+91.07	-53.89	605.64	SIDEWALK
L1107	152+85.07	-53.80	605.74	SIDEWALK
L1108	2001+13.50	-20.15	609.43	BEGIN SIDEWALK/MATCH EXISTING
L1109	2001+13.50	-26.04	609.56	BEGIN SIDEWALK/MATCH EXISTING
L1110	152+57.53	-14.50	605.11	FG END OF RADIUS
L1111	152+86.09	-26.49	604.85	FG MIDPOINT OF RADIUS
L1112	152+97.52	-55.28	605.20	FG END OF RADIUS
L1113	152+57.53	-54.50	N/A	CENTER OF 40' RADIUS
L1114	2001+13.50	-13.50	608.68	FG BEGIN PAVEMENT/MATCH EXISTING
L1115	2001+13.50	0.00	609.13	BEGIN PAVEMENT/MATCH EXISTING

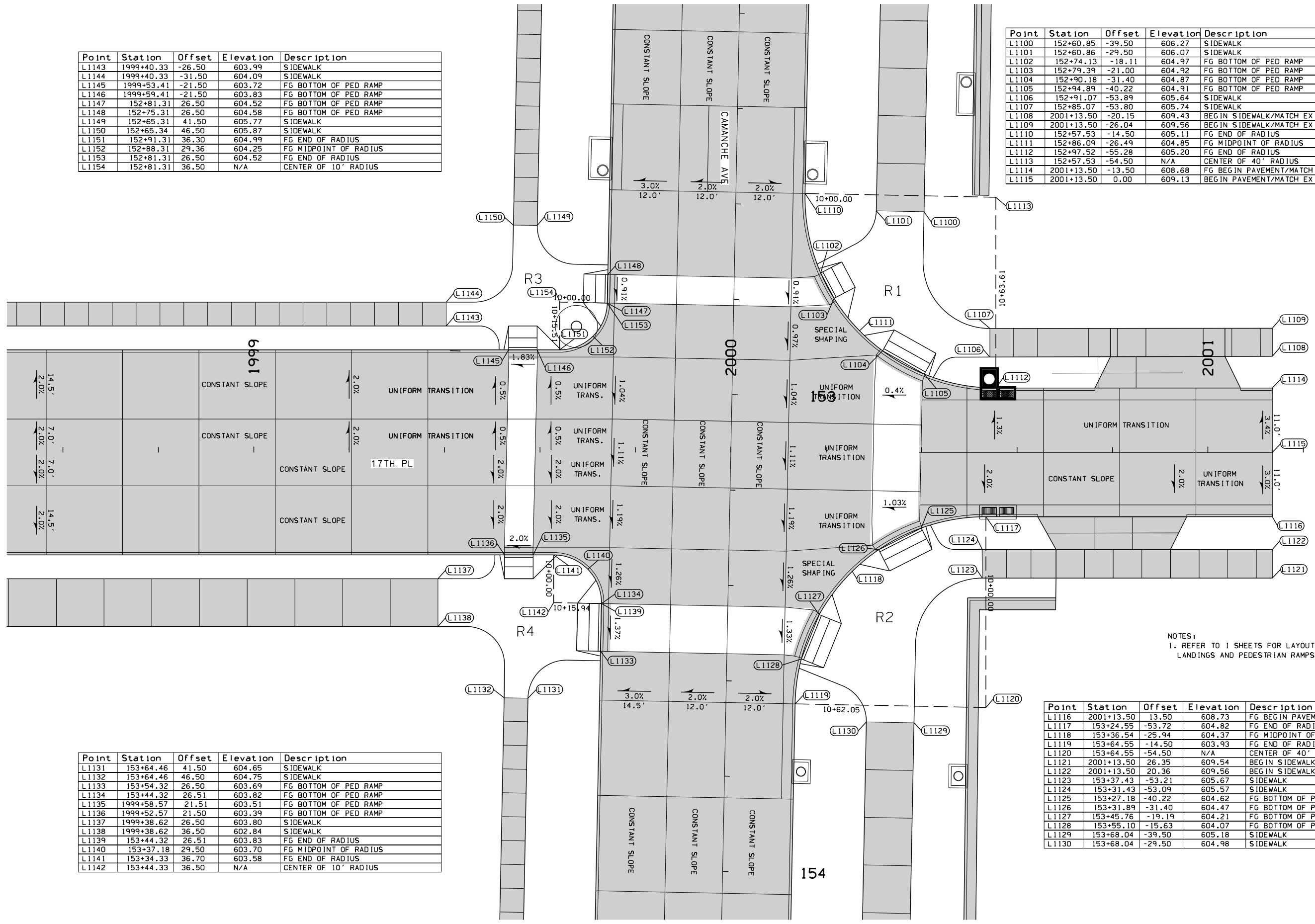
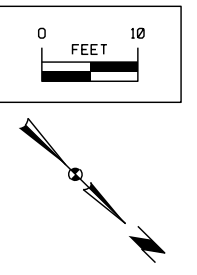

NOTES:  
1. REFER TO I SHEETS FOR LAYOUT OF LANDINGS AND PEDESTRIAN RAMPS.

Point	Station	Offset	Elevation	Description
L1131	153+64.46	41.50	604.65	SIDEWALK
L1132	153+64.46	46.50	604.75	SIDEWALK
L1133	153+54.32	26.50	603.69	FG BOTTOM OF PED RAMP
L1134	153+44.32	26.51	603.82	FG BOTTOM OF PED RAMP
L1135	1999+58.57	21.51	603.51	FG BOTTOM OF PED RAMP
L1136	1999+52.57	21.50	603.39	FG BOTTOM OF PED RAMP
L1137	1999+38.62	26.50	603.80	SIDEWALK
L1138	1999+38.62	36.50	602.84	SIDEWALK
L1139	153+44.32	26.51	603.83	FG END OF RADIUS
L1140	153+37.18	29.50	603.70	FG MIDPOINT OF RADIUS
L1141	153+34.33	36.70	603.58	FG END OF RADIUS
L1142	153+44.33	36.50	N/A	CENTER OF 10' RADIUS

Point	Station	Offset	Elevation	Description
L1116	2001+13.50	13.50	608.73	FG BEGIN PAVEMENT/MATCH EXISTING
L1117	153+24.55	-53.72	604.82	FG END OF RADIUS
L1118	153+36.54	-25.94	604.37	FG MIDPOINT OF RADIUS
L1119	153+64.55	-14.50	603.93	FG END OF RADIUS
L1120	153+64.55	-54.50	N/A	CENTER OF 40' RADIUS
L1121	2001+13.50	26.35	609.54	BEGIN SIDEWALK/MATCH EXISTING
L1122	2001+13.50	20.36	609.56	BEGIN SIDEWALK/MATCH EXISTING
L1123	153+37.43	-53.21	605.67	SIDEWALK
L1124	153+31.43	-53.09	605.57	SIDEWALK
L1125	153+27.18	-40.22	604.62	FG BOTTOM OF PED RAMP
L1126	153+31.89	-31.40	604.47	FG BOTTOM OF PED RAMP
L1127	153+45.76	-19.19	604.21	FG BOTTOM OF PED RAMP
L1128	153+55.10	-15.63	604.07	FG BOTTOM OF PED RAMP
L1129	153+68.04	-39.50	605.18	SIDEWALK
L1130	153+68.04	-29.50	604.98	SIDEWALK

17TH PLACE STAKING

R1

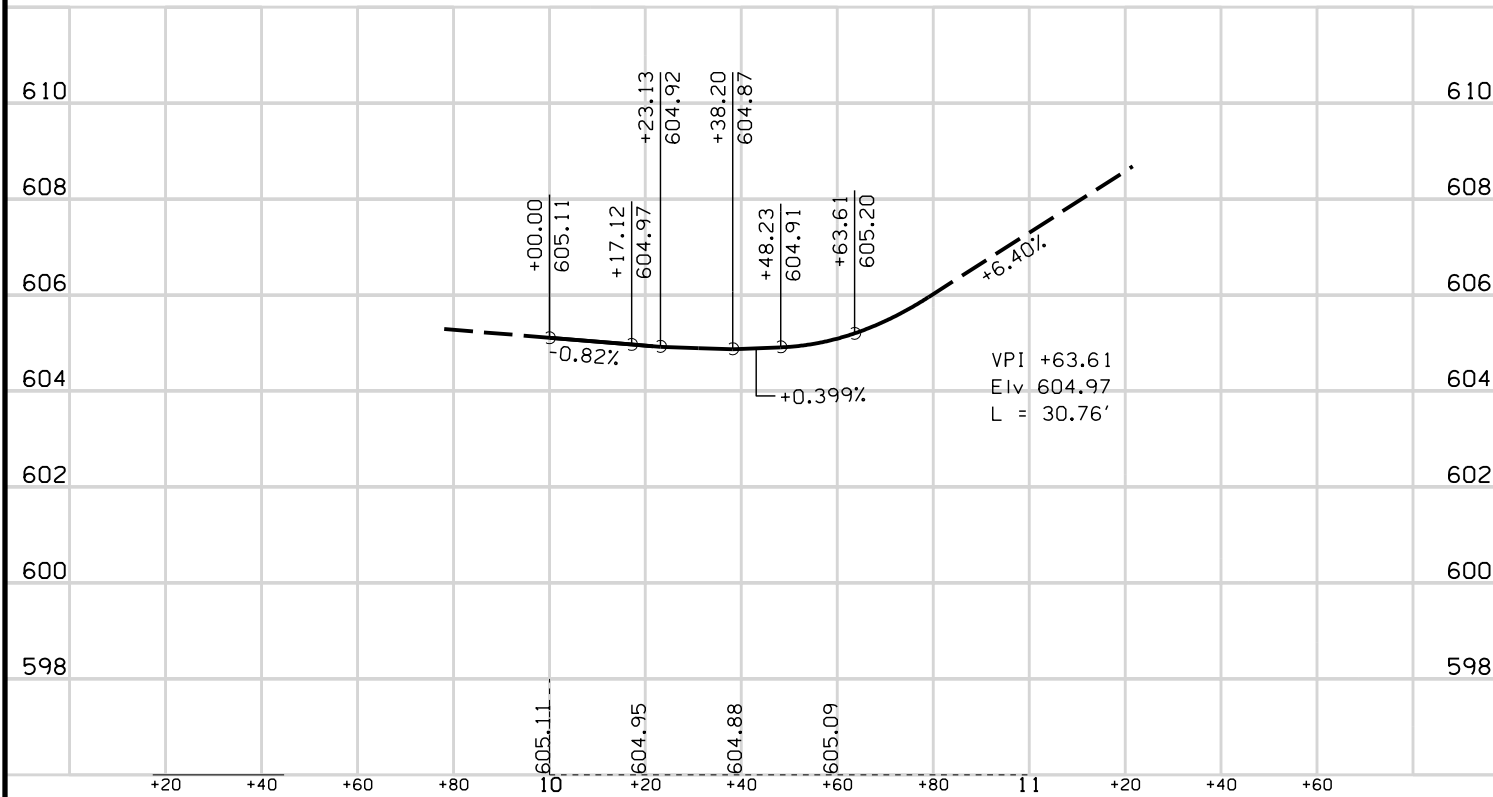

R2

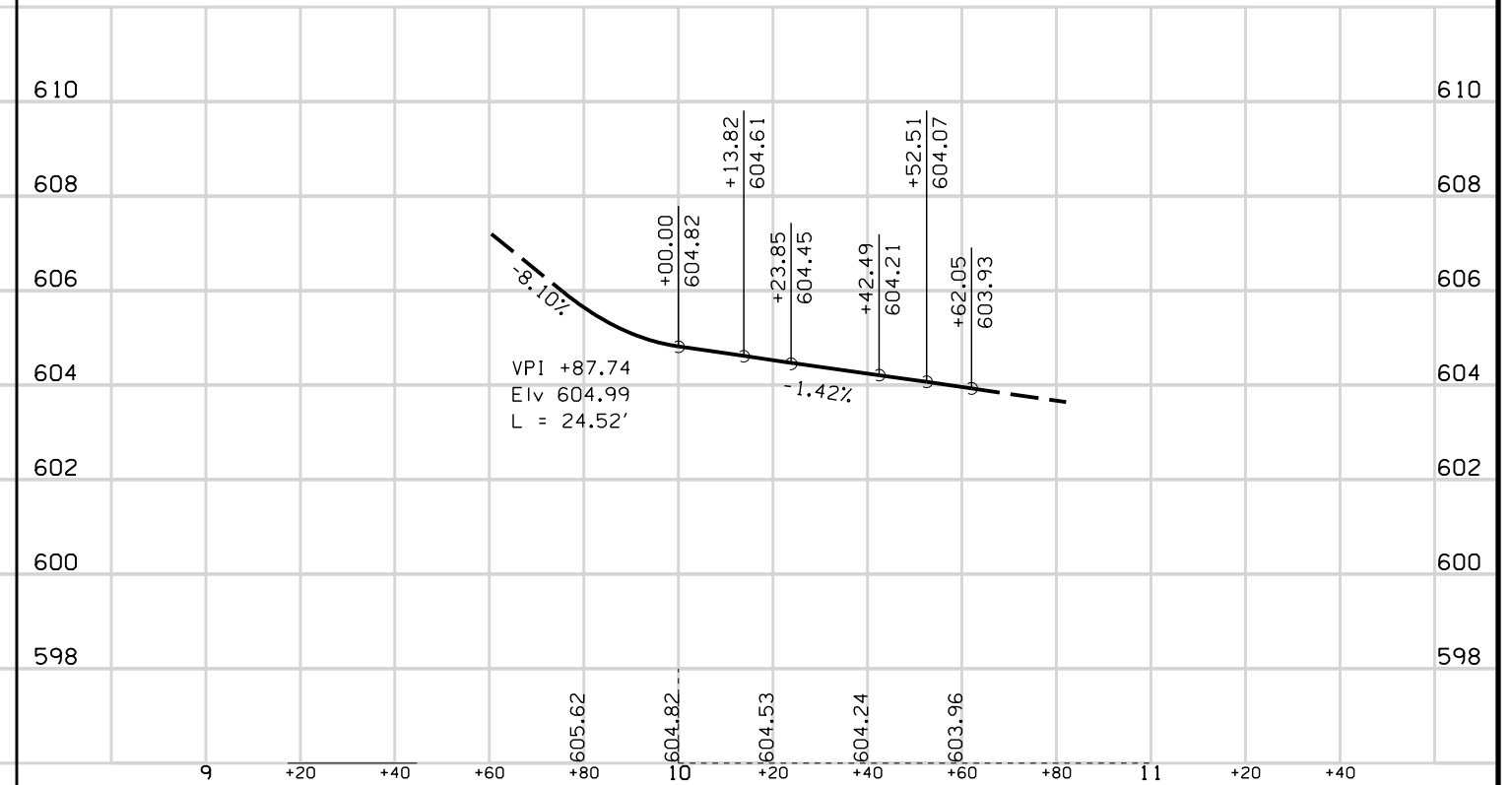

R3



R4

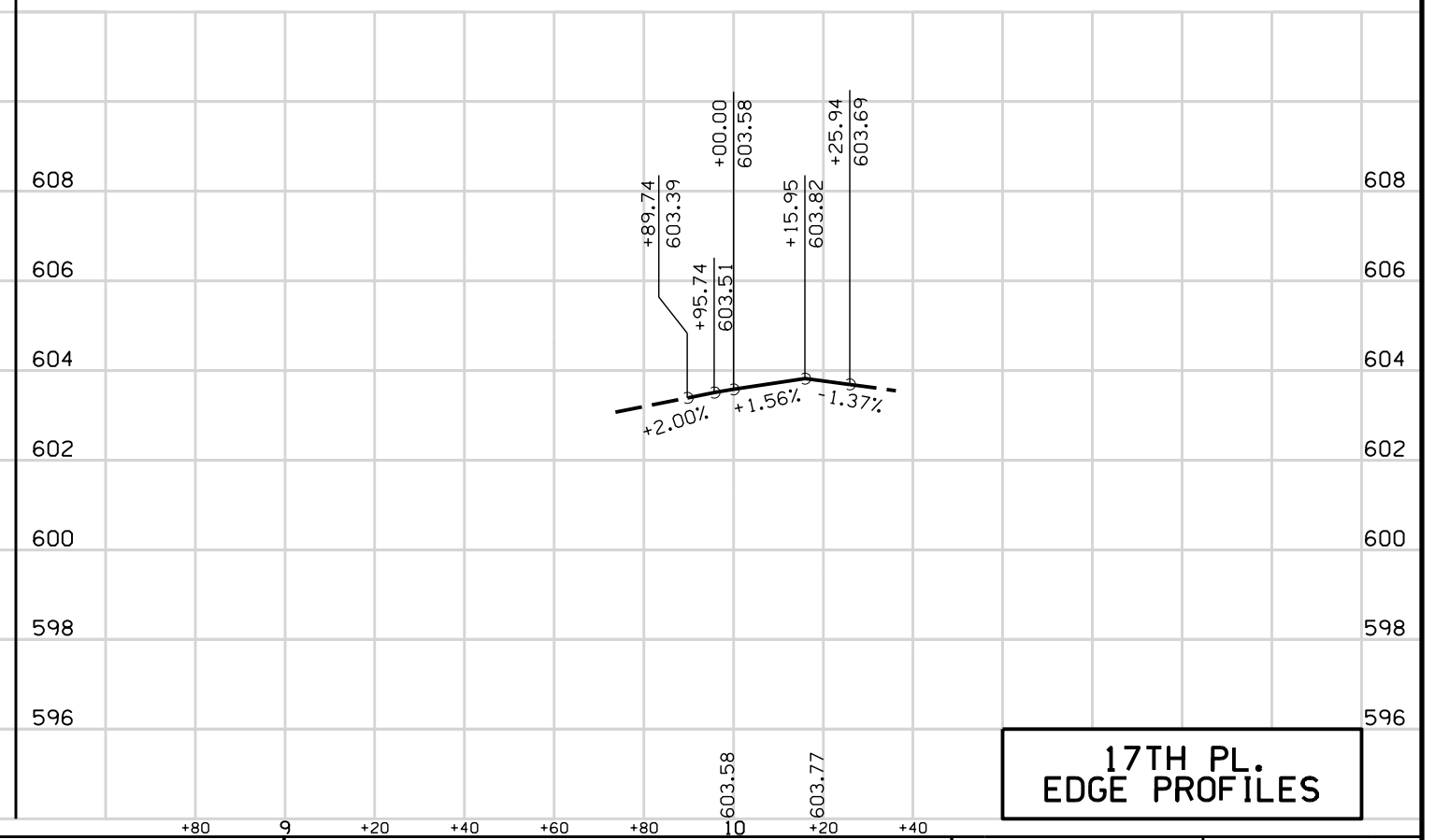

17TH PL. EDGE PROFILES

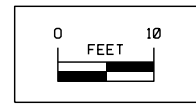

NOTES:  
 1. ALL LONGITUDINAL JOINTS WILL BE "KT-2" OR "L-2" UNLESS OTHERWISE NOTED.  
 2. ALL TRANSVERSE JOINTS WILL BE "CD" UNLESS OTHERWISE NOTED.

**17TH PLACE JOINTING**

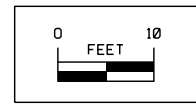

Point	Station	Offset	Elevation	Description
L1200	157+61.32	-39.50	603.82	SIDEWALK
L1201	157+61.32	-29.50	603.62	SIDEWALK
L1202	157+77.48	-31.39	603.18	FG BOTTOM OF PED RAMP
L1203	157+82.23	-40.20	603.22	FG BOTTOM OF PED RAMP
L1204	157+76.41	-54.35	604.22	SIDEWALK
L1205	157+80.44	-54.30	604.06	SIDEWALK
L1206	2101+15.76	-19.96	606.71	BEGIN SIDEWALK/MATCH EXISTING
L1207	2101+15.76	-23.96	606.74	BEGIN SIDEWALK/MATCH EXISTING
L1208	157+44.67	-14.50	603.03	FG END OF RADIUS
L1209	157+72.93	-26.06	603.15	FG MIDPOINT OF RADIUS
L1210	157+84.92	-54.12	603.37	FG END OF RADIUS
L1211	2100+80.04	-15.50	604.14	FG BEGIN PAVEMENT/MATCH EXISTING
L1212	2100+80.04	0.00	604.80	BEGIN PAVEMENT/MATCH EXISTING
L1213	2100+80.04	15.50	604.33	FG BEGIN PAVEMENT/MATCH EXISTING
L1214	2101+15.76	24.26	607.26	BEGIN SIDEWALK/MATCH EXISTING
L1215	2101+15.76	19.07	606.89	BEGIN SIDEWALK/MATCH EXISTING
L1216	158+24.85	-48.48	603.54	SIDEWALK
L1217	158+19.63	-48.57	603.44	SIDEWALK
L1218	158+18.83	-40.20	602.82	FG BOTTOM OF PED RAMP
L1219	158+23.58	-31.39	602.71	FG BOTTOM OF PED RAMP
L1220	158+41.63	-39.50	603.64	SIDEWALK
L1221	158+41.62	-29.50	603.44	SIDEWALK
L1222	158+16.14	-55.22	603.25	FG END OF RADIUS
L1223	158+27.74	-26.46	602.68	FG MIDPOINT OF RADIUS
L1224	158+56.39	-14.50	602.56	FG END OF RADIUS
L1225	158+56.40	-54.50	N/A	CENTER OF 40' RADIUS
L1226	157+44.67	-54.50	N/A	CENTER OF 40' RADIUS

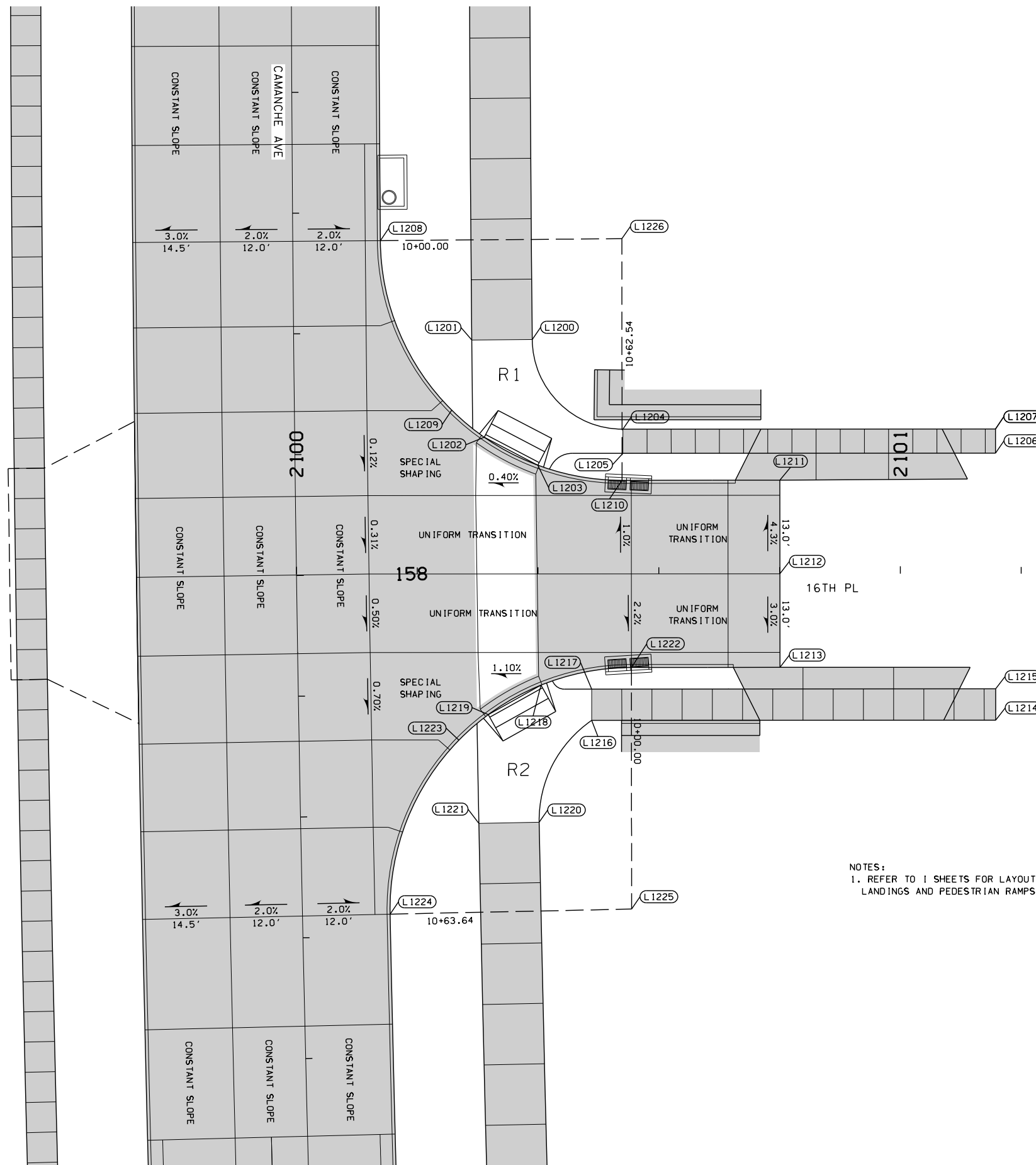

NOTES:  
 1. REFER TO I SHEETS FOR LAYOUT OF LANDINGS AND PEDESTRIAN RAMPS.

**16TH PLACE STAKING**

R1

R2

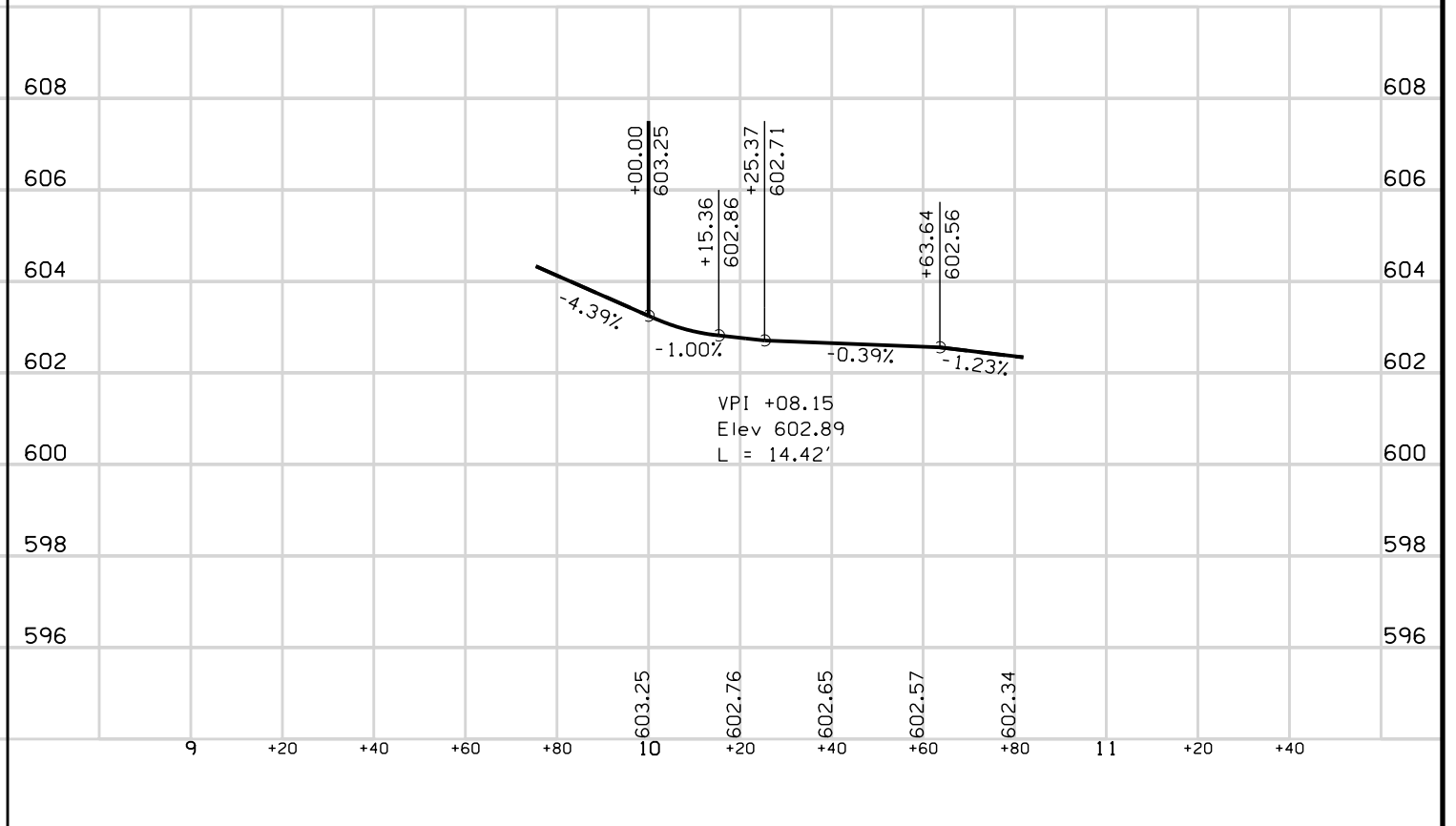
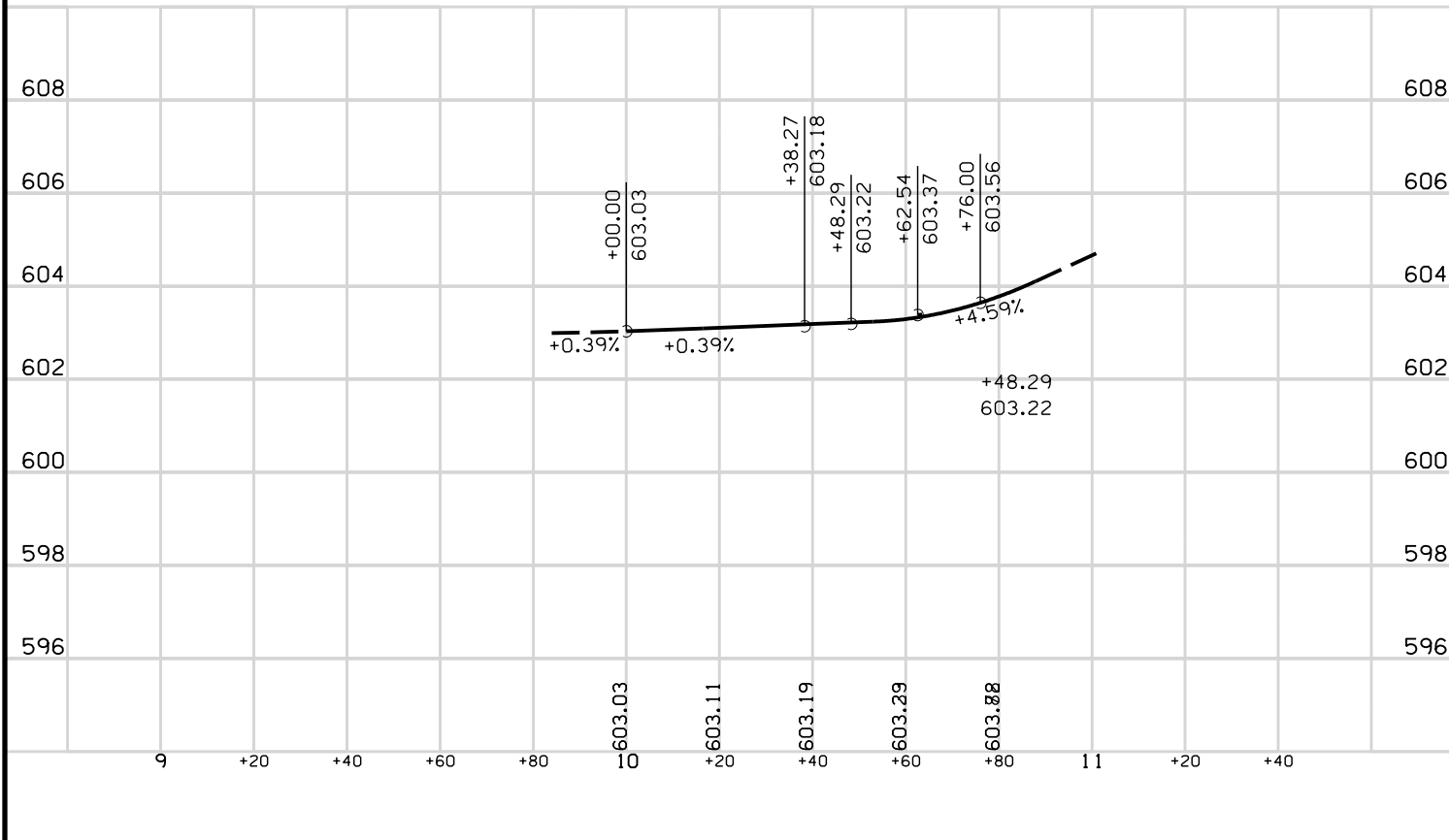

VPI +08.15  
Elev 602.89  
L = 14.42'

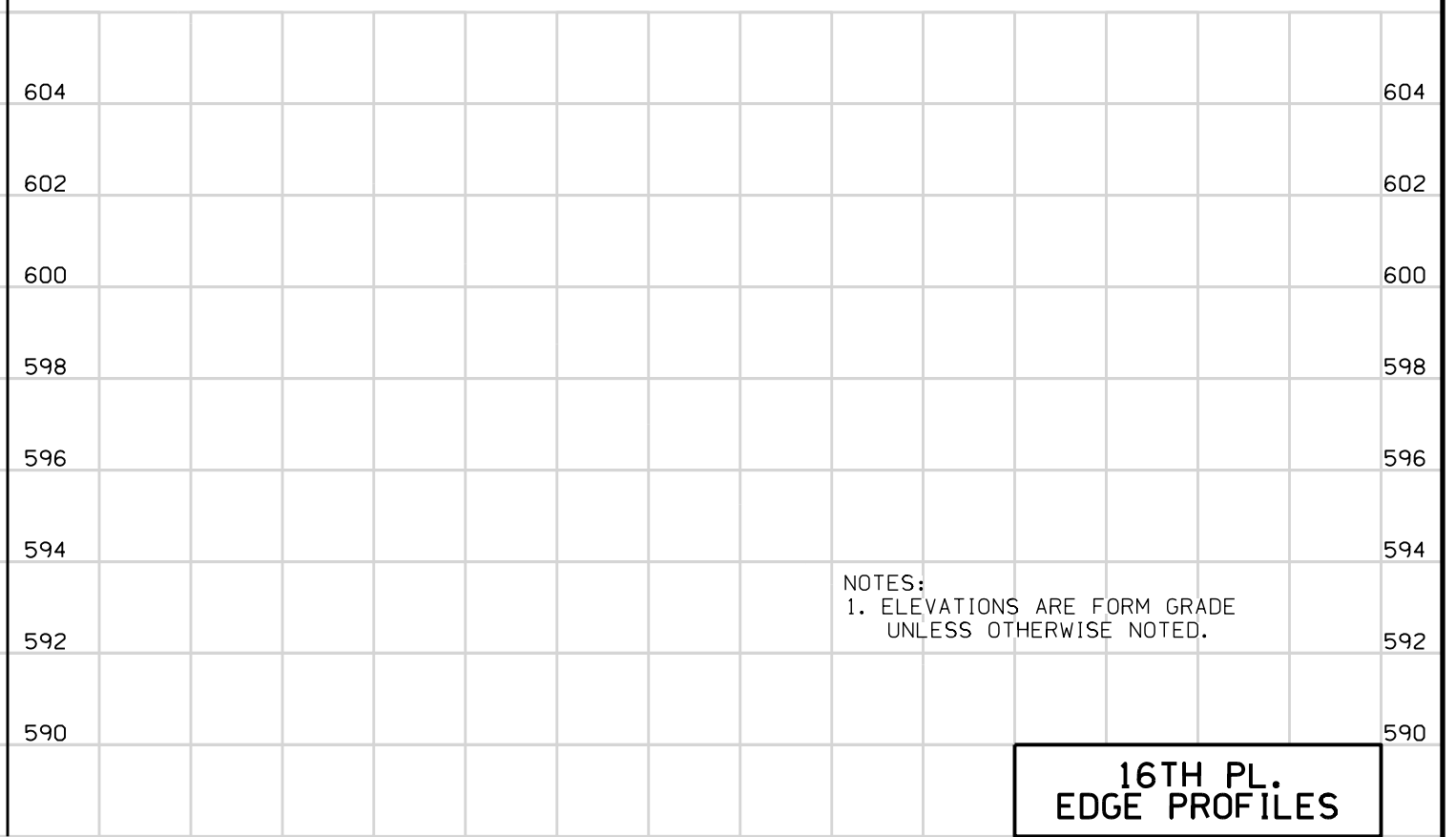

NOTES:  
1. ELEVATIONS ARE FORM GRADE  
UNLESS OTHERWISE NOTED.

**16TH PL.  
EDGE PROFILES**

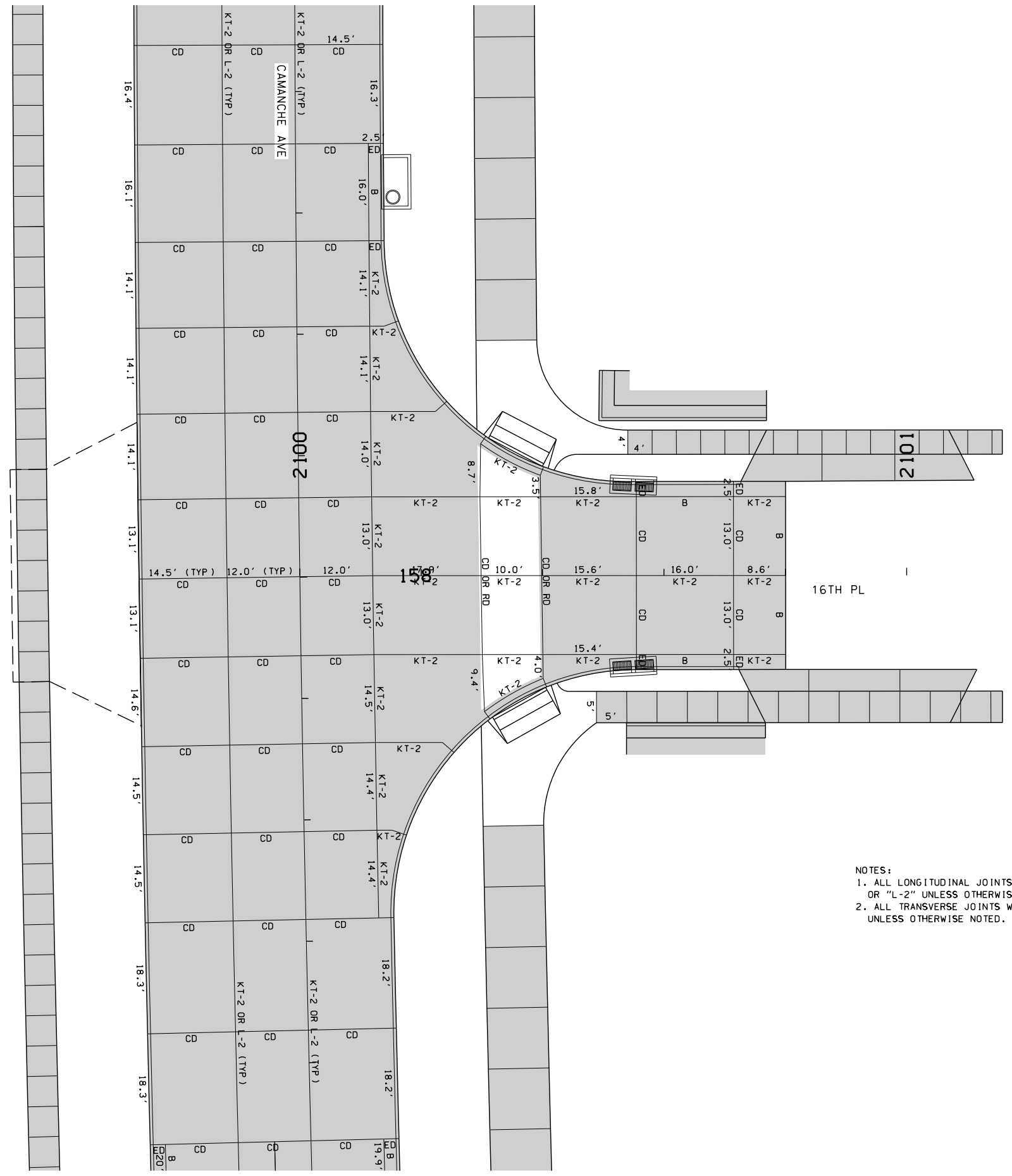
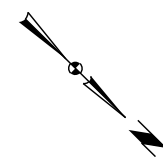
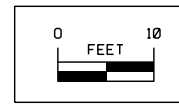

- NOTES:
1. ALL LONGITUDINAL JOINTS WILL BE "KT-2" OR "L-2" UNLESS OTHERWISE NOTED.
  2. ALL TRANSVERSE JOINTS WILL BE "CD" UNLESS OTHERWISE NOTED.

**16TH PLACE  
JOINTING**

Point	Station	Offset	Elevation	Description
L1345	2199+39.53	-26.50	600.48	SIDEWALK
L1346	2199+39.52	-31.50	600.58	SIDEWALK
L1347	2199+52.76	-21.50	600.27	FG BOTTOM OF PED RAMP
L1348	2199+58.76	-21.50	600.39	FG BOTTOM OF PED RAMP
L1349	165+49.50	26.50	600.63	FG BOTTOM OF PED RAMP
L1350	165+43.50	26.50	600.59	FG BOTTOM OF PED RAMP
L1351	165+33.51	41.50	601.63	SIDEWALK
L1352	165+33.49	46.50	601.73	SIDEWALK
L1353	165+59.51	36.39	600.49	FG END OF RADIUS
L1354	165+56.54	29.39	600.63	FG MIDPOINT OF RADIUS
L1355	165+49.50	26.50	600.63	FG END OF RADIUS
L1356	165+49.51	36.50	N/A	CENTER OF 10' RADIUS

Point	Station	Offset	Elevation	Description
L1300	165+26.36	-39.50	602.13	SIDEWALK
L1301	165+26.36	-29.50	601.93	SIDEWALK
L1302	165+41.89	-18.18	600.98	FG BOTTOM OF PED RAMP
L1303	165+47.13	-21.10	601.02	FG BOTTOM OF PED RAMP
L1304	165+57.76	-31.39	601.13	FG BOTTOM OF PED RAMP
L1305	165+62.47	-40.22	601.25	FG BOTTOM OF PED RAMP
L1306	165+65.03	-51.99	602.13	SIDEWALK
L1307	165+58.04	-52.49	602.27	SIDEWALK
L1308	2200+90.00	-13.85	603.89	BEGIN SIDEWALK/MATCH EXISTING
L1309	2200+90.00	-18.88	604.00	BEGIN SIDEWALK/MATCH EXISTING
L1310	165+25.11	-14.50	600.85	FG END OF RADIUS
L1311	165+25.36	-25.22	601.07	FG MIDPOINT OF RADIUS
L1312	165+65.01	-51.62	601.62	FG END OF RADIUS
L1313	165+25.11	-54.50	N/A	CENTER OF 40' RADIUS
L1314	165+67.64	-88.04	603.23	FG END TAPER
L1315	2200+90.00	-12.00	603.32	FG BEGIN PAVEMENT/MATCH EXISTING

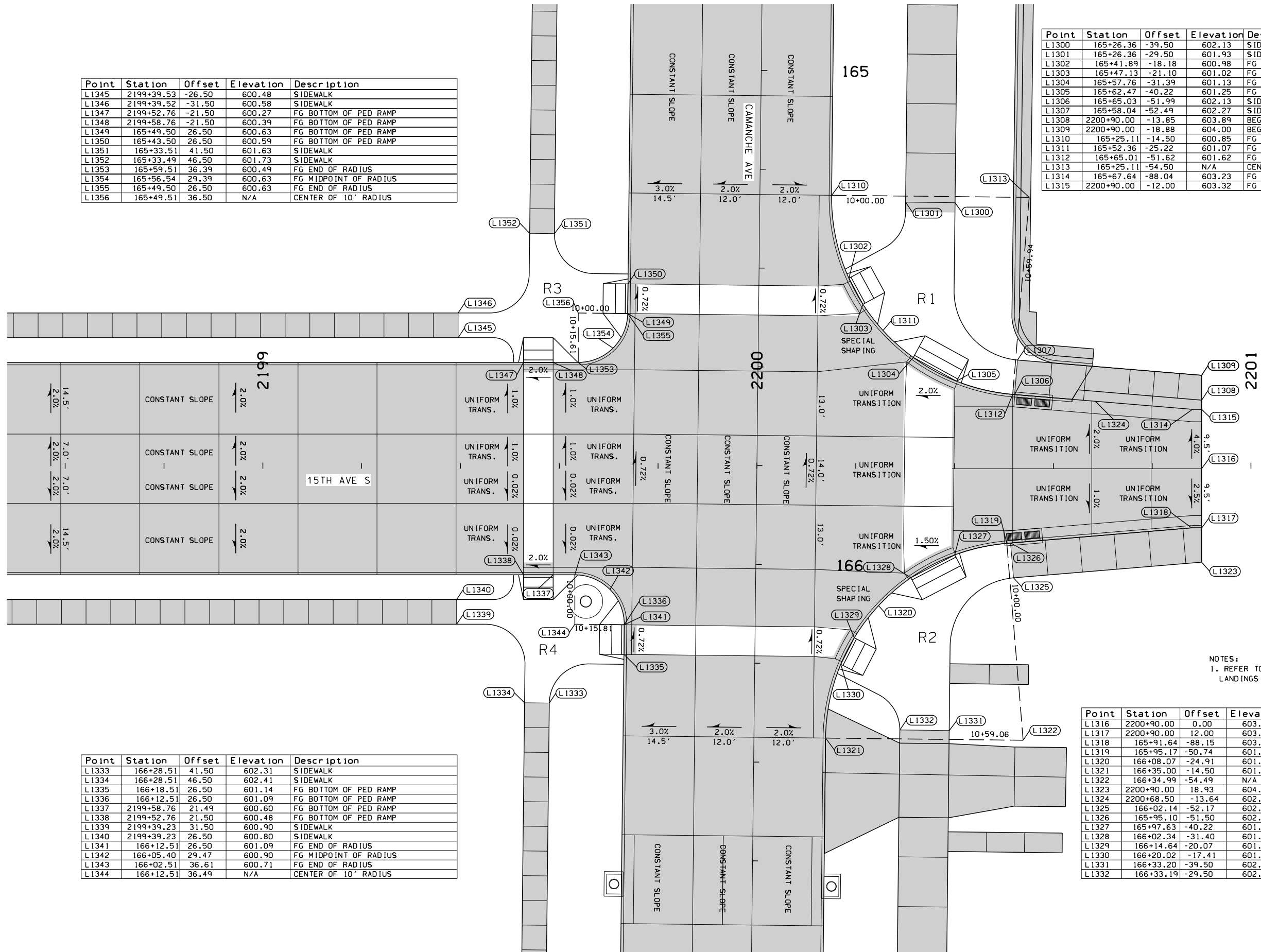
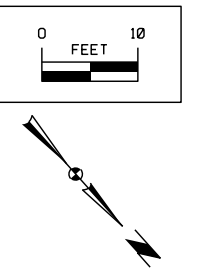

Point	Station	Offset	Elevation	Description
L1333	166+28.51	41.50	602.31	SIDEWALK
L1334	166+28.51	46.50	602.41	SIDEWALK
L1335	166+18.51	26.50	601.14	FG BOTTOM OF PED RAMP
L1336	166+12.51	26.50	601.09	FG BOTTOM OF PED RAMP
L1337	2199+58.76	21.49	600.60	FG BOTTOM OF PED RAMP
L1338	2199+52.76	21.50	600.48	FG BOTTOM OF PED RAMP
L1339	2199+39.23	31.50	600.90	SIDEWALK
L1340	2199+39.23	26.50	600.80	SIDEWALK
L1341	166+12.51	26.50	601.09	FG END OF RADIUS
L1342	166+05.40	29.47	600.90	FG MIDPOINT OF RADIUS
L1343	166+02.51	36.61	600.71	FG END OF RADIUS
L1344	166+12.51	36.49	N/A	CENTER OF 10' RADIUS

Point	Station	Offset	Elevation	Description
L1316	2200+90.00	0.00	603.80	BEGIN PAVEMENT/MATCH EXISTING
L1317	2200+90.00	12.00	603.50	FG BEGIN PAVEMENT/MATCH EXISTING
L1318	165+91.64	-88.15	603.39	FG BEGIN TAPER
L1319	165+95.17	-50.74	601.78	FG END OF RADIUS
L1320	166+08.07	-24.91	601.44	FG MIDPOINT OF RADIUS
L1321	166+35.00	-14.50	601.64	FG END OF RADIUS
L1322	166+34.99	-54.49	N/A	CENTER OF 40' RADIUS
L1323	2200+90.00	18.93	604.18	BEGIN SIDEWALK/MATCH EXISTING
L1324	2200+68.50	-13.64	602.75	BEGIN SIDEWALK/MATCH EXISTING
L1325	166+02.14	-52.17	602.43	SIDEWALK
L1326	165+95.10	-51.50	602.29	SIDEWALK
L1327	165+97.63	-40.22	601.40	FG BOTTOM OF PED RAMP
L1328	166+02.34	-31.40	601.38	FG BOTTOM OF PED RAMP
L1329	166+14.64	-20.07	601.49	FG BOTTOM OF PED RAMP
L1330	166+20.02	-17.41	601.53	FG BOTTOM OF PED RAMP
L1331	166+33.20	-39.50	602.92	SIDEWALK
L1332	166+33.19	-29.50	602.72	SIDEWALK

NOTES:  
1. REFER TO I SHEETS FOR LAYOUT OF LANDINGS AND PEDESTRIAN RAMPS.

15TH AVE. S  
STAKING

R1

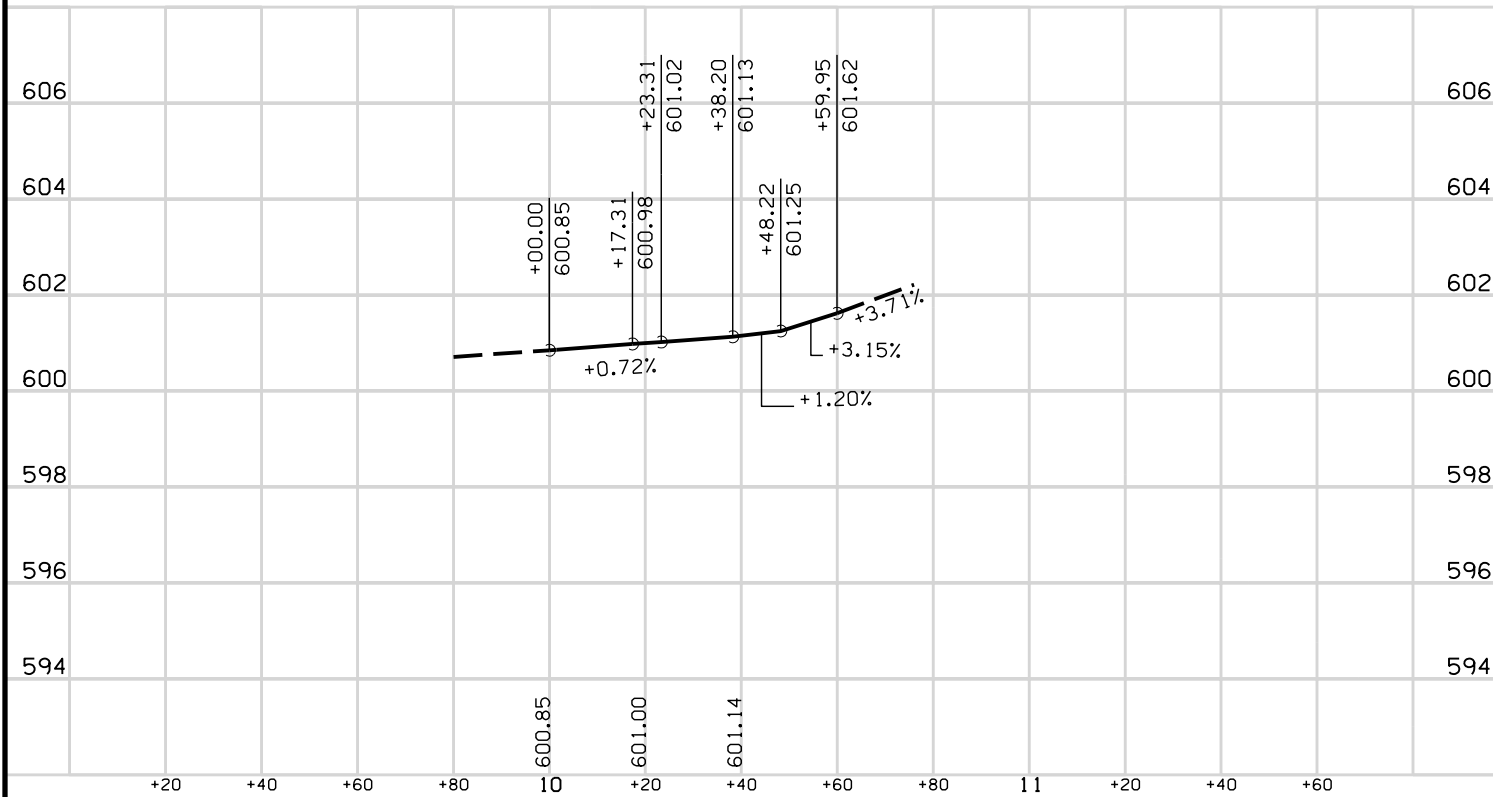

R2



R3

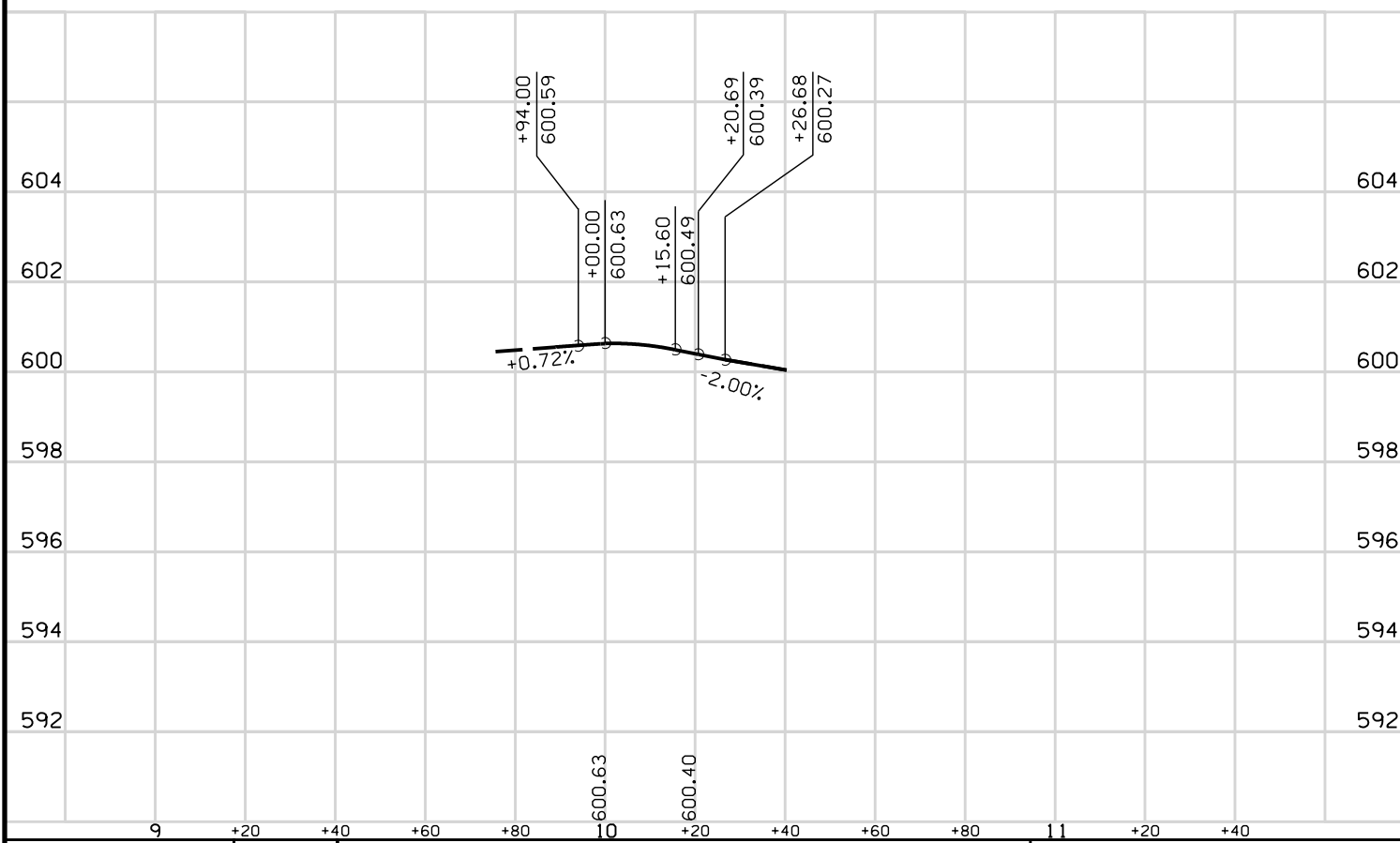

R4

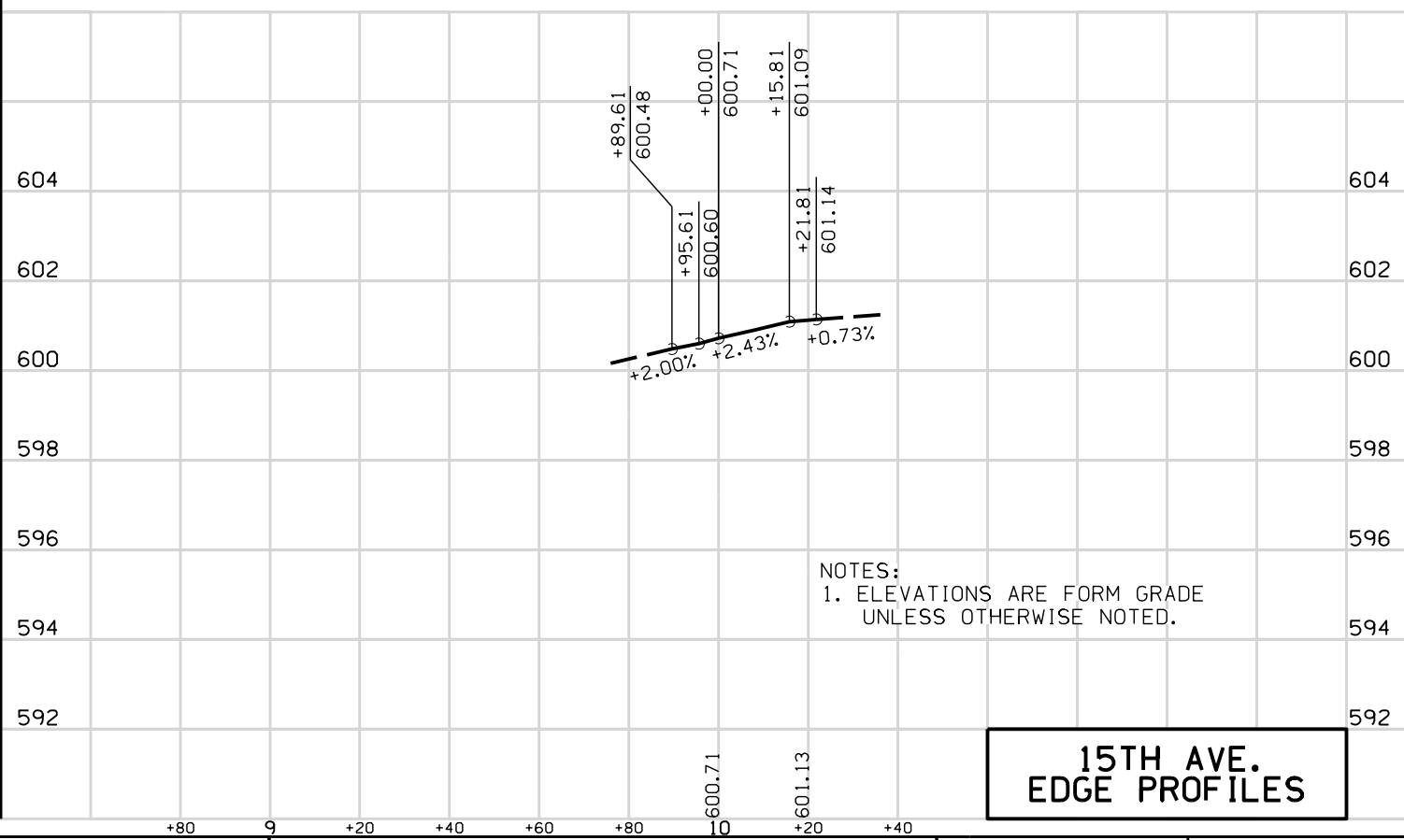

NOTES:  
1. ELEVATIONS ARE FORM GRADE  
UNLESS OTHERWISE NOTED.

15TH AVE.  
EDGE PROFILES



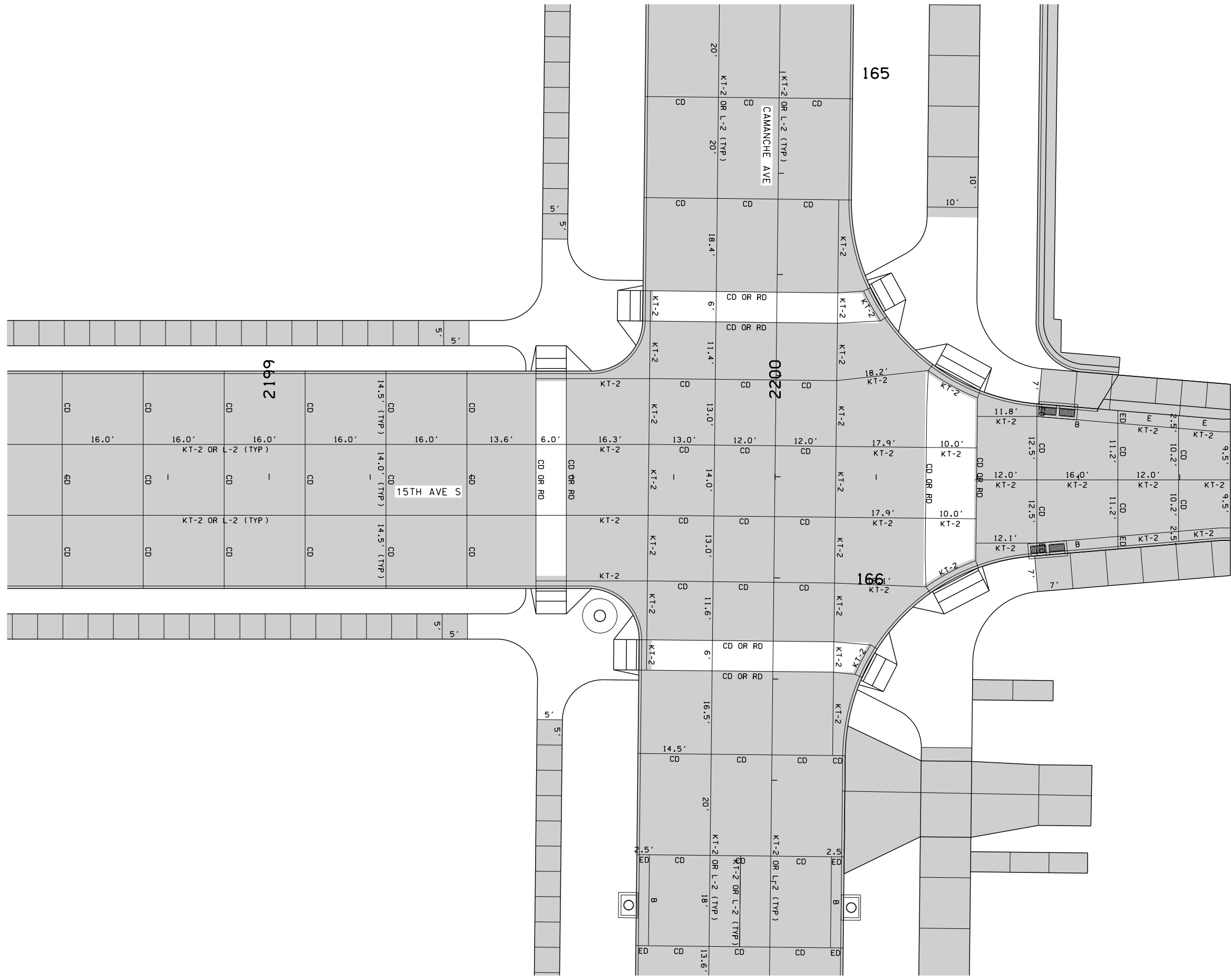
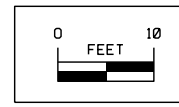

NOTES:  
 1. ALL LONGITUDINAL JOINTS WILL BE "KT-2" OR "L-2" UNLESS OTHERWISE NOTED.  
 2. ALL TRANSVERSE JOINTS WILL BE "CD" UNLESS OTHERWISE NOTED.

15TH AVE. S  
 JOINTING

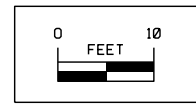

Point	Station	Offset	Elevation	Description
L1400	168+90.35	-39.50	602.62	SIDEWALK
L1401	168+90.35	-29.50	602.42	SIDEWALK
L1402	169+07.16	-31.40	601.49	FG BOTTOM OF PED RAMP
L1403	169+11.86	-40.22	601.57	FG BOTTOM OF PED RAMP
L1404	169+08.35	-51.54	602.56	SIDEWALK
L1405	169+02.35	-51.50	602.66	SIDEWALK
L1406	2300+90.00	-21.98	604.27	BEGIN SIDEWALK/MATCH EXISTING
L1407	2300+89.99	-27.98	604.32	BEGIN SIDEWALK/MATCH EXISTING
L1408	168+74.50	-14.50	601.69	FG END OF RADIUS
L1409	169+02.76	-26.19	601.53	FG MIDPOINT OF RADIUS
L1410	169+14.50	-54.43	601.83	FG END OF RADIUS
L1411	168+74.50	-54.50	N/A	CENTER OF 40' RADIUS
L1412	2300+90.00	-15.50	602.84	FG BEGIN PAVEMENT/MATCH EXISTING
L1413	2300+90.00	0.00	603.78	BEGIN PAVEMENT/MATCH EXISTING
L1414	2300+90.00	15.50	602.75	FG BEGIN PAVEMENT/MATCH EXISTING
L1415	169+45.50	-54.57	601.94	FG END OF RADIUS
L1416	169+57.20	-26.24	601.38	FG MIDPOINT OF RADIUS
L1417	169+85.50	-14.50	601.25	FG END OF RADIUS
L1418	169+85.50	-54.50	N/A	CENTER OF 40' RADIUS
L1419	2300+90.00	26.50	603.91	BEGIN SIDEWALK/MATCH EXISTING
L1420	2300+90.00	21.50	603.75	BEGIN SIDEWALK/MATCH EXISTING
L1421	169+56.56	-53.49	602.55	SIDEWALK
L1422	169+51.56	-53.48	602.45	SIDEWALK
L1423	169+48.14	-40.22	601.52	FG BOTTOM OF PED RAMP
L1424	169+52.85	-31.40	601.40	FG BOTTOM OF PED RAMP
L1425	169+70.56	-39.50	602.47	SIDEWALK
L1426	169+70.56	-29.50	602.27	SIDEWALK

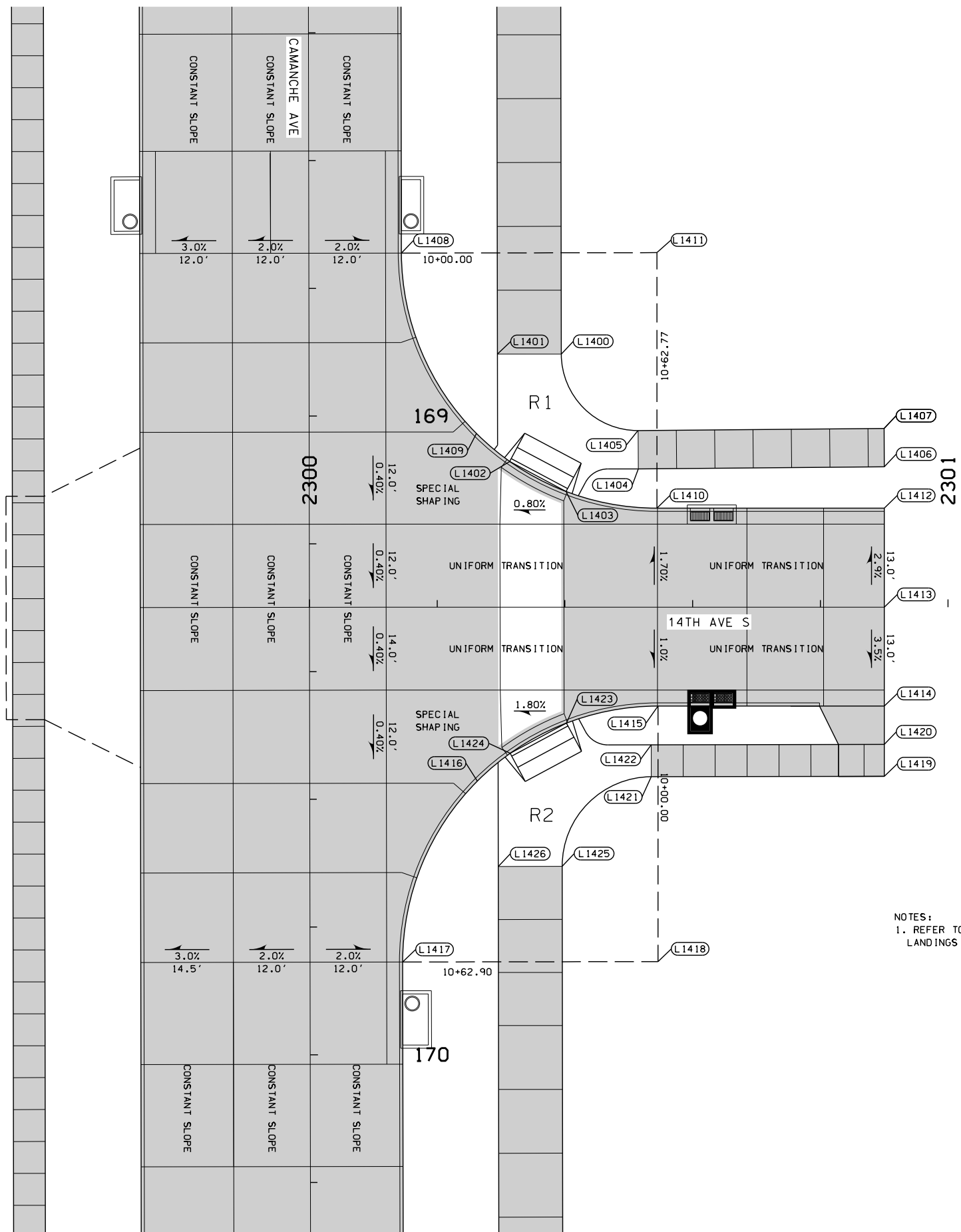

NOTES:  
 1. REFER TO I SHEETS FOR LAYOUT OF LANDINGS AND PEDESTRIAN RAMPS.

14TH AVE. S  
 STAKING

R1

R2

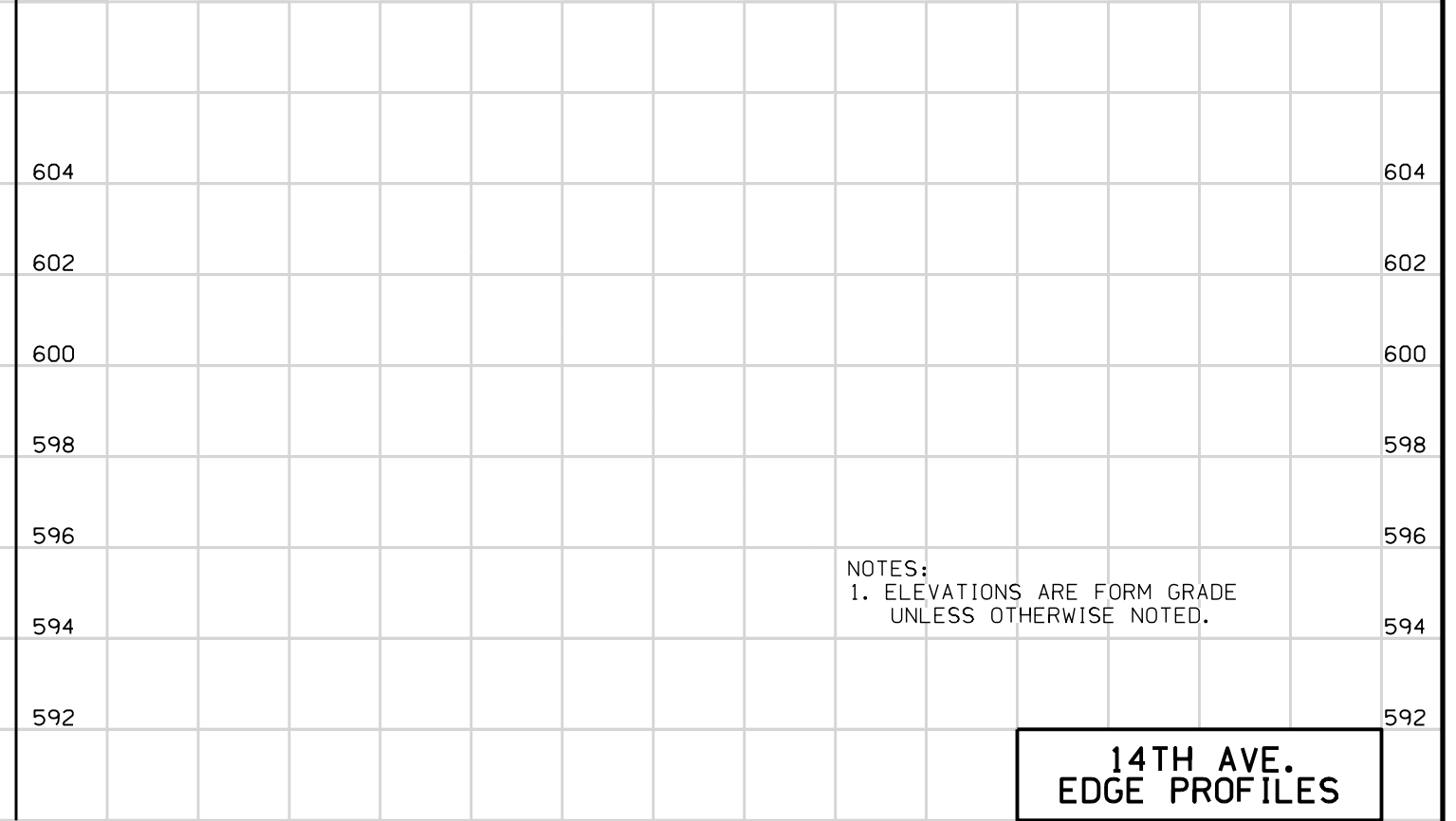
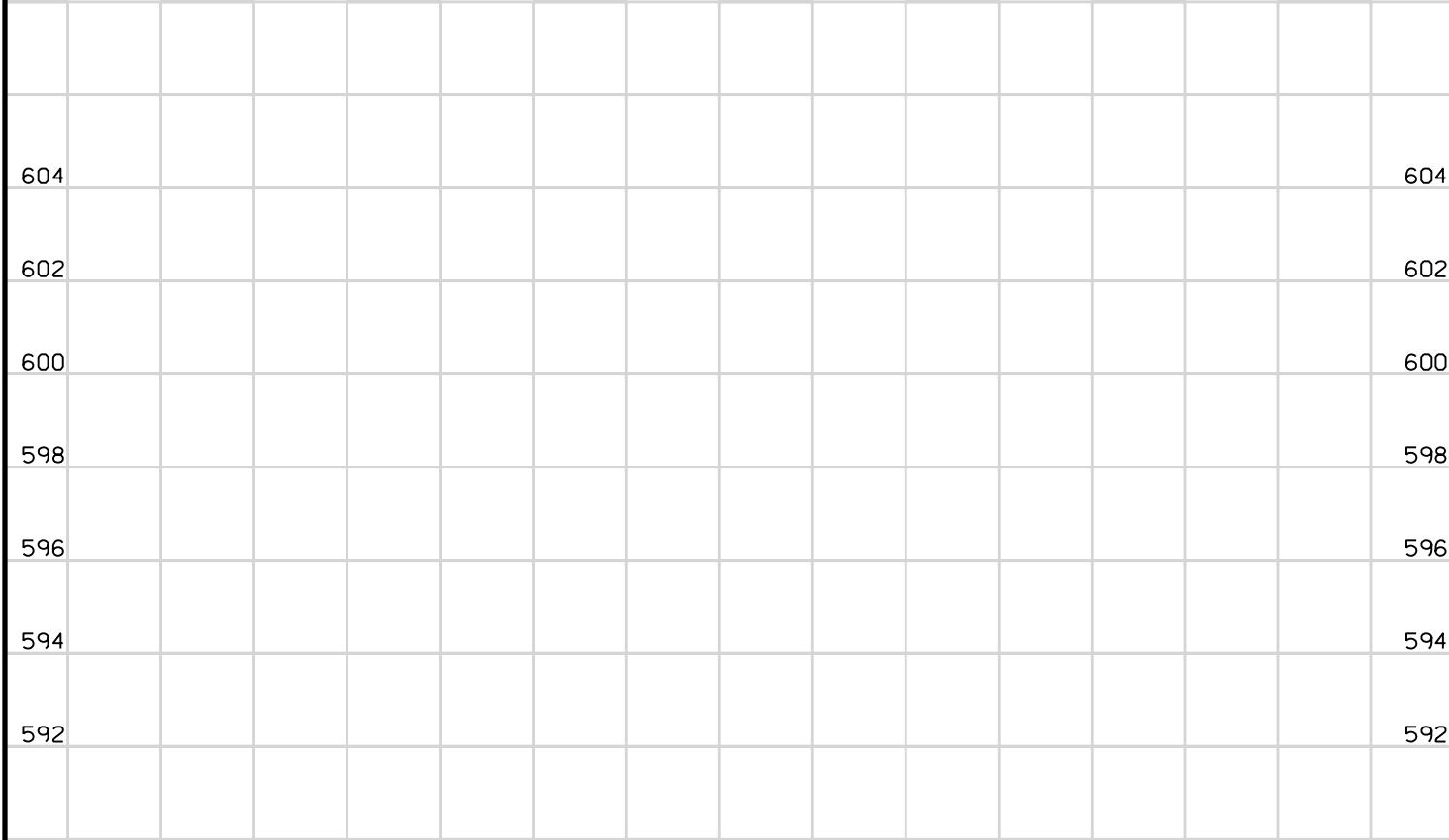
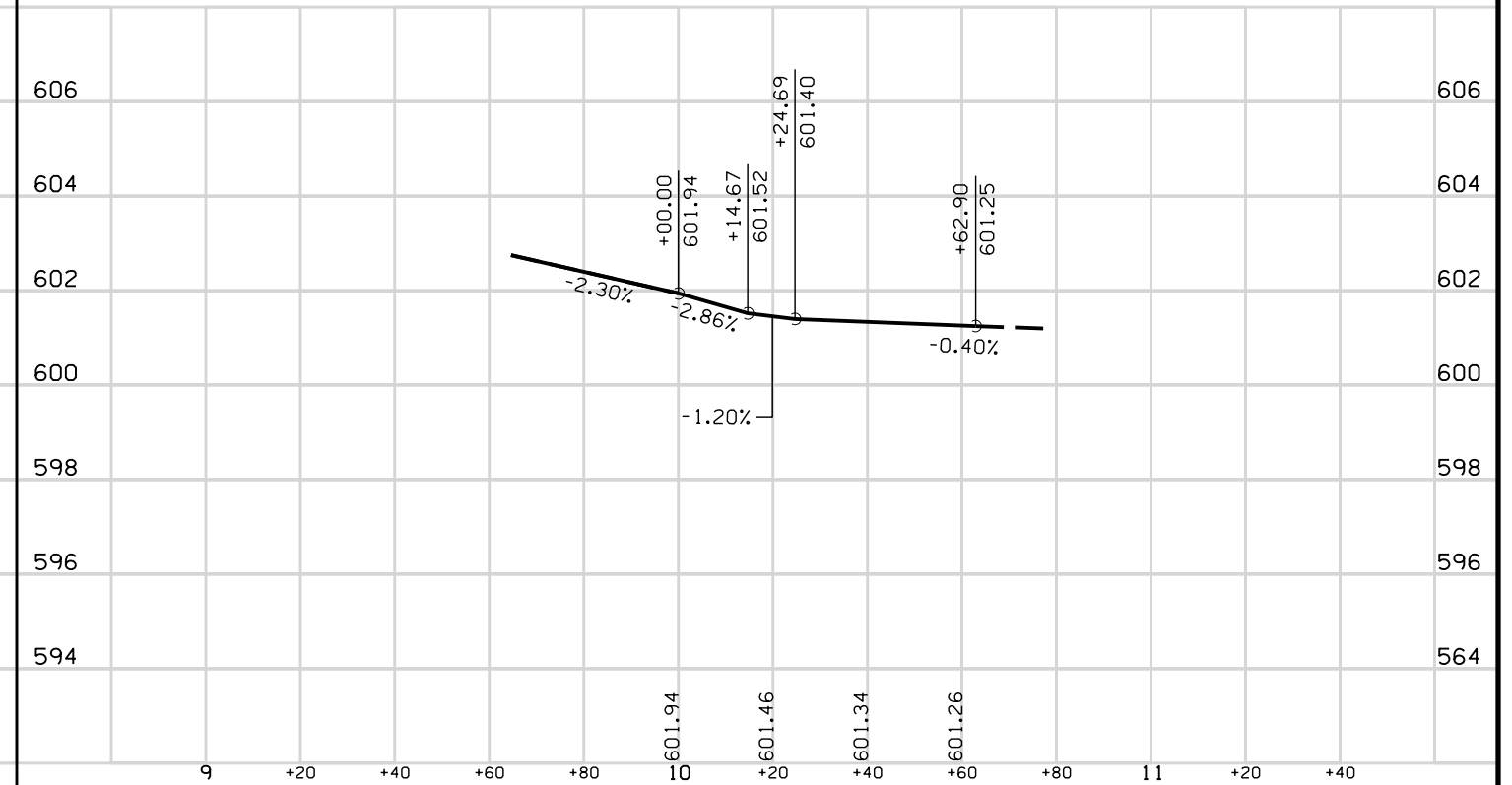
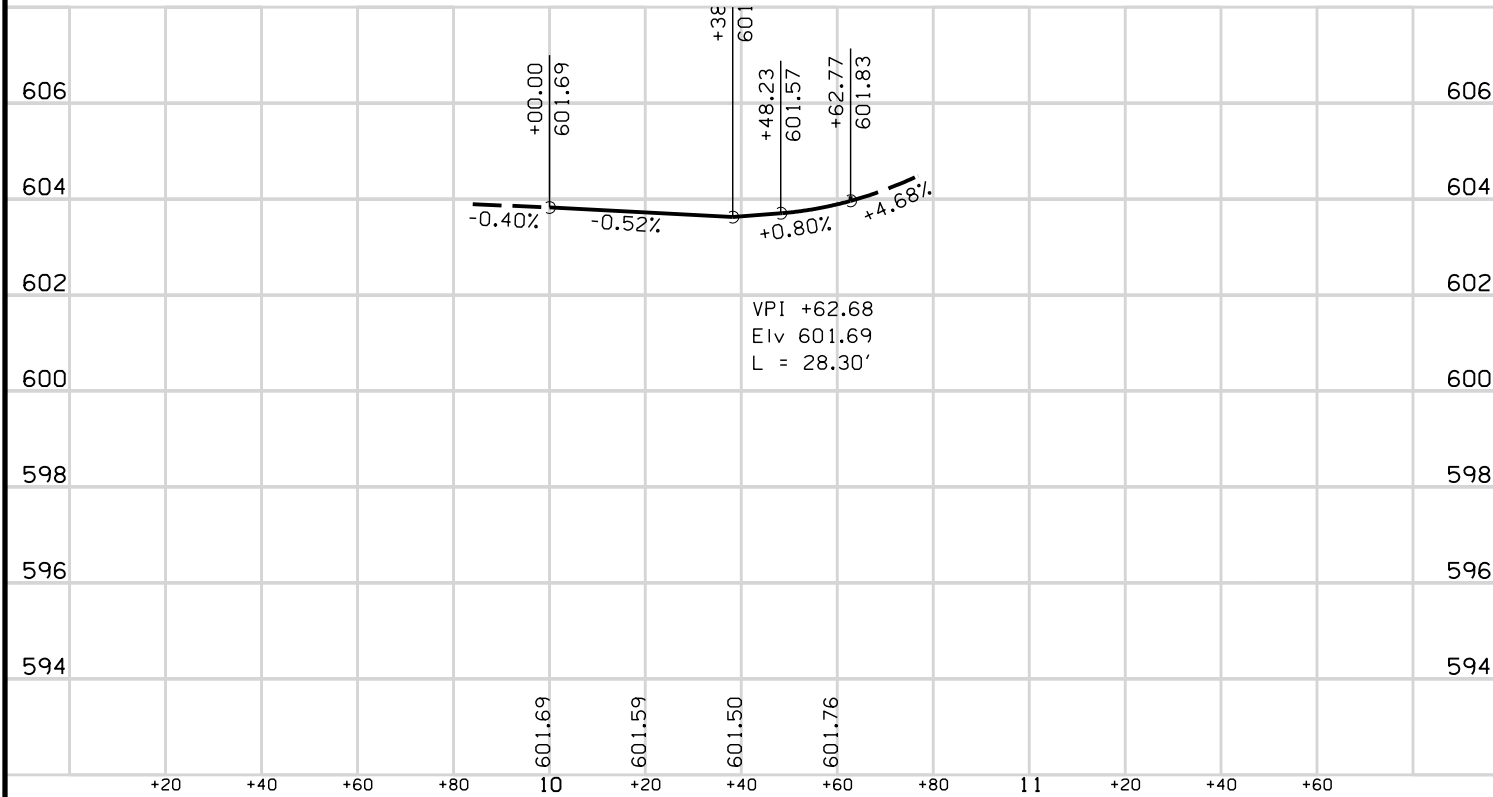

NOTES:  
1. ELEVATIONS ARE FORM GRADE  
UNLESS OTHERWISE NOTED.

**14TH AVE.  
EDGE PROFILES**

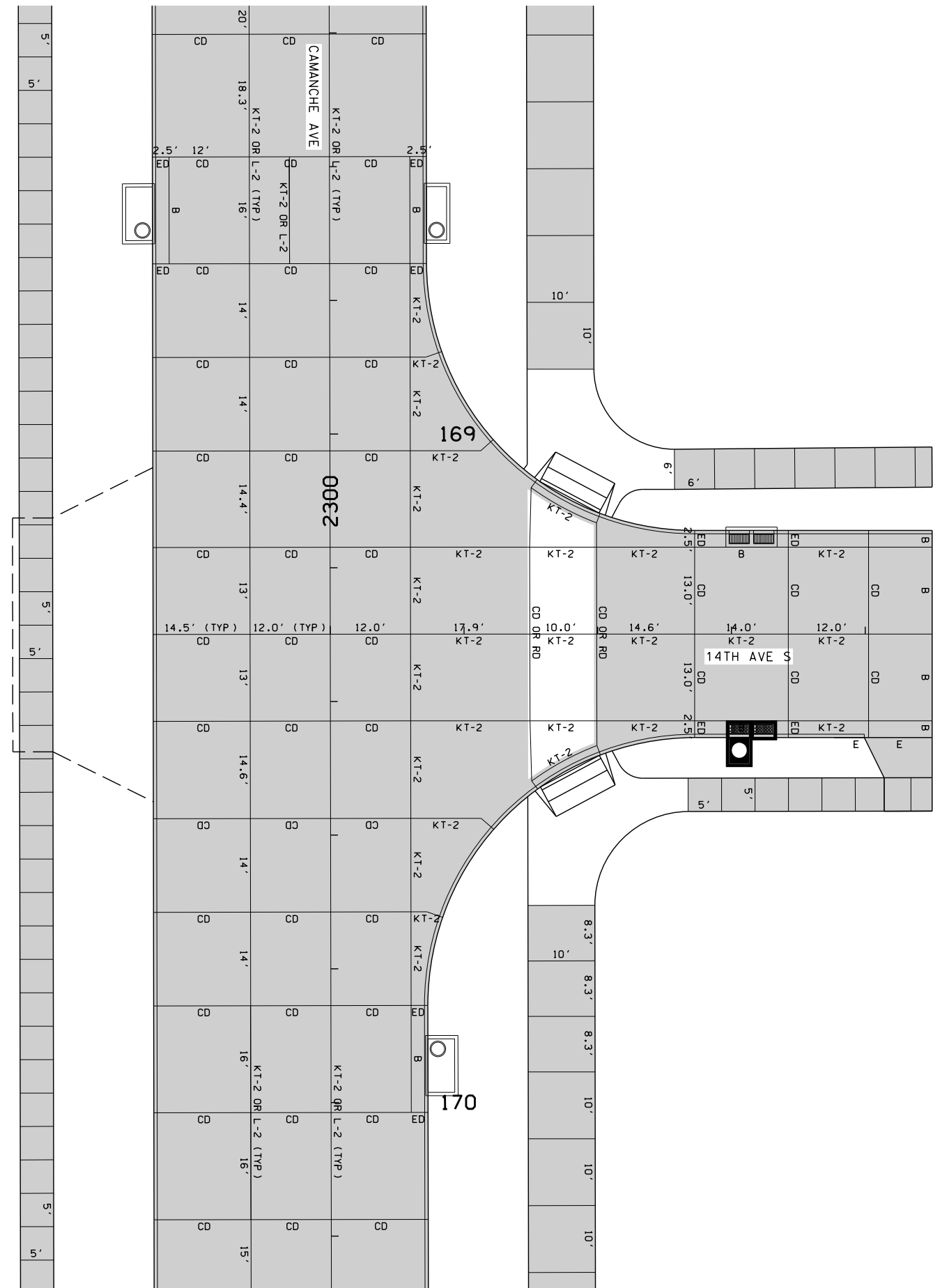
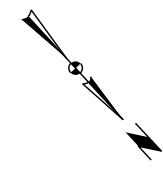
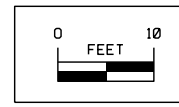

- NOTES:
1. ALL LONGITUDINAL JOINTS WILL BE "KT-2" OR "L-2" UNLESS OTHERWISE NOTED.
  2. ALL TRANSVERSE JOINTS WILL BE "CD" UNLESS OTHERWISE NOTED.

**14TH AVE. S  
JOINTING**

Point	Station	Offset	Elevation	Description
L1546	2398+75.00	-7.00	598.41	BEGIN PAVEMENT/MATCH EXISTING
L1547	2398+75.00	-21.50	598.12	FG BEGIN PAVEMENT/MATCH EXISTING
L1548	2399+00.00	-26.50	599.68	BEGIN SIDEWALK/MATCH EXISTING
L1549	2399+00.00	-31.50	599.78	BEGIN SIDEWALK/MATCH EXISTING
L1550	2399+39.56	-26.50	601.16	SIDEWALK
L1551	2399+39.55	-31.49	601.26	SIDEWALK
L1552	2399+53.03	-21.50	601.12	FG BOTTOM OF PED RAMP
L1553	2399+59.03	-21.50	601.24	FG BOTTOM OF PED RAMP
L1554	174+65.80	26.50	602.00	FG BOTTOM OF PED RAMP
L1555	174+59.80	26.50	602.03	FG BOTTOM OF PED RAMP
L1556	174+49.79	41.50	603.17	SIDEWALK
L1557	174+49.79	46.50	603.27	SIDEWALK
L1558	174+77.38	36.51	601.43	FG END OF RADIUS
L1559	174+74.45	29.43	601.71	FG MIDPOINT OF RADIUS
L1560	174+67.38	26.50	601.99	FG END OF RADIUS
L1561	174+67.38	36.50	N/A	CENTER OF 10' RADIUS

Point	Station	Offset	Elevation	Description
L1500	174+45.29	-39.50	603.18	SIDEWALK
L1501	174+45.30	-29.50	603.38	SIDEWALK
L1502	174+58.59	-18.59	602.43	FG BOTTOM OF PED RAMP
L1503	174+63.77	-21.63	602.40	FG BOTTOM OF PED RAMP
L1504	174+73.63	-31.40	602.36	FG BOTTOM OF PED RAMP
L1505	174+78.34	-40.22	602.45	FG BOTTOM OF PED RAMP
L1506	174+80.90	-52.05	603.11	SIDEWALK
L1507	174+73.01	-52.53	603.43	SIDEWALK
L1508	2400+90.00	-18.00	603.67	FG BEGIN PAVEMENT/MATCH EXISTING
L1509	2400+90.00	-23.40	604.29	BEGIN SIDEWALK/MATCH EXISTING
L1510	174+40.98	-14.50	602.50	FG END OF RADIUS
L1511	174+69.25	-26.21	602.37	FG MIDPOINT OF RADIUS
L1512	174+80.98	-54.46	602.73	FG END OF RADIUS
L1513	174+40.98	-54.50	N/A	CENTER OF 40' RADIUS
L1514	2400+90.00	-7.04	604.05	BEGIN PAVEMENT/MATCH EXISTING

Point	Station	Offset	Elevation	Description
L1530	175+47.87	46.50	602.81	SIDEWALK
L1531	175+47.87	41.50	602.71	SIDEWALK
L1532	175+37.86	26.51	601.66	FG BOTTOM OF PED RAMP
L1533	175+31.86	26.50	601.69	FG BOTTOM OF PED RAMP
L1534	2399+59.03	21.50	601.24	FG BOTTOM OF PED RAMP
L1535	2399+53.03	21.51	601.12	FG BOTTOM OF PED RAMP
L1536	2399+39.68	31.50	600.69	SIDEWALK
L1537	2399+39.68	26.50	601.16	SIDEWALK
L1538	2399+00.00	31.50	599.89	BEGIN SIDEWALK/MATCH EXISTING
L1539	2399+00.00	26.50	599.79	BEGIN SIDEWALK/MATCH EXISTING
L1540	175+30.38	26.50	601.69	FG END OF RADIUS
L1541	175+23.31	29.42	601.63	FG MIDPOINT OF RADIUS
L1542	175+20.38	36.49	601.38	FG END OF RADIUS
L1543	175+30.38	36.50	N/A	CENTER OF 10' RADIUS
L1544	2398+75.00	21.50	598.12	FG BEGIN PAVEMENT/MATCH EXISTING
L1545	2398+75.00	7.00	598.41	BEGIN PAVEMENT/MATCH EXISTING

Point	Station	Offset	Elevation	Description
L1515	2400+90.00	6.96	604.01	BEGIN PAVEMENT/MATCH EXISTING
L1516	2400+90.00	18.00	603.56	FG BEGIN PAVEMENT/MATCH EXISTING
L1517	2400+90.00	23.49	604.18	BEGIN SIDEWALK/MATCH EXISTING
L1518	175+17.05	-52.16	602.97	SIDEWALK
L1519	175+24.88	-52.62	603.28	SIDEWALK
L1520	175+19.61	-40.22	602.21	FG BOTTOM OF PED RAMP
L1521	175+24.32	-31.40	602.13	FG BOTTOM OF PED RAMP
L1522	175+33.92	-21.81	602.07	FG BOTTOM OF PED RAMP
L1523	175+39.07	-18.74	602.04	FG BOTTOM OF PED RAMP
L1524	175+52.39	-29.50	603.06	SIDEWALK
L1525	175+52.39	-39.50	603.26	SIDEWALK
L1526	175+16.98	-54.54	602.53	FG END OF RADIUS
L1527	175+28.68	-26.23	602.10	FG MIDPOINT OF RADIUS
L1528	175+56.98	-14.50	601.95	FG END OF RADIUS
L1529	175+56.98	-54.50	N/A	CENTER OF 40' RADIUS

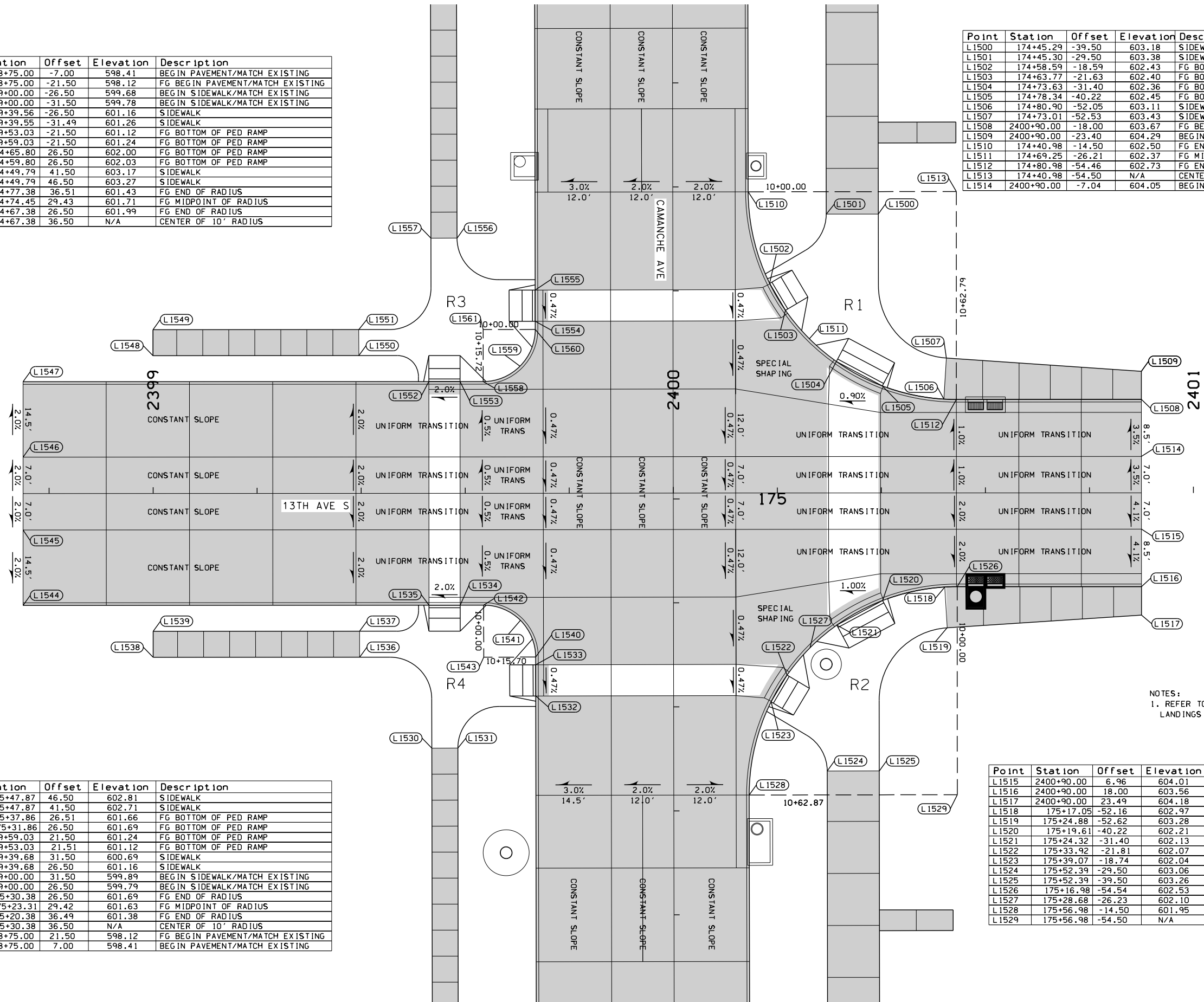
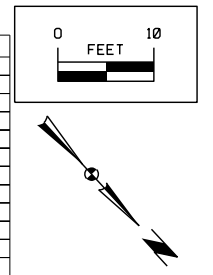

NOTES:  
1. REFER TO I SHEETS FOR LAYOUT OF LANDINGS AND PEDESTRIAN RAMPS.

**13TH AVE. S  
STAKING**

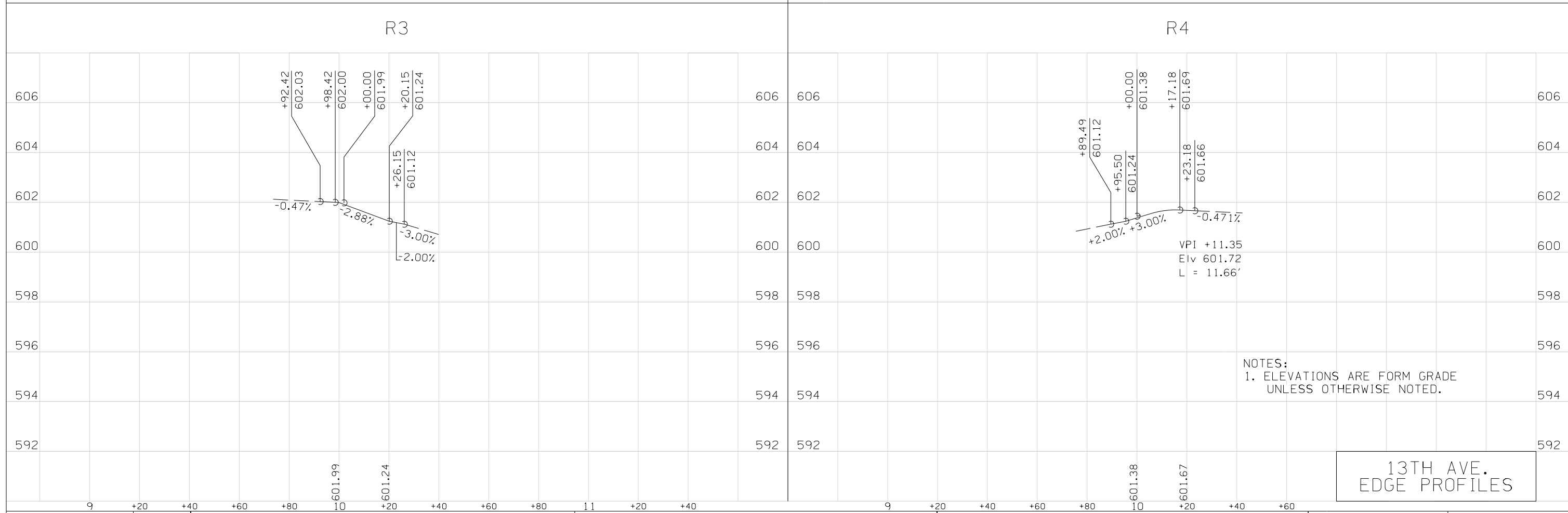
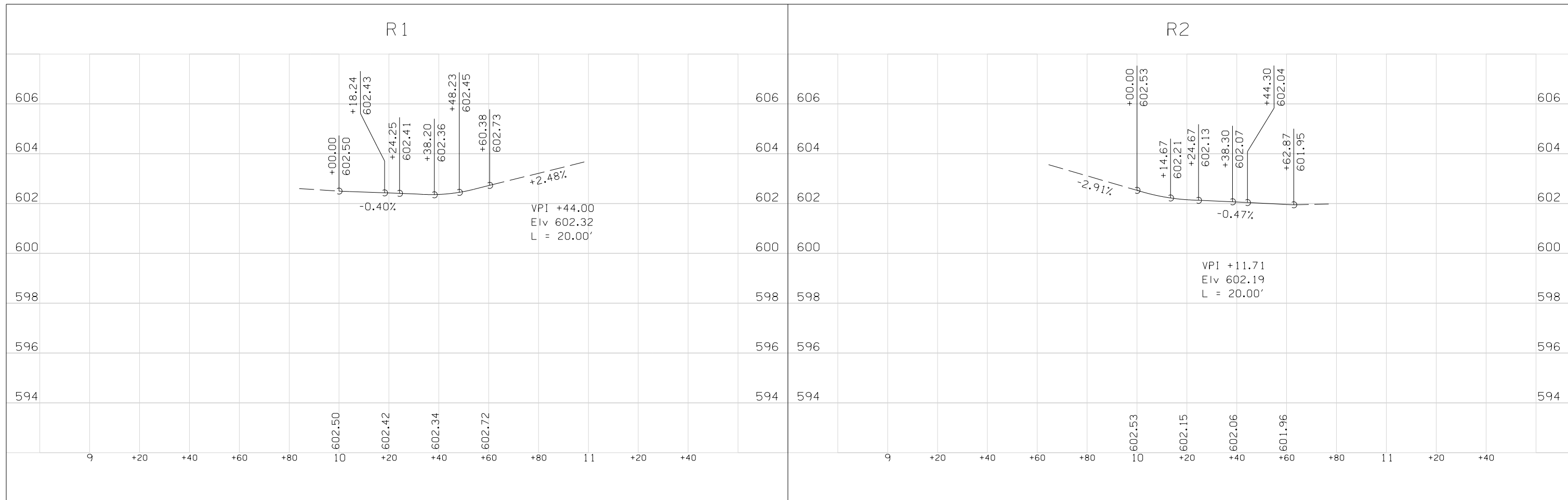

NOTES:  
1. ELEVATIONS ARE FORM GRADE  
UNLESS OTHERWISE NOTED.

13TH AVE.  
EDGE PROFILES

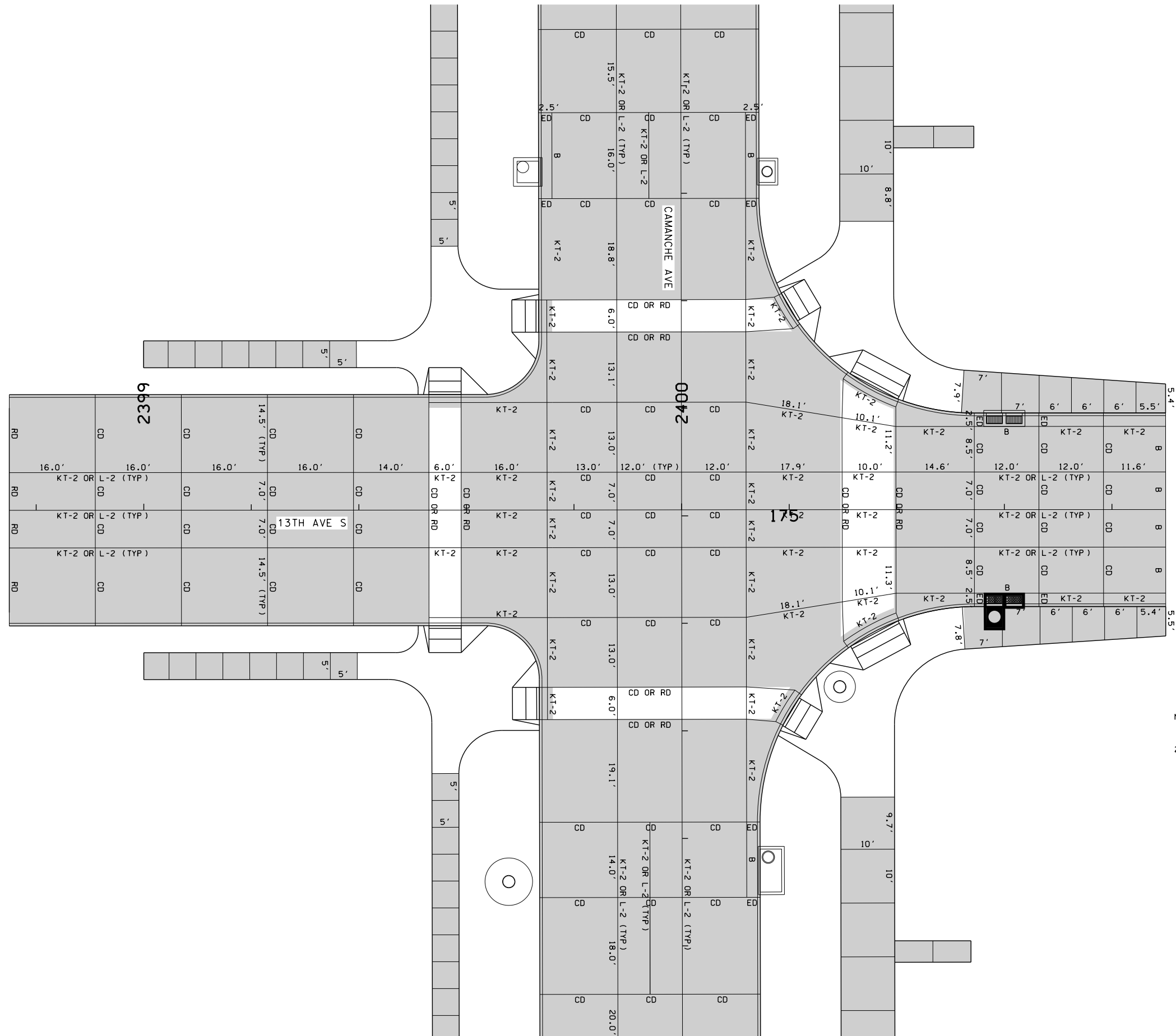
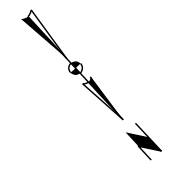
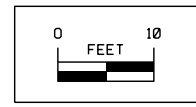

NOTES:  
 1. ALL LONGITUDINAL JOINTS WILL BE "KT-2" OR "L-2" UNLESS OTHERWISE NOTED.  
 2. ALL TRANSVERSE JOINTS WILL BE "CD" UNLESS OTHERWISE NOTED.

**13TH AVE. S  
 JOINTING**

Point	Station	Offset	Elevation	Description
L1631	181+17.30	41.50	600.04	SIDEWALK
L1632	181+17.30	46.50	600.14	SIDEWALK
L1633	181+07.30	26.50	598.98	FG BOTTOM OF PED RAMP
L1634	181+01.31	26.50	599.01	FG BOTTOM OF PED RAMP
L1635	2499+59.02	21.50	598.46	FG BOTTOM OF PED RAMP
L1636	2499+53.01	21.50	598.34	FG BOTTOM OF PED RAMP
L1637	2499+39.65	31.49	598.55	BEGIN SIDEWALK/MATCH EXISTING
L1638	2499+39.65	26.50	598.45	BEGIN SIDEWALK/MATCH EXISTING
L1639	181+01.30	26.50	599.01	FG END OF RADIUS
L1640	180+94.23	29.43	598.79	FG MIDPOINT OF RADIUS
L1641	180+91.30	36.49	598.58	FG END OF RADIUS
L1642	181+01.30	36.50	N/A	CENTER OF 10' RADIUS
L1643	2499+38.50	21.50	597.81	FG BEGIN PAVEMENT/MATCH EXISTING
L1644	2499+38.50	7.00	598.10	BEGIN PAVEMENT/MATCH EXISTING
L1645	2499+38.50	-7.00	598.10	BEGIN PAVEMENT/MATCH EXISTING
L1646	2499+38.50	-21.50	597.81	FG BEGIN PAVEMENT/MATCH EXISTING
L1647	2499+39.56	-26.50	598.55	BEGIN SIDEWALK/MATCH EXISTING
L1648	2499+39.56	-31.50	598.65	BEGIN SIDEWALK/MATCH EXISTING
L1649	2499+53.02	-21.50	598.40	FG BOTTOM OF PED RAMP
L1650	2499+59.02	-21.51	598.52	FG BOTTOM OF PED RAMP
L1651	180+38.30	26.50	599.30	FG BOTTOM OF PED RAMP
L1652	180+32.30	26.50	599.33	FG BOTTOM OF PED RAMP
L1653	180+22.41	41.49	600.48	SIDEWALK
L1654	180+22.27	46.50	600.58	SIDEWALK
L1655	180+48.30	36.51	598.69	FG END OF RADIUS
L1656	180+45.38	29.43	599.00	FG MIDPOINT OF RADIUS
L1657	180+38.30	26.50	599.30	FG END OF RADIUS
L1658	180+38.30	36.49	N/A	CENTER OF 10' RADIUS

Point	Station	Offset	Elevation	Description
L1600	180+17.90	-39.50	600.76	SIDEWALK
L1601	180+17.89	-29.50	600.58	SIDEWALK
L1602	180+31.13	-17.74	599.73	FG BOTTOM OF PED RAMP
L1603	180+36.45	-20.50	599.70	FG BOTTOM OF PED RAMP
L1604	180+48.03	-31.40	599.50	FG BOTTOM OF PED RAMP
L1605	180+52.73	-40.22	599.60	FG BOTTOM OF PED RAMP
L1606	180+52.43	-53.48	600.54	SIDEWALK
L1607	180+47.41	-53.49	600.64	SIDEWALK
L1608	2501+40.00	-17.45	605.12	BEGIN SIDEWALK/MATCH EXISTING
L1609	2501+40.00	-22.45	605.12	BEGIN SIDEWALK/MATCH EXISTING
L1610	180+15.37	-14.50	599.80	FG END OF RADIUS
L1611	180+43.65	-26.20	599.54	FG MIDPOINT OF RADIUS
L1612	180+55.37	-54.47	600.02	FG END OF RADIUS
L1613	180+15.37	-54.50	N/A	CENTER OF 40' RADIUS
L1614	2501+40.00	-14.50	604.08	FG BEGIN PAVEMENT/MATCH EXISTING
L1615	2501+40.00	0.00	605.03	BEGIN PAVEMENT/MATCH EXISTING

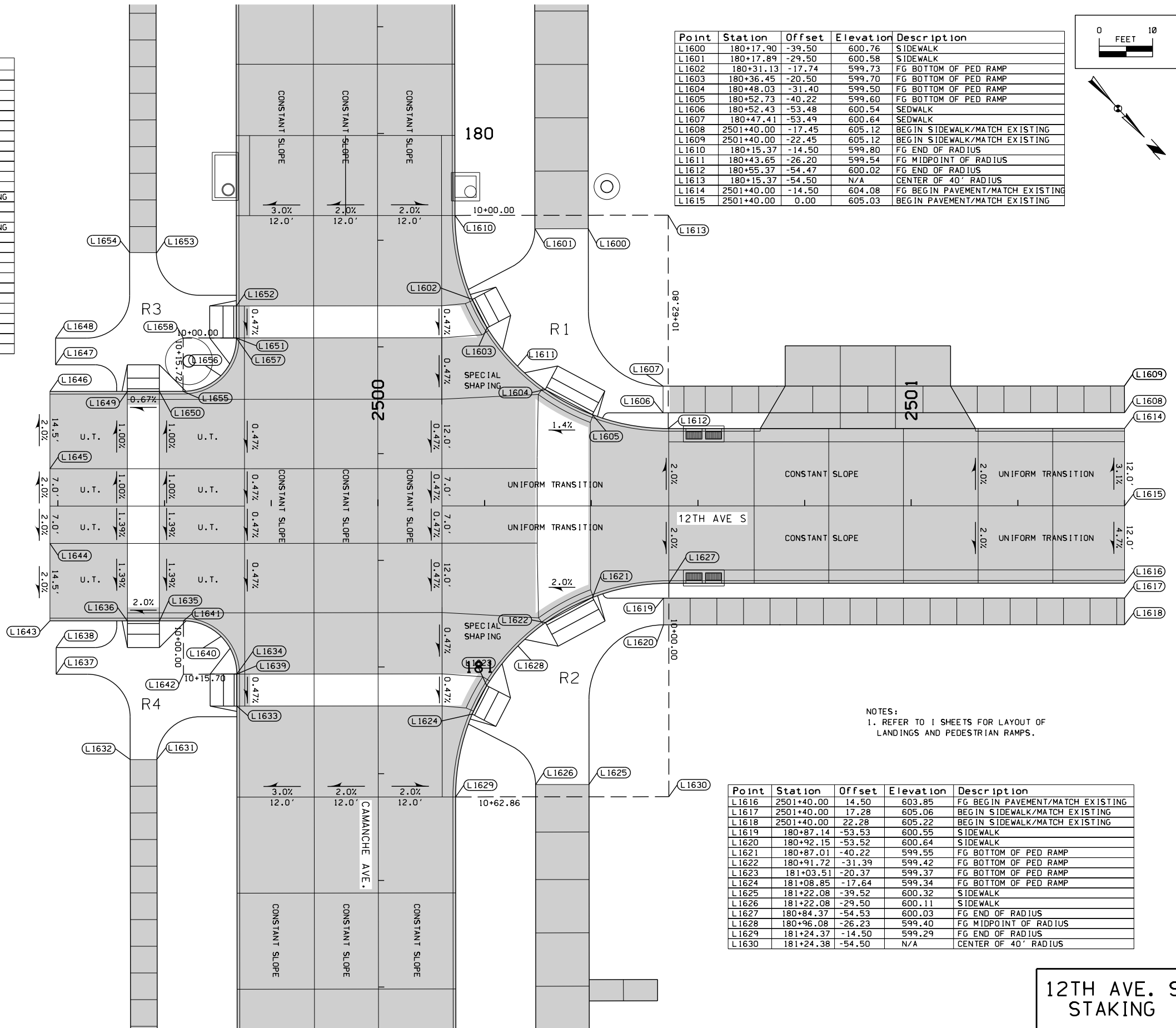
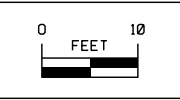

NOTES:  
1. REFER TO I SHEETS FOR LAYOUT OF LANDINGS AND PEDESTRIAN RAMPS.

Point	Station	Offset	Elevation	Description
L1616	2501+40.00	14.50	603.85	FG BEGIN PAVEMENT/MATCH EXISTING
L1617	2501+40.00	17.28	605.06	BEGIN SIDEWALK/MATCH EXISTING
L1618	2501+40.00	22.28	605.22	BEGIN SIDEWALK/MATCH EXISTING
L1619	180+87.14	-53.53	600.55	SIDEWALK
L1620	180+92.15	-53.52	600.64	SIDEWALK
L1621	180+87.01	-40.22	599.55	FG BOTTOM OF PED RAMP
L1622	180+91.72	-31.39	599.42	FG BOTTOM OF PED RAMP
L1623	181+03.51	-20.37	599.37	FG BOTTOM OF PED RAMP
L1624	181+08.85	-17.64	599.34	FG BOTTOM OF PED RAMP
L1625	181+22.08	-39.52	600.32	SIDEWALK
L1626	181+22.08	-29.50	600.11	SIDEWALK
L1627	180+84.37	-54.53	600.03	FG END OF RADIUS
L1628	180+96.08	-26.23	599.40	FG MIDPOINT OF RADIUS
L1629	181+24.37	-14.50	599.29	FG END OF RADIUS
L1630	181+24.38	-54.50	N/A	CENTER OF 40' RADIUS

12TH AVE. S  
STAKING



R1

R2

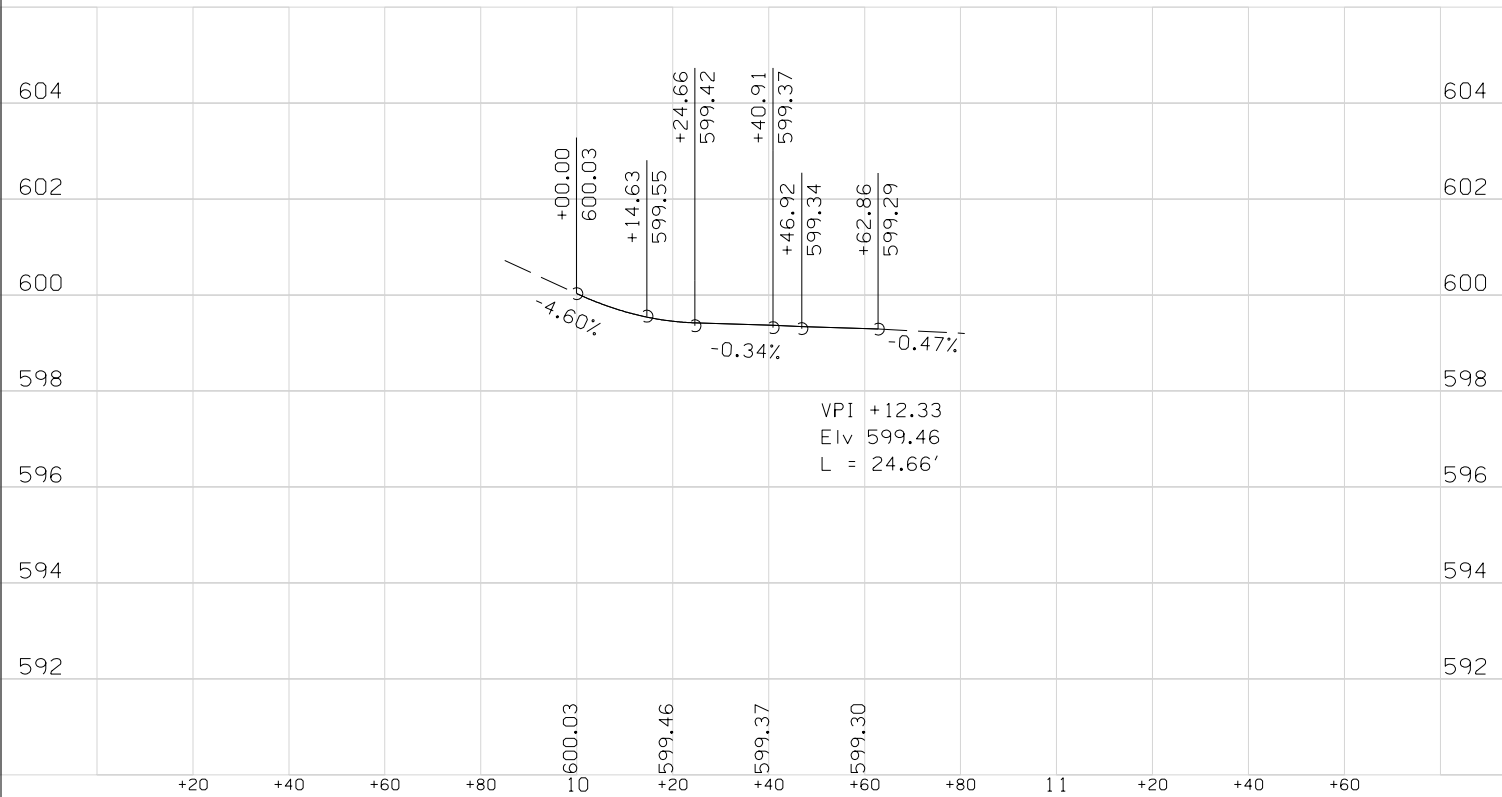
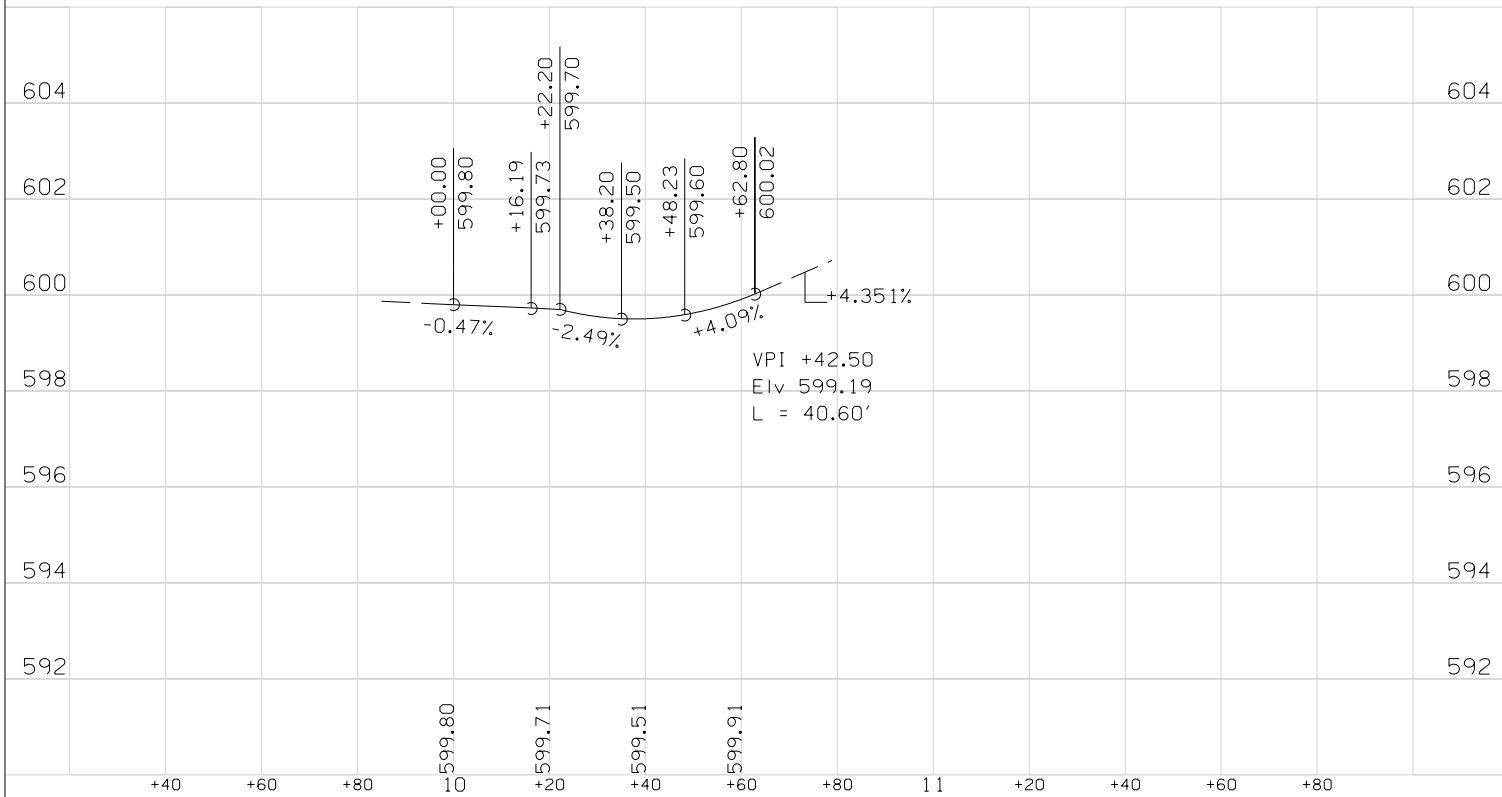

R3

R4

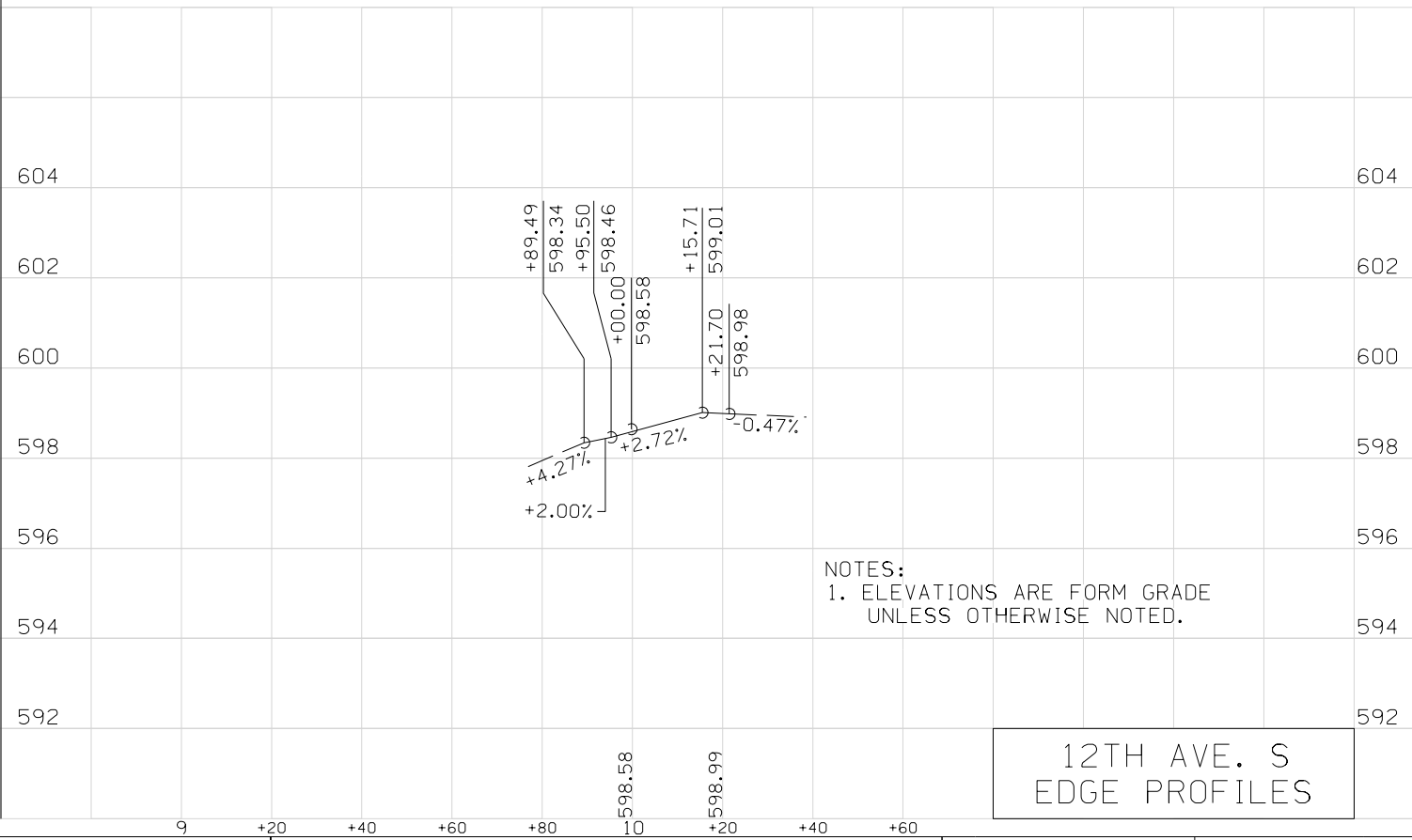
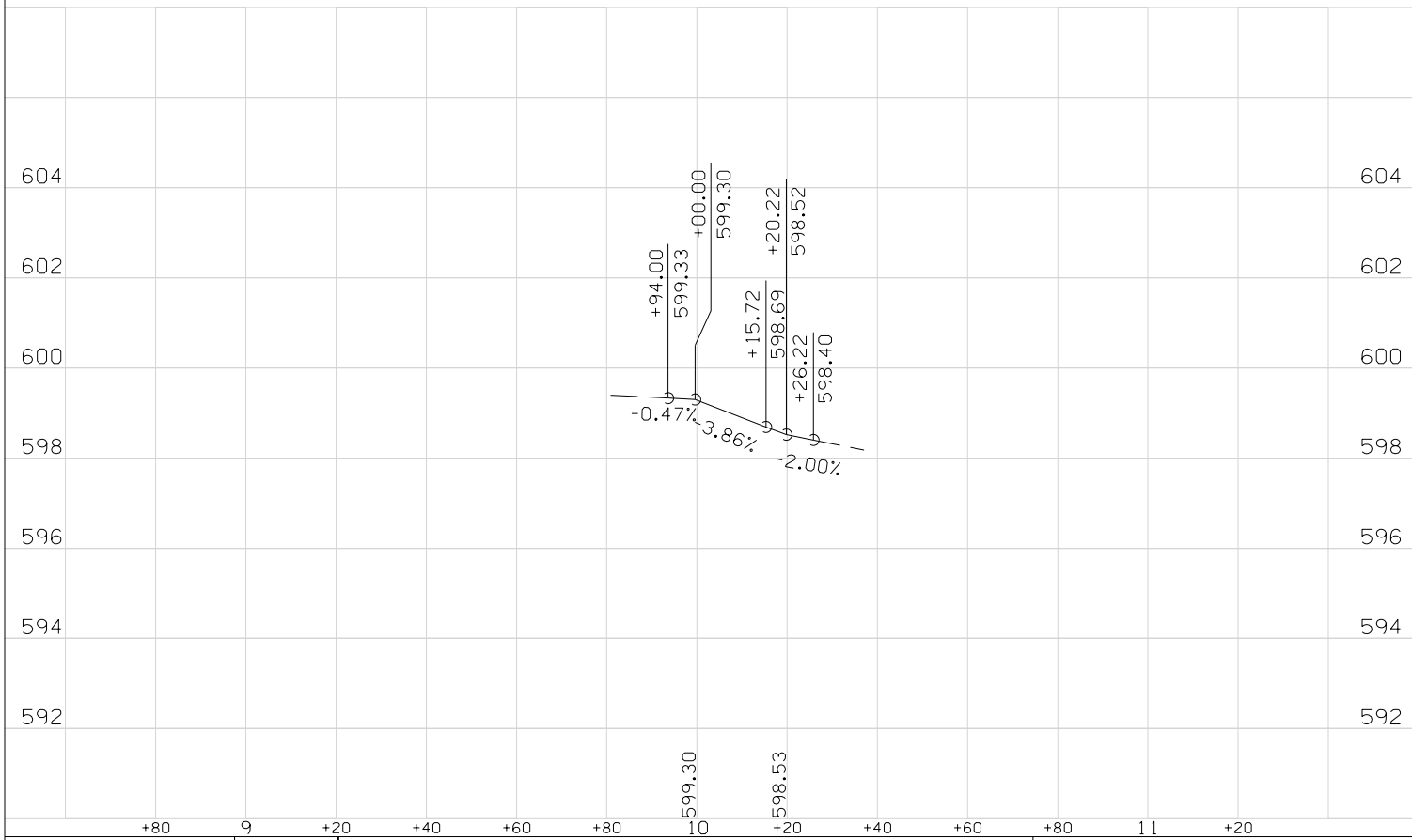

NOTES:  
1. ELEVATIONS ARE FORM GRADE  
UNLESS OTHERWISE NOTED.

12TH AVE. S  
EDGE PROFILES

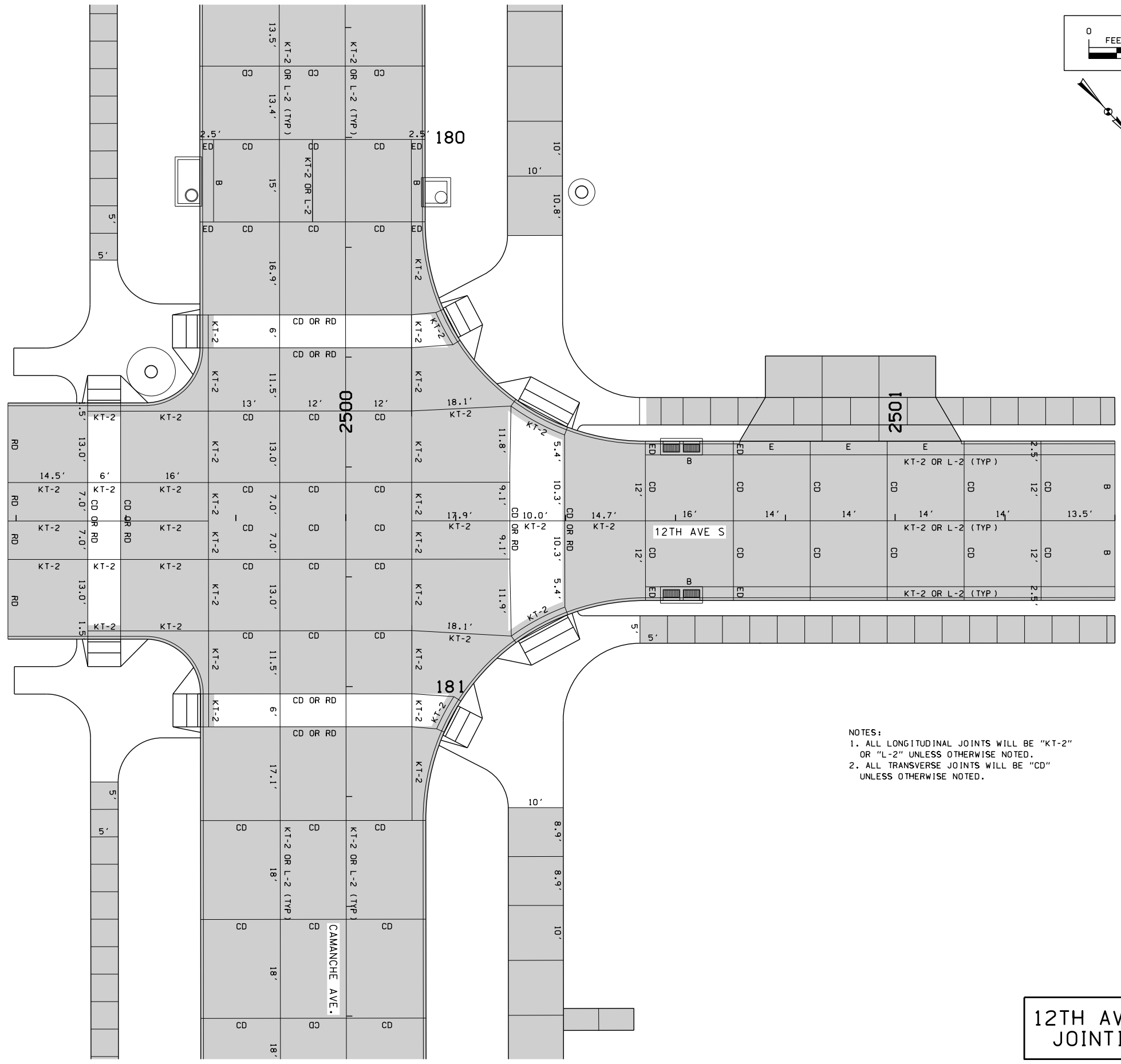
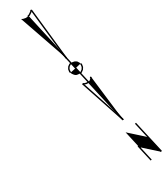
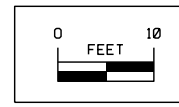

2499

- NOTES:
1. ALL LONGITUDINAL JOINTS WILL BE "KT-2" OR "L-2" UNLESS OTHERWISE NOTED.
  2. ALL TRANSVERSE JOINTS WILL BE "CD" UNLESS OTHERWISE NOTED.

12TH AVE. S  
JOINTING

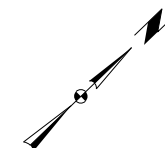
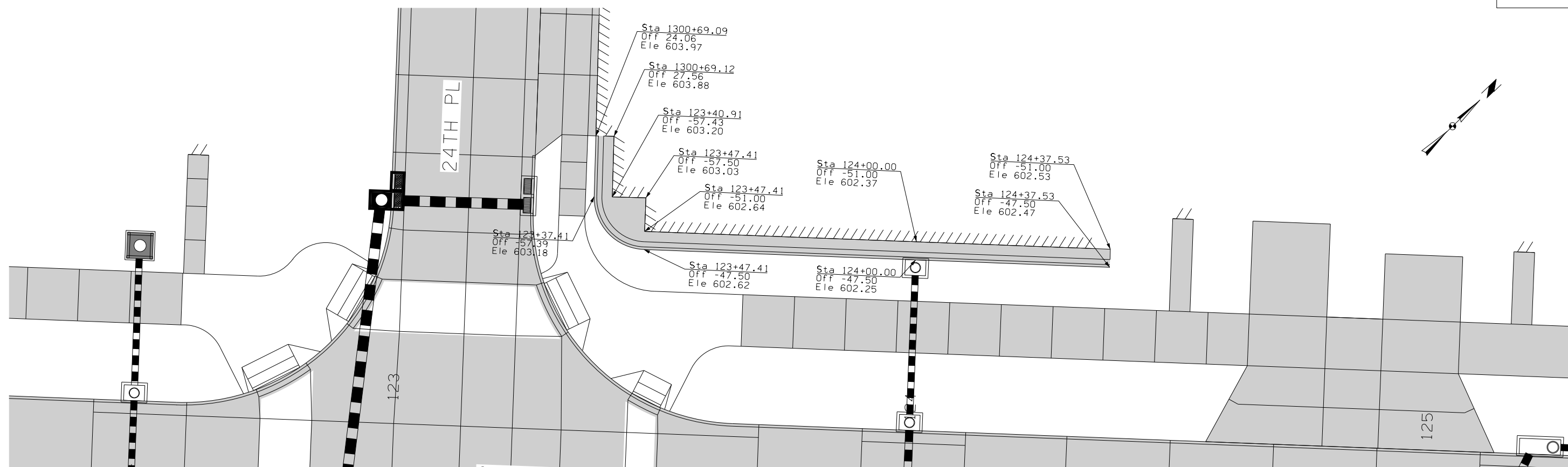
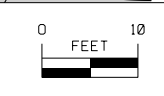
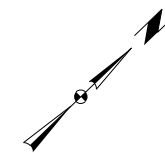
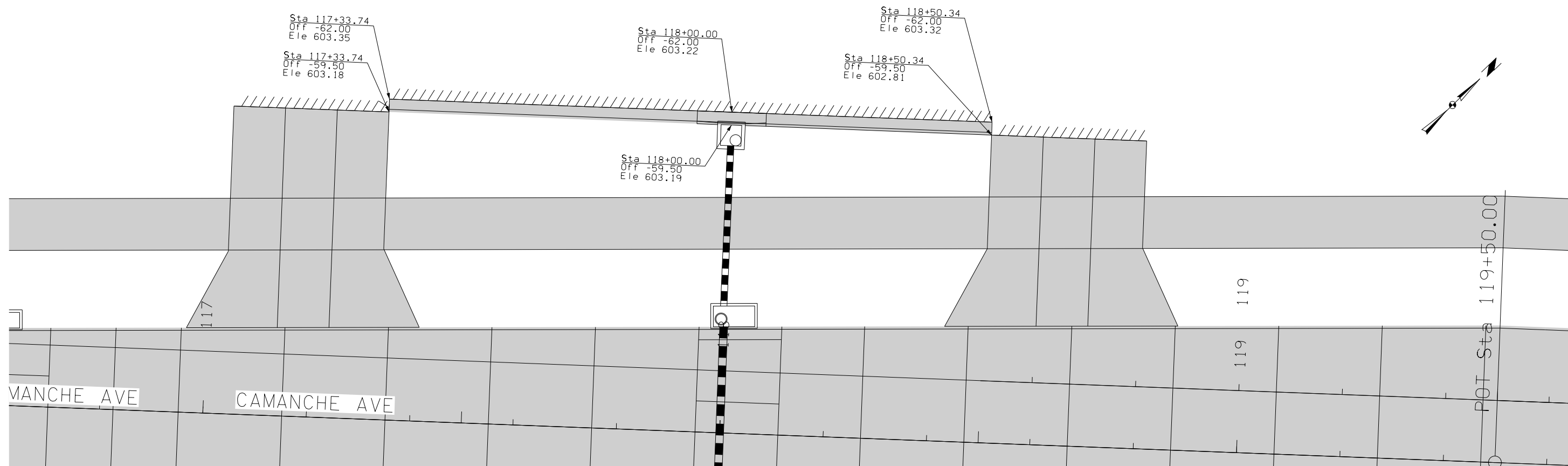

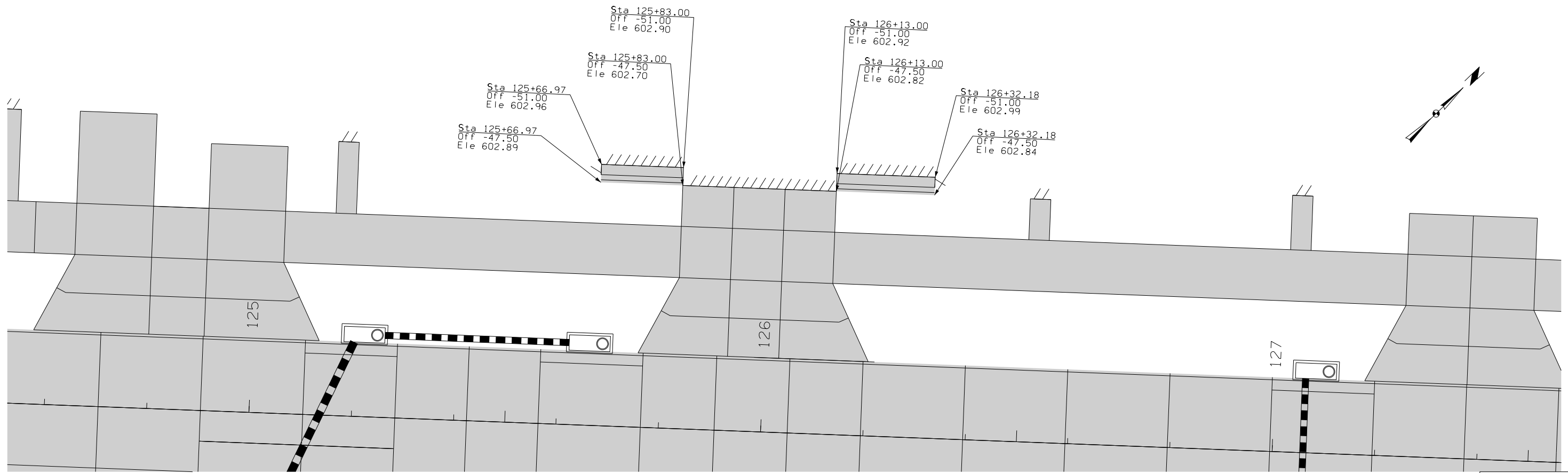

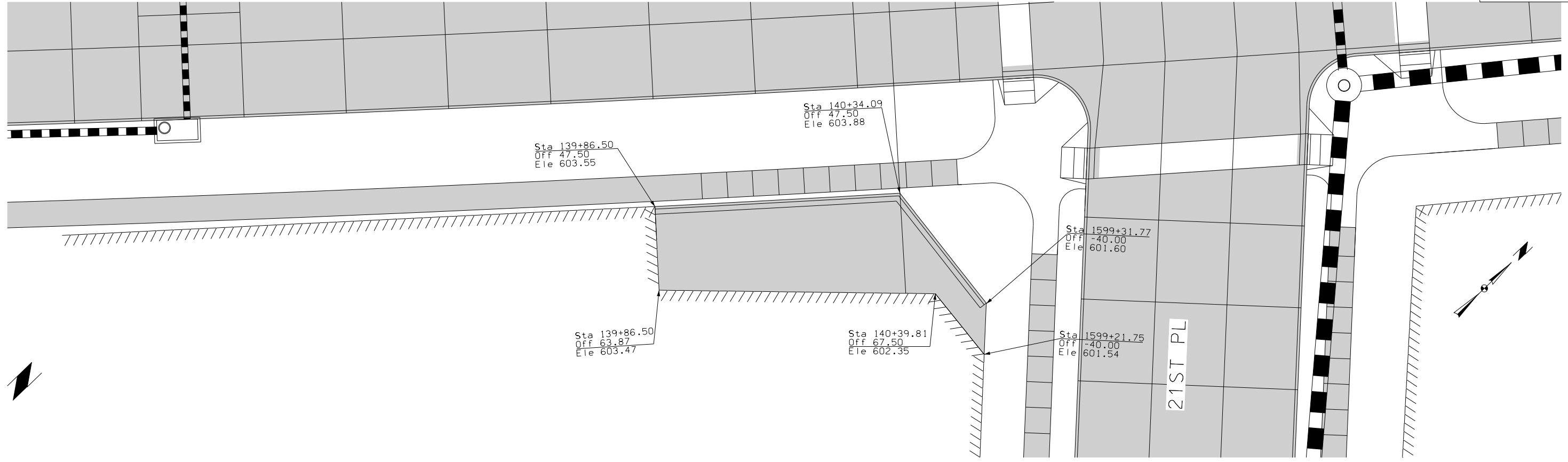
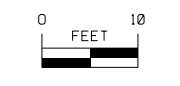
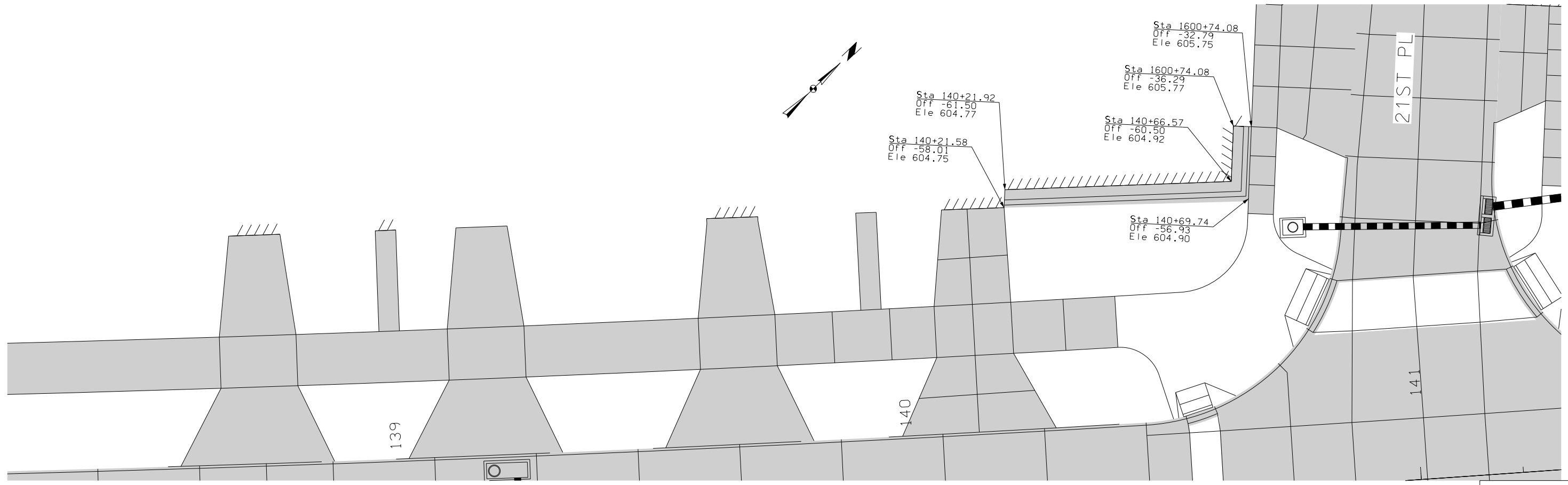

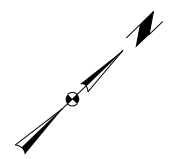
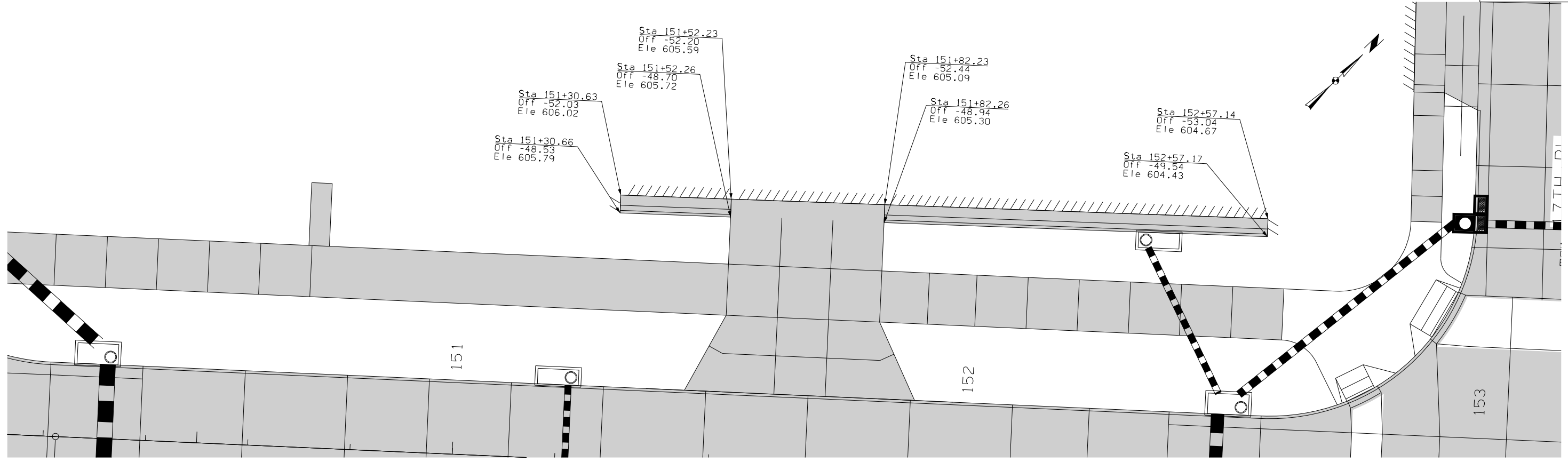
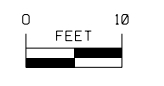
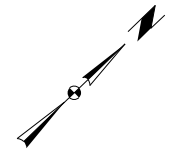
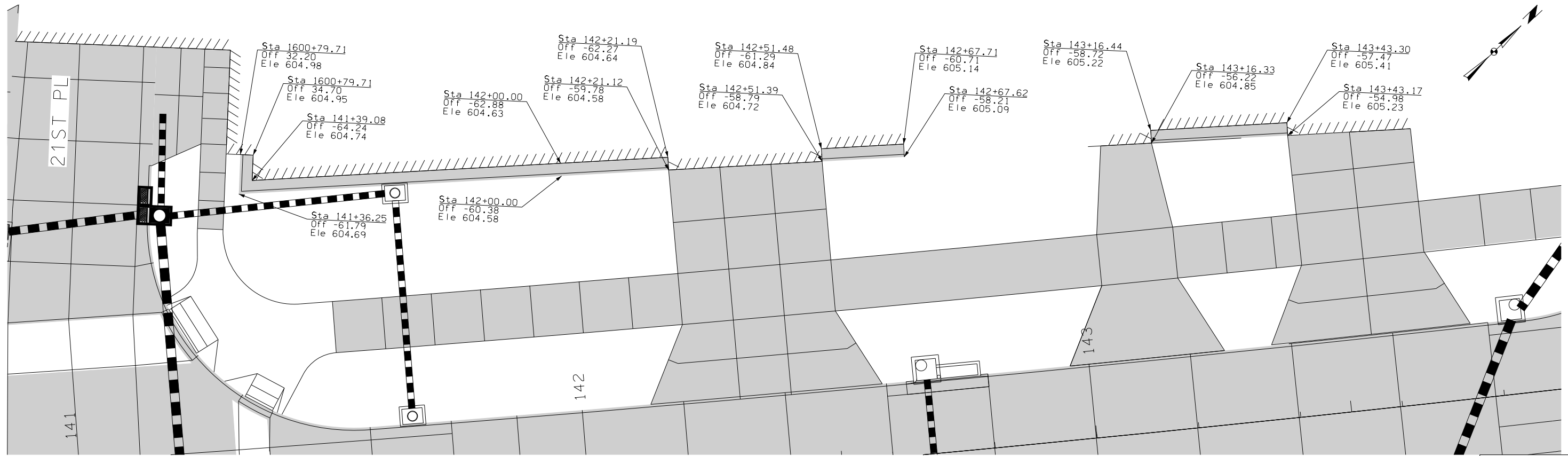

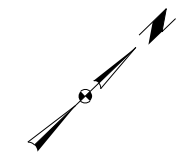
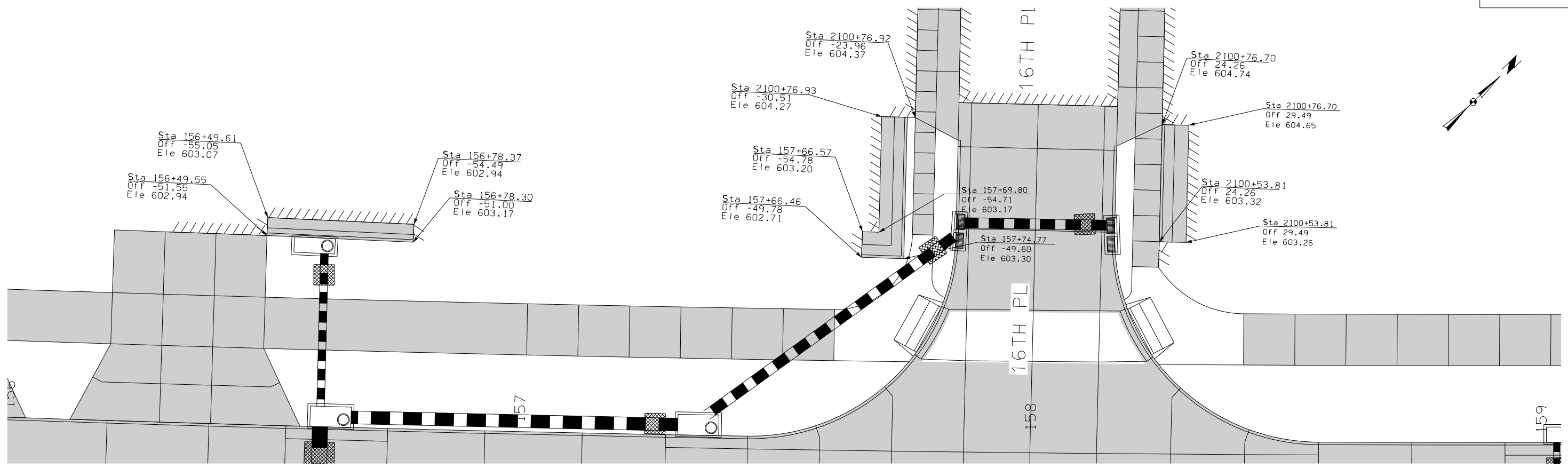
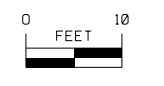
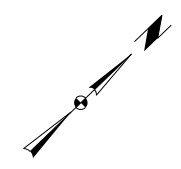
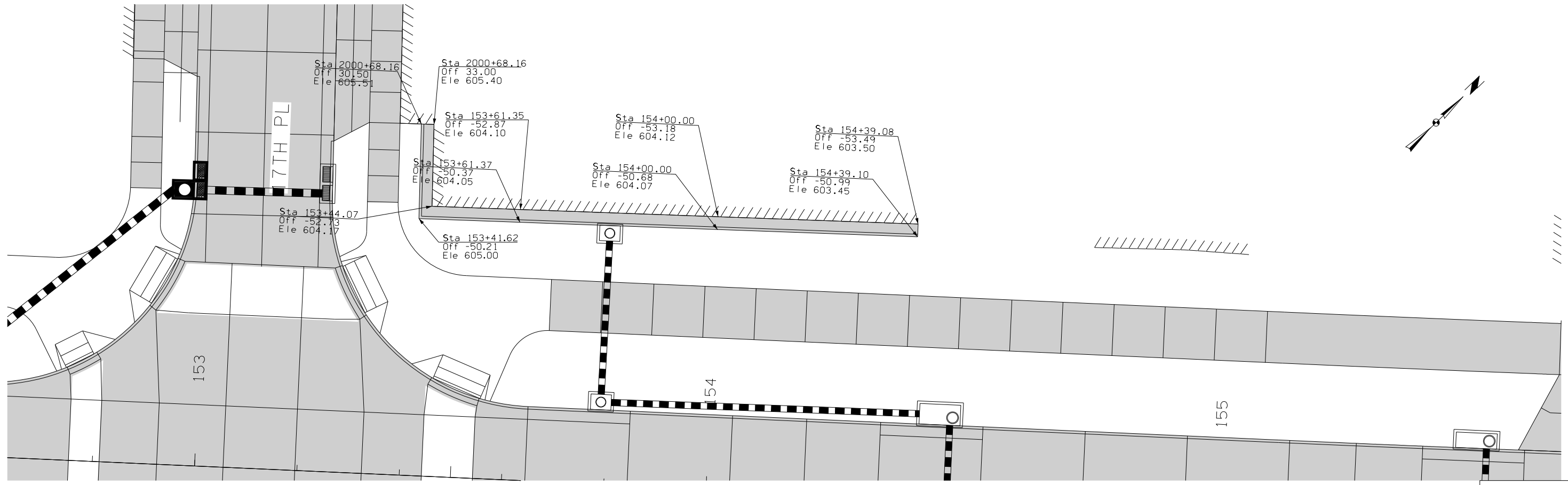

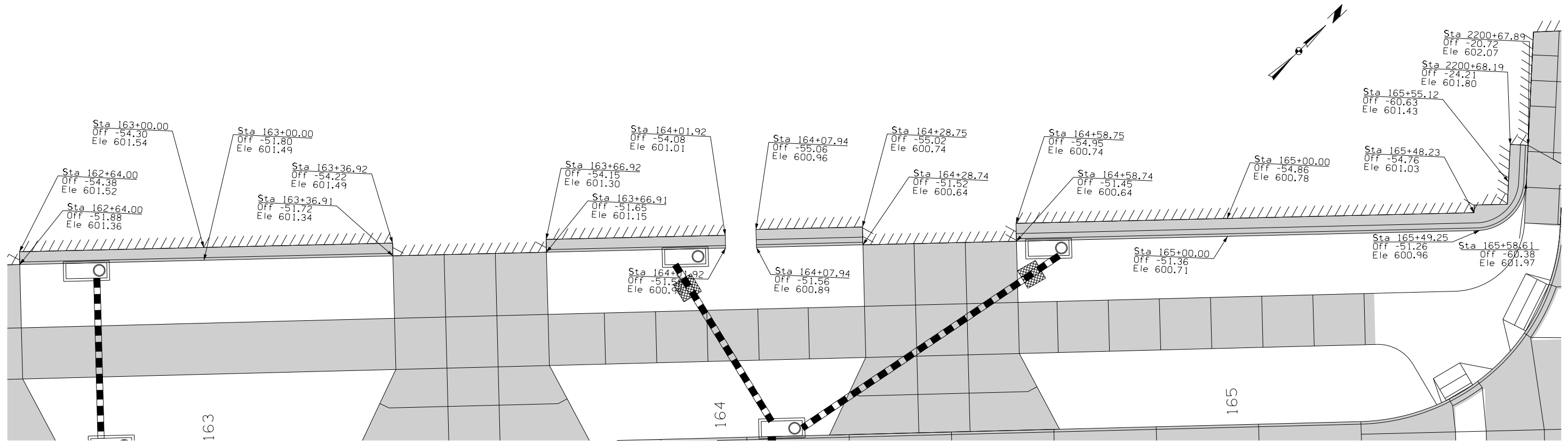
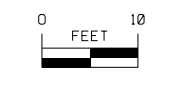
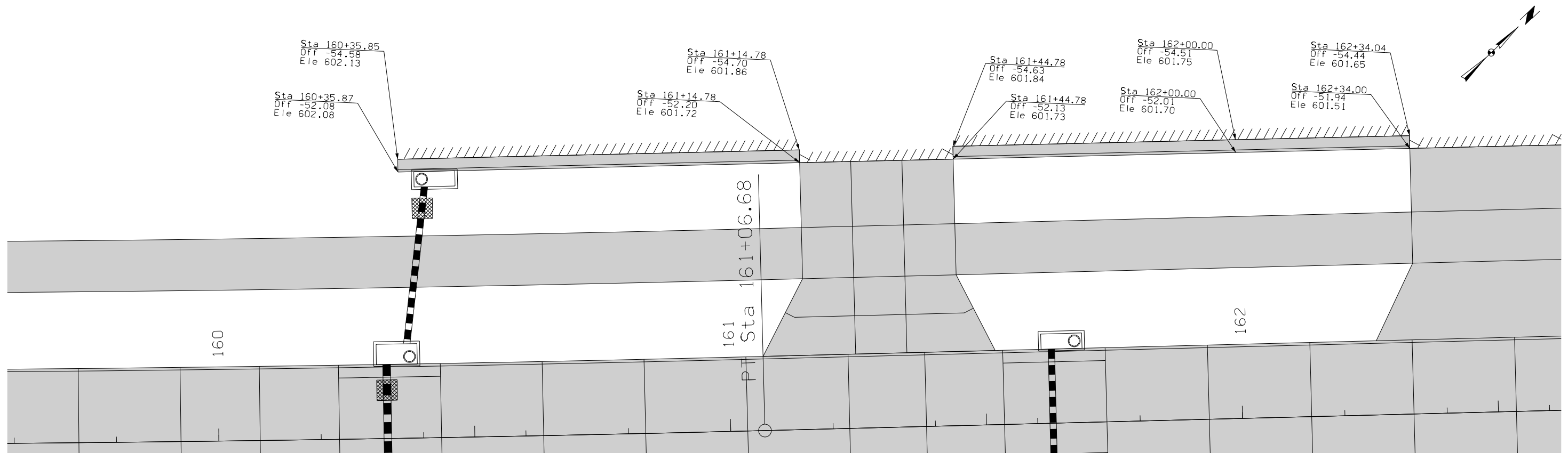



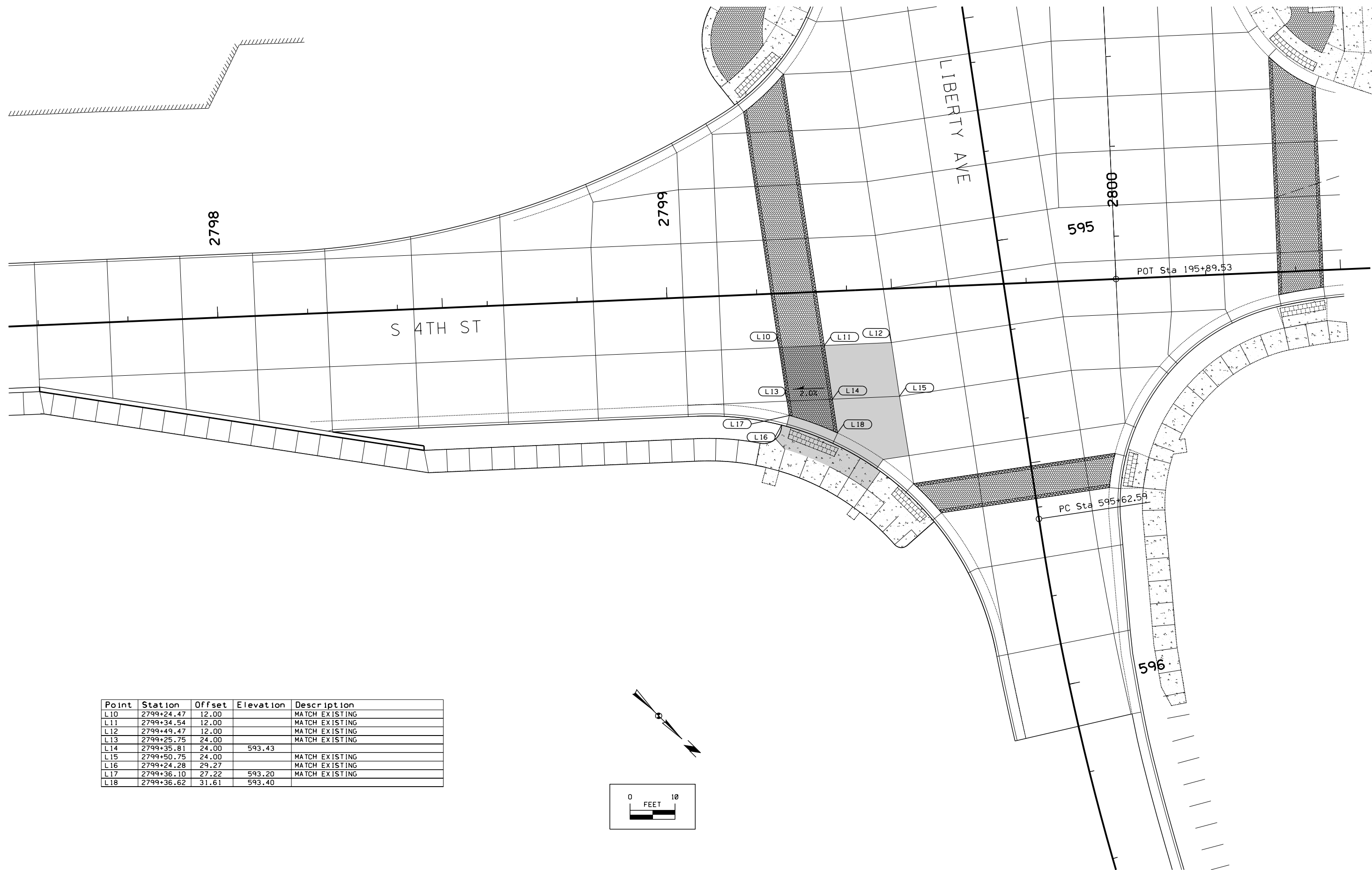

Point	Station	Offset	Elevation	Description
L10	2799+24.47	12.00		MATCH EXISTING
L11	2799+34.54	12.00		MATCH EXISTING
L12	2799+49.47	12.00		MATCH EXISTING
L13	2799+25.75	24.00		MATCH EXISTING
L14	2799+35.81	24.00	593.43	
L15	2799+50.75	24.00		MATCH EXISTING
L16	2799+24.28	29.27		MATCH EXISTING
L17	2799+36.10	27.22	593.20	MATCH EXISTING
L18	2799+36.62	31.61	593.40	

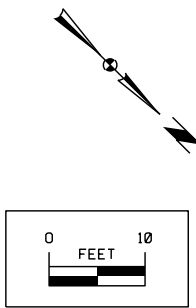

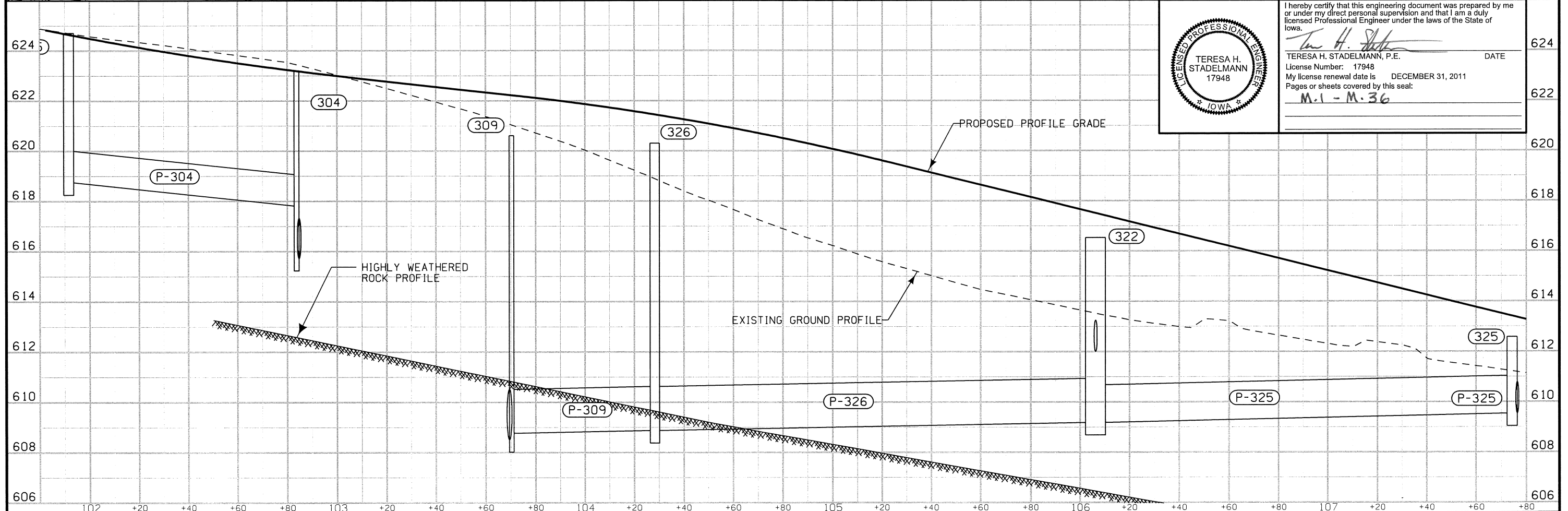
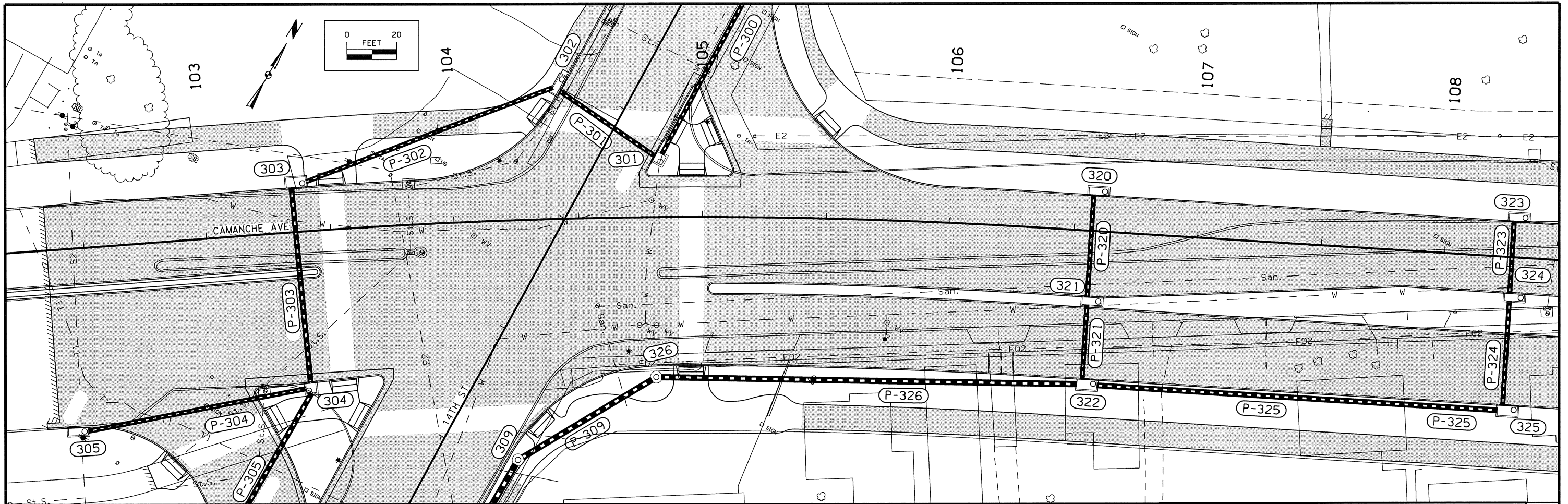

I hereby certify that this engineering document was prepared by me or under my direct personal supervision and that I am a duly licensed Professional Engineer under the laws of the State of Iowa.

*Teresa H. Stadelmann*  
 TERESA H. STADELMANN, P.E. DATE  
 License Number: 17948  
 My license renewal date is DECEMBER 31, 2011  
 Pages or sheets covered by this seal:  
 M.1 - M.36

TERESA H. STADELMANN  
 17948  
 IOWA

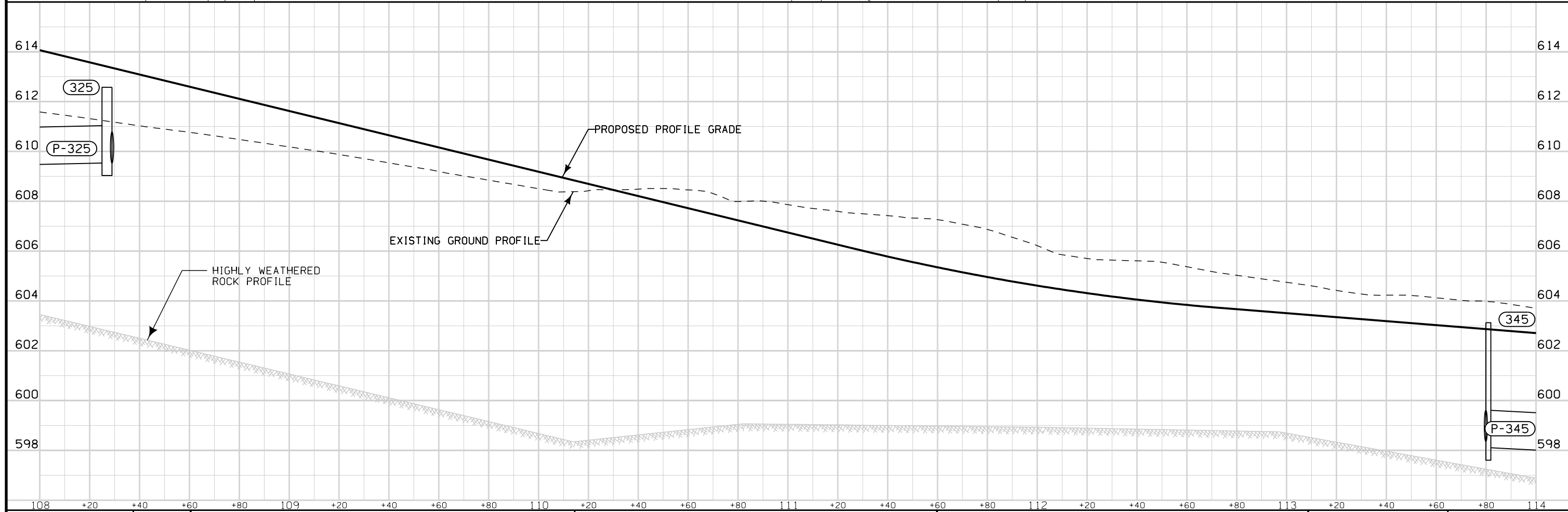
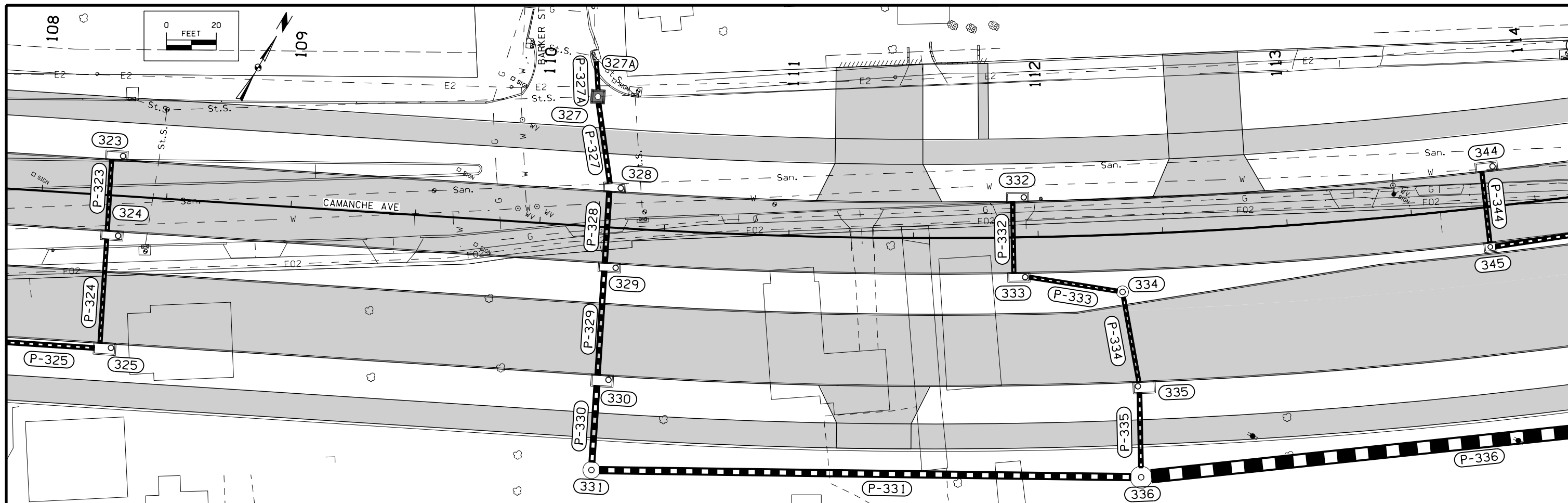

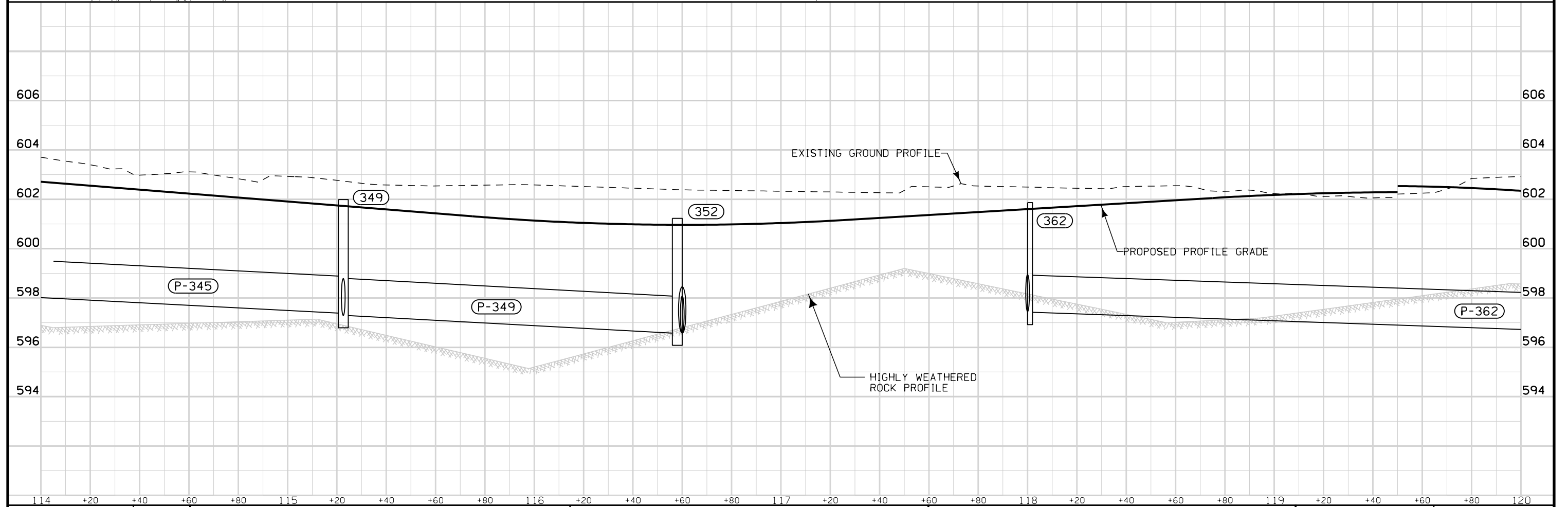
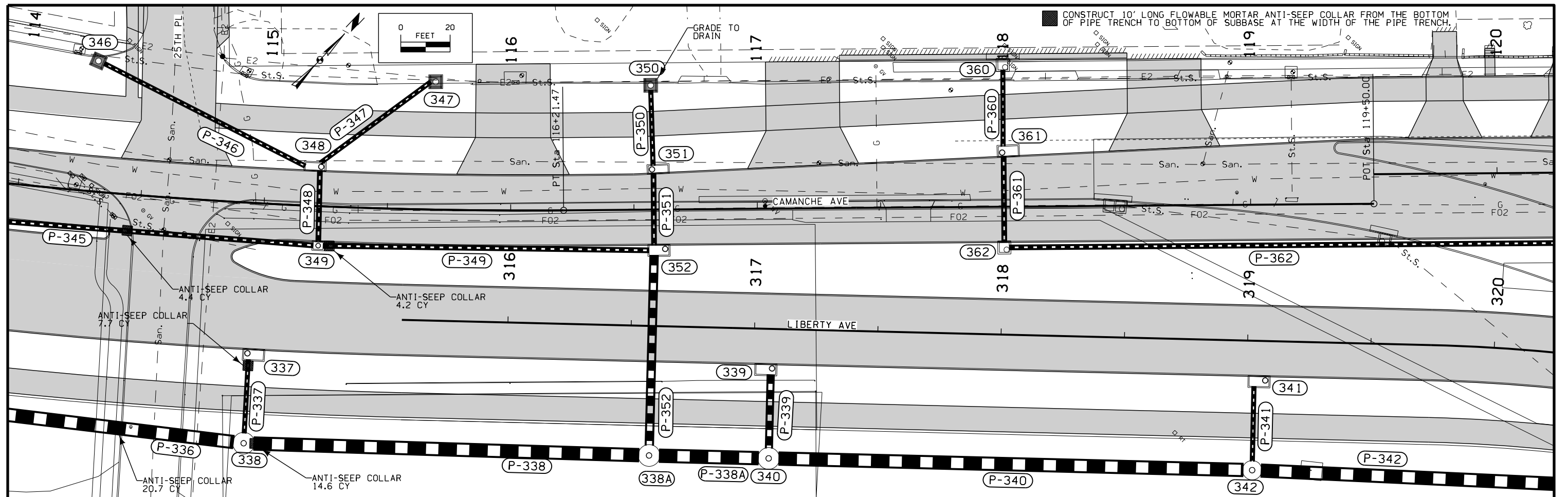



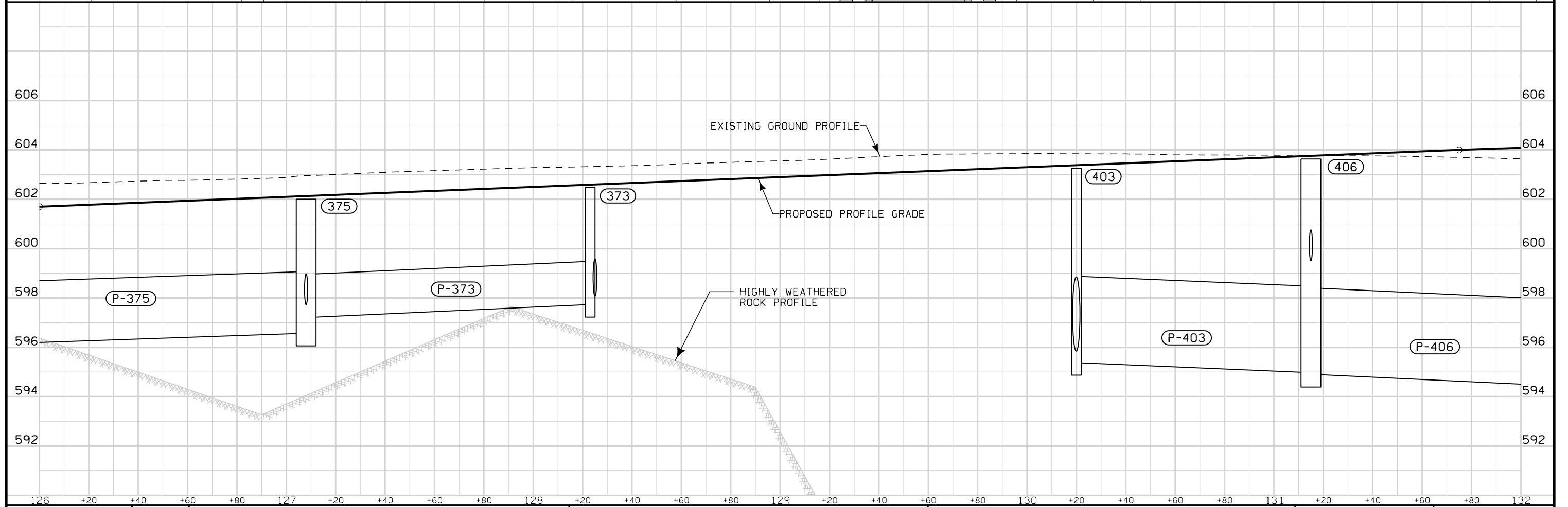
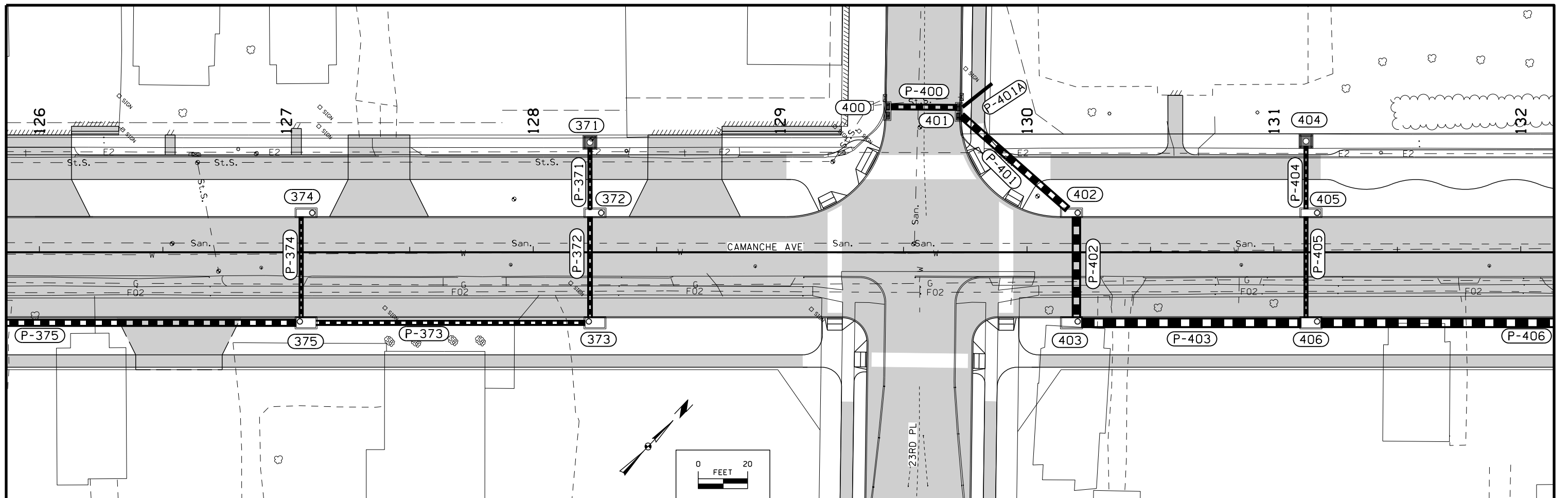

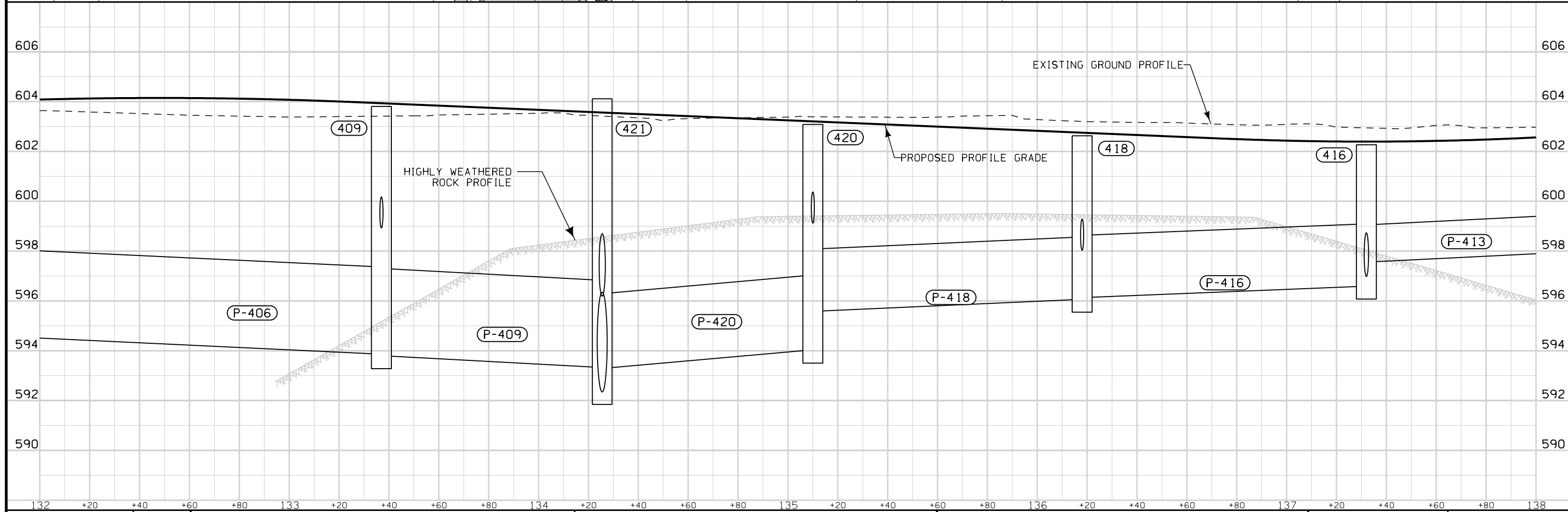
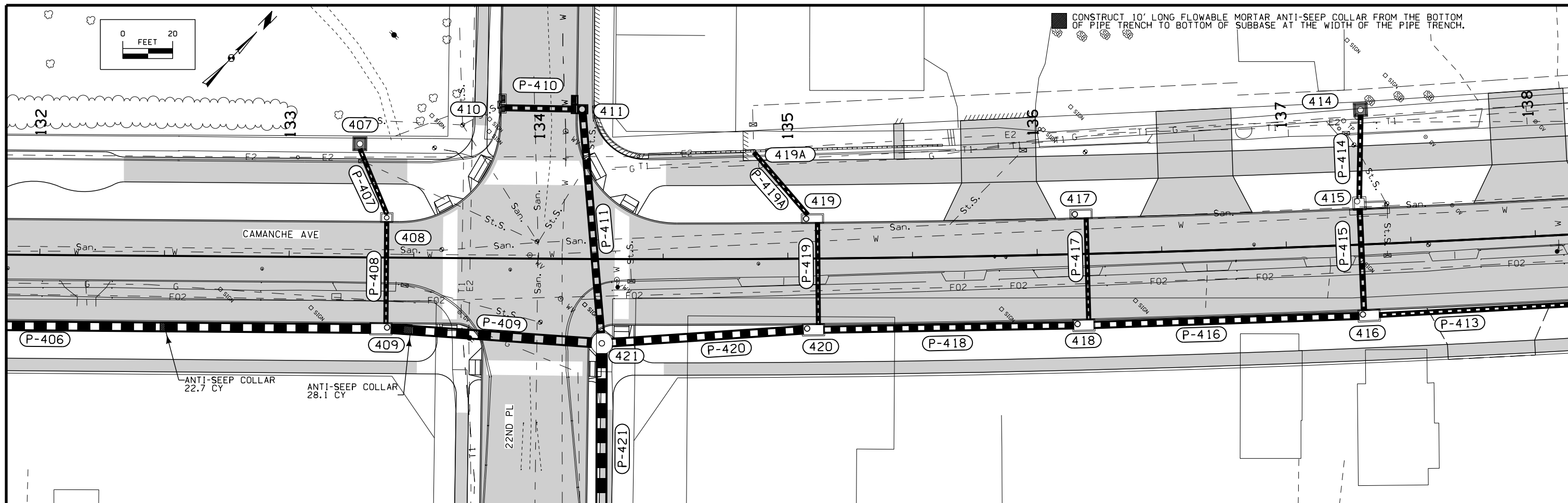

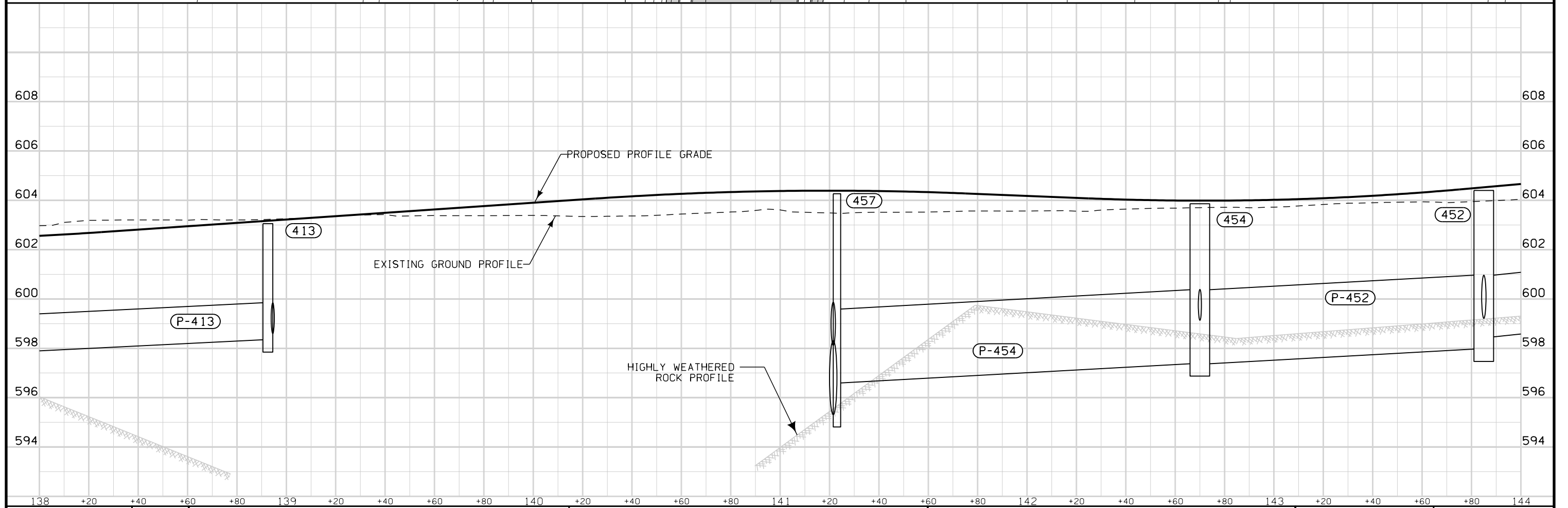
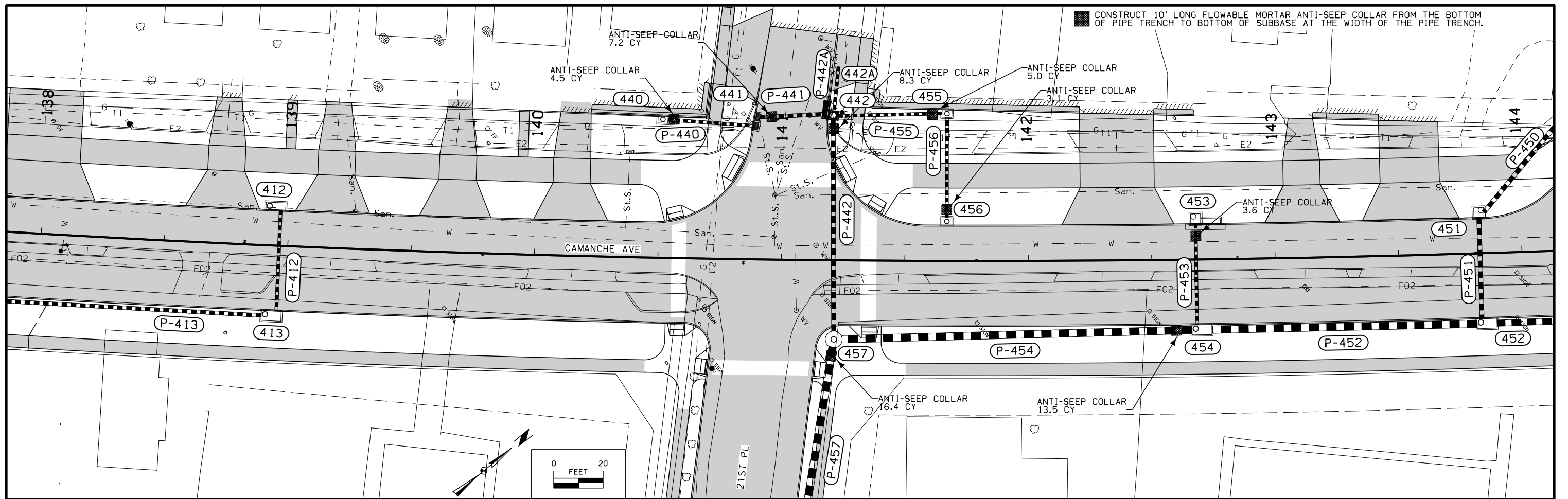



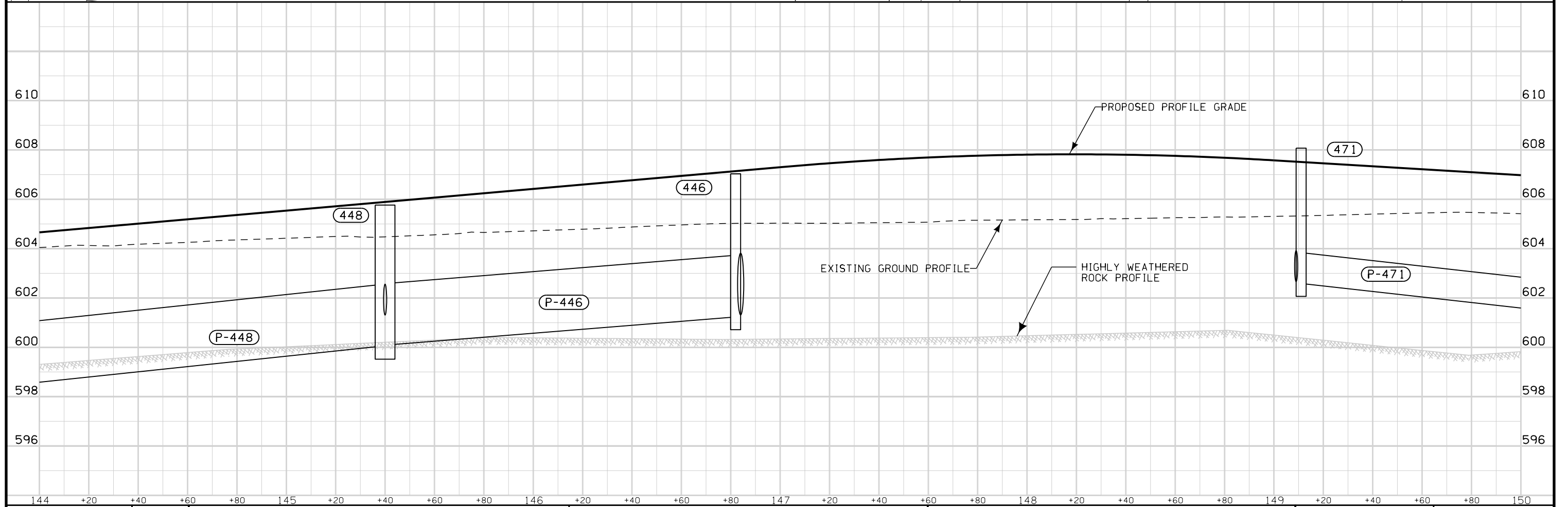
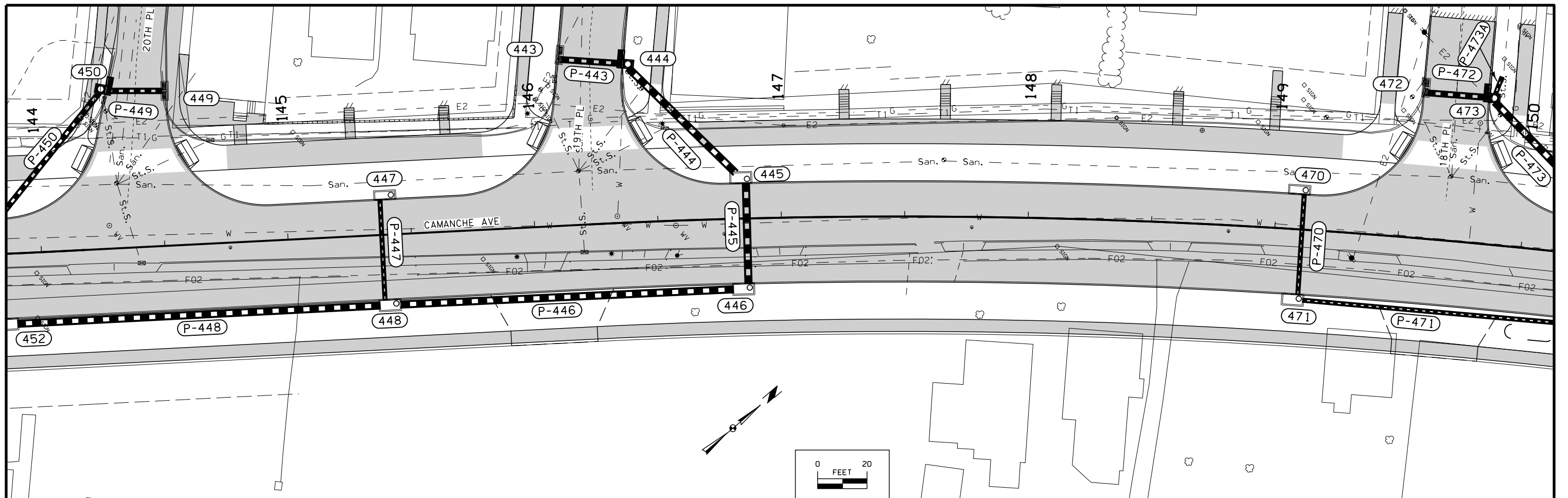

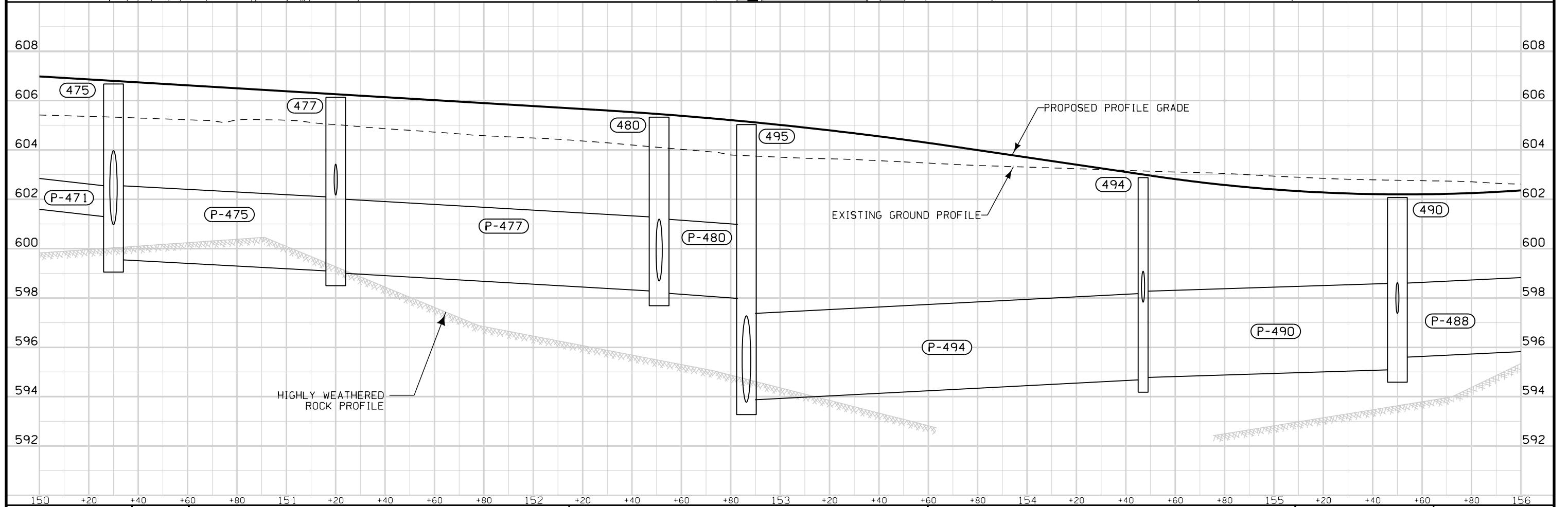
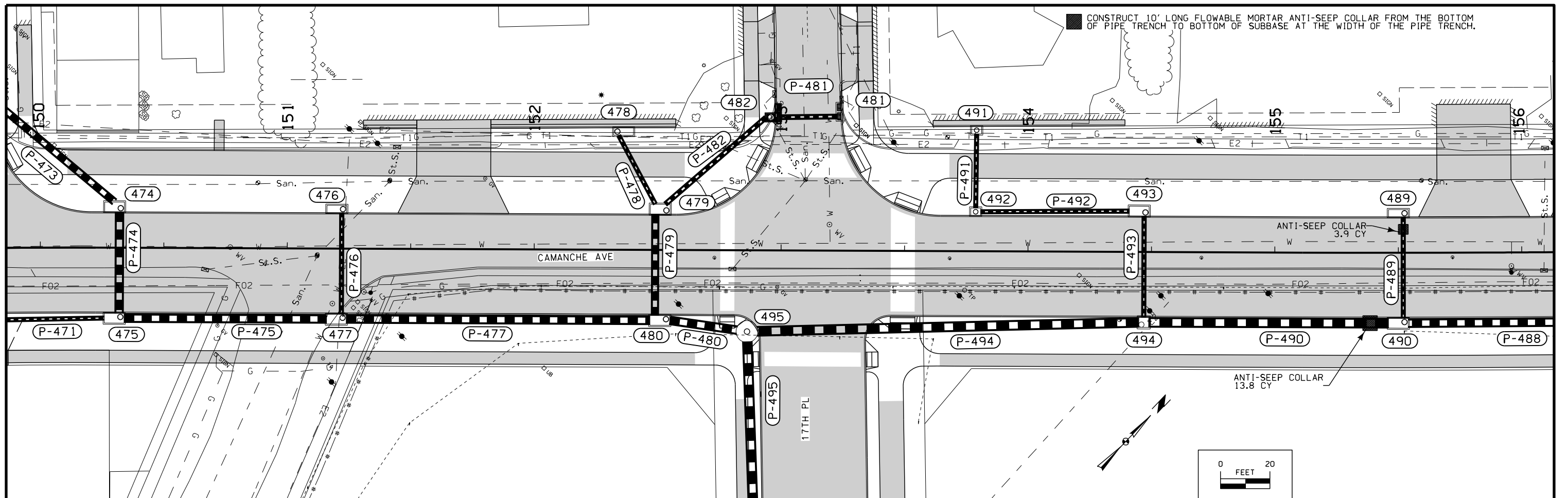

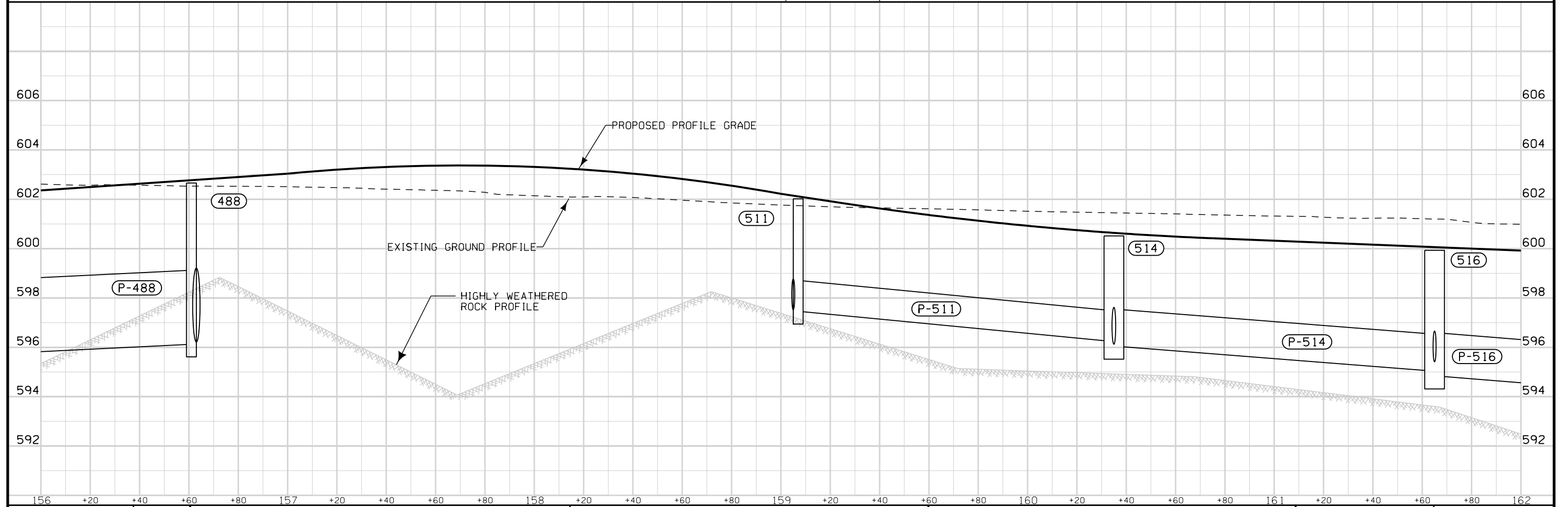
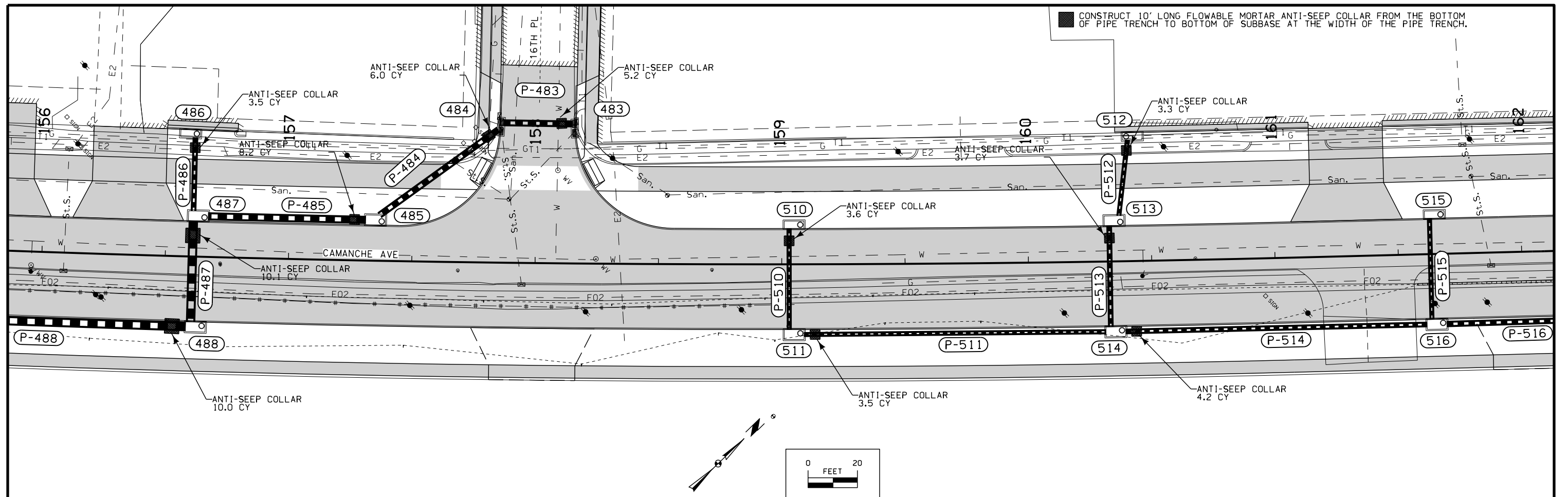

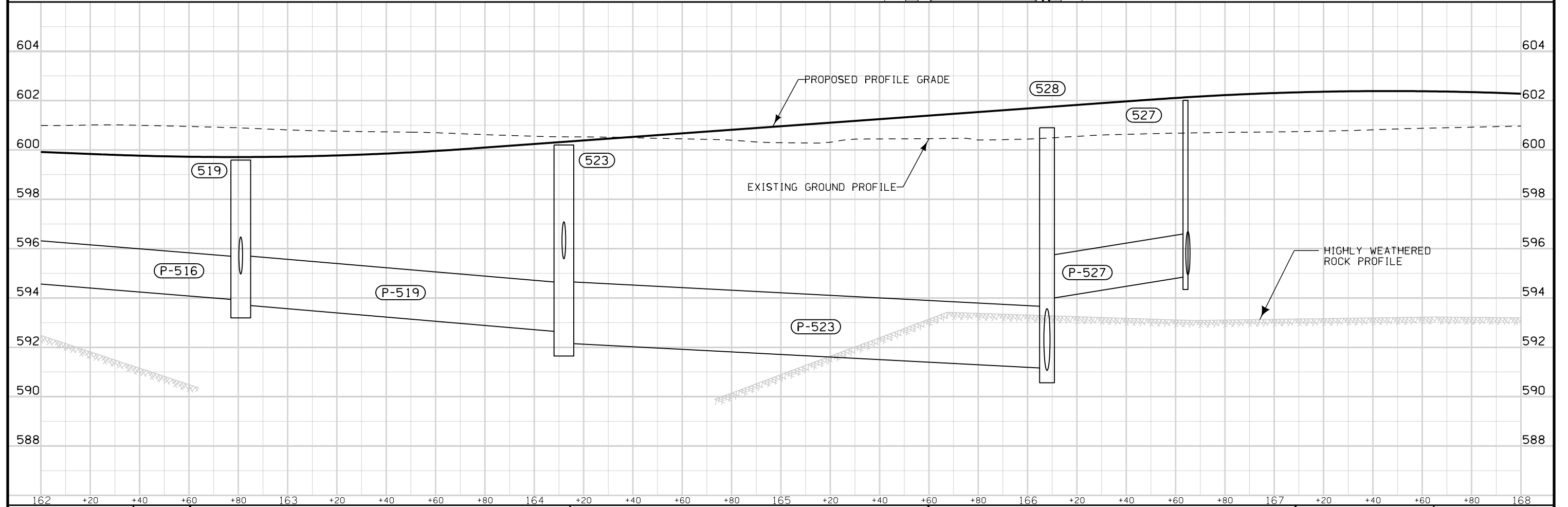
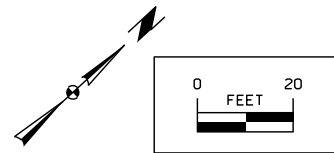
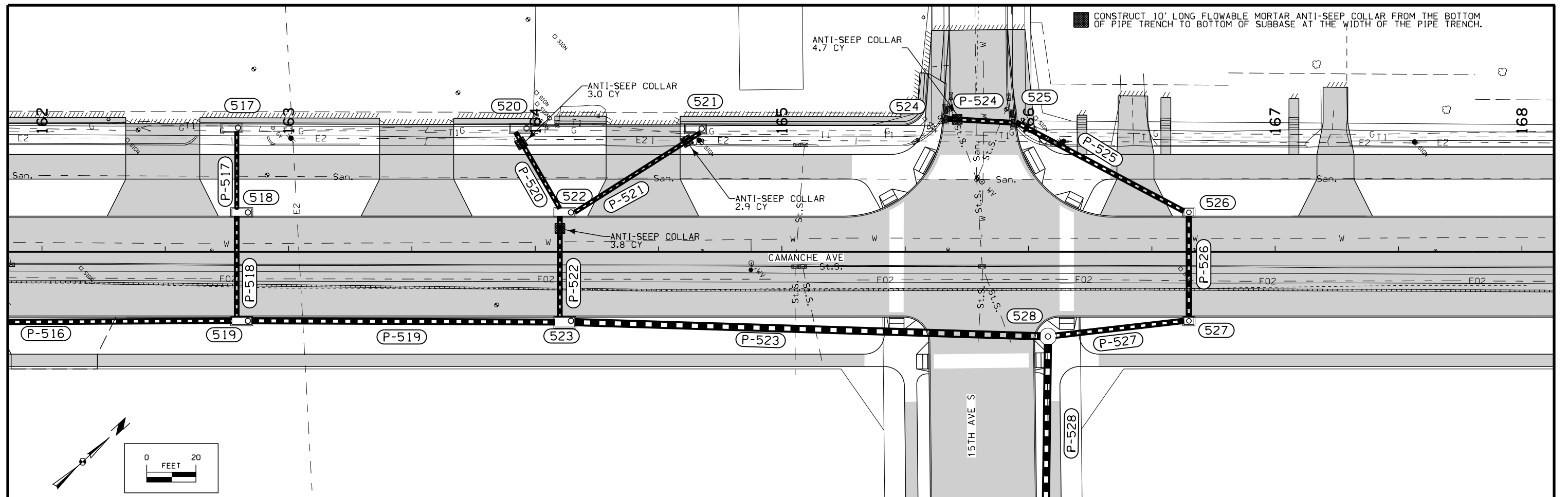

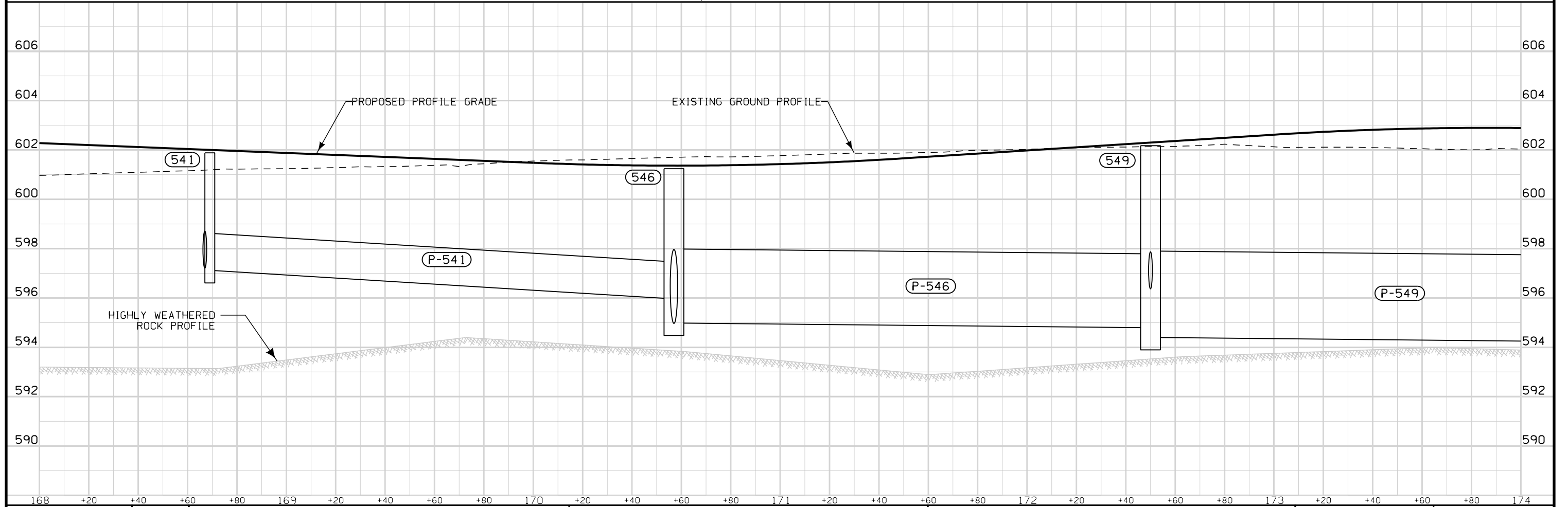
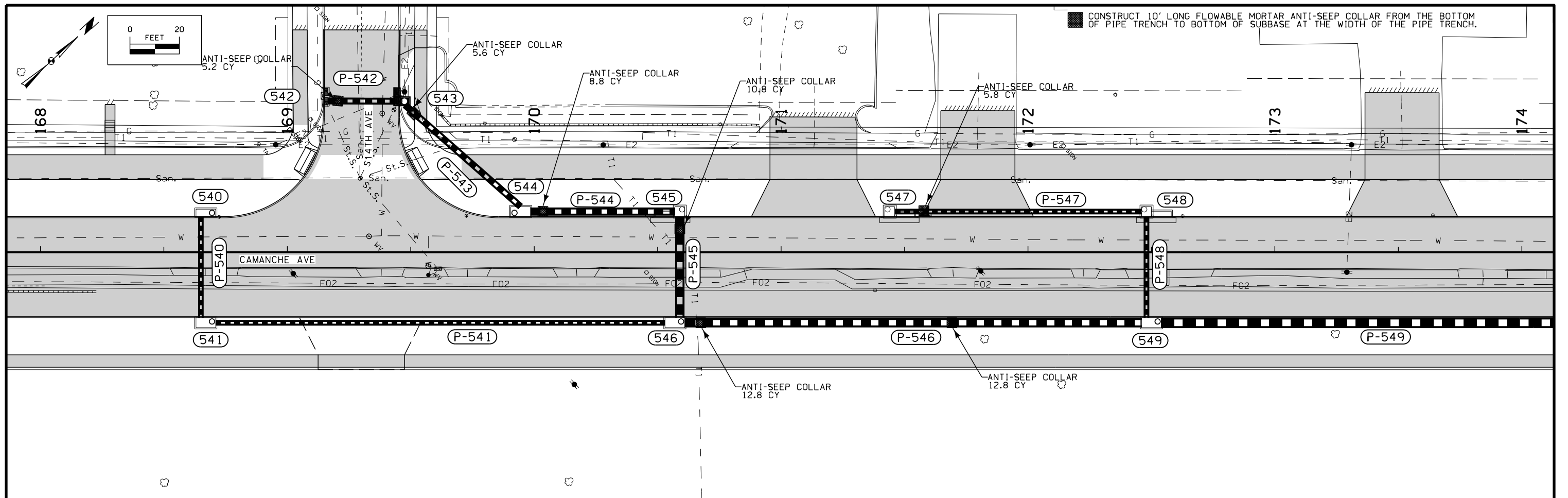

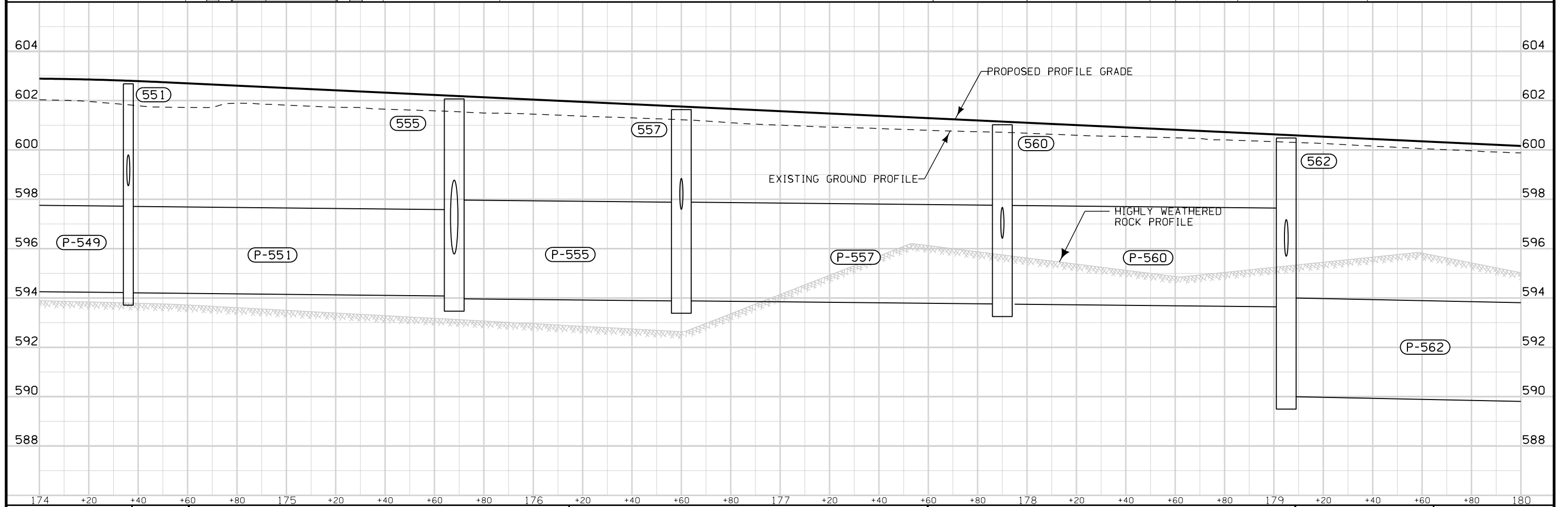
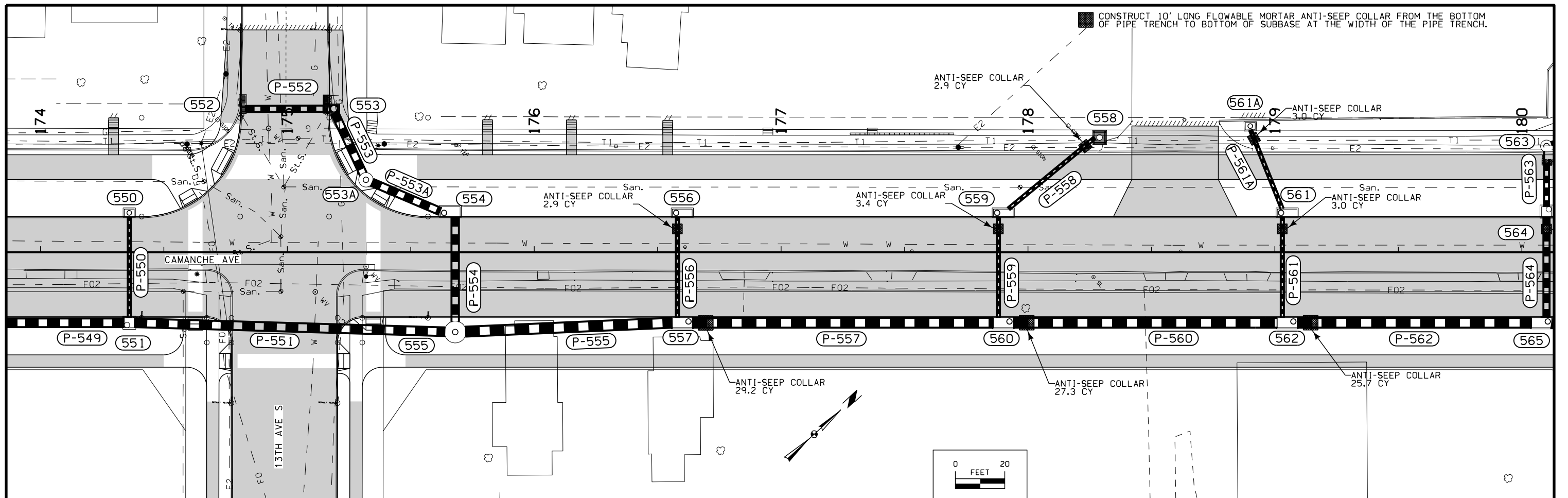

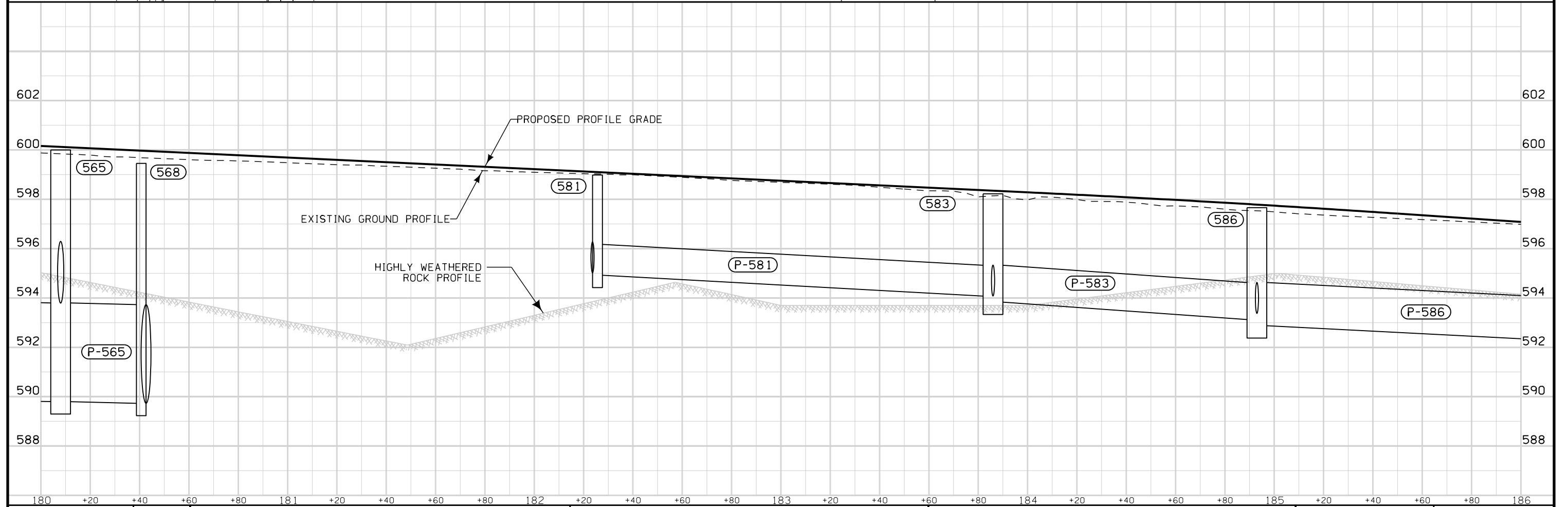
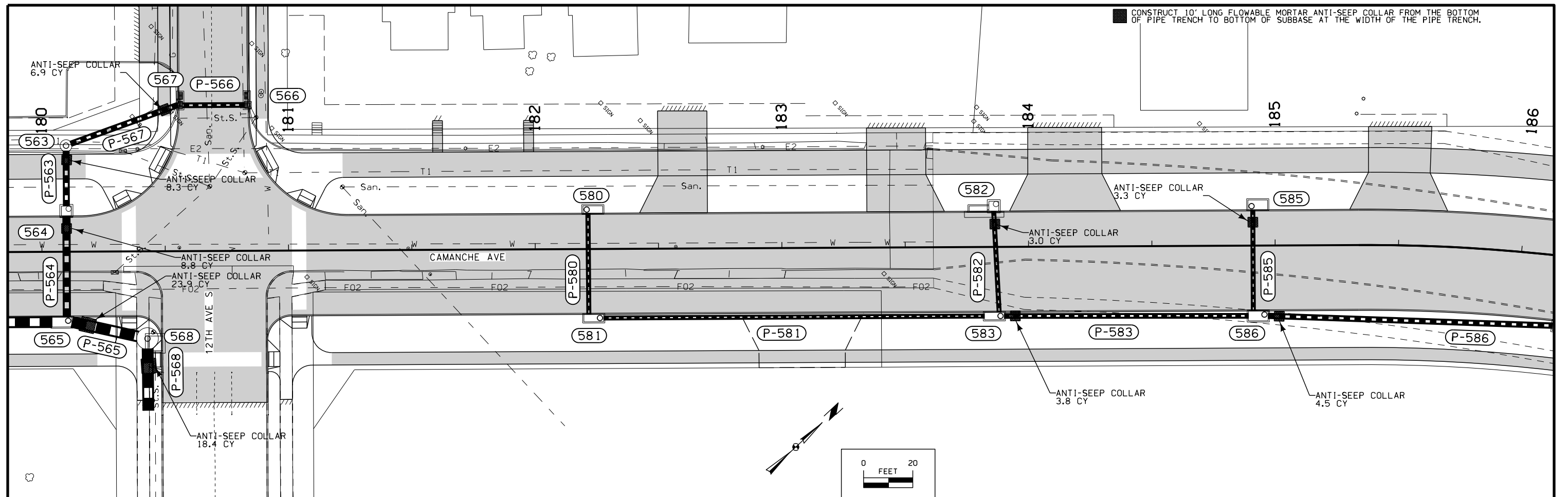

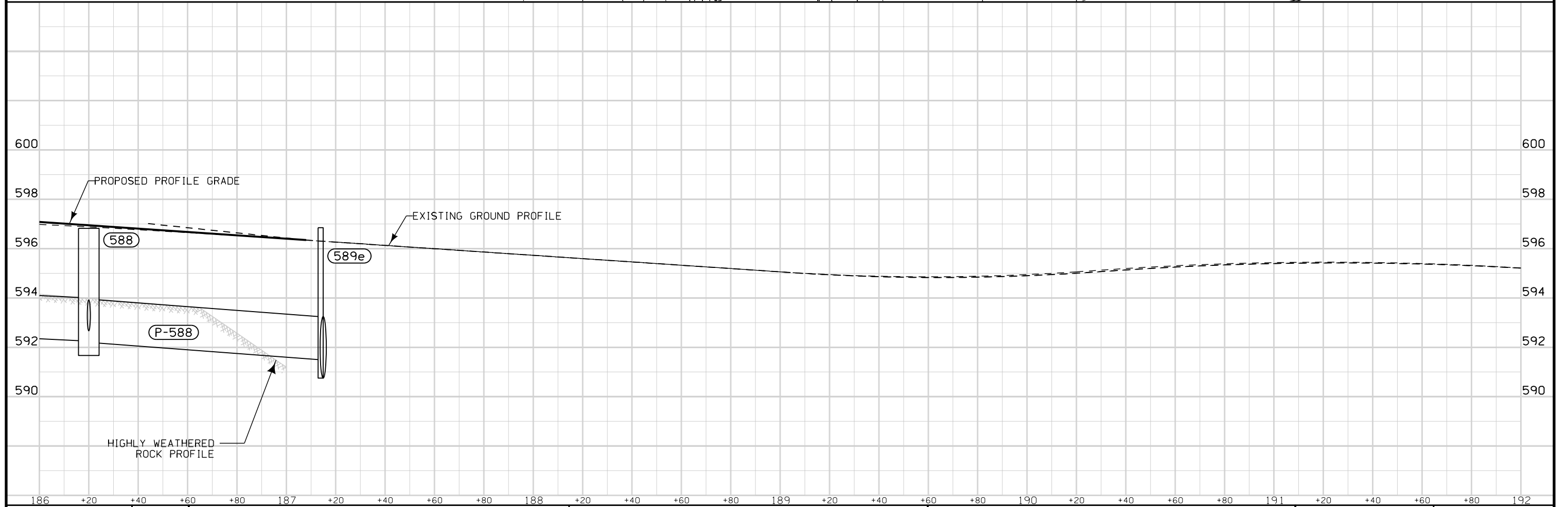
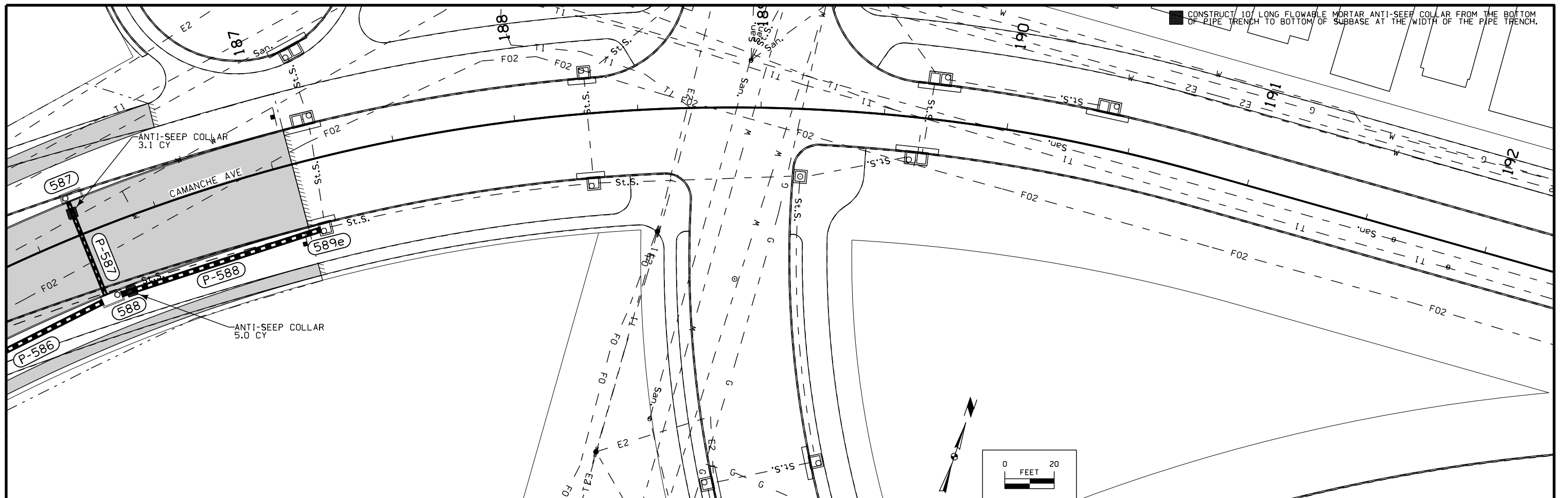



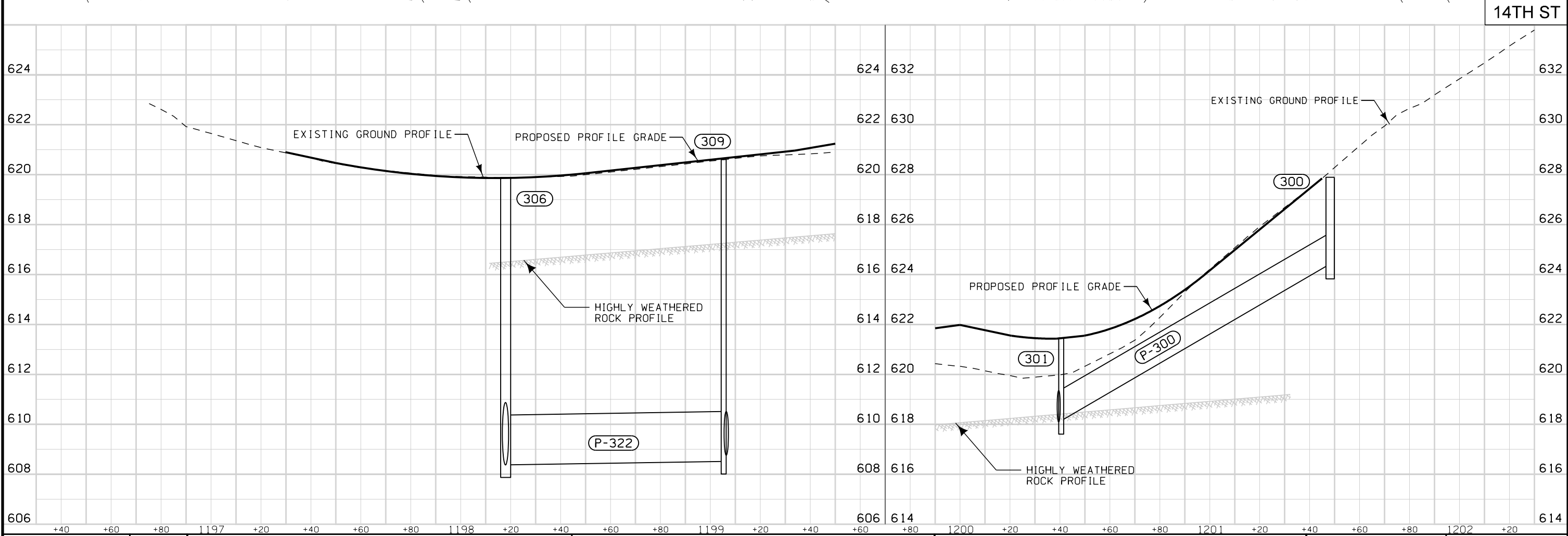
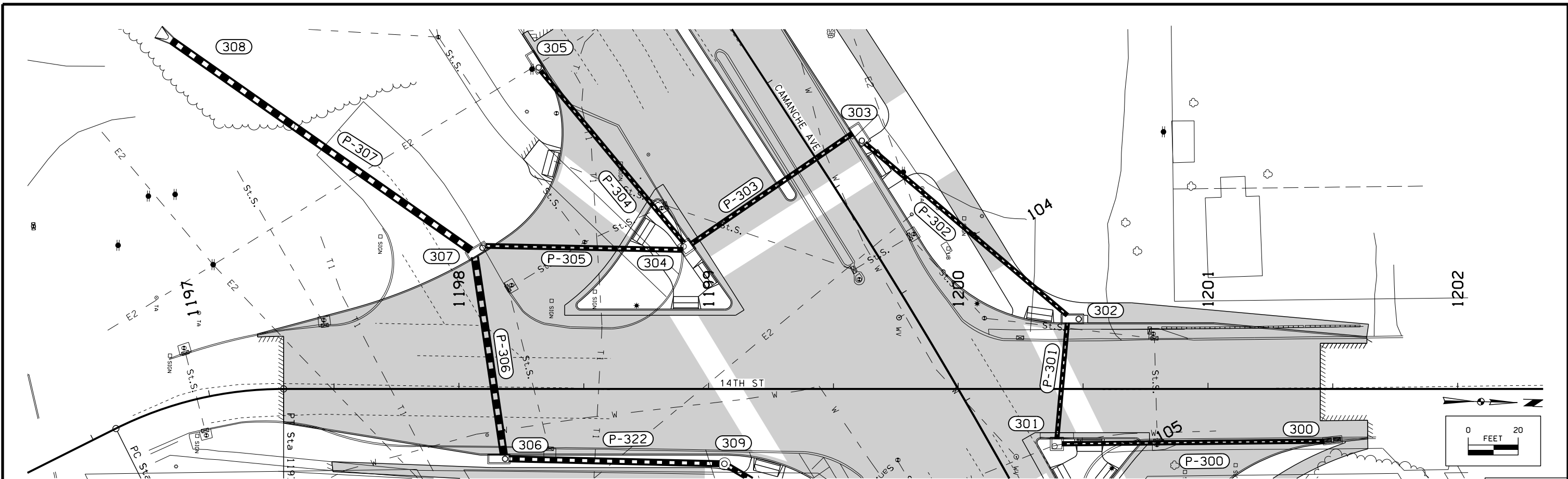

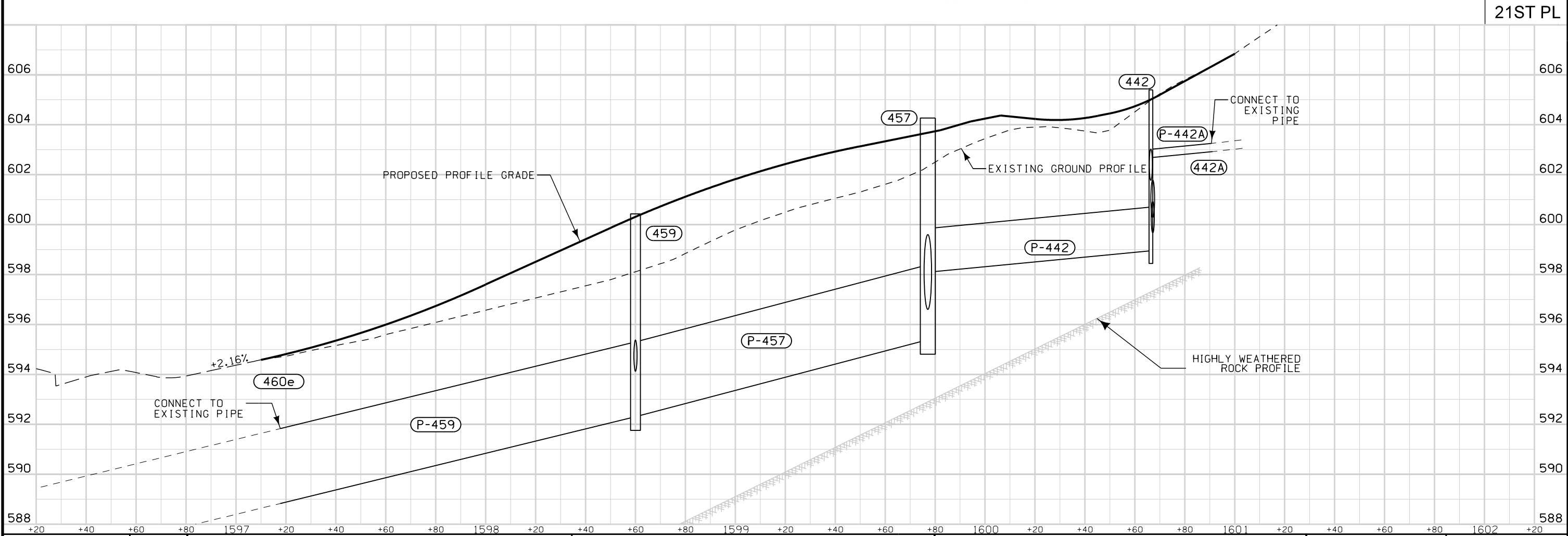
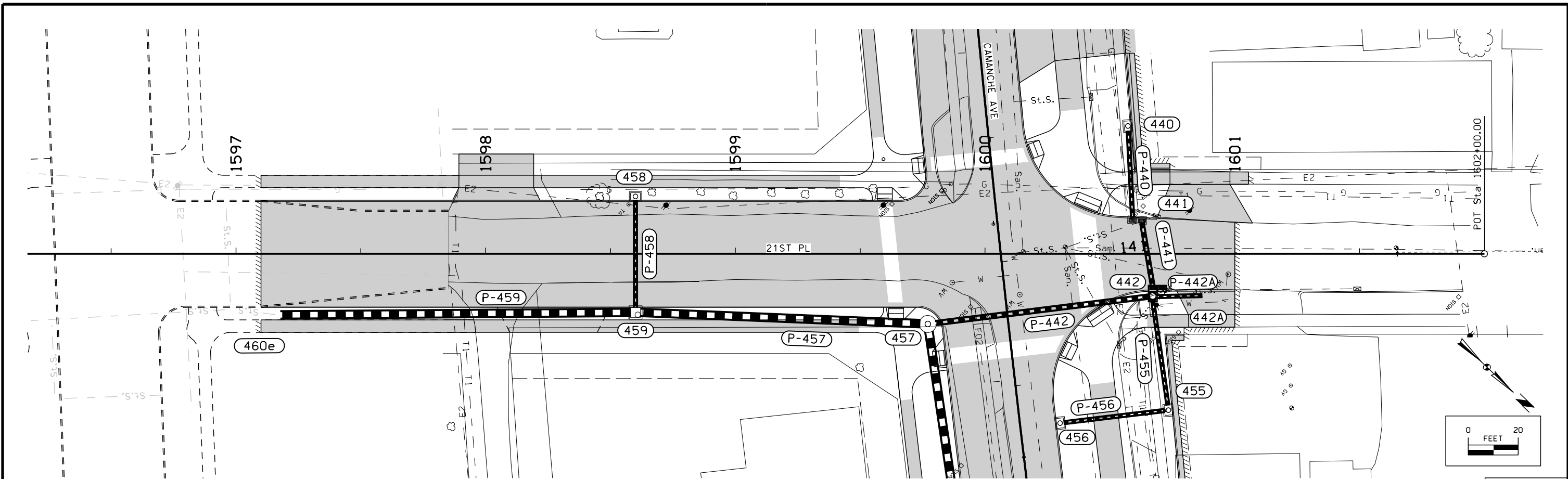



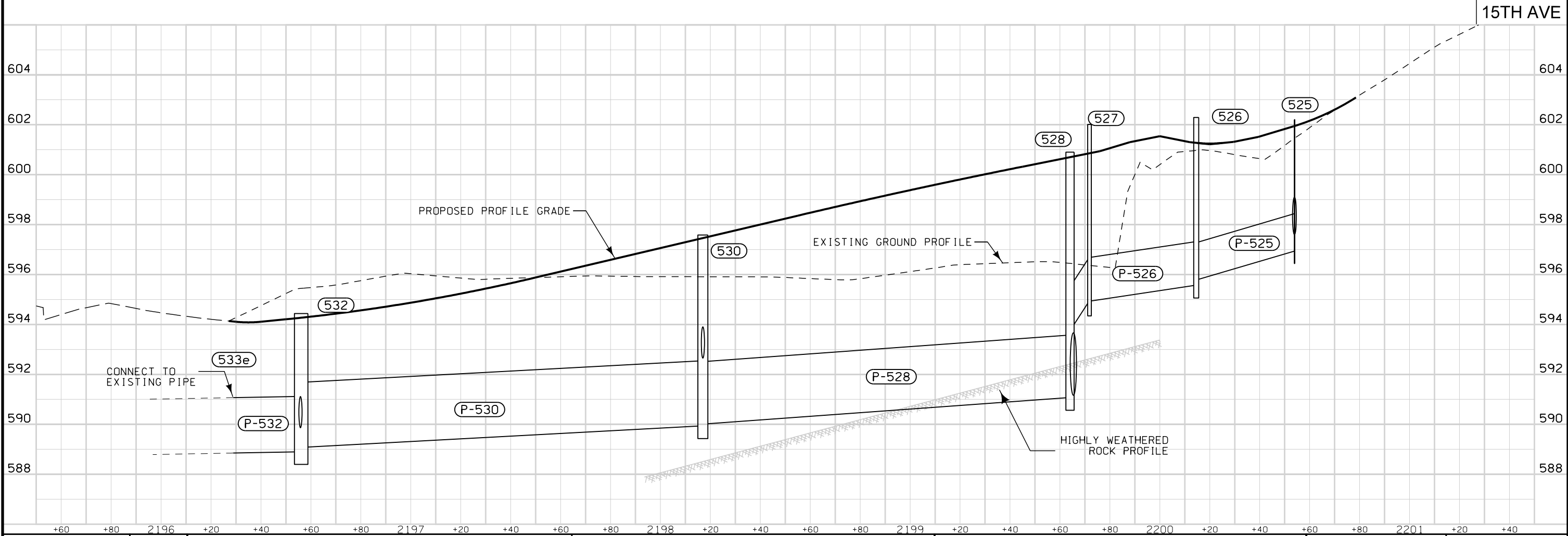
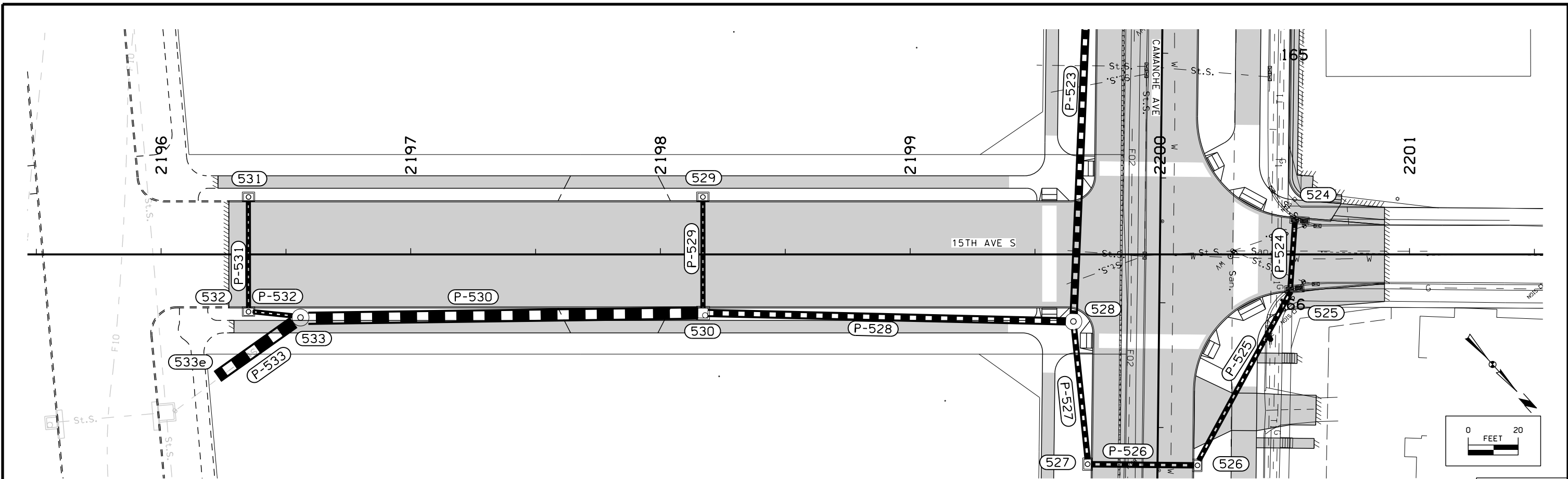

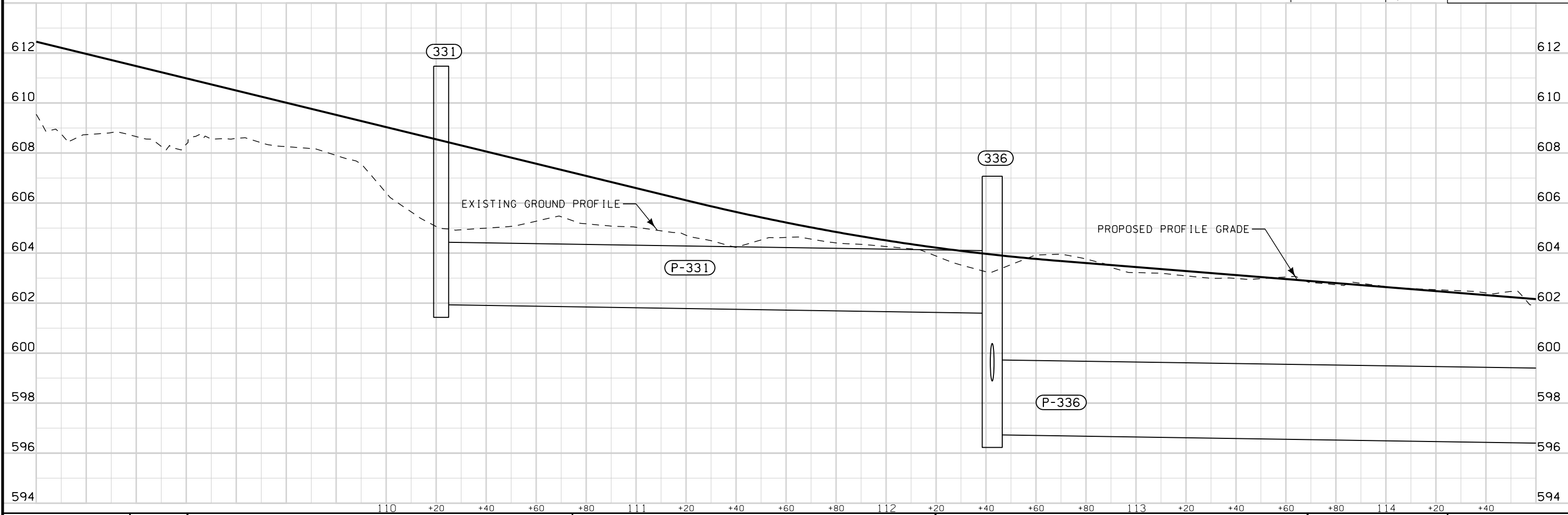
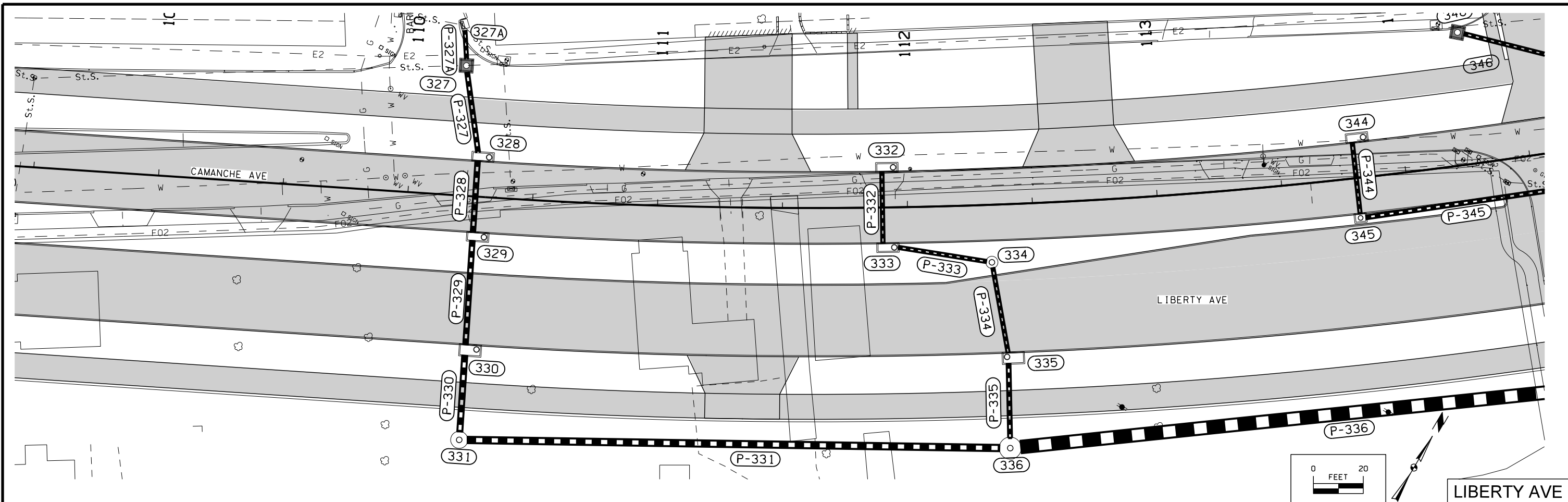

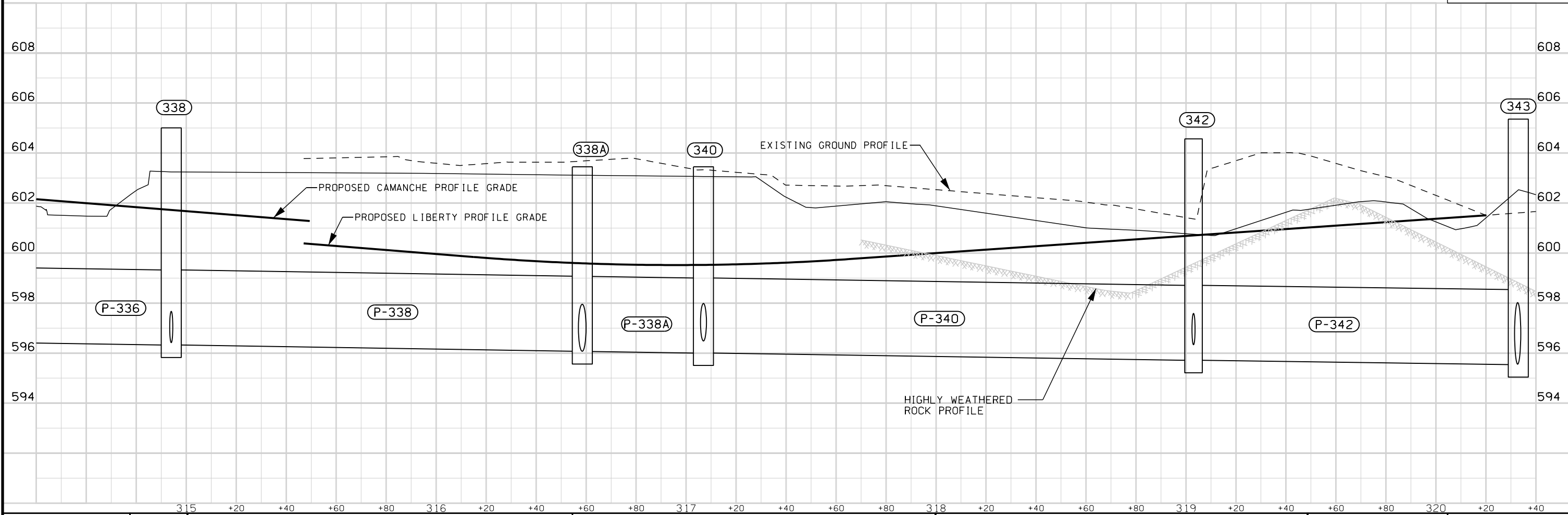
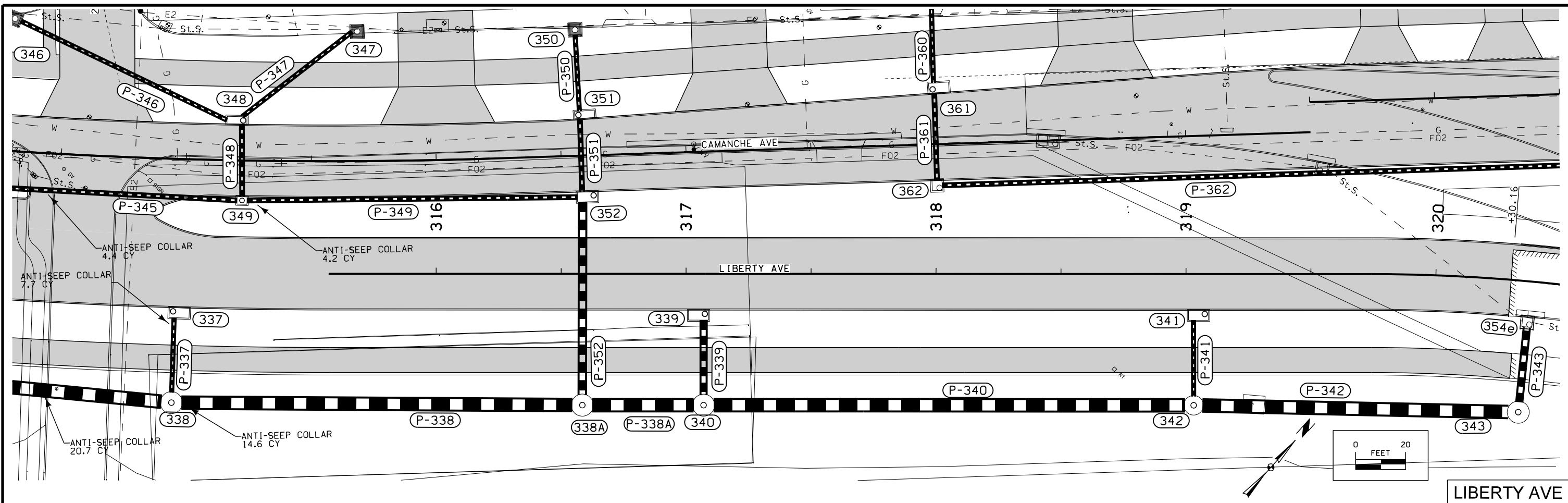

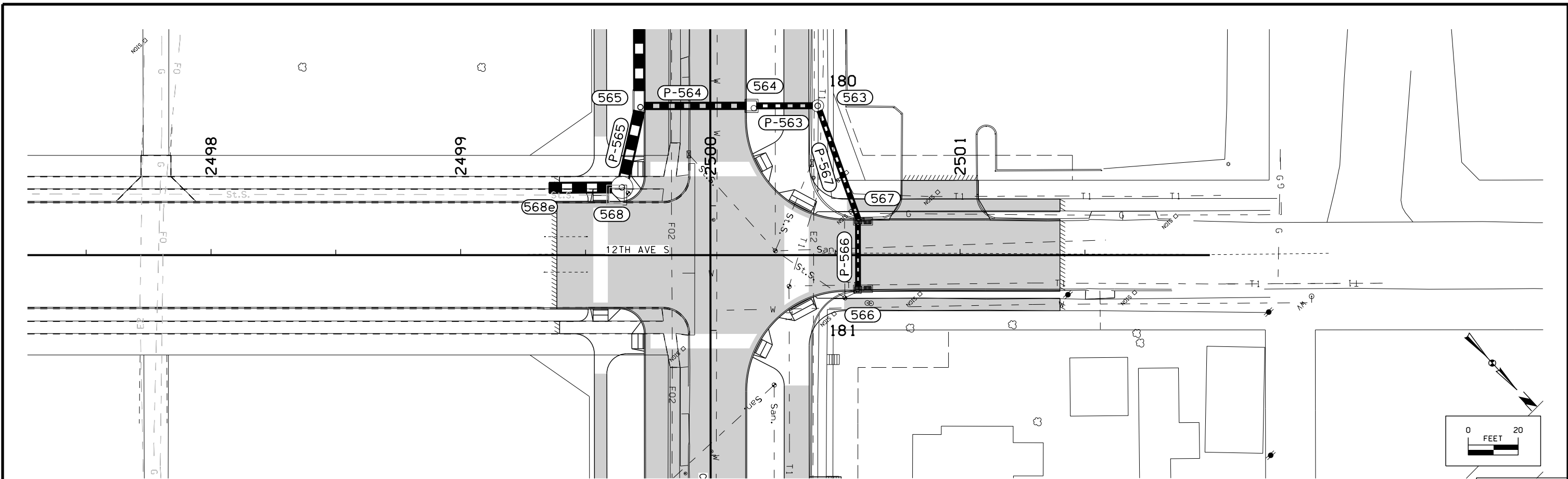

12TH AVE

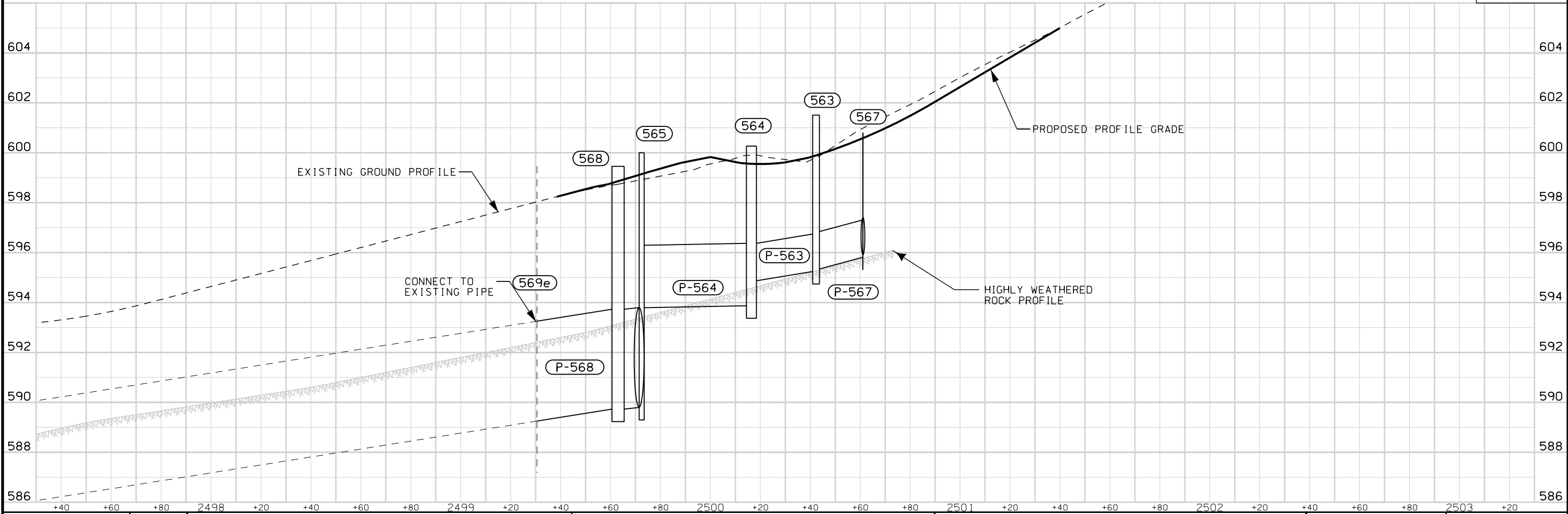

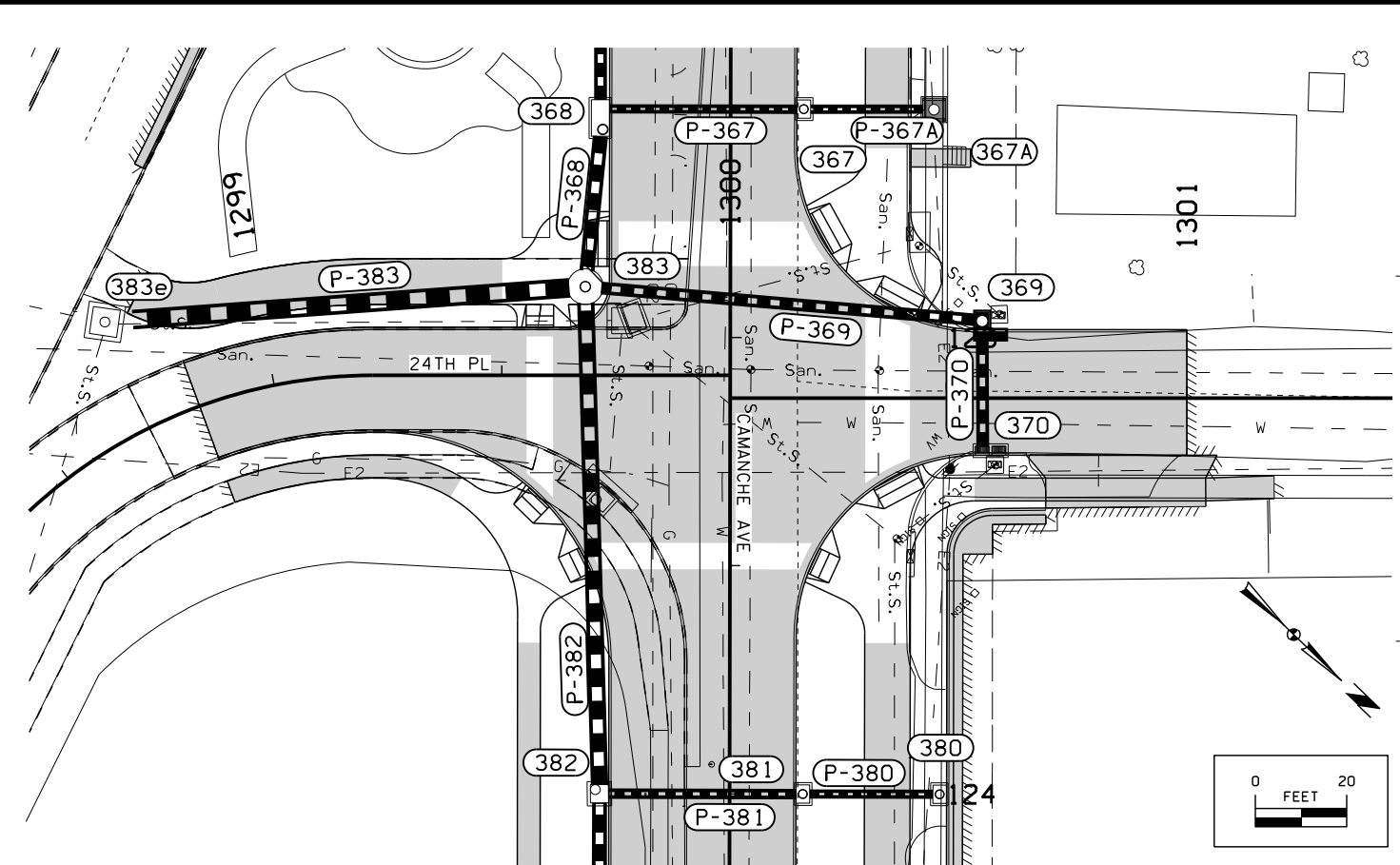

24TH PL

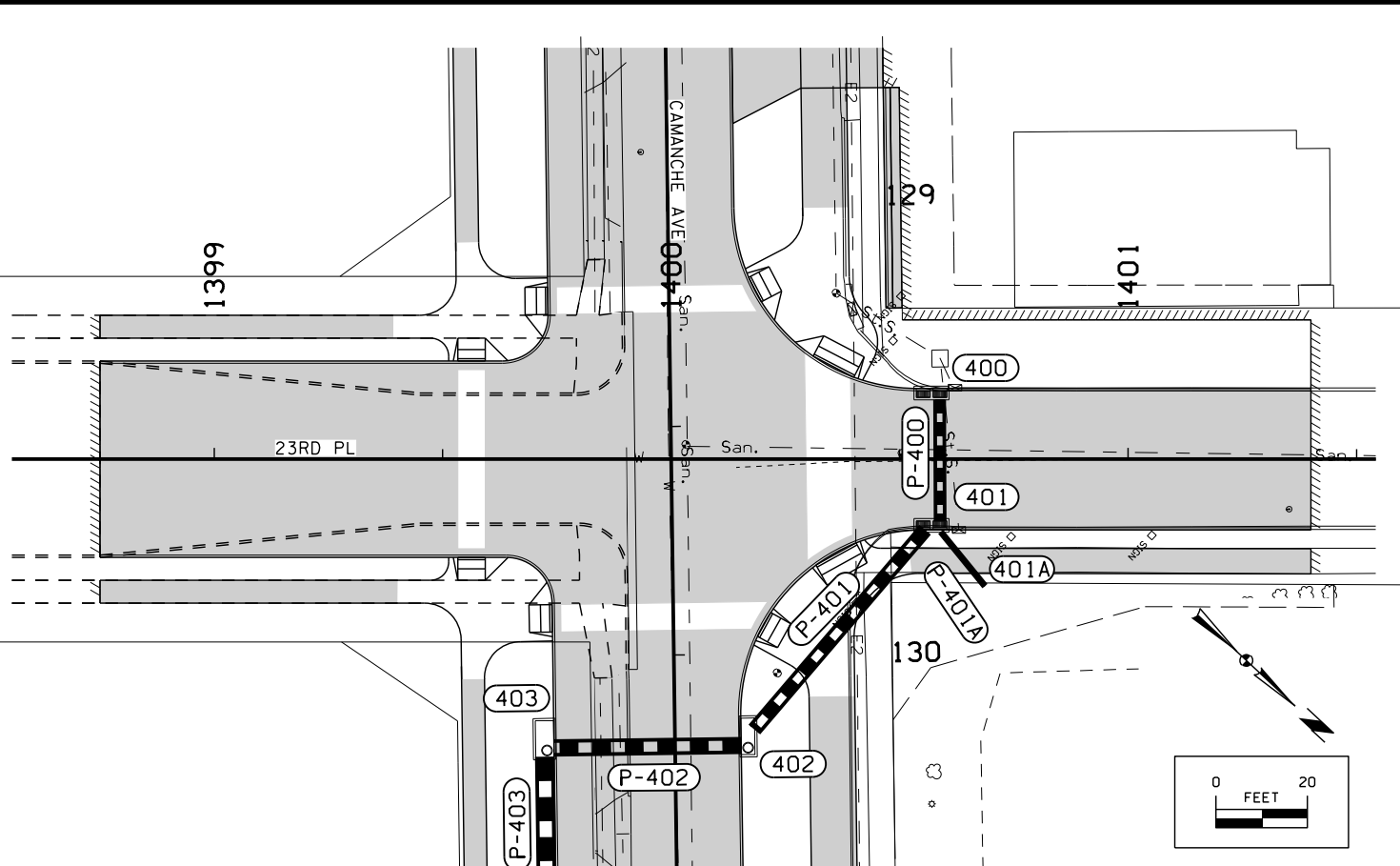

23RD PL

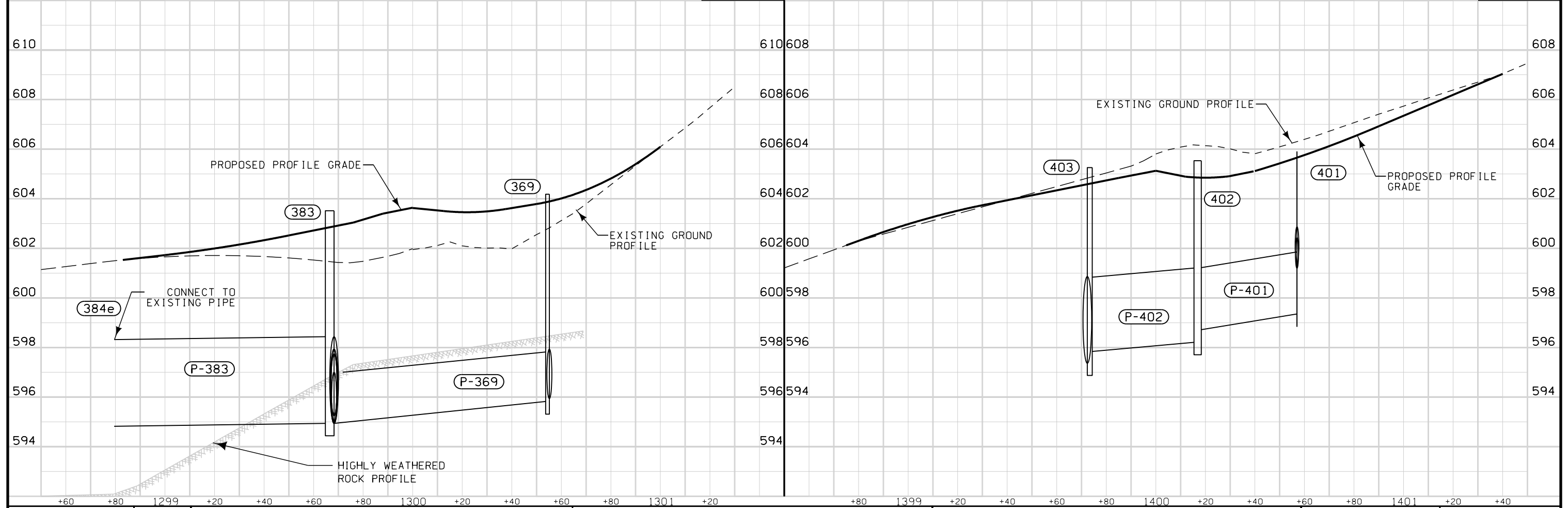



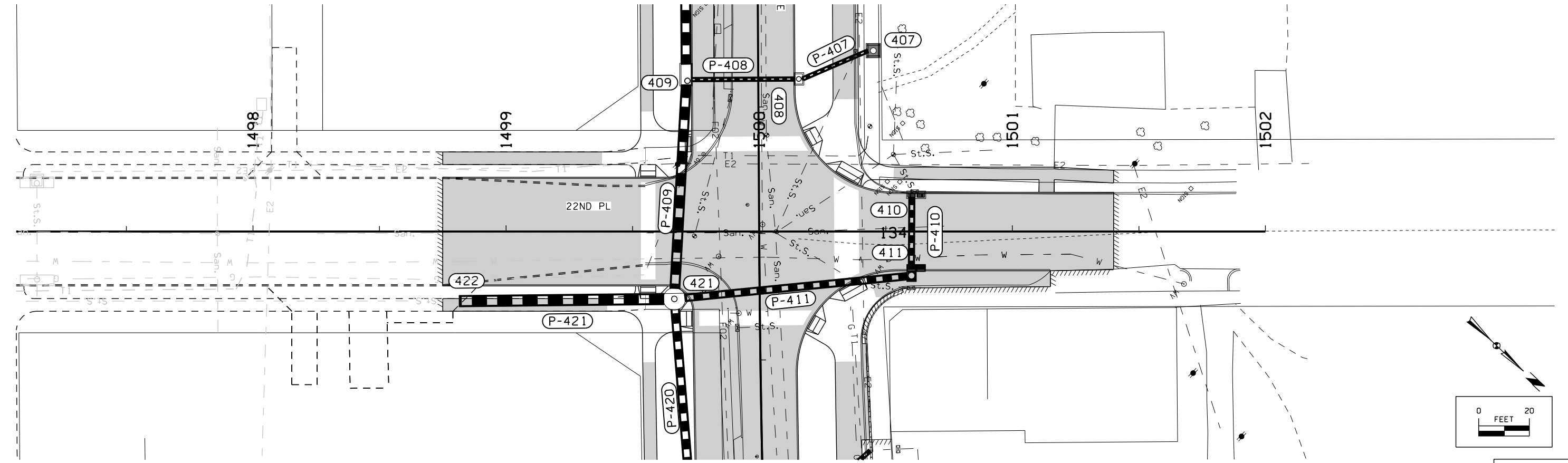

22ND PL

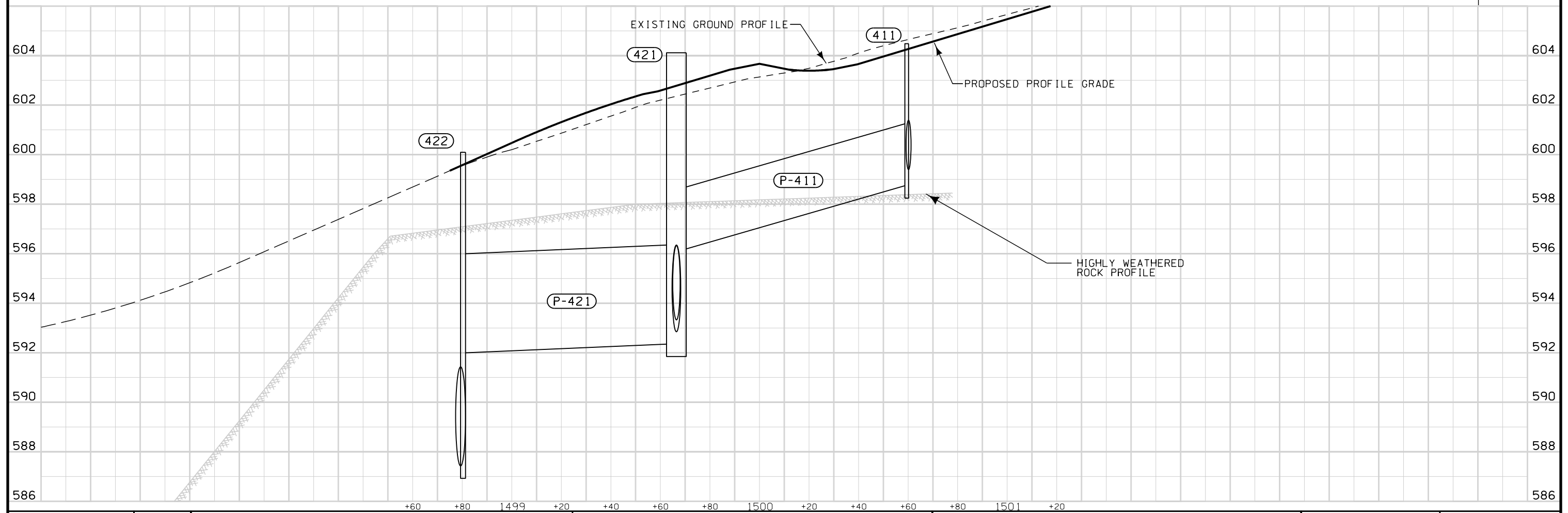

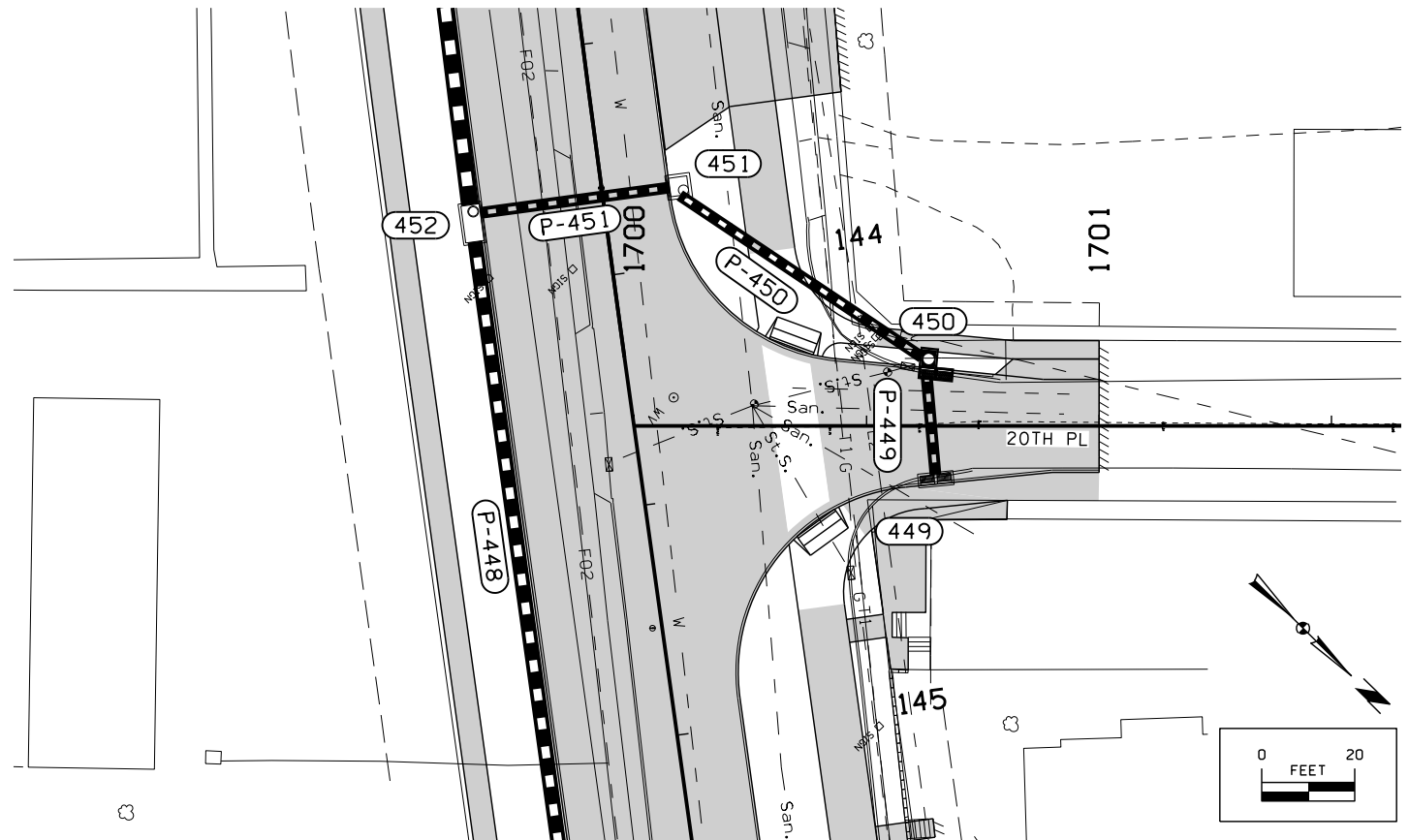

20TH PL

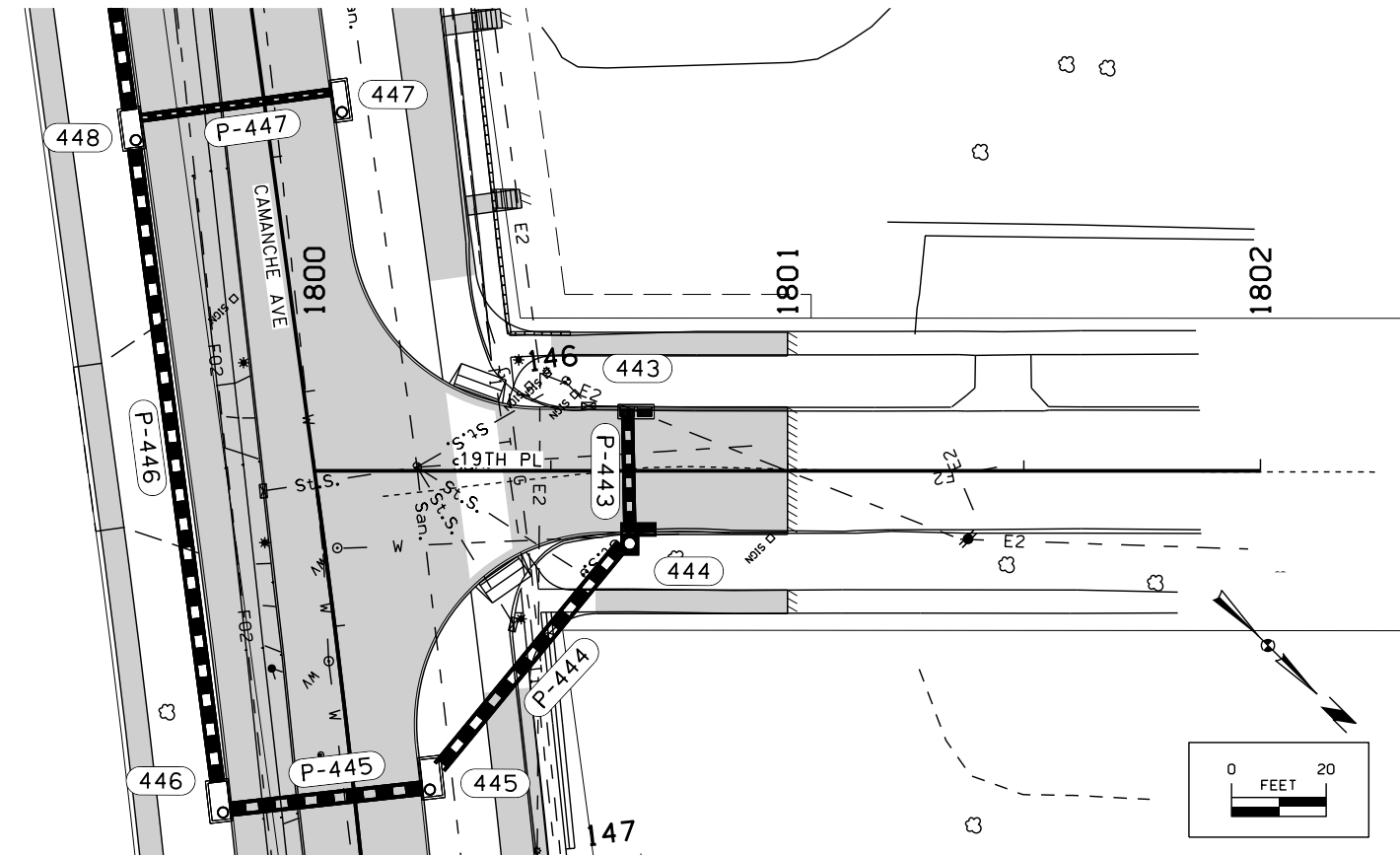

19TH PL

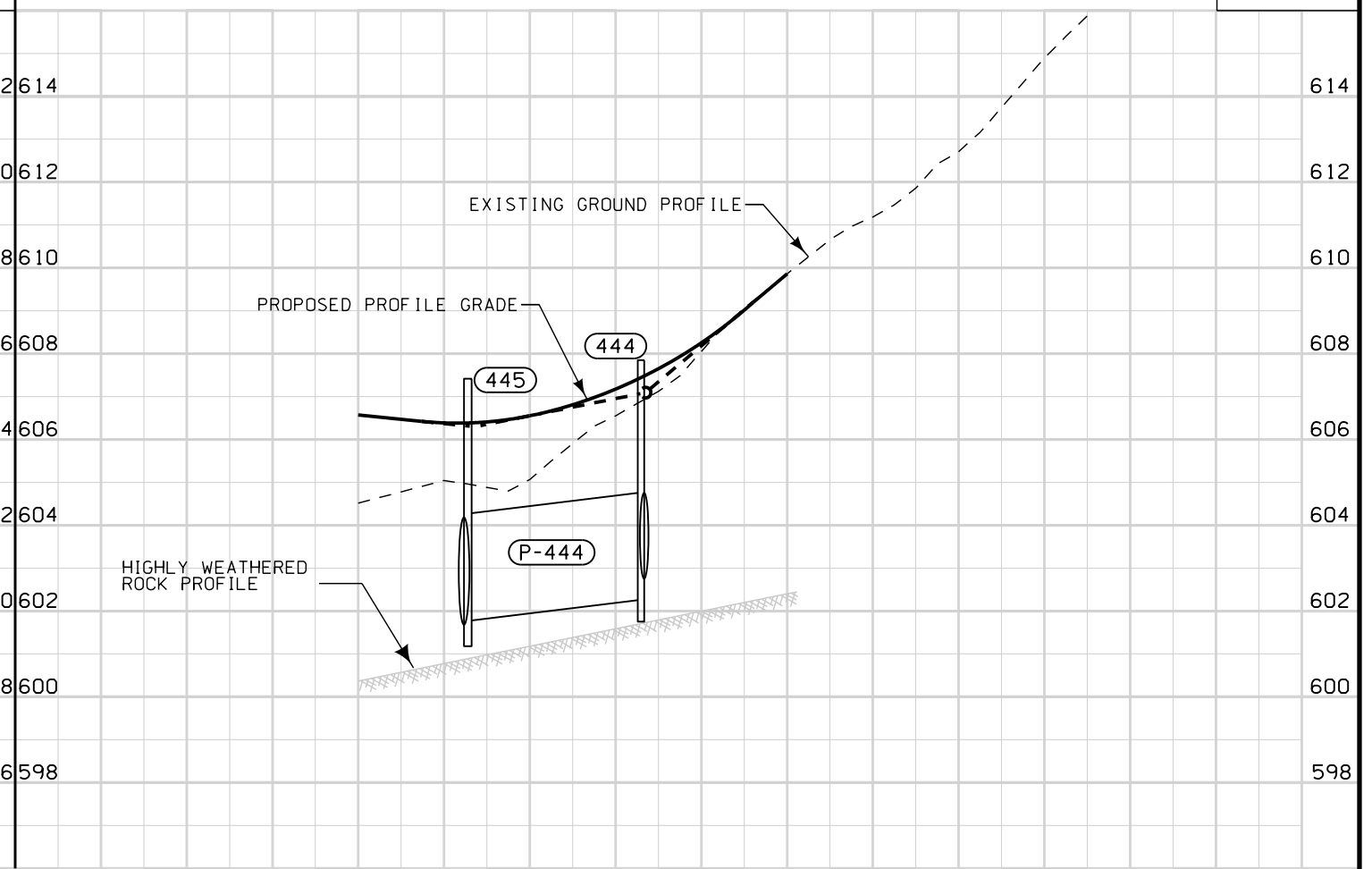
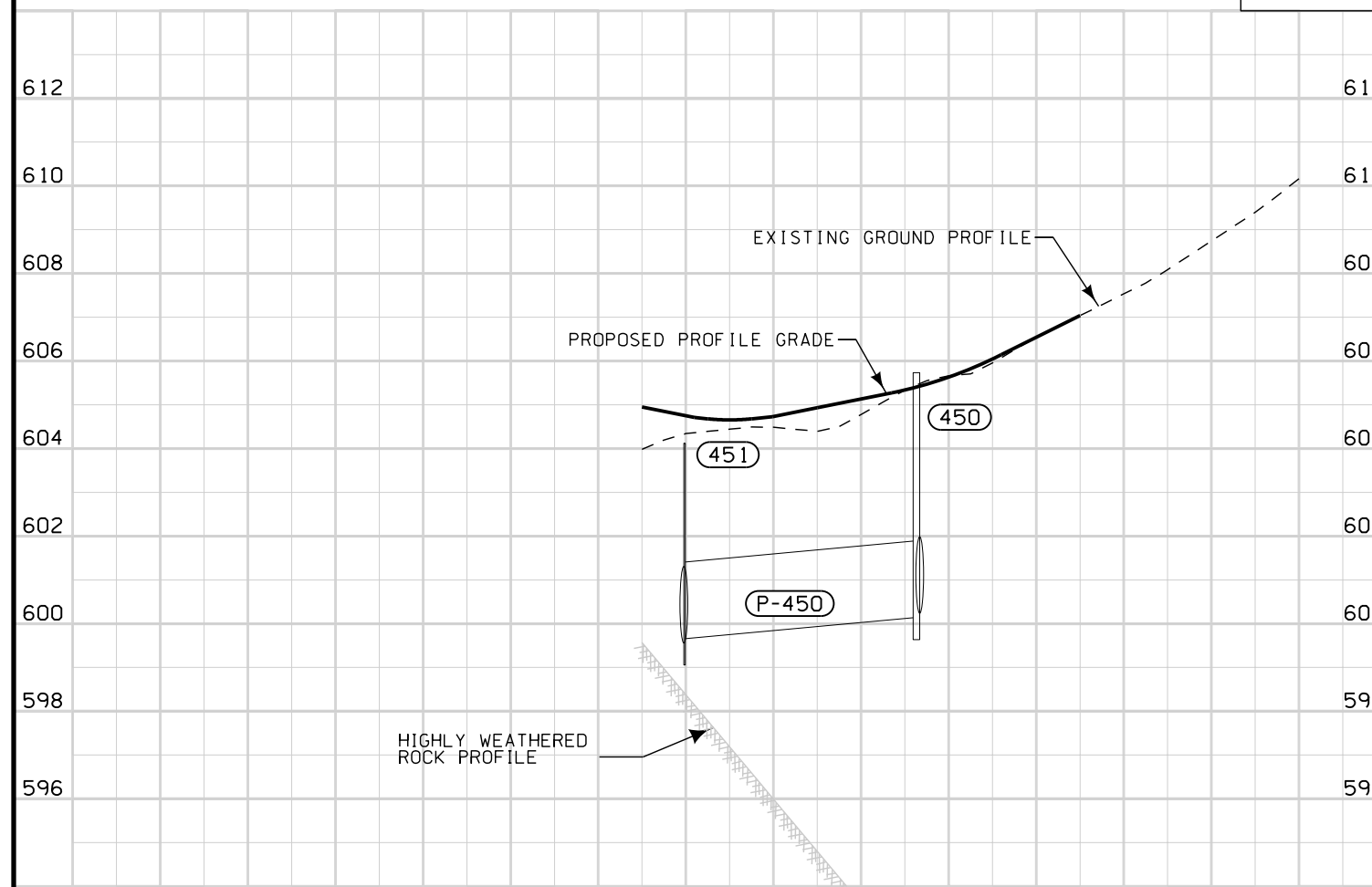

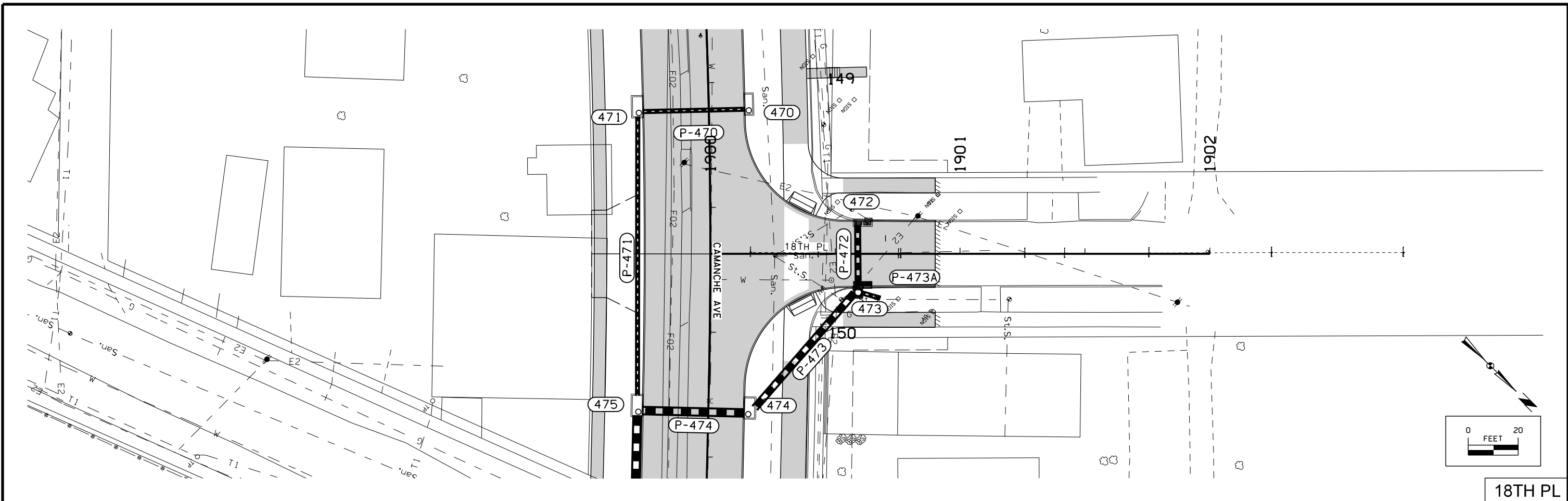

18TH PL

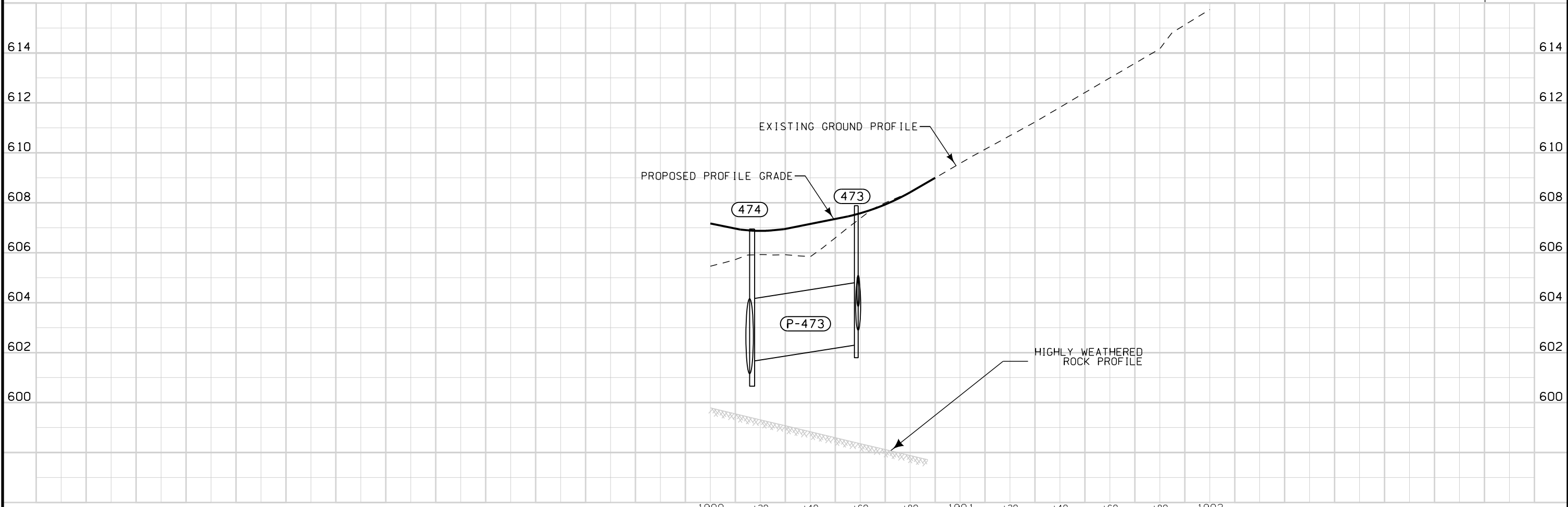

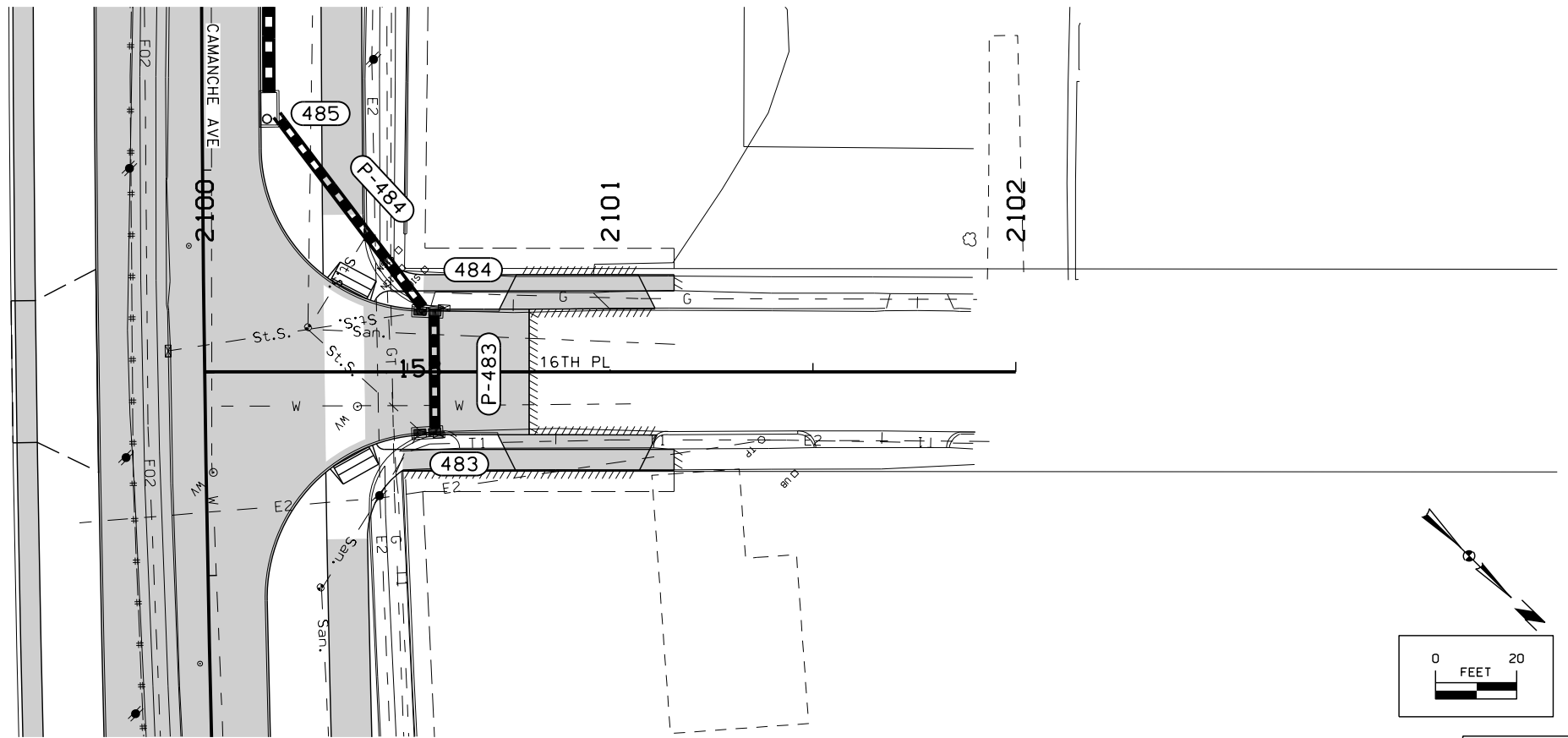

16TH PL

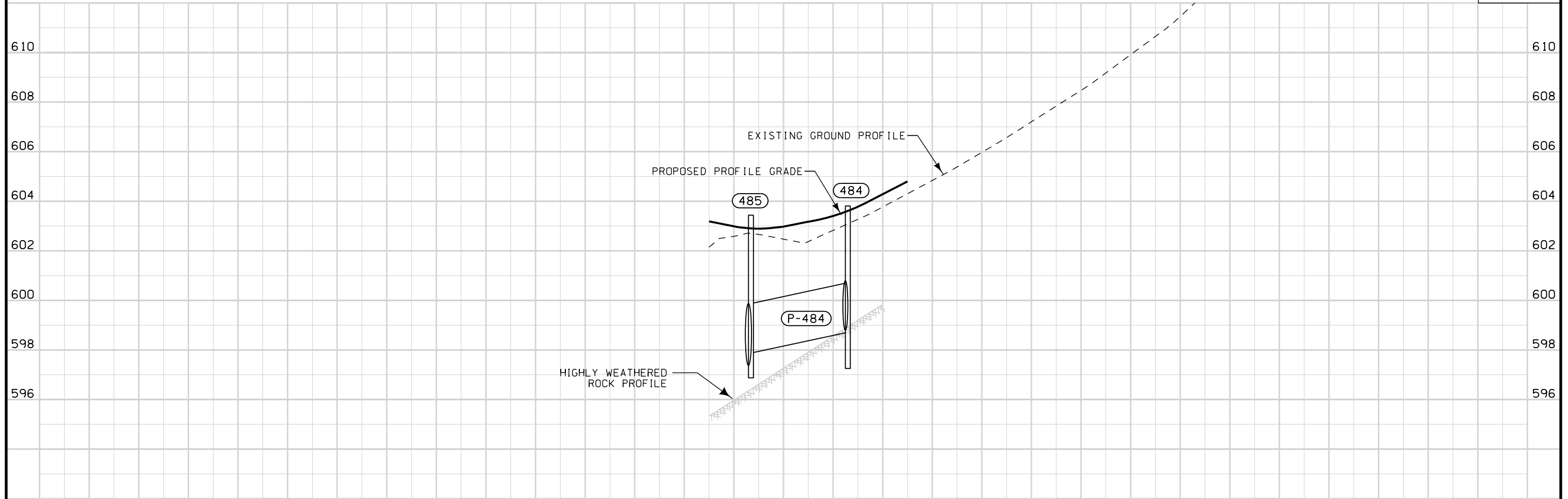

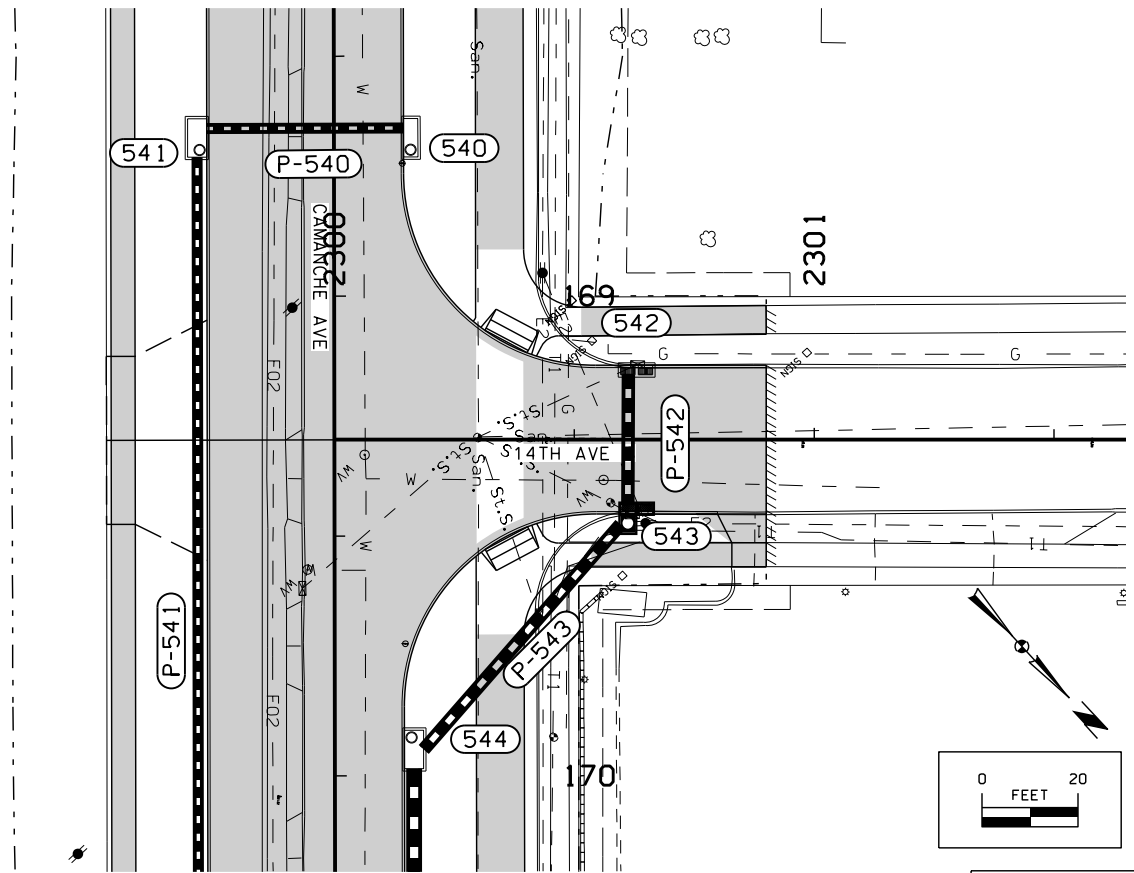

14TH AVE

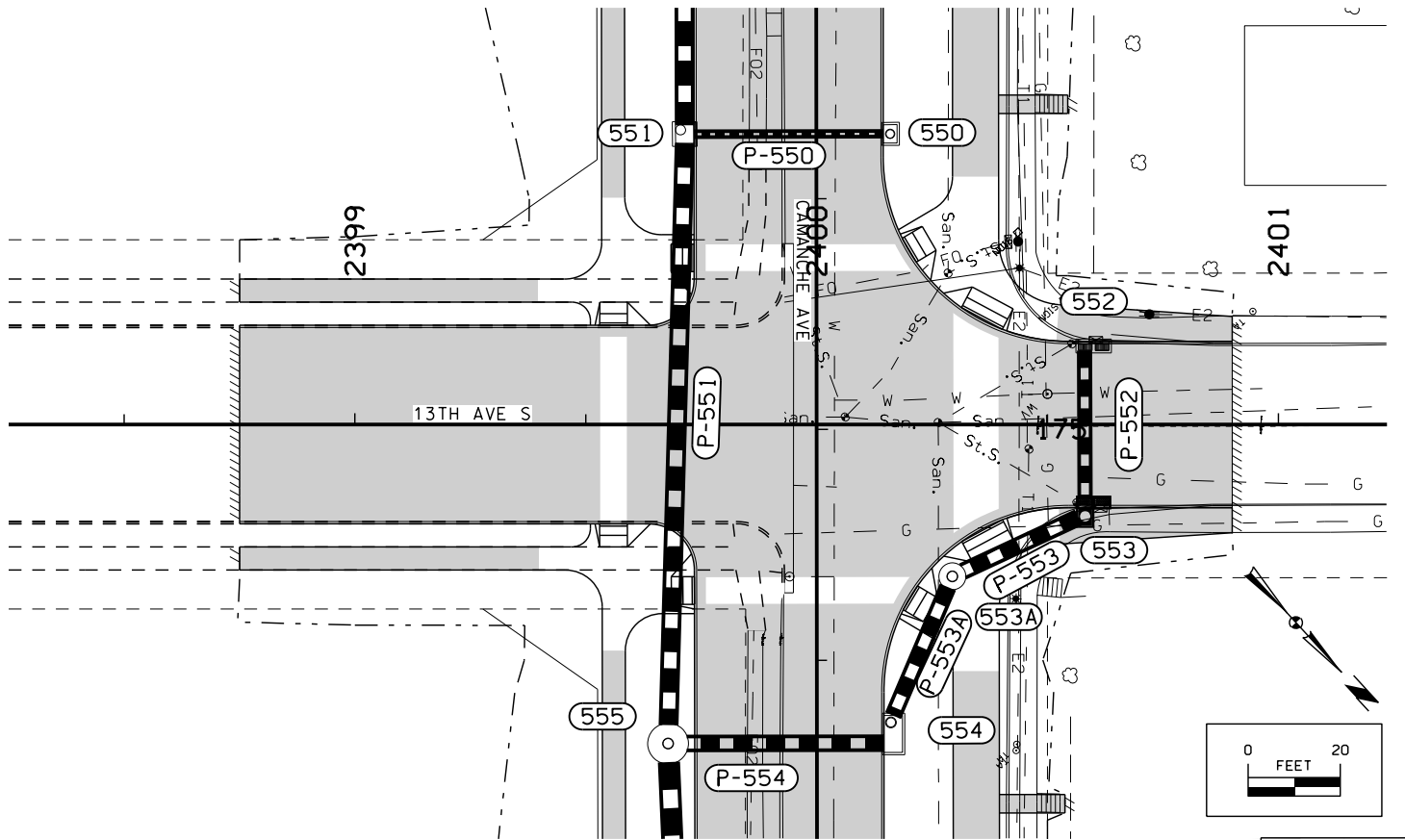

13TH AVE

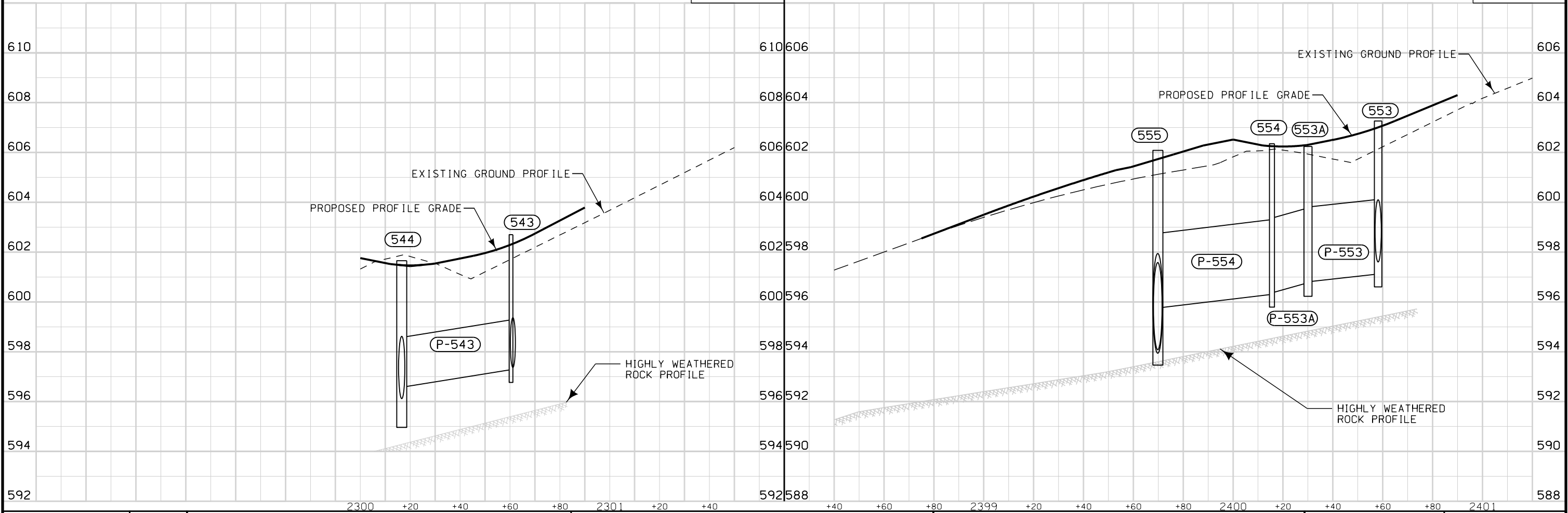

**LIST OF INTAKES AND UTILITY ACCESSSES**

\* Bid Item  
\*\* For SW-545

**LIST OF STORM SEWER PIPE**

104-58  
MOD

Design Length, Slope, and Flowlines are calculated from inside wall to inside wall along centerline of pipe. An additional 6 feet length is added to Design Length to account for estimated length to center of structures.

Number	Location Station and Offset	*Type or Standard Road Plan	Form Grade Elev.	Bottom Well Elev.	Extension Length** Feet	Notes	Line Number	Intake/Utility Access No.		Class 'D'	Pipe Diameter Inches	*Bid Length Feet	Design Length Feet	Slope %	Flow Lines		Rock Exc. Cu. Yds.	Granular Backfill Cu. Yds.	Pipe Profile Sheet No.	Notes
								From	To						Inlet Elevation	Outlet Elevation				
300	1201+49.99, 21.58' R	SW-505	627.99	618.40			P-300	300	301		15	112	106	1.00	618.40	617.40				
301	1200+39.50, 20.00' R	SW-508	621.14	616.80			P-301	301	302		15	53	47	1.00	617.30	616.83	21	108		
302	1200+45.70, 26.50' L	SW-509	620.98	616.23			P-302	302	303		15	113	107	1.00	616.73	615.67	10	76		
303	103+37.47, 17.75' L	SW-510	622.82	614.92			P-303	303	304		18	85	79	0.50	615.42	615.03		130		
304	103+37.41, 60.70' R	SW-508	622.04	614.43			P-304	304	305		15	100	94	1.00	617.53	616.60		103		
305	102+38.97, 71.51' R	SW-510	623.91	617.03			P-305	304	307		18	85	79	0.50	614.93	614.53	24	75		
306	1198+16.00, 26.50' R	SW-509	619.34	607.88			P-306	306	307		30	87	81	0.15	608.38	608.26	89	343		
307	1197+83.55, 41.40' R	SW-509	619.79	607.76			P-309	326	309		21	68	62	0.18	608.88	608.76	32	295		
308	101+33.38, 211.76' R	RF-3.30	612.00	608.00			P-320	320	321		15	47	41	1.00	612.81	612.40		15		
309	1199+06.35, 30.00' R	SW-401	620.77	608.01		48 Inch Dia	P-321	321	322		15	36	30	1.00	612.30	612.00		9		
320	106+59.06, 14.50' L	SW-509	617.52	612.31			P-322	309	306		24	91	85	0.16	608.51	608.38	161	410		
321	106+59.06, 26.50' R	SW-509	616.83	611.80			P-323	323	324		15	35	29	0.30	609.75	609.66				
322	106+59.06, 59.50' R	SW-510	615.99	608.68			P-324	324	325		15	48	42	0.30	609.66	609.54				
323	108+29.00, 14.50' L	SW-509	613.07	609.07			P-325	325	322		18	168	162	0.22	609.54	609.18		40		
324	108+29.06, 14.50' R	SW-509	613.07	609.07			P-326	322	326		21	174	168	0.18	609.18	608.88	20	438		
325	108+29.06, 59.50' R	SW-510	611.87	607.87			P-307	307	308		30	182	176	0.15	608.26	608.00	85	196		
326	104+81.00, 64.00' R	SW-401	620.30	608.38		48 Inch Dia						6								
327	110+20.00, 47.50' L	SW-513	609.26	603.67			P-327	327	328		18	37	31	0.63	604.17	603.97		5		
328	110+29.00, 14.50' L	SW-509	608.19	603.23			P-328	328	329		21	35	29	0.47	603.73	603.59		6		
329	110+29.00, 14.50' R	SW-509	608.19	602.99			P-329	329	330		21	48	42	0.60	603.49	603.24	14	5		
330	110+29.00, 59.50' R	SW-510	606.99	602.49			P-330	330	331		24	37	31	0.59	602.99	602.80	18	22		
331	110+27.00, 97.50' R	SW-401	611.46	601.46		72 Inch Dia	P-331	331	336		30	220	214	0.16	601.96	601.63		200		
332	111+92.00, 14.50' L	SW-509	604.46	600.46			P-332	332	333		15	35	29	0.80	600.98	600.75		1		
333	111+92.00, 14.50' R	SW-509	604.46	600.10			P-333	333	334		15	43	37	0.90	600.60	600.27		1		
334	112+33.00, 23.00' R	SW-401	604.10	599.16		48 Inch Dia	P-334	334	335		15	41	35	1.00	599.66	599.31		2		
335	112+40.00, 59.50' R	SW-510	602.56	598.56			P-335	335	336		18	36	30	0.49	599.06	598.91	12	20		
336	112+37.46, 97.50' R	SW-401	607.10	596.26		96 Inch Dia	P-336	336	338		ARCH	271	265	0.15	596.76	596.36	17	541		36"x58.5" Arch Pipe
337	114+99.00, 59.50' R	SW-510	600.42	596.42			P-337	337	338		15	37	31	2.01	597.05	596.45	277	24		
338	114+97.00, 97.50' R	SW-401	605.03	595.85		96 Inch Dia	P-338	338	338A		ARCH	163	157	0.16	596.35	596.11	24	160		36"x58.5" Arch Pipe
338A	316+58.50, 52.50' R	SW-401	603.48	595.59		96 Inch Dia	P-338A	338A	340		ARCH	47	41	0.15	596.09	596.03	167	28		36"x58.5" Arch Pipe
339	317+05.00, 14.50' R	SW-510	599.09	595.09			P-339	339	340		ARCH	36	30	2.07	597.13	596.51	48	4		18"x28.5" Arch Pipe
340	317+07.00, 52.50' R	SW-401	603.48	595.53		96 Inch Dia	P-340	340	342		ARCH	195	189	0.16	596.03	595.74	37	208		36"x58.5" Arch Pipe
341	319+05.00, 14.50' R	SW-510	600.52	596.31			P-341	341	342		15	37	31	1.45	596.81	596.37	235	21		
342	319+03.08, 52.50' R	SW-401	604.60	595.24		84 Inch Dia	P-342	342	343		ARCH	129	123	0.14	595.74	595.57	24	235		36"x58.5" Arch Pipe
343	320+37.90, 52.50' R	SW-401	605.38	595.07		96 Inch Dia	P-343	343	354e		ARCH	36	30	0.20	595.57	595.51	132	40		36"x58.5" Arch Pipe
344	113+82.00, 14.50' L	SW-509	602.56	598.25			P-344	344	345		15	35	29	1.37	598.75	598.36	24	4		
345	113+80.00, 14.50' R	SW-507	602.58	597.61			P-345	345	349		18	146	140	0.51	598.11	597.39		18		
346	114+30.76, 48.47' L	SW-513	602.80	598.77		4ft by 4ft	P-346	346	348		15	94	88	1.39	599.27	598.05				
347	115+68.64, 51.85' L	SW-513	602.62	597.54		4ft by 4ft	P-347	347	348		15	62	56	0.61	598.04	597.71				
348	115+20.00, 14.50' L	SW-509	601.46	596.96			P-348	348	349		18	35	29	0.57	597.46	597.29		3		
349	115+22.58, 14.50' R	SW-507	601.54	596.79			P-349	349	352		18	139	133	0.54	597.29	596.58	16	12		
350	116+57.17, 50.42' L	SW-513	602.83	596.82		4ft by 4ft	P-350	350	351		15	37	31	1.15	597.32	596.97		7		
351	116+60.00, 14.90' L	SW-509	600.67	596.22			P-351	351	352		18	36	30	0.49	596.72	596.58		2		
352	116+60.00, 14.50' R	SW-510	600.68	596.08			P-352	352	338A		ARCH	84	78	0.61	596.58	596.11	70	34		22.5"x36.25" Arch Pipe
354e	320+38.22, 14.50' R	Conn	601.23	595.01								6								
360	118+00.00, 59.50' L	SW-508	603.22	597.55			P-360	360	361		15	37	31	0.82	598.05	597.80		10		
361	118+02.00, 20.58' L	SW-510	601.21	597.07			P-361	361	362		18	41	35	0.35	597.57	597.45				
362	118+00.00, 14.50' R	SW-508	601.31	596.92			P-362	362	364		18	256	250	0.35	597.42	596.55		37		
363	120+56.00, 14.50' L	SW-509	601.72	597.72			P-363	363	364		15	47	41	0.80	598.26	597.93	119			
364	120+56.00, 26.50' R	SW-510	601.34	595.81			P-364	364	366		24	93	87	0.22	596.31	596.12		33		
365	121+51.00, 14.50' L	SW-509	602.31	598.31			P-365	365	366		15	47	41	0.94	598.90	598.51	78			
366	121+51.00, 26.50' R	SW-510	601.92	595.52			P-366	366	368		24	99	93	0.22	596.02	595.82		82		
367	122+50.00, 14.50' L	SW-507	603.25	599.25			P-367	367	368		15	47	41	1.50	599.84	599.23	46			
367A	122+49.96, 48.43' L	SW-513	602.70	598.70			P-367A	367A	367		15	35	29	0.61	600.04	599.86				
368	122+52.00, 26.50' R	SW-510	602.88	594.82			P-368	368	383		30	36	30	0.25	595.32	595.25		40		
369	1300+57.00, 15.00' L	SW-506	603.91	597.73			P-369	369	383		24	89	83	2.17	598.23	596.45	17	51		
370	1300+57.00, 12.50' R	SW-505	603.66	598.32			P-370	370	369		24	30	24	2.10	598.82	598.33	25	6		
371	128+22.96, 44.50' L	SW-513	603.00	598.71		4ft by 4ft	P-371	371	372		15	31	25	1.24	599.21	598.90				
372	128+25.00, 14.50' L	SW-509	602.31	598.05			P-372	372	373		18	47	41	1.16	598.55	598.07		1		
373	128+25.00, 26.50' R	SW-510	601.93	597.22			P-373	373	375		21	115	109	0.46	597.72	597.23		6		
374	127+08.00, 14.50' L	SW-509	601.84	597.84			P-374	374	375		15	47	41	1.54	598.36	597.73	13			
375	127+08.00, 26.50' R	SW-510	601.46	596.06			P-375	375	376		30	140	134	0.35	596.56	596.09		5		
376	125+66.00, 26.50' R	SW-510	600.96	595.49			P-376	376	379		30	64	58	0.40	595.99	595.76	39	8		
377	125+66.00, 14.50' L	SW-509	601.34	597.29			P-377	377	378		15	42	36	0.97	597.79	597.44	30			
378	125+22.00, 14.50' L	SW-509	601.46	596.69			P-378	378	379		18	51	45	0.80	597.19	596.84		7		
379	125+00.00, 26.50' R	SW-510	601.21	595.16			P-379	379	382		30	100	94	0.43	595.66	595.26		58		

**LIST OF INTAKES AND UTILITY ACCESSES**

\* Bid Item  
\*\* For SW-545

**LIST OF STORM SEWER PIPE**

104-58  
MOD

Design Length, Slope, and Flowlines are calculated from inside wall to inside wall along centerline of pipe. An additional 6 feet length is added to Design Length to account for estimated length to center of structures.

Number	Location Station and Offset	*Type or Standard Road Plan	Form Grade Elev.	Bottom Well Elev.	Extension Length** Feet	Notes	Line Number	Intake/Utility Access No.		Class 'D'	Pipe Diameter Inches	*Bid Length Feet	Design Length Feet	Slope %	Flow Lines		Rock Exc. Cu. Yds.	Granular Backfill Cu. Yds.	Pipe Profile Sheet No.	Notes
								From	To						Inlet Elevation	Outlet Elevation				
400	1400+62.00, 15.50' L	SW-505	603.53	597.44			P-400	400	401	24	33	27	2.02	597.94	597.39					
401	1400+62.00, 15.50' R	SW-505	603.53	596.35			P-401	401	402	30	71	65	0.97	596.85	596.22					
402	130+21.00, 14.50' L	SW-509	603.09	595.21			P-402	402	403	36	47	41	0.89	595.71	595.34					
403	130+21.00, 26.50' R	SW-510	602.71	594.37		SW-510 (MOD 5x8)	P-403	403	406	42	92	86	0.44	594.87	594.49					
404	131+13.00, 46.50' L	SW-513	604.00	599.54		4ft by 4ft	P-404	404	405	15	33	27	0.60	600.04	599.88					
405	131+15.00, 14.50' L	SW-509	603.47	599.28			P-405	405	406	15	47	41	0.65	599.78	599.51					
406	131+15.00, 26.50' R	SW-510	603.09	593.89		SW-510 (MOD 5x8)	P-406	406	409	42	220	214	0.47	594.39	593.38	25				
407	133+28.00, 46.50' L	SW-513	604.00	599.54		4ft by 4ft	P-407	407	408	15	36	30	1.15	600.04	599.71					
408	133+39.00, 14.50' L	SW-507	603.64	599.11			P-408	408	409	15	47	41	1.66	599.61	598.93					
409	133+37.00, 26.50' R	SW-510	603.26	592.78		SW-510 (MOD 5x8)	P-409	409	421	42	87	81	0.54	593.28	592.85					
410	1500+62.00, 15.50' L	SW-505	604.10	599.25			P-410	410	411	24	33	27	1.33	599.75	599.39	105				
411	1500+62.00, 15.50' R	SW-506	604.00	598.24			P-411	411	421	30	95	89	2.88	598.74	596.19					
412	138+94.50, 14.50' L	SW-509	602.89	598.48			P-412	412	413	15	48	42	0.93	598.98	598.60	27				
413	138+94.50, 26.50' R	SW-510	602.51	597.85			P-413	413	416	18	162	156	0.74	598.35	597.19	30				
414	137+32.00, 54.00' L	SW-513	603.00	598.56		4ft by 4ft	P-414	414	415	18	42	36	1.83	599.06	598.40					
415	137+30.00, 14.50' L	SW-545	602.11	597.55			P-415	415	416	21	47	41	2.61	598.05	596.98					
416	137+32.00, 26.50' R	SW-510	601.72	595.70			P-416	416	418	30	113	107	0.71	596.20	595.44	95				
417	136+18.00, 14.50' L	SW-509	602.46	597.76			P-417	417	418	15	47	41	0.56	598.26	598.03	9				
418	136+18.00, 26.50' R	SW-510	602.08	594.84			P-418	418	420	30	107	101	0.86	595.34	594.48	109				
419	135+10.00, 14.50' L	SW-509	602.92	598.92			P-419	419	420	15	47	41	0.94	599.51	599.12					
420	135+10.00, 26.50' R	SW-510	602.53	593.51		SW-510 (MOD 5x8)	P-420	420	421	36	84	78	0.88	594.01	593.33	117				
421	134+25.52, 33.74' R	SW-401	603.32	591.85		96 Inch Dia	P-421	421	422	48	88	82	0.43	592.35	592.00	106				
422e	1498+79.33, 27.51' R	Conn	600.09	586.93							6									
440	140+50.99, 57.53' L	SW-507	604.61	599.59			P-440	440	441	15	41	35	1.05	600.09	599.72					
441	1600+61.00, 14.48' L	SW-505	604.50	598.97			P-441	441	442	18	33	27	0.67	599.47	599.30					
442	1600+69.00, 15.00' R	SW-506	604.67	598.45			P-442	442	457	21	93	87	0.96	598.95	598.12					
443	1800+68.00, 13.50' L	SW-505	607.16	602.54			P-443	443	444	24	29	23	1.27	603.04	602.75					
444	1800+68.50, 13.50' R	SW-506	607.31	601.75			P-444	444	445	30	67	61	0.78	602.25	601.78					
445	146+84.00, 14.50' L	SW-510	606.87	601.18			P-445	445	446	30	47	41	0.89	601.68	601.32					
446	146+84.00, 26.50' R	SW-510	606.48	600.72			P-446	446	448	30	142	136	0.81	601.22	600.12	16				
447	145+40.00, 14.50' L	SW-509	605.60	601.08			P-447	447	448	15	47	41	0.67	601.58	601.31					
448	145+40.00, 26.50' R	SW-510	605.22	599.52			P-448	448	452	30	154	148	1.05	600.02	598.47	43				
449	1700+65.00, 12.49' R	SW-505	605.28	599.96			P-449	449	450	21	27	21	1.05	600.46	600.24					
450	1700+65.00, 12.30' L	SW-506	605.29	599.64			P-450	450	451	21	69	63	0.76	600.14	599.66					
451	143+83.00, 14.50' L	SW-508	604.22	599.06			P-451	451	452	21	48	42	0.84	599.56	599.22					
452	143+85.00, 26.50' R	SW-510	603.85	597.47		SW-510 (MOD 5x8)	P-452	452	454	36	114	108	0.55	597.97	597.38	32				
453	142+68.00, 14.50' L	SW-545	603.70	599.56			P-453	453	454	15	47	41	2.24	600.06	599.14					
454	142+70.00, 26.50' R	SW-510	603.31	596.78		SW-510 (MOD 5x8)	P-454	454	457	36	149	143	1.31	597.28	595.41	152				
455	141+67.00, 61.19' L	SW-507	604.36	599.63			P-455	455	442	15	49	43	1.10	600.13	599.67					
456	141+67.00, 14.50' L	SW-507	604.02	600.02			P-456	456	455	15	47	41	0.92	600.61	600.23					
457	141+21.51, 32.07' R	SW-401	604.27	594.81		72 Inch Dia	P-457	457	459	36	119	113	2.64	595.31	592.36					
458	1598+60.00, 21.50' L	SW-507	599.88	594.56			P-458	458	459	15	49	43	2.16	595.06	594.13					
459	1598+60.00, 21.50' R	SW-508	599.88	591.76		SW-508 (MOD 5x4)	P-459	459	460e	36	147	141	2.44	592.26	588.83					
460e	1597+15.76, 24.47' R	Conn	595.26	588.23							6									
470	149+09.00, 14.50' L	SW-509	607.24	602.63			P-470	470	471	15	48	42	1.13	603.13	602.66					
471	149+09.00, 26.50' R	SW-510	606.85	602.06			P-471	471	475	15	118	112	1.13	602.56	601.30					
472	1900+61.00, 13.50' L	SW-505	607.32	602.60			P-472	472	473	24	29	23	0.88	603.10	602.90					
473	1900+61.00, 13.50' R	SW-506	607.40	601.80			P-473	473	474	30	68	62	1.02	602.30	601.67					
474	150+30.00, 14.50' L	SW-510	606.51	600.66		SW-510 (MOD 5x8)	P-474	474	475	36	47	41	0.46	601.16	600.97					
475	150+30.00, 26.50' R	SW-510	606.12	599.05		SW-510 (MOD 5x8)	P-475	475	477	36	88	82	0.54	599.55	599.10	25				
476	151+20.00, 14.50' L	SW-509	605.97	601.97			P-476	476	477	15	47	41	0.94	602.56	602.18					
477	151+20.00, 26.50' R	SW-510	605.58	598.50		SW-510 (MOD 5x8)	P-477	477	480	36	129	123	0.58	599.00	598.29	15				
478	152+36.00, 49.37' L	SW-509	604.40	600.40			P-478	478	479	15	38	32	2.53	602.25	601.50					
479	152+51.00, 14.50' L	SW-510	605.16	598.32			P-479	479	480	30	47	41	0.30	598.82	598.69					
480	152+51.00, 26.50' R	SW-510	604.78	597.69		SW-510 (MOD 5x8)	P-480	480	495	36	34	28	0.74	598.19	597.98					
481	2000+56.00, 13.50' R	SW-505	604.90	600.27			P-481	481	482	18	29	23	1.18	600.77	600.50					
482	2000+56.00, 13.50' L	SW-506	605.34	599.90			P-482	482	479	18	60	54	1.09	600.40	599.81					
483	2100+63.00, 15.50' R	SW-505	603.58	598.68			P-483	483	484	24	33	27	1.42	599.18	598.79					
484	2100+63.00, 15.50' L	SW-506	603.61	598.19			P-484	484	485	24	71	65	1.24	598.69	597.89					
485	157+35.00, 14.50' L	SW-510	602.98	596.88			P-485	485	487	30	70	64	0.70	597.38	596.93	8				
486	156+59.00, 51.38' L	SW-509	602.96	598.96			P-486	486	487	18	36	30	3.64	599.78	598.84					
487	156+63.00, 14.50' L	SW-510	602.50	595.92		SW-510 (MOD 5x8)	P-487	487	488	36	47	41	0.51	596.42	596.21	9				
488	156+63.00, 26.50' R	SW-510	602.11	595.61		SW-510 (MOD 5x8)	P-488	488	490	36	112	106	0.48	596.11	595.60	21				
489	155+50.00, 14.50' L	SW-509	601.91	597.34			P-489	489	490	15	47	41	1.13	597.84	597.37					
490	155+50.00, 26.50' R	SW-510	601.53	594.59		SW-510 (MOD 5x8)	P-490	490	494	42	104	98	0.32	595.09	594.78					
491	153+79.00, 50.51' L	SW-507	603.90	599.90			P-491	491	492	15	37	31	2.02	600.77	600.20					
492	153+78.74, 14.50' L	SW-507	603.72	599.61			P-492	492	493	15	67	61	2.09	600.11	598.85					

**LIST OF INTAKES AND UTILITY ACCESSSES**

\* Bid Item  
\*\* For SW-545

**LIST OF STORM SEWER PIPE**

104-58  
MOD

Design Length, Slope, and Flowlines are calculated from inside wall to inside wall along centerline of pipe. An additional 6 feet length is added to Design Length to account for estimated length to center of structures.

Number	Location Station and Offset	*Type or Standard Road Plan	Form Grade Elev.	Bottom Well Elev.	Extension Length** Feet	Notes	Line Number	Intake/Utility Access No.		Class 'D'	Pipe Diameter Inches	*Bid Length Feet	Design Length Feet	Slope %	Flow Lines		Rock Exc. Cu. Yds.	Granular Backfill Cu. Yds.	Pipe Profile Sheet No.	Notes
								From	To						Inlet Elevation	Outlet Elevation				
498e	1996+08.00, 22.54' L	Conn	595.20	588.11			P-497	497	498e		42	209	203	0.91	590.45	588.61		171		
510	159+05.00, 14.50' L	SW-509	601.75	597.44																
511	159+05.00, 26.50' R	SW-510	601.47	596.94			P-510	510	511		15	47	41	1.02	597.94	597.52		4		
512	160+35.00, 52.08' L	SW-509	601.95	596.98			P-511	511	514		15	129	123	0.96	597.44	596.27		10		
513	160+35.00, 14.47' L	SW-510	600.35	596.09			P-512	512	513		15	37	31	2.36	597.48	596.84		2		
514	160+35.00, 26.50' R	SW-510	599.96	595.52			P-513	513	514		18	47	41	1.14	596.59	596.12		1		
515	161+65.00, 14.50' L	SW-509	599.77	595.61			P-514	514	516		18	129	123	0.78	596.02	595.06		11		
516	161+65.00, 26.50' R	SW-510	599.38	594.31			P-515	515	516		15	47	41	1.69	596.11	595.41		3		
517	162+77.00, 51.85' L	SW-509	601.40	596.14			P-516	516	519		21	114	108	0.81	594.81	593.94		26		
518	162+81.00, 14.50' L	SW-509	599.42	595.16			P-517	517	518		15	38	32	3.02	596.64	595.91		1		
519	162+81.00, 26.50' R	SW-509	599.04	593.19			P-518	518	519		18	47	41	1.68	595.66	594.97		2		
520	163+94.00, 51.59' L	SW-509	601.00	596.84			P-519	519	523		24	129	123	0.85	593.69	592.65		89		
521	164+65.00, 51.44' L	SW-509	600.60	596.60			P-520	520	522		15	42	36	2.95	597.34	596.53		1		
522	164+12.00, 14.50' L	SW-509	600.04	595.88			P-521	521	522		15	67	61	2.49	598.04	596.63				
523	164+12.00, 26.50' R	SW-510	599.65	591.65			P-522	522	523		18	47	41	1.93	596.38	595.59		1		
524	2200+59.00, 14.51' L	SW-505	601.83	597.22			P-523	523	528		30	195	189	0.52	592.15	591.17		348		
525	2200+59.00, 14.50' R	SW-505	601.98	596.44			P-524	524	525		18	32	26	2.72	597.72	597.04	55	5		
526	166+65.00, 14.50' L	SW-508	601.85	595.06			P-525	525	526		18	87	81	1.40	596.94	595.81		44		
527	166+65.00, 26.50' R	SW-507	601.46	594.34			P-526	526	527		21	47	41	1.50	595.56	594.94		37		
528	166+07.88, 34.32' R	SW-401	601.34	590.57		72 Inch Dia	P-527	527	528		21	59	53	1.60	594.84	594.00		52		
529	2198+17.00, 21.50' L	SW-507	597.03	592.62			P-528	528	530		30	150	144	0.72	591.07	590.03		243		
530	2198+17.00, 21.50' R	SW-508	597.03	589.43		SW-508 (MOD 5x4)	P-529	529	530		15	49	43	1.08	593.12	592.66		7		
531	2196+35.00, 21.50' L	SW-507	593.65	589.24			P-530	530	532		ARCH	180	174	0.48	589.93	589.09		59		31.3"x51.1" Arch Pipe
532	2196+37.00, 21.50' R	SW-510	593.66	588.59		SW-510 (MOD 5x8)	P-531	531	532		15	49	43	1.08	589.74	589.27		7		
533e	2196+02.07, 63.50' R	Conn	594.92	588.35			P-532	532	533e		ARCH	58	52	0.46	589.09	588.85		3		31.3"x51.1" Arch Pipe
540	168+67.00, 14.50' L	SW-509	601.72	596.94																
541	168+67.00, 26.50' R	SW-510	601.34	596.61			P-540	540	541		18	47	41	0.56	597.44	597.21		4		
542	2300+63.00, 15.50' L	SW-505	602.19	597.24			P-541	541	546		18	188	182	0.62	597.11	595.99		34		
543	2300+63.00, 15.50' R	SW-506	602.16	596.77			P-542	542	543		24	33	27	1.36	597.74	597.37		3		
544	169+94.50, 14.50' L	SW-510	601.21	594.96			P-543	543	544		24	69	63	1.06	597.27	596.61		8		
545	170+59.00, 14.50' L	SW-545	601.07	594.17			P-544	544	545		30	65	59	0.50	595.46	595.17		21		
546	170+57.00, 26.50' R	SW-510	600.69	593.99		SW-510 (MOD 5x8)	P-545	545	546		36	47	41	0.20	594.67	594.59		16		
547	171+44.00, 14.50' L	SW-545	601.33	597.20			P-546	546	549		36	191	185	0.29	594.49	593.95		133		
548	172+48.00, 14.50' L	SW-545	602.00	595.06			P-547	547	548		18	106	100	2.04	597.70	595.66		37		
549	172+50.00, 26.50' R	SW-510	601.63	591.59		SW-510 (MOD 5x8)	P-548	548	549		18	47	41	2.82	595.56	594.40		53		
550	174+36.00, 14.50' L	SW-507	602.52	598.50			P-549	549	551		42	186	180	0.29	592.09	591.57		483		
551	174+36.00, 26.50' R	SW-508	602.13	590.97		SW-508 (MOD 5x4)	P-550	550	551		15	47	41	1.08	599.00	598.55	121			
552	2400+60.00, 18.00' L	SW-505	602.82	597.25			P-551	551	555		42	133	127	0.30	591.47	591.09		396		
553	2400+60.00, 18.00' R	SW-506	602.66	596.60			P-552	552	553		30	38	32	0.48	597.75	597.60	87	3		
553A	175+31.86, 29.35' L	SW-401	602.78	596.23		60 Inch Dia	P-553	553	553A		36	34	28	1.00	597.10	596.83				
554	175+66.00, 14.50' L	SW-510	601.91	595.79			P-553A	553A	554		36	37	31	1.10	596.73	596.39				
555	175+68.00, 32.24' R	SW-401	602.25	590.09		96 Inch Dia	P-554	554	555		36	49	43	1.20	596.29	595.78		6		
556	176+60.00, 14.50' L	SW-509	601.47	597.47			P-555	555	557		48	91	85	0.19	590.59	590.43	59	258		
557	176+60.00, 26.50' R	SW-510	601.09	589.93		SW-510 (MOD 6x8)	P-556	556	557		15	47	41	1.13	598.06	597.60				
558	178+29.00, 47.50' L	SW-513	601.15	597.15		4ft by 4ft	P-557	557	560		48	128	122	0.18	590.43	590.21	155	335		
559	177+90.00, 14.50' L	SW-509	600.86	596.85			P-558	558	559		15	54	48	1.97	598.39	597.45				
560	177+90.00, 26.50' R	SW-510	600.47	589.71		SW-510 (MOD 6x8)	P-559	559	560		15	47	41	2.26	597.35	596.42		3		
561	179+05.00, 14.50' L	SW-509	600.32	595.68			P-560	560	562		48	113	107	0.19	590.21	590.00	116	259		
561A	178+85.00, 52.60' L	SW-507	601.20	596.10		Protect existing island	P-561	561	562		18	47	41	1.20	596.18	595.68		5		
562	179+05.00, 26.50' R	SW-510	599.93	589.50		SW-510 (MOD 6x8)	P-561A	561A	561		18	43	37	1.15	596.60	596.18		5		
563	180+10.00, 43.00' L	SW-401	601.70	594.09		48 Inch Dia	P-562	562	565		48	101	95	0.21	590.00	589.80		205		
564	180+10.00, 14.50' L	SW-508	599.83	593.37			P-563	563	564		21	29	23	0.51	594.59	594.47	122	15		
565	180+08.00, 26.50' R	SW-510	599.45	589.30		SW-510 (MOD 6x8)	P-564	564	565		30	47	41	0.19	593.87	593.79		6		
566	2500+61.10, 14.50' R	SW-505	600.29	595.64			P-565	565	568		48	34	28	0.25	589.80	589.73		9		
567	2500+61.10, 14.50' L	SW-505	600.29	595.03			P-566	566	567		18	31	25	1.04	596.14	595.88	35	4		
568	2499+64.58, 27.19' L	SW-401	599.64	589.23		96 Inch Dia	P-567	567	563		21	53	47	1.26	595.53	594.94	10	21		
569e	2497+02.79, 24.47' L	Conn	593.20	585.13			P-568e	568	569e		48	264	258	1.59	589.73	585.63	172	239		
580	182+23.46, 14.50' L	SW-509	598.82	594.75																
581	182+23.61, 26.50' R	SW-509	598.44	594.42			P-580	580	581		15	47	41	0.56	595.25	595.02				
582	183+86.00, 14.50' L	SW-545	598.06	594.04			P-581	581	583		15	161	155	0.55	594.92	594.08		1		
583	183+86.00, 26.50' R	SW-509	597.67	593.33			P-582	582	583		15	48	42	1.13	594.54	594.08		1		
585	184+93.00, 14.50' L	SW-510	597.49	593.30			P-583	583	586		18	105	99	0.71	593.83	593.13		3		
586	184+93.00, 26.50' R	SW-510	597.11	592.38			P-585	585	586		15	47	41	1.02	593.80	593.38	20	2		
587	186+20.00, 14.50' L	SW-509	596.65	592.63			P-586	586	588		21	122	116	0.53	592.88	592.27	14	3		
588	186+20.00, 26.50' R	SW-510	596.27	591.67			P-587	587	588		15	47	41	1.13	593.13	592.67	57	1		
589e	187+14.93, 28.41' R	Conn	596.85	590.25			P-588	588	589e		21	92	86	0.79	592.17	591.50	14	10		
700	129+86.11, 68.38' L	Conn	603.17	598.71																



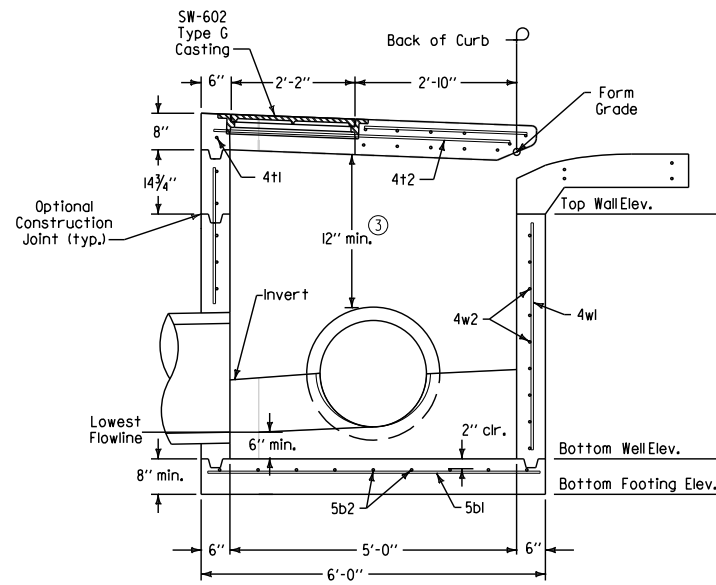

MODIFIED TYPICAL SECTION

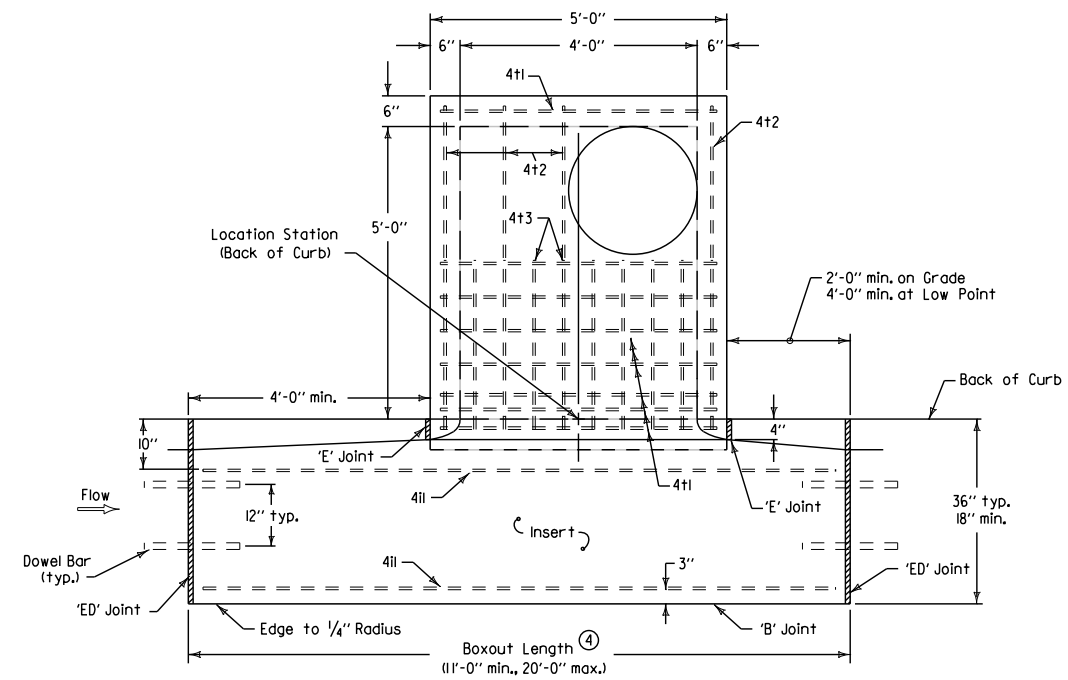

MODIFIED PLAN VIEW

ELEVATIONS SW-508 (MOD 5x4)		
S#	LOCATION	ELEVATION
382	Form Grade	602.94
382	Top Wall	601.77
382	Bottom Well	594.66
382	Bottom Footing	593.99
459	Form Grade	600.43
459	Top Wall	599.26
459	Bottom Well	591.76
459	Bottom Footing	591.09
494	Form Grade	602.88
494	Top Wall	601.71
494	Bottom Well	594.18
494	Bottom Footing	593.51
497	Form Grade	600.08
497	Top Wall	598.91
497	Bottom Well	589.95
497	Bottom Footing	589.28
530	Form Grade	597.58
530	Top Wall	596.41
530	Bottom Well	589.43
530	Bottom Footing	588.76
551	Form Grade	602.68
551	Top Wall	601.51
551	Bottom Well	590.97
551	Bottom Footing	590.30

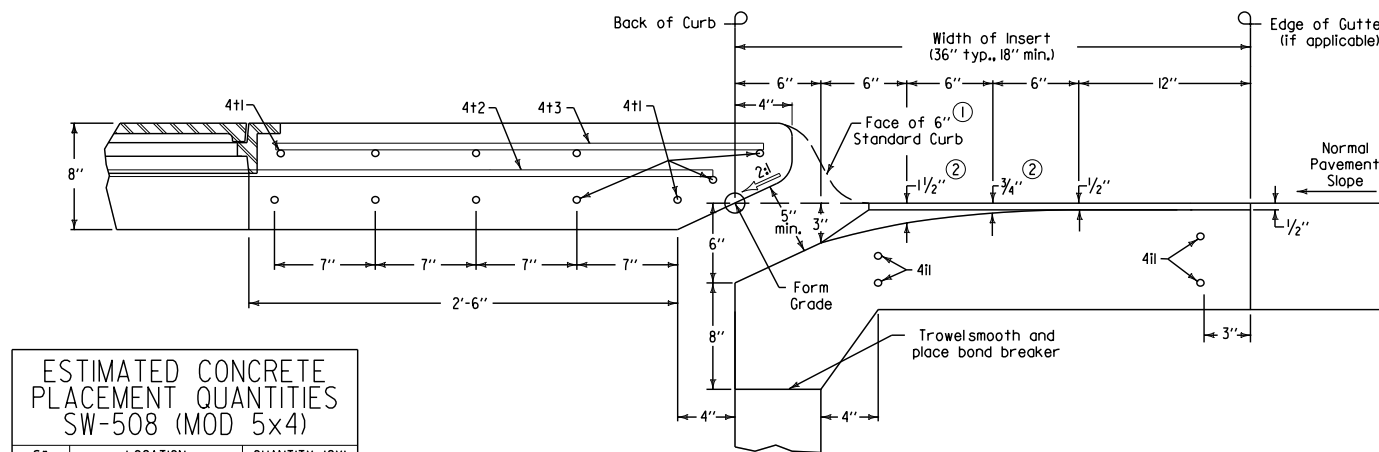

MODIFIED INSERT DETAIL

ESTIMATED CONCRETE PLACEMENT QUANTITIES SW-508 (MOD 5x4)		
S#	LOCATION	QUANTITY (CY)
ALL	Base	0.74
ALL	Top	2.40
ALL	Fillet	0.93
S-382	Walls (minus pipes)	2.59
S-459	Walls (minus pipes)	2.84
S-494	Walls (minus pipes)	2.58
S-497	Walls (minus pipes)	3.11
S-530	Walls (minus pipes)	2.38
S-551	Walls (minus pipes)	3.69

- ① Modify dimensions as required to accommodate other curb heights when specified.
  - ② Insert shaping may be modified for insert widths less than 36 inches. For an 18-inch insert, reduce dimensions indicated by 1/2 inch.
  - ③ 12-inch minimum wall height above all pipes.
  - ④ Transverse joint spacing on new concrete pavement is controlled by the intake boxout. Adjust adjacent joint spacing as required to accommodate boxouts.
- For retrofit intakes, match existing pavement joints. Stop any transverse pavement joints that do not conform to the minimum spacing requirements at the edge of the insert area.

REINFORCING BAR LIST SW-508 (MOD 5x4)						
Mark	Size	Location	Shape	Count	Length	Spacing
4t1	4	Top	—	12	4'-8"	See Insert Detail
4t2	4	Top	—	4	5'-6"	12"
4t3	4	Top	—	10	2'-10"	6"
5b1	5	Base	—	8	5'-6"	8"
5b2	5	Base	—	9	4'-6"	8"
4i1	4	Insert	—	4	Boxout Length minus 8"	See Plan
4w1	4	Walls	—	22	Wall Height minus 4"	12"
4w2	4	Walls	—	Varies	4'-8"	6"
4w3	4	Walls	—	Varies	5'-8"	6"

ELEVATIONS SW-510 (MOD 5x8)

S*	LOCATION	ELEVATION
403	Form Grade	603.25
403	Top Wall/Beam	602.08
403	Bottom Well	594.37
403	Bottom Footing	593.70
406	Form Grade	603.63
406	Top Wall/Beam	602.46
406	Bottom Well	593.89
406	Bottom Footing	593.22
409	Form Grade	603.81
409	Top Wall/Beam	602.64
409	Bottom Well	592.78
409	Bottom Footing	592.11
420	Form Grade	603.08
420	Top Wall/Beam	601.91
420	Bottom Well	593.51
420	Bottom Footing	592.84
452	Form Grade	604.40
452	Top Wall/Beam	603.23
452	Bottom Well	597.47
452	Bottom Footing	596.80
454	Form Grade	603.86
454	Top Wall/Beam	602.69
454	Bottom Well	596.78
454	Bottom Footing	596.11
474	Form Grade	606.95
474	Top Wall/Beam	605.78
474	Bottom Well	600.66
474	Bottom Footing	599.99
475	Form Grade	606.68
475	Top Wall/Beam	605.51
475	Bottom Well	599.05
475	Bottom Footing	598.38
477	Form Grade	606.14
477	Top Wall/Beam	604.97
477	Bottom Well	598.50
477	Bottom Footing	597.83
480	Form Grade	605.33
480	Top Wall/Beam	604.16
480	Bottom Well	597.69
480	Bottom Footing	597.02
487	Form Grade	603.05
487	Top Wall/Beam	601.88
487	Bottom Well	595.92
487	Bottom Footing	595.25
488	Form Grade	602.66
488	Top Wall/Beam	601.49
488	Bottom Well	595.61
488	Bottom Footing	594.94
490	Form Grade	602.07
490	Top Wall/Beam	600.90
490	Bottom Well	594.59
490	Bottom Footing	593.92
532	Form Grade	594.20
532	Top Wall/Beam	593.03
532	Bottom Well	588.59
532	Bottom Footing	587.92
546	Form Grade	601.24
546	Top Wall/Beam	600.07
546	Bottom Well	593.99
546	Bottom Footing	593.32
549	Form Grade	602.18
549	Top Wall/Beam	601.01
549	Bottom Well	591.59
549	Bottom Footing	590.92

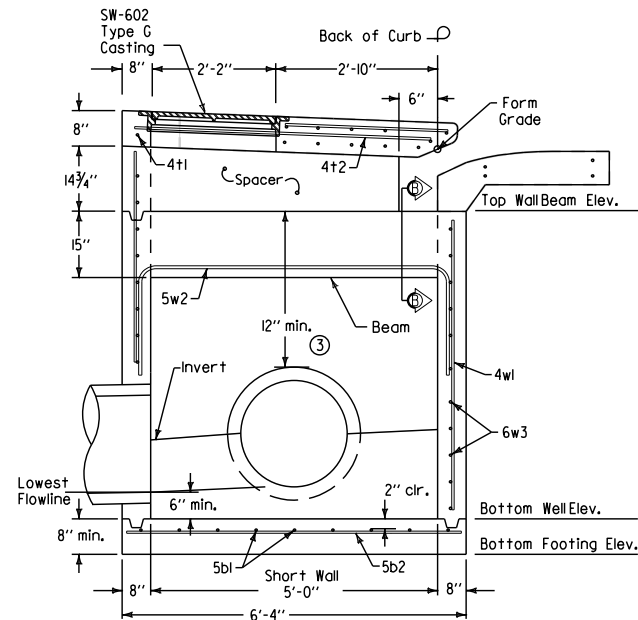

MODIFIED SECTION A-A

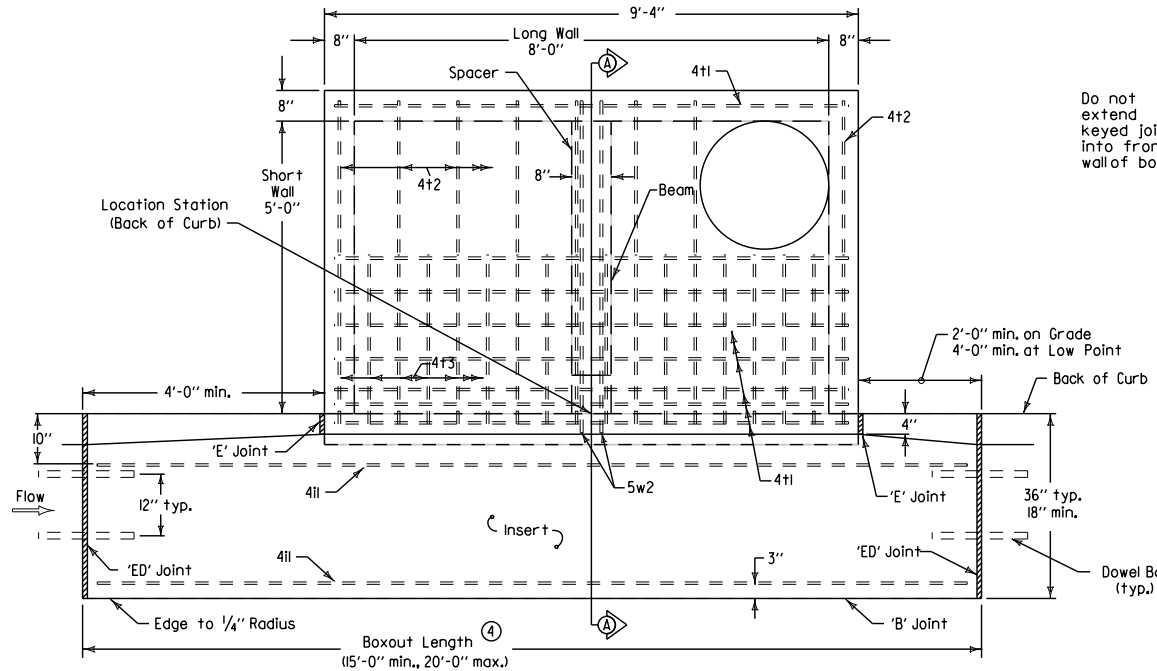

MODIFIED PLAN VIEW

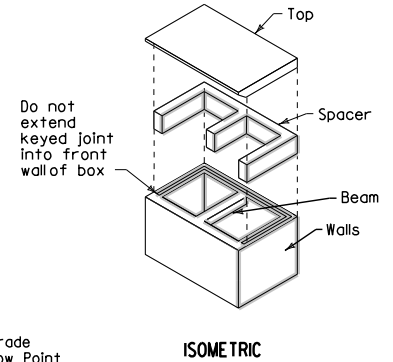

ESTIMATED CONCRETE PLACEMENT QUANTITIES SW-510 (MOD 5x8)

S*	LOCATION	QUANTITY (CY)
ALL	Base	1.46
ALL	Top	3.25
ALL	Fillet	1.85
ALL	Spacer	0.72
S-403	Beam & Walls (minus pipes)	5.10
S-406	Beam & Walls (minus pipes)	5.64
S-409	Beam & Walls (minus pipes)	6.55
S-420	Beam & Walls (minus pipes)	5.73
S-452	Beam & Walls (minus pipes)	3.86
S-454	Beam & Walls (minus pipes)	3.91
S-474	Beam & Walls (minus pipes)	3.41
S-475	Beam & Walls (minus pipes)	4.51
S-477	Beam & Walls (minus pipes)	4.30
S-480	Beam & Walls (minus pipes)	4.30
S-487	Beam & Walls (minus pipes)	4.16
S-488	Beam & Walls (minus pipes)	3.89
S-490	Beam & Walls (minus pipes)	4.11
S-532	Beam & Walls (minus pipes)	2.71
S-546	Beam & Walls (minus pipes)	4.03
S-549	Beam & Walls (minus pipes)	6.32

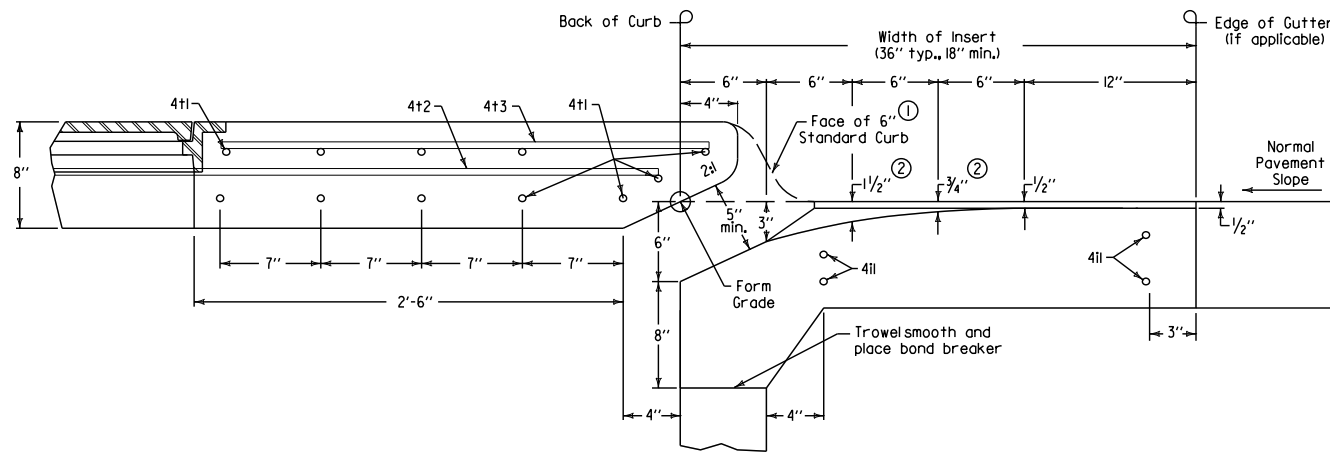

MODIFIED INSERT DETAIL

- ① Modify dimensions as required to accommodate other curb heights when specified.
  - ② Insert shaping may be modified for insert widths less than 36 inches. For an 18-inch insert, reduce dimensions indicated by 1/4 inch.
  - ③ 12-inch minimum wall height above all pipes.
  - ④ Transverse joint spacing on new concrete pavement is controlled by the intake boxout. Adjust adjacent joint spacing as required to accommodate boxouts.
- For retrofit intakes, match existing pavement joints. Stop any transverse pavement joints that do not conform to the minimum spacing requirements at the edge of the insert area.

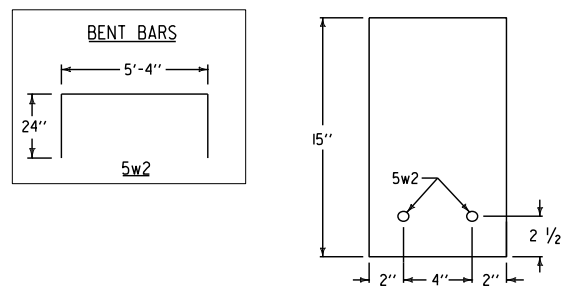

MODIFIED SECTION B-B

REINFORCING BAR LIST SW-510 (MOD 5x8)

Mark	Size	Location	Shape	Count	Length	Spacing
5b1	5	Base	—	9	8'-10"	8"
5b2	5	Base	—	14	5'-10"	8"
4t1	4	Insert	—	4	Boxout Length minus 8"	See Insert
4t1	4	Top	—	12	8'-10"	See Plan
4t2	4	Top	—	8	5'-6"	12"
4t3	4	Top	—	18	2'-10"	6"
4w1	4	Walls	—	30	Wall Height minus 4"	12"
5w2	5	Beam	—	2	9'-4"	4"
6w3	6	Long Walls	—	Varies	9'-0"	6"
6w4	6	Short Walls	—	Varies	6'-0"	6"

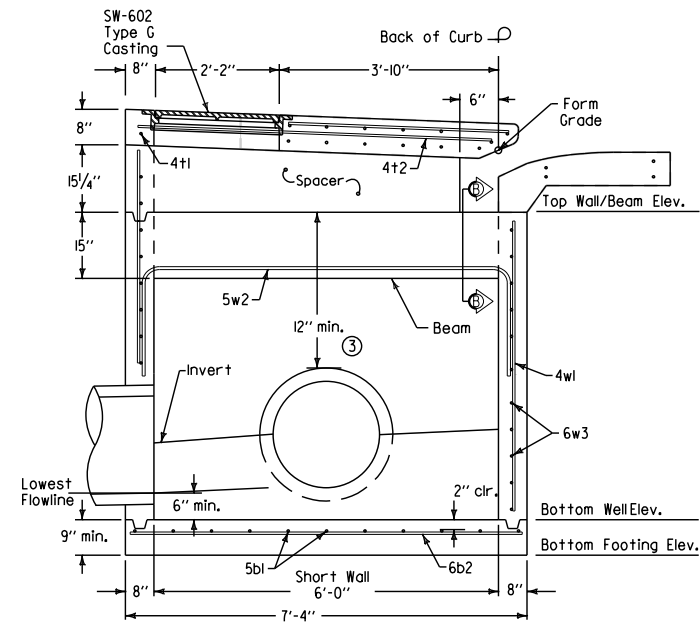

MODIFIED SECTION A-A

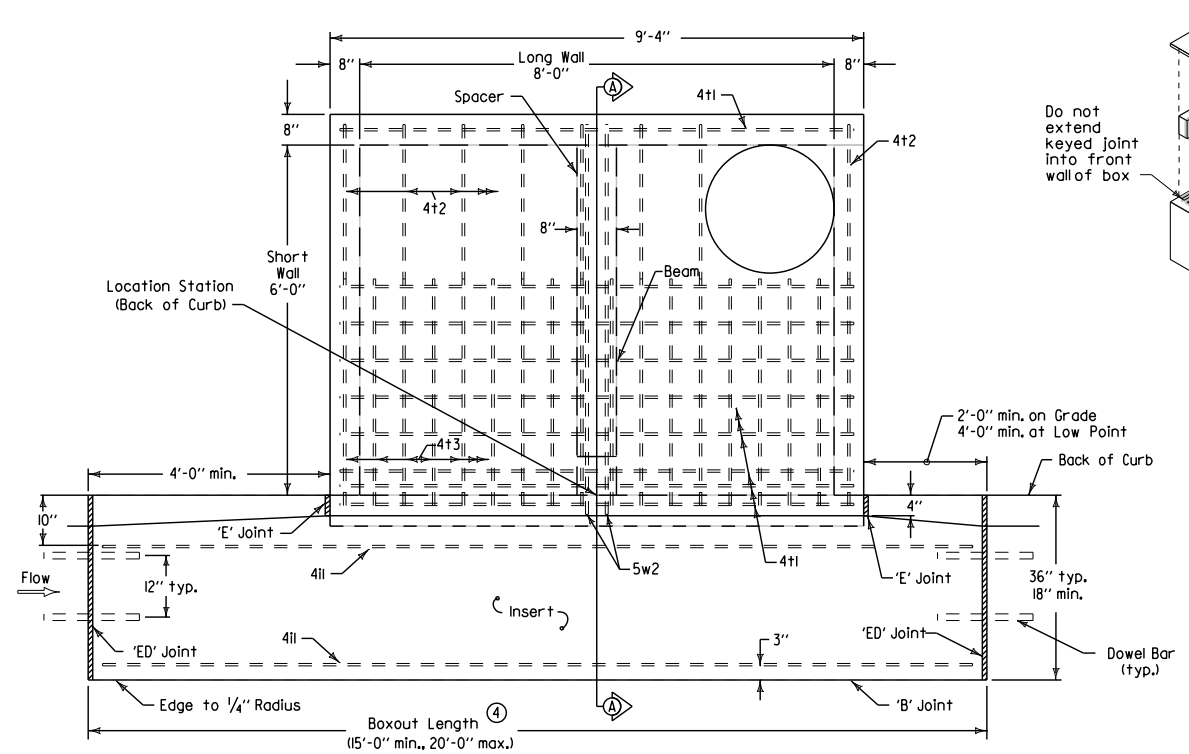

MODIFIED PLAN VIEW

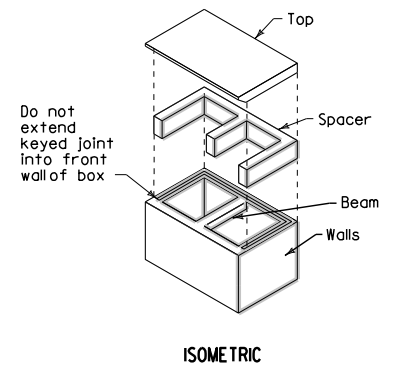

ISOMETRIC

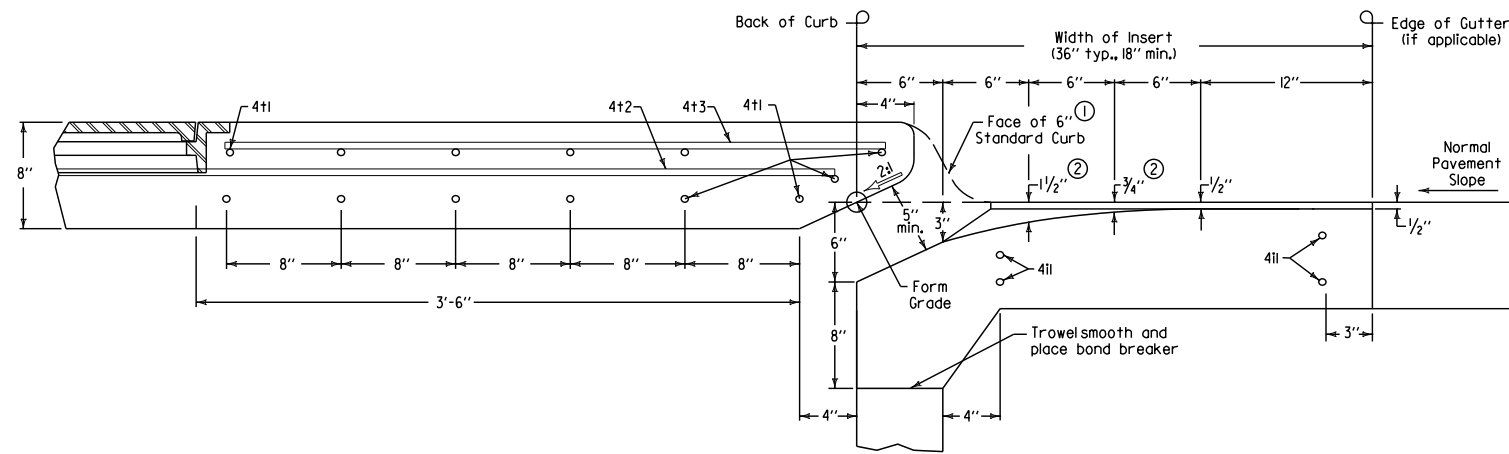

MODIFIED INSERT DETAIL

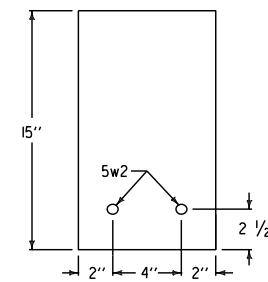
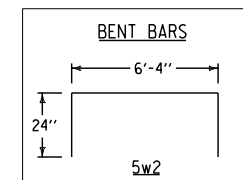

MODIFIED SECTION B-B

- ① Modify dimensions as required to accommodate other curb heights when specified.
  - ② Insert shaping may be modified for insert widths less than 36 inches. For an 18-inch insert, reduce dimensions indicated by 1/4 inch.
  - ③ 12-inch minimum wall height above all pipes.
  - ④ Transverse joint spacing on new concrete pavement is controlled by the intake boxout. Adjust adjacent joint spacing as required to accommodate boxouts.
- For retrofit intakes, match existing pavement joints. Stop any transverse pavement joints that do not conform to the minimum spacing requirements at the edge of the insert area.

ELEVATIONS SW-510 (MOD 6x8)		
S#	LOCATION	ELEVATION
557	Form Grade	601.64
557	Top Wall/Beam	600.47
557	Bottom Well	589.93
557	Bottom Footing	589.18
560	Form Grade	601.02
560	Top Wall/Beam	599.85
560	Bottom Well	589.71
560	Bottom Footing	588.96
562	Form Grade	600.48
562	Top Wall/Beam	599.31
562	Bottom Well	589.50
562	Bottom Footing	588.75
565	Form Grade	600.00
565	Top Wall/Beam	598.83
565	Bottom Well	589.30
565	Bottom Footing	588.55

ESTIMATED CONCRETE PLACEMENT QUANTITIES SW-510 (MOD 6x8)		
S#	LOCATION	QUANTITY (CY)
ALL	Base	1.90
ALL	Top	3.48
ALL	Fillet	2.67
ALL	Spacer	0.82
S-557	Beam & Walls (minus pipes)	7.41
S-560	Beam & Walls (minus pipes)	7.11
S-562	Beam & Walls (minus pipes)	6.86
S-565	Beam & Walls (minus pipes)	6.64

REINFORCING BAR LIST SW-510 (MOD 6x8)						
Mark	Size	Location	Shape	Count	Length	Spacing
5b1	5	Base	—	11	8'-10"	8"
6b2	6	Base	—	14	6'-10"	8"
4t1	4	Insert	—	4	Boxout Length minus 8"	See Insert
4t2	4	Top	—	14	8'-10"	See Plan
4t3	4	Top	—	8	6'-6"	12"
4t4	4	Top	—	18	3'-10"	6"
4w1	4	Walls	—	32	Wall Height minus 4"	12"
5w2	5	Beam	—	2	10'-4"	4"
6w3	6	Long Walls	—	Varies	9'-0"	6"
6w4	6	Short Walls	—	Varies	7'-0"	6"

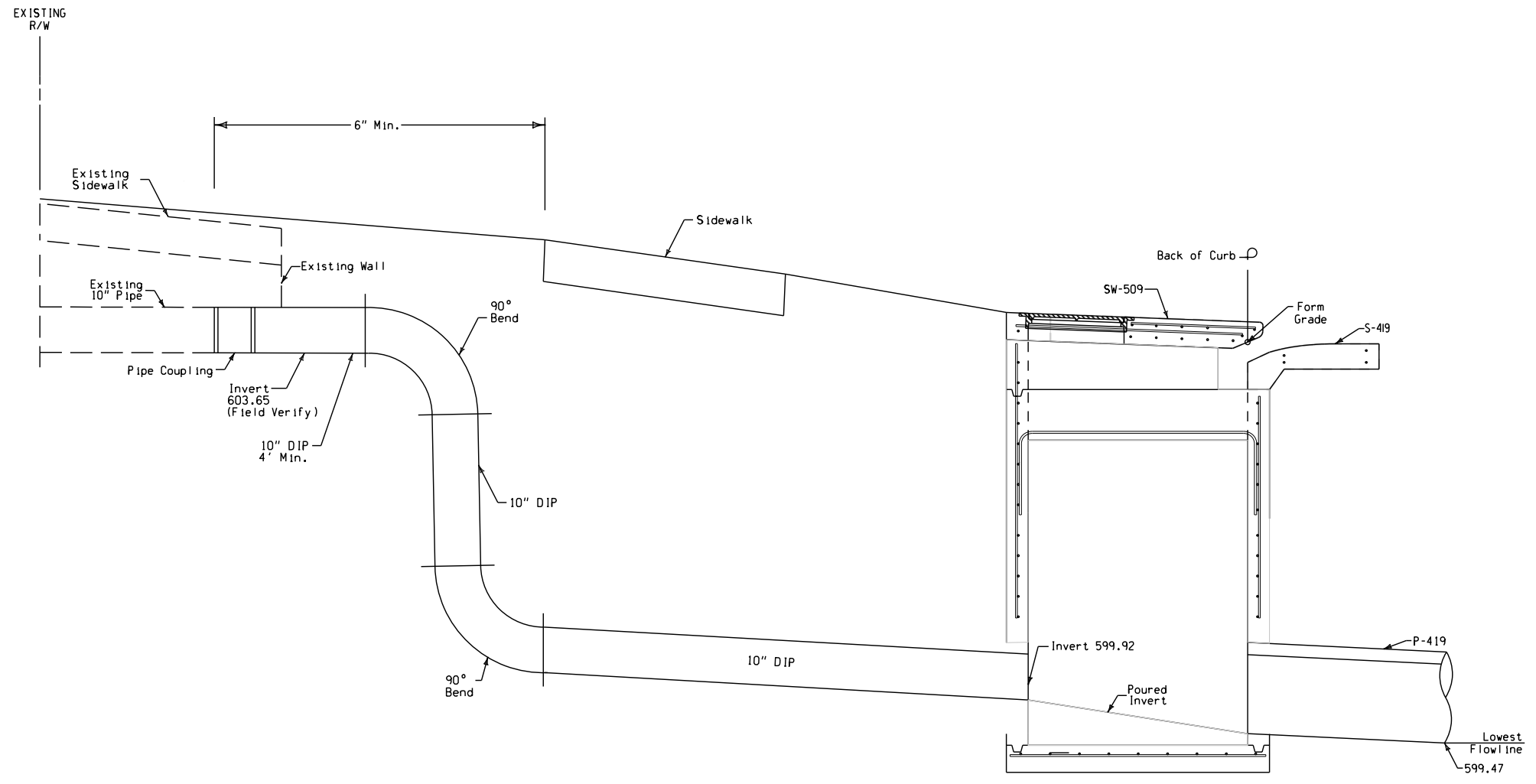

SECTION VIEW

SPECIAL STORM SEWER  
CONNECTION DETAIL

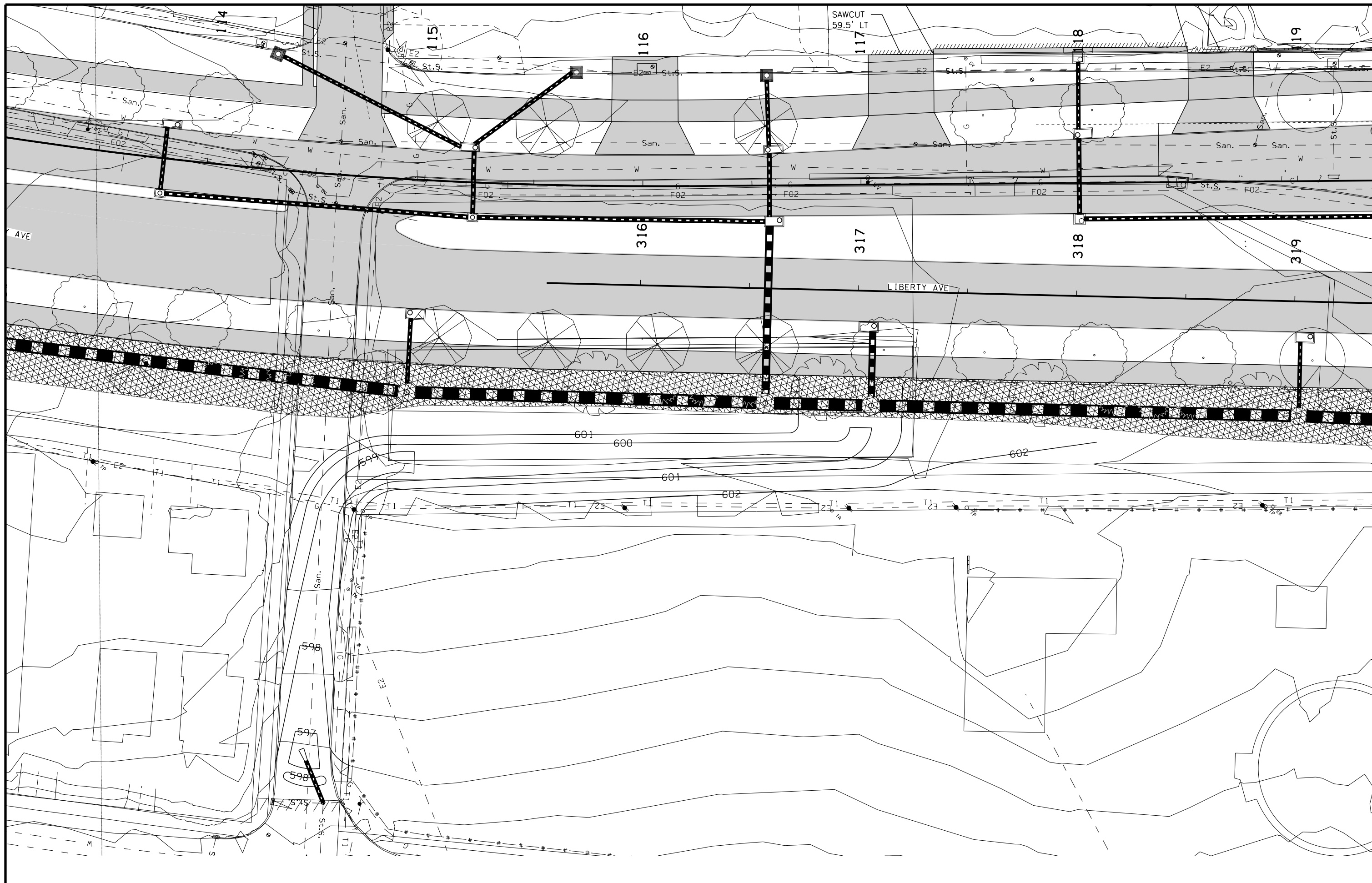

**TRAFFIC SIGNAL GENERAL NOTES**

1. ALL QUANTITIES SHOWN IN THE PLANS AND SPECIFICATIONS ARE FOR INFORMATIONAL AND ESTIMATING PURPOSES ONLY. THE CONTRACTOR'S LUMP SUM BID FOR THIS PROJECT SHALL INCLUDE ALL LABOR AND MATERIAL NECESSARY TO PROVIDE A COMPLETE AND FUNCTIONAL TRAFFIC SIGNAL SYSTEM IN CONFORMANCE WITH THE PLANS AND SPECIFICATIONS.
2. THE PLAN LOCATIONS OF UNDERGROUND UTILITIES ARE APPROXIMATE ONLY. THE CONTRACTOR SHALL NOTIFY ALL UTILITY COMPANIES PRIOR TO EXCAVATION ON THE PROJECT.
3. THE LOCATIONS OF ALL FOOTINGS, HANDHOLES, AND CONDUIT ARE TO BE COORDINATED WITH THE ENGINEER AND ARE SUBJECT TO ADJUSTMENT IN THE FIELD BY THE ENGINEER.
4. "GR/TR/PR" REPRESENTS "GR"= GROUND WIRE, "TR"= TRACER WIRE, AND "PR"= PULL ROPE.
5. THE STATIONS AND OFFSETS LISTED ON THE SIGNAL PLANS ARE TO THE CENTER OF THE ITEM UNLESS OTHERWISE NOTED.
6. ANY COMPONENTS OF AN EXISTING TRAFFIC SIGNAL INSTALLATION TO BE REMOVED, SHALL BE REMOVED BY THE CONTRACTOR AND DELIVERED TO THE CITY OF CLINTON PUBLIC WORKS, 925 S. 3RD STREET, UNLESS OTHERWISE DIRECTED BY THE PROJECT ENGINEER.
7. THE CONTRACTOR HAS THE OPTION TO BORE OR TRENCH CONDUIT; HOWEVER, THE SPECIFICATIONS REQUIRE THAT THE CONDUIT BE BORED UNDER PAVEMENT. PAVEMENT SHALL NOT BE DISTURBED BY CONSTRUCTION.
8. AREAS DISTURBED BY CONSTRUCTION SHALL BE RESTORED TO THEIR ORIGINAL CONDITION AT THE CONTRACTOR'S EXPENSE.
9. THE CONTRACTOR SHALL INSTALL ONE SIGNAL CABLE FROM EACH SIGNAL HEAD TO THE BASE OF THE POLE. A 5-CONDUCTOR CABLE SHALL BE USED FOR A 3-SECTION SIGNAL HEAD AND A 7-CONDUCTOR CABLE SHALL BE USED FOR EITHER A 4 OR 5 SECTION SIGNAL HEAD.
10. ALL MAST ARM MOUNTED SIGNAL HEADS SHALL COME FURNISHED WITH BACK-PLATES.
11. THE TRAFFIC SIGNAL CONTROLLER SHALL BE ORIENTED WITH THE BACK OF THE CABINET TOWARD THE INTERSECTION SUCH THAT THE SIGNAL HEADS CAN BE VIEWED WHILE FACING THE CONTROLLER, UNLESS OTHERWISE DIRECTED BY THE PROJECT ENGINEER.
12. A #6 A.W.G. BARE COPPER GROUND WIRE SHALL BE INSTALLED IN ALL PVC CONDUITS THAT CARRY 120 VOLT SIGNAL CABLES. ALL STEEL CONDUITS, POLES, PEDESTALS, AND THE CONTROLLER CABINET AT EACH INTERSECTION SHALL BE BONDED TO FORM A CONTINUOUS SYSTEM AND BE EFFECTIVELY GROUNDED. BONDING JUMPERS SHALL BE #6 A.W.G. BARE COPPER WIRE CONNECTED BY APPROVED CLAMPS.
13. ALL STREET LIGHT LUMINAIRE ARMS SHALL BE LOCATED AT 180 DEGREES TO THE POLE ACCESS HANDHOLE (PARALLEL WITH MAST ARM) UNLESS OTHERWISE NOTED. ALL LUMINAIRES SHALL BE A 35' MOUNTING HEIGHT.
14. THE CONTRACTOR SHALL STUB 2 FEET OF 2" PVC OUT OF HANDHOLE B. THE CONDUIT WILL BE USED BY THE LIGHTING CONTRACTOR FOR POWER SERVICE CONNECTION. THE LOCATION OF CONDUIT SHALL BE MARKED.
15. THE CONTRACTOR SHALL BE RESPONSIBLE FOR MAINTAINING THE EXISTING TRAFFIC SIGNAL SYSTEM DURING CONSTRUCTION. ANY DAMAGES TO THE THE EXISTING SYSTEM SHALL BE REPAIRED AT THE CONTRACTOR'S EXPENSE IMMEDIATELY AFTER THE DAMAGE HAS OCCURRED.
16. TRAFFIC SIGNAL POLE COLOR SHALL BE LUMEC #BE6 TEXTURE OR PROTECH COLOR #PP311B66, OCEAN BLUE TEXTURED. SIGNAL MAST ARM AND LUMINAIRE ARM SHALL BE NATURAL ALUMINUM. ALL POLES SHALL BE GALVANIZED BEFORE APPLYING POWDER COAT.
17. THE STREET NAME SIGNS SHALL HAVE BLUE BACKGROUND WITH WHITE LETTERING.
18. THE CONTRACTOR SHALL COMPLETELY REMOVE ANY EXISTING SIGNAL POLE AND CONTROLLER FOOTINGS.
19. THE CONTRACTOR SHALL REMOVE ALL EXISTING SIGNAL POLES, FOUNDATIONS, MAST ARMS, AND SIGNAL HEADS. EXISTING HANDHOLES SHALL BE REMOVED. CONTRACTOR SHALL REMOVE ALL WIRE AND CABLE FROM EXISTING CONDUIT. THE CONTRACTOR SHALL ABANDON ANY EXISTING CONDUITS UNLESS THEY ARE EXPOSED DURING CONSTRUCTION. EXPOSED CONDUITS SHALL BE COMPLETELY REMOVED.

**SIGNAL LEGEND**

PROPOSED		
		POWER SOURCE
		CABINET AND CONTROLLER
	1	TRAFFIC SIGNAL POLE, FOOTING SYMBOL, AND IDENTIFYING NUMBER
	3	PEDESTAL POLE, FOOTING SYMBOL, AND IDENTIFYING NUMBER
	1	WOODEN SIGNAL POLE AND IDENTIFYING NUMBER
	81	TRAFFIC SIGNAL HEAD WITH BACKPLATE SYMBOL AND IDENTIFYING NUMBER
	23	TRAFFIC SIGNAL HEAD SYMBOL AND IDENTIFYING NUMBER
	25	PEDESTRIAN HEAD SYMBOL AND IDENTIFYING NUMBER
	C	MAST ARM MOUNTED SIGN SYMBOL AND IDENTIFYING NUMBER
		VIDEO DETECTION CAMERA
		MICROWAVE DETECTOR
		EMERGENCY VEHICLE PREEMPTION
		LUMINAIRE
	31	DETECTOR LOOP SYMBOL AND IDENTIFYING NUMBER
	42	VIDEO DETECTION AREA SYMBOL AND IDENTIFYING NUMBER
	1	30"x48" "TUB" HANDHOLE SYMBOL AND IDENTIFYING NUMBER
	4	24" HANDHOLE SYMBOL AND IDENTIFYING NUMBER
	6E	EXISTING HANDHOLE SYMBOL AND IDENTIFYING NUMBER
		JUNCTION BOX SYMBOL
	26	PUSHBUTTON SYMBOL AND IDENTIFYING NUMBER
		TRENCHED SIGNAL CONDUIT
		PUSHED SIGNAL CONDUIT

	I hereby certify that this engineering document was prepared by me or under my direct personal supervision and that I am a duly licensed Professional Engineer under the laws of the State of Iowa.	
	J. ANDREW SWISHER, P.E. License Number: 17928 My license renewal date is DECEMBER 31, 2011 Pages or sheets covered by this seal: <u>N.1 - N.11</u>	DATE _____

TRAFFIC SIGNAGE

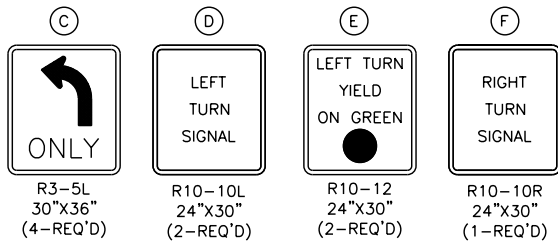

STREET NAME SIGNS

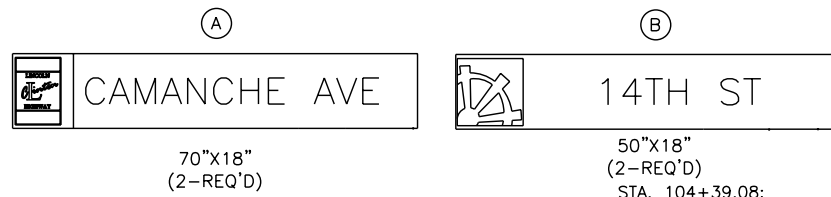

PEDESTRIAN PUSHBUTTON AND SIGNAL FACE MOUNTING

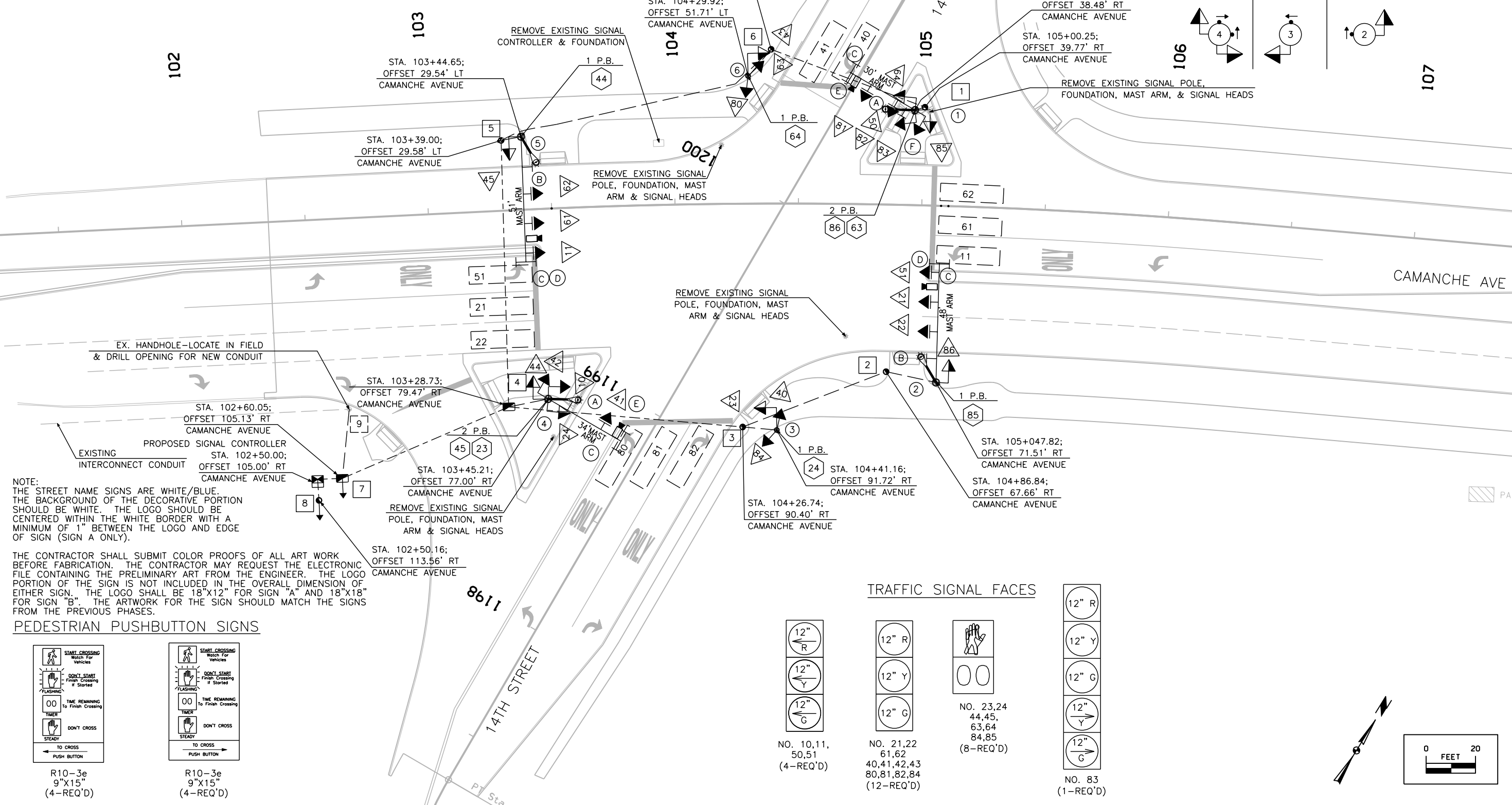
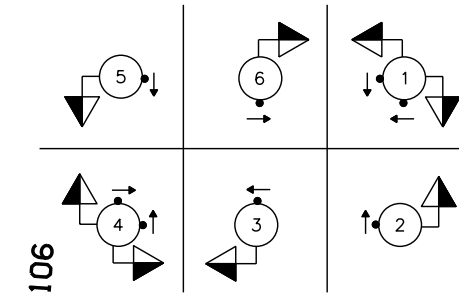

PEDESTRIAN PUSHBUTTON SIGNS

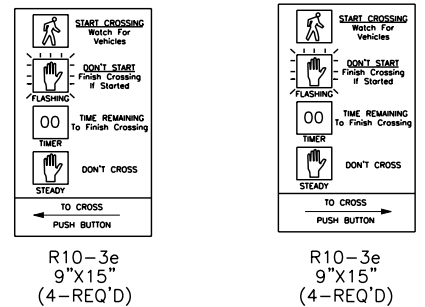

TRAFFIC SIGNAL FACES

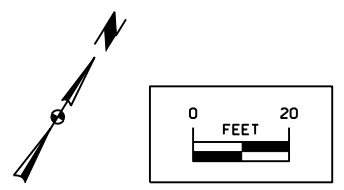
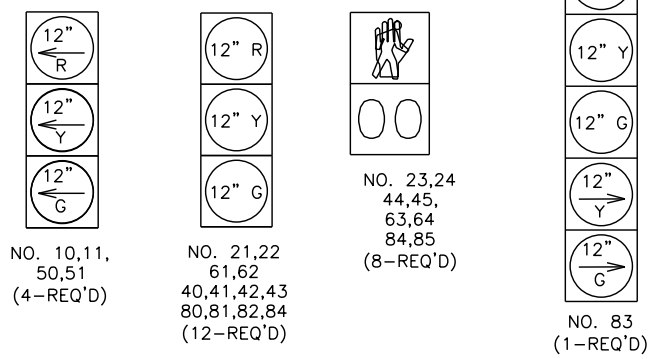

**LEGEND**

- SIG SIGNAL HEAD CABLE
- PED HD PEDESTRIAN HEAD CABLE
- PED PB PEDESTRIAN PUSHBUTTON CABLE
- CNTRL CONTROLLER
- LUM STREET LIGHT POWER CABLE
- N NEUTRAL
- LN1 POWER - LINE 1
- LN2 POWER - LINE 2
- GR GROUND WIRE 1c #6
- TR TRACER WIRE 1c #10
- PR PULL ROPE
- Y1 FUSED WYE CONNECTOR FOR STREET LIGHTING
- Y2 NON-FUSED WYE CONNECTOR FOR STREET LIGHTING
- Y3 NON-FUSED WYE CONNECTOR FOR STREET LIGHTING
- L1 FUSED IN-LINE CONNECTOR FOR STREET LIGHTING
- L2 NON-FUSED IN-LINE CONNECTOR FOR STREET LIGHTING
- DET SHIELDED LOOP DETECTOR LEAD-IN
- LOOP DETECTOR LOOP WIRE IN TUBING
- HH HANDHOLE
- VIDEO VIDEO DETECTION CABLE

1 4' OF 3" PVC  
2-12c  
1-VIDEO  
2-1c #8 (LUM)  
2-5c (PED HD)  
2-2c (PED PB)  
GR/TR/PR

6 2" PVC  
TO SOURCE OF POWER  
3-1c#6  
COORDINATE WITH UTILITY  
COMPANY FOR POWER  
SERVICE CONNECTION.

2 16' OF 3" PVC  
1-12c  
1-5c (PED HD)  
1-2c (PED PB)  
GR/TR/PR

7 2" PVC  
TO LIGHTING CONTROLLER  
2-1c#8 (LUM)  
GR/TR/PR

3 26' OF 4" PVC  
(2 CONDUITS)  
6 PR.-#19\*  
10-12c  
4-VIDEO  
8-5c (PED HD)  
8-2c (PED PB)  
GR/TR/PR

4 12' OF 2" PVC  
3-1c #6 (PWR)  
GR/TR/PR

5 2-L1 (20A FUSE)

EX. HANDHOLE  
EXIST.  
6 PR.-#19 INTERCONNECT\*

EX. INTERCONNECT  
CONDUIT  
PROPOSED  
SIGNAL CONTROLLER

TO LIGHTING  
CONTROLLER

TO SOURCE  
OF POWER

\*APPROXIMATELY 60' OF  
6 PR.-#19 SHOULD BE  
LOOPED IN EXISTING  
HANDHOLE 9. PULL  
TO NEW CONTROLLER.

**SUGGESTED TIMINGS (SECONDS)**

PHASE	1	2	3	4	5	6	7	8
MINIMUM GREEN	5	10	10	5	10	10	5	10
PASSAGE	1.0	3.0	3.0	1.0	3.0	3.0	1.0	3.0
MAXIMUM I	11.6	43.4	35	24	31	35	24	35
MAXIMUM II								
YELLOW CHANGE	3.8	3.8	4.4	3.8	3.8	4.4	3.8	3.8
RED CLEARANCE	2.2	2.2	1.6	2.2	2.2	1.6	2.2	2.2
WALK		7	7	7	7	7	7	7
PEDESTRIAN CLEARANCE		14	22	14	22	14	22	14
ADDED INITIAL								
TIME TO REDUCE								
TIME BEFORE REDUCTION								
MAXIMUM GAP								

**12-CONDUCTOR SIGNAL WIRE COLOR CODE**

INSULATION COLOR	STRIPE COLOR	SIGNAL INDICATION
WHITE	----	NEUTRAL
RED	----	RED
ORANGE	----	YELLOW
GREEN	----	GREEN
BLUE	----	<-Y(5-SEC)
BLACK	----	<-G(5-SEC)
RED	BLACK	<-R(LT 3-SEC)
GREEN	BLACK	<-G(LT 3-SEC)
ORANGE	BLACK	<-Y(LT 3-SEC)
BLUE	BLACK	Y->
WHITE	BLACK	G->
BLACK	WHITE	SPARE

**PHASE SEQUENCE CHART**

PHASE NUMBER	01+05			02+06			04+08			PHASE NUMBER
	01	02	03	04	05	06	07	08	09	
21, 22	R	R	R	G	Y	R	R	R	Y	21, 22
50, 51	G	Y	R	R	R	R	R	R	R	50, 51
61, 62	R	R	R	G	Y	R	R	R	Y	61, 62
10, 11	G	Y	R	R	R	R	R	R	R	10, 11
80, 81, 82, 84	R	R	R	R	R	R	G	Y	R	80, 81, 82, 84
83	G	Y	R	R	R	R	G	Y	R	83
40, 41, 42, 43	R	R	R	R	R	R	G	Y	R	40, 41, 42, 43
23, 24	DW	DW	DW	W	FDW	DW	DW	DW	DW	23, 24
44, 45	DW	DW	DW	DW	DW	DW	W	FDW	DW	44, 45
63, 64	DW	DW	DW	W	FDW	DW	DW	DW	DW	63, 64
85, 86	DW	DW	DW	DW	DW	DW	W	FDW	DW	84, 85

**PHASE DIAGRAM**

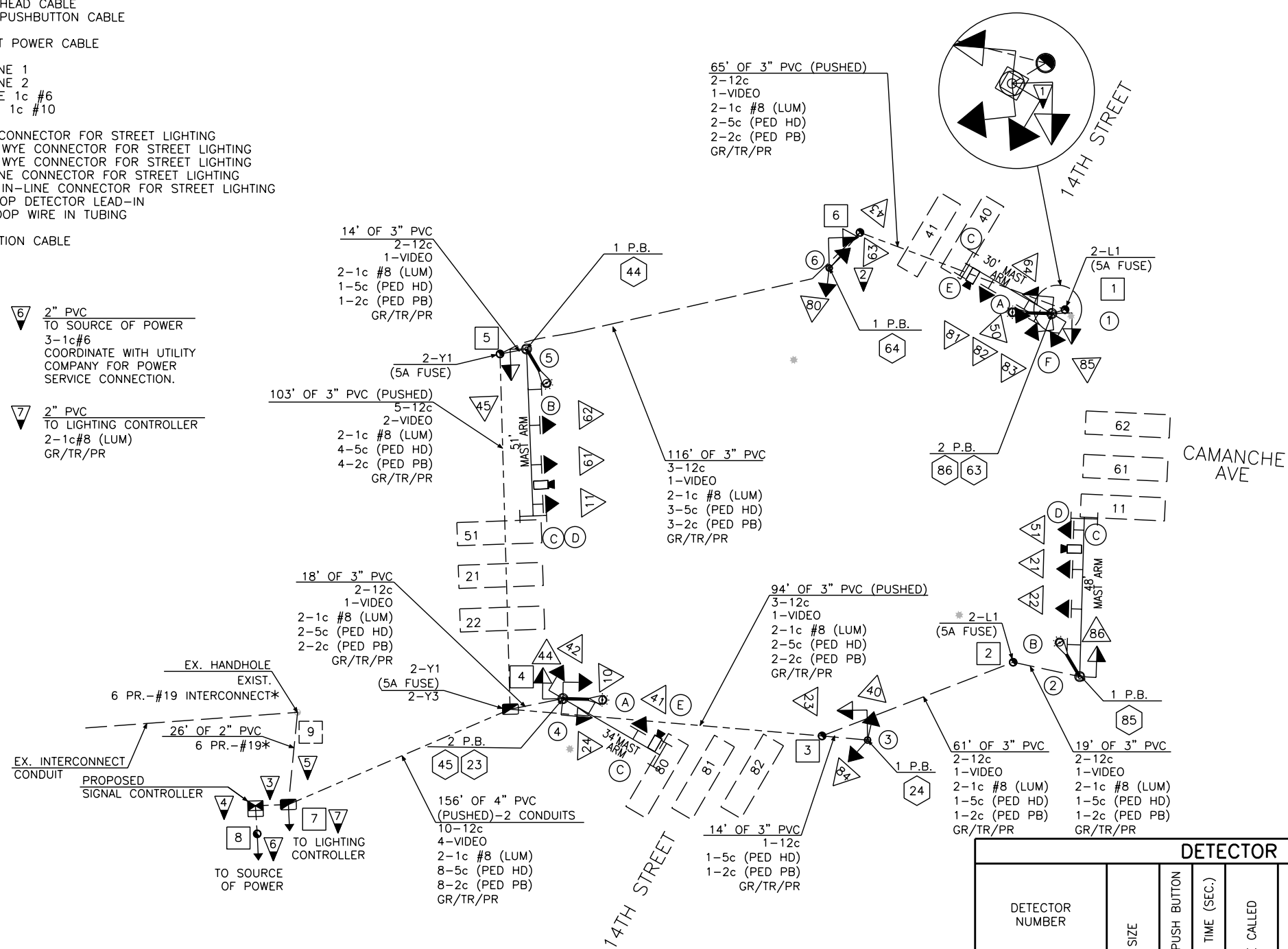

**DETECTOR SUMMARY**

DETECTOR NUMBER	LOOP SIZE	PED. PUSH BUTTON	DELAY TIME (SEC.)	PHASE CALLED	NO. OF CHANNELS	PRESENCE MODE	IMPULSE MODE	WIRED IN SERIES	COMMENTS
40	VIDEO			4	1	X			NONLOCKING
41	VIDEO			4	1	X			NONLOCKING
63, 64		X		6					
21	VIDEO			2	1	X			NONLOCKING
22	VIDEO			2	1	X			NONLOCKING
51	VIDEO			5	1	X			NONLOCKING
44, 45		X		4					
80	VIDEO			8	1	X			NONLOCKING
81	VIDEO			8	1	X			NONLOCKING
82	VIDEO			8	1	X			NONLOCKING
23, 24		X		2					
11	VIDEO			1	1	X			NONLOCKING
61	VIDEO			6	1	X			NONLOCKING
62	VIDEO			6	1	X			NONLOCKING
85, 86		X		8					

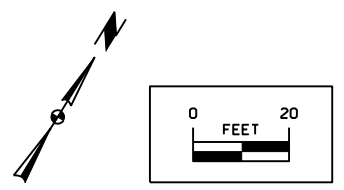



PHASE SEQUENCE CHART														
PHASE NUMBER	02			06			04			08			FLASHMODE	
	02	06	04	06	04	08	02	06	04	08	02	06		04
21, 22	G	Y	R	R	R	R	R	R	R	R	R	R	R	Y
61, 62	R	R	R	G	Y	R	R	R	R	R	R	R	R	Y
41, 42, 43	R	R	R	R	R	R	G	Y	R	R	R	R	R	R
81, 82	R	R	R	R	R	R	R	R	R	R	G	Y	R	R

SUGGESTED TIMINGS:				
Phase No.	2	4	6	8
Movement	EBTL	SBTL	WBTL	NBTL
Recall Mode	Min	None	Min	None
Max Split (sec)	42	24	64	20
Min Split (sec)	24.5	20	24.5	20
Yellow Time (sec)	3.8	4.4	3.8	4.4
All-red Time (sec)	2.2	1.6	2.2	1.6
Min Initial (sec)	4	4	4	4
Veh Ext (sec)	3	3	3	3
Min Gap (sec)	3	3	3	3

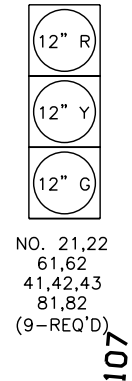

STA. 104+15.63  
OFFSET 29.5' LT

119.8' CENTER TO CENTER  
OVERHEAD SPAN

STA. 104+81.47  
OFFSET 71.06' RT

Notes:  
 1. Refer to J sheets for lane arrangement, staging information, and additional details.  
 2. The Contractor shall adjust the location of signal heads as necessary for staging.  
 3. The Contractor shall coordinate with the utility company for temporary service.  
 4. Operation, maintenance, and removal of the temporary signal shall be the responsibility of the Contractor.  
 5. The temporary signal shall remain active and fully functioning until the permanent signal is activated.

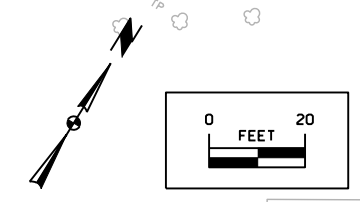
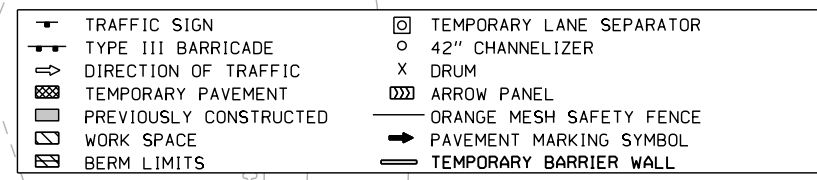

SUGGESTED TIMINGS:						
Phase No.	2	3	4	6	7	8
Movement	EBTL	NBT	SBTL	WBTL	SBT	NBTL
Recall Mode	Min	None	None	Min	None	None
Max Split (sec)	30	42	30	30	108	60
Min Split (sec)	30	30	30	30	90	60
Yellow Time (sec)	4	4	4	4	4	4
All-red Time (sec)	1	16	1	1	7	1
Min Initial (sec)	10	10	10	10	10	10
Veh Ext (sec)	3	3	3	3	3	3
Min Gap (sec)	3	3	3	3	3	3

PHASE SEQUENCE CHART						
PHASE NUMBER	02+06	04	08	FLASHMODE		
21, 22	G Y R R R R R R R Y					
61, 62	G Y R R R R R R R Y					
41, 42, 43	R R R G Y R R R R R					
81, 82	R R R R R R G Y R R					

SPLITS & PHASES			
30 s	30 s	30 s	60 s
			42 s

TRAFFIC SIGNAL FACES

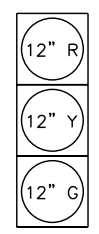

NO. 21,22  
31,32  
61,62  
41,42,43  
71,72  
81,82, 83  
(14-REQ'D)

- TRAFFIC SIGN
- TYPE III BARRICADE
- DIRECTION OF TRAFFIC
- TEMPORARY PAVEMENT
- PREVIOUSLY CONSTRUCTED
- WORK SPACE
- BERM LIMITS
- TEMPORARY LANE SEPARATOR
- 42" CHANNELIZER
- DRUM
- ARROW PANEL
- ORANGE MESH SAFETY FENCE
- PAVEMENT MARKING SYMBOL
- TEMPORARY BARRIER WALL

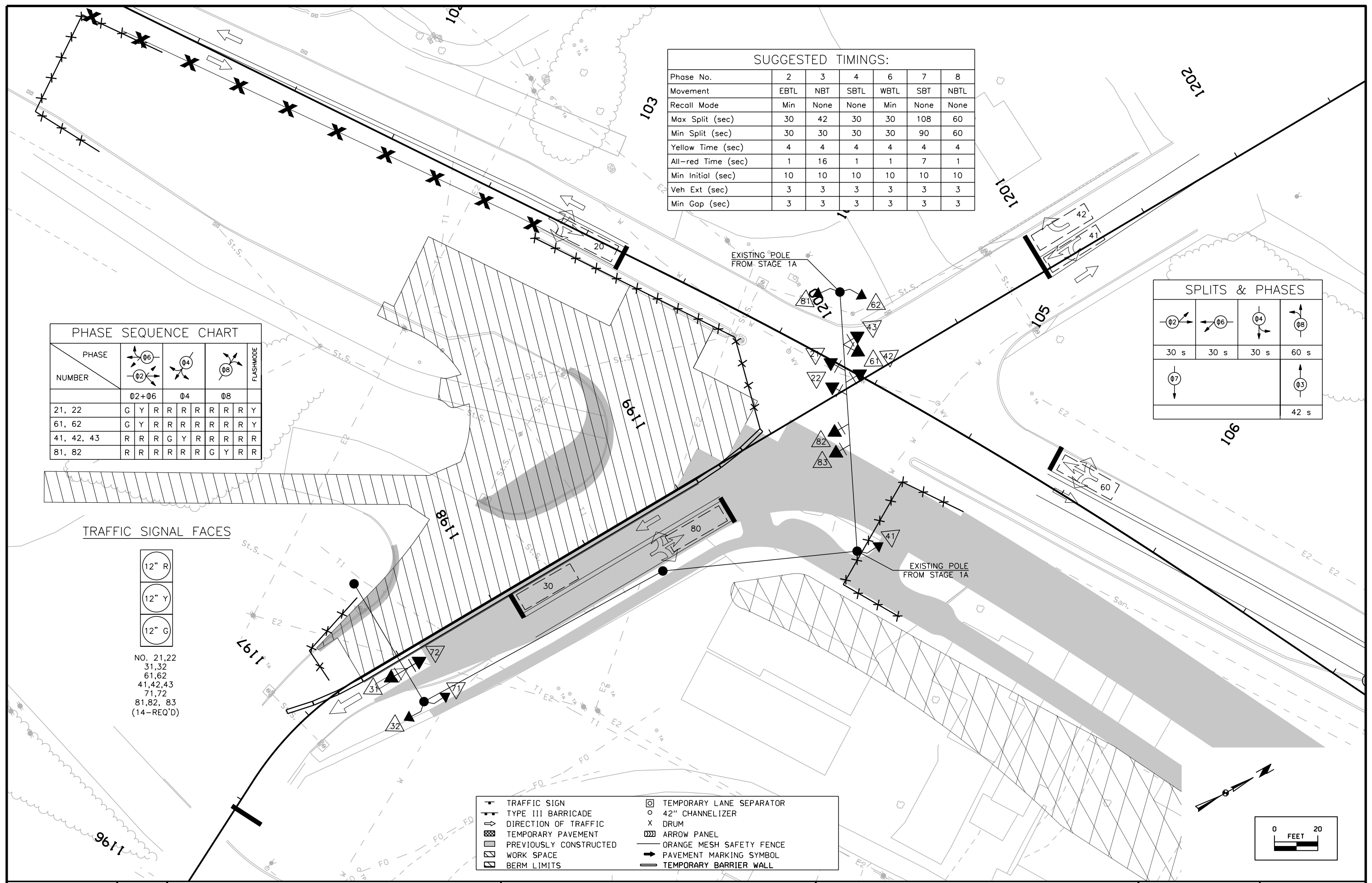
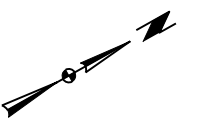
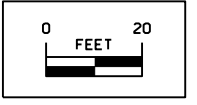

PHASE SEQUENCE CHART										
PHASE NUMBER	02	06	04	08	FLASHMODE					
21, 22	G	Y	R	R	R	R	R	R	R	Y
61, 62	G	Y	R	R	R	R	R	R	R	Y
41, 42, 43	R	R	R	G	Y	R	R	R	R	R
81, 82, 83	R	R	R	R	R	R	G	Y	R	R

SUGGESTED TIMINGS:				
Phase No.	2	4	6	8
Movement	EBTL	SBTL	WBTL	NBTL
Recall Mode	Min	None	Min	None
Max Split (sec)	110	20	110	20
Min Split (sec)	20	20	24.5	20
Yellow Time (sec)	3.8	4.4	3.8	4.4
All-red Time (sec)	2.2	1.6	2.2	1.6
Min Initial (sec)	4	4	4	4
Veh Ext (sec)	3	3	3	3
Min Gap (sec)	3	3	3	3

TRAFFIC SIGNAL FACES

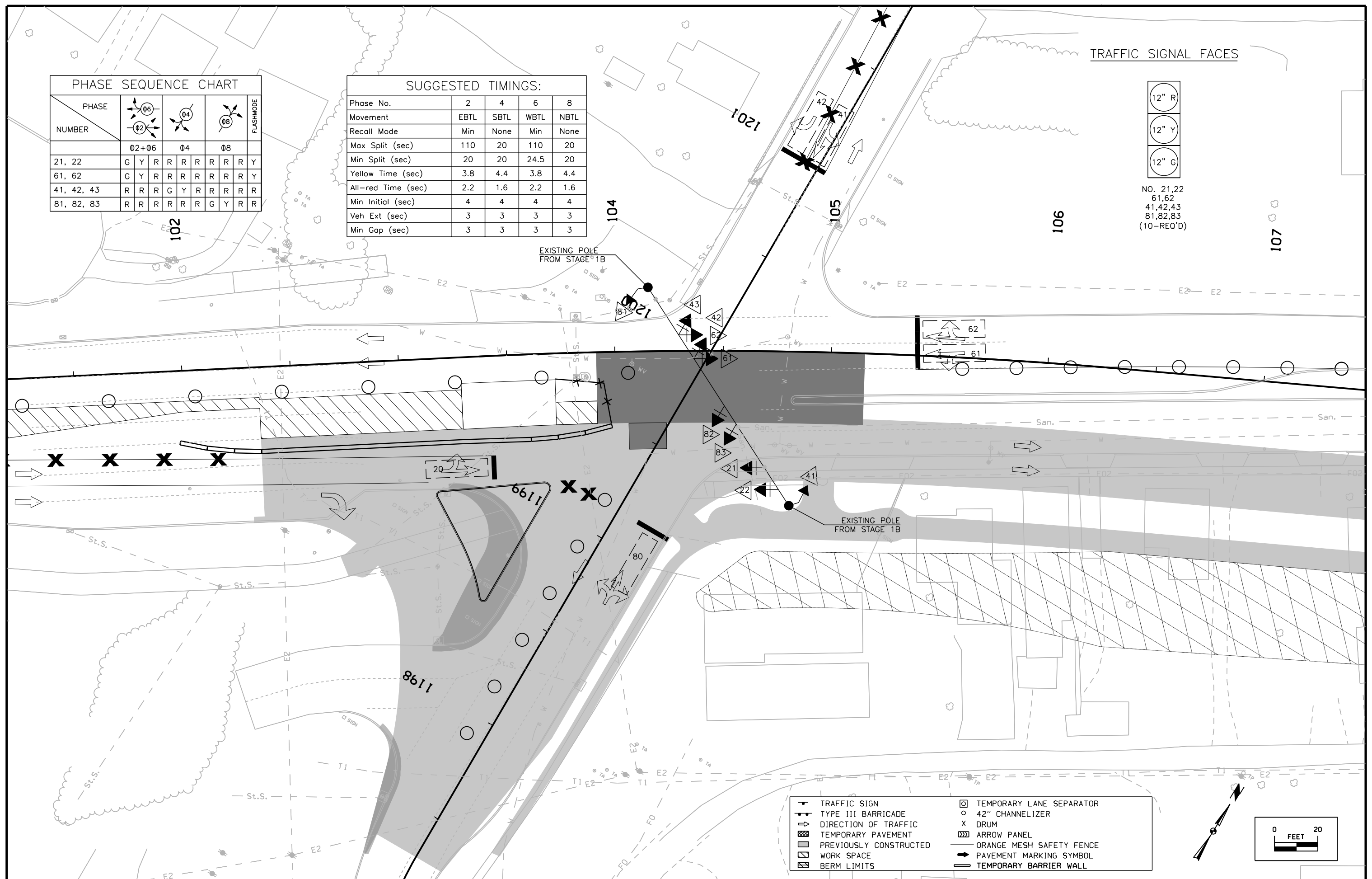
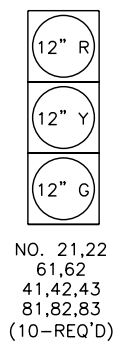

- TRAFFIC SIGN
- TYPE III BARRICADE
- DIRECTION OF TRAFFIC
- TEMPORARY PAVEMENT
- PREVIOUSLY CONSTRUCTED
- WORK SPACE
- BERM LIMITS
- TEMPORARY LANE SEPARATOR
- 42" CHANNELIZER
- DRUM
- ARROW PANEL
- ORANGE MESH SAFETY FENCE
- PAVEMENT MARKING SYMBOL
- TEMPORARY BARRIER WALL

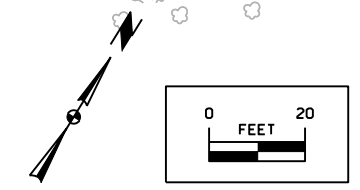

**PHASE SEQUENCE CHART**

PHASE NUMBER	02+06			08		
	06	02	08	06	02	08
21, 22	G	Y	R	R	R	R
61, 62	G	Y	R	R	R	R
81, 82, 83	R	R	R	G	Y	R

**TRAFFIC SIGNAGE**

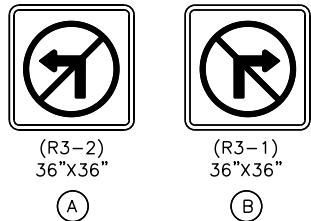

**TRAFFIC SIGNAL FACES**

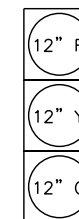

NO. 21,22  
61,62  
81,82,83  
(7-REQ'D)

**SUGGESTED TIMINGS:**

Phase No.	2	6	8
Movement	EBT	WBT	NBL
Recall Mode	Min	Min	None
Max Split (sec)	55	55	20
Min Split (sec)	20	24.5	20
Yellow Time (sec)	3.8	3.8	4.4
All-red Time (sec)	2.2	2.2	1.6
Min Initial (sec)	4	4	4
Veh Ext (sec)	3	3	3
Min Gap (sec)	3	3	3

- TRAFFIC SIGN
- TYPE III BARRICADE
- DIRECTION OF TRAFFIC
- TEMPORARY PAVEMENT
- PREVIOUSLY CONSTRUCTED
- WORK SPACE
- BERM LIMITS
- TEMPORARY LANE SEPARATOR
- 42" CHANNELIZER
- DRUM
- ARROW PANEL
- ORANGE MESH SAFETY FENCE
- PAVEMENT MARKING SYMBOL
- TEMPORARY BARRIER WALL

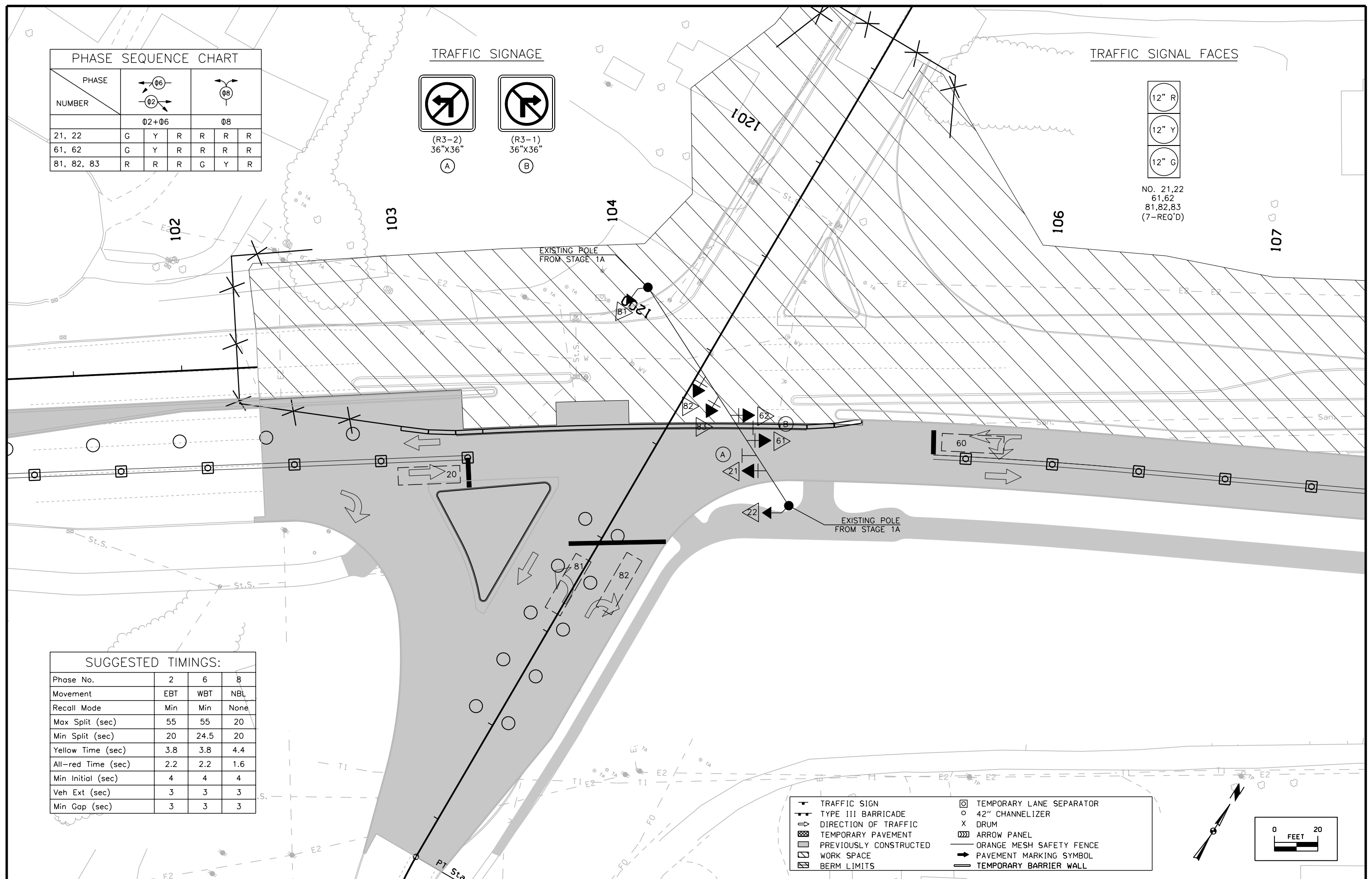
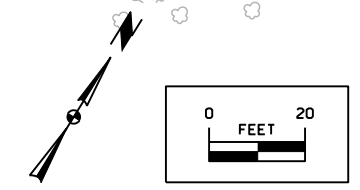

TRAFFIC SIGNAL POLE QUANTITIES						
14th Street and Camanche Avenue						
Pole No.	Mast-Arm Length	Signal Head Spacing			Remarks	
		A	B	C		D
		Feet	Feet	Feet	Feet	
1	30	20.5	8.5		INCLUDE (15') SINGLE STREETLIGHT LUMINAIRE ARM WITH TRANSFORMER BASE	
2	48	44.5	32.5	20.5	INCLUDE (15') SINGLE STREETLIGHT LUMINAIRE ARM WITH TRANSFORMER BASE	
3					PEDESTAL POLE	
4	34	24.5			INCLUDE (15') SINGLE STREETLIGHT LUMINAIRE ARM WITH TRANSFORMER BASE	
5	51	48.0	35.0	23.0	INCLUDE (15') SINGLE STREETLIGHT LUMINAIRE ARM WITH TRANSFORMER BASE	
6					PEDESTAL POLE	

SIGNAGE QUANTITIES							
14th Street and Camanche Avenue							
LEGEND LETTER=>		"A"	"B"	"C"	"D"	"E"	"F"
SIGN TYPE=>	Ped PB Sign	Camanche Ave	14th St	Left-Turn Only	Left Turn Signal	Left Turn Yield	Right Turn Signal
SIZE=>	9" x 15" R10-3e	*70" x 18"	*50" x 18"	30"x36" R3-5L	24"x30" R10-10L	24"x30" R10-12	24"x30" R10-10R
MOUNTING LOCATION=>	Vertical Shaft	Horizontal Arm	Horizontal Arm	Horizontal Arm	Horizontal Arm	Horizontal Arm	Horizontal Arm
Signal Pole No. 1	2	1		1		1	1
Signal Pole No. 2	1		1	1	1		
Signal Pole No. 3	1						
Signal Pole No. 4	2	1		1		1	
Signal Pole No. 5	1		1	1	1		
Signal Pole No. 6	1						
Totals=		8	2	2	4	2	2

TRAFFIC SIGNAL HEAD QUANTITIES								
14th Street and Camanche Avenue								
Pole No.	Signal Head Number(s)	3-Sect. 12" RYG	3-Sect. 12" Left Turn RYG Arrow	5-Sect. 12" RYG with Right Turn Y+G Arrow	12" Pedestrian with Countdown Timer	Back Plate	Mounting	
							OH	Side
1	81,82	2				2	2	
1	83			1				1
1	50		1					1
1	64, 85				2			2
2	51		1			1	1	
2	21, 22	2				2	2	
2	86				1			1
3	40, 84	2						2
3	23				1			1
4	41, 42	2					1	1
4	10		1					1
4	24, 44				2			2
5	11		1			1	1	
5	61, 62	2				2	2	
5	45				1			1
6	43, 80	2						2
6	63				1			1
Totals=		12	4	1	8	8	9	16

FOOTING AND HANDHOLE QUANTITIES				
14th Street and Camanche Avenue				
Item Number	Signal Base Type FILL	Hand-Hole Type HHL	Hand-Hole Type HHL	Comments
		24" Dia.	"Tub"	
Controller				Pad Mounted Controller W/Riser
Signal Pole No. 1	1			3'-0" Dia. x 10'-0" Deep Footing
Signal Pole No. 2	1			3'-0" Dia. x 12'-0" Deep Footing
Signal Pole No. 3	1			2'-0" Dia. x 3'-0" Deep Footing
Signal Pole No. 4	1			3'-0" Dia. x 10'-0" Deep Footing
Signal Pole No. 5	1			3'-0" Dia. x 14'-0" Deep Footing
Signal Pole No. 6	1			2'-0" Dia. x 3'-0" Deep Footing
Handhole No. 1		1		
Handhole No. 2		1		
Handhole No. 3		1		
Handhole No. 4		1		
Handhole No. 5		1		
Handhole No. 6		1		
Handhole No. 7			1	
Handhole No. 8		1		
Grand Totals=		6	7	1

\* THE LOGO PORTION OF THE STREET NAME SIGN IS NOT INCLUDED IN THE OVERALL DIMENSION OF EITHER SIGN. THE LOGO SHALL BE 18"x12" FOR SIGN "A" AND 18"x18" FOR SIGN "B". THE ARTWORK FOR THE SIGN SHOULD MATCH THE SIGNS FROM THE PREVIOUS PHASES.

OTHER STREET LIGHT QUANTITIES						
14th Street and Camanche Avenue						
WYE CONNECTORS						
LOCATION	L1 5A FUSE	L1 20A FUSE	L2	Y1 5A FUSE	Y2	Y3
At Handhole 1	2					
At Handhole 2	2					
At Handhole 5				2		
At Handhole 4				2		2
At Handhole 7		2				
Total	4	2	0	4	0	2

Temporary Traffic Signal System		
Item	Unit	Total
Temporary Traffic Signal System	L.S.	1

CONDUIT QUANTITIES IN FEET							
14TH STREET AND CAMANCHE AVENUE							
From	To	Trenched (Feet)			Pushed (Feet)		
		2" Dia. PVC	3" Dia. PVC	4" Dia. PVC	2" Dia. PVC	3" Dia. PVC	4" Dia. PVC
SIGNAL POLE 1	HANDHOLE 1		4				
	AT SIGNAL POLE 1	2					
HANDHOLE 1	HANDHOLE 6					65	
SIGNAL POLE 6	HANDHOLE 6		16				
	AT SIGNAL POLE 6	2					
SIGNAL POLE 2	HANDHOLE 2		19				
	SIGNAL POLE 2	2					
HANDHOLE 2	HANDHOLE 3		61				
SIGNAL POLE 3	HANDHOLE 3		14				
	AT SIGNAL POLE 3	2					
HANDHOLE 3	HANDHOLE 4					94	
SIGNAL POLE 4	HANDHOLE 4		18				
	AT SIGNAL POLE 4	2					
HANDHOLE 4	HANDHOLE 5					103	
SIGNAL POLE 5	HANDHOLE 5		14				
	AT SIGNAL POLE 5	2					
HANDHOLE 5	HANDHOLE 6			116			
HANDHOLE 4	HANDHOLE 7					156	
HANDHOLE 7	CONTROLLER			26			
CONTROLLER	HANDHOLE 8		12				
EX HANDHOLE 9	HANDHOLE 7		26				
Sub-Totals =		50	146	142	0	262	156
Extra =							
Grand Totals =		50	146	142	0	262	156

WIRE QUANTITIES IN FEET 14TH STREET AND CAMANCHE AVENUE													
From	To	Pull Rope	1c #10 Tracer	#6 Bare Copper	1c #8 Luminaire	1c #6 Power	6 PR. #19 Interconnect	Coax Video Camera	Power Video Camera	2c #14	5c #14	7c #14	12c #14
		SIGNAL POLE 1	HANDHOLE 1	6	6	6	12			6	6	12	12
	AT SIGNAL POLE 1				100			51	51	18	84	51	
HANDHOLE 1	HANDHOLE 6	73	73	73	146			73	73	146	146		146
SIGNAL POLE 6	HANDHOLE 6	18	18	18						18	18		18
	AT SIGNAL POLE 6									9	36		
SIGNAL POLE 2	AT HANDHOLE 2	21	21	21	42			21	21	21	21		42
	AT SIGNAL POLE 2				100			69	69	9	217		
HANDHOLE 2	HANDHOLE 3	69	69	69	138			69	69	69	69		138
SIGNAL POLE 3	HANDHOLE 3	16	16	16						16	16		16
	AT SIGNAL POLE 3									9	36		
HANDHOLE 3	HANDHOLE 4	102	102	102	204			102	102	204	204		306
SIGNAL POLE 4	HANDHOLE 4	20	20	20	40			20	20	40	40		40
	AT SIGNAL POLE 4				100			55	55	18	101		
HANDHOLE 4	HANDHOLE 5	111	111	111	222			222	222	444	444		555
SIGNAL POLE 5	HANDHOLE 5	16	16	16	32			16	16	16	16		32
	AT SIGNAL POLE 5				100			72	72	9	226		
HANDHOLE 5	HANDHOLE 6	122	122	122	244			122	122	366	366		366
HANDHOLE 4	HANDHOLE 7	80	80	80	160			320	320	640	640		800
HANDHOLE 7	CONTROLLER	21	21	21			21	84	84	168	168		210
CONTROLLER	HANDHOLE 8	20	20	20			60						
EX HANDHOLE 9	HANDHOLE 7						34						
Sub-Totals =		695	695	695	1640	60	55	1302	1302	2232	2860	51	2681
Extra =		35	35	35	82	3	3	66	66	112	143	3	135
Grand Totals =		730	730	730	1722	63	58	1368	1368	2344	3003	54	2816

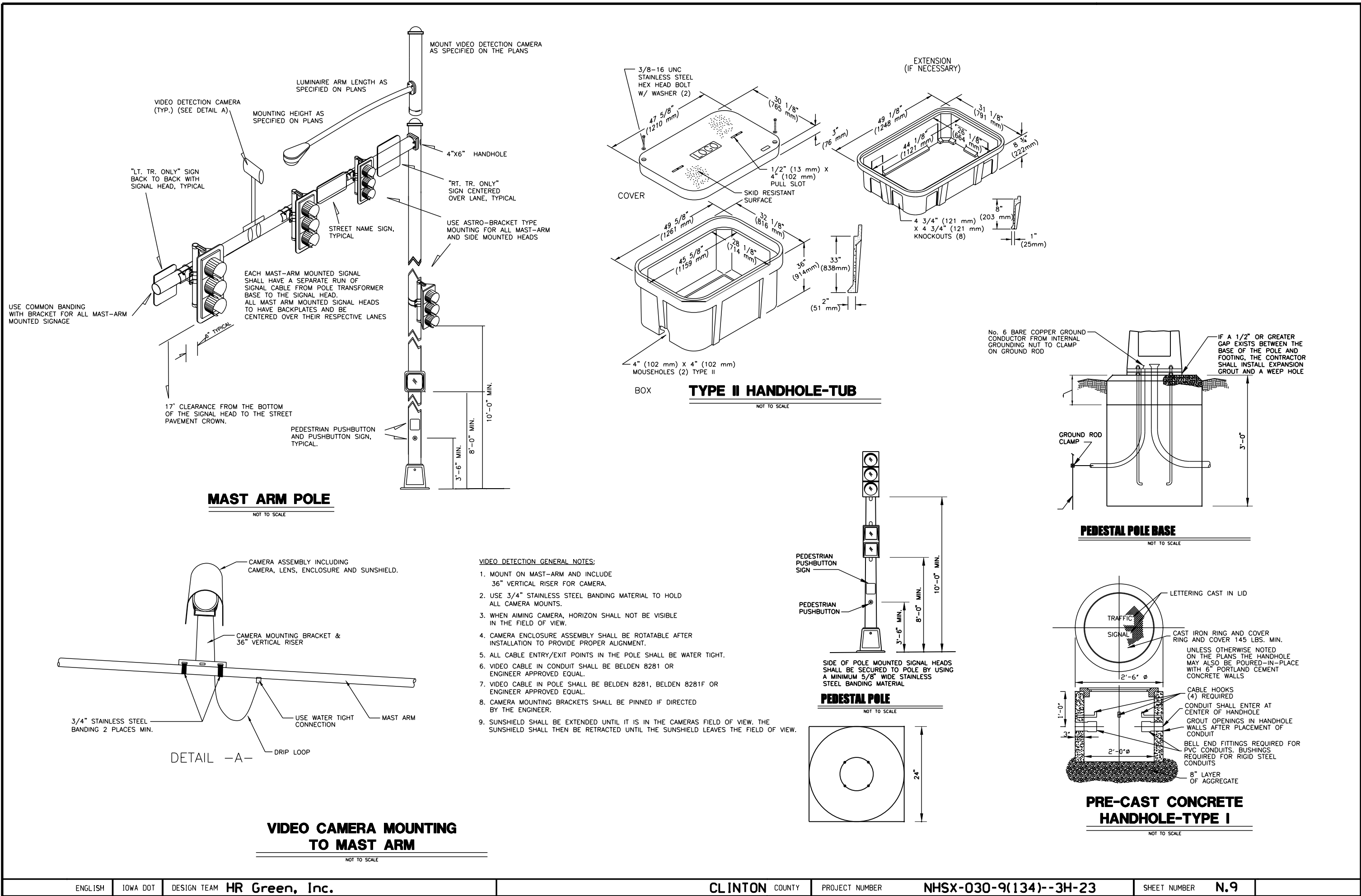

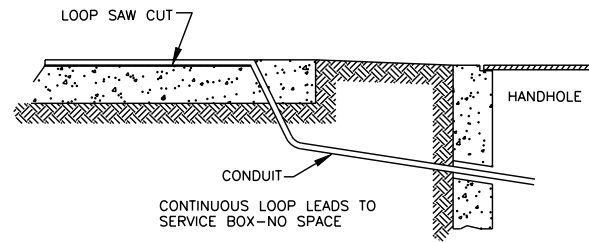

**DETECTOR CONDUIT ENTRY (NO CURB)**

NOT TO SCALE

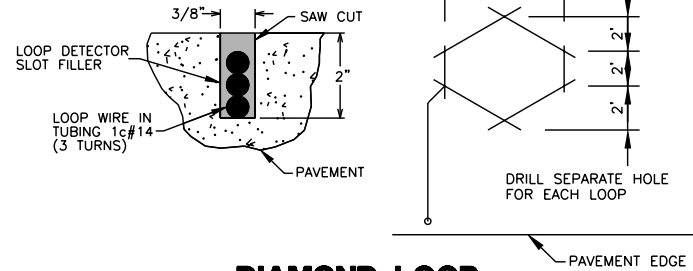

**DIAMOND LOOP**

NOT TO SCALE

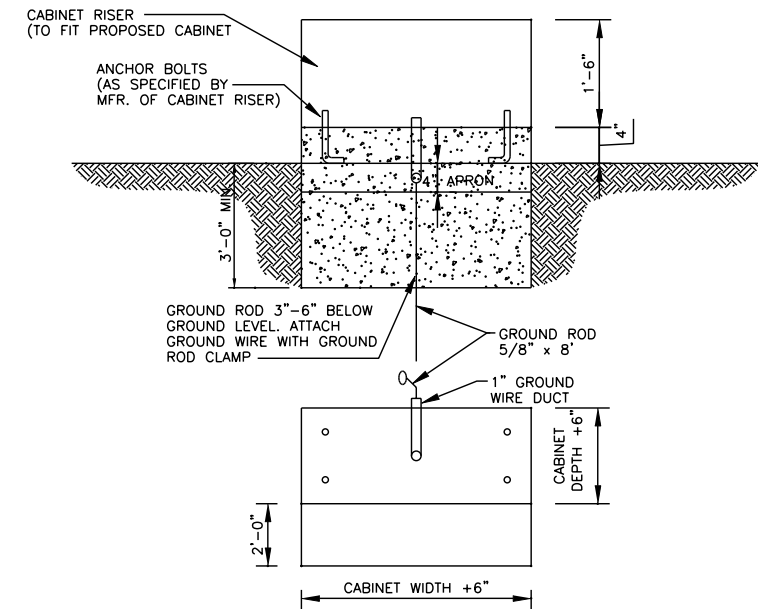

**CONTROLLER PAD**

NOT TO SCALE

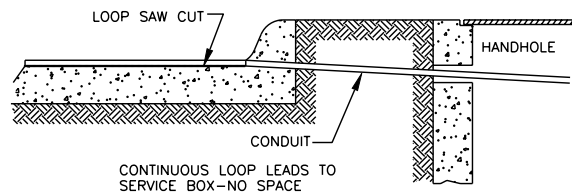

**DETECTOR CONDUIT ENTRY (CURB)**

NOT TO SCALE

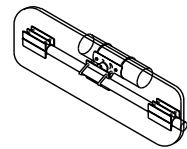

**MAST ARM MOUNT STREET SIGN BRACKET**

NOT TO SCALE

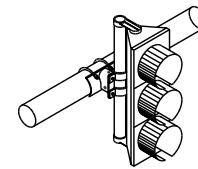

**MAST ARM MOUNTING BRACKET**

NOT TO SCALE

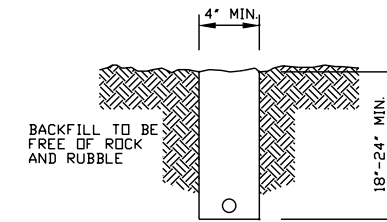

**TRENCHING IN UNPAVED AREAS**

NOT TO SCALE

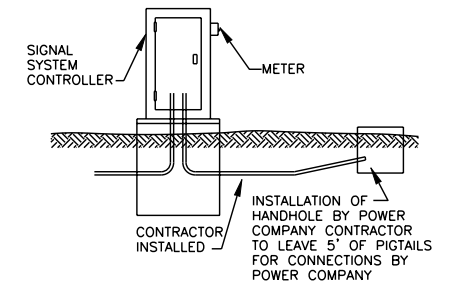

**POWER SERVICE**

NOT TO SCALE

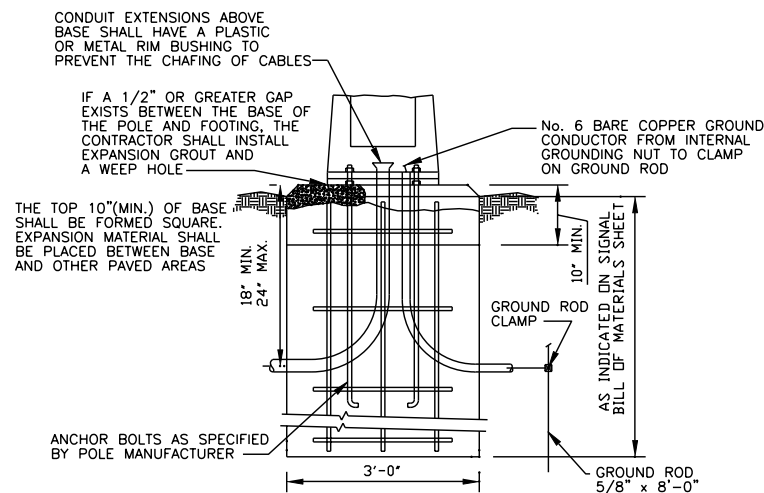

**MAST ARM POLE BASE**

NOT TO SCALE

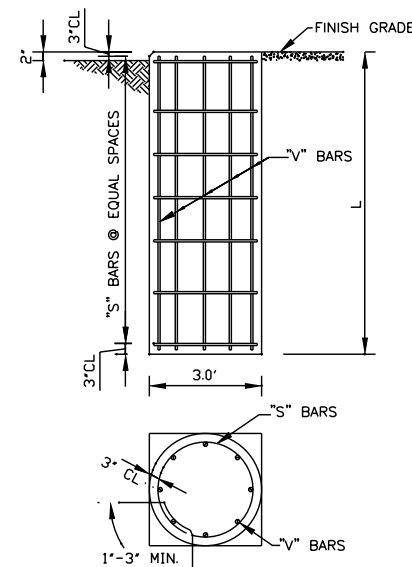

**MAST ARM POLE BASE REINFORCING STEEL**

NOT TO SCALE

MAST ARM LENGTH	FOOTING DIAMETER	DEPTH (L)	"V" BARS	"S" BARS
LESS THAN 40'	3'	10.0'	8-#7 BARS X 9'	10-#4 BARS @ 12" MAX.
41' - 49'	3'	12.0'	8-#7 BARS X 11'	12-#4 BARS @ 12" MAX.
50' - 55'	3'	14.0'	8-#7 BARS X 13'	14-#4 BARS @ 12" MAX.
56' - 60'	3'	16.0'	8-#10 BARS X 15'	16-#4 BARS @ 12" MAX.
61' - 70'	3.5'	21.0'	12-#10 BARS X 20'	21-#4 BARS @ 12" MAX.
71' - 80'	3.5'	23.0'	12-#10 BARS X 22'	23-#4 BARS @ 12" MAX.

**MAST ARM POLE BASE SCHEDULE**

NOT TO SCALE

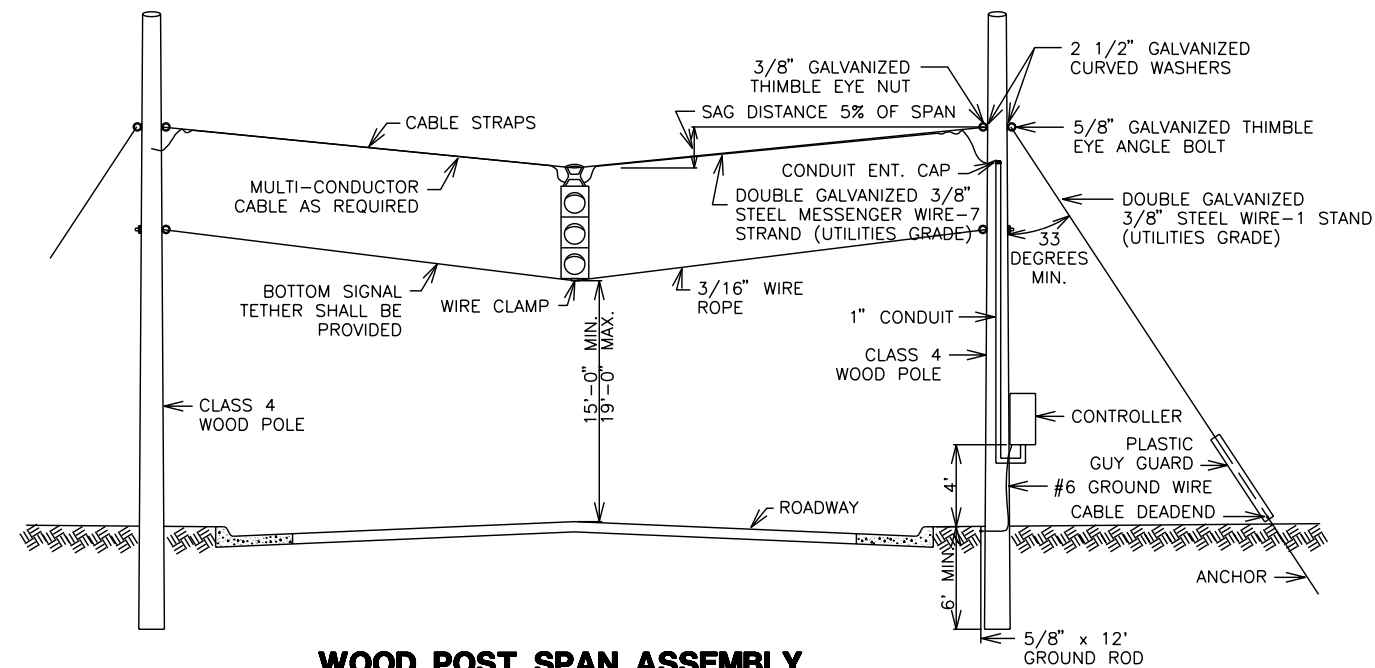

**WOOD POST SPAN ASSEMBLY  
TEMPORARY TRAFFIC SIGNAL**

NOT TO SCALE

**QUANTITY NOTES**

1. THE CONTRACTOR SHALL SUPPLY ALL NECESSARY SIGNAL HEADS, WOOD POLES, AND HARDWARE TO PROVIDE A FULLY FUNCTIONAL TEMPORARY AND FULLY ACTUATED TRAFFIC SIGNAL. THE CONTRACTOR'S LUMP SUM BID FOR THIS PROJECT SHALL INCLUDE ALL LABOR AND MATERIAL NECESSARY TO PROVIDE A COMPLETE, FUNCTIONAL, CONTRACTOR OWNED, AND CONTRACTOR MAINTAINED TEMPORARY TRAFFIC SIGNAL INSTALLATION AS SHOWN ON THE PLANS.
2. THE CONTRACTOR'S LUMP SUM BID FOR THIS PROJECT SHALL INCLUDE ALL COSTS TO MODIFY THE TEMPORARY SIGNAL AS NECESSARY FOR THE STAGING SEQUENCE SHOWN ON THE PLANS AND ALL COSTS TO REMOVE THE TEMPORARY SIGNAL AT THE COMPLETION OF CONSTRUCTION.
3. FINAL POSITIONING OF THE TRAFFIC SIGNAL POLES AND SIGNAL FACES TO BE DETERMINED IN THE FIELD AND ARE SUBJECT TO THE APPROVAL OF THE PROJECT ENGINEER.
4. ALL WIRING SHALL CONFORM TO THE NATIONAL ELECTRIC CODE AND LOCAL ORDINANCES AND REQUIREMENTS. ALL CABLE FOR THE INTERSECTION SIGNAL CIRCUITS SHALL BE MULTICONDUCTOR CABLE MEETING THE REQUIREMENTS OF I.M.S.A. SPECIFICATION 19.
5. THE TEMPORARY TRAFFIC SIGNAL SHALL BE FULLY ACTUATED. THE CONTRACTOR CAN CHOOSE FROM THE FOLLOWING LIST OF DETECTOR TYPES, SUBJECT TO THE APPROVAL OF THE PROJECT ENGINEER:
  - INDUCTIVE LOOP
  - MICROWAVE
  - MICROLOOP, PROBE
  - RADAR
  - ULTRASONIC
  - VIDEO IMAGE



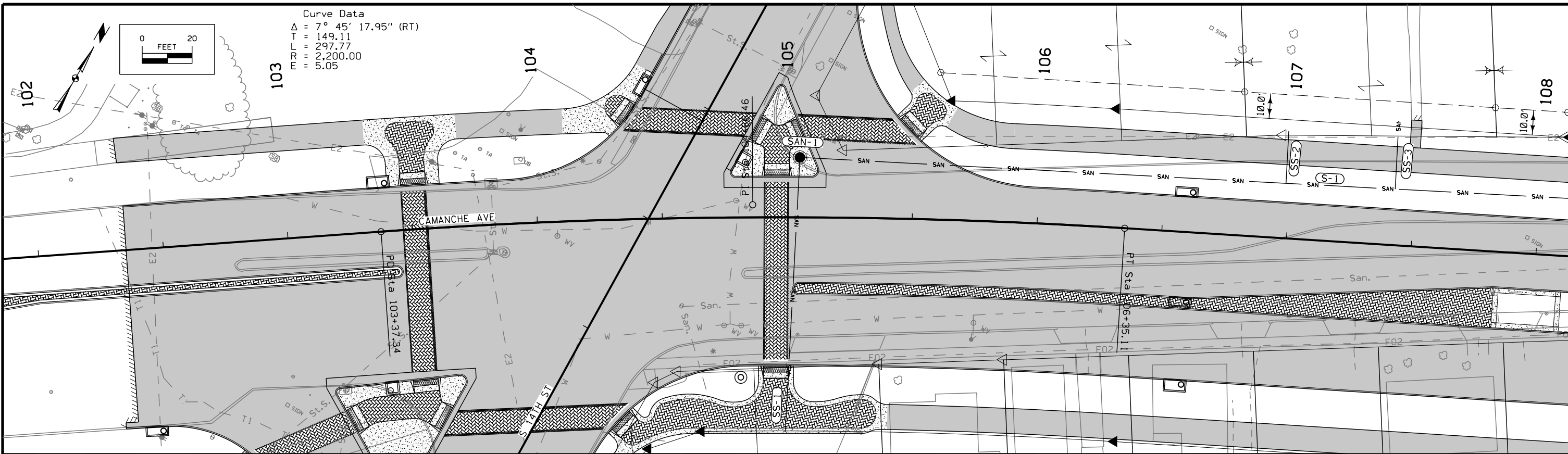

Curve Data  
 $\Delta = 7^\circ 45' 17.95''$  (RT)  
 $PT = 149.11$   
 $PI = 297.77$   
 $PC = 2,200.00$   
 $EA = 5.05$

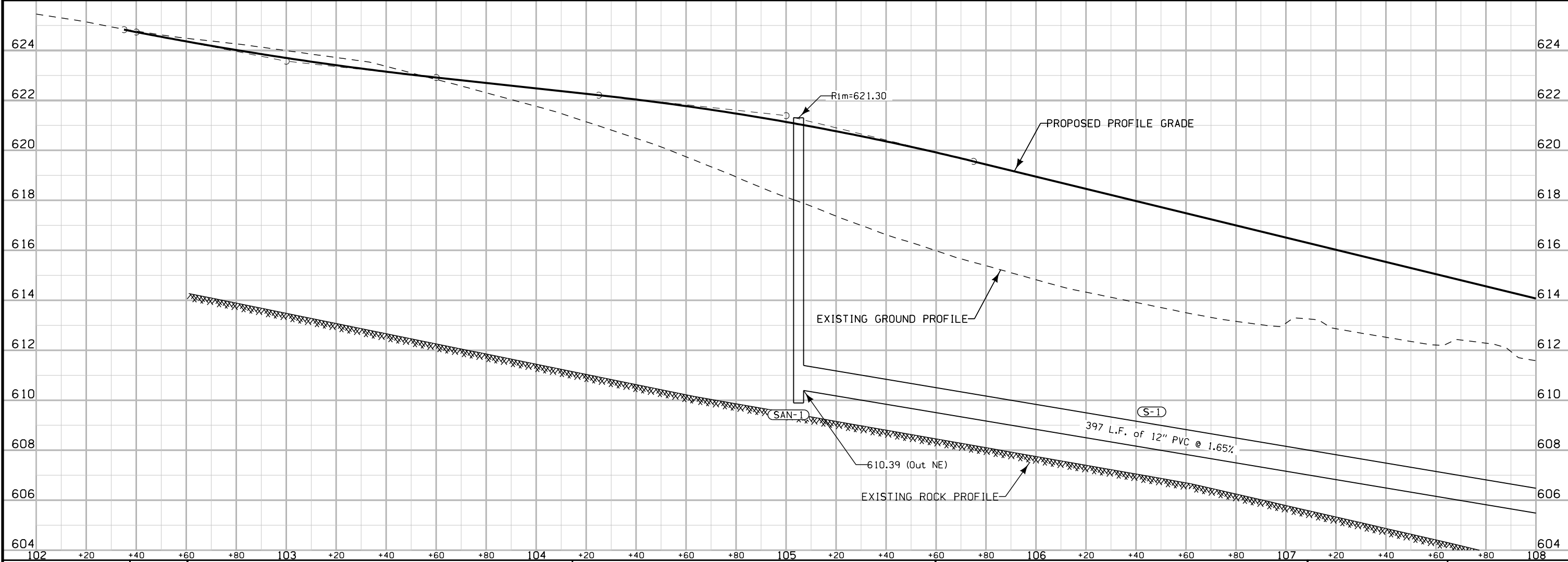
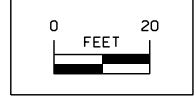

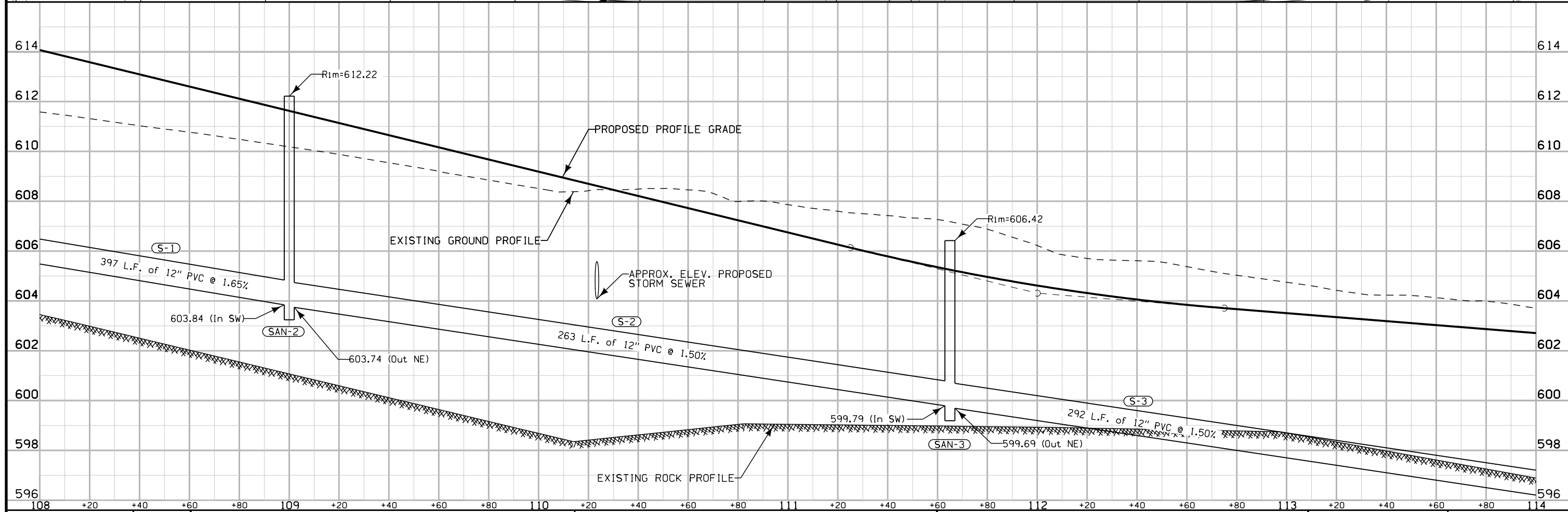
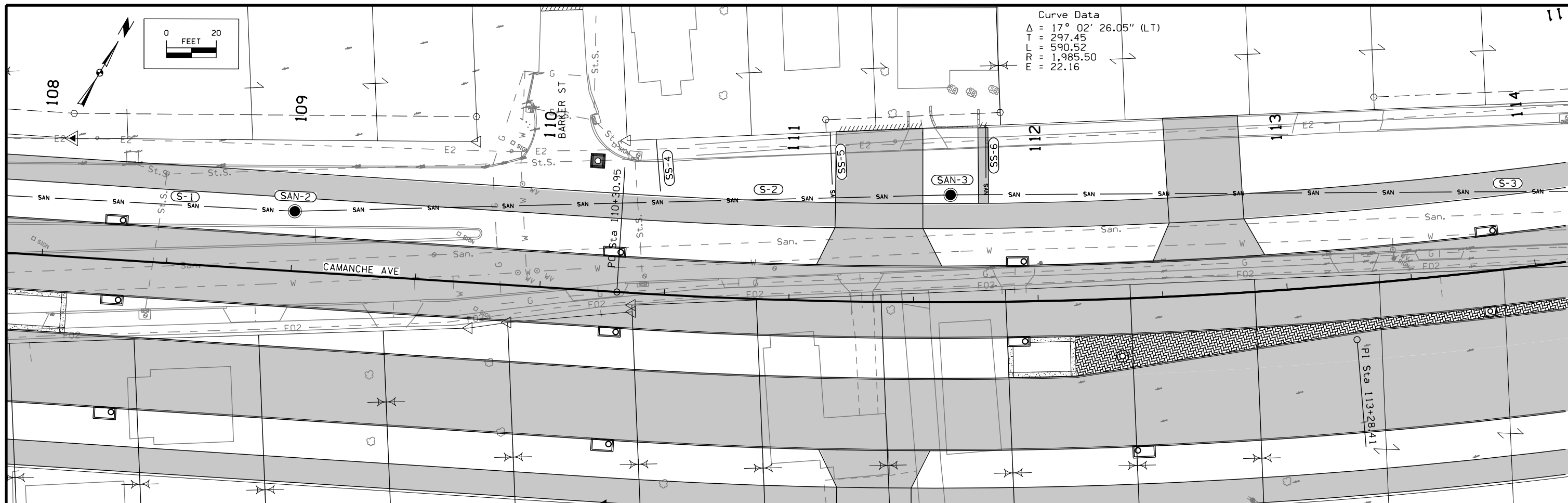

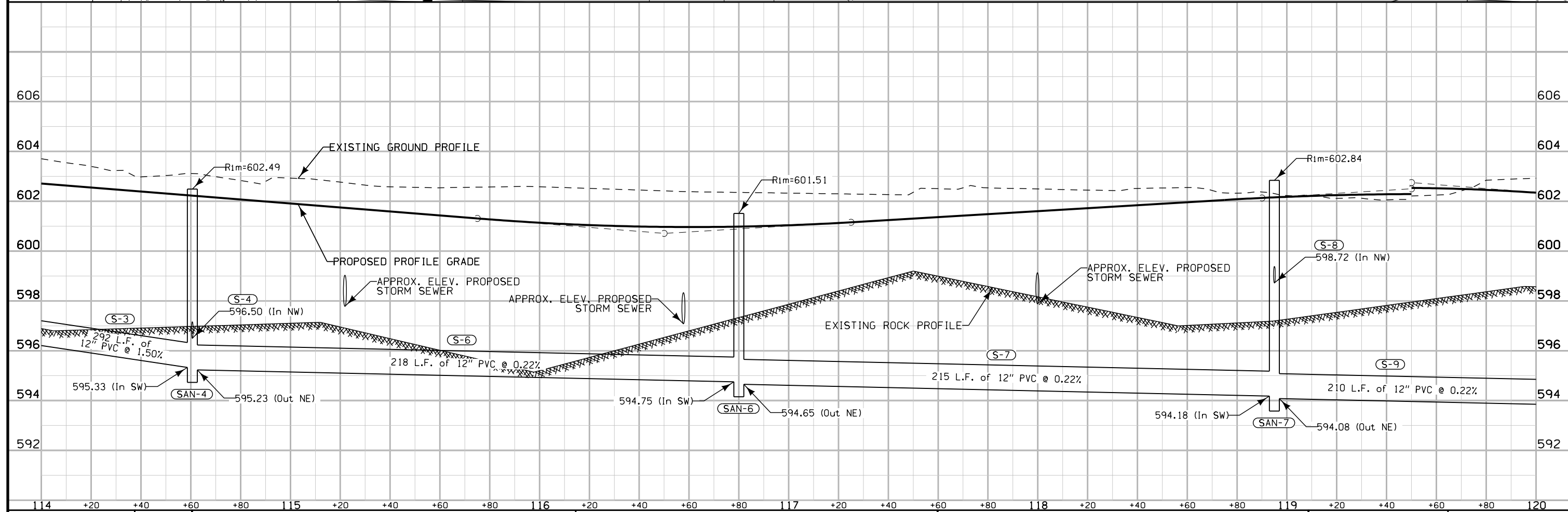
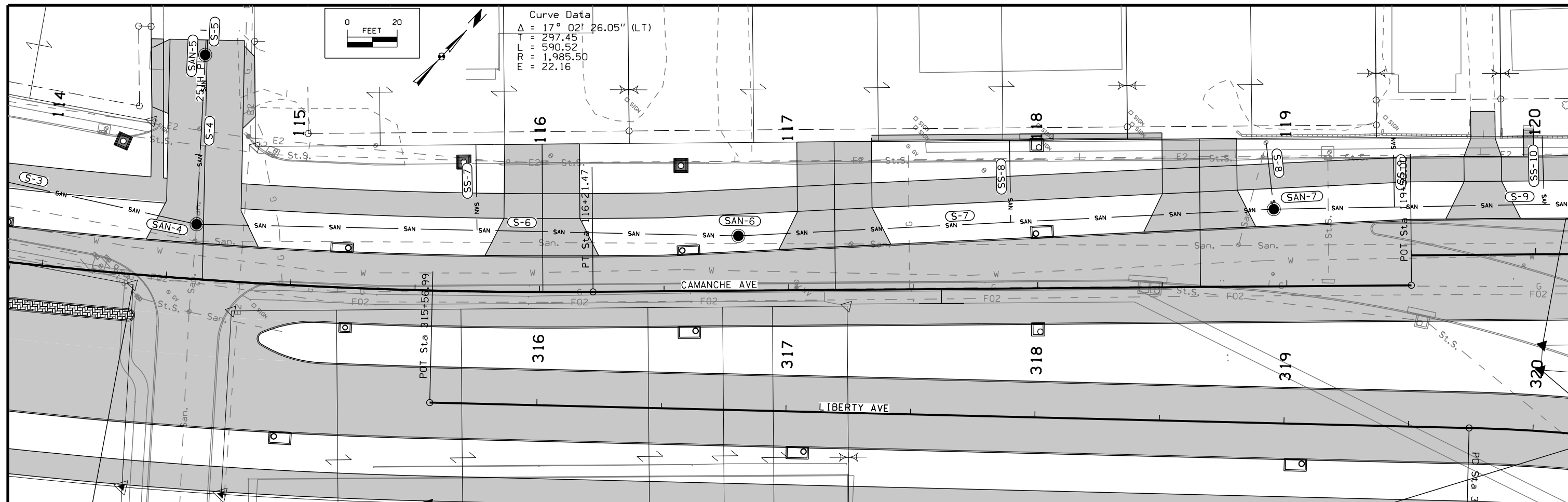

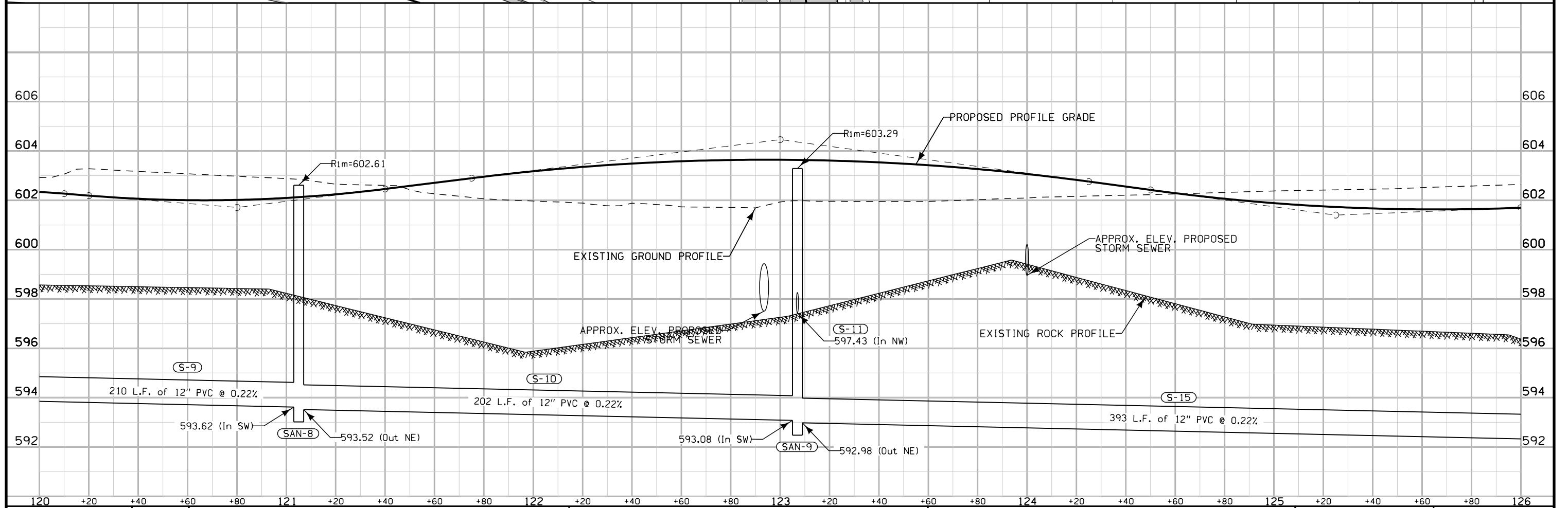
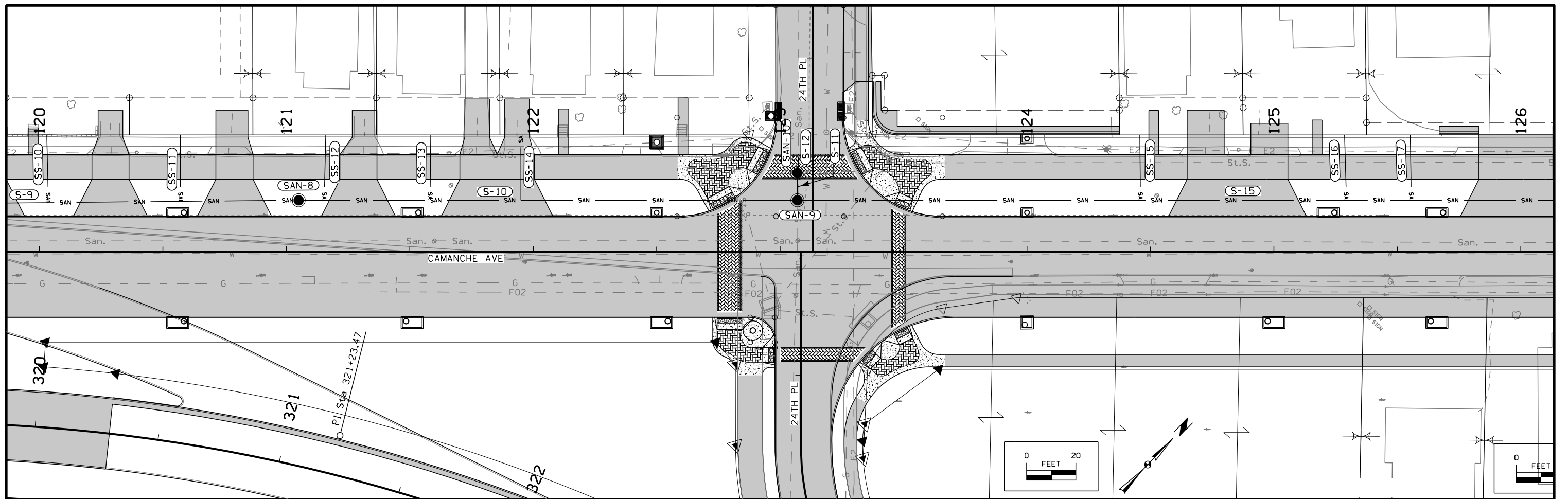

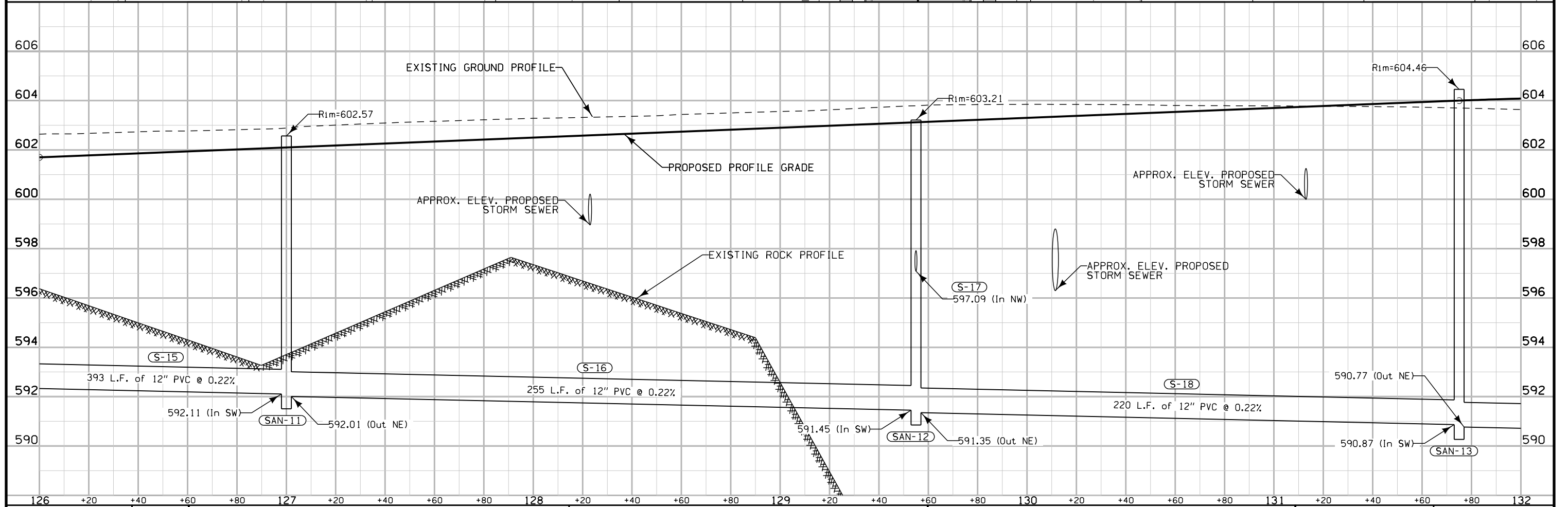
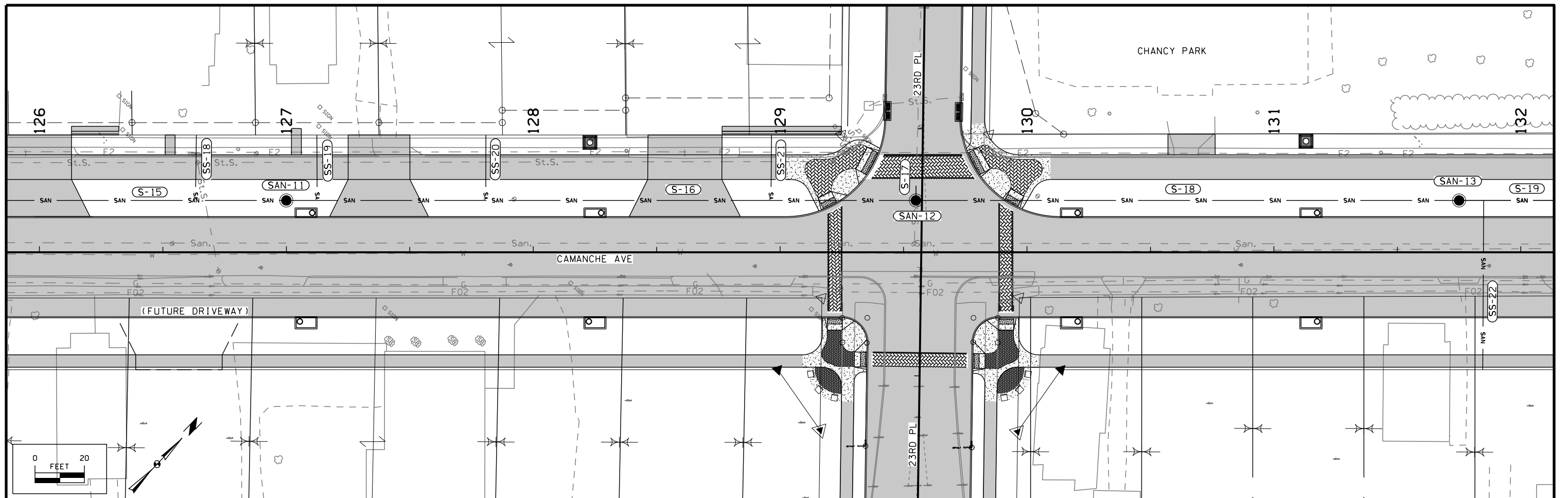

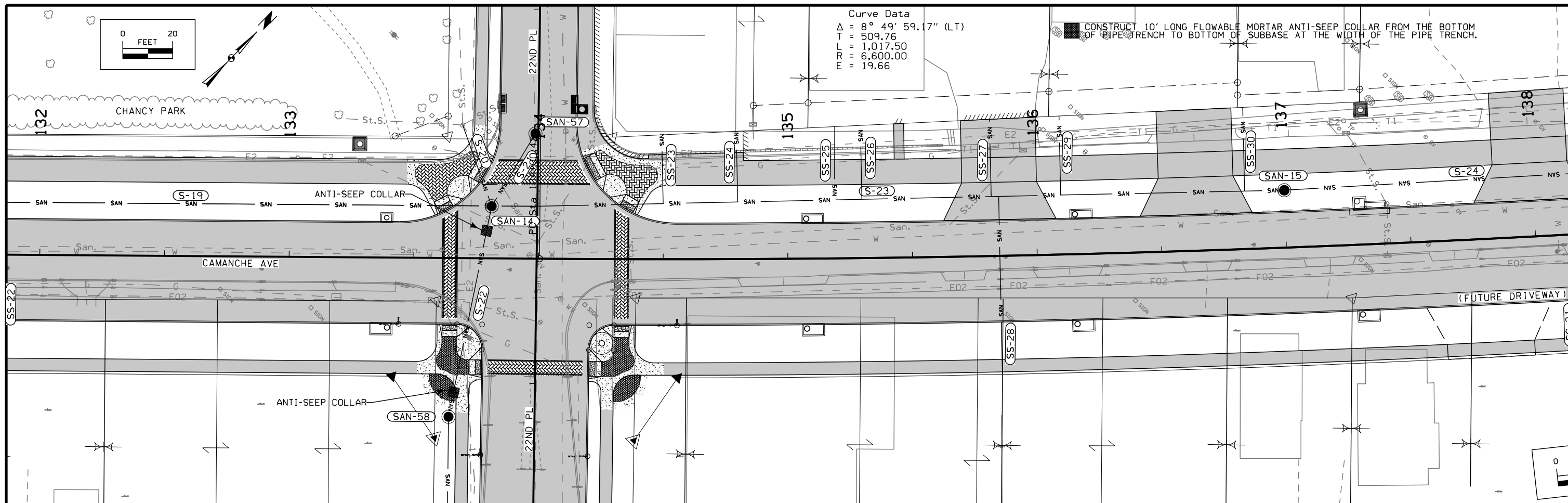

Curve Data  
 $\Delta = 8^\circ 49' 59.17''$  (LT)  
 T = 509.76  
 L = 1,017.50  
 P = 6,600.00  
 M = 19.66

CONSTRUCT 10' LONG FLOWABLE MORTAR ANTI-SEEP COLLAR FROM THE BOTTOM OF PIPE TRENCH TO BOTTOM OF SUBBASE AT THE WIDTH OF THE PIPE TRENCH.

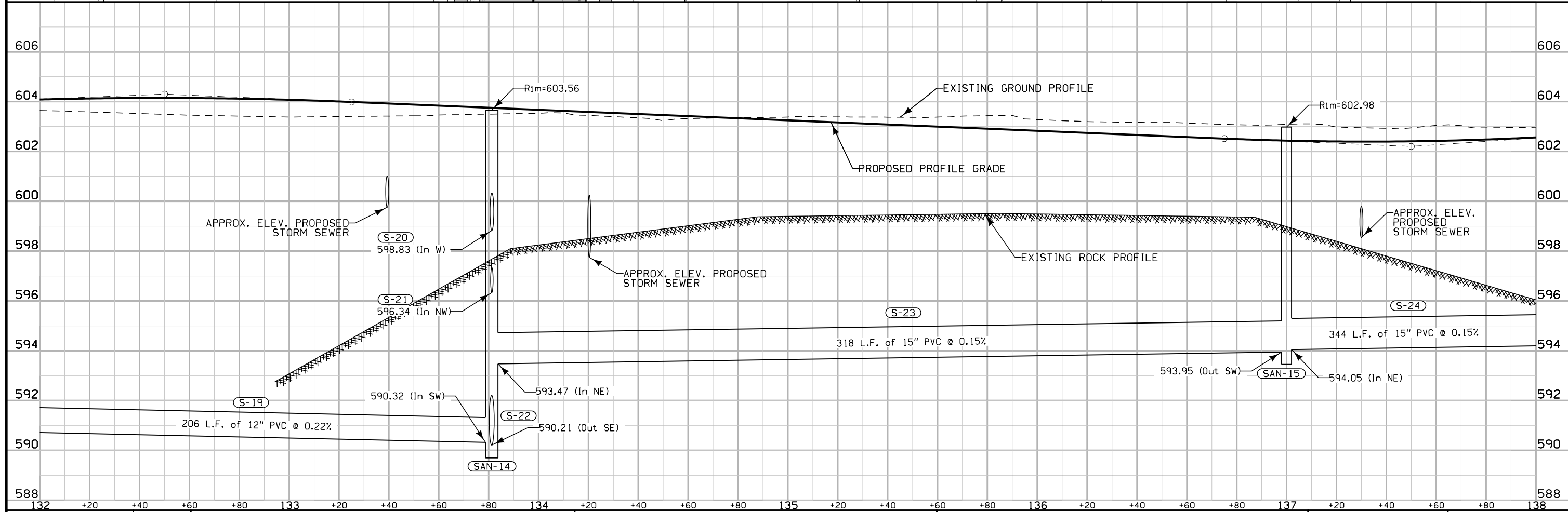

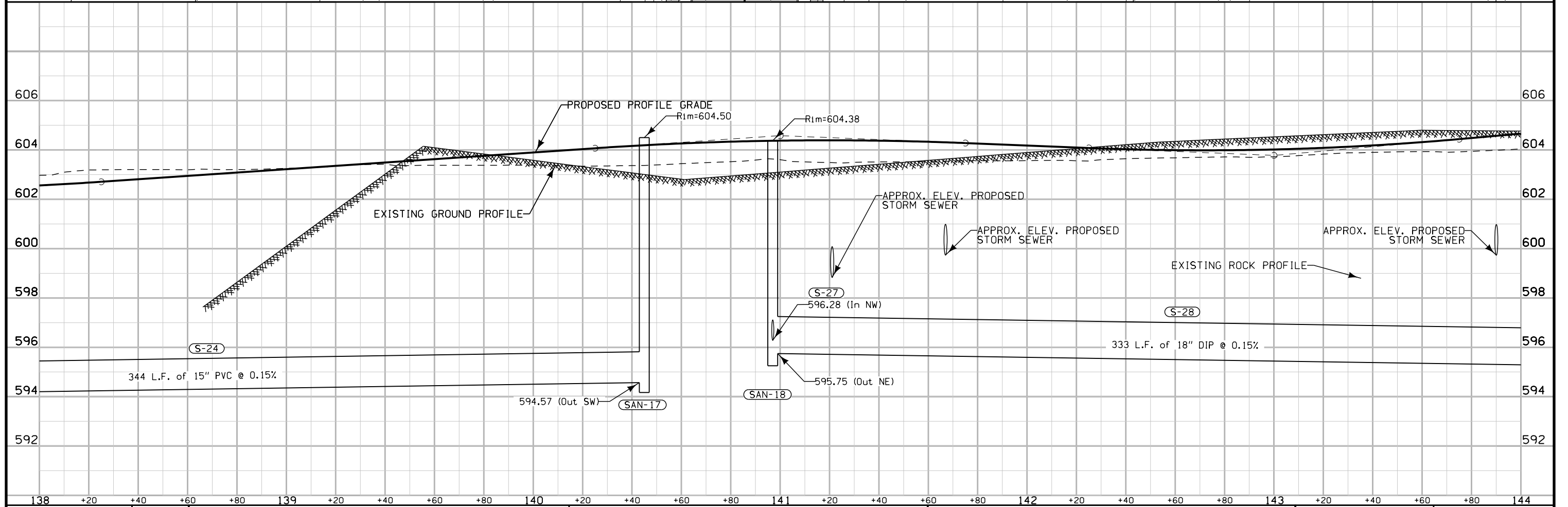
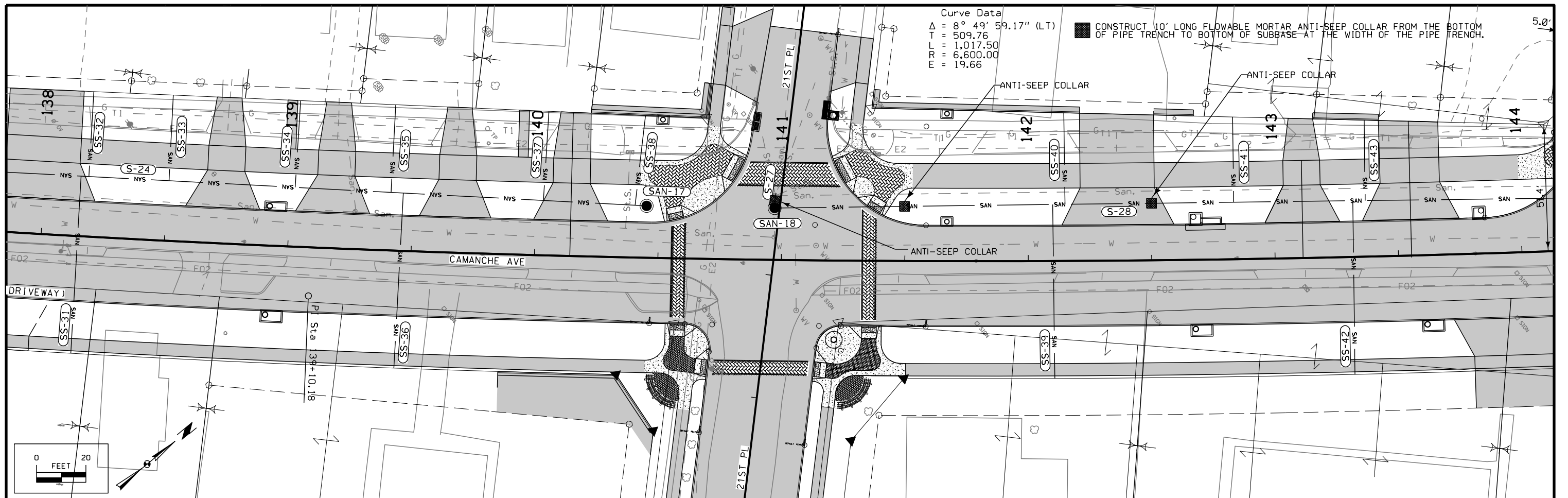

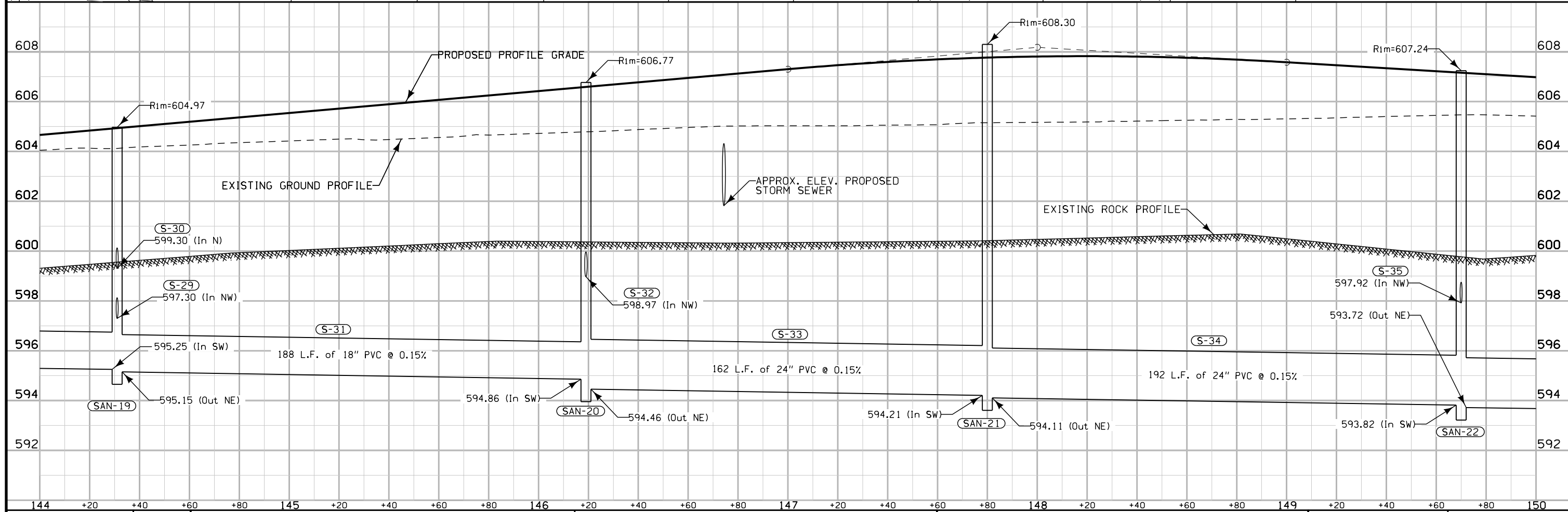
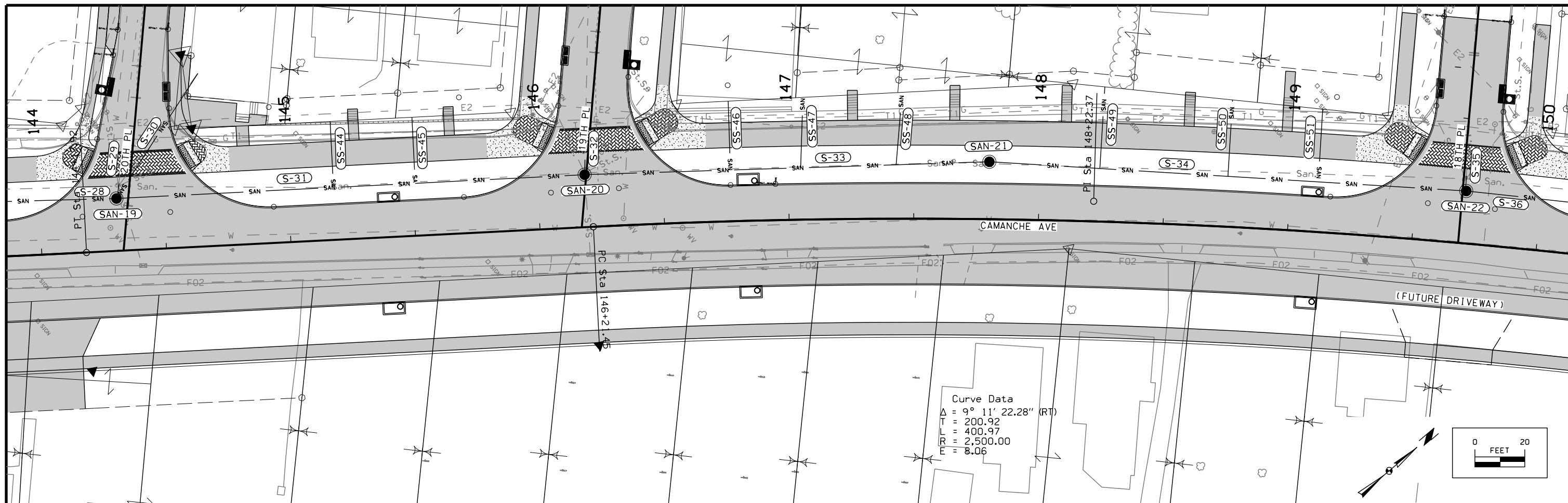



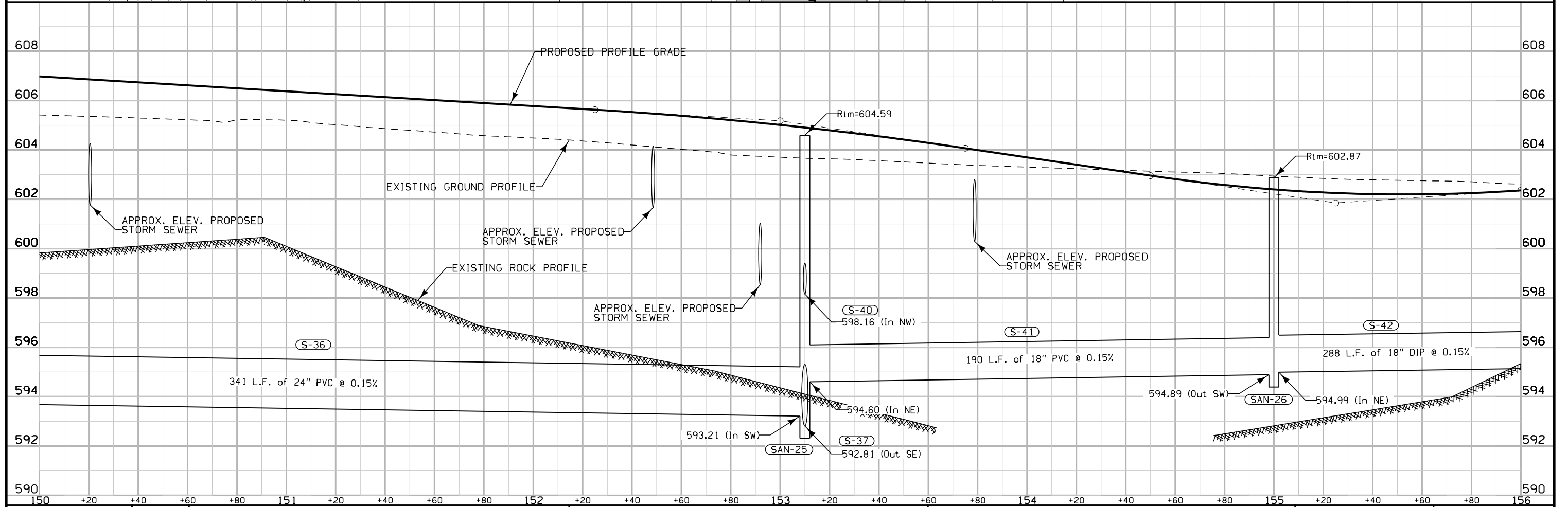
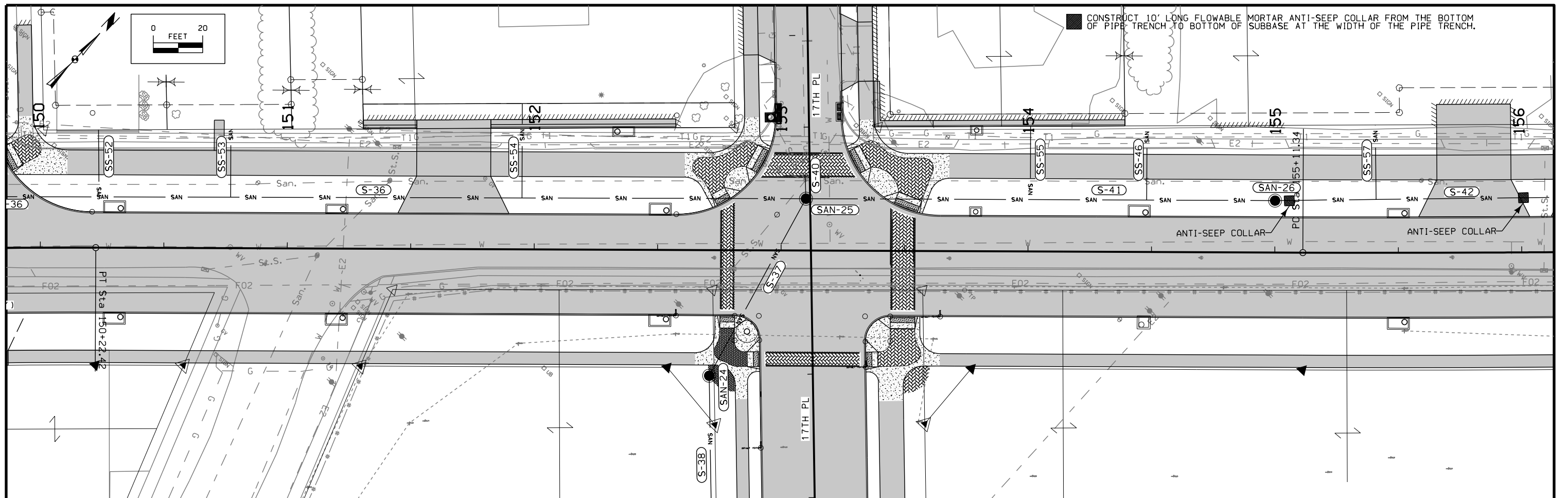

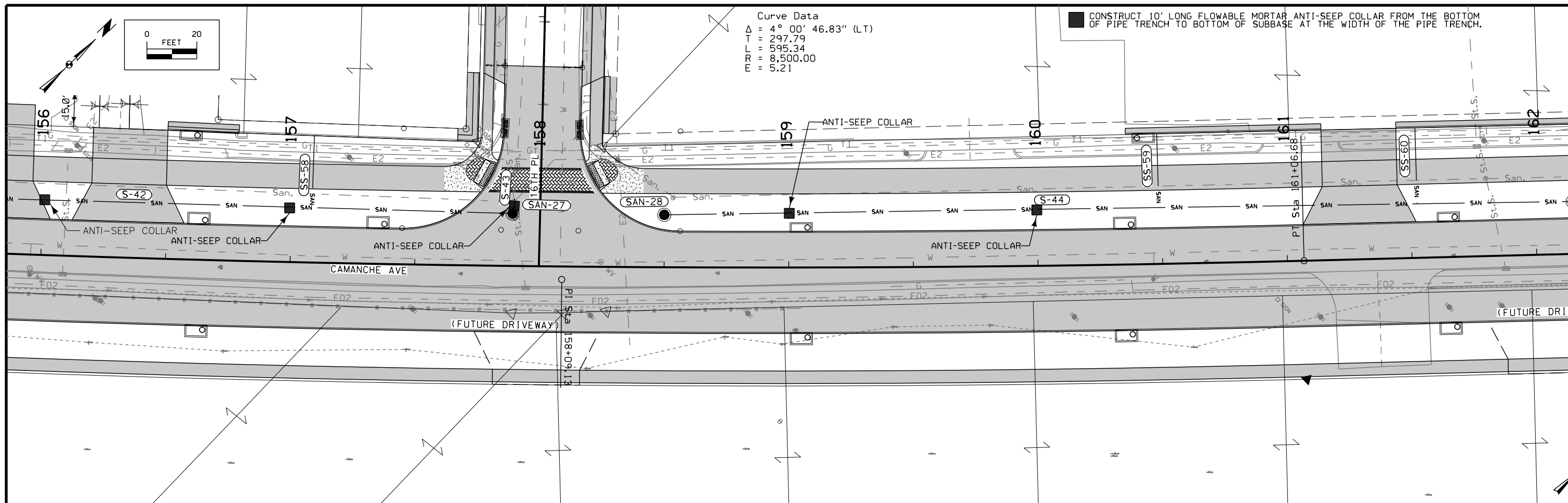

Curve Data  
 $\Delta = 4^\circ 00' 46.83''$  (LT)  
 $T = 297.79$   
 $L = 595.34$   
 $R = 8,500.00$   
 $E = 5.21$

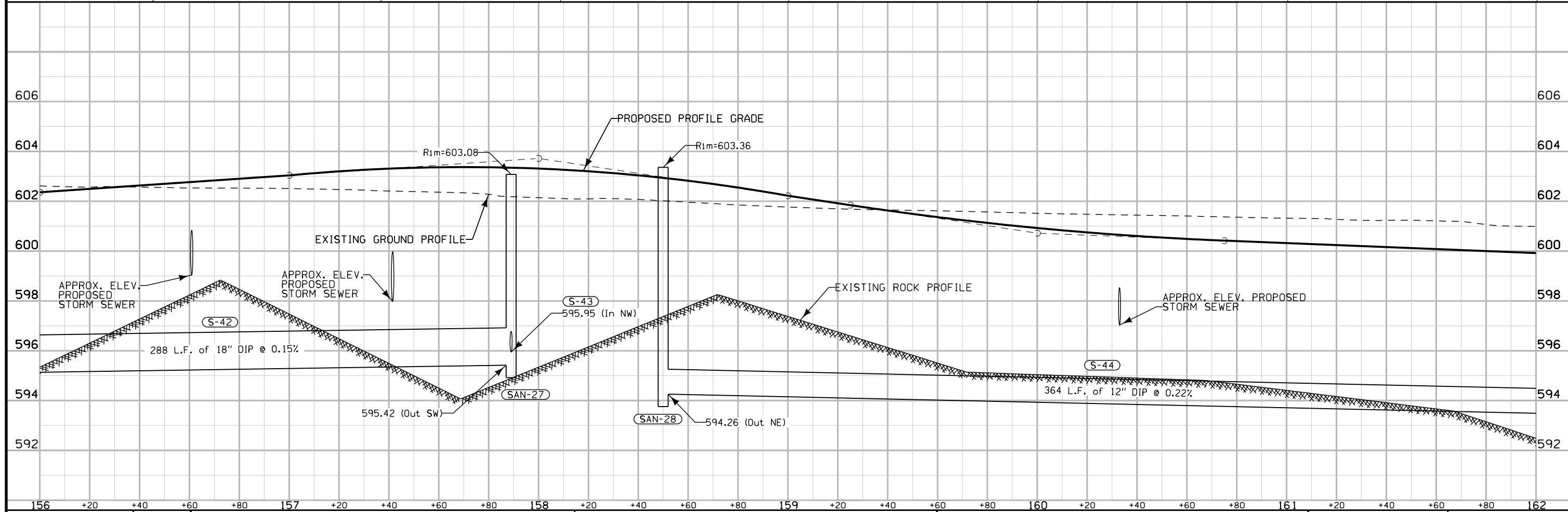

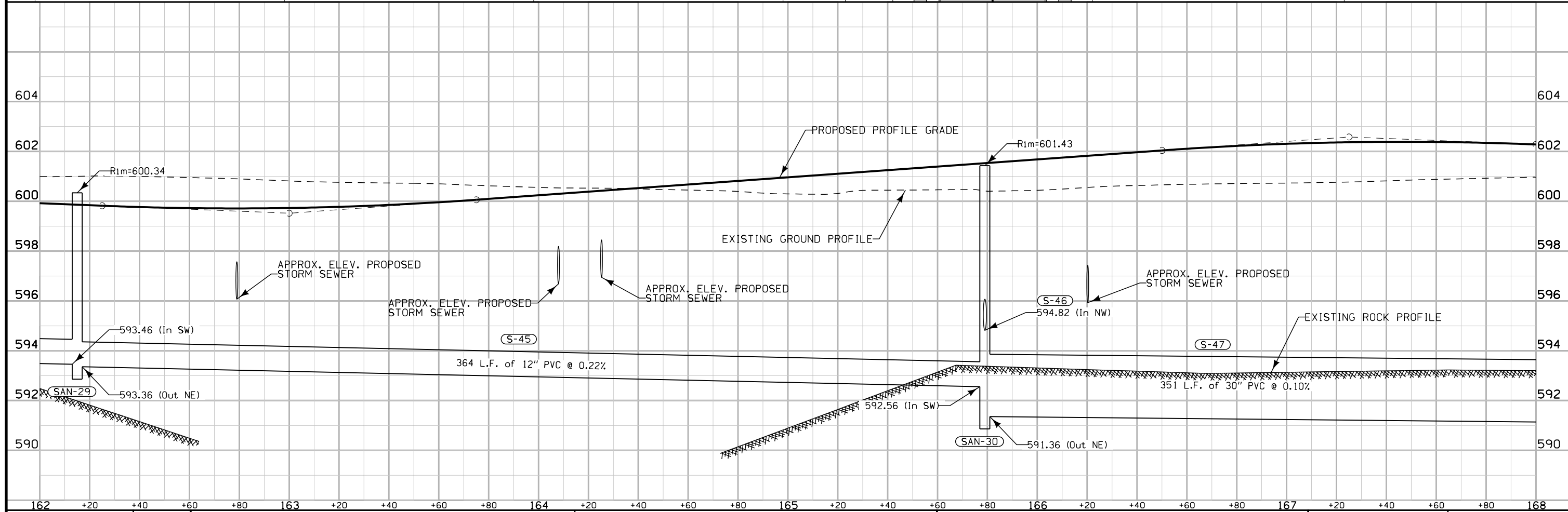
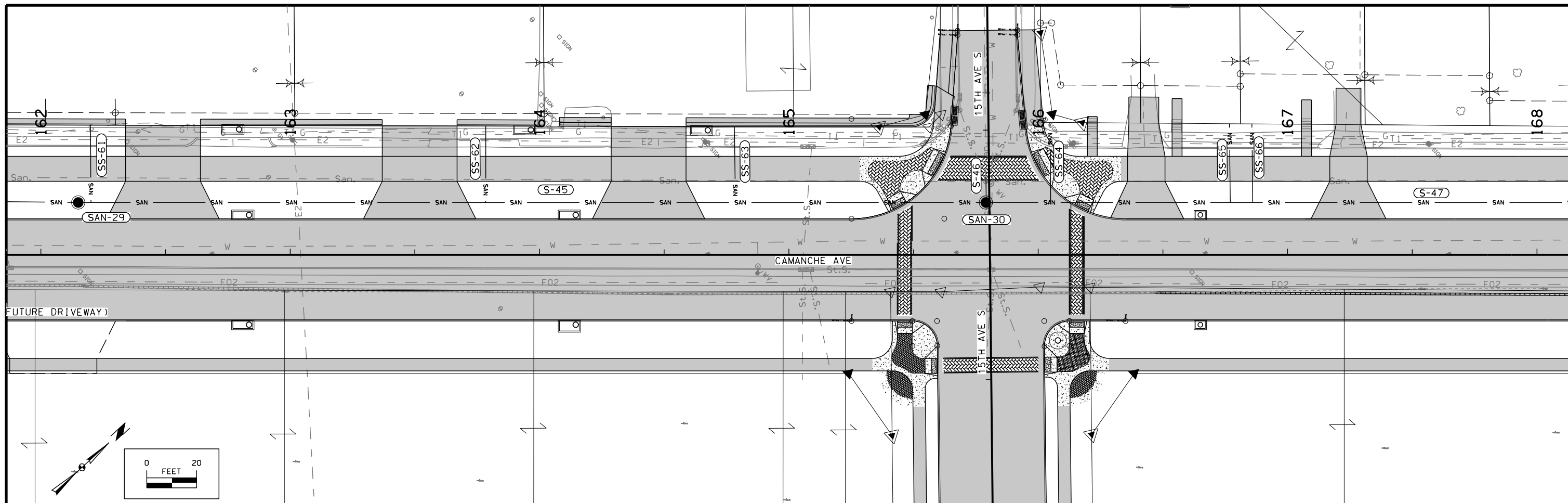

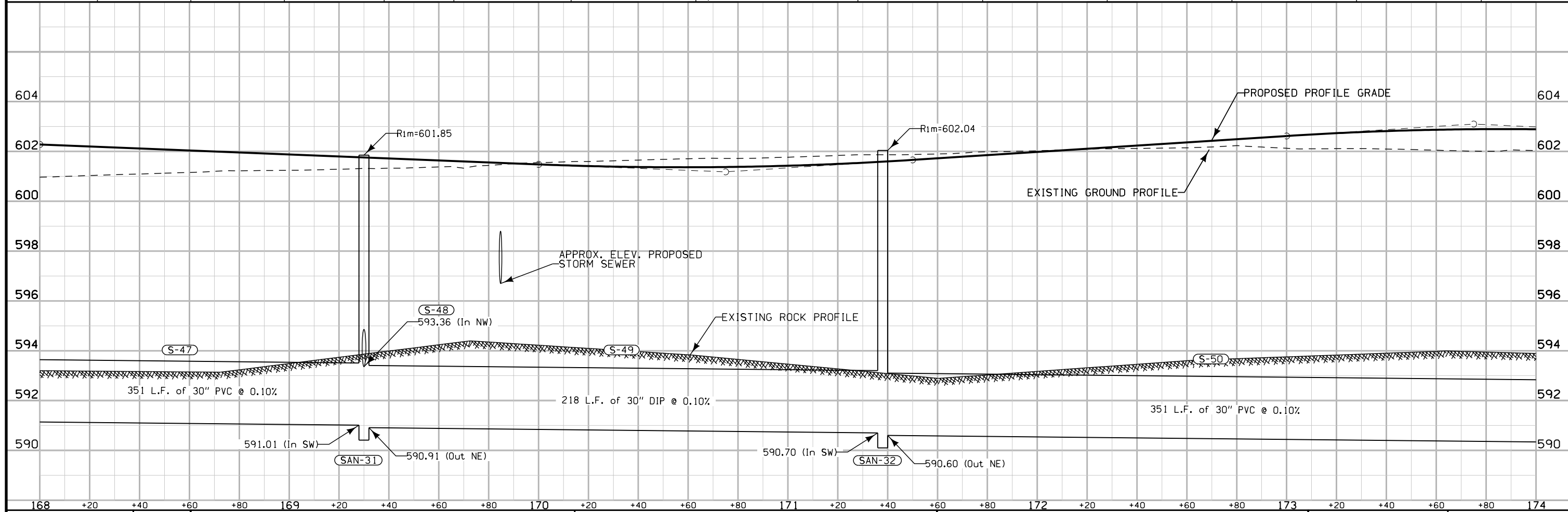
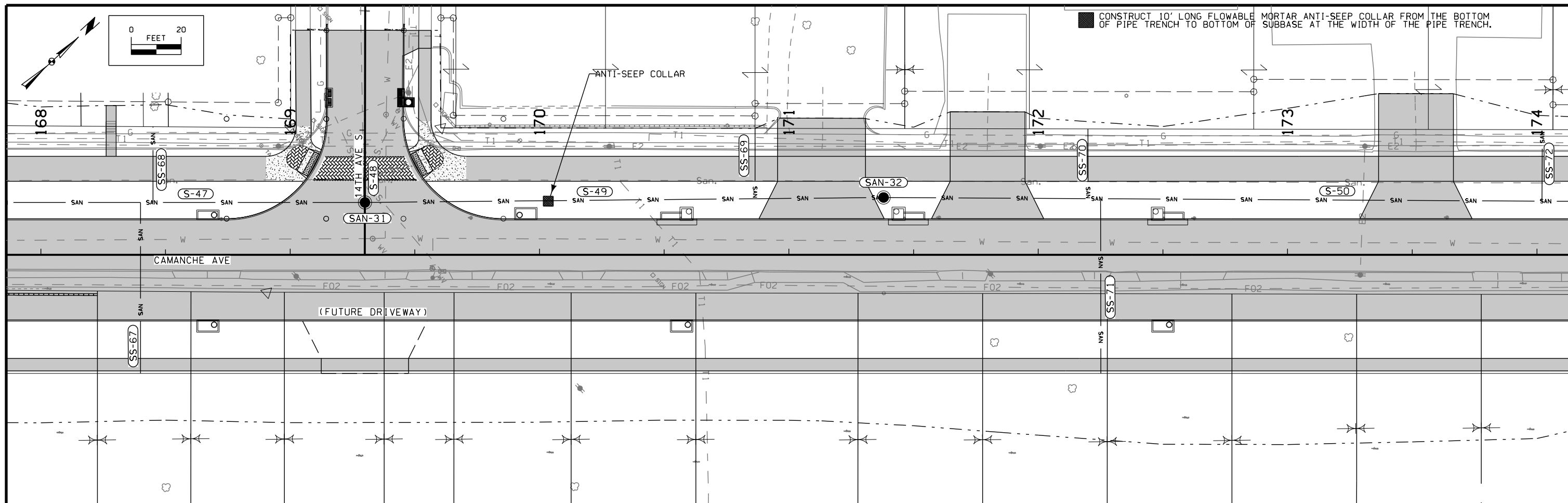

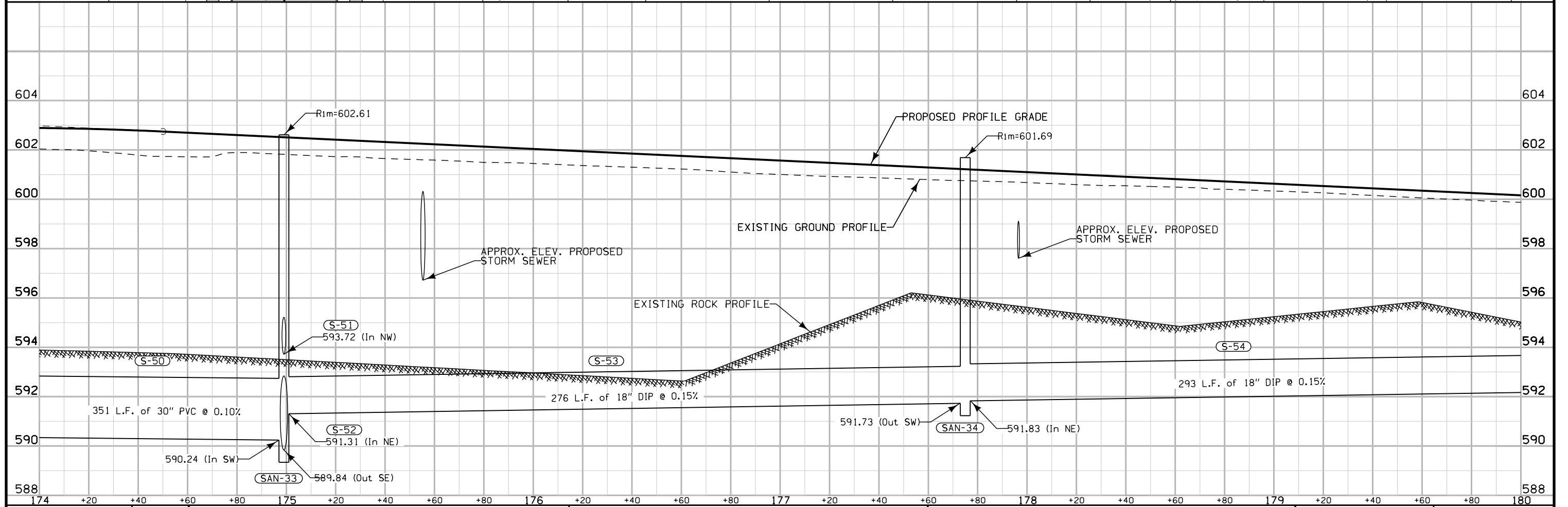
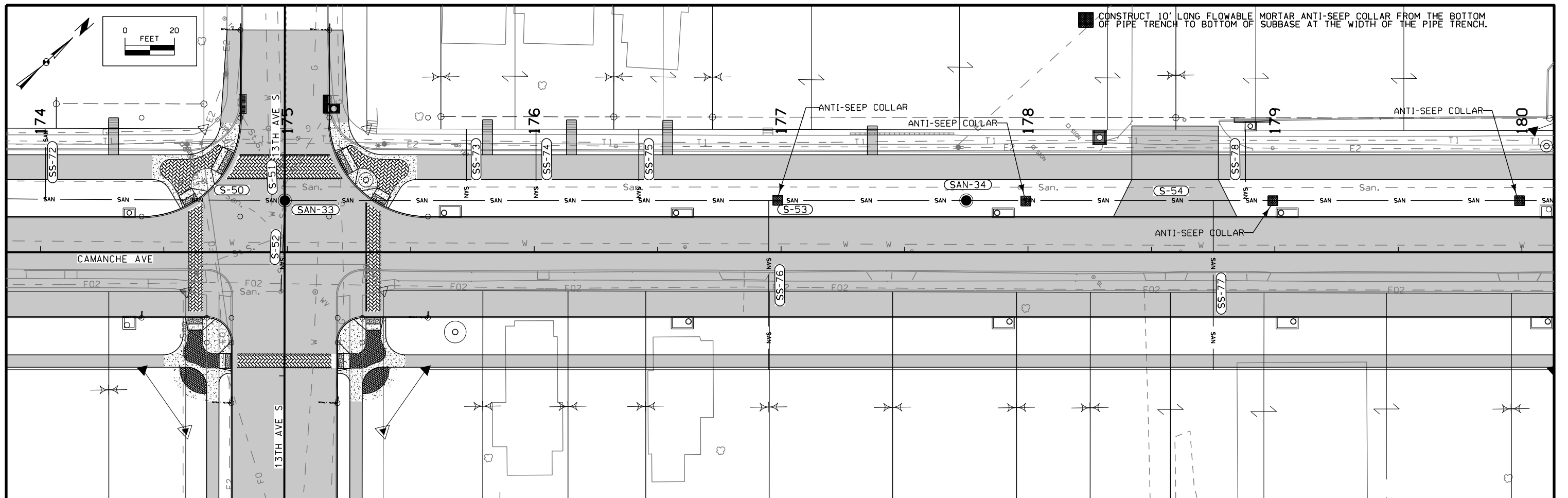

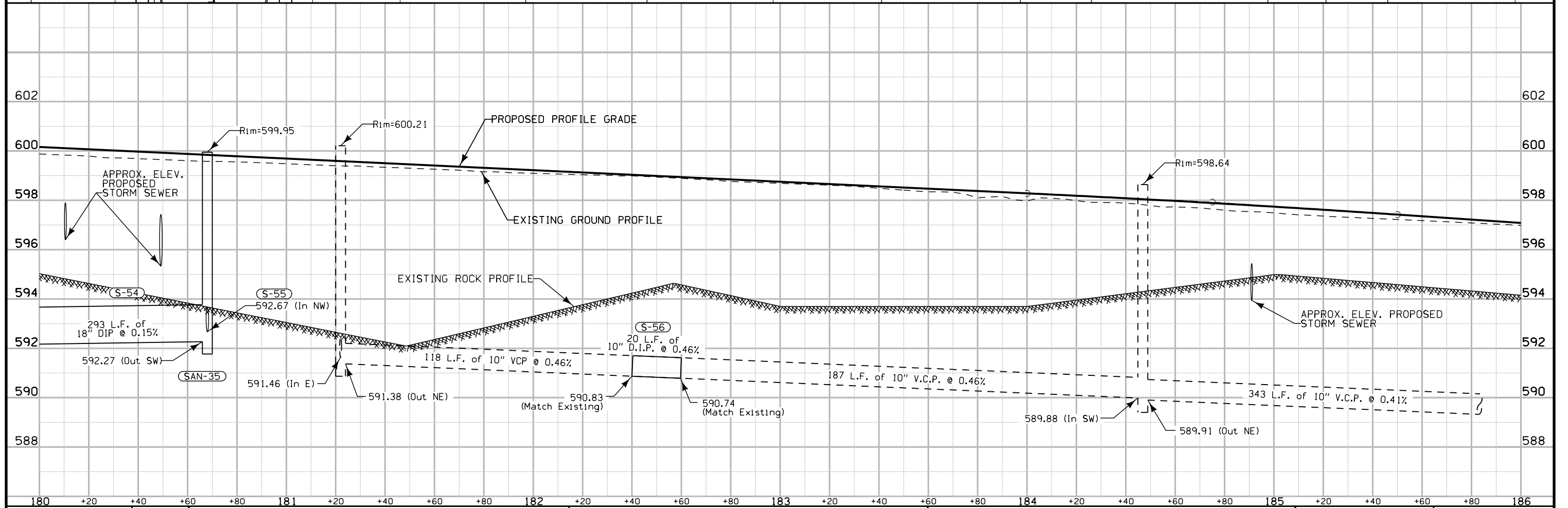
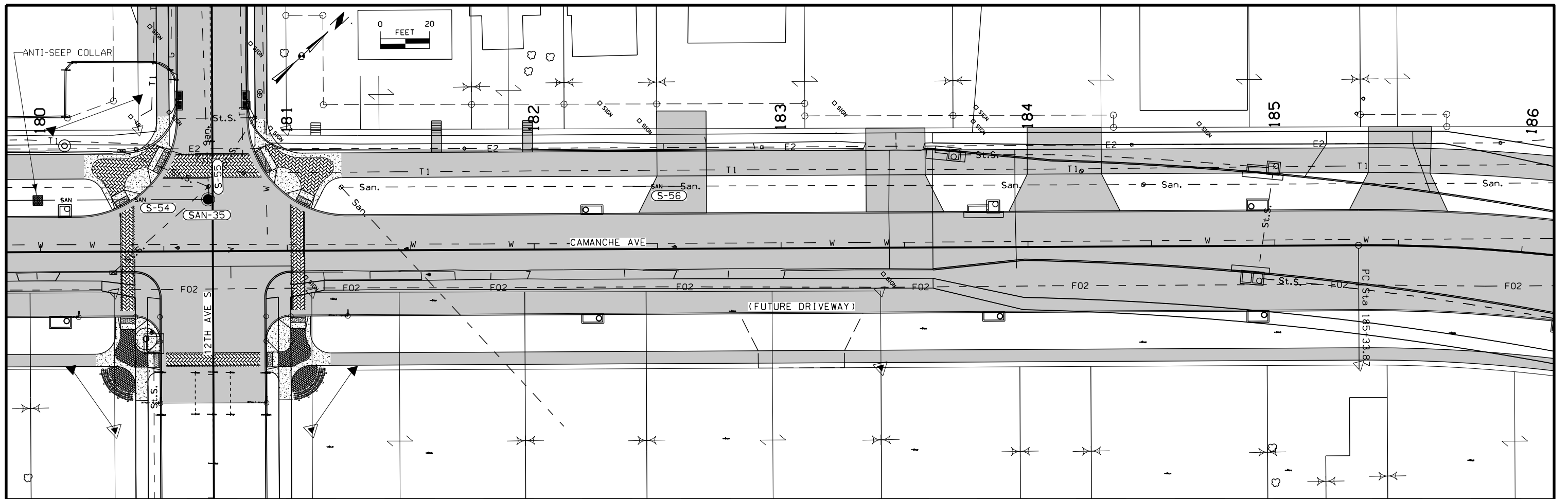

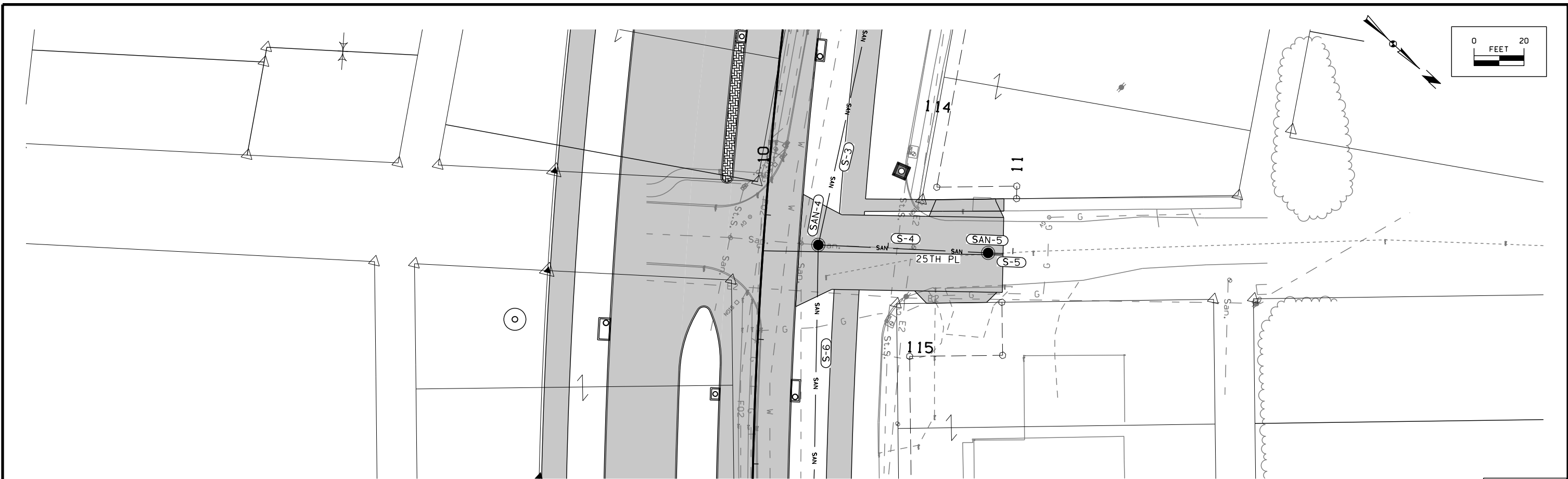

25TH PL

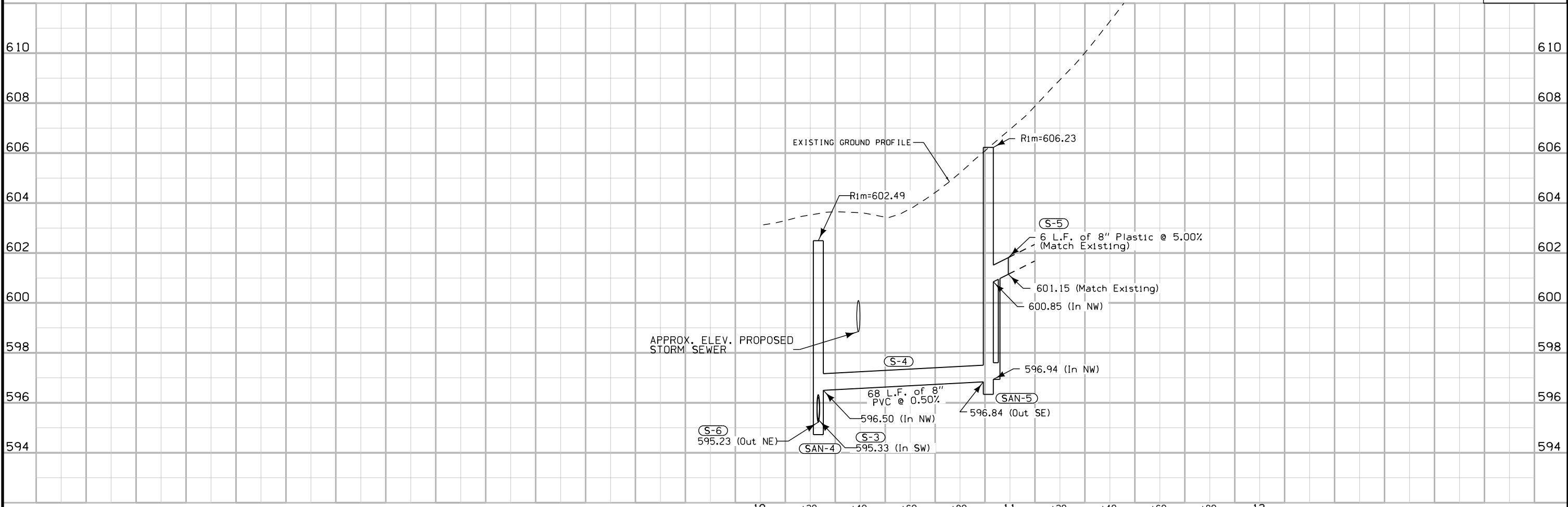

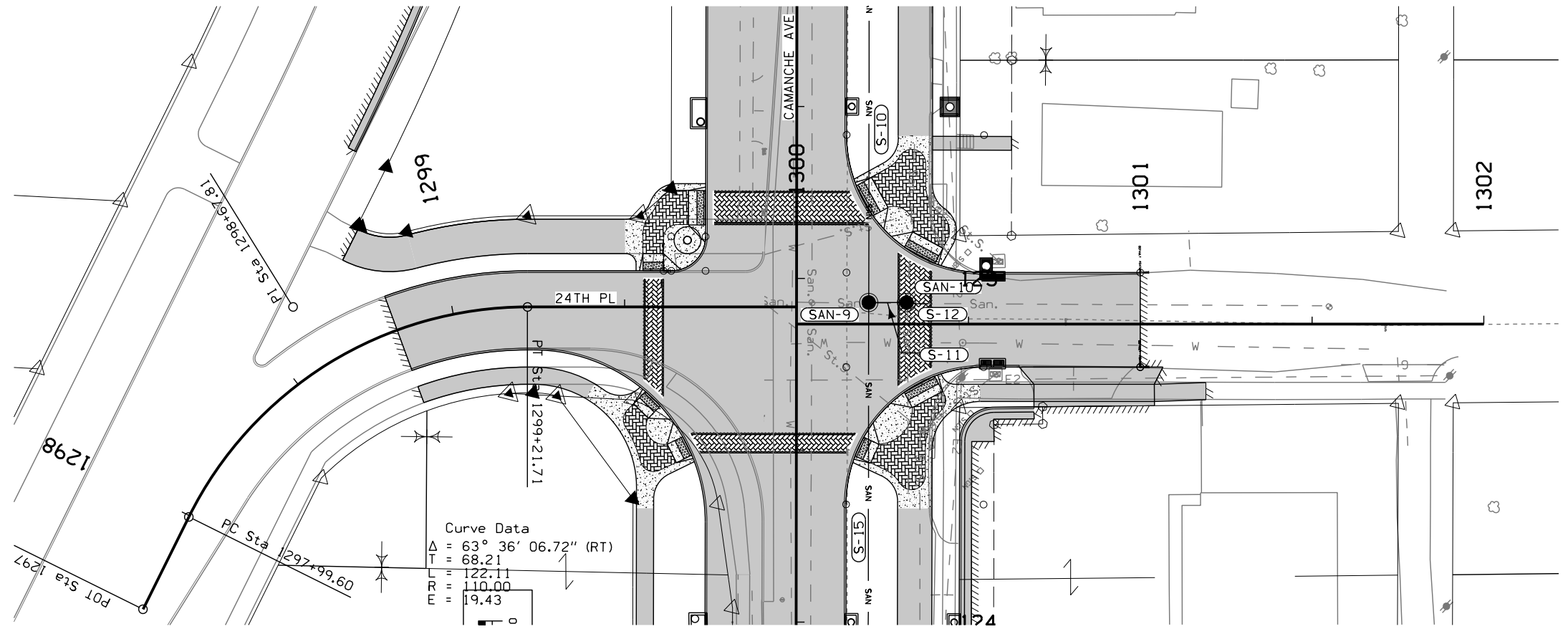

Curve Data  
 $\Delta = 63^\circ 36' 06.72''$  (RT)  
 T = 68.21  
 L = 122.11  
 R = 110.00  
 E = 19.43

24TH PL

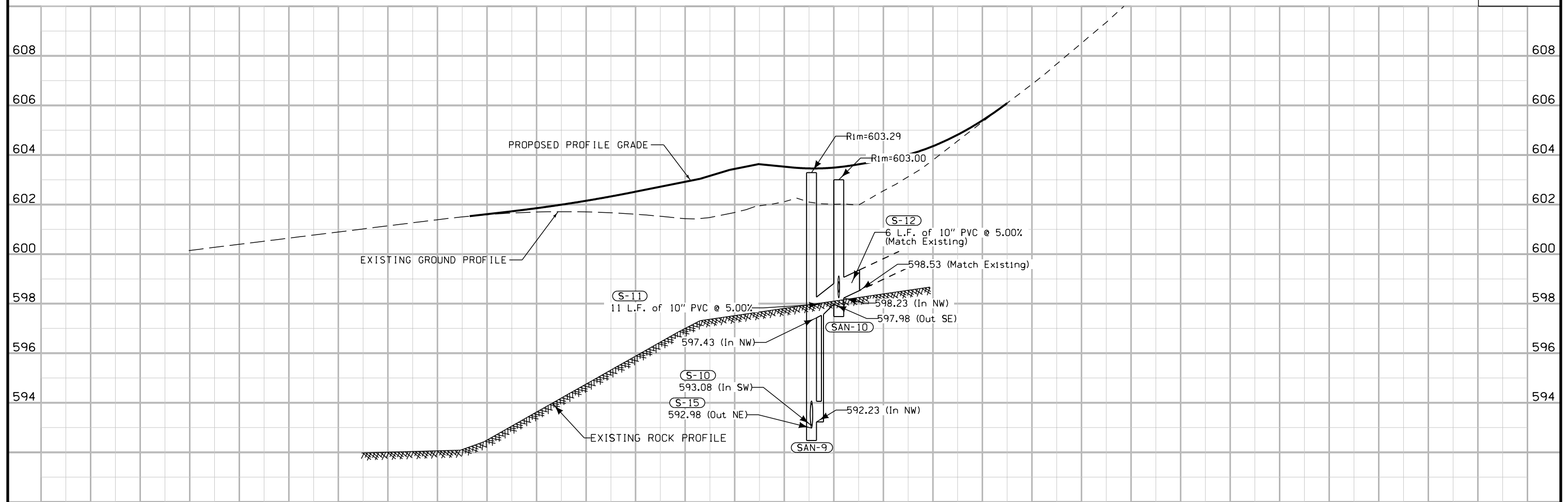



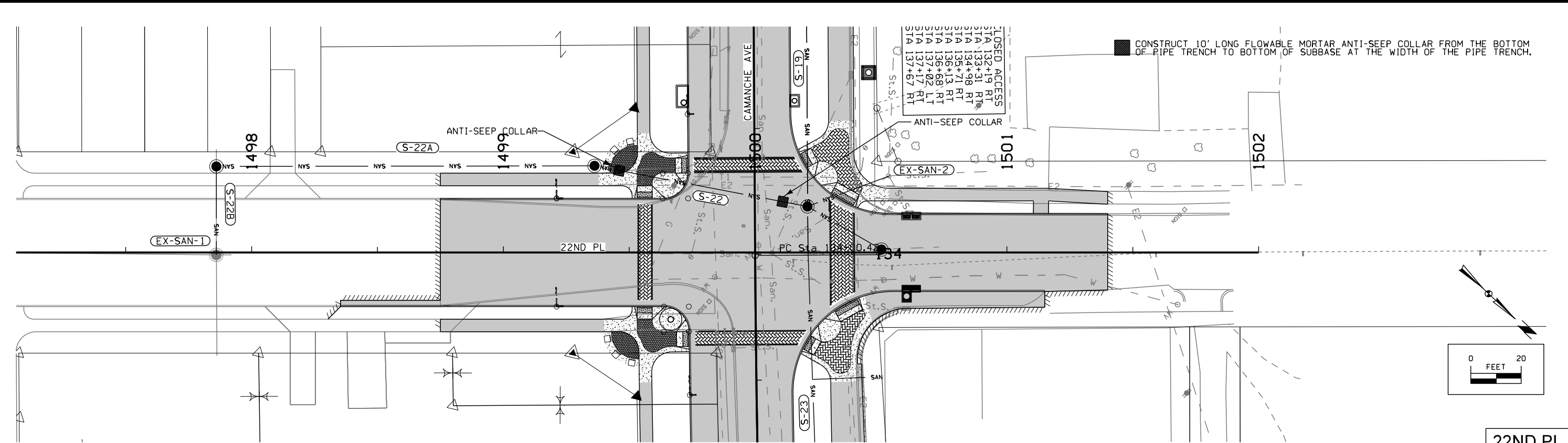

22ND PL

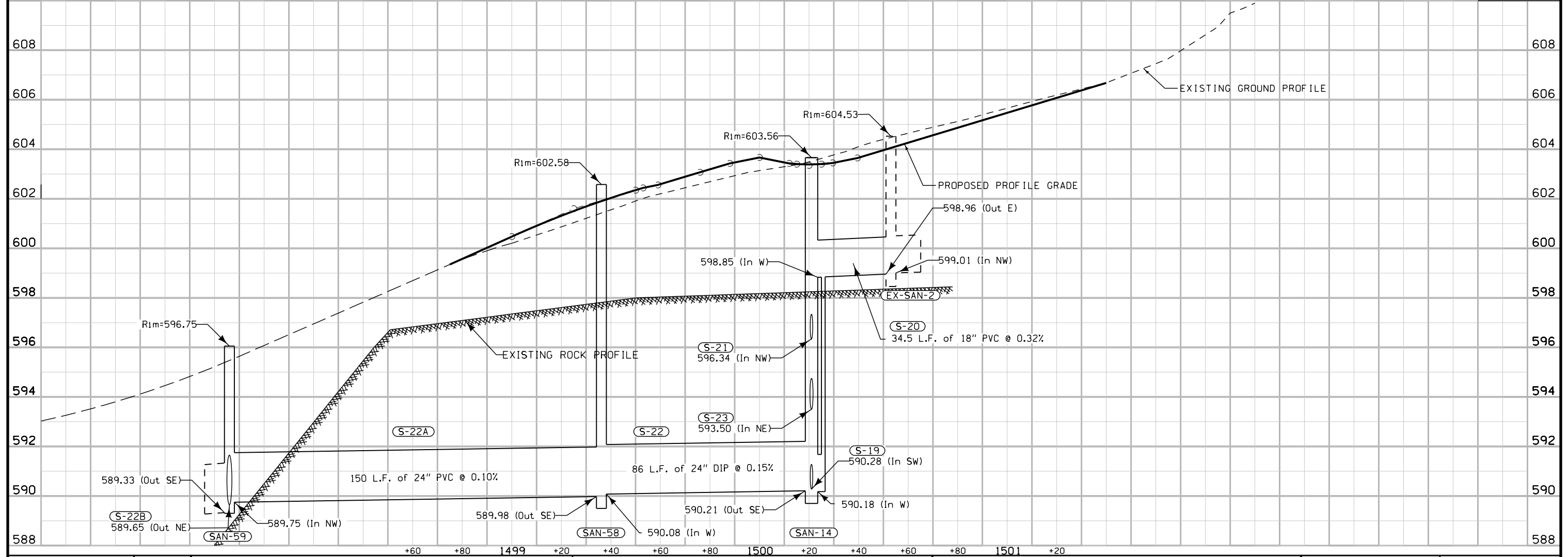

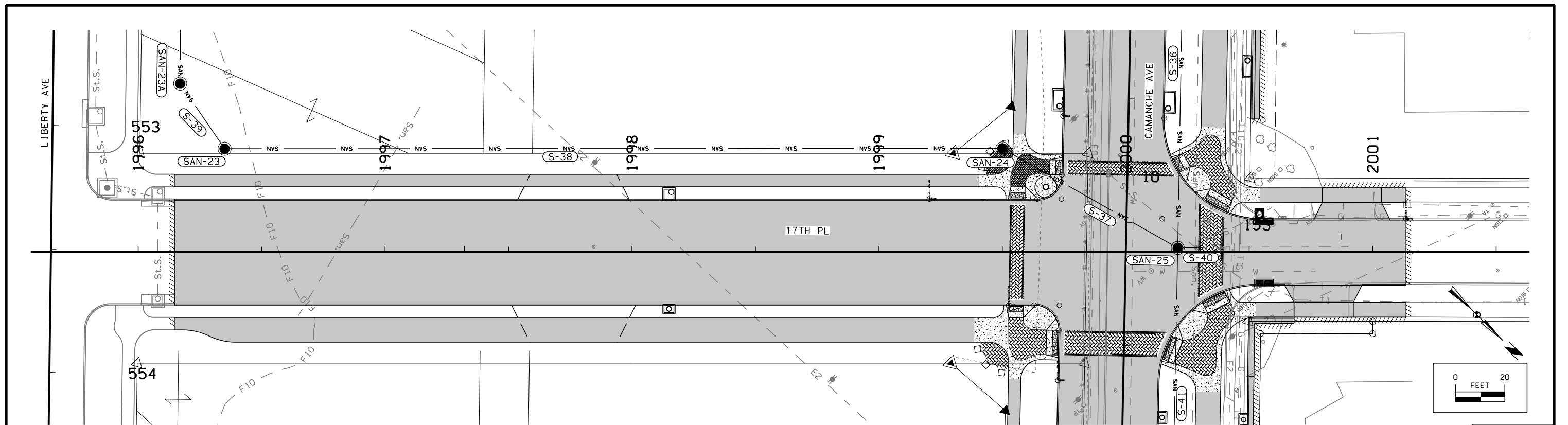

17TH PL

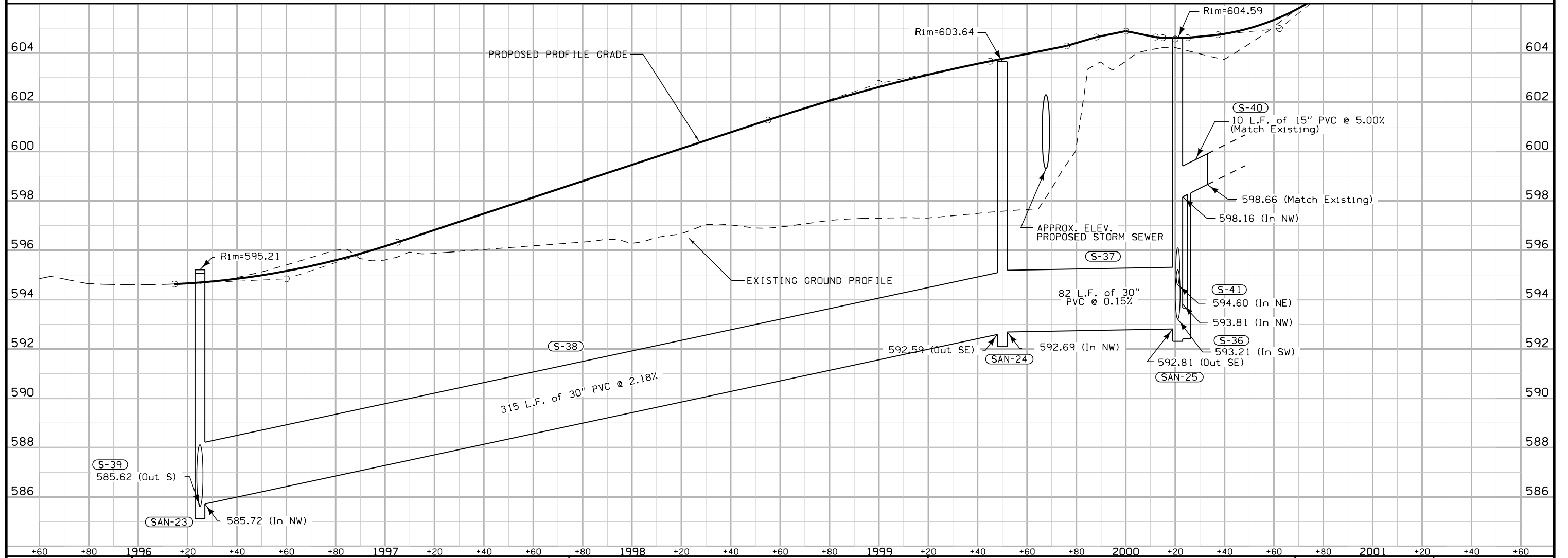

ENGLISH	IOWA DOT	DESIGN TEAM	<b>HR Green, Inc.</b>	CLINTON COUNTY	PROJECT NUMBER	<b>NHSX-030-9(134)--3H-23</b>	SHEET NUMBER	<b>0.18</b>
---------	----------	-------------	-----------------------	----------------	----------------	-------------------------------	--------------	-------------

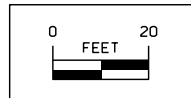
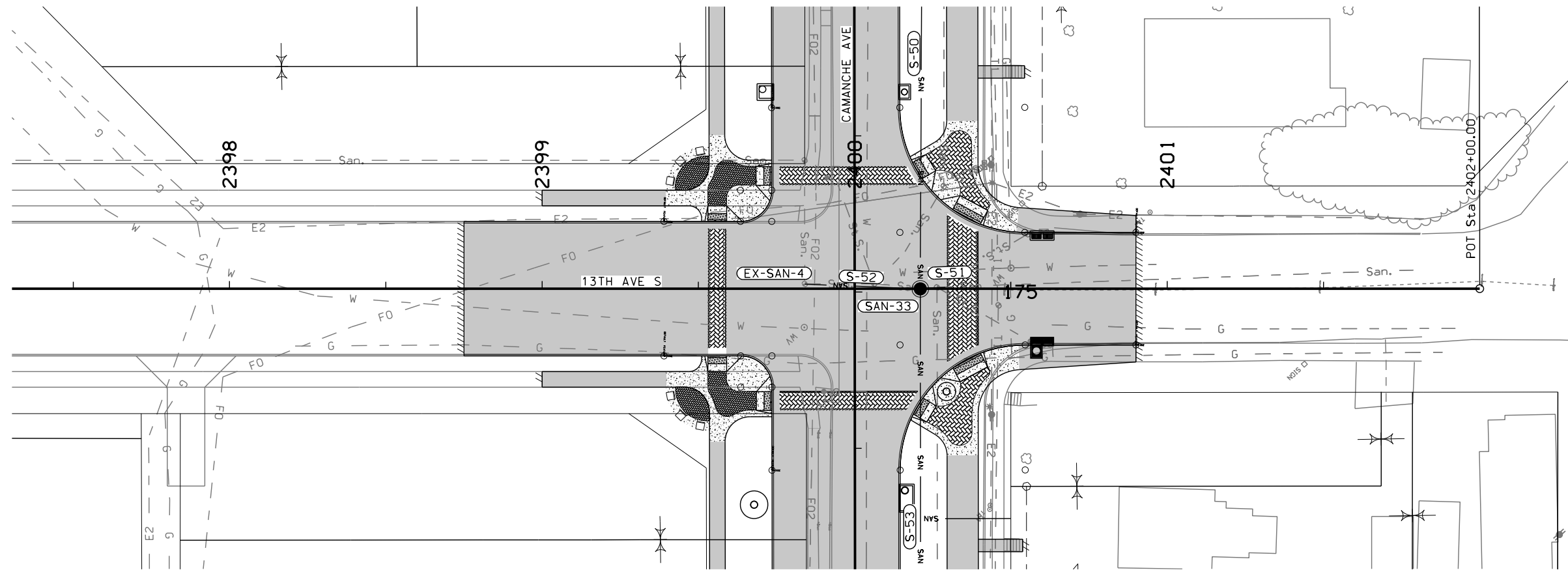

13TH AVE

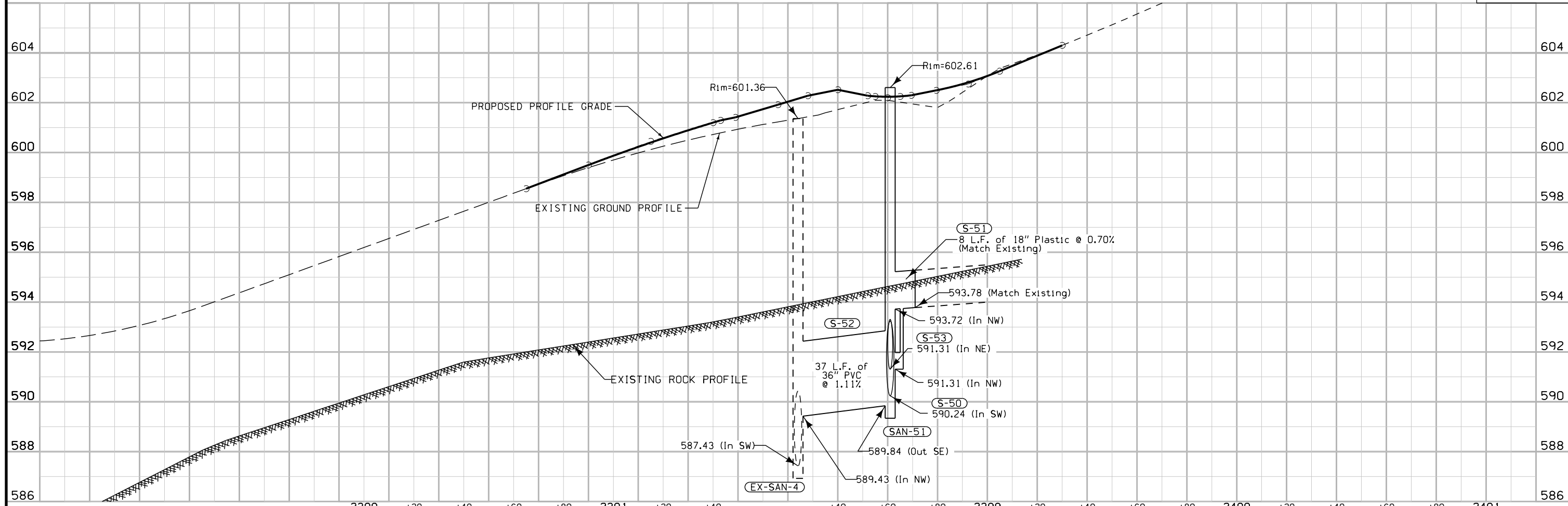

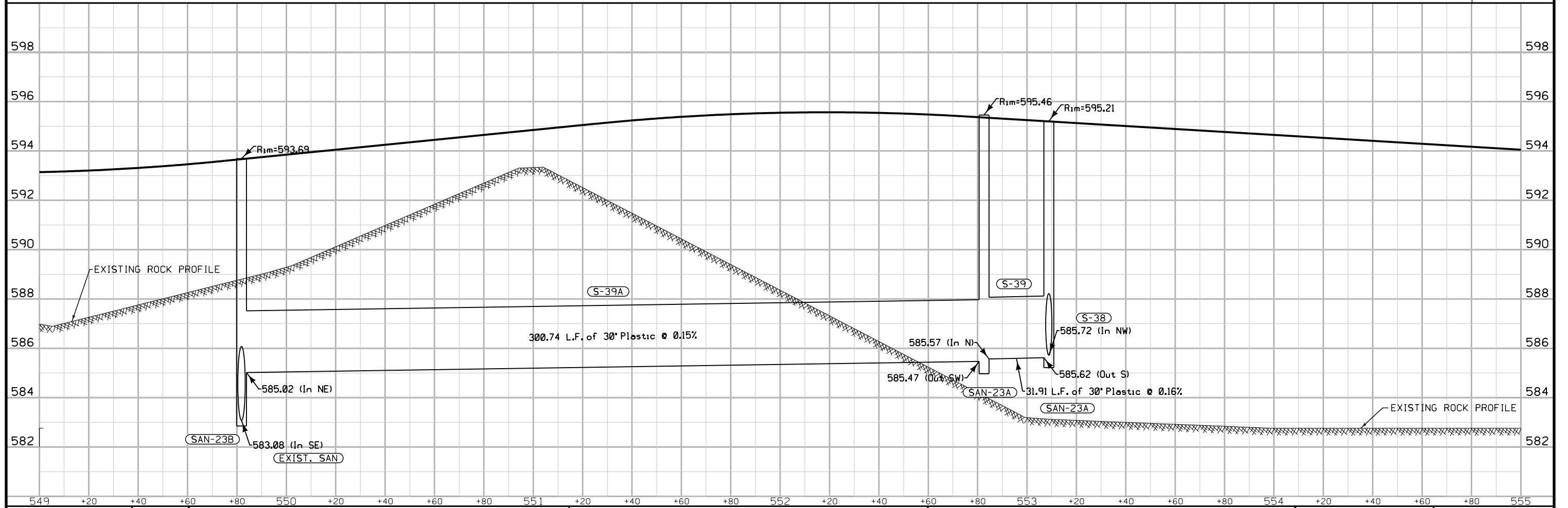
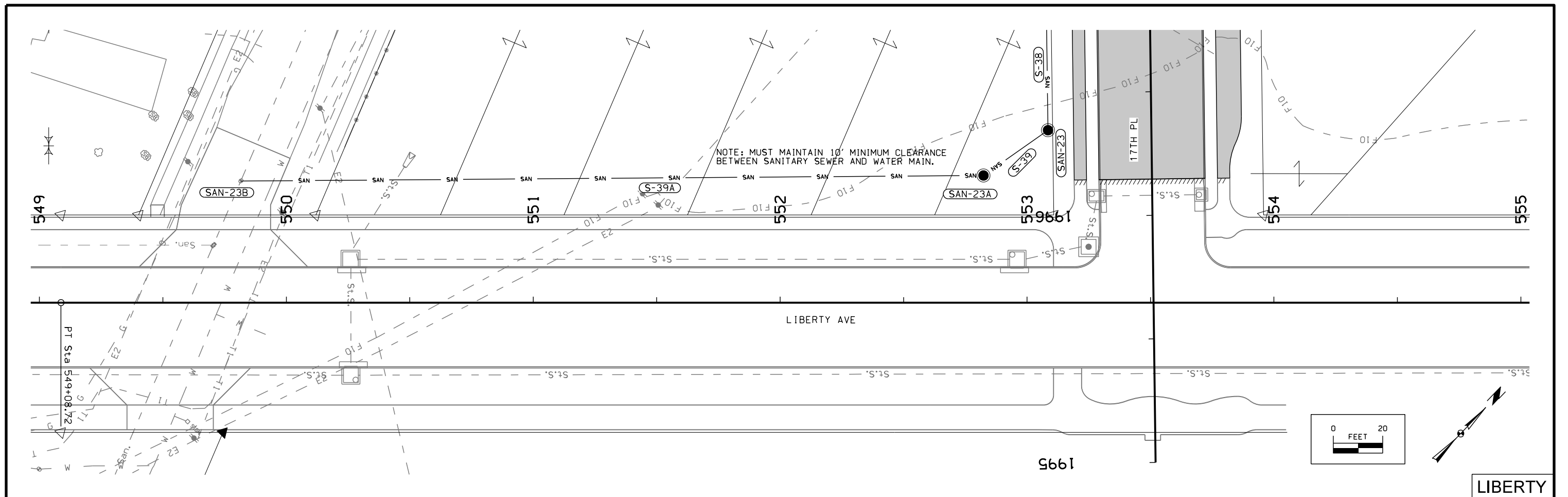

**LIST OF SANITARY SEWER UTILITY ACCESSES**

**LIST OF SANITARY SEWER PIPE**

\* To be used under pavement and drives

104-58  
MODIFIED

Number	Location Station	Type or Standard Road Plan	Top Rim Elev.	Bottom Well Elev.	Other Elev.	Granular Backfill Tons	Notes	Line Number	Sanitary Utility Access No.		Type	Pipe Diameter Inches	Length of Line Feet	Slope %	Flow Lines		Rock Exc. Cu. Yds.	Granular Backfill Tons	Flowable Mortar Cu. Yds.	Pipe Profile Sheet No.	Notes	
									From	To					Inlet Elevation	Outlet Elevation						
SAN-1	105+05.00, 24.00' LT	SW-301	621.03	609.89			48 IN DIA	S-1	SAN-1	SAN-2	PVC	12	396.36	1.65	610.39	603.84				0.1-0.2		
SAN-2	109+00.00, 24.00' LT	SW-301	612.22	603.24			48 IN DIA	S-2	SAN-2	SAN-3	PVC	12	263.04	1.5	603.74	599.79				0.2		
SAN-3	111+65.00, 43.00' LT	SW-301	606.61	599.19			48 IN DIA	S-3	SAN-3	SAN-4	PVC	12	291.25	1.5	599.69	595.33	74	38		0.2-0.3		
SAN-4	114+60.60, 22.00' LT	SW-301	602.65	594.73			48 IN DIA	S-4	SAN-4	SAN-5	PVC	8	68.09	0.5	596.84	596.50	13	185		0.15		
SAN-5	114+59.00, 90.07' LT	SW-301	606.39	596.34			48 IN DIA	S-5	SAN-5	114+58.9 96.0' LT	PVC	8	6	5	601.15	600.85		6		0.15	CONNECT TO EX SAN	
SAN-6	116+80.00, 22.00' LT	SW-301	601.42	594.15			48 IN DIA	S-6	SAN-4	SAN-6	PVC	12	217.54	0.22	595.23	594.18	97	50		0.3		
SAN-7	118+95.00, 31.00' LT	SW-301	602.67	593.58			48 IN DIA	S-7	SAN-6	SAN-7	PVC	12	215.19	0.22	594.65	594.18	164			0.3		
								S-8	SAN-7	118+92.2 57.7' LT	PVC	8	26.82	1	598.99	598.72				0.3		
SAN-8	121+05.00, 21.00' LT	SW-301	602.60	593.02			48 IN DIA	S-9	SAN-7	SAN-8	PVC	12	210.01	0.22	594.08	593.62	199			0.3-0.4		
SAN-9	123+07.00, 21.00' LT	SW-301	603.46	592.48			48 IN DIA	S-10	SAN-8	SAN-9	PVC	12	202	0.22	593.52	593.08	173	170		0.4		
SAN-10	1300+32.00, 6.27' LT	SW-301	603.50	597.48			48 IN DIA	S-11	SAN-9	SAN-10	PVC	10	11	5	597.98	597.43	3	10		0.16		
								S-12	SAN-10	1300+38.4 5.9' LT	PVC	10	6	5	598.53	598.23		3		0.16	CONNECT TO EX SAN	
SAN-11	127+00.00, 21.00' LT	SW-301	602.57	591.51			48 IN DIA	S-15	SAN-9	SAN-11	PVC	12	393	0.22	592.98	592.11	321	225		0.4-0.5		
								S-16	SAN-11	SAN-12	PVC	12	255	0.22	592.01	591.45	123	269		0.5		
SAN-12	129+55.00, 21.00' LT	SW-301	602.83	590.85			48 IN DIA	S-17	1400+27.0 2.4' LT	SAN-12	PVC	10	6		MATCH EX.	597.09		8		0.5	CONNECT TO EX SAN	
SAN-13	131+75.00, 21.00' LT	SW-301	603.94	590.27			48 IN DIA	S-18	SAN-12	SAN-13	PVC	12	220	0.22	591.35	590.87		318		0.5		
								S-19	SAN-13	SAN-14	PVC	12	206	0.22	590.77	590.32	138	385		0.5-0.6		
								S-20	1500+53.1 30.4' LT	SAN-14	PVC	18	34.5	0.46	599.01	598.85		11		0.17	CONNECT TO EX MH	
SAN-57	1500+50.17, 1.16' LT	SW-301	603.95	595.88			48 IN DIA	S-21	1500+50.2 1.16' LT	SAN-14	PVC	12	34.03		MATCH EX.	596.34		3	13		0.6	CONNECT TO EX SAN
SAN-58	1499+36.21, 34.46' LT	SW-301	602.58	595.88			48 IN DIA	S-22	SAN-58	SAN-14	DIP	24	86.1	0.15	590.21	590.08	292	873	9	0.17	CONNECT TO EX SAN, NOTE 1	
SAN-59	1499+86.00, 34.22' LT	SW-301	596.05	589.26			48 IN DIA	S-22-A	SAN-59	SAN-58	DIP	24	150.2	0.1	589.98	589.75				0.17	CONNECT TO EX SAN	
								S-22-B	1497+86.0 0.93' LT	SAN-59	DIP	24	35.2		589.65	MATCH EX.				0.17	CONNECT TO EX SAN	
SAN-14	133+99.00, 21.00' LT	SW-301	603.34	589.28			48 IN DIA	S-23	SAN-14	SAN-15	PVC	15	317.91	0.15	593.95	593.47	334	183		0.6		
SAN-15	137+00.00, 23.00' LT	SW-301	602.81	593.45			48 IN DIA	S-24	SAN-15	SAN-17	PVC	15	343.82	0.15	594.57	594.05	85			0.6-0.7		
SAN-17	140+45.00, 21.00' LT	SW-301	604.66	594.17			48 IN DIA	S-27	1600+33.1 2.3' LT	SAN-18	PVC	10	6		MATCH EX.	596.28		18	12		0.7	CONNECT TO EX SAN, NOTE 1
SAN-18	140+97.00, 21.00' LT	SW-301	604.17	595.25			48 IN DIA	S-28	SAN-18	SAN-19	PVC	18	332.94	0.15	595.75	595.25	214	246	26	0.7-0.8	NOTE 1	
								S-29	1700+26.6 4.2' LT	SAN-19	PVC	10	6		MATCH EX.	597.30		4	16		0.8	CONNECT TO EX SAN
								S-30	SAN-19	1700+73.4 23.5' RT	PVC	10	59.85		MATCH EX.	599.30		9	44		0.8	CONNECT TO EX SAN
SAN-19	144+31.00, 21.00' LT	SW-301	604.60	594.65			48 IN DIA	S-31	SAN-19	SAN-20	PVC	18	188	0.15	595.15	594.86	206	430		0.8		
								S-32	1800+27.1 1.00' LT	SAN-20	PVC	12	6		MATCH EX.	598.97		3	16		0.8	CONNECT TO EX SAN
SAN-20	146+19.00, 21.00' LT	SW-301	606.37	593.96			48 IN DIA	S-33	SAN-20	SAN-21	PVC	24	162.38	0.15	594.46	594.21	208	289		0.8		
SAN-21	147+80.00, 23.00' LT	SW-301	608.30	593.61			48 IN DIA	S-34	SAN-21	SAN-22	PVC	24	191.64	0.15	594.11	593.82	256	331		0.8		
								S-35	1900+27.0 0.96' RT	SAN-22	PVC	10	6		MATCH EX.	597.92		3	26		0.8	CONNECT TO EX SAN
SAN-22	149+70.00, 21.00' LT	SW-301	606.87	593.22			48 IN DIA	S-36	SAN-22	SAN-25	PVC	24	340.44	0.15	593.72	593.21	309	504		0.8-0.9		
SAN-23B	1996+18.6, 368.98' LT	SW-301	593.69	585.85			72 IN DIA	S-39A	SAN-23B	SAN-23A	PVC	30	300.74	0.15	585.47	585.02	307			0.20		
SAN-23A	1996+17.01, 68.23' LT	SW-301	595.46	584.97			72 IN DIA	S-39	SAN-23A	SAN-23	PVC	30	31.91	0.15	585.62	585.57	12			0.20		
SAN-23	996+35.00, 42.00' LT	SW-301	595.21	585.12			72 IN DIA	S-38	SAN-23	SAN-24	PVC	30	315	2.18	592.59	585.72	117			0.18		
SAN-24	999+50.00, 42.00' LT	SW-301	605.95	592.09			60 IN DIA	S-37	SAN-24	SAN-25	PVC	30	81.68	0.15	592.81	592.69	28	274		0.18		
SAN-25	153+10.00, 21.00' LT	SW-301	604.61	592.31			60 IN DIA	S-40	SAN-25	2000+31.0 1.8' LT	PVC	15	10	5	598.66	598.16		13		0.18	CONNECT TO EX SAN	
SAN-26	155+00.00, 21.00' LT	SW-301	602.87	594.39			48 IN DIA	S-41	SAN-25	SAN-26	PVC	18	190	0.15	594.89	594.60		166		0.9		
								S-42	SAN-26	SAN-27	DIP	18	288.3	0.15	595.42	594.99	51	56	26	0.9-0.10	NOTE 1	
								S-43	2100+26.9 10.4' LT	SAN-27	DIP	10	6		MATCH EX.	595.95		13	10		0.10	CONNECT TO EX SAN, NOTE 1
SAN-27	157+89.00, 21.00' LT	SW-301	602.90	594.92			48 IN DIA	S-44	SAN-28	SAN-29	DIP	12	364.35	0.22	594.26	593.46	153		23	0.10-0.11	NOTE 1	
SAN-28	158+50.00, 21.00' LT	SW-301	603.26	593.76			48 IN DIA	S-45	SAN-29	SAN-30	PVC	12	364	0.20	593.36	592.56	13	138		0.11		
SAN-29	162+15.00, 21.00' LT	SW-301	600.34	592.86			48 IN DIA	S-46	2200+31.0 1.3' LT	SAN-30	PVC	15	10		MATCH EX.	594.82		14			0.11	CONNECT TO EX SAN
SAN-30	165+79.00, 21.00' LT	SW-301	601.24	590.86			60 IN DIA	S-47	SAN-30	SAN-31	PVC	30	351	0.1	591.36	591.01	189	298		0.11-0.12		
								S-48	2300+31.0 0.5' LT	SAN-31	PVC	18	10		MATCH EX.	593.36		2	28		0.12	CONNECT TO EX SAN
SAN-31	169+30.00, 21.00' LT	SW-301	601.47	590.1			60 IN DIA	S-49	SAN-31	SAN-32	DIP	30	208.01	0.1	590.91	590.7	147	163	43	0.12	NOTE 1	
SAN-32	171+38.00, 23.00' LT	SW-301	602.14	590.1			60 IN DIA	S-50	SAN-32	SAN-33	PVC	30	361.01	0.1	590.60	590.24	255	252		0.12-0.13		
								S-52	2399+84.1 1.45' LT	SAN-33	PVC	36	36.96	1.11	589.84	589.43	37	199		0.19	CONNECT TO EX MH	
SAN-33	174+99.00, 21.00' LT	SW-301	602.44	589.34			60 IN DIA	S-51	SAN-33	2400+29.0 0.4' LT	PVC	18	8	0.7	593.78	593.72	3	25		0.19		





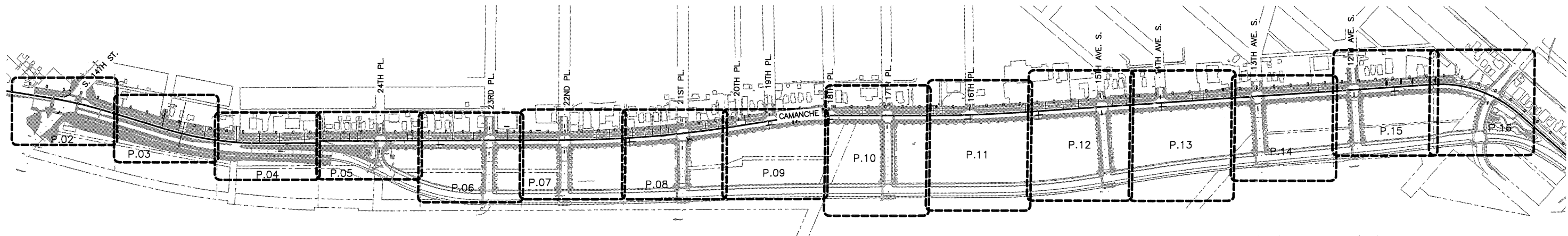

CONTINUED ON SHEET 0.22







**LEGEND**

-  ROADWAY LIGHTING UNIT
-  PEDESTRIAN LIGHTING UNIT
-  LIGHTING CONTROLLER
-  HAND HOLE, RM-38
-  UNDERGROUND DUCT
-  REFERENCED NOTE
-  LIGHT FIXTURE IDENTIFICATION NUMBER

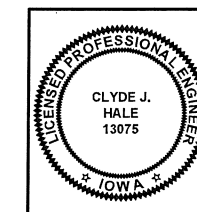

I hereby certify that this engineering document was prepared by me or under my direct personal supervision and that I am a duly licensed Professional Engineer under the laws of the State of Iowa.

*Clyde J. Hale*  
 CLYDE J. HALE, P.E. DATE  
 License Number: 13075  
 My license renewal date is December 31, 2011.  
 Pages or sheets covered by this seal:  
 - ALL P. SHEETS

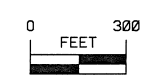
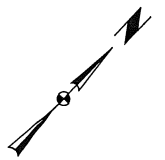



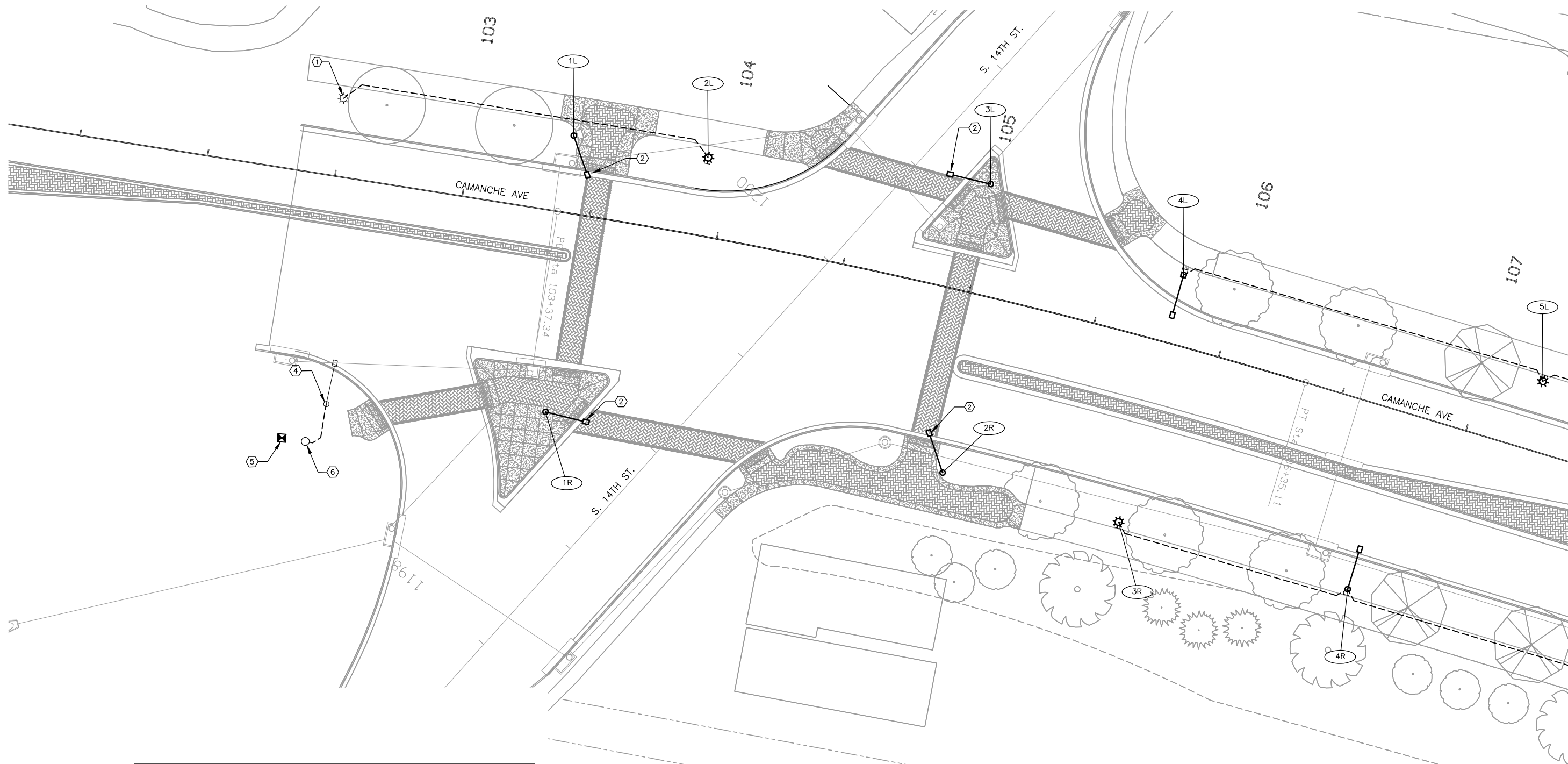

- NOTES:**
- ① EXTEND CIRCUIT FROM EXISTING LIGHTING UNIT TO NEW LIGHTING UNIT. CIRCUIT EXIST-1. EXISTING LIGHTING UNIT HAS CONDUIT STUBBED FROM BASE.
  - ② TYPE L3 LIGHTING UNIT MOUNTED ATOP TRAFFIC SIGNAL.
  - ③ NOT USED
  - ④ EXTEND CIRCUIT FROM EXISTING LIGHTING UNIT TO NEW TRAFFIC CONTROL HANDHOLE. CIRCUIT EXIST-2. EXISTING LIGHTING UNIT HAS CONDUIT STUBBED FROM BASE. WIRING FROM TRAFFIC CONTROL HANDHOLE TO LIGHT MAST ARMS FOR LIGHTING UNIT TYPE L3 BY SIGNAL CONTRACTOR.
  - ⑤ NEW TRAFFIC CONTROL CABINET.
  - ⑥ NEW TRAFFIC CONTROL HANDHOLE.

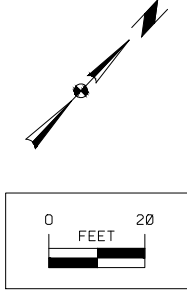

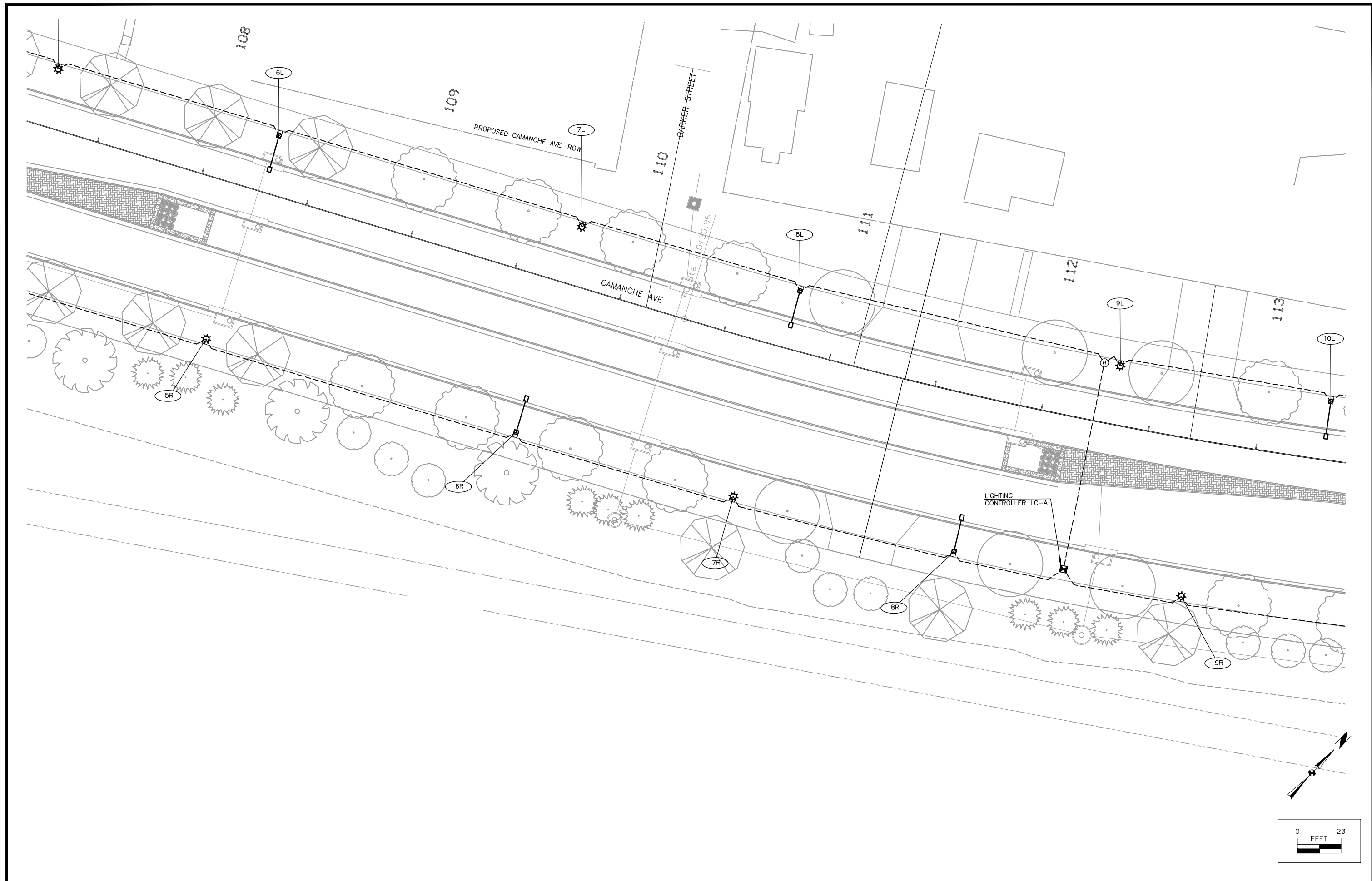

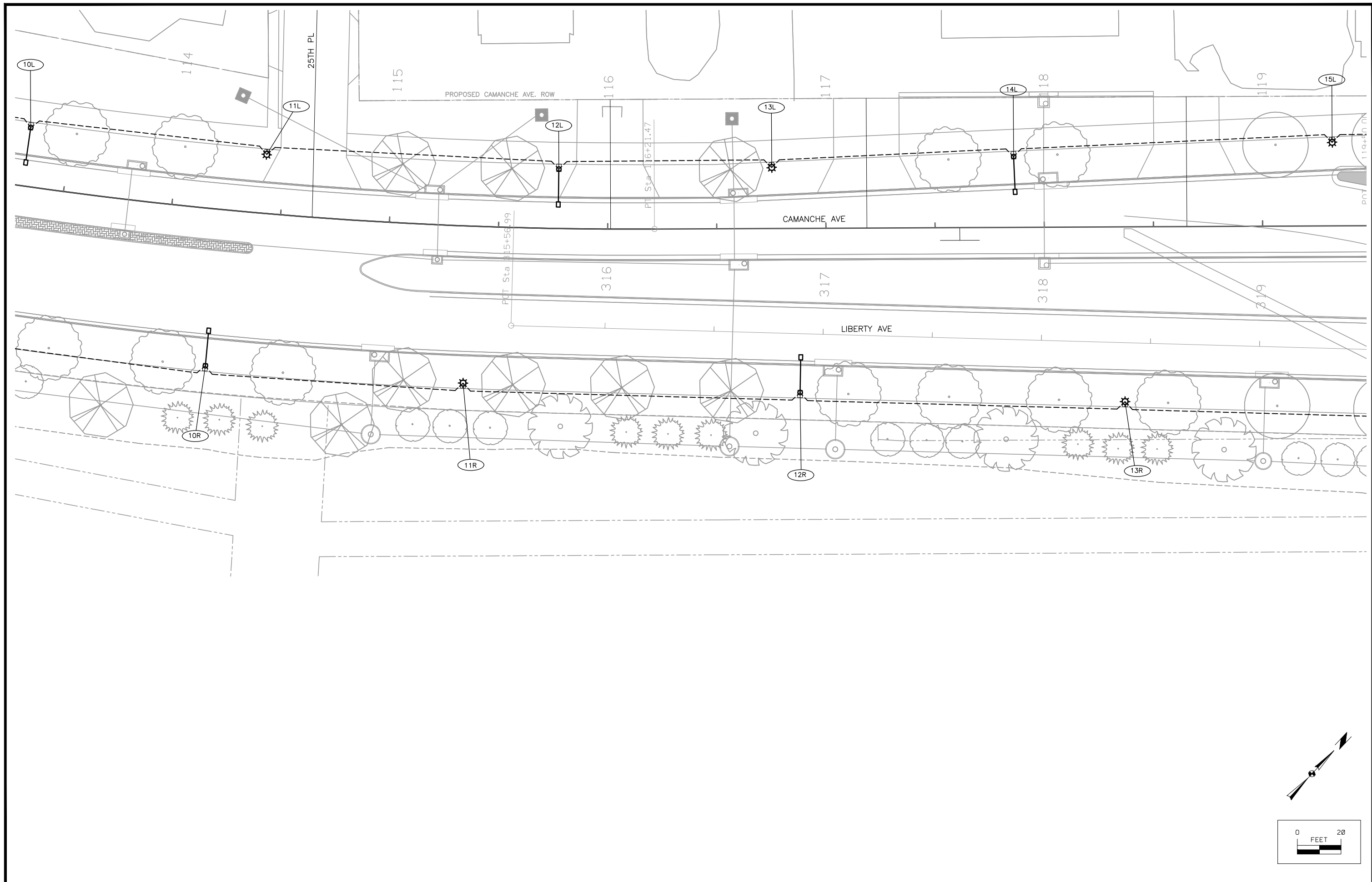

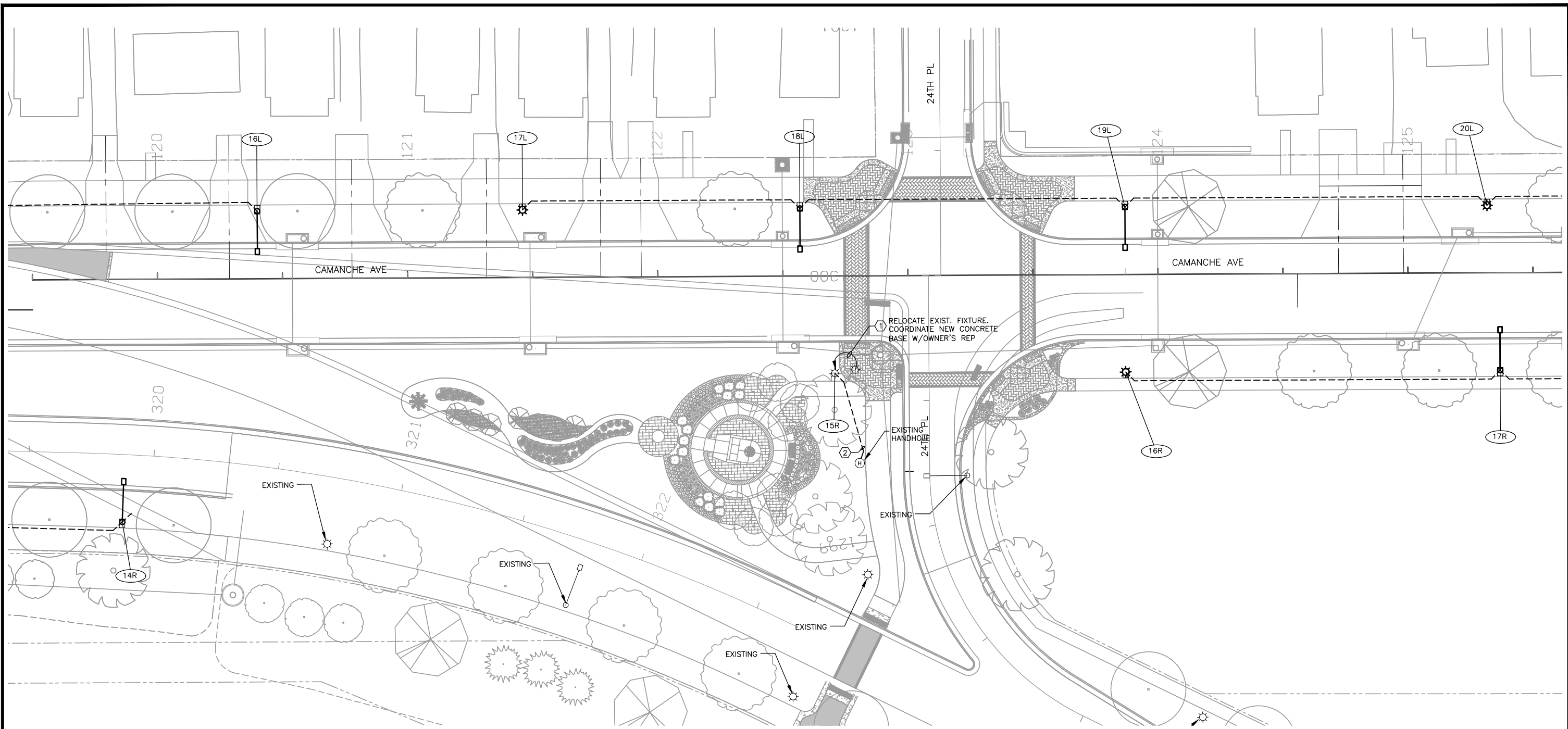

**NOTES:**

- ① RELOCATE EXISTING LIGHTING UNIT.
- ② EXTEND CIRCUIT FROM RELOCATED LIGHTING UNIT TO EXISTING HANDHOLE. CIRCUIT EXIST-4

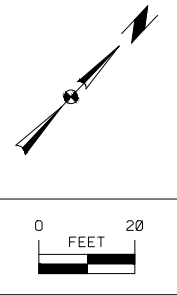

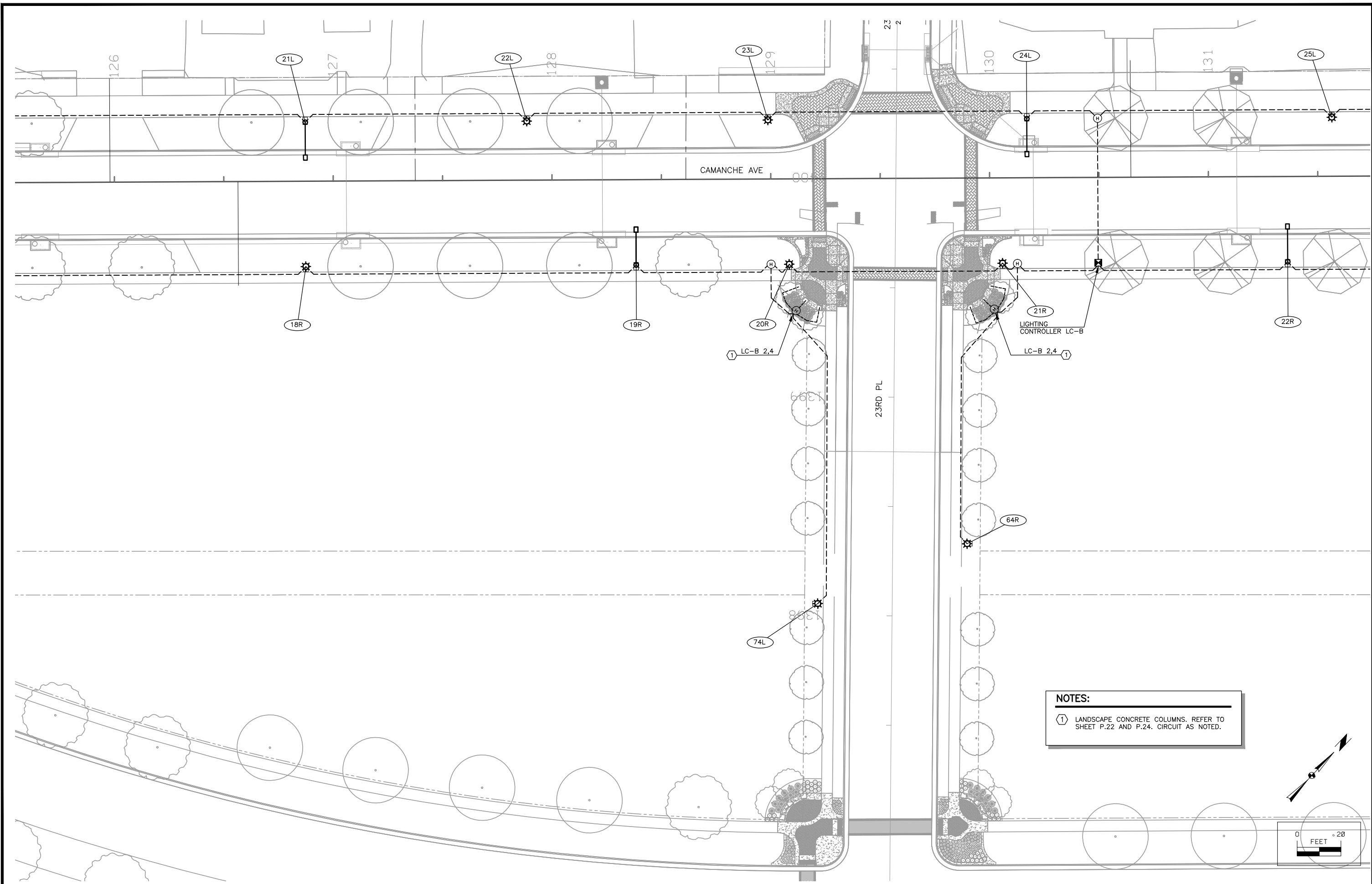

**NOTES:**  
 (1) LANDSCAPE CONCRETE COLUMNS. REFER TO SHEET P.22 AND P.24. CIRCUIT AS NOTED.

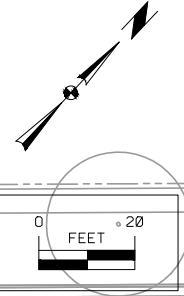

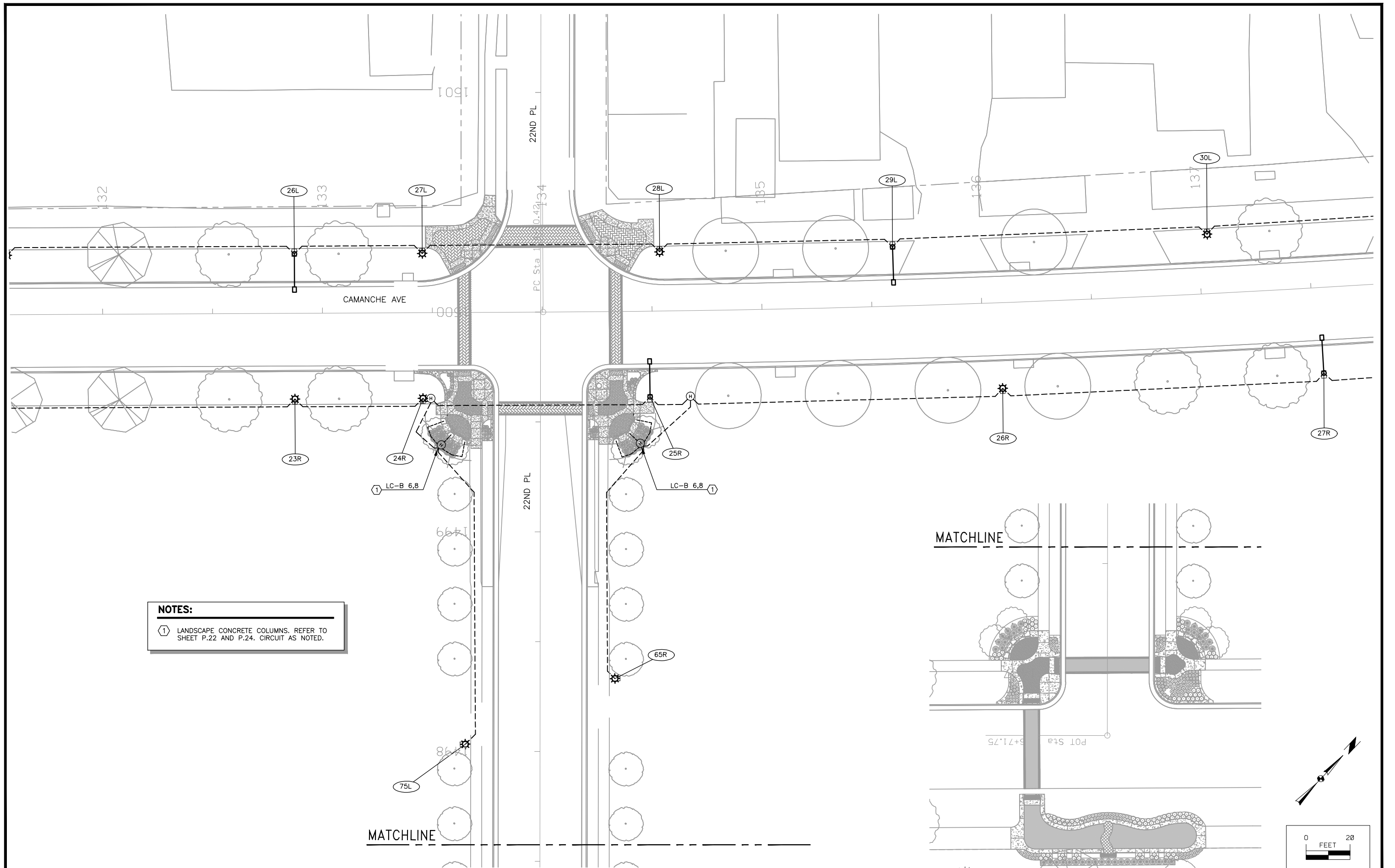

**NOTES:**

① LANDSCAPE CONCRETE COLUMNS. REFER TO SHEET P.22 AND P.24. CIRCUIT AS NOTED.

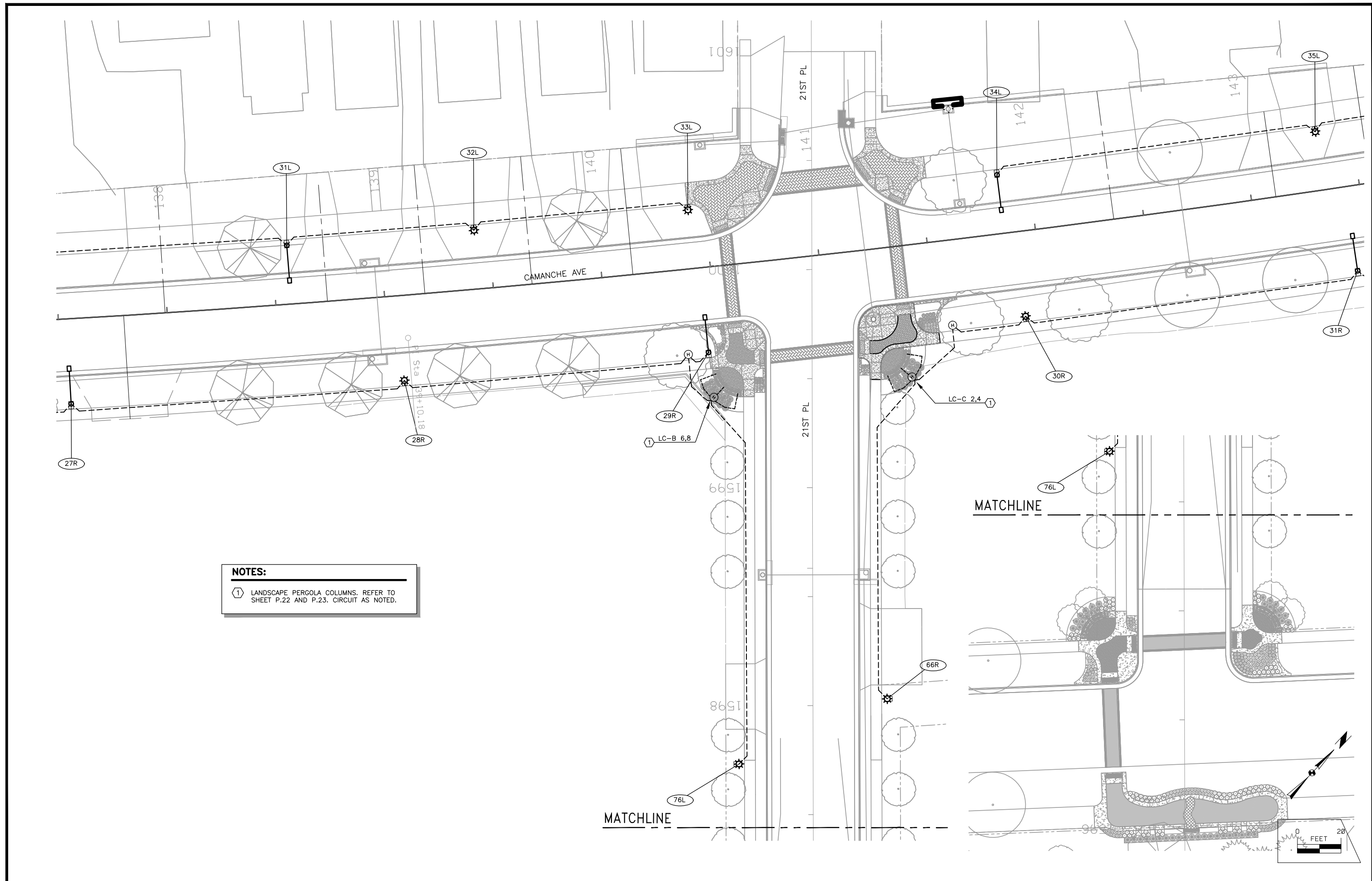

**NOTES:**

① LANDSCAPE PERGOLA COLUMNS. REFER TO SHEET P.22 AND P.23. CIRCUIT AS NOTED.

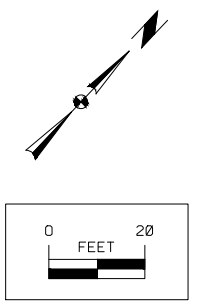
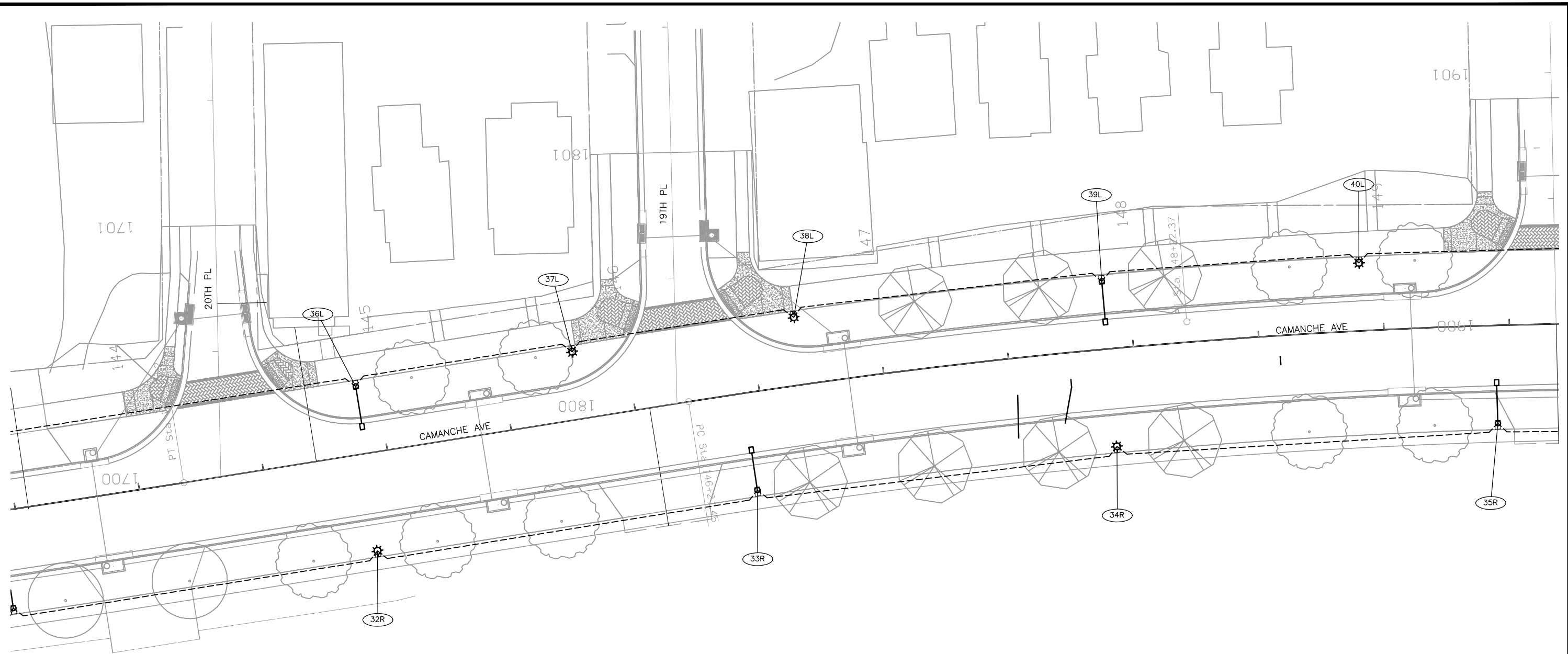



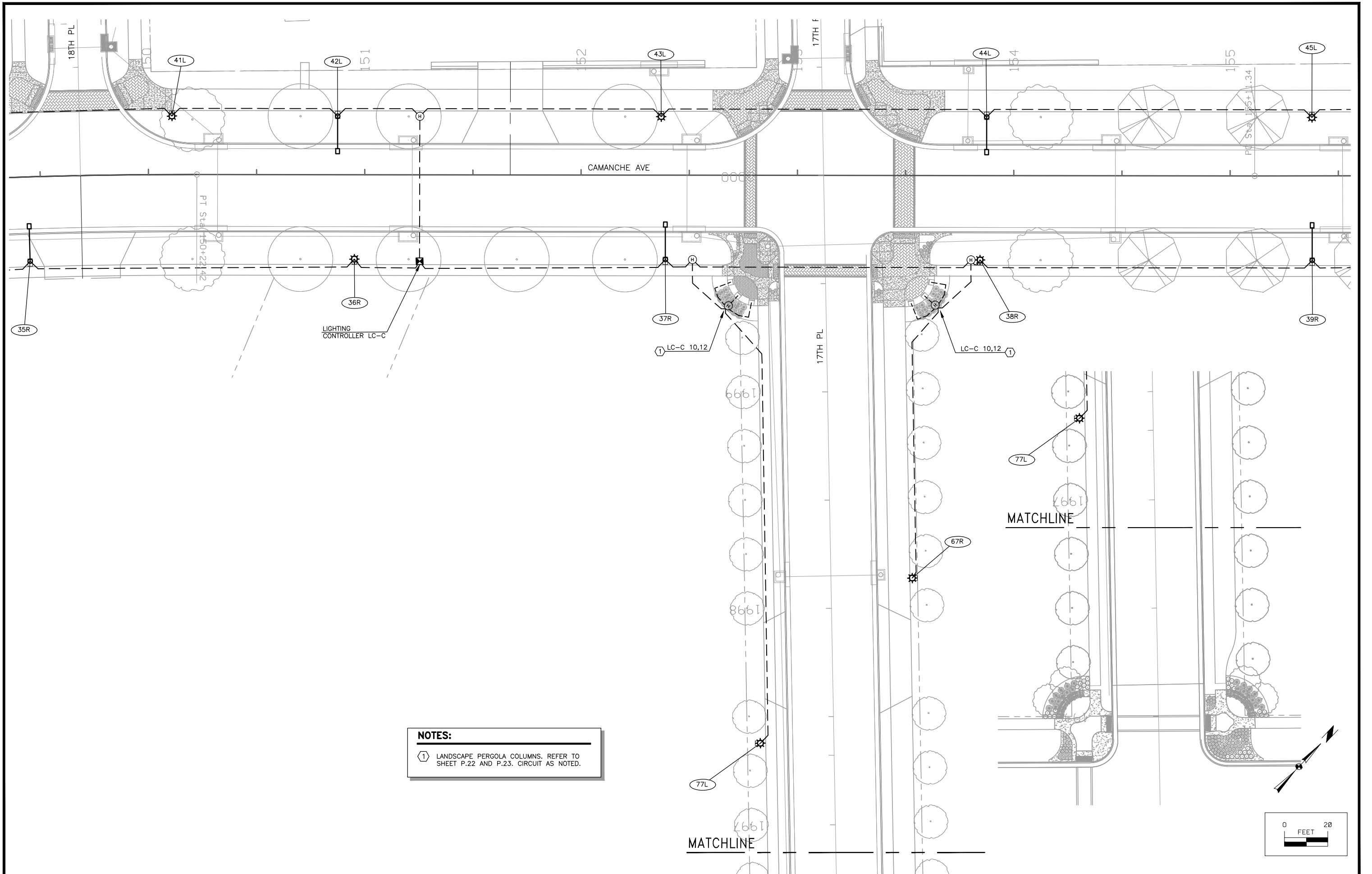

**NOTES:**

① LANDSCAPE PERGOLA COLUMNS. REFER TO SHEET P.22 AND P.23. CIRCUIT AS NOTED.

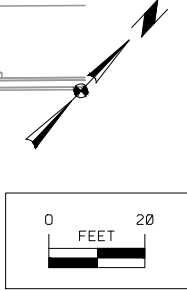

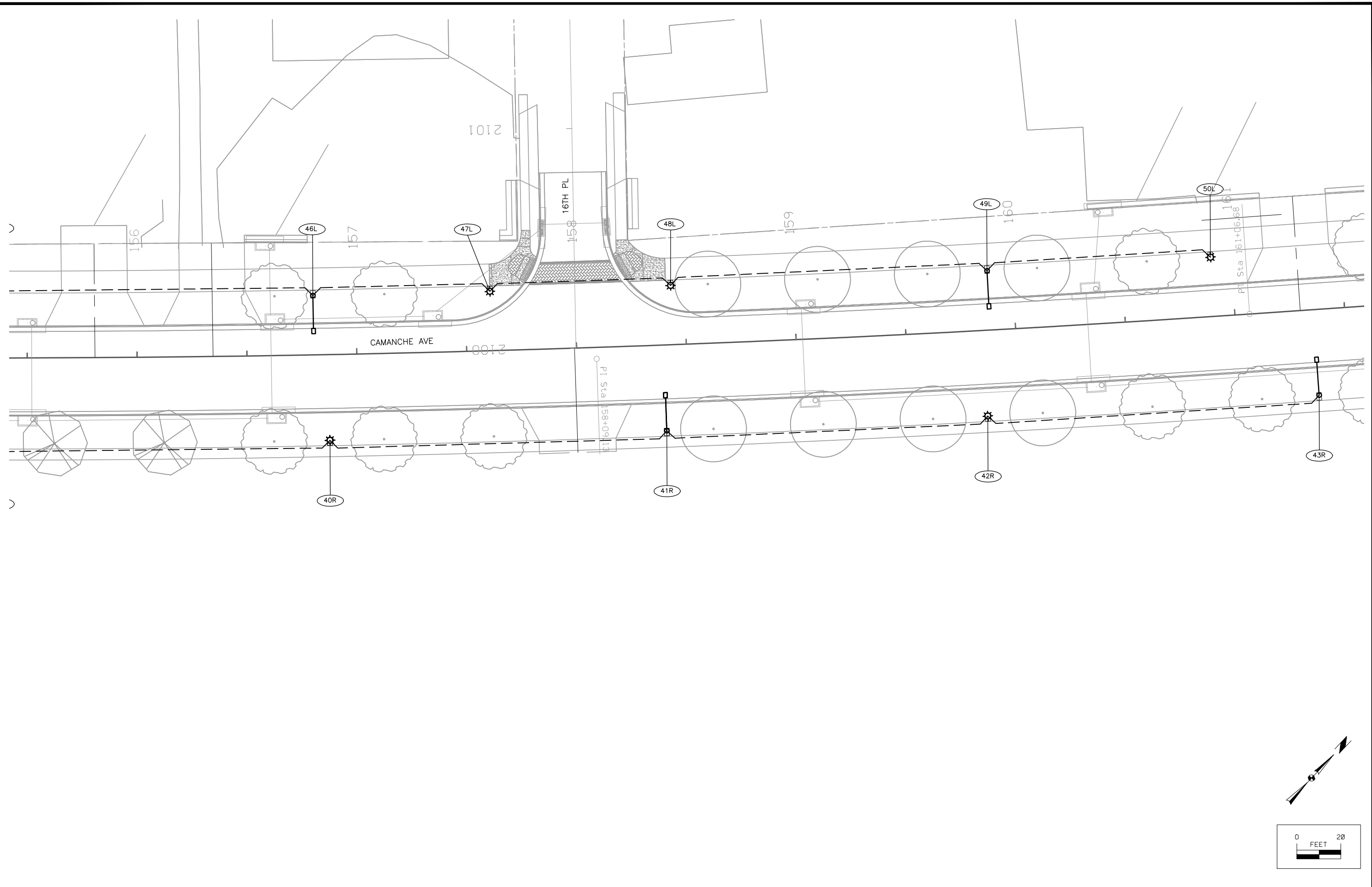

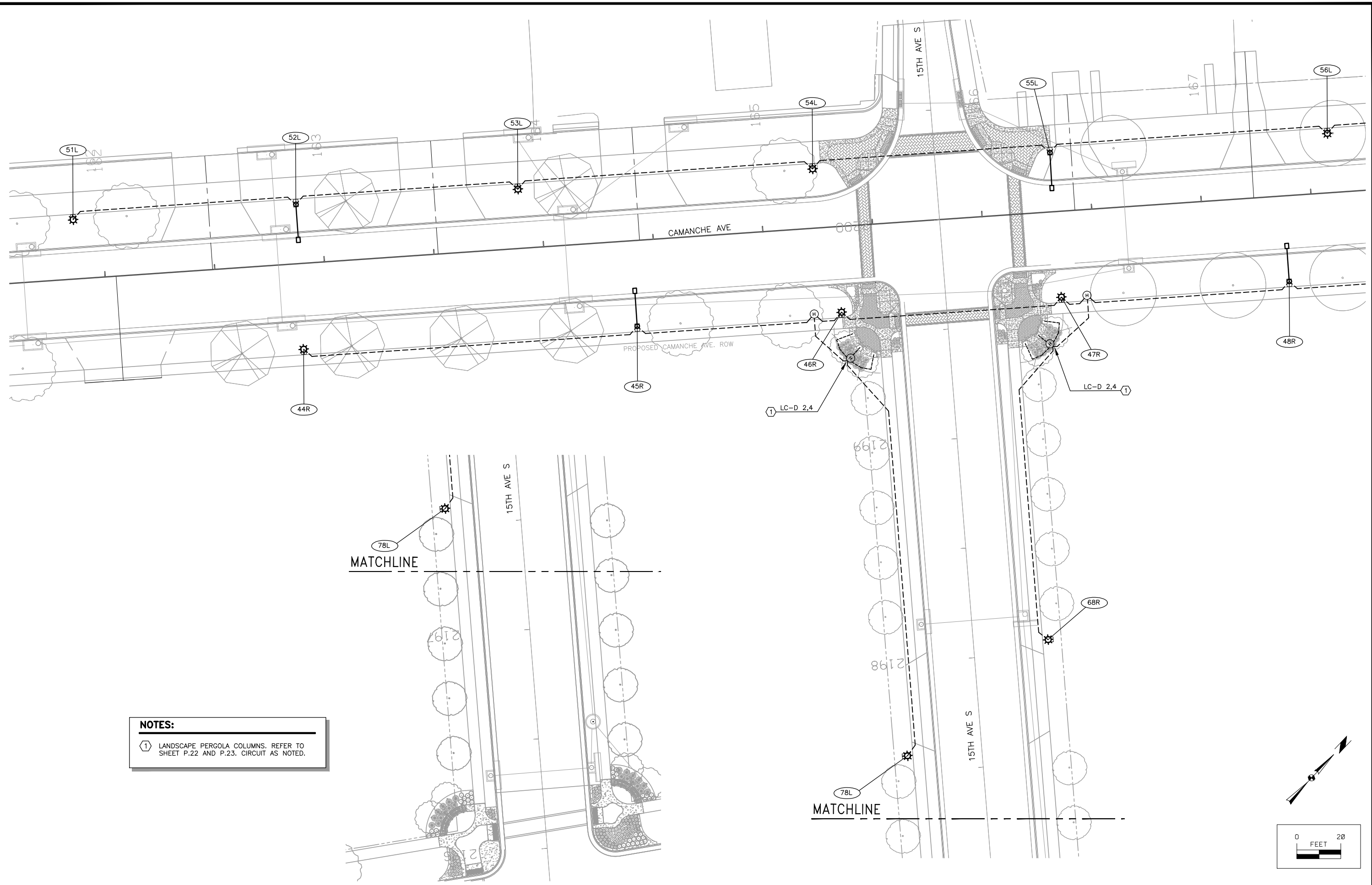

**NOTES:**

① LANDSCAPE PERGOLA COLUMNS. REFER TO SHEET P.22 AND P.23. CIRCUIT AS NOTED.

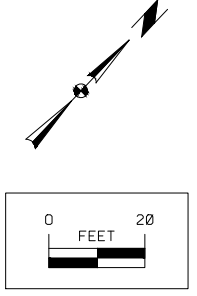

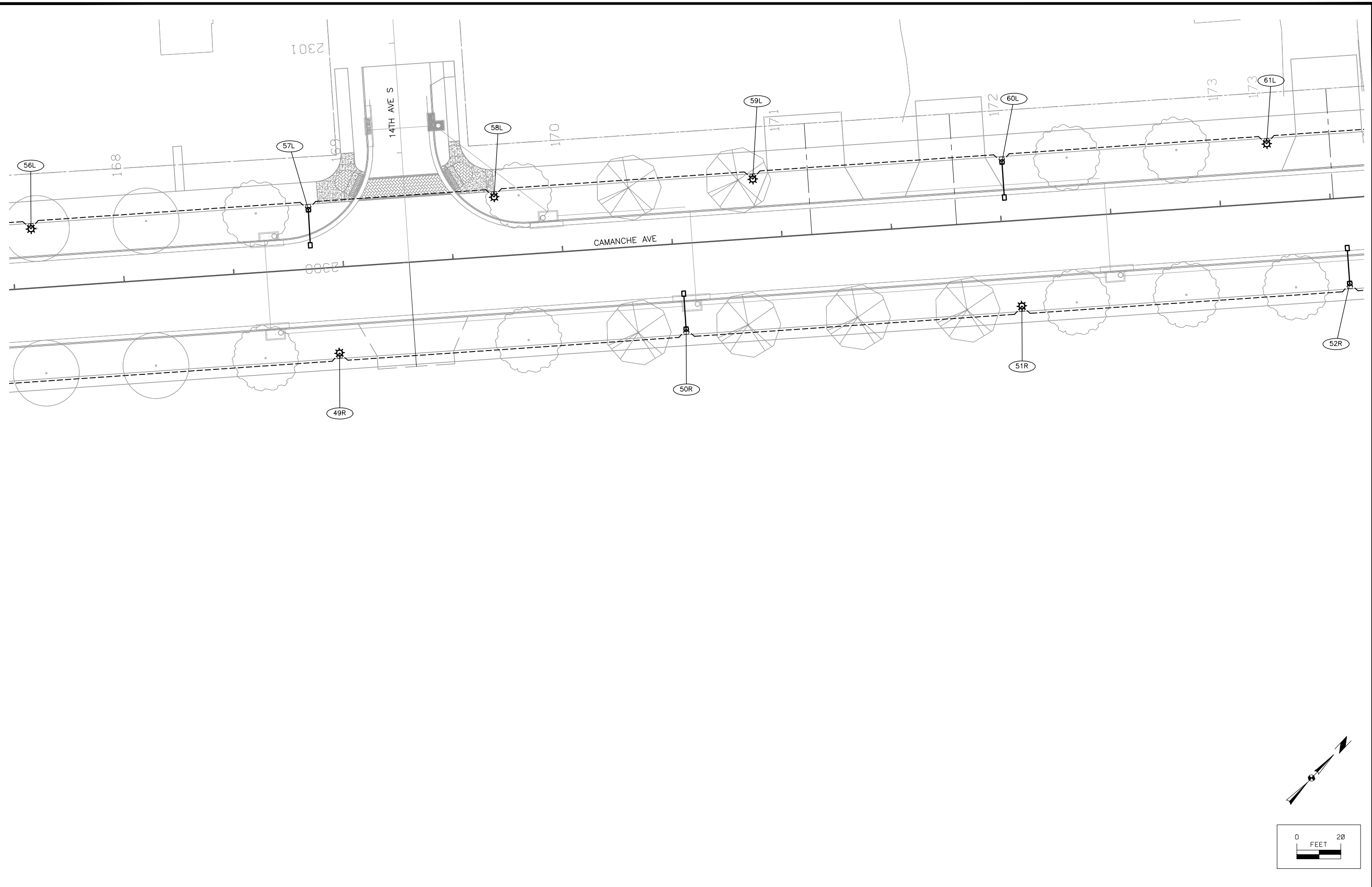

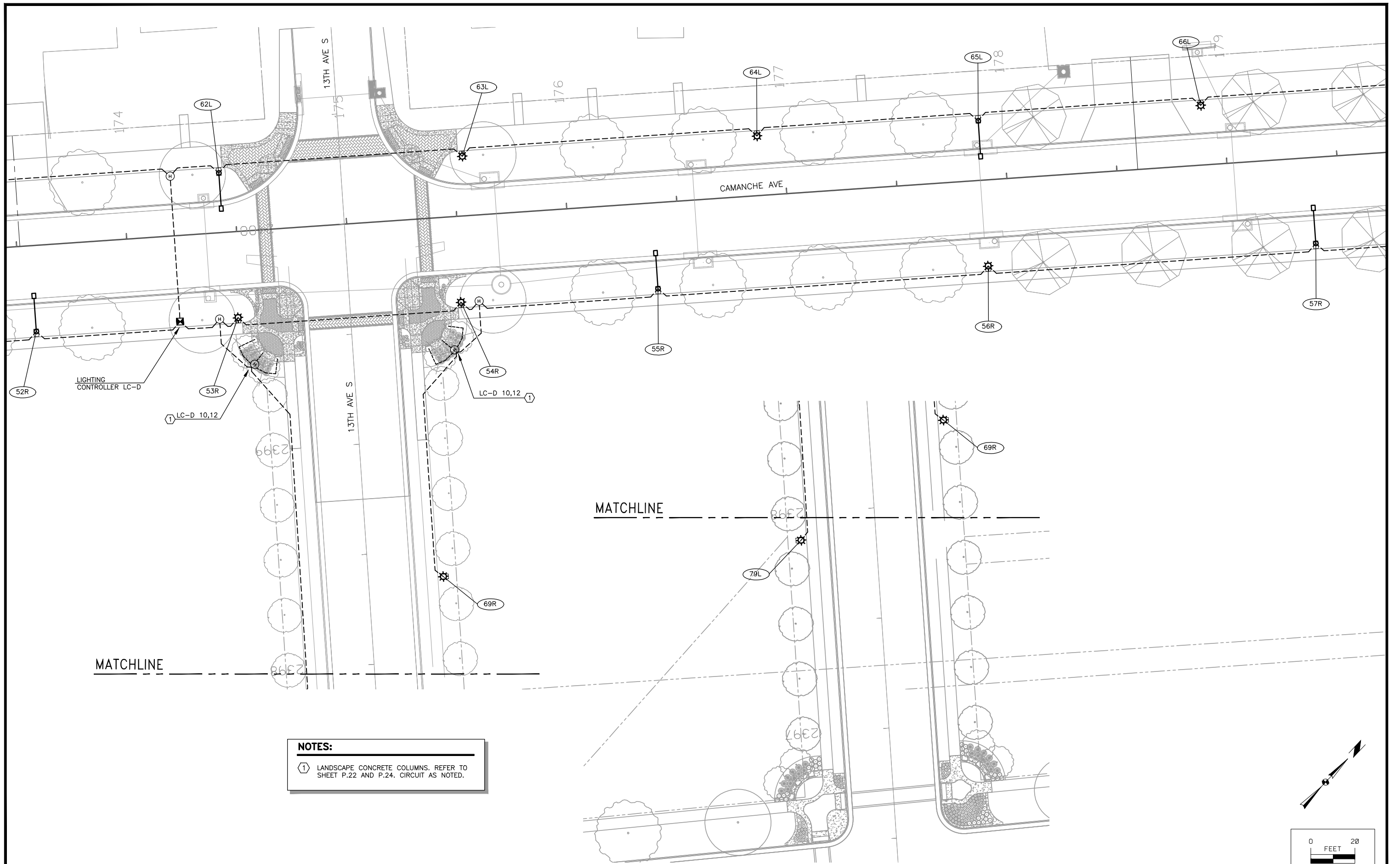

**NOTES:**  
 ① LANDSCAPE CONCRETE COLUMNS. REFER TO SHEET P.22 AND P.24. CIRCUIT AS NOTED.

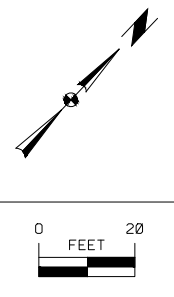

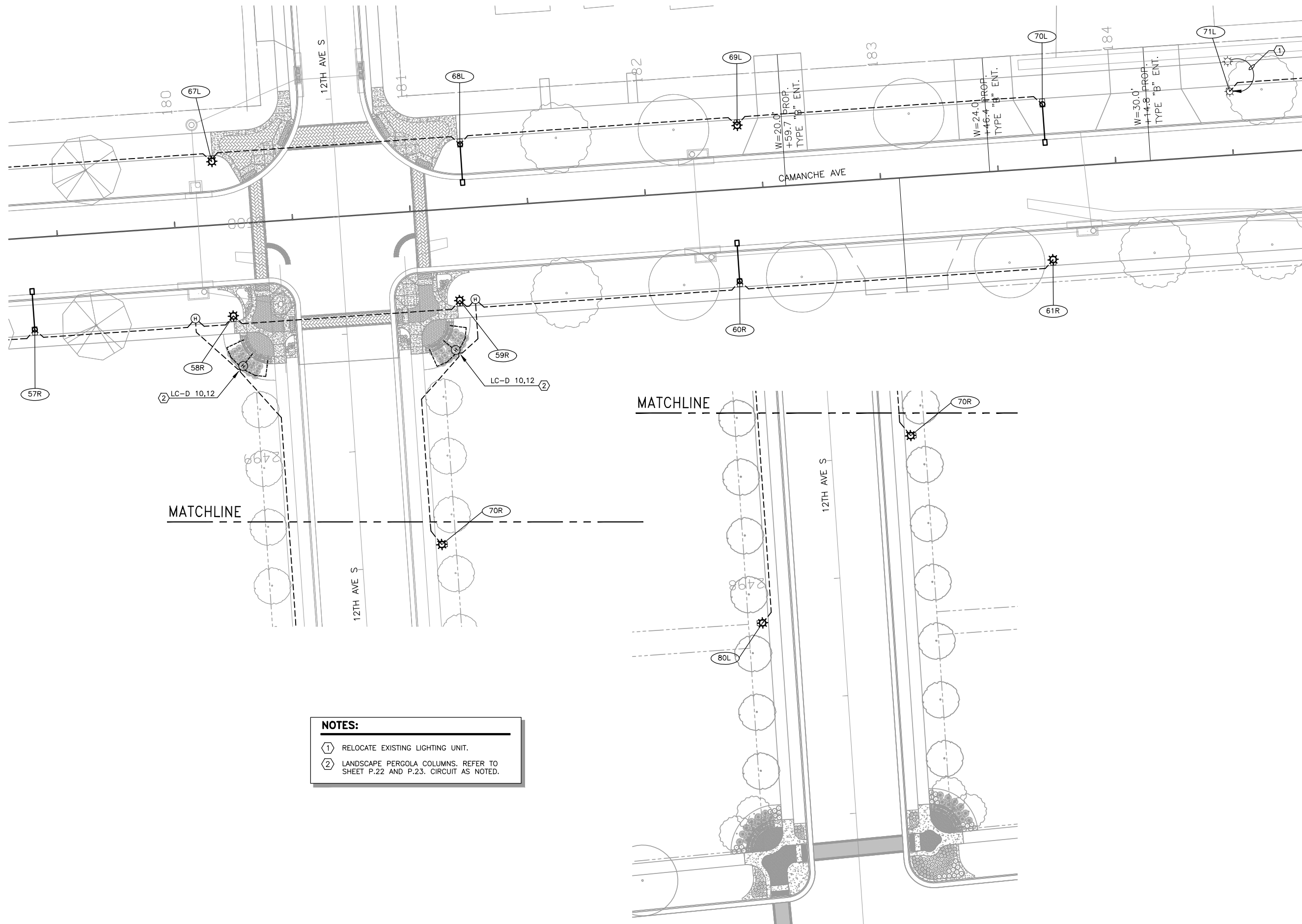

**NOTES:**

- ① RELOCATE EXISTING LIGHTING UNIT.
- ② LANDSCAPE PERGOLA COLUMNS. REFER TO SHEET P.22 AND P.23. CIRCUIT AS NOTED.

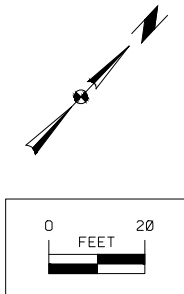

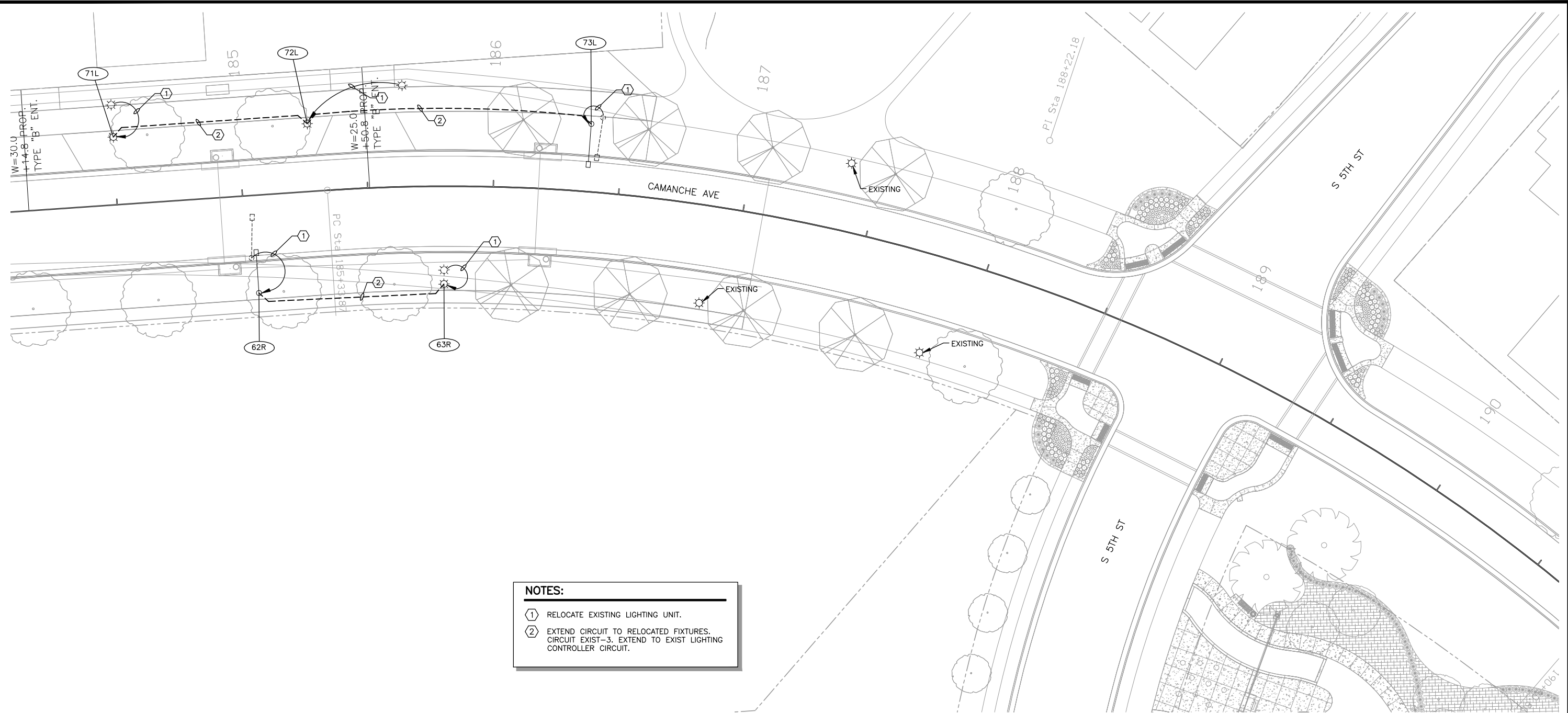

- NOTES:**
- ① RELOCATE EXISTING LIGHTING UNIT.
  - ② EXTEND CIRCUIT TO RELOCATED FIXTURES. CIRCUIT EXIST-3. EXTEND TO EXIST LIGHTING CONTROLLER CIRCUIT.

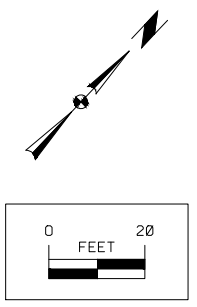

LIGHTING UNIT SCHEDULE											
TYPE	DESCRIPTION	FIXTURE MODEL	DISTRIBUTION	VOLT	LAMP	POLE MODEL	FINISH	DESCRIPTION	HEIGHT	BREAKAWAY COMPONENTS	FINISH
L1	DECORATIVE PEDESTRIAN LIGHTING UNIT WITH SINGLE LUMINAIRE MOUNTED ON 14" DECORATIVE ALUMINUM POLE. CUSTOM BLUE TEXTURED PAINT.	LUMEC AT30-SHA3M-ACDR-240-1 FINAL 4992780TD SUN VALLEY 43-1050-14FT-P127/CS4092-HR-III LUMCA CP6119-MD9128	TYPE III	240V	150HPS GE LU150/SBY/XL	LUMEC AMU8-14 BE6TX SUN VALLEY LUMCA	LUMINAIRE: BLUE POWDER COAT TO MATCH LUMEC BE6TX POLE, BASE COVER: BLUE POWDER COAT TO MATCH LUMEC BE6TX FINAL: COPPER POWDER COAT	STRAIGHT ALUMINUM POLE, 4" NOMINAL DIAMETER UPPER PORTION WITH 8" NOMINAL DIAMETER LOWER PORTION. BREAKAWAY COUPLING CAST ALUMINUM BREAK-AWAY COUPLING COVERS TO MATCH POLE COMPLETE WITH GALVANIZED ANCHOR BOLTS. POLE SELECTION SUITABLE TO WITHSTAND 90MPH (MINIMUM) WIND LOAD. REFER TO CALCULATION REQUIREMENTS.	14'	TESTED TO MEET OR EXCEED ASHTO STANDARDS FOR STRUCTURAL SUPPORTS FOR LUMINAIRES TESTED AND APPROVED IN ACCORDANCE WITH NCHRP 350 HOT DIPPED GALVANIZED IN ACCORDANCE WITH ASTM A153	POWDER COAT ALL COMPONENTS MATCHING LUMEC BE6TX
L2	ROADWAY LIGHTING UNIT SINGLE LUMINAIRE MOUNTED ON 15' ARM. 250 HPS, FULL CUT OFF, FLAT GLASS, TYPE 3 DISTRIBUTION BREAK-AWAY BOLTS AND DECORATIVE BASE COVER	LUMEC 250 HPS-HBM-1-0TA/240-CWA-PAL LUMARK HPRC-FL-3-250-MT GENERAL ELECTRIC M-250R2	TYPE III	240V	250 HPS GE LU250/SBY/XL	LUMEC LMS-1A-PPV-VSP-LMS-30-PPV-1X36-PPV-12-DEC-BE6TX-LMS12977A UNITED LIGHTING STANDARDS SSTA-2-33.5115-OD-HH-CC-VD VALMONT 320BTA458074D1-CUSTOMCOLOR-CUSTOM BASE	LUMINAIRE: STANDARD GREY POLE, TRUSS ARM, BASE COVER: BLUE POWDER COAT TO MATCH LUMEC BE6TX	31' TAPERED ALUMINUM POLE WITH ALUMINUM SINGLE 15' BOLT ON ARM TRUSS-ARM EXTENSION, RISE TO 32.5' ABOVE POLE BASE. CUSTOM POWDER COAT. CUSTOM DECORATIVE COVER TO CONCEAL BOLTS AND BREAK-AWAY COUPLINGS. REFER TO DRAWINGS. COMPLETE WITH GALVANIZED ANCHOR BOLTS. POLE SELECTION SUITABLE TO WITHSTAND 90MPH (MINIMUM) WIND LOAD. REFER TO CALCULATION REQUIREMENTS. PROVIDE VIBRATION DAMPENER	32'	BREAKAWAY COUPLING CAST ALUMINUM COVER PAINTED TO MATCH POLE. TESTED TO MEET OR EXCEED ASHTO STANDARDS FOR STRUCTURAL SUPPORTS FOR LUMINAIRES TESTED AND APPROVED IN ACCORDANCE WITH NCHRP 350 HOT DIPPED GALVANIZED IN ACCORDANCE WITH ASTM A153	POWDER COAT ALL COMPONENTS MATCHING LUMEC BE6TX
L3	ROADWAY LIGHTING UNIT MOUNTED ON TRAFFIC SIGNAL ARM 250 HPS, FULL CUT OFF, FLAT GLASS, TYPE 3 DISTRIBUTION	LUMEC 250 HPS-HBM-1-0TA/240-CWA-PAL LUMARK HPRC-FL-3-250-MT GENERAL ELECTRIC M-250R2	TYPE III	240V	250 HPS GE LU250/SBY/XL	N/A	LUMINAIRE: STANDARD GREY	REFER TO TRAFFIC SIGNAL PLANS AND SPECIFICATIONS	N/A	REFER TO TRAFFIC SIGNAL PLANS AND SPECIFICATIONS	
L4	EXISTING PEDESTRIAN LIGHTING UNIT TO BE RELOCATED	EXISTING	N/A	N/A	EXISTING	EXISTING	N/A	EXISTING FIXTURE, PROVIDE NEW GALVANIZED ANCHOR BOLTS	14'	EXISTING	N/A
L5	EXISTING ROADWAY LIGHTING UNIT TO BE RELOCATED	EXISTING	N/A	N/A	EXISTING	EXISTING	N/A	EXISTING FIXTURE, PROVIDE NEW GALVANIZED ANCHOR BOLTS	32'	EXISTING	N/A

POLE STRUCTURAL CALCULATION REQUIREMENTS  
1. CALCULATIONS SHALL BE INCLUDED WITH POLE SUBMITTAL.  
2. CALCULATIONS SHALL BE CERTIFIED BY A LICENSED PROFESSIONAL ENGINEER. ENGINEER'S LICENSING INFORMATION SHALL BE INCLUDED WITH THE CALCULATIONS IN THE FORM OF THE ENGINEER'S STAMP OR LETTER.  
3. CALCULATIONS SHALL INCLUDE COMBINED STRESS RATIO CALCULATION AT POLE BASE, BASE PLATE STRESS, AND ANCHOR BOLT STRENGTH AND EMBEDMENT.  
4. CALCULATIONS SHALL BE ARRANGED TO CLEARLY INDICATE CALCULATION CRITERIA, ASSUMPTIONS, SAFETY FACTORS, ETC. COMPUTER GENERATED OUTPUT ALONE IS NOT SUFFICIENT.  
5. CALCULATIONS SHALL INCLUDE ALL ACCESSORIES NOTED IN THE SCHEDULE.

**GENERAL LIGHTING UNIT NOTES**

- ALL LIGHT FIXTURES SHALL HAVE TOOL-FREE ACCESS TO THE INTERIOR OF THE LUMINAIRE.
- ALL LIGHT FIXTURES SHALL BE WATER TIGHT AND HERMETICALLY SEALED GASKET.
- ALL LIGHT BASE COVERS TO BE CAST ALUMINUM.
- ALL ALUMINUM LIGHT SURFACES SHALL BE CHEMICALLY TREATED PRIOR TO POWDER COATING TO ENSURE PROPER ADHESION OF THE PAINT. THE COMPONENTS SHALL BE WASHED IN ORDER TO REMOVE GREASE AND DIRT, DRIED, AND THEN HOT ETCHED IN PHOSPHORIC ACID, AND RINSED AGAIN TO REMOVE ANY REMAINING PHOSPHORIC ACID.
- ALL POWDER COATED LIGHT SURFACES SHALL BE WARRANTED AGAINST CORROSION, PEELING, CRACKING, AND FADING FOR 5 YEARS.
- CONTRACTOR SHALL SUBMIT SHOP DRAWINGS FOR ALL LIGHTS, POLES, AND PRECAST CONCRETE BASES; AND COLOR CHIPS FOR ALL POWDER COAT COLORS.

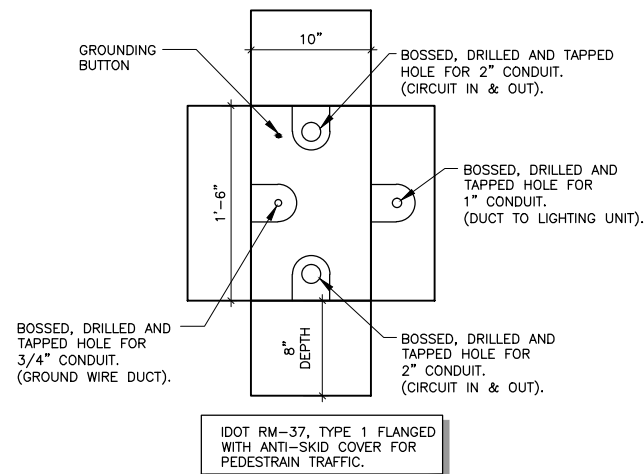

**LIGHTING UNIT L1, L2, L4, L5. JUNCTION BOX CONFIGURATION**

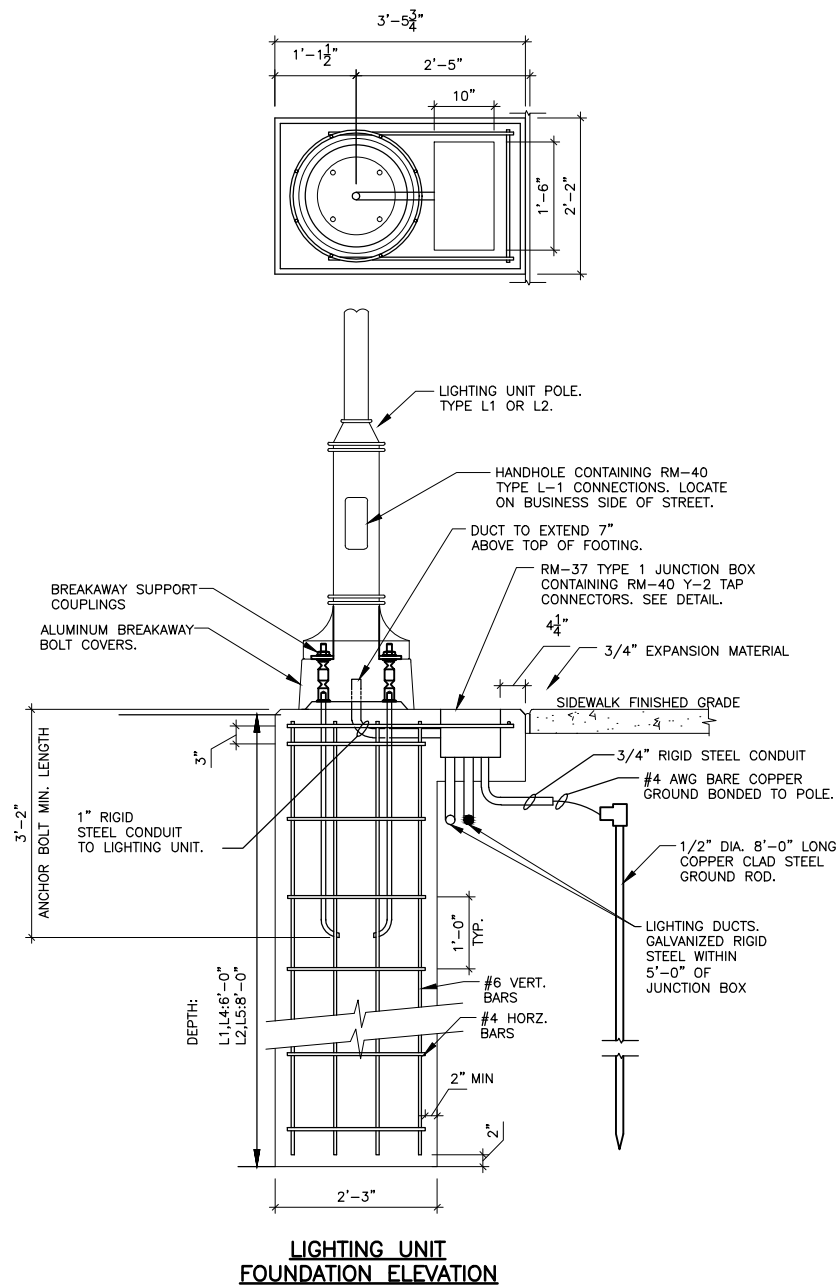

**LIGHTING UNIT FOUNDATION ELEVATION**

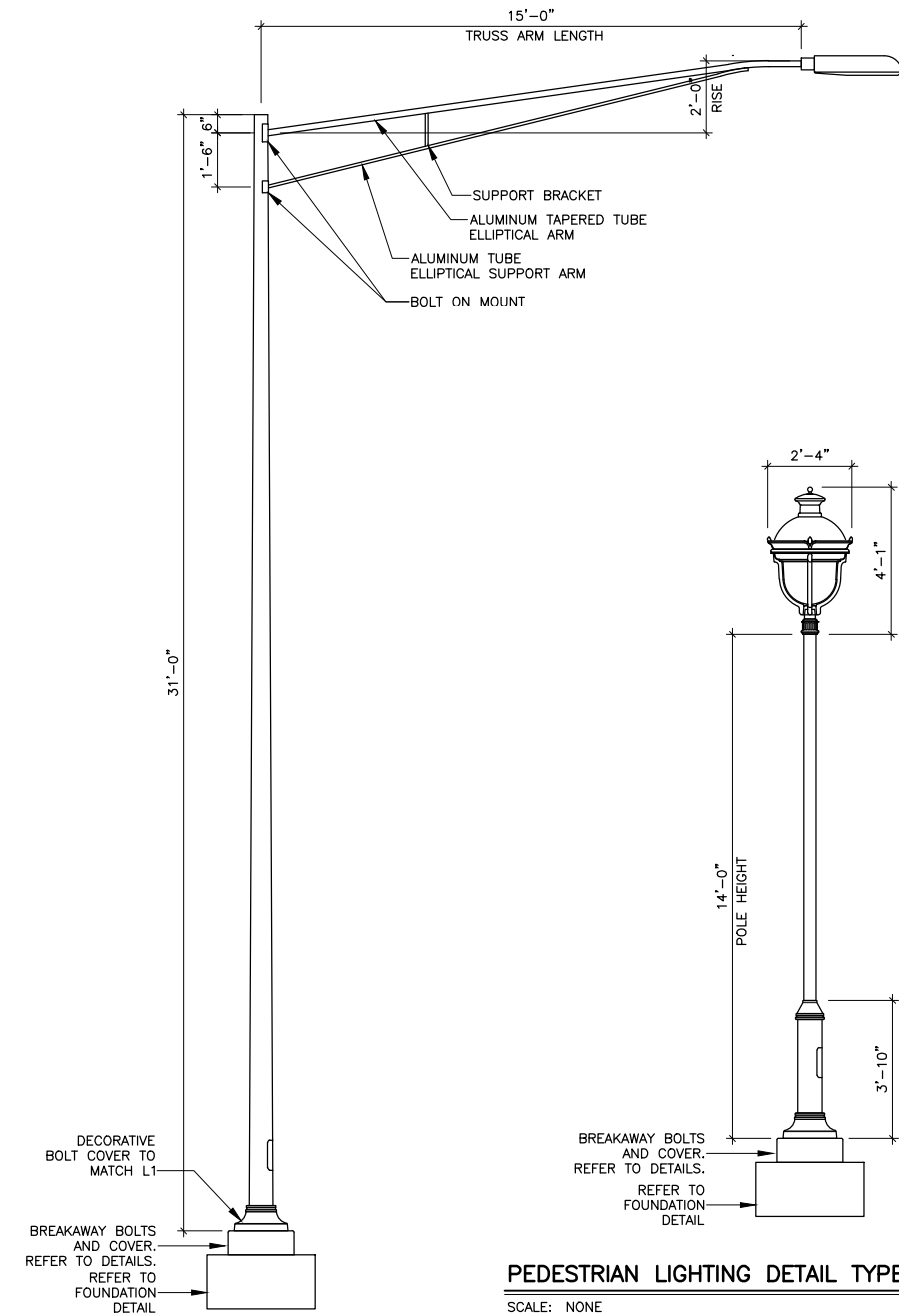

**PEDESTRIAN LIGHTING DETAIL TYPE L1**

**STREET LIGHTING DETAIL-TYPE L2**

SCALE: NONE

SCALE: NONE



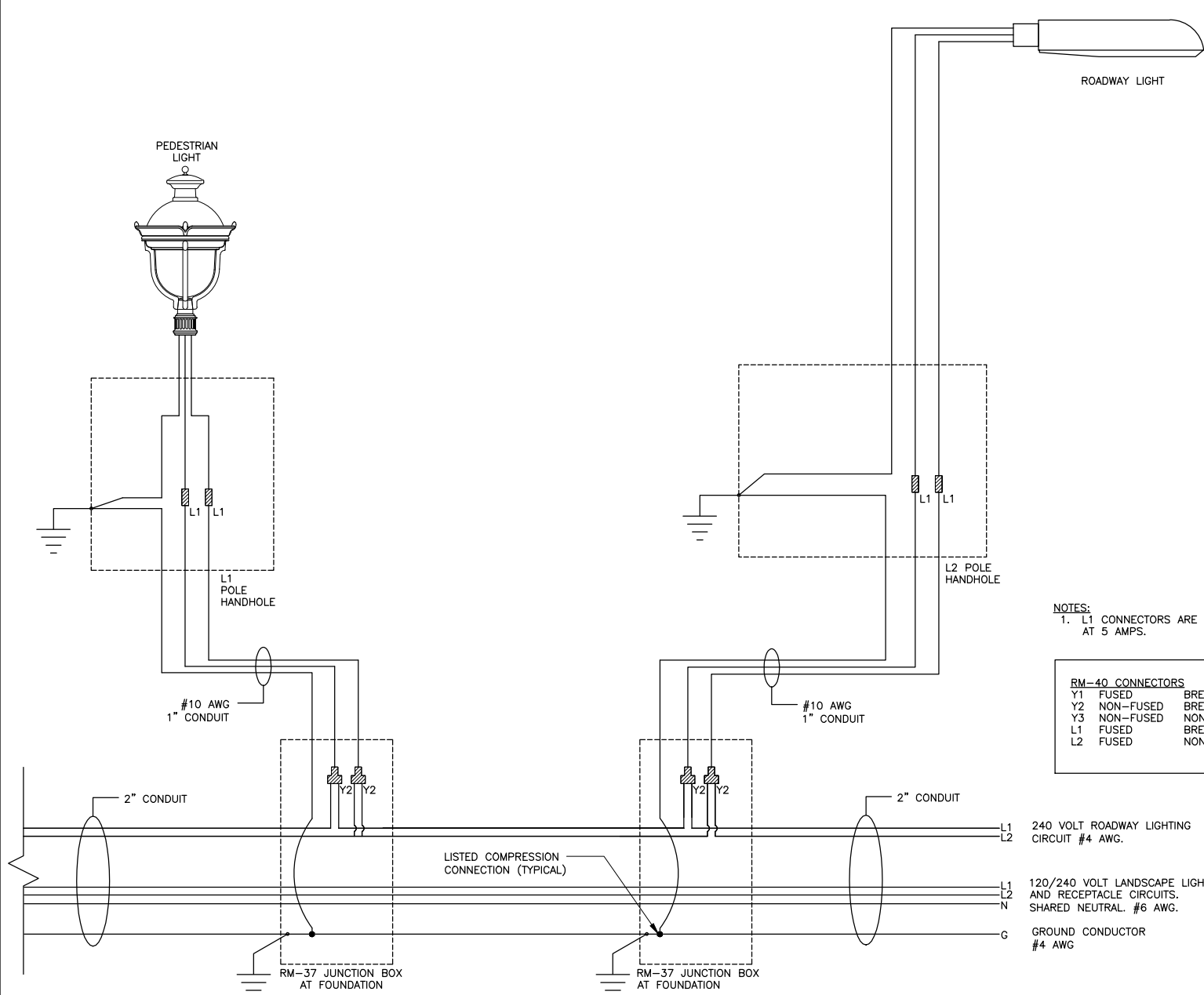

**1 TYPICAL CIRCUIT SCHEMATIC**  
SCALE: NOT TO SCALE

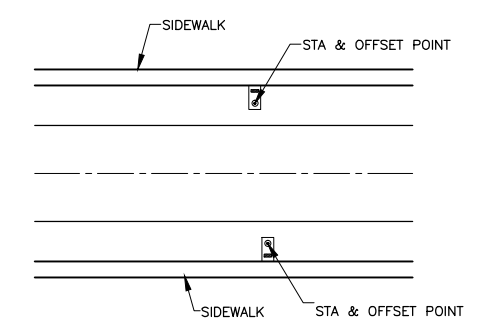

**2 LUMINAIRE AND FOOTING ORIENTATION DETAIL**  
SCALE: NOT TO SCALE

- NOTES:**  
1. L1 CONNECTORS ARE TO BE FUSED AT 5 AMPS.
- | RM-40 CONNECTORS |                         |
|------------------|-------------------------|
| Y1               | FUSED BREAKAWAY         |
| Y2               | NON-FUSED BREAKAWAY     |
| Y3               | NON-FUSED NON-BREAKAWAY |
| L1               | FUSED BREAKAWAY         |
| L2               | FUSED NON-BREAKAWAY     |

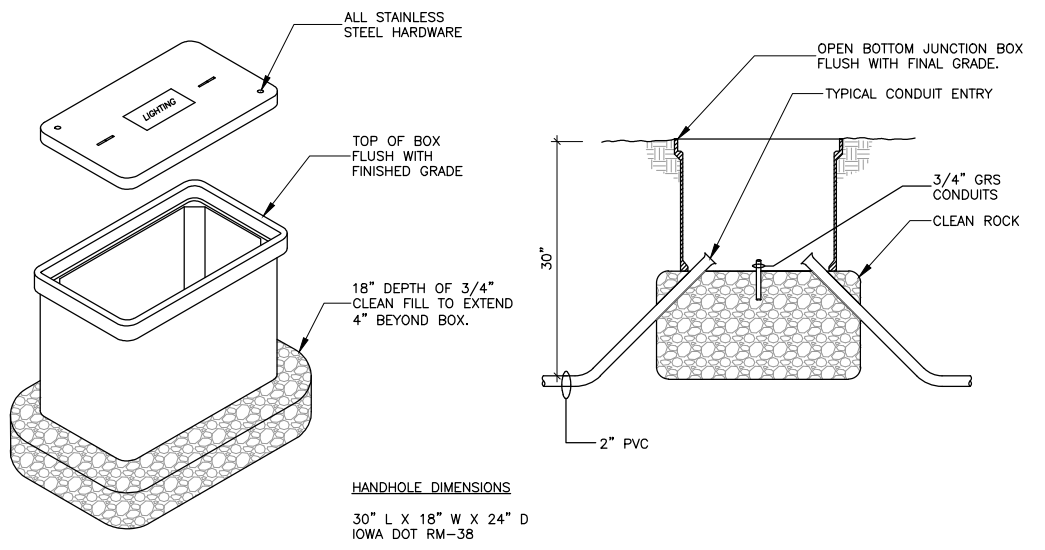

**3 HANDHOLE DETAIL**  
SCALE: NOT TO SCALE

- HIGHWAY LIGHTING DATA:**
- GENERAL**
1. LIGHTING INSTALLATION SHALL BE IN ACCORDANCE WITH IOWA DOT STANDARD SPECIFICATION SECTION 2523, HIGHWAY LIGHTING UNLESS OTHERWISE NOTED.
  2. LIGHTING MATERIALS SHALL BE IN ACCORDANCE WITH IOWA DOT STANDARD SPECIFICATION 4185, HIGHWAY LIGHTING MATERIALS UNLESS OTHERWISE NOTED.
  3. CONTRACTOR SHALL COORDINATE ROUTING AND INSTALLATION OF CONDUIT SYSTEM WITH EXISTING AND PROPOSED UTILITIES, STRUCTURES AND EQUIPMENT. CONTRACTOR SHALL BE RESPONSIBLE TO OBTAIN LOCATES ON ALL UNDERGROUND UTILITIES AND VERIFY CLEARANCES BEFORE BORING, TRENCHING OR EXCAVATION.

- ELECTRIC SERVICE**
1. THE CONTRACTOR SHALL COORDINATE ELECTRICAL SERVICE INCLUDING METER INSTALLATIONS, TRANSFORMER AND PAD LOCATIONS AND ORIENTATIONS AND ENERGIZATION WITH THE UTILITY.
  2. THE INSTALLATION SHALL MEET ALL UTILITY AND NEC CODES AND REQUIREMENTS.
  3. THE CONTRACTOR SHALL PROVIDE A CONCRETE TRANSFORMER PAD FOR THE UTILITY PAD MOUNTED TRANSFORMERS. PAD TO BE BUILT TO UTILITY SPECIFICATIONS.
  4. ELECTRIC SERVICE FOR TRAFFIC SIGNALS IS NOT INDICATED ON 'P' SHEETS AND IS THE RESPONSIBILITY OF THE SIGNAL CONTRACTOR.

- UNDERGROUND CIRCUITS**
1. INSTALL DUCTS 3 FEET BELOW FINISHED GRADE AND PROVIDE PLASTIC ELECTRICAL WARNING TAPE IN TRENCH ABOVE ALL CONDUIT AT 1'-6" BELOW FINISH GRADE.
  2. WIRING INSTALLED IN CONDUIT SHALL BE SINGLE-CONDUCTOR COPPER TYPE XHHW (PER IDOT STANDARD SPECIFICATIONS) FOR PHASE, NEUTRAL, AND GROUND CONDUCTORS THHN/THWN WIRE IS PROHIBITED.
  3. SEE WIRE AND CABLE TABULATION FOR CONDUCTOR SIZES.
  4. SEE TABULATION OF ELECTRICAL DUCTS FOR CONDUIT TYPES AND SIZES. ALL CIRCUITS SHALL CONTAIN AN EQUIPMENT GROUND CONDUCTOR EQUAL TO THE SIZE OF THE LARGEST PHASE CONDUCTOR IN THE CONDUIT.
  5. CONDUIT WITHIN 5'-0" OF LIGHTING CONTROL CABINETS, JUNCTION BOXES AND LIGHTING UNITS SHALL BE GALVANIZED RIGID STEEL.
  6. COORDINATE CONDUIT ROUTING WITH LANDSCAPE PLANTINGS. DO NOT LOCATE CONDUIT BENEATH TREES.
  7. HANDHOLES TO BE RM-38.
  8. JUNCTION BOXES AT LIGHTING UNITS TO BE RM-37 AS DETAILED.

- 1. ROADWAY LIGHTING**
1. ALL LIGHTING UNITS, JUNCTION BOXES, HANDHOLES OR ENCLOSURES SHALL BE CONNECTED TO THE GROUNDING SYSTEM. PROVIDE AND INSTALL GROUND RODS AND GROUNDING ELECTRODE CONDUCTORS AT ALL LIGHTING UNITS, CONTROL STATIONS, HANDHOLES, ETC. PER NEC AND IDOT STANDARD SPECIFICATIONS.
  2. PHASE TAP CONNECTORS SHALL BE MADE WITH RM-40 Y-1 CONNECTORS WITH 20 AMP FUSES IN FOOTING. RM-40 L-1 CONNECTORS WITH 5 AMP FUSES SHALL BE PLACED INSIDE POLE SHAFT HANDHOLES.
  3. ALL LIGHTING LOADS SHALL BE CONNECTED 'LINE-TO-LINE'.
  4. ALL LAMPS SHALL BE HIGH PRESSURE SODIUM STANDBY TYPE WITH A DUAL ARC TUBE DESIGN. 40,000 HOUR MINIMUM RATED LIFE.
  5. TOUCH UP ALL NICKS & SCRATCHES ON LIGHTING UNITS WITH FACTORY SUPPLIED TOUCH-UP PAINT.

- 1. LIGHTING CONTROL STATIONS**
- STATIONS AND OFFSET LOCATIONS SHOWN ON THE DRAWINGS ARE TO CENTER OF LIGHTING CONTROL STATION CONCRETE PADS. THE CONTRACTOR SHALL VERIFY THE LOCATION AND ORIENTATION OF THE LIGHTING CONTROL STATIONS WITH THE ENGINEER AND SHALL COORDINATE THE INSTALLATION DURING CONSTRUCTION.

- 1. SUBMITTALS**
- PROVIDE SUBMITTALS ON THE FOLLOWING MATERIALS/EQUIPMENT.
- A. LIGHTING CONTROL STATIONS
  - B. LUMINAIRES
  - C. POLES, MAST ARMS INCLUDING WIND LOAD CALCULATIONS AND COLOR CHIPS.
  - D. BREAKAWAY SUPPORT COUPLINGS
  - E. WIRE AND CABLE
  - F. CONNECTORS
  - G. CONDUIT
  - H. PRECAST BASES.

**LIGHTING CONTROL CABINET CONSTRUCTION SPECIFICATION**

**1. GENERAL**

THE LIGHTING CONTROL CABINET SHALL BE A SINGLE PHASE, 3 WIRE WEATHERPROOF CABINET, AND SHALL CONTAIN CIRCUIT BREAKERS, LIGHTING CONTACTOR, METER SOCKET, PHOTOELECTRIC CONTROL (PHOTOCELL), KEY SWITCH, TIMER, POWER DISTRIBUTION BLOCKS, AND NEUTRAL/GROUND BONDING BAR. THE CABINET SHALL BE DEAD FRONT

THE CABINET AND ITS CONTENTS SHALL COMPLY WITH THE REQUIREMENTS OF THE UNDERWRITERS LABORATORY INC. (UL) STANDARDS UL-508 AND UL-508A. THE ENCLOSURE SHALL HAVE A NEMA 3R RATING.

**2. CABINET ENCLOSURE**

THE LIGHTING SERVICE CABINET SHALL BE CONSTRUCTED FROM A MINIMUM 1/8" THICK ALUMINUM CONFORMING TO THE REQUIREMENTS OF ASTM B 209 FOR 5052-H32 ALUMINUM SHEET.

THE CABINET SHALL HAVE TWO COMPARTMENTS. THE RIGHT COMPARTMENT SHALL PROVIDE SPACE FOR THE LIGHTING SERVICE PANEL AND THE TIMER AND PHOTOELECTRIC CONTROL CIRCUITS. THE CABINET SHALL HAVE AN ENCLOSED LEFT COMPARTMENT TO PROVIDE SPACE FOR SPLICING THE SERVICE ENTRANCE CONDUCTORS TO THE METER AND TO THE ROADWAY LIGHTS MAIN CIRCUIT BREAKER.

THE CABINET SHALL HAVE A WEATHERTIGHT HINGED DOOR OPENING TO THE RIGHT (RIGHTHANDED DOOR). THE DOOR SHALL BE EQUIPPED WITH A THREE-POINT LOCKING MECHANISM THAT OPERATES FROM A SINGLE EASY-TURNING HANDLE. THE CABINET DOOR SHALL LOCK WITH A STANDARD POLICE LOCK AND KEY. (4 KEYS SHALL BE FURNISHED). THE DOOR SHALL HAVE LOUVERED VENTS WITH SCREENING OR PERFORATED METAL. THE HINGES, HINGE PINS, LOCKS AND LOCK COVERS SHALL BE OF STAINLESS STEEL OR OTHER NON-CORRODING MATERIAL. HINGES MAY BE WELDED ON OR FASTENED WITH STAINLESS STEEL TAMPERPROOF BOLTS.

TWO CIRCULAR WINDOWS SHALL BE AT THE RIGHT UPPER BACK CORNER OF THE CABINET FOR THE PHOTOCELL. ONE WINDOW SHALL BE ON THE BACK CABINET WALL. THE WINDOW SHALL HAVE A DIAMETER OF 3-1/2". THE WINDOWS SHALL BE OF 1/8" THICK CLEAR POLYCARBONATE AND BE INSTALLED IN A MANNER THAT DOES NOT SACRIFICE THE WEATHER-TIGHTNESS OR THE SECURITY OF THE CABINET.

THE CABINET TOP SHALL BE CROWNED OR SLANTED TO THE REAR TO PREVENT STANDING WATER, AND SHALL PROVIDE A 2" OVERHANG.

THE LIFTING EARS SHALL HAVE A LIFTING CAPACITY EQUAL TO THE WEIGHT OF THE COMPLETELY WIRED CABINET PLUS 25 PERCENT, A 500 lbs. CAPACITY MINIMUM.

THE EXTERIOR SEAMS FOR CABINET AND DOORS SHALL BE CONTINUOUSLY WELDED OR SEALED WITH SILICON SEALANT. ALL EXTERIOR WELDS SHALL BE GROUND SMOOTH. ALL SHARP EDGES SHALL BE FILED.

ANCHOR BOLTS SHALL BE PROVIDED FOR PAD MOUNTING. A SOLID BUTYL RUBBER GASKET SHALL BE PROVIDED FOR BETWEEN THE PAD AND THE CABINET.

APPROVED MANUFACTURERS:  
STATES ELECTRIC MFG. CO. OF MINNEAPOLIS, MN  
AMP MANUFACTURING & SUPPLY INC. OF MINNEAPOLIS, MN  
BISON PROFAB OF MAGNOLIA, TX  
HERITAGE MANUFACTURING OF WAYNE, NE

**3. ELECTRICAL EQUIPMENT AND WIRING**

A SELF-CONTAINED METER SOCKET, CONFORMING TO UTILITY REQUIREMENTS SHALL BE MOUNTED TO THE LEFT CABINET WALL FACING TO THE LEFT. FOR UNMETERED FEED POINTS, A METER JUMPER SHALL BE FURNISHED AND INSTALLED BY THE CONTRACTOR.

THE LIGHTING SERVICE CABINET SHALL HAVE CIRCUIT BREAKERS, AND LIGHTING CONTACTORS AS INDICATED ON THE DRAWING SCHEMATICS AND SCHEDULES.

THE CIRCUIT BREAKERS SHALL BE THERMAL-MAGNETIC TYPE, SQUARE D, CUTLER HAMMER OR GENERAL ELECTRIC. EACH BRANCH CIRCUIT BREAKER SHALL BE BOLTED ONTO A COPPER BUS. THE MAIN SERVICE ENTRANCE CIRCUIT BREAKERS SHALL BE UL LISTED FOR SUCH USE. NON-CONTACTOR CONTROLLED BRANCH CIRCUIT BREAKERS SHALL BE PROVIDED AS INDICATED ON THE DRAWINGS. THE BRANCH CIRCUIT BREAKERS SHALL BE SIZED TO ACCOMMODATE A NO. 4 AWG WIRE WITHOUT SPLITTING.

ALL LIGHTING CONTACTORS SHALL BE 2-POLE, NORMALLY OPEN, ELECTRICALLY HELD, AND SHALL BE RATED FOR TUNGSTEN FILAMENT AND BALLAST LIGHTING LOADS. THE CONTACTORS CONTACTS SHALL BE RATED FOR 240VAC, MIN. THE CONTACTORS COIL SHALL BE RATED FOR 120VAC. THE CONTROL COIL SHALL BE ACTUATED BY A PHOTOCELL OR TIMER AND PROTECTED BY A 15 AMP CIRCUIT BREAKER ON THE LINE SIDE, AS SHOWN IN THE LIGHTING CONTROLLER SCHEMATIC. THE LIGHTING CONTACTORS SHALL BE ALLEN BRADLEY 500FL, CUTLER HAMMER CN35, OR SQUARE D TYPE S, CLASS 8903.

THE MAIN BREAKERS, LIGHTING CONTACTOR, AND BRANCH CIRCUIT BREAKERS SHALL BE MOUNTED ON A REMOVABLE PANEL. A SEPARATE DEAD FRONT SHALL COVER THE PANEL AND SHALL BE HINGED ON ONE SIDE AND HELD IN PLACE WITH QUICK RELEASE CAPTIVE FASTENERS. MAIN CIRCUIT BREAKERS SHALL BE SERVICE ENTRANCE RATED.

ALL NEUTRAL/GROUND BONDING BARS, BUS BARS AND ELECTRICAL CONDUCTORS SHALL BE COPPER. ALL TERMINALS SHALL BE UL LISTED FOR COPPER AND ALUMINUM WIRES. ALL WIRING INSIDE THE CABINET SHALL BE SUFFICIENT LENGTH TO ALLOW FOR CONTRACTION.

**4. PHOTOELECTRIC CONTROL**

A PHOTOELECTRIC CONTROL MOUNTING RECEPTACLE (EEI/NEMA STANDARD 3-TERMINAL TWIST-LOCK TYPE), SHALL BE MOUNTED WITHIN THE CABINET NEAR THE POLYCARBONATE WINDOW. THE WIRES TO THE PHOTOELECTRIC CONTROL MOUNTING RECEPTACLE SHALL BE SINGLE CONDUCTOR NO. 14 AWG. STRANDED COPPER CONDUCTORS. THE PHOTOELECTRIC CONTROL SHALL BE OF A SOLID STATE CRYSTAL SENSING TYPE WITH AN INVERTED TURN-ON / TURN-OFF DESIGN.

THE PHOTOELECTRIC CONTROL DEVICE SHALL HAVE A "TURN ON" LEVEL OF 32 LUX AT THE APPROPRIATE VOLTAGE. THE "TURN OFF" LEVEL OF THE CONTROL DEVICE SHALL BE 60% OF THE TURN-ON VALUE.

**5. TIMER**

THE ELECTRONIC TIME SWITCH SHALL BE A PROGRAMMABLE SOLID STATE DIGITAL ELECTRONIC TYPE CAPABLE OF CONTROLLING 2 CIRCUITS INDEPENDENTLY FROM A CENTRAL LOCATION. A MANUAL CONTROL SHALL BE PROVIDED FOR EACH CIRCUIT TO ENABLE SWITCHING EITHER CIRCUIT "ON" OR "OFF".

THE TIME SWITCH SHALL PROVIDE FOR FULL YEAR CONTROL AND PROVIDE THE CAPABILITY OF BEING PROGRAMMED FOR HOLIDAYS BY MONTH AND DATE ASSIGNMENT. A TOTAL OF 320 SET POINTS SHALL BE PROVIDED AND SHALL BE ASSIGNABLE IN ANY COMBINATION TO ON TIMES, OFF TIMES, DAYLIGHT SAVING TIME DATES AND HOLIDAYS. A SOLID STATE CIRCUIT SHALL PROTECT PROGRAM AND TIME OF DAY DATA FOR A MINIMUM OF 24 HOURS.

THE TIME SWITCH IS TO BE POWERED BY A 120 V.A.C.-60 Hz. SOURCE. SWITCH CONFIGURATION TO BE SPDT FOR EACH CIRCUIT WITH A RATING OF 15A UL LISTED. THE TIME SWITCH SHALL BE AN INTERMATIC INC., MODEL ET70215C.

**6. KEY SWITCH**

THE KEY SWITCH SHALL BE MOUNTED ON THE CONTROL STATION ACCESS DOOR. THE SWITCH SHALL BE KEY OPERATED FROM THE EXTERIOR OF THE CABINET. PROVIDE A MINIMUM OF (4) KEYS.

HEAVY DUTY SELECTOR SWITCH, 3 POSITION MAINTAINED-KEY OPERATED: SQUARE D TYPE K, CLASS 9001, ALLEN BRADLEY 800T SERIES OR CUTLER HAMMER 10250T SERIES.

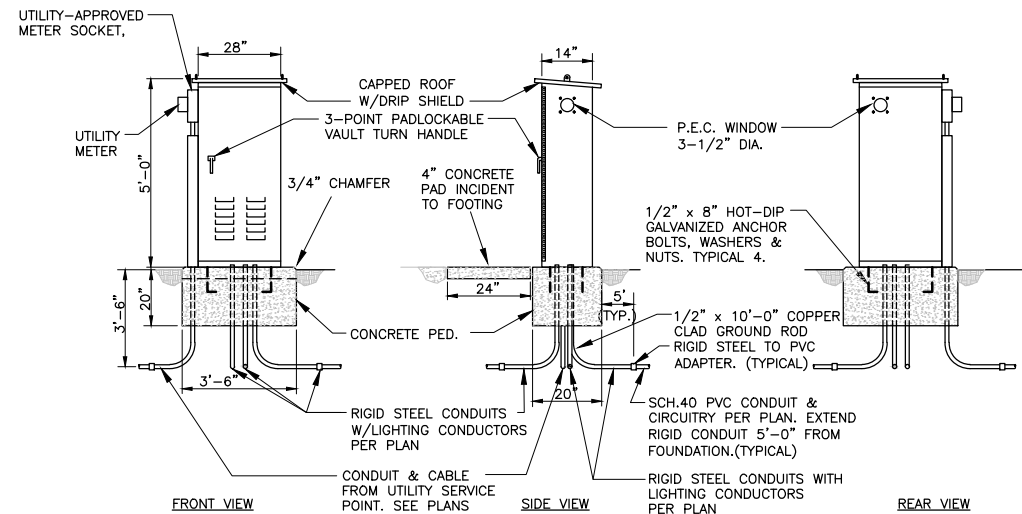

**LIGHTING CONTROL CABINET ELEVATIONS**  
NOT TO SCALE

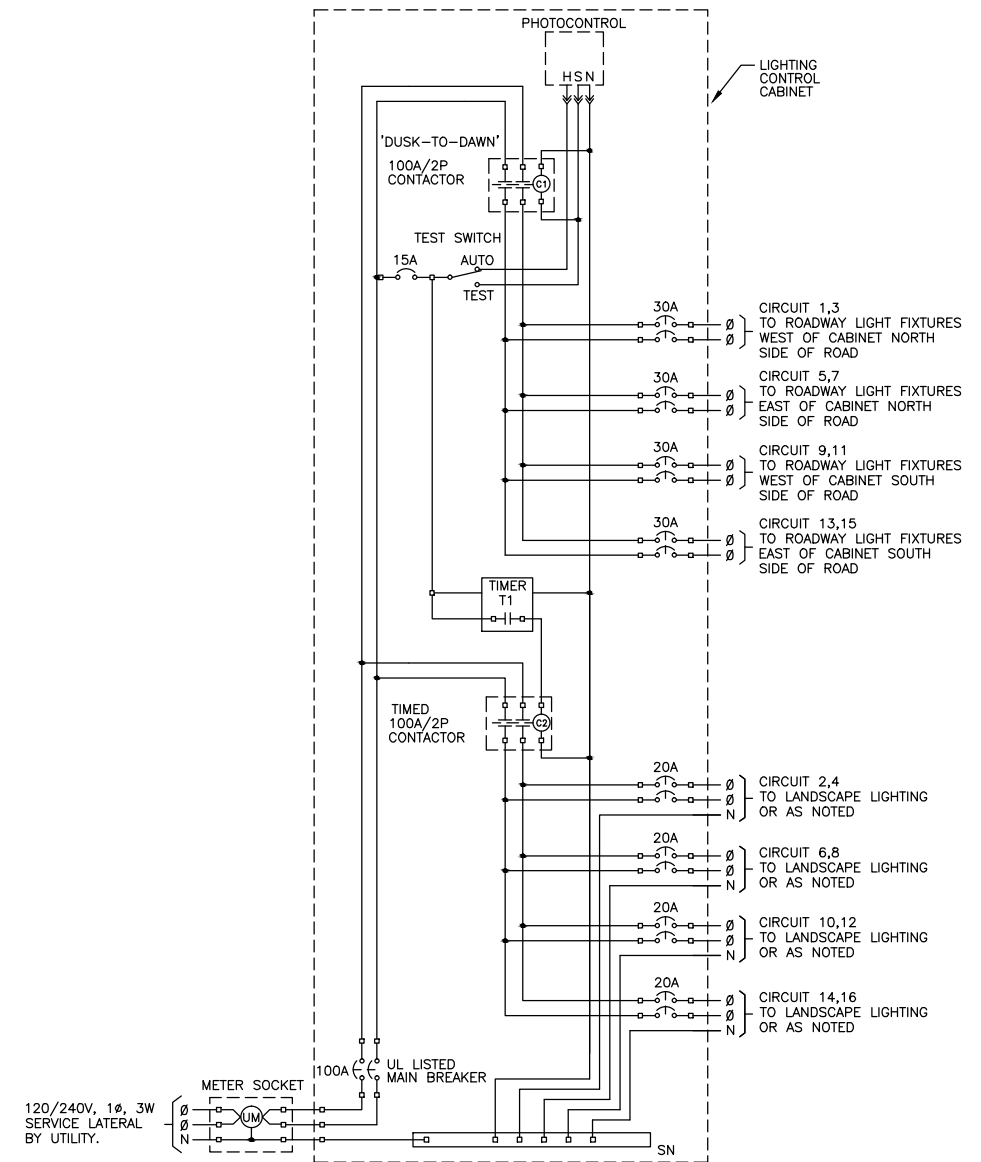

**LIGHTING CONTROL CABINET SCHEMATIC (LC-A, LC-B, LC-C, & LC-D)**  
NOT TO SCALE

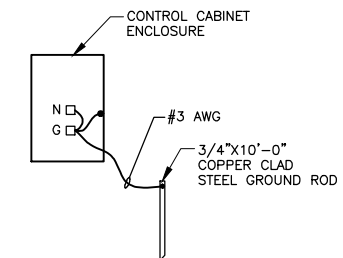

**LIGHTING CONTROL CABINET GROUNDING**  
NOT TO SCALE

TABULATION OF LIGHTING INSTALLATIONS

108-1  
Modified

NO.	LOCATION		TYPE	FOOTING TYPE 1	LIGHTING CONTROLLER	CIRCUIT	REMARKS
	STATION						
1	L	REFER TO 'N' SHEETS	L3	SPECIAL	LC-A	1,3	CAMANCHE AVE
2	L	103+91.08, 30.32 LT	L1	SPECIAL	EXISTING	EXISTING	CAMANCHE AVE
3	L	REFER TO 'N' SHEETS	L3	SPECIAL	LC-A	1,3	CAMANCHE AVE
4	L	105+78.51, 27.00 LT	L2	SPECIAL	LC-A	1,3	CAMANCHE AVE
5	L	107+23.05, 27.00 LT	L1	SPECIAL	LC-A	1,3	CAMANCHE AVE
6	L	108+28.77, 27.00 LT	L2	SPECIAL	LC-A	1,3	CAMANCHE AVE
7	L	109+73.82, 27.00 LT	L1	SPECIAL	LC-A	1,3	CAMANCHE AVE
8	L	110+78.75, 27.00 LT	L2	SPECIAL	LC-A	1,3	CAMANCHE AVE
9	L	112+31.76, 27.00 LT	L1	SPECIAL	LC-A	5,7	CAMANCHE AVE
10	L	113+31.00, 27.00 LT	L2	SPECIAL	LC-A	5,7	CAMANCHE AVE
11	L	114+41.30, 27.00 LT	L1	SPECIAL	LC-A	5,7	CAMANCHE AVE
12	L	115+77.20, 27.00 LT	L2	SPECIAL	LC-A	5,7	CAMANCHE AVE
13	L	116+75.28, 28.00 LT	L1	SPECIAL	LC-A	5,7	CAMANCHE AVE
14	L	117+86.12, 32.45 LT	L2	SPECIAL	LC-A	5,7	CAMANCHE AVE
15	L	119+32.05, 38.25 LT	L1	SPECIAL	LC-A	5,7	CAMANCHE AVE
16	L	120+40.00, 27.00 LT	L2	SPECIAL	LC-A	5,7	CAMANCHE AVE
17	L	121+46.08, 27.00 LT	L1	SPECIAL	LC-B	1,3	CAMANCHE AVE
18	L	122+57.00, 27.00 LT	L2	SPECIAL	LC-B	1,3	CAMANCHE AVE
19	L	123+87.00, 27.00 LT	L2	SPECIAL	LC-B	1,3	CAMANCHE AVE
20	L	125+31.78, 27.00 LT	L1	SPECIAL	LC-B	1,3	CAMANCHE AVE
21	L	126+87.33, 27.00 LT	L2	SPECIAL	LC-B	1,3	CAMANCHE AVE
22	L	127+88.58, 27.00 LT	L1	SPECIAL	LC-B	1,3	CAMANCHE AVE
23	L	128+98.79, 27.00 LT	L1	SPECIAL	LC-B	1,3	CAMANCHE AVE
24	L	130+17.13, 27.00 LT	L2	SPECIAL	LC-B	1,3	CAMANCHE AVE
25	L	131+56.55, 27.00 LT	L1	SPECIAL	LC-B	5,7	CAMANCHE AVE
26	L	132+87.32, 27.00 LT	L2	SPECIAL	LC-B	5,7	CAMANCHE AVE
27	L	133+45.53, 27.00 LT	L1	SPECIAL	LC-B	5,7	CAMANCHE AVE
28	L	134+53.74, 27.00 LT	L1	SPECIAL	LC-B	5,7	CAMANCHE AVE
29	L	135+60.20, 27.00 LT	L2	SPECIAL	LC-B	5,7	CAMANCHE AVE
30	L	137+04.01, 27.00 LT	L1	SPECIAL	LC-B	5,7	CAMANCHE AVE
31	L	138+56.98, 27.00 LT	L2	SPECIAL	LC-B	5,7	CAMANCHE AVE
32	L	139+43.44, 27.00 LT	L1	SPECIAL	LC-B	5,7	CAMANCHE AVE
33	L	140+42.36, 27.00 LT	L1	SPECIAL	LC-B	5,7	CAMANCHE AVE
34	L	141+85.60, 27.00 LT	L2	SPECIAL	LC-C	1,3	CAMANCHE AVE
35	L	143+33.48, 27.00 LT	L1	SPECIAL	LC-C	1,3	CAMANCHE AVE
36	L	144+91.58, 27.00 LT	L2	SPECIAL	LC-C	1,3	CAMANCHE AVE
37	L	145+78.84, 27.00 LT	L1	SPECIAL	LC-C	1,3	CAMANCHE AVE
38	L	146+67.62, 27.00 LT	L1	SPECIAL	LC-C	1,3	CAMANCHE AVE
39	L	147+89.83, 27.00 LT	L2	SPECIAL	LC-C	1,3	CAMANCHE AVE
40	L	148+91.41, 27.00 LT	L1	SPECIAL	LC-C	1,3	CAMANCHE AVE
41	L	150+10.96, 27.00 LT	L1	SPECIAL	LC-C	1,3	CAMANCHE AVE
42	L	150+87.45, 27.00 LT	L2	SPECIAL	LC-C	1,3	CAMANCHE AVE
43	L	152+37.00, 27.00 LT	L1	SPECIAL	LC-C	5,7	CAMANCHE AVE
44	L	153+87.45, 27.00 LT	L2	SPECIAL	LC-C	5,7	CAMANCHE AVE
45	L	155+37.87, 27.00 LT	L1	SPECIAL	LC-C	5,7	CAMANCHE AVE
46	L	156+80.48, 27.00 LT	L2	SPECIAL	LC-C	5,7	CAMANCHE AVE
47	L	157+61.32, 27.00 LT	L1	SPECIAL	LC-C	5,7	CAMANCHE AVE
48	L	158+43.83, 27.00 LT	L1	SPECIAL	LC-C	5,7	CAMANCHE AVE
49	L	159+88.47, 27.00 LT	L2	SPECIAL	LC-C	5,7	CAMANCHE AVE
50	L	160+90.66, 27.00 LT	L1	SPECIAL	LC-C	5,7	CAMANCHE AVE
51	L	161+87.20, 27.00 LT	L1	SPECIAL	LC-D	1,3	CAMANCHE AVE
52	L	162+88.85, 27.00 LT	L2	SPECIAL	LC-D	1,3	CAMANCHE AVE
53	L	163+90.07, 27.00 LT	L1	SPECIAL	LC-D	1,3	CAMANCHE AVE
54	L	165+24.52, 27.00 LT	L1	SPECIAL	LC-D	1,3	CAMANCHE AVE
55	L	166+32.80, 27.00 LT	L2	SPECIAL	LC-D	1,3	CAMANCHE AVE
56	L	167+59.32, 27.00 LT	L1	SPECIAL	LC-D	1,3	CAMANCHE AVE
57	L	168+85.83, 27.00 LT	L2	SPECIAL	LC-D	1,3	CAMANCHE AVE
58	L	169+70.56, 27.00 LT	L1	SPECIAL	LC-D	1,3	CAMANCHE AVE
59	L	170+88.51, 27.00 LT	L1	SPECIAL	LC-D	1,3	CAMANCHE AVE
60	L	172+02.19, 27.00 LT	L2	SPECIAL	LC-D	1,3	CAMANCHE AVE
61	L	173+22.97, 27.00 LT	L1	SPECIAL	LC-D	1,3	CAMANCHE AVE
62	L	174+43.75, 27.00 LT	L2	SPECIAL	LC-D	5,7	CAMANCHE AVE
63	L	175+54.38, 27.00 LT	L1	SPECIAL	LC-D	5,7	CAMANCHE AVE
64	L	176+88.31, 27.00 LT	L1	SPECIAL	LC-D	5,7	CAMANCHE AVE
65	L	177+88.83, 27.00 LT	L2	SPECIAL	LC-D	5,7	CAMANCHE AVE
66	L	178+89.98, 27.00 LT	L1	SPECIAL	LC-D	5,7	CAMANCHE AVE
67	L	180+17.51, 27.00 LT	L1	SPECIAL	LC-D	5,7	CAMANCHE AVE
68	L	181+23.05, 27.00 LT	L2	SPECIAL	LC-D	5,7	CAMANCHE AVE
69	L	182+40.86, 27.00 LT	L1	SPECIAL	LC-D	5,7	CAMANCHE AVE
70	L	183+70.67, 27.00 LT	L2	SPECIAL	LC-D	5,7	CAMANCHE AVE
71	L	184+50.31, 27.00 LT	L4	SPECIAL	EXISTING	EXISTING	EXIST. LTG UNIT TO BE RELOCATED
72	L	185+27.69, 27.00 LT	L4	SPECIAL	EXISTING	EXISTING	EXIST. LTG UNIT TO BE RELOCATED
73	L	186+36.97, 27.00 LT	L5	SPECIAL	EXISTING	EXISTING	EXIST. LTG UNIT TO BE RELOCATED
74	L	129+20.53, 34.00 LT	L1	SPECIAL	LC-B	9,11	23RD PL
75	L	133+64.07, 34.00 LT	L1	SPECIAL	LC-B	13,15	22ND PL
76	L	140+39.91, 34.00 LT	L1	SPECIAL	LC-B	13,15	21ST PL
77	L	152+83.23, 34.00 LT	L1	SPECIAL	LC-C	13,15	17TH PL
78	L	165+49.27, 34.00 LT	L1	SPECIAL	LC-D	9,11	15TH AVE S
79	L	174+64.68, 34.00 LT	L1	SPECIAL	LC-D	13,15	13TH AVE S
80	L	180+35.66, 34.00 LT	L1	SPECIAL	LC-D	13,15	12TH AVE S

TABULATION OF LIGHTING INSTALLATIONS

108-1  
Modified

NO.	LOCATION		TYPE	FOOTING TYPE 1	LIGHTING CONTROLLER	CIRCUIT	REMARKS
	STATION						
1	R	REFER TO 'N' SHEETS	L3	SPECIAL	LC-A	9,11	CAMANCHE AVE
2	R	REFER TO 'N' SHEETS	L3	SPECIAL	LC-A	9,11	CAMANCHE AVE
3	R	105+79.45, 72.00 RT	L1	SPECIAL	LC-A	9,11	CAMANCHE AVE
4	R	106+73.84, 72.00 RT	L2	SPECIAL	LC-A	9,11	CAMANCHE AVE
5	R	108+23.65, 72.00 RT	L1	SPECIAL	LC-A	9,11	CAMANCHE AVE
6	R	109+72.16, 72.00 RT	L2	SPECIAL	LC-A	9,11	CAMANCHE AVE
7	R	110+74.46, 72.00 RT	L1	SPECIAL	LC-A	9,11	CAMANCHE AVE
8	R	111+75.09, 72.00 RT	L2	SPECIAL	LC-A	9,11	CAMANCHE AVE
9	R	112+77.61, 72.00 RT	L1	SPECIAL	LC-A	13,15	CAMANCHE AVE
10	R	114+22.27, 72.00 RT	L2	SPECIAL	LC-A	13,15	CAMANCHE AVE
11	R	115+36.48, 72.00 RT	L1	SPECIAL	LC-A	13,15	CAMANCHE AVE
12	R	116+87.82, 27.00 RT	L2	SPECIAL	LC-A	13,15	LIBERTY AVE
13	R	118+36.63, 27.00 RT	L1	SPECIAL	LC-A	13,15	LIBERTY AVE
14	R	119+85.44, 27.00 RT	L2	SPECIAL	LC-A	13,15	LIBERTY AVE
15	R	122+71.10, 39.00 RT	L4	SPECIAL	EXISTING	EXISTING	EXIST. LTG UNIT TO BE RELOCATED
16	R	123+87.00, 39.00 RT	L1	SPECIAL	LC-B	9,11	CAMANCHE AVE
17	R	125+36.78, 39.00 RT	L2	SPECIAL	LC-B	9,11	CAMANCHE AVE
18	R	126+87.33, 39.00 RT	L1	SPECIAL	LC-B	9,11	CAMANCHE AVE
19	R	128+38.29, 39.00 RT	L2	SPECIAL	LC-B	9,11	CAMANCHE AVE
20	R	129+08.26, 39.00 RT	L1	SPECIAL	LC-B	9,11	CAMANCHE AVE
21	R	130+05.77, 39.00 RT	L1	SPECIAL	LC-B	9,11	CAMANCHE AVE
22	R	131+36.05, 39.00 RT	L2	SPECIAL	LC-B	13,15	CAMANCHE AVE
23	R	132+87.32, 39.00 RT	L1	SPECIAL	LC-B	13,15	CAMANCHE AVE
24	R	133+45.53, 39.00 RT	L1	SPECIAL	LC-B	13,15	CAMANCHE AVE
25	R	134+48.61, 39.00 RT	L2	SPECIAL	LC-B	13,15	CAMANCHE AVE
26	R	136+08.20, 39.00 RT	L1	SPECIAL	LC-B	13,15	CAMANCHE AVE
27	R	137+53.61, 39.00 RT	L2	SPECIAL	LC-B	13,15	CAMANCHE AVE
28	R	139+05.90, 39.00 RT	L1	SPECIAL	LC-B	13,15	CAMANCHE AVE
29	R	140+45.14, 39.00 RT	L2	SPECIAL	LC-B	13,15	CAMANCHE AVE
30	R	141+90.62, 39.00 RT	L1	SPECIAL	LC-C	9,11	CAMANCHE AVE
31	R	143+43.40, 39.00 RT	L2	SPECIAL	LC-C	9,11	CAMANCHE AVE
32	R	144+89.77, 39.00 RT	L1	SPECIAL	LC-C	9,11	CAMANCHE AVE
33	R	146+43.31, 39.00 RT	L2	SPECIAL	LC-C	9,11	CAMANCHE AVE
34	R	147+89.83, 39.00 RT	L1	SPECIAL	LC-C	9,11	CAMANCHE AVE
35	R	149+44.18, 39.00 RT	L2	SPECIAL	LC-C	9,11	CAMANCHE AVE
36	R	150+95.26, 39.00 RT	L1	SPECIAL	LC-C	9,11	CAMANCHE AVE
37	R	152+38.97, 39.00 RT	L2	SPECIAL	LC-C	13,15	CAMANCHE AVE
38	R	153+84.47, 39.00 RT	L1	SPECIAL	LC-C	13,15	CAMANCHE AVE
39	R	155+37.87, 39.00 RT	L2	SPECIAL	LC-C	13,15	CAMANCHE AVE
40	R	156+87.03, 39.00 RT	L1	SPECIAL	LC-C	13,15	CAMANCHE AVE
41	R	158+39.68, 39.00 RT	L2	SPECIAL	LC-C	13,15	CAMANCHE AVE
42	R	159+85.22, 39.00 RT	L1	SPECIAL	LC-C	13,15	CAMANCHE AVE
43	R	161+35.71, 39.00 RT	L2	SPECIAL	LC-C	13,15	CAMANCHE AVE
44	R	162+87.85, 39.00 RT	L1	SPECIAL	LC-D	9,11	CAMANCHE AVE
45	R	164+39.99, 39.00 RT	L2	SPECIAL	LC-D	9,11	CAMANCHE AVE
46	R	165+33.23, 39.00 RT	L1	SPECIAL	LC-D	9,11	CAMANCHE AVE
47	R	166+33.50, 39.00 RT	L1	SPECIAL	LC-D	9,11	CAMANCHE AVE
48	R	167+37.41, 39.00 RT	L2	SPECIAL	LC-D	9,11	CAMANCHE AVE
49	R	168+95.51, 39.00 RT	L1	SPECIAL	LC-D	9,11	CAMANCHE AVE
50	R	170+53.60, 39.00 RT	L2	SPECIAL	LC-D	9,11	CAMANCHE AVE
51	R	172+06.71, 39.00 RT	L1	SPECIAL	LC-D	9,11	CAMANCHE AVE
52	R	173+56.27, 39.00 RT	L2	SPECIAL	LC-D	9,11	CAMANCHE AVE
53	R	174+47.95, 39.00 RT	L1	SPECIAL	LC-D	13,15	CAMANCHE AVE
54	R	175+49.30, 39.00 RT	L1	SPECIAL	LC-D	13,15	CAMANCHE AVE
55	R	176+38.80, 39.00 RT	L2	SPECIAL	LC-D	13,15	CAMANCHE AVE
56	R	177+88.83, 39.00 RT	L1	SPECIAL	LC-D	13,15	CAMANCHE AVE
57	R	179+37.71, 39.00 RT	L2	SPECIAL	LC-D	13,15	CAMANCHE AVE
58	R	180+22.17, 39.00 RT	L1	SPECIAL	LC-D	13,15	CAMANCHE AVE
59	R	181+18.38, 39.00 RT	L1	SPECIAL	LC-D	13,15	CAMANCHE AVE
60	R	182+37.42, 39.00 RT	L2	SPECIAL	LC-D	13,15	CAMANCHE AVE
61	R	183+70.67, 39.00 RT	L1	SPECIAL	LC-D	13,15	CAMANCHE AVE
62	R	185+03.92, 39.00 RT	L5	SPECIAL	EXISTING	EXISTING	EXIST. LTG UNIT TO BE RELOCATED
63	R	185+80.27, 39.00 RT	L4	SPECIAL	EXISTING	EXISTING	EXIST. LTG UNIT TO BE RELOCATED
64	R	129+88.90, 34.00 RT	L1	SPECIAL	LC-B	9,11	23RD PL
65	R	134+31.46, 34.00 RT	L1	SPECIAL	LC-B	13,15	22ND PL
66	R	141+08.38, 34.00 RT	L1	SPECIAL	LC-C	9,11	21ST PL
67	R	153+53.35, 37.60 RT	L1	SPECIAL	LC-C	13,15	17TH PL
68	R	166+16.74, 34.00 RT	L1	SPECIAL	LC-D	9,11	15TH AVE S
69	R	175+32.74, 34.00 RT	L1	SPECIAL	LC-D	13,15	13TH AVE S
70	R	181+03.72, 34.00 RT	L1	SPECIAL	LC-D	13,15	12TH AVE S

CIRCUIT SCHEDULE									
LIGHTING CONTROLLER: LC-A VOLTAGE: 120/240, 1Ø, 3W.									
DESCRIPTION	KW	AMP TRIP	POLE	CCT. NO.	CCT. NO.	POLE	AMP TRIP	KW	DESCRIPTION
NW ROADWAY LIGHTING	1.9	30	2	1	2	2	20		SPARE
-	-	30	-	3	4	-	20		-
NE ROADWAY LIGHTING	1.9	30	2	5	6	2	20		SPARE
-	-	30	-	7	8	-	20		-
SW ROADWAY LIGHTING	2.1	30	2	9	10	2	20		SPARE
-	-	30	-	11	12	-	20		-
SE ROADWAY LIGHTING	1.5	30	2	13	14				
-	-	30	-	15	16				
SPARE		30	2	17	18				
-		30	-	19	20				

CIRCUIT SCHEDULE									
LIGHTING CONTROLLER: LC-B VOLTAGE: 120/240, 1Ø, 3W.									
DESCRIPTION	KW	AMP TRIP	POLE	CCT. NO.	CCT. NO.	POLE	AMP TRIP	KW	DESCRIPTION
NW ROADWAY LIGHTING	1.9	30	2	1	2	2	20		LANDSCAPE FEATURE SW
-	-	30	-	3	4	-	20		-
NE ROADWAY LIGHTING	2.0	30	2	5	6	2	20		LANDSCAPE FEATURE SE
-	-	30	-	7	8	-	20		-
SW ROADWAY LIGHTING	1.7	30	2	9	10	2	20		SPARE
-	-	30	-	11	12	-	20		-
SE ROADWAY LIGHTING	2.5	30	2	13	14	2	20		SPARE
-	-	30	-	15	16	-	20		-
SPARE		30	2	17	18				
-		30	-	19	20				

CIRCUIT SCHEDULE									
LIGHTING CONTROLLER: LC-C VOLTAGE: 120/240, 1Ø, 3W.									
DESCRIPTION	KW	AMP TRIP	POLE	CCT. NO.	CCT. NO.	POLE	AMP TRIP	KW	DESCRIPTION
NW ROADWAY LIGHTING	2.1	30	2	1	2	2	20		LANDSCAPE FEATURE SW
-	-	30	-	3	4	-	20		-
NE ROADWAY LIGHTING	1.8	30	2	5	6	2	20		SPARE
-	-	30	-	7	8	-	20		-
SW ROADWAY LIGHTING	1.8	30	2	9	10	2	20		LANDSCAPE FEATURE SE
-	-	30	-	11	12	-	20		-
SE ROADWAY LIGHTING	2.1	30	2	13	14	2	20		SPARE
-	-	30	-	15	16	-	20		-
SPARE		30	2	17	18				
-		30	-	19	20				

CIRCUIT SCHEDULE									
LIGHTING CONTROLLER: LC-D VOLTAGE: 120/240, 1Ø, 3W.									
DESCRIPTION	KW	AMP TRIP	POLE	CCT. NO.	CCT. NO.	POLE	AMP TRIP	KW	DESCRIPTION
NW ROADWAY LIGHTING	2.4	30	2	1	2	2	20		LANDSCAPE FEATURE SW
-	-	30	-	3	4	-	20		-
NE ROADWAY LIGHTING	2.1	30	2	5	6	2	20		SPARE
-	-	30	-	7	8	-	20		-
SW ROADWAY LIGHTING	2.5	30	2	9	10	2	20		LANDSCAPE FEATURE SE
-	-	30	-	11	12	-	20		-
SE ROADWAY LIGHTING	2.7	30	2	13	14	2	20		SPARE
-	-	30	-	15	16	-	20		-
SPARE	1.0	30	2	17	18				
-	-	30	-	19	20				

TABULATION OF WIRE, CABLE AND CONNECTORS																							
CIRCUIT NUMBER	RM-40 CONNECTORS								PHASE AND NEUTRAL LINES								GROUND				REMARKS		
	TYPE	QUAN. NO.	TYPE	QUAN. NO.	TYPE	QUAN. NO.	TYPE	QUAN. NO.	SIZE A.W.G.	QUAN. L.F.	SIZE A.W.G.	QUAN. L.F.	SIZE A.W.G.	QUAN. L.F.	SIZE A.W.G.	QUAN. L.F.	SIZE A.W.G.	QUAN. L.F.	SIZE A.W.G.	QUAN. L.F.			
EXIST-1	L1	2	Y2	2																6	184	1 LIGHTING UNIT, EXISTING CIRCUIT	
EXIST-2																				6	80	LIGHTING POWER TO TRAFFIC SIGNAL CABINET , EXISTING CIRCUIT	
EXIST-3																				6	1054	LIGHTING POWER TO RELOCATED LIGHTS , EXISTING CIRCUIT	
EXIST-4																				6	94	LIGHTING UNIT 15R TO EXISTING HANDHOLE	
SERV LAT																				3	288	FOUR(4) SERVICE LATERALS RUNS	
LC-A 1,3	L1	14	Y2	14					4	1416									4	708	NW ROADWAY LIGHTING CKT. 7 LIGHTING UNITS		
LC-A 5,7	L1	16	Y2	16					4	1772									4	886	NE ROADWAY LIGHTING CKT. 8 LIGHTING UNITS		
LC-A 9,11	L1	16	Y2	16					4	1884									4	942	SW ROADWAY LIGHTING CKT. 8 LIGHTING UNITS		
LC-A 13,15	L1	18	Y2	18					4	1538									4	769	SE ROADWAY LIGHTING CKT. 9 LIGHTING UNITS		
LC-B 1,3	L1	16	Y2	16					4	2196									4	1098	NW ROADWAY LIGHTING CKT. 8 LIGHTING UNITS		
LC-B 5,7	L1	18	Y2	18					4	1948									4	974	NE ROADWAY LIGHTING CKT. 9 LIGHTING UNITS		
LC-B 9,11	L1	16	Y2	16					4	1930									4	965	SW ROADWAY LIGHTING CKT. 8 LIGHTING UNITS		
LC-B 13,15	L1	22	Y2	22					4	3074									4	1537	SE ROADWAY LIGHTING CKT. 11 LIGHTING UNITS		
LC-B 2,4							Y3	4											6	666	SW LANDSCAPE CKT. 6 CONCRETE COLUMNS(2 STRUCTURES)		
LC-B 6,8							Y3	6											6	3369	SE LANDSCAPE CKT. 6 CONCRETE COLUMNS(2 STRUCTURES), 3 PERGOLA COLUMNS(1 STRUCTURE)		
LC-C 1,3	L1	18	Y2	18					4	2300									4	1150	NW ROADWAY LIGHTING CKT. 9 LIGHTING UNITS		
LC-C 5,7	L1	16	Y2	16					4	1862									4	931	NE ROADWAY LIGHTING CKT. 8 LIGHTING UNITS		
LC-C 9,11	L1	16	Y2	16					4	3106									4	1553	SW ROADWAY LIGHTING CKT. 8 LIGHTING UNITS		
LC-C 13,15	L1	18	Y2	18					4	2766									4	1383	SE ROADWAY LIGHTING CKT. 9 LIGHTING UNITS		
LC-C 2,4							Y3	2											6	3072	SE LANDSCAPE CKT. 3 PERGOLA COLUMNS(1 STRUCTURE)		
LC-C 10,12							Y3	4											6	1068	SW LANDSCAPE CKT. 6 PERGOLA COLUMNS(2 STRUCTURES)		
LC-D 1,3	L1	22	Y2	22					4	2756									4	1378	NW ROADWAY LIGHTING CKT. 11 LIGHTING UNITS		
LC-D 5,7	L1	18	Y2	18					4	2030									4	1015	NE ROADWAY LIGHTING CKT. 9 LIGHTING UNITS		
LC-D 9,11	L1	22	Y2	22					4	2518									4	1259	SW ROADWAY LIGHTING CKT. 11 LIGHTING UNITS		
LC-D 13,15	L1	26	Y2	26					4	3744									4	1872	SE ROADWAY LIGHTING CKT. 13 LIGHTING UNITS		
LD-D 2,4							Y3	4											6	2973	SW LANDSCAPE CKT. 6 PERGOLA COLUMNS(2 STRUCTURES)		
LC-D 10,12							Y3	8											6	2700	SE LANDSCAPE CKT. 6 COLUMNS(2 STRUCTURES), 6 PERGOLA COLUMNS(2 STRUCTURES)		
CROSSINGS									4	650									4	325	CAMANCHE CROSSINGS(4)		
TOTAL	L1	294	Y2	294	Y3	28			4	37490	6	15444	3	288					4	18745	6	838	

LANDSCAPE LIGHTING BID ITEM COMPONENT TABULATION

BID ITEM	PROJ QTY	TYPE	DESCRIPTION	UNITS	FF-1	FF-2	FF-3	LED TYPE 1	LED TYPE 2	C-14	C-8 TEE	MTG CLIPS	CONV CONN	1.6A CONV	4.0 A CONV	JB-1	JB-2	JB-3	JB-4	JB-5	WIRE NUTS	GFCI-1	WFIU-1
PERGOLA COLUMNS	24																						
		FF-3	FLUSH-MOUNTED FLOOD	EA			1																
		JB-2	SQUARE JUNCTION BOXES LOCATED BACK OF BASES	EA													1						
		LED TYPE 2	12 V FLEX. ROPE LED, 2.5 FT. LENGTH IN EACH BASE	FT				2.75															
		ACC.	C14 - CHANNEL	FT					2.75														
		ACC.	C8 - T CONNECTOR	EA						1													
		ACC.	C-12 MOUNTING CLIPS	EA							3												
		ACC.	POWER TO LED CONVERSION CONNECTOR	EA									1										
		ACC.	LED DRIVER	EA											1								
		JB-5	ONE GANG BOX (CENTER COLUMNS ONLY)	EA																	1		
		ACC.	DUPLEX GFCI RECEPTACLE (CENTER COLUMNS ONLY)	EA																		1	
		ACC.	NON-METALLIC WEATHERPROOF-WHILE-IN-USE COVER (CENTER COLUMNS ONLY)	EA																			1
			SUBTOTALS	EA	0	0	24	0	66	66	24	72	24	0	24	0	24	0	0	0	8	0	8
CONCRETE COLUMNS	18																						
		JB-2	SQUARE JUNCTION BOXES LOCATED BACK OF STONES	EA																			
		LED TYPE 2	12 V FLEXIBLE ROPE LED, SHORT LENGTH IN EACH STONE	FT				2.75															
		ACC.	C14 - CHANNEL	FT					2.75														
		ACC.	C8 - T CONNECTOR	EA						1													
		ACC.	C-12 MOUNTING CLIPS	EA							3												
		ACC.	POWER TO LED CONVERSION CONNECTOR	EA									1										
		ACC.	LED DRIVER	EA											1								
			SUBTOTALS	EA	0	0	0	0	50	50	18	54	18	18	0	0	18	0	0	0	0	0	0

TABULATION OF ELECTRICAL DUCTS				
LOCATION	CONDUIT TYPE	DIA. Inches	LENGTH Feet	REMARKS
TRANSFORMER TO LC-A	GRS	2"	20	SERVICE LATERAL BY UTILITY
TRANSFORMER TO LC-B	GRS	2"	20	SERVICE LATERAL BY UTILITY
TRANSFORMER TO LC-C	GRS	2"	20	SERVICE LATERAL BY UTILITY
TRANSFORMER TO LC-D	GRS	2"	20	SERVICE LATERAL BY UTILITY
LC-A CAMANCHE AVE CROSSING	SCH 80 PVC	3	106	
LC-B CAMANCHE AVE CROSSING	SCH 80 PVC	3	73	
LC-C CAMANCHE AVE CROSSING	SCH 80 PVC	3	73	
LC-D CAMANCHE AVE CROSSING	SCH 80 PVC	3	73	
EXIST-1	SCH 40 PVC	2	184	EXTENSION OF EXISTING CIRCUIT TO NEW LIGHTING UNIT
EXIST-2	SCH 40 PVC	2	40	EXTEND EXISTING CIRCUIT TO NEW TRAFFIC HH
EXIST-3	SCH 40 PVC	2	527	REPLACE EXISTING CIRCUITS TO RELOCATED LIGHTS
EXIST-4	SCH 40 PVC	2	47	LIGHTING CIRCUIT FROM 15R TO HH
LC-A NORTH-WEST CIRCUIT	SCH 40 PVC	2	708	
LC-A NORTH-EAST CIRCUIT	SCH 40 PVC	2	886	
LC-A SOUTH-WEST CIRCUIT	SCH 40 PVC	2	942	
LC-A SOUTH-EAST CIRCUIT	SCH 40 PVC	2	769	
LC-B NORTH-WEST CIRCUIT	SCH 40 PVC	2	1098	
LC-B NORTH-EAST CIRCUIT	SCH 40 PVC	2	974	
LC-B SOUTH-WEST CIRCUIT	SCH 40 PVC	2	965	
LC-B SOUTH-EAST CIRCUIT	SCH 40 PVC	2	1537	
LC-C NORTH-WEST CIRCUIT	SCH 40 PVC	2	1150	
LC-C NORTH-EAST CIRCUIT	SCH 40 PVC	2	931	
LC-C SOUTH-WEST CIRCUIT	SCH 40 PVC	2	1553	
LC-C SOUTH-EAST CIRCUIT	SCH 40 PVC	2	1383	
LC-D NORTH-WEST CIRCUIT	SCH 40 PVC	2	1378	
LC-D NORTH-EAST CIRCUIT	SCH 40 PVC	2	1015	
LC-D SOUTH-WEST CIRCUIT	SCH 40 PVC	2	1259	
LC-D SOUTH-EAST CIRCUIT	SCH 40 PVC	2	1872	
TOTAL			19623	

- NOTES:
- QUANTITIES SHOWN ON THIS TABULATION ARE FOR ASSISTANCE IN THE BIDDING PROCESS, AND ARE CONSIDERED INCIDENTAL TO THE BID ITEMS LISTED HEREIN.
  - CONDUIT AND WIRE FROM HANDHOLE TO LANDSCAPE STRUCTURES ARE INCLUDED IN THE LANDSCAPE BID ITEM.
  - QUANTITIES SHOWN ARE APPROXIMATE. DEPENDING ON WHICH LIGHTING MANUFACTURER IS CHOSEN; QUANTITIES, PHYSICAL DIMENSIONS, AND MOUNTING SCHEMES MAY VARY. QUANTITY VARIANCES WILL NOT BE GROUNDS FOR ADDITIONAL PAYMENT.

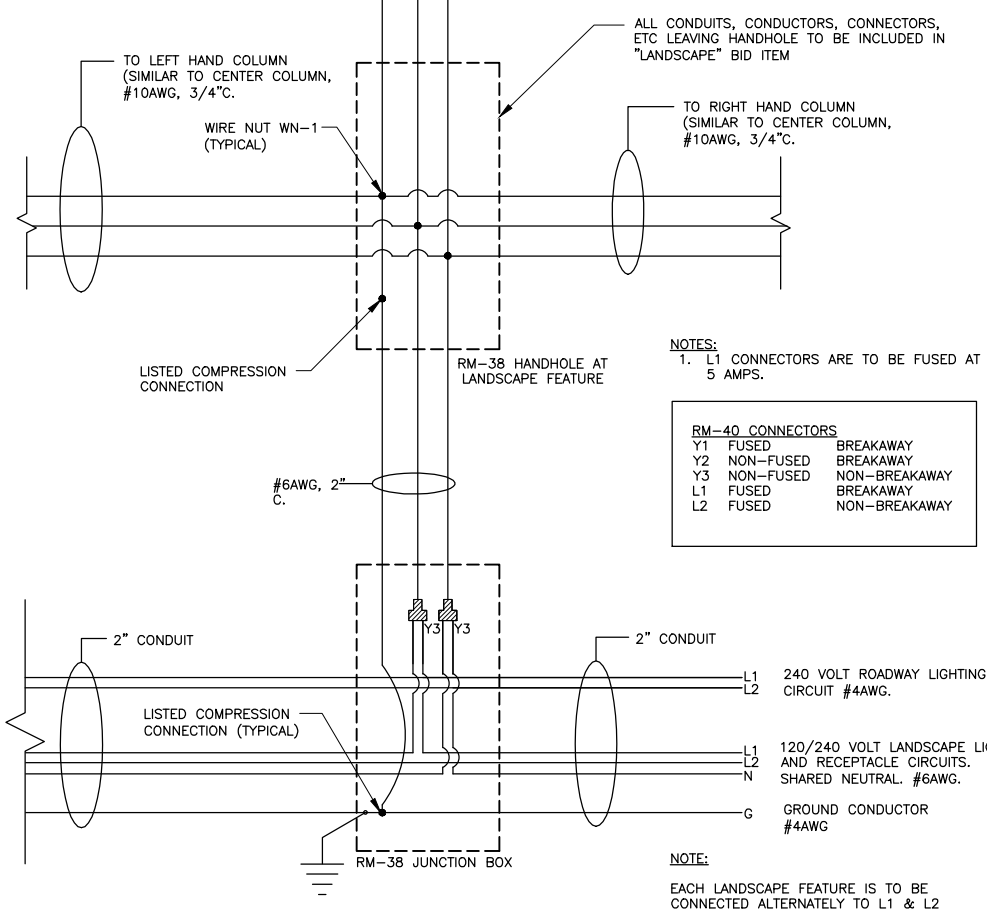
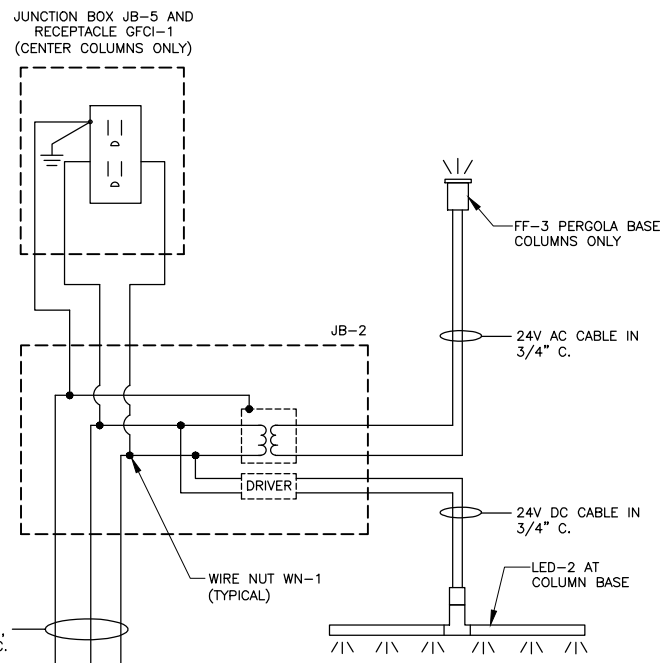

**4 TYPICAL LANDSCAPE PERGOLA COLUMN LIGHTING CIRCUIT SCHEMATIC**  
SCALE: NOT TO SCALE

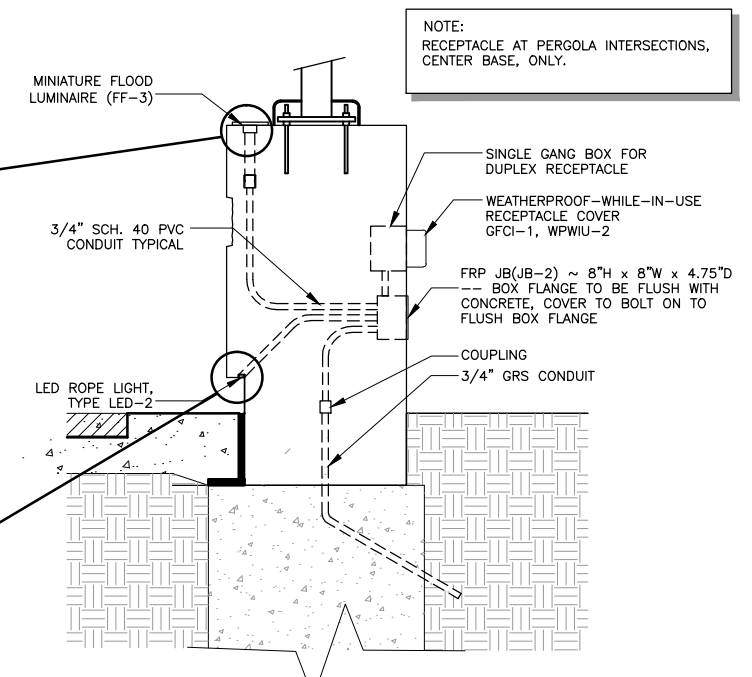
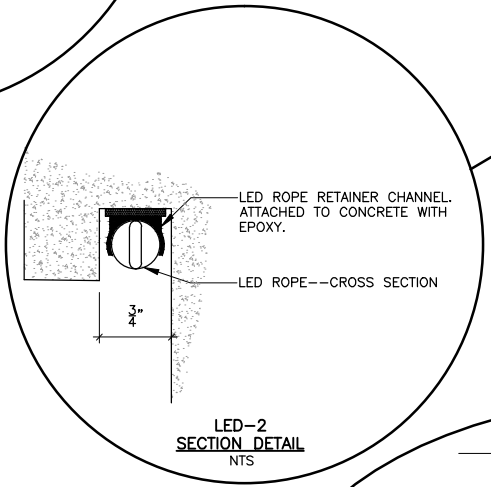
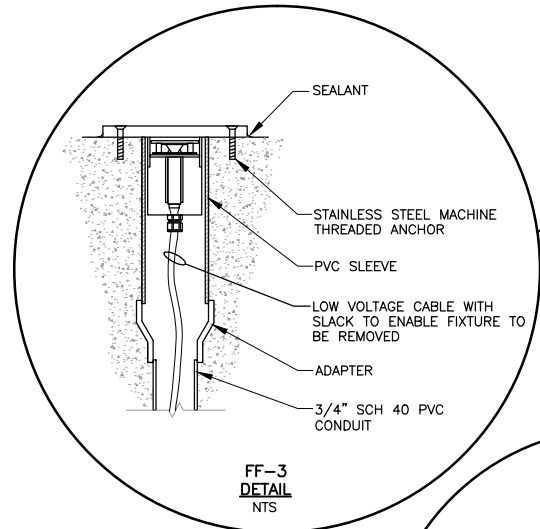
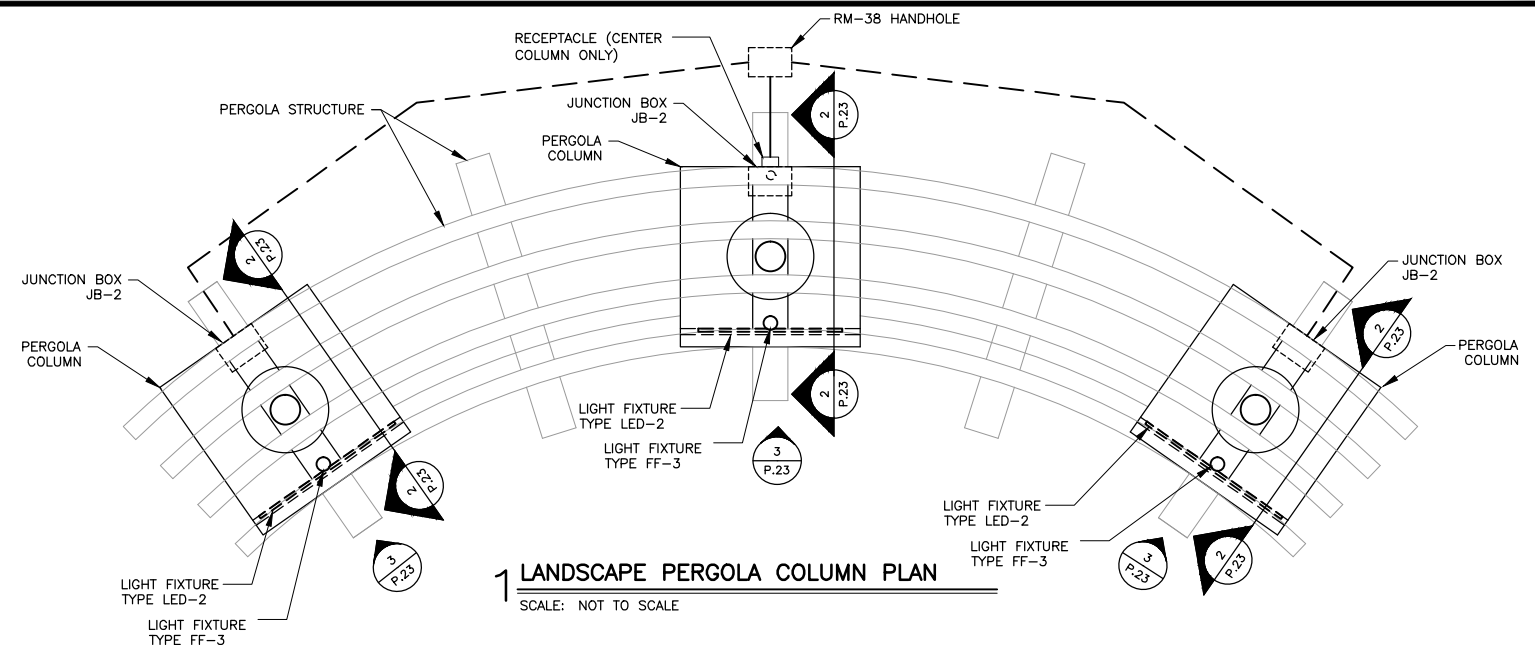

**2 PERGOLA COLUMN SECTION**  
SCALE: NOT TO SCALE

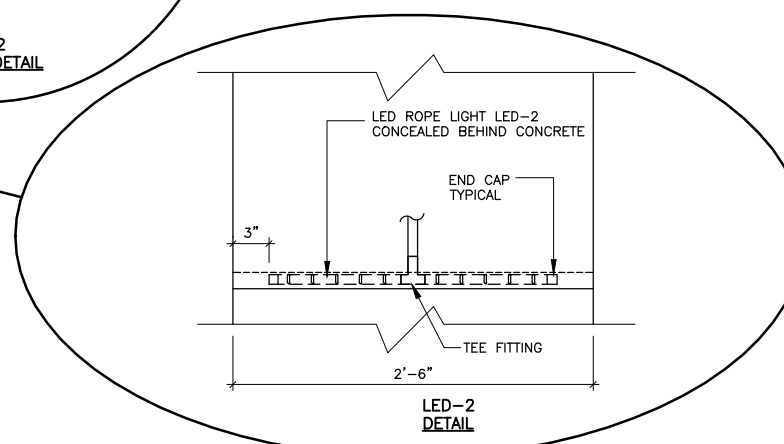
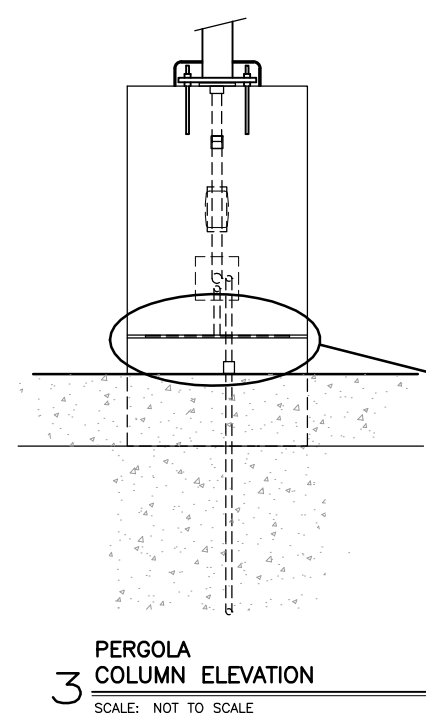

- LED-2 INSTALLATION NOTES**
1. INSTALL PER MANUFACTURER'S INSTRUCTIONS
  2. CUT LED ROPE LIGHT ONLY AT DESIGNATED CUT MARKS (3" O.C.)
  3. ROUGH-IN CONDUIT FOR LED-2 TO BE ON CENTERLINE OF COLUMN TO ENSURE SYMMETRICAL LIGHT DISTRIBUTION.

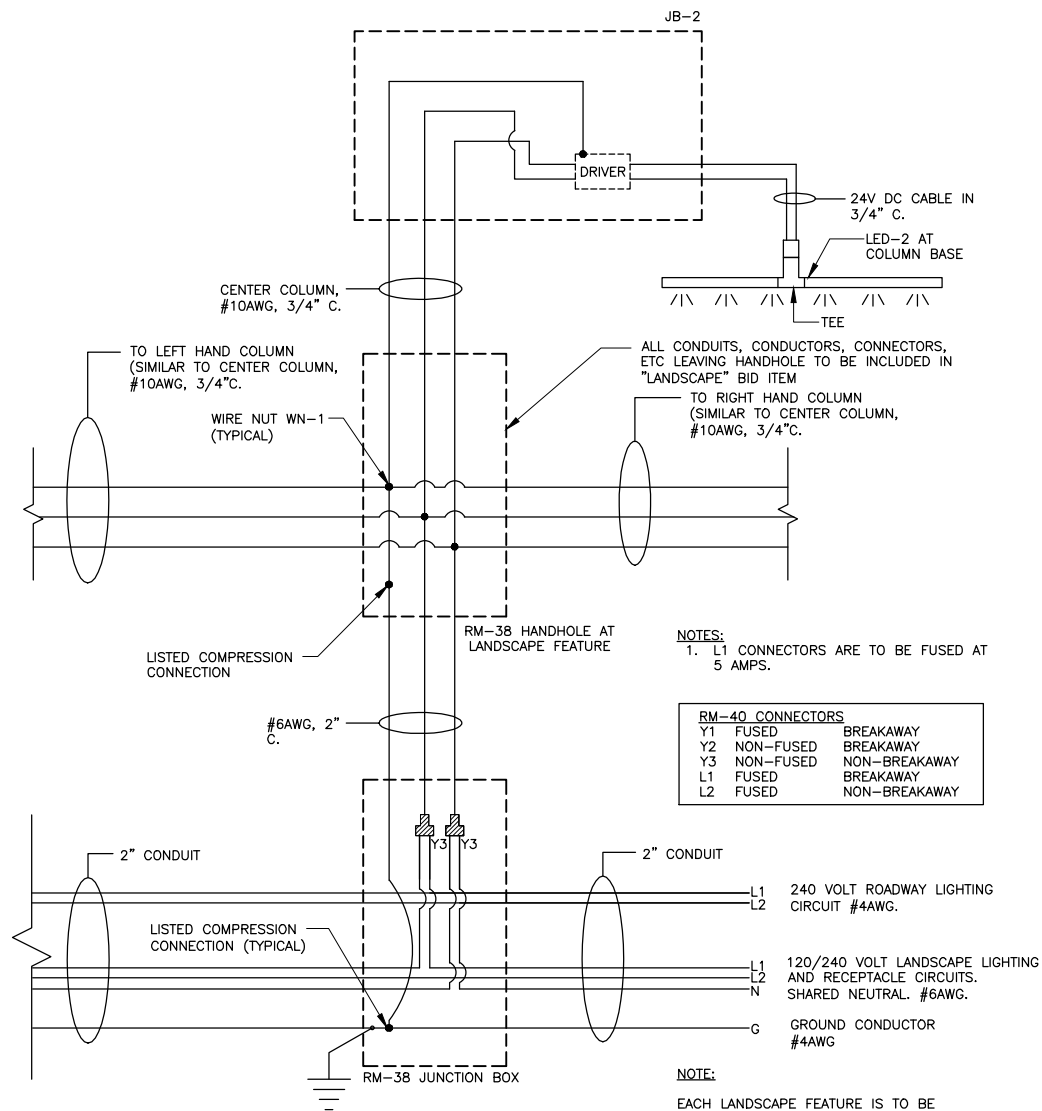

NOTES:  
1. L1 CONNECTORS ARE TO BE FUSED AT 5 AMPS.

RM-40 CONNECTORS	
Y1 FUSED	BREAKAWAY
Y2 NON-FUSED	BREAKAWAY
Y3 NON-FUSED	NON-BREAKAWAY
L1 FUSED	BREAKAWAY
L2 FUSED	NON-BREAKAWAY

NOTE:  
EACH LANDSCAPE FEATURE IS TO BE CONNECTED ALTERNATELY TO L1 & L2

**4 TYPICAL LANDSCAPE CONCRETE COLUMN LIGHTING CIRCUIT SCHEMATIC**  
SCALE: NOT TO SCALE

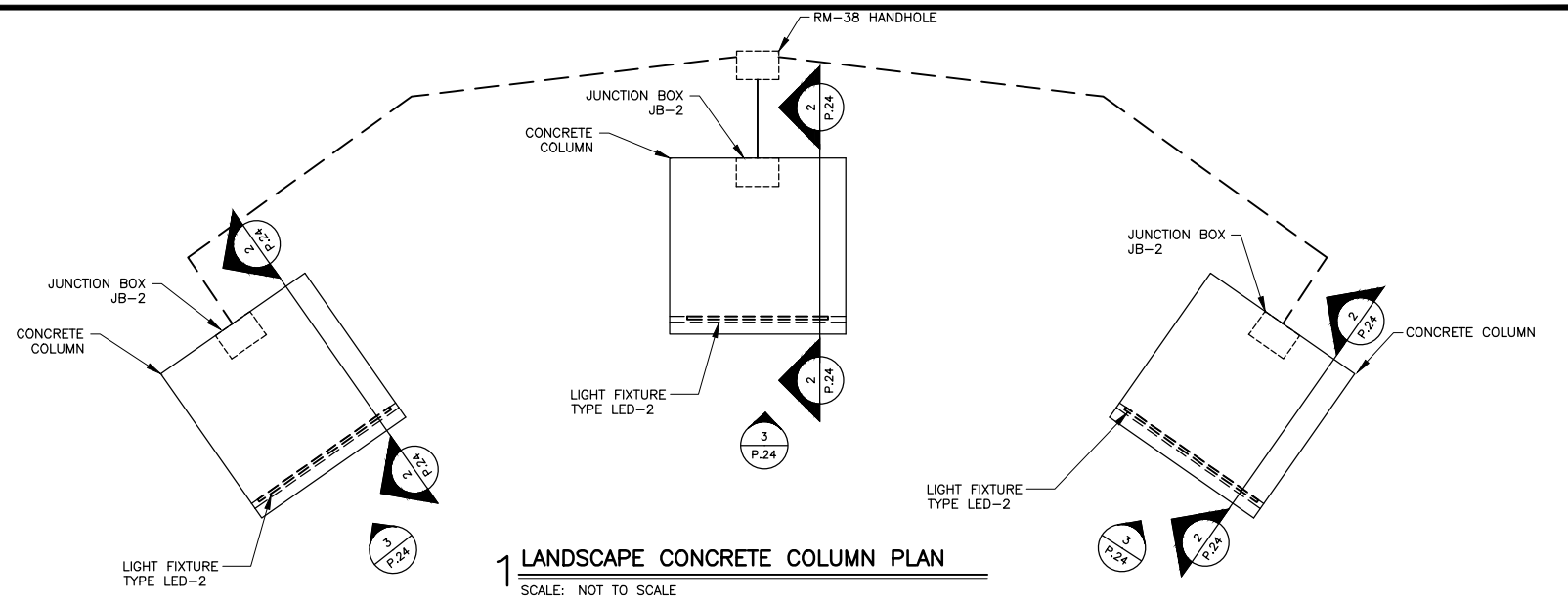

**1 LANDSCAPE CONCRETE COLUMN PLAN**  
SCALE: NOT TO SCALE

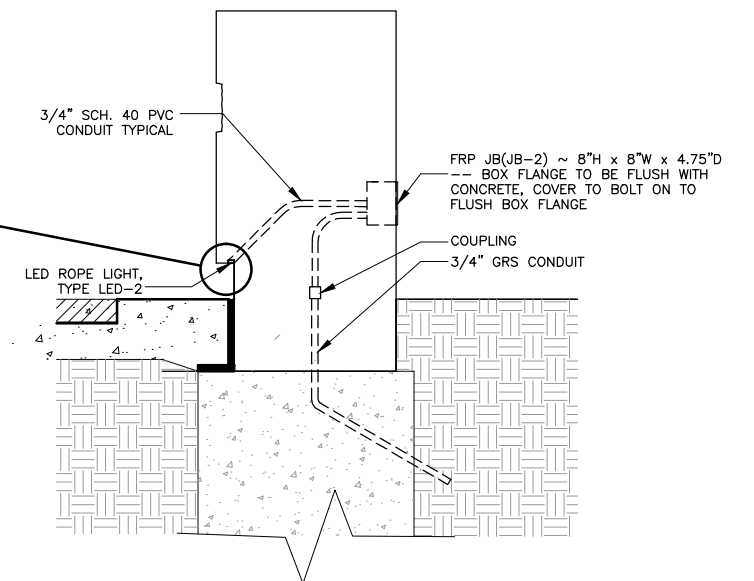
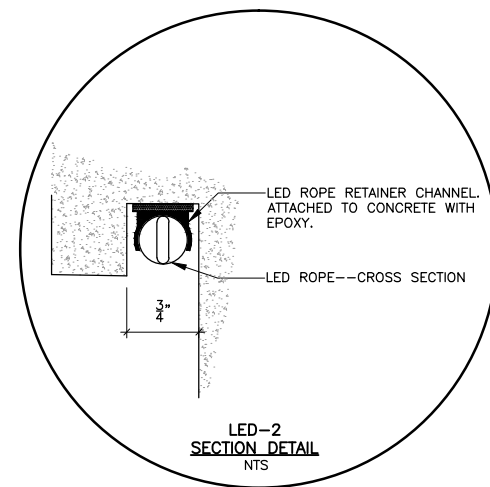

**2 CONCRETE COLUMN SECTION**  
SCALE: NOT TO SCALE

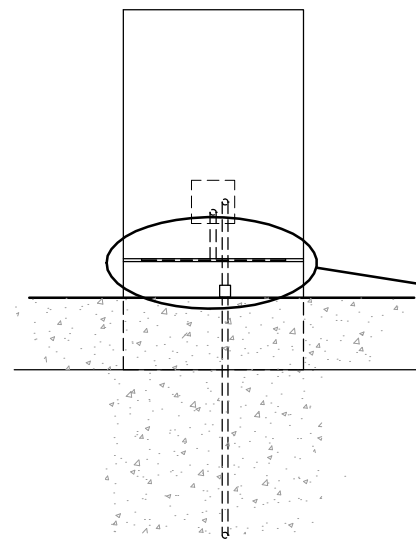

**3 CONCRETE COLUMN ELEVATION**  
SCALE: NOT TO SCALE

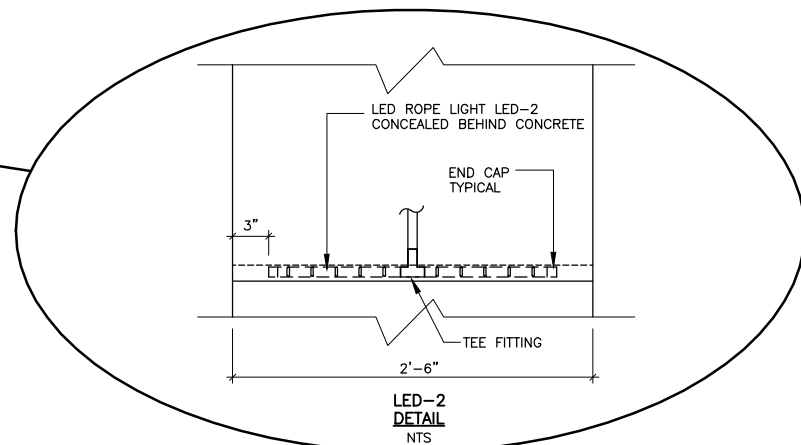

- LED-2 INSTALLATION NOTES**
1. INSTALL PER MANUFACTURER'S INSTRUCTIONS
  2. CUT LED ROPE LIGHT ONLY AT DESIGNATED CUT MARKS (3" O.C.)
  3. ROUGH-IN CONDUIT FOR LED-2 TO BE ON CENTERLINE OF COLUMN TO ENSURE SYMMETRICAL LIGHT DISTRIBUTION.

LANDSCAPE LIGHTING COMPONENT SCHEDULE									
TYPE	DESCRIPTION	CONFIGURATION NOTES	LAMPS	VOLTS	WATTS	UNITS	REQUIRED RATINGS	ADDITIONAL REQUIREMENTS AND OR ACCESSORIES	ACCEPTABLE MFRS
FF-1	NOT USED	N/A	OMIT						
FF-2	NOT USED	N/A	OMIT						
FF-3	FLANGE-MOUNTED FLOOD LIGHT TYPE 3	CONSTRUCTION: BRASS, 2-1/4" OD MAX. OPTICS: MEDIUM FLOOD, RECTILINEAR LENS LAMP: 8W LED, 3K FINISH: POWDER COAT BRONZE LENS: CLEAR	BASE: N/A TYPE: LED, 3000K	12	8	EACH	WET LOCATION	BK LIGHTING BRASS LED UPLIGHT, 50,000 HOUR, L70 RATED, 12V POWER SOURCE	BK LIGHTING: SERIES B-GD-LED-E22-MFL-BZ-P-13 NO SUBSTITUTIONS
LED-1	NOT USED	N/A	N/A	-	-	-	N/A		
LED-2	LED "ROPE" TYPE 2	ENCASED IN FLEXIBLE TRANSLUCENT TUBING COLOR: BLUE	BASE: N/A TYPE: LED	12	1.0	/LF	MAX LENGTH = 23'	LED ROPE FIELD CUTS ALLOWED, EVERY 3", INCLUDES: "T" CONNECTOR, C14 ADHESIVE-BACKED MOUNTING CHANNEL, POWER TO LED CONVERSION CONNECTOR, LED DRIVER, 12VDC OUTPUT	BL INNOVATIVE LIGHTING: LED 12V SERIES
JB-1	NOT USED	N/A	OMIT						
JB-2	CAST-IN-CONCRETE RECTANGULAR JUNCTION BOX	CAST BOX IN COLUMNS' BACK SIDE; BOX SIDES TO BE FLUSH WITH CONCRETE AND ALLOW COVER TO BE FASTENED DOWN WITHOUT INTERFERENCE OF COLUMNS' CONCRETE SURFACE.	N/A	N/A	N/A	EACH	NEMA 4X	ENCLOSURE TO BE FIBER REINFORCED POLYESTER, COVER TO BE FASTENED WITH 4 STAINLESS STEEL SCREWS OVERALL ROUGH OUTSIDE DIMENSIONS 8"H x 8"W x 5"D. PROVIDE PANEL TO MOUNT TRANSFORMERS AND/OR DRIVERS. NOTE: COORDINATE ENCLOSURE DIMENSIONS WITH LED MFR. REQUIRED POWER SUPPLIES -- ALL LED POWER SUPPLIES/CONVERTERS MUST FIT INSIDE THESE JUNCTION BOXES.	ALLIED MOULDED PRODUCTS: #AMU1084F HOFFMAN: #A1066JFGR STAHLIN: #CL907W
JB-3	NOT USED	N/A	OMIT						
JB-4	NOT USED	N/A	OMIT						
JB-5	CAST-IN-CONCRETE RECTANGULAR JUNCTION BOX	1-GANG BOX, 3/4" PVC CONDUIT CONNECTORS TO HOUSE GFCI-1 WITH WPWIU-1 COVER.	N/A	N/A	N/A	EACH	STANDARD	ENCLOSURE TO BE CONSTRUCTED OF PVC APPROXIMATELY 2" x 4" INSIDE DIMENSIONS EQUIVALENT TO 1 "GANG" SIZE BOX. MUST BE ABLE TO MOUNT WEATHERPROOF-WHILE-IN-USE COVER AND SEAL TO THE BOX FLANGE WITHOUT INTERFERENCE FROM CONCRETE SURFACE.	CARLON HUBBELL WIREMOLD
GFCI-1	DUPLEX GFI EQUIPPED RECEPTACLE	NEMA 5-20R,5MA GFCI W/ MANUAL TEST & RESET BUTTON ON FACE	N/A	120	N/A	EACH	UL 498 WEATHER RESISTANT	CENTER BASE OF PERGOLAS -- SEE PLAN DETAILS AND SCHEDULES	PASS & SEYMOUR #2095 SERIES LEVITON #6899 SERIES BRYANT #GF53 SERIES
WPWIU-1	WEATHER-PROOF-WHILE-IN USE GFCI RECEPTACLE COVERS	TRANSPARENT POLYCARBONATE WITH PAD LOCKABLE FEATURE	N/A	N/A	N/A	EACH	NEMA 3R	CENTER BASE OF PERGOLAS -- SEE PLAN DETAILS AND SCHEDULES	APPLETON #WCIU1 O-Z GEDNEY # WCIU1 HUBBELL #WP826MHP
WN-1	WIRE NUTS	MUST CONTAIN INTEGRAL SILICONE SEAL IN EACH INDIVIDUAL WIRE NUT	N/A	600	N/A	EACH	UL 486D DIRECT BURIAL	FOR ALL WIRE NUTS UTILIZED TO INTERCONNECT LUMINAIRES, RECEPTACLES, AND ACCESSORIES	IDEAL INDUSTRIES, UNDERGROUND WIRE CONNECTOR, MODELS 60,64,66 NO SUBSTITUTIONS



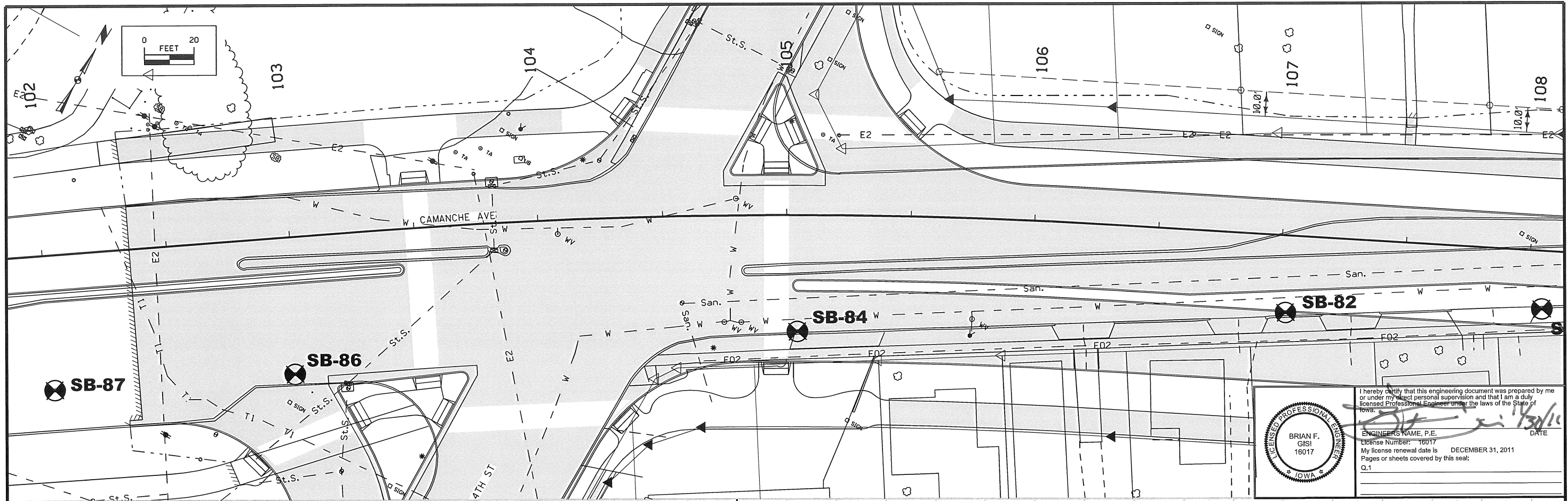

I hereby certify that this engineering document was prepared by me or under my direct personal supervision and that I am a duly licensed Professional Engineer under the laws of the State of Iowa.

ENGINEER'S NAME, P.E. *Brian F. Gisi* DATE *1/30/11*  
 License Number: 16017  
 My license renewal date is DECEMBER 31, 2011  
 Pages or sheets covered by this seal: Q.1

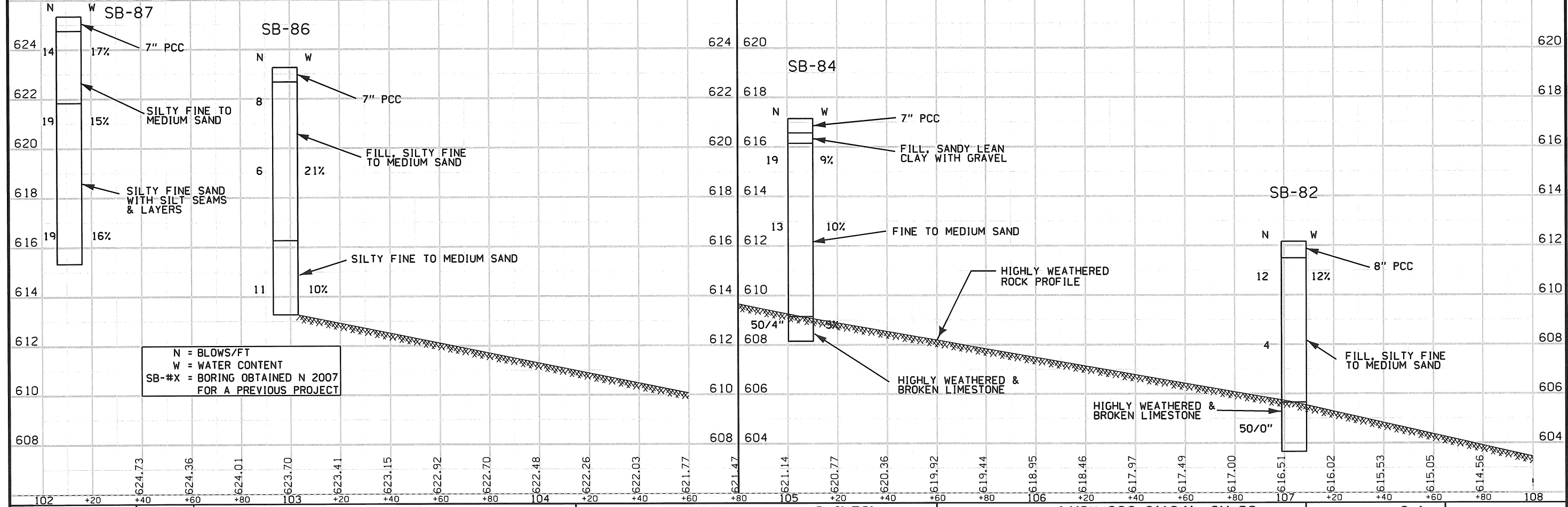

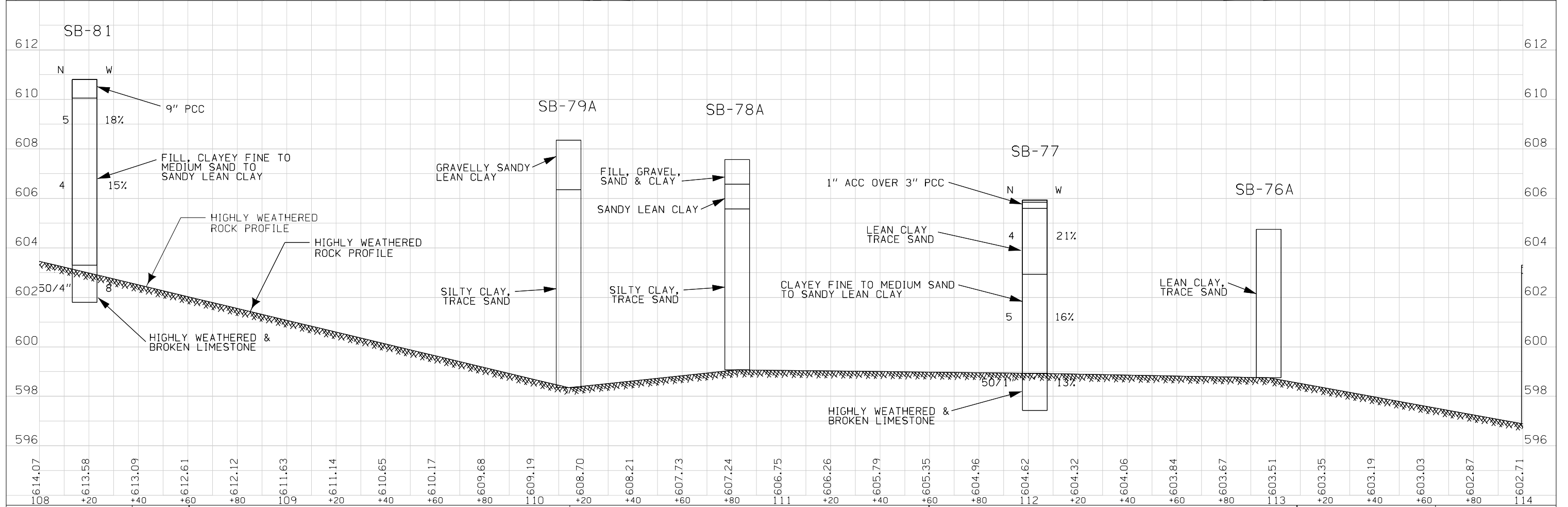

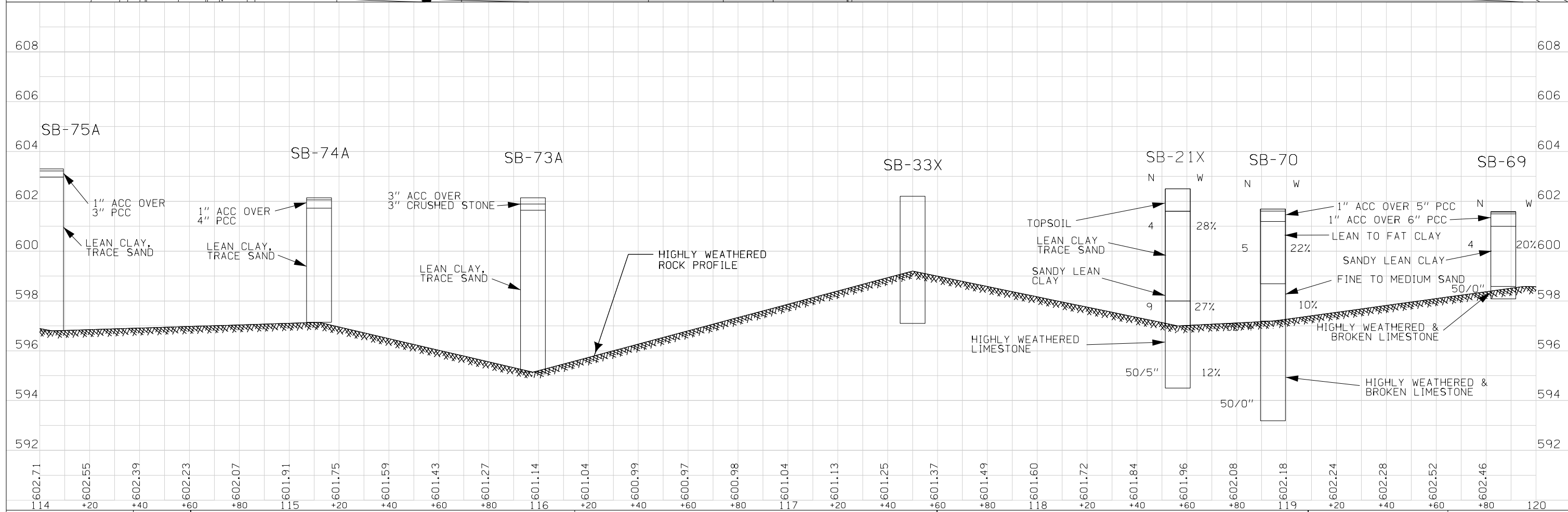
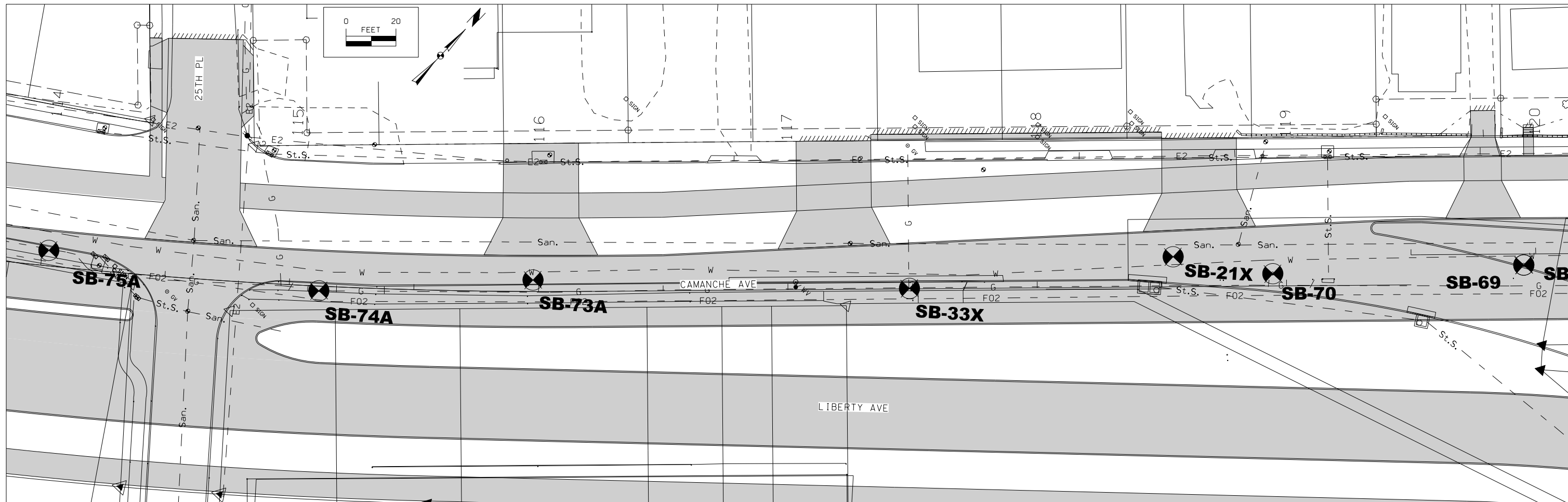

602.71	602.55	602.39	602.23	602.07	601.91	601.75	601.59	601.43	601.27	601.14	601.04	600.99	600.97	600.98	601.04	601.13	601.25	601.37	601.49	601.60	601.72	601.84	601.96	602.08	602.18	602.24	602.28	602.52	602.46	
114	+20	+40	+60	+80	115	+20	+40	+60	+80	116	+20	+40	+60	+80	117	+20	+40	+60	+80	118	+20	+40	+60	+80	119	+20	+40	+60	+80	120

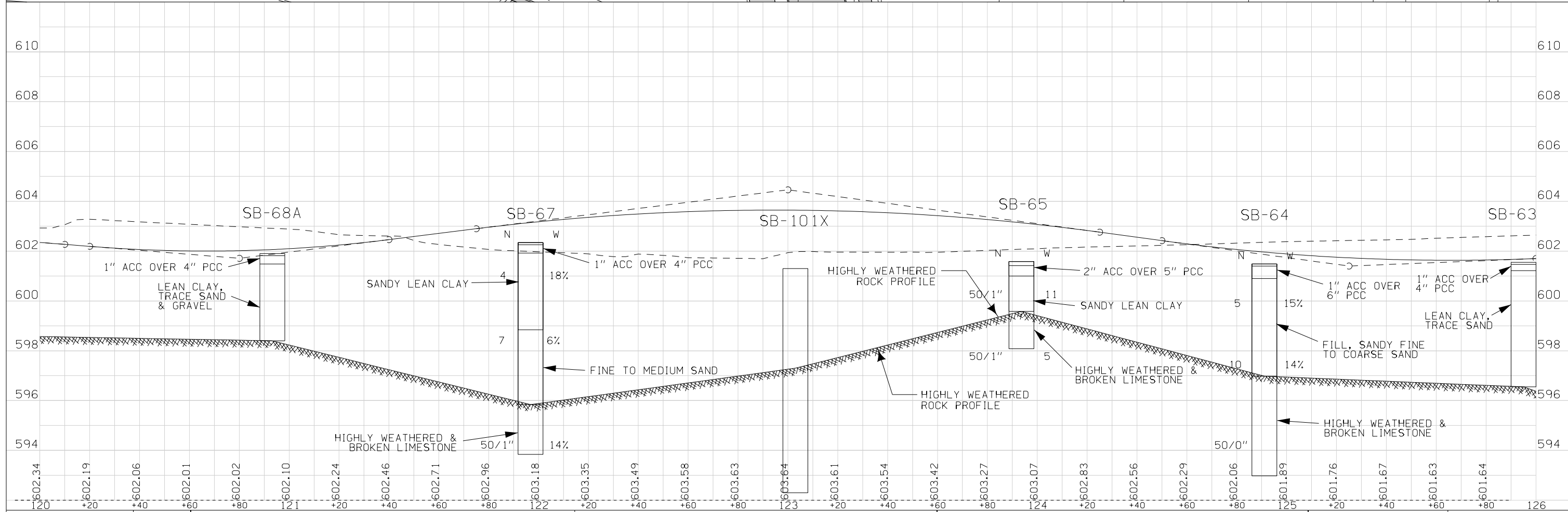
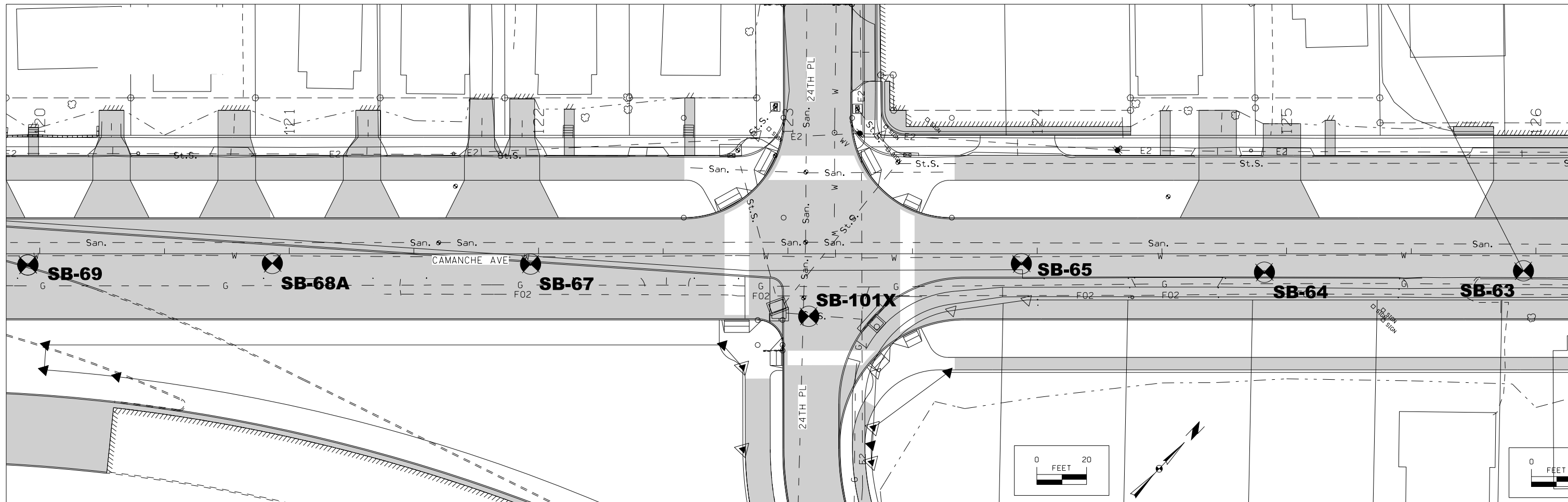

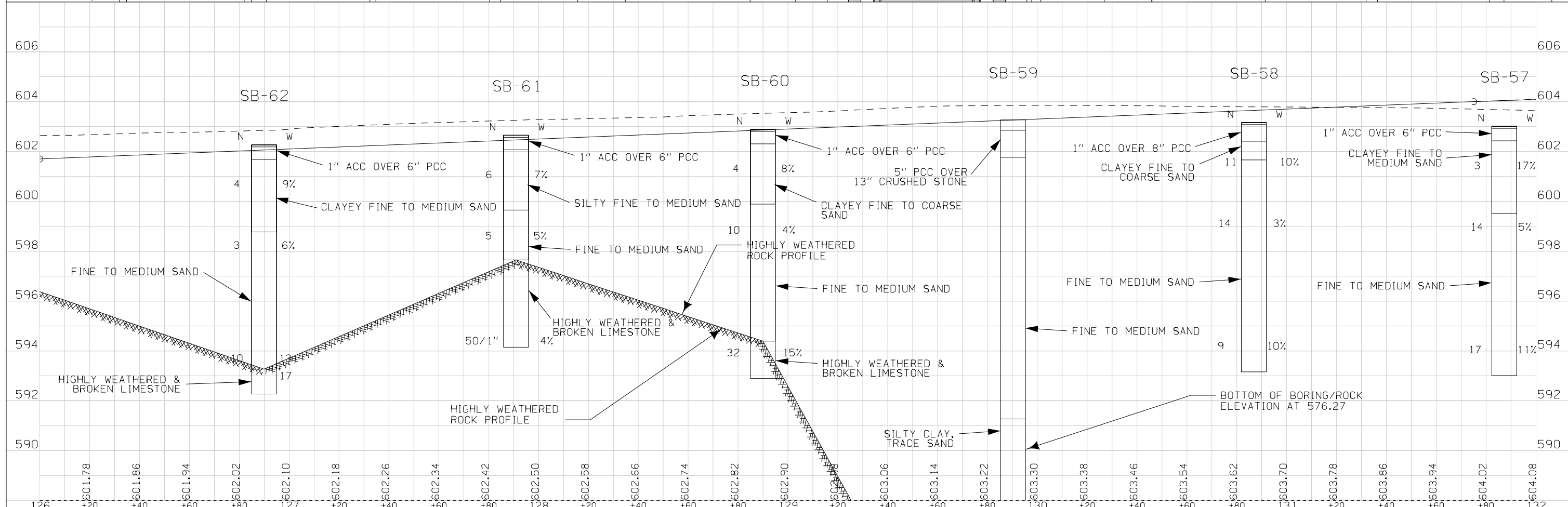
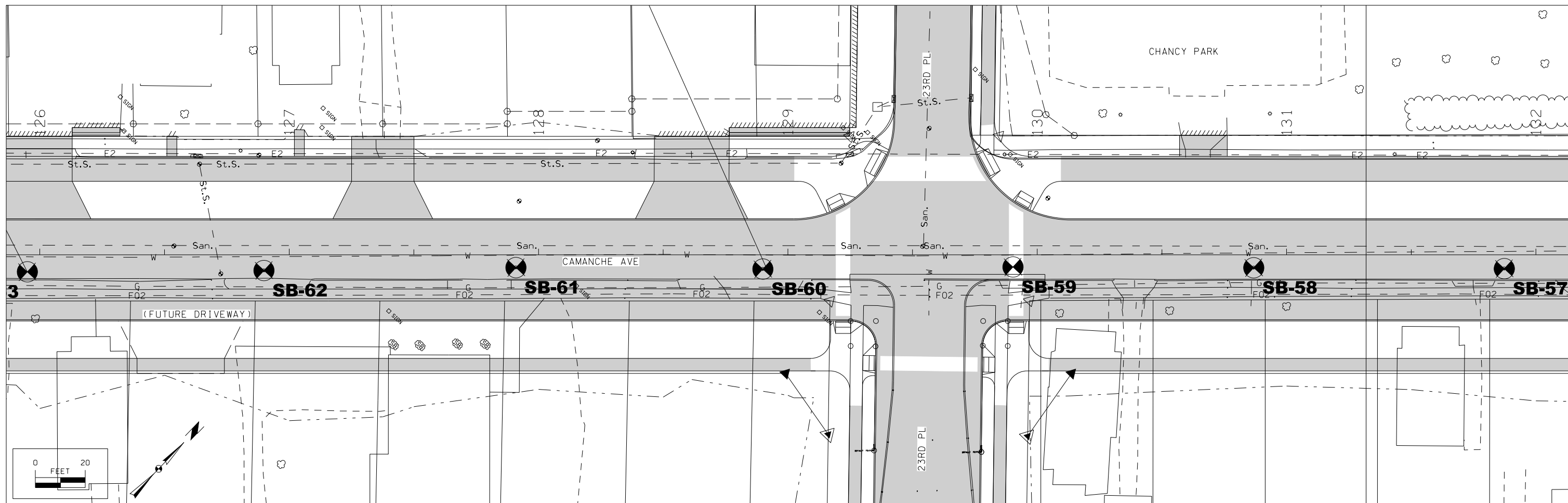

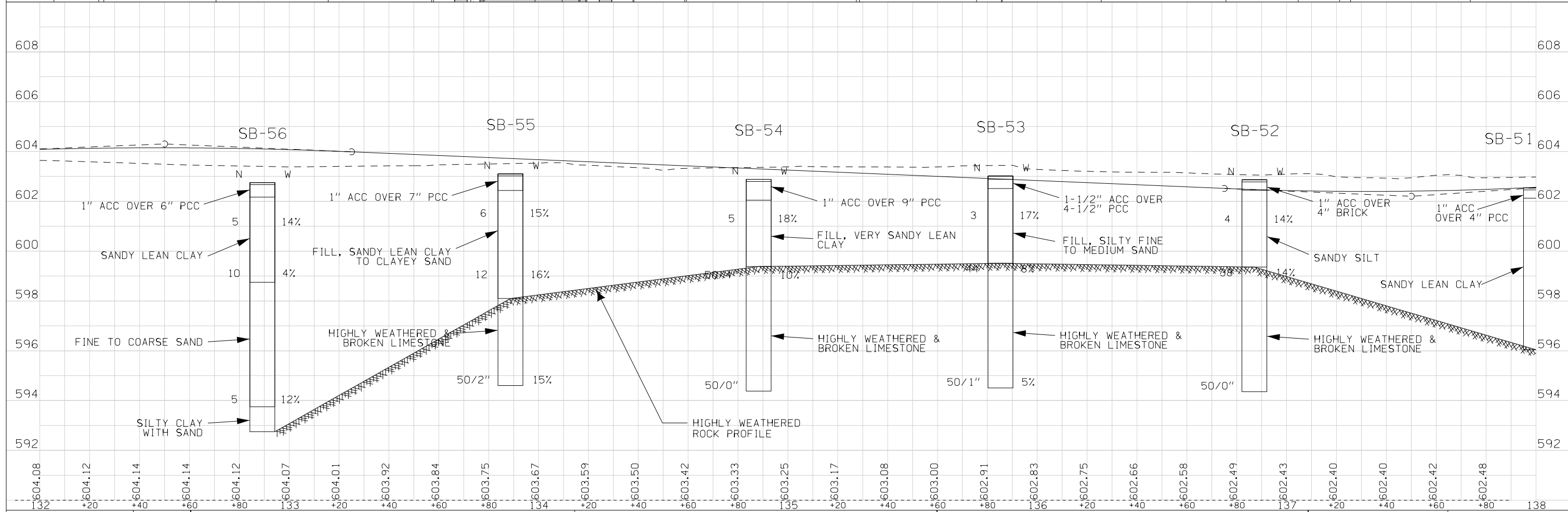
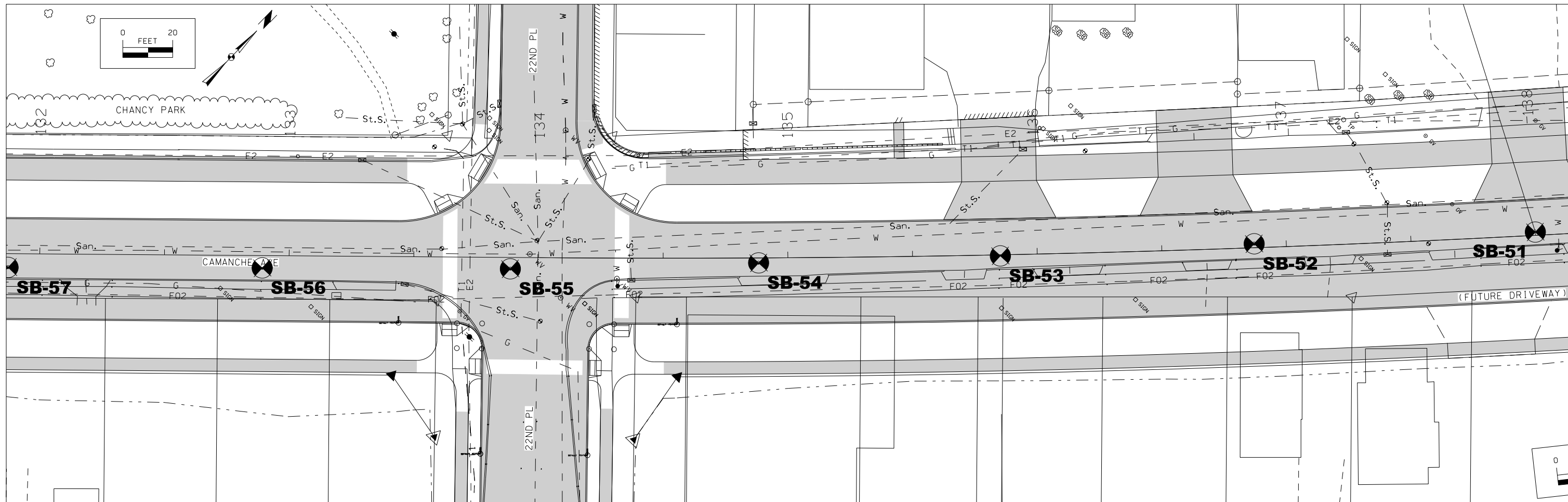



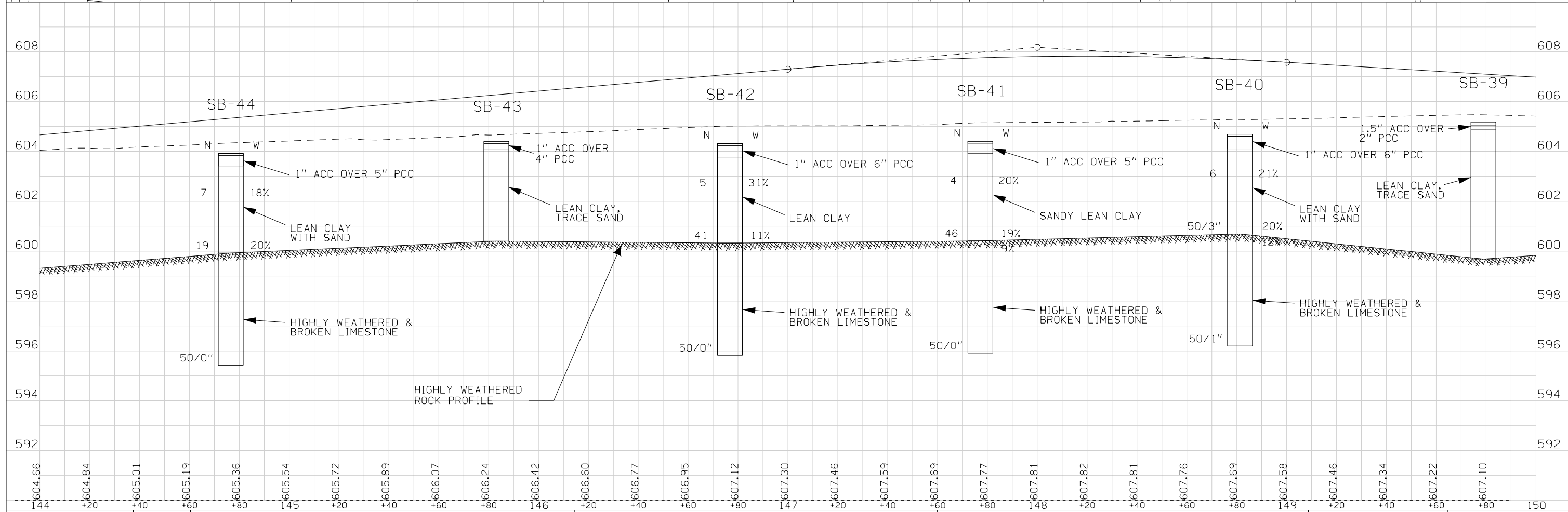
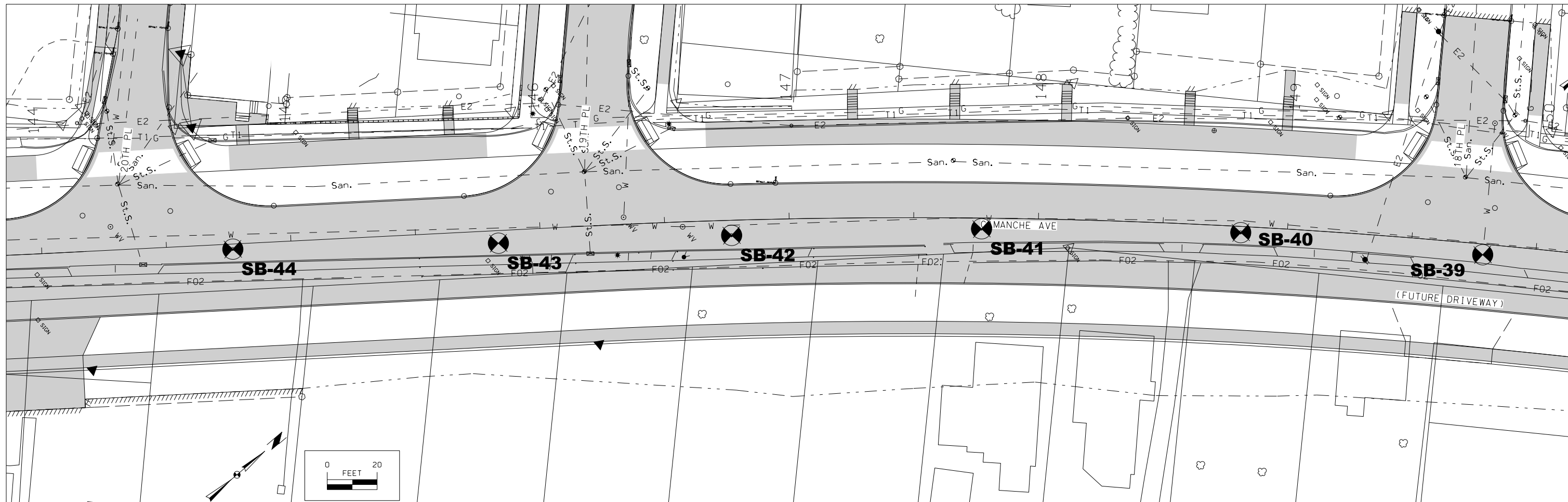



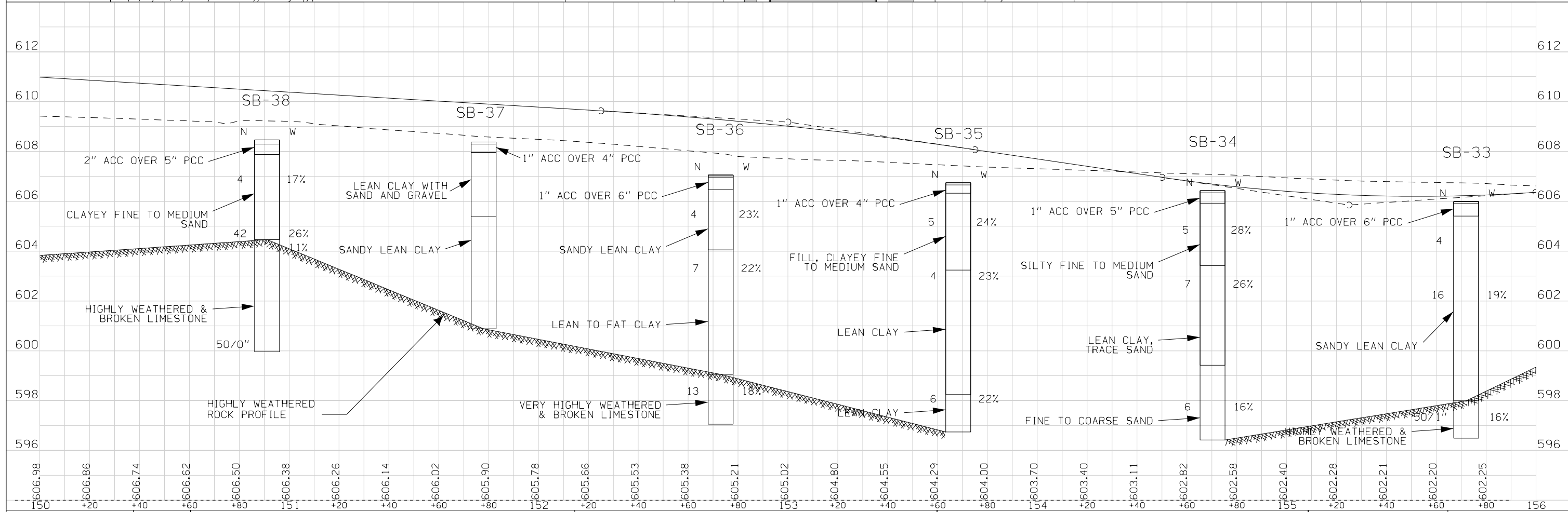
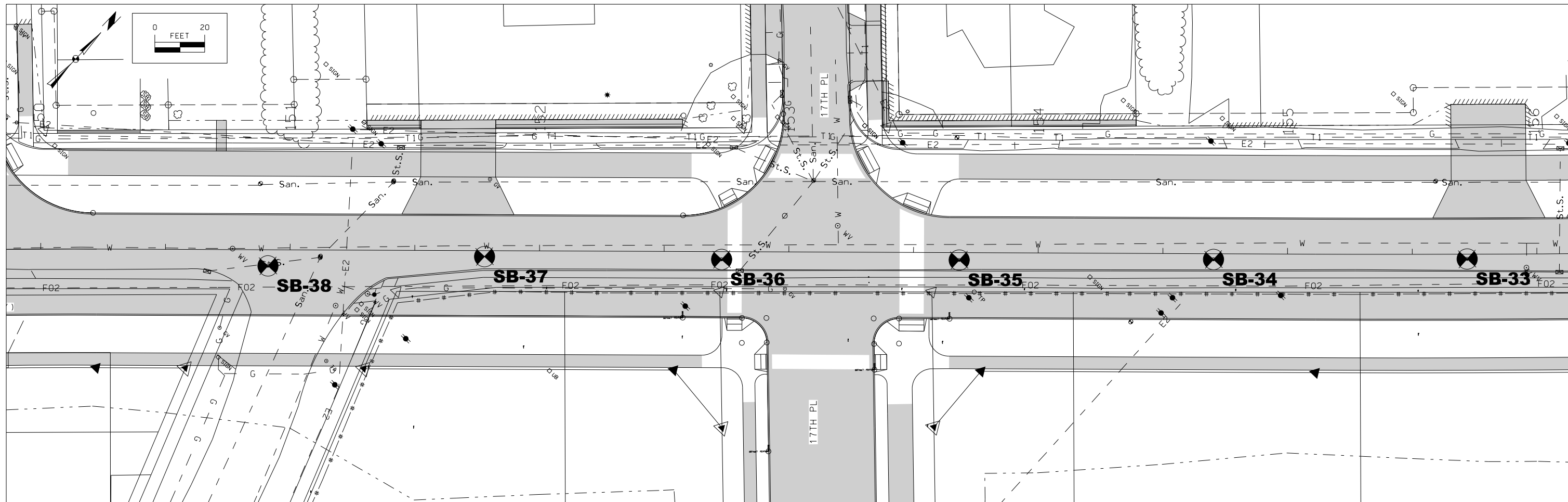

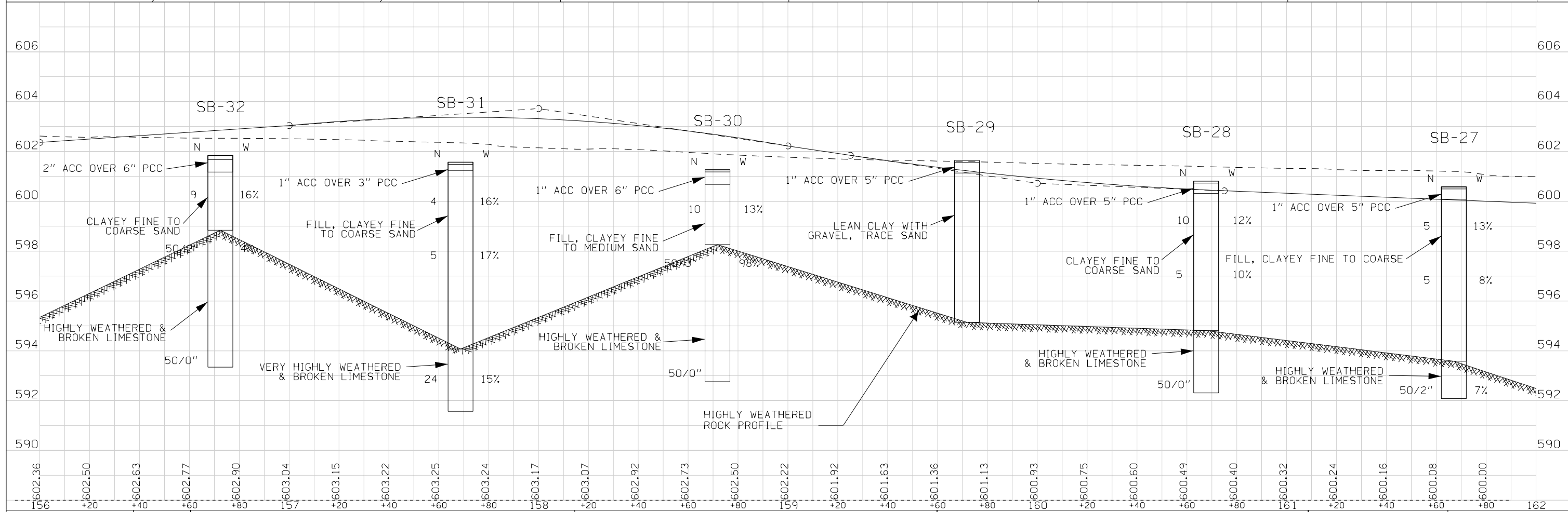
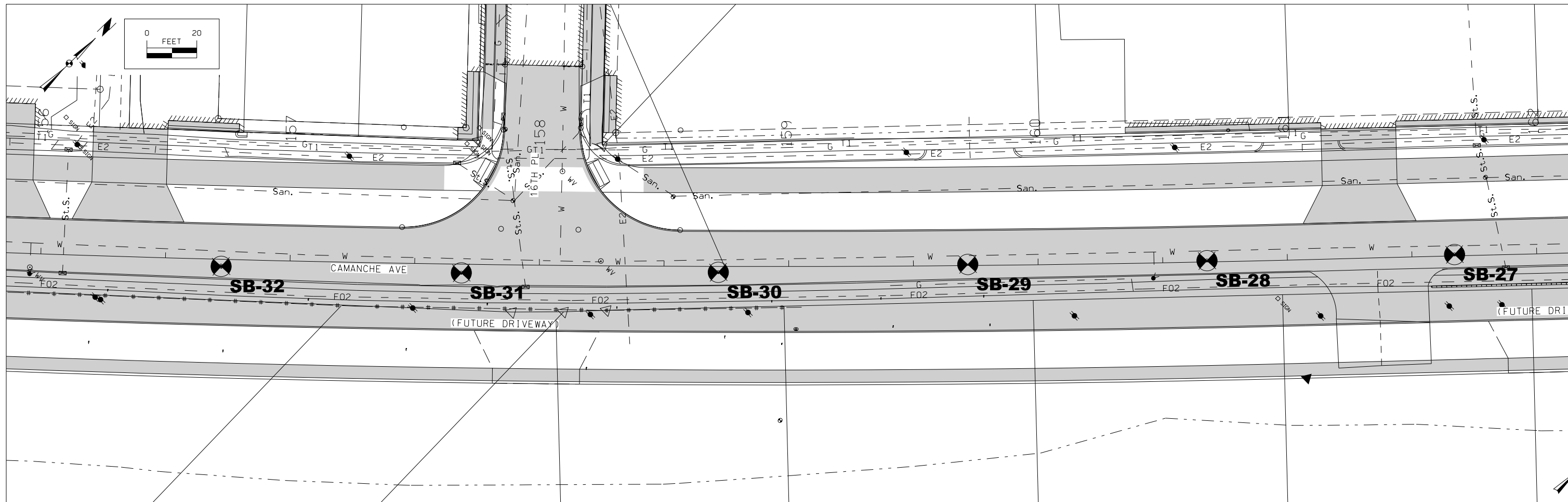

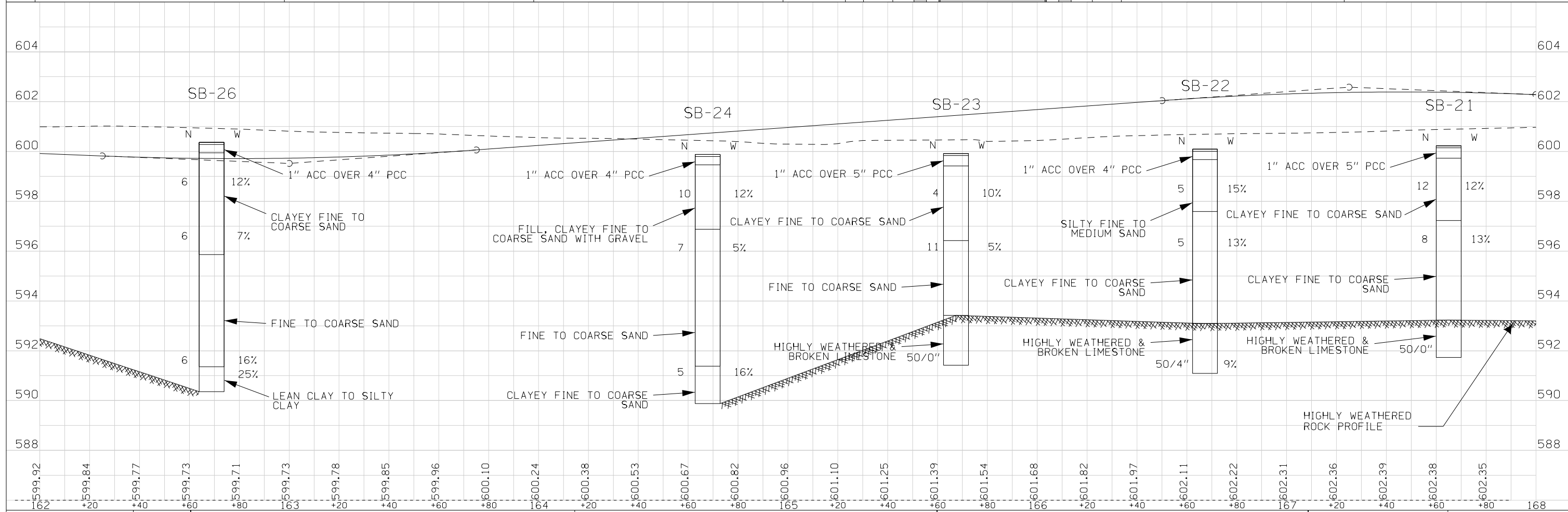
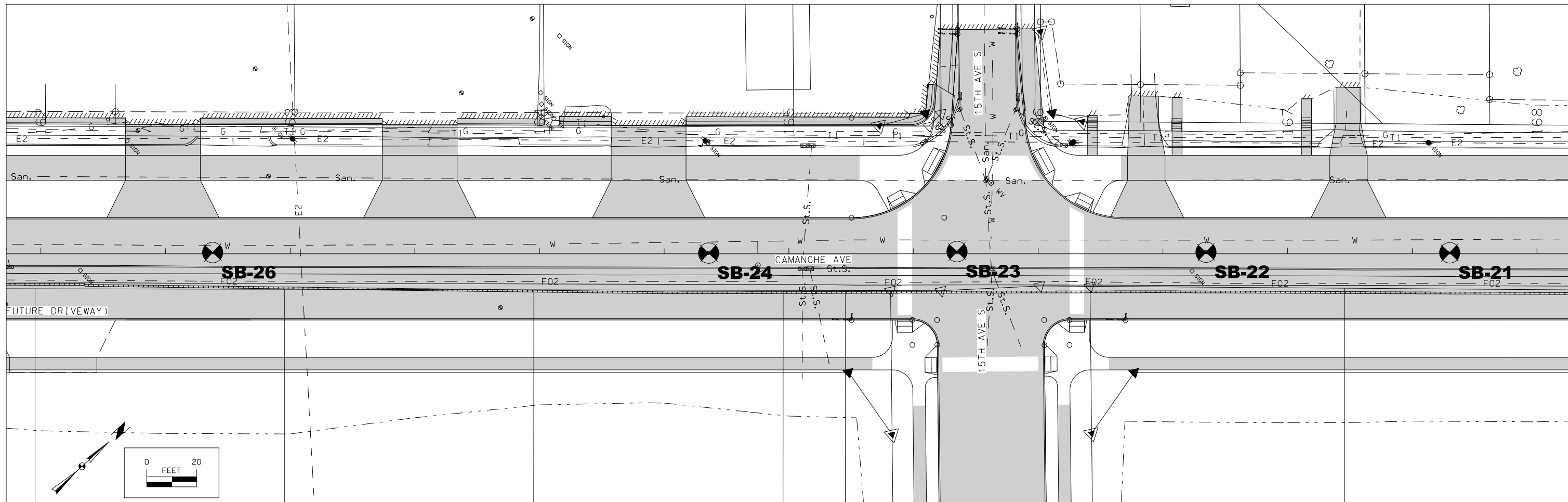

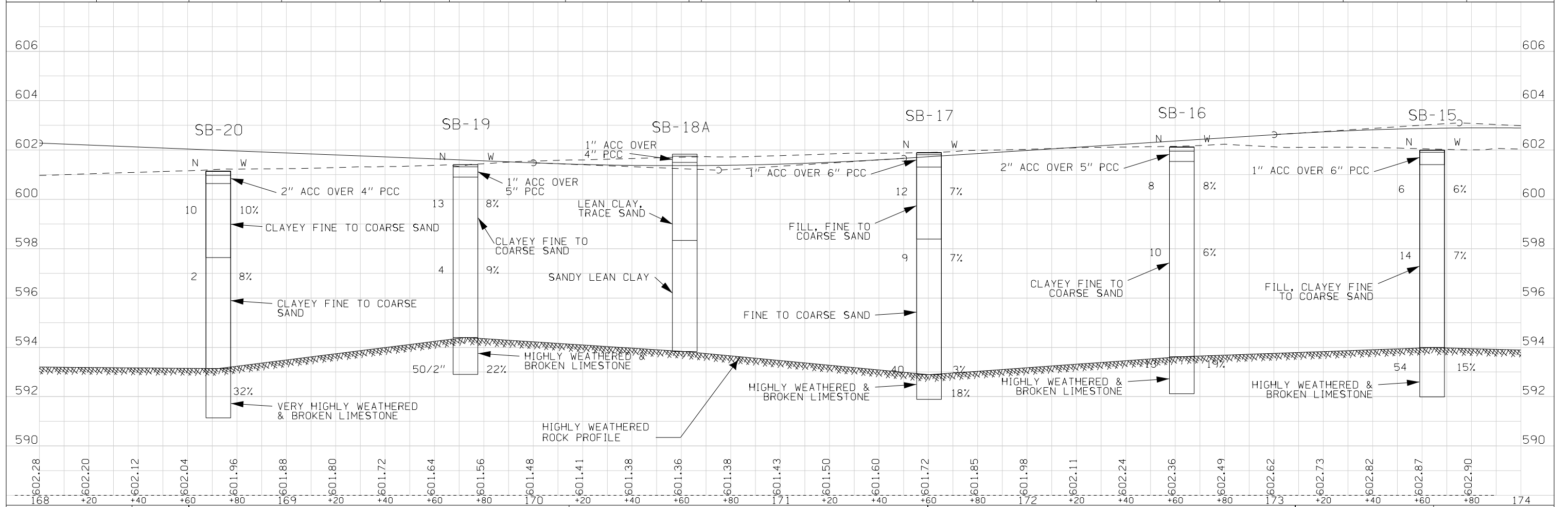
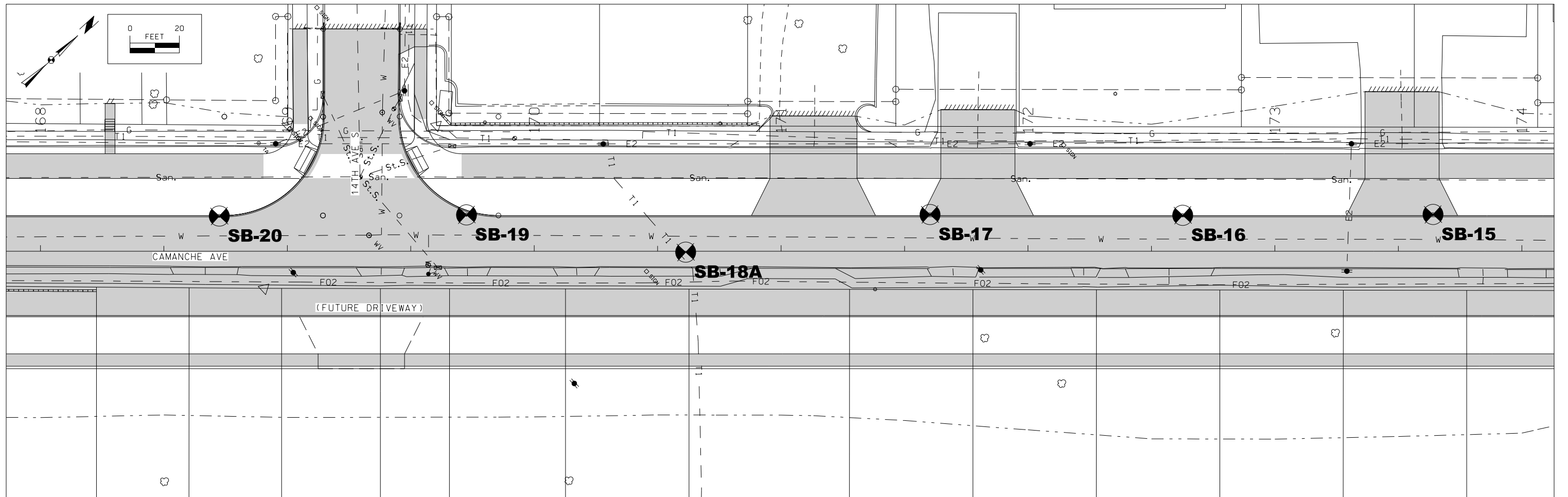

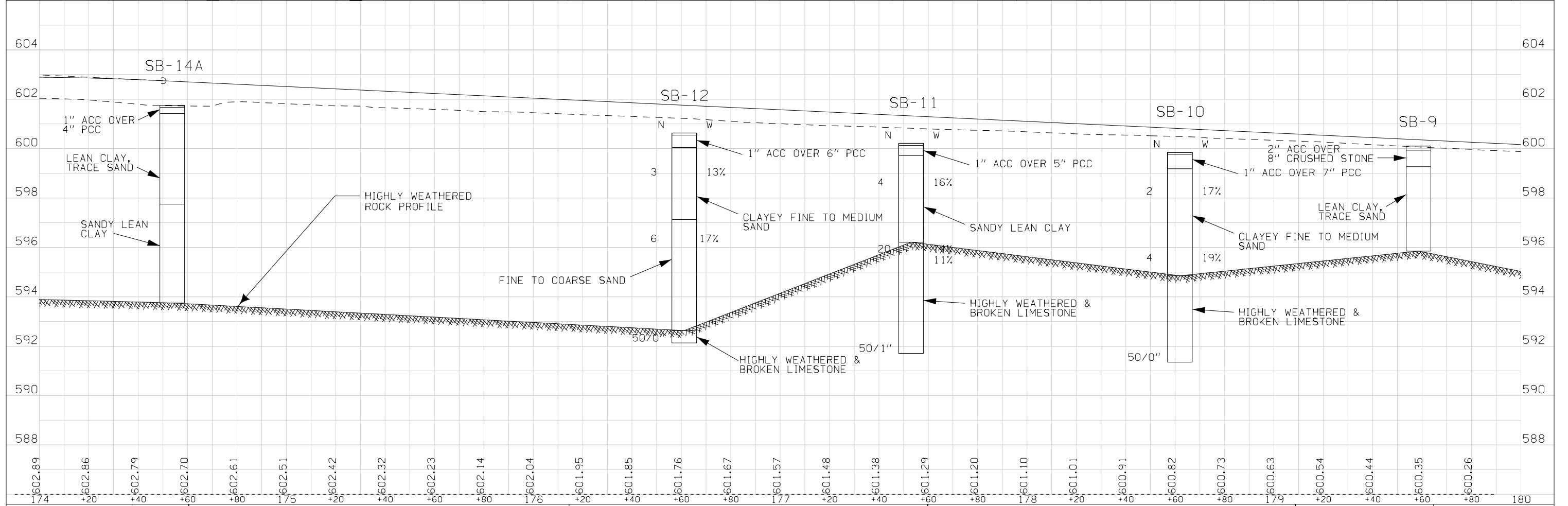
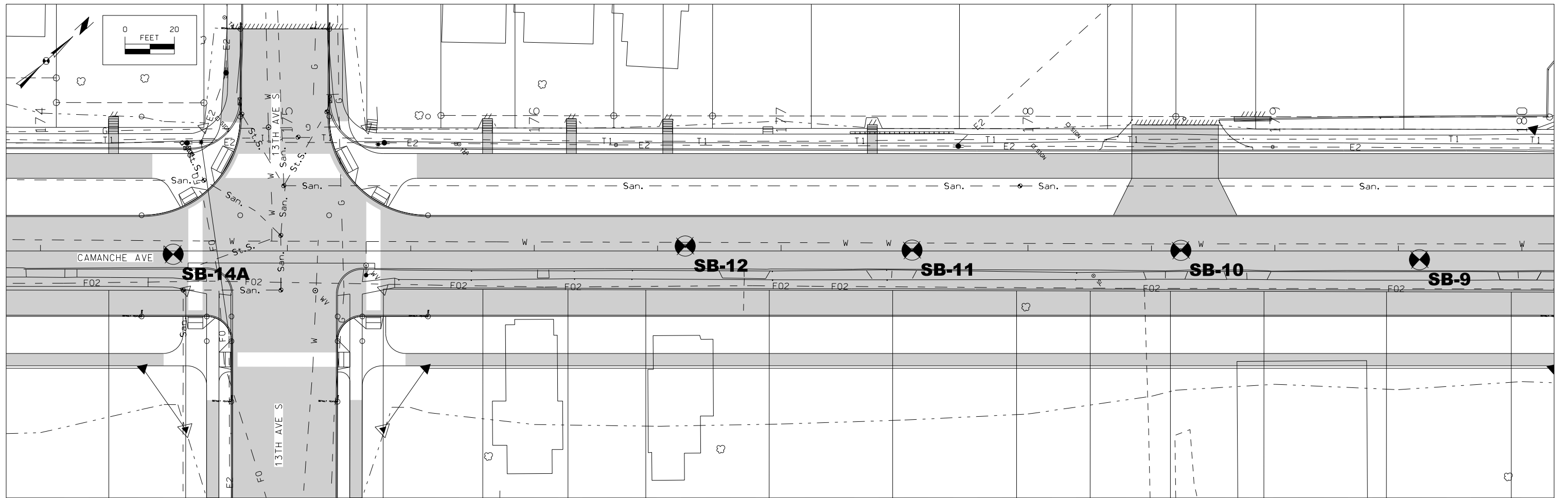

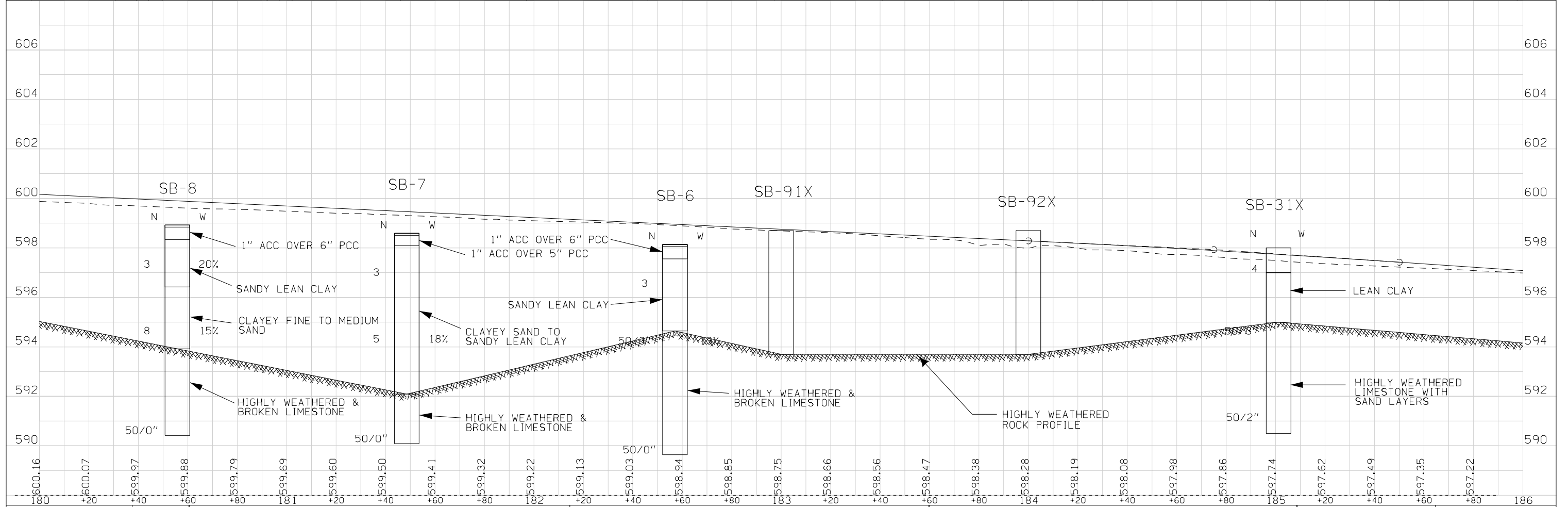
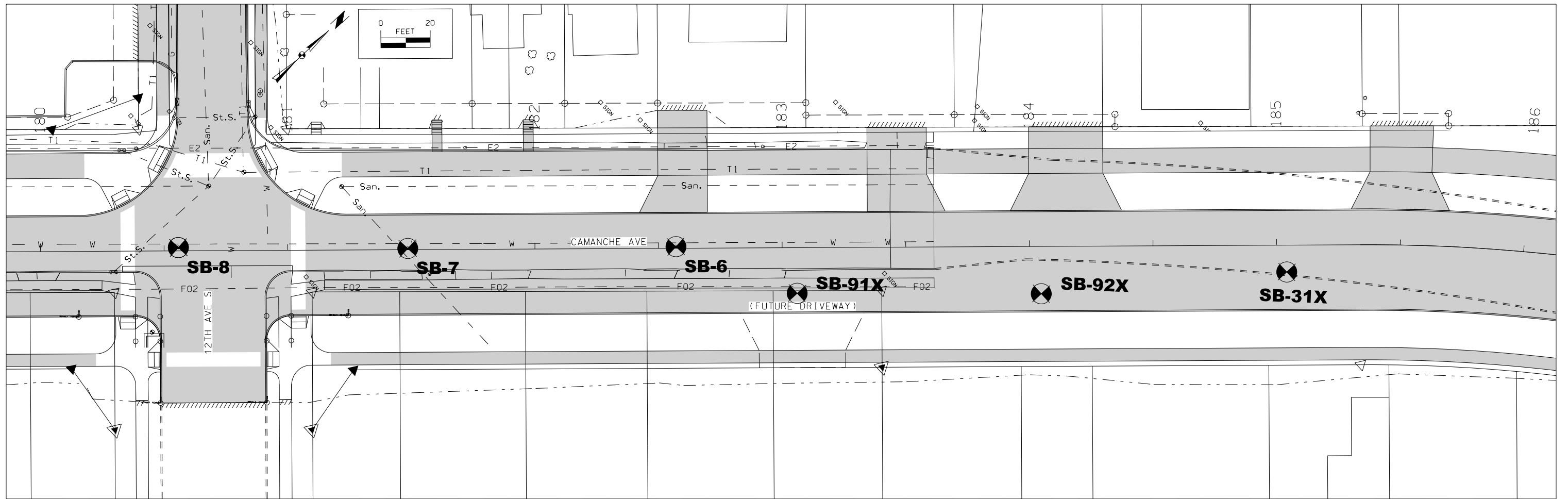

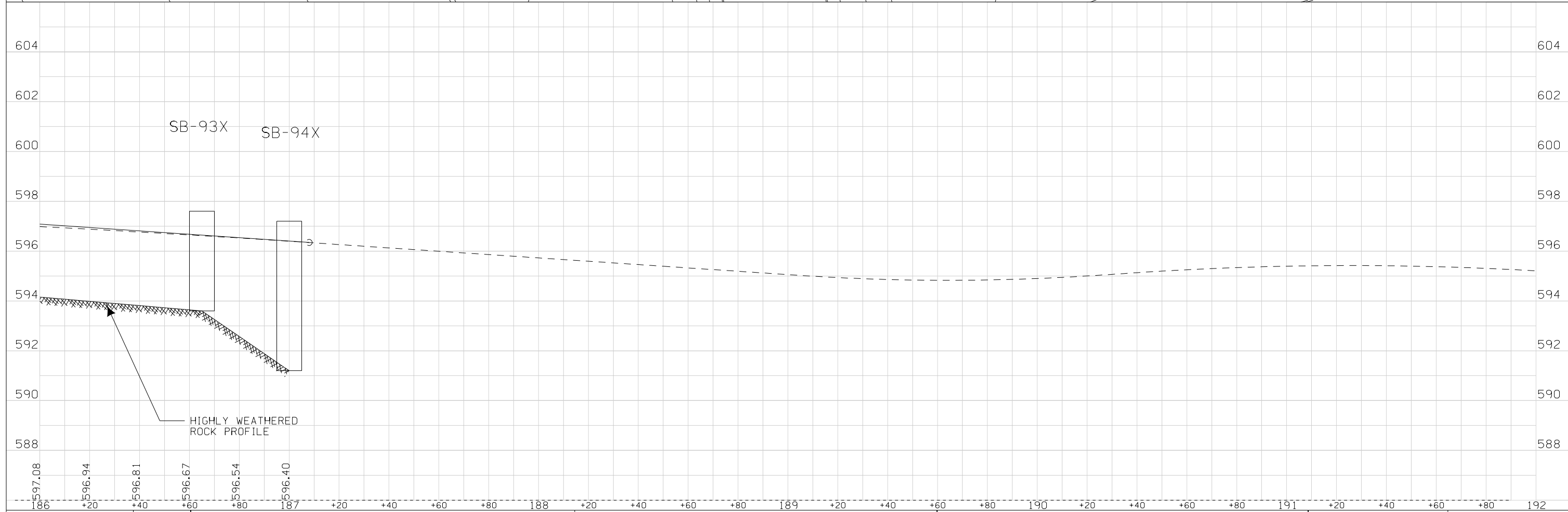
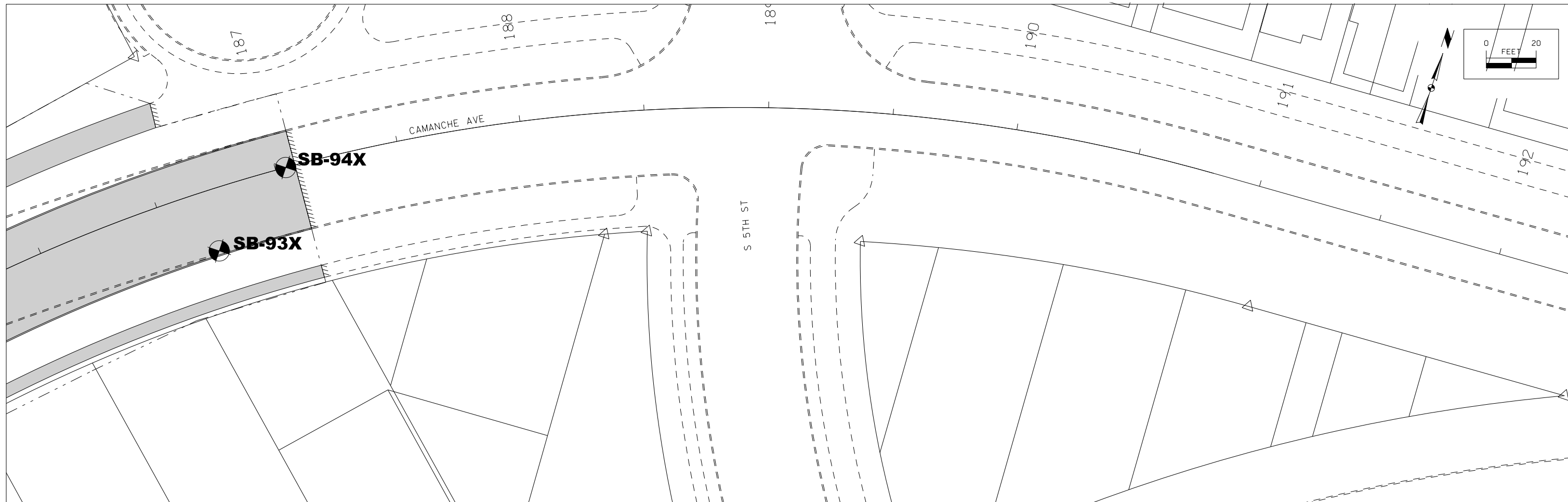

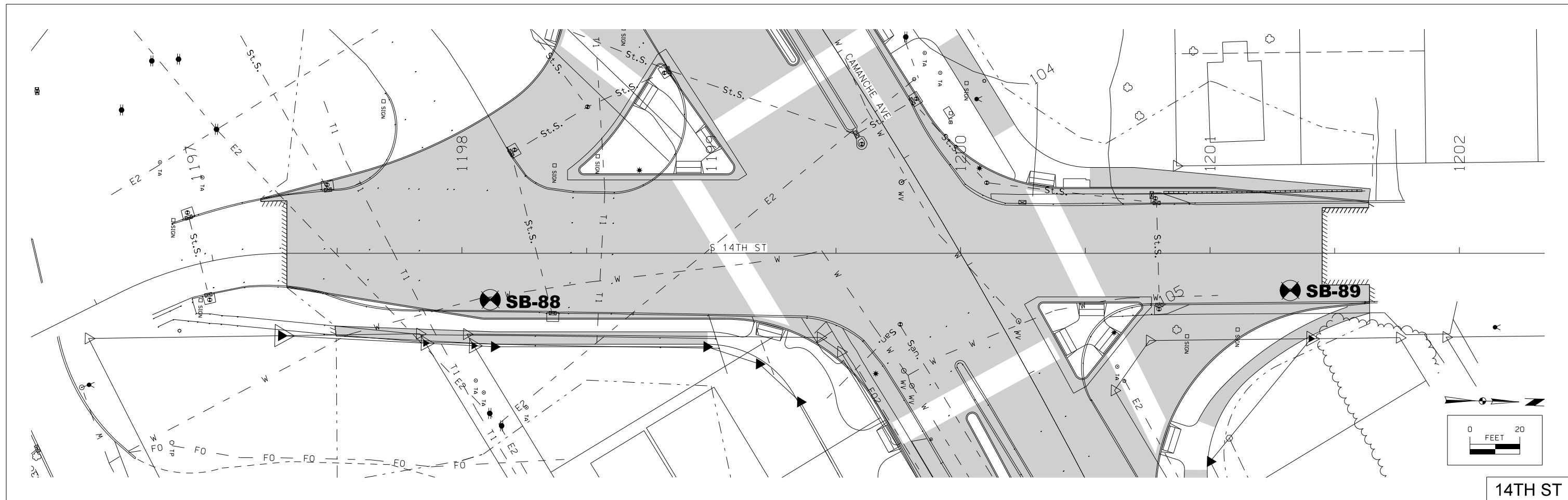

14TH ST

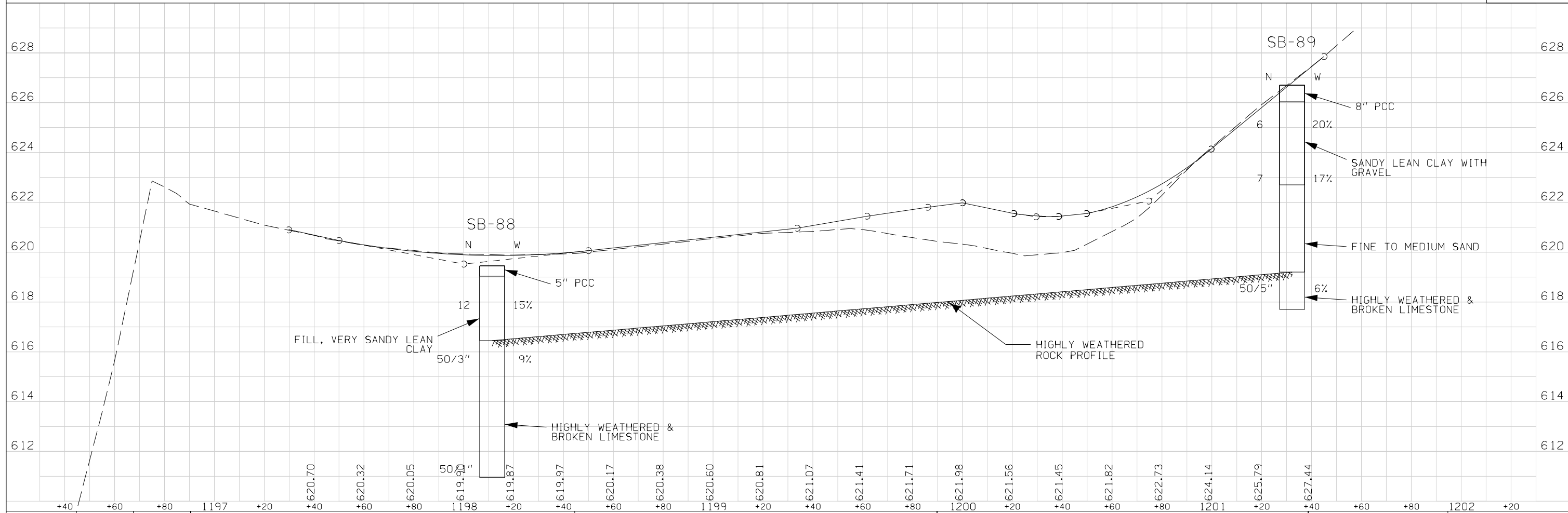



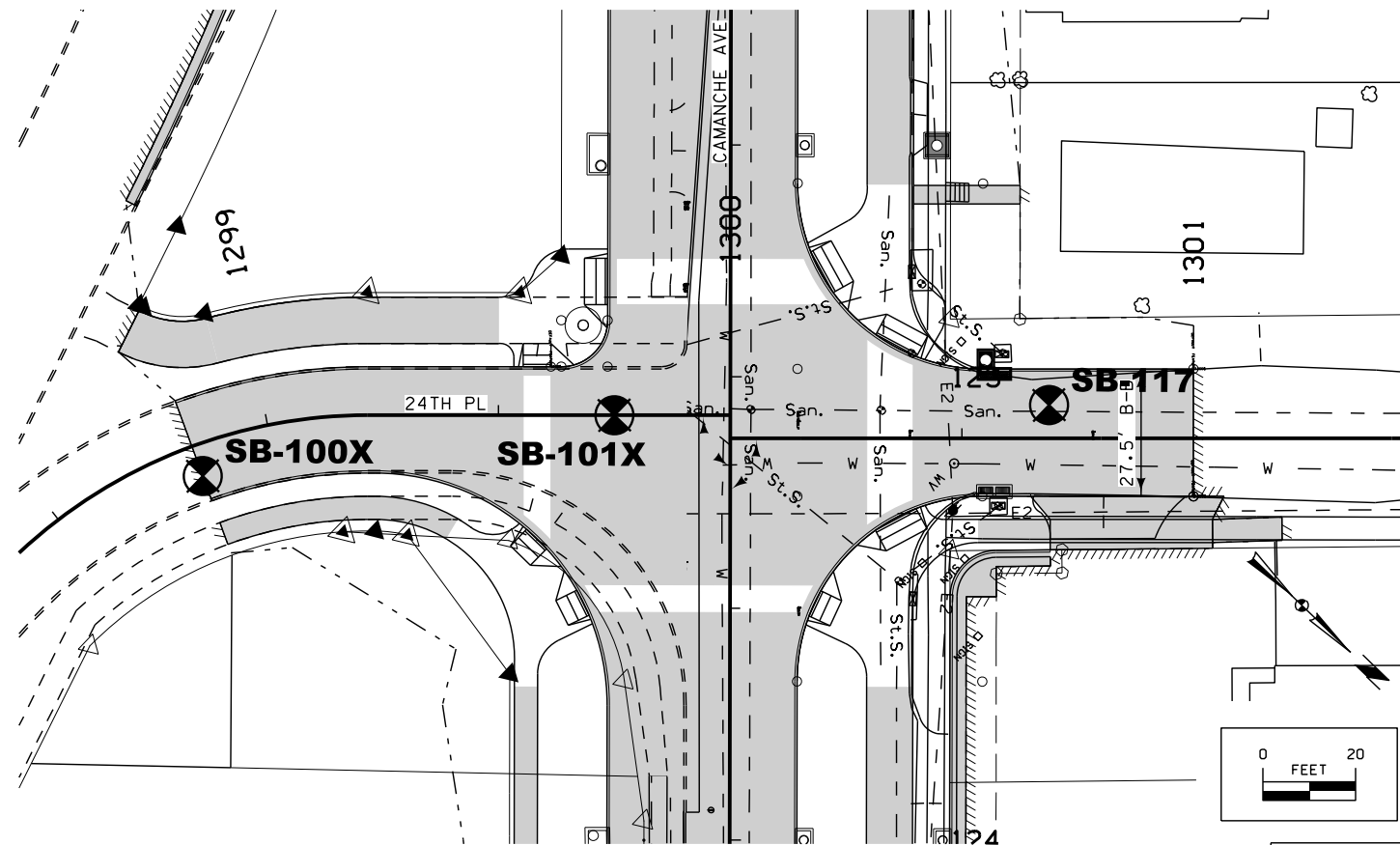

24TH PL

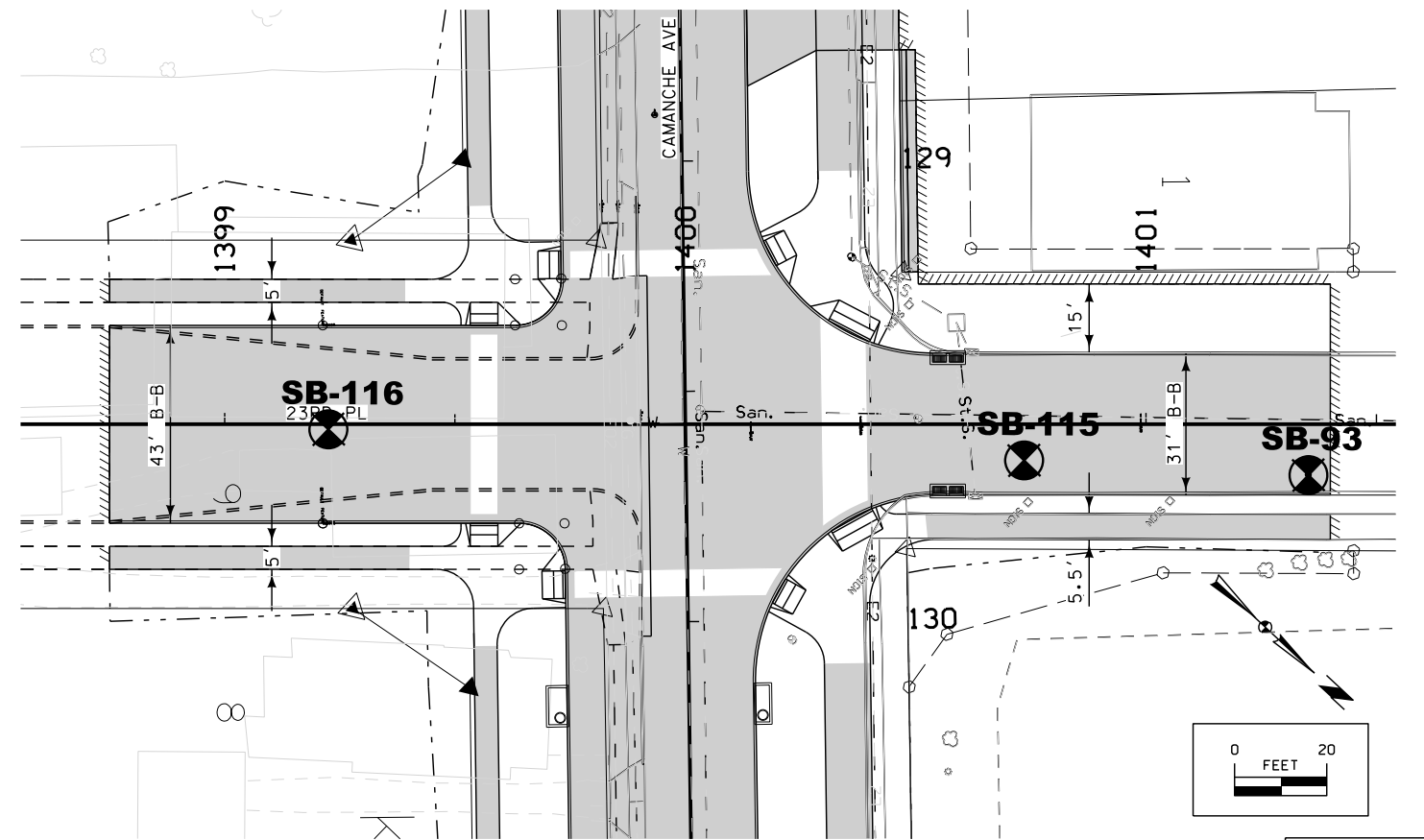

23RD PL

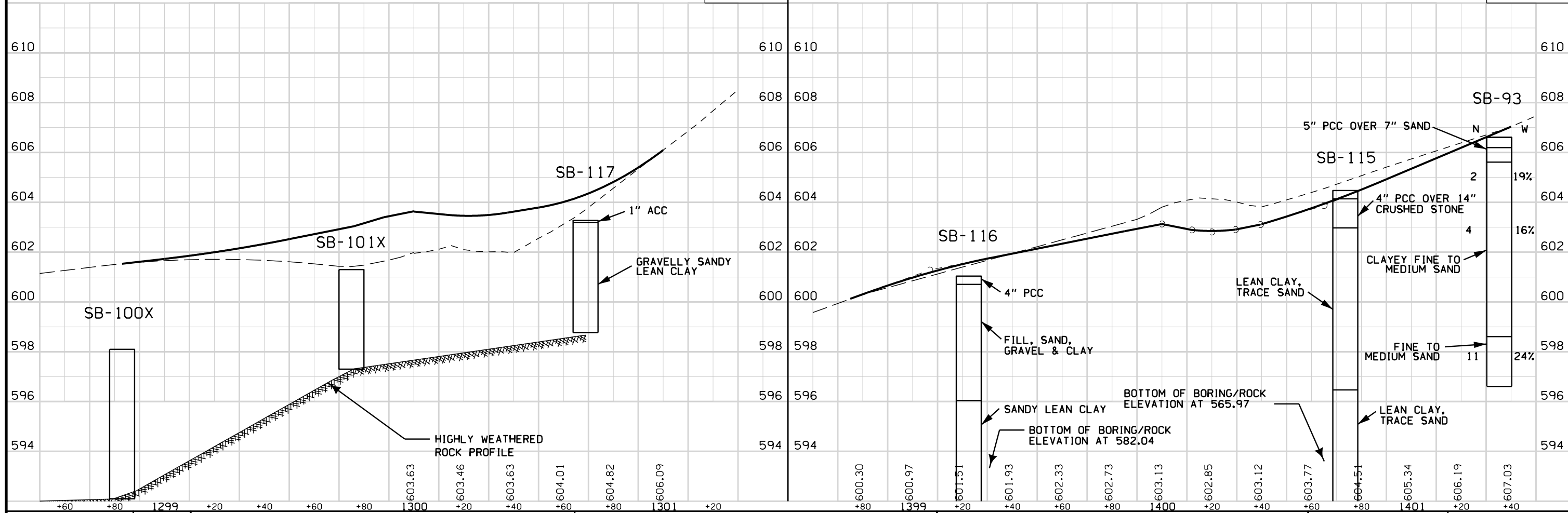

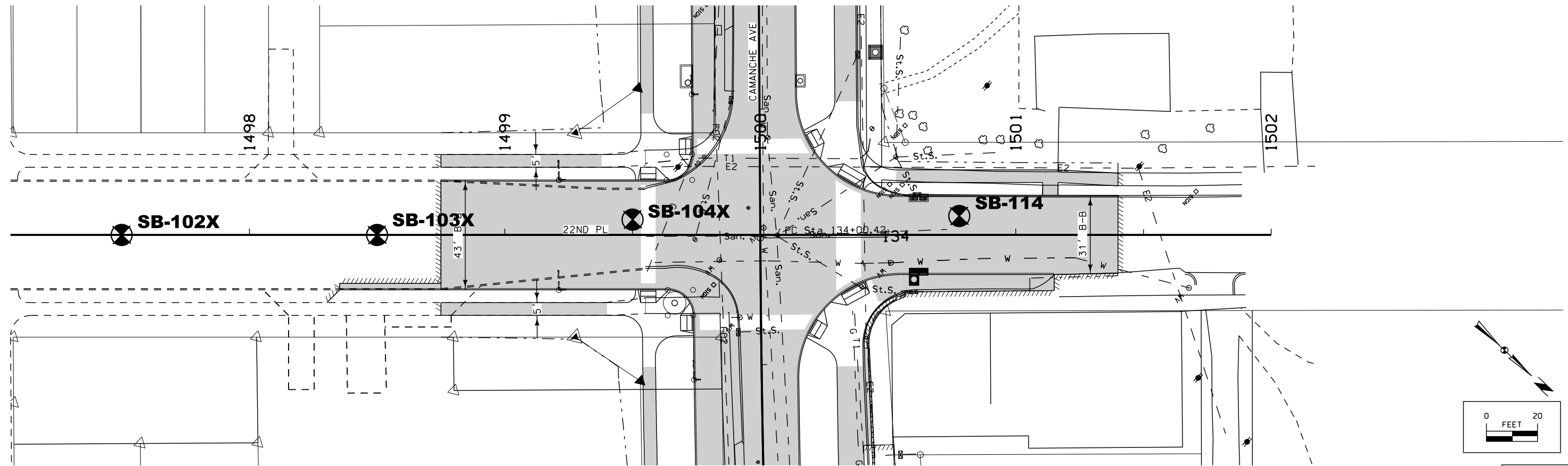

22ND PL

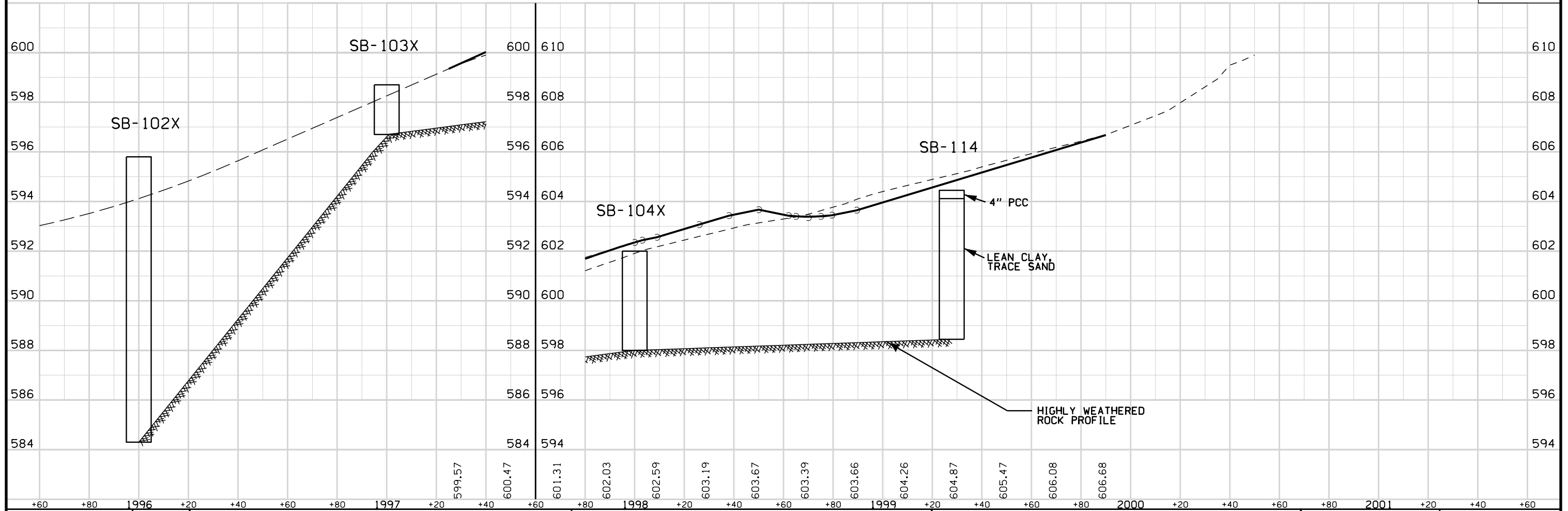

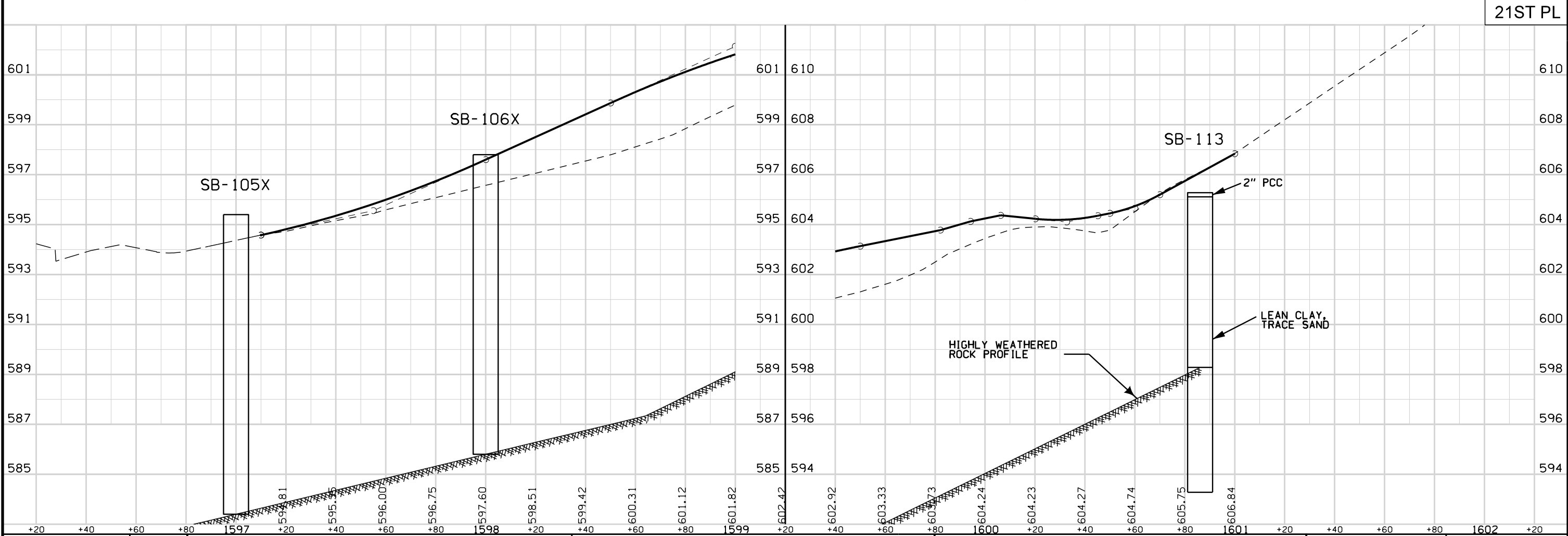
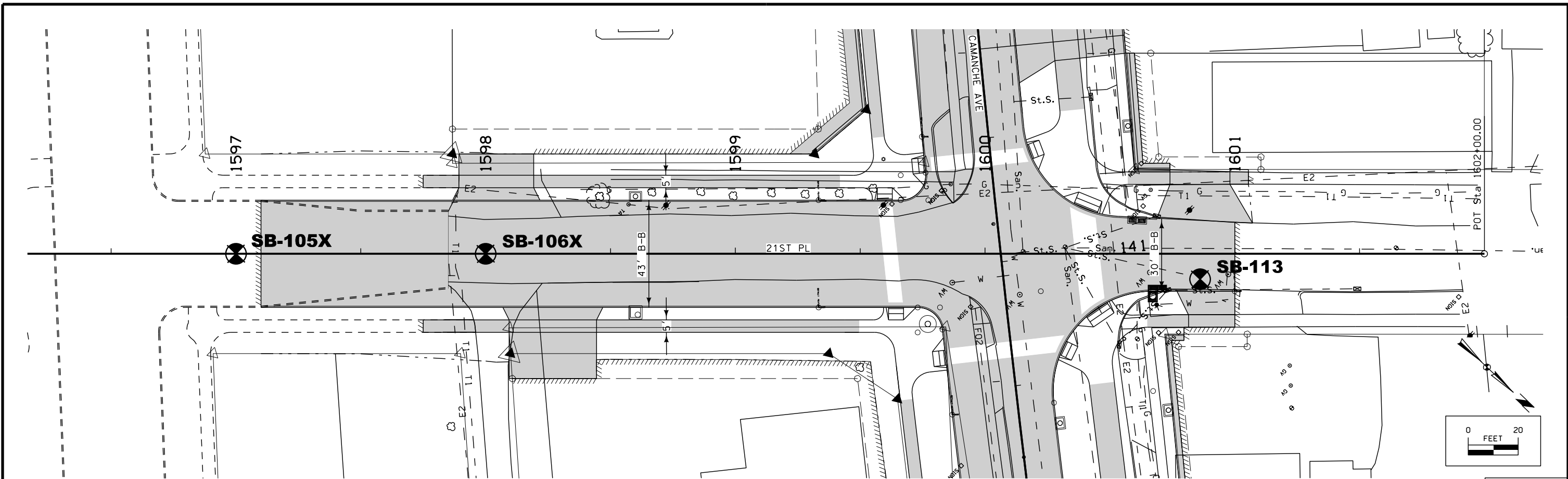

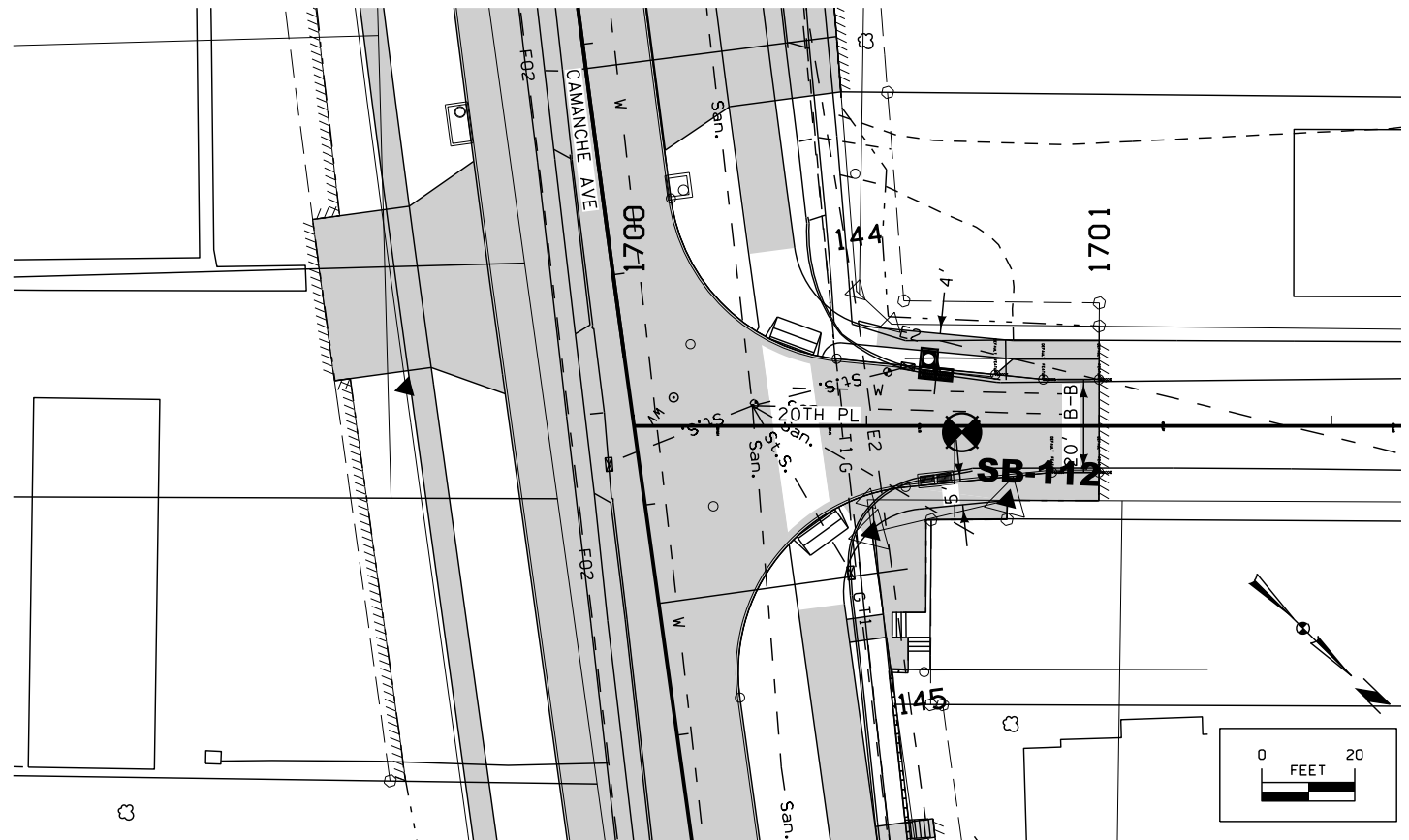

20TH PL

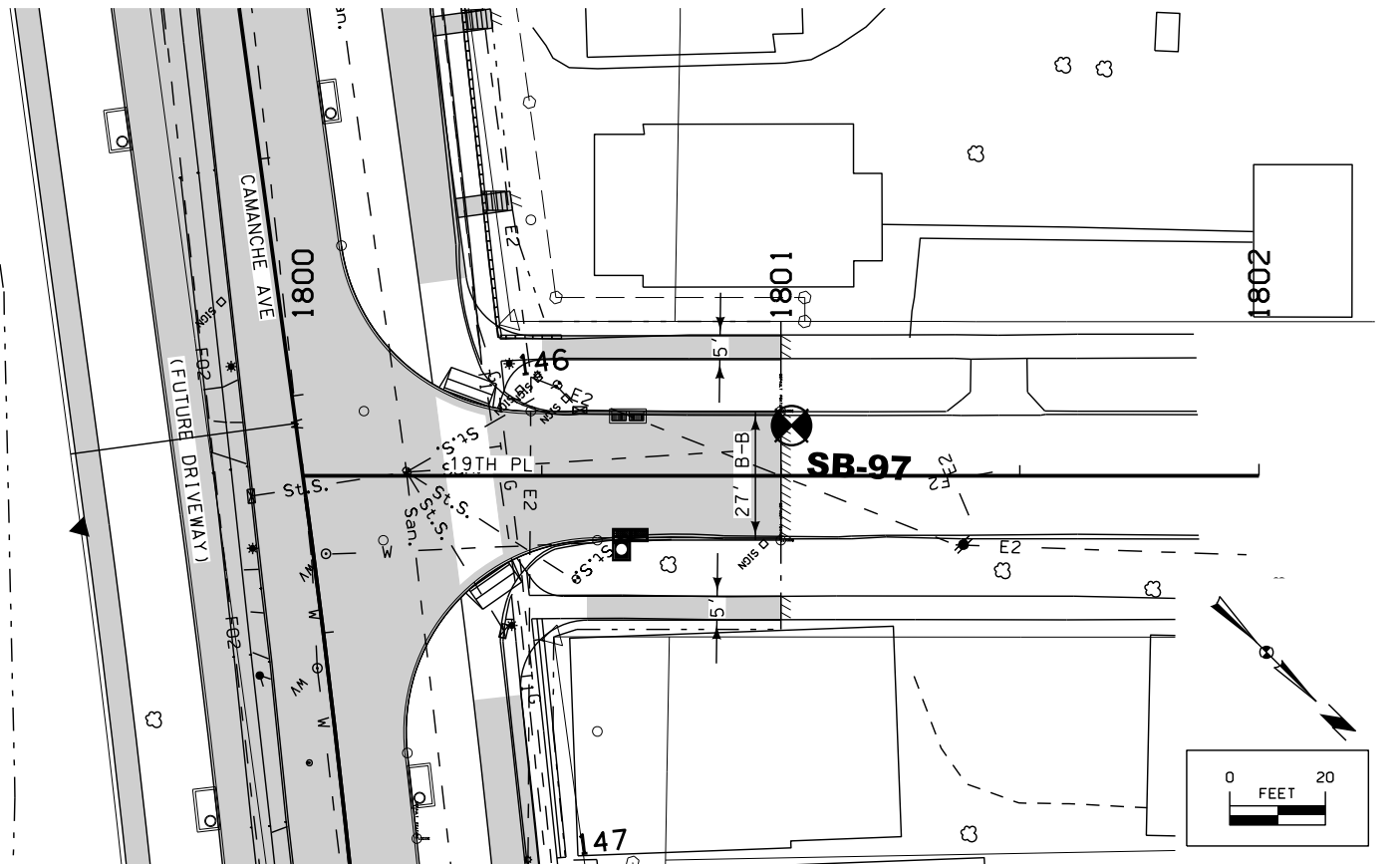

19TH PL

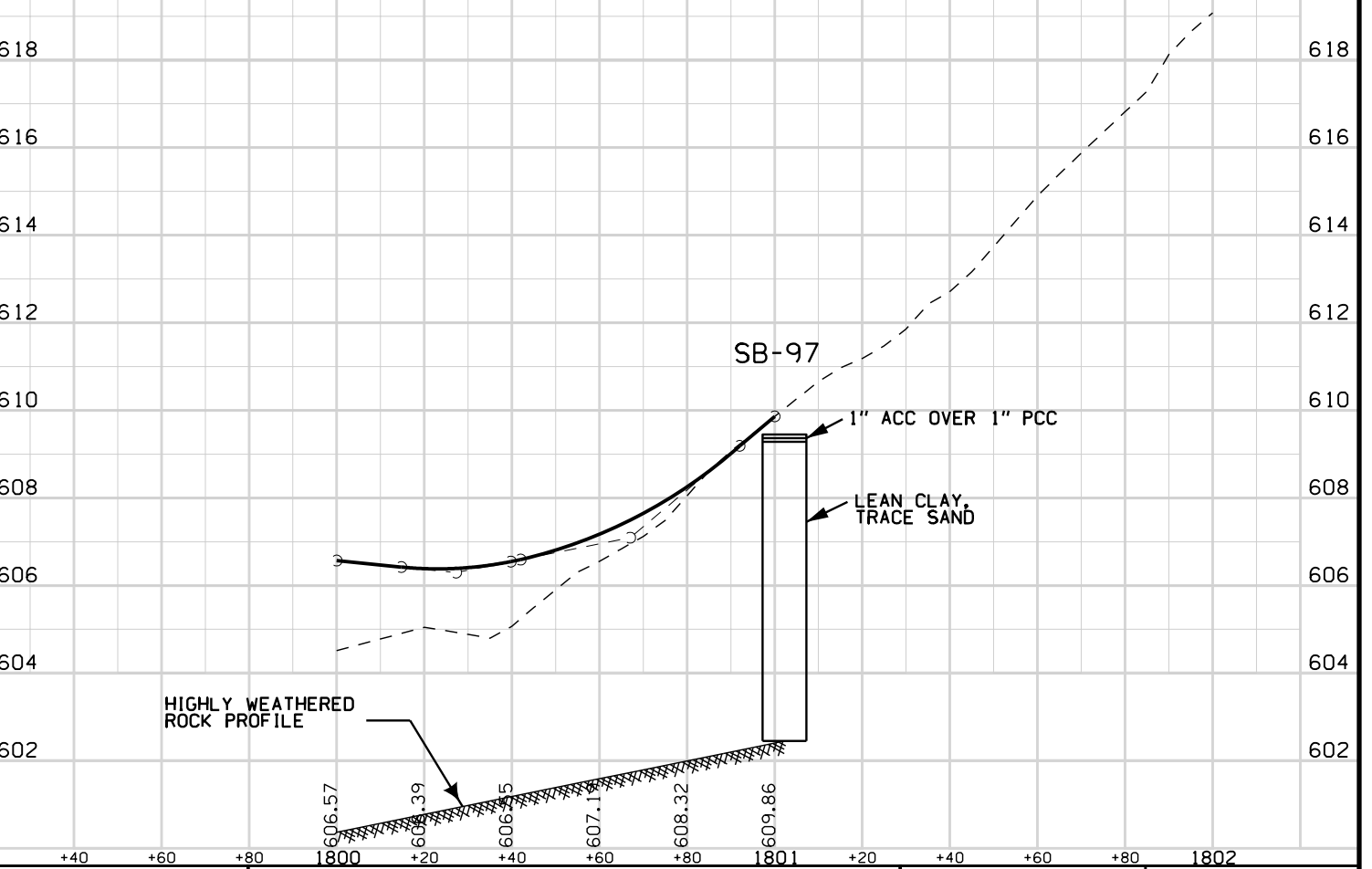
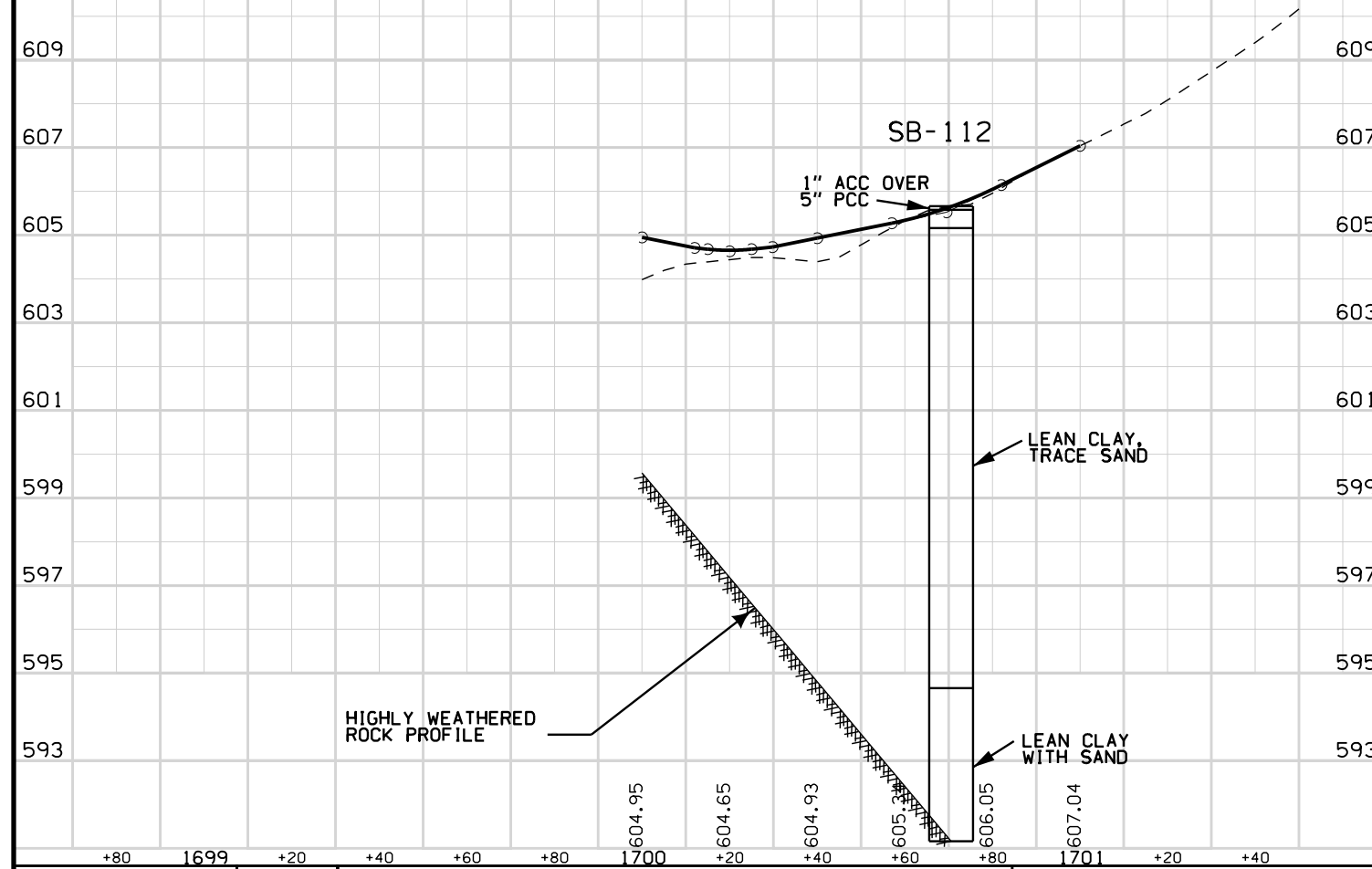

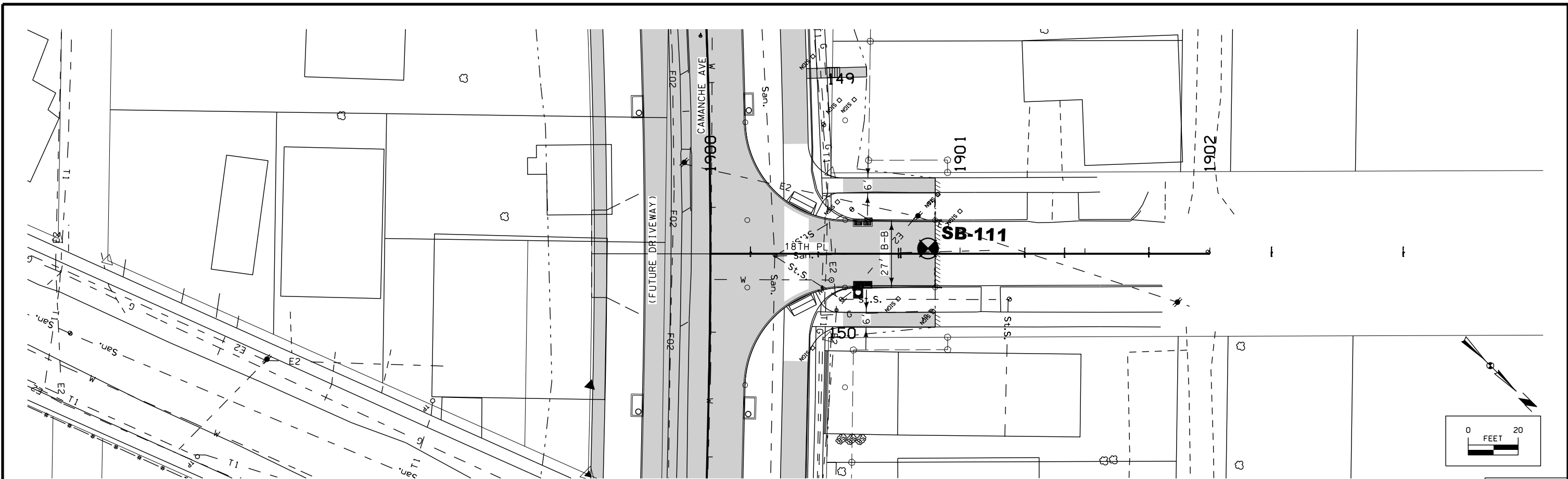

18TH PL

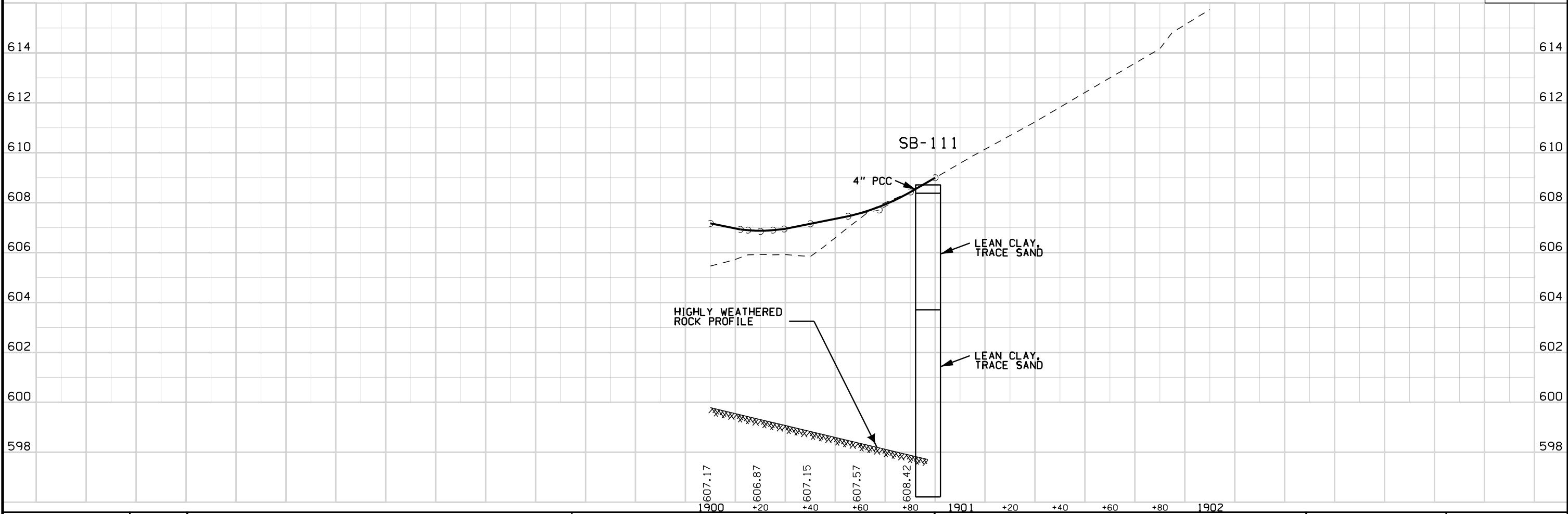

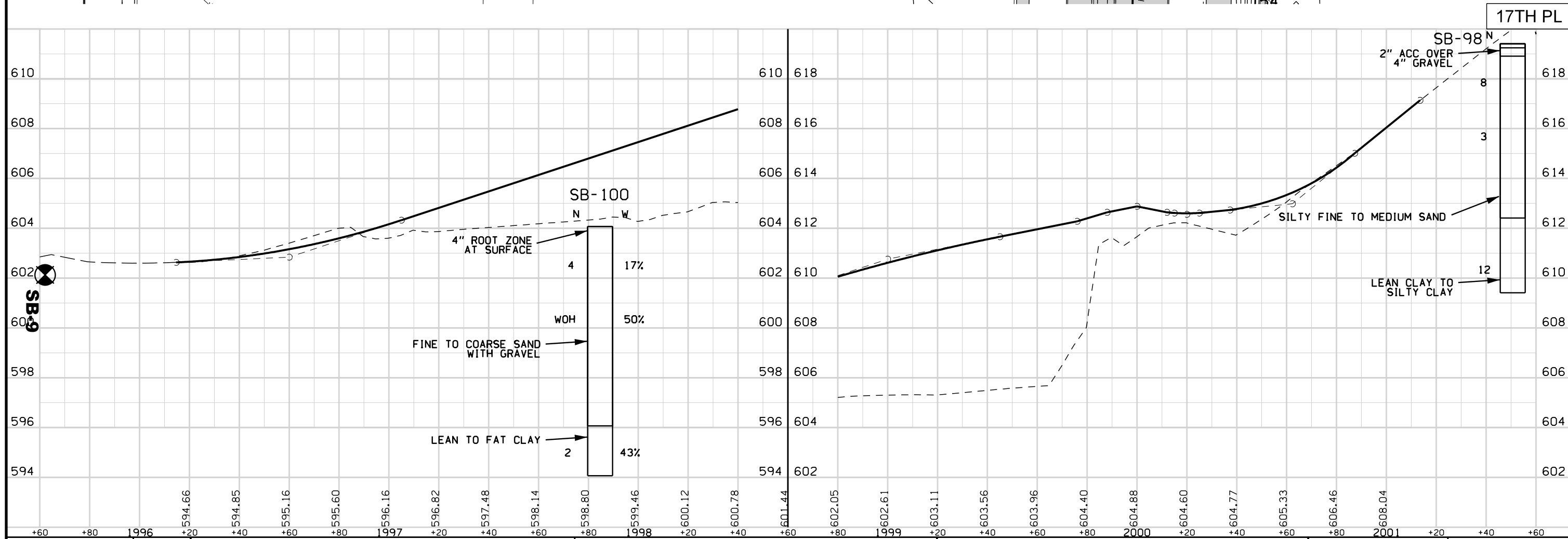
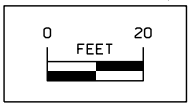
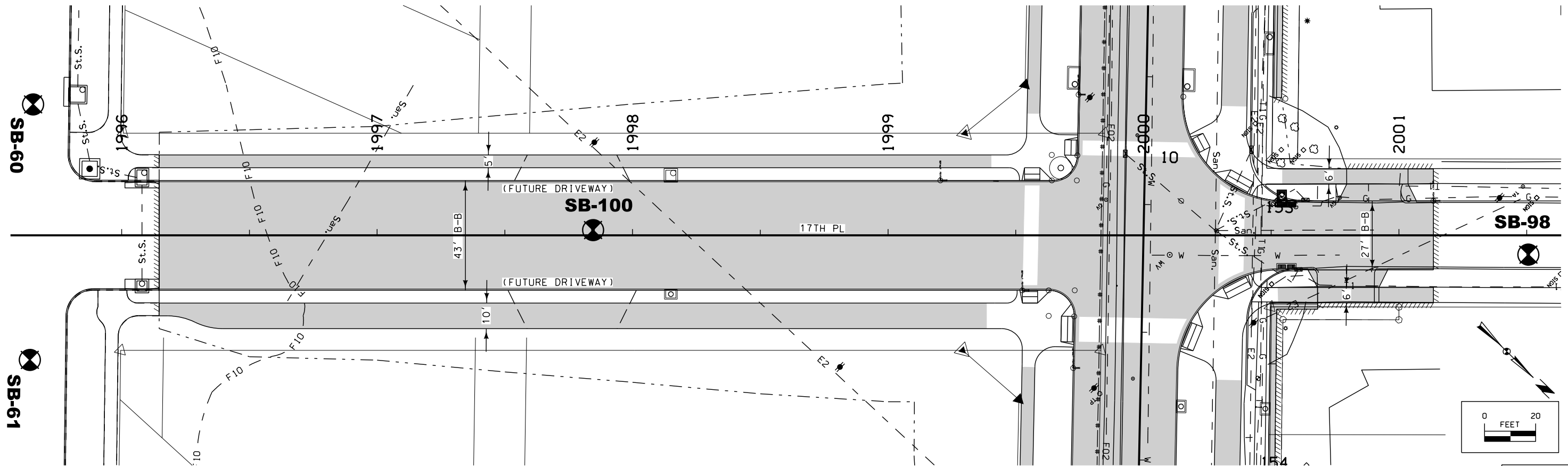

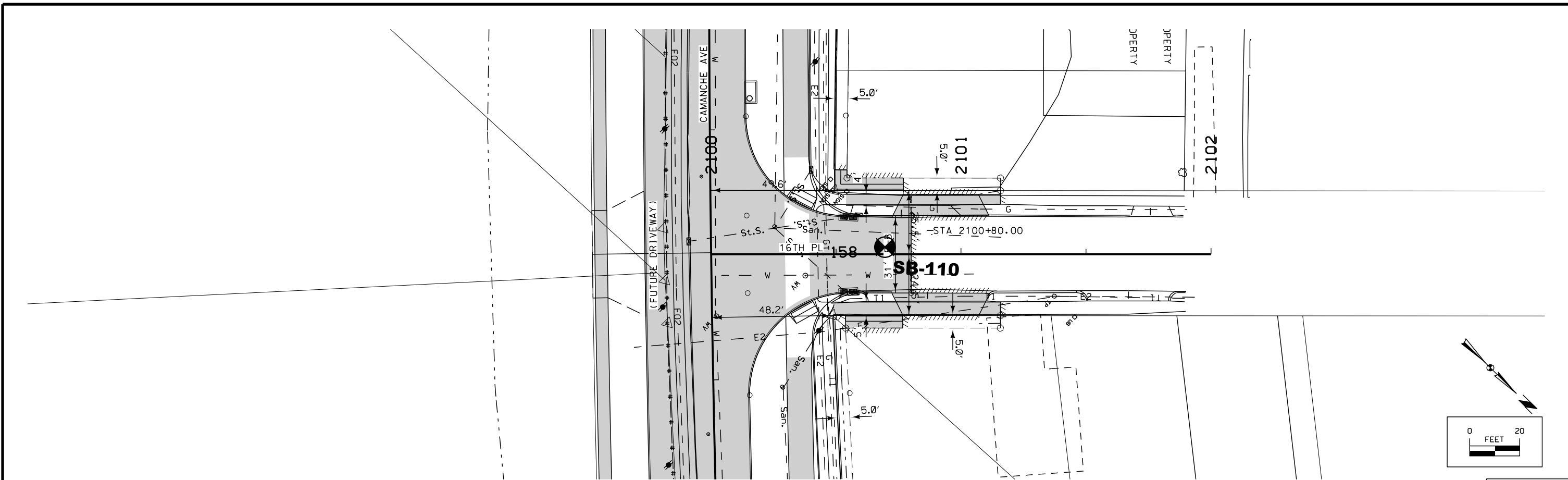

16TH PL

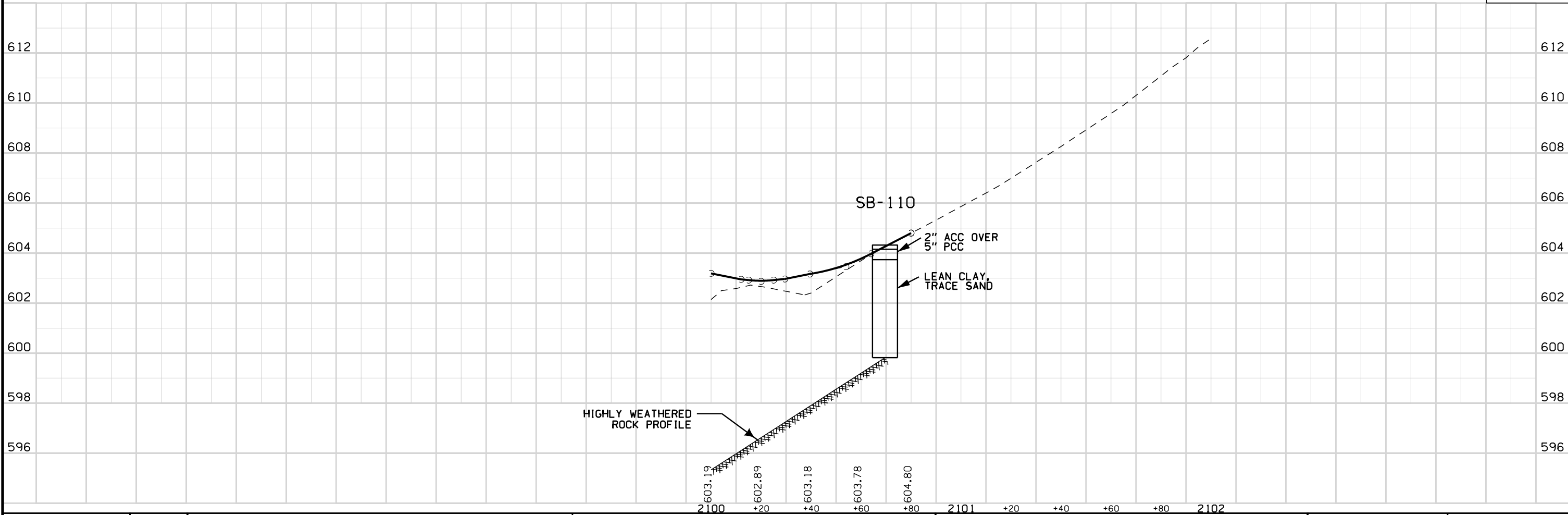

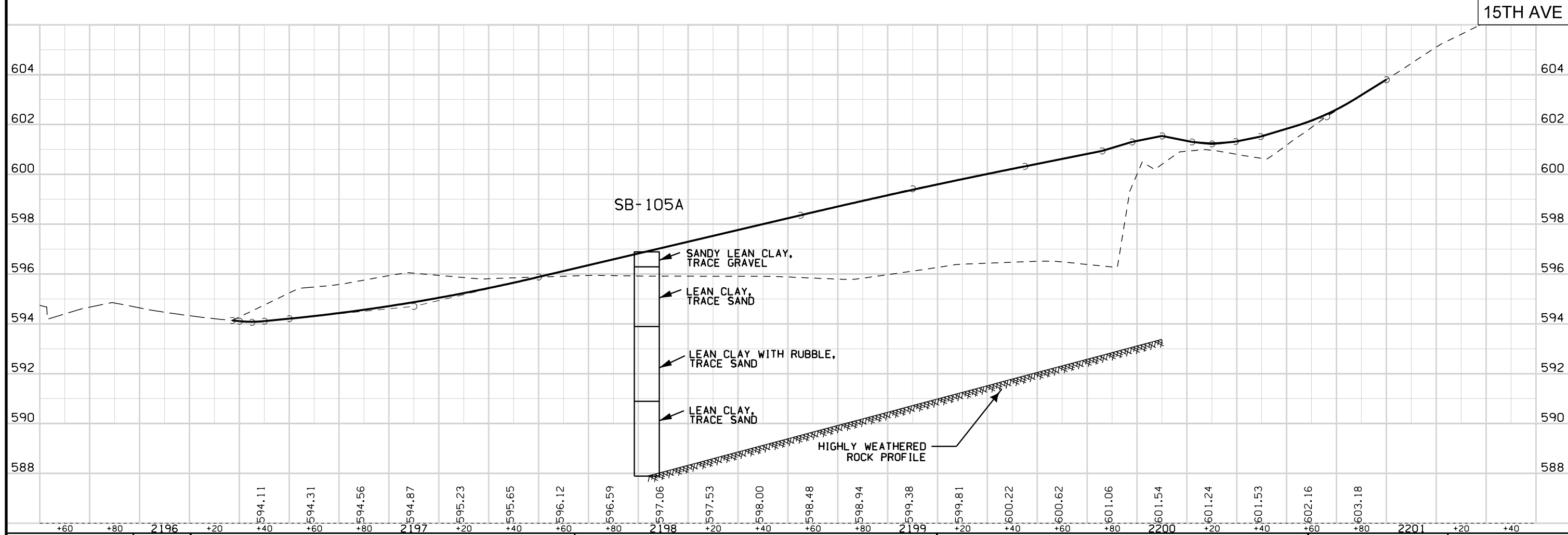
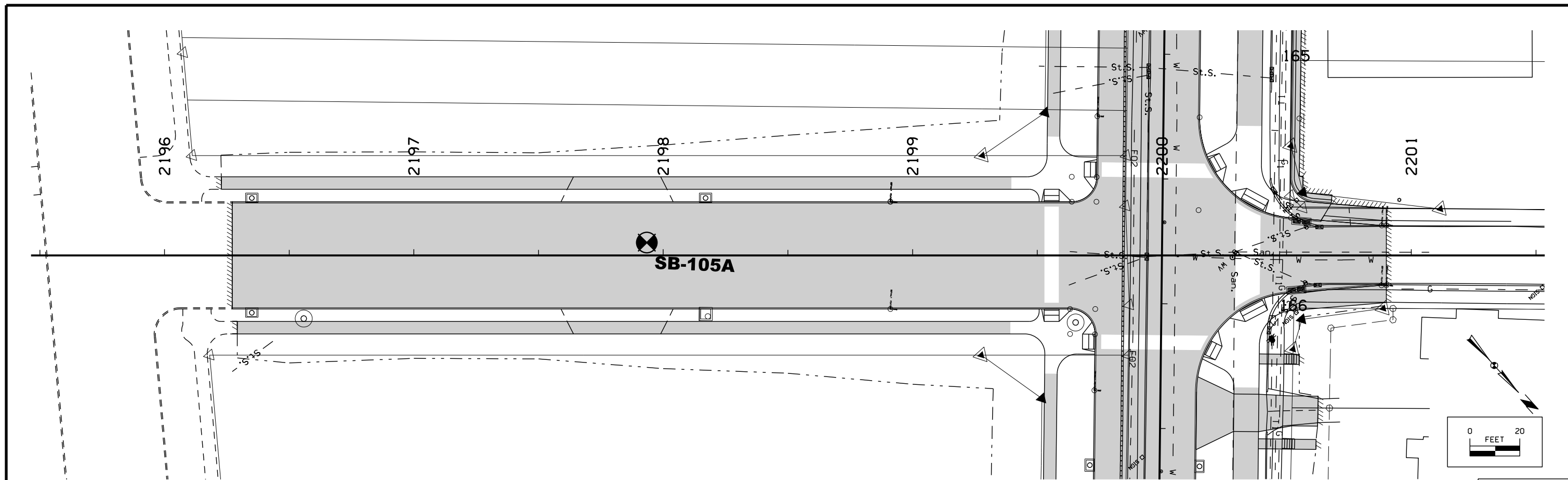



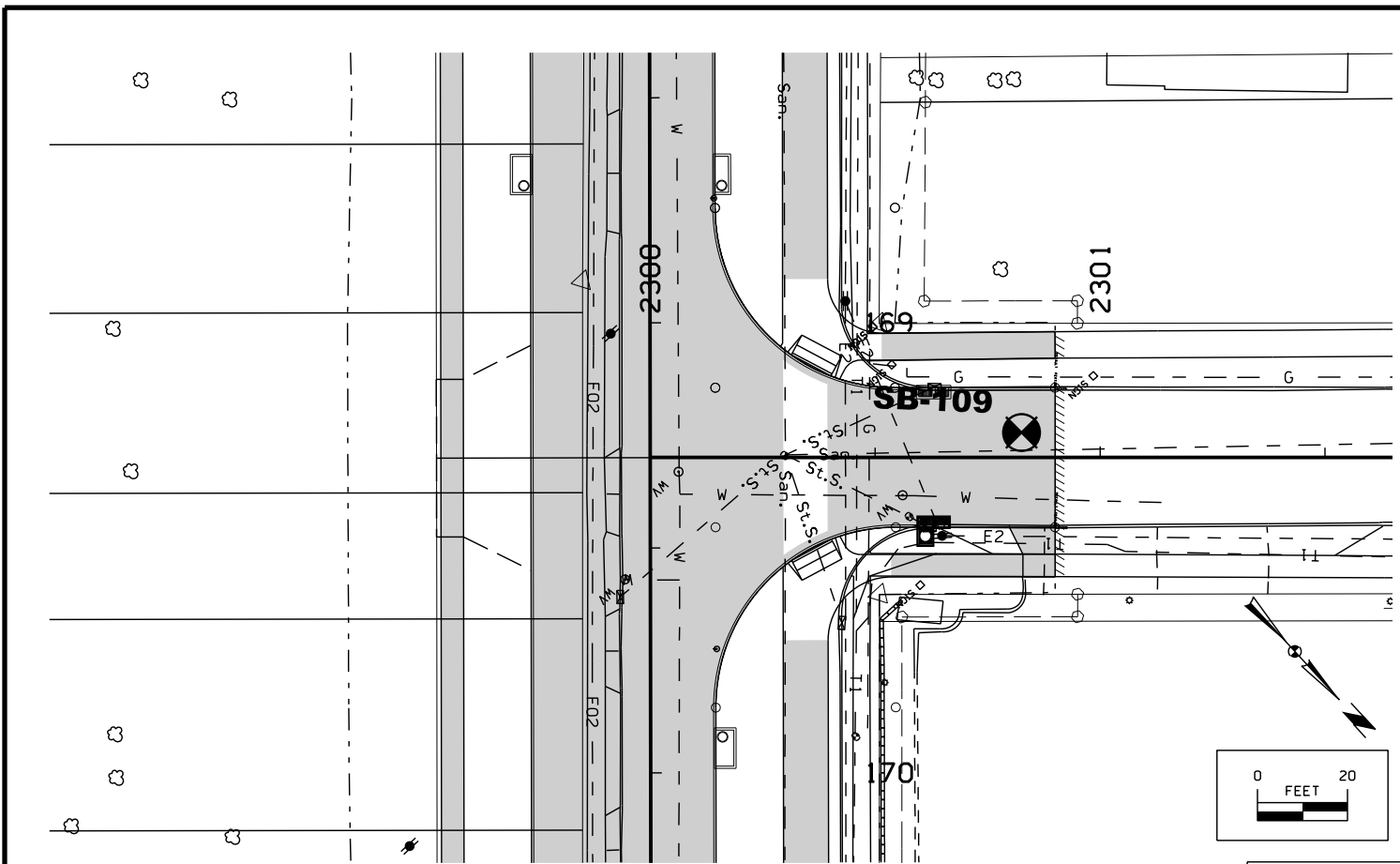

14TH AVE

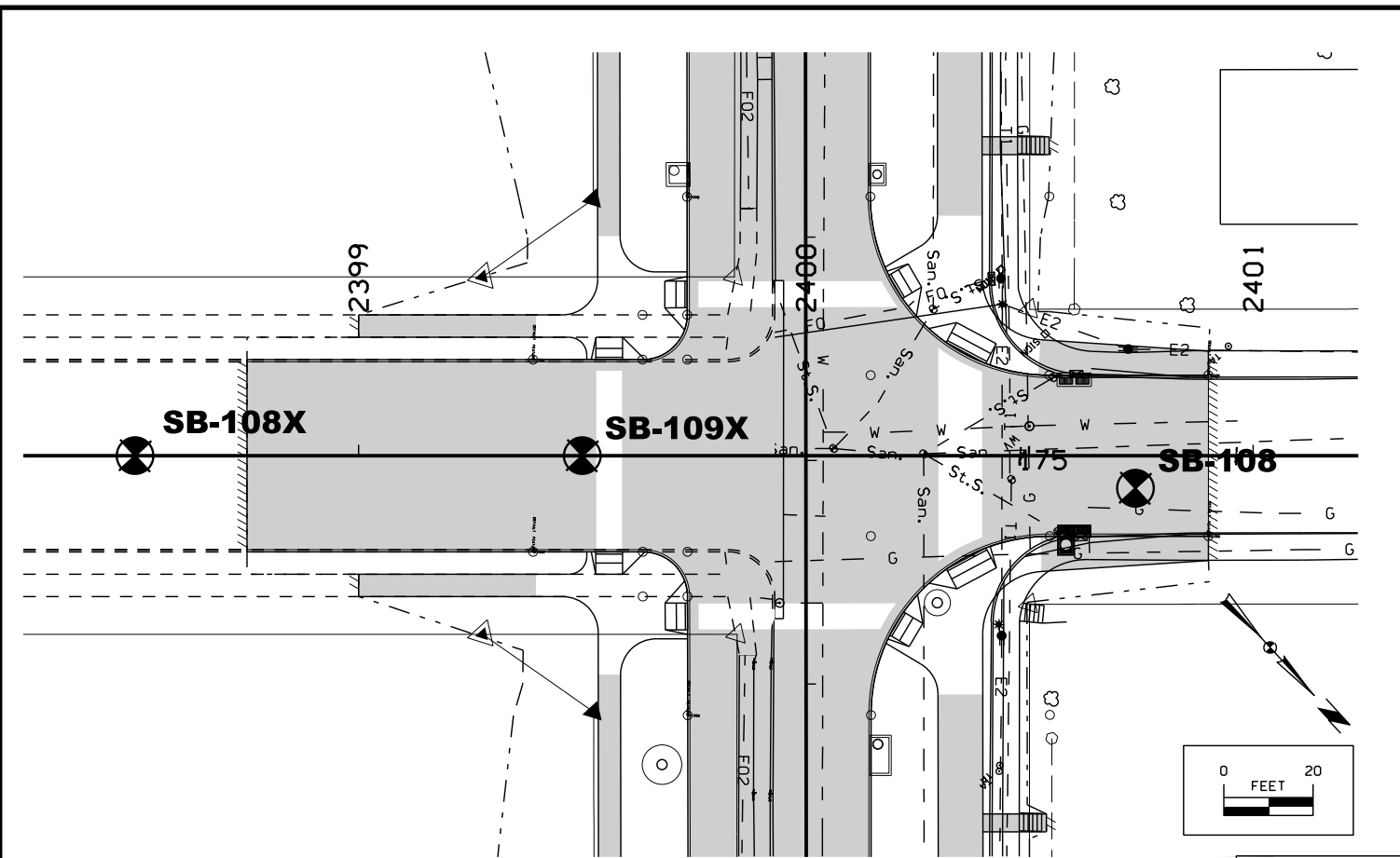

13TH AVE

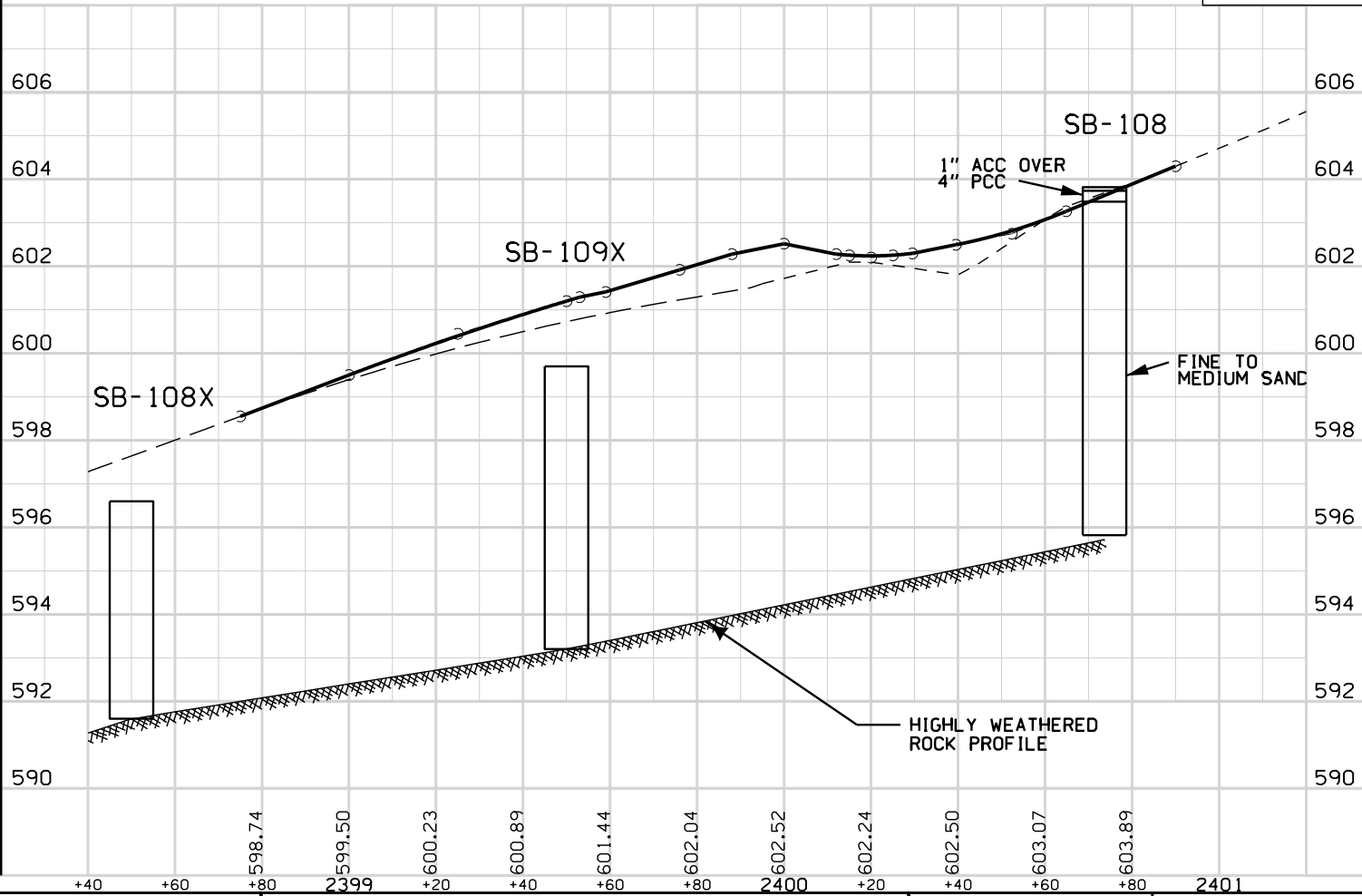
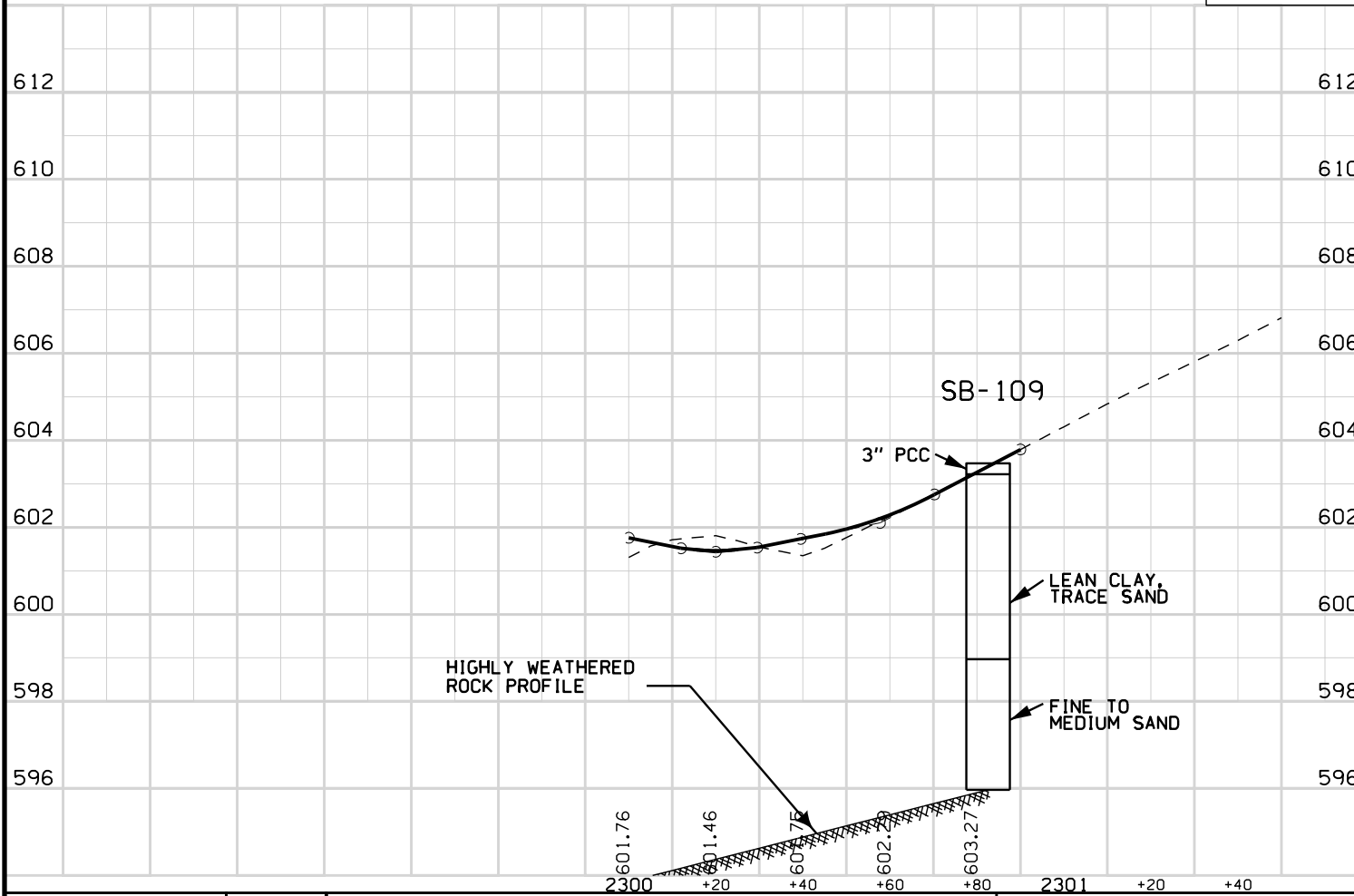

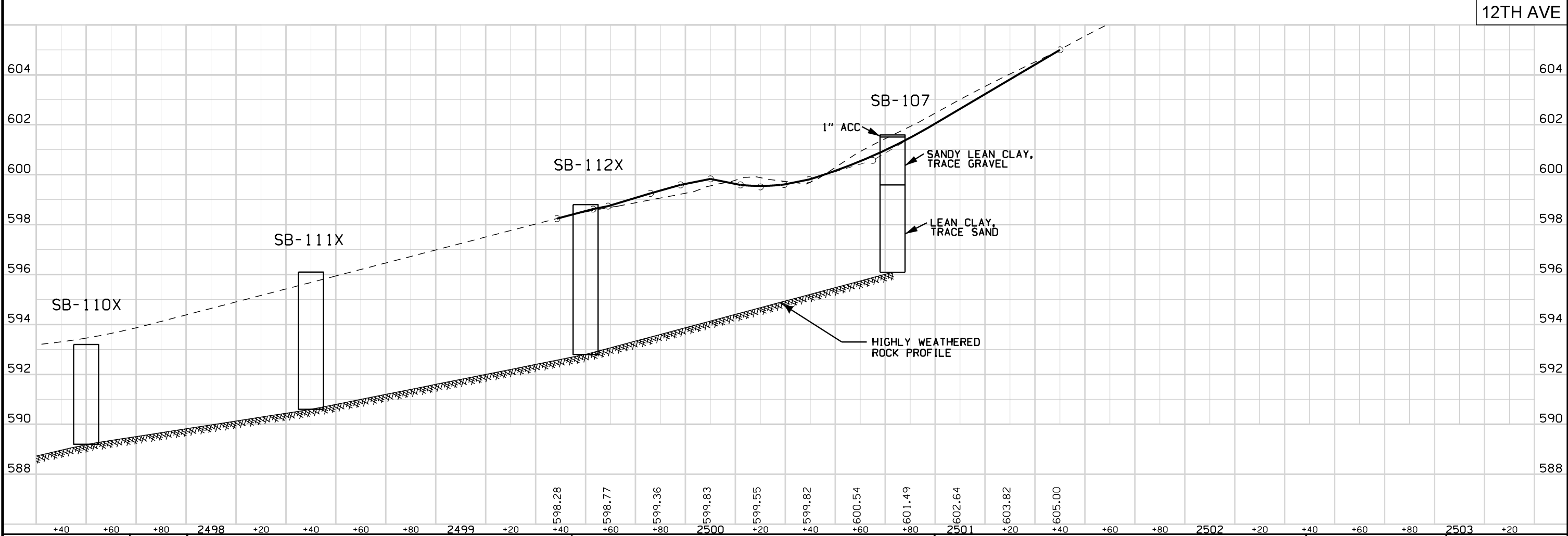
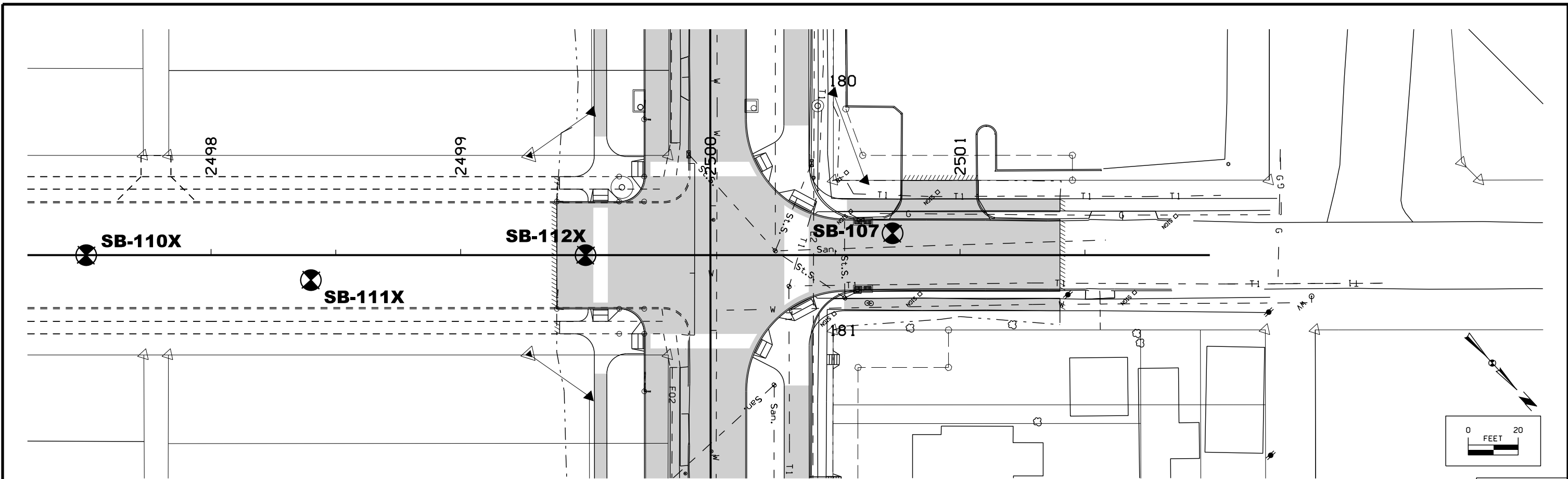















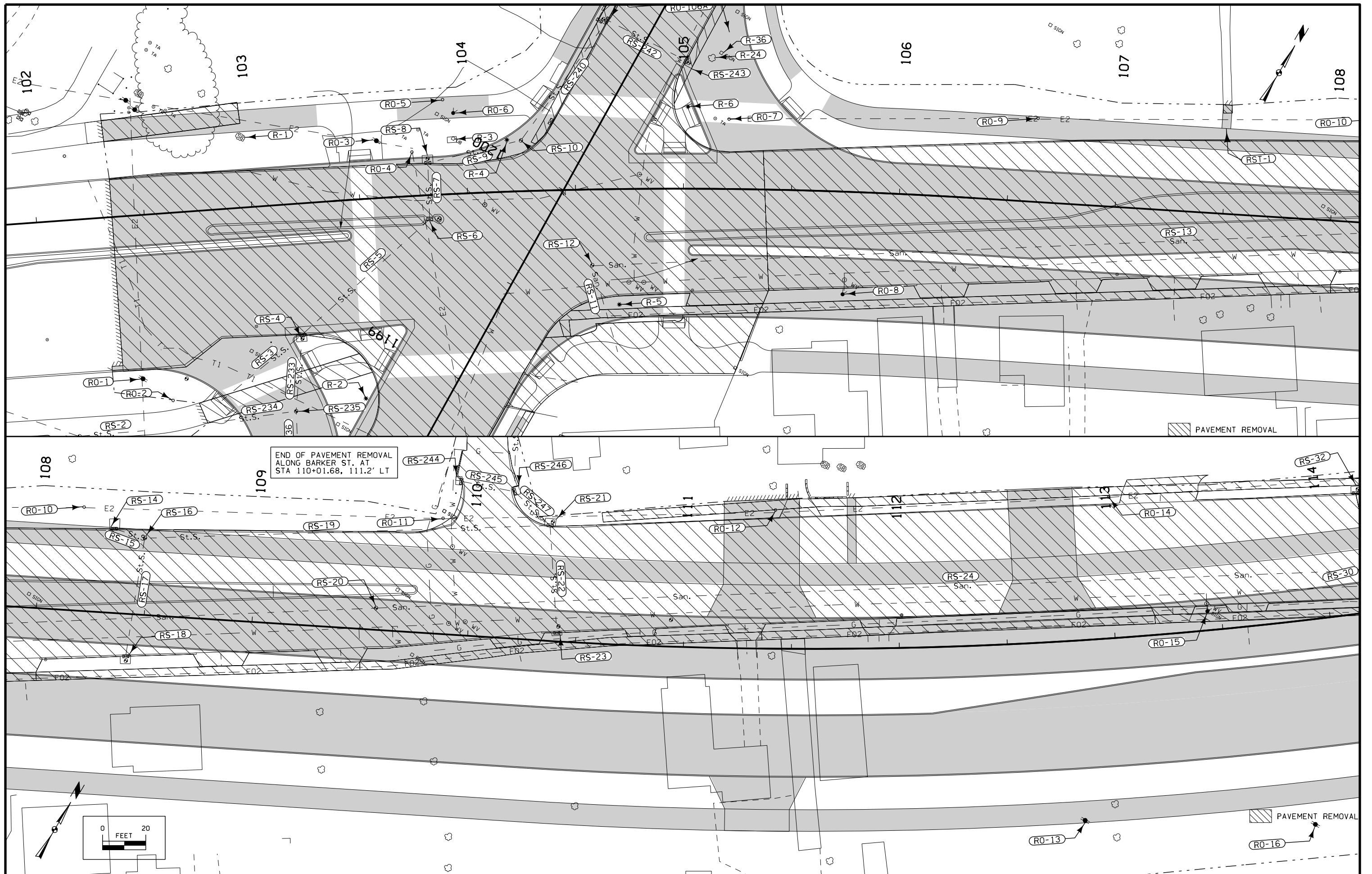

END OF PAVEMENT REMOVAL  
ALONG BARKER ST. AT  
STA 110+01.68, 111.2' LT

PAVEMENT REMOVAL

PAVEMENT REMOVAL

