

INDEX OF SHEETS	
No.	DESCRIPTION
A Sheets	Title Sheets
A.1	Title Sheet
A.2	Location Map Sheet
B Sheets	Typical Cross Sections and Details
B.1 - 10	Typical Cross Sections and Details
D Sheets	Mainline Plan and Profile Sheets
* D.1	Plan & Profile Legend & Symbol Information Sheet
* D.2 - 6	Southwest Arterial
E Sheets	Side Road Plan and Profile Sheets
* E.1 - 2	Access Road "B"
* E.2	Knepper Lane
* E.3	U.S. 61 Connector Road "A"
* E.4	U.S. 61 Connector Road "B"
* E.5	Olde Davenport Road
K Sheets	Interchange Sheets
* K.1	Southwest Arterial & U.S. 61
* K.2	U.S. 61 Ramp "A"
* K.3	U.S. 61 Loop "B"
* K.4	U.S. 61 Loop "C"
* K.5	U.S. 61 Ramp "D"
W Sheets	Mainline Cross Sections
W.1	Cross Sections Legend & Symbol Information Sheet
W.2 - 144	Mainline Cross Sections
X Sheets	Side Road Cross Sections
X.1 - 48	Side Road Cross Sections
Y Sheets	Ramp Cross Sections
Y.1 - 18	Ramp Cross Sections
* Color Plan Sheets	



Highway Division

PLANS OF PROPOSED IMPROVEMENT ON THE

PRIMARY ROAD SYSTEM DUBUQUE COUNTY GRADING

US 61/US 151 to US 20 (SW Arterial in Dubuque)
Catfish Creek to Old Davenport Rd.

SCALES: As Noted

Refer to the Proposal Form for list of applicable specifications.

Value Engineering Saves. Refer to Article 1105.14 of the Specifications.

MILEAGE SUMMARY			105-1 09-27-94
Div.	Location	Lin. Ft.	Miles
	Southwest Arterial		
	Sta. 250+25.00 to Sta. 300+00.00	4975.00	0.942
	Sta. 315+00.00 to Sta. 380+48.56	6548.56	1.240
	Access Road "B"		
	Sta. 58+00.00 to Sta. 100+00.00	4200.00	0.795
	U.S. 61 Connector Road "A"		
	Sta. 6+95.00 to Sta. 29+44.05	2249.05	0.426
	Silverwood Drive		
	Sta. 16+50.00 to Sta. 18+80.00	230.00	0.044
	U.S. 61 Connector Road "B"		
	Sta. 10+55.12 to Sta. 40+00.00	2944.88	0.558
	Ramp A		
	Sta. 1519+08.66 to Sta. 1536+48.79	1740.13	0.330
	Loop B		
	Sta. 2522+75.00 to Sta. 2530+26.57	751.57	0.142
	Loop C		
	Sta. 3522+48.98 to Sta. 3529+94.64	745.66	0.141
	Ramp D		
	Sta. 4517+38.72 to Sta. 4531+87.06	1448.34	0.274
	Project Totals=	25833.13	4.892

DESIGN DATA RURAL

20--	AADT	N/A	V.P.D.
2030	AADT	21,100	V.P.D.
2030	DHV	2030	V.P.H.
	TRUCKS	--	%
	Total		
	Design ESALs	--	

INDEX OF SEALS

SHEET NO.	NAME	TYPE
A.1	Mark D. Durbahn, PE AECOM	Primary Signature Block

REVISIONS

TOTAL

238

PROJECT IDENTIFICATION NUMBER

94-31-032-010

PROJECT NUMBER

NHSX-032-1(36)--3H-31

R.O.W. PROJECT NUMBER

NHSN-032-1(20)--2R-31



APPROVED

CITY ENGINEER

DATE

CITY OF DUBUQUE, IOWA

I hereby certify that this Engineering document was prepared by me or under my direct personal supervision and that I am a duly Licensed Professional Engineer under the laws of the State of Iowa.

PRELIMINARY PLANS

MARK DURBAHN
13157
Date _____
License number 13157
My license renewal date is December 31, 2016
Pages or sheets covered by this seal:
A.1-2, B.1-10, D.1-6, E.1-5, K.1-5
W.1-144, X.1-48, Y.1-18

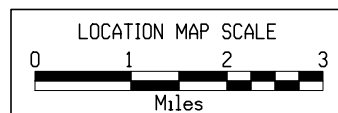
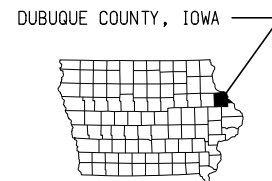
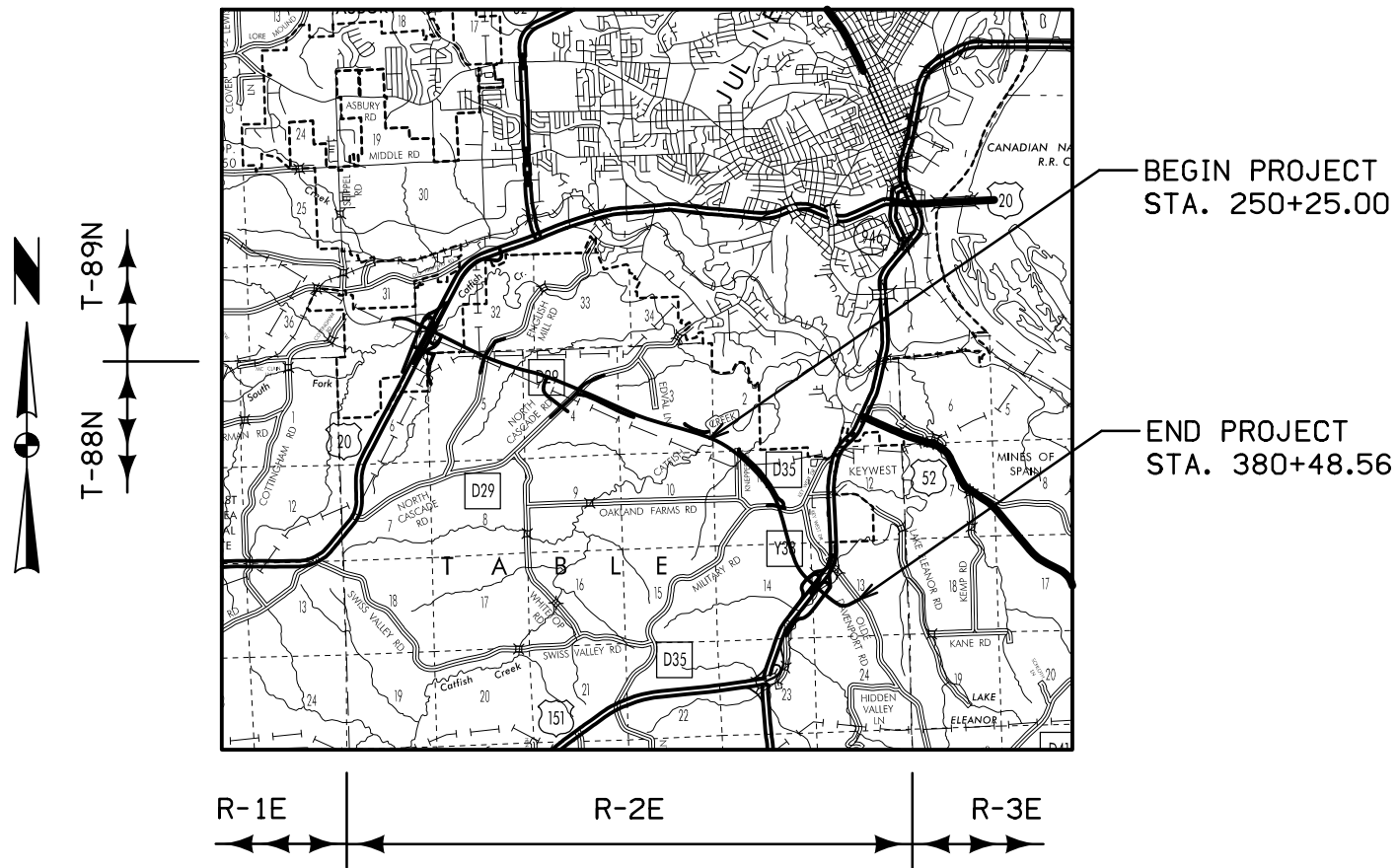

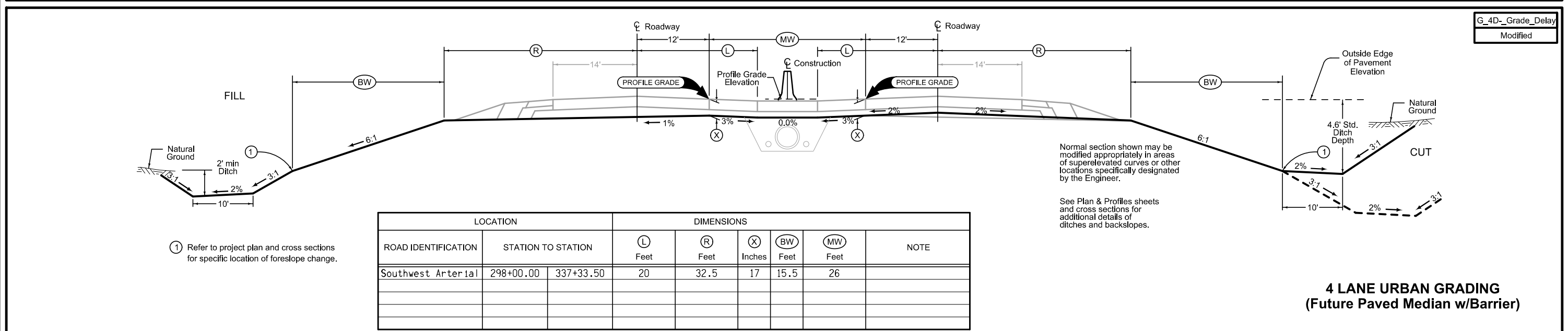
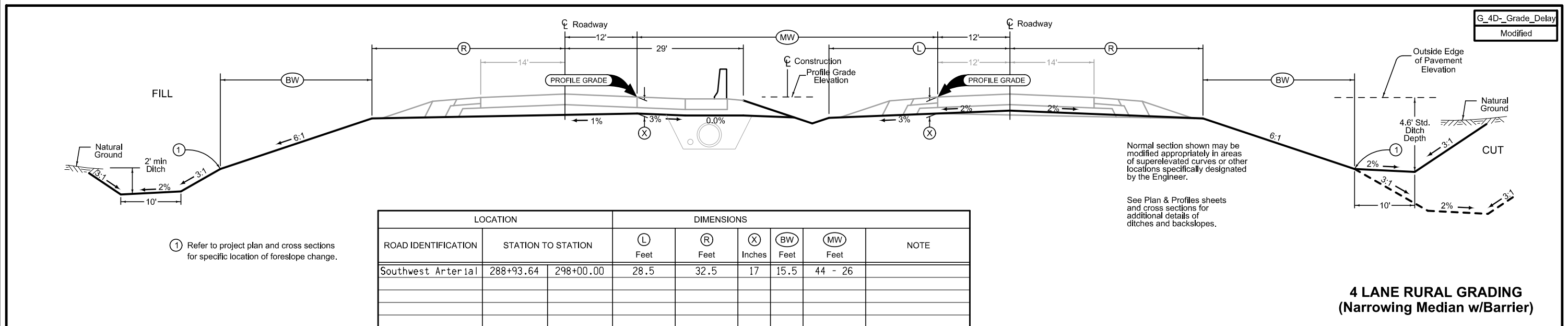
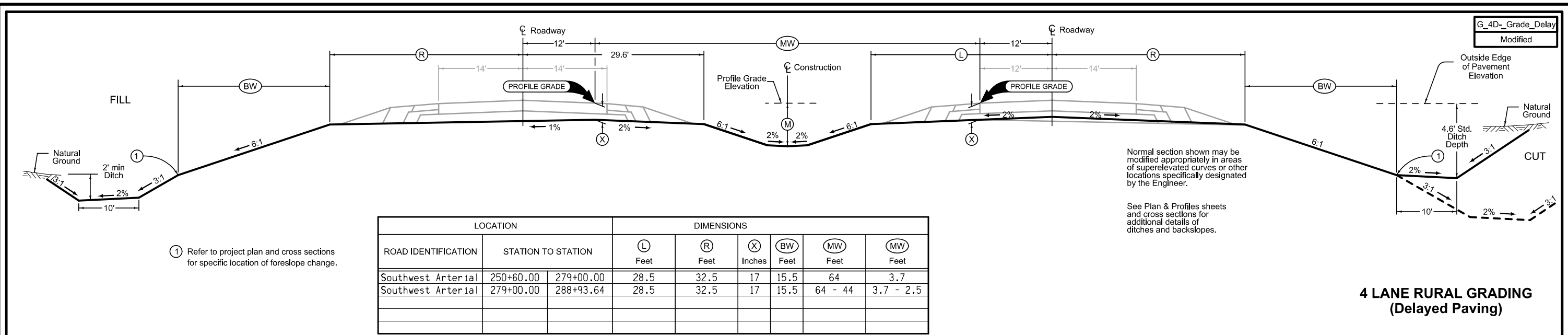

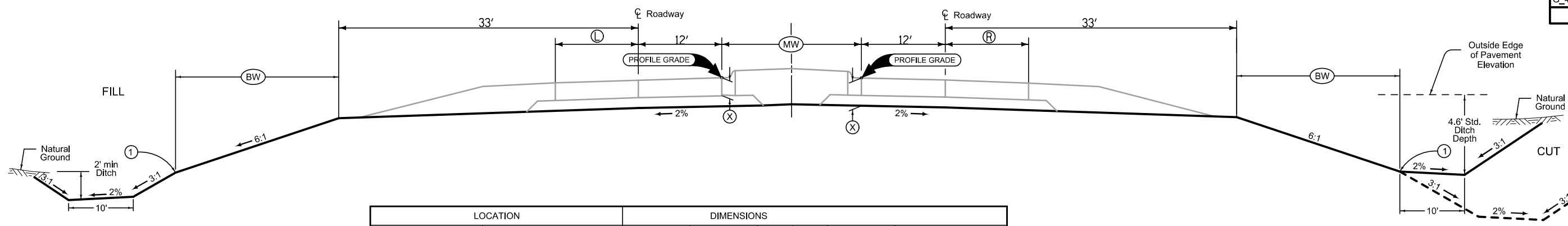

LOCATION		DIMENSIONS						NOTE
ROAD IDENTIFICATION	STATION TO STATION	L Feet	R Feet	X Inches	BW Feet	MW Feet		
Southwest Arterial	337+33.50 - 337+65.22	14	14 - 20	17	15.5	26		
Southwest Arterial	337+65.22 - 339+94.15	14	-	17	15.5	26	Left Side Only	
Southwest Arterial	339+94.15 - 340+54.42	14	-	17	15.5	26 - 24.7	Left Side Only	
Southwest Arterial	340+54.42 - 342+19.52	14	-	17	15.5	24.7 - 17.9	Left Side Only	
Southwest Arterial	362+50.61 - 362+66.82	16.4 - 11.6	-	17	NA	14.8 - 14	Left Side Only	

NOTE: Normal section shown may be appropriately modified for areas specifically designated by the Engineer such as intersections or superelevated curves.
① Refer to Standard Road Plan DR-303.

**4 LANE URBAN/RURAL GRADING
(Future Raised Median w/Rural Ditches)**

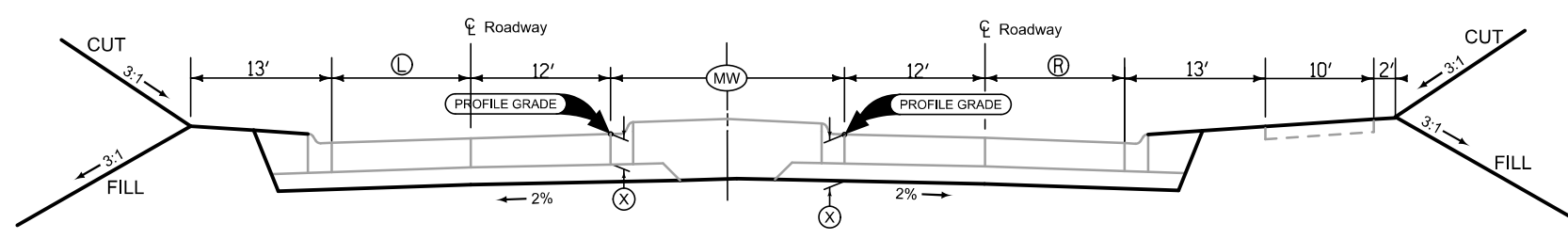

LOCATION		DIMENSIONS						NOTE
ROAD IDENTIFICATION	STATION TO STATION	L Feet	R Feet	X Inches	BW Feet	MW Feet		
Southwest Arterial	337+65.22 - 339+94.15	-	20 - 12	17	NA	26	Right Side Only	
Southwest Arterial	339+94.15 - 340+54.42	-	12	17	NA	26 - 24.7	Right Side Only	
Southwest Arterial	340+54.42 - 342+19.52	-	12	17	NA	24.7 - 17.9	Right Side Only	
Southwest Arterial	348+75.73 - 348+99.15	5	5	17	NA	8		
Southwest Arterial	348+75.73 - 350+34.30	5	5 - 14	17	NA	8		
Southwest Arterial	350+34.30 - 350+39.98	5	14	17	NA	8		
Southwest Arterial	355+61.48 - 355+98.97	5	14	17	NA	8		
Southwest Arterial	361+80.17 - 362+50.61	13.4	5	17	NA	16.9 - 14.8		
Southwest Arterial	362+50.61 - 362+66.82	-	5	17	NA	14.8 - 14	Right Side Only	

NOTE: Normal section shown may be appropriately modified for areas specifically designated by the Engineer such as intersections or superelevated curves.
① Refer to Standard Road Plan DR-303.

**4 LANE URBAN GRADING
(Future Raised Median)**

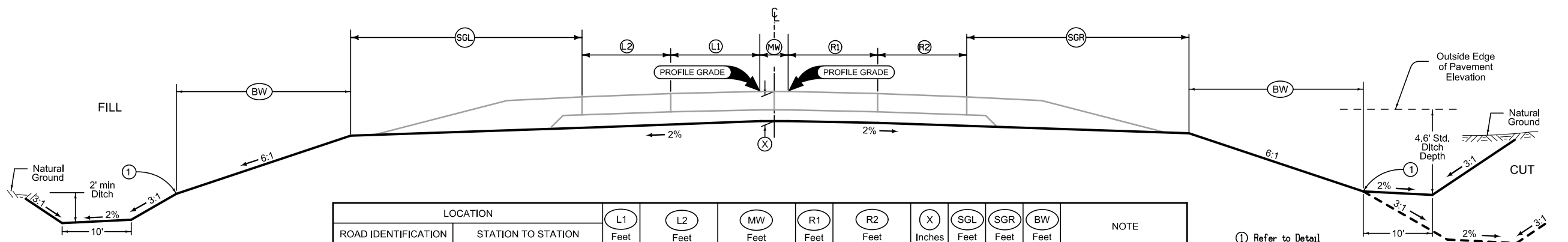

LOCATION		L1 Feet	L2 Feet	MW Feet	R1 Feet	R2 Feet	X Inches	SGL Feet	SGR Feet	BW Feet	NOTE
Southwest Arterial	362+66.82 - 362+84.56	12	11.6-7.1	14-13.14	12	8.0-5.5	17	18.3	18.3	19.7	
Southwest Arterial	362+84.56 - 363+08.85	12	7.1-5.3	13.14-11.96	12	5.5-2.0	17	18.3	18.3	19.7	
Southwest Arterial	363+08.85 - 363+60.45	12	5.3-2.0	11.96-9.44	14	0	17	18.3	18.3	19.7	
Southwest Arterial	363+60.45 - 365+53.57	14	0	9.44-0.0	14	0	17	18.3	18.3	19.7	
Southwest Arterial	365+53.57 - 378+80.00	14	0	0	14	0	17	18.3	18.3	19.7	
Southwest Arterial	378+80.00 - 379+41.17	12	2.0-8.1	0	14	0	17	18.3	18.3	19.7	
Southwest Arterial	379+41.17 - 379+66.39	12	8.1-10.7	0	12	2.0-6.3	17	18.3	18.3	19.7	
Southwest Arterial	379+66.39 - 380+37.37	12	*	0	12	*	17	18.3	18.3	19.7	Intersection Grading

Notes:
Normal sections shown may be modified appropriately in areas of superelevated curves or other locations specifically designated by the Engineer.
See appropriate Typical Sections in this plan for details of ditches and backslopes.

① Refer to Detail Project Plan and Cross Sections for specific locations of foreslope change.

**2-4 LANE RURAL GRADING
(Future Paving)**

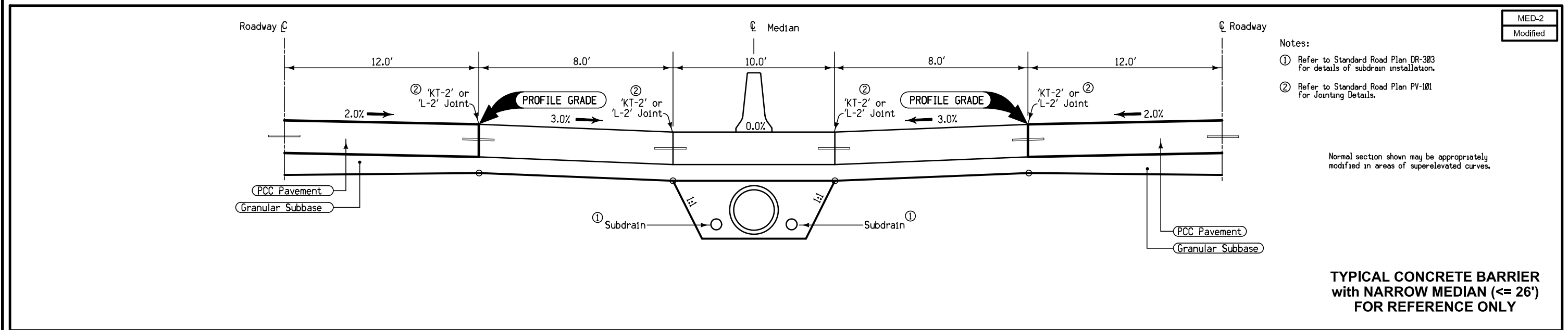
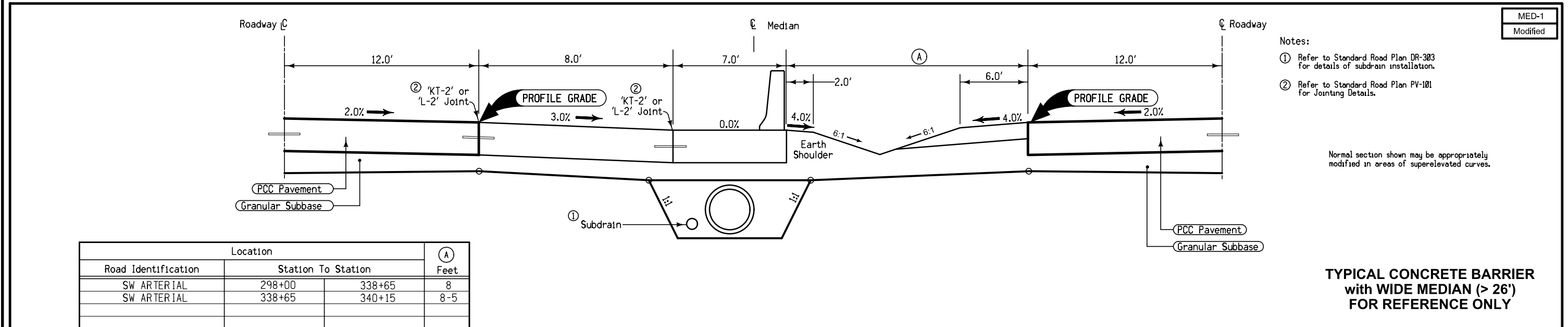
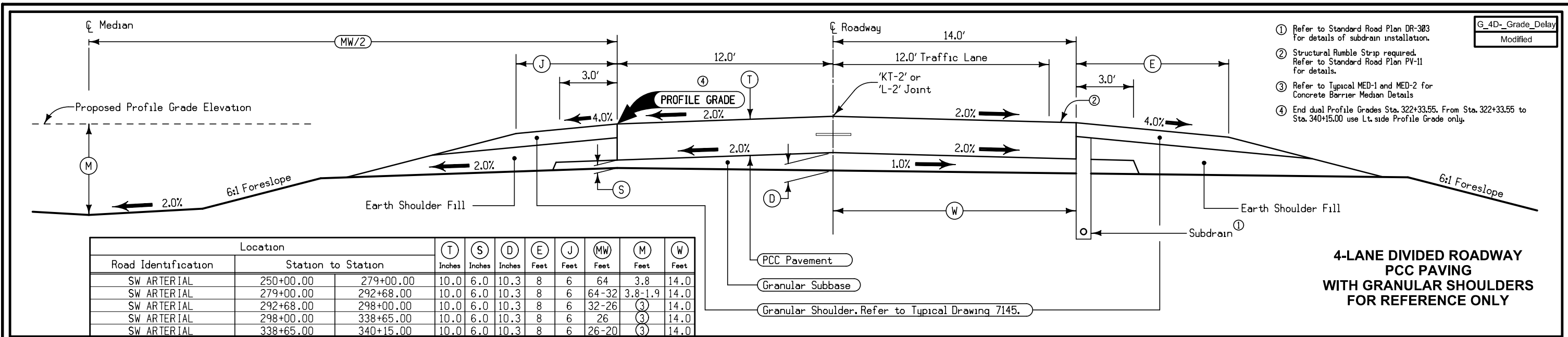

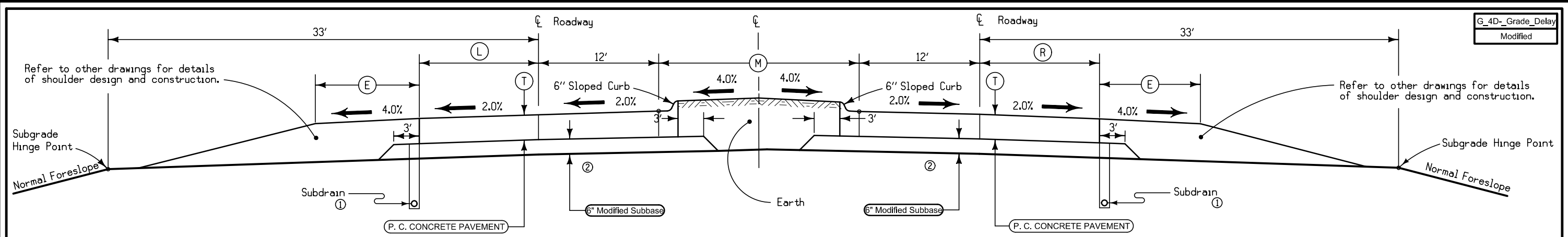

NOTE: Normal section shown may be appropriately modified for areas specifically designated by the Engineer such as intersections or superelevated curves.

① Refer to Standard Road Plan DR-303.

② End dual Profile Grades Sta. 322+33.55. From Sta. 322+33.55 to Sta. 340+15.00 use Lt. side Profile Grade only.

LOCATION		T	M	E	L	R	SHOULDER TYPE
ROAD IDENTIFICATION	STATION TO STATION	Inches	Feet	Feet	Feet	Feet	
SW ARTERIAL	340+15.00 359+68.14	10.0	14	8	14	14	GRANULAR
SW ARTERIAL	359+68.14 364+68.14	10.0	14-0	8	14	14	GRANULAR

**4-LANE DIVIDED ROADWAY
PCC PAVEMENT WITH CURBED MEDIAN
FOR REFERENCE ONLY**

LOCATION		MAINLINE						SHLDR
ROAD IDENTIFICATION	STATION TO STATION	T	D	L	R	A	B	G
		Inches	Inches	Feet	Feet	Feet	Feet	Feet
Connector Road	1500+35.56 1502+15	9	6			26	12	10
Connector Road	1502+15 1504+25	9	6			26-12	12	10
Connector Road	1504+25 1516+22.23	9	6			12	12	10
Connector Road	1516+22.23 1521+02.19	9	6			12	12-28	10
Connector Road	1521+02.19 1522+62.87	9	6			12	28	10

Dimensions are symmetrical about the centerline.

Normal sections shown may be appropriately modified for areas specifically designated by the Engineer such as intersections or superelevated curves.

① Refer to DR-303.

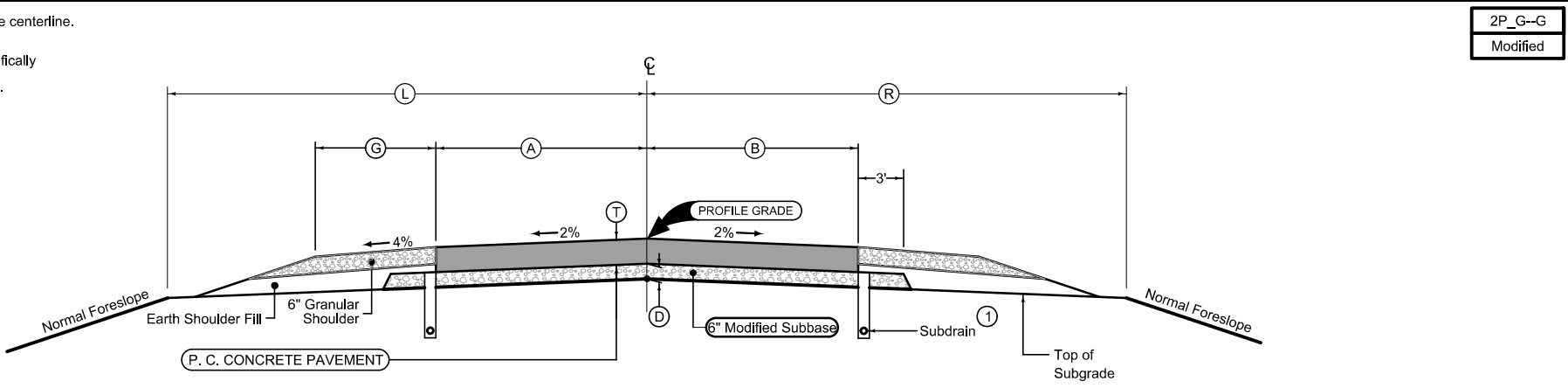

Mainline Pavement:
Transverse joints: CD at 20' spacing
Longitudinal joint: L-2

**2-LANE PCC PAVING (Granular Shoulders)
FOR REFERENCE ONLY**

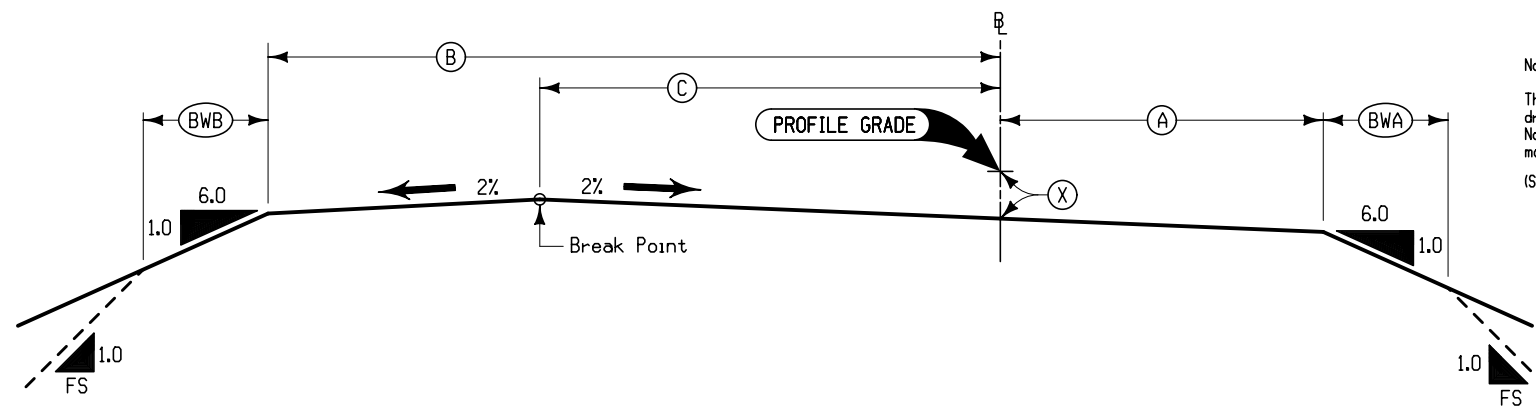

Notes:
This section is typical only. Refer to other drawings for additional details.
Normal section shown may be appropriately modified in areas of superelevated curves.
(Section view is in direction of Traffic)

LOCATION				DIMENSIONS						
INTERCHANGE	RAMP	STATION TO STATION		(A) Feet	(B) Feet	(C) Feet	(X) Inches	FS	(BWB) Feet	(BWA) Feet
US-20	B	2502+35.00	2520+96.61	16	32.5	16	10	3	19.75	18
US-61	A	1522+38.78	1536+00.00	16	32.5	16	10	3	17.50	18
US-61	D	4517+73.72	4531+87.06	16	32.5	16	10	3	17.50	18

TYPICAL CROSS SECTION
RAMP GRADING

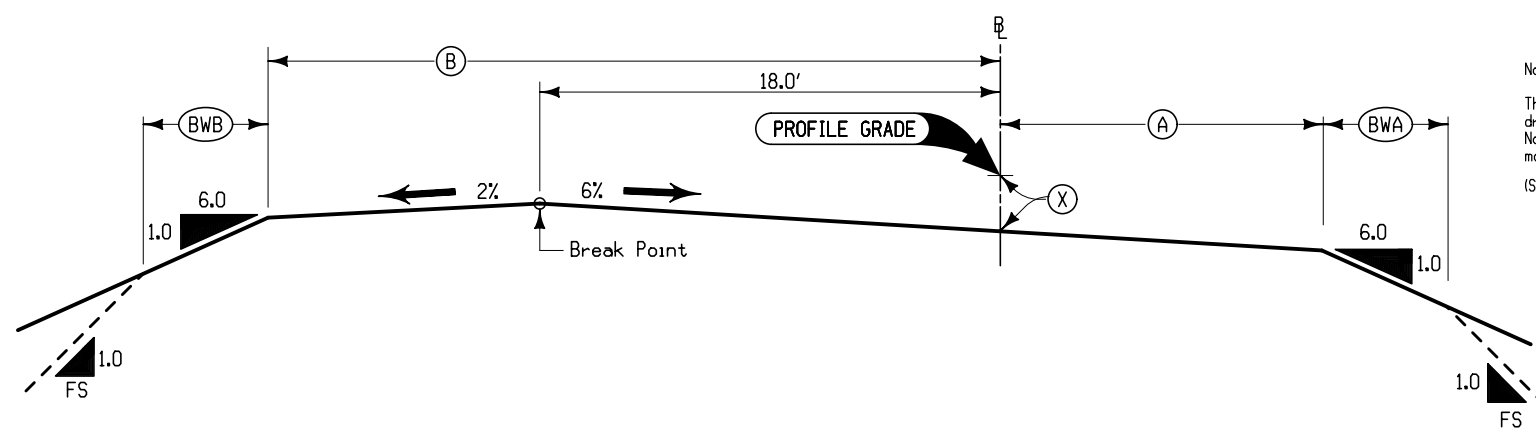

Notes:
This section is typical only. Refer to other drawings for additional details.
Normal section shown may be appropriately modified in areas of superelevated curves.
(Section view is in direction of Traffic)

LOCATION				DIMENSIONS						
INTERCHANGE	LOOP	STATION TO STATION		(A) Feet	(B) Feet	(X) Inches	FS	(BWB) Feet	(BWA) Feet	
US-61	B	2522+75.00	2530+26.57	20.8	34.5	10	3	17.5	13.2	
US-61	C	3522+48.98	3529+88.90	20.8	34.5	10	3	17.5	13.2	

TYPICAL CROSS SECTION
LOOP GRADING

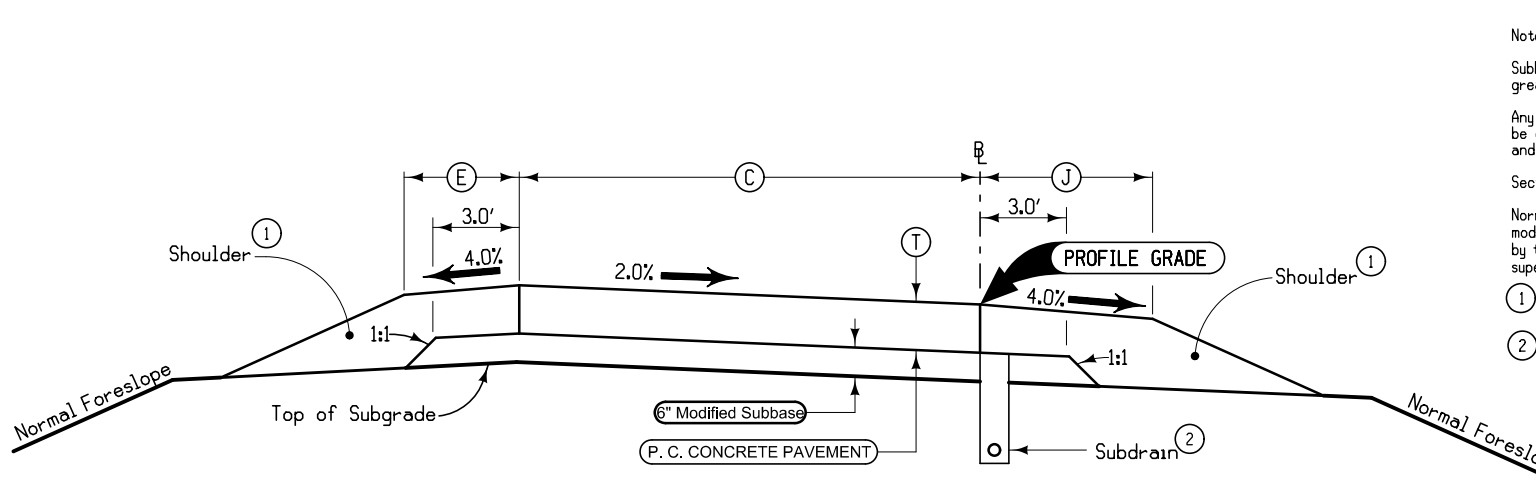

Notes:
Subbase may be constructed to a width greater than that indicated.
Any such extra width of subbase shall be considered incidental to other work and not be measured for payment.
Section view is in direction of traffic.
Normal section shown may be appropriately modified for areas specifically designated by the Engineer, such as intersections or superelevated curves.
① Refer to other drawing for details of shoulder design and construction.
② Refer to Standard Road Plan DR-303, for details of subdrain installation.

LOCATION				DIMENSIONS				SHOULDER TYPE
INTERCHANGE	RAMP	STATION TO STATION		(T) Inches	(C) Feet	(E) Feet	(J) Feet	
US-61	A	1522+38.78	1536+00.00	10	16	4	6	Granular
US-61	B	2522+75.00	2530+26.57	10	18	4	6	Paved
US-61	C	3522+48.98	3529+88.90	10	18	4	6	Paved
US-61	D	4517+73.72	4531+87.06	10	16	4	6	Granular

TYPICAL CROSS SECTION
PCC RAMP PAVING
FOR REFERENCE ONLY

2_Grade
Modified

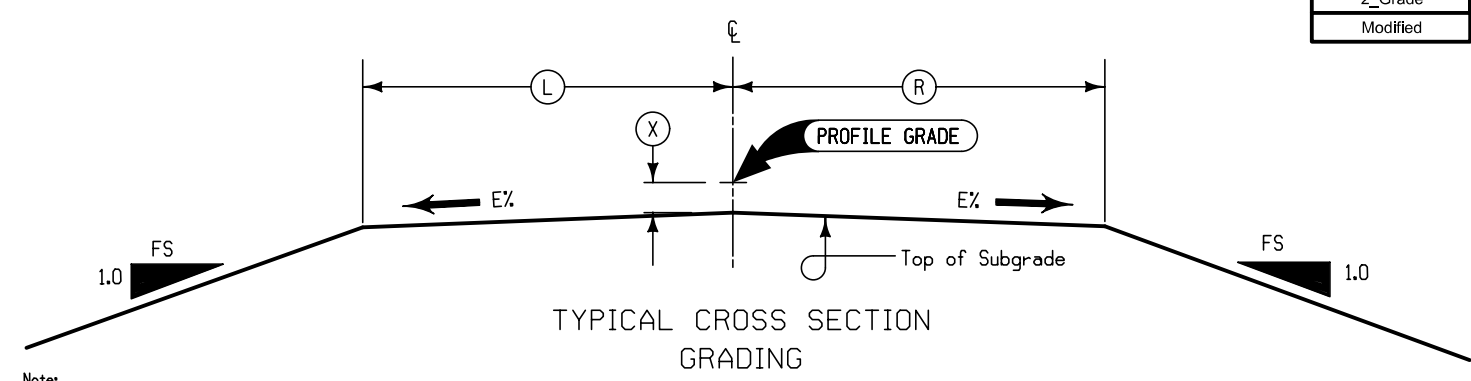

Notes:
Normal sections shown may be modified appropriately in areas of super-elevated curves or other locations specifically designated by the Engineer.
See appropriate Typical Sections in this plan for details of ditches and backslopes.

LOCATION		L	R	X	FS	E%
ROAD IDENTIFICATION	STATION TO STATION	Feet	Feet	Inches		
US-61 CONNECTOR ROAD A	6+95.00 29+64.88	22.3	22.3	14.5	3	2
SILVERWOOD DRIVE	15+60.00 19+87.79	22.3	22.3	14.5	3	2
US-61 CONNECTOR ROAD B	10+55.12 BRIDGE	22.3	22.3	14.5	3	2
US-61 CONNECTOR ROAD B	BRIDGE 39+65.00	22.3	22.3	14.5	3	2

2P_G-G
Modified

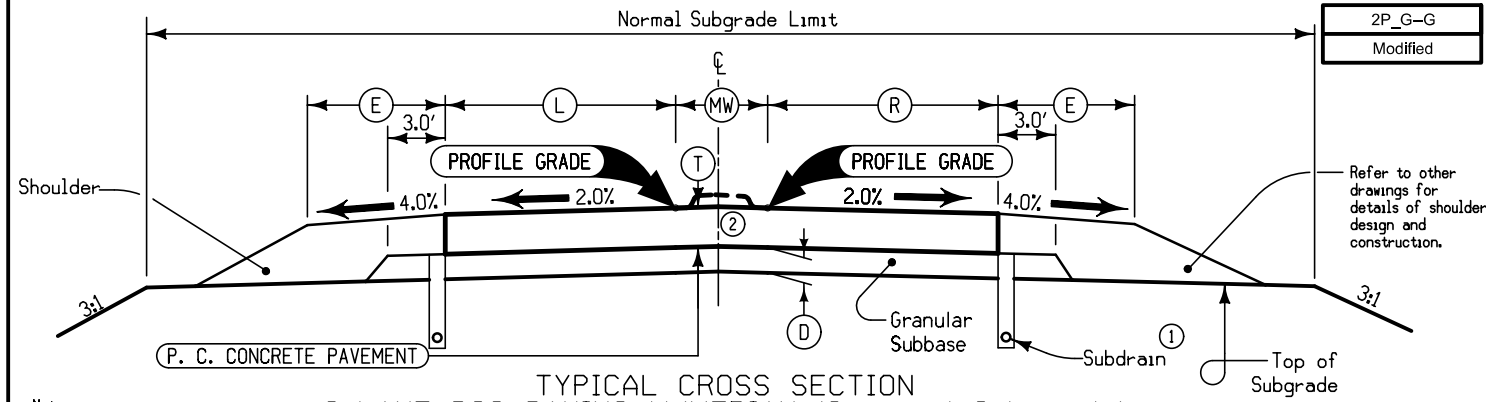

Notes:
Normal sections shown may be appropriately modified for areas specifically designated by the Engineer such as inter-sections or super-elevated curves.
① Refer to Standard Road Plan DR-303.
② 'FLAT' (2% CROWN) or 'RAISED' Median

LOCATION		T	D	E	L	R	MW	MEDIAN TYPE	SHOULDER TYPE
ROAD IDENTIFICATION	STATION TO STATION	Inches	Inches	Feet	Feet	Feet	Feet		
US-61 CONNECTOR ROAD A	6+95.00 29+64.88	8.5	6	4	14	14	14	FLAT	GRAVEL
US-61 CONNECTOR ROAD A	10+55.12 39+65.00	8.5	6	4	14	14	14	RAISED	GRAVEL
US-61 CONNECTOR ROAD B								FLAT	GRAVEL
US-61 CONNECTOR ROAD B								RAISED	GRAVEL

2P_G-G
Modified

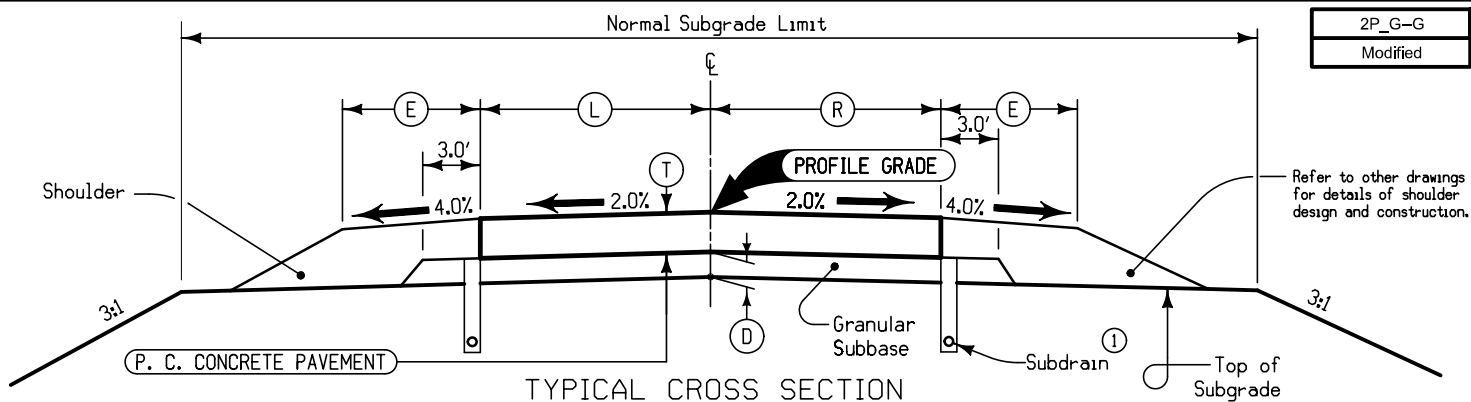

Notes:
Normal sections shown may be appropriately modified for areas specifically designated by the Engineer such as inter-sections or super-elevated curves.
① Refer to Standard Road Plan DR-303.

LOCATION		T	D	E	L	R	SHOULDER TYPE
ROAD IDENTIFICATION	STATION TO STATION	Inches	Inches	Feet	Feet	Feet	
US-61 CONNECTOR ROAD A	6+95.00 29+64.88	8.5	6	4	14	14	GRAVEL
SILVERWOOD DRIVE	15+60.00 19+87.79	8.5	6	4	14	14	GRAVEL
US-61 CONNECTOR ROAD B	10+55.12 BRIDGE	8.5	6	4	14	14	GRAVEL
US-61 CONNECTOR ROAD B	BRIDGE 39+65.00	8.5	6	4	14	14	GRAVEL

2_Grade_Gran
Modified

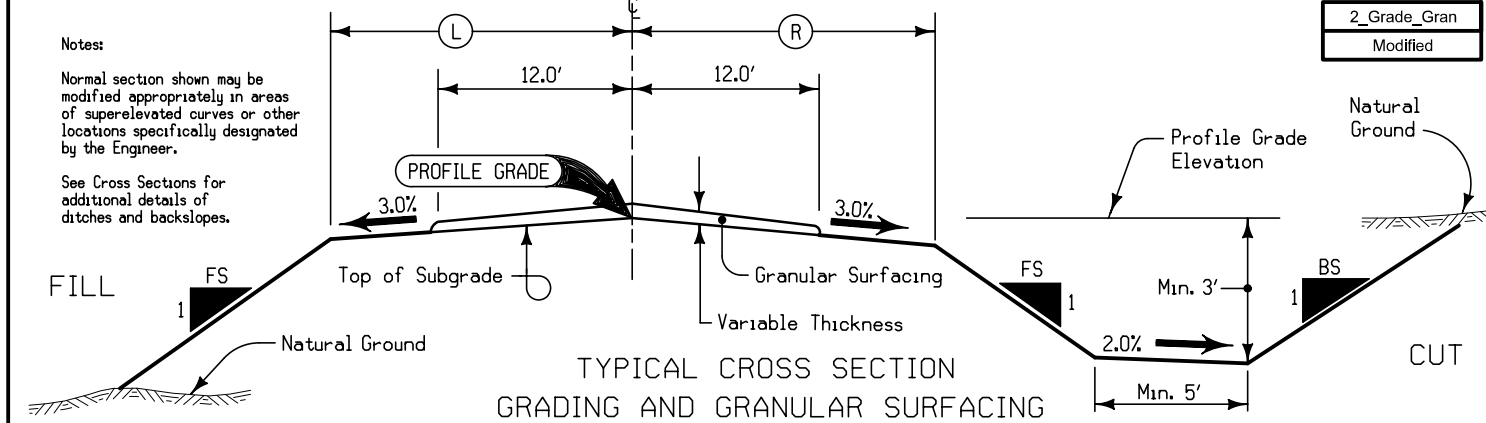

Notes:
Normal section shown may be modified appropriately in areas of super-elevated curves or other locations specifically designated by the Engineer.
See Cross Sections for additional details of ditches and backslopes.
Granular Surfacing shall be placed as follows:
Stage 1 (Grading) Design application rate 15 tons per mile.
Stage 2 (Paving) Design application rate 15 tons per mile.

LOCATION		DIMENSIONS		SLOPES	
ROAD IDENTIFICATION	STATION TO STATION	L	R	FS	BS
ACCESS ROAD "B"	58+48.96 99+90.88	15	15	3	3
KNEPPER LANE TURNAROUND				3	3

2_Grade
Modified

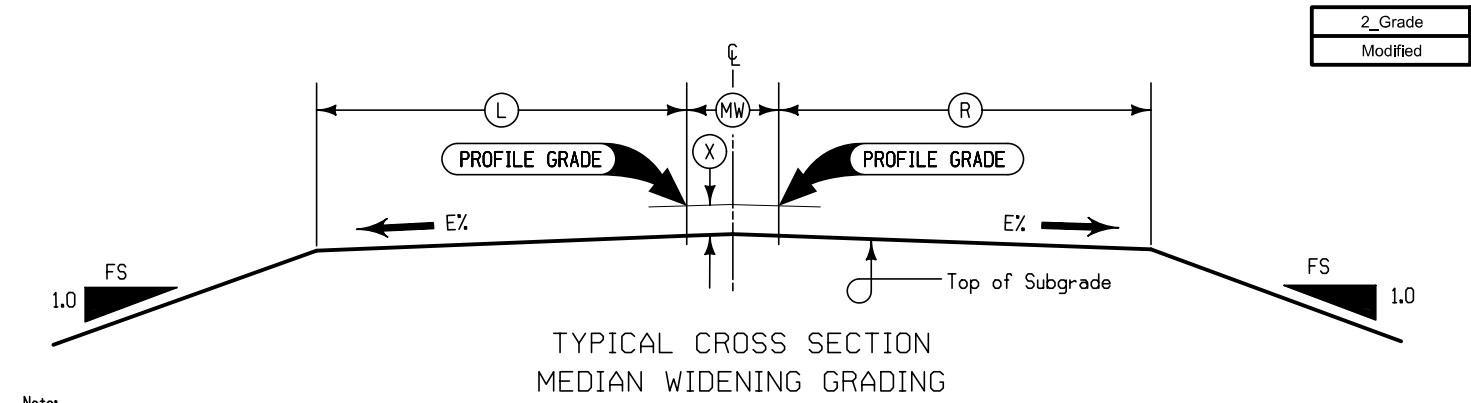

Notes:
Normal sections shown may be modified appropriately in areas of super-elevated curves or other locations specifically designated by the Engineer.
See appropriate Typical Sections in this plan for details of ditches and backslopes.

LOCATION		L	R	MW	X	FS	E%
ROAD IDENTIFICATION	STATION TO STATION	Feet	Feet	Feet	Inches		
US-61 CONNECTOR ROAD A	6+95.00 29+64.88	22.3	22.3		14.5	3	2
US-61 CONNECTOR ROAD A	15+60.00 19+87.79	22.3	22.3		14.5	3	2
US-61 CONNECTOR ROAD B	10+55.12 BRIDGE	22.3	22.3		14.5	3	2
US-61 CONNECTOR ROAD B	BRIDGE 39+65.00	22.3	22.3		14.5	3	2

4110
10-15-13

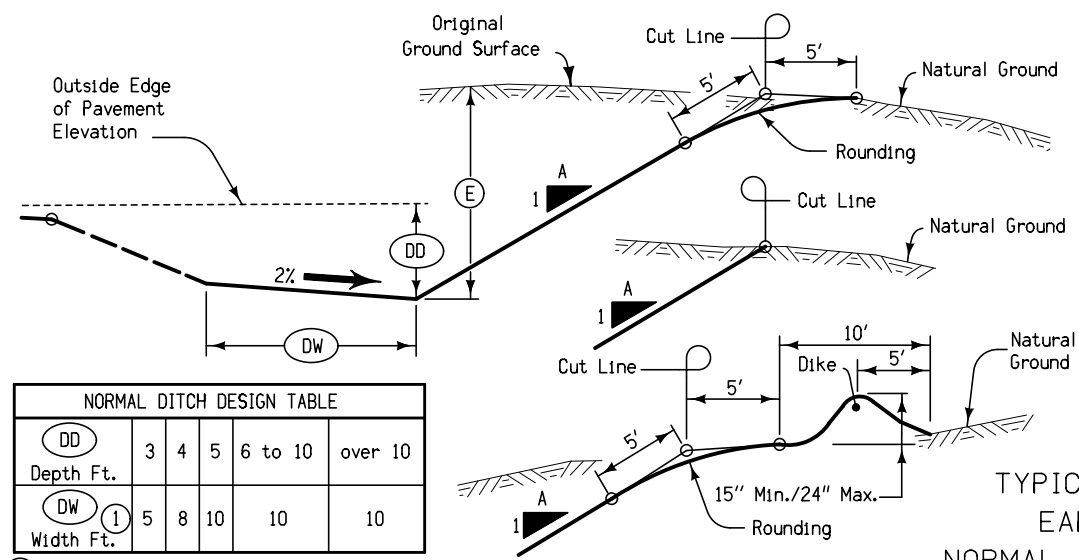

For normal conditions, backslopes (A) shall be 3.0 on 1.0 for E depths less than 25', unless specified otherwise. Refer to detail project plans and cross sections for Ditch Depth or for Special Ditches.

Refer to project plans for locations of areas where rounding of the back slope is not required.

Refer to plans for locations of intercepting ditches. Dike for intercepting ditch shall be made by taking earth from roadway side. Do not excavate back of dike.

TYPICAL CROSS SECTION
EARTH EXCAVATION
NORMAL DITCH AND BACKSLOPE

NORMAL DITCH DESIGN TABLE					
DD	3	4	5	6 to 10	over 10
Depth Ft.					
DW	5	8	10	10	10
Width Ft.					

① A 100' transition should be used between width changes.

4104
Modified

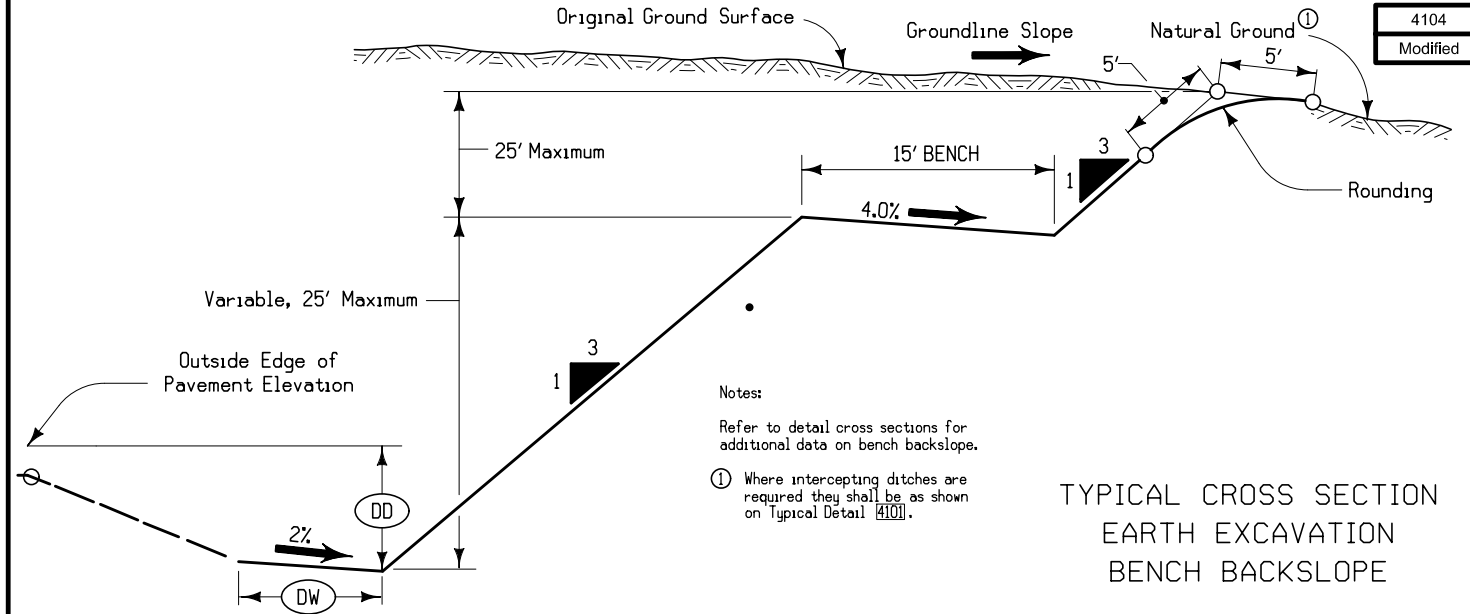

Notes:
Refer to detail cross sections for additional data on bench backslope.
① Where intercepting ditches are required they shall be as shown on Typical Detail 4101.

TYPICAL CROSS SECTION
EARTH EXCAVATION
BENCH BACKSLOPE

4111
10-15-13

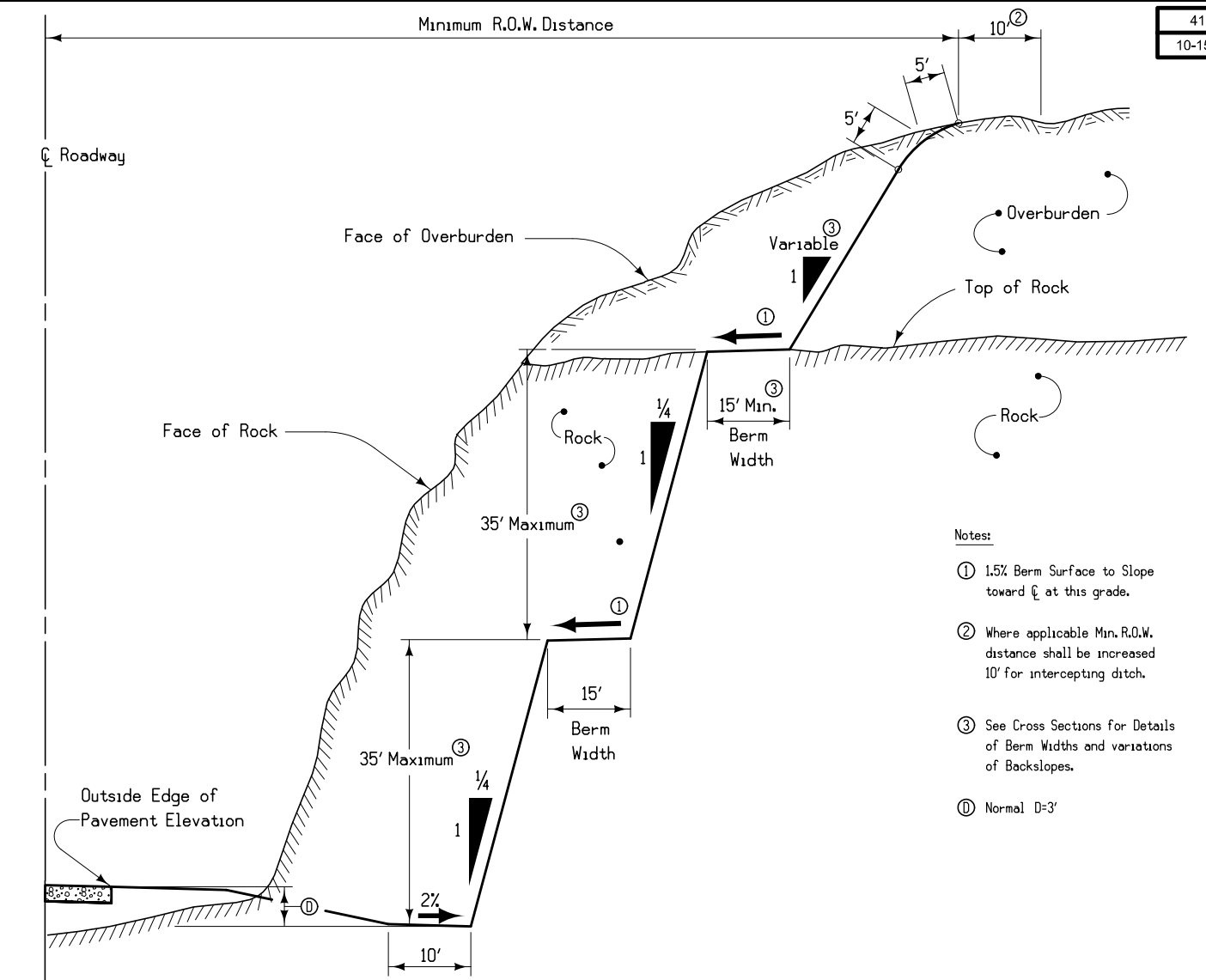

Notes:
① 1.5% Berm Surface to Slope toward C at this grade.
② Where applicable Min. R.O.W. distance shall be increased 10' for intercepting ditch.
③ See Cross Sections for Details of Berm Widths and variations of Backslopes.
④ Normal D=3'

EXCAVATION IN ROCK
USING PRE-SPLITTING METHOD

4107
Modified

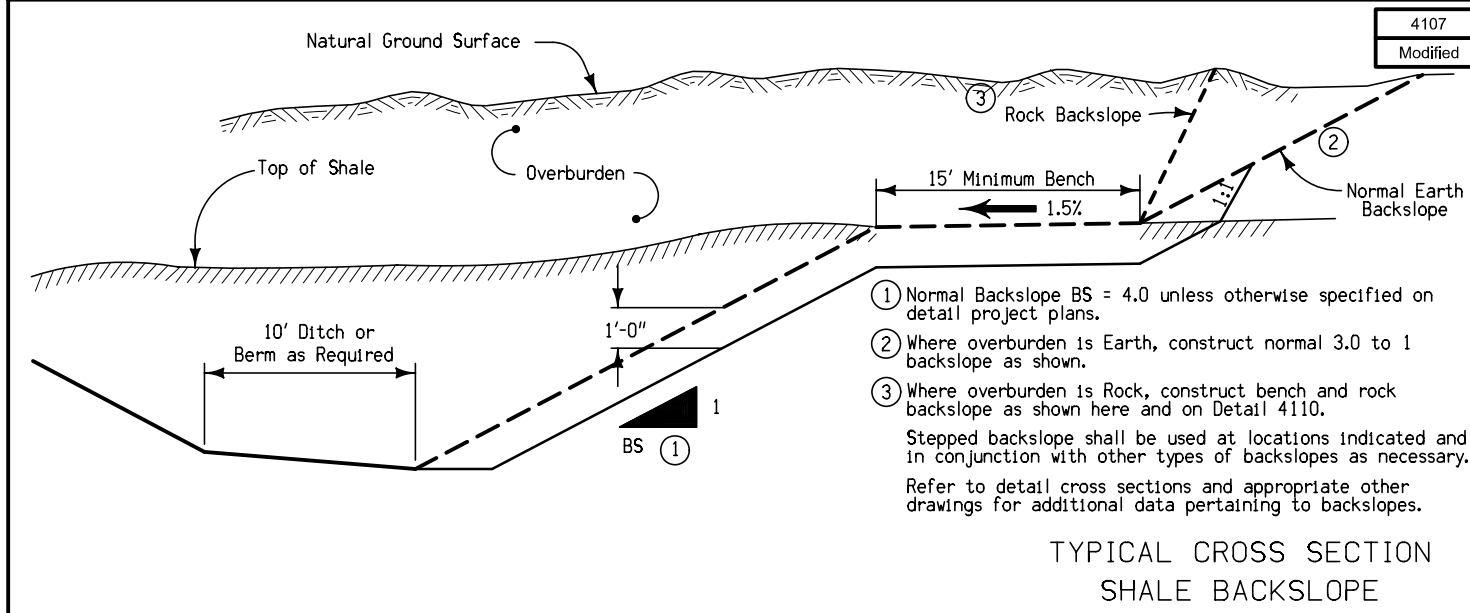

Notes:
① Normal Backslope BS = 4.0 unless otherwise specified on detail project plans.
② Where overburden is Earth, construct normal 3.0 to 1 backslope as shown.
③ Where overburden is Rock, construct bench and rock backslope as shown here and on Detail 4110.
Stepped backslope shall be used at locations indicated and in conjunction with other types of backslopes as necessary.
Refer to detail cross sections and appropriate other drawings for additional data pertaining to backslopes.

TYPICAL CROSS SECTION
SHALE BACKSLOPE

AECOM-1

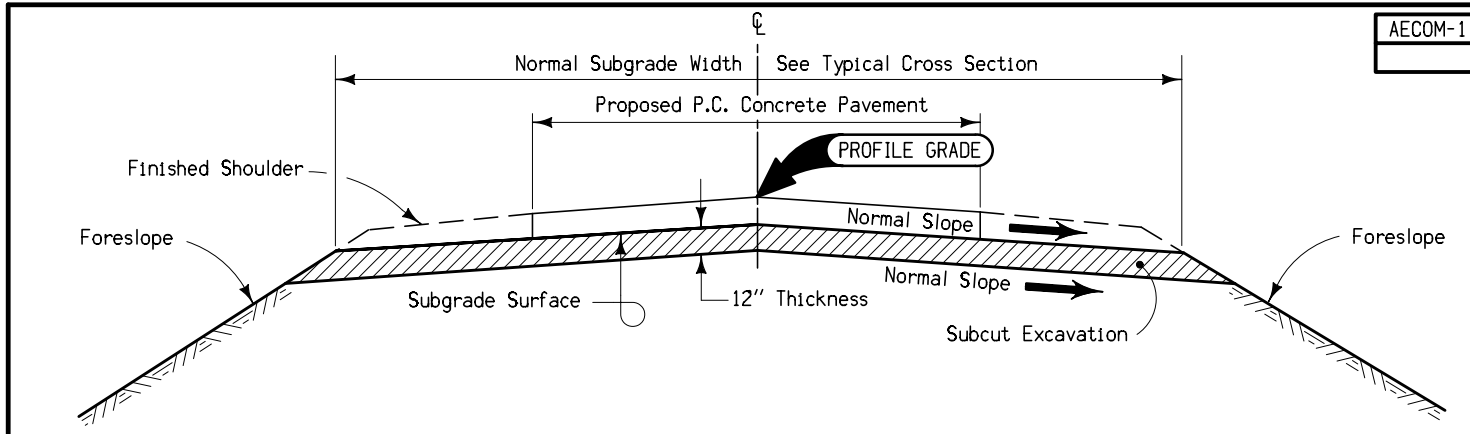

Contractor shall excavate Class 12 area indicated, dispose of the material and replace with suitable backfill. If subcut excavation is in Shale, then backfill shall be with Cohesive Select Soil, meeting the requirements of Article 2102.02, D, 1, a. If subcut excavation is in Limestone, then backfill may be with Select Soil (quantified within these plans), or the contractor may optionally use Special Backfill at no additional cost to the project.
See T-Sheet quantities for additional information.
See typical cross sections for ditches and backslopes.

TYPICAL CROSS SECTION
SUBCUT EXCAVATION AND BACKFILL
IN ROCK AND SHALE

PATH-1

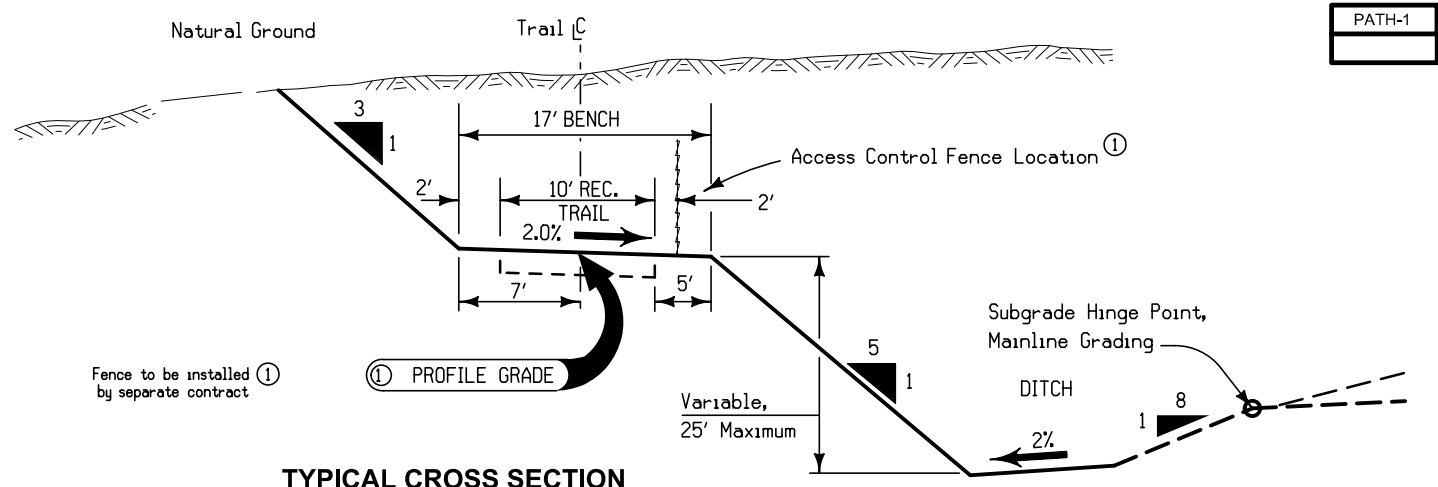

**TYPICAL CROSS SECTION
SHARED USE PATH
BENCHED INTO BACKSLOPE**
Sta. 8359+25± to Sta. 8369+00±, 'Bike8'
Sta. 8372+14± to Sta. 8379+30±, 'Bike8'

PATH-2

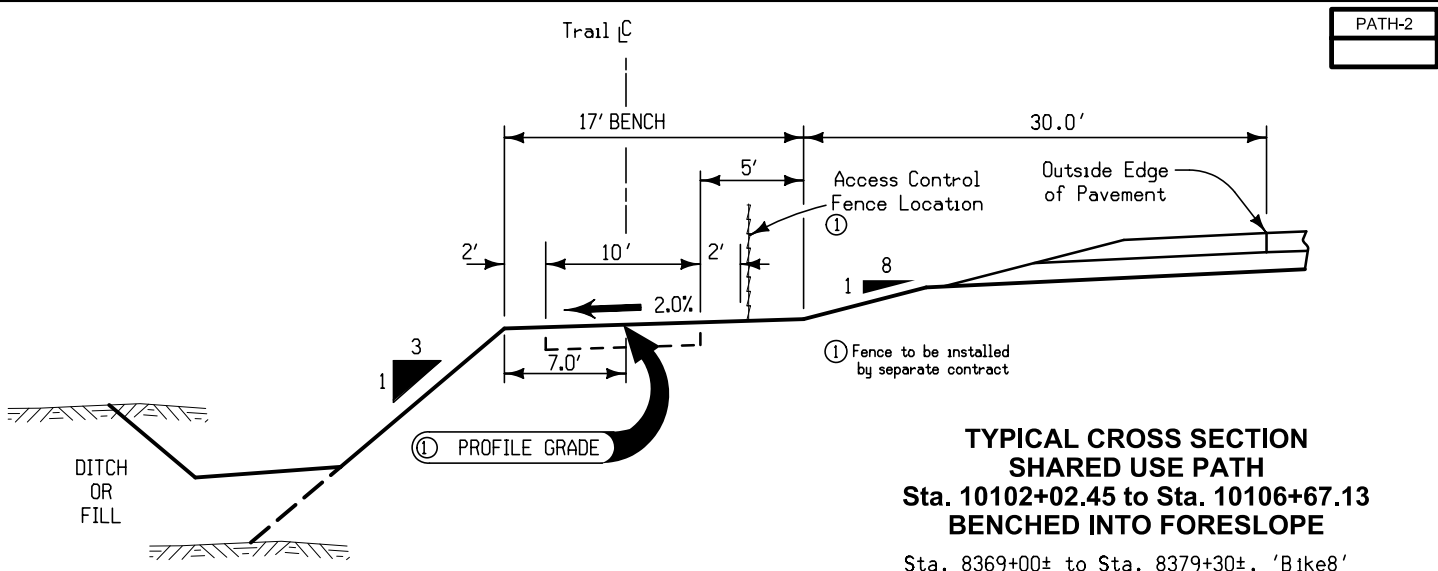

**TYPICAL CROSS SECTION
SHARED USE PATH**
Sta. 10102+02.45 to Sta. 10106+67.13
BENCHED INTO FORESLOPE
Sta. 8369+00± to Sta. 8379+30±, 'Bike8'

PATH-3

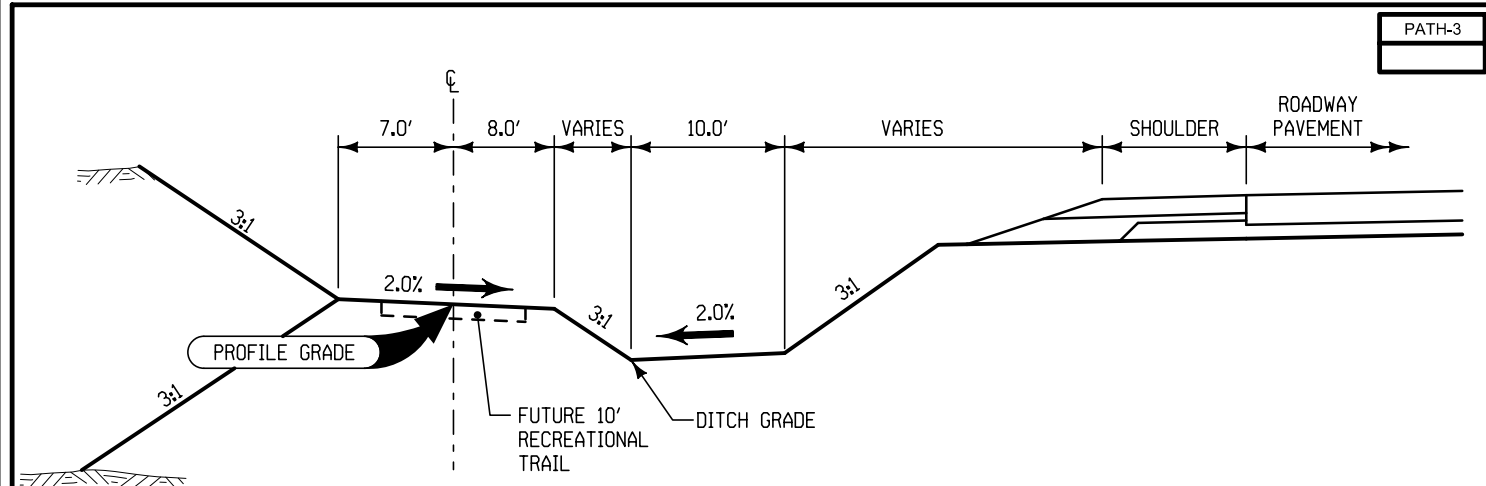

**TYPICAL CROSS SECTION
SHARED USE PATH**
Sta. 50178+00 to Sta. 50187+50

4101
04-20-10

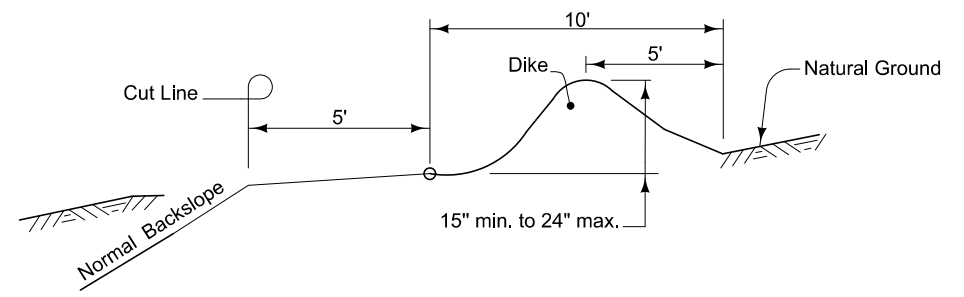

Refer to plans for locations of intercepting ditches. Dike for intercepting ditch shall be made by taking earth from roadway side. Do not excavate back of dike.

**TYPICAL CROSS SECTION
INTERCEPTING DITCH**

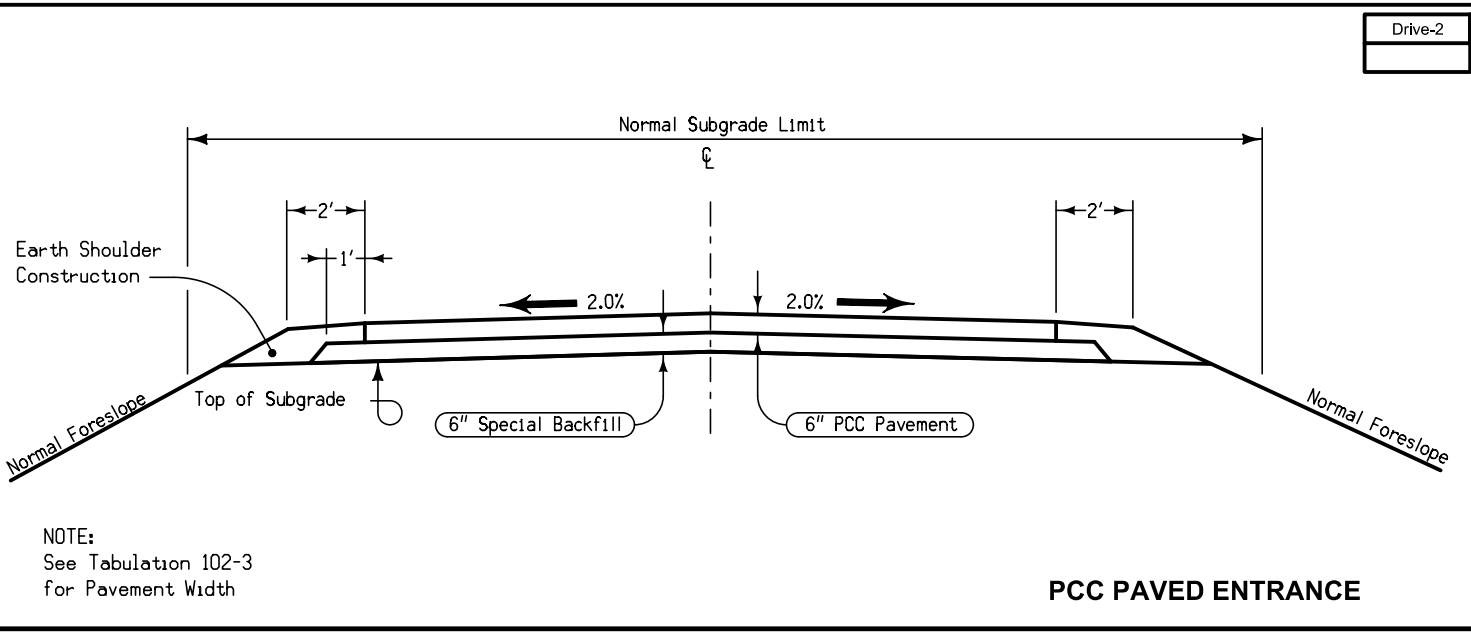
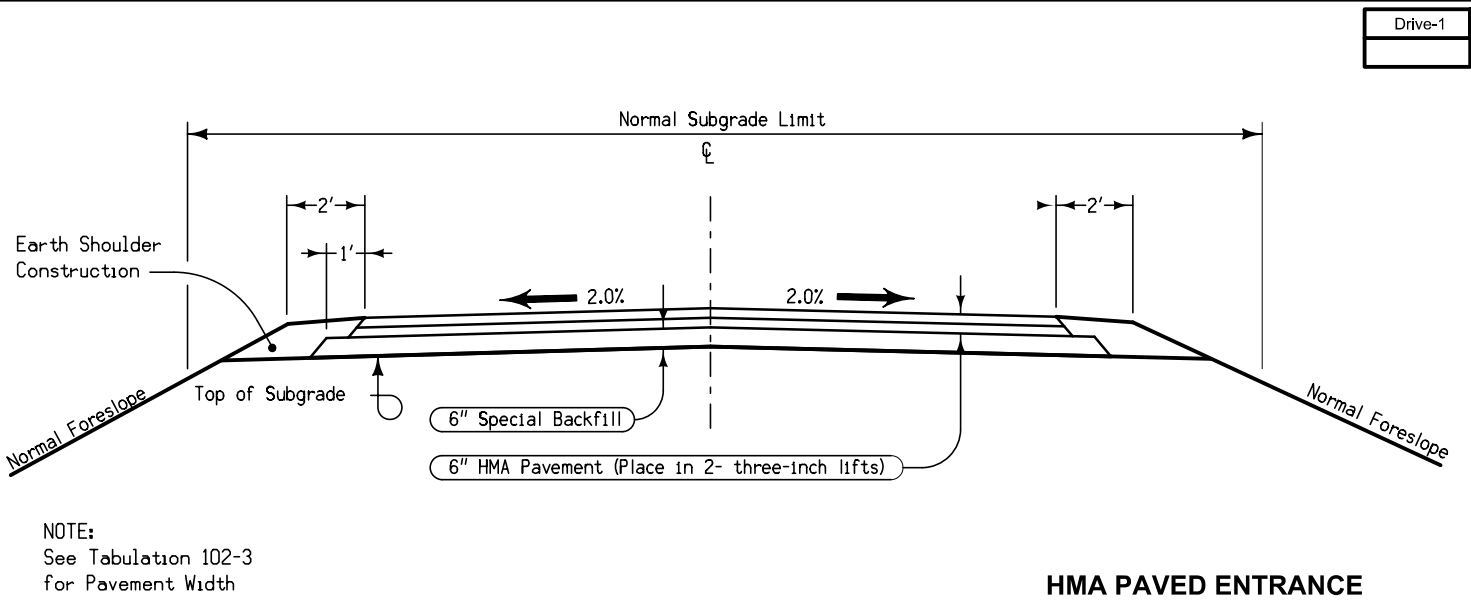
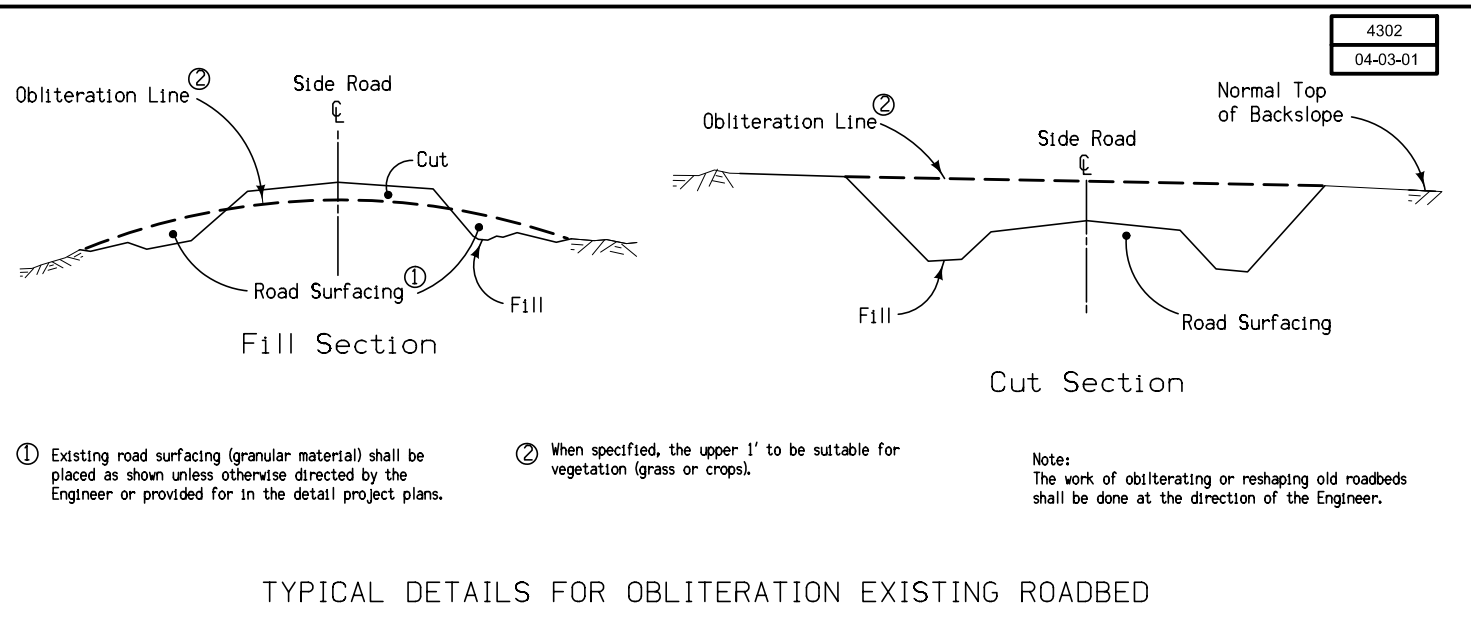

X-4
SPECIAL

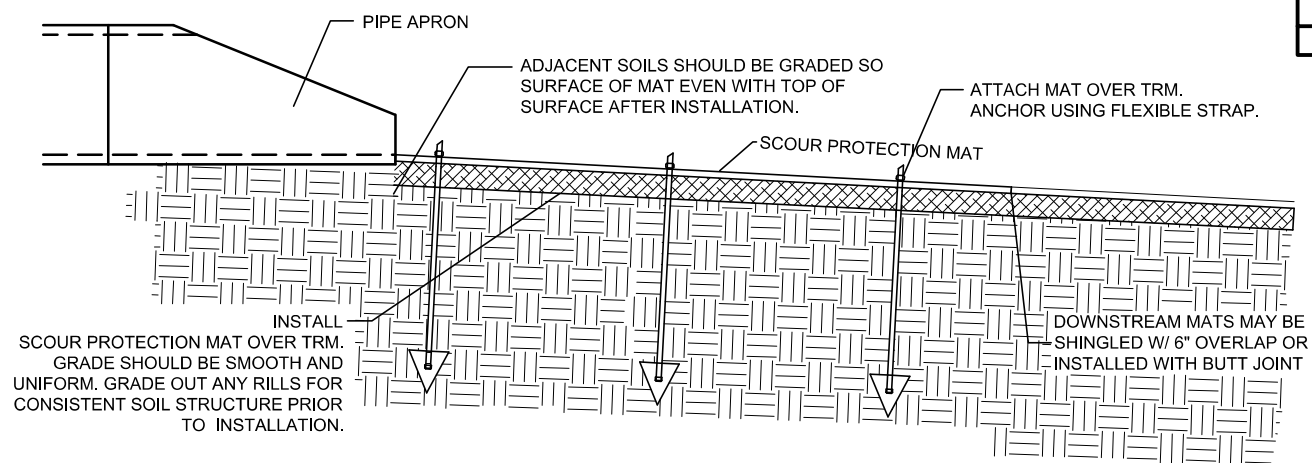

Refer to Tabulation 100-22 for additional information.

TYPICAL TURF REINFORCEMENT MAT (TRM) AND SCOUR PROTECTION MAT PLACEMENT

X-5
SPECIAL

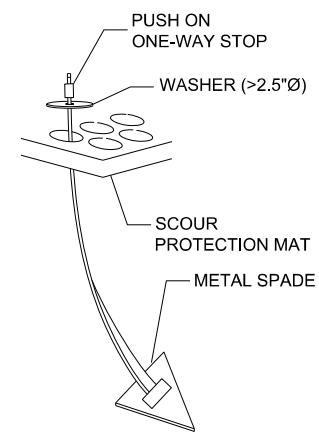

TYPICAL SCOUR PROTECTION MAT ANCHOR

X-6
SPECIAL

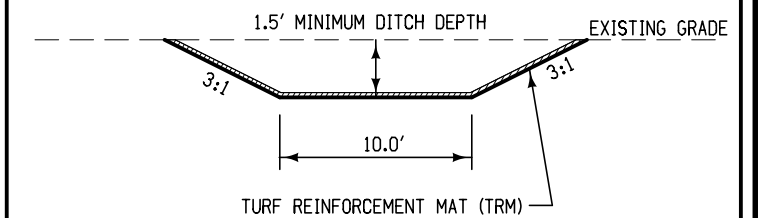

REFER TO TAB 100-22 FOR LOCATION

SPECIAL DITCH TYPICAL SECTION

SURVEY SYMBOLS

	Interstate Highway Symbol		Septic Tank
	U.S. Highway Symbol		Cistern
	Iowa Highway Symbol		L.P. Gas Tank (No Footing)
	County Road Highway Symbol		Underground Storage Tank
	Evergreen Tree		Latrine
	Deciduous Tree		Luminaire
	Fruit Tree		Traffic Signal
	Shrub (Bushes)		Traffic Signal with Luminaire
	Timber		TP Telephone Pedestal
	Hedge		TVP Television Pedestal
	Stump		Telephone Pole
	Swamp		Telephone Pole (Second Company)
	Rock Outcrop		Telephone Pole (Third Company)
	Broken Concrete		Telephone Pole (Fourth Company)
	Revetment (Rip Rap)		Telephone Pole (Fifth Company)
	Cemetery		Power Pole
	Grave		Power Pole (Second Company)
	Cave		Power Pole (Third Company)
	Sink Hole		Power Pole (Fourth Company)
	Board Fence		Power Pole (Fifth Company)
	Chain Link or Security Fence		Electrical Highline Tower (Metal or Concrete)
	Wire Fence		Telephone Riser Pole
	Terrace		Power Riser Pole
	Earth Dam or Dike (Existing)		Telegraph Pole
	Earth Dam or Dike (Proposed)		Satellite TV Dish
	Tile Outlet		Guardrail (Beam or Cable)
	Edge of Water		GP Guard Post (one or two)
	Existing Drainage		GP Guard Post (over two)
	Proposed Drainage		FP Filler Pipe
	Right of Way Rail or Lot Corner		GV Gas Valve
	Concrete Monument		WV Water Valve
	Well		SL Speed Limit Sign
	Windmill		MM Mile Marker Post
	Beehive Intake		SIGN Sign
	Existing Intake		WHU Water Hook Up
	Proposed Intake		RT Radio Tower
	Existing Utility Access (Manhole)		TA Tower Anchor
	Proposed Utility Access (Manhole)		EB Electric Box
	Fire Hydrant		TCB Traffic Signal Control Box
	Water Hydrant (Rural)		RRB Rail Road Signal Control Box
			TSB Telephone Switch Box

UTILITY LEGEND

	City of Dubuque Water Works Bob Schiesl 563-589-4270 bschiesl@cityofdubuque.org
	Alliant Energy (formerly Interstate Light and Power) Jason Hogan 608-458-4871 jasonhogan@alliantenergy.com
	Black Hills Energy (formerly Aquila) Brad Fleming 402-221-2714 brad.fleming@blackhillscorp.com
	BP Pipelines (North America) Inc. David Sommerfeld 630-536-2729 david.sommerfeld@bp.com
	Maquoketa Valley Rural Electric James Lauzon 319-462-3541 jlauzon@mvec.com
	Mediacom (cable TV) Bob Frazor 563-387-6119 bfrazor@mediacomcc.com
	Windstream Communications (formerly PAETEC) Terry Burke 641-787-2259 terry.r.burke@windstream.com
	Centurylink (formerly Qwest Communications) Steven Parker 515-265-0968 steven.parker4@centurylink.com

PLAN VIEW COLOR LEGEND OF PLAN AND PROFILE SHEETS

LINEWORK	Design Color No.	Description
Green	(2)	Existing Topographic Features and Labels
Blue	(1)	Proposed Alignment, Stationing, Tic Marks, and Alignment Annotation
Magenta	(5)	Existing Utilities
SHADING		
Design Color No.	Description	
Yellow	(4)	Highlight for Critical Notes or Features
Red	(3)	Delineates Restricted Areas
Lavender	(9)	Temporary Pavement Shading
Gray, Light	(48)	Proposed Pavement Shading
Gray, Med	(80)	Proposed Granular Shading
Gray, Dark	(112)	Proposed Grade and Pave Shading "In conjunction with a paving project"
Brown, Light	(236)	Grading Shading
Tan	(8)	Proposed Sidewalk Shading
Blue, Light	(230)	Proposed Sidewalk Landing Shading
Pink	(11)	Proposed Sidewalk Ramp Shading

PROFILE VIEW COLOR LEGEND OF PLAN AND PROFILE SHEETS

LINEWORK	Design Color No.	Description
Green	(2)	Existing Ground Line Profile
Blue	(1)	Proposed Profile and Annotation
Magenta	(5)	Existing Utilities
Blue, Light	(230)	Proposed Ditch Grades, Left
Black	(0)	Proposed Ditch Grades, Median
Rust	(14)	Proposed Ditch Grades, Right

Symbol	Description
	Reference Point
	Station
	Survey Line
	Section Corner
	Ground Line Intercept
	Saw Cut
	Guardrail
	Trench Drain
	High Tension Cable Guardrail
	Sheet Pile
	Pavement Removal
	Clearing & Grubbing Area

RIGHT-OF-WAY LEGEND

	Proposed Right-of-Way
	Existing Right of Way
	Existing and Proposed Right-of-Way
	Easement and Existing Right-of-Way
	Easement (Temporary)
	Easement
	Access Control
	Property Line



PLAN AND PROFILE LEGEND AND SYMBOL INFORMATION SHEET

(COVERS SHEET SERIES D, E, F, & K)

For Shared Use Path Details Refer to Sheets S.1 -S.2

TABLE MOUND TWP.
T-88N R-2E
SEC. 11

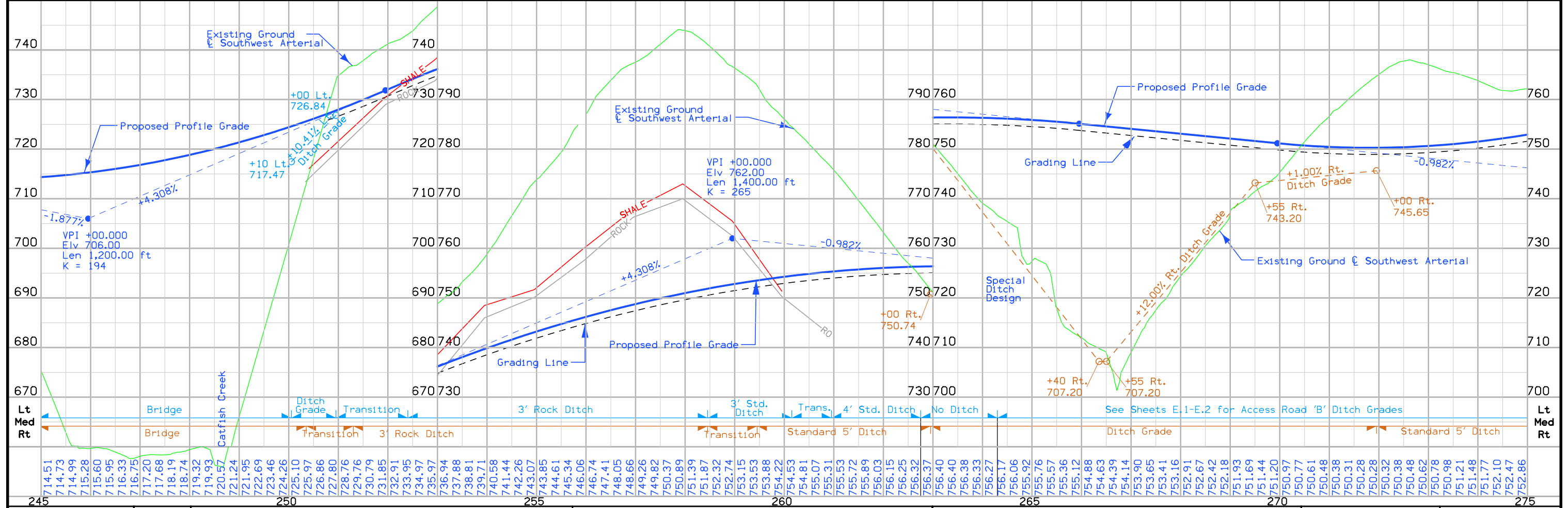
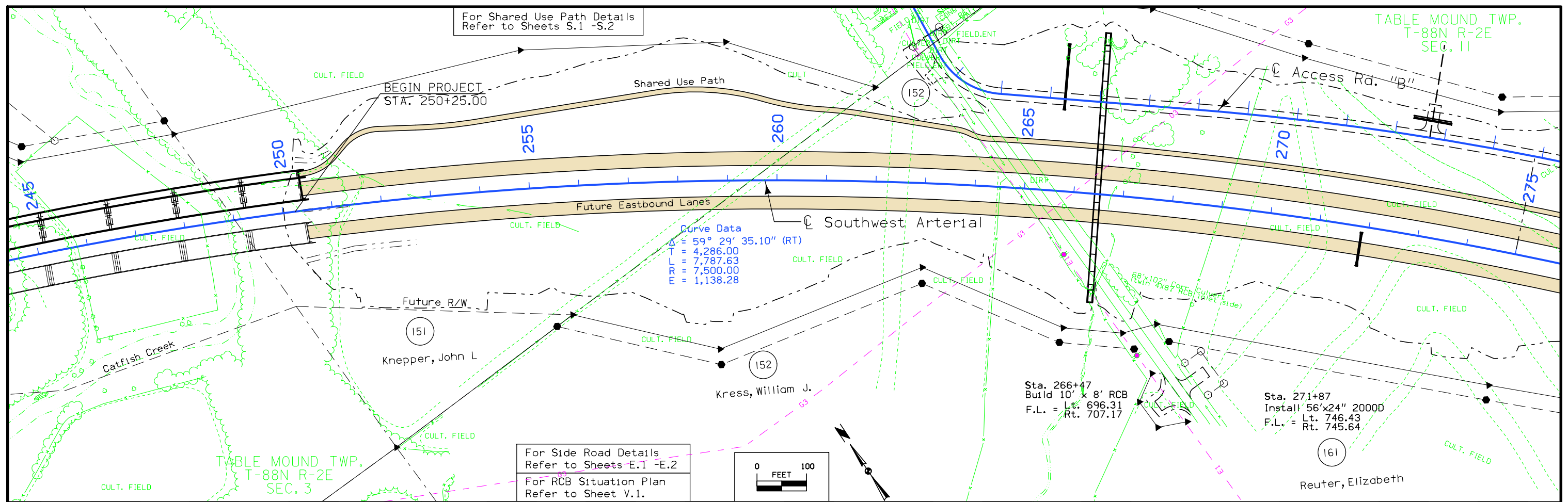

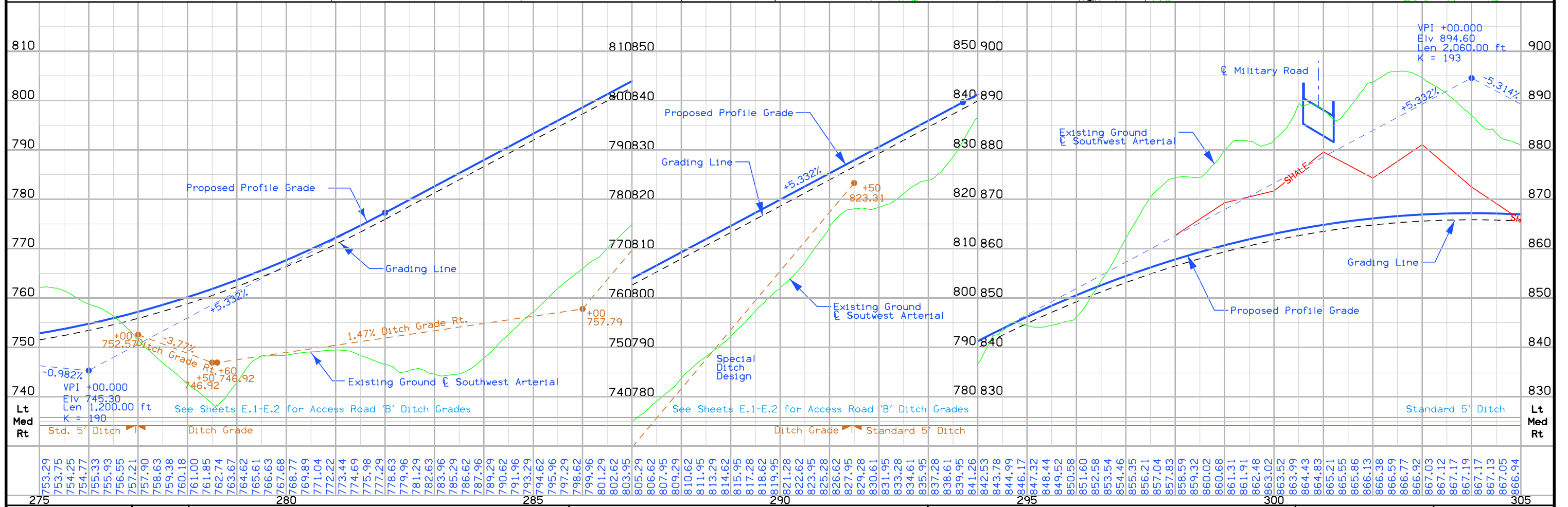
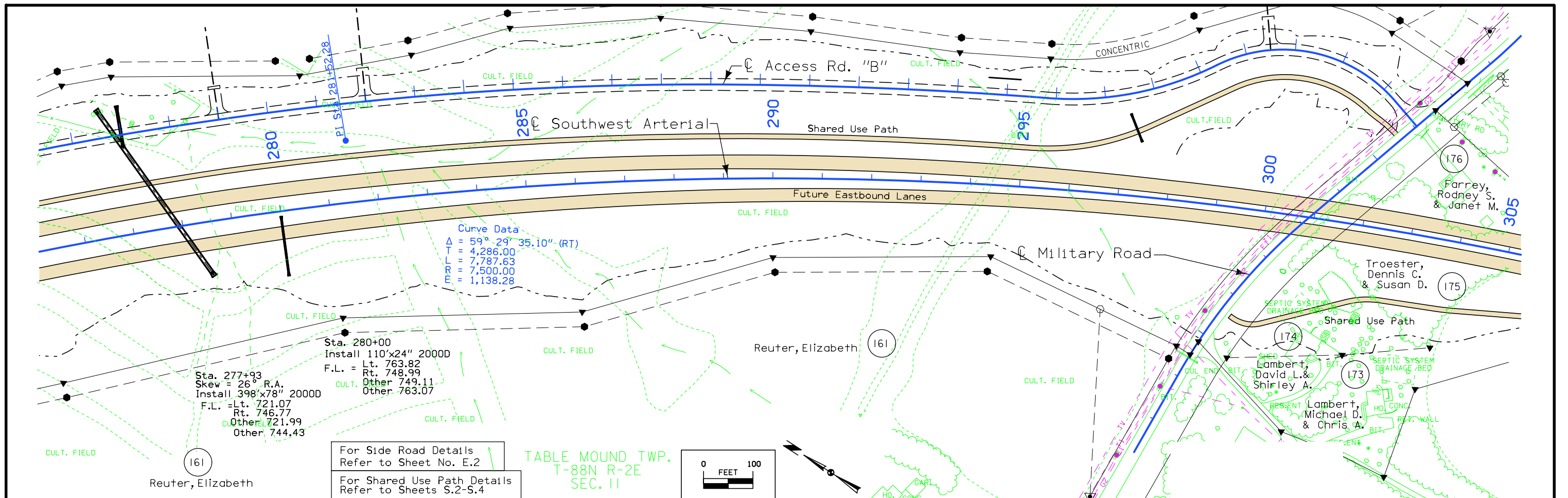

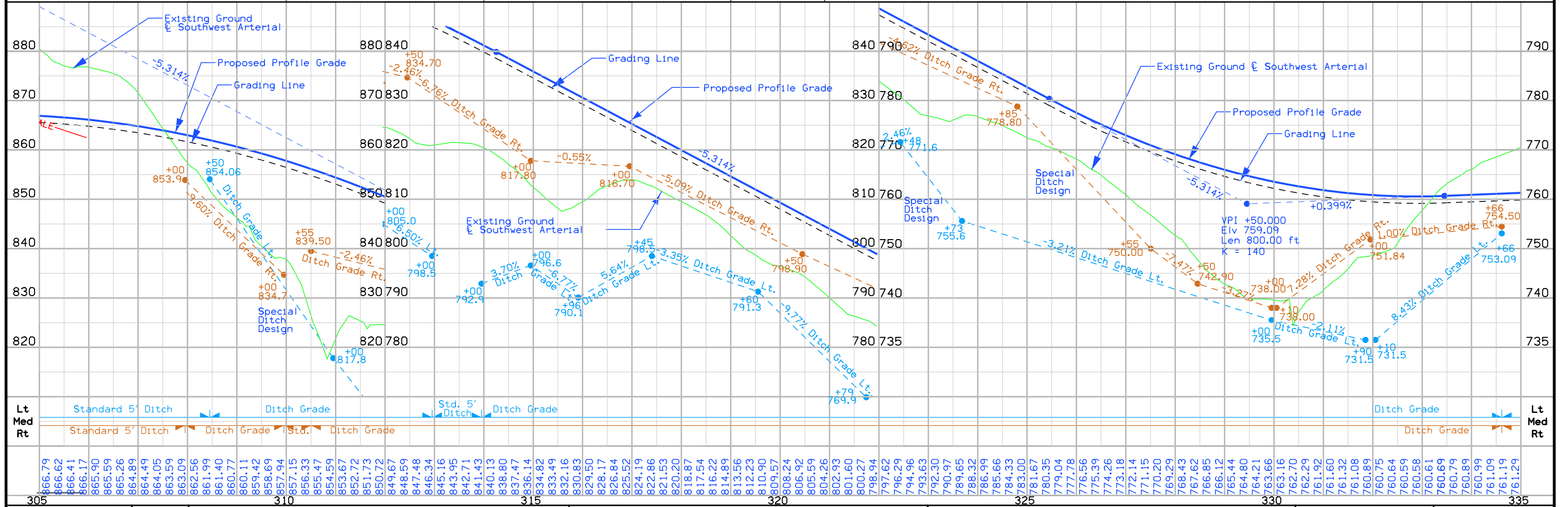
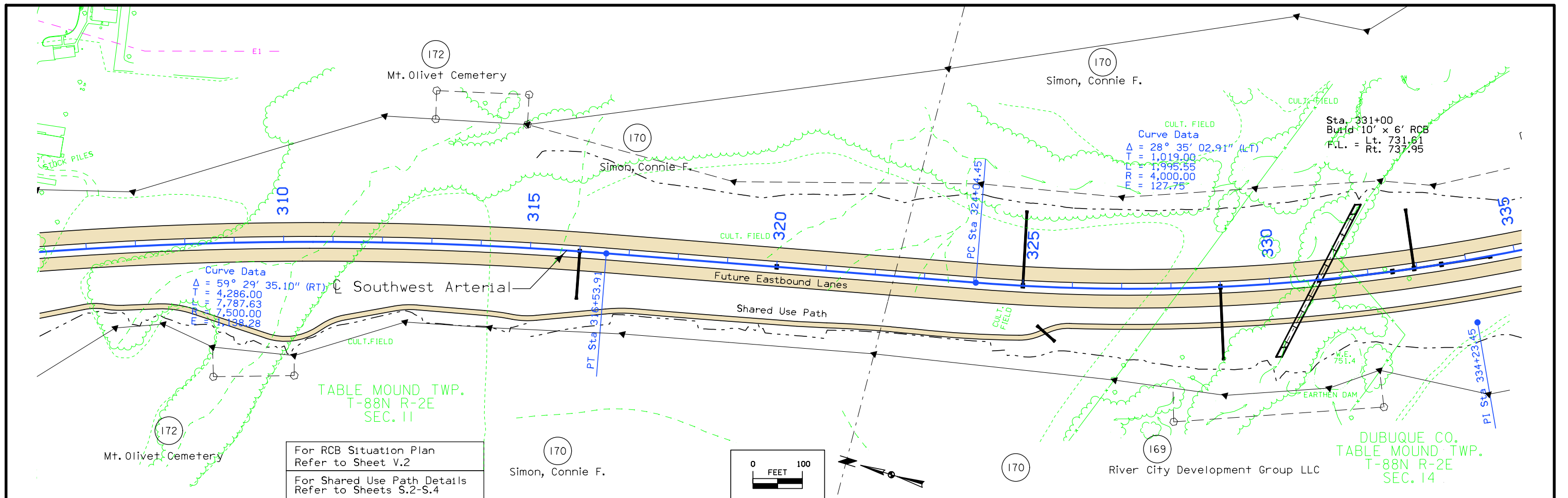

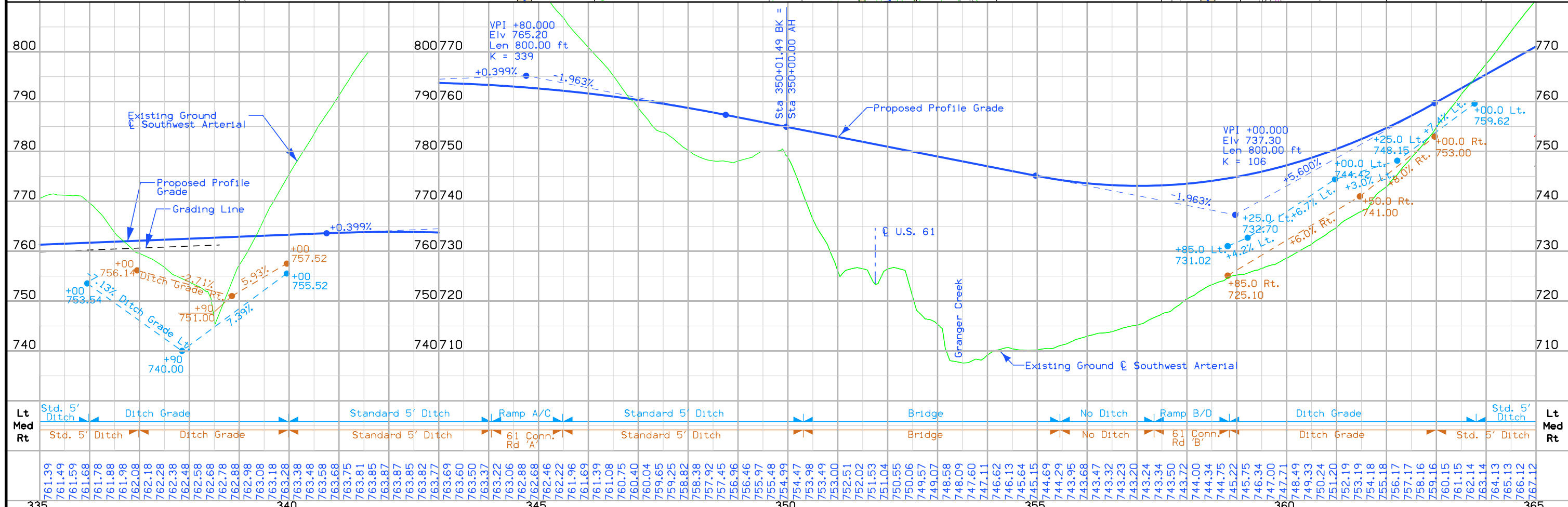
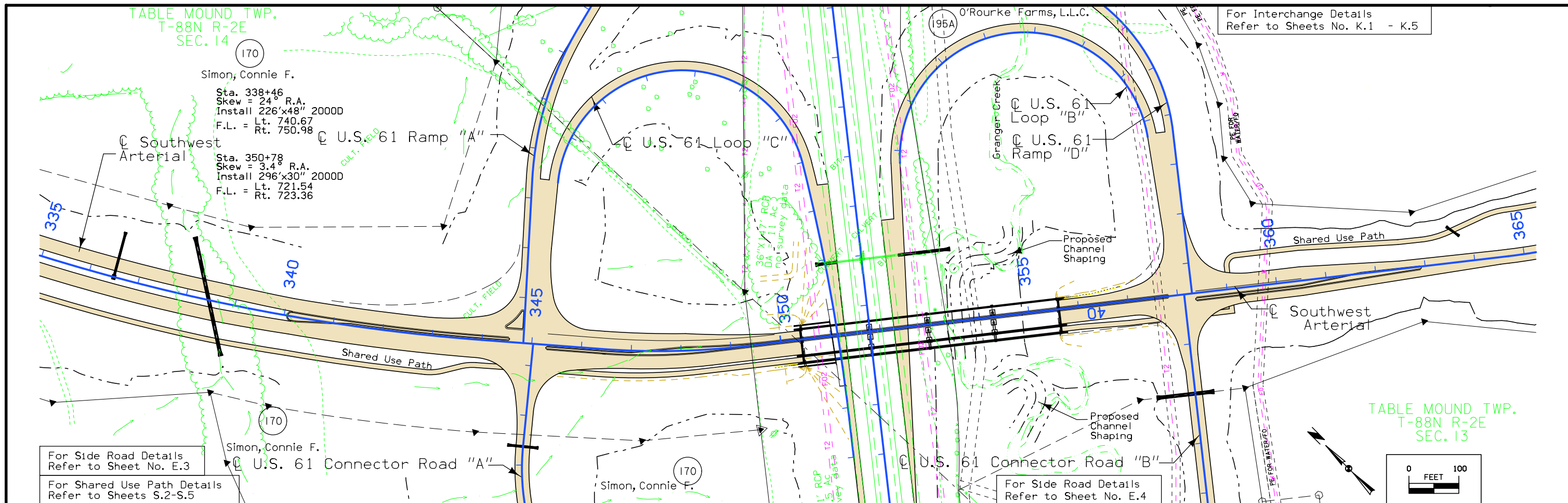

Lt	Std. 5' Ditch	Ditch Grade	Standard 5' Ditch	Ramp A/C	Standard 5' Ditch	Bridge	No Ditch	Ramp B/D	Ditch Grade	Std. 5' Ditch	Lt
Med	Std. 5' Ditch	Ditch Grade	Standard 5' Ditch	61 Conn. Rd 'A'	Standard 5' Ditch	Bridge	No Ditch	61 Conn. Rd 'B'	Ditch Grade	Std. 5' Ditch	Med
Rt	Std. 5' Ditch	Ditch Grade	Standard 5' Ditch	61 Conn. Rd 'A'	Standard 5' Ditch	Bridge	No Ditch	61 Conn. Rd 'B'	Ditch Grade	Std. 5' Ditch	Rt

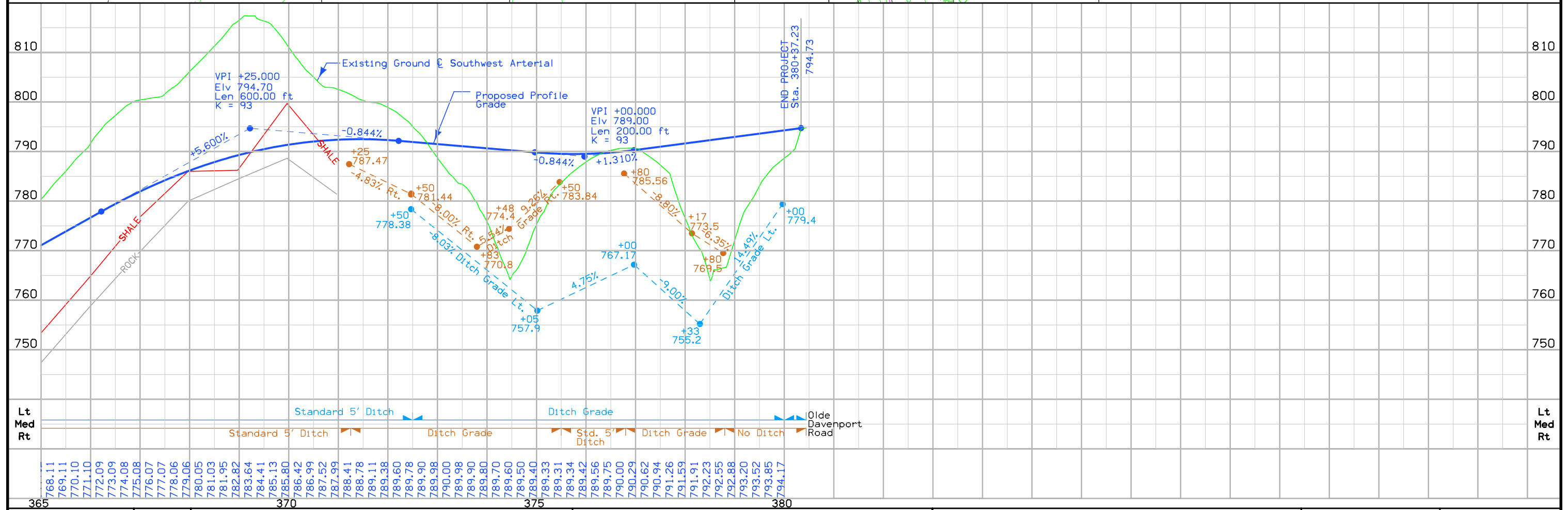
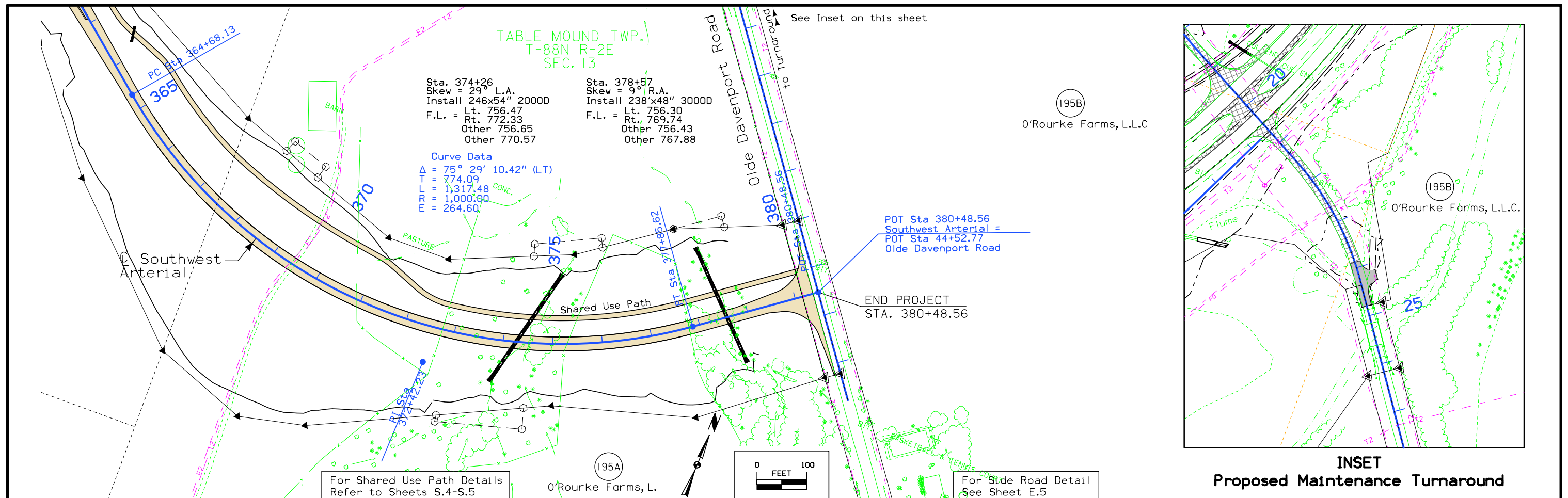

TABLE MOUND TWP.
T-88N R-2E
SEC. 2

For Shared Use Path Detail
Refer to Sheets S.1 -S.2
For RCB Situation Plan
Refer to Sheet V.1

TABLE MOUND TWP.
T-88N R-2E
SEC. 11

For Main Line Details
Refer to Sheets D.2

ACCESS LOCATIONS
Sta. 58+26 C
Sta. 68+70 Lt.
Sta. 75+00 Lt.
Sta. 78+00 Lt.

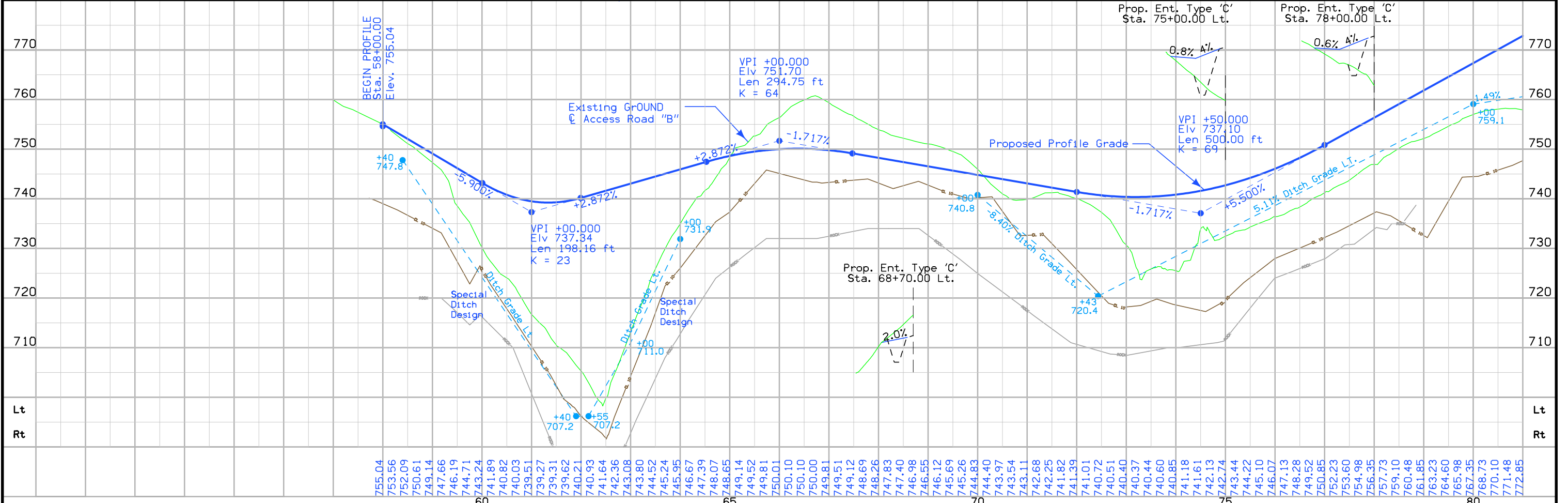
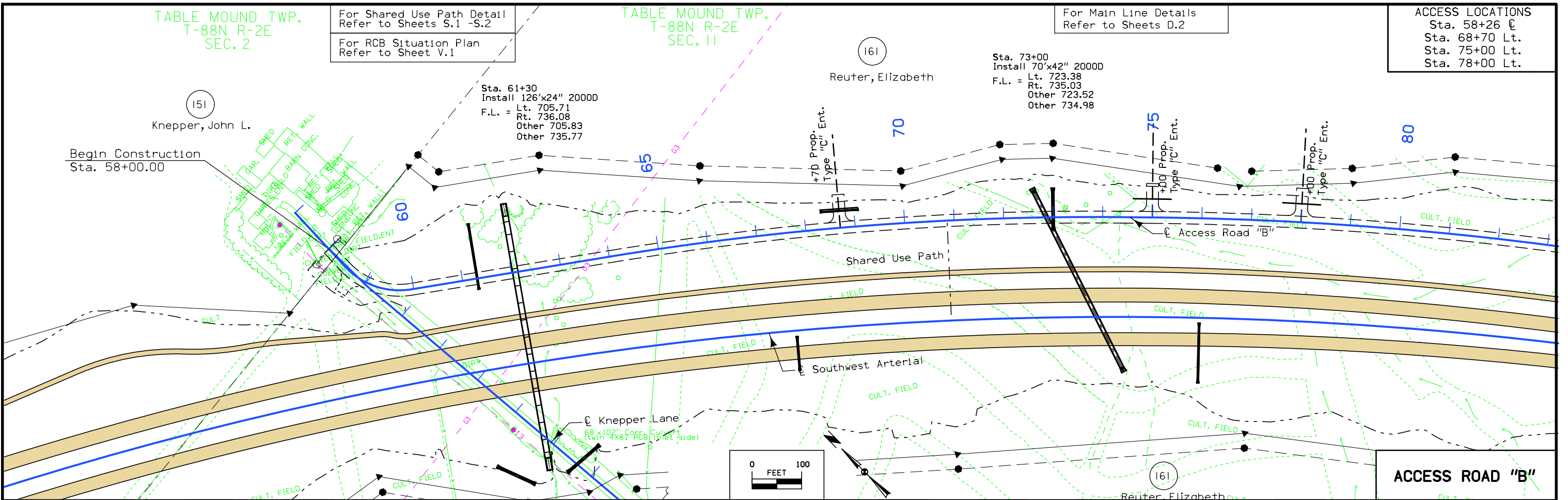
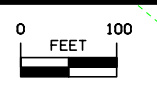

TABLE MOUND T-61
T-88N R-2E
SEC. 1
Reuter, Elizabeth

For Main Line Details
Refer to Sheets D.1-D.2

For Shared Use Path Detail
Refer to Sheets S.1-S.2



ACCESS LOCATIONS
Sta. 97+00 Lt.

ACCESS LOCATIONS
Sta. 5066+80 Lt.

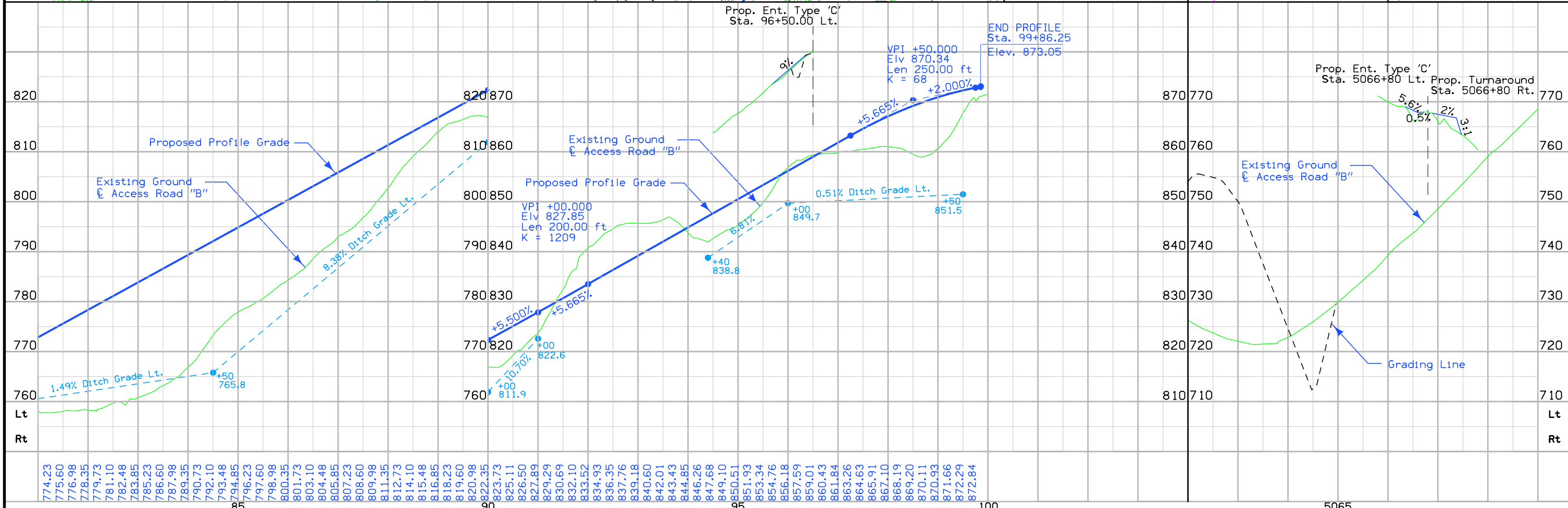
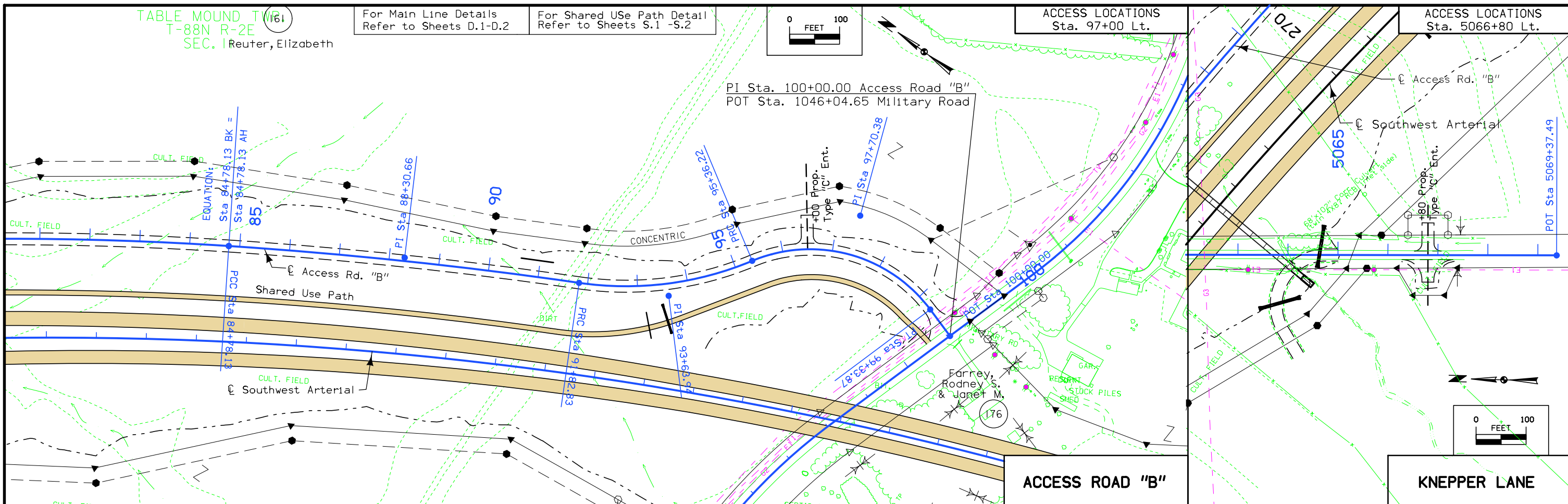

For Side Road Details Refer to Sheet No. E.6
 For RCB Situation Plan Refer to Sheet No. V.3
 For Mainline Details Refer to Sheet No. D.5
 For Interchange Details Refer to Sheets No. K.1 -K.5

ACCESS LOCATIONS
 Sta. 20+90 Jt & Lt
 Sta. 22+40 Jt & Rt

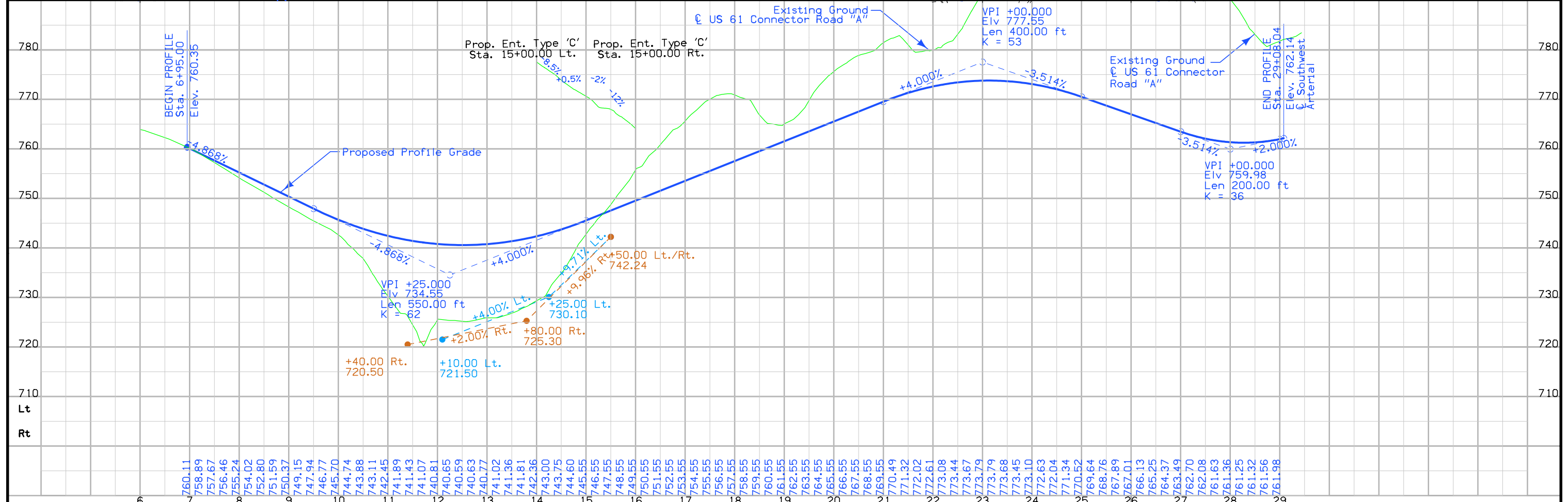
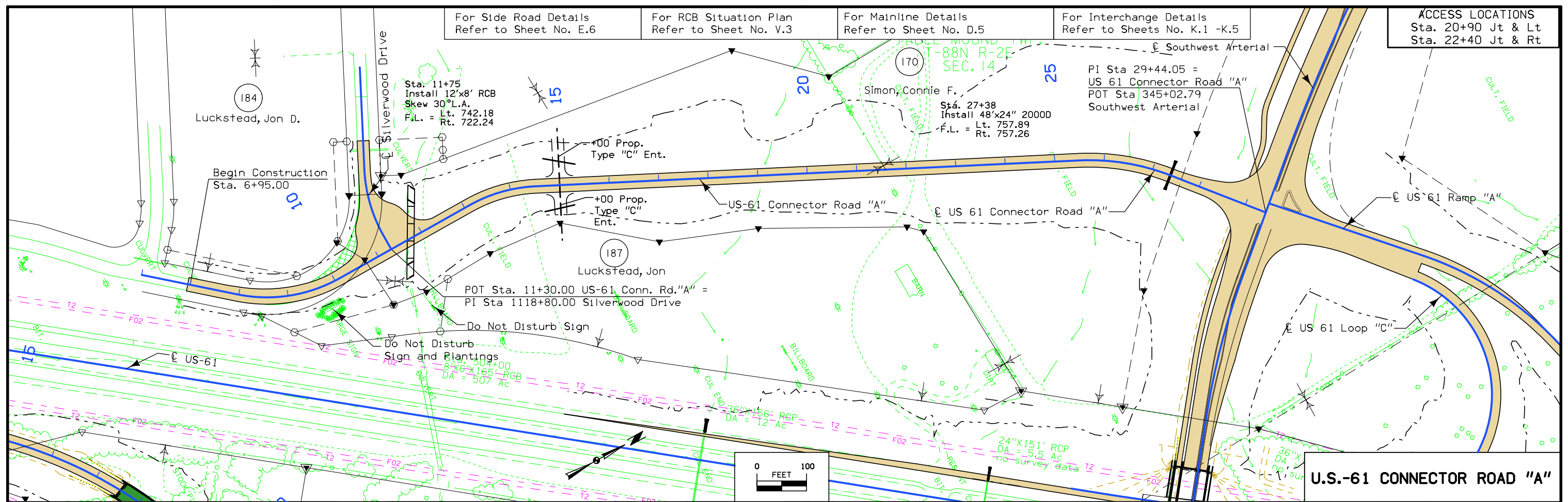

ENGLISH	IOWA DOT	DESIGN TEAM	AECOM	DUBUQUE COUNTY	PROJECT NUMBER	NHSX-032-1(36)--3H-31	SHEET NUMBER	E.3
---------	----------	-------------	--------------	----------------	----------------	------------------------------	--------------	------------

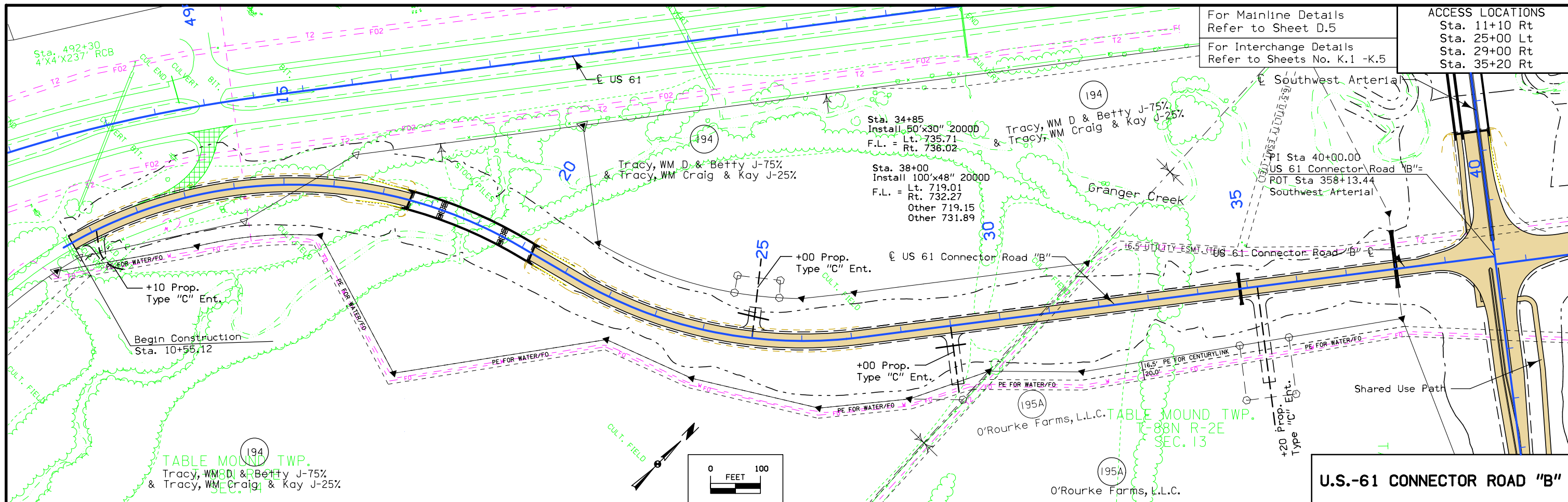

For Mainline Details Refer to Sheet D.5
 For Interchange Details Refer to Sheets No. K.1 -K.5

ACCESS LOCATIONS
 Sta. 11+10 Rt
 Sta. 25+00 Lt
 Sta. 29+00 Rt
 Sta. 35+20 Rt

U.S.-61 CONNECTOR ROAD "B"

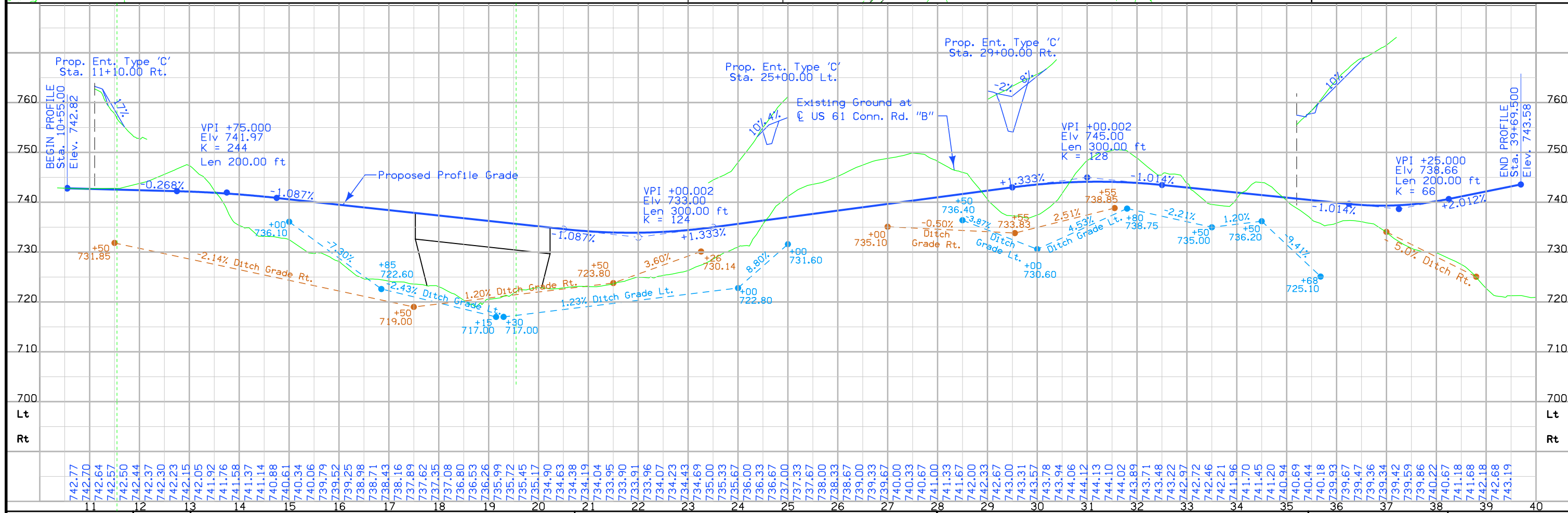

For Mainline Details
Refer to Sheet D.6

OLDE DAVENPORT ROAD

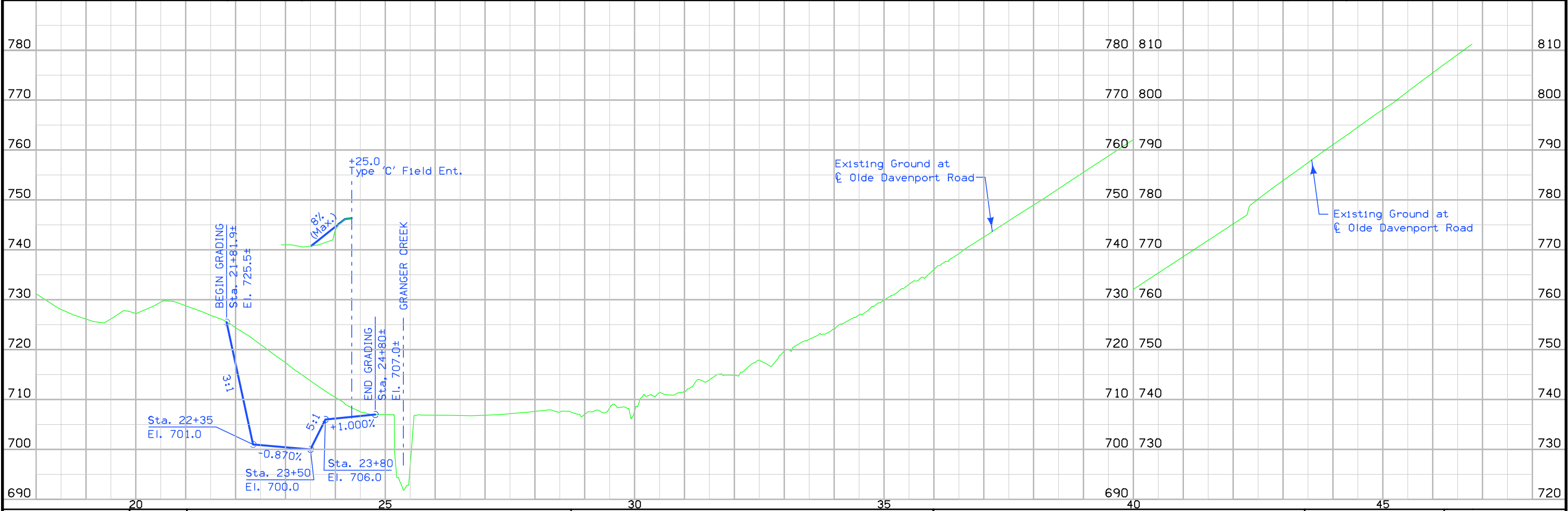
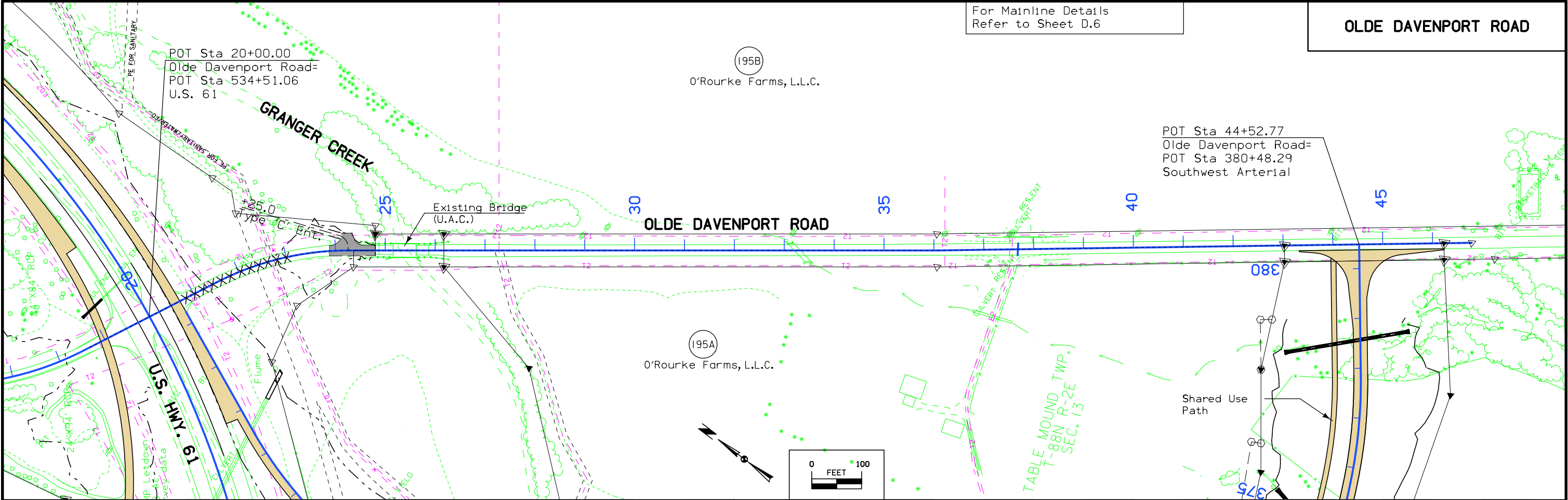

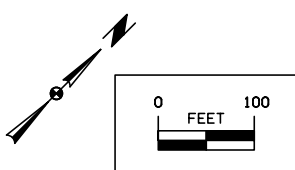
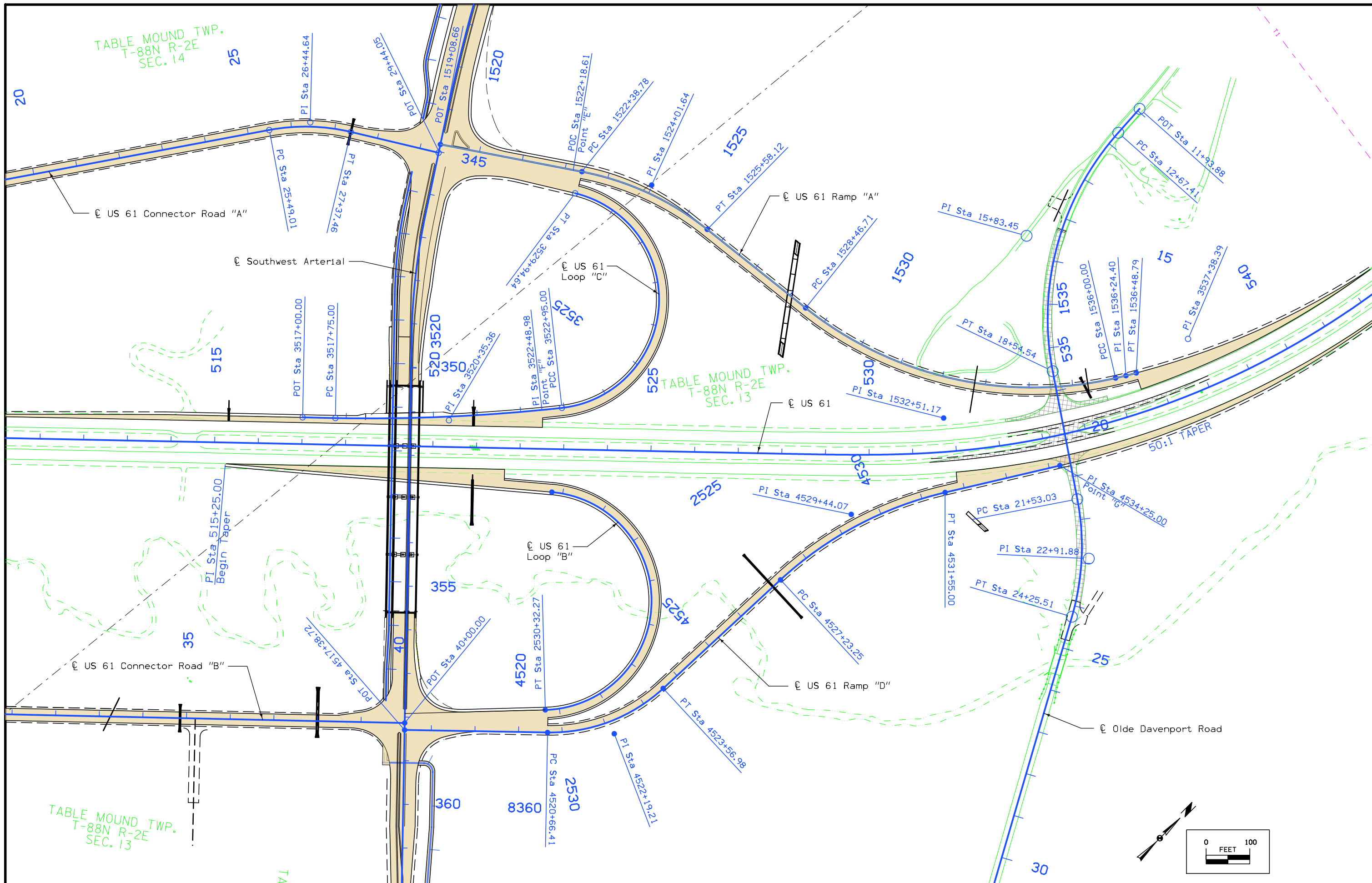

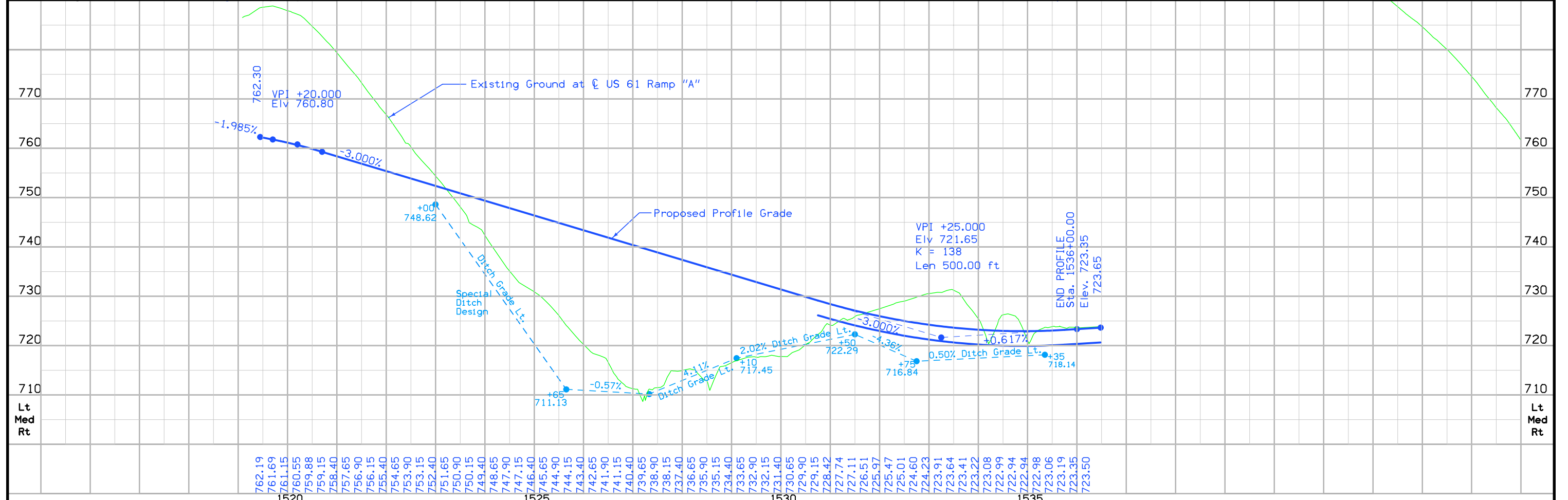
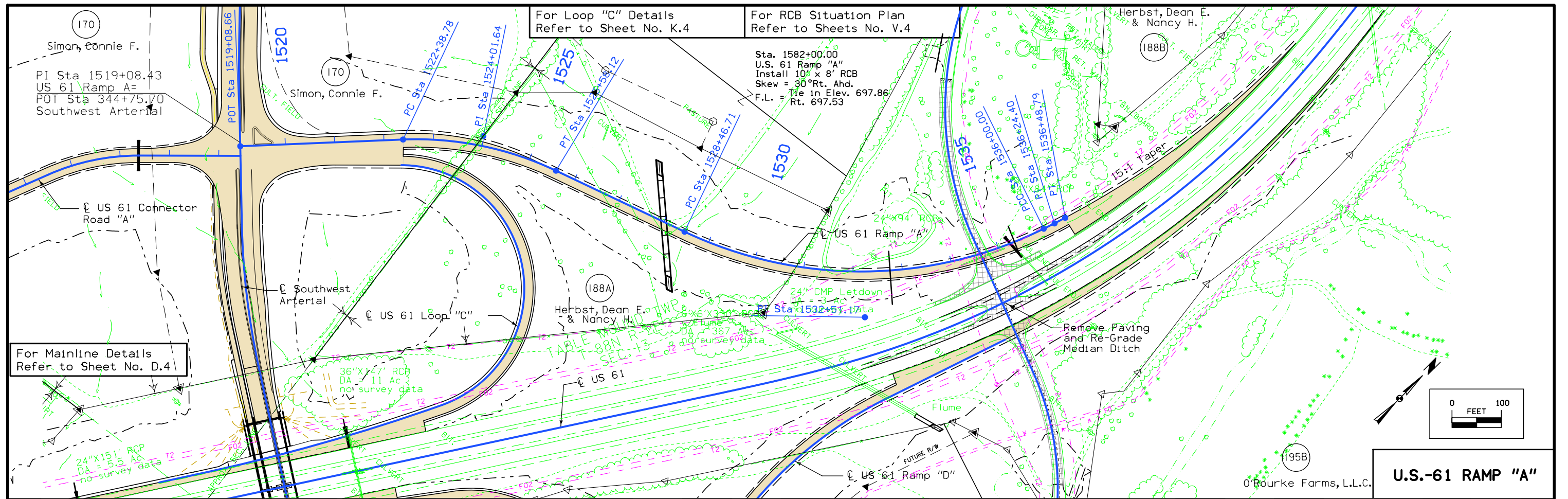

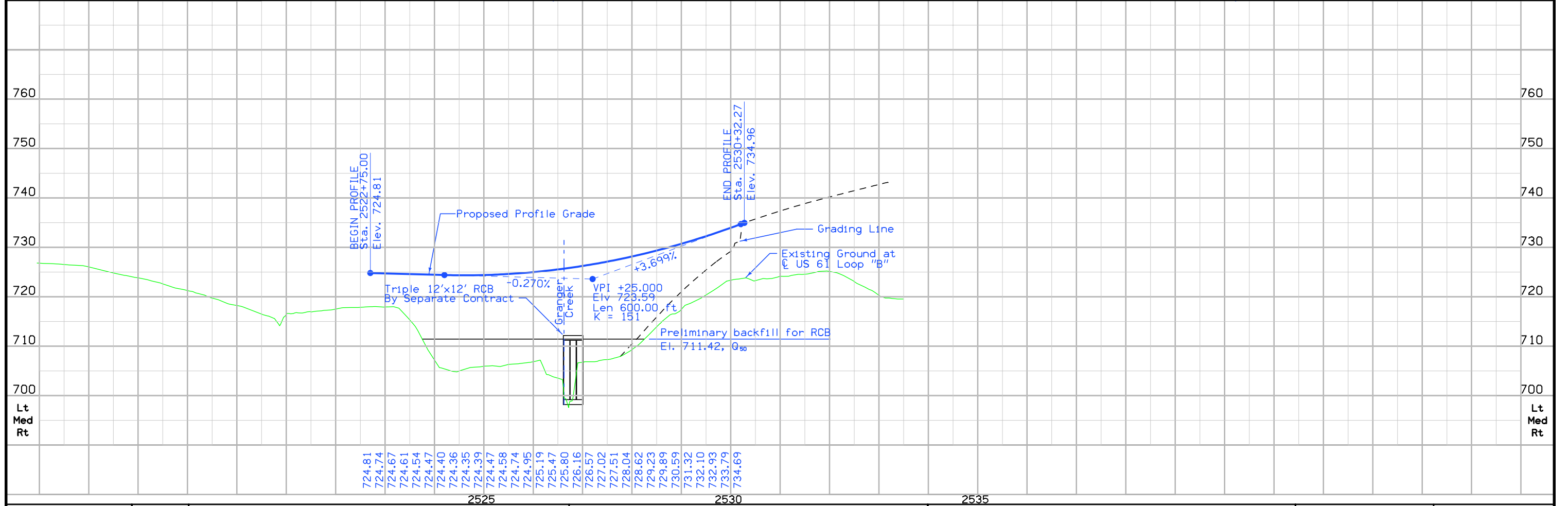
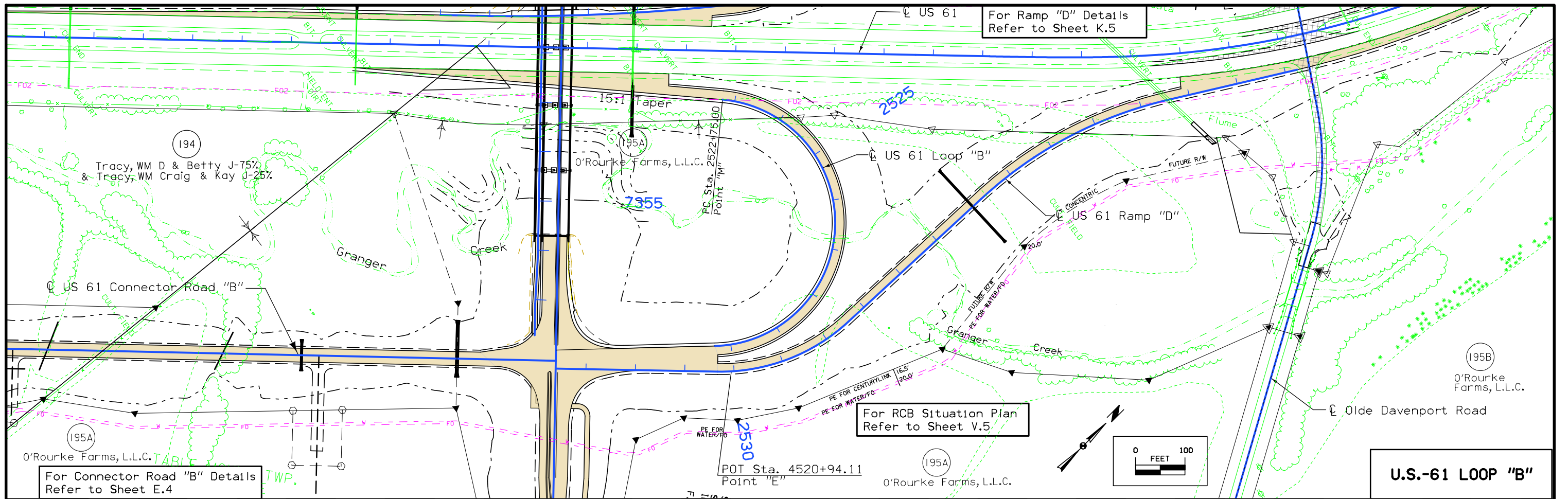

ENGLISH	IOWA DOT	DESIGN TEAM	AECOM	DUBUQUE COUNTY	PROJECT NUMBER	NHSX-032-1(36)--3H-31	SHEET NUMBER	K.3
---------	----------	-------------	--------------	----------------	----------------	------------------------------	--------------	------------

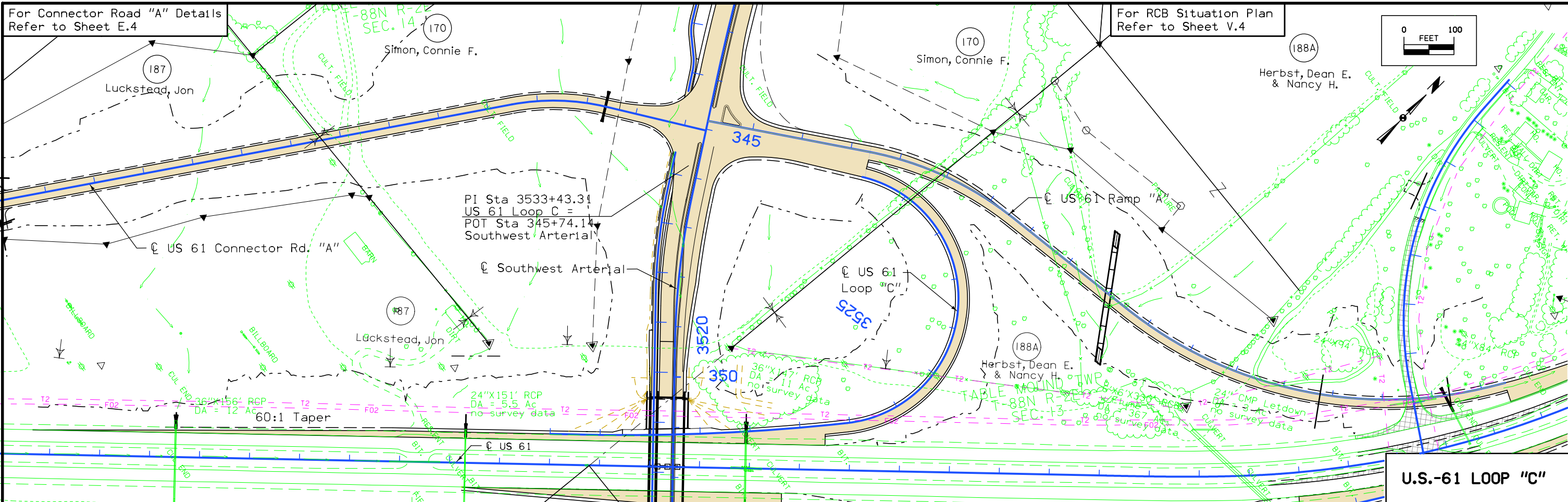

U.S.-61 LOOP "C"

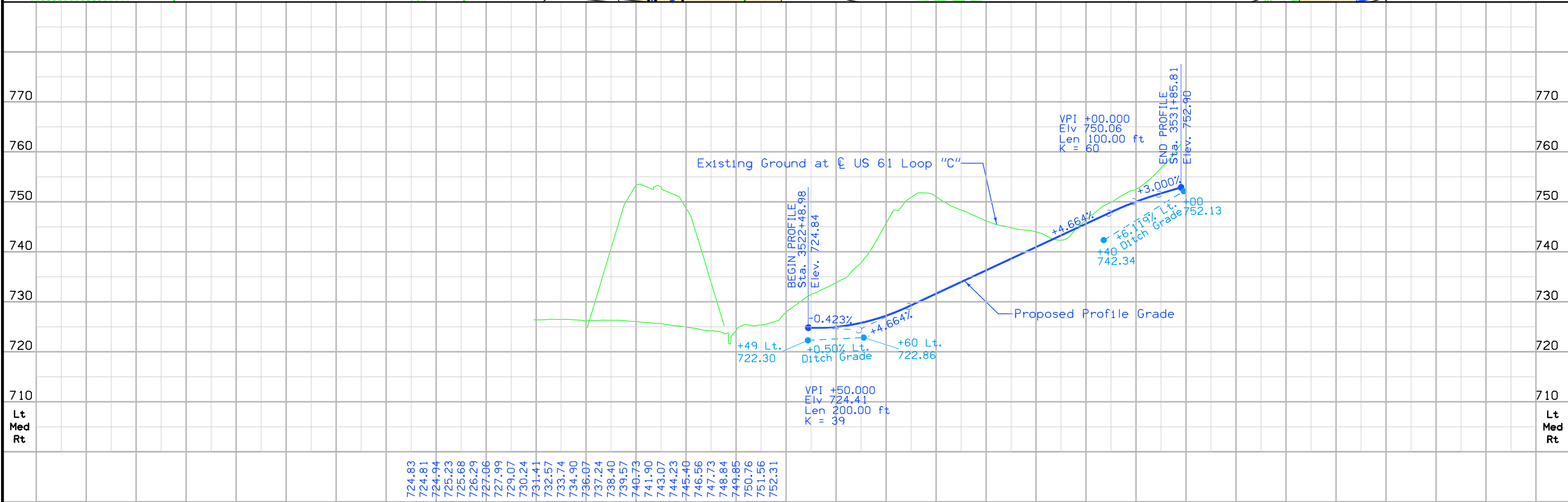

724.83
724.81
724.94
725.23
725.68
726.29
727.06
727.99
729.07
730.24
731.41
732.57
733.74
734.90
736.07
737.24
738.40
739.57
740.73
741.90
743.07
744.23
745.40
746.56
747.73
748.84
749.85
750.76
751.56
752.31

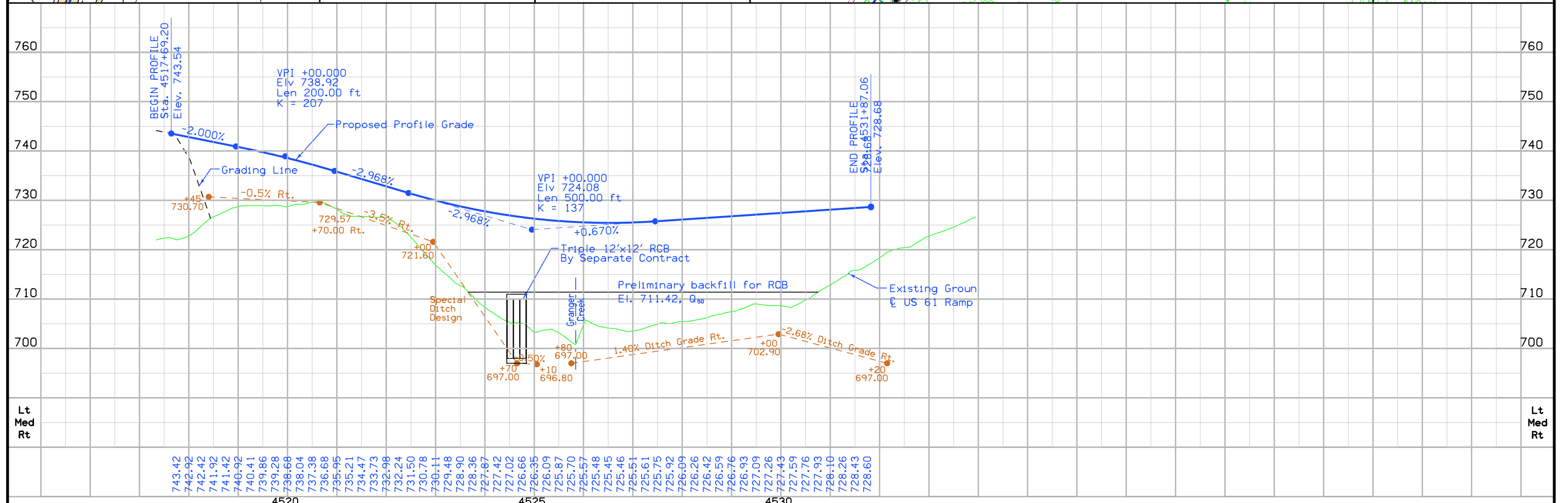
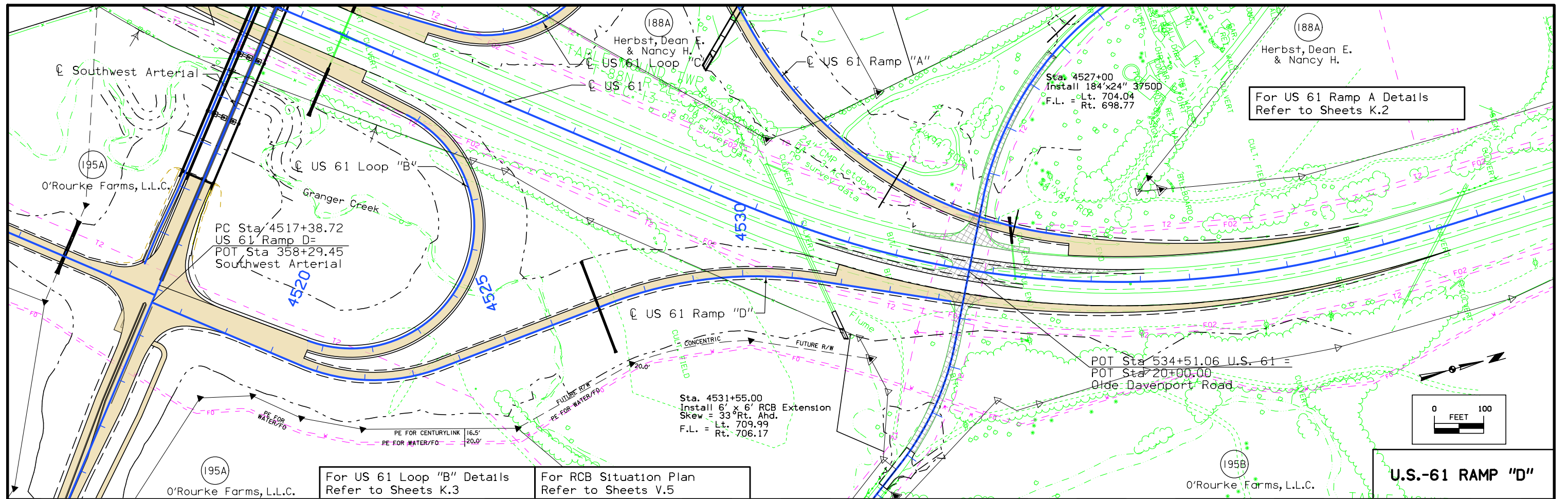

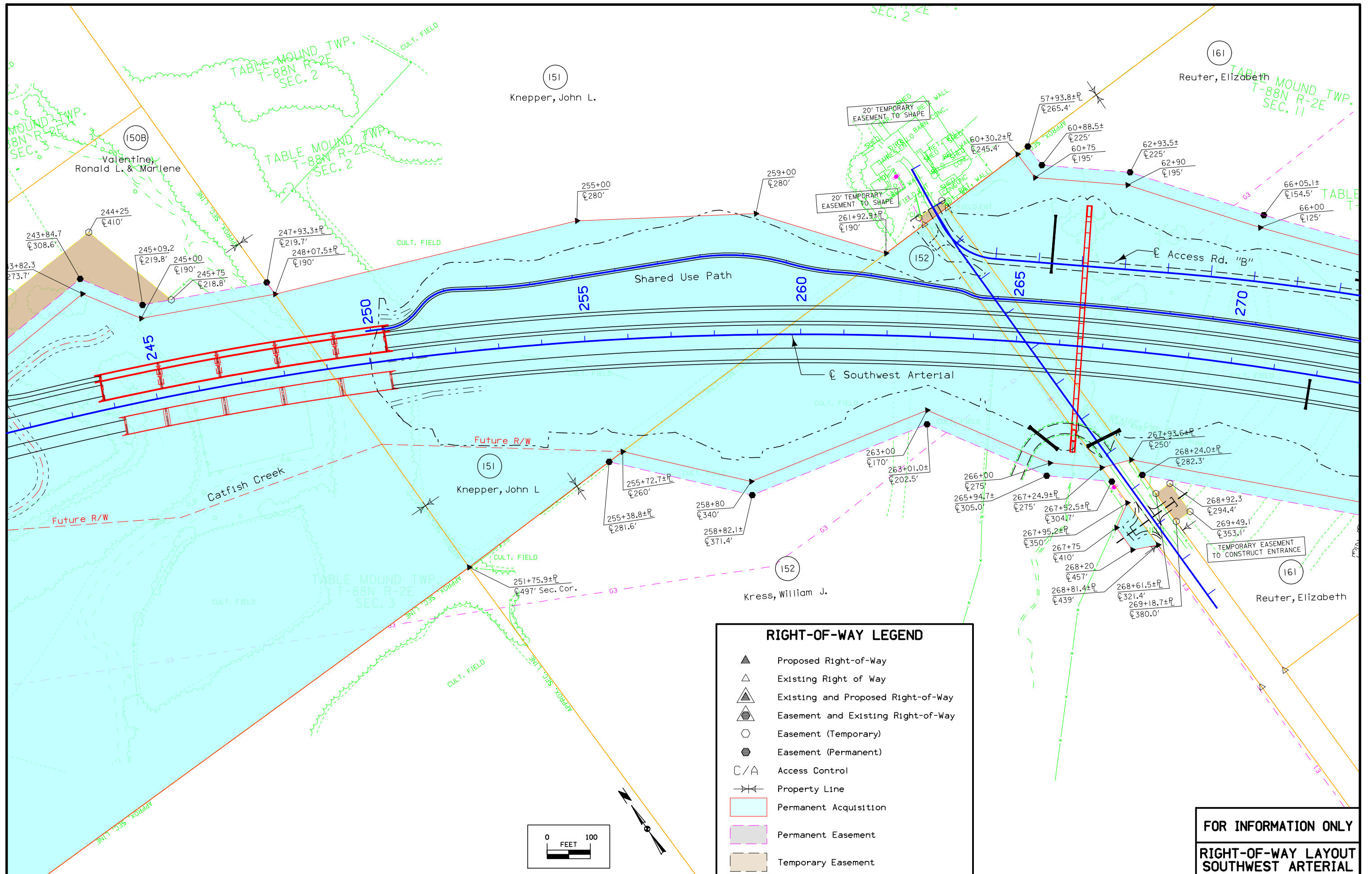

RIGHT-OF-WAY LEGEND	
	Proposed Right-of-Way
	Existing Right of Way
	Existing and Proposed Right-of-Way
	Easement and Existing Right-of-Way
	Easement (Temporary)
	Easement (Permanent)
	Access Control
	Property Line
	Permanent Acquisition
	Permanent Easement
	Temporary Easement

FOR INFORMATION ONLY
RIGHT-OF-WAY LAYOUT
SOUTHWEST ARTERIAL

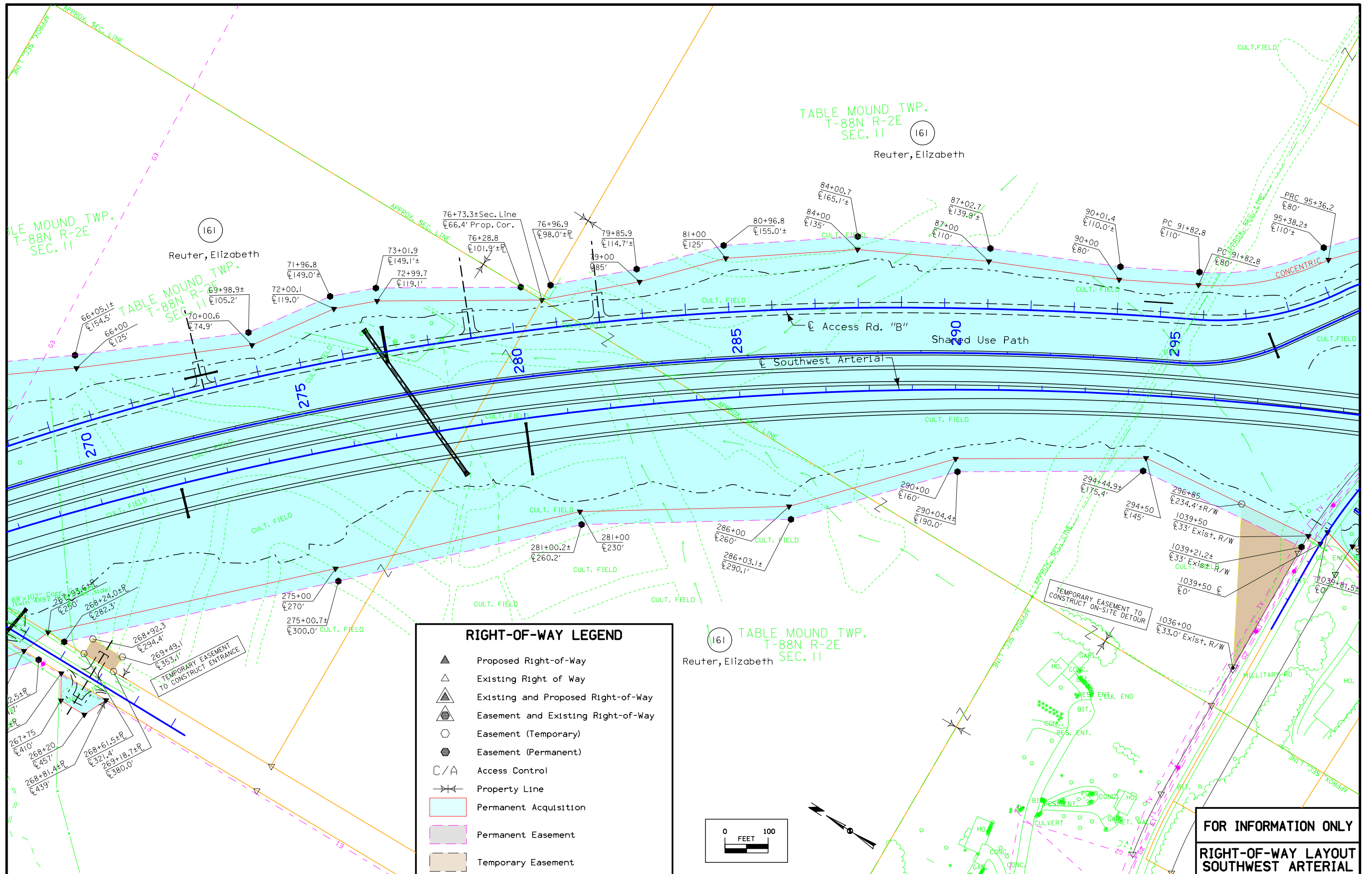

RIGHT-OF-WAY LEGEND

	Proposed Right-of-Way
	Existing Right of Way
	Existing and Proposed Right-of-Way
	Easement and Existing Right-of-Way
	Easement (Temporary)
	Easement (Permanent)
	Access Control
	Property Line
	Permanent Acquisition
	Permanent Easement
	Temporary Easement

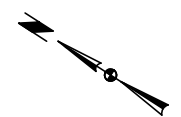
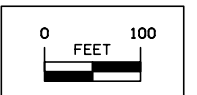

FOR INFORMATION ONLY
RIGHT-OF-WAY LAYOUT
SOUTHWEST ARTERIAL

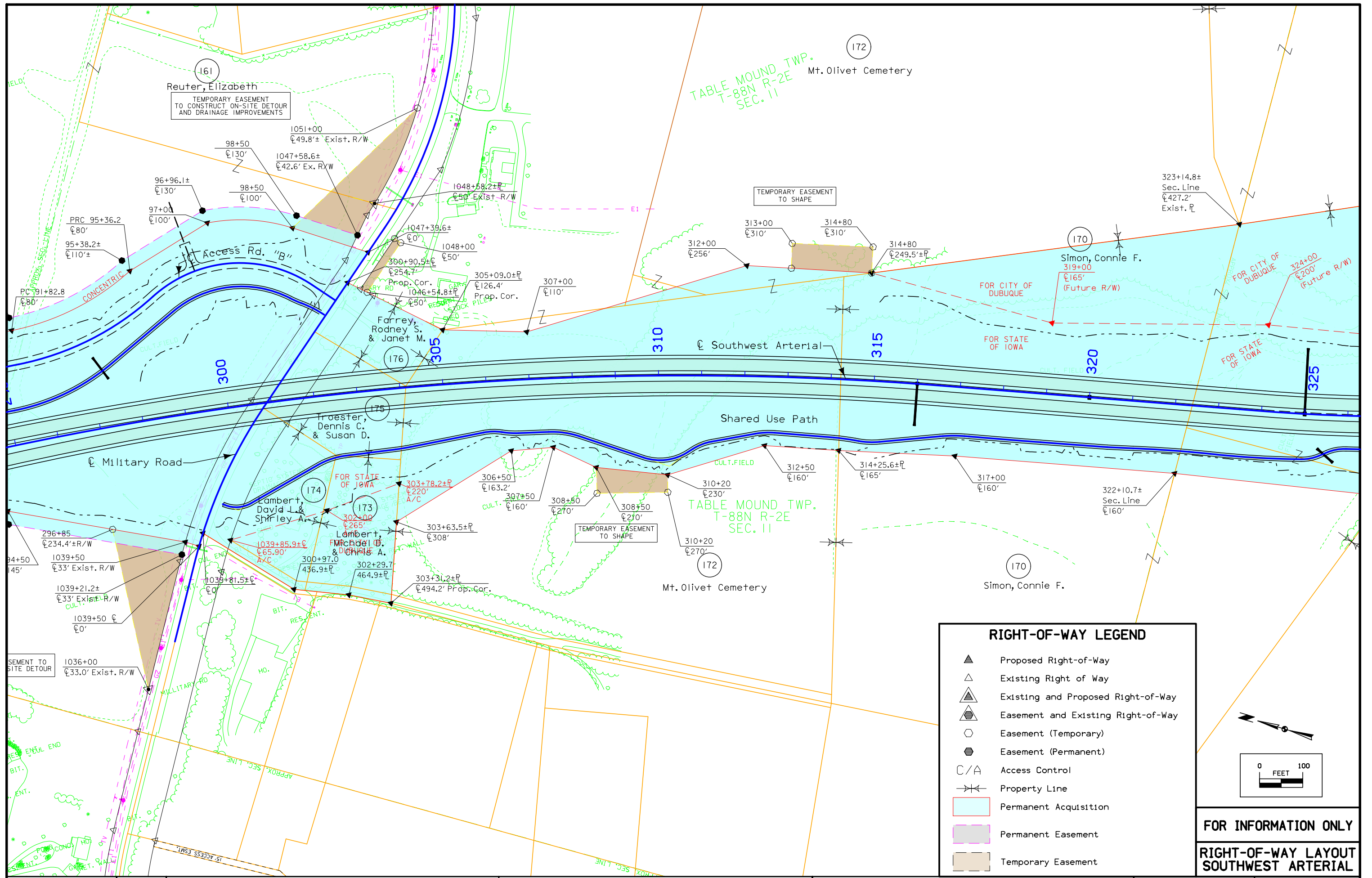

RIGHT-OF-WAY LEGEND

- Proposed Right-of-Way
- Existing Right of Way
- Existing and Proposed Right-of-Way
- Easement and Existing Right-of-Way
- Easement (Temporary)
- Easement (Permanent)
- Access Control
- Property Line
- Permanent Acquisition
- Permanent Easement
- Temporary Easement

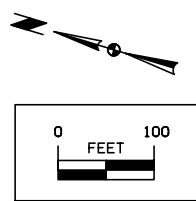

FOR INFORMATION ONLY
RIGHT-OF-WAY LAYOUT
SOUTHWEST ARTERIAL

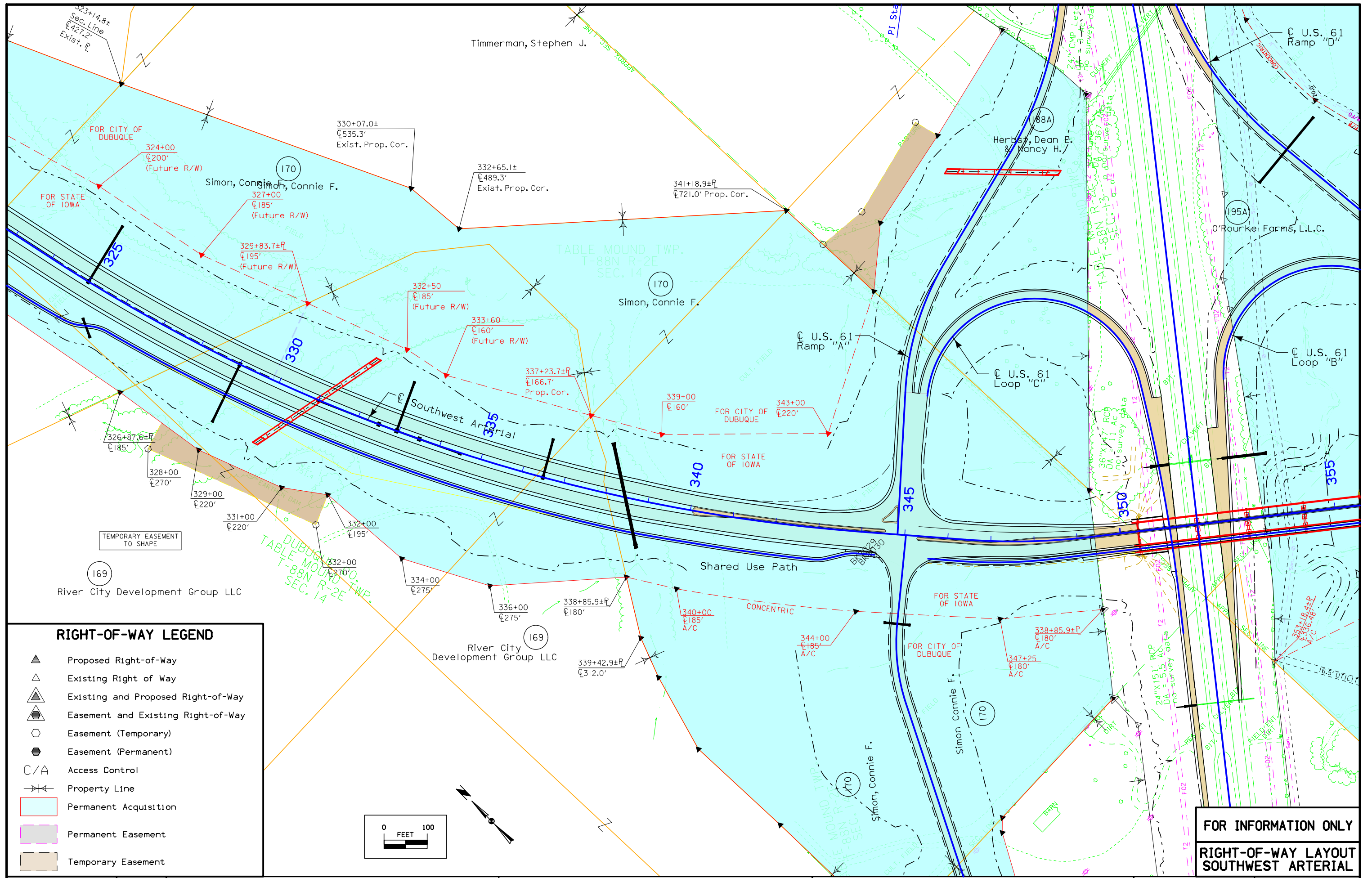

RIGHT-OF-WAY LEGEND

- ▲ Proposed Right-of-Way
- △ Existing Right of Way
- ▲ Existing and Proposed Right-of-Way
- ⊕ Easement and Existing Right-of-Way
- Easement (Temporary)
- Easement (Permanent)
- C/A Access Control
- ⊗ Property Line
- Permanent Acquisition
- Permanent Easement
- Temporary Easement

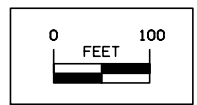

FOR INFORMATION ONLY
RIGHT-OF-WAY LAYOUT
SOUTHWEST ARTERIAL

FOR INFORMATION ONLY
RIGHT-OF-WAY LAYOUT
SOUTHWEST ARTERIAL

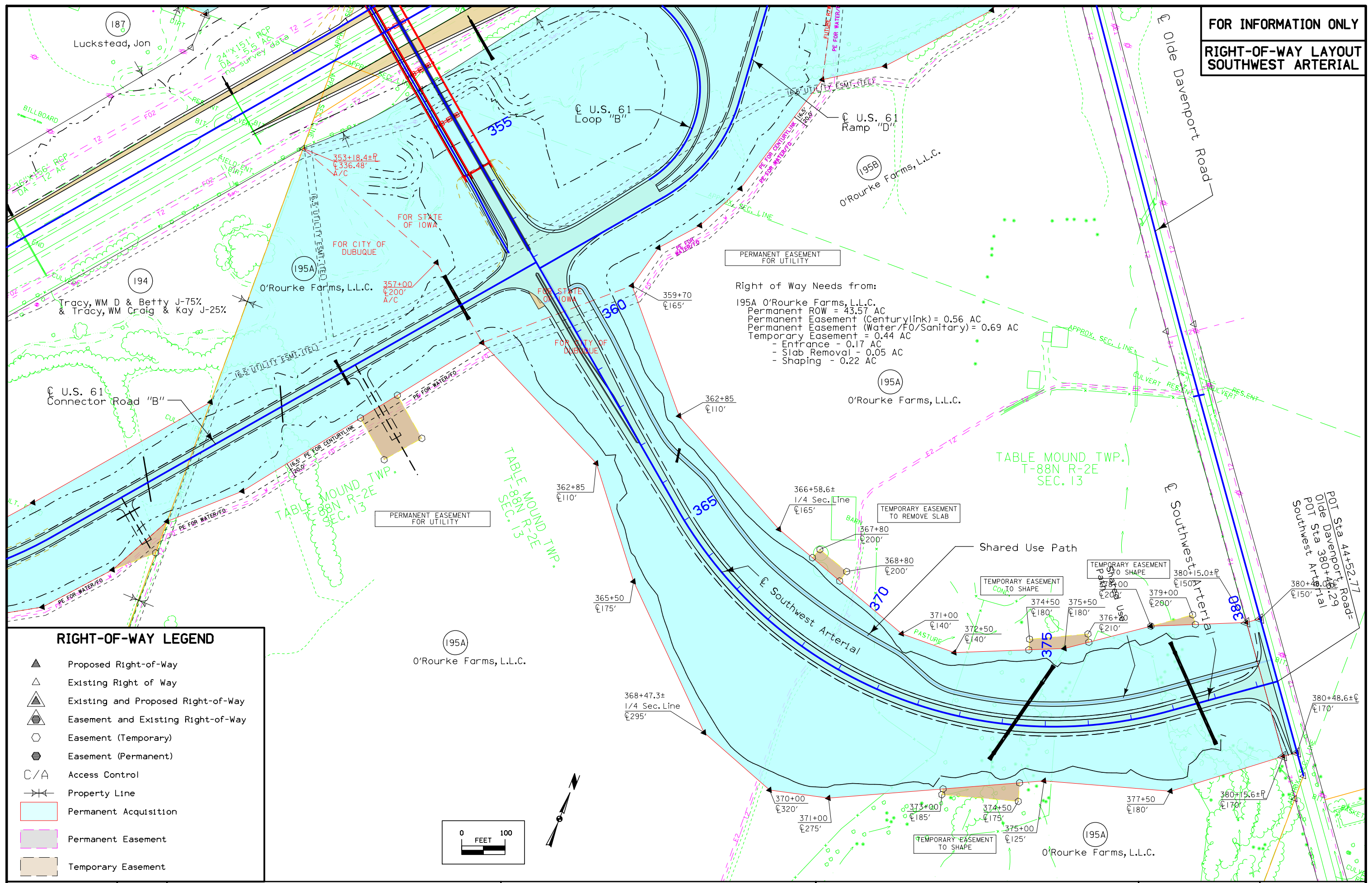

PERMANENT EASEMENT FOR UTILITY

Right of Way Needs from:
 195A O'Rourke Farms, L.L.C.
 Permanent ROW = 43.57 AC
 Permanent Easement (Centurylink) = 0.56 AC
 Permanent Easement (Water/F0/Sanitary) = 0.69 AC
 Temporary Easement = 0.44 AC
 - Entrance - 0.17 AC
 - Slab Removal - 0.05 AC
 - Shaping - 0.22 AC

RIGHT-OF-WAY LEGEND

- ▲ Proposed Right-of-Way
- △ Existing Right of Way
- ▲ Existing and Proposed Right-of-Way
- ⊕ Easement and Existing Right-of-Way
- Easement (Temporary)
- Easement (Permanent)
- C/A Access Control
- ⊗ Property Line
- Permanent Acquisition
- Permanent Easement
- Temporary Easement

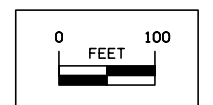

RIGHT-OF-WAY LEGEND

- Proposed Right-of-Way
- Existing Right of Way
- Existing and Proposed Right-of-Way
- Easement and Existing Right-of-Way
- Easement (Temporary)
- Easement (Permanent)
- Access Control
- Property Line
- Permanent Acquisition
- Permanent Easement
- Temporary Easement

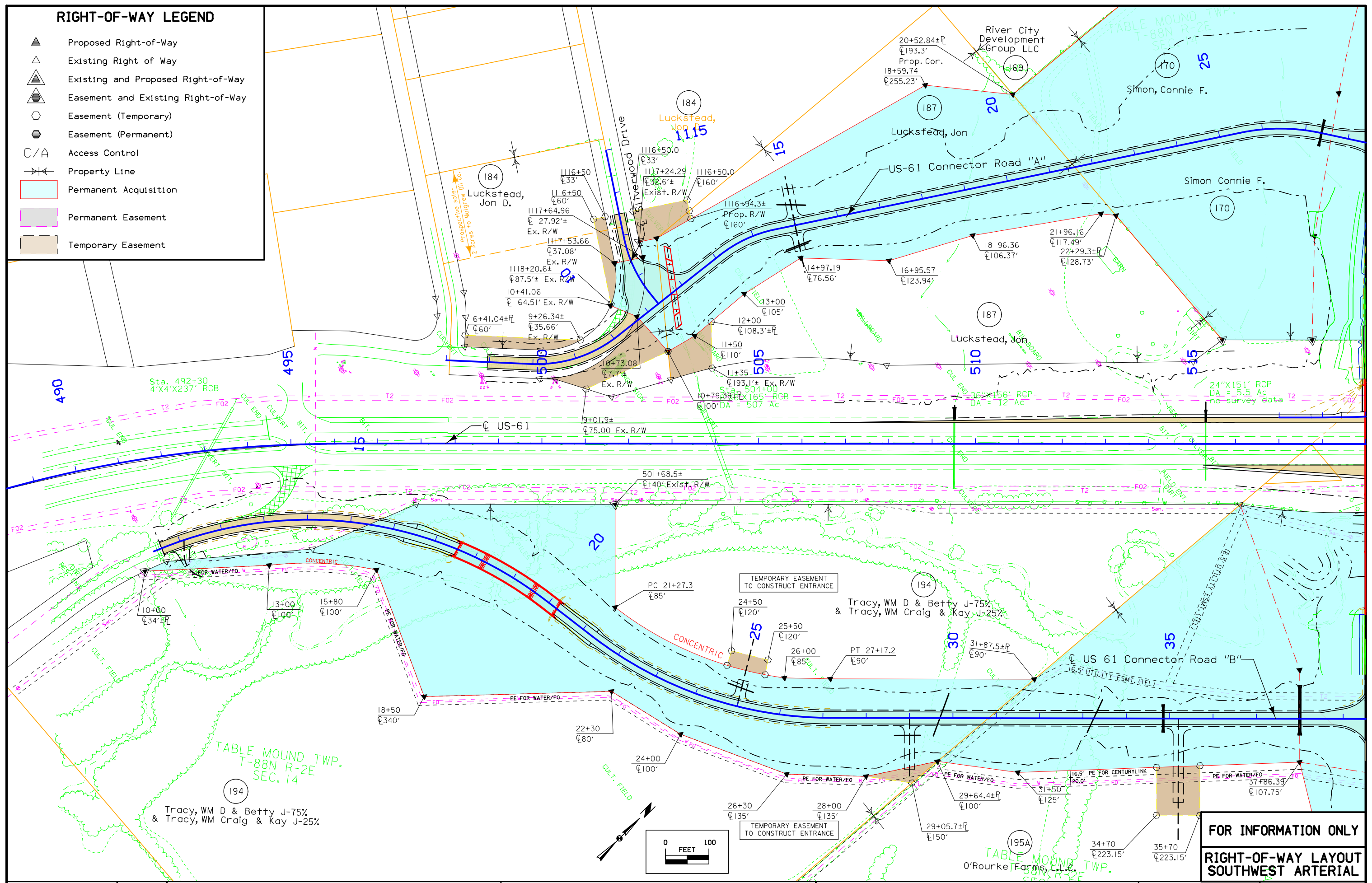

FOR INFORMATION ONLY
RIGHT-OF-WAY LAYOUT
SOUTHWEST ARTERIAL

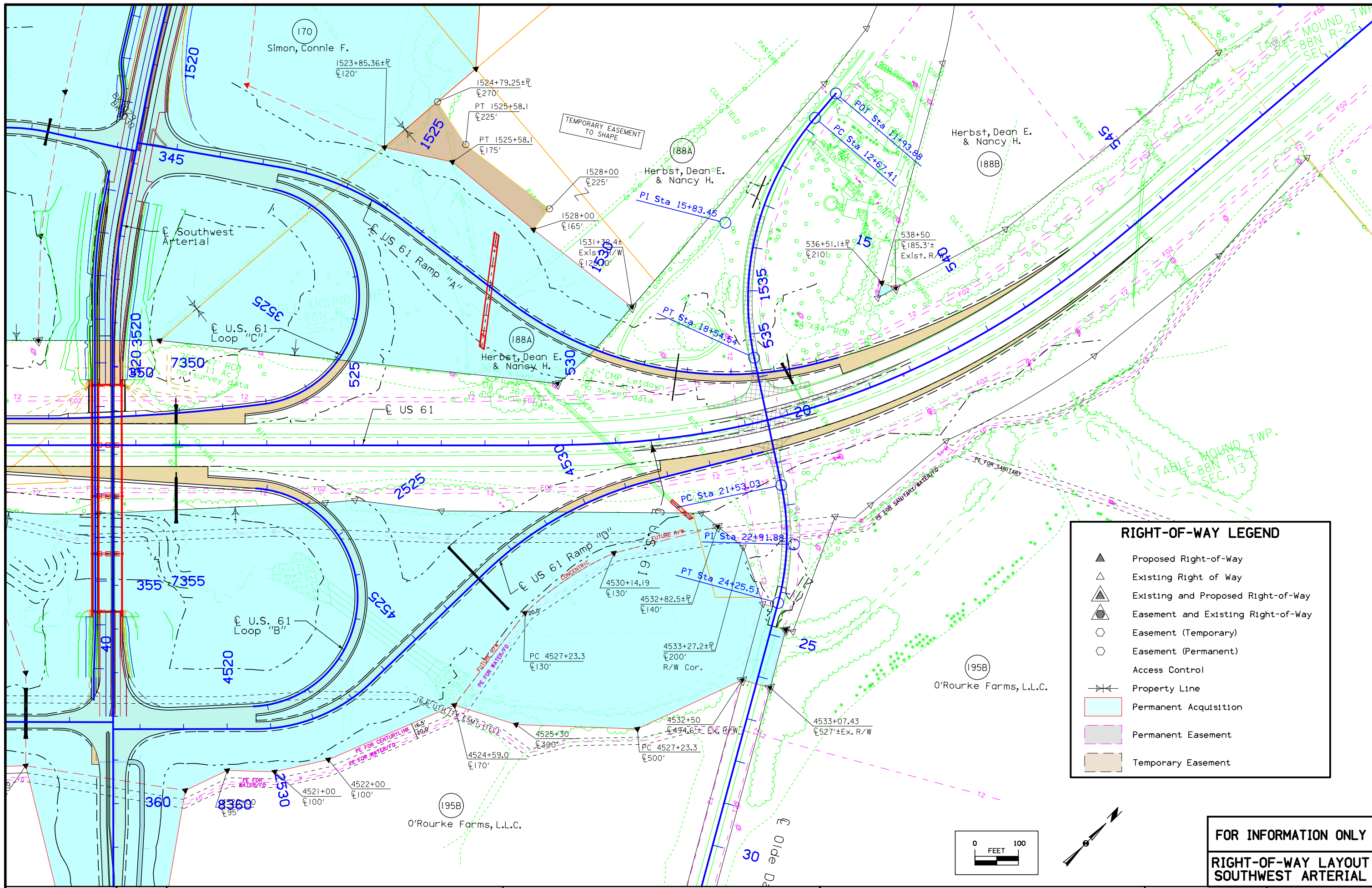

RIGHT-OF-WAY LEGEND

- Proposed Right-of-Way
- Existing Right of Way
- Existing and Proposed Right-of-Way
- Easement and Existing Right-of-Way
- Easement (Temporary)
- Easement (Permanent)
- Access Control
- Property Line
- Permanent Acquisition
- Permanent Easement
- Temporary Easement

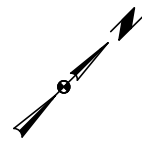
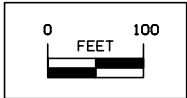

FOR INFORMATION ONLY
RIGHT-OF-WAY LAYOUT
SOUTHWEST ARTERIAL

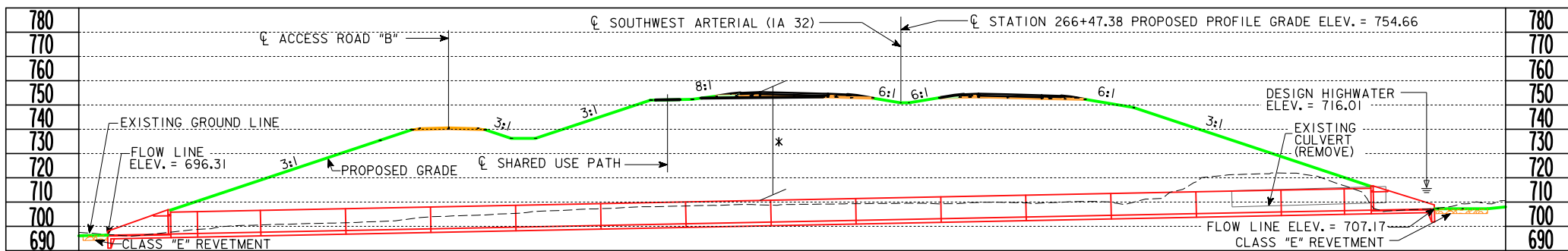

LONGITUDINAL SECTION ALONG CL BOX CULVERT
 * DESIGN FILL = 44'
 ANTICIPATED SETTLEMENT = xx

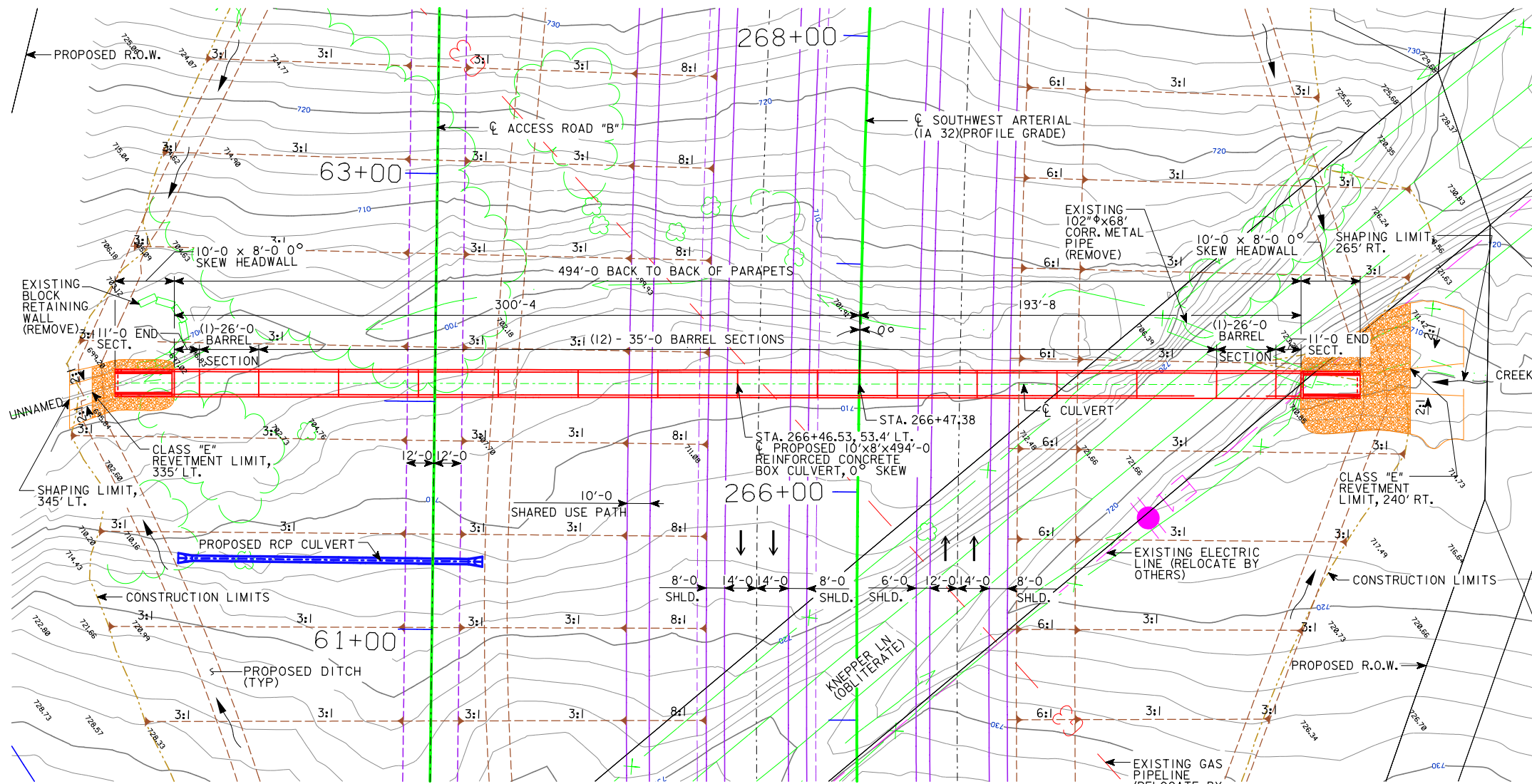

SITUATION PLAN

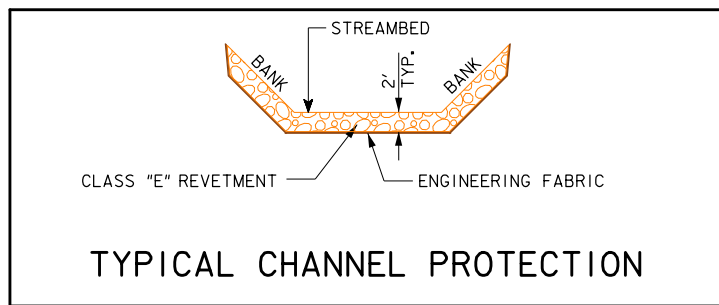

ESTIMATED REVETMENT QUANTITIES			
LOCATION	REVTMENT CL. "E" (TON)	ENGINEERING FABRIC (SY)	EXCAVATION (CY)
INLET	245	230	155
OUTLET	105	95	65
TOTALS	350	325	220

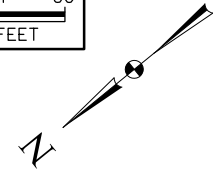

BENCHMARK:

BM #18- 7" SPIKE IN POWER POLE W/ TRANSFORMER WEST SIDE OF KNEPPER LANE- 1ST POLE SOUTH OF BUILDINGS AT NORTH END OF KNEPPER LANE 3641282.47 NORTH, 5676928.55 EAST, ELEV. 758.32

PROFILE GRADE ON SW ARTERIAL (IA 32)

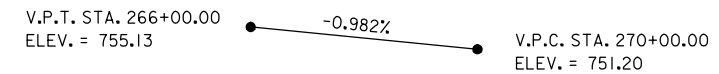

CURVE DATA SW ARTERIAL (IA 32)

ENTERING CURVE DATA (CURVE 21006)
 P.I. STA. 281+52.29
 DELTA = 59° 29' 35.10" (RT)
 DEGREE = 0° 45' 50.20"
 TANGENT = 4,286.00'
 LENGTH = 7,787.63'
 RADIUS = 7,500.00'
 EXTERNAL = 1,138.28'
 LONG CHORD = 7,442.46'
 MID. ORD. = 988.28'
 P.C. STA. 238+66.28
 P.T. STA. 316+53.91

HYDRAULIC DATA

DRAINAGE AREA = 375 ACRES
 DESIGN DISCHARGE, Q50 = 619 CFS
 DESIGN HIGH WATER ELEVATION, Q50 = 716.01

LOCATION

SW ARTERIAL (IA 32)
 OVER UNNAMED CREEK
 T-88N, R-2E
 SECTION 11
 TABLE MOUND TWP
 DUBUQUE COUNTY
 CITY OF DUBUQUE
 LAT. 42.4535224°
 LONG. -90.6988353°

TRAFFIC ESTIMATE

Year	AADT	NA	V.P.D.
2015		NA	%
2030		16,000	%
		7	%

PLAN NOTES

1. SEE SHEET D.I FOR UTILITY LEGEND.
2. ALL UNITS ARE IN FEET AND INCHES UNLESS NOTED OTHERWISE.
3. SEE 'J' SHEETS FOR STAGING DETAILS.
4. SEE 'D' SHEETS FOR ADDITIONAL PIPE INFORMATION.
5. SEE CROSS SECTIONS FOR ADDITIONAL APPROACH SECTION INFORMATION.

DESIGN FOR 0° SKEW
10'x8'x494'-Ø REINFORCED CONCRETE BOX CULVERT
C.I.P. SITUATION PLAN
 STA. 266+47.38 APRIL, 2016
DUBUQUE COUNTY
 IOWA DEPARTMENT OF TRANSPORTATION - HIGHWAY DIVISION
 DESIGN SHEET NO. 1 OF 1 FILE NO. _____ DESIGN NO. _____

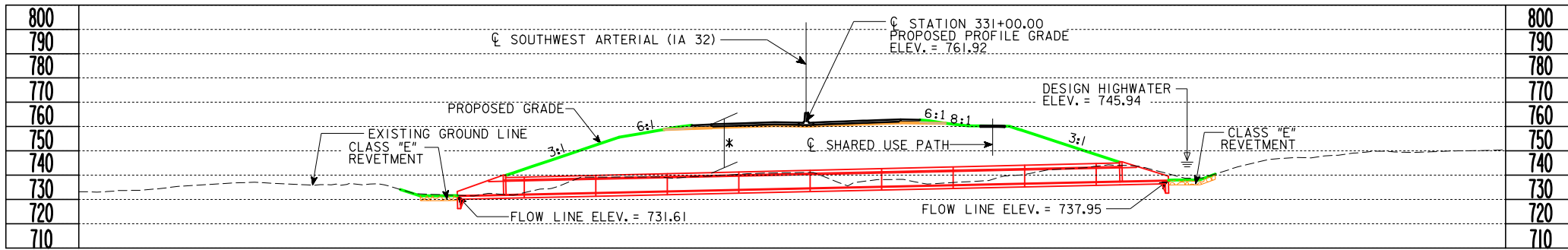

LONGITUDINAL SECTION ALONG CL BOX CULVERT

* DESIGN FILL = 21'
ANTICIPATED SETTLEMENT = xx

BENCHMARK:

BM #14- 7" SPIKE IN CORNER POST 2000' SOUTH OF MILITARY ROAD ON EXTENSION OF DRIVE AT MT. ST. BERNARD ROAD AT NORTH-SOUTH FENCE / EAST-WEST FENCE T-INTERSECTION 3636697.07 NORTH, 5678865.76 EAST, ELEV. 769.84

PROFILE GRADE ON SW ARTERIAL (IA 32)

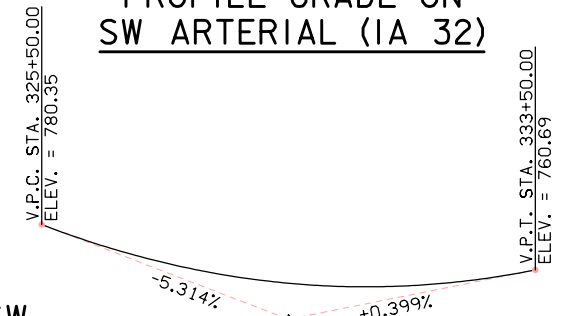

CURVE DATA SW ARTERIAL (IA 32)

ENTERING CURVE DATA (CURVE 21007)
P.I. STA. 334+23.45
DELTA = 28° 35' 02.91" (LT)
DEGREE = 1° 25' 56.62"
TANGENT = 1,019.00'
LENGTH = 1,995.55'
RADIUS = 4,000.00'
EXTERNAL = 127.75'
LONG CHORD = 1,974.92'
MID. ORD. = 123.80'
P.C. STA. 324+04.45
P.T. STA. 344+00.00

HYDRAULIC DATA

DRAINAGE AREA = 202 ACRES
DESIGN DISCHARGE, Q50 = 393 CFS
DESIGN HIGH WATER ELEVATION, Q50 = 745.94

LOCATION

SW ARTERIAL (IA 32)
OVER UNNAMED CREEK
T-88N, R-2E
SECTION 14
TABLE MOUND TWP.
DUBUQUE COUNTY
CITY OF DUBUQUE
LAT. 42.4379511°
LONG. -90.6886064°

TRAFFIC ESTIMATE

2015	AADT	NA	V.P.D.
	TRUCKS	NA	%
2030	AADT	16,000	V.P.D.
	TRUCKS	7	%

PLAN NOTES

- SEE SHEET D.1 FOR UTILITY LEGEND.
- ALL UNITS ARE IN FEET AND INCHES UNLESS NOTED OTHERWISE.
- SEE 'J' SHEETS FOR STAGING DETAILS.
- SEE 'D' SHEETS FOR ADDITIONAL PIPE INFORMATION.
- SEE CROSS SECTIONS FOR ADDITIONAL APPROACH SECTION INFORMATION.

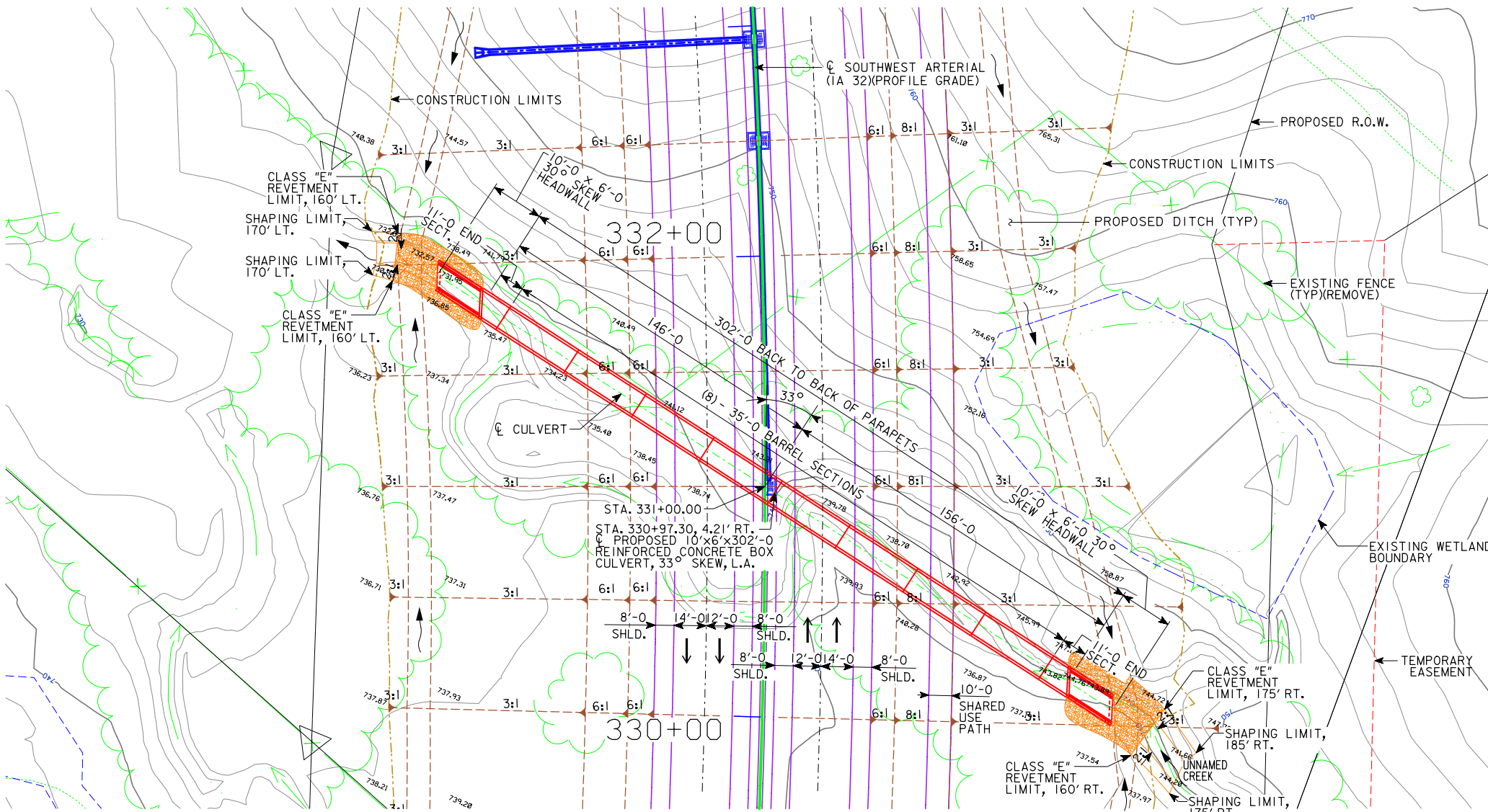

SITUATION PLAN

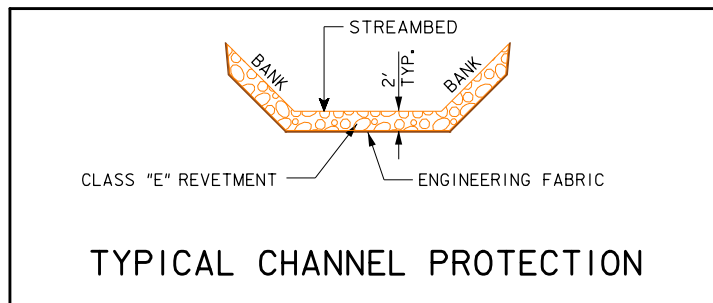

ESTIMATED REVETMENT QUANTITIES

LOCATION	REVTMENT CL. "E" (TON)	ENGINEERING FABRIC (SY)	EXCAVATION (CY)
INLET	115	110	70
OUTLET	95	85	60
TOTALS	210	195	130

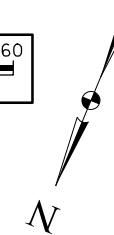

DESIGN FOR 33° SKEW (L.A.)
10'x6'x302'-0 REINFORCED CONCRETE BOX CULVERT
C.I.P. SITUATION PLAN

STA. 331+00.00 APRIL, 2016
DUBUQUE COUNTY
IOWA DEPARTMENT OF TRANSPORTATION - HIGHWAY DIVISION
DESIGN SHEET NO. 1 OF 1 FILE NO. DESIGN NO.

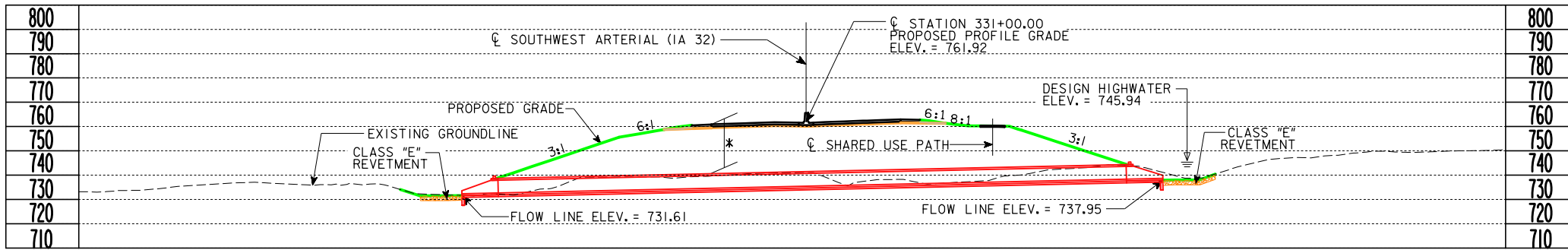

LONGITUDINAL SECTION ALONG CL BOX CULVERT

* DESIGN FILL = 21'
ANTICIPATED SETTLEMENT = xx

BENCHMARK:

BM #14- 7" SPIKE IN CORNER POST 2000' SOUTH OF MILITARY ROAD ON EXTENSION OF DRIVE AT MT. ST. BERNARD ROAD AT NORTH-SOUTH FENCE / EAST-WEST FENCE T-INTERSECTION 3636697.07 NORTH, 5678865.76 EAST, ELEV. 769.84

PROFILE GRADE ON SW ARTERIAL (IA 32)

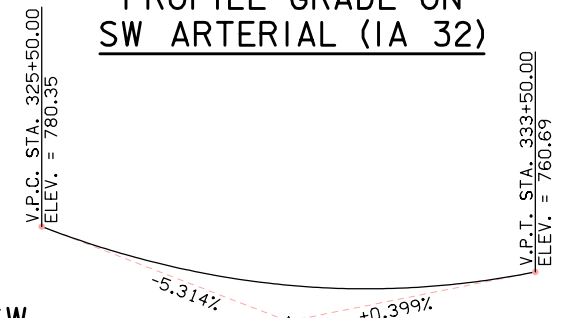

CURVE DATA SW ARTERIAL (IA 32)

ENTERING CURVE DATA (CURVE 21007)
P.I. STA. 334+23.45
DELTA = 28° 35' 02.91" (LT)
DEGREE = 1° 25' 56.62"
TANGENT = 1,019.00'
LENGTH = 1,995.55'
RADIUS = 4,000.00'
EXTERNAL = 127.75'
LONG CHORD = 1,974.92'
MID. ORD. = 123.80'
P.C. STA. 324+04.45
P.T. STA. 344+00.00

HYDRAULIC DATA

DRAINAGE AREA = 202 ACRES
DESIGN DISCHARGE, Q50 = 393 CFS
DESIGN HIGH WATER ELEVATION, Q50 = 745.94

LOCATION

SW ARTERIAL (IA 32)
OVER UNNAMED CREEK
T-88N, R-2E
SECTION 14
TABLE MOUND TWP.
DUBUQUE COUNTY
CITY OF DUBUQUE
LAT. 42.4379511°
LONG. -90.6886064°

TRAFFIC ESTIMATE

Year	AADT	Trucks %	V.P.D.
2015	NA	NA	%
2030	16,000	7	%

PLAN NOTES

- SEE SHEET D.1 FOR UTILITY LEGEND.
- ALL UNITS ARE IN FEET AND INCHES UNLESS NOTED OTHERWISE.
- SEE 'J' SHEETS FOR STAGING DETAILS.
- SEE 'D' SHEETS FOR ADDITIONAL PIPE INFORMATION.
- SEE CROSS SECTIONS FOR ADDITIONAL APPROACH SECTION INFORMATION.

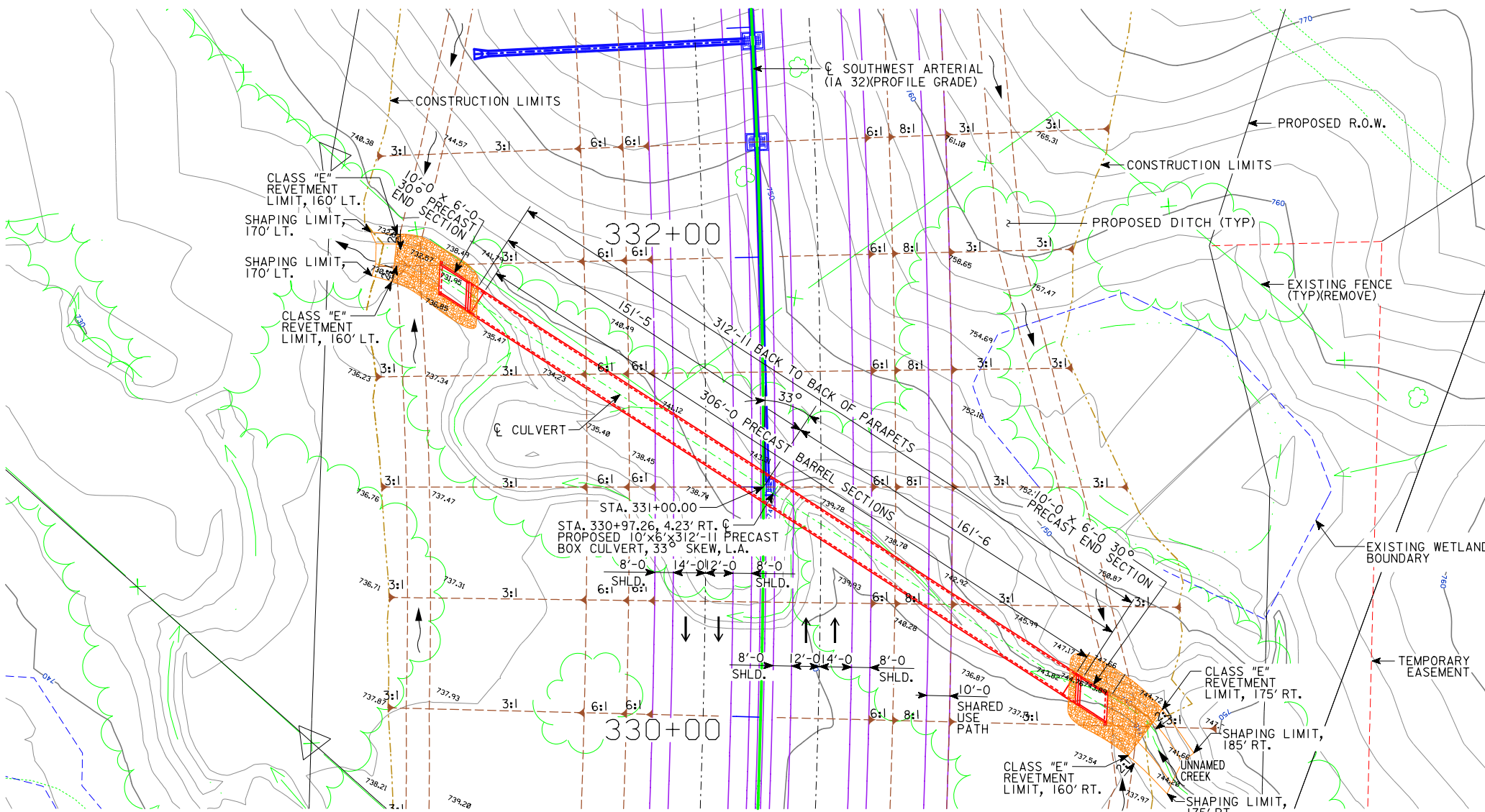

SITUATION PLAN

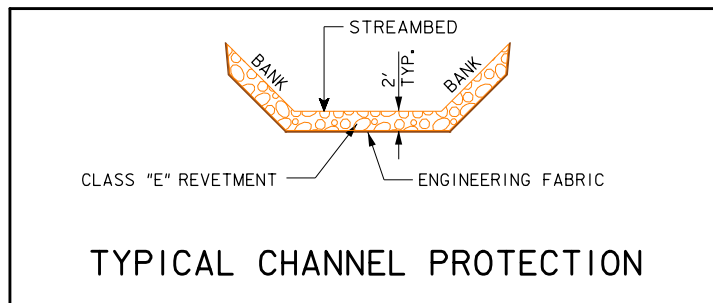

ESTIMATED REVETMENT QUANTITIES

LOCATION	REVTMENT CL. "E" (TON)	ENGINEERING FABRIC (SY)	EXCAVATION (CY)
INLET	120	110	75
OUTLET	100	90	65
TOTALS	220	200	140

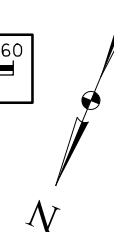

DESIGN FOR 33° SKEW (L.A.)
10'x6'x312'-11 PRECAST CONCRETE BOX CULVERT
PRECAST SITUATION PLAN

STA. 331+00.00 APRIL, 2016
DUBUQUE COUNTY
IOWA DEPARTMENT OF TRANSPORTATION - HIGHWAY DIVISION
DESIGN SHEET NO. 1 OF 1 FILE NO. DESIGN NO.

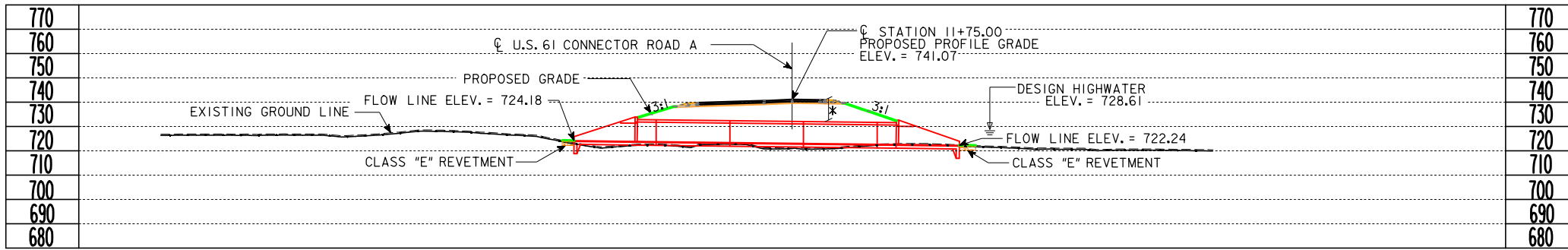

BENCHMARK:

BM 61.1 - "X" CUT ON LIGHT POLE BASE AT INTERSECTION OF HWY 61 AND EAST TAMARACK DRIVE.
 3631743.07 NORTH, 5679648.31 EAST, ELEV. 762.39
 BM 61.2 - 12" SPIKE EAST SIDE POWER POLE-WEST SIDE OF HWY 61-6TH POWER POLE NORTH OF EAST TAMARACK DRIVE.
 3632616.75 NORTH, 5680247.46 EAST, ELEV. 725.65

PROFILE GRADE ON U.S. 61 CONN. ROAD A

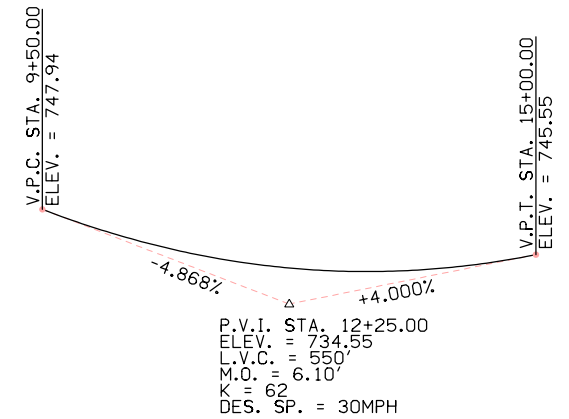

LONGITUDINAL SECTION ALONG CL BOX CULVERT

* DESIGN FILL = 9'
 ANTICIPATED SETTLEMENT = XX

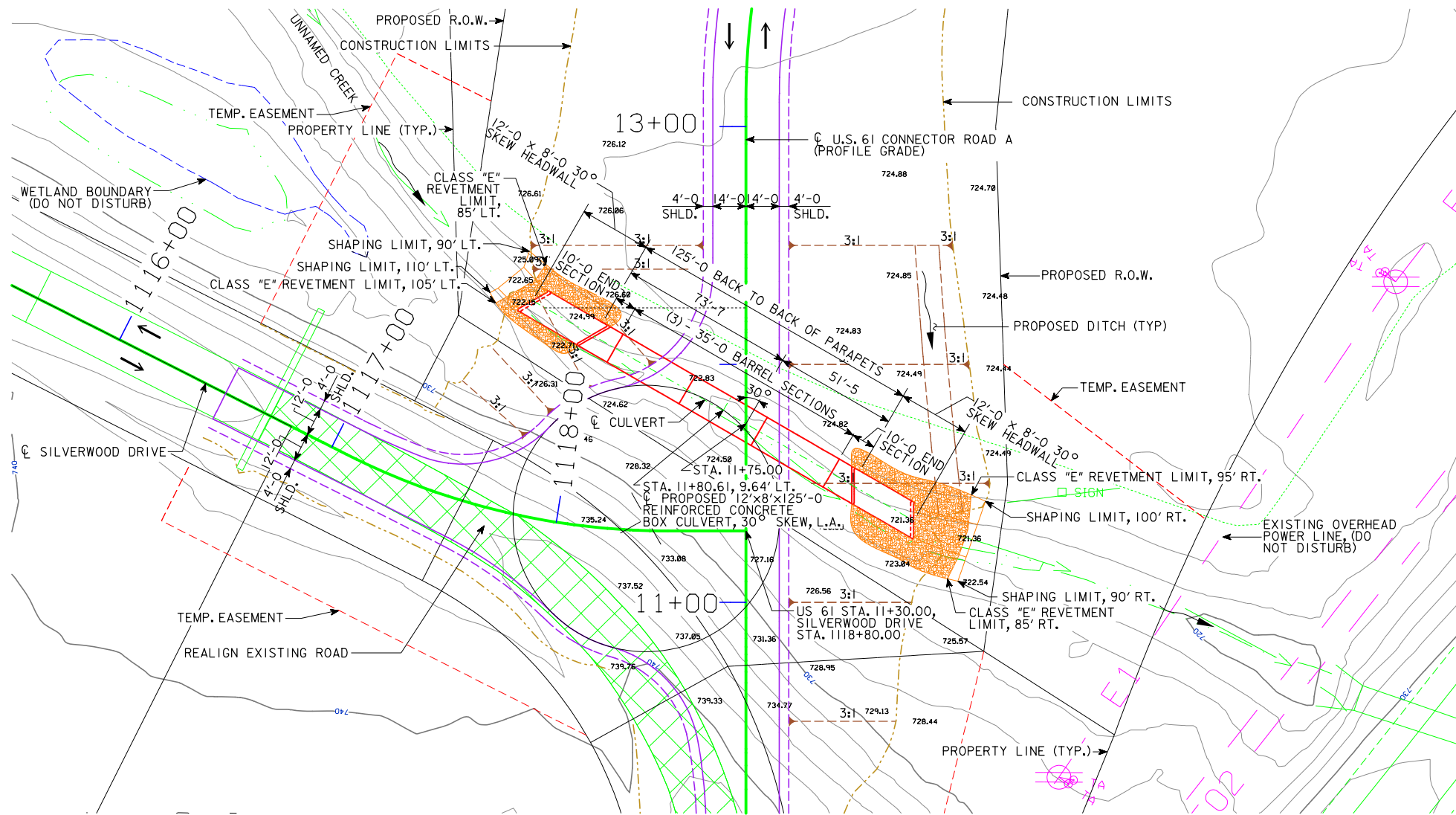

U.S. 61 CONNECTOR ROAD A ALIGNMENT

U.S. 61 CONN. ROAD A TANGENT BETWEEN CURVES
 PT STA. 10+10.54
 PC STA. 13+11.56

HYDRAULIC DATA

DRAINAGE AREA = 613 ACRES
 DESIGN DISCHARGE, Q50 = 763 CFS
 DESIGN HIGH WATER ELEVATION, Q50 = 728.61

TRAFFIC ESTIMATE

2015 AADT	NA	V.P.D.
TRUCKS	NA	%
2030 AADT	3,300	V.P.D.
TRUCKS	7	%

LOCATION

U.S. 61 CONNECTOR ROAD A OVER UNNAMED CREEK
 T-88N, R-2E
 SECTION 14
 TABLE MOUND TWP.
 DUBUQUE COUNTY
 CITY OF DUBUQUE
 LAT. 42.4305329°
 LONG. -90.6890486°

PLAN NOTES

- SEE SHEET D.1 FOR UTILITY LEGEND.
- ALL UNITS ARE IN FEET AND INCHES UNLESS NOTED OTHERWISE.
- SEE 'J' SHEETS FOR STAGING DETAILS.
- SEE 'D' SHEETS FOR ADDITIONAL PIPE INFORMATION.
- SEE CROSS SECTIONS FOR ADDITIONAL APPROACH SECTION INFORMATION.
- CALLOUTS BASED ON US 61 CONNECTOR ROAD A UNLESS OTHERWISE NOTED.

SITUATION PLAN

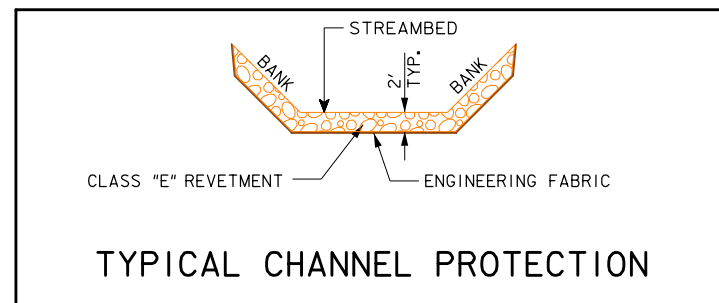

ESTIMATED REVETMENT QUANTITIES

LOCATION	REVETMENT CL. "E" (TON)	ENGINEERING FABRIC (SY)	EXCAVATION (CY)
INLET	85	80	55
OUTLET	180	170	115
TOTALS	265	250	170

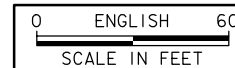

DESIGN FOR 30° SKEW (L.A.)
12'x8'x125'-0" REINFORCED CONCRETE BOX CULVERT
C.I.P. SITUATION PLAN
 STA. 11+75.00 APRIL, 2016
DUBUQUE COUNTY
 IOWA DEPARTMENT OF TRANSPORTATION - HIGHWAY DIVISION
 DESIGN SHEET NO. 1 OF 1 FILE NO. DESIGN NO.

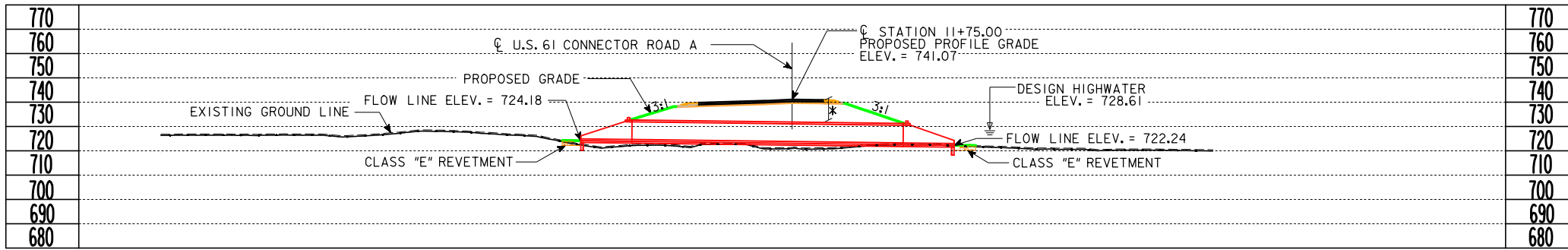

BENCHMARK:
 BM 61.1 - "X" CUT ON LIGHT POLE BASE AT INTERSECTION OF HWY 61 AND EAST TAMARACK DRIVE. 3631743.07 NORTH, 5679648.31 EAST, ELEV. 762.39
 BM 61.2 - 12" SPIKE EAST SIDE POWER POLE-WEST SIDE OF HWY 61-6TH POWER POLE NORTH OF EAST TAMARACK DRIVE. 3632616.75 NORTH, 5680247.46 EAST, ELEV. 725.65

PROFILE GRADE ON U.S. 61 CONN. ROAD A

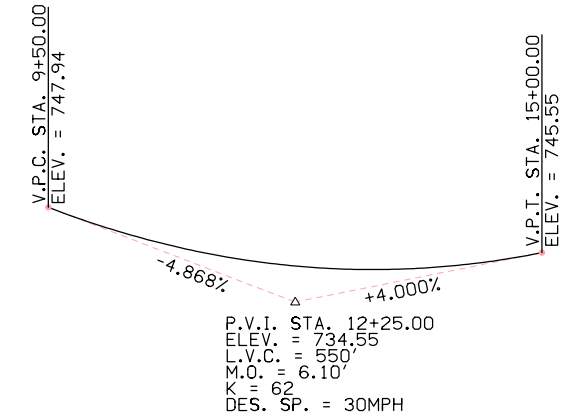

LONGITUDINAL SECTION ALONG CL BOX CULVERT

* DESIGN FILL = 9'
 ANTICIPATED SETTLEMENT = XX

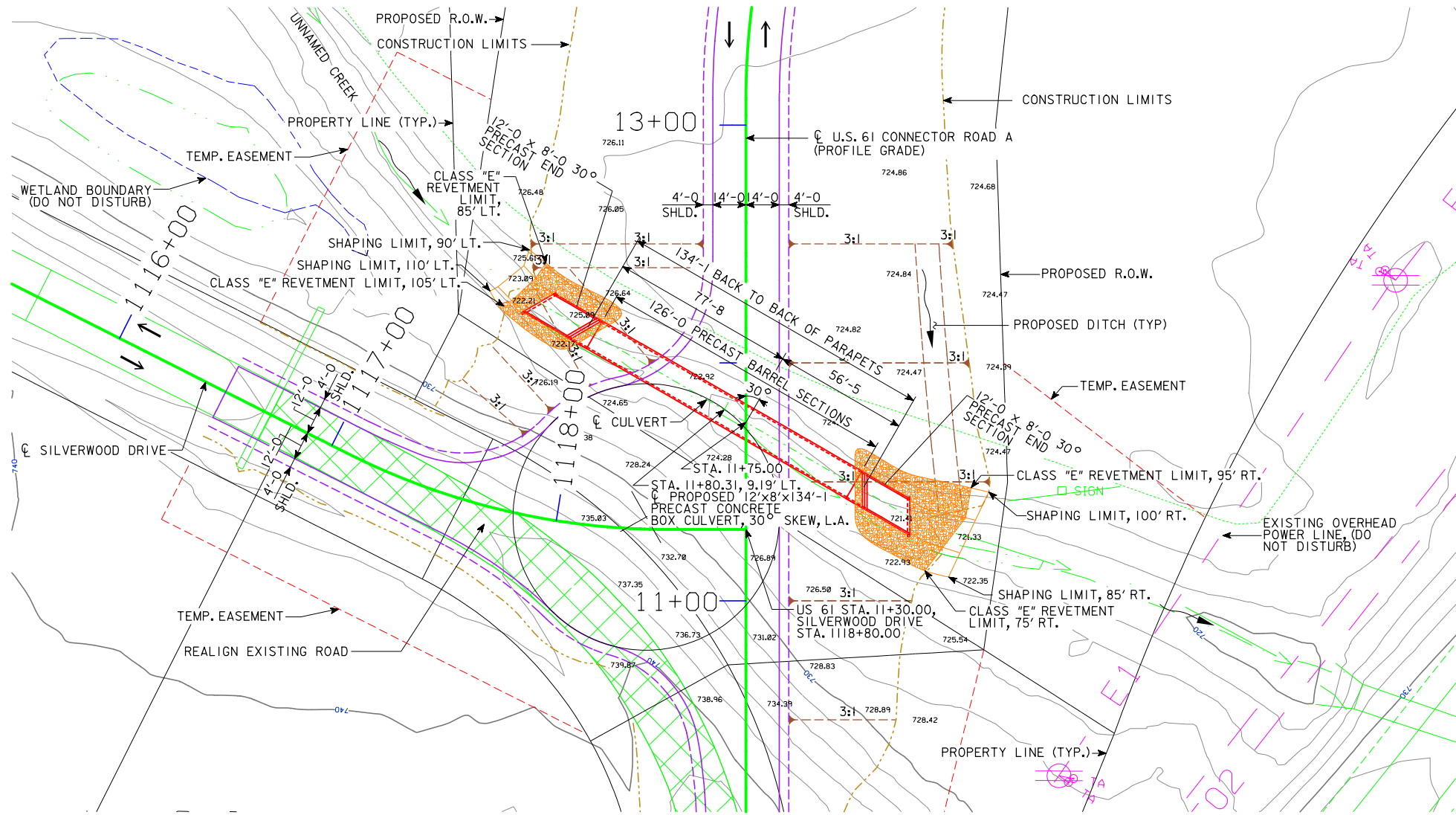

U.S. 61 CONNECTOR ROAD A ALIGNMENT

U.S. 61 CONN. ROAD A TANGENT BETWEEN CURVES
 PT STA. 10+10.54
 PC STA. 13+11.56

HYDRAULIC DATA

DRAINAGE AREA = 613 ACRES
 DESIGN DISCHARGE, Q50 = 763 CFS
 DESIGN HIGH WATER ELEVATION, Q50 = 728.61

TRAFFIC ESTIMATE

2015	AADT	NA	V.P.D.
	TRUCKS	NA	%
2030	AADT	3,300	V.P.D.
	TRUCKS	7	%

LOCATION

U.S. 61 CONNECTOR ROAD A OVER UNNAMED CREEK
 T-88N, R-2E
 SECTION 14
 TABLE MOUND TWP.
 DUBUQUE COUNTY
 CITY OF DUBUQUE
 LAT. 42.4305329°
 LONG. -90.6890486°

PLAN NOTES

1. SEE SHEET D.1 FOR UTILITY LEGEND.
2. ALL UNITS ARE IN FEET AND INCHES UNLESS NOTED OTHERWISE.
3. SEE 'J' SHEETS FOR STAGING DETAILS.
4. SEE 'D' SHEETS FOR ADDITIONAL PIPE INFORMATION.
5. SEE CROSS SECTIONS FOR ADDITIONAL APPROACH SECTION INFORMATION.
6. CALLOUTS BASED ON US 61 CONNECTOR ROAD A UNLESS OTHERWISE STATED.

SITUATION PLAN

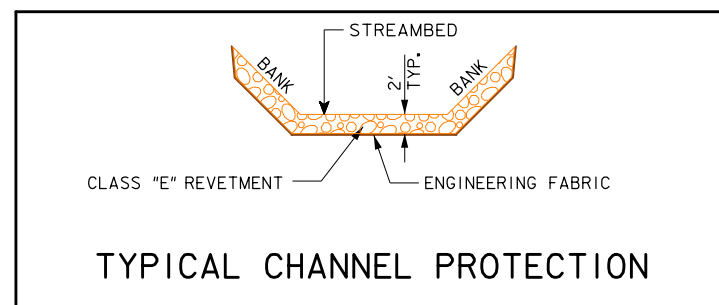

ESTIMATED REVETMENT QUANTITIES

LOCATION	REVTMENT CL. "E" (TON)	ENGINEERING FABRIC (SY)	EXCAVATION (CY)
INLET	90	85	55
OUTLET	160	150	100
TOTALS	250	235	155

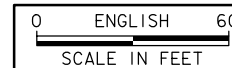

DESIGN FOR 30° SKEW (L.A.)
12'x8'x134'-1 PRECAST CONCRETE BOX CULVERT
PRECAST SITUATION PLAN
 STA. 11+75.00 APRIL, 2016
DUBUQUE COUNTY
 IOWA DEPARTMENT OF TRANSPORTATION - HIGHWAY DIVISION
 DESIGN SHEET NO. 1 OF 1 FILE NO. DESIGN NO.

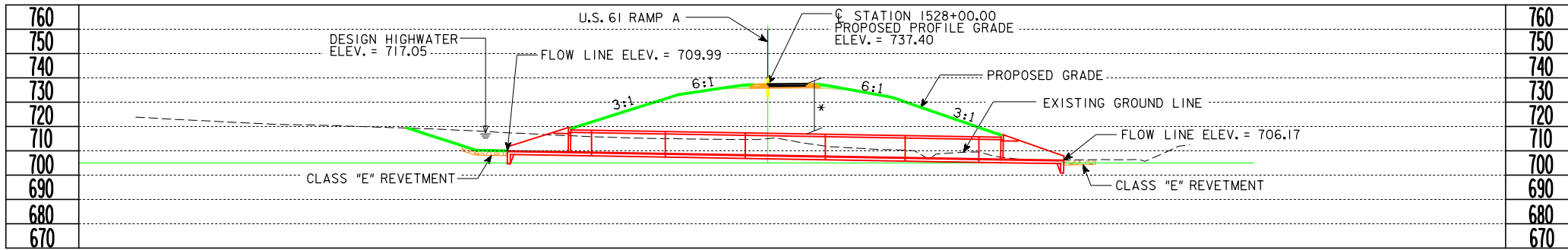

BENCHMARK:

BM 61.4 - 12" SPIKE EAST SIDE POWER POLE-WEST SIDE OF HWY 61-4TH POWER POLE SOUTH OF COUNTY ROAD Y38. 3634165.11 NORTH, 5681433.36 EAST, ELEV. 752.87
 GO 36 - REBAR 6" DEEP IN EDGE OF SOUTHEAST SHOULDER OF HWY 61-108' (+/-) SOUTH OF OLDE DAVENPORT ROAD CENTERLINE, 17.5' (+/-) NORTHWEST OF EAST "DO NOT ENTER" SIGN. 3634727.74 NORTH, 5682148.64 EAST, ELEV. 727.86

PROFILE GRADE ON U.S. 61 RAMP A

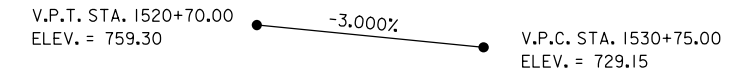

LONGITUDINAL SECTION ALONG C BOX CULVERT

* DESIGN FILL = 21'
 ANTICIPATED SETTLEMENT = XX

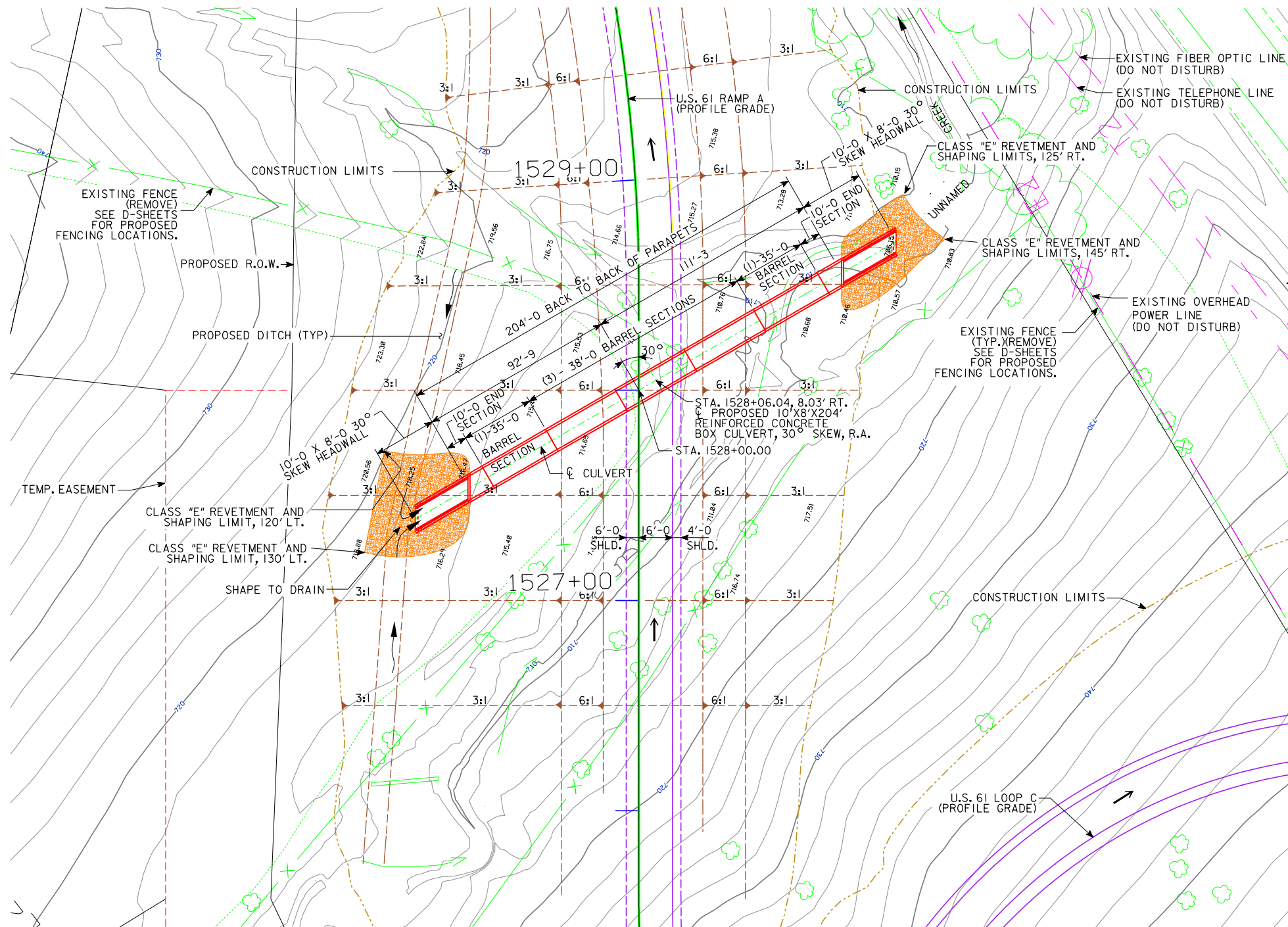

U.S. 61 RAMP A ALIGNMENT

U.S. 61 RAMP A TANGENT BETWEEN CURVES
 PT STA. 1525+58.12
 PC STA. 1528+46.71

HYDRAULIC DATA

DRAINAGE AREA = 347 ACRES
 DESIGN DISCHARGE, Q50 = 613 CFS
 DESIGN HIGH WATER ELEVATION, Q50 = 717.05

TRAFFIC ESTIMATE

2015	AADT	NA	V.P.D.
	TRUCKS	NA	%
2030	AADT	6,200	V.P.D.
	TRUCKS	7	%

LOCATION

U.S. 61 RAMP A OVER UNNAMED CREEK
 T-88N, R-2E
 SECTION 13
 TABLE MOUND TWP.
 DUBUQUE COUNTY
 CITY OF DUBUQUE
 LAT. 42.4358319°
 LONG. -90.6831264°

PLAN NOTES

- SEE SHEET D.1 FOR UTILITY LEGEND.
- ALL UNITS ARE IN FEET AND INCHES UNLESS NOTED OTHERWISE.
- SEE 'J' SHEETS FOR STAGING DETAILS.
- SEE 'D' SHEETS FOR ADDITIONAL PIPE INFORMATION.
- SEE CROSS SECTIONS FOR ADDITIONAL APPROACH SECTION INFORMATION.

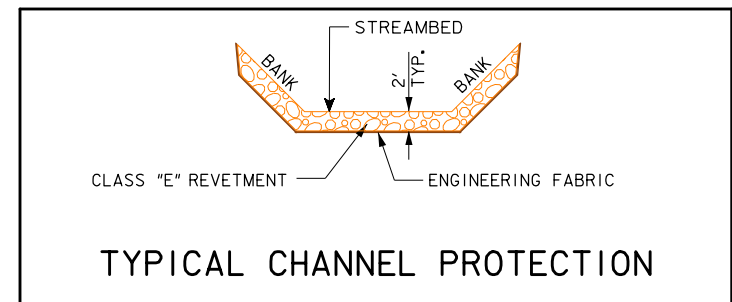

ESTIMATED REVETMENT QUANTITIES

LOCATION	REVETMENT CL. "E" (TON)	ENGINEERING FABRIC (SY)	EXCAVATION (CY)
INLET	235	215	150
OUTLET	155	140	100
TOTALS	390	355	250

SITUATION PLAN



DESIGN FOR 30° SKEW (R.A.)
10'x8'x204'-Ø REINFORCED CONCRETE BOX CULVERT
C.I.P. SITUATION PLAN
 STA. 1528+00.00 APRIL, 2016
DUBUQUE COUNTY
 IOWA DEPARTMENT OF TRANSPORTATION - HIGHWAY DIVISION
 DESIGN SHEET NO. 1 OF 1 FILE NO. DESIGN NO.

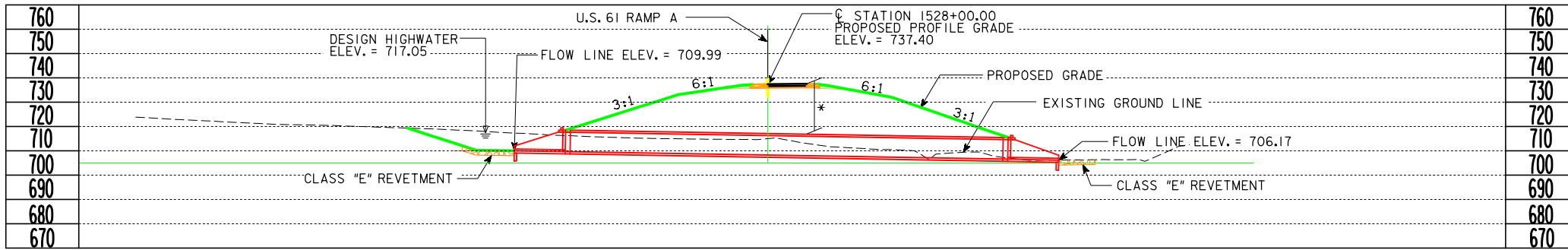

BENCHMARK:

BM 61.4 - 12" SPIKE EAST SIDE POWER POLE-WEST SIDE OF HWY 61-4TH POWER POLE SOUTH OF COUNTY ROAD Y38. 3634165.11 NORTH, 5681433.36 EAST, ELEV. 752.87
 GO 36 - REBAR 6" DEEP IN EDGE OF SOUTHEAST SHOULDER OF HWY 61-108' (+/-) SOUTH OF OLDE DAVENPORT ROAD CENTERLINE, 17.5' (+/-) NORTHWEST OF EAST "DO NOT ENTER" SIGN, 3634727.74 NORTH, 5682148.64 EAST, ELEV. 727.86

PROFILE GRADE ON U.S. 61 RAMP A

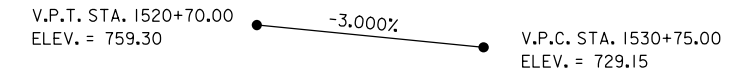

LONGITUDINAL SECTION ALONG C BOX CULVERT

* DESIGN FILL = 21'
 ANTICIPATED SETTLEMENT = XX

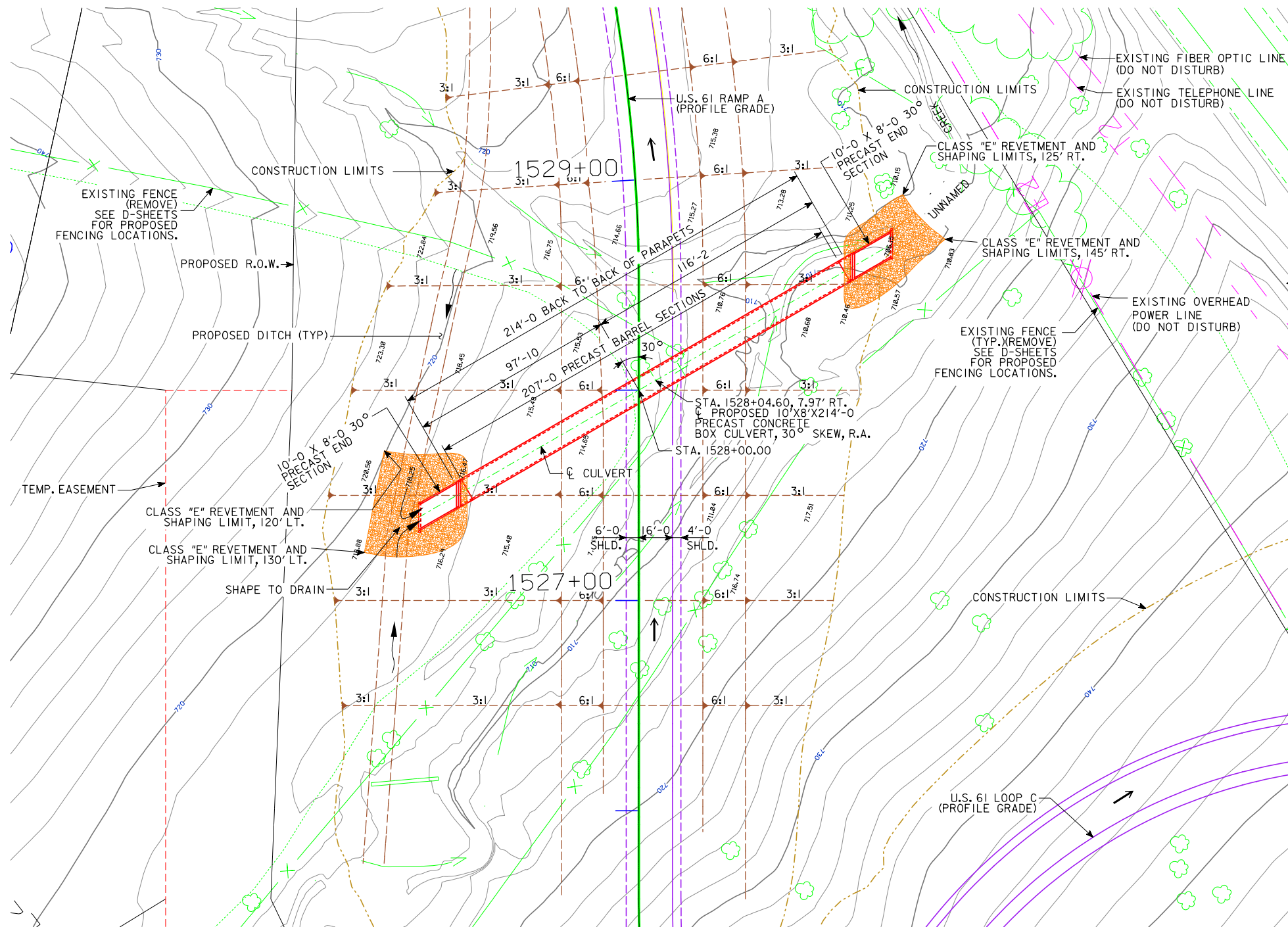

U.S. 61 RAMP A ALIGNMENT

U.S. 61 RAMP A TANGENT BETWEEN CURVES
 PT STA. 1525+58.12
 PC STA. 1528+46.71

HYDRAULIC DATA

DRAINAGE AREA = 347 ACRES
 DESIGN DISCHARGE, Q50 = 613 CFS
 DESIGN HIGH WATER ELEVATION, Q50 = 717.05

TRAFFIC ESTIMATE

2015	AADT	NA	V.P.D.
	TRUCKS	NA	%
2030	AADT	6,200	V.P.D.
	TRUCKS	7	%

LOCATION

U.S. 61 RAMP A OVER UNNAMED CREEK
 T-88N, R-2E
 SECTION 13
 TABLE MOUND TWP.
 DUBUQUE COUNTY
 CITY OF DUBUQUE
 LAT. 42.4358319°
 LONG. -90.6831264°

PLAN NOTES

- SEE SHEET D.1 FOR UTILITY LEGEND.
- ALL UNITS ARE IN FEET AND INCHES UNLESS NOTED OTHERWISE.
- SEE 'J' SHEETS FOR STAGING DETAILS.
- SEE 'D' SHEETS FOR ADDITIONAL PIPE INFORMATION.
- SEE CROSS SECTIONS FOR ADDITIONAL APPROACH SECTION INFORMATION.

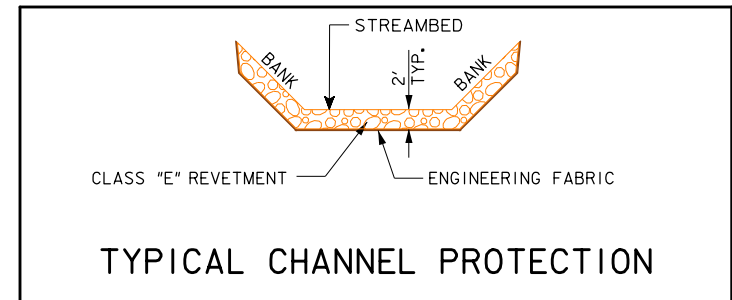

ESTIMATED REVETMENT QUANTITIES

LOCATION	REVETMENT CL. "E" (TON)	ENGINEERING FABRIC (SY)	EXCAVATION (CY)
INLET	240	220	150
OUTLET	160	145	100
TOTALS	400	365	250

SITUATION PLAN



DESIGN FOR 30° SKEW (R.A.)
10'x8'x214'-Ø PRECAST CONCRETE BOX CULVERT
PRECAST SITUATION PLAN
 STA. 1528+00.00 APRIL, 2016
DUBUQUE COUNTY
 IOWA DEPARTMENT OF TRANSPORTATION - HIGHWAY DIVISION
 DESIGN SHEET NO. 1 OF 1 FILE NO. DESIGN NO.

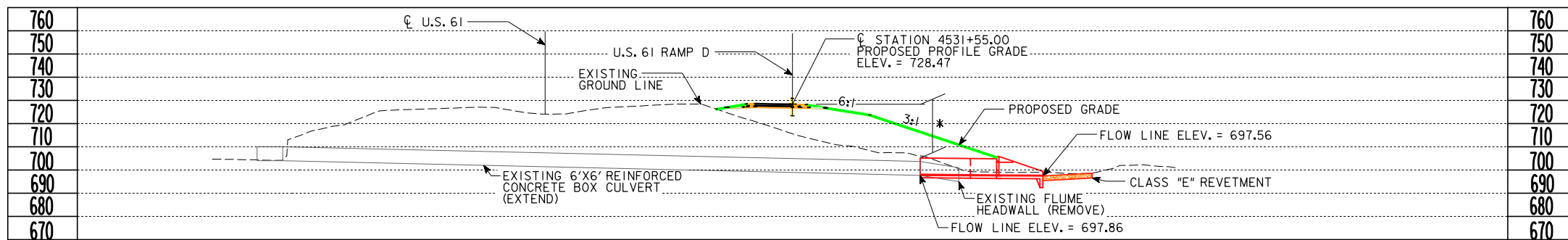

LONGITUDINAL SECTION ALONG CL BOX CULVERT

* DESIGN FILL = 22'
ANTICIPATED SETTLEMENT = XX

BENCHMARK:
GO 36 - REBAR 6" DEEP IN EDGE OF SOUTHEAST SHOULDER OF HWY 61, 108' (+/-) SOUTH OF OLDE DAVENPORT ROAD CENTERLINE, 17.5' (+/-) NORTHWEST OF EAST "DO NOT ENTER" SIGN. 3634727.74 NORTH, 5682148.64 EAST, ELEV. 727.86.
BM 61.5 - 12" SPIKE WEST SIDE POWER POLE EAST SIDE OF HWY 61-3RD POWER POLE NORTH OF OLDE DAVENPORT ROAD. 3634933.50 NORTH, 5682309.86 EAST, ELEV. 722.79.

PROFILE GRADE ON U.S. 61 RAMP D

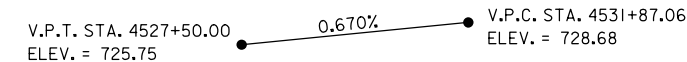

**CURVE DATA
U.S. 61 RAMP D**

ENTERING CURVE DATA (CURVE 20403)
P.I. STA. 4529+44.07
DELTA = 29° 37' 32.60" (RT)
DEGREE = 6° 51' 42.37"
TANGENT = 220.82'
LENGTH = 431.75'
RADIUS = 835.00'
EXTERNAL = 28.70'
LONG CHORD = 426.96'
MID. ORD. = 27.75'
P.C. STA. 4527+23.25
P.T. STA. 4531+55.00

HYDRAULIC DATA

DRAINAGE AREA = 367 ACRES
DESIGN DISCHARGE, Q50 = 511 CFS

LOCATION

U.S. 61 RAMP D OVER UNNAMED CREEK
T-88N, R-2E
SECTION 13
TABLE MOUND TWP.
DUBUQUE COUNTY
CITY OF DUBUQUE
LAT. 42.4358452°
LONG. -90.6807450°

TRAFFIC ESTIMATE

2015	AADT	NA	V.P.D.
	TRUCKS	NA	%
2030	AADT	6,100	V.P.D.
	TRUCKS	7	%

PLAN NOTES

- DRAINAGE THROUGH EXISTING CULVERT/CHANNEL MUST BE MAINTAINED THROUGHOUT CONSTRUCTION.
- SEE SHEET D.1 FOR UTILITY LEGEND.
- ALL UNITS ARE IN FEET AND INCHES UNLESS NOTED OTHERWISE.
- SEE 'J' SHEETS FOR STAGING DETAILS.
- SEE 'D' SHEETS FOR ADDITIONAL PIPE INFORMATION.
- SEE CROSS SECTIONS FOR ADDITIONAL APPROACH SECTION INFORMATION.
- CALLOUTS BASED ON U.S. 61 RAMP D STATIONING UNLESS OTHERWISE STATED.

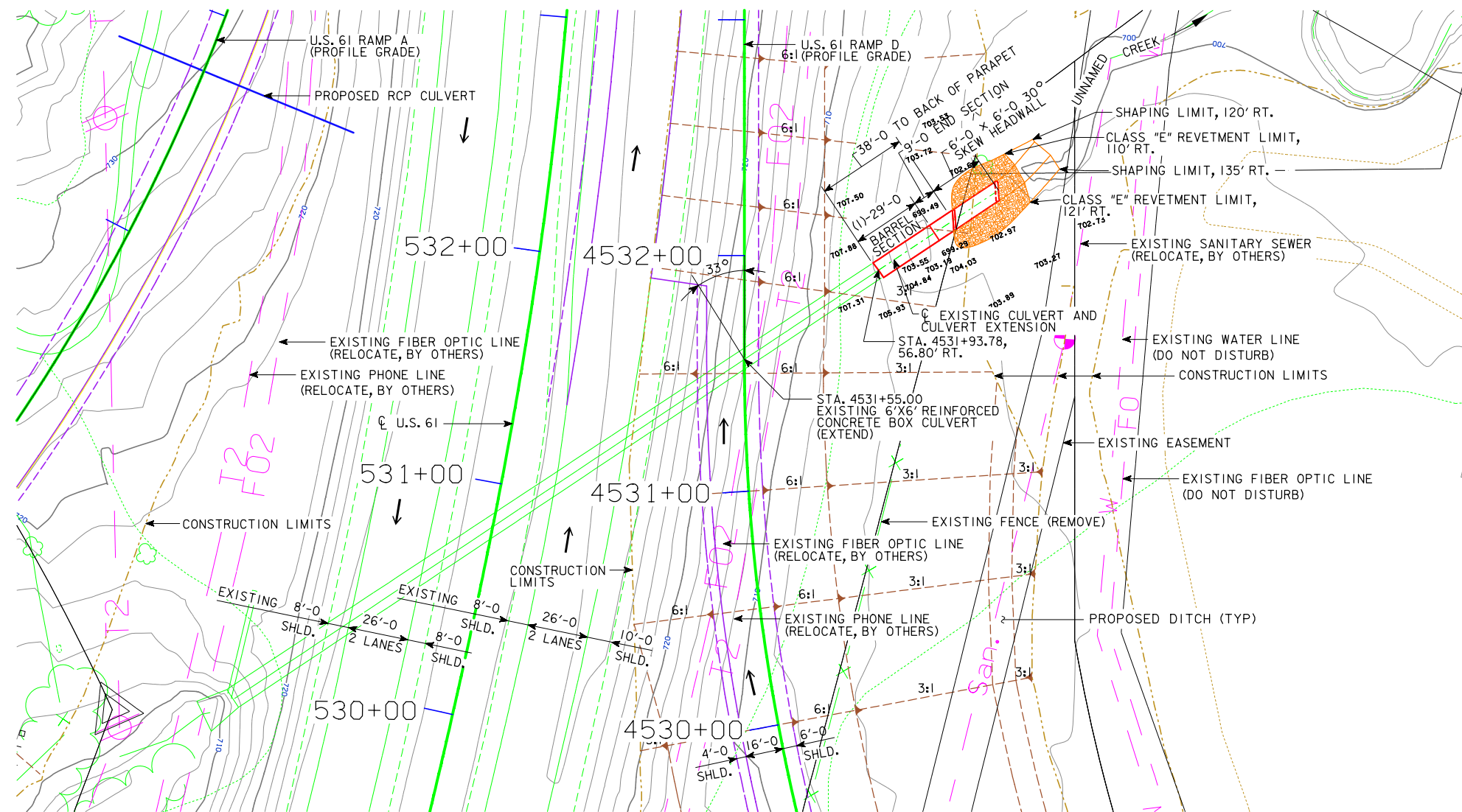

SITUATION PLAN

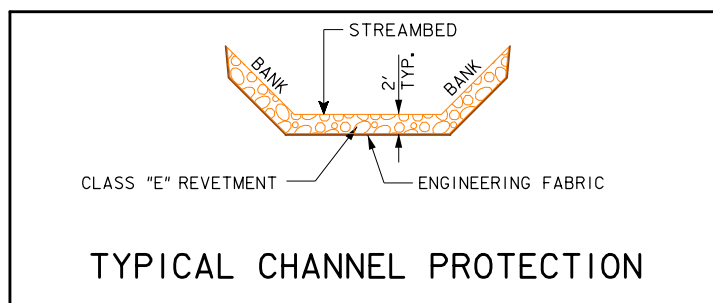

TYPICAL CHANNEL PROTECTION

ESTIMATED REVETMENT QUANTITIES

LOCATION	REVETMENT CL. "E" (TON)	ENGINEERING FABRIC (SY)	EXCAVATION (CY)
INLET	--	--	--
OUTLET	75	70	50
TOTALS	75	70	50

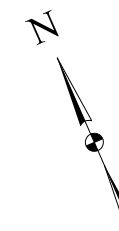

DESIGN FOR 33° SKEW (R.A.)
6'x6' REINFORCED CONCRETE BOX CULVERT EXTENSION
C.I.P. SITUATION PLAN

STA. 4531+55.00 APRIL, 2016
DUBUQUE COUNTY
IOWA DEPARTMENT OF TRANSPORTATION - HIGHWAY DIVISION
DESIGN SHEET NO. 1 OF 1 FILE NO. _____ DESIGN NO. _____

LINE STYLE LEGEND OF CROSS SECTION SHEETS (ROAD)

- Existing Ground Line
- ===== Proposed Template
- ===== Proposed Topsoil Placement
- Additional Topsoil Removal
- Subgrade Treatment
- Granular Shoulder
- ===== Pavement
- Existing Pipe\RCB
- ===== Proposed Pipe\RCB
- ===== Proposed Dike
- ===== All Elements Associated with Proposed Entrances

LINE STYLE LEGEND OF CROSS SECTION SHEETS (SOILS)

- TS----- Topsoil (Class 10)
- Slope Dressing Only
- CL 10----- Class 10 Materials
- SEL LO----- Select Loams And Clay-Loams
- SEL SA----- Select Sand
- UNS A----- Unsuitable Type A Disposal
- UNS B----- Unsuitable Type B Disposal
- UNS C----- Unsuitable Type C Disposal
- SHALE----- Shale
- WASTE----- Waste
- B&W LS----- Broken and Weathered Rock
- ROCK----- Solid Rock
- BLDRS----- Boulders

Note: All layer lines and descriptions identify layers above the line.

Note: Vertical or near vertical lines connecting soil layers at edges of cross sections are only for the purpose of calculating template quantities and do not depict soil stratification.

SYMBOL LEGEND OF CROSS SECTION SHEETS

- Existing ROW
----- Existing Right-of-Way Limit
- Proposed ROW
----- Proposed Right-of-Way Limit
- Temporary ROW
----- Temporary Right-of-Way Limit

CROSS SECTION

(COVERS SHEET SERIES W, X, Y, & Z)

Southwest Arterial East Grading

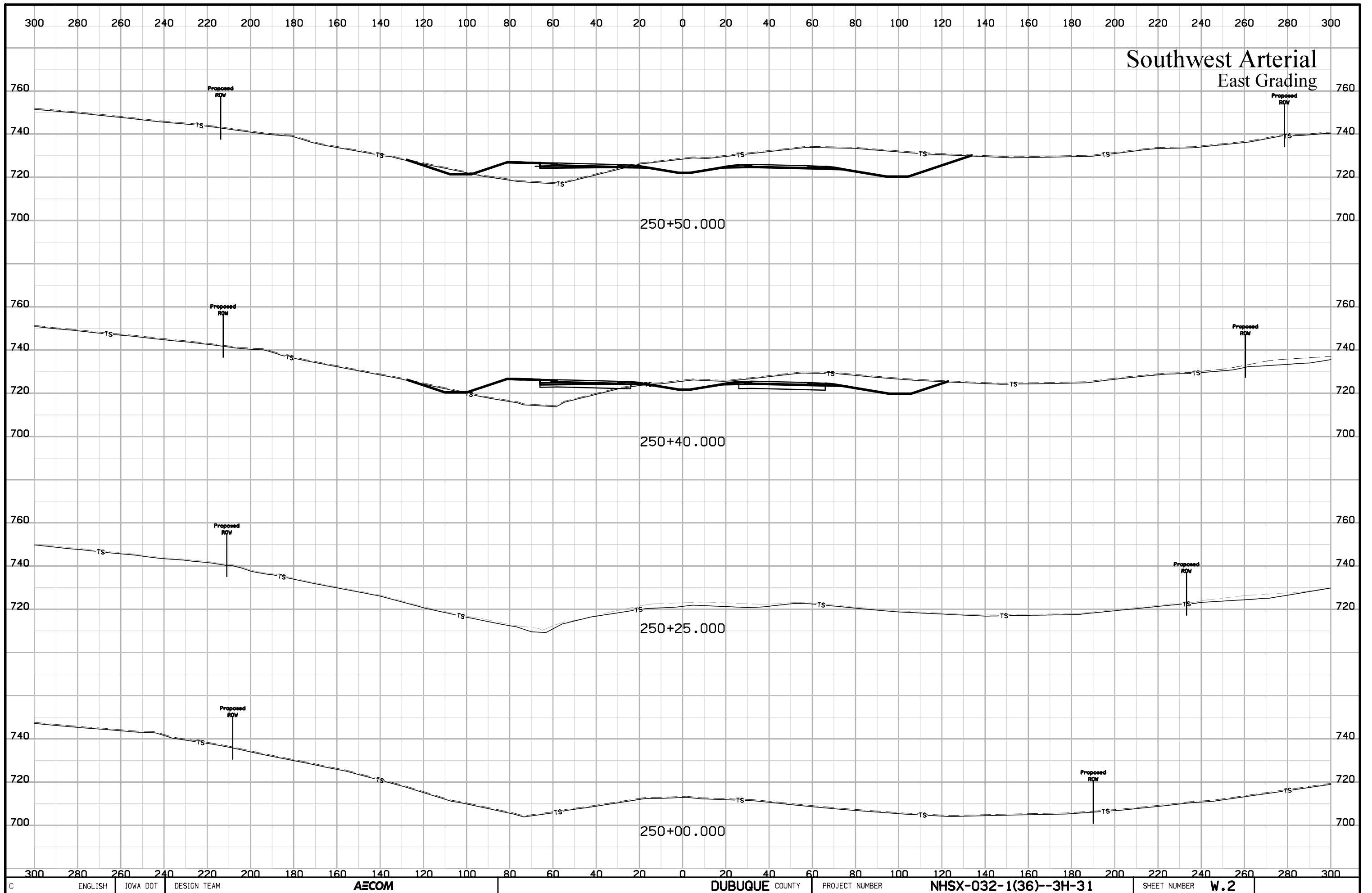

Southwest Arterial East Grading

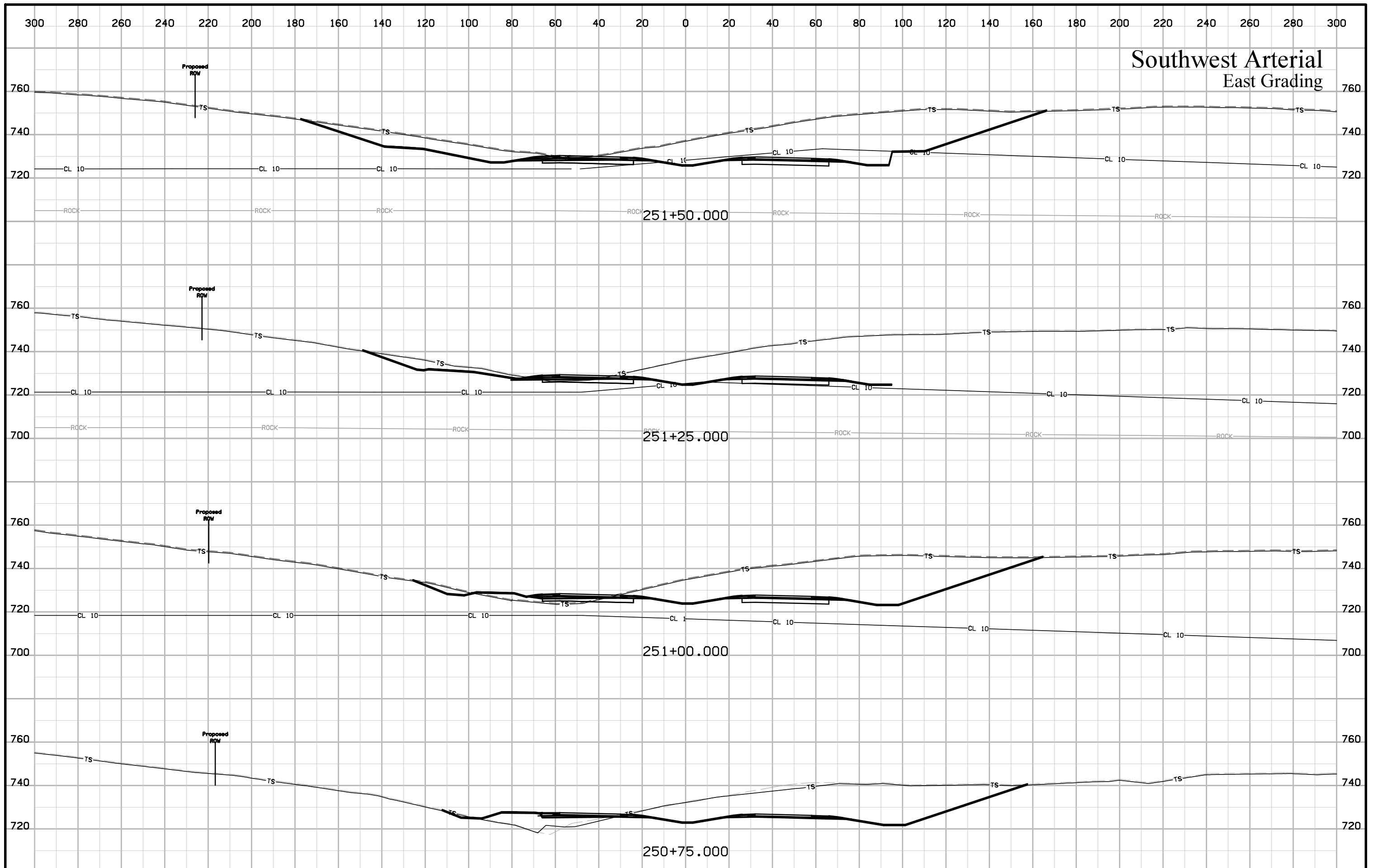

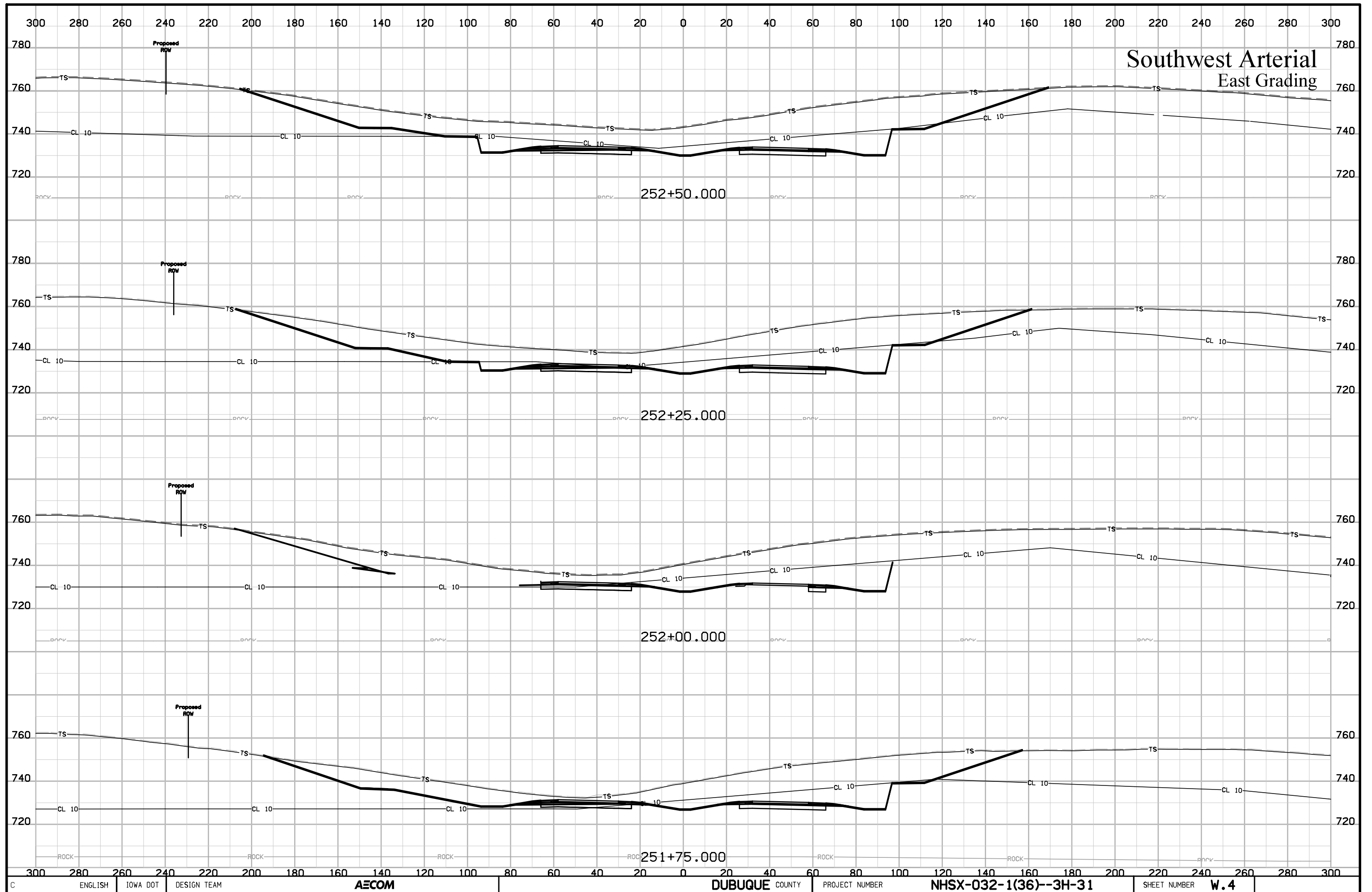

Southwest Arterial
East Grading

Southwest Arterial East Grading

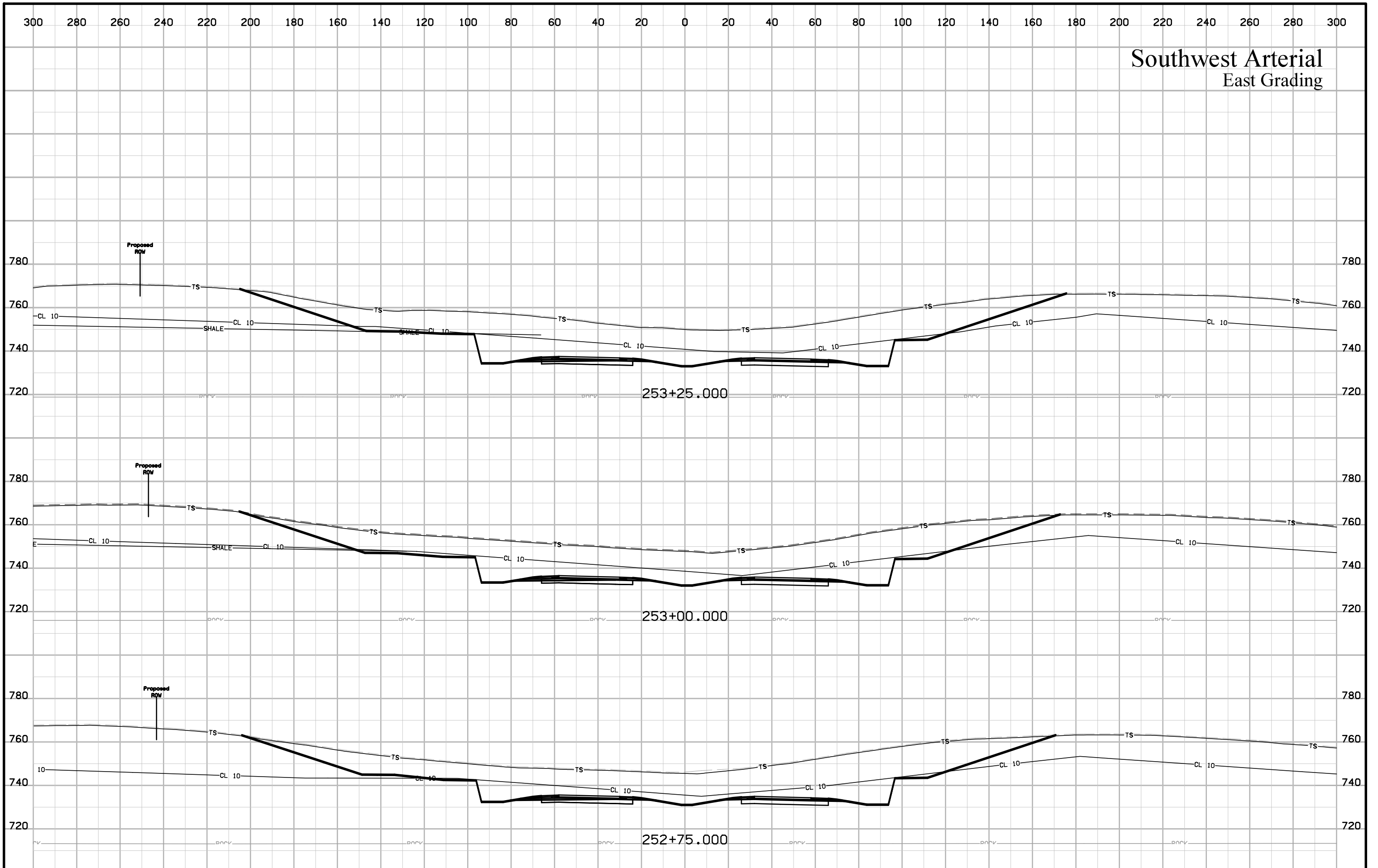

Southwest Arterial East Grading

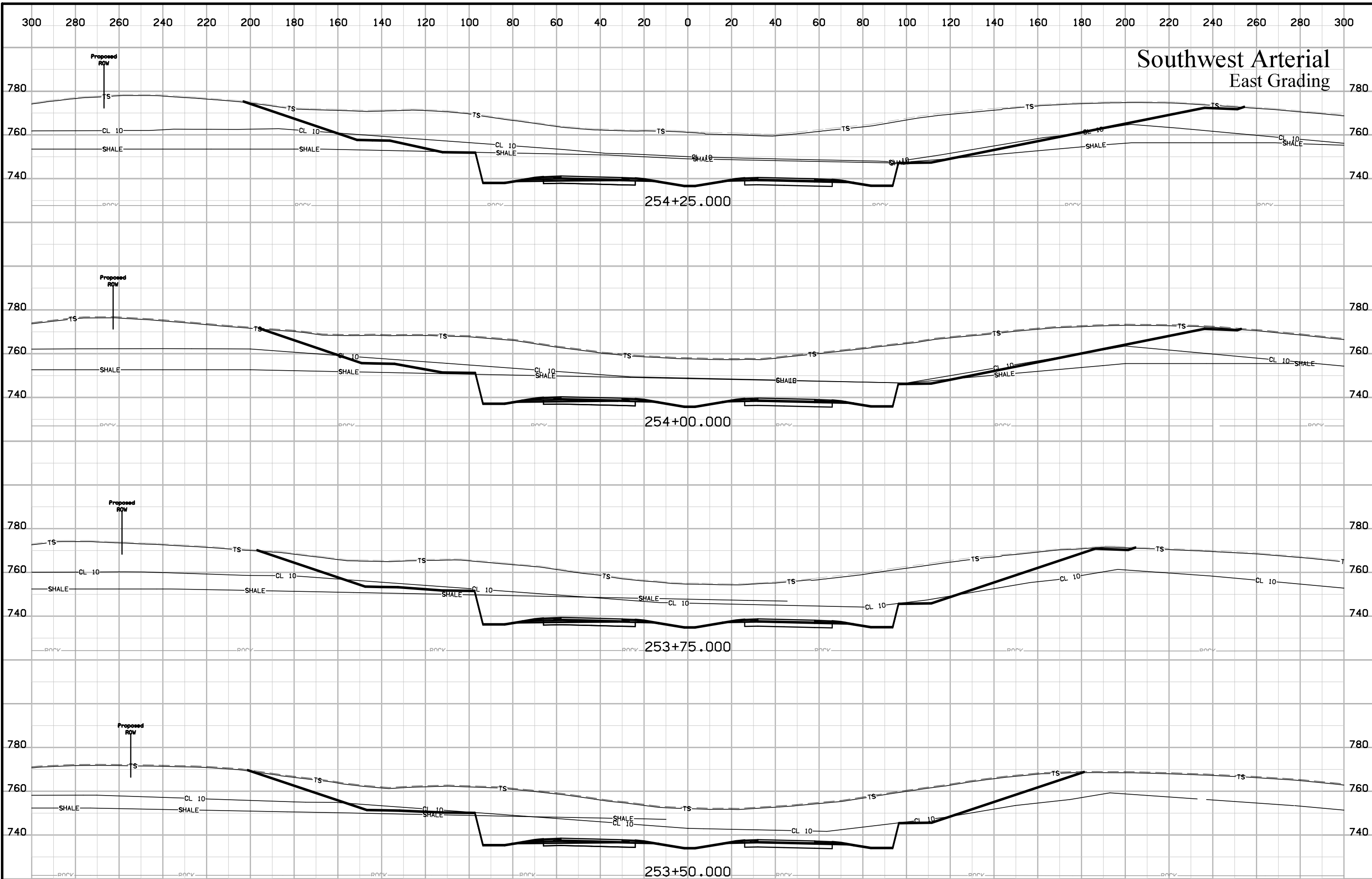

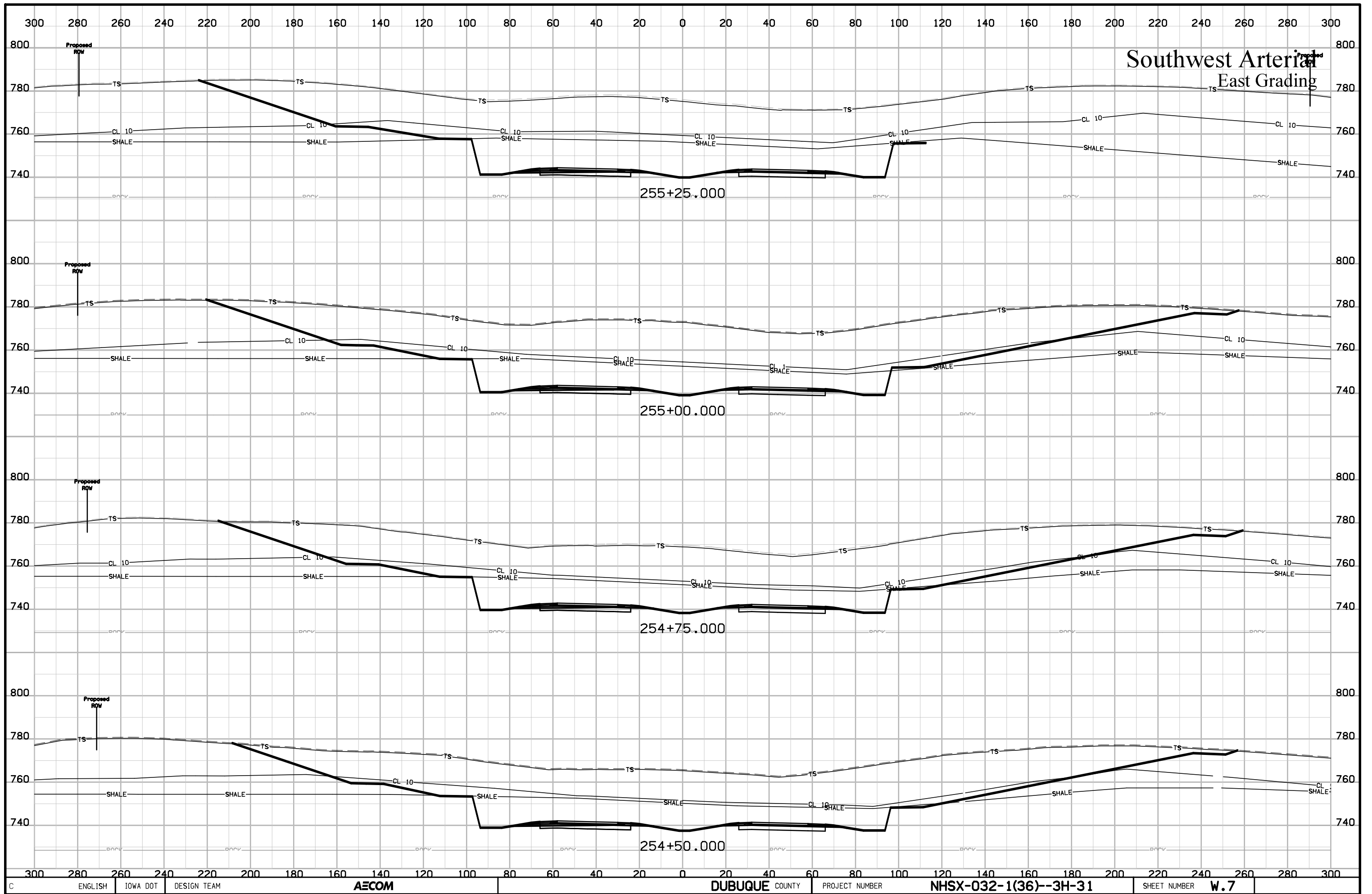

Southwest Arterial East Grading

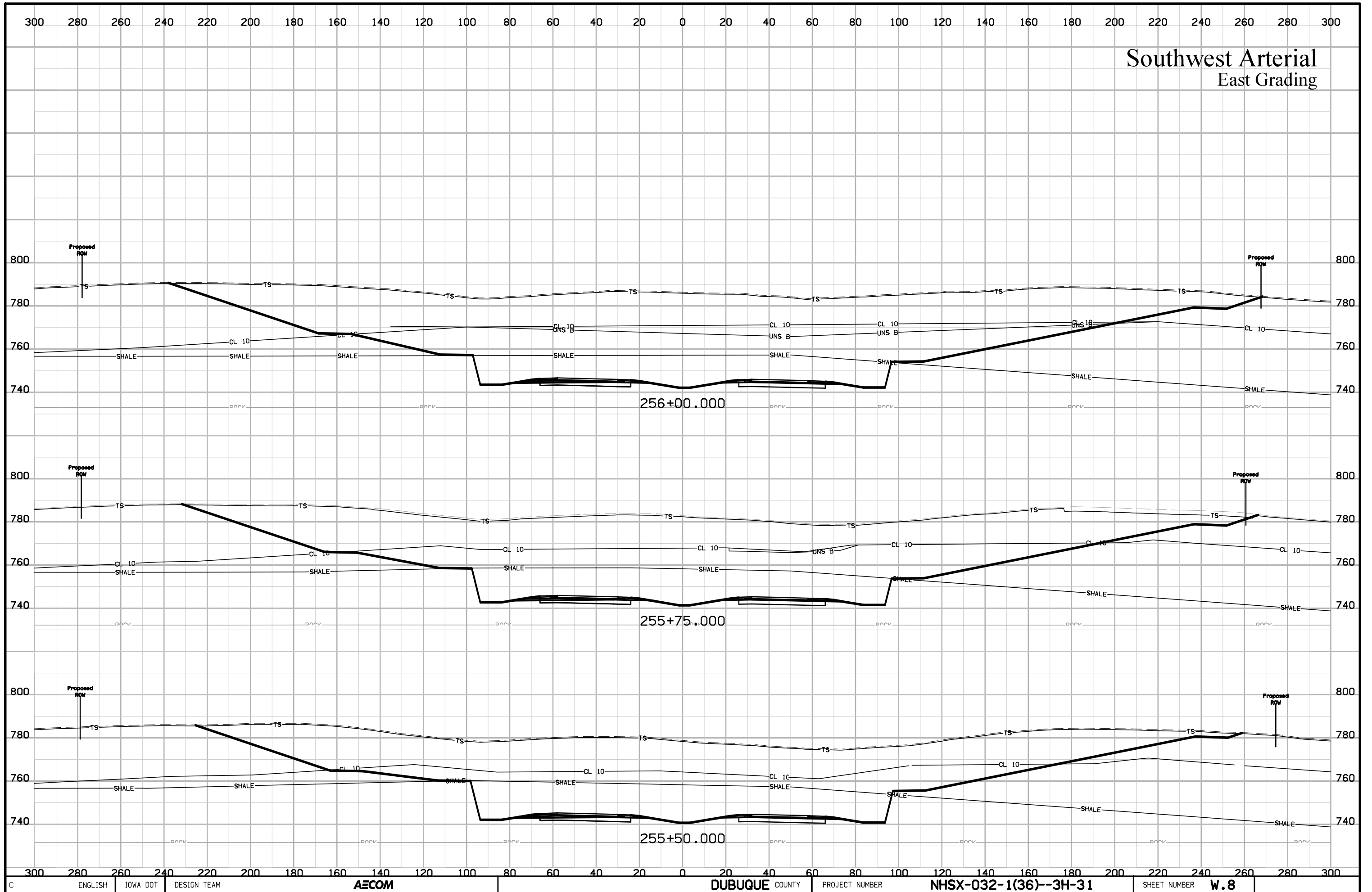

Southwest Arterial East Grading

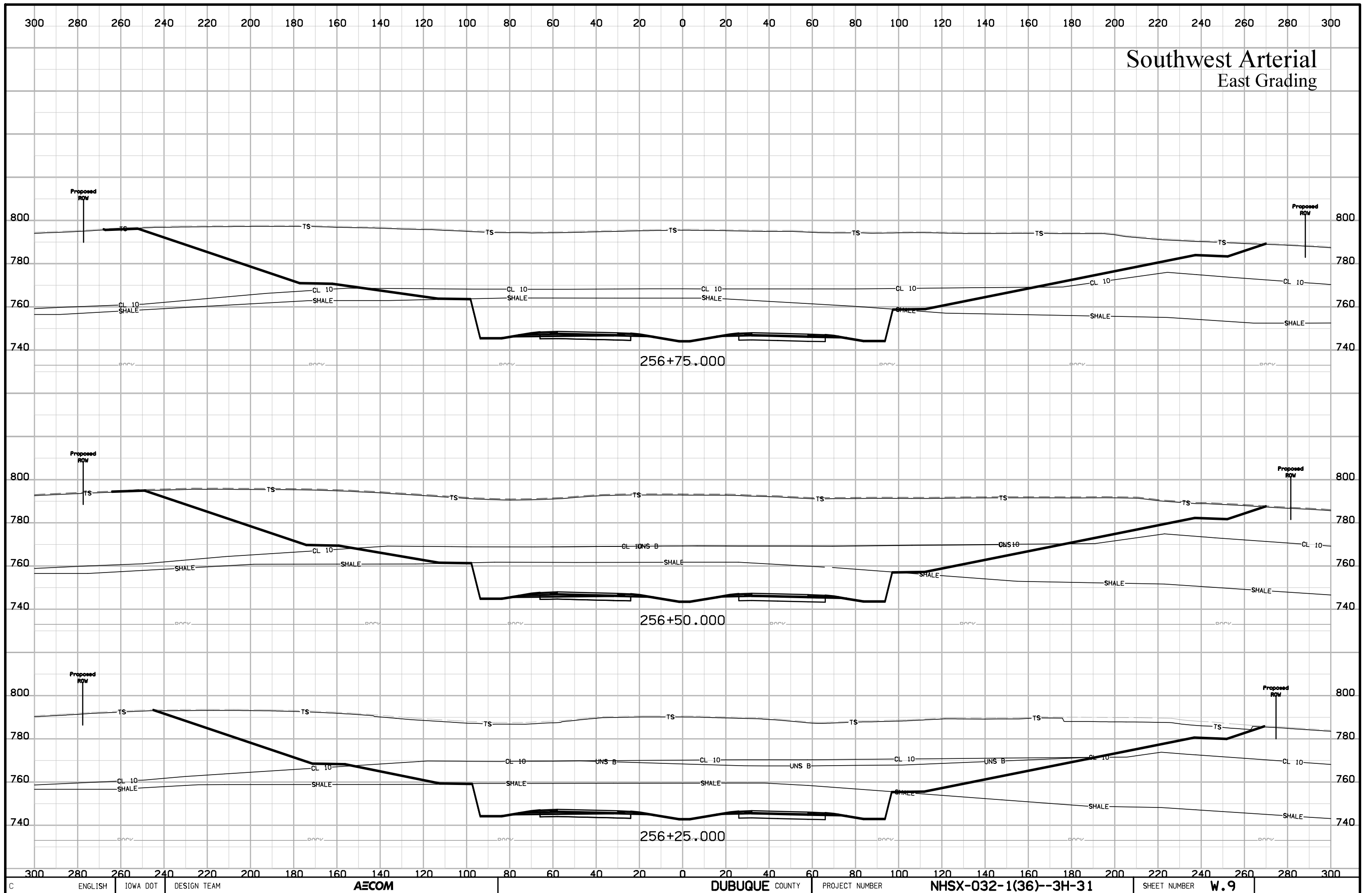

Southwest Arterial East Grading

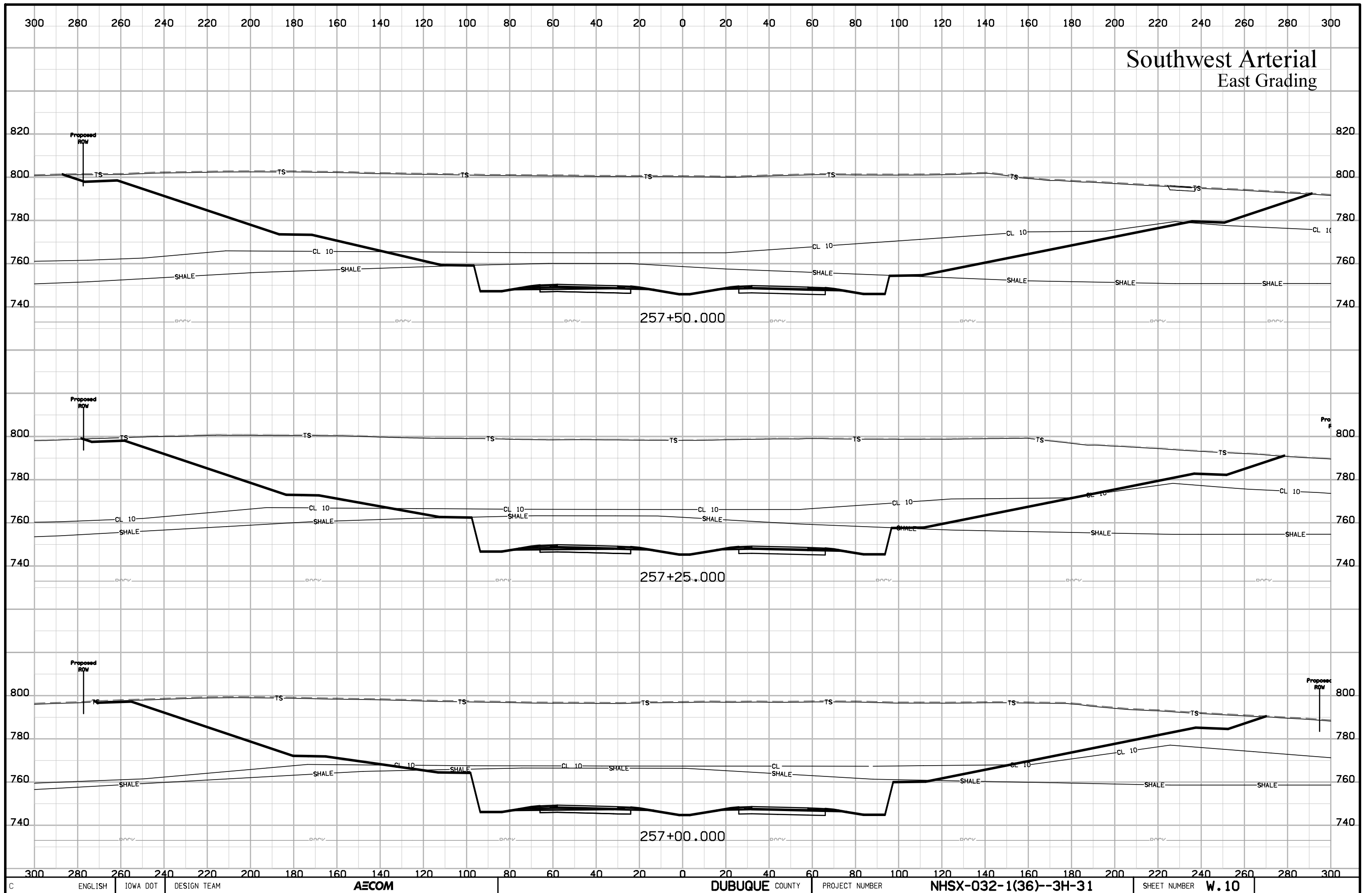

Southwest Arterial East Grading

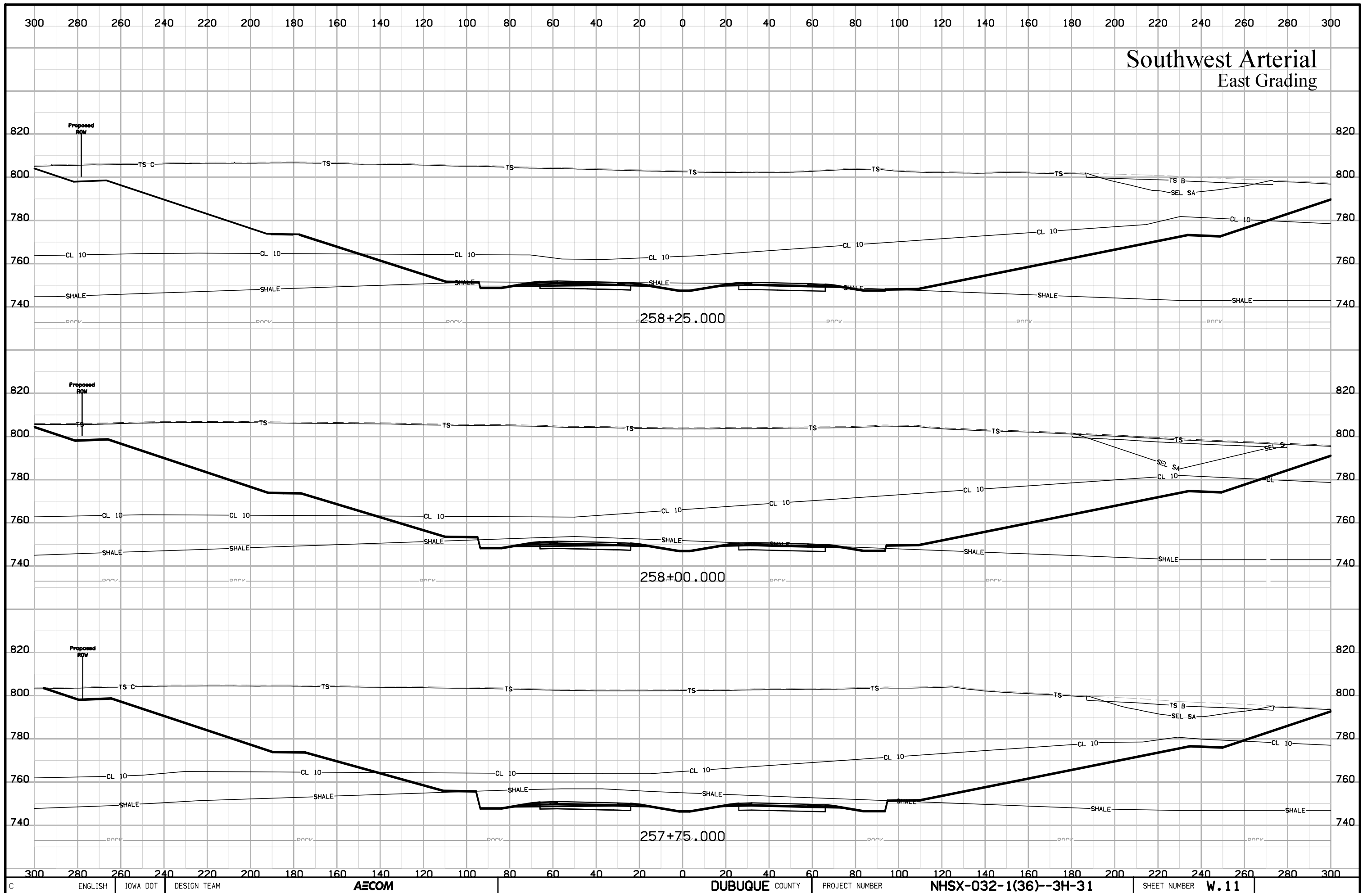

Southwest Arterial East Grading

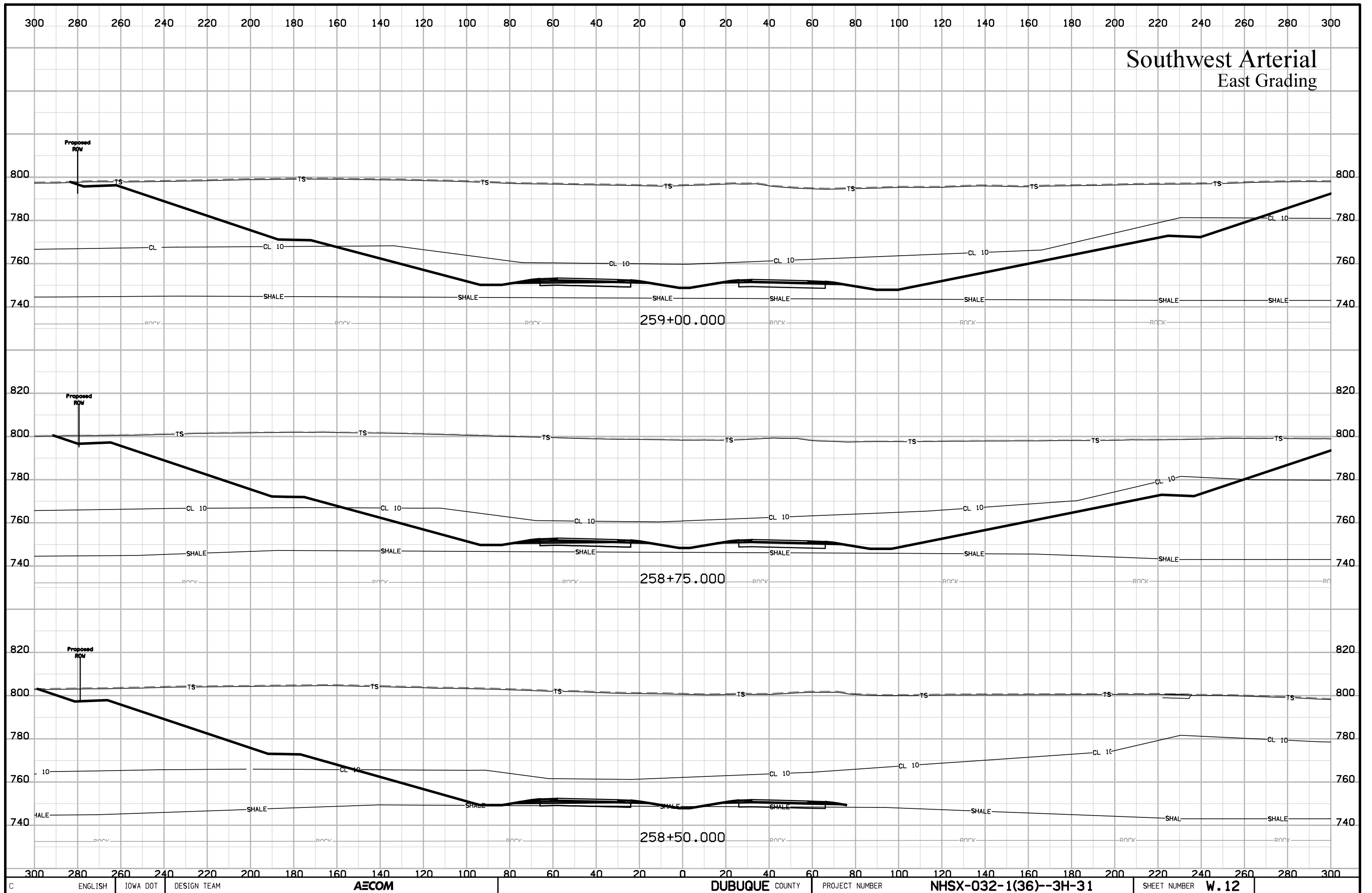

Southwest Arterial East Grading

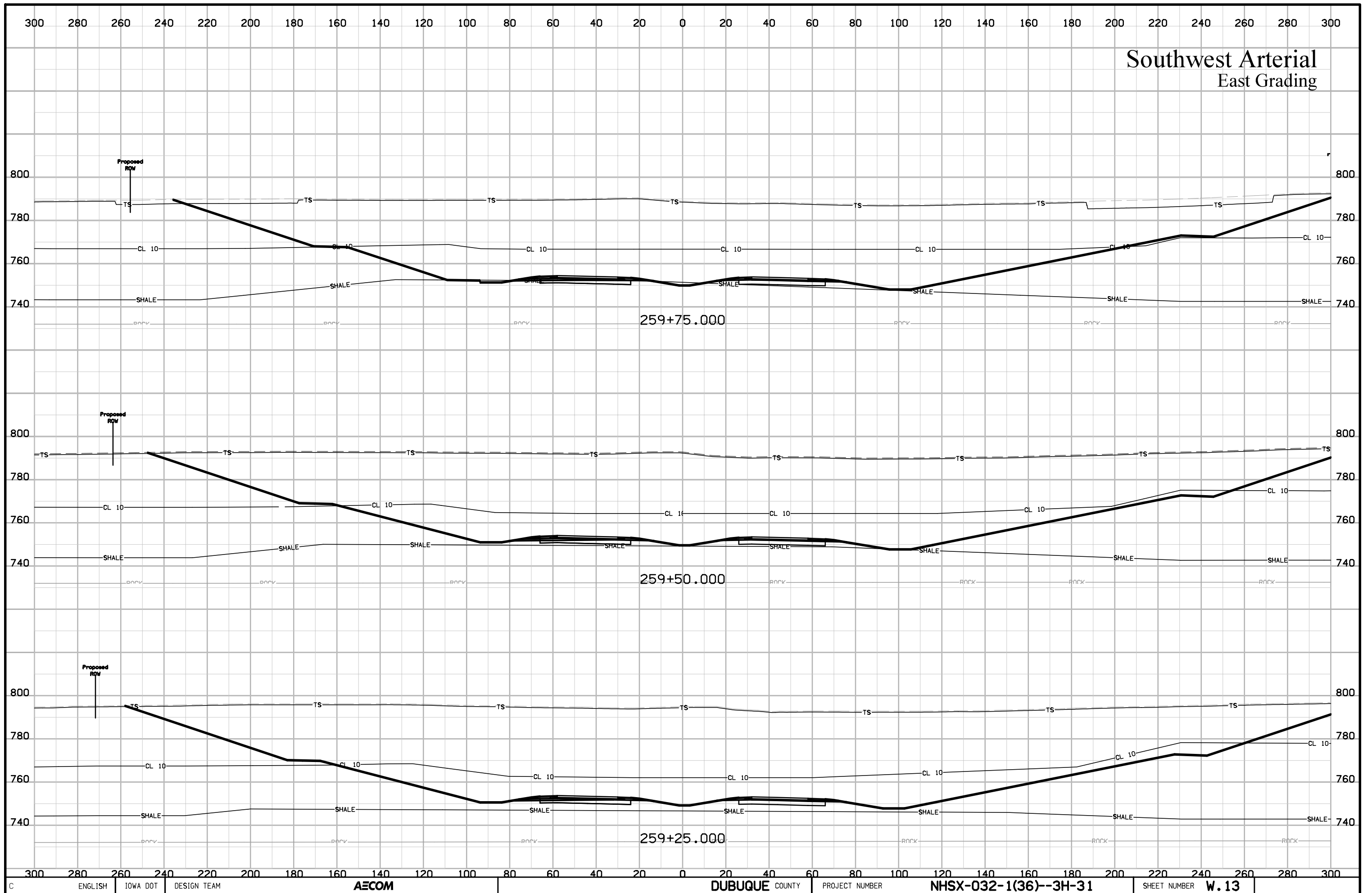

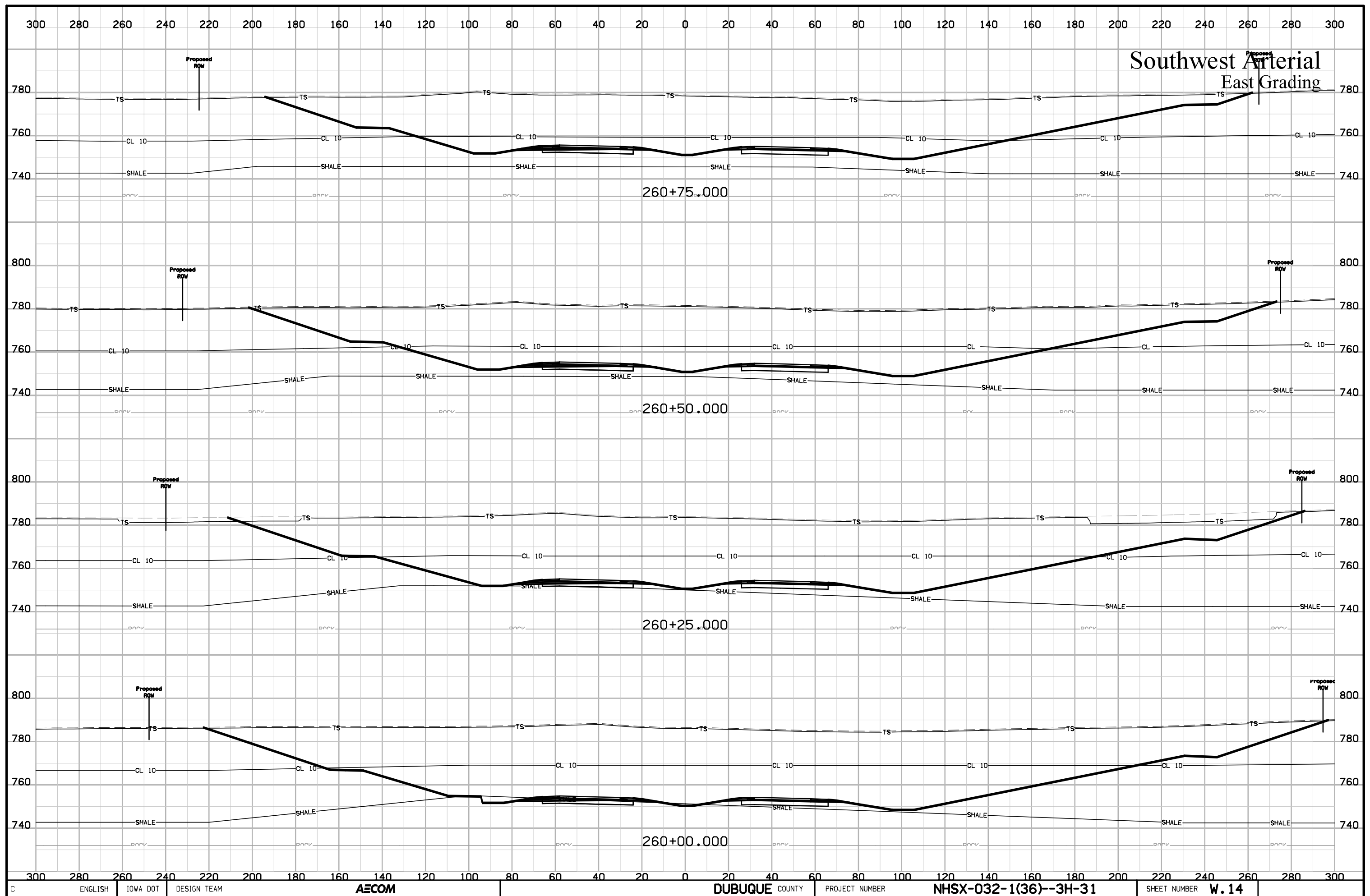

Southwest Arterial East Grading

Southwest Arterial East Grading

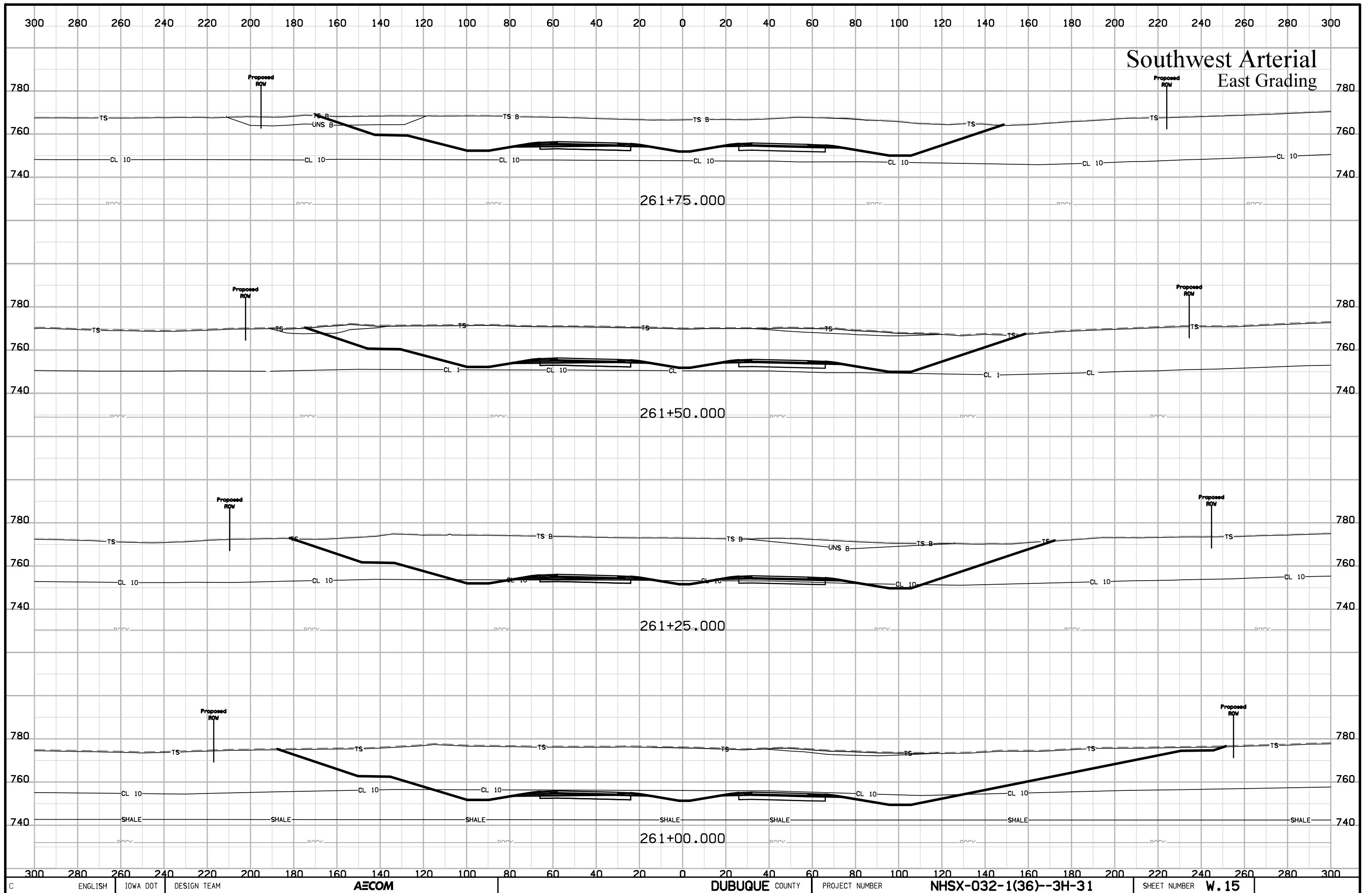

300 280 260 240 220 200 180 160 140 120 100 80 60 40 20 0 20 40 60 80 100 120 140 160 180 200 220 240 260 280 300

Southwest Arterial East Grading

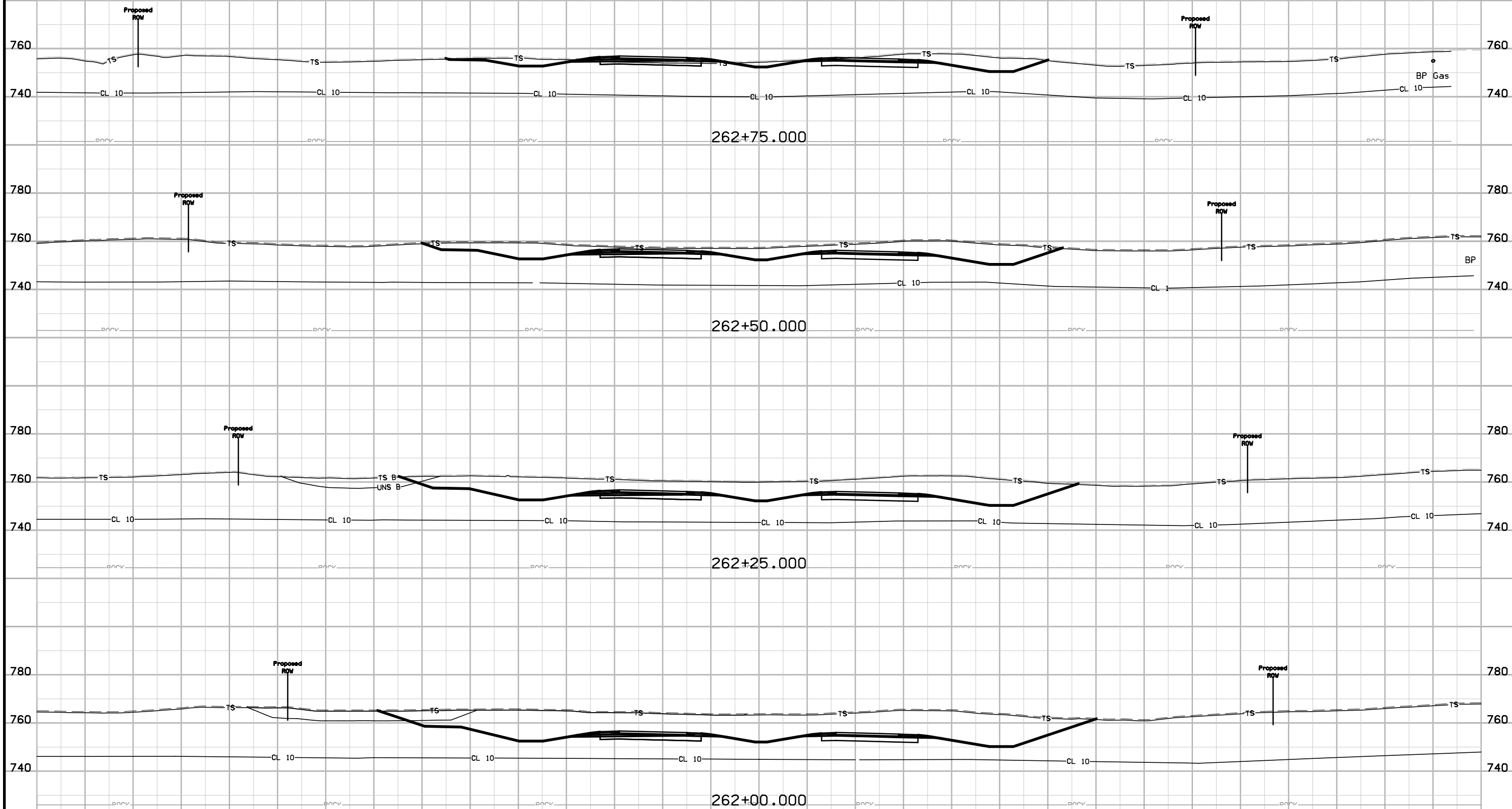

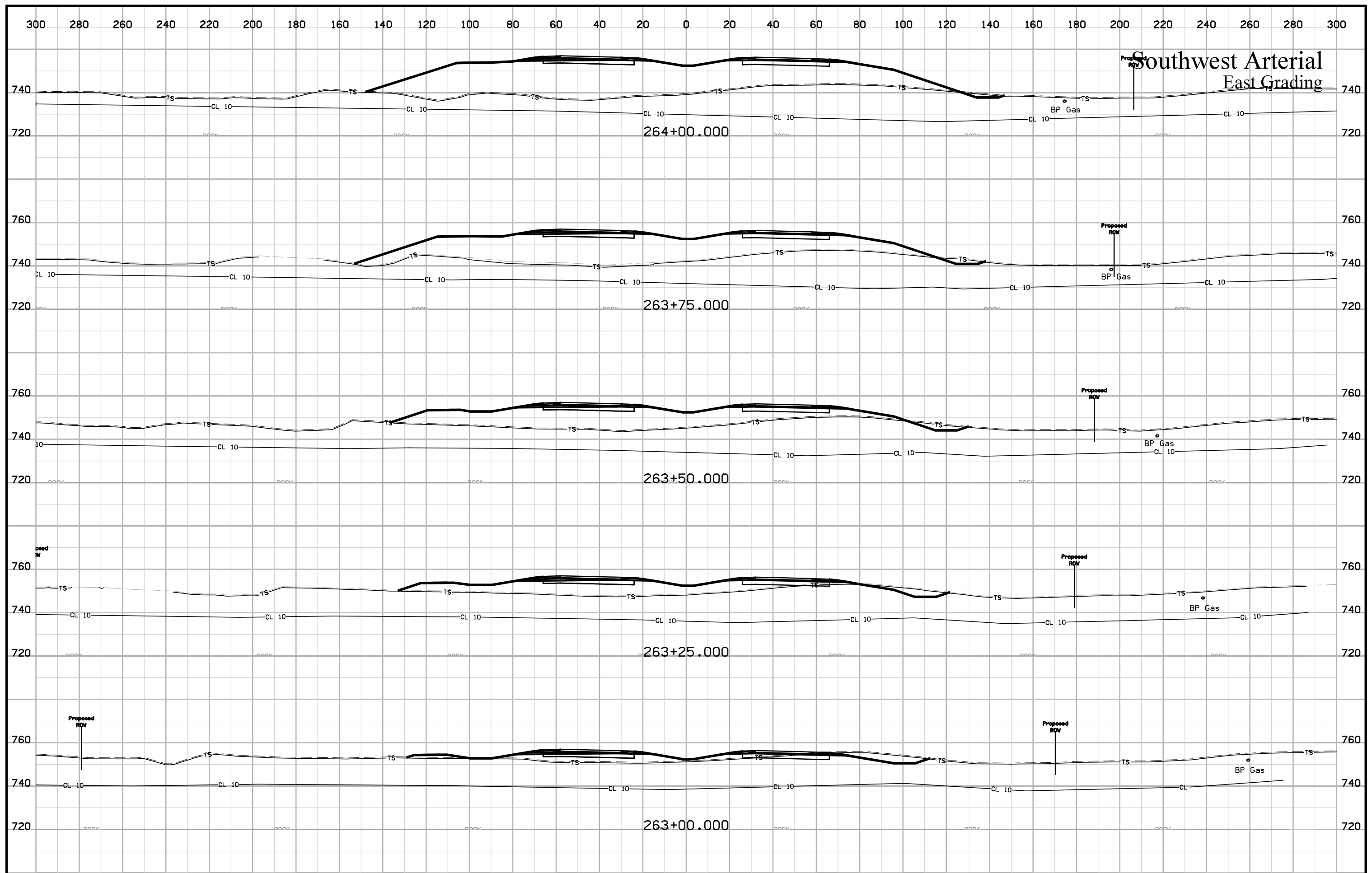

**Southwest Arterial
East Grading**

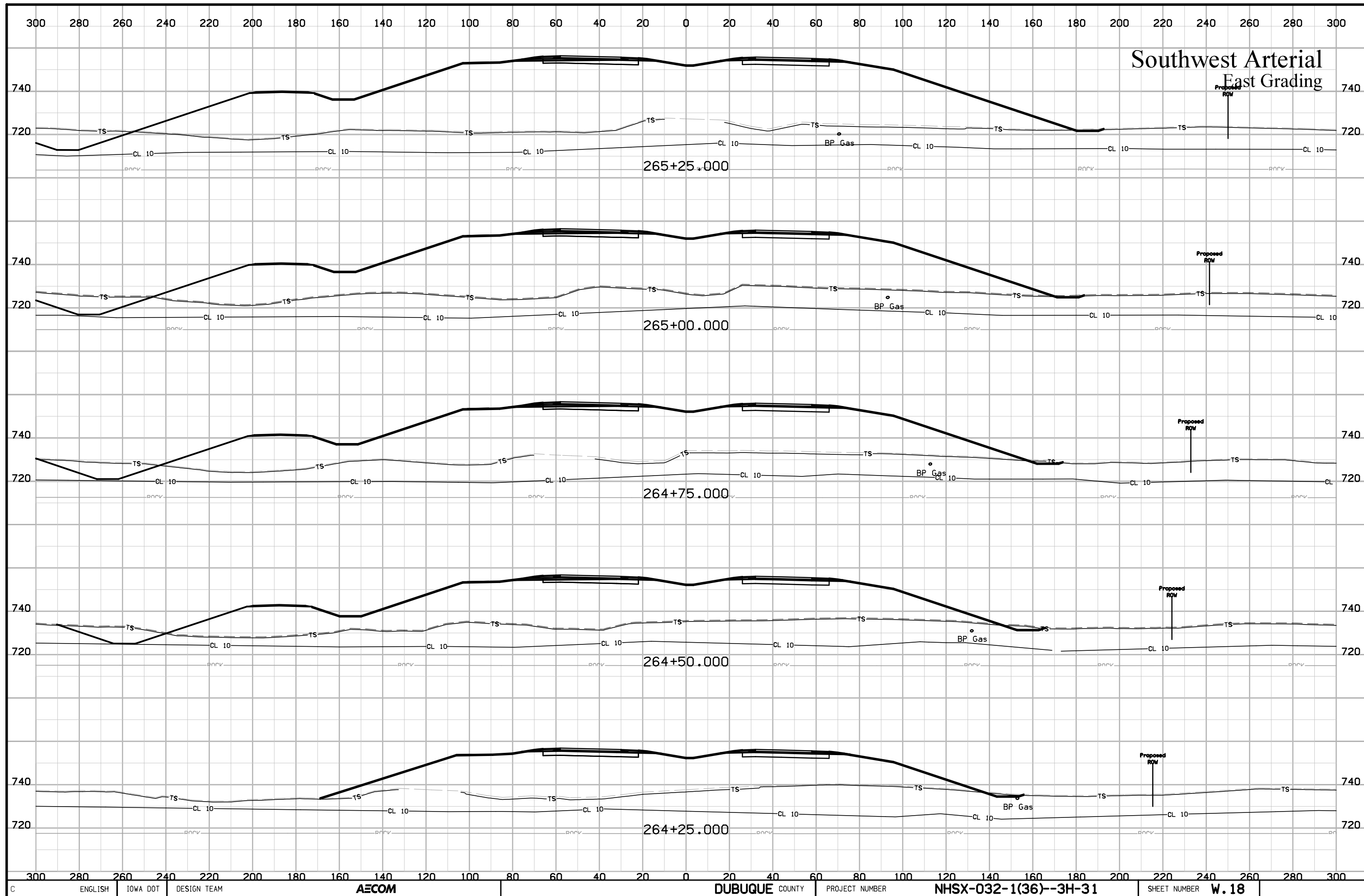

Southwest Arterial East Grading

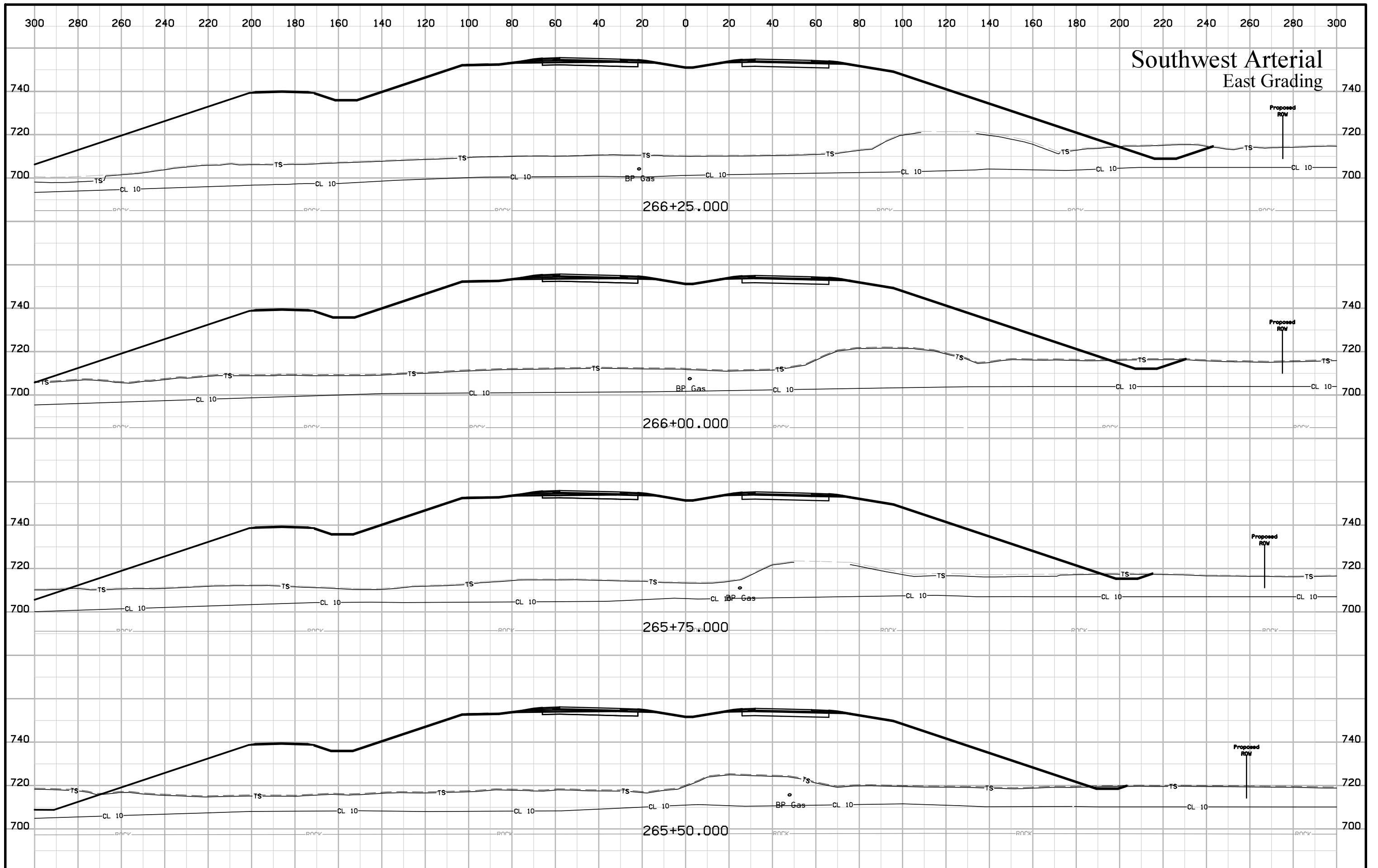

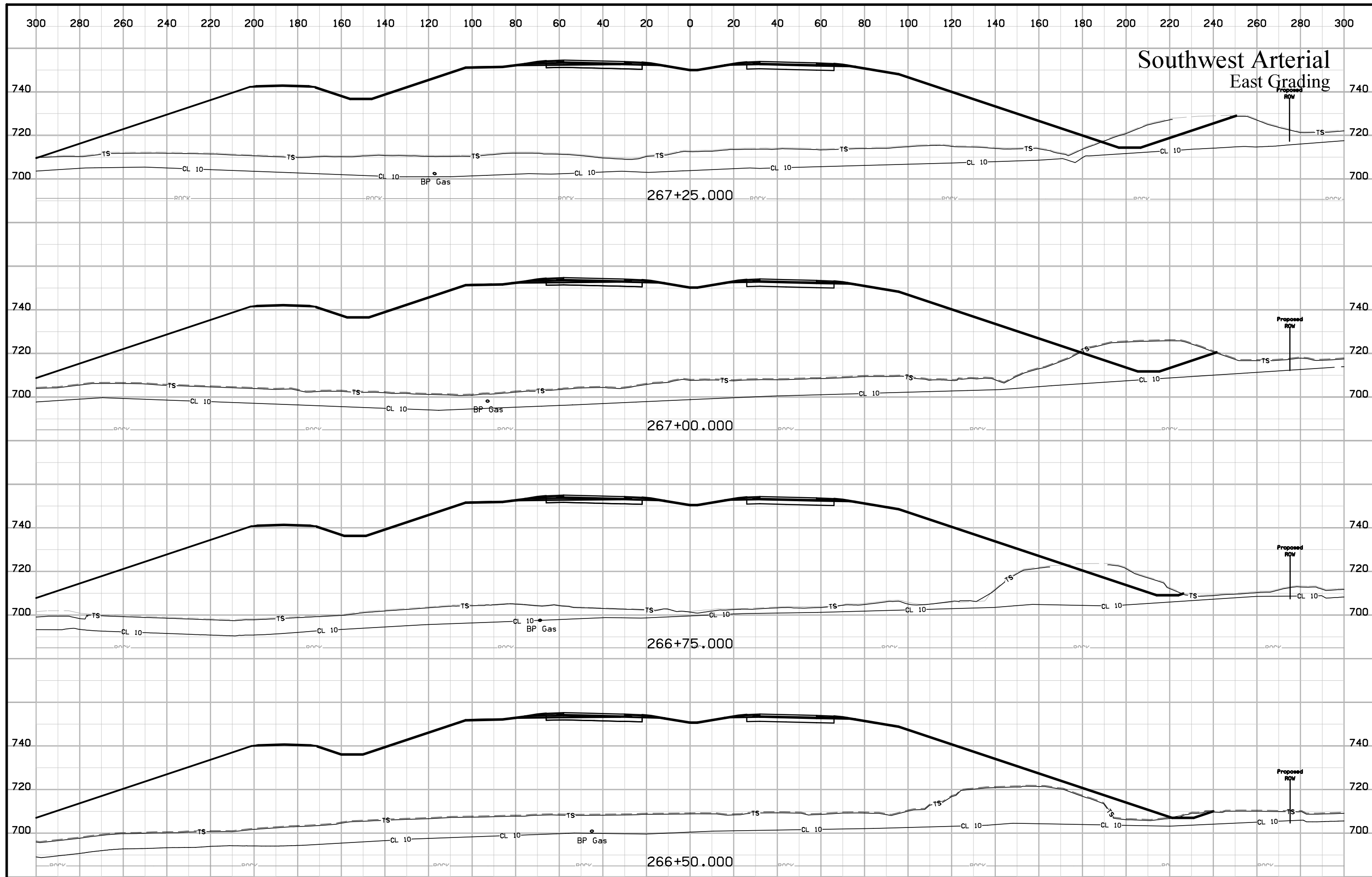

Southwest Arterial East Grading

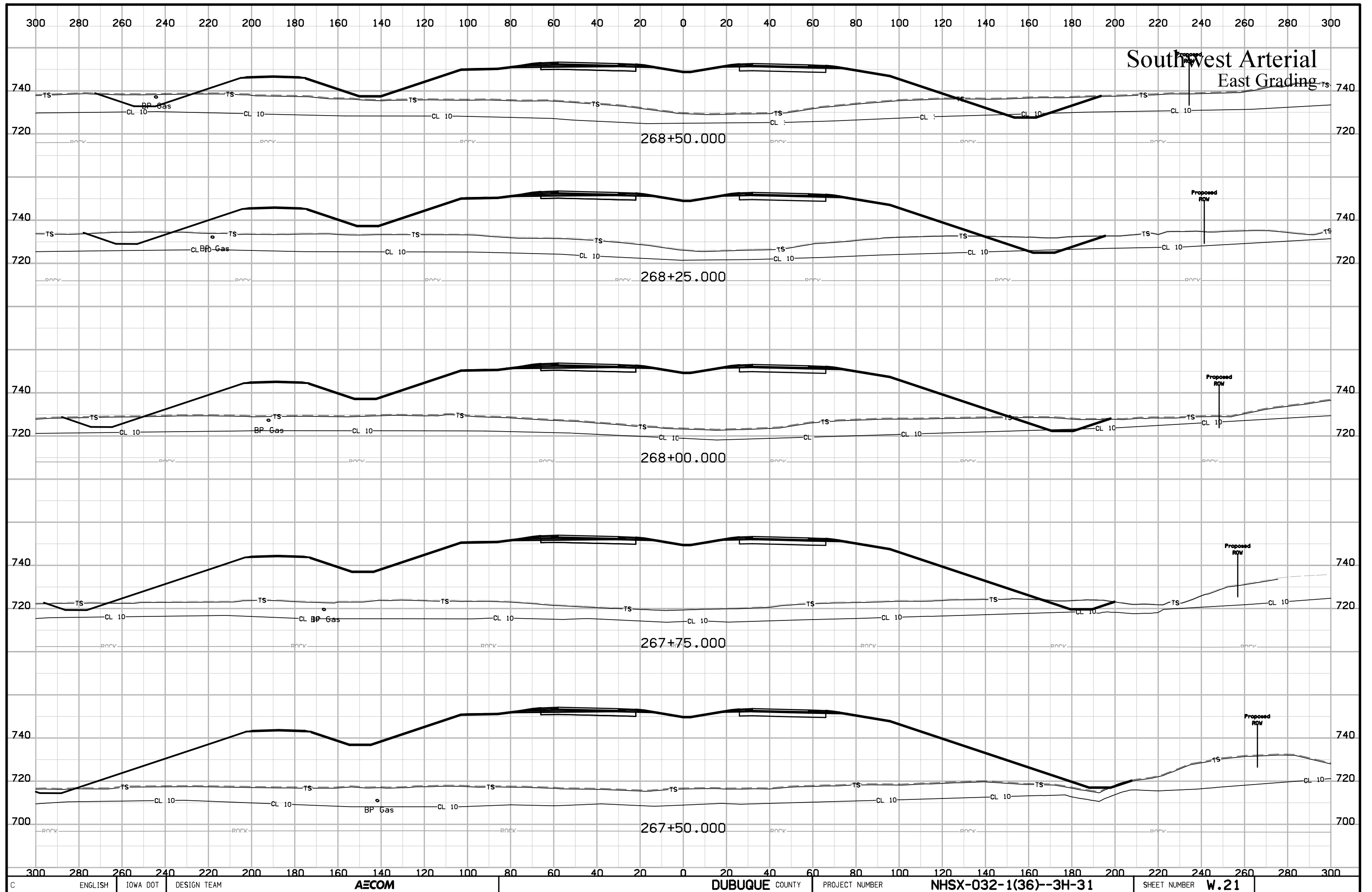

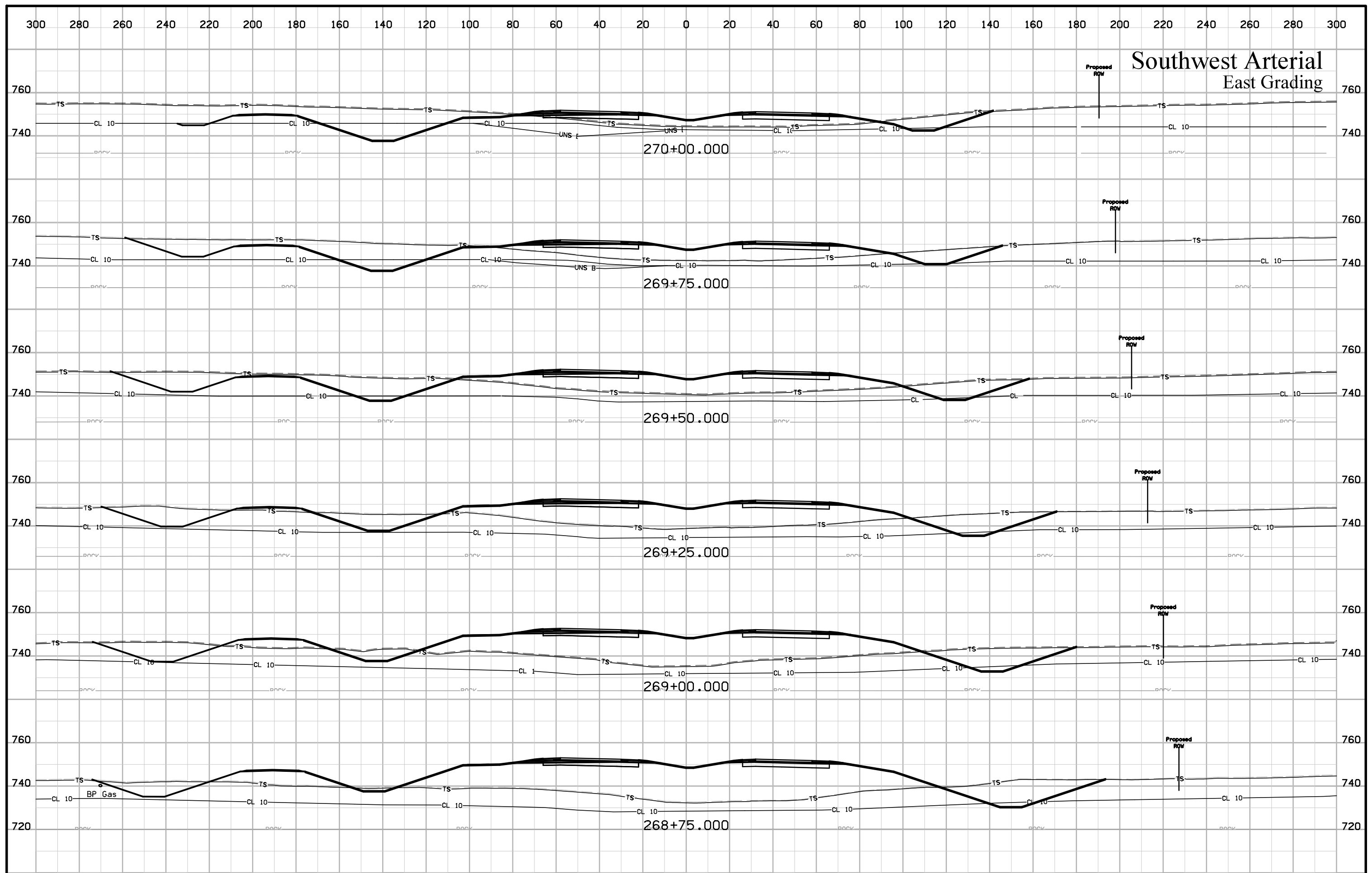

Southwest Arterial East Grading

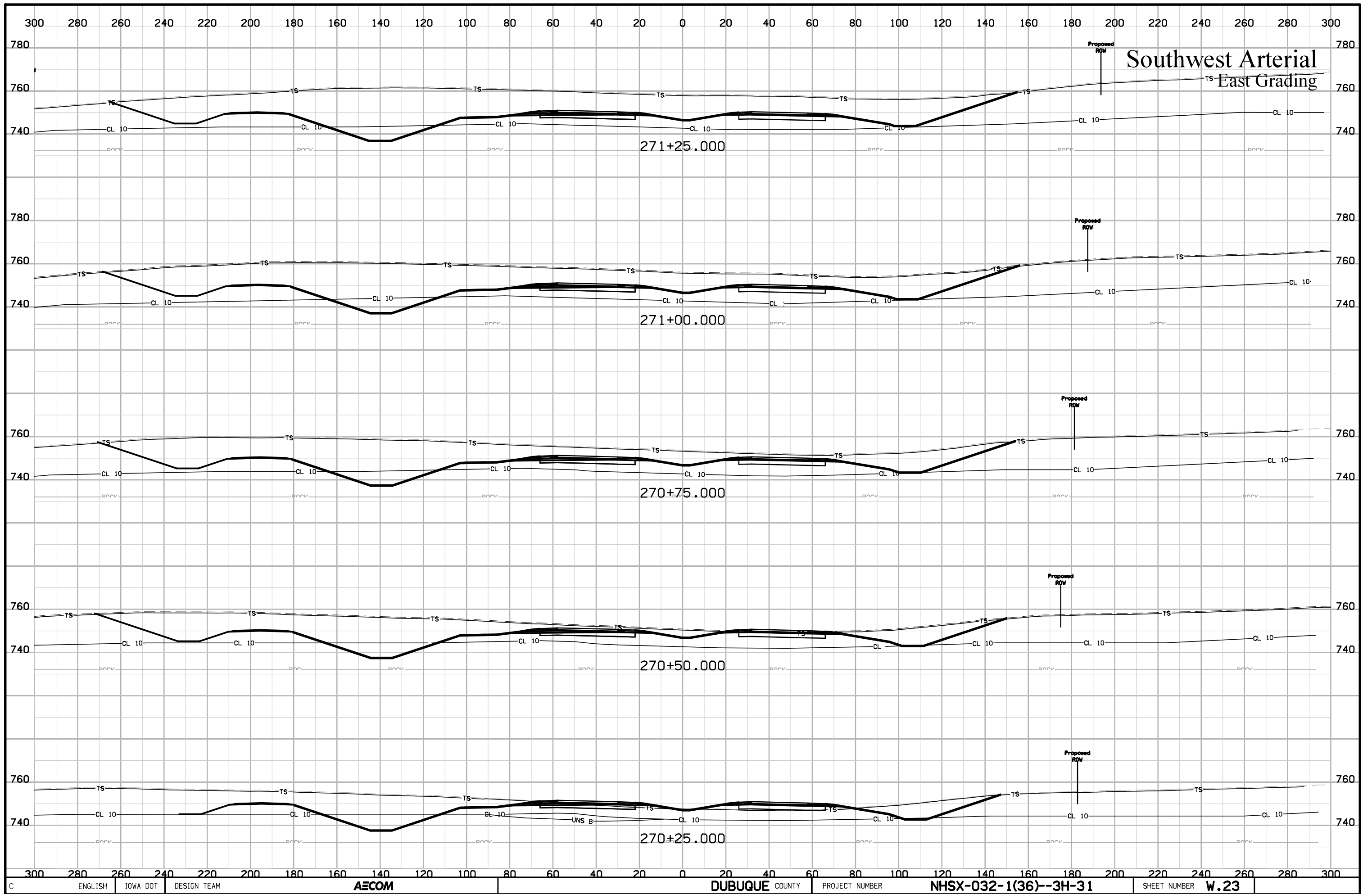

Southwest Arterial East Grading

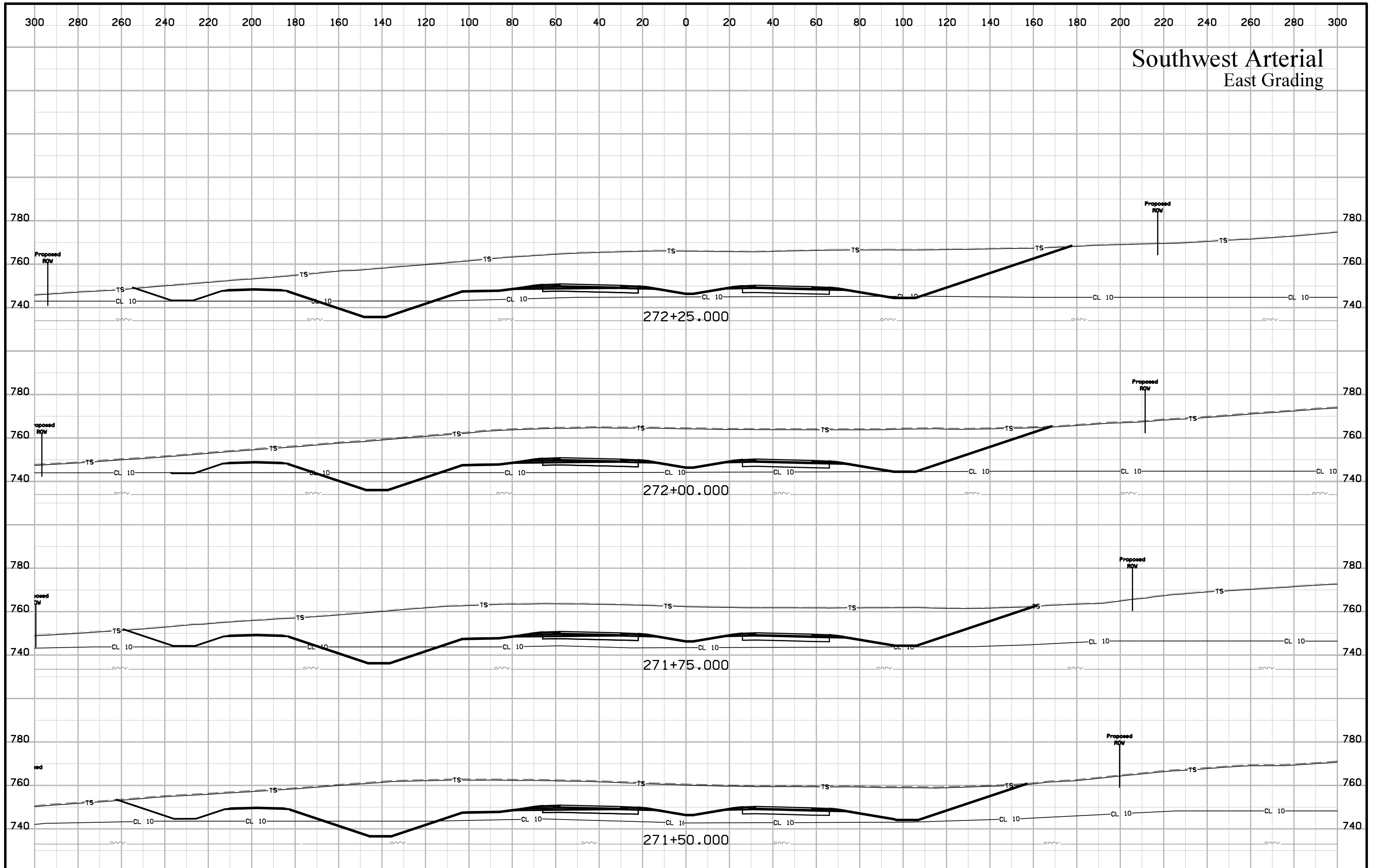

Southwest Arterial East Grading

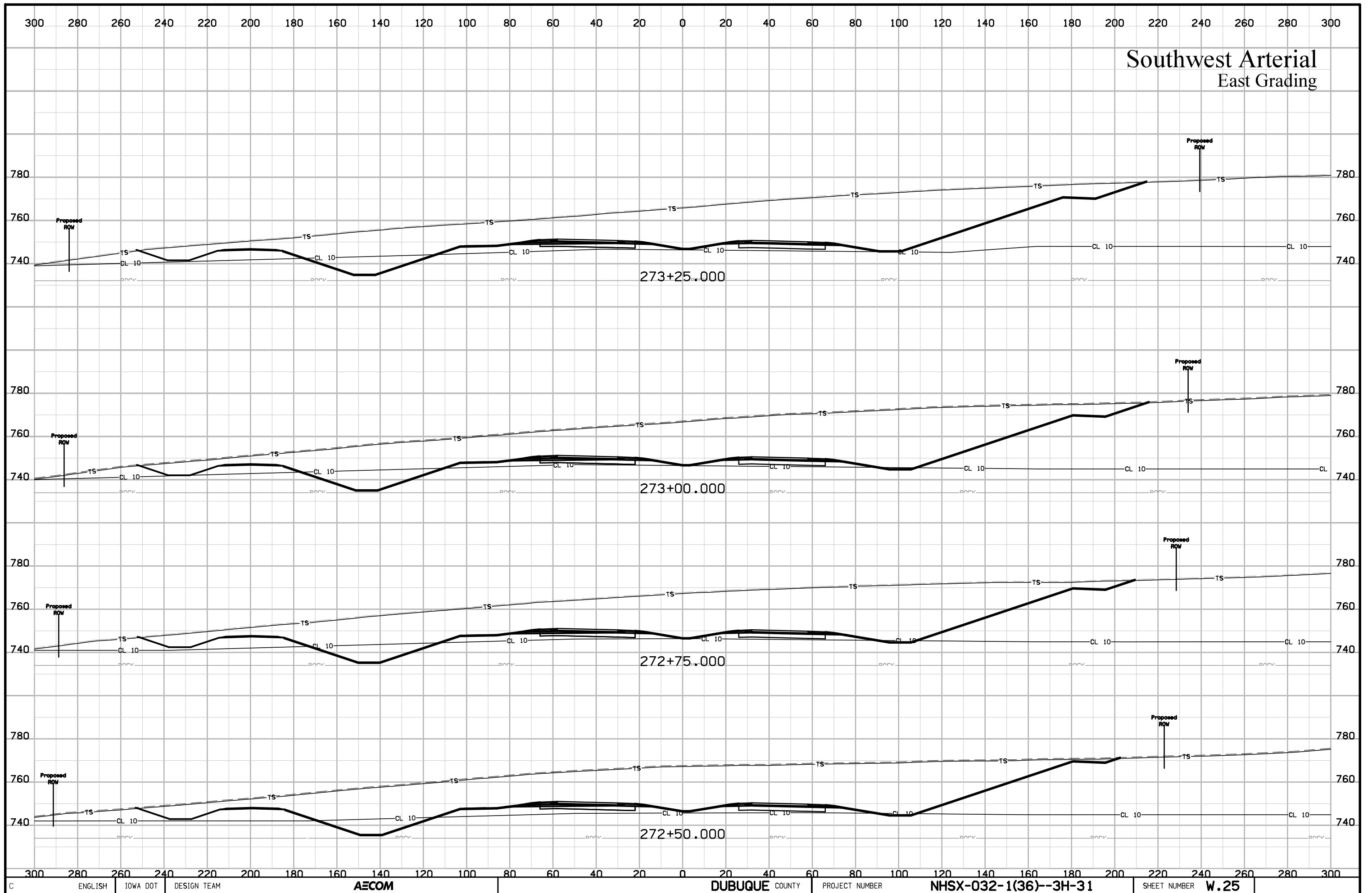

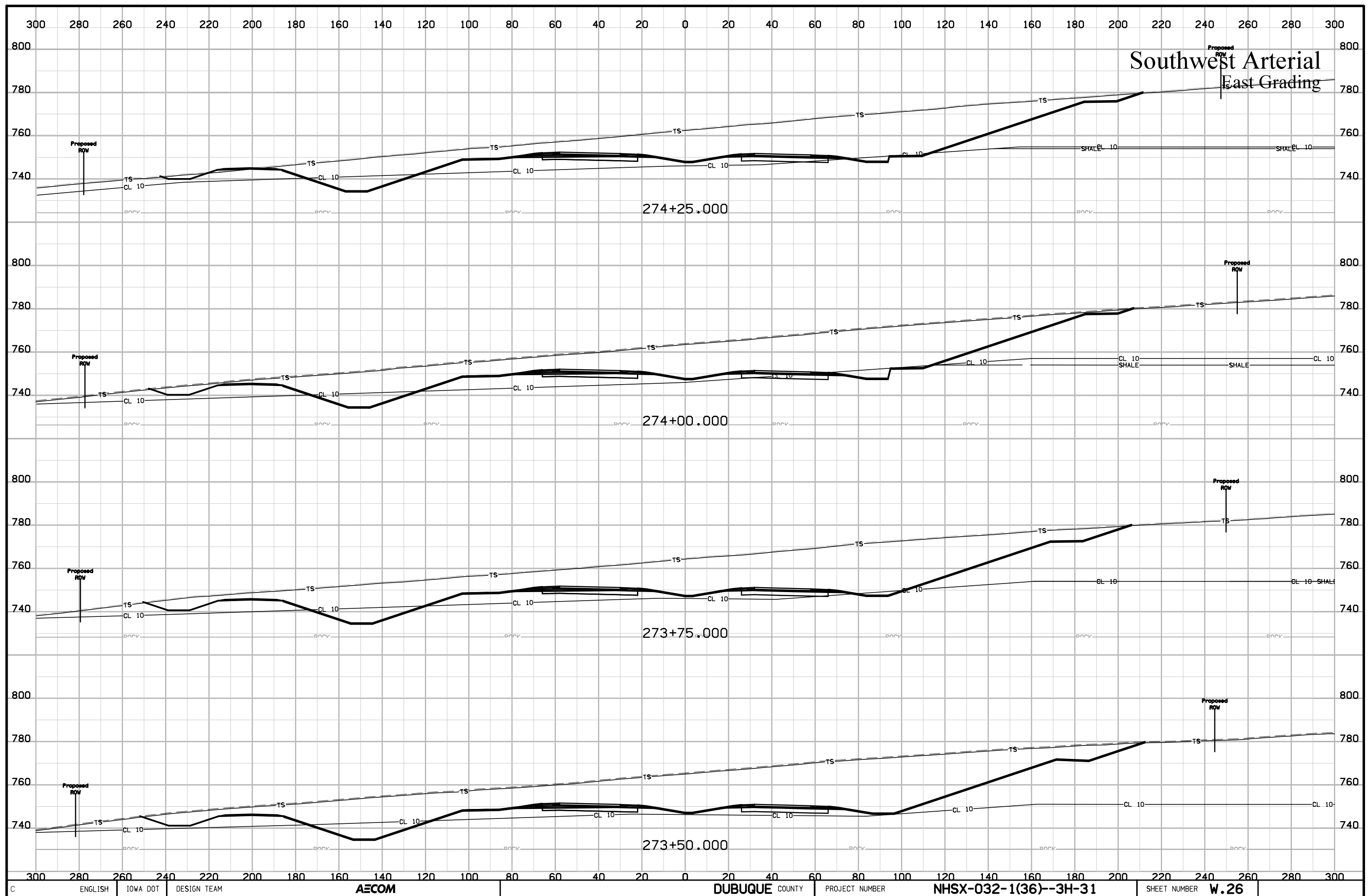

Southwest Arterial East Grading

Southwest Arterial East Grading

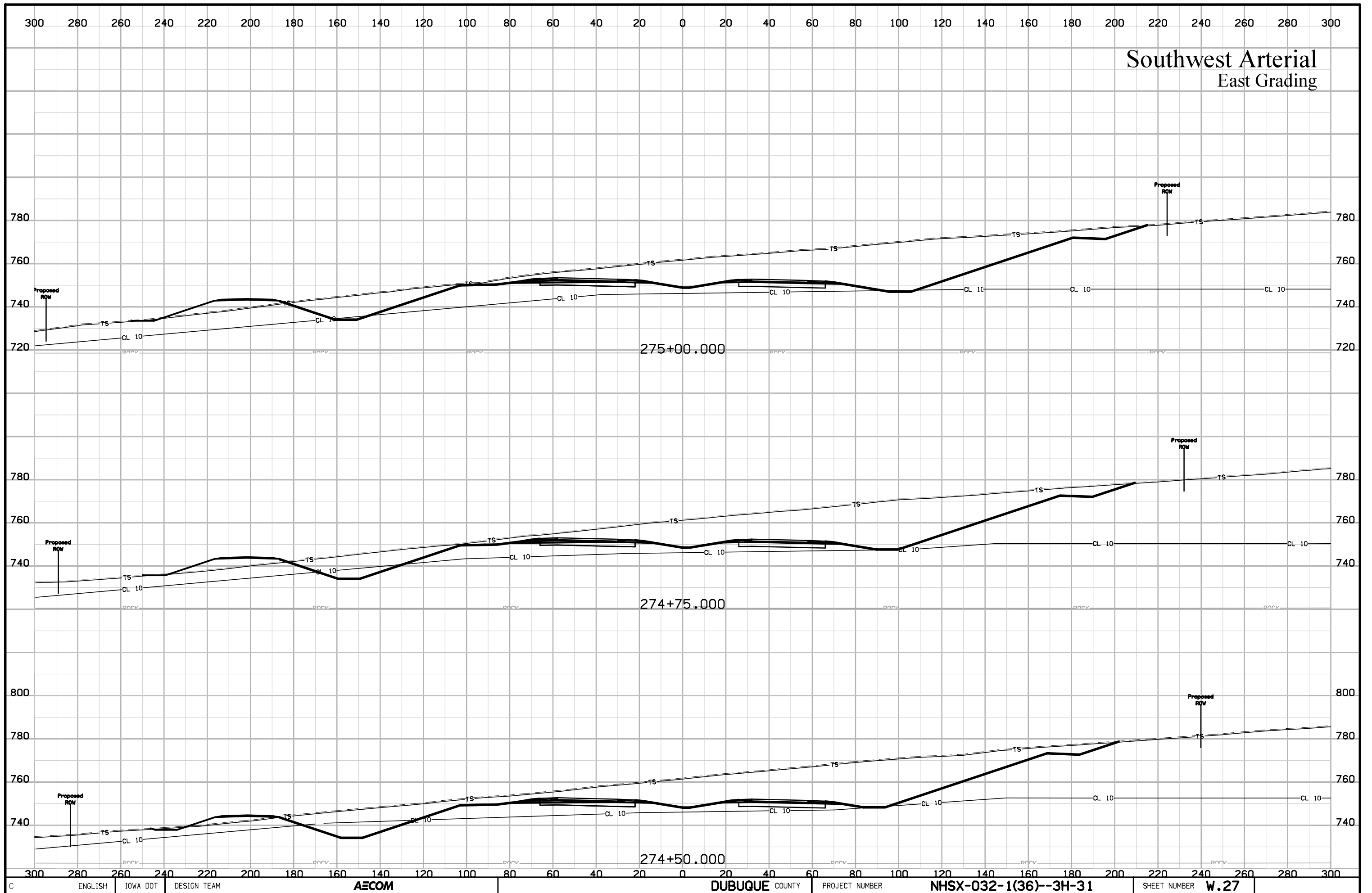

Southwest Arterial East Grading

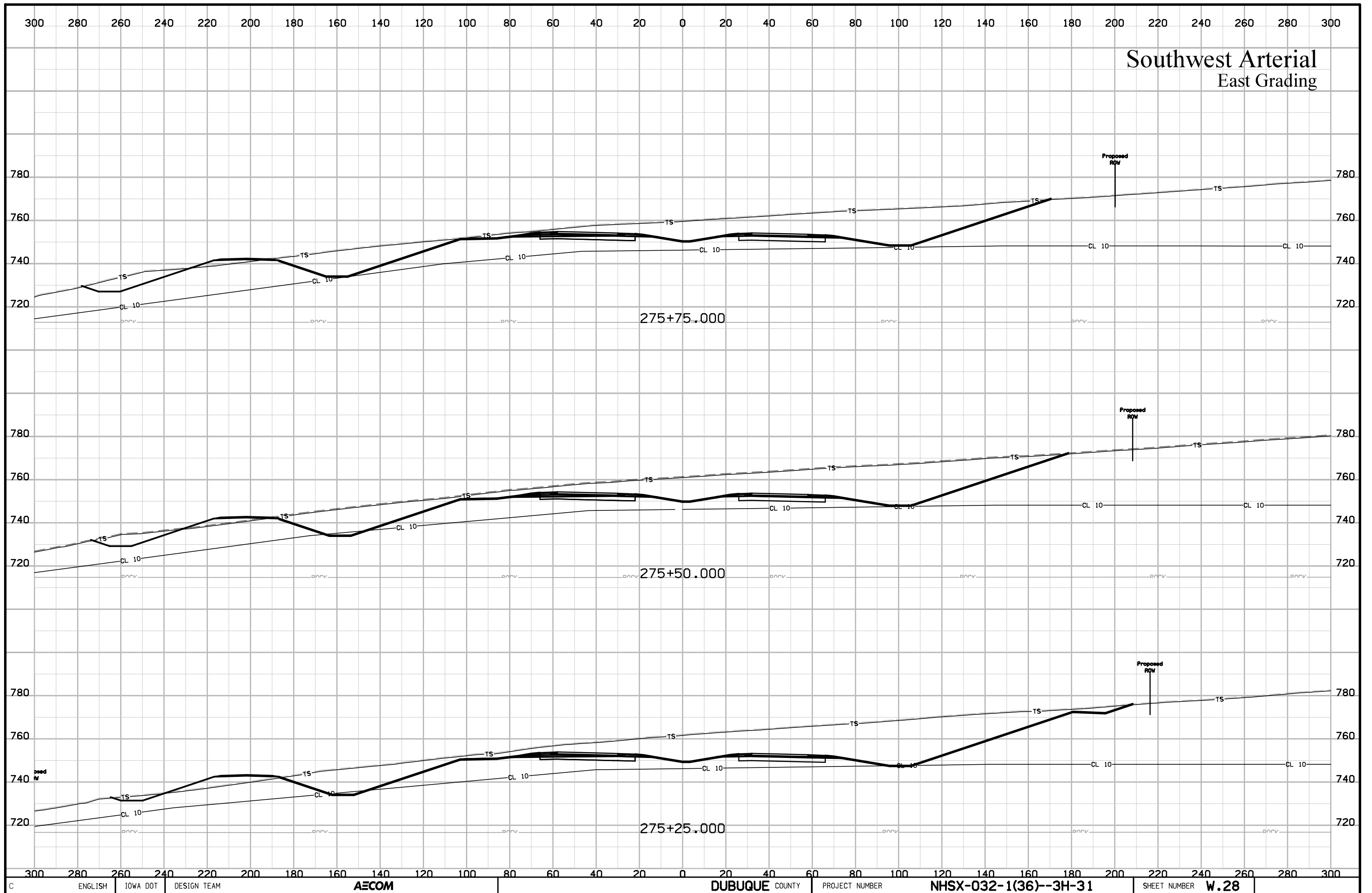

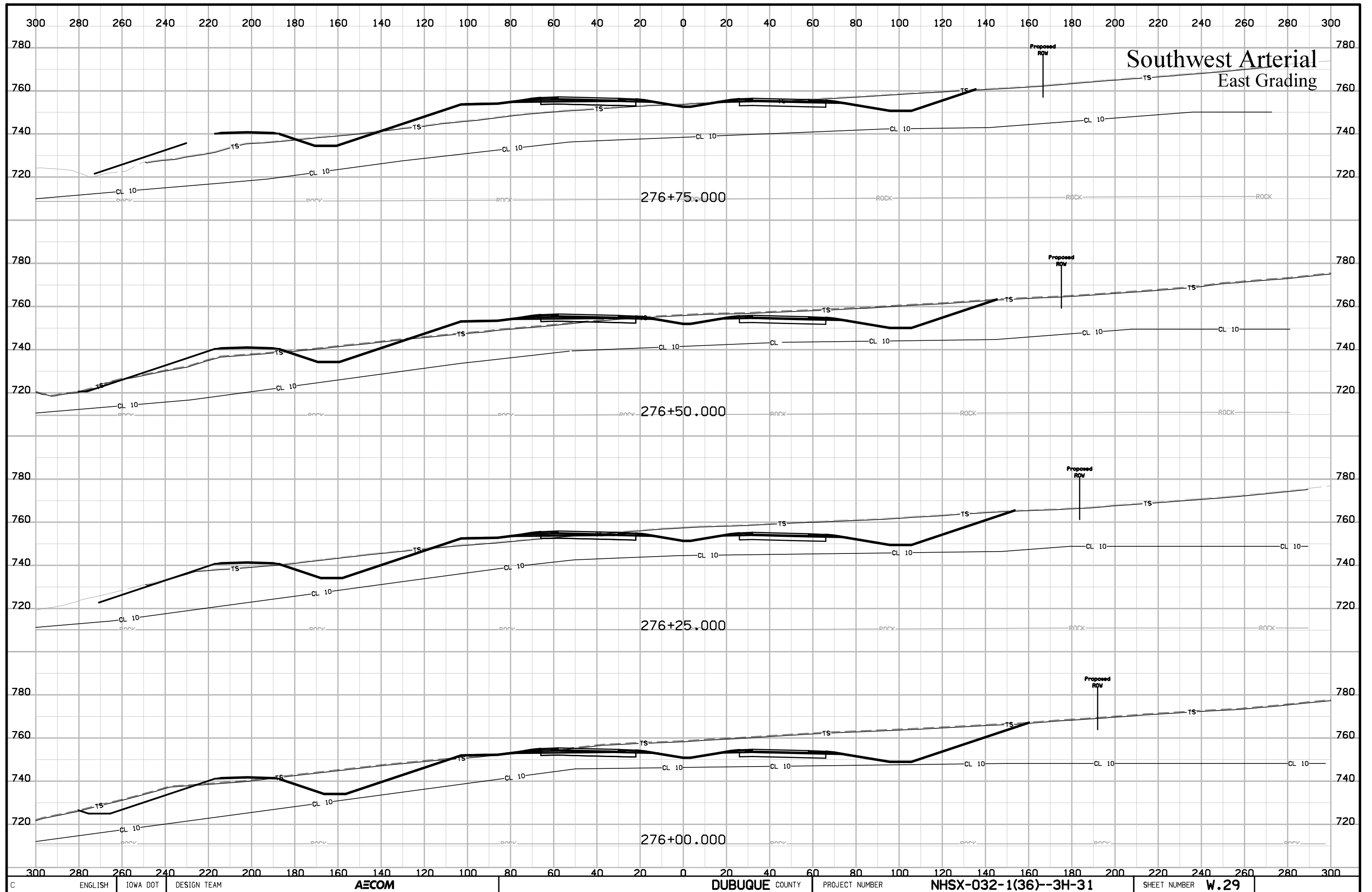

Southwest Arterial East Grading

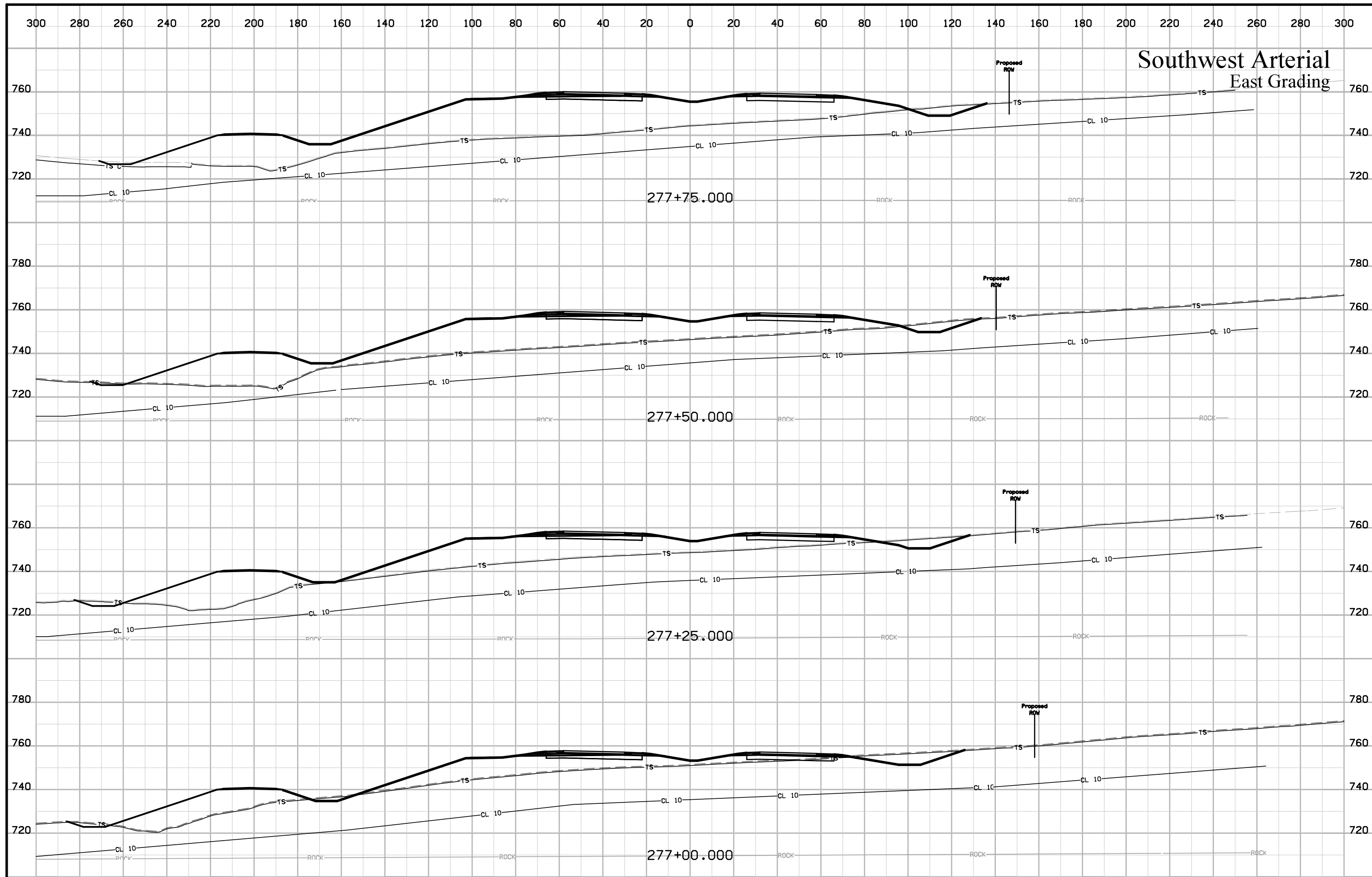

Southwest Arterial East Grading

Southwest Arterial East Grading

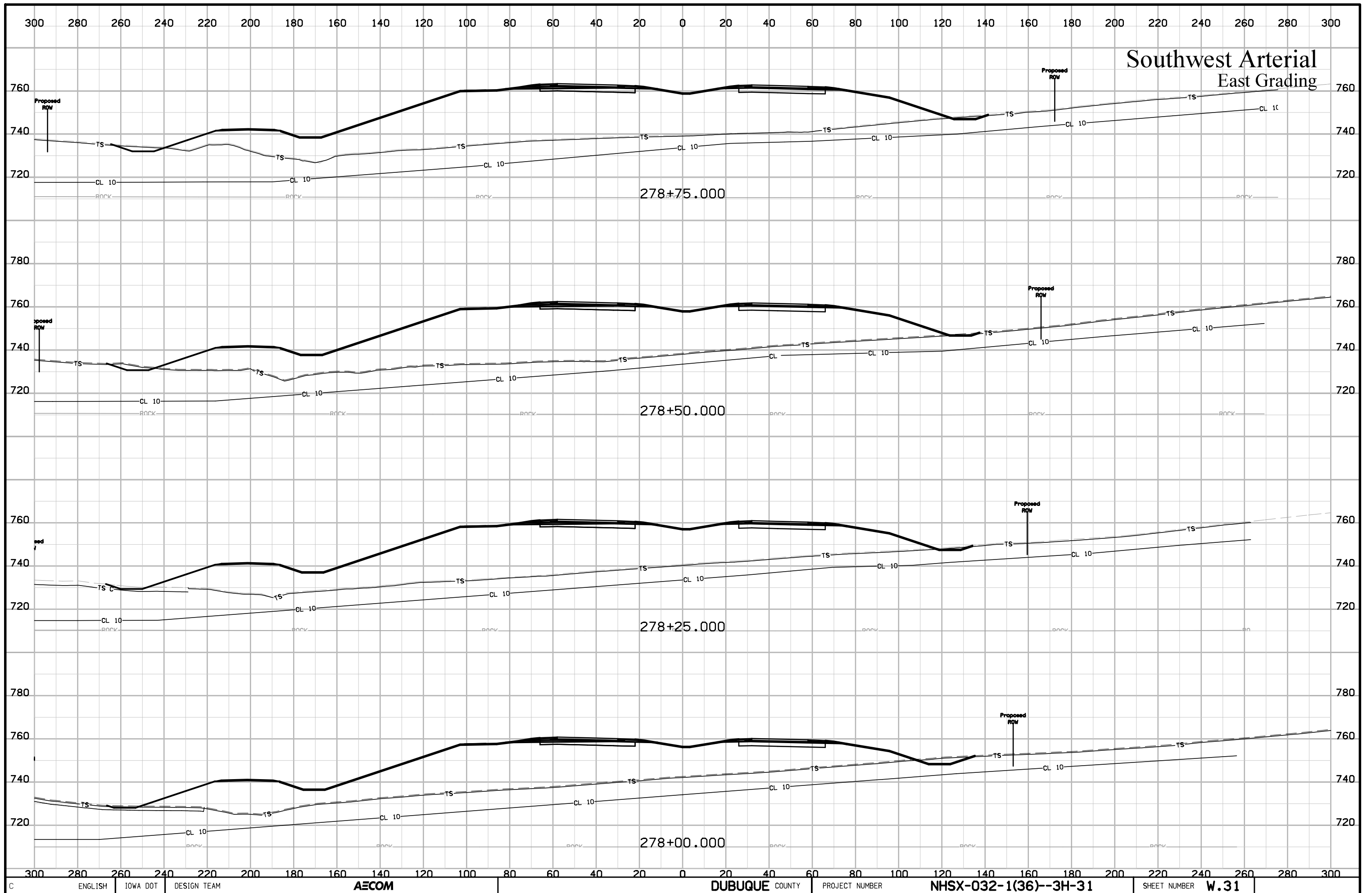

Southwest Arterial East Grading

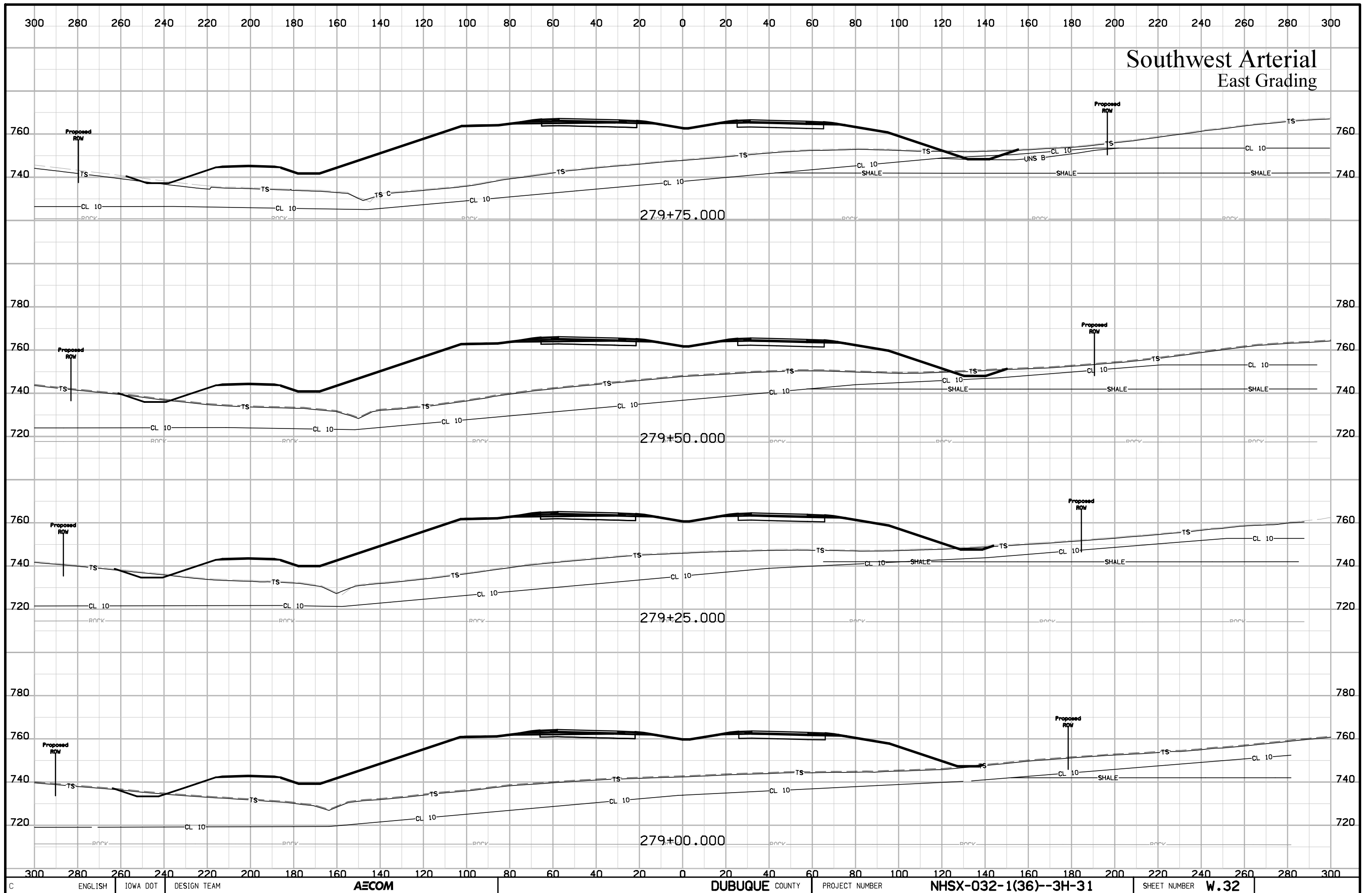

Southwest Arterial East Grading

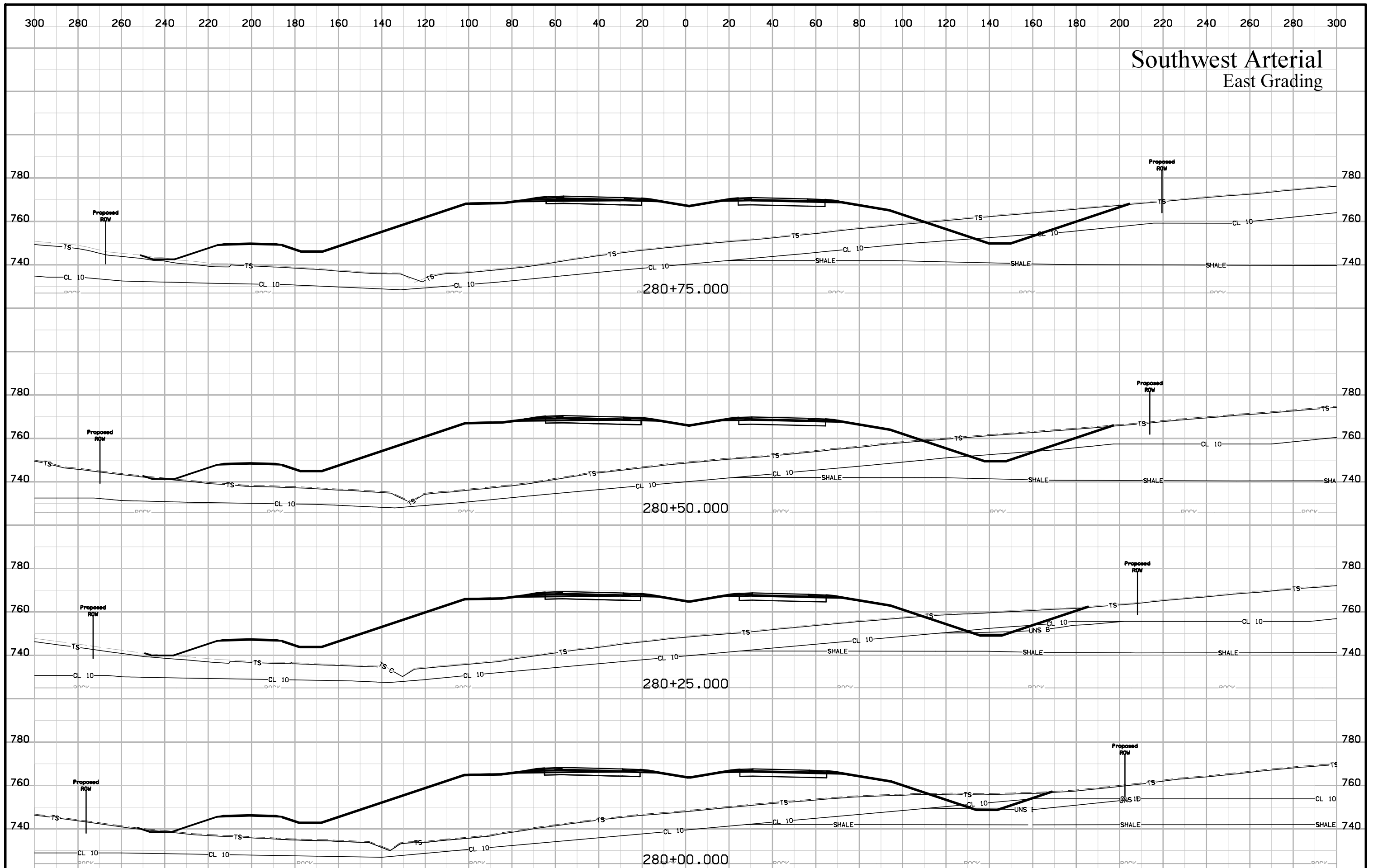

Southwest Arterial East Grading

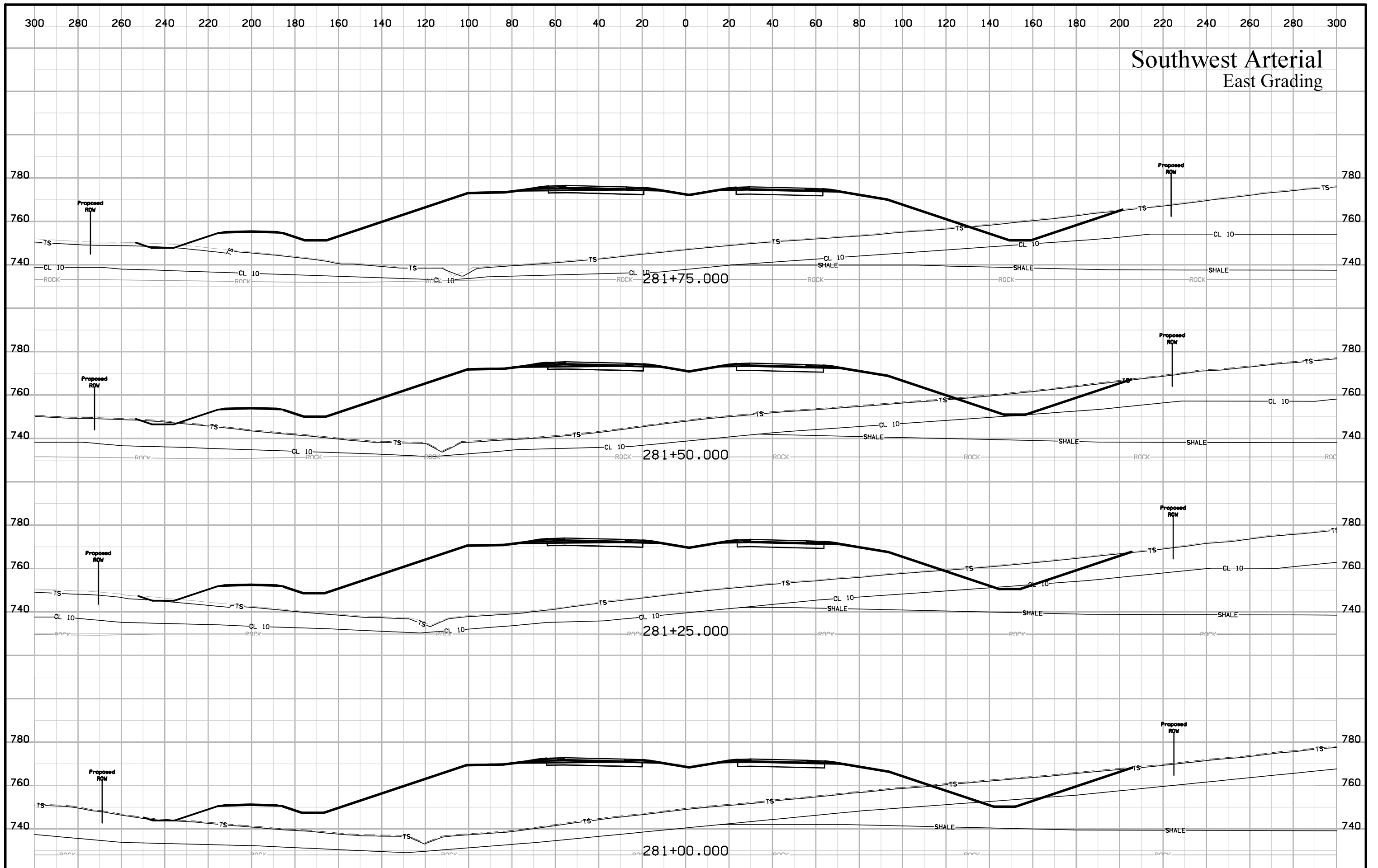

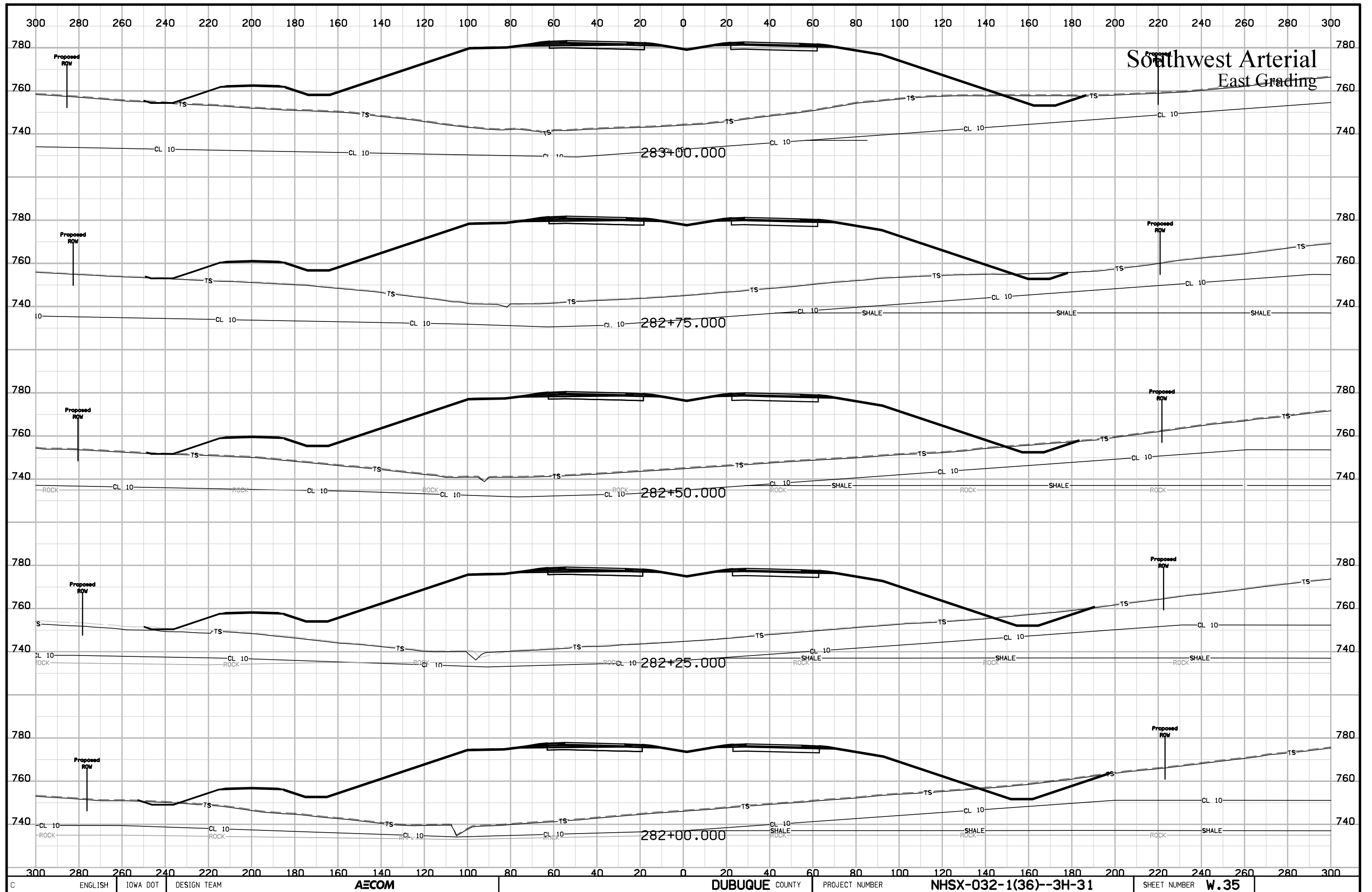

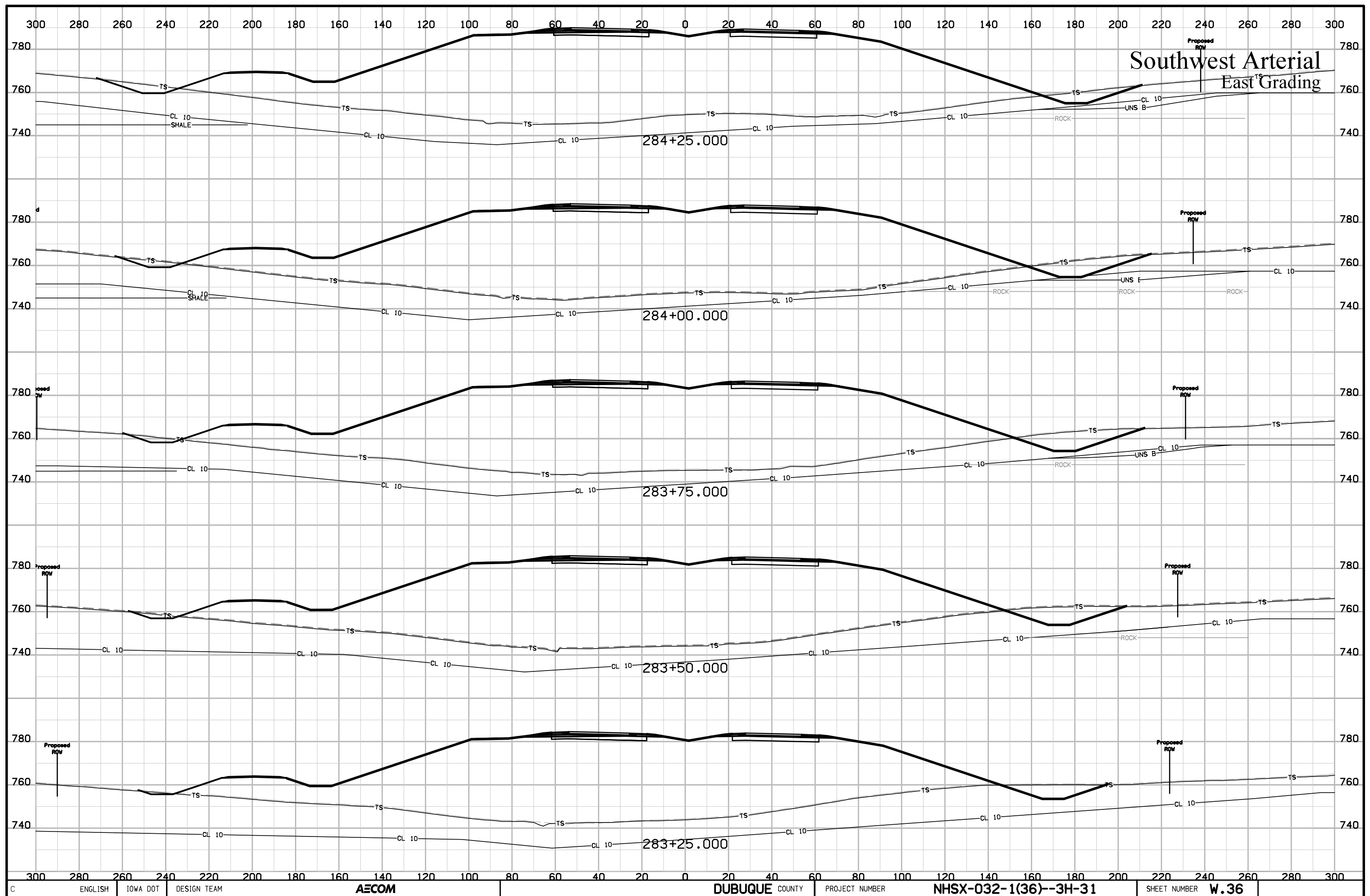

Southwest Arterial East Grading

Southwest Arterial East Grading

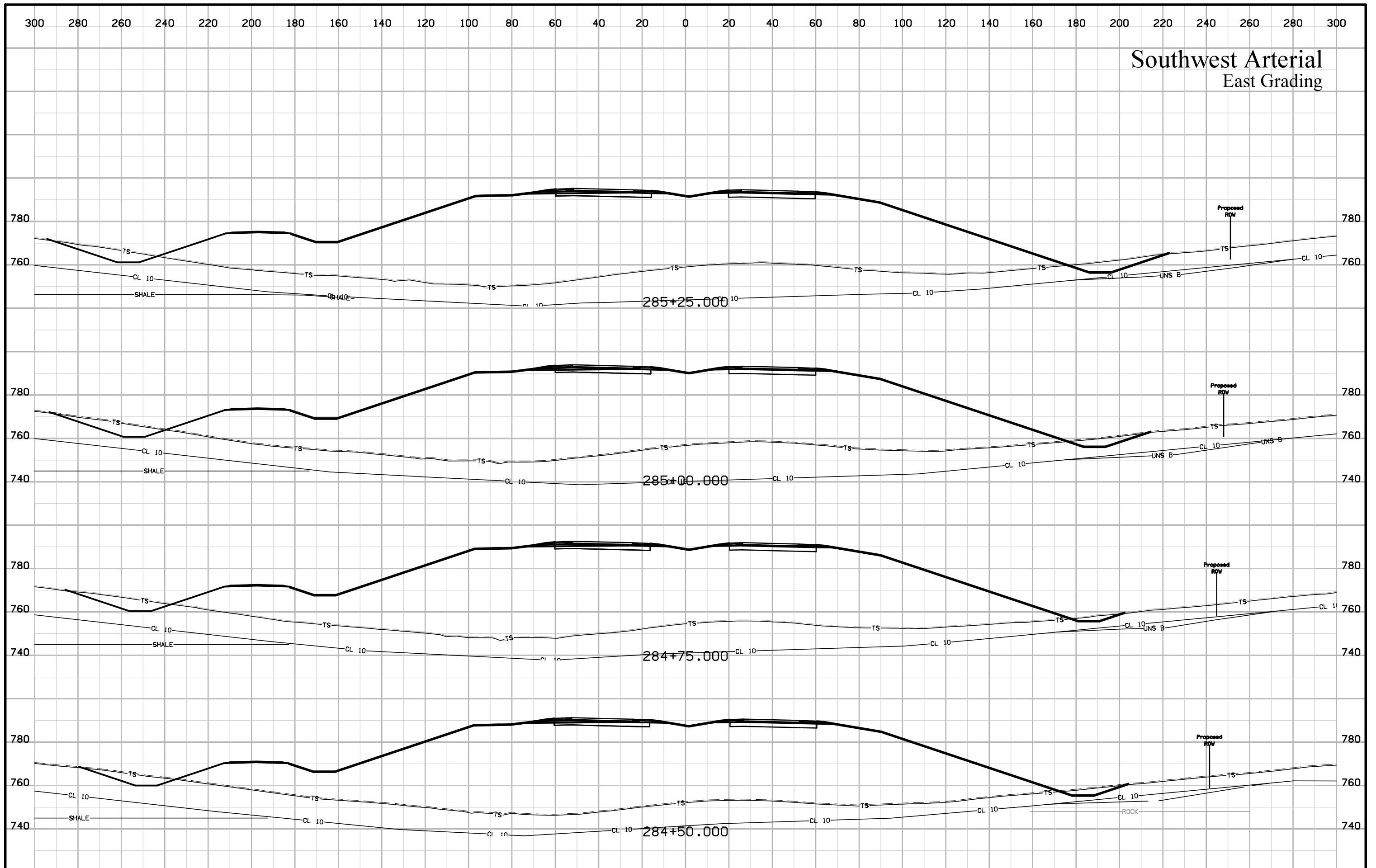

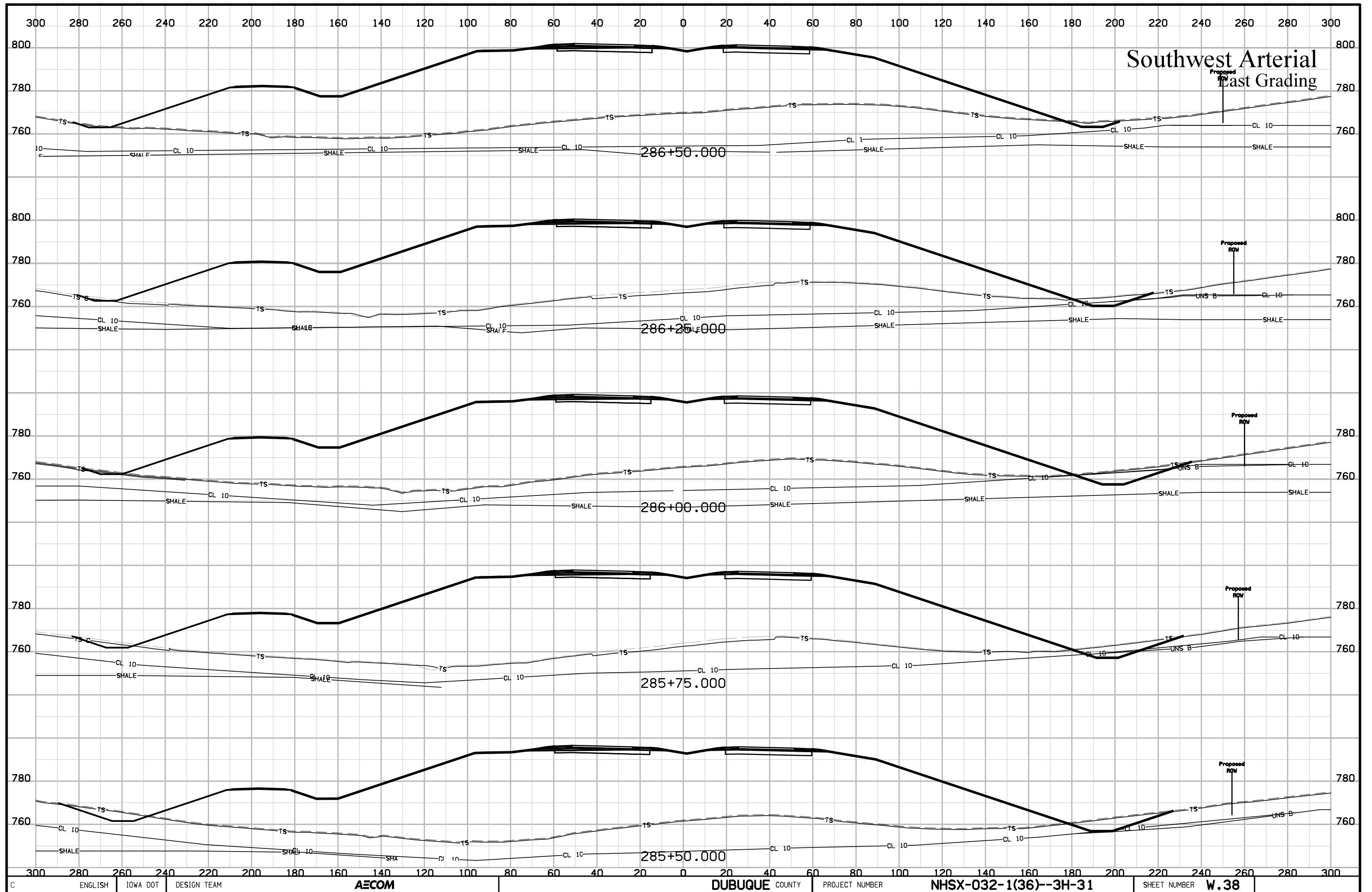

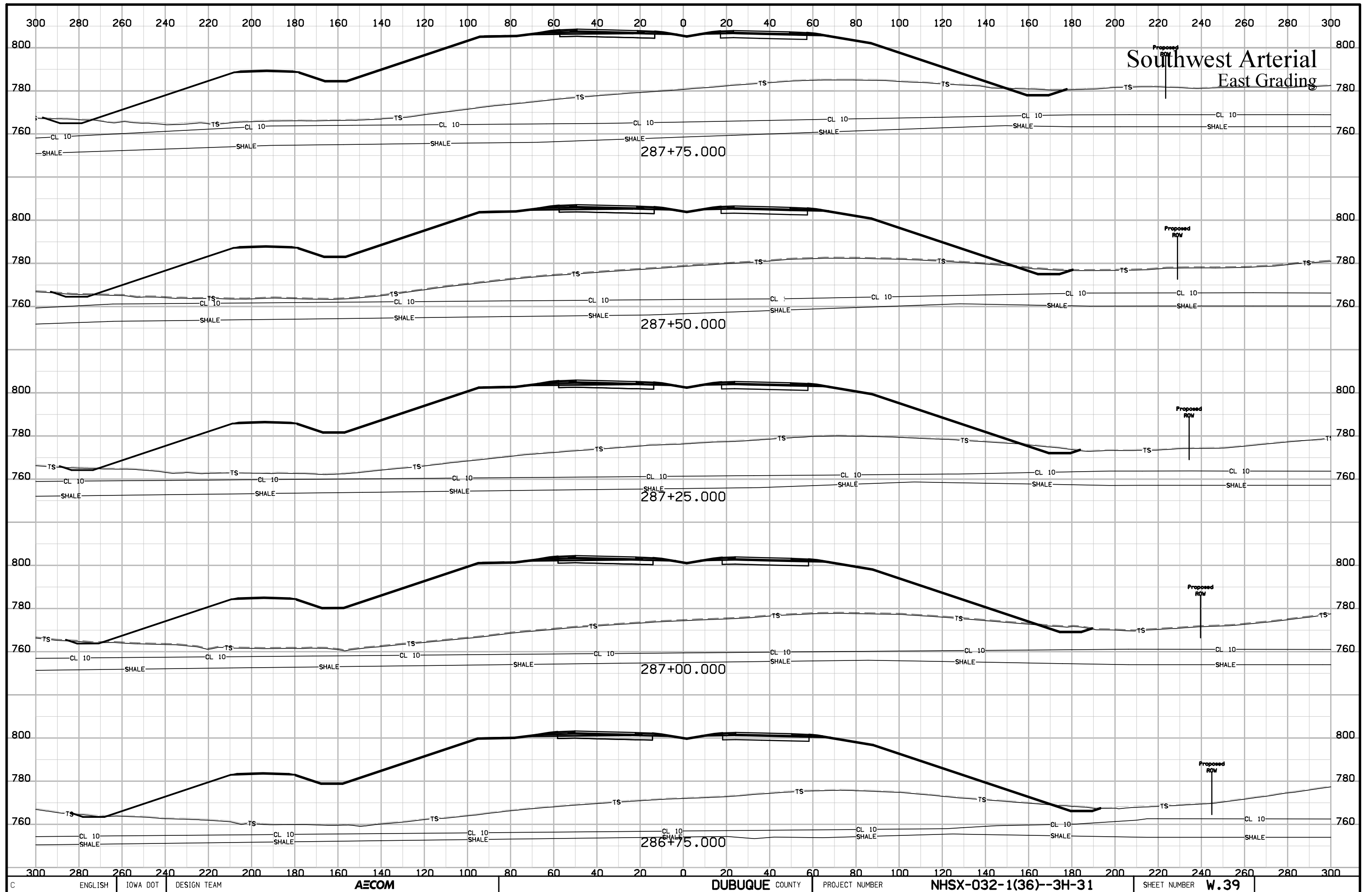

Southwest Arterial East Grading

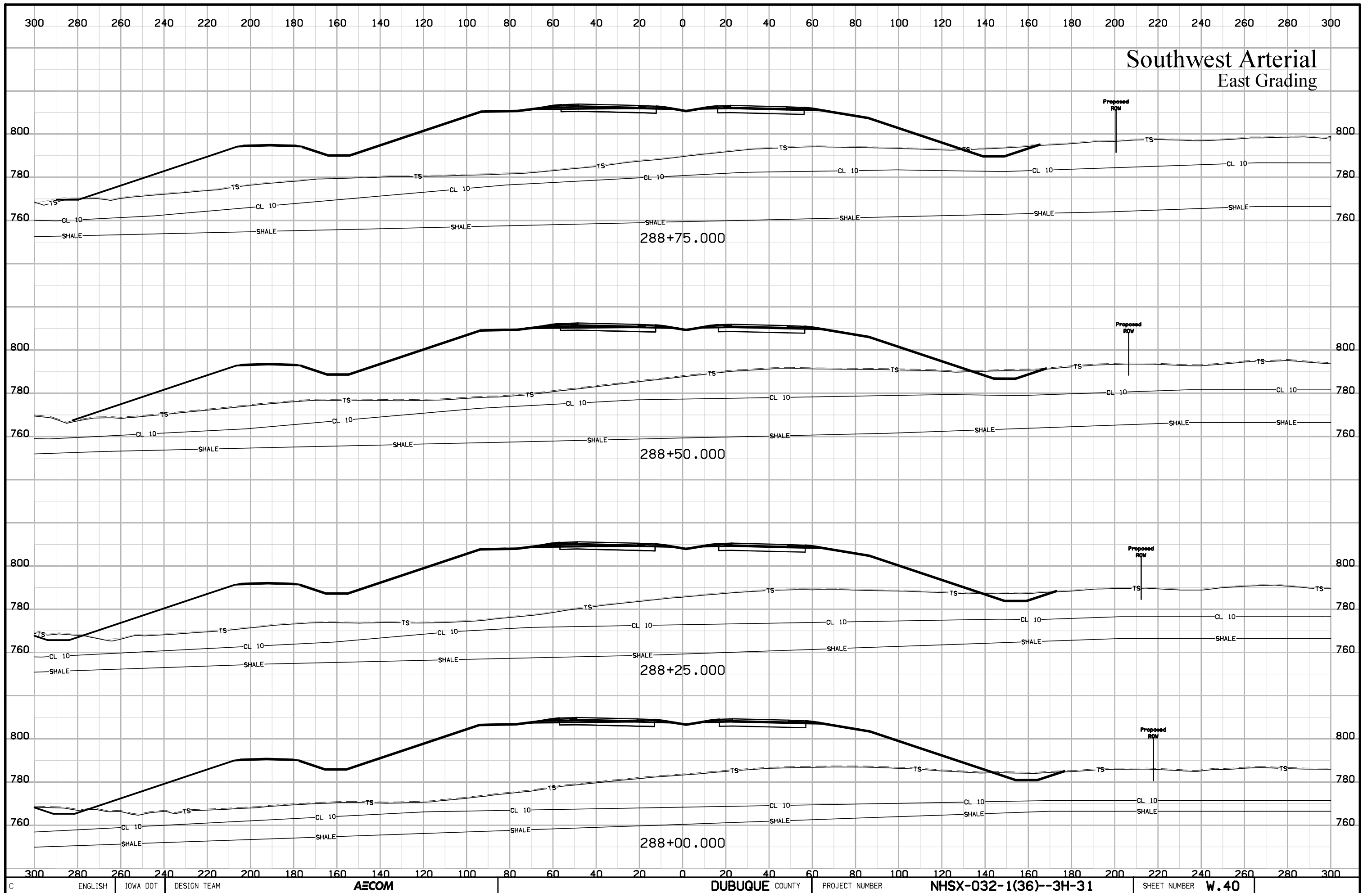

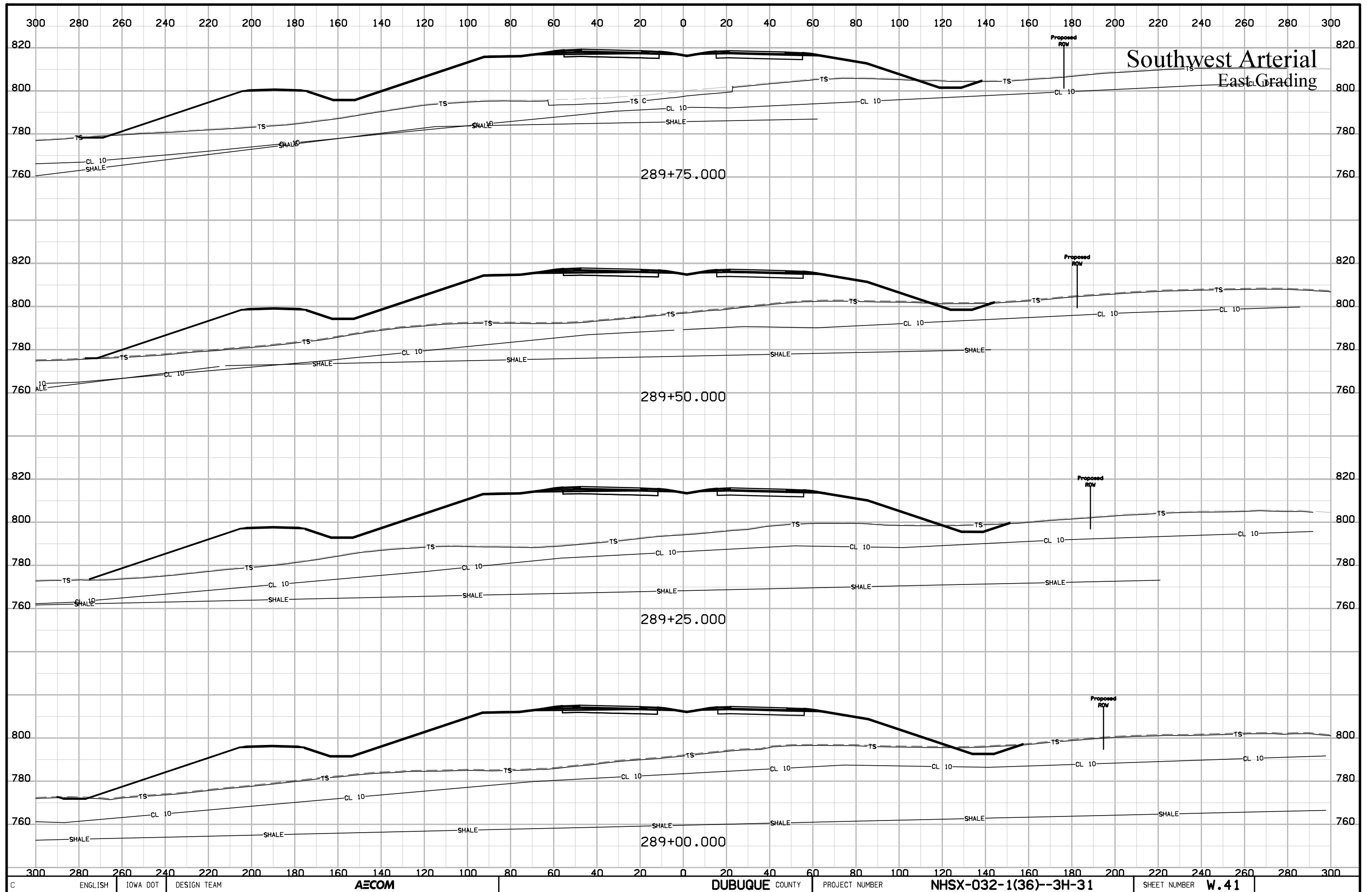

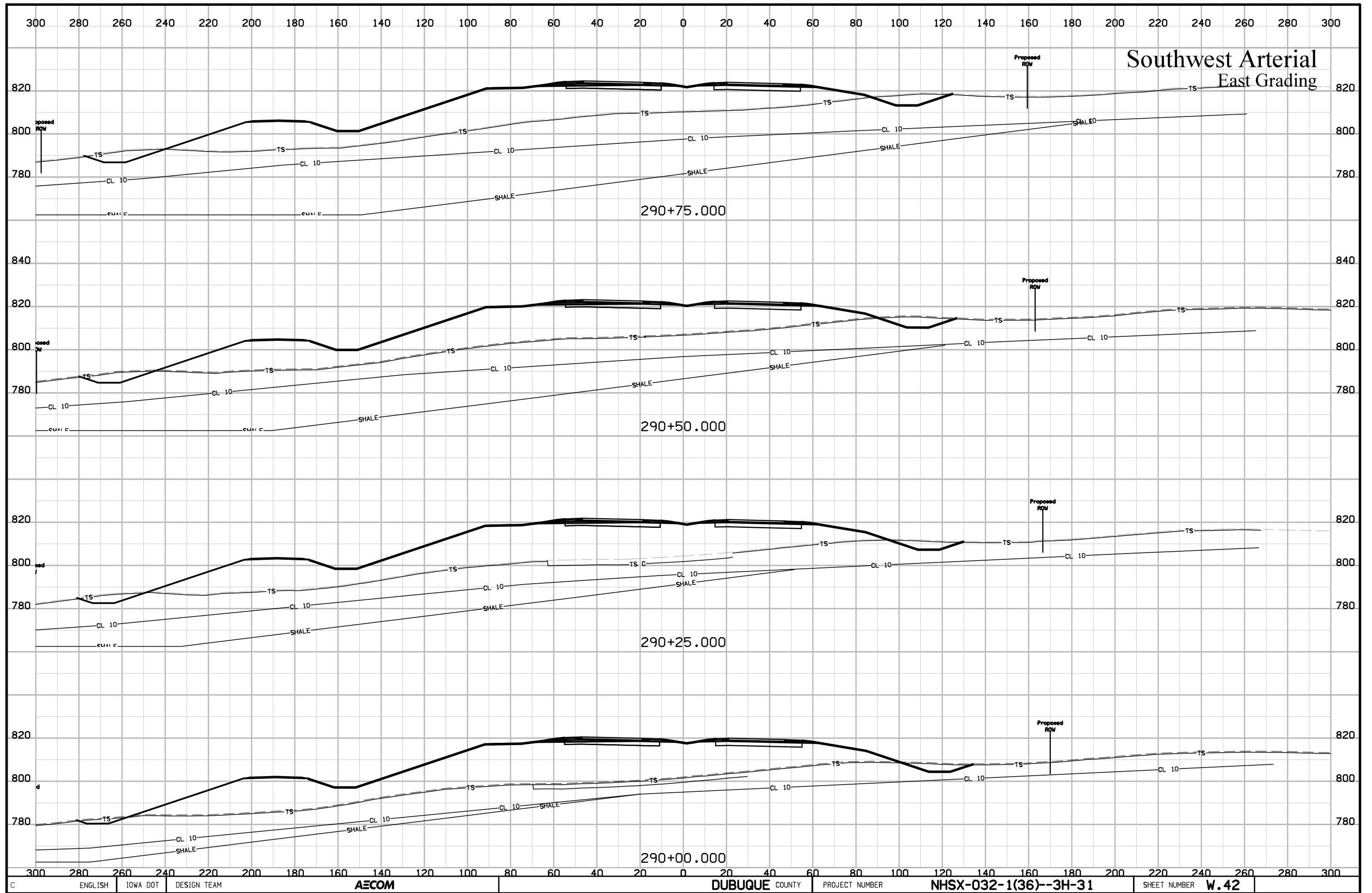

300 280 260 240 220 200 180 160 140 120 100 80 60 40 20 0 20 40 60 80 100 120 140 160 180 200 220 240 260 280 300

Southwest Arterial East Grading

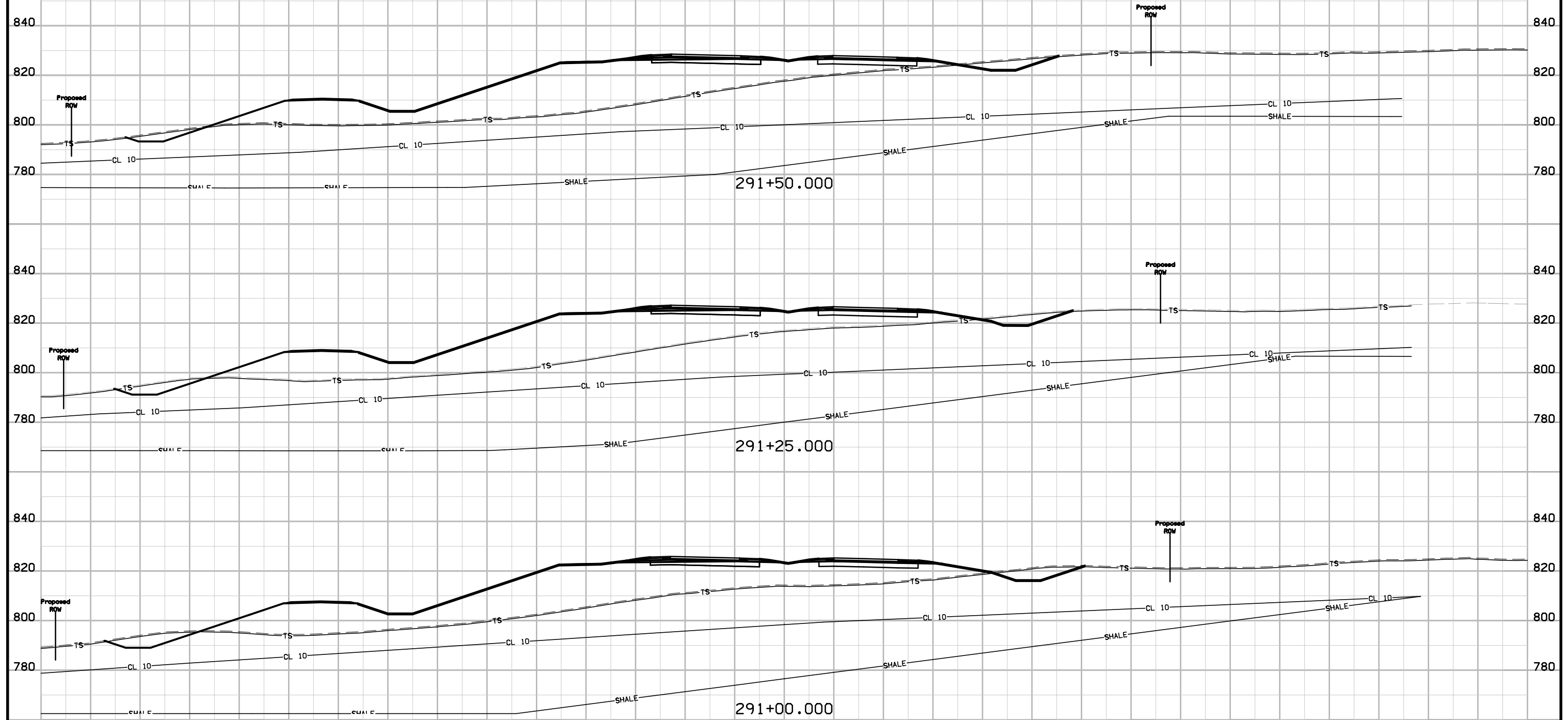

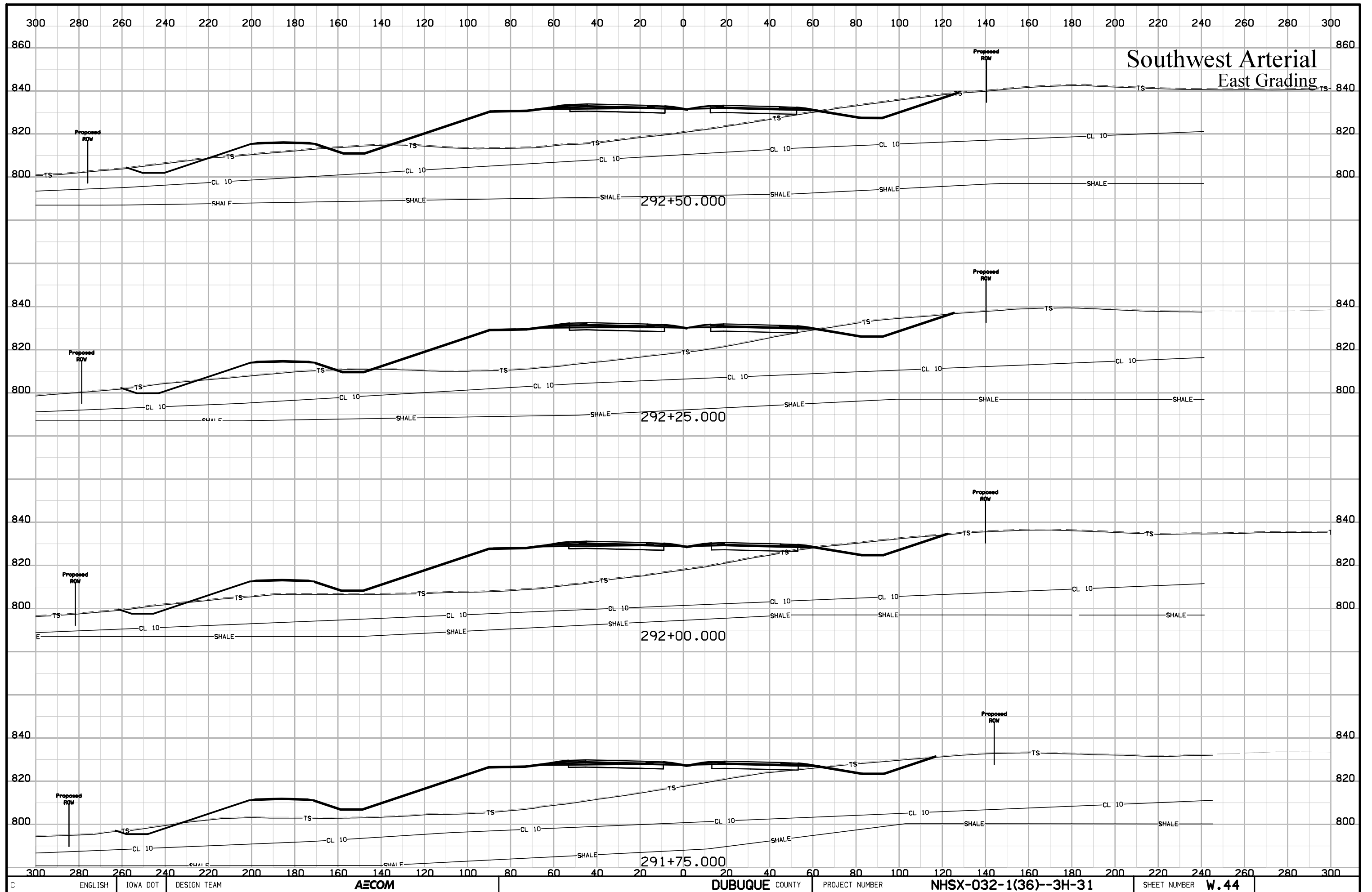

300 280 260 240 220 200 180 160 140 120 100 80 60 40 20 0 20 40 60 80 100 120 140 160 180 200 220 240 260 280 300

Southwest Arterial East Grading

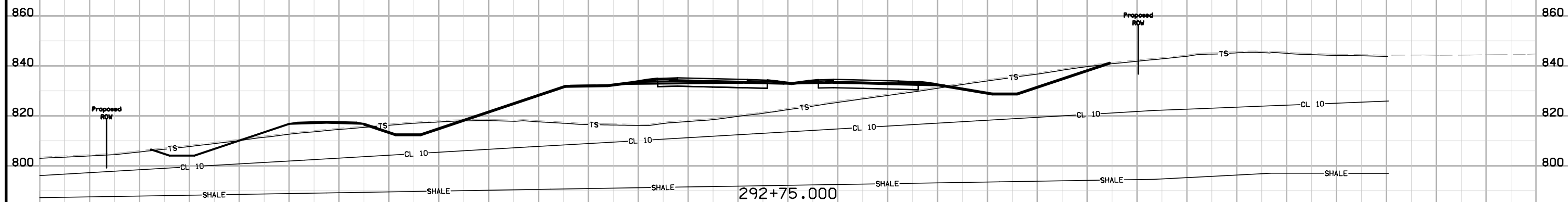
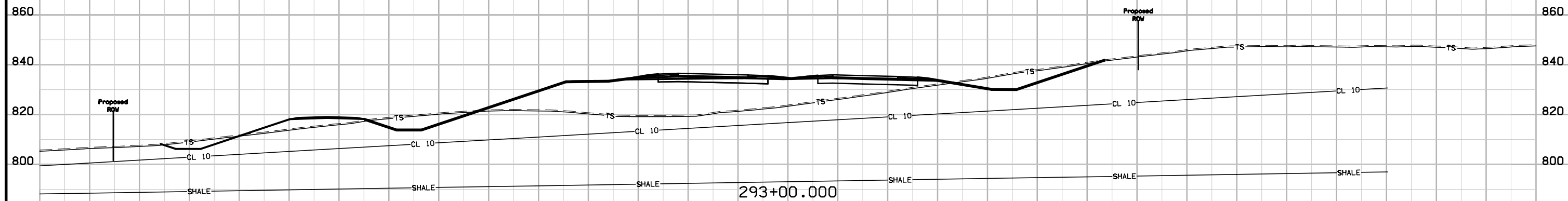
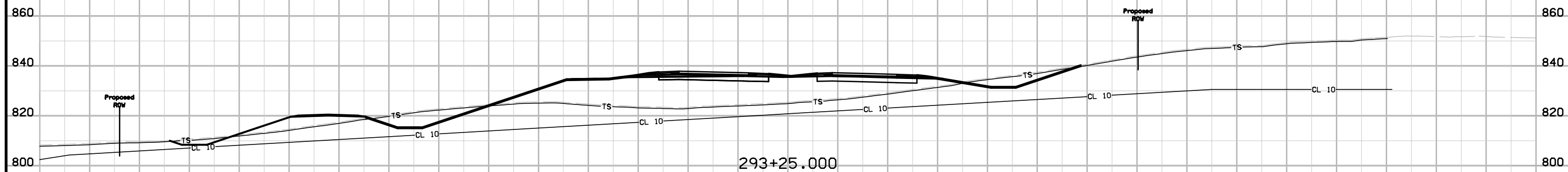

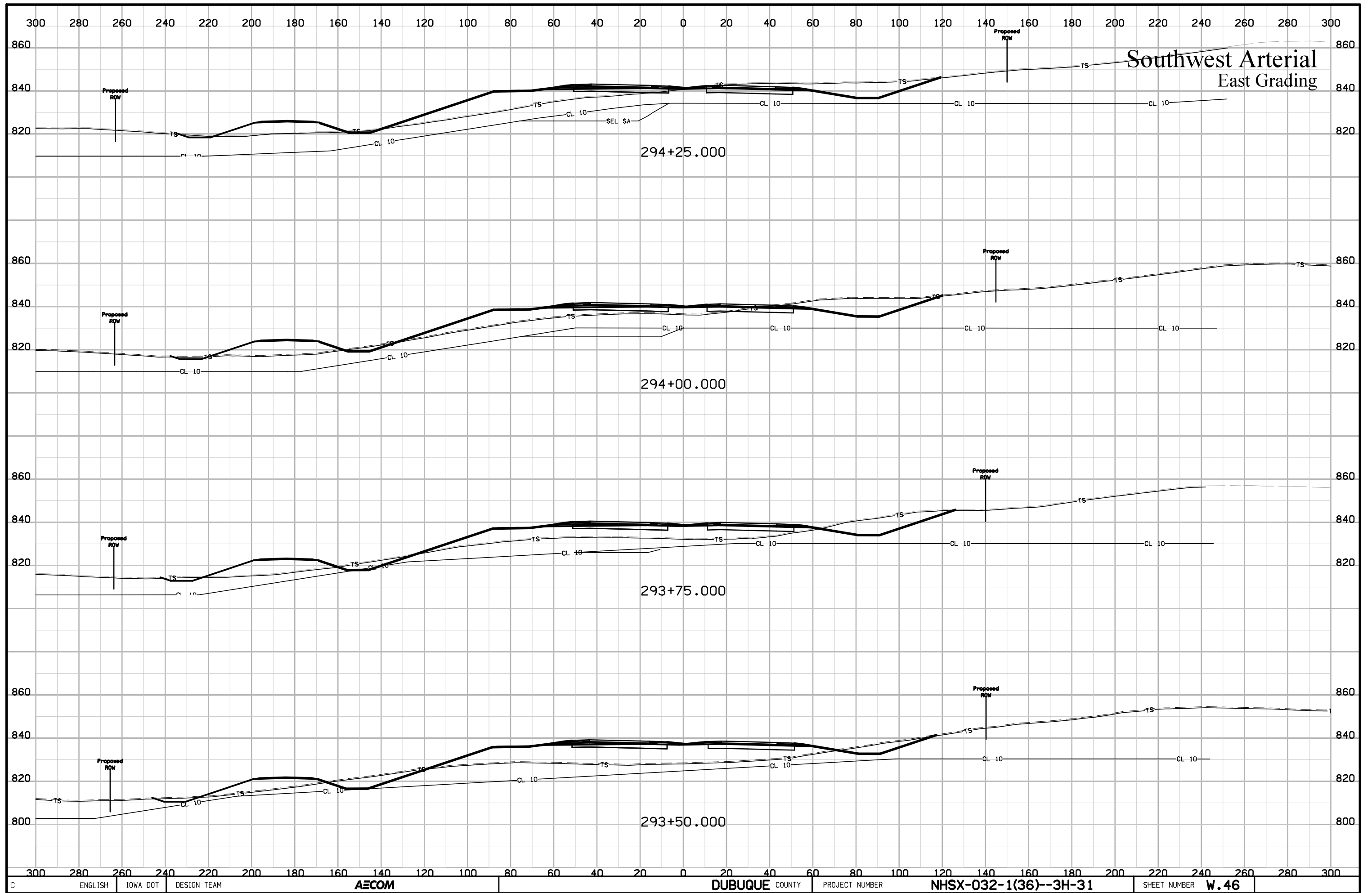

Southwest Arterial
East Grading

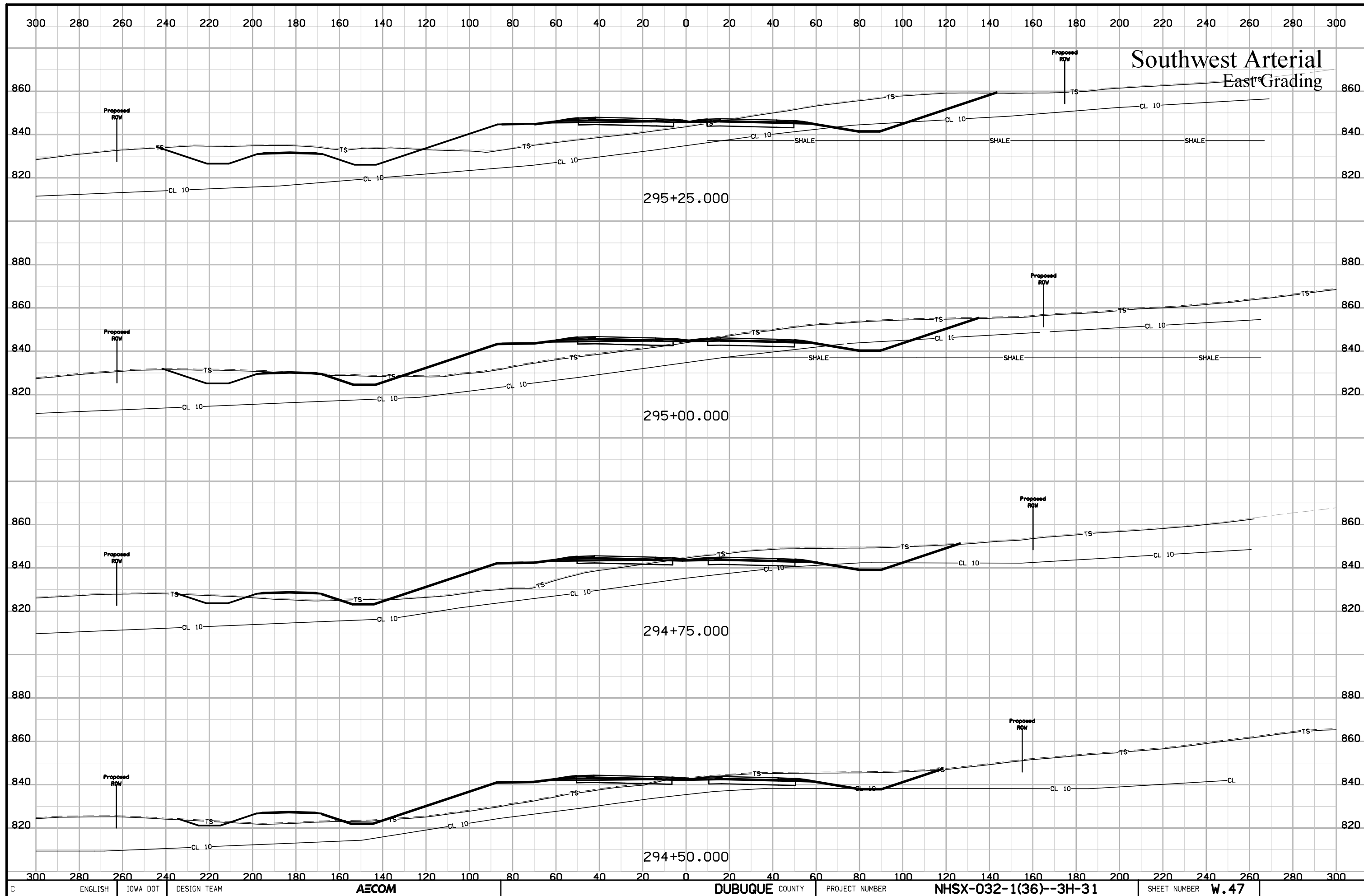

Southwest Arterial
East Grading

300 280 260 240 220 200 180 160 140 120 100 80 60 40 20 0 20 40 60 80 100 120 140 160 180 200 220 240 260 280 300

Southwest Arterial East Grading

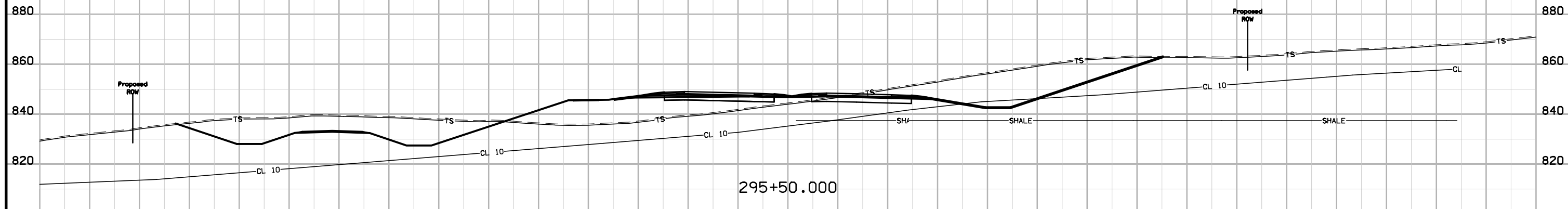
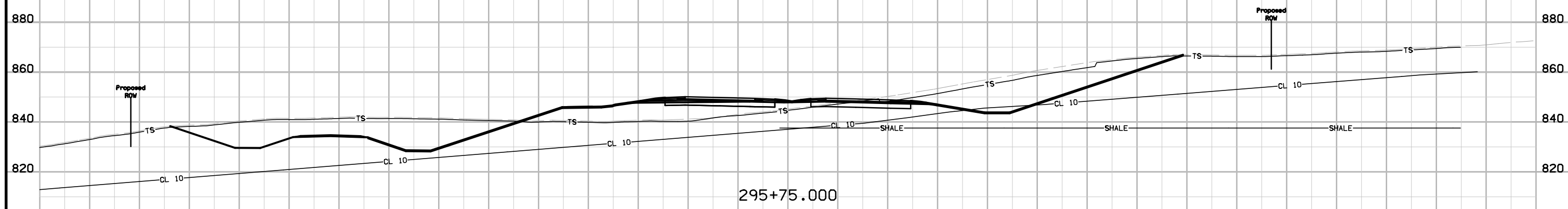
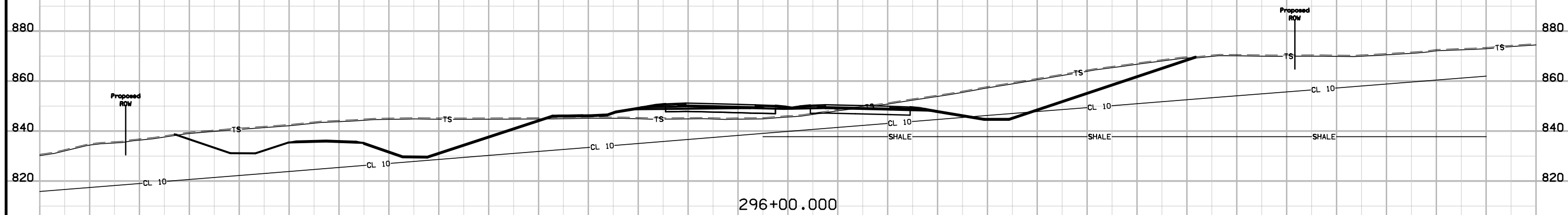

Southwest Arterial East Grading

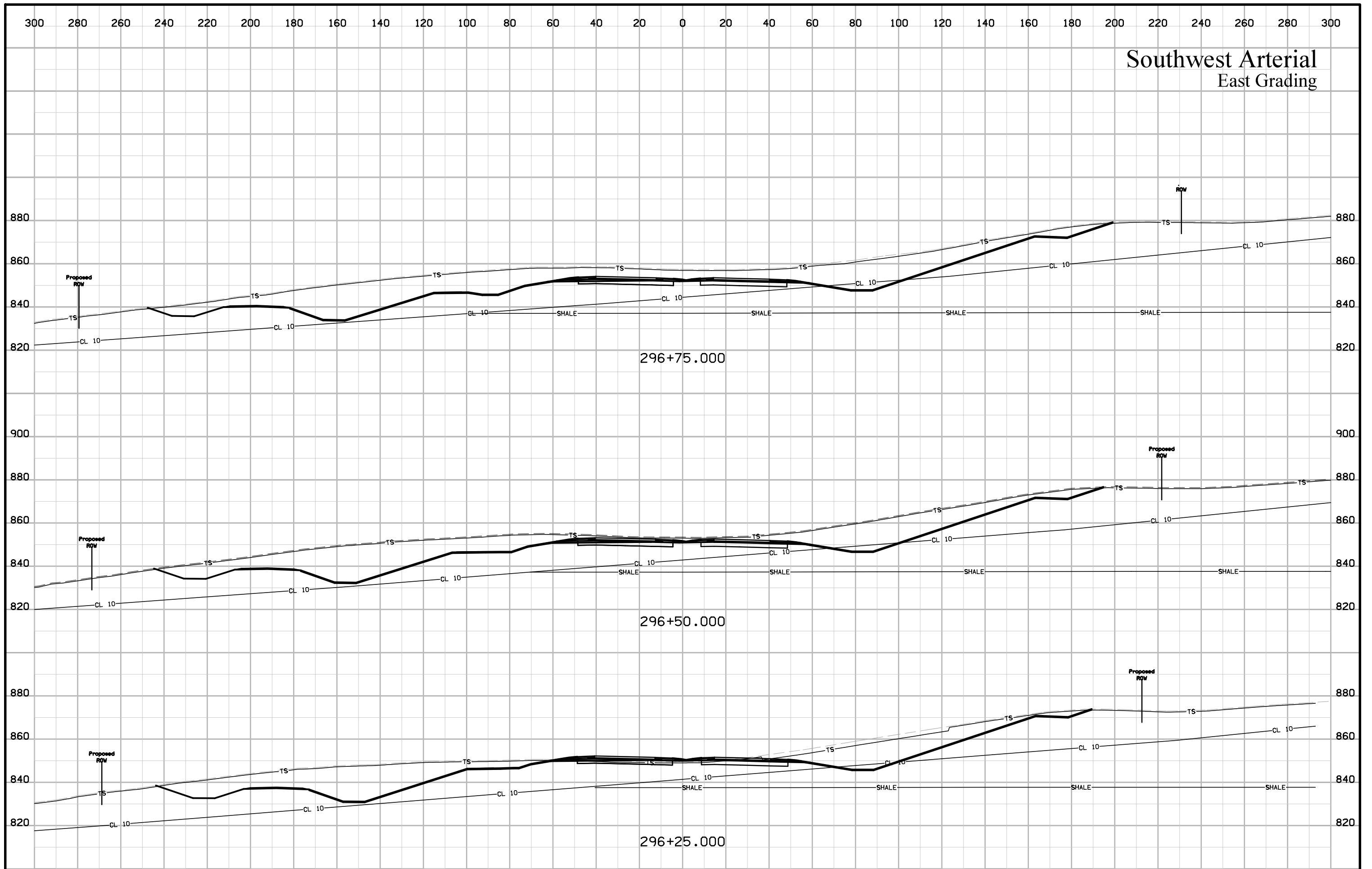

Southwest Arterial East Grading

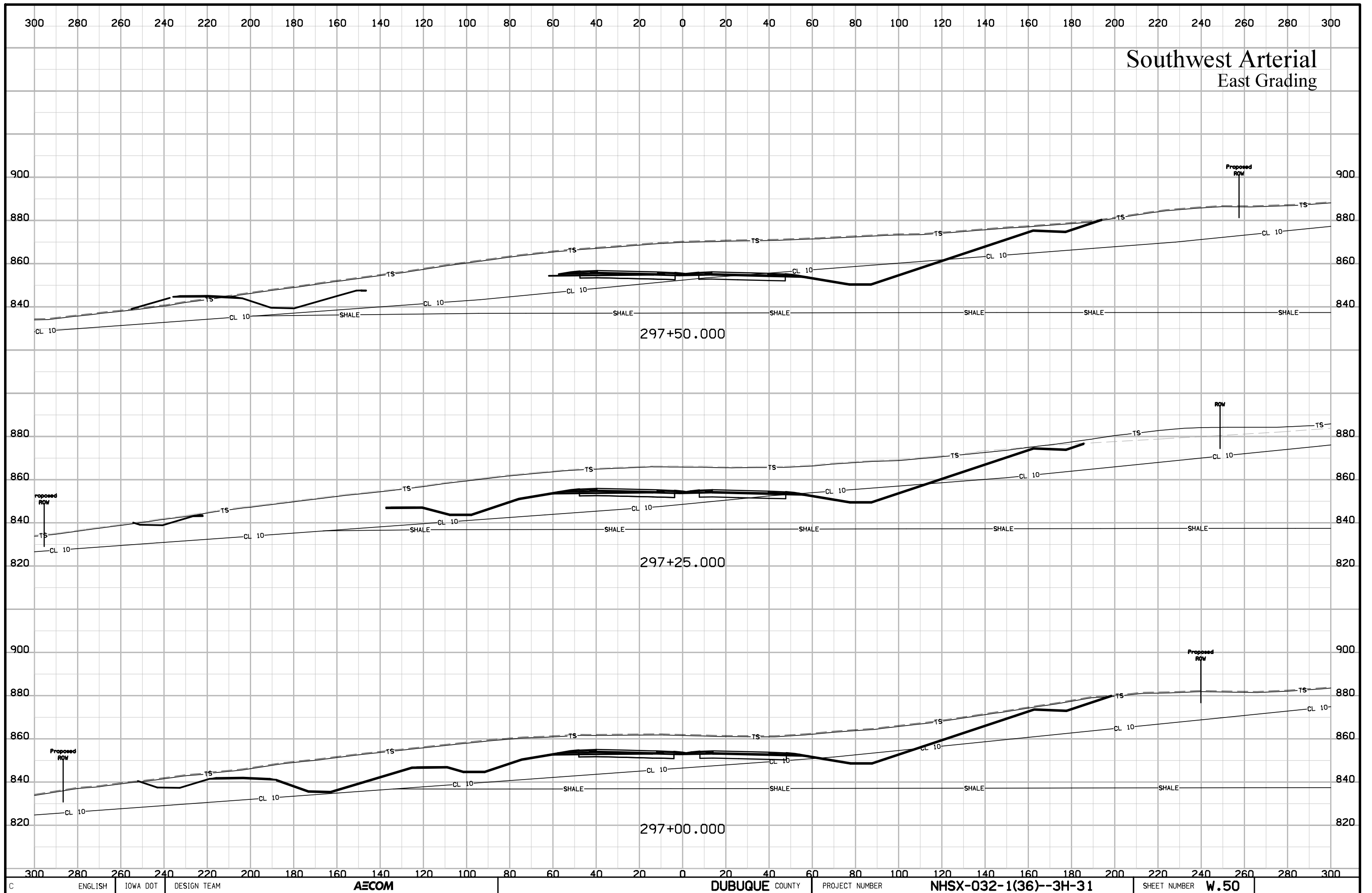

Southwest Arterial East Grading

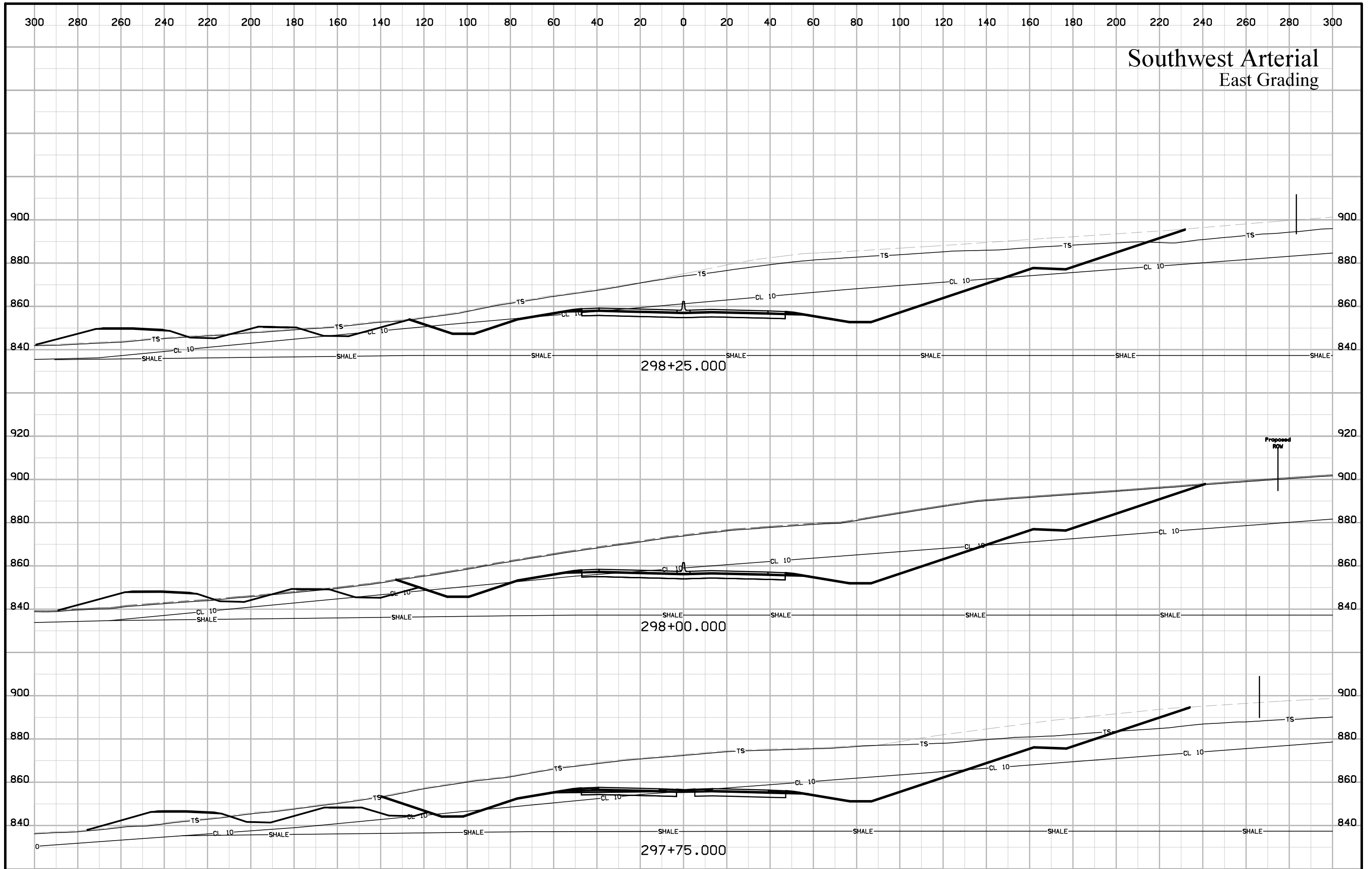

Southwest Arterial East Grading

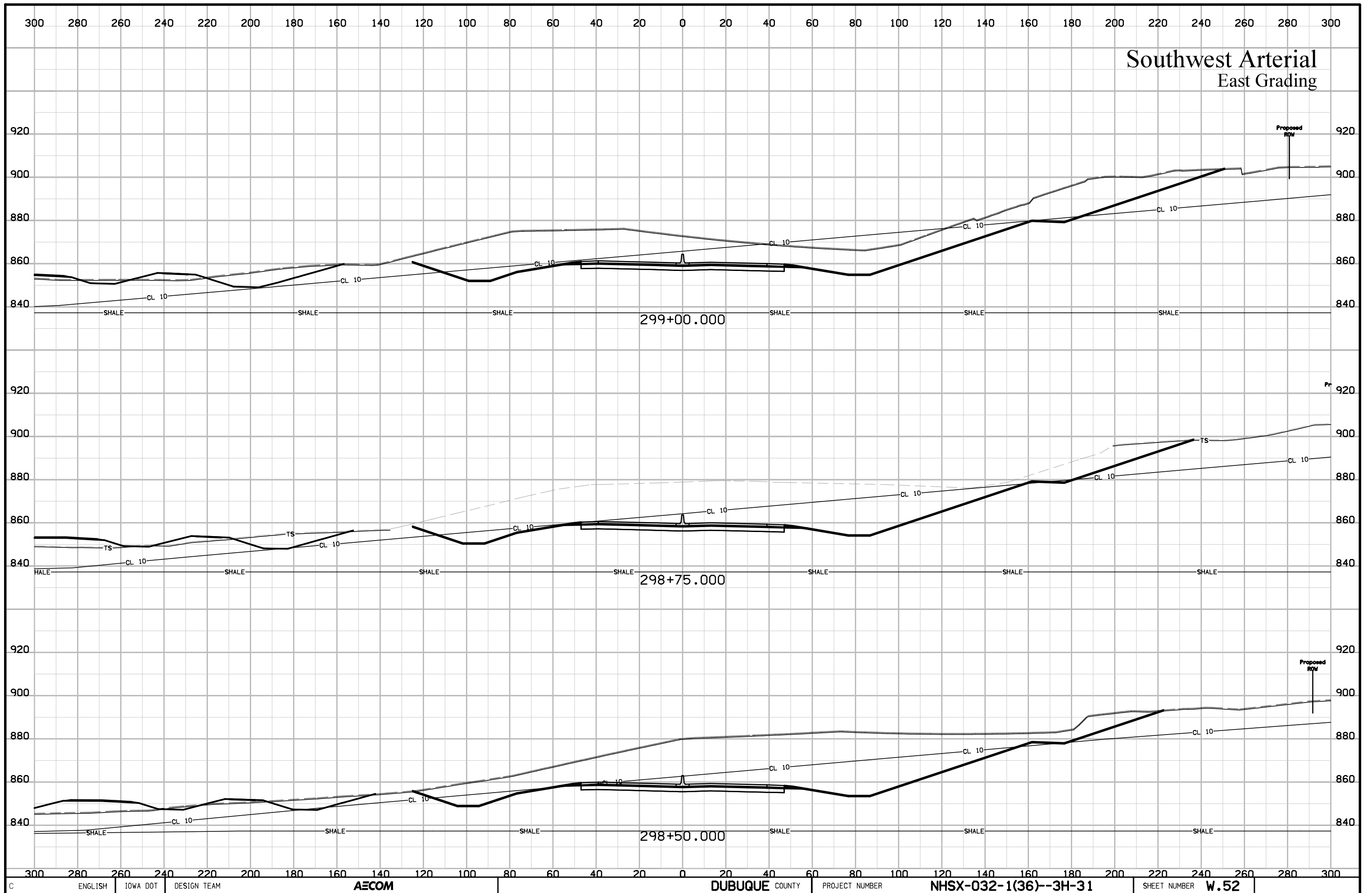

Southwest Arterial East Grading

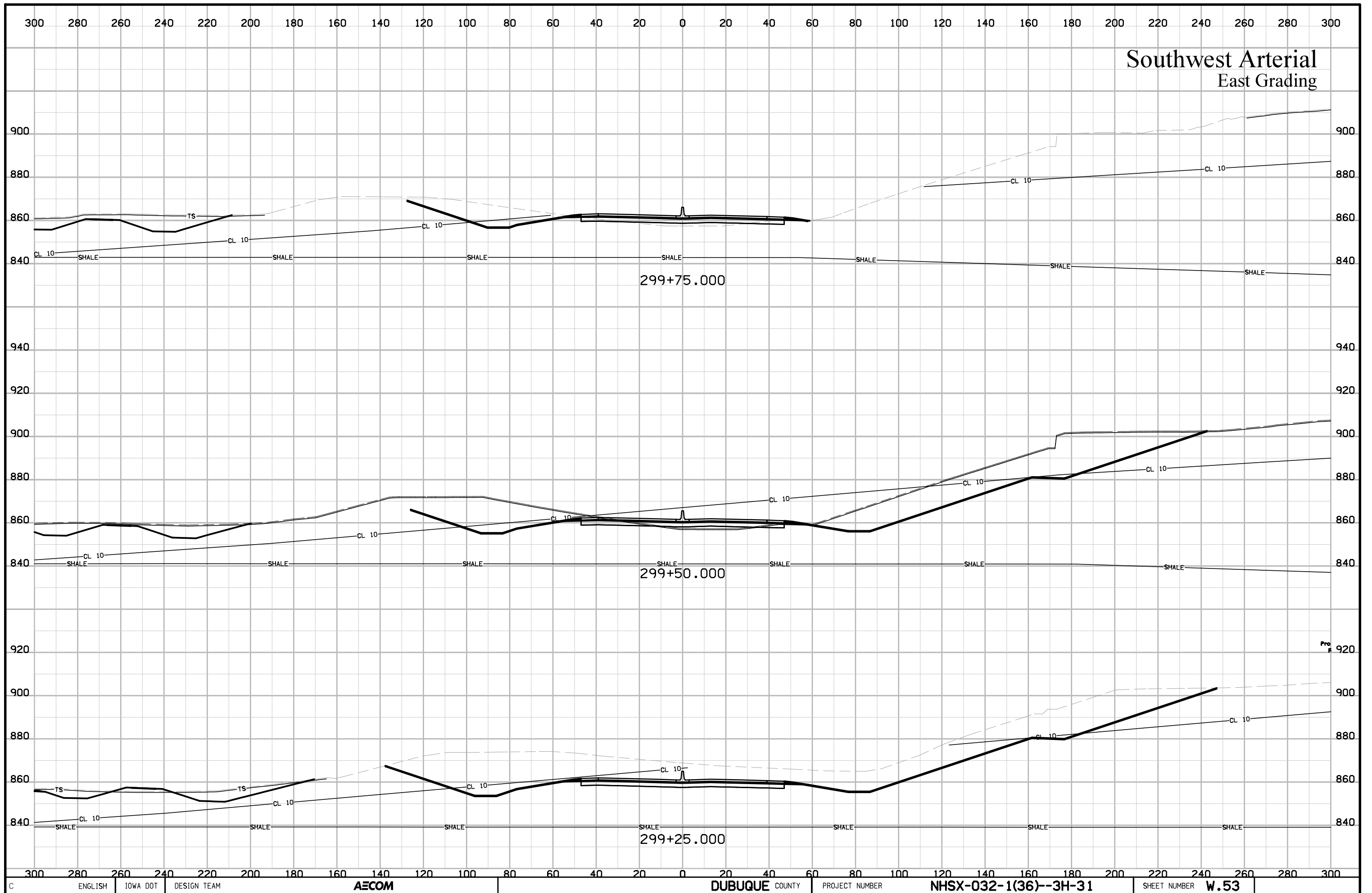

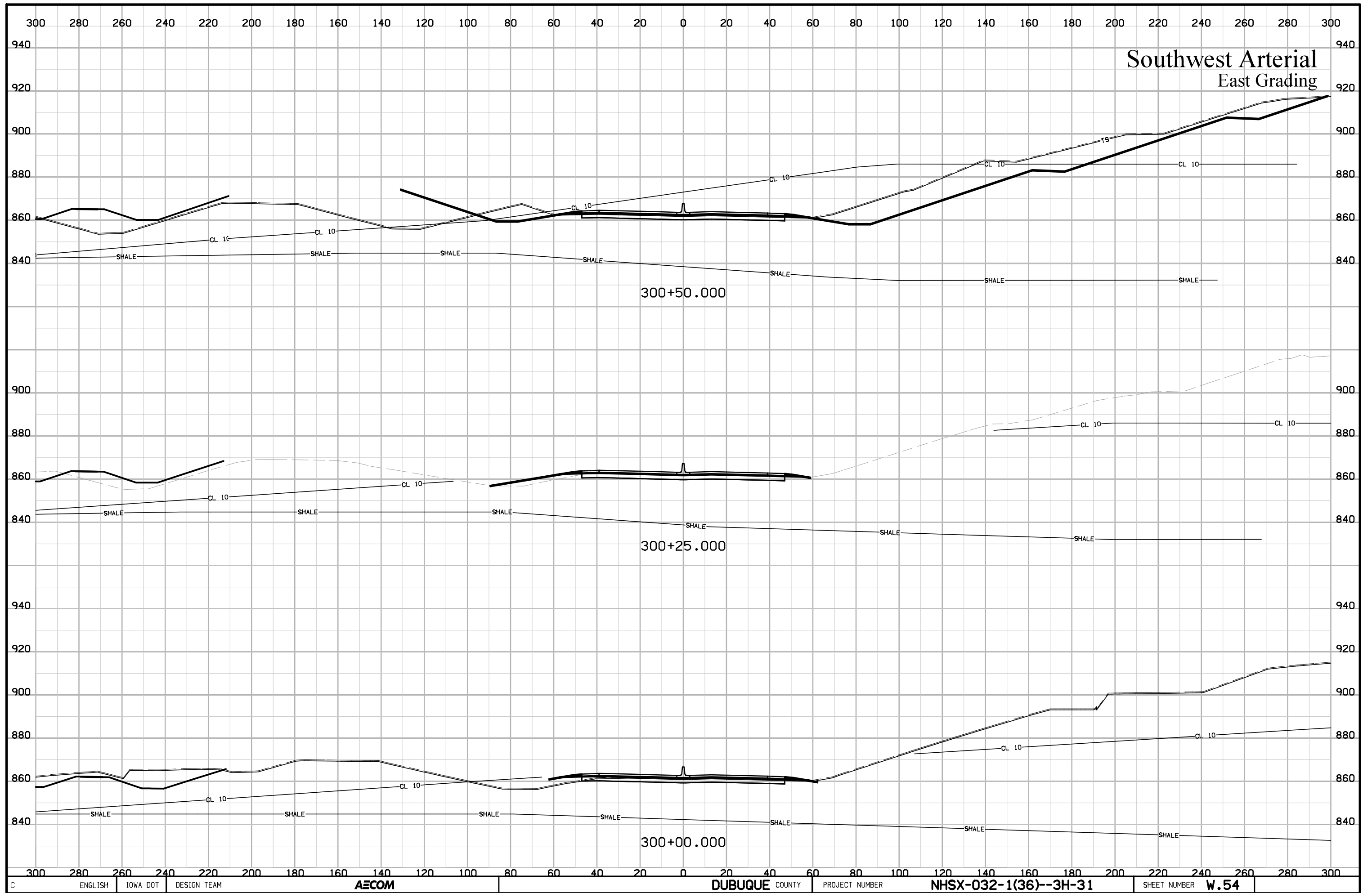

Southwest Arterial
East Grading

300+50.000

300+25.000

300+00.000

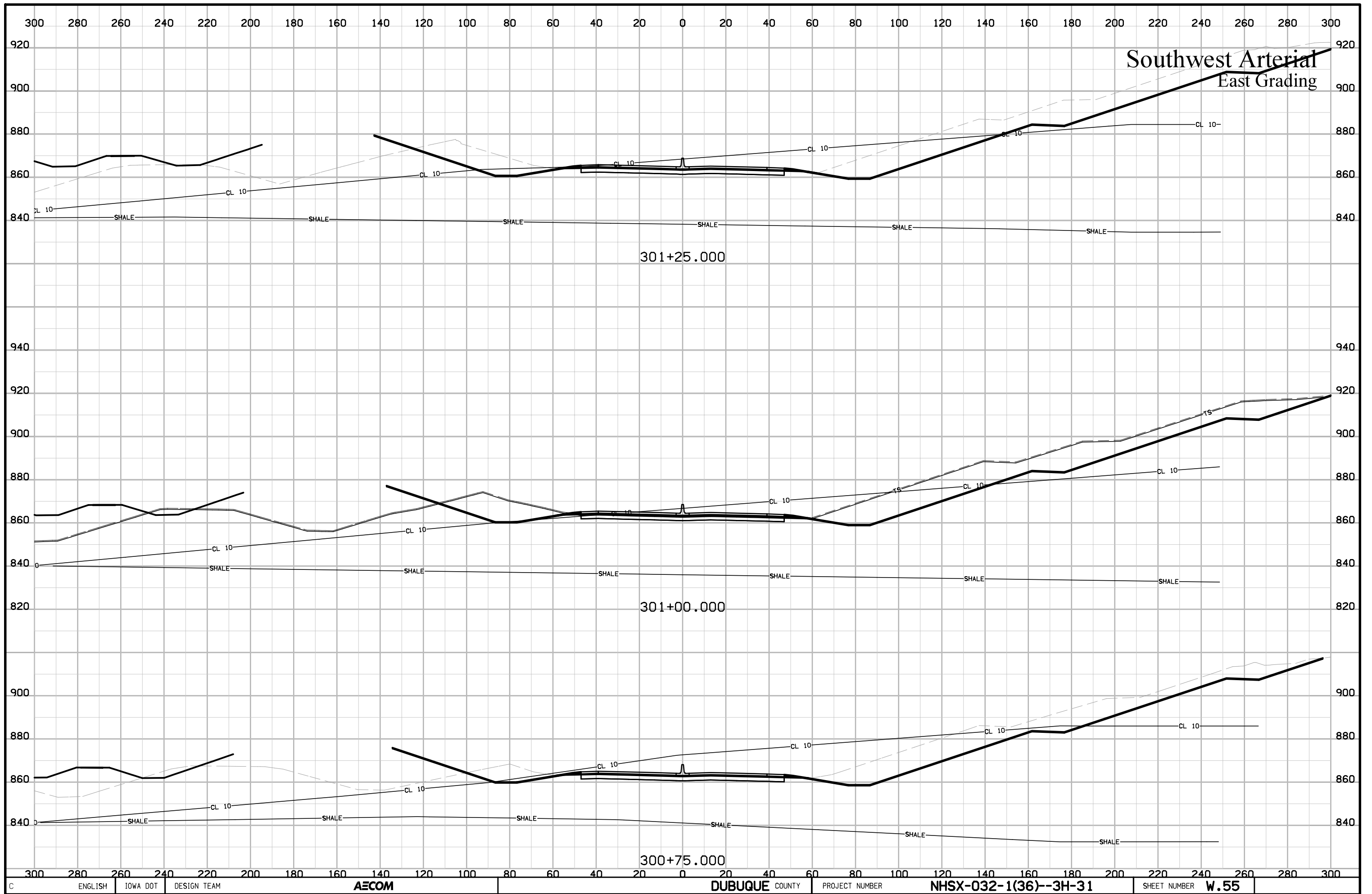

Southwest Arterial
East Grading

301+25.000

301+00.000

300+75.000

Southwest Arterial East Grading

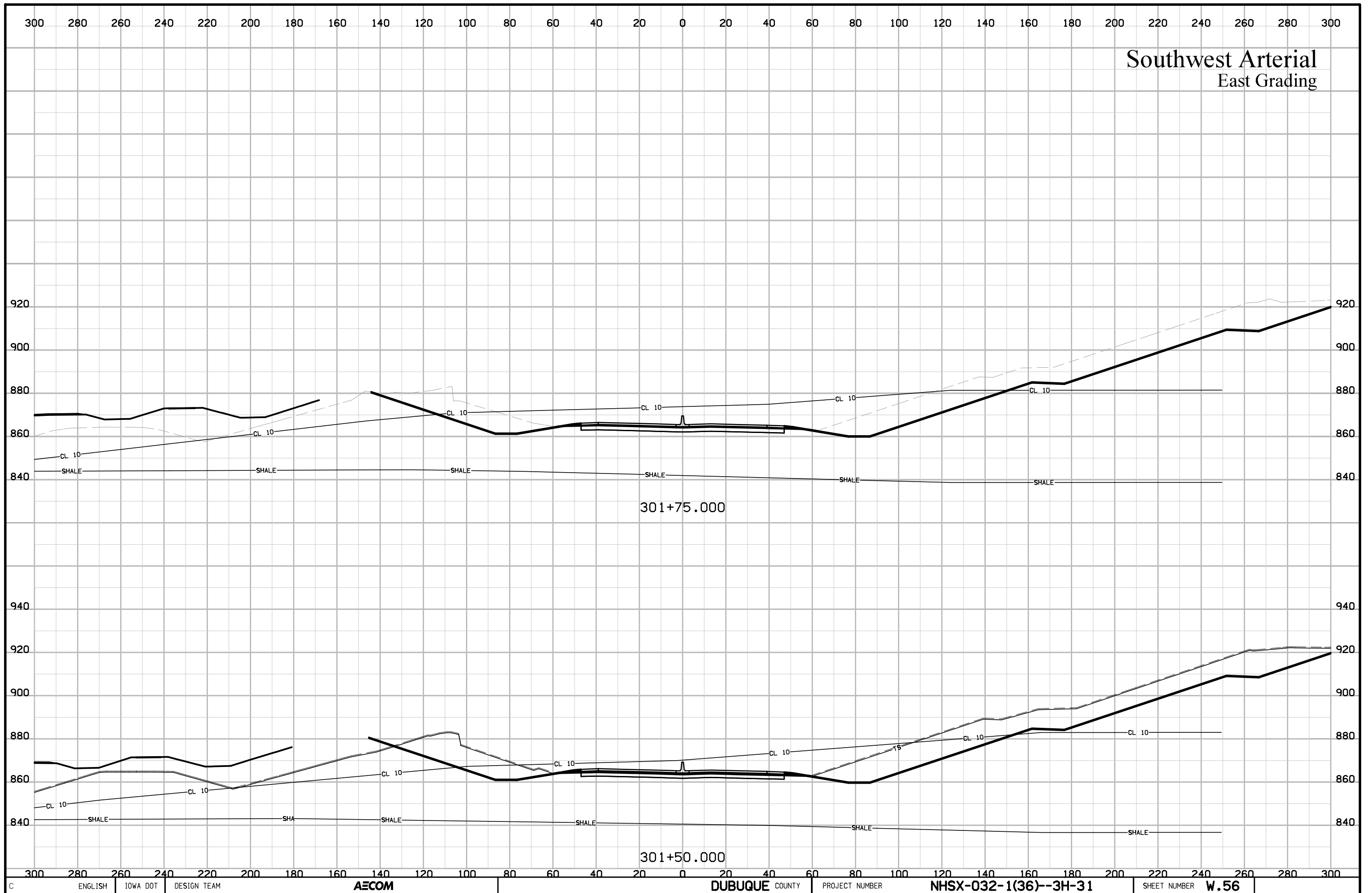

Southwest Arterial East Grading

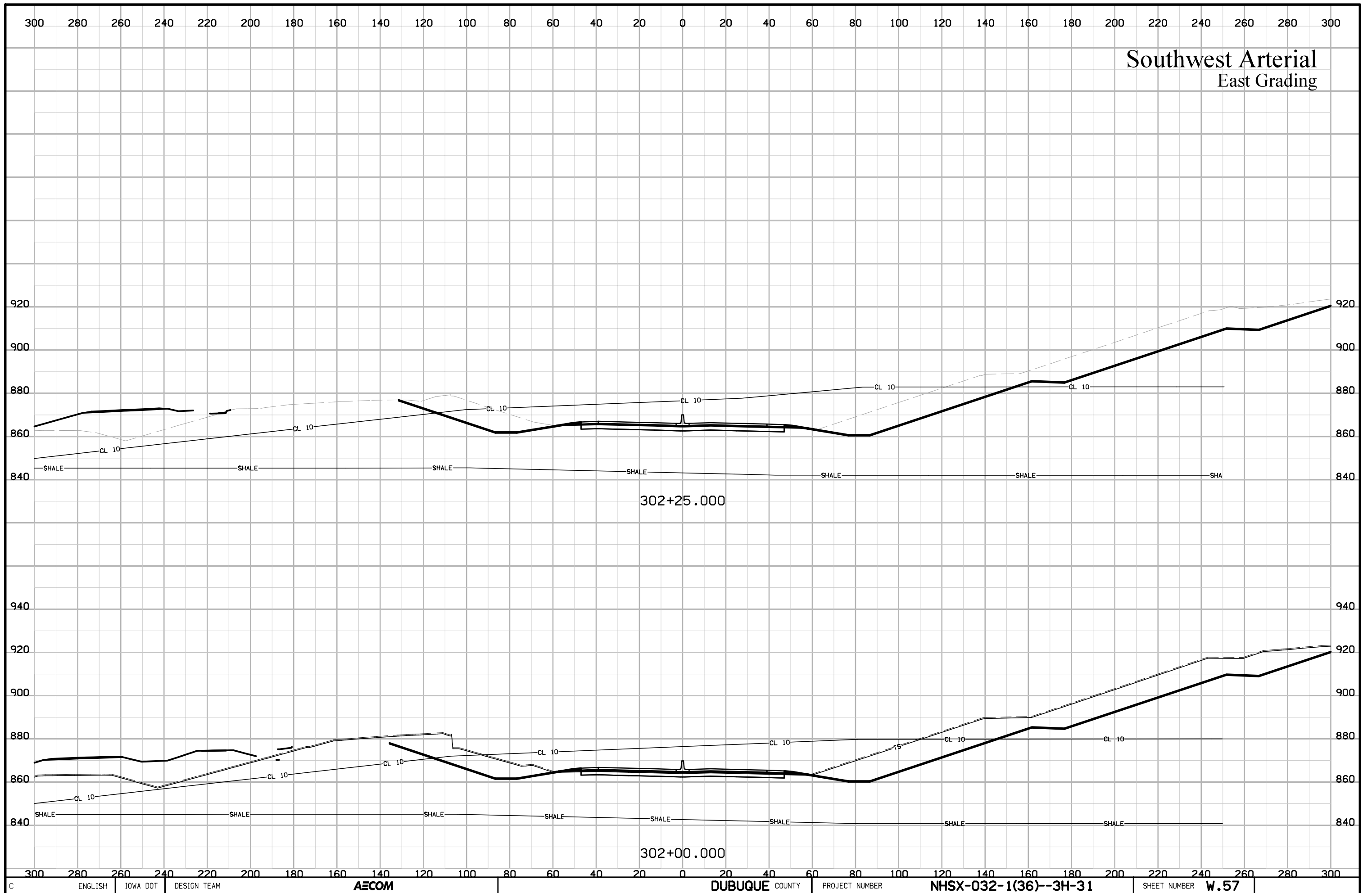

Southwest Arterial East Grading

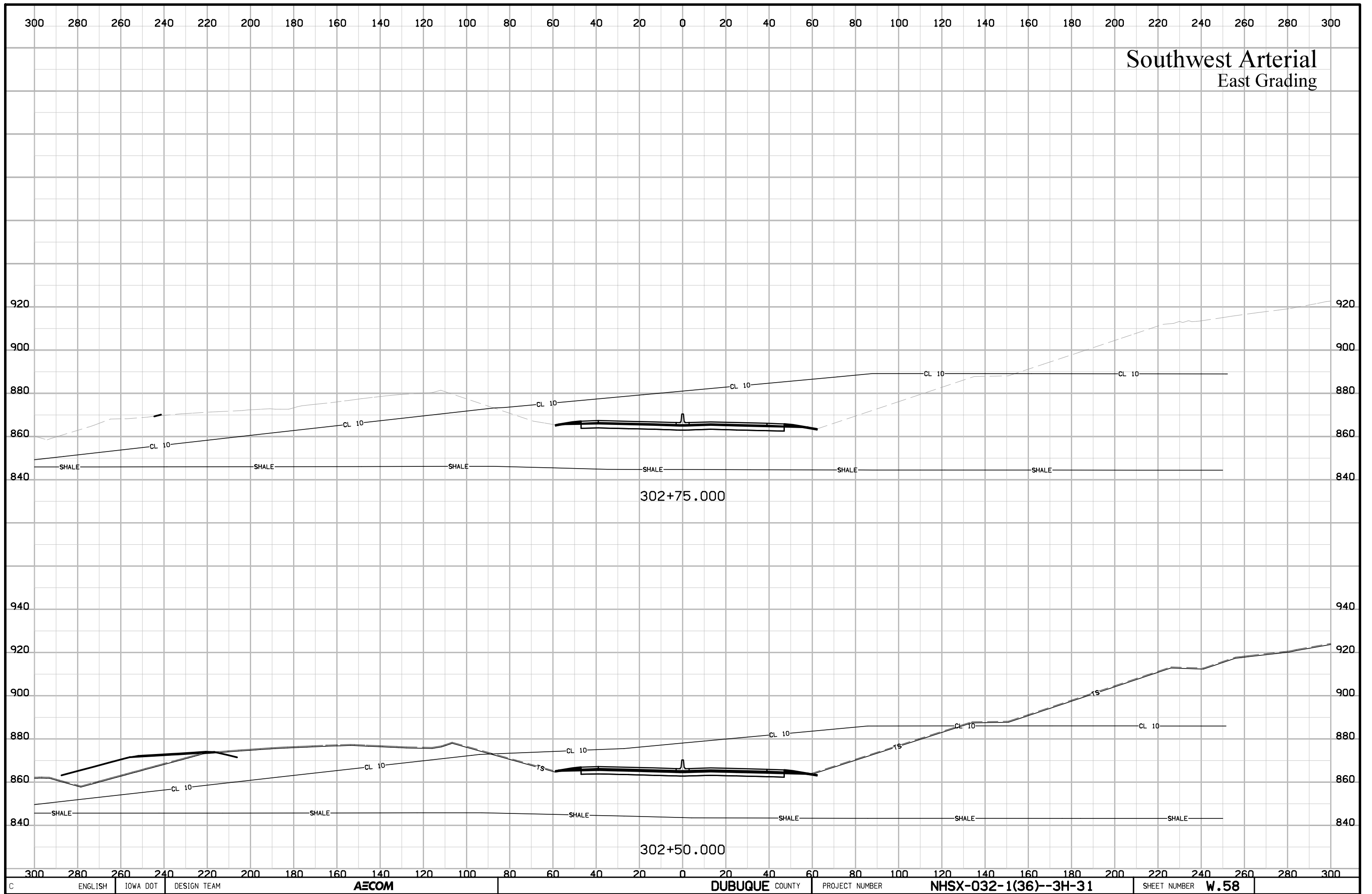

300 280 260 240 220 200 180 160 140 120 100 80 60 40 20 0 20 40 60 80 100 120 140 160 180 200 220 240 260 280 300

Southwest Arterial East Grading

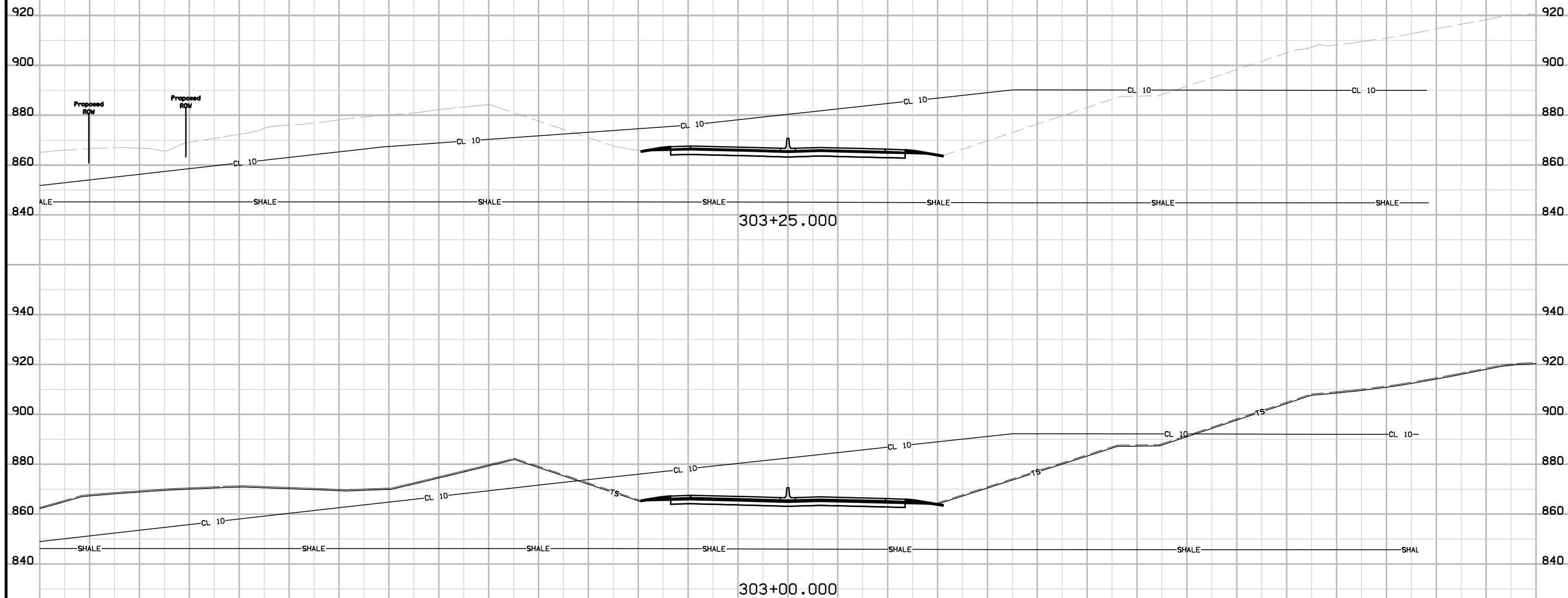

300 280 260 240 220 200 180 160 140 120 100 80 60 40 20 0 20 40 60 80 100 120 140 160 180 200 220 240 260 280 300

Southwest Arterial East Grading

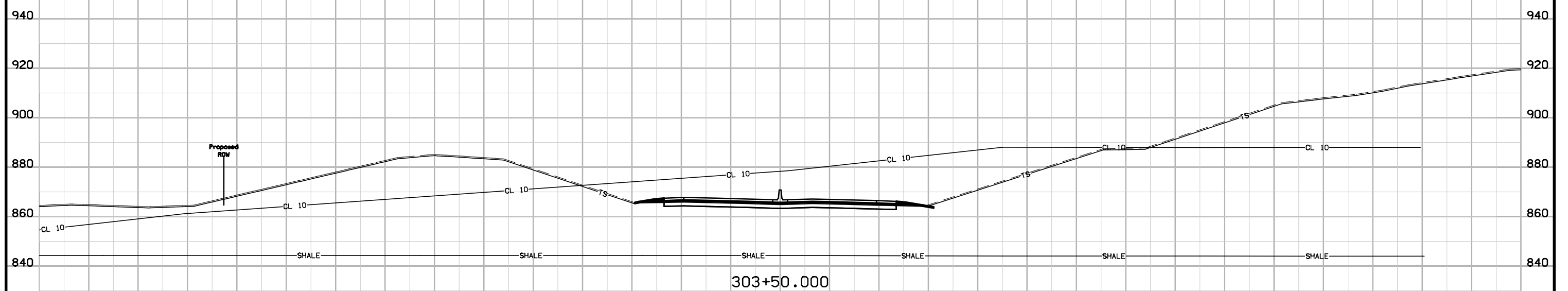
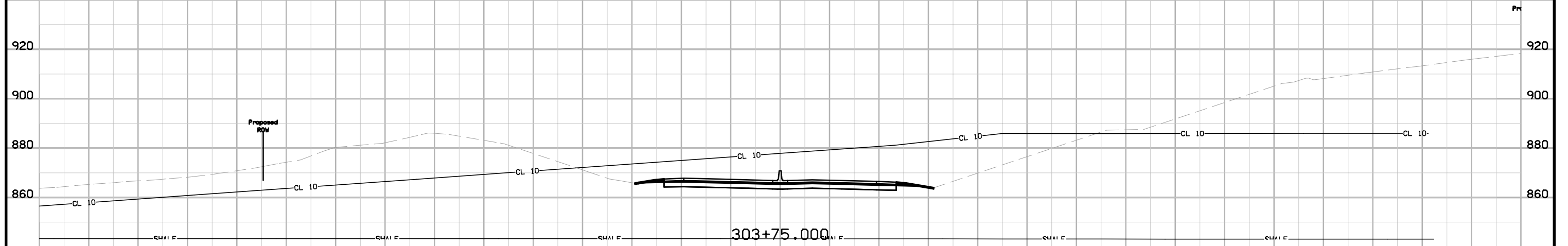

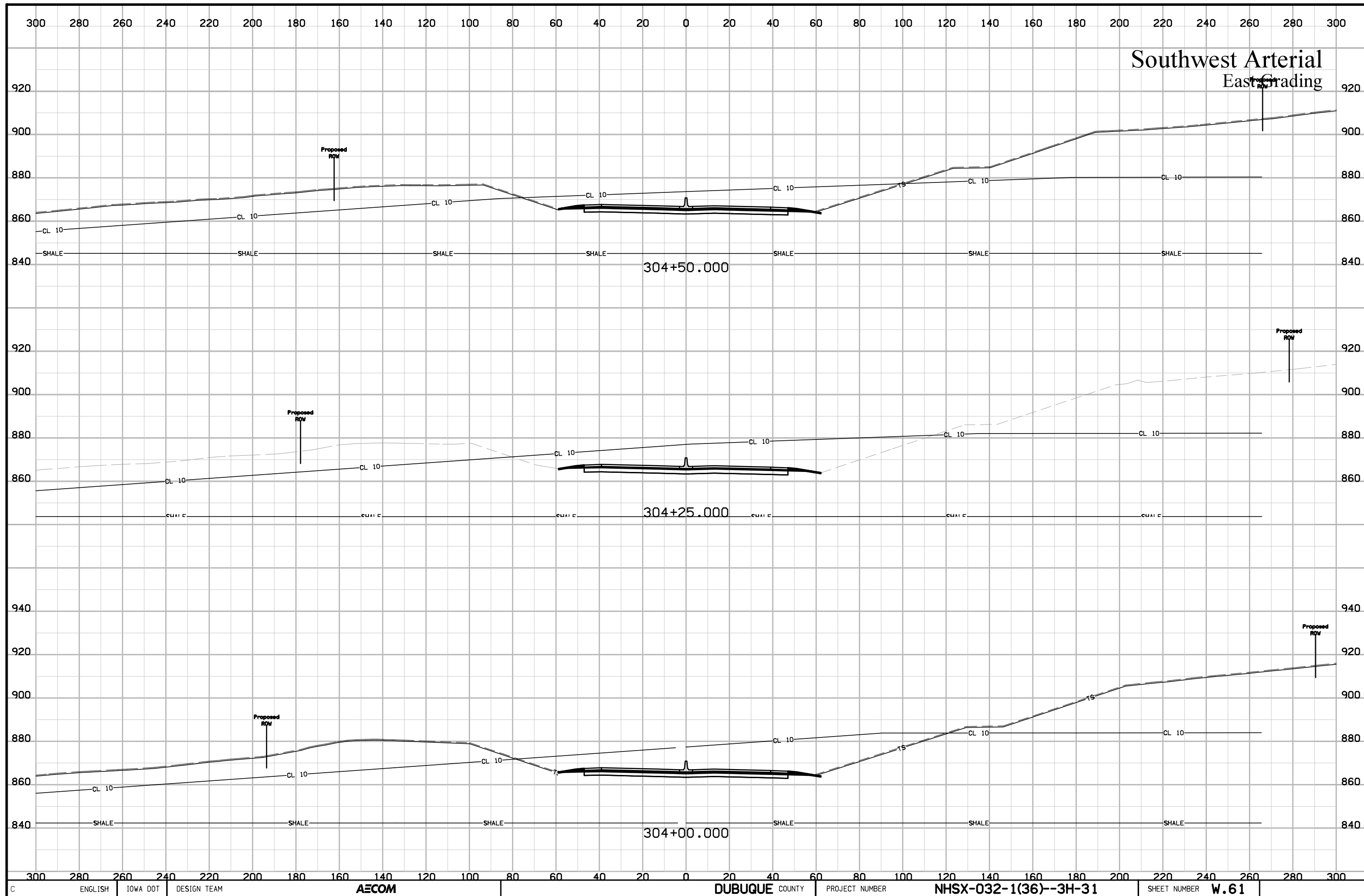

Southwest Arterial East Grading

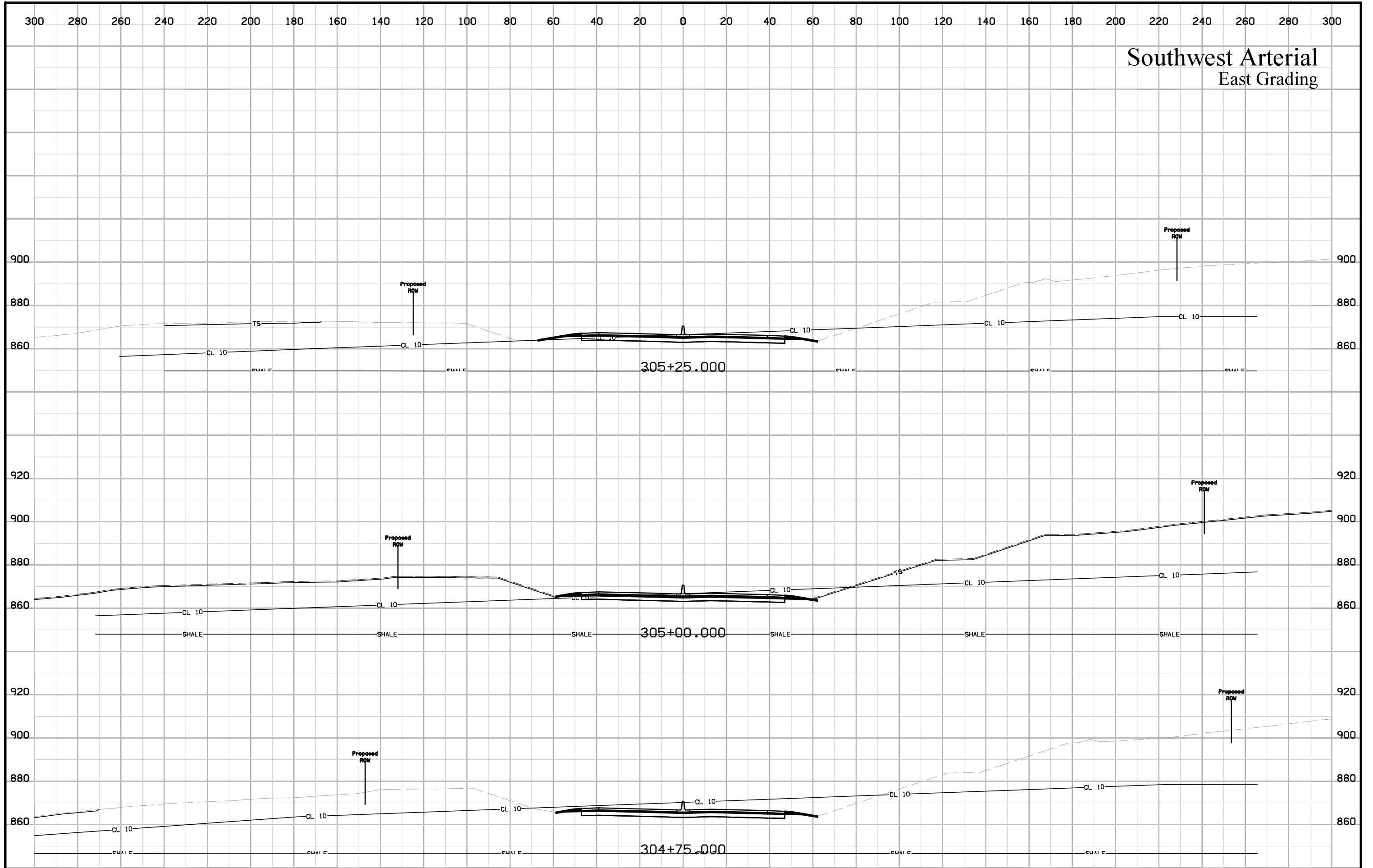

Southwest Arterial East Grading

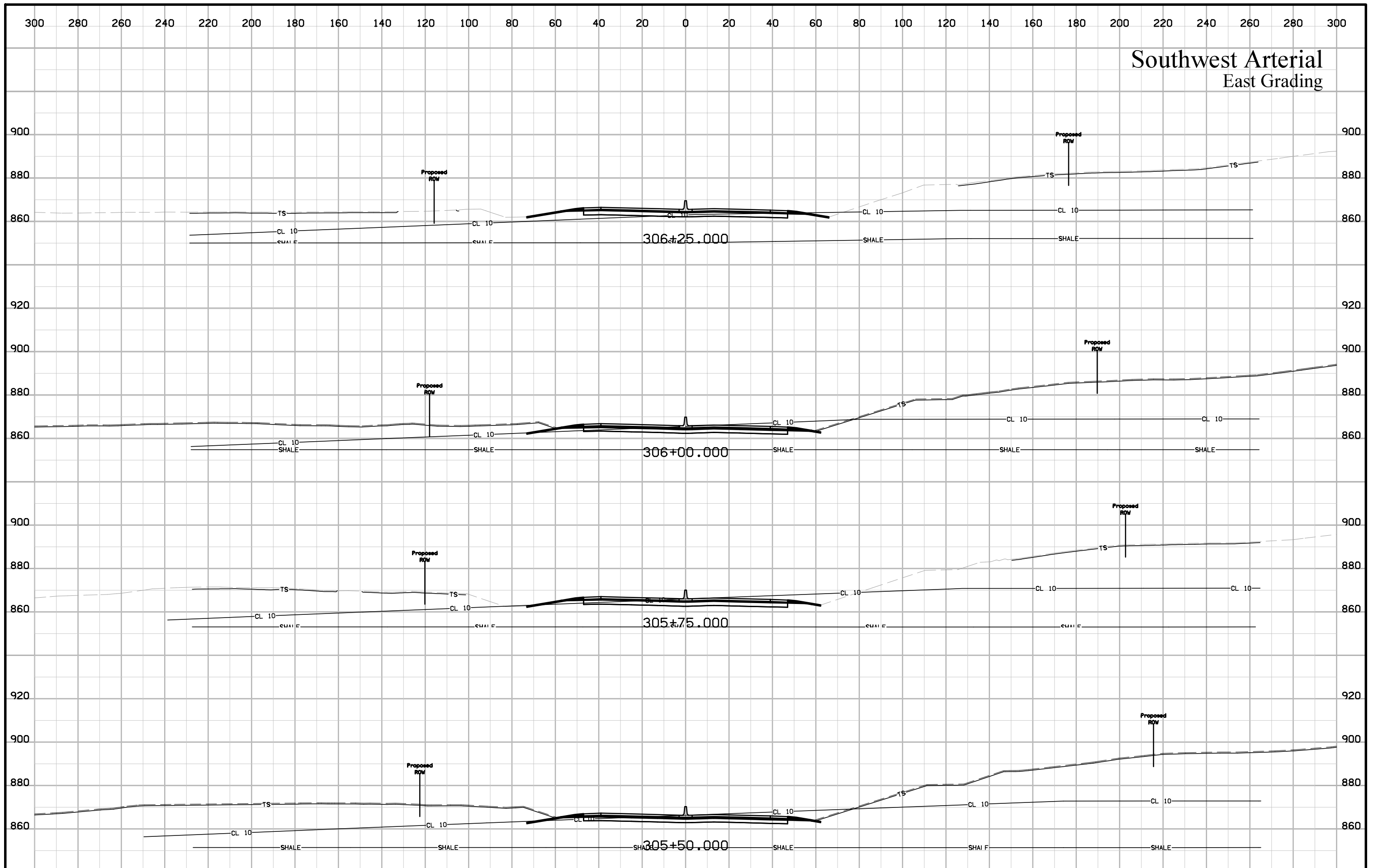

300 280 260 240 220 200 180 160 140 120 100 80 60 40 20 0 20 40 60 80 100 120 140 160 180 200 220 240 260 280 300

Southwest Arterial East Grading

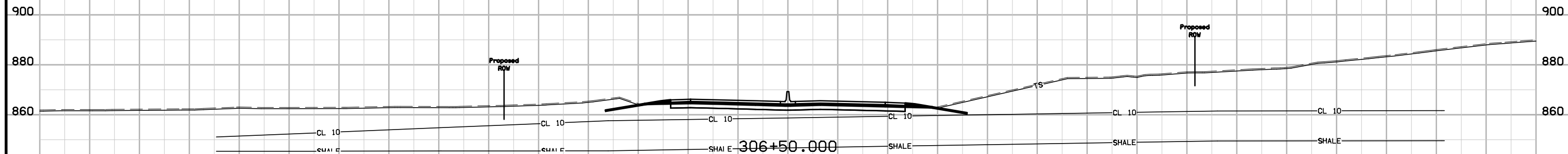
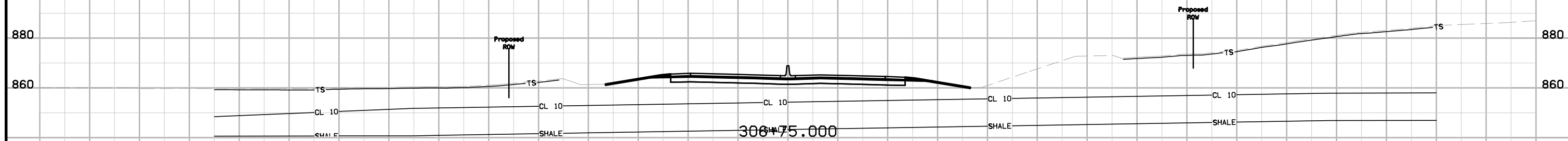
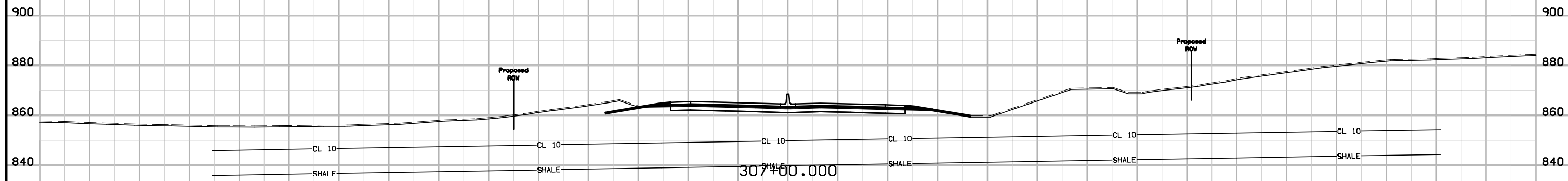
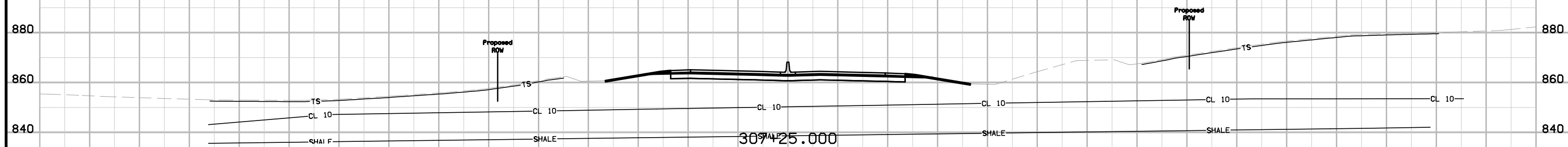

300 280 260 240 220 200 180 160 140 120 100 80 60 40 20 0 20 40 60 80 100 120 140 160 180 200 220 240 260 280 300

Southwest Arterial East Grading

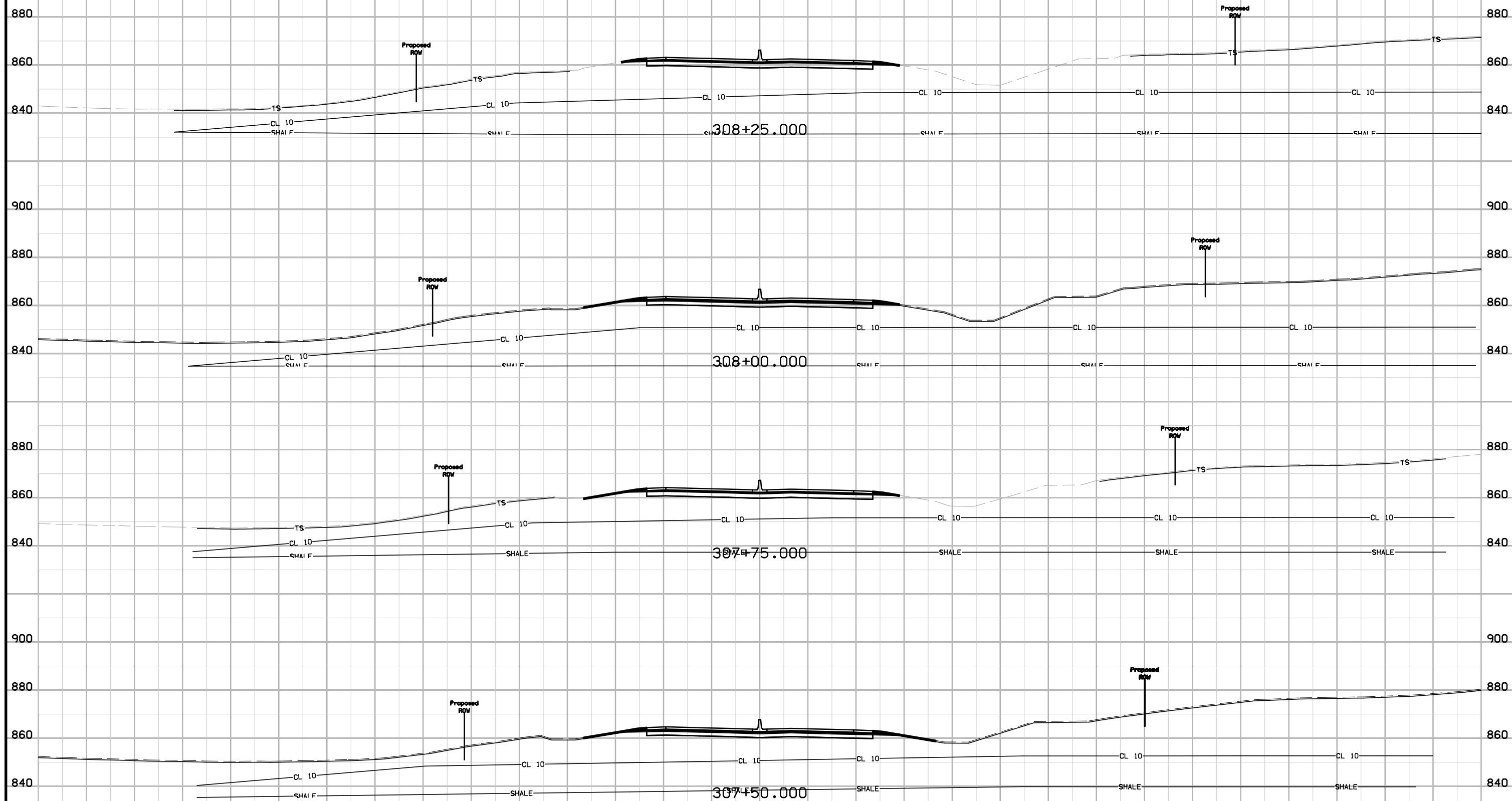

Southwest Arterial East Grading

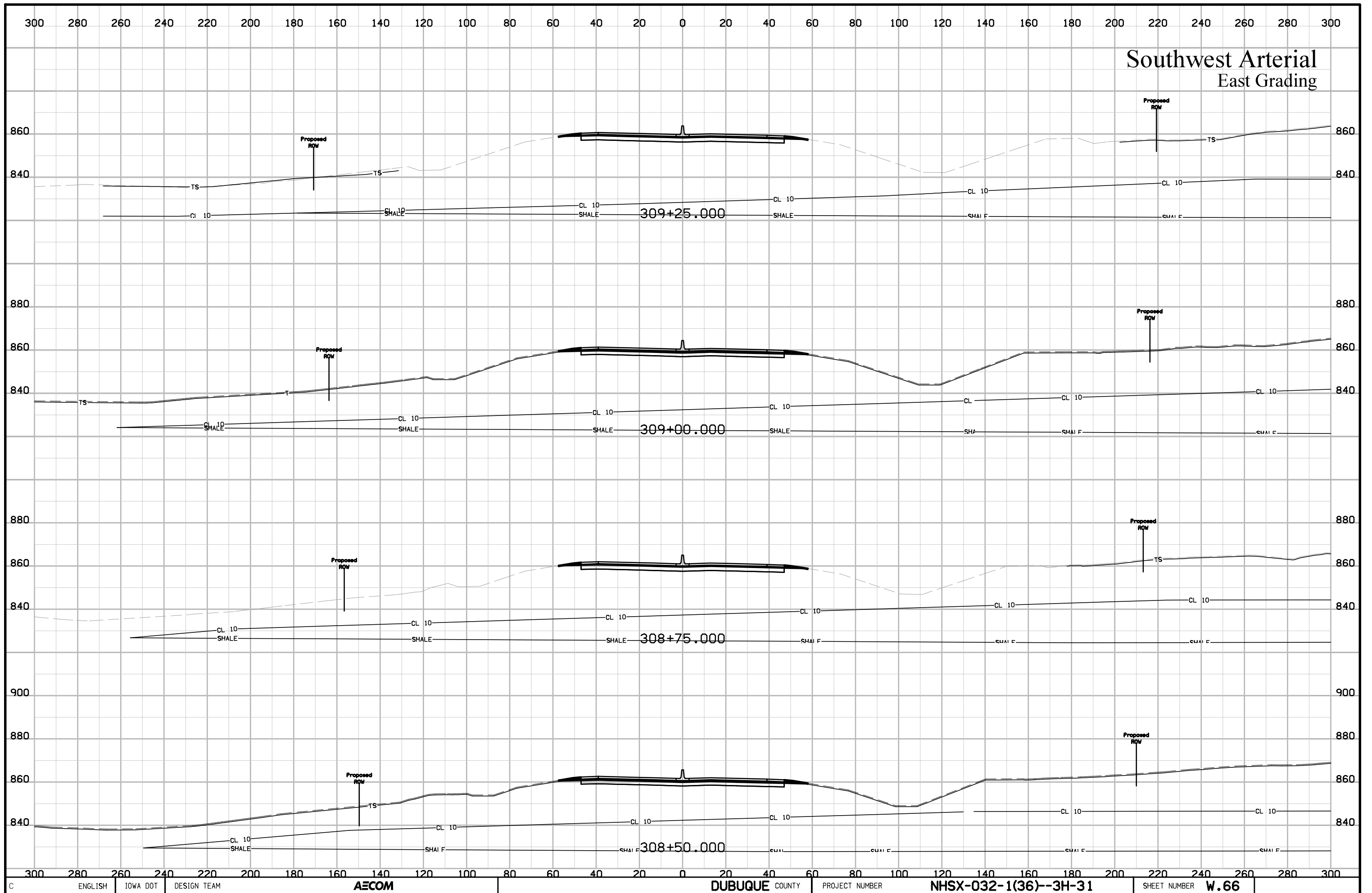

Southwest Arterial East Grading

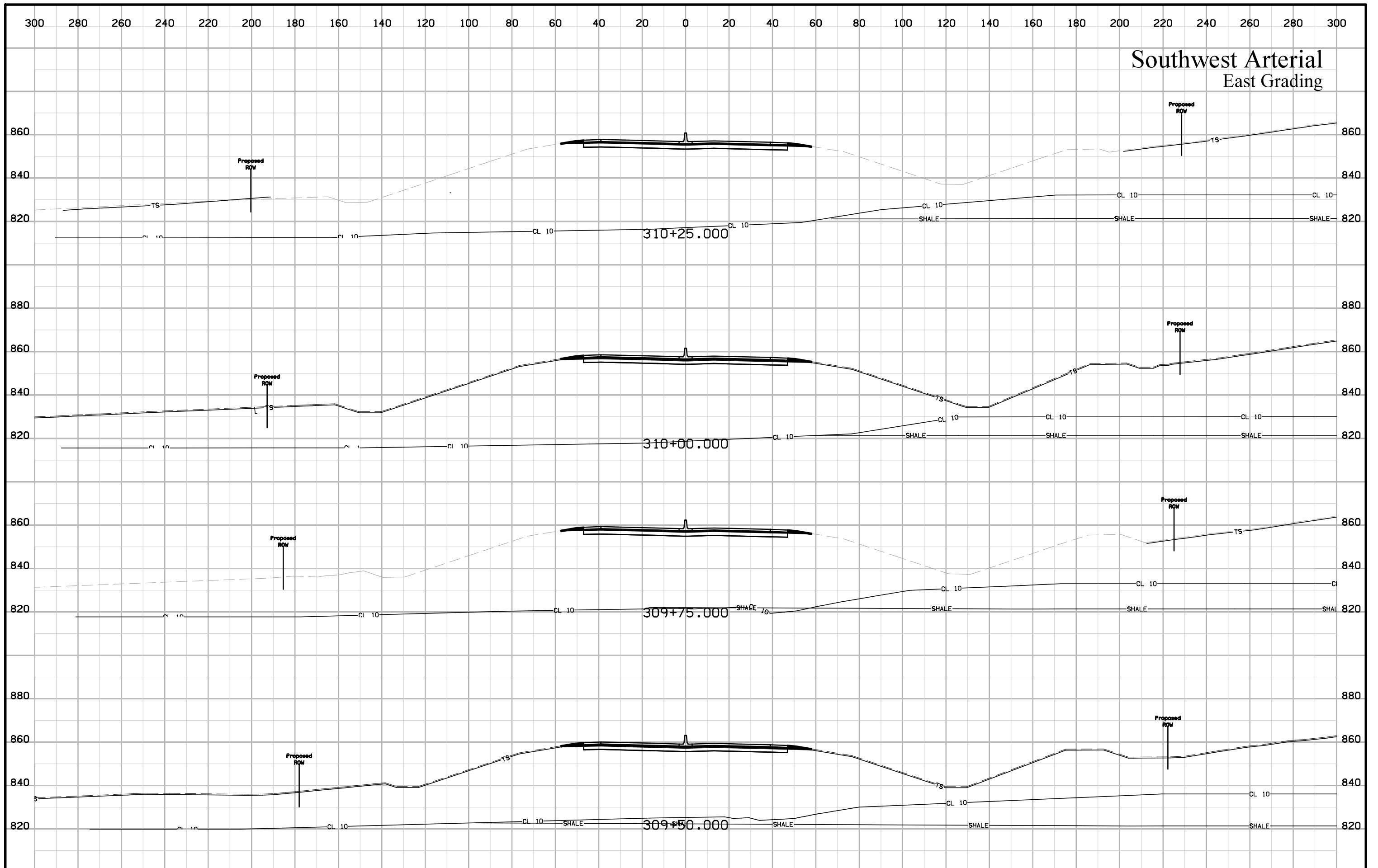

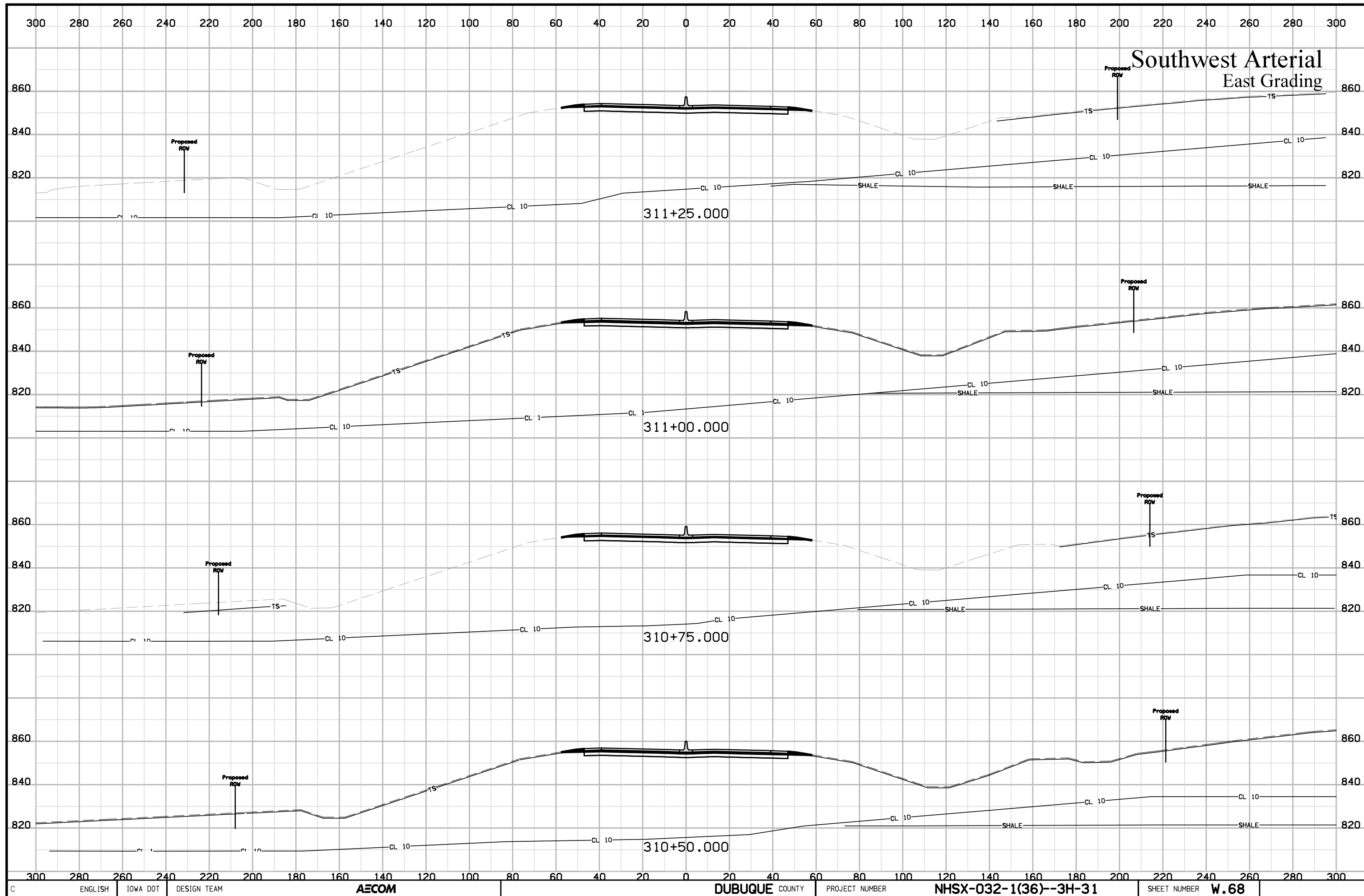

Southwest Arterial East Grading

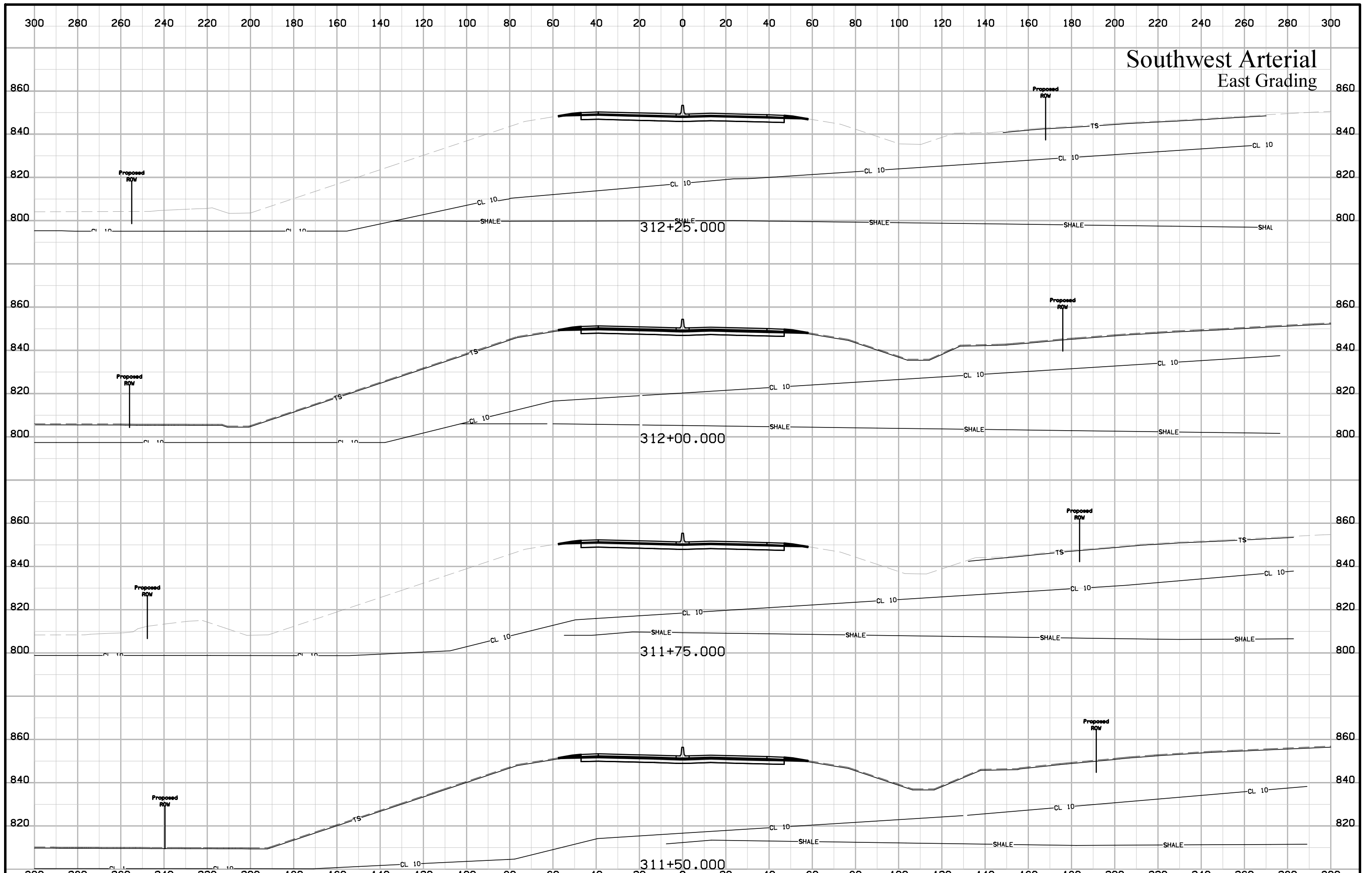

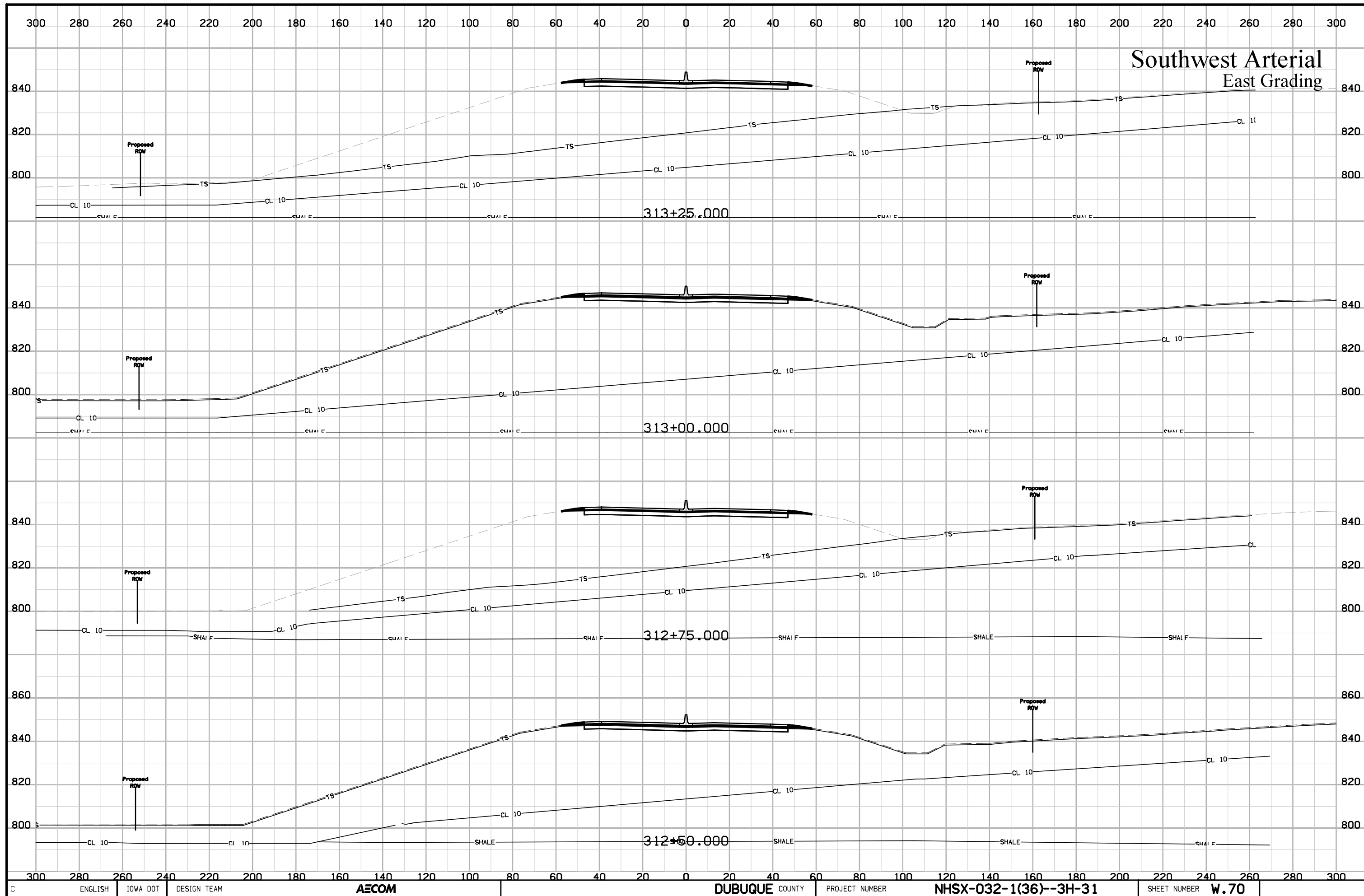

Southwest Arterial East Grading

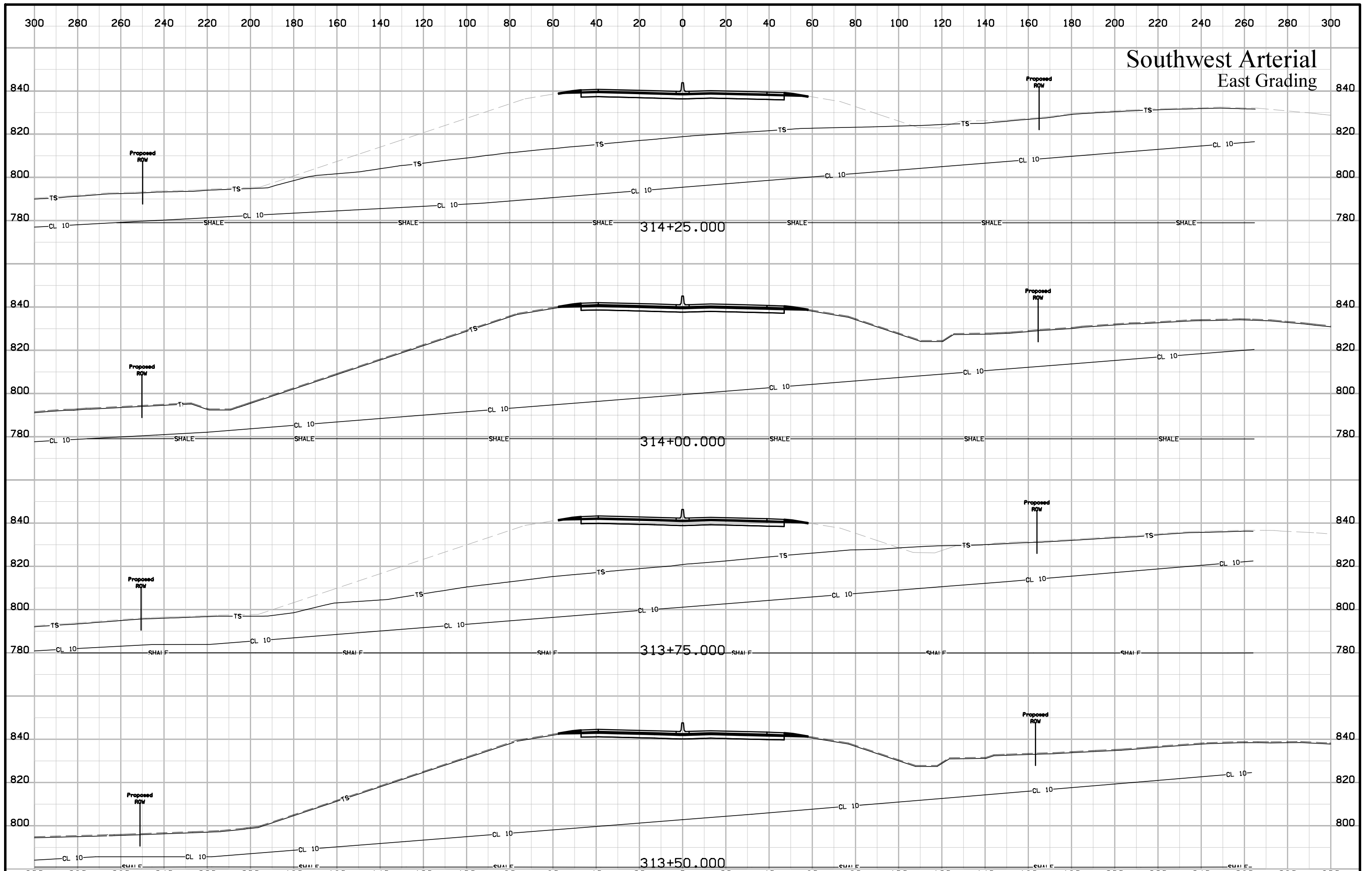

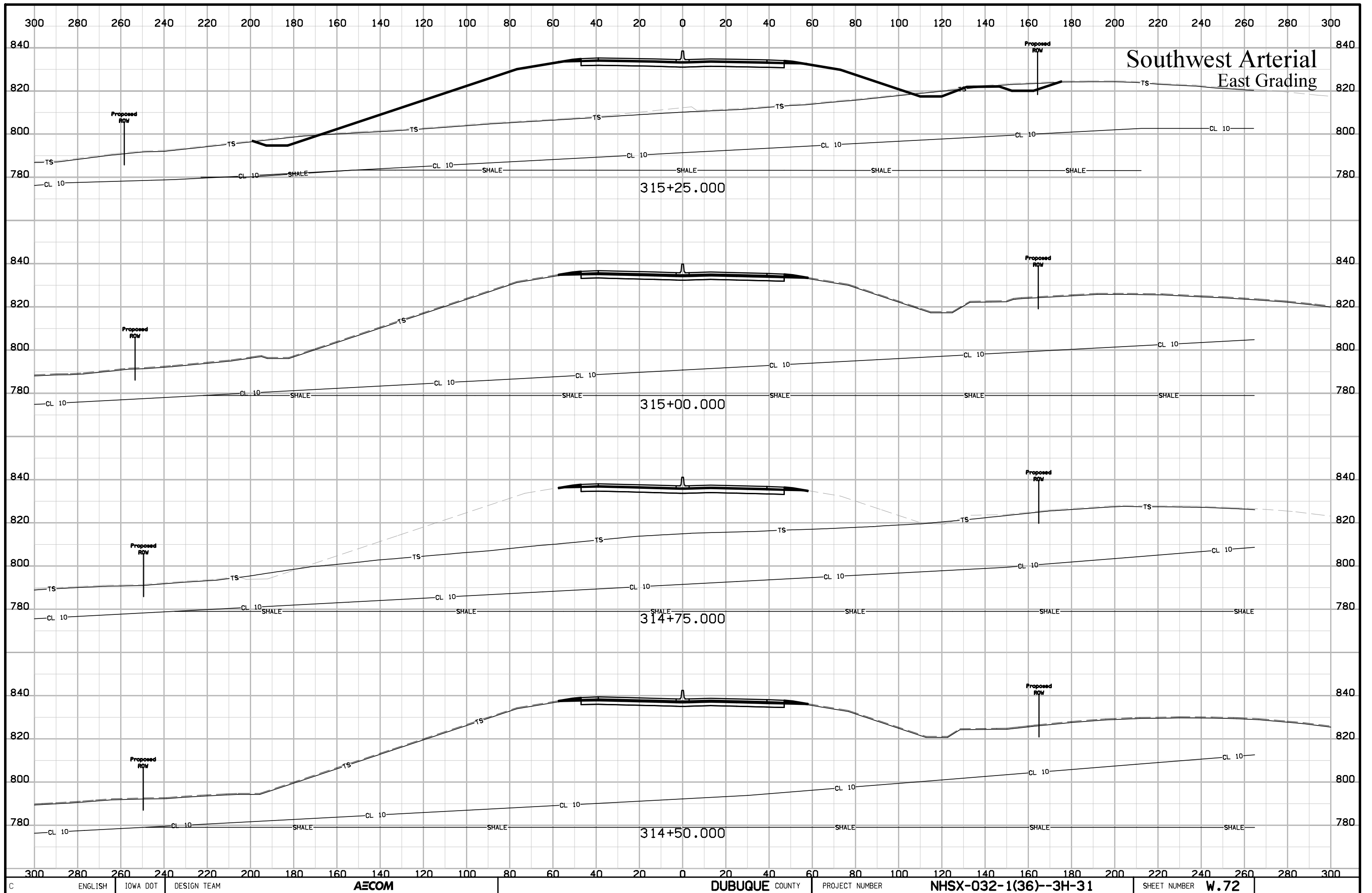

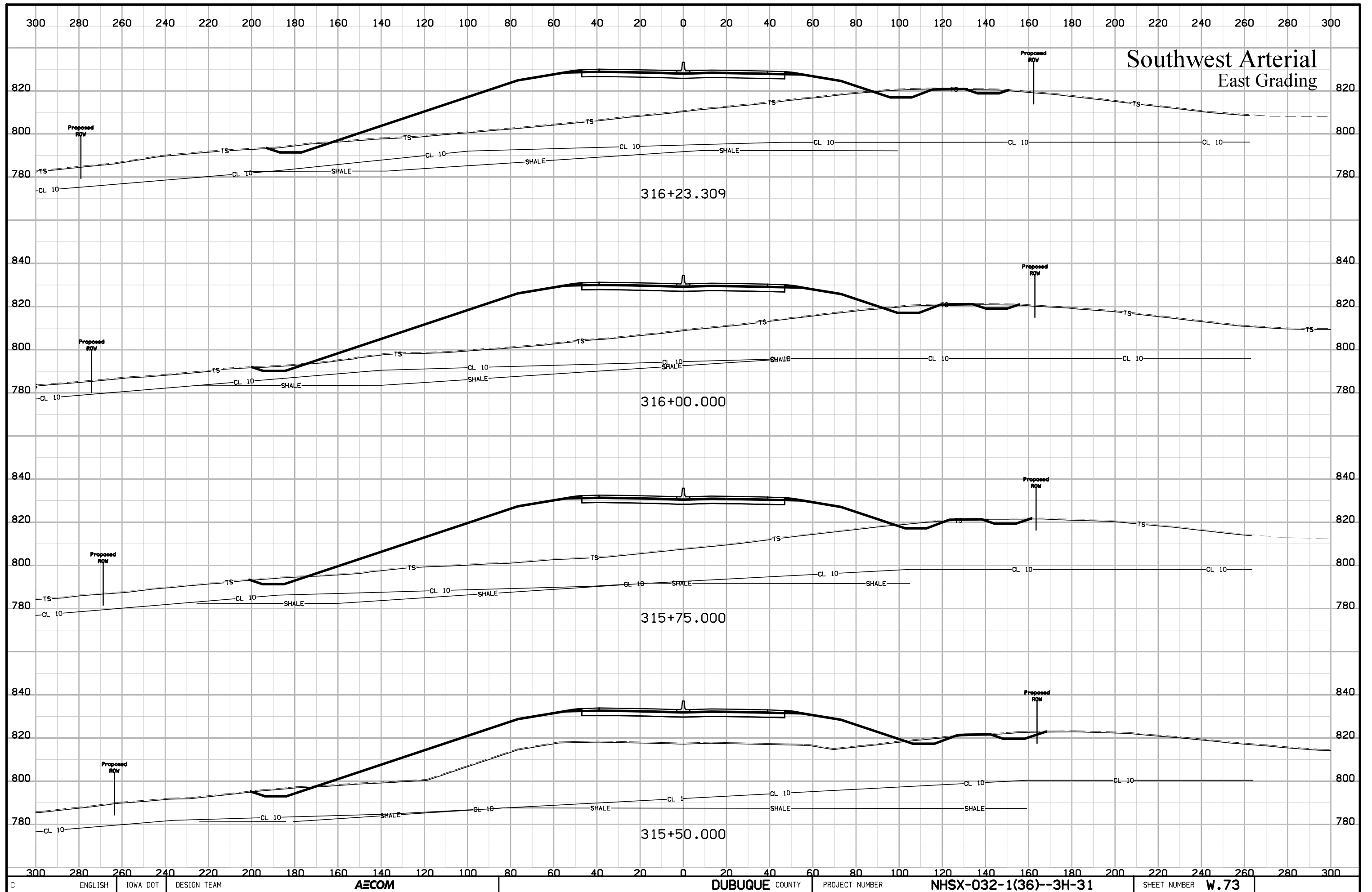

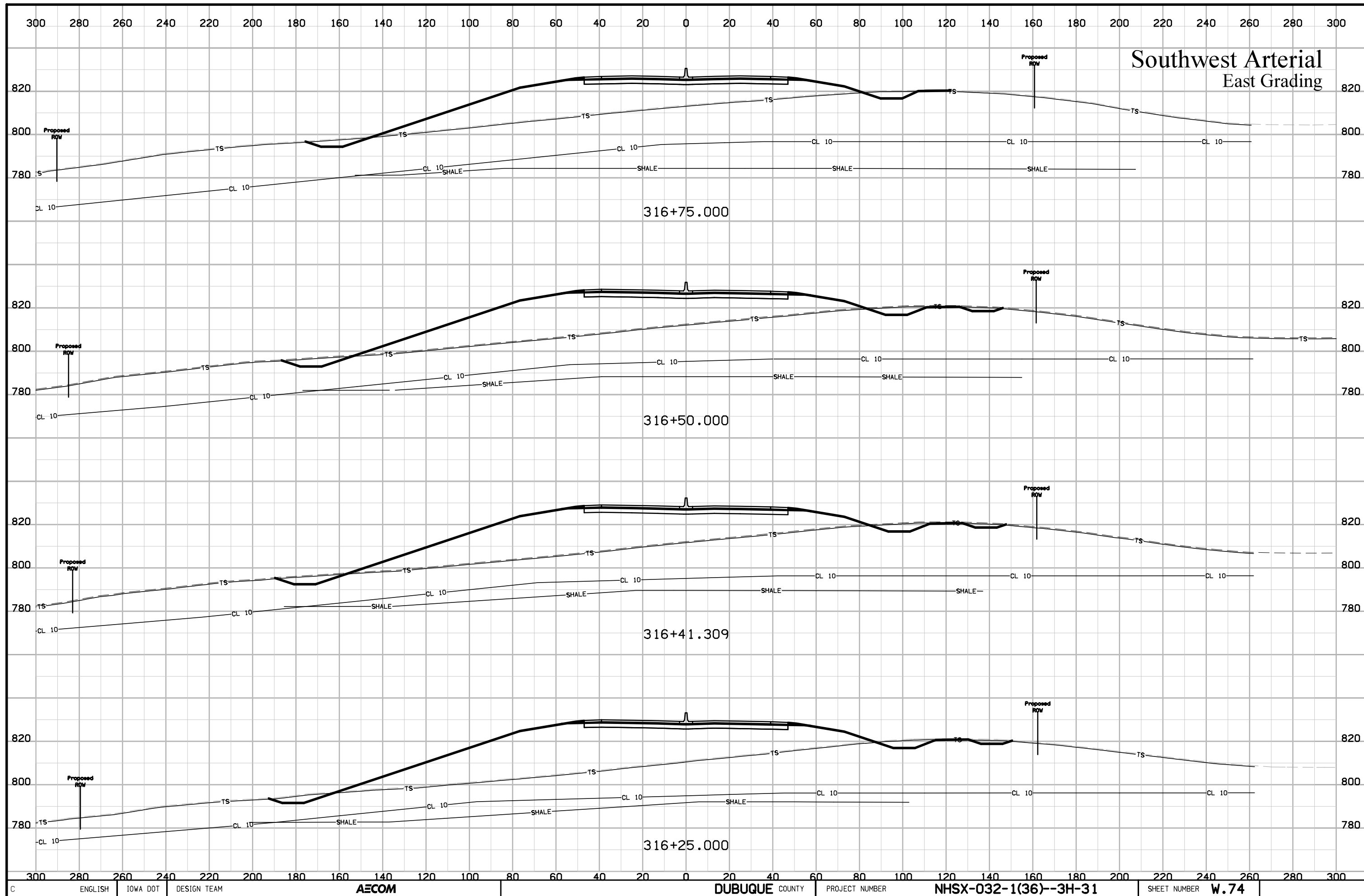

Southwest Arterial
East Grading

316+75.000

316+50.000

316+41.309

316+25.000

Southwest Arterial East Grading

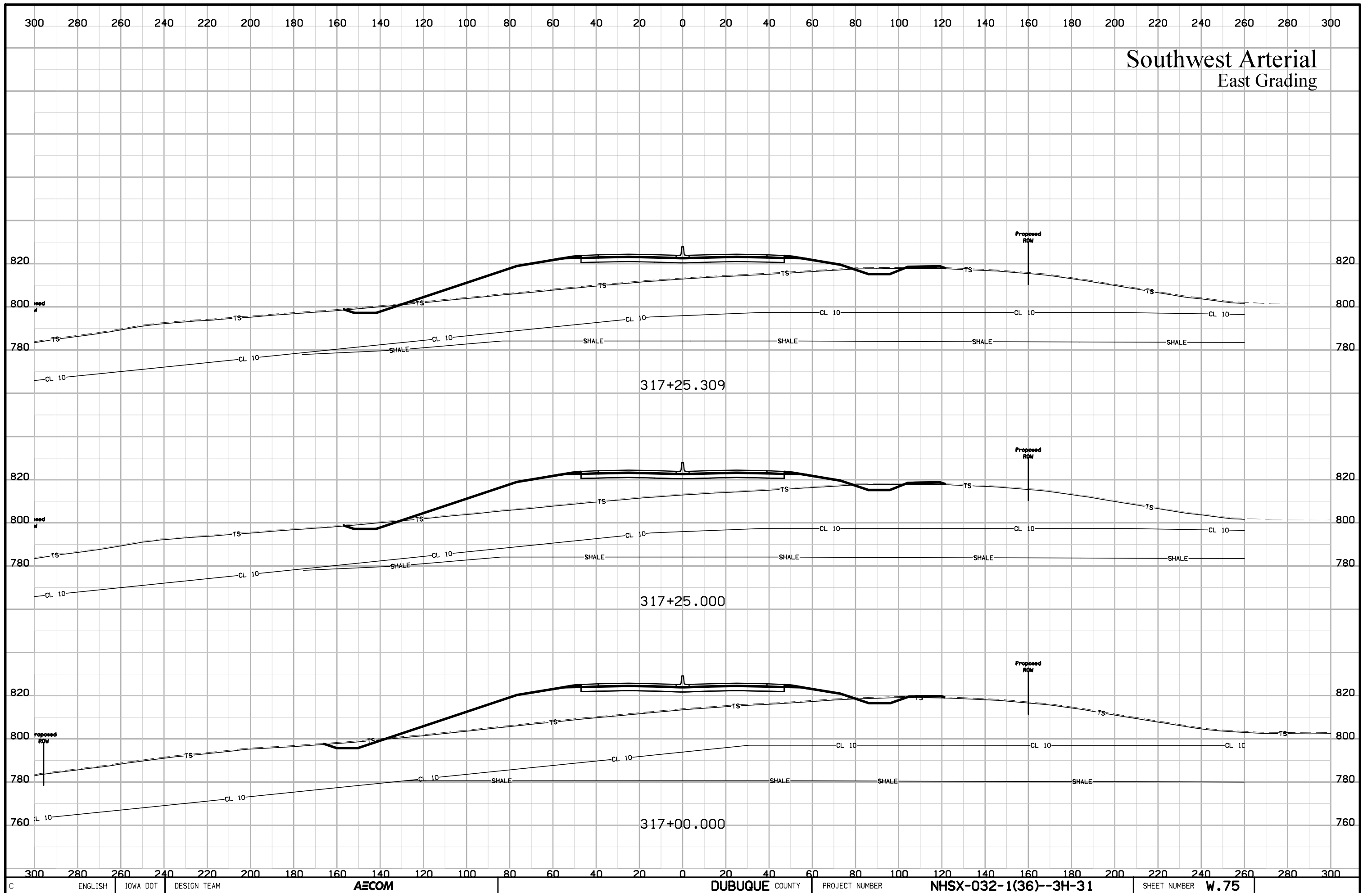

Southwest Arterial East Grading

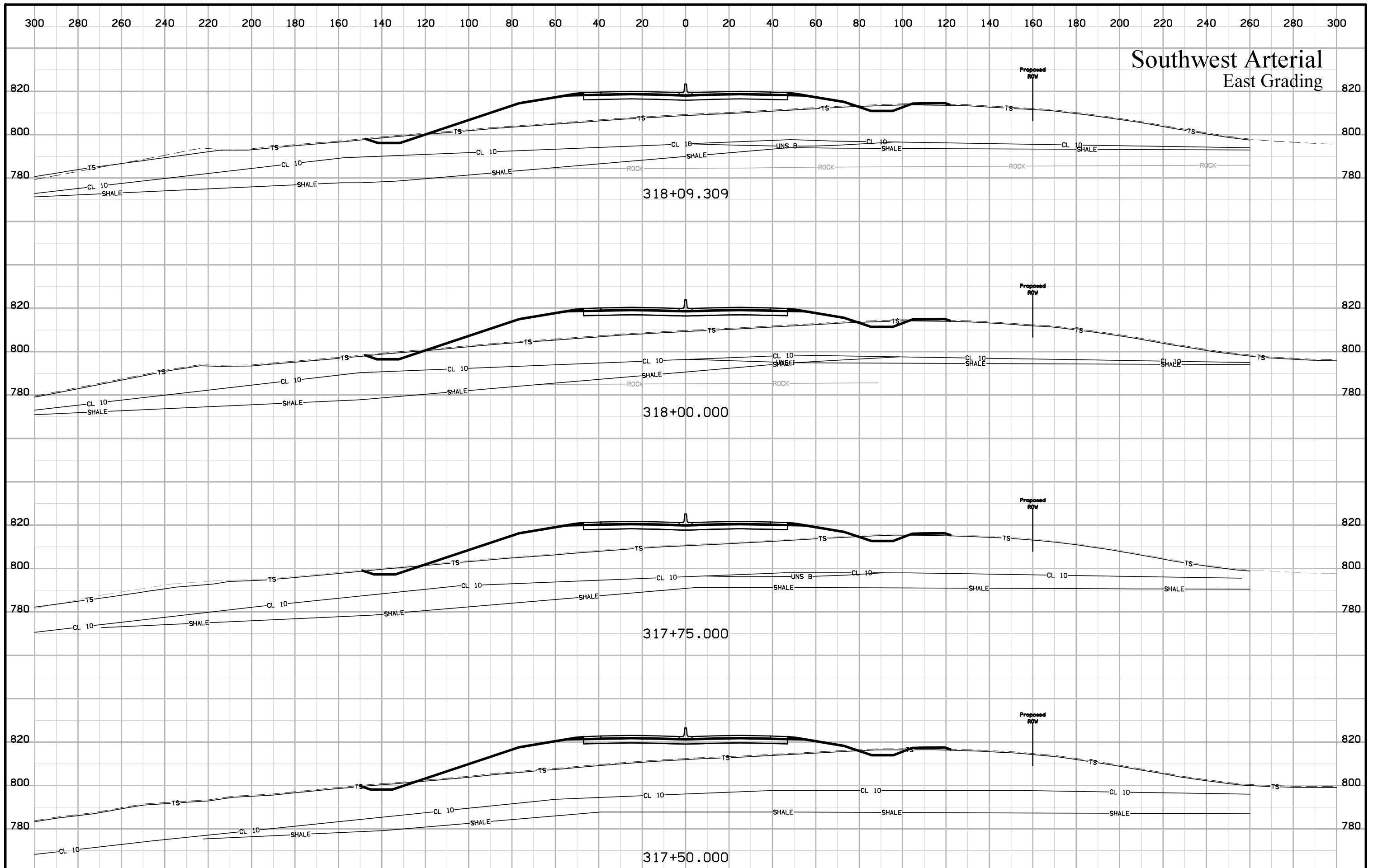

Southwest Arterial East Grading

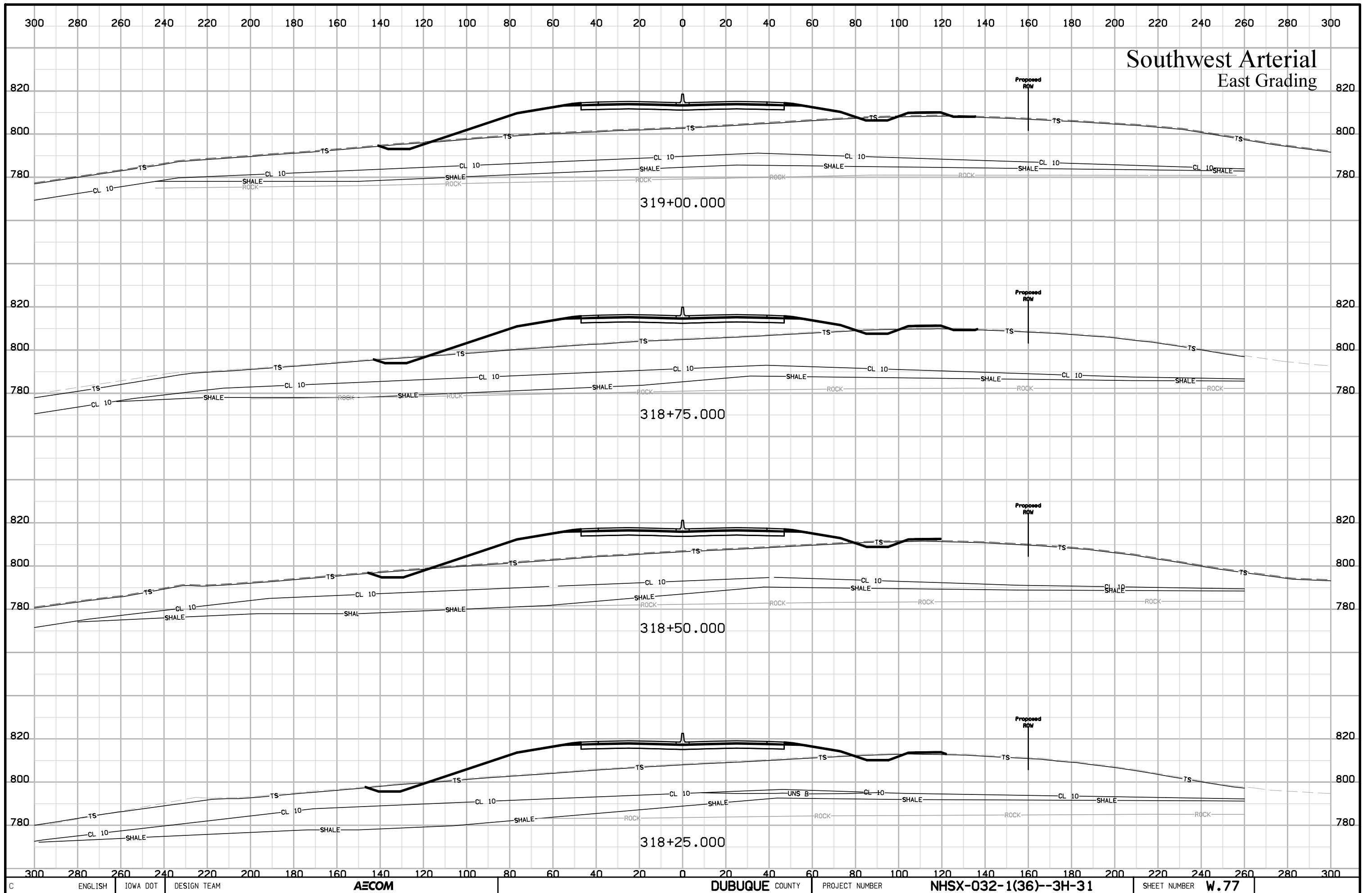

Southwest Arterial East Grading

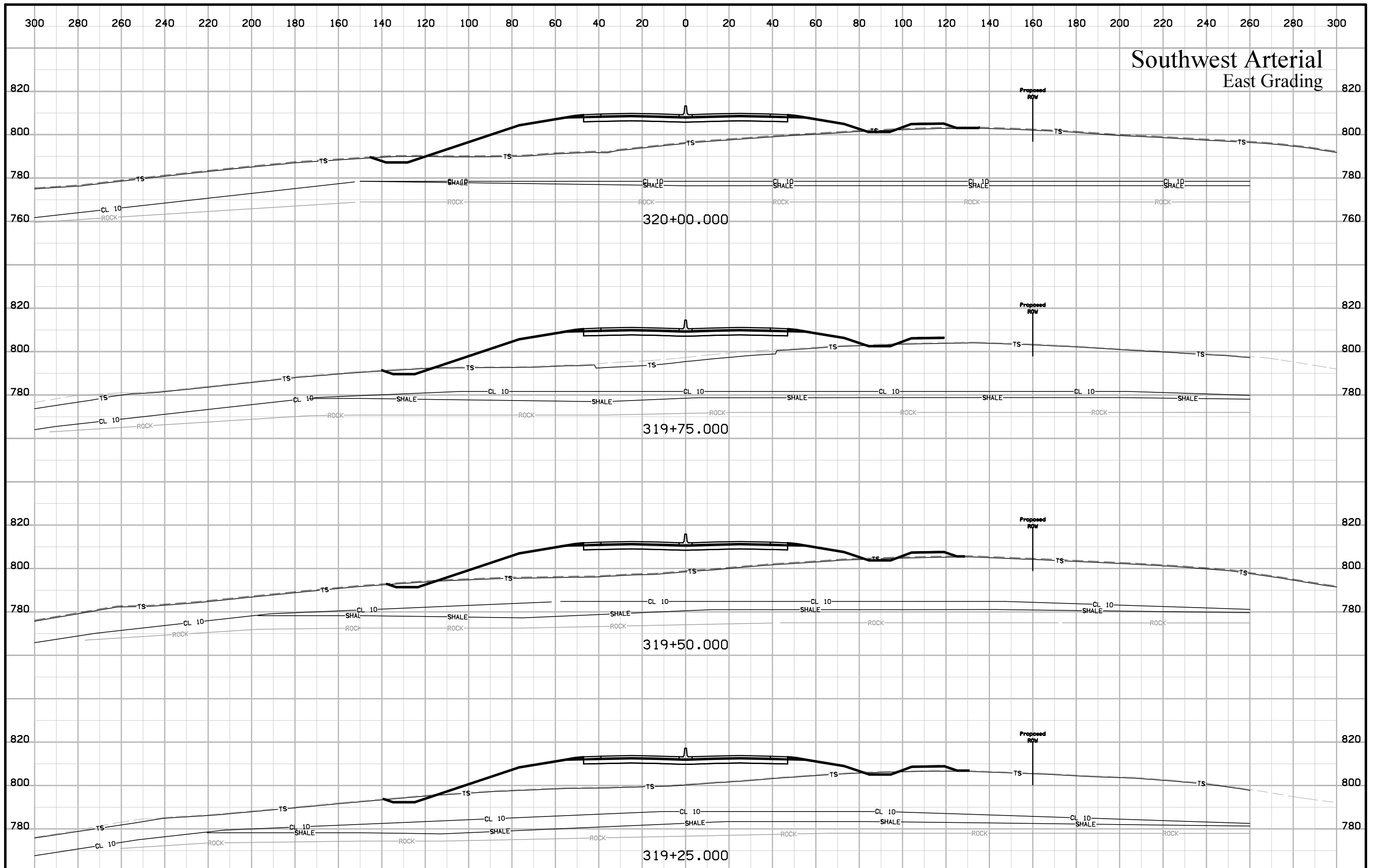

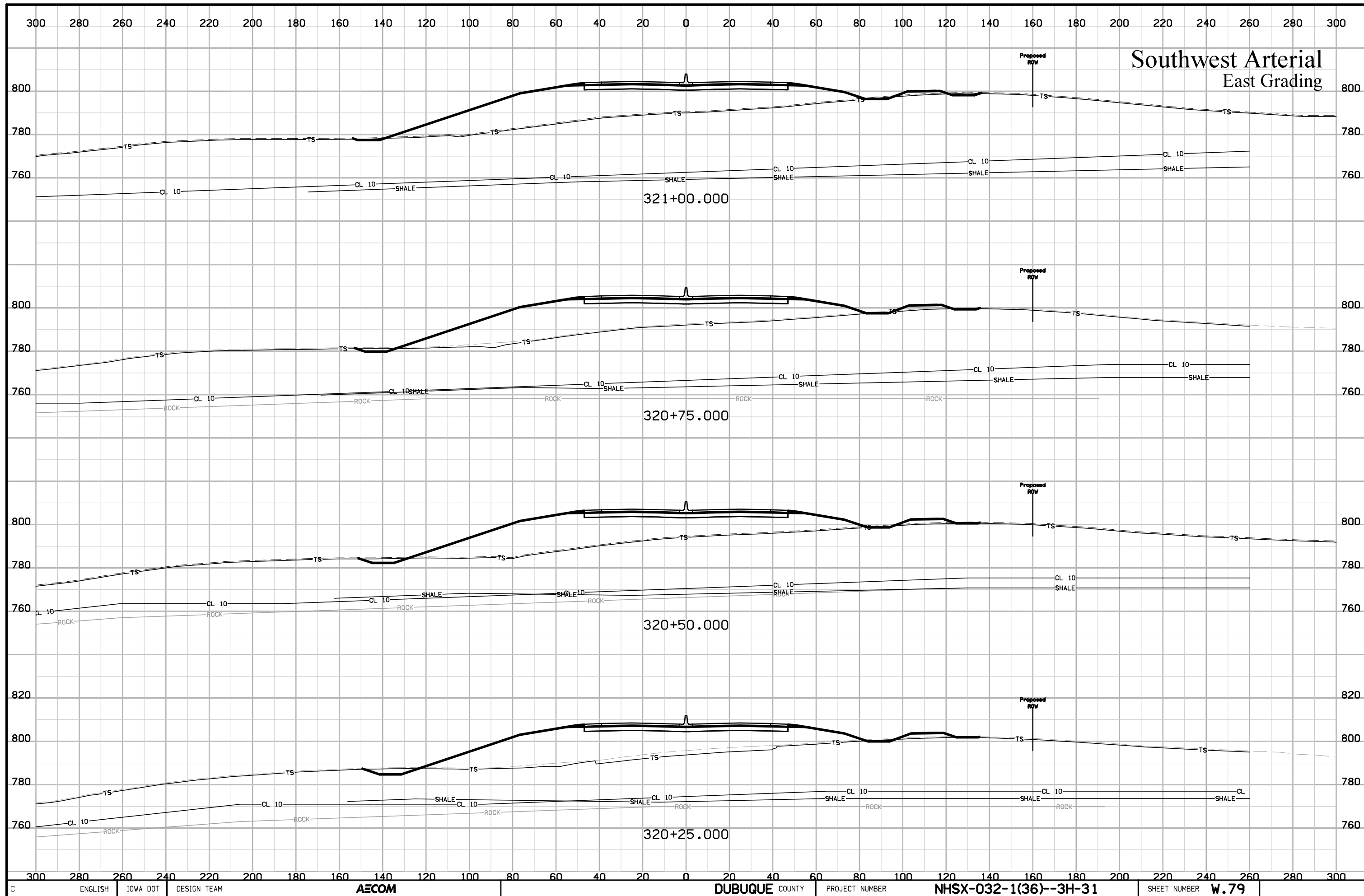

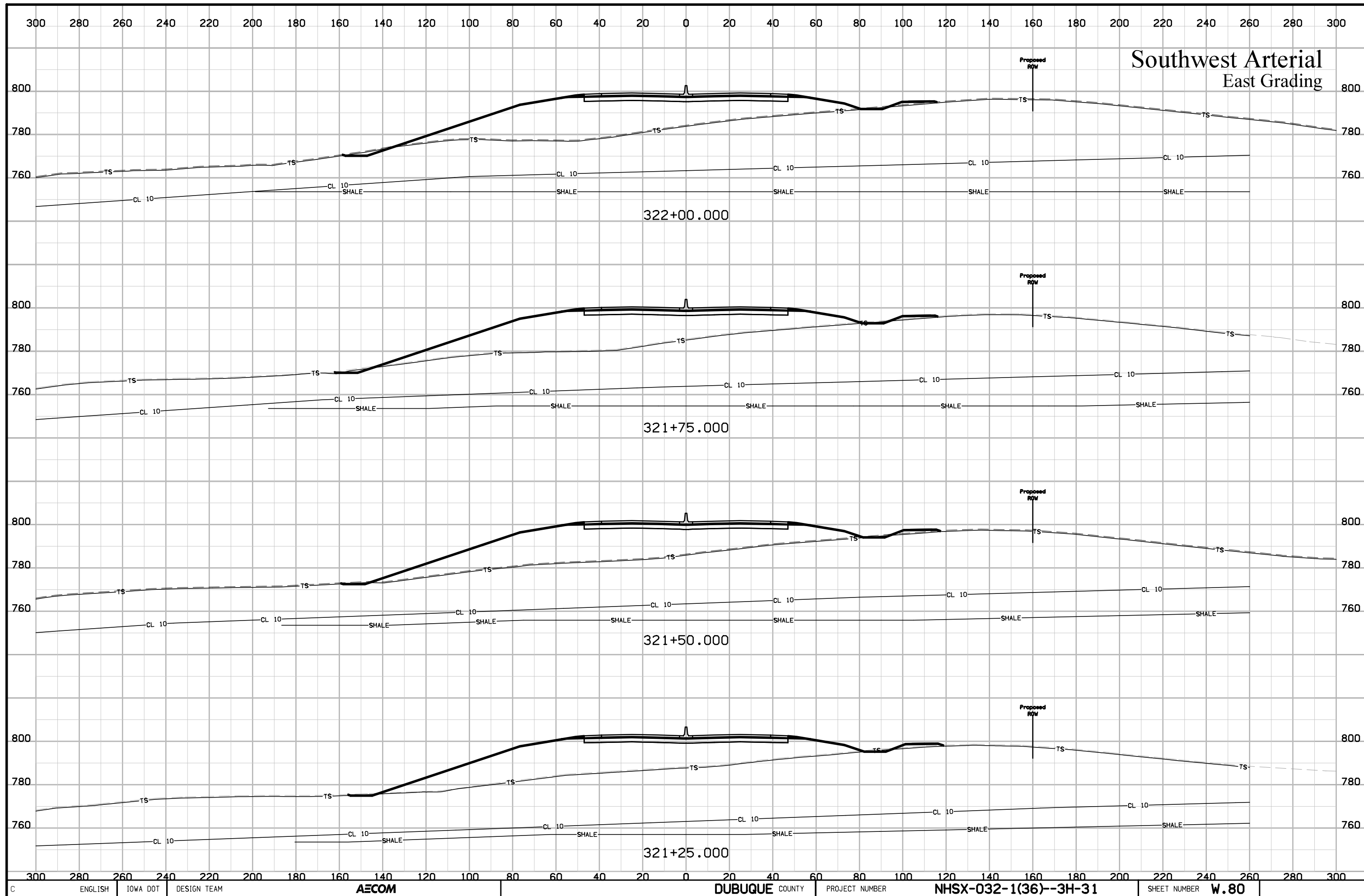

Southwest Arterial East Grading

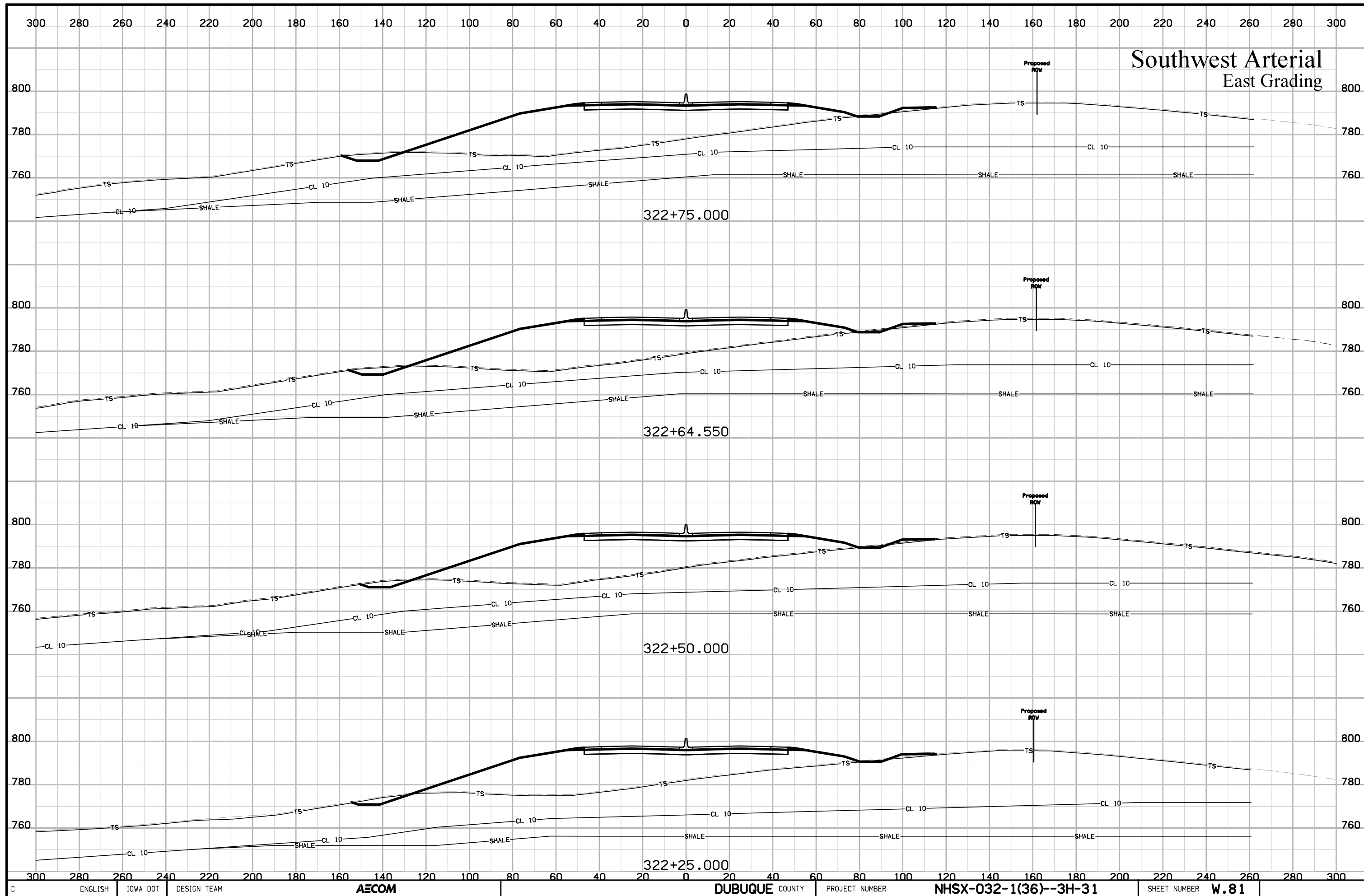

Southwest Arterial East Grading

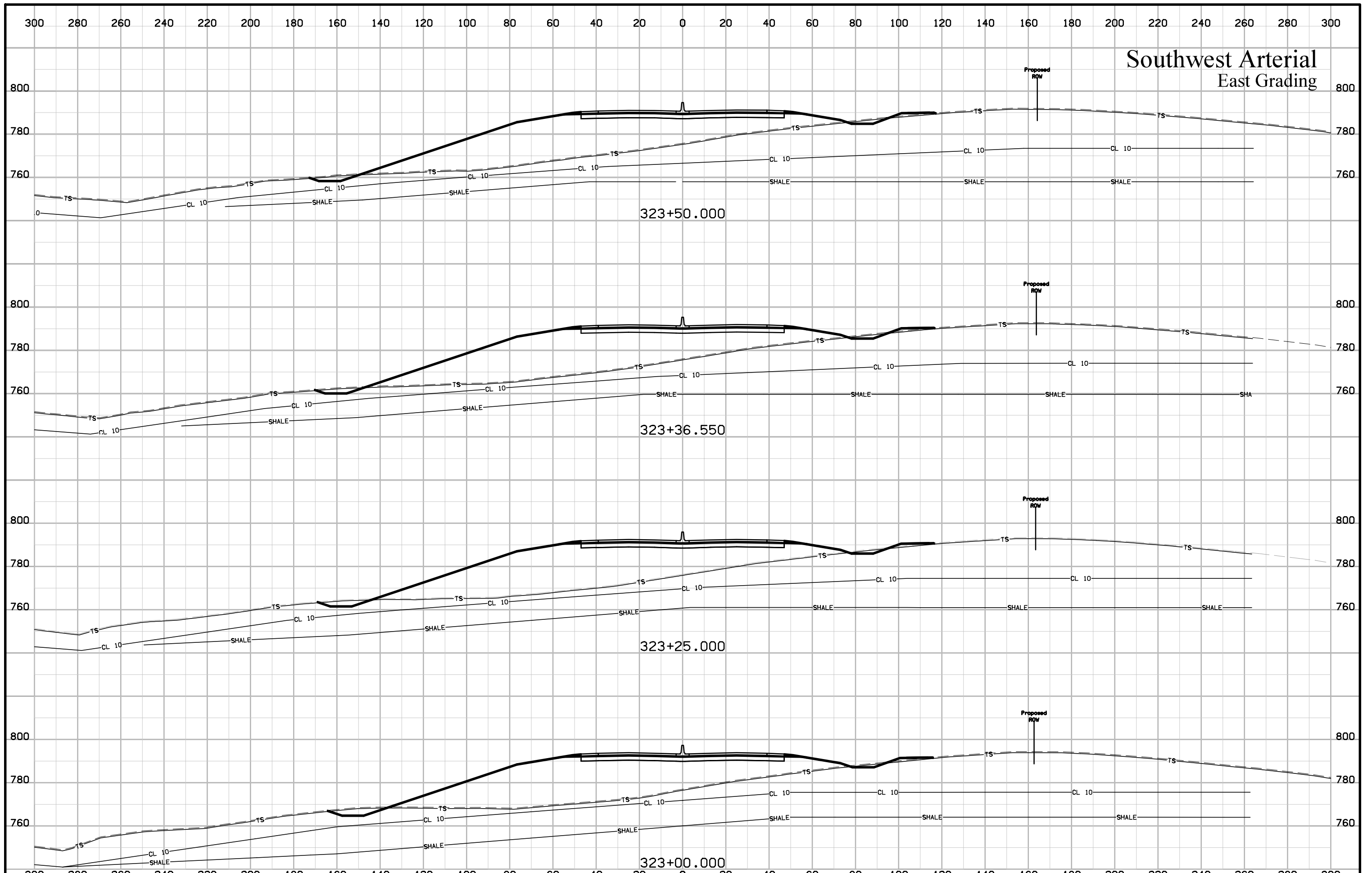

Southwest Arterial East Grading

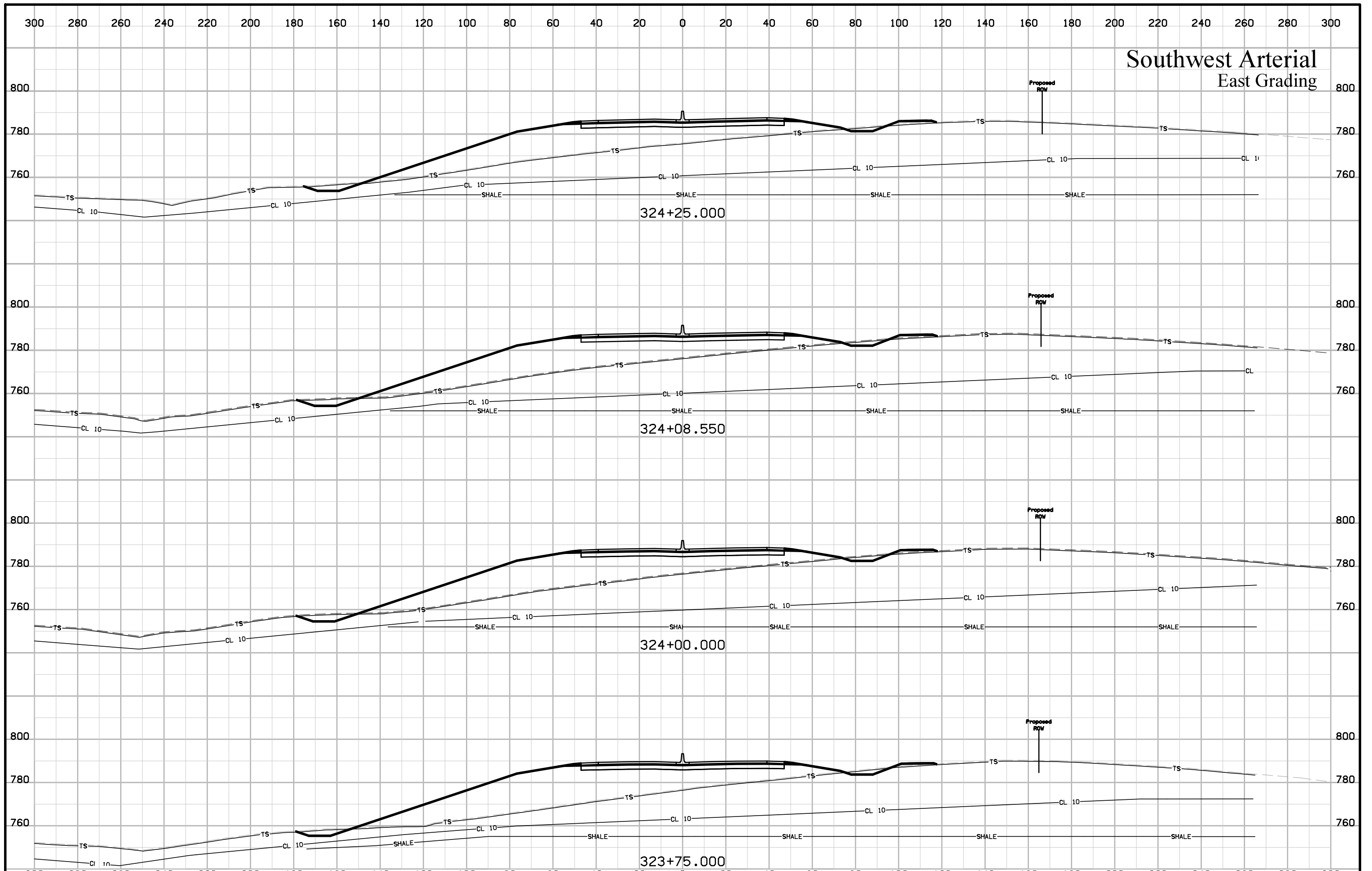

Southwest Arterial East Grading

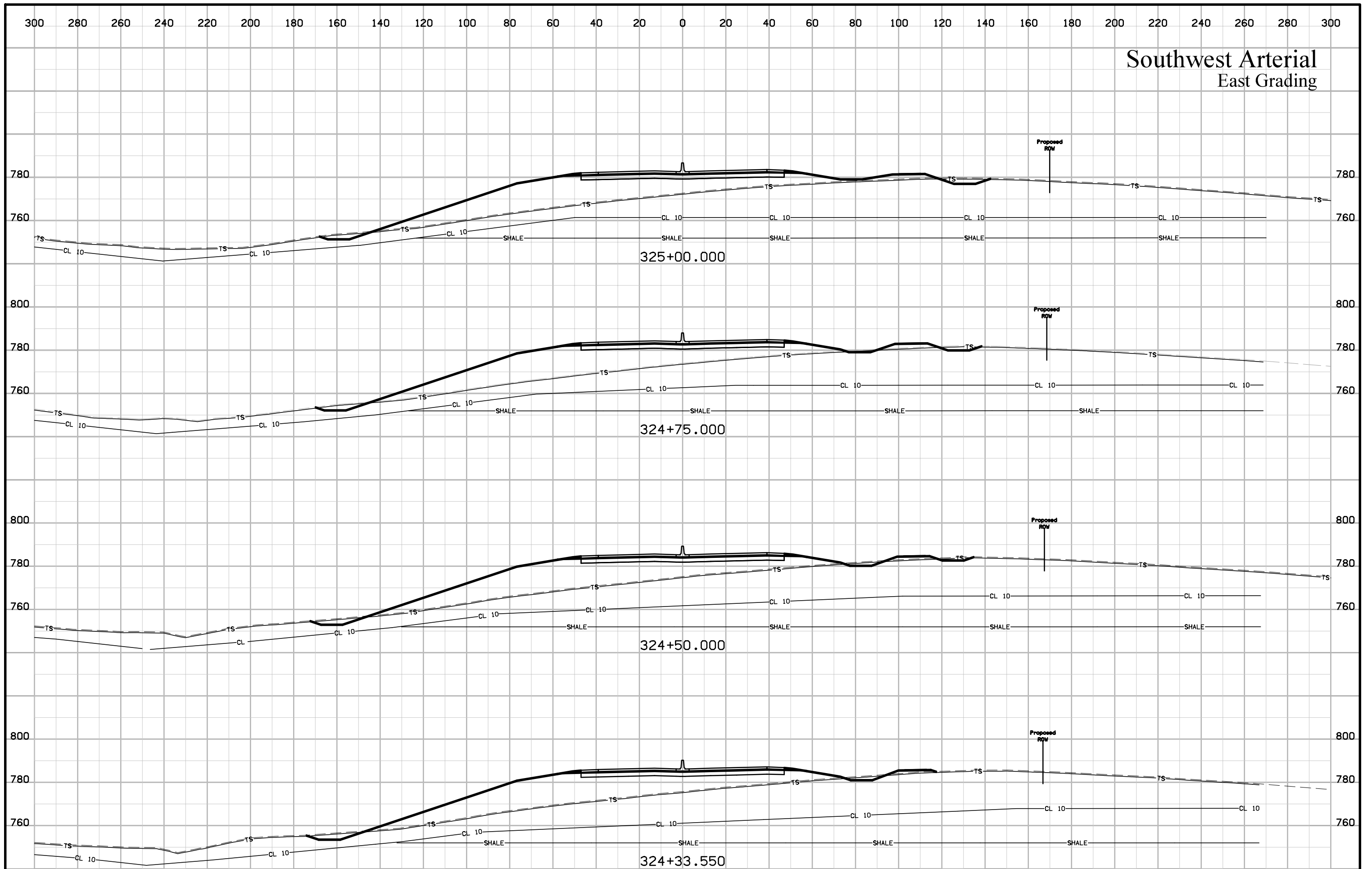

Southwest Arterial East Grading

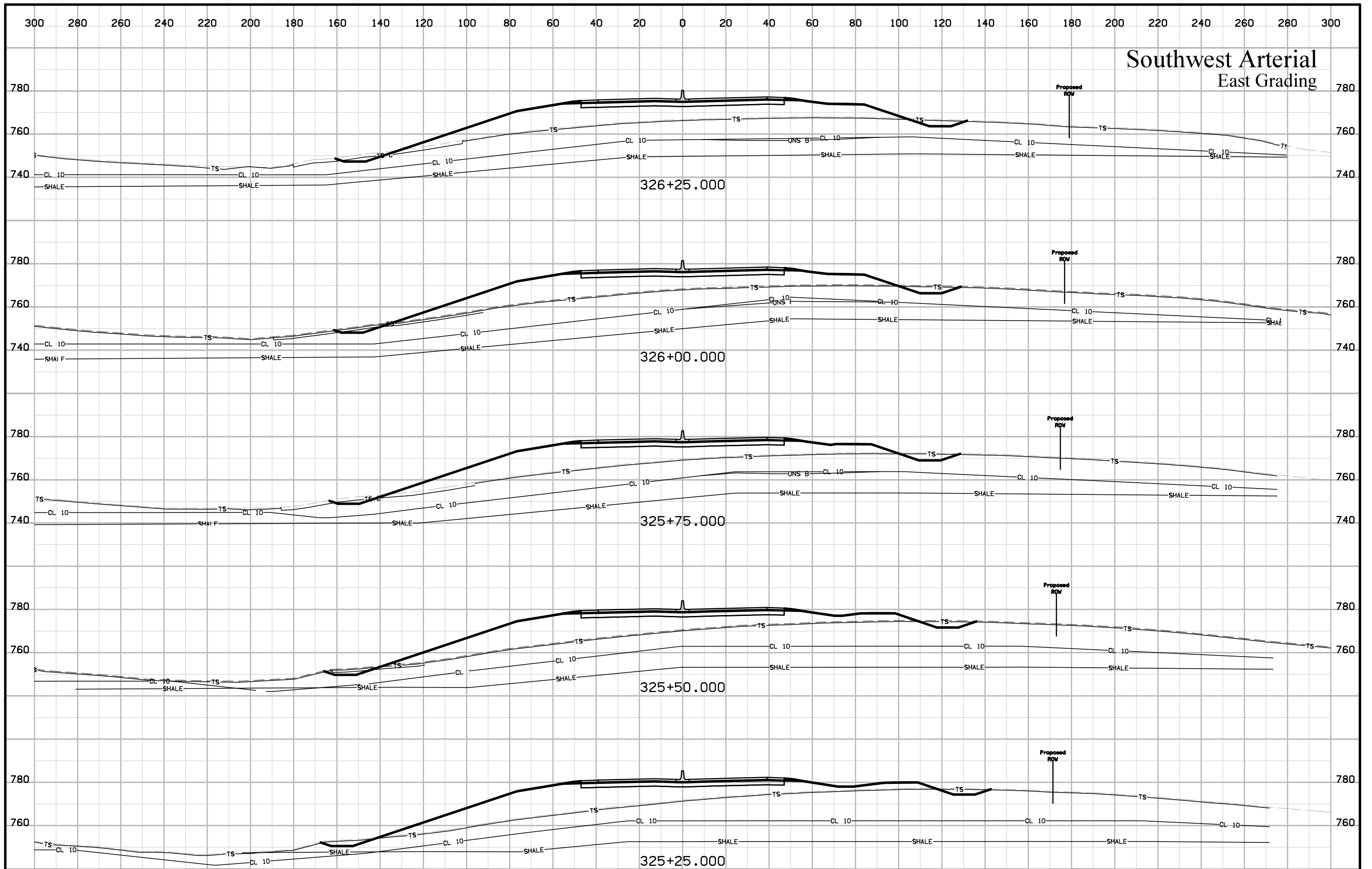

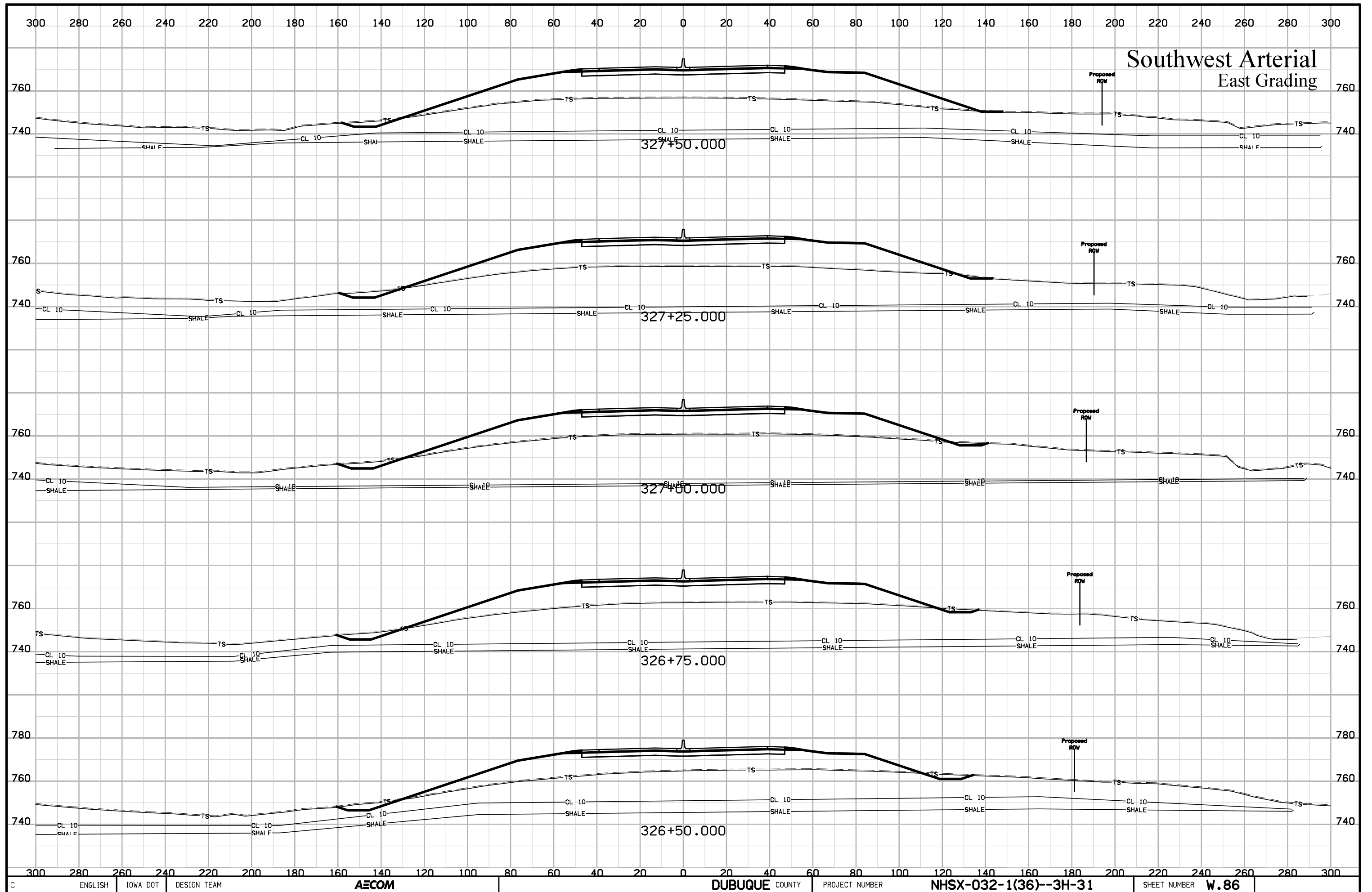

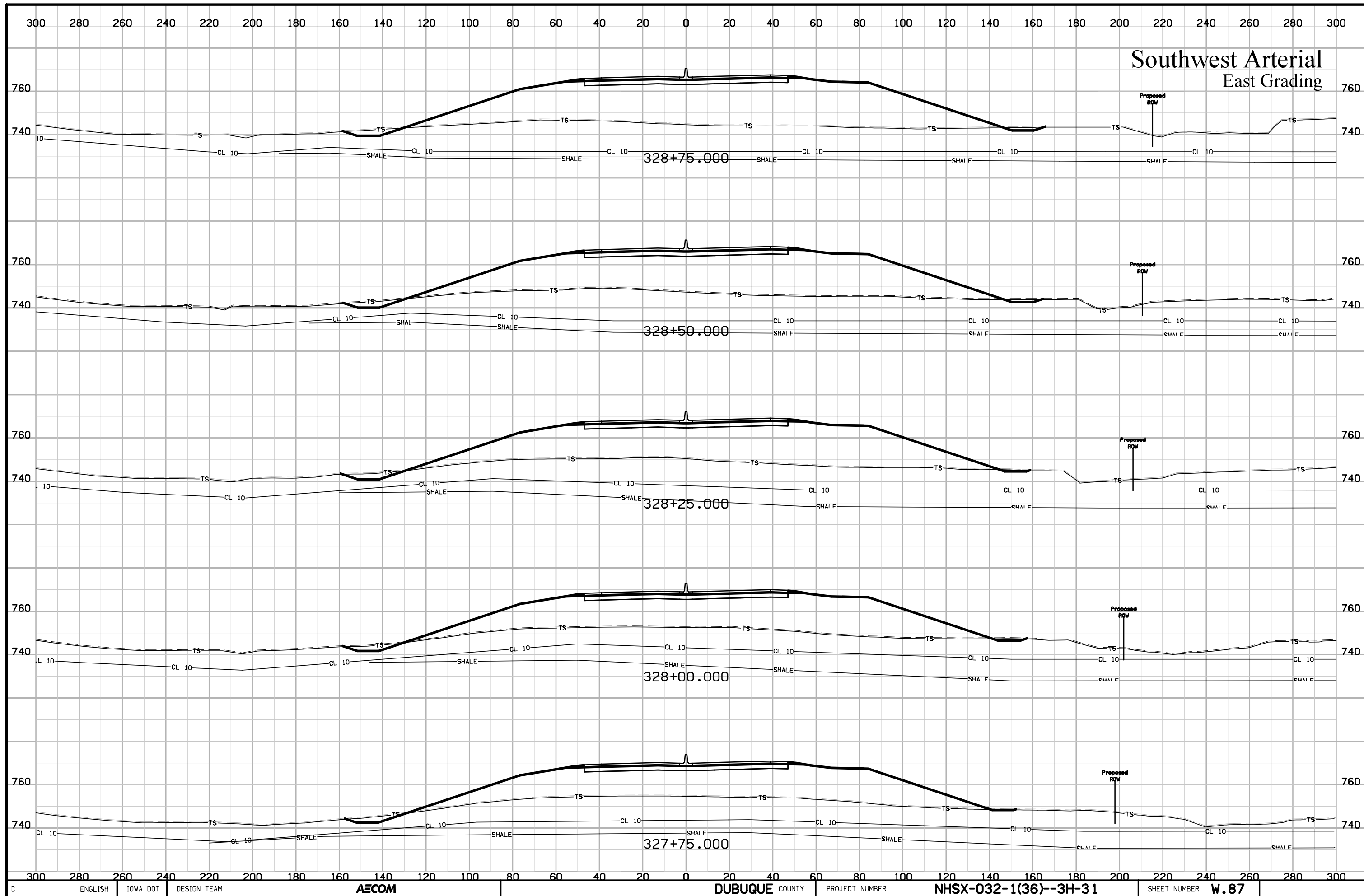

Southwest Arterial East Grading

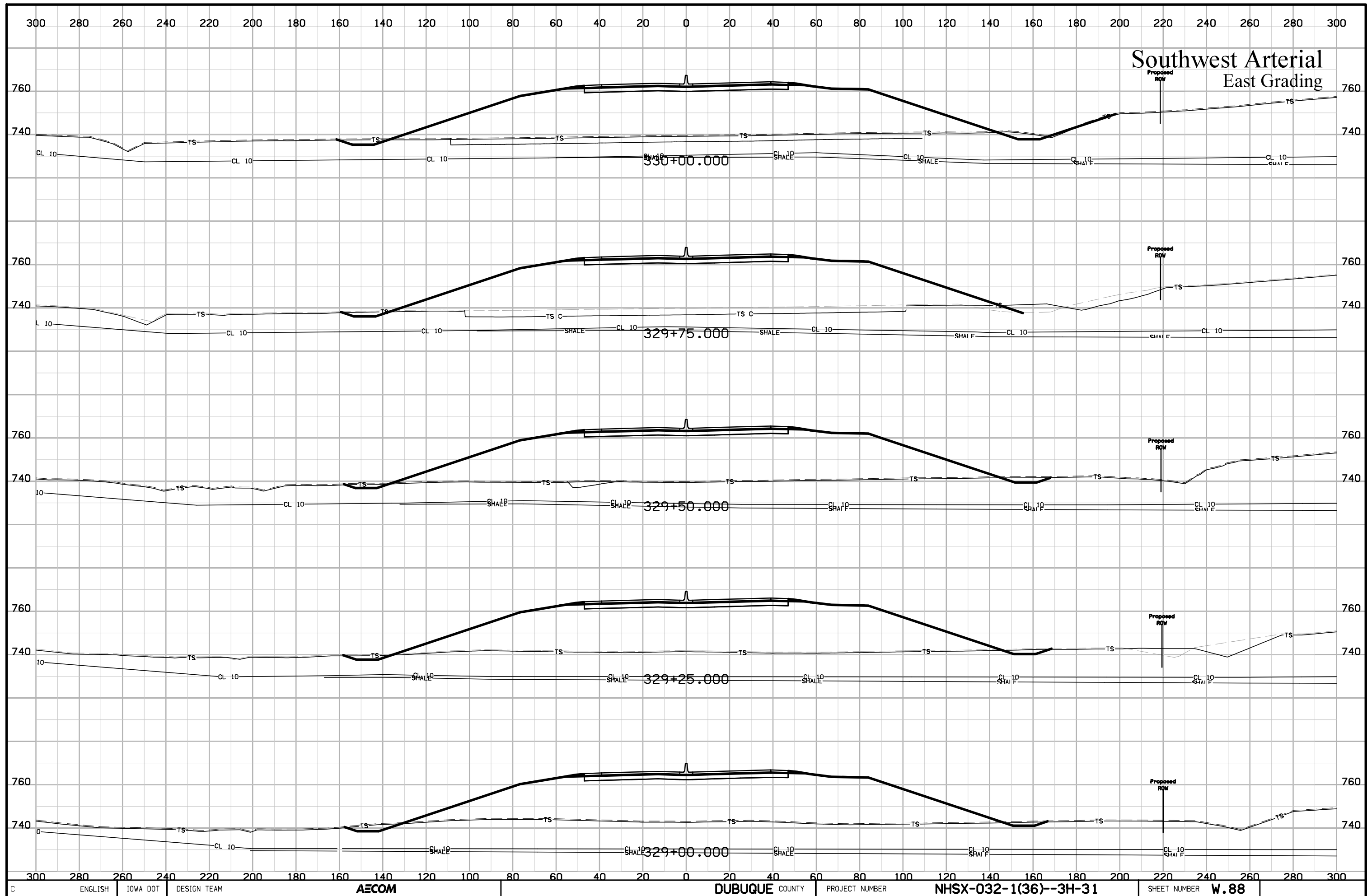

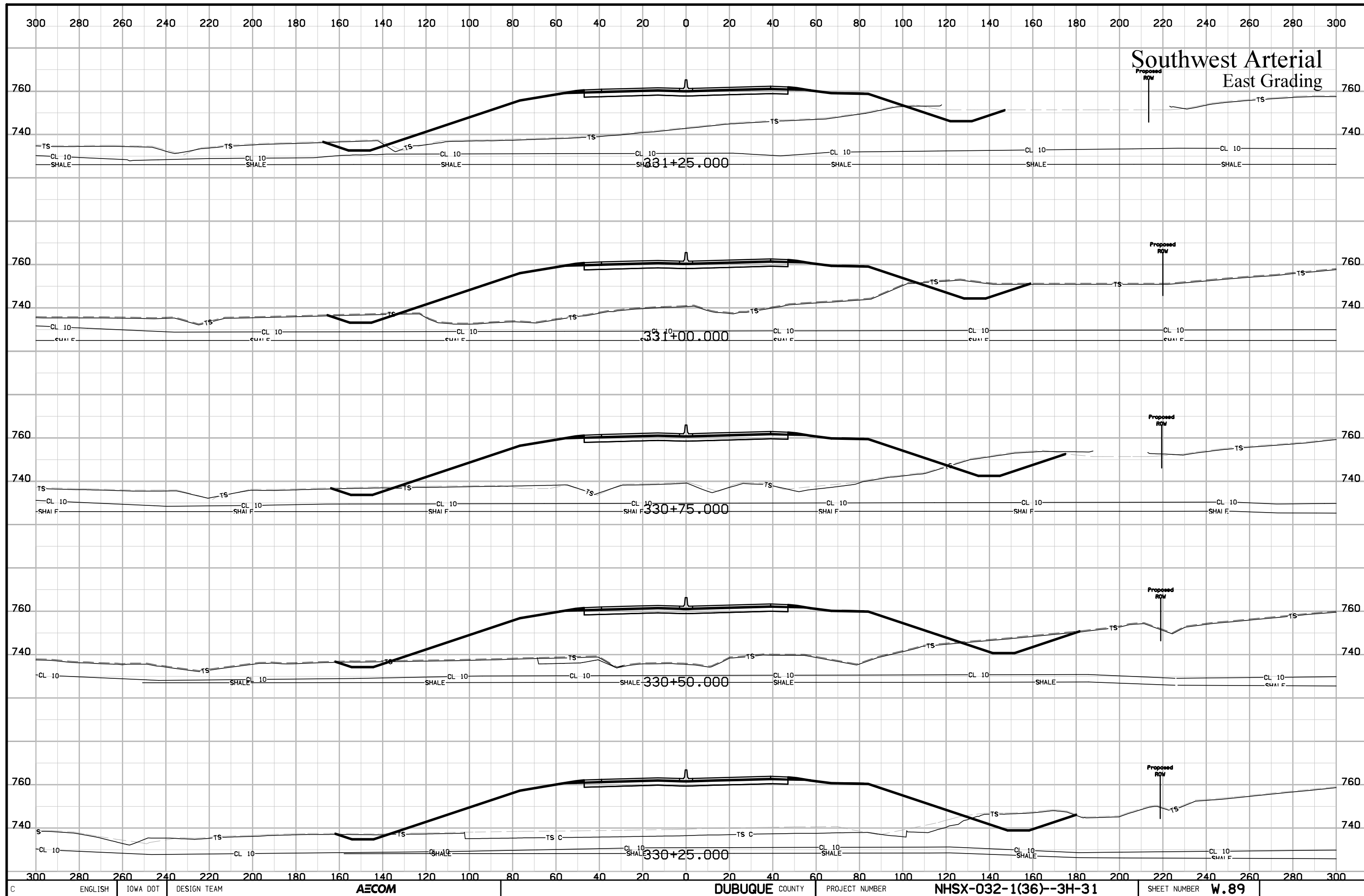

Southwest Arterial East Grading

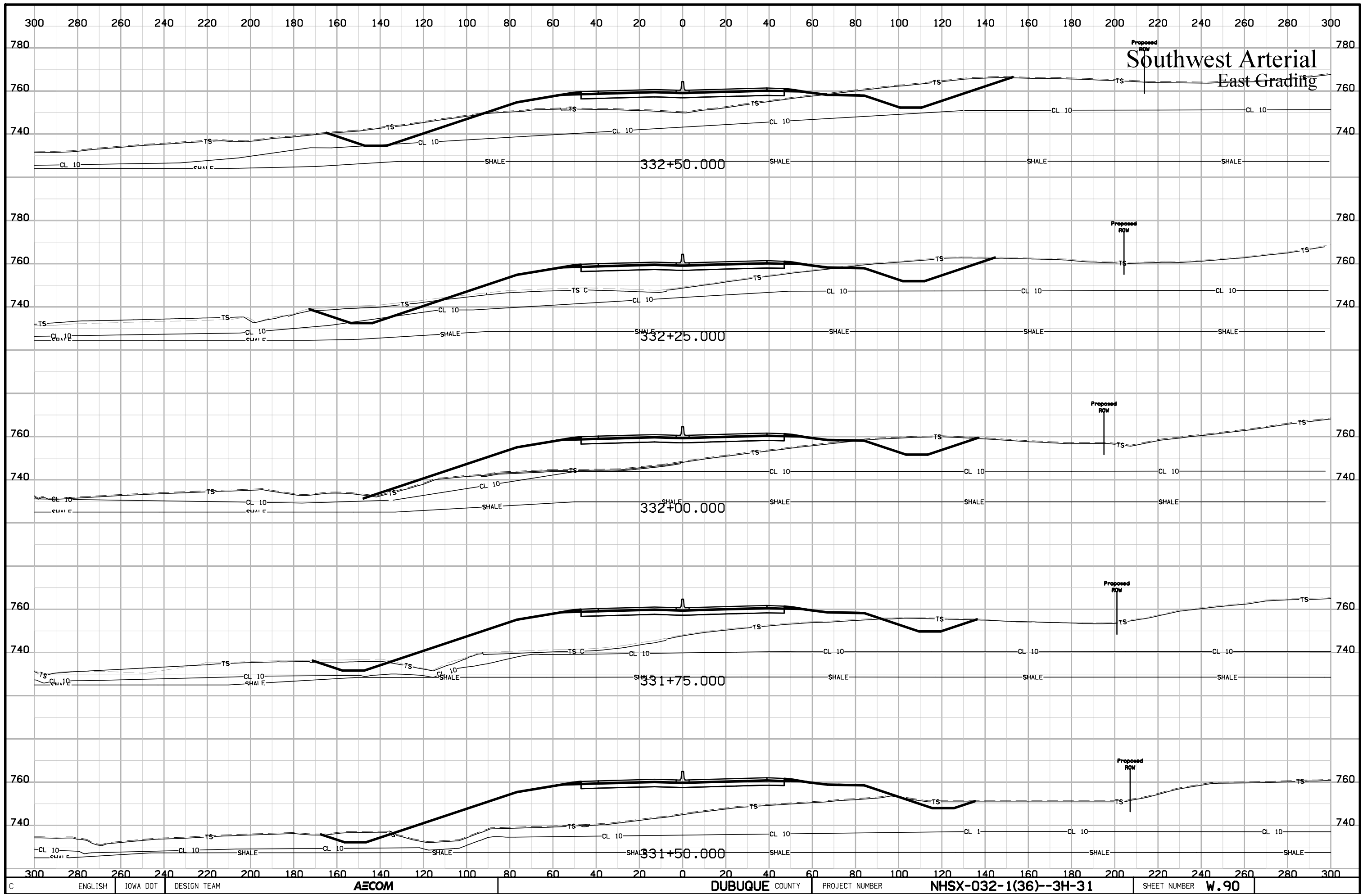

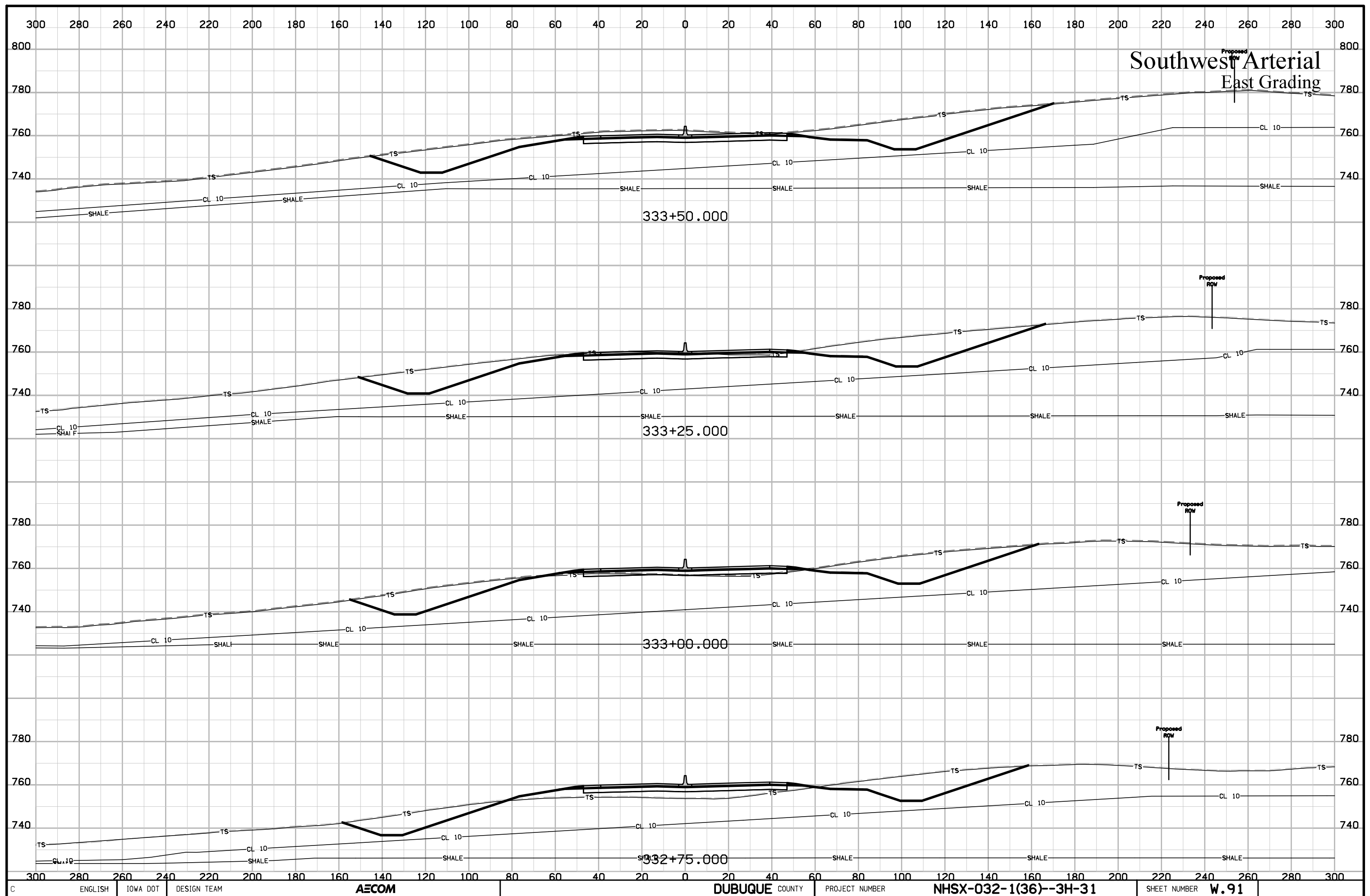

Southwest Arterial East Grading

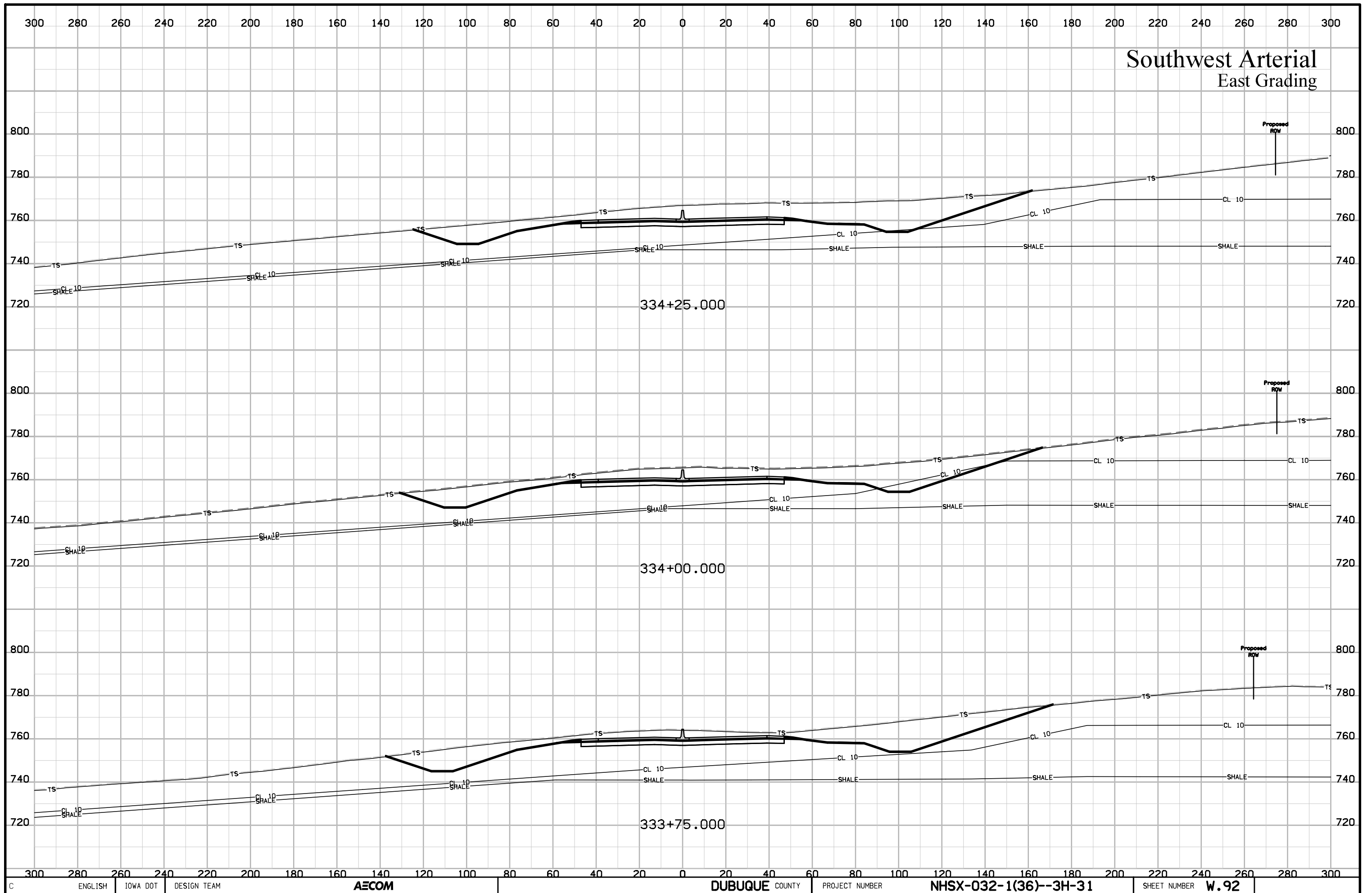

Southwest Arterial East Grading

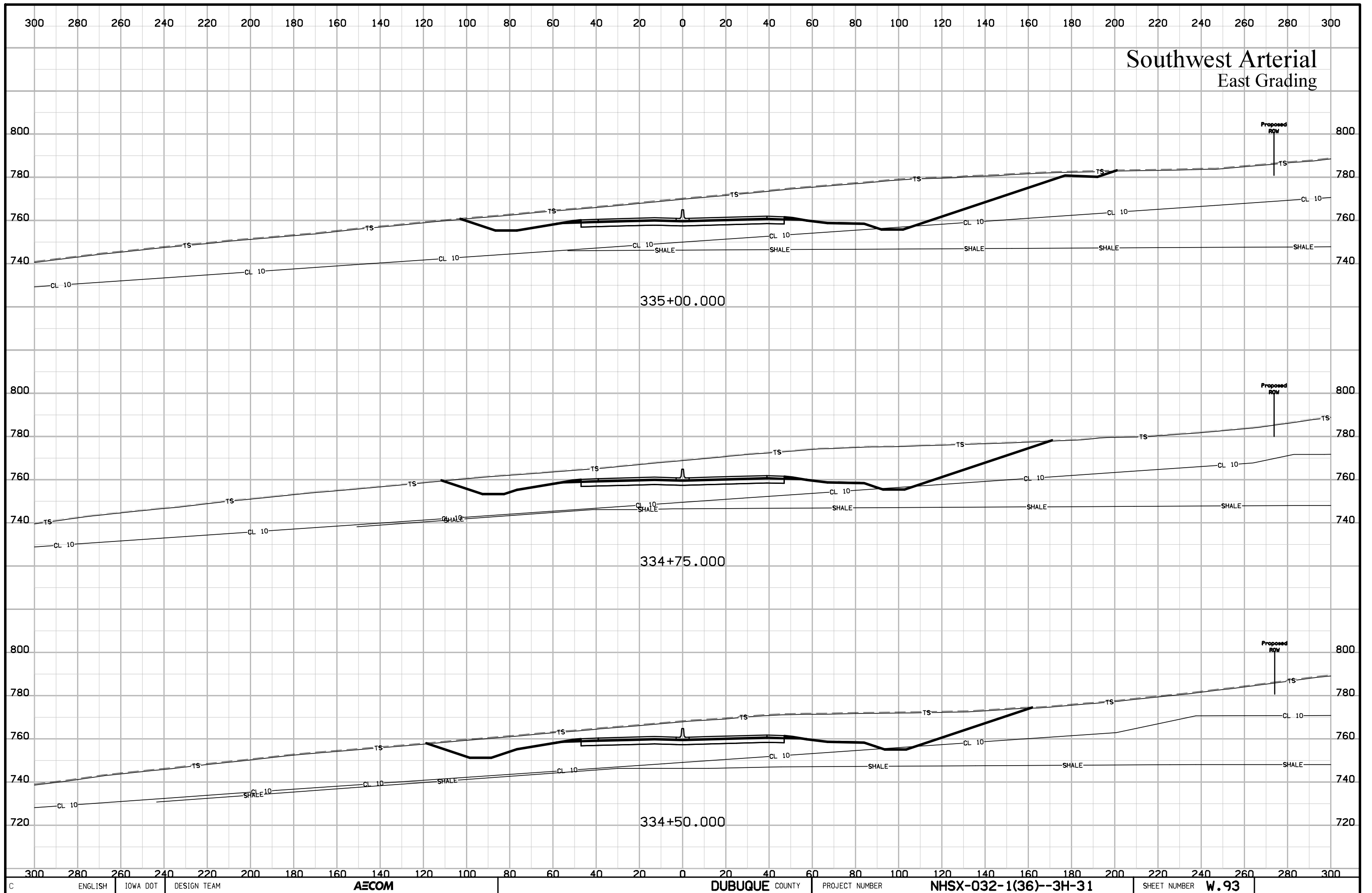

Southwest Arterial East Grading

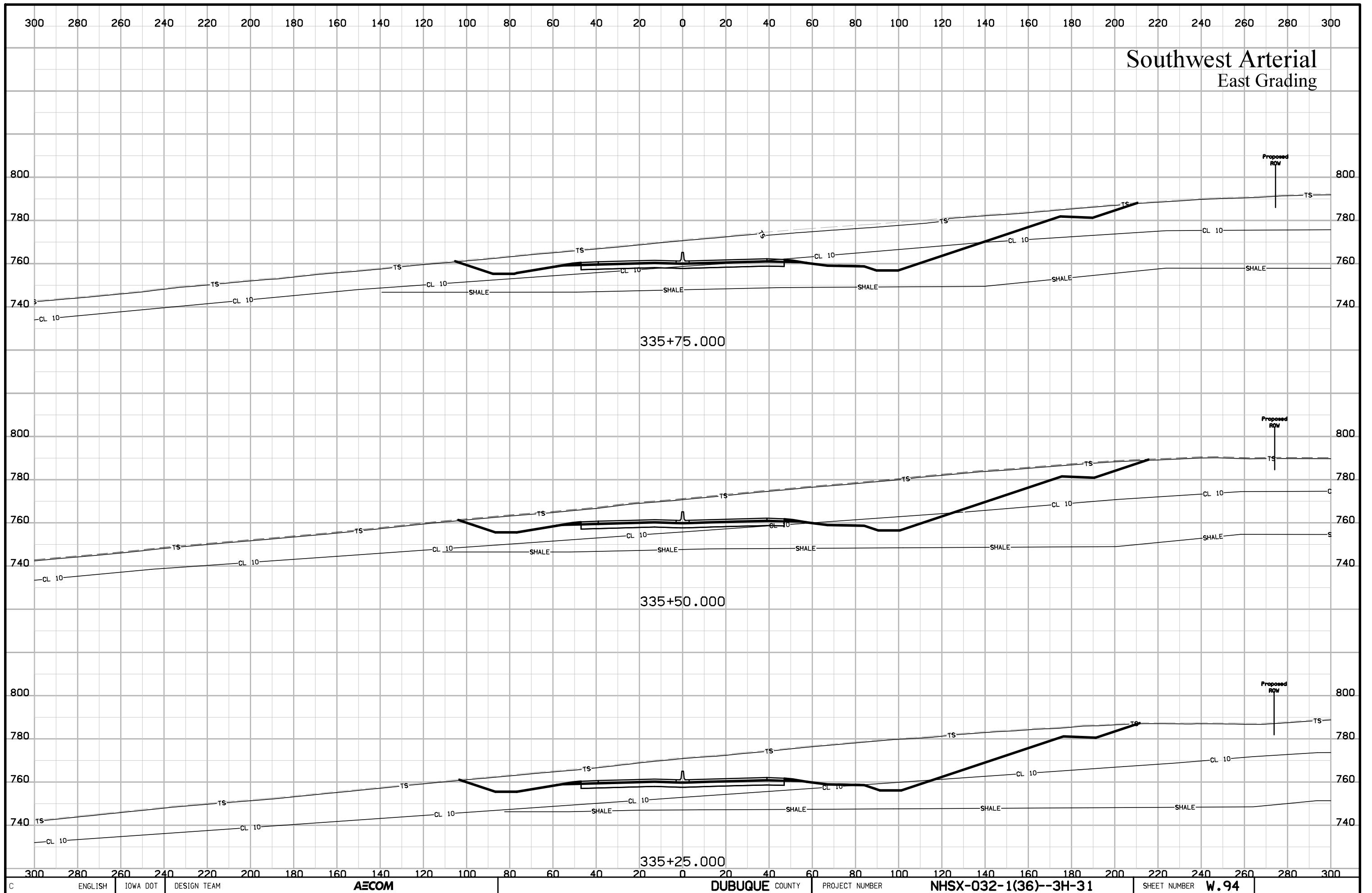

Southwest Arterial East Grading

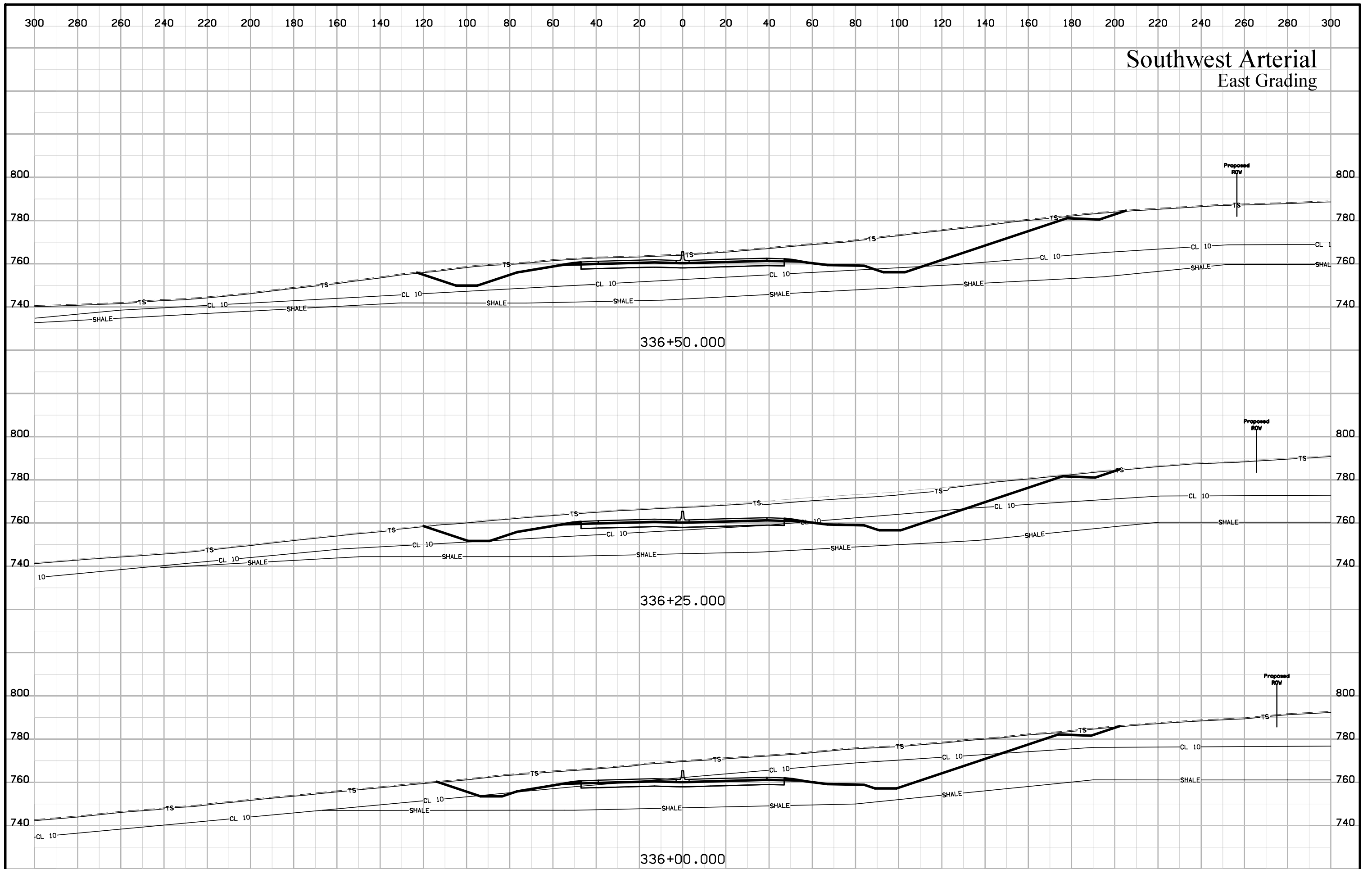

Southwest Arterial East Grading

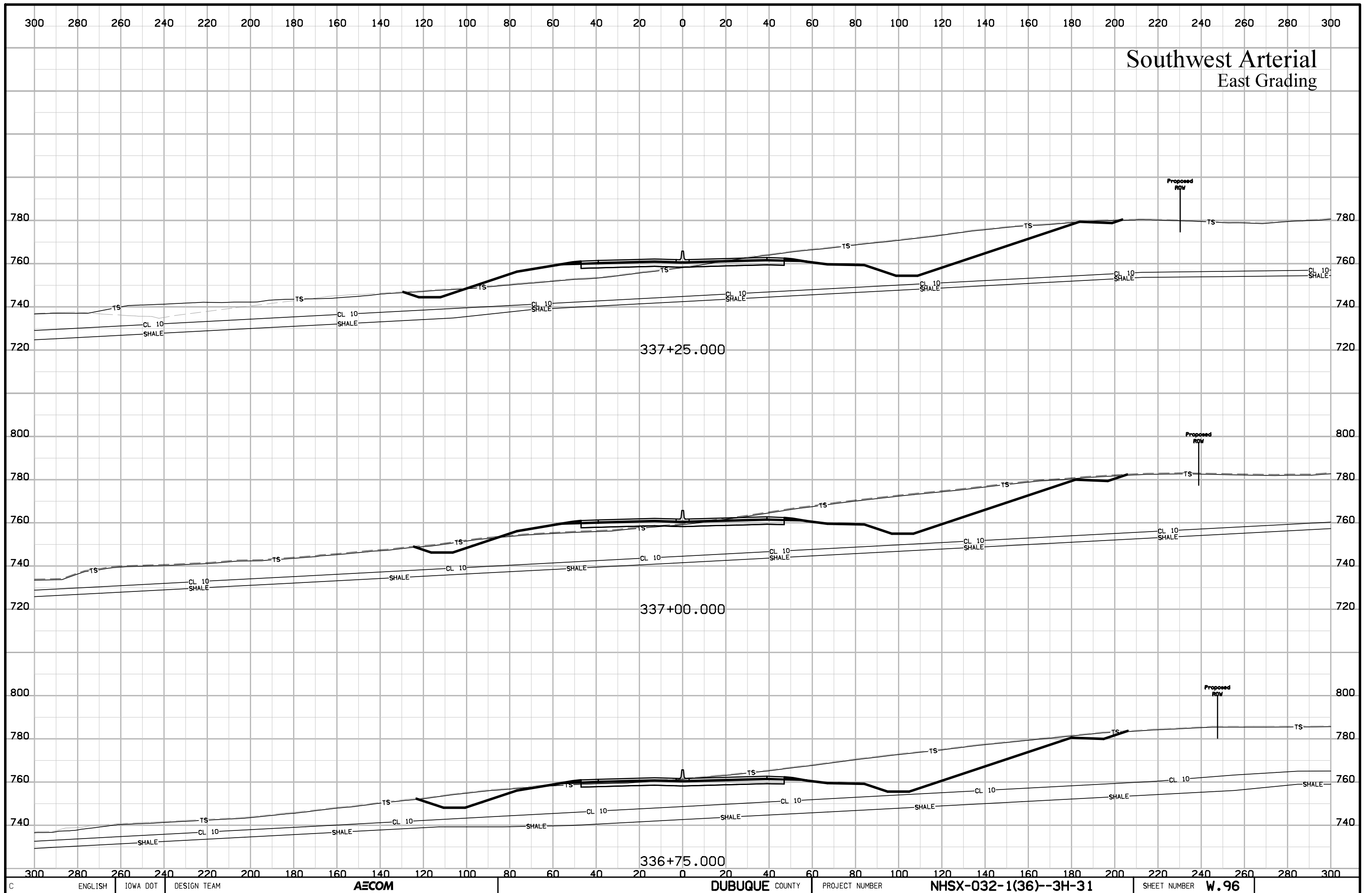

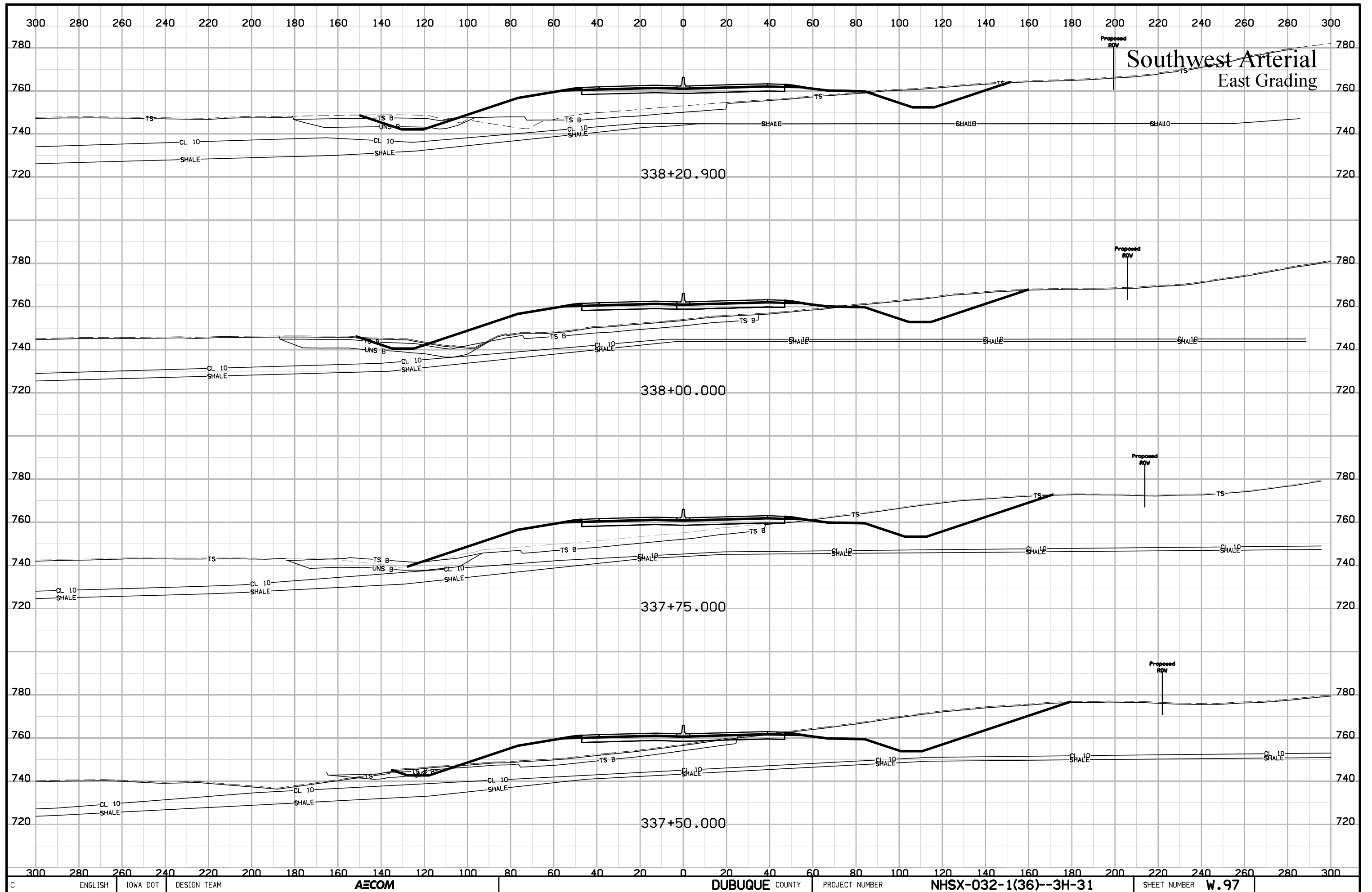

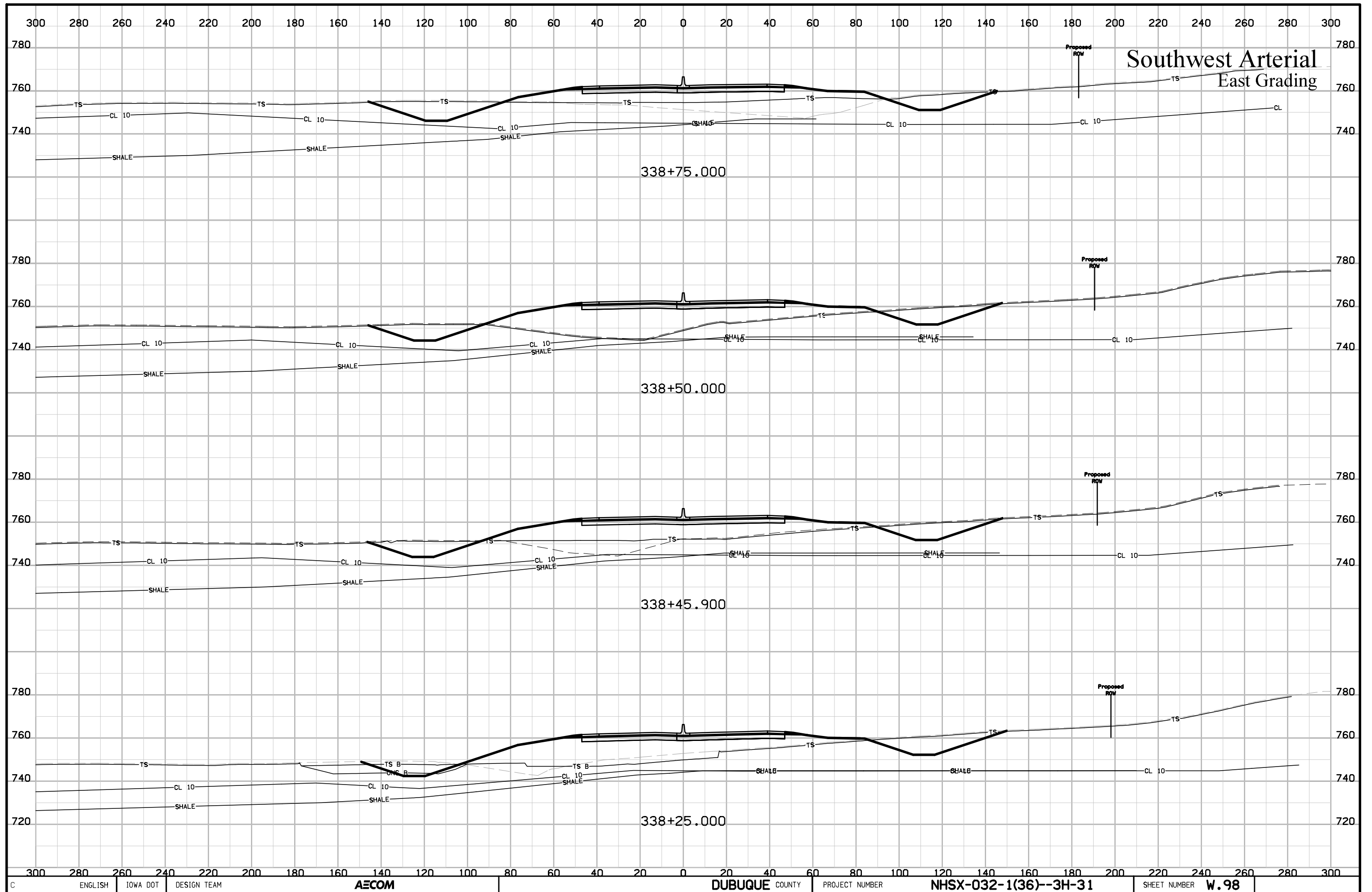

Southwest Arterial East Grading

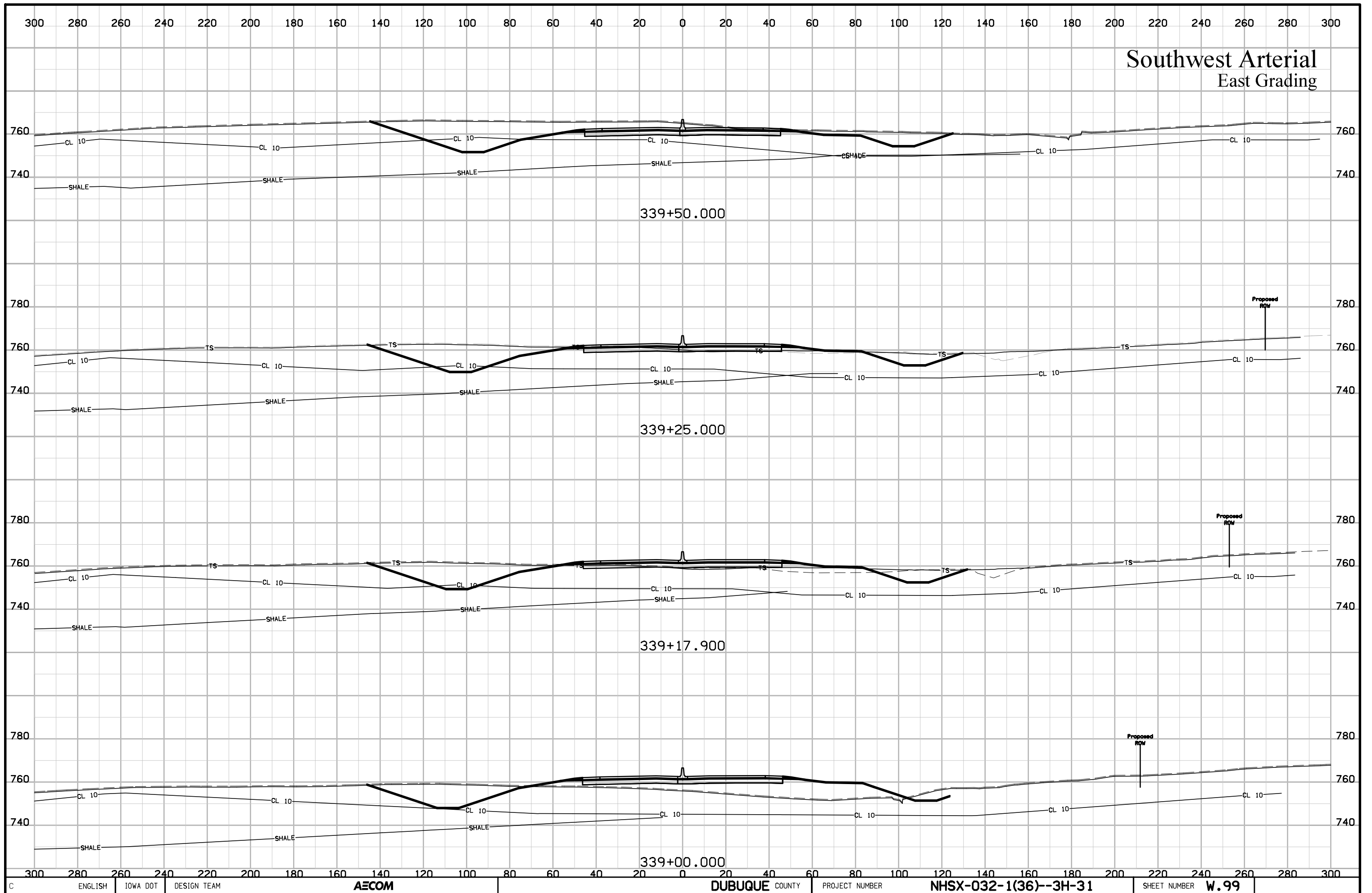

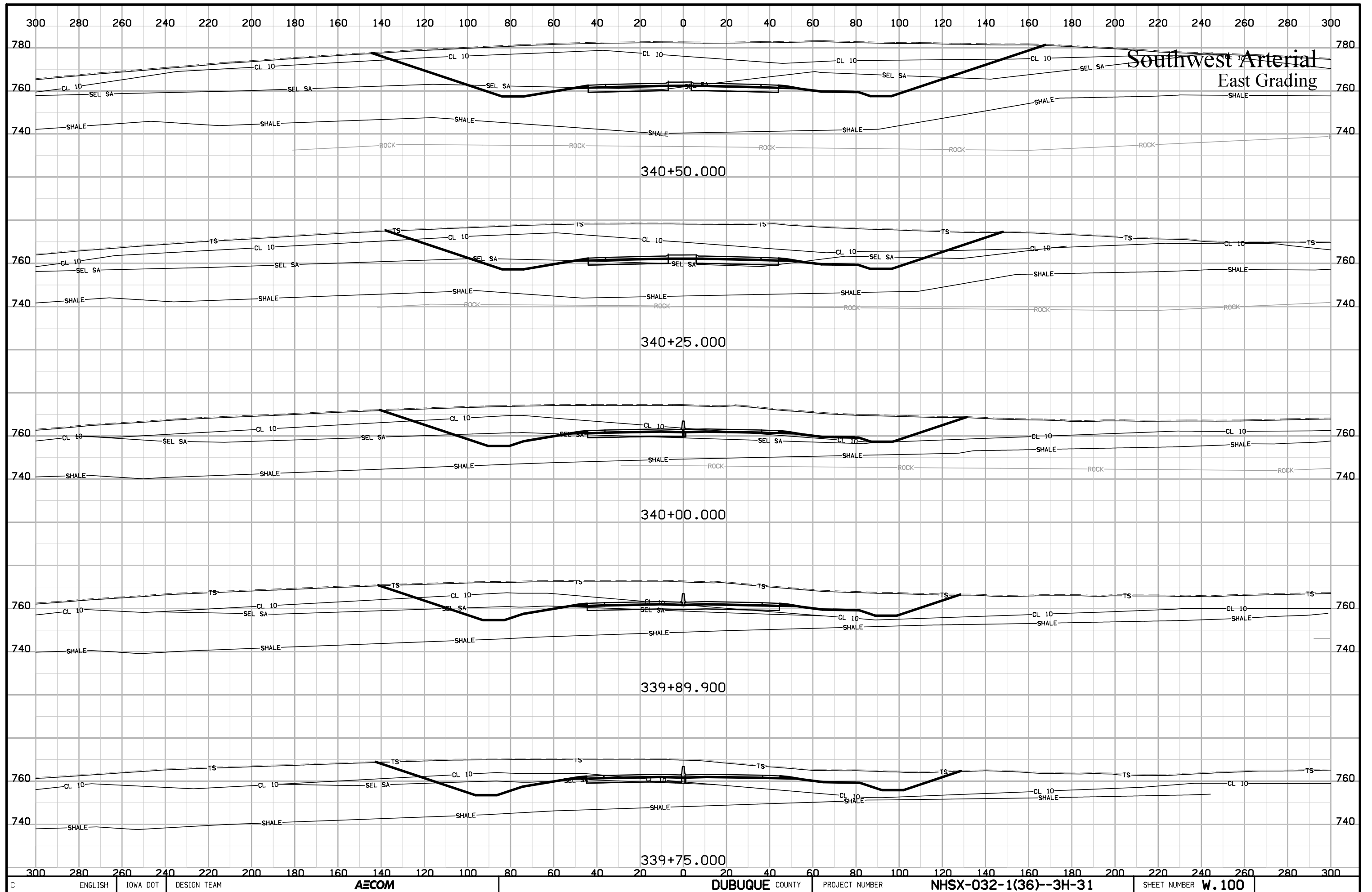

Southwest Arterial
East Grading

Southwest Arterial East Grading

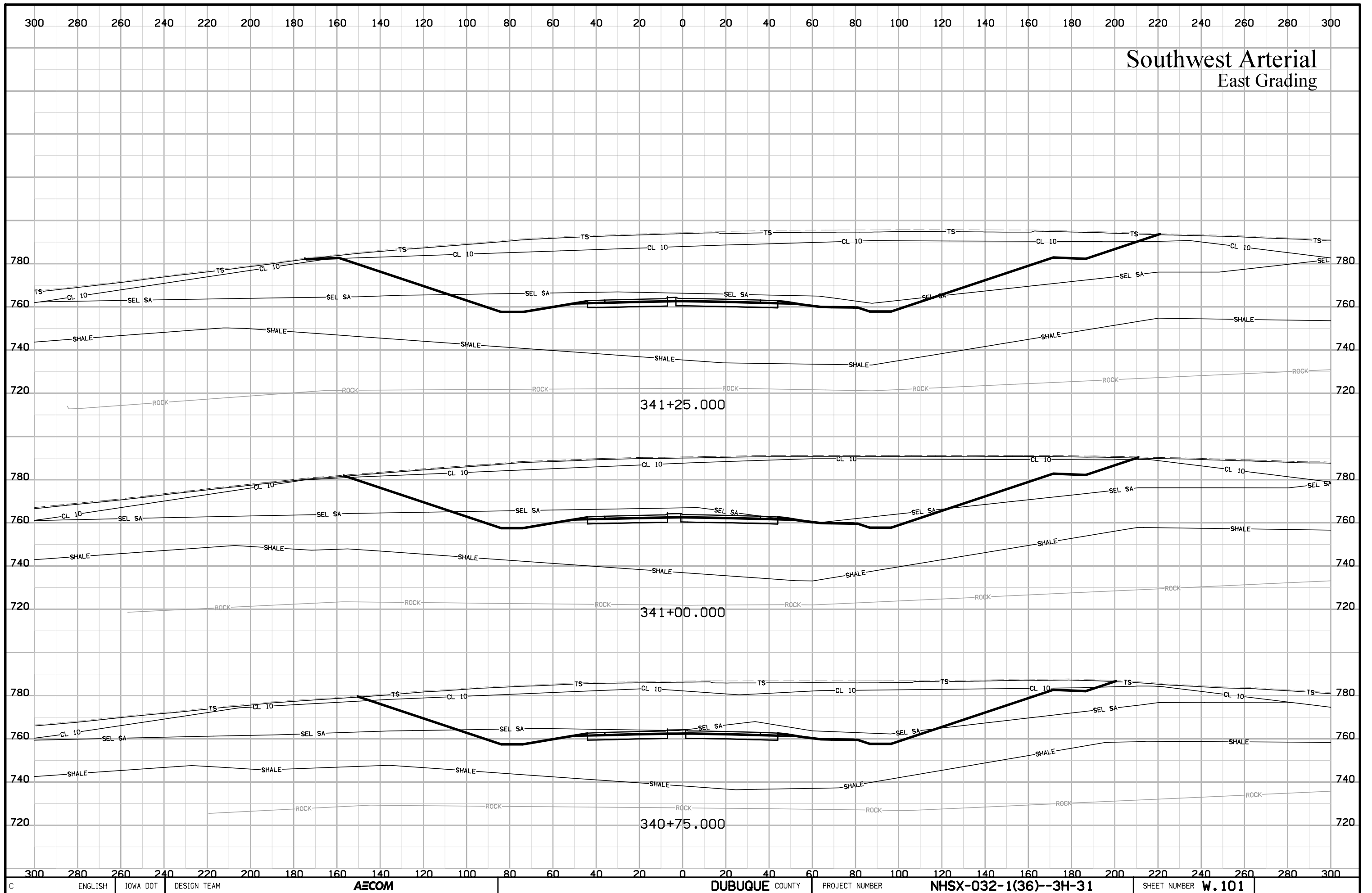

Southwest Arterial East Grading

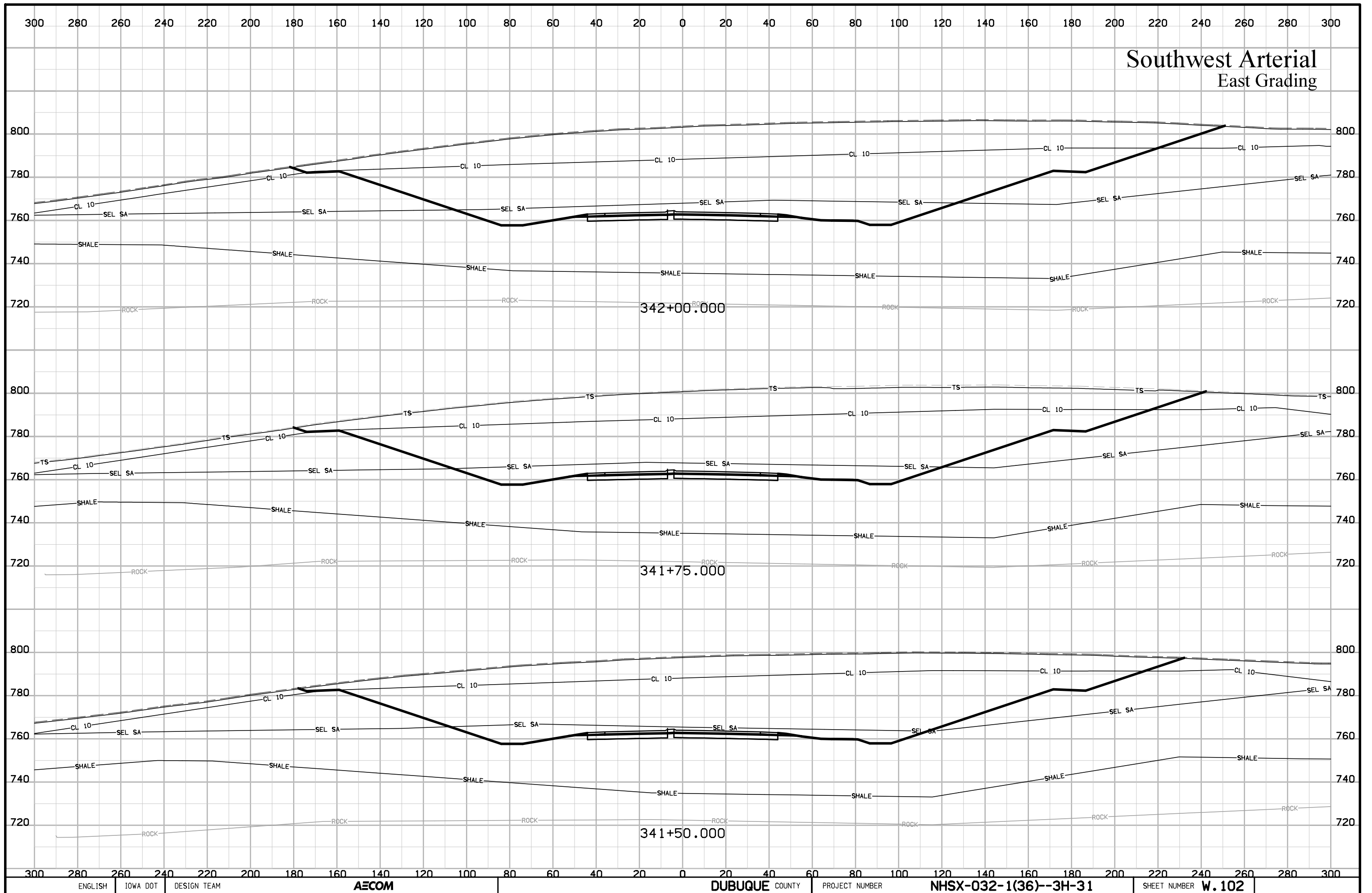

Southwest Arterial East Grading

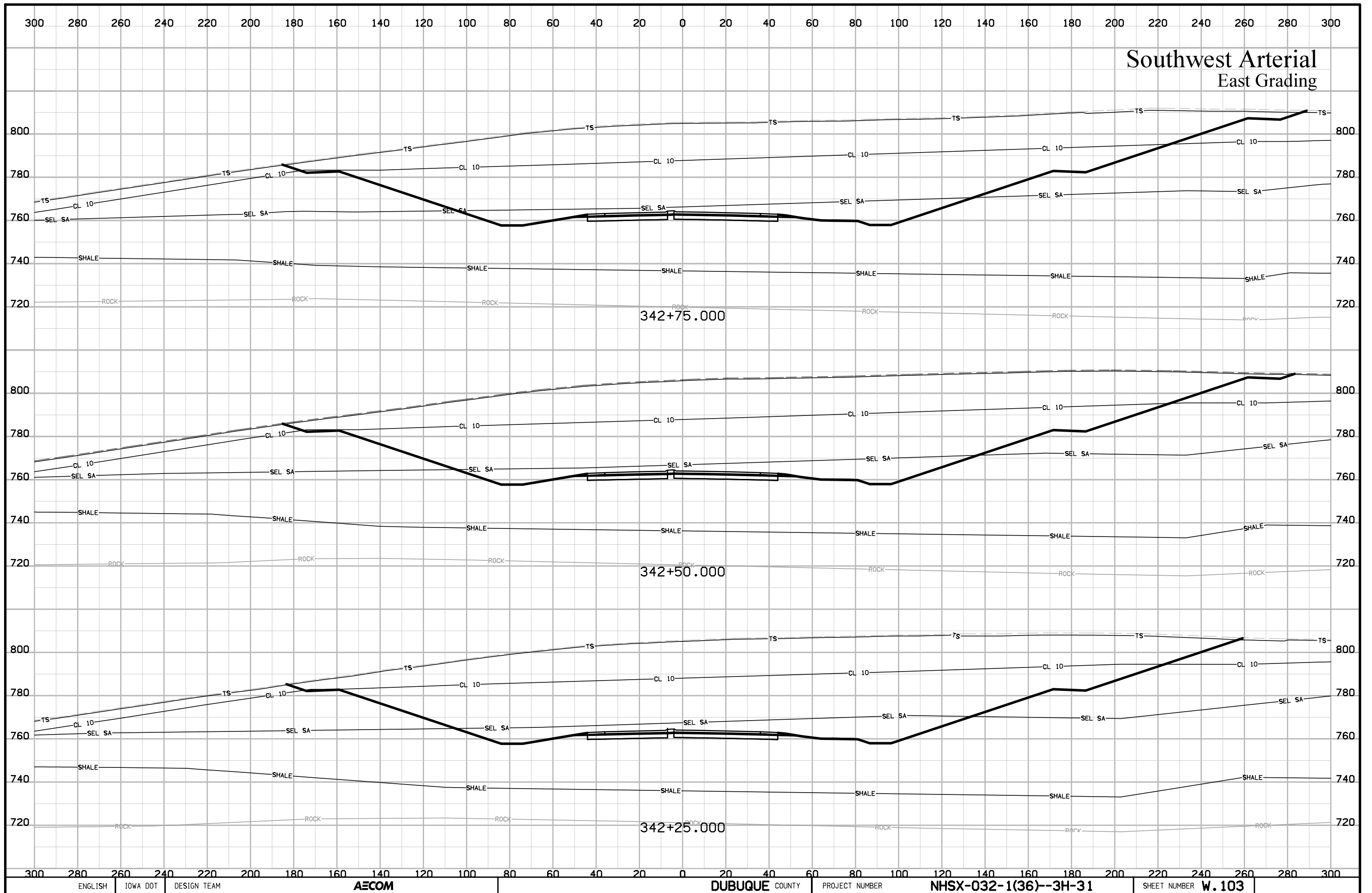

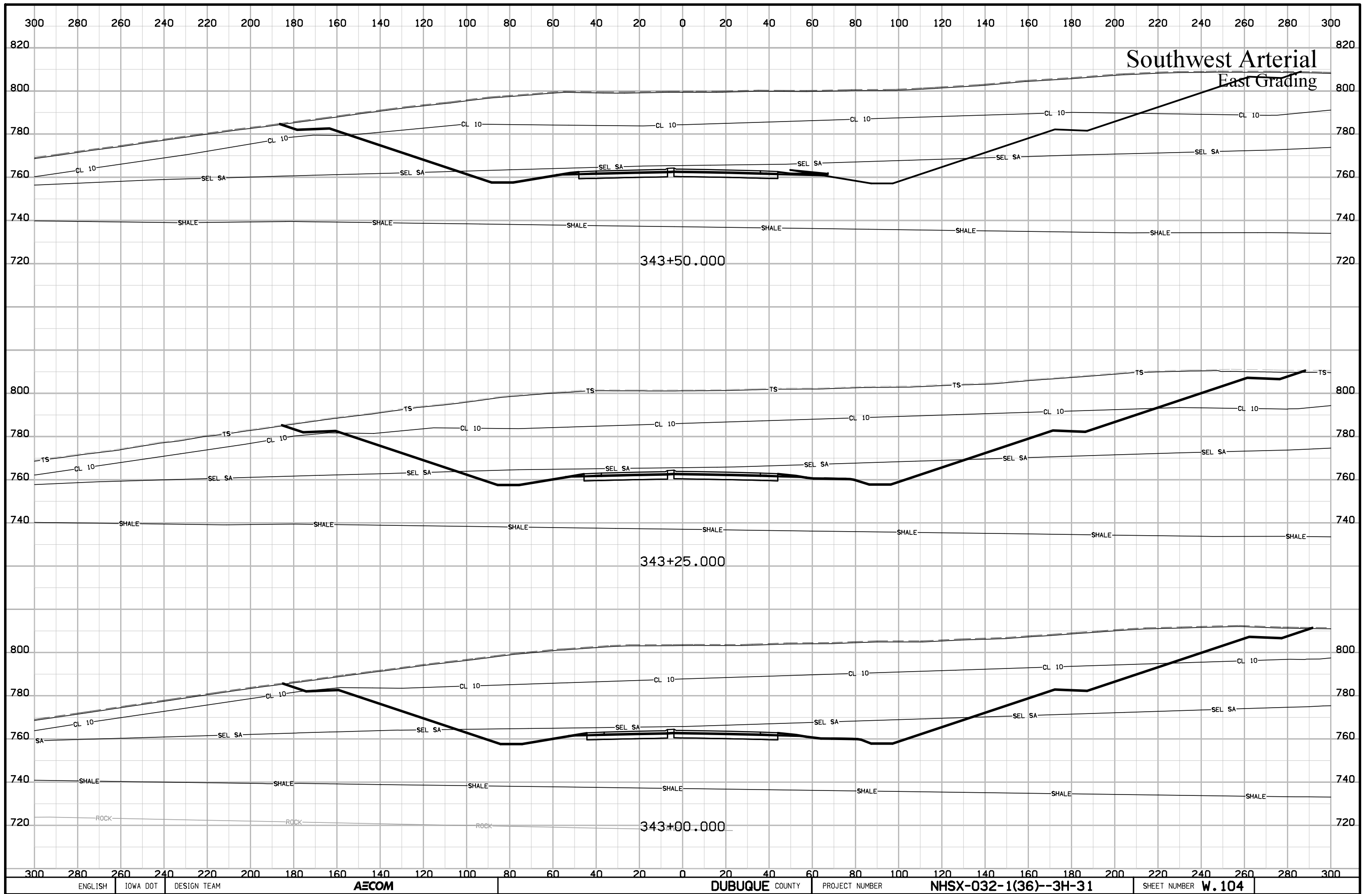

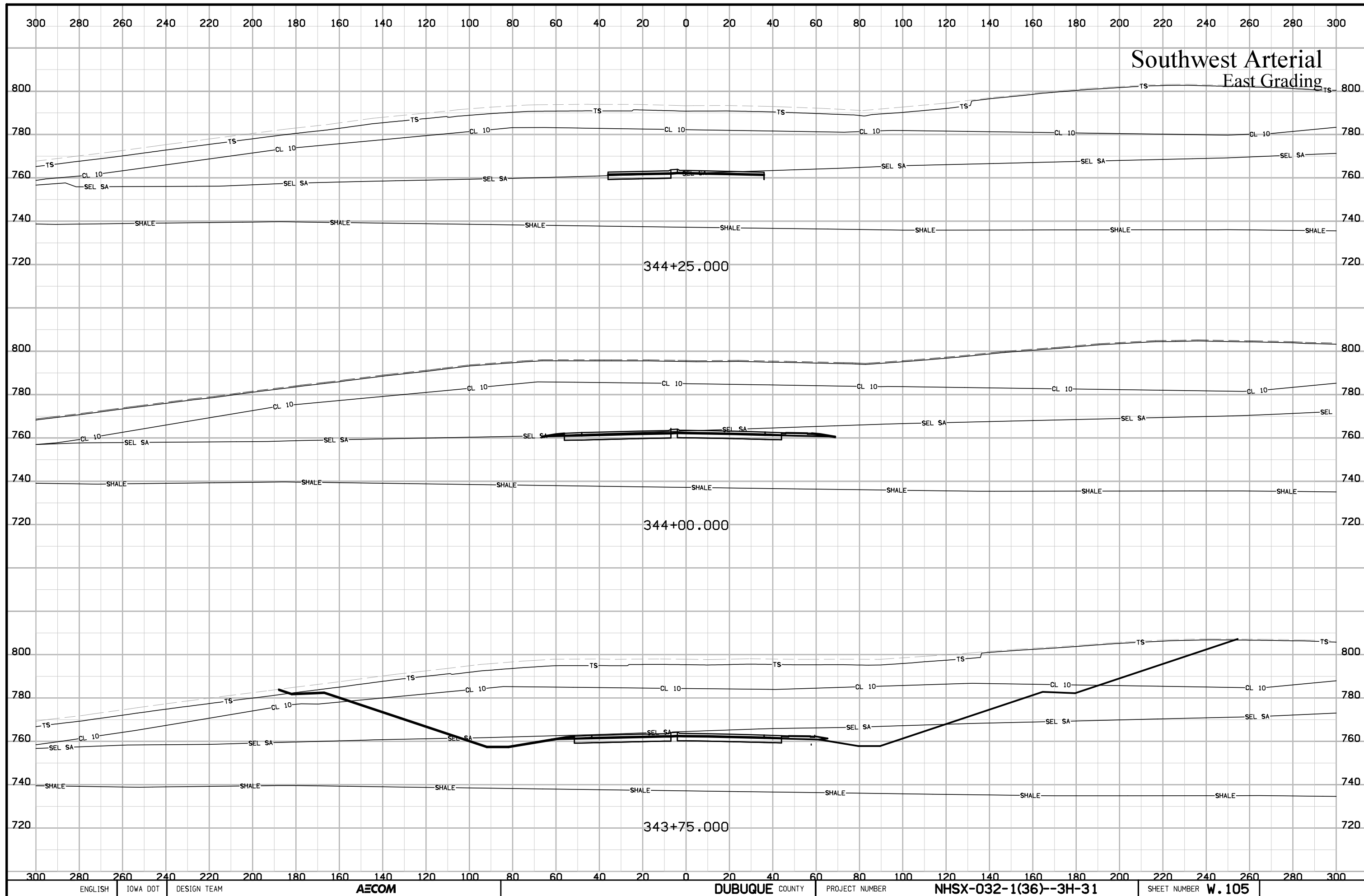

Southwest Arterial East Grading

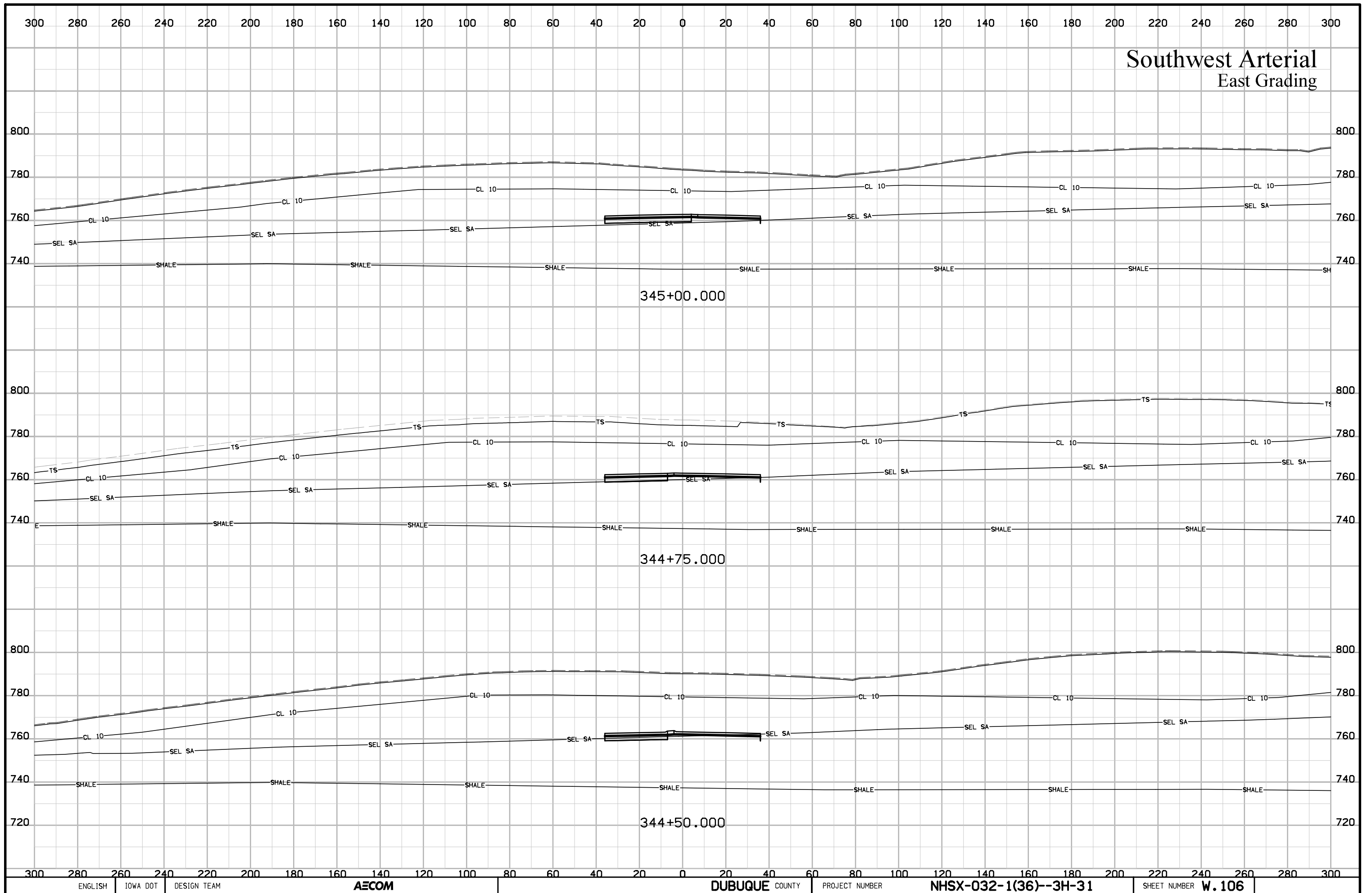

Southwest Arterial East Grading

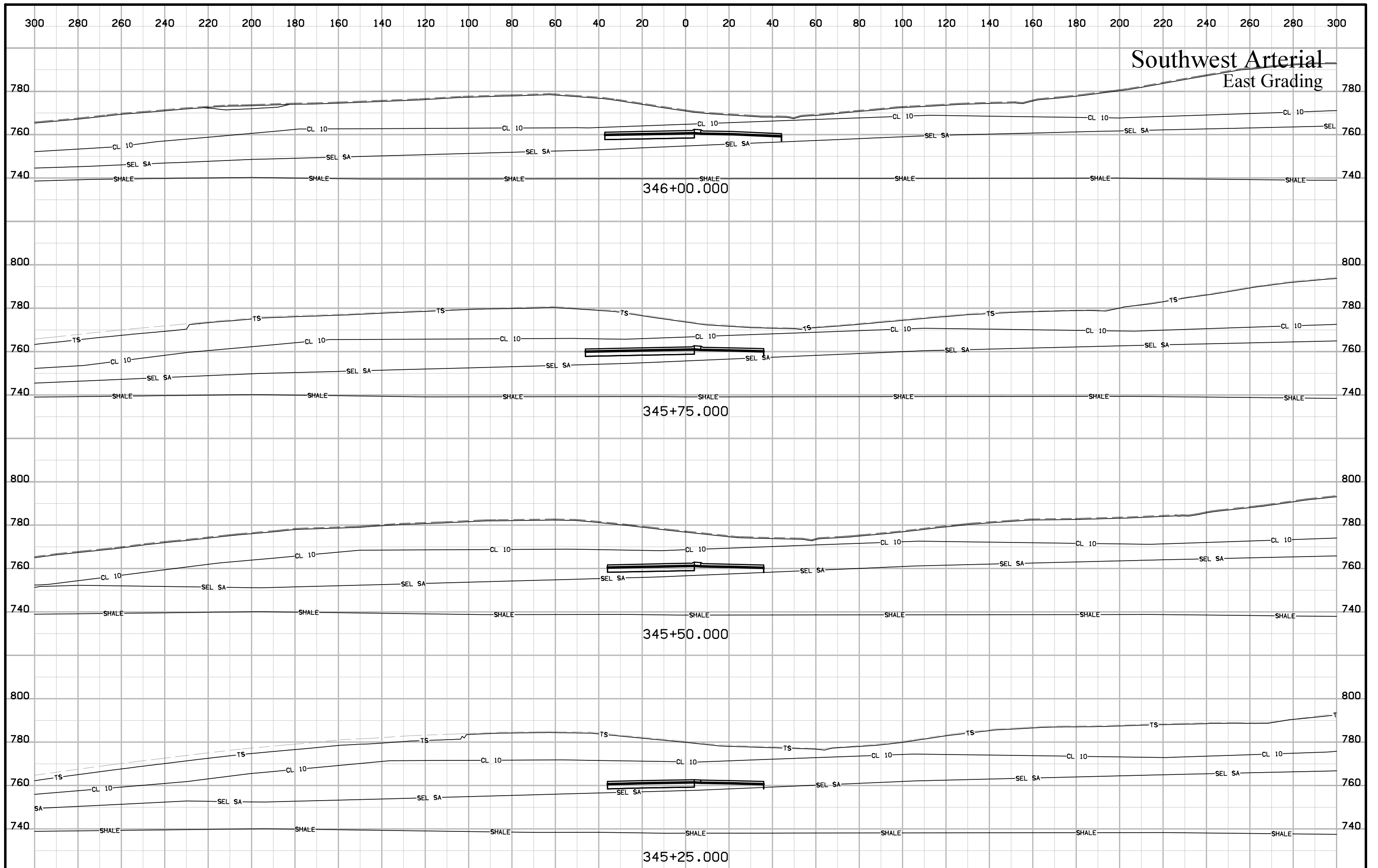

Southwest Arterial East Grading

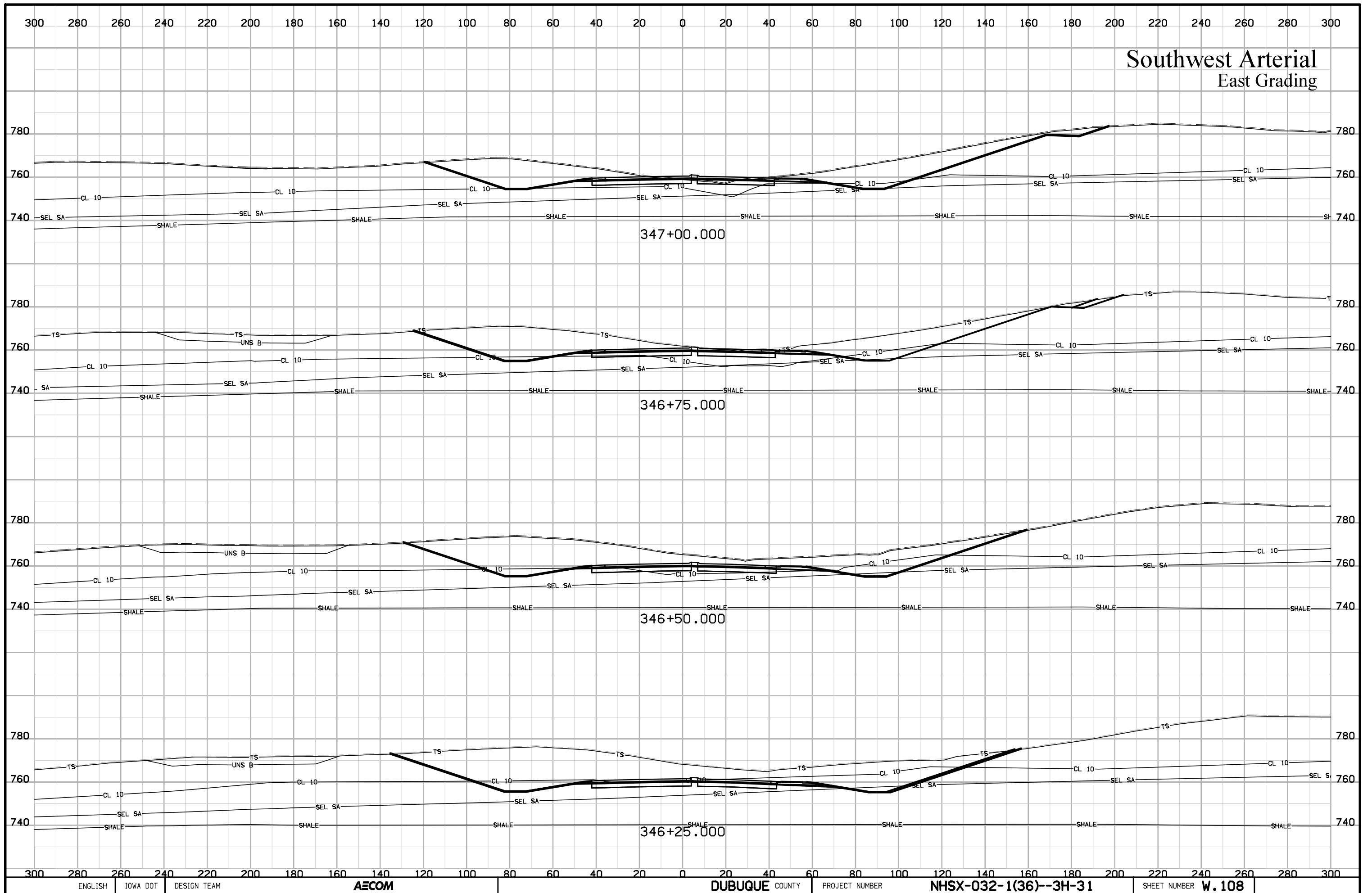

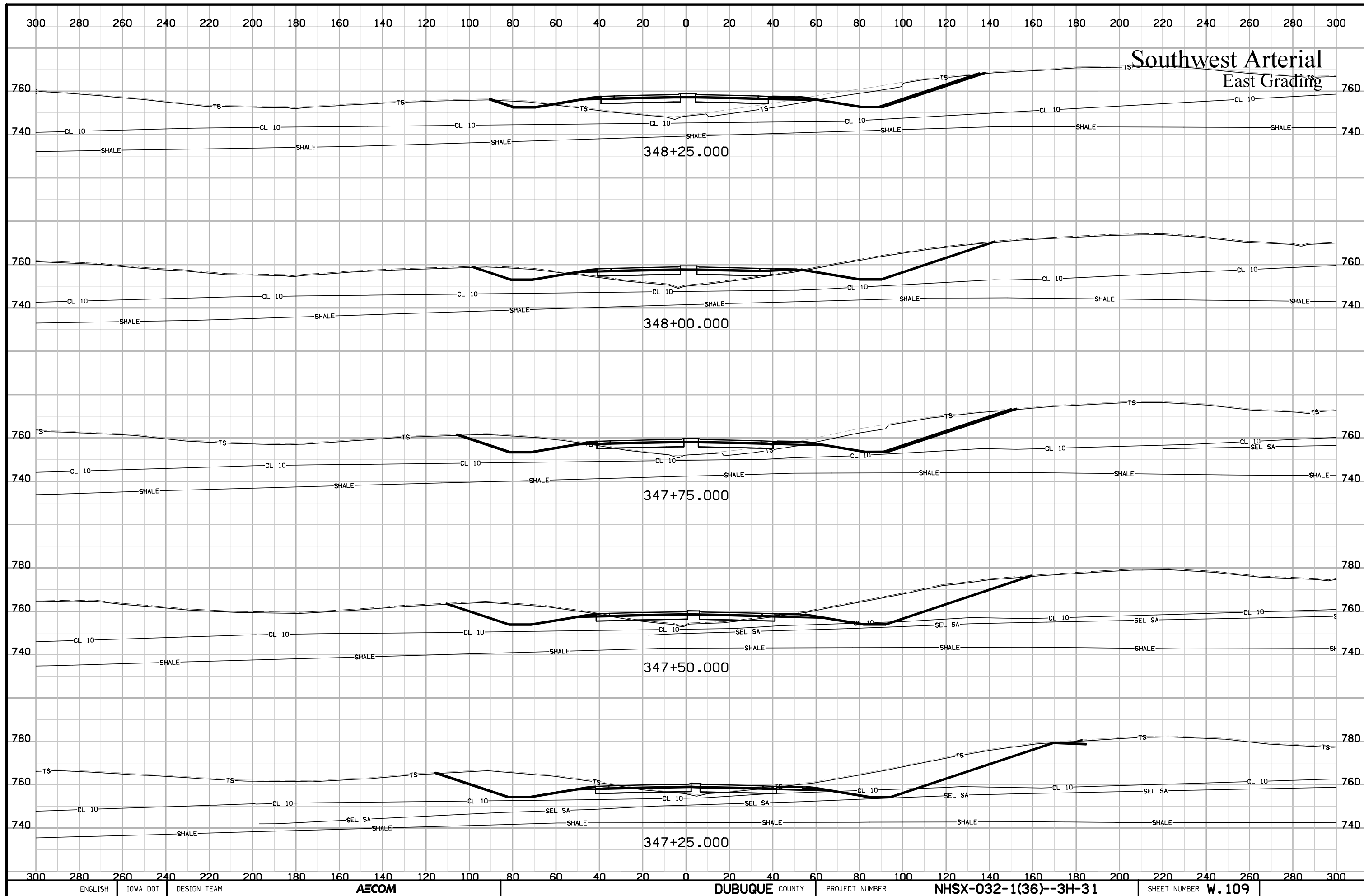

**Southwest Arterial
East Grading**

348+25.000

348+00.000

347+75.000

347+50.000

347+25.000

Southwest Arterial East Grading

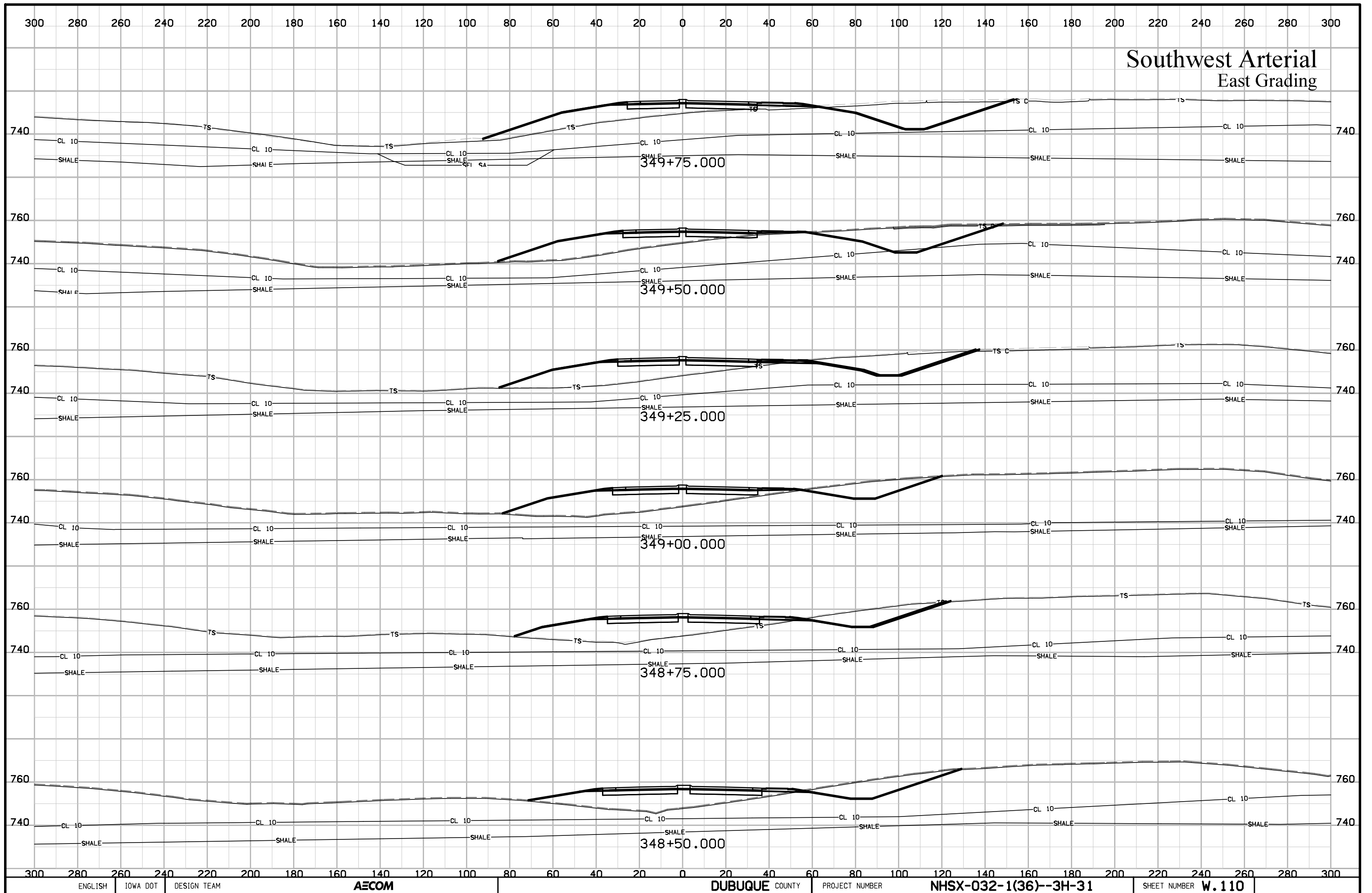

300 280 260 240 220 200 180 160 140 120 100 80 60 40 20 0 20 40 60 80 100 120 140 160 180 200 220 240 260 280 300

Southwest Arterial East Grading

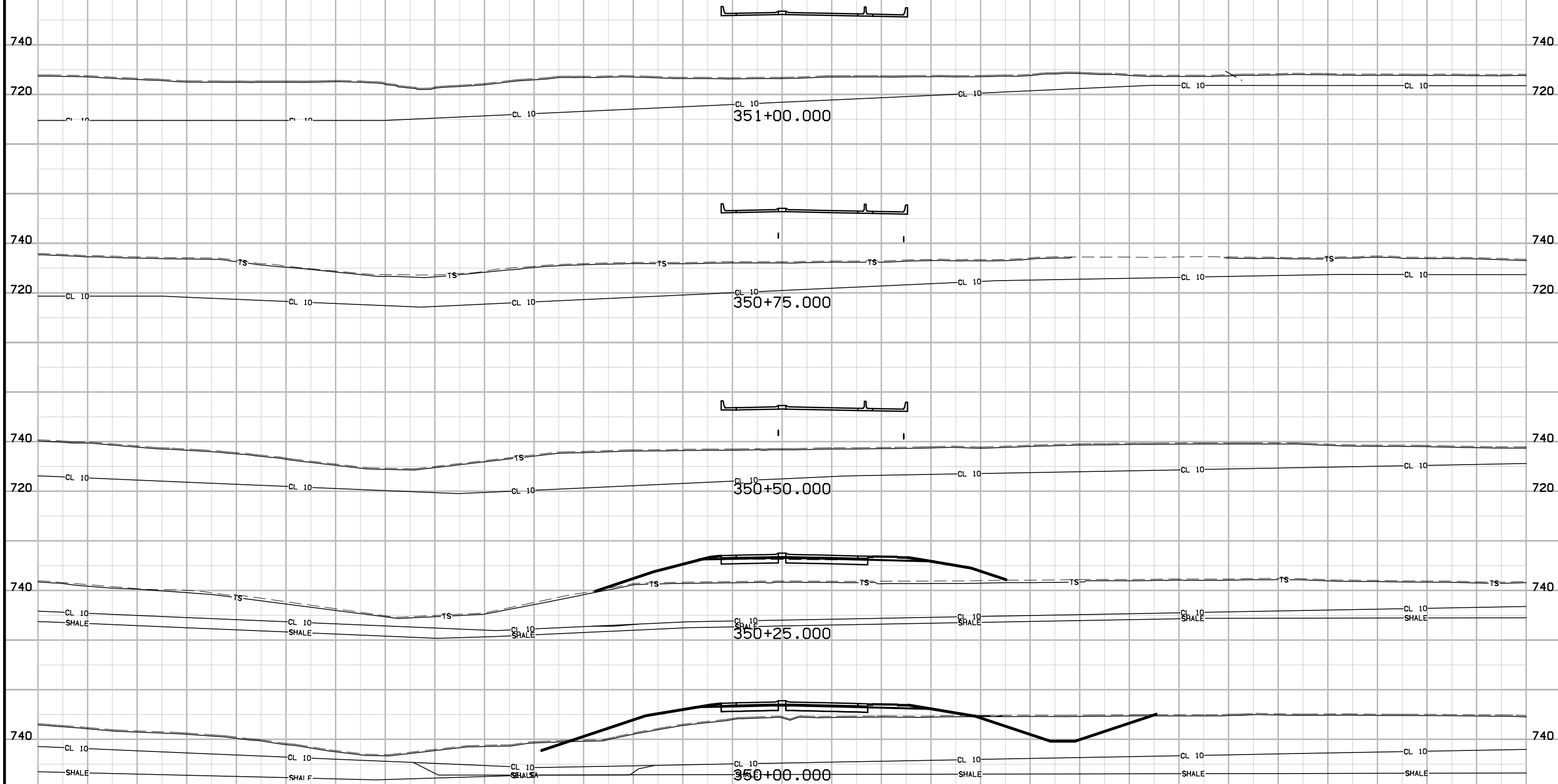

Southwest Arterial East Grading

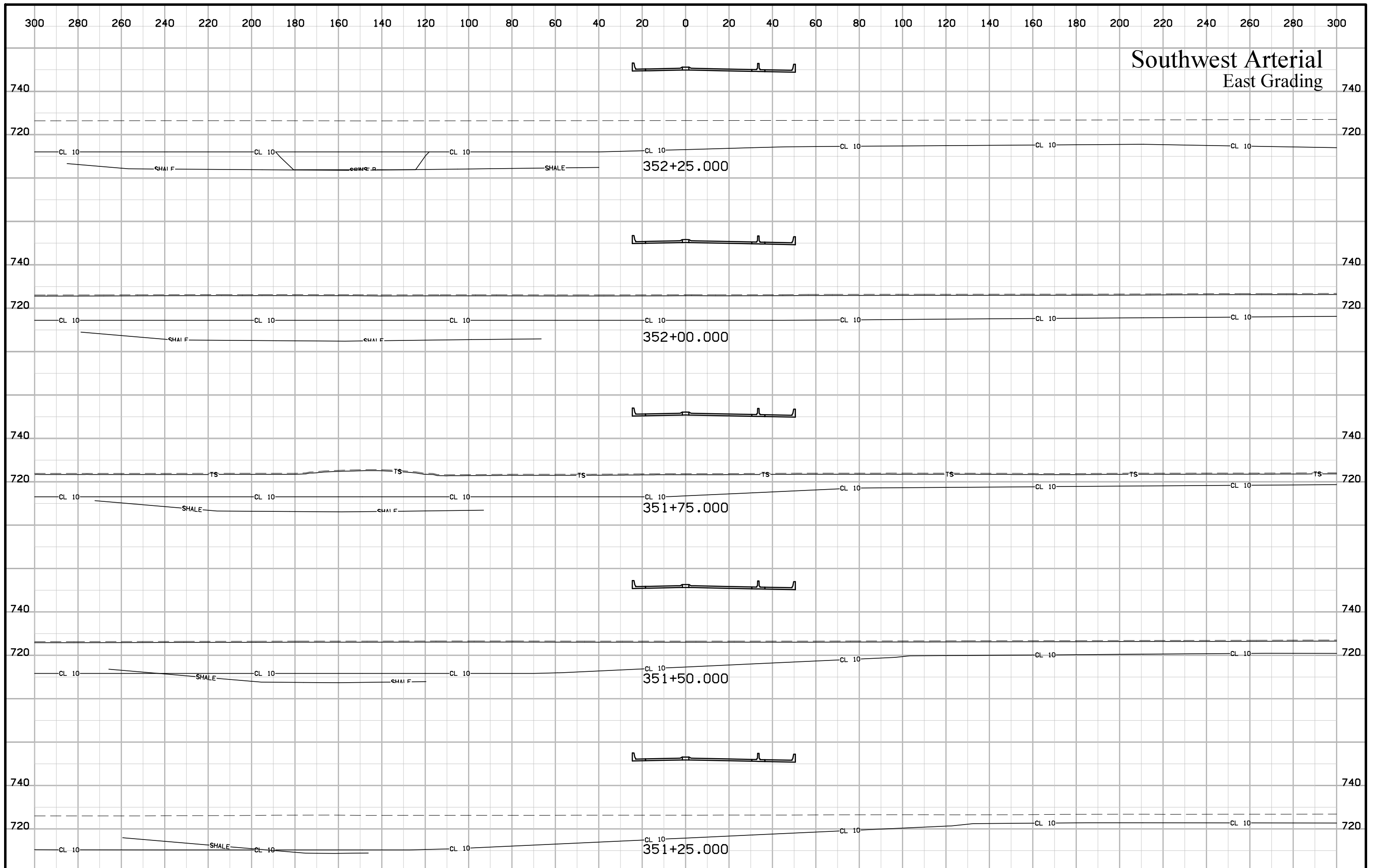

Southwest Arterial East Grading

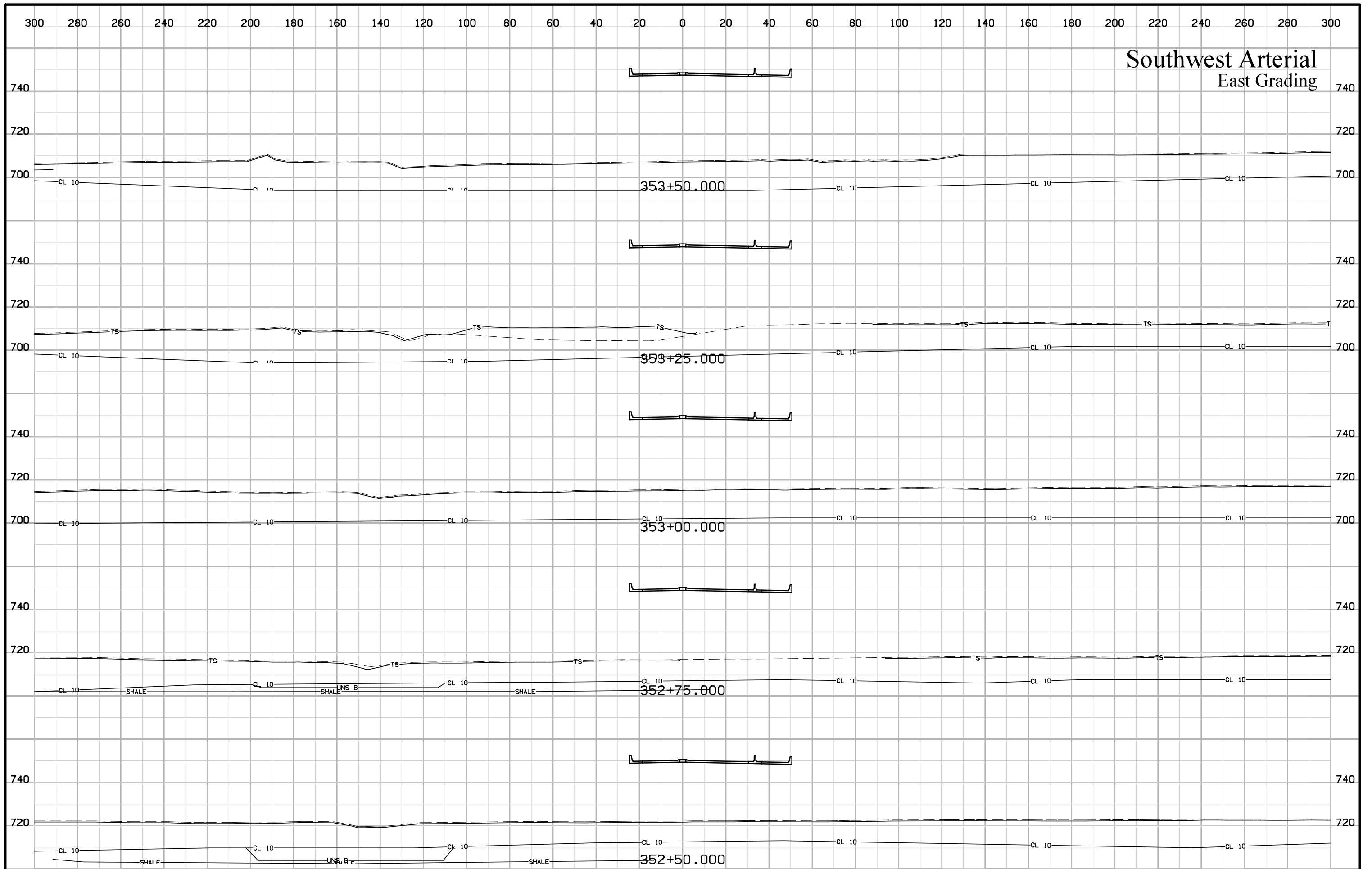

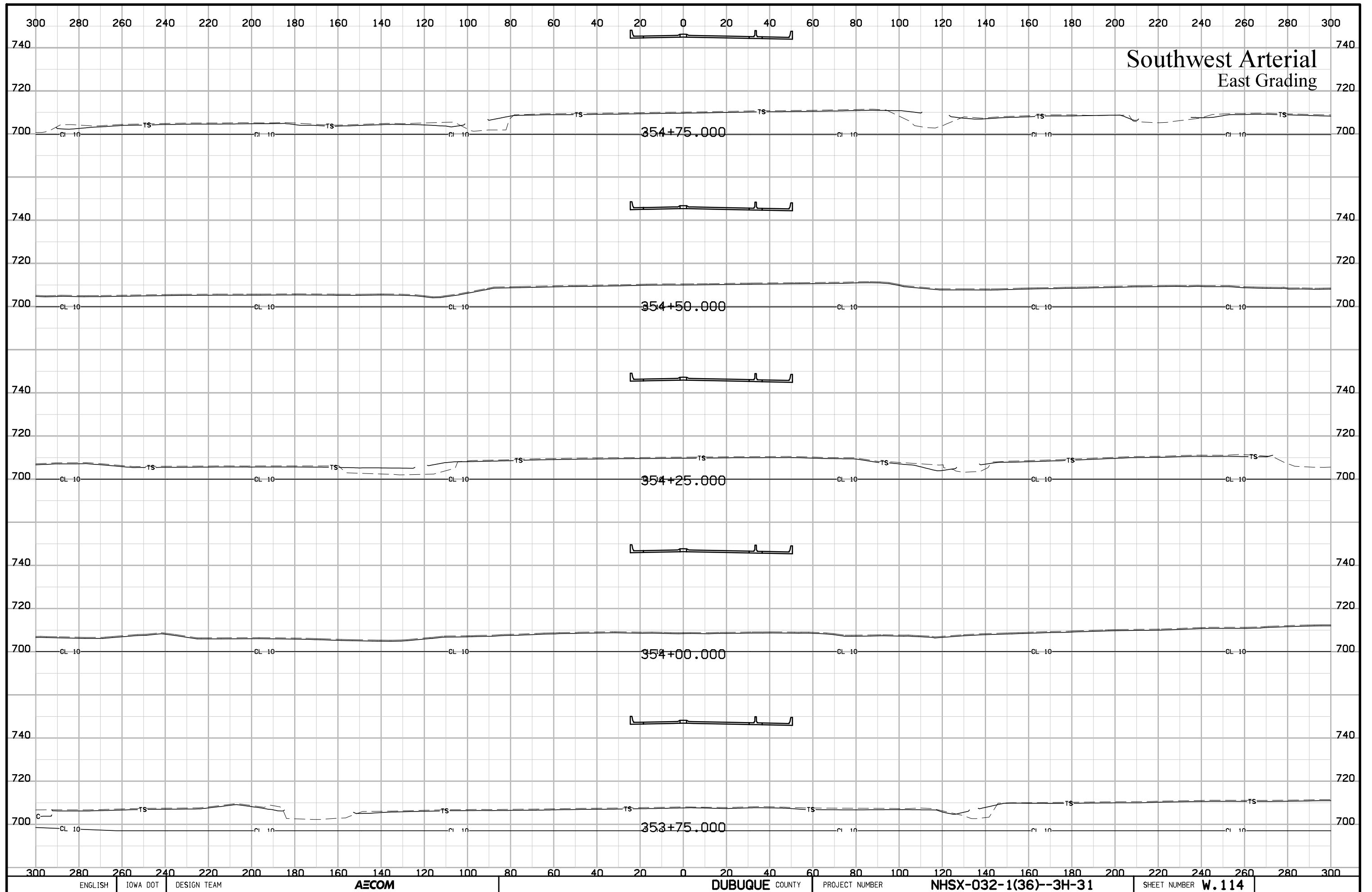

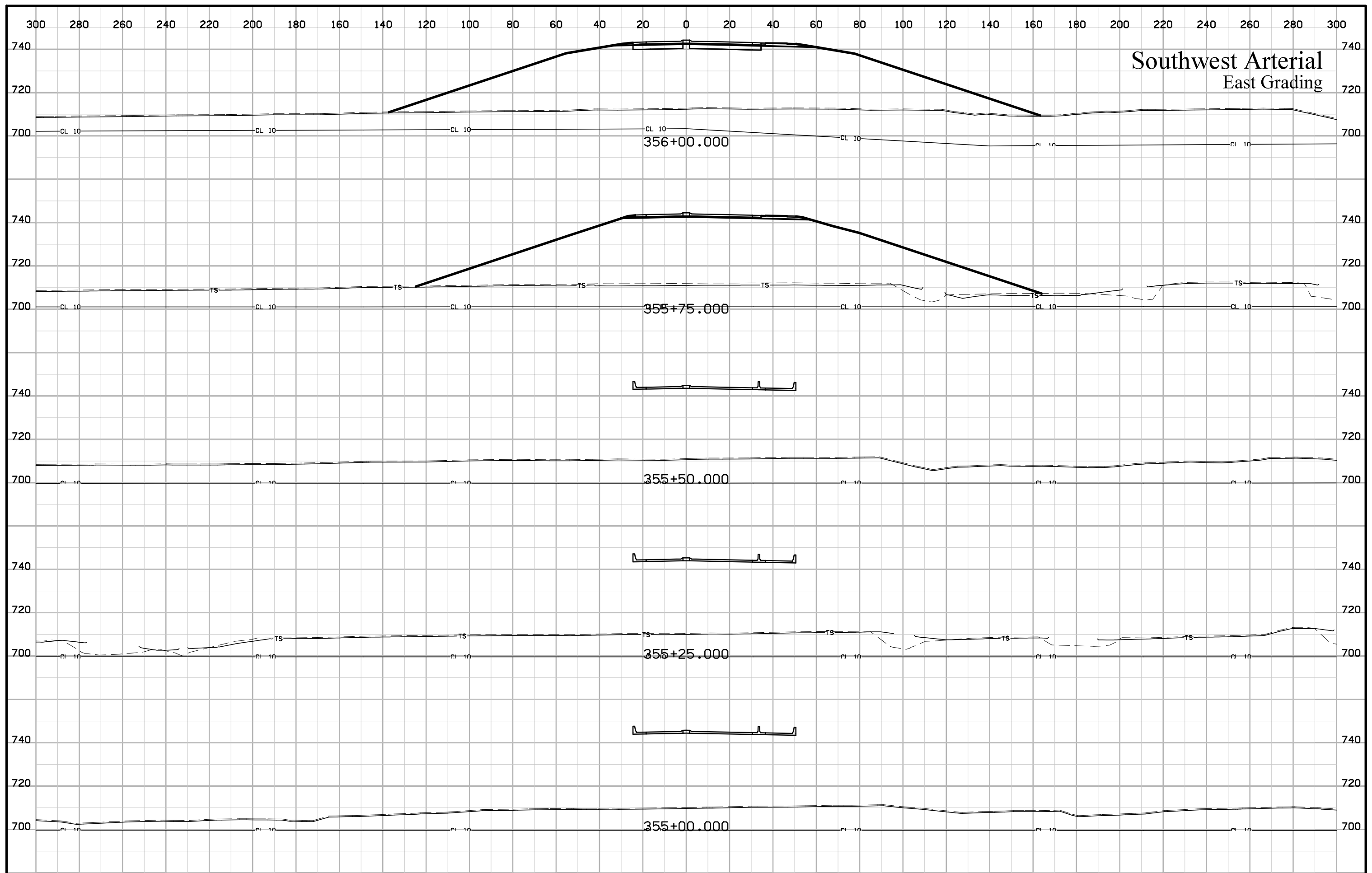

Southwest Arterial
East Grading

CL 10
356+00.000

CL 10
355+75.000

CL 10
355+50.000

CL 10
355+25.000

CL 10
355+00.000

Southwest Arterial East Grading

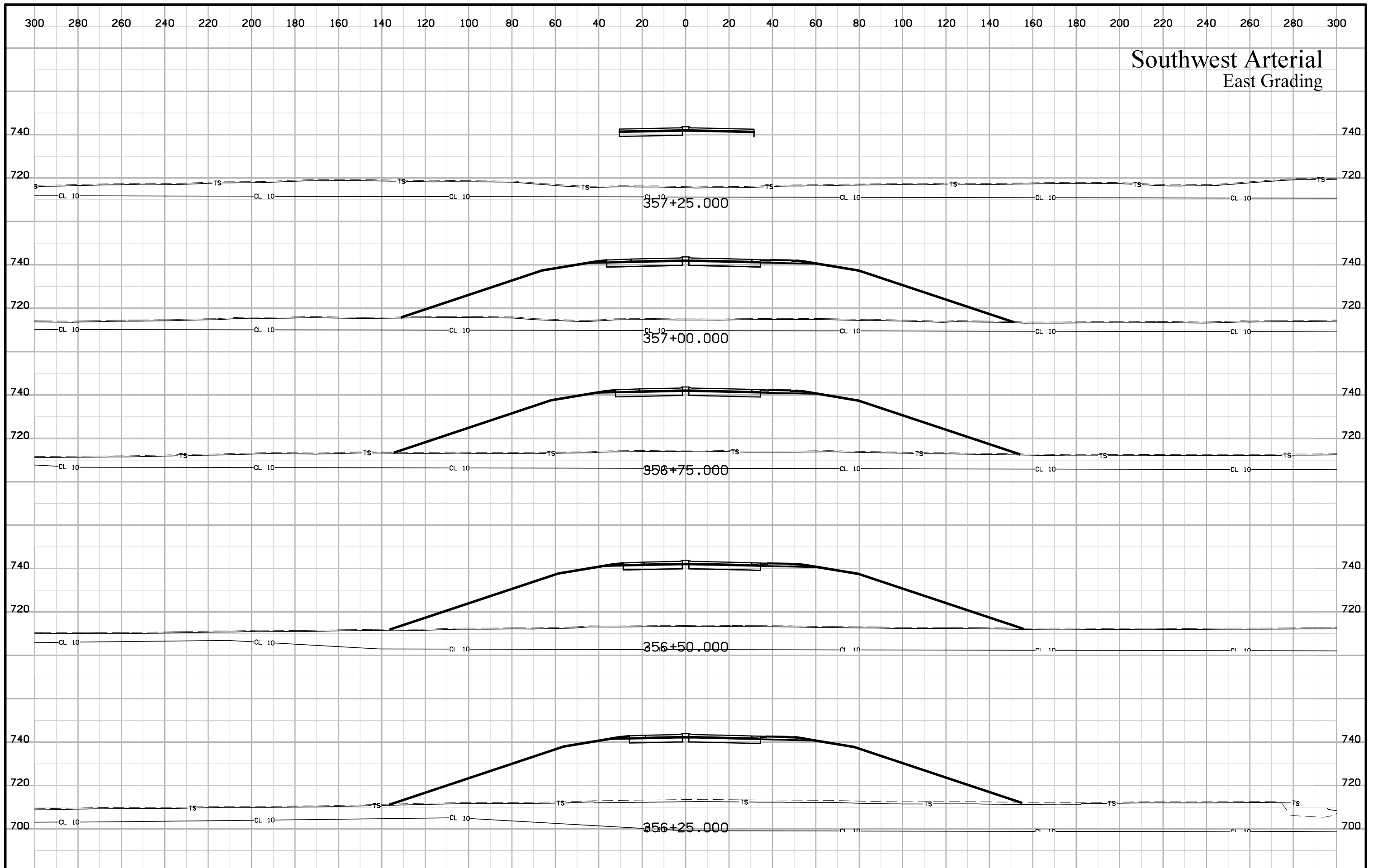

Southwest Arterial East Grading

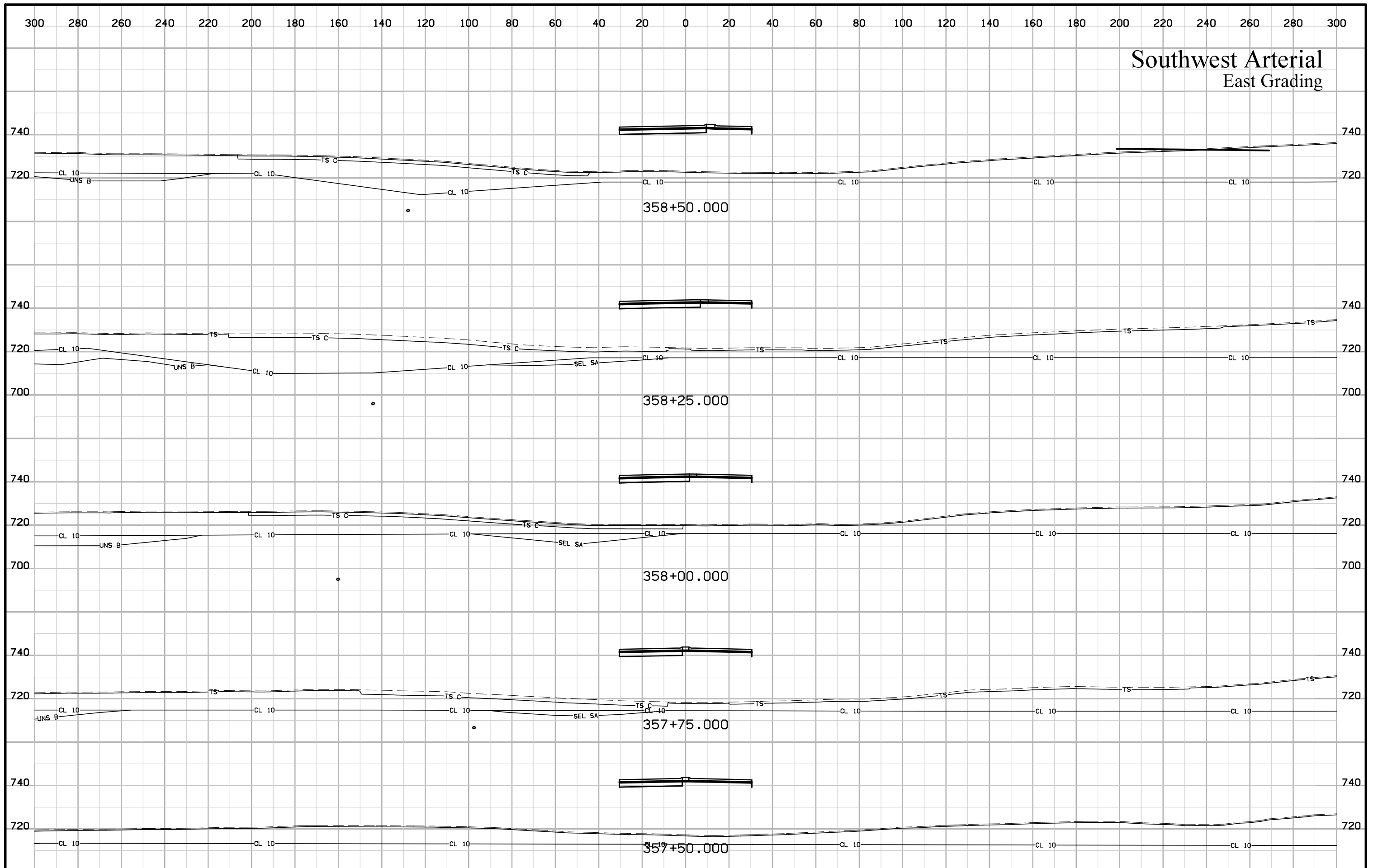

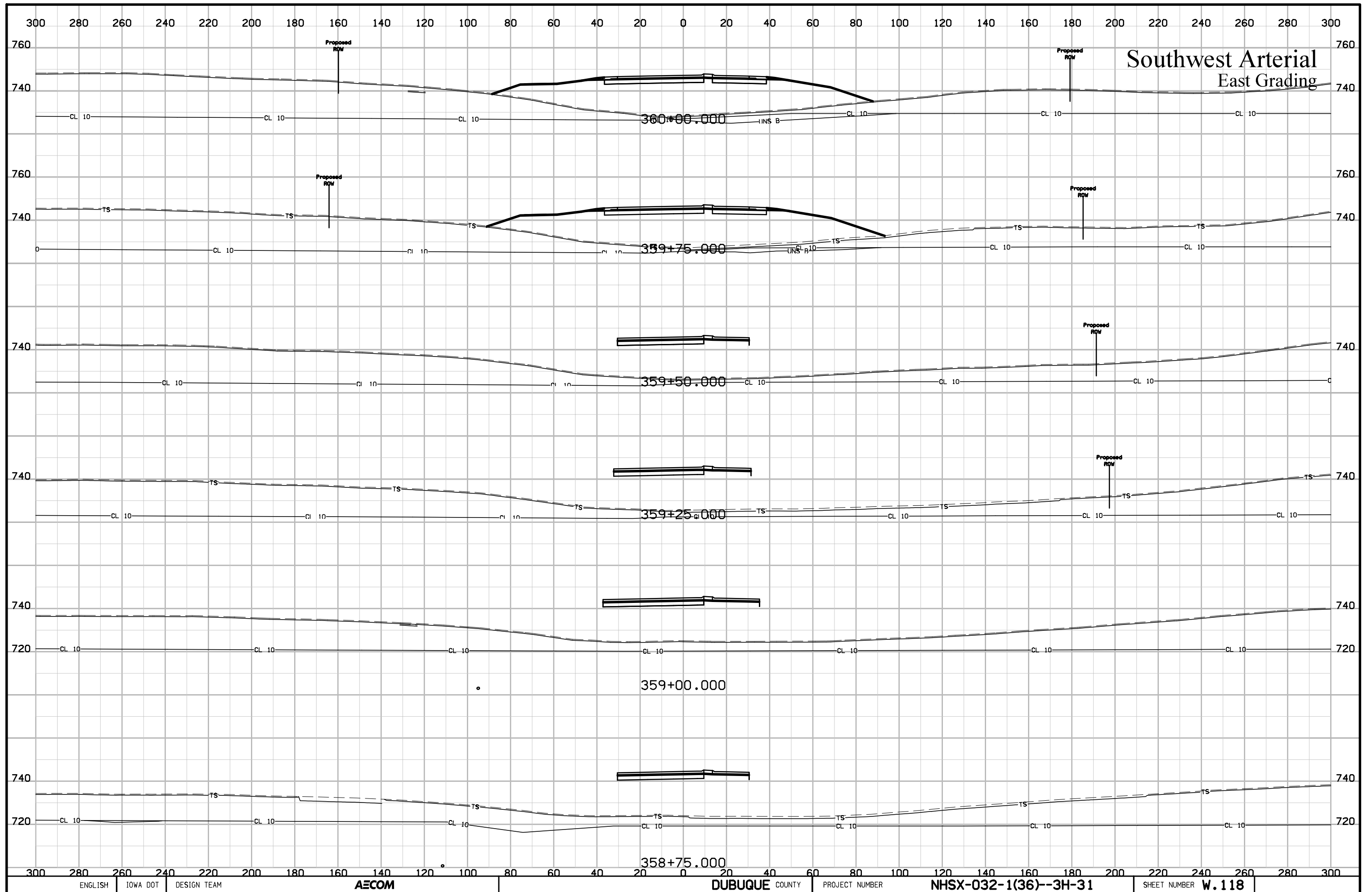

Southwest Arterial East Grading

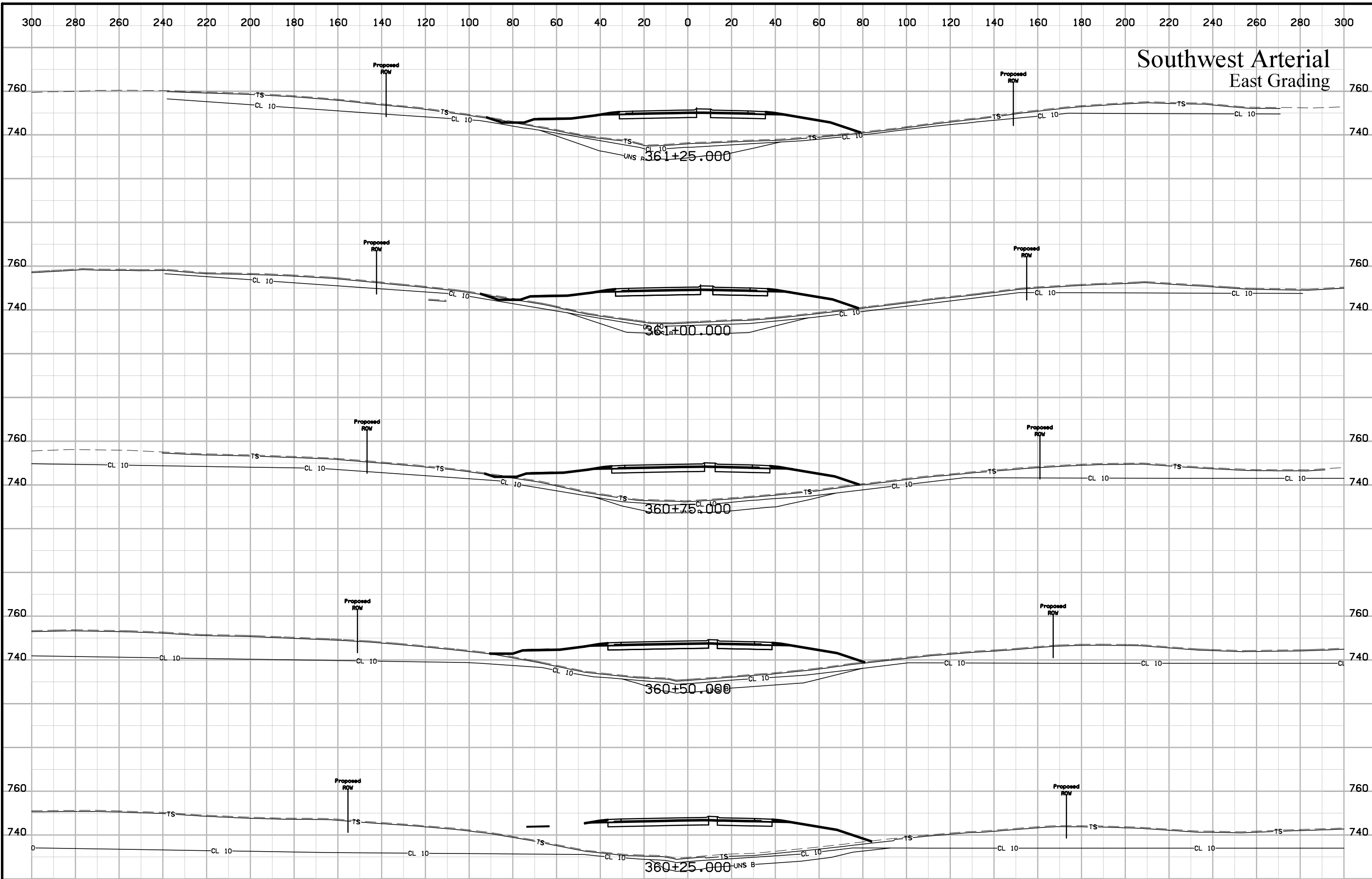

Southwest Arterial East Grading

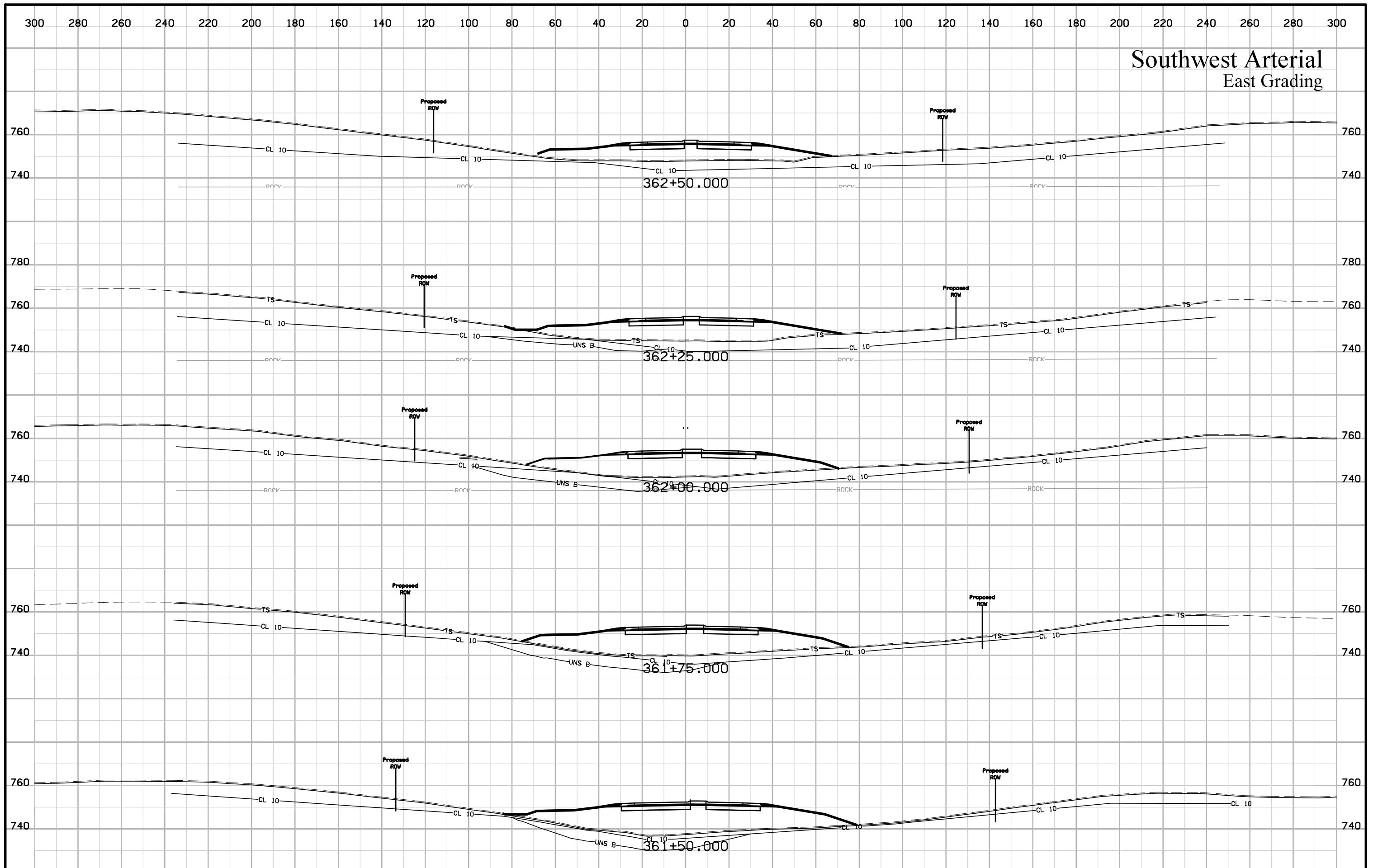

Southwest Arterial East Grading

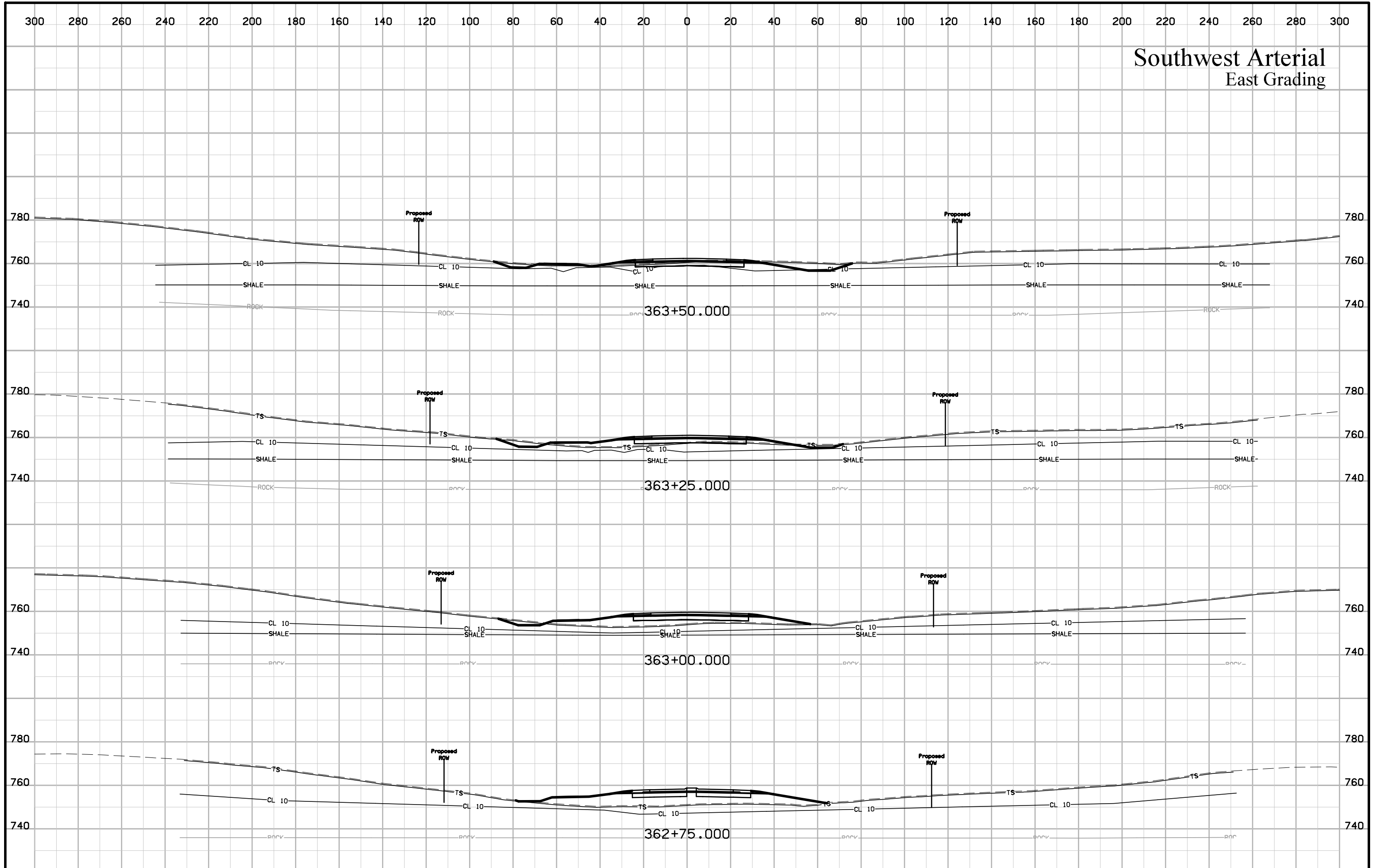

Southwest Arterial East Grading

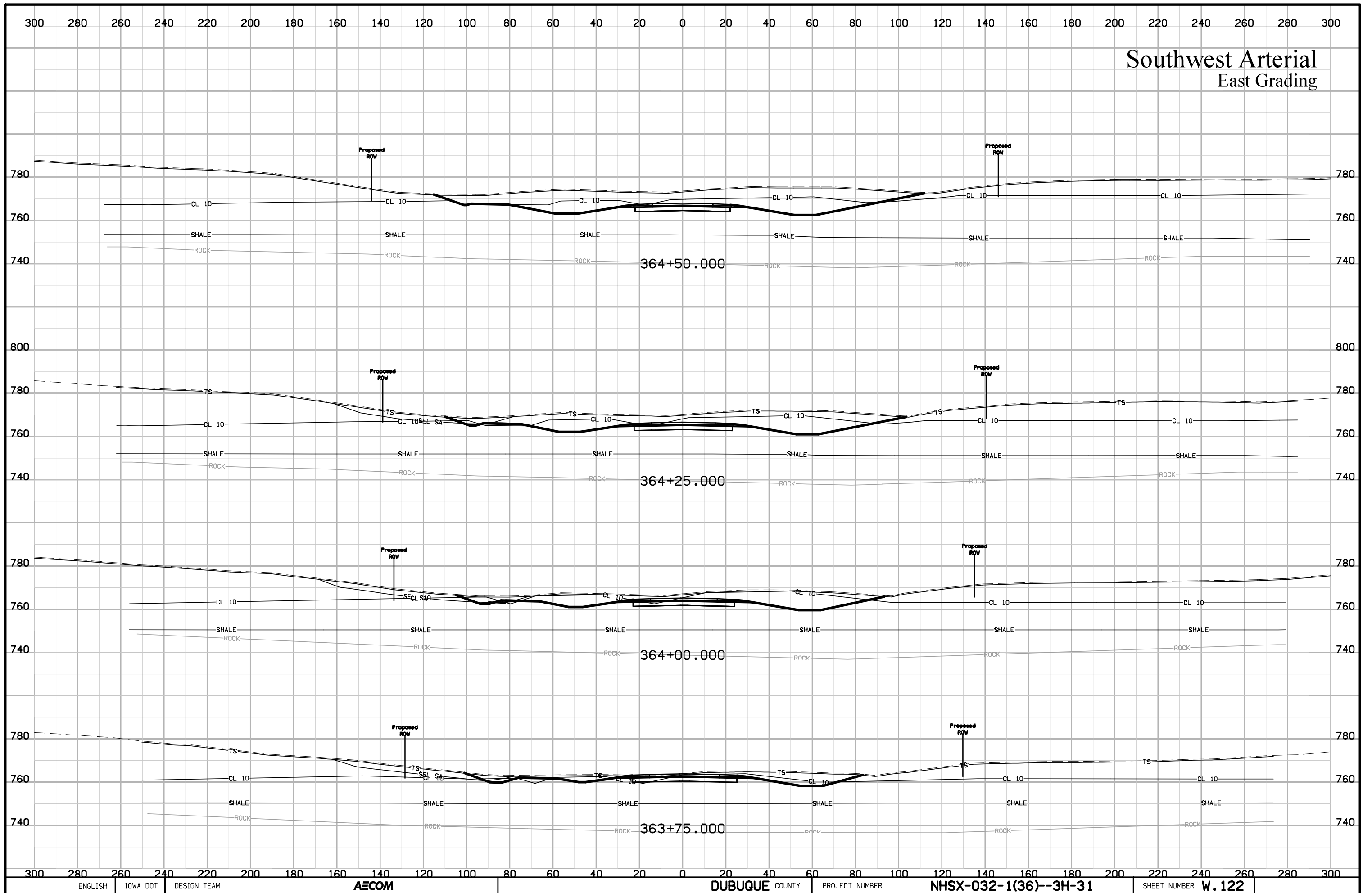

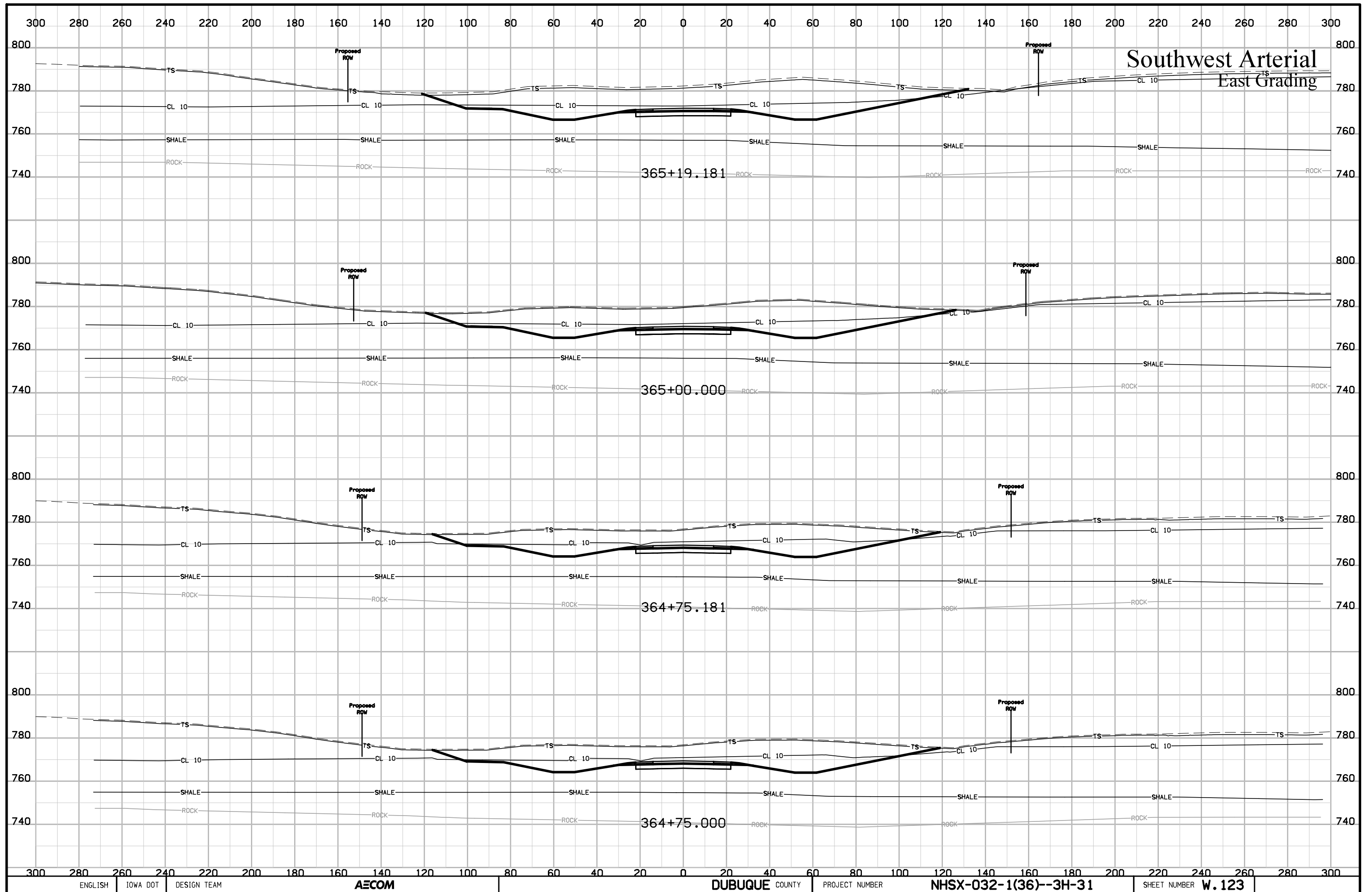

Southwest Arterial East Grading

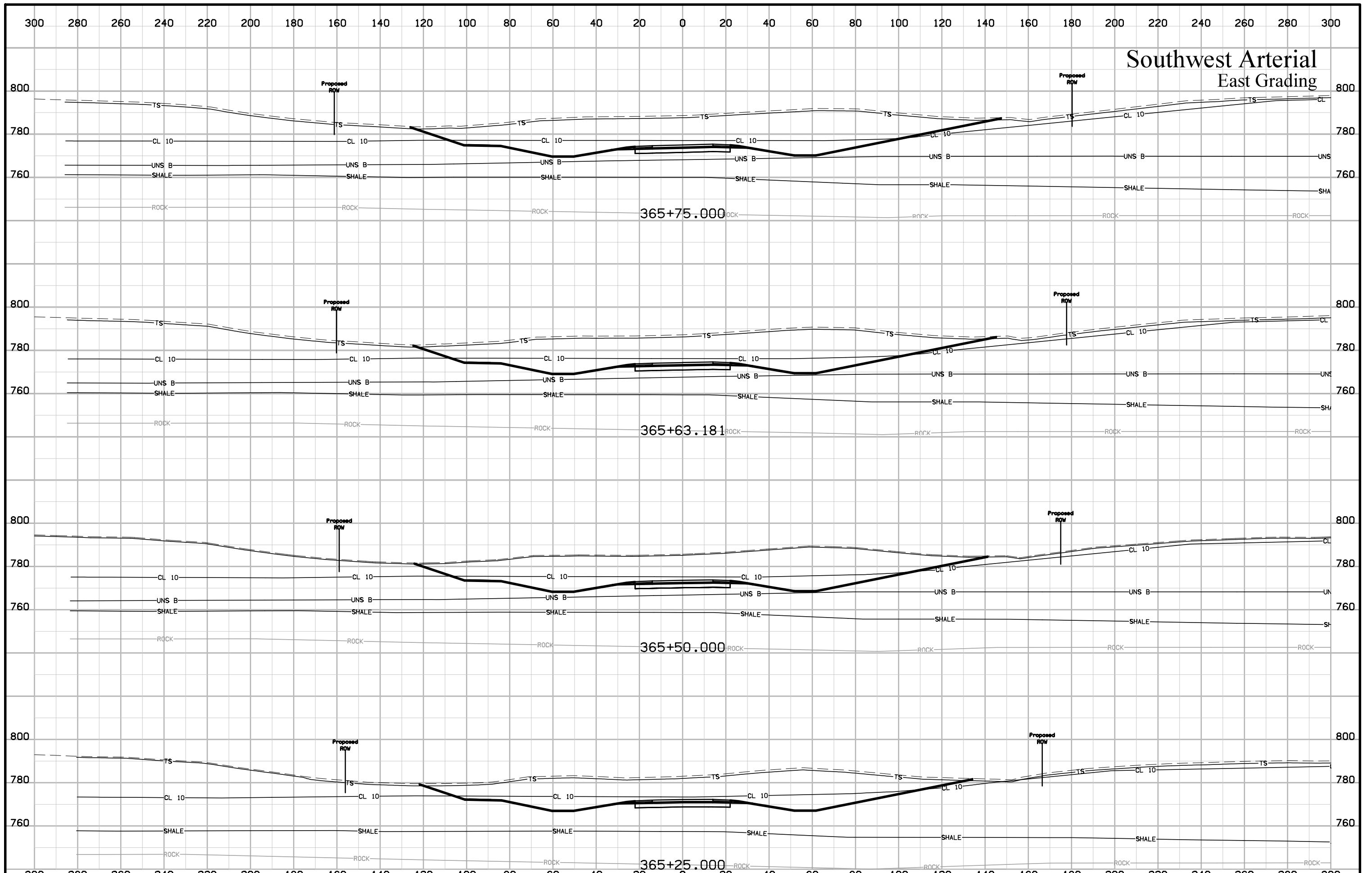

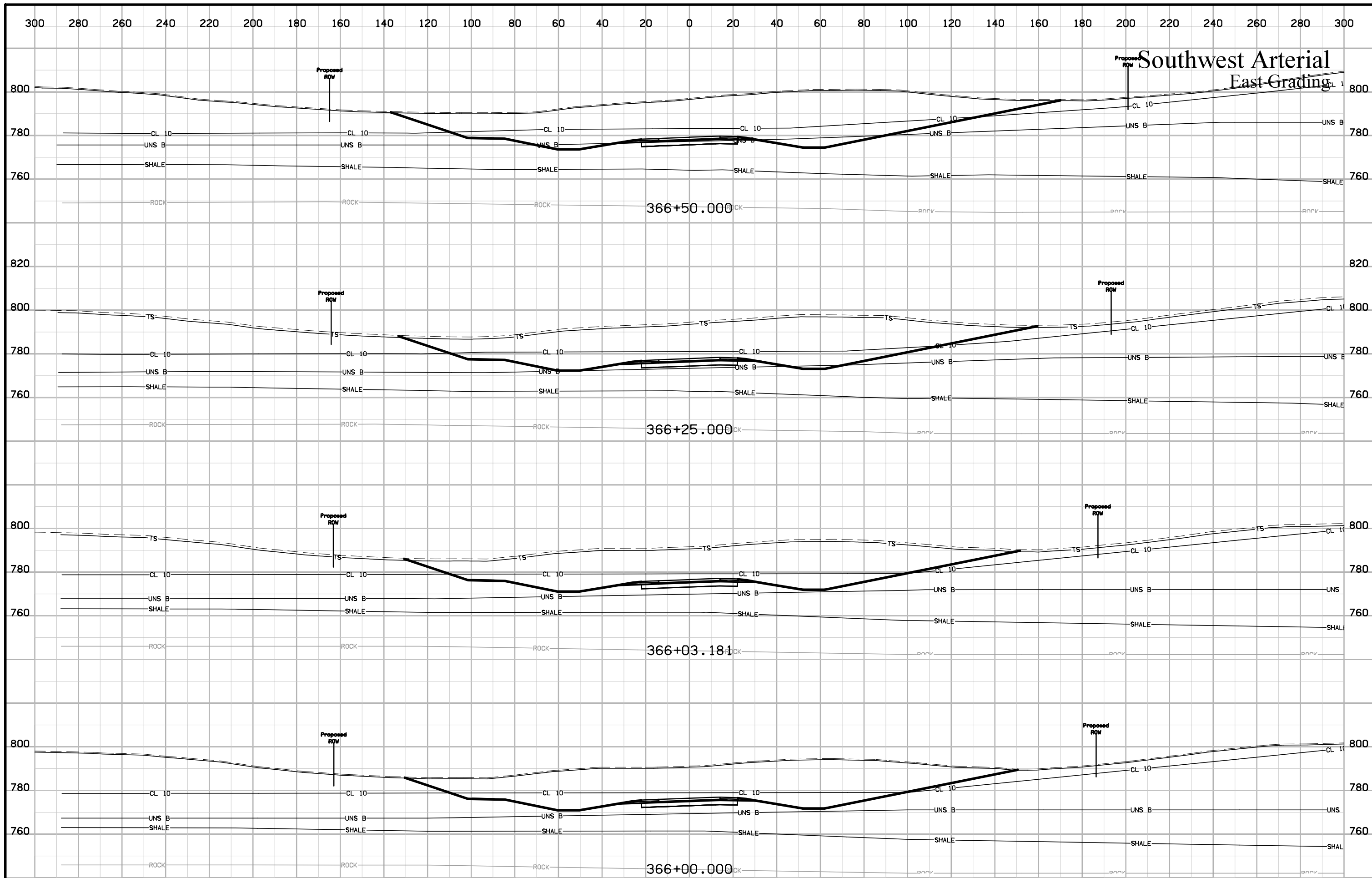

Southwest Arterial East Grading

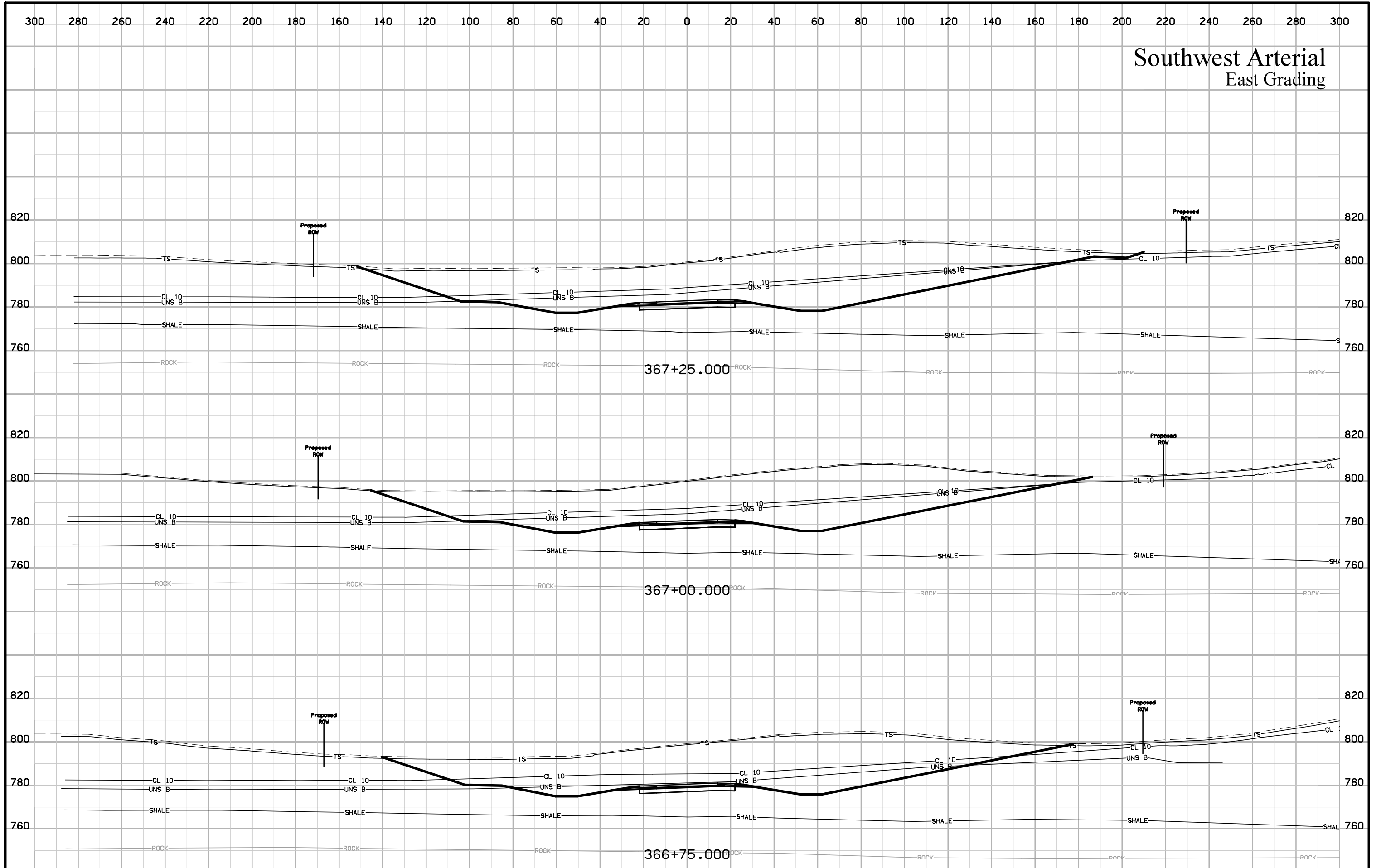

Southwest Arterial East Grading

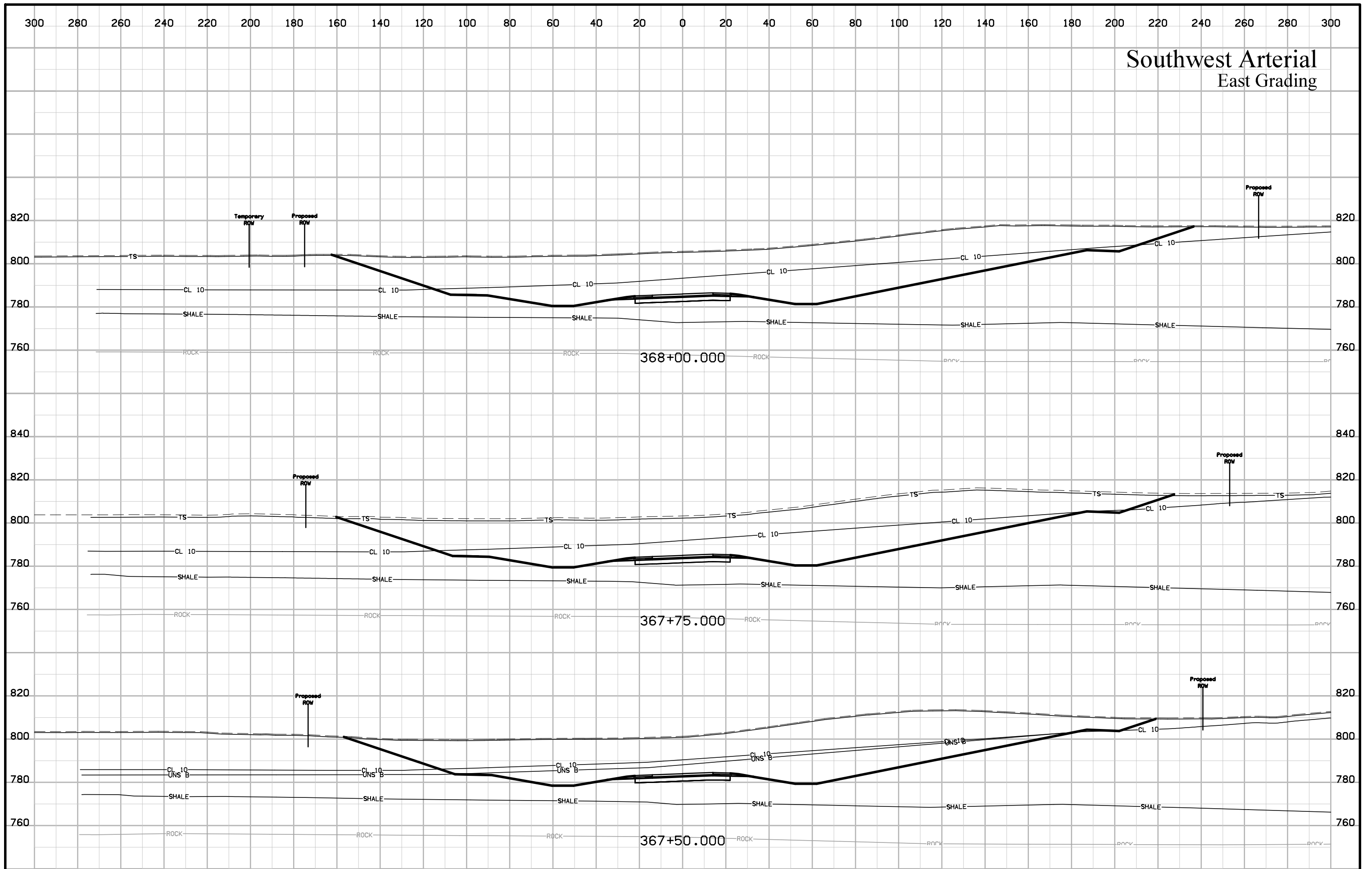

Southwest Arterial East Grading

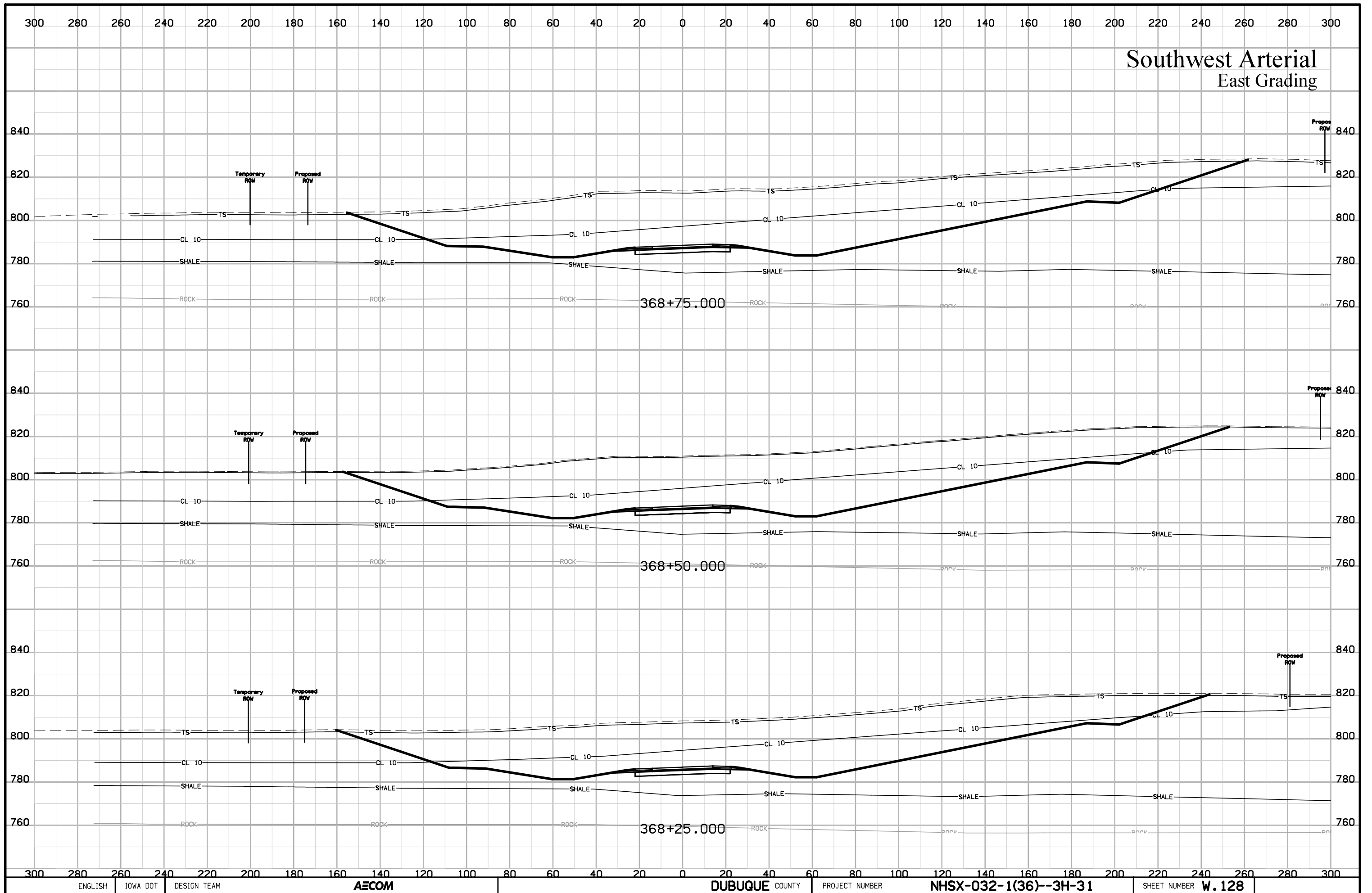

Southwest Arterial East Grading

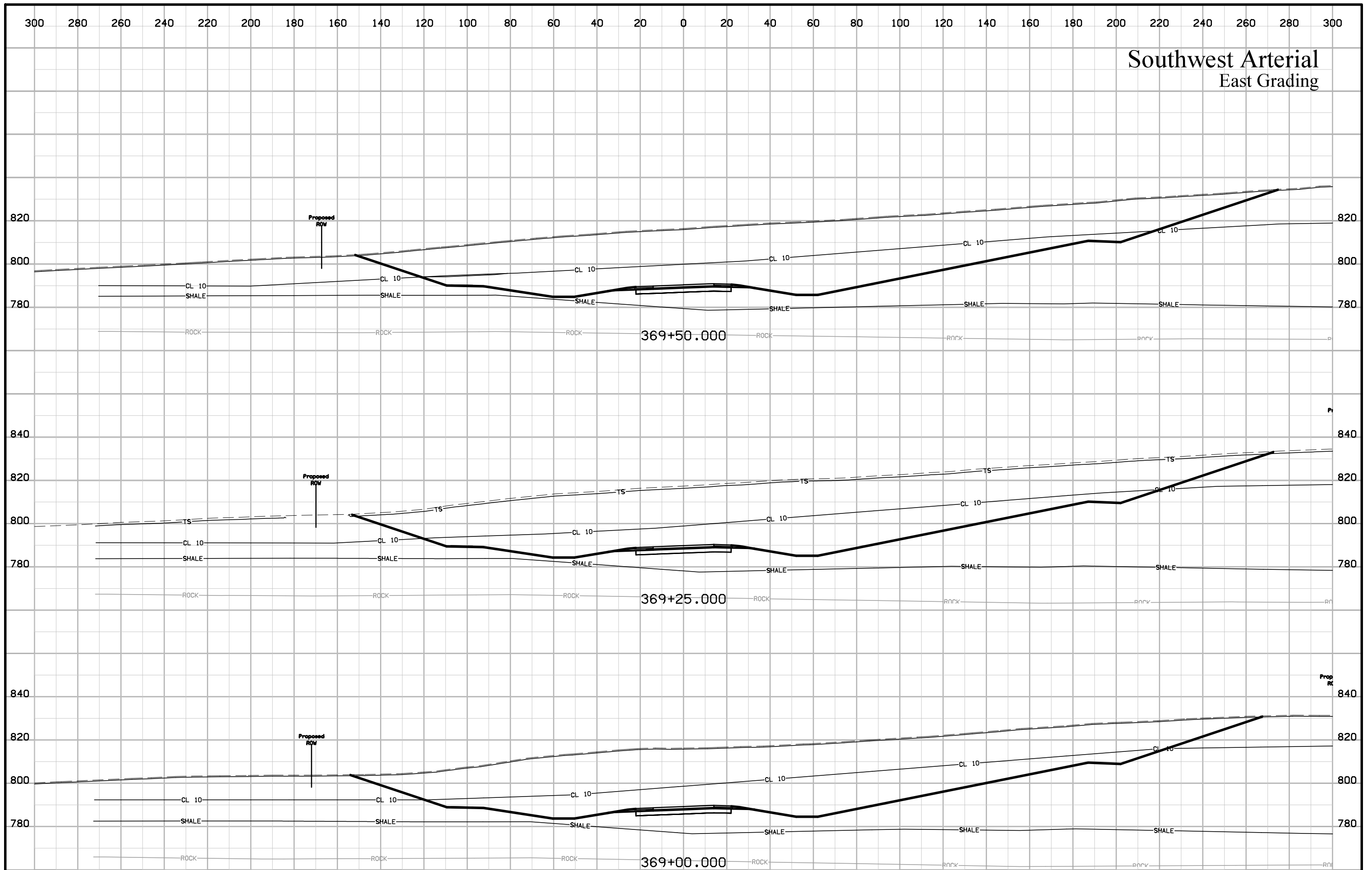

Southwest Arterial East Grading

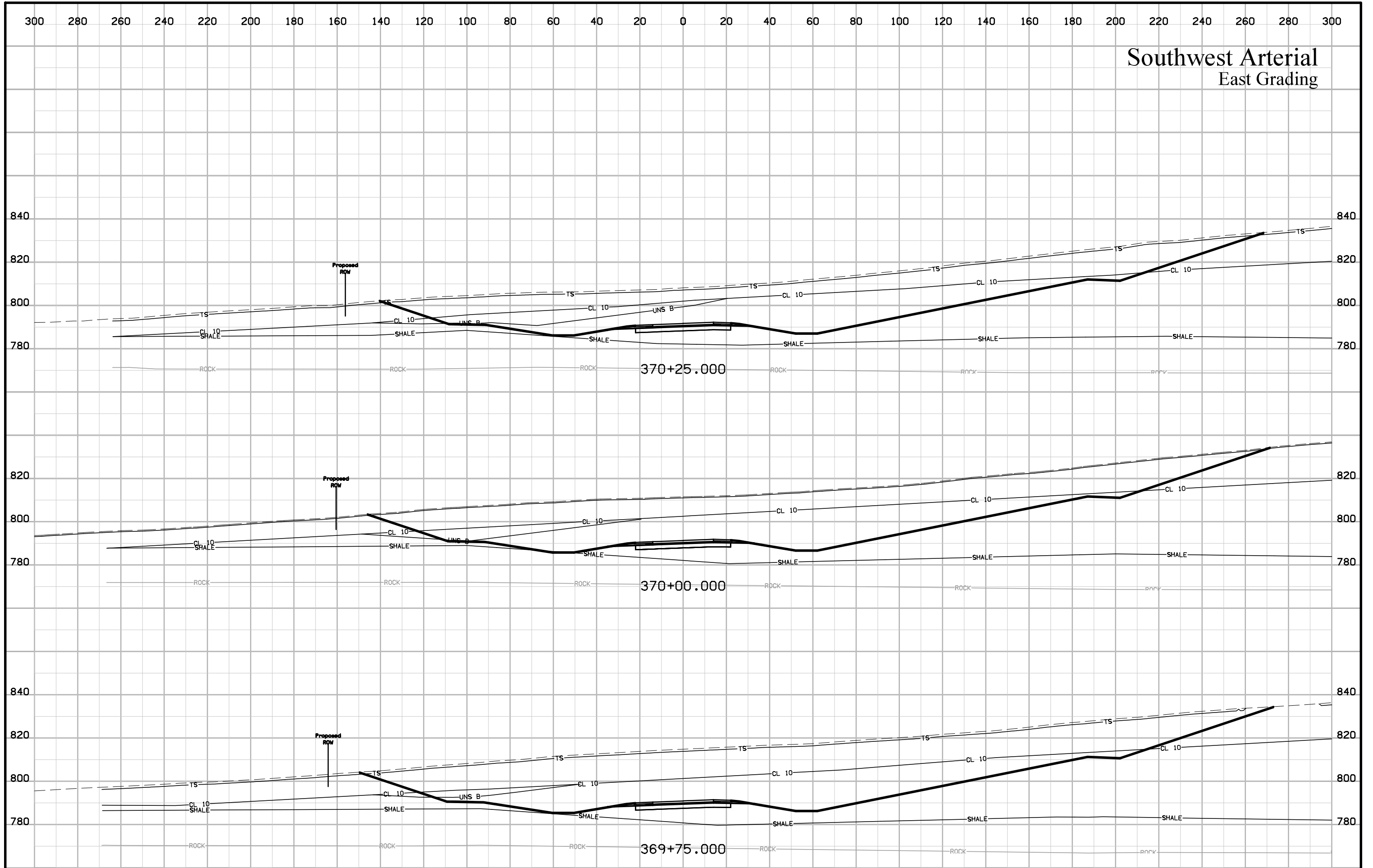

Southwest Arterial East Grading

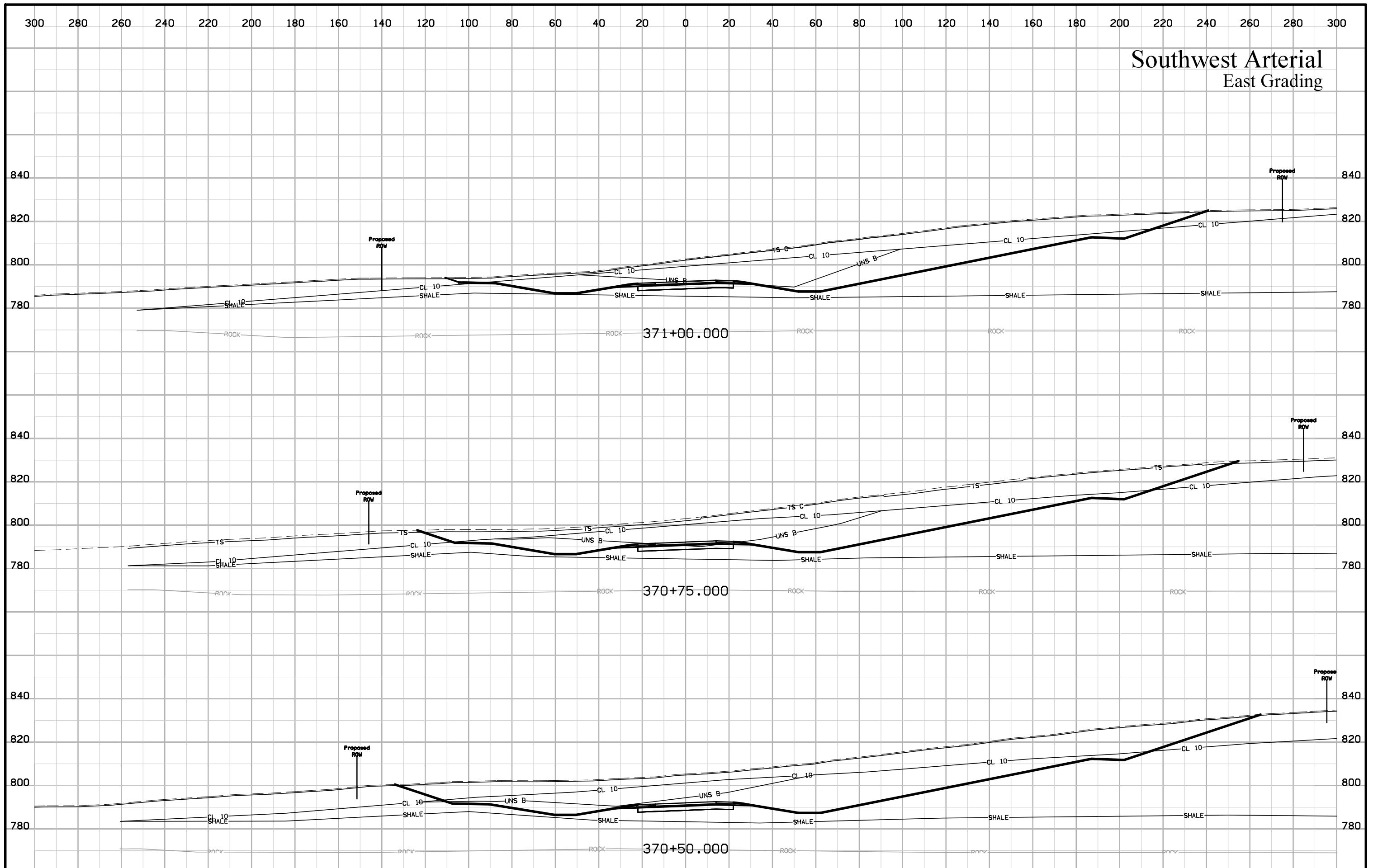

Southwest Arterial East Grading

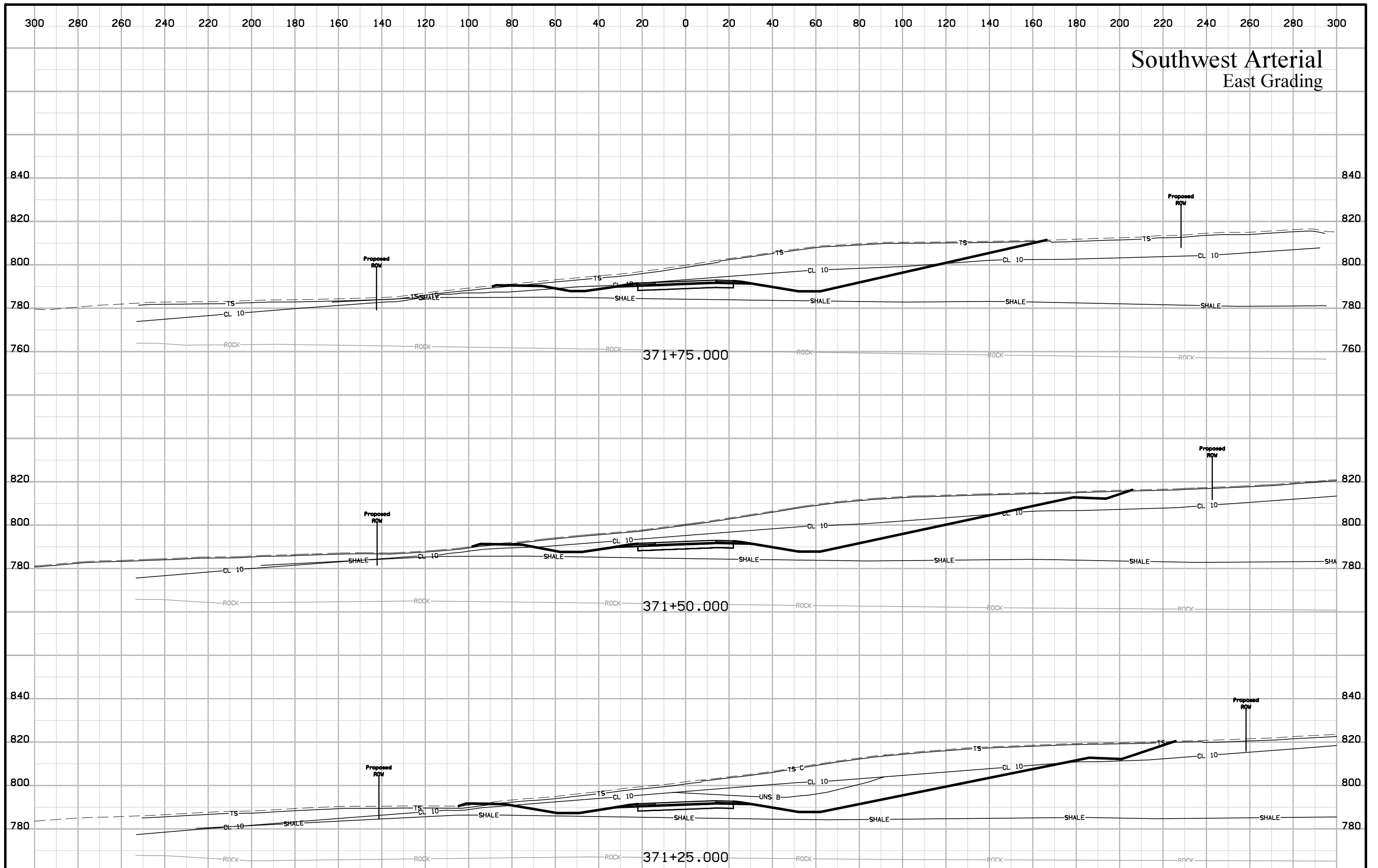

Southwest Arterial East Grading

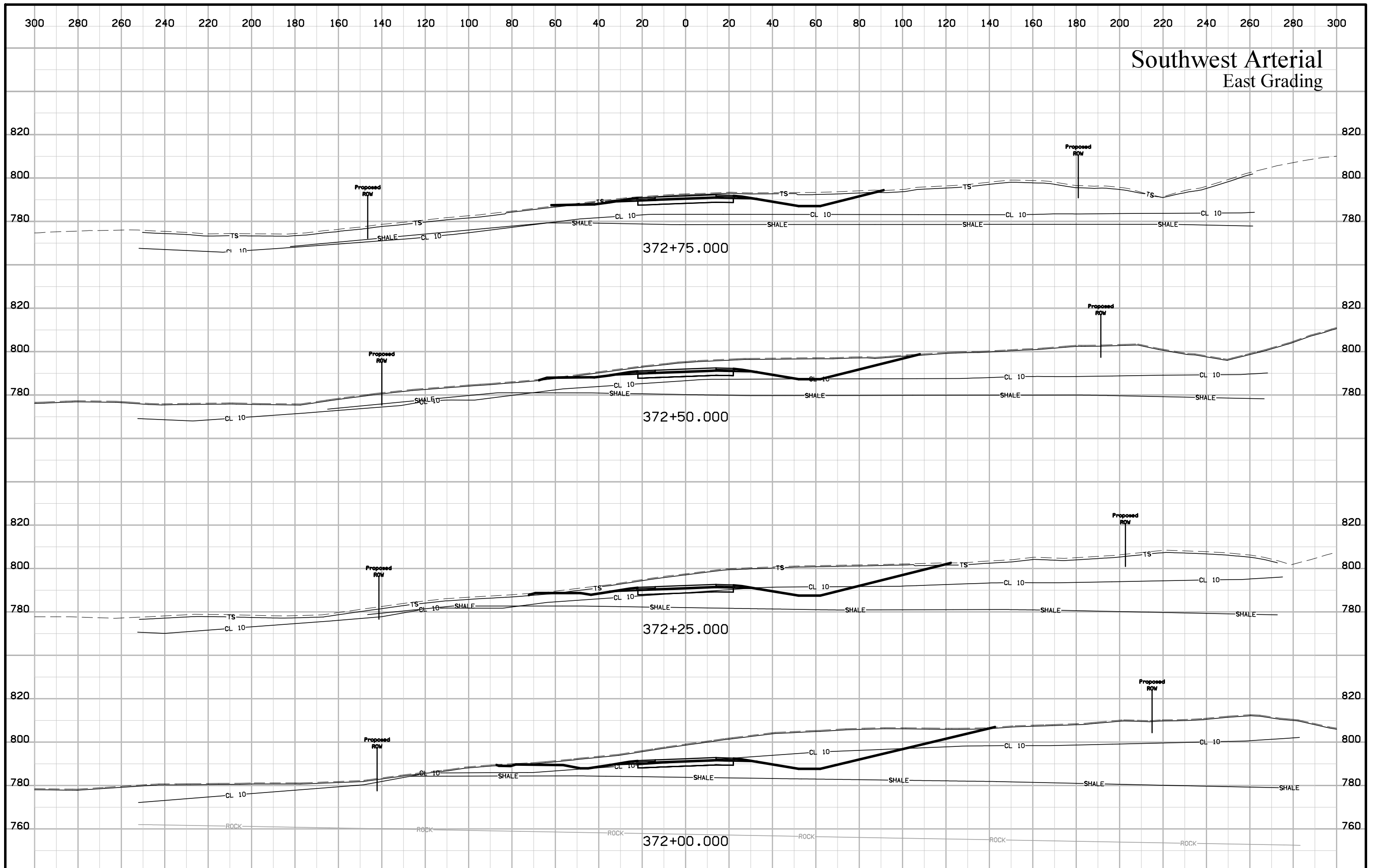

Southwest Arterial East Grading

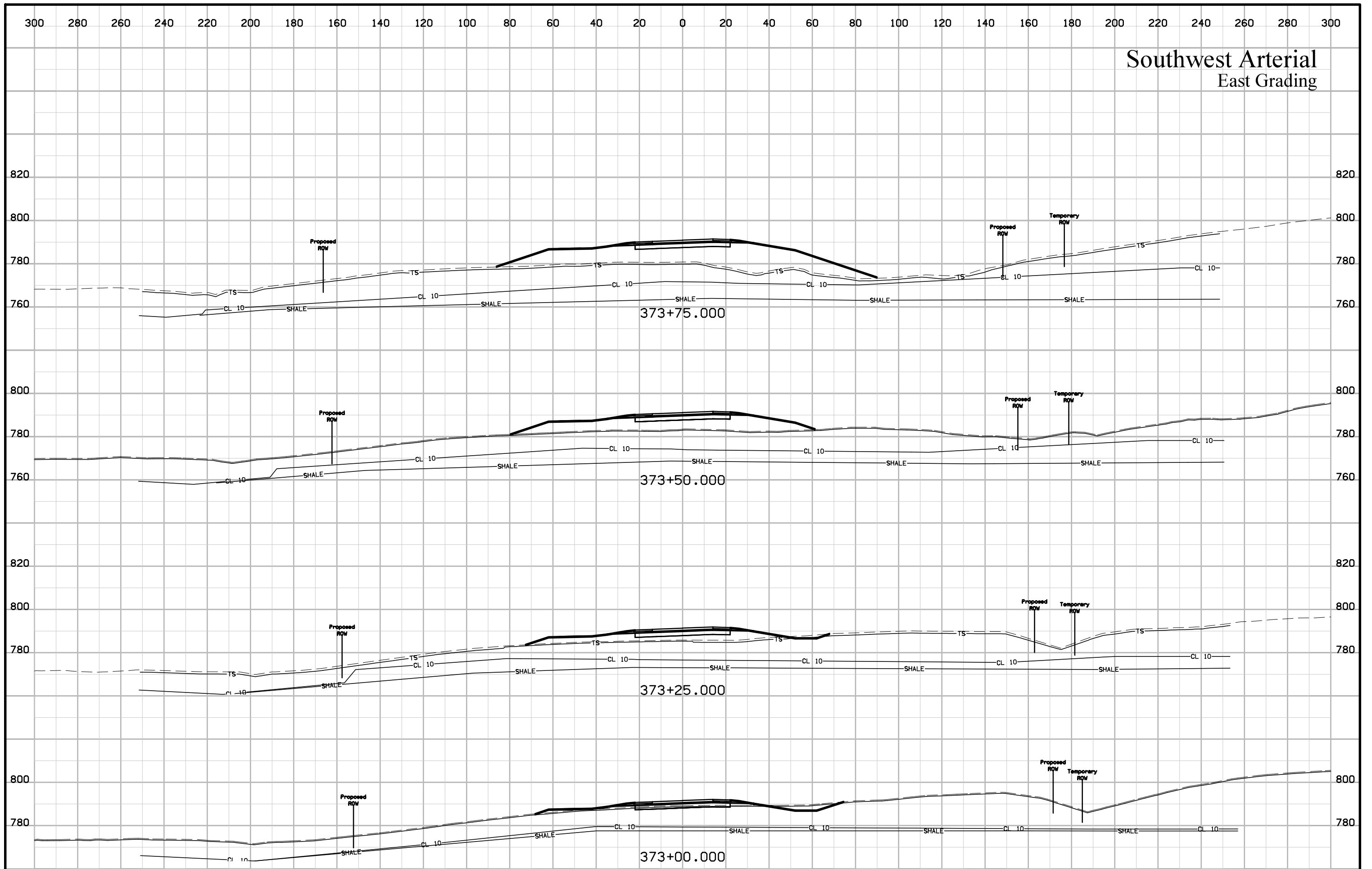

Southwest Arterial East Grading

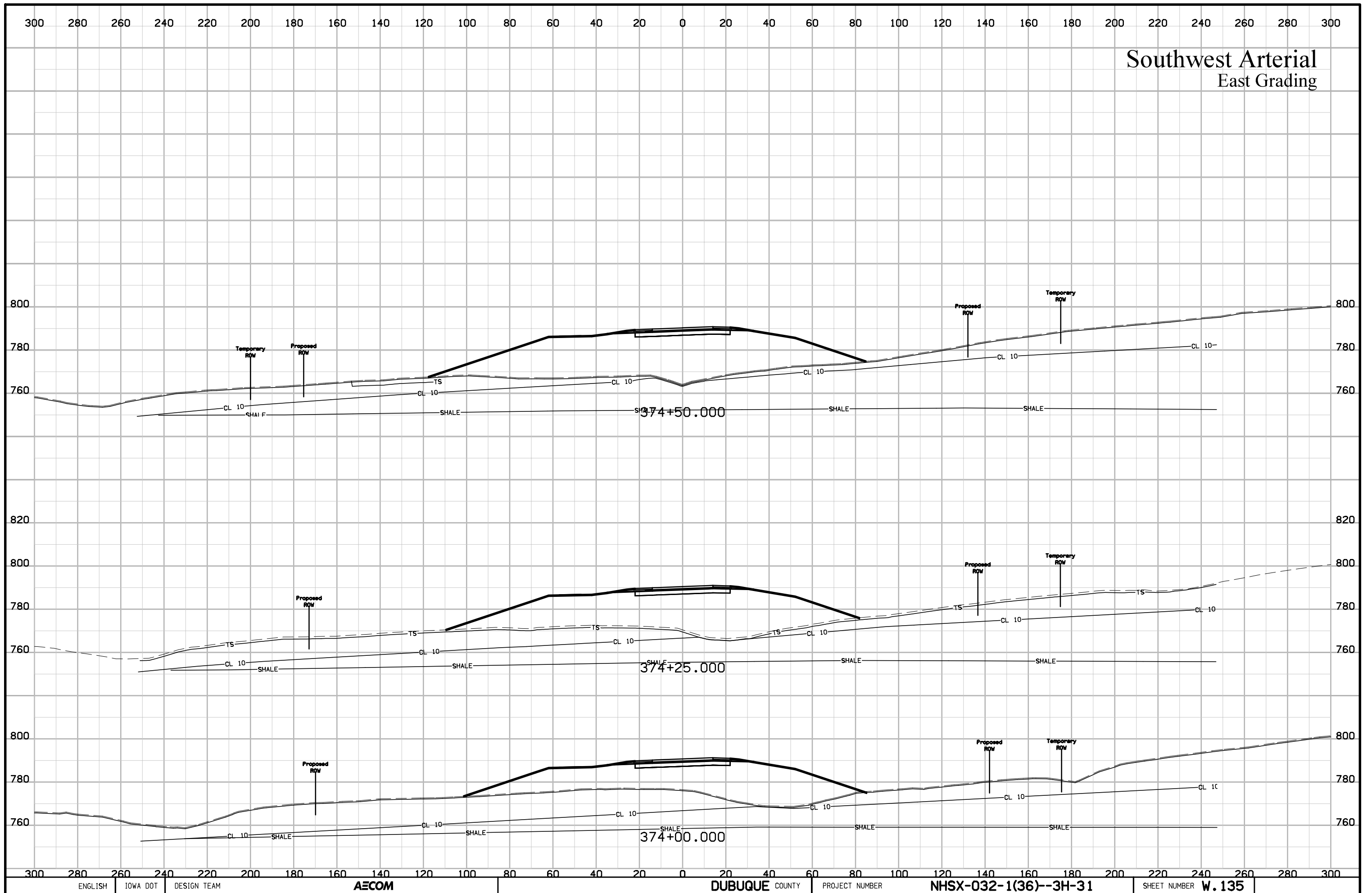

Southwest Arterial East Grading

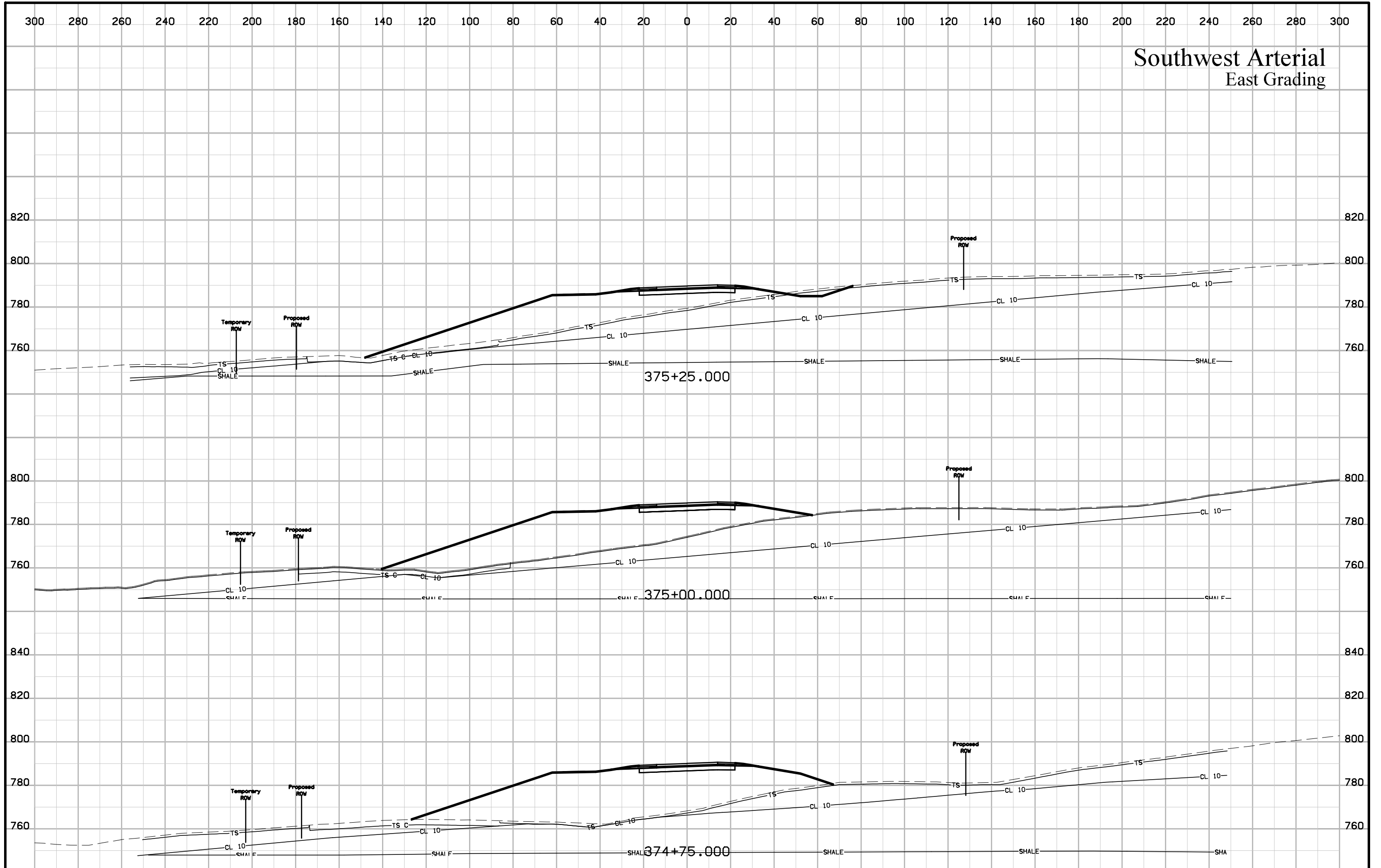

300 280 260 240 220 200 180 160 140 120 100 80 60 40 20 0 20 40 60 80 100 120 140 160 180 200 220 240 260 280 300

Southwest Arterial East Grading

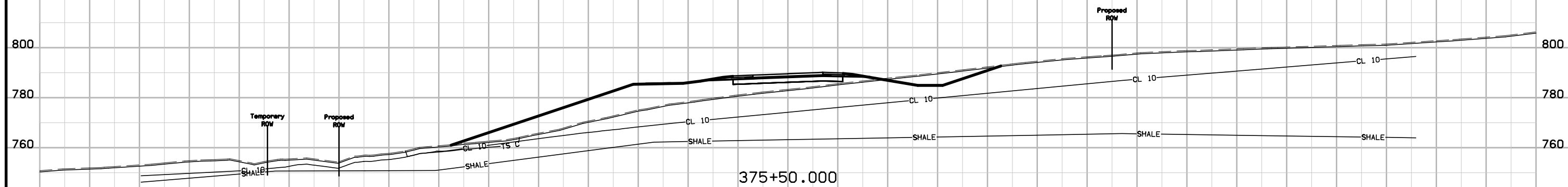
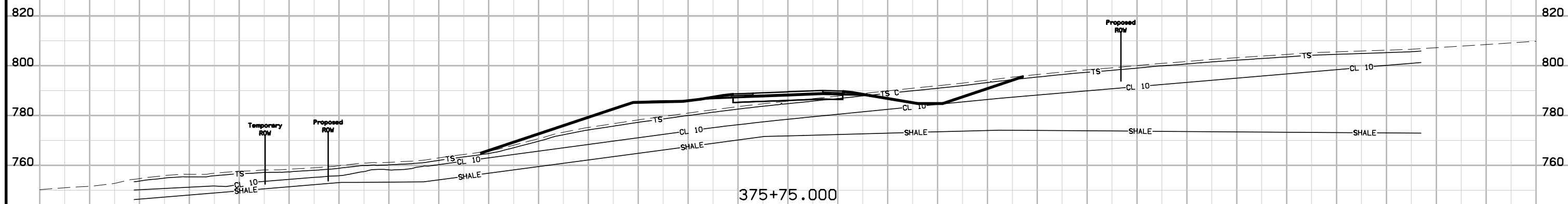
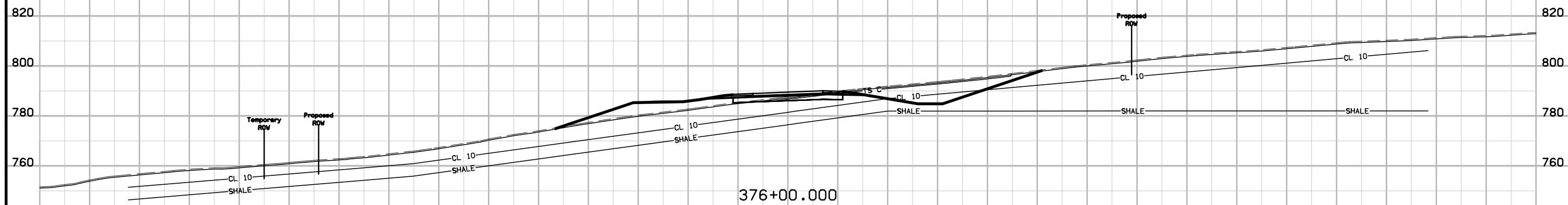

Southwest Arterial East Grading

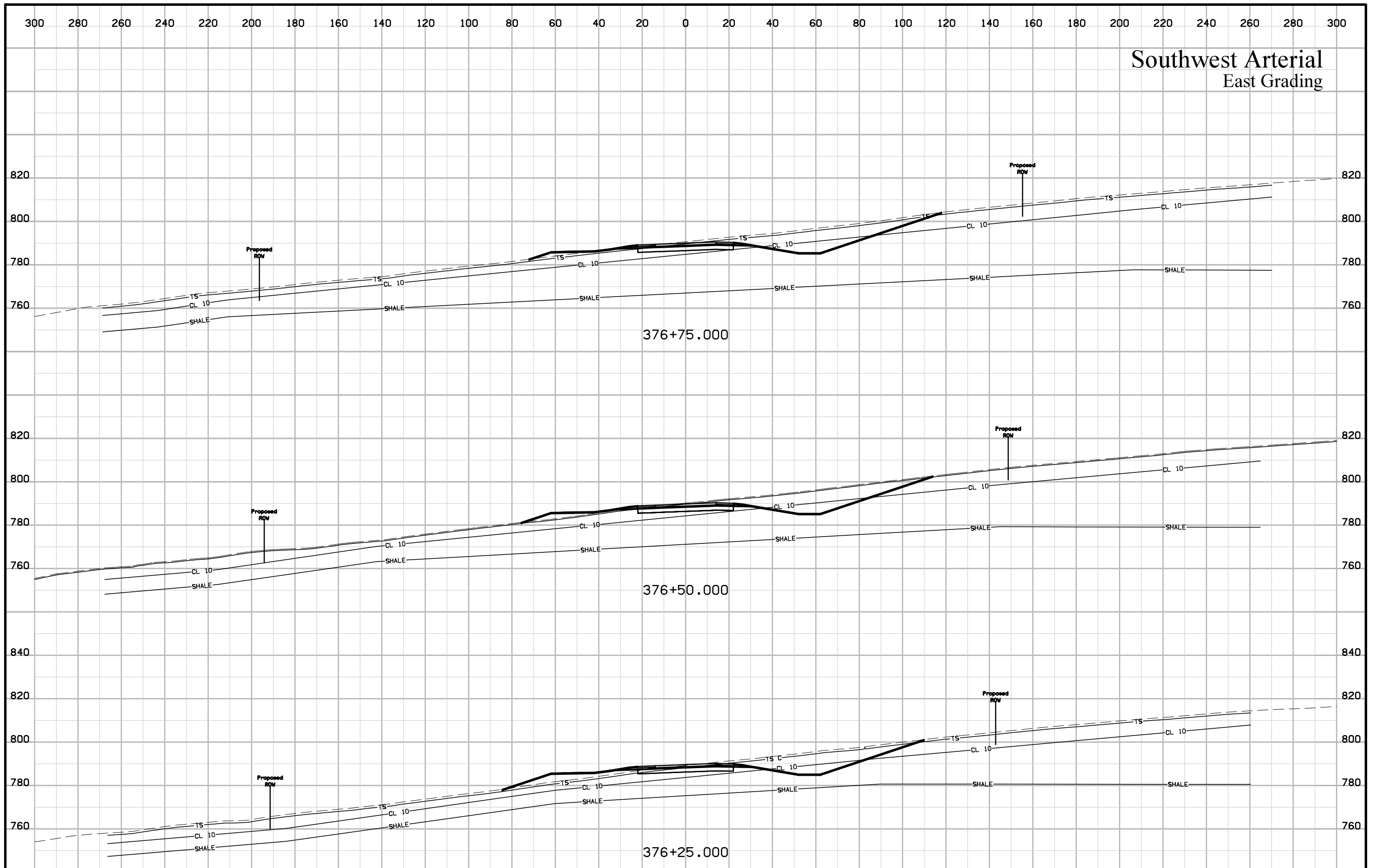

Southwest Arterial East Grading

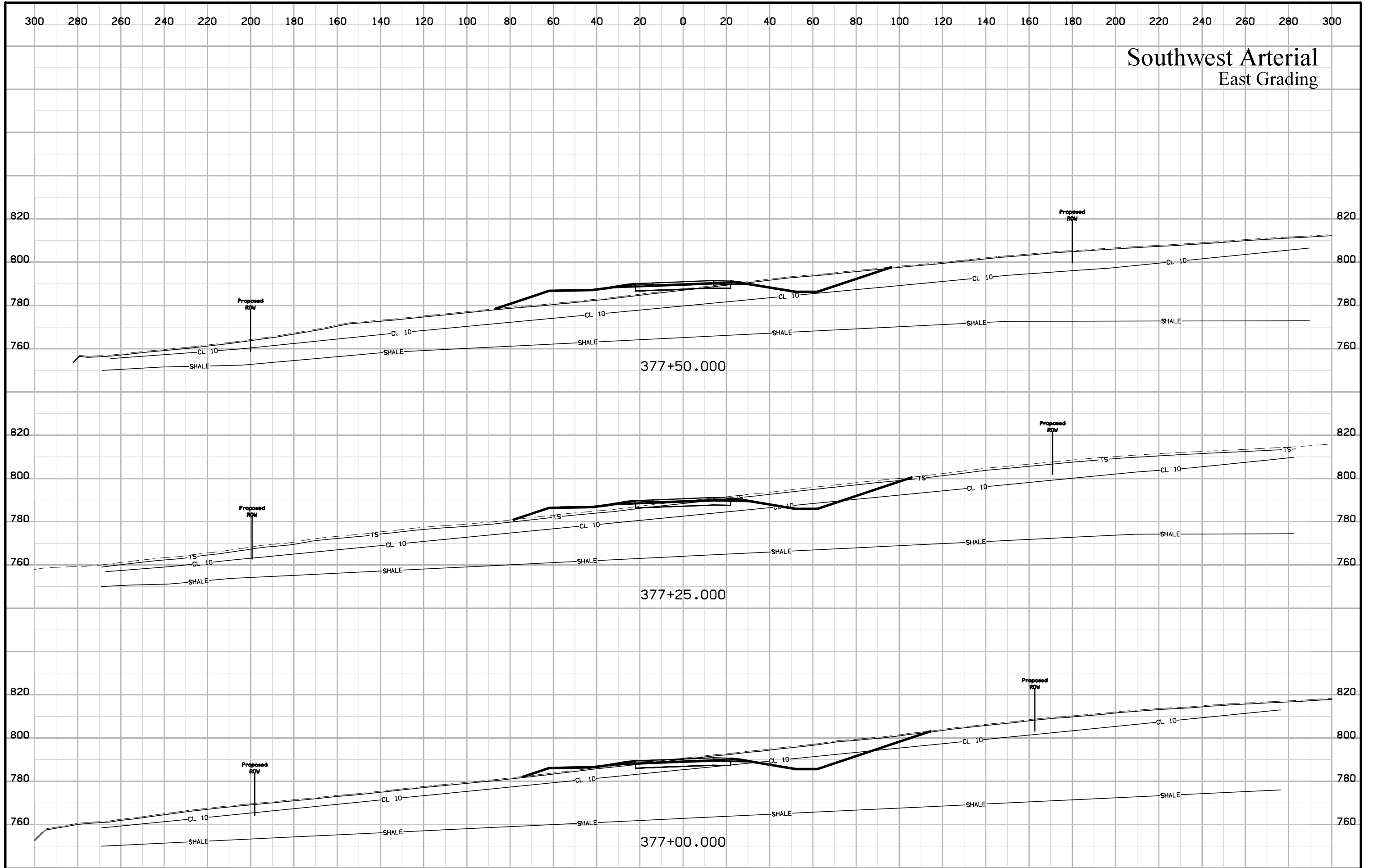

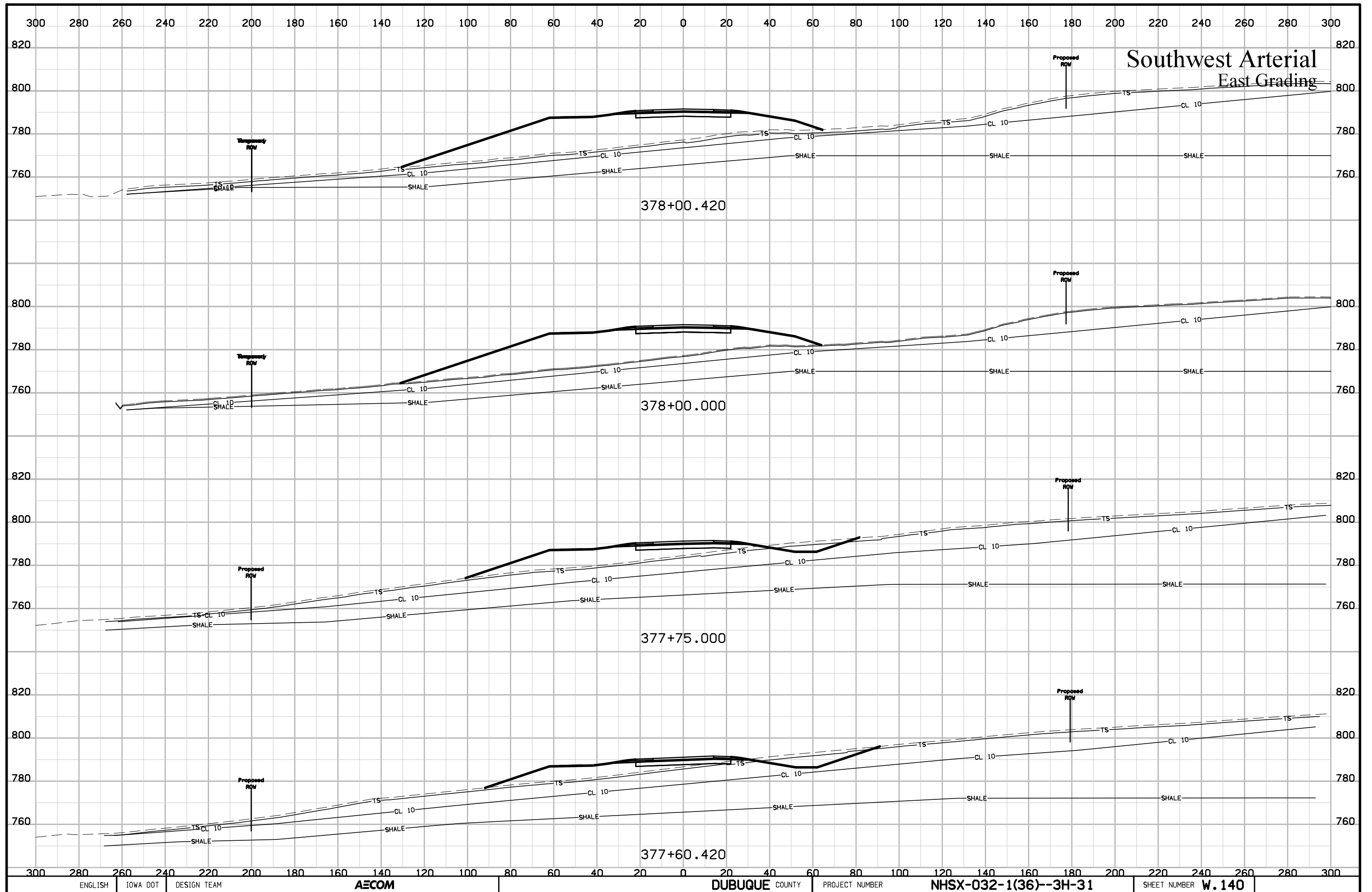

Southwest Arterial East Grading

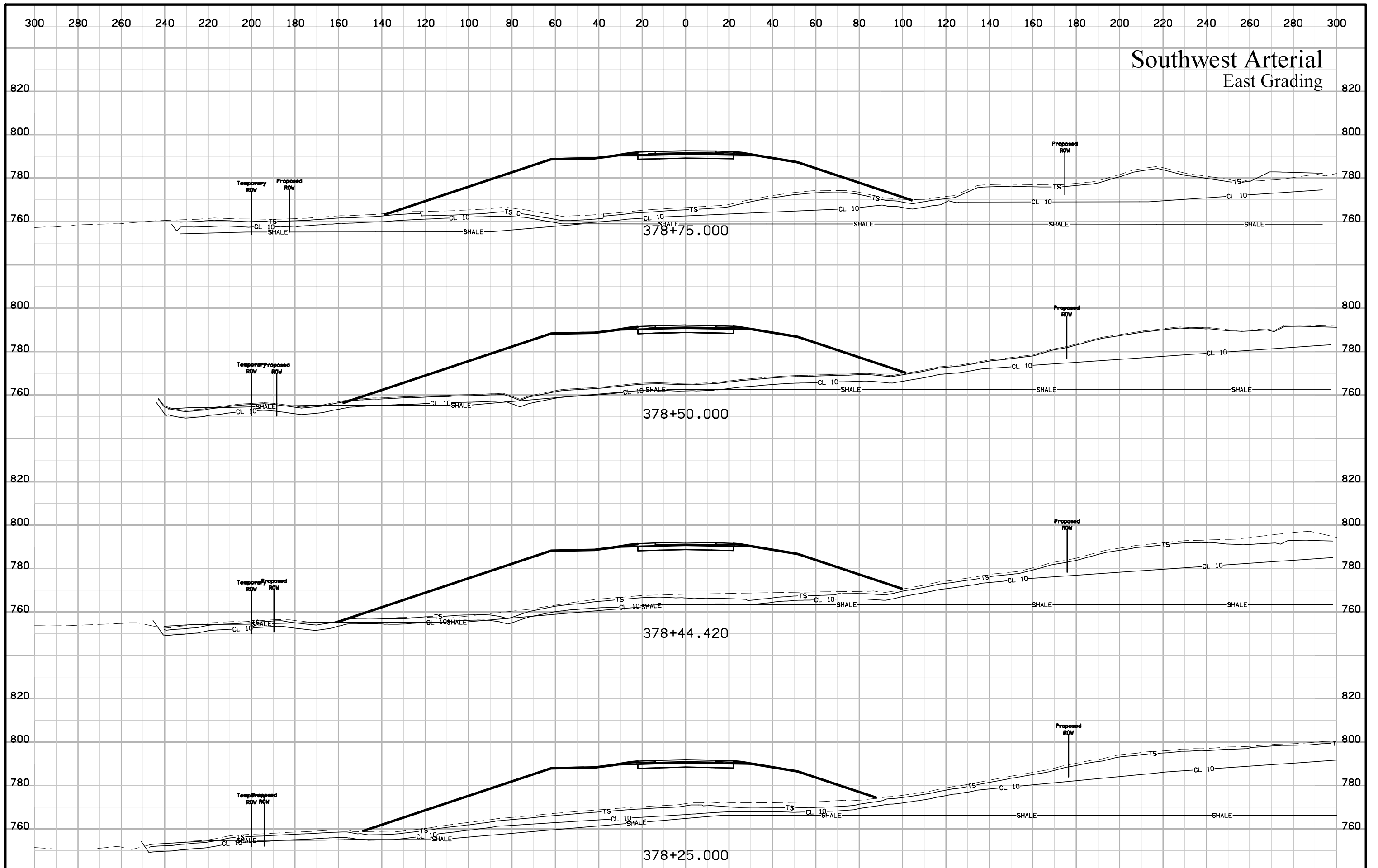

300 280 260 240 220 200 180 160 140 120 100 80 60 40 20 0 20 40 60 80 100 120 140 160 180 200 220 240 260 280 300

Southwest Arterial East Grading

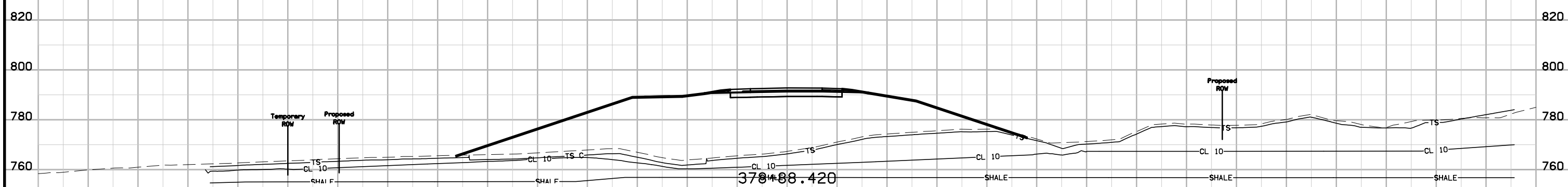
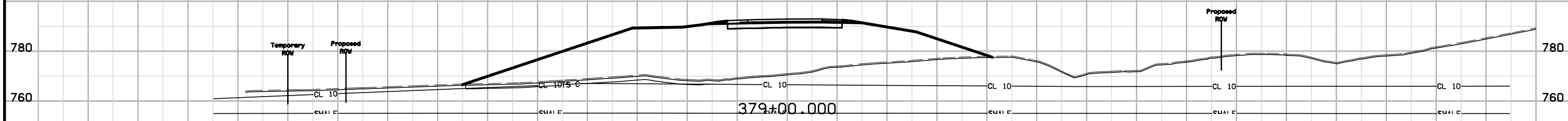
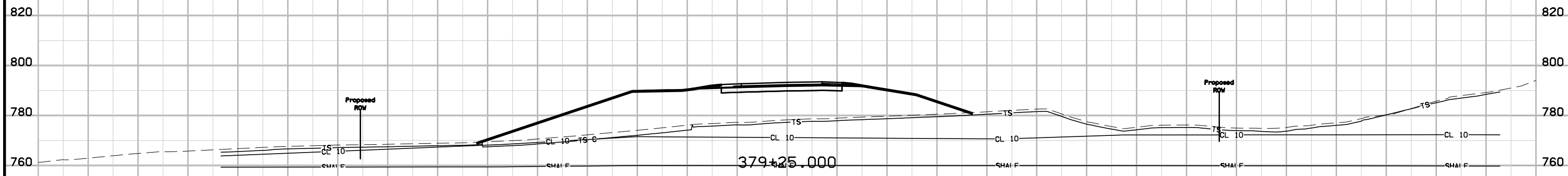
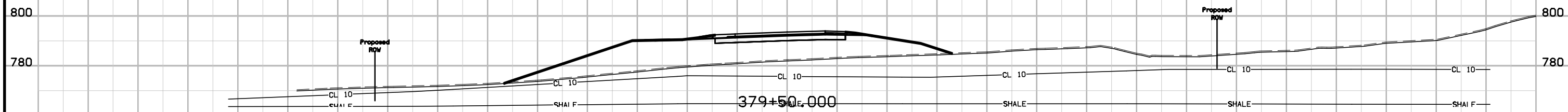

300 280 260 240 220 200 180 160 140 120 100 80 60 40 20 0 20 40 60 80 100 120 140 160 180 200 220 240 260 280 300

Southwest Arterial East Grading

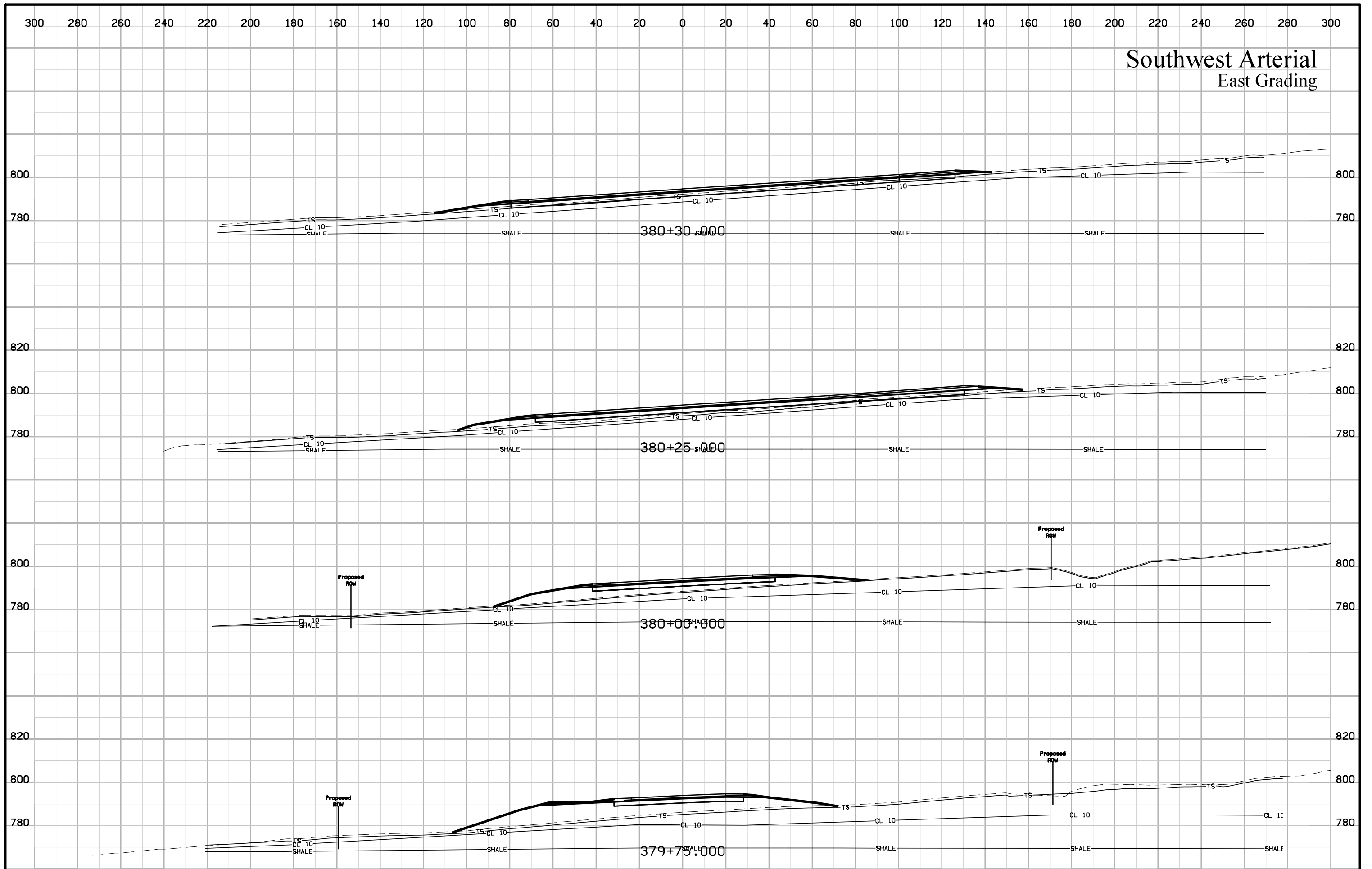

300 280 260 240 220 200 180 160 140 120 100 80 60 40 20 0 20 40 60 80 100 120 140 160 180 200 220 240 260 280 300

Southwest Arterial East Grading

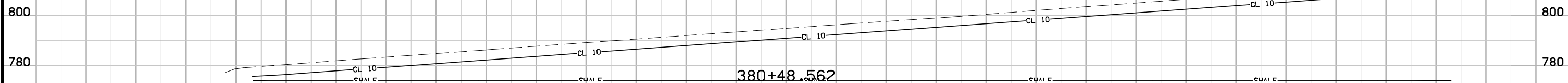

300 280 260 240 220 200 180 160 140 120 100 80 60 40 20 0 20 40 60 80 100 120 140 160 180 200 220 240 260 280 300

ENGLISH IOWA DOT DESIGN TEAM

AECOM

DUBUQUE COUNTY

PROJECT NUMBER

NHSX-032-1(36)--3H-31

SHEET NUMBER **W.144**

US 61 SB East Grading

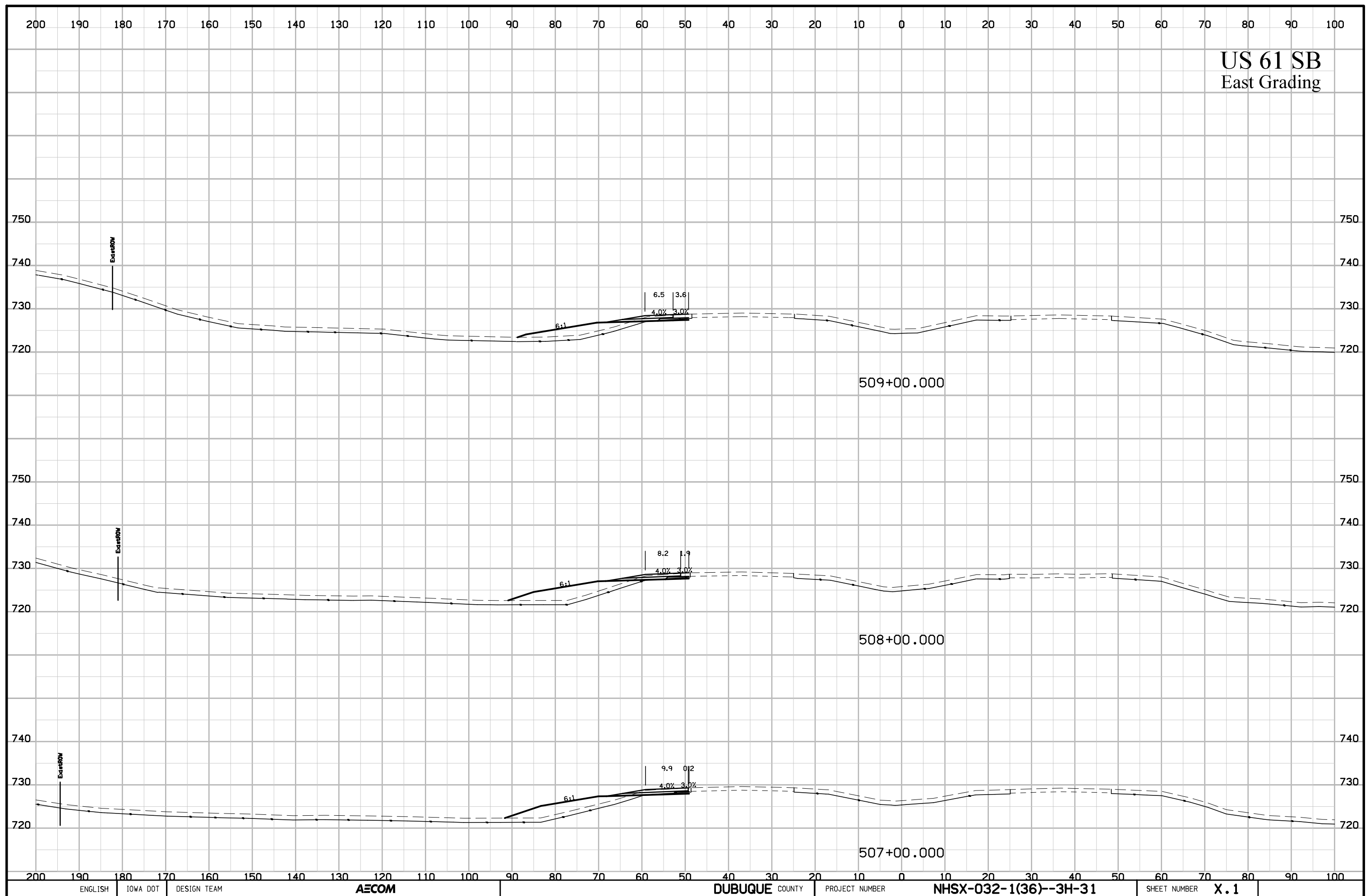

US 61 SB East Grading

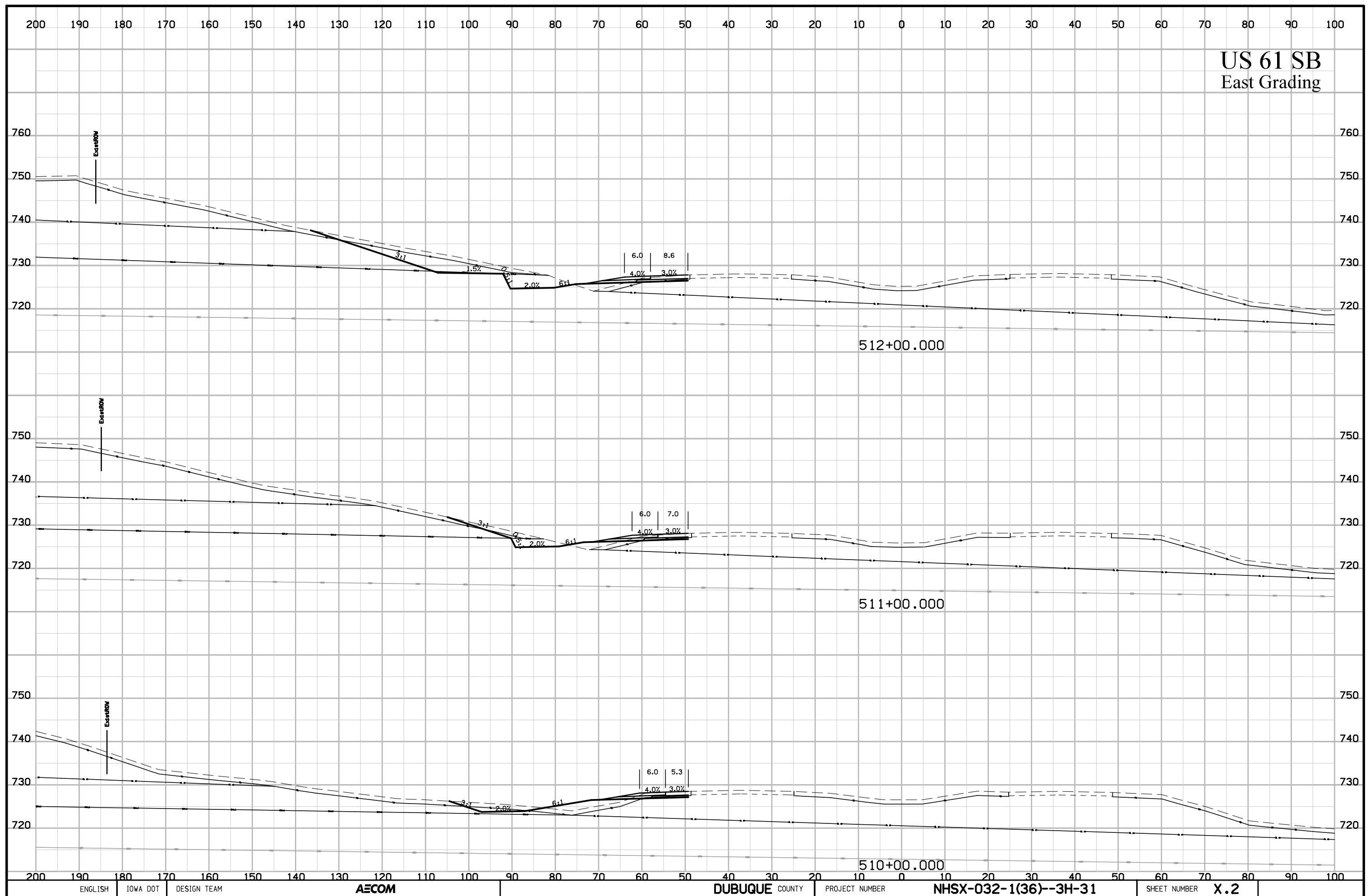

US 61 SB

East Grading

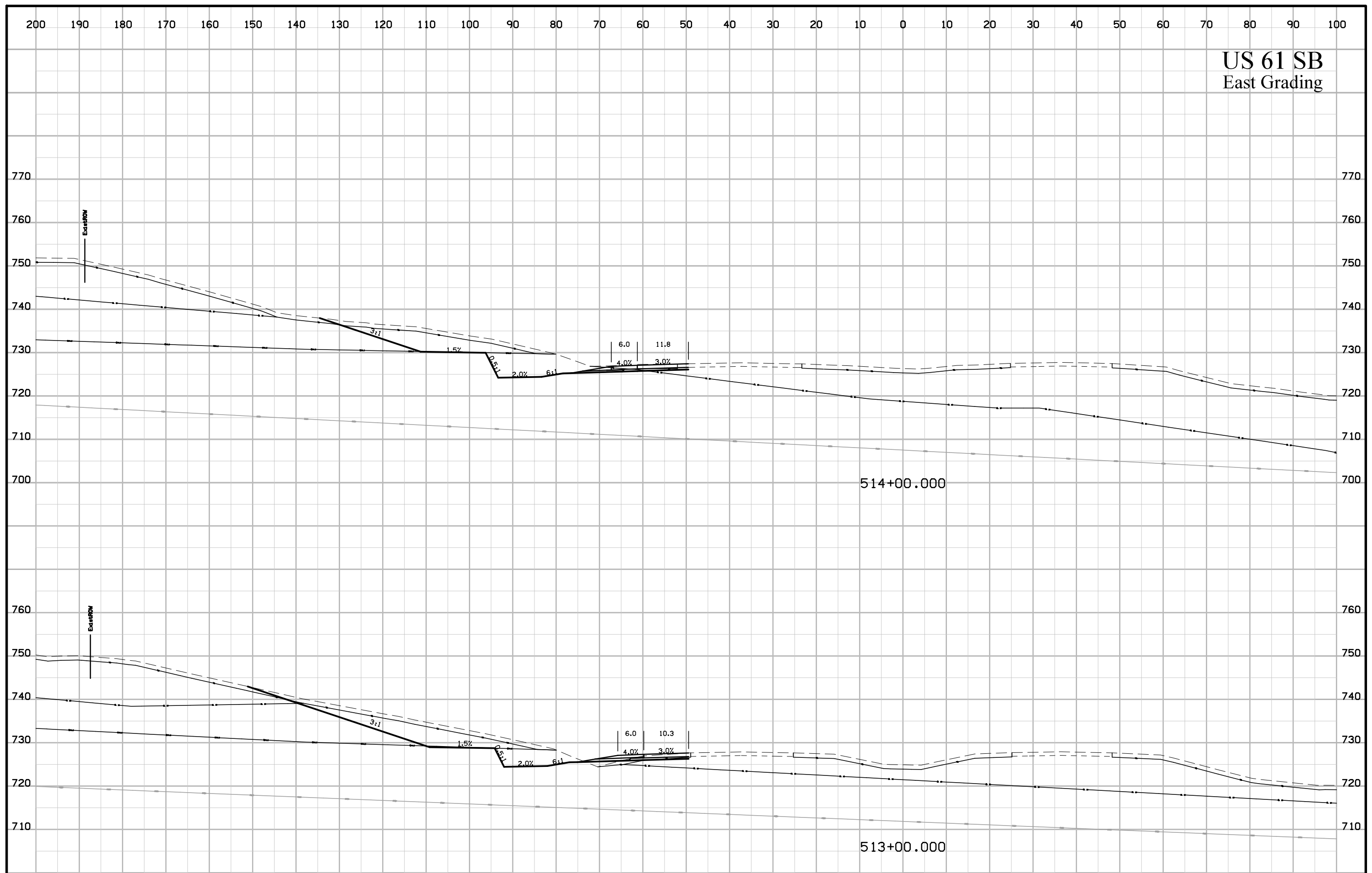

US 61 SB
East Grading

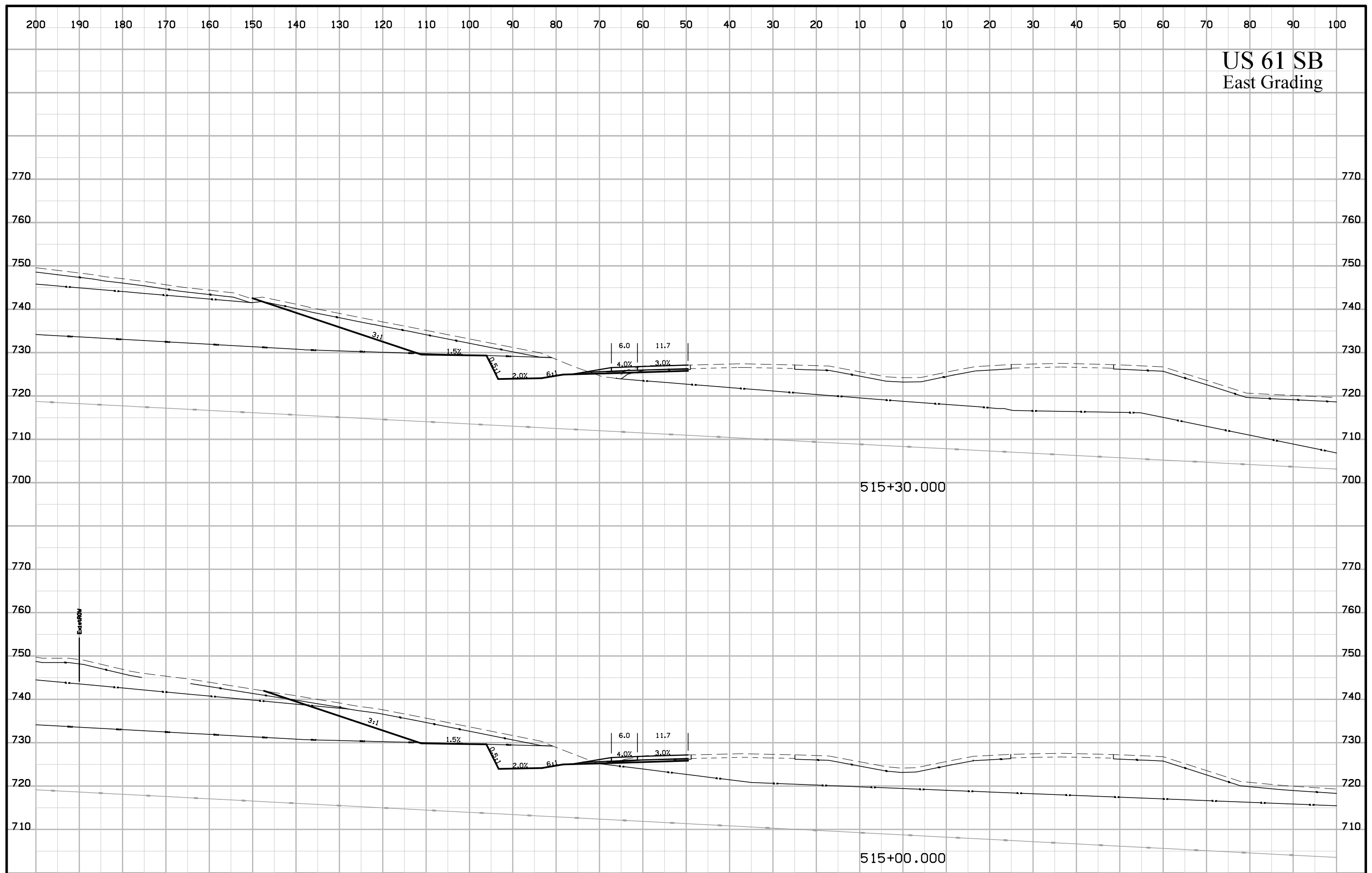

US 61 SB East Grading

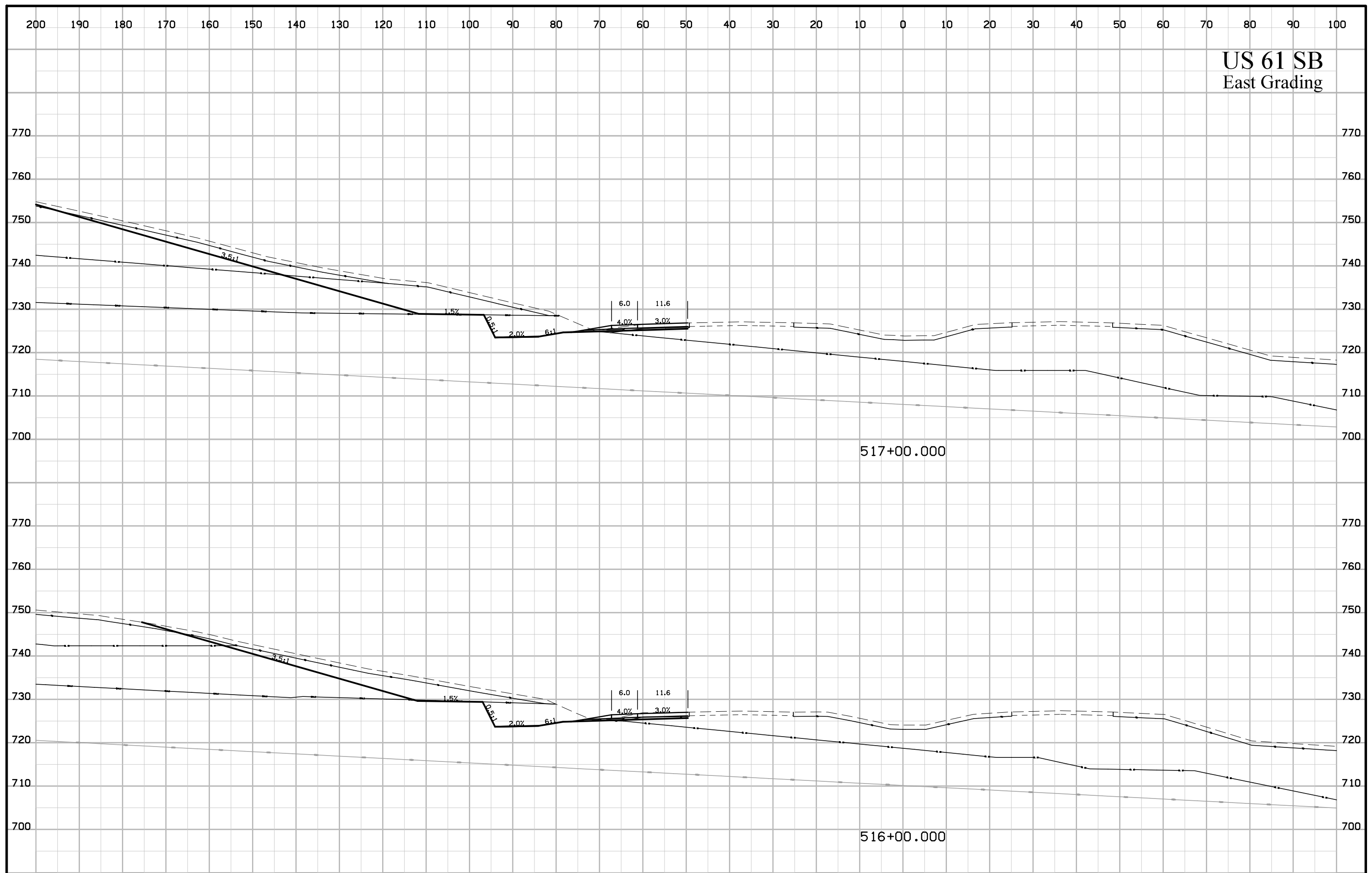

US 61 SB
East Grading

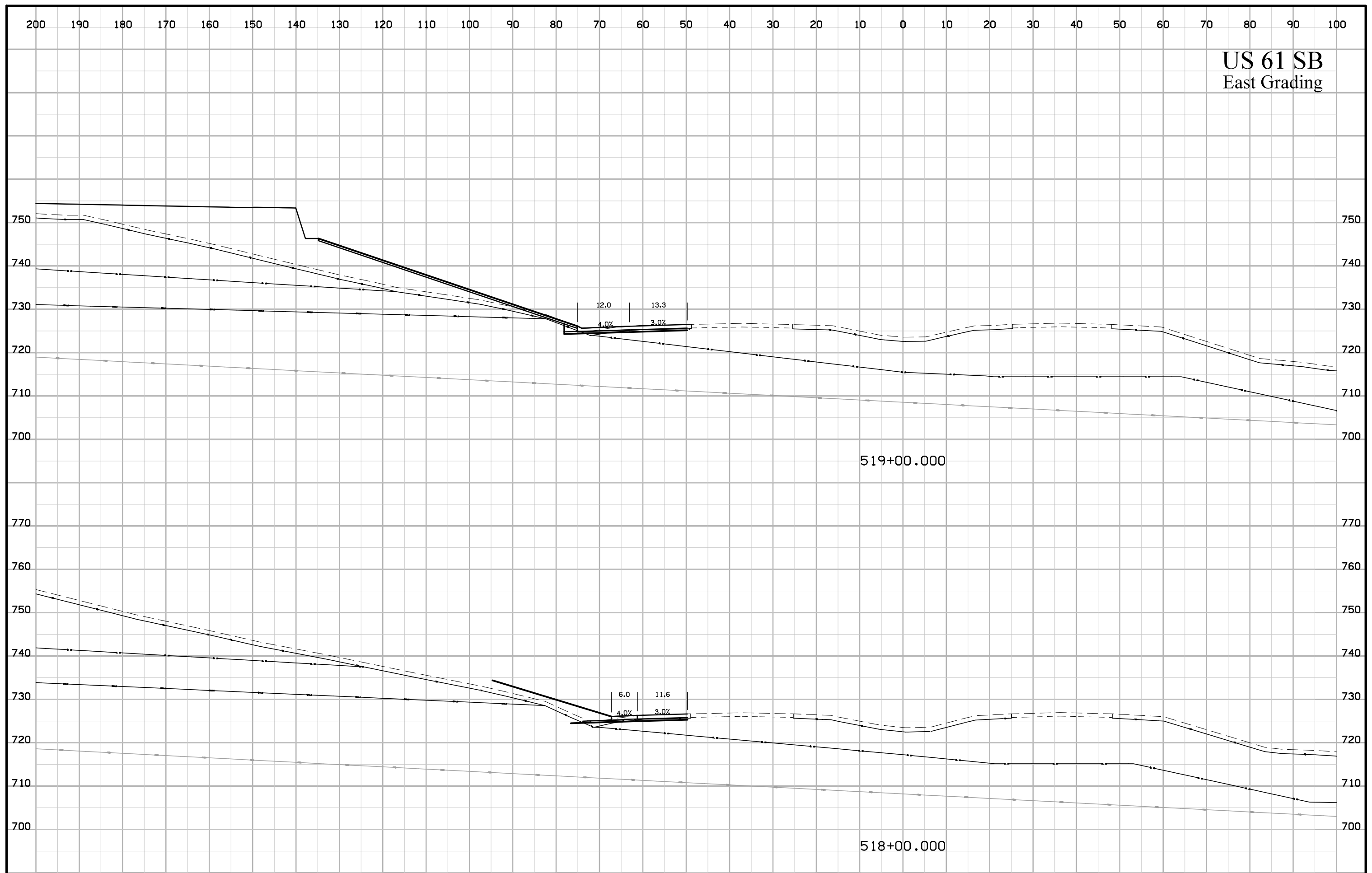

US 61 SB
East Grading

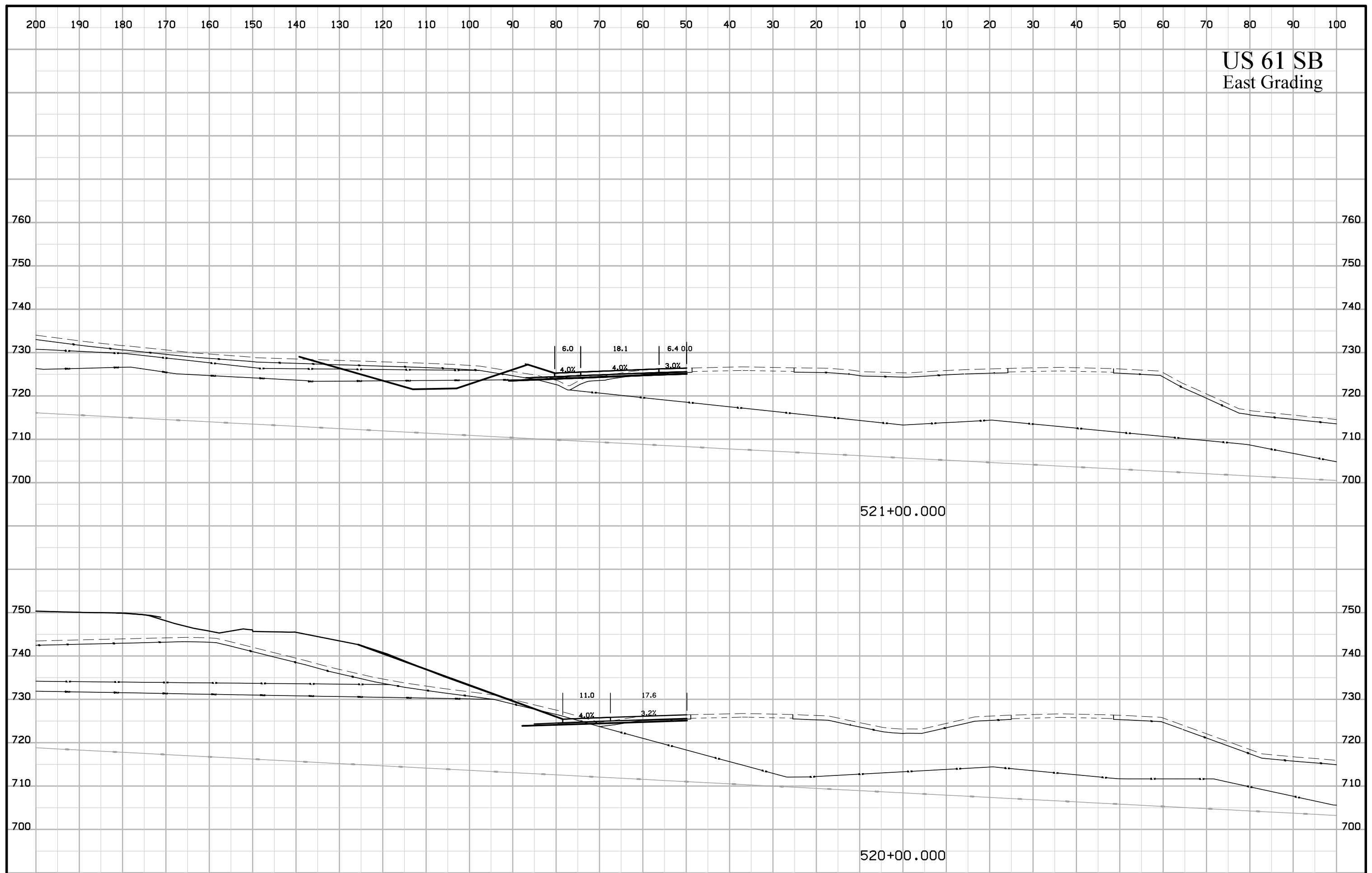

US 61 SB

East Grading



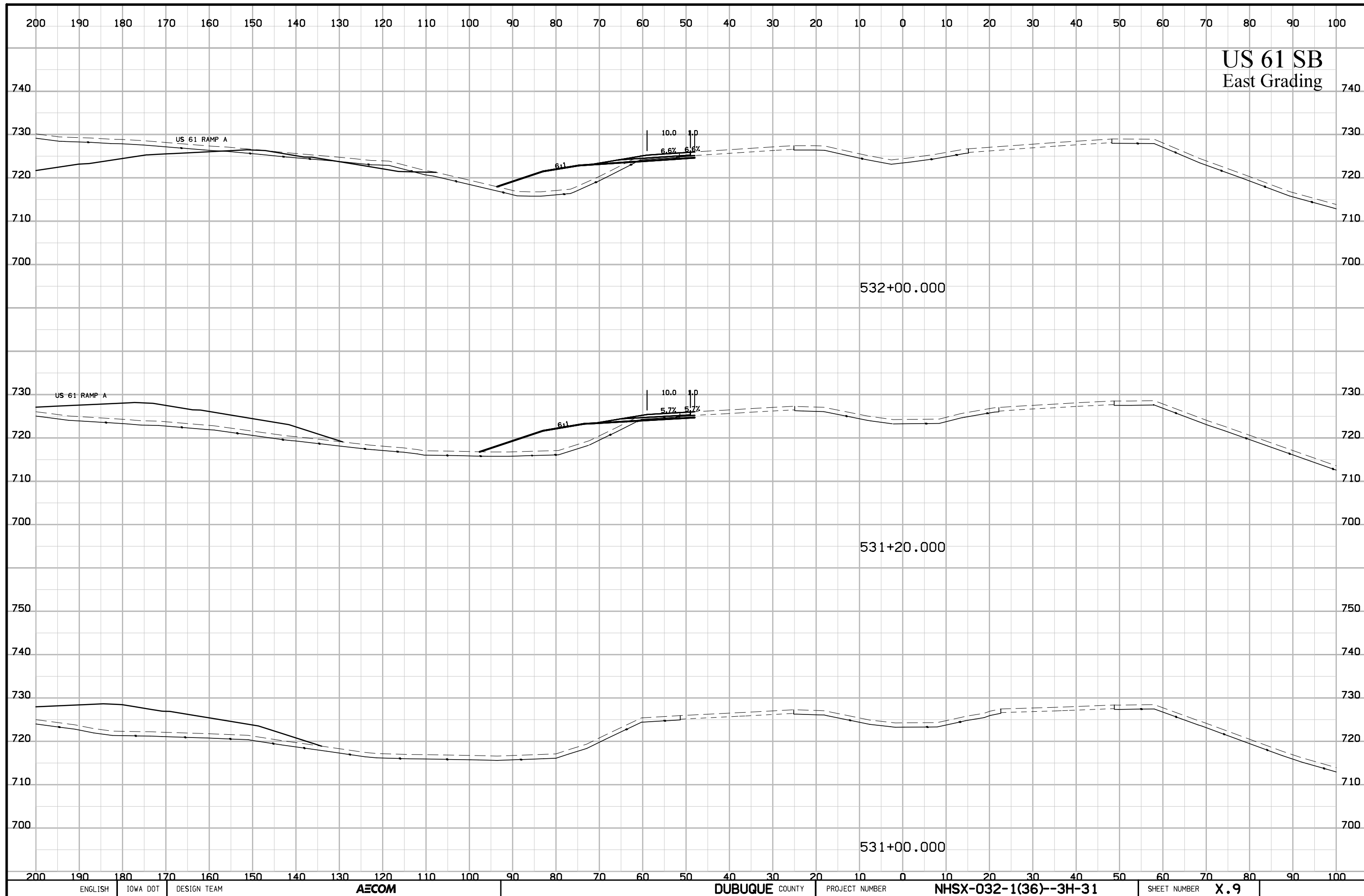

US 61 SB
East Grading

532+00.000

531+20.000

531+00.000

US 61 SB
East Grading

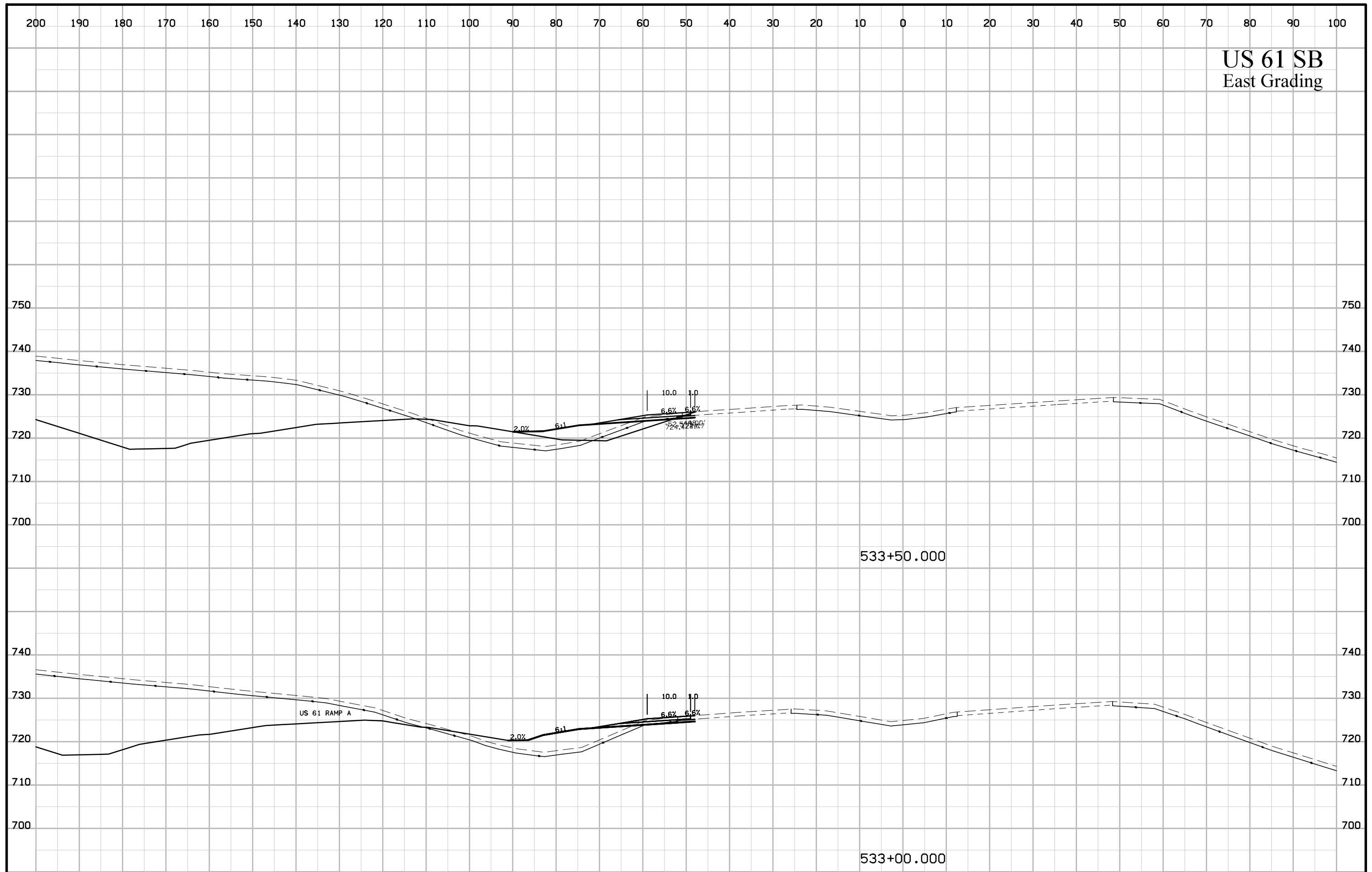

200 190 180 170 160 150 140 130 120 110 100 90 80 70 60 50 40 30 20 10 0 10 20 30 40 50 60 70 80 90 100

US 61 SB East Grading

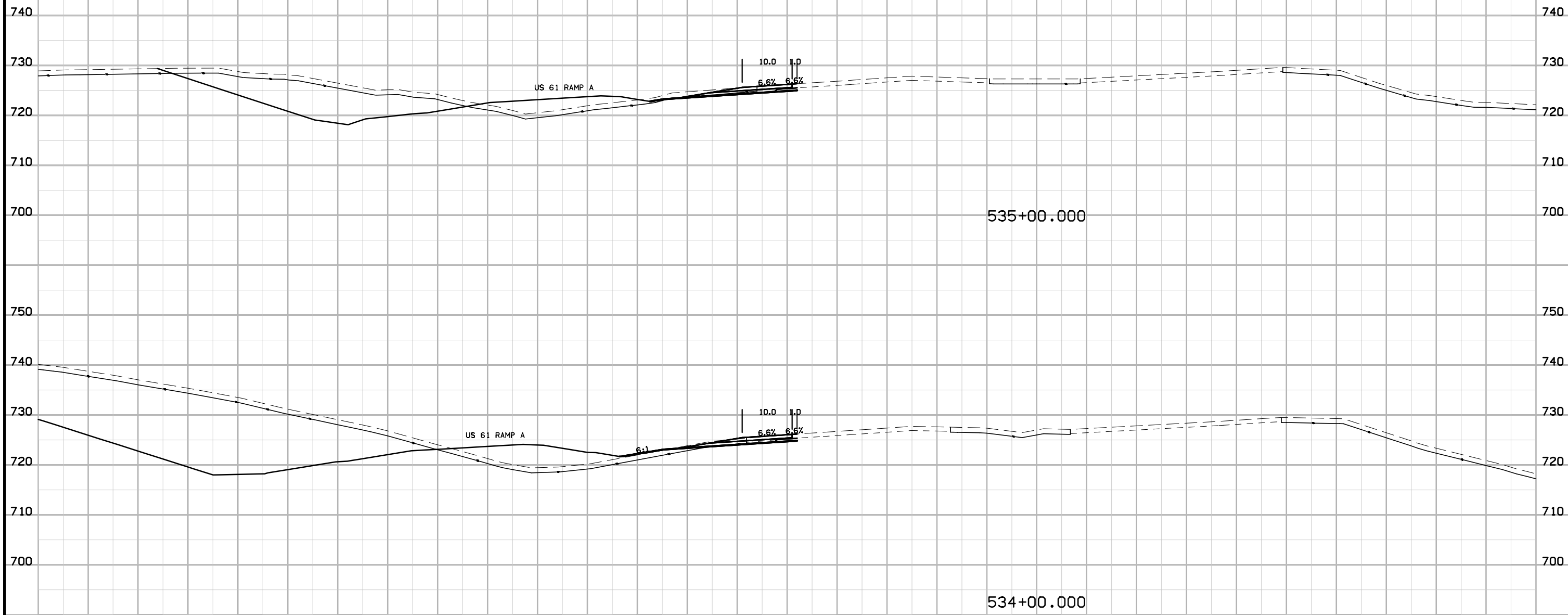

200 190 180 170 160 150 140 130 120 110 100 90 80 70 60 50 40 30 20 10 0 10 20 30 40 50 60 70 80 90 100

ENGLISH IOWA DOT DESIGN TEAM

AECOM

DUBUQUE COUNTY

PROJECT NUMBER

NHSX-032-1(36)--3H-31

SHEET NUMBER **X.11**

US 61 SB
East Grading

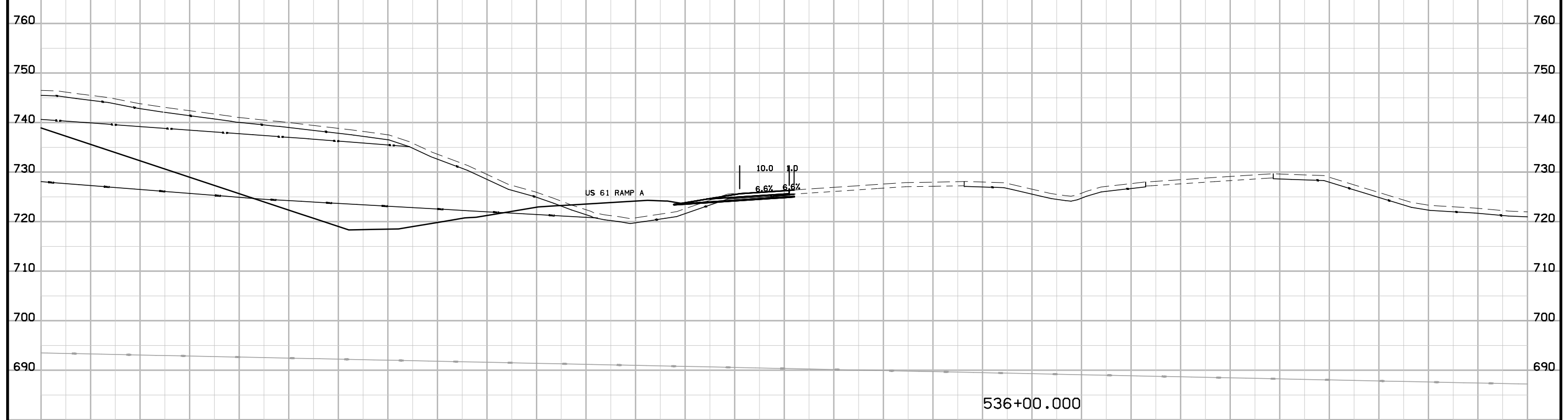
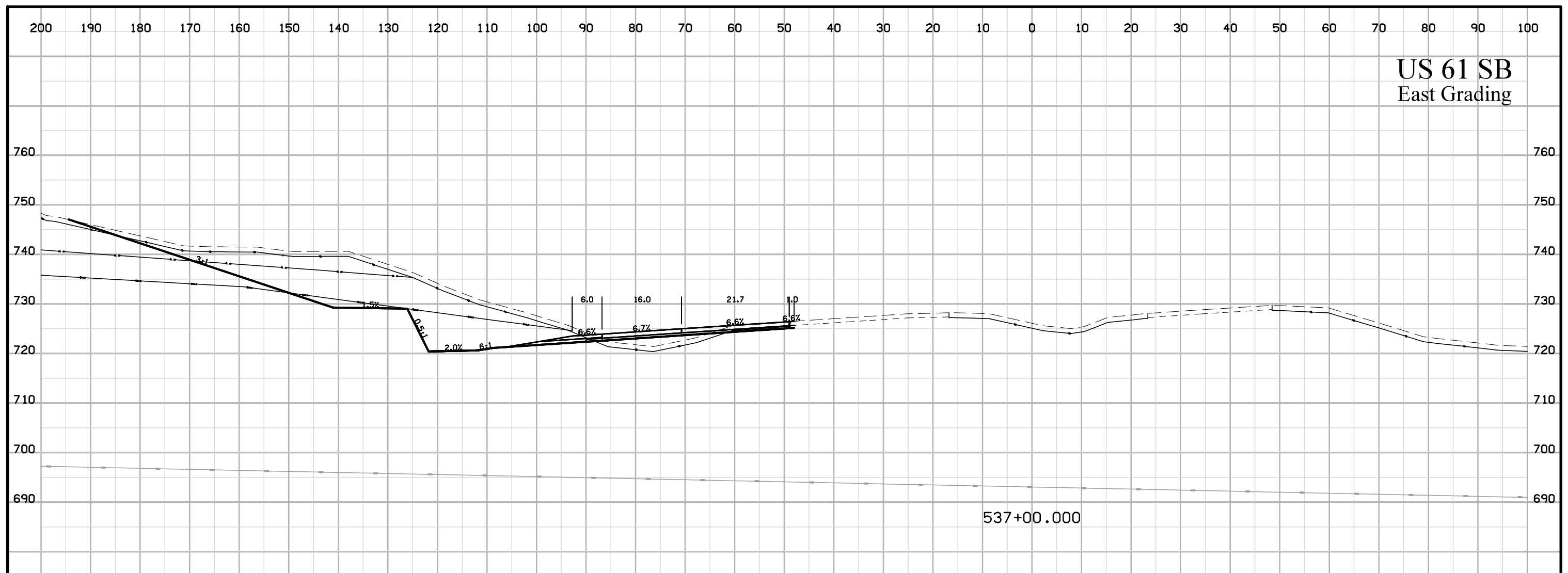

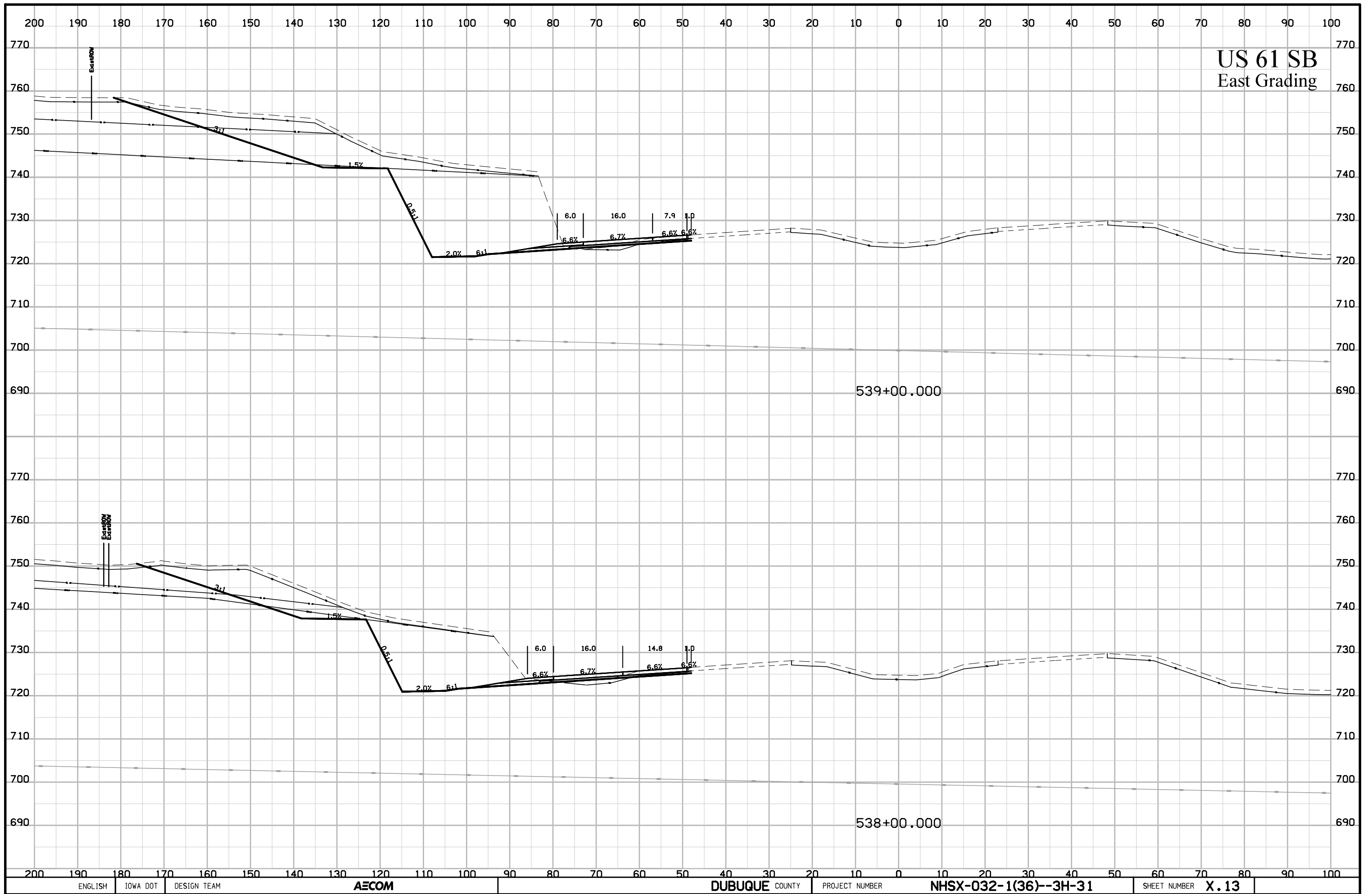

US 61 SB
East Grading

539+00.000

538+00.000

US 61 SB
East Grading



US 61 SB
East Grading

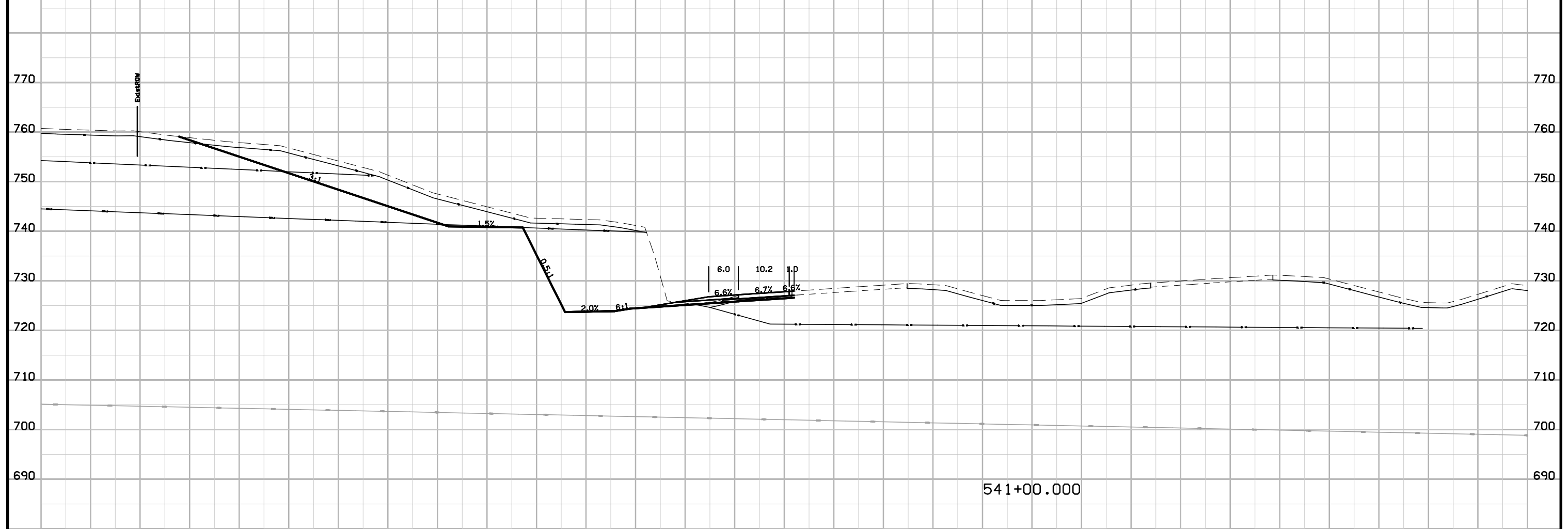
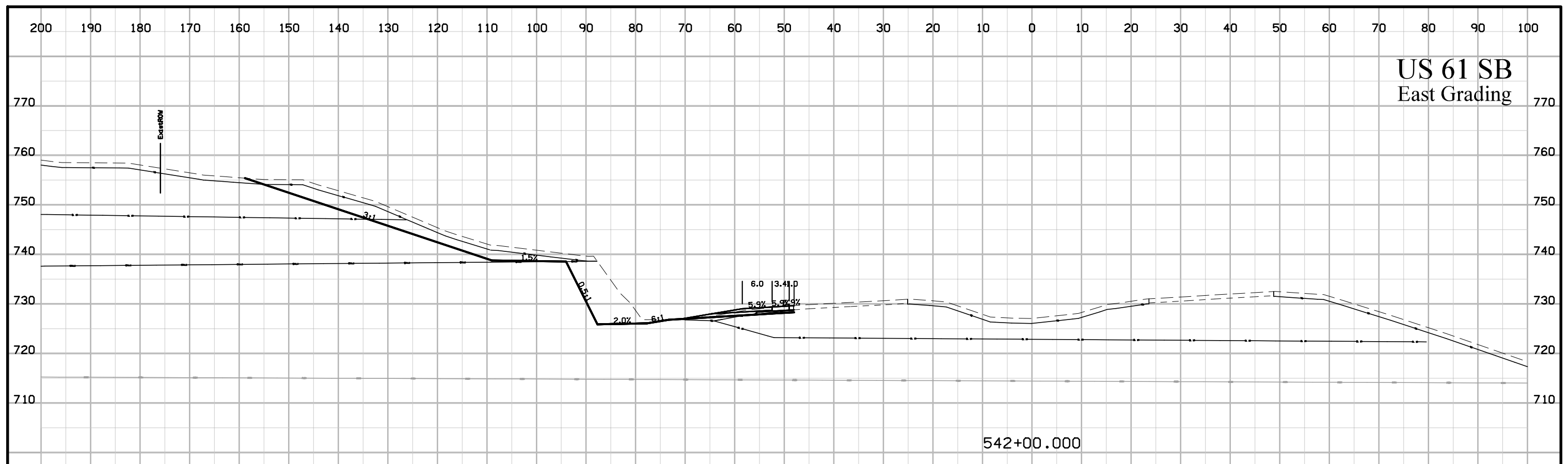

US 61 SB East Grading

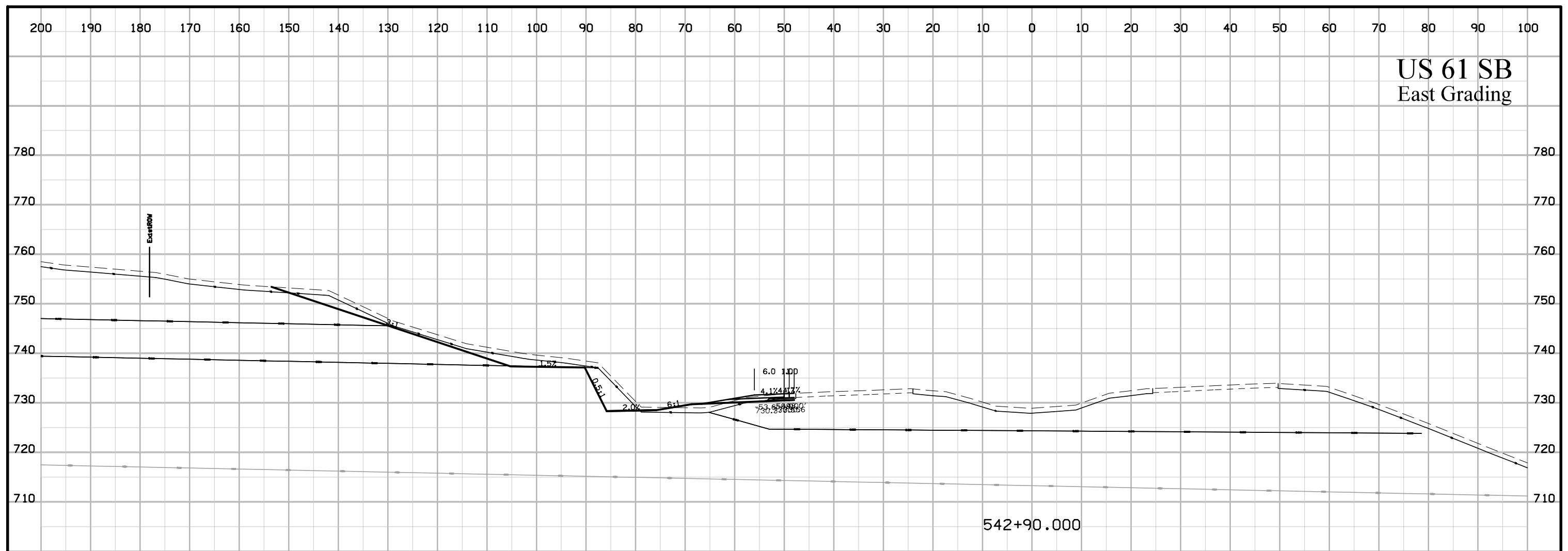

US 61 NB and Median East Grading

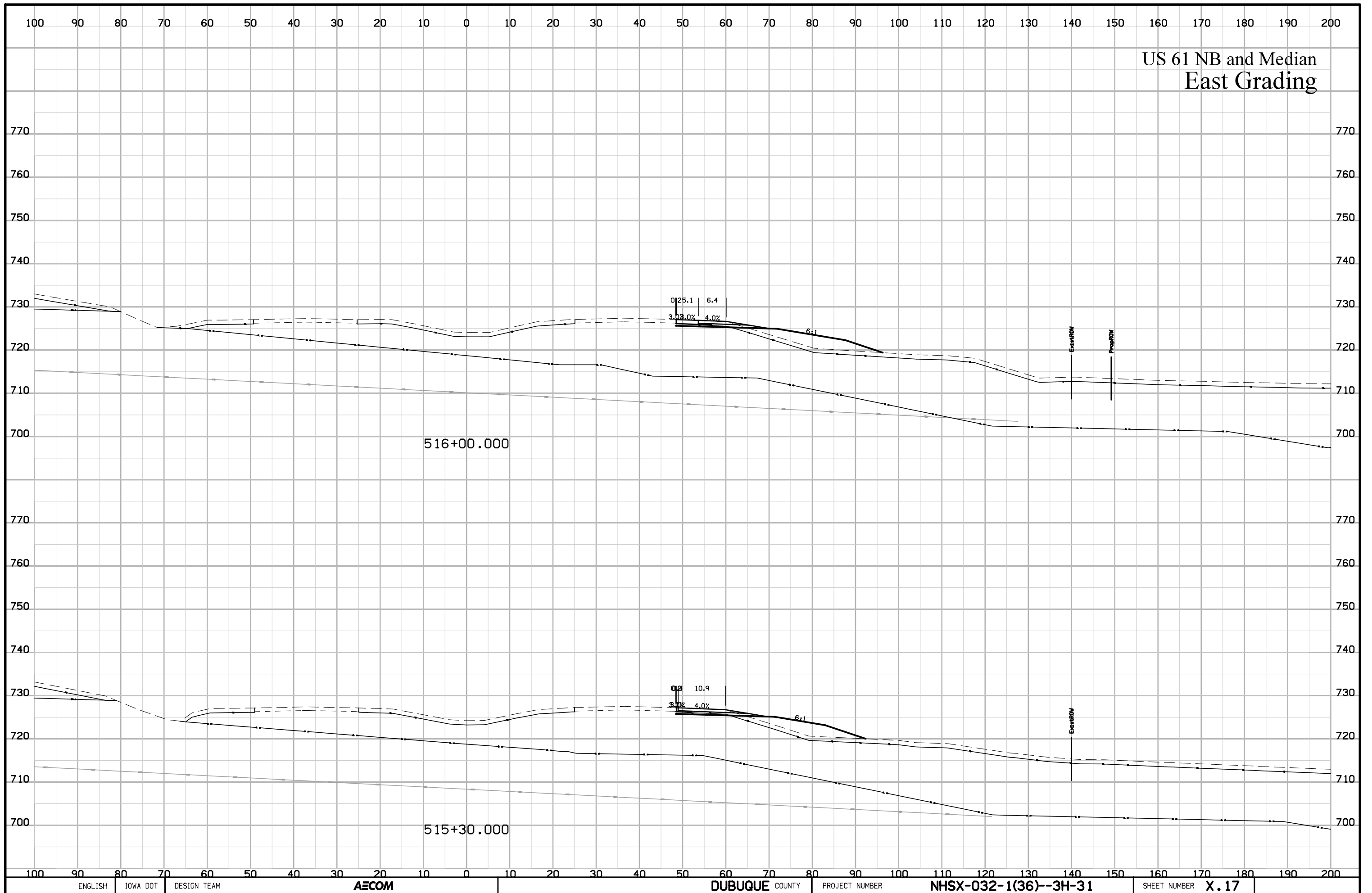

US 61 NB and Median East Grading

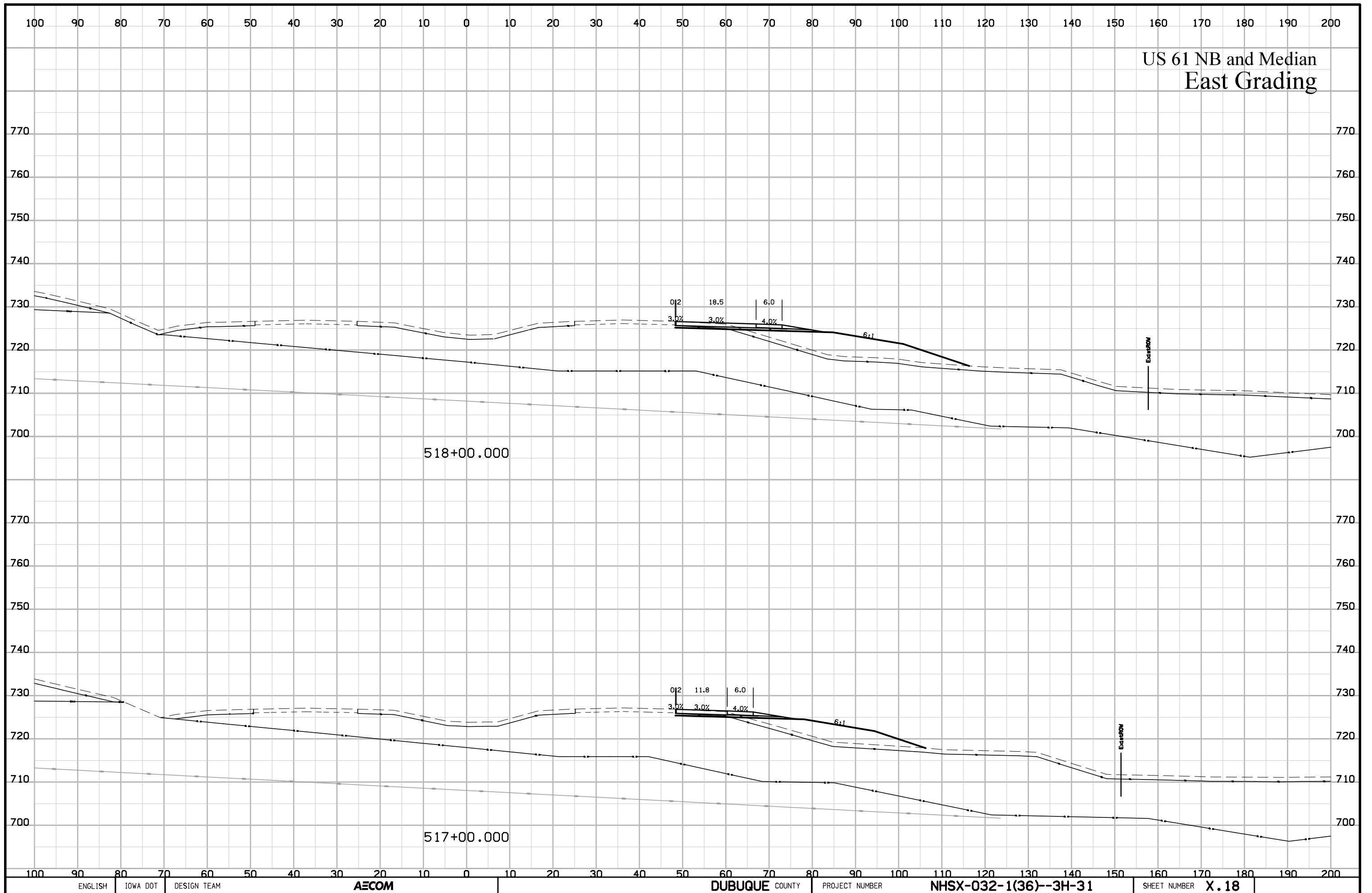

US 61 NB and Median East Grading

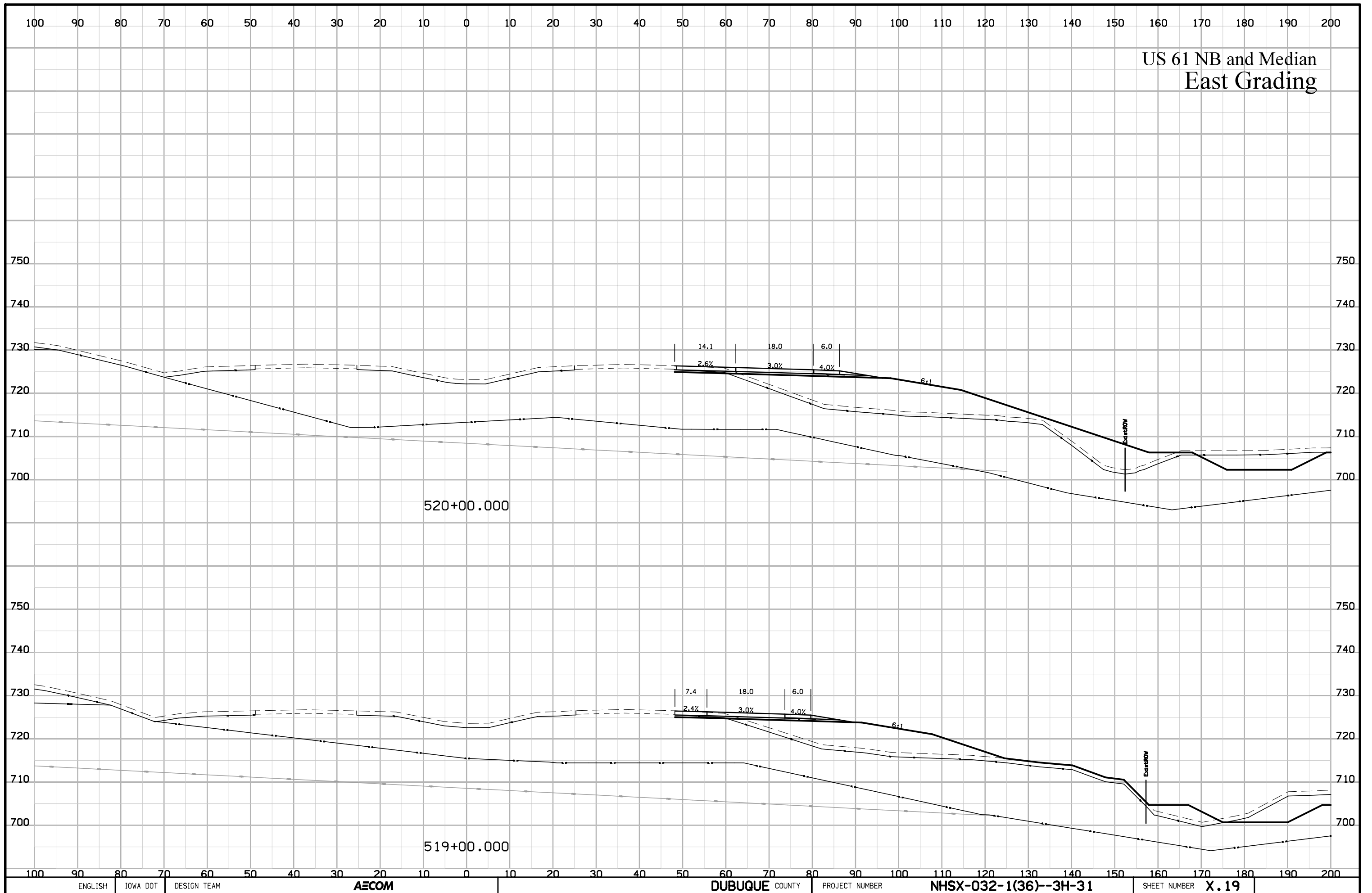

US 61 NB and Median East Grading

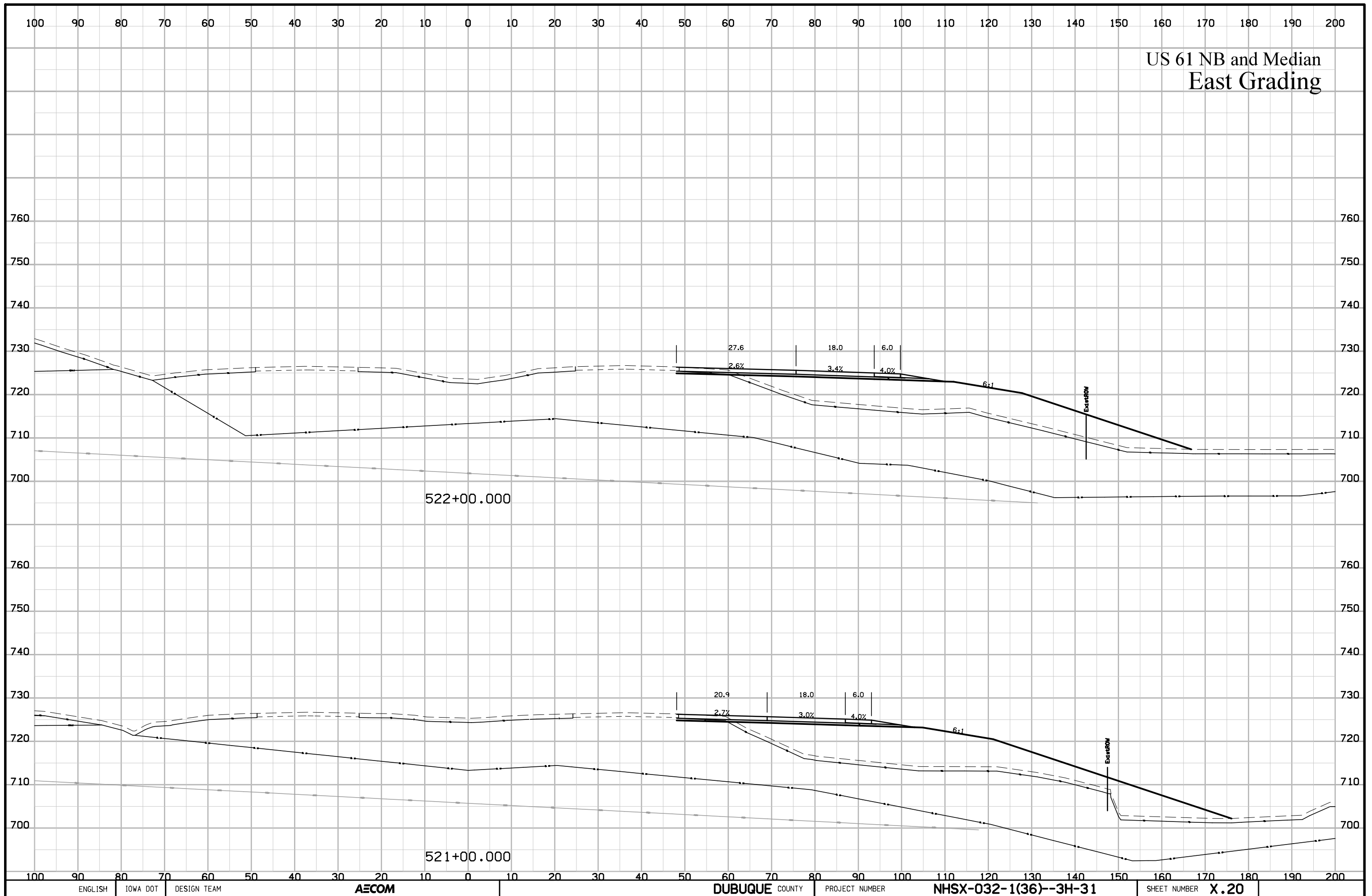

US 61 NB and Median East Grading

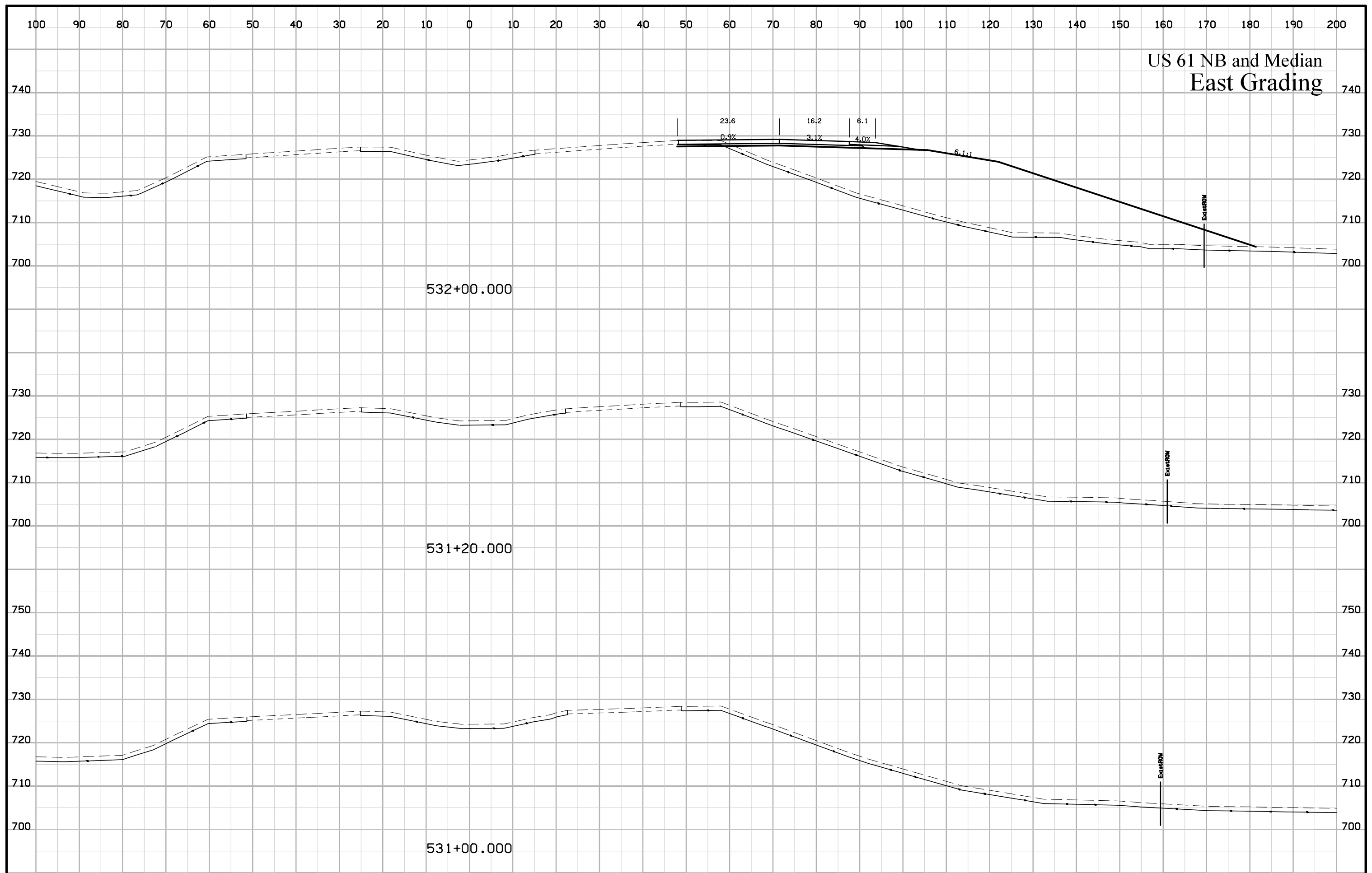

US 61 NB and Median East Grading

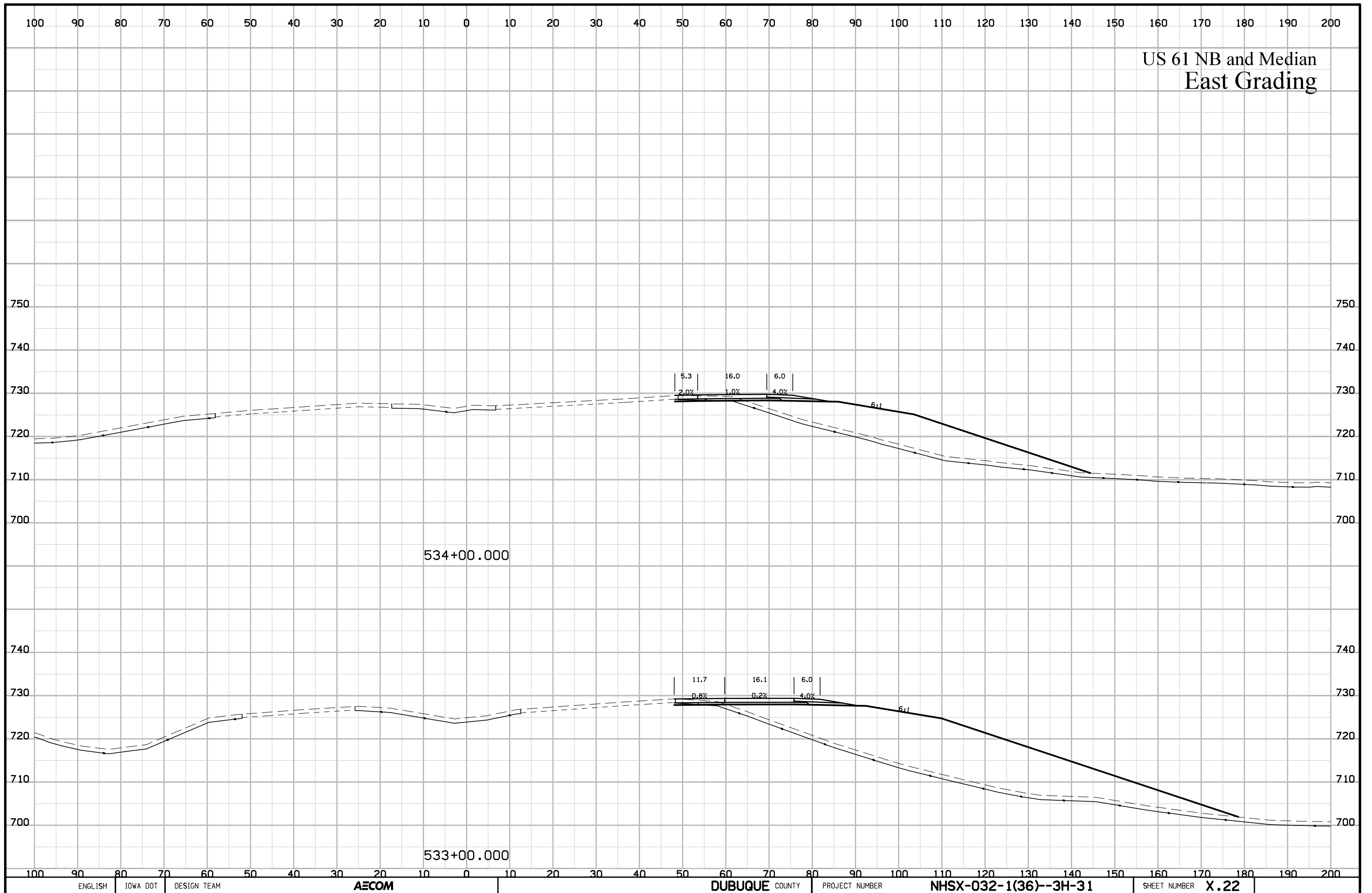

US 61 NB and Median East Grading

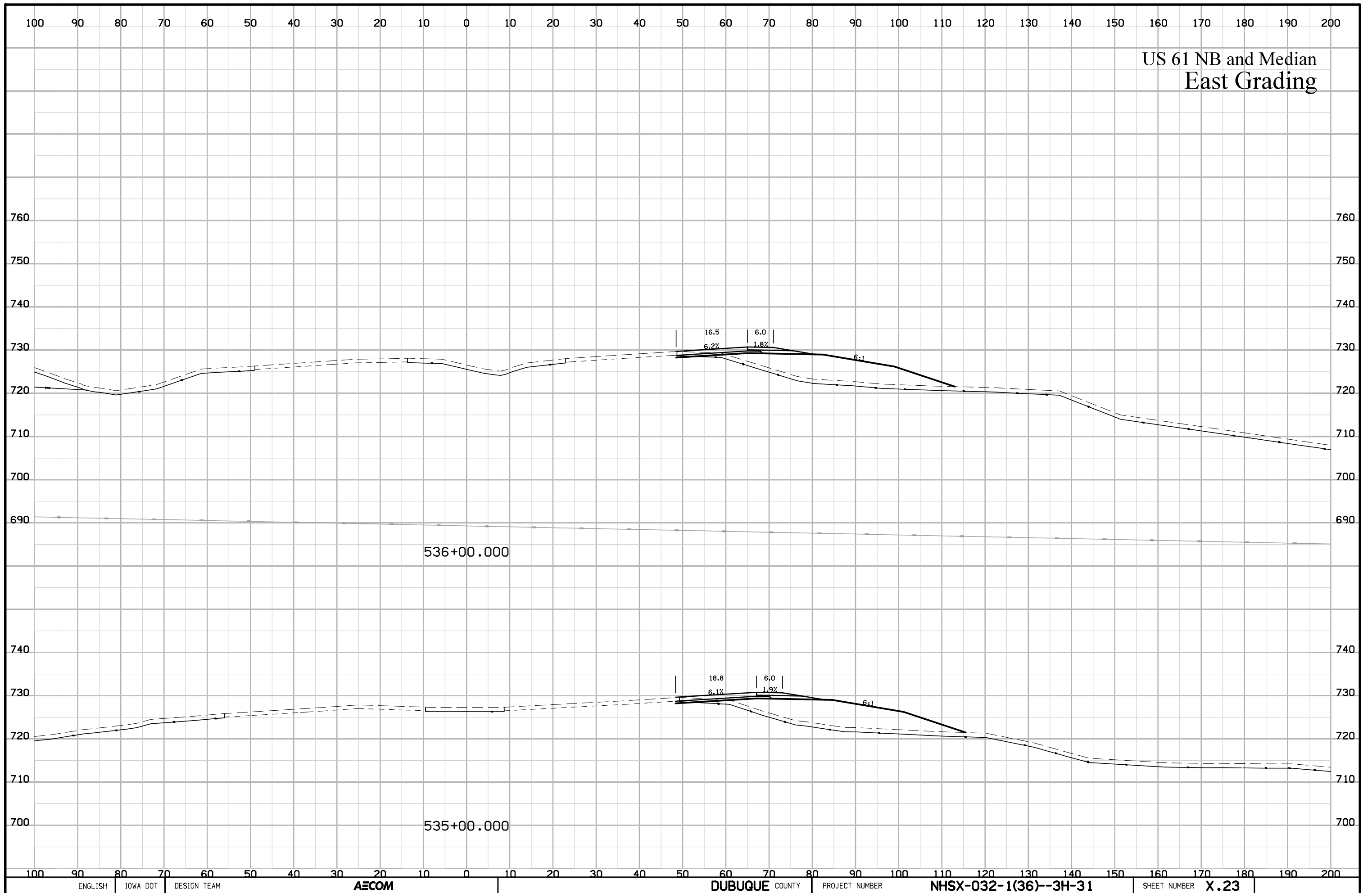

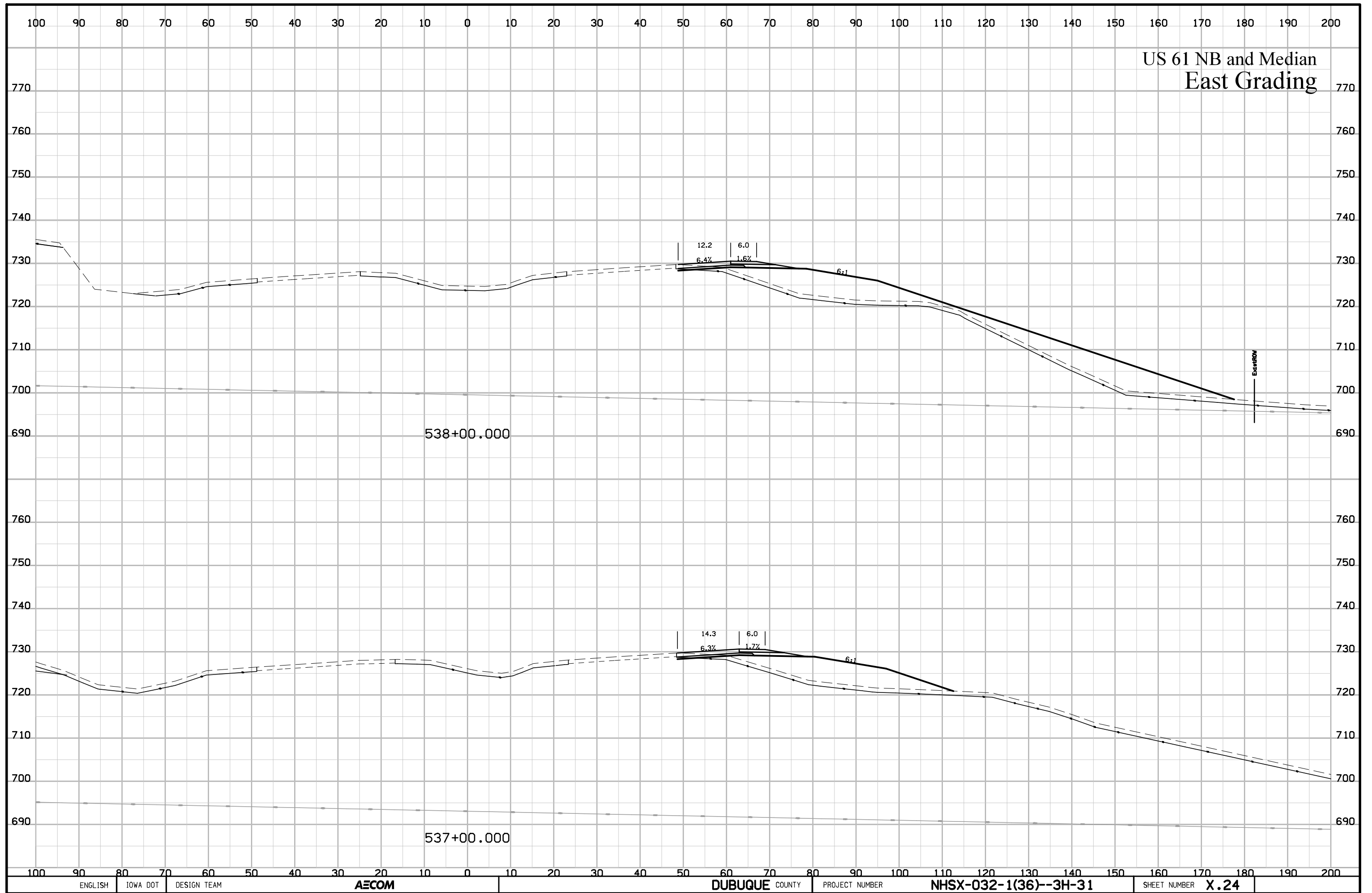

US 61 NB and Median
East Grading

538+00.000

537+00.000

Vertical Curve

US 61 NB and Median East Grading

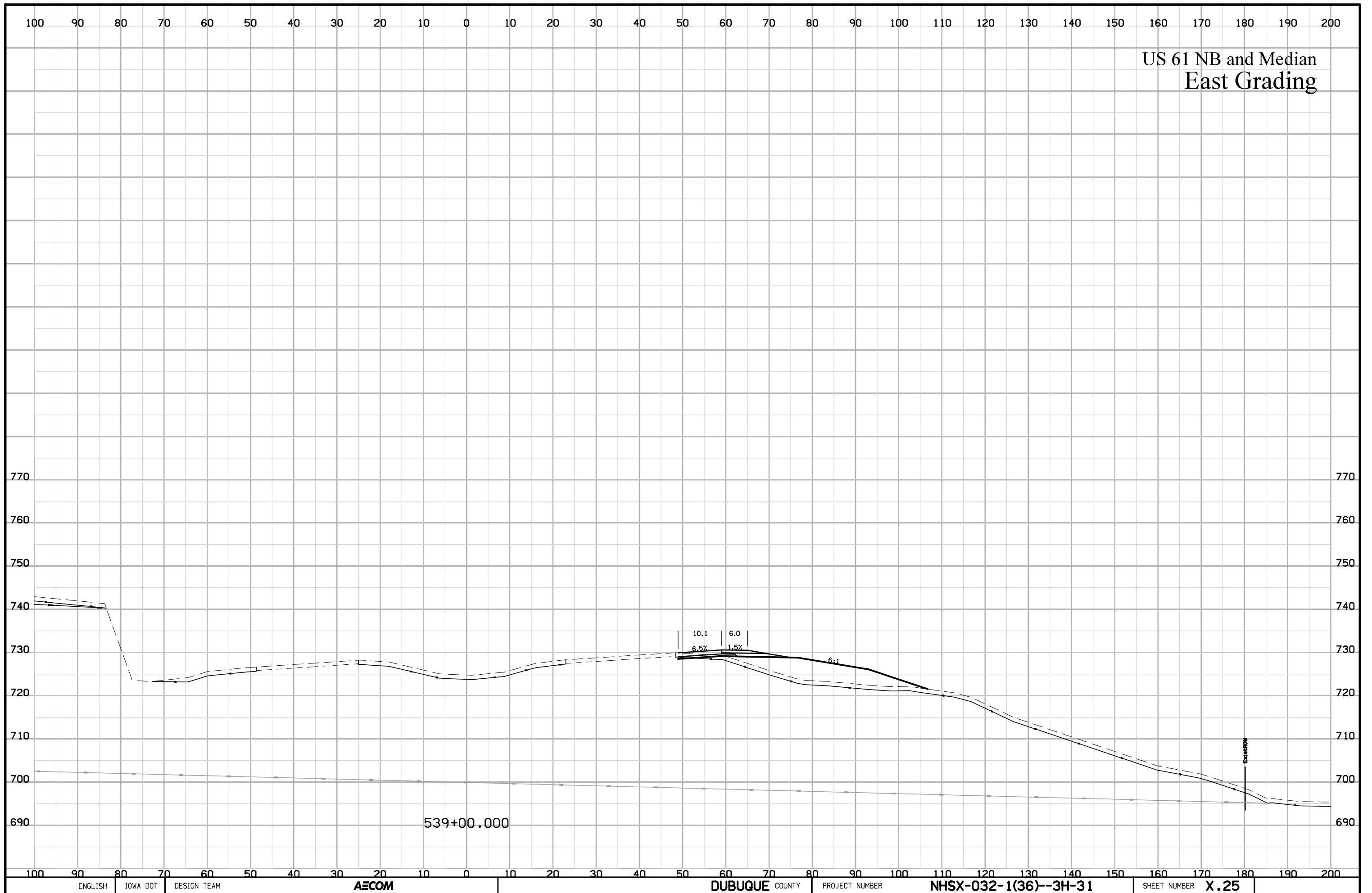

US 61 NB and Median East Grading

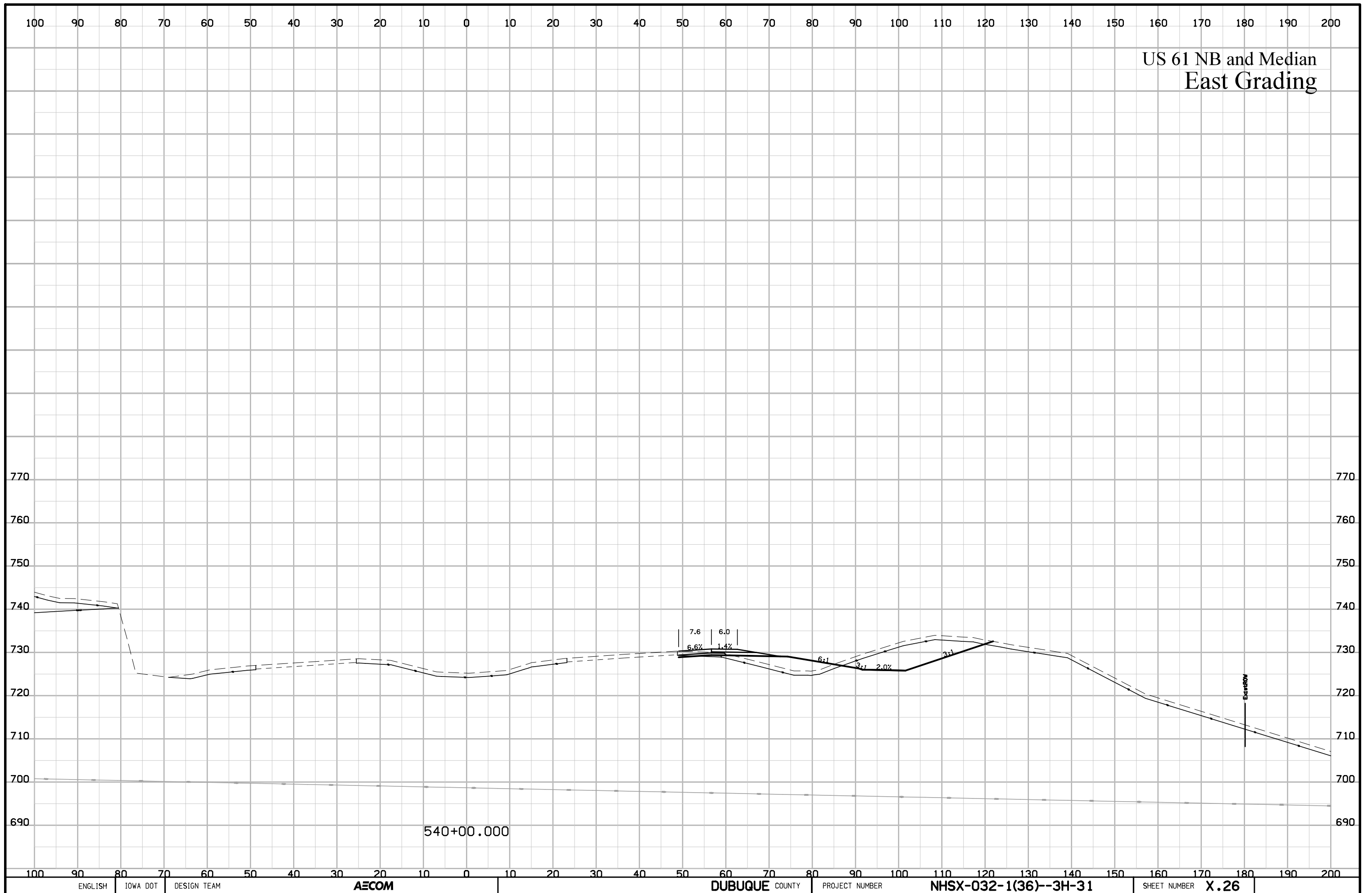

US 61 NB and Median East Grading

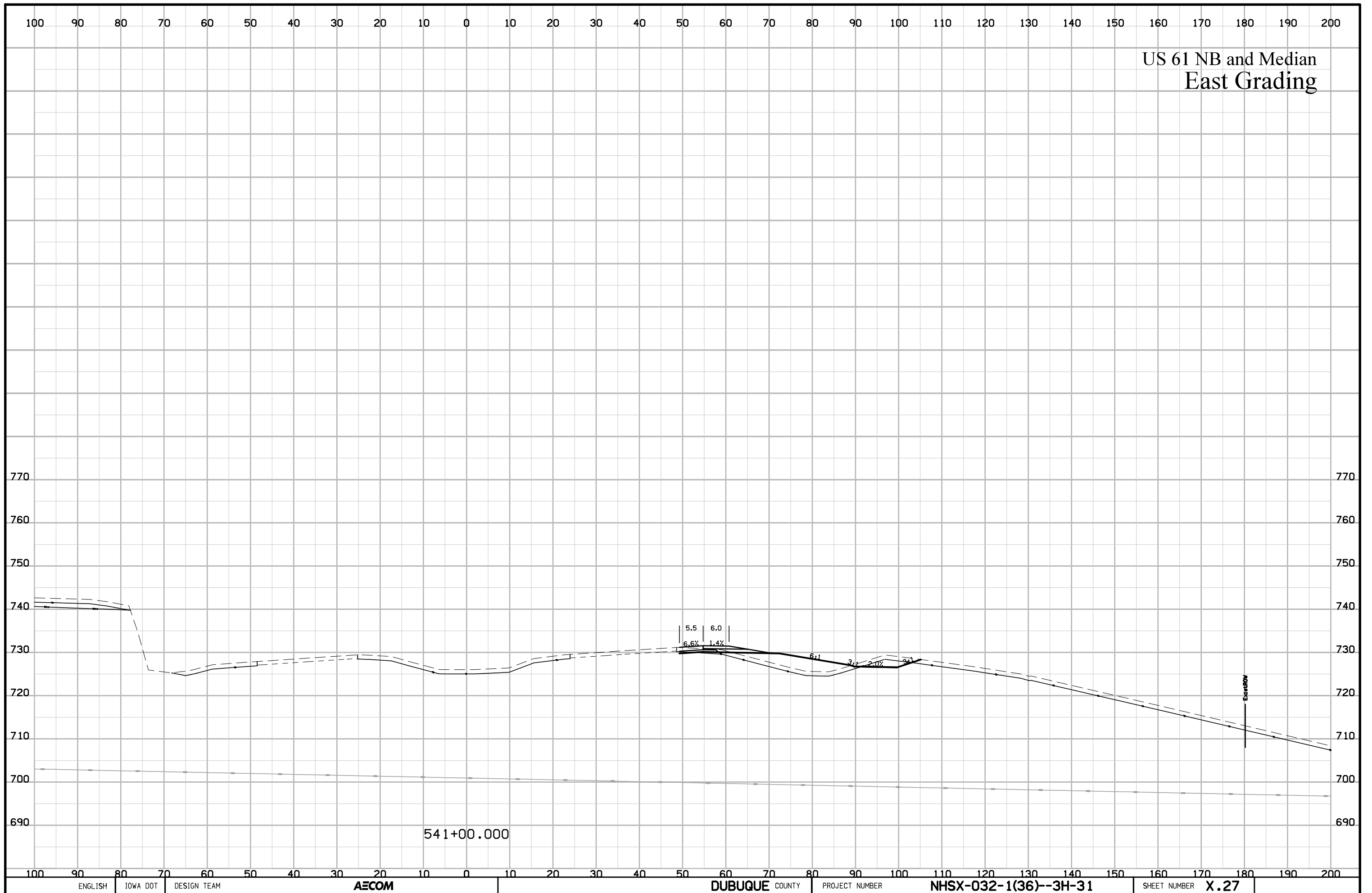

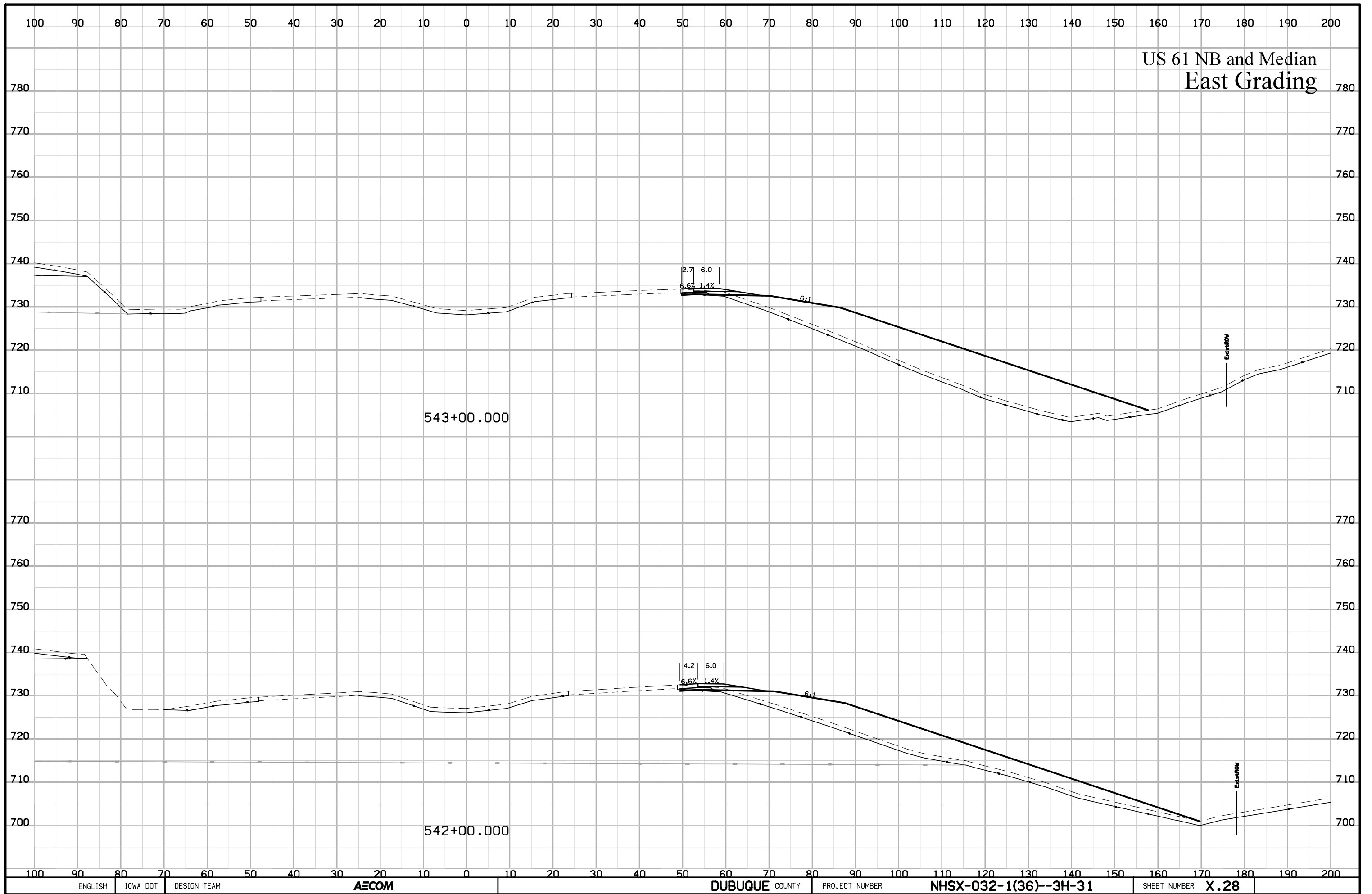

US 61 NB and Median East Grading

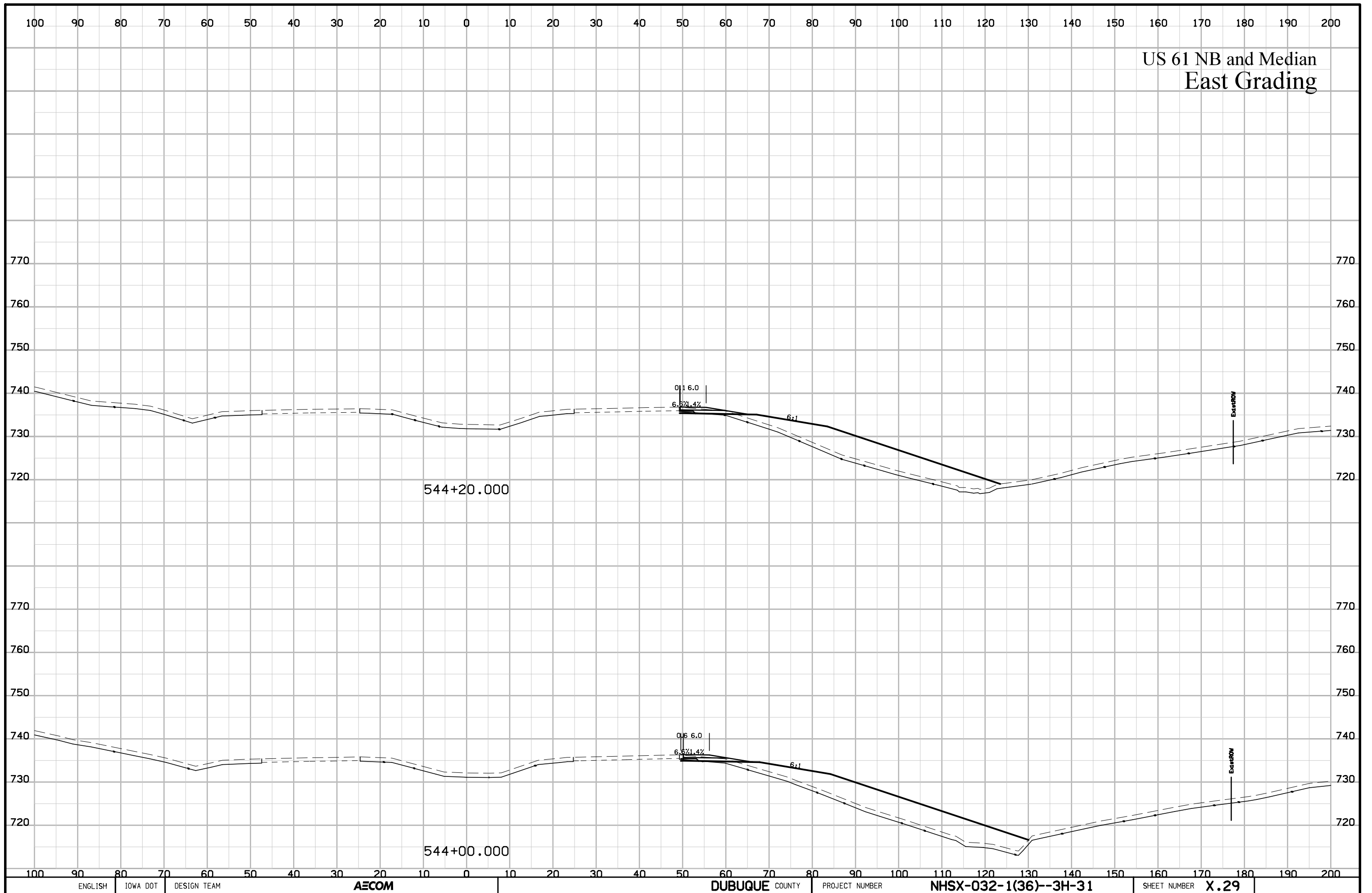

US 61 Connector Road A Southwest Arterial

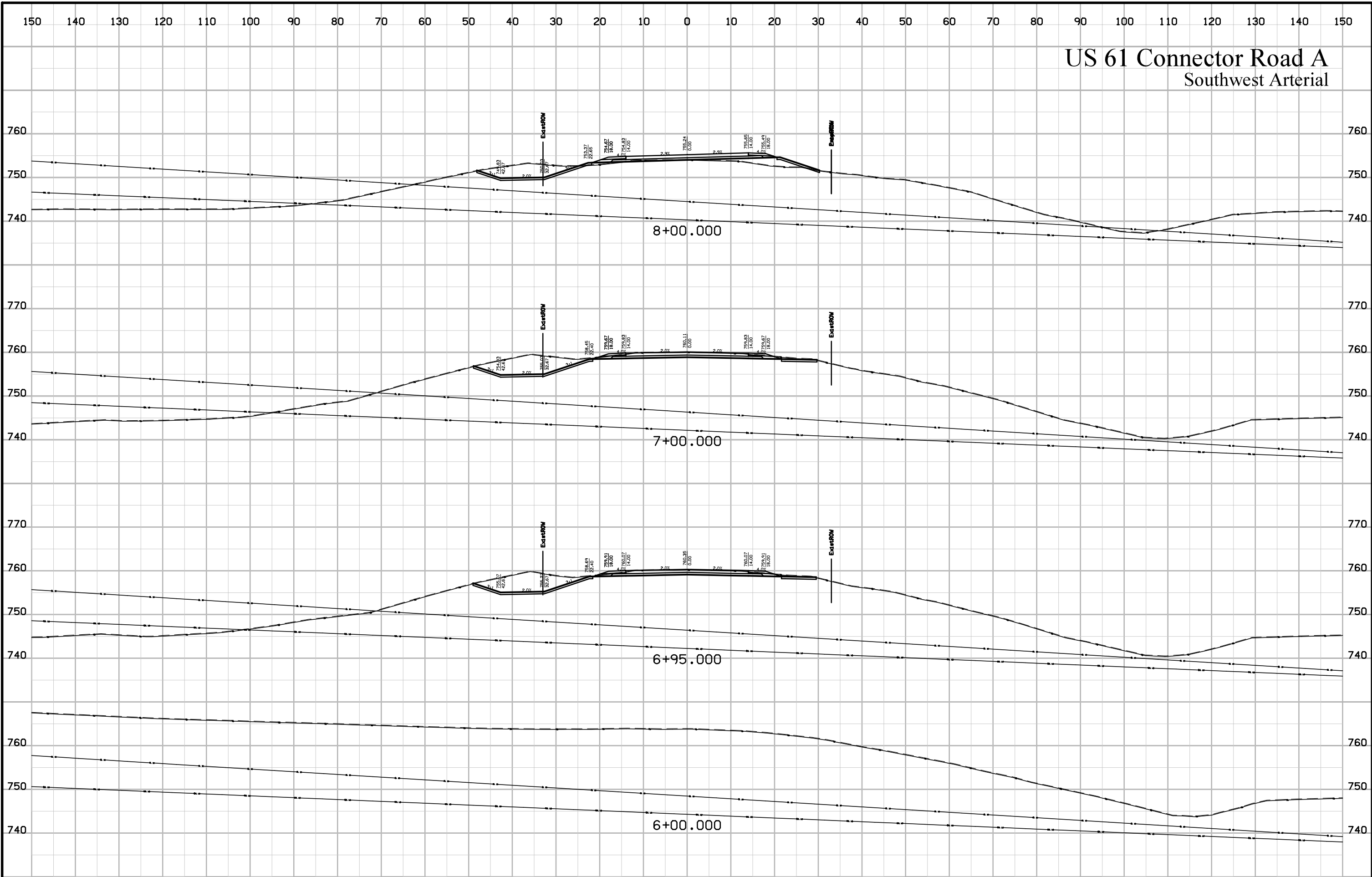

US 61 Connector Road A Southwest Arterial

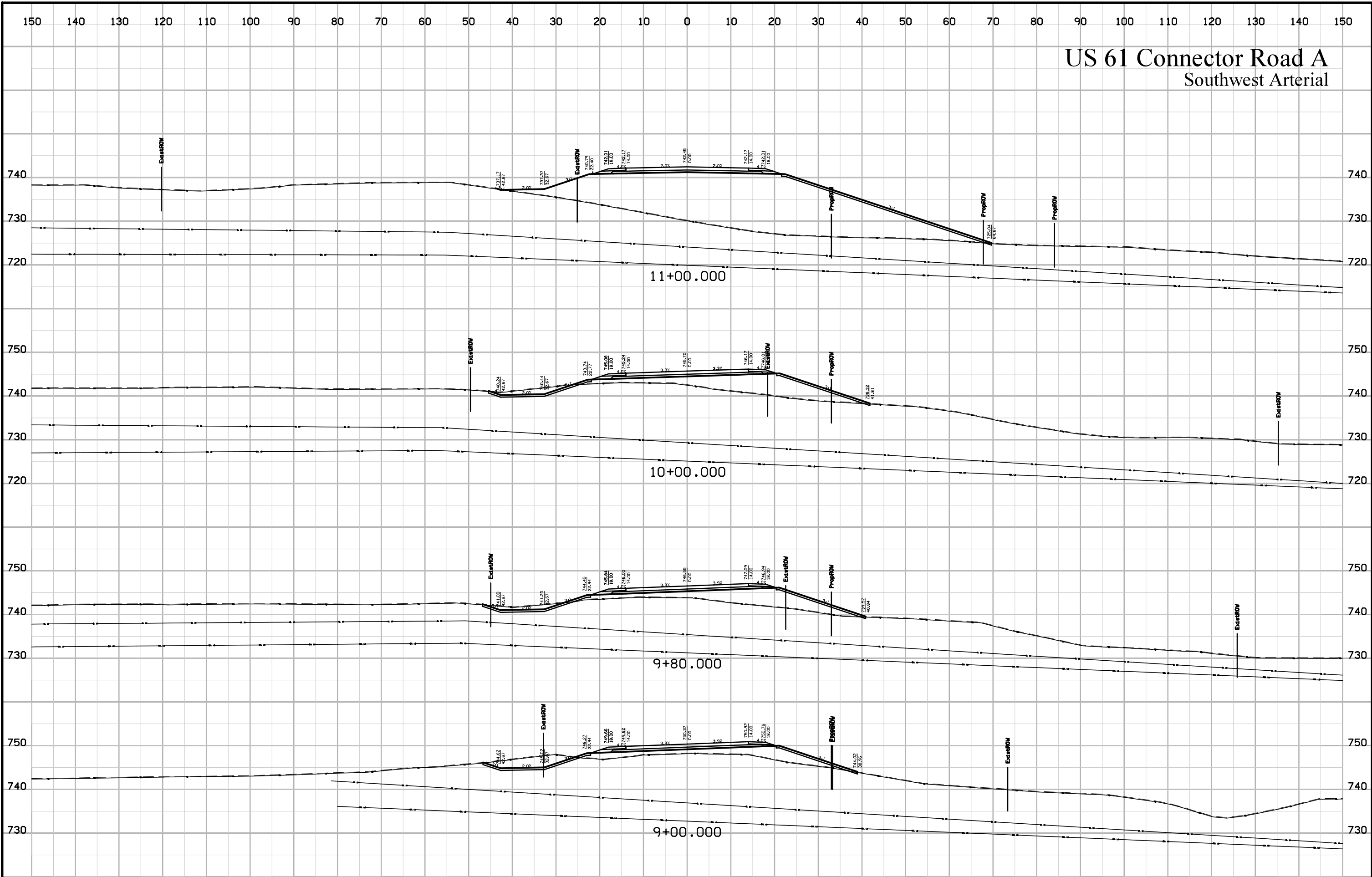

US 61 Connector Road A Southwest Arterial

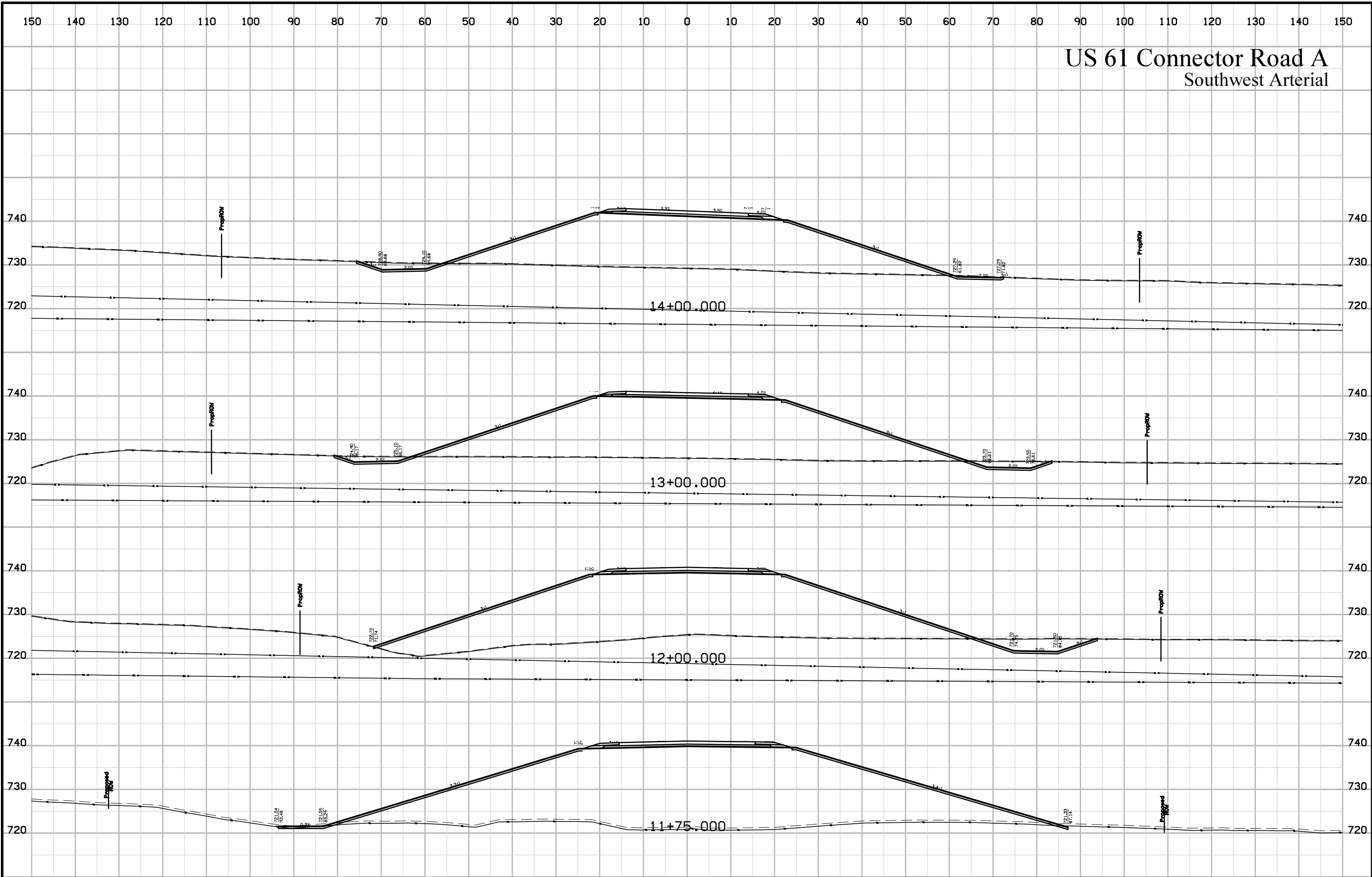

US 61 Connector Road A Southwest Arterial

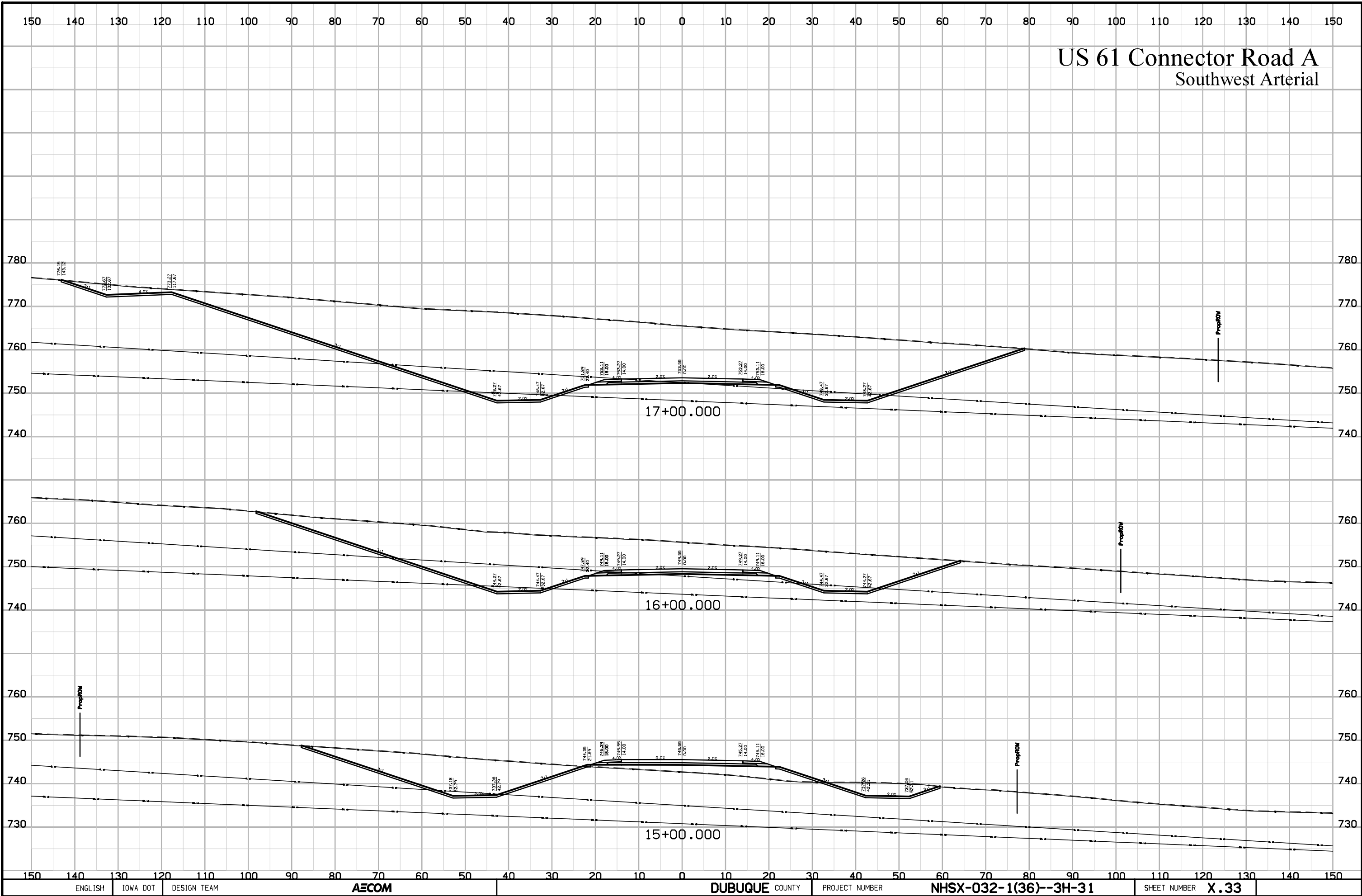

US 61 Connector Road A Southwest Arterial

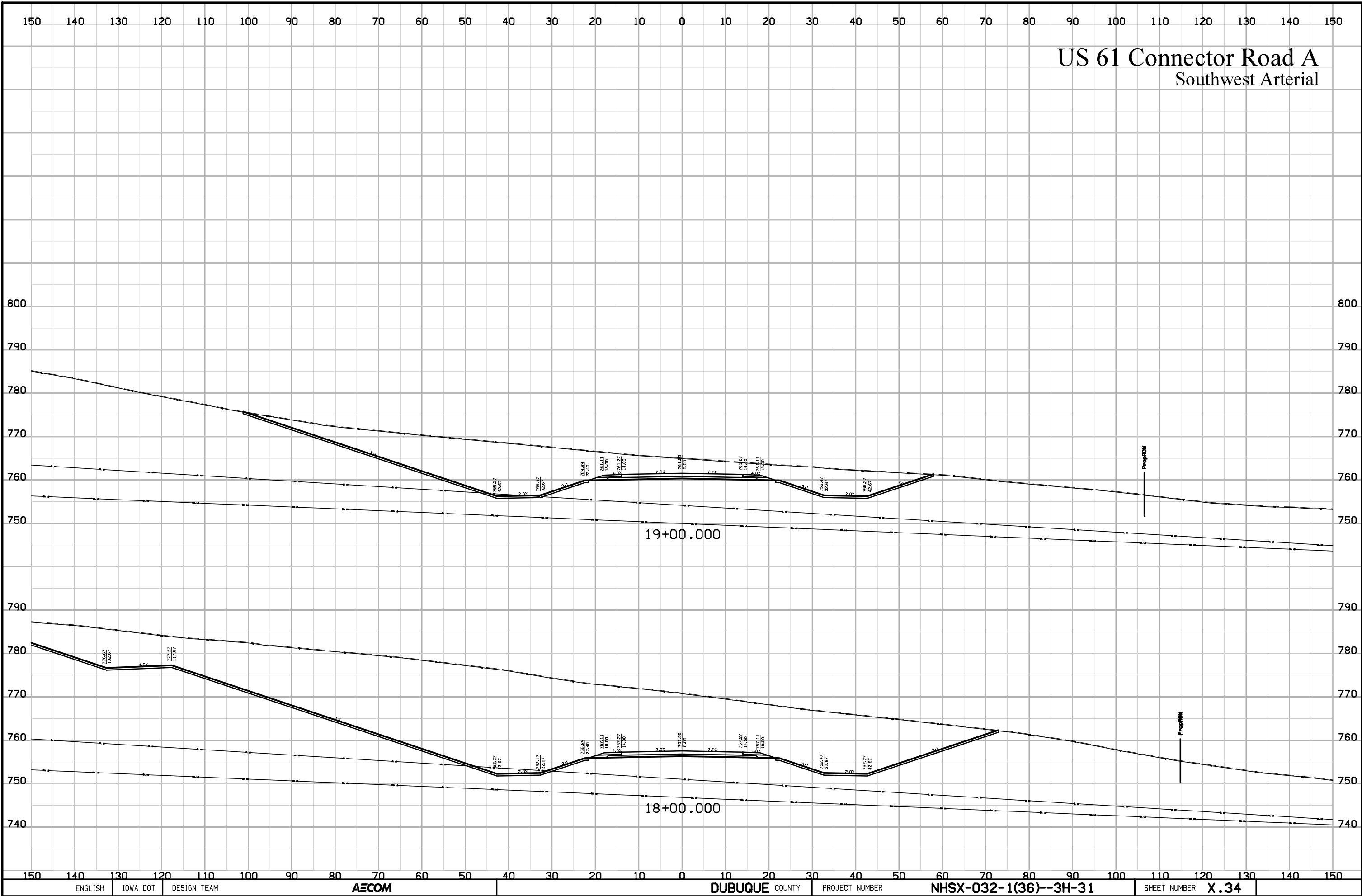

US 61 Connector Road A Southwest Arterial

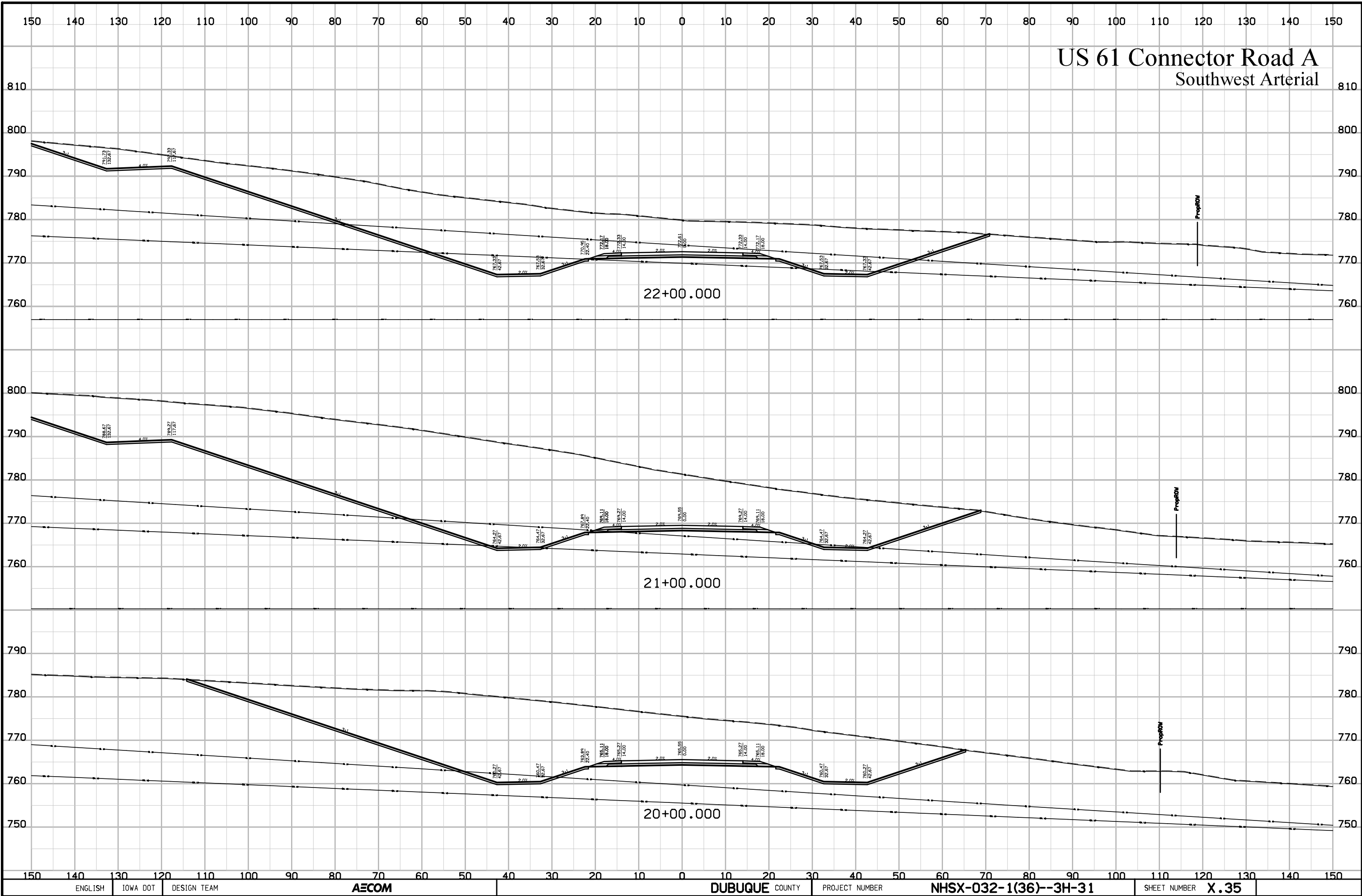

US 61 Connector Road A Southwest Arterial

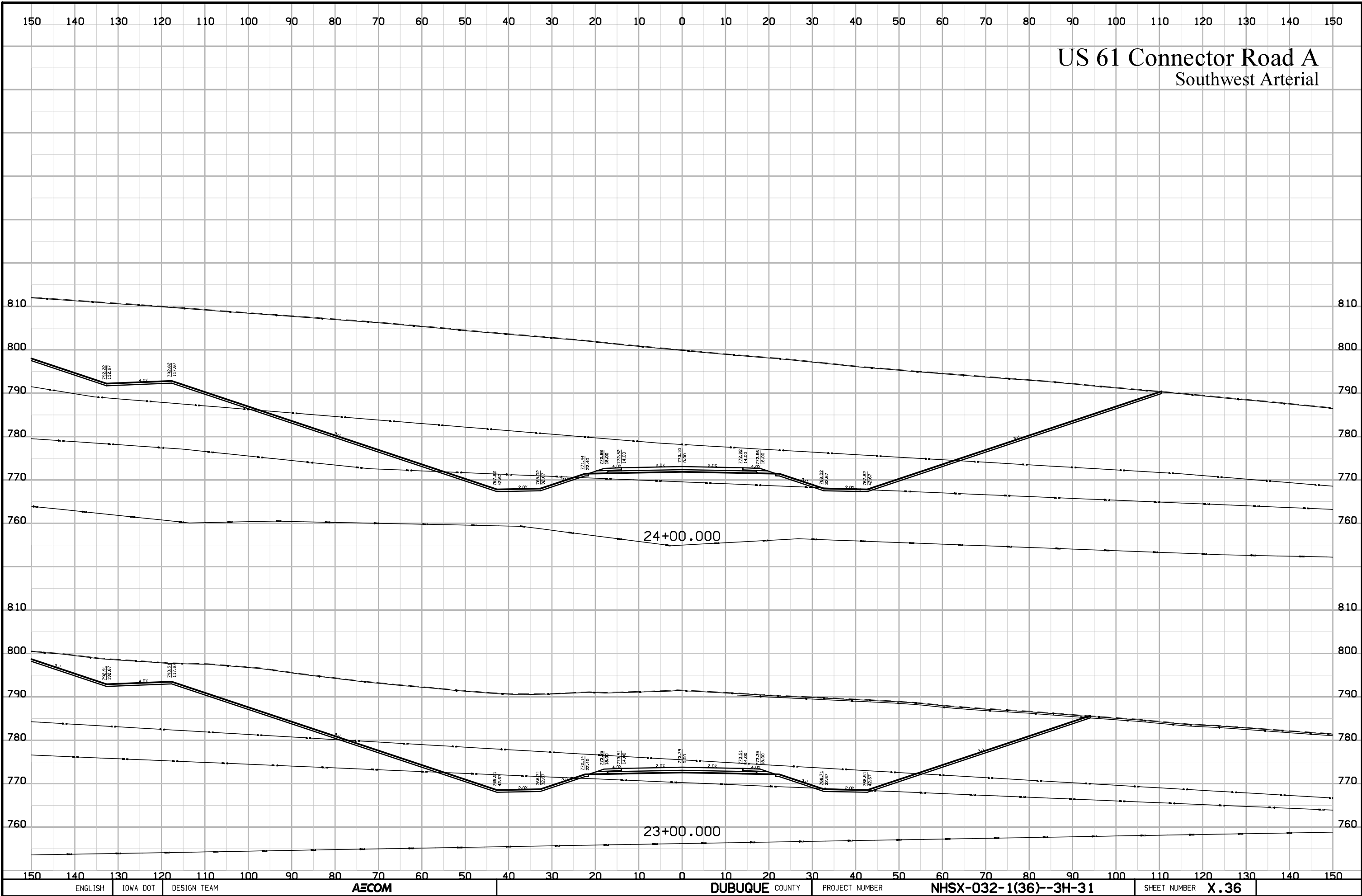

US 61 Connector Road A Southwest Arterial

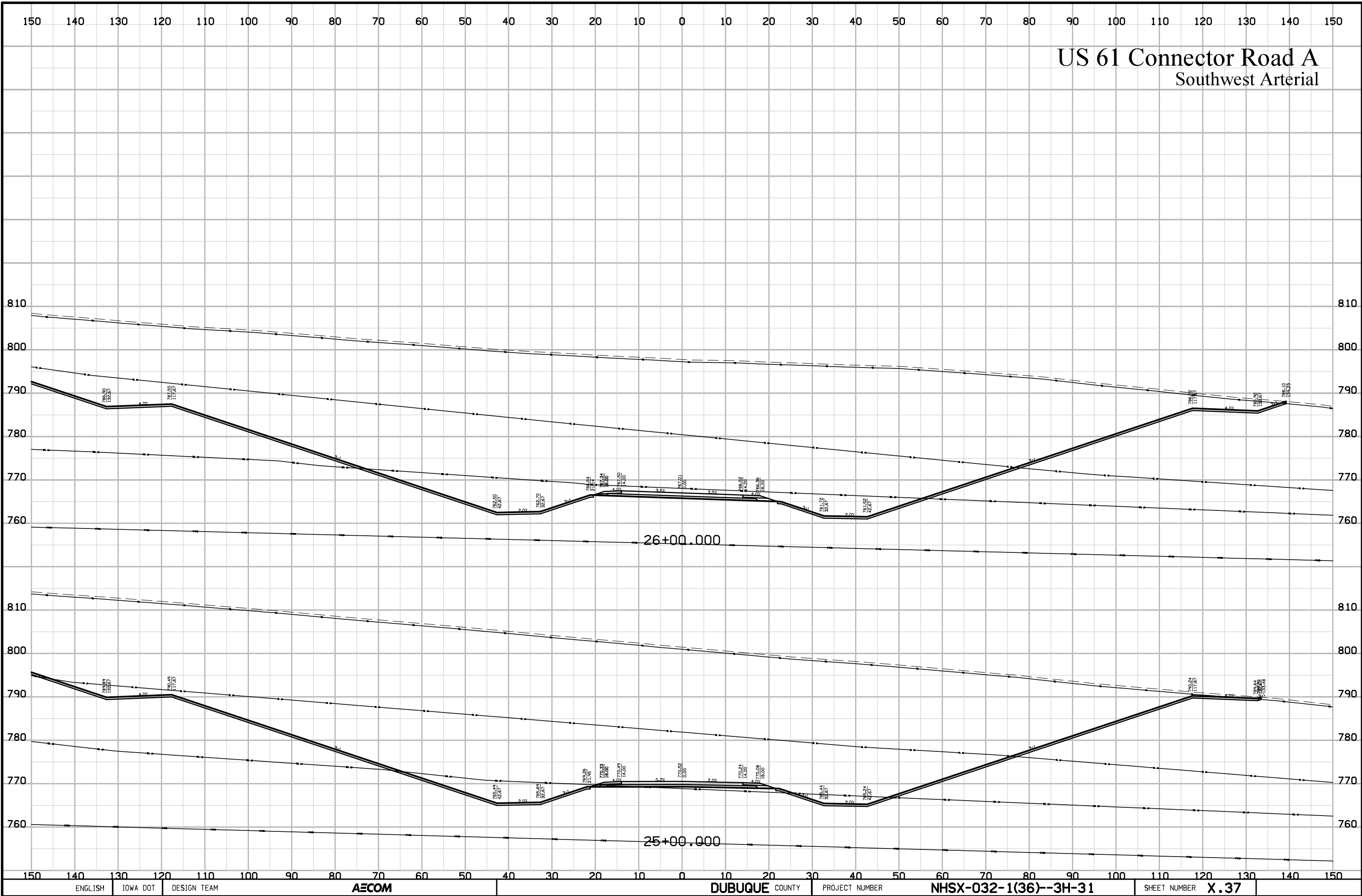

US 61 Connector Road A Southwest Arterial

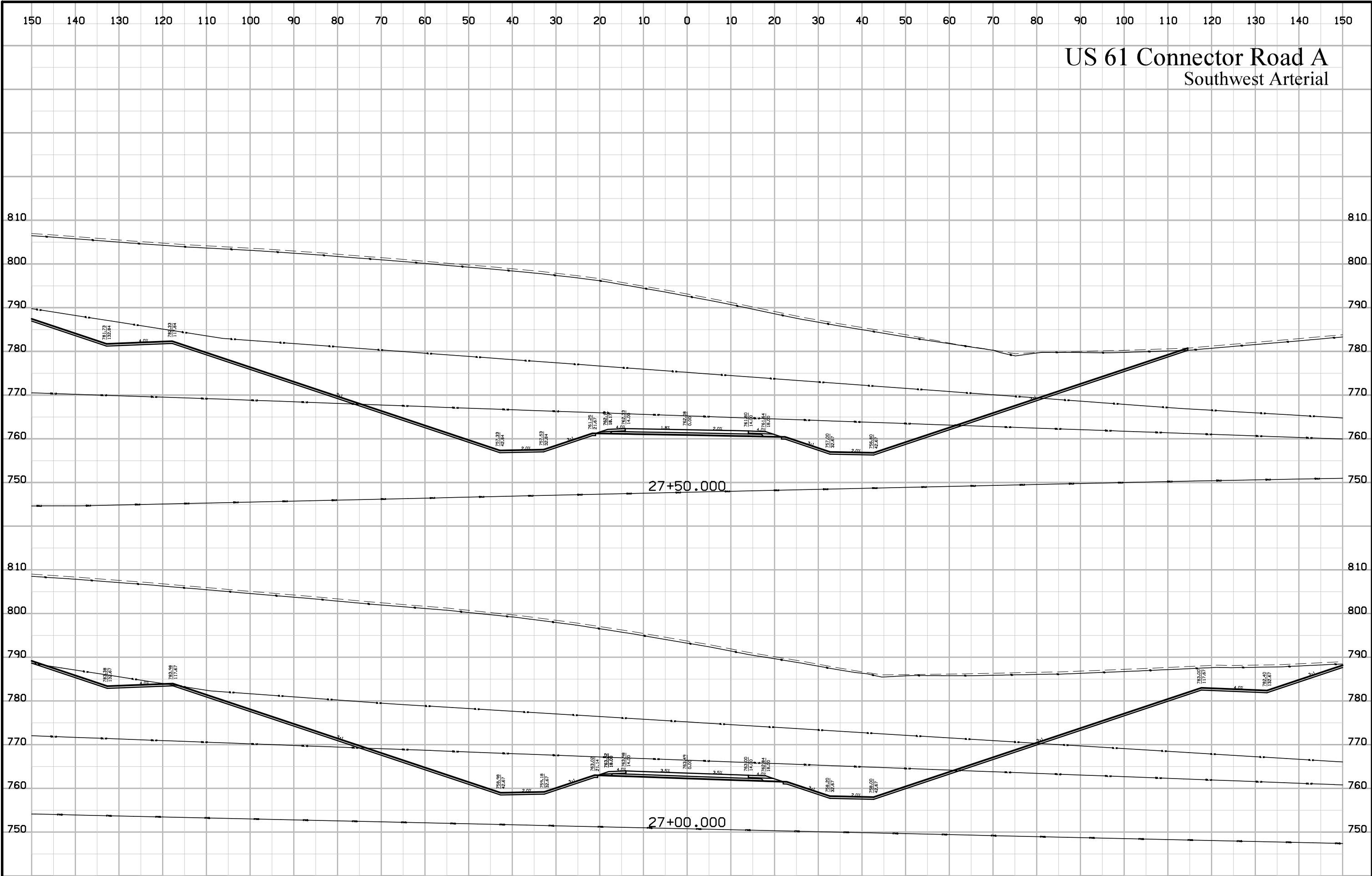

US 61 Connector Road A

Southwest Arterial

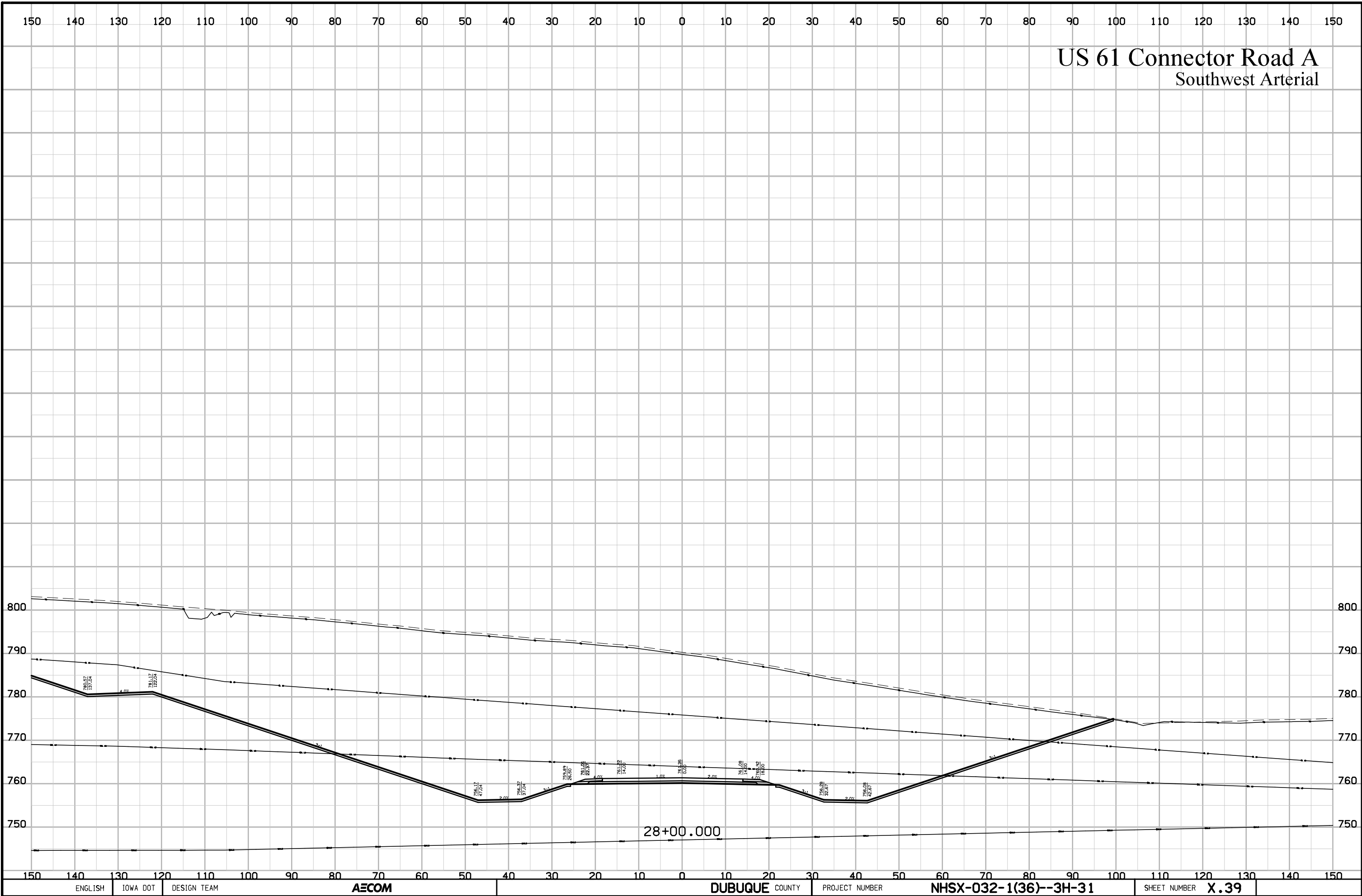

US 61 Connector Road B Southwest Arterial

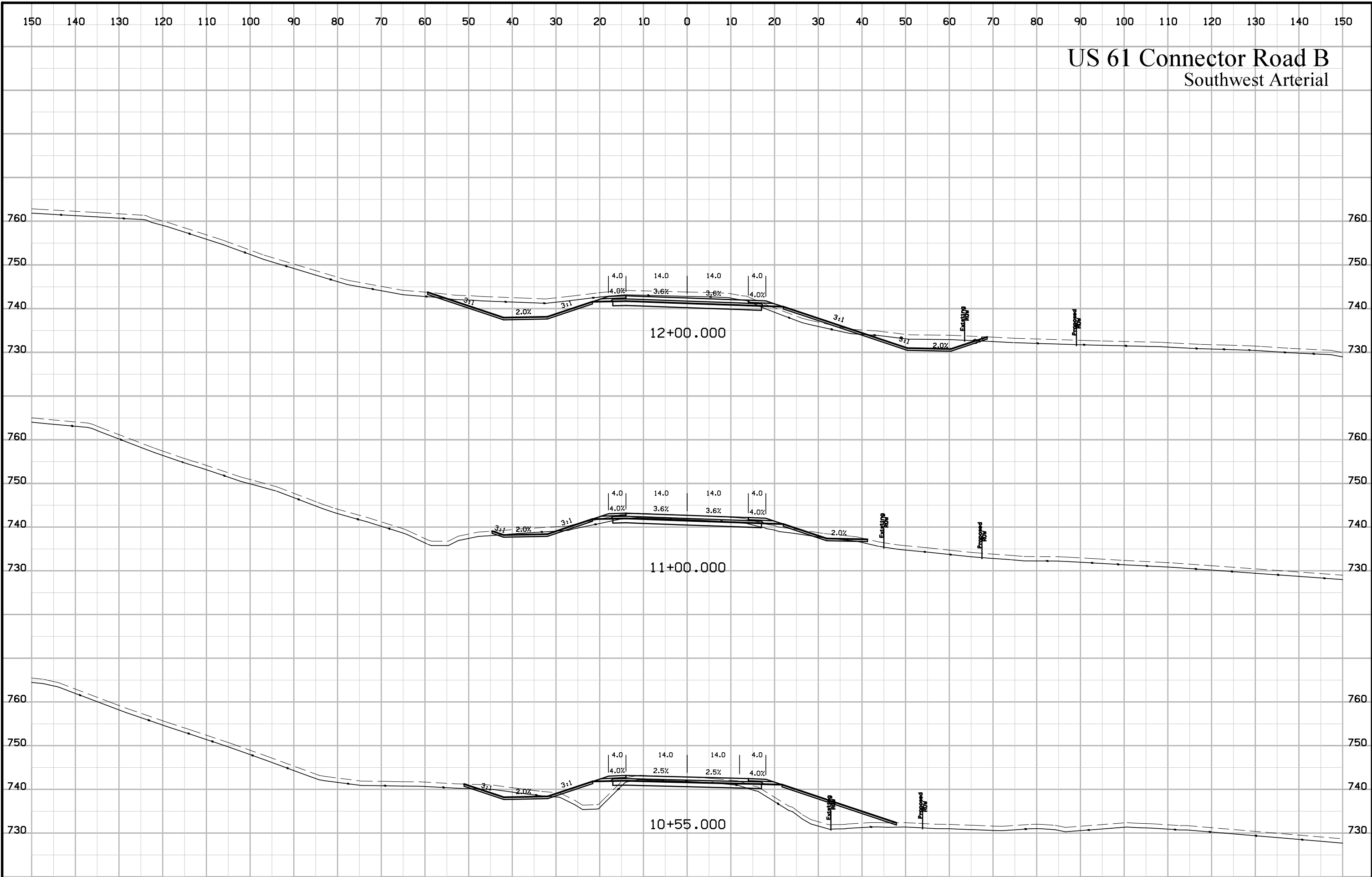

US 61 Connector Road B Southwest Arterial

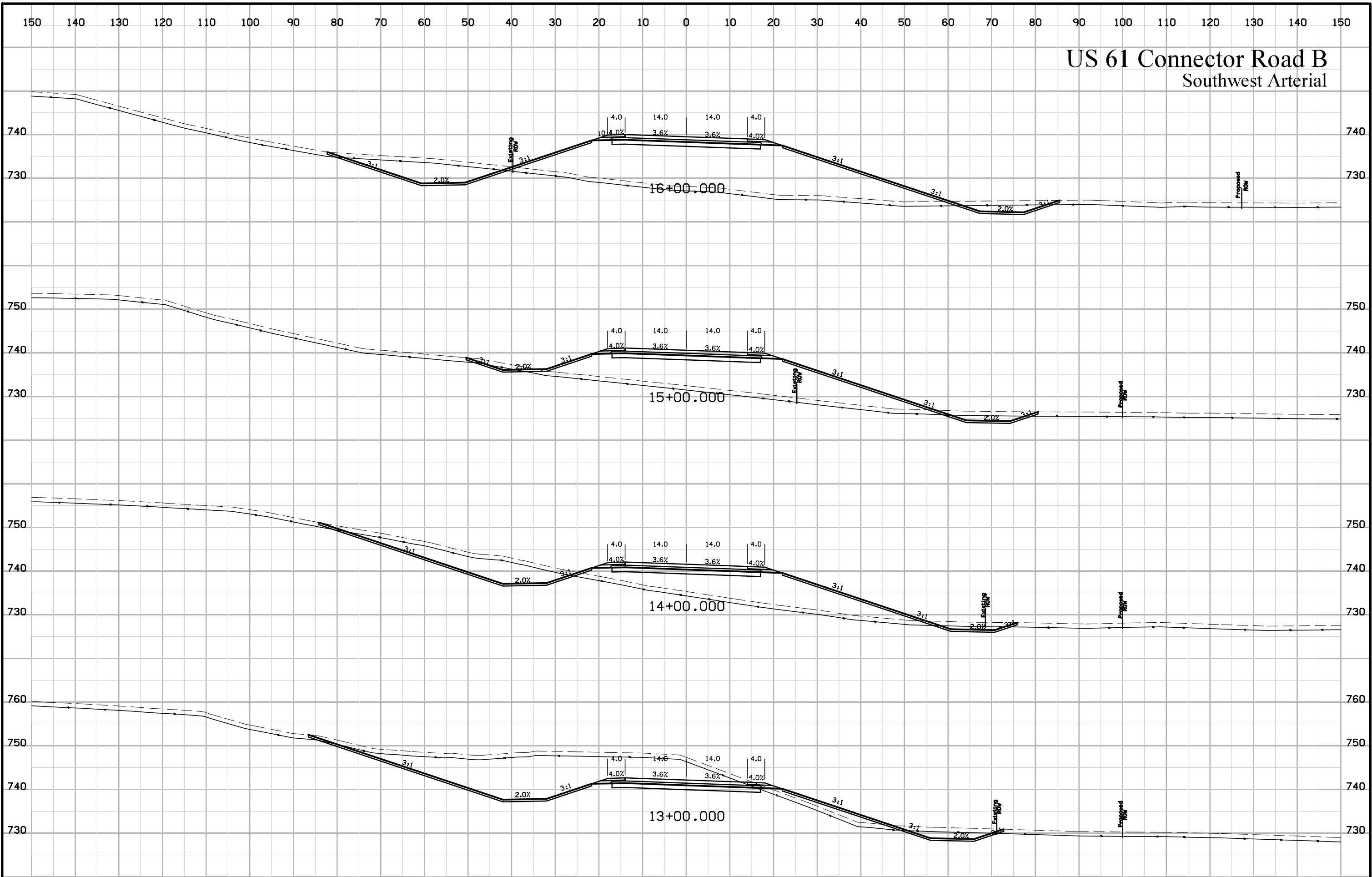

US 61 Connector Road B Southwest Arterial

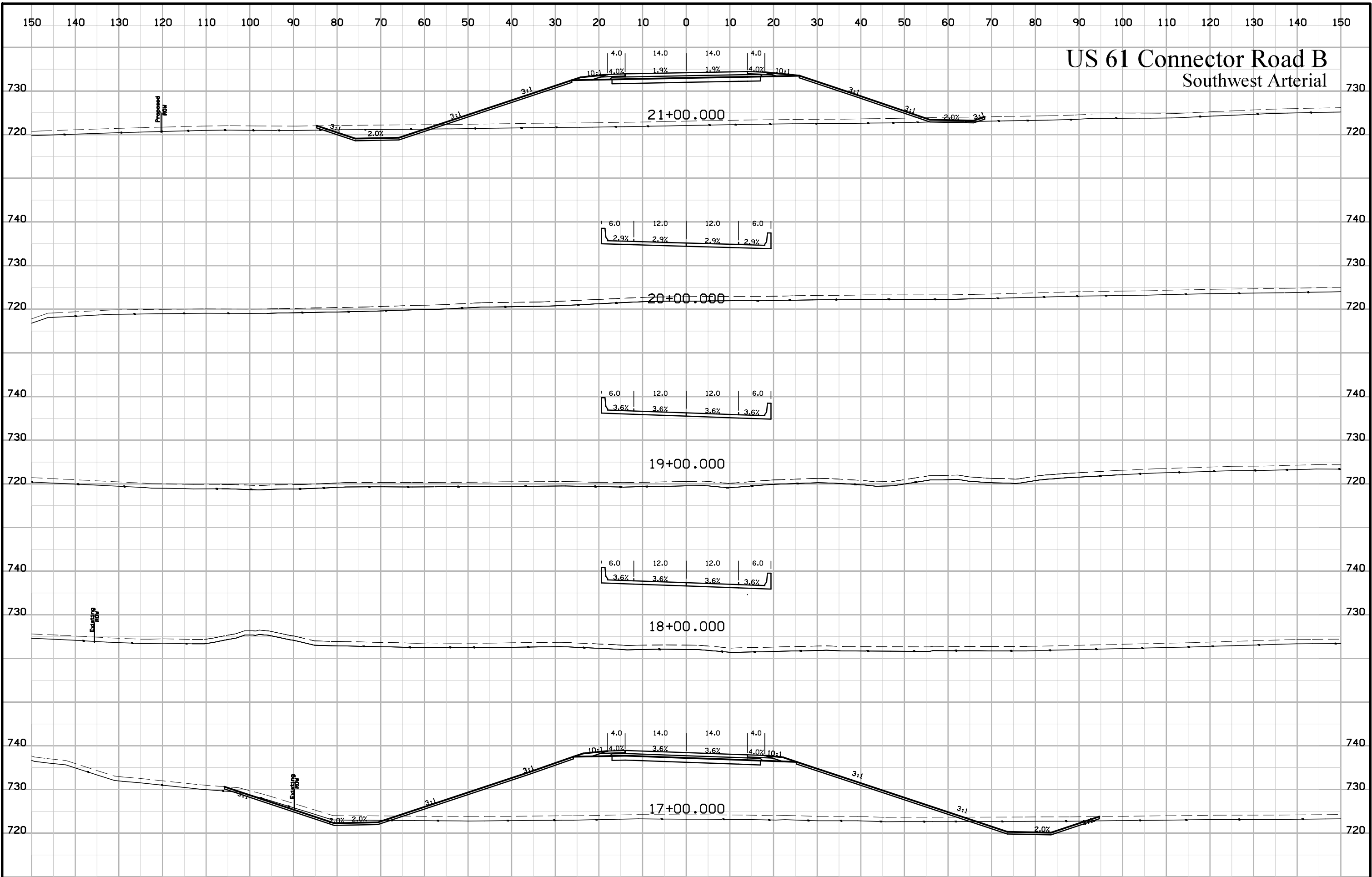

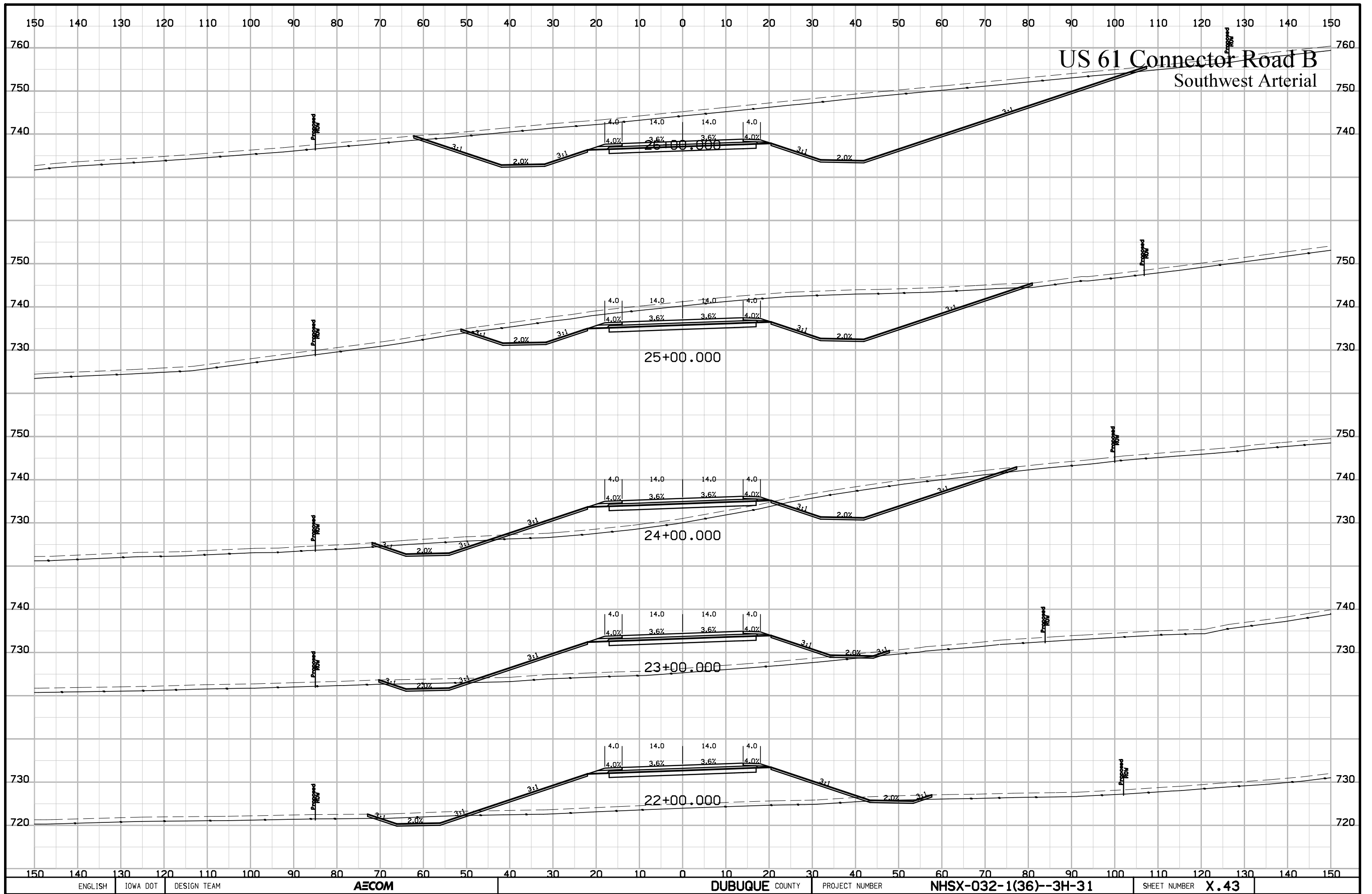

US 61 Connector Road B

Southwest Arterial

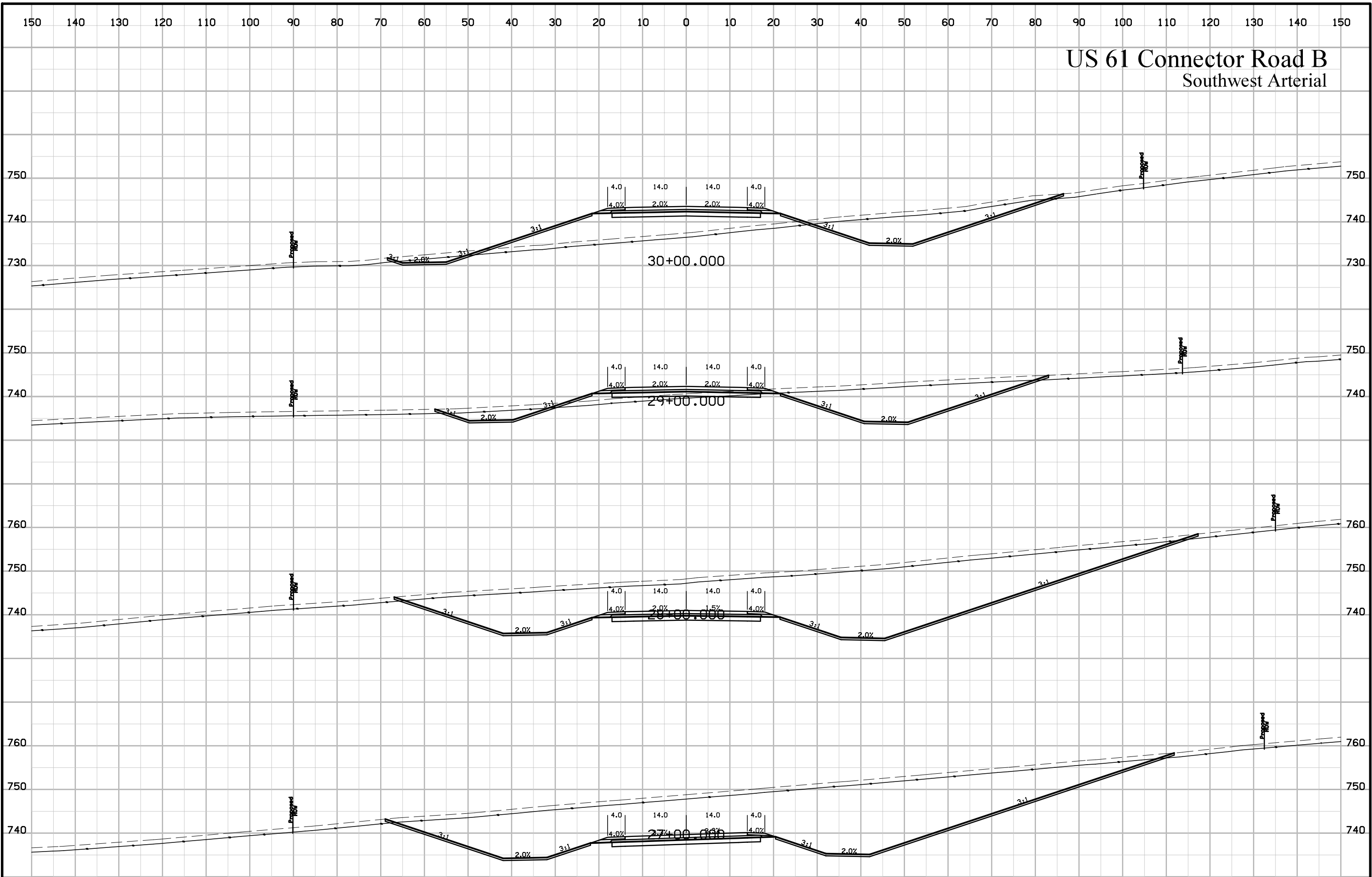

US 61 Connector Road B

Southwest Arterial

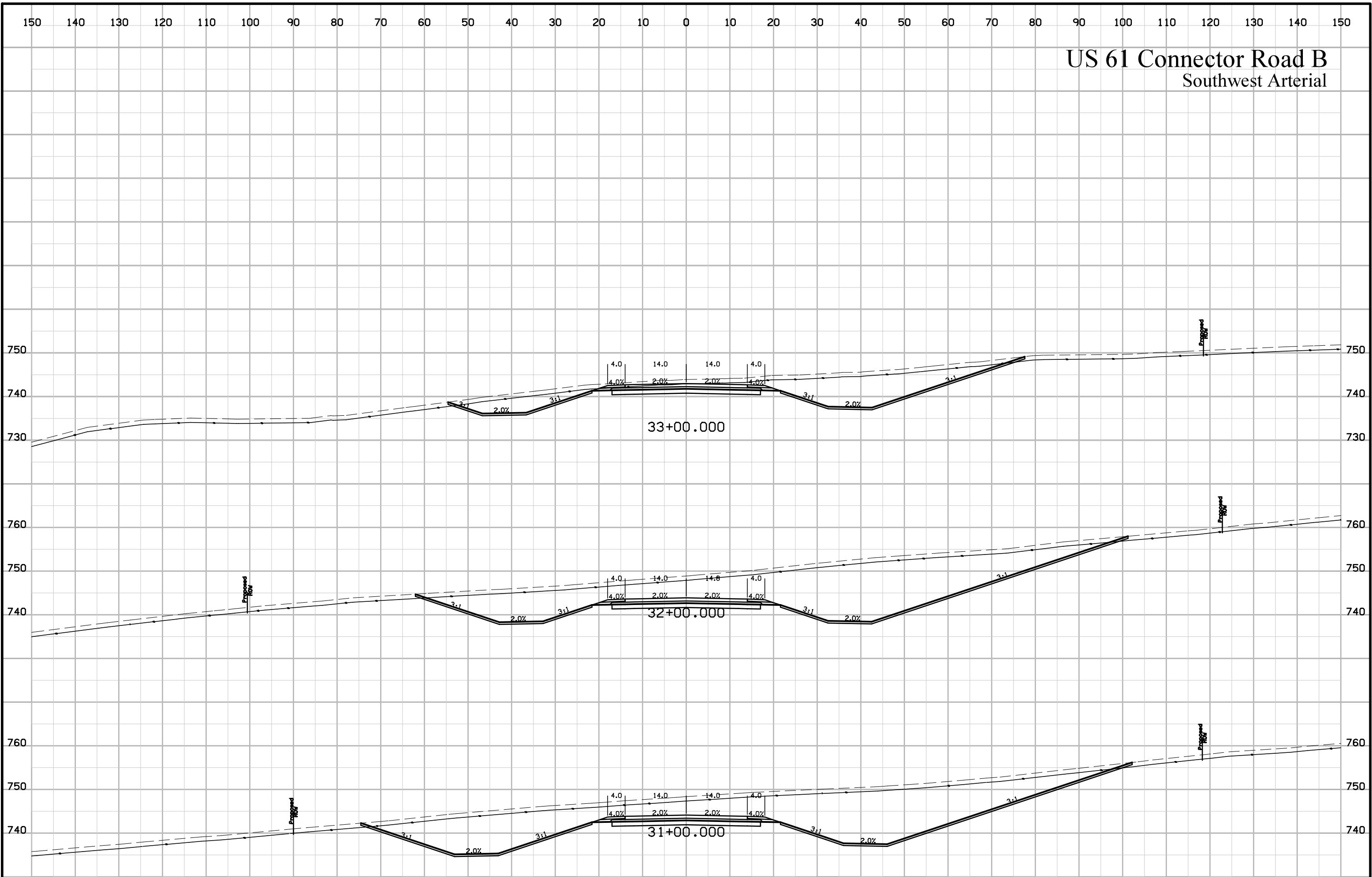

US 61 Connector Road B

Southwest Arterial

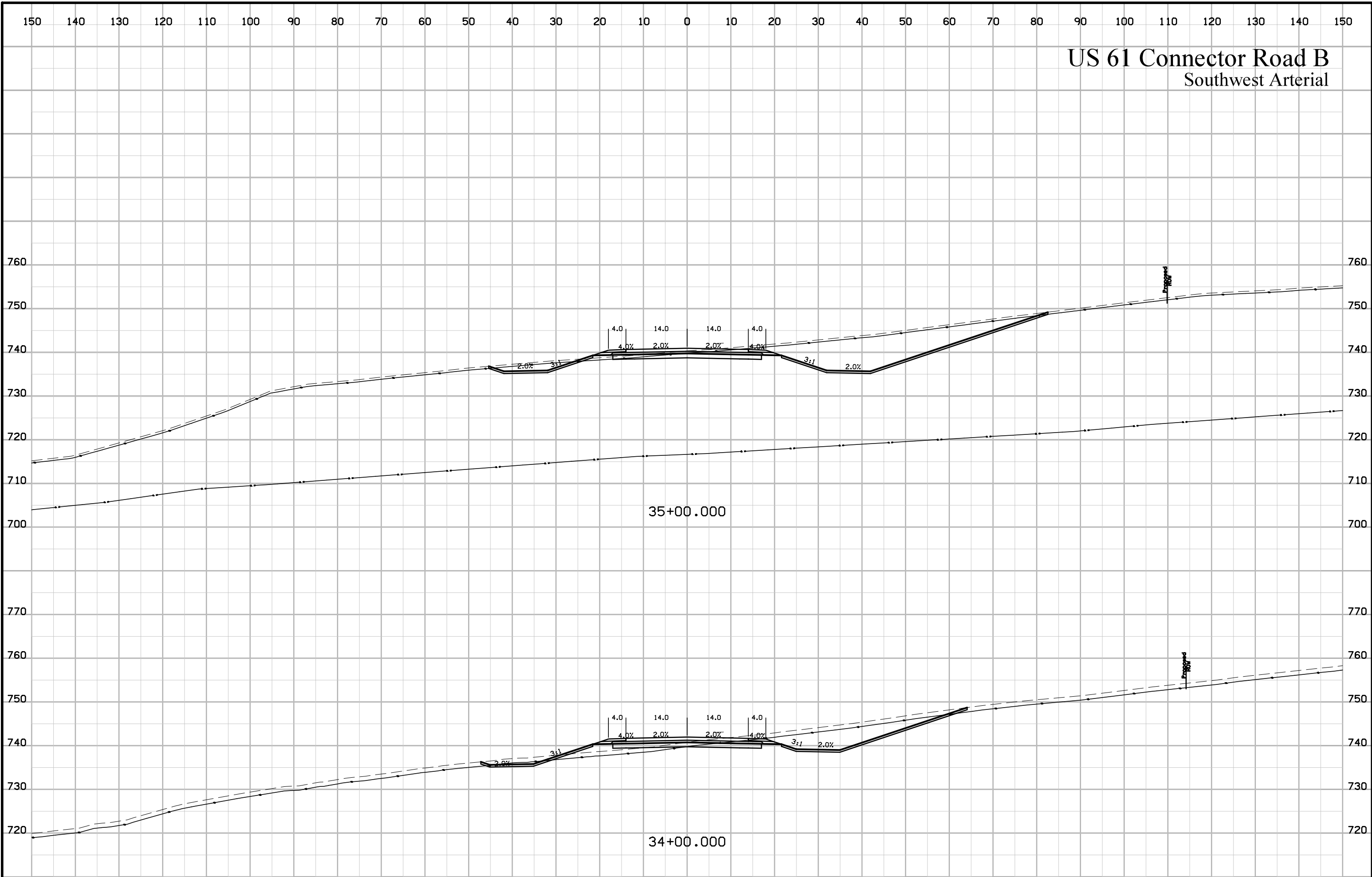

US 61 Connector Road B

Southwest Arterial

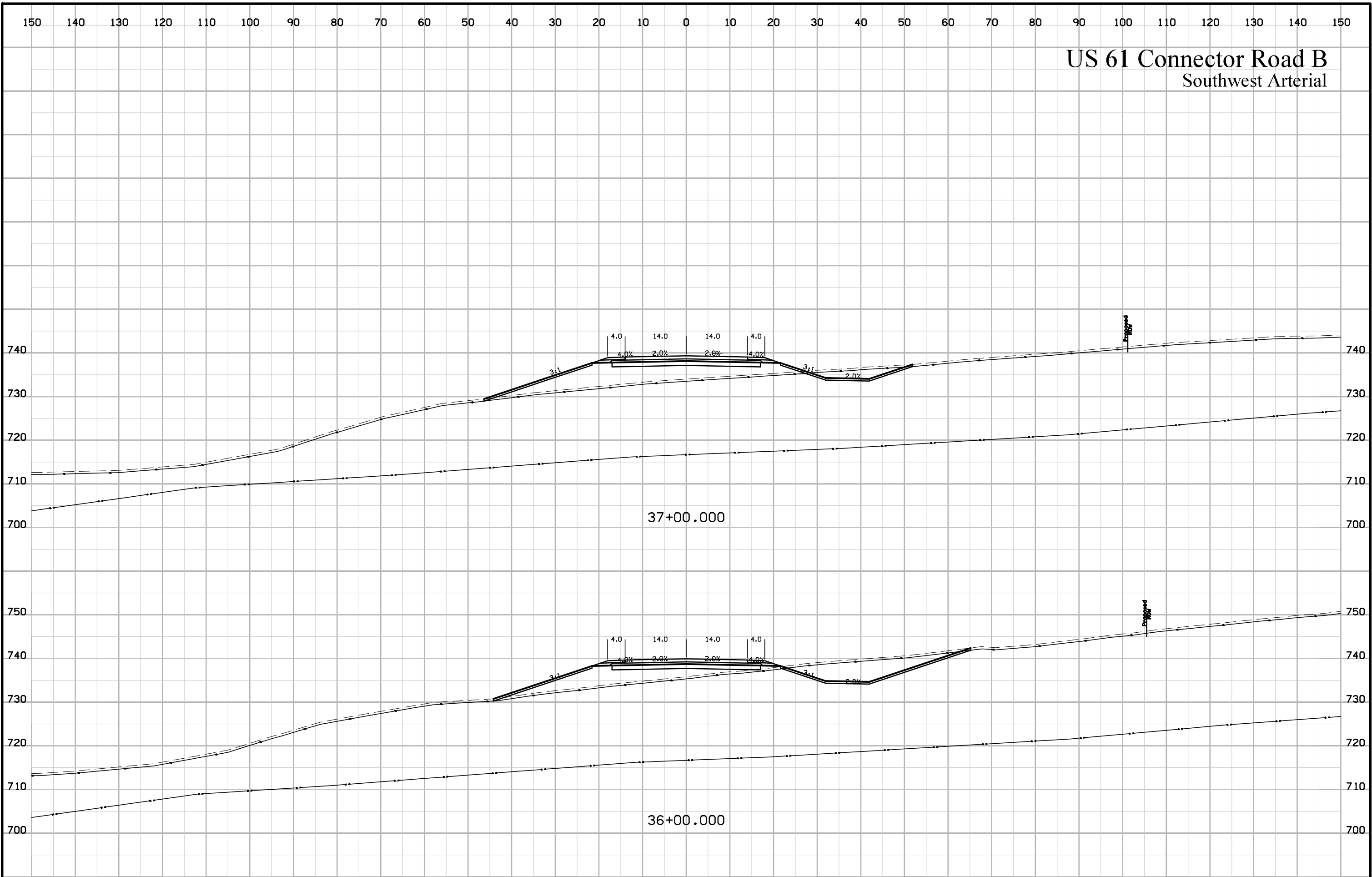

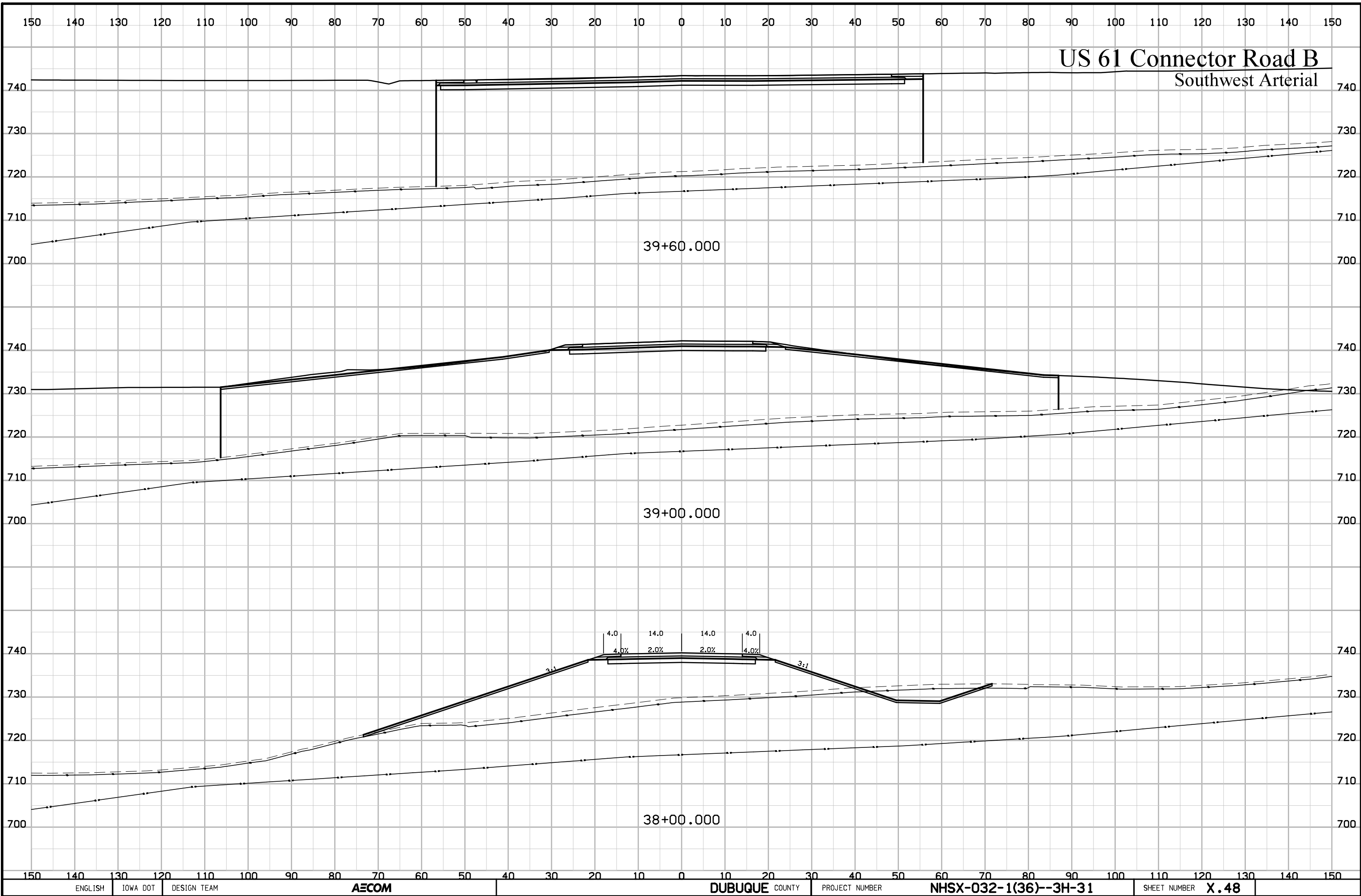

US 61 Connector Road B
Southwest Arterial

39+60.000

39+00.000

38+00.000

4.0 14.0 14.0 4.0
4.0% 2.0% 2.0% 4.0%

US 61 Ramp A East Grading

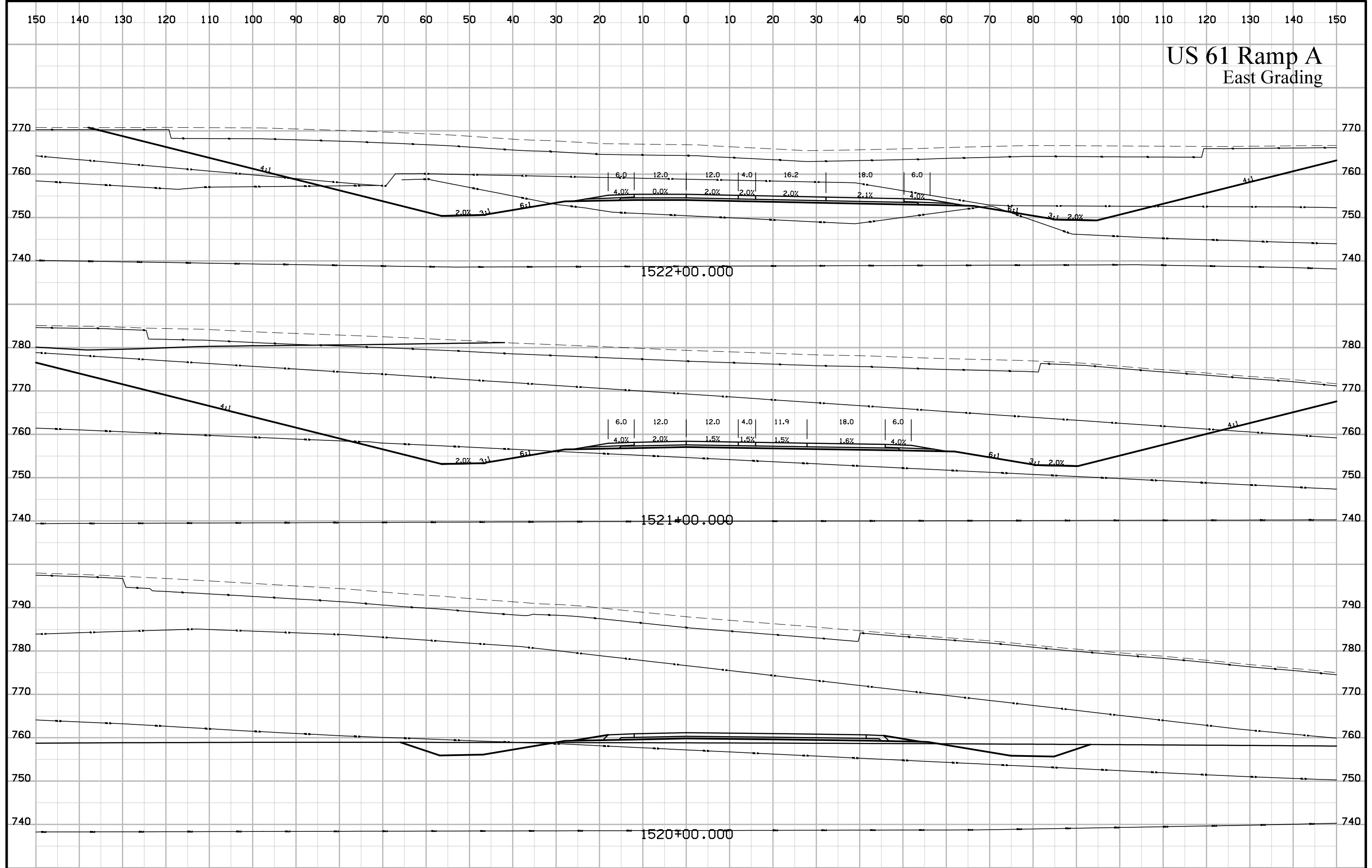

US 61 Ramp A East Grading

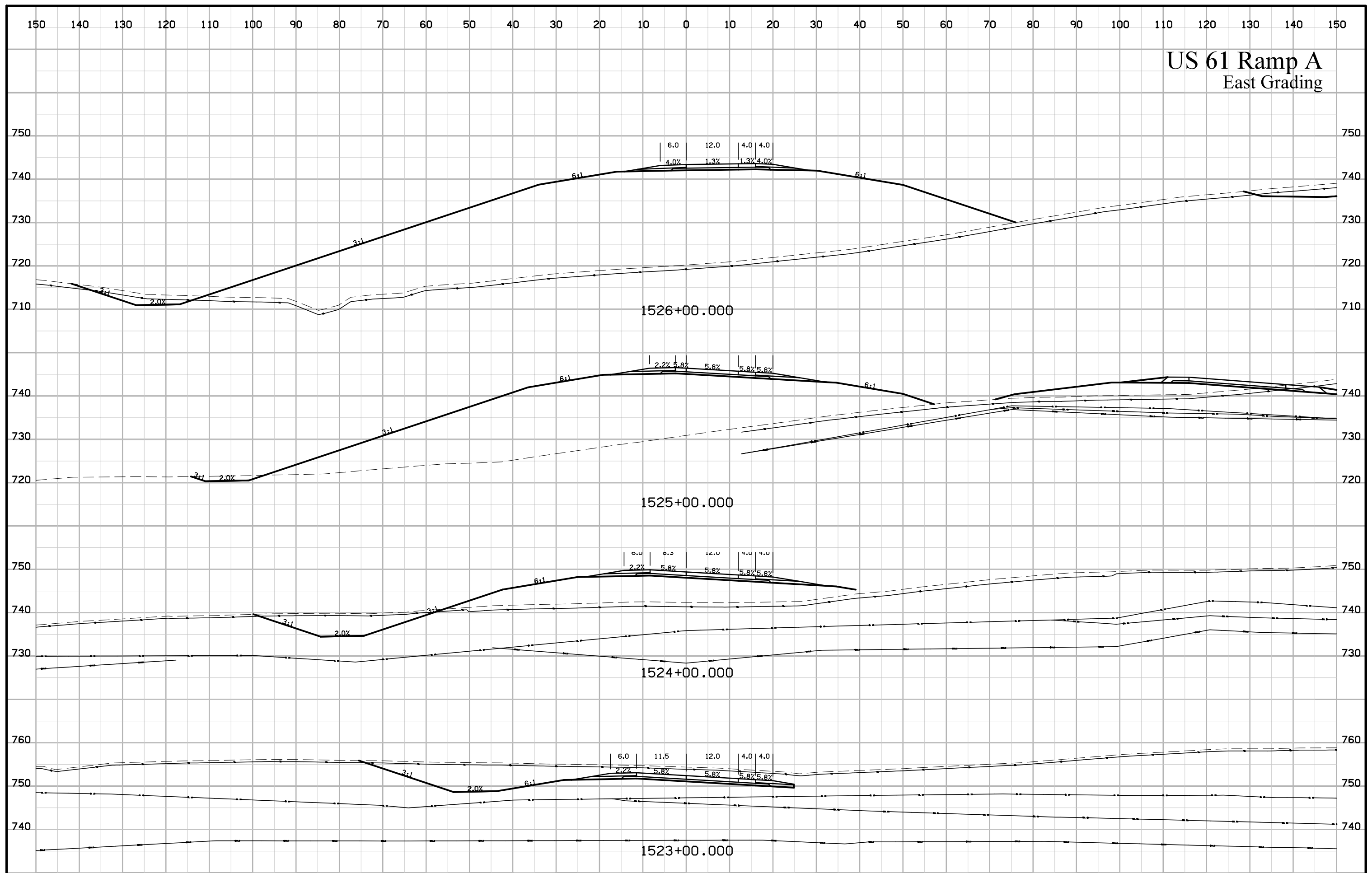

US 61 Ramp A East Grading

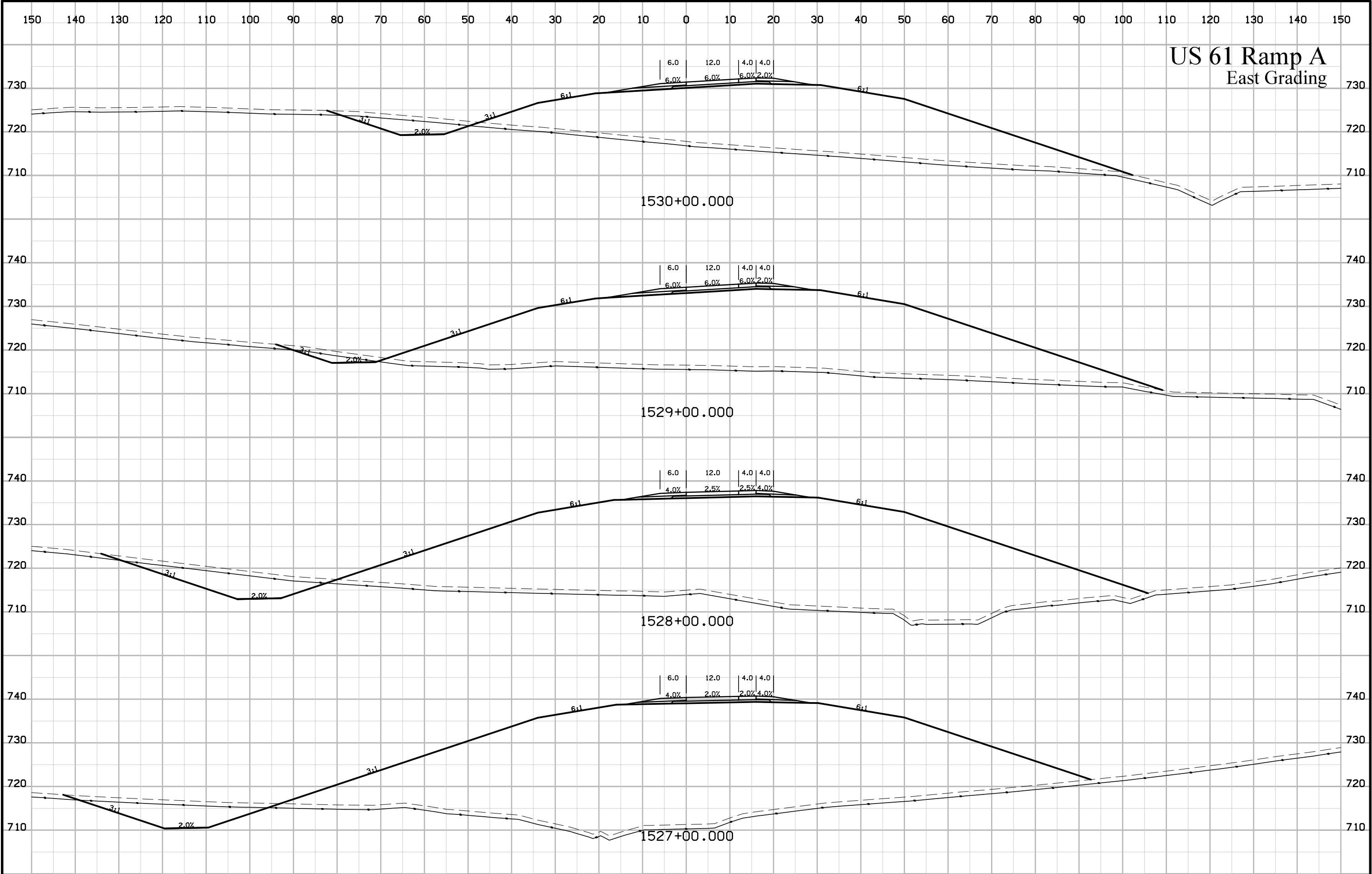

US 61 Ramp A East Grading

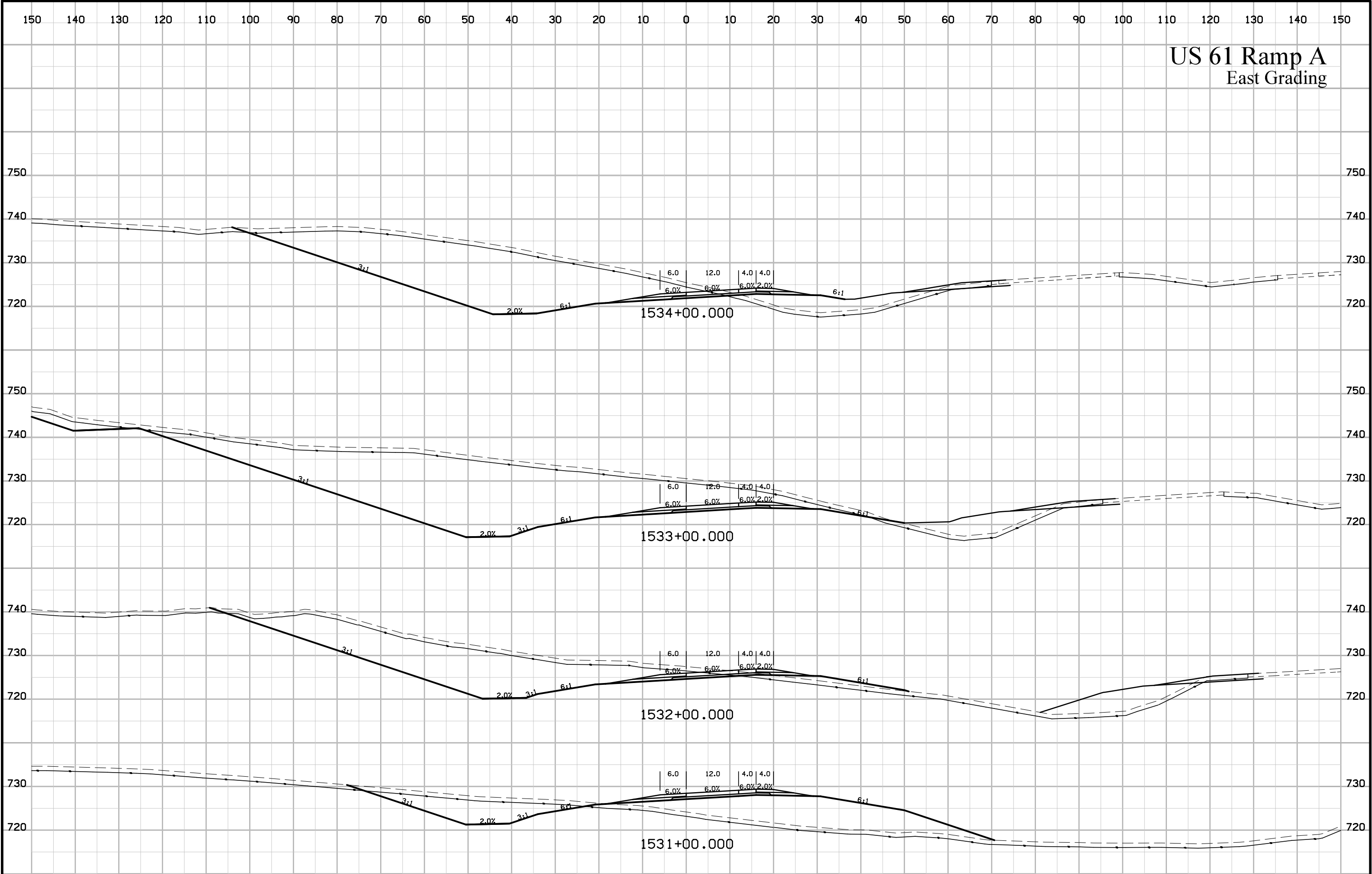

US 61 Ramp A East Grading

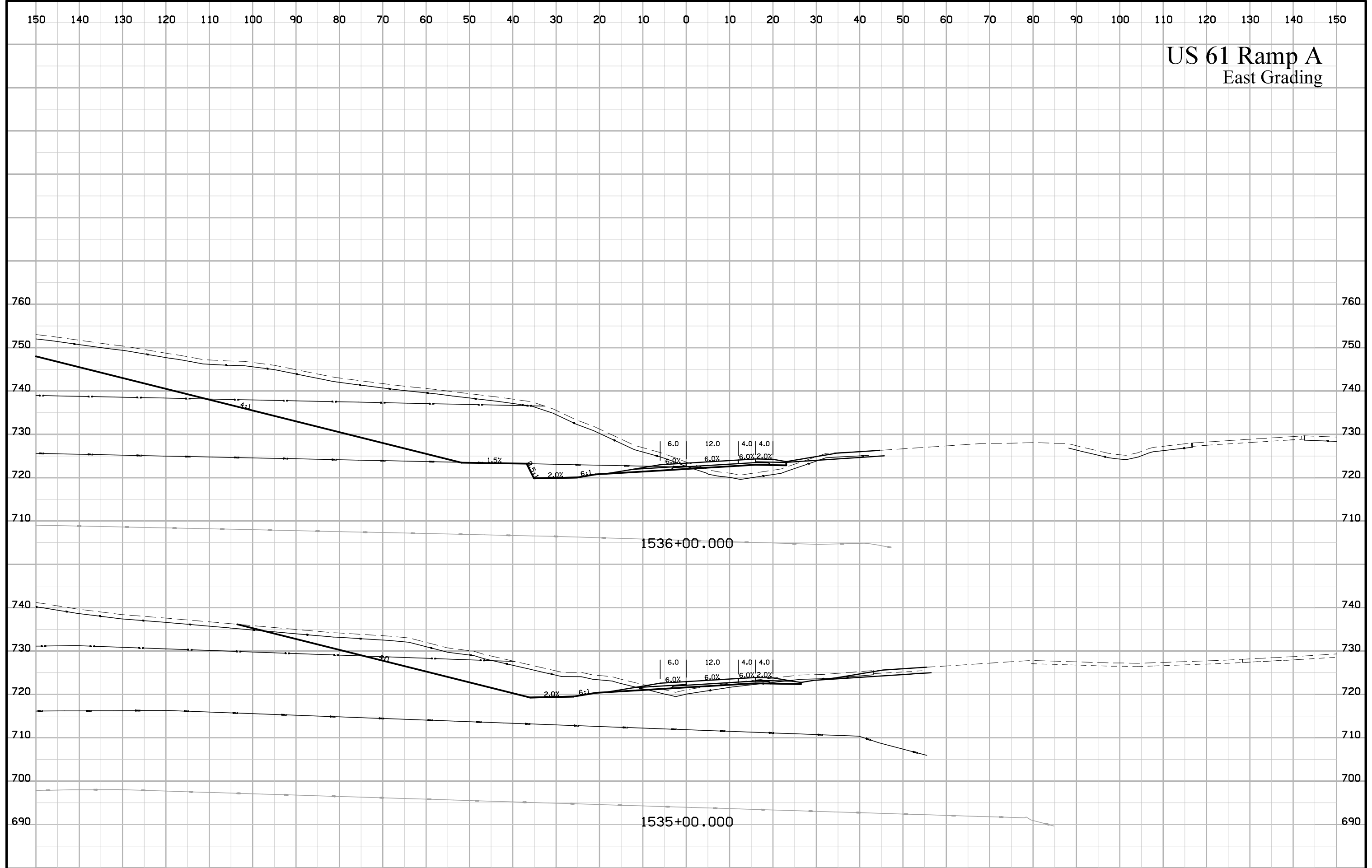

US 61 Loop C East Grading

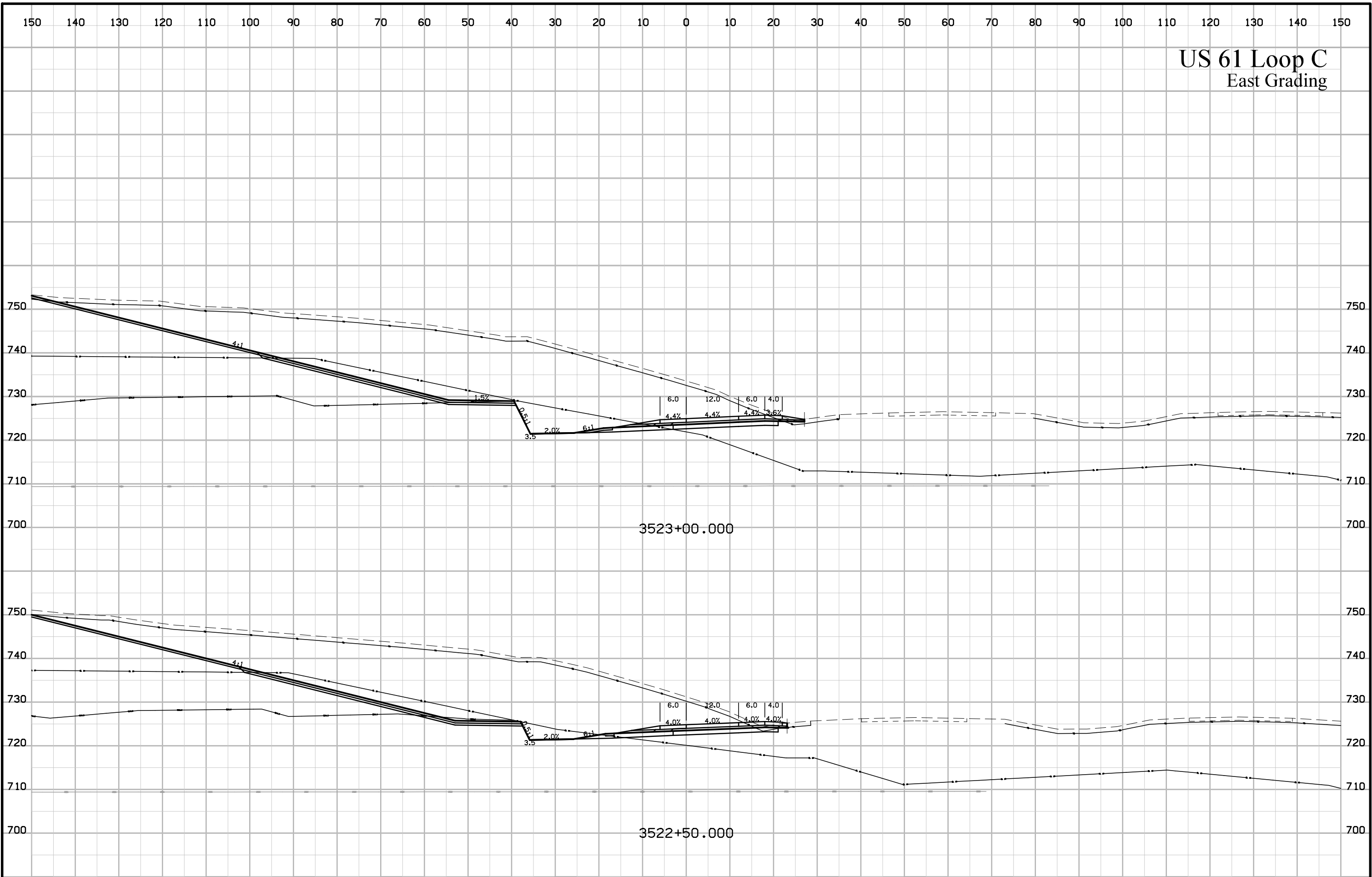

US 61 Loop C East Grading

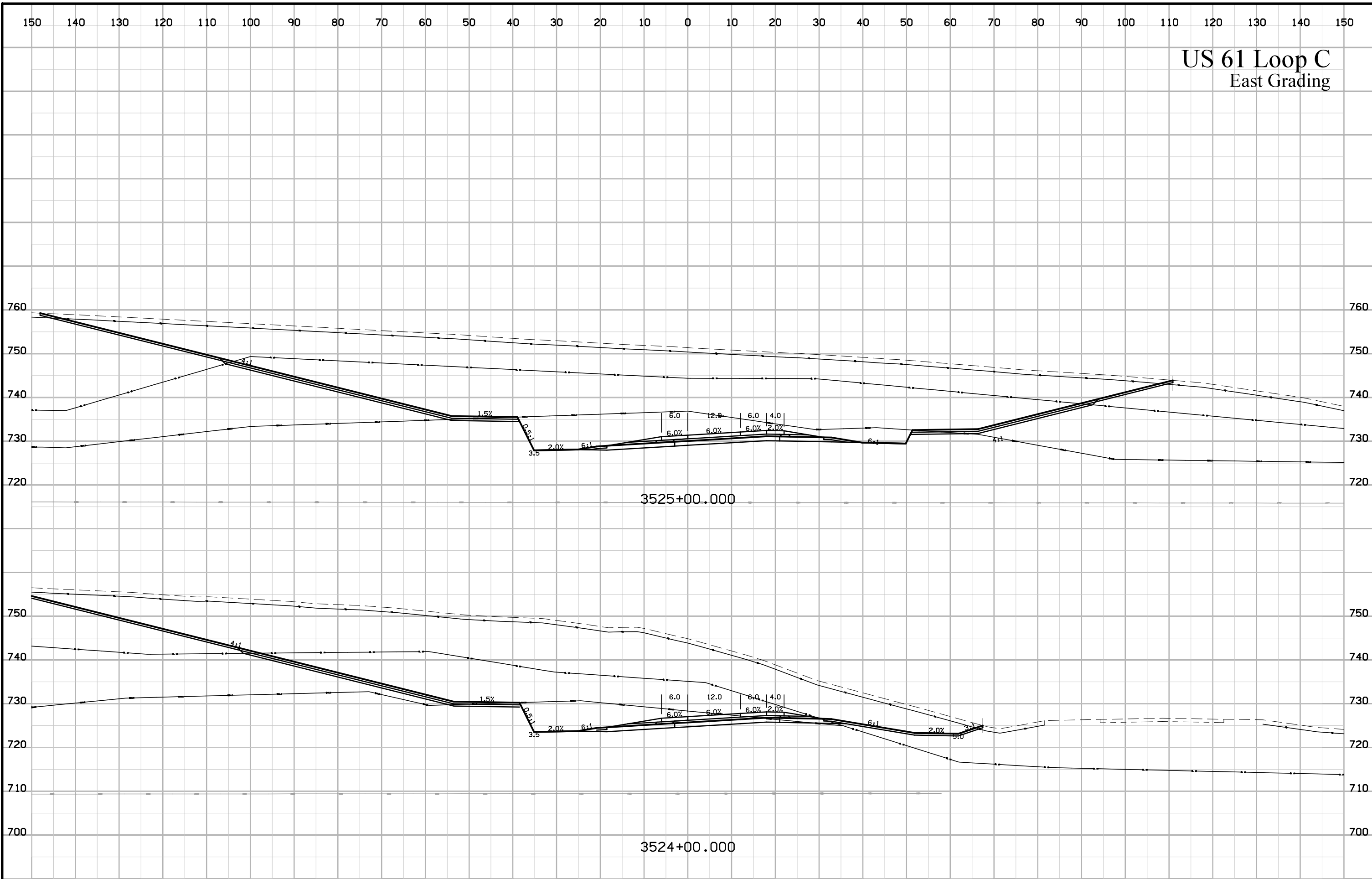

US 61 Loop C East Grading

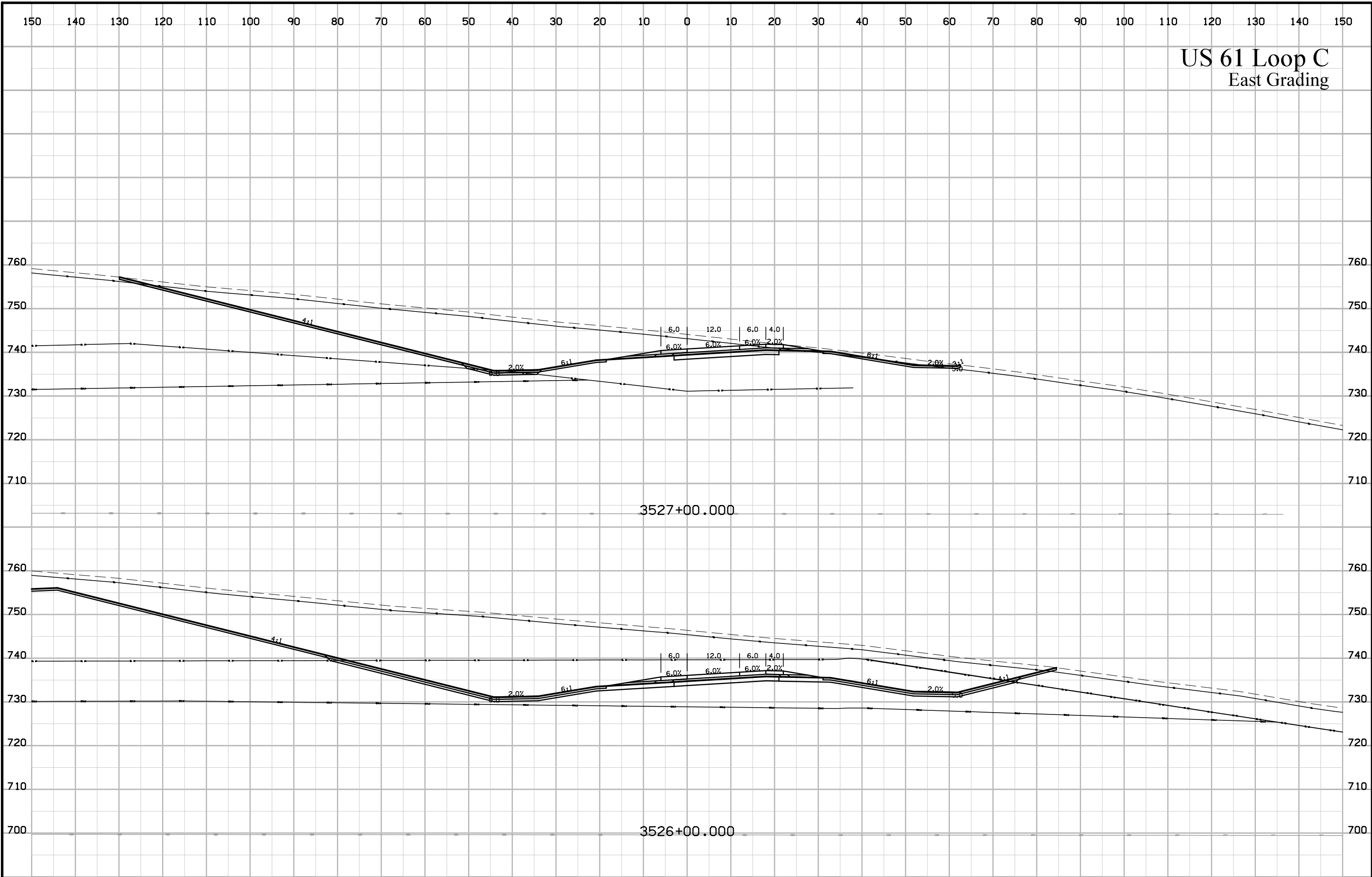

US 61 Ramp D East Grading

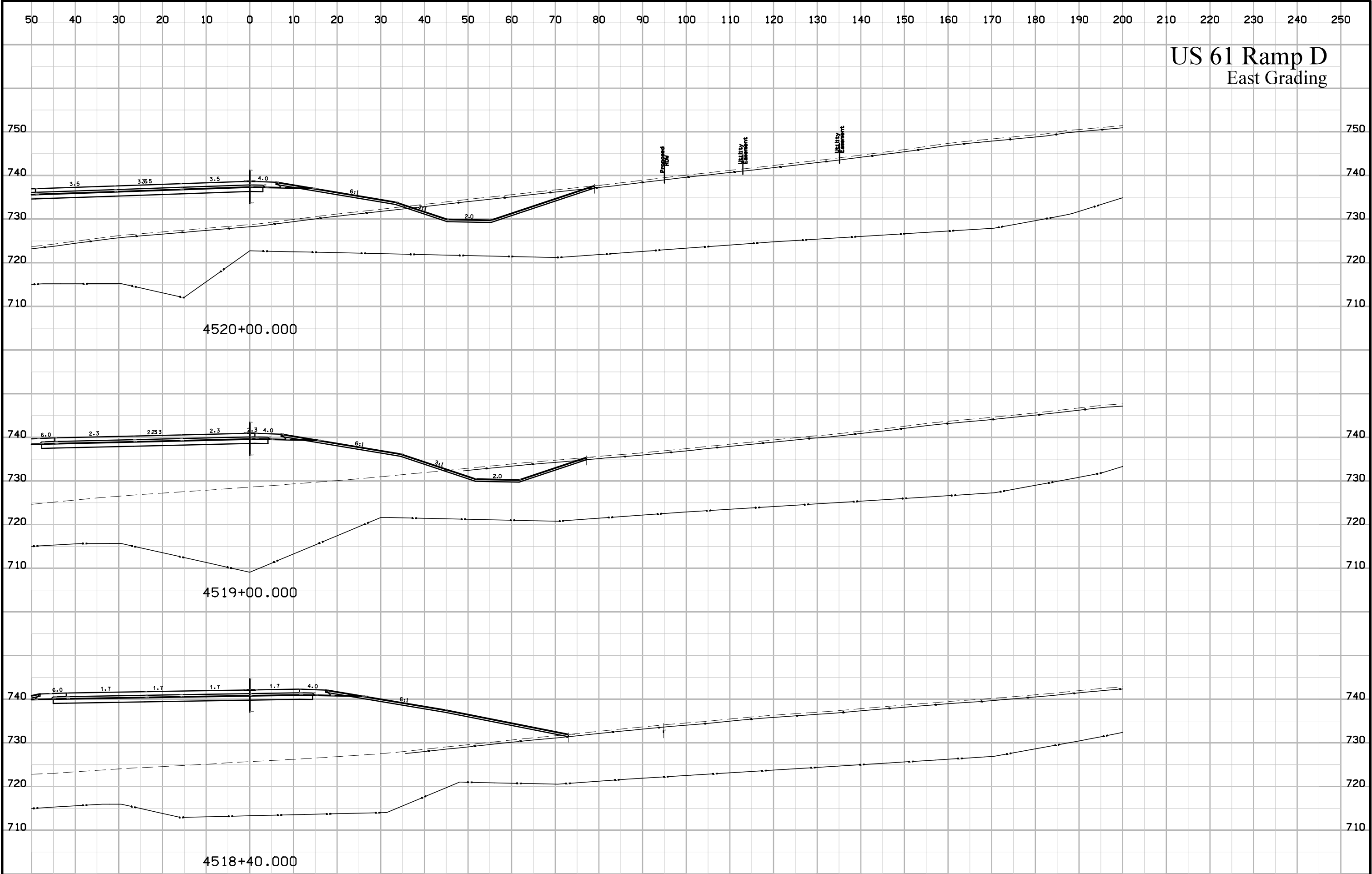

US 61 Ramp D East Grading

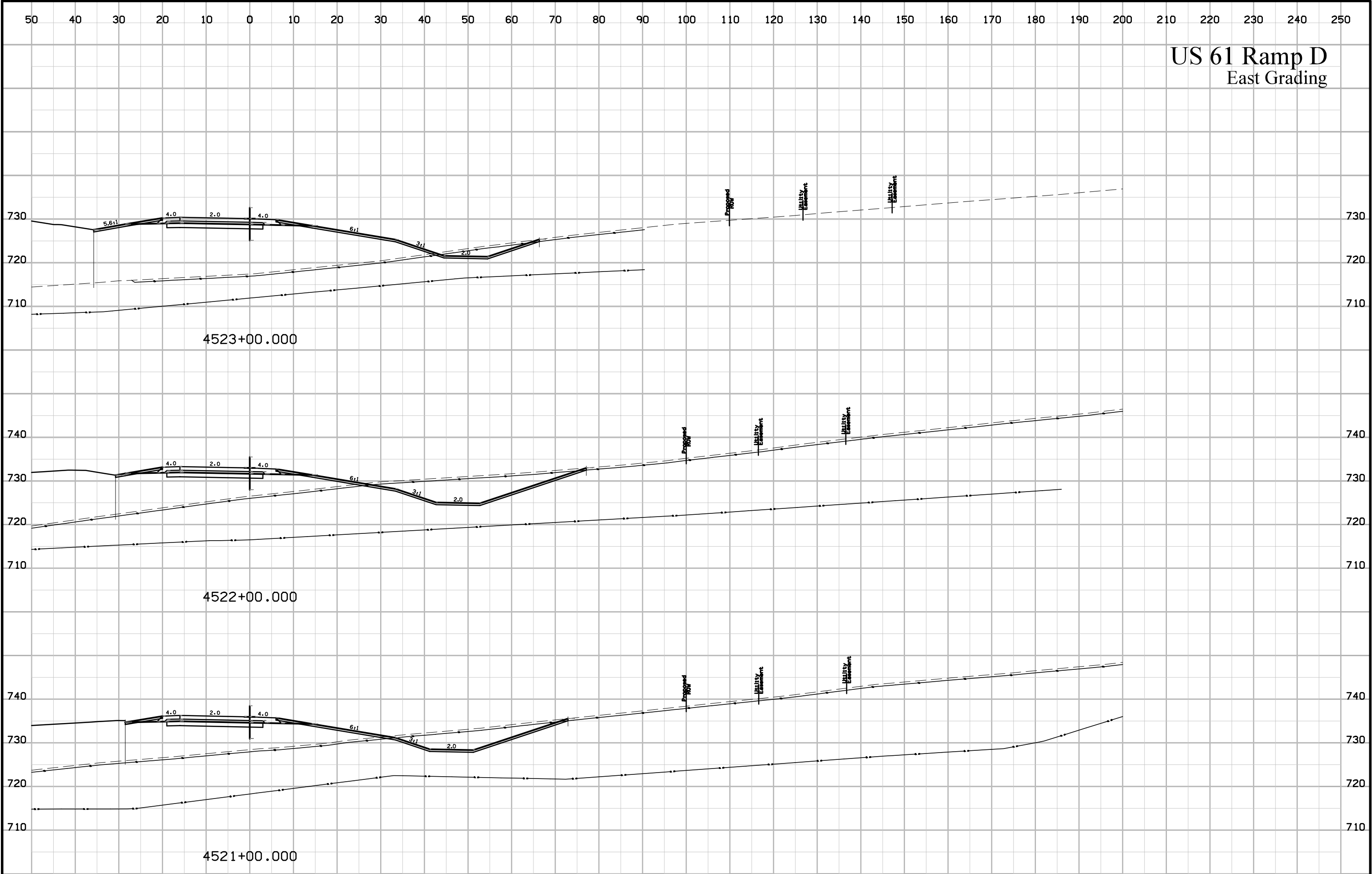

US 61 Ramp D East Grading

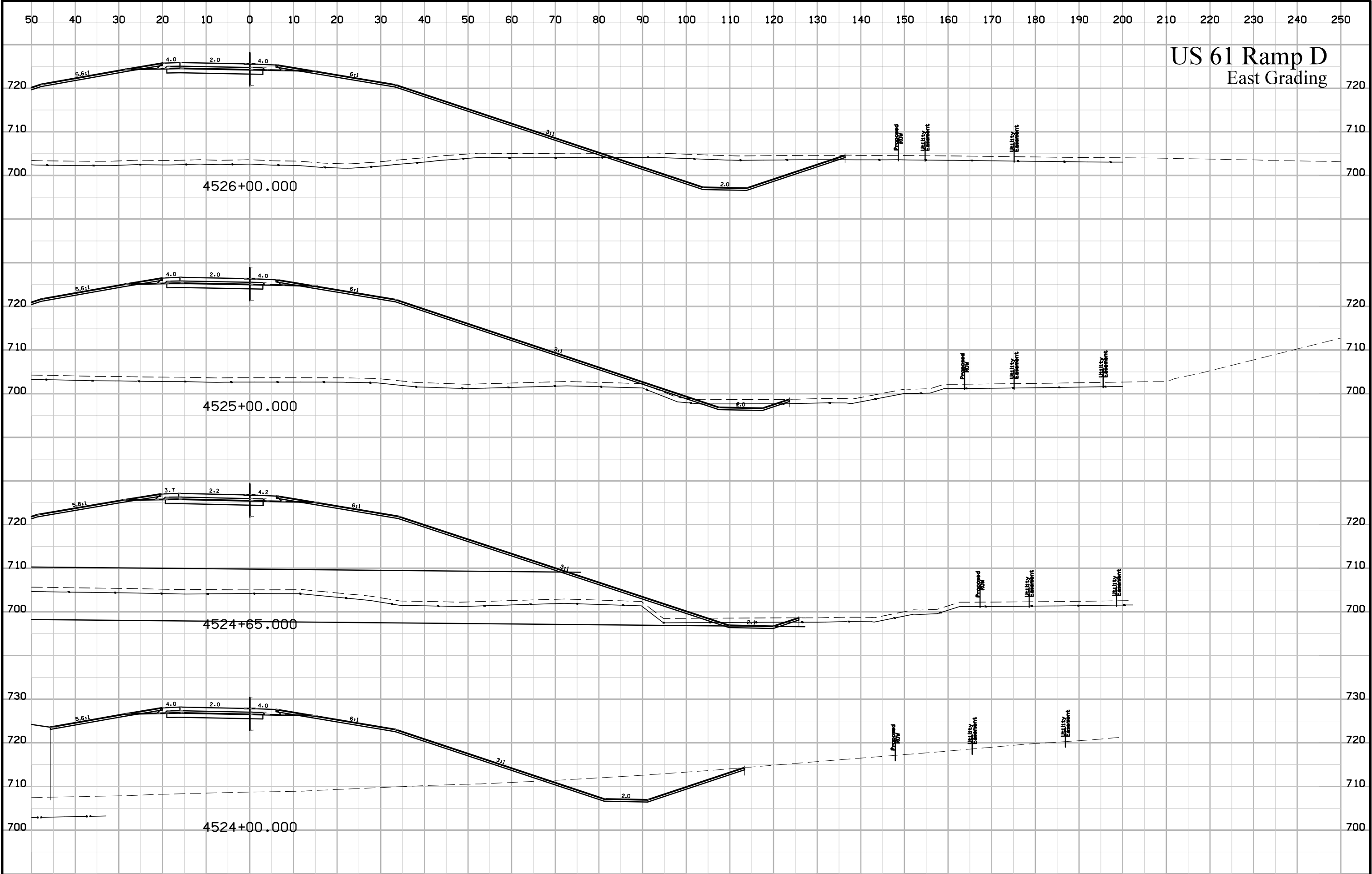

US 61 Ramp D East Grading

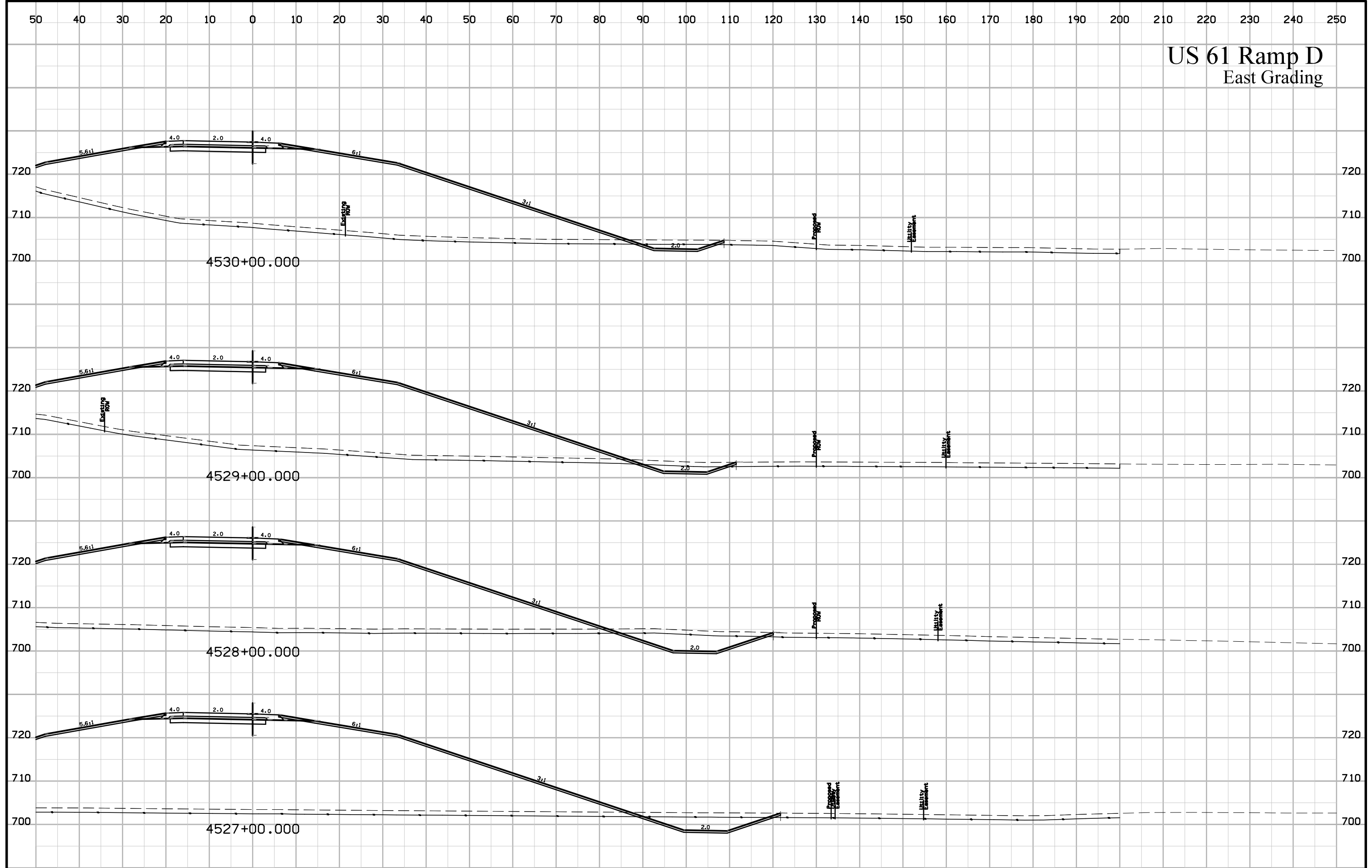

US 61 Ramp D East Grading

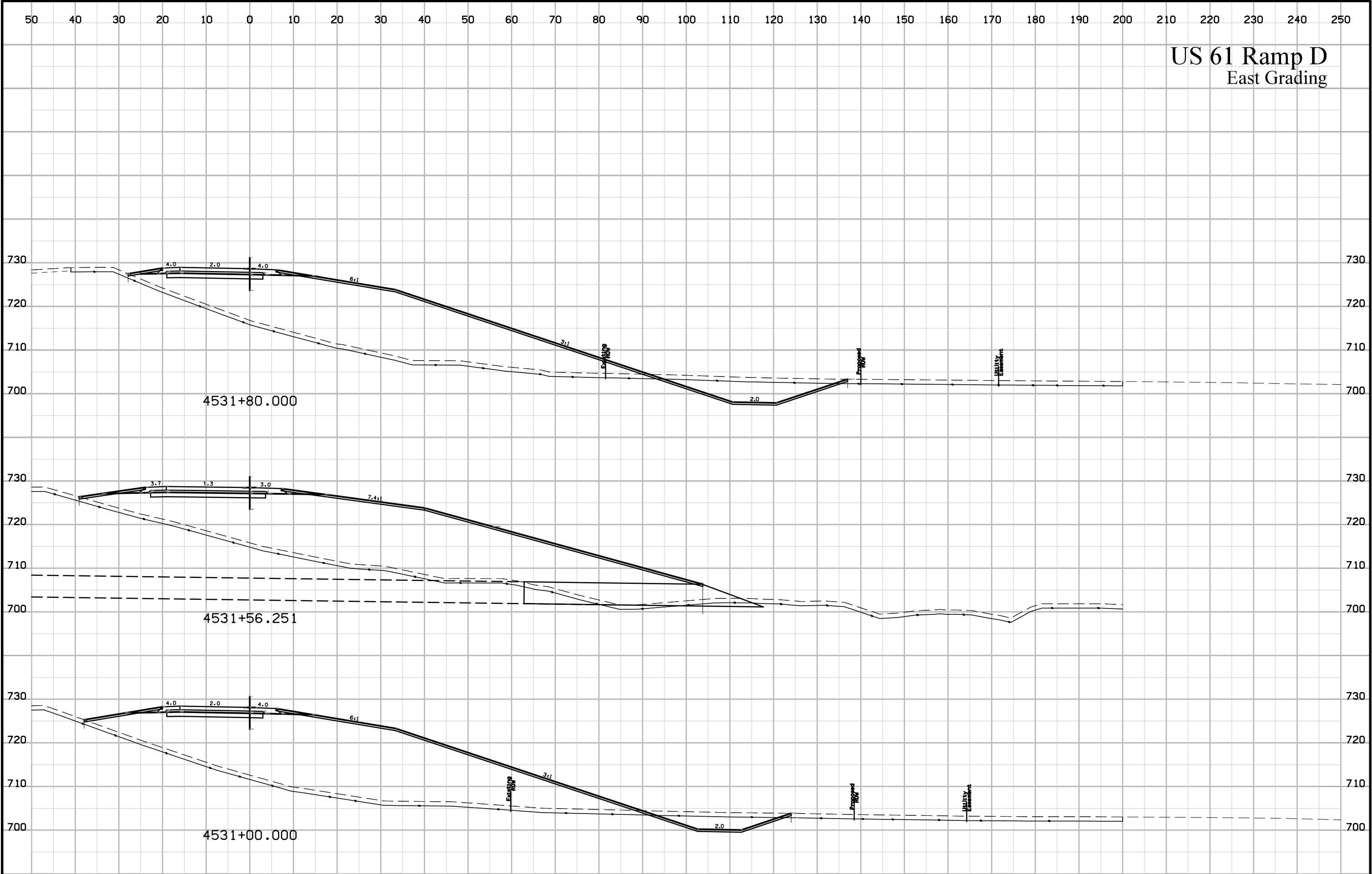

US 61 Loop B East Grading

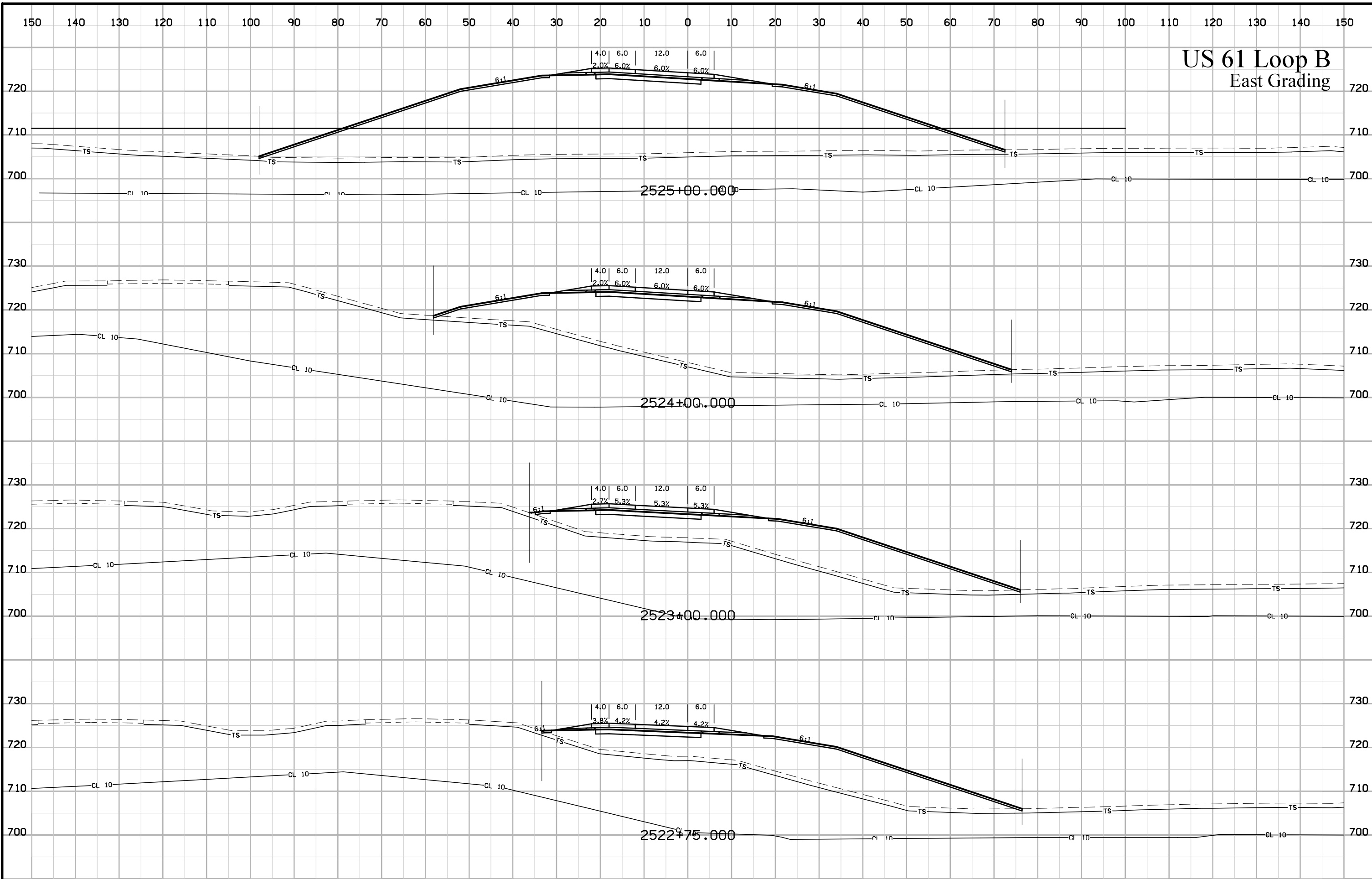

US 61 Loop B East Grading

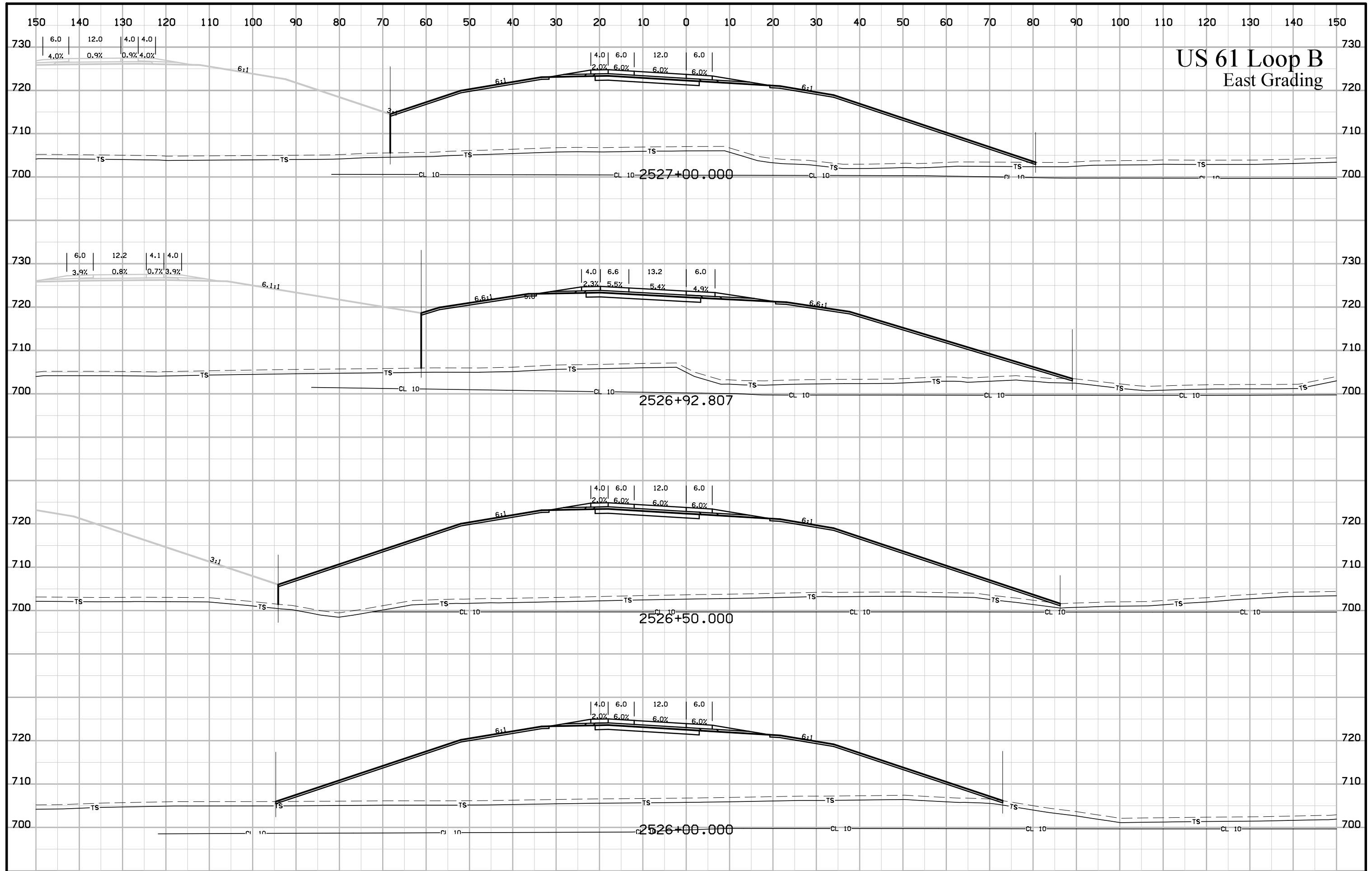

US 61 Loop B East Grading

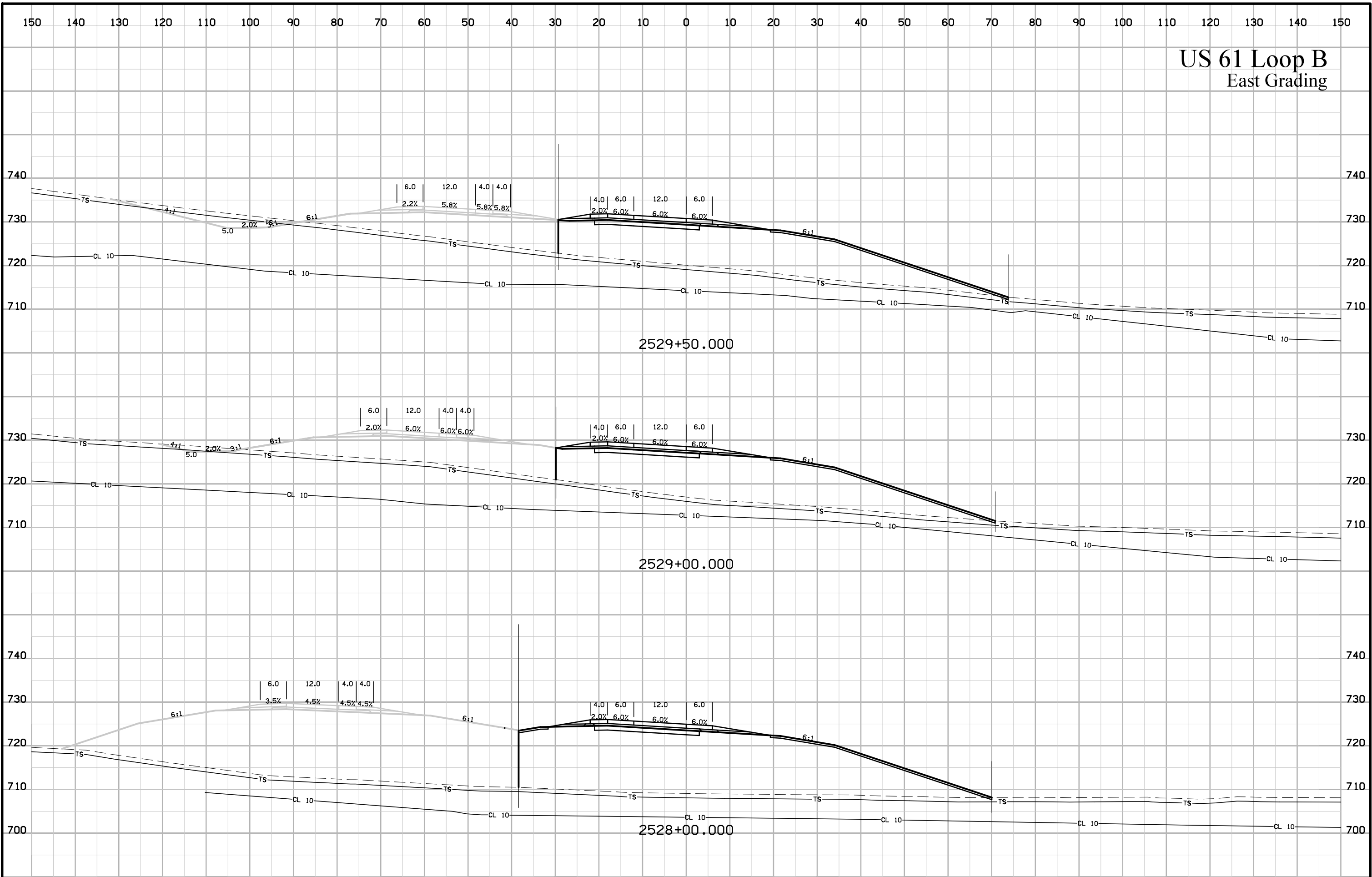

US 61 Loop B East Grading

