

No.	DESCRIPTION
A Sheets	Title Sheets
A.1	Title Sheet
A.2	Project Location Map
B Sheets	Typical Cross Sections and Details
B.1 - 11	Roadway Typical Sections & Details
C Sheets	Quantities and General Information
C.1 - 2	Drainage Structure by Road Contractor
D Sheets	Mainline Plan and Profile Sheets
* D.1	Plan & Profile Legend & Symbol Information Sheet
* D.2 - 15	Mainline Plan & Profile
E Sheets	Side Road Plan and Profile Sheets
* E.1	Side Road Plan & Profile
G Sheets	Survey Sheets
G.1 - 3	Survey Control Reference Ties & Bench Marks
G.4 - 5	Horizontal Control Tab & Curve Data
J Sheets	Traffic Control and Staging Scrolls
J.1	Traffic Control & Staging Notes
* J.2	Traffic Control & Staging Legend
* J.3 - 6	Staging Typical
* J.7 - 26	Traffic Control & Staging
K Sheets	Ramp Plan and Profile Sheets
* K.1	US 34 Connector Plan and Profile
L Sheets	Geometric and Staking Sheets
L.1 - 10	US 34 Connector Plan and Profile
N Sheets	Traffic and Safety Sheets
* N.1	Intersection Signal Plan
V Sheets	Culvert Plat Plans
* V.1 - 6	Culvert Plat Plans
W Sheets	Mainline Cross Sections
W.1	Cross Section Legend & Symbol Information Sheet
W.2 - 57	US 34 Cross Sections
X Sheets	Side Road Cross Sections
X.1 - 3	IA 48 Cross Sections
Y Sheets	Ramp Cross Sections
Y.1 - 3	US 34 Connector Cross Sections * Color Plan Sheets

H Sheets



Highway Division

PLANS OF PROPOSED IMPROVEMENT ON THE

PRIMARY ROAD SYSTEM

MONTGOMERY COUNTY

PCC PAVEMENT - GRADE AND REPLACE

US 34 from W. of IA 48 to Co. Rd H34

SCALES: As Noted

Refer to the Proposal Form for list of applicable specifications.

Value Engineering Saves. Refer to Article 1105.14 of the Specifications.



For Project Location Map
Refer to Sheet A.2

DESIGN DATA URBAN			
2023	AADT	4700	V.P.D.
2043	AADT	5700	V.P.D.
2043	DHV	590	V.P.H.
	TRUCKS	13	%
	Total		
	Design ESALs	N/A	

REVISIONS

TOTAL

143

PROJECT IDENTIFICATION NUMBER

16-69-034-010

PROJECT NUMBER

NHSX-034-2(60)--3H-69

R.O.W. PROJECT NUMBER

NHSN-034-2(64)--2R-69

PRELIMINARY PLANS

Subject to change by final design.

D5 PLAN SUBMITTAL

Date: June 4, 2021

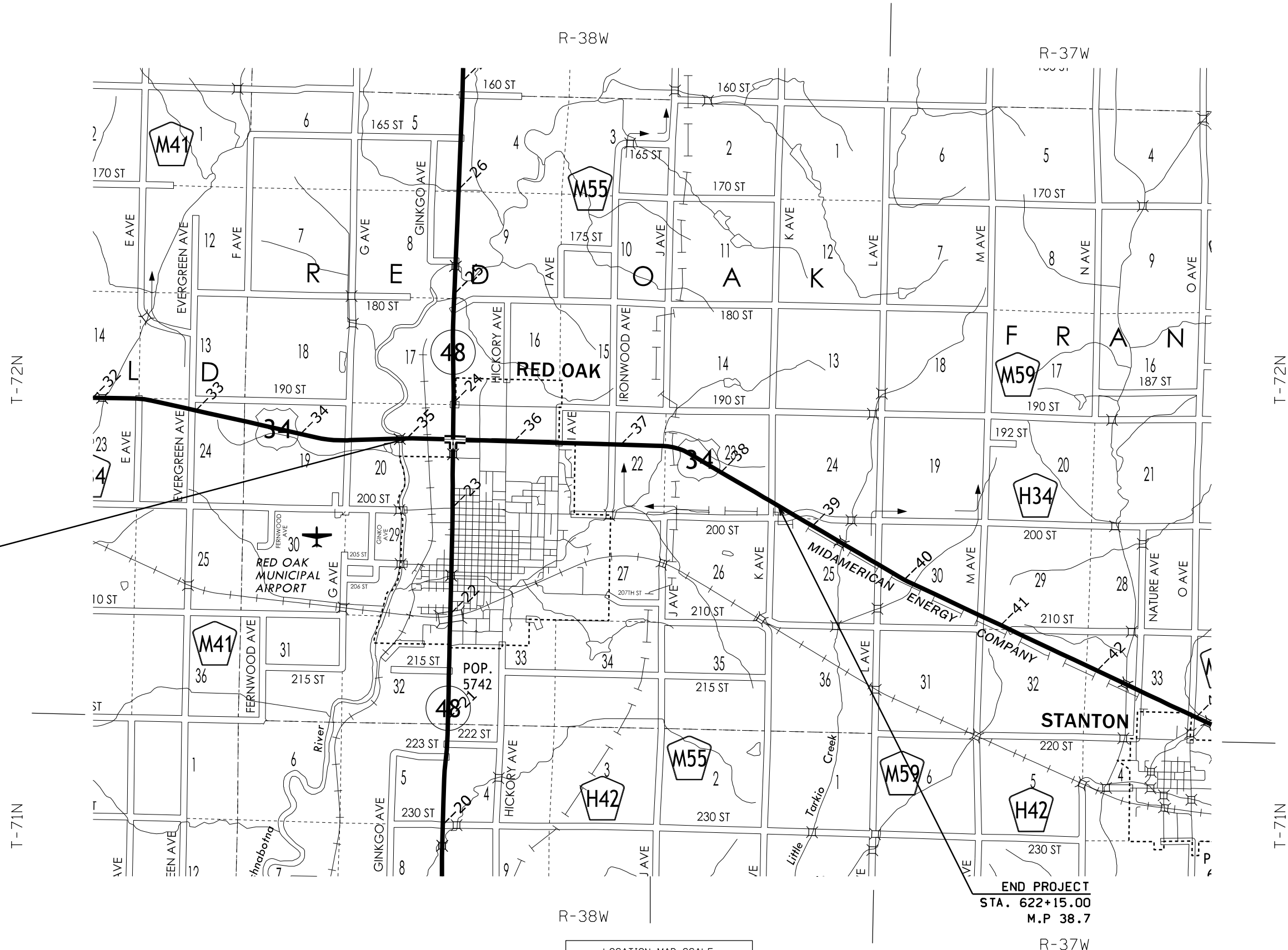

BEGIN PROJECT
 STA. 426+46.57
 M.P. 35.0

END PROJECT
 STA. 622+15.00
 M.P. 38.7

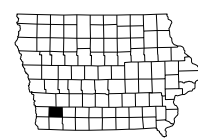
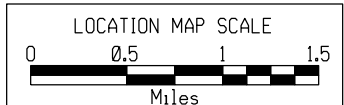

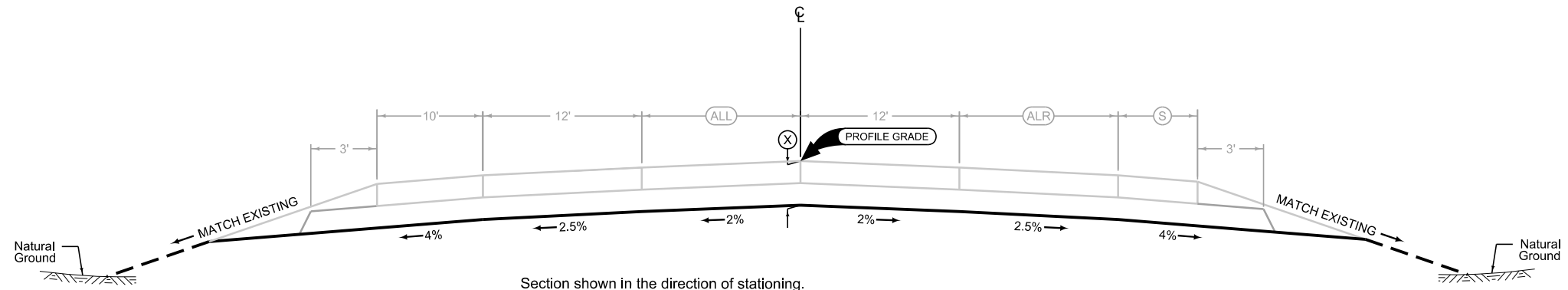

Section shown in the direction of stationing.

BEGIN STATION	END STATION	Direction of Travel	ALL Feet	ALR Feet	S Feet	X Inches
445+78.02	446+99.78	US 34	1.9-6	0	10	21.0
446+99.78	447+99.00	US 34	6-9.5	0	10	21.0
447+99.00	448+59.00	US 34	9.5-12	0-4	10-6	21.0
448+59.00	449+79.00	US 34	9.5-12	4-12	6	21.0
449+79.00	451+56.89	US 34	12	12	6	21.0

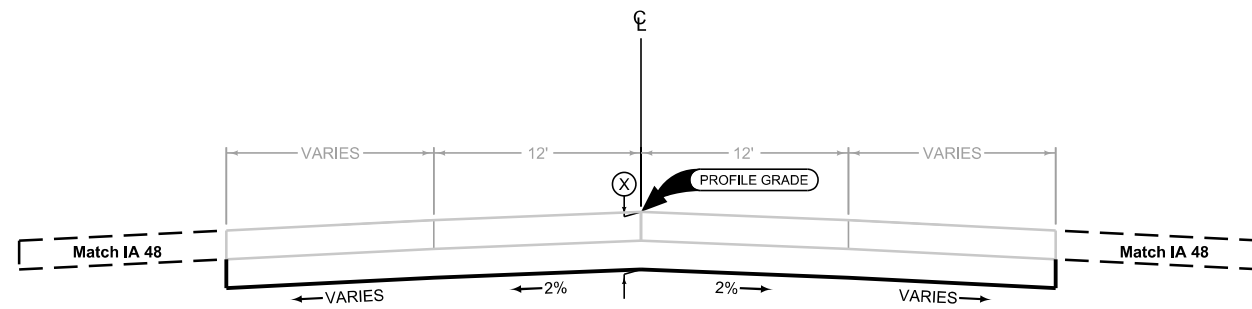

Section shown in the direction of stationing.

BEGIN STATION	END STATION	Direction of Travel	X Inches
451+56.89	452+11.85	US 34	21.0

① Refer to project plan and cross sections for specific location of foreslope change.

**MAINLINE US 34
GRADING**

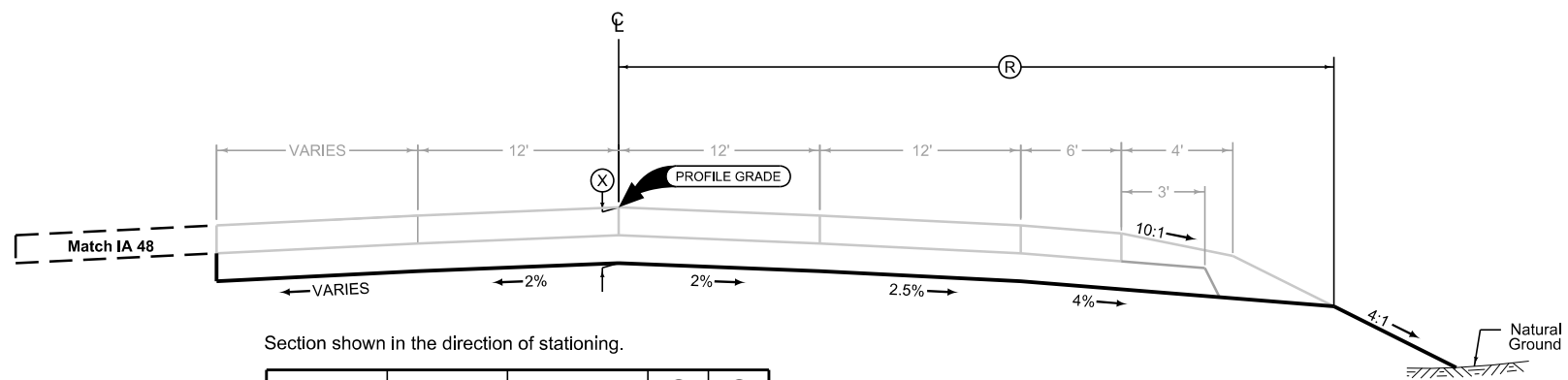

Section shown in the direction of stationing.

BEGIN STATION	END STATION	Direction of Travel	(R) Feet	(X) Inches
452+11.85	452+77.95	US 34	41.2	21.0

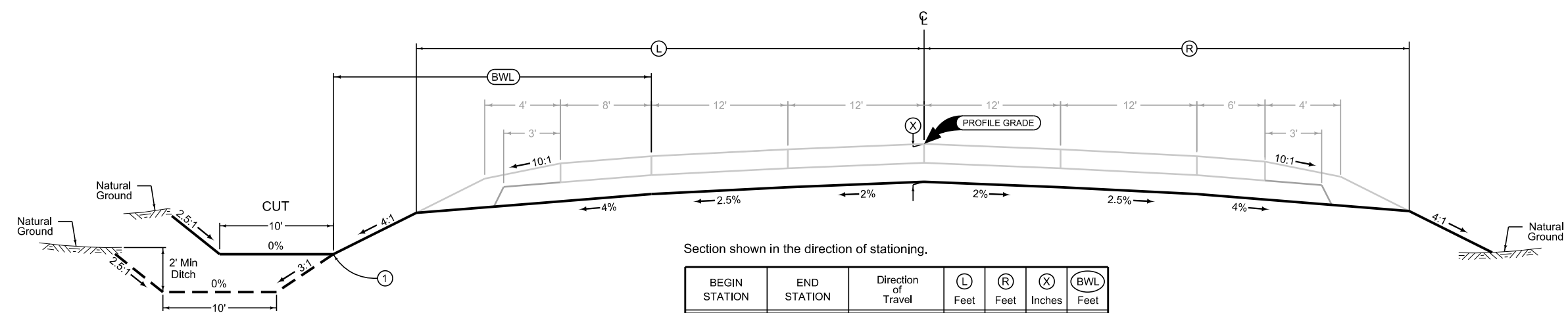

Section shown in the direction of stationing.

BEGIN STATION	END STATION	Direction of Travel	(L) Feet	(R) Feet	(X) Inches	(BWL) Feet
452+77.95	453+38.44	US 34	43.2	41.2	21.0	20

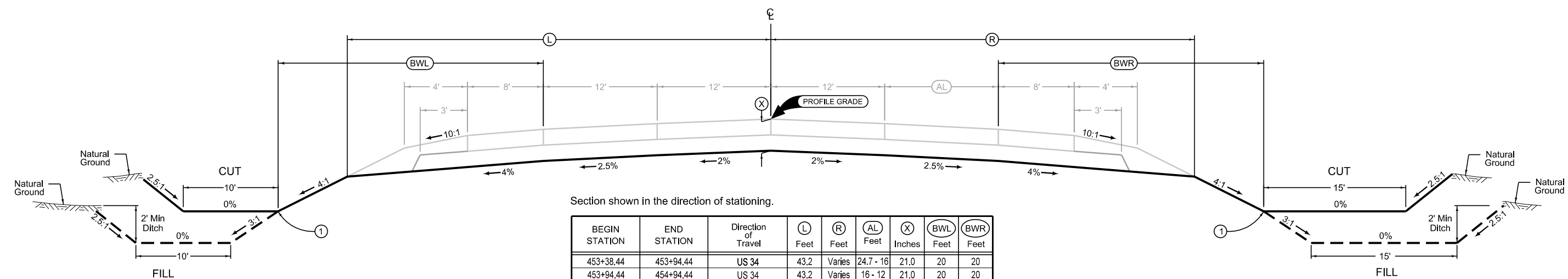

Section shown in the direction of stationing.

BEGIN STATION	END STATION	Direction of Travel	(L) Feet	(R) Feet	(AL) Feet	(X) Inches	(BWL) Feet	(BWR) Feet
453+38.44	453+94.44	US 34	43.2	Varies	24.7 - 16	21.0	20	20
453+94.44	454+94.44	US 34	43.2	Varies	16 - 12	21.0	20	20
454+94.44	478+50.00	US 34	43.2	43.2	12	21.0	20	20

① Refer to project plan and cross sections for specific location of foreslope change.

**MAINLINE US 34
GRADING**

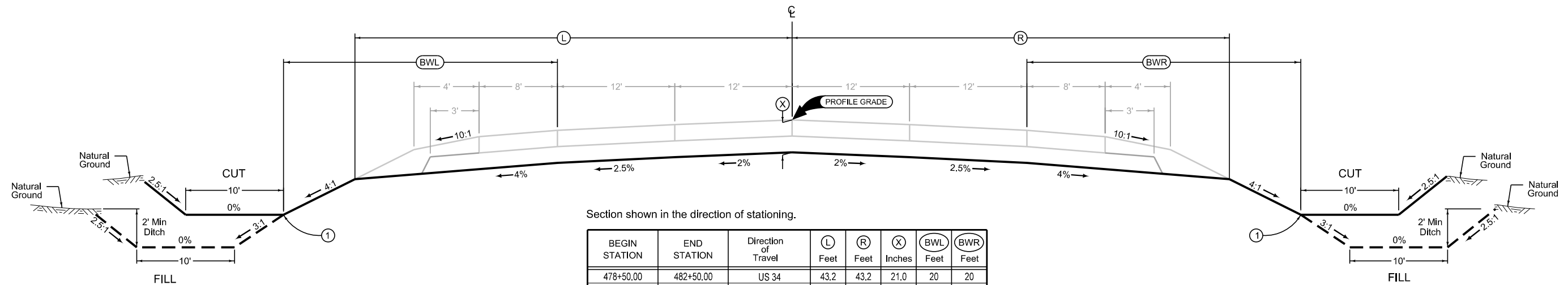

Section shown in the direction of stationing.

BEGIN STATION	END STATION	Direction of Travel	(L) Feet	(R) Feet	(X) Inches	(BWL) Feet	(BWR) Feet
478+50.00	482+50.00	US 34	43.2	43.2	21.0	20	20

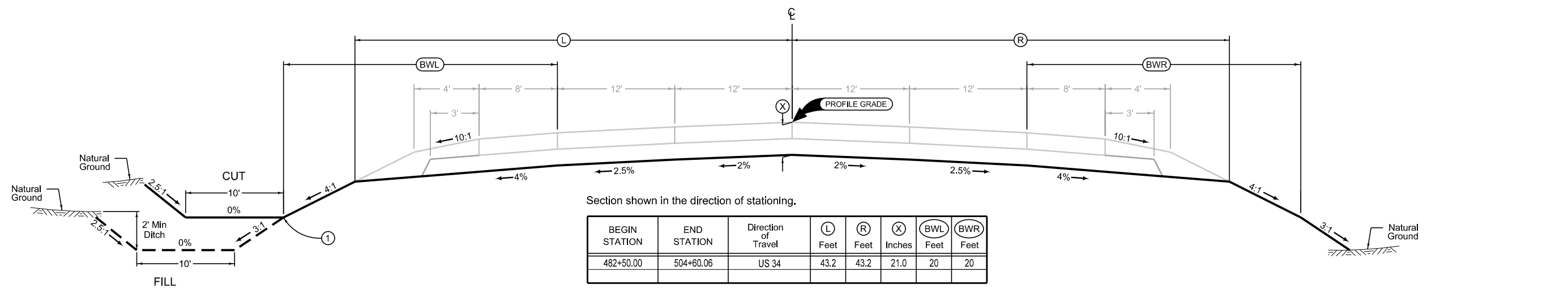

Section shown in the direction of stationing.

BEGIN STATION	END STATION	Direction of Travel	(L) Feet	(R) Feet	(X) Inches	(BWL) Feet	(BWR) Feet
482+50.00	504+60.06	US 34	43.2	43.2	21.0	20	20

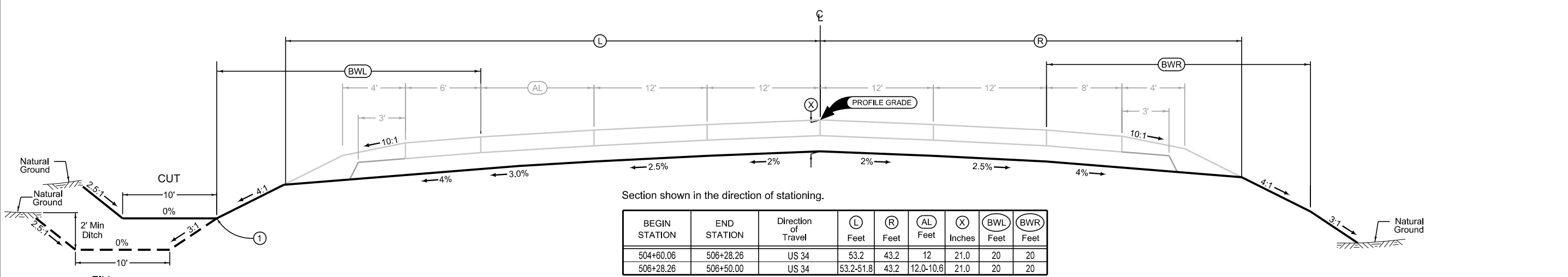

Section shown in the direction of stationing.

BEGIN STATION	END STATION	Direction of Travel	(L) Feet	(R) Feet	(AL) Feet	(X) Inches	(BWL) Feet	(BWR) Feet
504+60.06	506+28.26	US 34	53.2	43.2	12	21.0	20	20
506+28.26	506+50.00	US 34	53.2-51.8	43.2	12.0-10.6	21.0	20	20

① Refer to project plan and cross sections for specific location of foreslope change.

**MAINLINE US 34
GRADING**

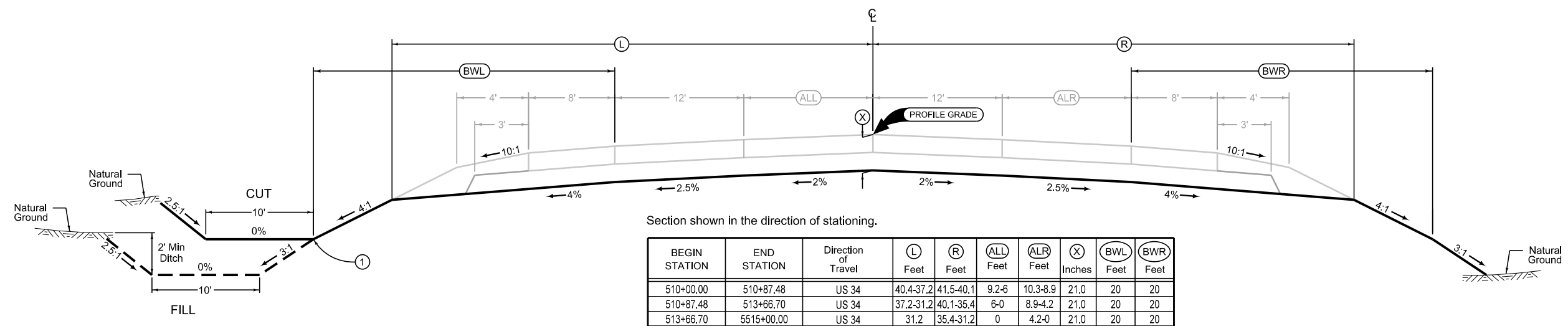
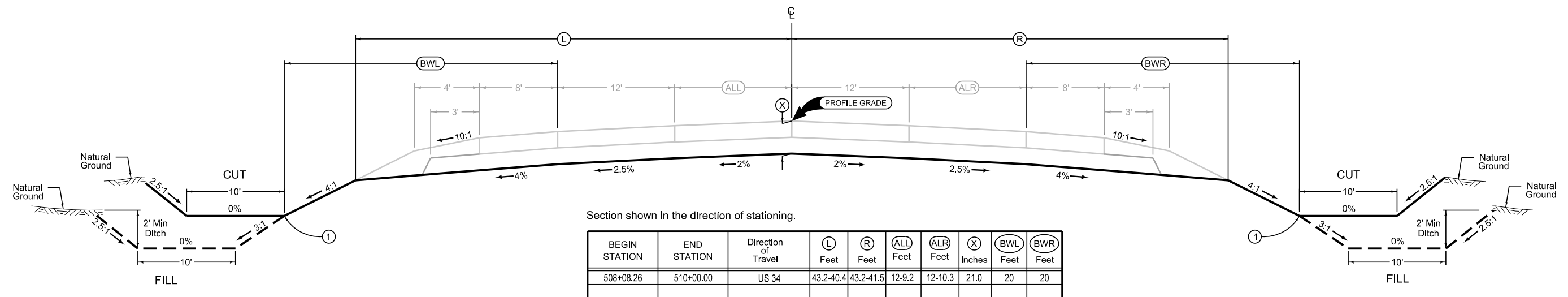
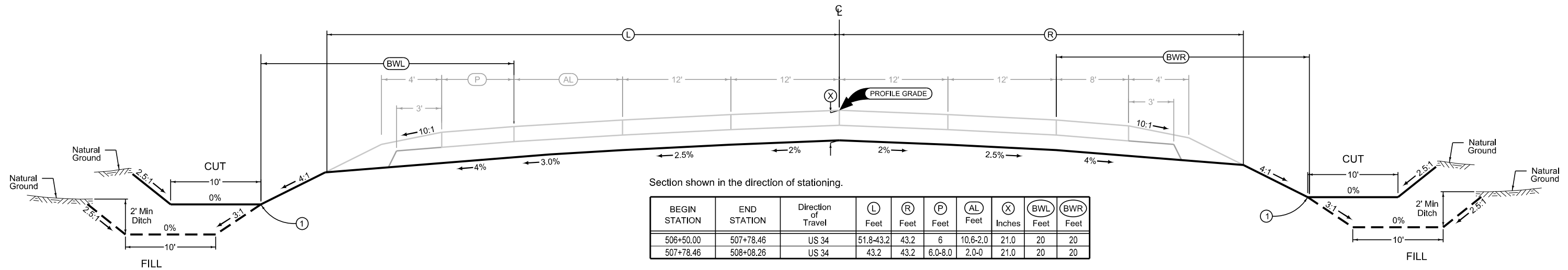

① Refer to project plan and cross sections for specific location of foreslope change.

**MAINLINE US 34
GRADING**

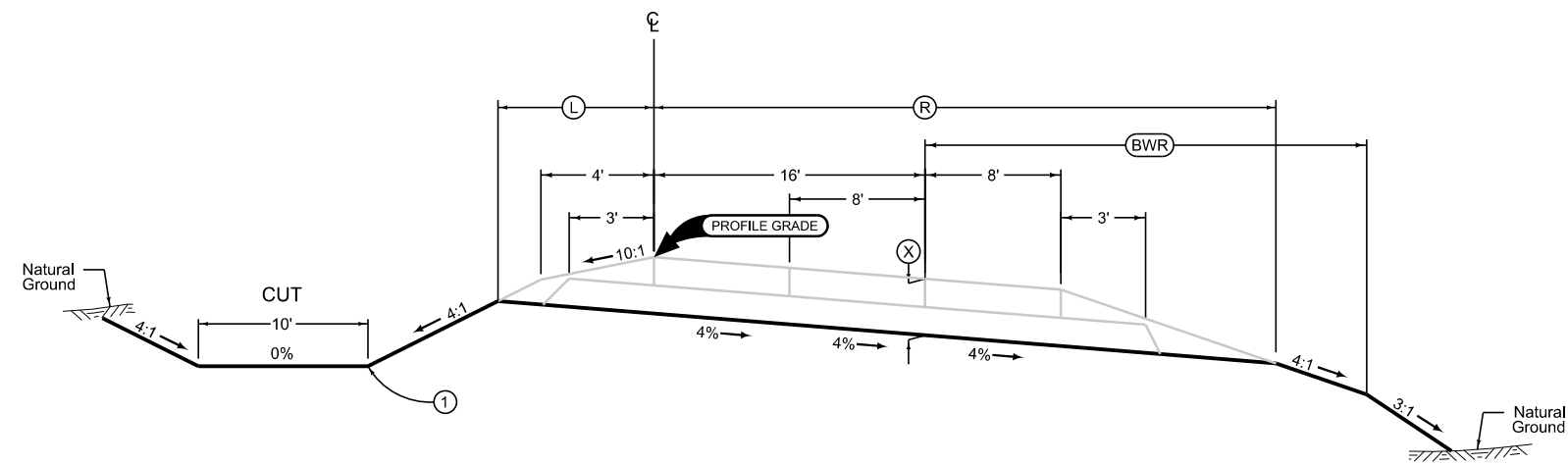

Section shown in the direction of stationing.

BEGIN STATION	END STATION	Direction of Travel	(L) Feet	(R) Feet	(BWR) Feet	(X) Inches
4451+74.47	4453+00.00	US 34 Connector	8.1	32.3	20	21.0

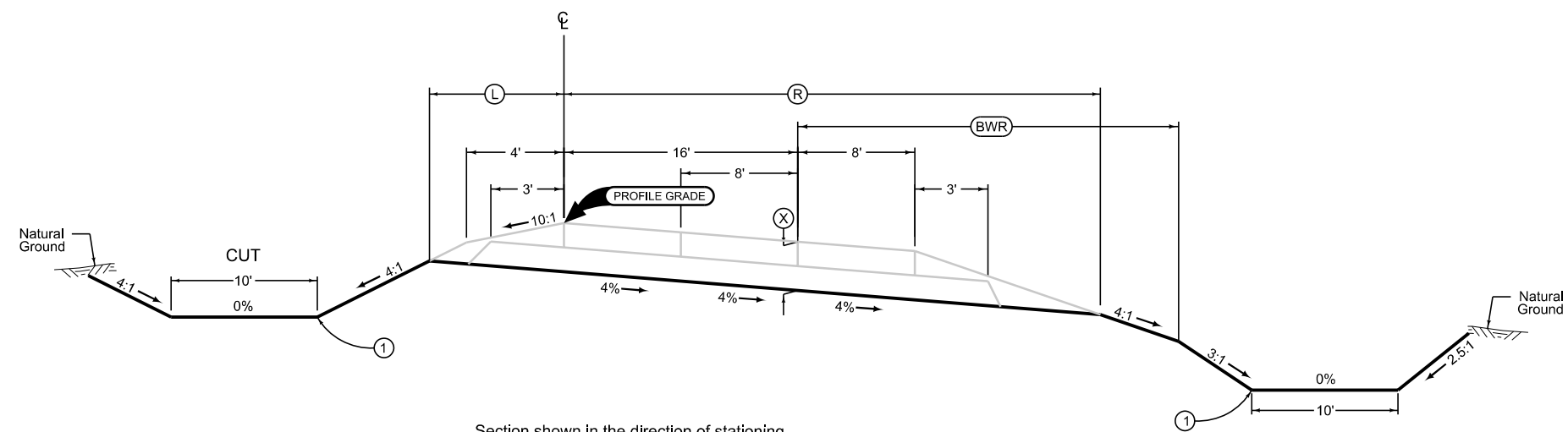

Section shown in the direction of stationing.

BEGIN STATION	END STATION	Direction of Travel	(L) Feet	(R) Feet	(BWR) Feet	(X) Inches
4453+00.00	4453+94.44	US 34 Connector	8.1	32.3	20	21.0

① Refer to project plan and cross sections for specific location of foreslope change.

**US 34 CONNECTOR
GRADING**

Full Depth PCC Combination Shoulder

BEGIN STATION	END STATION	⊕ Feet	⊗ Inches
445+78.02	450+55.86	8	21.0
REFER TO L SHEETS FOR RETURN DETAILS			

Full Depth PCC Combination Shoulder

BEGIN STATION	END STATION	⊕ Feet	⊗ Inches
445+78.02	447+99.00	4	21.0
447+99.00	448+58.80	4-0	21.0
448+58.80	450+95.00	0	21.0
REFER TO L SHEETS FOR RETURN DETAILS			

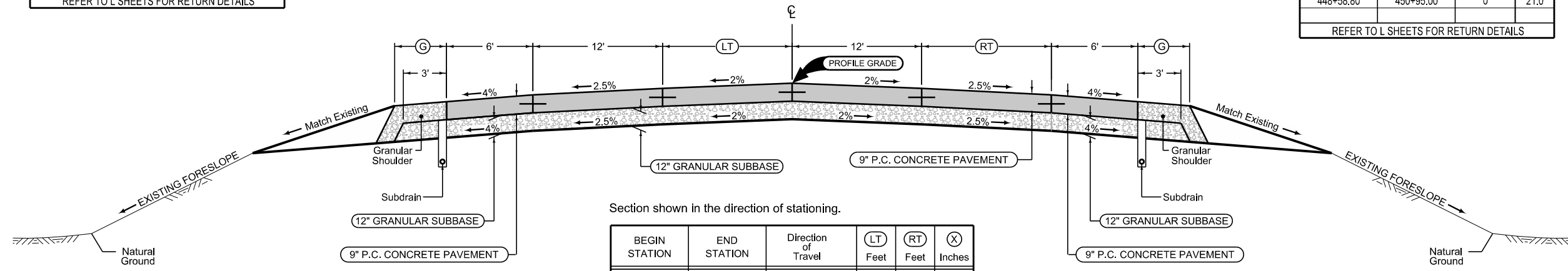

Section shown in the direction of stationing.

BEGIN STATION	END STATION	Direction of Travel	LT Feet	RT Feet	⊗ Inches
445+78.02	447+00.72	US 34	1.9 - 6.0	0	21.0
447+00.72	447+99.00	US 34	6.0 - 9.5	0	21.0
447+99.00	449+79.00	US 34	9.5 - 12	0 - 12	21.0
449+79.00	450+95.00	US 34	12	12	21.0

**MAINLINE US 34
PAVING**

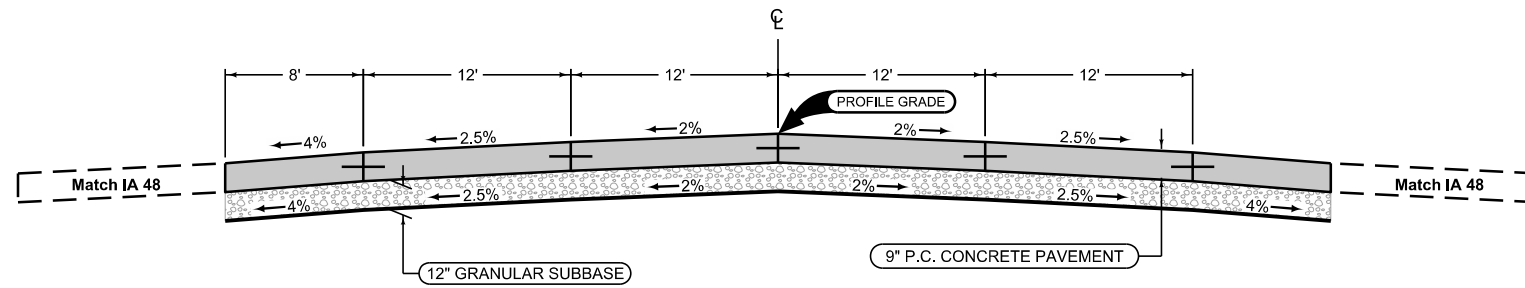

Section shown in the direction of stationing.

BEGIN STATION	END STATION	Direction of Travel	(X) Inches
450+95.00	452+11.85	US 34	21.0

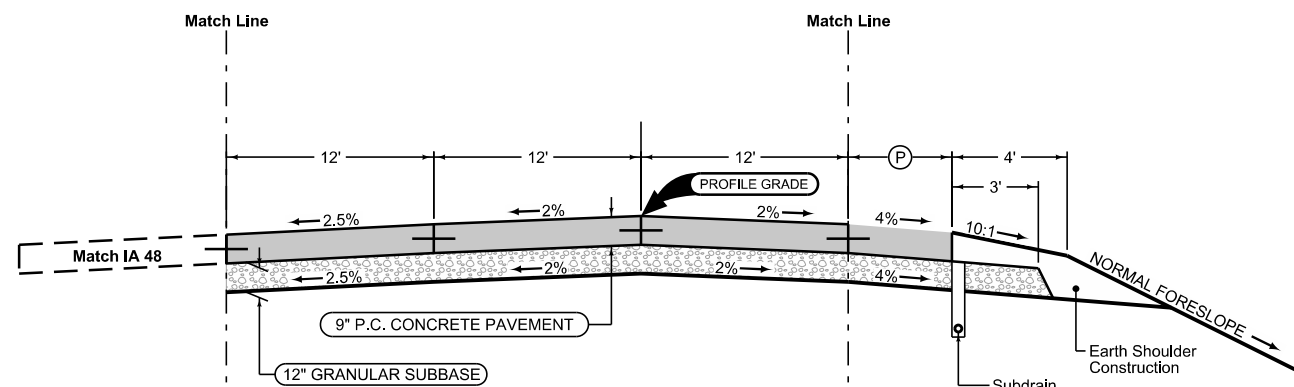

Full Depth PCC Shoulder

BEGIN STATION	END STATION	(P) Feet	(X) Inches
452+11.85	453+38.44	6	21.0

REFER TO L SHEETS FOR RETURN DETAILS

Section shown in the direction of stationing.

BEGIN STATION	END STATION	Direction of Travel	(X) Inches
452+11.85	454+94.44	US 34	21.0

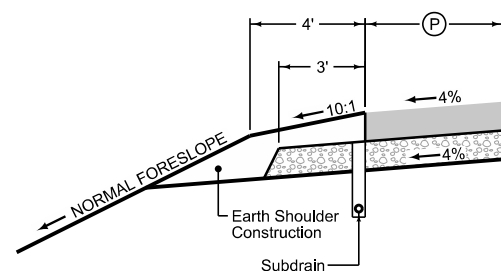

Full Depth PCC Shoulder

BEGIN STATION	END STATION	(P) Feet	(X) Inches
452+77.95	454+94.44	6	21.0

REFER TO L SHEETS FOR RETURN DETAILS

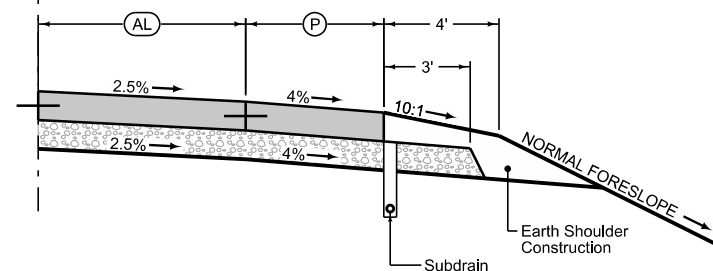

Auxiliary Lane and Full Depth PCC Shoulder

BEGIN STATION	END STATION	(AL) Feet	(P) Feet	(X) Inches
453+38.44	453+94.44	24.7 - 16	8	21.0
453+94.44	454+94.44	16 - 12	8	21.0

REFER TO L SHEETS FOR RETURN DETAILS

**MAINLINE US 34
PAVING**

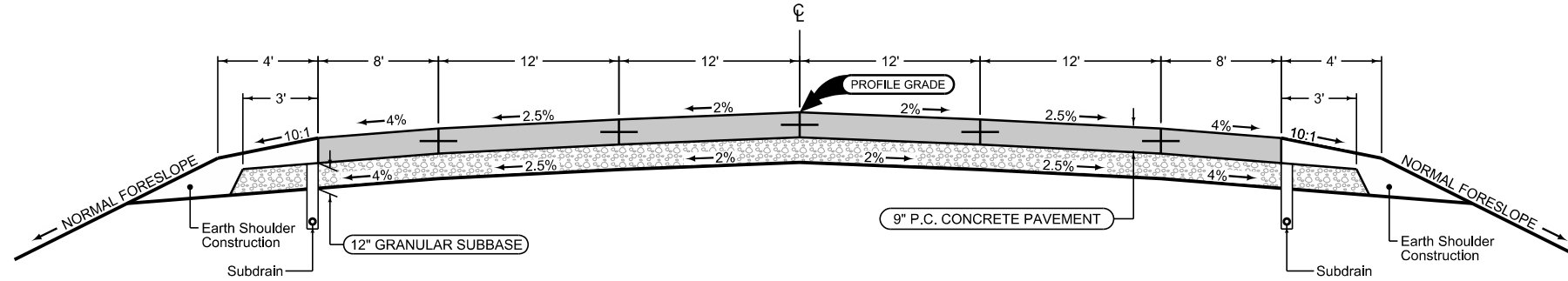

Section shown in the direction of stationing.

BEGIN STATION	END STATION	Direction of Travel	(X) Inches
454+94.44	509+00.00	US 34	21.0

Full Depth PCC Shoulder

BEGIN STATION	END STATION	(P) Feet	(X) Inches
509+00.00	510+50.27	8	21.0
510+50.27	510+80.00	8 - 10	21.0
510+80.00	515+00.00	10	21.0

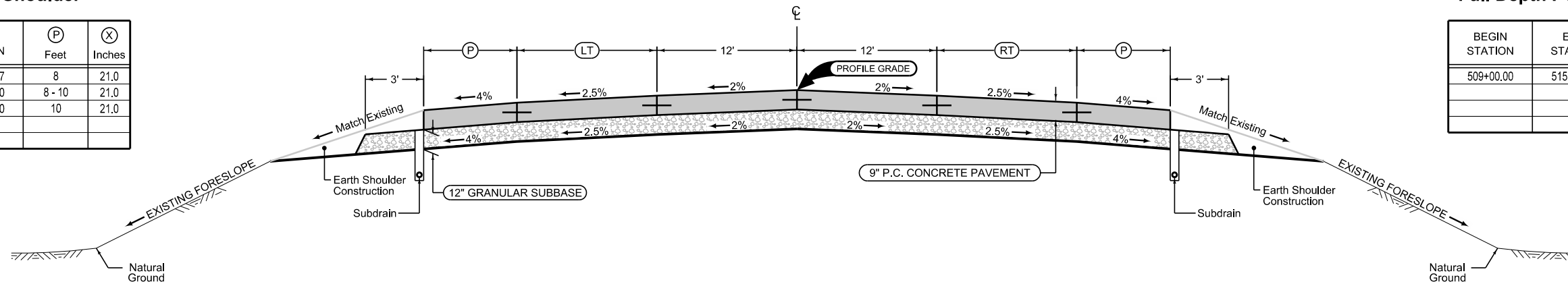

Section shown in the direction of stationing.

BEGIN STATION	END STATION	Direction of Travel	(LT) Feet	(RT) Feet	(X) Inches
509+00.00	510+80.00	US 34	12 - 0	12 - 9	21.0
510+80.00	515+00.00	US 34	0	9 - 2	21.0

Full Depth PCC Shoulder

BEGIN STATION	END STATION	(P) Feet	(X) Inches
509+00.00	515+00.00	8	21.0

**MAINLINE US 34
PAVING**

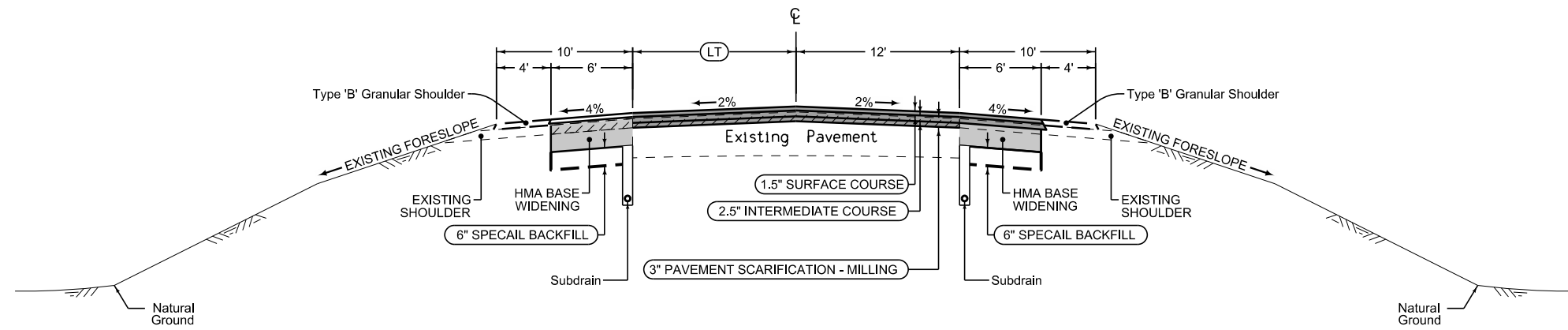

HMA RESURFACING WITH BASE WIDENING

Section shown in the direction of stationing.

BEGIN STATION	END STATION	Direction of Travel	(LT) Feet
426+46.57	438+11.63	US 34	12
GAP FOR RAILROAD APPROACH SECTION			
440+23.55	444+20.56	US 34	12
444+20.56	445+69.15	US 34	12.0 - 13.7
555+25.00	598+50.00	US 34	12

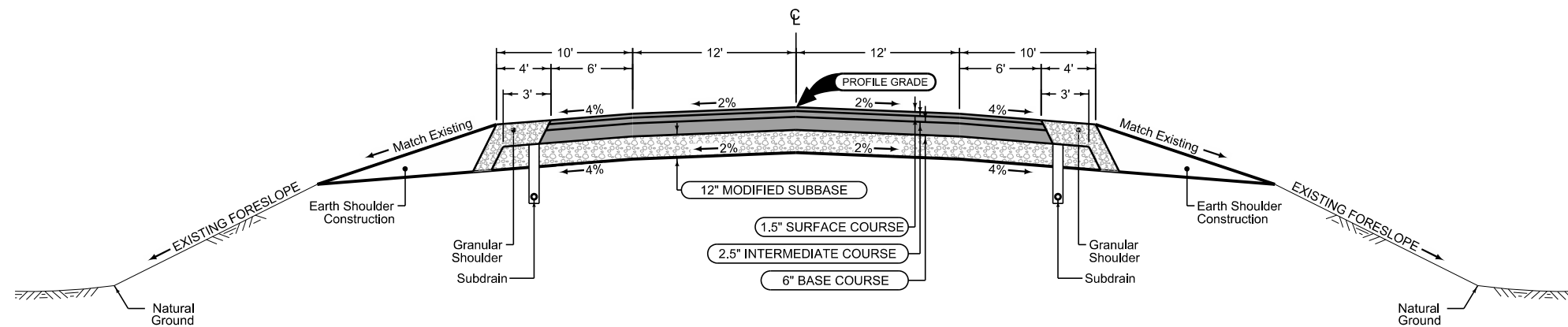

FULL DEPTH RECONSTRUCTION HMA TYPICAL

Section shown in the direction of stationing.

BEGIN STATION	END STATION	Direction of Travel
515+00.00	555+25.00	US 34
598+50.00	622+15.00	US 34
REFER TO C SHEETS FOR FULL-DEPTH PATCHES		

**RURAL
MAINLINE US 34
HMA PAVING OPTIONS**

BEGIN STATION	END STATION	(P) Feet	(X) Inches
1031+66.25	1032+63.57	8	21.0
1034+94.46	1035+25.00	8	21.0
REFER TO L SHEETS FOR RETURN DETAILS			

Full Depth PCC Shoulder

BEGIN STATION	END STATION	(P) Feet	(X) Inches
1031+66.25	1032+72.06	8	21.0
1032+72.06	1033+75.39	6	21.0
REFER TO L SHEETS FOR RETURN DETAILS			

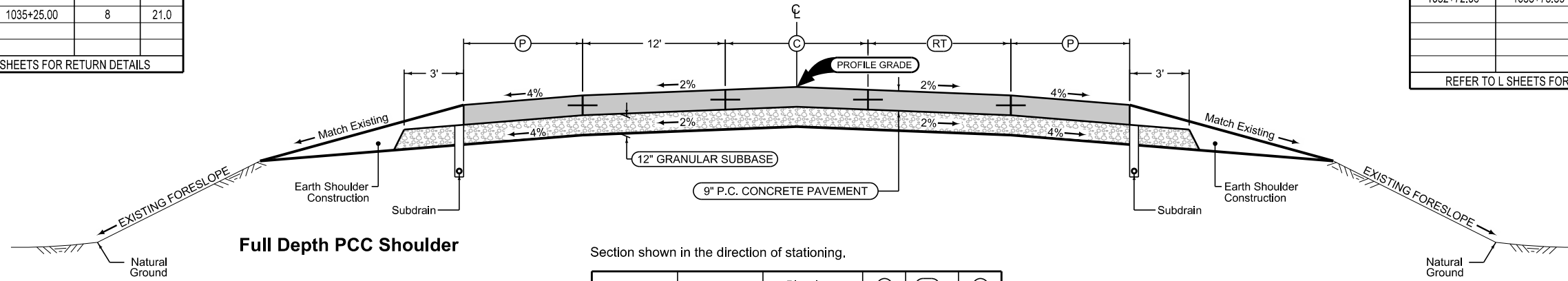

Full Depth PCC Shoulder

Section shown in the direction of stationing.

BEGIN STATION	END STATION	Direction of Travel	(C) Feet	(RT) Feet	(X) Inches
1031+66.25	1031+77.07	IA 48	14	12	21.0
1031+77.07	1032+55.45	IA 48	14	12 - 29.5	21.0
1032+55.45	1032+72.06	IA 48	14	29.5 - 38.4	21.0
1032+72.06	1035+25.00	IA 48	14	12	21.0

**IOWA 48
PAVING**

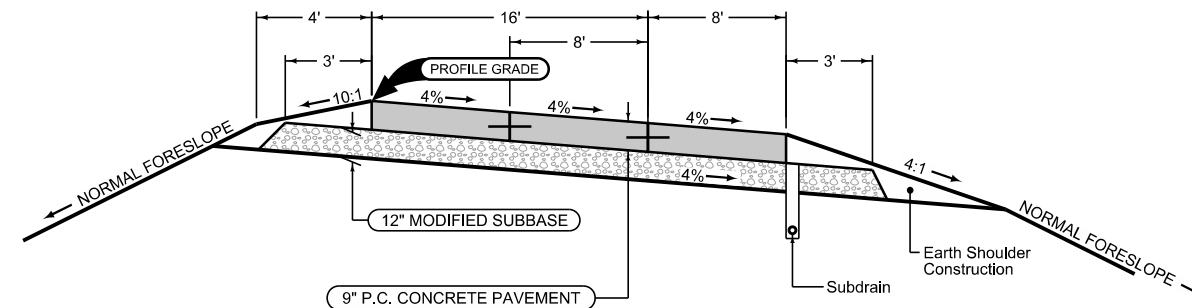

Section shown in the direction of stationing.

BEGIN STATION	END STATION	Direction of Travel	⊗ Inches
4451+74.47	4453+94.44	US 34 Connector	21.0

**US 34 CONNECTOR
PAVING**

DRAINAGE STRUCTURE BY ROAD CONTRACTOR

Length of unclassified pipe calculated is based on using Reinforced Concrete Pipe.

- * Not a bid item
- ① Diameter or equivalent diameter
- ② UNCL = Unclassified Pipe CMP = Corrugated Metal Pipe RCP = Reinforced Concrete Pipe LCP = Arch or Elliptical Low Clearance Pipe SARC = Steel Arch Pipe
- ③ Backfill according to DR-101

Drainage Area ACRE	Location	Type	Size ①	Kind Of Pipe ②	Length New Const. LF	Bedding Class	Design Cover (H) FT	Camber* (DR-102) FT	Apron No.		Apron Guard* (DR-213) No.	Elbow* (DR-141) No.	Diaphragm* (DR-501) No.	Tee Section* (DR-142) No.	"D" Section* (DR-141) No.	Reducer* No.	Type 'C' Connections* (DR-122) Type	Connected Pipe Joint* (DR-121) Type	4" Perforated Subdrain* FT	Flow Line Elevations				Dimensions Lin. Ft.				Skew Ahead Degrees		Dike			Class 20 CY	Flowable Mortar CY	Floodable* Backfill CY	Porous* Backfill CY	Flooded Backfill CY	Remarks							
									IN	OUT										Lt.	Rt.	Other	Other	Total		Extensions		Lt.	Rt.	Lt.	Rt.	Lt.							Rt.	Location Station	Top Elevation	Type	(A)	(B)	(A+B)
98.4	465+15.76	DR-601	42	RCP	58	B	2.0		1	1										1035.54	1034.66			36.5	37.5														(1)						
	465+16.01	DR-601	42	RCP	58	B	2.0		1	1										1035.54	1034.66			36.5	37.5															(2)					
	465+16.25	DR-601	42	RCP	58	B	2.0		1	1										1035.54	1034.66			36.5	37.5															(3)					
15.4	465+11.88	DR-601	36	LCP	68	B	2.5		1	1										1035.20	1036.96			38.4	45.6		5													(4)					
	475+70.25	DR-601	42	RCP	106	B	2.6		1(5)	1										1061.57	1058.46	1063.32 (6)		61.5	60.5			32												(7)					
46.0	475+62	DR-601	42	RCP	106	B	2.6		1(5)	1										1061.57	1058.46	1063.32 (6)		61.5	60.5			32												(7)					
	475+53.74	DR-601	42	RCP	106	B	2.6		1(5)	1										1061.57	1058.46	1063.32 (6)		61.5	60.5			32												(7)					
22.0	482+97.18	DR-621	42	RCP	42	B			1	1							C-1	2		1097.92	1088.30	1091.78 (8)	1089.58 (9)	65.5	78.8	65.5	78.8													(10)					
14.0	492+26.83	DR-653	36	UNCL	58	B				1							C-3	1																					(13)						
1.0	4452+40	DR-601	18	RCP	48	B	3.2		1	1										1035.90	1033.19			15.8	44.3																				
<p>Remarks</p> <p>(1) Offset 56.64' Rt from US 34 alignment. Part of 98.4 acre drainage area.</p> <p>(2) Offset 63.64' Rt from US 34 alignment. Part of 98.4 acre drainage area.</p> <p>(3) Offset 70.63' Rt from US 34 alignment. Part of 98.4 acre drainage area.</p> <p>(4) Offset 54.54' Lt from US 34 alignment.</p> <p>(5) Refer to DR-205 for inlet aprons.</p> <p>(6) Top elevation of end wall. Refer to DR-205.</p> <p>(7) Part of 46 acre drainage area.</p> <p>(8) Refer to DR-122 13° 24' elbow Lt.</p> <p>(9) Refer to DR-122 3° 11' elbow Rt.</p> <p>(10) Refer to DR-621. A=18' B=24'</p> <p>(11) Refer to DR-122. 13° elbow</p> <p>(12) Refer to DR-653. 15° elbow</p> <p>(13) Refer to DR-653. B=36' C=2' E=20' L=8'</p>																																													

FULL-DEPTH PATCHES

Possible Standards: PR-101, PR-102, PR-103, PR-104, PR-105, and PR-140.

Count	Location		Dimension			PCC Patches				HMA Patches	Composite HMA	Subbase Patches	Subbase Patch w/ 'EF' Joint	Patch Subdrain	'CD' Joints	'CT' Joints	'EF' Joints	Anchor Lugs Removal	Remarks
	Station	Reference Location Sign	Lane	Length	Width	With Dowels	Without Dowels	C R C	Ramp with Dowels										
	L, R, or B	FT	FT	IN	PR-103 SY	PR-102 SY	PR-104 SY	PR-105 SY											
	573+62.50		L	275.0	18.0	10.0					550.0								572+25 to 575+00
	580+62.50		L	75.0	18.0	10.0					150.0								580+25 to 581+00
	595+07.50		L	65.0	18.0	10.0					130.0								594+75 to 595+40

SURVEY SYMBOLS

○ LUM Luminaire	— UV Underground Utility Vault
□ SIGN SI Sign	- - e1 - - ELA Underground Electric Line Co. 1
■ ROW Right of Way Rail	- - e2 - - ELB Underground Electric Line Co. 2
⚡ PPA Power Pole Co. 1	- - e3 - - ELC Underground Electric Line Co. 3
⚡ PRA Power Riser Co. 1	- - w - - WLA Underground Water Line Co. 1
✳ TEV Evergreen Tree	- - t1 - - TLA Underground Telephone Line Co. 1
🌿 SHR Shrub	- - t2 - - TLB Underground Telephone Line Co. 2
🌳 TDC Tree Deciduous	- - t3 - - TLC Underground Telephone Line Co. 3
🌾 SWAMP	- - g - - GLA Underground Gas Line Co. 1
🚰 LP L.P. Tank	- - f0 - - FOA Underground Fiber Optic Co. 1
○ OUT Tile Outlet	- - f02 - - FOB Underground Fiber Optic Co. 2
★ TSG Traffic Signal	- - s1.s. - - STA Storm Sewer Co. 1
🚰 IN Storm Sewer Intake	- - s1.s.2 - - STB Storm Sewer Co. 2
🐝 INB Storm Sewer Intake Beehive	
⊕ MH Utility Access (Manhole)	
BB BB Billboard	
○ MIS Miscellaneous	
○ FLG Flaggpole	
○ MM Mile Marker Post	
□ SIGN SL Speed Limit Sign	
○ TP TPD Telephone Pedestal	
□ TCB TCB Utilities	
□ EB EB Electrical Box	
○ WV WV Water Valve	
🔥 FHYD Fire Hydrant	
□ UB UB Utility Box	
○ TVP TVP TV Pedestal	
TLN Tree Line	
TIL Tile Line	
FCL Chain Link and Security Fence	
FW Wire Fence	
FWD Wood Fence	
DU Centerline Draw or Stream (Up)	
D Centerline Draw or Stream (Down)	
DIK Centerline of Dike or Dam	
EW Edge of Water	
BNK Stream Bank	
GDL Guard Rail Steel	
RIP Rip-Rap	
RR Centerline of Railroad Tracks	

UTILITY LEGEND

GENERAL LOCATES: IOWA ONE CALL 800-292-8989

PLAN VIEW COLOR LEGEND OF PLAN AND PROFILE SHEETS

LINEWORK	Design Color No.	Description
Green	(2)	Existing Topographic Features and Labels
Blue	(1)	Proposed Alignment, Stationing, Tic Marks, and Alignment Annotation
Magenta	(5)	Existing Utilities
SHADING	Design Color No.	Description
Yellow	(4)	Highlight for Critical Notes or Features
Red	(3)	Delineates Restricted Areas
Lavender	(9)	Temporary Pavement Shading
Gray, Light	(48)	Proposed Pavement Shading
Gray, Med	(80)	Proposed Granular Shading
Gray, Dark	(112)	Proposed Grade and Pave Shading "In conjunction with a paving project"
Brown, Light	(236)	Grading Shading
Tan	(8)	Proposed Sidewalk Shading
Blue, Light	(230)	Proposed Sidewalk Landing Shading
Pink	(11)	Proposed Sidewalk Ramp Shading

PROFILE VIEW COLOR LEGEND OF PLAN AND PROFILE SHEETS

LINEWORK	Design Color No.	Description
Green	(2)	Existing Ground Line Profile
Blue	(1)	Proposed Profile and Annotation
Magenta	(5)	Existing Utilities
Blue, Light	(230)	Proposed Ditch Grades, Left
Black	(0)	Proposed Ditch Grades, Median
Rust	(14)	Proposed Ditch Grades, Right

Symbol	Description
Reference Point	Survey Line
Station	Section Corner
Ground Line Intercept	Saw Cut
Guardrail	Trench Drain
HighTension Cable Guardrail	Sheet Pile
Pavement Removal	Clearing & Grubbing Area

Symbol	Description
Proposed Right-of-Way	Existing Right of Way
Existing and Proposed Right-of-Way	Easement and Existing Right-of-Way
Easement (Temporary)	Easement
Access Control	Property Line

Symbol	Description
Acquisition Outline	Conceptual Outline

PLAN AND PROFILE LEGEND AND SYMBOL INFORMATION SHEET

(COVERS SHEET SERIES D, E, & K)

Curve Data
 $\Delta = 3^\circ 42' 21.85''$ (RT)
 T = 370.83
 L = 741.41
 R = 11,462.13
 E = 6.00

Red Oak TWP.
 T-72N R-38W
 SEC. 20

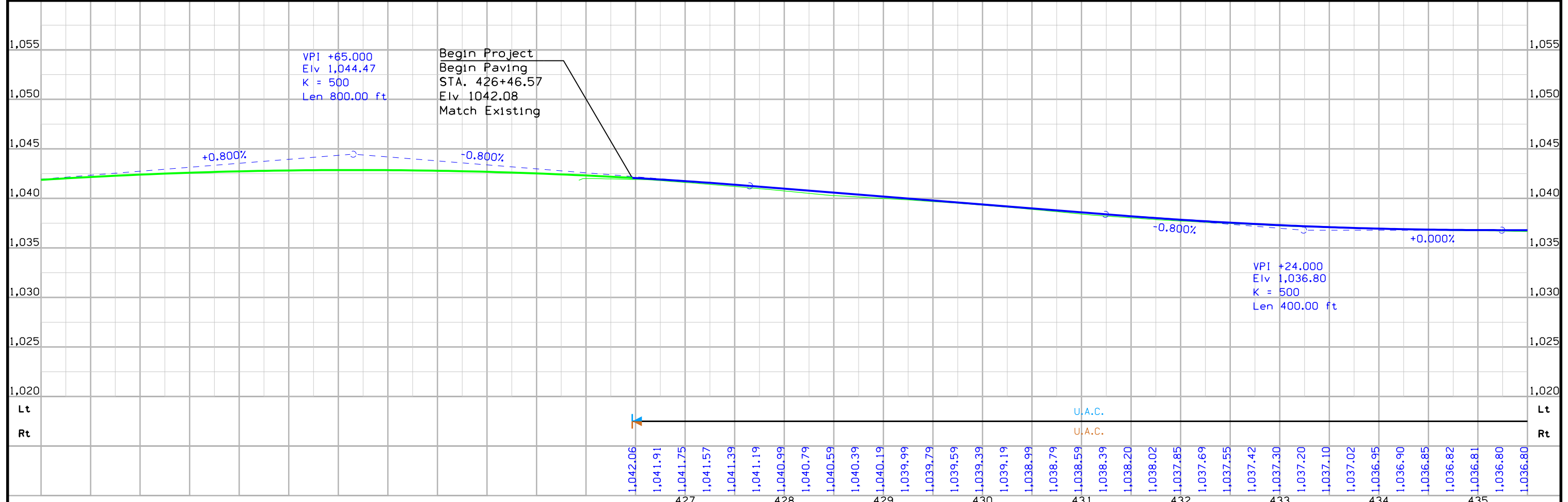
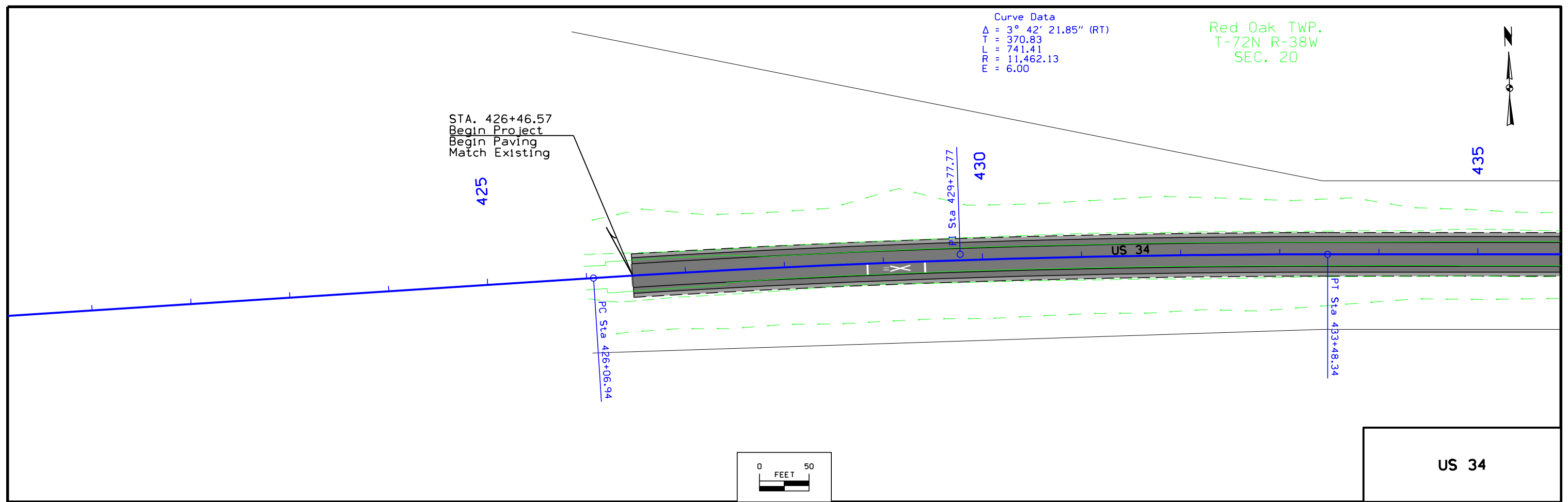

FILE NO.	ENGLISH	DESIGN TEAM	Iowa DOT \ HDR	MONTGOMERY COUNTY	PROJECT NUMBER	NHSX-034-2(60)--3H-69	SHEET NUMBER	D.2
----------	---------	-------------	----------------	-------------------	----------------	-----------------------	--------------	-----

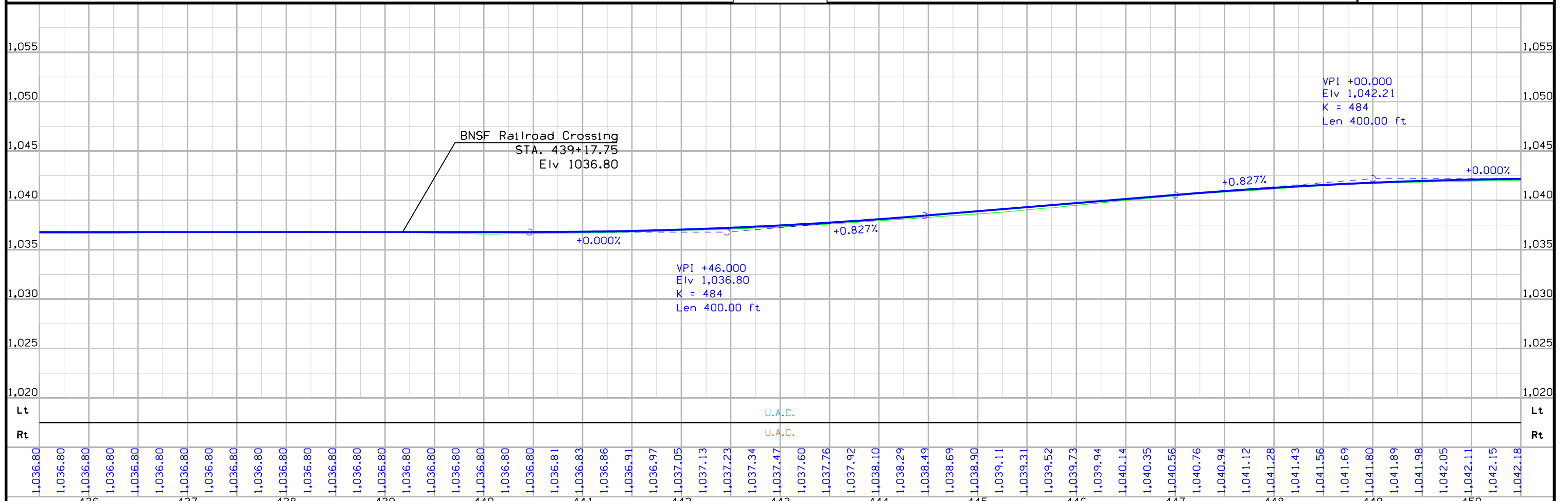
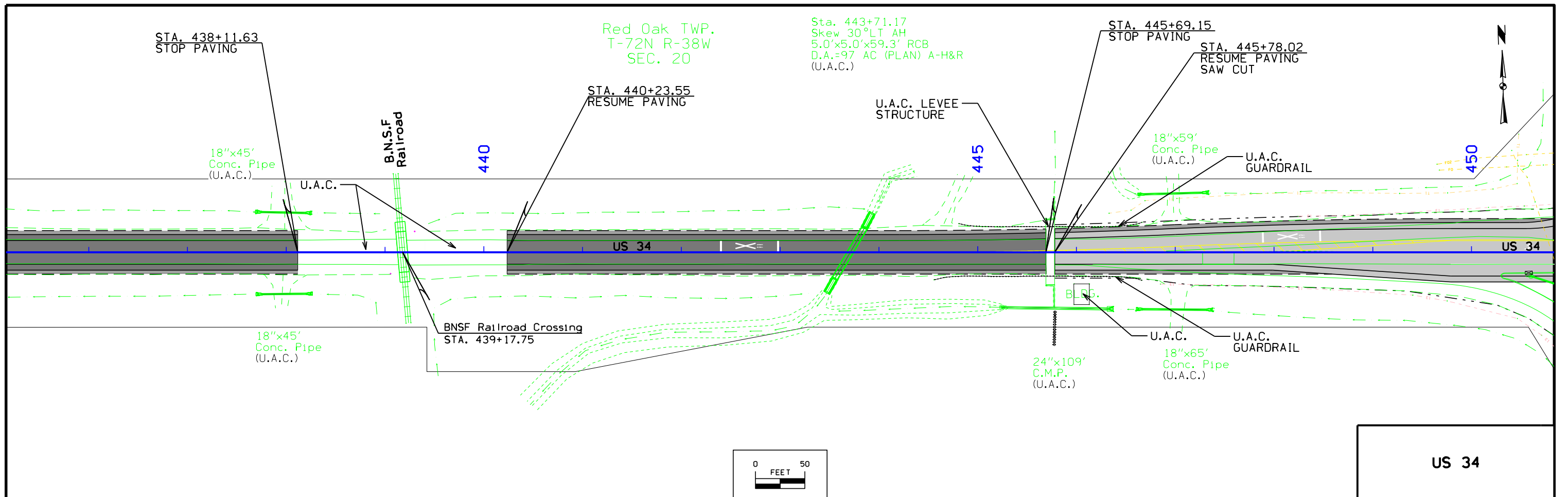

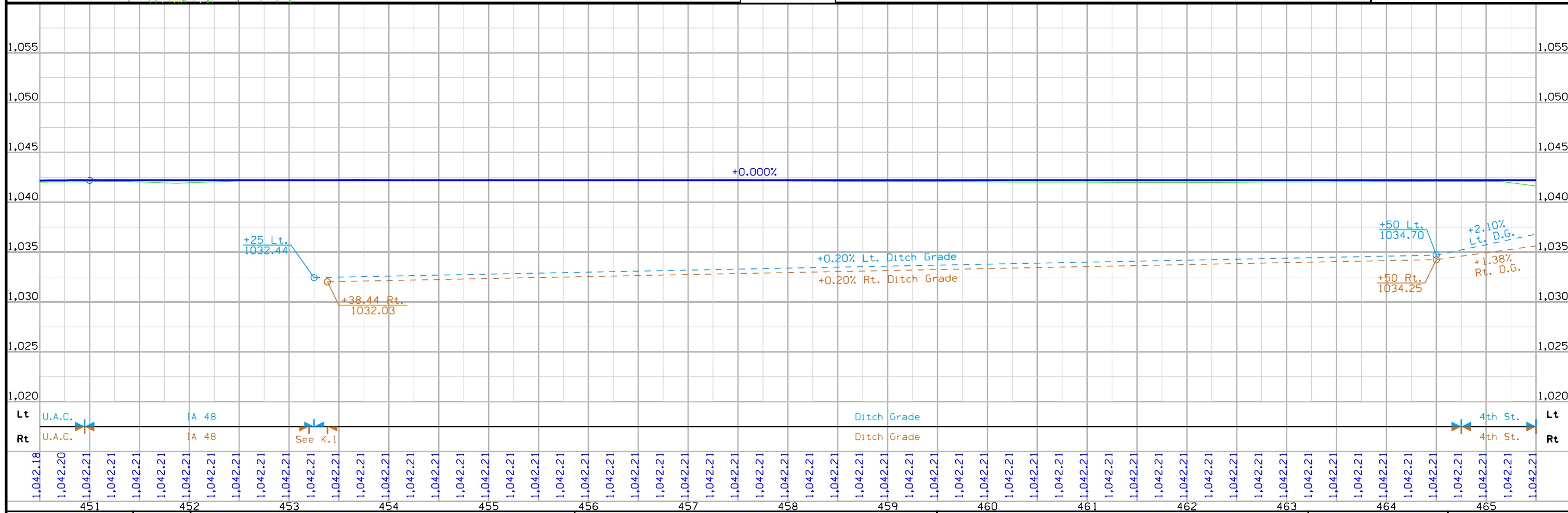
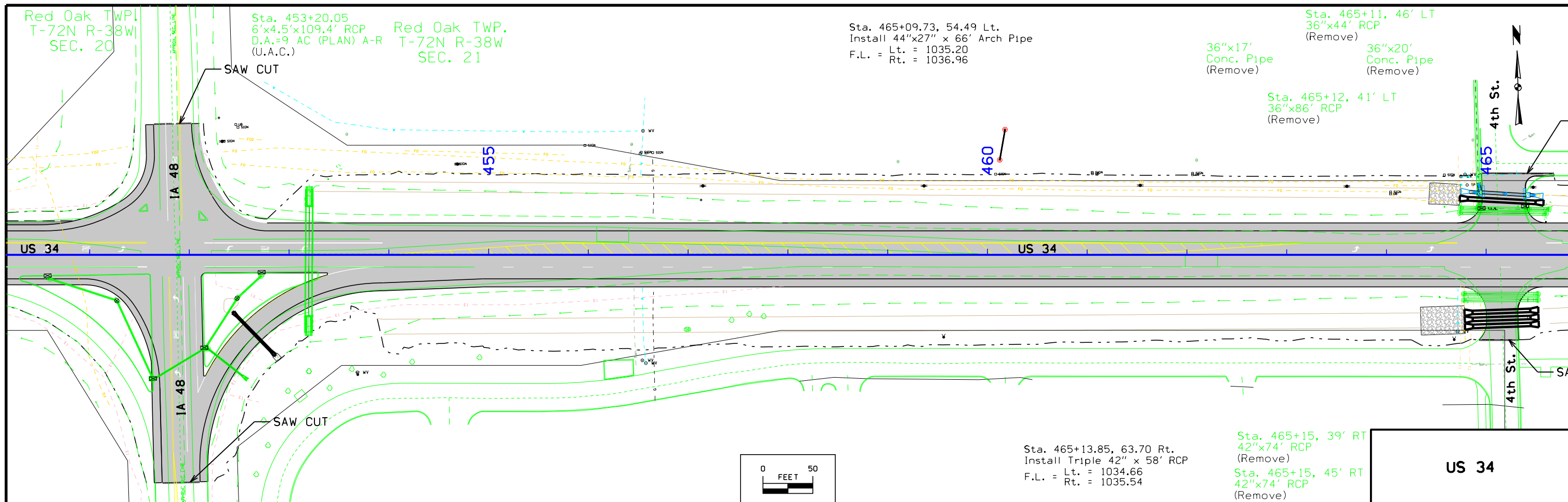

FILE NO.	ENGLISH	DESIGN TEAM	Iowa DOT \ HDR		MONTGOMERY COUNTY			PROJECT NUMBER	NHSX-034-2(60)--3H-69			SHEET NUMBER	D.4	
----------	---------	-------------	----------------	--	-------------------	--	--	----------------	-----------------------	--	--	--------------	-----	--

Red Oak TWP.
T-72N R-38W
SEC. 21

36"x735'
Plastic
(Remove)

+60 Prop. Dike
Type "G" Dike
Elev. 1065.96

Sta. 475+62.00
Install Triple 42" x 106' RCP
Skew = 32° 00' 00"
F.L. = Lt. = 1061.57
Rt. = 1058.46
Other = 1063.32 (DR-205)

36"x47'
Conc. Pipe
(Remove)

36"x6.5'
Conc. Pipe
(Remove)

Sta. 478+37.94
36"x110.1' RCP
D.A.=16 AC (PLAN) A-H
(Fill & Abandon)

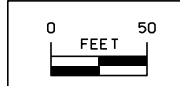
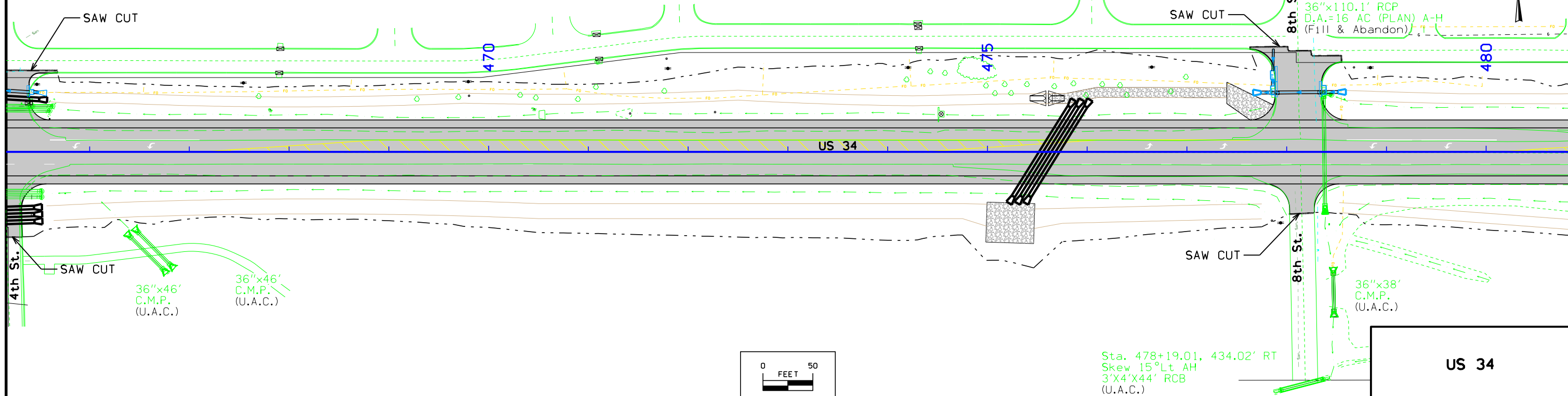

Sta. 478+19.01, 434.02' RT
Skew 15° Lt AH
3'x4'x44' RCB
(U.A.C.)

US 34

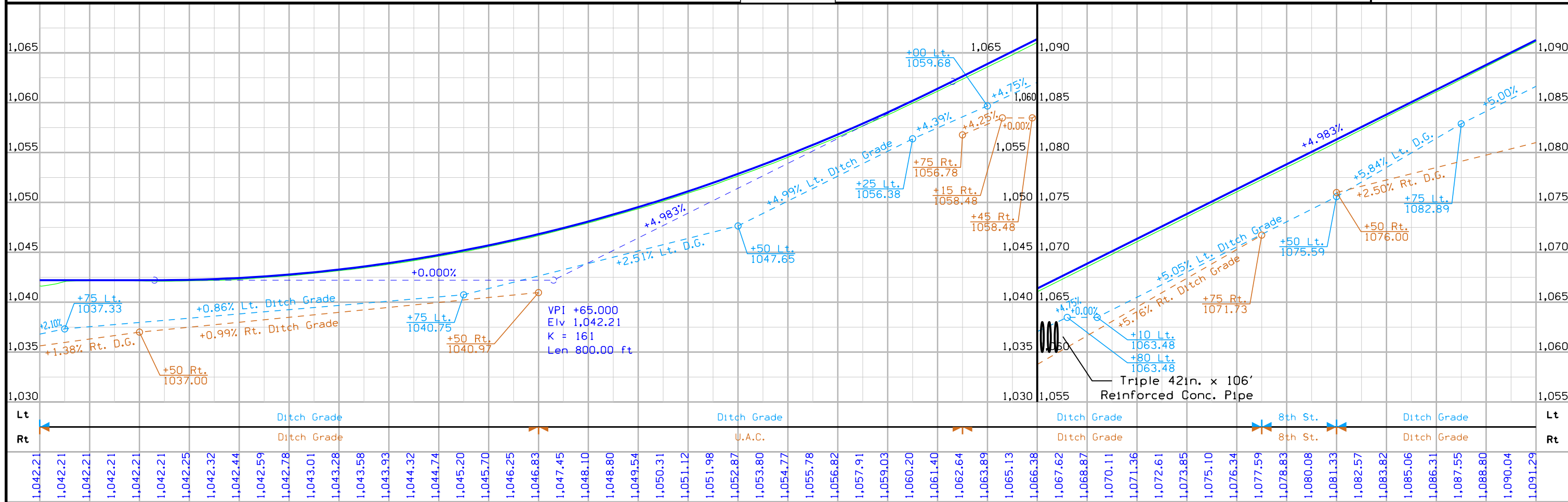

+05 Prop. Dike
Type "G" Dike
Elev. 1099.70

Extend 42" x 18' RCP
F.L. = Lt. = 1097.92
Rt. = 1091.71
Other = 1091.78 (Type C-1 Collar)

Sta. 482+97.18
Skew 30 LT AH
42"x105.7' RCP
D.A.=22 AC (PLAN) A-H
(Extend)

Sta. 488+13.15, 56.58 Lt.
Install 24" x 84' RCP
F.L. = Lt. = 1121.13
Rt. = 1125.73

Sta. 488+17.66, 40.1' LT
18"x80.8' RCP
(Remove)

Red Oak TWP.
T-72N R-38W
SEC. 21

+70 Prop. Dike
Type "G" Dike
Elev. 1145.80

Sta. 493+36.47, 110.67' LT
36"x110' RCP
(U.A.C.)

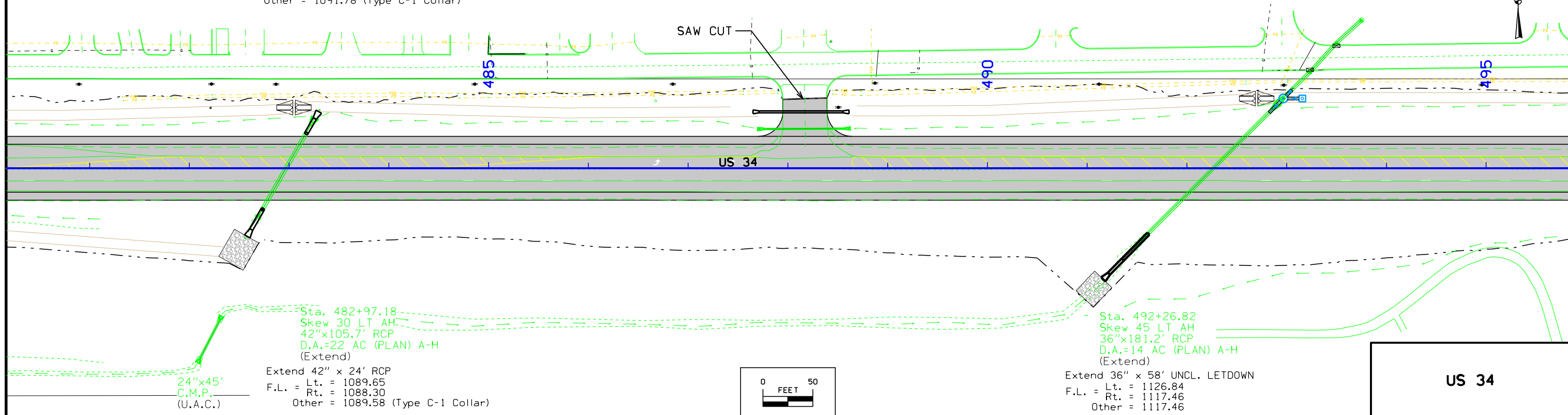

Sta. 482+97.18
Skew 30 LT AH
42"x105.7' RCP
D.A.=22 AC (PLAN) A-H
(Extend)

Extend 42" x 24' RCP
F.L. = Lt. = 1089.65
Rt. = 1088.30
Other = 1089.58 (Type C-1 Collar)

24"x45'
C.M.P.
(U.A.C.)

Sta. 492+26.82
Skew 45 LT AH
36"x181.2' RCP
D.A.=14 AC (PLAN) A-H
(Extend)

Extend 36" x 58' UNCL. LETDOWN
F.L. = Lt. = 1126.84
Rt. = 1117.46
Other = 1117.46

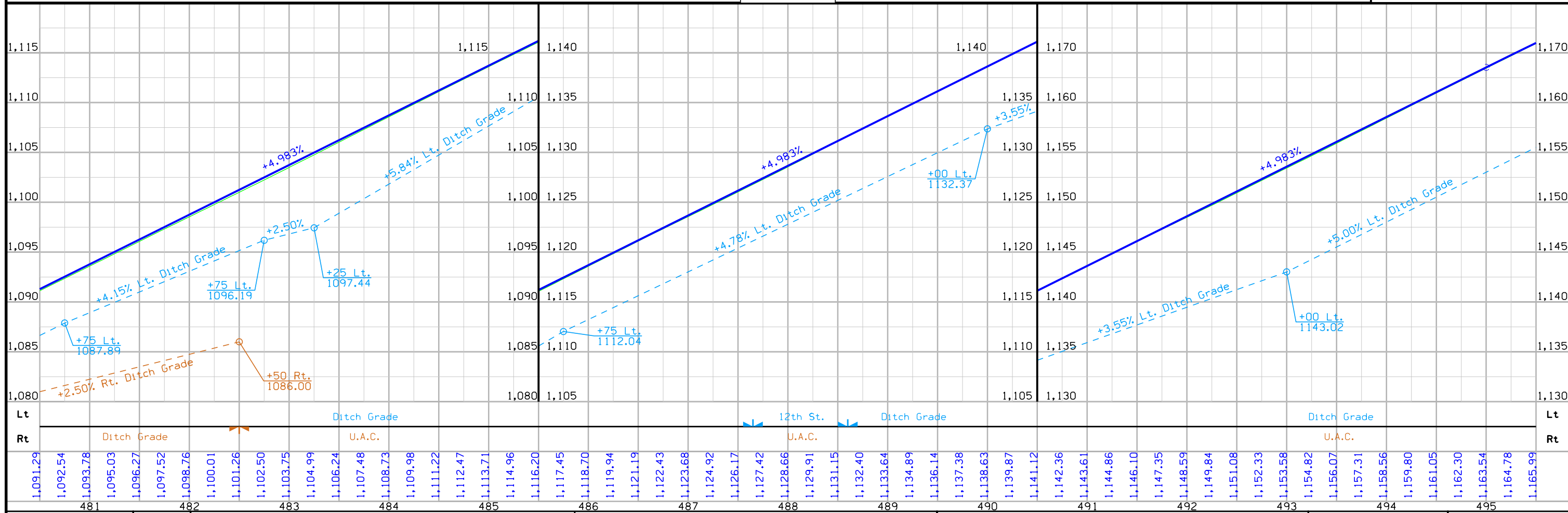
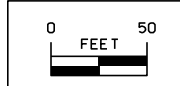

FILE NO.	ENGLISH	DESIGN TEAM	Iowa DOT \ HDR	MONTGOMERY COUNTY	PROJECT NUMBER	NHSX-034-2(60)--3H-69	SHEET NUMBER	D.6
----------	---------	-------------	-----------------------	-------------------	----------------	------------------------------	--------------	------------

Red Oak TWP.
T-72N R-38W
SEC. 21

Red Oak TWP.
T-72N R-38W
SEC. 22

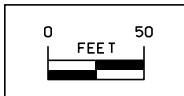
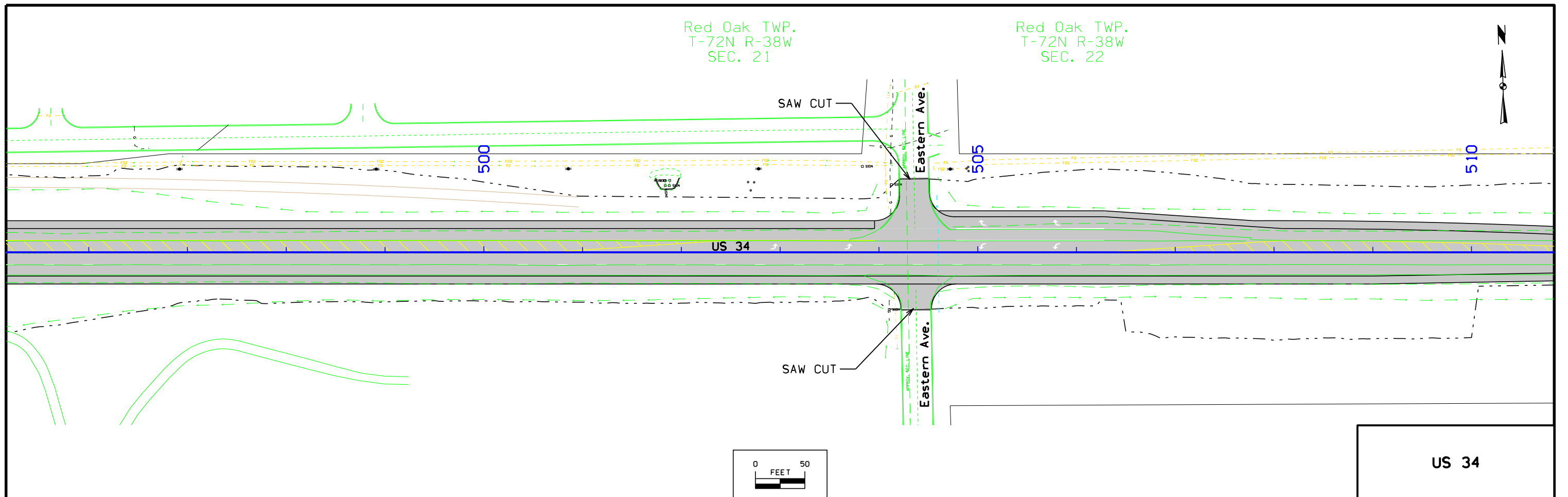

US 34

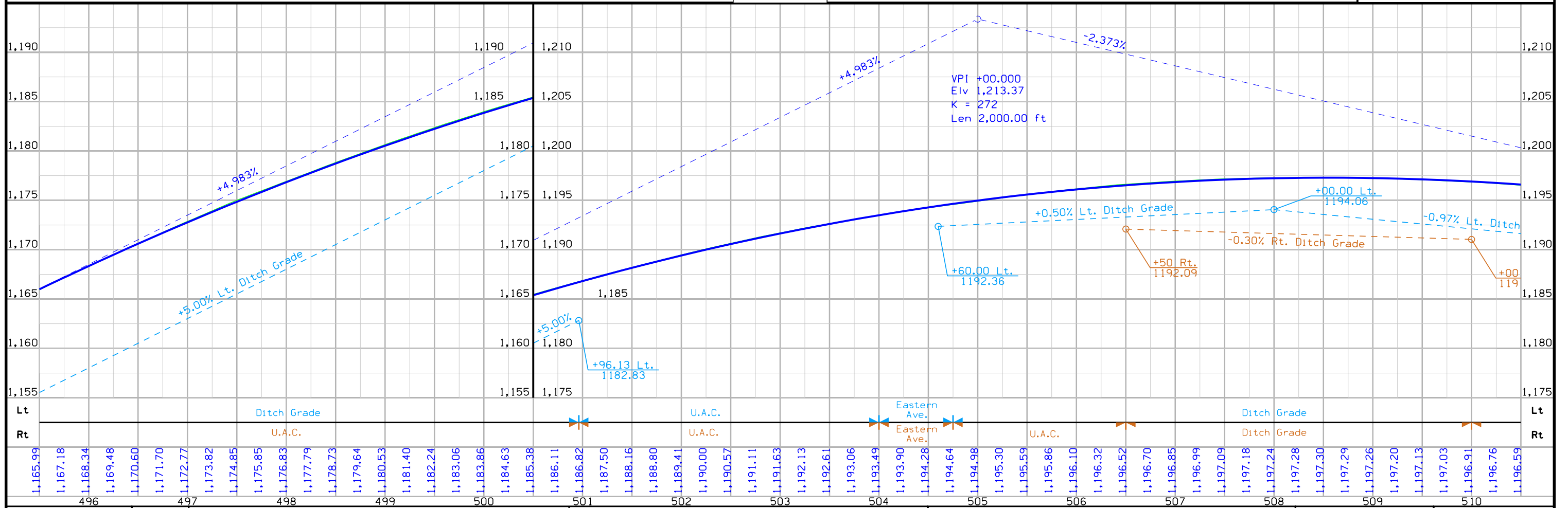

FILE NO.	ENGLISH	DESIGN TEAM	Iowa DOT \ HDR	MONTGOMERY COUNTY	PROJECT NUMBER	NHSX-034-2(60)--3H-69	SHEET NUMBER	D.7
----------	---------	-------------	----------------	-------------------	----------------	-----------------------	--------------	-----

Sta. 513+19.62
24"x59.2' RCP
D.A.=1.5 AC (PLAN) A-R
(U.A.C.)

Red Oak TWP.
T-72N R-38W
SEC. 22

Sta. 520+44.52
Skew 30°RT AH
2'x3.3'x159.7' RCB
D.A.=14 AC (PLAN) A-H
(U.A.C.)

Sta. 523+14.76
CATTLE CROSSING
4'x6'x80' RCB
(U.A.C.)

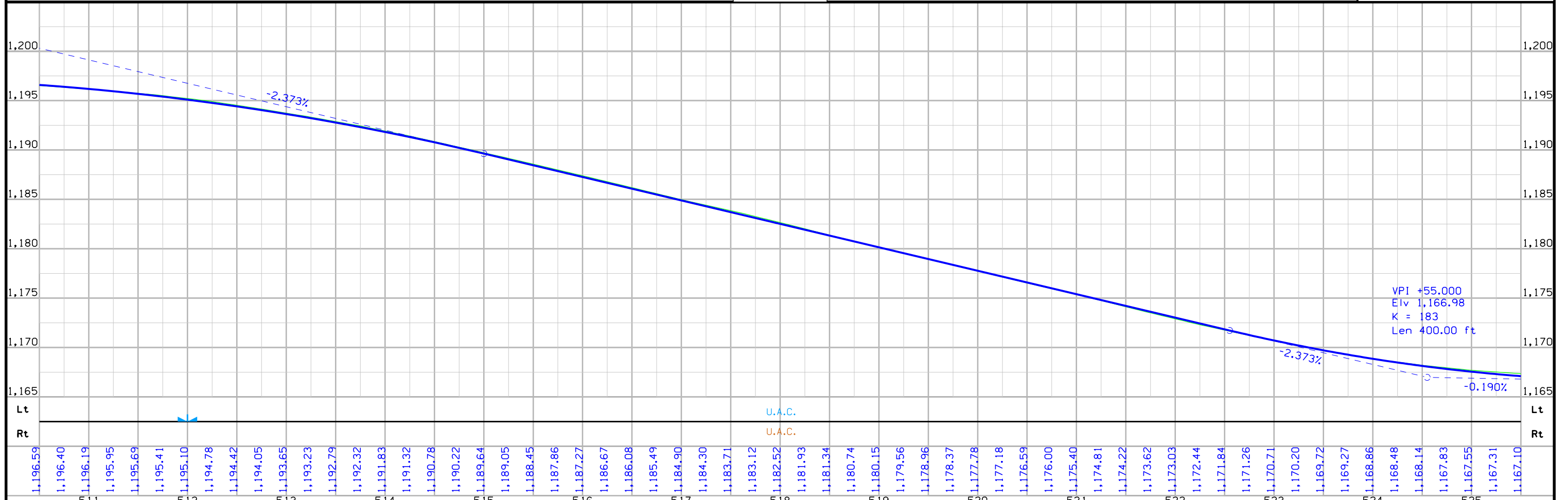
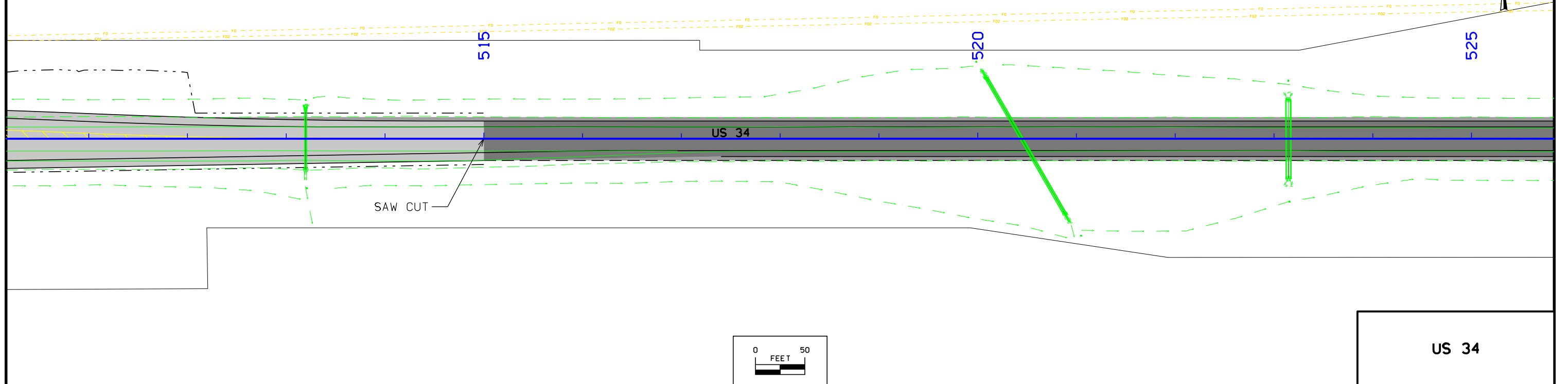

FILE NO.	ENGLISH	DESIGN TEAM	Iowa DOT \ HDR	MONTGOMERY COUNTY	PROJECT NUMBER	NHSX-034-2(60)--3H-69	SHEET NUMBER	D.8
----------	---------	-------------	----------------	-------------------	----------------	-----------------------	--------------	-----

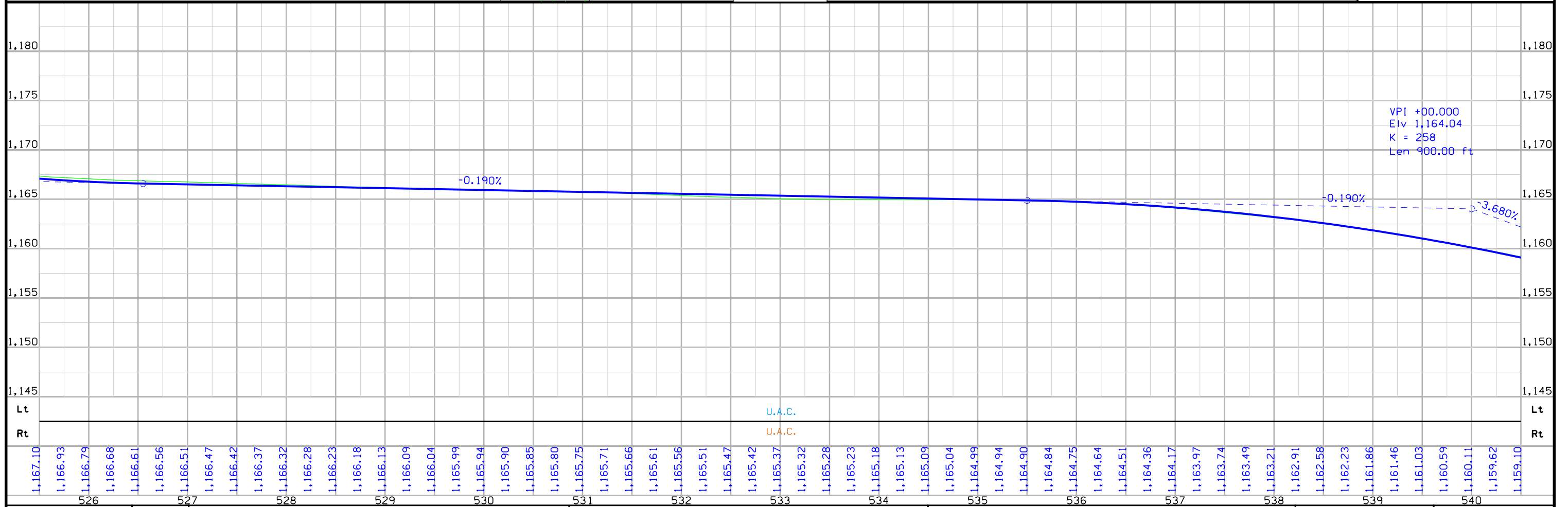
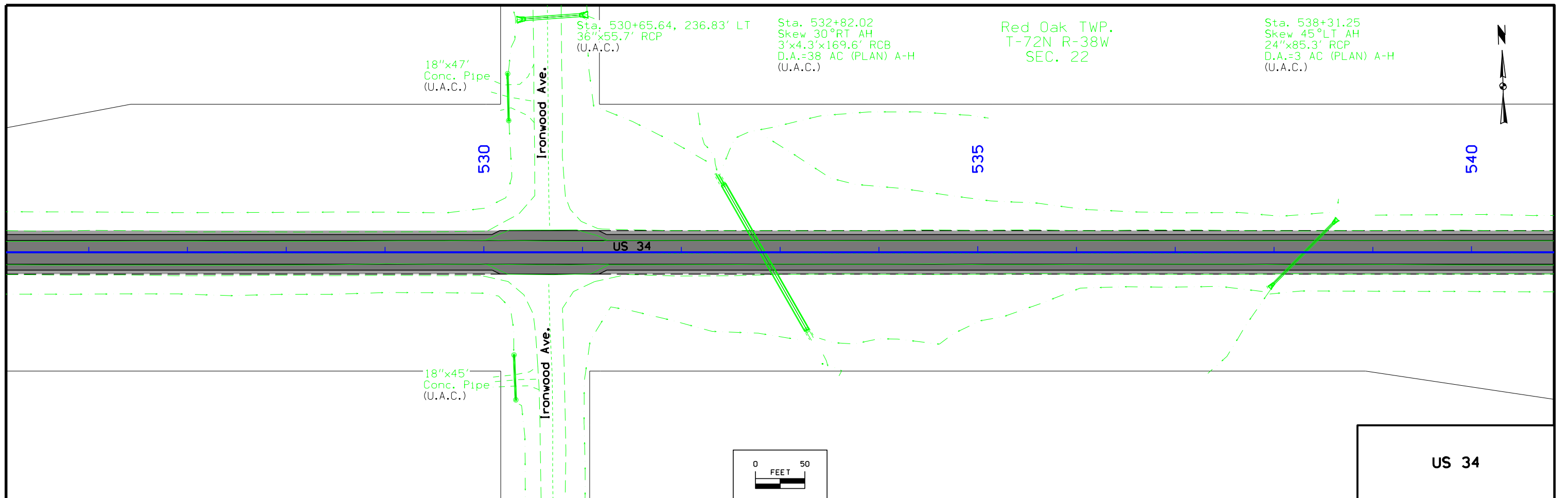

FILE NO.	ENGLISH	DESIGN TEAM	Iowa DOT \ HDR	MONTGOMERY COUNTY	PROJECT NUMBER	NHSX-034-2(60)--3H-69	SHEET NUMBER	D.9
----------	---------	-------------	----------------	-------------------	----------------	-----------------------	--------------	-----

Red Oak TWP.
T-72N R-38W
SEC. 22

SCS PI Sta 562+75.54
 $\Delta = 28^\circ 42' 39.86''$ (RT)
 Theta = $1^\circ 59' 56.84''$
 Ls = 200.00
 Ts = 833.65
 Es = 92.97
 P = 0.58

K = 100.00
 Xc = 199.98
 Yc = 2.33
 LT = 133.34
 ST = 66.67
 LC = 199.99

Curve Data
 $\Delta = 24^\circ 42' 46.17''$ (RT)
 T = 627.86
 L = 1,236.18
 R = 2,866.05
 E = 67.97

545

550

555

US 34

PI Sta 555+75.23
 TS Sta 554+41.11

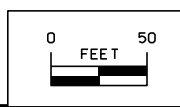

Sta. 554+63.51
 TWIN 8'x10.5'x166.4' RCB
 D.A.=1350 AC (PLAN) A-H
 (U.A.C.)

US 34

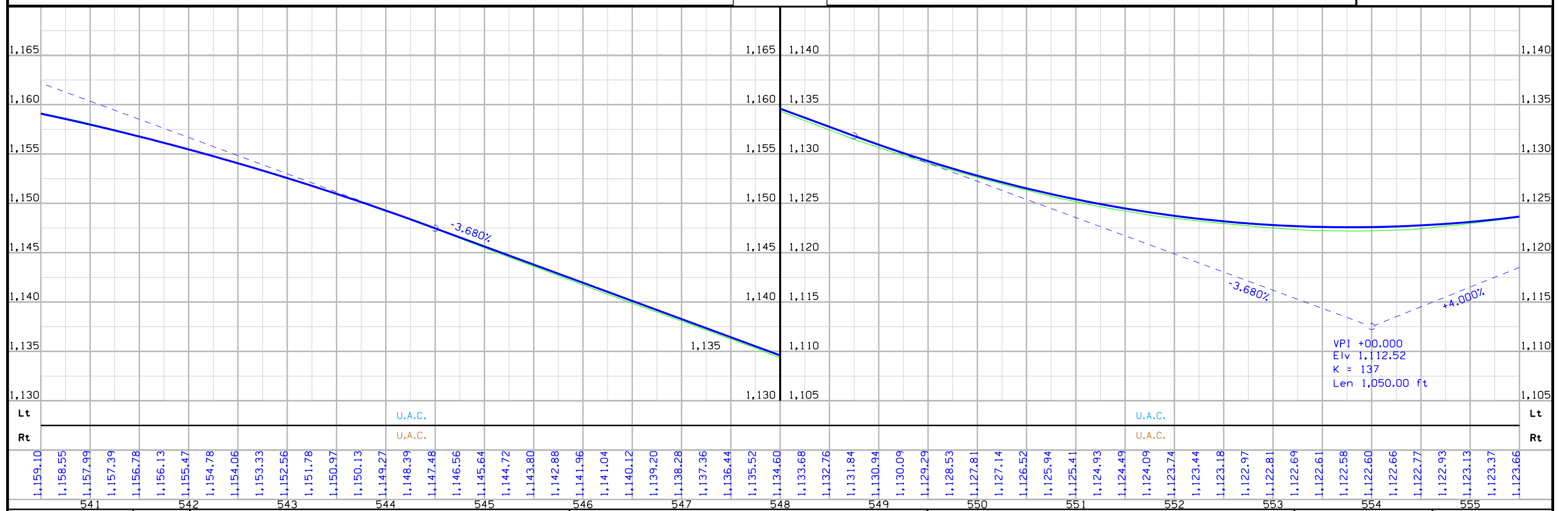

SCS PI Sta 562+75.54
 $\Delta = 28^\circ 42' 39.86''$ (RT)
 Theta = $1^\circ 59' 56.84''$
 Ls = 200.00
 Es = 833.65
 F = 92.97
 P = 0.58

K = 100.00
 Xc = 199.98
 Yc = 2.33
 LT = 133.34
 ST = 66.67
 LC = 199.99

Curve Data
 $\Delta = 24^\circ 42' 46.17''$ (RT)
 T = 627.86
 L = 1,236.18
 RL = 2,866.05
 E = 67.97

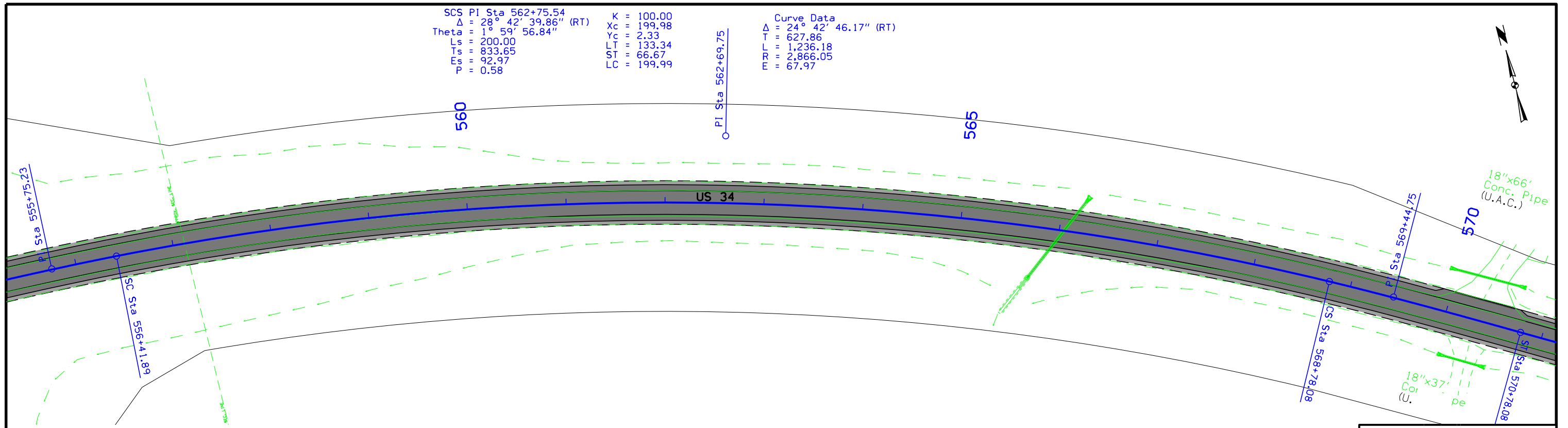

Red Oak TWP.
 T-72N R-38W
 SEC. 22

Red Oak TWP.
 T-72N R-38W
 SEC. 23

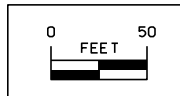

Sta. 566+05.01
 Skew 30°LT AH
 24"x97.9' RCP
 D.A.=5 AC (PLAN) A-H
 (U.A.C.)

US 34

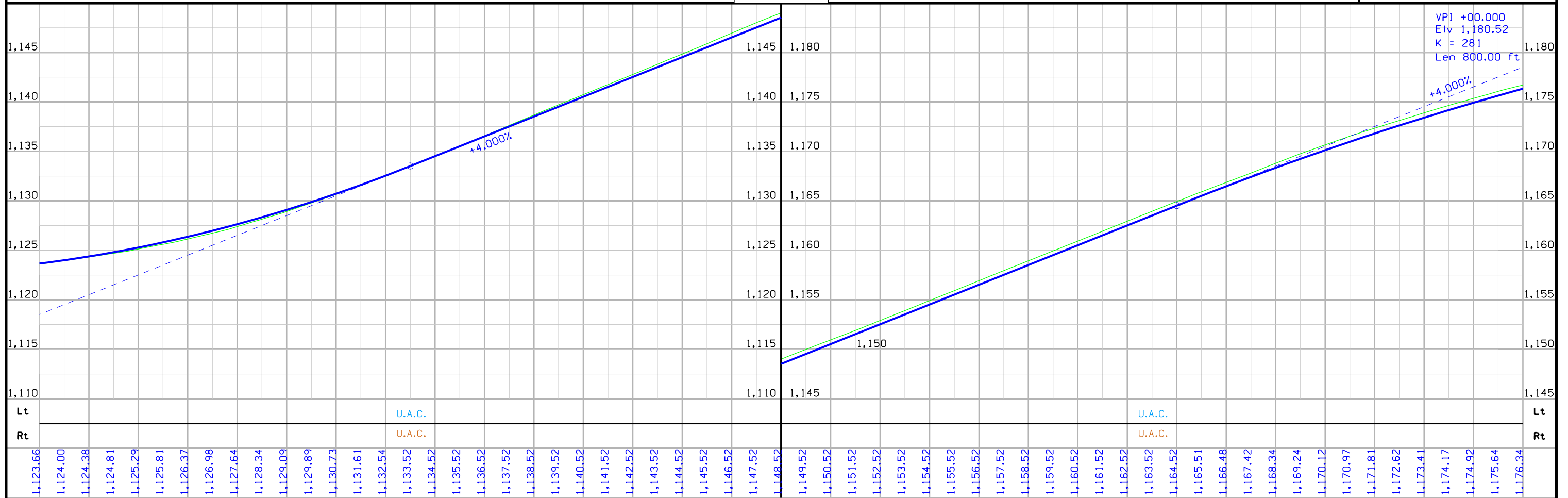

FILE NO.	ENGLISH	DESIGN TEAM	Iowa DOT \ HDR	MONTGOMERY COUNTY	PROJECT NUMBER	NHSX-034-2(60)--3H-69	SHEET NUMBER	D.11
2:39:40 PM	6/4/2021	SRANNEY	pw://HDR_US_Central_01/3047/10169946/SHT_6903460.D01.dgn					

SCS PI Sta 562+75.54
 $\Delta = 28^\circ 42' 39.86''$ (RT) K = 100.00
 $\Delta = 24^\circ 42' 46.17''$ (RT) Xc = 199.98
Theta = $1^\circ 59' 56.84''$ Yc = 2.33
Ls = 200.00 LT = 133.34 T = 627.86
Ts = 833.65 ST = 66.67 L = 1,236.18
Es = 92.97 LC = 199.99 R = 2,866.05
P = 0.58 E = 67.97

Red Oak TWP.
T-72N R-38W
SEC. 23

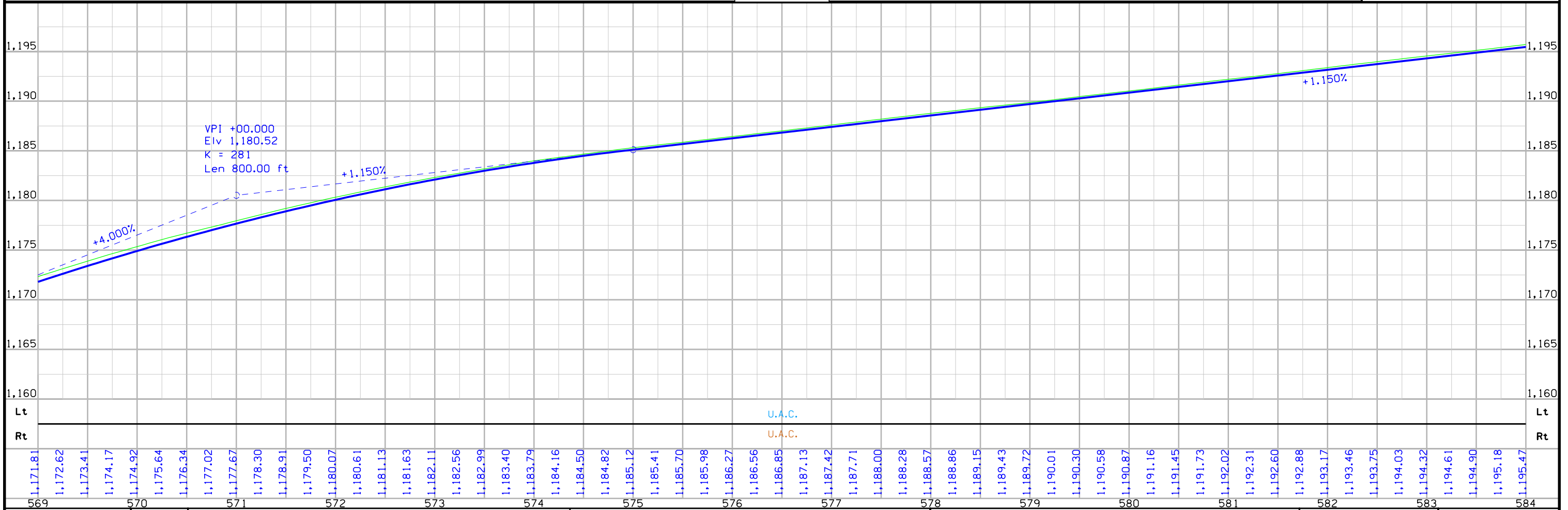
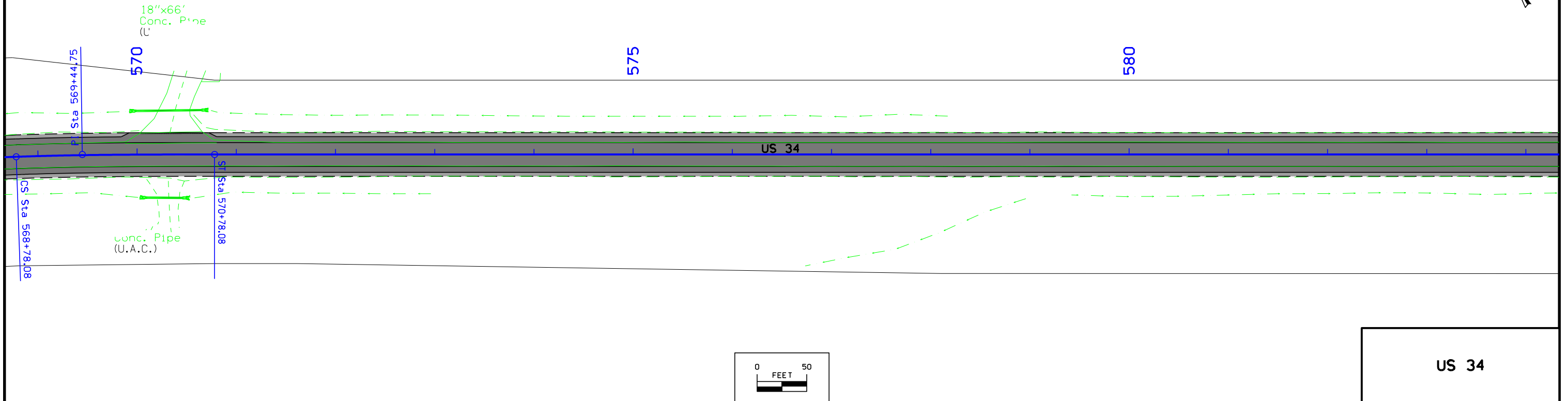
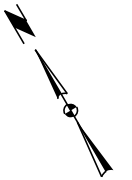

FILE NO.	ENGLISH	DESIGN TEAM	Iowa DOT \ HDR	MONTGOMERY COUNTY	PROJECT NUMBER	NHSX-034-2(60)--3H-69	SHEET NUMBER	D.12
----------	---------	-------------	----------------	-------------------	----------------	-----------------------	--------------	------

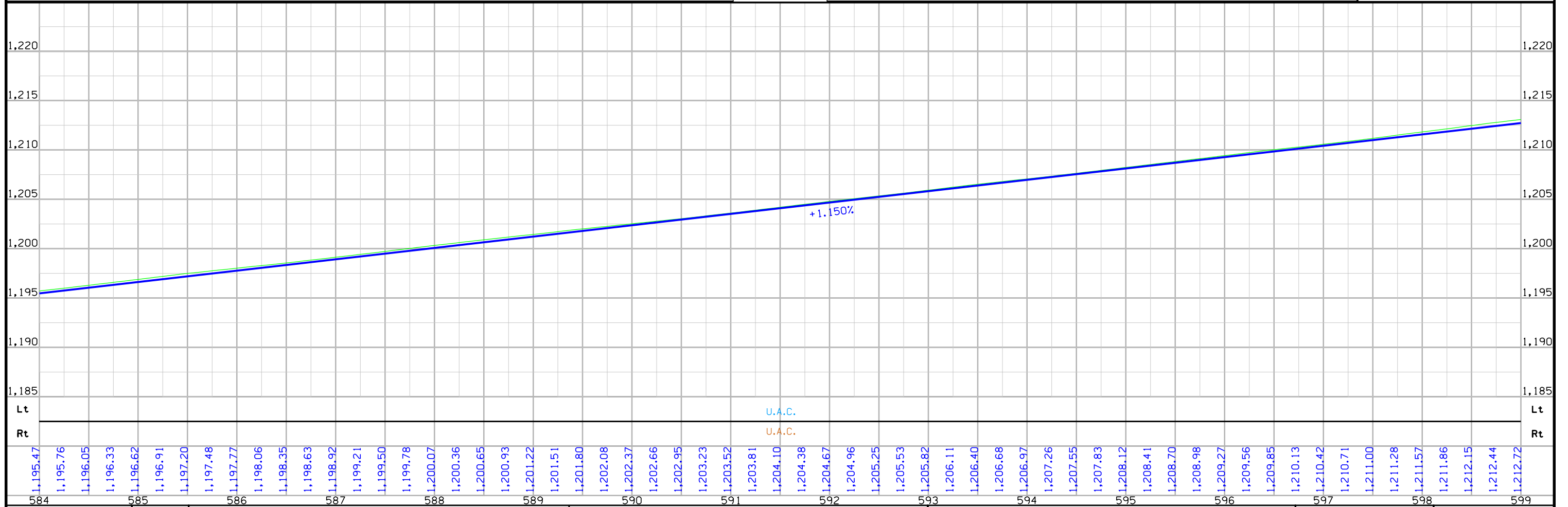
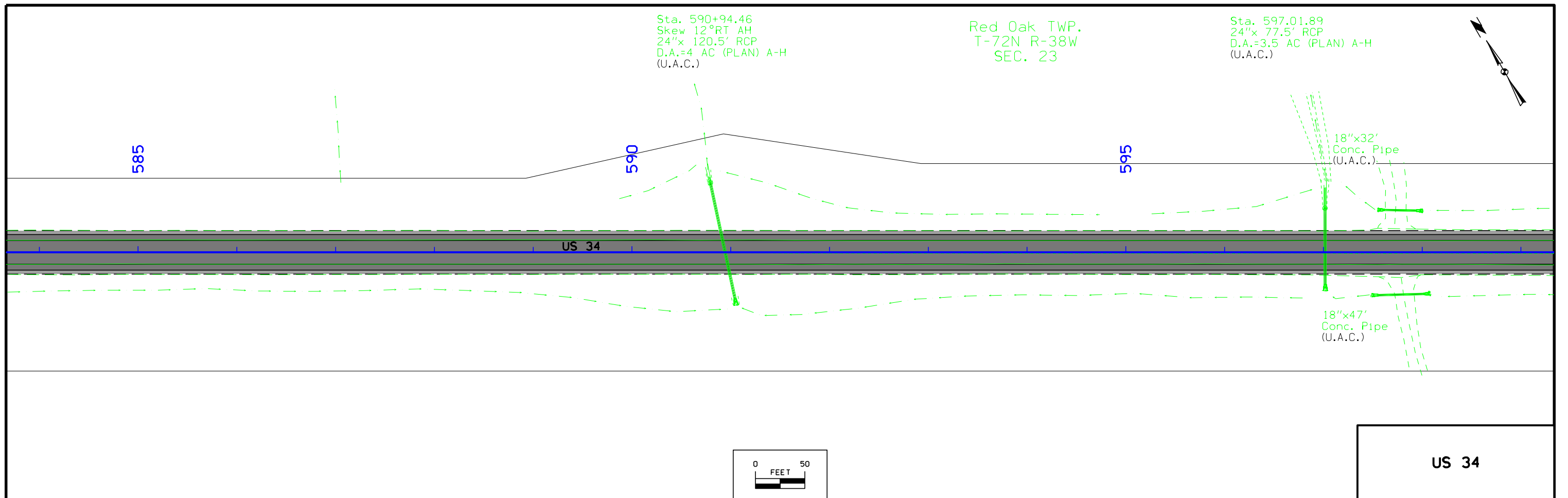

FILE NO.	ENGLISH	DESIGN TEAM	Iowa DOT \ HDR	MONTGOMERY COUNTY	PROJECT NUMBER	NHSX-034-2(60)--3H-69	SHEET NUMBER	D.13
----------	---------	-------------	----------------	-------------------	----------------	-----------------------	--------------	------

Red Oak TWP.
T-72N R-38W
SEC. 23

Sta. 611+41.86
2' x 3.3' x 158.5' RCB
D.A.=15 AC (PLAN) A-H
(U.A.C.)

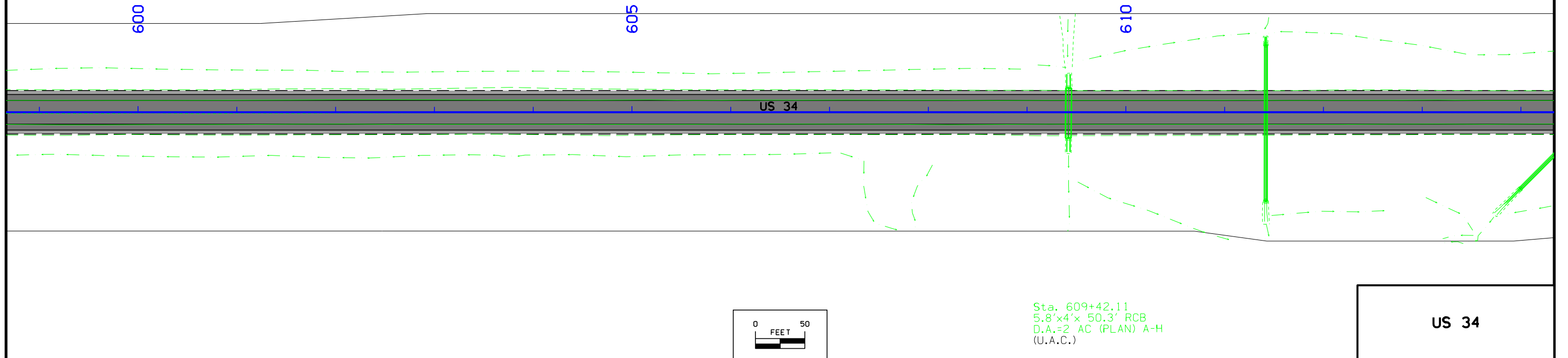
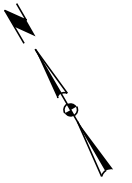

Sta. 609+42.11
5.8' x 4' x 50.3' RCB
D.A.=2 AC (PLAN) A-H
(U.A.C.)

US 34

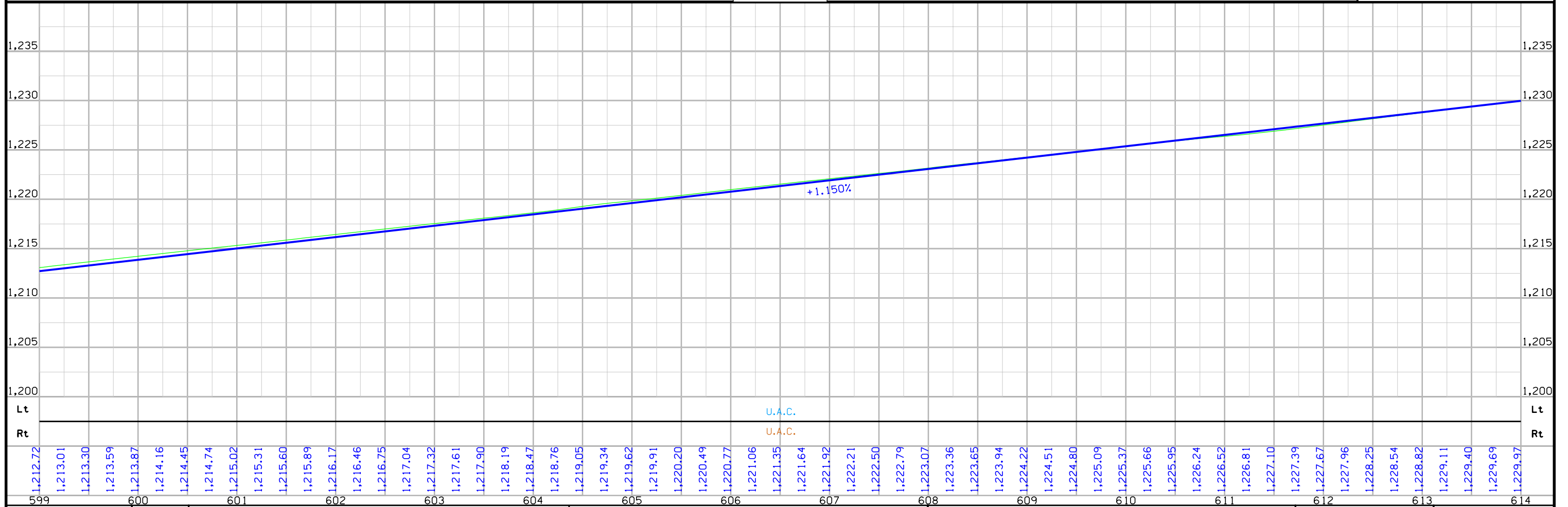

U.A.C.

U.A.C.

FILE NO.	ENGLISH	DESIGN TEAM	Iowa DOT \ HDR	MONTGOMERY COUNTY	PROJECT NUMBER	NHSX-034-2(60)--3H-69	SHEET NUMBER	D.14
----------	---------	-------------	----------------	-------------------	----------------	-----------------------	--------------	------

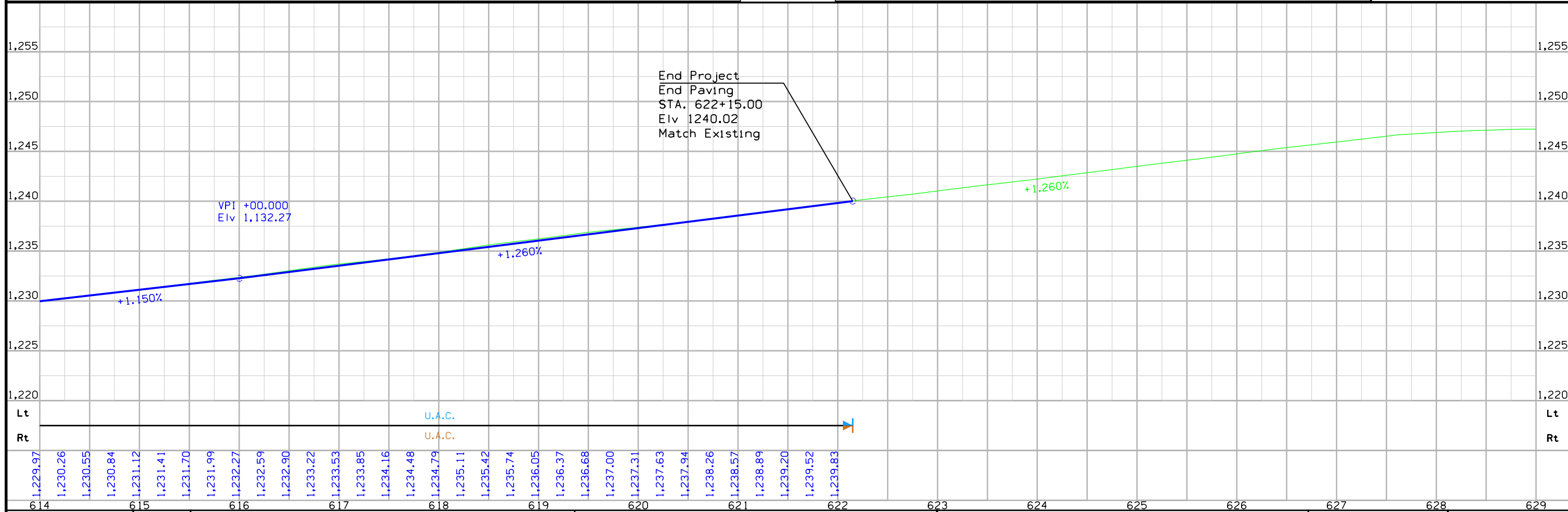
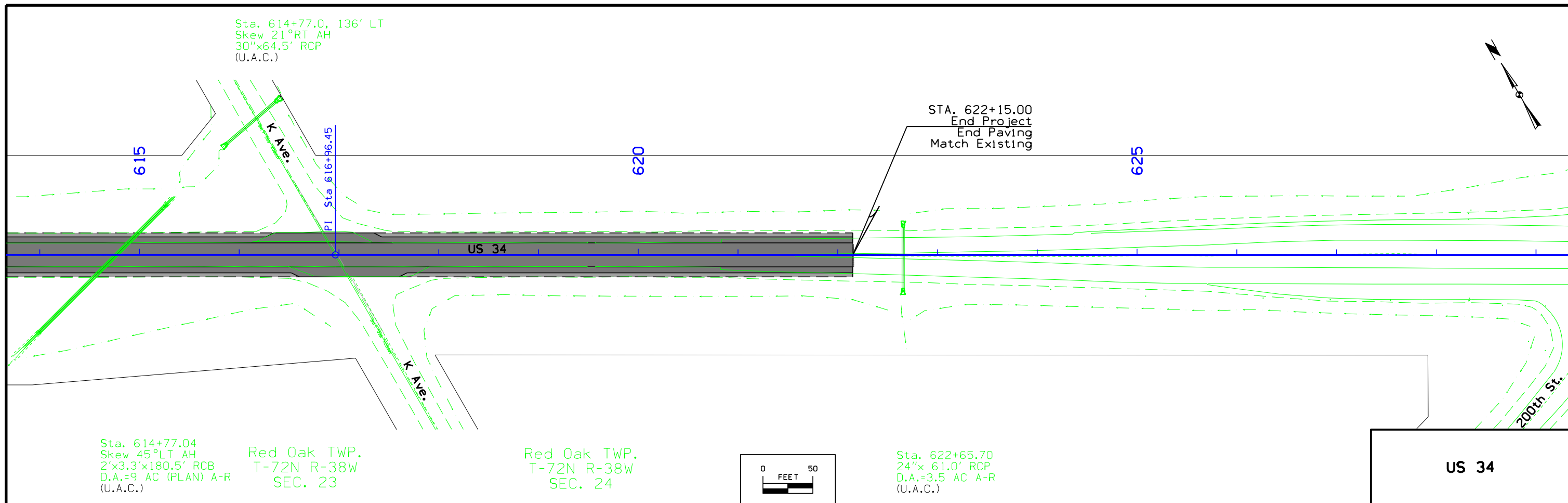

FILE NO.	ENGLISH	DESIGN TEAM	Iowa DOT \ HDR	MONTGOMERY COUNTY	PROJECT NUMBER	NHSX-034-2(60)--3H-69	SHEET NUMBER	D.15
----------	---------	-------------	----------------	-------------------	----------------	-----------------------	--------------	------

Red Oak TWP.
T-72N R-38W
SEC. 20

1025

1030

STA. 1031+66.25
Begin Paving

450

1035

STA. 1035+25.00
End Paving

IA 48

IA 48

US 34

US 34

Red Oak TWP.
T-72N R-38W
SEC. 21

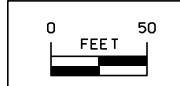

Sta. 453+20.05
6'x4.5'x109.4' RCP
D.A.=9 AC (PLAN) A-R
(U.A.C.)

IA 48

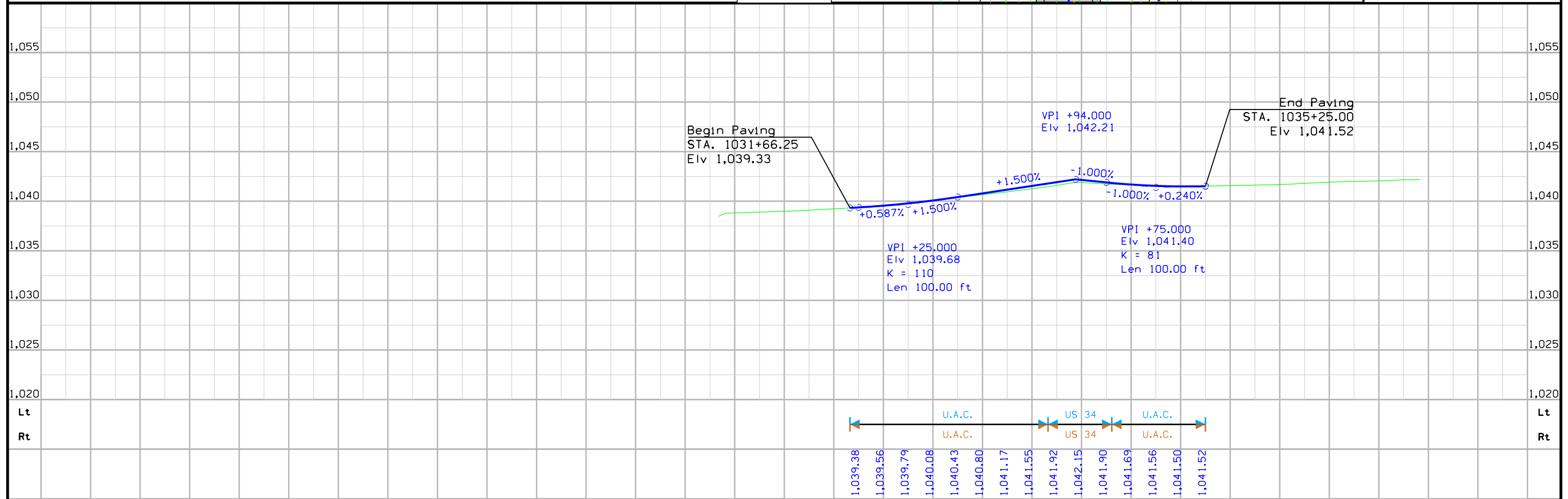

Survey Information

Montgomery County
NHSN-034-2(64)--2R-69
Us 34 / W of IA 48 to US 71
PIN 16-69-034-010
Sap-0946.0

Party Personnel

Scott Liddell - Survey Party Chief – District 4
Nate Epperson - Assistant Survey Party Chief

Date(s) of Survey

Begin Date 02/01/2019
End Date 07/03/2019

General Information

Measurement units for this survey are US survey feet. This survey is for proposed Resurfacing on US 34. Project datum and control information is provided by Design Survey Office. This project is a Full Field DTM with Statewide LiDAR. The utilities were not believed to be affected. No locates were requested.

Vertical Control

Vertical datum for this survey is NAVD88 (Computed using Geoid12b). GRS80 Ellipsoidal Height was computed at project Pts. 69034001, 69034002, 69034003, 69034004, and F108 by doing concurrent 6-hour static observations. The project control is relative to nearby Iowa RTN Base Stations.

This survey observed 1 NGS Control Monuments with published NAVD88 heights to compare to local ground control:

NGS 2nd. order class 0 mark designated F108 has a published Elev. Of 1117.97
Survey Elev. = 1117.867

Horizontal Control

The project coordinate system for this survey is Iowa RCS Zone 12 (U.S. Survey Feet). This survey control is relative to IaRTN reference stations. IaRTN Reference Station coordinates are relative to the National Reference Station network datum: NAD83 (2011) for Epoch 2010.00. Coordinates were determined by conducting concurrent 6-hour static observations on Project Pts. 69034001, 69034002, 69034003, 69034004, and F108.

Alignment Information

Alignment was provided by the district.

CONTROL POINT VICINITY MAP

This map is a guide to the vicinity of the primary project control points
 Primary control is for use with RTK base stations and for RTN validation.
 Future surveys will use primary project control to establish temporary control as needed for construction or other surveying applications.

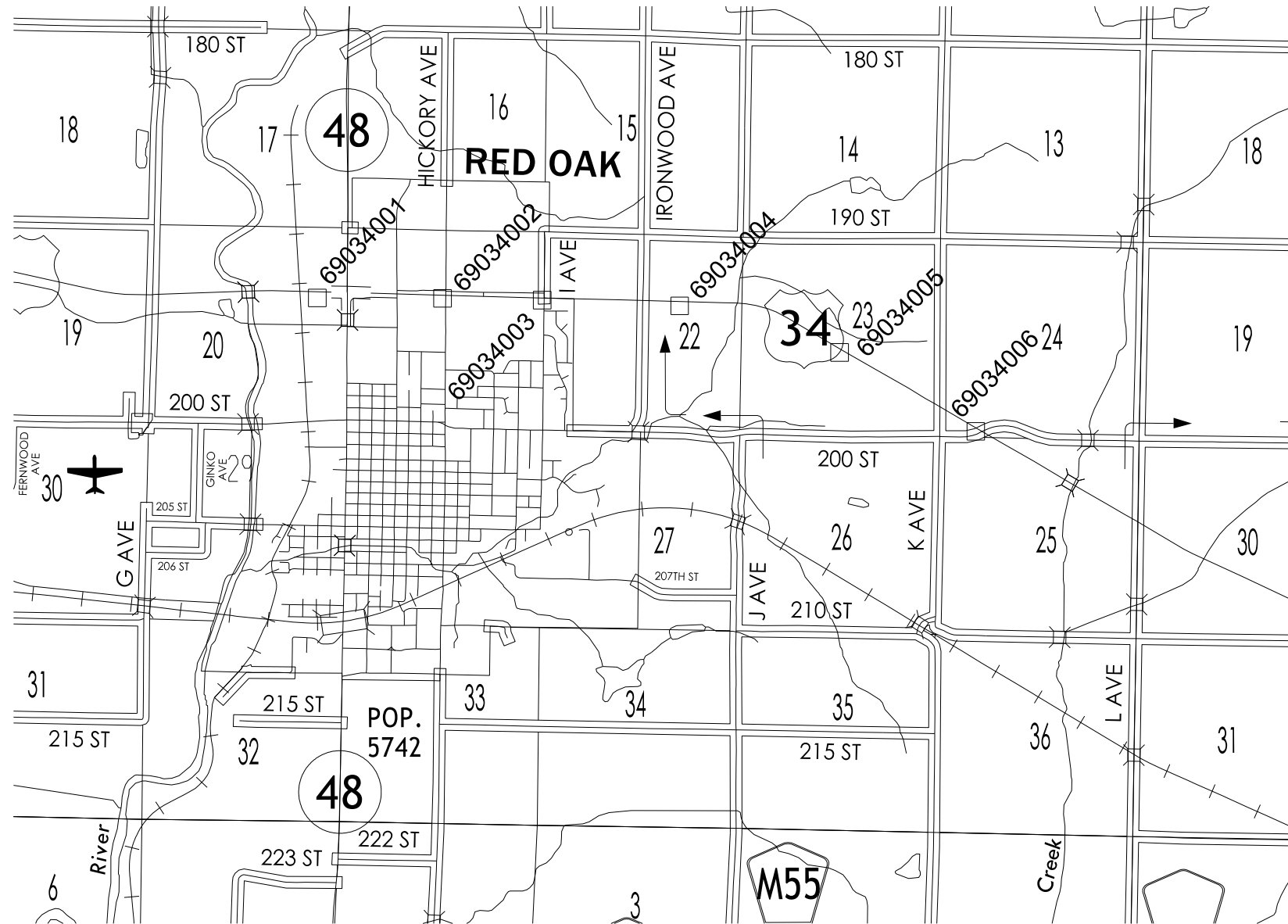

HORIZ. DATUM: NAD83(2011) EPOCH 2010.00

VERT. DATUM: NAVD88

1a. Regional Coordinate System Zone 12

Coordinate listing from next sheet will be used with 1aRTN for monument recovery. No other reference ties are given.

HORIZONTAL AND VERTICAL PROJECT CONTROL COORDINATE LISTING

HORIZ. DATUM: NAD83(2011) EPOCH 2010.00

VERT. DATUM: NAVD88

Ia. Regional Coordinate System Zone 12

POINT NO.	NORTHING	EASTING	ELEV.	DESCRIPTION
69034001	6243169.371	22090031.618	1046.281	FENO SET IOWA DOT FENO MONUMENT 3" DEEP IN TOP OF LEVY. 0.1 MILES WEST ALONG HWY 34 FROM THE INTERSECTION OF HWY 34 AND HWY 48 IN THE TOWN OF RED OAK, IA., 165' SOUTH OF CL HWY 34, 138' SOUTHEAST OF THE CENTER OF HEADWALL AT INSIDE FACE RCB CULVERT, AND 129' SOUTHWEST OF HWY 34 SIGN POST.
69034002	6243157.272	22093371.793	1072.675	FENO SET IOWA DOT FENO MONUMENT 3" DEEP. 87' SOUTH OF CL HWY 34, 89' WEST OF CL 8 TH ST. IN THE TOWN OF RED OAK, IA., 62' NORTH OF THE CL RECREATION TRAIL, AND 68' WEST OF LUMINAIRE POLE
69034003	6243110.838	22096028.307	1190.898	FENO FOUND 4"X 4" CONCRETE MONUMENT WITH ½" REBAR 2" DEEP. 62' SOUTH OF CL HWY 34, 54' WEST OF CL EASTERN AVE. IN THE TOWN OF RED OAK IA., 27' WEST OF GAS PIPELINE VENT, AND 18' SOUTHEAST OF MERGE AHEAD SIGN POST.
69034004	6242957.418	22099694.209	1180.482	FENO SET IOWA DOT FENO MONUMENT 3" DEEP. 0.1 MILES EAST ALONG HWY 34 FROM THE INTERSECTION OF HWY 34 AND IRONWOOD AVE IN MONTGOMERY COUNTY IA., 117' SOUTH OF CL HWY 34, 25' NORTH O WIRE ROW FENCE, AND 51' SOUTHWEST OF ROW RAIL.
69034005	6241713.996	22103959.179	1207.503	FENO SET IOWA DOT FENO MONUMENT 3" DEEP. 1.0 MILES EAST ALONG HWY 34 FROM THE INTERSECTION OF HWY 34 AND IRONWOOD AVE IN MONTGOMERY COUNTY IA., 98' SOUTH OF CL HWY 34, 21' NORTH OF WIRE ROW FENCE, AND 108' WEST OF MILE MARKER 38 POST.
69034006	6239612.177	22107591.703	1242.390	FENO FOUND 4"X 4" CONCRETE MONUMENT WITH ½" REBAR FLUSH WITH GROUND. 85' SOUTH OF CL HWY 34, 80' WEST OF CL COUNTY ROAD H34, 55' NORTHWEST OF LUMINAIRE POLE, AND 44' SOUTHWEST OF LUMINAIRE POLE.

ALIGNMENT COORDINATES

101-16
10-20-09

Name	Location	Point on Tangent			Begin Spiral			Begin Curve			Simple Curve PI or Master PI of SCS			End Curve			End Spiral			
		Station	Coordinates		Station	Coordinates		Station	Coordinates		Station	Coordinates		Station	Coordinates		Station	Coordinates		
			Y (Northing)	X (Easting)		Y (Northing)	X (Easting)		Y (Northing)	X (Easting)		Y (Northing)	X (Easting)		Y (Northing)	X (Easting)		Y (Northing)	X (Easting)	
MAINLINE																				
US 34																				
PH3017		399+96.70	6,243,258.59	22,085,646.98																
341								426+06.94	6,243,357.69	22,088,255.33	429+77.77	6,243,371.77	22,088,625.90	433+48.34	6,243,361.86	22,088,996.60				
342B					554+41.89	6,243,038.85	22,101,085.83				555+75.23	6,243,035.29	22,101,219.13				556+41.89	6,243,031.19	22,101,285.67	
342								556+41.89	6,243,031.19	22,101,285.67	562+69.75	6,242,992.53	22,101,912.34	568+78.08	6,242,695.43	22,102,465.45				
342A					568+78.08	6,242,695.43	22,102,465.45				569+44.75	6,242,663.88	22,102,524.19				570+78.08	6,242,596.72	22,102,639.38	
3000		616+96.45	6,240,270.69	22,106,629.24																
A3003		693+47.11	6,236,416.79	22,113,238.33																
SIDE ROAD																				
IA 48																				
1000		1018+00.00	6,241,718.78	22,090,829.56																
1001		1043+00.00	6,244,218.77	22,090,836.35																
RAMP																				
US 34 CONNECTOR																				
34CONNECTOR-1								4450+75.48	6,243,095.83	22,090,836.30	4452+80.34	6,243,300.69	22,090,836.86	4453+94.44	6,243,295.22	22,091,041.64				

GEOMETRIC DESIGN U.S. 34 MAINLINE, SIDEROADS, AND RAMPS

SPIRAL OR CIRCULAR CURVE DATA

101-17
04-19-11

Name	Location	Δ _s	Horizontal Alignment Data												Remarks			
			Spiral Data						Curve Data									
			θ _s	L _s	T _s	E _s	X _c	Y _c	L.T.	S.T.	Δ _c	T	L	R		E		
MAINLINE US 34																		
341																		
342																		
RAMP US 34 CONNECTOR 34CONNECTOR-1																		

GEOMETRIC DESIGN U.S. 34 MAINLINE, SIDEROADS, AND RAMPS

NO ACCESS RIGHTS ARE TO BE ACQUIRED ON THIS PROJECT.

ACCESS CONTROL PREVIOUSLY ACQUIRED

RED OAK TWP.
SEC 21-72-38

①
RR69, LLC

②
AVE-PLP
PROPERTIES LLC

457+01
±92'±EX R/W

460+03±P
±91'

464+78±P
±91'

COMMERCE DRIVE

N. FOURTH ST.

N

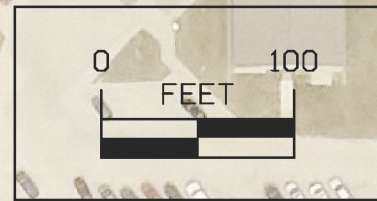

Right of Way Design Information	
THIS SHEET INCLUDED FOR INFORMATION ONLY	
ROW Team: ATINKEN /JLARSON	
ROW #: NHSN-034-2(64)--2R-69	
Plan Date: 11/09/21	
Color Legend:	
	Property Lines
	Temporary Easement
	Permanent Acquisition

TRAFFIC CONTROL PLAN

Refer to Staging Notes for Traffic Control Plan details.

1. Traffic shall be maintained on US 34 at all times with the exception of offsite detours in Stage 6.
2. Contractor shall not encroach into BNSF Railroad Right of Way.
3. Closures.
 - A. The time length, and duration of lane closures shall be as approved by the Engineer. The department reserves the right to modify these restrictions to accommodate specific contractor activities and unforeseen traffic conditions.
 - B. The Contractor will be allowed to temporarily close US 34 access points in the following order:
 - Stage 3 - 4th Street (South)
 - Stage 4 - One US 34 access at 4th Street (North), 8th Street (North), or Senate Avenue Access Drive may be closed at a time.
 - Stage 5 - One US 34 access at 4th Street (South), 8th Street (South), or Eastern Avenue (South) may be closed at a time.

STAGING NOTES

Stage 1
Summary:
Construct Eastbound US from station 515+00.00 to 622+15.00.
Traffic:
Maintain traffic on US 34 utilizing lane closures. Maintain existing access to and from US 34.

Stage 2
Summary:
Construct Westbound US 34 from station 515+00.00 to 622+15.00. Construct temporary widening along Westbound US 34 from stations 515+00.00 to 520+50.00
Traffic:
Maintain traffic on US 34 utilizing lane closures. Maintain existing access to and from US 34.

Stage 3
Summary:
Begin grading South of US 34 between Iowa 48 and 4th Street.
Construct US 34 access to the South at 4th Street and Eastbound US 34 shoulder pavement between 456+50.00 and 475+15.00. Construct temporary widening of existing US 34 Eastbound and Iowa 48 Southbound.
Traffic:
Close outside Eastbound US 34 lane and maintain Eastbound traffic in inside lane. Temporarily close US 34 access to the South at 4th Street.

Stage 4
Summary:
Construct Westbound US 34 between stations 451+79.29 and 515+00.00. Construct Northbound Iowa 48 from station 1033+94.17 to 1035+25.00. Construct US 34 access to the North at 4th Street, 8th Street, Senate Avenue Access Drive, and Eastern Avenue.
Traffic:
Shift Eastbound and Westbound US 34 South. Stage construct Eastern Avenue to maintain local access at all times. No more than 1 US 34 access to the North at 4th Street, 8th Street, and Senate Avenue Access Drive may be closed at a time.

Stage 5
Summary:
Construct Eastbound US 34 from stations 451+79.29 and 515+00.00. Construct Northbound Iowa 48 from stations 1031+66.25 to 1033+94.17. Construct US 34 access to the South at 8th Street and Eastern Avenue. Construct US 34 Connector from stations 4451+74.47 to 4453+94.44.
Traffic:
Shift Westbound and Eastbound US 34 traffic North. Maintain access to Senate Avenue, 4th Street, 8th Street, and Eastern Avenue.

Stage 6
Summary:
Construct US 34 from stations 445+78.02 to 451+79.29. Construct Southbound Iowa 48 from stations 1031+66.25 to 1035+25.00.
Traffic:
Begin offsite detour of Westbound and Eastbound US 34 traffic at G Avenue, South to 200th Street, East to Iowa 48, and north to US 34. Coordinate construction operations with Railroad and Red Oak Levee Management. Stage construct to maintain access to levee and field entrances at all times.

Stage 7
Summary:
Construct Eastbound US 34 pavement with base widening from station 426+46.57 to 445+69.15.
Traffic:
End offsite detour of Westbound and Eastbound US 34. Coordinate construction operations with Railroad and Red Oak Levee Management. Maintain traffic on US 34 utilizing lane closures. Maintain access to levee and field entrances at all times.

Stage 8
Summary:
Construct Westbound US 34 pavement with base widening from station 426+46.57 to 445+69.15.
Traffic:
Coordinate construction operations with Railroad and Red Oak Levee Management. Maintain traffic on US 34 utilizing lane closures. Maintain access to levee and field entrances at all times.

**CROSS SECTION VIEW COLOR LEGEND
OF TRAFFIC CONTROL AND STAGING SHEETS**

SHADING	Design Color No.	
Green, Light	(225)	Existing Pavement Shading
Gray, Light	(48)	Previously Constructed Pavement Shading
Gray, Med	(80)	Previously Constructed Granular Surface Shading
Blue, Light	(230)	Proposed Pavement Shading
Lavender	(9)	Temporary Pavement Shading
Brown, Med	(237)	Future Proposed Pavement Shading

**CROSS SECTION VIEW PATTERN AND SYMBOL LEGEND
OF TRAFFIC CONTROL AND STAGING SHEETS**

	Pavement Removal		Proposed Granular Shoulder
	Proposed Granular Subbase		Temporary Shoulder
	Proposed Special Backfill		Existing Shoulder Strengthening
	Temporary Barrier Rail		Permanent Barrier Rail
			Channelizing Device

PLAN VIEW COLOR LEGEND OF TRAFFIC CONTROL AND STAGING SHEETS

LINEWORK	Design Color No.	
Green	(2)	Existing Topographic Features and Labels
Magenta	(5)	Pavement Marking Call Outs
Blue	(1)	Proposed Alignment, Stationing, Tic Marks, and Alignment Annotation
Yellow	(4)	Pavement Markings, Yellow
Off White	(254)	Pavement Markings, White
Violet	(15)	Temporary barrier rail, Unpinned
Flush Orange	(228)	Temporary barrier rail, Pinned

SHADING	Design Color No.	
Green, Light	(225)	Existing Pavement Shading
Gray, Light	(48)	Previously Constructed Pavement Shading
Gray, Med	(80)	Proposed Granular Surface Shading
Gray, Med	(80)	Previously Constructed Granular Surface Shading
Blue, Light	(230)	Proposed Pavement Shading
Lavender	(9)	Temporary Pavement Shading
Brown, Light	(236)	Proposed Grading Limits Shading
Pink, Dark	(13)	Proposed MSE or CIP Wall Shading
Red	(3)	Proposed Bridge Shading and Sign Trusses
Black w/Gray, Light Fill	(0,48)	Previously Constructed Structure
Pink, Light	(11)	Previously Constructed Temporary Pavement Shading

**PLAN VIEW PATTERN AND SYMBOL LEGEND
OF TRAFFIC CONTROL AND STAGING SHEETS**

	Channelizing Device		Crash Cushion (Temp or Perm)
	Drum		Traffic Signal
	Temporary Lane Separator		Flagger
	Tubular Marker		Temporary Floodlighting
	Channelizer Marker		Traffic Sign
	Concrete Barrier Marker		Type III Barricade
	Delineator		Type A Warning Light
	Temporary Barrier Rail		Direction of Traffic
	Pavement Removal		Safety Closure
	Sand Barrel Layout		Lane Identification
	Safety Fence		Temporary Shoring

NOTE: Device spacing according to Standard Road Plans unless specifically dimensioned.

**TRAFFIC CONTROL
AND
STAGING
LEGEND AND SYMBOL
INFORMATION SHEET**

(COVERS SHEET SERIES J)

STAGE 1 & 7 TYPICAL

ALTERNATING
ONE-WAY
TRAFFIC

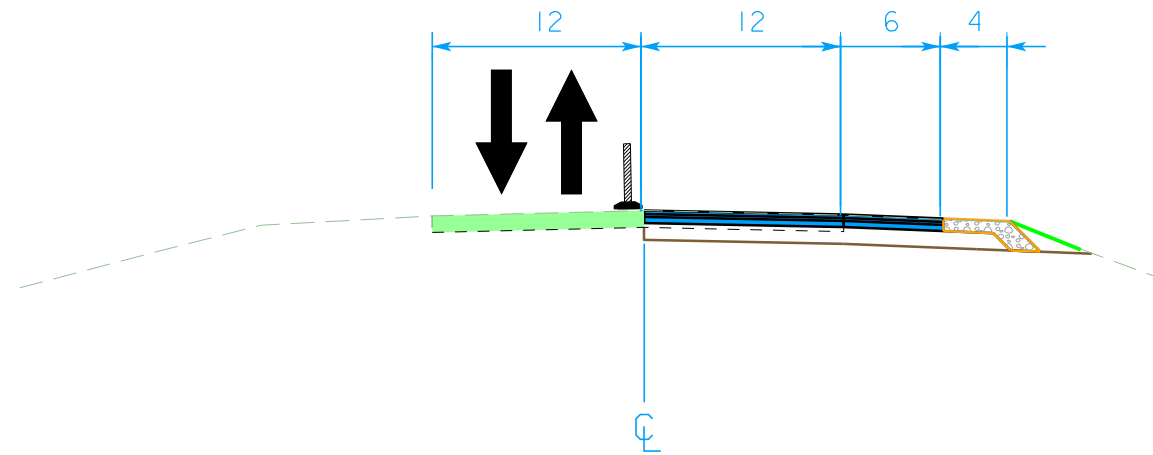

STAGE 2 & 8 TYPICAL

ALTERNATING
ONE-WAY
TRAFFIC

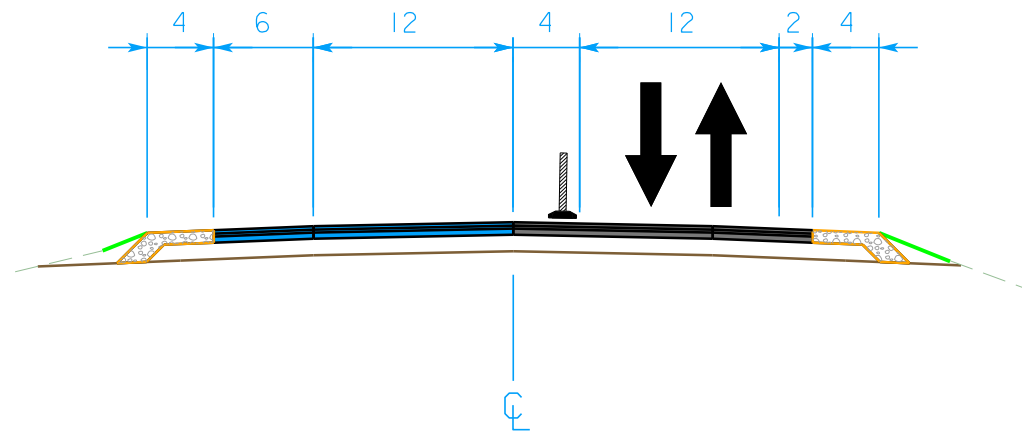

STAGE 3 TYPICAL - STATION 468+00.00

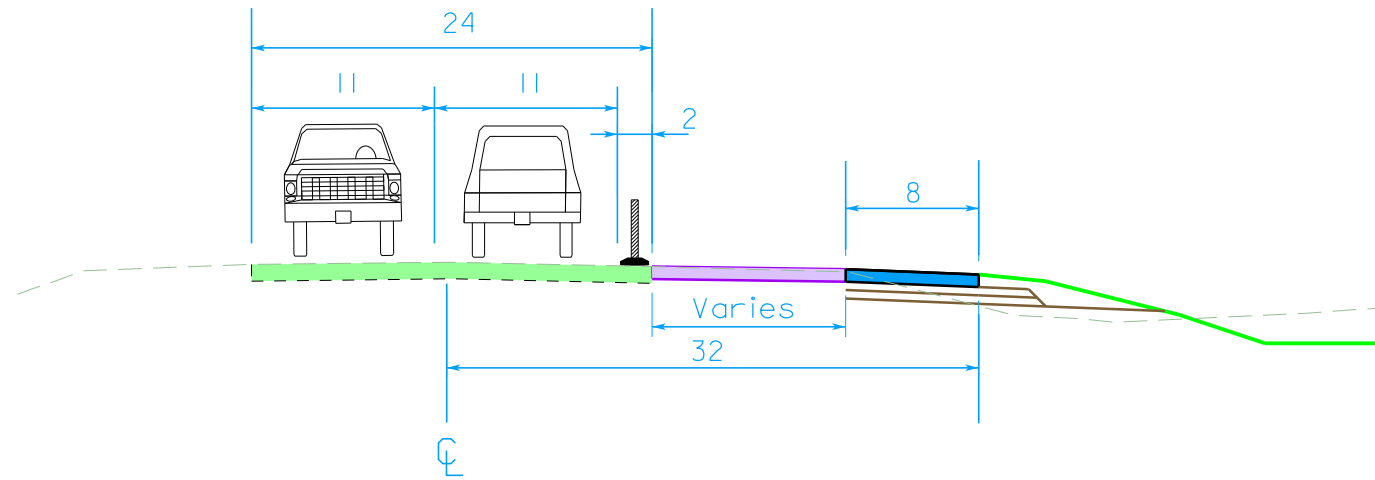

STAGE 3 TYPICAL - STATION 486+00.00

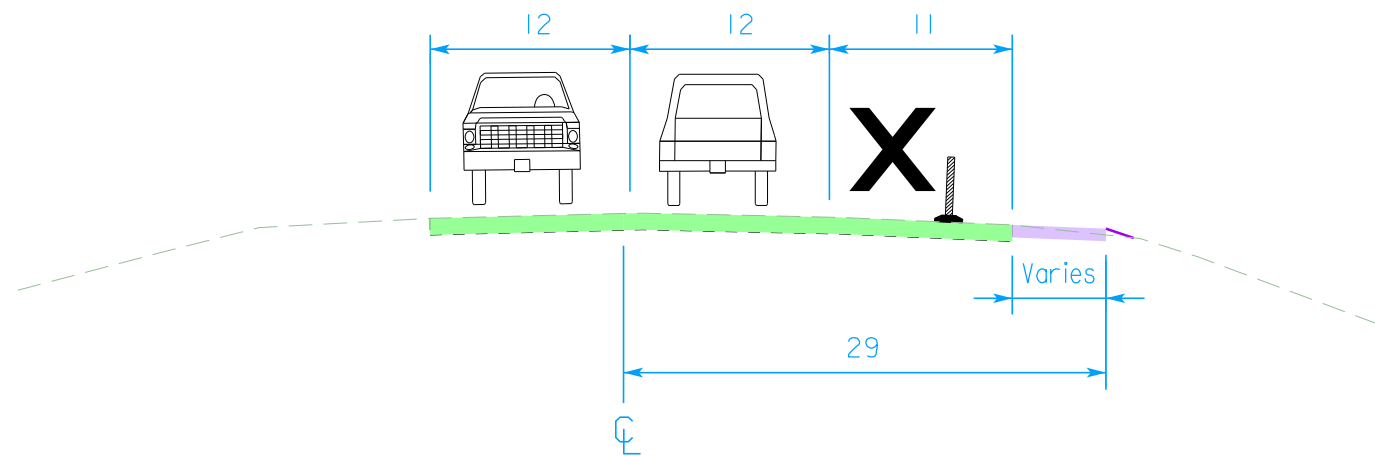

STAGE 4 TYPICAL - STATION 470+00.00

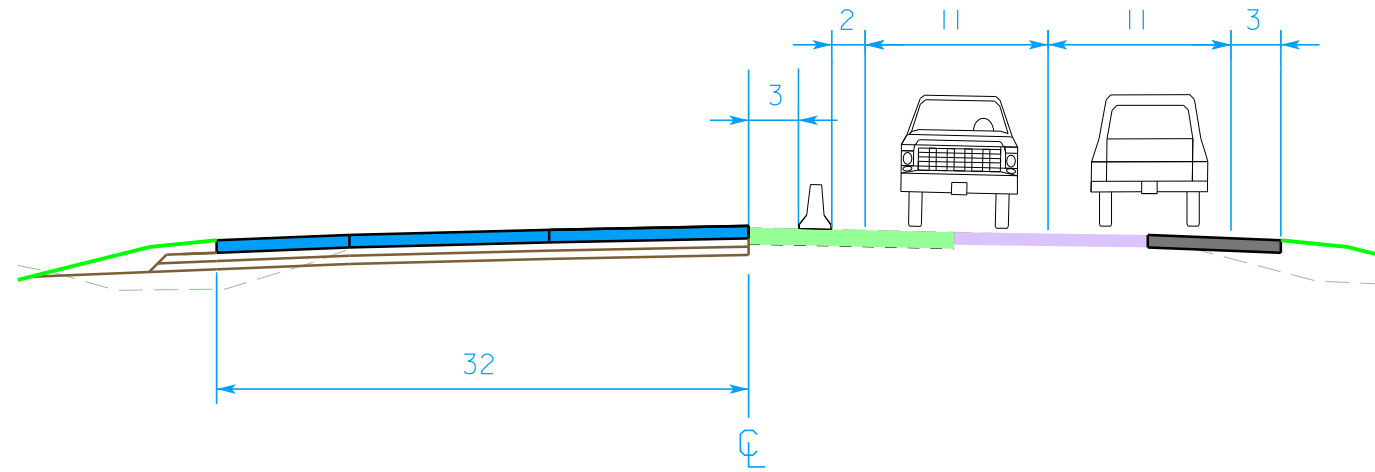

STAGE 4 TYPICAL - STATION 490+00.00

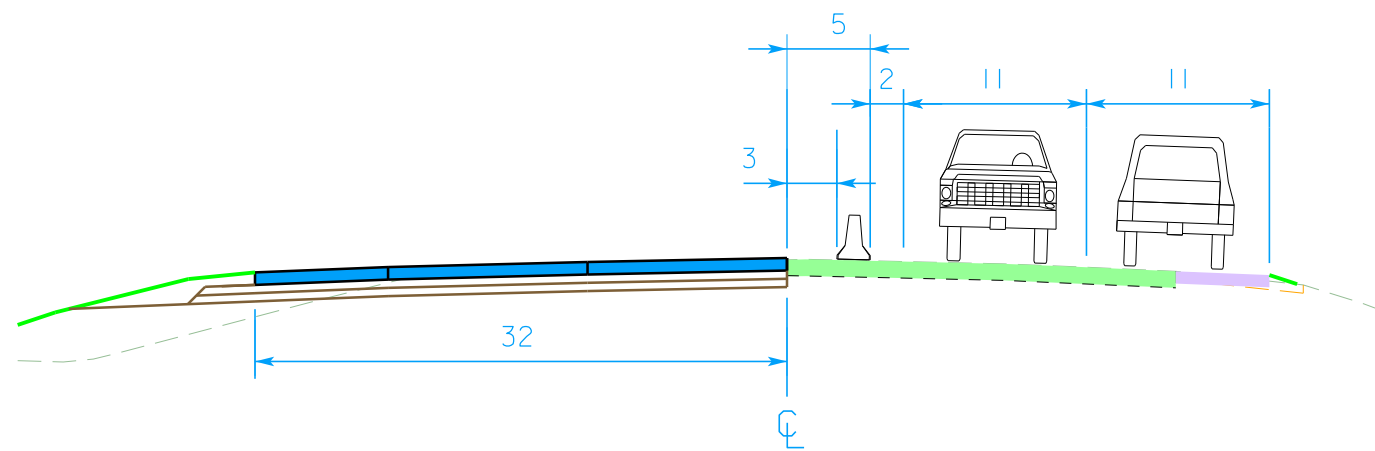

STAGE 5 TYPICAL - STATION 470+00.00

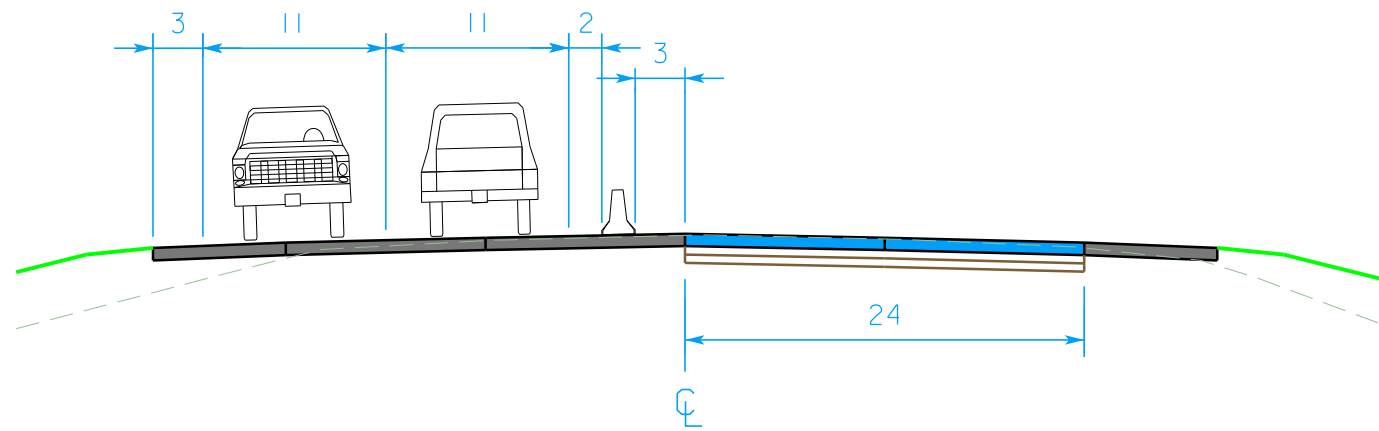

STAGE 5 TYPICAL - STATION 490+00.00

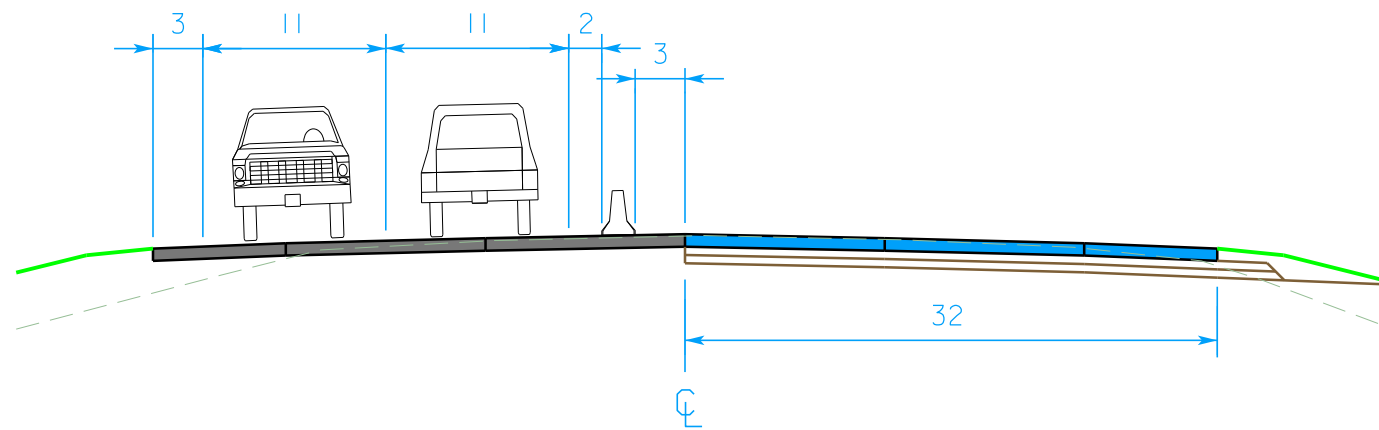

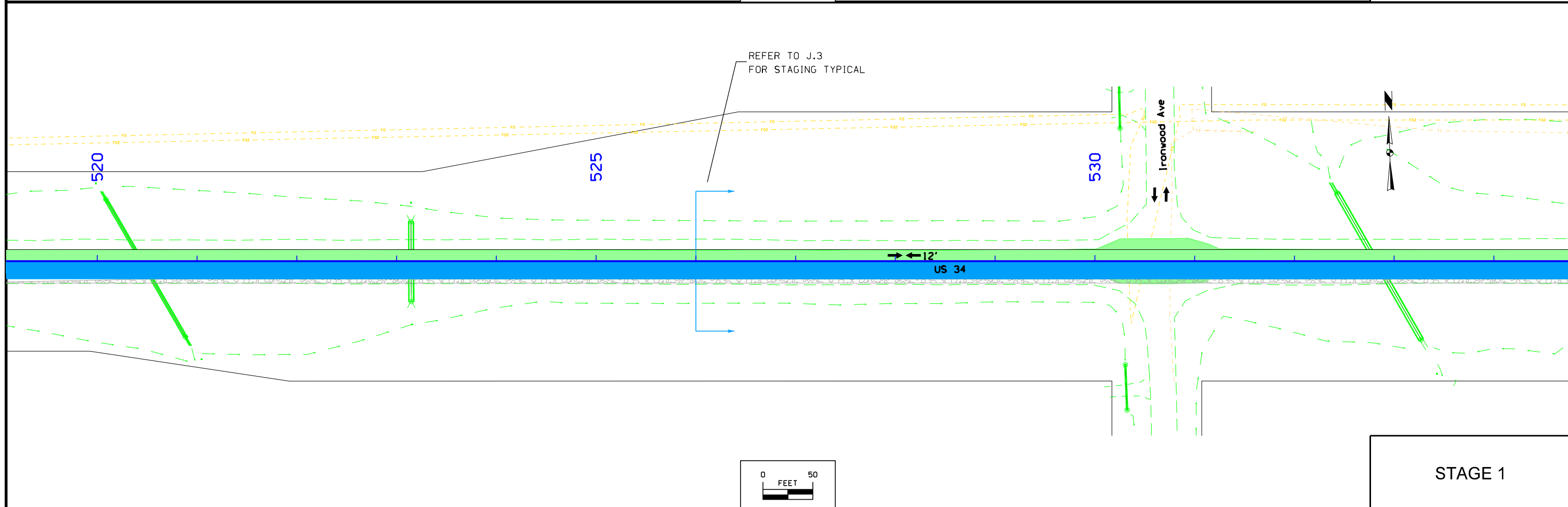
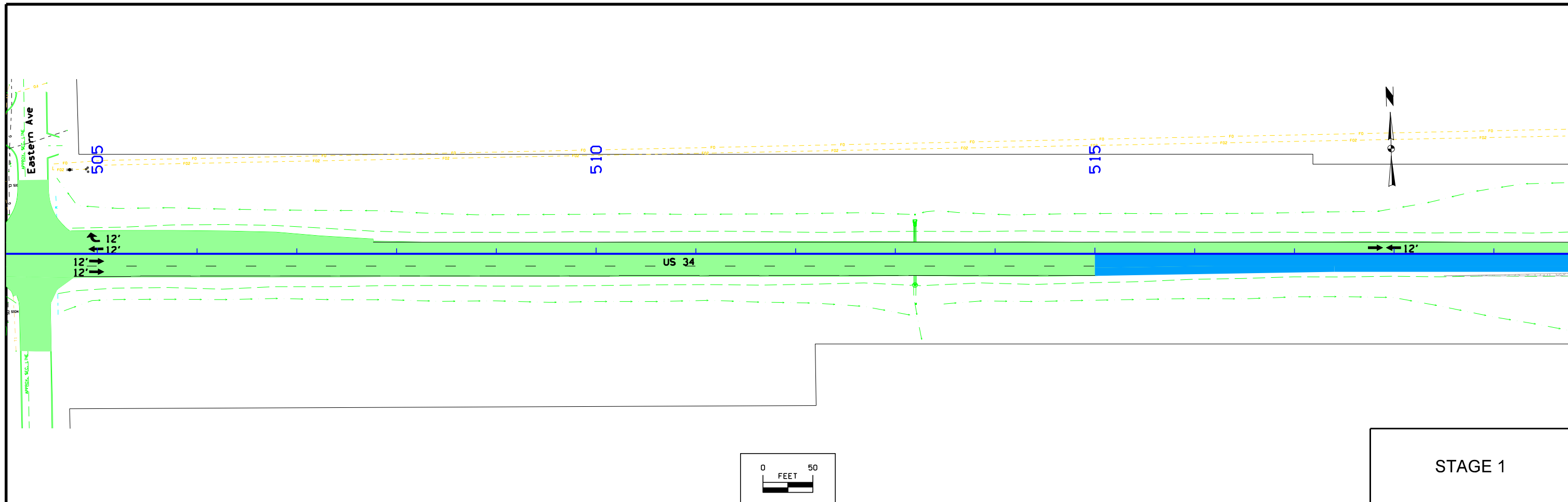

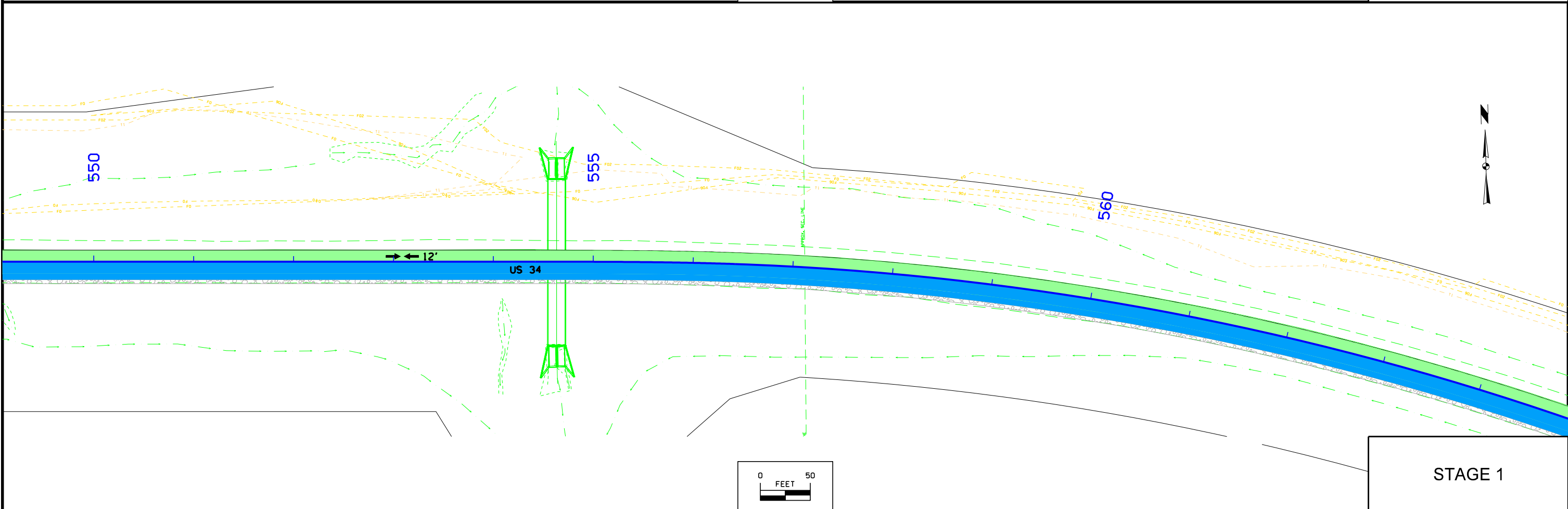
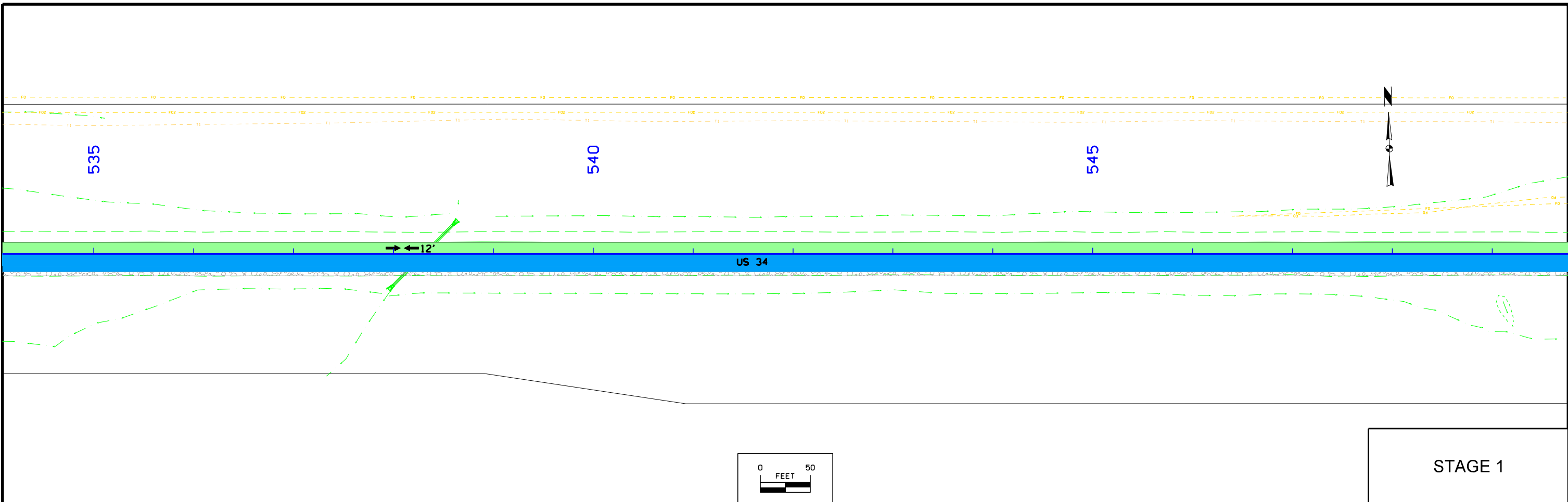

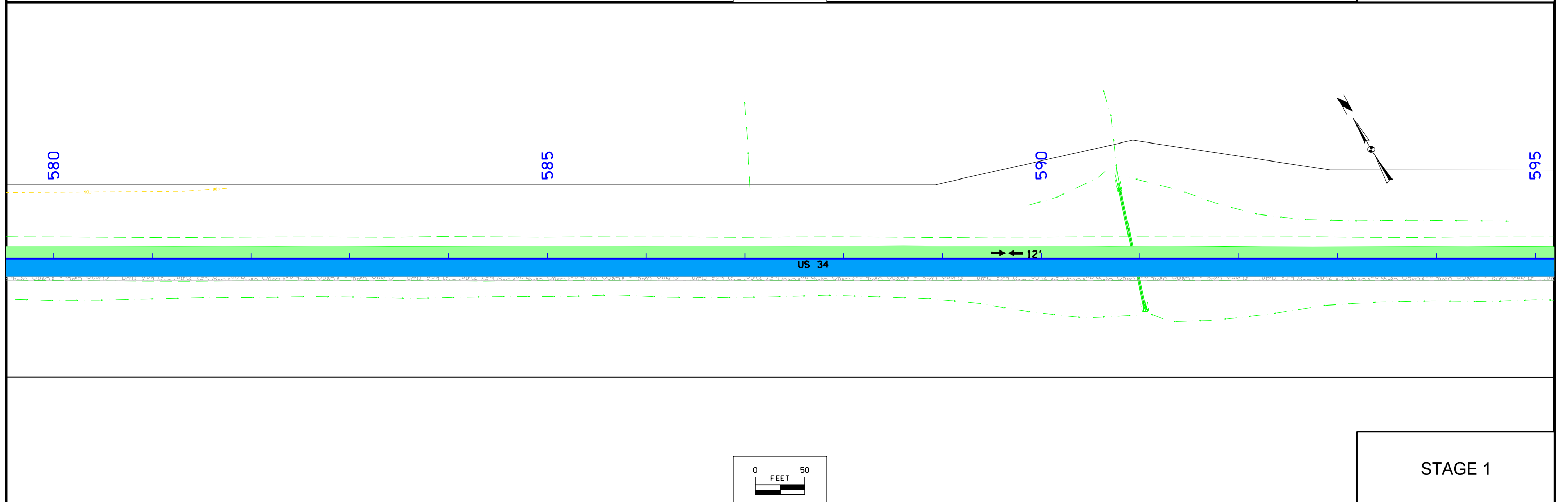
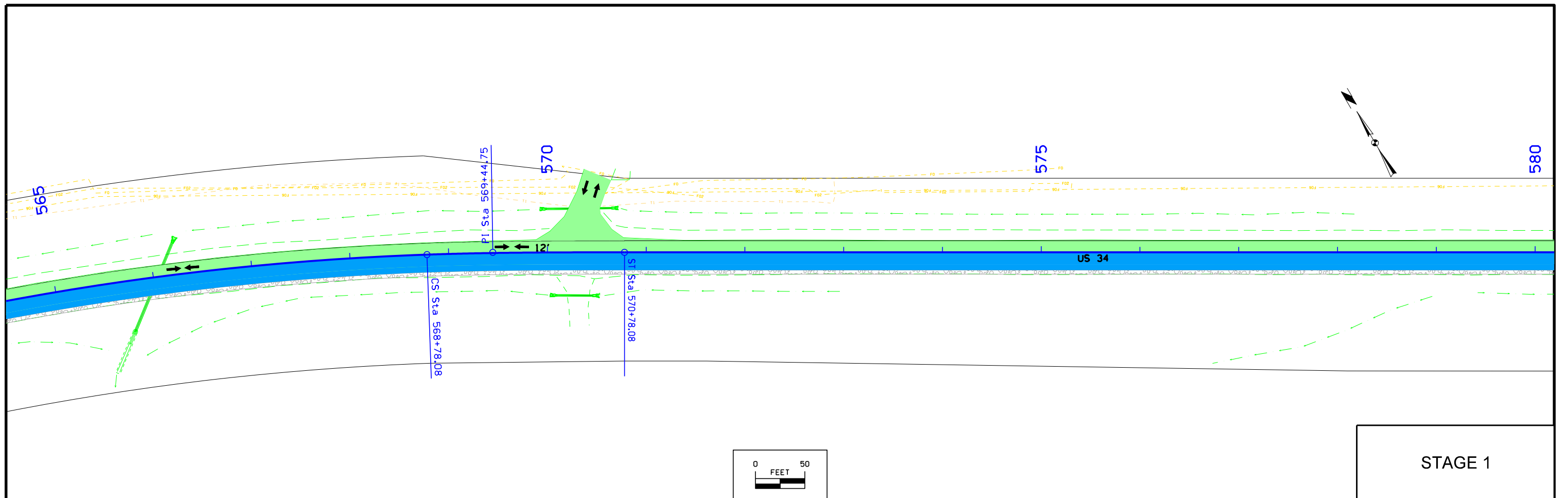

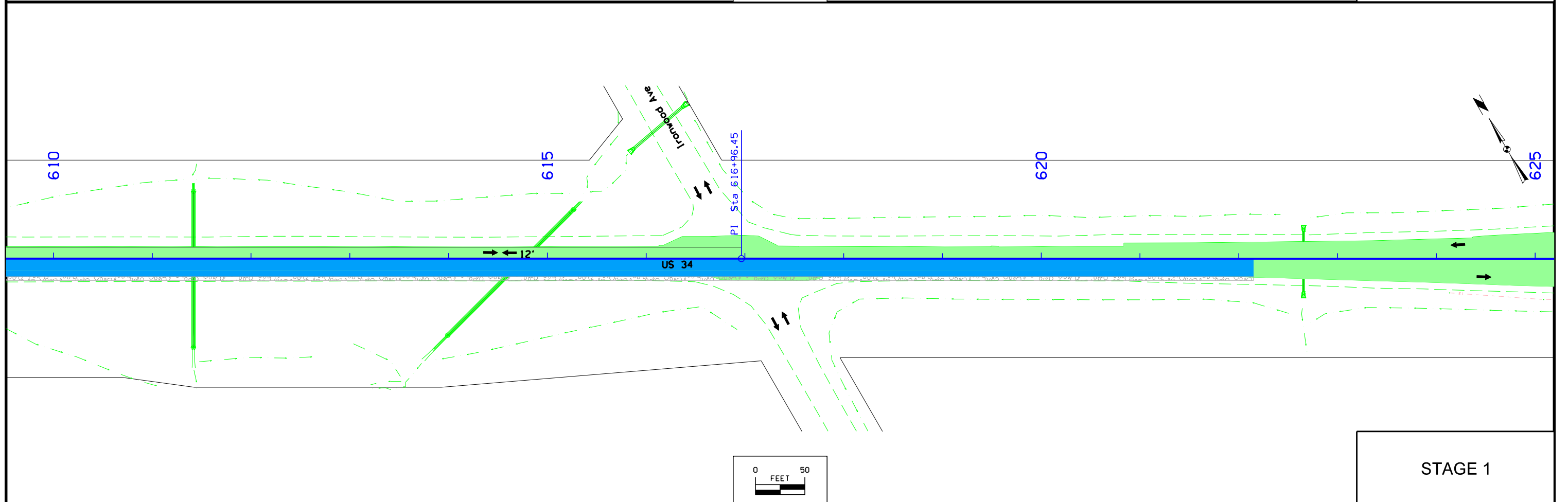
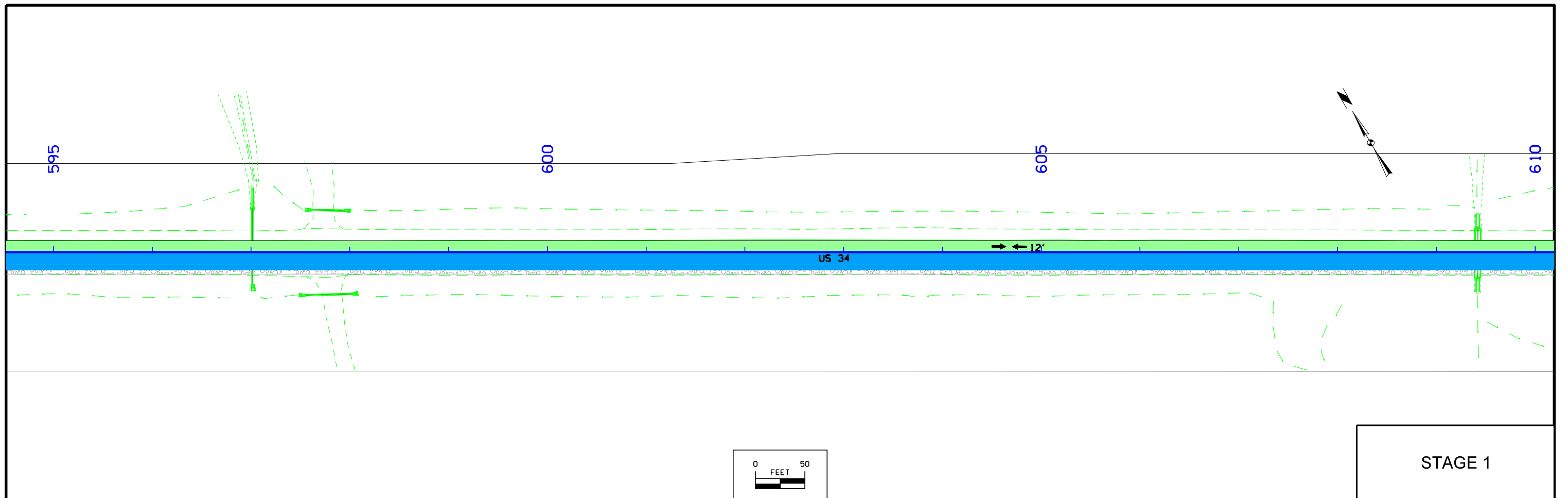

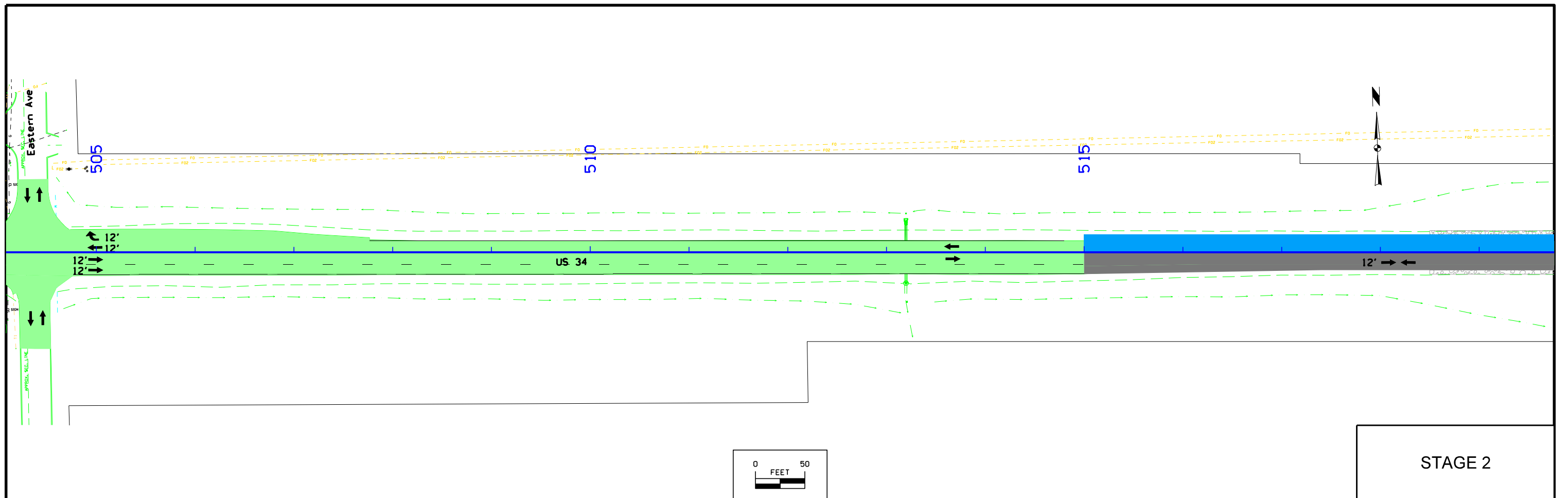

STAGE 2

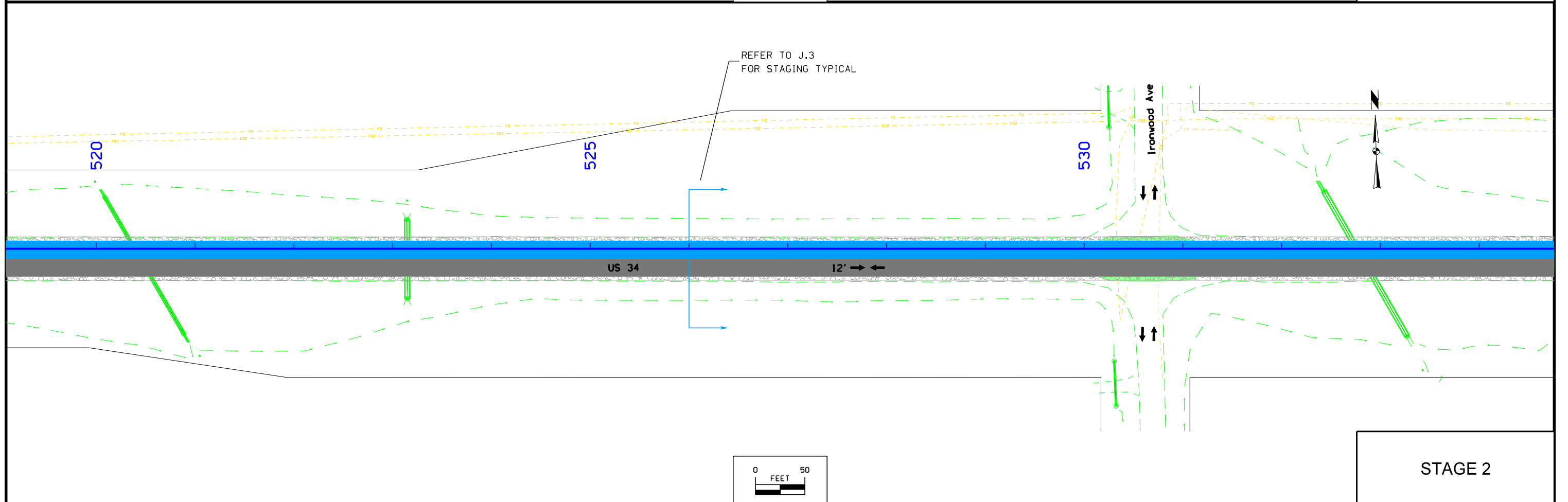

REFER TO J.3
FOR STAGING TYPICAL

STAGE 2

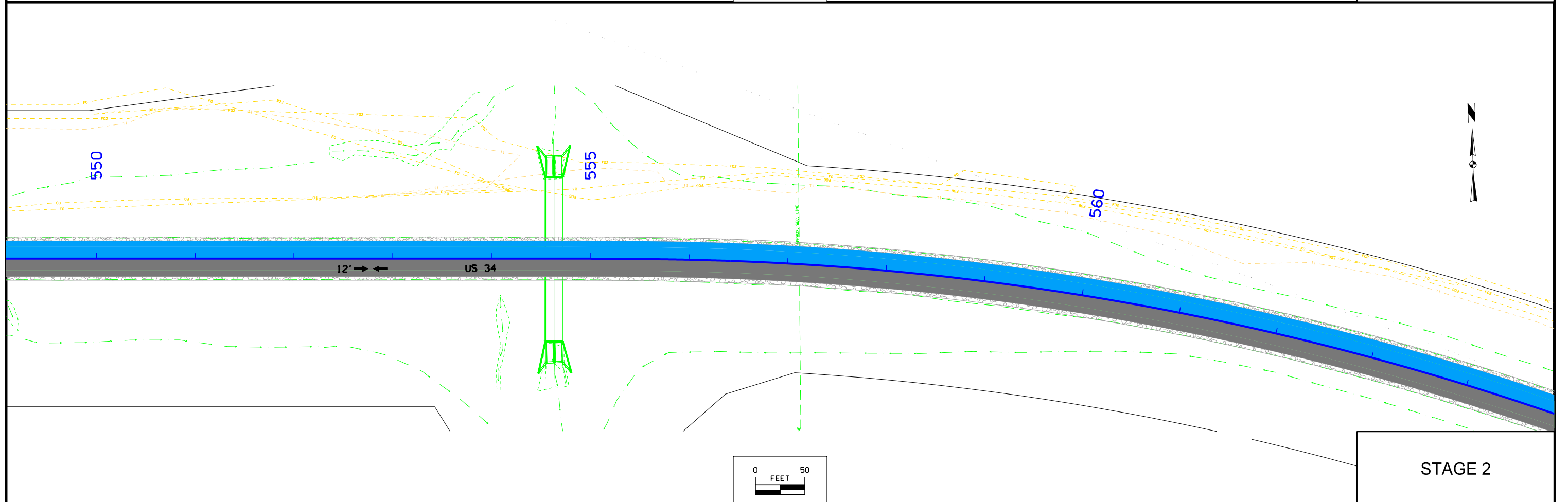
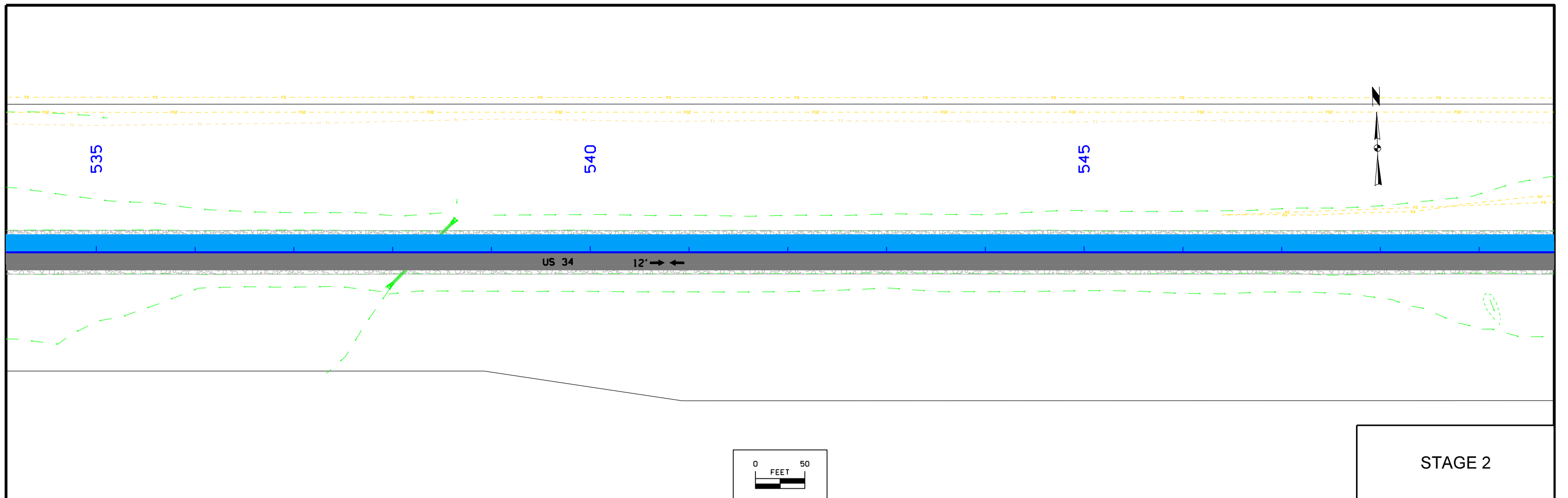

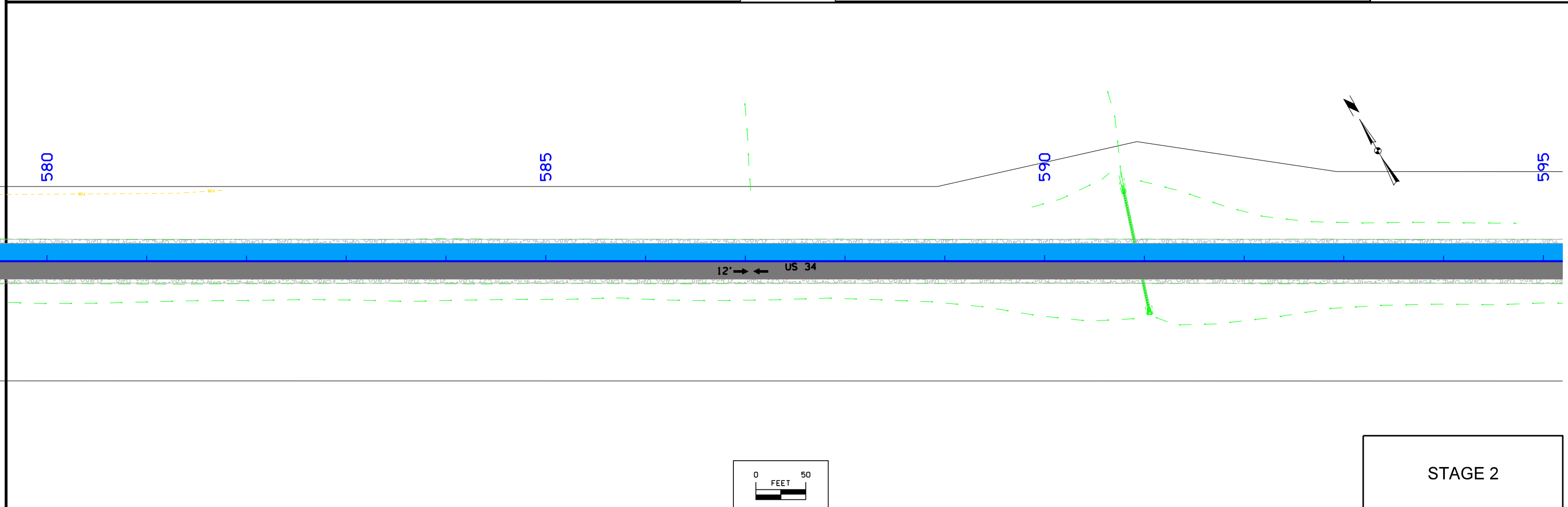
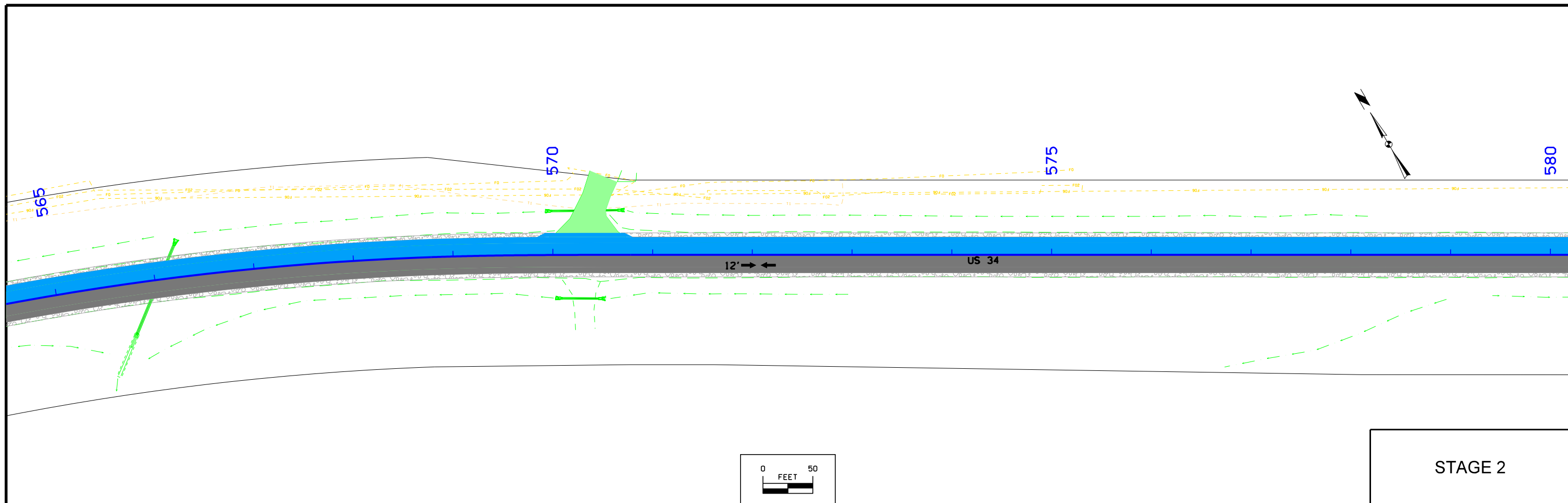

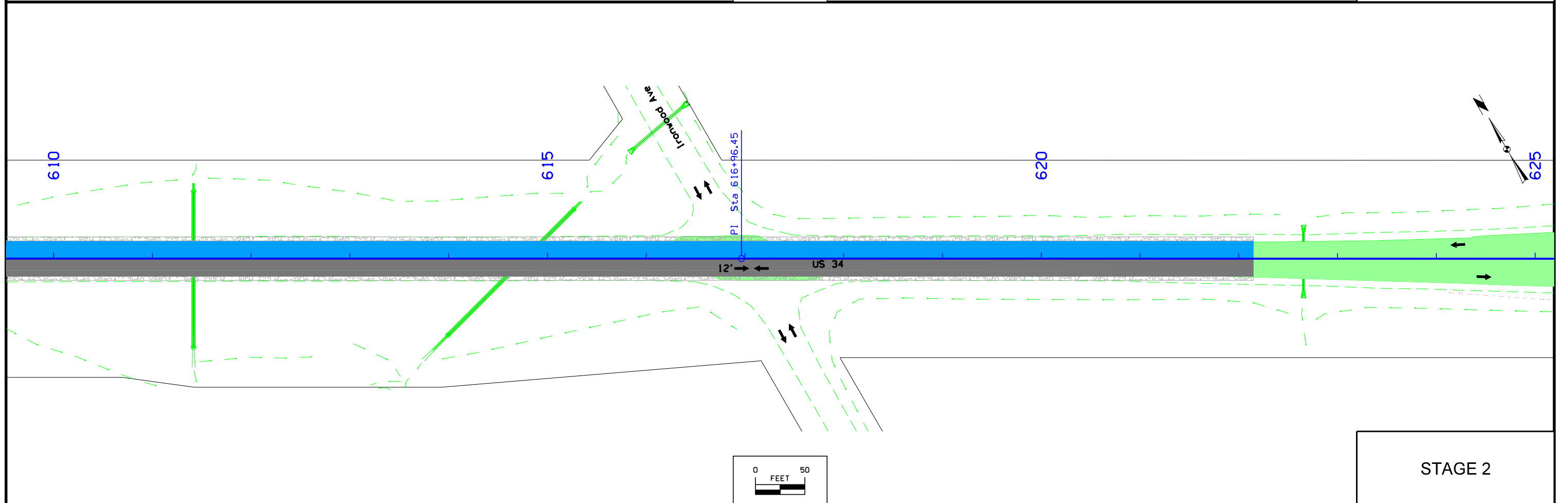
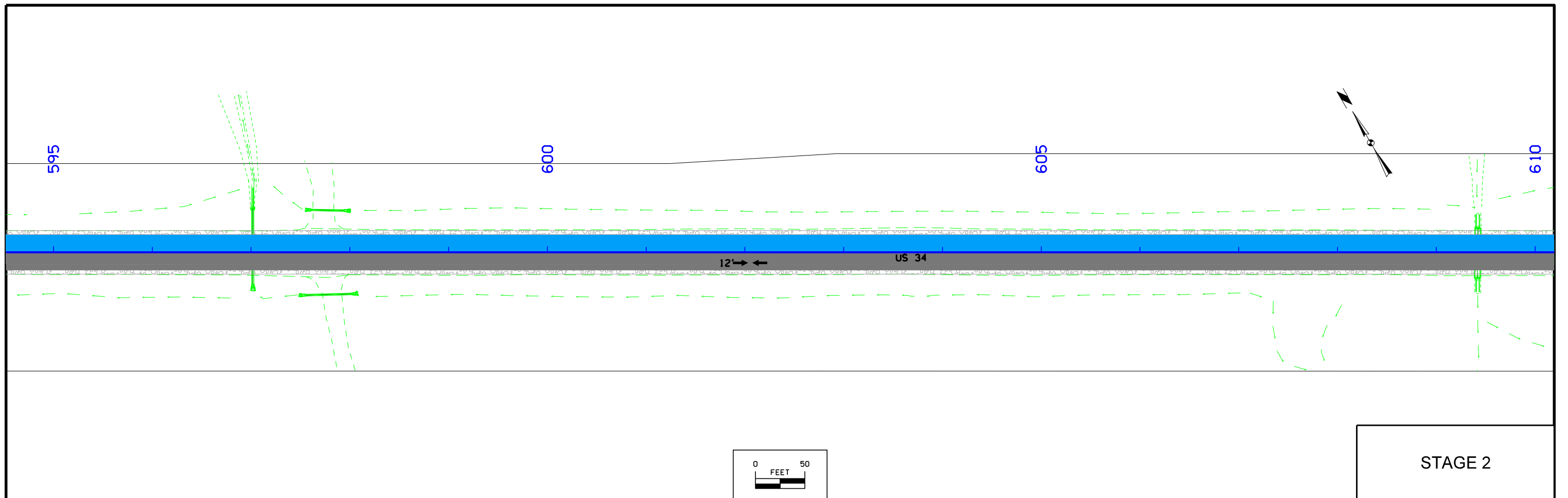

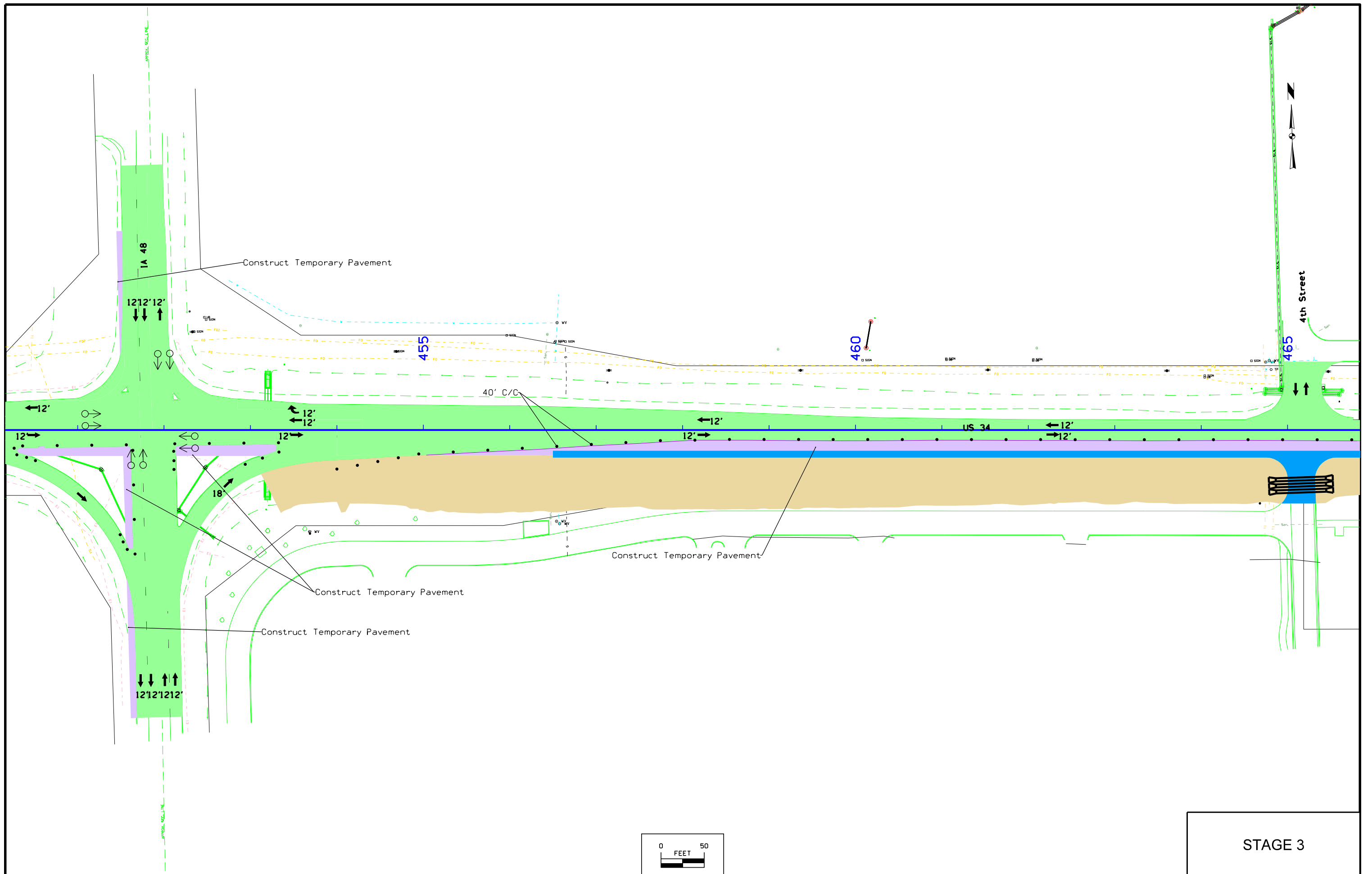

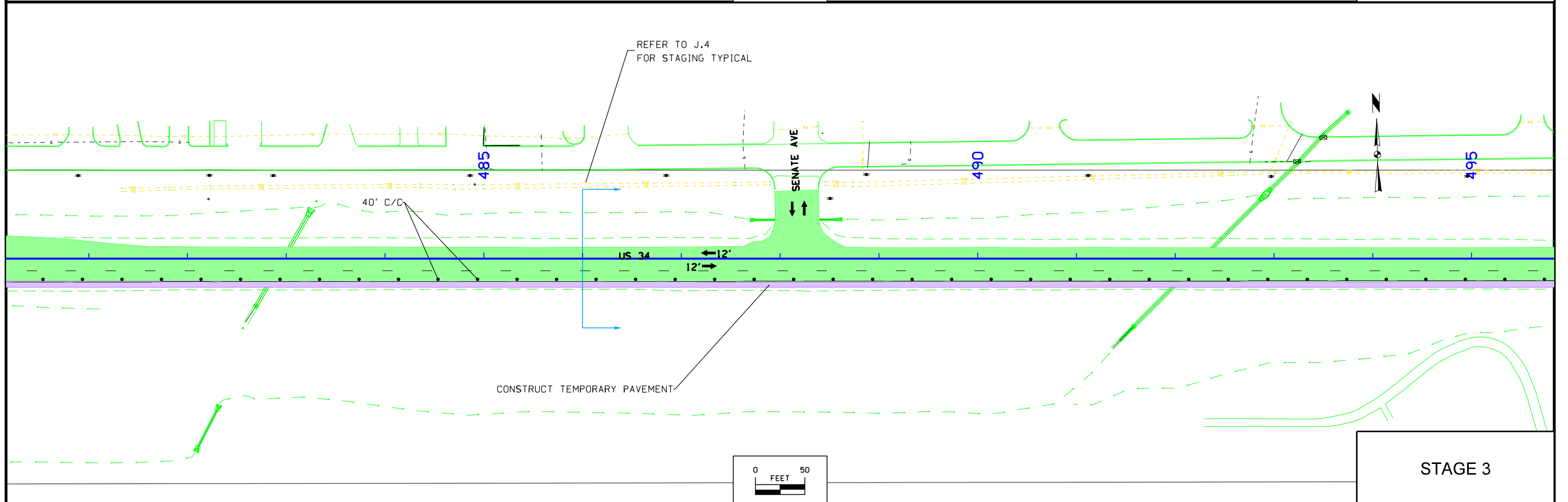
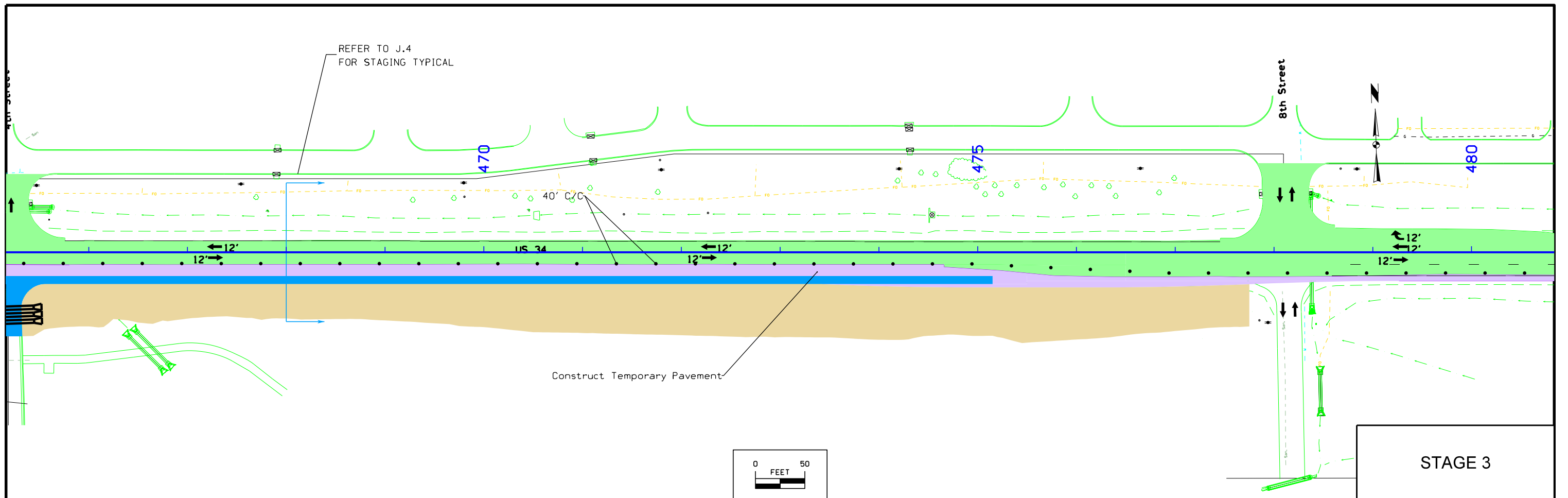

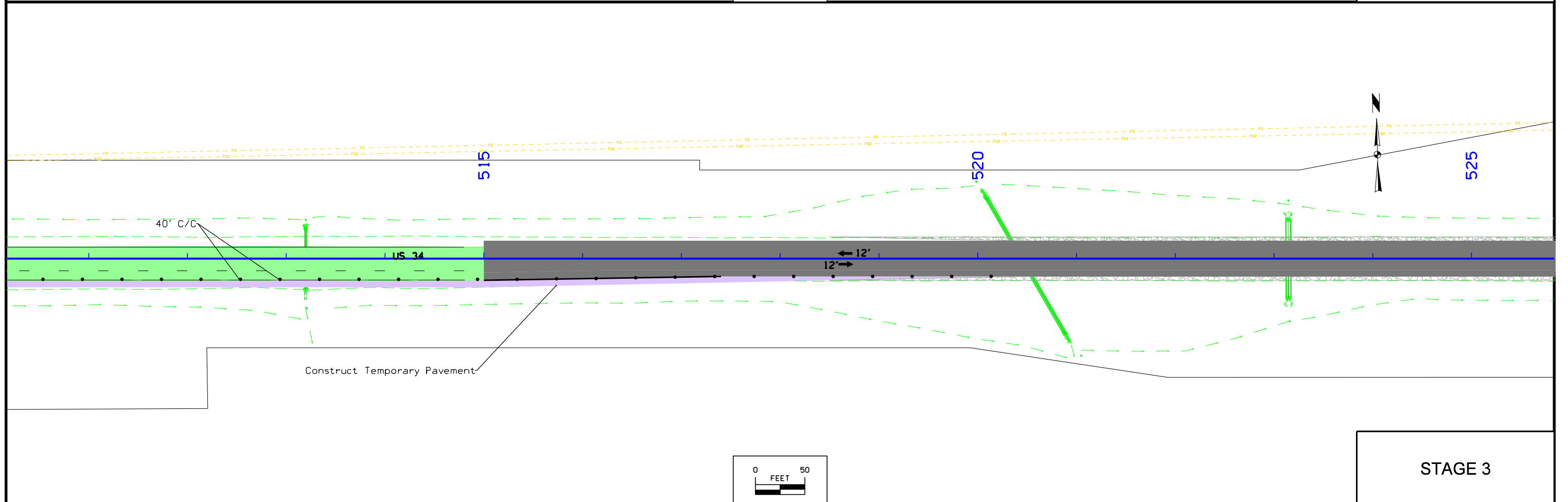
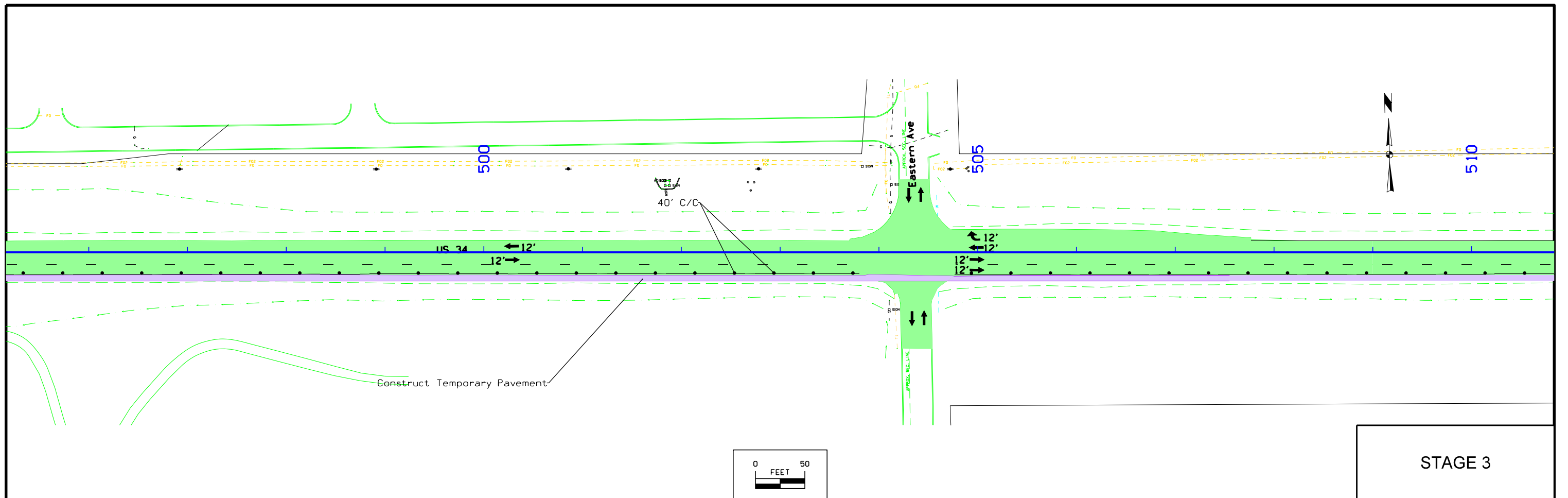

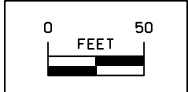
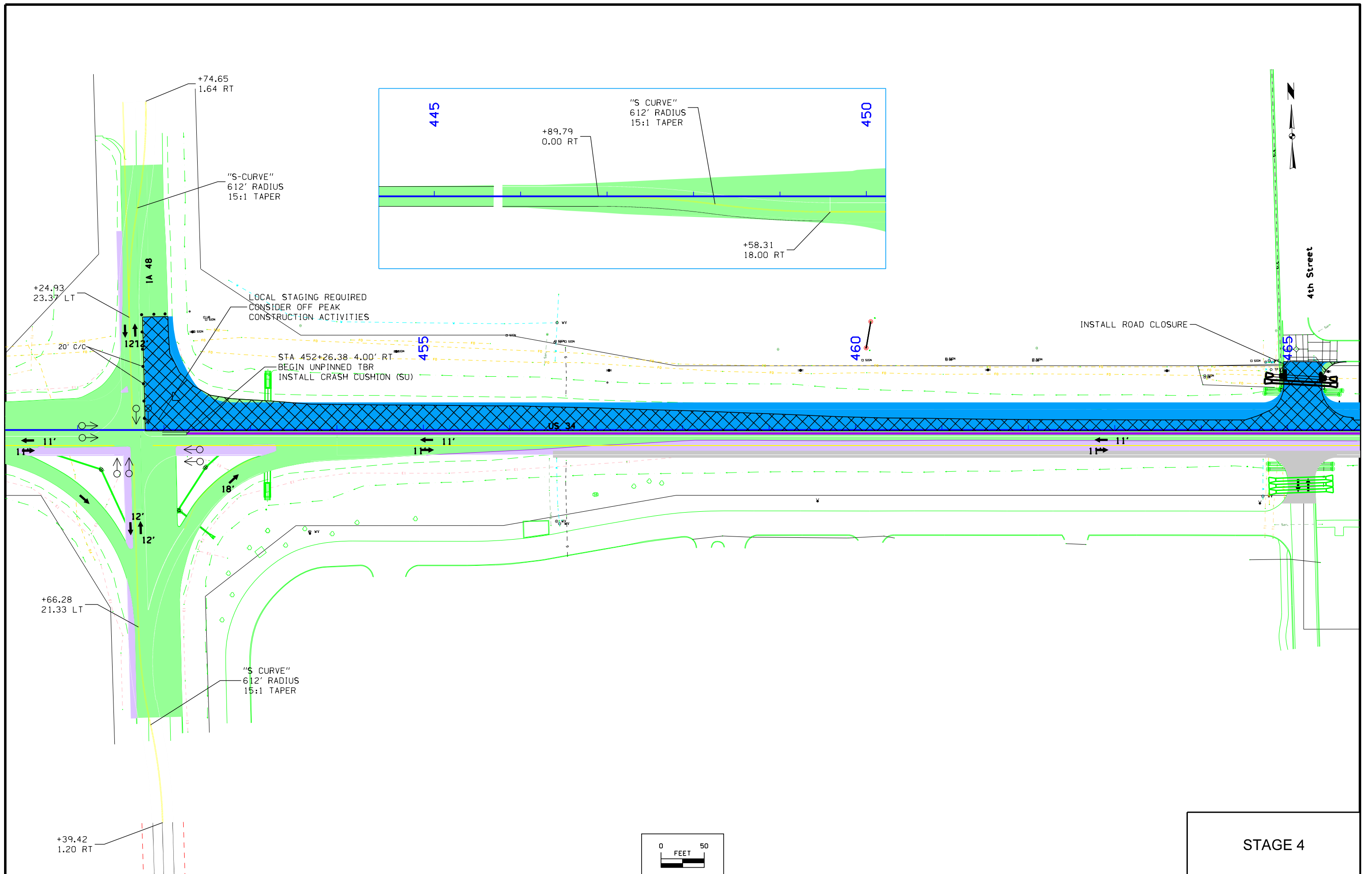

STAGE 4

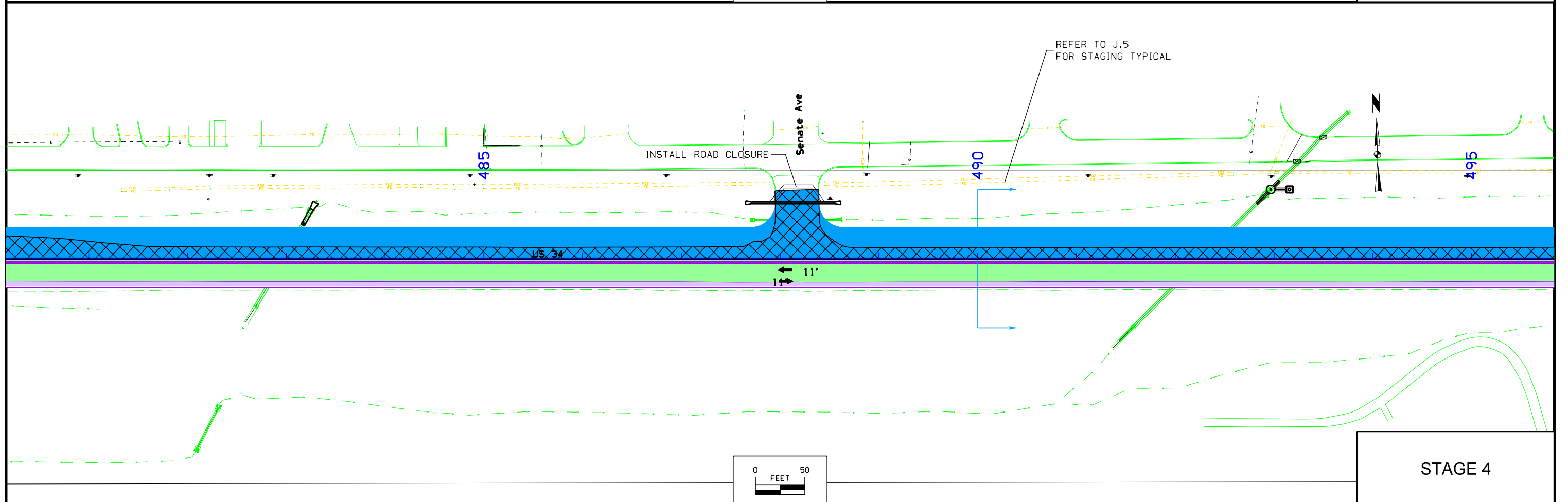
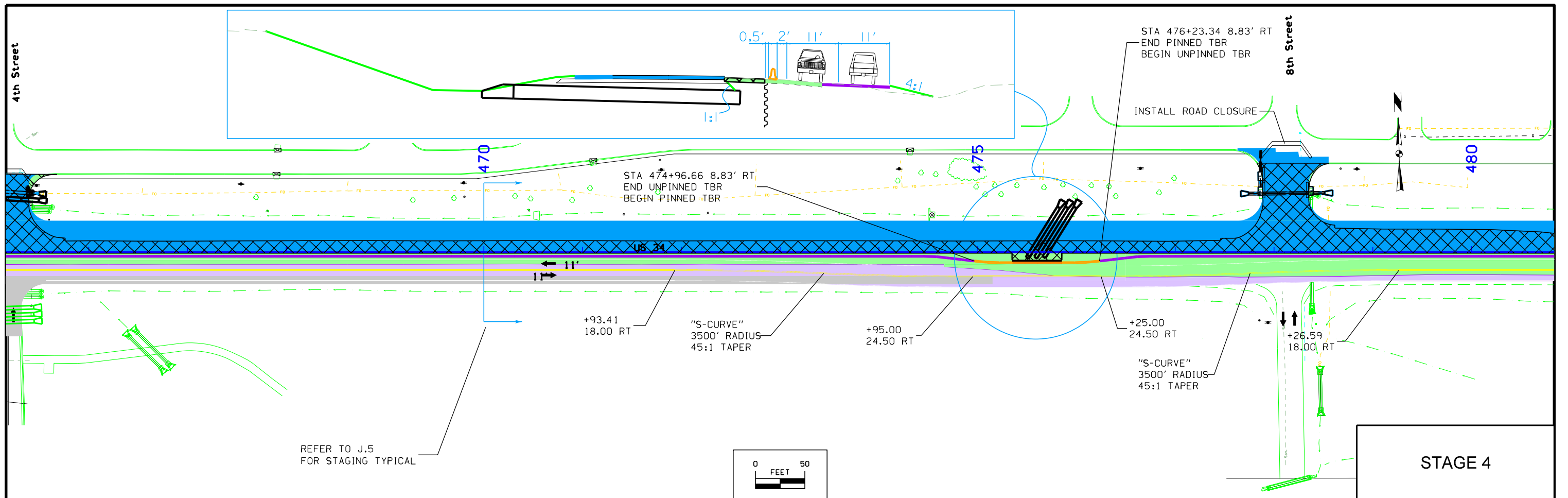

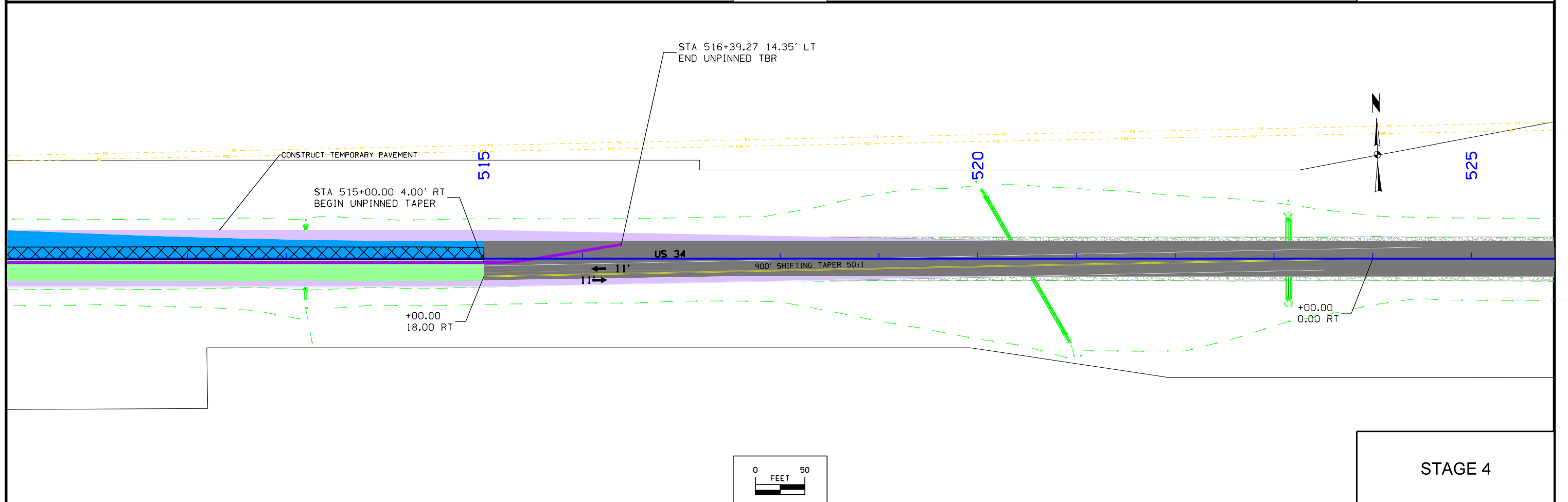
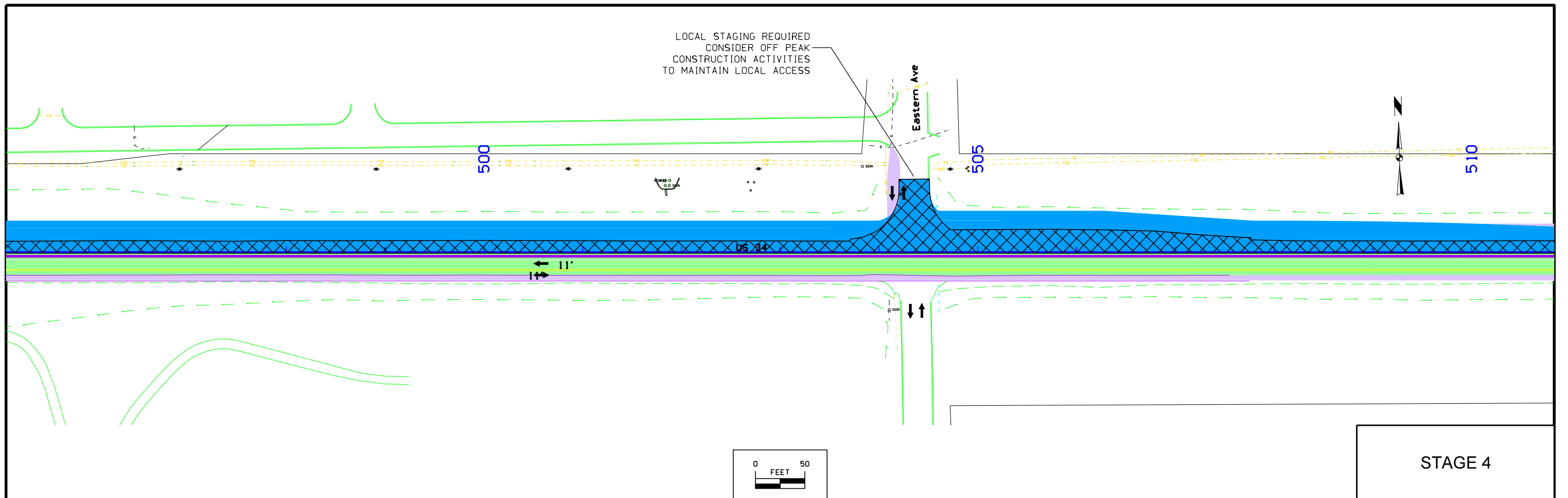

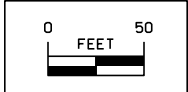
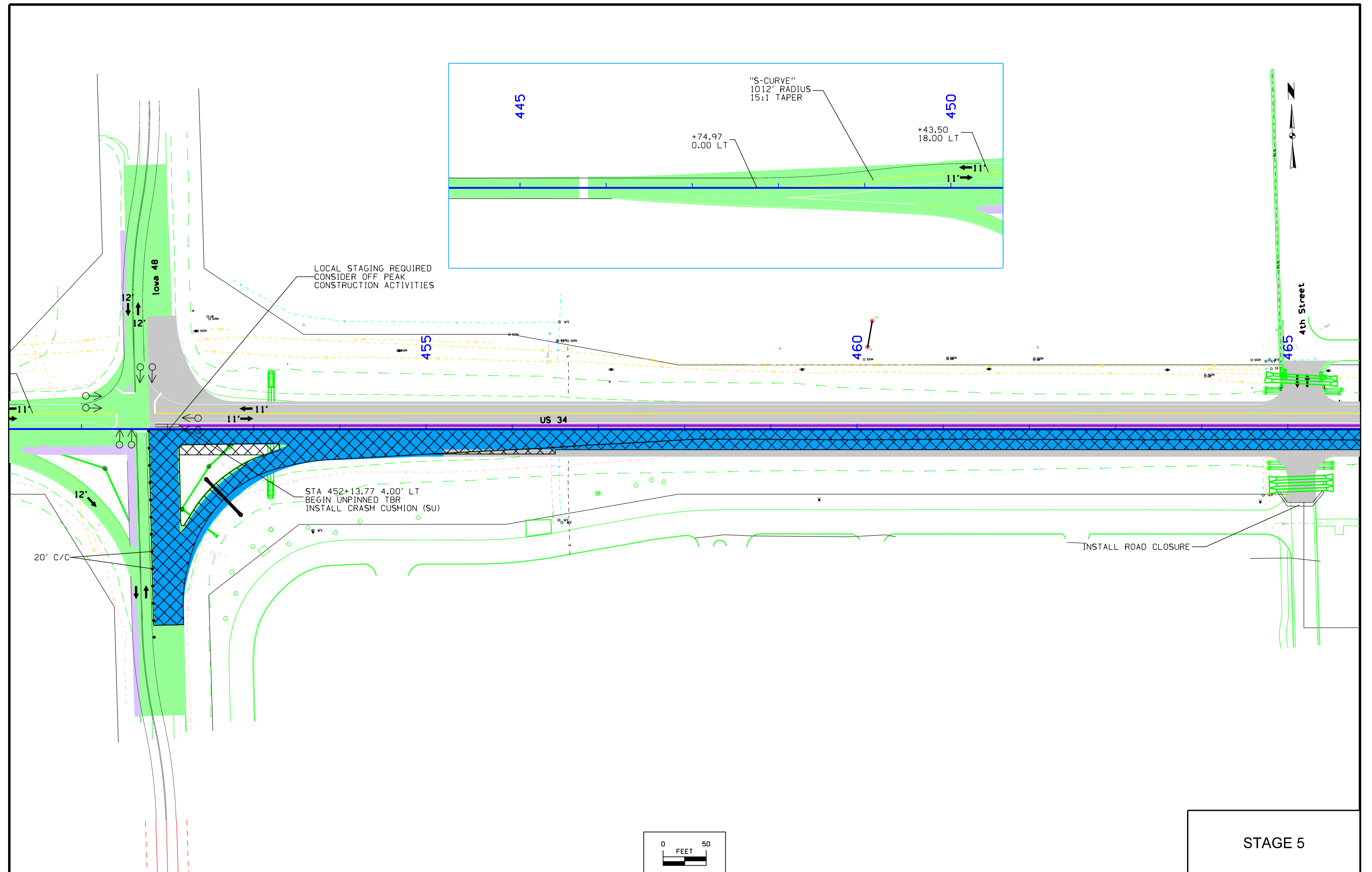

STAGE 5

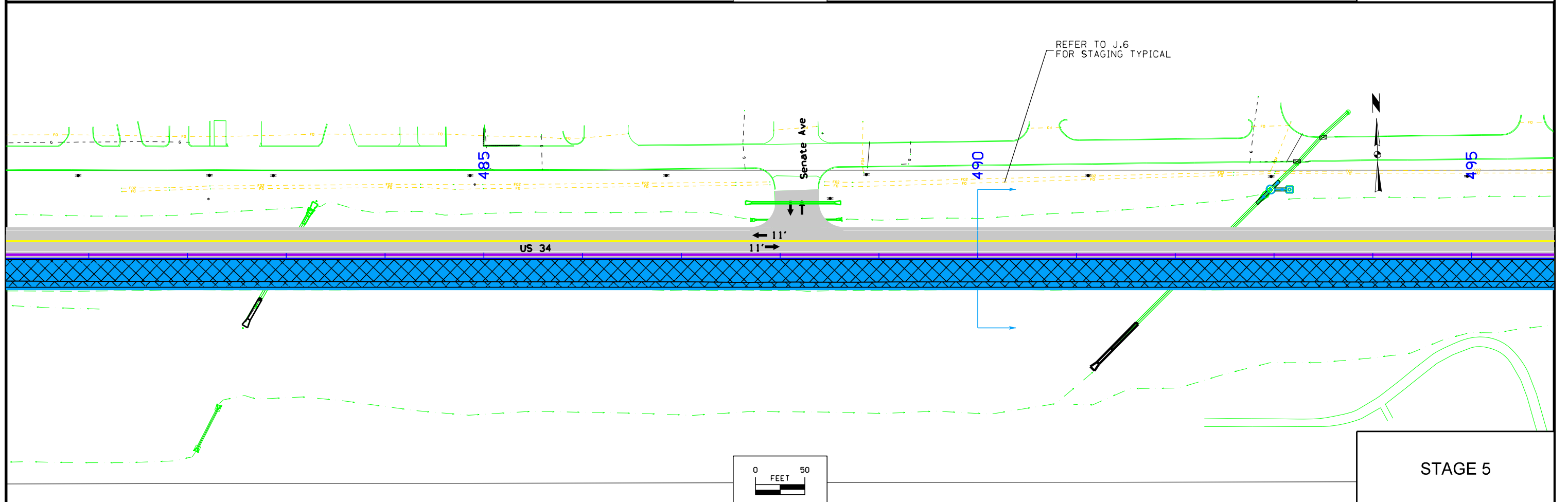
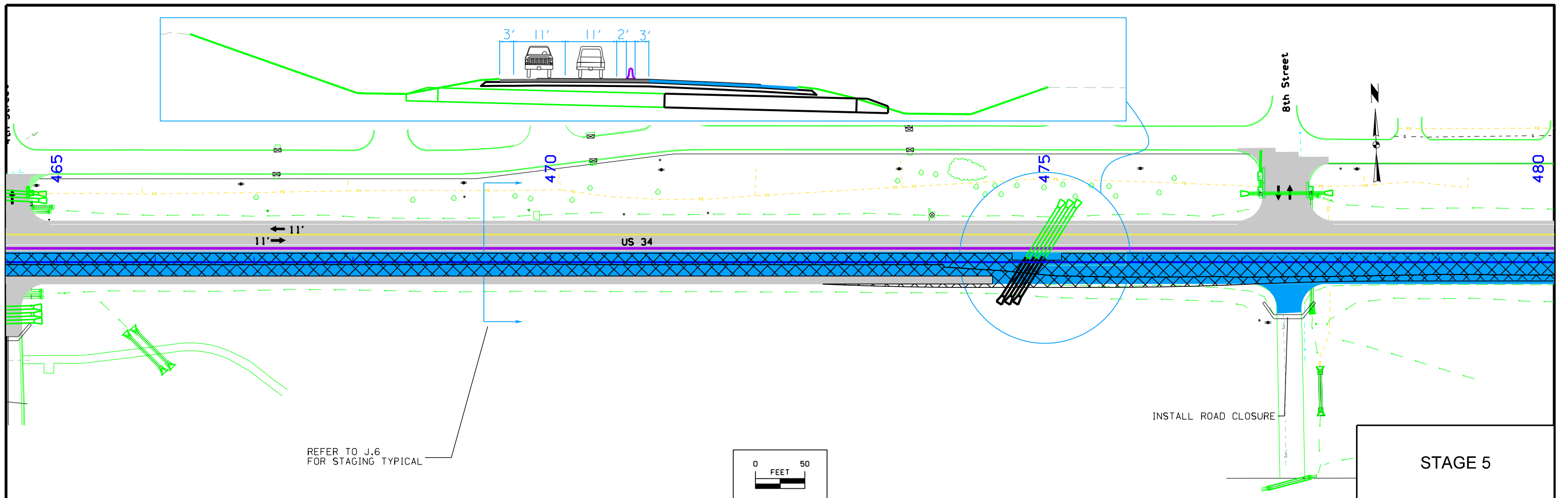

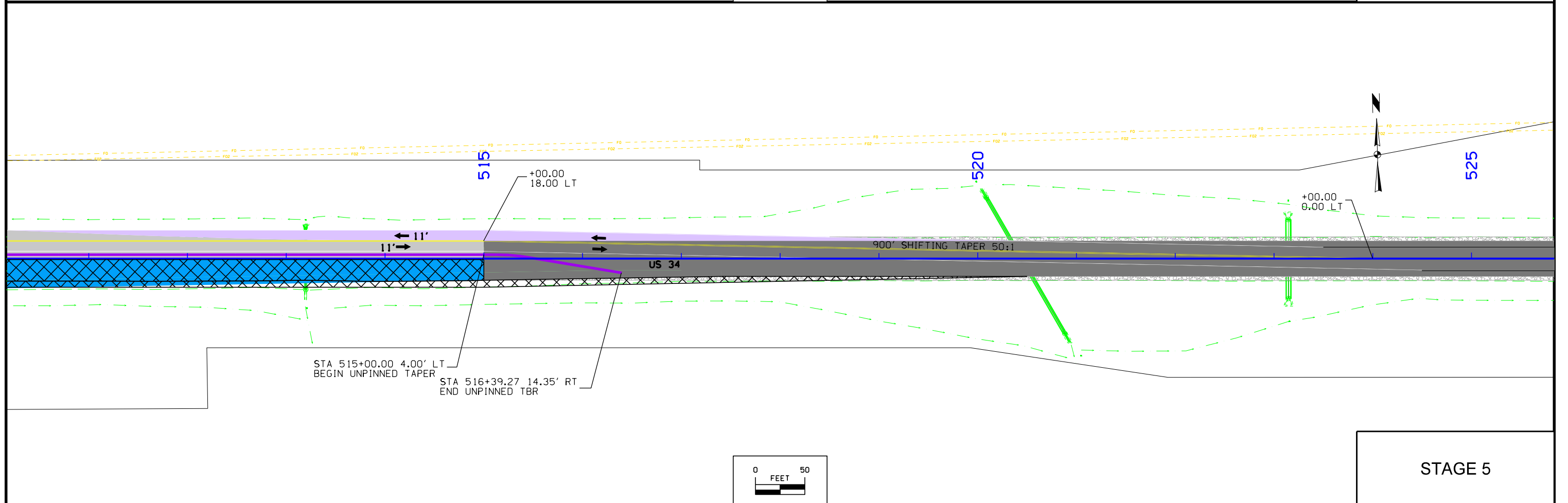
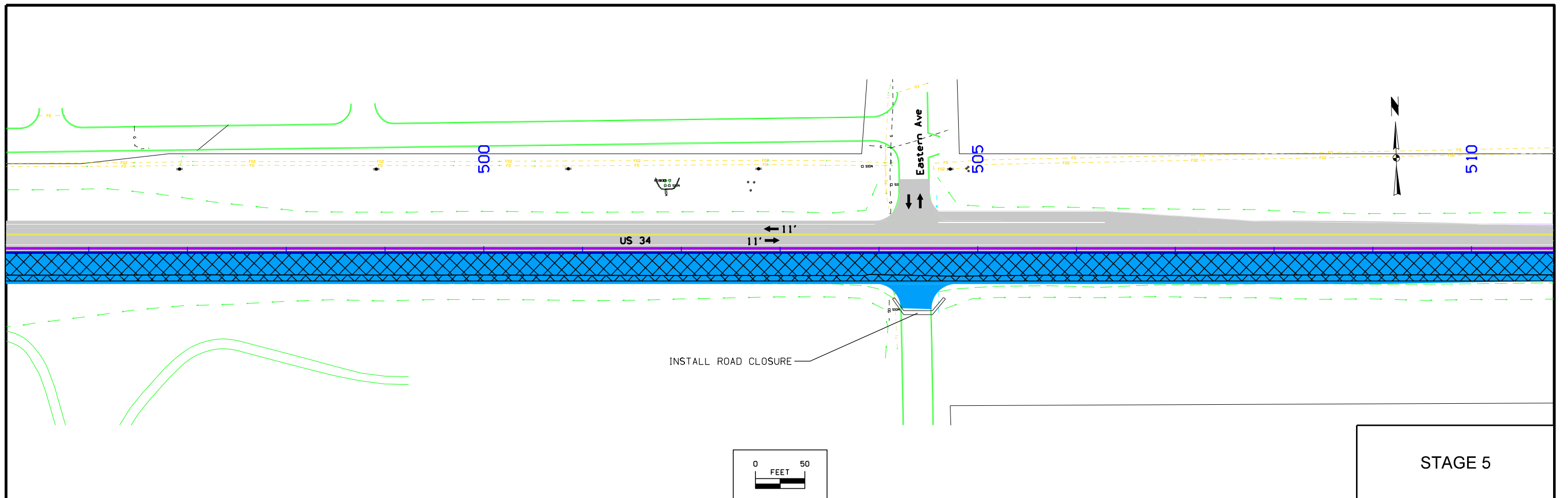

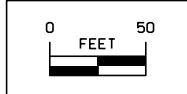
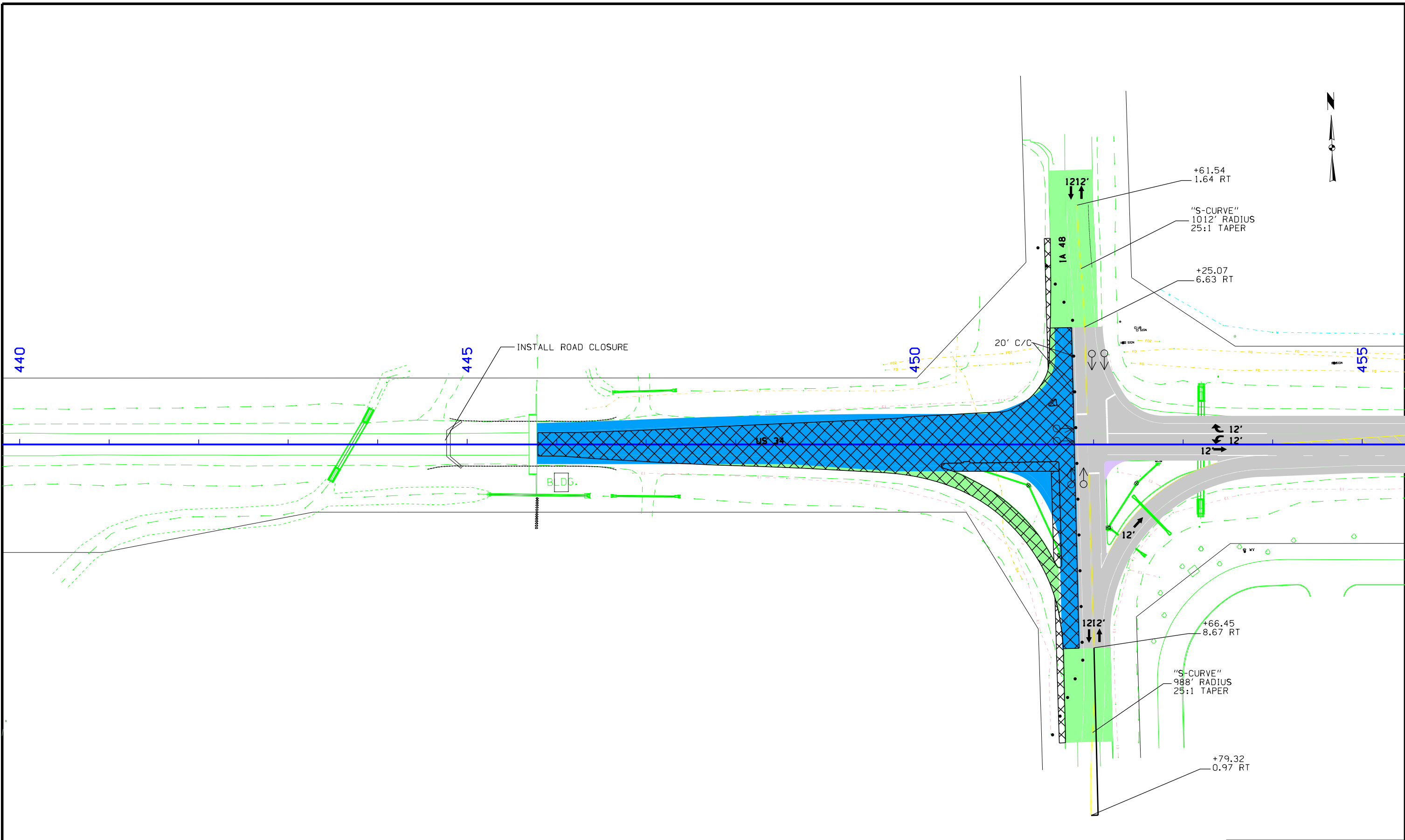

STAGE 6

Curve Data
 $\Delta = 3^\circ 42' 21.85''$ (RT)
 $T = 370.83$
 $L = 741.41$
 $R = 11,462.13$
 $E = 6.00$

REFER TO J.3
 FOR STAGING TYPICAL

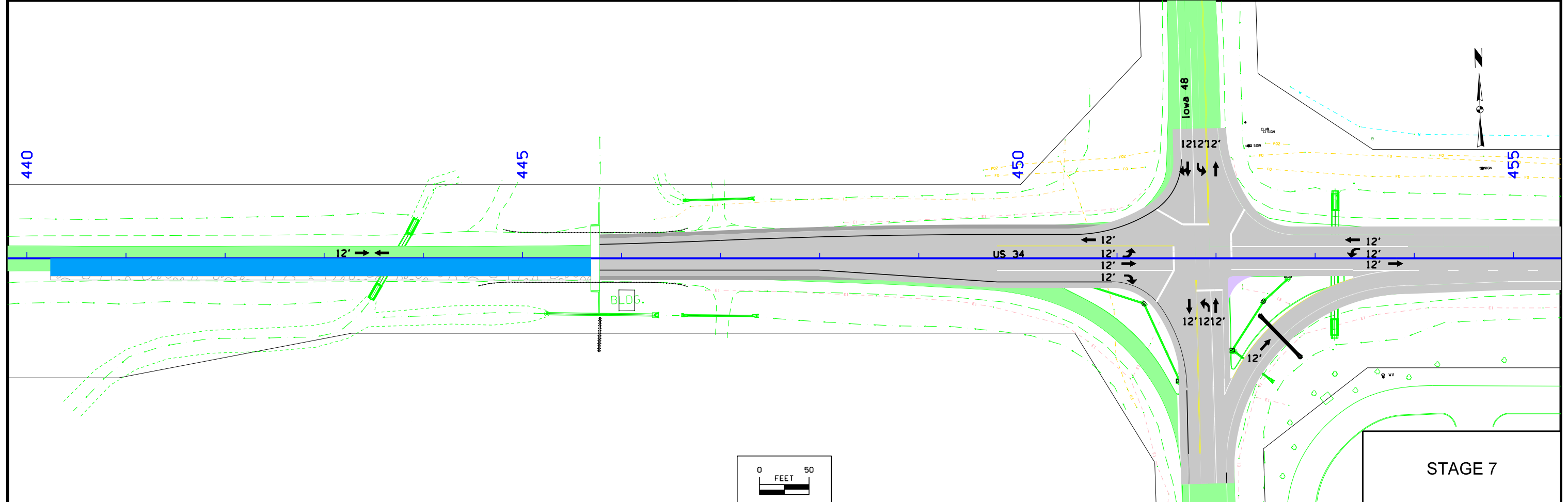
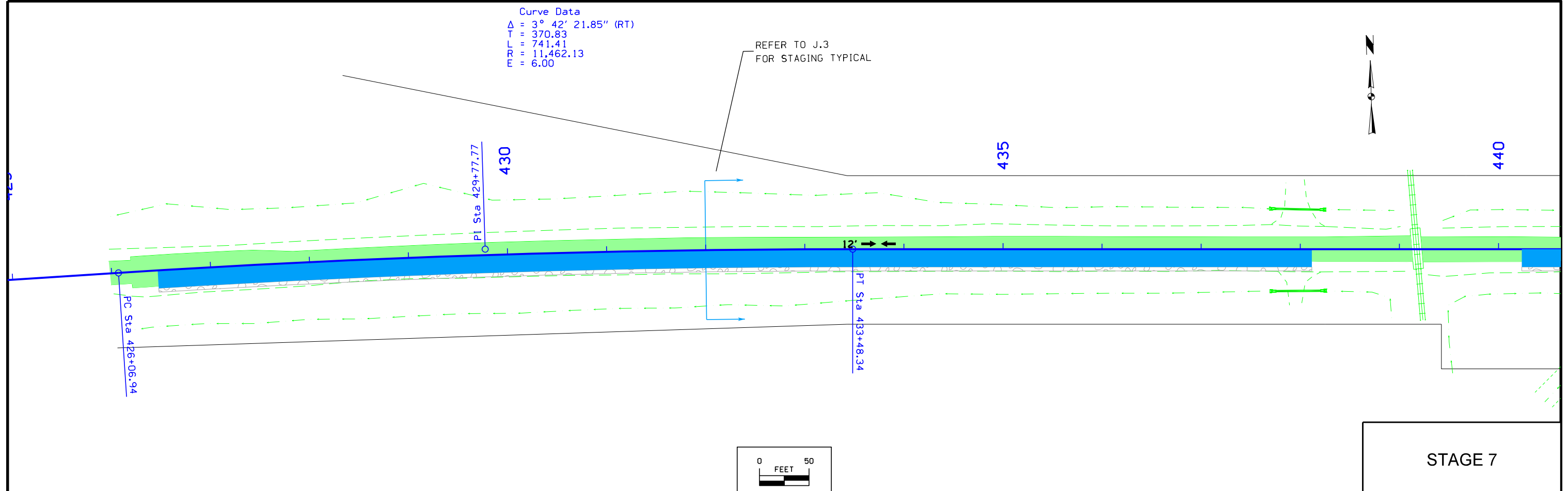

Curve Data
 $\Delta = 3^\circ 42' 21.85''$ (RT)
 $T = 370.83$
 $L = 741.41$
 $R = 11,462.13$
 $E = 6.00$

REFER TO J.3
 FOR STAGING TYPICAL

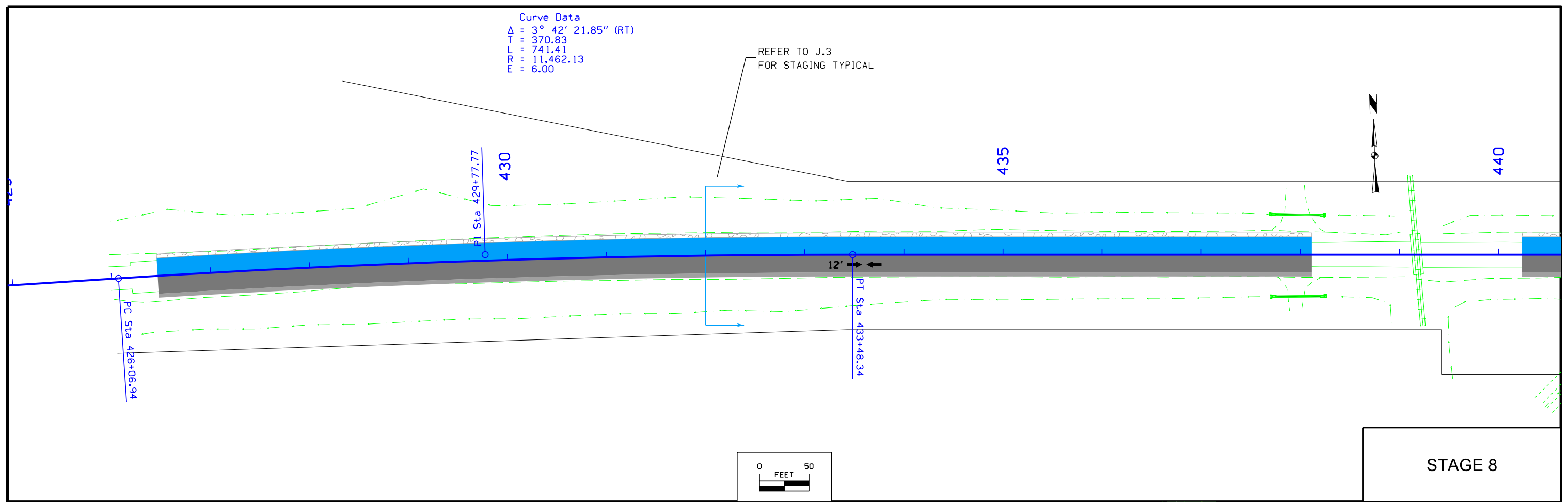

STAGE 8

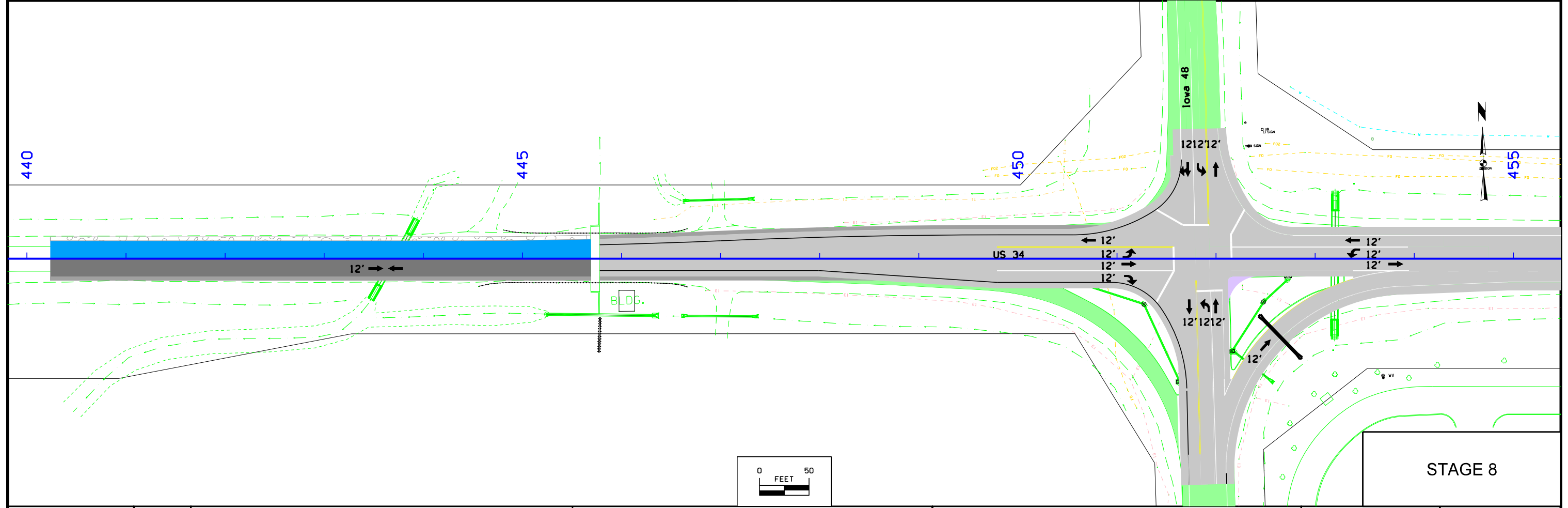

STAGE 8

Red Oak TWP.
T-72N R-38W
SEC. 20

Sta. 453+20.05
8'x4.5'x109.4' RCP
D.A.=9 AC (PLAN) A-R
(U.A.C.)

Red Oak TWP.
T-72N R-38W
SEC. 21

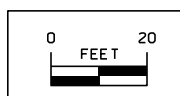
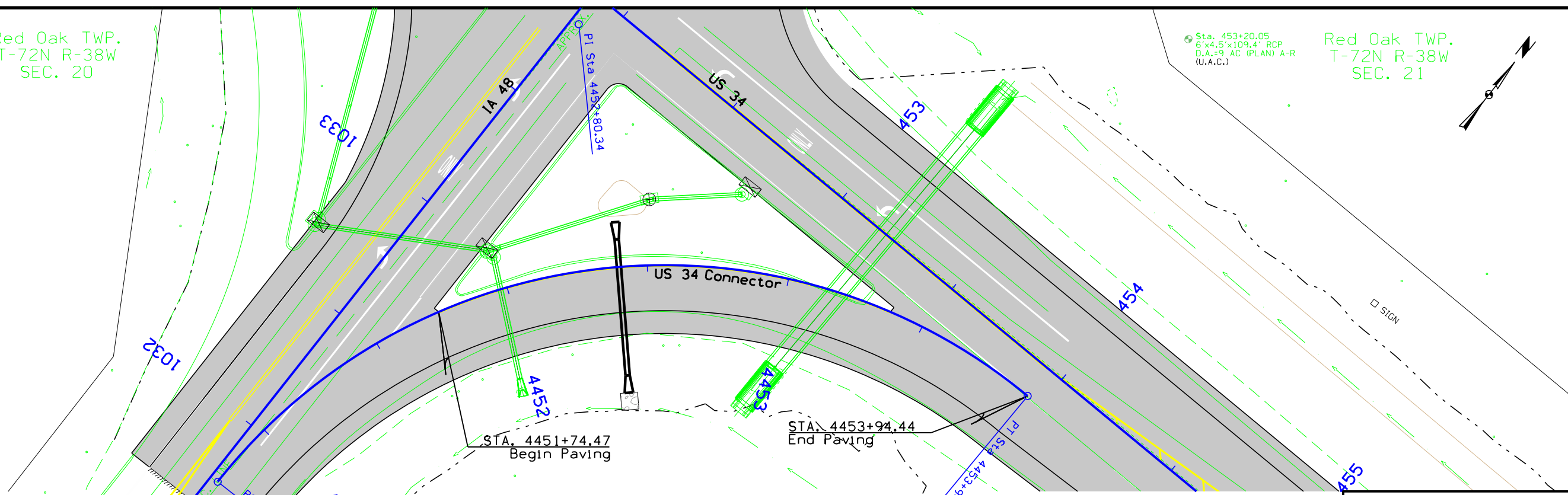
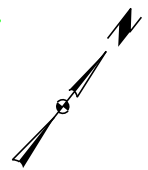

Sta. 4452+40.00
Install 18" x 48' RCP
F.L. = Lt. = 1035.90
Rt. = 1033.19

US 34 Connector

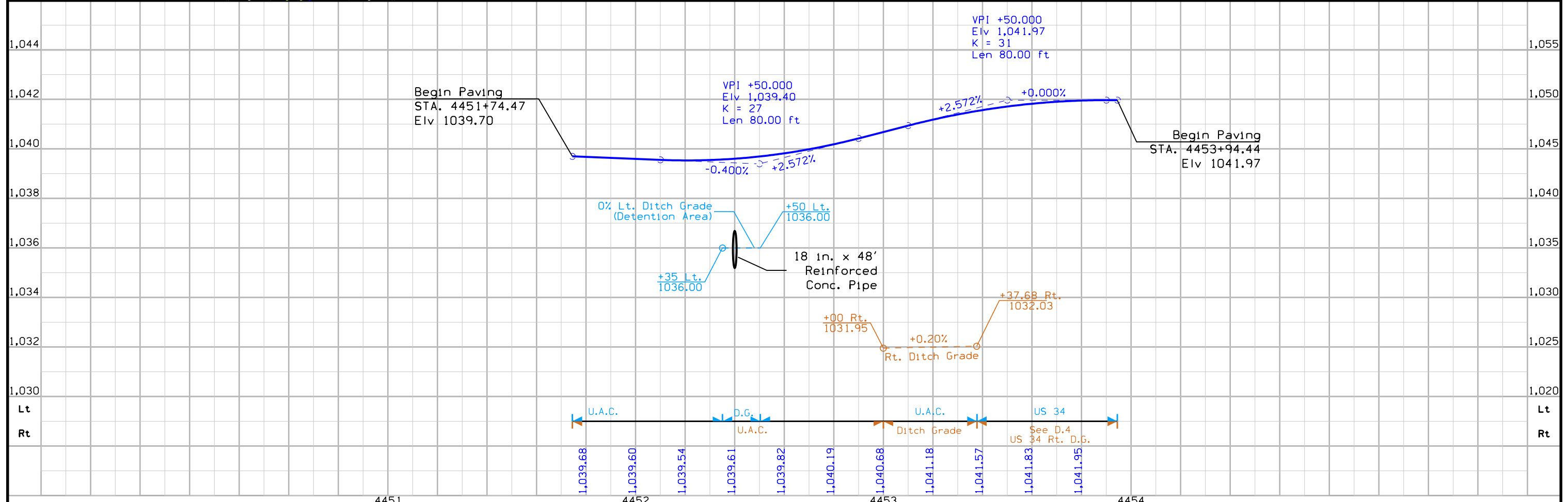

FILE NO.	ENGLISH	DESIGN TEAM	Iowa DOT \ HDR	MONTGOMERY COUNTY	PROJECT NUMBER	NHSX-034-2(60)--3H-69	SHEET NUMBER	K.1
----------	---------	-------------	----------------	-------------------	----------------	-----------------------	--------------	-----

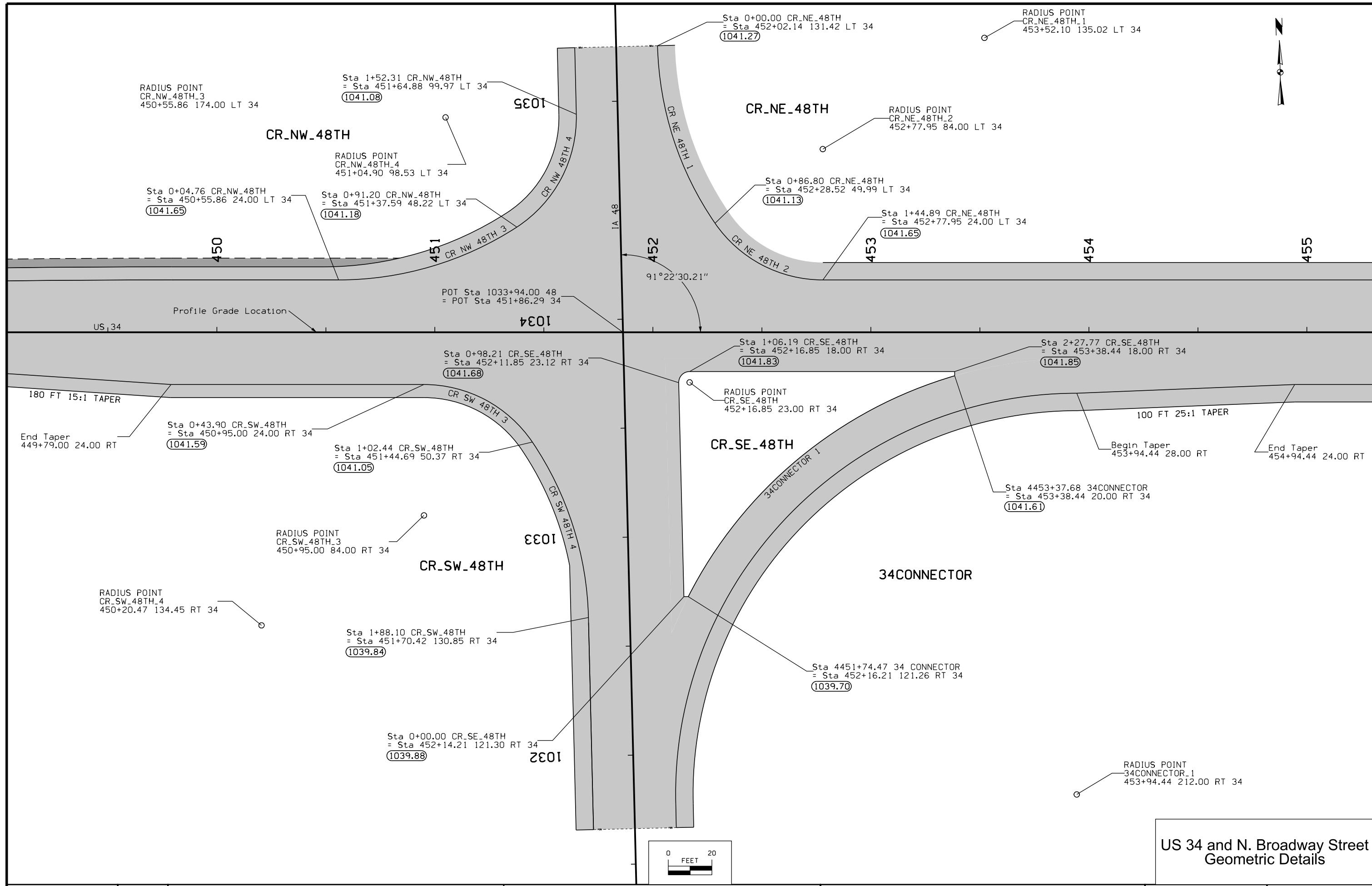

US 34 and N. Broadway Street
Geometric Details

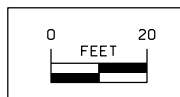
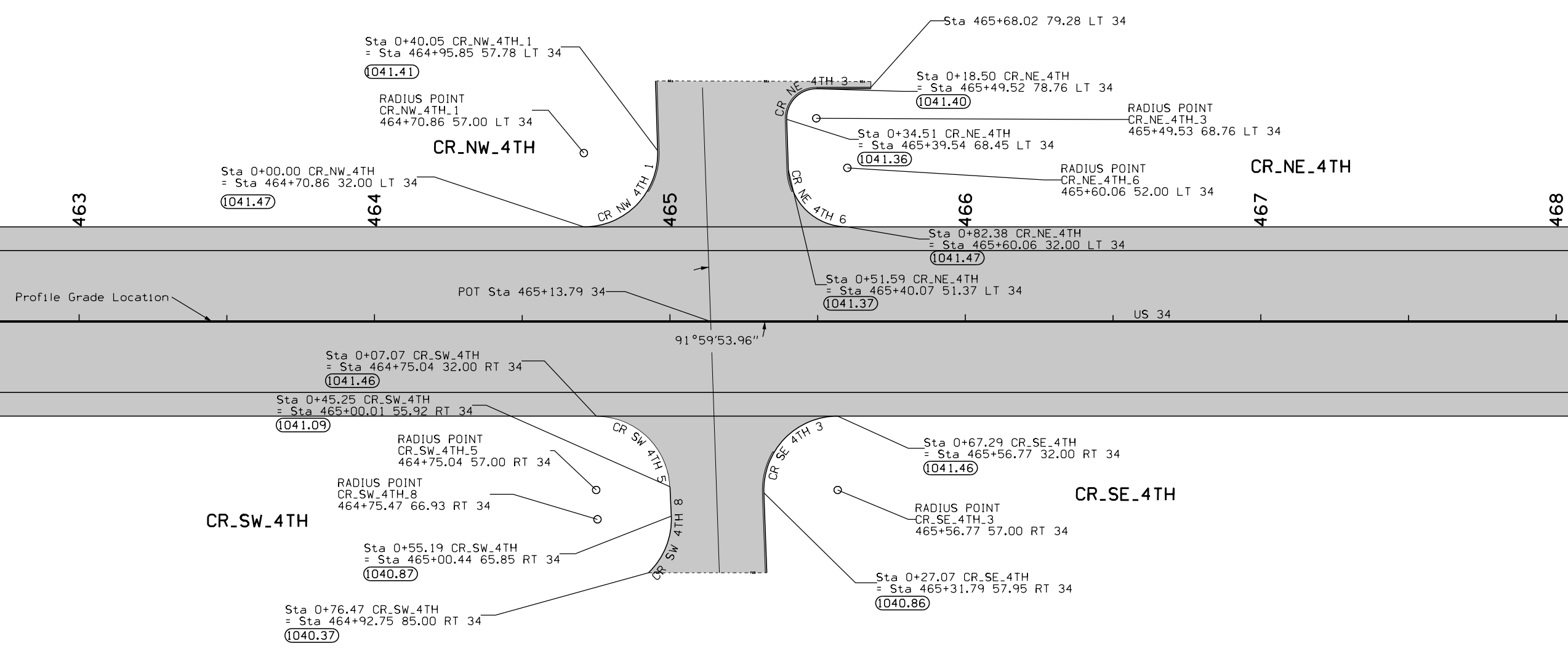

US 34 and N. 4th Street
Geometric Details

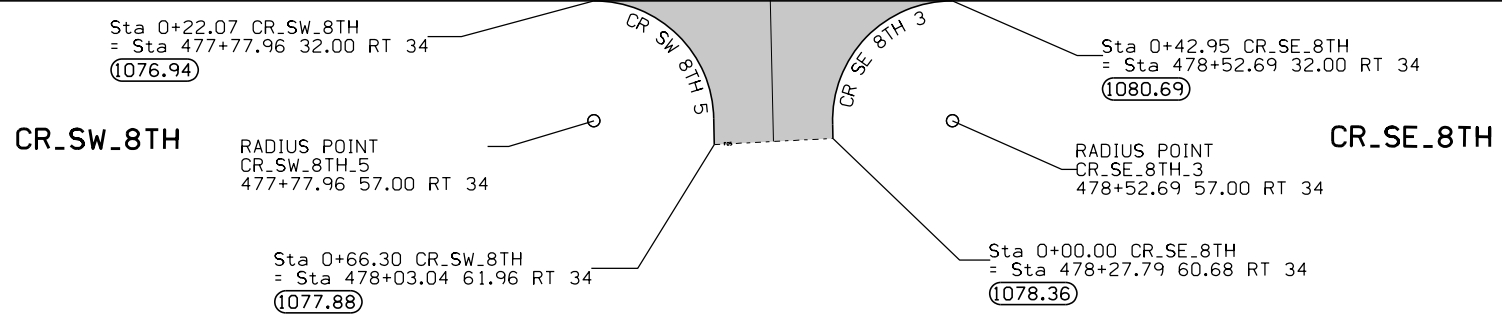
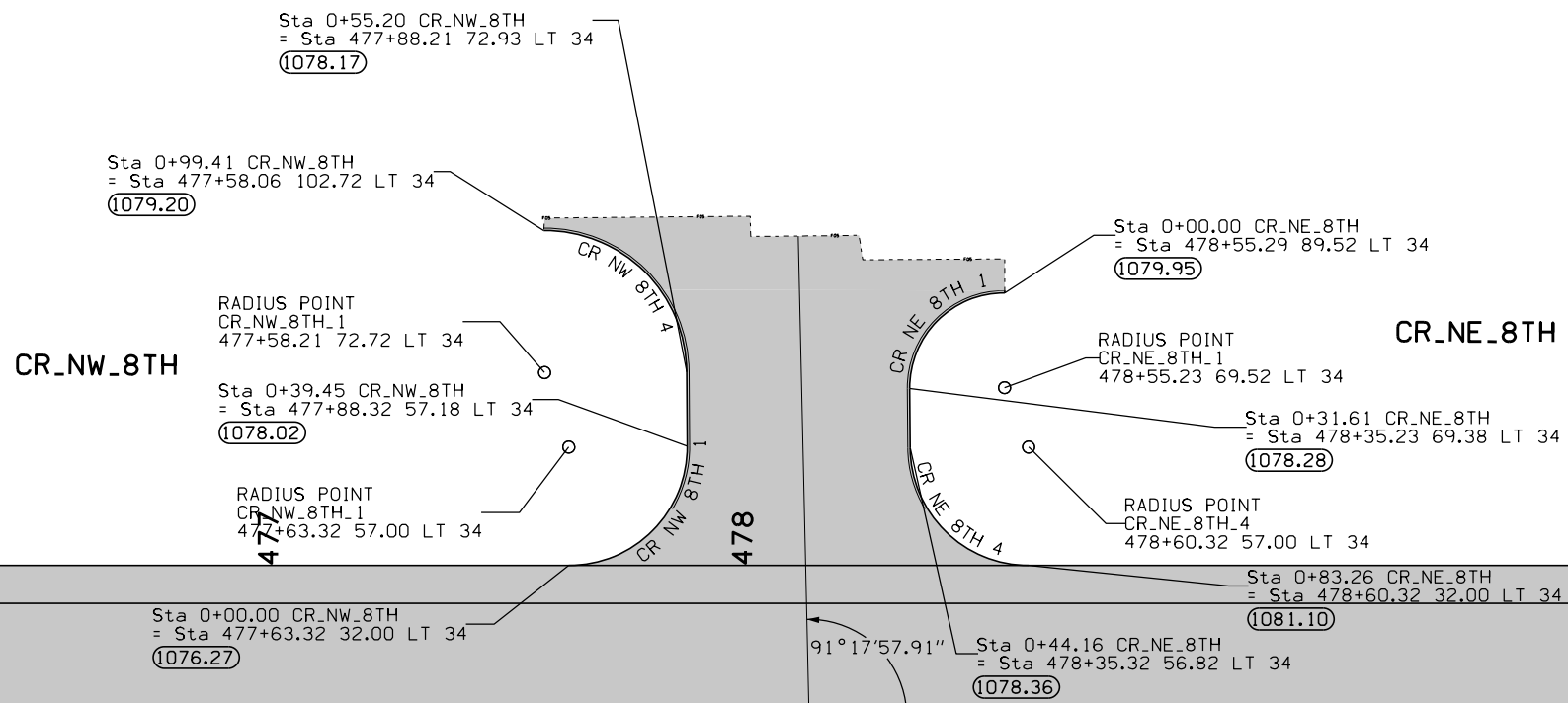

Profile Grade Location

476

477

478

480

481

US 34

POT Sta 478+13.99 34

91°17'57.91"

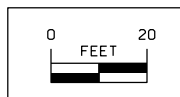

US 34 and N. 8th Street
Geometric Details

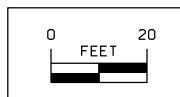
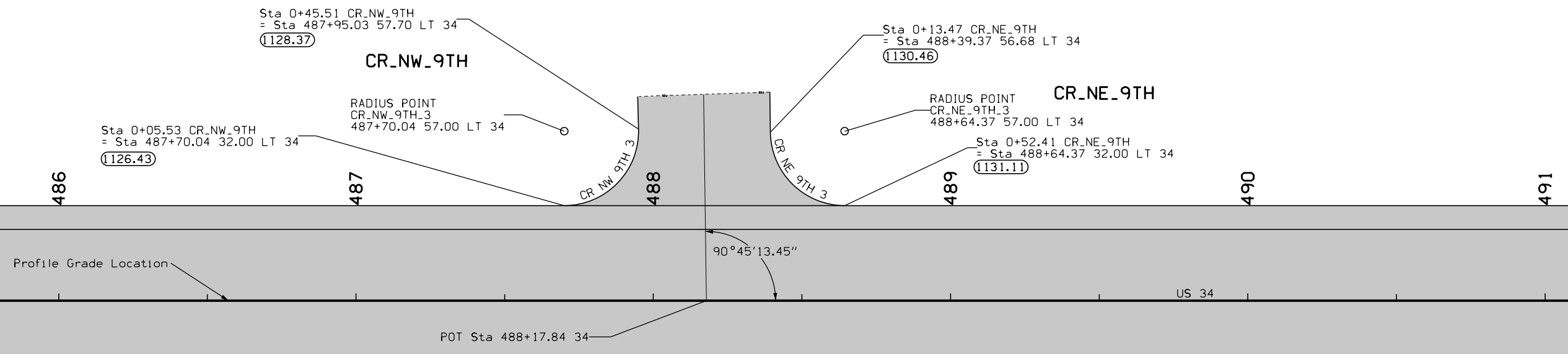

US 34 and Senate Avenue
Geometric Details

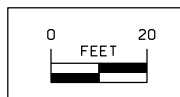
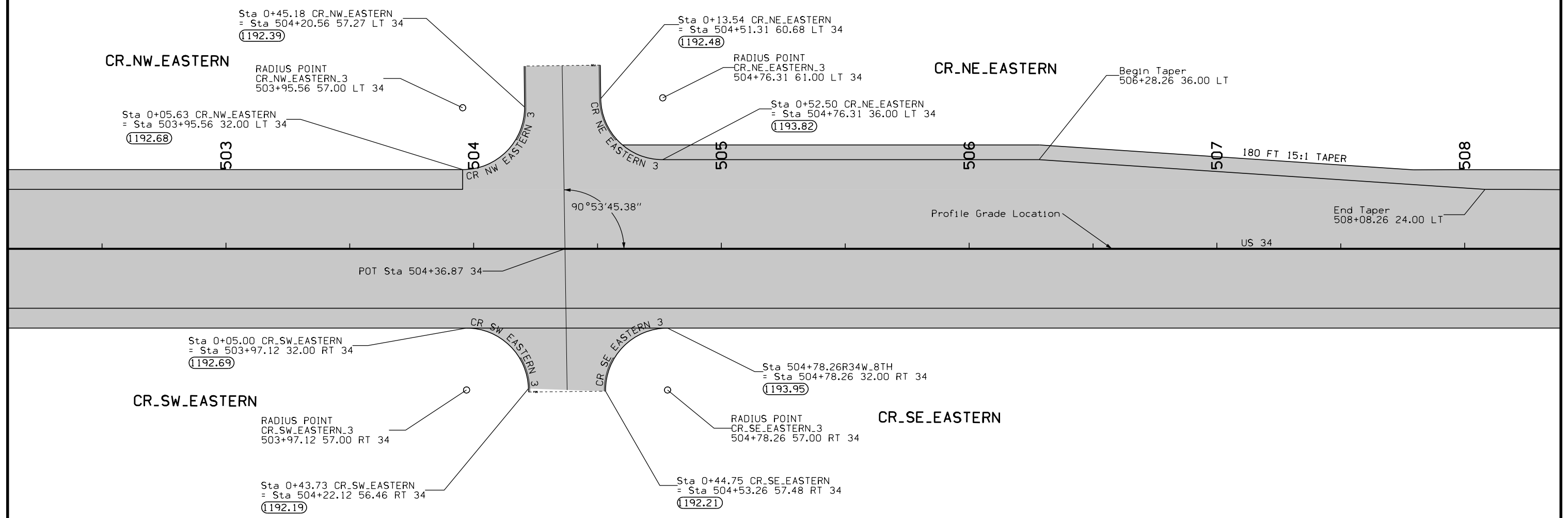

US 34 and Eastern Avenue
Geometric Details

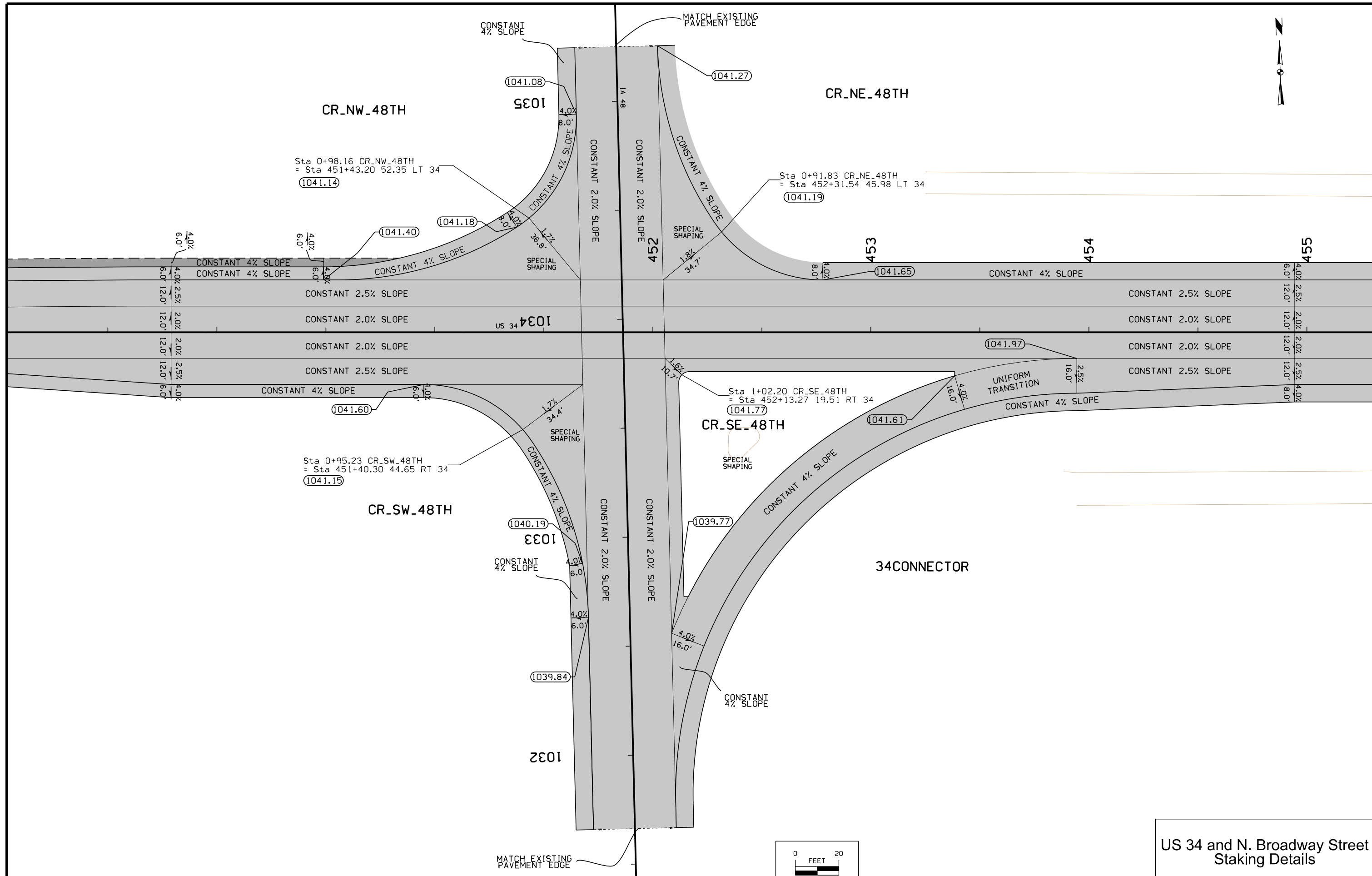

US 34 and N. Broadway Street
Staking Details

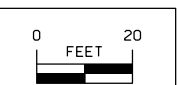

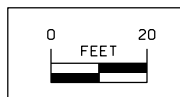
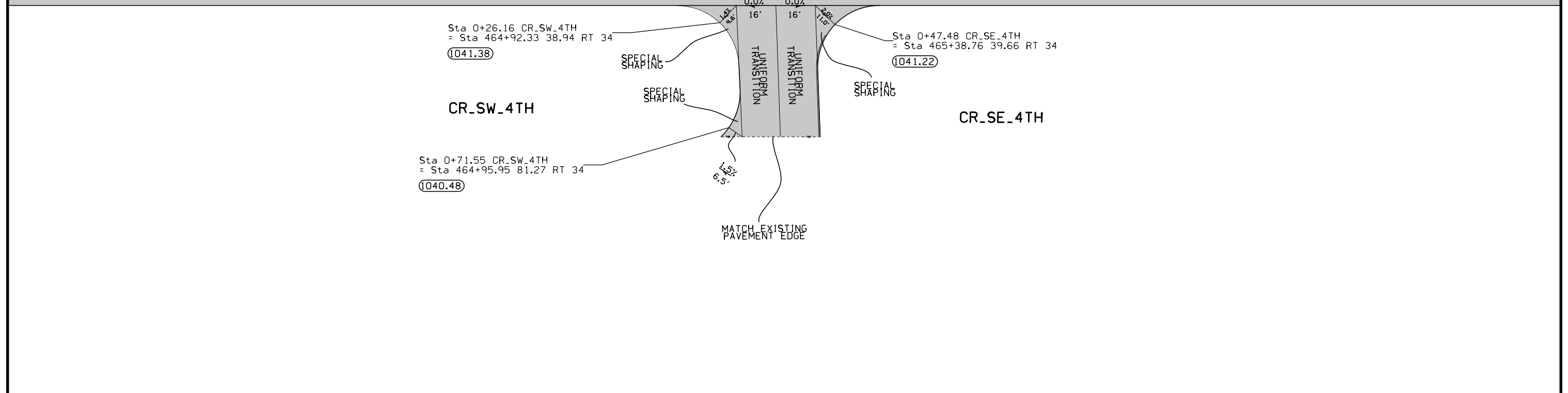
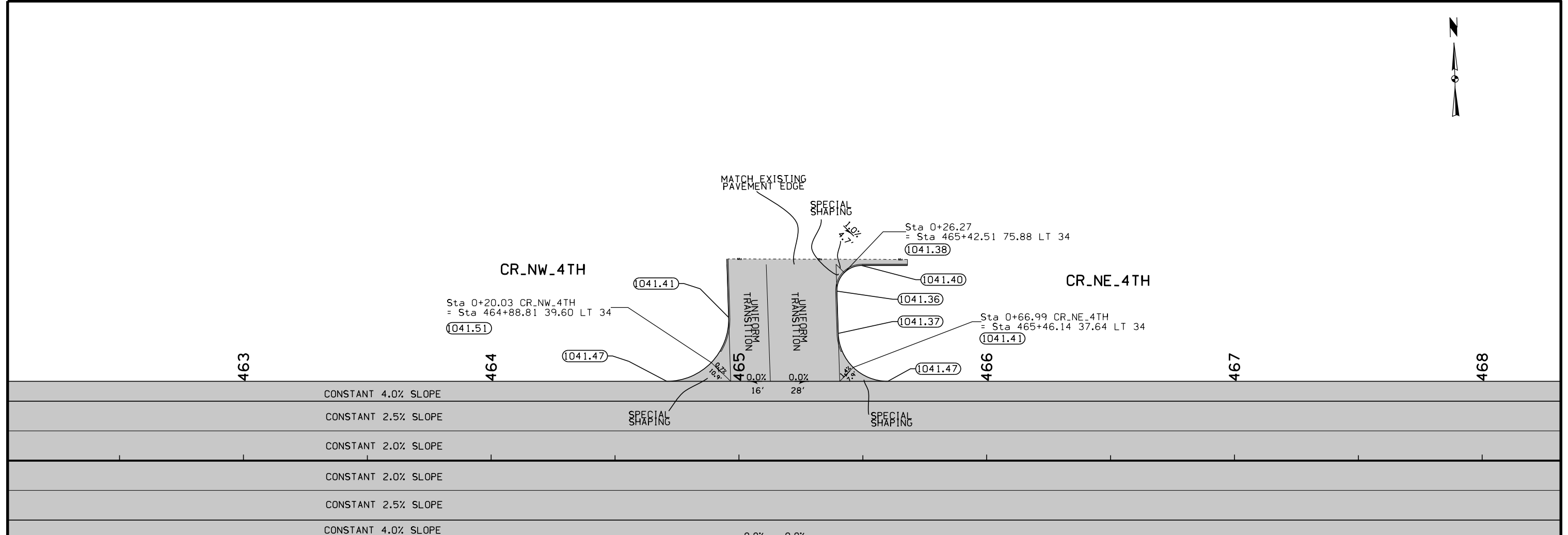

US 34 and N. 4th Street
Staking Details



CR_NW_8TH

CR_NE_8TH

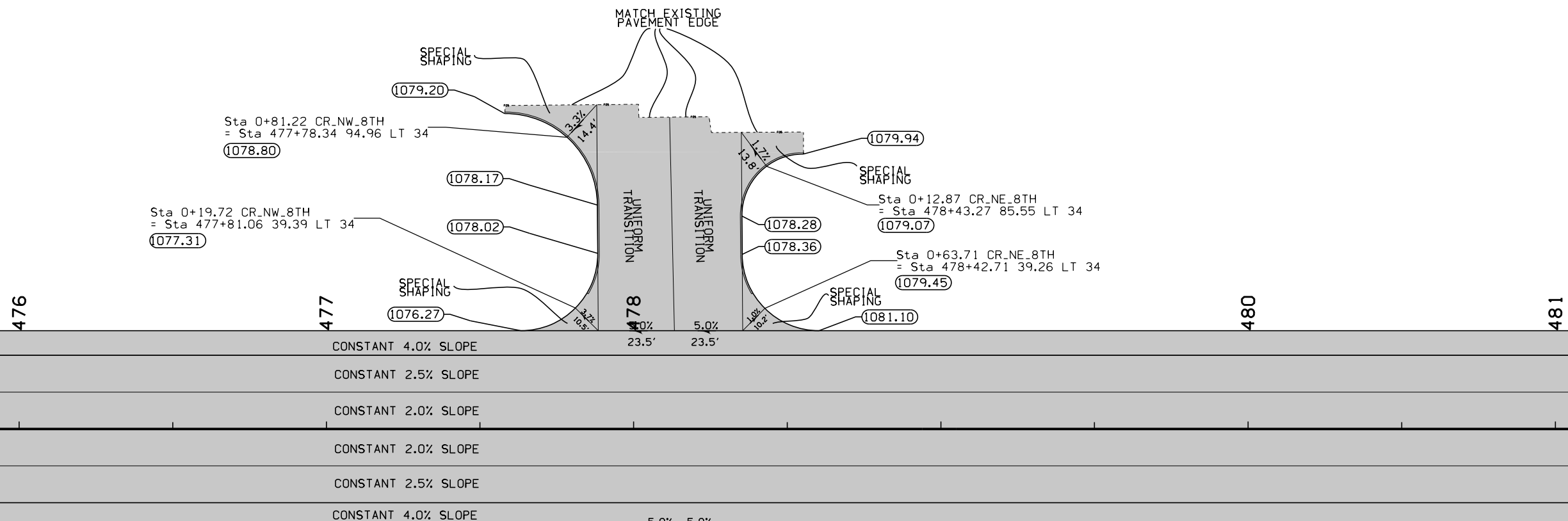

476

477

478

480

481

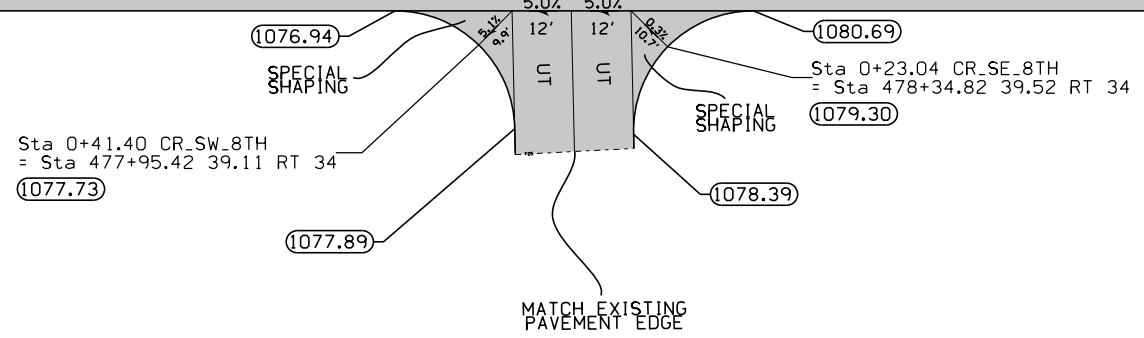

CR_SW_8TH

CR_SE_8TH

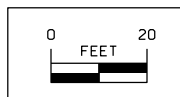

US 34 and N. 8th Street
Staking Details

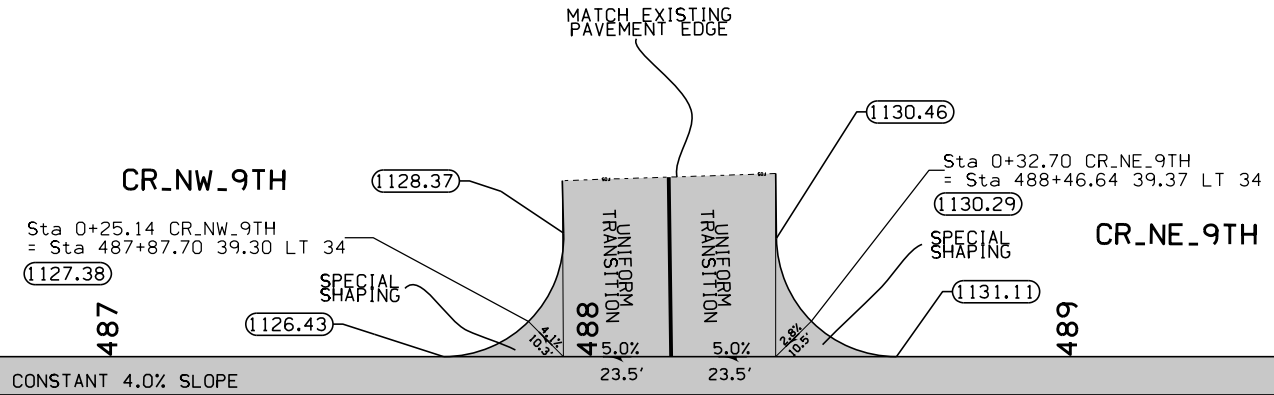

CONSTANT 4.0% SLOPE

CONSTANT 2.5% SLOPE

CONSTANT 2.0% SLOPE

CONSTANT 2.0% SLOPE

CONSTANT 2.5% SLOPE

CONSTANT 4.0% SLOPE

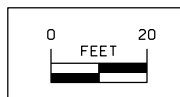

US 34 and Senate Avenue
Staking Details



CR_NW_EASTERN

CR_NE_EASTERN

Sta 0+25.15 CR_NW_EASTERN
= Sta 504+13.15 39.24 LT 34
(1192.83)

Sta 0+34.72 CR_NE_EASTERN
= Sta 504+60.00 42.06 LT 34
(1193.36)

Sta 0+24.66 CR_SW_EASTERN
= Sta 504+14.82 39.34 RT 34
(1192.65)

Sta 0+25.14 CR_SE_EASTERN
= Sta 504+60.59 39.31 RT 34
(1193.08)

CR_SW_EASTERN

CR_SE_EASTERN

MATCH EXISTING
PAVEMENT EDGE

MATCH EXISTING
PAVEMENT EDGE

(1192.39)
SPECIAL
SHAPING

(1192.48)
SPECIAL
SHAPING

(1192.68)

(1193.82)

(1192.69)
SPECIAL
SHAPING

(1193.95)
SPECIAL
SHAPING

(1192.19)

(1192.21)

CONSTANT 4.0% SLOPE

CONSTANT 2.5% SLOPE

CONSTANT 2.0% SLOPE

CONSTANT 2.0% SLOPE

CONSTANT 2.5% SLOPE

CONSTANT 4.0% SLOPE

CONSTANT 4.0% SLOPE

CONSTANT 2.5% SLOPE

UNIFORM
TRANSITION

CONSTANT 2.5% SLOPE

4.0%
6.0' 12'
2.5%

1.5%
16'
1.5%

1.5%
16'
2.5%

503

504

505

506

507

508

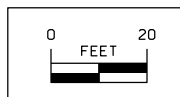

US 34 and Eastern Avenue
Staking Details

SIGNING
INSTALLATION DETAILS

TRAFFIC SIGNAL FACES
All indicators shall be LED

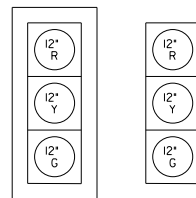

Head No.	Head No.
21 22	23 43
41 42	63 83
61 62	
81 82	

ID LETTER	SIGN ID NUMBER	SIGN DES.	SIGN SIZE	SIGNING NOTES
A	D3-1	Street Name	Var. x 18	
B	R3-5L	Lt Turn Only	30 x 36	
C	R3-5R	Rt Turn Only	30 x 36	

All sign brackets for mastarm mounted signs shall be furnished as part of the traffic signal equipment.

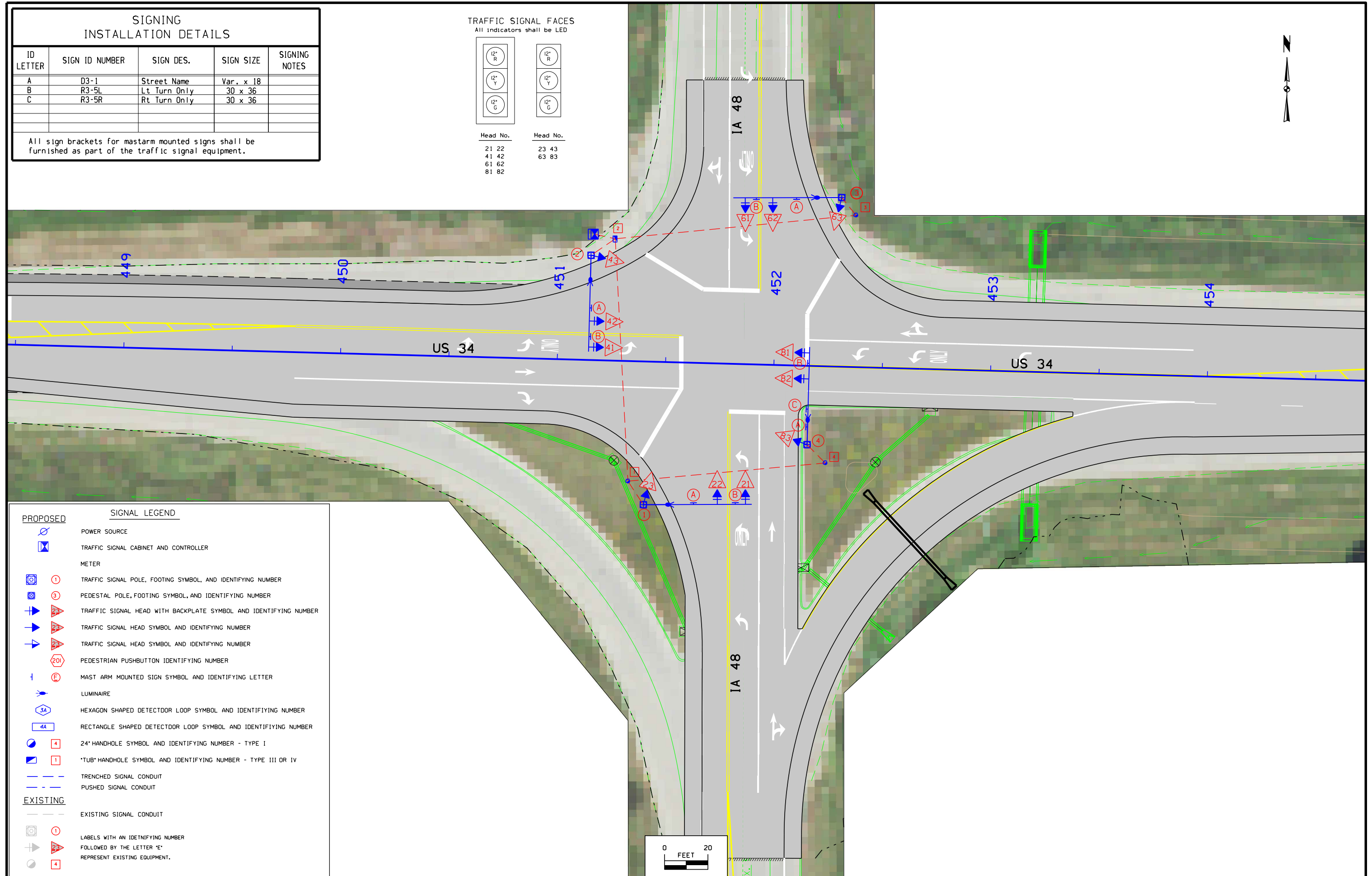

PROPOSED

SIGNAL LEGEND

- POWER SOURCE
- TRAFFIC SIGNAL CABINET AND CONTROLLER
- METER
- TRAFFIC SIGNAL POLE, FOOTING SYMBOL, AND IDENTIFYING NUMBER
- PEDESTAL POLE, FOOTING SYMBOL, AND IDENTIFYING NUMBER
- TRAFFIC SIGNAL HEAD WITH BACKPLATE SYMBOL AND IDENTIFYING NUMBER
- TRAFFIC SIGNAL HEAD SYMBOL AND IDENTIFYING NUMBER
- TRAFFIC SIGNAL HEAD SYMBOL AND IDENTIFYING NUMBER
- PEDESTRIAN PUSHBUTTON IDENTIFYING NUMBER
- MAST ARM MOUNTED SIGN SYMBOL AND IDENTIFYING LETTER
- LUMINAIRE
- HEXAGON SHAPED DETECTOR LOOP SYMBOL AND IDENTIFYING NUMBER
- RECTANGLE SHAPED DETECTOR LOOP SYMBOL AND IDENTIFYING NUMBER
- 24" HANDHOLE SYMBOL AND IDENTIFYING NUMBER - TYPE I
- "TUB" HANDHOLE SYMBOL AND IDENTIFYING NUMBER - TYPE III OR IV
- TRENCHED SIGNAL CONDUIT
- PUSHED SIGNAL CONDUIT

EXISTING

- EXISTING SIGNAL CONDUIT
- LABELS WITH AN IDENTIFYING NUMBER
- FOLLOWED BY THE LETTER 'E'
- REPRESENT EXISTING EQUIPMENT.

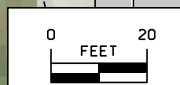

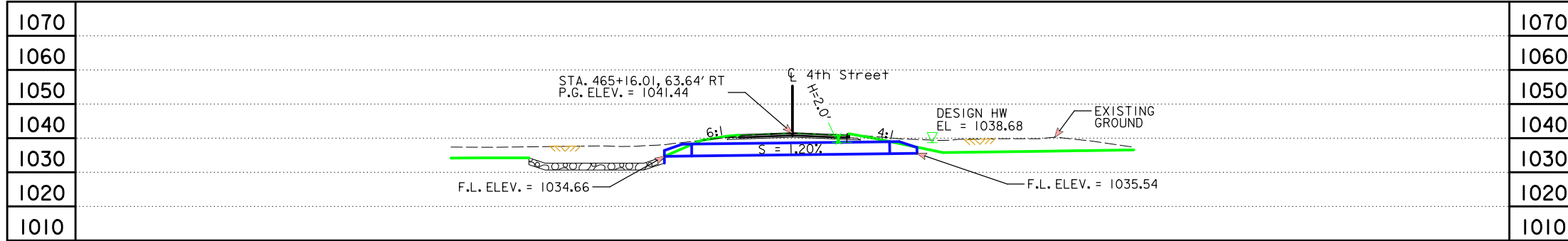

LONGITUDINAL SECTION ALONG ϕ CULVERT

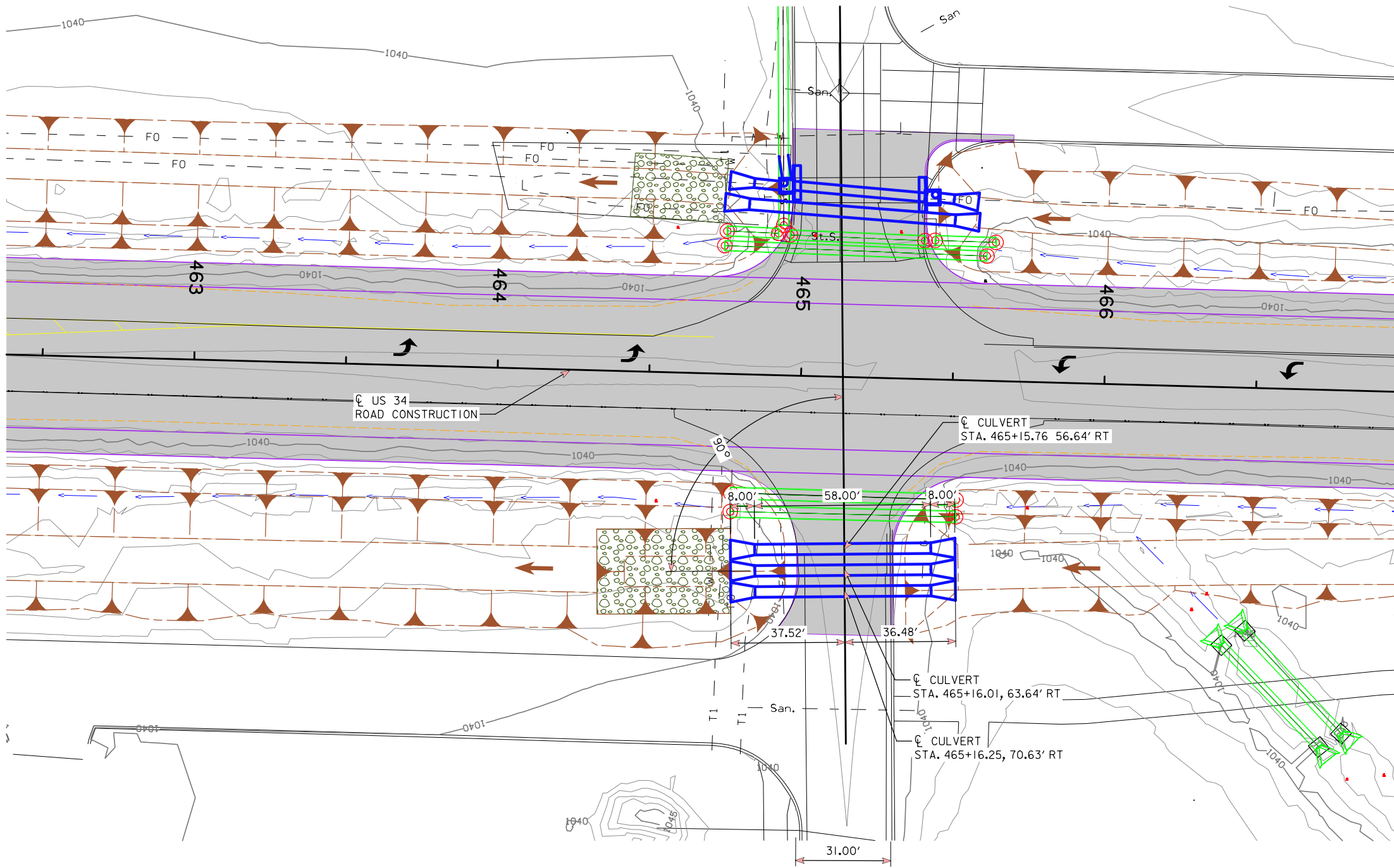

PLAT PLAN

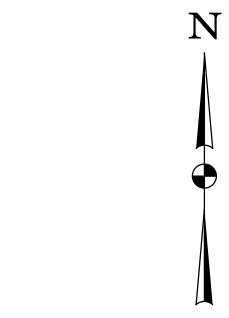

US 34 TRAFFIC ESTIMATE

2023	AADT	4700	V.P.D.
2043	AADT	5700	V.P.D.
2043	DHV	590	V.P.H.
	TRUCKS	13	%
	TOTAL DESIGN ESALs	N/A	

LOCATION

US 34
T-72 N R-38 W
SECTION 21
RED OAK TOWNSHIP
MONTGOMERY COUNTY

HYDRAULIC DATA

DRAINAGE AREA = 98.4 ACRES - ROLLING
Q₅₀ = 146 CFS
HW ELEV. = 1038.68

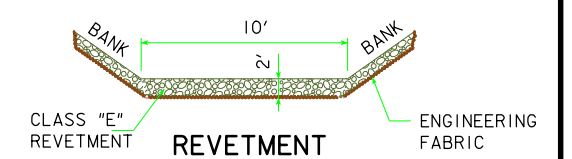

QUANTITIES

CLASS 'E' REVETMENT 130 TONS
ENGINEERING FABRIC 170 SQ. YDS.

NOTE:
ALL DIMENSIONS ARE IN FEET (FT) UNLESS OTHERWISE NOTED OR SHOWN. ALL ELEVATION AND STATIONS ARE IN FEET (FT). FOR SPOT ELEVATIONS ADD 1000 FT.

DESIGN FOR A 0.00° SKEW
TRIPLE 42 in. x 58' REINFORCED CONC. PIPE

PLAT PLAN
STA. 465+16.01, 63.64' RT (ϕ US 34) APRIL, 2021
MONTGOMERY COUNTY
IOWA DEPARTMENT OF TRANSPORTATION - HIGHWAY DIVISION
DESIGN SHEET NO. 1 OF 1 FILE NO. 31397 DESIGN NO. _____



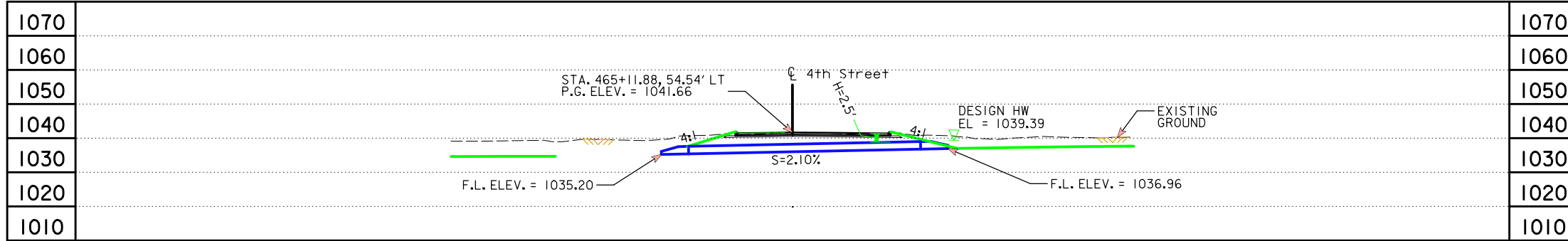

LONGITUDINAL SECTION ALONG CL CULVERT

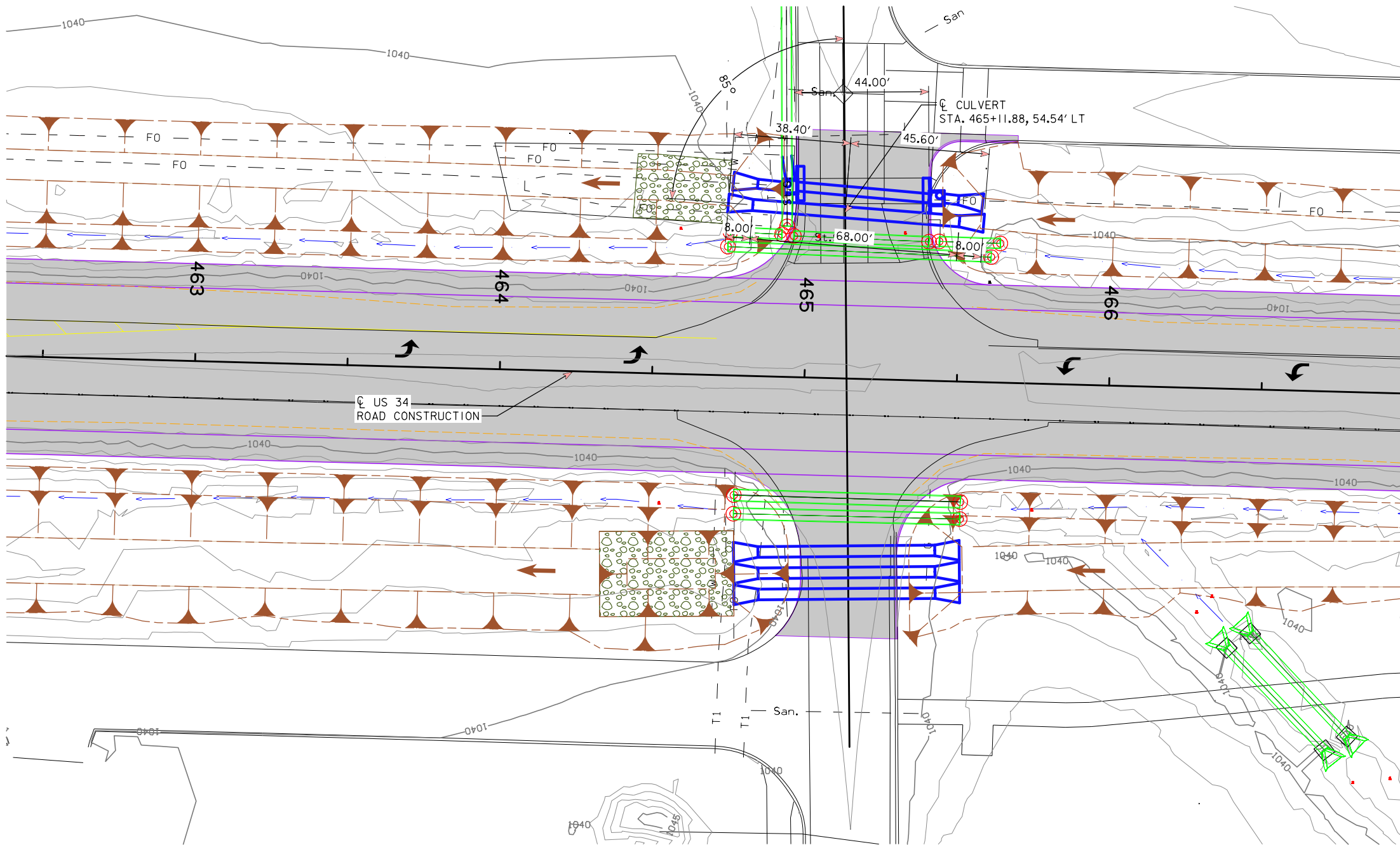

PLAT PLAN

US 34 TRAFFIC ESTIMATE

2023 AADT	4700	V.P.D.
2043 AADT	5700	V.P.D.
2043 DHV	590	V.P.H.
TRUCKS	13	%
TOTAL DESIGN ESALs	N/A	

LOCATION

US 34
T-72 N R-38 W
SECTION 21
RED OAK TOWNSHIP
MONTGOMERY COUNTY

HYDRAULIC DATA

DRAINAGE AREA = 15.4 ACRES - ROLLING
Q₅₀ = 36 CFS
HW ELEV. = 1039.39

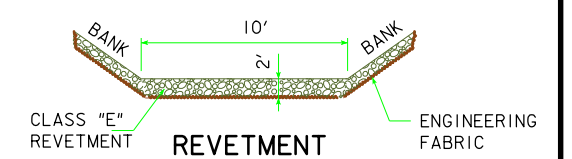

QUANTITIES

CLASS 'E' REVETMENT	68 TONS
ENGINEERING FABRIC	95 SQ. YDS.

NOTE:
ALL DIMENSIONS ARE IN FEET (FT) UNLESS OTHERWISE NOTED OR SHOWN. ALL ELEVATION AND STATIONS ARE IN FEET (FT). FOR SPOT ELEVATIONS ADD 1000 FT.

DESIGN FOR A 5.0000° SKEW LT. AHD.
36 in. x 68'
LOW CLEARANCE
REINFORCED CONC. PIPE
PLAT PLAN
STA. 465+11.88, 54.54' LT (CL US 34) APRIL, 2021
MONTGOMERY COUNTY
IOWA DEPARTMENT OF TRANSPORTATION - HIGHWAY DIVISION
DESIGN SHEET NO. 1 OF 1 FILE NO. 31397 DESIGN NO.



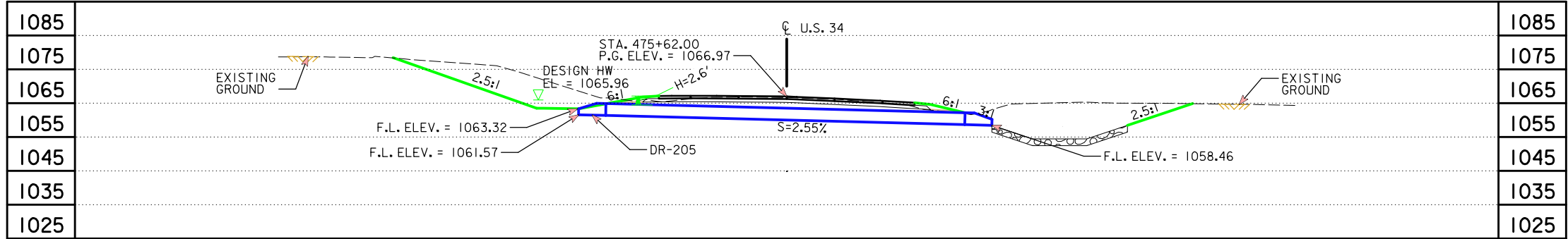

LONGITUDINAL SECTION ALONG ϕ CULVERT

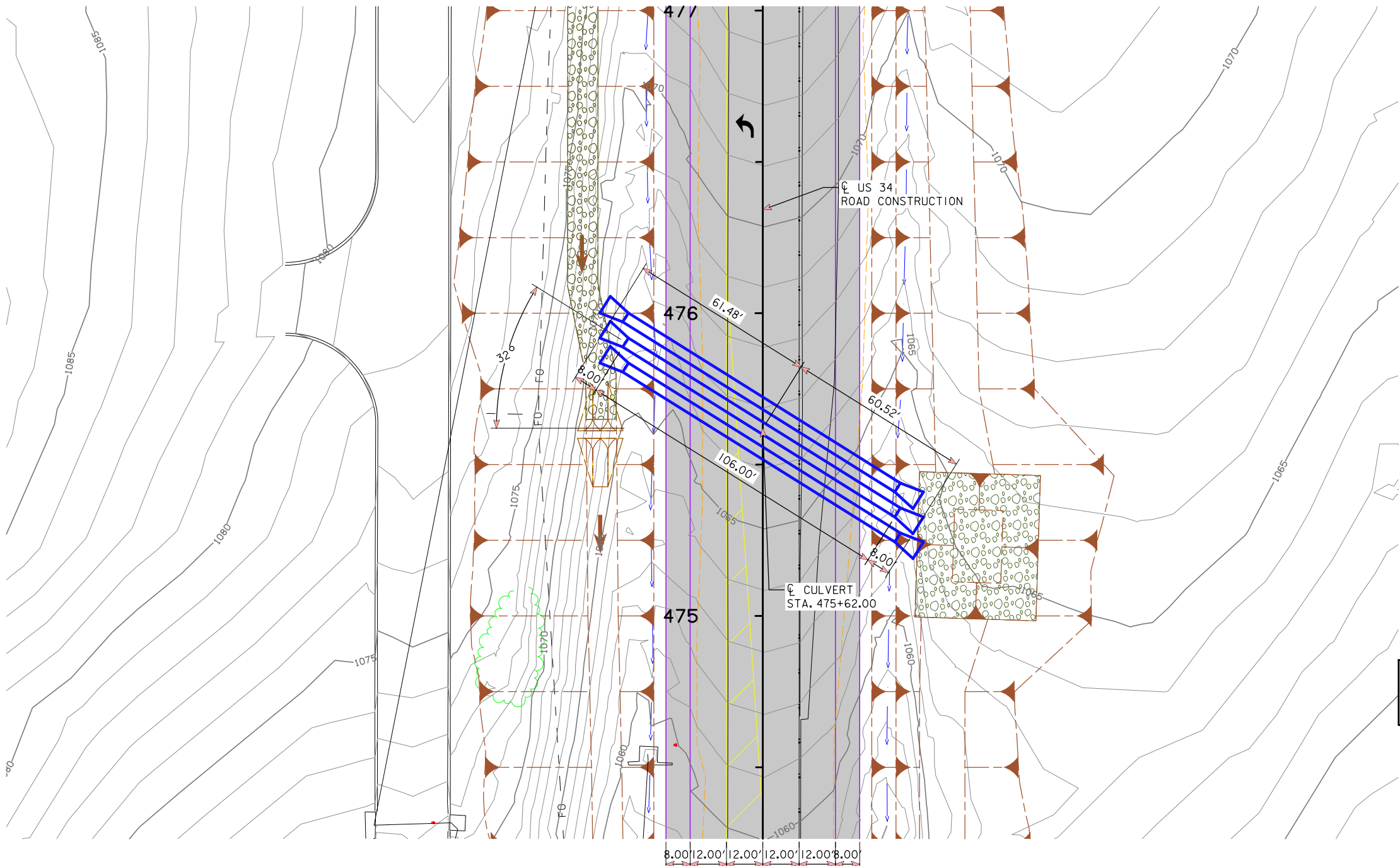
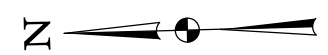

PLAT PLAN

US 34 TRAFFIC ESTIMATE

2023	AADT	4700	V.P.D.
2043	AADT	5700	V.P.D.
2043	DHV	590	V.P.H.
	TRUCKS	13	%
	TOTAL DESIGN ESALs	N/A	

LOCATION

US 34
T-72 N R-38 W
SECTION 21
RED OAK TOWNSHIP
MONTGOMERY COUNTY

HYDRAULIC DATA

DRAINAGE AREA = 46.0 ACRES - HILLY
Q₅₀ = 110 CFS
HW ELEV. = 1065.96

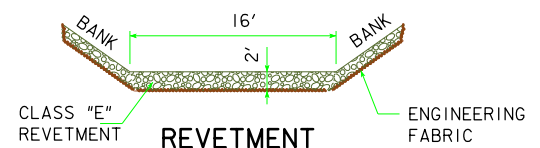

QUANTITIES

CLASS 'E' REVETMENT 202 TONS
ENGINEERING FABRIC 253 SQ. YDS.

NOTE:
ALL DIMENSIONS ARE IN FEET (FT) UNLESS OTHERWISE NOTED OR SHOWN. ALL ELEVATION AND STATIONS ARE IN FEET (FT). FOR SPOT ELEVATIONS ADD 1000 FT.

DESIGN FOR A 32.00° SKEW LT. AHD.
TRIPLE 42 in. x 106' REINFORCED CONC. PIPE

PLAT PLAN
STA. 475+62.00 (ϕ US 34) APRIL, 2021
MONTGOMERY COUNTY
IOWA DEPARTMENT OF TRANSPORTATION - HIGHWAY DIVISION
DESIGN SHEET NO. 1 OF 1 FILE NO. 31397 DESIGN NO. _____



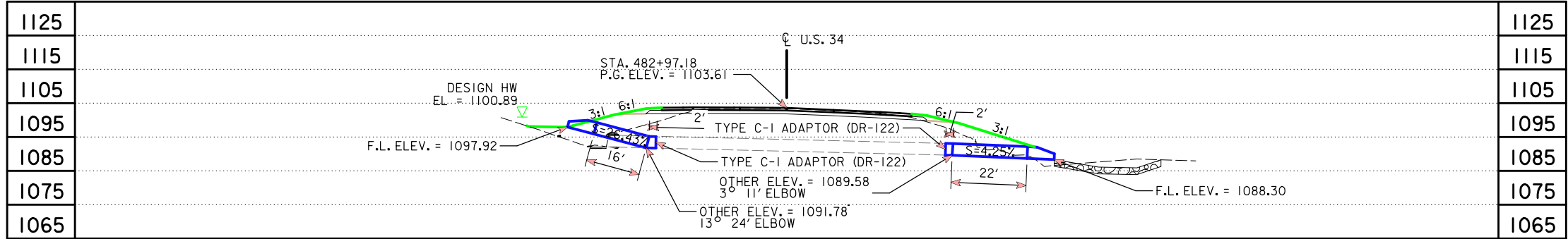

LONGITUDINAL SECTION ALONG CL CULVERT

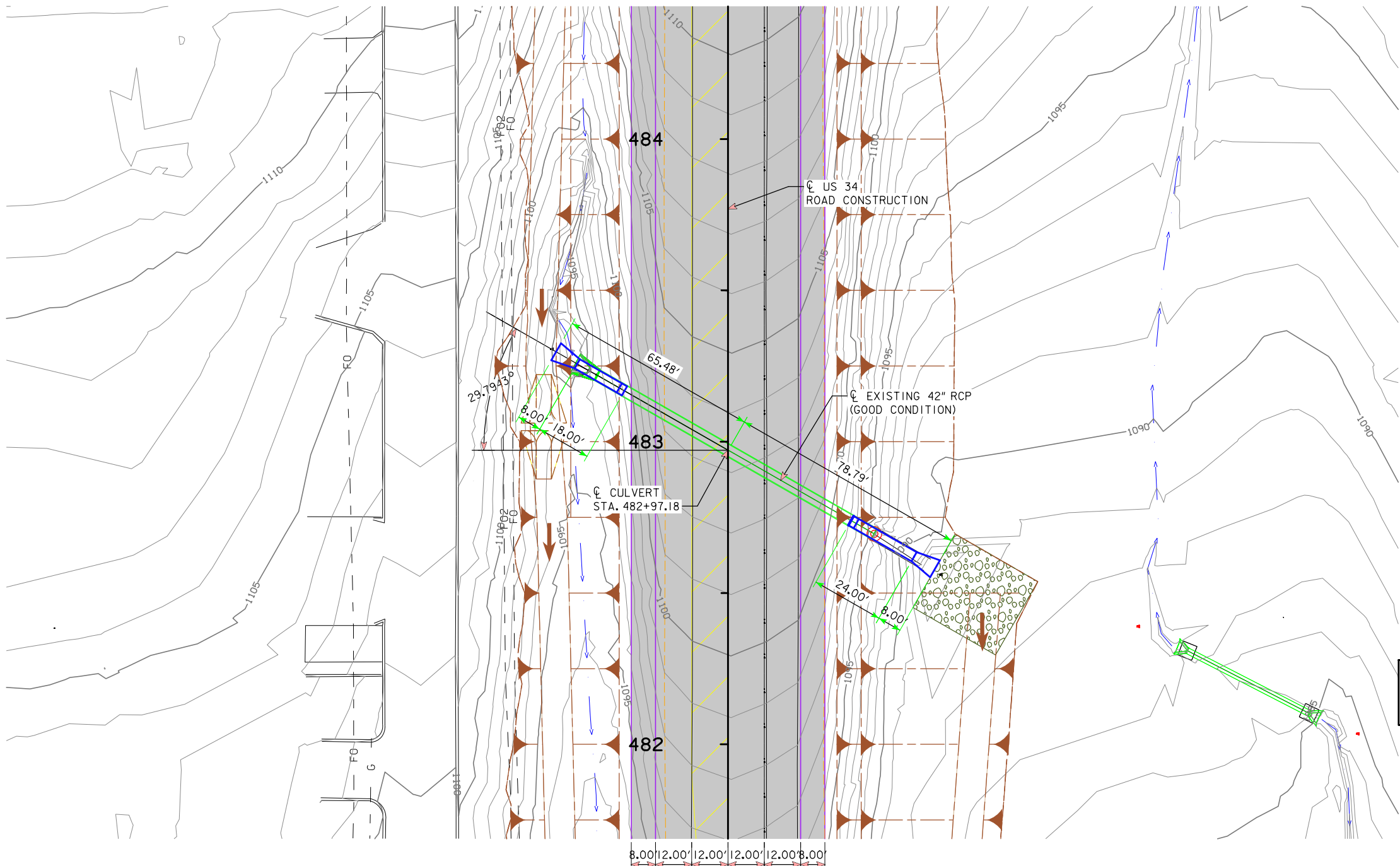
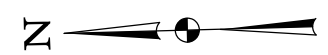

PLAT PLAN

US 34 TRAFFIC ESTIMATE

2023 AADT	4700	V.P.D.
2043 AADT	5700	V.P.D.
2043 DHV	590	V.P.H.
TRUCKS	13	%
TOTAL DESIGN ESALS	N/A	

LOCATION

US 34
T-72 N R-38 W
SECTION 21
RED OAK TOWNSHIP
MONTGOMERY COUNTY

HYDRAULIC DATA

DRAINAGE AREA = 22.0 ACRES - ROLLING
Q₅₀ = 47 CFS
HW ELEV. = 1100.89

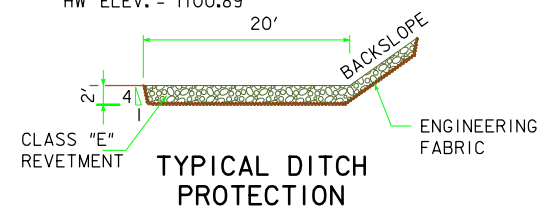

QUANTITIES

CLASS 'E' REVETMENT 93 TONS
ENGINEERING FABRIC 125 SQ. YDS.

NOTE:
ALL DIMENSIONS ARE IN FEET (FT) UNLESS OTHERWISE NOTED OR SHOWN. ALL ELEVATION AND STATIONS ARE IN FEET (FT). FOR SPOT ELEVATIONS ADD 1000 FT.

DESIGN FOR A 0.00° SKEW
42 in. x 42'
REINFORCED CONCRETE PIPE

PLAT PLAN
STA. 482+97.18 (CL US 34) APRIL, 2021
MONTGOMERY COUNTY

IOWA DEPARTMENT OF TRANSPORTATION - HIGHWAY DIVISION
DESIGN SHEET NO. 1 OF 1 FILE NO. 31397 DESIGN NO.



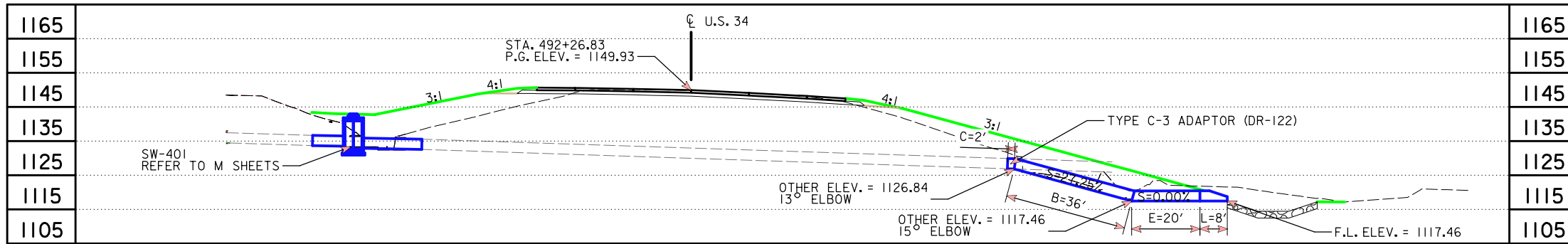

LONGITUDINAL SECTION ALONG CULVERT

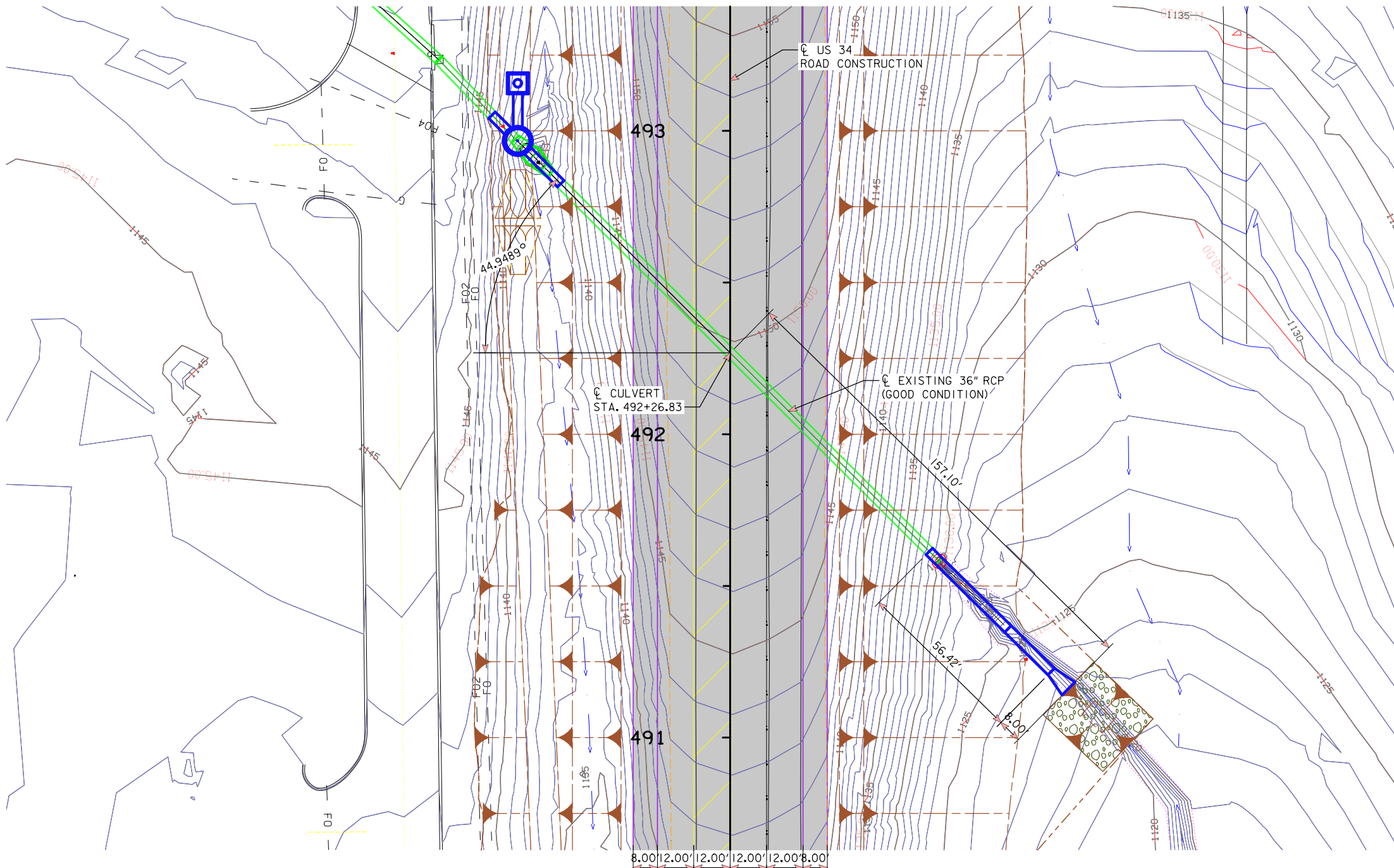
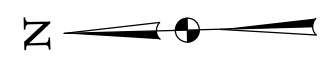

PLAT PLAN

US 34 TRAFFIC ESTIMATE

2023 AADT	4700	V.P.D.
2043 AADT	5700	V.P.D.
2043 DHV	590	V.P.H.
TRUCKS	13	%
TOTAL DESIGN ESALS	N/A	

LOCATION

US 34
T-72 N R-38 W
SECTION 21
RED OAK TOWNSHIP
MONTGOMERY COUNTY

HYDRAULIC DATA

DRAINAGE AREA TOTAL = 14.0 ACRES - ROLLING
URBAN = 11.2 ACRES
RURAL = 2.8 ACRES
Q₅₀ = 33 CFS

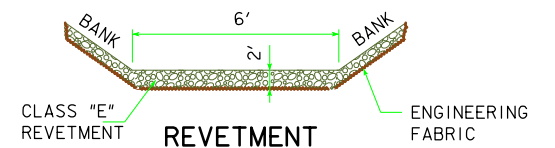

QUANTITIES

CLASS 'E' REVETMENT 68 TONS
ENGINEERING FABRIC 95 SQ. YDS.

NOTE:
ALL DIMENSIONS ARE IN FEET (FT) UNLESS OTHERWISE NOTED OR SHOWN. ALL ELEVATION AND STATIONS ARE IN FEET (FT). FOR SPOT ELEVATIONS ADD 1000 FT.

DESIGN FOR A 0.00° SKEW
36 in. x 58'
UNCLASSIFIED LETDOWN PIPE

PLAT PLAN
STA. 492+26.83 (C U.S. 34) APRIL, 2021
MONTGOMERY COUNTY

IOWA DEPARTMENT OF TRANSPORTATION - HIGHWAY DIVISION
DESIGN SHEET NO. 1 OF 1 FILE NO. 31397 DESIGN NO.



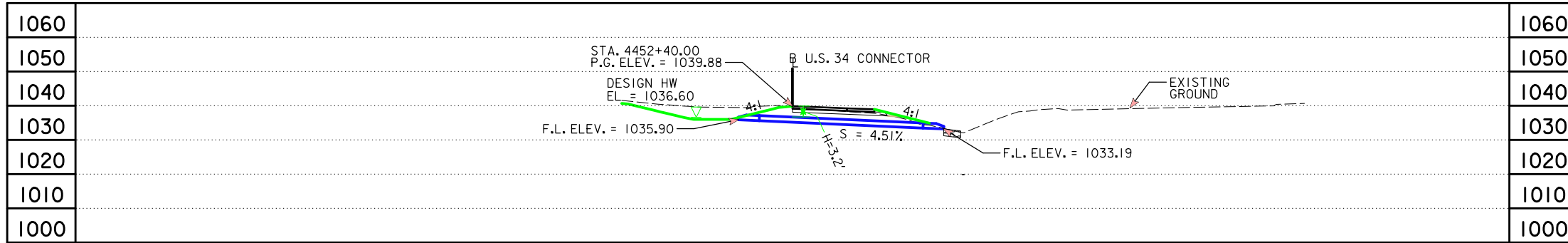

LONGITUDINAL SECTION ALONG ϕ CULVERT

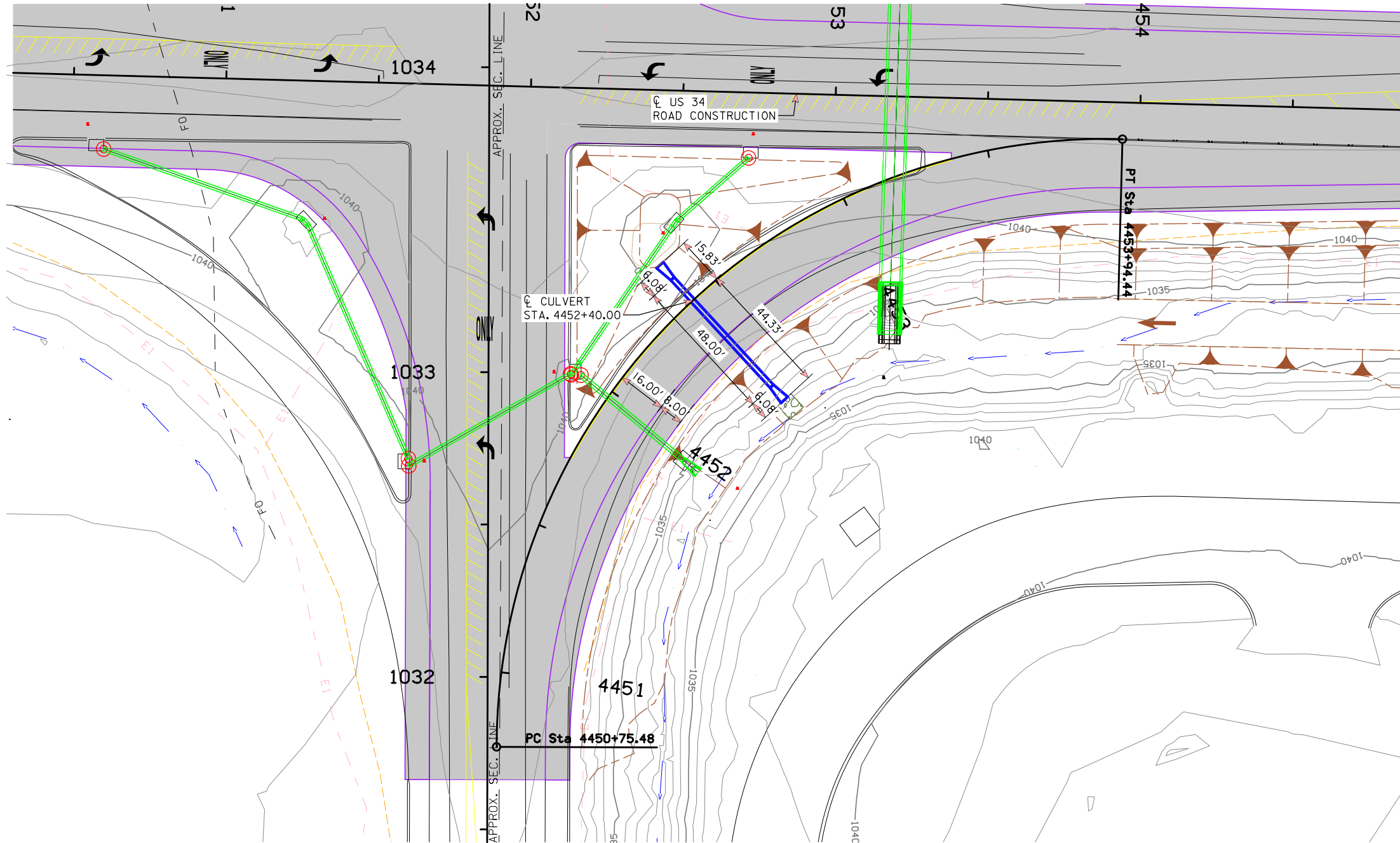

PLAT PLAN

US 34 TRAFFIC ESTIMATE

2023 AADT	4700	V.P.D.
2043 AADT	5700	V.P.D.
2043 DHV	590	V.P.H.
TRUCKS	13	%
TOTAL DESIGN ESALS	N/A	

LOCATION

US 34
T-72 N R-38 W
SECTION 21
RED OAK TOWNSHIP
MONTGOMERY COUNTY

HYDRAULIC DATA

DRAINAGE AREA = 1.0 ACRES - FLAT
Q₅₀ = 2 CFS
HW ELEV. = 1036.60

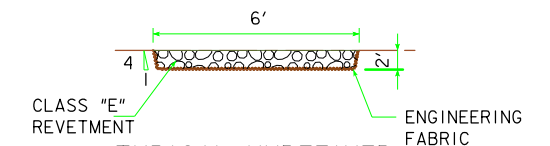

TYPICAL UNDEFINED CHANNEL PROTECTION

QUANTITIES

CLASS 'E' REVETMENT 4 TONS
ENGINEERING FABRIC 10 SQ. YDS.

NOTE:
ALL DIMENSIONS ARE IN FEET (FT) UNLESS OTHERWISE NOTED OR SHOWN. ALL ELEVATION AND STATIONS ARE IN FEET (FT). FOR SPOT ELEVATIONS ADD 1000 FT.

DESIGN FOR A 0.00° SKEW
18 in. x 48'
REINFORCED CONC. PIPE

PLAT PLAN
STA. 4452+40.00 (ϕ US 34 CONNECTOR) APRIL, 2021
MONTGOMERY COUNTY

IOWA DEPARTMENT OF TRANSPORTATION - HIGHWAY DIVISION
DESIGN SHEET NO. 1 OF 1 FILE NO. 31397 DESIGN NO.

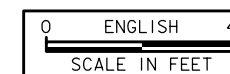

LINE STYLE LEGEND OF CROSS SECTION SHEETS (ROAD)

- Proposed Finished Grade of Adjacent Template
- - - - - Existing Ground Line
- Proposed Template
- Proposed Topsoil Placement
- - - - - Additional Topsoil Removal
- Subgrade Treatment
- - - - - Granular Shoulder
- Pavement
- - - - - Existing Pipe\R/CB
- Proposed Pipe\R/CB
- Proposed Dike
- All Elements Associated with Proposed Entrances

LINE STYLE LEGEND OF CROSS SECTION SHEETS (SOILS)

- TS ————— Topsoil (Class 10)
- SLOPE DRESSING — Slope Dressing Only
- CL 10 ————— Class 10 Materials
- SEL LO ————— Select Loams And Clay-Loams
- SEL SA ————— Select Sand
- UNS A ————— Unsuitable Type A Disposal
- UNS B ————— Unsuitable Type B Disposal
- UNS C ————— Unsuitable Type C Disposal
- SHALE ————— Shale
- WASTE ————— Waste
- B&W LS ————— Broken and Weathered Rock
- ROCK ————— Solid Rock
- BLDRS ————— Boulders

Note: All layer lines and descriptions identify layers above the line.

Note: Vertical or near vertical lines connecting soil layers at edges of cross sections are only for the purpose of calculating template quantities and do not depict soil stratification.

SYMBOL LEGEND OF CROSS SECTION SHEETS

- Existing ROW
|
Existing Right-of-Way Limit
- Proposed ROW
|
Proposed Right-of-Way Limit
- Temporary ROW
|
Temporary Right-of-Way Limit

**CROSS SECTION
LEGEND AND SYMBOL
INFORMATION SHEET**

(COVERS SHEET SERIES W, X, Y, & Z)

US 34 Preliminary

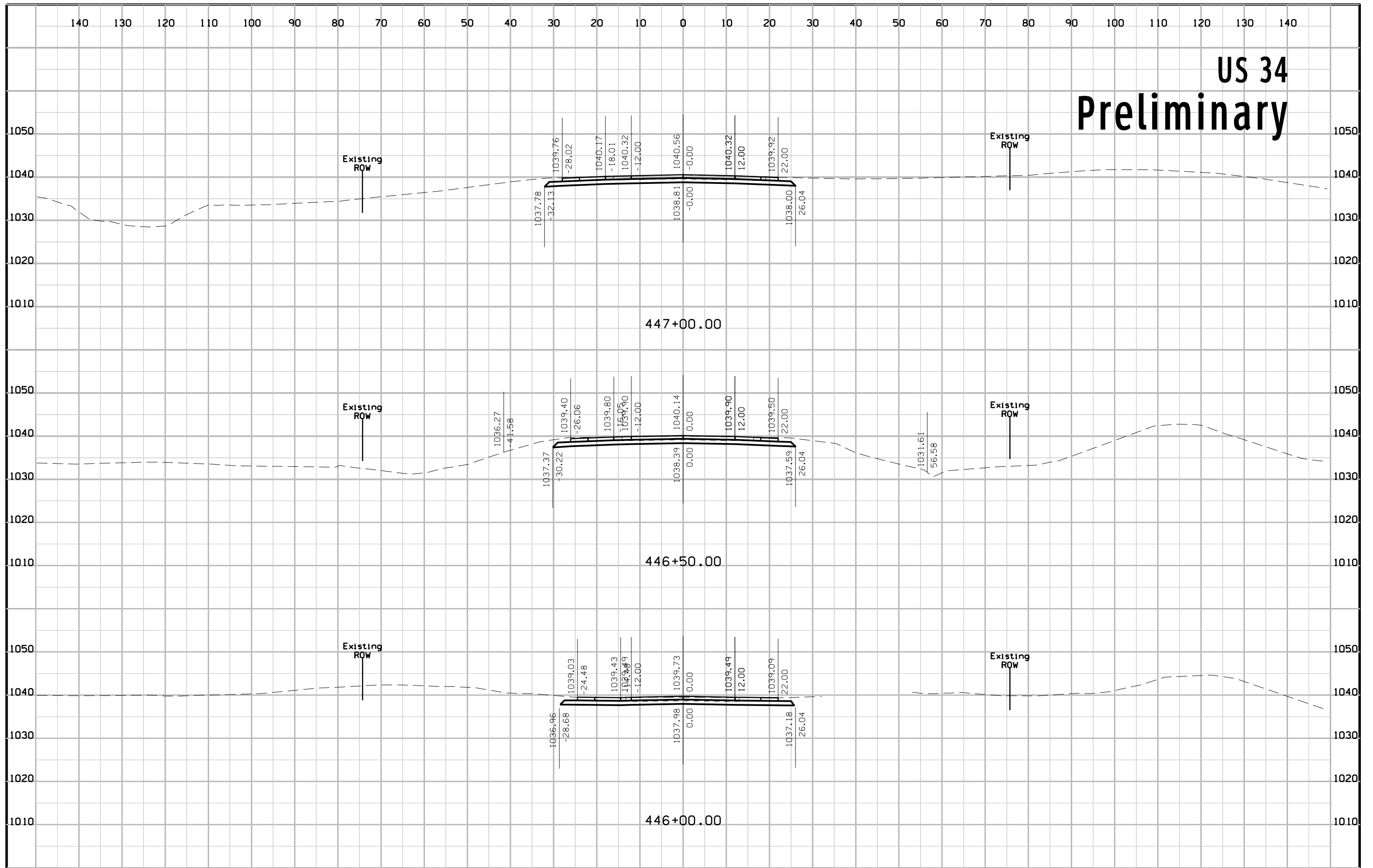

US 34 Preliminary

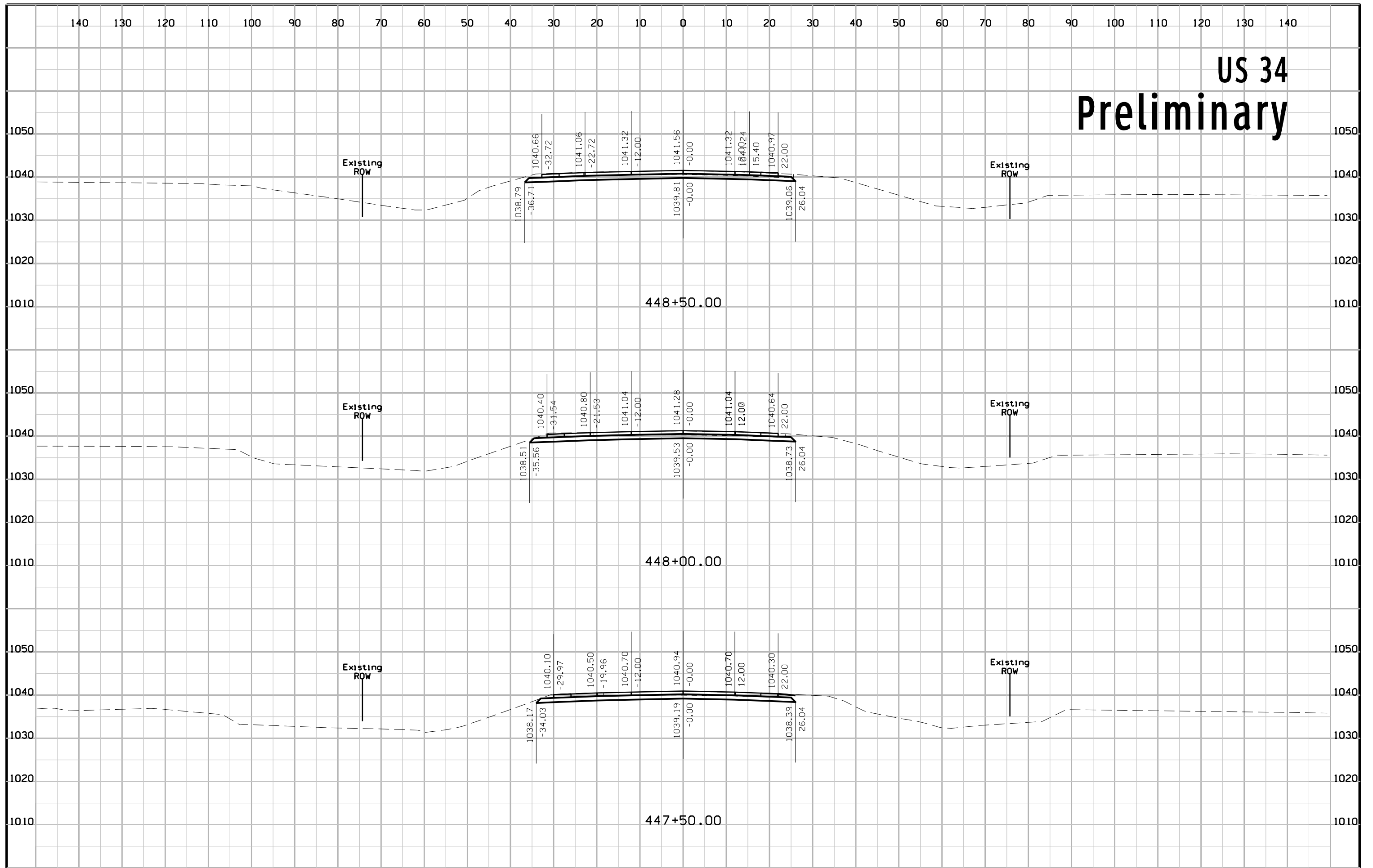

US 34 Preliminary

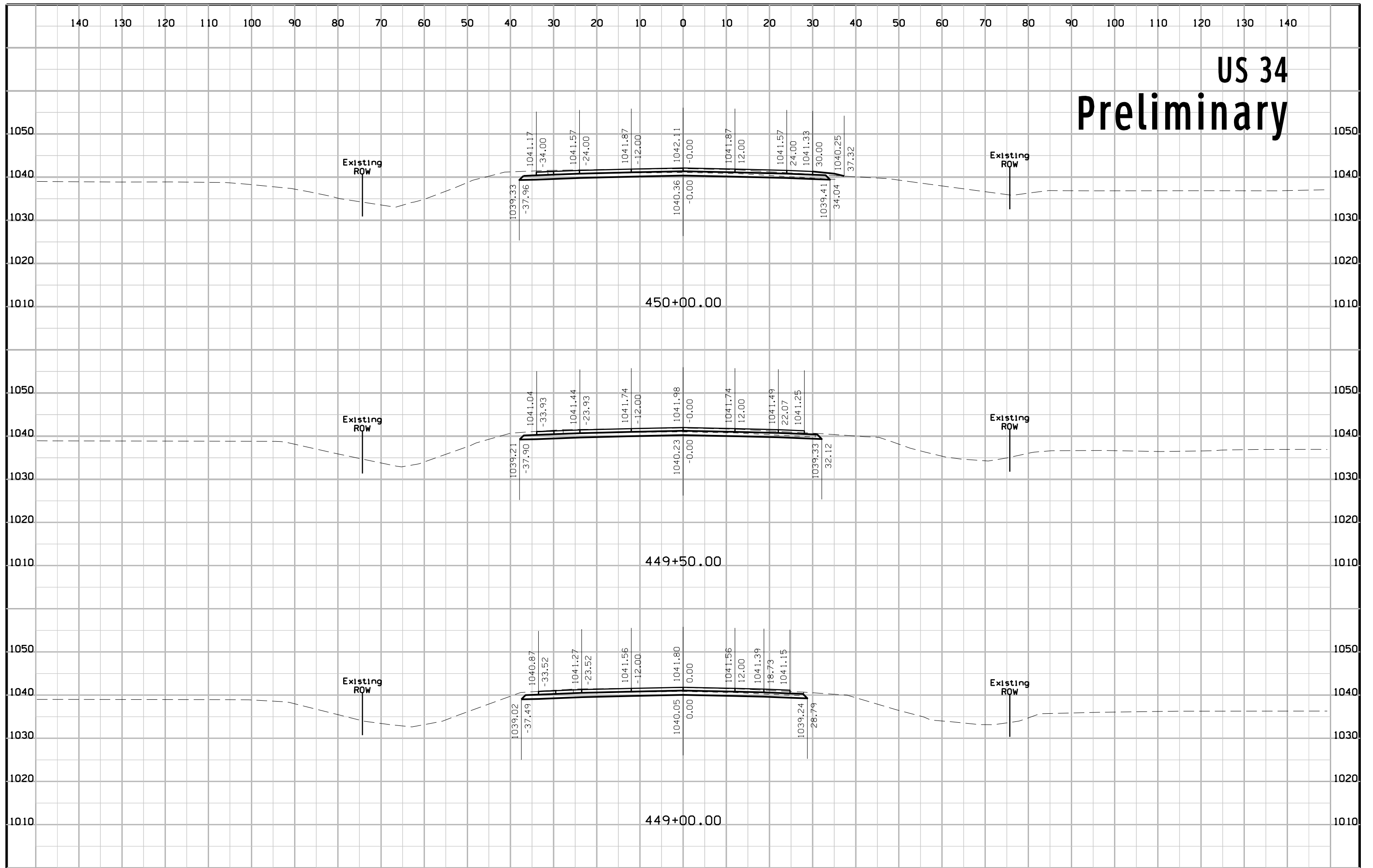

US 34 Preliminary

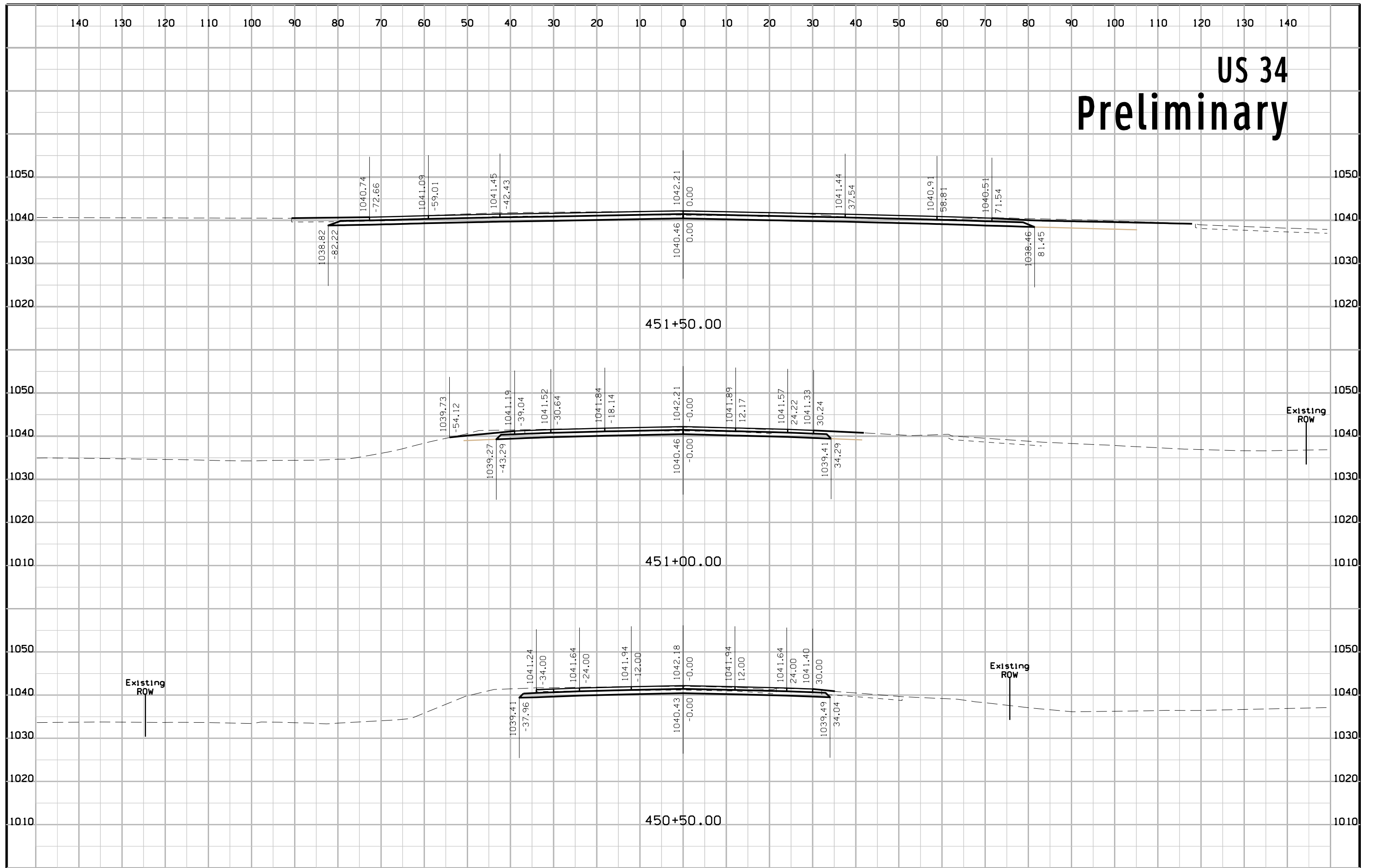

US 34 Preliminary

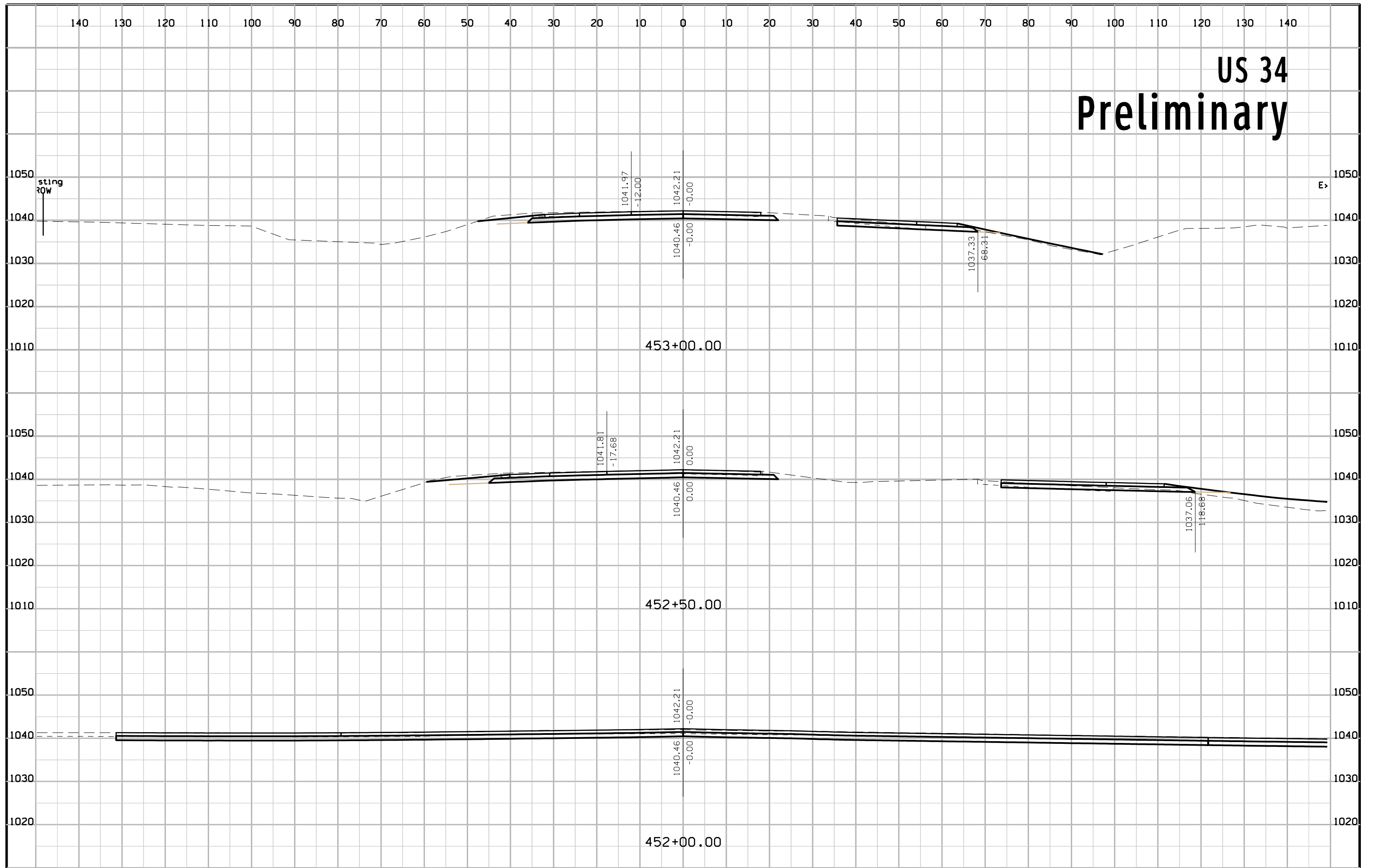

US 34 Preliminary

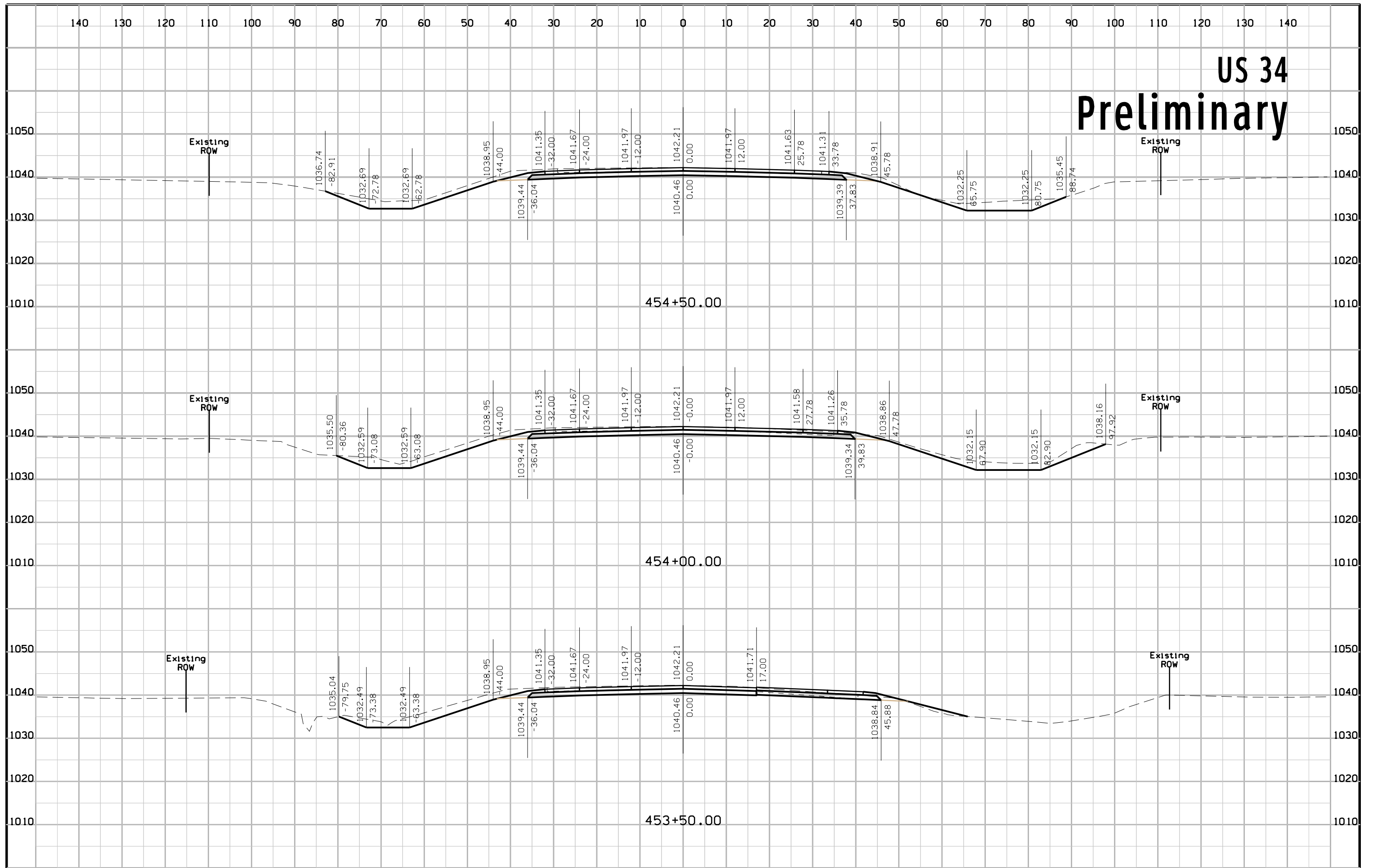

US 34 Preliminary

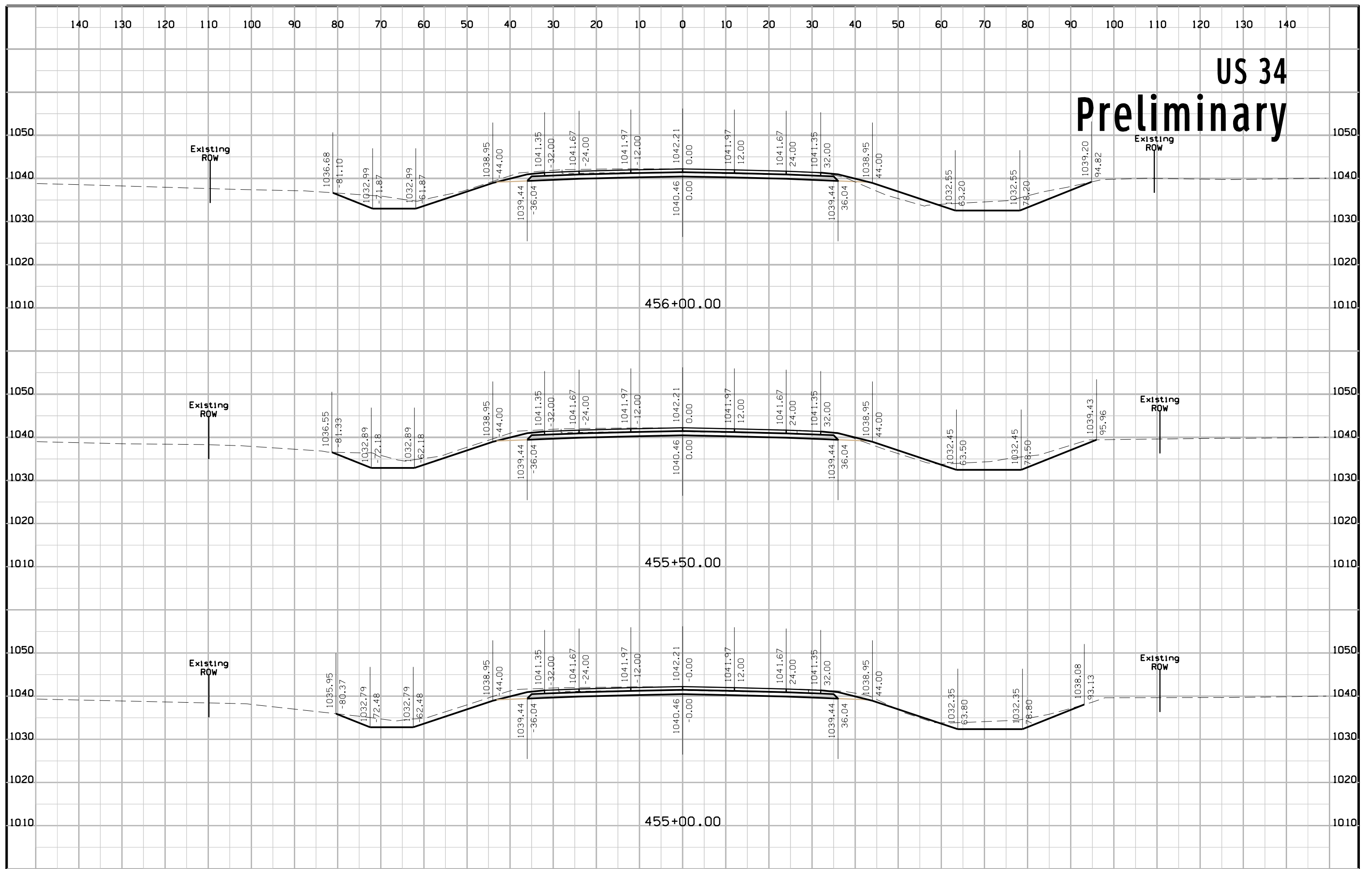

US 34 Preliminary

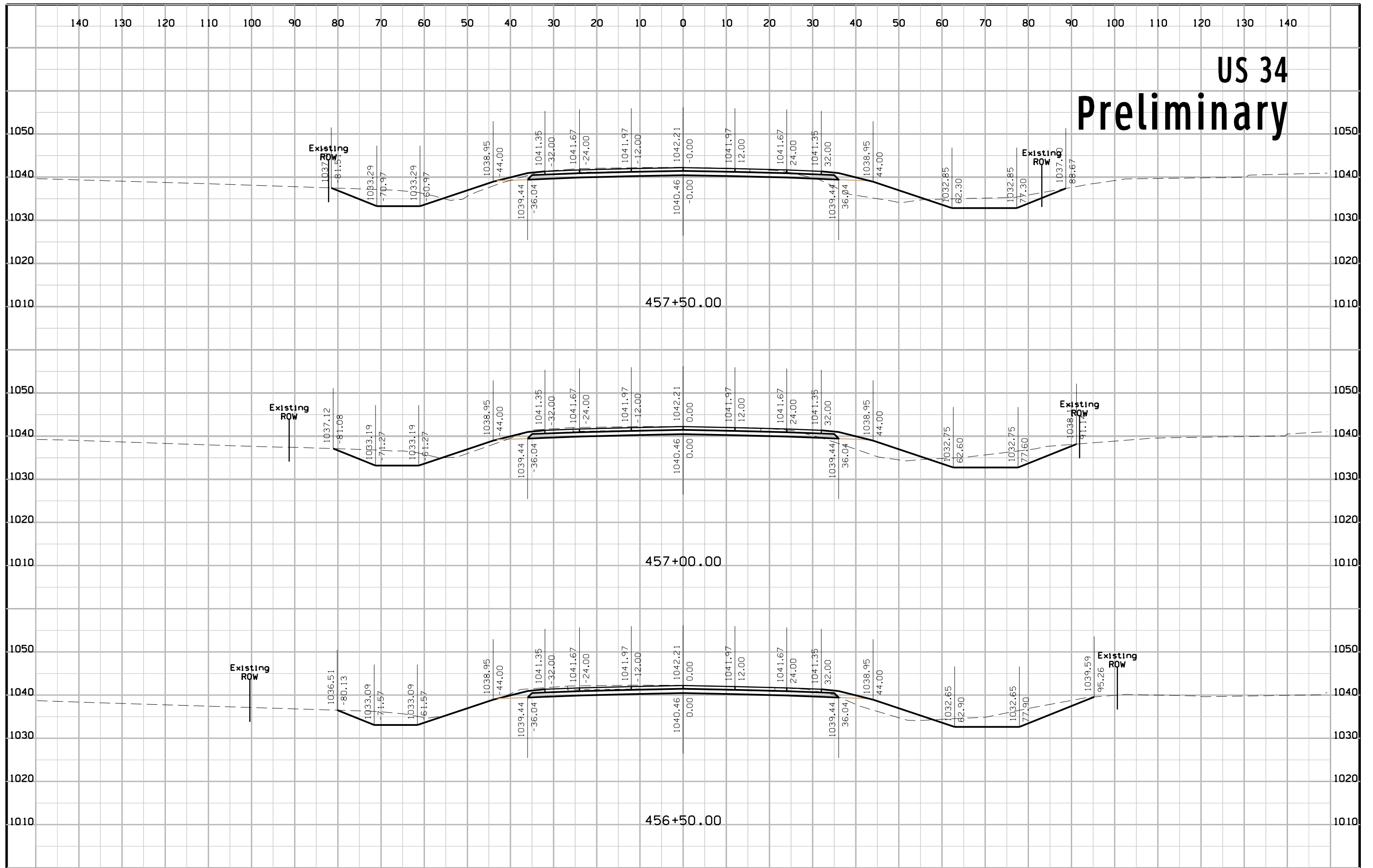

US 34

Preliminary

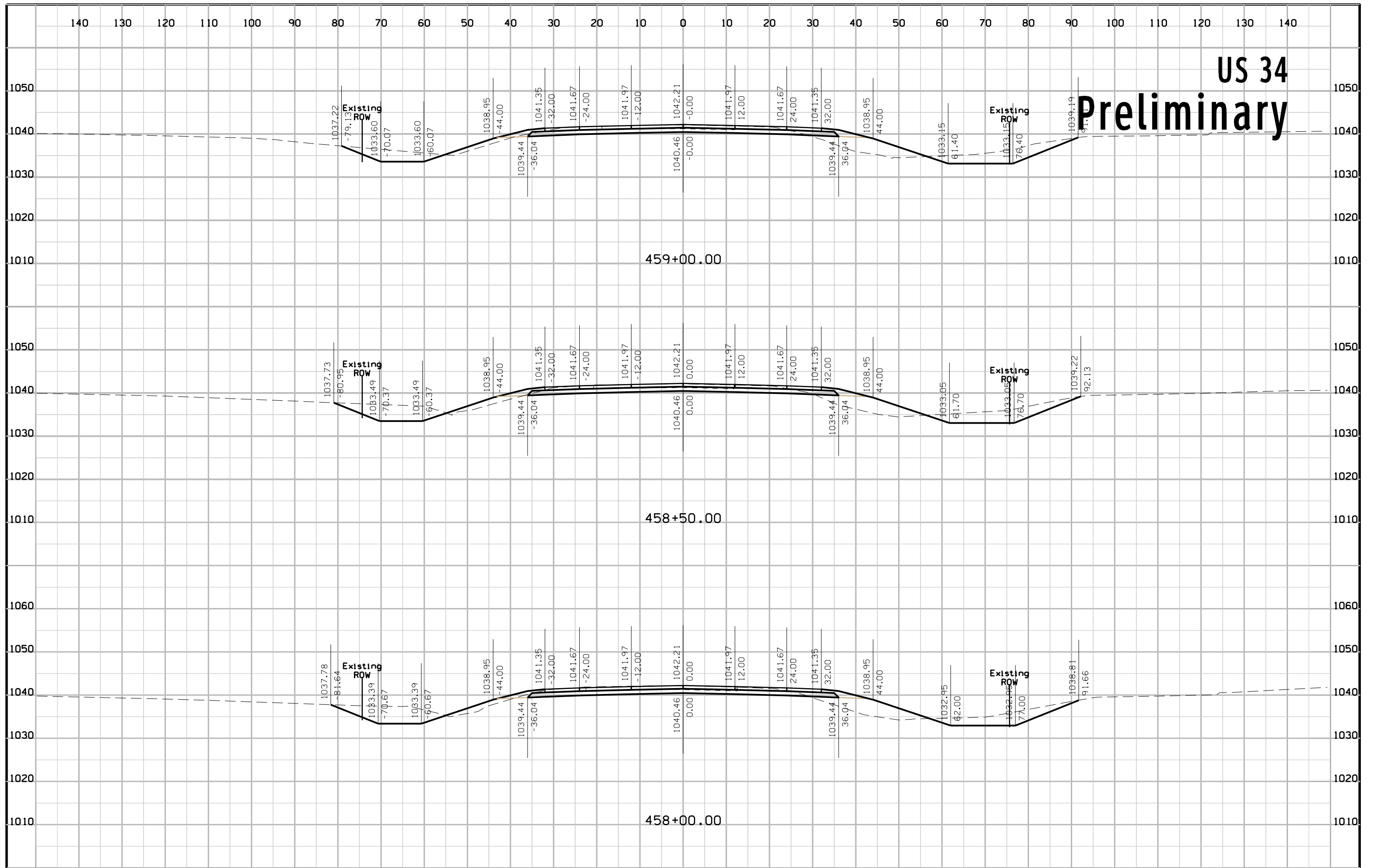

459+00.00

458+50.00

458+00.00

US 34 Preliminary

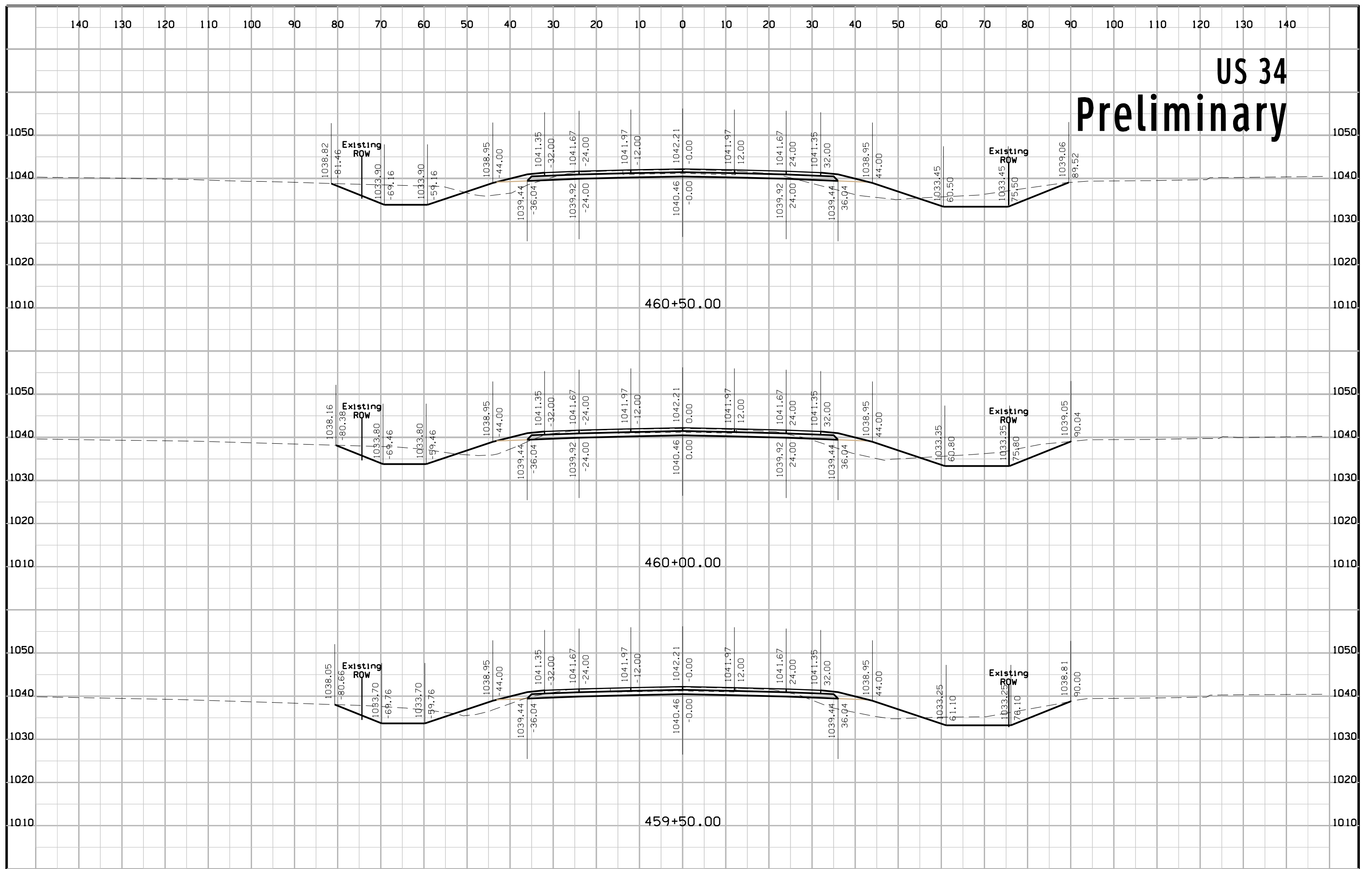

US 34 Preliminary

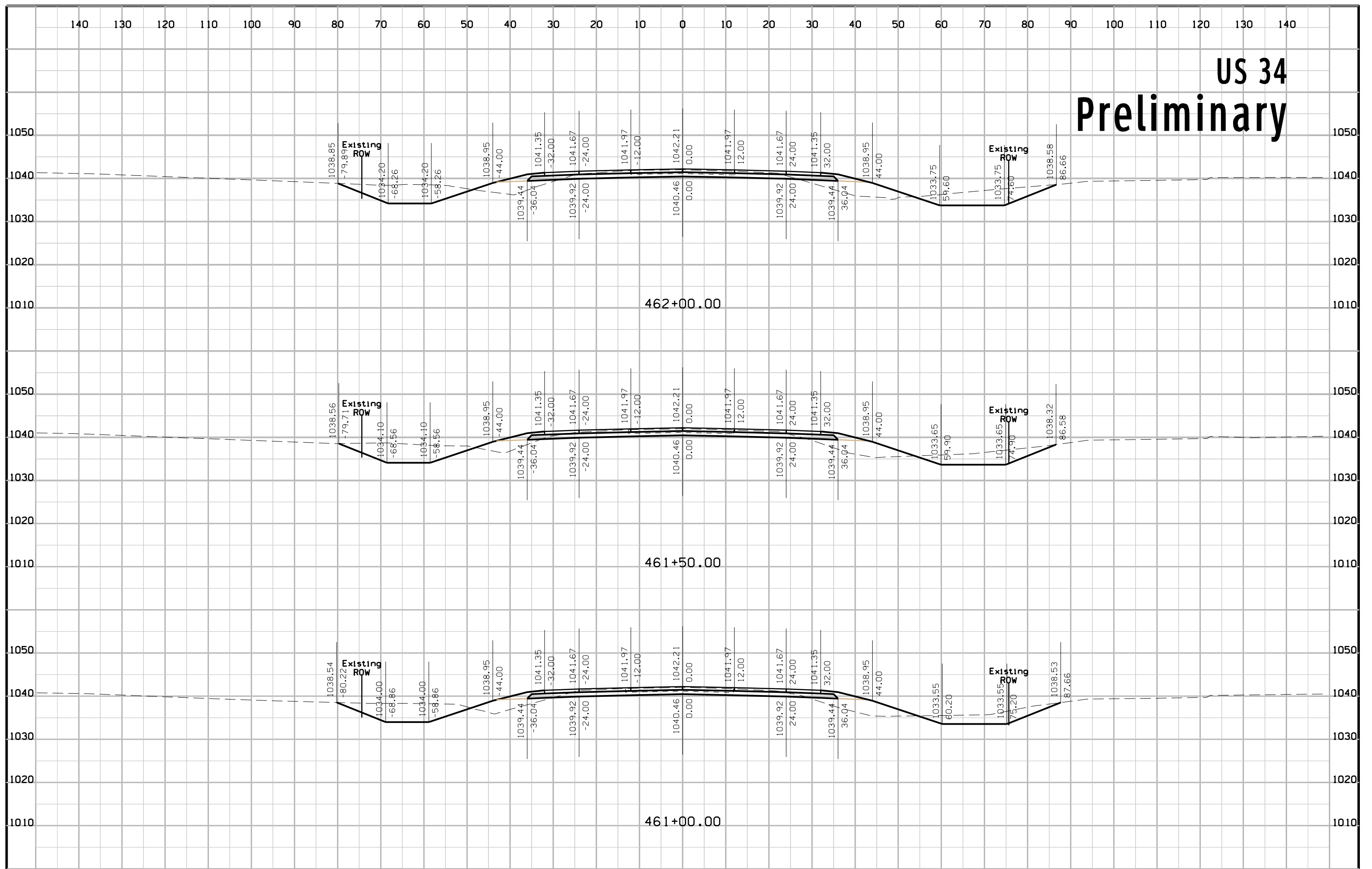

US 34 Preliminary

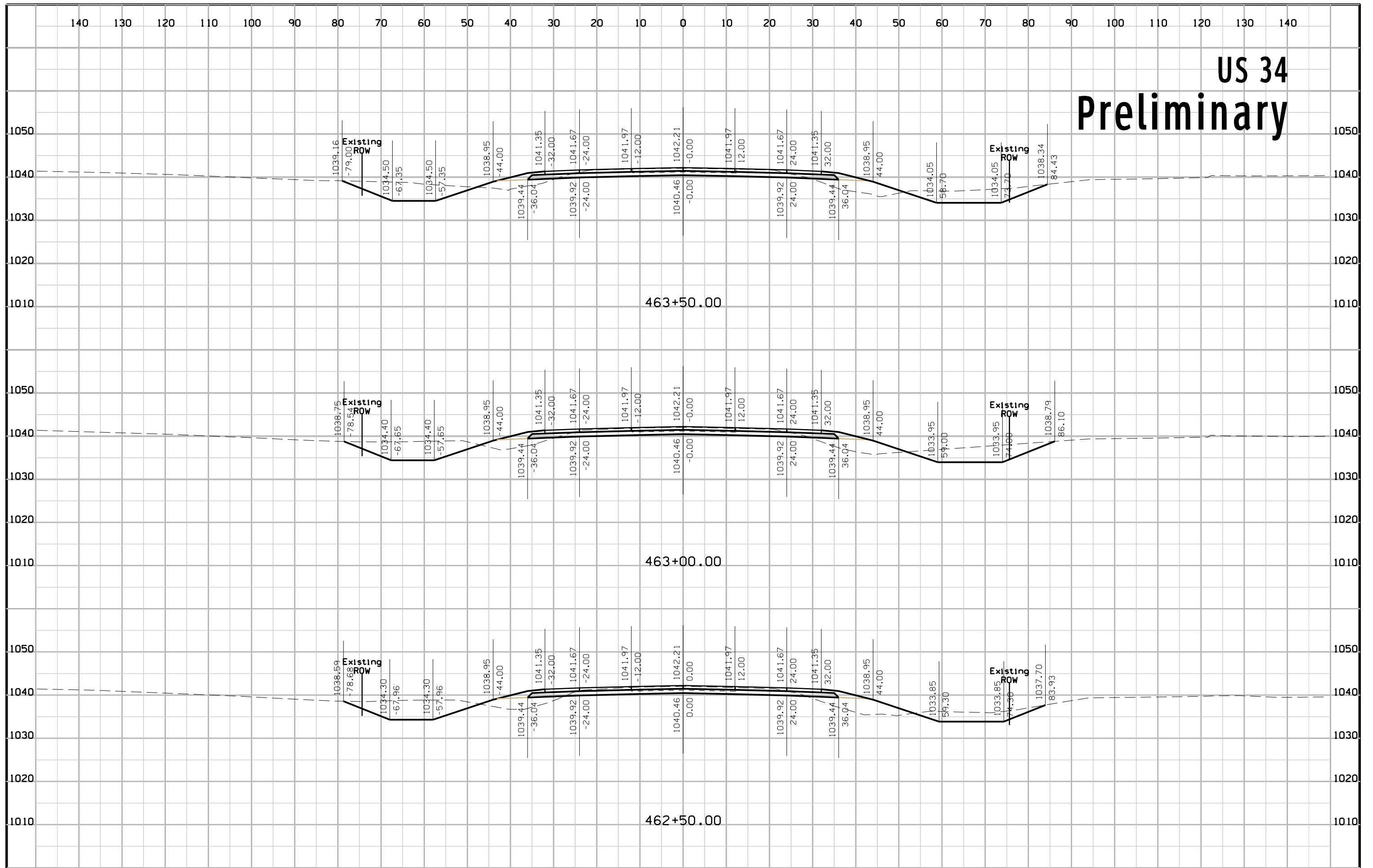

US 34 Preliminary

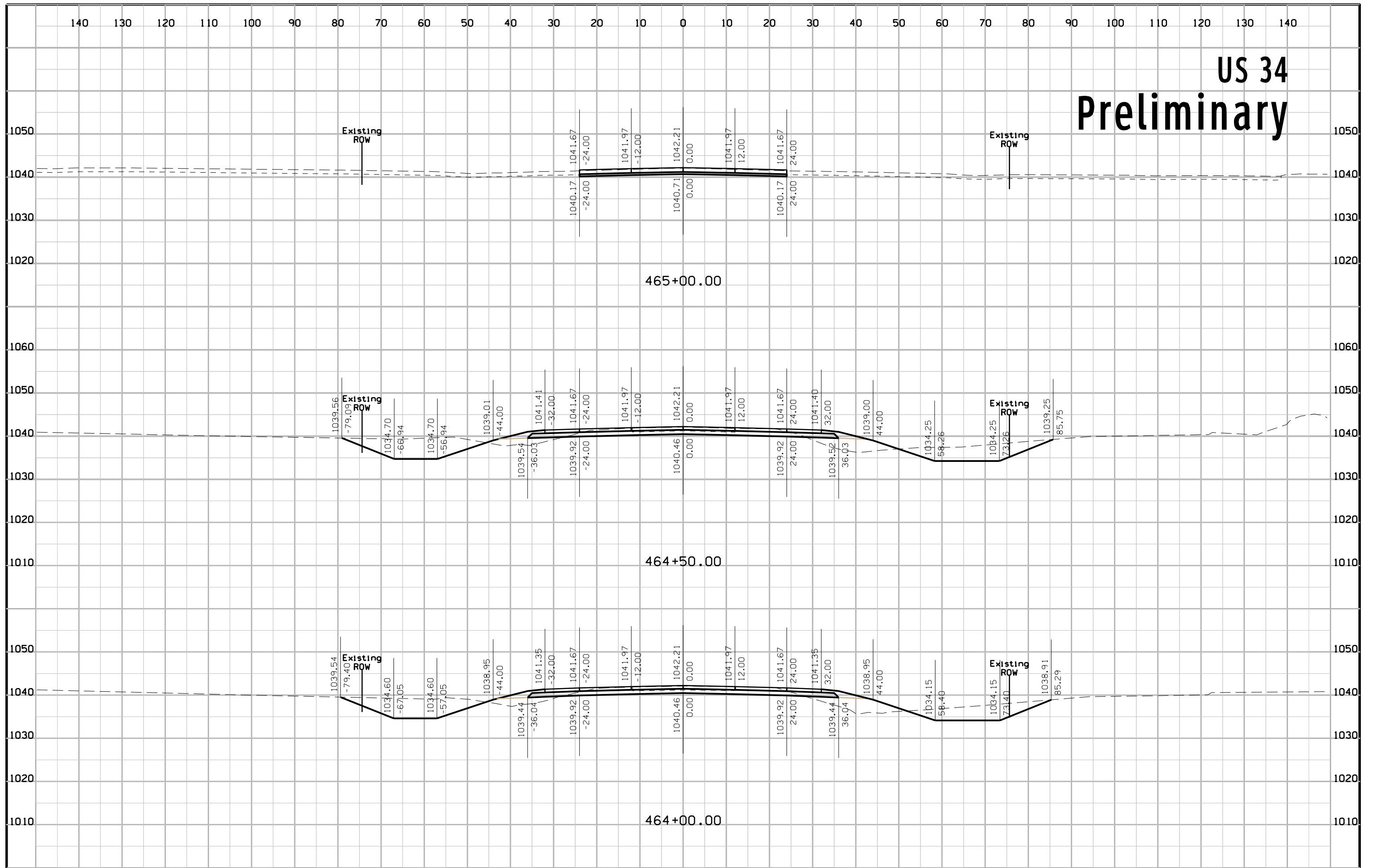

US 34 Preliminary

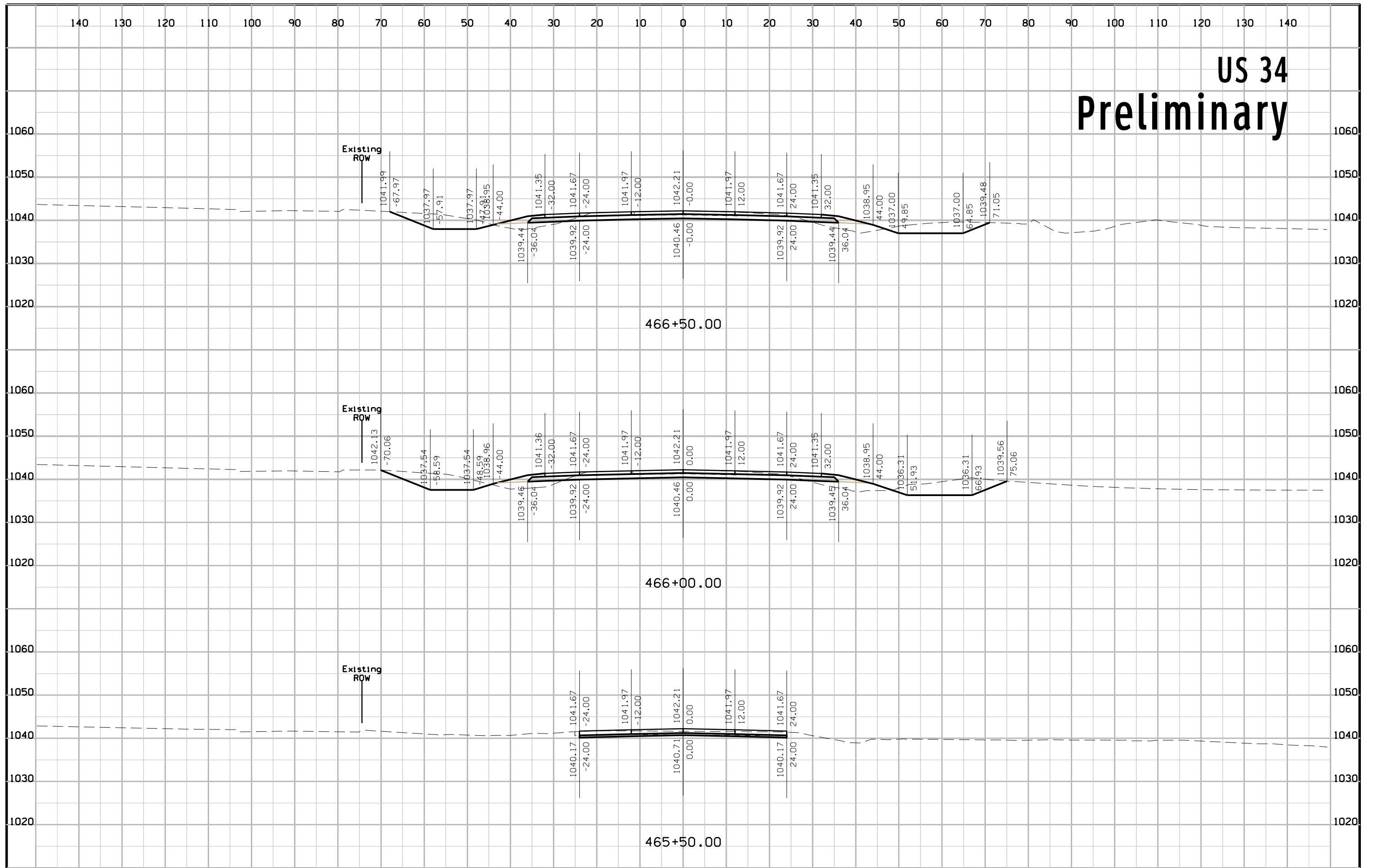

US 34 Preliminary

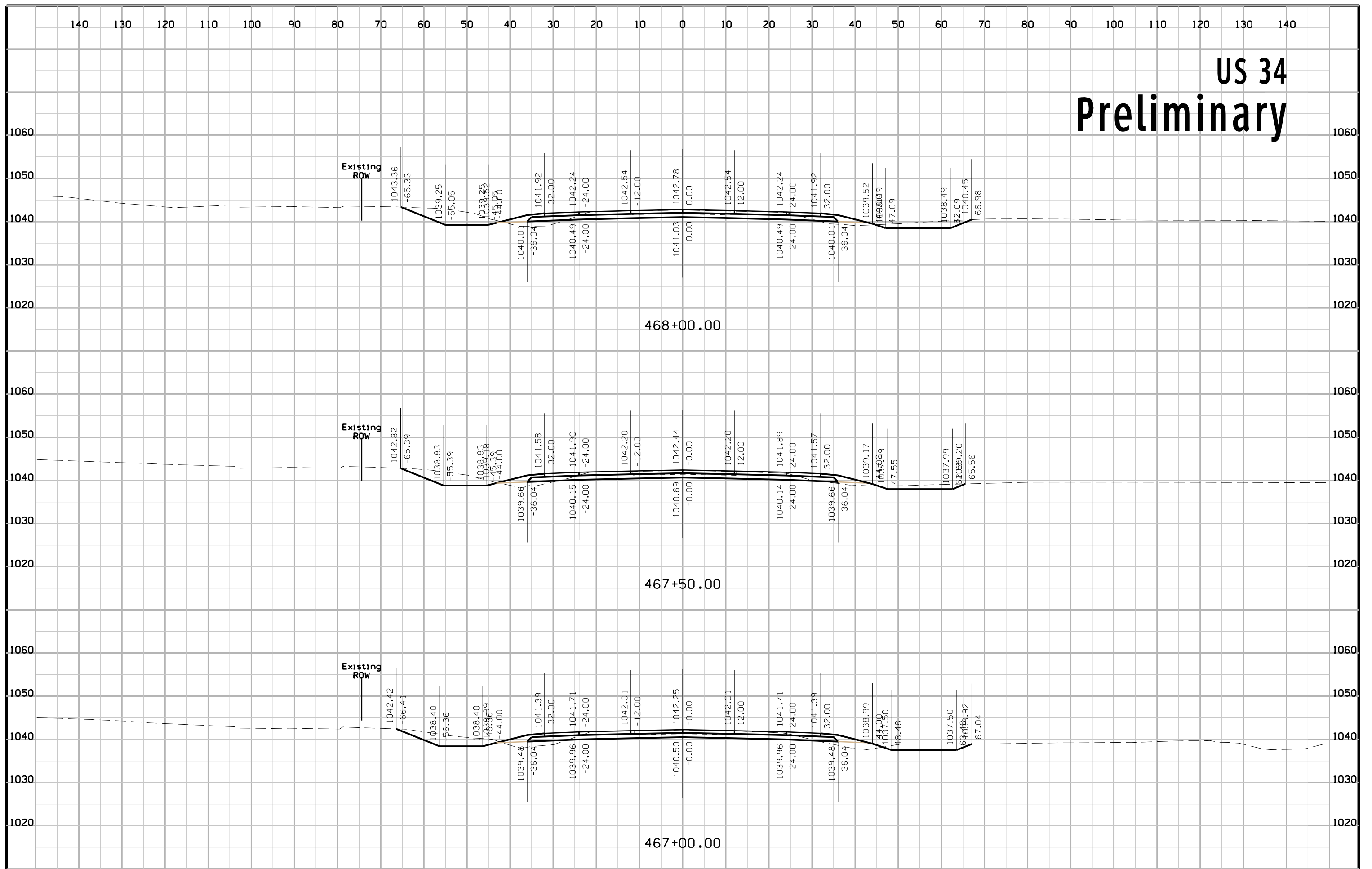

US 34 Preliminary

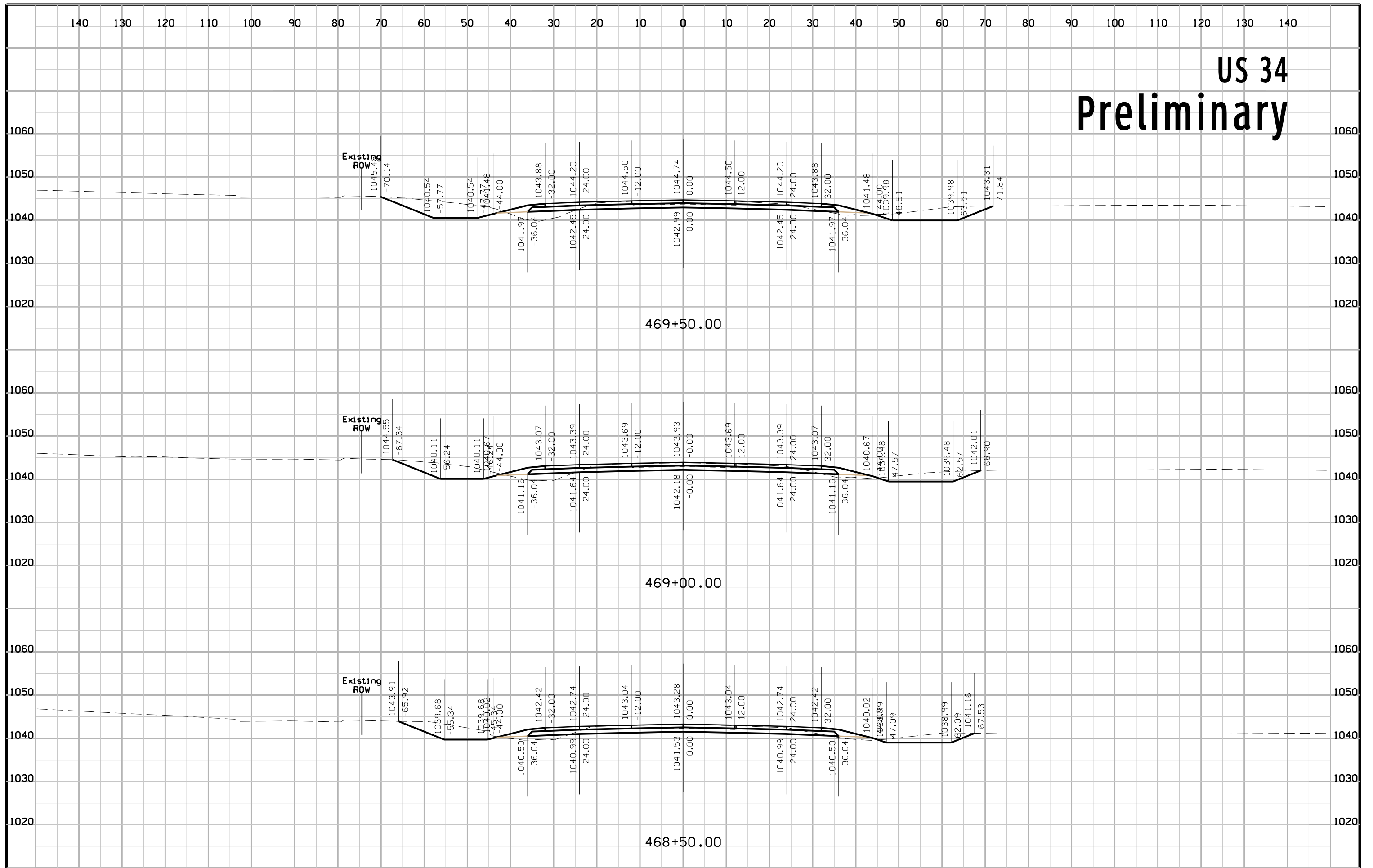

US 34 Preliminary

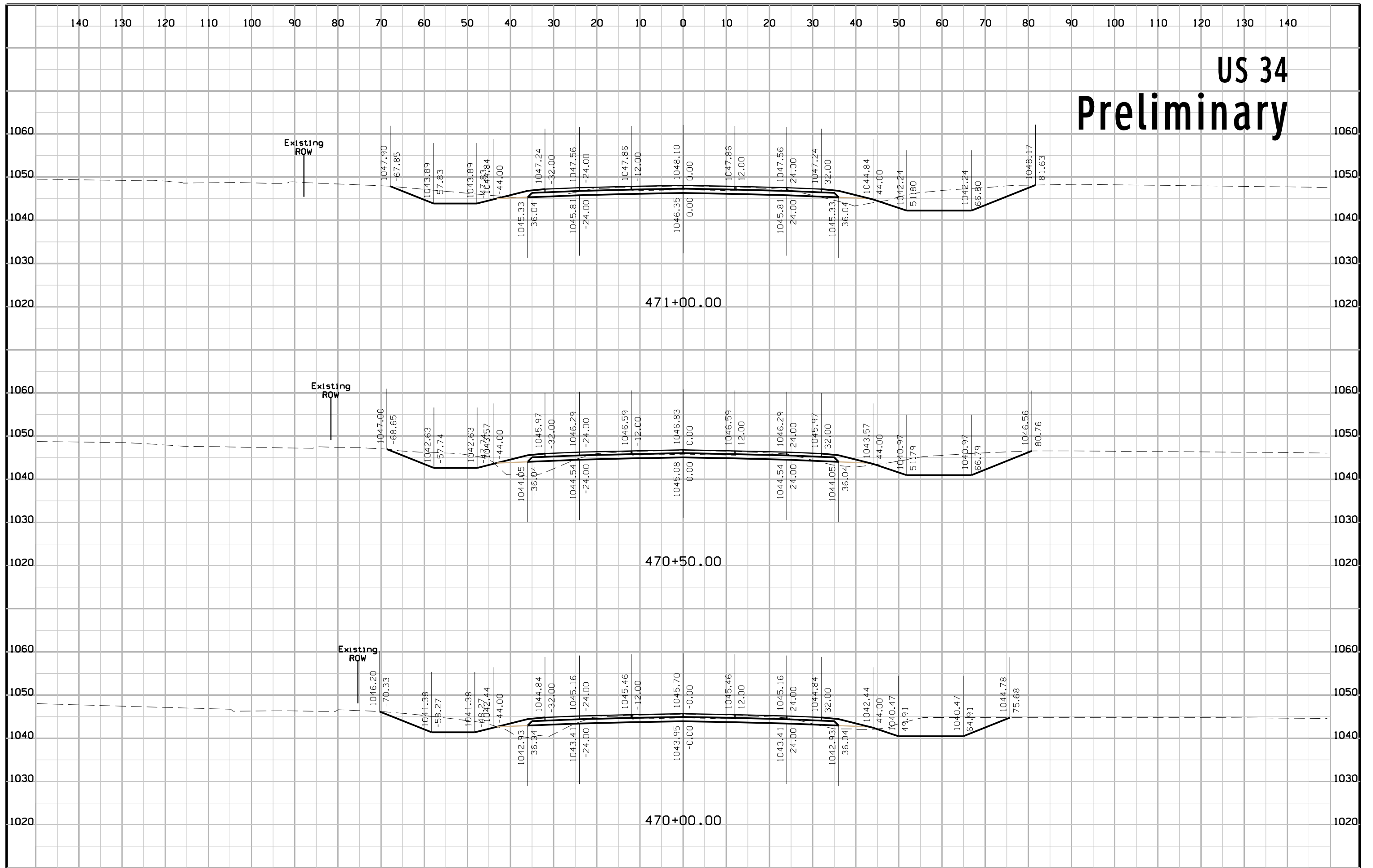

US 34 Preliminary

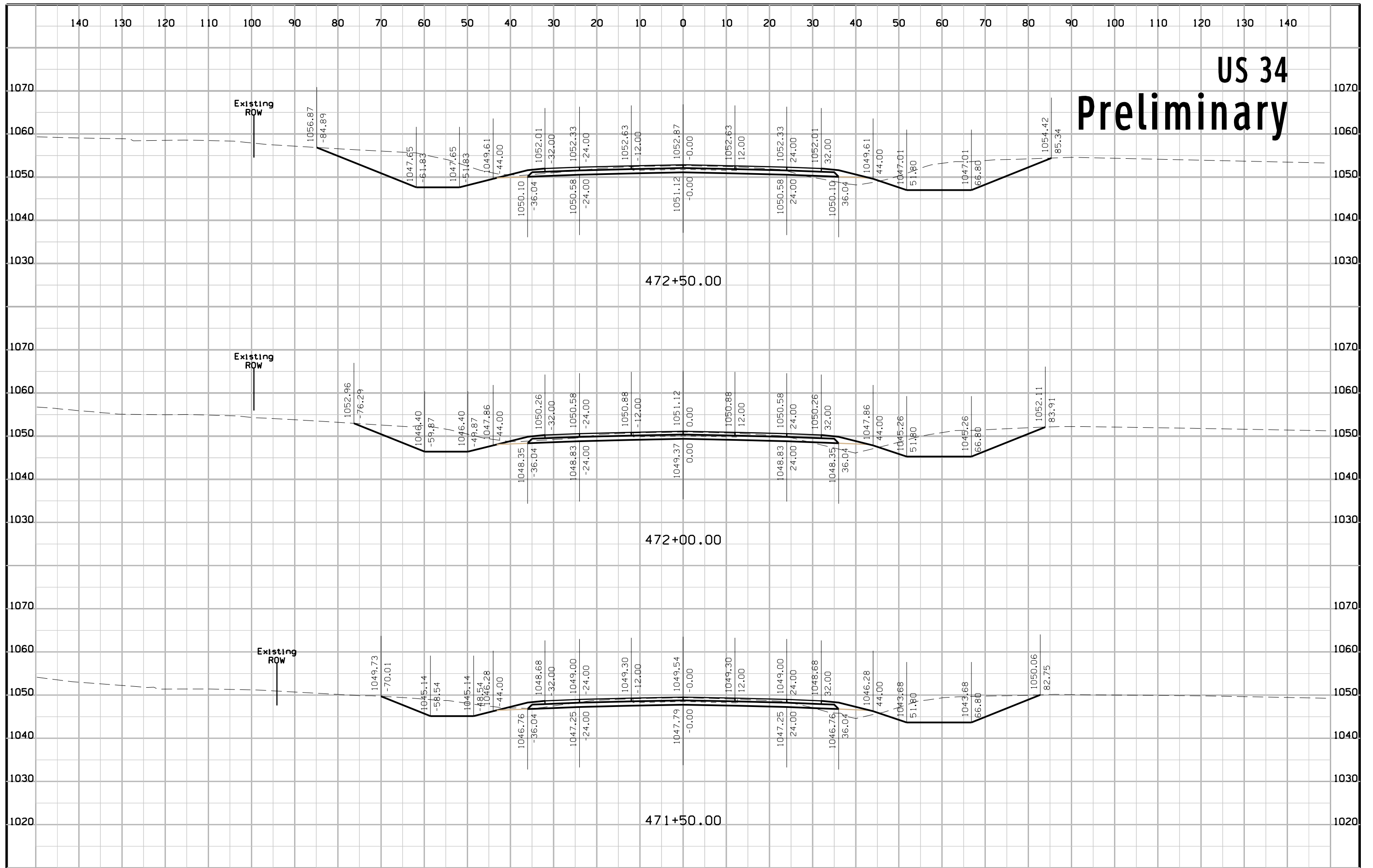

US 34 Preliminary

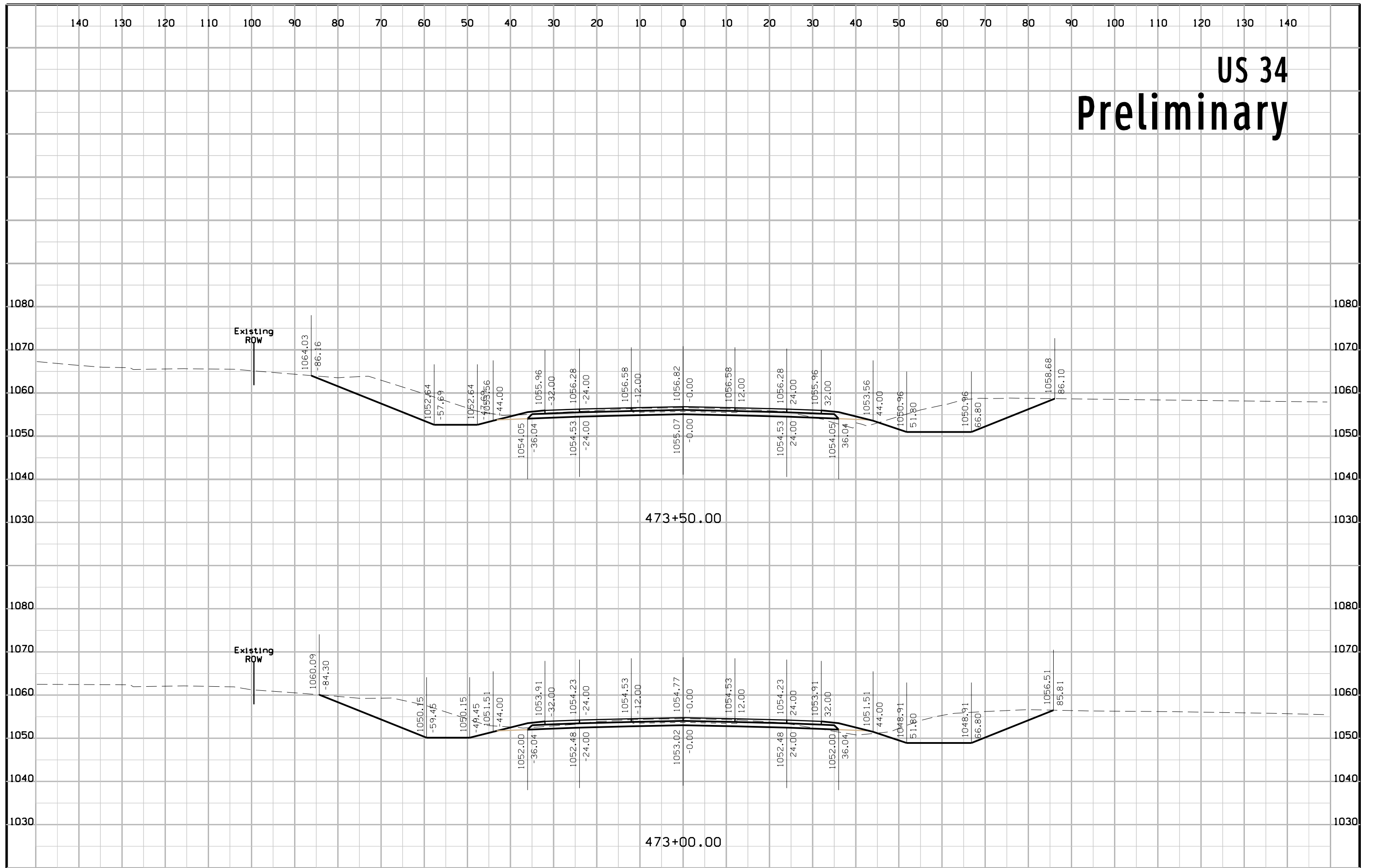

US 34 Preliminary

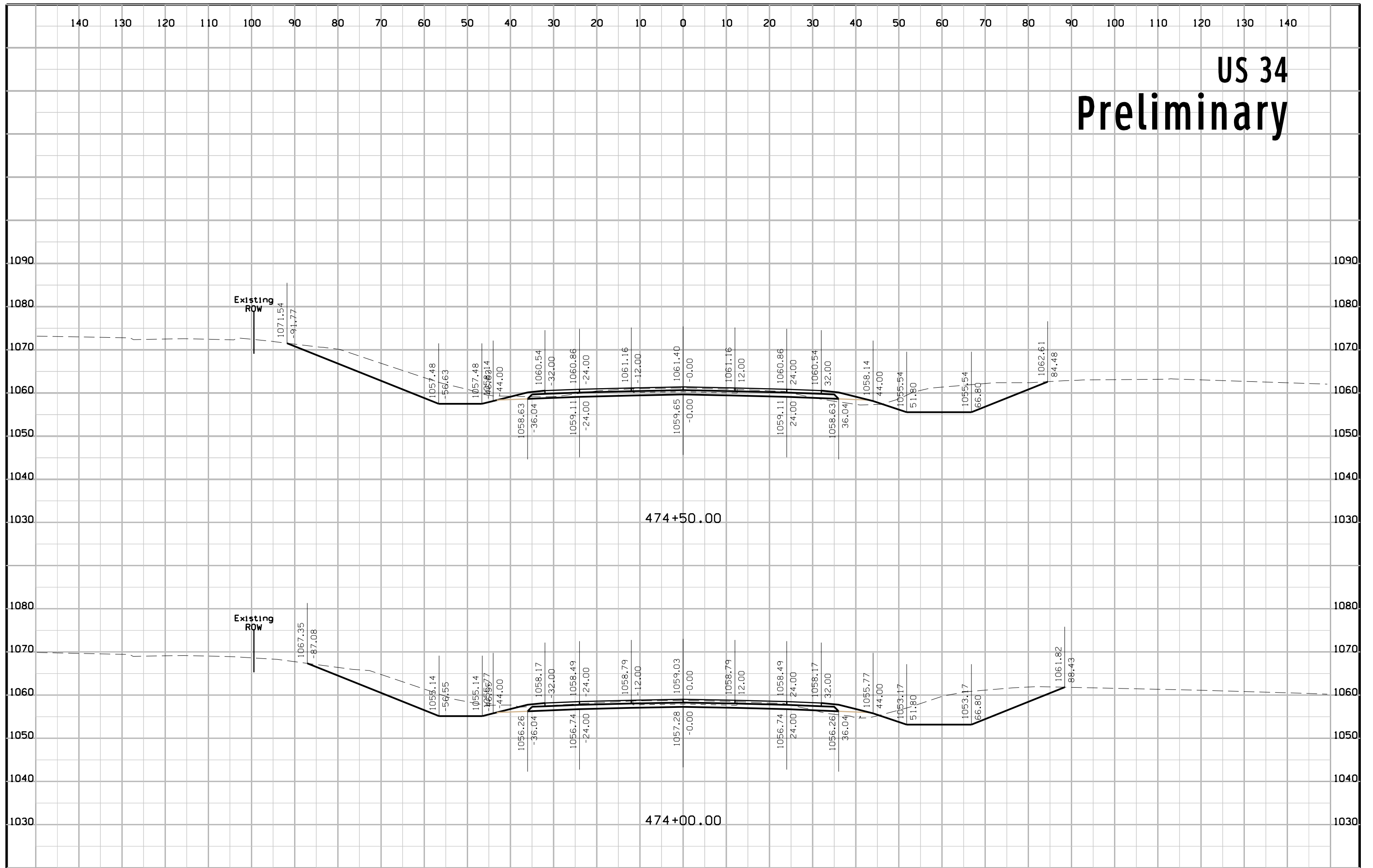

US 34 Preliminary

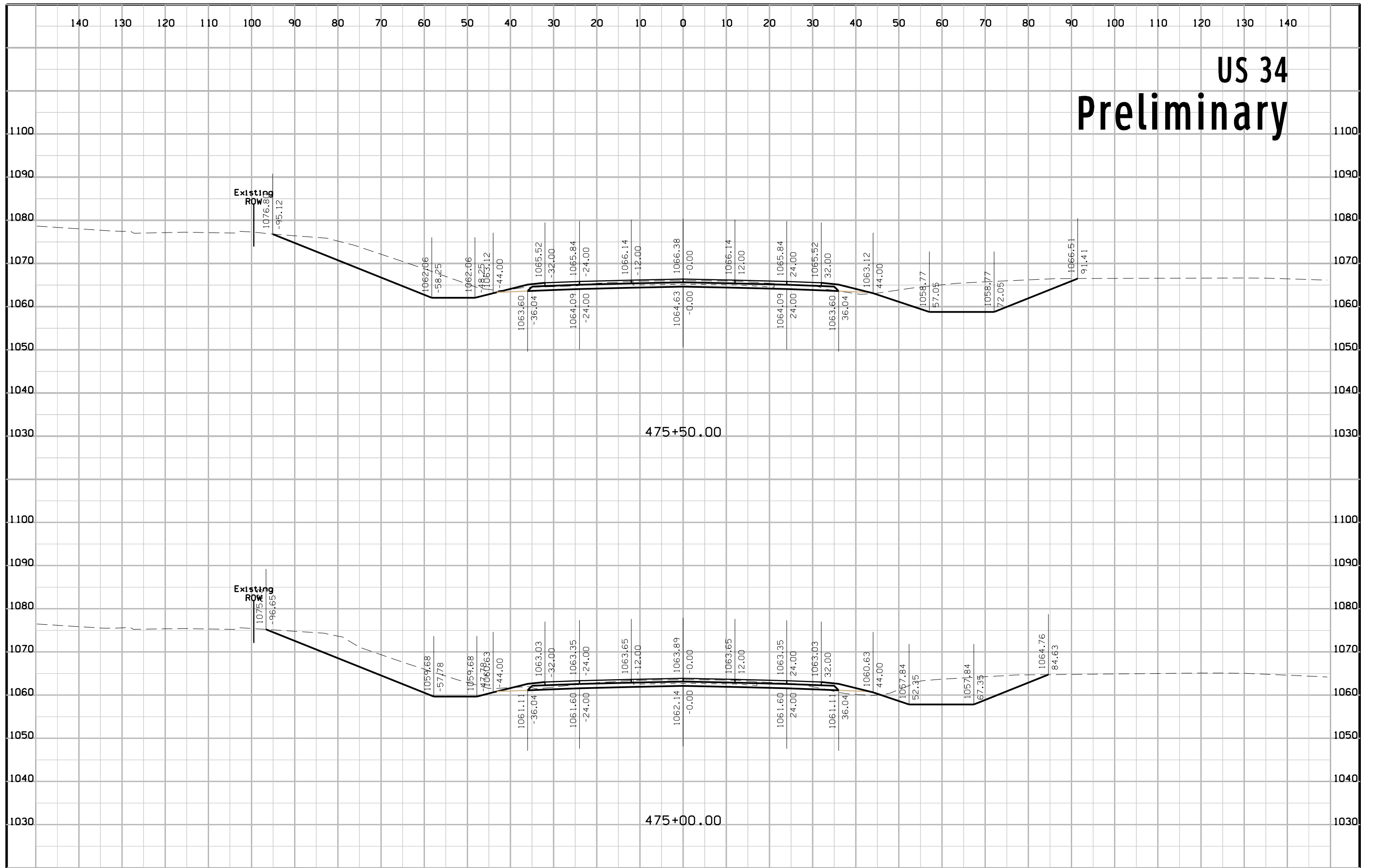

US 34 Preliminary

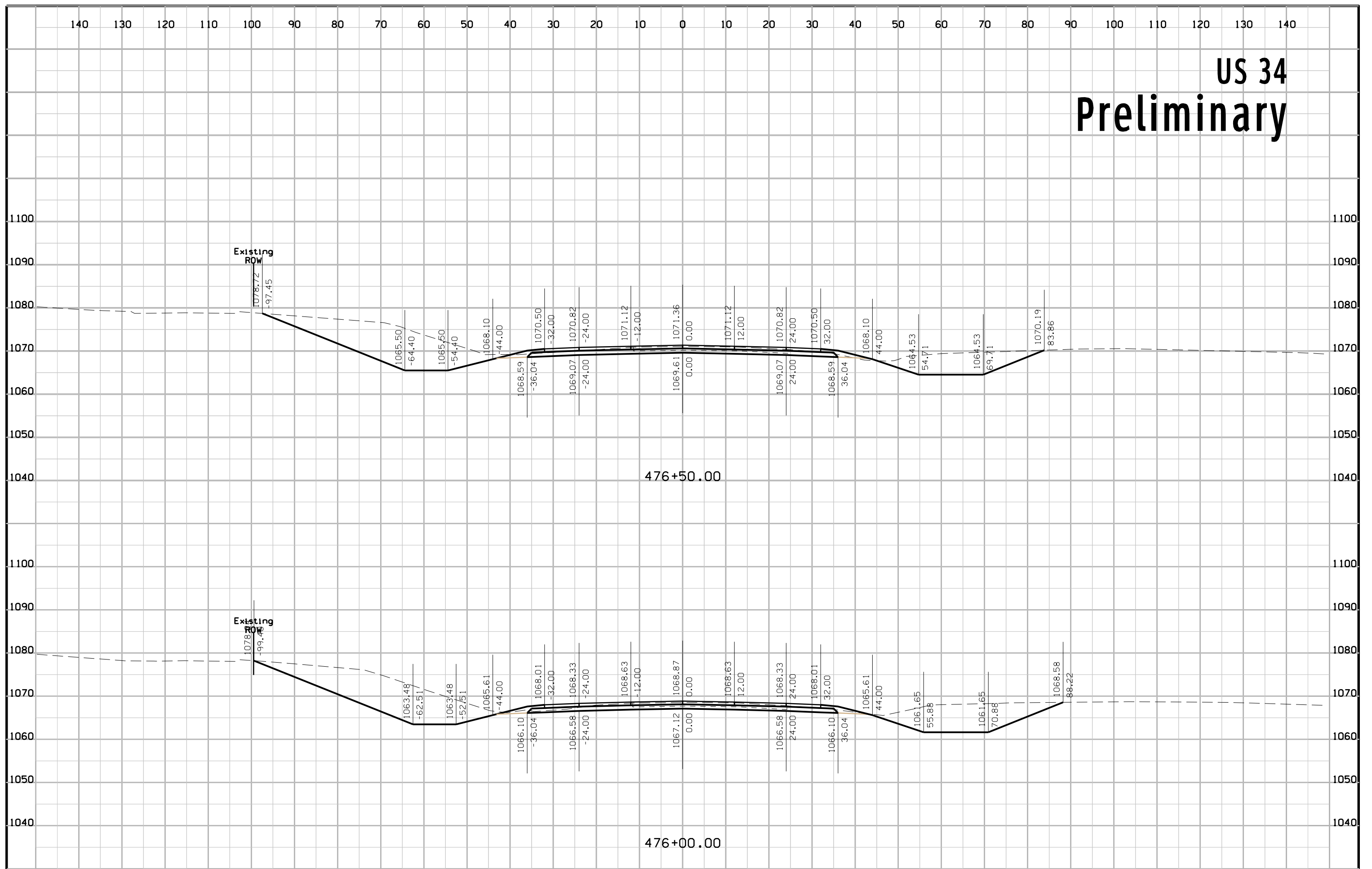

US 34 Preliminary

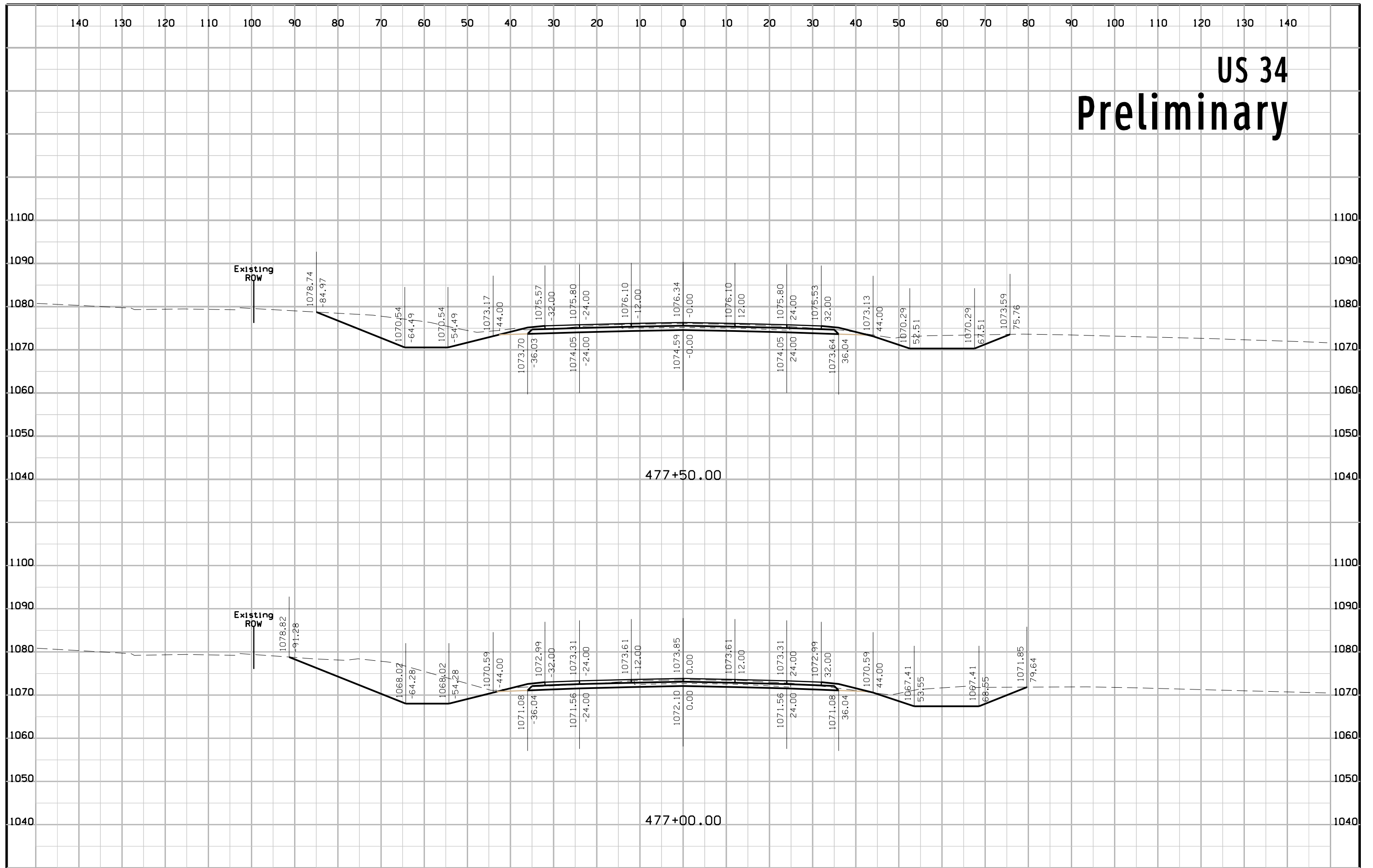

US 34 Preliminary

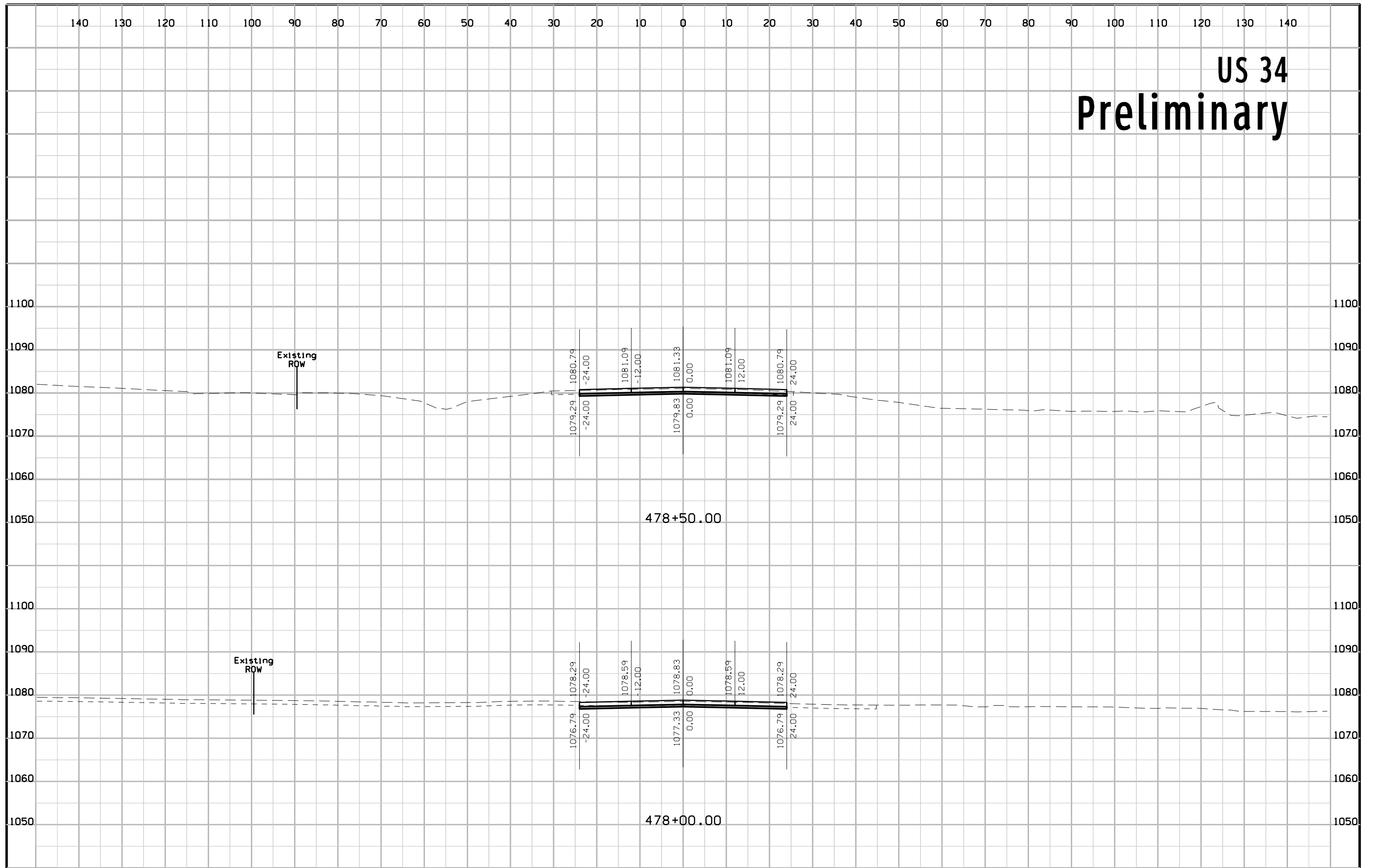

US 34 Preliminary

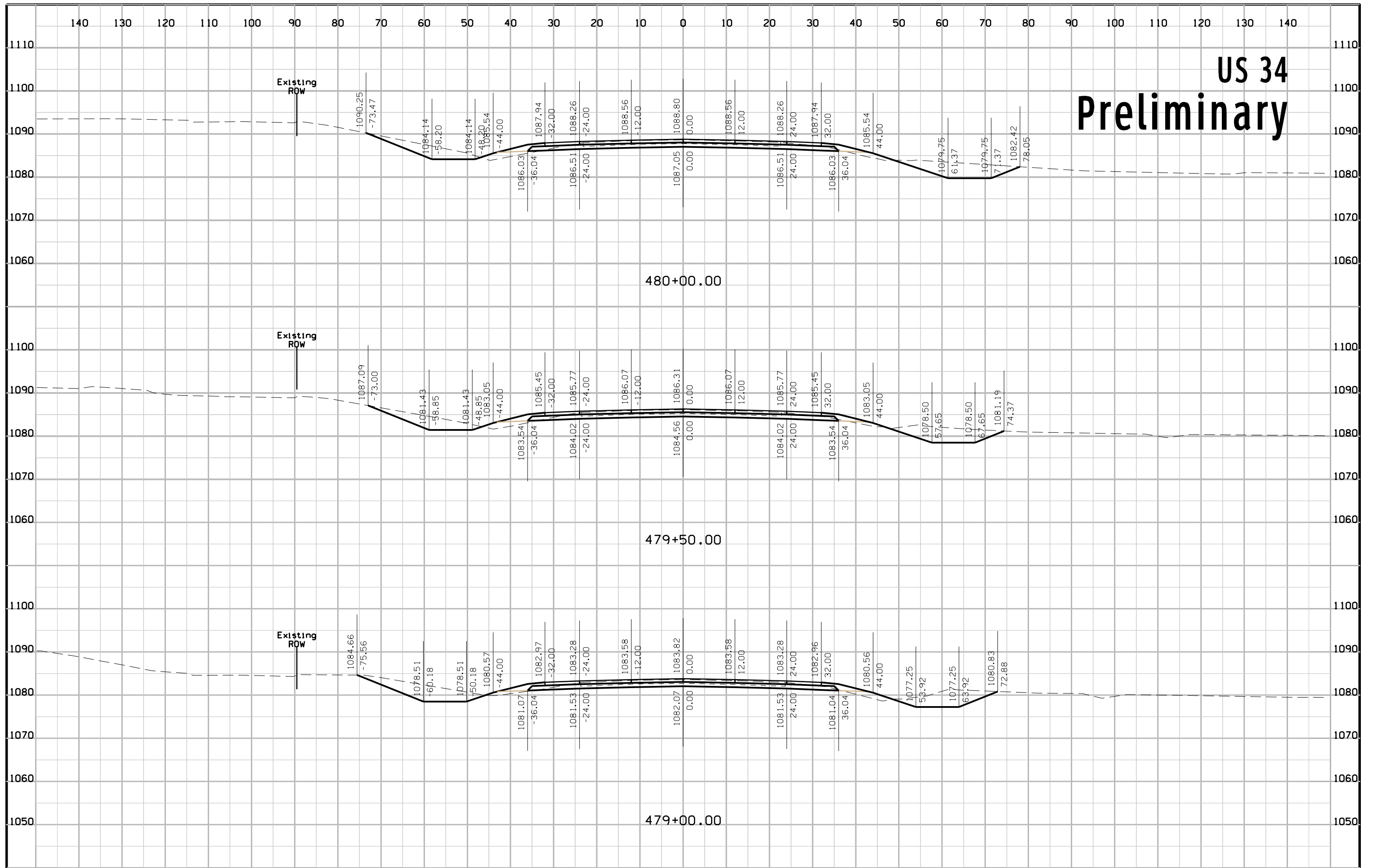

US 34 Preliminary

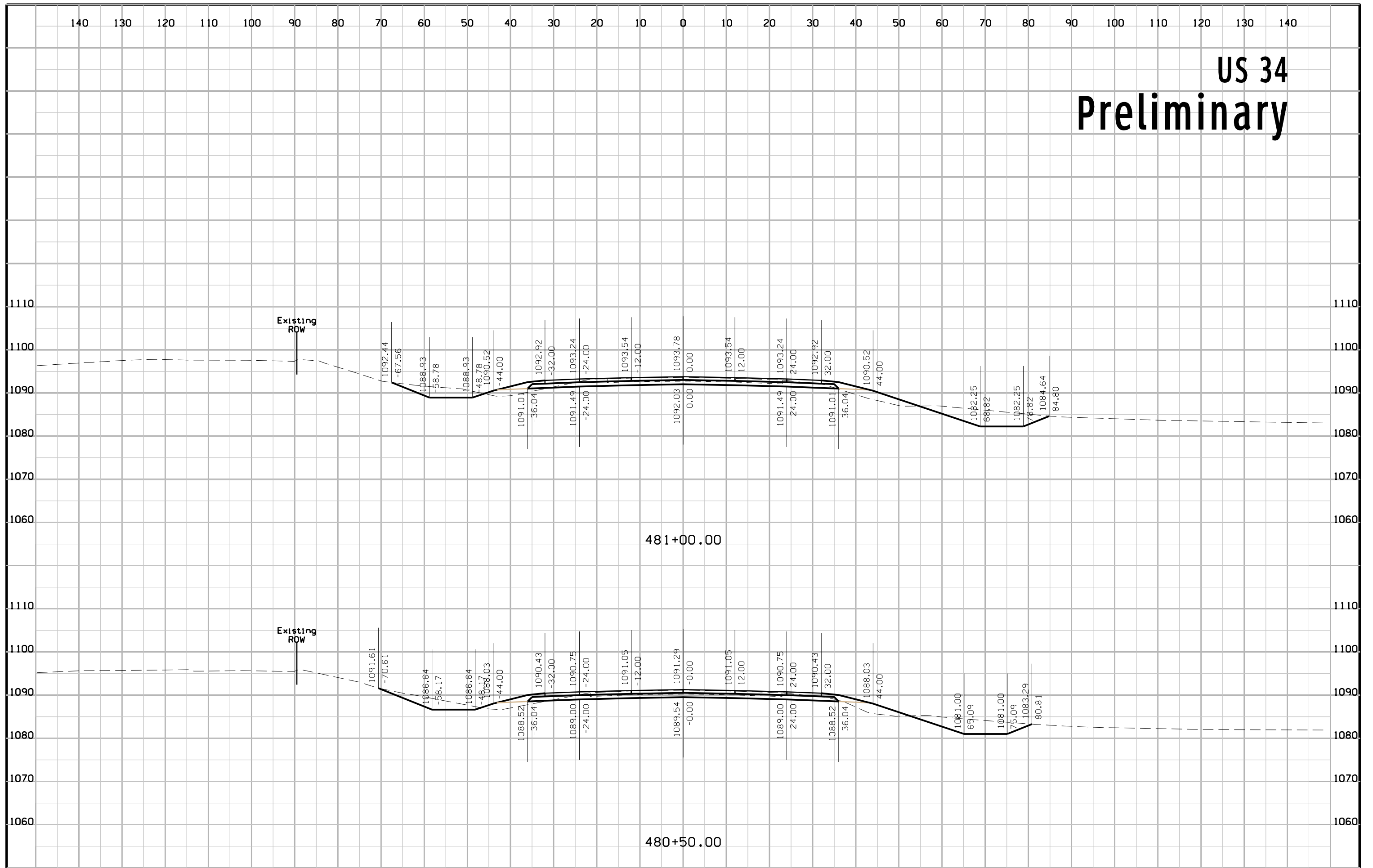

US 34 Preliminary

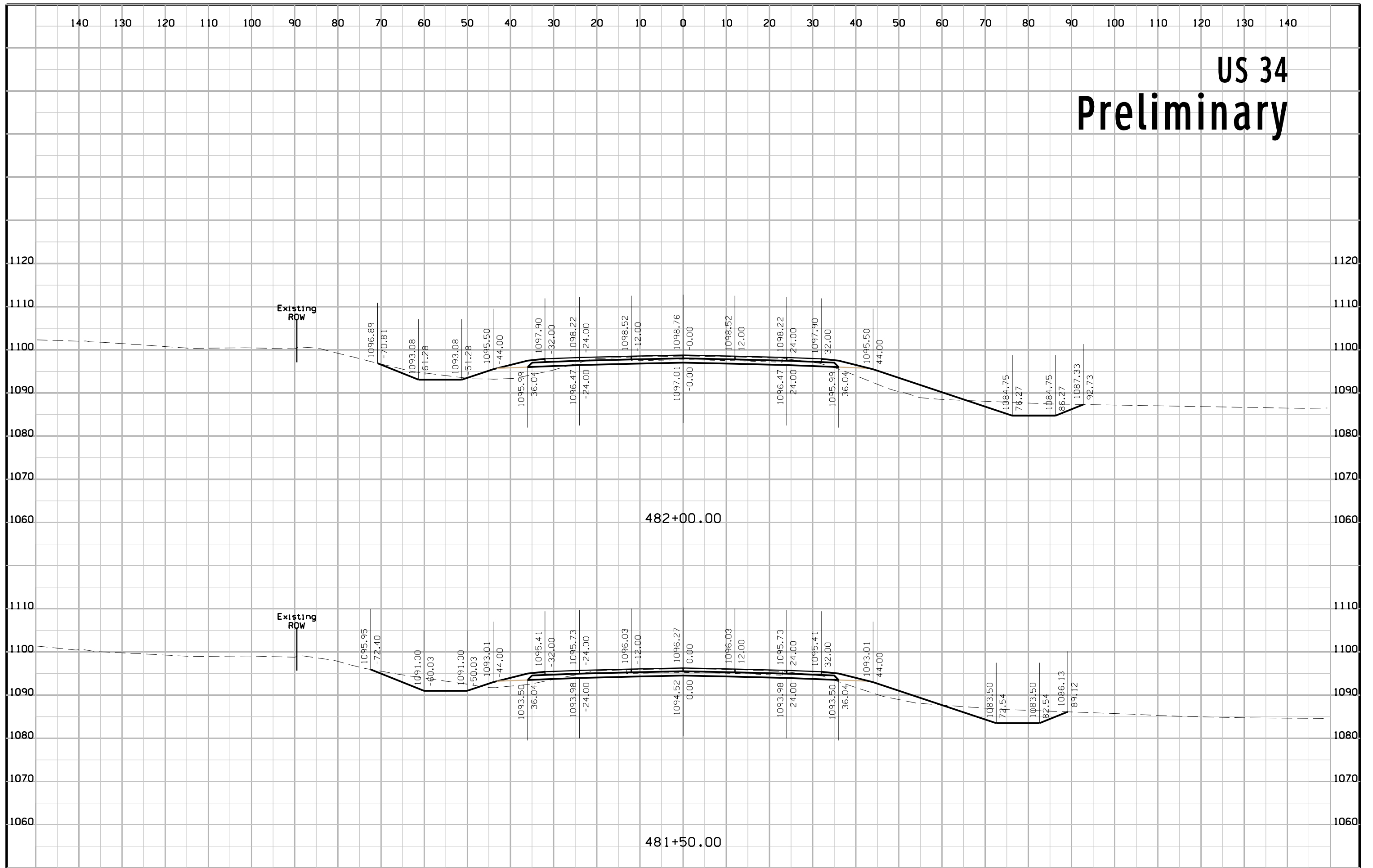

US 34 Preliminary

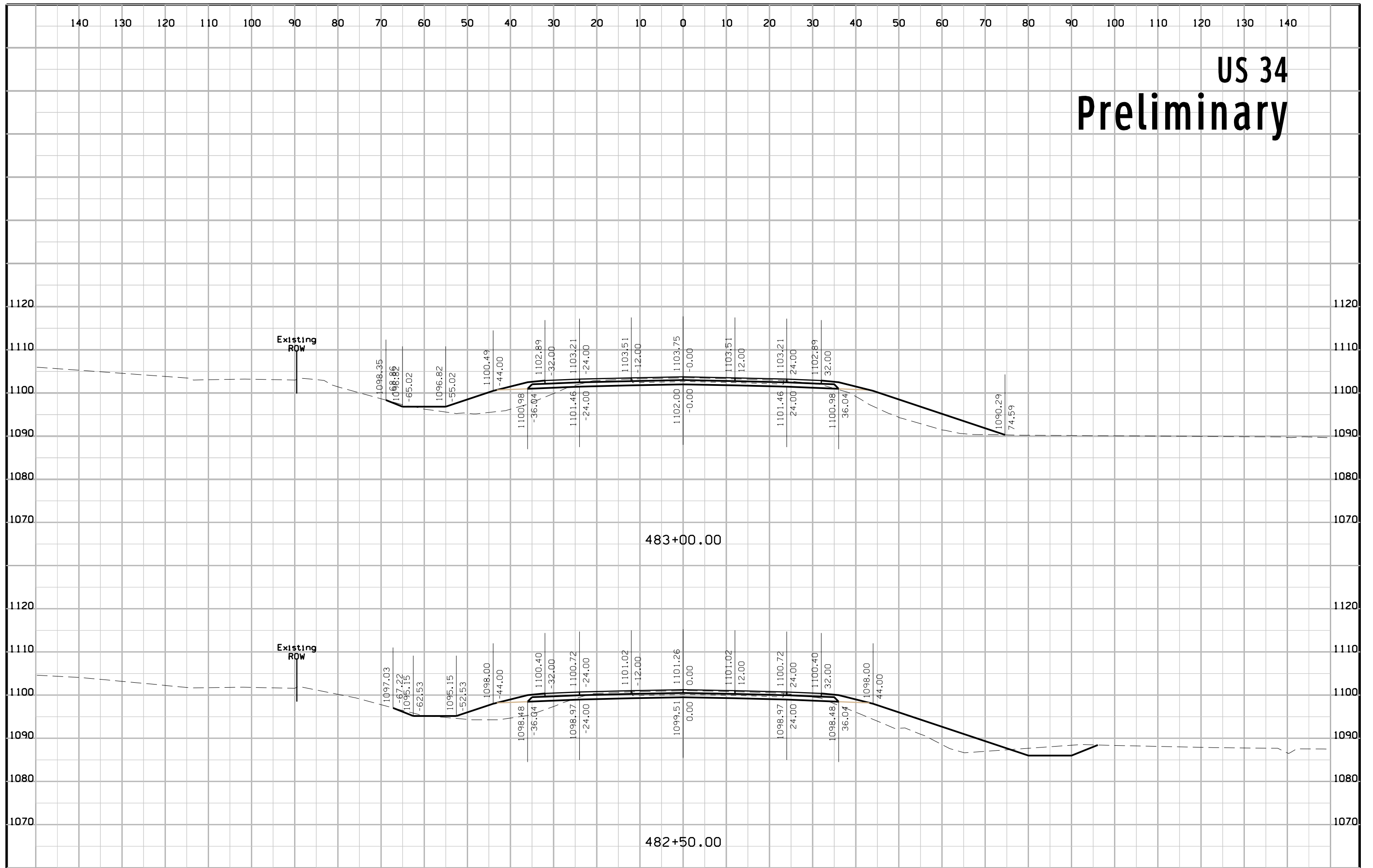

US 34 Preliminary

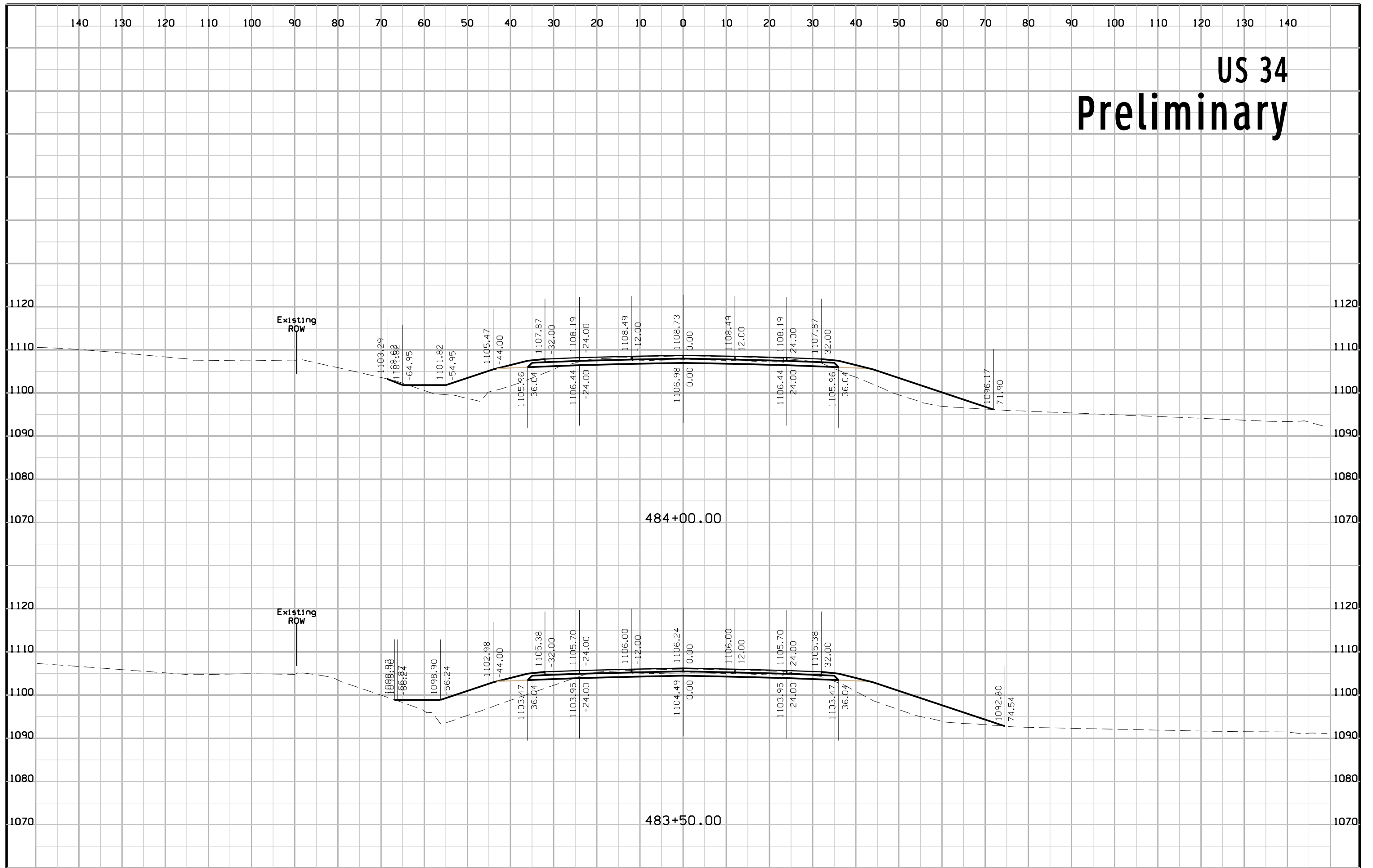

US 34 Preliminary

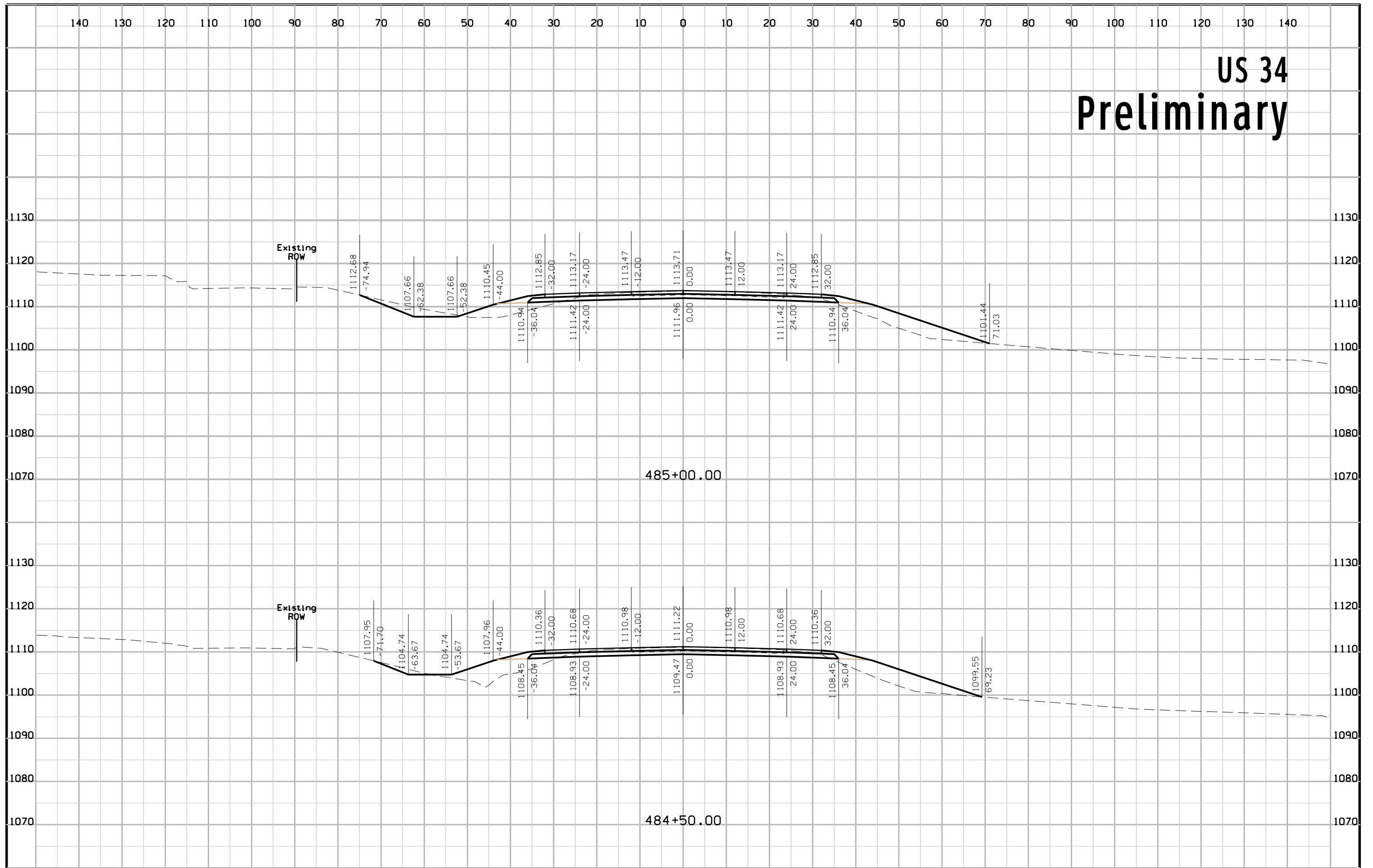

US 34 Preliminary

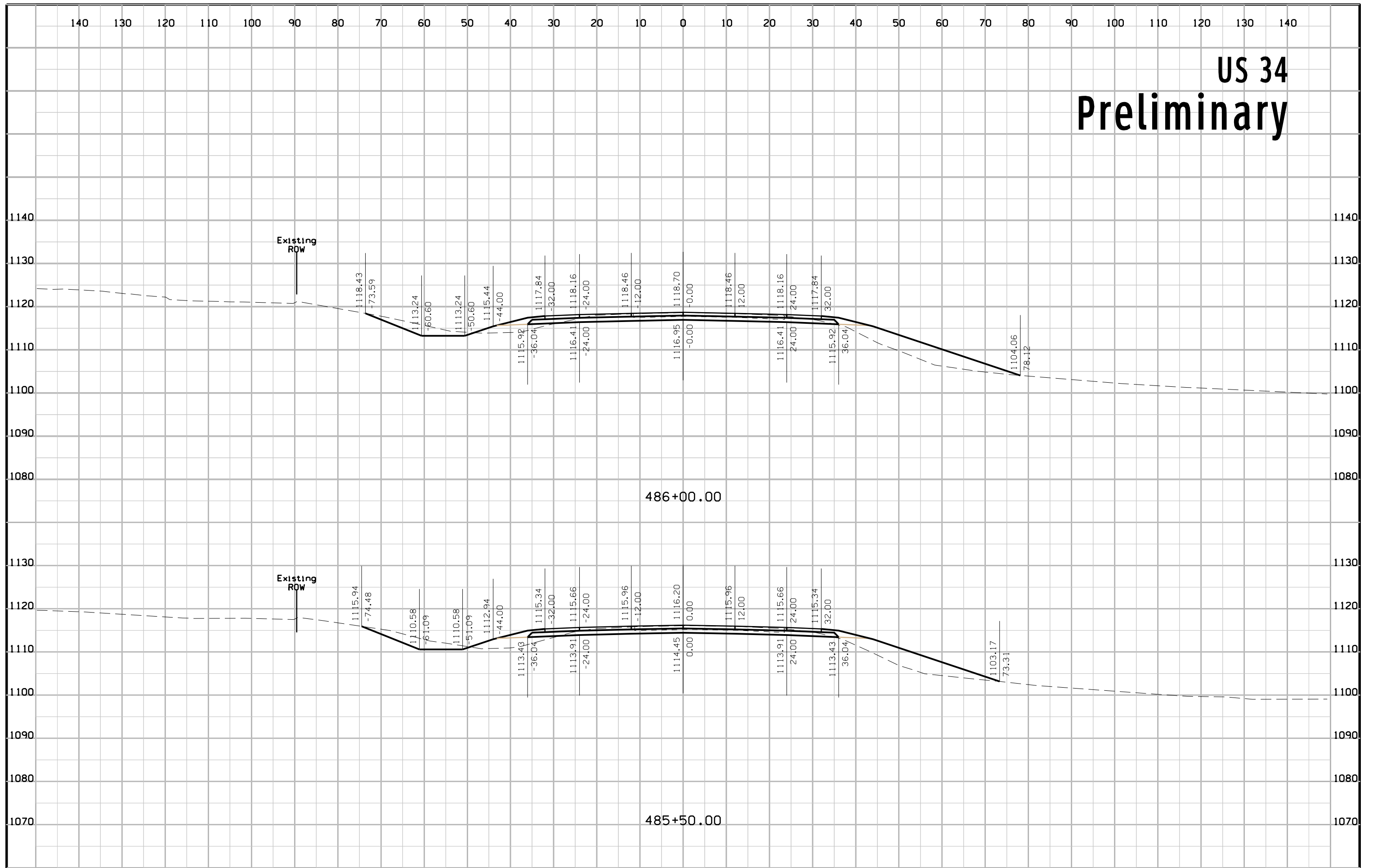

US 34 Preliminary

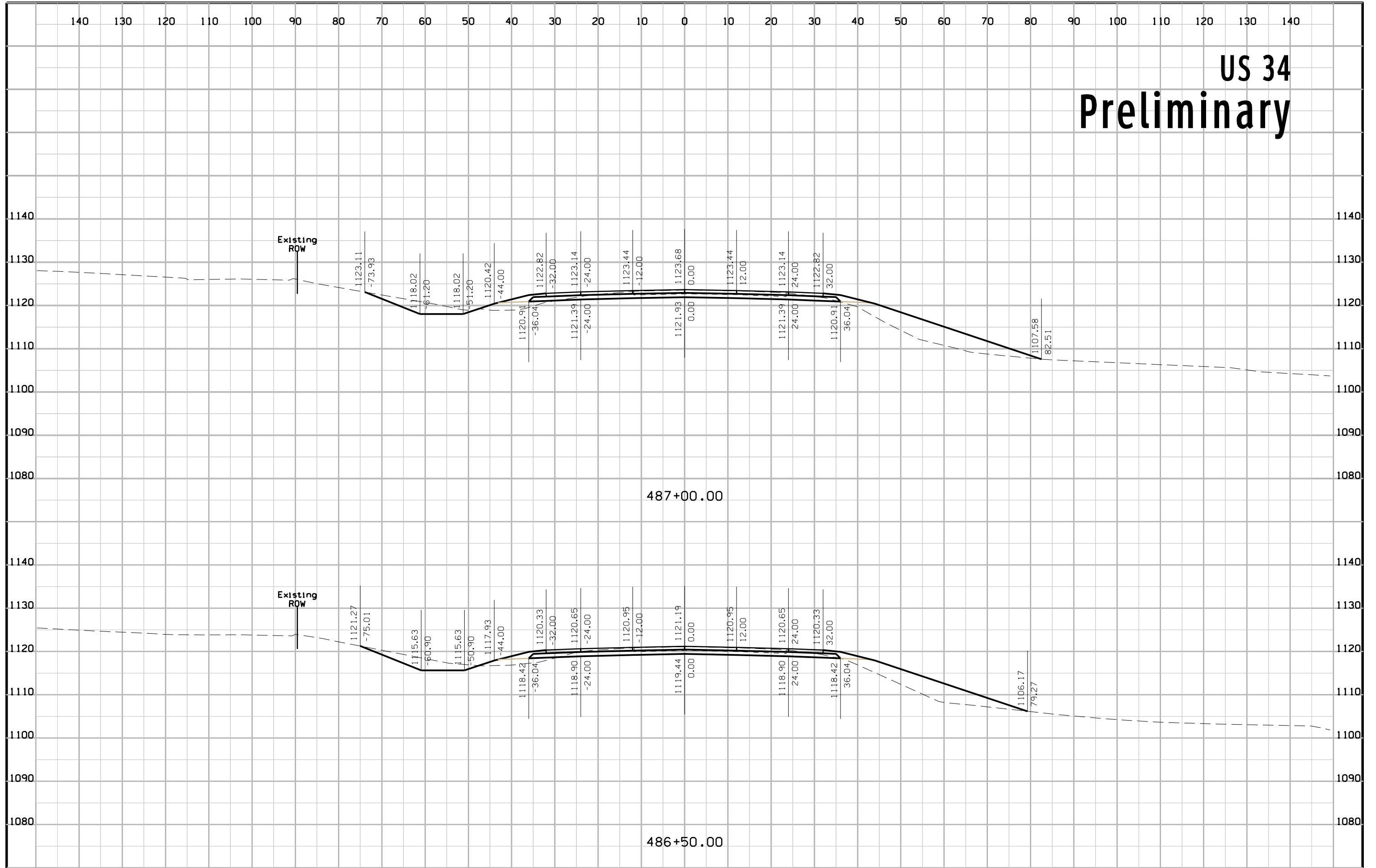

US 34 Preliminary

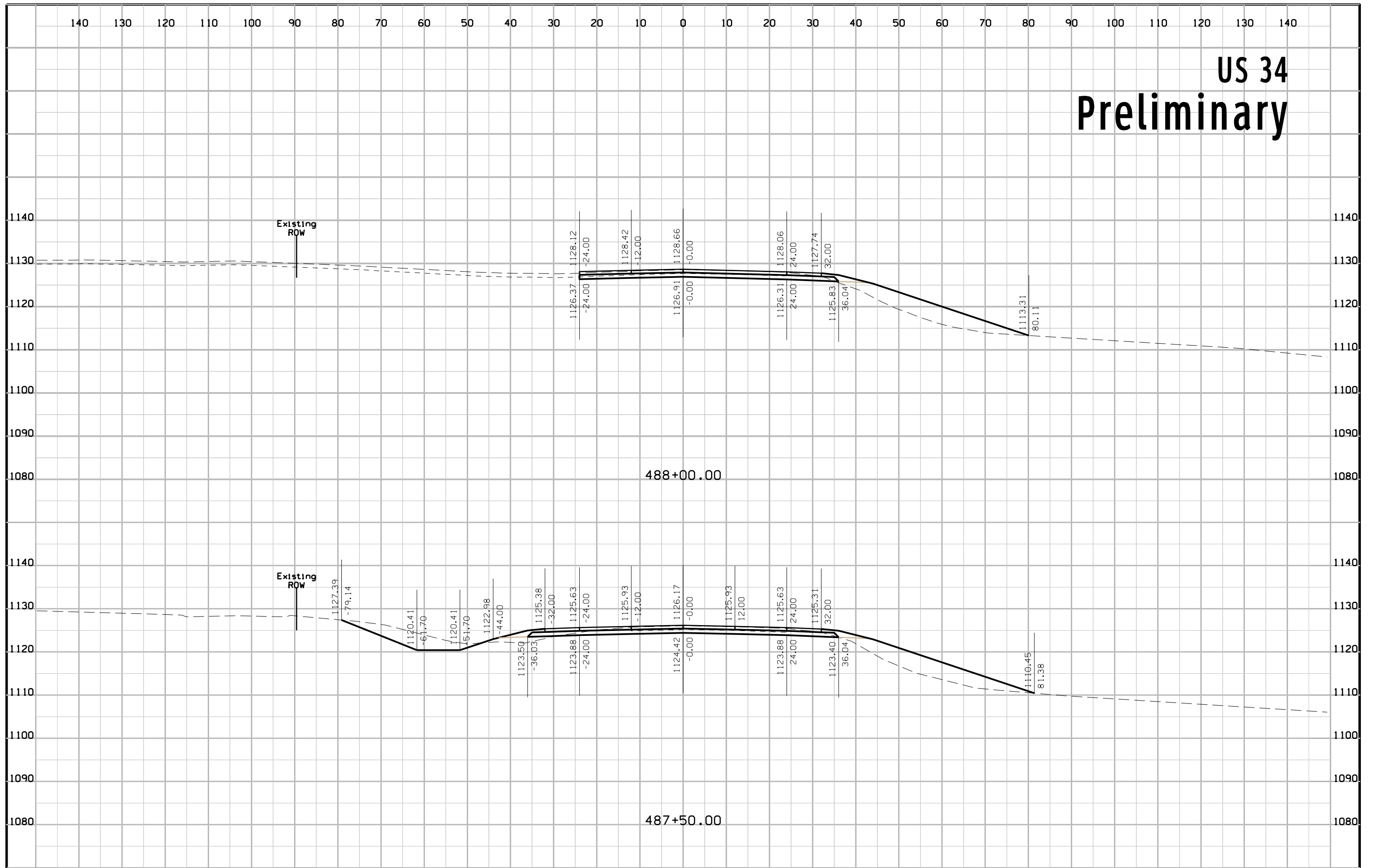

US 34 Preliminary

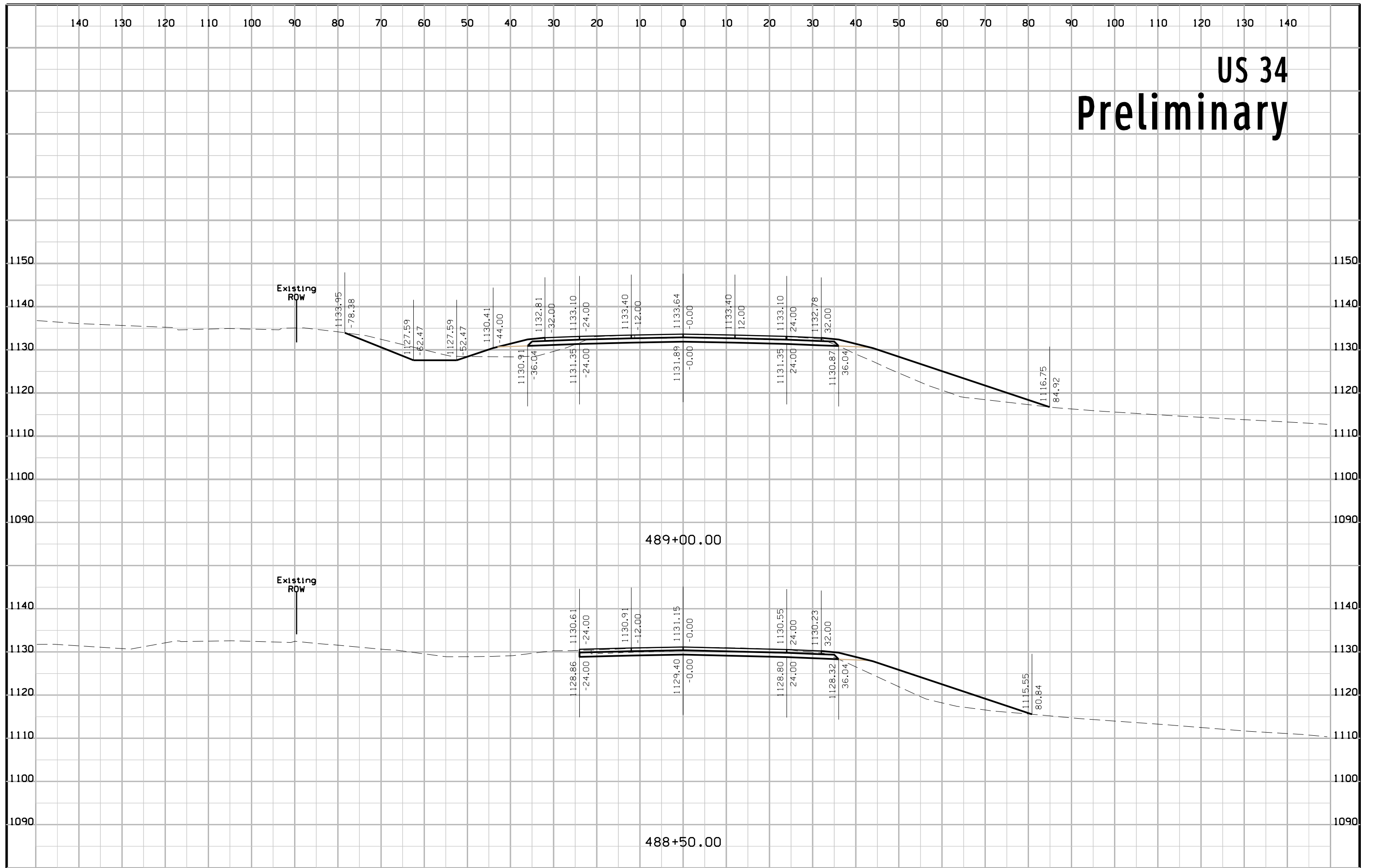

US 34 Preliminary

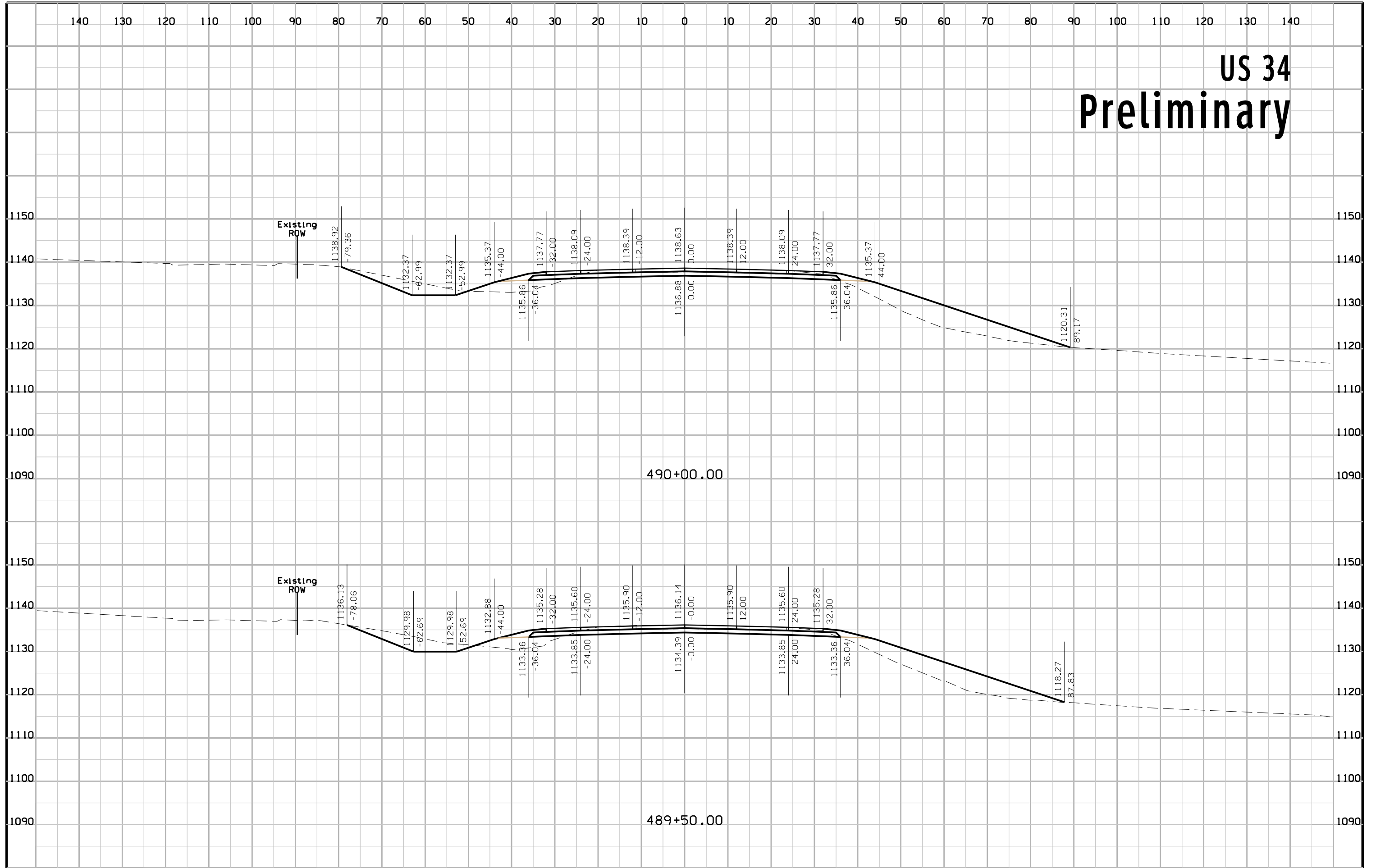

US 34 Preliminary

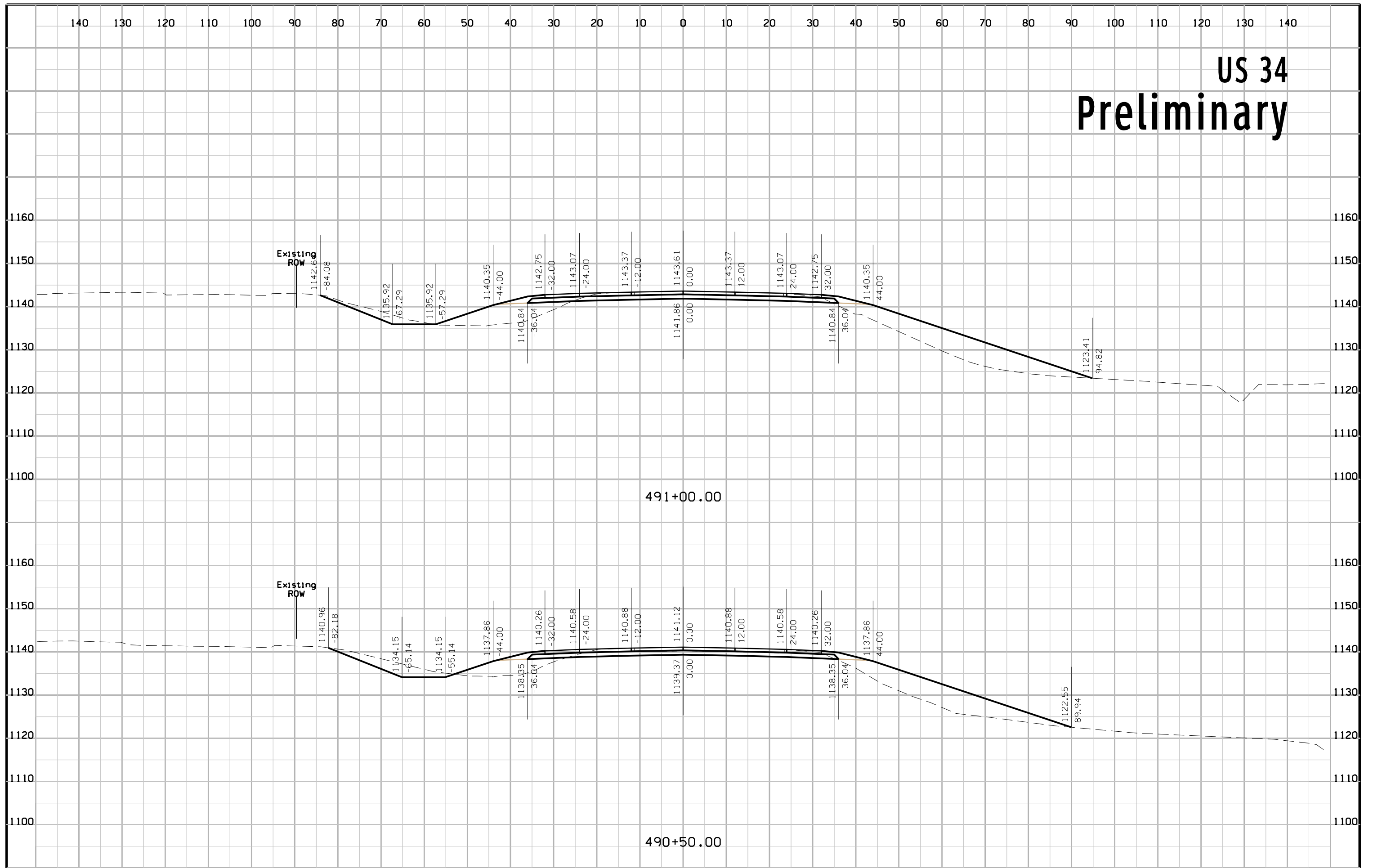

US 34 Preliminary

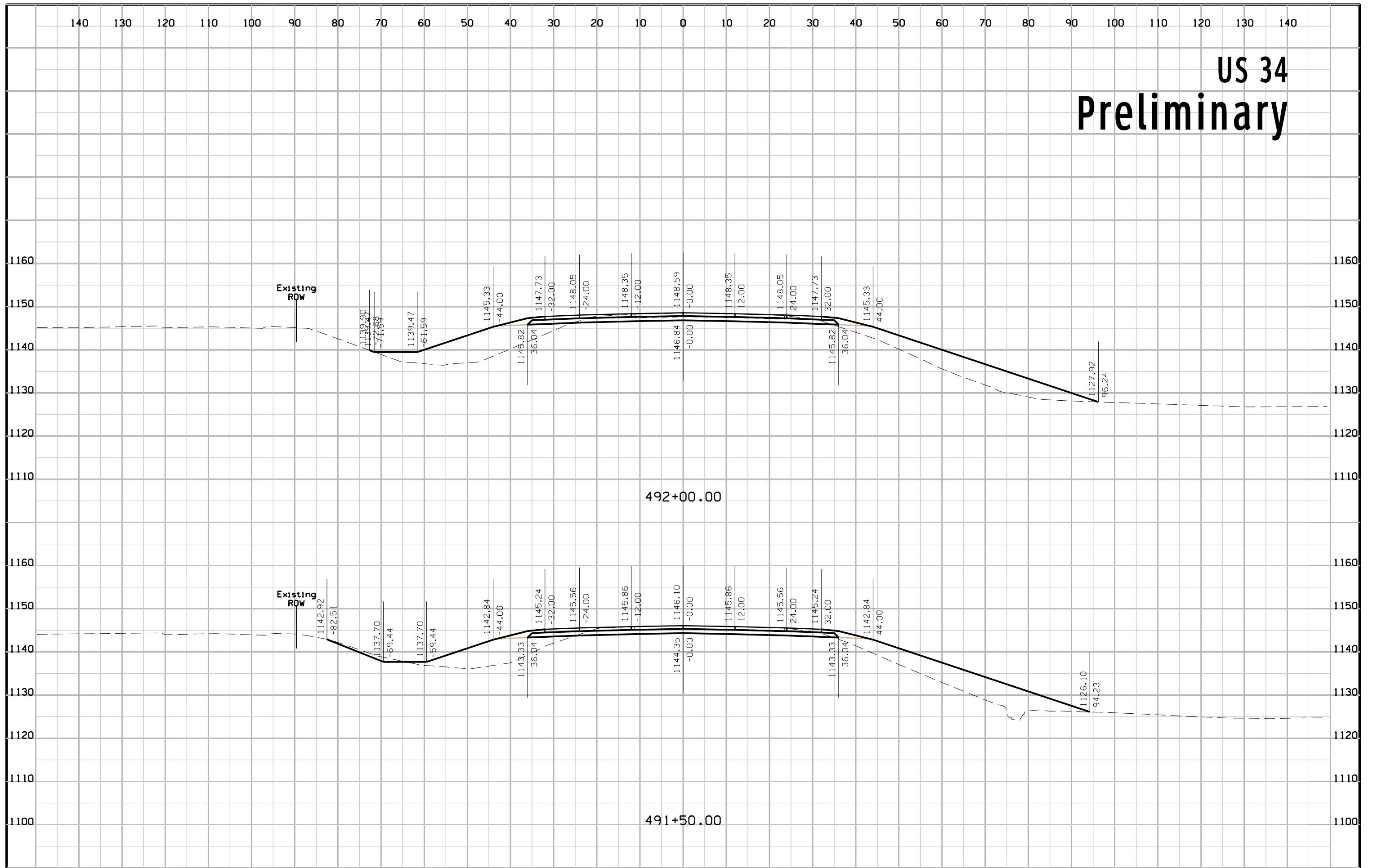

US 34 Preliminary

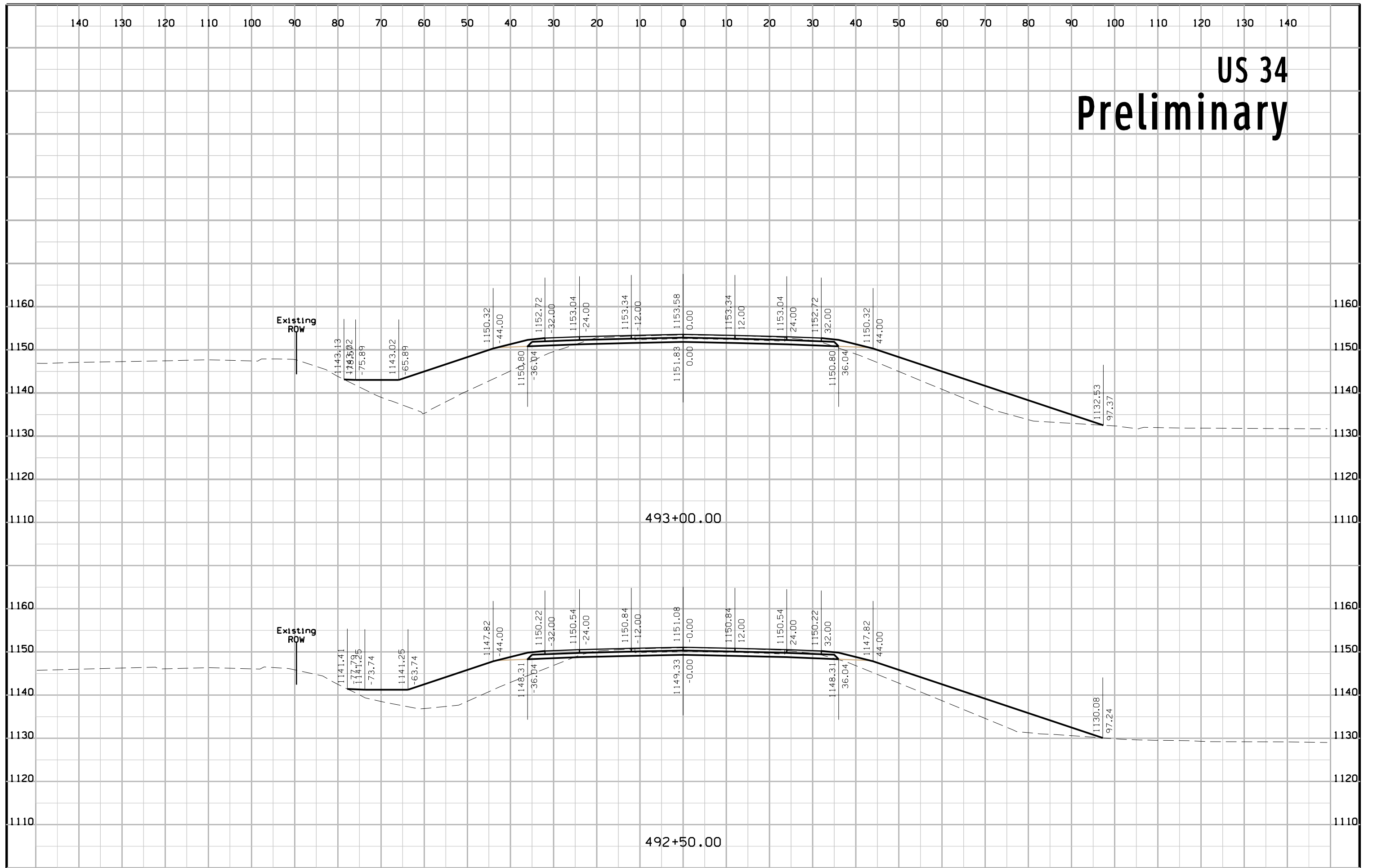

US 34 Preliminary

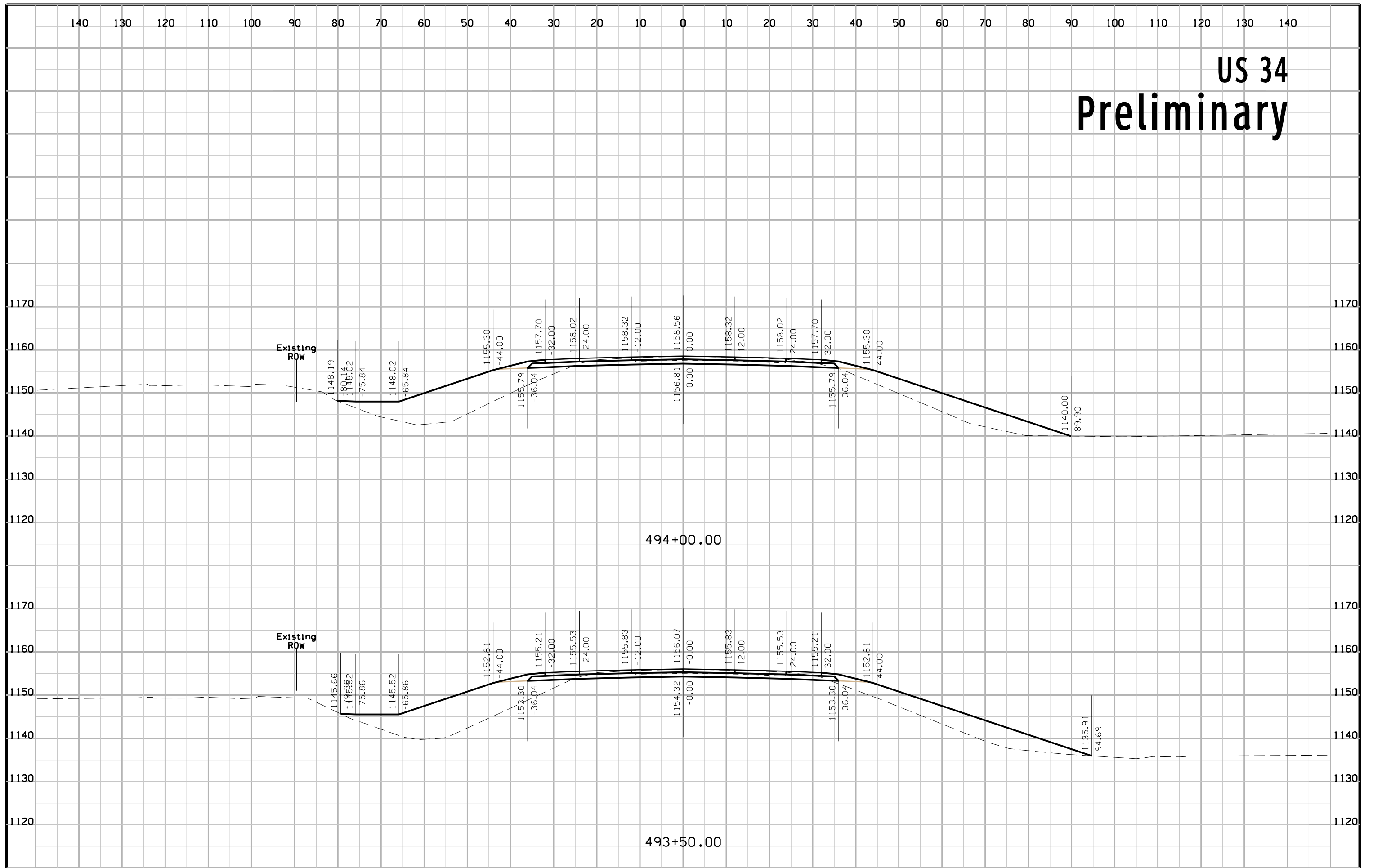

US 34 Preliminary

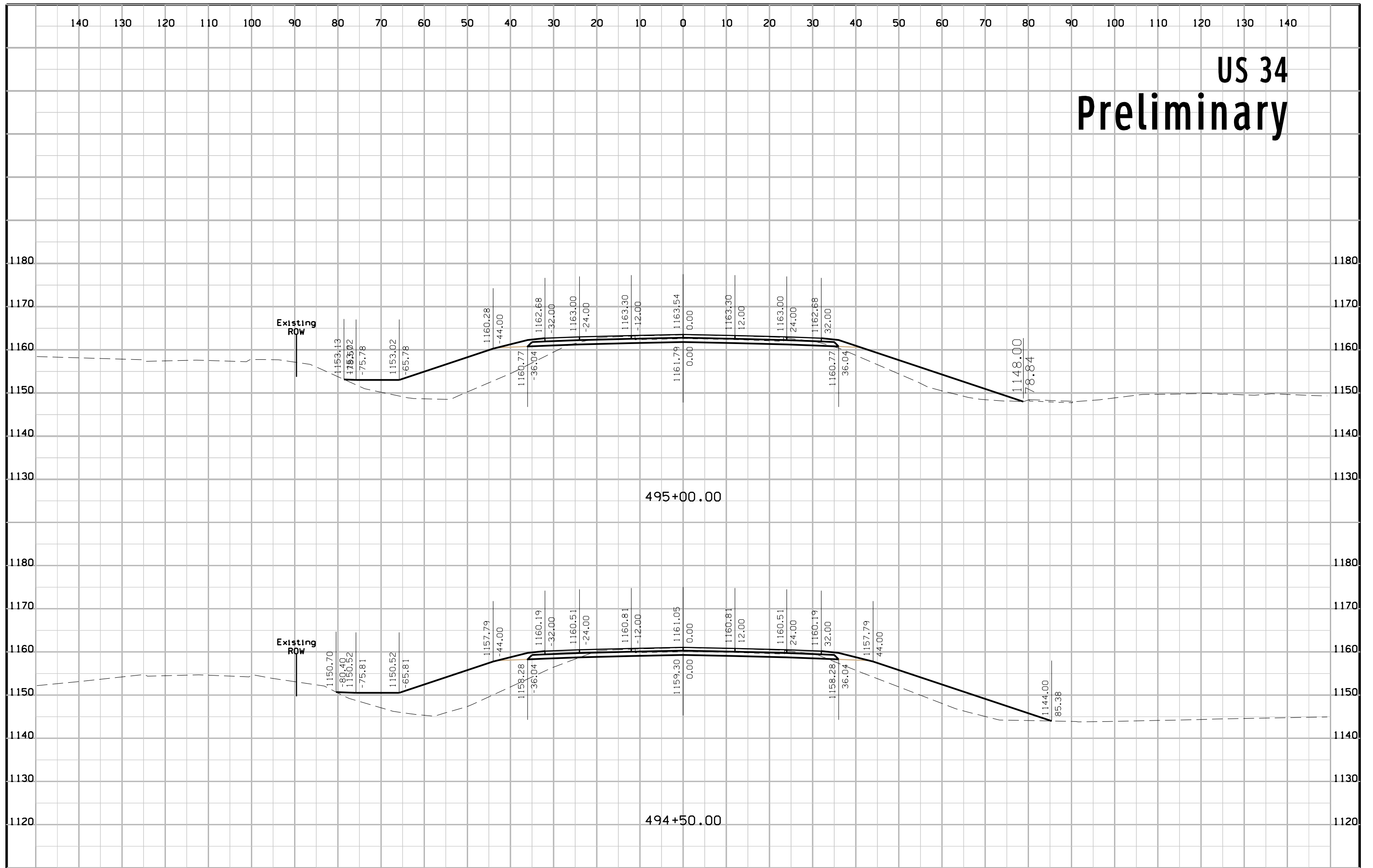

US 34 Preliminary

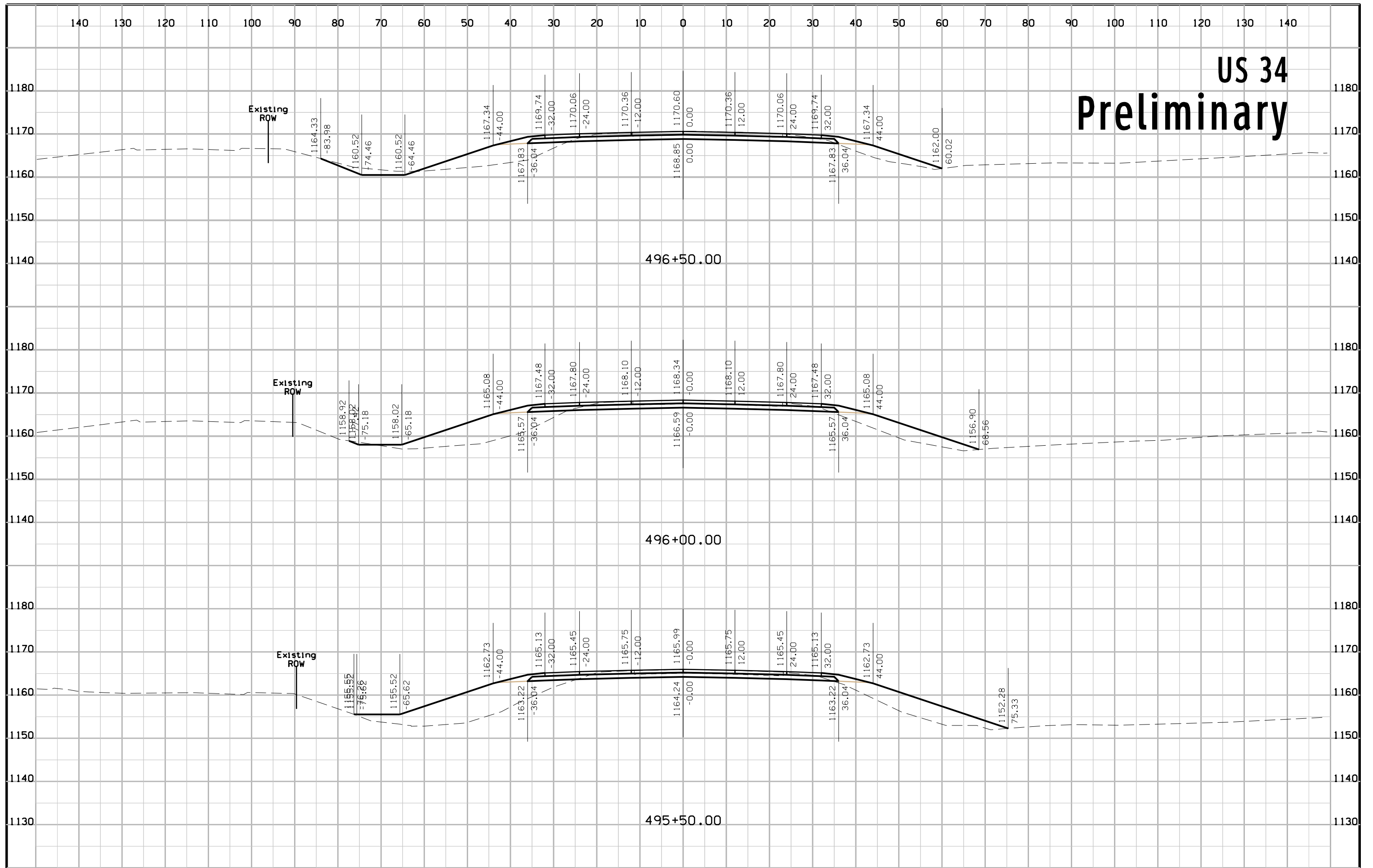

US 34 Preliminary

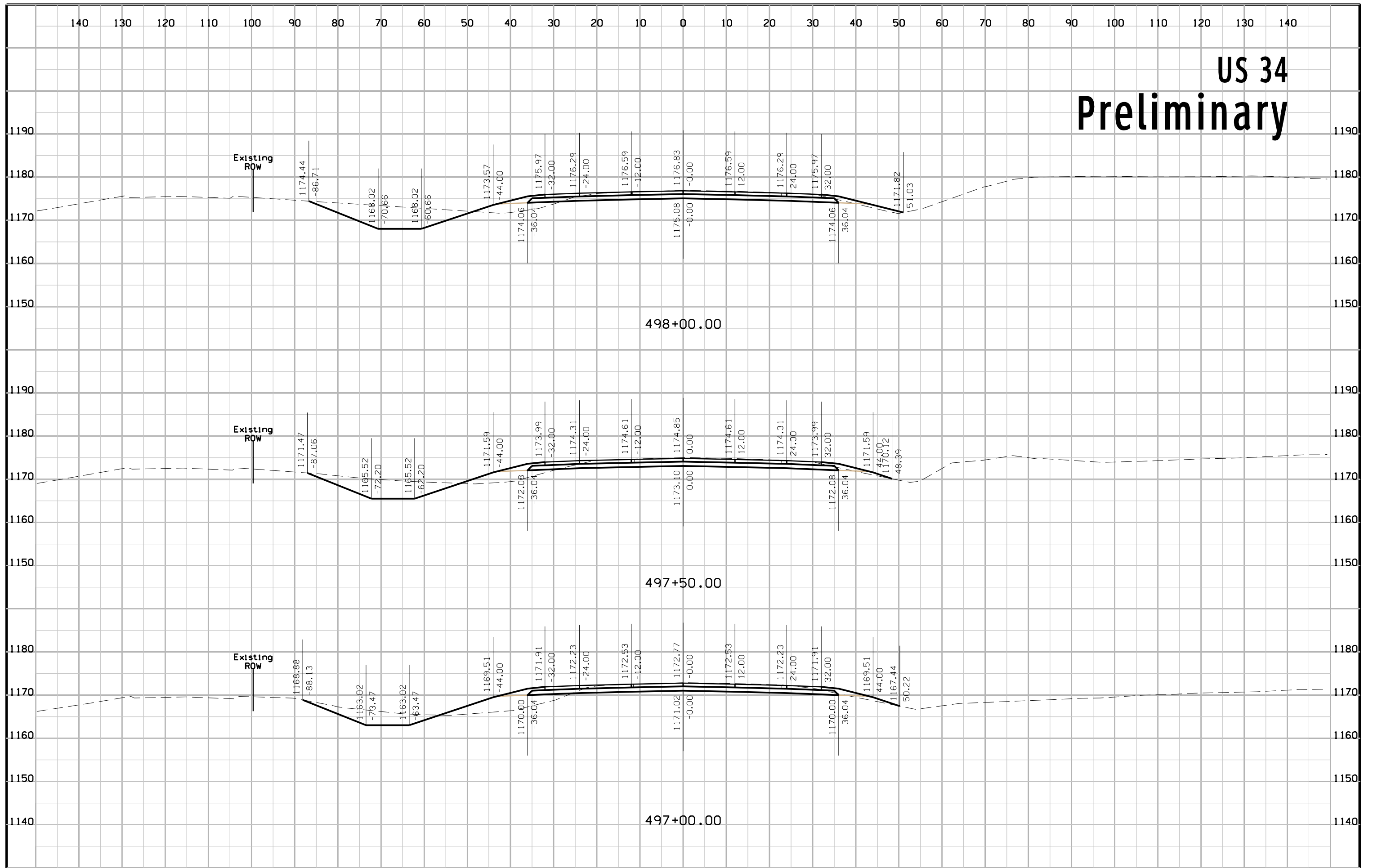

US 34 Preliminary

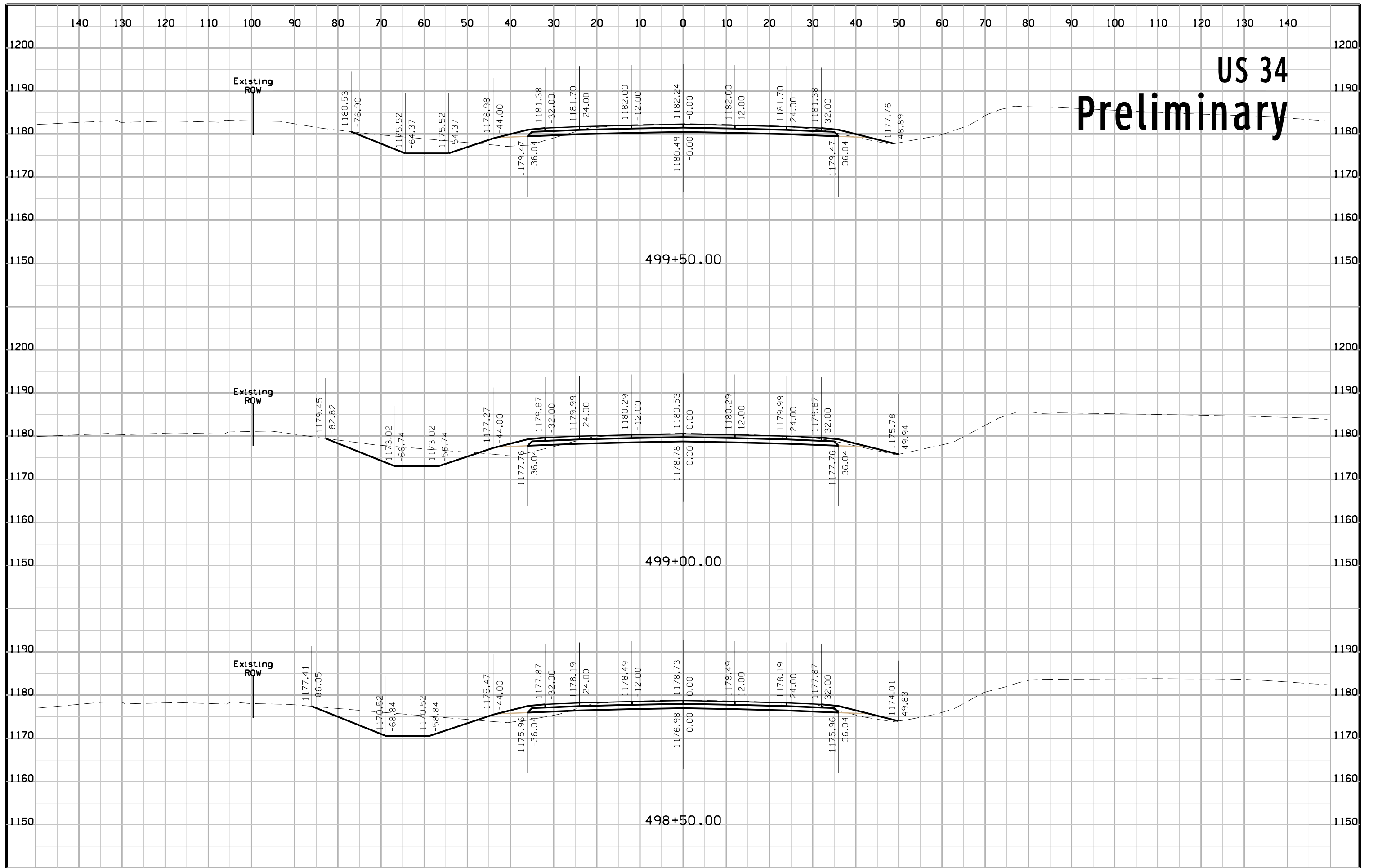

US 34 Preliminary

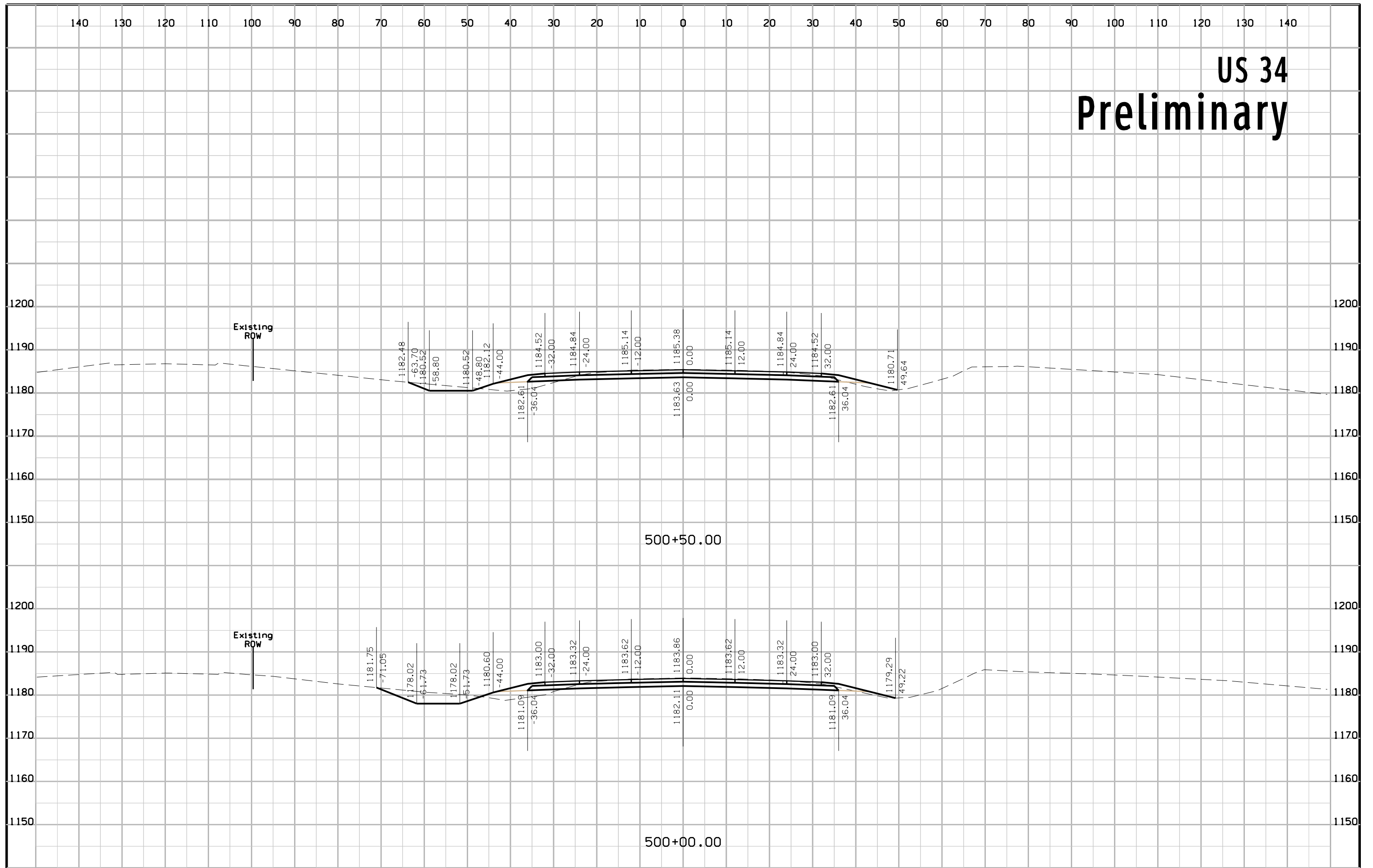

US 34 Preliminary

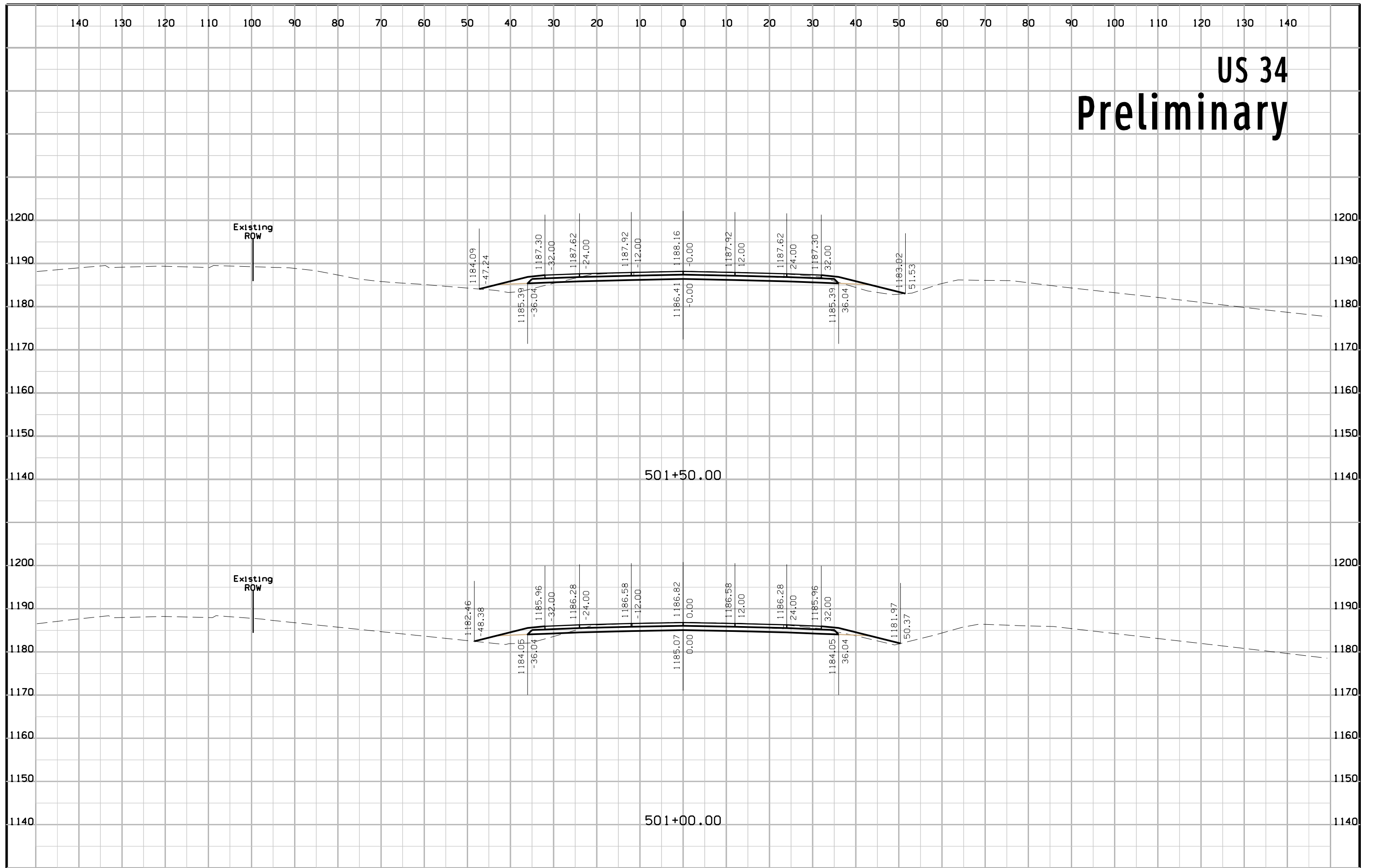

US 34 Preliminary

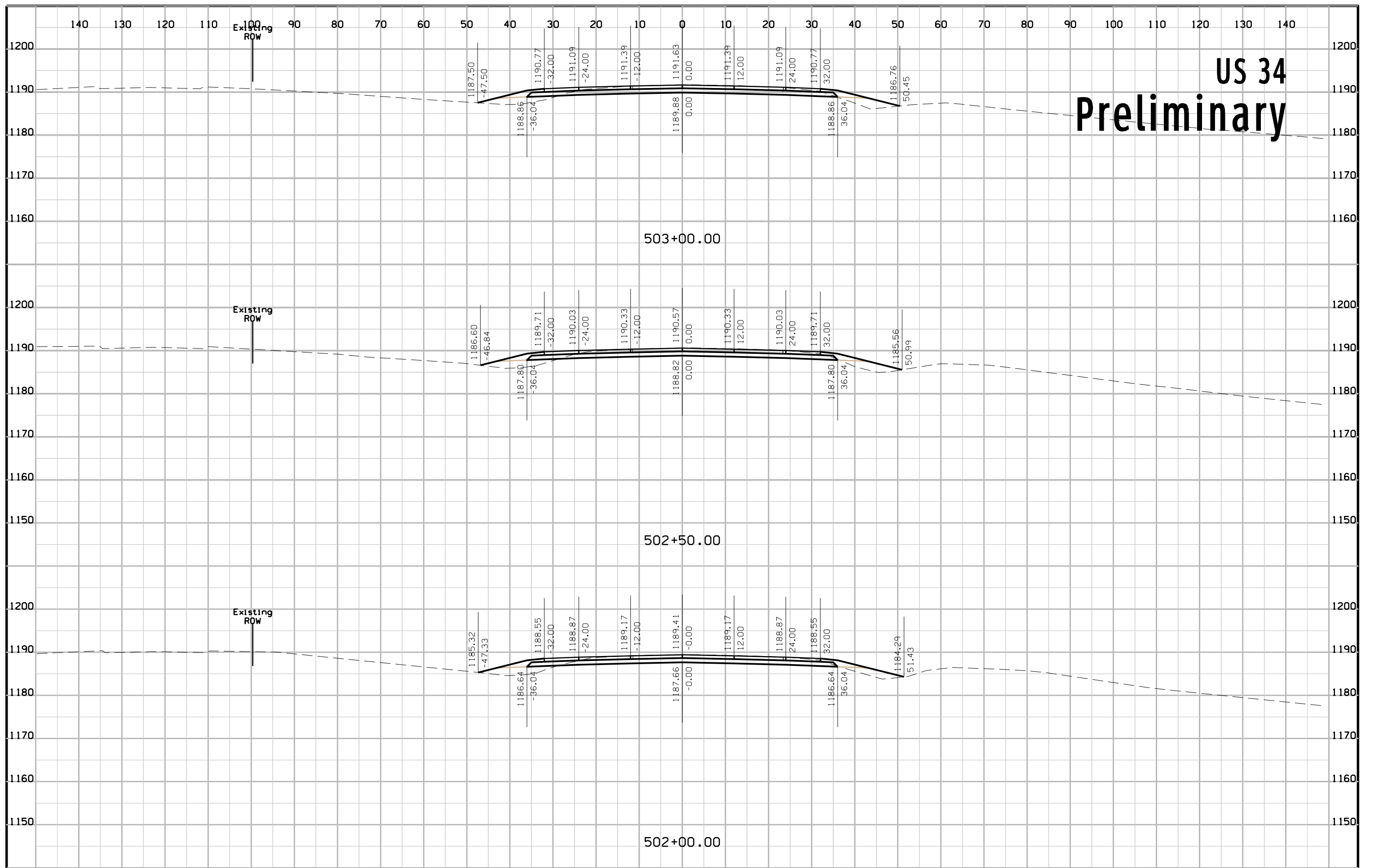

US 34 Preliminary

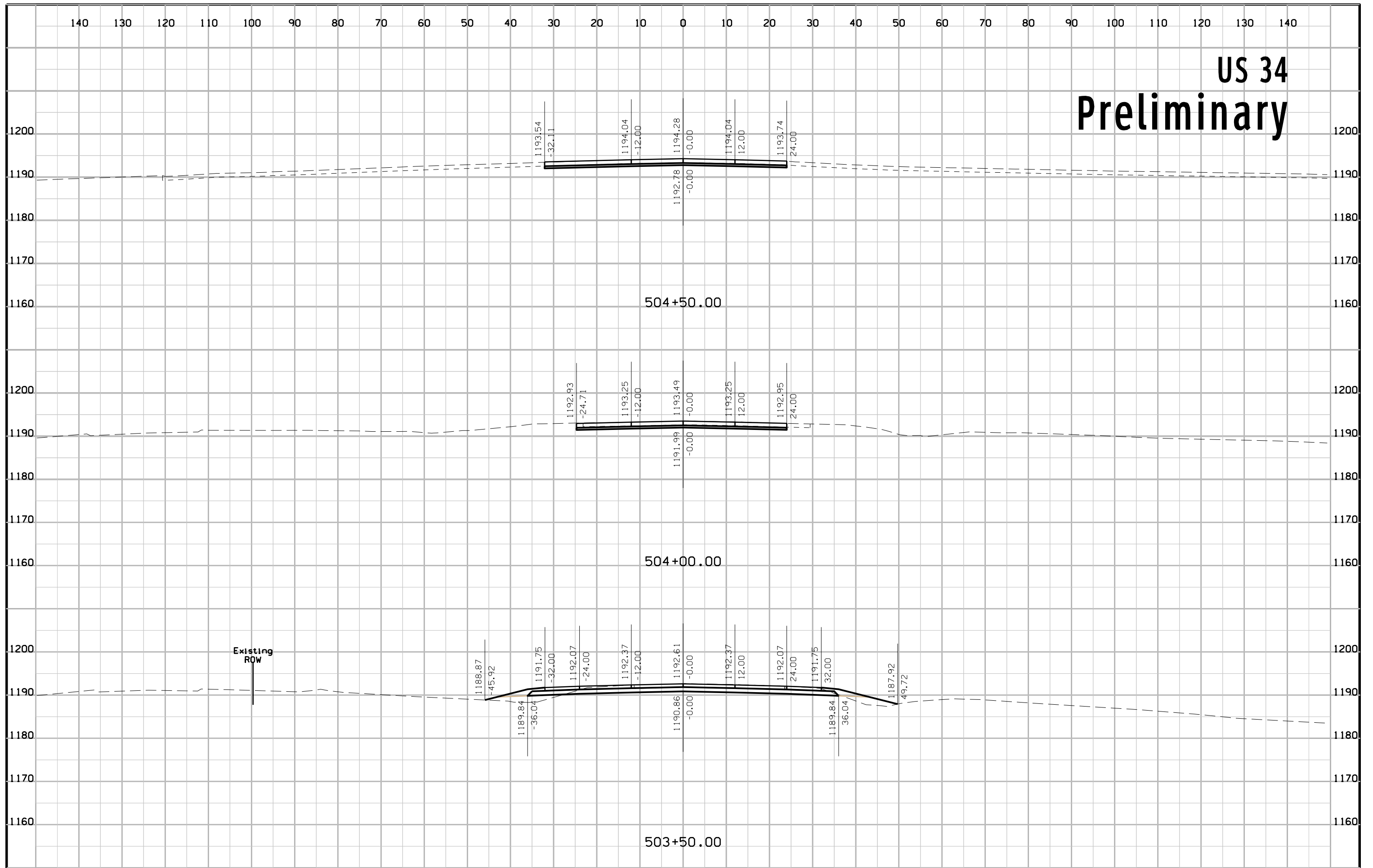

US 34 Preliminary

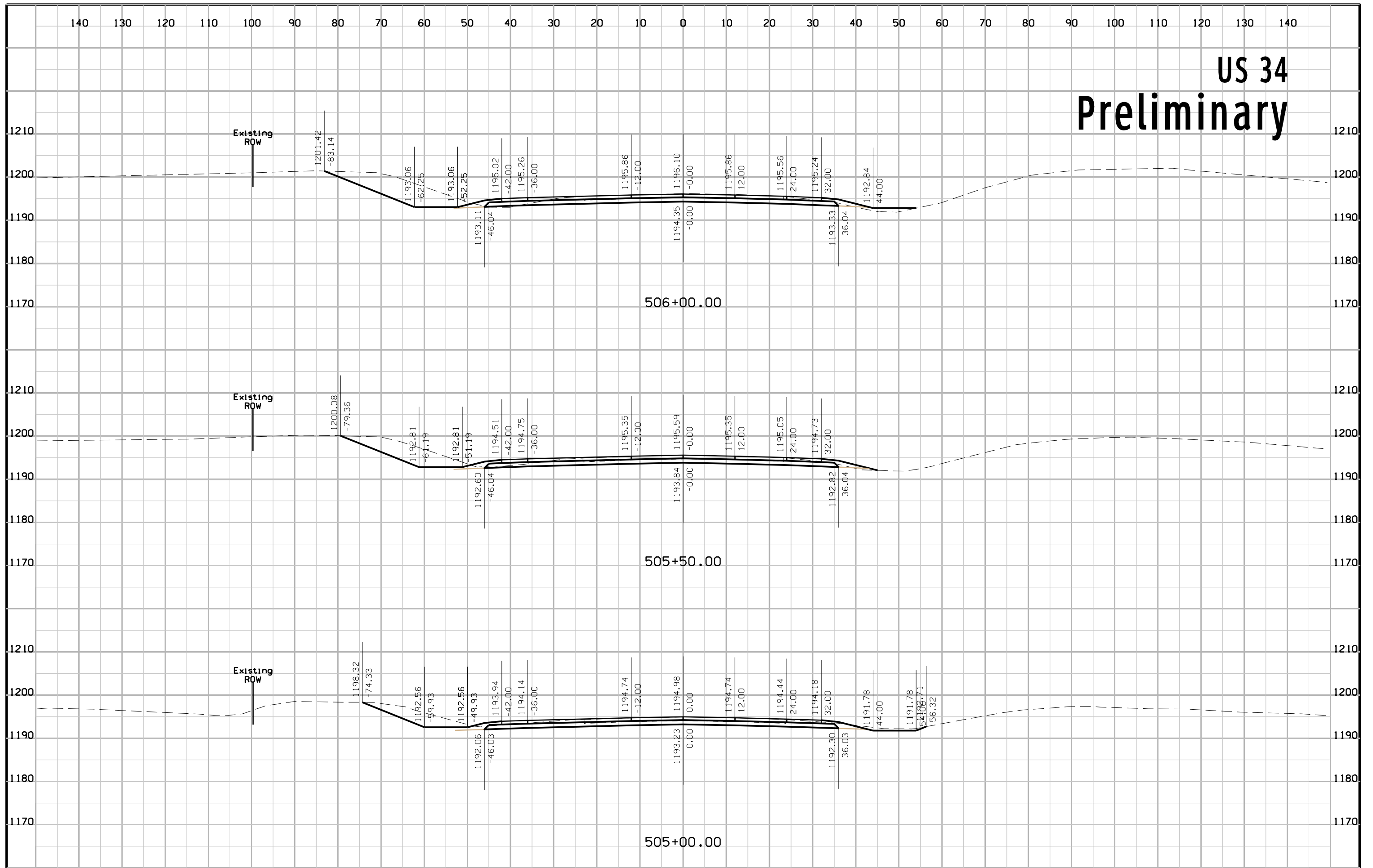

US 34 Preliminary

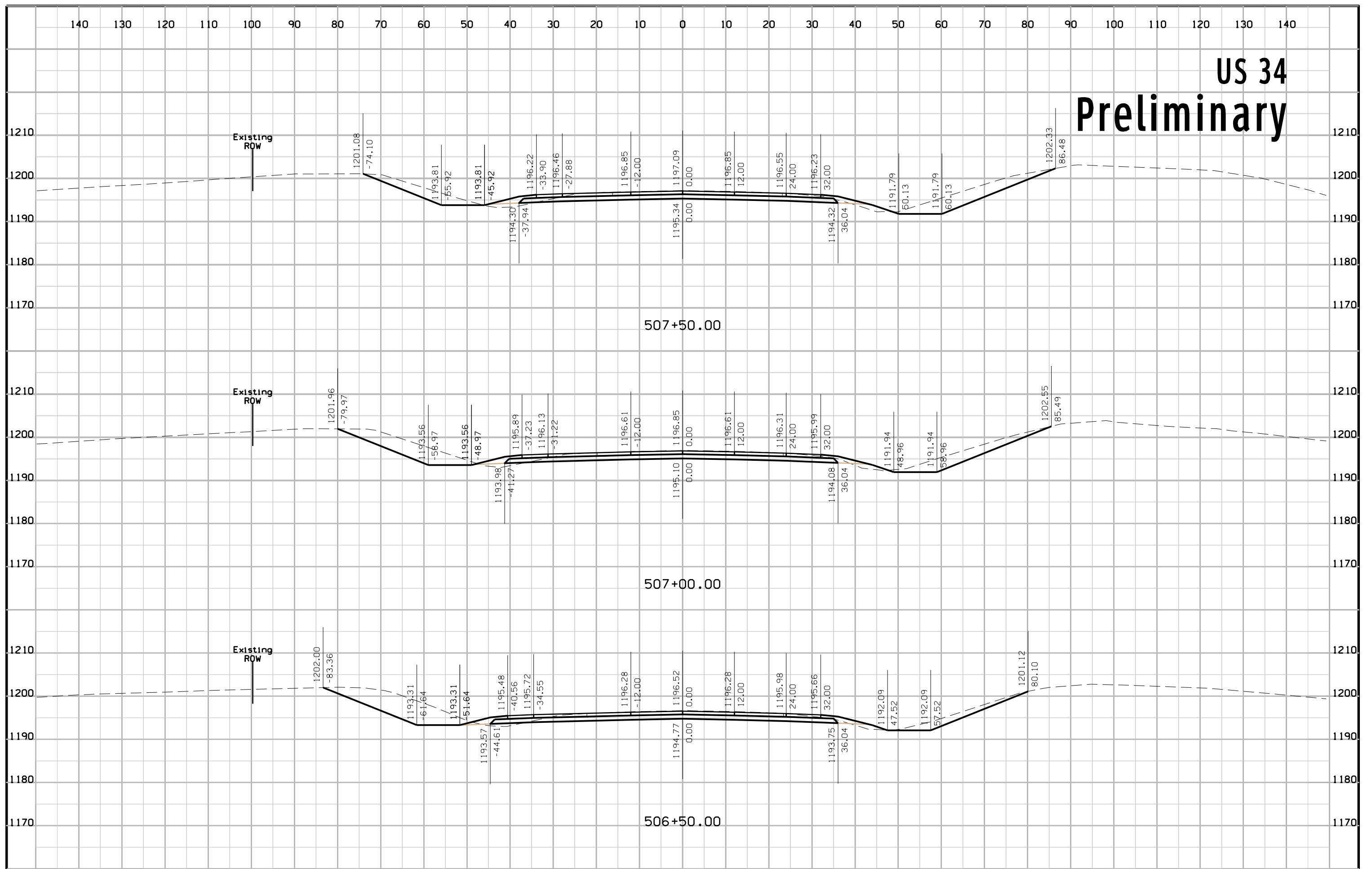

US 34 Preliminary

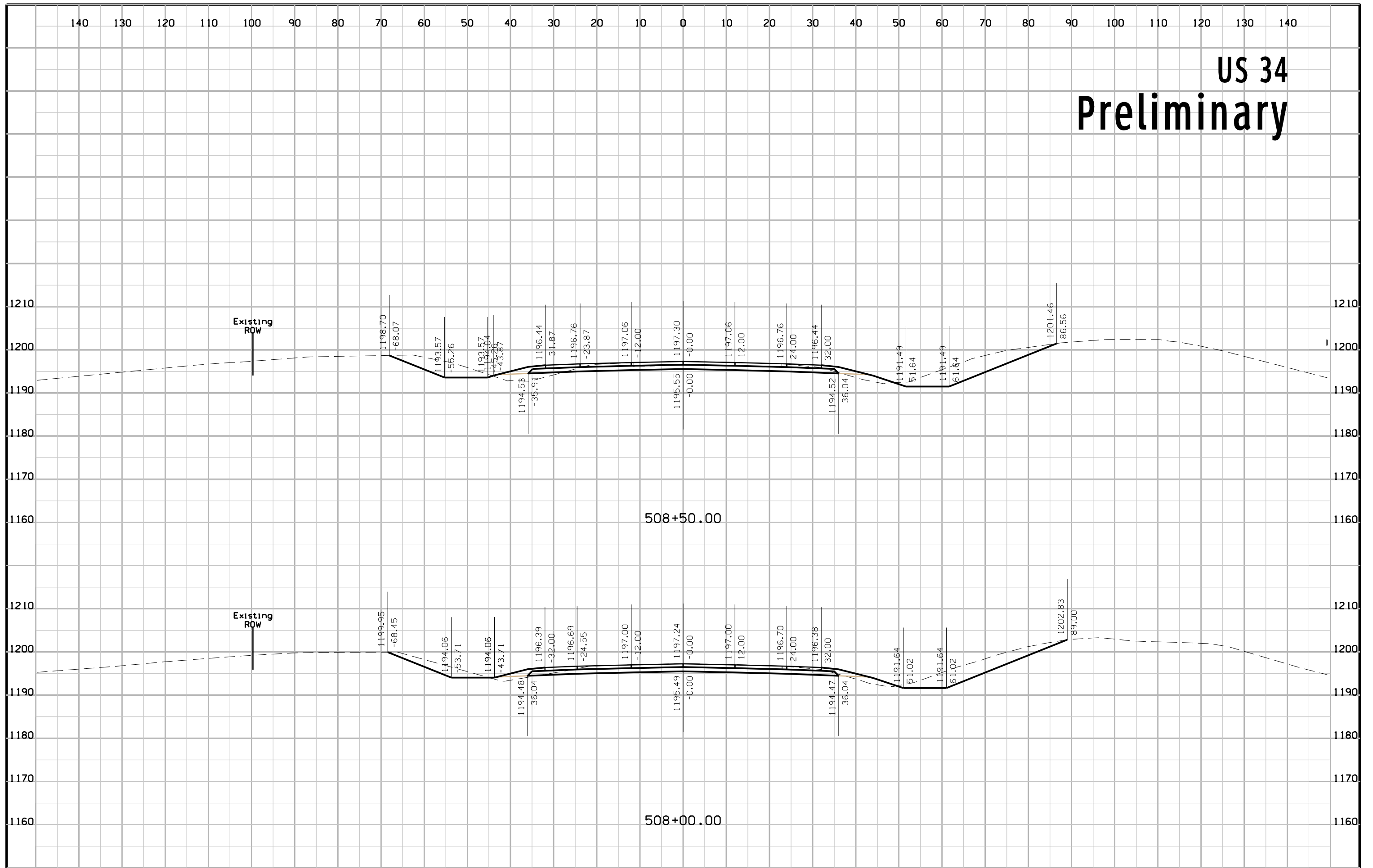

US 34 Preliminary

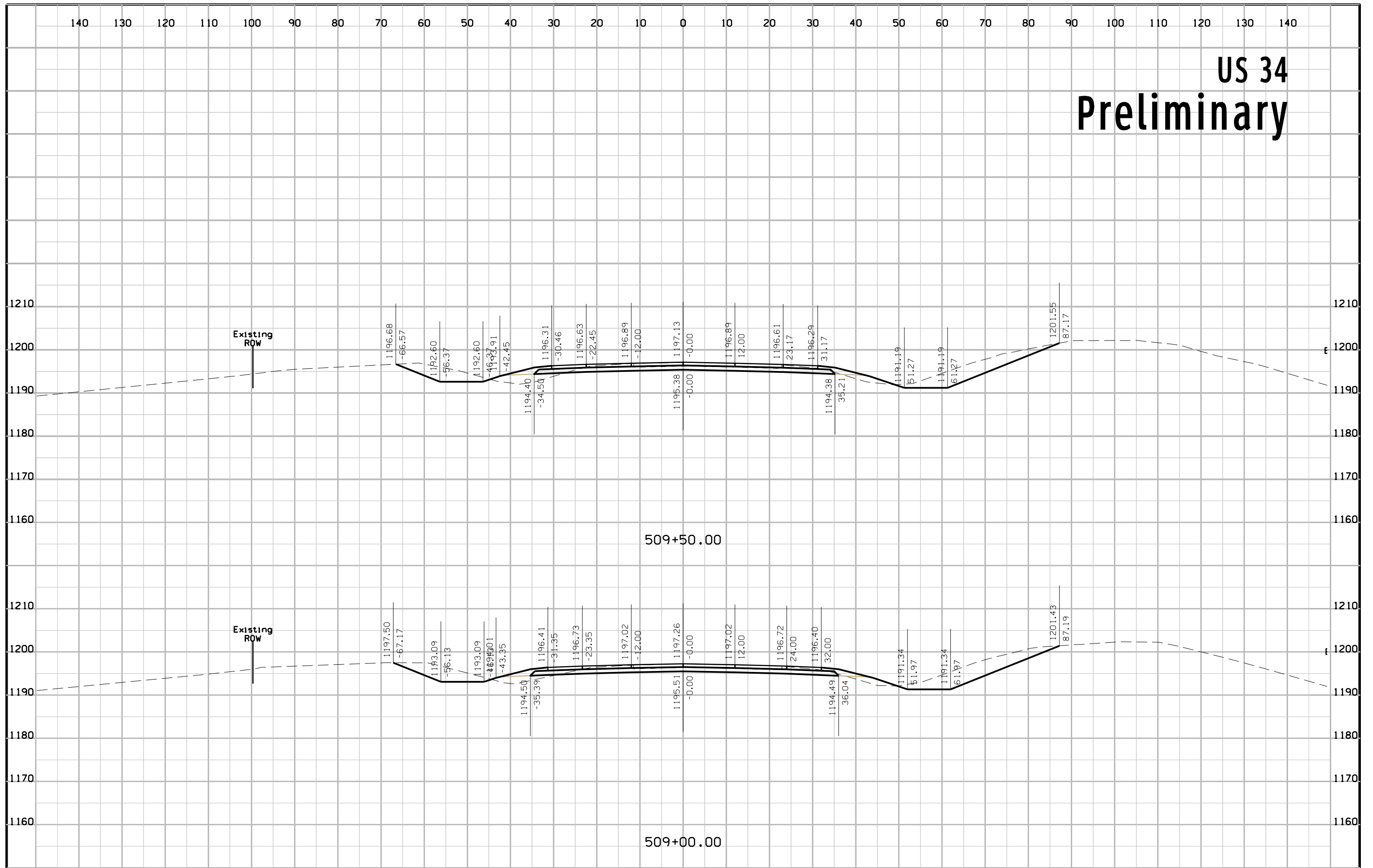

US 34 Preliminary

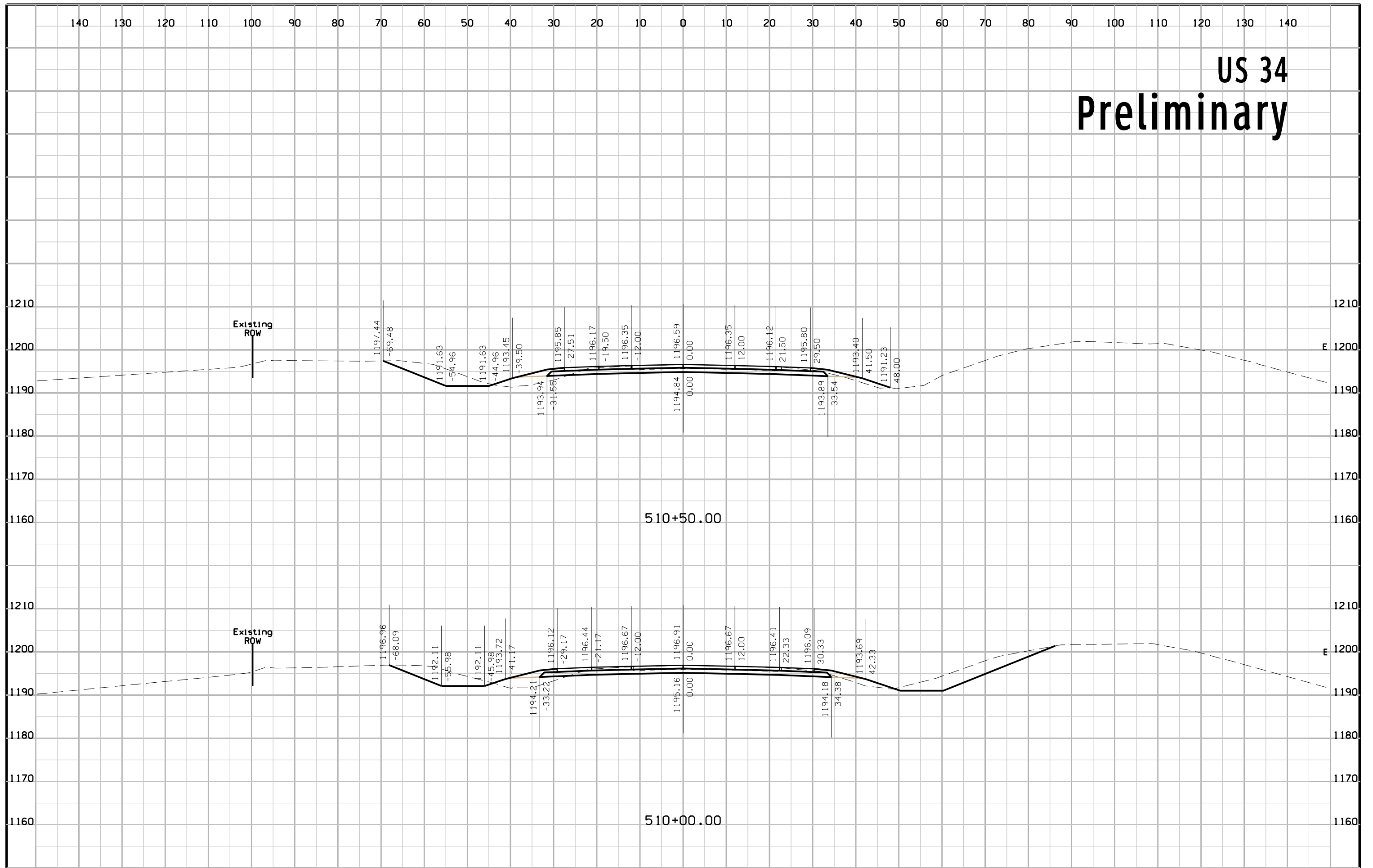

US 34 Preliminary

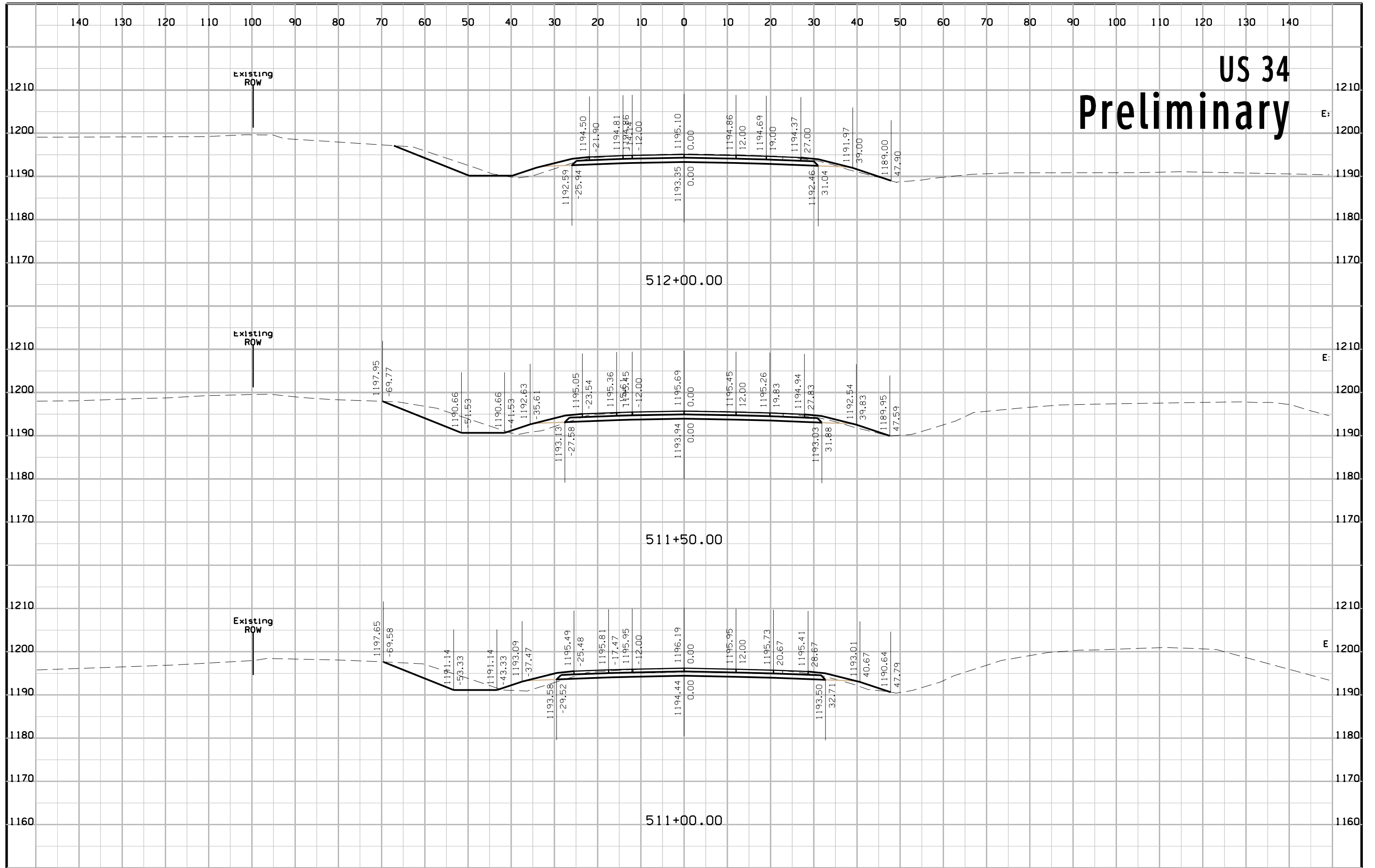

US 34 Preliminary

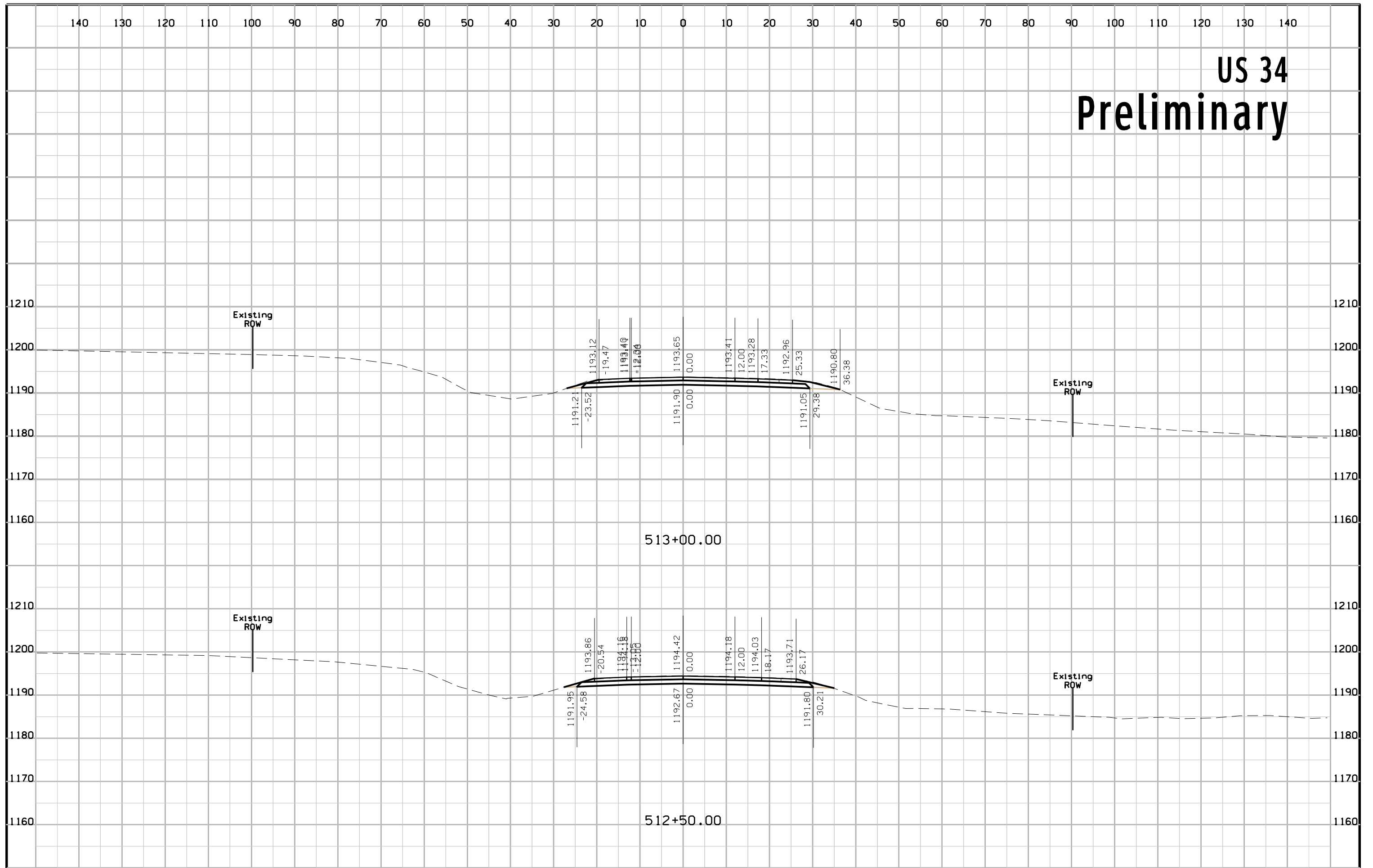

US 34 Preliminary

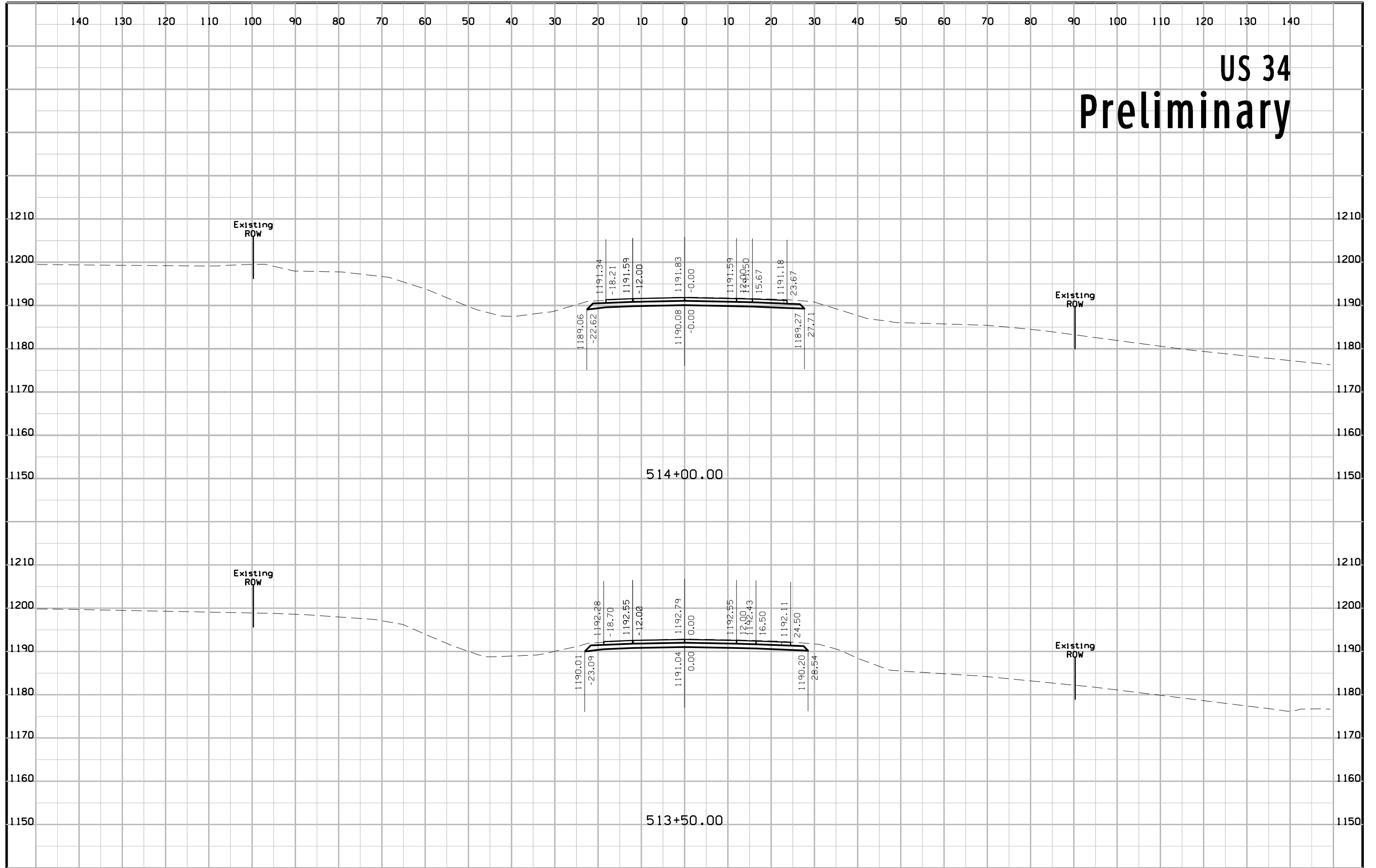

US 34 Preliminary

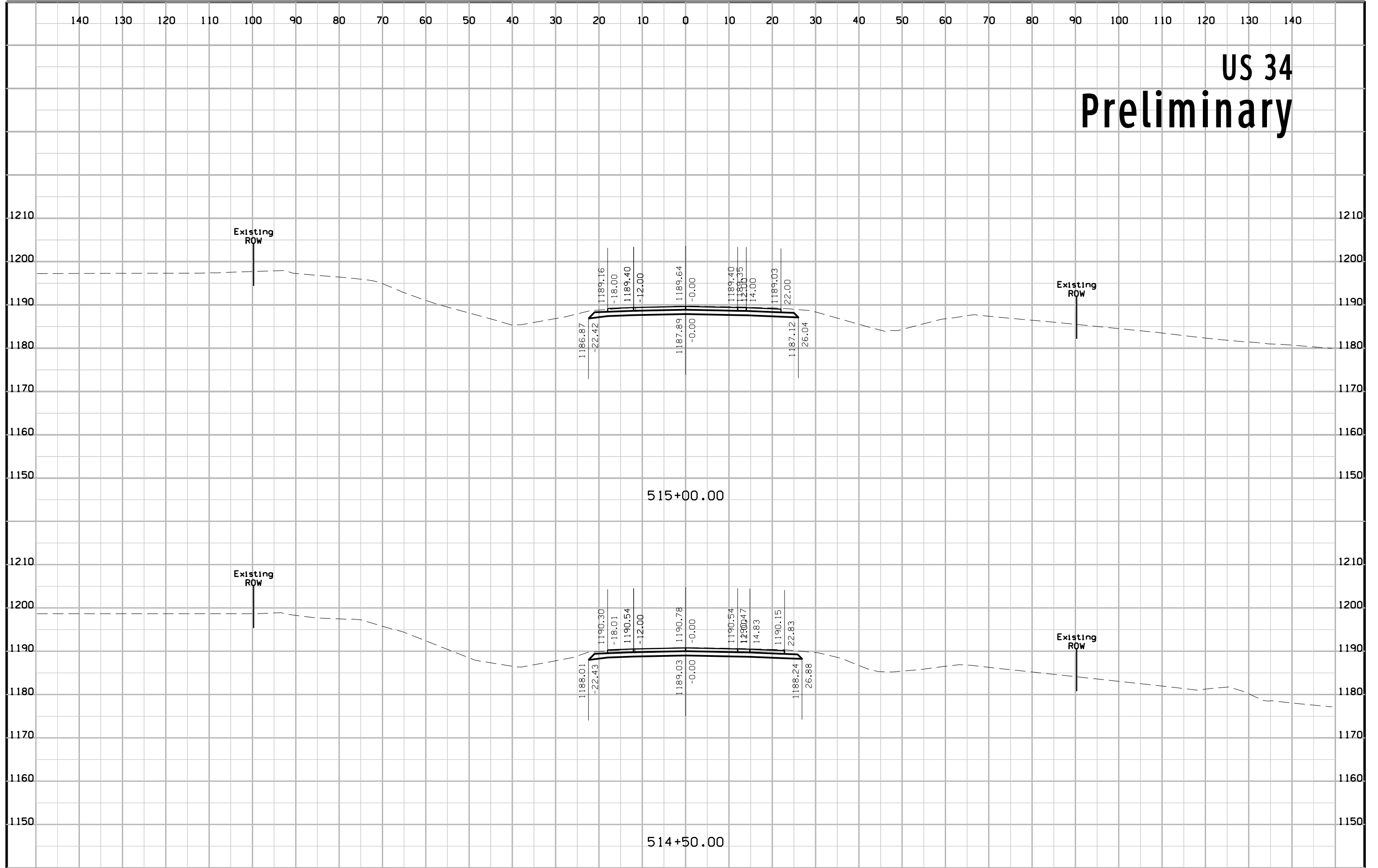

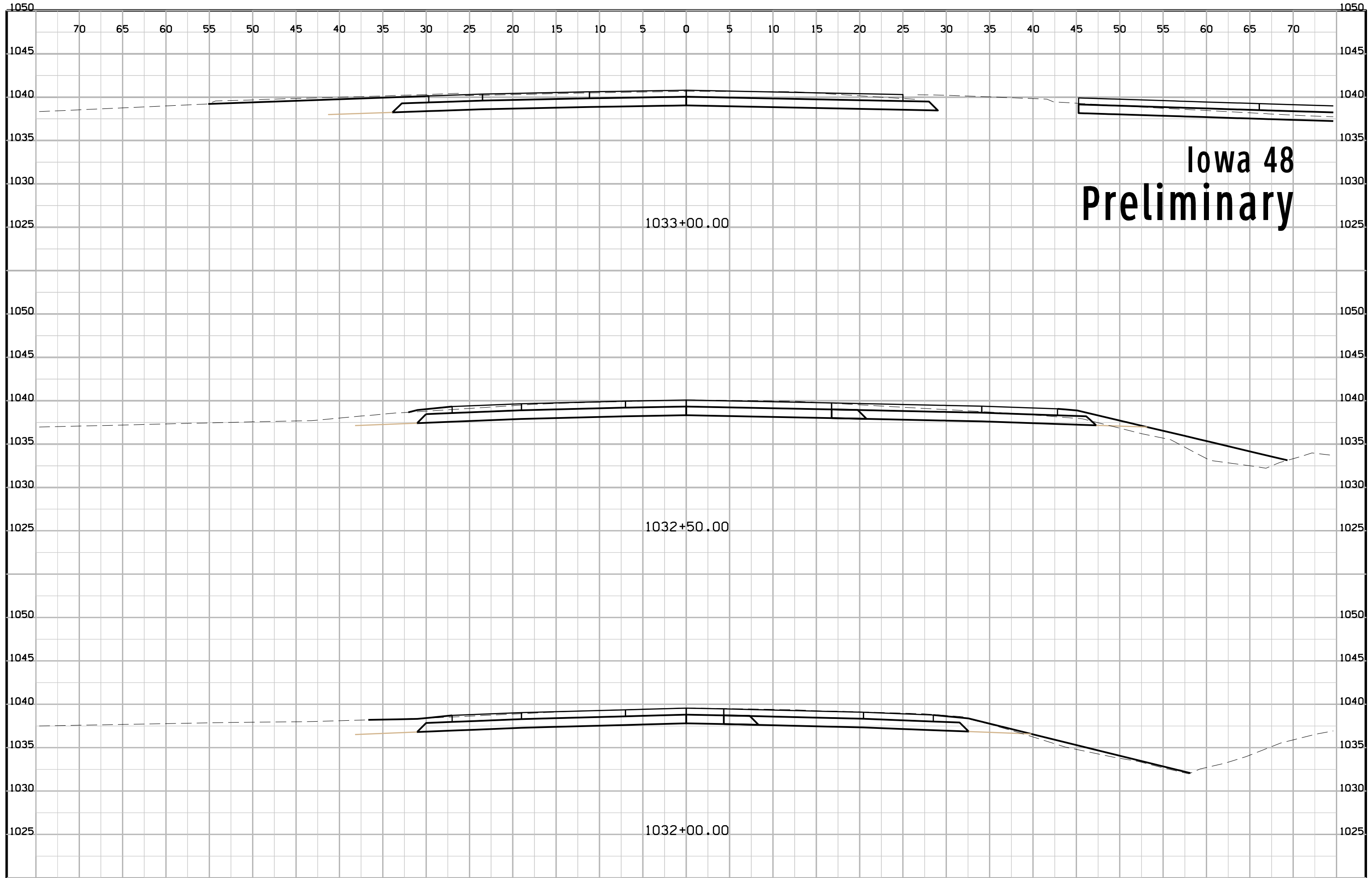

Iowa 48
Preliminary

1033+00.00

1032+50.00

1032+00.00

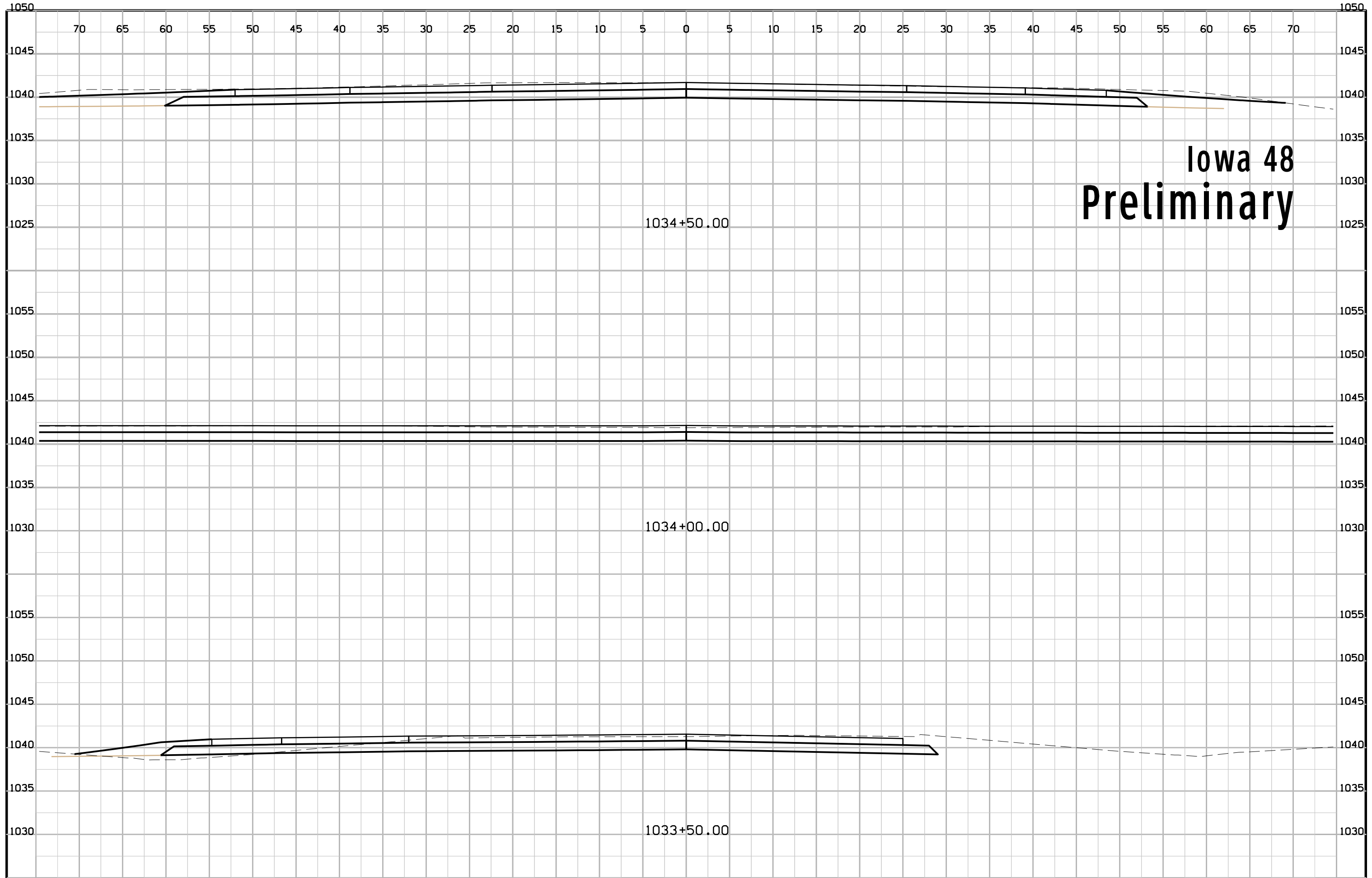

Iowa 48
Preliminary

FILE NO.	ENGLISH	DESIGN TEAM	Iowa DOT \ HDR	MONTGOMERY COUNTY	PROJECT NUMBER	NHSX-034-2(60)--3H-69	SHEET NUMBER	X.2
----------	---------	-------------	----------------	-------------------	----------------	-----------------------	--------------	-----

Iowa 48 Preliminary

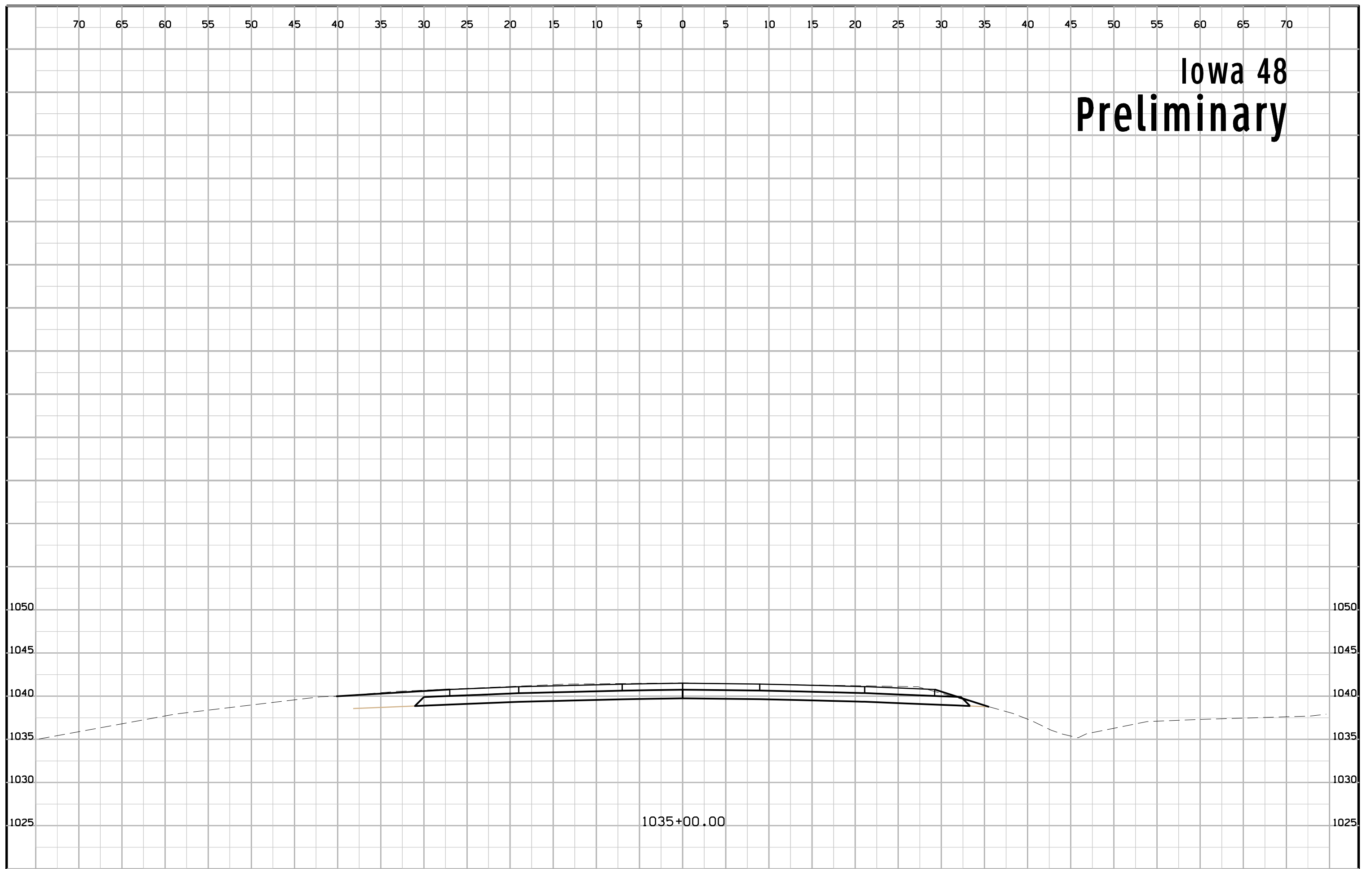

US 34 CONNECTOR Preliminary

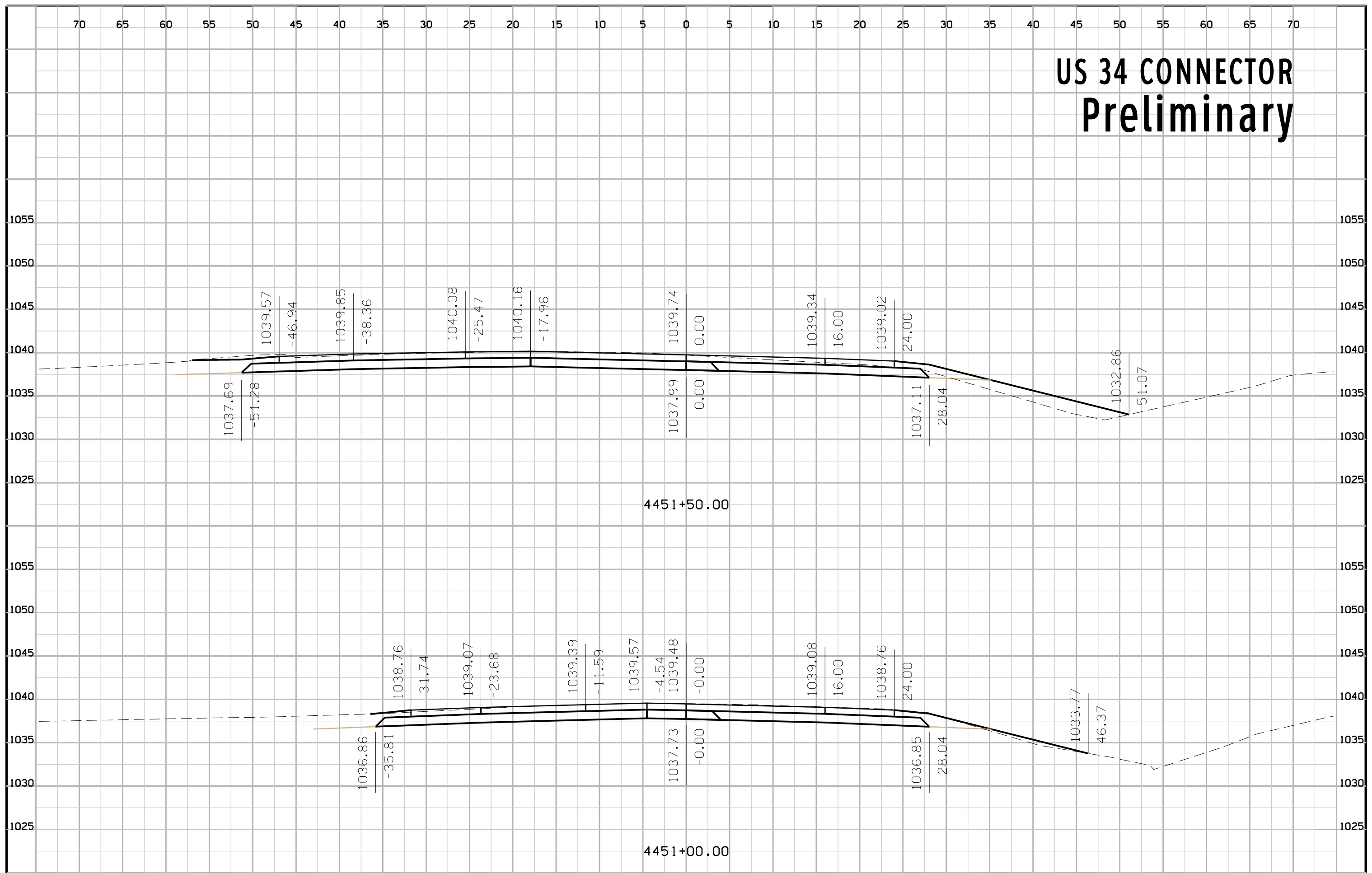

US 34 CONNECTOR Preliminary

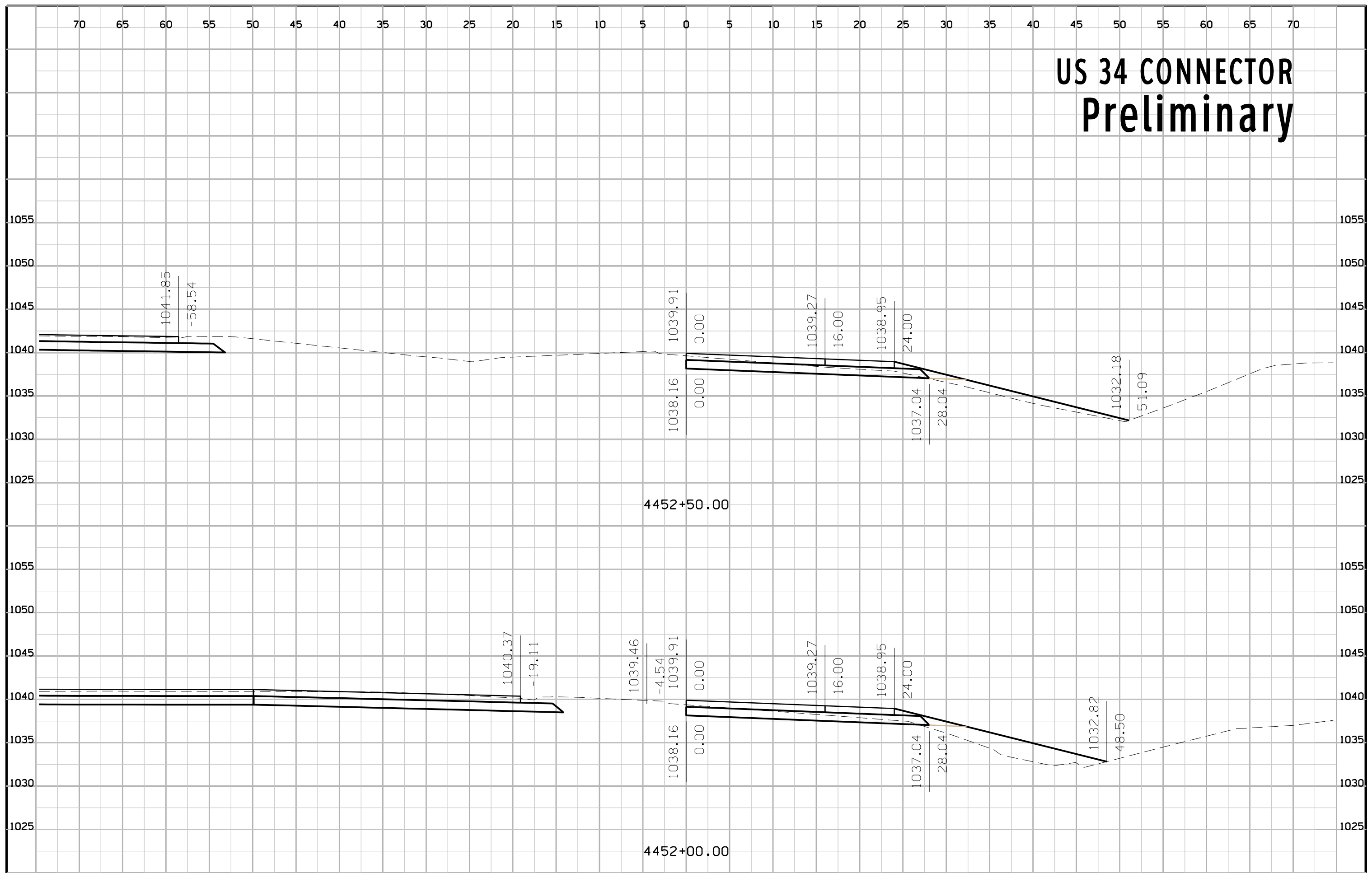

US 34 CONNECTOR Preliminary

