

DES MOINES/ LOUISA CO.
PCC PAVEMENT - GRADE AND REPLACE
NHS-61-2(50)--19-29
 LETTING DATE

INDEX OF SHEETS	
No.	DESCRIPTION
A Sheets	Title Sheets
A.1	Title Sheet
A.2	Location Map Sheet
A.3	General Review Question
A.4	D-2 Issues of Concern/Discussion Items
B Sheets	Typical Cross Sections and Details
B.1 - 7	Typical Cross Sections and Details
D Sheets	Mainline Plan and Profile Sheets
* D.1	Plan & Profile Legend & Symbol Information Sheet
* D.2 - 39	US 61
E Sheets	Side Road Plan and Profile Sheets
* E.1	Mark Twain Drive
* E.2	Memorial Park Road / Lakeside Drive
* E.3	Plank Road
* E.4	Flint Bottom Road / Upper Flint Road
* E.5	Tanner Lane
* E.6	130th Street / 32nd Avenue
* E.7	Pfeiff Road / 124th Avenue
* E.8	Iowa City Road
* E.9	Existing US 61 Connection at Iowa City Road
* E.10	150th Street / Center Avenue
* E.11	Existing US 61 Connection at 150th Street
* E.12	160th Street
* E.13	170th Street / Stoney Hollow Road
* E.14	Dodgeville Road / 180th Street
* E.15	182nd Street
* E.16	190th Street / Sperry Road
* E.17	198th Street
* E.18	Pleasant Grove Road
* E.19	210th Street (West)
* E.20	210th Street (East)
F Sheets	Detour or Temporary Pavement Sheets
* F.1 - 6	Detour Plan and Profile Sheets
G Sheets	Survey Sheets
G.1 - 6	Reference Ties and Bench Marks
G.7 - 11	Horizontal Control Tab. & Super for all Alignments
J Sheets	Traffic Control and Staging Sheets
J.1	Staging Notes
* J.2	Staging Plan
V Sheets	Bridge and Culvert Situation Plans
* V.1 - 6	Bridge and Culvert Situation Plans
W Sheets	Mainline Cross Sections
W.1	Cross Sections Legend & Symbol Information Sheet
W.2 - 210	US 61



PLANS OF PROPOSED IMPROVEMENT ON THE

PRIMARY ROAD SYSTEM DES MOINES/LOUISA COUNTY PCC PAVEMENT - GRADE AND REPLACE

US 61

From north of Burlington to approximately 1 mile north of IA 78

SCALES: As Noted

Refer to the Proposal Form for list of applicable specifications.

Value Engineering Saves. Refer to Article 1105.15 of the Specifications.

NO MILEAGE SUMMARY



REVISIONS

TOTAL
PROJECT IDENTIFICATION NUMBER
9729061070
PROJECT NUMBER
NHS-61-2(50)--19-29
R.O.W. PROJECT NUMBER
--

INDEX OF SHEETS	
No.	DESCRIPTION
X Sheets	Side Road Cross Sections
X.1 - 2	Mark Twain Dr
X.3 - 8	Memorial Park Rd / Lakeside Dr
X.9 - 18	Plank Rd
X.19 - 30	Flint Bottom Rd / Upper Flint Rd
X.31 - 37	Tanner Ln
X.38 - 40	130th St
X.41 - 47	Pfeiff Rd / 124th Ave
X.48 - 51	Iowa City Rd
X.52 - 61	Existing US 61 Connection at Iowa City Rd
X.62 - 66	150th St / Center Ave
X.67 - 78	Existing US 61 Connection at 150th St
X.79 - 84	160th St
X.85 - 95	170th St / Stoney Hollow Rd
X.96 - 99	Dodgeville Rd / 180th St
X.100 - 102	182nd St
X.103 - 106	190th St / Sperry Rd
X.107 - 108	198th St
X.109 - 110	Pleasant Grove Rd
X.111 - 112	210th St (West)
X.113 - 115	210th St (East)
	* Color Plan Sheets

**PRELIMINARY EARTHWORK
QUANTITY SUMMARY**

	Excavation (CYD)	Embankment In Place (CYD)
US 61 (N. of Burlington to 210th St.)	1,043,690	515,780

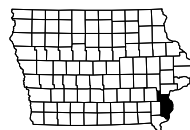

For Project Location Map Refer to Sheet A.2

DESIGN DATA RURAL			
2010	AADT	7,900	V.P.D.
2038	AADT	11,400	V.P.D.
2038	DHV	980	V.P.H.
	TRUCKS	14	%
	Total		
	Design ESALs	--	

INDEX OF SEALS		
SHEET NO.	NAME	TYPE
A.1	X	Primary Signature Block
X	X	X

PRELIMINARY PLANS

Subject to change by final design.

D2 PLAN - Date: May 16, 2014

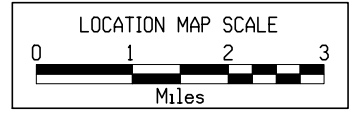
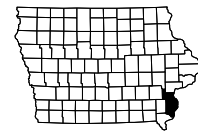

ENGLISH

IOWA DOT

DESIGN TEAM **Stanley Consultants Inc.**

DES MOINES/LOUISA COUNTY

PROJECT NUMBER

NHS-61-2(50)--19-29

SHEET NUMBER **A.2**

General Review Question

Are any of the following needed?

- Field Laboratory?
 - Field Office?
 - Construction Survey?
 - Will the Contractor handle removal and reinstallation of signs?
- Or
- Will District Maintenance crews handle removal and reinstallation of signs?

Are there existing drainage problems?

Tile lines location?

Utility Coordination Discussion. Process following D-2?

- power
- telephone
- fiber optic
- gas

Current posted speed limit

Speed Limit during construction?

How should fencing be handled along the ROW?

Will rumble strips along paved county roads need to be included with this project?

Who will provide information regarding special events?

D-2 Issues of Concern/Discussion Items

1. Design Criteria review.
2. Sheet D.4
 - a. Discuss the dual (shared) ditches between Sta. 1205 and Sta. 1215.
 - b. Note request for clarification of Flint River / Flint Creek name designation.
 - c. Discuss multiuse trail layout.
 - d. Discuss length of barrier rail along trail, north and south of SB Flint Creek Bridge.
 - e. Discuss possible lighting and additional approach guardrail.
3. Sheet D.22 and D.24
 - a. Discuss the dual (shared) ditches between Sta. 1480 and Sta. 1520.
4. Sheet E.3
 - a. Discussion regarding existing road berm at Plank Rd
 - b. Discussion regarding drainage in vicinity of multiuse trail loop.
5. Sheet E.5
 - a. Sta. 1254+18.70 – Tanner Lane(Lt. side of ML)...Will this pond be acquired in total/allow filling in pond?

D-2 Issues of Concern/Discussion Items

6. Sheet E.7
 - a. Sta. 1306+18.49 – Pfeiff Rd (Lt.)...Design Manual 6A-8 regarding non-paved crossroads
 1. Approximately 100 ft of tangent alignment should be placed between the edge of traveled way on the primary route and the point of P.C. or P.T. of an approach curve. Current design provides 90'.
7. Sheets F.5, V.5, and V.6
 - a. Staged construction to be utilized to build culvert under traffic. Options discussed with design team.
 - i. Precast barrels
 - ii. Accelerated construction
 - iii. Diversion pipe
8. Sheet V.3
 - a. Design flow increased due to updated 2013 regression equations resulting in additional barrel.
 - i. Is 2.3' headwater acceptable at this location?
 - OR
 - Should we consider larger barrels to reduce headwater to less than 1'?
9. General Questions:
 - a. Can we connect existing tile lines to new culverts? If so, this may require additional survey/field investigation.

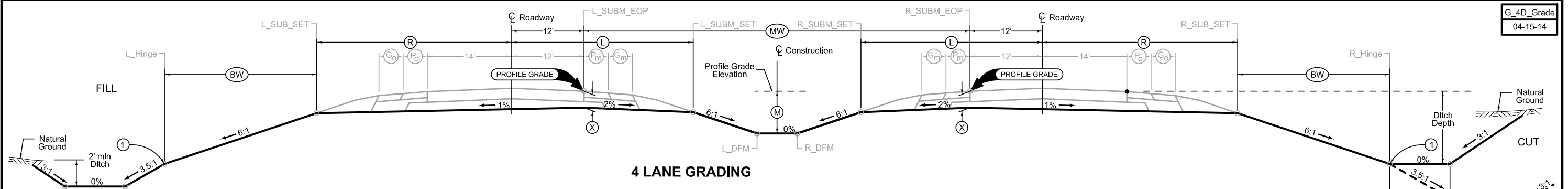

4 LANE GRADING

LOCATION		DIMENSIONS					
ROAD IDENTIFICATION	STATION TO STATION	L Feet	R Feet	X Inches	BW Feet	MW Feet	M Feet
US 61	1159+50.00 1714+00.00	29.2	33.1	18	18.5	64	4

Normal section shown may be modified appropriately in areas of superelevated curves or other locations specifically designated by the Engineer.

See Plan & Profile sheets and cross sections for additional details of ditches and backslopes.

① Refer to project plan and cross sections for specific location of foreslope change.

US HIGHWAY 61

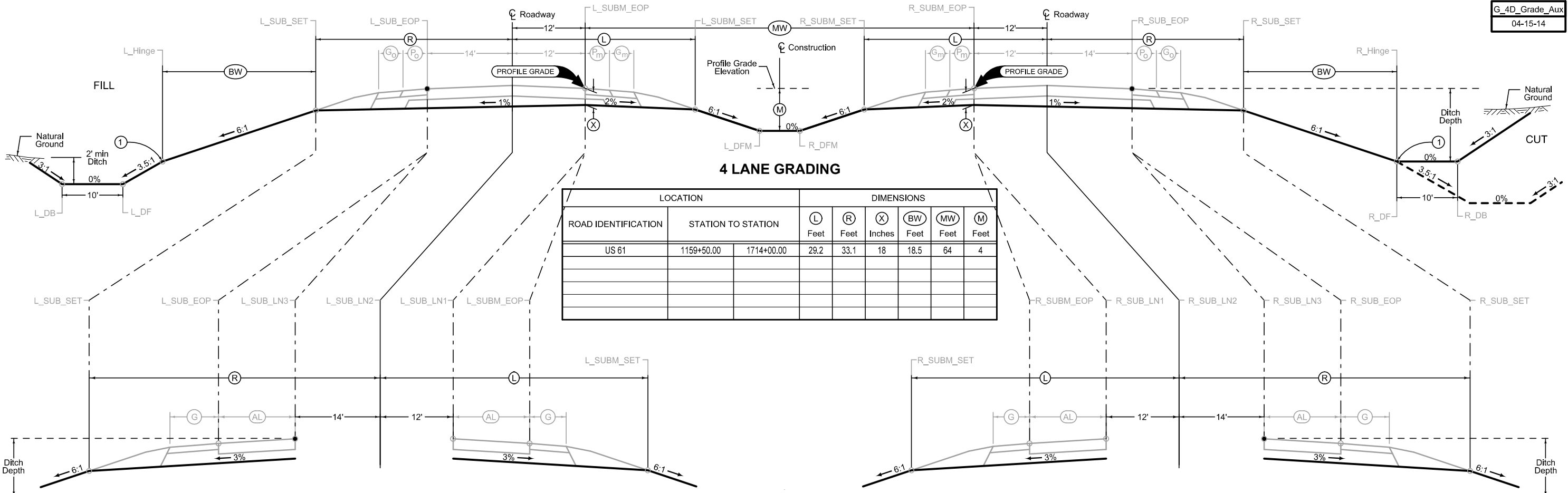

LOCATION		DIMENSIONS						
ROAD IDENTIFICATION	STATION TO STATION	L Feet	R Feet	X Inches	BW Feet	MW Feet	M Feet	
US 61	1159+50.00 - 1714+00.00	29.2	33.1	18	18.5	64	4	

Auxiliary Lane Grading

LOCATION			R
ROAD IDENTIFICATION	STATION TO STATION		Feet
US 61	1217+58.15	1226+11.41	
US 61	1704+44.97	1711+84.97	

Auxiliary Lane Grading

LOCATION			L
ROAD IDENTIFICATION	STATION TO STATION		Feet
US 61	1168+59.83	1175+58.55	
US 61	1216+47.45	1225+05.51	
US 61	1254+91.14	1262+33.13	
US 61	1278+67.21	1286+09.72	
US 61	1307+04.38	1314+40.95	
US 61	1346+37.05	1353+77.05	
US 61	1385+46.79	1392+86.79	
US 61	1438+86.76	1446+24.57	
US 61	1490+97.11	1498+37.11	
US 61	1545+86.47	1553+26.47	
US 61	1598+95.24	1606+34.94	
US 61	1638+98.53	1646+38.53	
US 61	1652+27.69	1659+67.69	
US 61	1703+96.14	1711+36.14	

Auxiliary Lane Grading

LOCATION			L
ROAD IDENTIFICATION	STATION TO STATION		Feet
US 61	1159+84.14	1166+94.14	
US 61	1183+77.76	1192+37.76	
US 61	1207+80.60	1215+22.20	
US 61	1246+05.72	1253+45.72	
US 61	1269+72.50	1277+09.71	
US 61	1297+92.70	1305+36.17	
US 61	1337+38.41	1344+77.84	
US 61	1376+36.91	1383+76.91	
US 61	1429+69.67	1437+13.15	
US 61	1481+88.54	1489+28.54	
US 61	1536+78.67	1544+18.67	
US 61	1589+90.28	1597+30.28	
US 61	1643+19.06	1650+59.06	
US 61	1694+84.90	1702+24.90	

Auxiliary Lane Grading

LOCATION			R
ROAD IDENTIFICATION	STATION TO STATION		Feet
US 61	1206+50.85	1213+96.51	
US 61	1589+28.42	1596+68.36	

Normal section shown may be modified appropriately in areas of superelevated curves or other locations specifically designated by the Engineer.

See Plan & Profile sheets and cross sections for additional details of ditches and backslopes.

① Refer to project plan and cross sections for specific location of foreslope change.

US HIGHWAY 61

LOCATION		DIMENSIONS				
ROAD IDENTIFICATION	STATION TO STATION	W Feet	L Feet	R Feet	X Inches	FS
Memorial Park Rd	11163+50.00	24	24.0	24.0	21	4
Lakeside Dr	11168+32.00	22	19.5	19.5	21	3
Plank Rd	11181+25.00	24	24.0	24.0	21	4
Flint Bottom Rd	11205+75.00	24	25.8	25.8	21	4
Upper Flint Rd	11216+44.78	24	24.0	24.0	21	4
Tanner Conn. to Exist. US 61	11254+76.74	24	22.2	22.2	21	4
Iowa City Rd (Rt)	11346+09.19	24	22.2	22.2	21	4
Exist. US 61 Conn. at IC Rd	21341+38.99	24	22.2	22.2	21	4
150th St / Center Ave (Rt)	11385+20.14	24	22.2	22.2	21	4
Exist. US 61 Conn. at 150th	21380+76.64	24	22.2	22.2	21	4
Dodgeville Rd	11541+00.00	24	24.0	24.0	21	4
Sperry Rd	11598+71.33	24	25.8	25.8	21	4
198th St	11638+71.87	24	22.2	22.2	21	4
Pleasant Grove Rd	11648+75.00	24	24.0	24.0	21	4
210th St (Lt)	11699+50.83	24	24.0	24.0	21	4

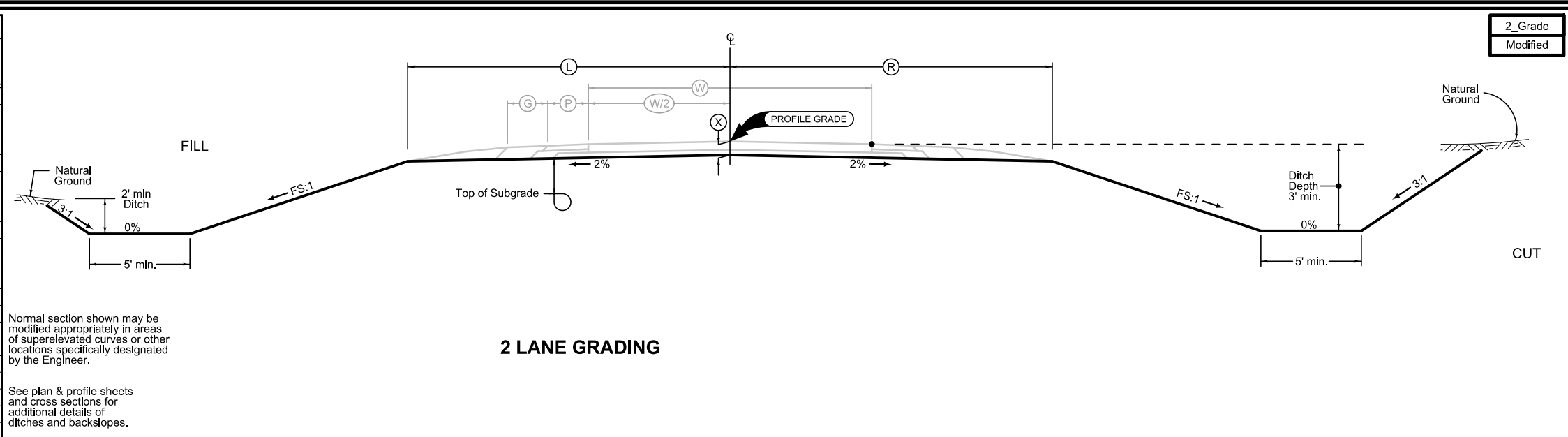

2_Grade
Modified

LOCATION		DIMENSIONS					
ROAD IDENTIFICATION	STATION TO STATION	W Feet	L Feet	R Feet	FS	BS	DW Feet
Mark Twain Dr	11162+12.51	11	15	15	3	3	5
Tanner Ln (Lt)	11250+00.00	10	10	10	3	3	5
130th St / 32nd Ave	11278+42.46	11	15	15	3	3	5
Pfeiff Rd / 124th Ave (Lt)	11301+75.00	11	15	15	3	3	5
Pfeiff Rd / 124th Ave (Rt)	11306+80.49	11	15	15	3	3	5
Iowa City Rd (Lt)	11342+00.00	11	15	15	3	3	5
150th St / Center Ave (Lt)	11381+00.00	11	15	15	3	3	5
160th St (Lt)	11434+00.00	11	15	15	3	3	5
160th St (Rt)	11438+61.23	11	15	15	3	3	5
170th St	11478+50.00	11	15	15	3	3	5
Stoney Hollow Rd	11490+75.06	11	15	15	3	3	5
180th St	11545+64.32	11	15	15	3	3	5
182nd St	11561+45.48	11	15	15	3	3	5
190th St	11594+50.00	11	15	15	3	3	5
210th St (Rt)	11703+73.83	11	15	15	3	3	5

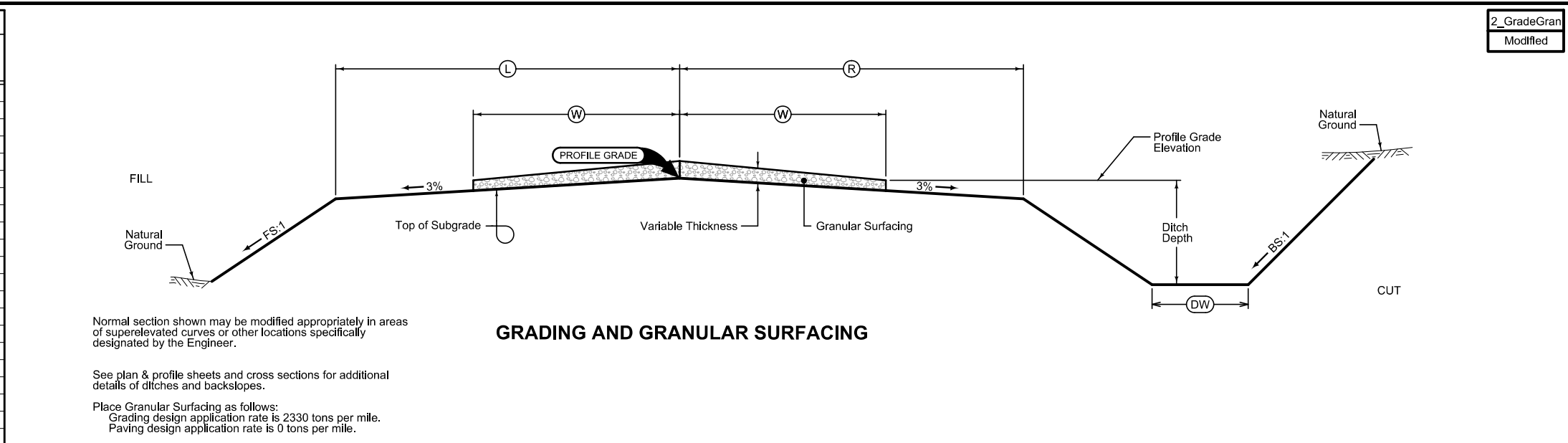

2_GradeGran
Modified

Combination Shoulder

Shoulder Jointing:
Longitudinal joint: B

4_C_10-19-10				
Direction of Travel	BEGIN STATION	END STATION	(P) Feet	(G) Feet
NB	1159+50.00	1710+00.00	4	2
SB	1159+50.00	1714+00.00	4	2

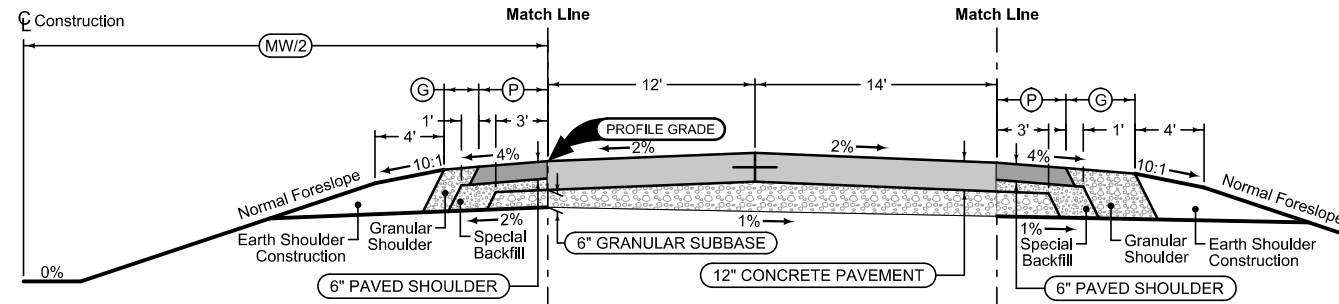

Section shown in the direction of traffic.

Mainline Jointing:
Transverse joints: CD at 20' spacing
Longitudinal joint: L-2

4DP_10-19-10				
Direction of Travel	BEGIN STATION	END STATION	(MW) Feet	
NB	1159+50.00	1710+00.00	64	
SB	1159+50.00	1714+00.00	64	

Combination Shoulder

Shoulder Jointing:
Longitudinal joint: B

4_C_10-19-10				
Direction of Travel	BEGIN STATION	END STATION	(P) Feet	(G) Feet
NB	1159+50.00	1710+00.00	4	4
SB	1159+50.00	1714+00.00	4	4

Auxiliary Lane

Longitudinal joint: L or KT
Transverse joint: Match Mainline

4_AuxLane_PCC_10-19-10				
Direction of Travel	BEGIN STATION	END STATION	(AL) Feet	
NB	1159+84.14	1166+94.14	12	
SB	1168+59.83	1175+58.55	12	
NB	1183+77.76	1192+37.76	12	
NB	1207+80.60	1215+22.20	12	
SB	1216+47.45	1225+05.51	12	
NB	1246+05.72	1253+45.72	12	
SB	1254+91.14	1262+33.13	12	
NB	1269+72.50	1277+09.71	12	
SB	1278+67.21	1286+09.72	12	
NB	1297+92.70	1305+36.17	12	
SB	1307+04.38	1314+40.95	12	
NB	1337+38.41	1344+77.84	12	
SB	1346+37.05	1353+77.05	12	
NB	1376+36.91	1383+76.91	12	
SB	1385+46.79	1392+86.79	12	
NB	1429+69.67	1437+13.15	12	
SB	1438+86.76	1446+24.57	12	
NB	1481+88.54	1489+28.54	12	
SB	1490+97.11	1498+37.11	12	
NB	1536+78.67	1544+18.67	12	
SB	1545+86.47	1553+26.47	12	
NB	1589+90.28	1597+30.28	12	
SB	1598+95.24	1606+34.94	12	
SB	1638+98.53	1646+38.53	12	
NB	1643+19.06	1650+59.06	12	
SB	1652+27.69	1659+67.69	12	
NB	1694+84.90	1702+24.90	12	
SB	1703+96.14	1711+36.14	12	

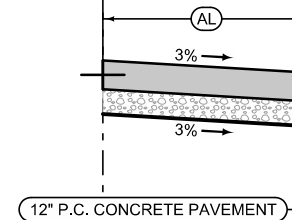
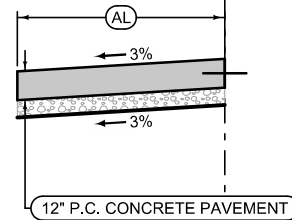

Auxiliary Lane

Longitudinal joint: L or KT
Transverse joint: Match Mainline

4_AuxLane_PCC_10-19-10				
Direction of Travel	BEGIN STATION	END STATION	(AL) Feet	
NB	1206+50.85	1213+96.51	12	
SB	1217+58.15	1226+11.41	12	
NB	1589+28.42	1596+68.36	12	
SB	1704+44.97	1711+84.97	12	

See Tab 100-24 for pavement quantities.
See Tab 112-9 for shoulder quantities.

US HIGHWAY 61

Match Line

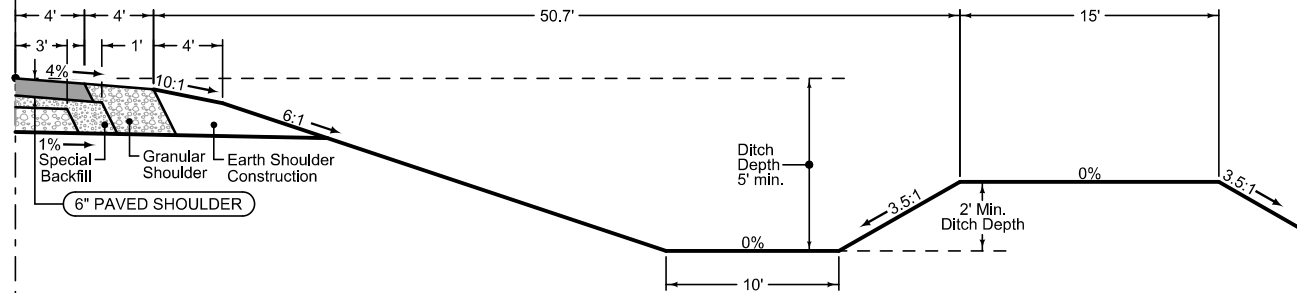
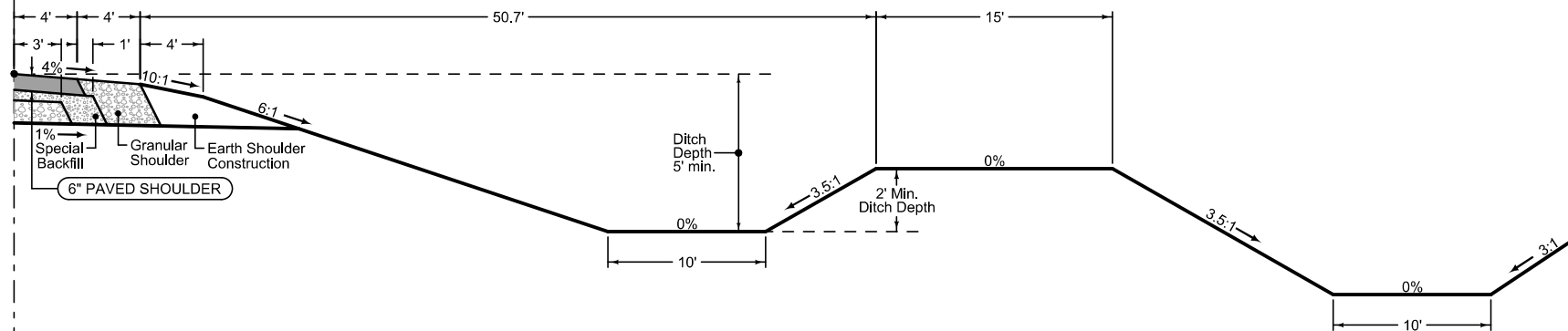
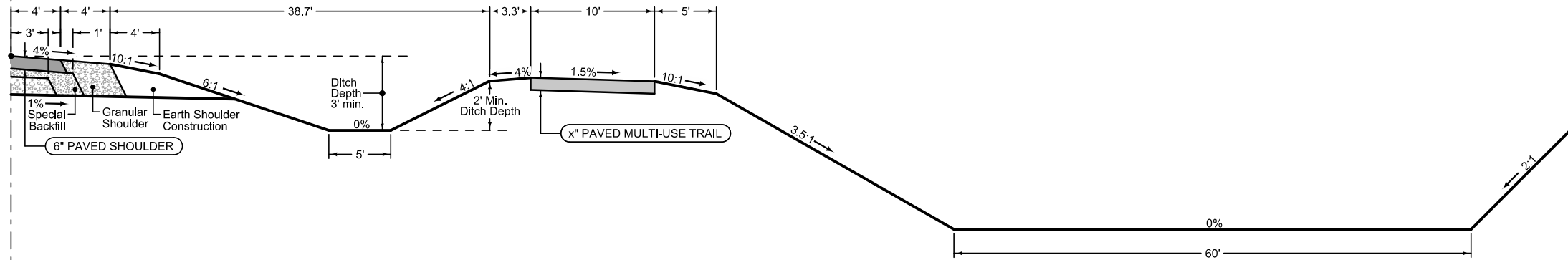
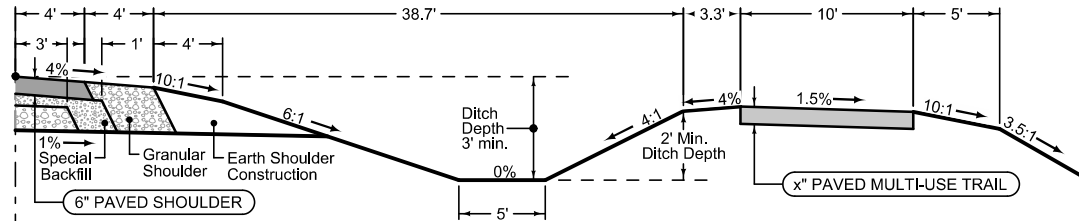
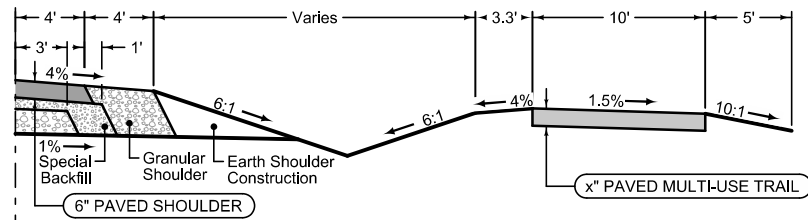

Special V-Ditch with Multi-Use Trail

Direction of Travel	BEGIN STATION	END STATION
SB	1200+65.00	1201+75.00

Standard 2' Ditch with Multi-Use Trail

Direction of Travel	BEGIN STATION	END STATION
SB	1201+75.00	1204+00.00
SB	1212+00.00	1215+50.00

Standard 2' Ditch with Multi-Use Trail and Special Ditch

Direction of Travel	BEGIN STATION	END STATION
SB	1204+00.00	1212+00.00

Special 2' Fill Ditch with Lower Ditch

Direction of Travel	BEGIN STATION	END STATION
NB	1461+00.00	1466+25.00
NB	1480+00.00	1489+50.00
NB	1501+75.00	1517+75.00

Special 2' Fill Ditch

Direction of Travel	BEGIN STATION	END STATION
NB	1466+25.00	1470+55.00
NB	1473+90.00	1475+85.00

US HIGHWAY 61

Granular Shoulder

ROAD IDENTIFICATION	STATION TO STATION		Ⓒ Feet
Memorial Park Rd	11163+50.00	11167+16.00	6
Lakeside Dr	11168+32.00	11170+00.00	4
Plank Rd	11181+00.00	11192+48.05	6
Flint Bottom Rd	11205+75.00	11215+24.69	8
Upper Flint Rd	11216+44.78	11222+75.00	6
Tanner Conn. to Exist. US 61	11254+76.74	11259+61.78	4
Dodgeville Rd	11541+00.00	11544+44.30	6
Sperry Rd	11598+71.33	11601+00.00	8
198th St	11638+71.87	11641+00.00	4
Pleasant Grove Rd	11648+75.00	11650+85.03	6
210th St (Lt)	11699+50.83	11702+50.83	6

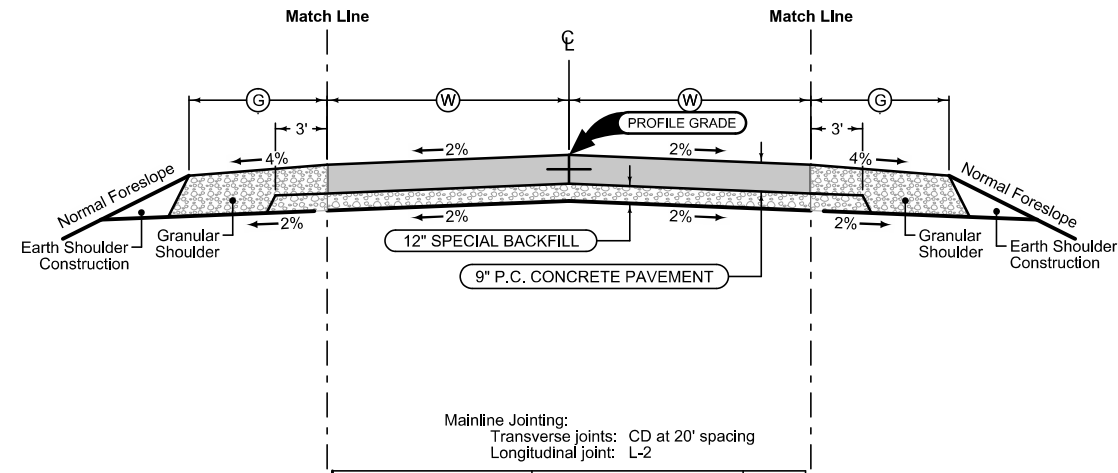

Mainline Jointing:
 Transverse joints: CD at 20' spacing
 Longitudinal joint: L-2

ROAD IDENTIFICATION	STATION TO STATION		⒱ Feet
Memorial Park Rd	11163+50.00	11167+16.00	12
Lakeside Dr	11168+32.00	11170+00.00	11
Plank Rd	11181+00.00	11192+48.05	12
Flint Bottom Rd	11205+75.00	11215+24.69	12
Upper Flint Rd	11216+44.78	11222+75.00	12
Tanner Conn. to Exist. US 61	11254+76.74	11259+61.78	12
Dodgeville Rd	11541+00.00	11544+44.30	12
Sperry Rd	11598+71.33	11601+00.00	12
198th St	11638+71.87	11641+00.00	12
Pleasant Grove Rd	11648+75.00	11650+85.03	12
210th St (Lt)	11699+50.83	11702+50.83	12

Granular Shoulder

ROAD IDENTIFICATION	STATION TO STATION		Ⓒ Feet
Memorial Park Rd	11163+50.00	11167+16.00	6
Lakeside Dr	11168+32.00	11170+00.00	4
Plank Rd	11181+00.00	11192+48.05	6
Flint Bottom Rd	11205+75.00	11215+24.69	8
Upper Flint Rd	11216+44.78	11222+75.00	6
Tanner Conn. to Exist. US 61	11254+76.74	11259+61.78	4
Dodgeville Rd	11541+00.00	11544+44.30	6
Sperry Rd	11598+71.33	11601+00.00	8
198th St	11638+71.87	11641+00.00	4
Pleasant Grove Rd	11648+75.00	11650+85.03	6
210th St (Lt)	11699+50.83	11702+50.83	6

See Tab 100-24 for pavement quantities.
 See Tab 112-9 for shoulder quantities.

SIDE ROADS

ROAD IDENTIFICATION	LOCATION STATION TO STATION		DIMENSIONS		6" Special Backfill Tons/Station	Earth Shoulder Construction Station
			HMA	PCC		
			(SGW) Feet	(SGW) Feet		
Detour Pavement 1	51451+00.00	51455+32.09			34	
Detour Pavement 2	51451+68.55	51459+55.18			34	
Detour Pavement 3	51591+32.15	51603+08.49			34	
Detour Pavement 4	51612+89.56	51627+47.09			34	
Detour Pavement 5	41714+00.00	41720+92.97			34	
Detour Pavement 6	51710+00.00	51728+46.21			34	

Quantity calculations based on vertical pavement edges.
Normal section shown may be modified appropriately in areas of superelevated curves or other locations specifically designated by the Engineer.

① Possible HMA 1:1 slope

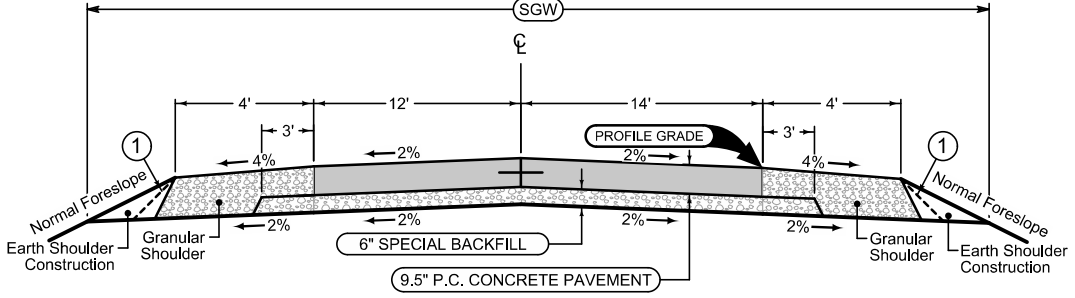













DETOUR PAVING

DETOURS







SURVEY SYMBOLS









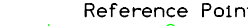

UTILITY LEGEND

PLAN VIEW COLOR LEGEND OF PLAN AND PROFILE SHEETS

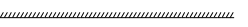

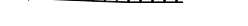





LINEWORK	Design Color No.	
Green	(2)	 Existing Topographic Features and Labels
Blue	(1)	 Proposed Alignment, Stationing, Tic Marks, and Alignment Annotation
Magenta	(5)	 Existing Utilities
SHADING	Design Color No.	
Yellow	(4)	 Highlight for Critical Notes or Features
Red	(3)	 Delineates Restricted Areas
Lavender	(9)	 Temporary Pavement Shading
Gray, Light	(48)	 Proposed Pavement Shading
Gray, Med	(80)	 Proposed Granular Shading
Gray, Dark	(112)	 Proposed Grade and Pave Shading "In conjunction with a paving project"
Brown, Light	(236)	 Grading Shading
Tan	(8)	 Proposed Sidewalk Shading
Blue, Light	(230)	 Proposed Sidewalk Landing Shading
Pink	(11)	 Proposed Sidewalk Ramp Shading

PROFILE VIEW COLOR LEGEND OF PLAN AND PROFILE SHEETS

LINEWORK	Design Color No.	
Green	(2)	 Existing Ground Line Profile
Blue	(1)	 Proposed Profile and Annotation
Magenta	(5)	 Existing Utilities
Blue, Light	(230)	 Proposed Ditch Grades, Left
Black	(0)	 Proposed Ditch Grades, Median
Rust	(14)	 Proposed Ditch Grades, Right

 Reference Point	Survey Line
 Station	
 Section Corner	
 Ground Line Intercept	
 Saw Cut	
 Guardrail	
 Trench Drain	
 HighTension Cable Guardrail	
 Sheet Pile	
 Pavement Removal	 Clearing & Grubbing Area
 Pavement Obliterate	

RIGHT-OF-WAY LEGEND

 Proposed Right-of-Way
 Existing Right of Way
 Existing and Proposed Right-of-Way
 Easement and Existing Right-of-Way
 Easement (Temporary)
 Easement
 Access Control
 Property Line

**PLAN AND PROFILE
LEGEND AND SYMBOL
INFORMATION SHEET**

(COVERS SHEET SERIES D, E, F, & K)

For Side Road Details
Refer to Sheet No. E.2

FLINT RIVER TWP.
T-70N R-3W
SEC. 24

Sta. 1174+75
Install 24" X ' 2000D
F.L. = Lt. ?
Rt. ?

Curve Data
 $\Delta = 11^\circ 02' 05.48" (RT)$
 $T = 627.87$
 $L = 1,251.86$
 $R = 6,500.00$
 $E = 30.25$
 $e = 3.27$
 $L = 144'$
 $x = 90'$

Inlet Sta. 1177+75, 108' Lt.
Install 24" x ' PEP Letdown
F.L. = South 619.10
Other ?
Other ?
North 598.20

Inlet Sta. 1180+25, 110' Lt.
Install 24" x ' PEP Letdown
F.L. = South 597.00
Other ?
Other ?
North 573.90

Inlet Sta. 1187+00, 110' Lt.
Install 30" x ' PEP Letdown
F.L. = South 567.90
Other ?
Other ?
North 555.40

Sta. 1184+25
Install 24" X ' 2000D
F.L. = Lt. ?
Rt. ?

Sta. 1159+50.00
Begin Project
Begin Grading

POT Sta. 1161+50.50
=POT Sta. 11161+50.50

POT Sta. 1167+74.00
=POT Sta. 11167+74.00

+XX Prop.
Type M DiKE
Elev. =

+XX Prop.
Type M DiKE
Elev. =

Prop. 24" Uncl Ent Pipe

(Remove)
24"x100' CMP

US 61 (ML061.S)

PC Sta. 1169+63.47

+XX Prop.
Type M DiKE
Elev. =

+XX Prop.
Type M DiKE
Elev. =

(Remove)
Sta 1175+39
24" x 136" Conc. Pipe
With Junction Box Rt.
DA = 2.47 Ac. H

(Remove)
Sta 1176+19, Rt.
30" x 112" CMP
With Intake at +84 Rt.
DA = Ac. H

(Remove)
Sta 1177+20, Rt.
30" x 118" CMP
With 36" x 36" x 8.5' RCB
DA = Ac. H

(Remove)
Sta 1178+08, Rt.
36" x 36" x 32' RCB
With Intake and Stub Flume
DA = Ac. H

(U.A.C.)
Sta 1182+34, Rt
48" x 39" CMP
with 1/2 Pipe Letdown
DA = 23.01 Ac. H

(Remove)
Sta 1166+45
24" x 80" Conc. Pipe
DA = 1.24 Ac. H

(Remove)
Sta 1168+54
24" x 177" Conc. Pipe
DA = 13.00 Ac. H

(U.A.C.)
Sta 1170+08, Rt.
28" x 20" x 15' CMP
Arch Pipe with Headwall
DA = Ac. H

(Remove)
Sta 1173+24
24" x 74" Conc. Pipe
DA = 0.89 Ac. H

(Remove)
Sta 1173+91, Lt.
24" x 44" CMP Letdown
DA = Ac. H

Sta. 1166+50
Install 24" X ' 2000D
F.L. = Lt. ?
Rt. ?

Sta. 1169+25.00
Install 24" X ' 2000D
Skew = 15° Rt. Ahd.
F.L. = Lt. 649.40
Rt. 647.70

Sta. 1175+25.00
Install 24" X ' 2000D
Skew = 15° Rt. Ahd.
F.L. = Lt. 630.20
Rt. 628.30

FLINT RIVER TWP.
T-70N R-3W
SEC. 24

Inlet Sta. 1176+50, 158' Rt.
Install 30" x ' PEP Letdown
F.L. = South 621.30
Other ?
Other ?
North 600.80

Inlet Sta. 1178+00, 165' Rt.
Install 30" x ' PEP Letdown
F.L. = South 600.20
Other ?
Other ?
North 578.80



For Profile Details
Refer to Sheet No. D.3

US 61

For Side Road Details
Refer to Sheet No. E.1

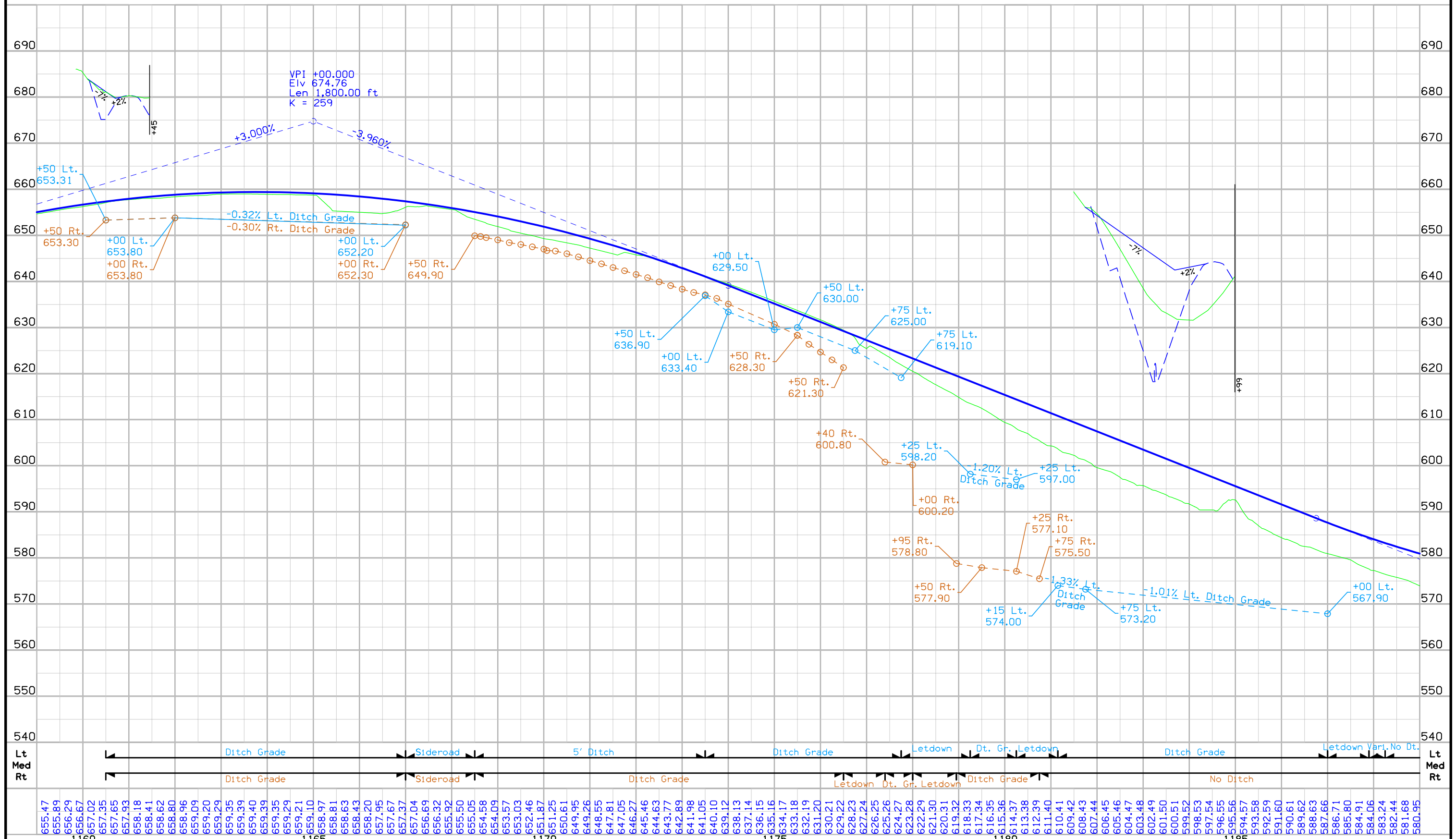

For Side Road Details
Refer to Sheet No. E.3

For Side Road Details
Refer to Sheet No. E.4

FLINT RIVER TWP.
T-70N R-3W
SEC. 24

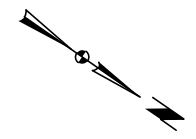

Sta. 1195+56.10
Begin Concrete Barrier (BA-103)
Sta. 1197+31.10
End Concrete Barrier (BA-103)

Sta. 1200+02.78
Begin Concrete Barrier (BA-103)

Sta. 1201+27.78
End Concrete Barrier (BA-103)

POT Sta. 1193+06.94
=POT Sta. 11193+06.94

POT Sta. 1215+84.72
=POT Sta. 11215+84.72

100°00'00"

105°00'00"

Sta. 1192+25
Install 24" X ' 2000D
F.L. = Lt. ?
Rt. ?

Sta. 1195+00
Install 24" X ' 2000D
F.L. = Lt. ?
Rt. ?

Sta. 1209+00
Install 24" X ' 2000D
F.L. = Lt. ?
Rt. ?

Sta. 1217+50
Install 24" X ' 2000D
F.L. = Lt. ?
Rt. ?

FLINT RIVER TWP.
T-70N R-3W
SEC. 24

FLINT RIVER TWP.
T-70N R-3W
SEC. 13

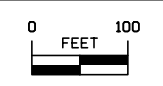

For Bridge Situation Plan
Refer to Sheets No. V.1 - V.2

For Profile Details
Refer to Sheet No. D.5

US 61

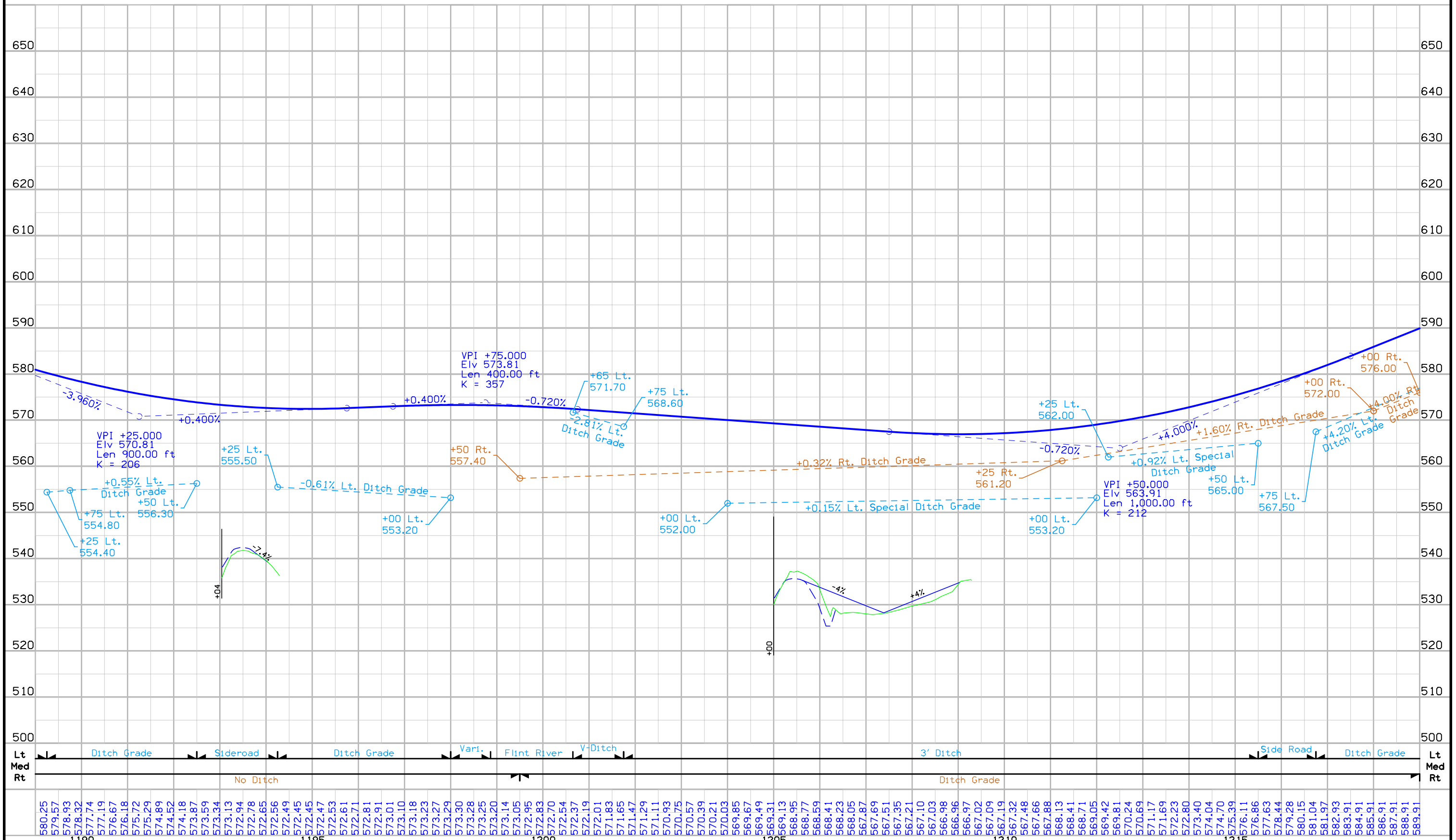



FLINT RIVER TWP.
T-70N R-3W
SEC. 14

Curve Data
Δ = 33° 00' 00.00" (RT)
T = 2,073.49
L = 4,031.71
R = 7,000.00
E = 300.64
F = 3.0%
G = 135'
X = 90'

Inlet Sta. 1225+00, 109' Lt.
Install 24" x ' PEP Letdown
F.L. = South 597.50
Other ?
Other ?
North 609.70

PI Sta. 1227+54.55

FLINT RIVER TWP.
T-70N R-3W
SEC. 13

Prop. 18" Uncl Ent Pipe
#68 Prop. Jnt. Type 'C' Ent.

US 61 (ML061.S)

+XX Prop. Type M Dike Elev. =

Sta. 1240+00
Install 24" X ' 2000D
F.L. = Lt. ?
Rt. ?

+XX Prop. Type M Dike Elev. =

Sta. 1227+50
Install 24" X ' 2000D
F.L. = Lt. ?
Rt. ?

Sta. 1237+50
Install 36" X 2000D/PEP
Skew = 20° Lt. Ahd.
F.L. = Lt. 653.30
Other ? 631.50
Other ?
Rt. 631.00
Ditch Outlet

Inlet Sta. 1238+25, 118' Rt.
Install 24" X ' Uncl. Letdown
F.L. = South 631.00
Other ?
Other ?
North 654.40

DA = 13.10 Ac. VH

DA = 1.98 Ac. R

FLINT RIVER TWP.
T-70N R-3W
SEC. 13

DA = 7.91 Ac. R

Inlet Sta. 1220+25, 100' Rt.
Install 24" x ' PEP Letdown
F.L. = South 575.90
Other ?
Other ?
North 589.00

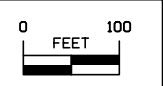

For Profile Details Refer to Sheet No. D.7

US 61

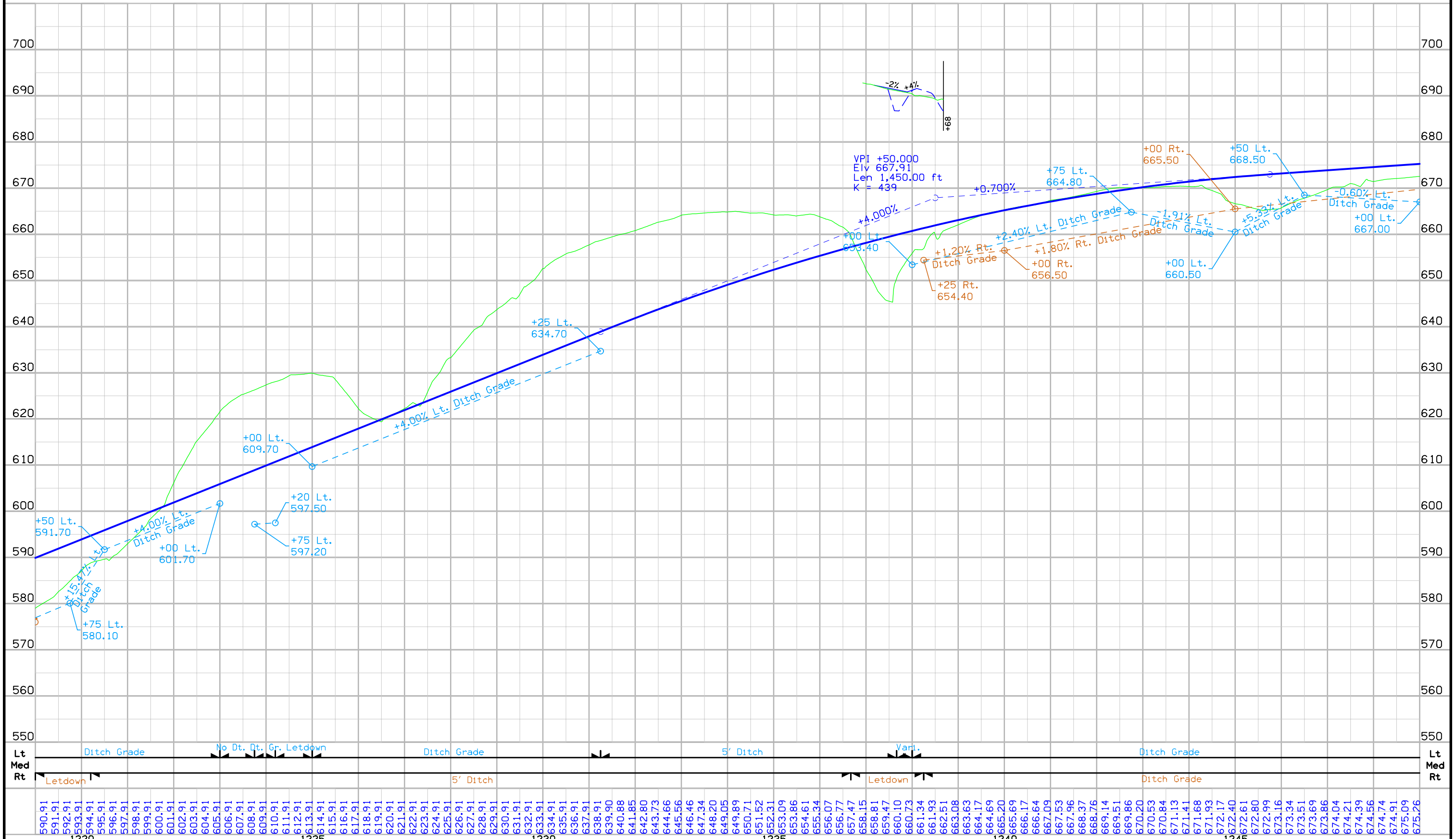

For Side Road Details
Refer to Sheet No. E.5

FLINT RIVER TWP.
T-70N R-3W
SEC. 14

FLINT RIVER TWP.
T-70N R-3W
SEC. 11

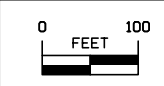
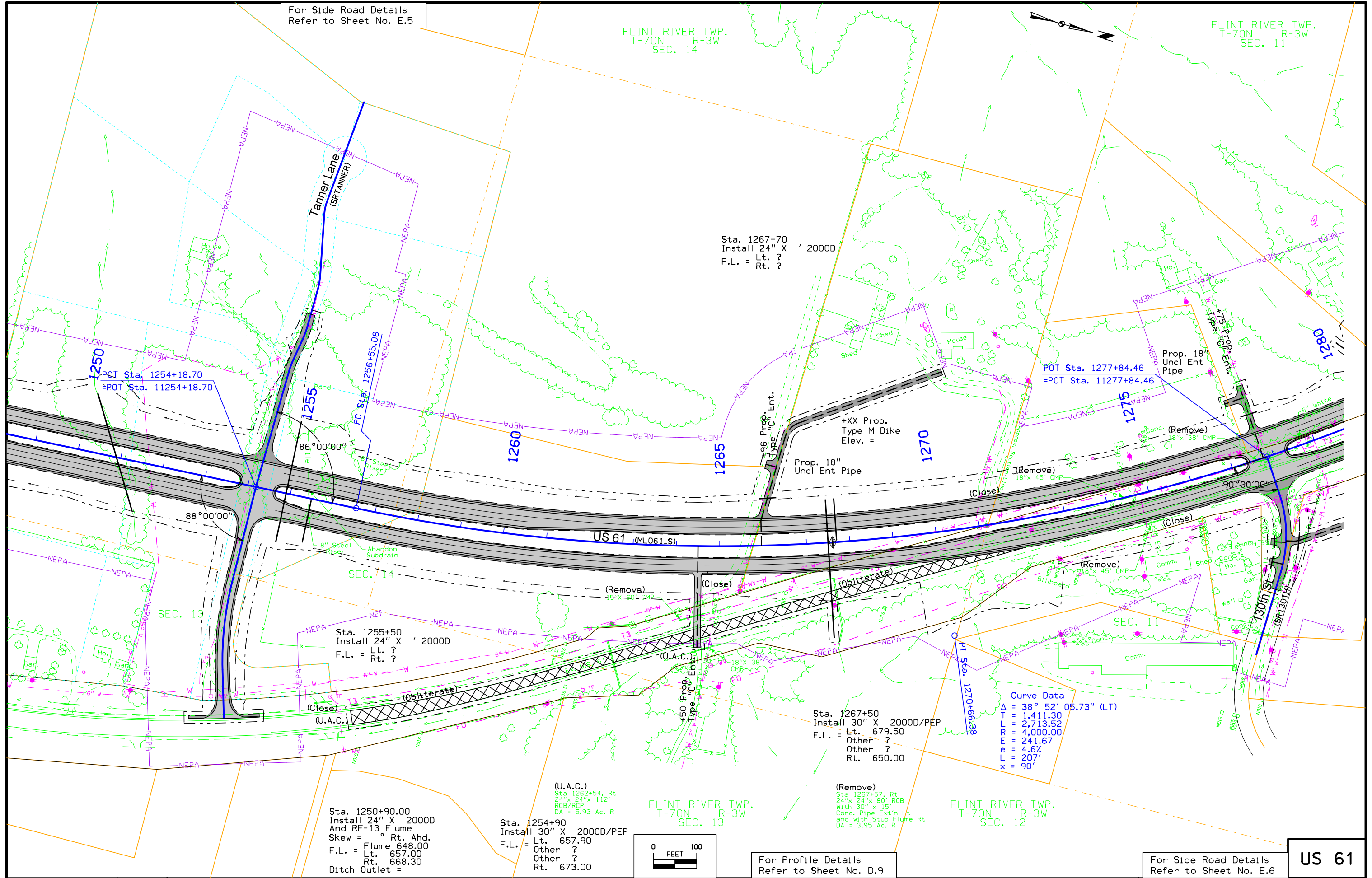

For Profile Details
Refer to Sheet No. D.9

For Side Road Details
Refer to Sheet No. E.6

US 61

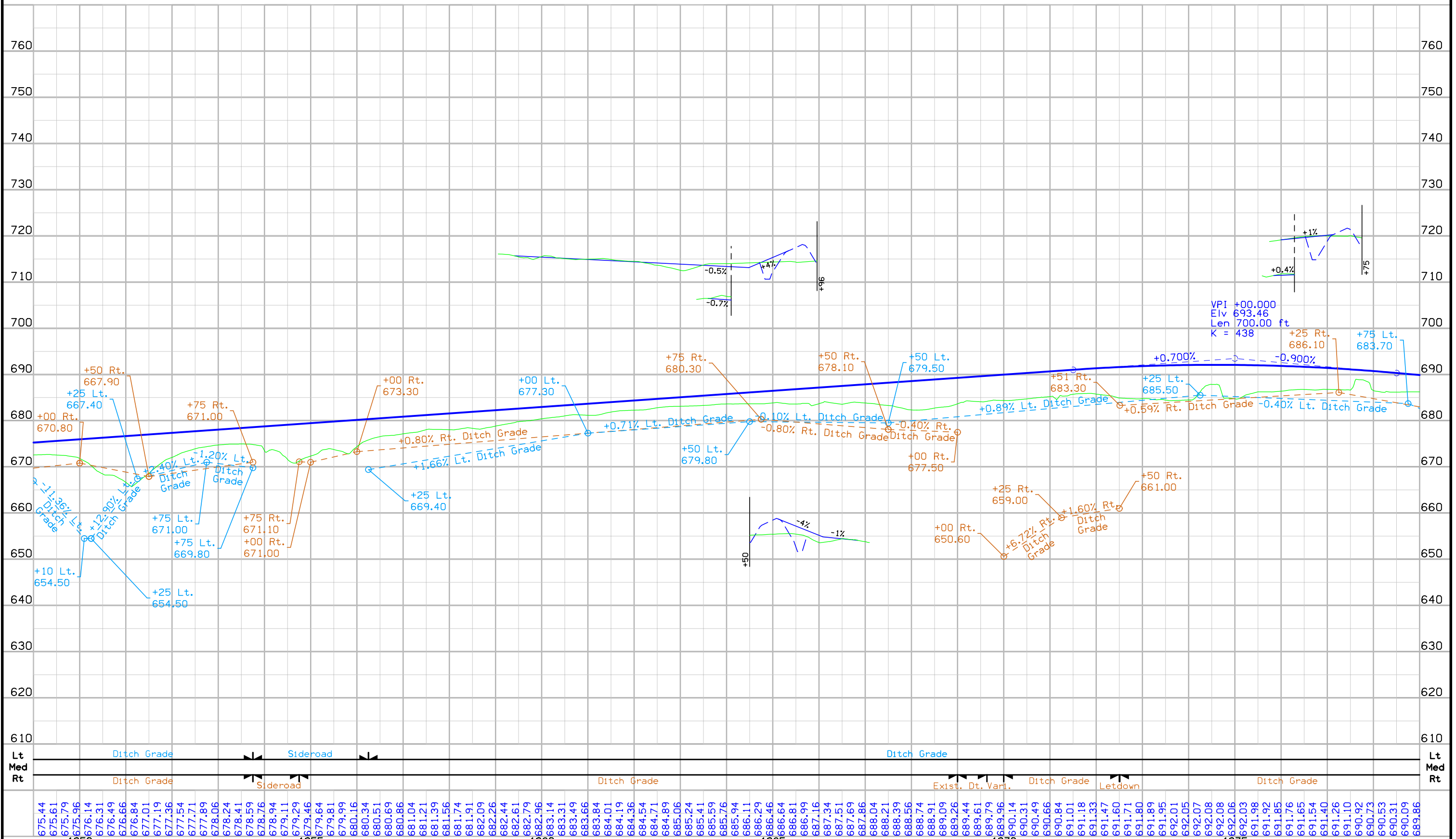

For Side Road Details
Refer to Sheet No. E.7

FLINT RIVER TWP.
T-70N R-3W
SEC. 11

Inlet Sta. 1285+25, 155' Lt.
Install 24" X 20000 PEP Letdown
F.L. = South 661.00
Other ?
Other ?
North 684.90

Sta. 1292+00
Install 24" X 20000
F.L. = Lt. ?
Rt. ?

Prop. Uncl Ent Pipe
+26 Prop. "C" Ent.
Type "C" Ent.
+XX Prop. Type M Dike
Elev. =

POT Sta. 1306+18.49
-POT Sta. 11306+18.49

US 61 (M.O.B.L.S.)

124th St

(Obturate)

(Remove)
Sta 1281+88
24" x 24" x 62' RCB
With 30" x 22" Conc Pipe Ext Rt. and
With 30" x 17" Conc Pipe Ext Lt.
Ext Ext Skewed 14'
DA = 18.04 Ac. R

DA = 18.04 Ac. R DA = 27.92 Ac. R

(Remove)
Sta 1285+80
24" x 36" x 44' RCB
With 30" x 12" Conc Pipe Ext Rt. and
With 30" x 12" Conc Pipe Ext Lt. and
RF-13 Flume Lt.
DA = 27.92 Ac. R

Sta. 1281+48.00
Install 36" X 20000/PEP
Skew = 30° Rt. Ahd.
Lt. 659.00
F.L. = Other ?
Other ?
Rt. 678.20

Sta. 1282+30
Install 24" X 20000
F.L. = Lt. ?
Rt. ?

Sta. 1285+30
Install 42" X 20000/PEP
Skew = 30° Rt. Ahd.
Lt. 661.00
F.L. = Other ?
Other ?
Rt. 681.10

FLINT RIVER TWP.
T-70N R-3W
SEC. 11

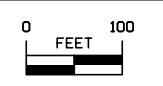

For Profile Details
Refer to Sheet No. D.11

US 61

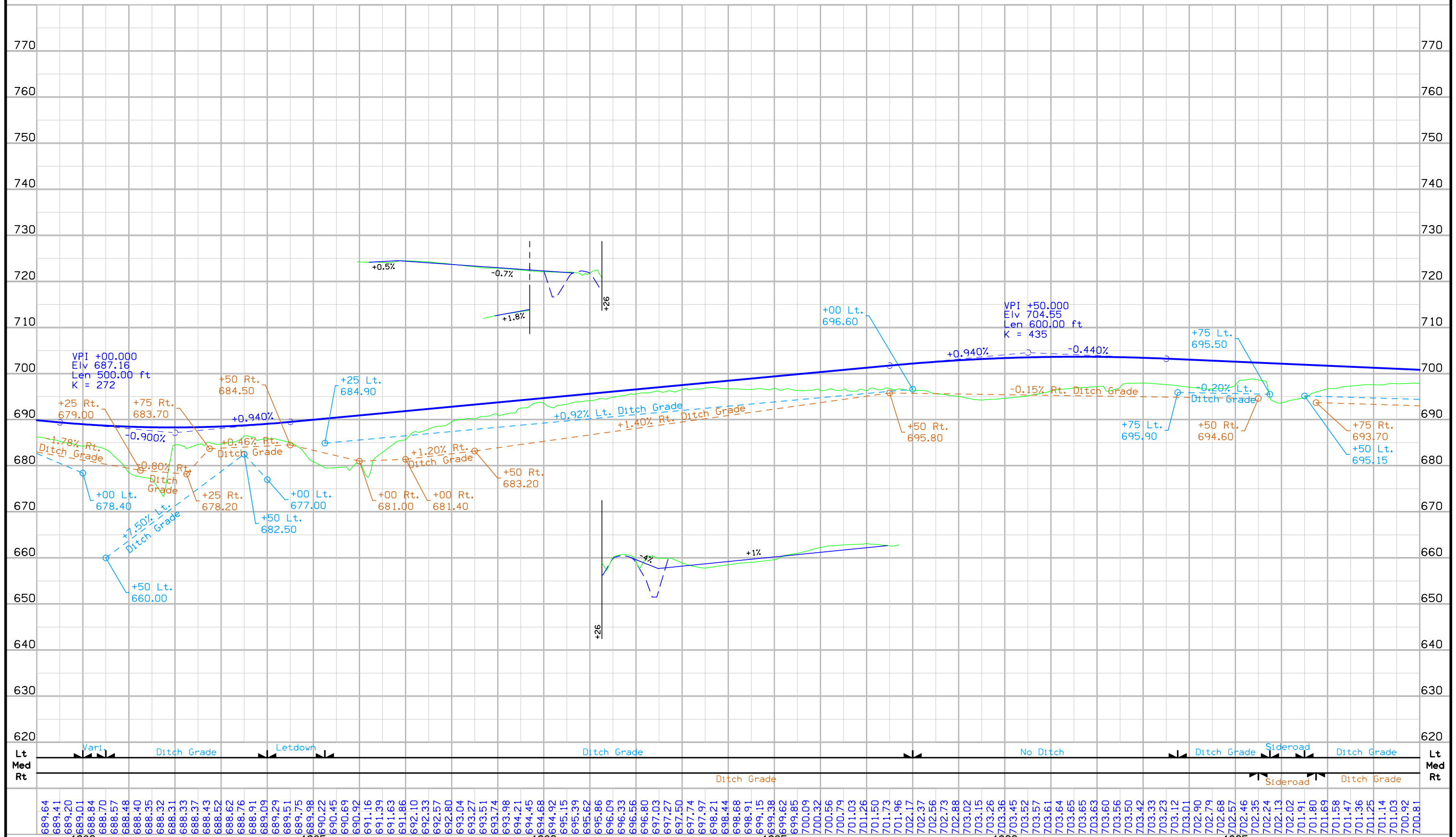

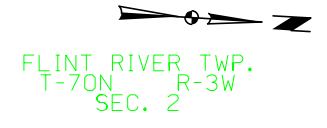

Curve Data
 $\Delta = 44^\circ 57' 52.48''$ (RT)
 T = 1,340.88
 L = 2,542.69
 R = 3,240.00
 E = 266.50
 e = 5.2%
 L = 234'
 x = 90'

Sta. 1313+00
 Install 24" X ' 20000
 F.L. = Lt. ?
 Rt. ?

Sta. 1338+50
 Install 24" X ' 20000
 F.L. = Lt. ?
 Rt. ?

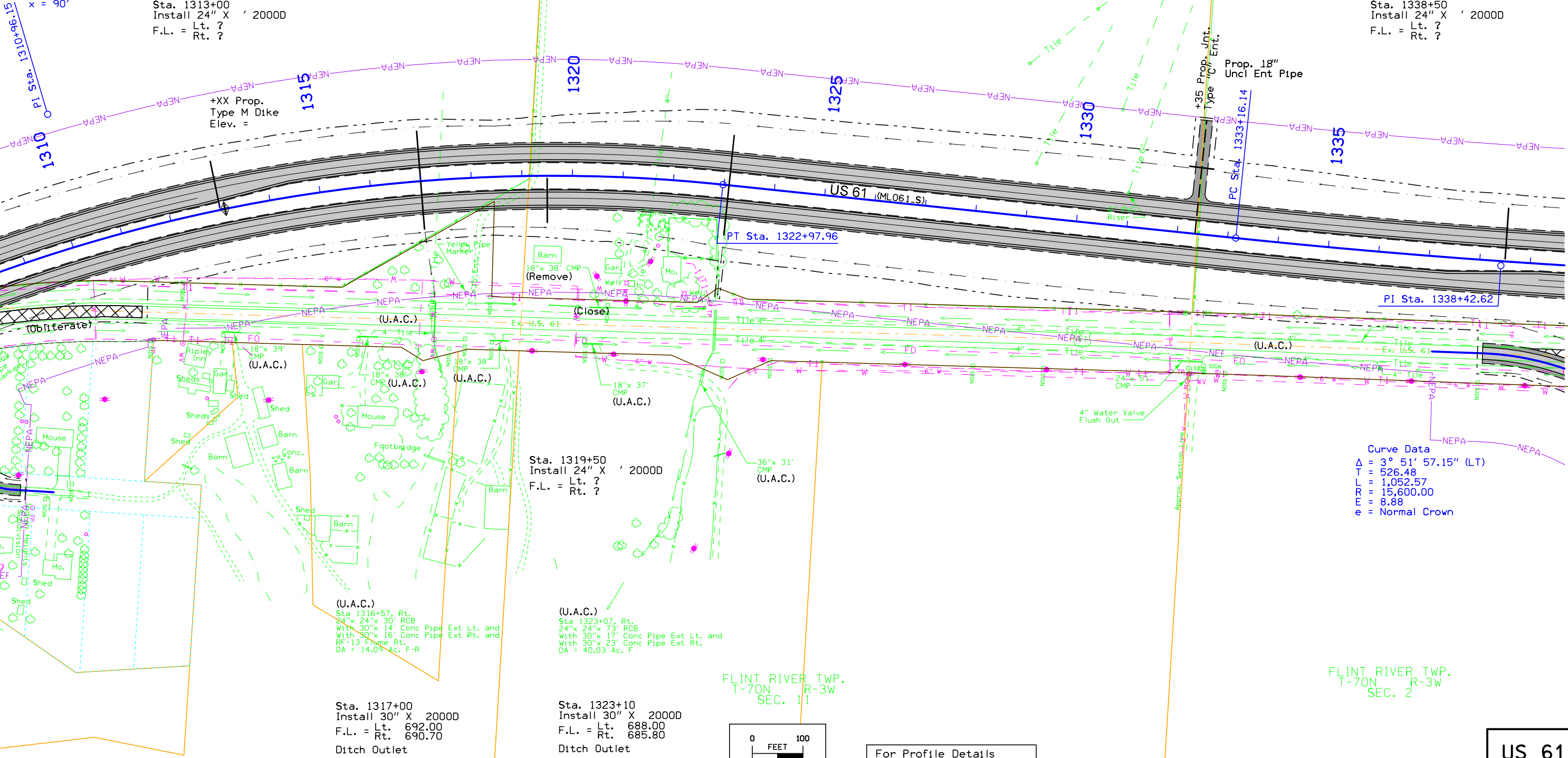

+XX Prop.
 Type M Dike
 Elev. =

Prop. 18"
 Uncl Ent Pipe

US 61 (ML061-S)

PT Sta. 1322+97.96

PI Sta. 1338+42.62

Sta. 1319+50
 Install 24" X ' 20000
 F.L. = Lt. ?
 Rt. ?

Curve Data
 $\Delta = 3^\circ 51' 57.15''$ (LT)
 T = 526.48
 L = 1,052.57
 R = 15,600.00
 E = 8.88
 e = Normal Crown

(U.A.C.)
 Sta 1316+57, Rt.
 24" x 24" x 30" RCB
 With 30" x 14" Conc Pipe Ext Lt. and
 With 30" x 16" Conc Pipe Ext Rt. and
 RF-13 Flame Rt.
 DA = 14.09 Ac. F-R

(U.A.C.)
 Sta 1323+07, Rt.
 24" x 24" x 73" RCB
 With 30" x 17" Conc Pipe Ext Lt. and
 With 30" x 23" Conc Pipe Ext Rt.
 DA = 40.03 Ac. F

Sta. 1317+00
 Install 30" X 20000
 F.L. = Lt. 692.00
 Rt. 690.70
 Ditch Outlet

Sta. 1323+10
 Install 30" X 20000
 F.L. = Lt. 688.00
 Rt. 685.80
 Ditch Outlet

FLINT RIVER TWP.
 T-70N R-3W
 SEC. 11

FLINT RIVER TWP.
 T-70N R-3W
 SEC. 2

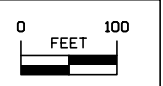

For Profile Details
 Refer to Sheet No. D.13

US 61

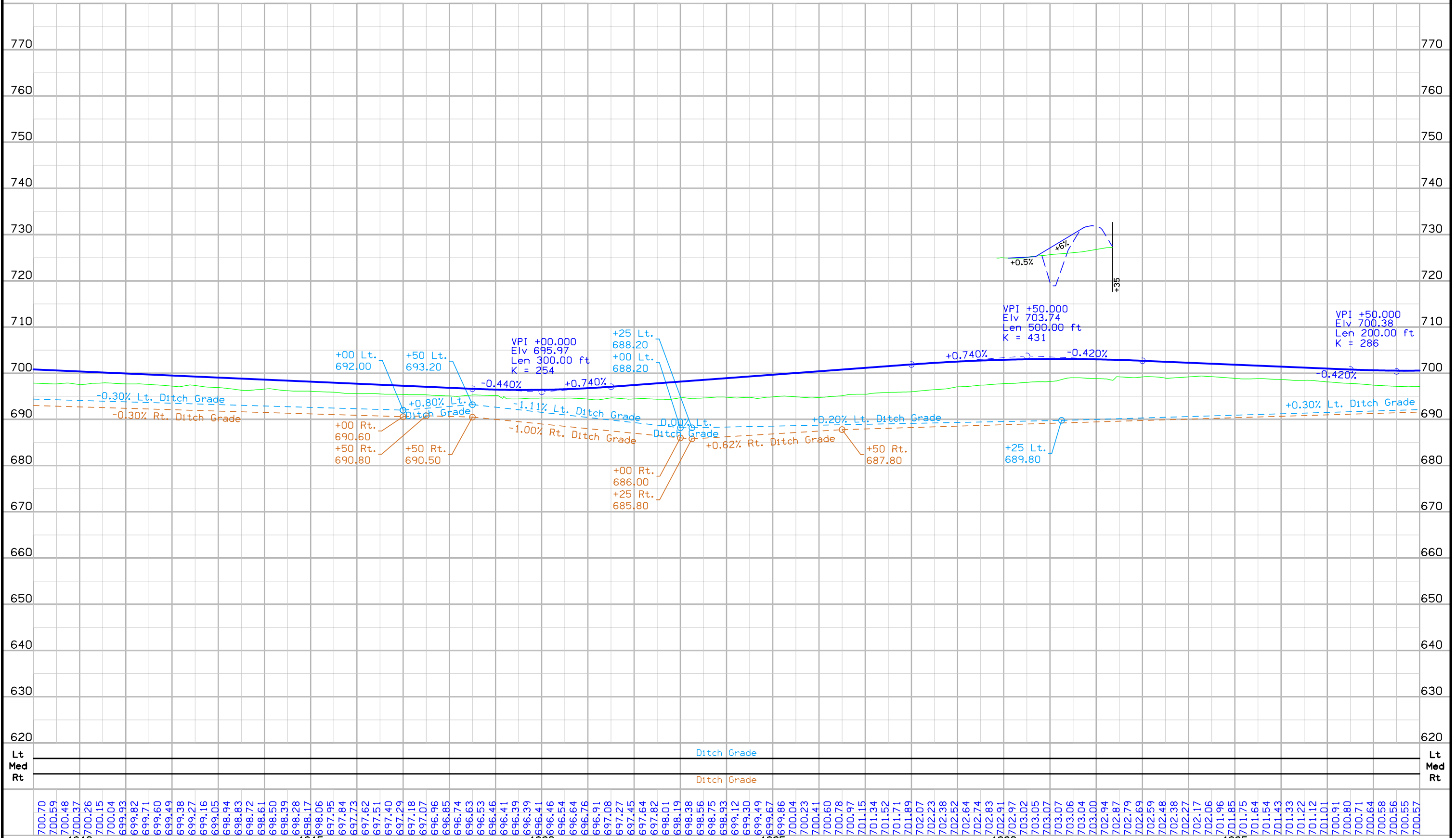

For Side Road Details
Refer to Sheet No. E.8

FLINT RIVER TWP.
T-70N R-3W
SEC. 2

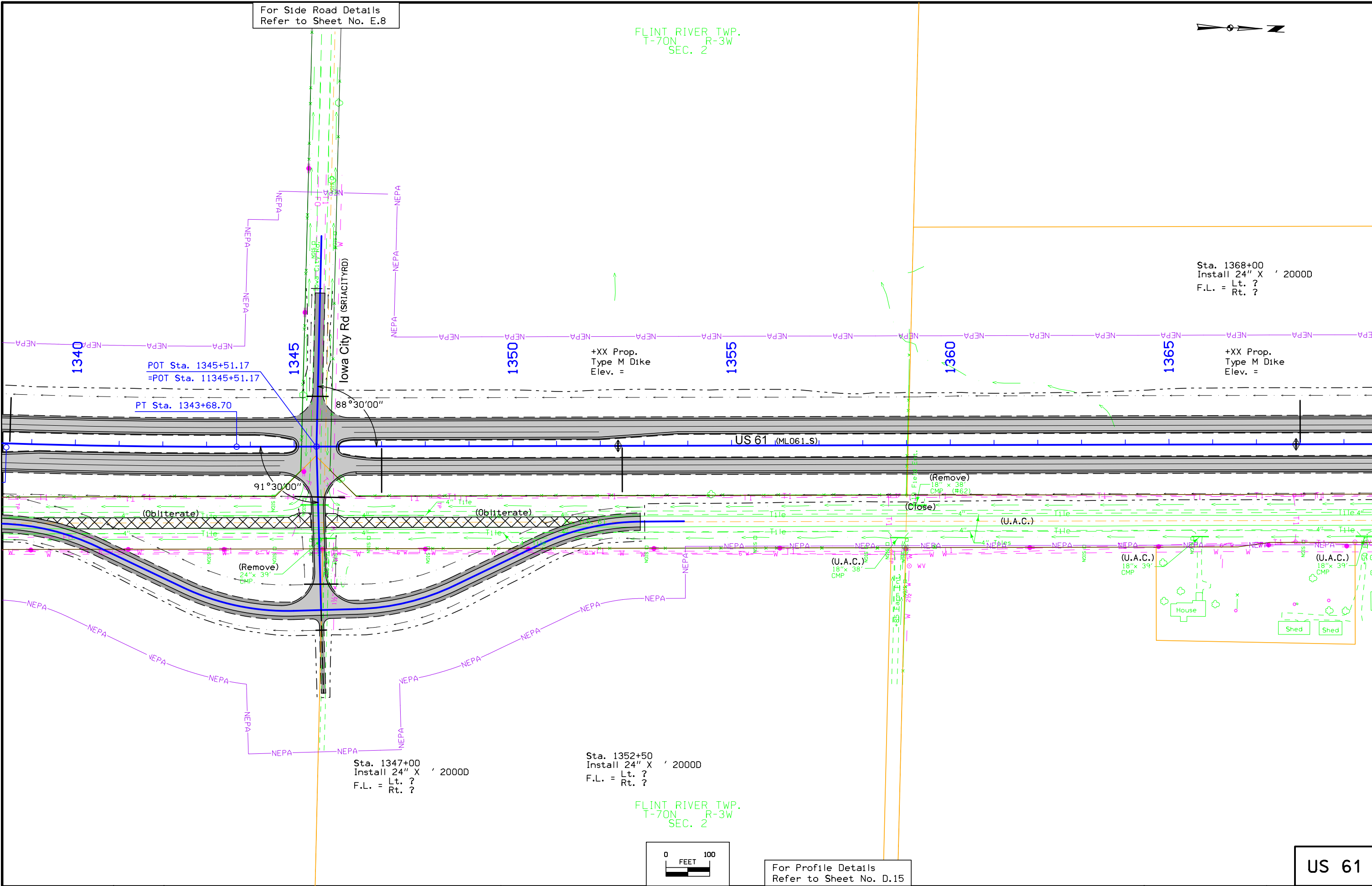
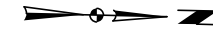

Sta. 1368+00
Install 24" X ' 20000
F.L. = Lt. ?
Rt. ?

+XX Prop.
Type M Dike
Elev. =

+XX Prop.
Type M Dike
Elev. =

POT Sta. 1345+51.17
=POT Sta. 11345+51.17

PT Sta. 1343+68.70

91°30'00"

88°30'00"

US 61 (ML061-S)

(Obliiterate)

(Obliiterate)

(Close)

(U.A.C.)

(Remove)
24" x 39"
CMP

(U.A.C.)
18" x 38"
CMP

(U.A.C.)
18" x 39"
CMP

(U.A.C.)
18" x 39"
CMP

Sta. 1347+00
Install 24" X ' 20000
F.L. = Lt. ?
Rt. ?

Sta. 1352+50
Install 24" X ' 20000
F.L. = Lt. ?
Rt. ?

FLINT RIVER TWP.
T-70N R-3W
SEC. 2

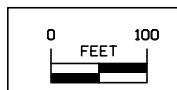

For Profile Details
Refer to Sheet No. D.15

US 61

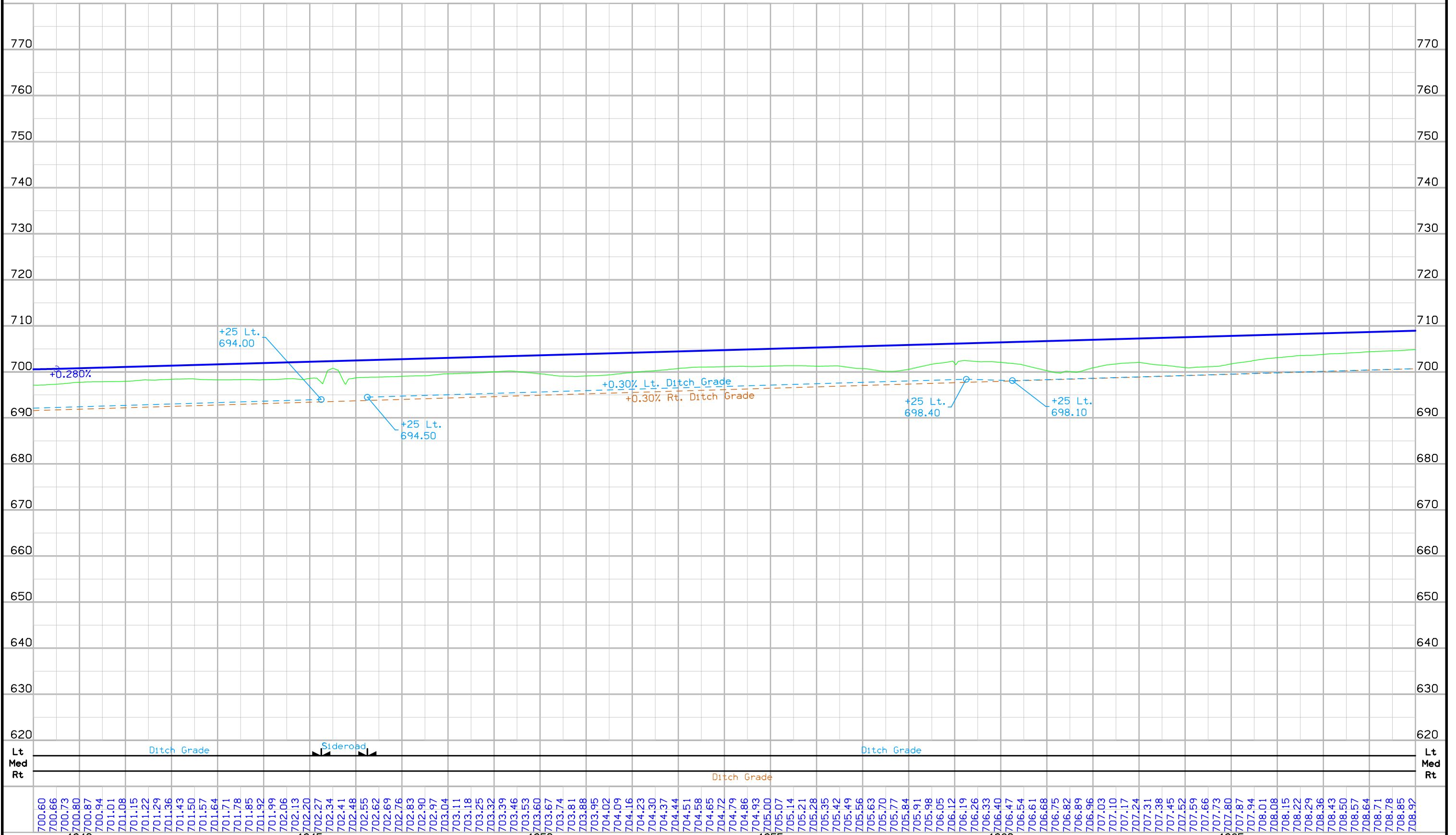

For Side Road Details
Refer to Sheet No. E.10

FLINT RIVER TWP.
T-70N R-3W
SEC. 2

FRANKLIN TWP.
T-71N R-3W
SEC. 35

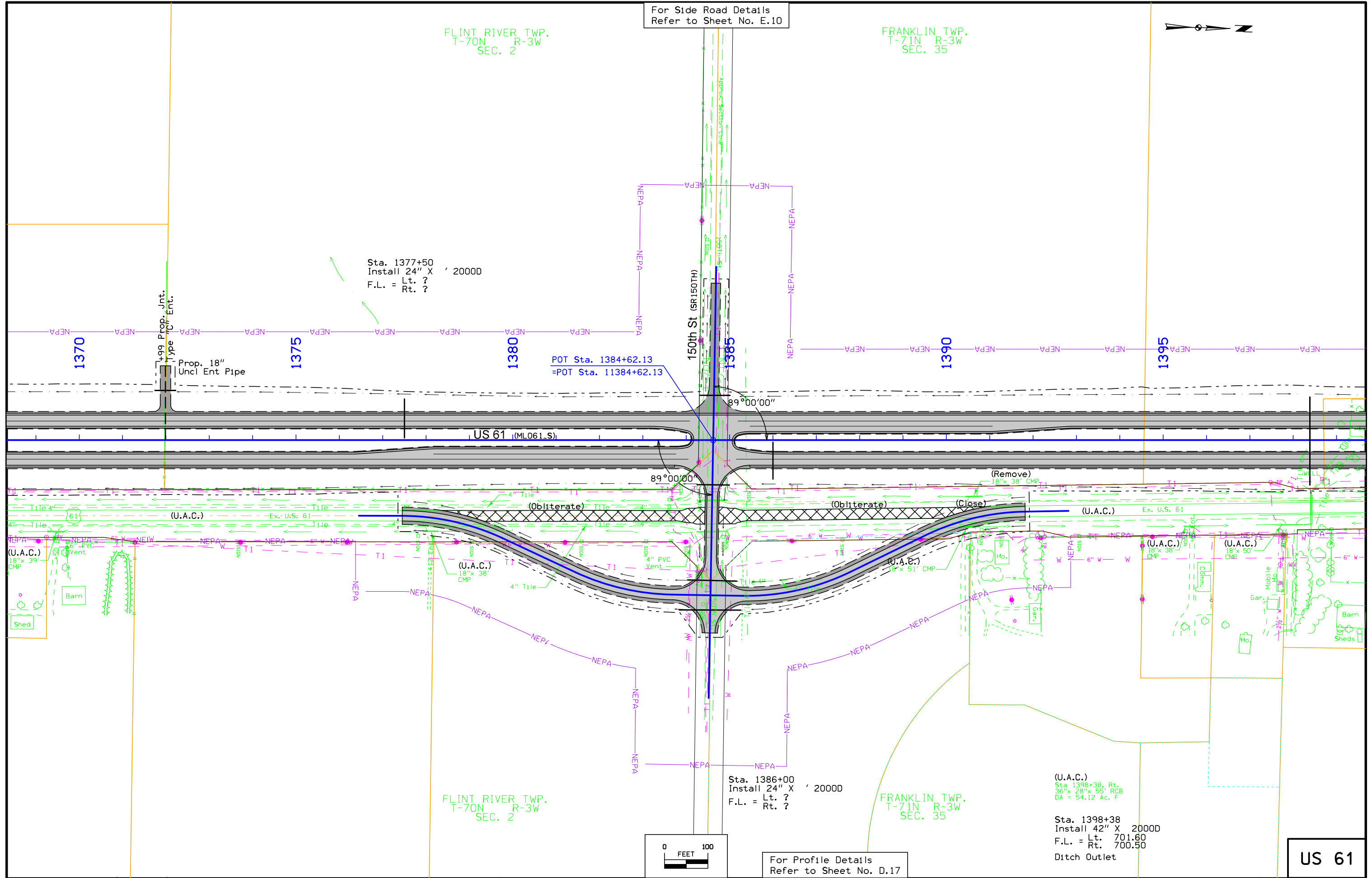
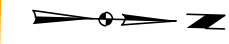

Sta. 1377+50
Install 24" X ' 20000
F.L. = Lt. ?
Rt. ?

POT Sta. 1384+62.13
=POT Sta. 11384+62.13

Sta. 1386+00
Install 24" X ' 20000
F.L. = Lt. ?
Rt. ?

(U.A.C.)
Sta 1398+38, Rt.
36" x 28" x 55' RCB
DA = 54.12 Ac. F

Sta. 1398+38
Install 42" X 20000
F.L. = Lt. 701.60
Rt. 700.50
Ditch Outlet



For Profile Details
Refer to Sheet No. D.17

US 61

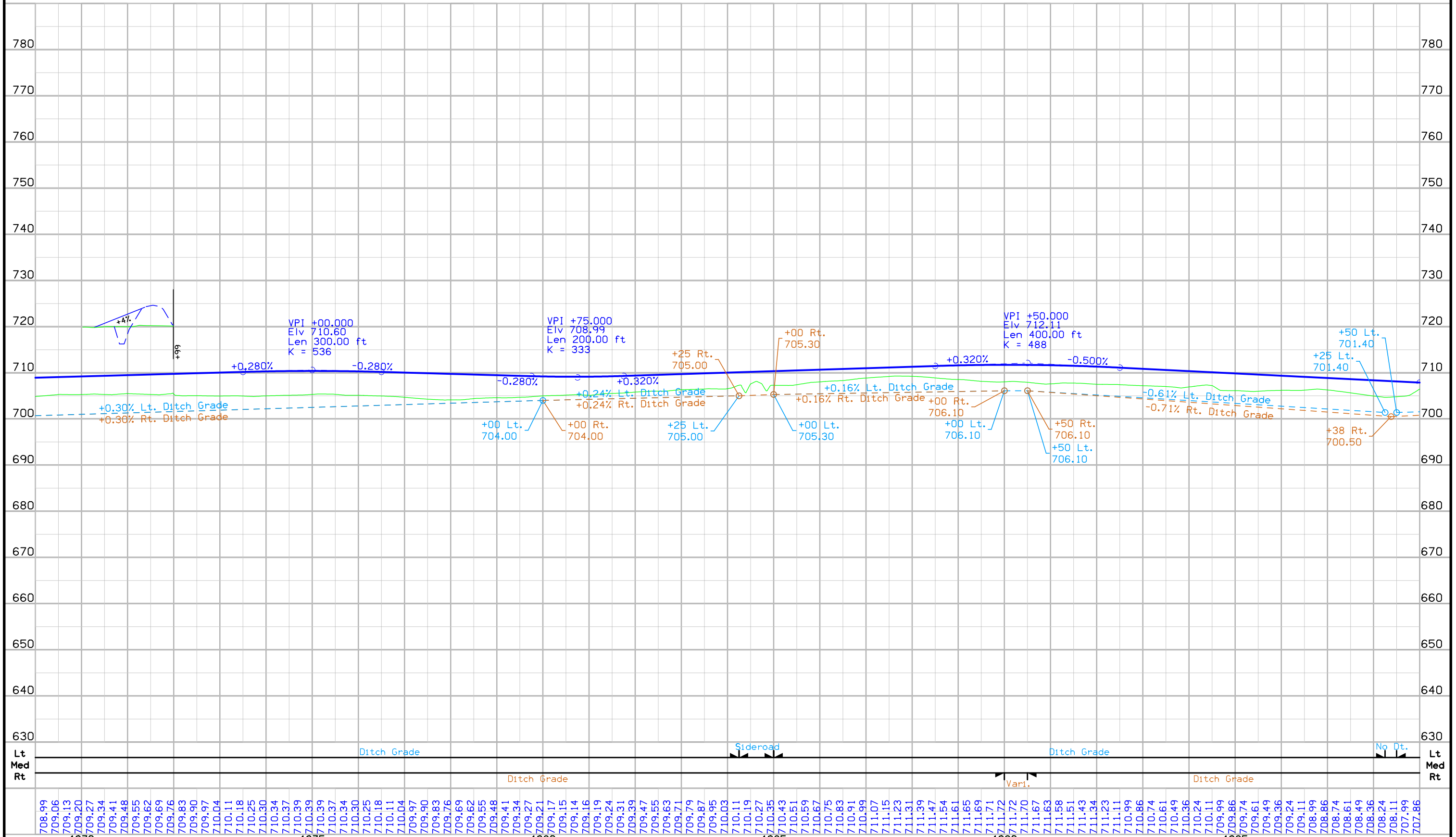

FRANKLIN TWP.
T-71N R-3W
SEC. 35



Sta. 1400+50
Install 24" X ' 20000
Lt. ?
F.L. = Rt. ?

Sta. 1424+50
Install 24" X ' 20000
Lt. ?
F.L. = Rt. ?

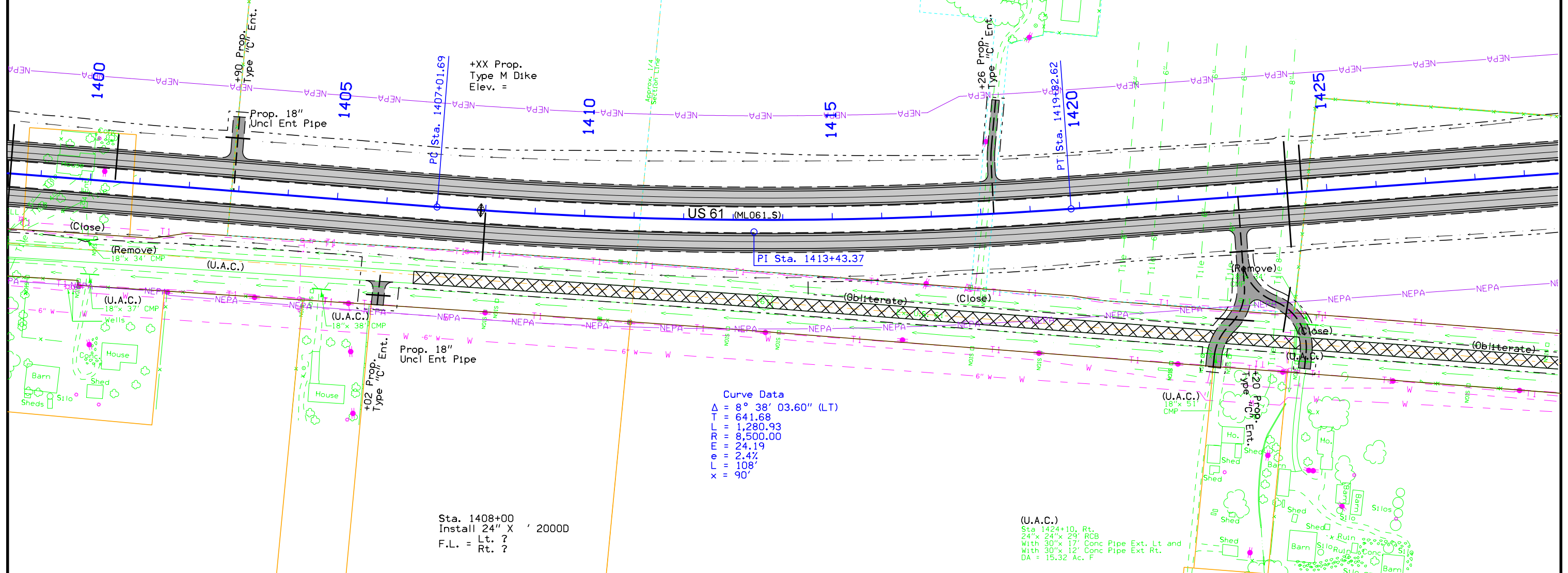

Curve Data
 $\Delta = 8^\circ 38' 03.60''$ (LT)
 $T = 641.68$
 $L = 1,280.93$
 $R = 8,500.00$
 $E = 24.19$
 $e = 2.4\%$
 $L = 108'$
 $x = 90'$

Sta. 1408+00
Install 24" X ' 20000
Lt. ?
F.L. = Rt. ?

(U.A.C.)
 Sta. 1424+10, Rt.
 24" x 24" x 29" RCB
 With 30" x 17" Conc Pipe Ext. Lt and
 With 30" x 12" Conc Pipe Ext Rt.
 DA = 15.32 Ac. F

Sta. 1424+20
Install 36" X 20000
F.L. = Lt. 712.20
Rt. 711.10
Ditch Outlet

FRANKLIN TWP.
T-71N R-3W
SEC. 35

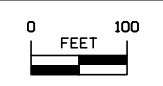

For Profile Details
Refer to Sheet No. D.19

US 61

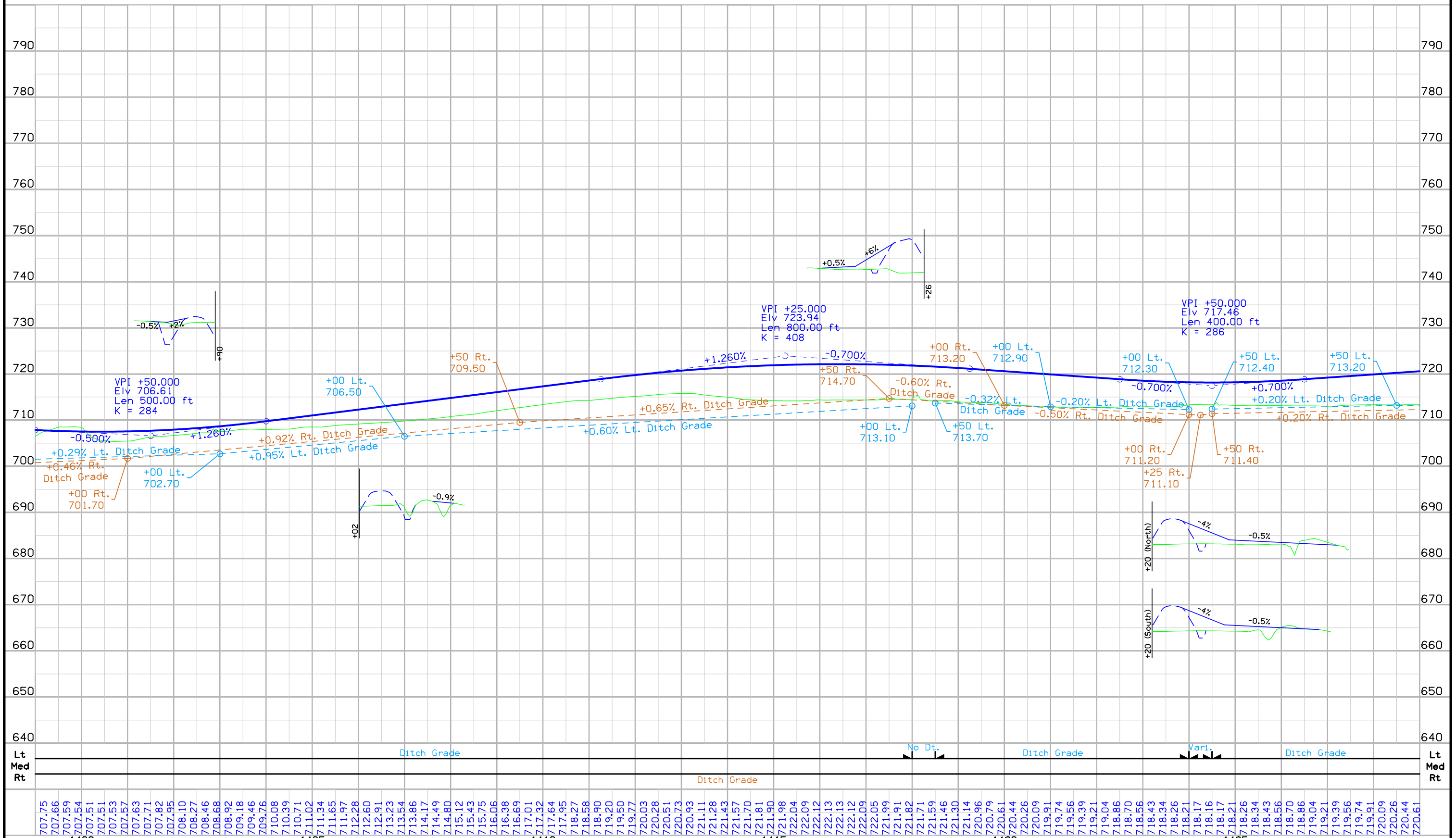

Lt		Ditch Grade		No Dt.		Ditch Grade		Vari.		Ditch Grade		Rt	
Med												Med	
Rt												Rt	

FRANKLIN TWP.
T-71N R-3W
SEC. 35

Curve Data
Δ = 21° 43' 32.54" (RT)
T = 621.75
L = 1,228.56
R = 3,240.00
E = 59.12
e = 5.27
L = 234'
x = 90'

For Side Road Details
Refer to Sheet No. E.12

FRANKLIN TWP.
T-71N R-3W
SEC. 26

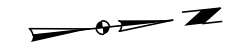

Sta. 1436+50
Install 24" X
F.L. = Lt. ?
Rt. ?

POT Sta. 1437+99.06
=POT Sta. 11437+99.06

PI Sta. 1436+33.99

DA = 0.3 Ha. H-R

160th St (SR160H)

1440

1445

1450

Sta. 1457+50
Install 24" X
F.L. = Lt. ?
Rt. ?

+XX Prop.
Type M Dike
Elev. =

Prop. 18" Uncl Ent Pipe

PC Sta. 1454+60.92

(Remove)
15" x 34" Ent. Pipe

(Remove)
18" x 61" CMP
PVC Pipe
El. 709.3

US 61 (ML061-S)

PT Sta. 1442+40.81

(Remove)
18" x 38" CMP

(Close)

(Obturate)

(U.A.C.)

Sta 1447+18
DA = 9.14 Ac. R
(Carry Back)

(U.A.C.)
Sta 1445+07, Rt.
48" x 36" x 70' RCB
With Stub Flume Rt.
DA = 42.01 Ac. F-R

(Remove)
Sta 1455+18
42" x 82' RCP
With Stub Flume Rt
DA = 20 Ac. R

Sta. 1443+73
Install 48" X 2000D
Skew = 20° Rt. Ahd.
F.L. = Lt. 705.20
Rt. 701.70
Ditch Outlet

Sta. 1455+28
Install 42" X 2000D
And RF-13 Flume
Skew = 15° Rt. Ahd.
F.L. = Lt. 698.60
Rt. 692.00
Other 685.00

Sta. 1450+00
Install 24" X
F.L. = Lt. ?
Rt. ?

FRANKLIN TWP.
T-71N R-3W
SEC. 35

FRANKLIN TWP.
T-71N R-3W
SEC. 26

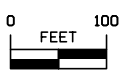

For Profile Details
Refer to Sheet No. D.21

US 61

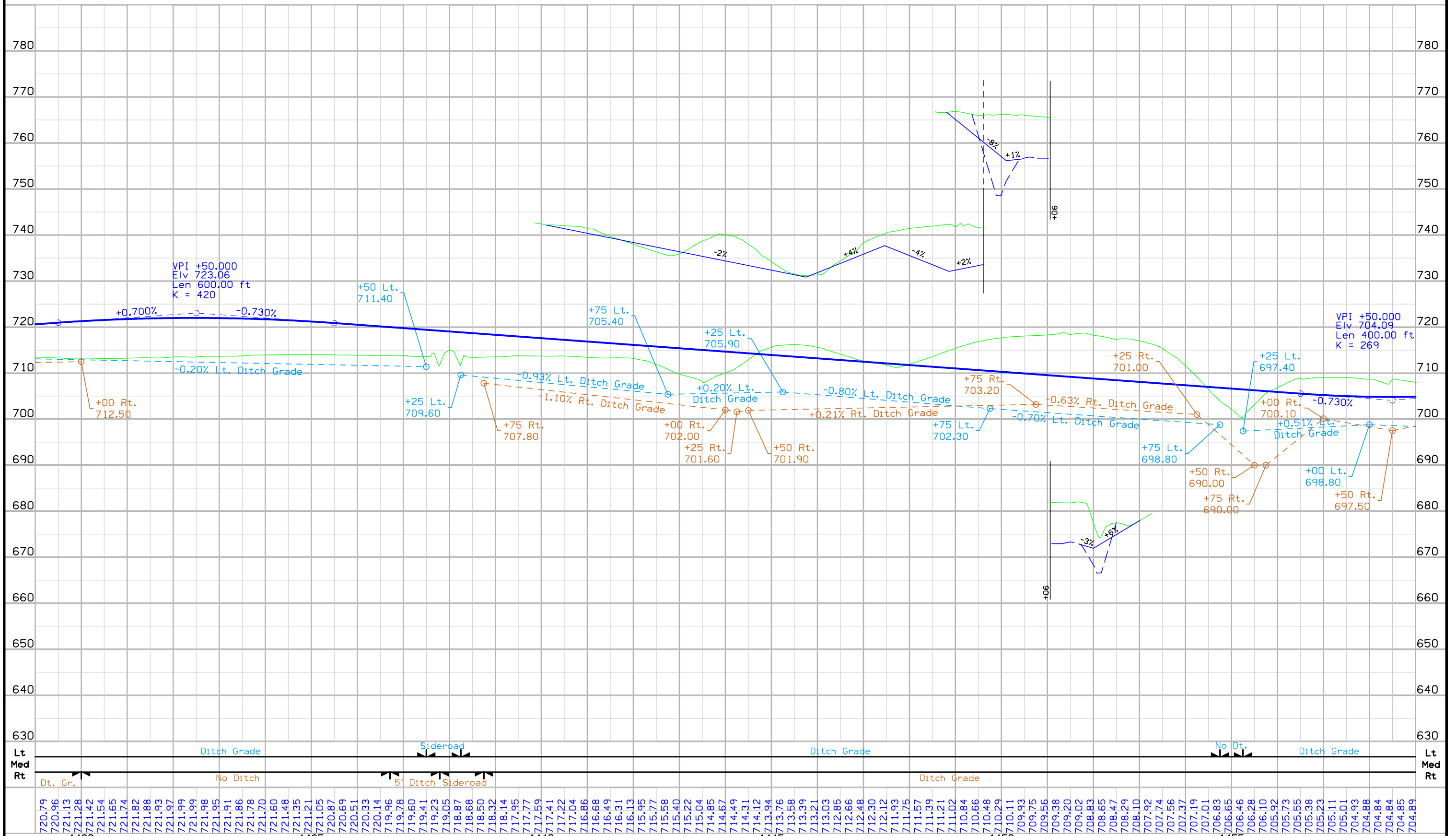



FRANKLIN TWP.
T-71N R-3W
SEC. 26

Sta. 1463+50
Install 24" X ' 20000
F.L. = Lt. ?
Rt. ?

Sta. 1472+00
Install 24" X ' 20000
F.L. = Lt. ?
Rt. ?

Sta. 1487+75
Install 24" X ' 20000
F.L. = Lt. ?
Rt. ?

+XX Prop.
Type M Dike
Elev. =
Prop. 18" Uncl Ent Pipe

+XX Prop.
Type M Dike
Elev. =

+45 Prop. 'c' Ent.

Curve Data
 $\Delta = 13^\circ 02' 59.18''$ (LT)
T = 743.44
L = 1,480.45
R = 6,500.00
E = 42.38
e = 3.2%
L = 144'
x = 90'

(Plug and Abandon)
Sta 1462+95
48"x 42"x 97' RCB
W/ Drop Inlet Lt & Flume Rt
DA = 37.07 Ac. R

(Remove)
Sta 1468+55 Lt.
24"x 24"x 41' RCB
With 30'x 19' Conc Pipe Ext Lt. and
With 30'x 20' Conc Pipe Ext Rt.
DA = 22.49 Ac. R

(Remove)
Sta 1481+26
24"x 24"x 41' RCB
With 30'x 26' Conc Pipe Ext Lt and
With 30'x 25' Conc Pipe Ext Rt
With 18"-13 Flume Rt
DA = 37.07 Ac. R

Sta. 1462+62
Install 48" X ' 20000/PEP
Skew = 06°30' Lt. Ahd.
F.L. = Lt. 698.00
Other 696.00
Other ?
Rt. 681.00

Sta. 1467+37
Install 36" X ' 20000/PEP
Skew = Lt. Ahd.
F.L. = Lt. 701.80
Other 699.60
Other ?
Rt. 684.00
Ditch Outlet

Sta. 1481+52
Install 30" X ' 20000/PEP
Skew = 06° Rt. Ahd.
F.L. = Lt. 707.70
Other ?
Other ?
Rt. 697.00

FRANKLIN TWP.
T-71N R-3W
SEC. 26

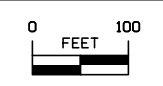

For Profile Details
Refer to Sheet No. D.23

US 61

Stoney Hollow Rd (R150104H) STONEY

For Plan Details
Refer to Sheet No. D.22

US 61

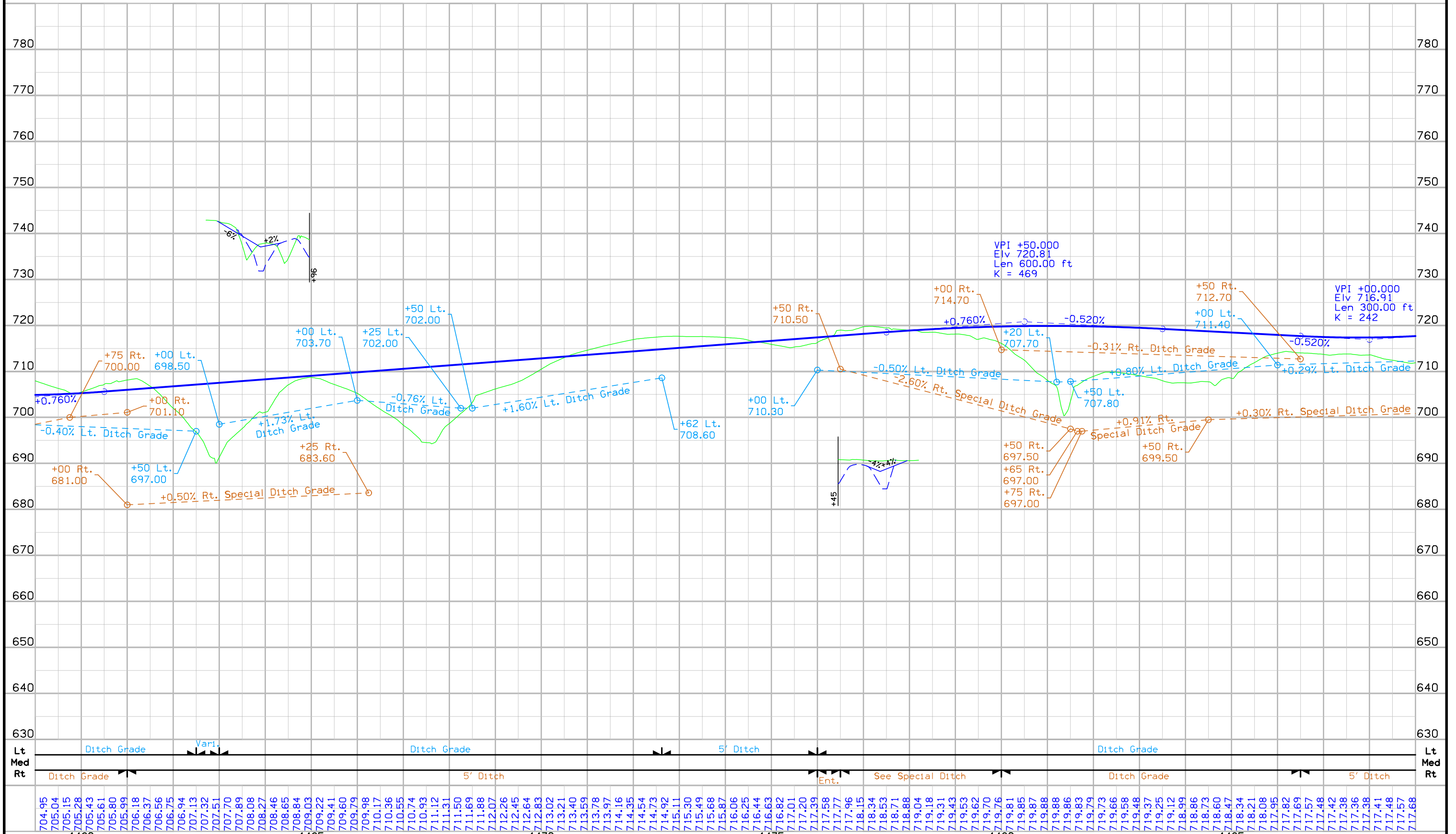

Lt	Ditch Grade										Varl.	Ditch Grade										5' Ditch	Ditch Grade										Lt																																																																																							
Med																																																																																																																								
Rt	Ditch Grade											5' Ditch										Ent.	See Special Ditch											5' Ditch										Rt																																																																												
	704.95	705.04	705.15	705.28	705.43	705.61	705.80	705.99	706.18	706.37	706.56	706.75	706.94	707.13	707.32	707.51	707.70	707.89	708.08	708.27	708.46	708.65	708.84	709.03	709.22	709.41	709.60	709.79	709.98	710.17	710.36	710.55	710.74	710.93	711.12	711.31	711.50	711.69	711.88	712.07	712.26	712.45	712.64	712.83	713.02	713.21	713.40	713.59	713.78	713.97	714.16	714.35	714.54	714.73	714.92	715.11	715.30	715.49	715.68	715.87	716.06	716.25	716.44	716.63	716.82	717.01	717.20	717.39	717.58	717.77	717.96	718.15	718.34	718.53	718.71	718.88	719.04	719.18	719.31	719.43	719.53	719.62	719.70	719.76	719.81	719.85	719.87	719.88	719.88	719.86	719.83	719.79	719.73	719.66	719.58	719.48	719.37	719.25	719.12	718.99	718.86	718.73	718.60	718.47	718.34	718.21	718.08	717.95	717.82	717.69	717.57	717.48	717.41	717.38	717.36	717.38	717.41	717.48	717.57	717.68
	1460										1465										1470										1475										1480										1485																																																																					

For Side Road Details
Refer to Sheet No. E.13

FRANKLIN TWP.
T-71N R-3W
SEC. 23



Sta. 1491+50
Install 24" X ' 20000
F.L. = Lt. ?
Rt. ?

Sta. 1505+50
Install 24" X ' 20000
F.L. = Lt. ?
Rt. ?

+XX Prop.
Type M Dike
Elev. =

Prop. 18"
Uncl Ent Pipe
(Remove)
18" x 36' CMP
(Remove)
18" x 50' CMP

POT Sta. 1490+13.04
=POT Sta. 11490+13.04

(Remove)
Sta. 1491+64, Lt.
39' x 39' x 74' RCB
Skew 36°05'16" Lt. Ahd.
DA = 47.94 Ac. R

Sta. 1491+72
Install 48" X ' 20000
Skew = 21° Lt. Ahd.
F.L. = Lt. 710.00
Rt. 705.90

(Remove)
Sta. 1504+40, Lt.
24" x 24" x 32' RCB
With 30" x 16' Conc. Pipe Ext Lt
and with 30" x 16' Conc. Pipe Ext Rt
DA = 4.94 Ac. F

Sta. 1504+50
Install 30" X ' 20000
Lt. 720.90
F.L. = Other
Rt. 714.10

(Remove)
Sta. 1509+23, Lt.
24" x 24" x 38' RCB
With 30" x 16' Conc. Pipe Ext Lt
and with 30" x 16' Conc. Pipe Ext Rt
DA = 18.04 Ac. F-R

Sta. 1509+15
Install 30" X ' 20000
Lt. 723.00
F.L. = Rt. 718.50

(Remove)
Sta. 1519+30, Lt.
24" x 24" x 30' RCB
With 30" x 18' Conc. Pipe Ext Lt and
With 30" x 17' Conc. Pipe Ext Rt
DA = 11.12 Ac. F-R

Sta. 1519+40
Install 30" X ' 20000
Lt. 726.40
F.L. = Rt. 723.40

FRANKLIN TWP.
T-71N R-3W
SEC. 23



For Profile Details
Refer to Sheet No. D.25

US 61

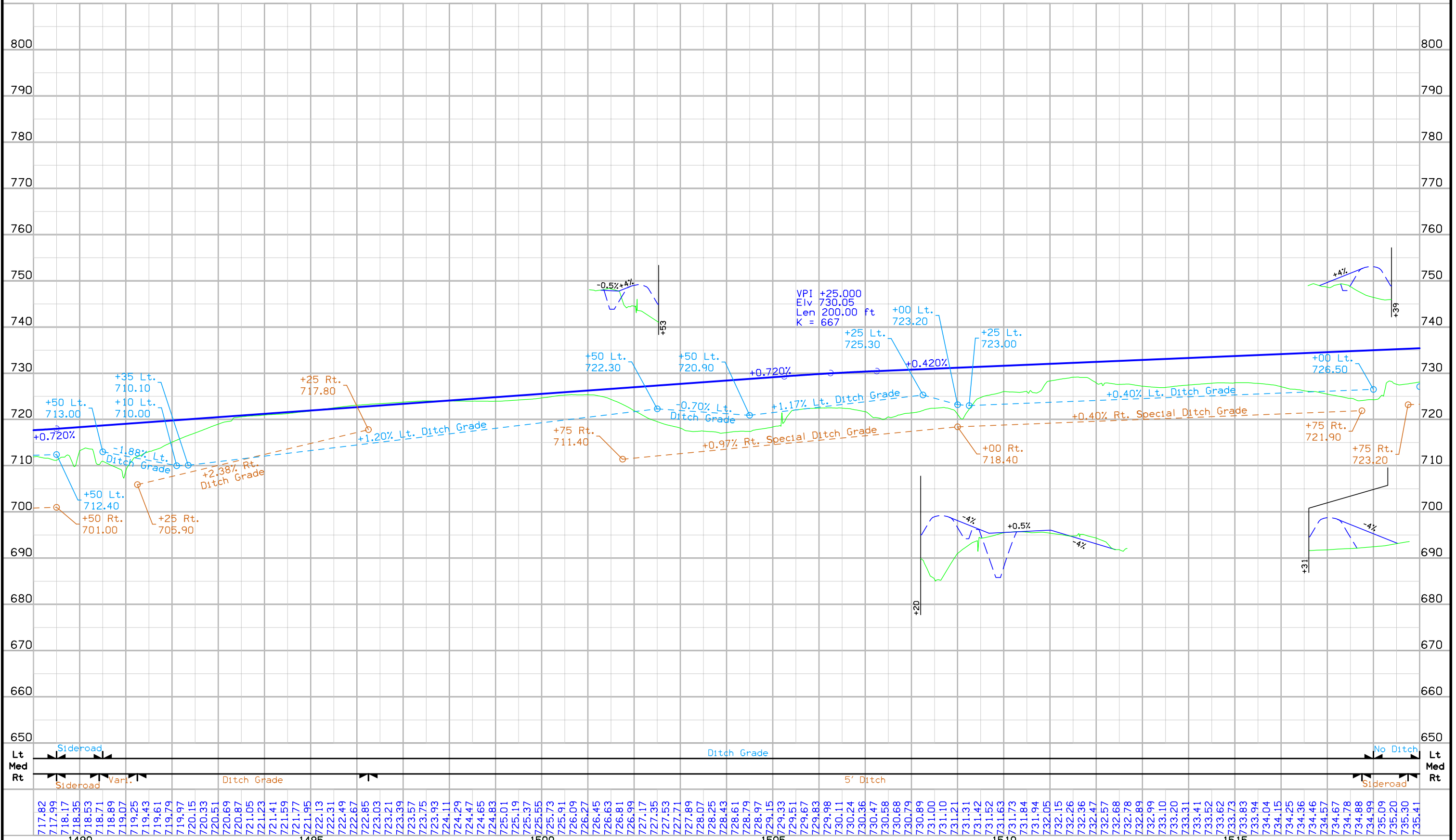

717.82	718.17	718.35	718.53	718.71	718.89	719.25	719.43	719.61	719.79	720.15	720.33	720.51	720.69	720.87	721.05	721.23	721.41	721.59	721.77	721.95	722.13	722.31	722.49	722.67	722.85	723.03	723.21	723.39	723.57	723.75	723.93	724.11	724.29	724.47	724.65	724.83	725.01	725.19	725.37	725.55	725.73	725.91	726.09	726.27	726.45	726.63	726.81	726.99	727.17	727.35	727.53	727.71	727.89	728.07	728.25	728.43	728.61	728.79	728.97	729.15	729.33	729.51	729.67	729.83	729.98	730.11	730.24	730.36	730.47	730.58	730.68	730.79	730.89	731.00	731.10	731.21	731.31	731.42	731.52	731.63	731.73	731.84	731.94	732.05	732.15	732.26	732.36	732.47	732.57	732.68	732.78	732.89	732.99	733.10	733.20	733.31	733.41	733.52	733.62	733.73	733.83	733.94	734.04	734.15	734.25	734.36	734.46	734.57	734.67	734.78	734.88	734.99	735.09	735.20	735.30	735.41
--------	--------	--------	--------	--------	--------	--------	--------	--------	--------	--------	--------	--------	--------	--------	--------	--------	--------	--------	--------	--------	--------	--------	--------	--------	--------	--------	--------	--------	--------	--------	--------	--------	--------	--------	--------	--------	--------	--------	--------	--------	--------	--------	--------	--------	--------	--------	--------	--------	--------	--------	--------	--------	--------	--------	--------	--------	--------	--------	--------	--------	--------	--------	--------	--------	--------	--------	--------	--------	--------	--------	--------	--------	--------	--------	--------	--------	--------	--------	--------	--------	--------	--------	--------	--------	--------	--------	--------	--------	--------	--------	--------	--------	--------	--------	--------	--------	--------	--------	--------	--------	--------	--------	--------	--------	--------	--------	--------	--------	--------	--------	--------	--------	--------	--------	--------	--------

For Side Road Details
Refer to Sheet No. E.14

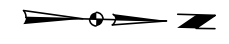

FRANKLIN TWP.
T-71N R-3W
SEC. 23

FRANKLIN TWP.
T-71N R-3W
SEC. 14

Sta. 1519+50
Install 24" X ' 20000
F.L. = Lt. ?
Rt. ?

Sta. 1534+50
Install 24" X ' 20000
F.L. = Lt. ?
Rt. ?

Sta. 1546+50
Install 24" X ' 20000
F.L. = Lt. ?
Rt. ?

+XX Prop.
Type M Dike
Elev. =

+XX Prop.
Type M Dike
Elev. =

POT Sta. 1545+02.31
=POT Sta. 11545+02.31

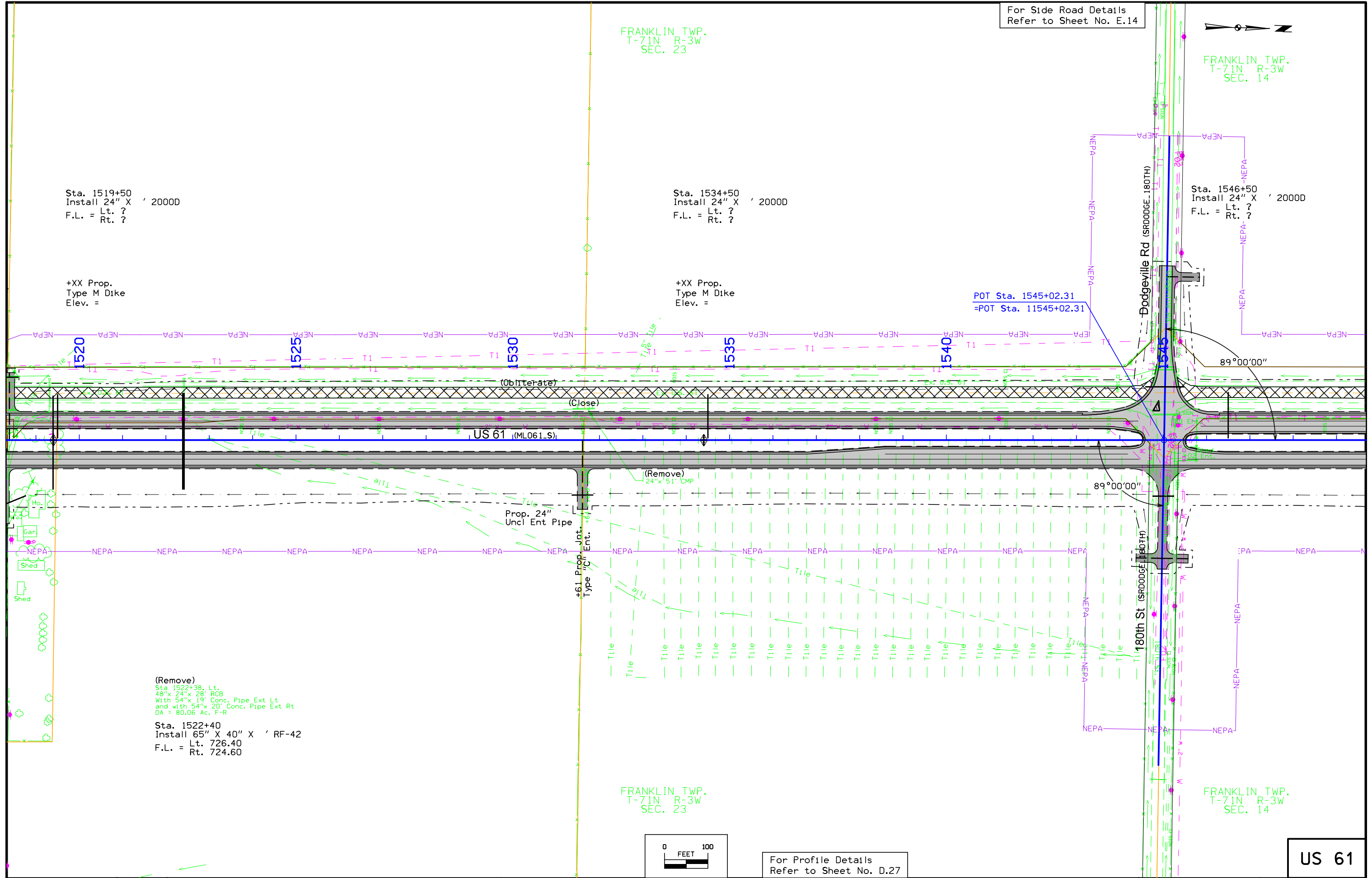

(Remove)
Sta 1522+38, Lt.
48" x 24" x 28' RCB
With 54" x 19' Conc. Pipe Ext Lt
and with 54" x 20' Conc. Pipe Ext Rt
DA = 80.06 Ac. F-R

Sta. 1522+40
Install 65" X 40" X ' RF-42
F.L. = Lt. 726.40
Rt. 724.60

FRANKLIN TWP.
T-71N R-3W
SEC. 23

FRANKLIN TWP.
T-71N R-3W
SEC. 14

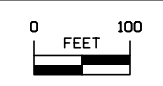

For Profile Details
Refer to Sheet No. D.27

US 61

For Plan Details
Refer to Sheet No. D.26

US 61

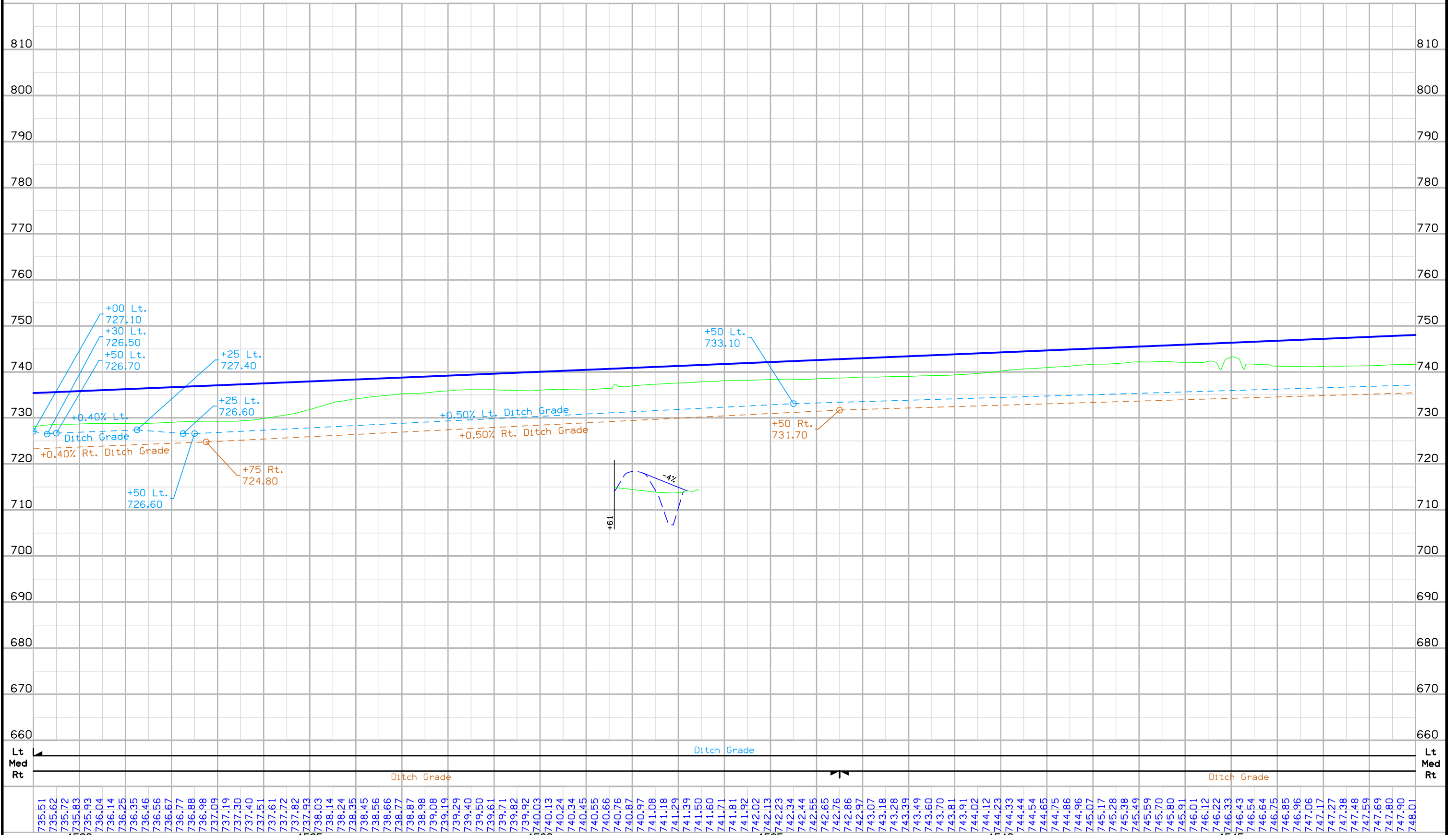

FRANKLIN TWP.
T-71N R-3W
SEC. 14

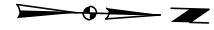

Sta. 1555+00
Install 24" X ' 2000D
F.L. = Lt. ?
Rt. ?

Sta. 1571+00
Install 24" X ' 2000D
F.L. = Lt. ?
Rt. ?

+XX Prop.
Type M Dike
Elev. =

Prop. 30" Uncl Ent Pipe

Prop. 12" Uncl Ent Pipe

1550

1555

1560

1565

1570

1575

PC Sta. 1576+28.34

US 61 (ML061.S)

88°45'00"

POT Sta. 1560+83.47
=POT Sta. 11560+83.47

182nd St (SR182ND)

F02

FRANKLIN TWP.
T-71N R-3W
SEC. 14

(Remove)
30" x 43" CMP
(Remove)
30" x 38" CMP

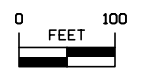

For Side Road Details
Refer to Sheet No. E.15

For Profile Details
Refer to Sheet No. D.29

US 61

For Plan Details
Refer to Sheet No. D.28

US 61

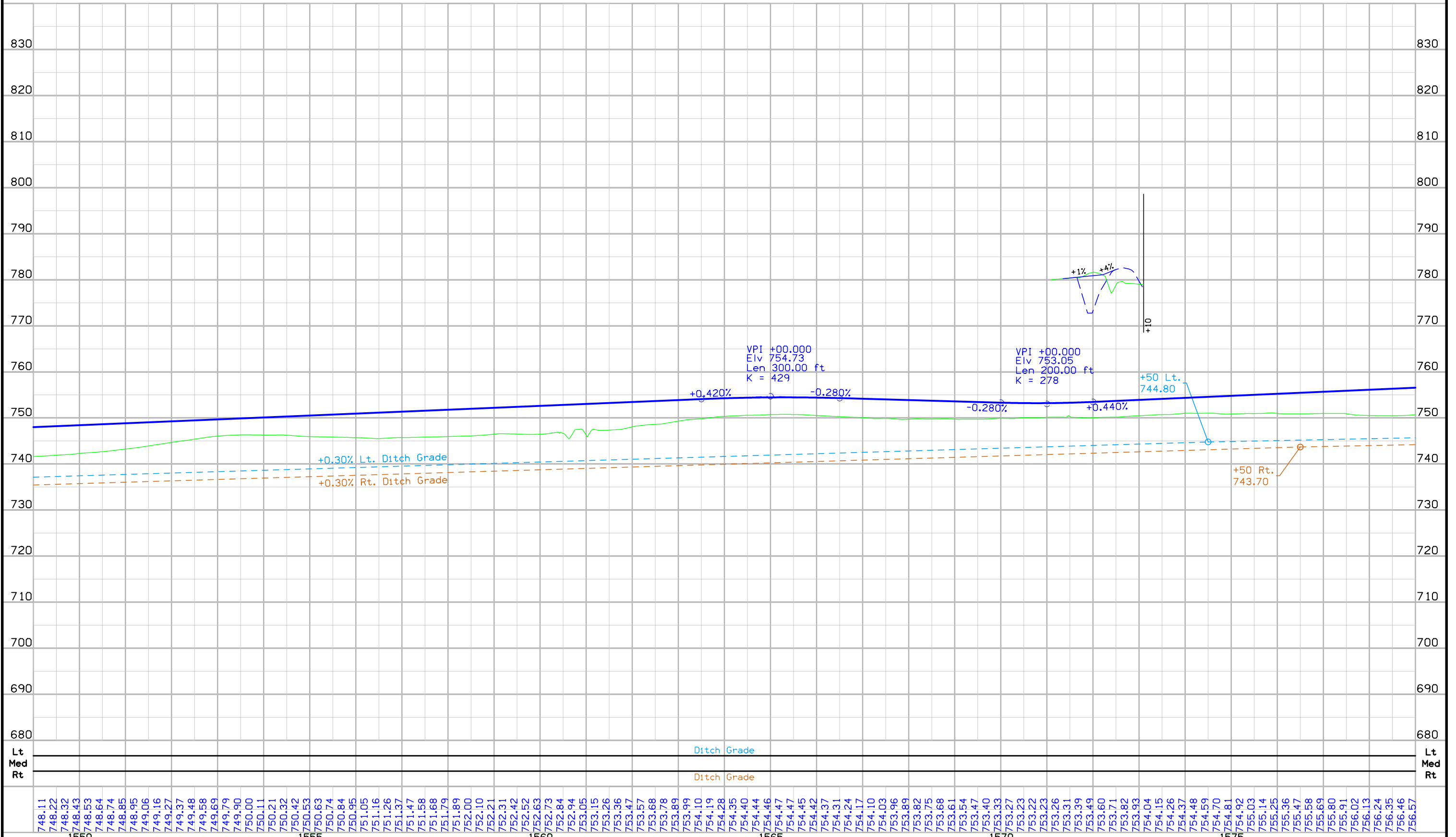

Lt																										Lt																																																																																														
Med																										Med																																																																																														
Rt																										Rt																																																																																														
	748.11	748.22	748.32	748.43	748.53	748.64	748.74	748.85	748.95	749.06	749.16	749.27	749.37	749.48	749.58	749.69	749.79	749.90	750.00	750.11	750.21	750.32	750.42	750.53	750.63	750.74	750.84	750.95	751.05	751.16	751.26	751.37	751.47	751.58	751.68	751.79	751.89	752.00	752.10	752.21	752.31	752.42	752.52	752.63	752.73	752.84	752.94	753.05	753.15	753.26	753.36	753.47	753.57	753.68	753.78	753.89	753.99	754.10	754.19	754.28	754.35	754.40	754.44	754.46	754.47	754.47	754.45	754.42	754.37	754.31	754.24	754.17	754.10	754.03	753.96	753.89	753.82	753.75	753.68	753.61	753.54	753.47	753.40	753.33	753.27	753.23	753.22	753.23	753.26	753.31	753.39	753.49	753.60	753.71	753.82	753.93	754.04	754.15	754.26	754.37	754.48	754.59	754.70	754.81	754.92	755.03	755.14	755.25	755.36	755.47	755.58	755.69	755.80	755.91	756.02	756.13	756.24	756.35	756.46	756.57

For Side Road Details
Refer to Sheet No. E.16

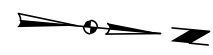

FRANKLIN TWP.
T-71N R-3W
SEC. 14

FRANKLIN TWP.
T-71N R-3W
SEC. 11

Sta. 1592+75
Install 24" X ' 20000
F.L. = Lt. ?
Rt. ?

POT Sta. 1598+12.97
=POT Sta. 11598+12.97

Sta. 1599+50
Install 24" X ' 20000
F.L. = Lt. ?
Rt. ?

Curve Data
 $\Delta = 5^\circ 13' 15.67''$ (LT)
T = 747.73
L = 1,494.43
R = 16,400.00
E = 17.04
e = Normal Crown

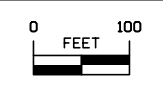

For Profile Details
Refer to Sheet No. D.31

US 61

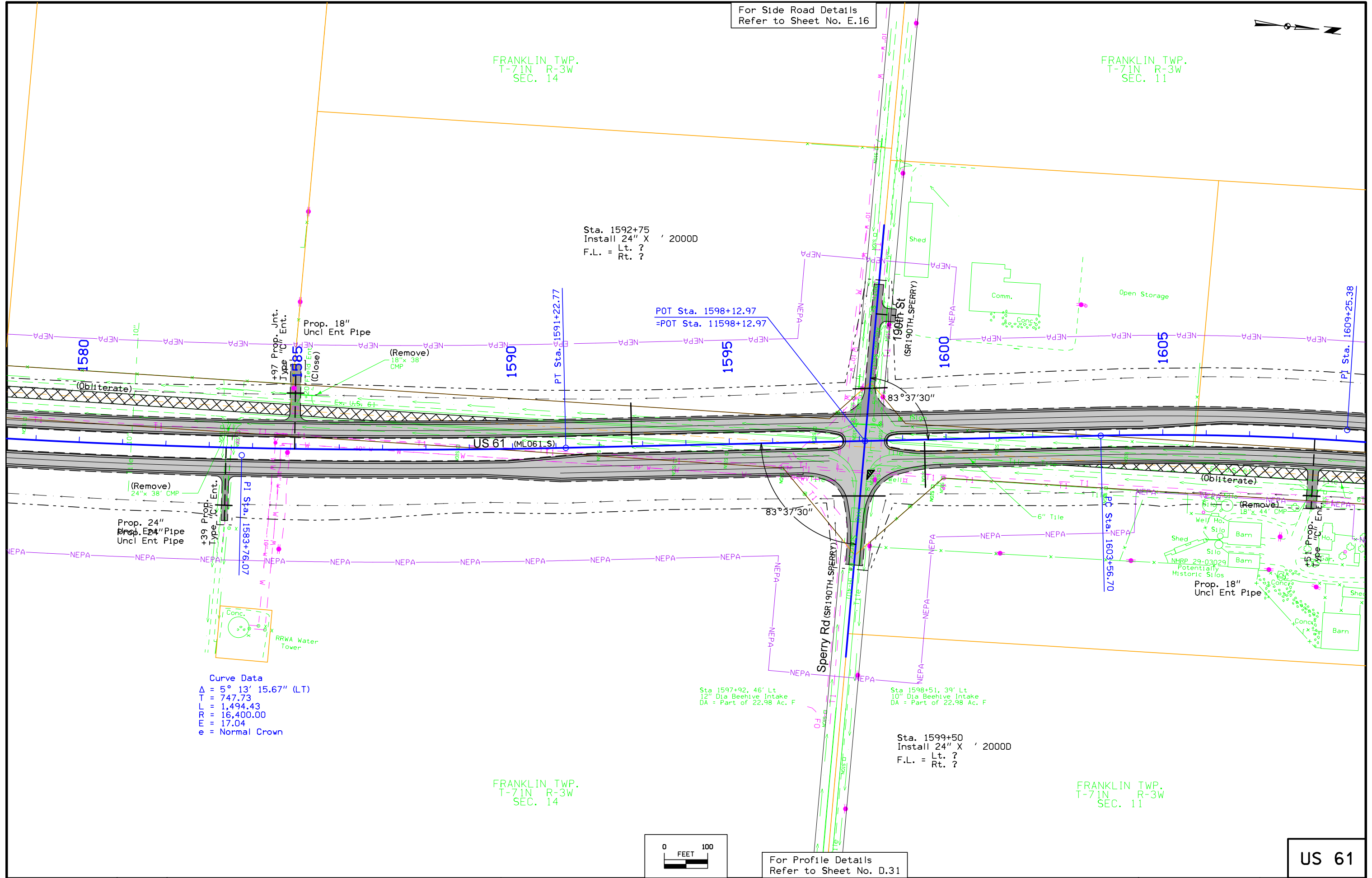

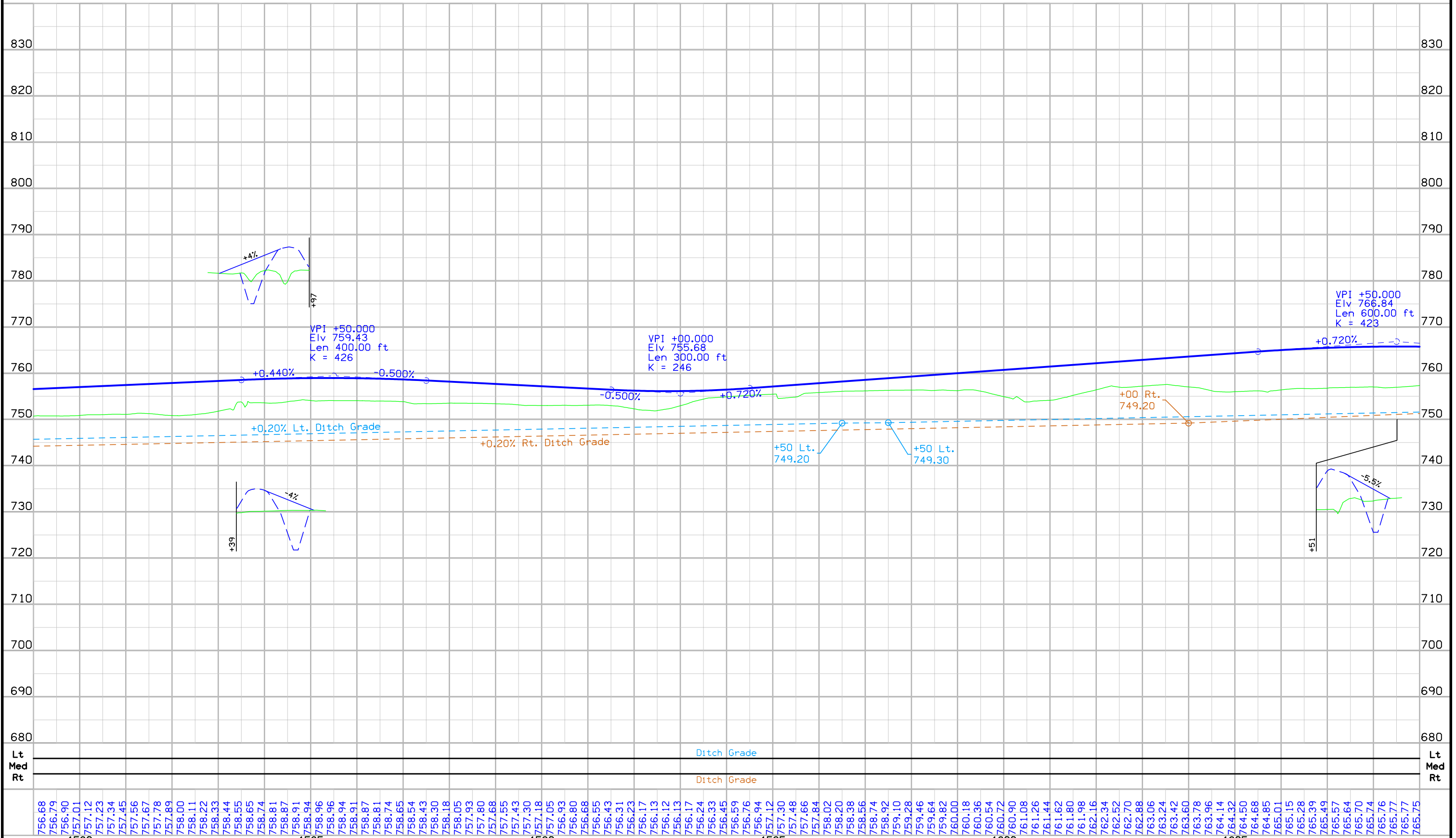

FRANKLIN TWP.
T-71N R-3W
SEC. 11

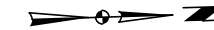

Curve Data
 $\Delta = 9^\circ 59' 59.99''$ (RT)
 $T = 568.68$
 $L = 1,134.46$
 $R = 6,500.00$
 $E = 24.83$
 $e = 3.2\%$
 $L = 144'$
 $X = 90'$

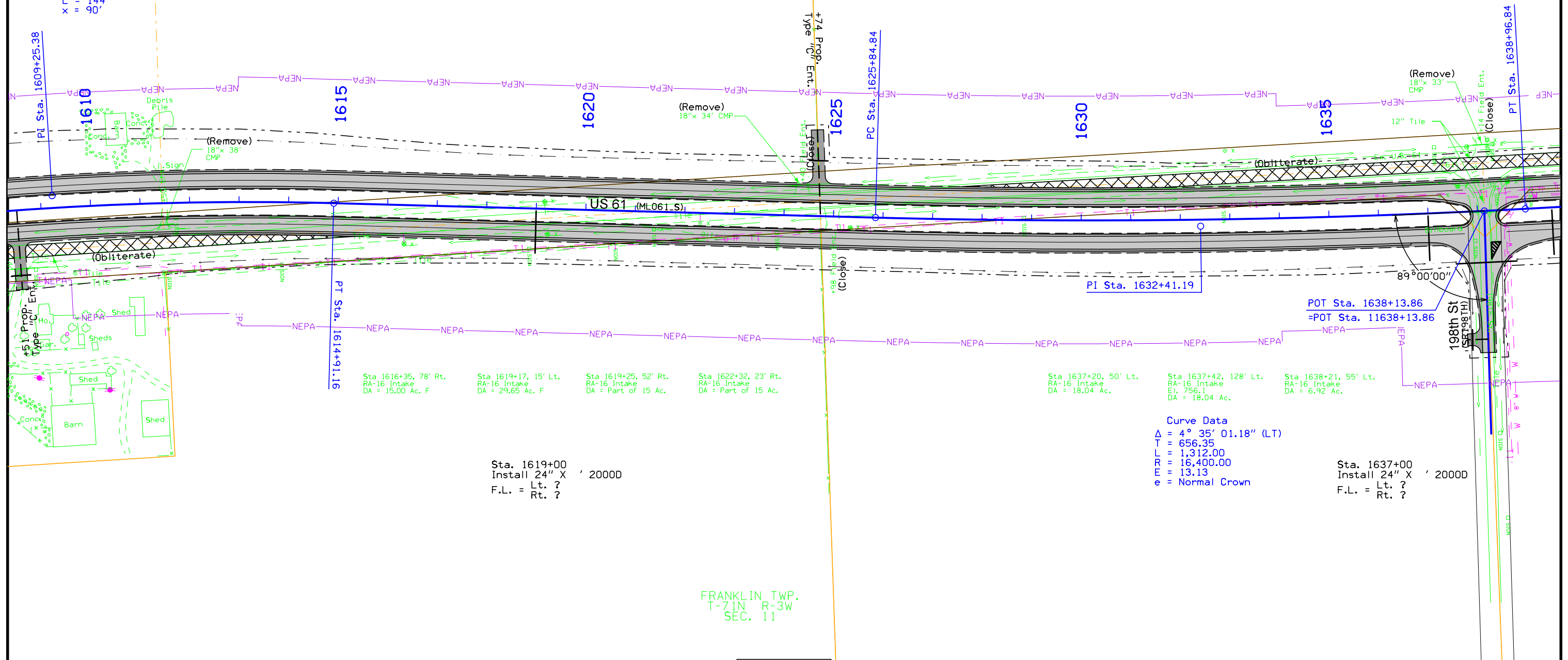

Sta 1616+35, 78' Rt.
RA-16 Intake
DA = 15.00 Ac. F

Sta 1619+17, 15' Lt.
RA-16 Intake
DA = 29.65 Ac. F

Sta 1619+25, 52' Rt.
RA-16 Intake
DA = Part of 15 Ac.

Sta 1622+32, 23' Rt.
RA-16 Intake
DA = Part of 15 Ac.

Sta 1637+20, 50' Lt.
RA-16 Intake
DA = 18.04 Ac.

Sta 1637+42, 128' Lt.
RA-16 Intake
El. 756.1
DA = 18.04 Ac.

Sta 1638+21, 55' Lt.
RA-16 Intake
DA = 6.92 Ac.

Sta. 1619+00
Install 24" X ' 2000D
F.L. = Lt. ?
Rt. ?

Curve Data
 $\Delta = 4^\circ 35' 01.18''$ (LT)
 $T = 656.35$
 $L = 1,312.00$
 $R = 16,400.00$
 $E = 13.13$
 $e = \text{Normal Crown}$

Sta. 1637+00
Install 24" X ' 2000D
F.L. = Lt. ?
Rt. ?

FRANKLIN TWP.
T-71N R-3W
SEC. 11

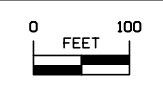

For Profile Details
Refer to Sheet No. D.33

For Side Road Details
Refer to Sheet No. E.17

US 61

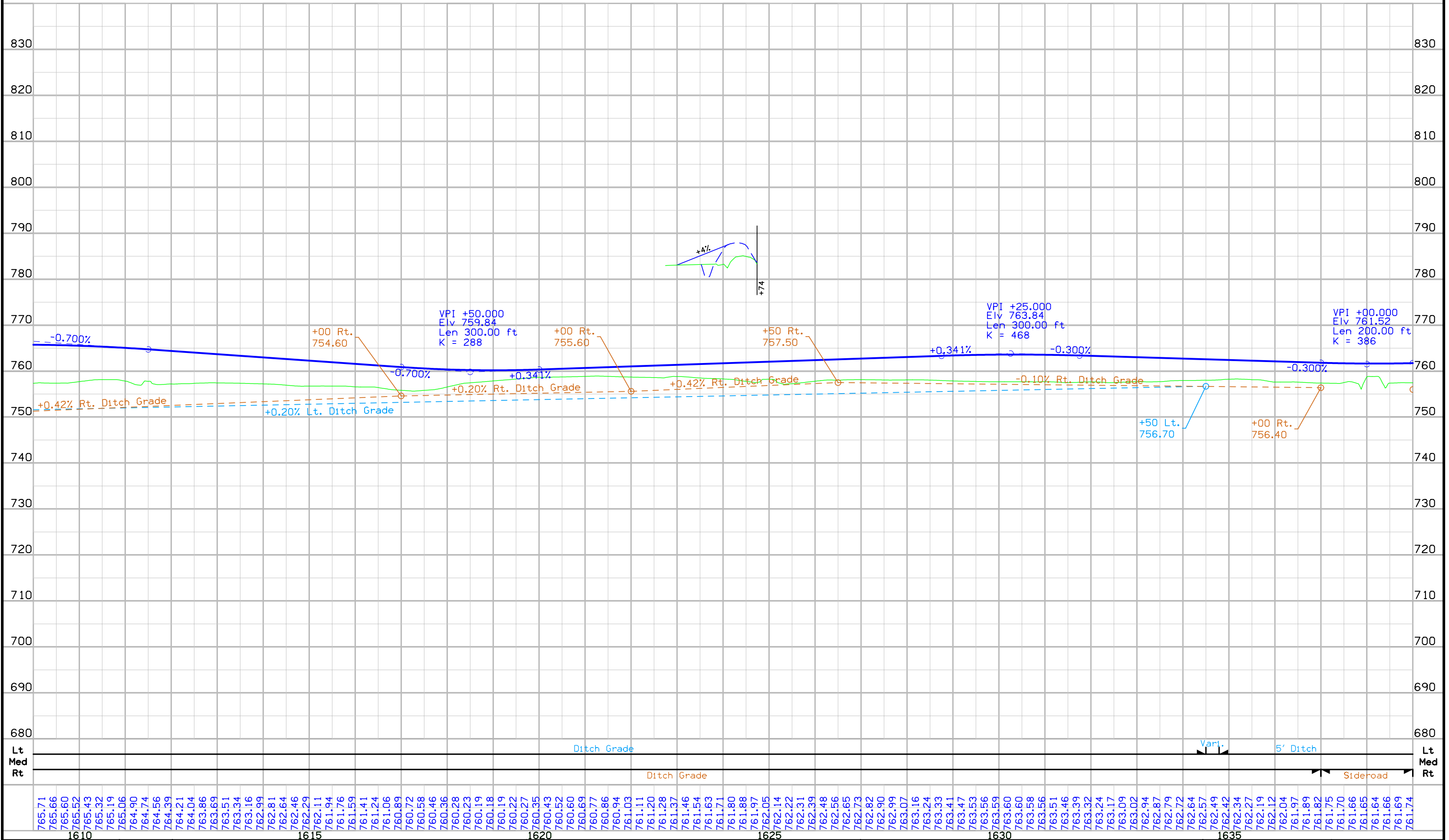

For Side Road Details
Refer to Sheet No. E.18

FRANKLIN TWP.
T-71N R-3W
SEC. 11

FRANKLIN TWP.
T-71N R-3W
SEC. 2

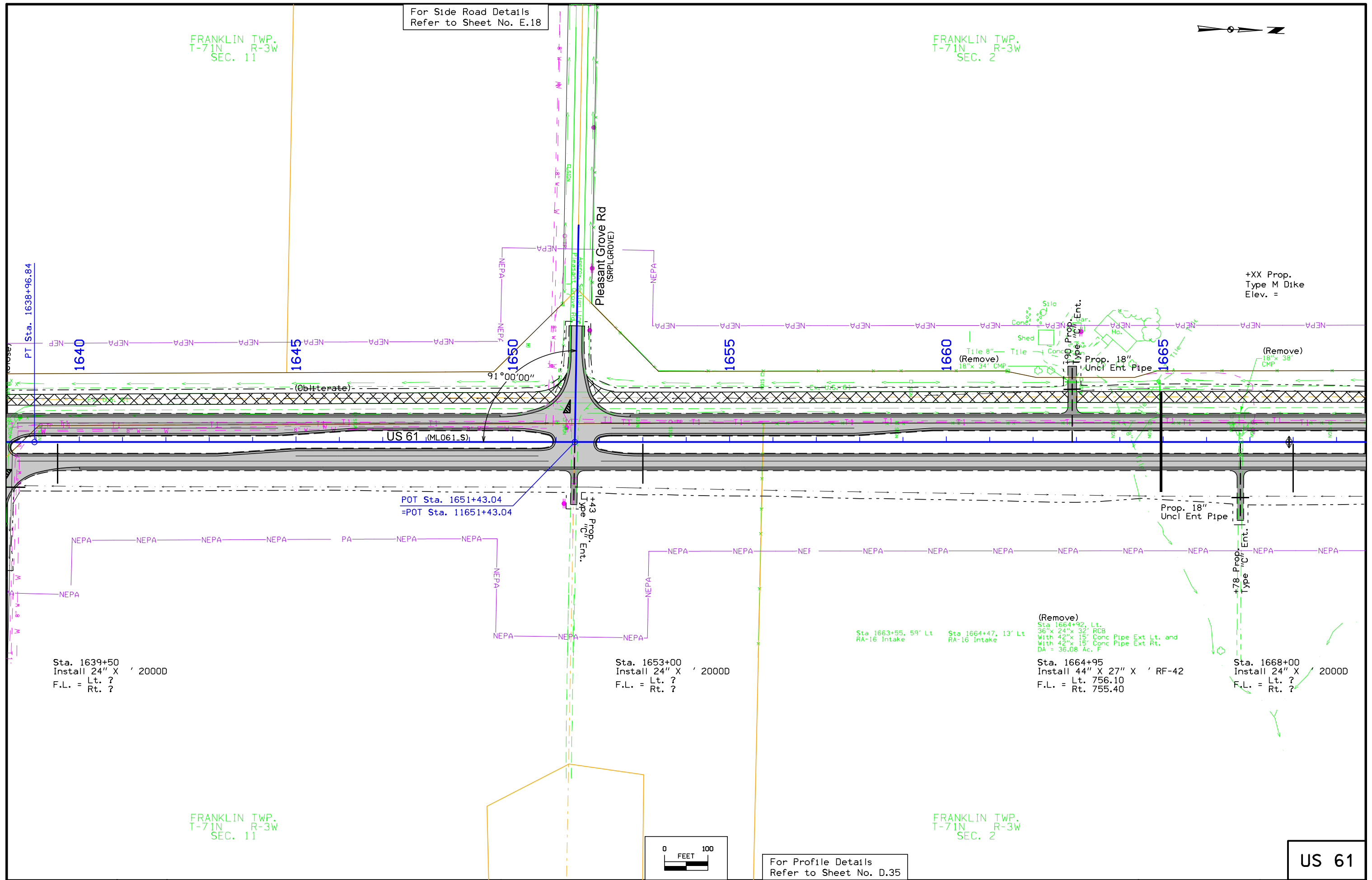
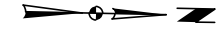

+XX Prop.
Type M Dike
Elev. =

Sta. 1639+50
Install 24" X ' 20000
F.L. = Lt. ?
Rt. ?

POT Sta. 1651+43.04
=POT Sta. 11651+43.04

Sta. 1653+00
Install 24" X ' 20000
F.L. = Lt. ?
Rt. ?

Sta 1663+55, 59' Lt
RA-16 Intake

Sta 1664+47, 13' Lt
RA-16 Intake

(Remove)
Sta 1664+92, Lt.
36" x 24" x 32' RCB
With 42" x 15" Conc Pipe Ext Lt. and
With 42" x 15" Conc Pipe Ext Rt.
DA = 36.08 Ac. F

Sta. 1664+95
Install 44" X 27" X ' RF-42
F.L. = Lt. 756.10
Rt. 755.40

Sta. 1668+00
Install 24" X ' 20000
F.L. = Lt. ?
Rt. ?

FRANKLIN TWP.
T-71N R-3W
SEC. 11

FRANKLIN TWP.
T-71N R-3W
SEC. 2



For Profile Details
Refer to Sheet No. D.35

US 61

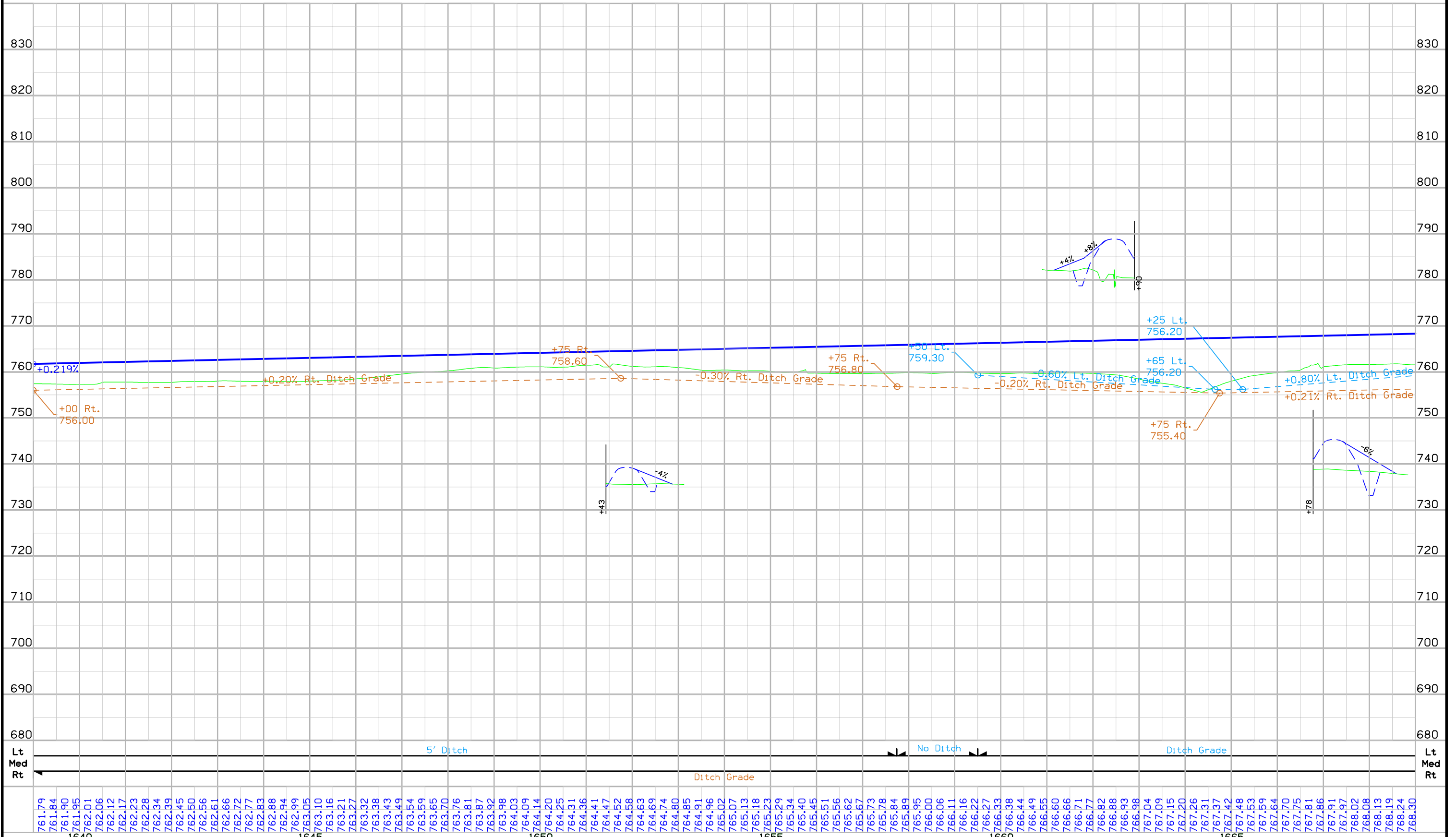

761.79	761.84	761.90	761.95	762.01	762.06	762.12	762.17	762.23	762.28	762.34	762.39	762.45	762.50	762.56	762.61	762.66	762.72	762.77	762.83	762.88	762.94	762.99	763.05	763.10	763.16	763.21	763.27	763.32	763.38	763.43	763.49	763.54	763.59	763.65	763.70	763.76	763.81	763.87	763.92	763.98	764.03	764.09	764.14	764.20	764.25	764.31	764.36	764.41	764.47	764.52	764.58	764.63	764.69	764.74	764.80	764.85	764.91	764.96	765.02	765.07	765.13	765.18	765.23	765.29	765.34	765.40	765.45	765.51	765.56	765.62	765.67	765.73	765.78	765.84	765.89	765.95	766.00	766.06	766.11	766.16	766.22	766.27	766.33	766.38	766.44	766.49	766.55	766.60	766.66	766.71	766.77	766.82	766.88	766.93	766.98	767.04	767.09	767.15	767.20	767.26	767.31	767.37	767.42	767.48	767.53	767.59	767.64	767.70	767.75	767.81	767.86	767.91	767.97	768.02	768.08	768.13	768.19	768.24	768.30
--------	--------	--------	--------	--------	--------	--------	--------	--------	--------	--------	--------	--------	--------	--------	--------	--------	--------	--------	--------	--------	--------	--------	--------	--------	--------	--------	--------	--------	--------	--------	--------	--------	--------	--------	--------	--------	--------	--------	--------	--------	--------	--------	--------	--------	--------	--------	--------	--------	--------	--------	--------	--------	--------	--------	--------	--------	--------	--------	--------	--------	--------	--------	--------	--------	--------	--------	--------	--------	--------	--------	--------	--------	--------	--------	--------	--------	--------	--------	--------	--------	--------	--------	--------	--------	--------	--------	--------	--------	--------	--------	--------	--------	--------	--------	--------	--------	--------	--------	--------	--------	--------	--------	--------	--------	--------	--------	--------	--------	--------	--------	--------	--------	--------	--------	--------	--------	--------	--------	--------



FRANKLIN TWP.
T-71N R-3W
SEC. 2

Sta 1675+30, 131' Lt
RA-16 Intake
DA = Part of 45 Ac. F-R

+XX Prop.
Type M Dike
Elev. =

+03 Prop. Jnt.
Type 'C' Ent.

+99 Prop. Jnt.
Type 'C' Ent.

Prop. 18" Uncl Ent Pipe

Prop. 18" Uncl Ent Pipe

(Remove)
18" x 38"
CMP
+36 Ent.
(Close)

US 61 (ML061.S)

Windmill

Sta. 1683+00
Install 24" X ' 2000D
F.L. = Lt. ?
Rt. ?

Sta 1675+57, Lt.
36" x 28" x 54' RCB
DA = 105.02 Ac. F-R

Sta. 1674+40
Install 36" X ' 2000D
Skew = 27°30' Lt. Ahd.
F.L. = Lt. 757.20
Rt. 754.50

FRANKLIN TWP.
T-71N R-3W
SEC. 2

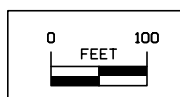

For Profile Details
Refer to Sheet No. D.37

US 61

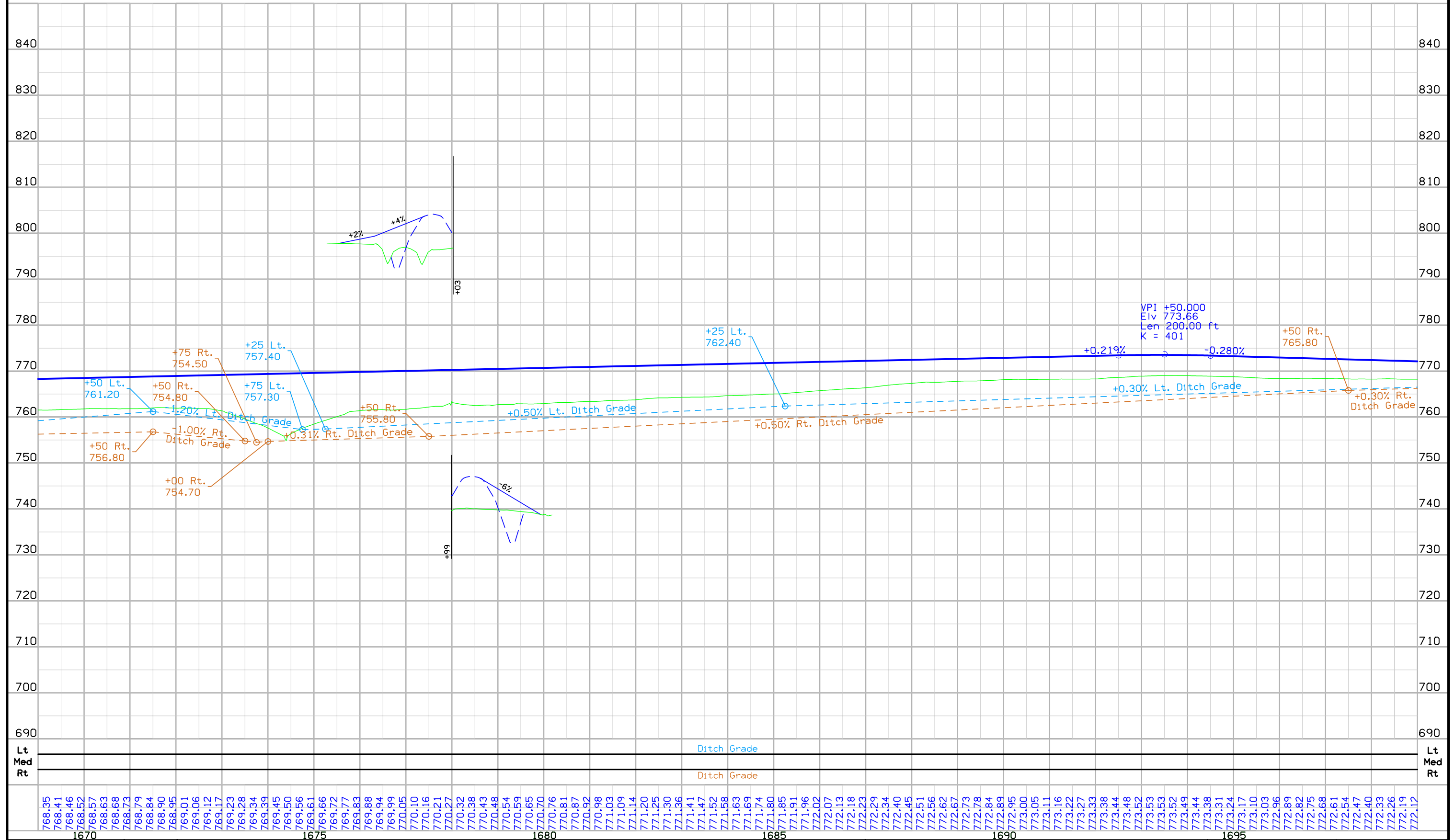

FRANKLIN TWP.
T-71N R-3W
SEC. 2

YELLOW SPRING TWP.
T-72N R-3W
SEC. 35

For Side Road Details
Refer to Sheet No. E.19

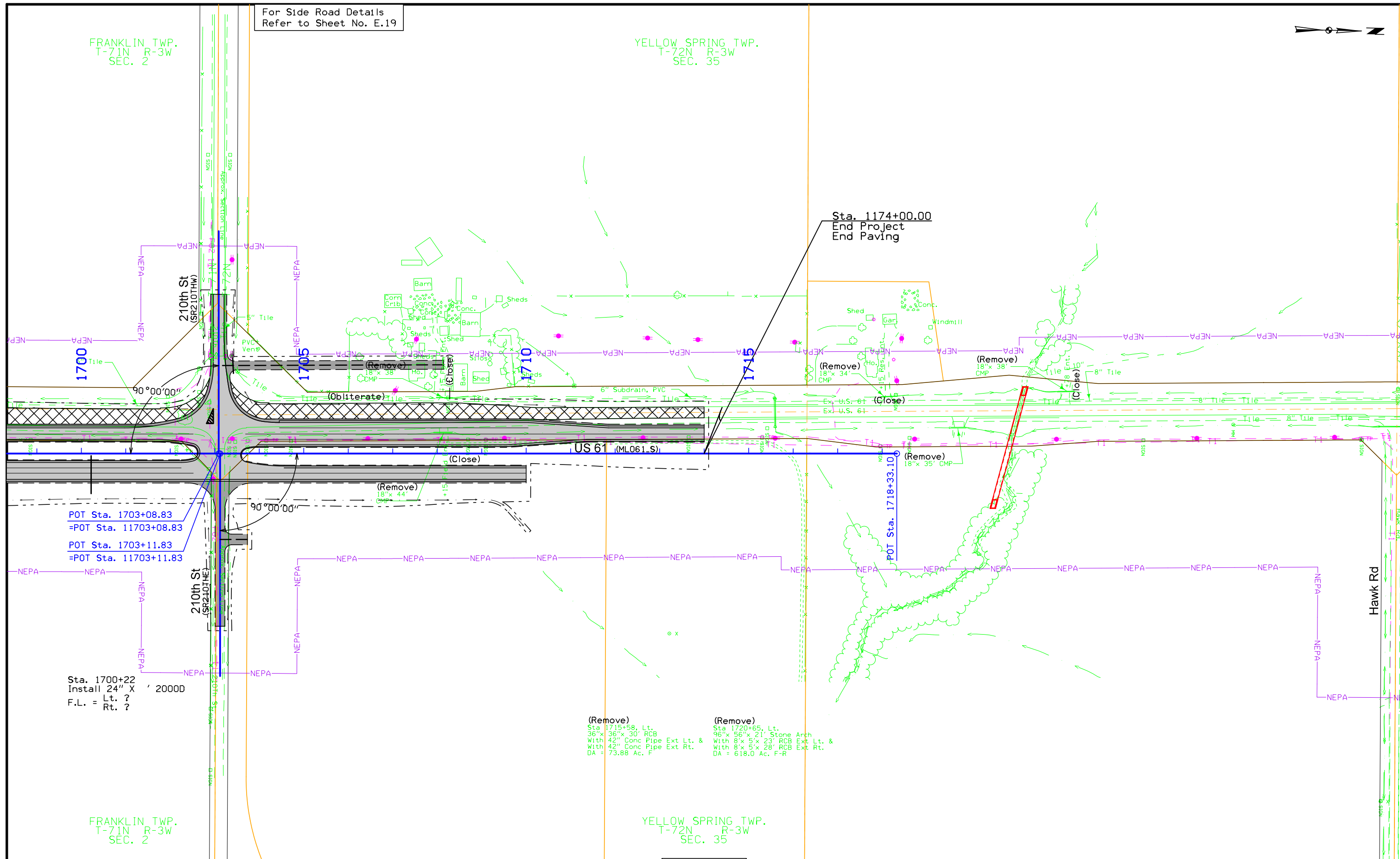
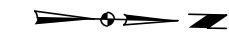

POT Sta. 1703+08.83
=POT Sta. 11703+08.83
POT Sta. 1703+11.83
=POT Sta. 11703+11.83

Sta. 1700+22
Install 24" X ' 20000
F.L. = Lt. ?
Rt. ?

(Remove)
Sta 1715+58, Lt.
36"x 30" RCB
With 42" Conc Pipe Ext Lt. &
With 42" Conc Pipe Ext Rt.
DA = 73.88 Ac. F

(Remove)
Sta 1720+65, Lt.
96"x 56"x 21" Stone Arch
With 8'x 5'x 23" RCB Ext Lt. &
With 8'x 5'x 28" RCB Ext Rt.
DA = 618.0 Ac. F-R



For Side Road Details
Refer to Sheet No. E.20

For Profile Details
Refer to Sheet No. D.39

For Culvert Situation Plan
Refer to Sheets No. V.5 - V.6

US 61

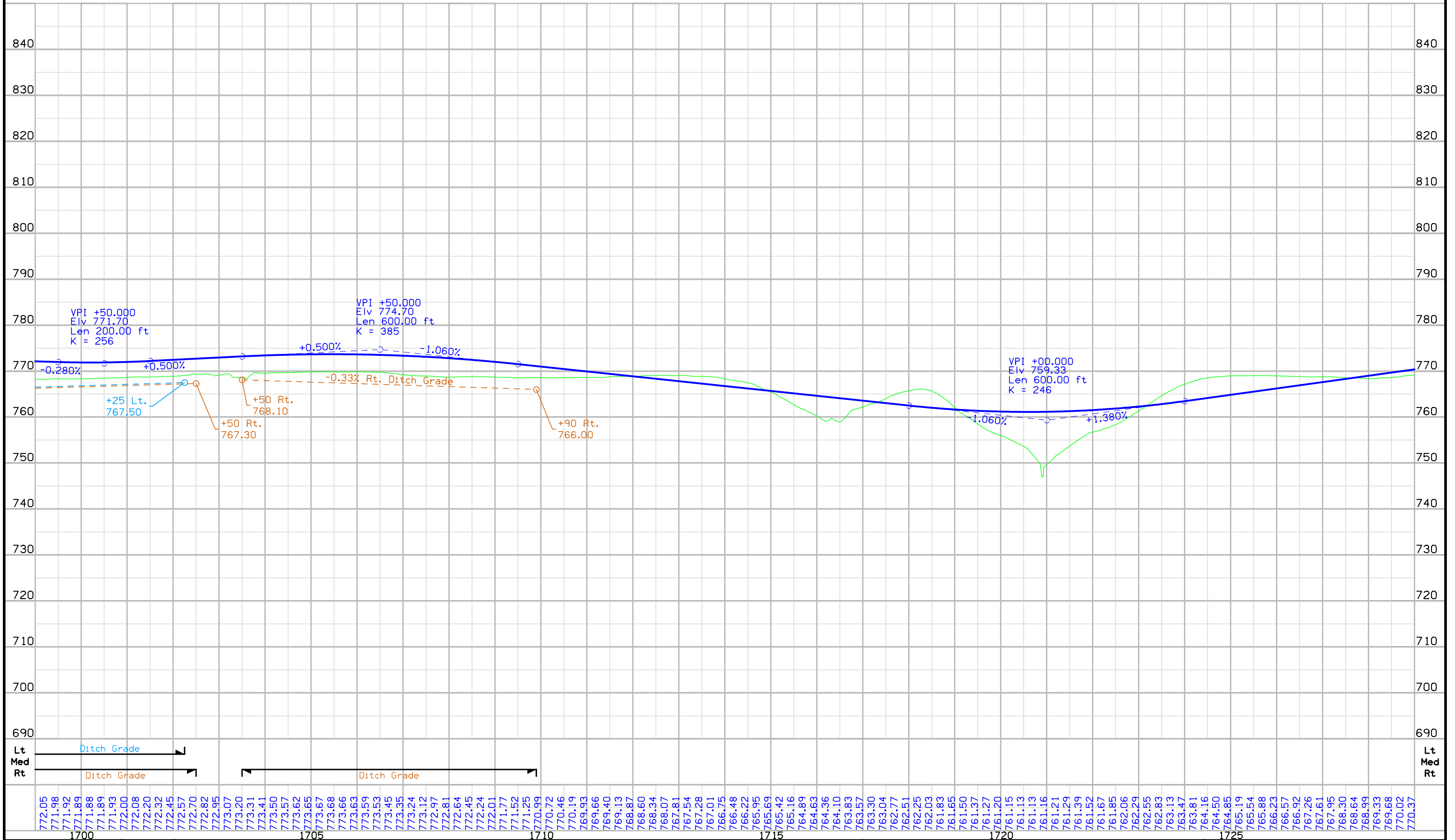

1700	1705	1710	1715	1720	1725
772.05	771.98	771.92	771.89	771.88	771.89
771.93	772.00	772.20	772.32	772.45	772.57
772.70	772.82	772.95	773.07	773.20	773.31
773.41	773.50	773.62	773.65	773.67	773.68
773.66	773.63	773.59	773.53	773.45	773.35
773.24	773.12	772.97	772.81	772.64	772.45
772.24	772.01	771.77	771.52	771.25	770.99
770.72	770.46	770.19	769.93	769.66	769.40
769.13	768.87	768.60	768.34	768.07	767.81
767.54	767.28	767.01	766.75	766.48	766.22
765.95	765.69	765.42	765.16	764.89	764.63
764.36	764.10	763.83	763.57	763.30	763.04
762.77	762.51	762.25	762.03	761.83	761.65
761.50	761.37	761.27	761.20	761.15	761.13
761.13	761.13	761.16	761.21	761.29	761.39
761.52	761.67	761.85	762.06	762.29	762.55
762.83	763.13	763.47	763.81	764.16	764.50
764.85	765.19	765.54	765.88	766.23	766.57
766.92	767.26	767.61	767.95	768.30	768.64
768.99	769.33	769.68	770.02	770.37	

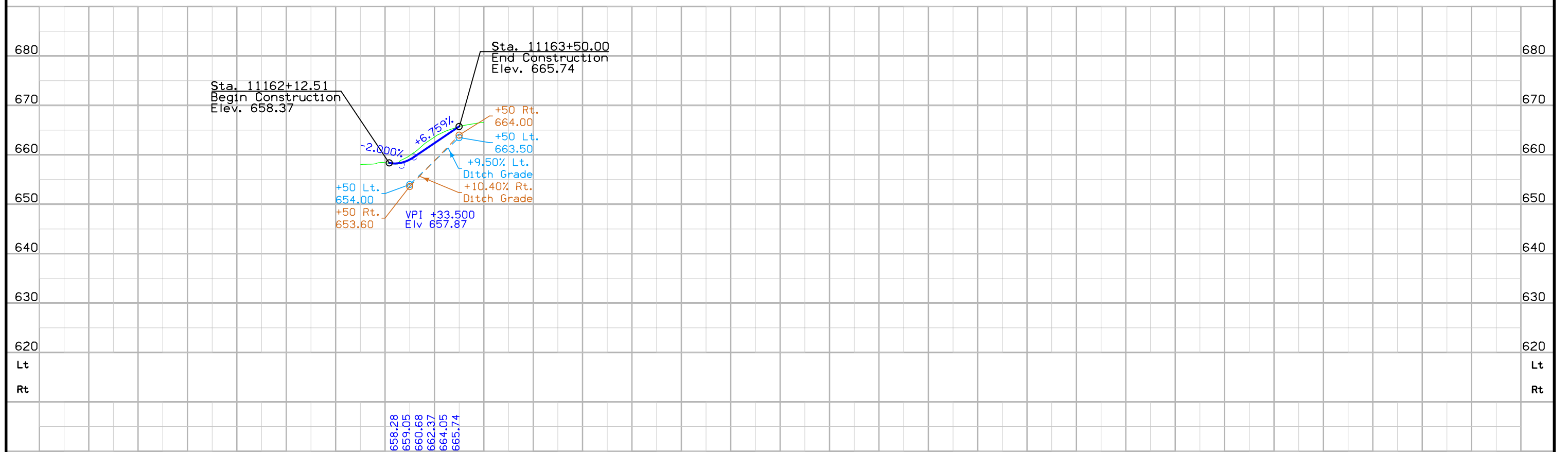
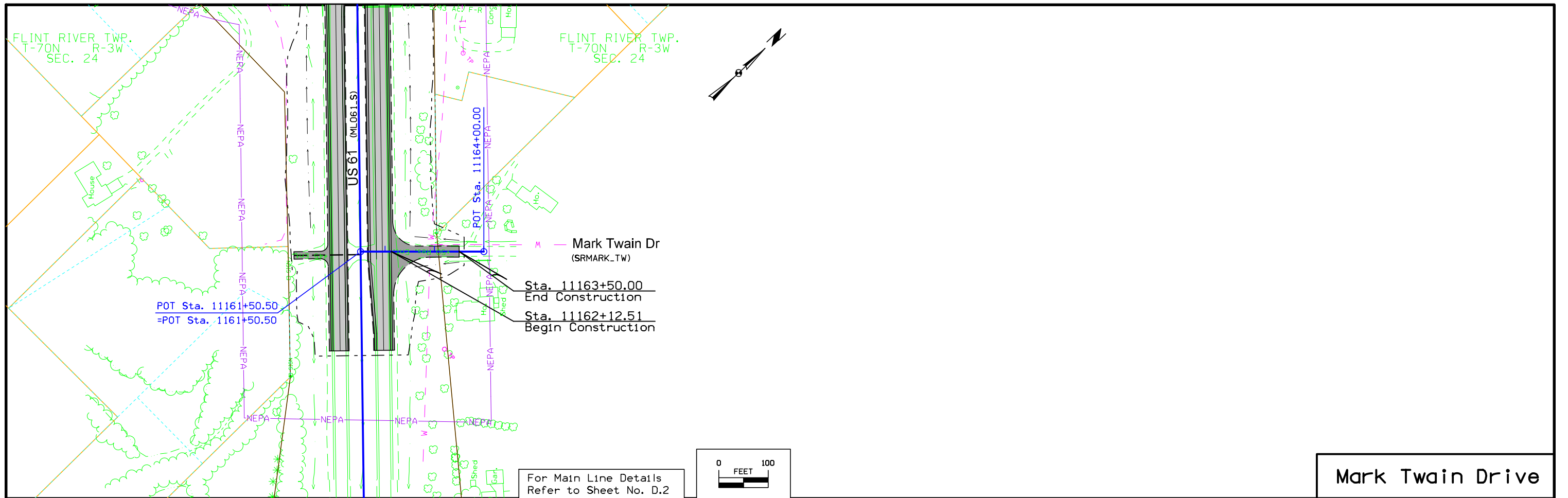

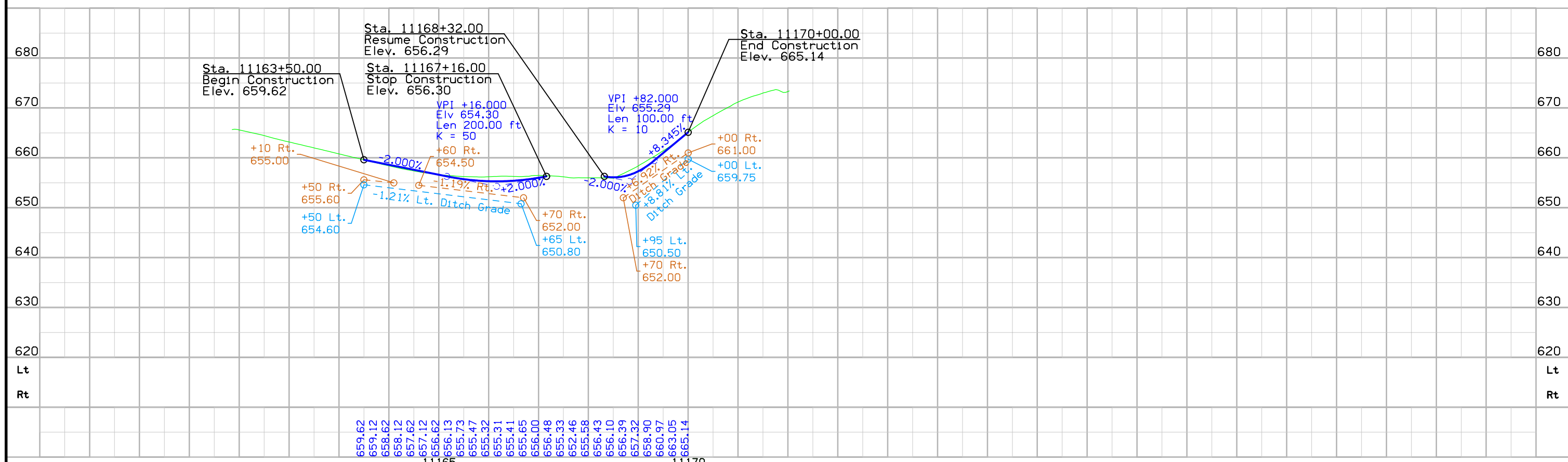
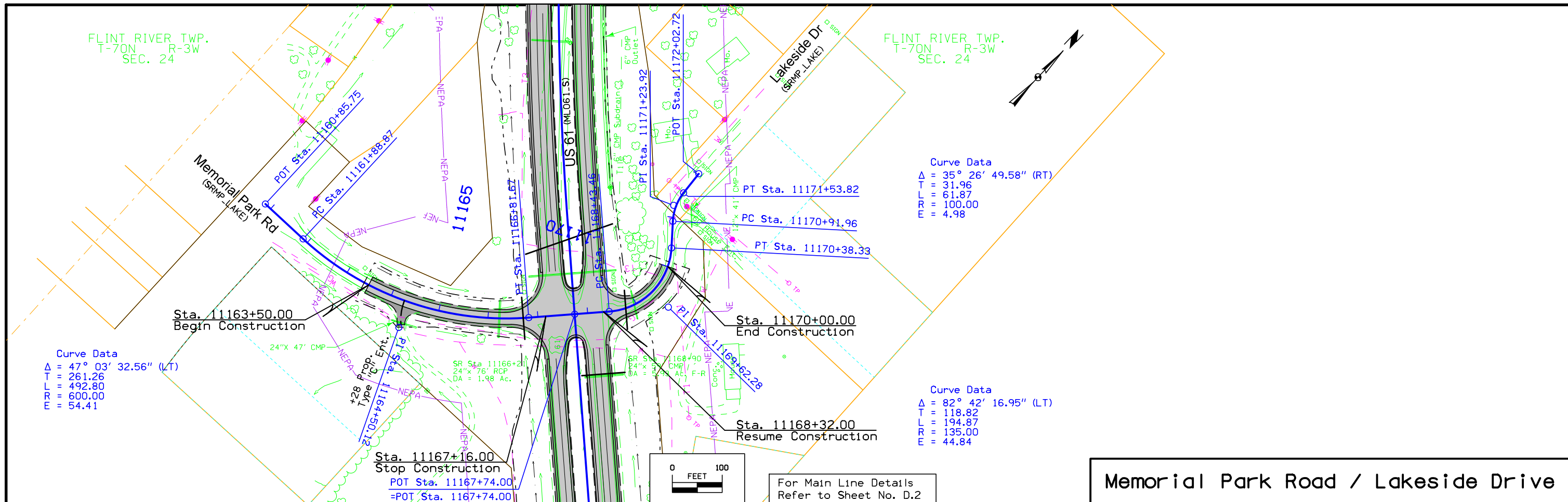

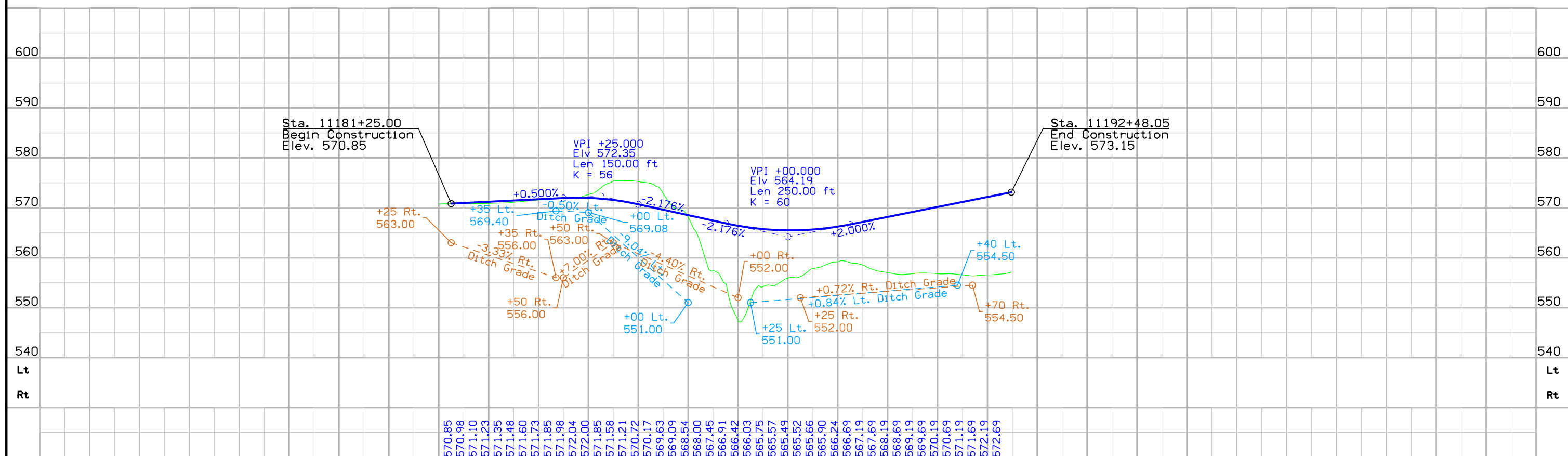
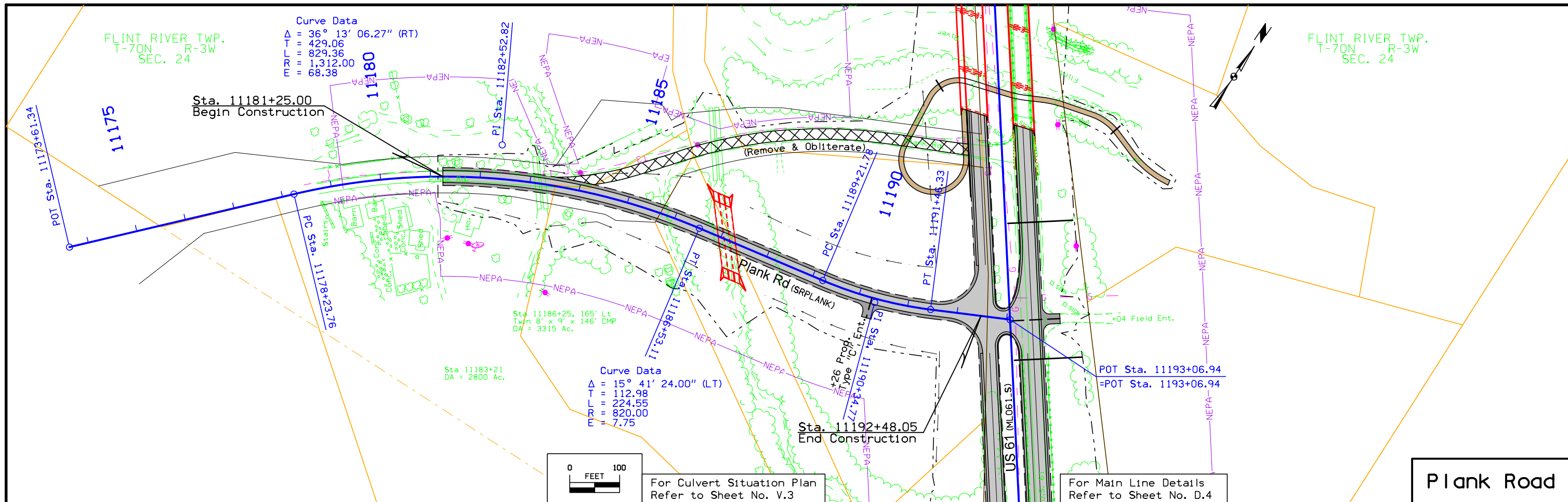

11175	11180	11185	11190
570.85	570.98	571.10	571.23
571.35	571.48	571.60	571.73
571.85	571.98	572.04	572.00
571.85	571.58	571.21	570.72
570.17	569.09	568.54	567.45
566.42	566.03	565.57	565.49
565.52	565.66	565.90	566.24
566.69	567.19	567.69	568.19
568.69	569.19	570.19	570.69
571.19	571.69	572.19	572.69

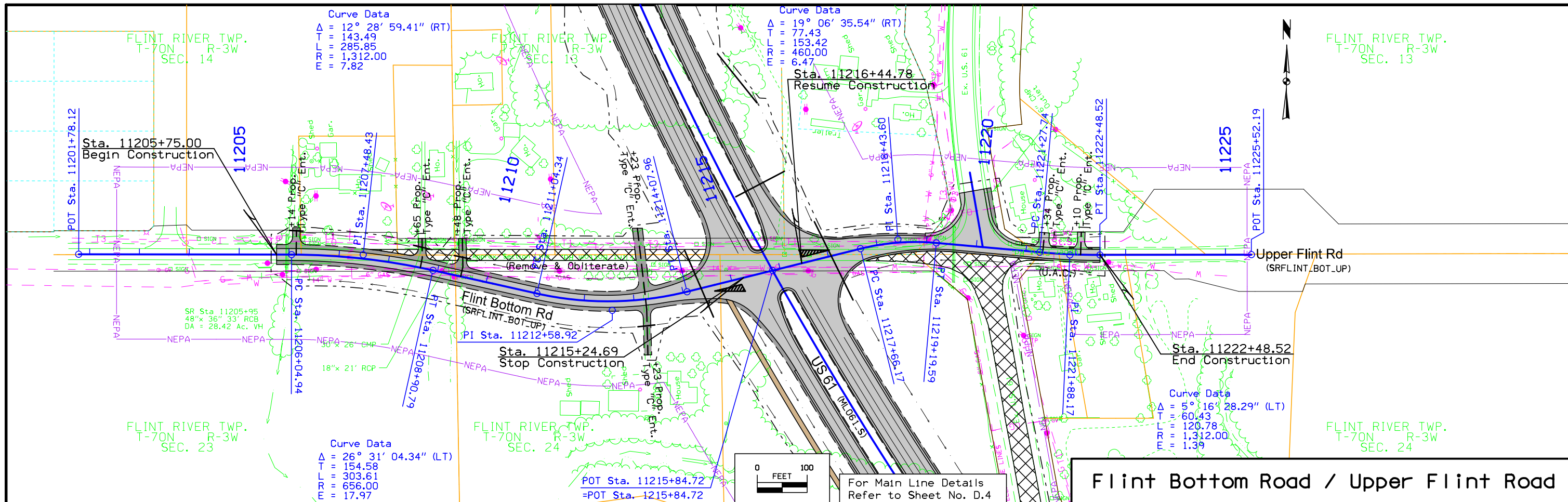

Flint Bottom Road / Upper Flint Road

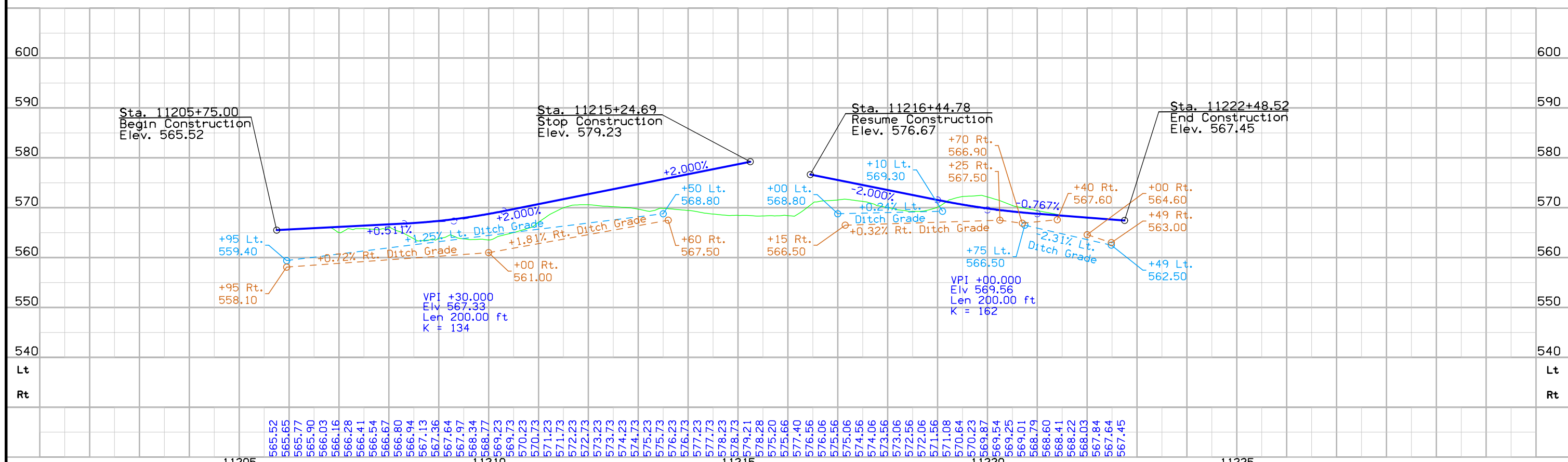

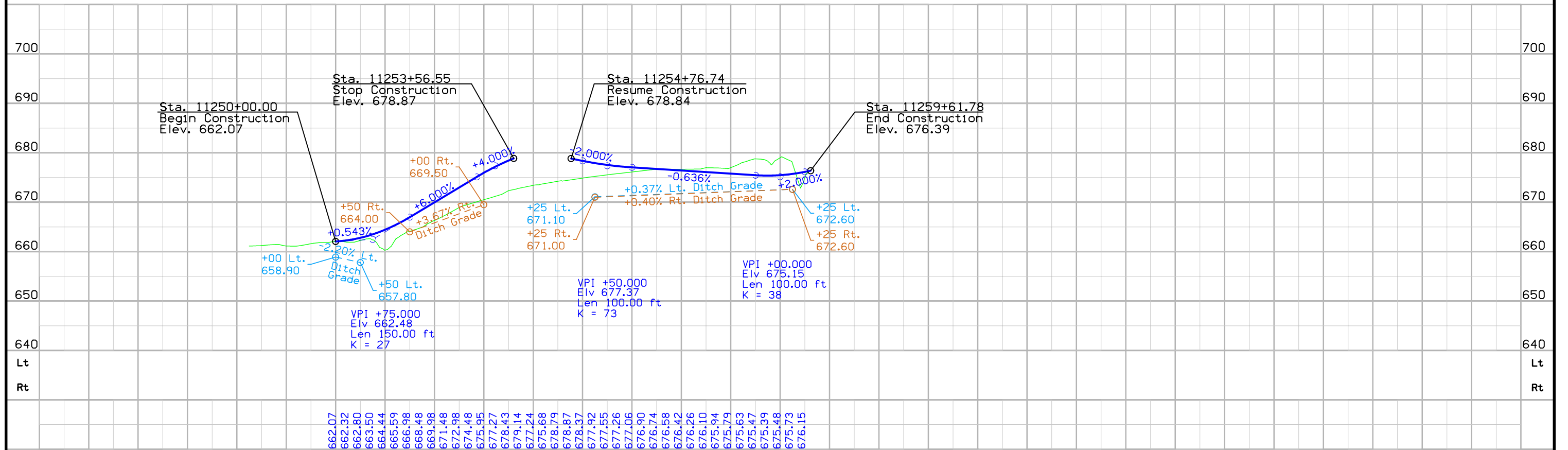
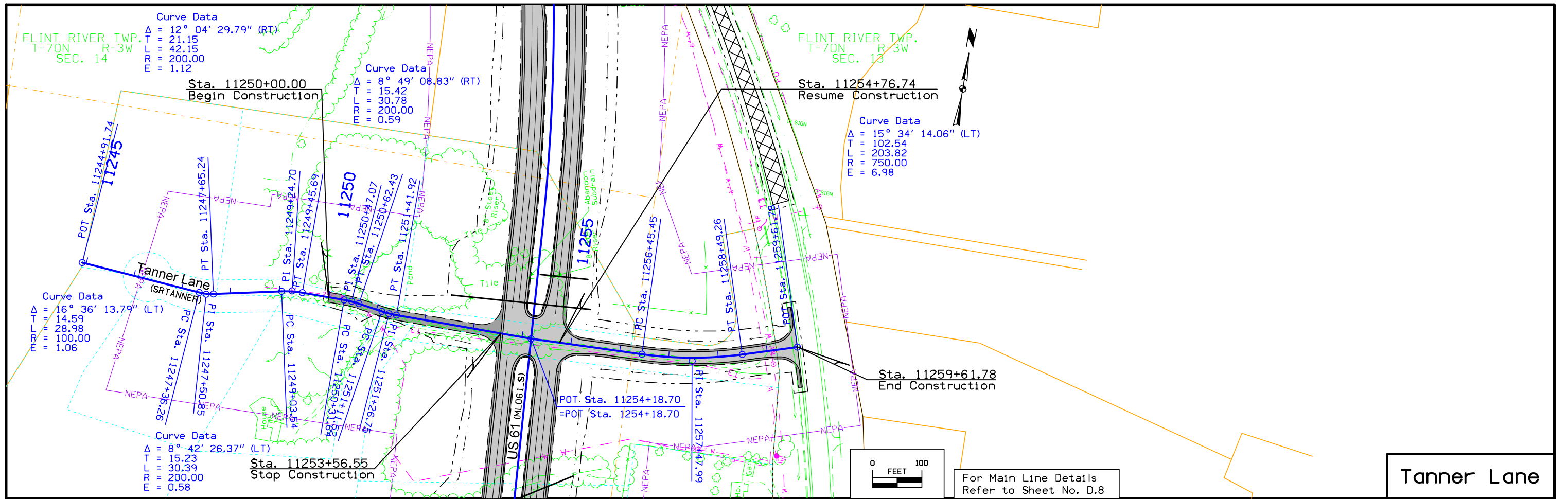

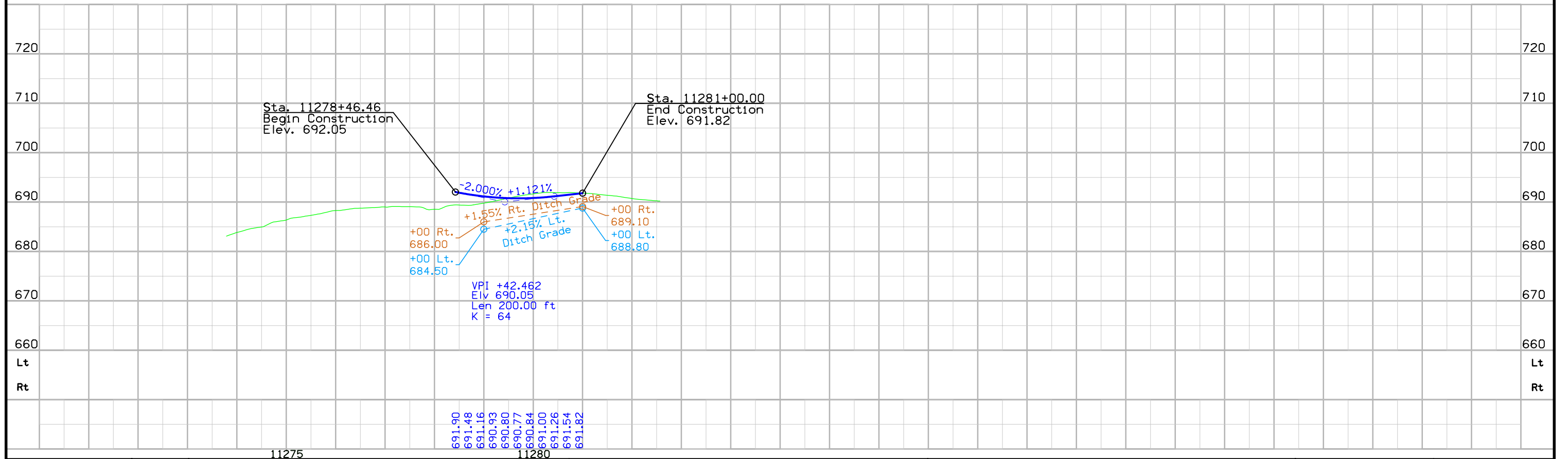
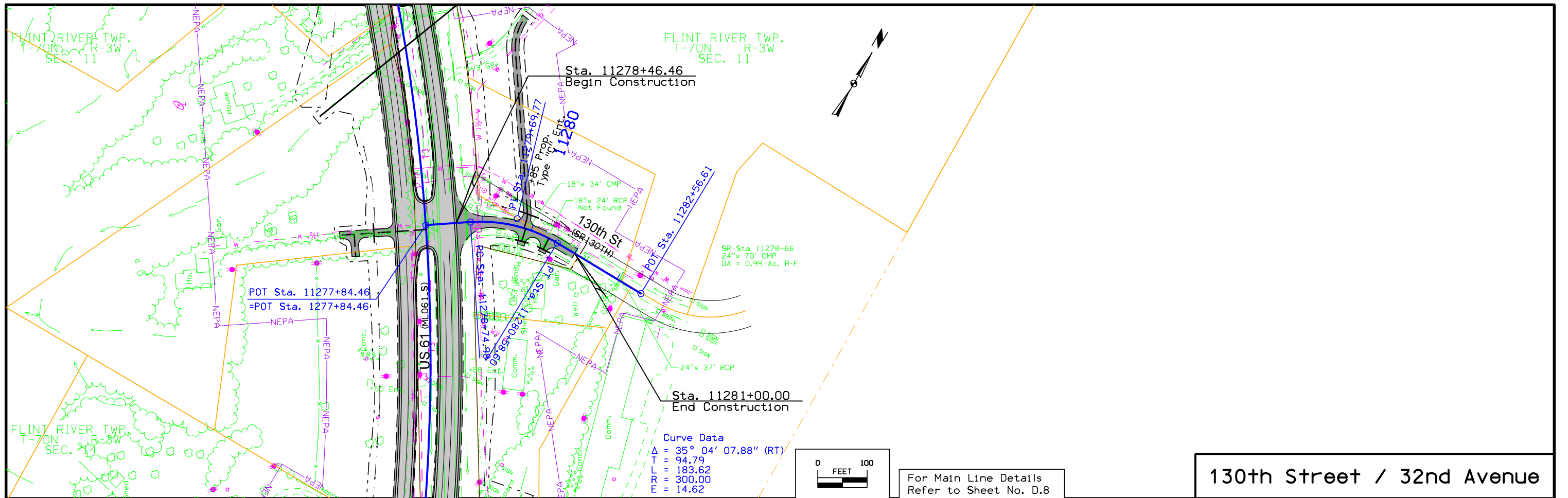

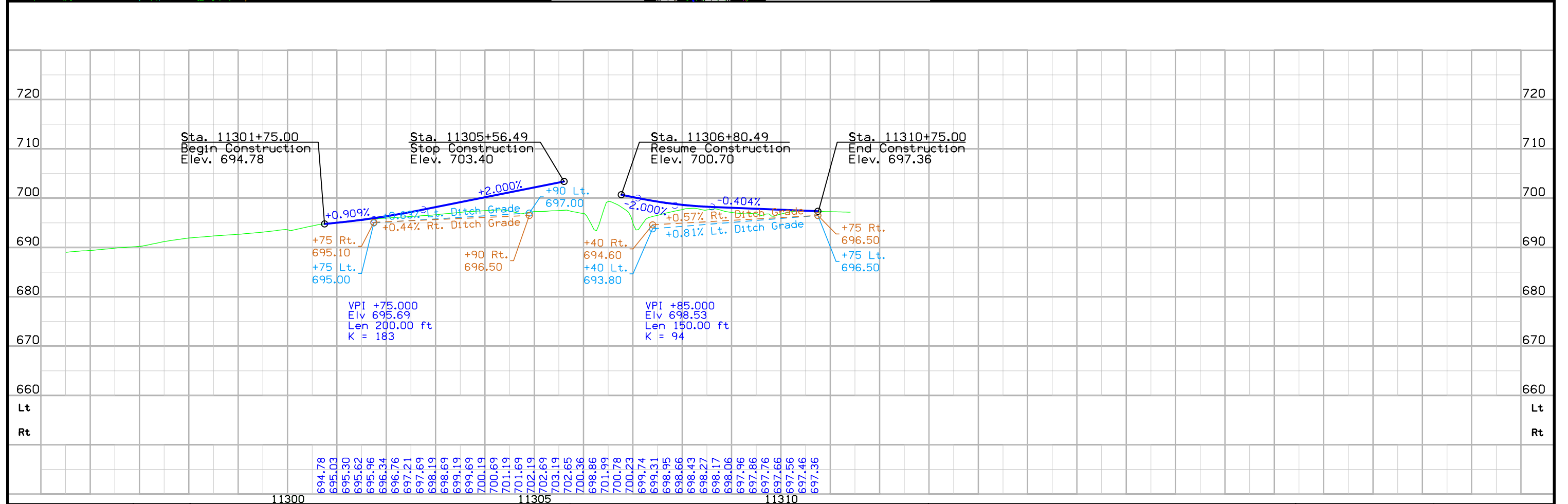
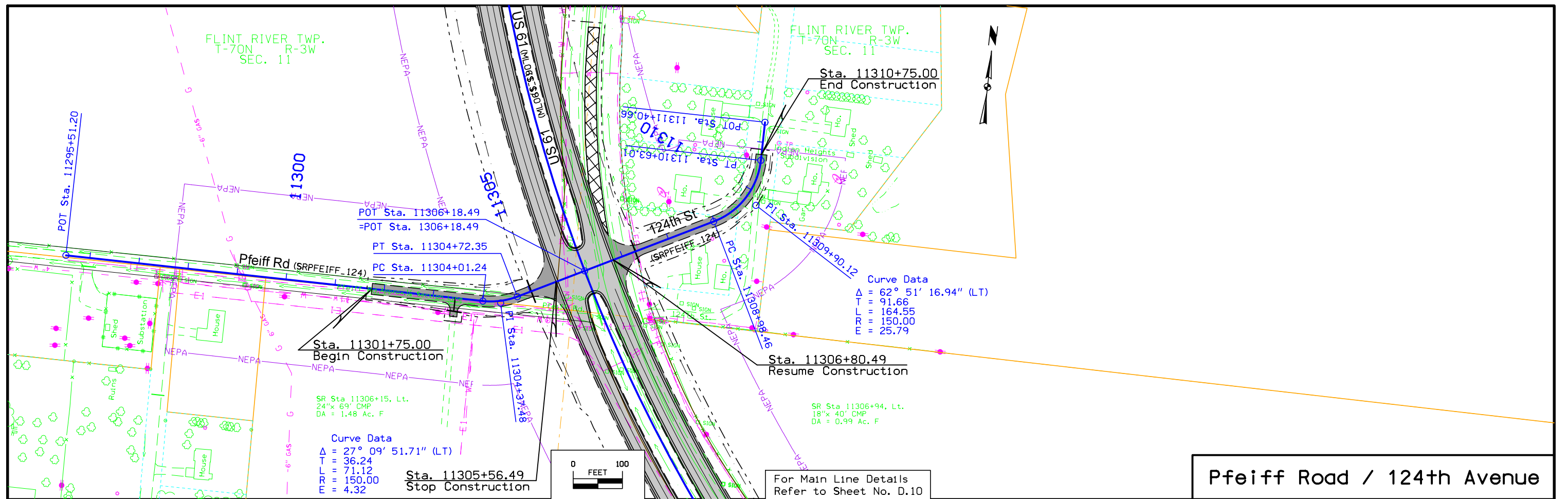

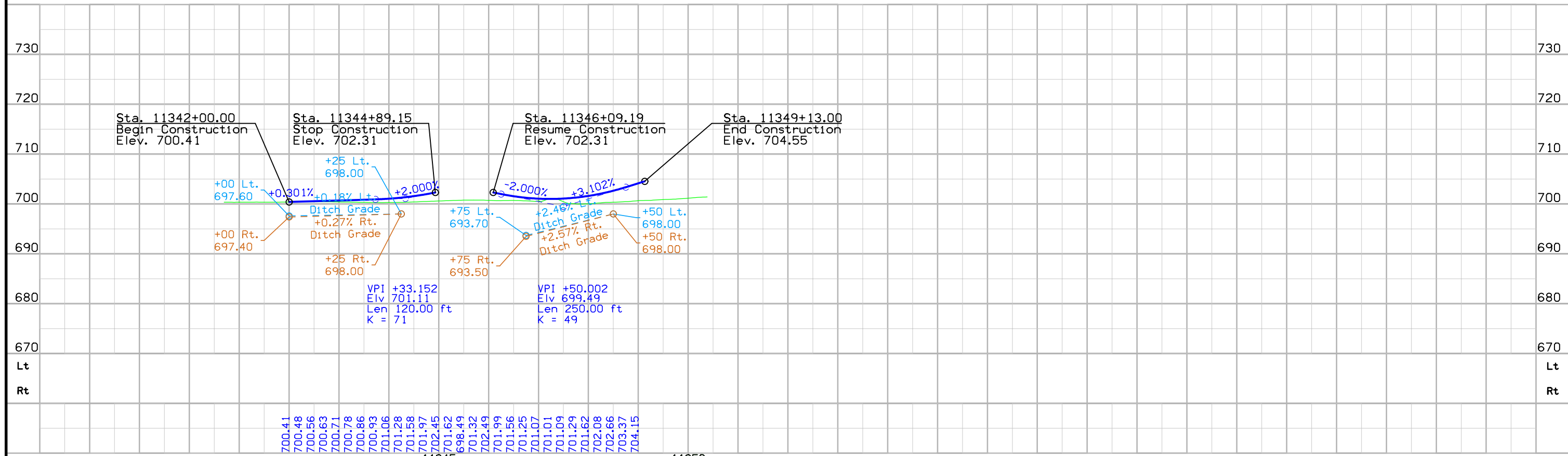
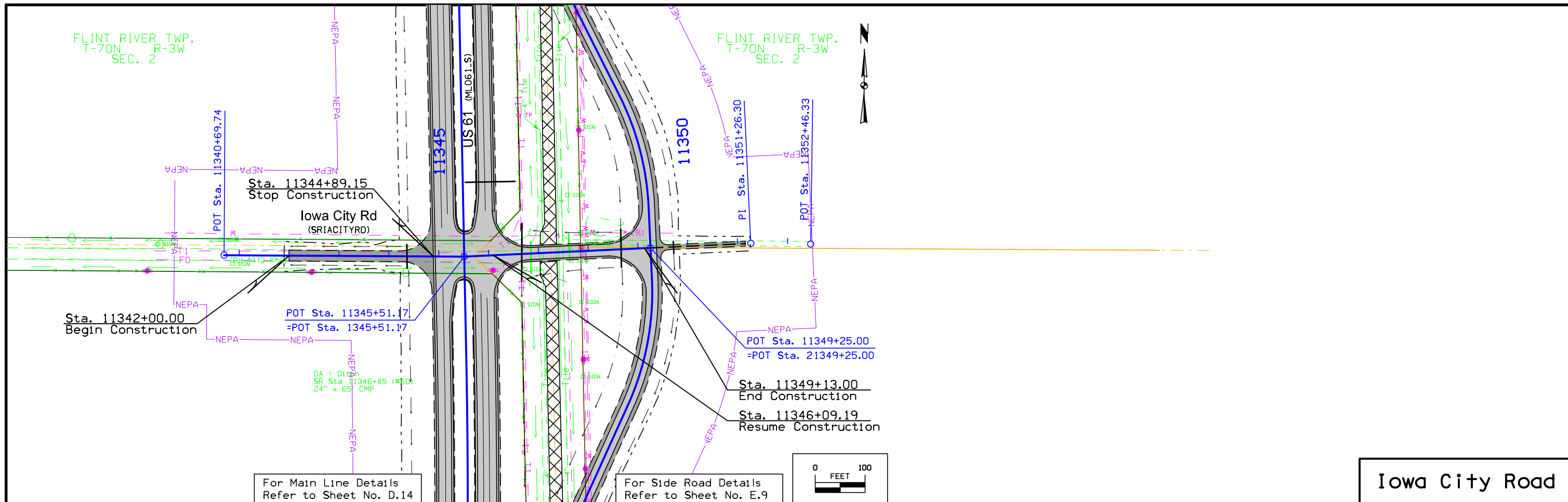

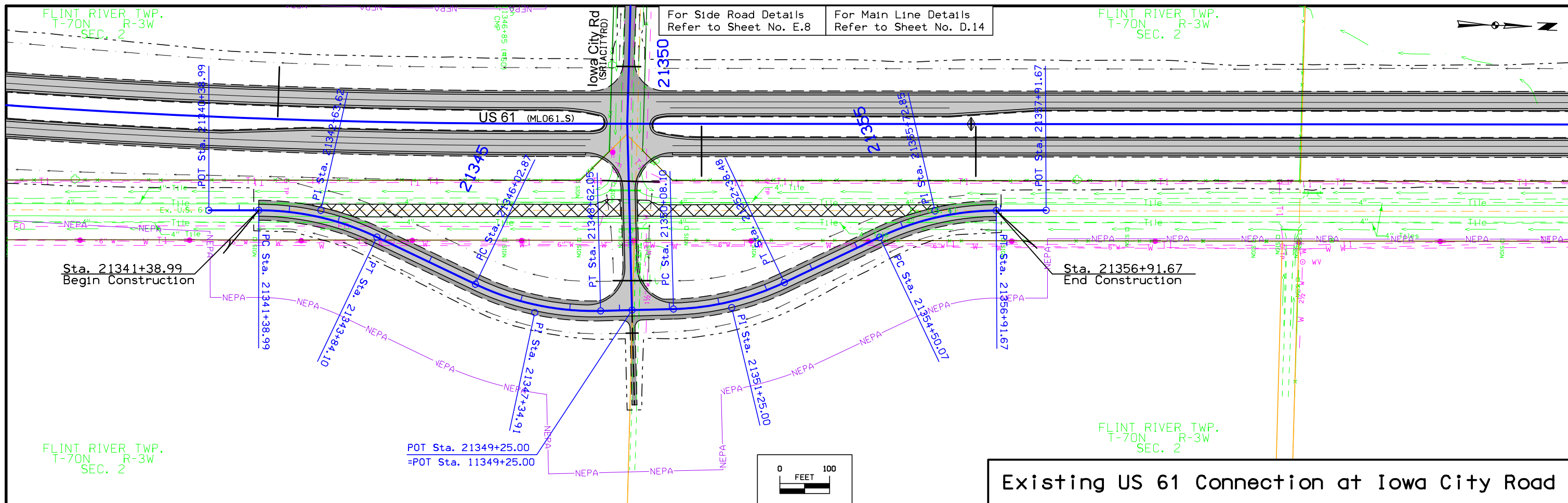

Existing US 61 Connection at Iowa City Road

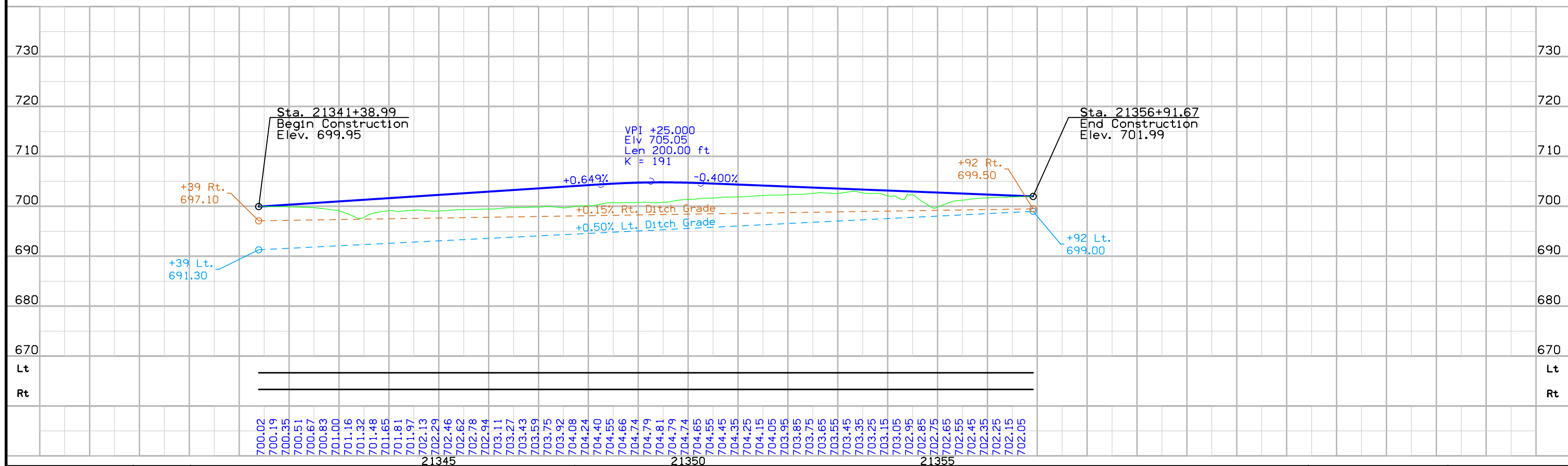

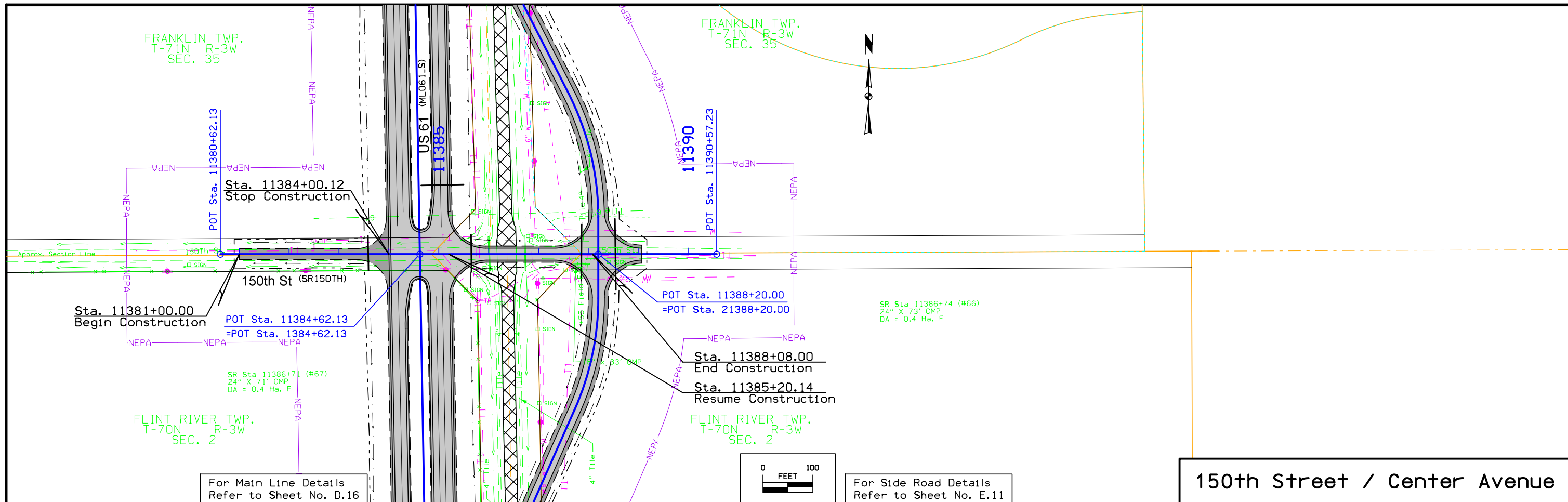

For Main Line Details
Refer to Sheet No. D.16

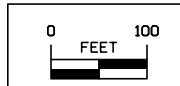

For Side Road Details
Refer to Sheet No. E.11

150th Street / Center Avenue

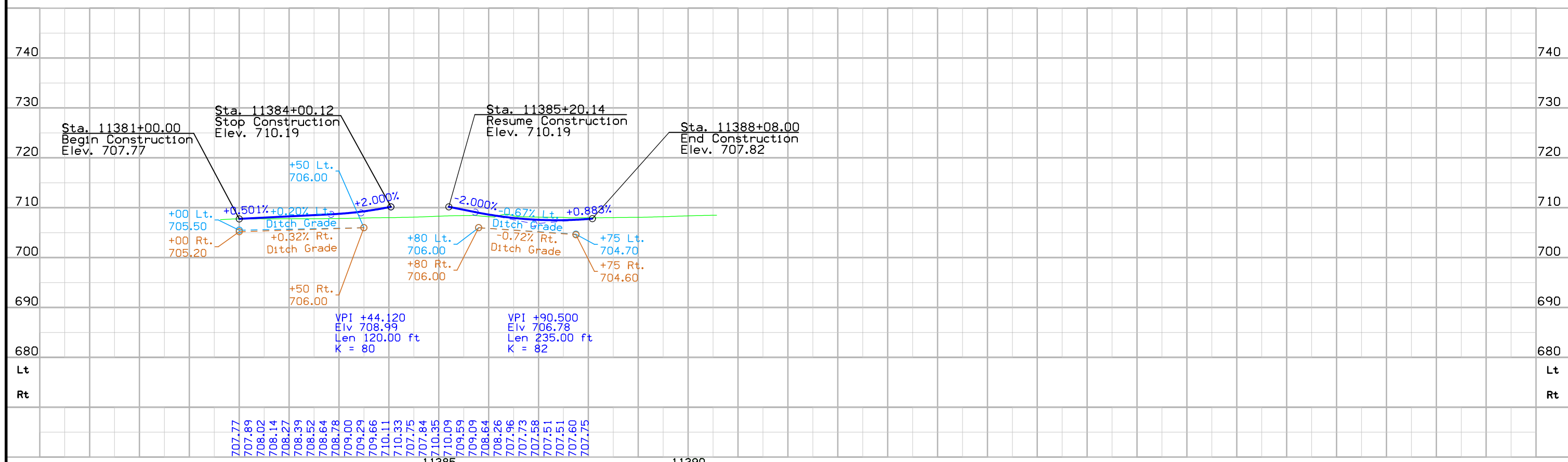

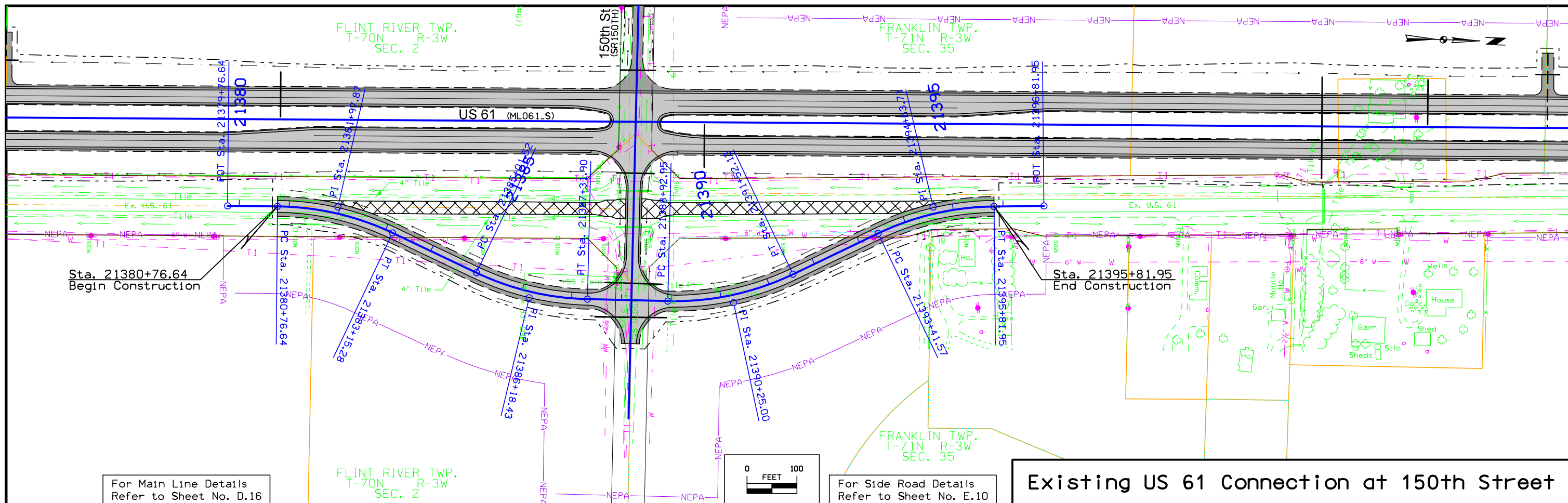

For Side Road Details
Refer to Sheet No. E.10

Existing US 61 Connection at 150th Street

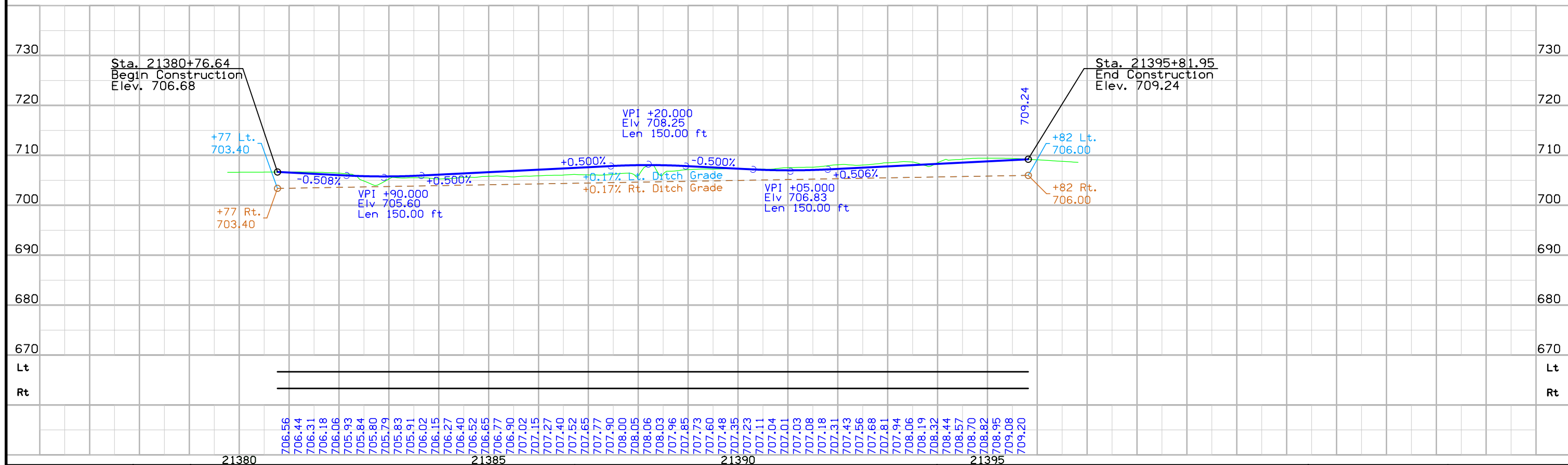

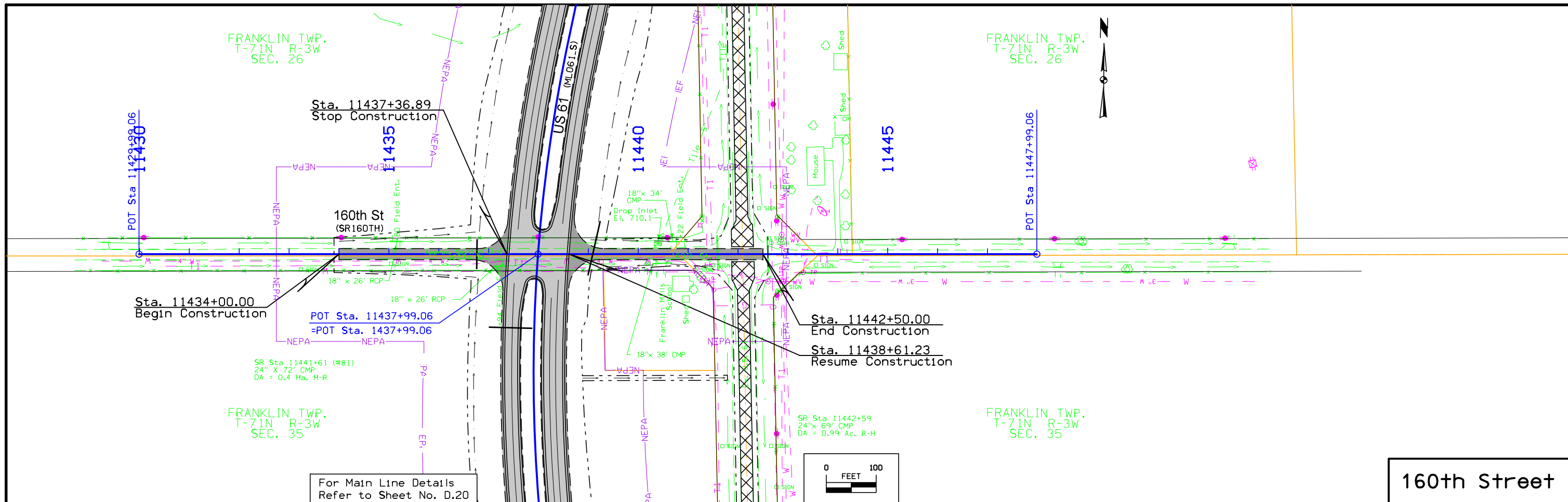

For Main Line Details
Refer to Sheet No. D.20

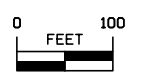

160th Street

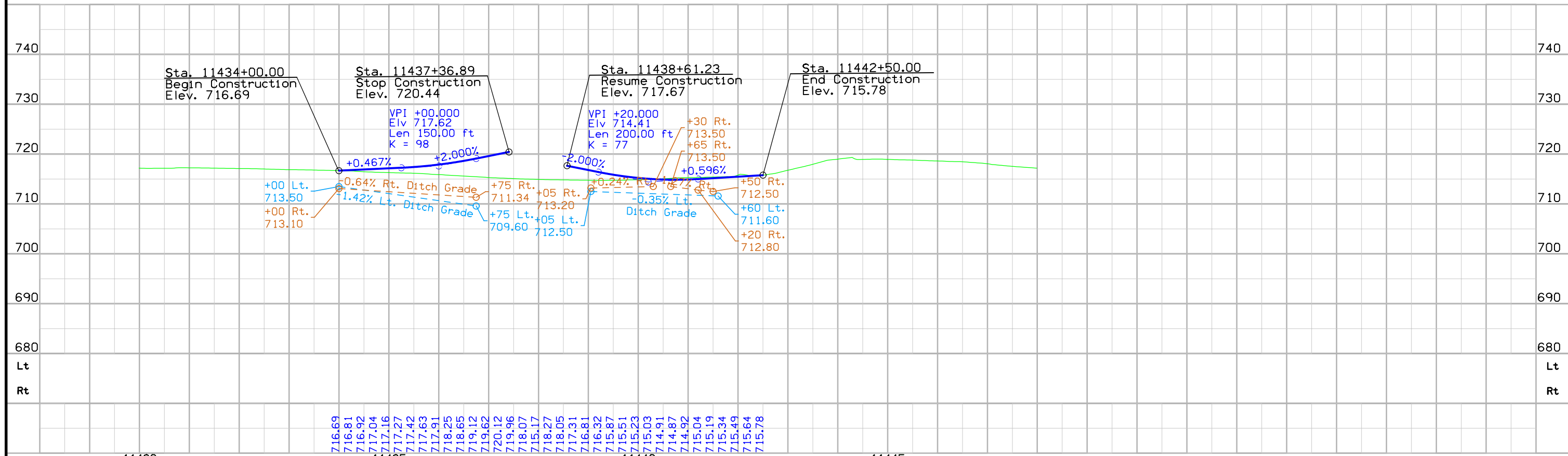

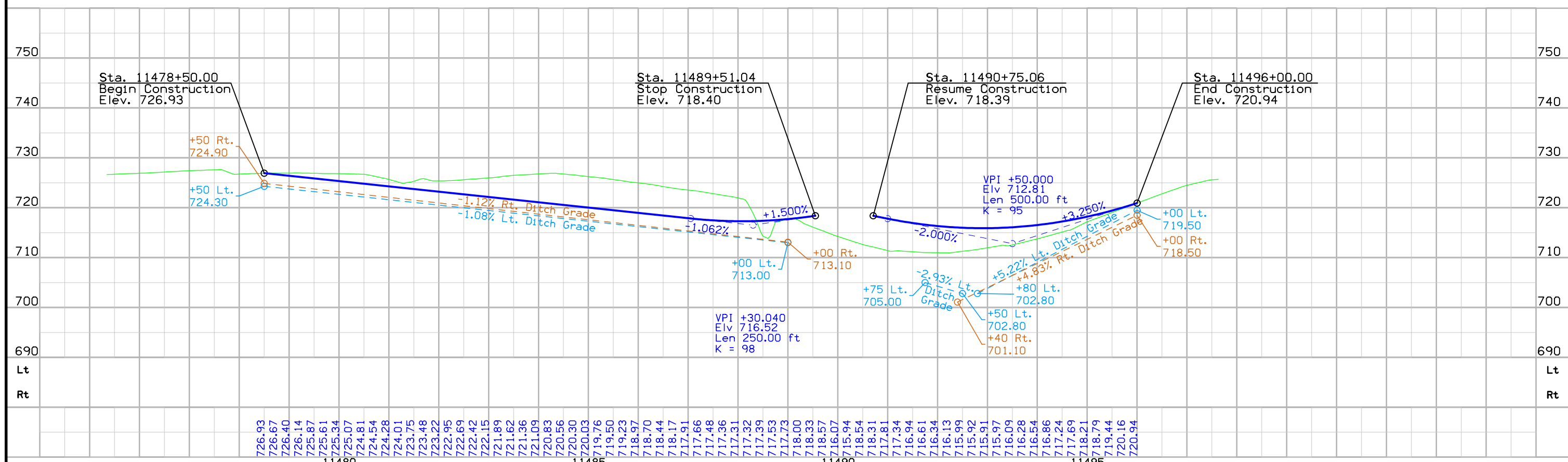
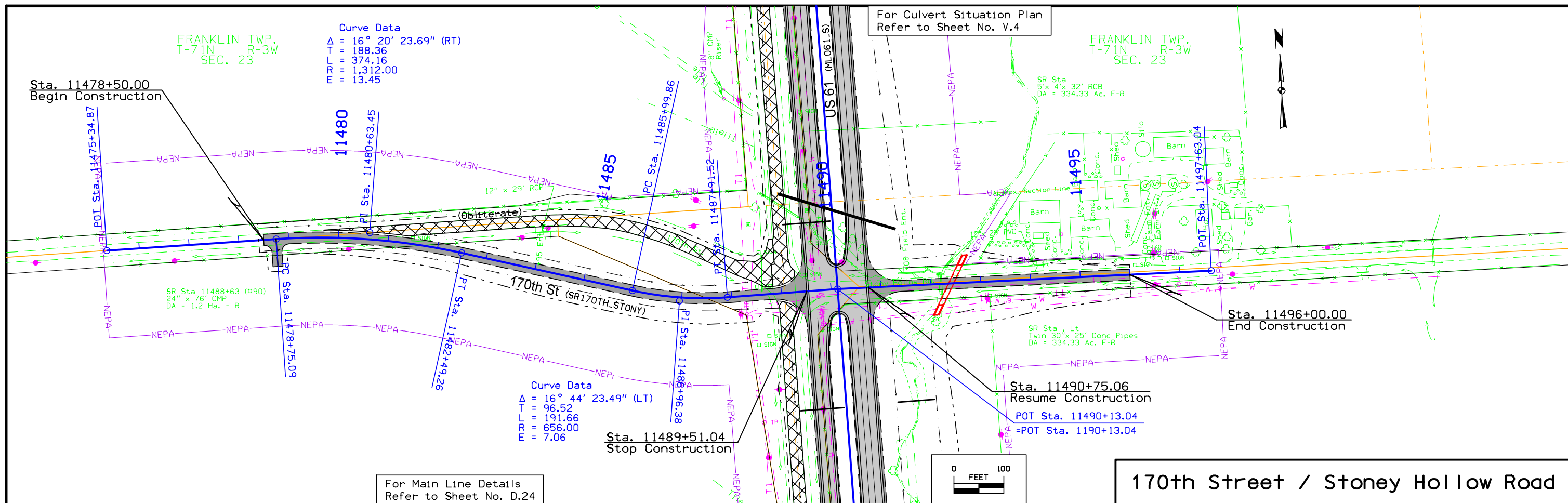

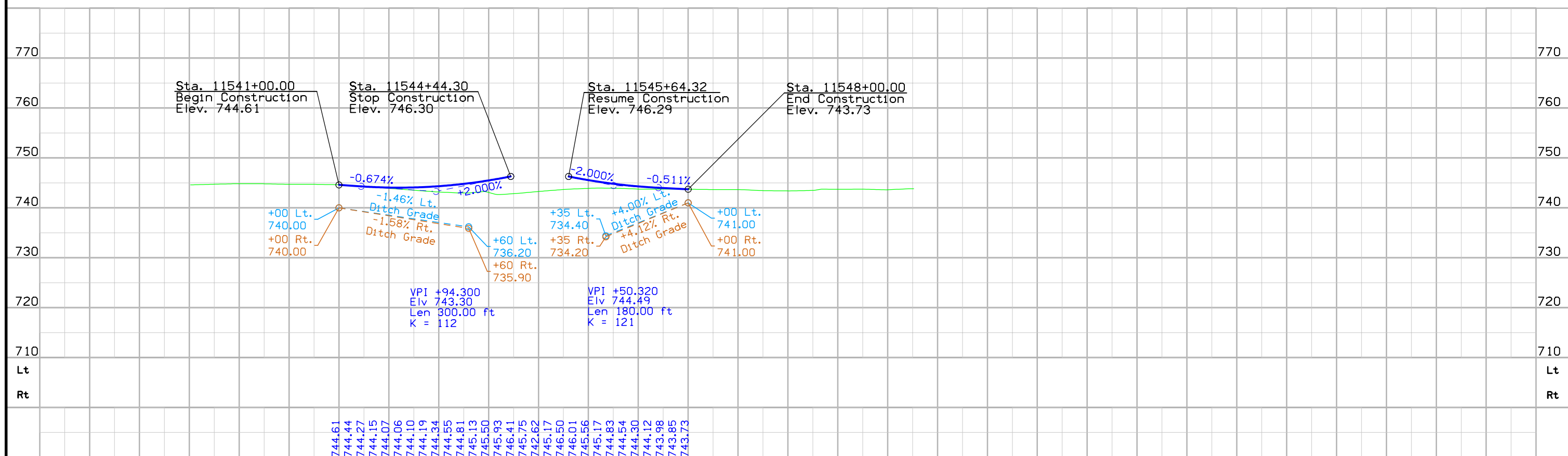
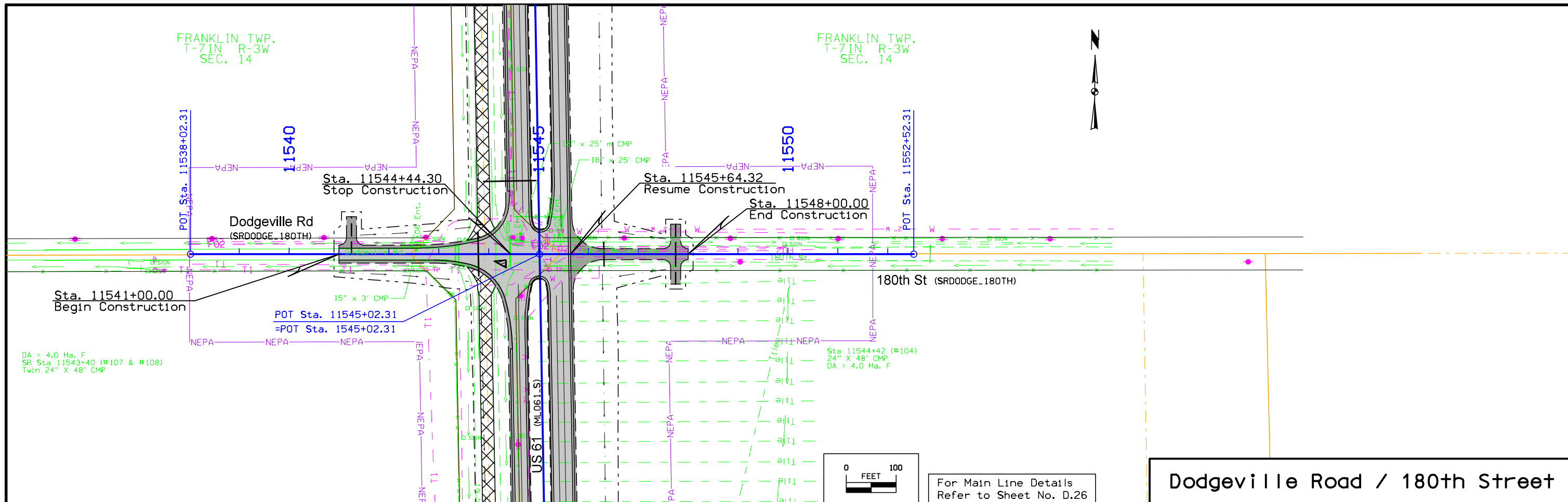

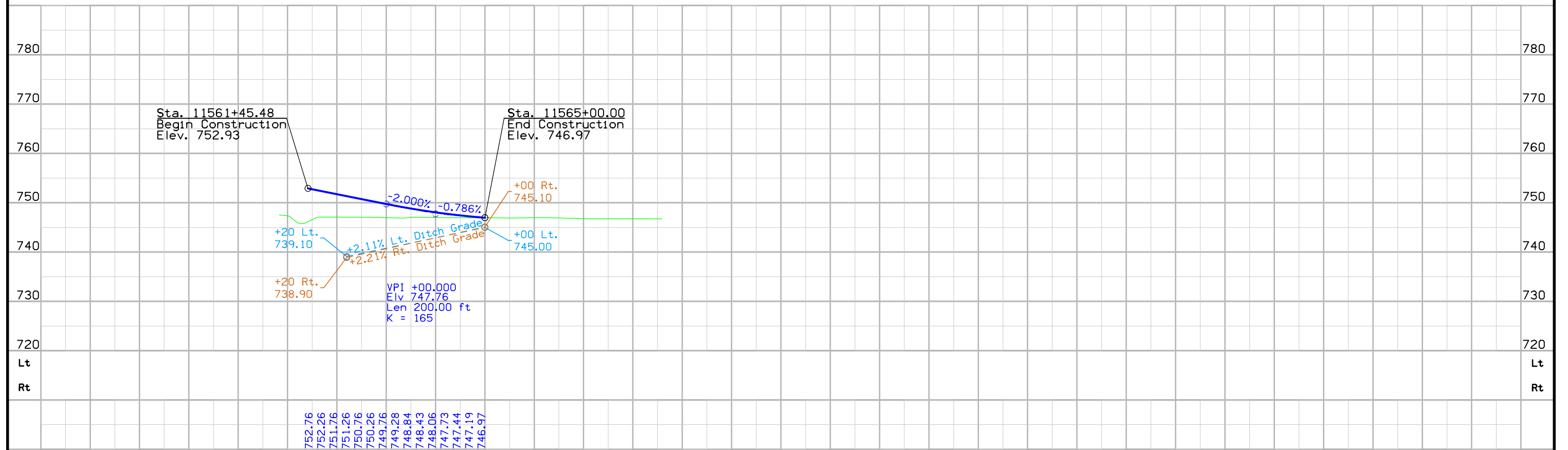
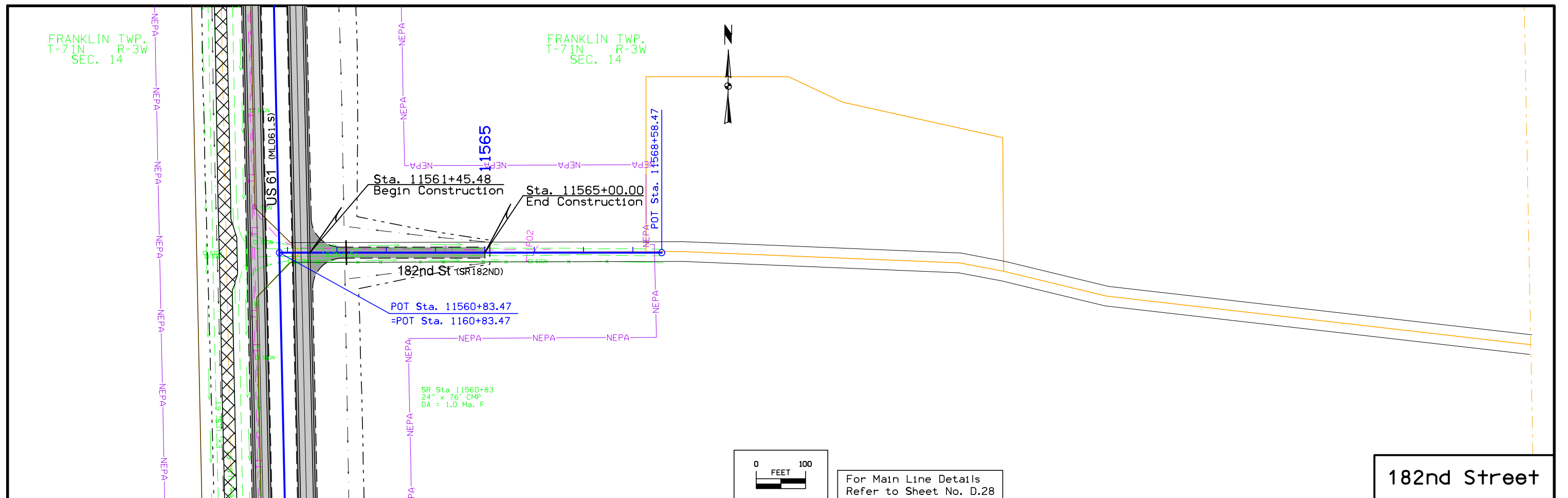

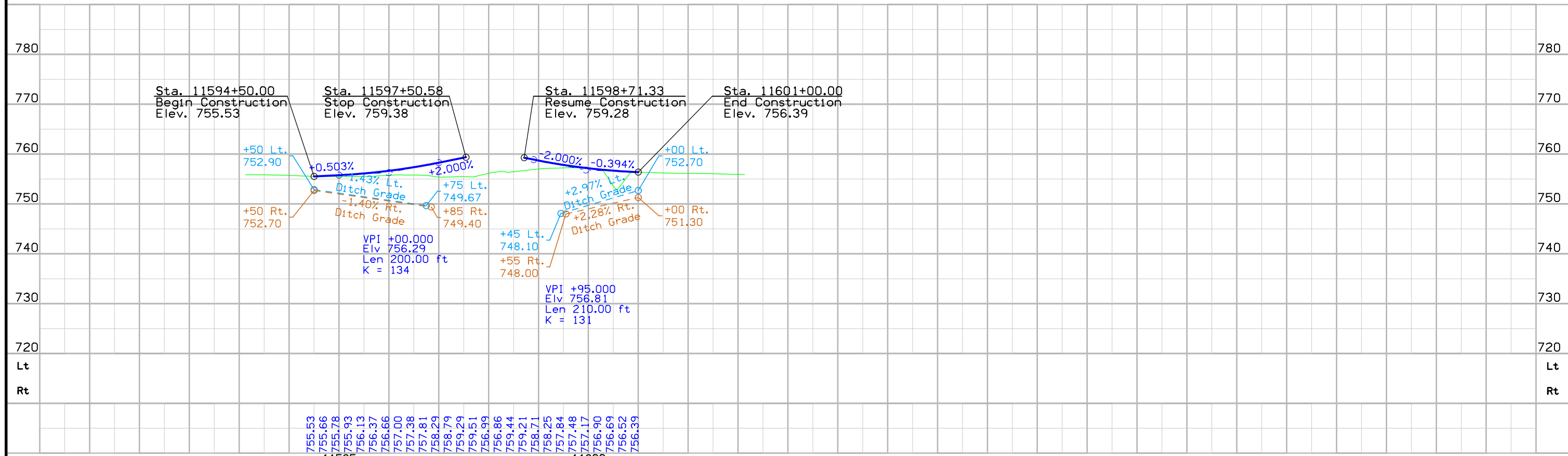
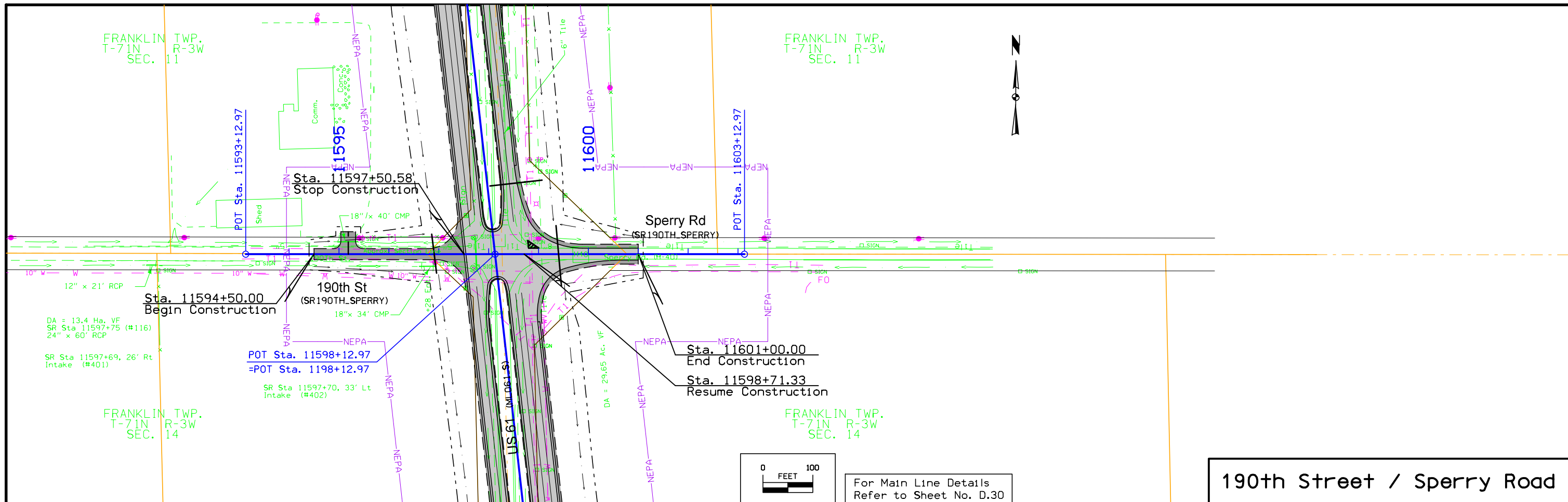

FRANKLIN TWP.
T-71N R-3W
SEC. 11

FRANKLIN TWP.
T-71N R-3W
SEC. 11

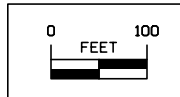
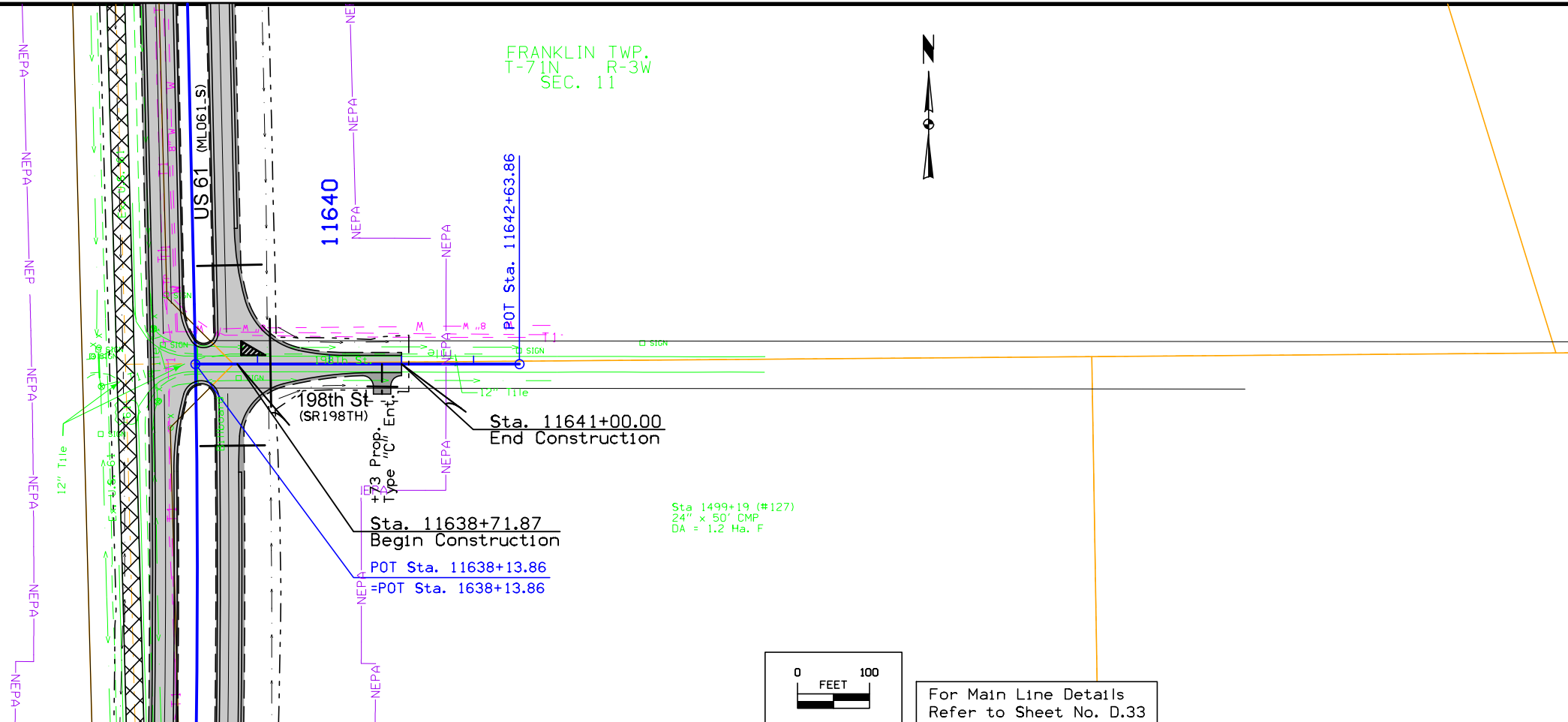

For Main Line Details
Refer to Sheet No. D.33

198th Street



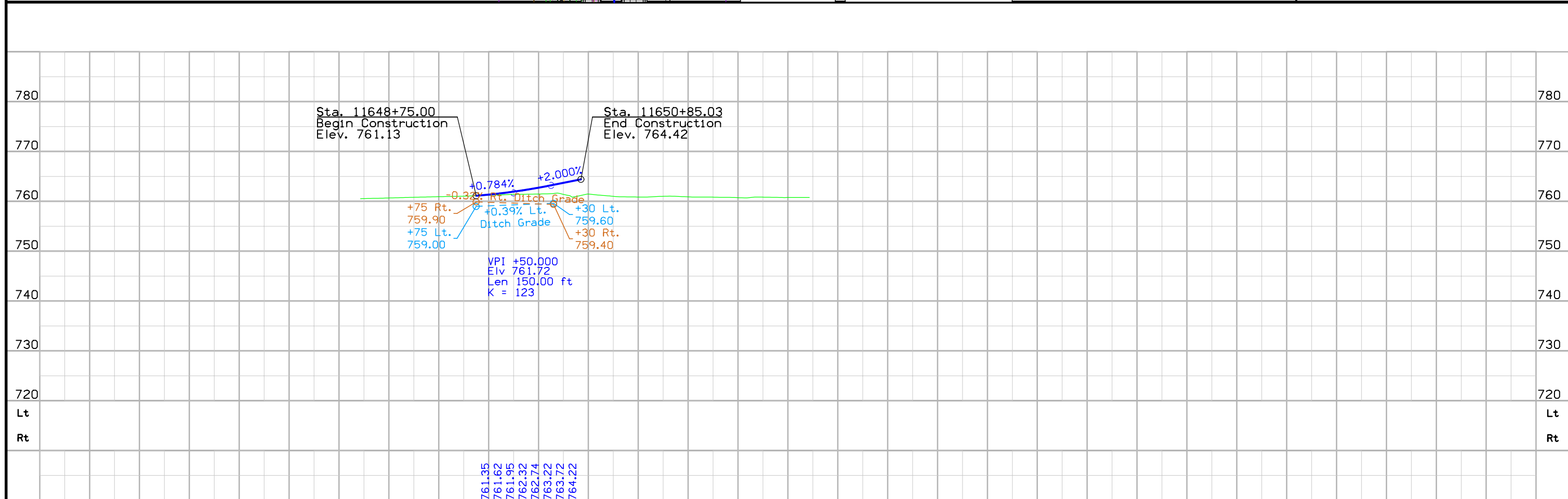
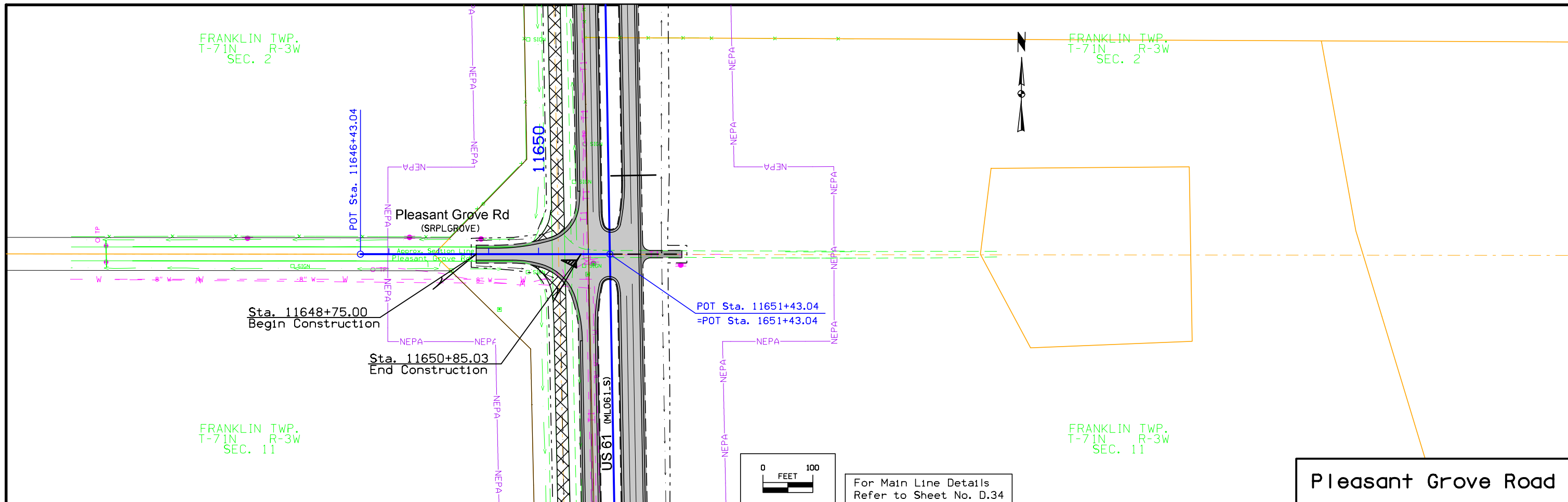

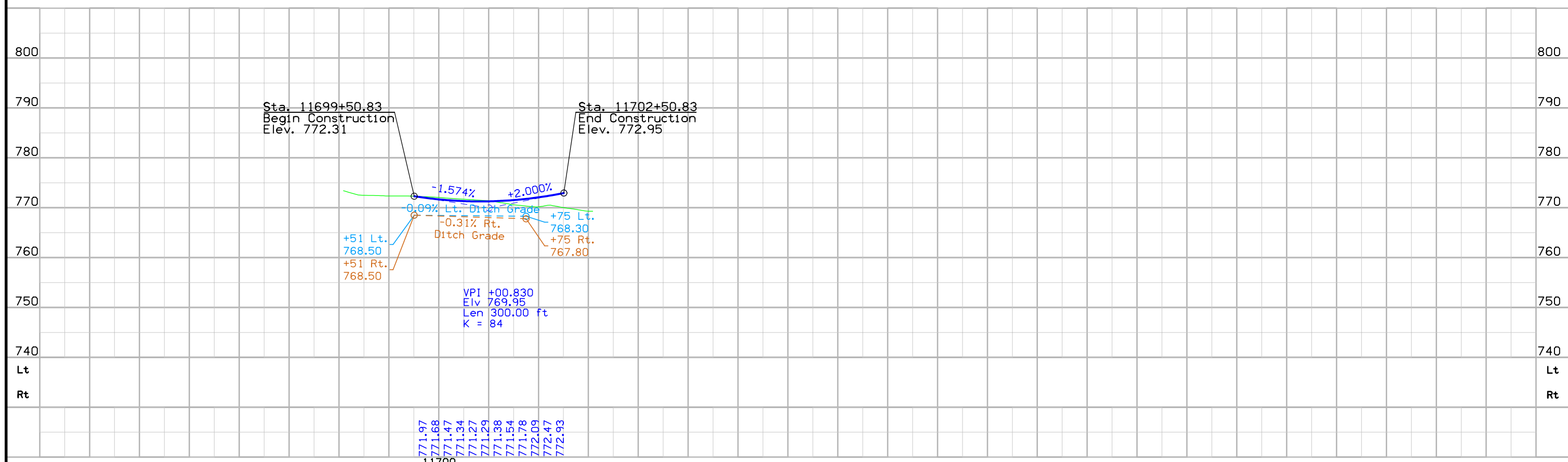
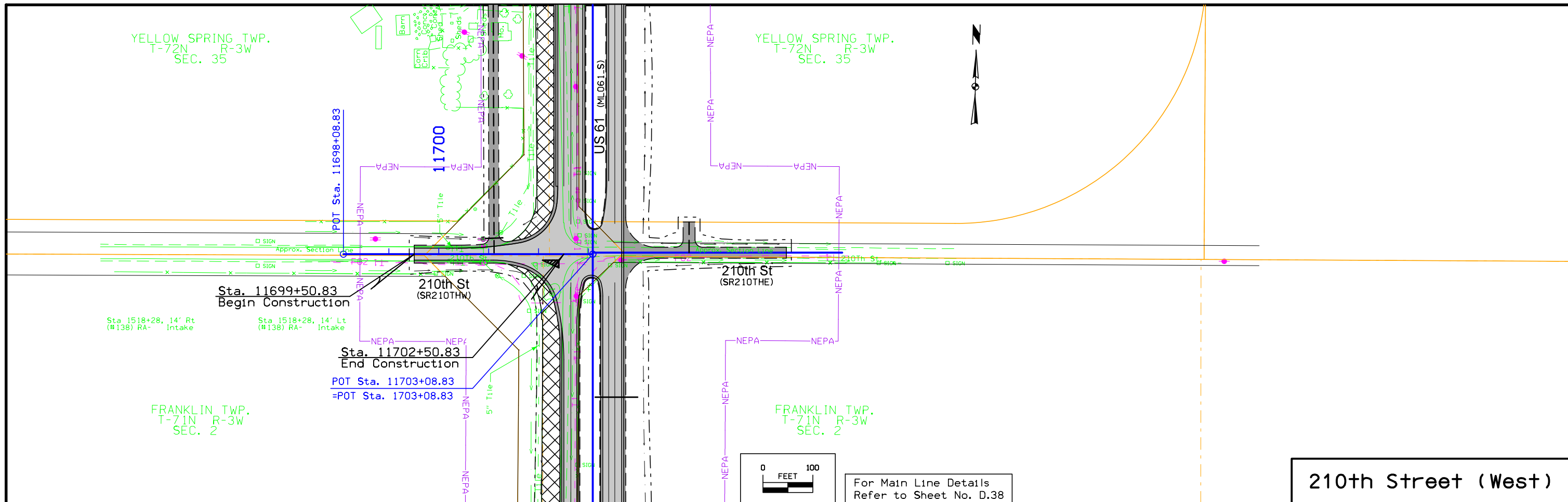

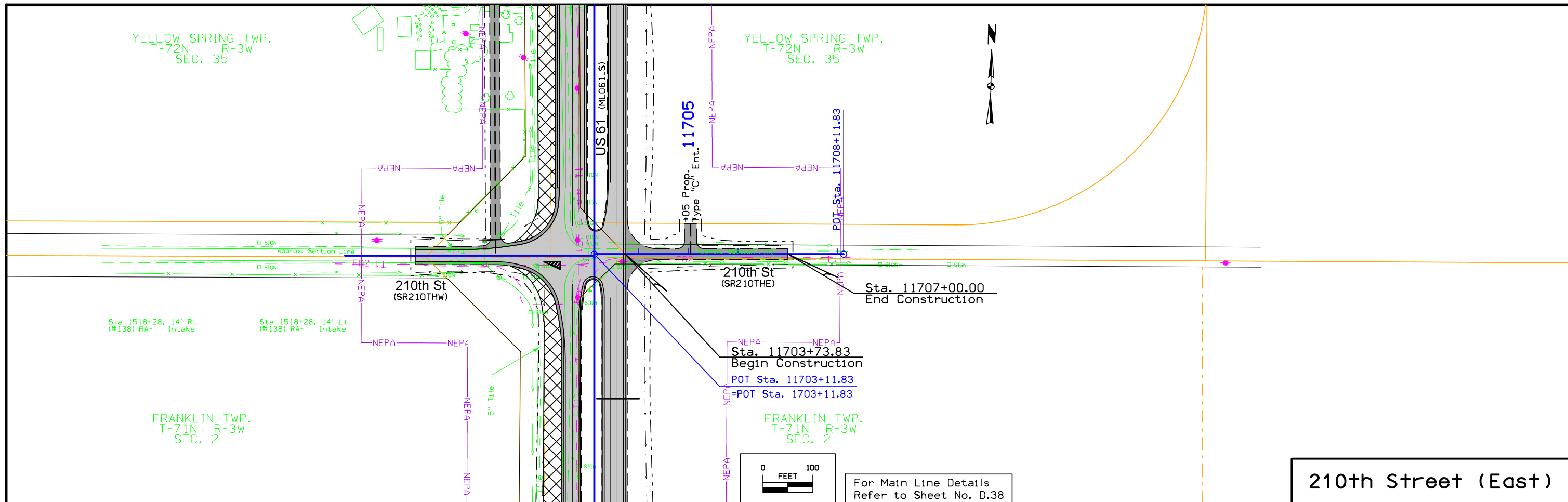

210th Street (East)

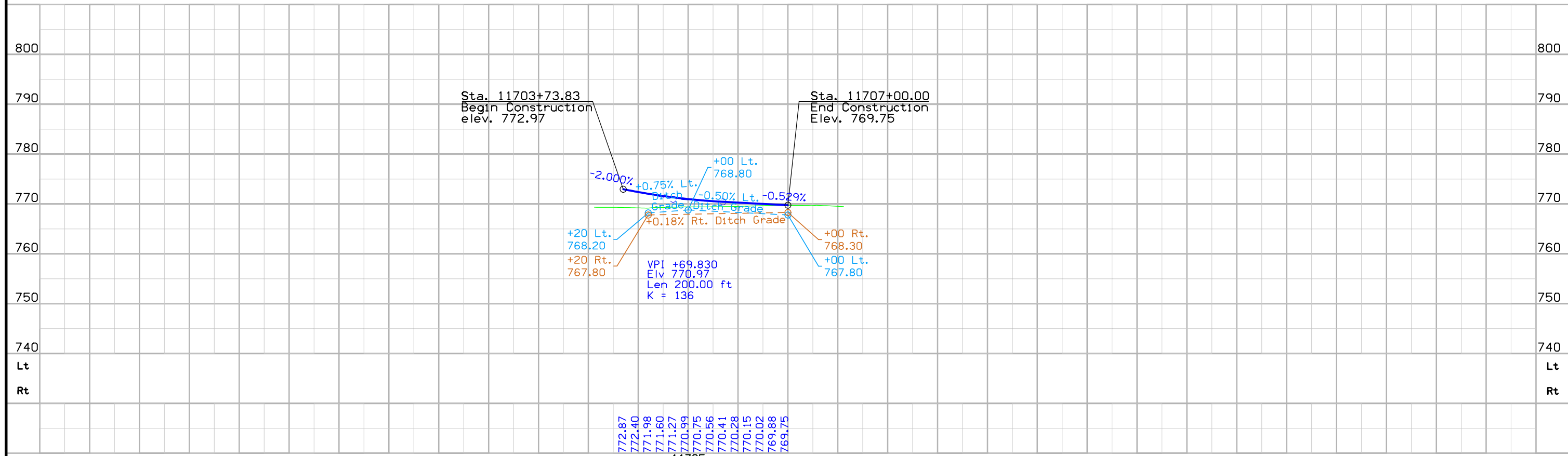

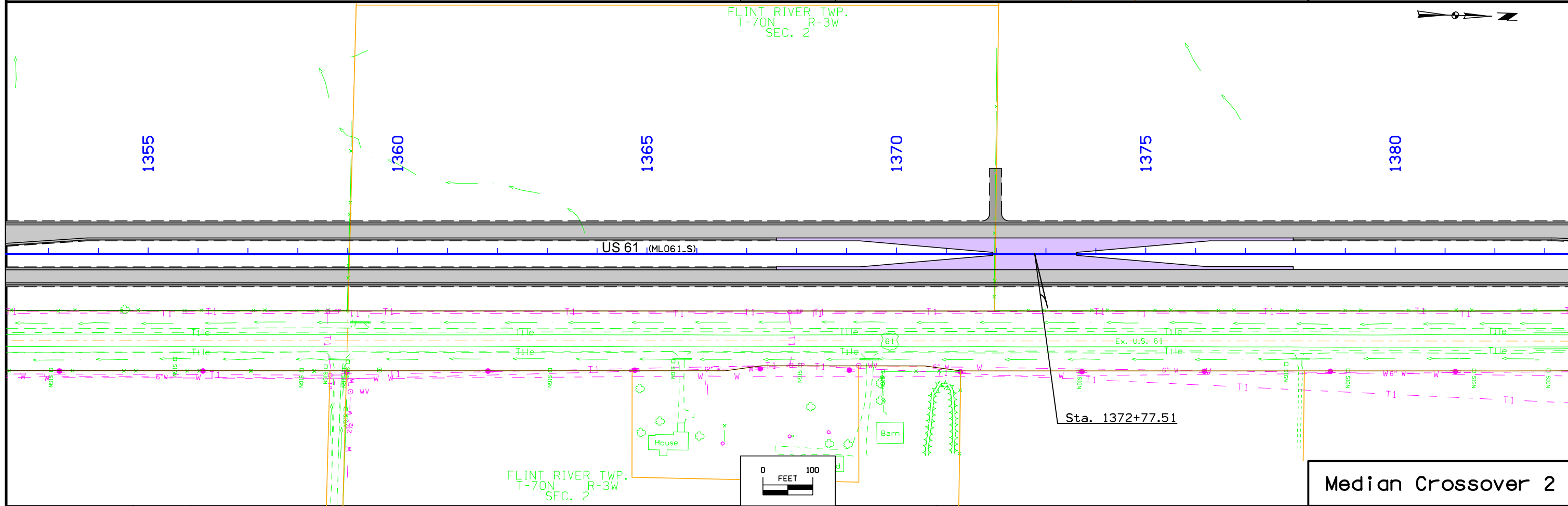
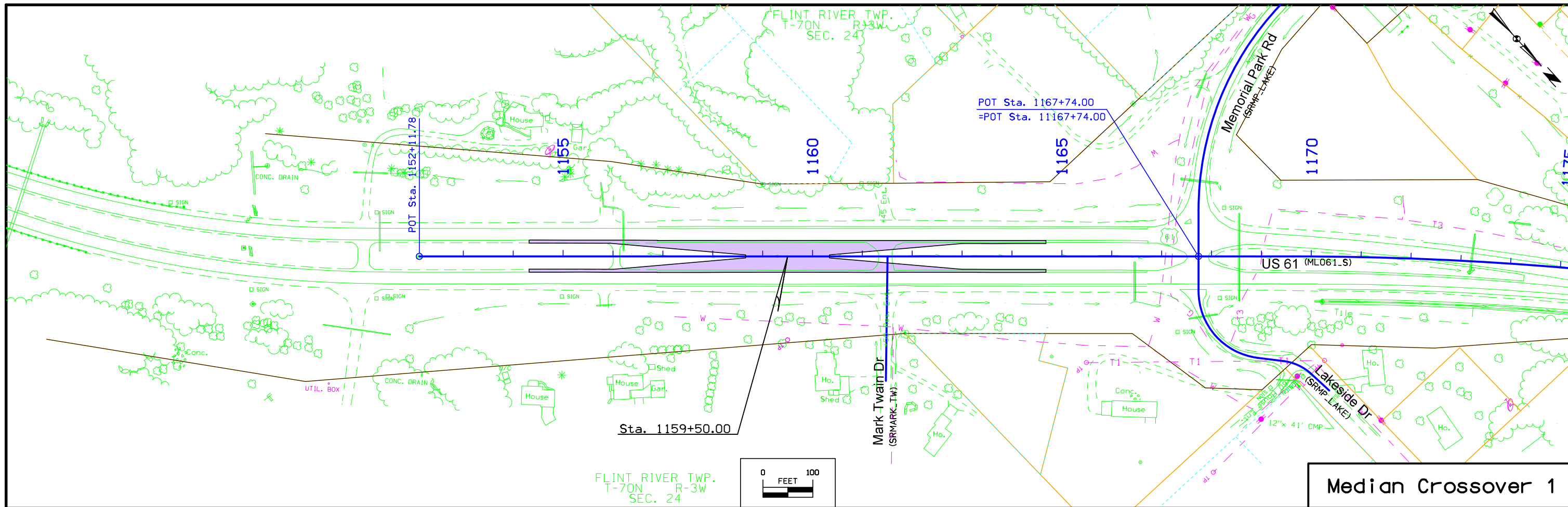

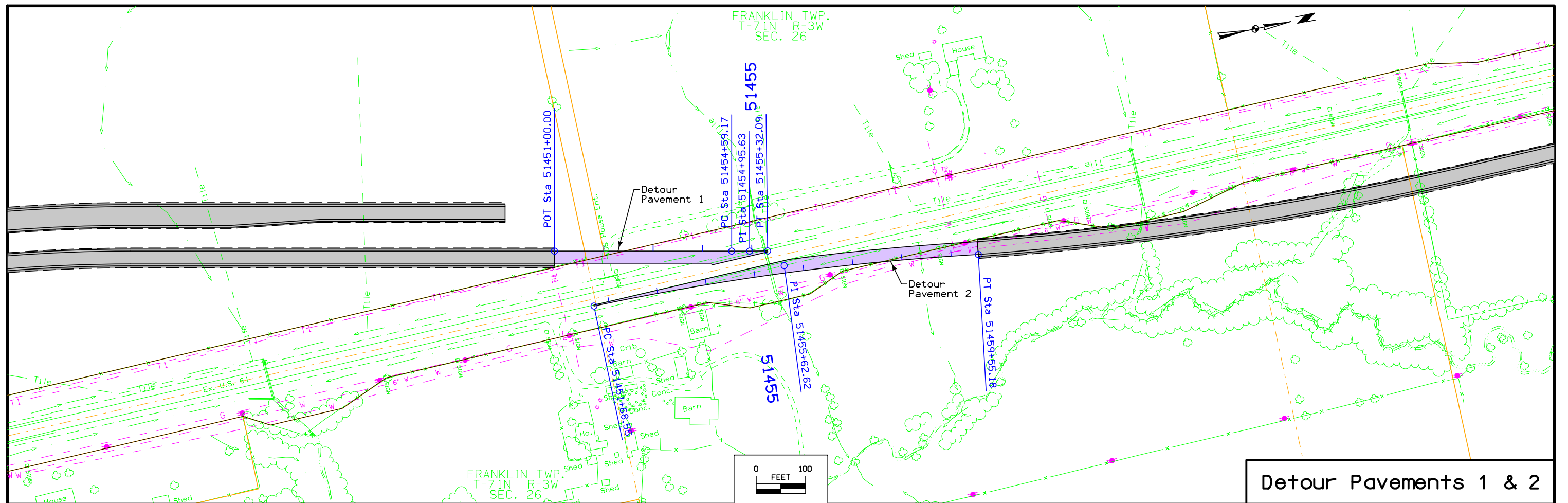

Detour Pavements 1 & 2

Detour Pavement 1

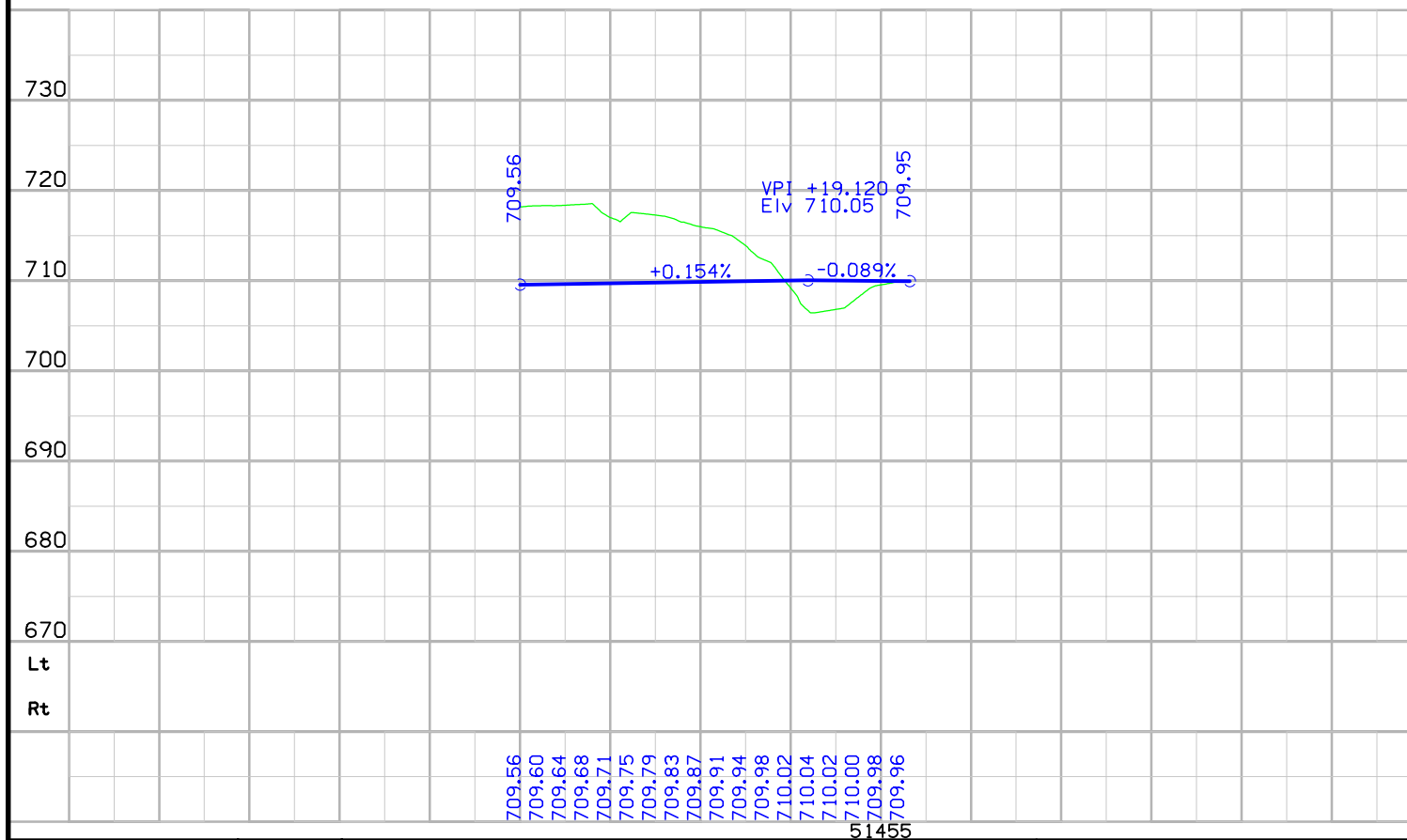

Detour Pavement 2

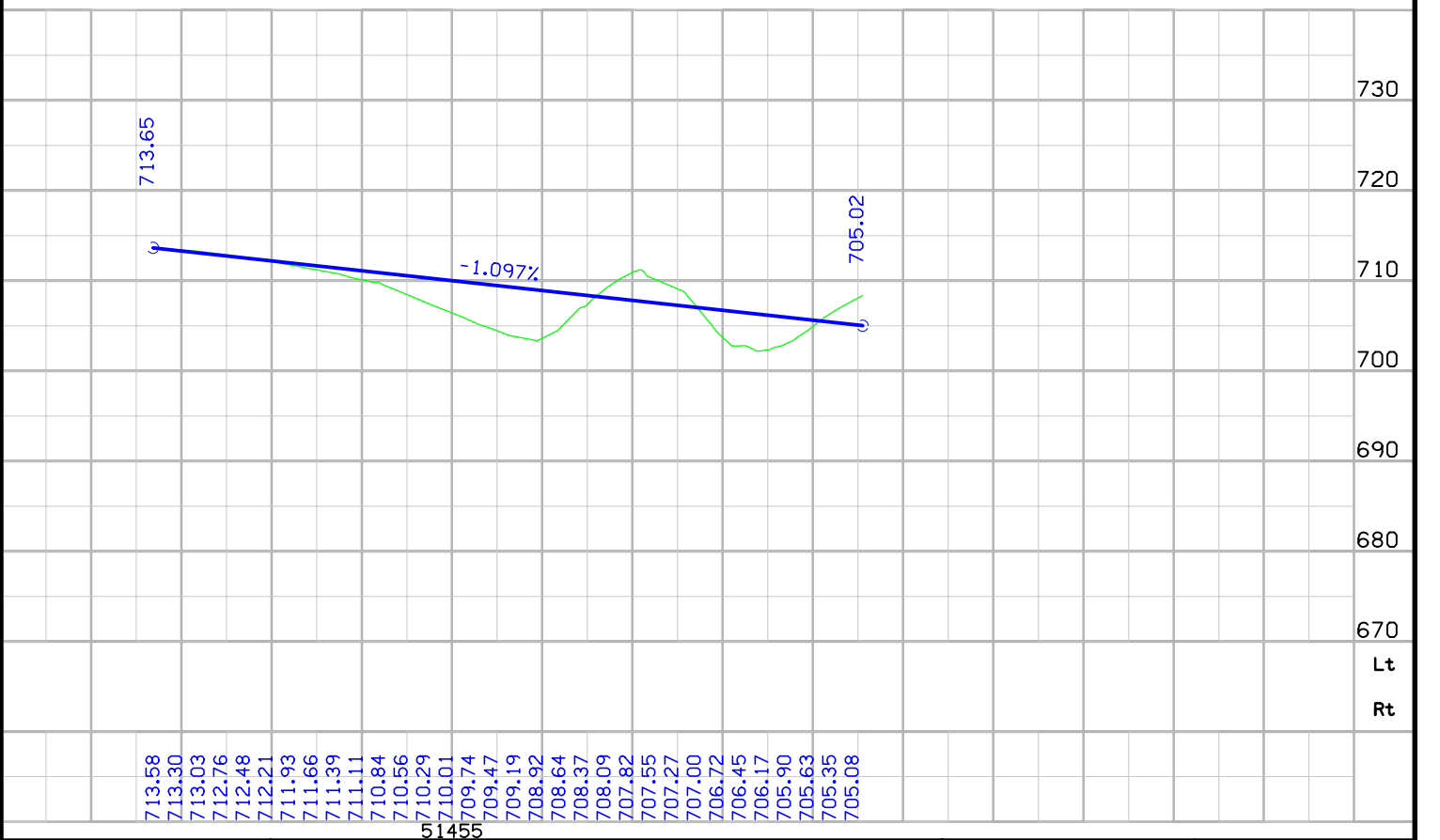

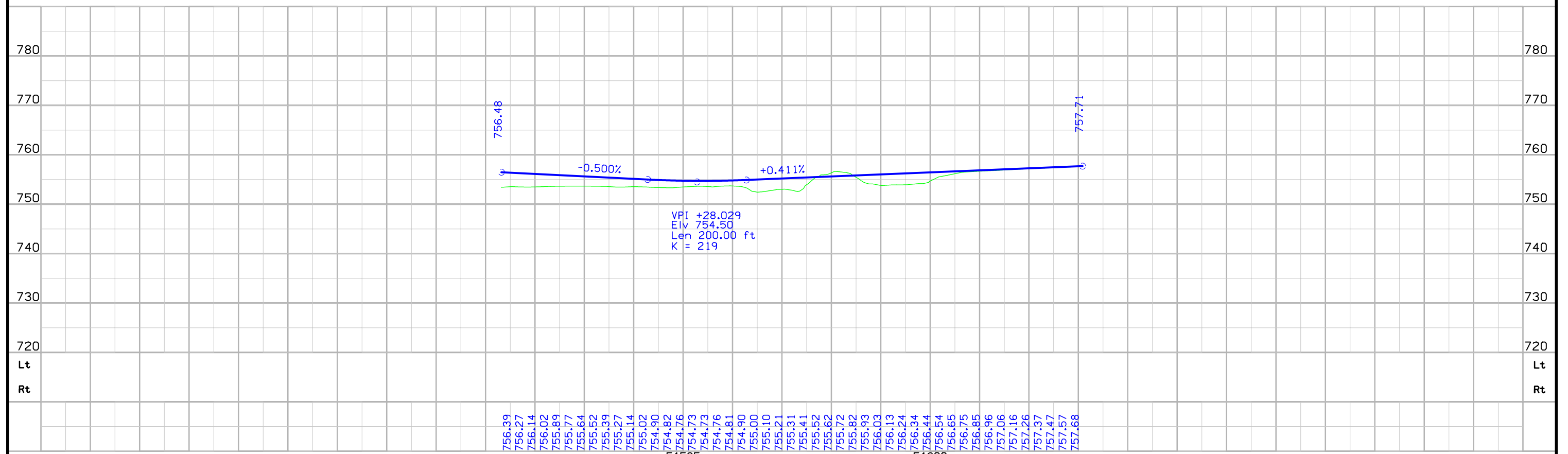
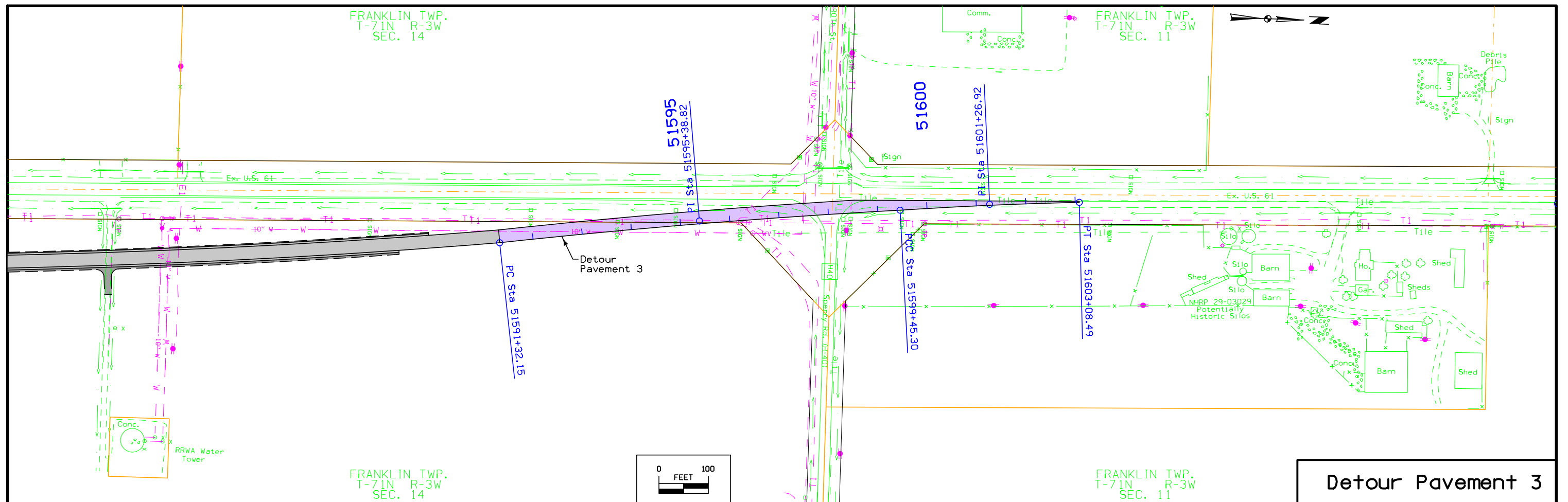

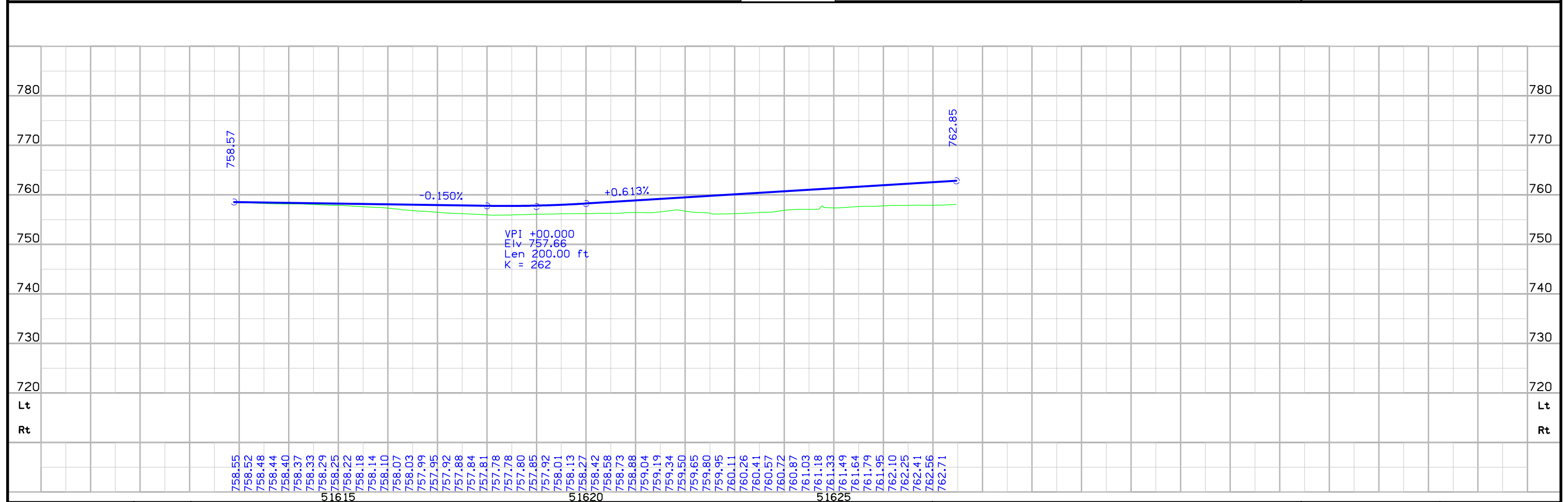
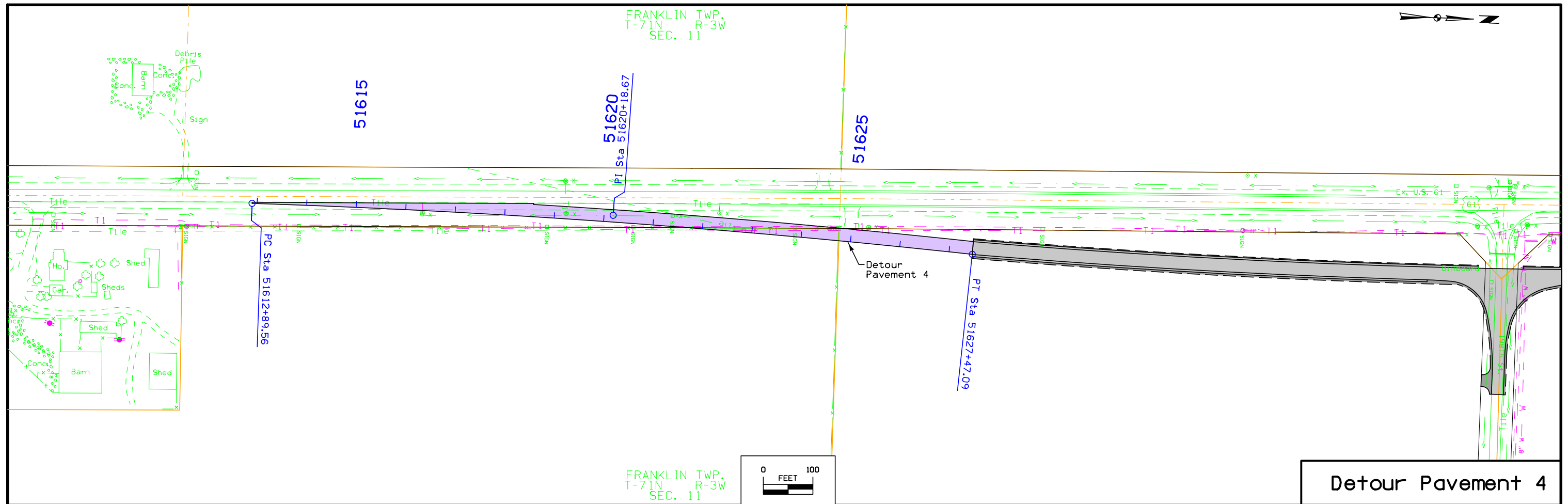

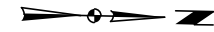

YELLOW SPRING TWP.
T-72N R-3W
SEC. 35

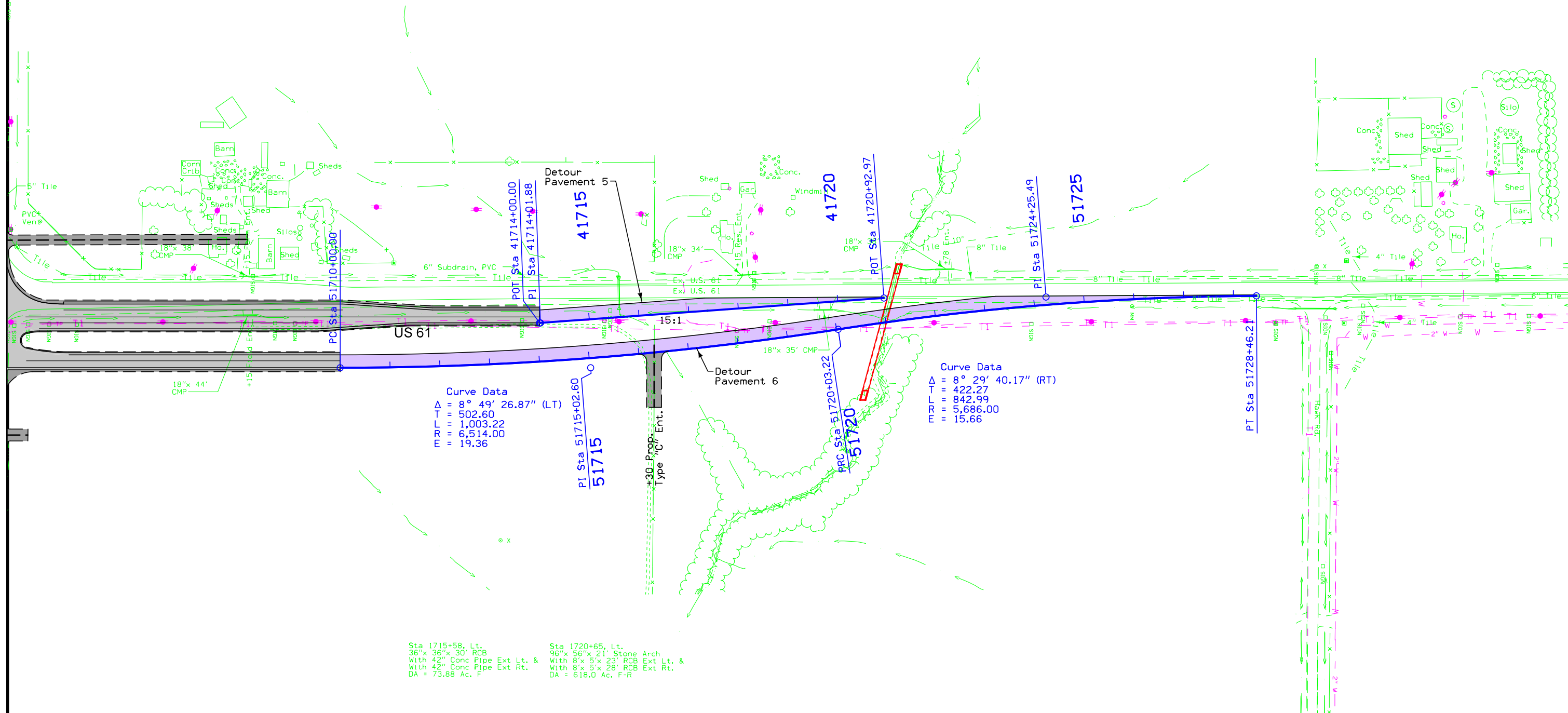

Curve Data
 $\Delta = 8^\circ 49' 26.87''$ (LT)
T = 502.60
L = 1,003.22
RR = 6,514.00
E = 19.36

Curve Data
 $\Delta = 8^\circ 29' 40.17''$ (RT)
T = 422.27
L = 842.99
RR = 5,686.00
E = 15.66

Sta 1715+58, Lt. 36"x 36"x 30' RCB
With 42" Conc Pipe Ext Lt. &
With 42" Conc Pipe Ext Rt. DA = 73.88 Ac. F

Sta 1720+65, Lt. 96"x 56"x 21' Stone Arch
With 8"x 9"x 23' RCB Ext Lt. &
With 8"x 9"x 23' RCB Ext Rt. DA = 618.0 Ac. F-R

YELLOW SPRING TWP.
T-72N R-3W
SEC. 35

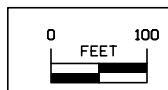

For Culvert Situation Plan
Refer to Sheets No. V.5 - V.6

Detour Pavements 5 & 6

US 61 Detour 5

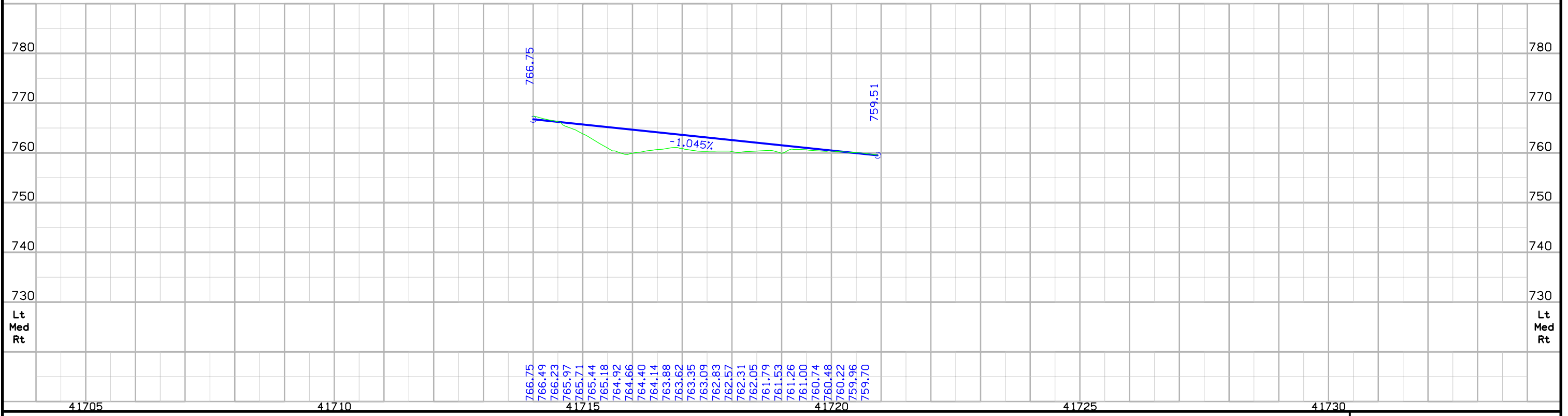

US 61 Detour 6

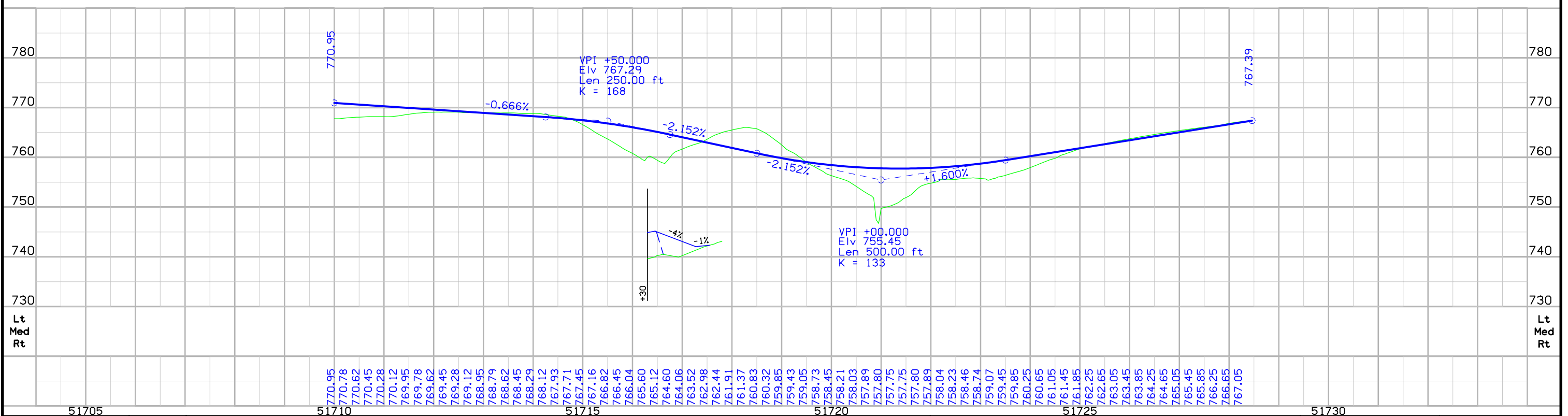

Survey Information

Horizontal Control -

Control Monuments used for this project consisted of 11 Des Moines County GPS Monuments and 2 Louisa County GPS Monuments. These monuments are all 5/8" diameter aluminum rods with 2.5" diameter aluminum caps encased in 5" diameter PVC pipes with aluminum access covers. All monuments were previously set as part of countywide GPS control networks. Each monument was observed for a minimum of two 5 minute RTK sessions, at differing times of day using the Iowa RTN as a reference station. The monuments completely surround the project area, are approximately 1 to 2 miles east or west of the existing US 61 alignment and are spaced 3 to 4 miles apart north and south. These monuments are considered to be in safe locations that will survive construction.

Control Points used for this project consisted of 80 iron pins that were previously set along the existing Highway 61 alignment. These points were used for the initial survey work completed in 1999 and recovered for the new survey work. An additional 3 iron pins were set to supplement the points recovered. Points are no more than 1300 feet apart and intervisible. All points were observed for a minimum of two 5 minute RTK sessions, at differing times of day using the Iowa RTN as a reference station.

All Control Monuments and Control Points were referenced to at least three durable physical objects and complete sketches were made in the field notes.

GPS Horizontal Errors	Mean Error of Observations	0.034
	Standard Deviation of Error	0.021

Coordinate System -

The coordinate system used is NAD83(CORS) (Epoch 2002.00) Iowa State Plane, South Zone, U. S. Survey Feet. The 13 Control Monuments were used to compute an average scale factor for the project area to convert from grid distances to ground distances. After applying the scale factor, a shift was applied to hold a central point in the job at true state plane coordinate values.

A sample of these initial coordinate values was compared to the coordinates from the previous work. This resulted in a scale difference of 0.62' over the entire length of the project or approximately 0.03' per mile. To ensure all previous work would merge seamlessly with the new work, the average scale factor initially computed was adjusted to correct the difference. The shift was also recomputed to better fit the previous work.

Final Scale and Shift Parameters-	Scale Factor	0.99992280532
	Northing Shift	-27.7970
	Easting Shift	-176.3040

Vertical Control -

The vertical datum used is NAVD88. Benchmarks for this project consisted of 82 benchmarks that were previously established along the existing Highway 61 alignment. These were used for the initial survey work completed in 1999 and recovered for the new survey work. An additional 21 benchmarks were established to supplement the ones recovered. Benchmarks are spaced no more than 1300' apart.

The levels were started at an offsite benchmark, run to the job just North of the BOP and then run along the existing US 61 corridor. Side legs were added as necessary. The levels were run through all control points and all benchmarks. The levels were closed out on 2 separate offsite benchmarks. The levels were run in approximately 0.5 to 1 mile segments, each segment was closed back on its starting point at the end of each day.

The original benchmark used at the South end of the project in 1999 was not found. However, Des Moines County notes were found where this benchmark had been transferred to another location. We started our leveling at this point, MW#701. The closing benchmarks were NGS N126, point MW#725 and a USGS monument 20RWM, point MW#730. This USGS monument was also used in 1999 for the previous work.

The average closure error was 0.014' over 32 looped segments. All looped segments were left unadjusted. Holding the Des Moines County elevation value of the starting benchmark MW#701 resulted in a closure of +0.08' on both NGS N126, MW#725 and USGS monument 20RWM, MW#730. A comparison of the 1999 benchmark elevations and the new elevations showed an average difference of +0.085' using 51 common points that should have held stable since the previous work was done.

Assuming that the starting benchmark elevation was in error and based on the above information all computed elevations were adjusted by -0.08 to better match the 2 closing benchmarks and the benchmarks previously used on this project.

HORIZONTAL CONTROL

Table with 5 columns: Point, North, East, Elevation, Description. Contains 129 rows of control point data.

HORIZONTAL CONTROL (CONT.)

Table with 5 columns: Point, North, East, Elevation, Description. Contains 3 rows of control point data.

VERTICAL CONTROL

Table with 5 columns: Point, North, East, Elevation, Description. Contains 68 rows of vertical control data.

VERTICAL CONTROL (CONT.)

Table with 5 columns: Point, North, East, Elevation, Description. Contains 20 rows of vertical control data.

HORIZONTAL CONTROL MONUMENTS

Table with 5 columns: Point, North, East, Elevation, Description. Contains 13 rows of monument data.

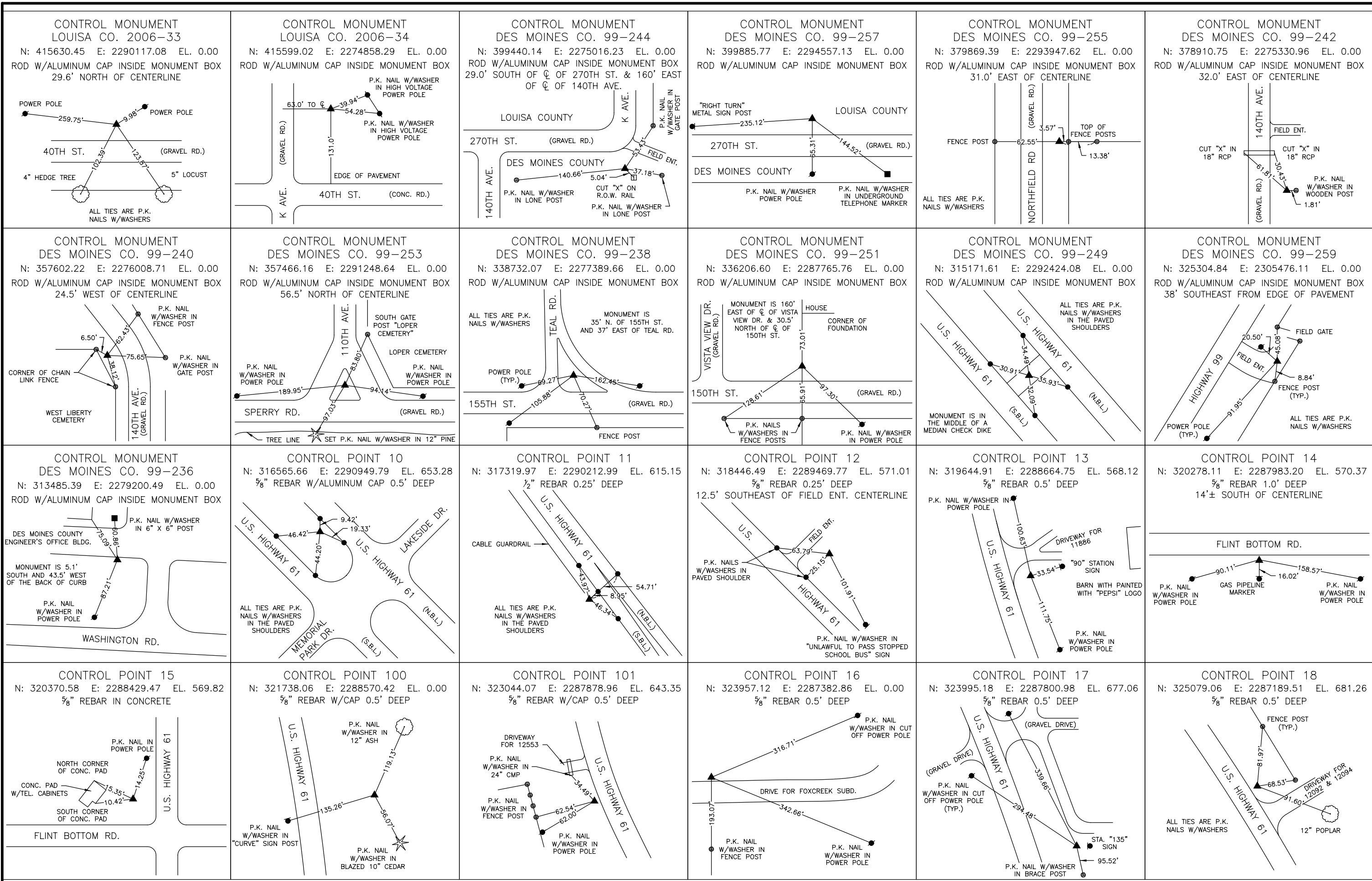

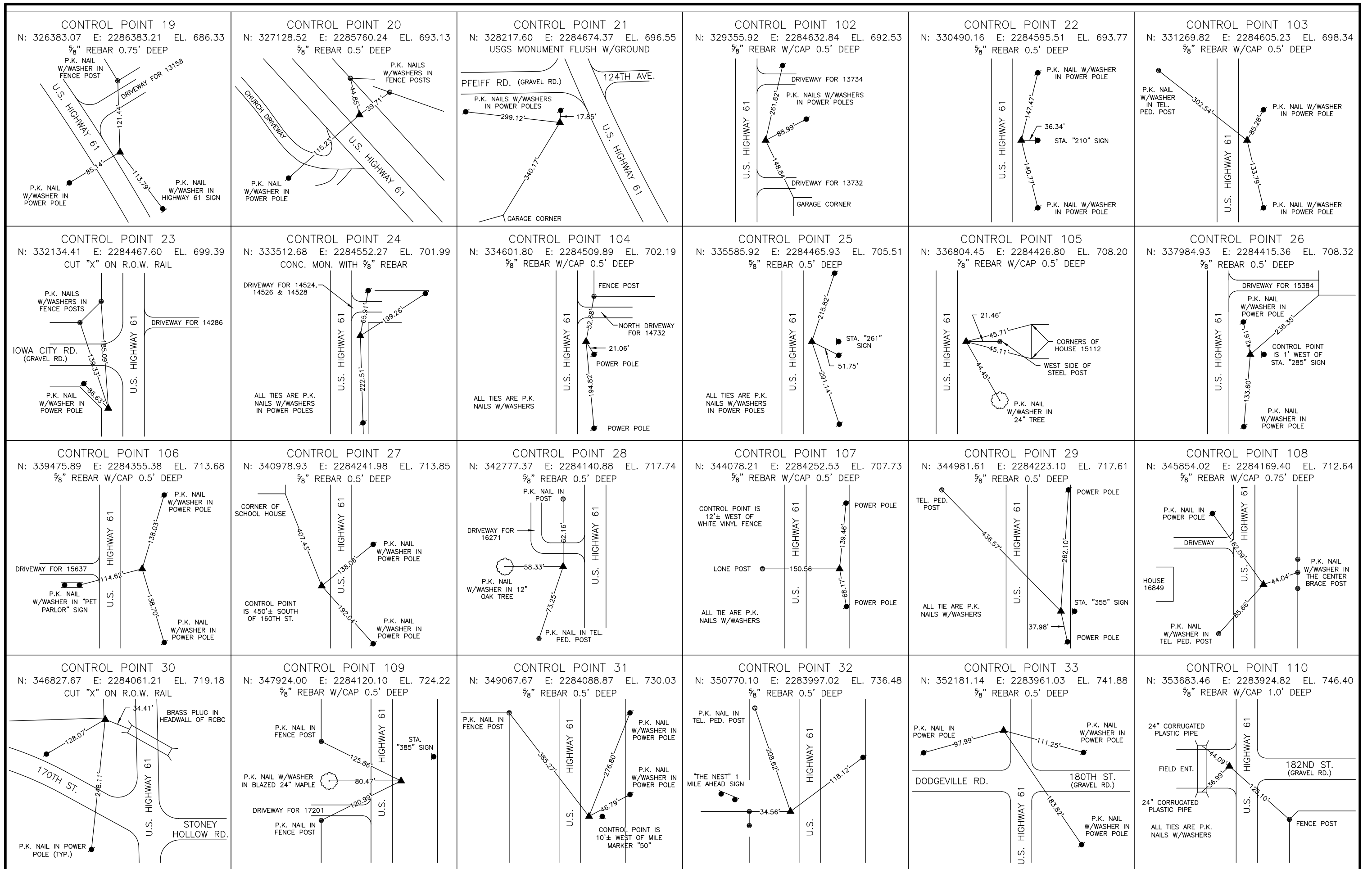

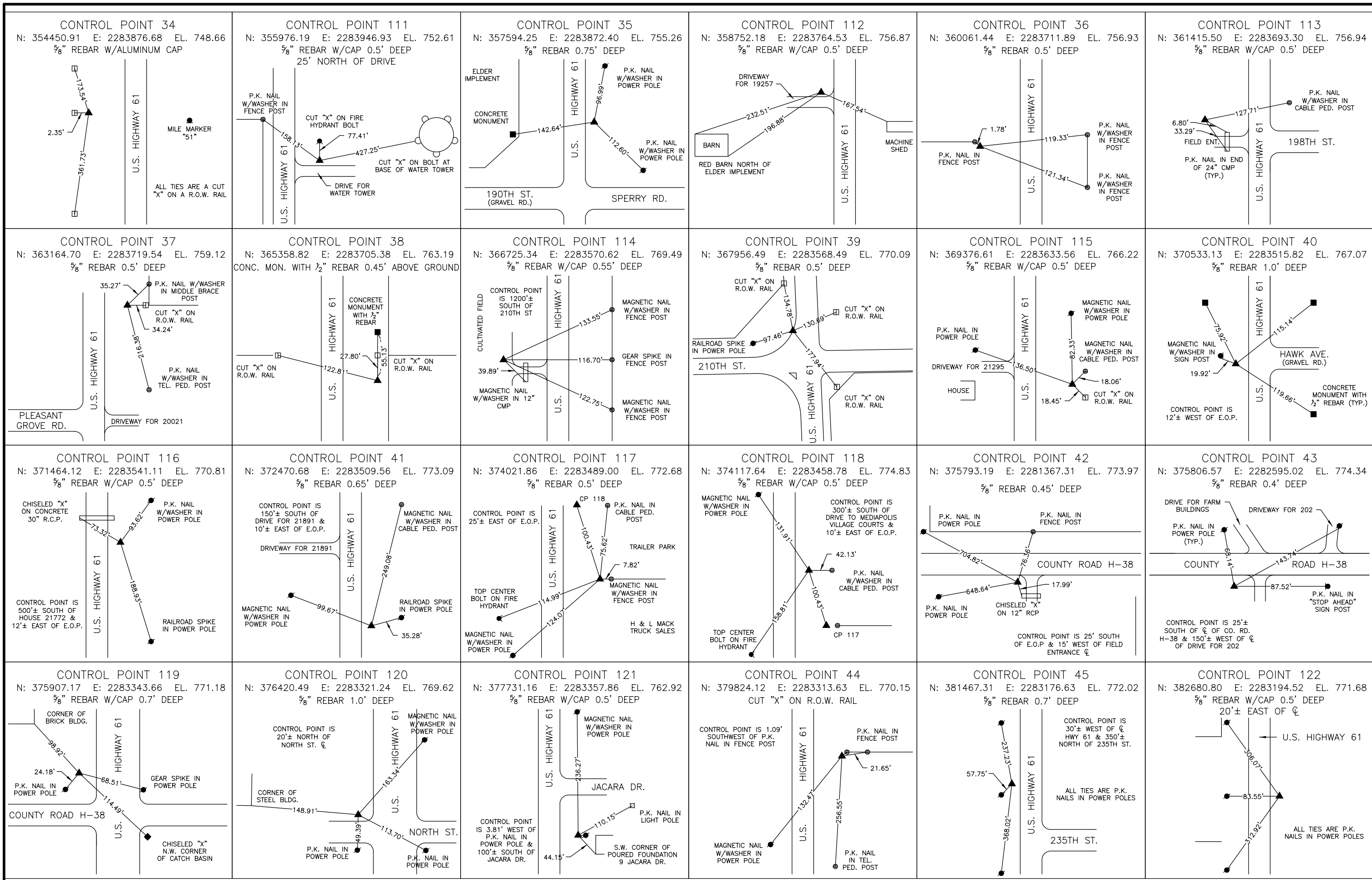

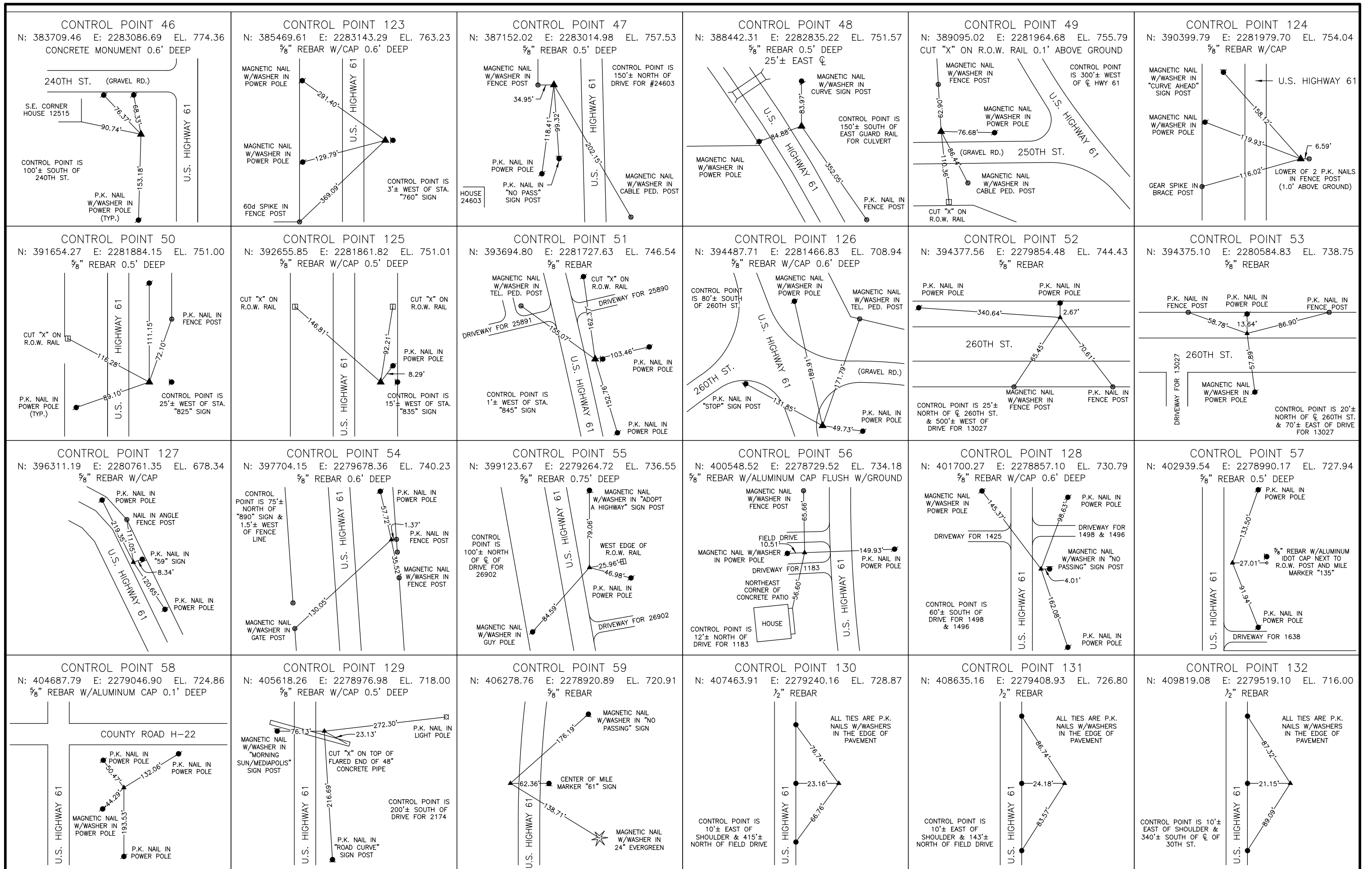

ALIGNMENT COORDINATES

101-16
10-20-09

Name	Location	Point on Tangent		Begin Spiral		Begin Curve		Simple Curve PI or Master PI of SCS			End Curve			End Spiral		
		Station	Coordinates		Station	Coordinates		Station	Coordinates		Station	Coordinates		Station	Coordinates	
			Y (Northing)	X (Easting)		Y (Northing)	X (Easting)		Y (Northing)	X (Easting)		Y (Northing)	X (Easting)		Y (Northing)	X (Easting)
US 61																
20502		1152+11.78	315,421.27	2,292,174.99												
20503								1169+63.47	316,600.02	2,290,879.25						
20504											1175+91.34	317,022.53	2,290,414.80			
20505														1182+15.33	317,526.13	2,290,039.82
20506								1206+81.06	319,503.81	2,288,567.20						
20507											1227+54.55	321,166.89	2,287,328.84			
20508														1247+12.77	323,236.13	2,287,196.05
20509								1256+55.08	324,176.50	2,287,135.70						
20510											1270+66.38	325,584.90	2,287,045.31			
20511														1283+68.59	326,624.75	2,286,091.12
20512								1297+55.27	327,646.46	2,285,153.57						
20513											1310+96.15	328,634.43	2,284,247.00			
20514														1322+97.96	329,974.11	2,284,303.71
20515								1333+16.14	330,991.37	2,284,346.78						
20516											1338+42.62	331,517.38	2,284,369.05			
20517														1343+68.70	332,043.70	2,284,355.81
20518								1407+01.69	338,374.68	2,284,196.49						
20519											1413+43.37	339,016.15	2,284,180.35			
20520														1419+82.62	339,647.94	2,284,068.08
20521								1430+12.25	340,661.69	2,283,887.95						
20522											1436+33.99	341,273.85	2,283,779.17			
20523														1442+40.81	341,882.79	2,283,904.72
20524								1454+60.92	343,077.76	2,284,151.10						
20525											1462+04.36	343,805.89	2,284,301.22			
20526														1469+41.37	344,549.11	2,284,283.06
20527								1576+28.34	355,232.89	2,284,021.96						
20528											1583+76.07	355,980.40	2,284,003.69			
20529														1591+22.77	356,723.15	2,283,917.48
20530								1603+56.70	357,948.85	2,283,775.21						
20531											1609+25.38	358,513.73	2,283,709.64			
20532														1614+91.16	359,081.42	2,283,743.16
20533								1625+84.84	360,173.20	2,283,807.62						
20534											1632+41.19	360,828.40	2,283,846.31			
20535														1638+96.84	361,484.61	2,283,832.51
20536		1718+33.10	369,419.11	2,283,665.66												
Mark Twain Dr																
39000		11161+50.50	316,052.95	2,291,480.61												
39001		11164+00.00	316,235.30	2,291,650.91												
Memorial Park Rd / Lakeside Dr																
40100		1160+85.75	316,206.85	2,290,417.11												
40101								11161+88.87	316,208.01	2,290,520.22						
40102											11164+50.12	316,210.97	2,290,781.46			
40103														11166+81.67	316,404.22	2,290,957.27
40104								11168+43.46	316,523.90	2,291,066.14						
40105											11169+62.28	316,611.79	2,291,146.10			
40106														11170+38.33	316,702.26	2,291,069.07
40107								11170+91.96	316,743.10	2,291,034.31						
40108											11171+23.92	316,767.43	2,291,013.59			
40109														11171+53.82	316,799.27	2,291,010.82
40110		11172+02.72	316,847.98	2,291,006.59												
Plank Rd																
41100		11173+61.34	317,470.31	2,287,741.83												
41101								11178+23.76	317,809.60	2,288,056.01						
41102											11182+52.82	318,124.42	2,288,347.53			
41103														11186+53.11	318,206.16	2,288,768.74
41104								11189+21.78	318,257.34	2,289,032.48						
41105											11190+34.77	318,278.86	2,289,143.40			
41106														11191+46.33	318,329.58	2,289,244.36
41107		11193+06.94	318,401.67	2,289,387.87												
Flint Bottom Rd / Upper Flint Rd																
42100		11201+78.12	320,285.77	2,286,684.32												
42101								11206+04.94	320,287.56	2,287,111.14						
42102											11207+48.43	320,288.17	2,287,254.63			
42103														11208+90.79	320,257.74	2,287,394.86
42104								11211+04.34	320,212.45	2,287,603.56						
42105											11212+58.92	320,179.68	2,287,754.62			

ALIGNMENT COORDINATES

101-16
10-20-09

Name	Location	Point on Tangent		Begin Spiral		Begin Curve		Simple Curve PI or Master PI of SCS			End Curve		End Spiral			
		Station	Coordinates		Station	Coordinates		Station	Coordinates		Station	Coordinates		Station	Coordinates	
			Y (Northing)	X (Easting)		Y (Northing)	X (Easting)		Y (Northing)	X (Easting)		Y (Northing)	X (Easting)		Y (Northing)	X (Easting)
Flint Bottom Rd / Upper Flint Rd (Cont.)																
42106												11214+07.96	320,217.79	2,287,904.42		
42107								11217+66.17	320,306.12	2,288,251.57						
42108											11218+43.60	320,325.21	2,288,326.61			
42109												11219+19.59	320,318.69	2,288,403.76		
42110								11221+27.74	320,301.15	2,288,611.18						
42111											11221+88.17	320,296.05	2,288,671.39			
42112												11222+48.52	320,296.52	2,288,731.82		
42113		11225+52.19	320,298.85	2,289,035.48												
Tanner Ln / Connection to US 61																
43100		11244+91.74	323,940.94	2,286,228.99												
43101								11247+36.26	323,920.71	2,286,472.68						
43102											11247+50.85	323,919.50	2,286,487.22			
43103												11247+65.24	323,922.50	2,286,501.50		
43104								11249+03.54	323,950.92	2,286,636.85						
43105											11249+24.70	323,955.27	2,286,657.55			
43106												11249+45.69	323,955.19	2,286,678.70		
43107								11250+31.64	323,954.86	2,286,764.65						
43108											11250+47.07	323,954.80	2,286,780.08			
43109												11250+62.43	323,952.38	2,286,795.31		
43110								11251+11.52	323,944.67	2,286,843.79						
43111											11251+26.75	323,942.28	2,286,858.83			
43112												11251+41.92	323,942.19	2,286,874.06		
43113											11254+18.70	323,940.61	2,287,150.84			
43114								11256+45.45	323,947.23	2,287,377.48						
43115											11257+47.99	323,950.22	2,287,479.98			
43116												11258+49.26	323,980.61	2,287,577.91		
43117		11259+61.78	324,013.96	2,287,685.37												
130th St																
44100		11277+84.46	326,167.11	2,286,453.28												
44101								11278+74.98	326,217.96	2,286,528.18						
44102											11279+69.77	326,271.20	2,286,606.60			
44103												11280+58.60	326,269.72	2,286,701.38		
44104		11282+56.61	326,266.62	2,286,899.36												
Pfeiff Rd / 124th Ave																
45100		11295+51.20	328,266.98	2,283,612.67												
45101								11304+01.24	328,268.63	2,284,462.71						
45102											11304+37.48	328,268.70	2,284,498.95			
45103												11304+72.35	328,285.31	2,284,531.16		
45104								11308+98.46	328,480.58	2,284,909.89						
45105											11309+90.12	328,522.58	2,284,991.36			
45106												11310+63.01	328,614.24	2,284,991.15		
45107		11311+40.66	328,691.89	2,284,990.98												
Iowa City Rd																
46100		11340+69.74	332,226.60	2,283,869.79												
46101											11345+51.17	332,226.11	2,284,351.22			
46102											11351+26.30	332,255.62	2,284,925.59			
46103		11352+46.33	332,254.55	2,285,045.61												
Exst. US 61 Conn. at Iowa City Rd																
46500		21340+38.99	331,391.87	2,284,546.53												
46501								21341+38.99	331,491.83	2,284,543.95						
46502											21342+63.62	331,616.42	2,284,540.74			
46503												21343+84.10	331,730.22	2,284,591.55		
46504								21346+02.87	331,929.98	2,284,680.73						
46505											24347+34.91	332,050.55	2,284,734.56			
46506												21348+62.05	332,182.42	2,284,727.79		
46507								21350+08.10	332,328.28	2,284,720.29						
46508											21351+25.00	332,445.03	2,284,714.29			
46509												21352+38.48	332,549.25	2,284,661.32		
46510								21354+50.07	332,737.87	2,284,565.46						
46511											21355+72.85	332,847.33	2,284,509.83			
46512												21356+91.67	332,970.06	2,284,506.03		
46513		21357+91.67	333,070.00	2,284,502.93												

ALIGNMENT COORDINATES

101-16
10-20-09

Name	Location	Point on Tangent			Begin Spiral			Begin Curve			Simple Curve PI or Master PI of SCS			End Curve			End Spiral		
		Station	Coordinates		Station	Coordinates		Station	Coordinates		Station	Coordinates		Station	Coordinates		Station	Coordinates	
			Y (Northing)	X (Easting)		Y (Northing)	X (Easting)		Y (Northing)	X (Easting)		Y (Northing)	X (Easting)		Y (Northing)	X (Easting)		Y (Northing)	X (Easting)
150th St																			
47100		11380+62.13	336,132.75	2,283,852.84															
47101		11384+62.13	336,135.84	2,284,252.83															
47102		11390+57.23	336,140.42	2,284,847.91															
Ex1st. US 61 Conn. at 150th St																			
47500		21379+76.64	335,323.43	2,284,447.68															
47501								21380+76.64	335,423.40	2,284,445.41									
47502											21381+97.87	335,544.60	2,284,442.65						
47503														21383+15.28	335,655.72	2,284,491.11			
47504								21385+01.52	335,826.44	2,284,565.54									
47505											21386+18.43	335,933.60	2,284,612.27						
47506														21387+31.90	336,050.50	2,284,611.37			
47507								21388+92.95	336,211.55	2,284,610.13									
47508											21390+25.00	336,343.59	2,284,609.11						
47509														21391+52.13	336,460.77	2,284,548.26			
47510								21393+41.57	336,628.89	2,284,460.96									
47511											21394+63.71	336,737.29	2,284,404.67						
47512														21395+81.95	336,859.33	2,284,399.56			
47513		21396+81.95	336,959.24	2,284,395.37															
160th St																			
48100		11429+99.06	341,439.65	2,283,045.26															
48101		11447+99.06	341,452.59	2,284,845.22															
170th St / Stoney Hollow Rd																			
49100		11475+34.87	346,771.28	2,282,773.15															
49101								11478+75.09	346,777.22	2,283,113.33									
49102											11480+63.45	346,780.51	2,283,301.66						
49103														11482+49.26	346,730.68	2,283,483.31			
49104								11485+99.86	346,637.89	2,283,821.55									
49105											11486+96.38	346,612.39	2,283,914.50						
49106														11487+91.52	346,614.75	2,284,010.99			
49107											11490+13.04	346,620.16	2,284,232.44						
49108		11497+63.04	346,618.86	2,284,982.44															
Dodgeville Rd / 180th St																			
50100		11538+02.31	352,102.91	2,283,398.35															
50101		11552+52.31	352,113.03	2,284,848.32															
182nd St																			
51100		11560+83.47	353,688.48	2,284,059.70															
51101		11568+58.47	353,690.51	2,284,834.70															
190th St / Sperry Rd																			
52100		11593+12.97	357,406.59	2,283,337.90															
52101		11603+12.97	357,410.89	2,284,337.89															
198th St																			
53100		11638+13.86	361,401.64	2,283,834.04															
53101		11642+63.86	361,400.97	2,284,284.04															
Pleasant Grove Rd																			
54100		11646+43.04	362,728.74	2,283,306.31															
54101		11651+43.04	362,730.53	2,283,806.31															
210th St (West)																			
55100		11698+08.83	367,884.67	2,283,197.82															
55101		11703+08.83	367,895.18	2,283,697.71															
210th St (East)																			
55102		11703+11.83	367,898.18	2,283,697.64															
55103		11708+11.83	367,908.69	2,284,197.53															

SPIRAL OR CIRCULAR CURVE DATA

101-17
04-19-11

Name	Location	Δ _{scs}	Horizontal Alignment Data										Remarks			
			Spiral Data					Curve Data								
			θ _s	L _s	T _s	E _s	X _c	Y _c	L.T.	S.T.	Δ _c	T	L	R	E	
US 61																
20504	1175+91.34										0° 52' 53.30"	627.87	1,251.86	6,500.00	30.25	
20507	1227+54.55										0° 49' 06.64"	2,073.49	4,031.71	7,000.00	300.64	
20510	1270+66.38										1° 25' 56.62"	1,411.30	2,713.52	4,000.00	241.67	
20513	1310+96.15										1° 46' 06.20"	1,340.88	2,542.69	3,240.00	266.50	
20516	1338+42.62										0° 22' 02.21"	526.48	1,052.57	15,600.00	8.88	
20519	1413+43.37										0° 40' 26.64"	641.68	1,280.93	8,500.00	24.19	
20522	1436+33.99										1° 46' 06.20"	621.75	1,228.56	3,240.00	59.12	
20525	1462+04.36										0° 52' 53.30"	743.44	1,480.45	6,500.00	42.38	
20528	1583+76.07										0° 20' 57.71"	747.73	1,494.43	16,400.00	17.04	
20531	1609+25.38										0° 52' 53.30"	568.68	1,134.46	6,500.00	24.83	
20534	1632+41.19										0° 20' 57.71"	656.35	1,312.00	16,400.00	13.13	
Memorial Park Rd / Lakeside Dr																
40101	11164+50.12										9° 32' 57.47"	261.26	492.80	600.00	54.41	
40102	11169+62.28										42° 26' 28.75"	118.82	194.87	135.00	44.84	
40103	11171+23.92										57° 17' 44.81"	31.96	61.87	100.00	4.98	
Plank Rd																
41101	11182+52.82										4° 22' 01.40"	429.06	829.36	1,312.00	68.38	
41102	11190+34.77										6° 59' 14.24"	112.98	224.55	820.00	7.75	
Flint Bottom Rd / Upper Flint Rd																
42101	11207+48.43										4° 22' 01.40"	143.49	285.85	1,312.00	7.82	
42102	11212+58.92										8° 44' 02.81"	154.58	303.61	656.00	17.97	
42103	11218+43.60										12° 27' 20.18"	77.43	153.42	460.00	6.47	
42104	11221+88.17										4° 22' 01.40"	60.43	120.78	1,312.00	1.39	
42502	21221+42.69										3° 03' 50.20"	50.82	101.61	1,870.00	0.69	
Tanner Ln / Connection to US 61																
43102	11247+50.85										57° 17' 44.81"	14.59	28.98	100.00	1.06	
43105	11249+24.70										28° 38' 52.40"	21.15	42.15	200.00	1.12	
43108	11250+47.07										28° 38' 52.40"	15.42	30.78	200.00	0.59	
43111	11251+26.75										28° 38' 52.40"	15.23	30.39	200.00	0.58	
43115	11257+47.99										7° 38' 21.97"	102.54	203.82	750.00	6.98	
130th St																
44101	11279+69.77										19° 05' 54.94"	94.79	183.62	300.00	14.62	
Pfeiff Rd / 124th Ave																
45101	11304+37.48										38° 11' 49.87"	36.24	71.12	150.00	4.32	
45102	11309+90.12										38° 11' 49.87"	91.66	164.55	150.00	25.79	
Iowa City Rd																
46501	21342+63.62										10° 25' 02.69"	124.63	245.11	550.00	13.94	
46504	21347+34.91										10° 25' 02.69"	132.04	259.18	550.00	15.63	
46507	21351+25.00										10° 25' 02.69"	116.91	230.38	550.00	12.29	
46510	21355+72.85										10° 25' 02.69"	122.78	241.60	550.00	13.54	
150th St																
47501	21381+97.87										10° 25' 02.69"	121.23	238.64	550.00	13.20	
47504	21386+18.43										10° 25' 02.69"	116.91	230.38	550.00	12.29	
47507	21390+25.00										10° 25' 02.69"	132.04	259.18	550.00	15.63	
47510	21394+63.71										10° 25' 02.69"	122.14	240.38	550.00	13.40	
170th St / Stoney Hollow Rd																
49101	11480+63.45										4° 22' 01.40"	188.36	374.16	1,312.00	13.45	
49102	11486+96.38										8° 44' 02.81"	96.52	191.66	656.00	7.06	

SUPERELEVATION DATA

See PV-300 Series

Road Identification	Circular Curve or Spiral Curve Name	Radius	Superelevation Data			Standard Road Plan	Section A-A	Section B-B	Section C-C	Section D-D	Section E-E	Section F-F	Case A	Case B	Case C	Case S	Case T	Case U	Remarks
			e	L	x														
			FT	%	FT														
US 61	20504	6500	3.2	144	90	PV-302	1167+72.67	1168+62.67	1169+52.67	1170+06.67			1169+63.47						
							1184+06.13	1183+16.13	1182+26.13	1181+72.13			1182+15.33						
US 61	20507	7000	3.0	135	90	PV-302	1204+96.56	1205+86.56	1206+76.56	1207+21.56			1206+81.06						
							1248+97.27	1248+07.27	1247+17.27	1246+72.27			1247+12.77						
US 61	20510	4000	4.6	207	90	PV-302	1254+20.18	1255+10.18	1256+00.18	1257+17.18			1256+55.08		1256+90.18	1256+90.18			
							1286+03.49	1285+13.49	1284+23.49	1283+06.49			1283+68.59		1283+33.49	1283+33.49			
US 61	20513	3240	5.2	234	90	PV-302	1295+01.47	1295+91.47	1296+81.47	1298+25.47			1297+55.27		1297+71.47	1297+71.47			
							1325+51.76	1324+61.76	1323+71.76	1322+27.76			1322+97.96		1322+81.76	1322+81.76			
US 61	20519	8500	2.4	108	90	PV-302	1405+36.09	1406+26.09	1407+16.09	1407+34.09				1407+01.69					
							1421+48.22	1420+58.22	1419+68.22	1419+50.22				1419+82.62					
US 61	20522	3240	5.2	234	90	PV-302	1427+58.45	1428+48.45	1429+38.45	1430+82.45			1430+12.25		1430+28.45	1430+28.45			
							1444+94.61	1444+04.61	1443+14.61	1441+70.61			1442+40.81		1442+24.61	1442+24.61			
US 61	20525	6500	3.2	144	90	PV-302	1452+70.12	1453+60.12	1454+50.12	1455+04.12			1454+60.92						
							1471+32.17	1470+42.17	1469+52.17	1468+98.17			1469+41.37						
US 61	20531	6500	3.2	144	90	PV-302	1601+65.90	1602+55.90	1603+45.90	1603+99.90			1603+56.70						
							1616+81.96	1615+91.96	1615+01.96	1614+47.96			1614+91.16						

STAGING NOTES

It is not the intent of the sequence of construction to confine the Contractor's activities to the area of suggested stages alone. It is understood that some of the various steps, though listed in numerical order, may occur simultaneously. Therefore, the Contractor may conduct several operations concurrently on the project, provided that the existing traffic is maintained and that these operations do not conflict with the staging indicated here in.

It is recognized that as various activities related to the construction progress, certain situations may arise which will preclude adhering to the original construction sequence or, which in the opinion of the Contractor, would readily adhere itself to a more efficient staging operation. Should this occur, and the Contractor desire to deviate from the original plan, they shall submit an alternate plan for approval by the Engineer.

Stage 1.

Traffic:

- Close SB US 61 lanes to traffic between the multilane crossover centered on Sta. 1159+50 and Sta. 1175+00 just north of Memorial Park Road.
- Maintain NB and SB US 61 traffic on existing NB US 61 from beginning of project to the end of the project located at Sta. 1728+52.98 just south of Hawk Road.
- Maintain traffic at all times to side roads.
- Maintain traffic at all times to properties.

Construction:

- Remove existing NB and SB US 61 median shoulder along the limits of the multilane crossover centered on Sta. 1159+50.
- Remove existing SB US 61 pavement between Sta. 1159+50 south of Mark Twain Road and approximate Sta. 1175+00 north of Memorial Park Road.
- Grade proposed SB lanes of US 61 between Sta. 1159+50 south of Mark Twain Road and the south side of the proposed Flint Creek bridge.
- Grade proposed SB lanes of US 61 between the north side of the proposed Flint Creek bridge and Sta. 1450+00 just north of 160th St.
- Grade proposed NB lanes of US 61 between Sta. 1206+50 just north of Flint Creek and Sta. 1266+00 just north of Tanner Lane.
- Grade proposed NB lanes of US 61 between Sta. 1312+00 just north of Pfeiff Road and Sta. 1451+00 just north of 160th St.
- Grade proposed NB lanes of US 61 between Sta. 1459+50 just north of 160th St. and Sta. 1591+00 just south of Sperry Road/190th St.
- Drive sheetpile and remove 26 ft. of existing culvert located at approximate ML Sta. 1720+95.22 just south of Hawk Road.
- Construct Stage 1 of the proposed 10'x6'x242' RCB Culvert located at approximate ML Sta. 1720+81.80 just south of Hawk Road.
- Grade proposed NB lanes of US 61 between Sta. 1627+50 just south of 198th St and the end of the project located at Sta. 1728+52.98 just south of Hawk Road.
- Construct proposed SB US 61 bridge over Flint Creek.

Stage 2 Phase 1.

Traffic:

- Maintain closure of SB US 61 north of the multilane crossover centered on Sta. 1159+50.
- Maintain NB and SB US 61 traffic on existing NB US 61 from beginning of project to the end of the project located at Sta. 1728+52.98 just south of Hawk Road.
- Maintain traffic at all times to side roads.
- Maintain traffic at all times to properties.

Construction:

- Pave proposed SB lanes of US 61 between the multilane crossover centered on Sta. 1159+50 and the new Flint Creek bridge.
- Pave proposed SB lanes of US 61 between the new Flint Creek bridge and Sta. 1450+00 just north of 160th St.
- Pave proposed NB lanes of US 61 between Sta. 1206+50 just north of Flint Creek and Sta. 1266+00 just north of Tanner Lane.
- Pave proposed NB lanes of US 61 between Sta. 1312+00 just north of Pfeiff Road and Sta. 1451+00 just north of 160th St.
- Pave proposed NB lanes of US 61 between Sta. 1459+50 just north of 160th St. and Sta. 1591+00 just south of Sperry Road/190th St.
- Pave proposed NB lanes of US 61 between Sta. 1627+50 just south of 198th St and the end of the project located at Sta. 1728+52.98 just south of Hawk Road.
- Grade and pave any side roads that intersect the new NB or SB US 61 roadway.
- Grade and pave any property entrances that intersect the new NB or SB US 61 roadway.

Stage 2 Phase 2.

Traffic:

- Maintain closure of SB US 61 north of the multilane crossover centered on Sta. 1159+50.
- Maintain NB and SB US 61 traffic on existing NB US 61 between the multilane crossover centered on Sta. 1159+50 and the end of the project located at Sta. 1728+52.98 just south of Hawk Road.
- Maintain traffic at all times to side roads.
- Maintain traffic at all times to properties.

Construction:

- Grade and Pave the multilane crossover centered on Sta. 1159+50.
- Grade and pave the multilane median cross over centered at Sta. 1371+00 just south of Center Ave.
- Grade and pave the NB US 61 detour pavement (1) west of existing US 61 between Sta. 1451+00 and Sta. 1455+30 just north of 160th St.
- Grade and pave the NB US 61 detour pavement (2) east of existing US 61 between Sta. 1451+80 and Sta. 1459+50 just north of 160th St.
- Grade and pave the NB US 61 detour pavement (3) east of existing US 61 between Sta. 1591+00 and Sta. 1603+00 just north of Sperry Road/190th St.
- Grade and pave the NB US 61 detour pavement (4) east of existing US 61 between Sta. 1612+85 and Sta. 1627+50 just south of 198th St.
- Grade and Pave the NB US 61 detour pavement (6) between Sta. 1714+00 and the existing US 61 roadway at Sta. 1728+52.98 just south of Hawk Road.

STAGING NOTES

Stage 3 Phase 1.

Traffic:

- Shift NB and SB US 61 traffic from the existing NB lanes of US 61 onto the new SB US 61 lanes between the multilane crossover centered on Sta. 1159+50 and the multilane crossover centered on Sta. 1371+00 just south of Center Ave.
- Shift NB and SB US 61 traffic from the new SB lanes onto the new NB lanes of US 61 at the multilane crossover centered on Sta. 1371+00.
- Shift NB and SB US 61 traffic from the NB lanes at the temporary detour pavement at Sta. 1591+00 onto existing US 61 pavement and then back across to the NB lanes at the temporary detour pavement at Sta. 1612+85.
- Continue north in the NB lanes of new US 61 to the temporary detour pavement at Sta. 1714+00 and finally cross back over to the existing US 61 2 lane roadway at on the temporary detour pavement located at Sta. 1728+52.98 just south of Hawk Road.
- Maintain traffic at all times to side roads.
- Maintain traffic at all times to properties.

Construction:

- Grade and Pave NB US 61 between Sta. 1159+72 south of Mark Twain Drive and new Flint Creek bridge.
- Grade and Pave NB US 61 between the new Flint Creek bridge and Sta. 1206+50 just south of Upper Flint Road.
- Grade and Pave NB US 61 between Sta. 1266+00 just north of Tanner Lane to Sta. 1312+00 just north of Pfeiff Road.
- Grade and Pave SB US 61 between Sta. 1450+00 just north of 160th St. to Sta. 1714+00 just north of 210th St.
- Grade and Pave the SB US 61 detour pavement (5) between Sta. 1714+00 and the existing US 61 roadway at Sta. 1721+04.90 just south of Hawk Road.
- Grade and pave any remaining side roads that intersect with the new NB or SB US 61 roadway.
- Grade and pave any remaining property entrances that intersect with the new NB or SB US 61 roadway.
- Construct the new NB US 61 bridge over Flint Creek.

Stage 3 Phase 2.

Traffic:

- Open the new NB and SB lanes to full NB and SB traffic between the multilane median crossover centered on Sta. 1159+50 and the multilane median crossover centered on Sta. 1371+00.
- Shift NB US 61 traffic into the SB lanes between the multilane median crossover at Sta. 1371+00 and the end of the project located at Sta. 1721+04.90 just south of Hawk Road.
- Maintain traffic at all times to side roads.
- Maintain traffic at all times to properties.

Construction:

- Remove remaining portion of existing culvert located at approximate ML Sta. 1720+95.22 just south of Hawk Road.
- Construct final stage of proposed 10'x6'x242' RCB Culvert located at Sta. 1720+81.98 just south of Hawk Road.
- Remove temporary detour pavement (1) and (2) and existing pavement between Sta. 1451+00 and Sta. 1459+50.
- Grade and pave the permanent NB US 61 pavement between Sta. 1451+00 and Sta. 1459+50.
- Remove temporary detour pavement (3) and (4).
- Remove existing pavement between Sta. 1594+00 and Sta. 1622+00.
- Grade and pave the permanent NB US 61 pavement between Sta. 1591+00 and Sta. 1627+50.
- Grade and pave the permanent pavement connections for maintaining traffic on existing US 61 at Iowa City Road and Center Ave.
- Grade and pave all right and left turn lanes located at Sta. 1159+50 and Sta. 1598+12.97.

Stage 3 Phase 3.

Traffic:

- Open the NB and SB lanes to full NB and SB traffic between the multilane median crossover at Sta. 1371+00 and of the project.
- Open all side roads intersecting the new US 61 lanes to traffic.
- Open all property entrances intersecting the new US 61 lanes to traffic.

Construction:

- Remove the multilane median crossover located at Sta. 1371+00.
- Grade and pave right and left turn lanes located at Sta. 1371+00 and any other intersections not having been graded and paved previously.
- Clean up of all debris and final erosion control/seeding/fertilizing of entire project.

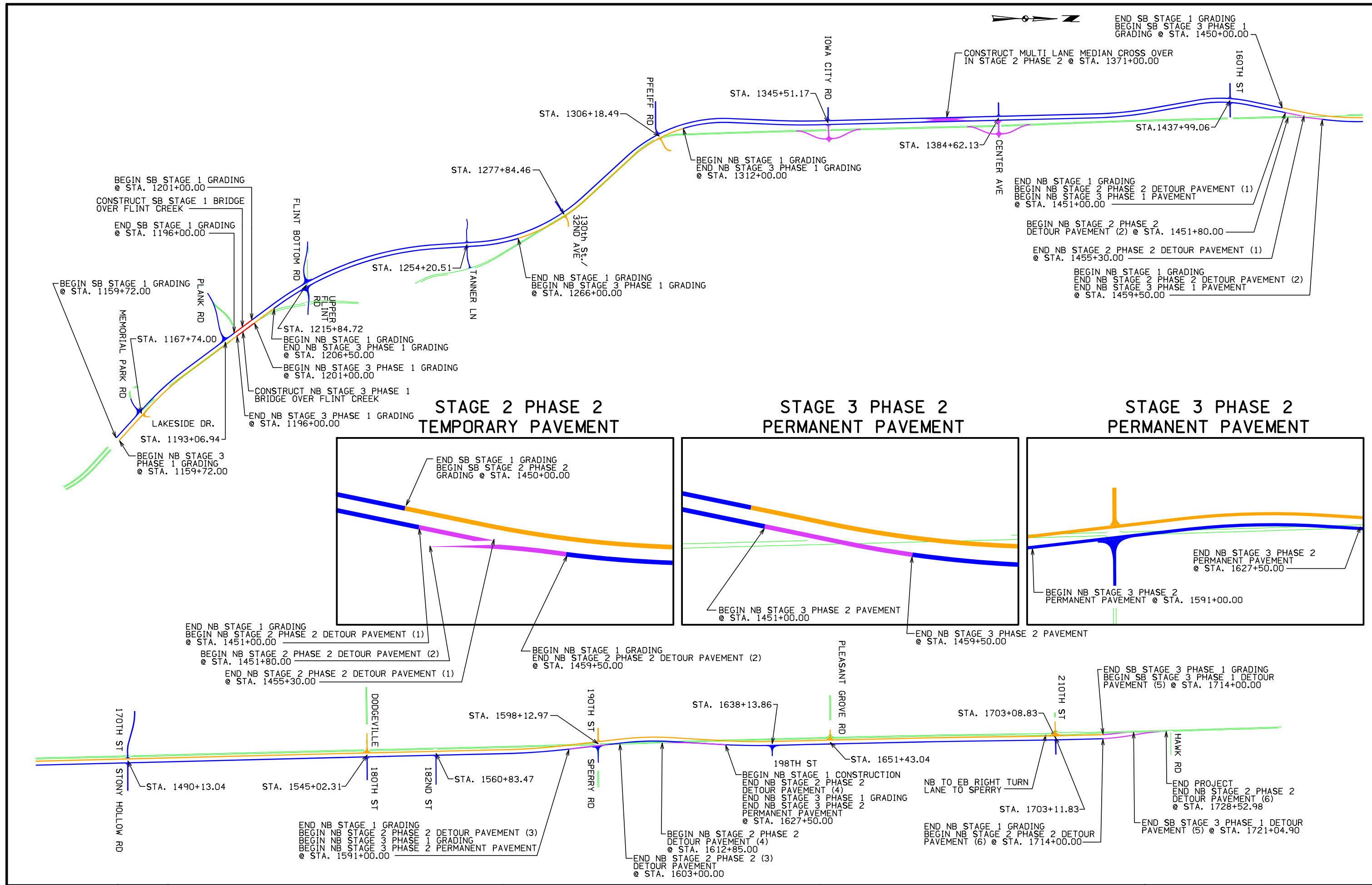

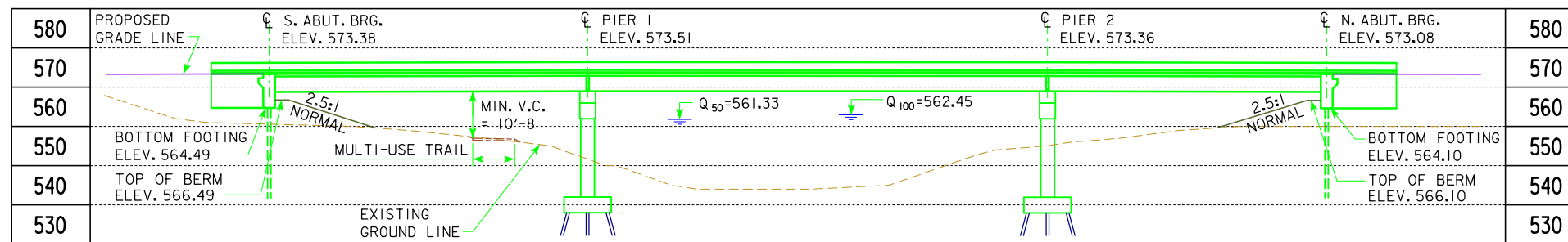

LONGITUDINAL SECTION ALONG CL S.B. US 61

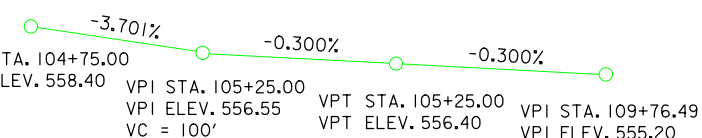
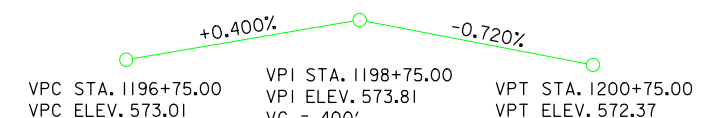

PROPOSED PROFILE GRADE MULTI-USE TRAIL

NOTES:
 ALL UNITS ARE IN FEET UNLESS NOTED OTHERWISE.
 TOP OF BRIDGE DECK AT CL S.B. US 61 IS 0.21' ABOVE THE PROFILE GRADE TO ACCOUNT FOR DECK CROSS SLOPE AND PARABOLIC CROWN.
 AN IOWA DNR FLOOD PLAIN CONSTRUCTION PERMIT WILL BE REQUIRED.
 SEE SHEET V.2 FOR N.B. US 61 BRIDGE OVER FLINT CREEK.

HYDRAULIC DATA

DRAINAGE AREA = 130 SQ. MI.
 STREAM SLOPE = 2.32 FT./MI.
 AVG. LOW WATER STAGE = ????

Q₅₀ = 11,500 CFS
 STAGE = 561.33
 BACKWATER = -0.05 FT.

Q₁₀₀ = 13,500 CFS
 STAGE = 562.45
 BACKWATER = -0.06 FT.
 AVG. BRIDGE VELOCITY = 6.5 FPS

Q₂₀₀ = 18,100 CFS
 STAGE = 564.58
 CALCULATED DESIGN SCOUR = ????

Q₅₀₀ = 19,700 CFS
 STAGE = 565.68
 AVG. BRIDGE VELOCITY = 7.4 FPS
 CALCULATED CHECK SCOUR = ????

ROADWAY OVERTOP ????
 STA. ???+??

50, 100 & 500 YR. STAGES AND DISCHARGES FROM DES MOINES COUNTY, IOWA AND UNINCORPORATED AREA F.I.S., DATED AUGUST 2011.

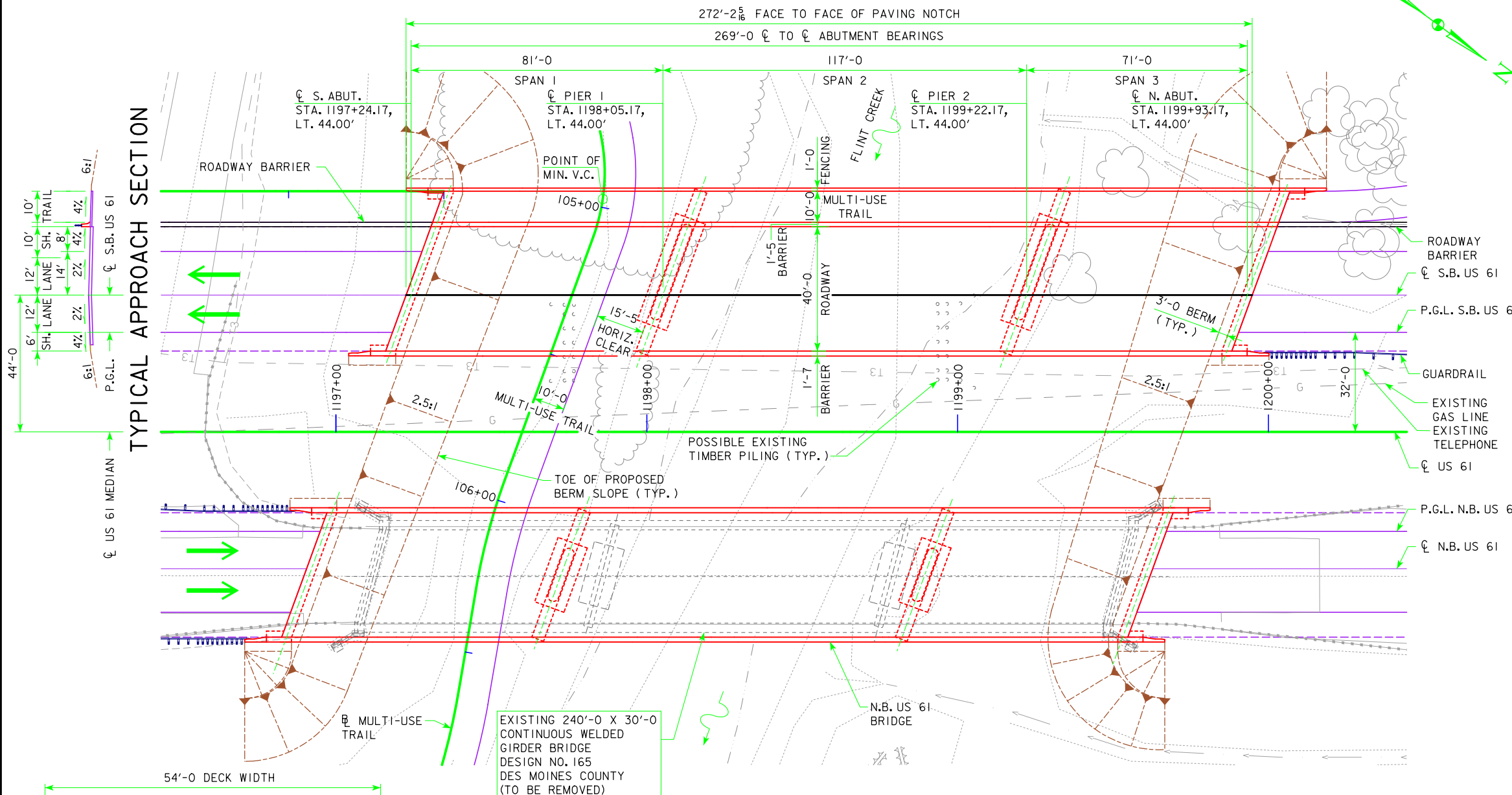

SITUATION PLAN

MINIMUM VERTICAL CLEARANCE

OVERHEAD STATION = 1197+85.85, OFFSET 74.92' LT.
 OVERHEAD ELEVATION = 572.94
 DEPTH OF SUPERSTRUCTURE = 4'-7"
 UNDERPASS STATION = 104+97.29
 UNDERPASS ELEVATION = 557.66
 REQUIRED MIN. VERTICAL CLEARANCE = 10'-8"
 PROVIDED MIN. VERTICAL CLEARANCE = 10'-0"

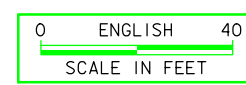

UTILITIES LEGEND:

- G GAS LINE
- T3 TELEPHONE

LOCATION

S.B. US 61
 OVER FLINT CREEK
 T-70N R-3W
 SECTION 24
 FLINT RIVER TOWNSHIP
 DES MOINES COUNTY

TRAFFIC ESTIMATE

200_ AADT	V.P.D.
202_ AADT	V.P.D.
202_ DHV	V.P.H.
TRUCKS	%

PRELIMINARY

DESIGN FOR 20° SKEW (L.A.)
269'-0" x 40'-0" PRETENSIONED PRESTRESSED CONCRETE BEAM S.B. BRIDGE
 81'-0" AND 71'-0" END SPANS (BTC BEAM) 117' INTERIOR SPAN
SITUATION PLAN
 US 61 STA. 1198+58.67, LT. 44.00' MAY 2014
DES MOINES COUNTY
 IOWA DEPARTMENT OF TRANSPORTATION - HIGHWAY DIVISION
 DESIGN SHEET NO. 1 OF 1 FILE NO. _____ DESIGN NO. XXXX

PROPOSED BRIDGE CROSS SECTION

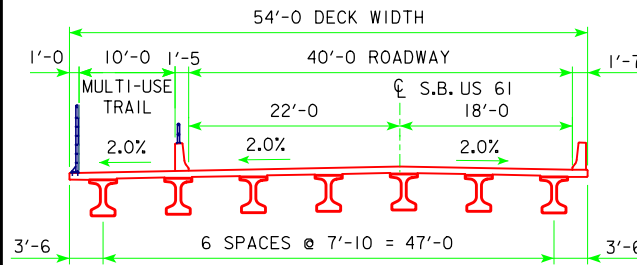

		BENCH MARK NO.				
580	CL S. ABUT. BRG. ELEV. 573.29	CL PIER 1 ELEV. 573.48	CL PIER 2 ELEV. 573.44	CL N. ABUT. BRG. ELEV. 573.22	PROPOSED GRADE LINE	580
570						570
560						560
550	BOTTOM FOOTING ELEV. 564.55				BOTTOM FOOTING ELEV. 564.54	550
540	TOP OF BERM ELEV. 566.55				TOP OF BERM ELEV. 566.54	540
530	EXISTING GROUND LINE					530

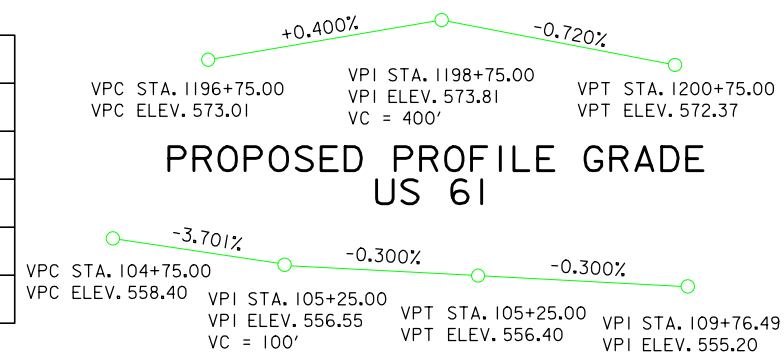

LONGITUDINAL SECTION ALONG CL N.B. US 61

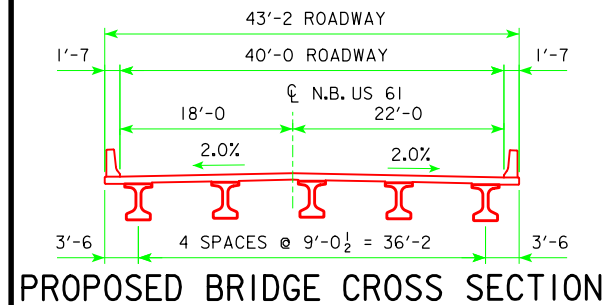

PROPOSED BRIDGE CROSS SECTION

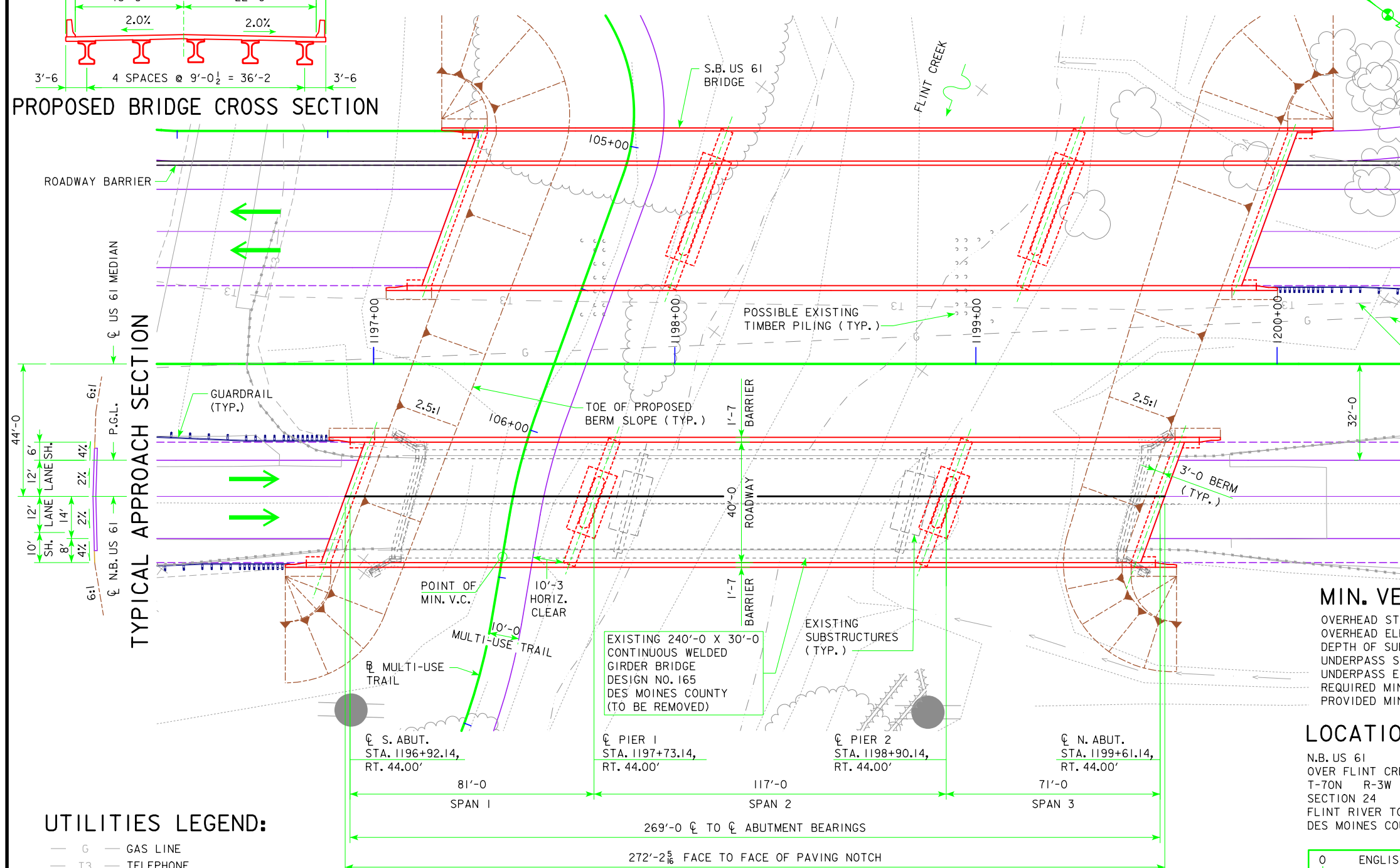

PROPOSED PROFILE GRADE MULTI-USE TRAIL

NOTES:
ALL UNITS ARE IN FEET UNLESS NOTED OTHERWISE.
TOP OF BRIDGE DECK AT CL N.B. US 61 IS 0.21' ABOVE THE PROFILE GRADE TO ACCOUNT FOR DECK CROSS SLOPE AND PARABOLIC CROWN.
AN IOWA DNR FLOOD PLAIN CONSTRUCTION PERMIT WILL BE REQUIRED.
SEE SHEET V.1 FOR S.B. US 61 BRIDGE OVER FLINT CREEK.

HYDRAULIC DATA

DRAINAGE AREA = 130 SQ. MI.
STREAM SLOPE = 2.32 FT./MI.
AVG. LOW WATER STAGE = ????.

 $Q_{50} = 11,500$ CFS
STAGE = 561.73
BACKWATER = -0.06 FT.

 $Q_{100} = 13,500$ CFS
STAGE = 562.91
BACKWATER = -0.08 FT.
AVG. BRIDGE VELOCITY = 7.1 FPS

 $Q_{200} = 18,100$ CFS
STAGE = 565.14
CALCULATED DESIGN SCOUR = ????.

 $Q_{500} = 19,700$ CFS
STAGE = 566.29
AVG. BRIDGE VELOCITY = 8.2 FPS
CALCULATED CHECK SCOUR = ????.

 ROADWAY OVERTOP ????.
STA. ???+???

MIN. VERTICAL CLEARANCE

OVERHEAD STATION = 1197+42.76, OFFSET 64.08' RT
OVERHEAD ELEVATION = 573.07
DEPTH OF SUPERSTRUCTURE = 4'-7"
UNDERPASS STATION = 106+43.15
UNDERPASS ELEVATION = 556.20
REQUIRED MINIMUM VERTICAL CLEARANCE = 10'-0"
PROVIDED MINIMUM VERTICAL CLEARANCE = 12'-3"

TRAFFIC ESTIMATE

200. AADT - V.P.D.
202. AADT - V.P.D.
202. DHV - V.P.H.
TRUCKS - %

LOCATION

N.B. US 61
OVER FLINT CREEK
T-70N R-3W
SECTION 24
FLINT RIVER TOWNSHIP
DES MOINES COUNTY

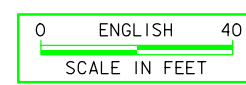

UTILITIES LEGEND:

- G - GAS LINE
- T3 - TELEPHONE

SITUATION PLAN

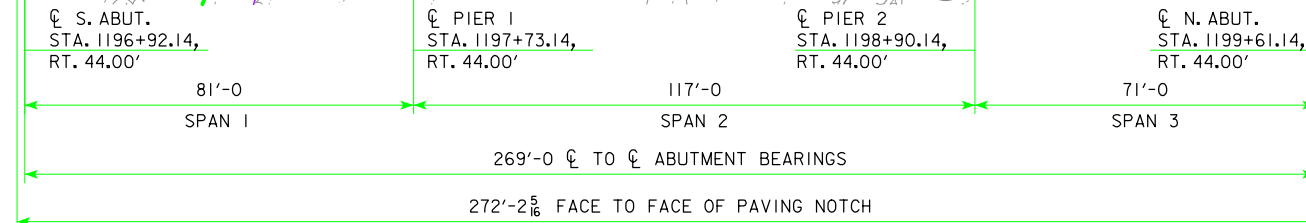

PRELIMINARY
DESIGN FOR 20° SKEW (L.A.)
**269'-0" x 40'-0" PRETENSIONED
PRESTRESSED CONCRETE BEAM N.B. BRIDGE**
81'-0" AND 71'-0" END SPANS (BTC BEAM) 117' INTERIOR SPAN
SITUATION PLAN
US 61 STA. 1198+26.64, RT. 44.00' MAY 2014
DES MOINES COUNTY
IOWA DEPARTMENT OF TRANSPORTATION - HIGHWAY DIVISION
DESIGN SHEET NO. 1 OF 1 FILE NO. DESIGN NO. XXXX

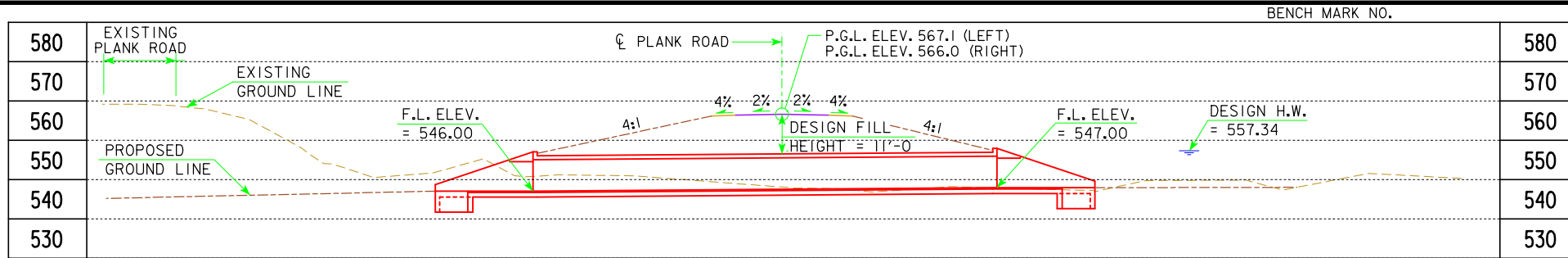

LONGITUDINAL SECTION ALONG ϕ CULVERT

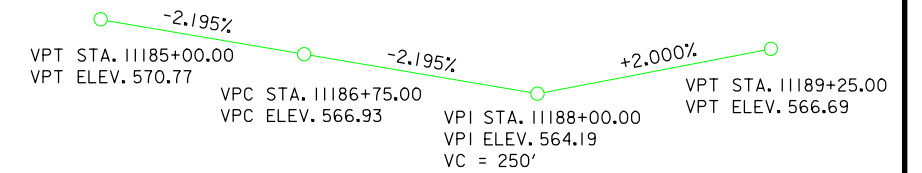

PROPOSED PROFILE GRADE ON PLANK ROAD

PLANK ROAD CURVE DATA

PI STA. 11182+52.82
 $\Delta = 36^\circ 13' 06.27''$ (RT)
 $D = 4^\circ 22' 01.40''$
 $T = 429.061$
 $L = 829.3552$
 $E = 68.3758$
 $R = 1,312.0$
 $e = 68.3758$
 $I = 815.6156$
 $x = 64.9889$
 PC STA. 11178+23.76
 PT STA. 11186+53.11

HYDRAULIC DATA

DRAINAGE AREA = 3315 ACRES
 $Q_{50} = 2,710$ CFS
 HW ELEV. = 557.34
 STREAM SLOPE = 42.7 FT./MI.

NOTES:

- ALL UNITS IN FEET UNLESS NOTED OTHERWISE.
- DRAINAGE THROUGH EXISTING CULVERT/CHANNEL MUST BE MAINTAINED THROUGHOUT CONSTRUCTION.
- THE SIDE SLOPE OF 4:1 TO BE STEEPENED AROUND HEADWALLS TO ACCOMMODATE THE USE OF STANDARD HEADWALL DETAILS.

UTILITIES LEGEND:

— T3 — EXISTING TELEPHONE

LOCATION

PLANK ROAD OVER HONEY CREEK
 T-70N R-3W
 SECTION 24
 FLINT RIVER TOWNSHIP
 DES MOINES COUNTY

TRAFFIC ESTIMATE

200_ AADT — V.P.D.
 202_ AADT — V.P.D.
 202_ DHV — V.P.H.
 TRUCKS — %
 TOTAL DESIGN ESALs —

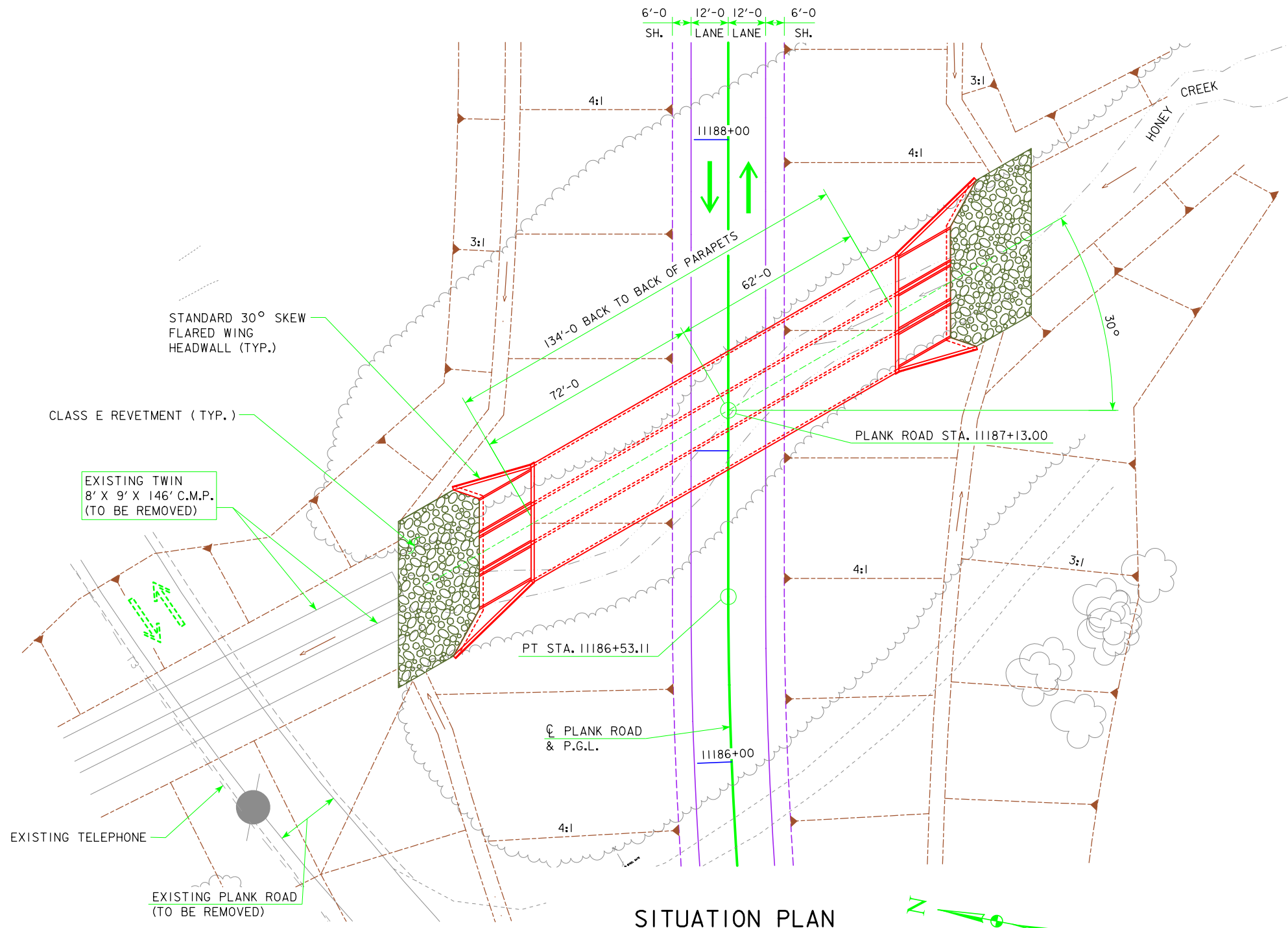

SITUATION PLAN

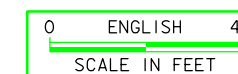
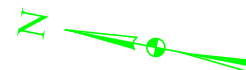

DESIGN FOR 30° SKEW (R.A.)
TRIPLE 10' x 8' x 134'-0" REINFORCED CONCRETE BOX CULVERT
 SITUATION PLAN
 US 61 STA. 11187+13.00 MAY 2014
DES MOINES COUNTY
 IOWA DEPARTMENT OF TRANSPORTATION - HIGHWAY DIVISION
 DESIGN SHEET NO. 1 OF 1 FILE NO. _____ DESIGN NO. XXXX

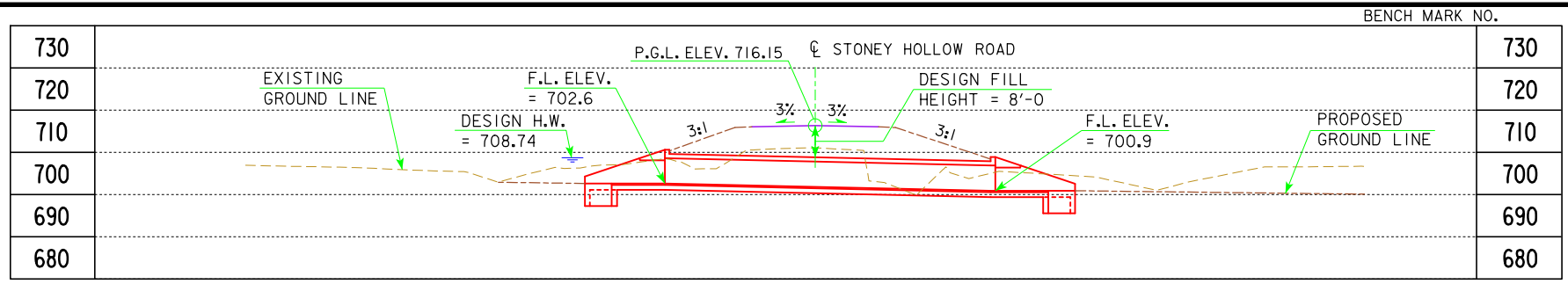

LONGITUDINAL SECTION ALONG ϕ CULVERT

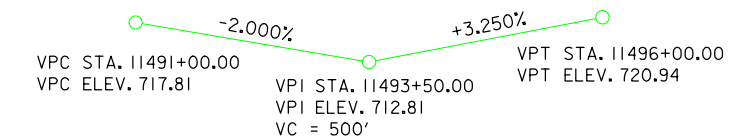

PROPOSED PROFILE GRADE ON STONEY HOLLOW ROAD

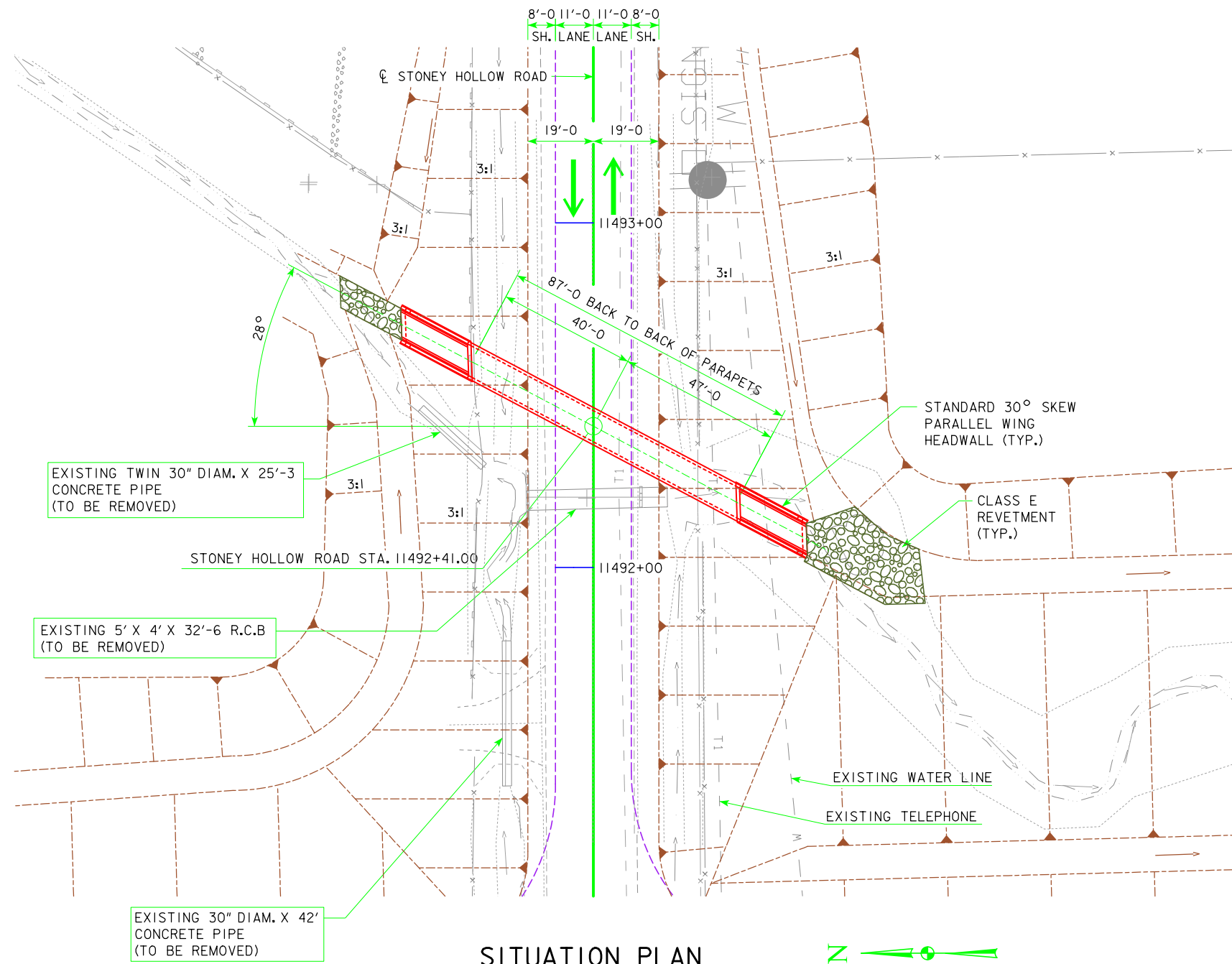

SITUATION PLAN

HYDRAULIC DATA

DRAINAGE AREA = 335 ACRES
 $Q_{50} = 300$ CFS
 HW ELEV. = 708.74
 STREAM SLOPE = 28.1 FT./MI.

NOTES:

- ALL UNITS IN FEET UNLESS NOTED OTHERWISE.
- DRAINAGE THROUGH EXISTING CULVERT/CHANNEL MUST BE MAINTAINED THROUGHOUT CONSTRUCTION.
- STAGED CONSTRUCTION DETAILS TO BE FINALIZED AS DESIGN PROGRESSES.

UTILITIES LEGEND:

- T1 TELEPHONE
- W WATER LINE

LOCATION

STONEY HOLLOW OVER
 DRAINAGE DITCH
 T-71N R-3W
 SECTION 23
 FRANKLIN TOWNSHIP
 DES MOINES COUNTY

TRAFFIC ESTIMATE

200_ AADT	-	V.P.D.
202_ AADT	-	V.P.D.
202_ DHV	-	V.P.H.
TRUCKS	-	%
TOTAL DESIGN ESALs	-	

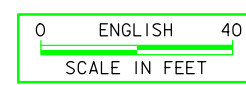

DESIGN FOR 28° SKEW (L.A.)
8' x 6' x 87'-0 REINFORCED CONCRETE BOX CULVERT
 SITUATION PLAN
 STONEY HOLLOW RD STA. 11492+41.00 MAY 2014
DES MOINES COUNTY
 IOWA DEPARTMENT OF TRANSPORTATION - HIGHWAY DIVISION
 DESIGN SHEET NO. 1 OF 1 FILE NO. _____ DESIGN NO. XXXX

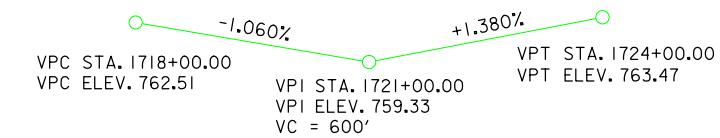
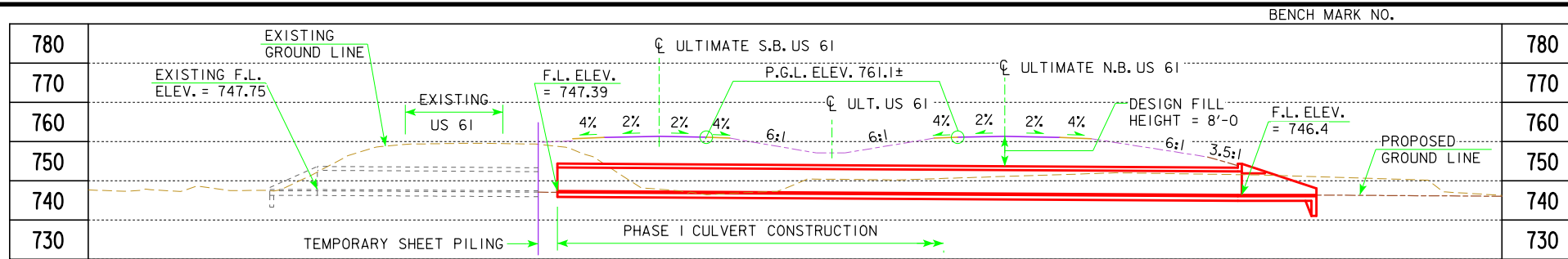

PROPOSED PROFILE GRADE ON ULTIMATE US 61

LONGITUDINAL SECTION ALONG ϕ CULVERT

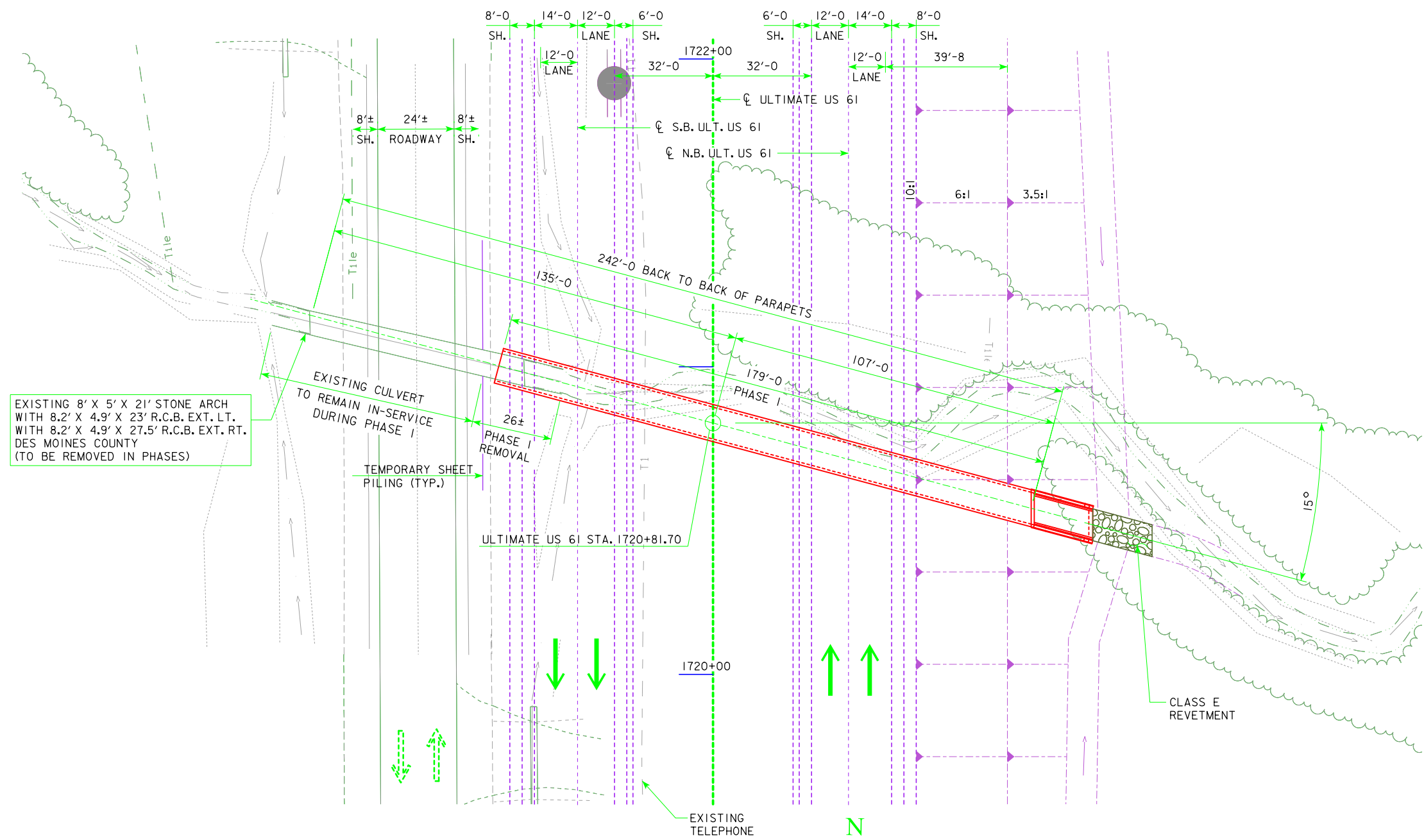

HYDRAULIC DATA

DRAINAGE AREA = 618 ACRES
 Q_{50} = 450 CFS
 HW ELEV. = 754.67
 STREAM SLOPE = 12.3 FT./MI.

NOTES:

- ALL UNITS IN FEET UNLESS NOTED OTHERWISE.
- DRAINAGE THROUGH EXISTING CULVERT/CHANNEL MUST BE MAINTAINED THROUGHOUT CONSTRUCTION.
- CULVERT LENGTH TO ACCOMMODATE ULTIMATE US 61 TO BE BUILT IN FUTURE CONSTRUCTION PHASES. CULVERT SHALL ALSO ACCOMMODATE EXISTING US 61 WHICH WILL REMAIN IN-SERVICE UNTIL FUTURE CONSTRUCTION PHASES ARE COMPLETE.
- STAGED CONSTRUCTION DETAILS TO BE FINALIZED AS DESIGN PROGRESSES.

UTILITIES LEGEND:

— T1 — TELEPHONE

LOCATION

US 61 OVER
 DRAINAGE DITCH
 T-72N R-3W
 SECTION 35
 YELLOW SPRING TOWNSHIP
 DES MOINES COUNTY

TRAFFIC ESTIMATE

200_ AADT	—	V.P.D.
202_ AADT	—	V.P.D.
202_ DHV	—	V.P.H.
TRUCKS	—	%
TOTAL DESIGN ESALS	—	

SITUATION PLAN

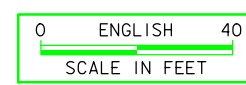
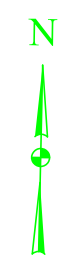

DESIGN FOR 15° SKEW (L.A.)
10' x 6' x 242'-0 REINFORCED CONCRETE BOX CULVERT
 SITUATION PLAN
 ULTIMATE US 61 STA. 1720+81.70 MAY 2014
DES MOINES COUNTY
 IOWA DEPARTMENT OF TRANSPORTATION - HIGHWAY DIVISION
 DESIGN SHEET NO. 1 OF 2 FILE NO. _____ DESIGN NO. XXXX

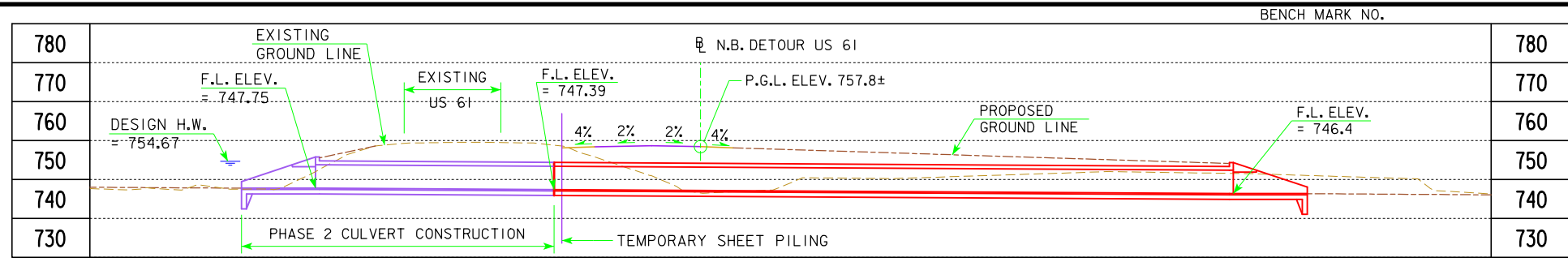

LONGITUDINAL SECTION ALONG ϕ CULVERT

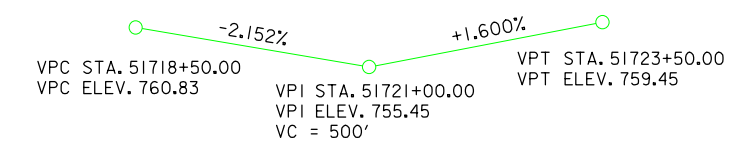

PROPOSED PROFILE GRADE ON DETOUR N.B. US 61

HYDRAULIC DATA

DRAINAGE AREA = 618 ACRES
 $Q_{50} = 450$ CFS
 HW ELEV. = 754.67
 STREAM SLOPE = 12.3 FT./MI.

NOTES:

- ALL UNITS IN FEET UNLESS NOTED OTHERWISE.
- DRAINAGE THROUGH EXISTING CULVERT/CHANNEL MUST BE MAINTAINED THROUGHOUT CONSTRUCTION.
- PHASE 2 CONSTRUCTION INCLUDES REMOVAL OF REMAINDER OF EXISTING CULVERT AND COMPLETING CONSTRUCTION OF PROPOSED CULVERT. EXISTING US 61 WILL BE IN-SERVICE DURING FUTURE TRAFFIC STAGING AND THEREFORE WILL NEED TO BE REPLACED AFTER CULVERT CONSTRUCTION IS COMPLETE.
- STAGED CONSTRUCTION DETAILS TO BE FINALIZED AS DESIGN PROGRESSES.

UTILITIES LEGEND:

— T1 — TELEPHONE

LOCATION

US 61 OVER DRAINAGE DITCH
 T-72N R-3W
 SECTION 35
 YELLOW SPRING TOWNSHIP
 DES MOINES COUNTY

TRAFFIC ESTIMATE

200_ AADT	—	V.P.D.
202_ AADT	—	V.P.D.
202_ DHV	—	V.P.H.
TRUCKS	—	%
TOTAL DESIGN ESALS	—	

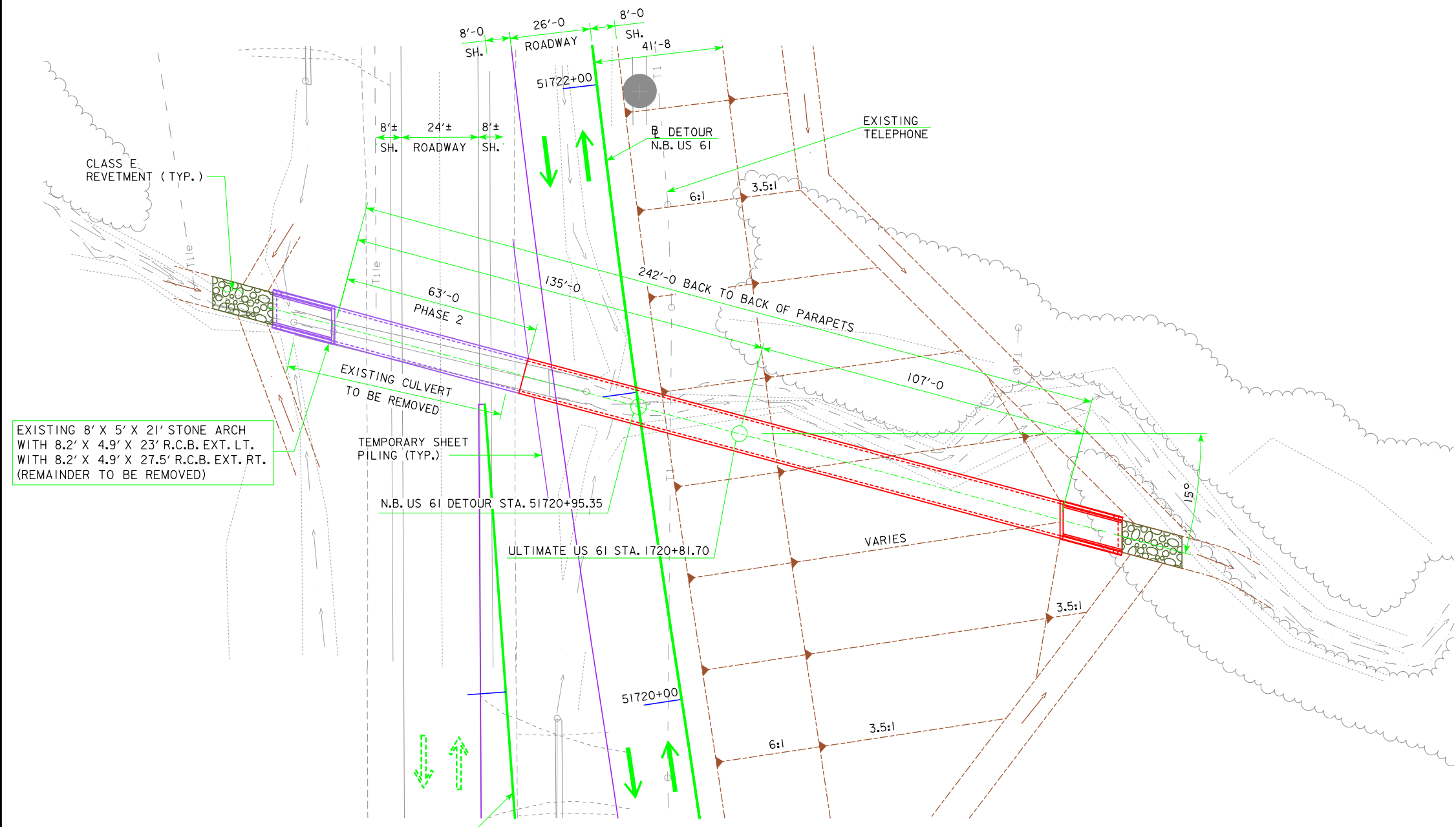

SITUATION PLAN

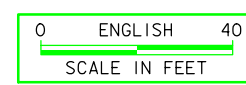
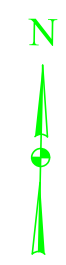

DESIGN FOR 15° SKEW (L.A.)
10' x 6' x 242'-0 REINFORCED CONCRETE BOX CULVERT
 SITUATION PLAN
 ULTIMATE US 61 STA. 1720+81.70
 DES MOINES COUNTY
 IOWA DEPARTMENT OF TRANSPORTATION - HIGHWAY DIVISION
 DESIGN SHEET NO. 2 OF 2 FILE NO. _____ DESIGN NO. XXXX
 MAY 2014

LINE STYLE LEGEND OF CROSS SECTION SHEETS (ROAD)

- - - - - - Existing Ground Line
- Proposed Template
- Proposed Topsoil Placement
- - - - - Additional Topsoil Removal
- Subgrade Treatment
- - - - - Granular Shoulder
- Pavement
- - - - - Existing Pipe\RCB
- Proposed Pipe\RCB
- Proposed Dike
- All Elements Associated with Proposed Entrances

LINE STYLE LEGEND OF CROSS SECTION SHEETS (SOILS)

- TS——— Topsoil (Class 10)
- TS A——— Topsoil (Type A Disposal)
- TS B——— Topsoil (Type B Disposal)
- TS C——— Topsoil (Type C Disposal)
- CL 10——— Class 10 Materials
- SEL LO——— Select Loams And Clay-Loams
- SEL SA——— Select Sand
- UNS A——— Unsuitable Type A Disposal
- UNS B——— Unsuitable Type B Disposal
- UNS C——— Unsuitable Type C Disposal
- SHALE——— Shale
- WASTE——— Waste
- B&W LS——— Broken and Weathered Rock
- ROCK——— Solid Rock
- BLDRS——— Boulders

Note: All layer lines and descriptions identify layers above the line.

Note: Vertical or near vertical lines connecting soil layers at edges of cross sections are only for the purpose of calculating template quantities and do not depict soil stratification.

SYMBOL LEGEND OF CROSS SECTION SHEETS

- Existing ROW
|
Existing Right-of-Way Limit
- Proposed ROW
|
Proposed Right-of-Way Limit
- Temporary ROW
|
Temporary Right-of-Way Limit

**CROSS SECTION
LEGEND AND SYMBOL
INFORMATION SHEET**

(COVERS SHEET SERIES W, X, Y, & Z)

US 61 Preliminary

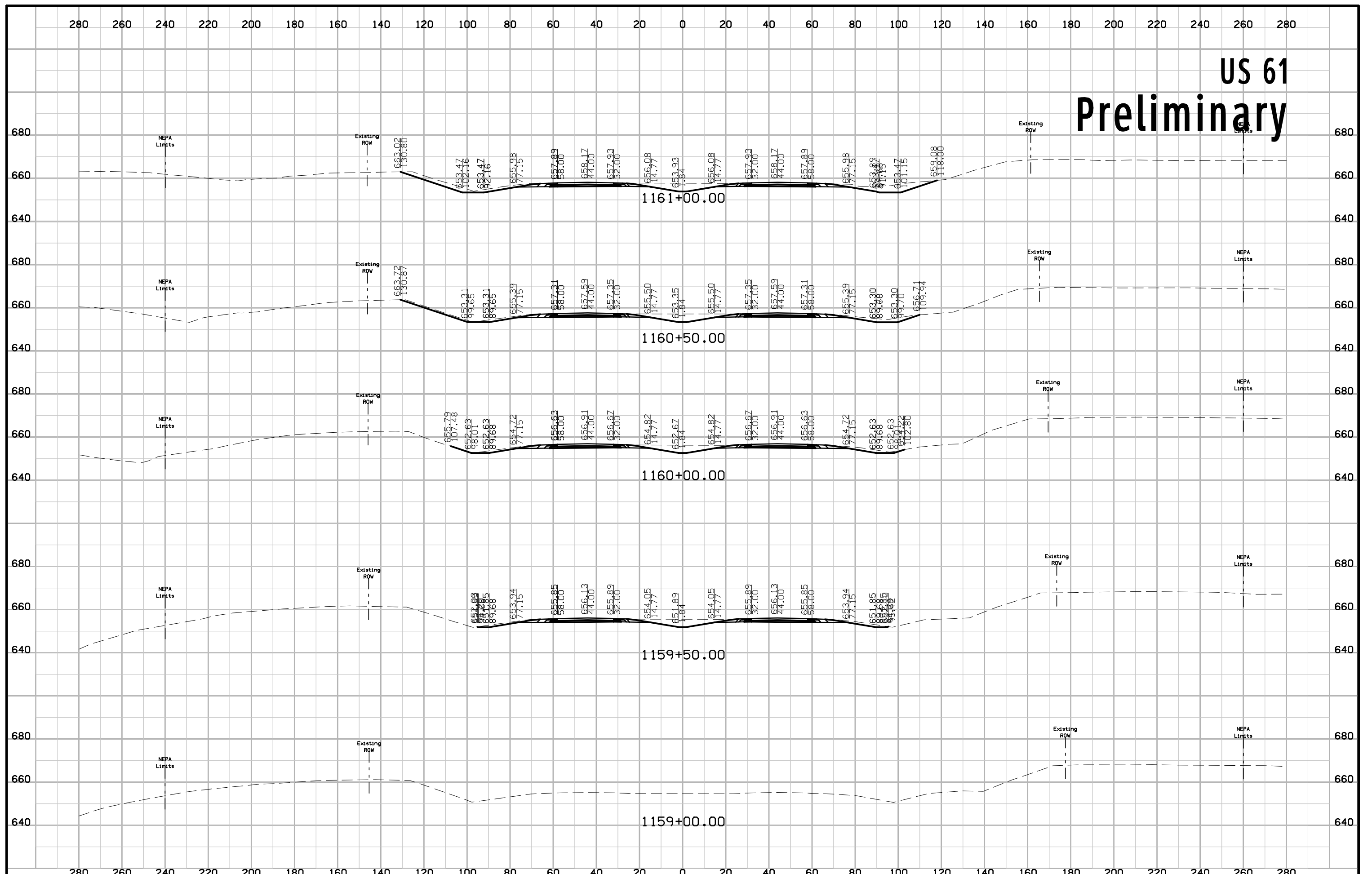

US 61 Preliminary

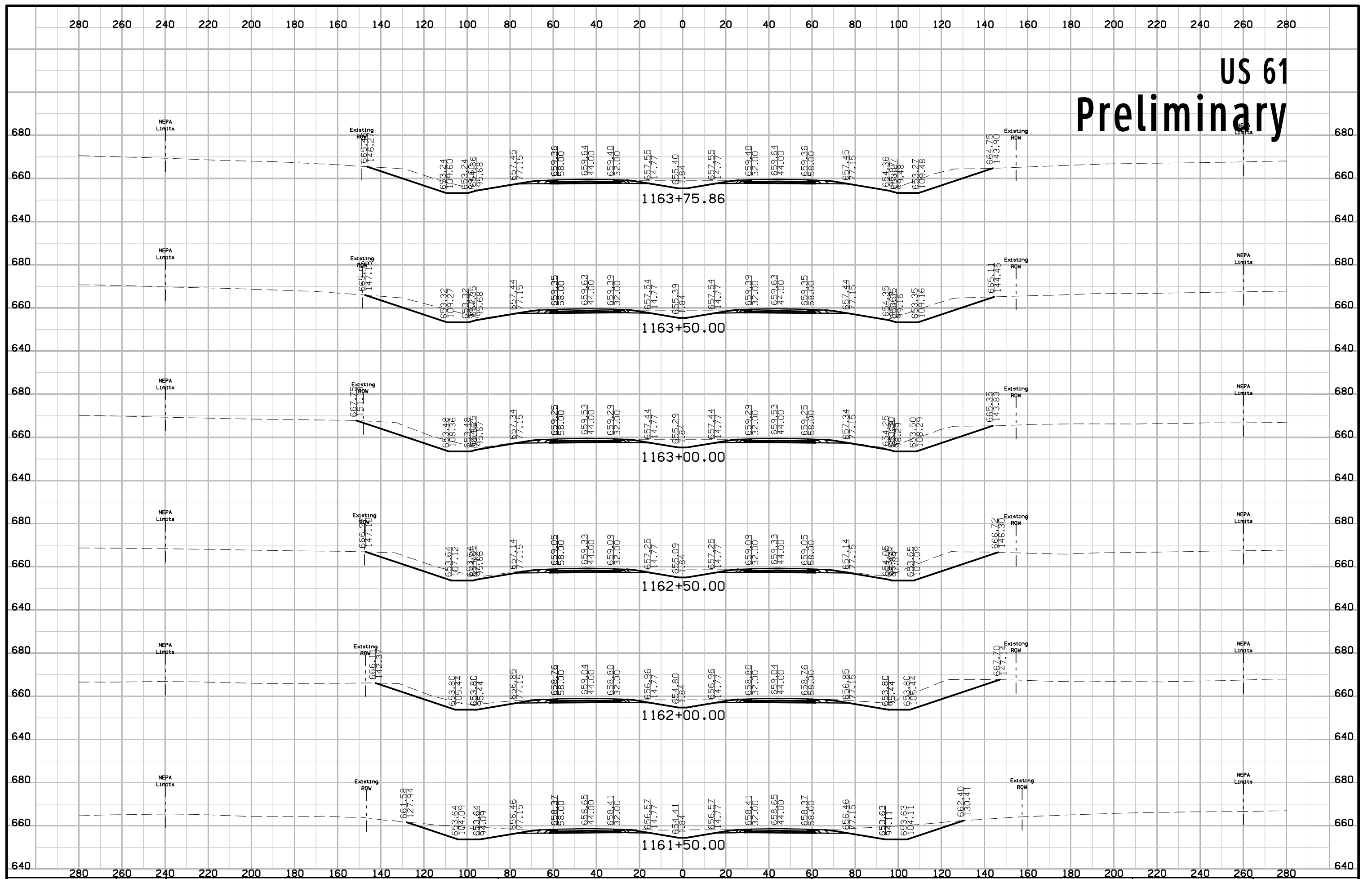

US 61 Preliminary

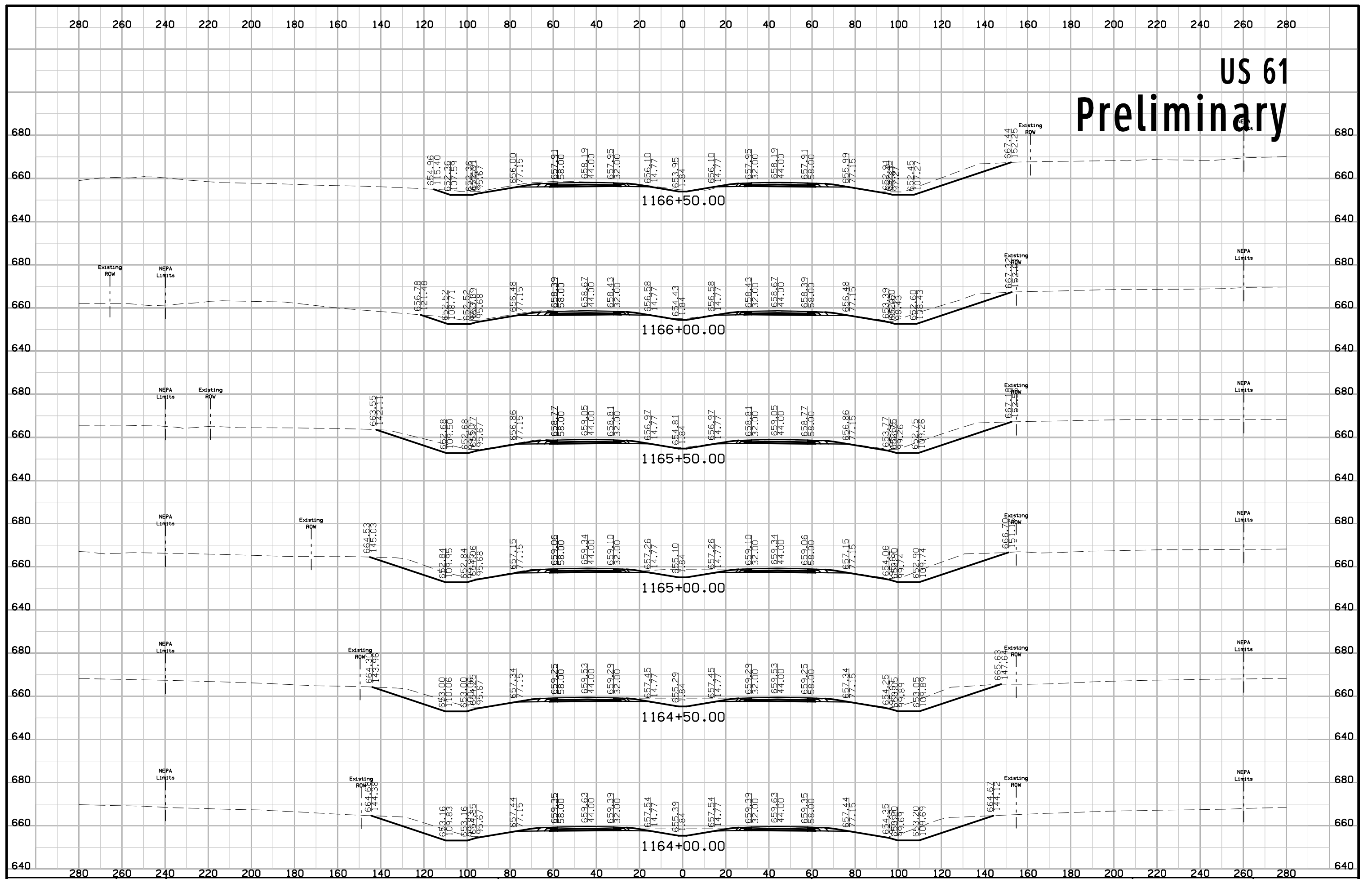

US 61 Preliminary

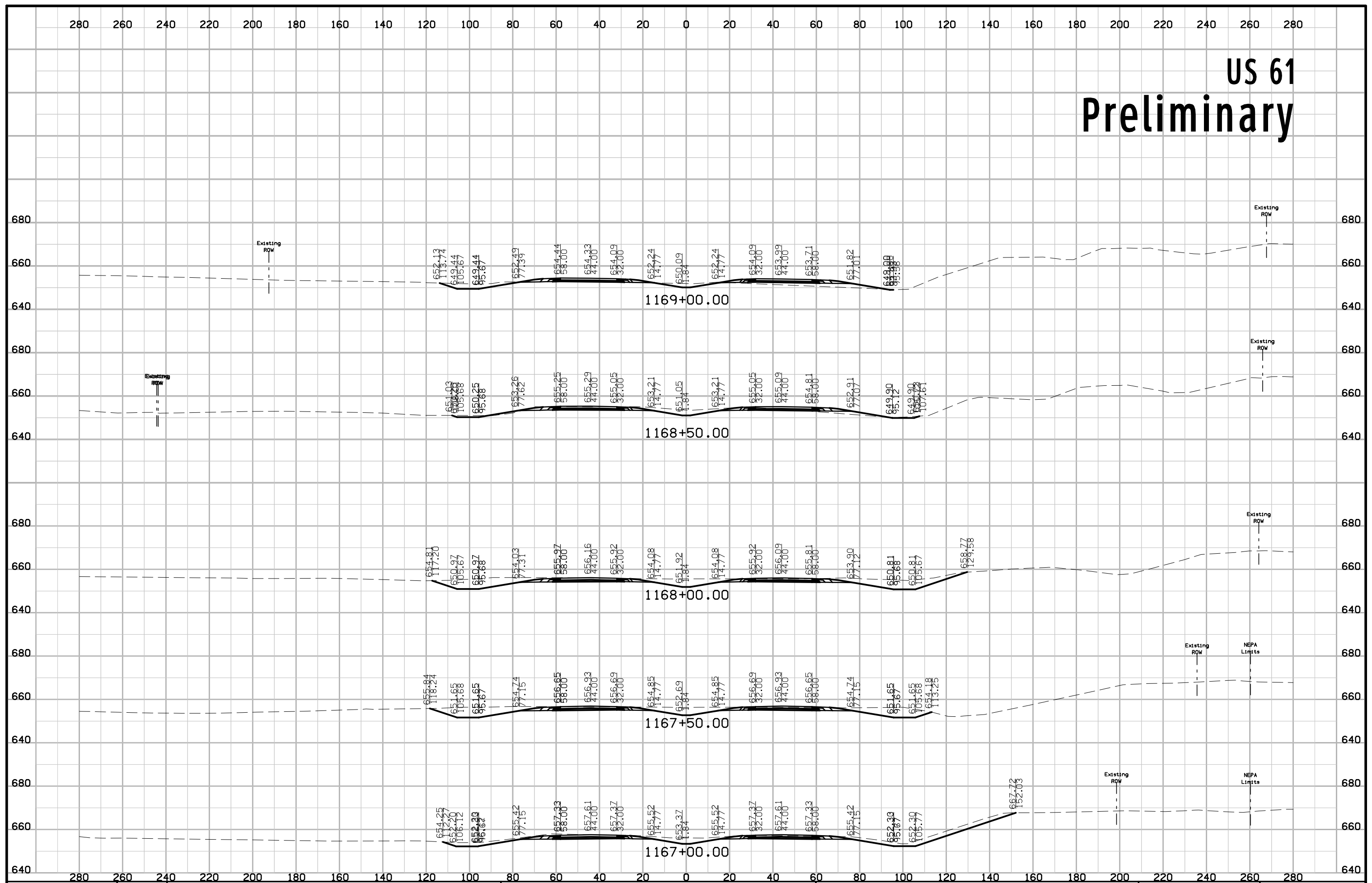

US 61 Preliminary

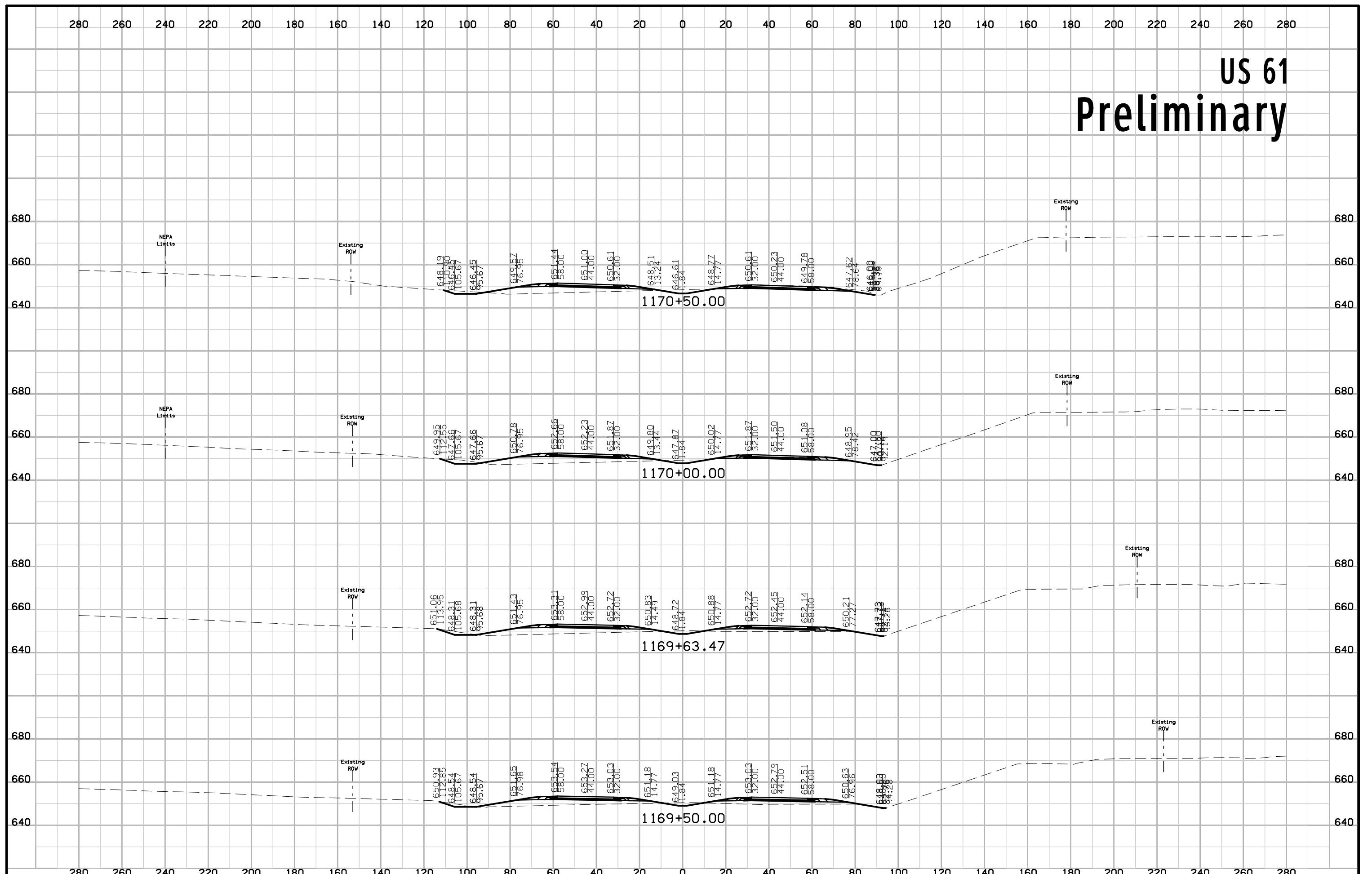

US 61 Preliminary

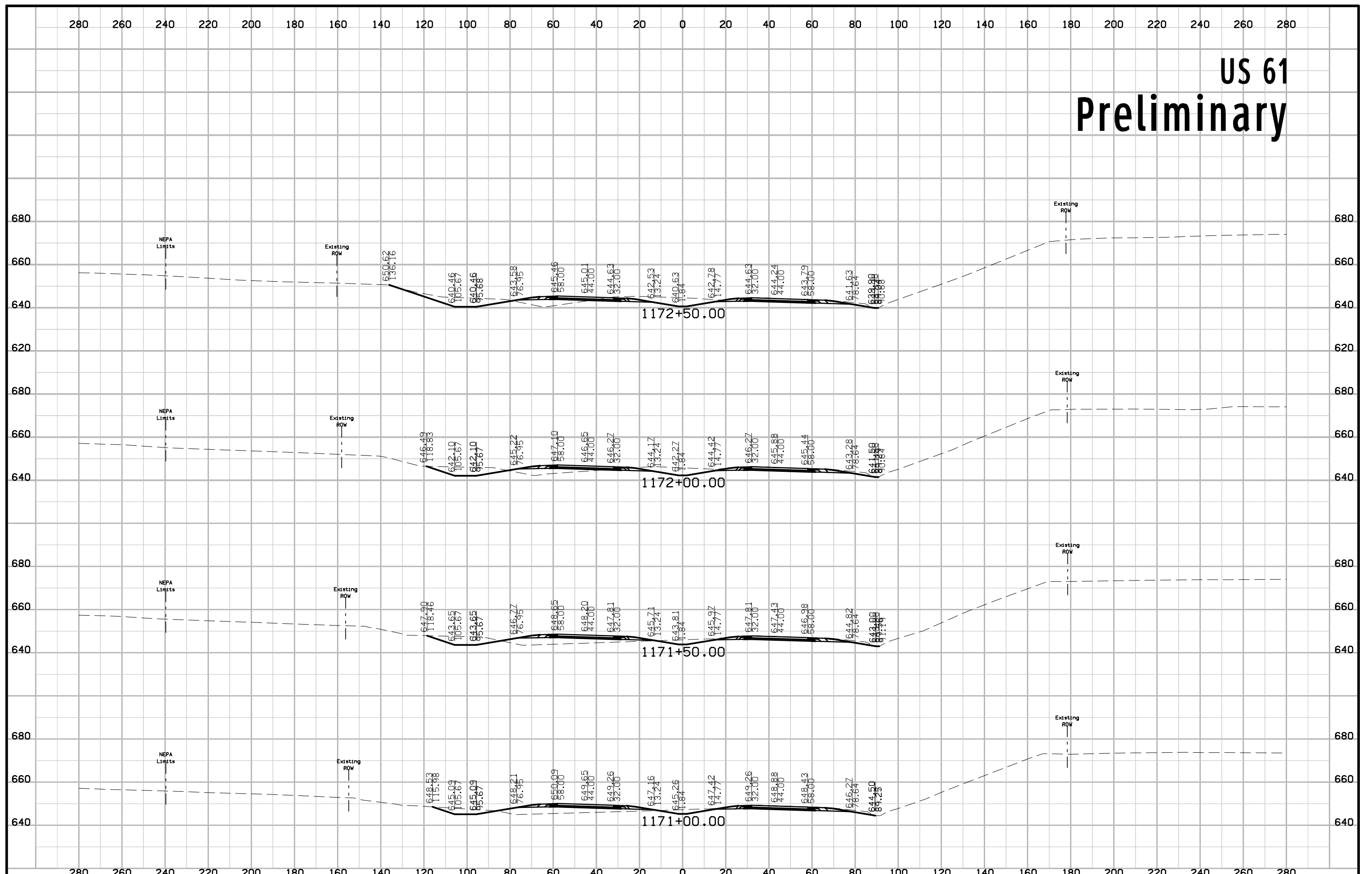

US 61 Preliminary

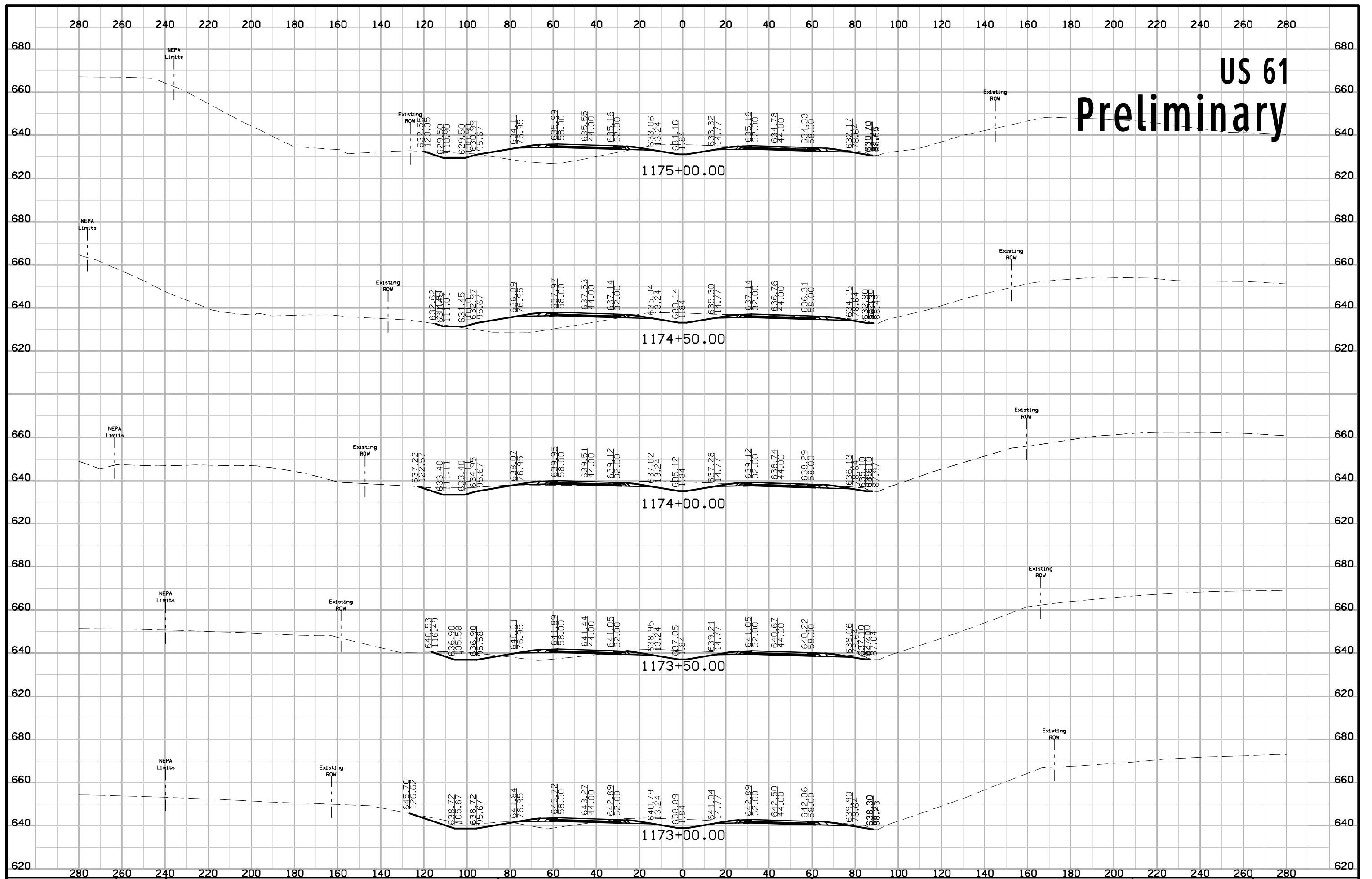

US 61 Preliminary

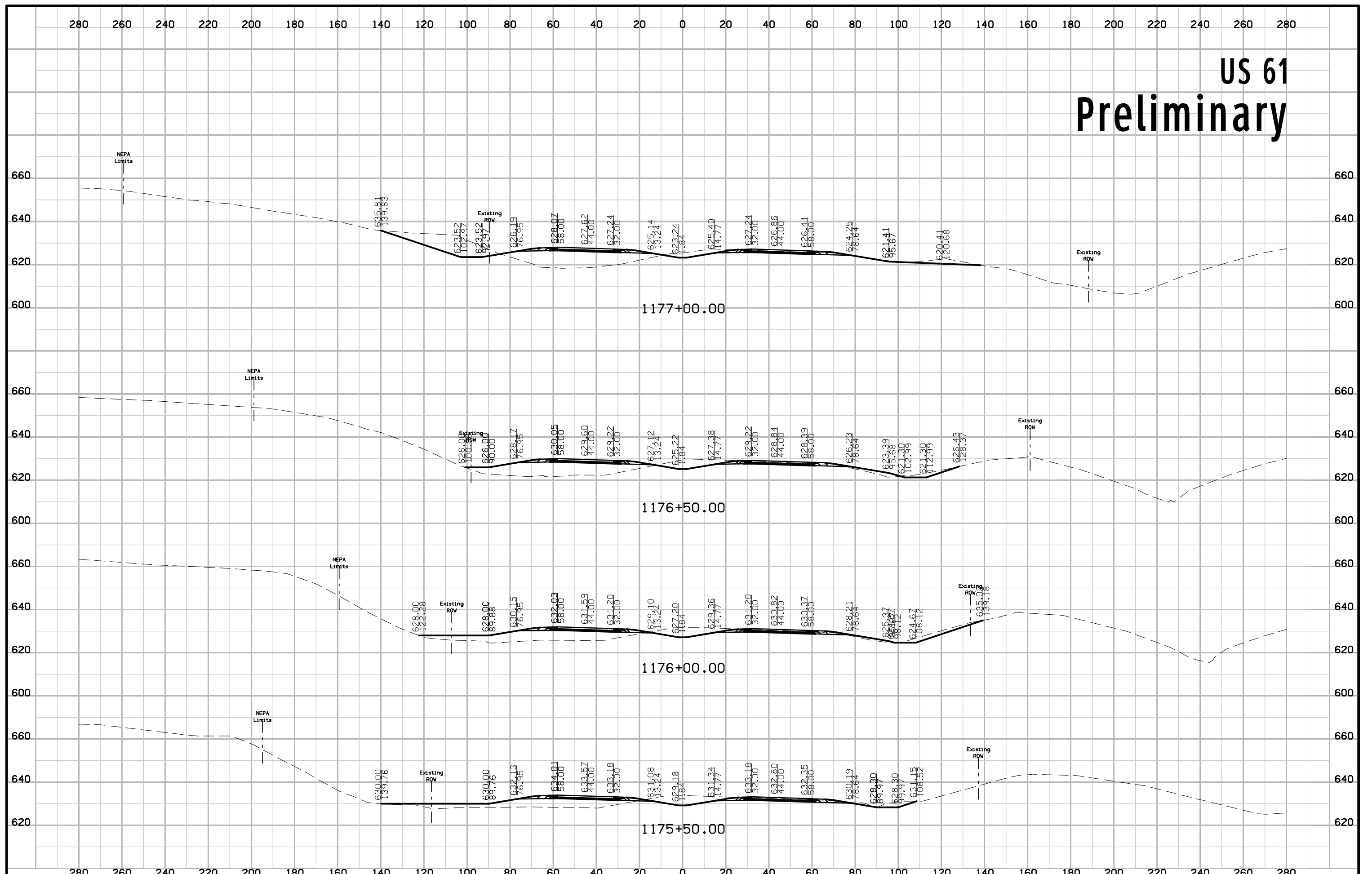

US 61 Preliminary

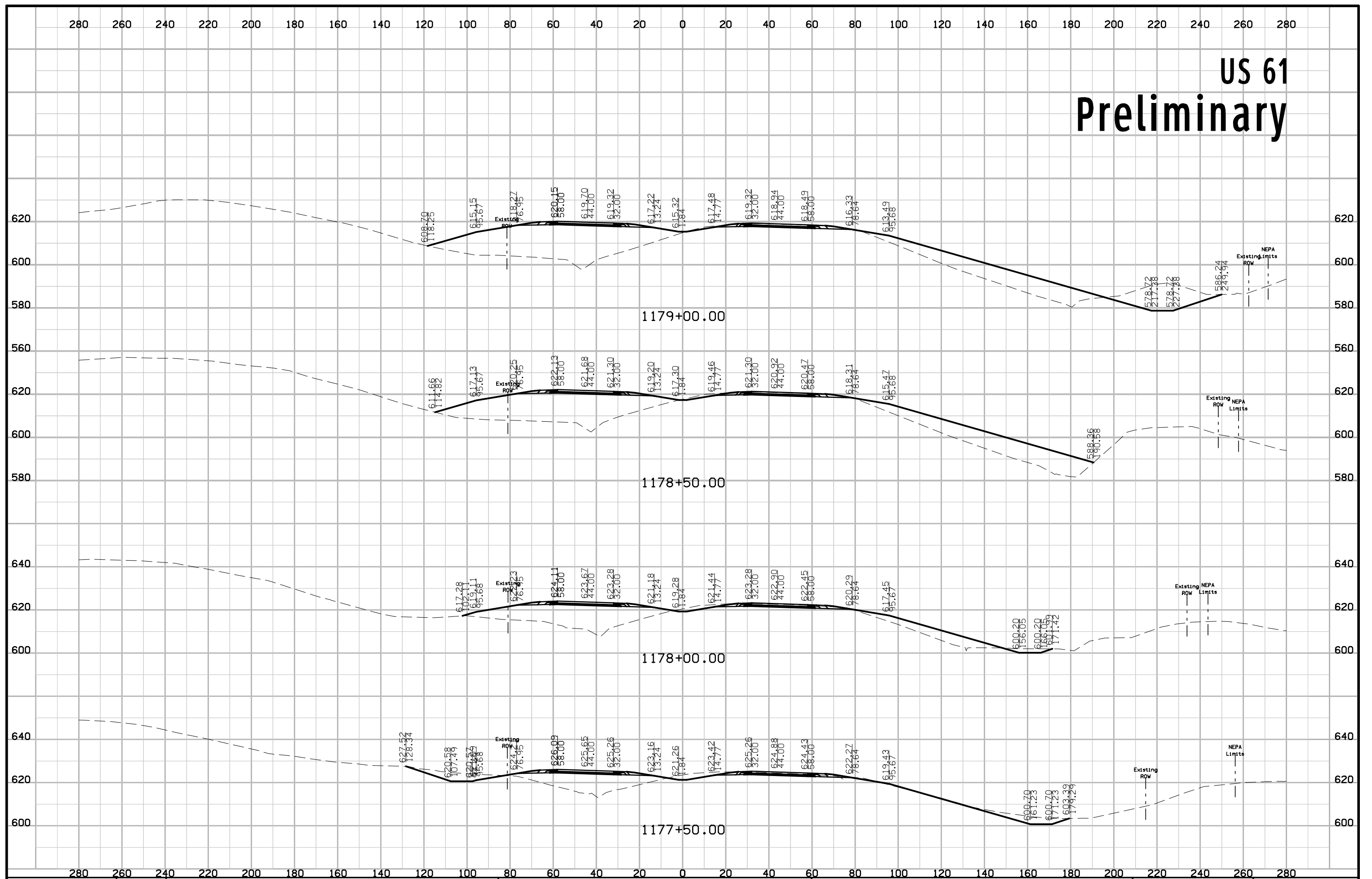

US 61 Preliminary

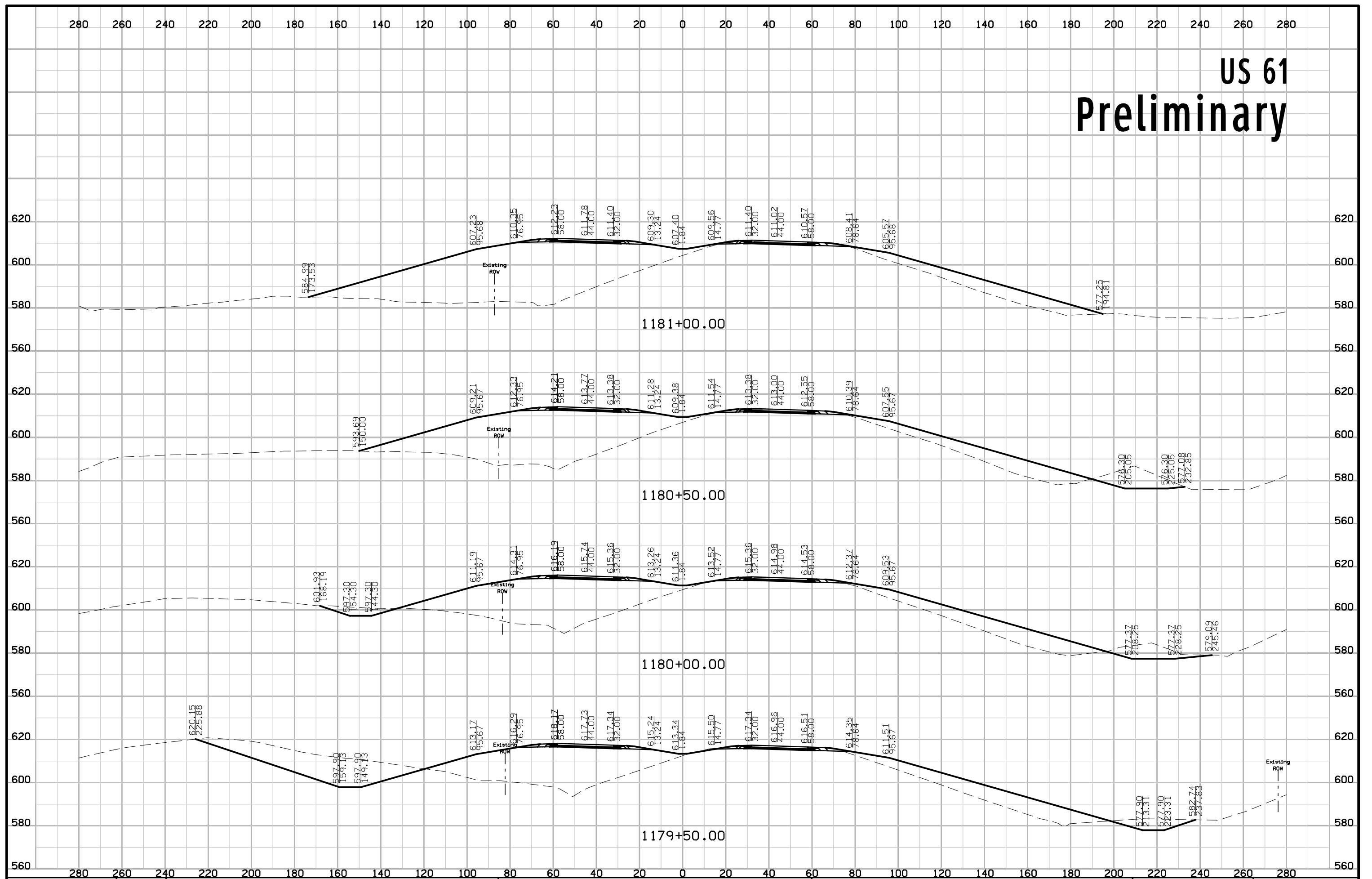

US 61 Preliminary

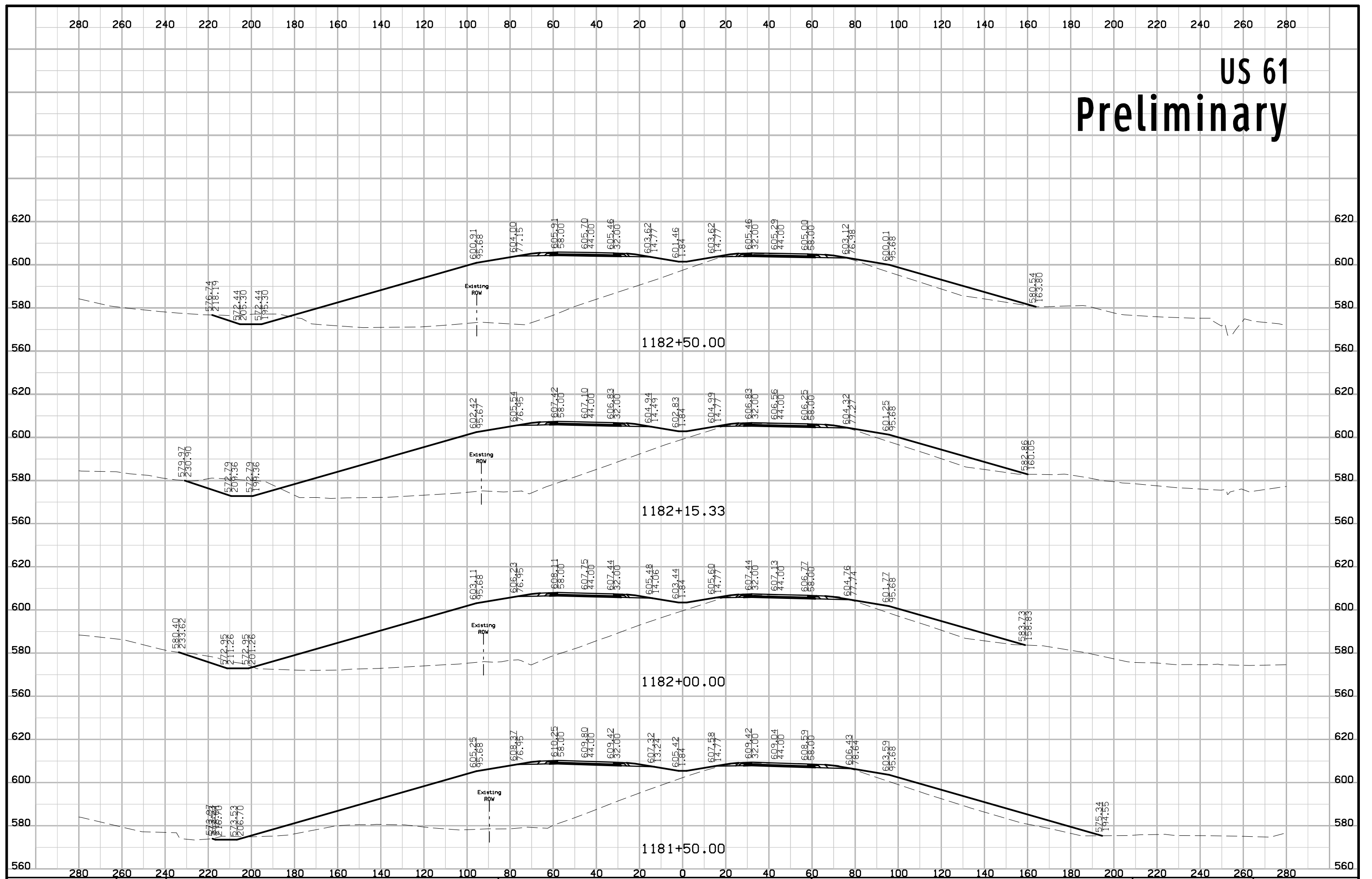

US 61 Preliminary

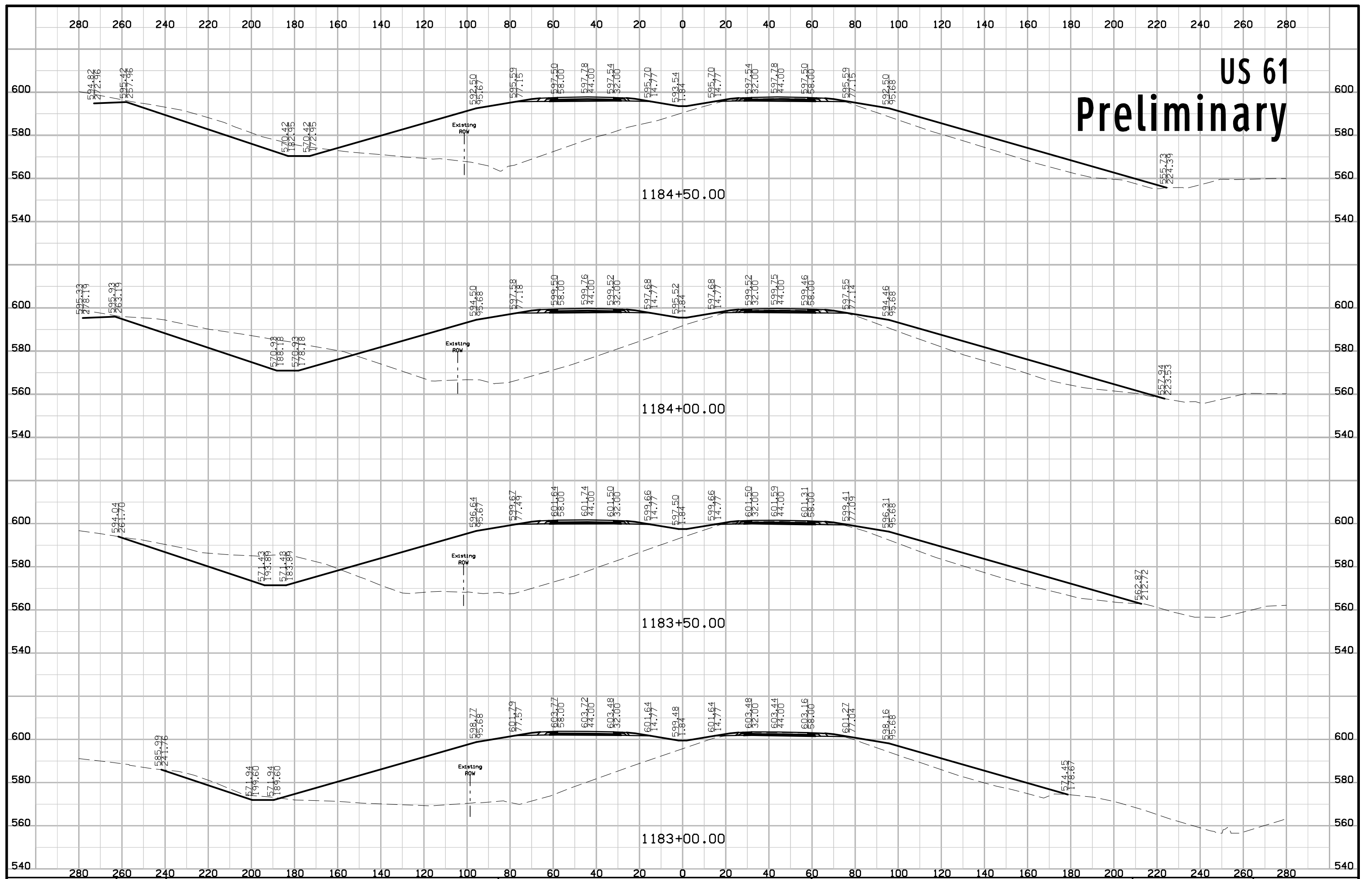

US 61 Preliminary

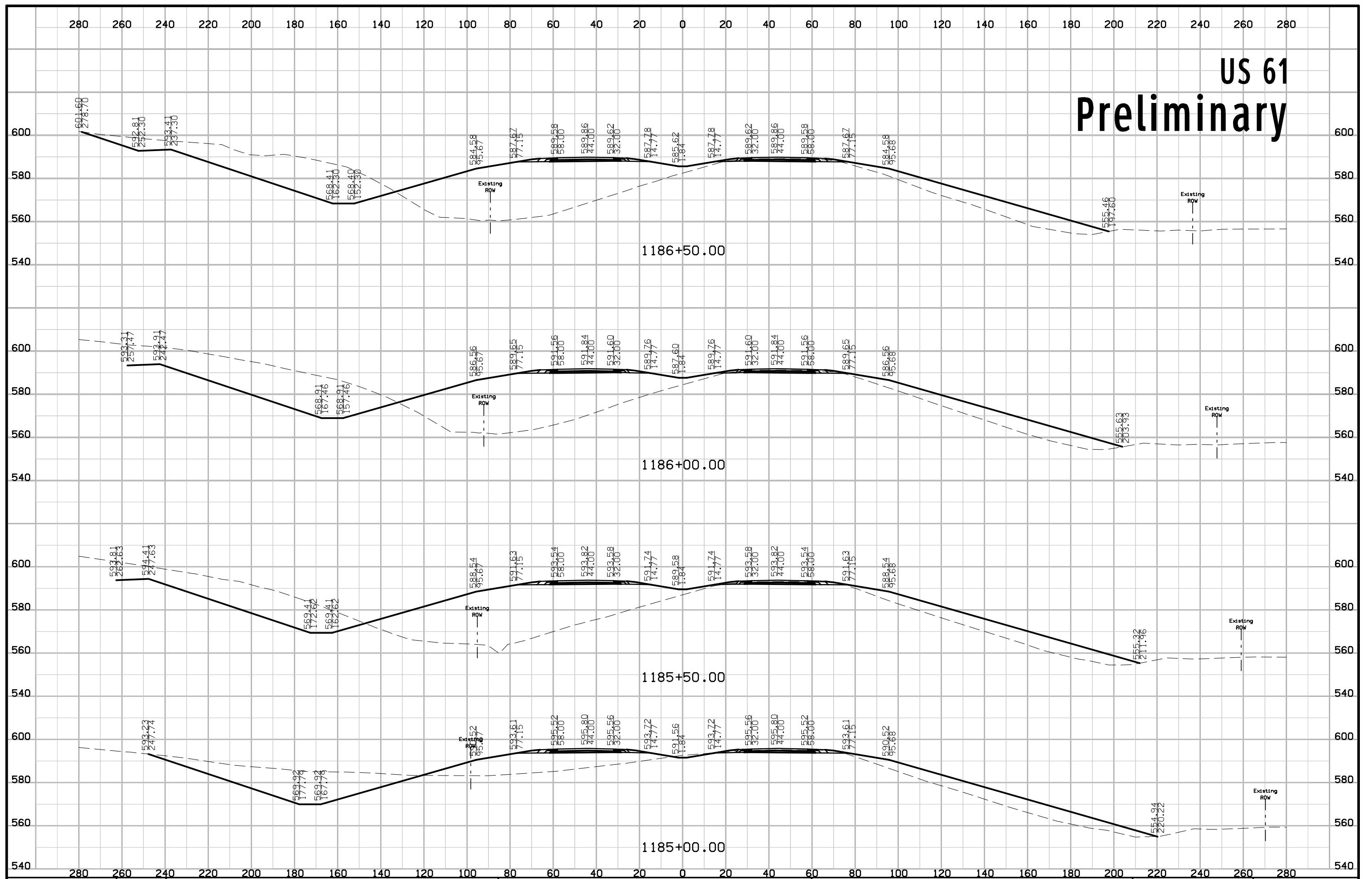

US 61 Preliminary

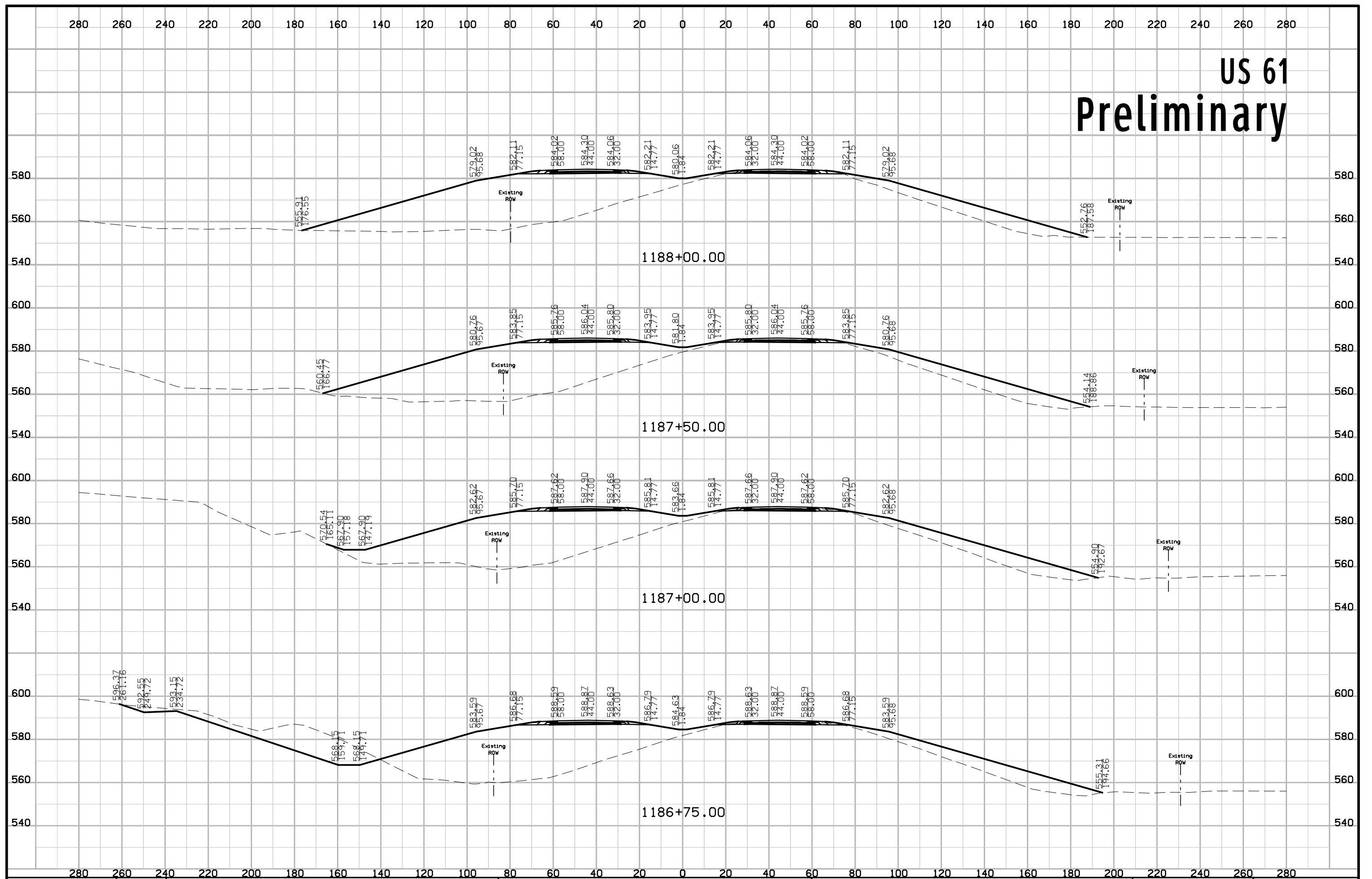

US 61 Preliminary

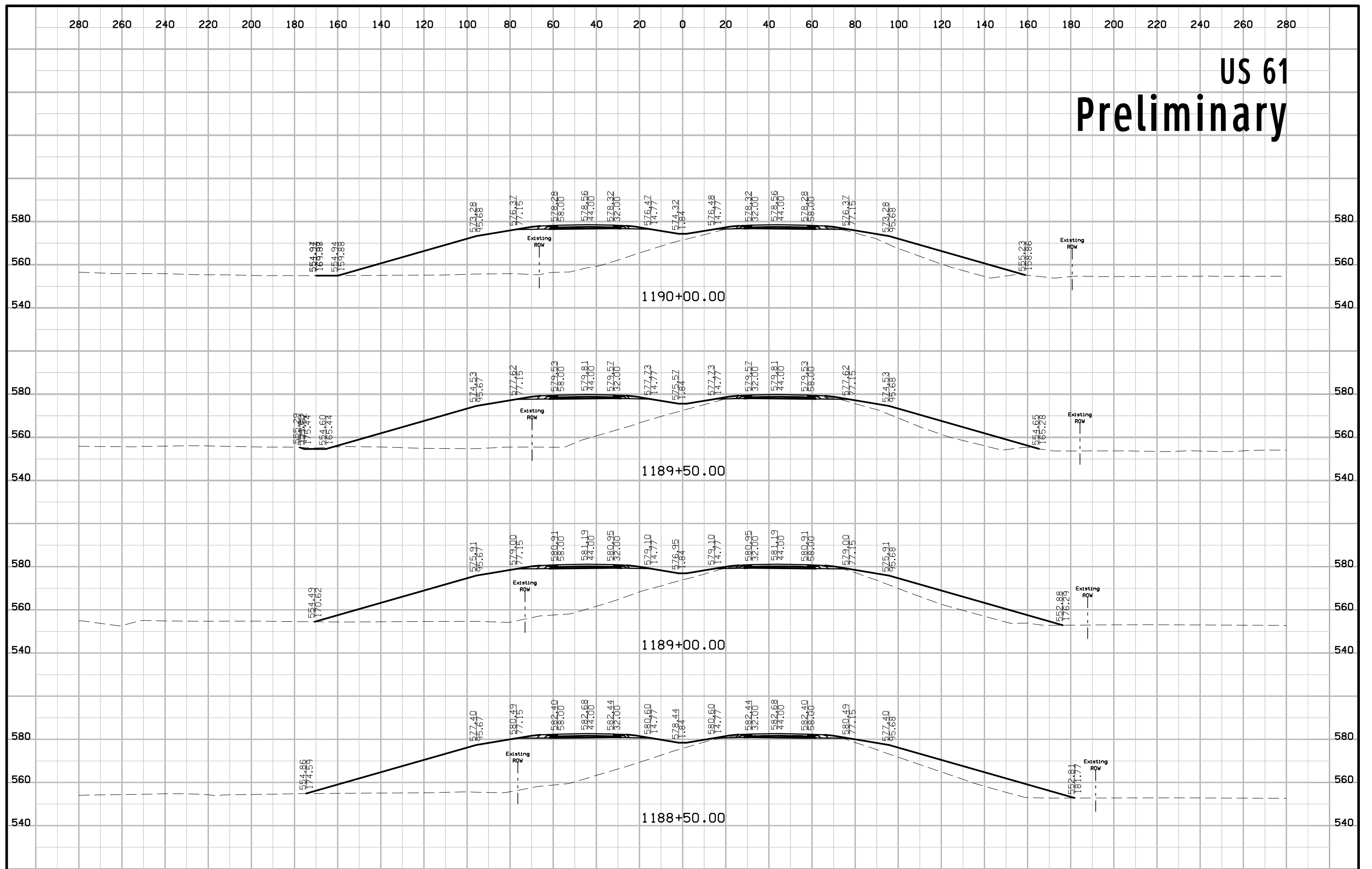

US 61 Preliminary

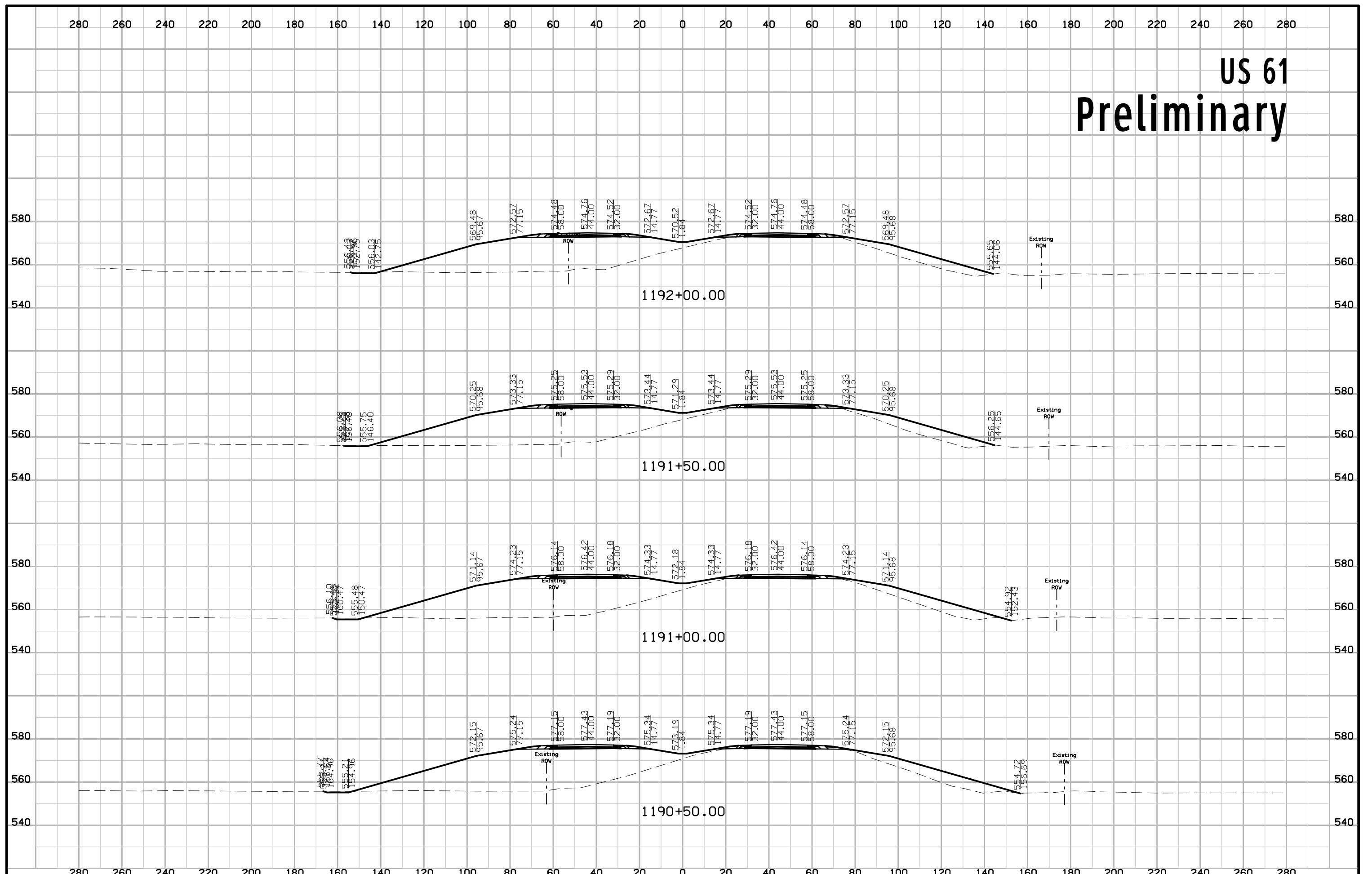

US 61 Preliminary

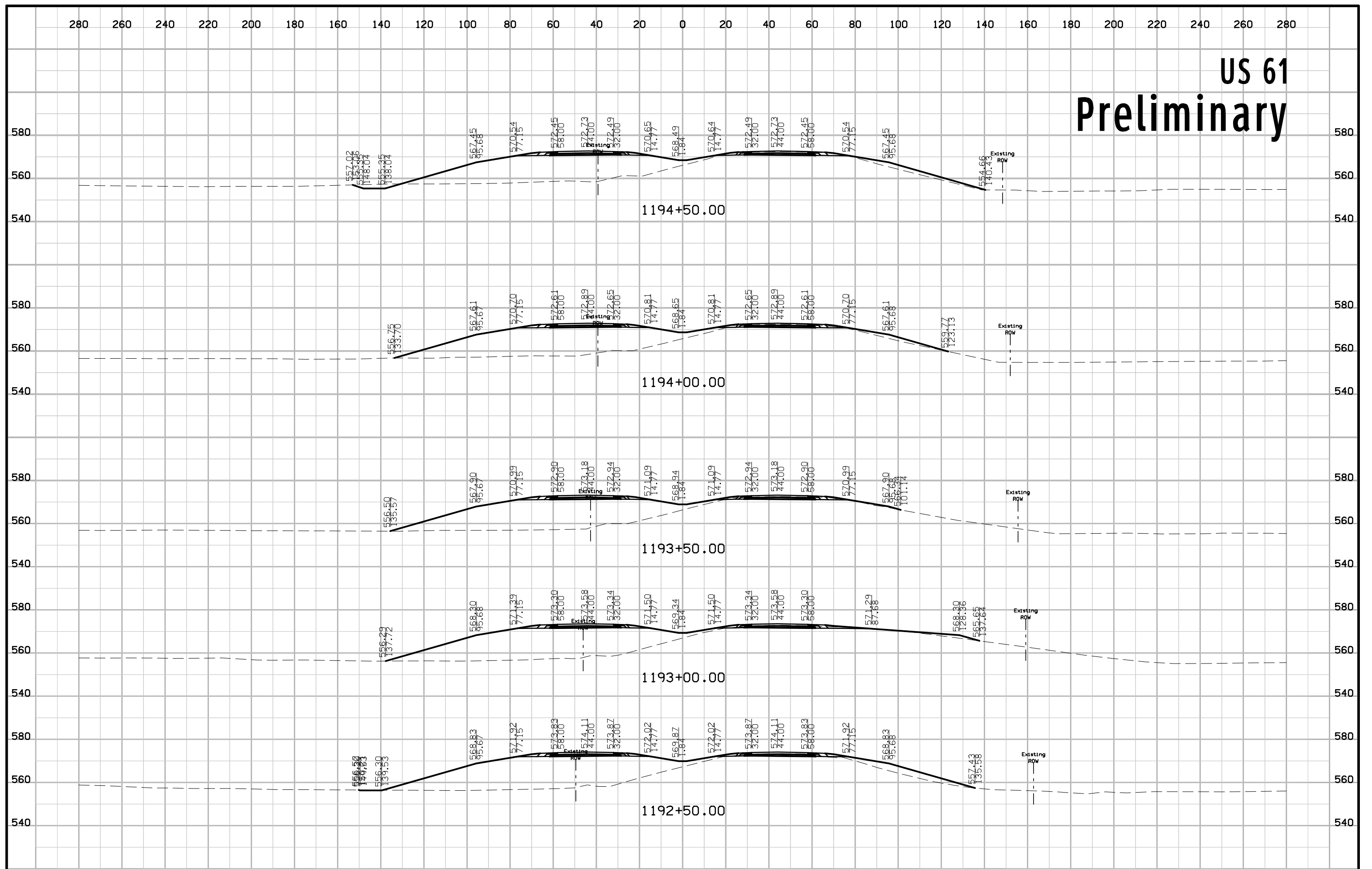

US 61 Preliminary

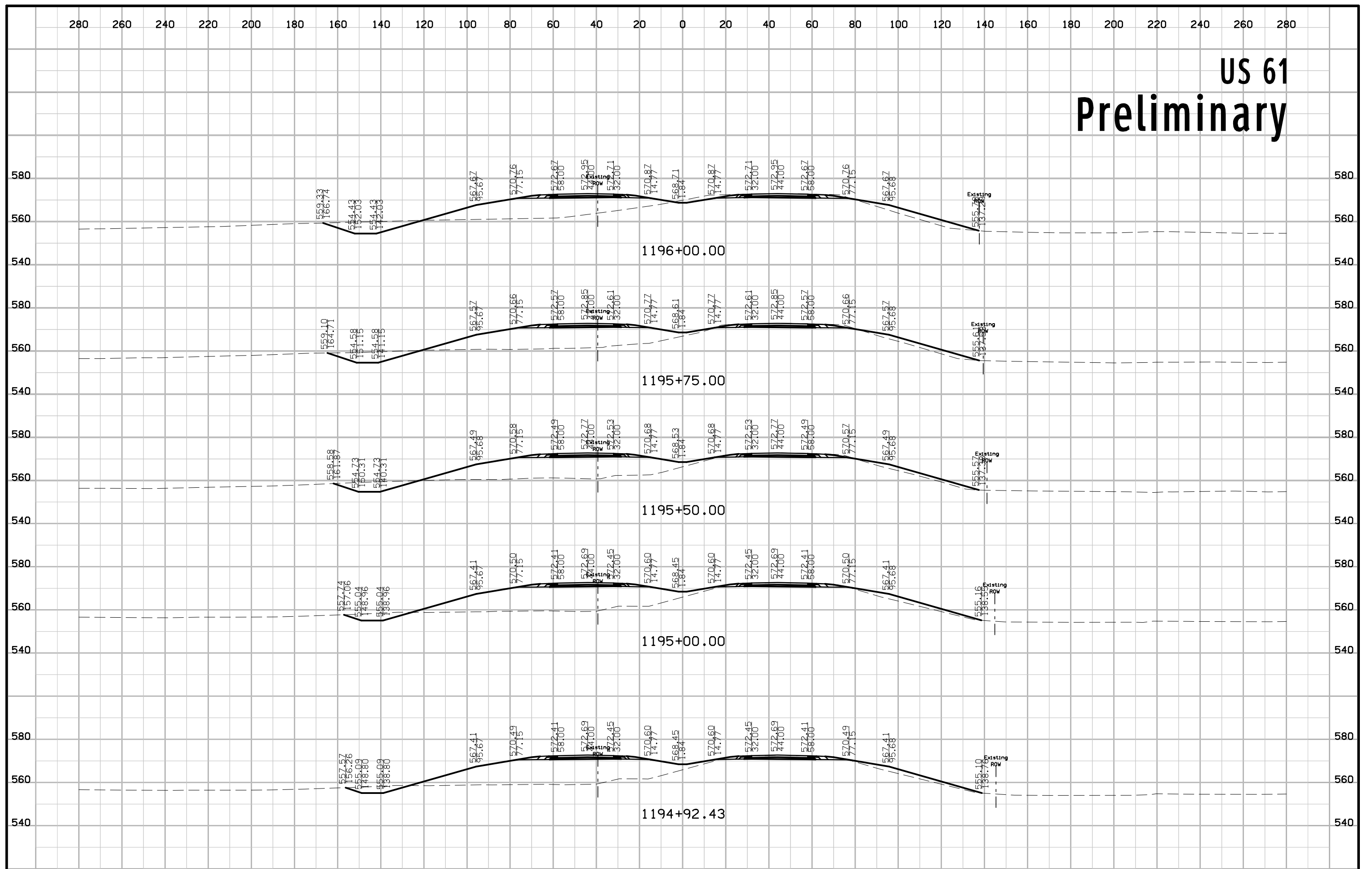

US 61 Preliminary

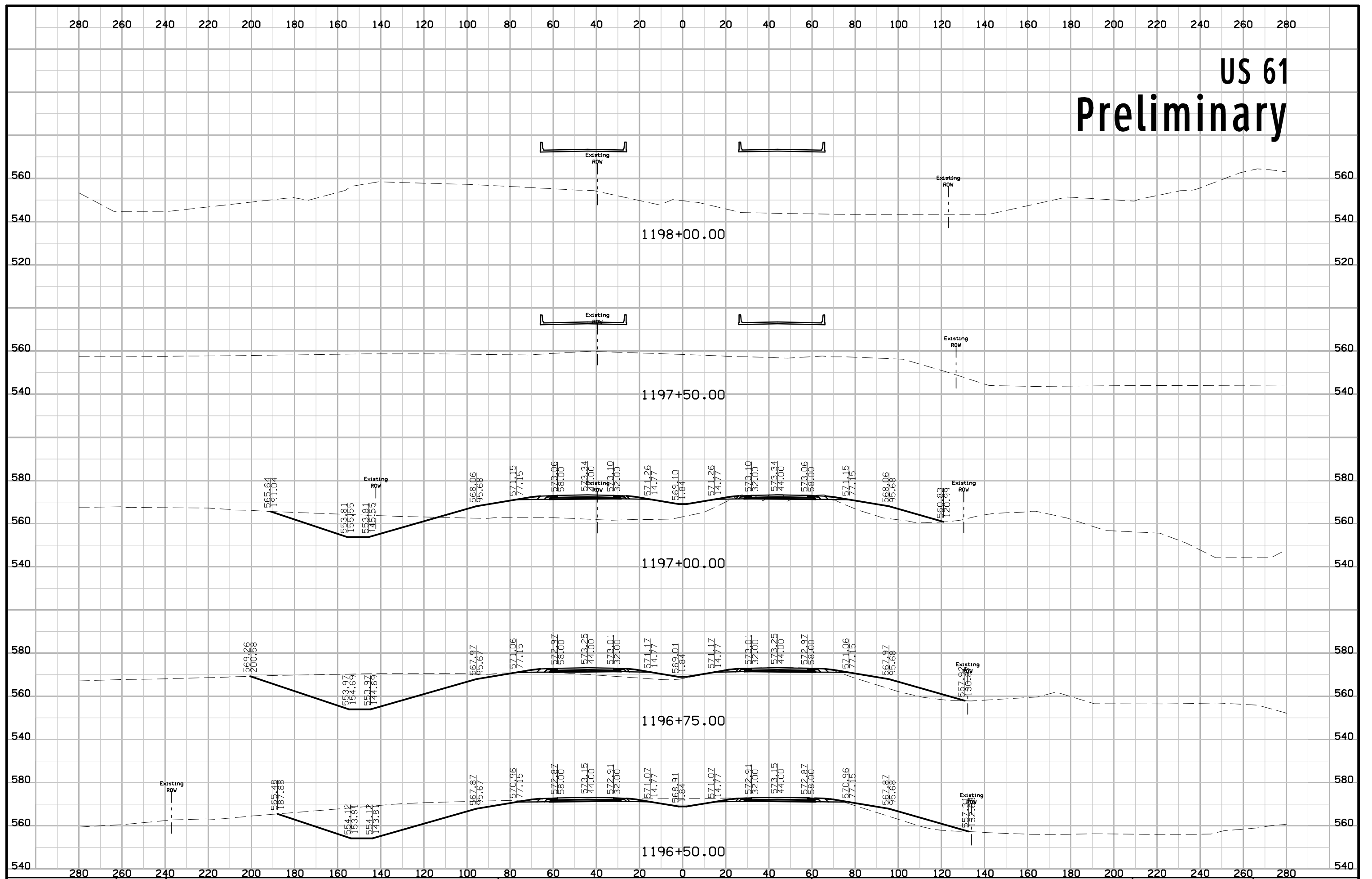

US 61 Preliminary

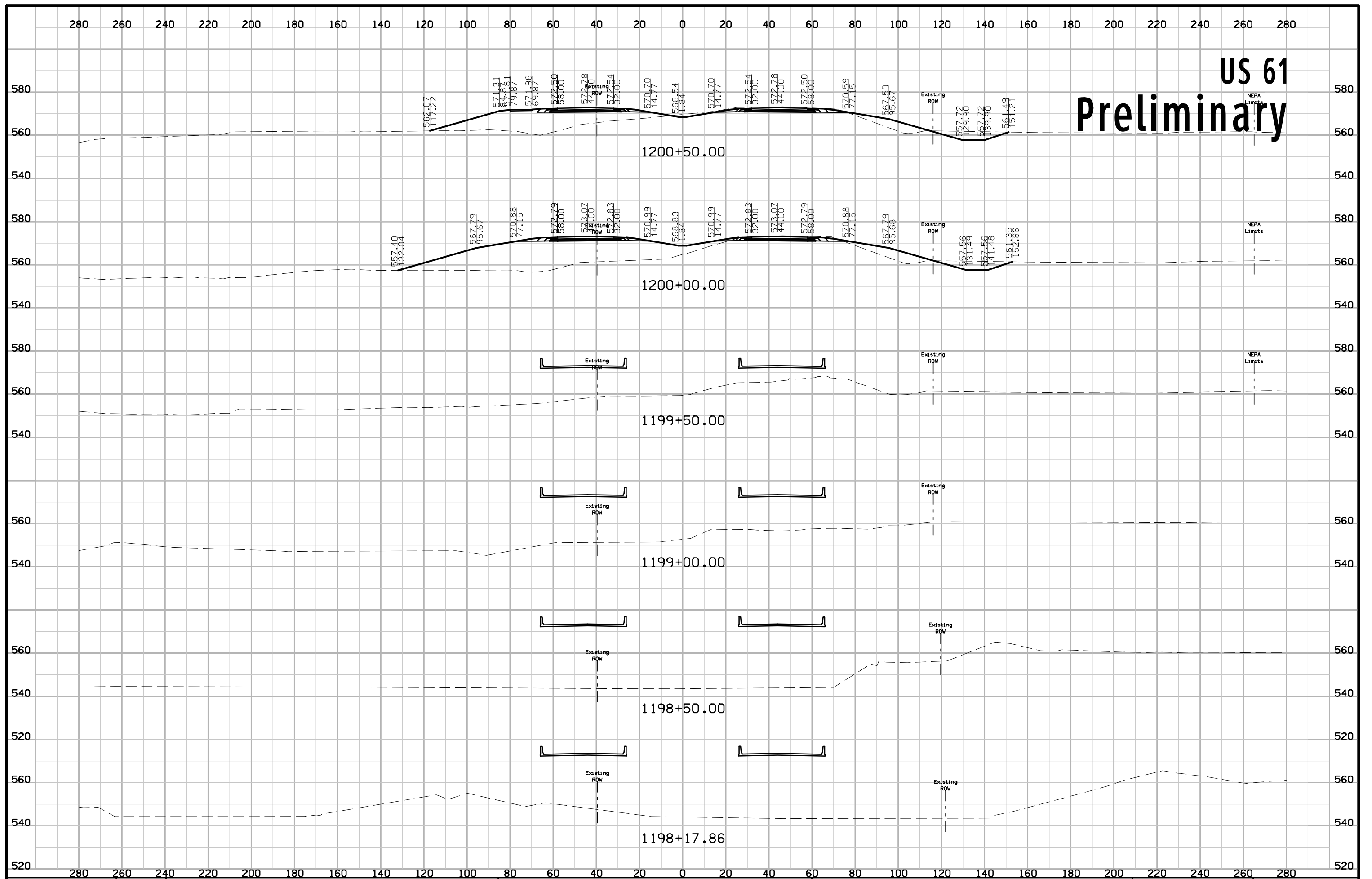

US 61 Preliminary

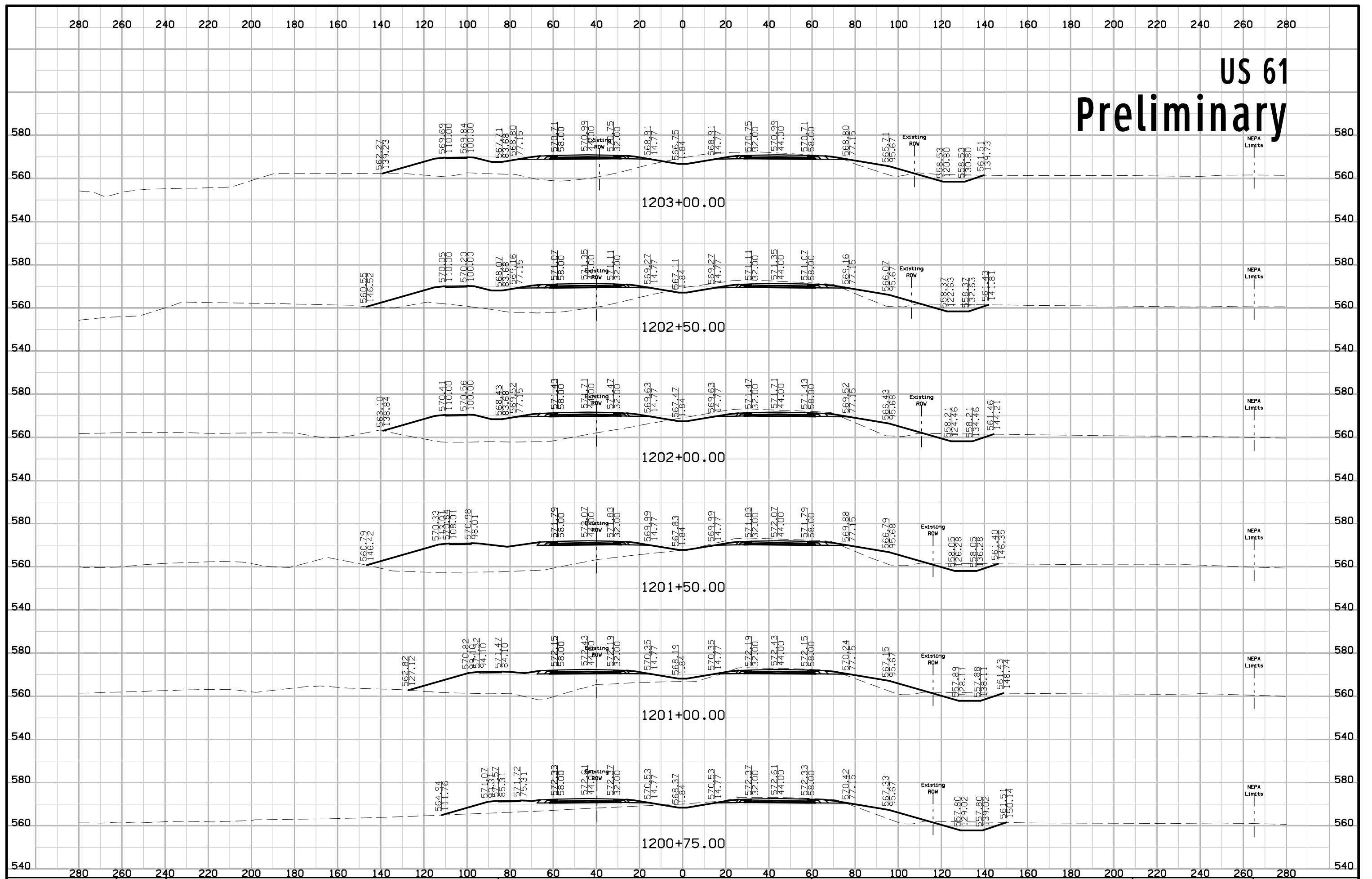

US 61 Preliminary

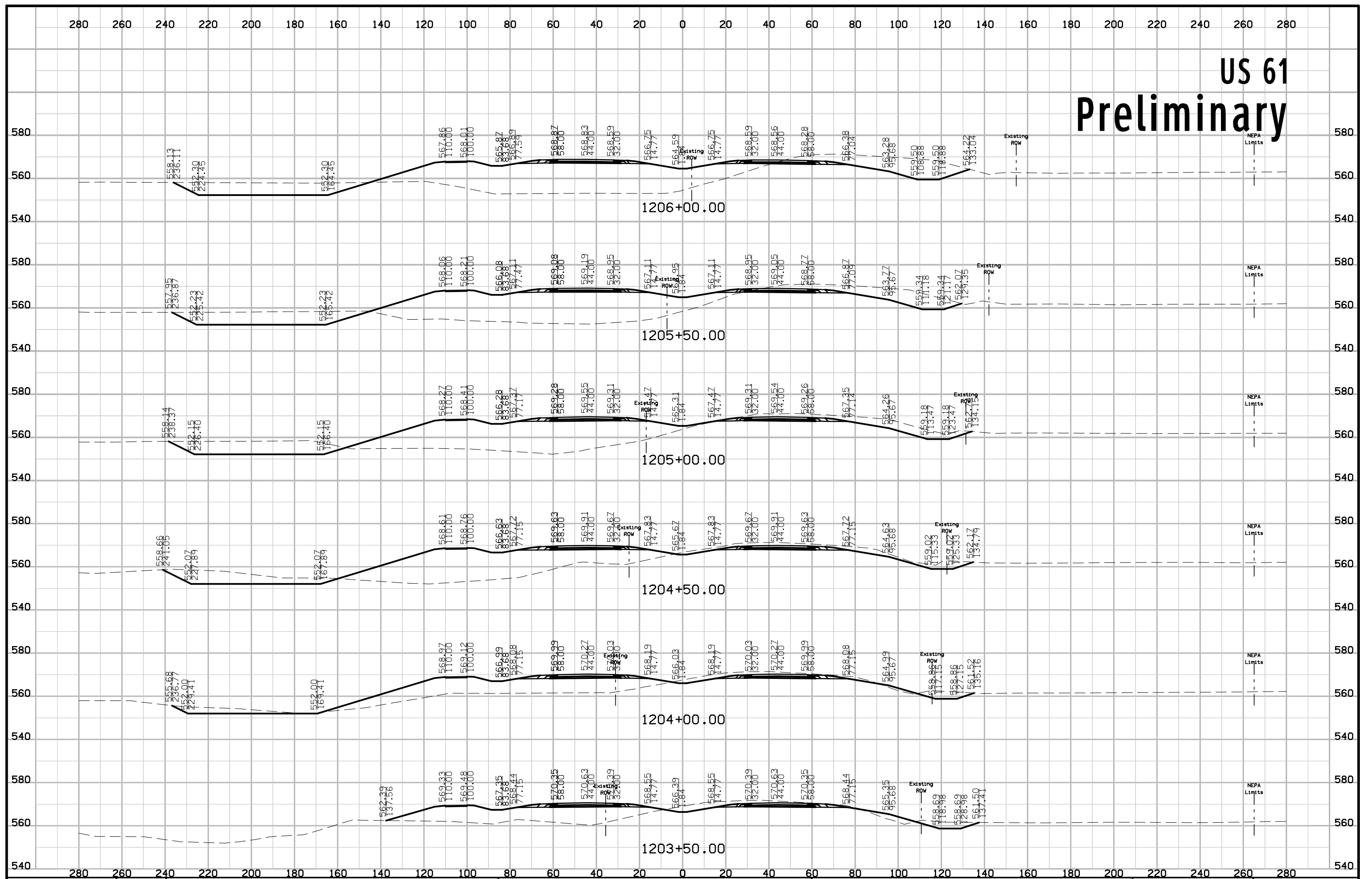

US 61 Preliminary

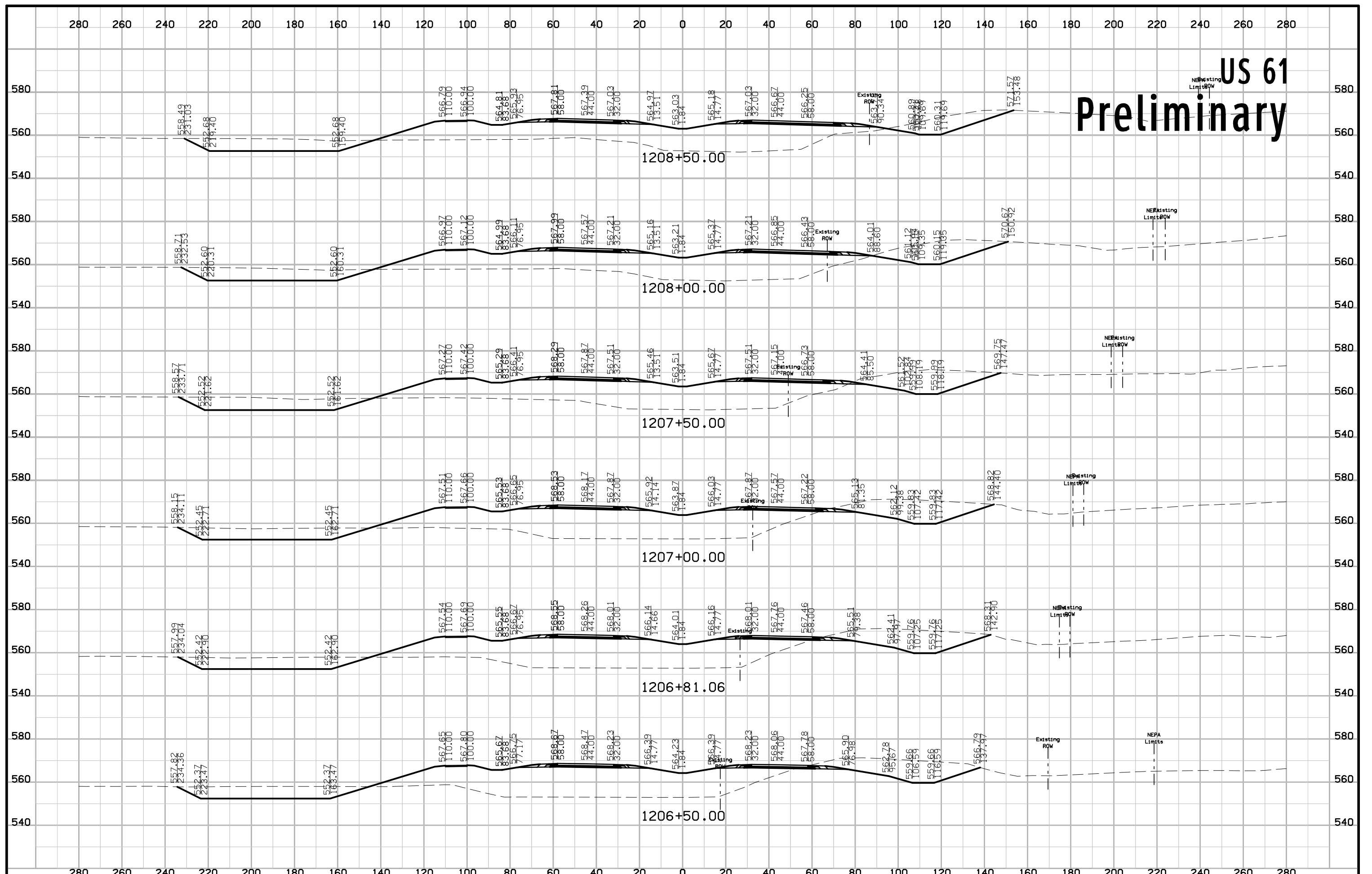

US 61 Preliminary

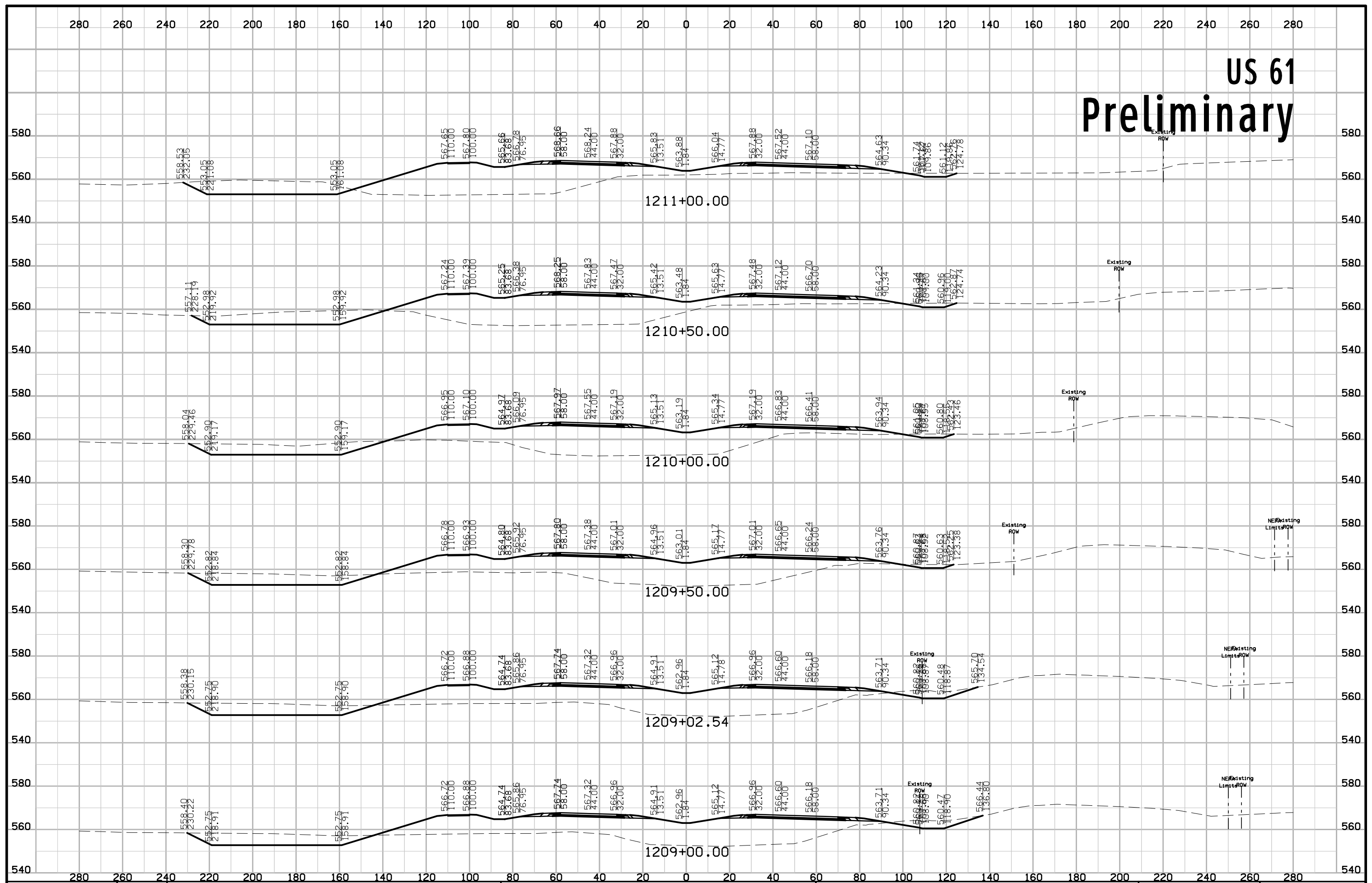

US 61 Preliminary

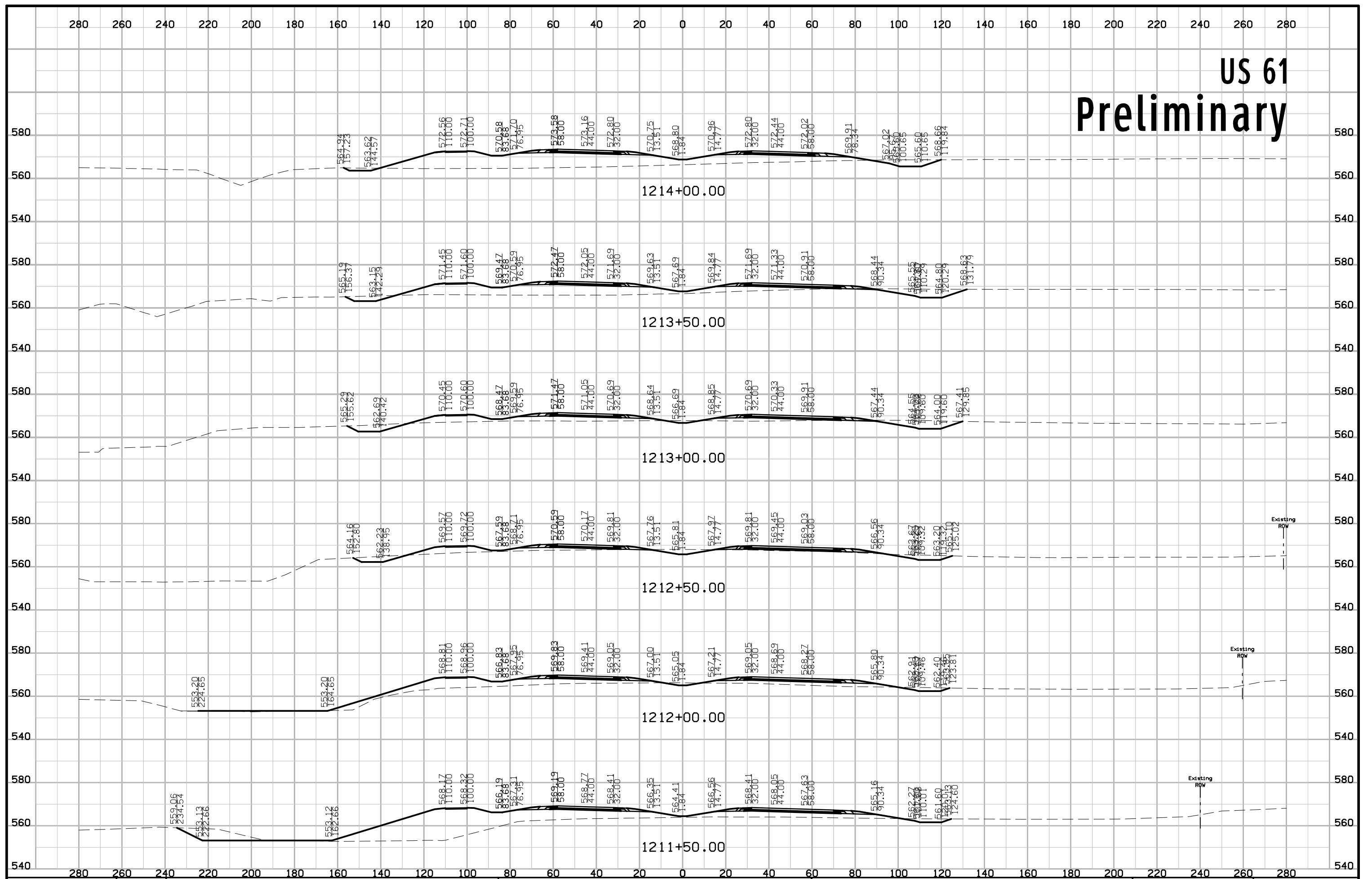

US 61 Preliminary

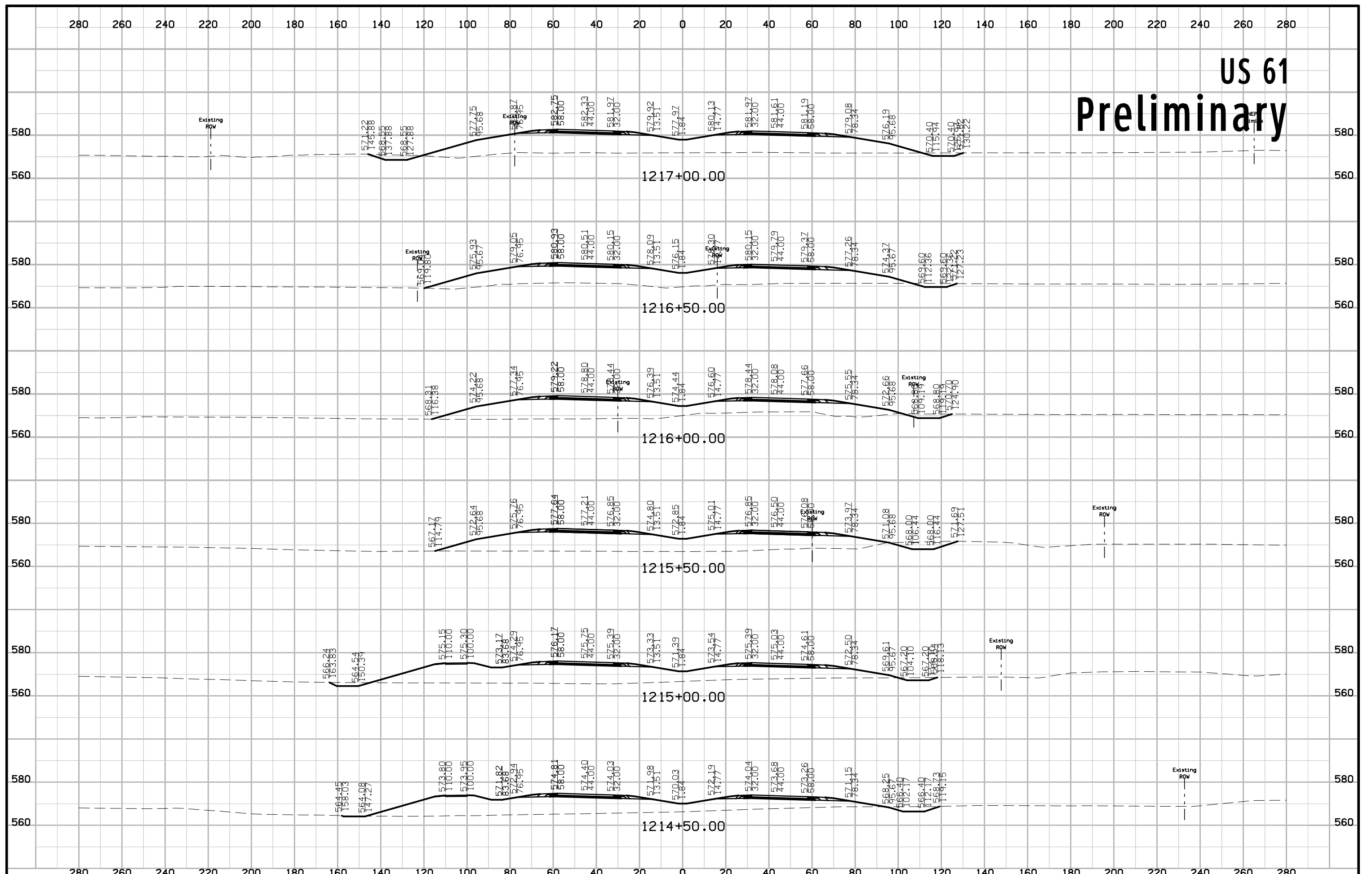

US 61 Preliminary

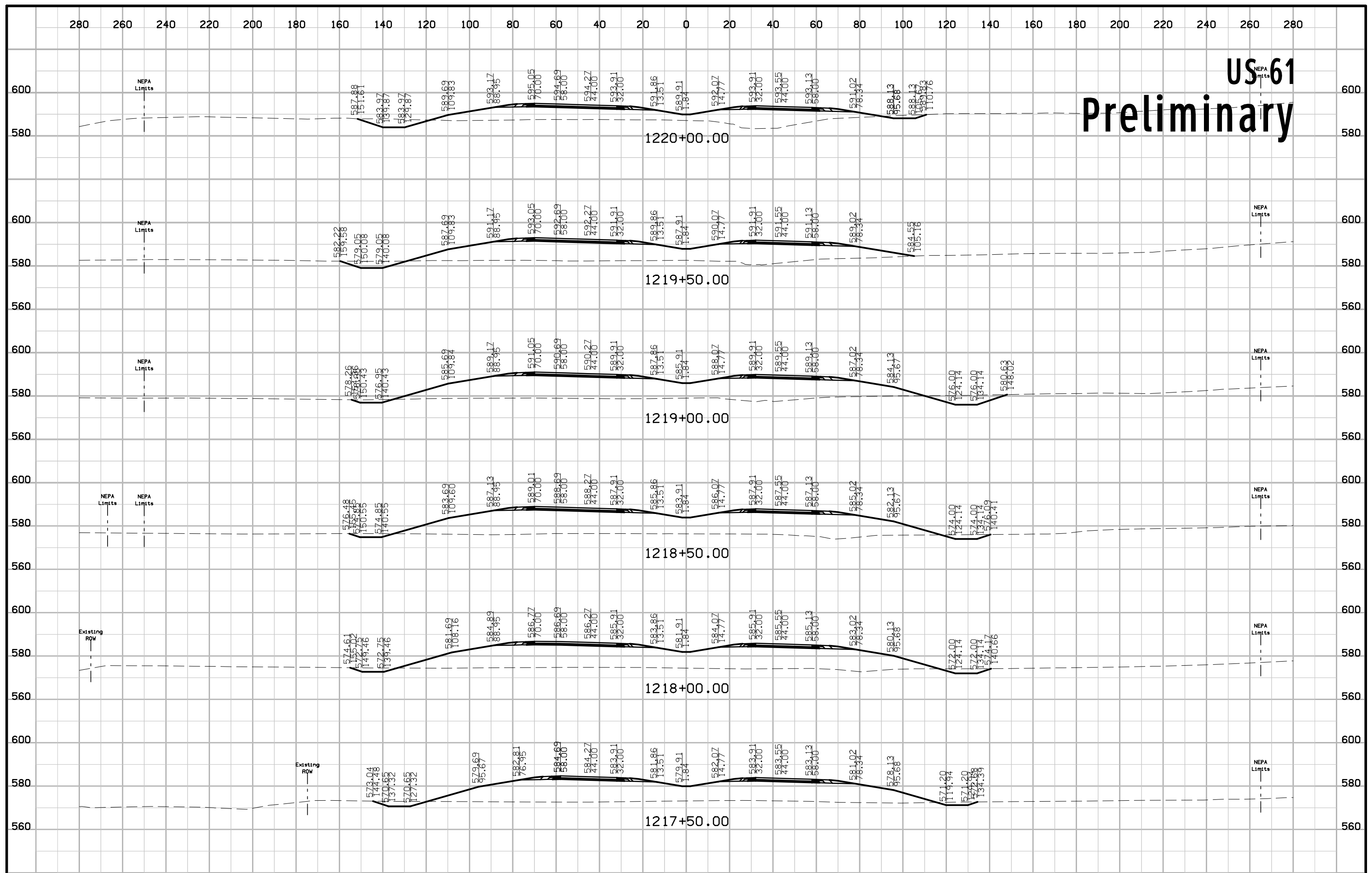

US 61 Preliminary

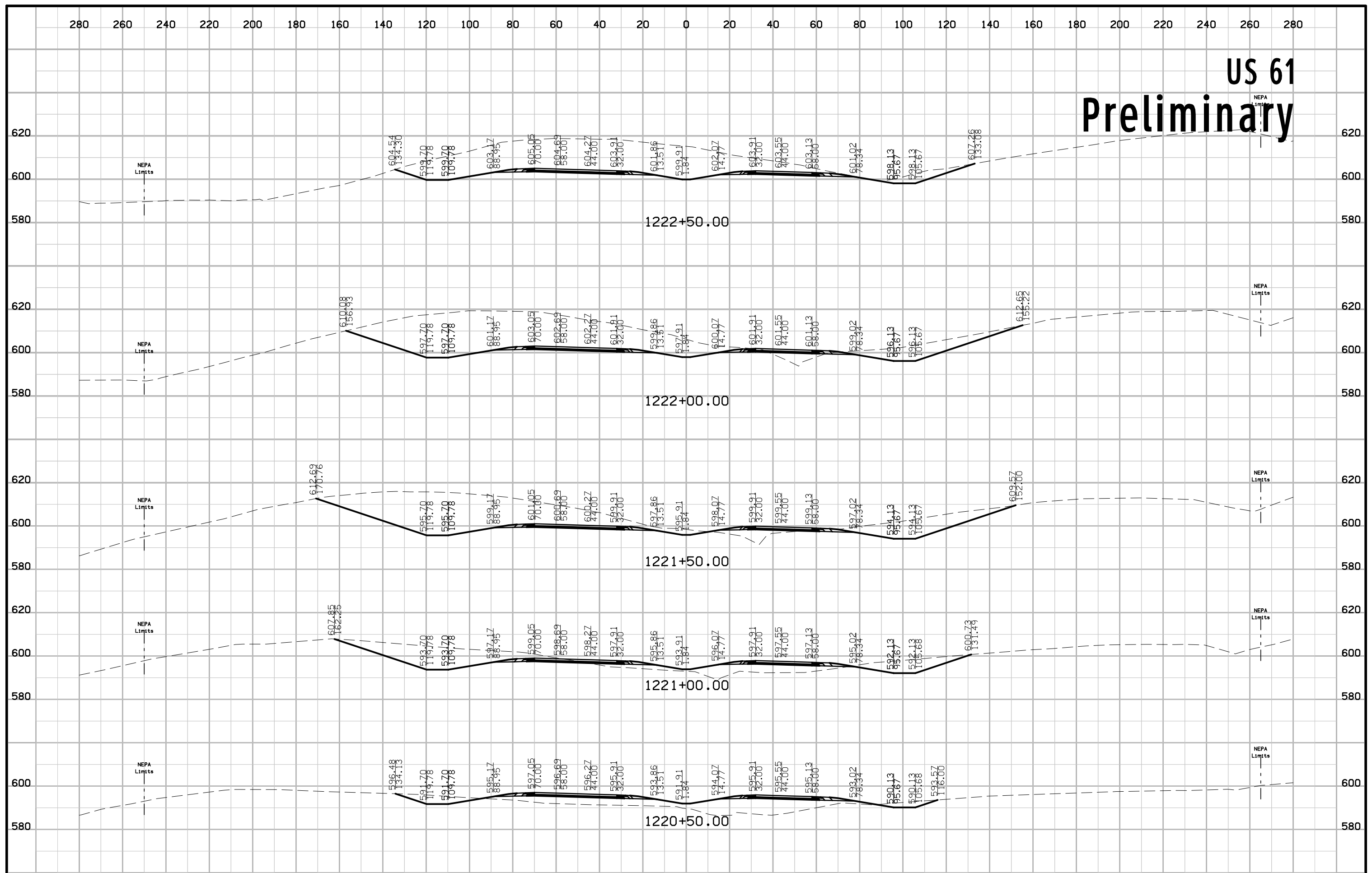

US 61 Preliminary

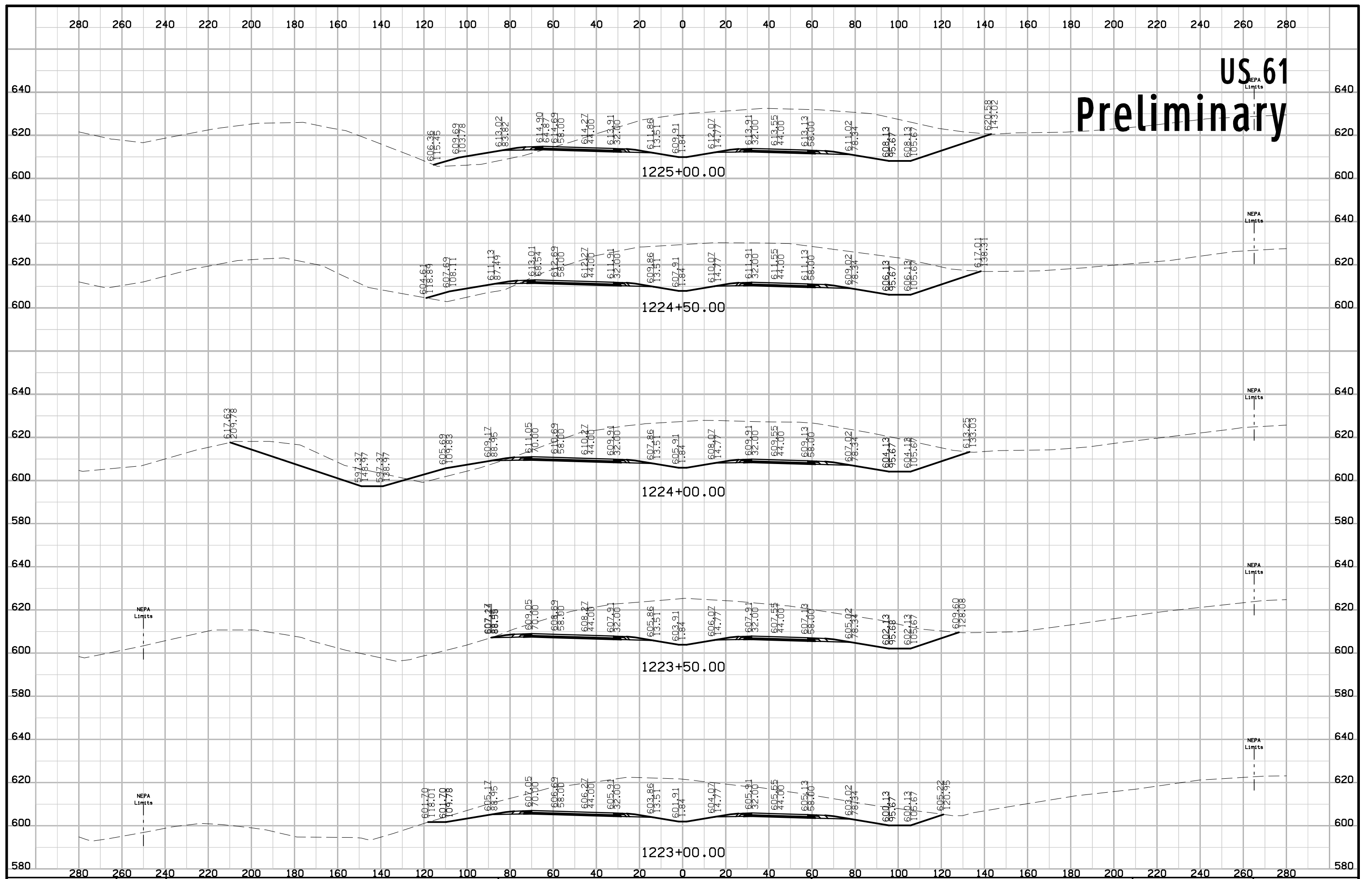

US 61 Preliminary

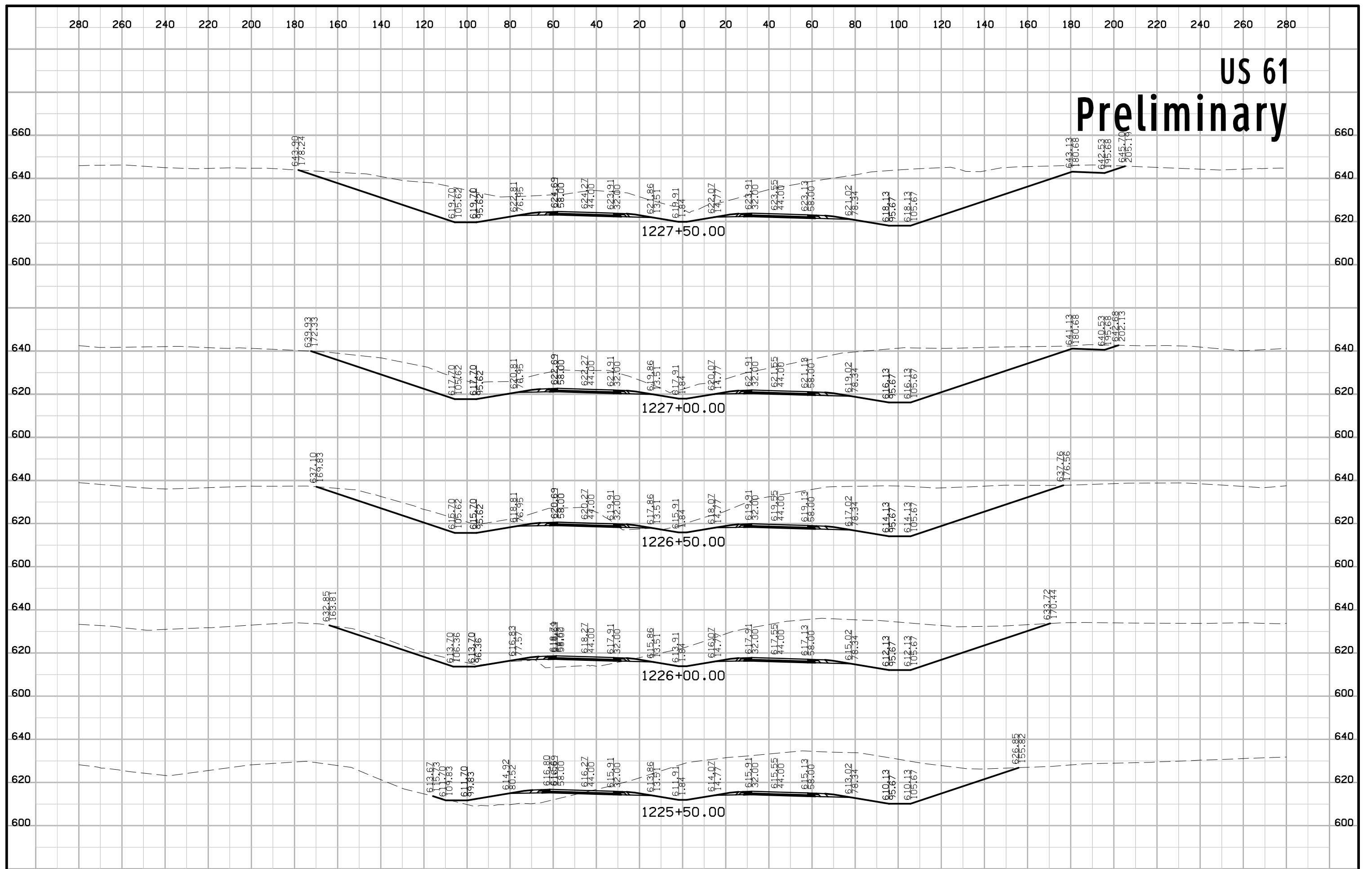

US 61 Preliminary

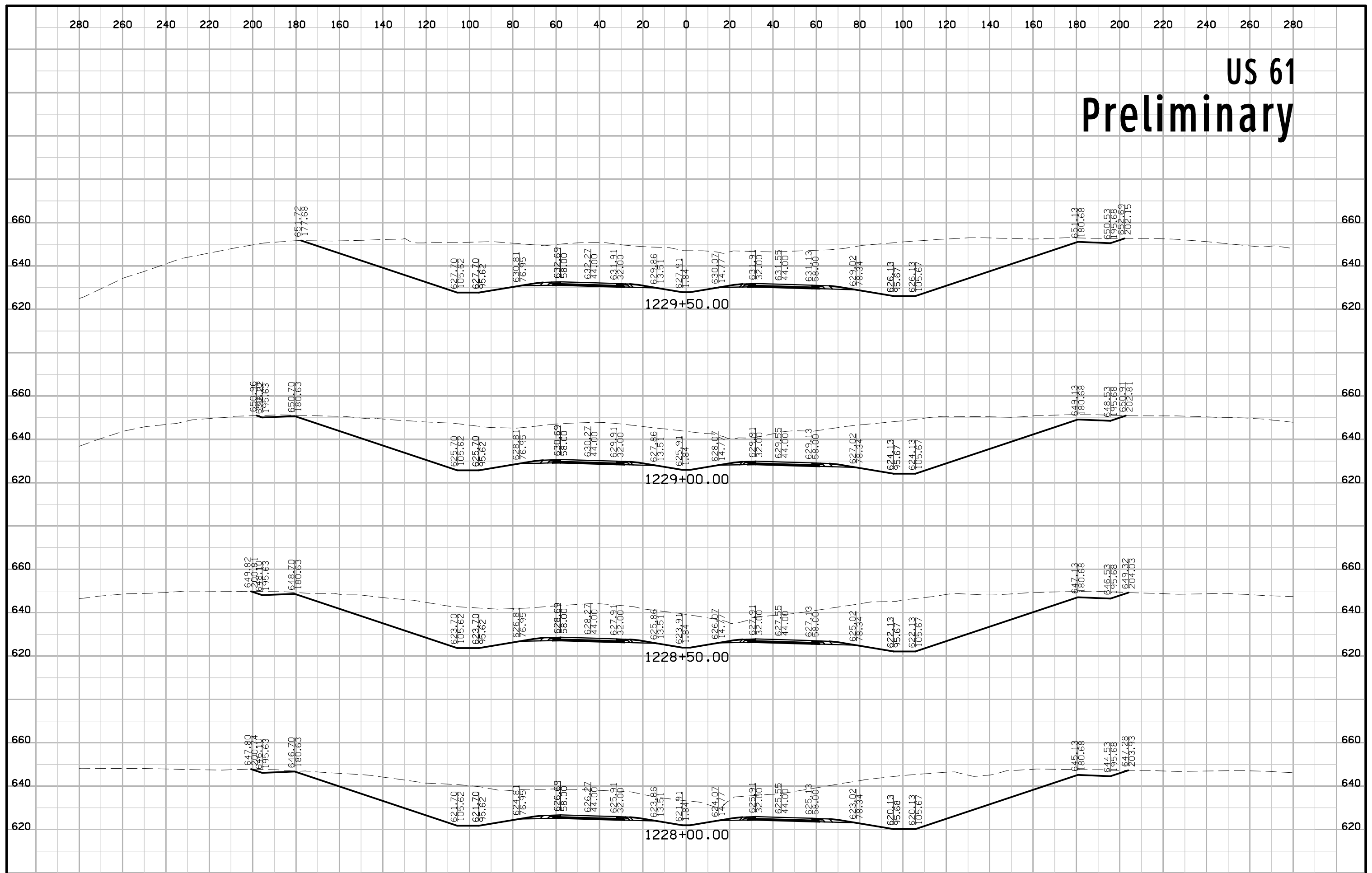

US 61 Preliminary

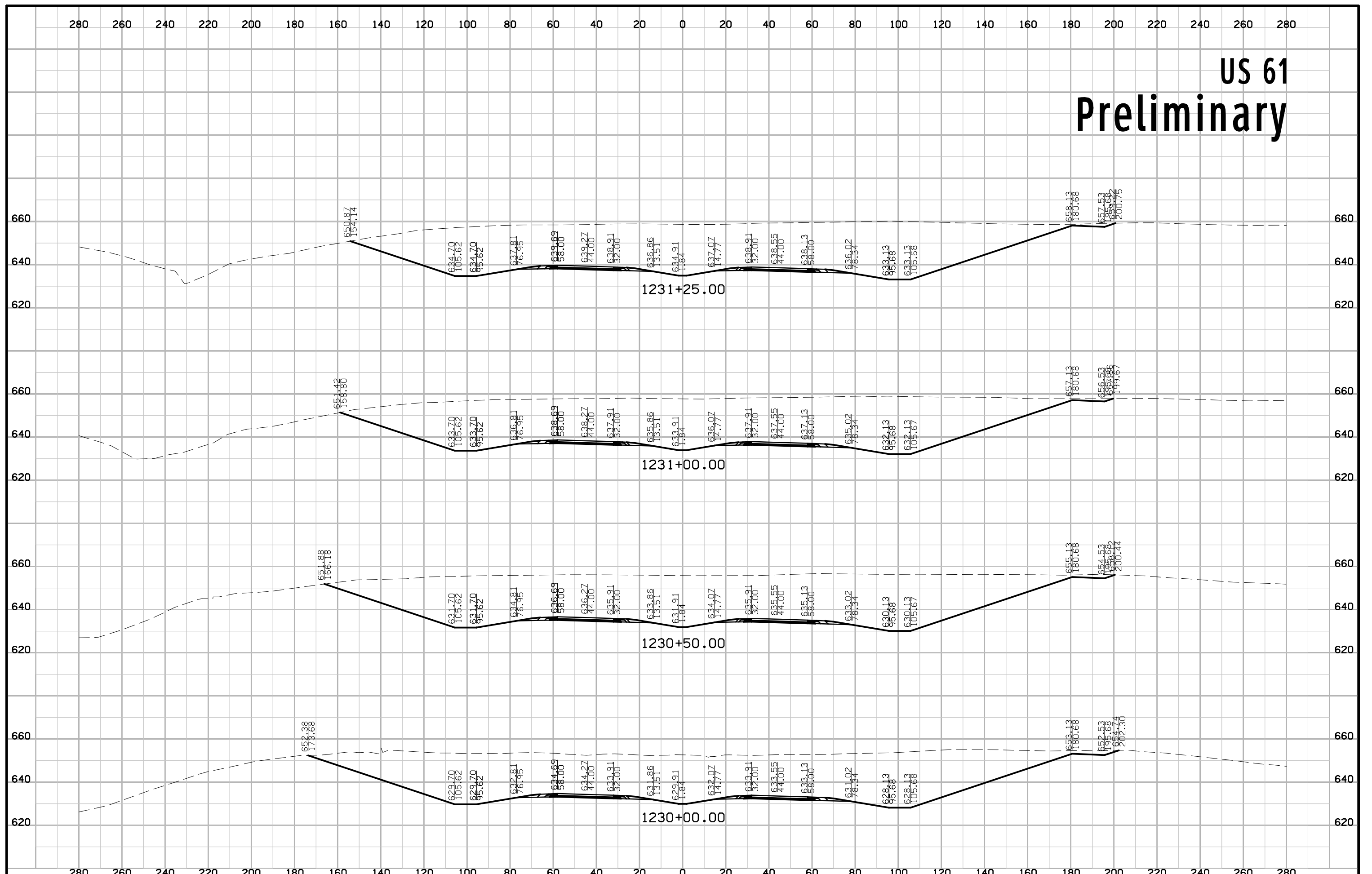

US 61 Preliminary

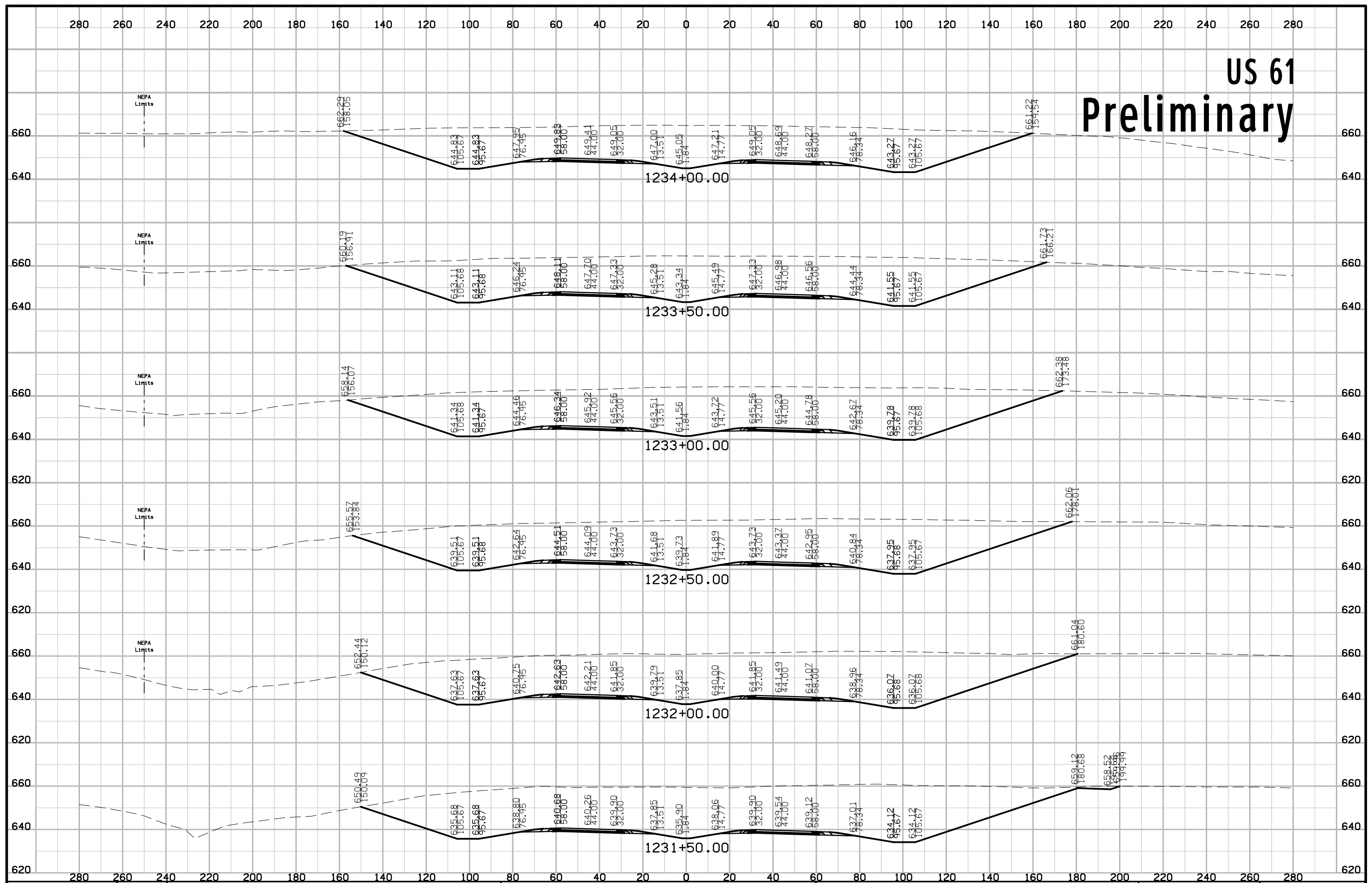

US 61 Preliminary

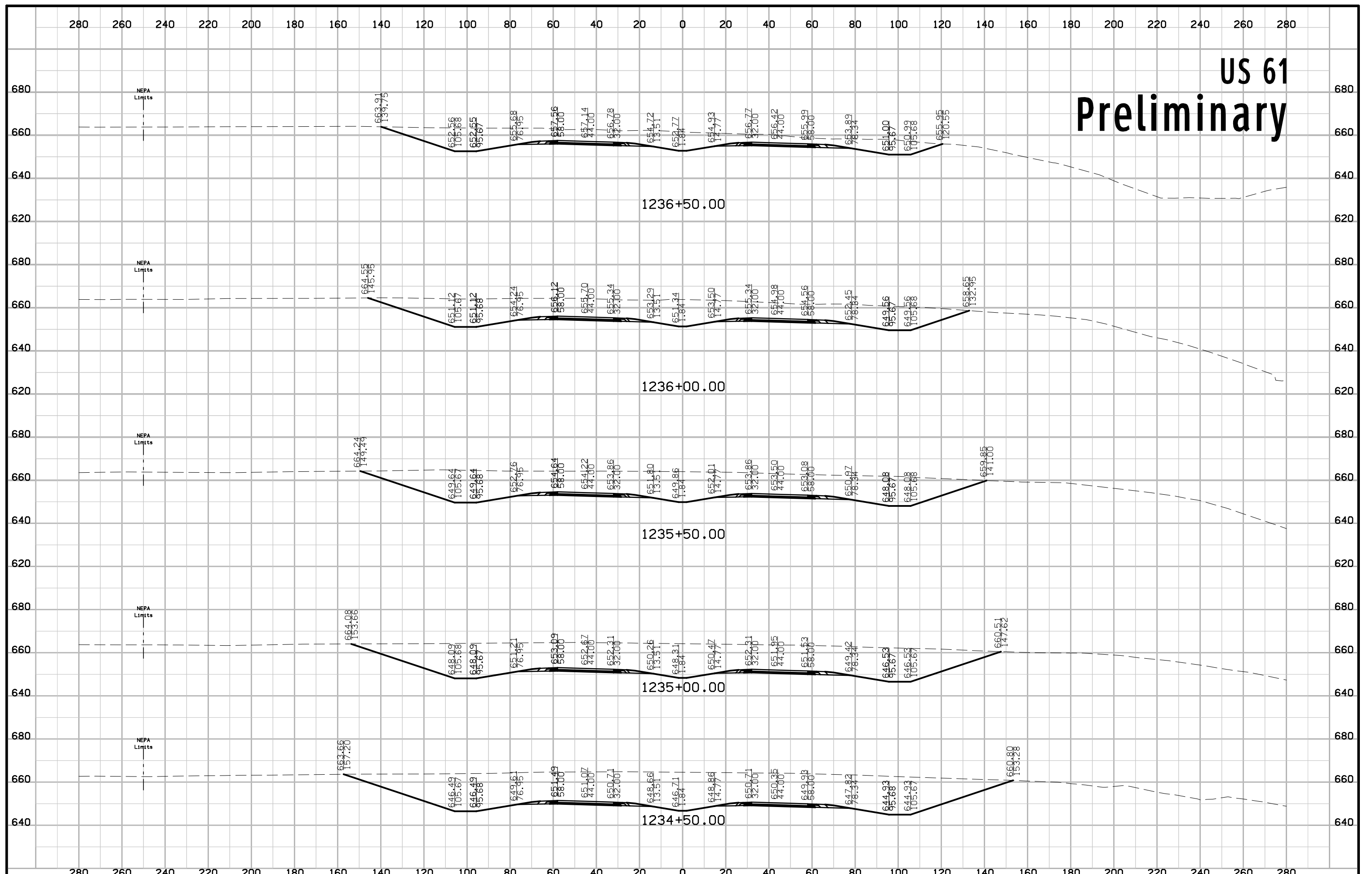

US 61 Preliminary

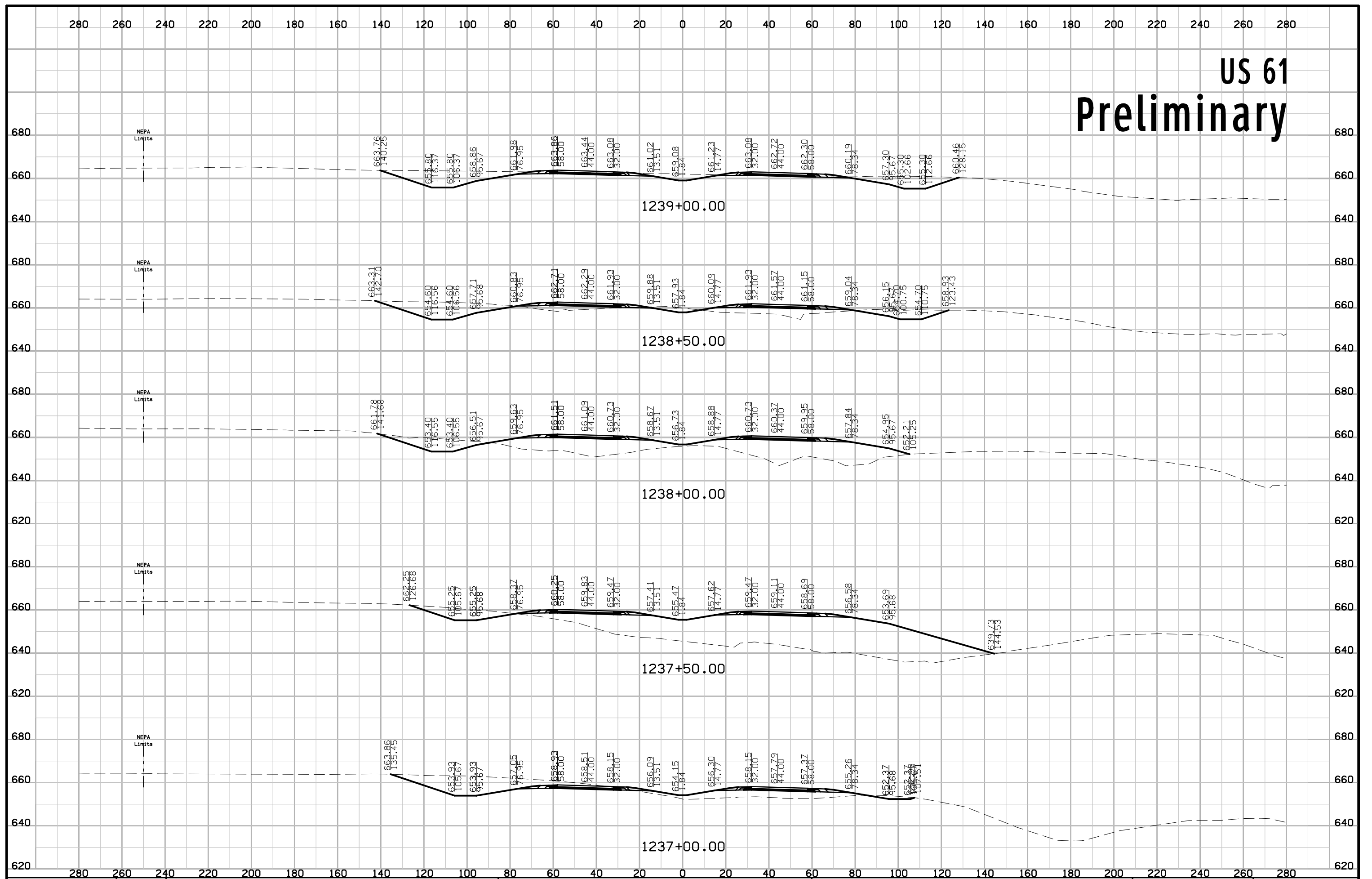

US 61 Preliminary

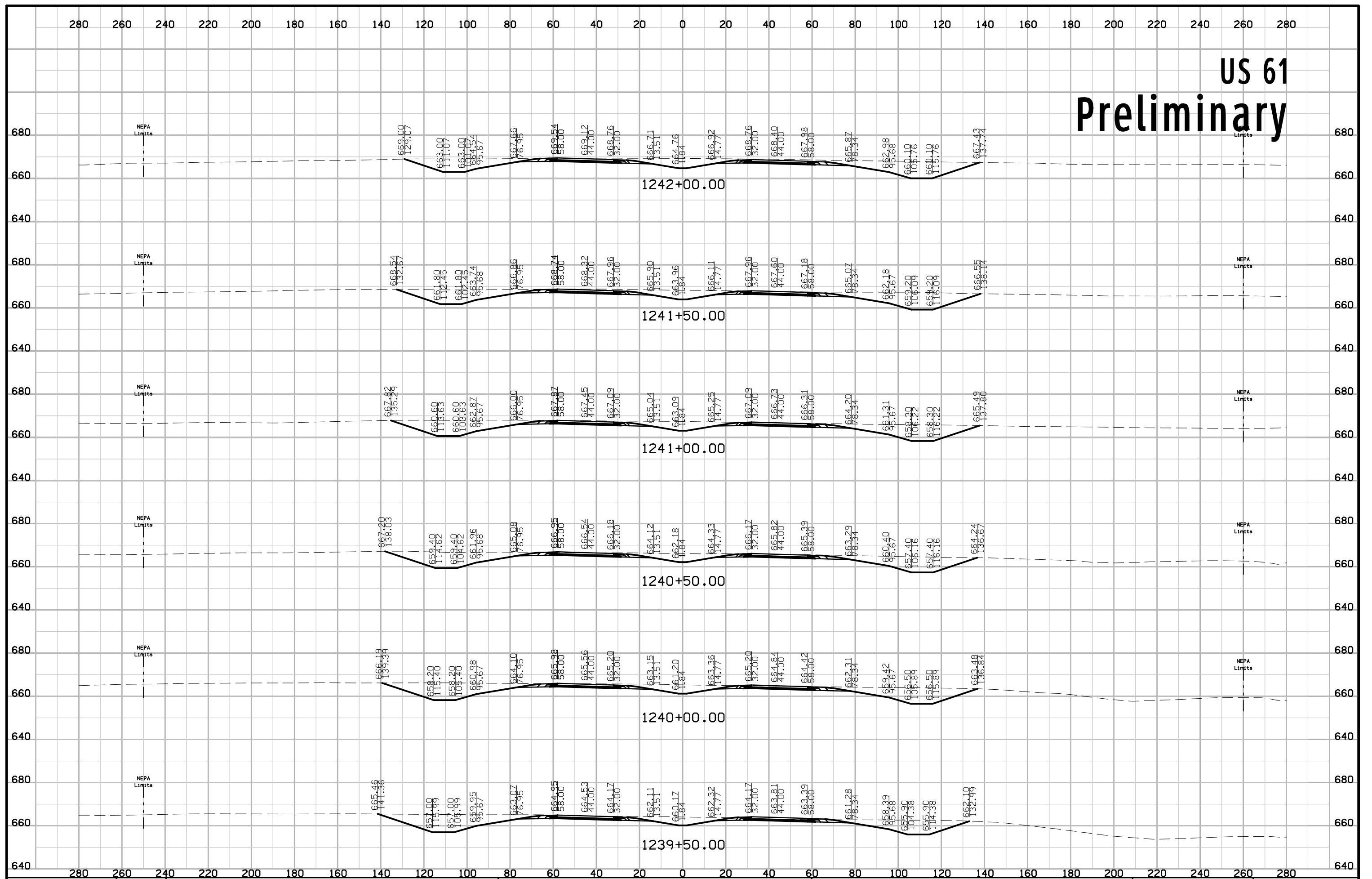

US 61 Preliminary

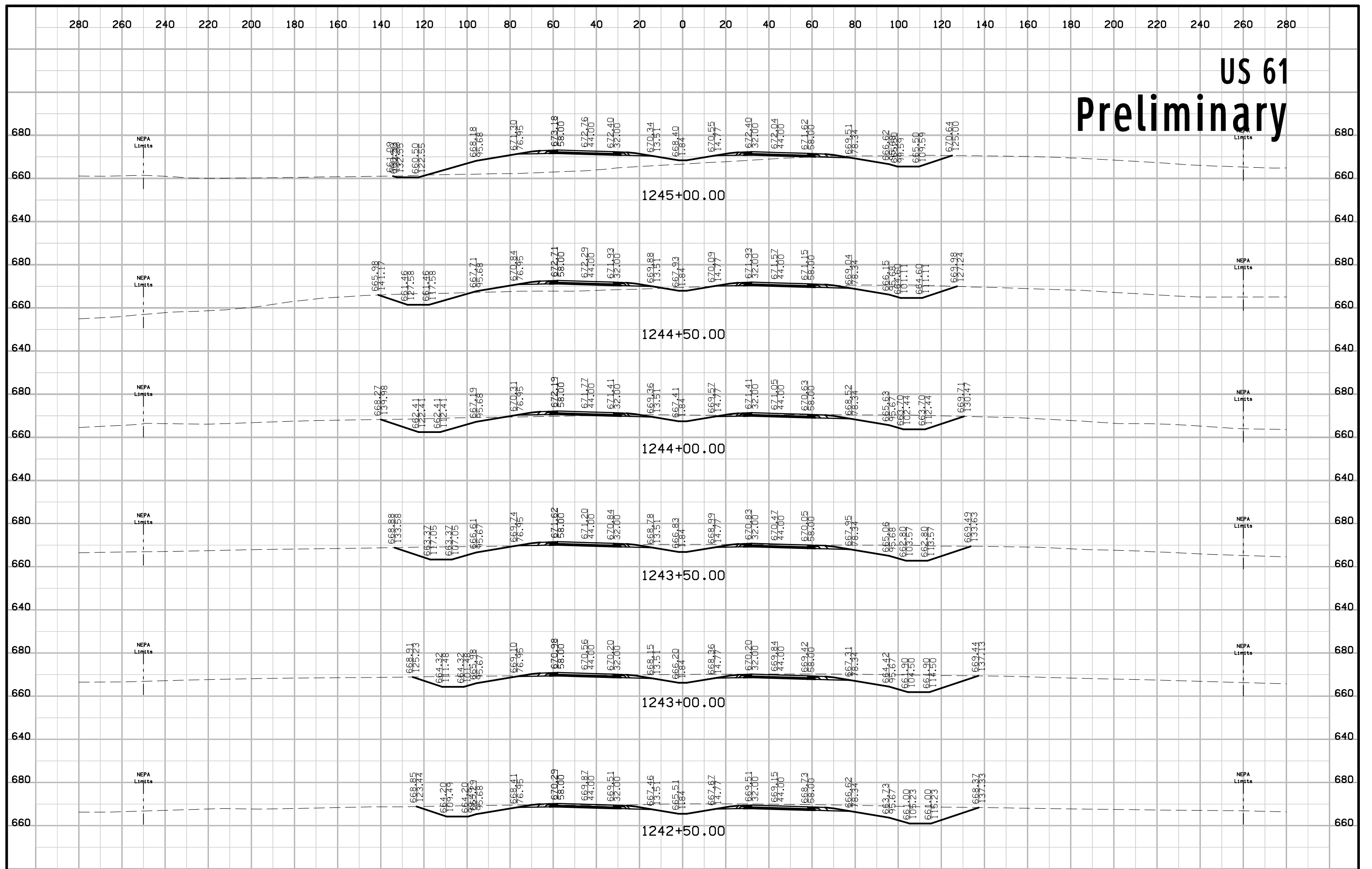

US 61 Preliminary

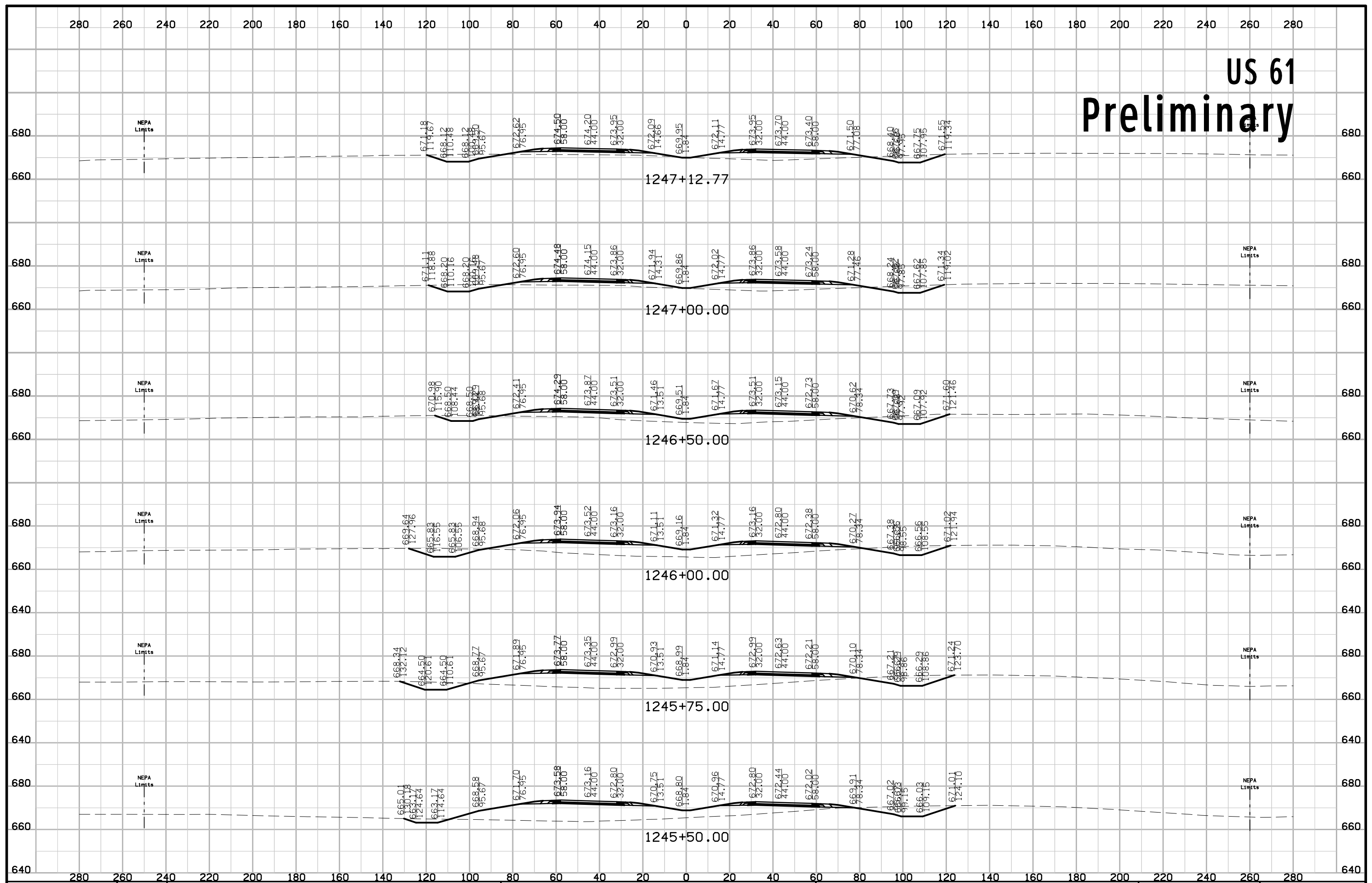

US 61 Preliminary

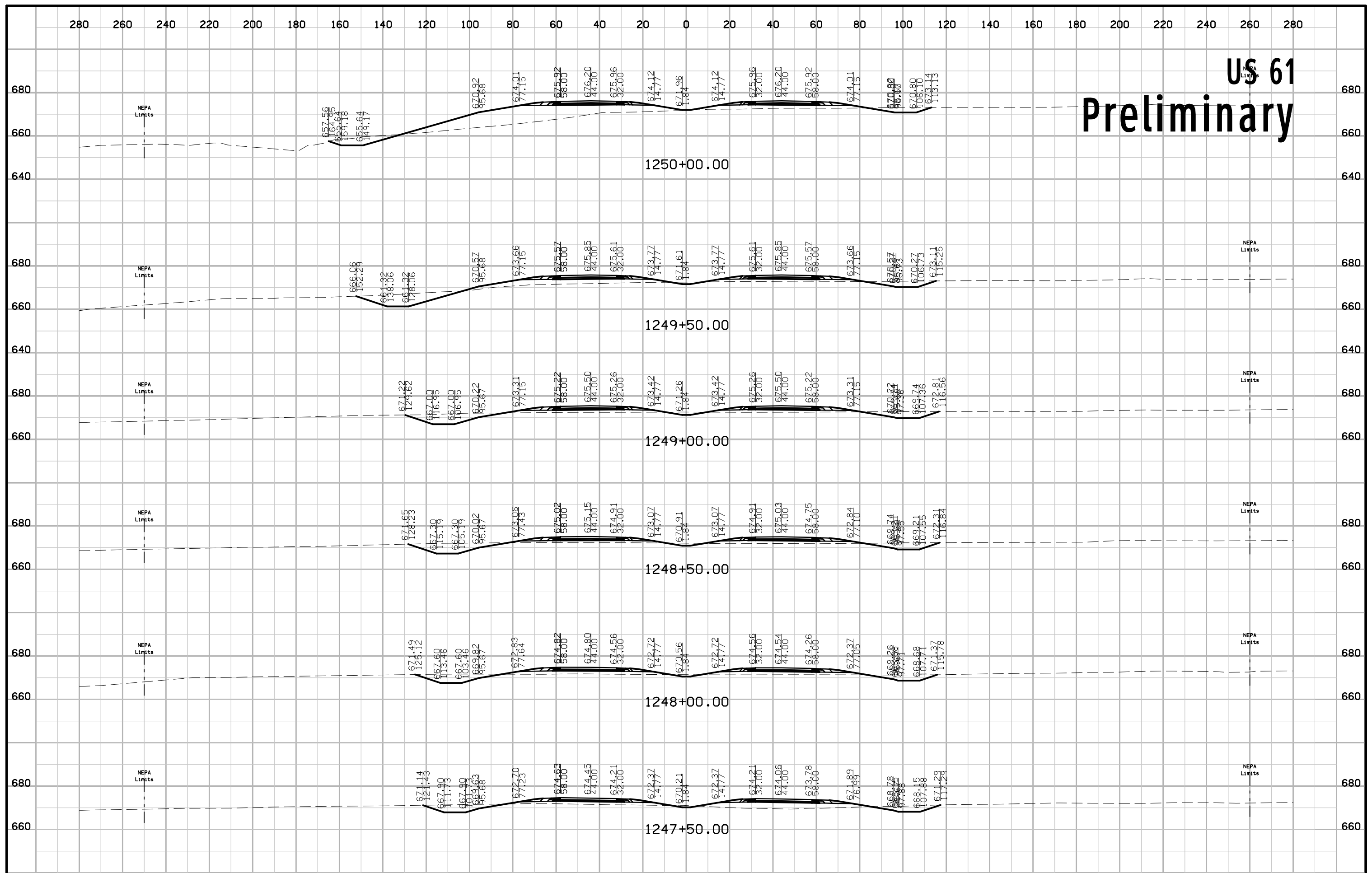

US 61 Preliminary

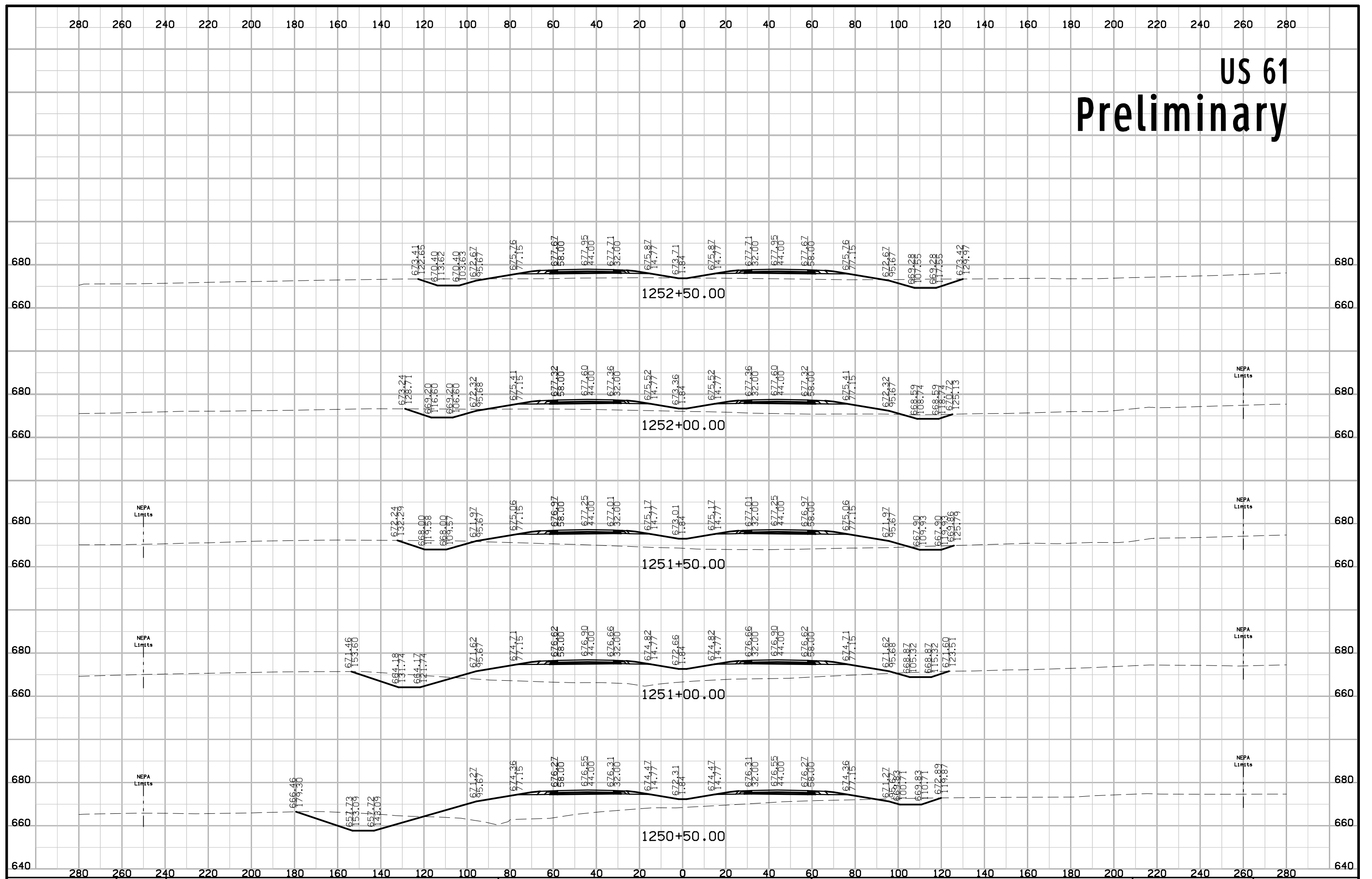

US 61 Preliminary

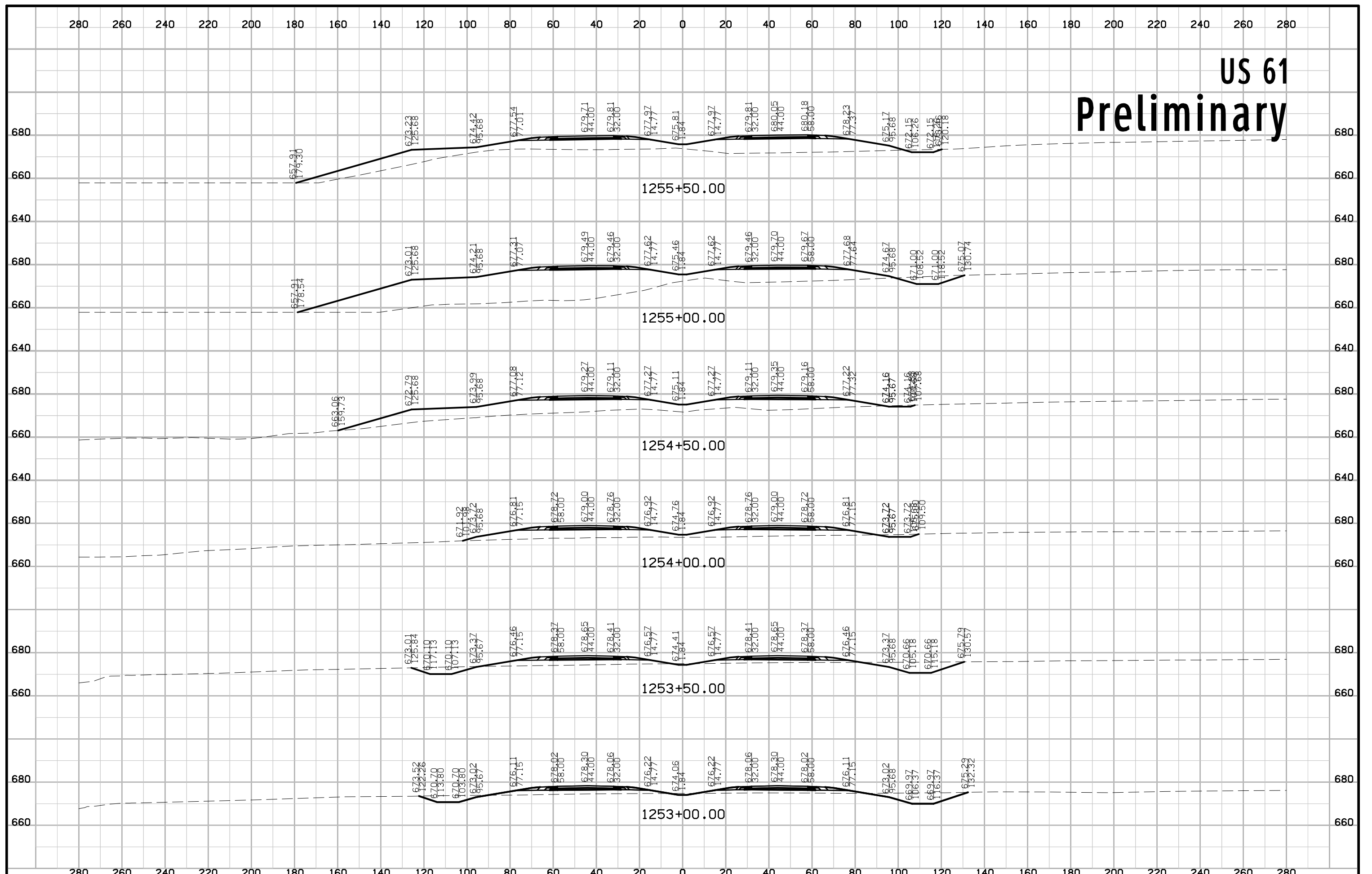

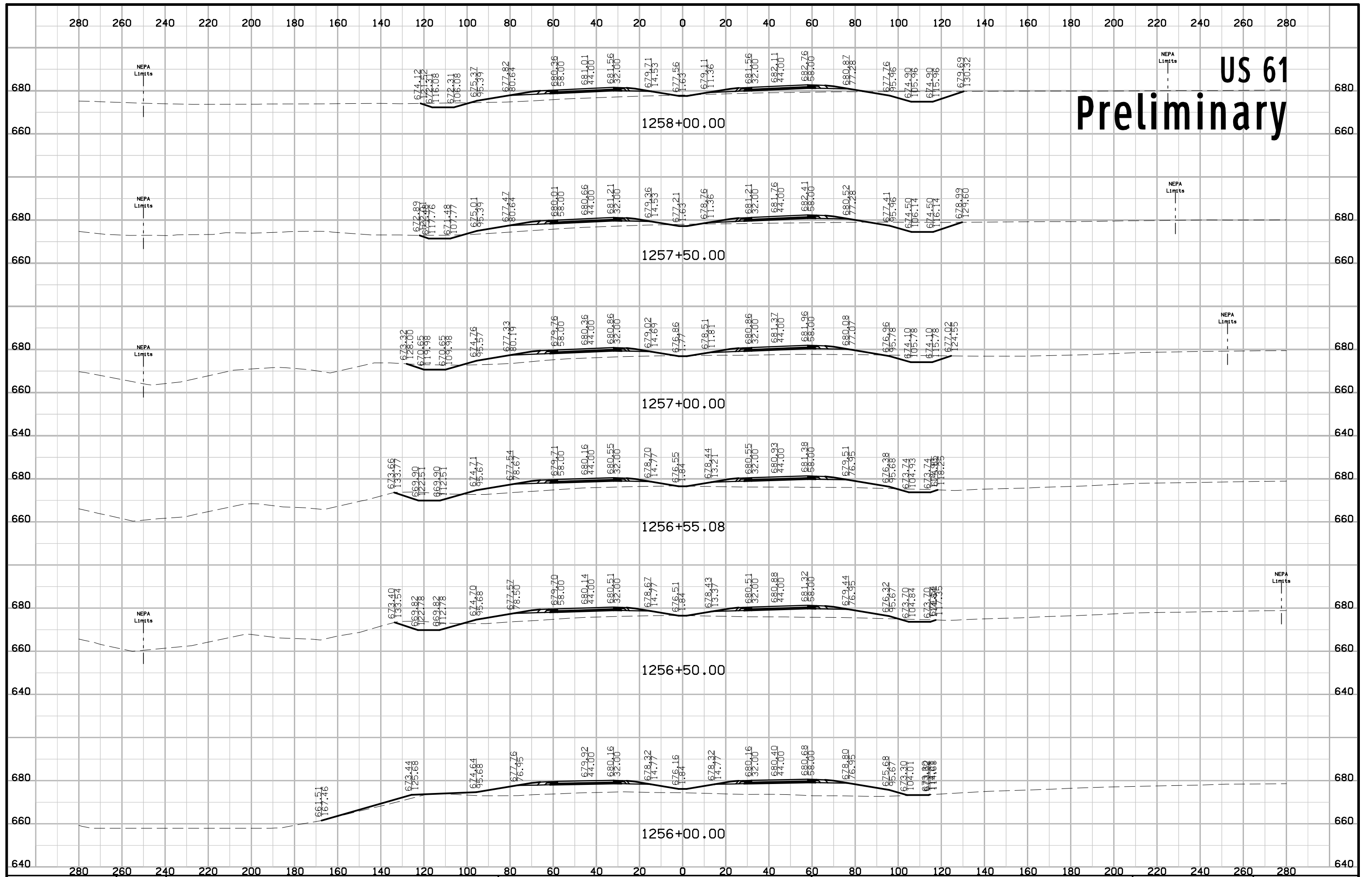

US 61

Preliminary

NEPA Limits

NEPA Limits

NEPA Limits

US 61 Preliminary

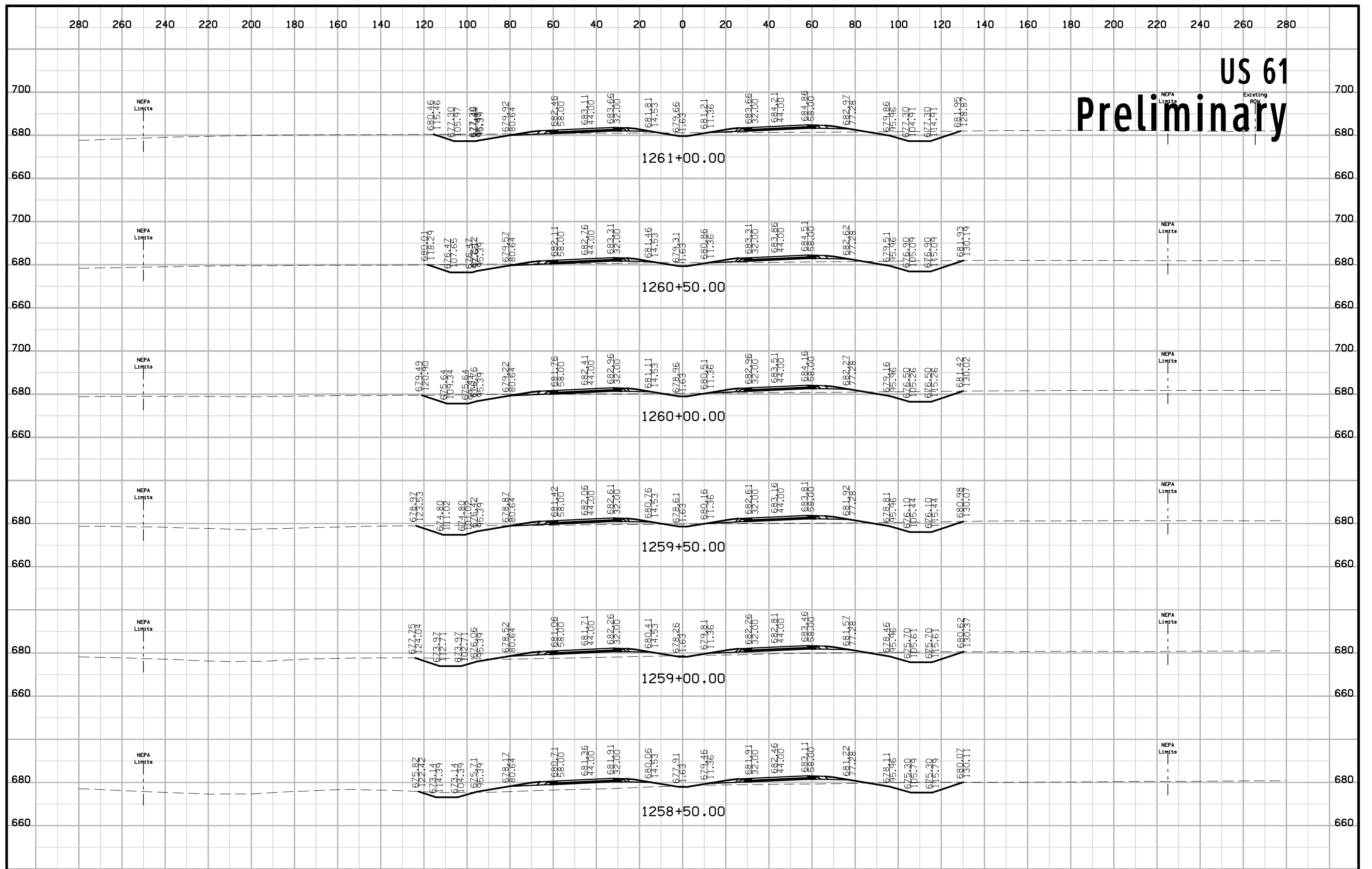

US 61 Preliminary

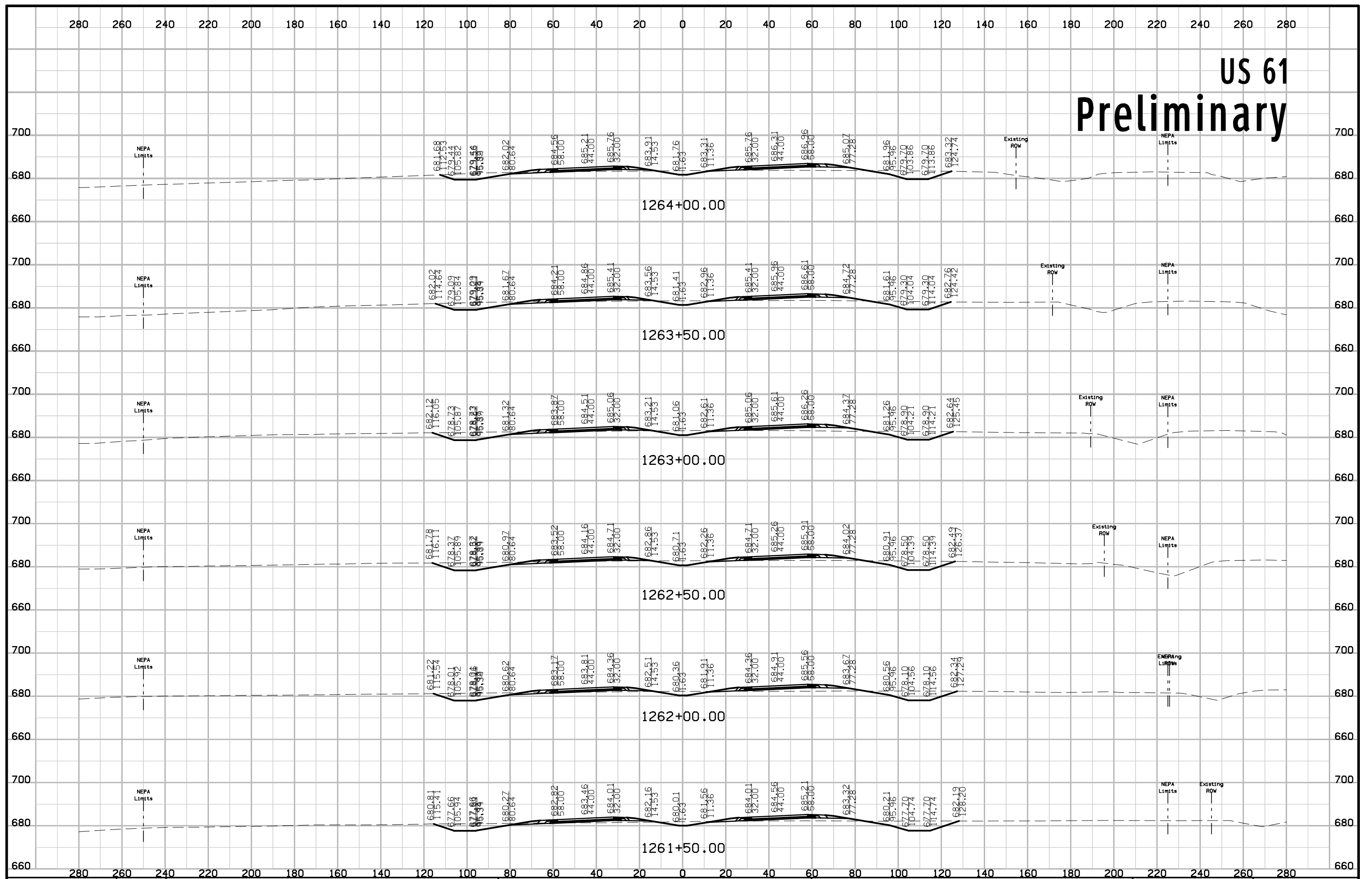

US 61 Preliminary

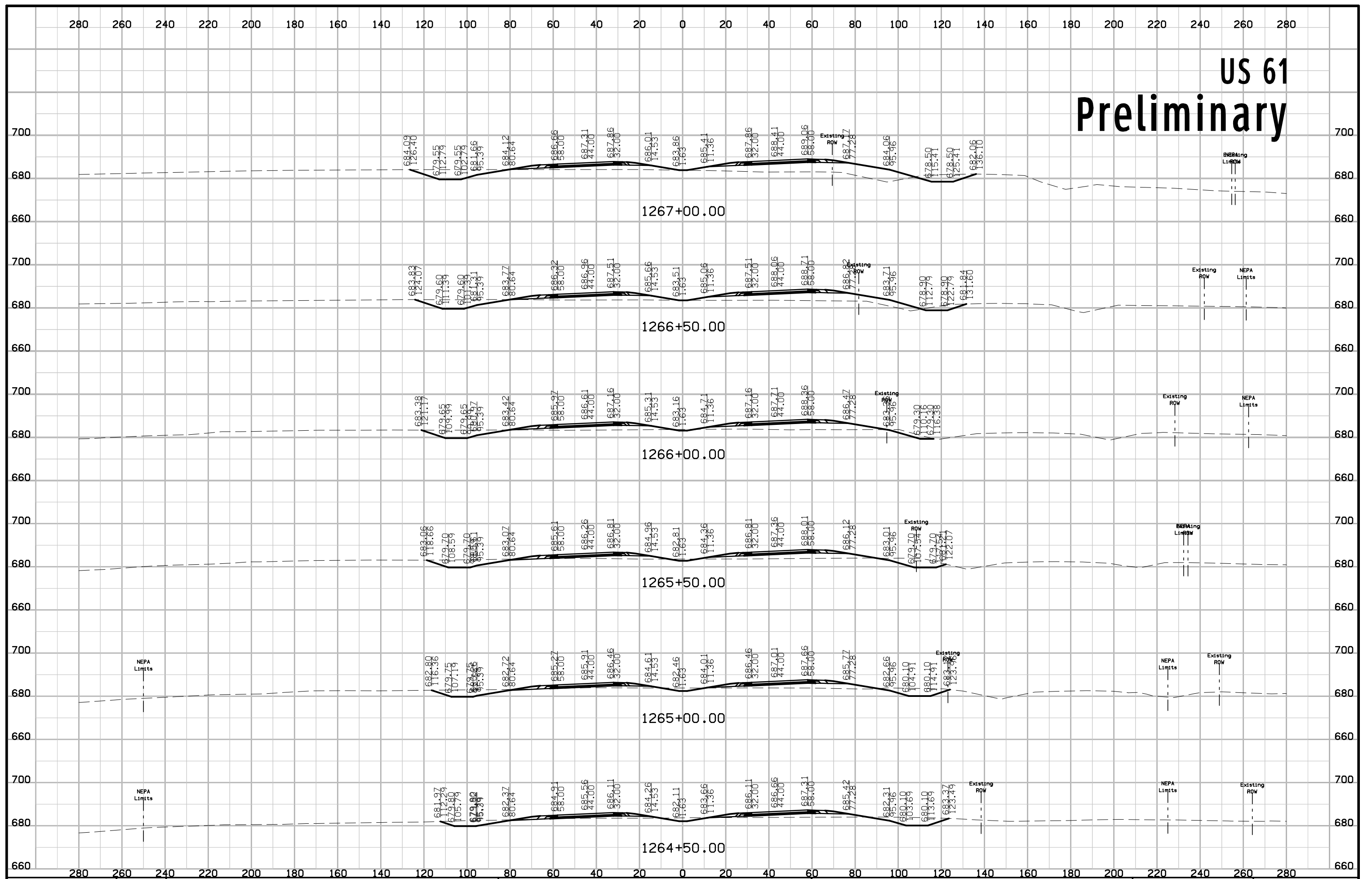

US 61 Preliminary

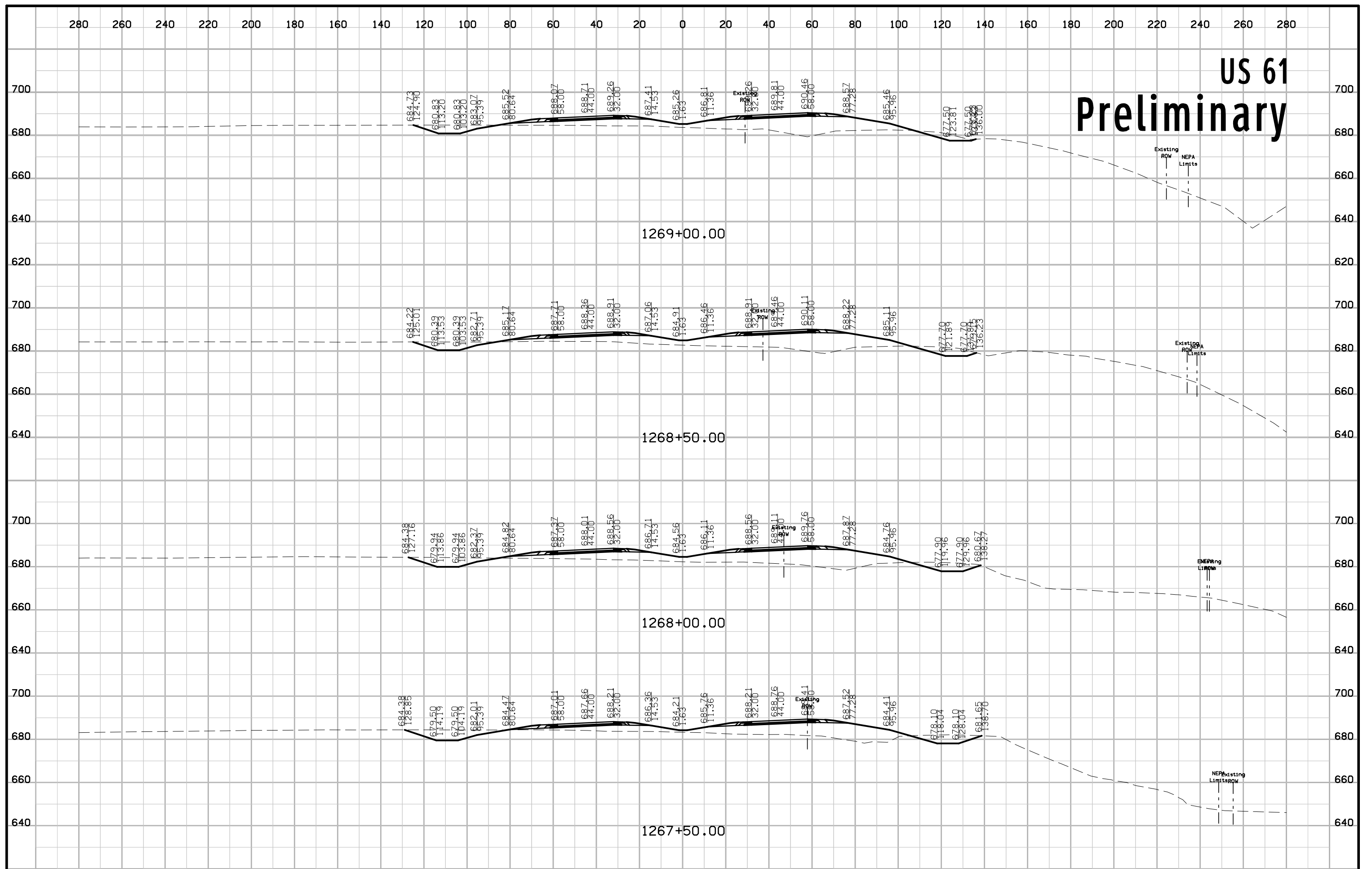

US 61 Preliminary

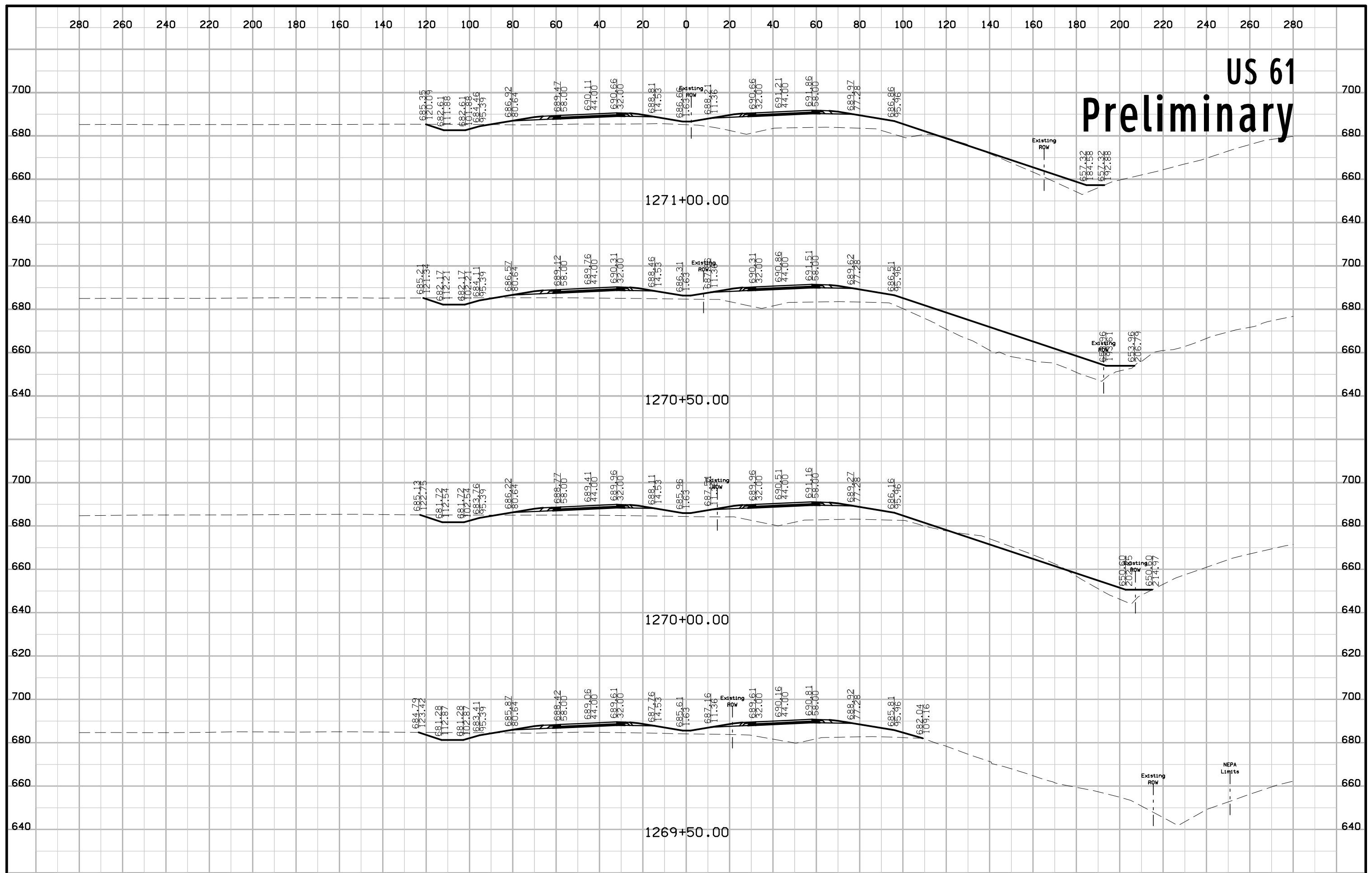

US 61 Preliminary

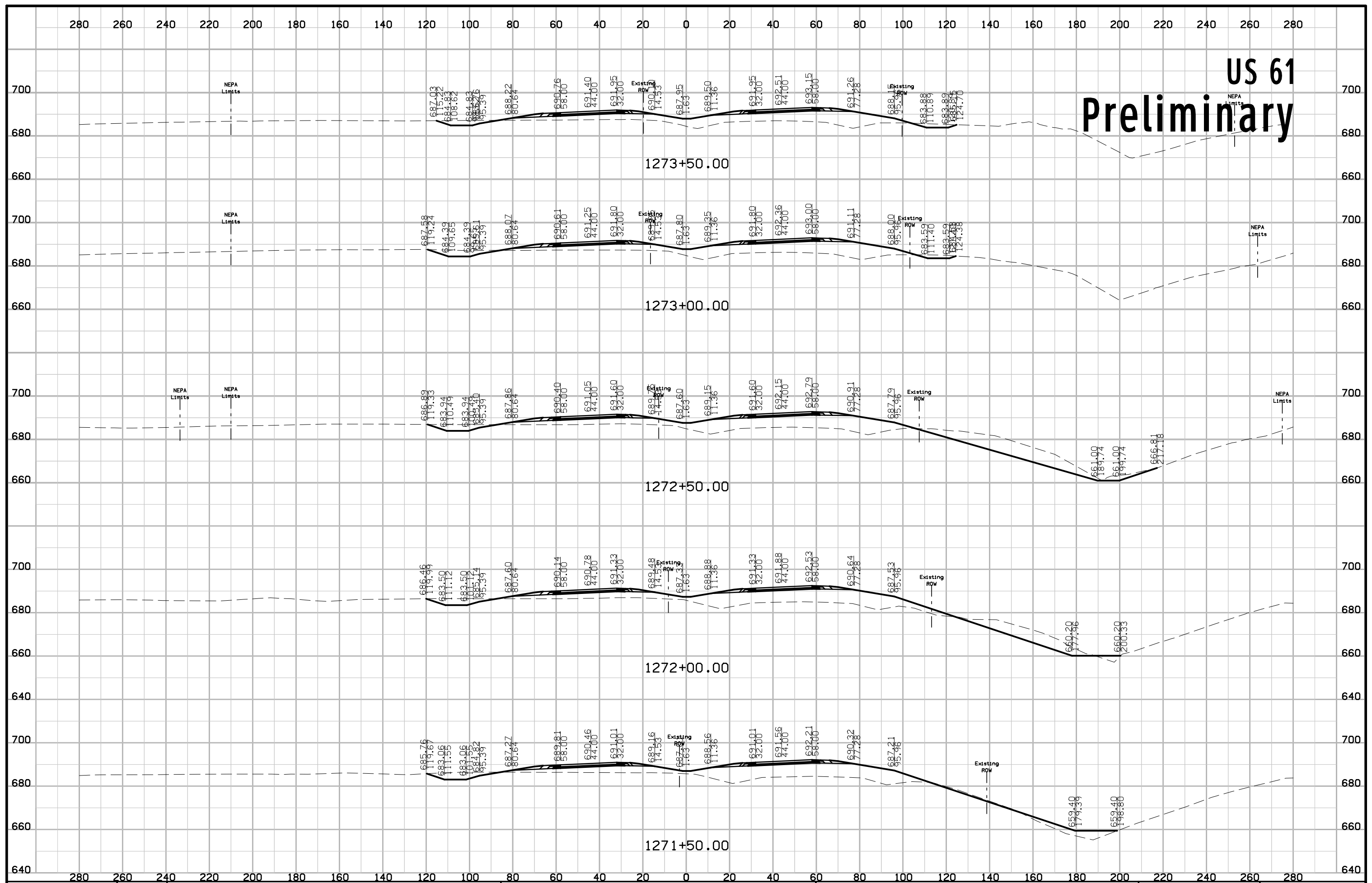

US 61 Preliminary

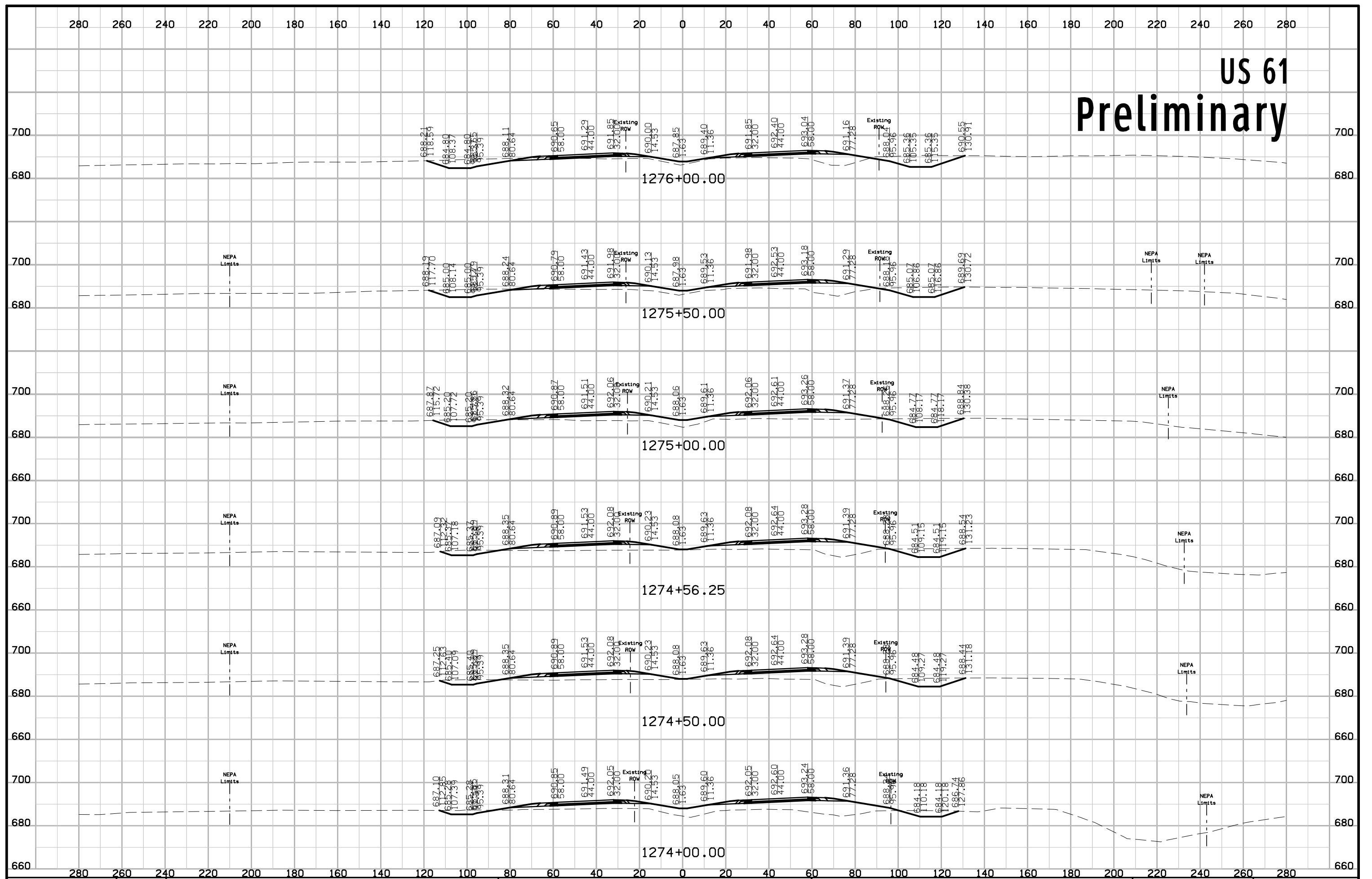

US 61 Preliminary

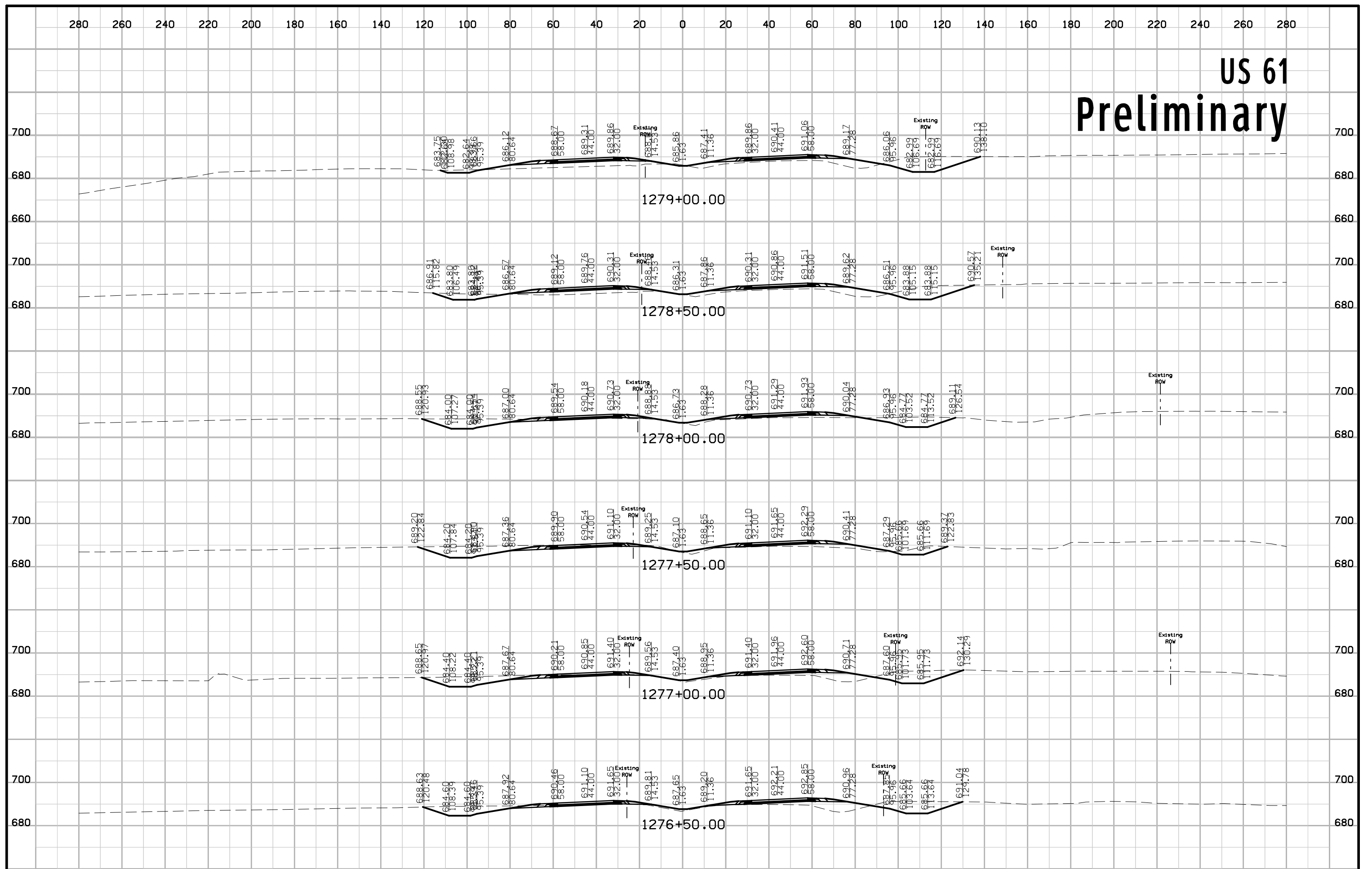

US 61 Preliminary

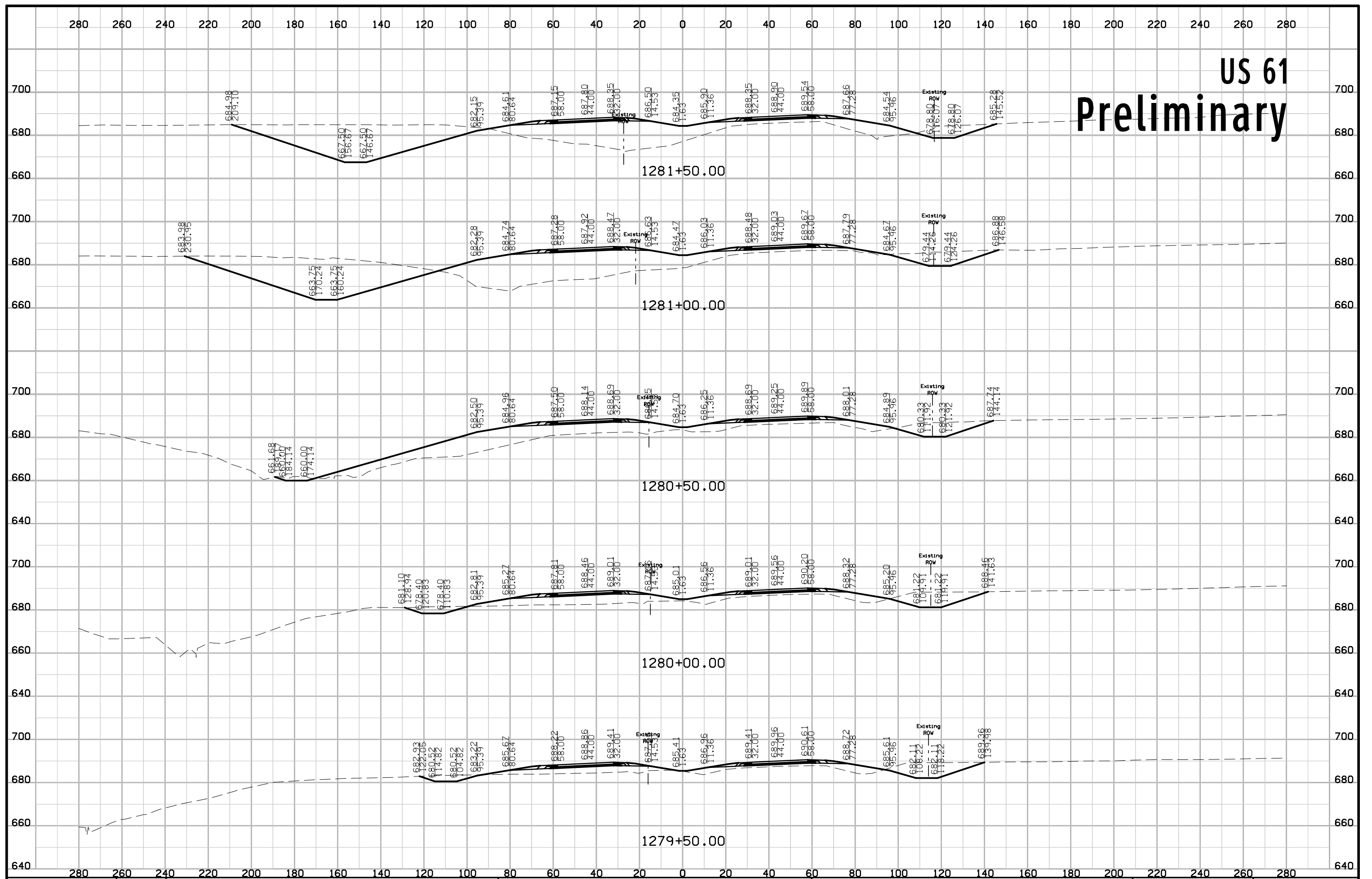

US 61 Preliminary

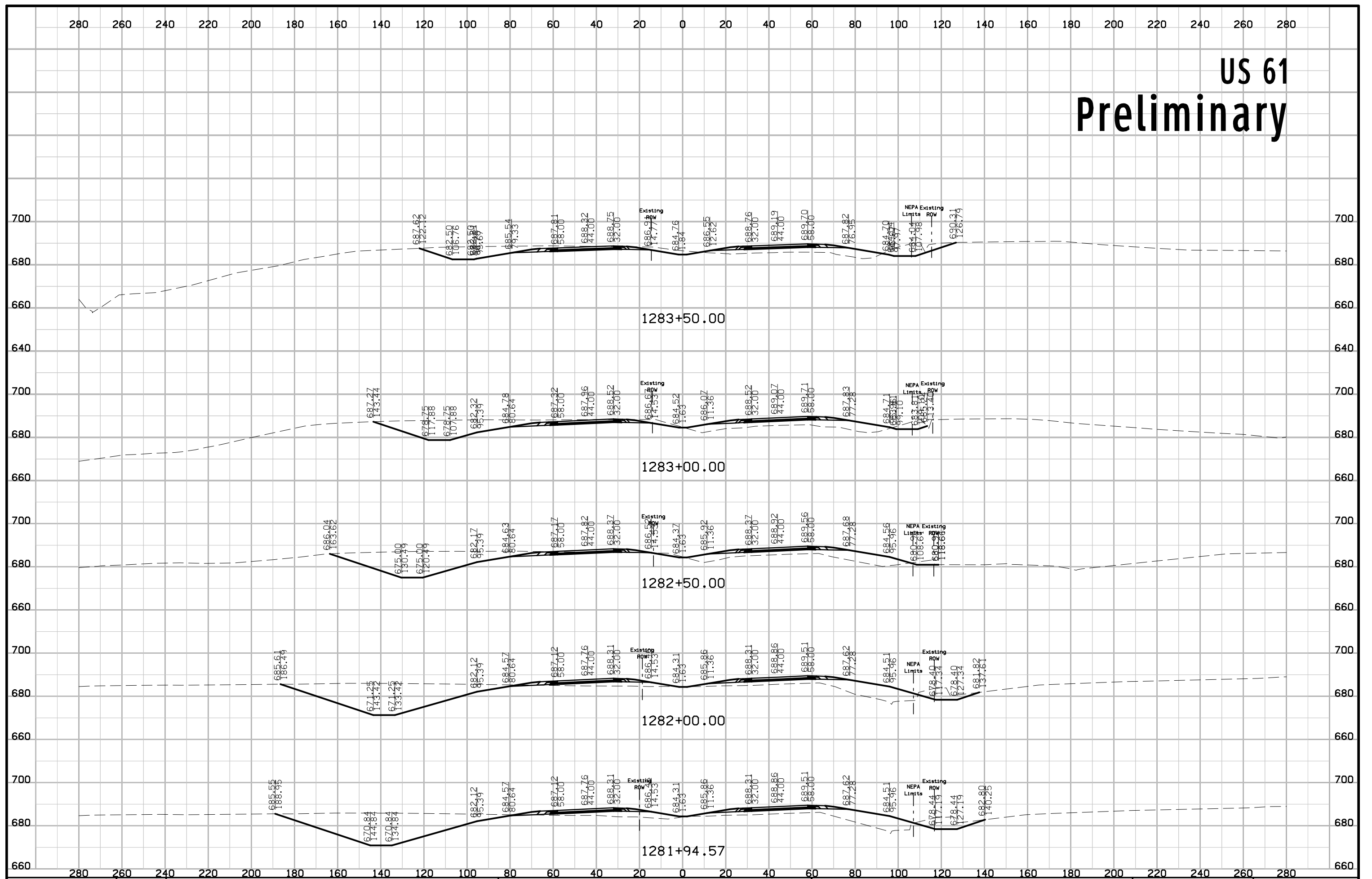

US 61 Preliminary

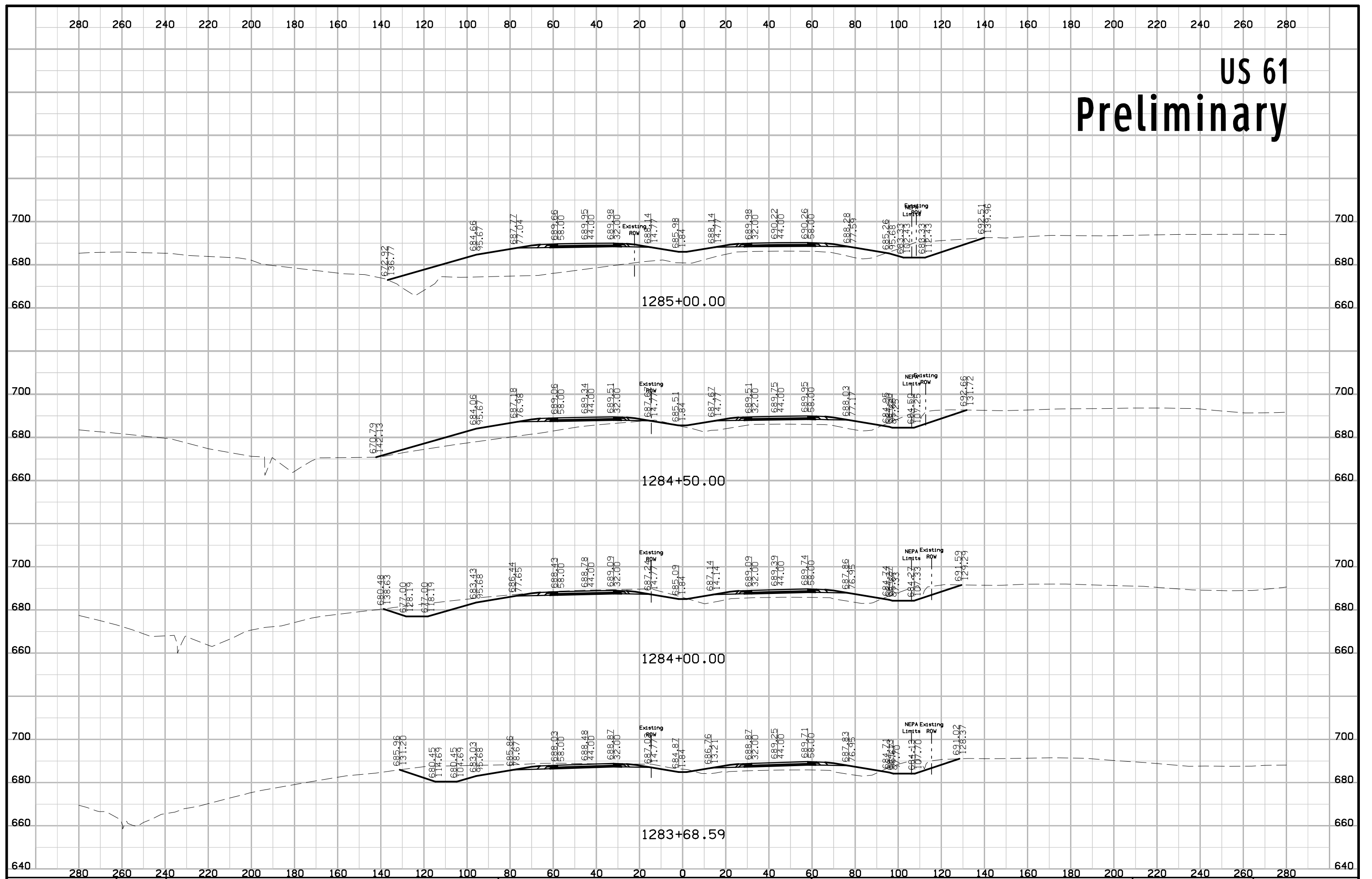

US 61 Preliminary

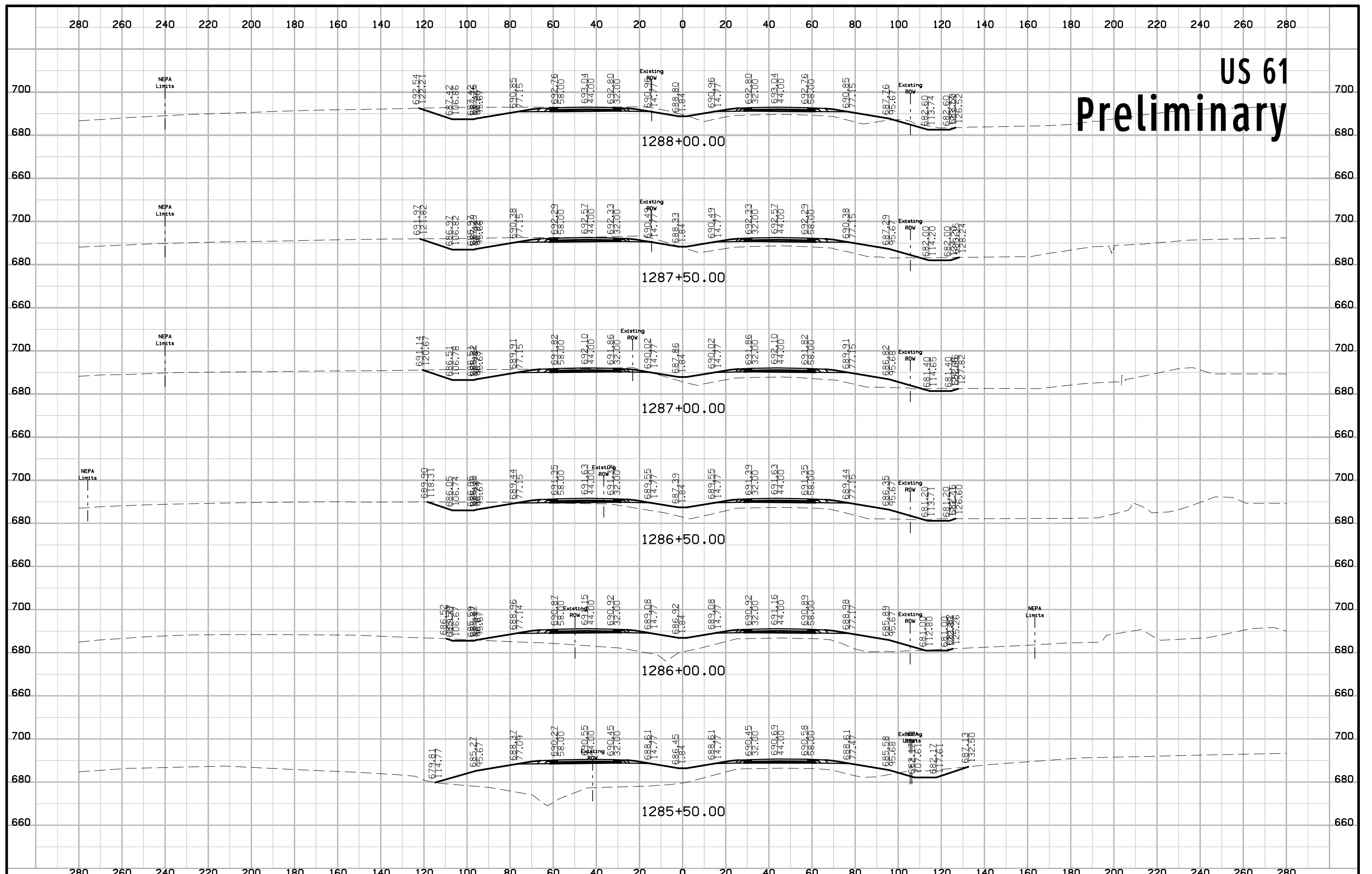

US 61 Preliminary

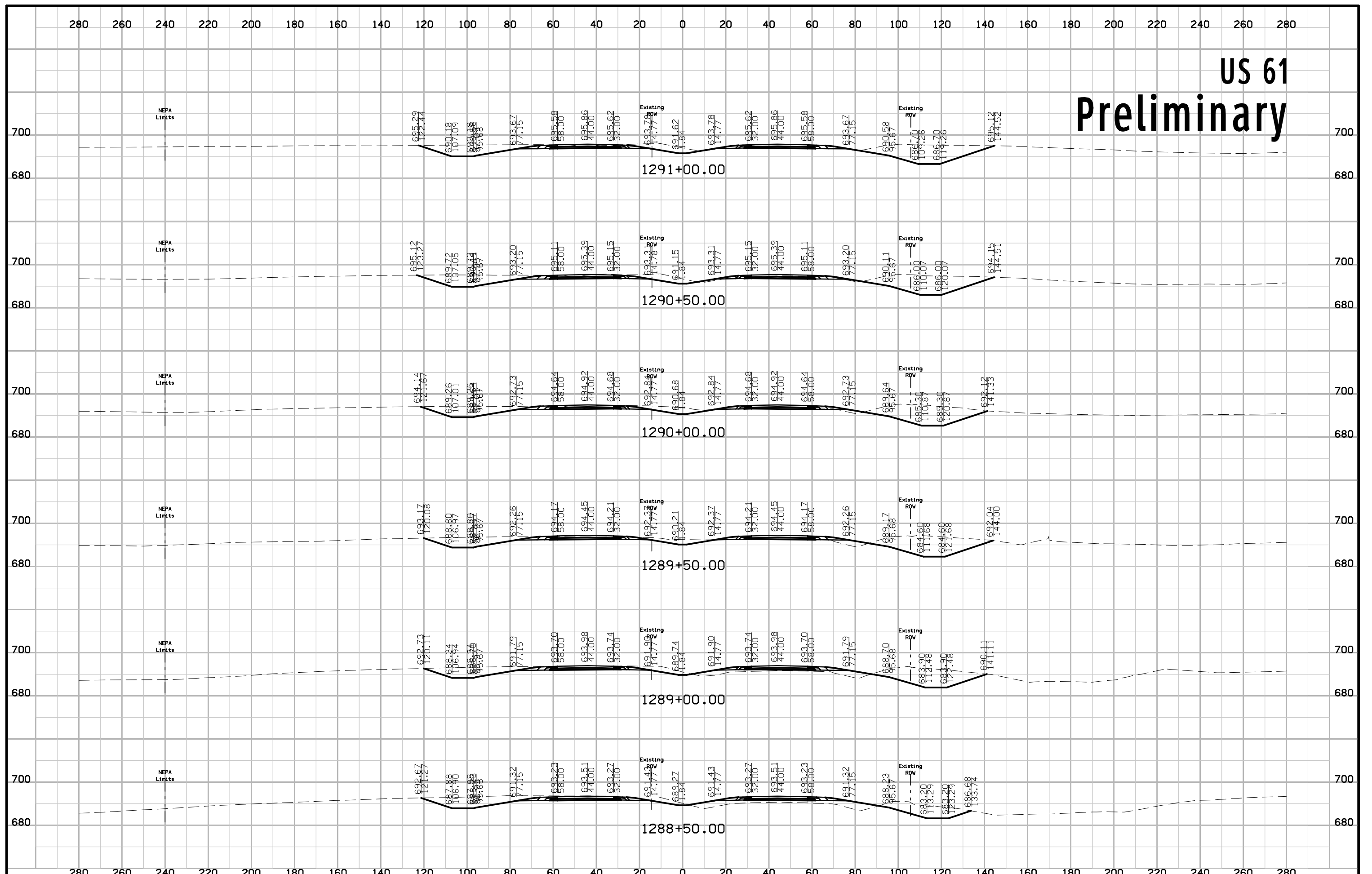

US 61 Preliminary

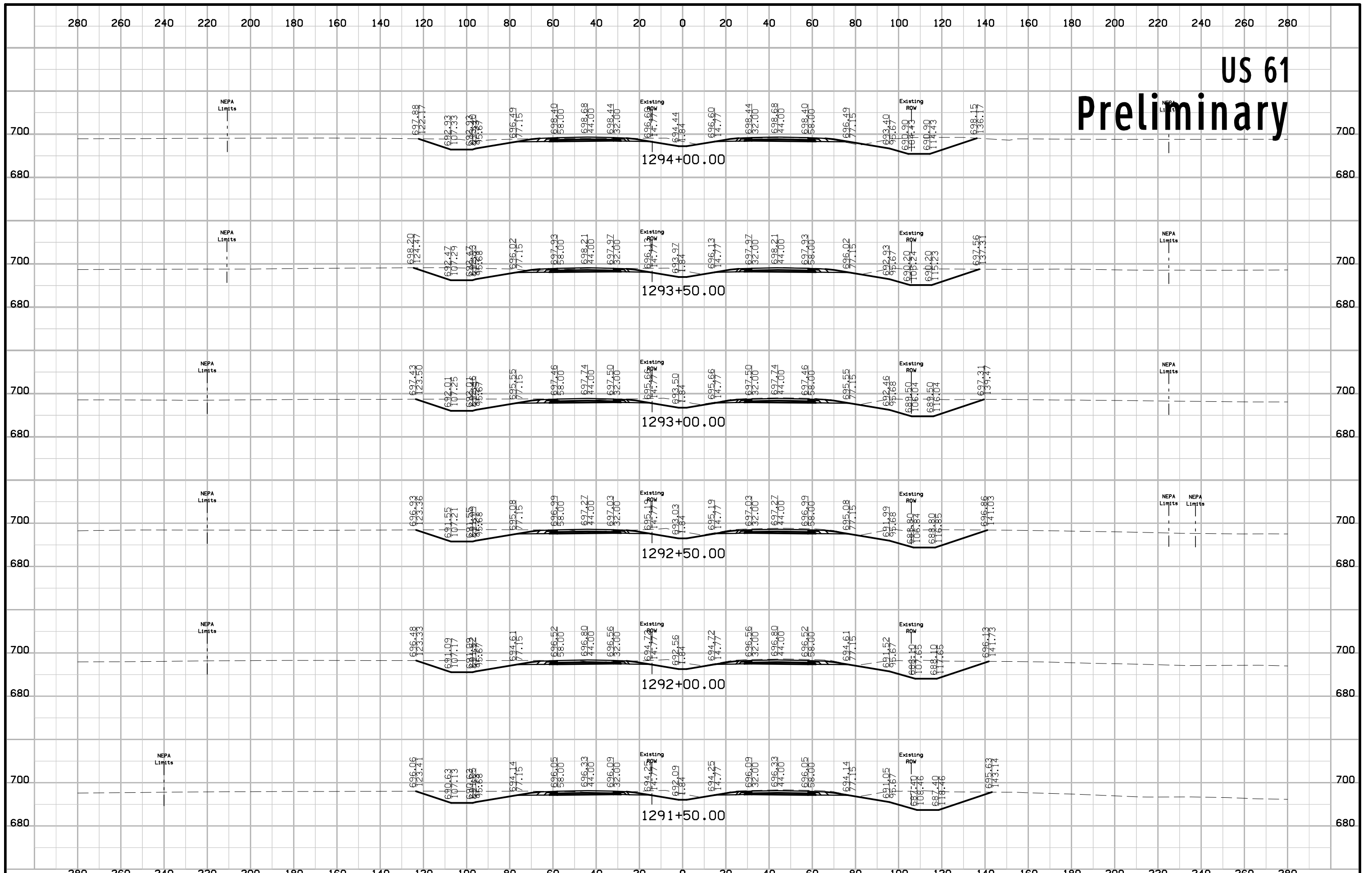

US 61 Preliminary

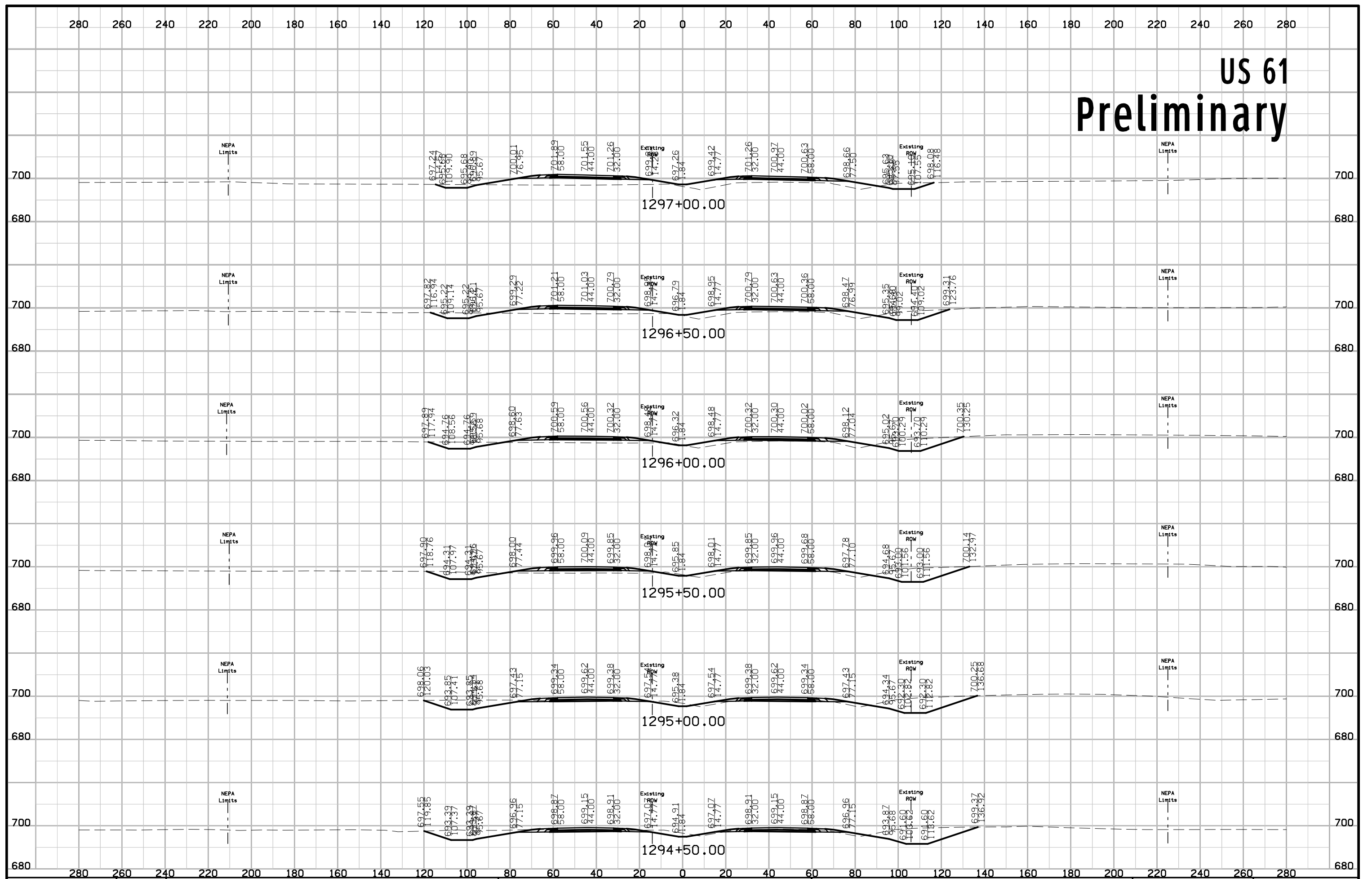

US 61 Preliminary

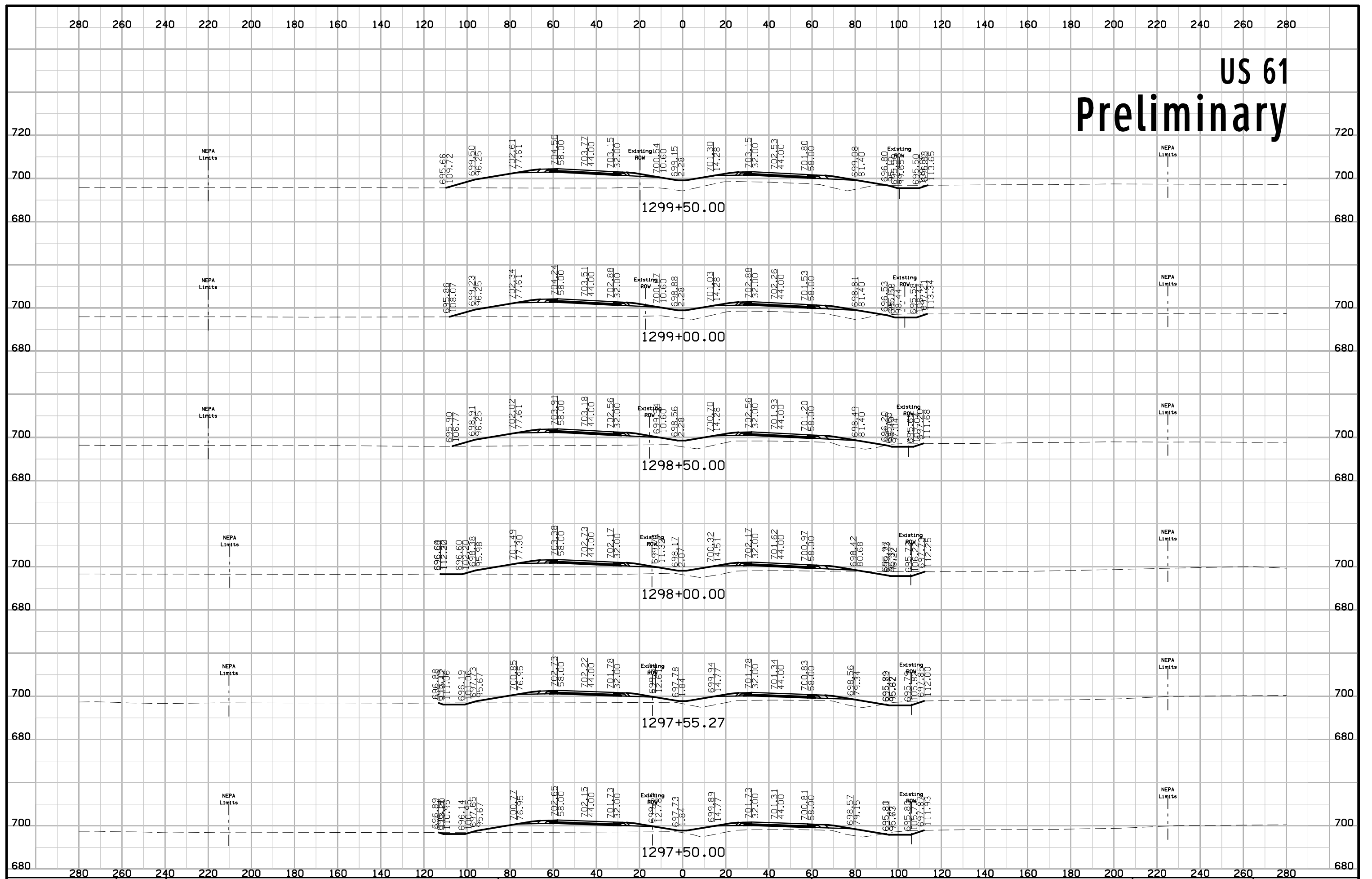

US 61 Preliminary

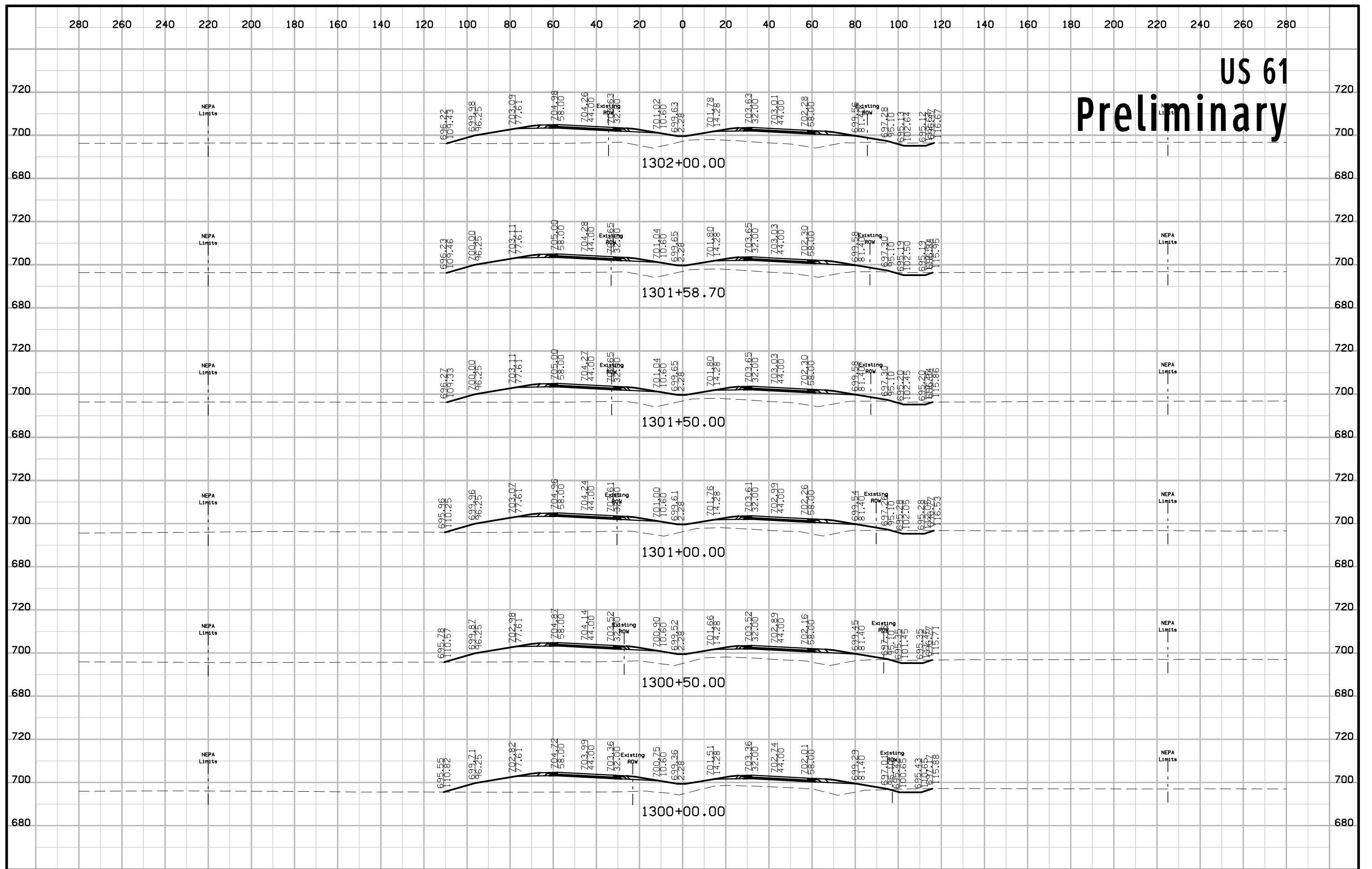

US 61 Preliminary

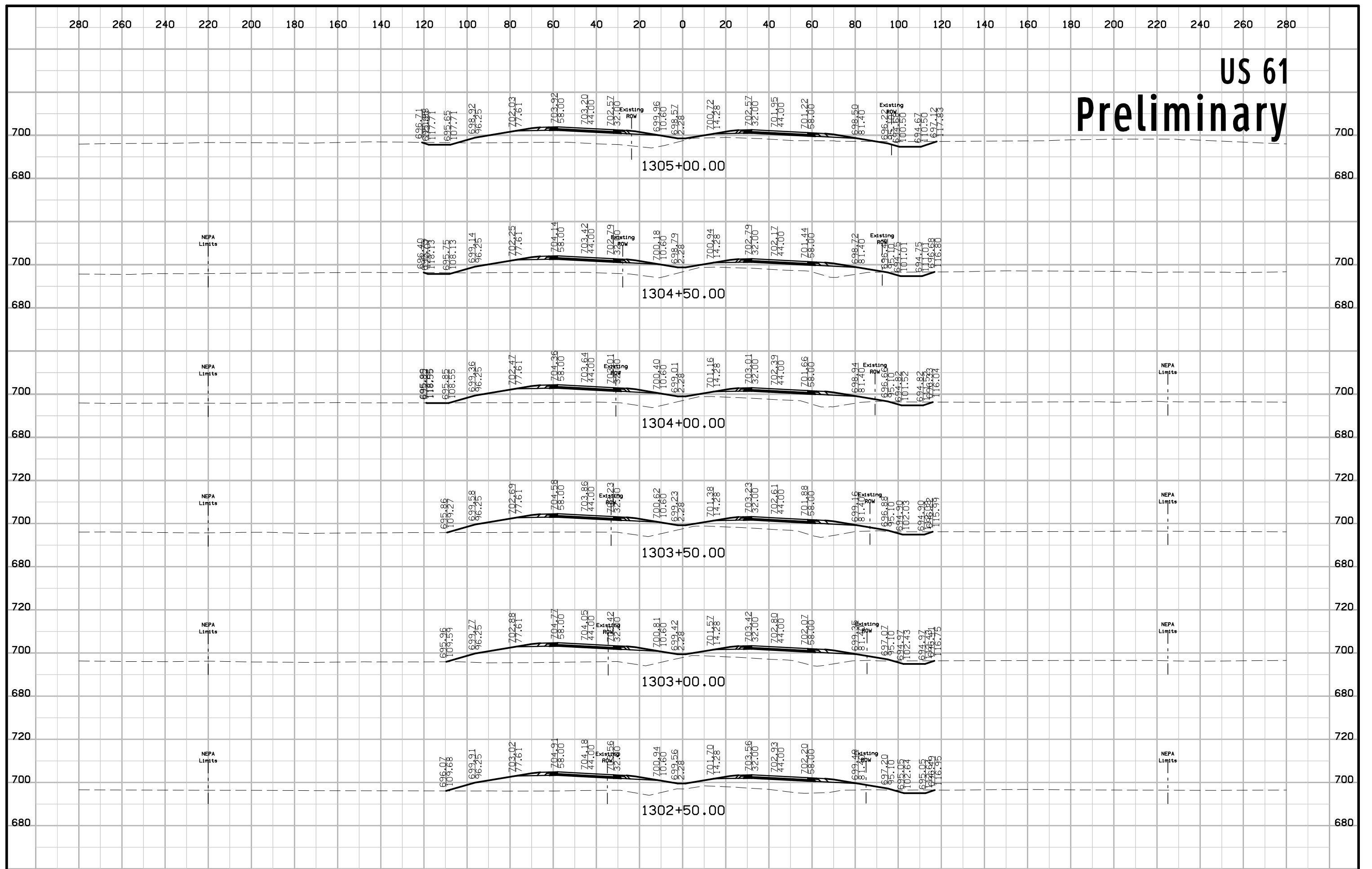

US 61 Preliminary

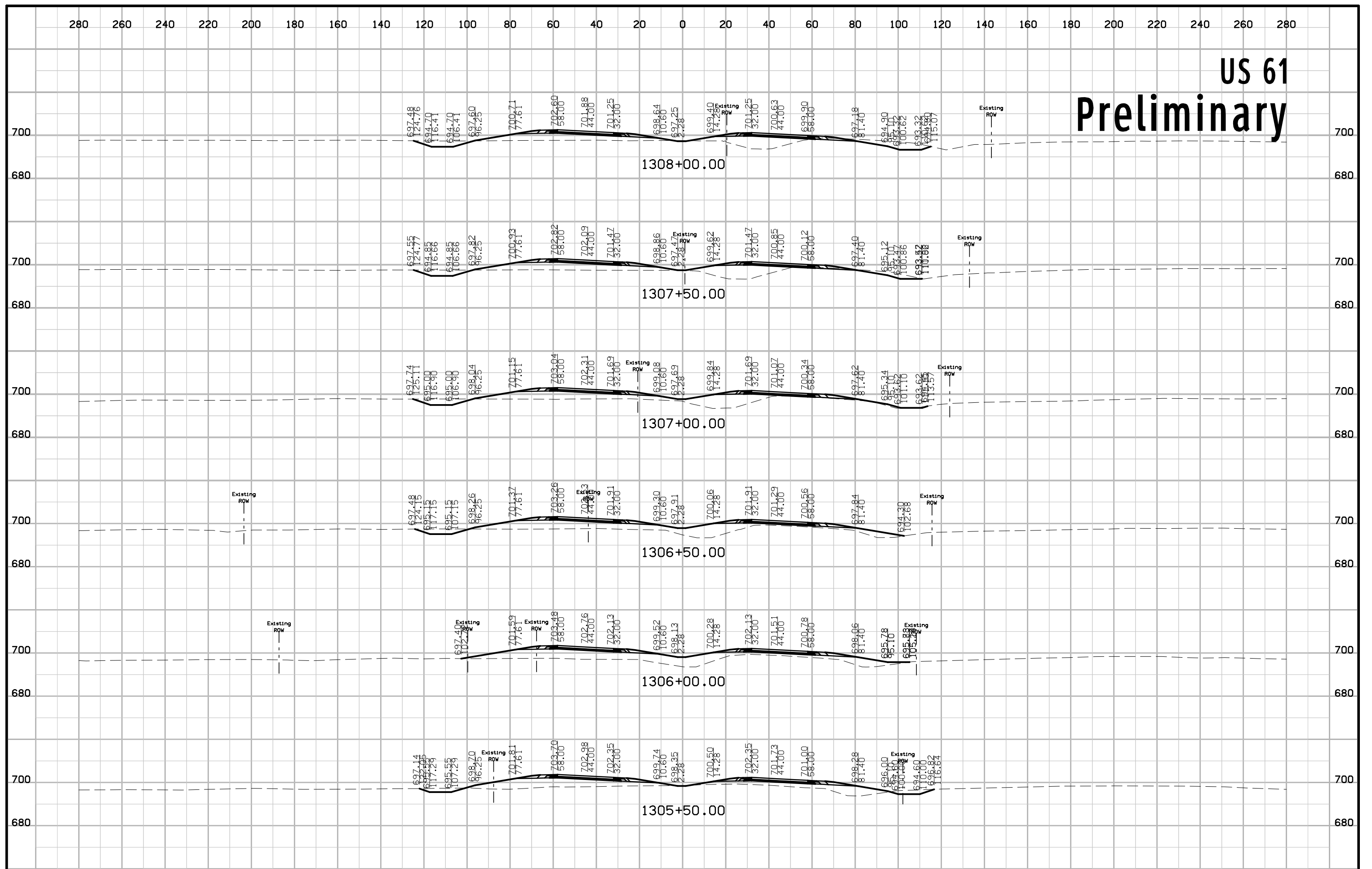

US 61 Preliminary

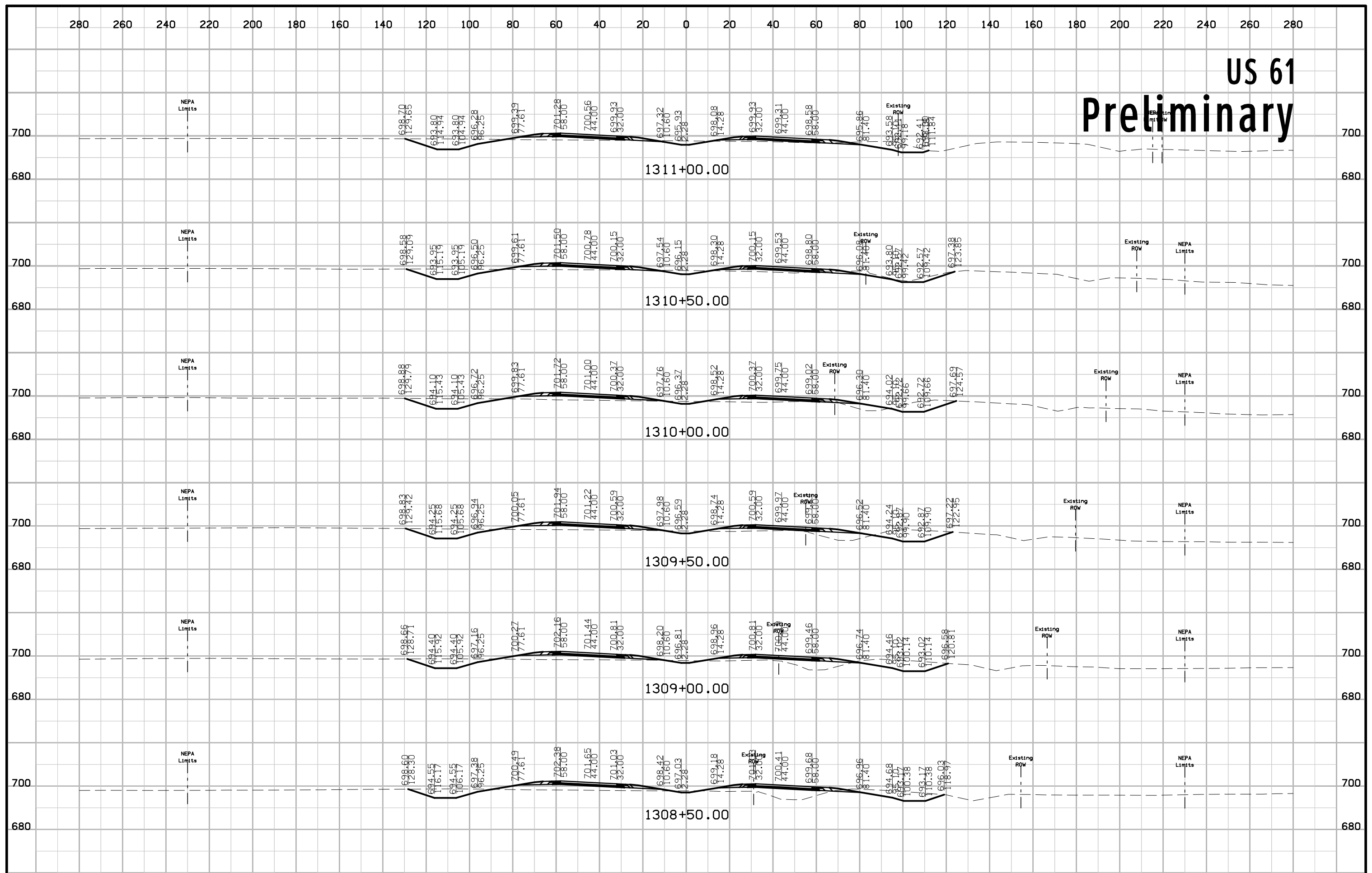

US 61

Preliminary

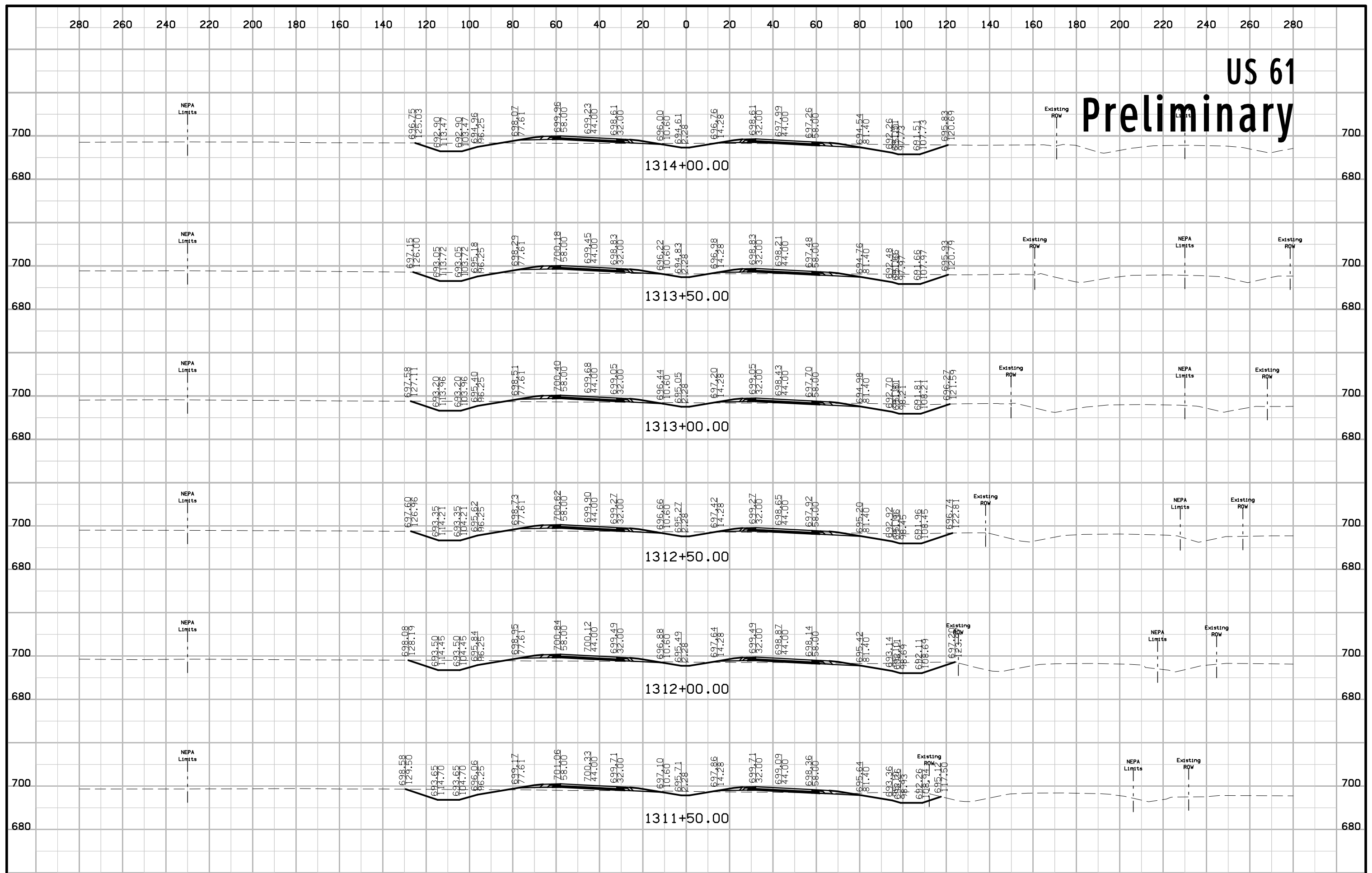

US 61 Preliminary

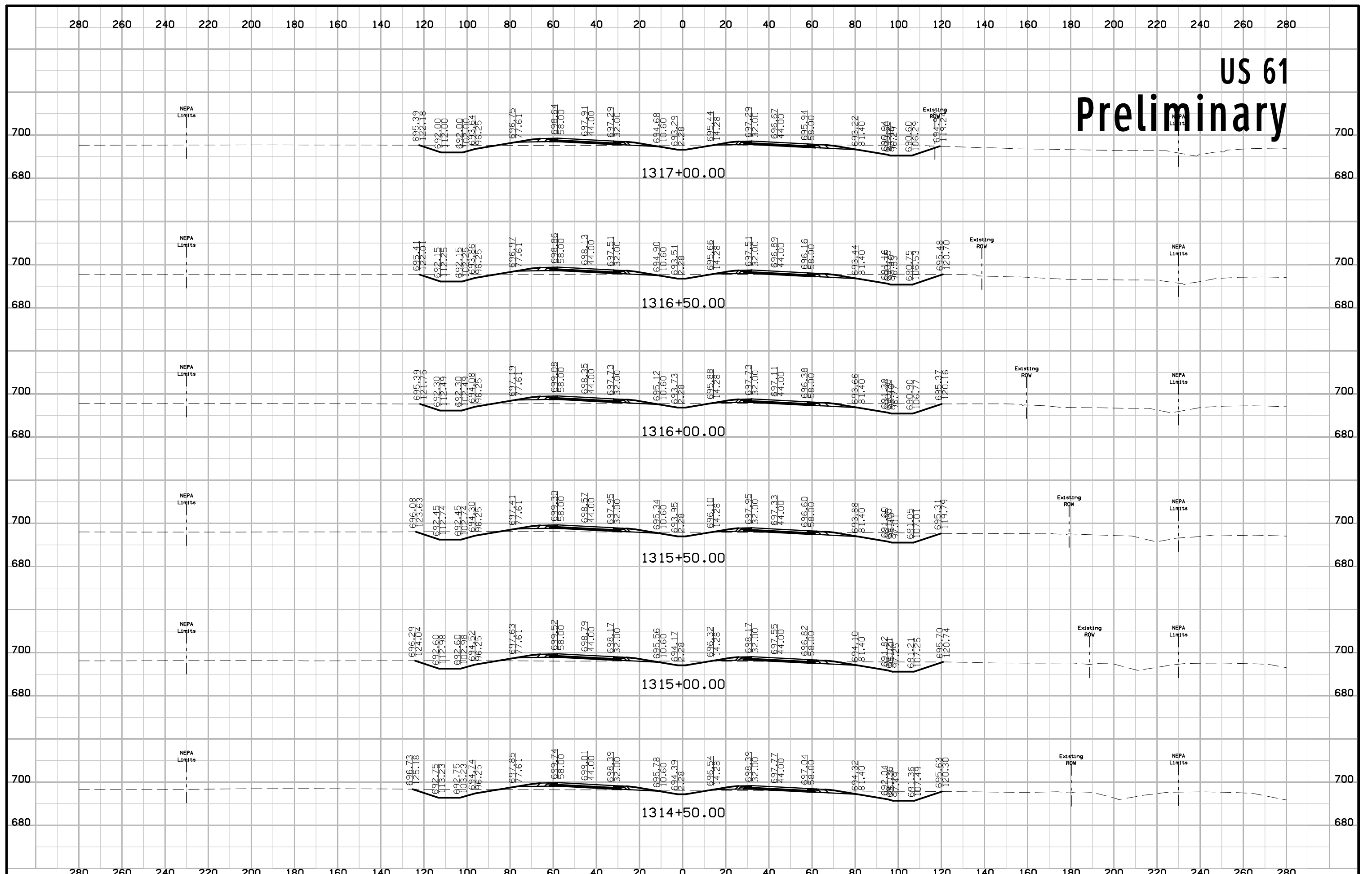

US 61 Preliminary

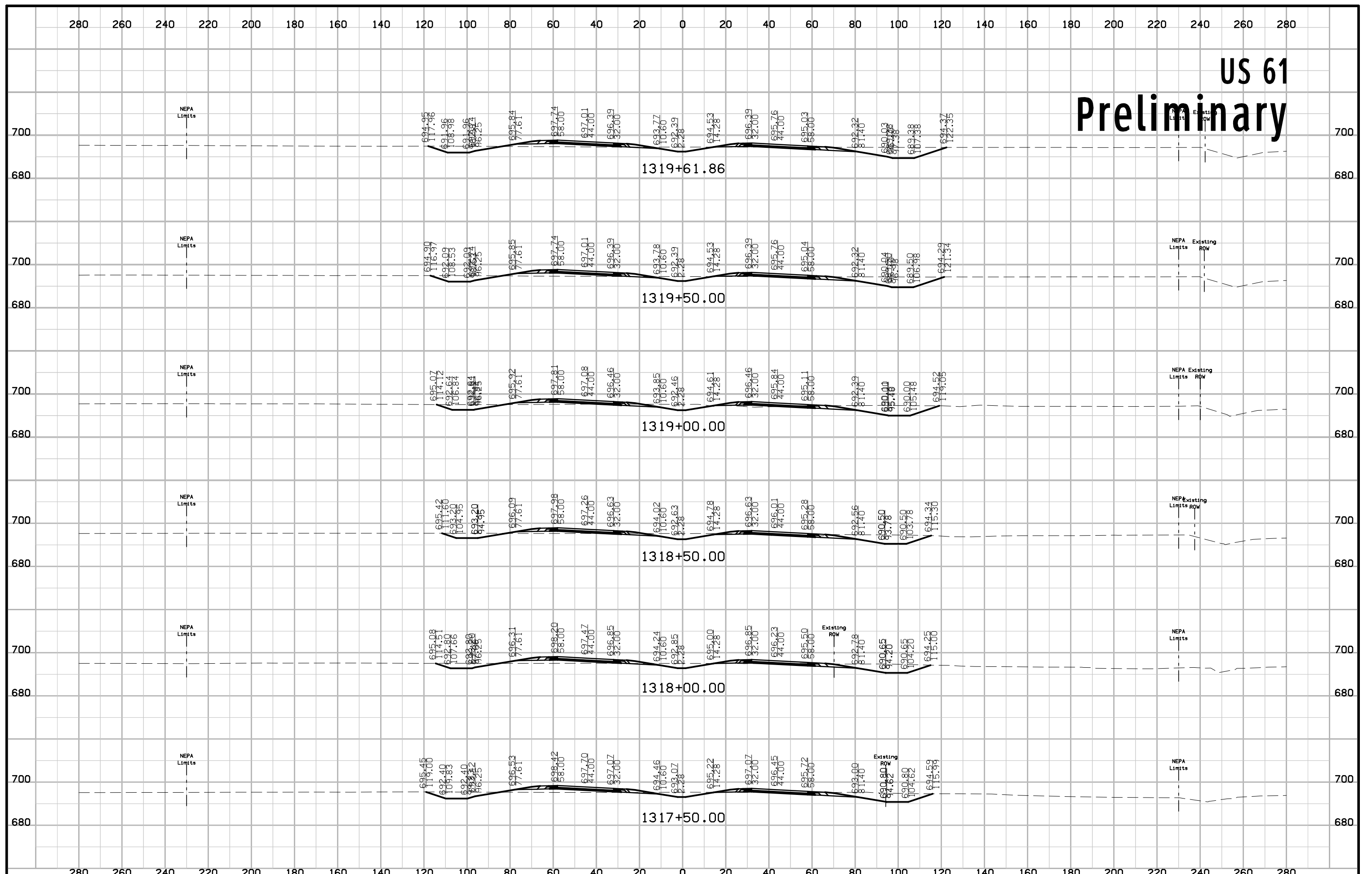

US 61 Preliminary

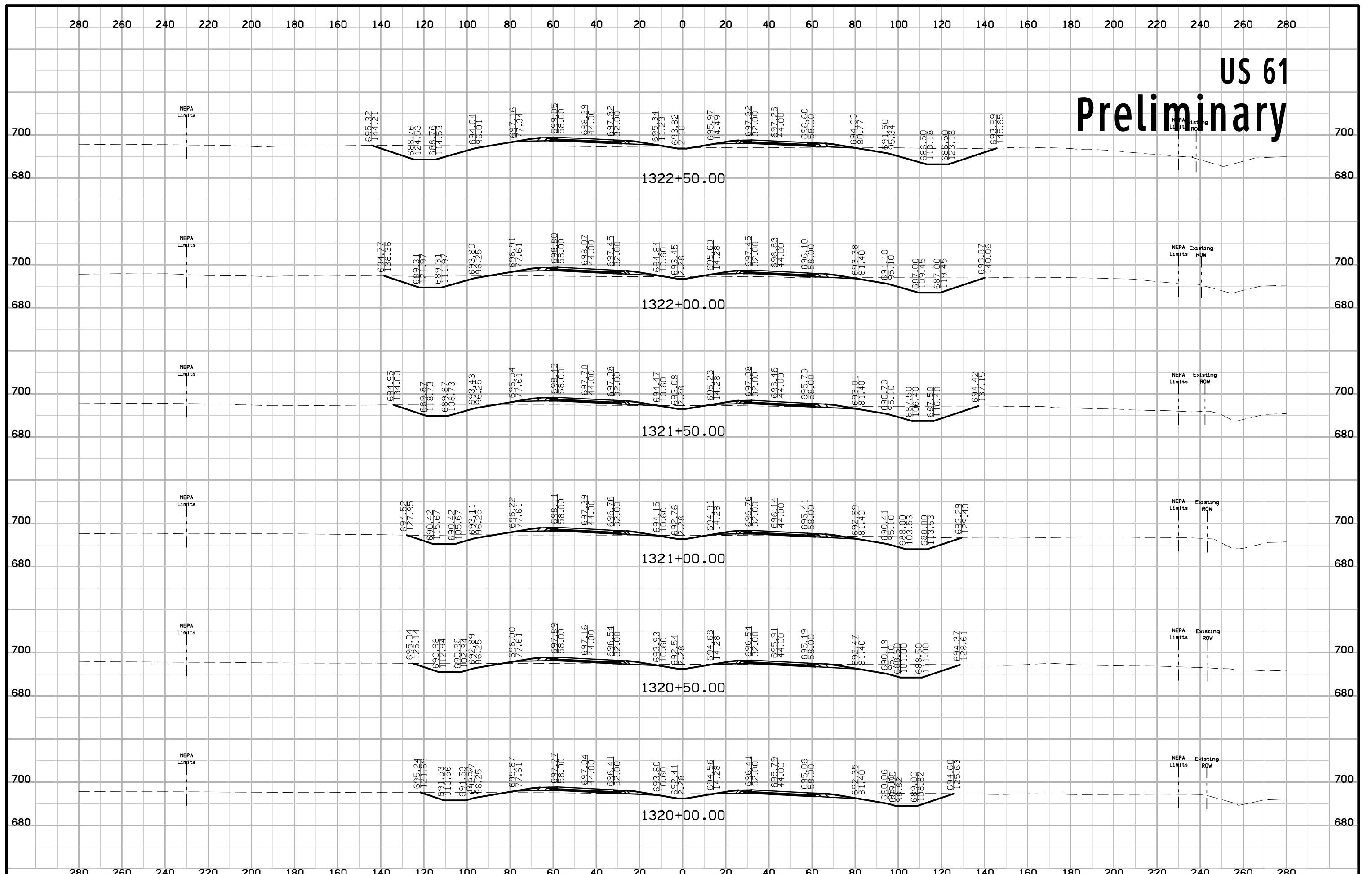

US 61 Preliminary

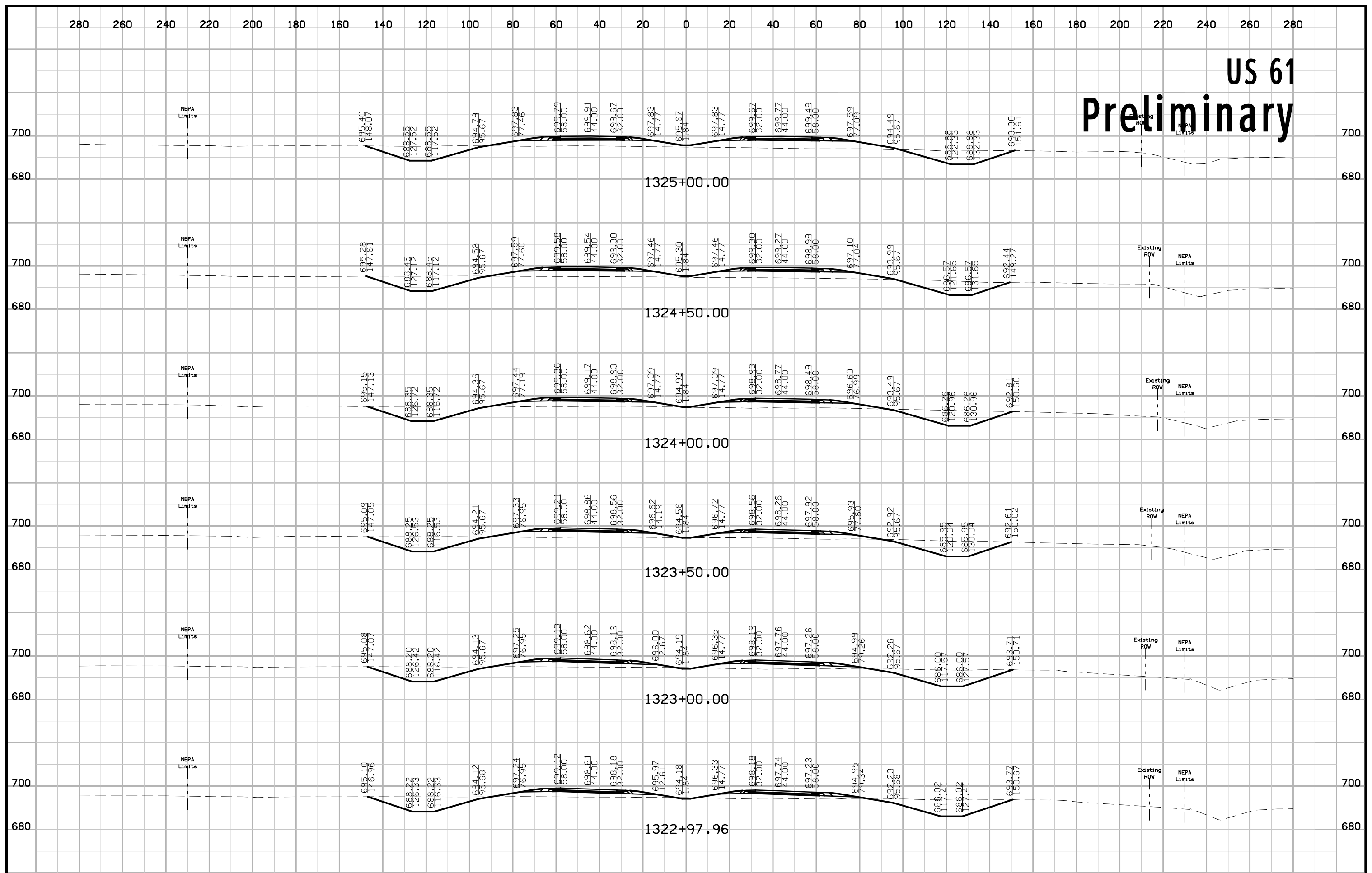

US 61

Preliminary

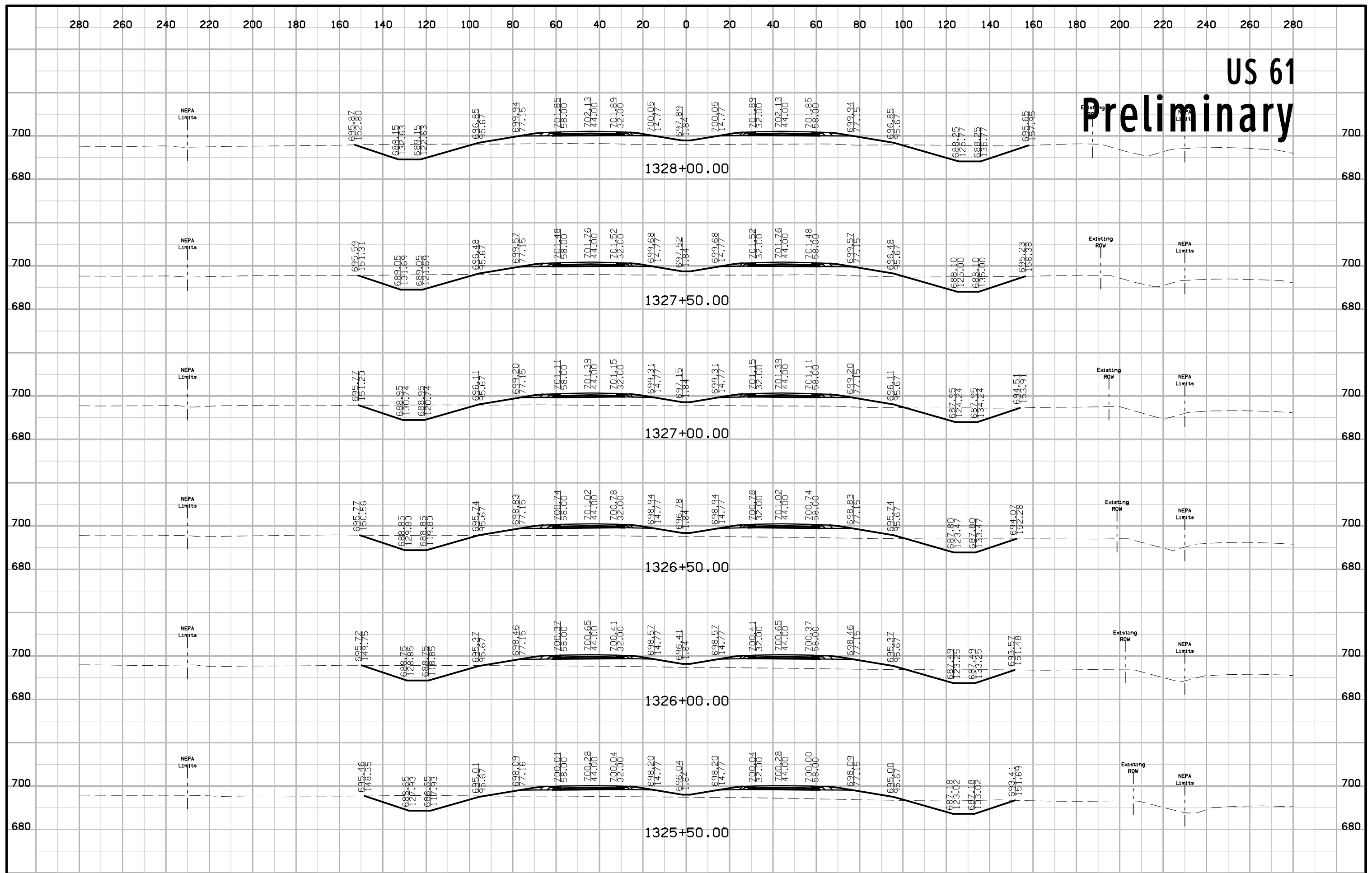

US 61 Preliminary

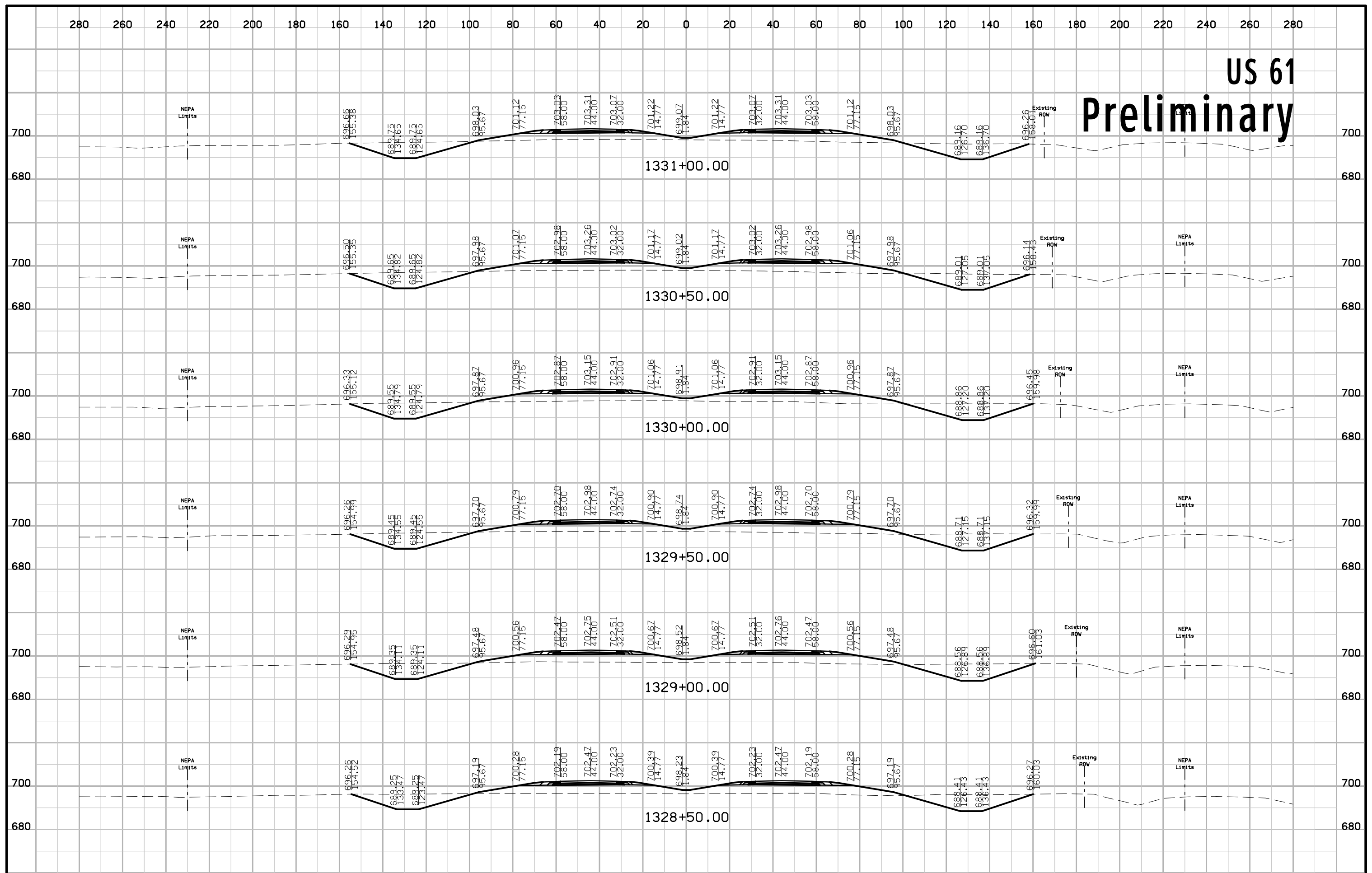

US 61 Preliminary

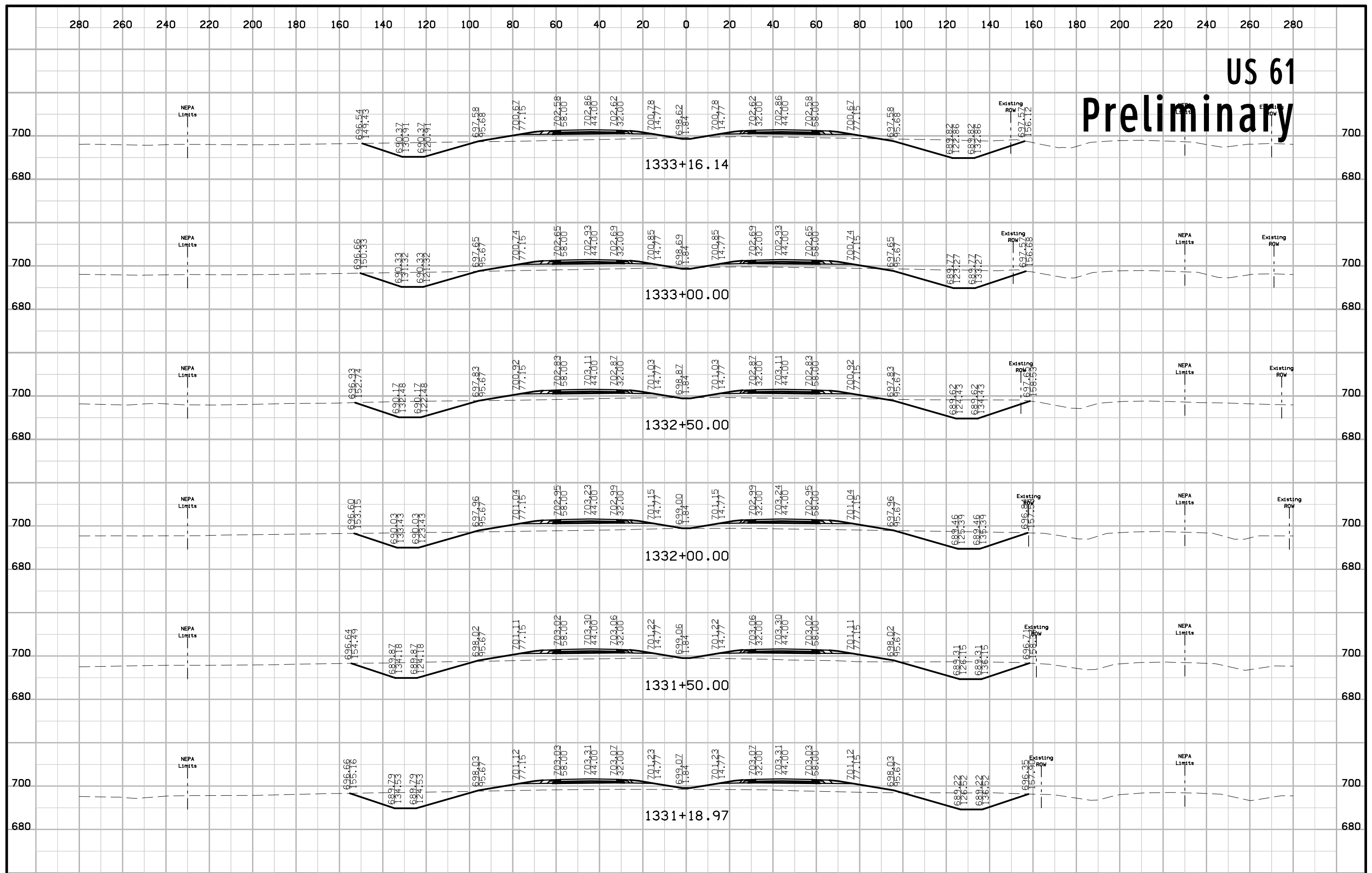

US 61 Preliminary

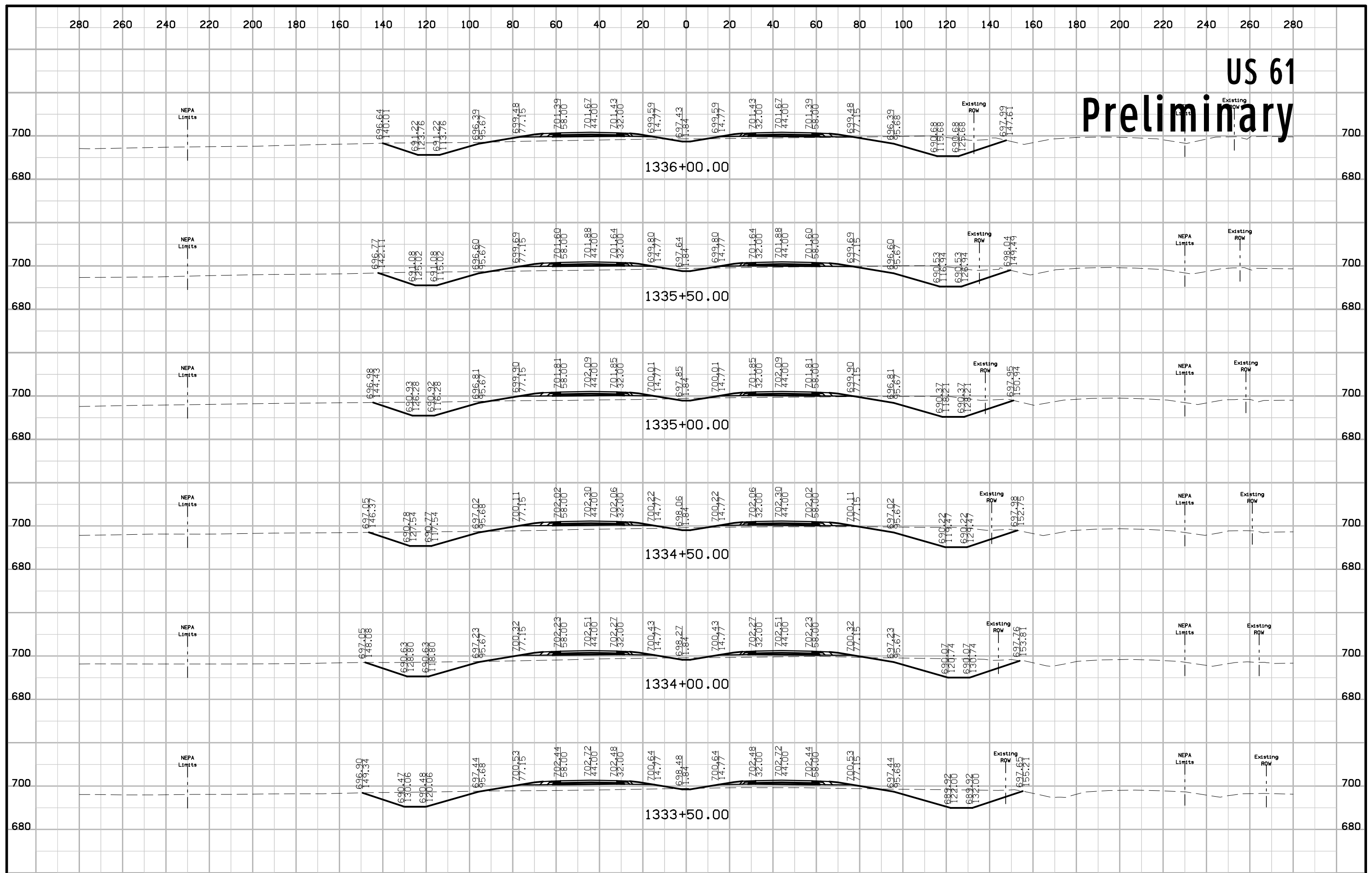

US 61 Preliminary

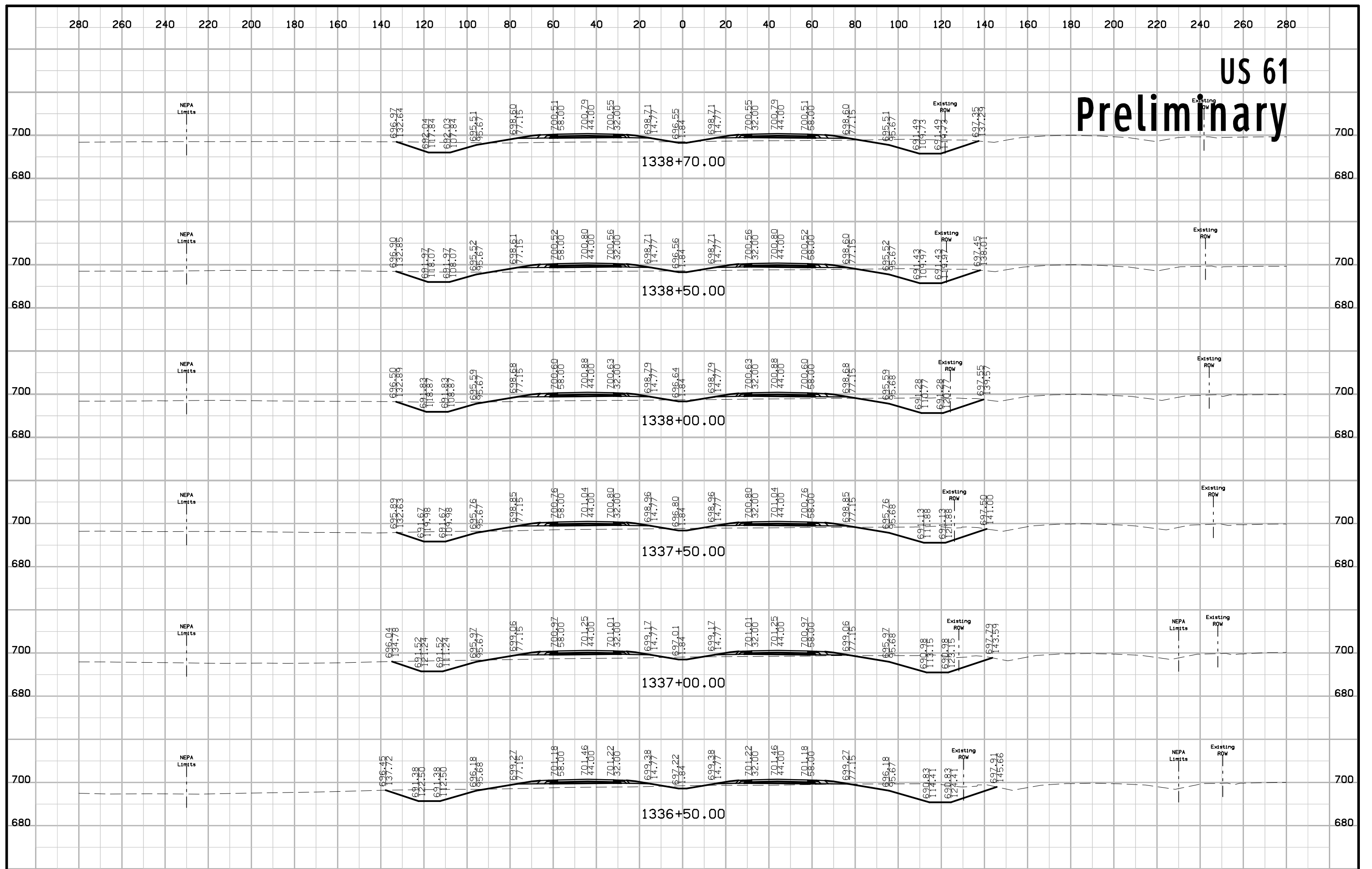

US 61 Preliminary

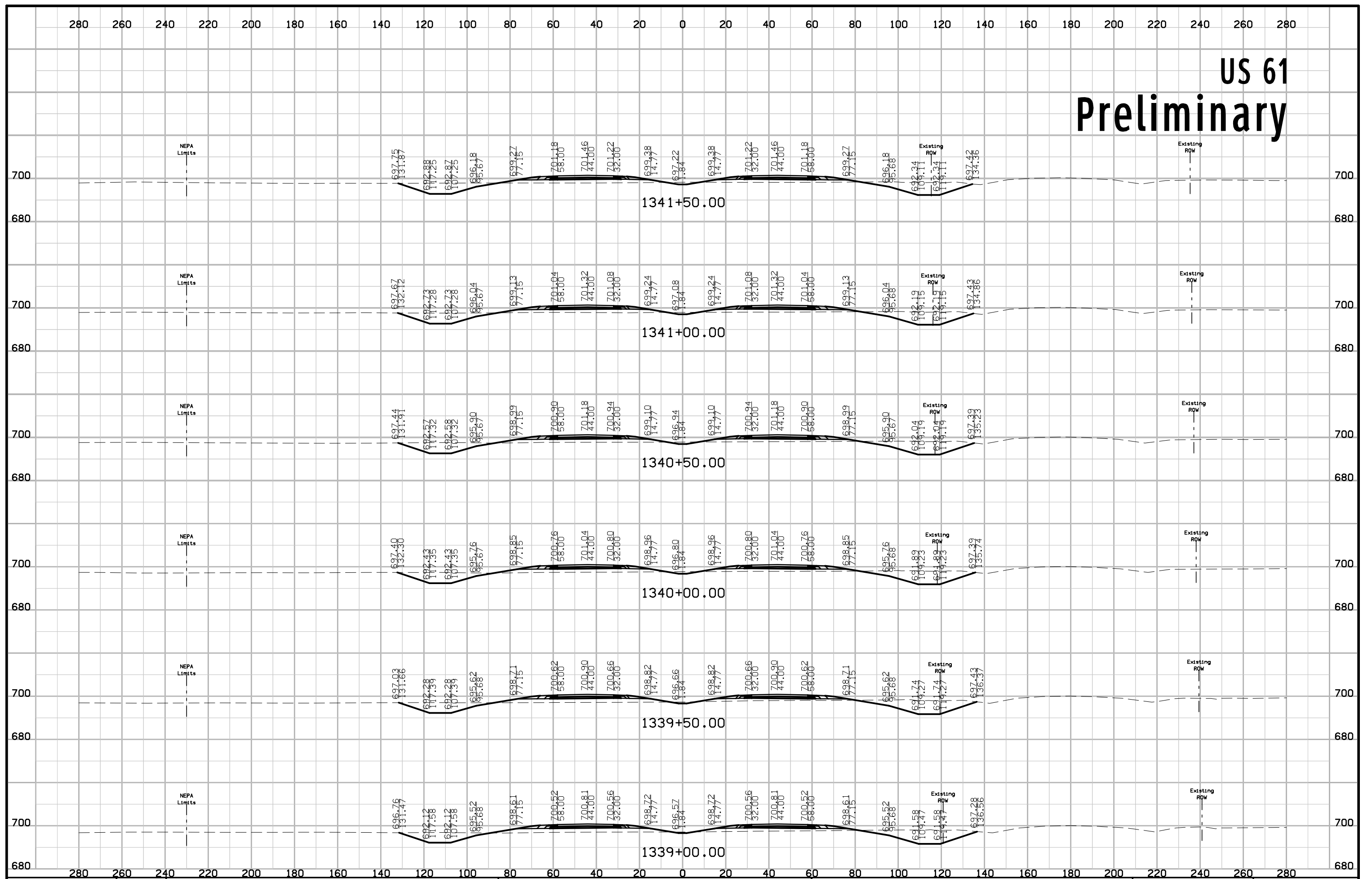

US 61 Preliminary

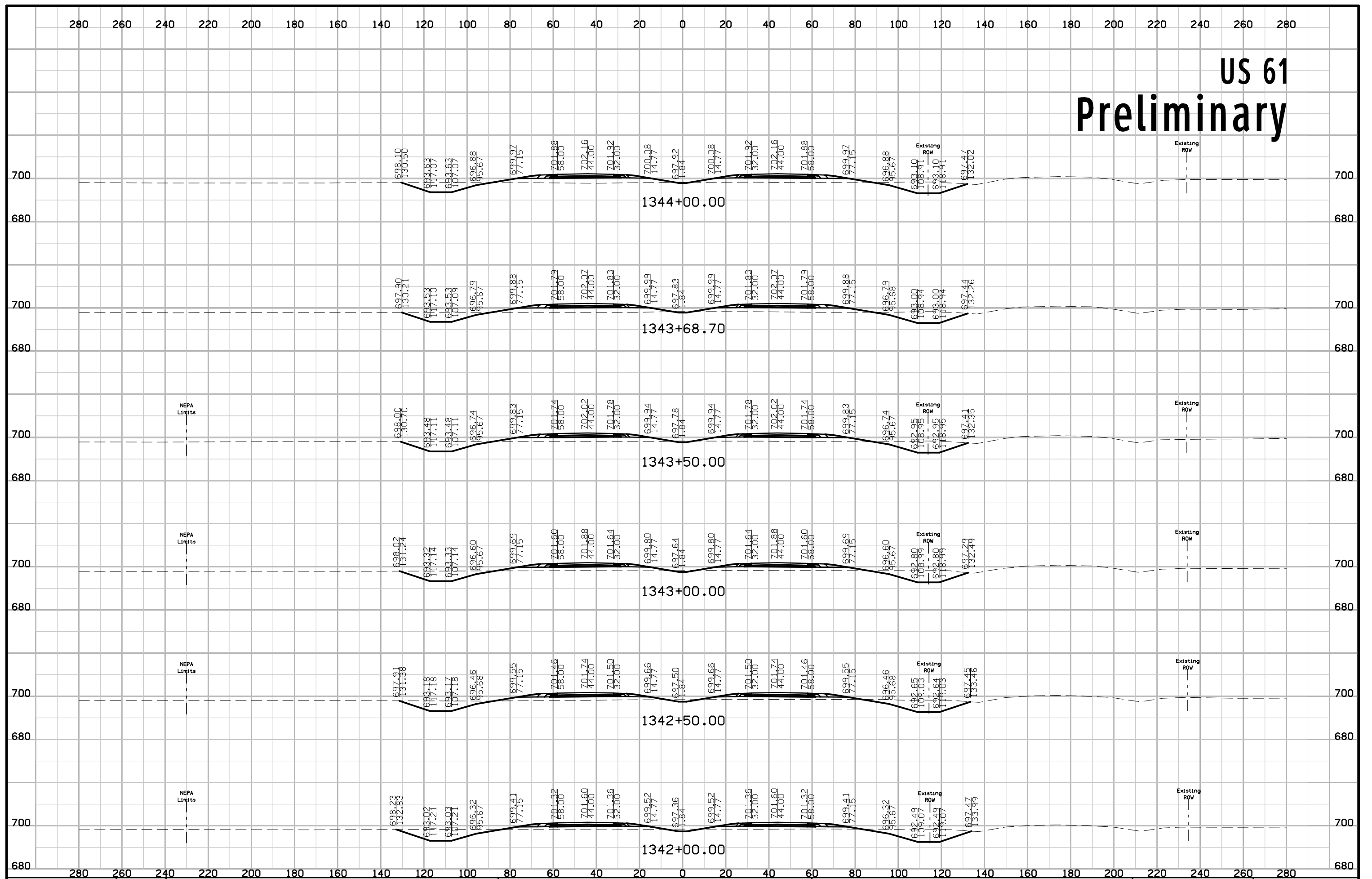

US 61 Preliminary

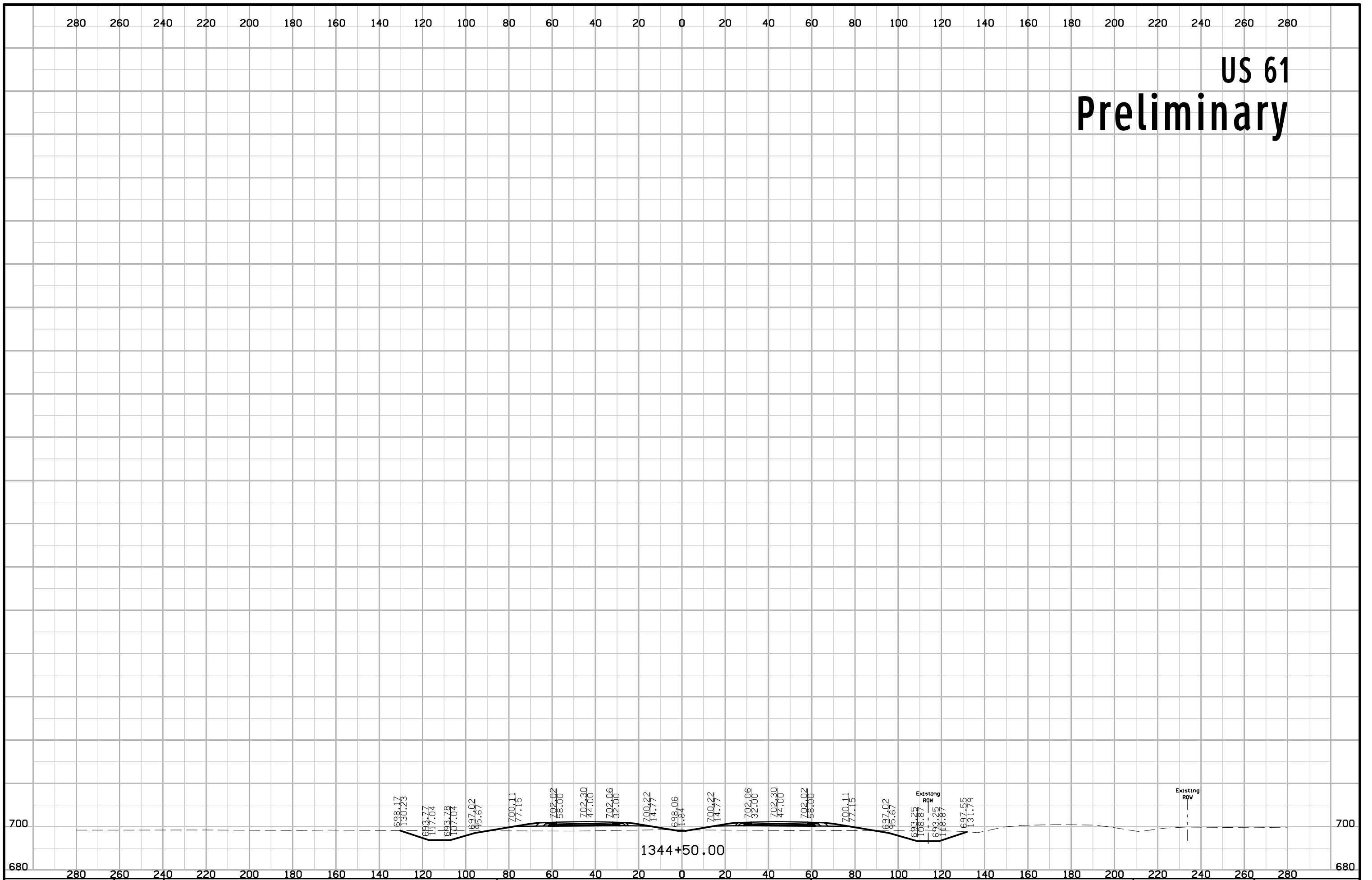

US 61 Preliminary

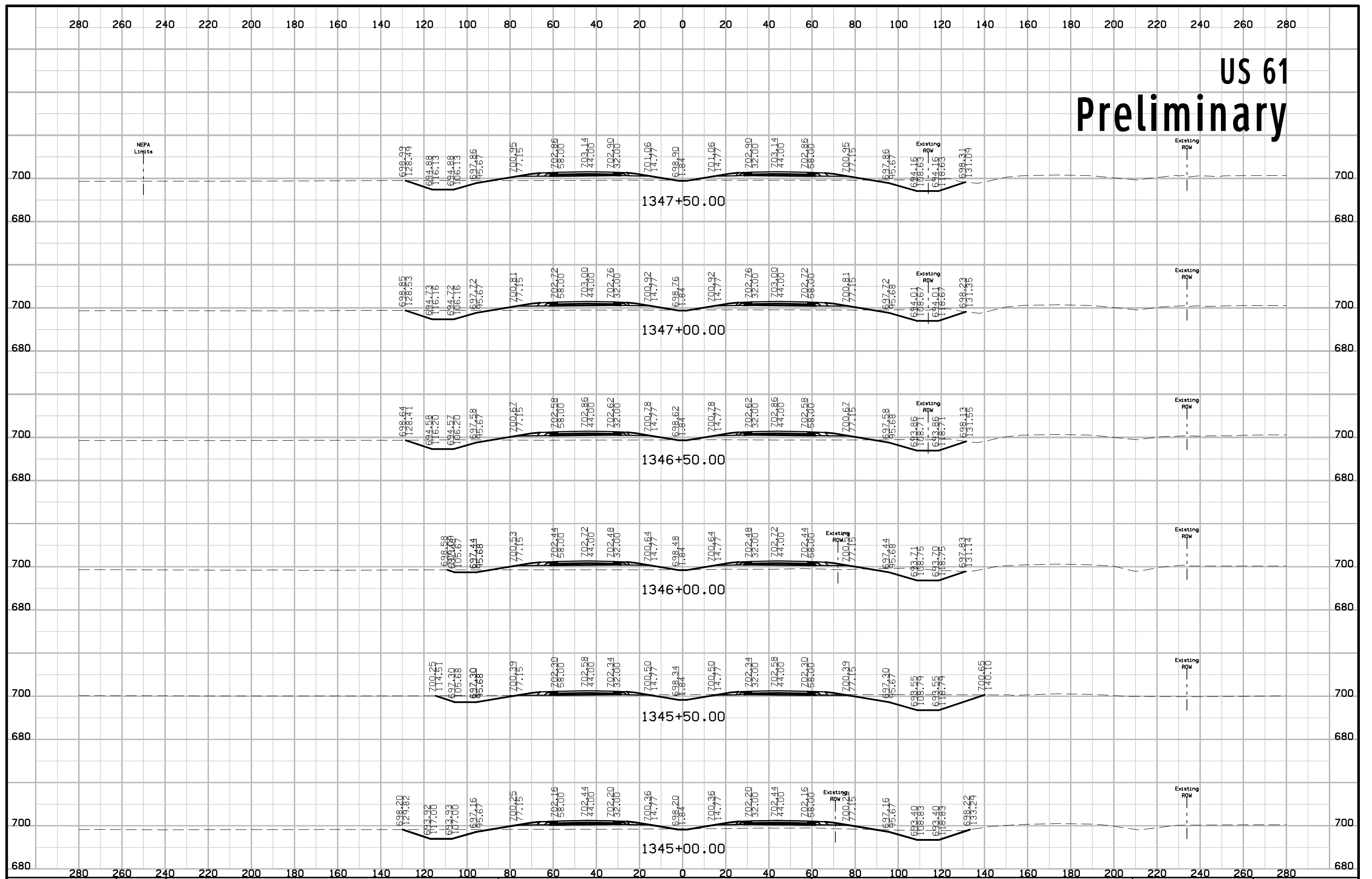

NEPA
Limits

Existing
ROW

Existing
ROW

Existing
ROW

Existing
ROW

Existing
ROW

Existing
ROW

US 61 Preliminary

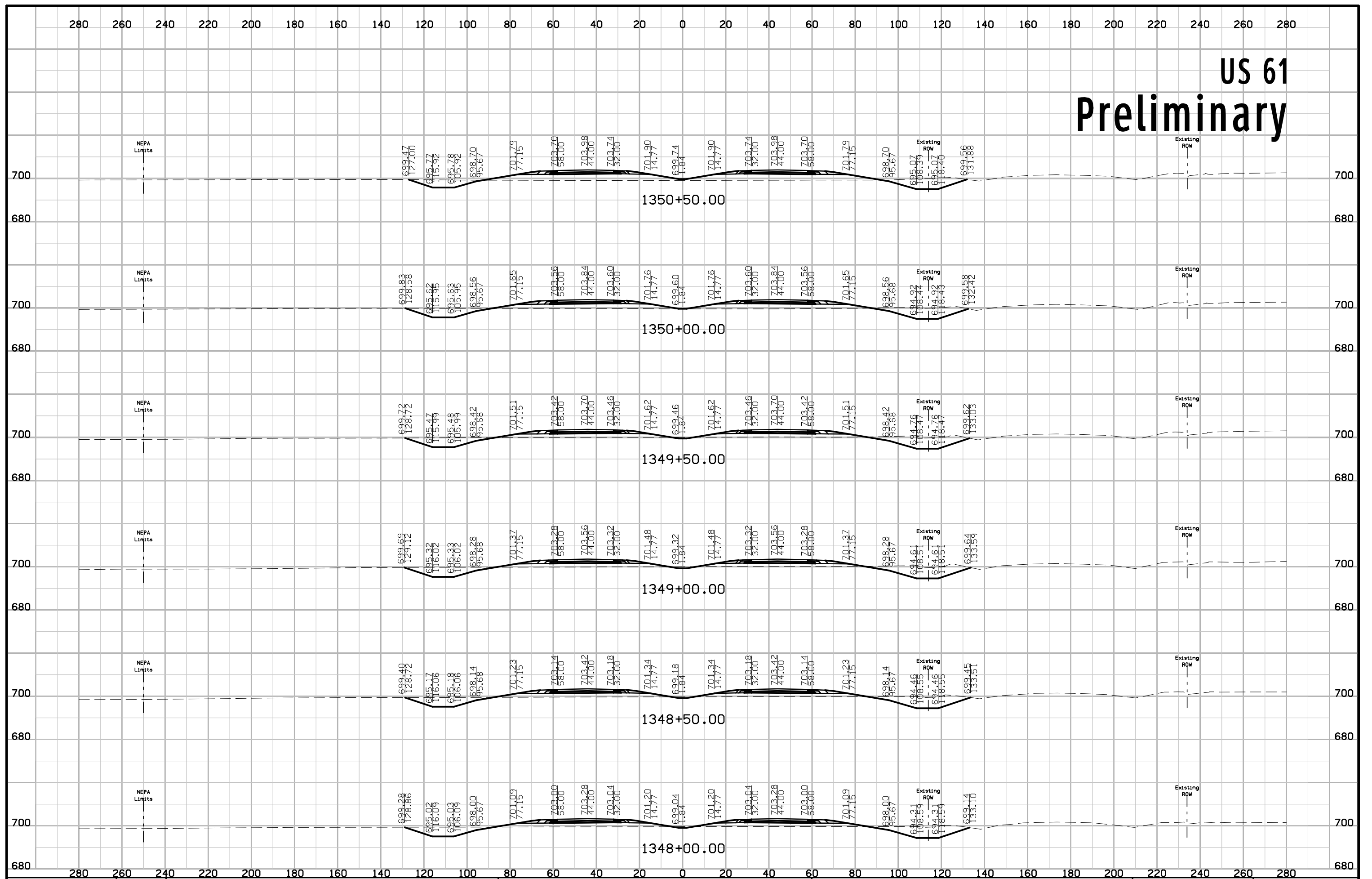

US 61 Preliminary

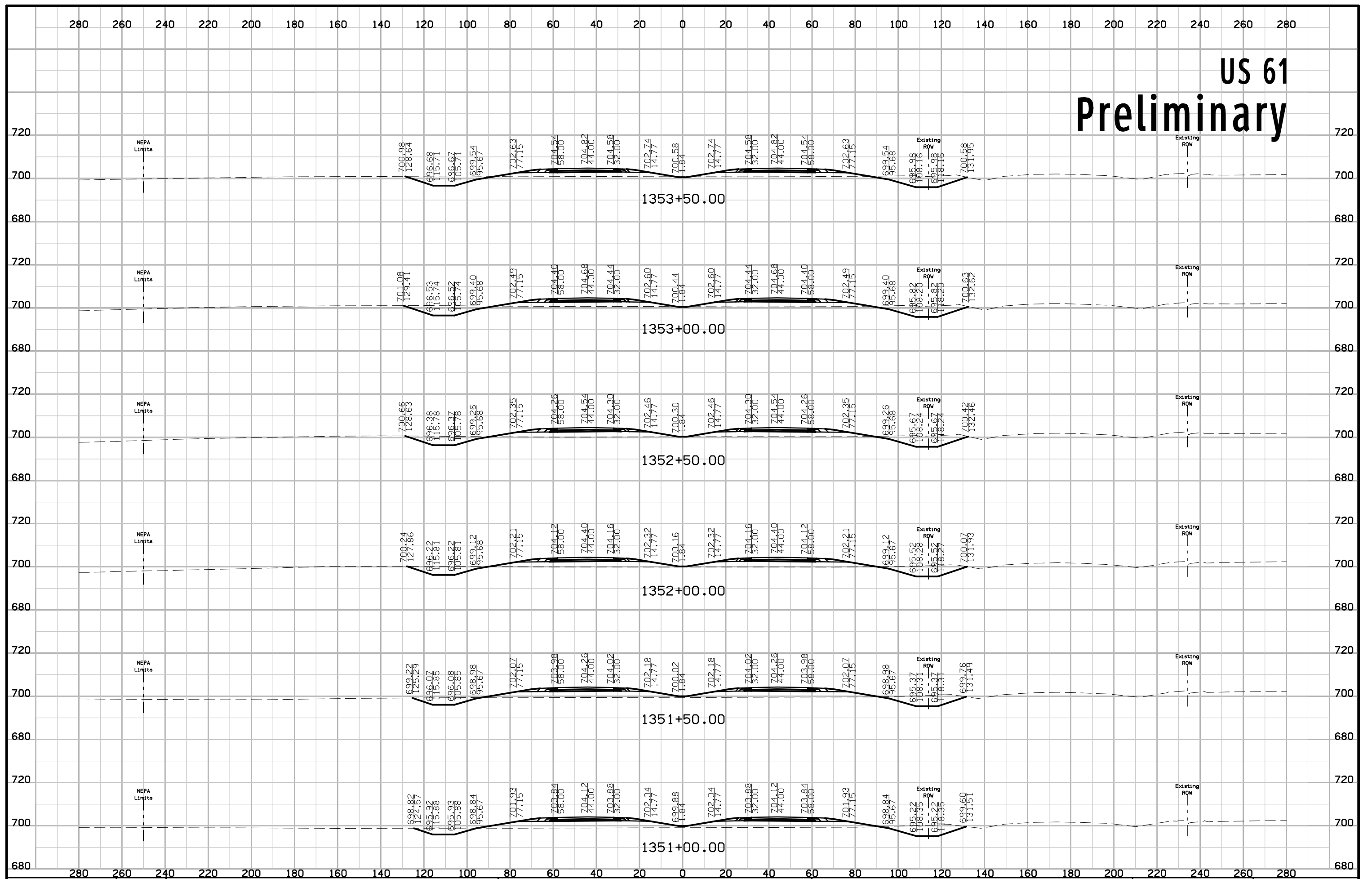

US 61 Preliminary

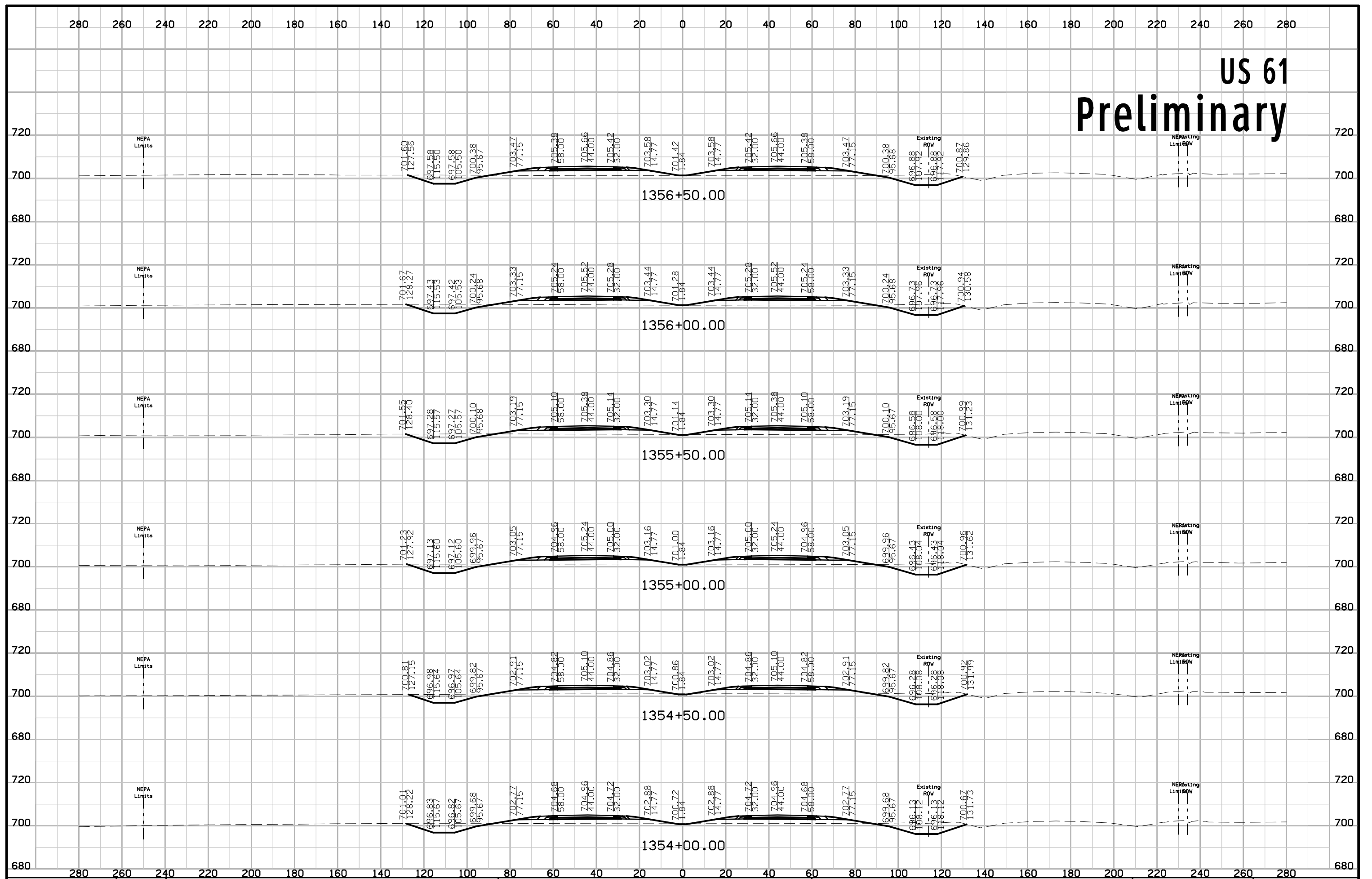

US 61 Preliminary

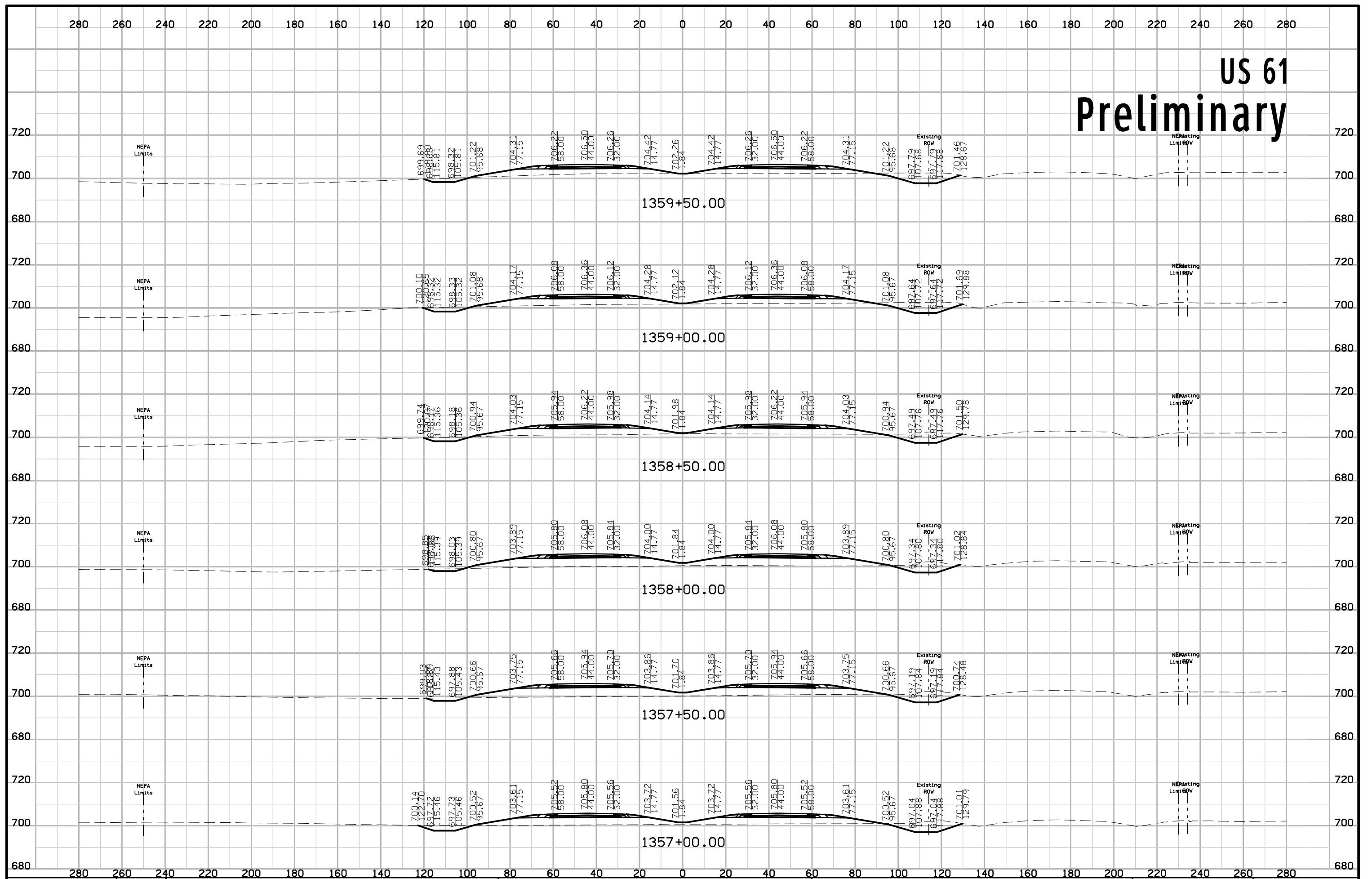

US 61 Preliminary

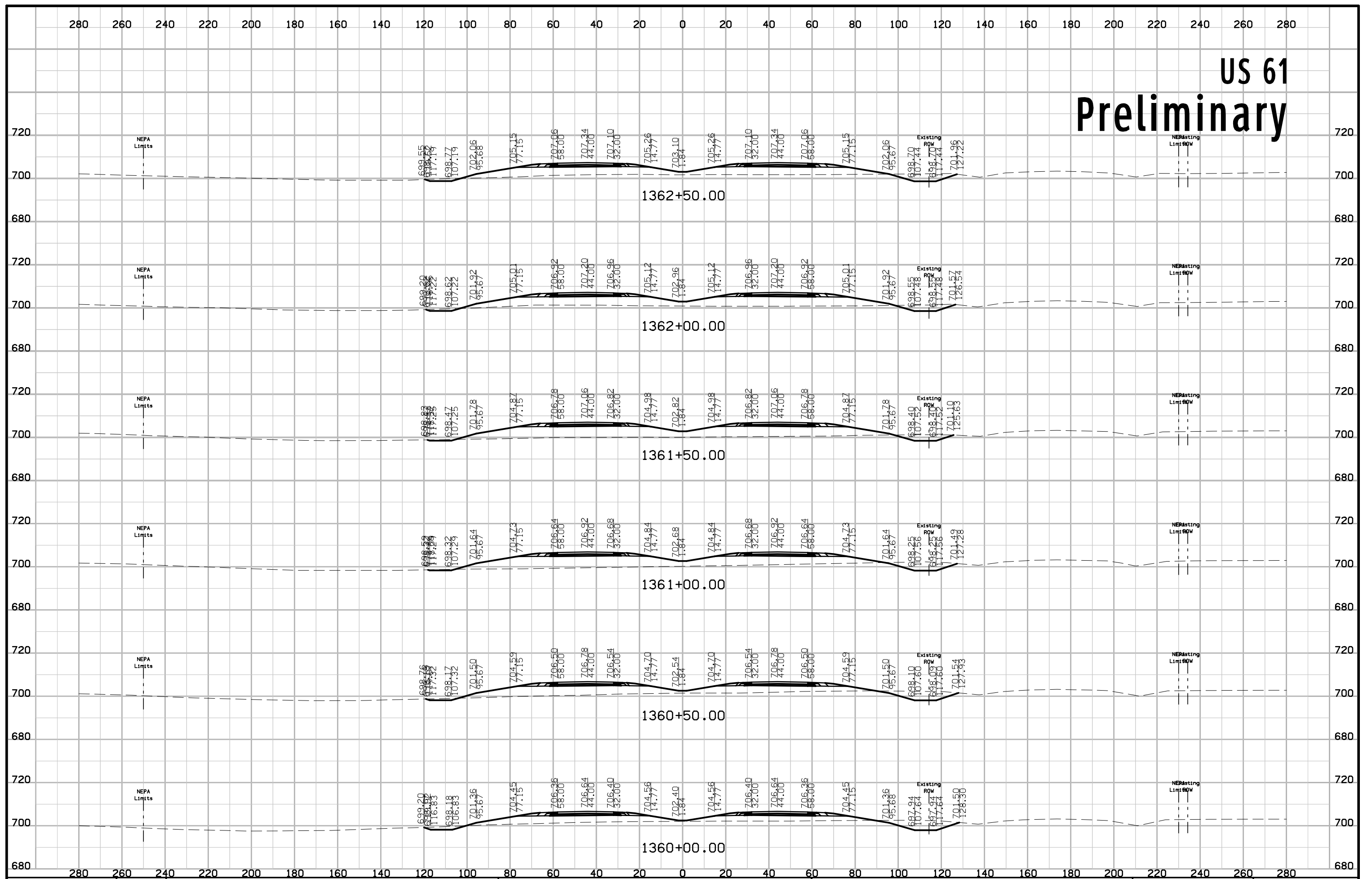

US 61 Preliminary

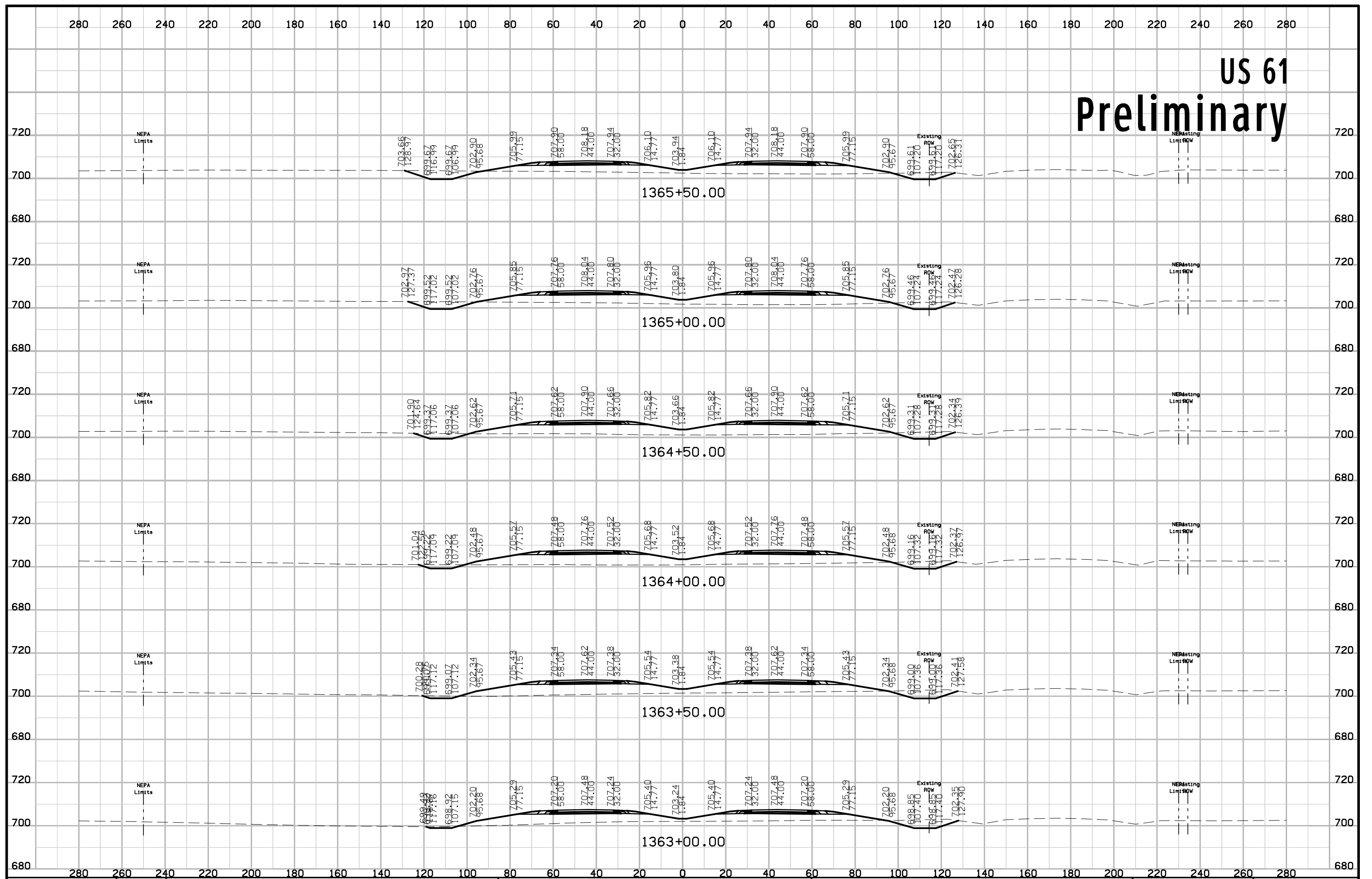

US 61 Preliminary

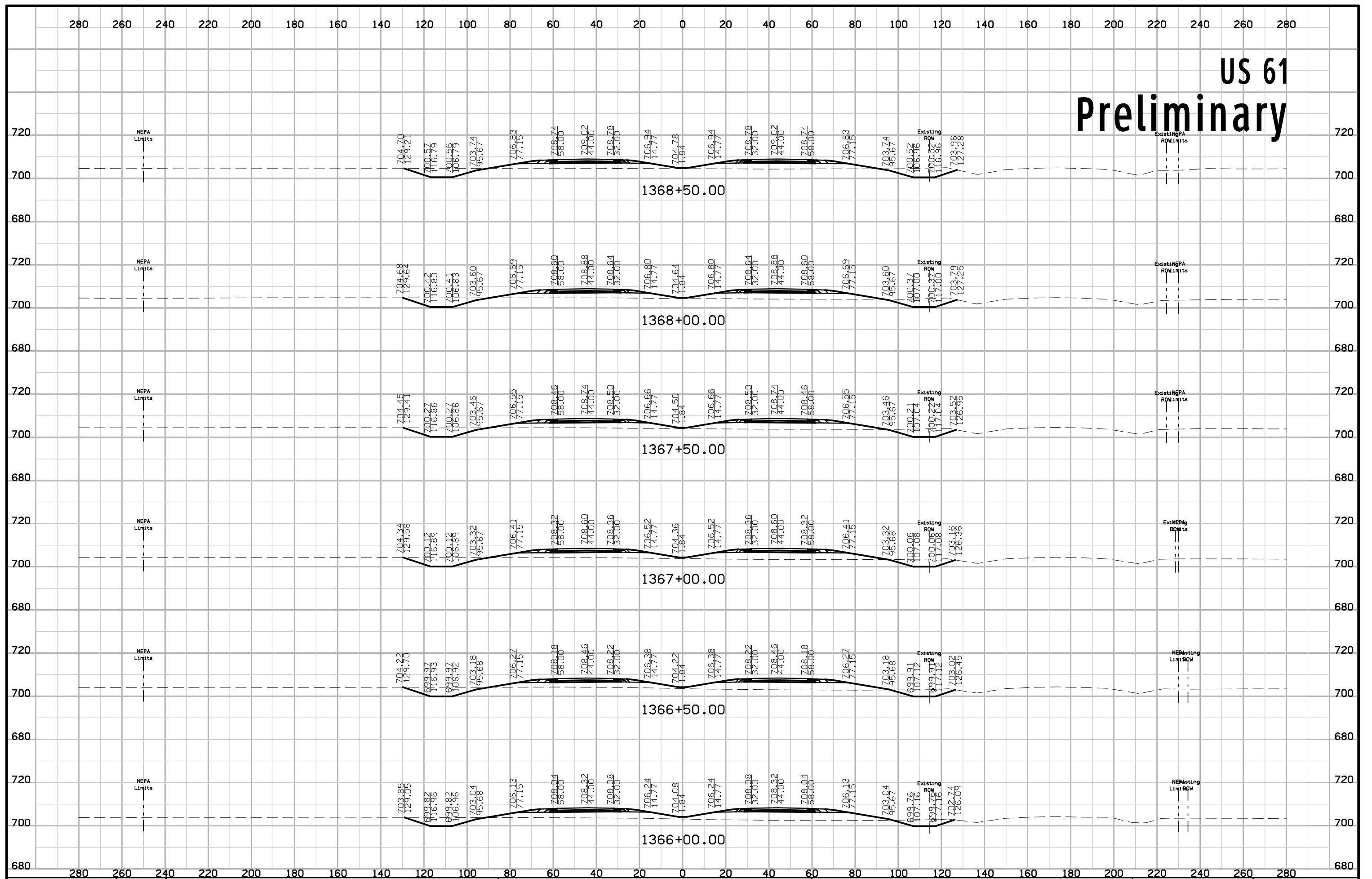

US 61 Preliminary

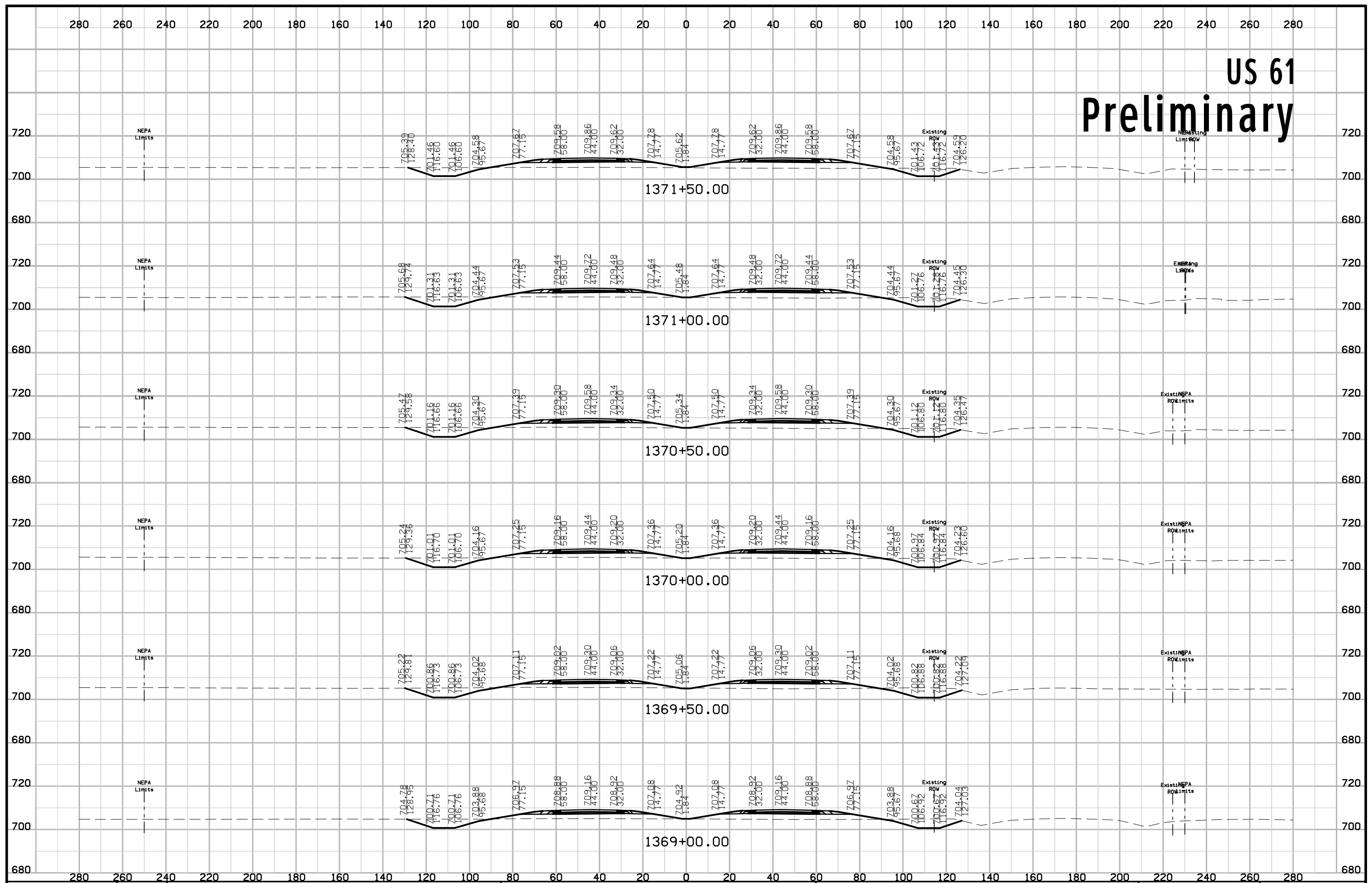

US 61 Preliminary

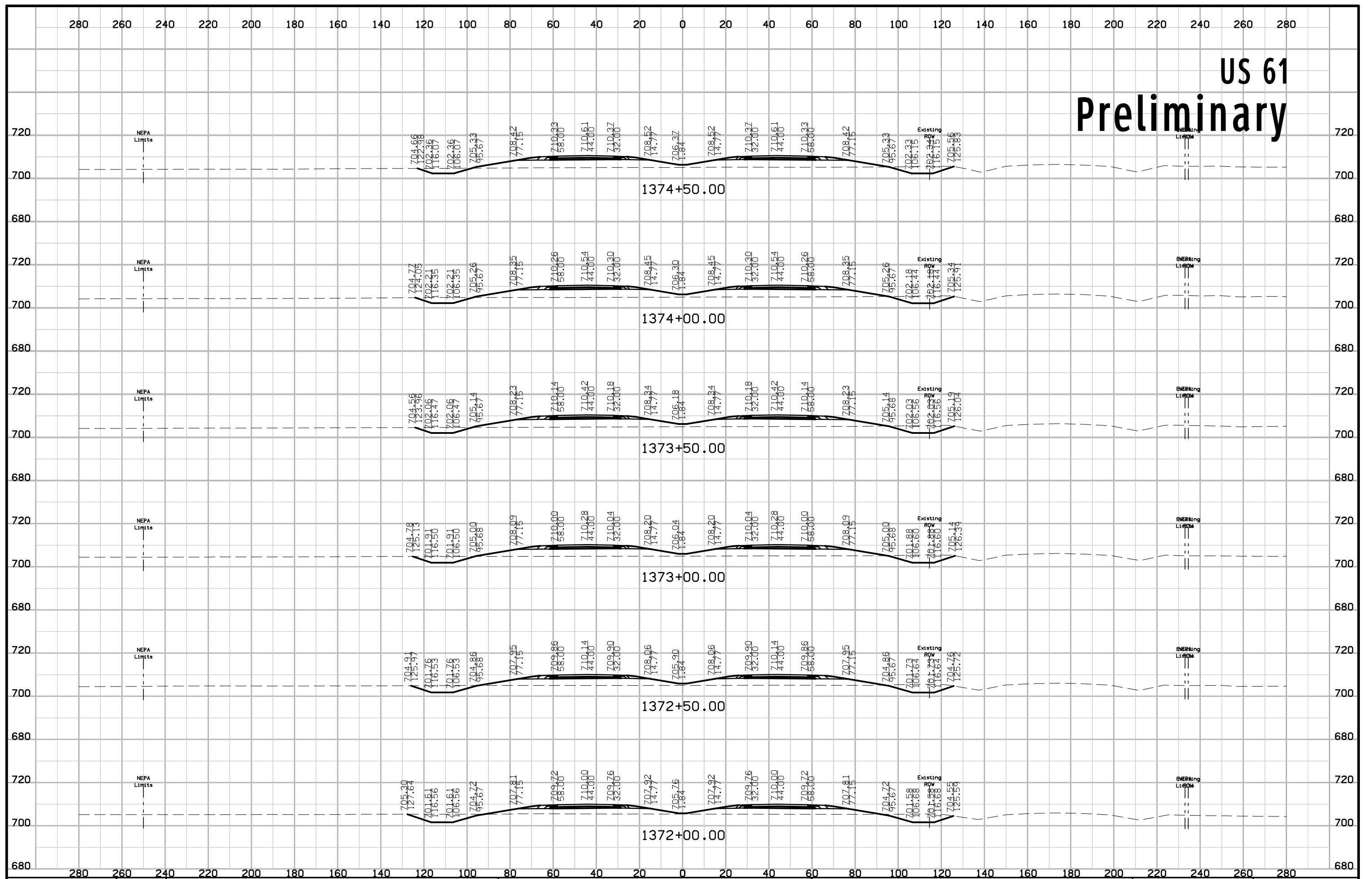

US 61 Preliminary

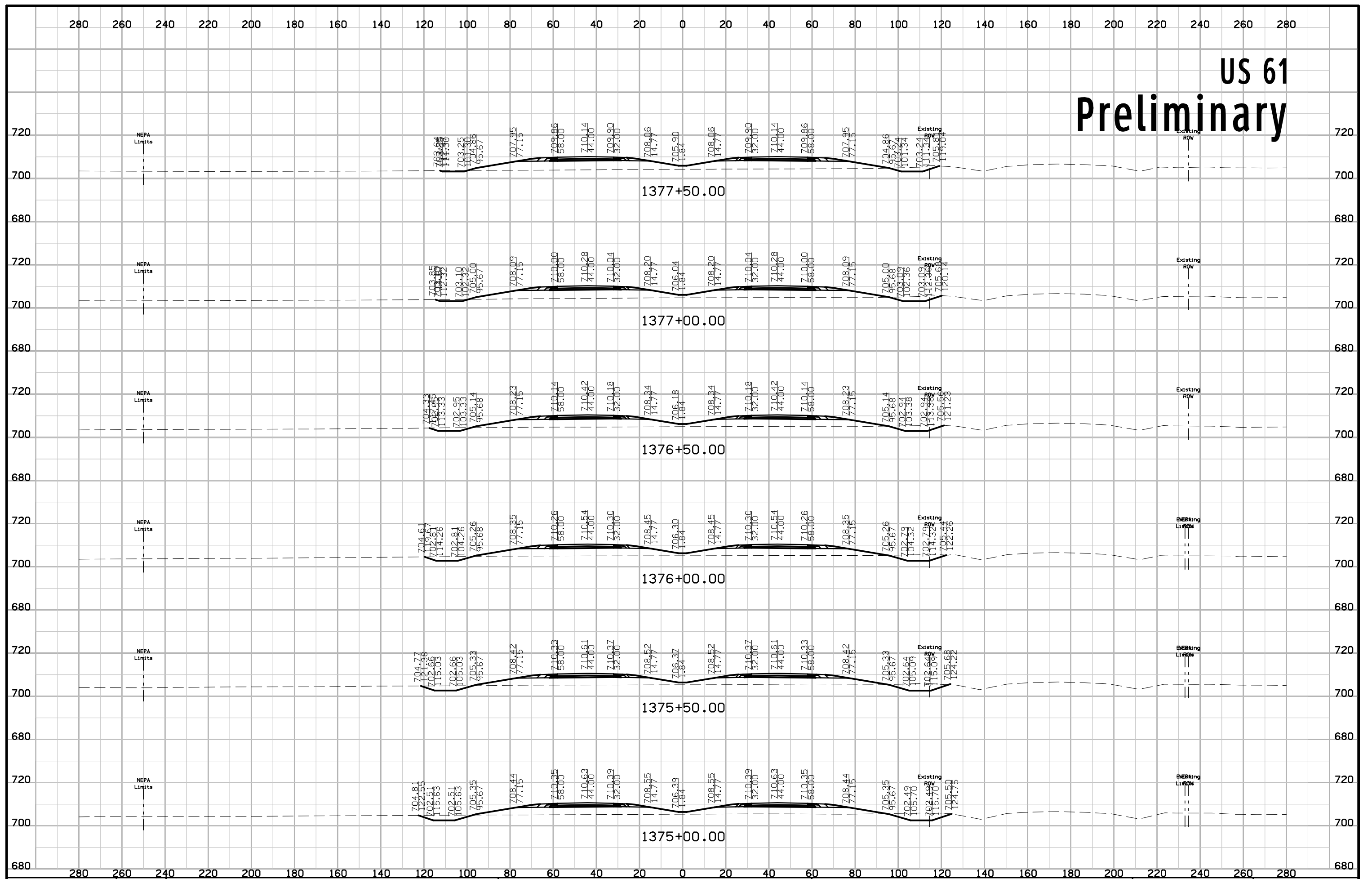

US 61 Preliminary

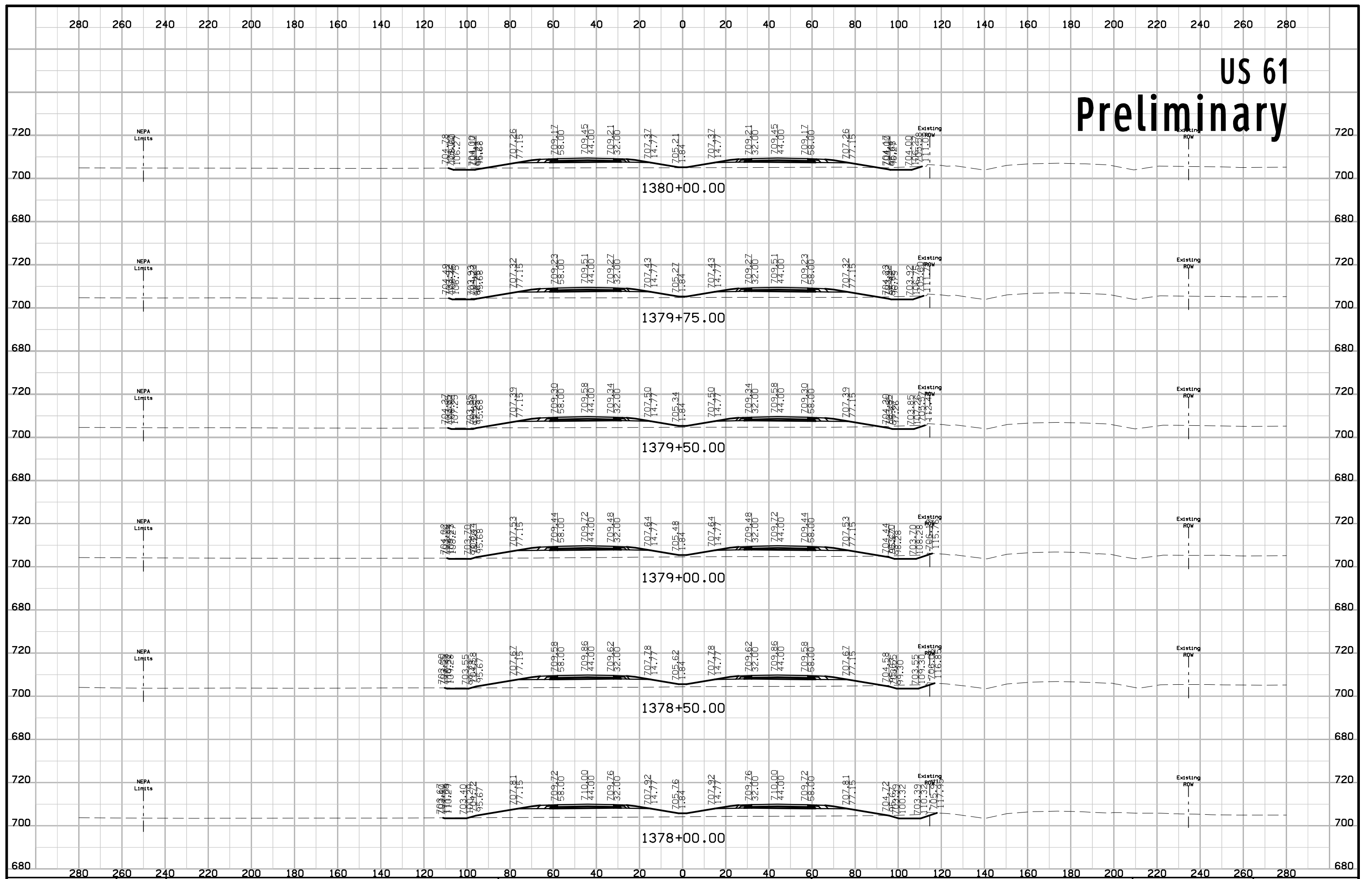

US 61 Preliminary

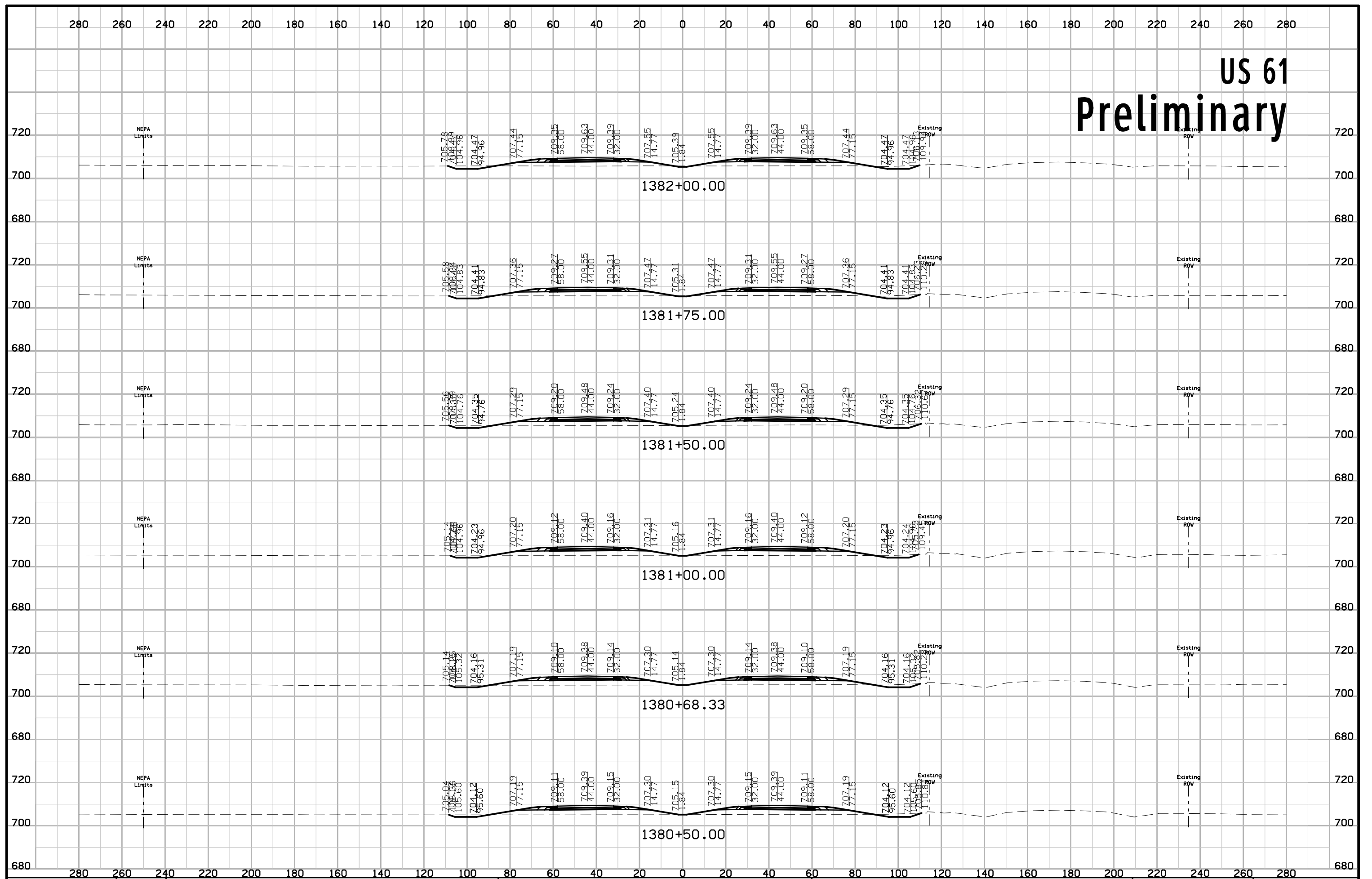

US 61 Preliminary

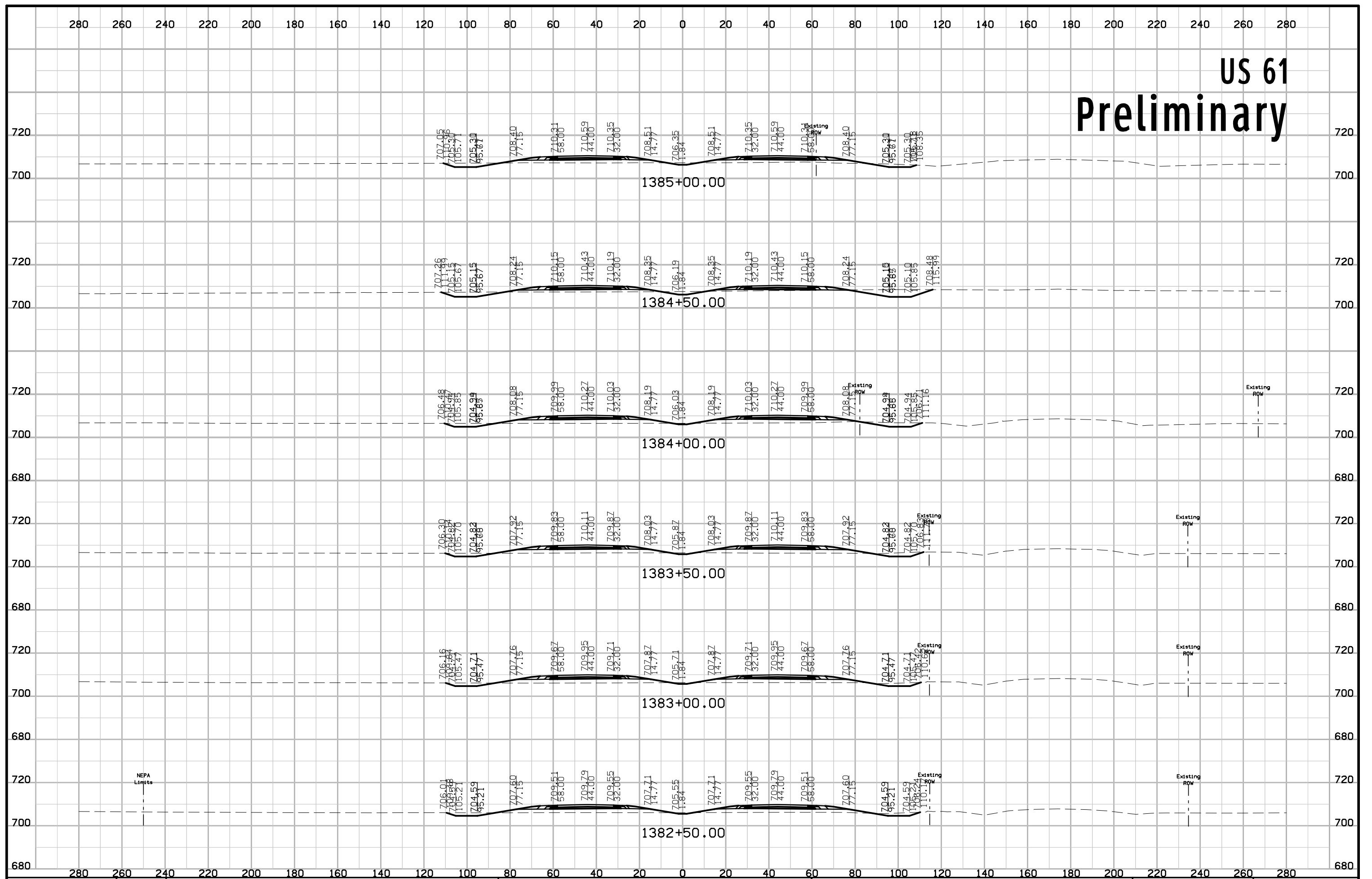

US 61 Preliminary

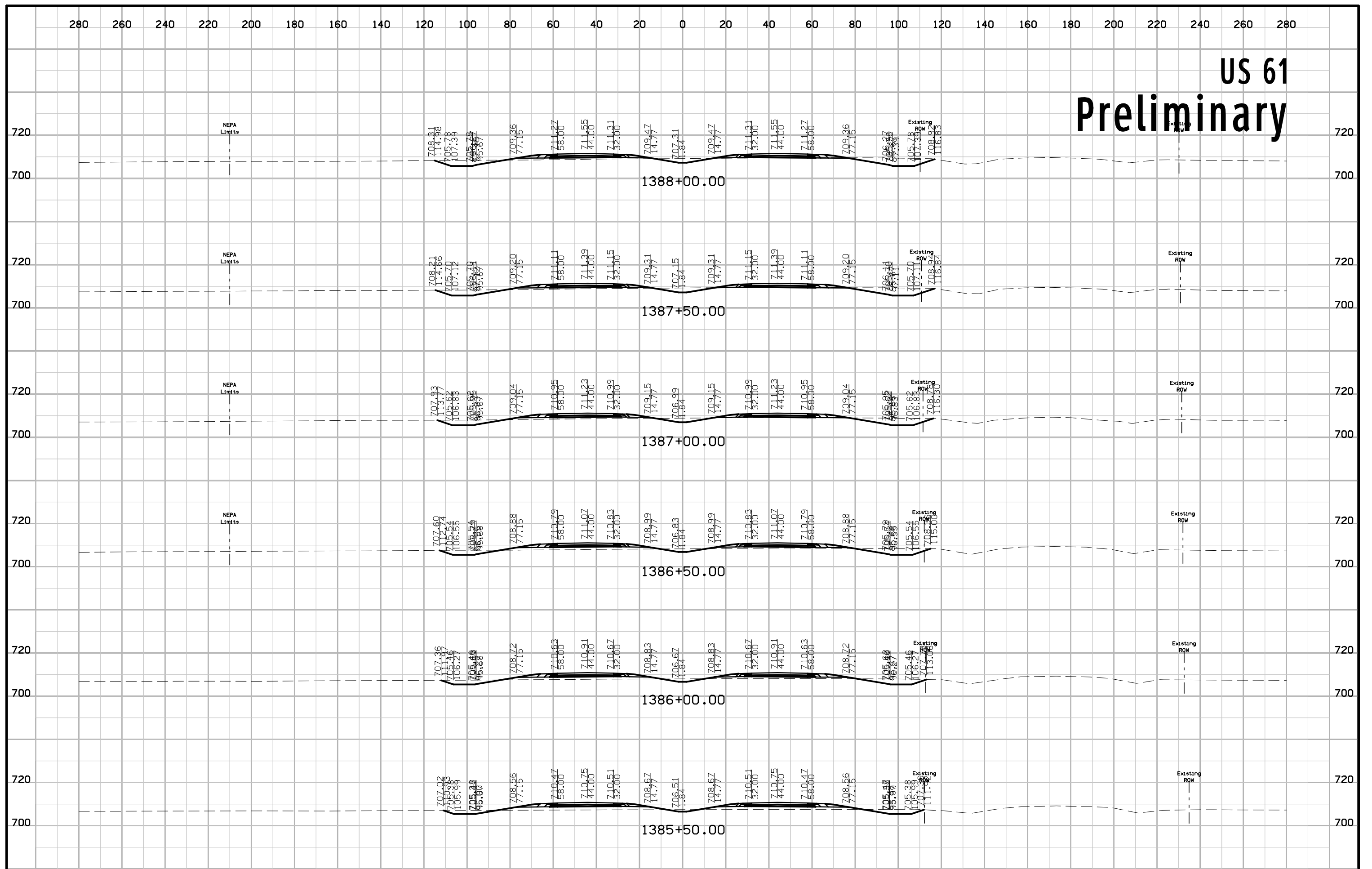

US 61 Preliminary

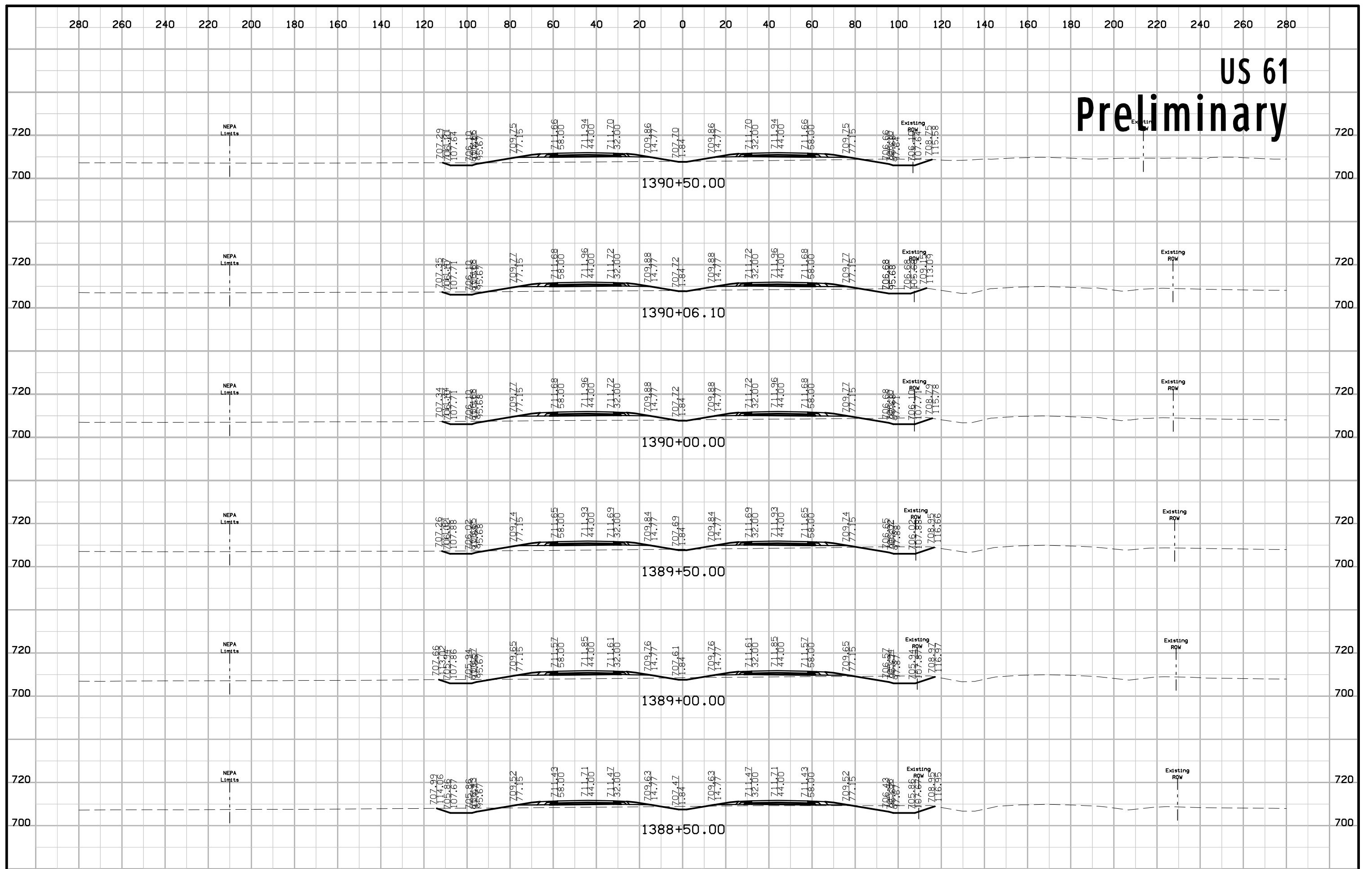

US 61 Preliminary

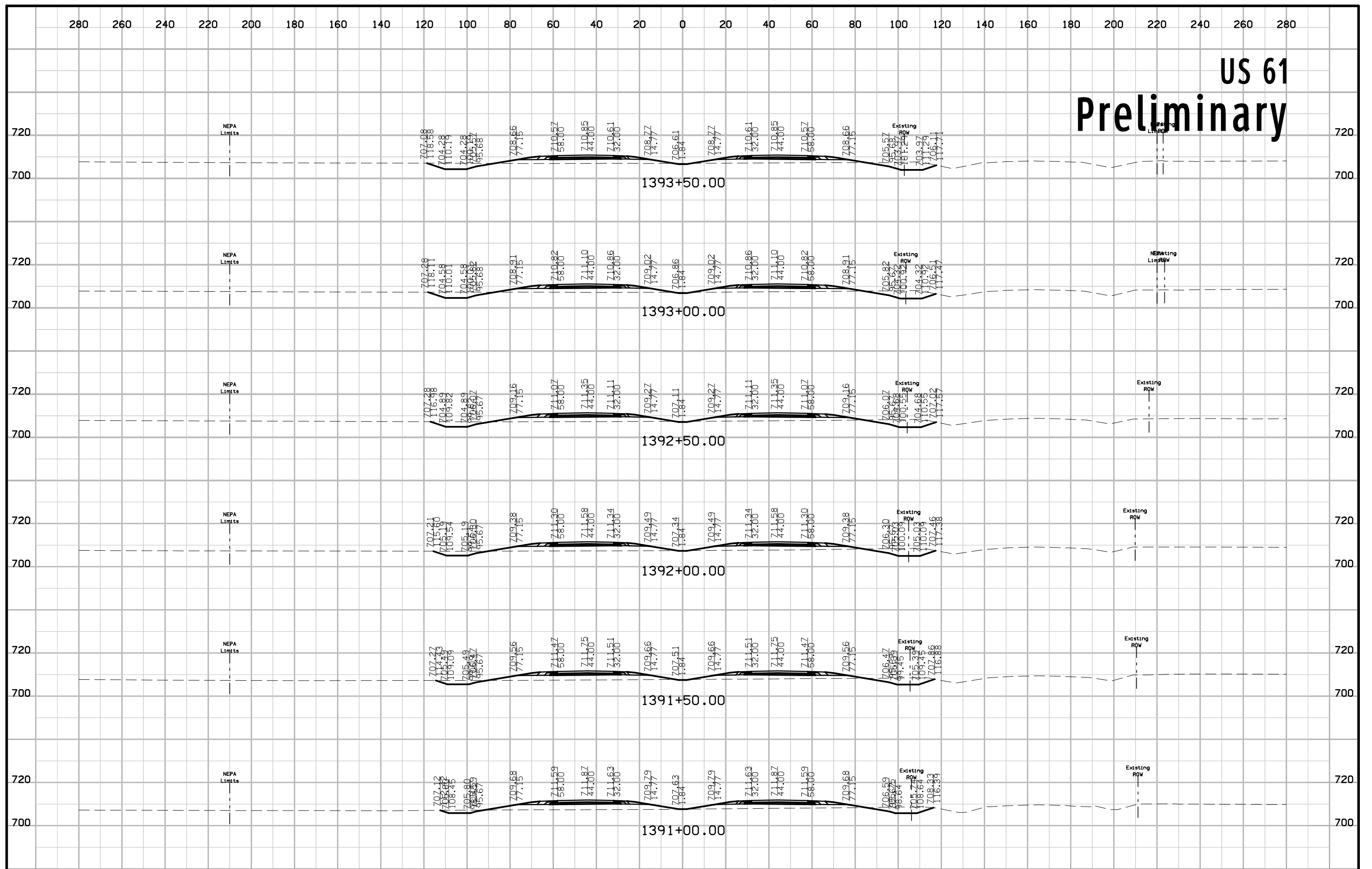

US 61 Preliminary

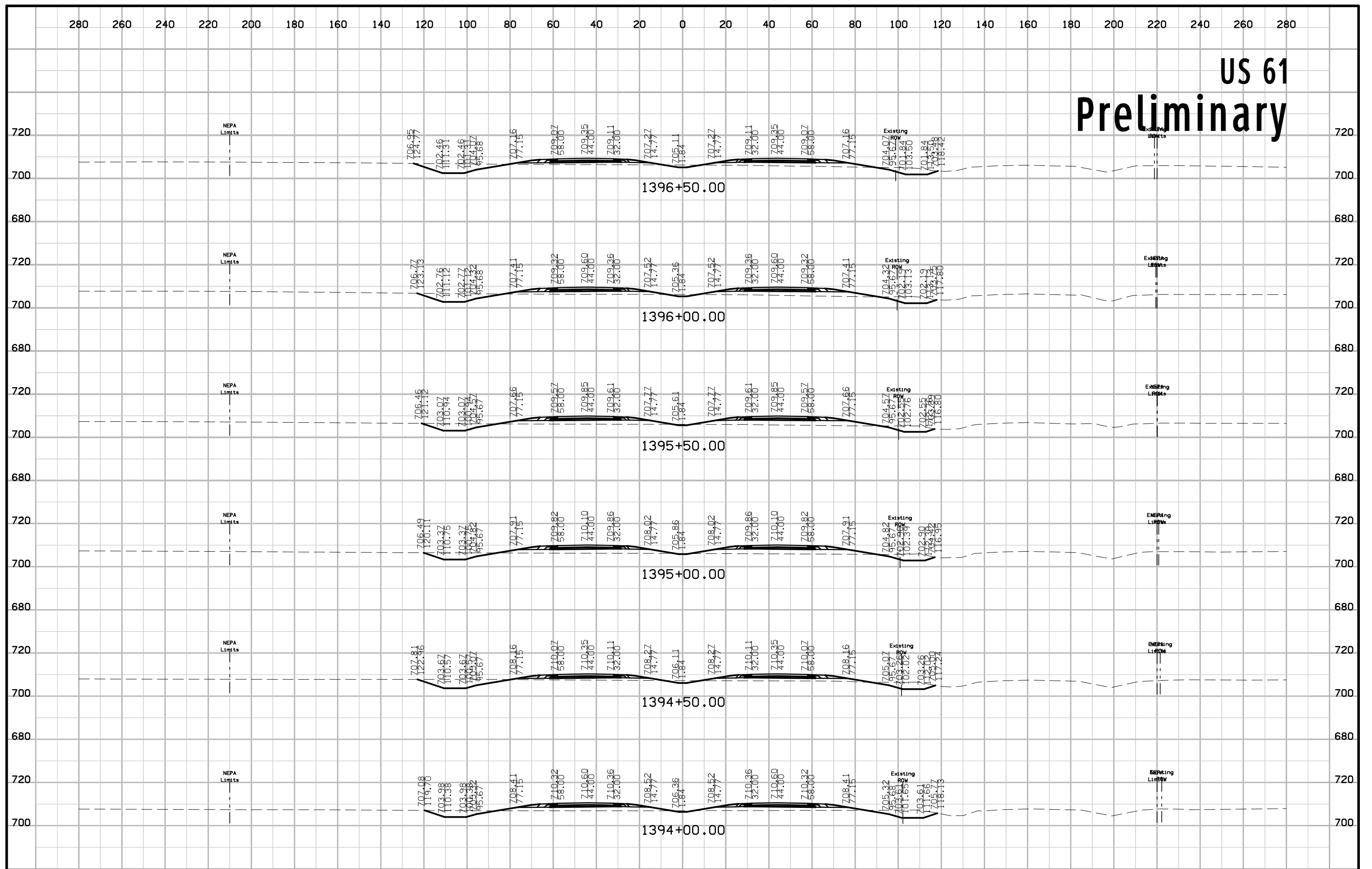

US 61 Preliminary

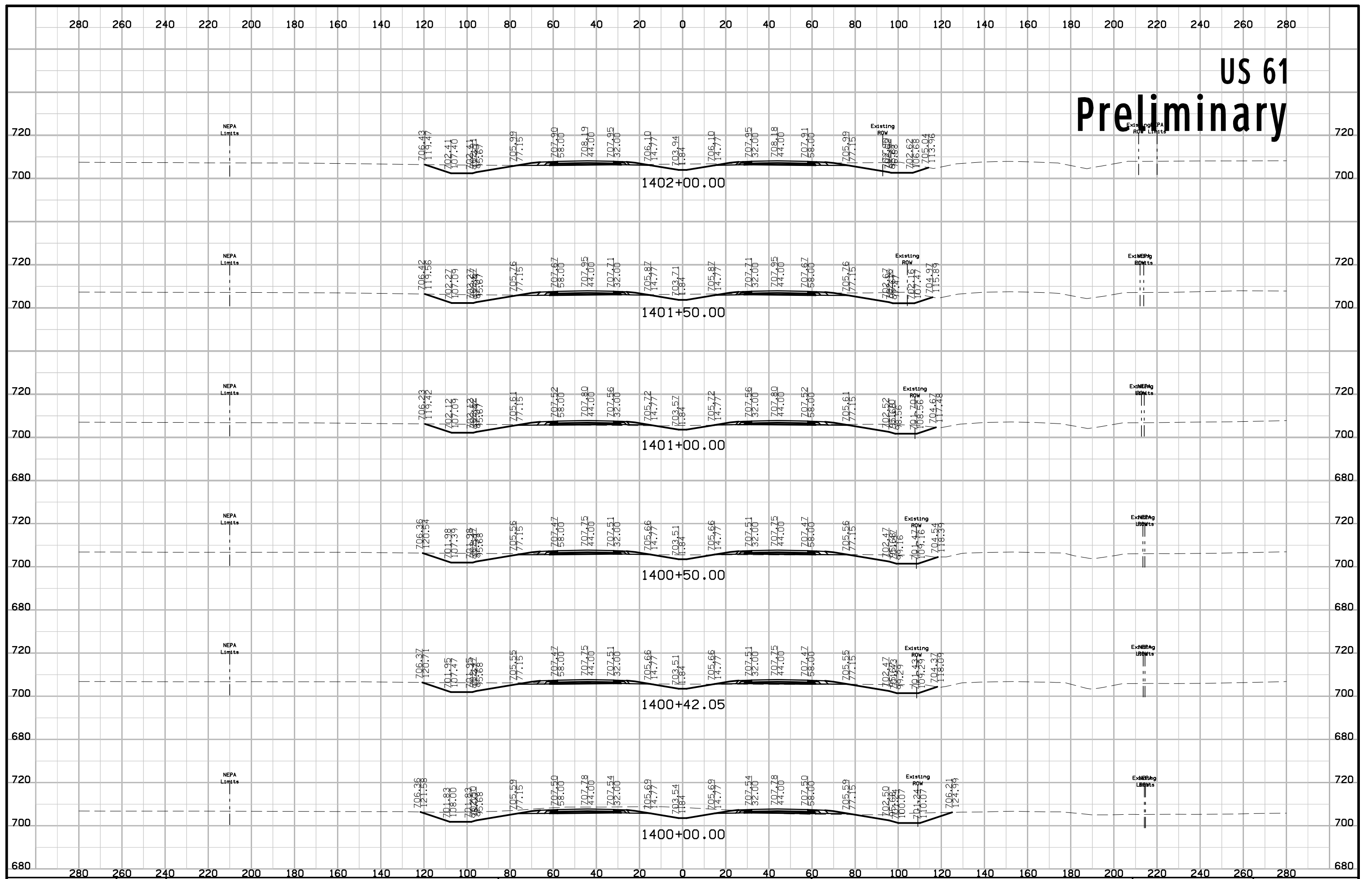

US 61 Preliminary

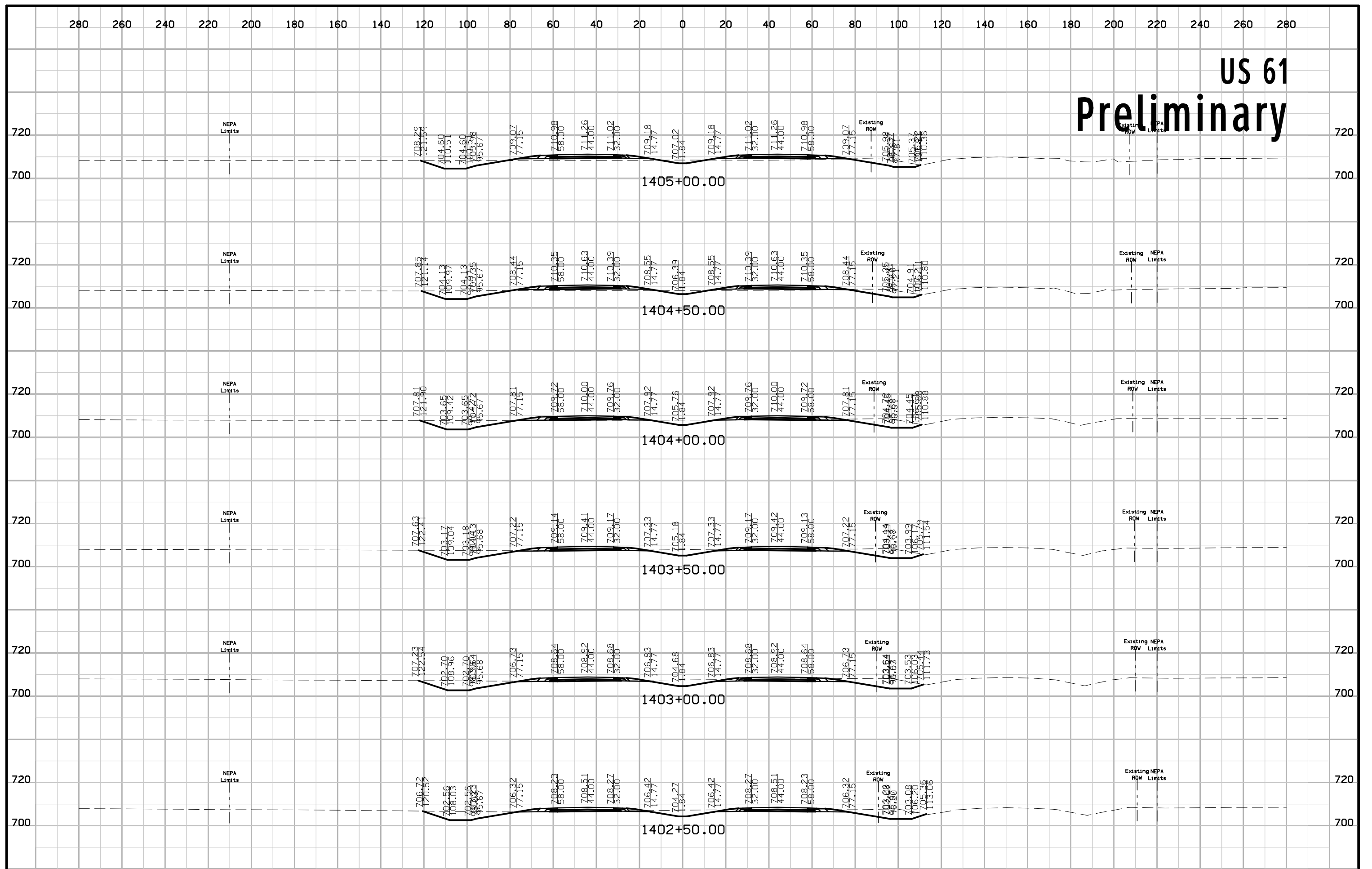

US 61 Preliminary

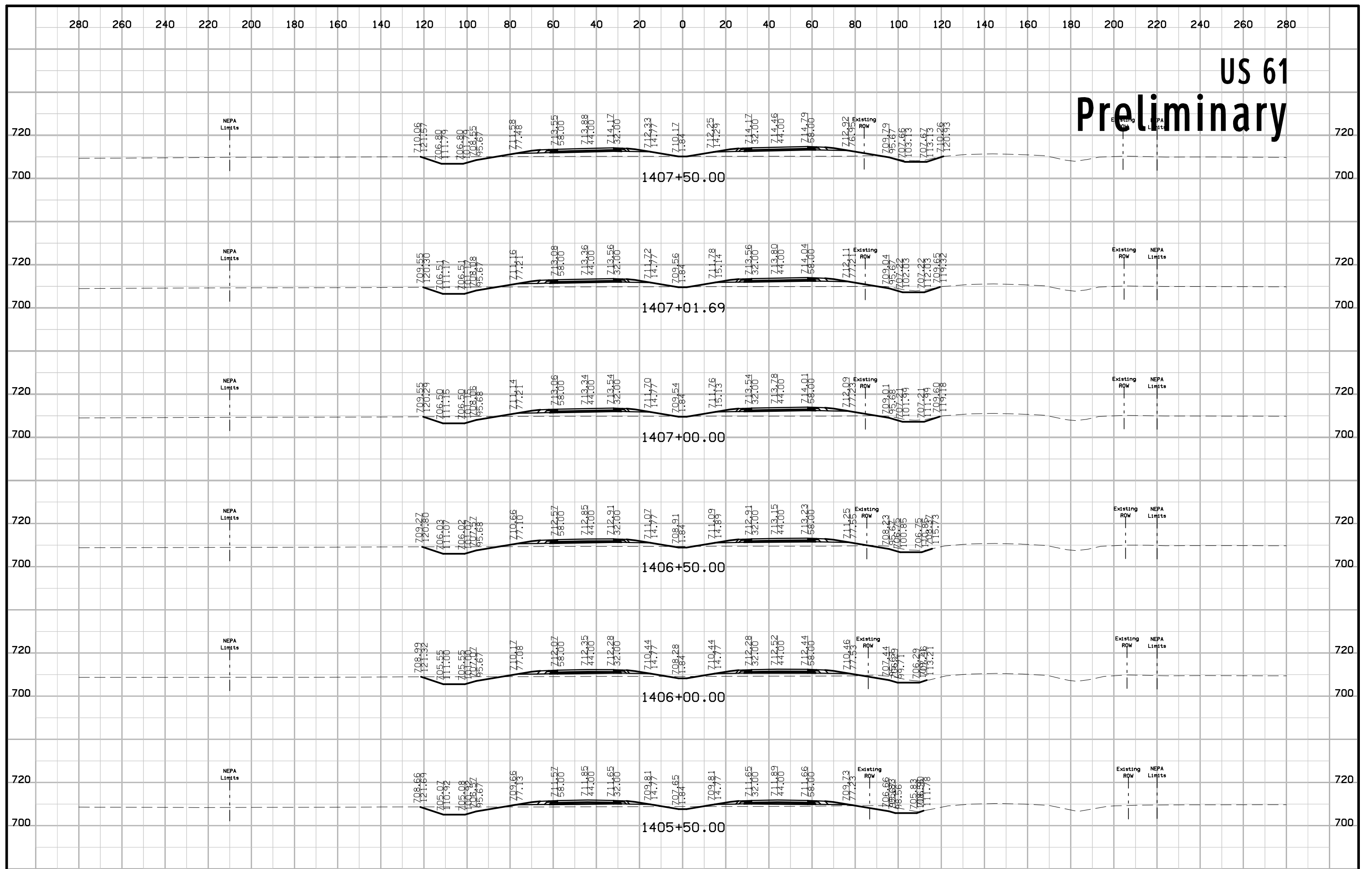

US 61 Preliminary

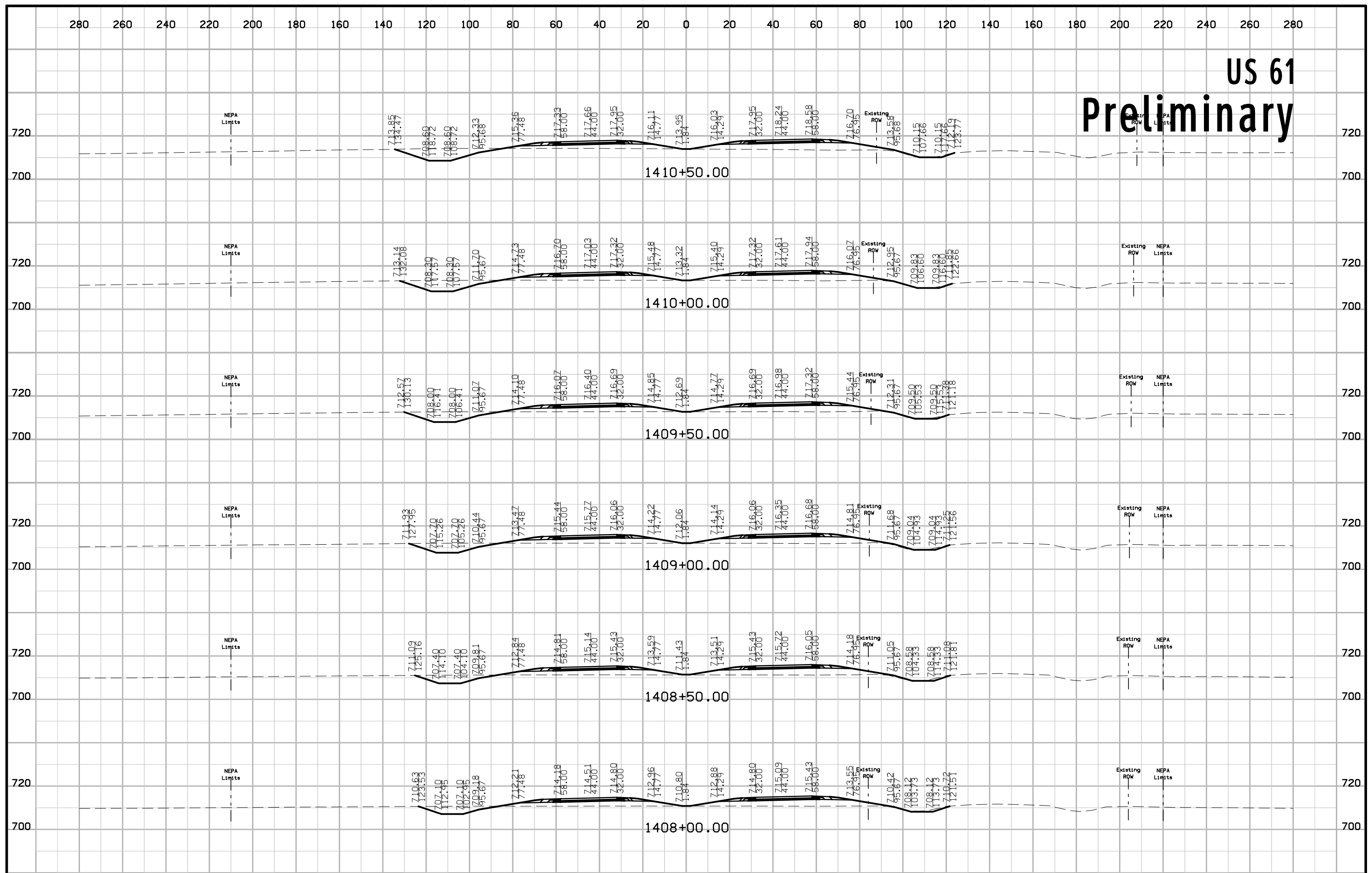

US 61 Preliminary

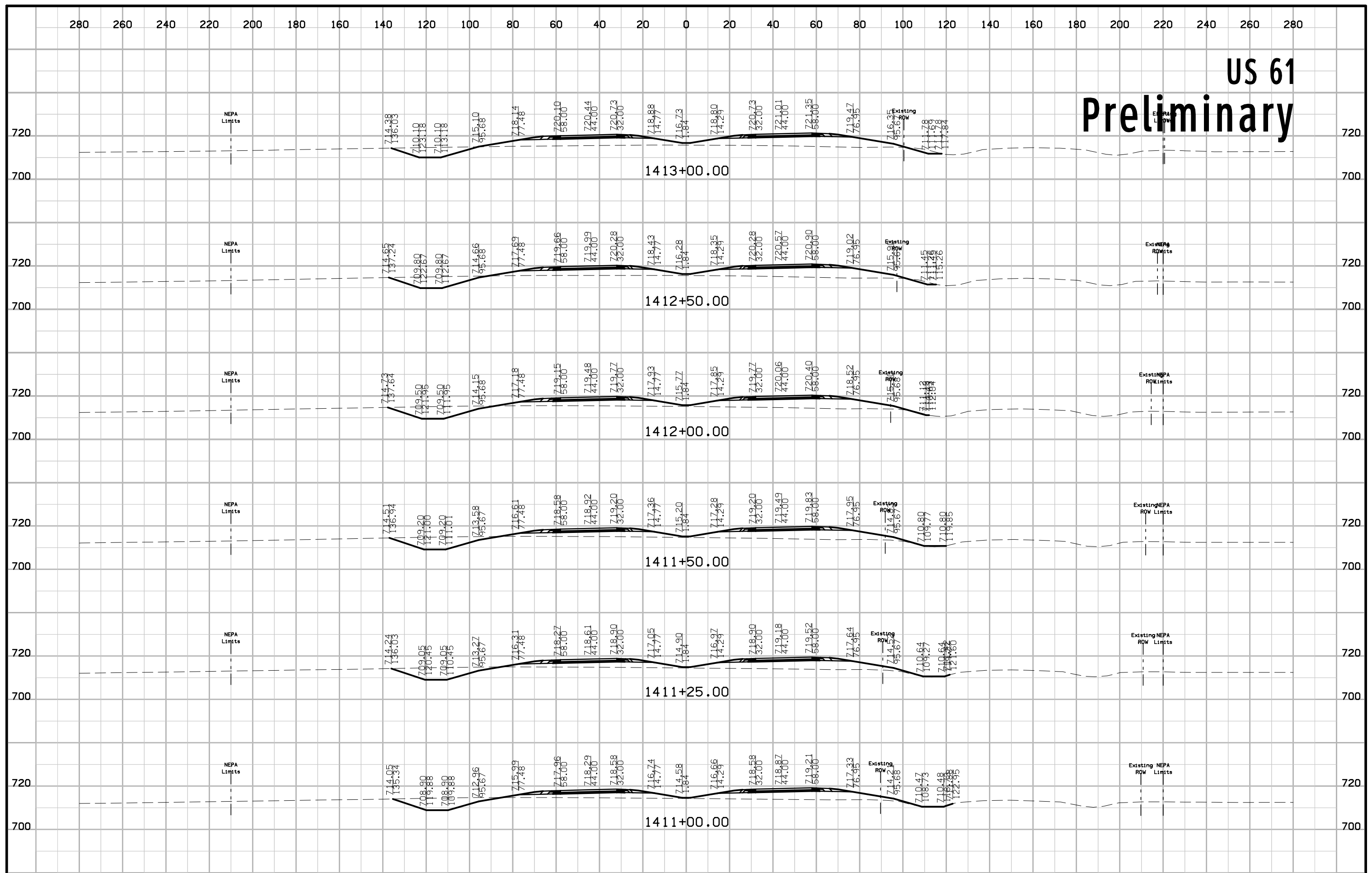

US 61 Preliminary

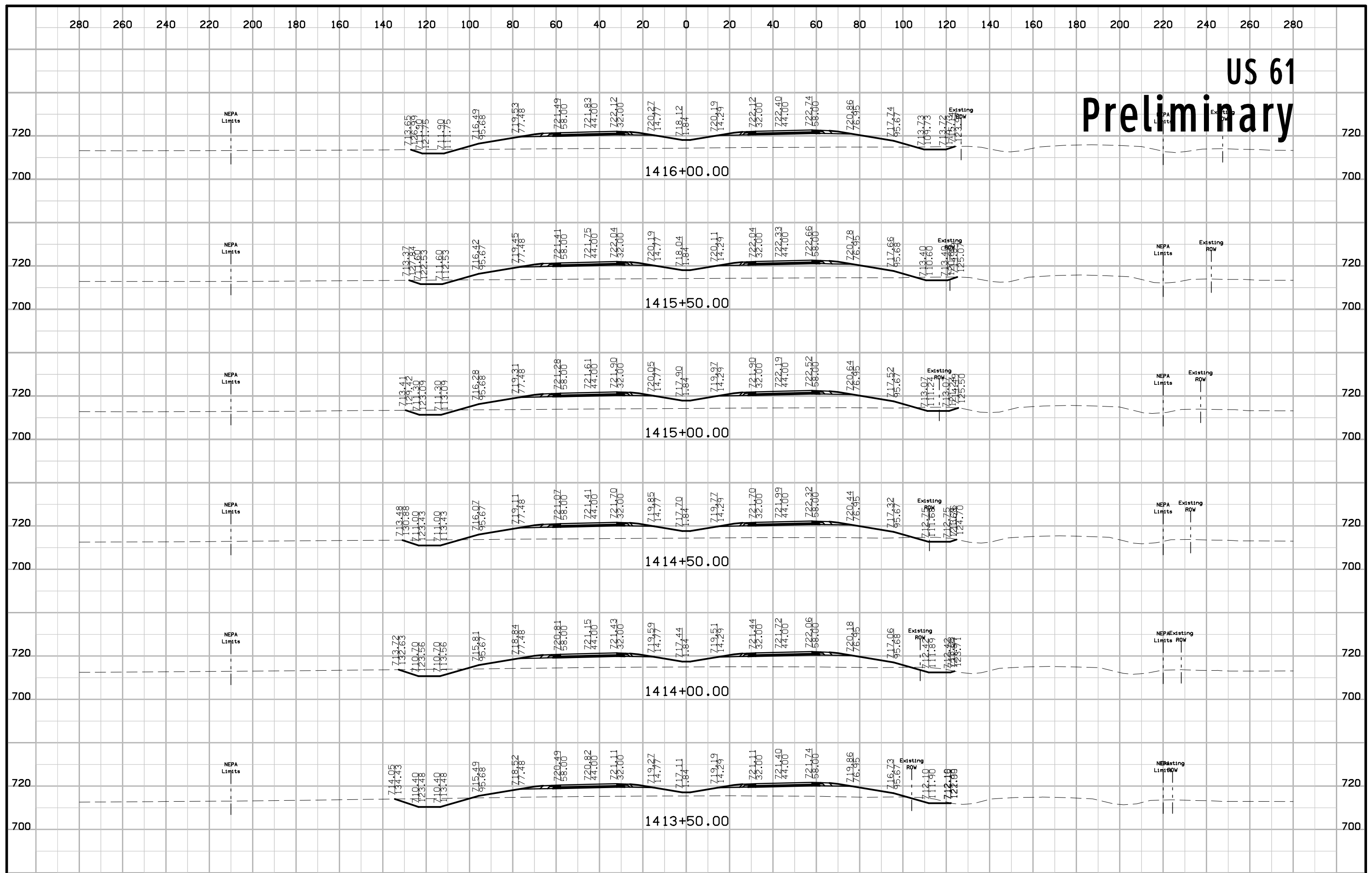

US 61

Preliminary

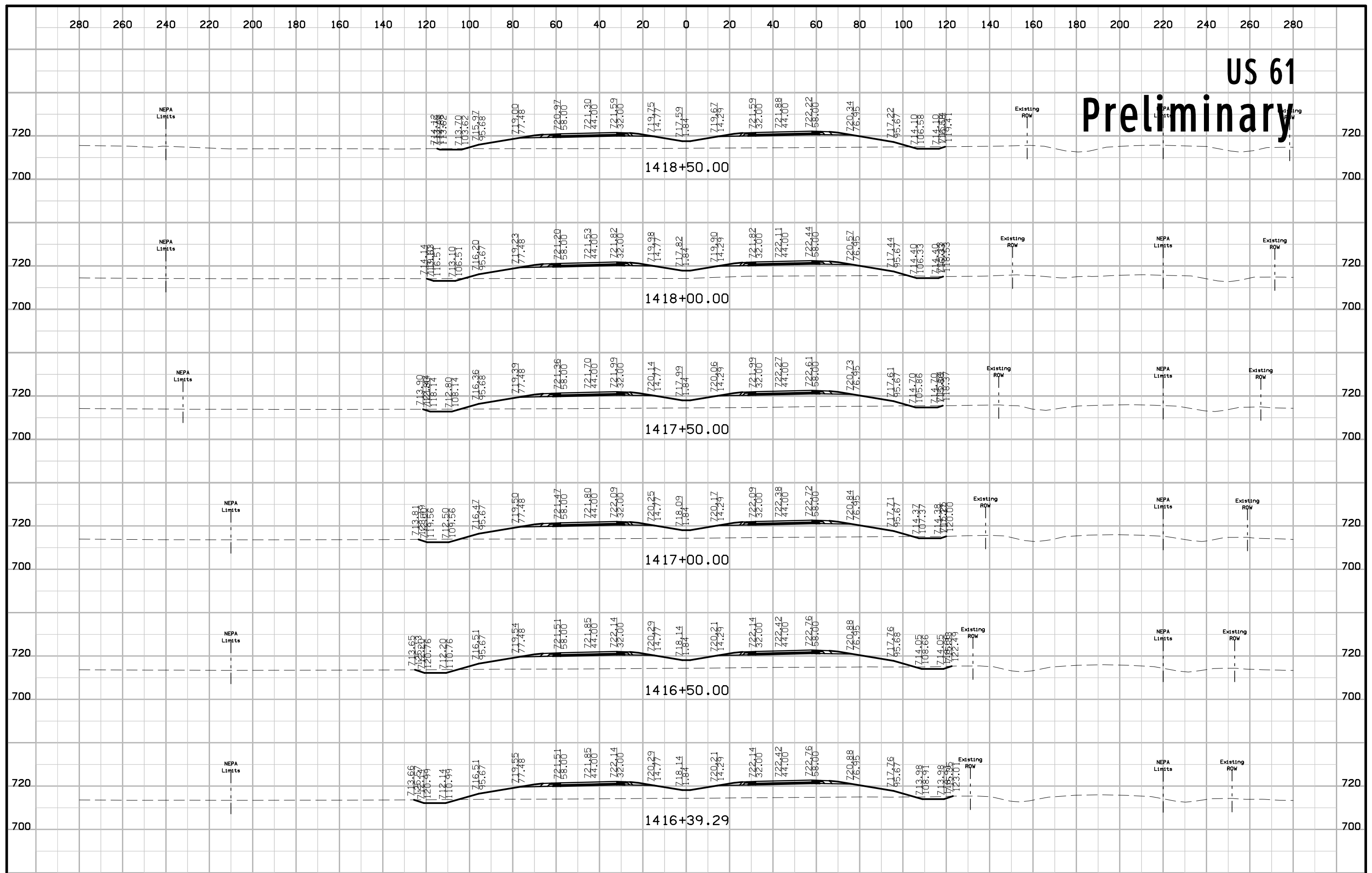

US 61 Preliminary

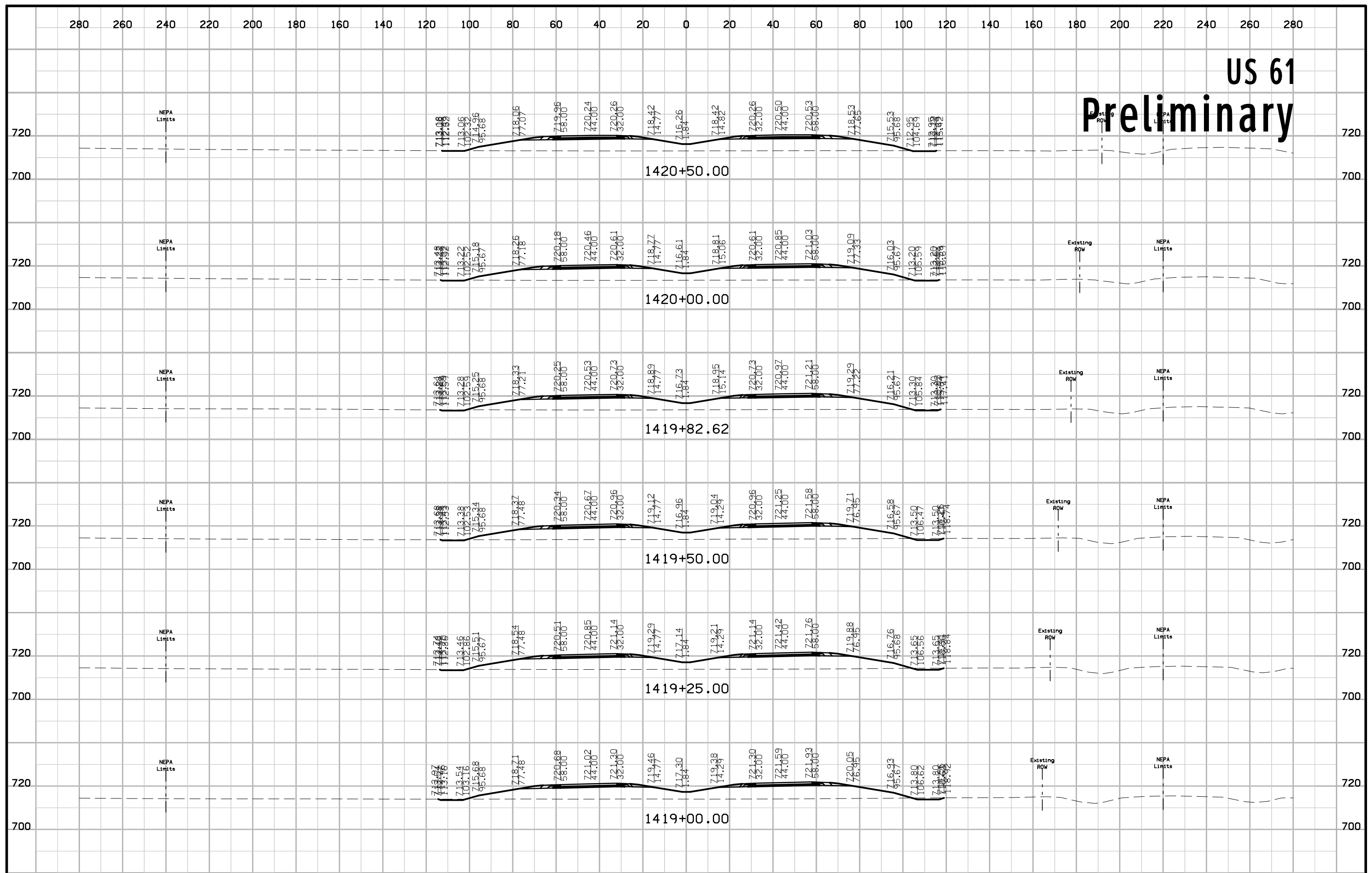

US 61 Preliminary

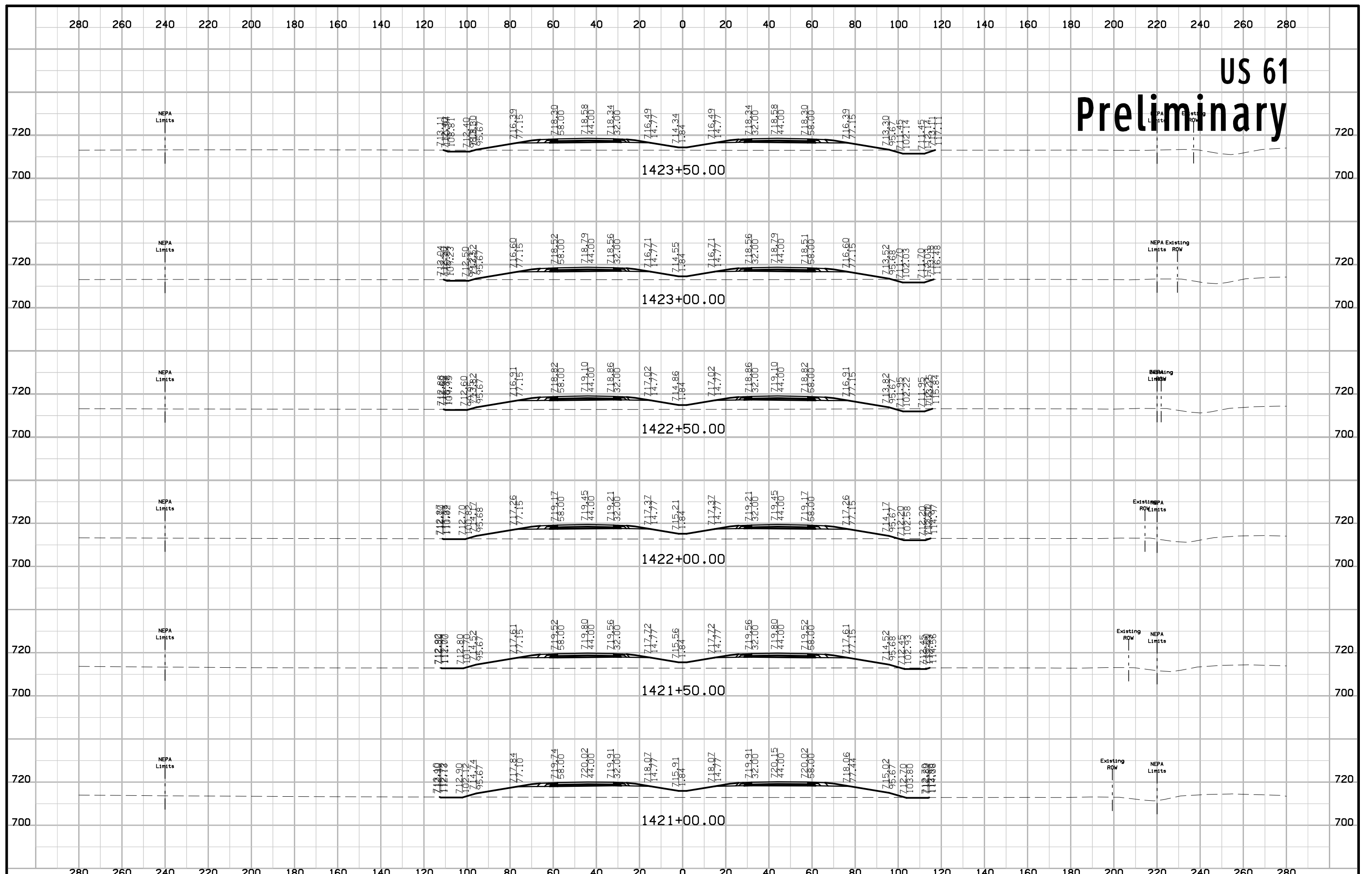

US 61 Preliminary

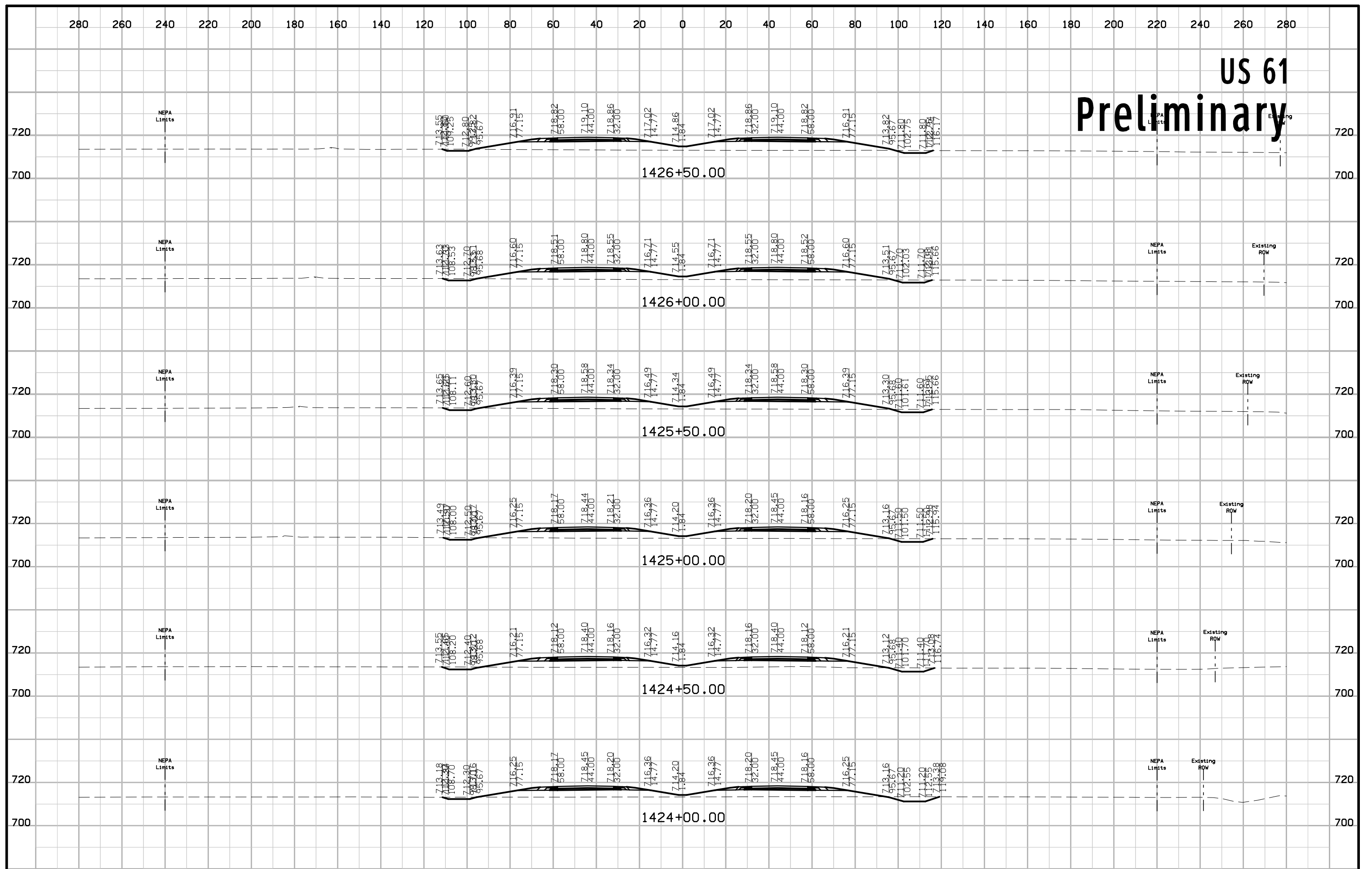

US 61 Preliminary

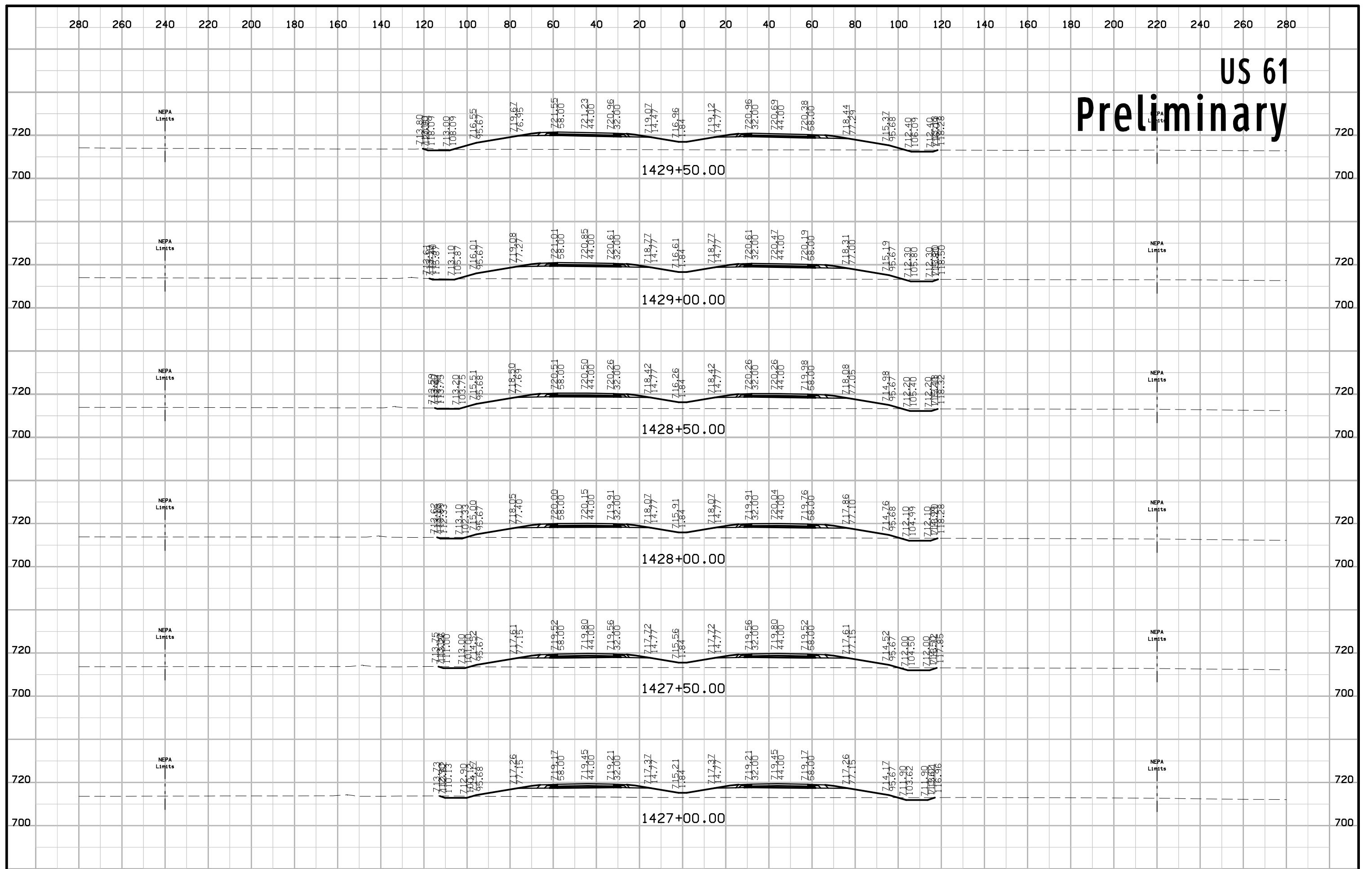

US 61 Preliminary

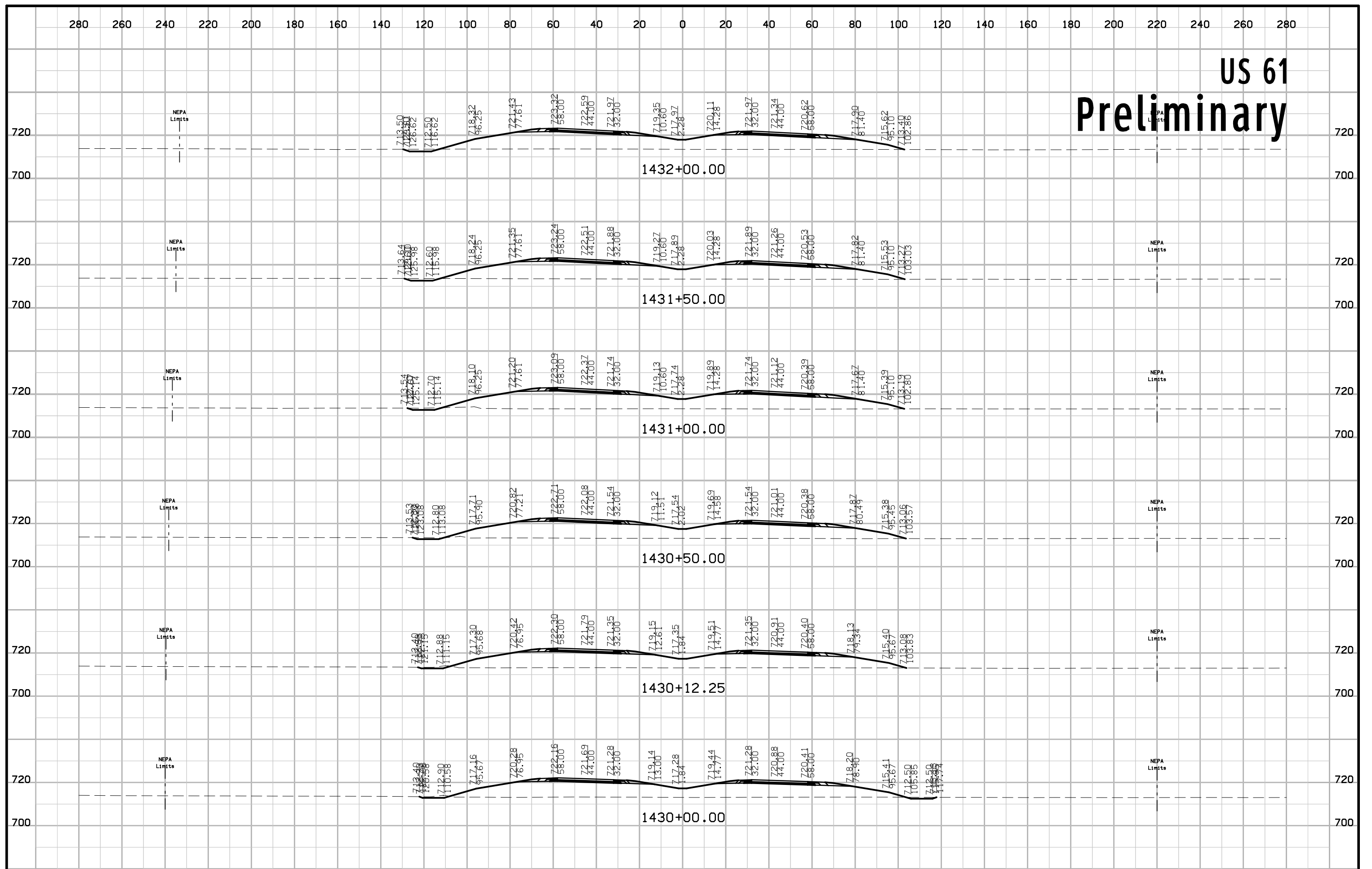

US 61 Preliminary

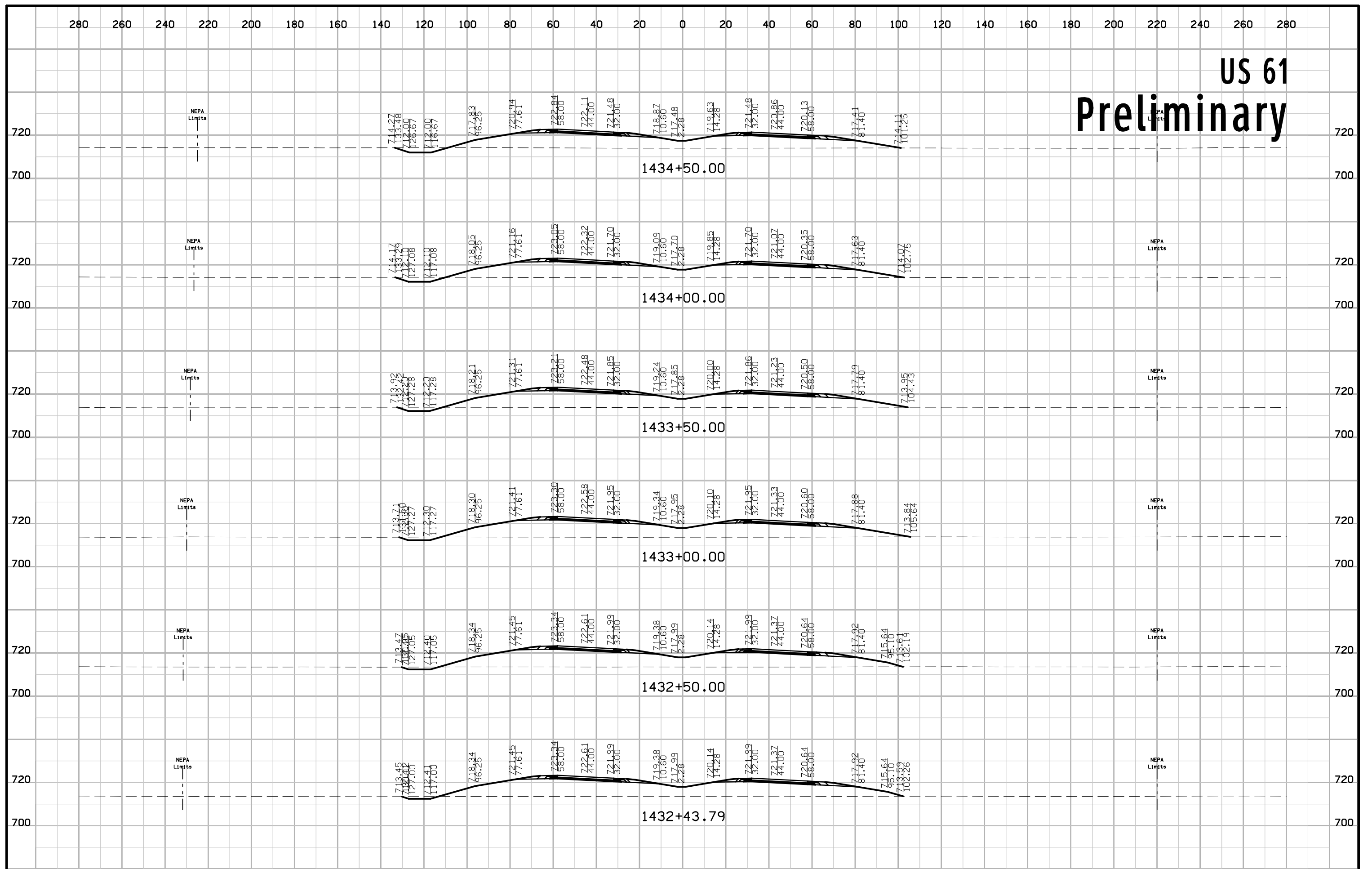

US 61 Preliminary

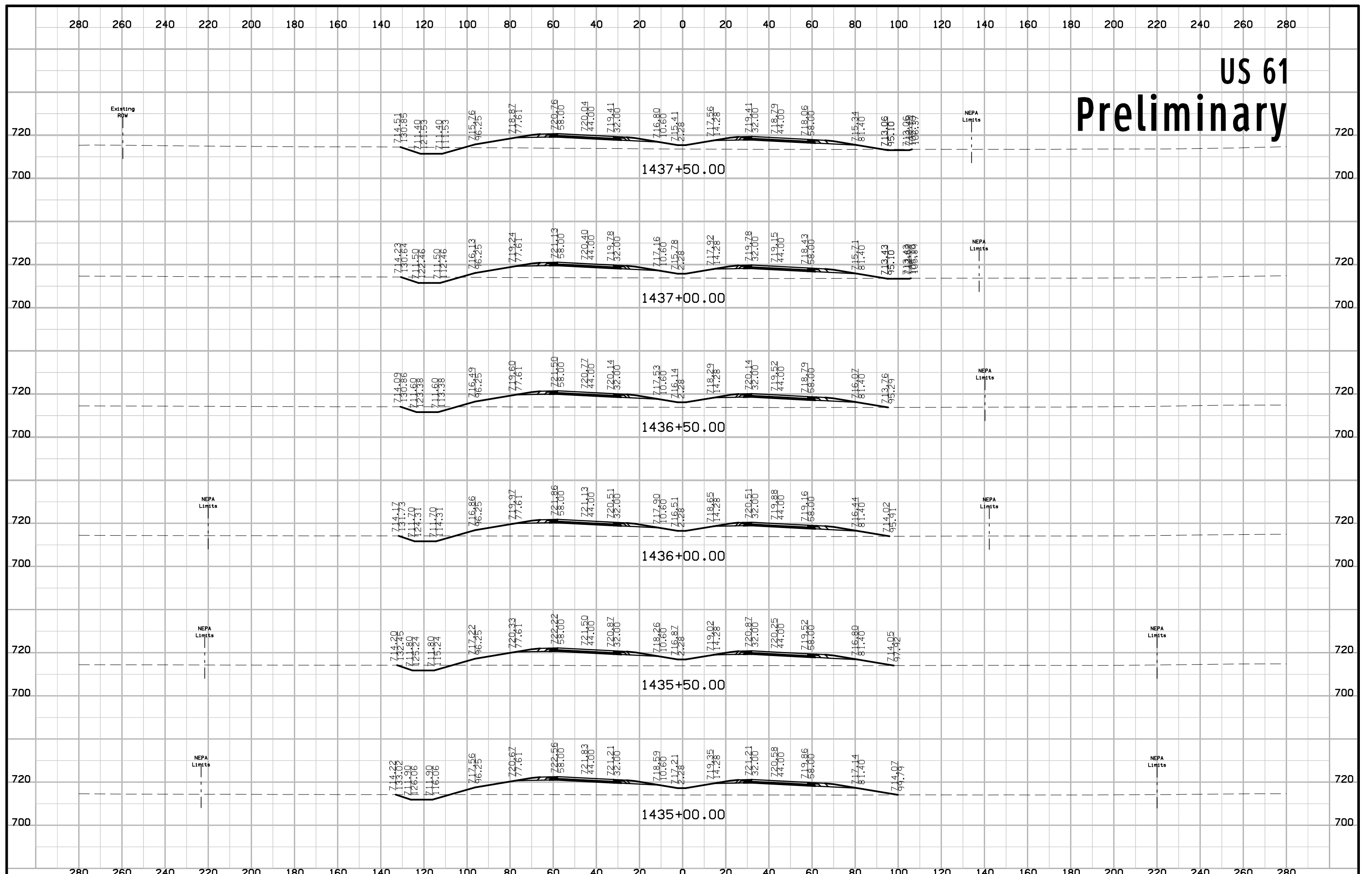

US 61 Preliminary

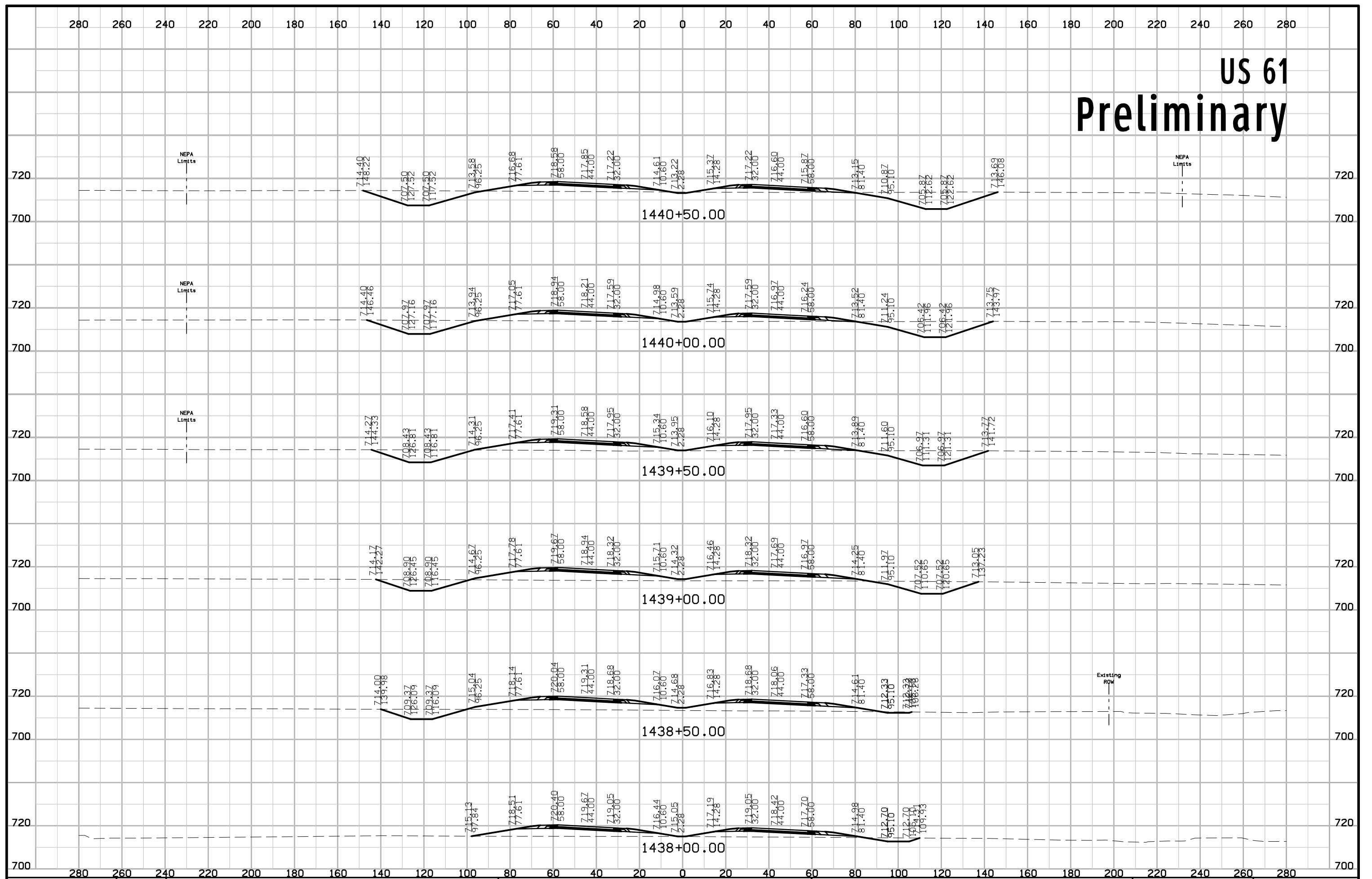

US 61 Preliminary

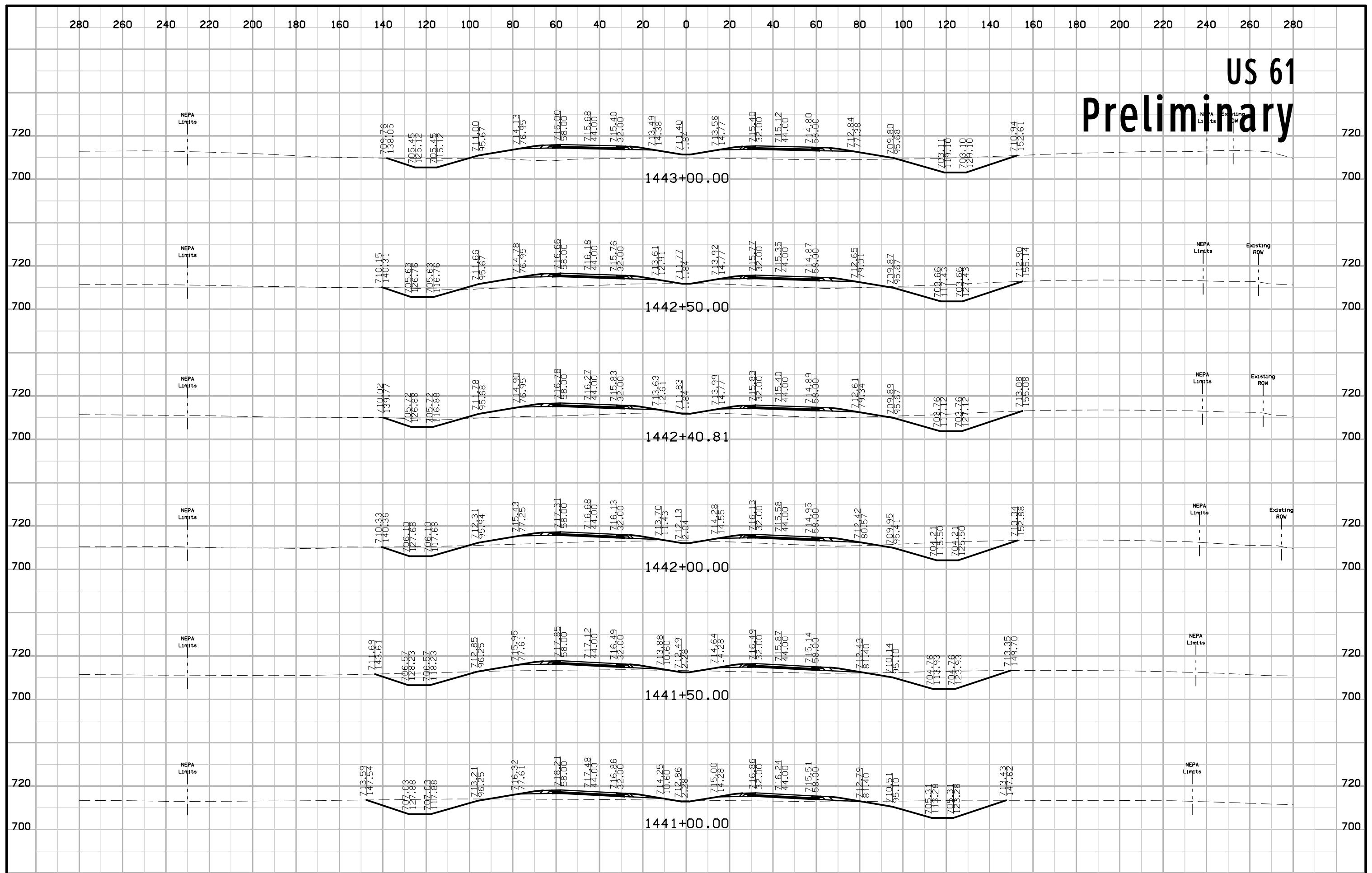

US 61 Preliminary

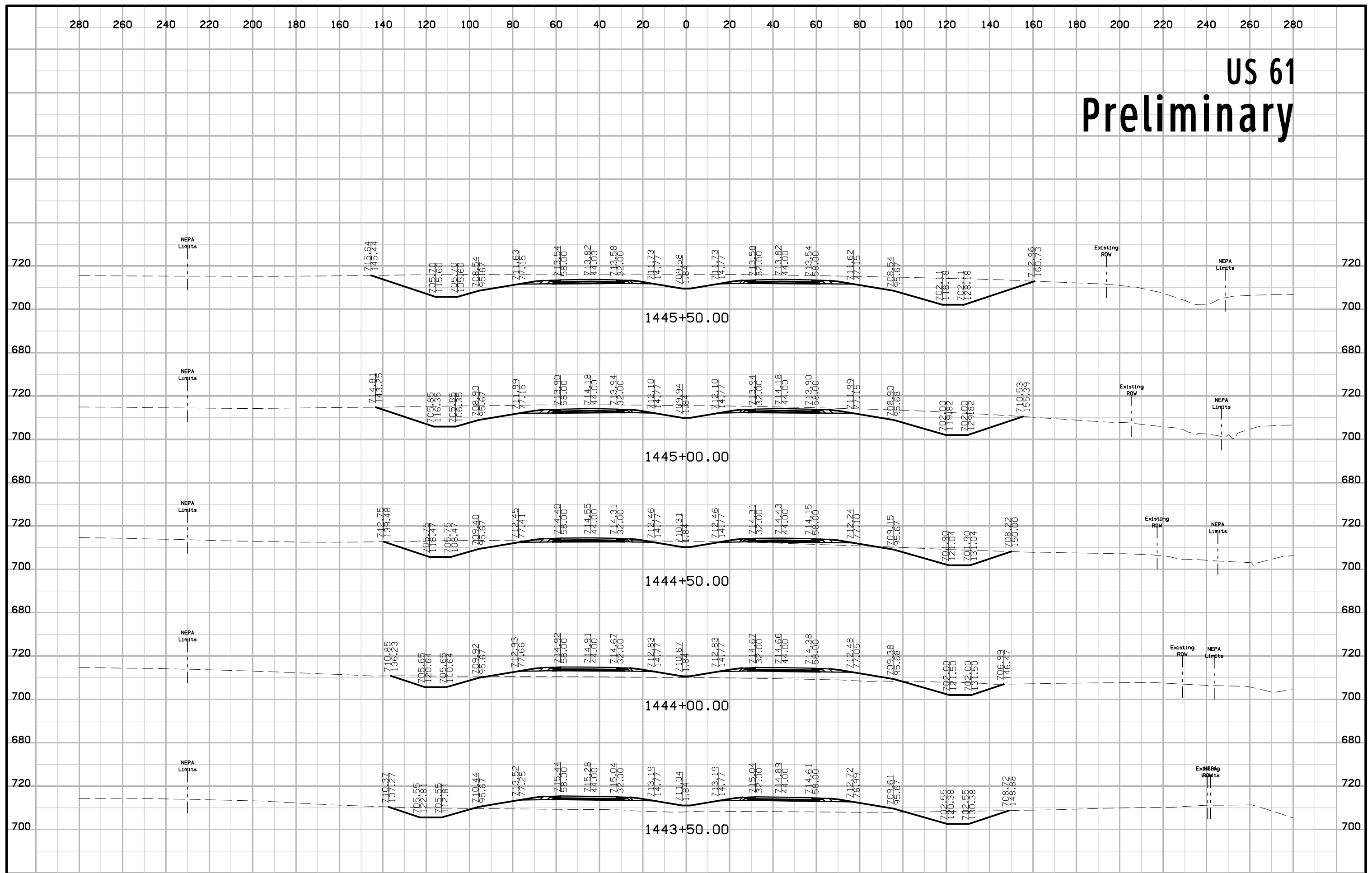

US 61 Preliminary

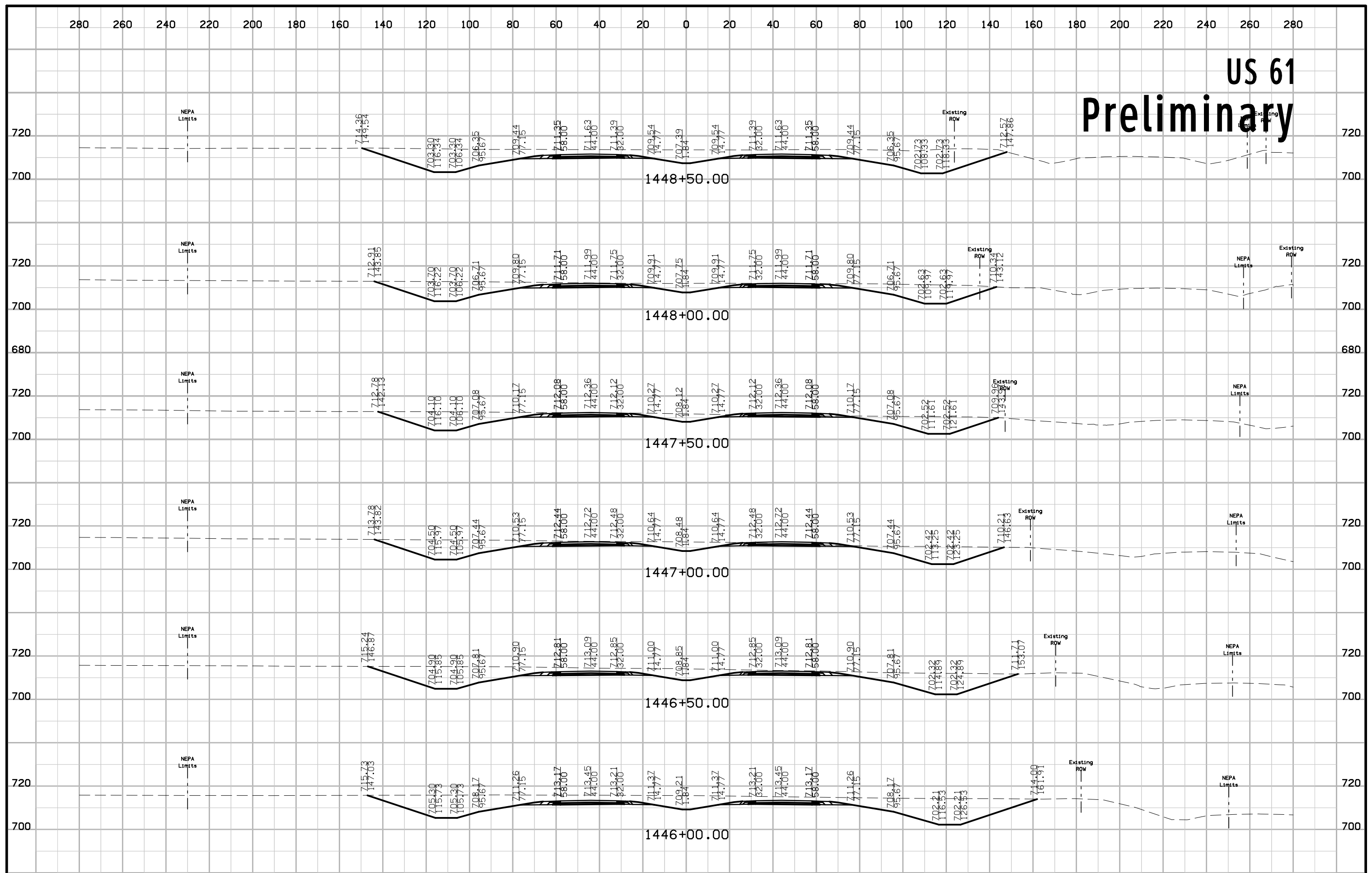

US 61

Preliminary

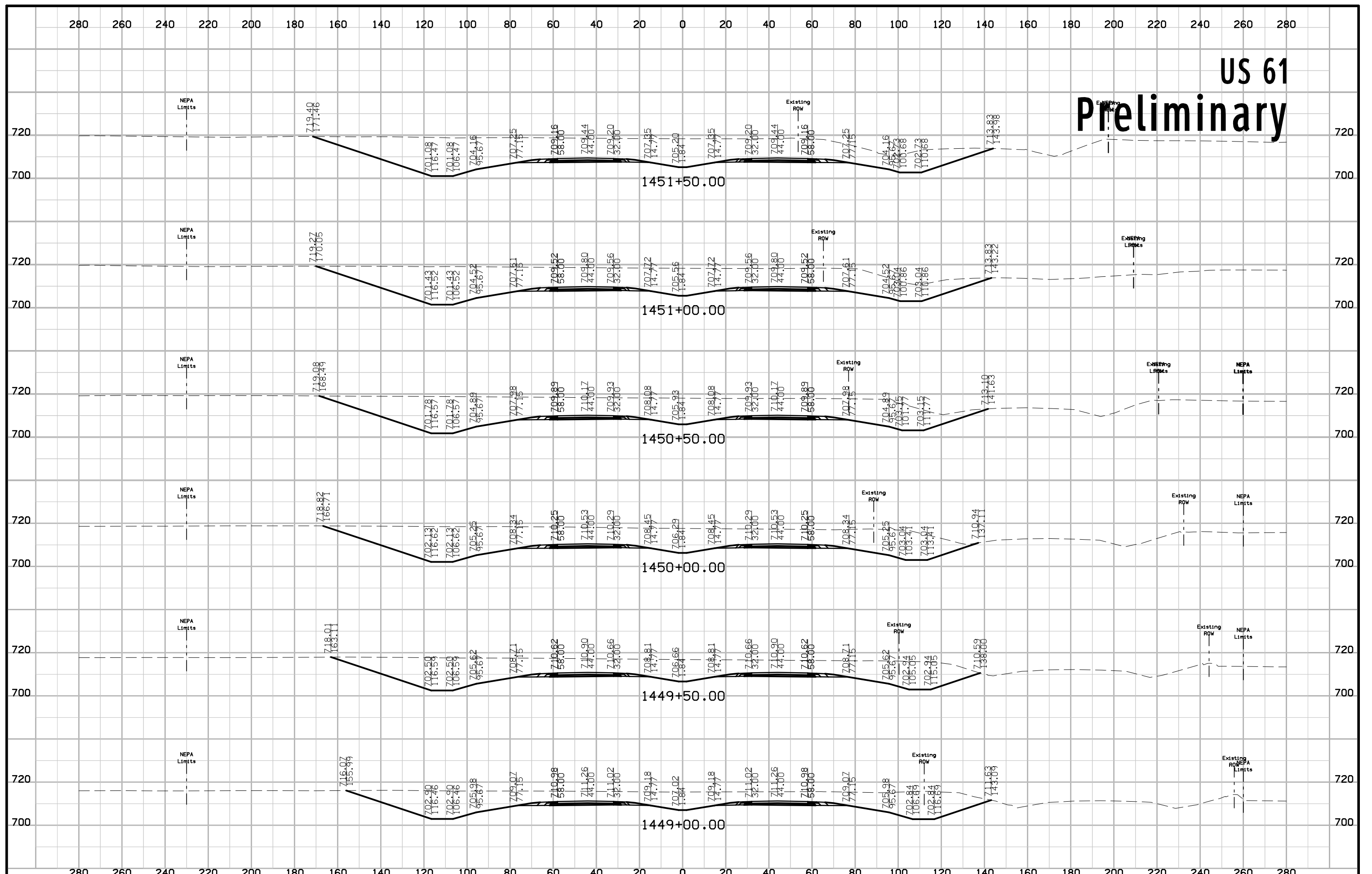

US 61 Preliminary

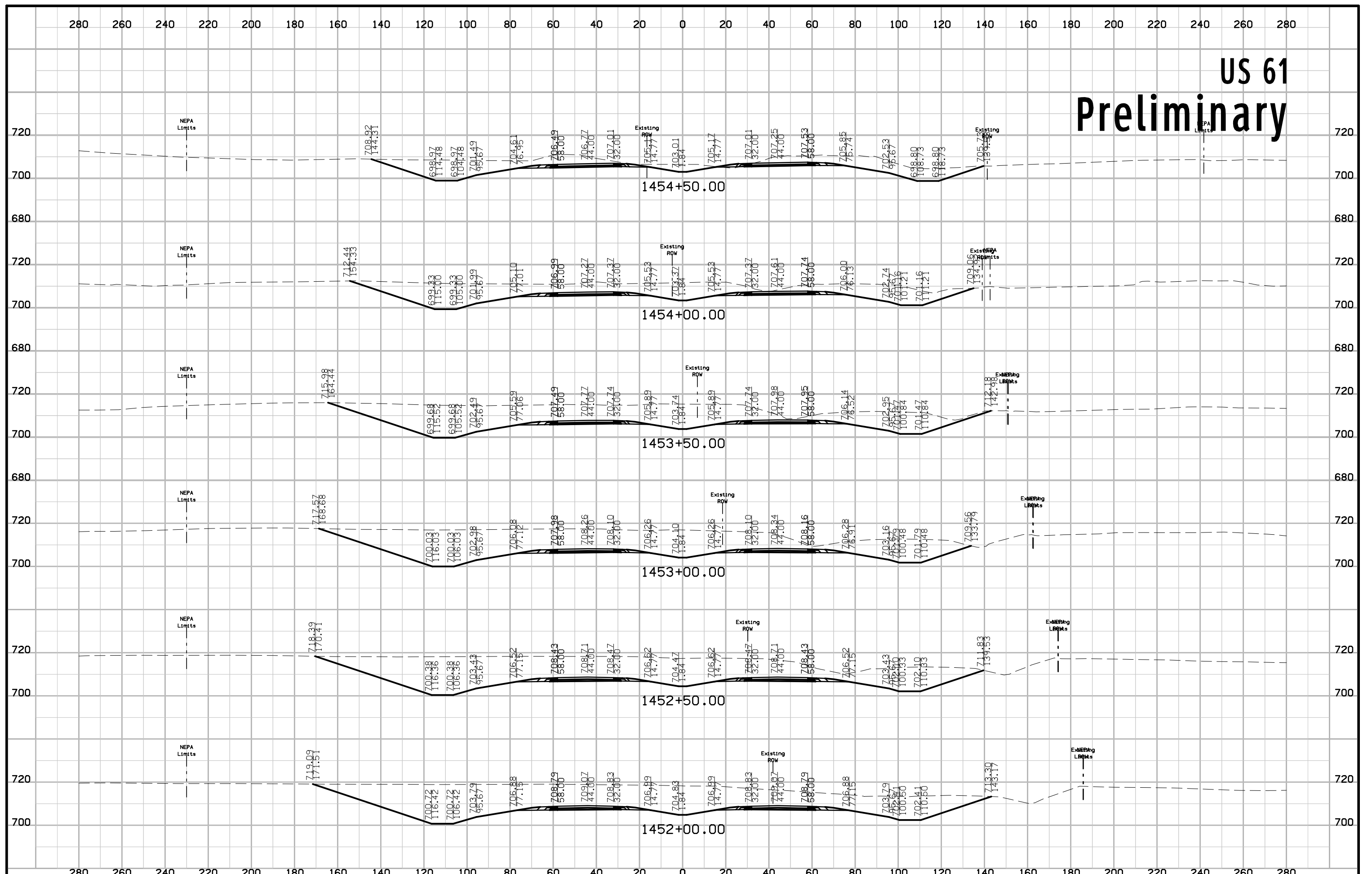

US 61 Preliminary

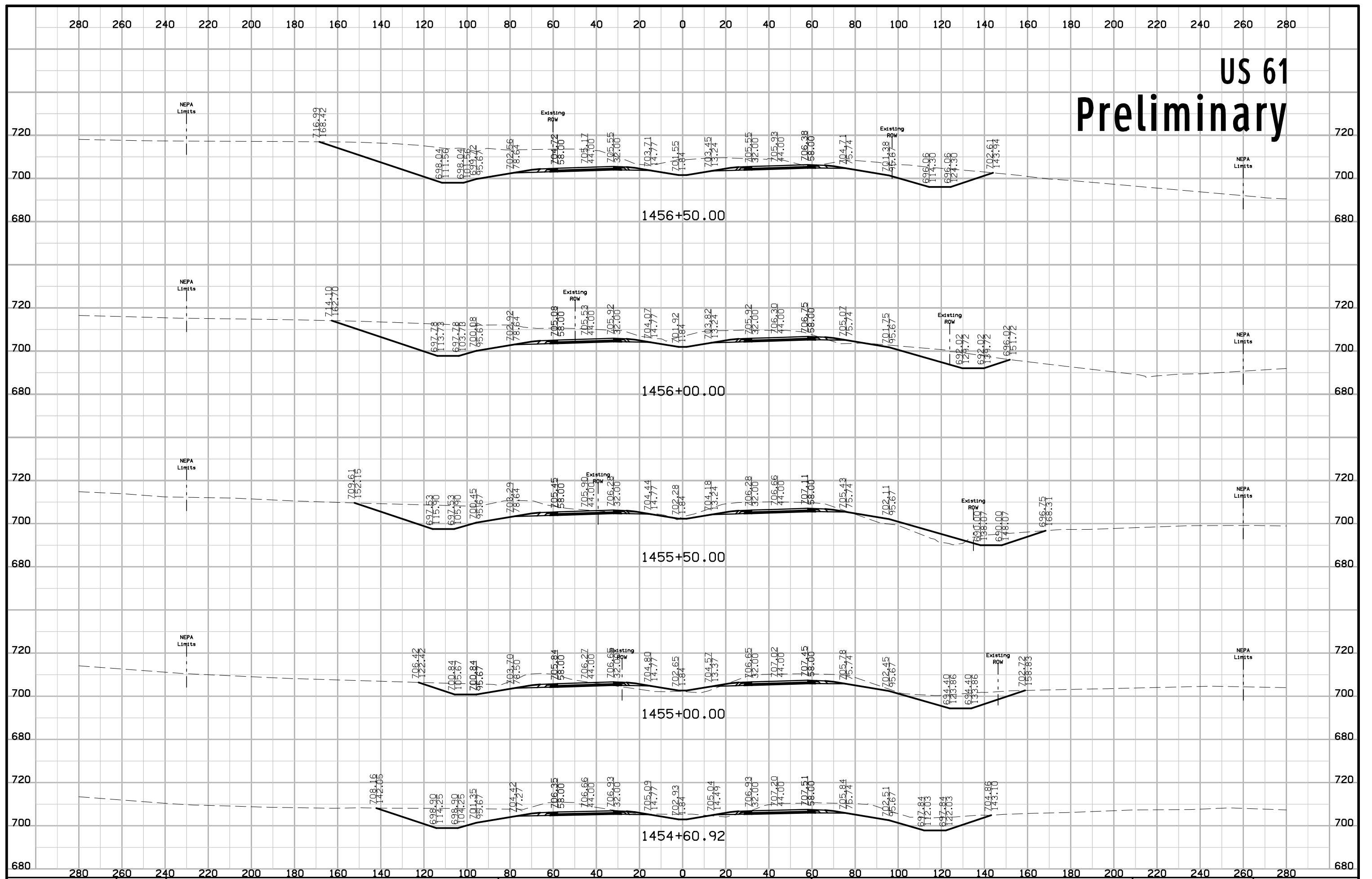

US 61 Preliminary

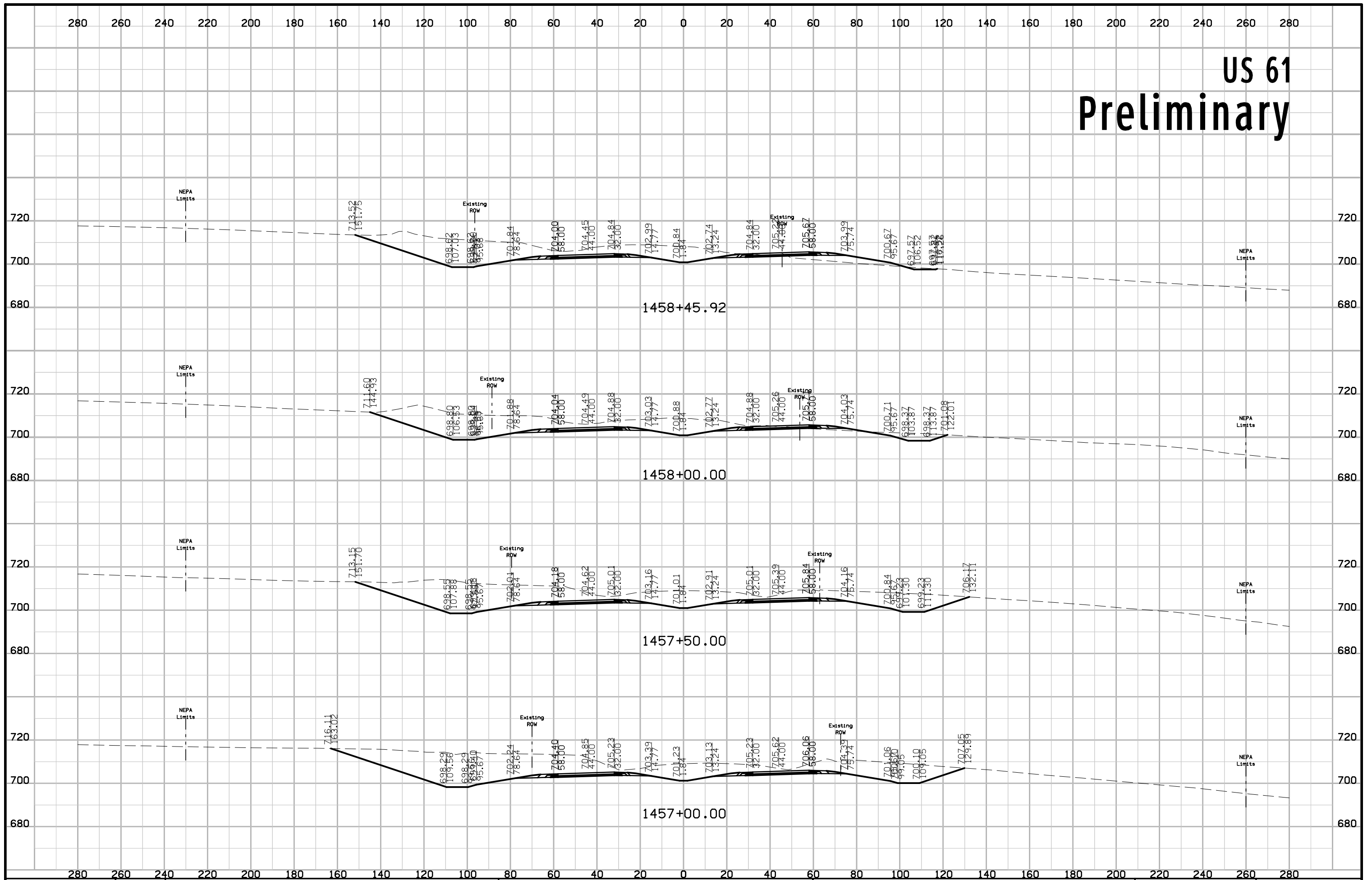

5:32:20 PM 5/14/2014 08725 c:\projects\datasource-1\common\d0250879\29061050w05.sht

US 61 Preliminary

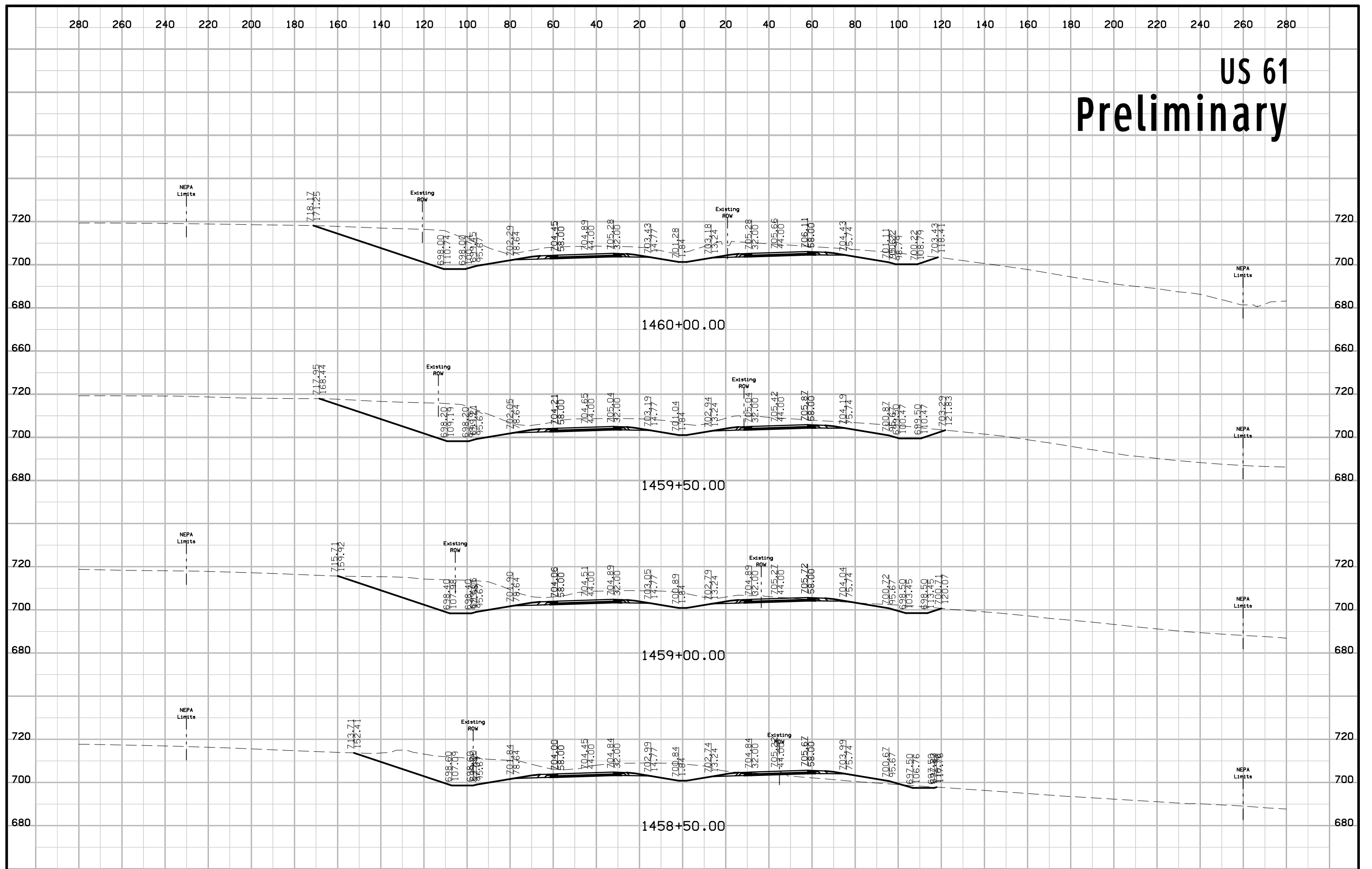

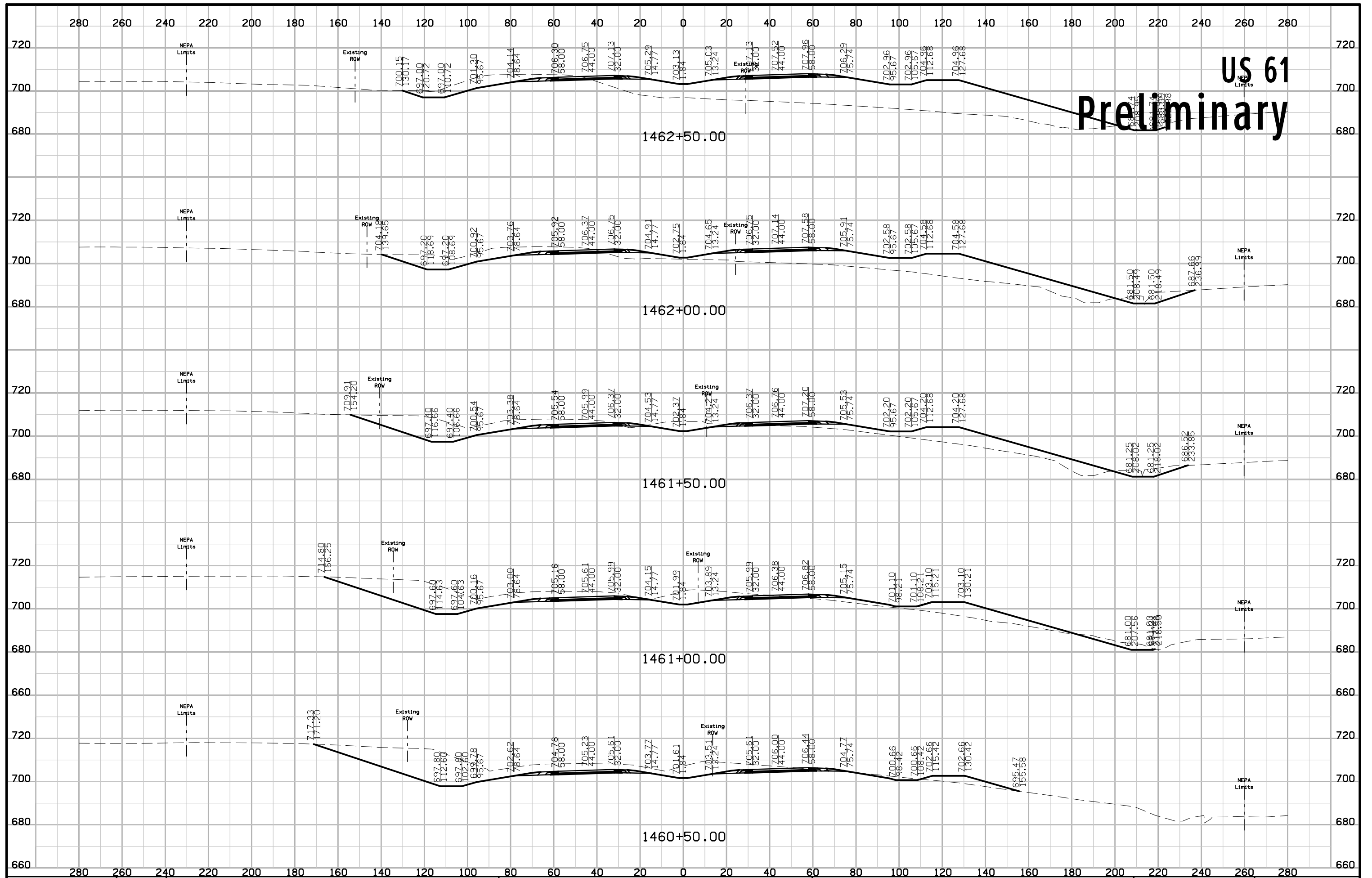

US 61 Preliminary

US 61 Preliminary

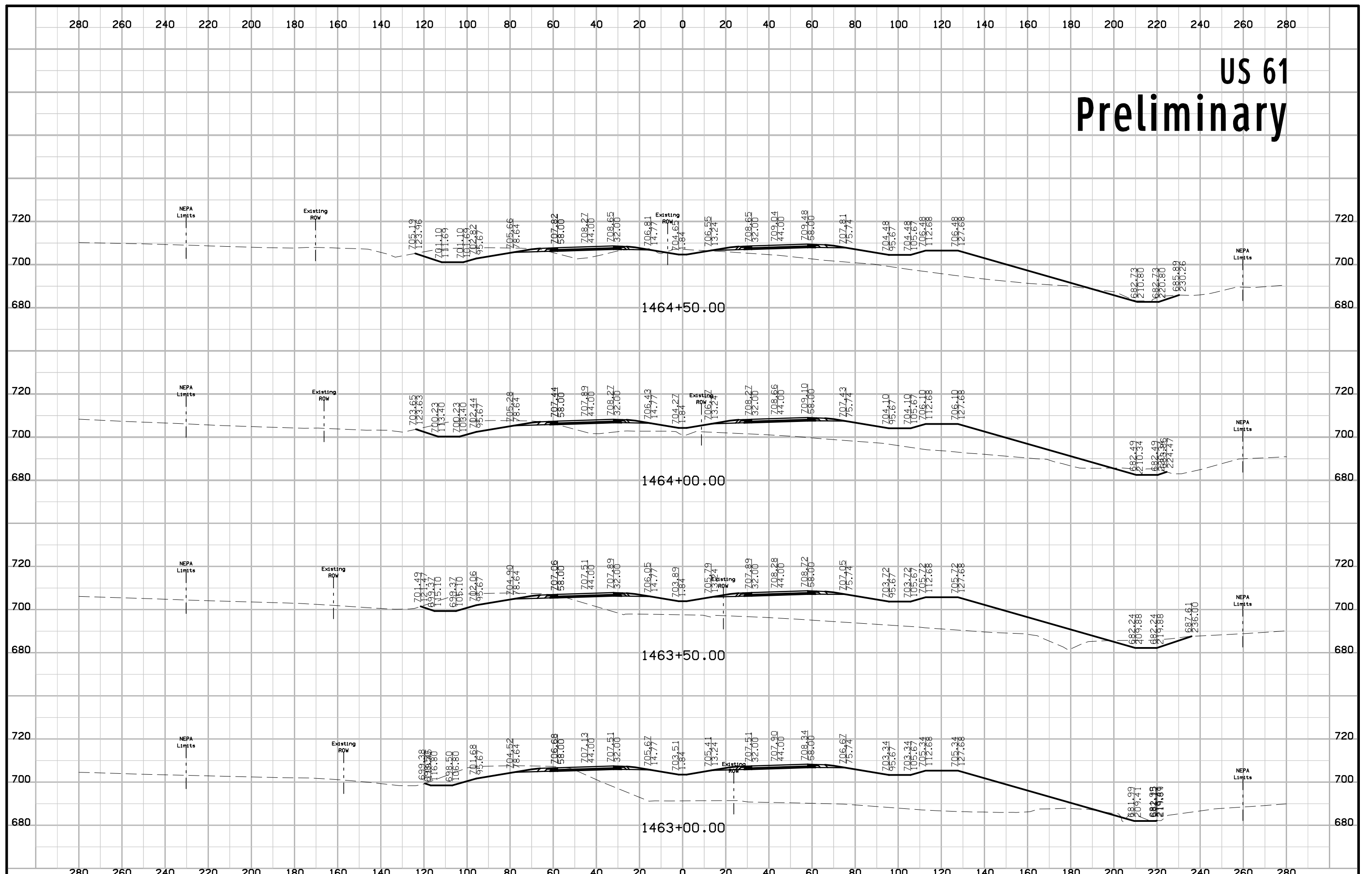

US 61 Preliminary

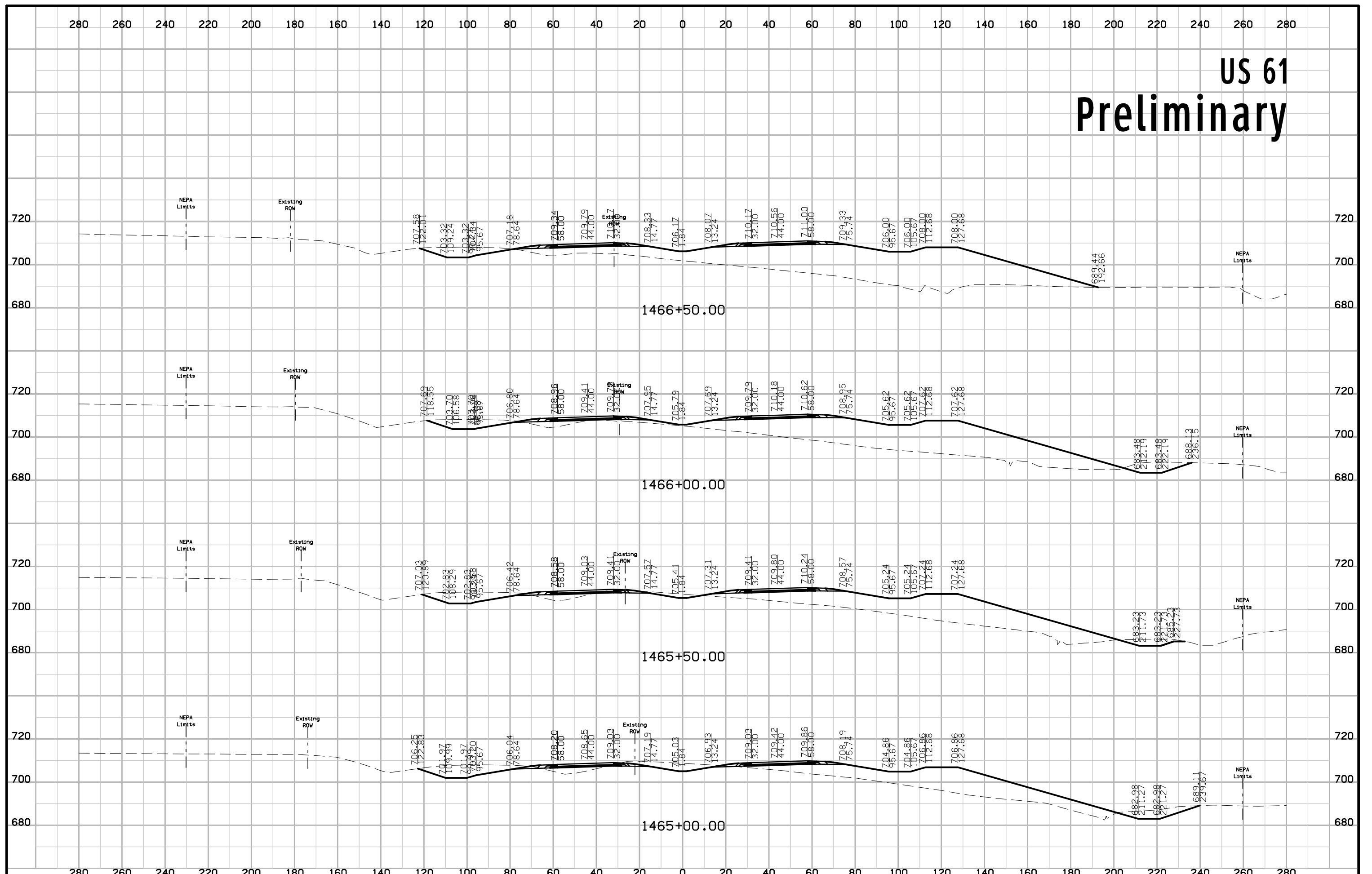

US 61 Preliminary

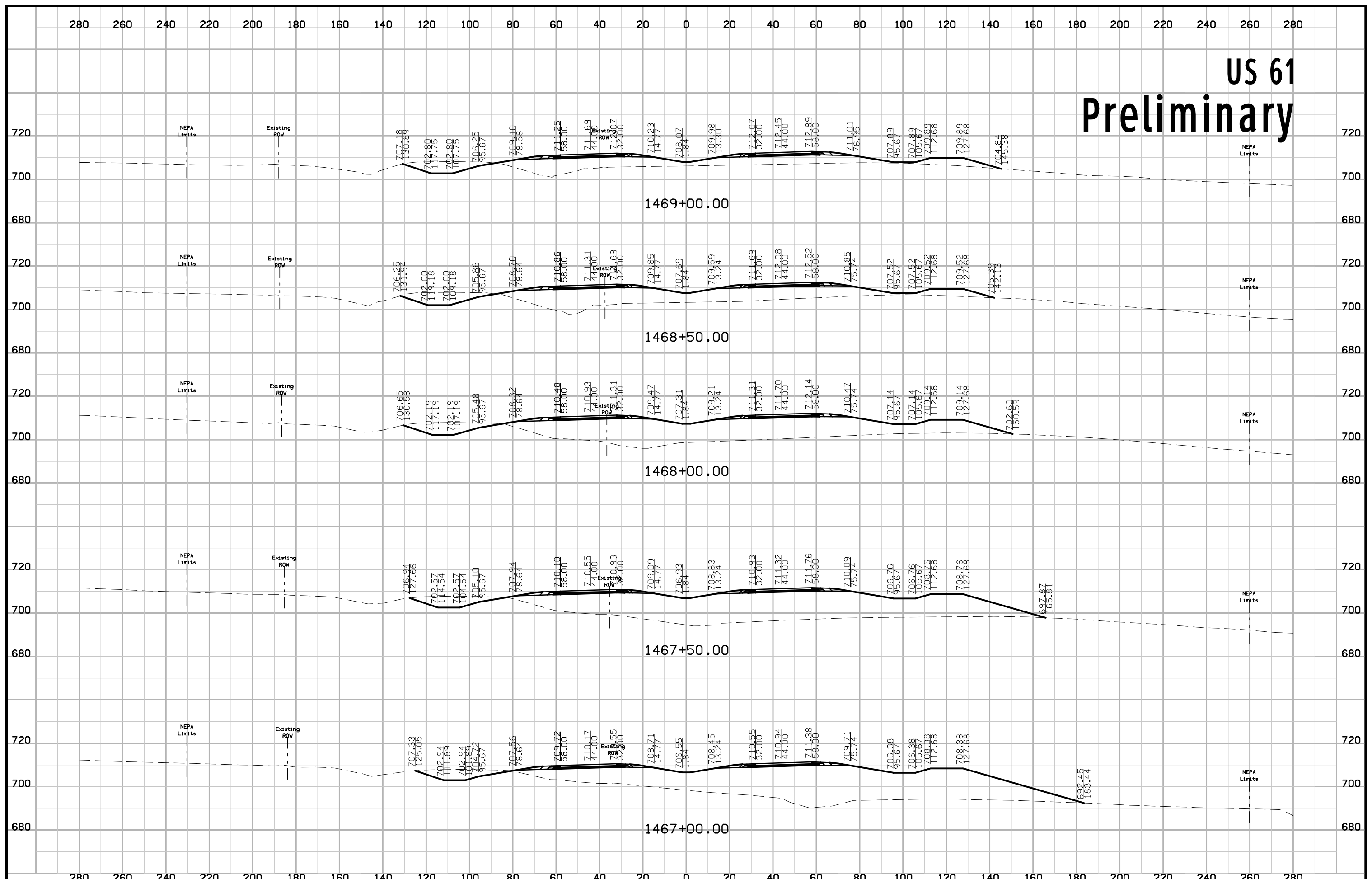

US 61 Preliminary

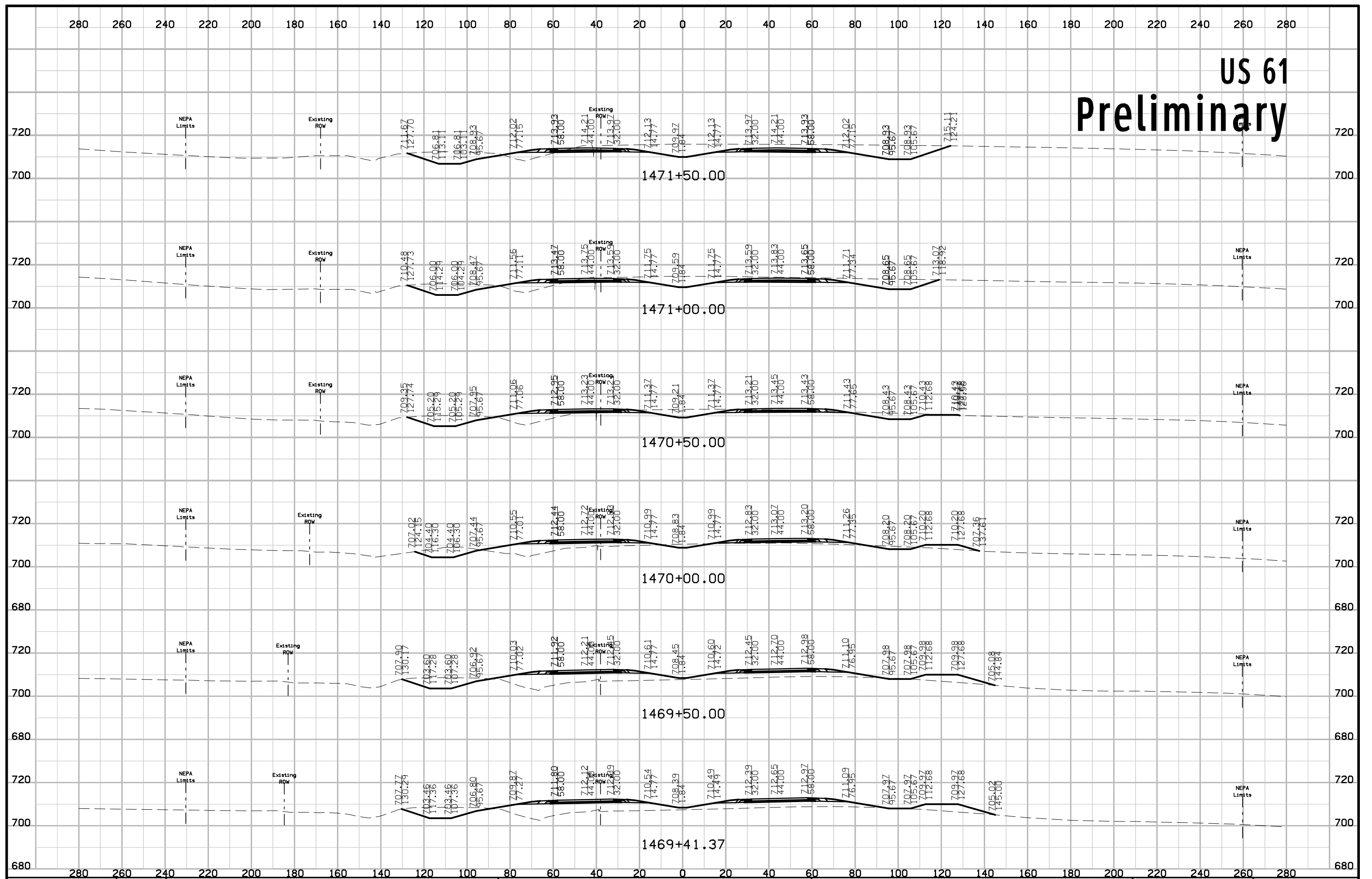

US 61 Preliminary

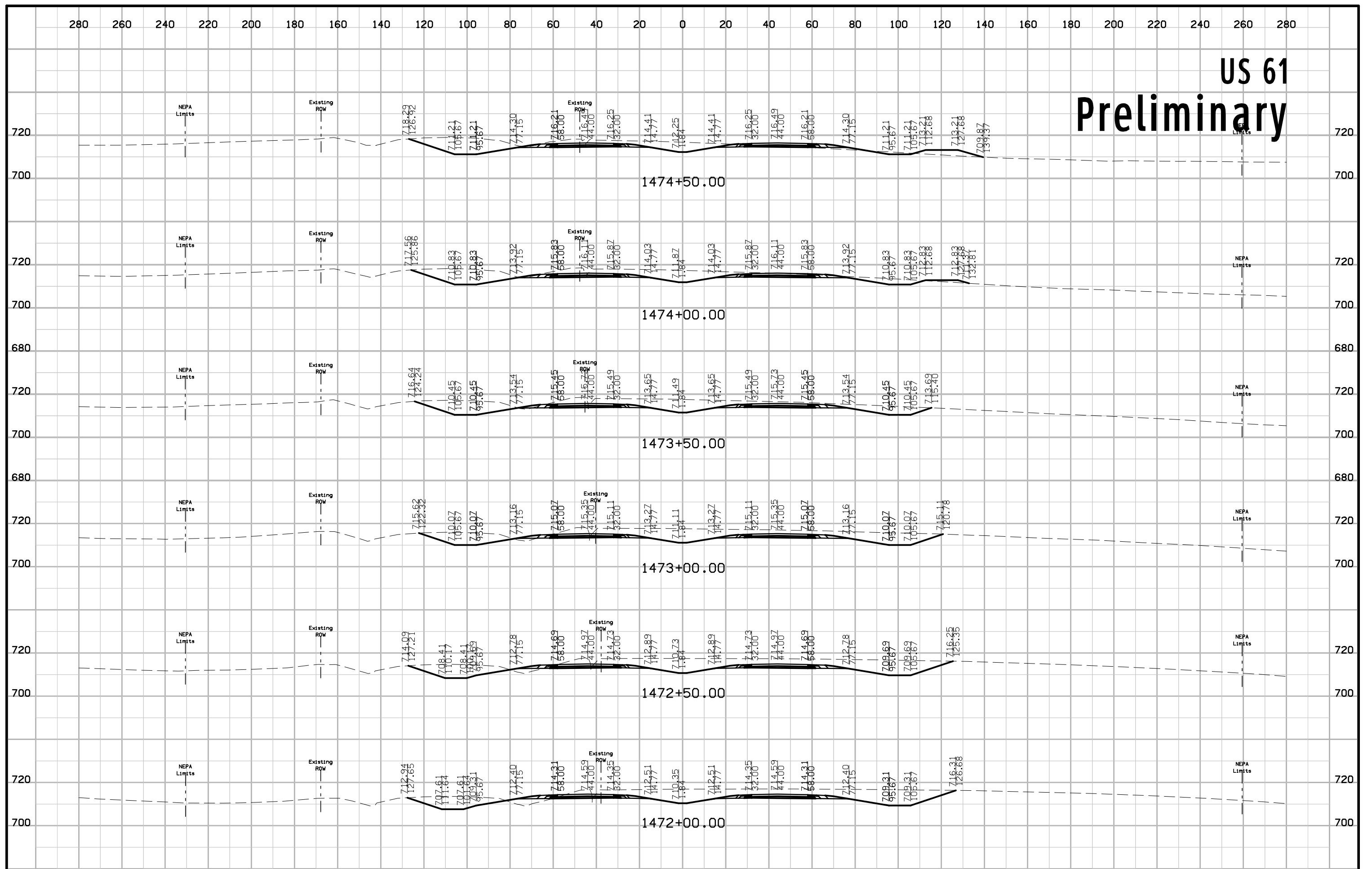

US 61 Preliminary

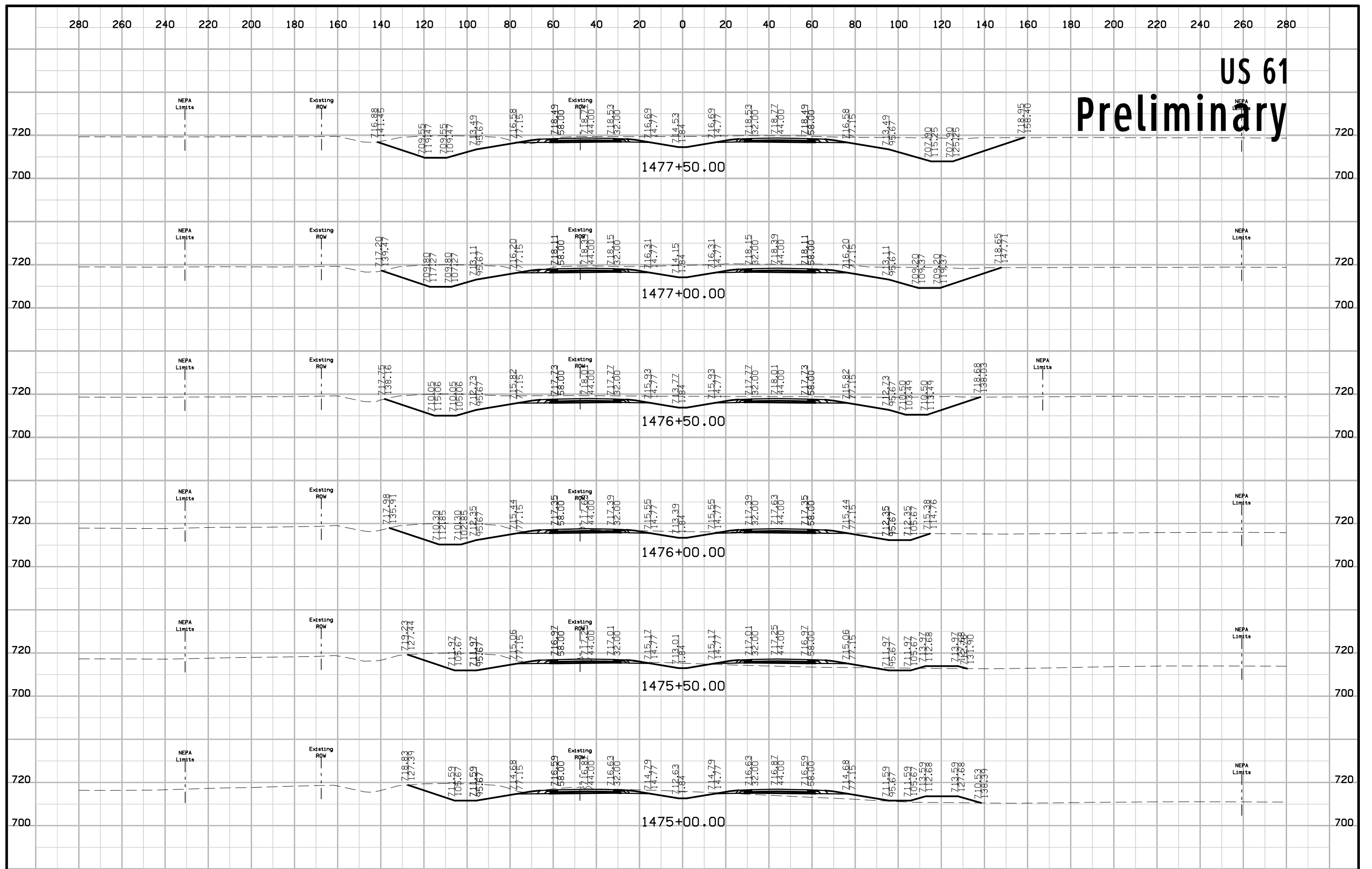

US 61 Preliminary

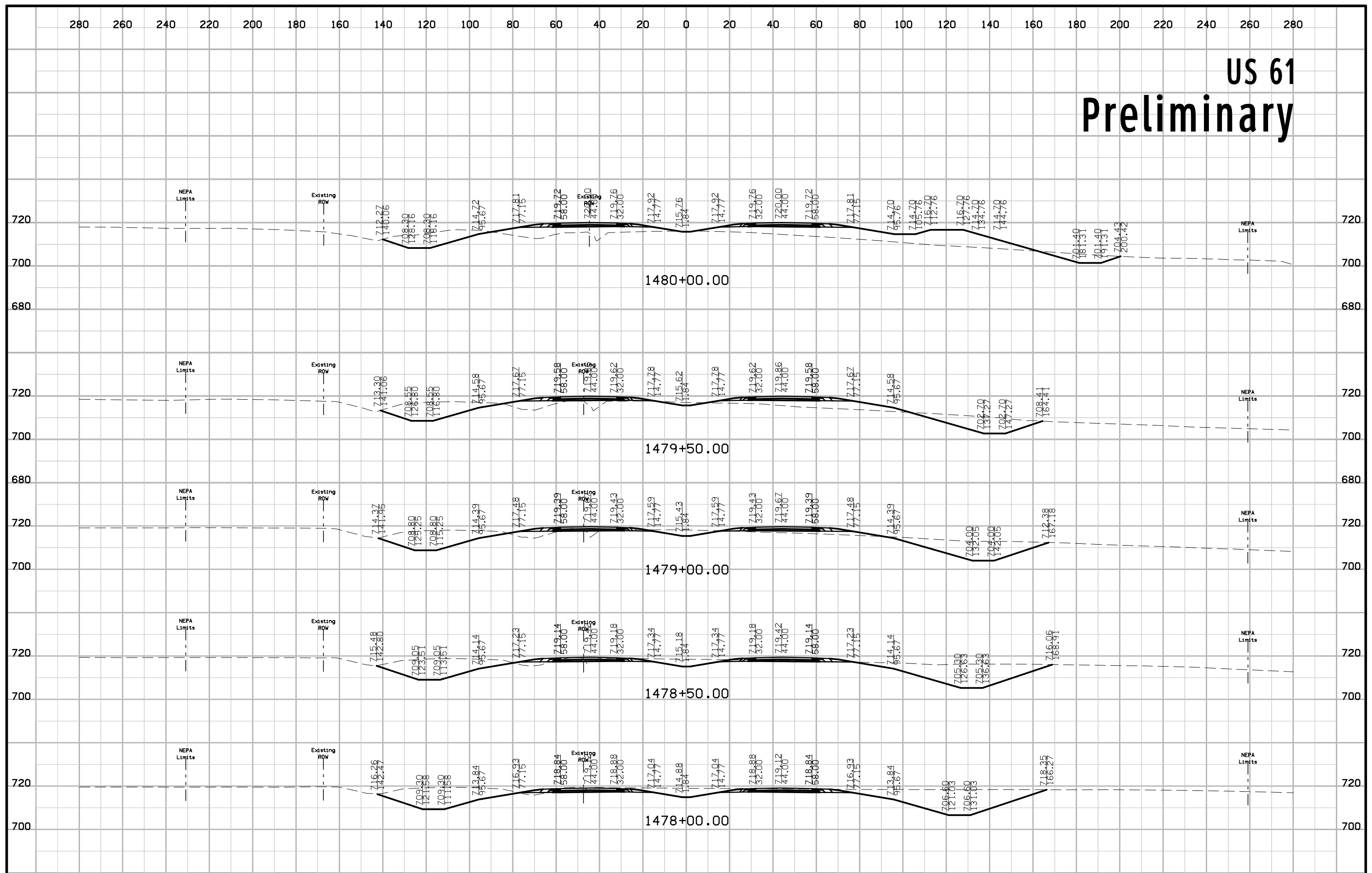

US 61 Preliminary

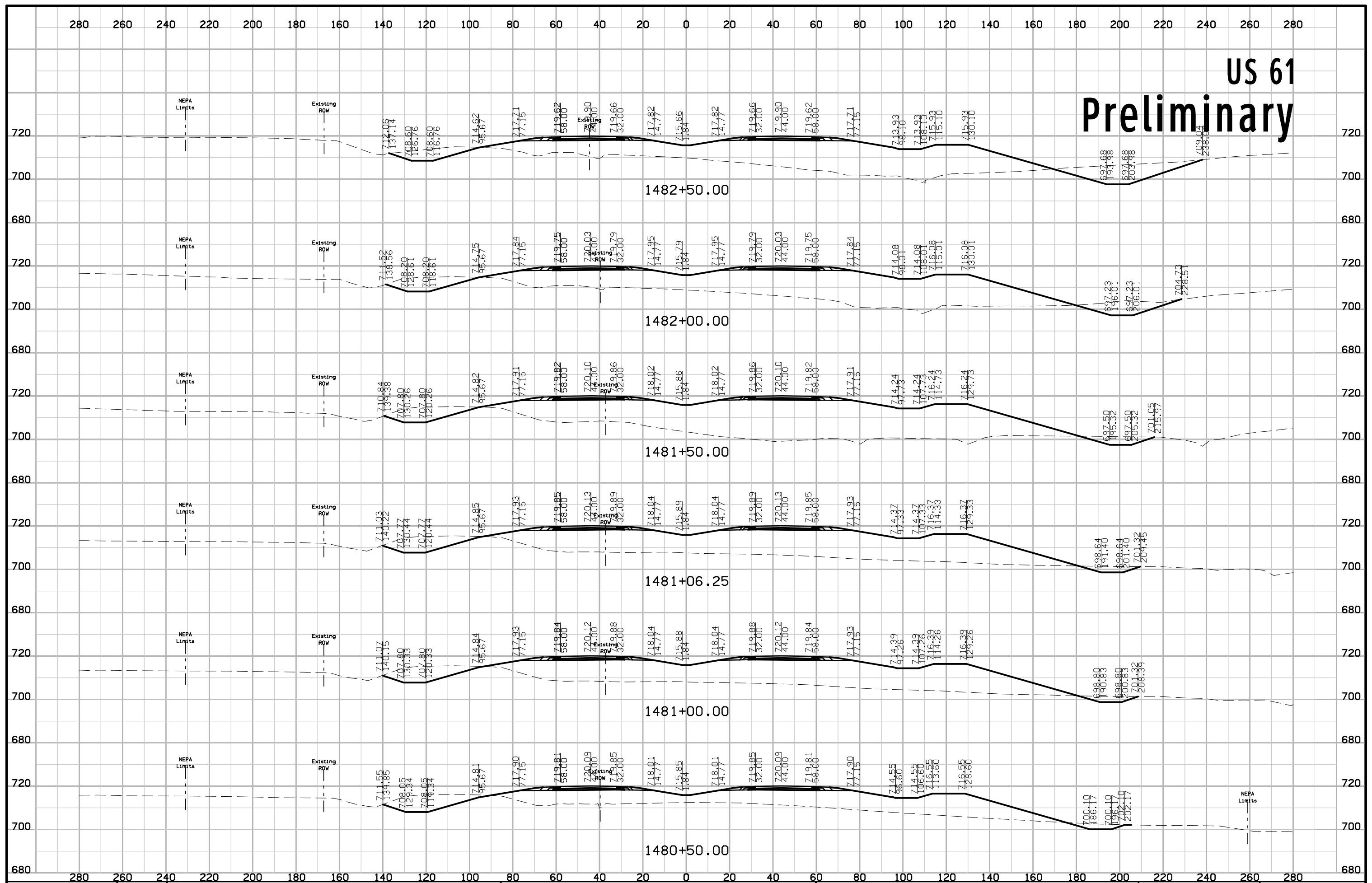

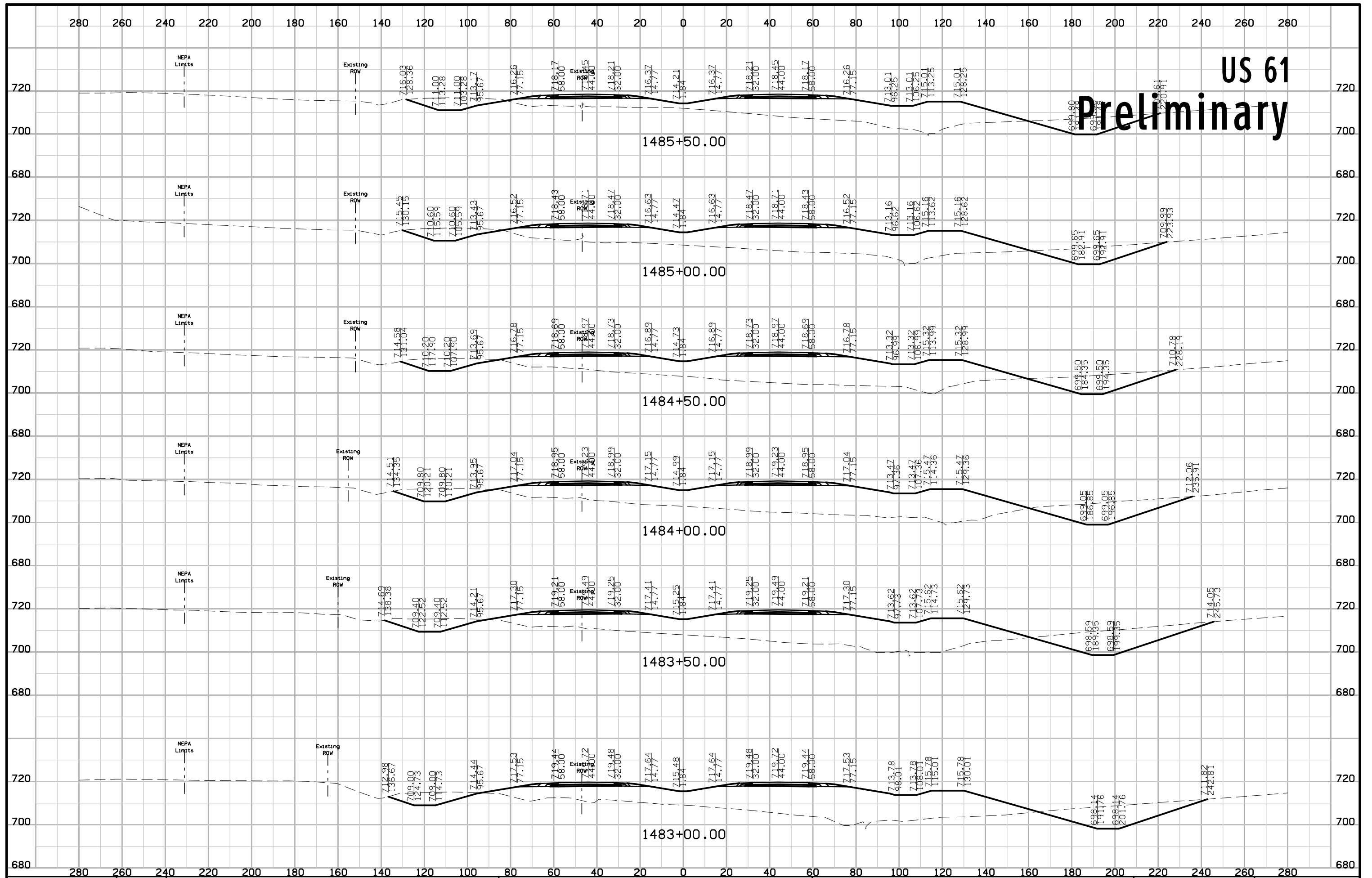

US 61 Preliminary

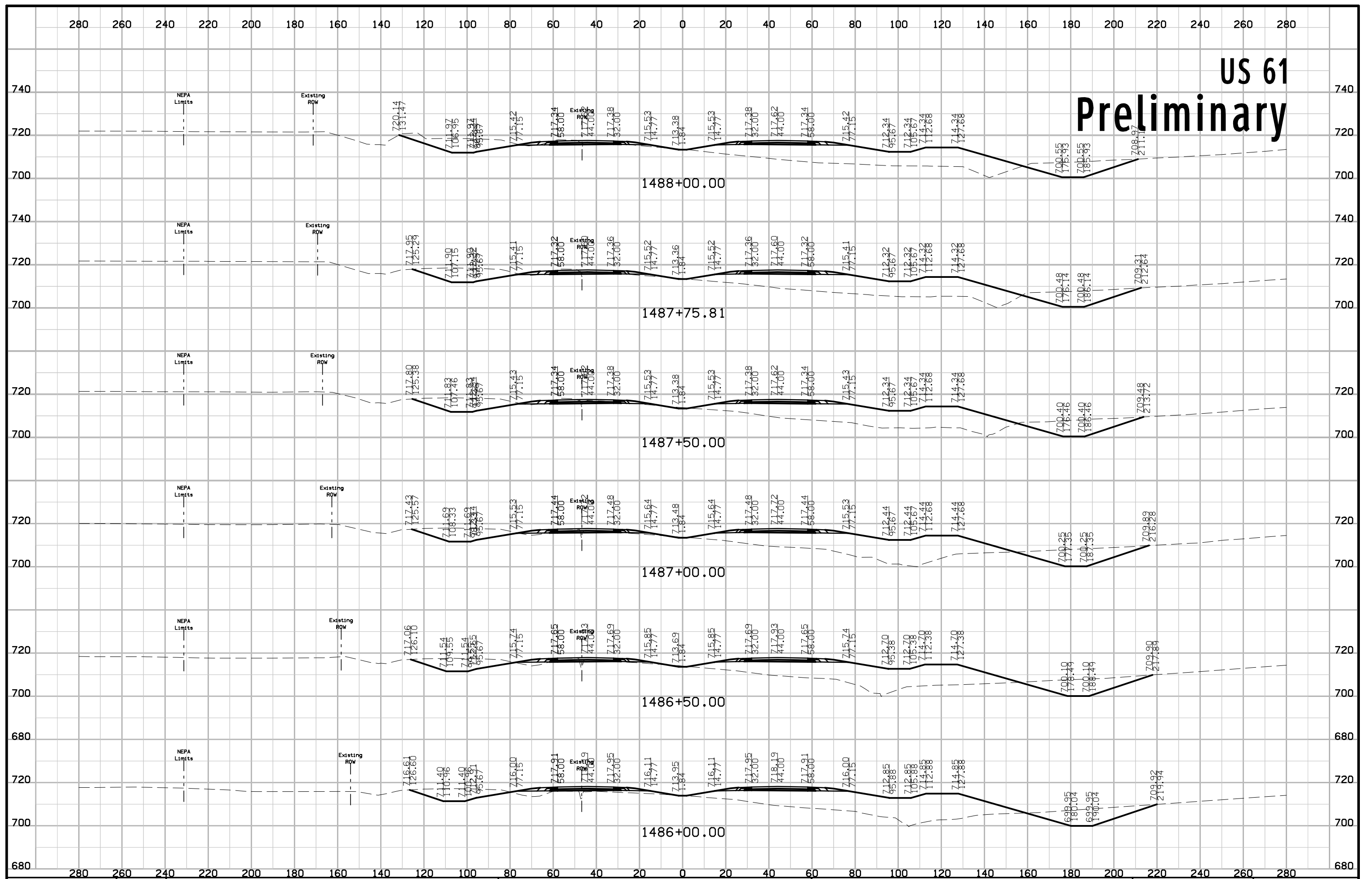

US 61 Preliminary

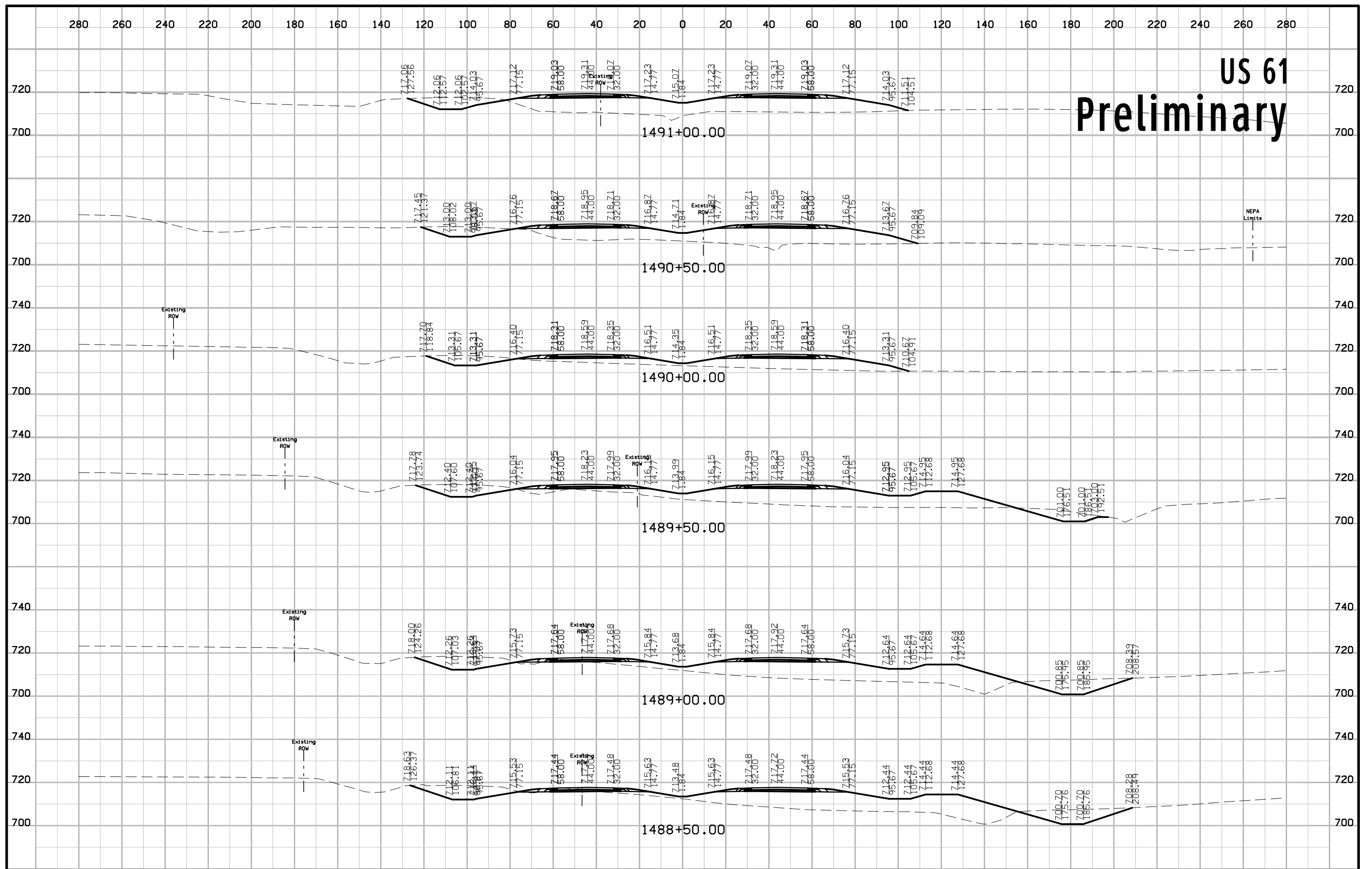

US 61 Preliminary

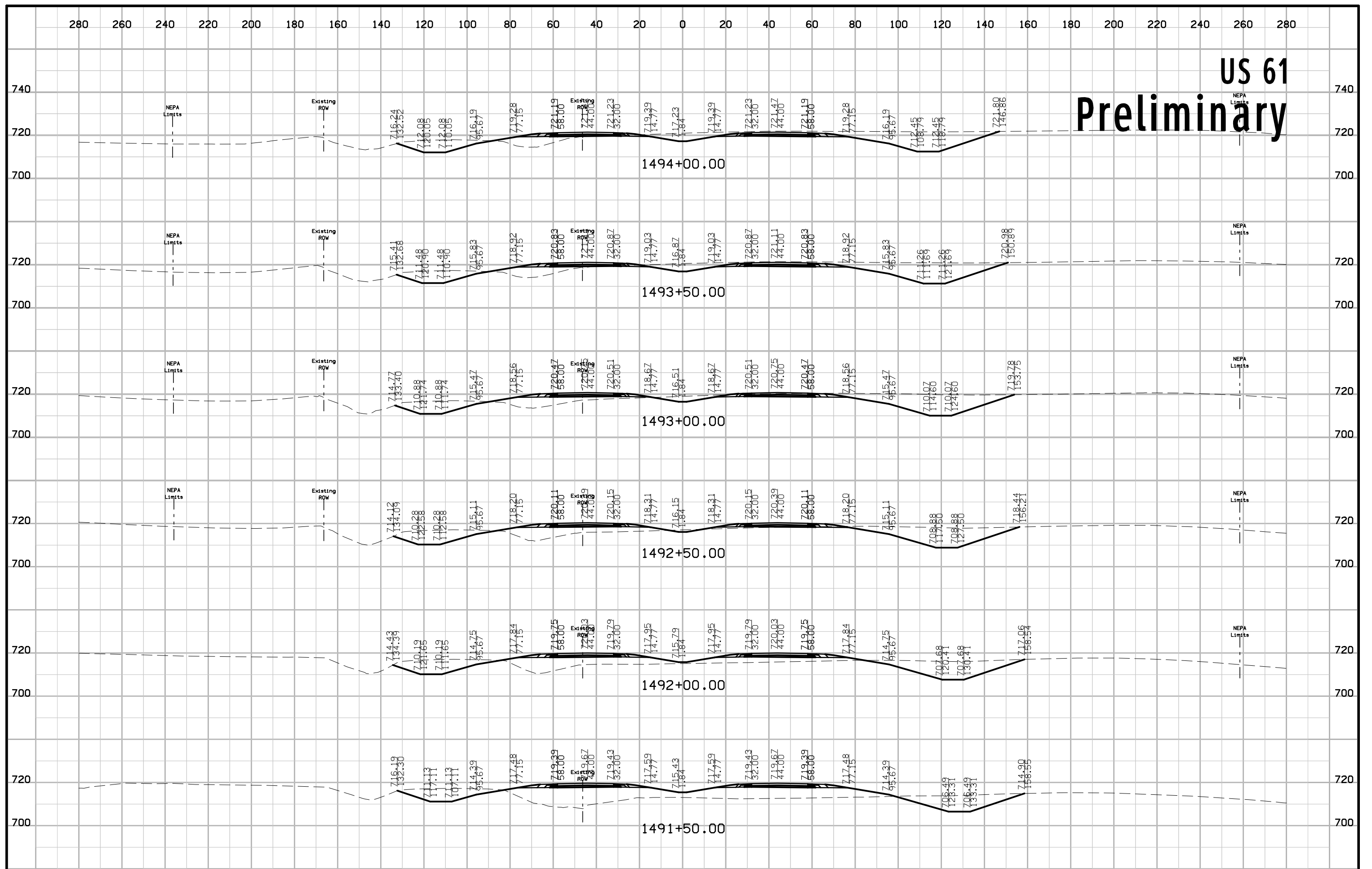

US 61 Preliminary

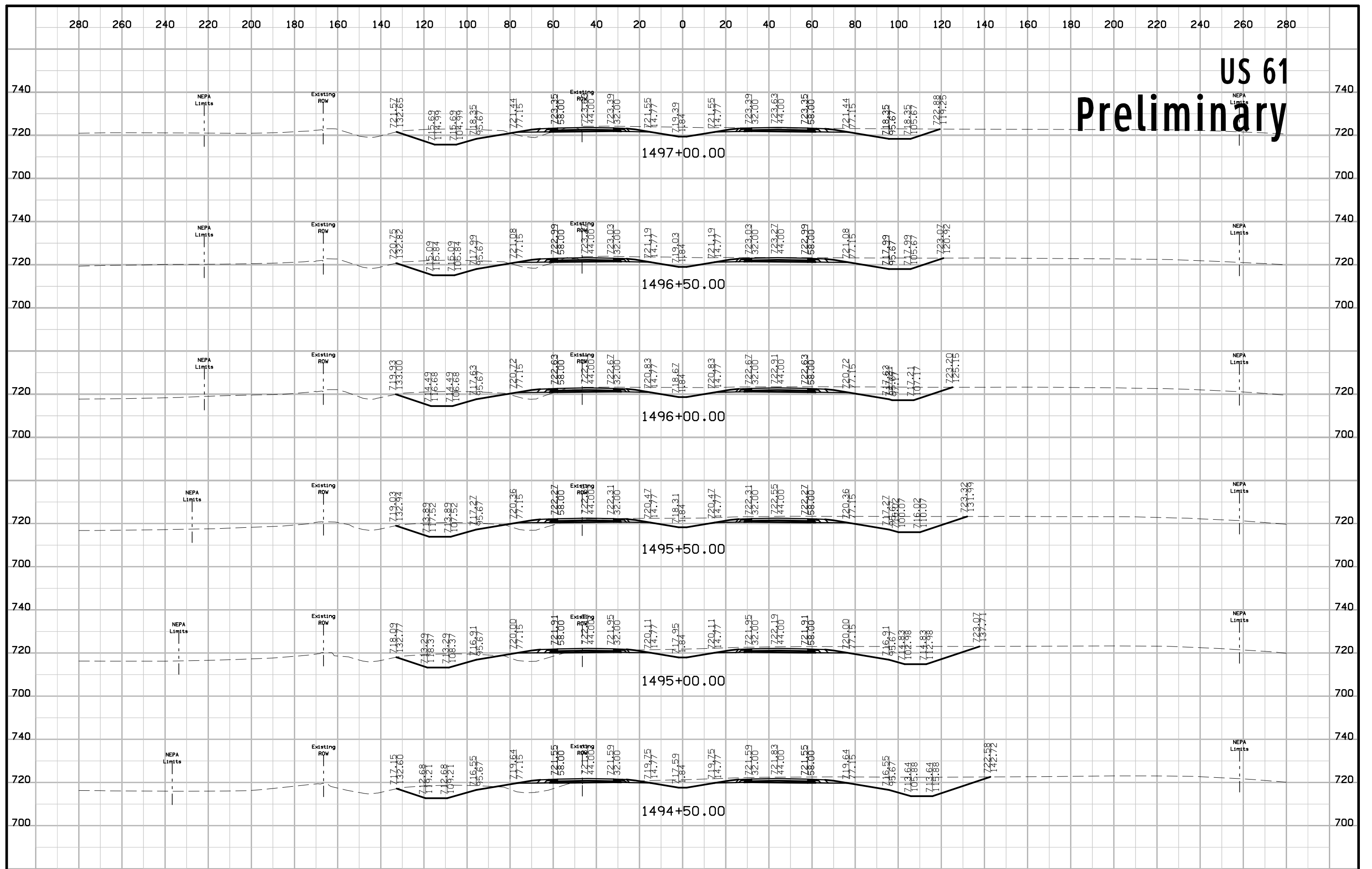

US 61 Preliminary

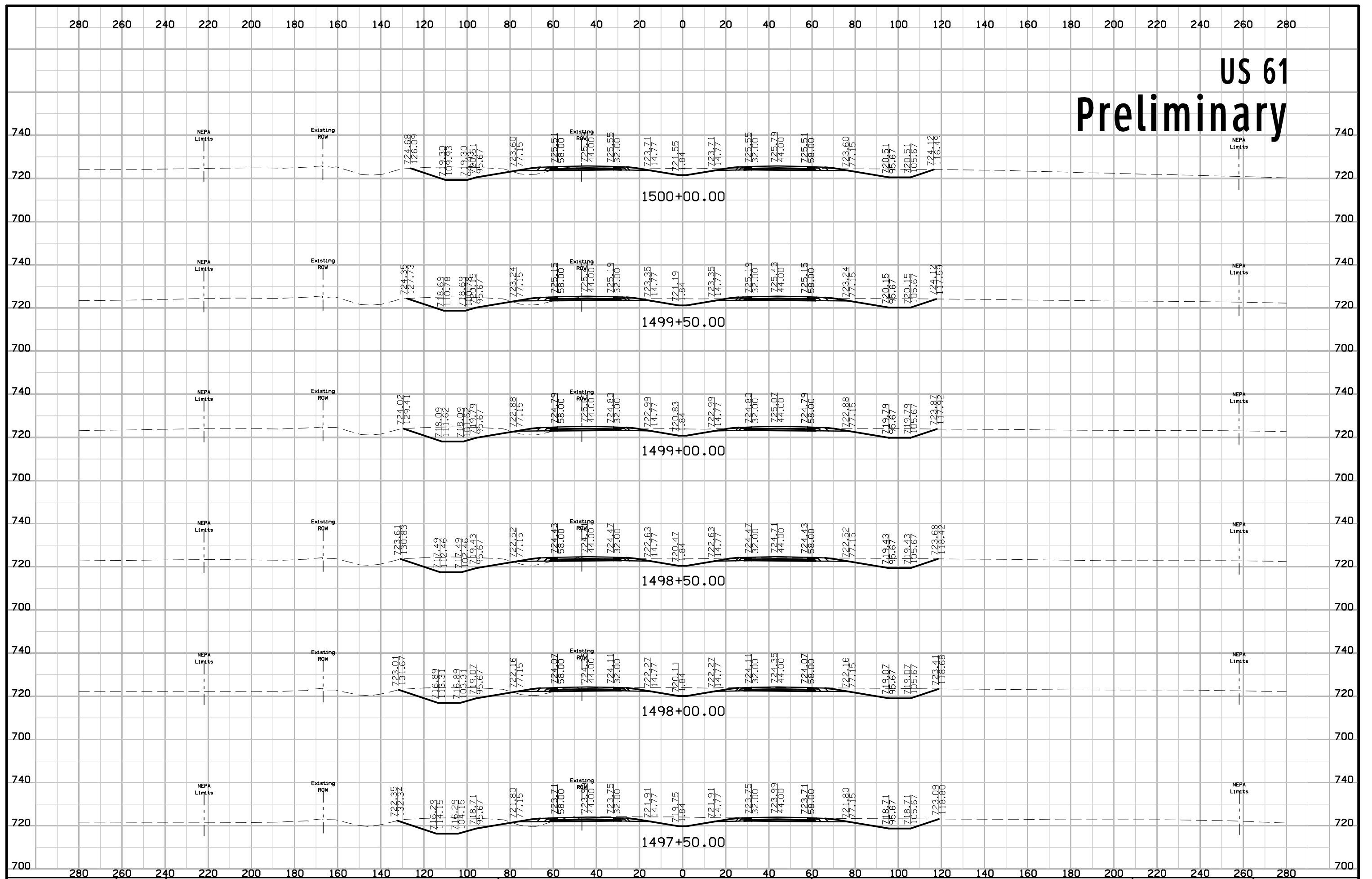

US 61 Preliminary

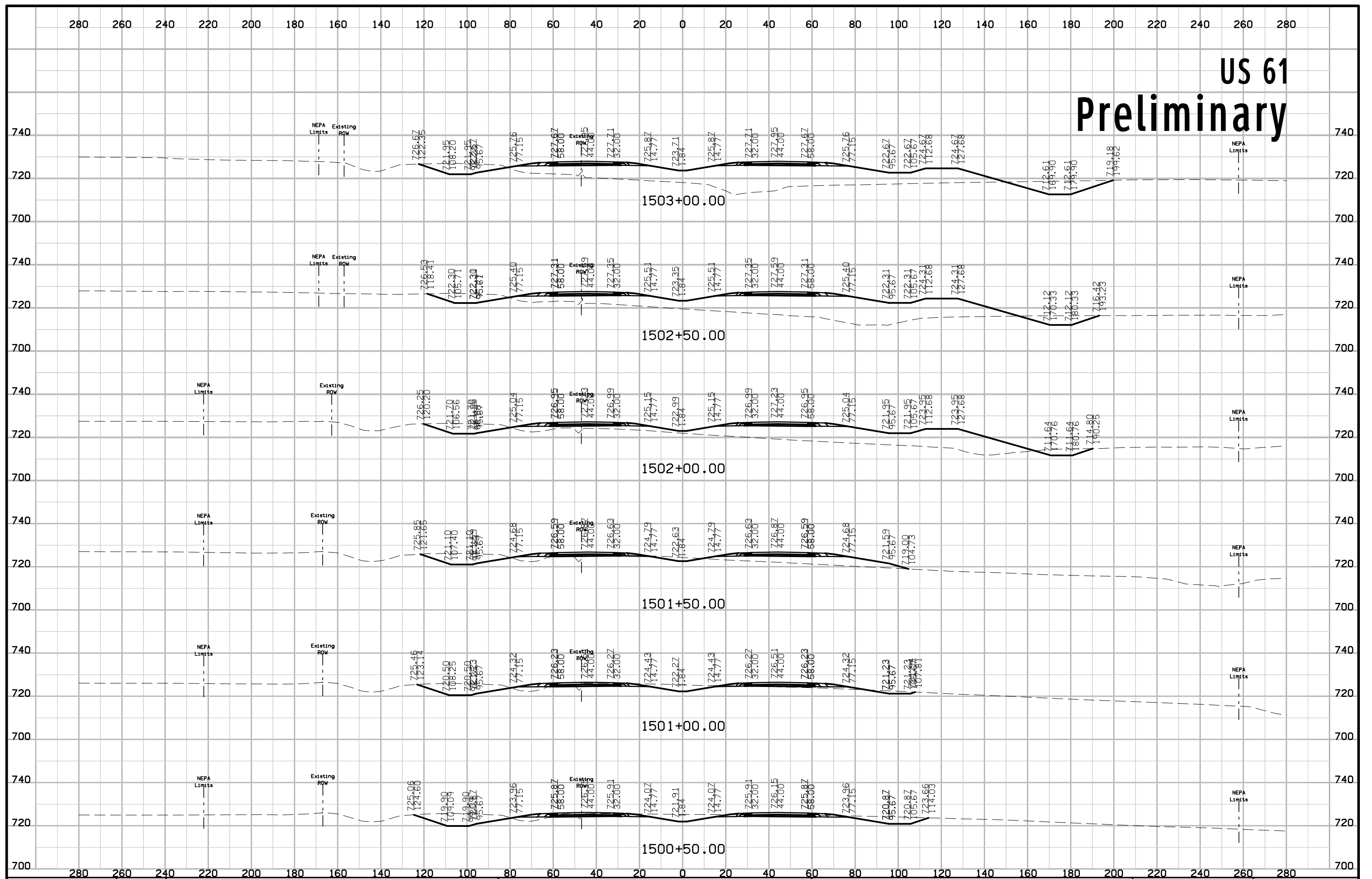

US 61 Preliminary

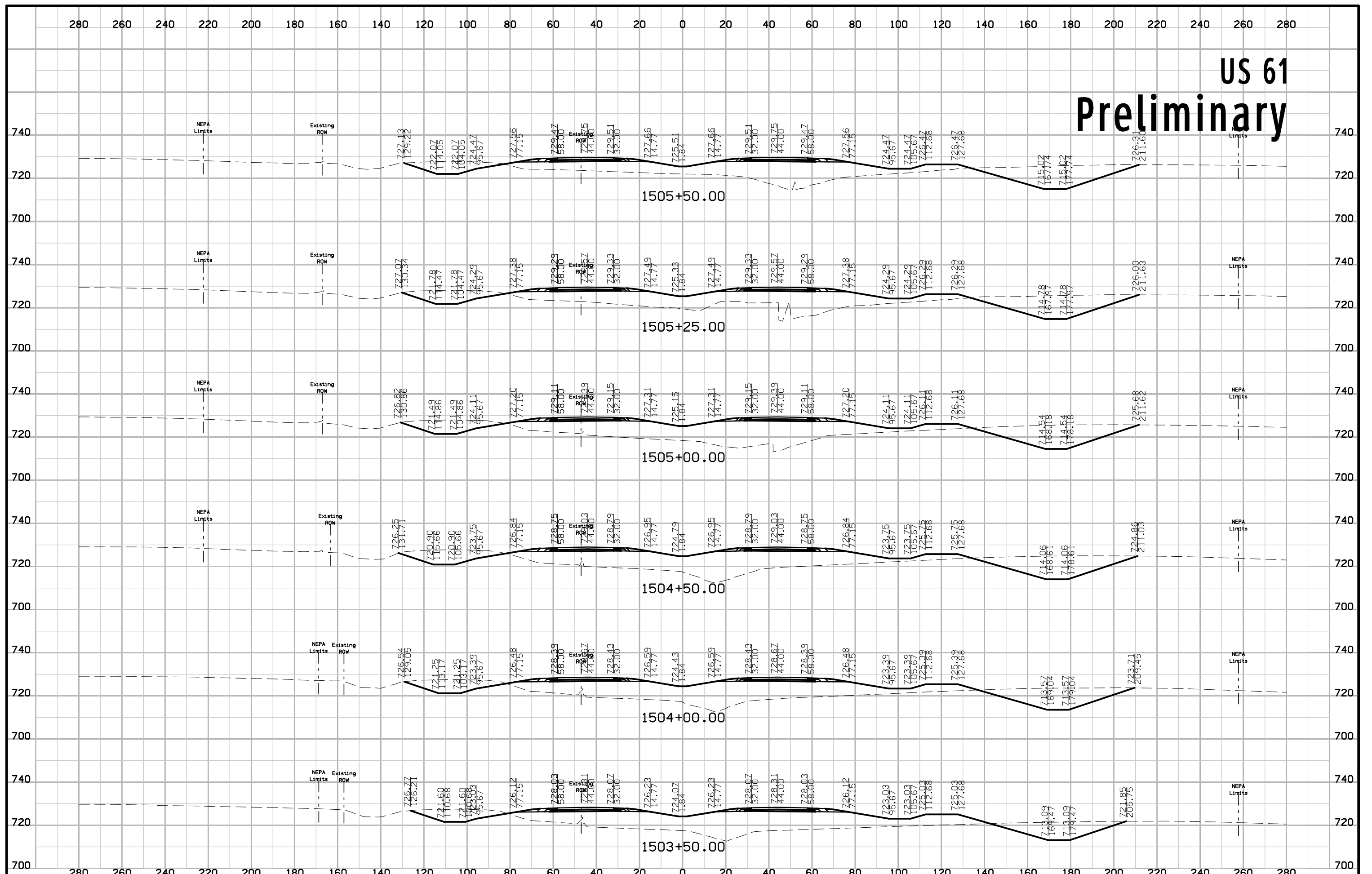

US 61 Preliminary

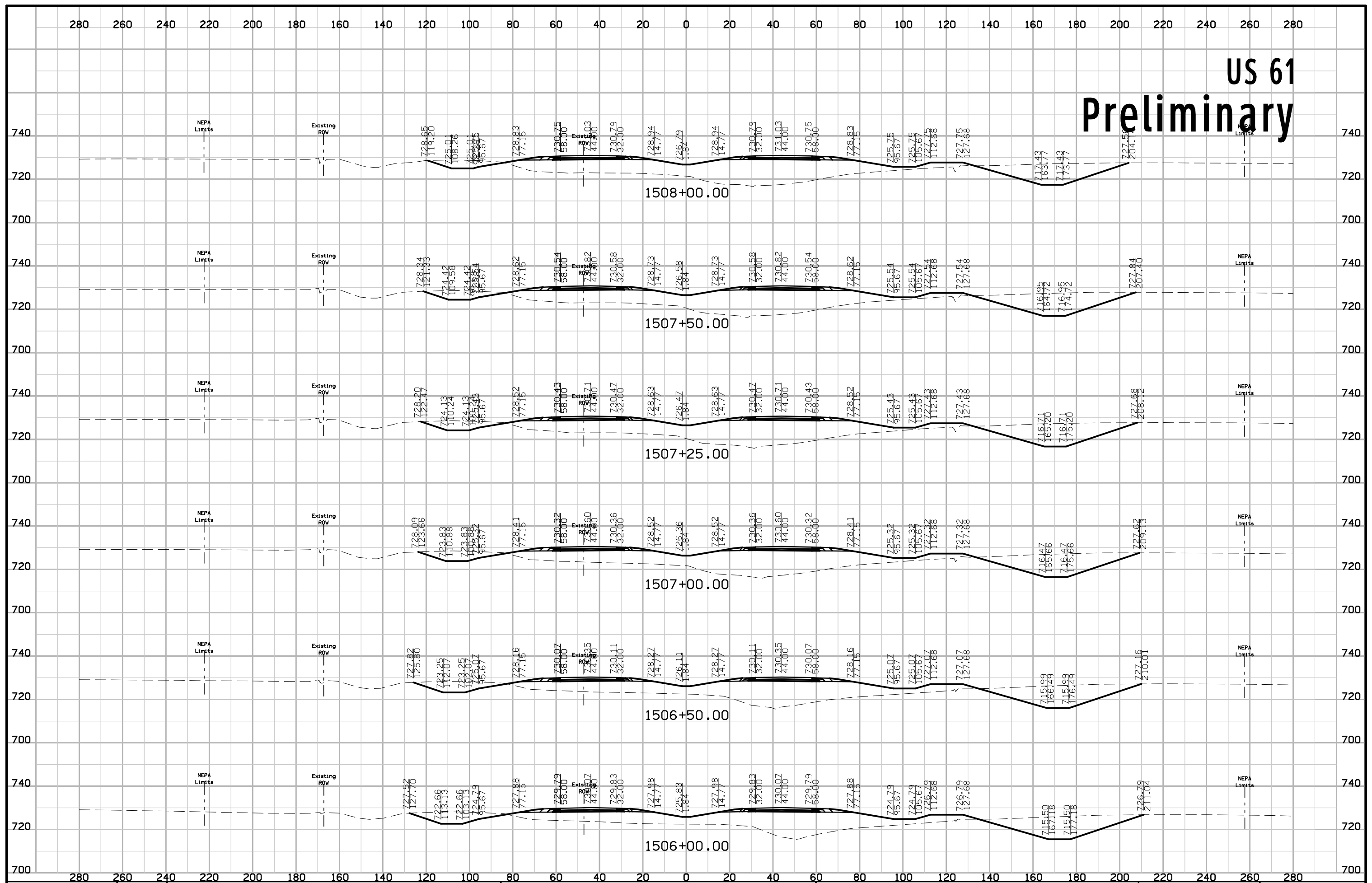

US 61 Preliminary

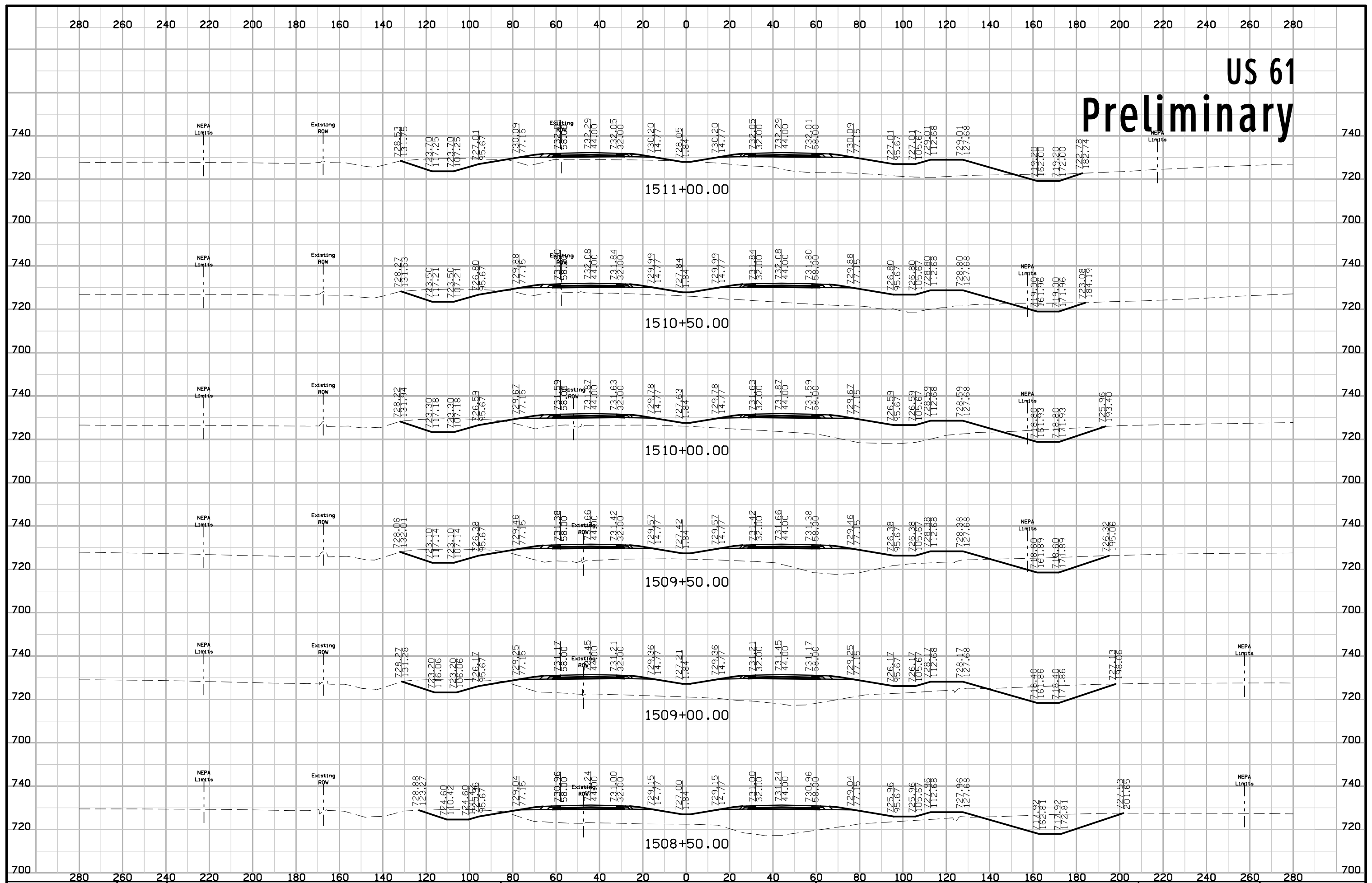

US 61 Preliminary

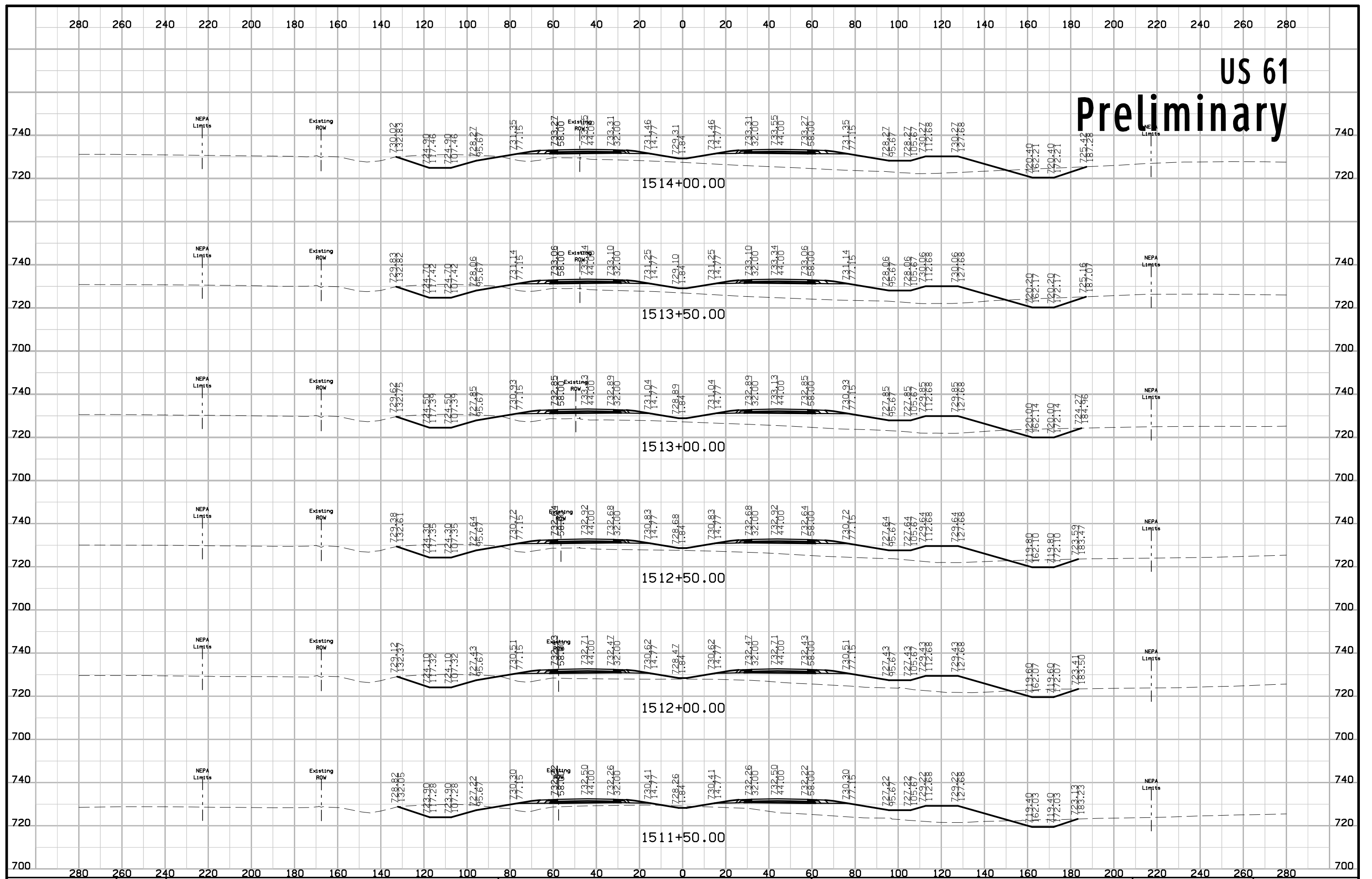

US 61 Preliminary

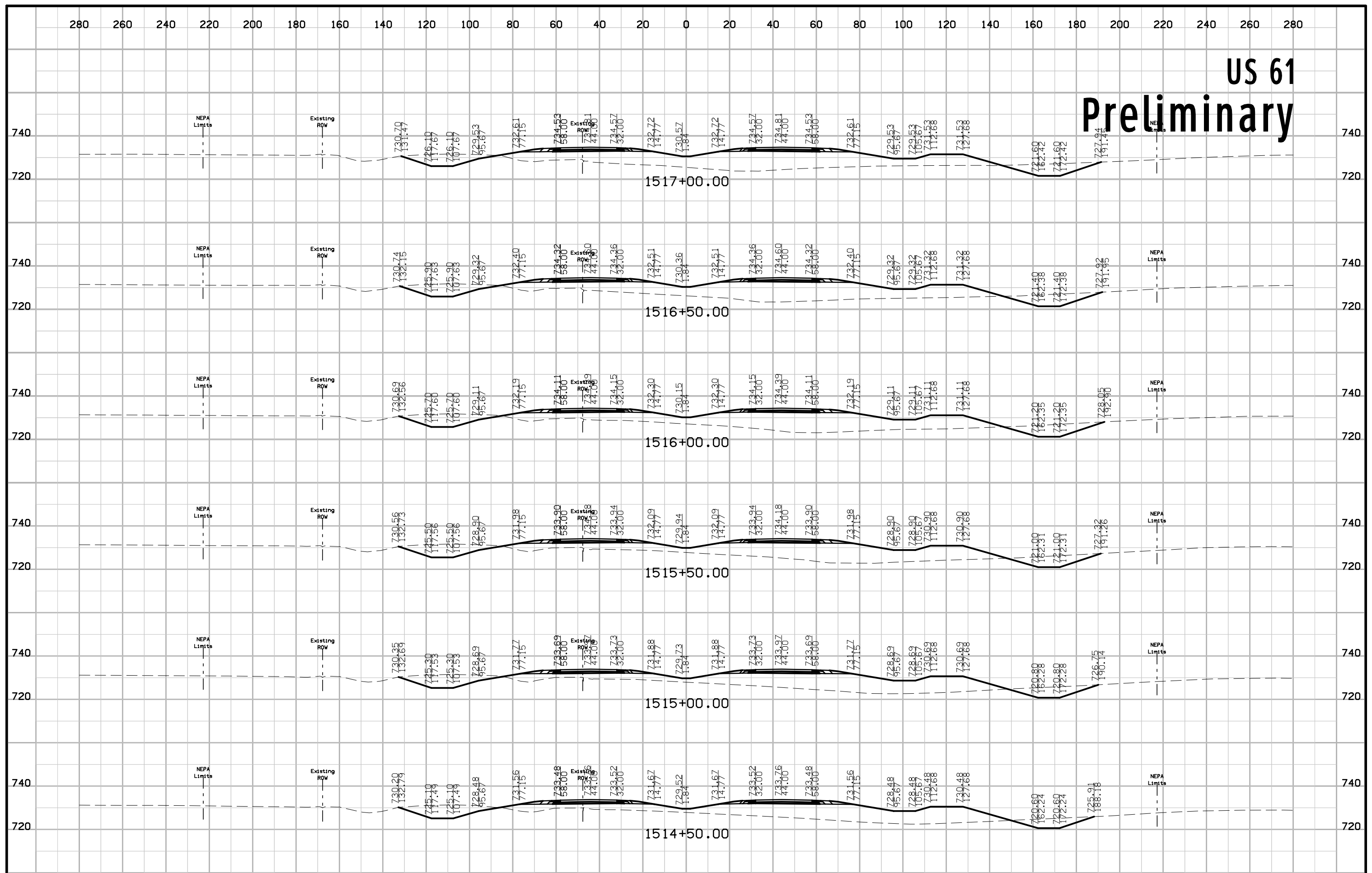

US 61 Preliminary

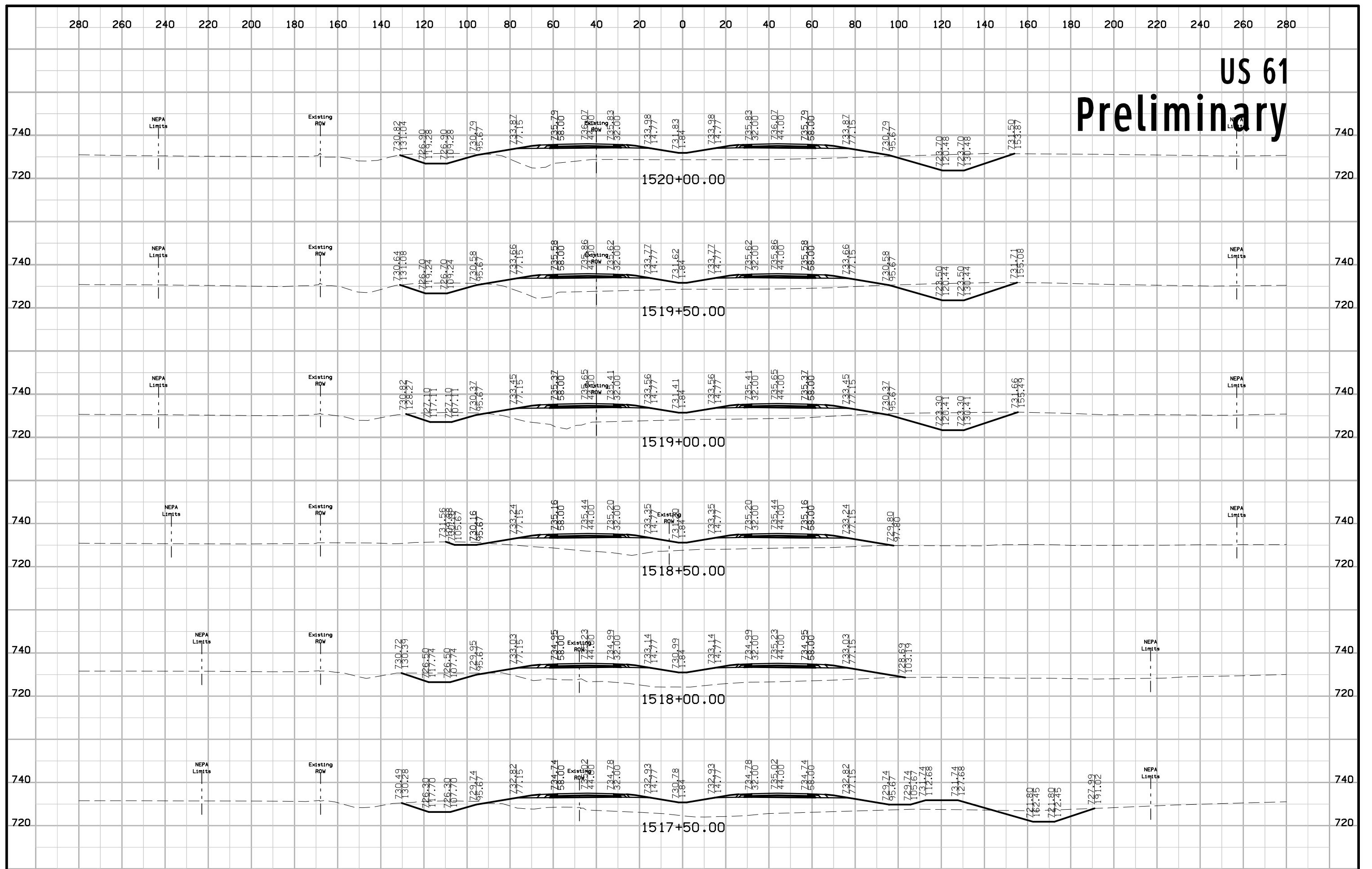

US 61 Preliminary

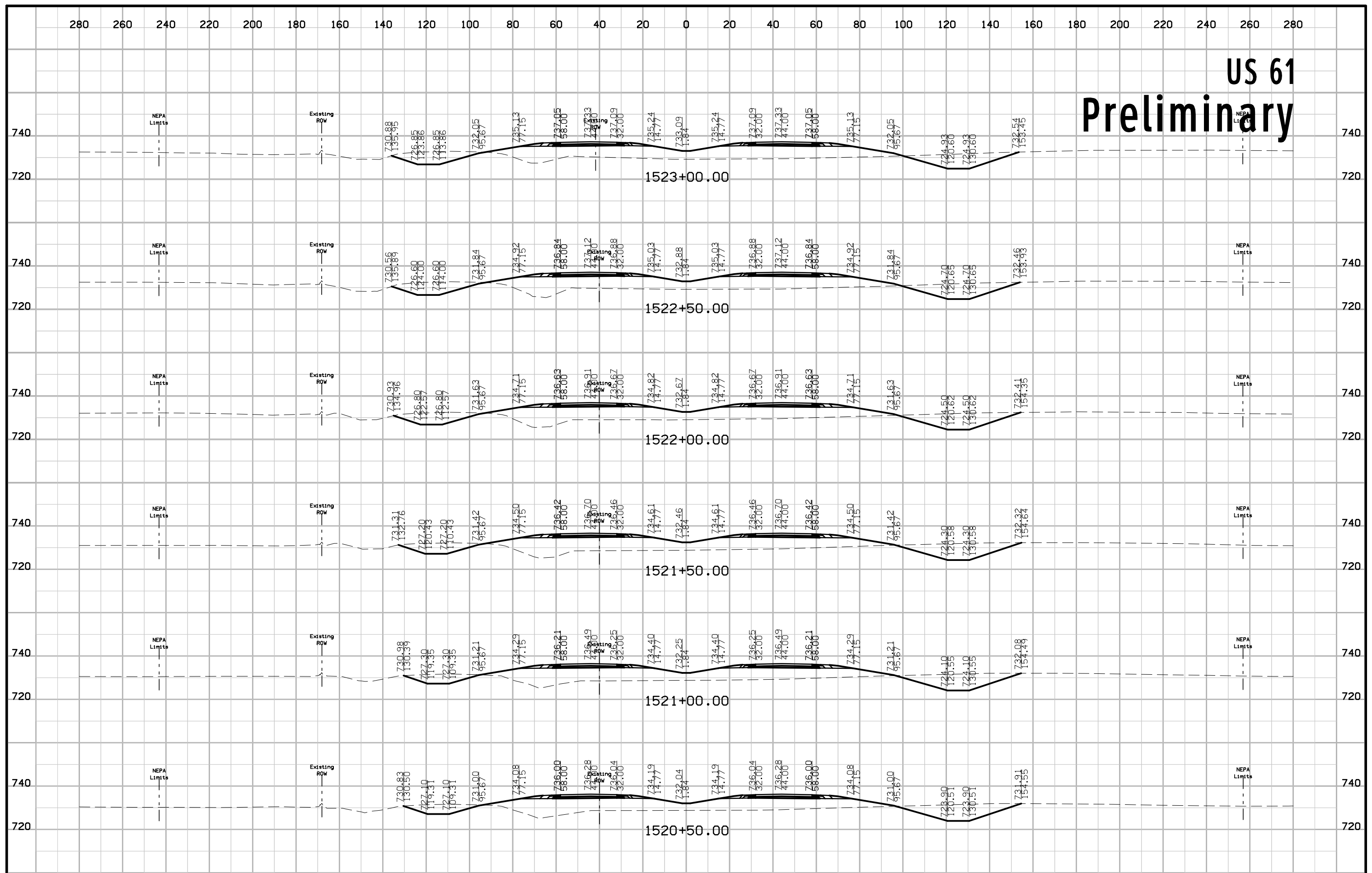

US 61 Preliminary

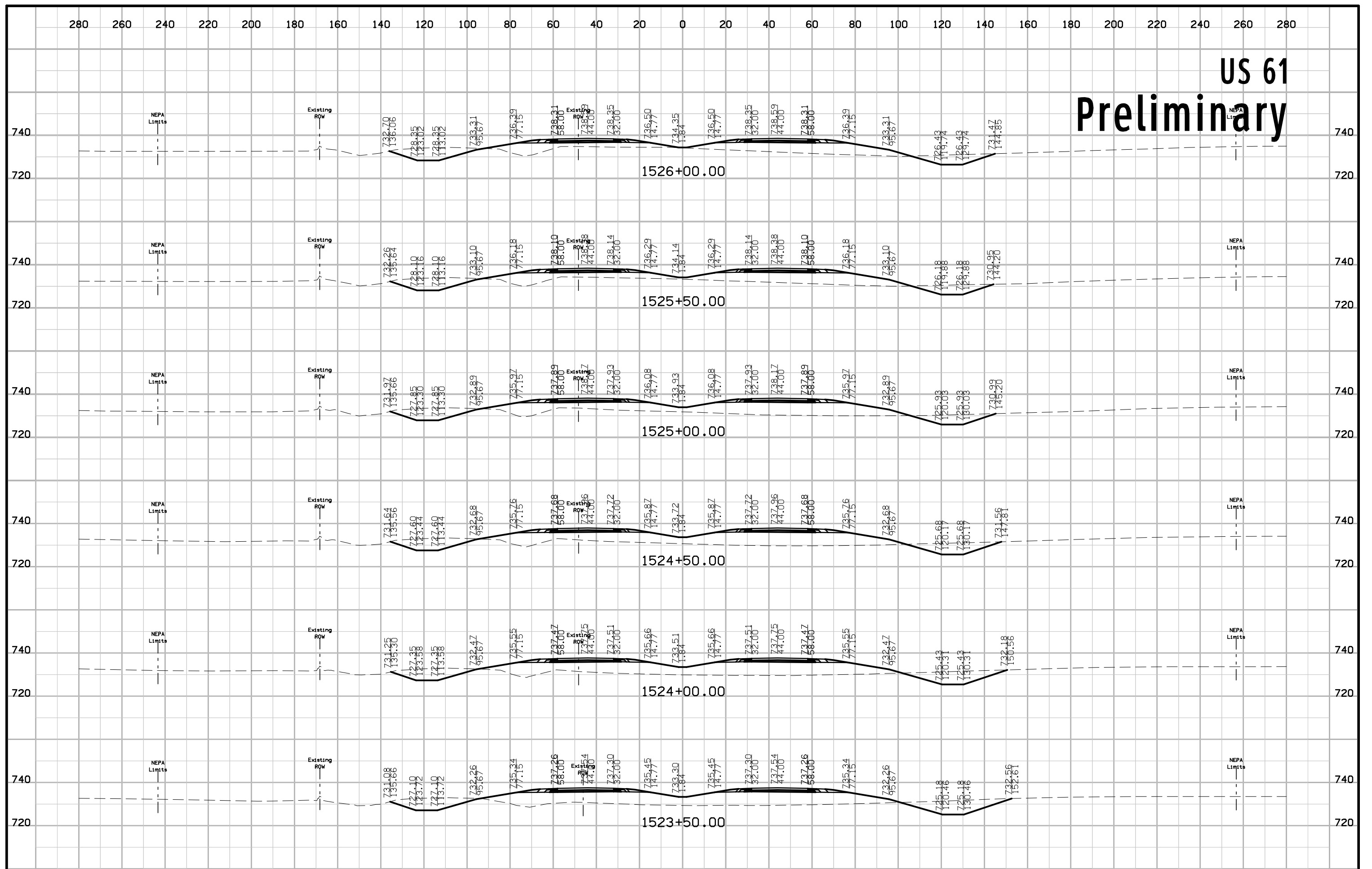

US 61 Preliminary

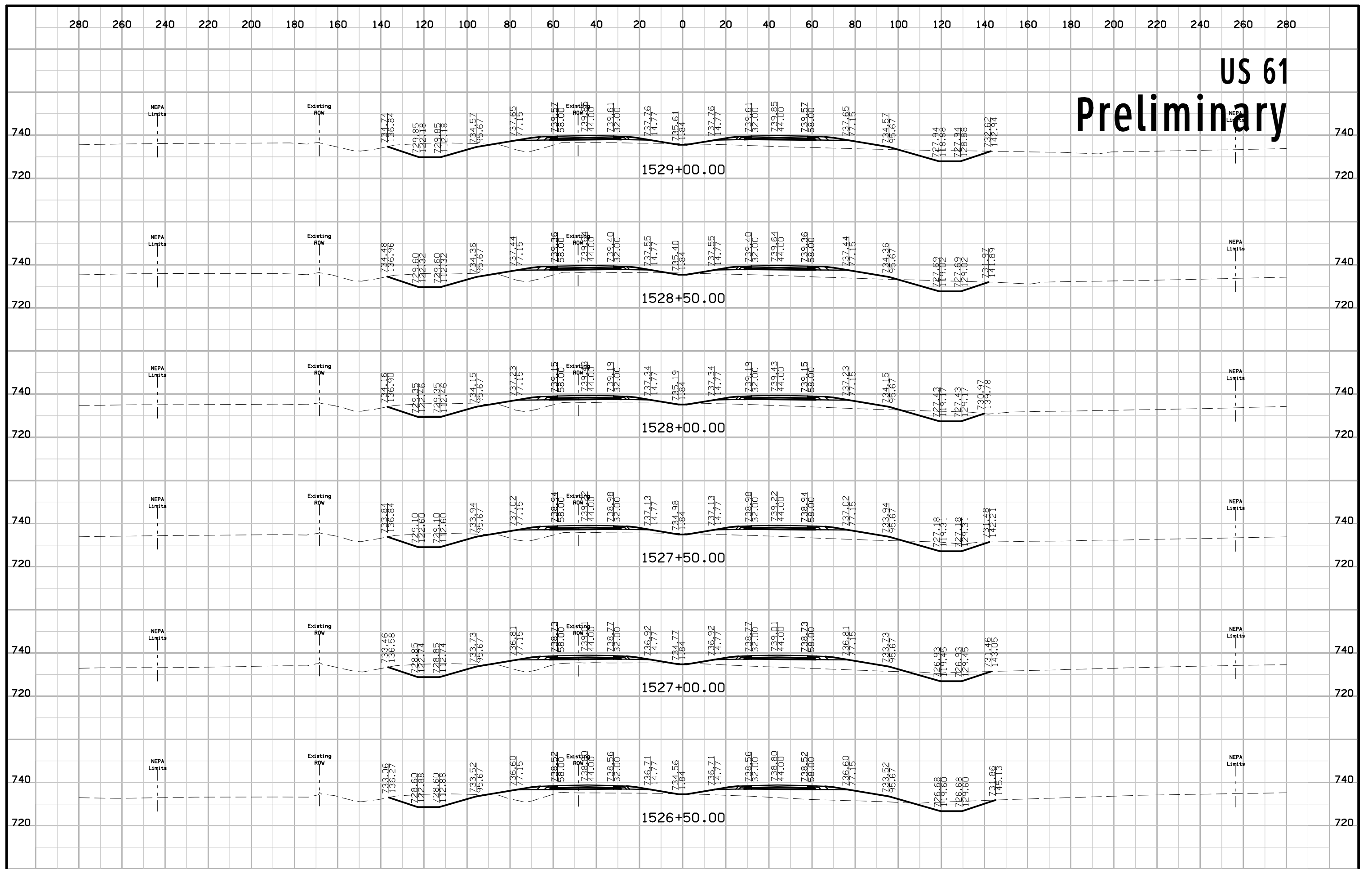

US 61 Preliminary

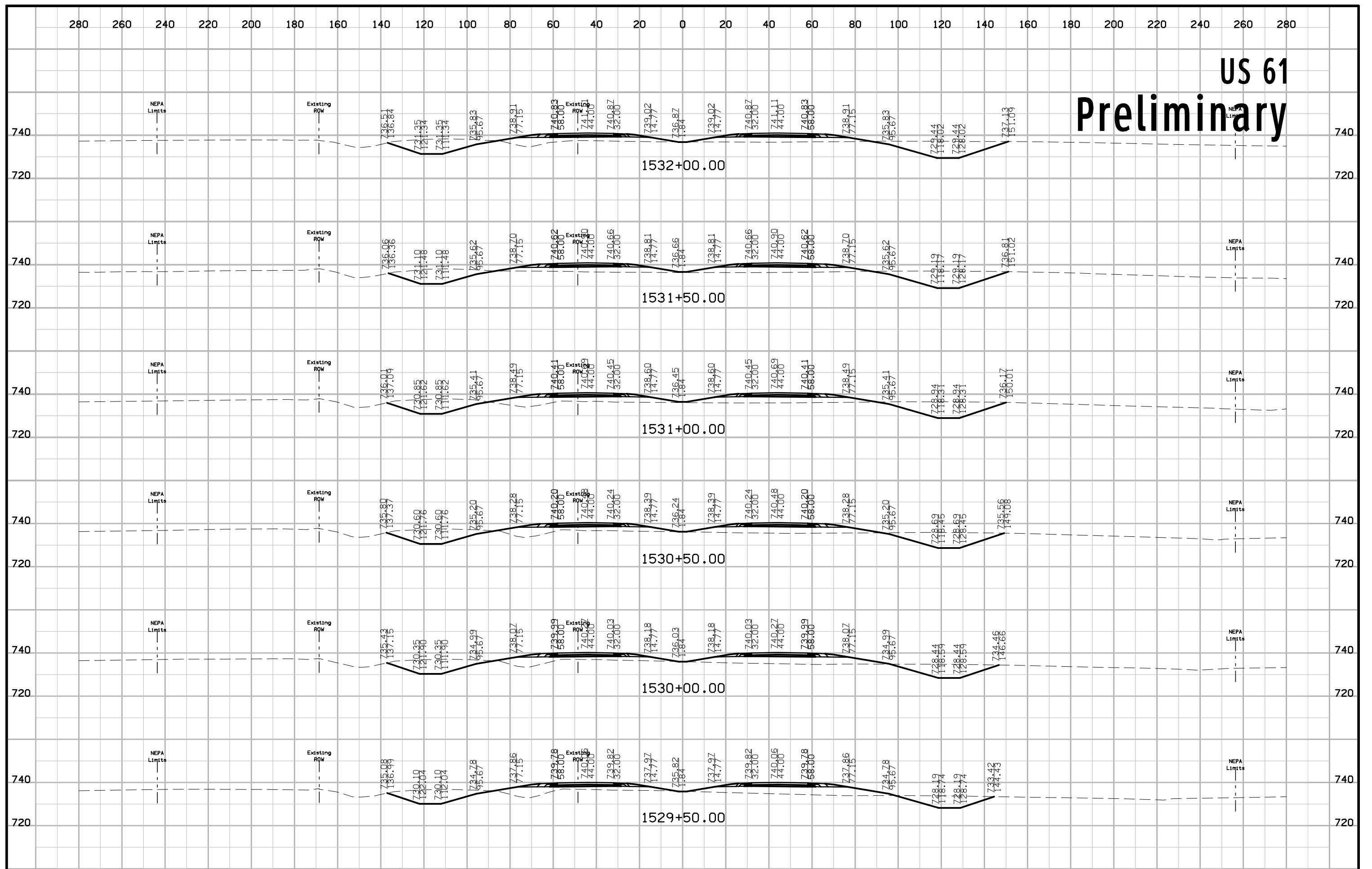

US 61 Preliminary

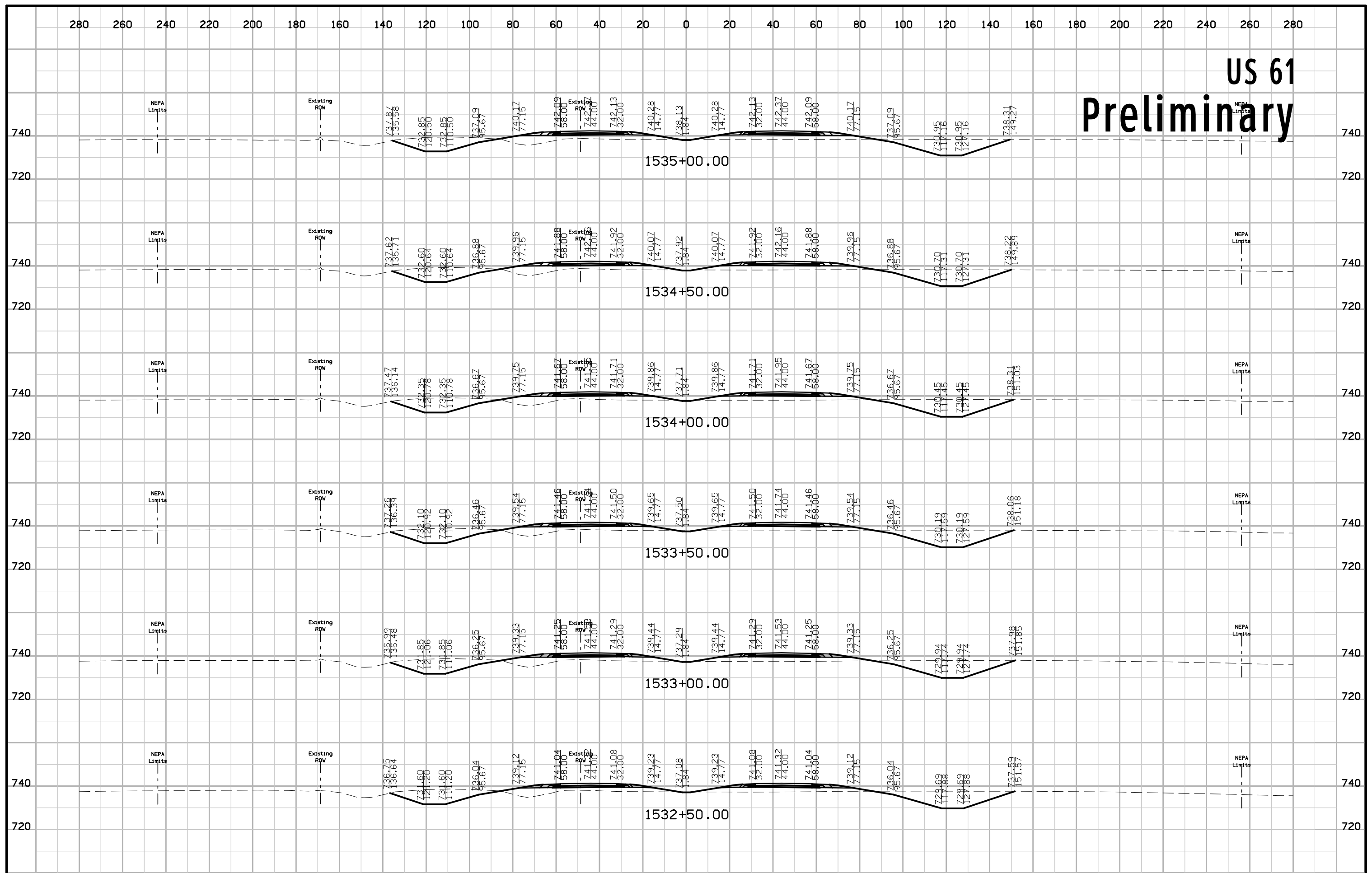

US 61 Preliminary

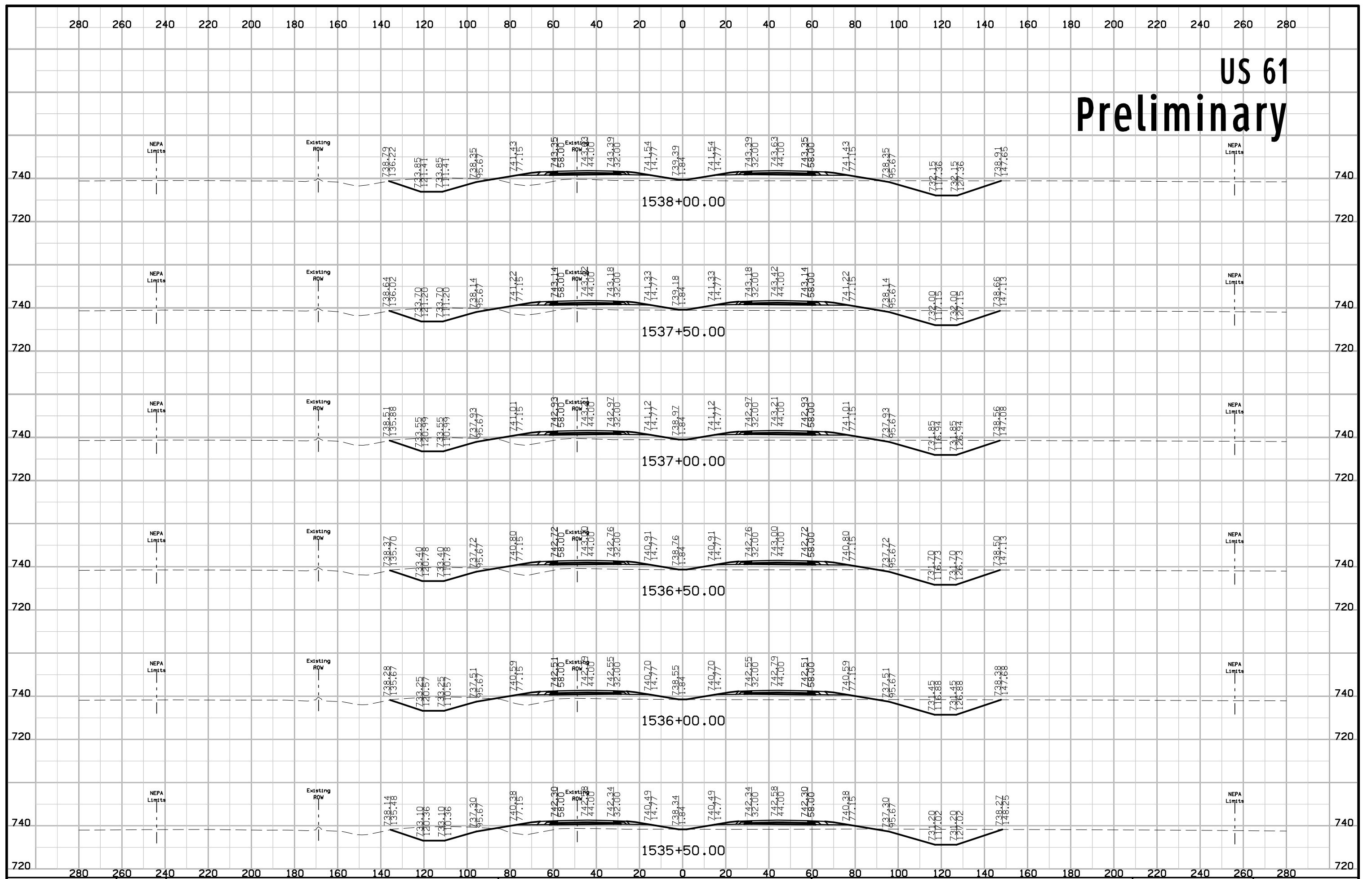

US 61 Preliminary

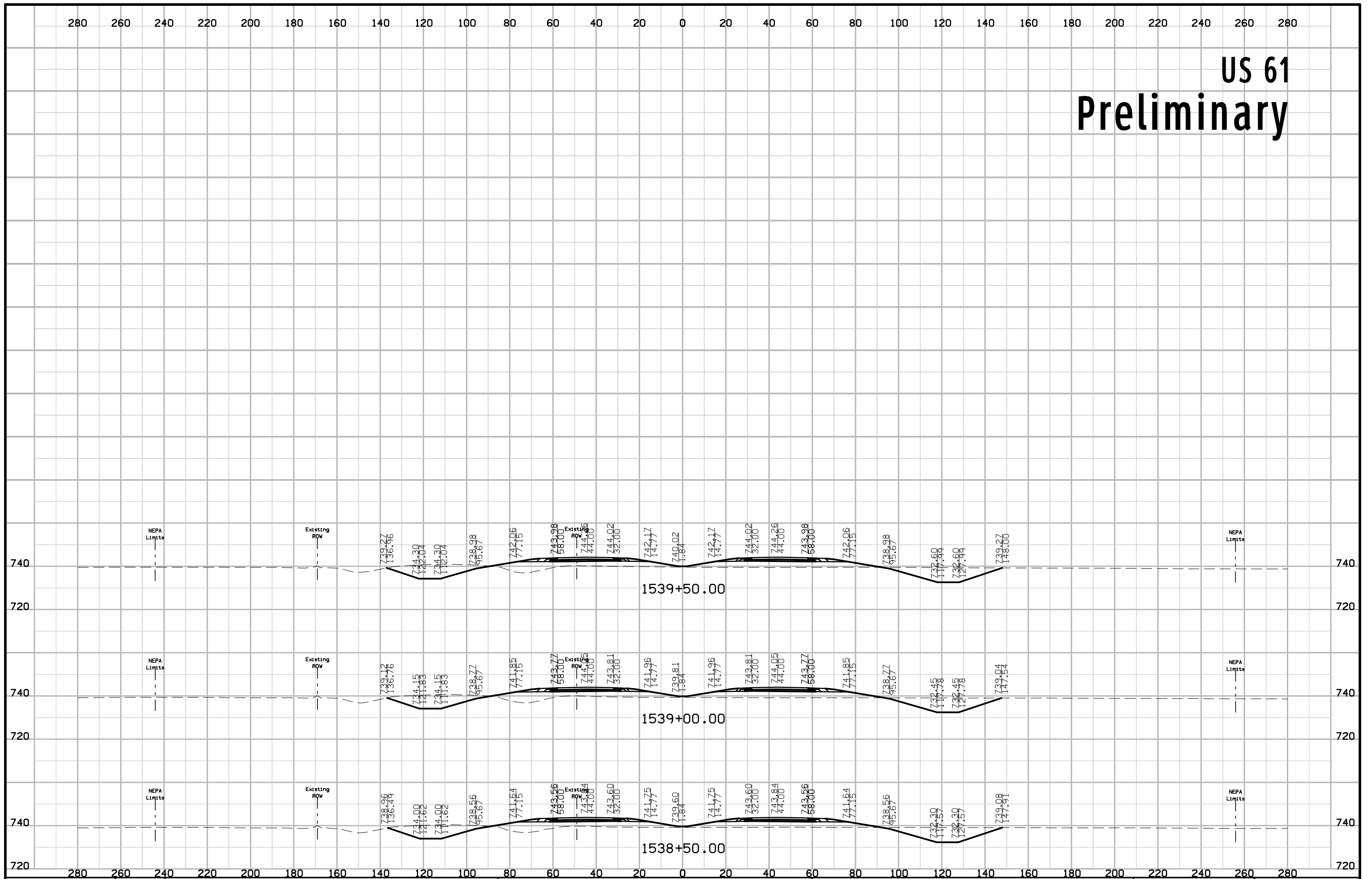

US 61 Preliminary

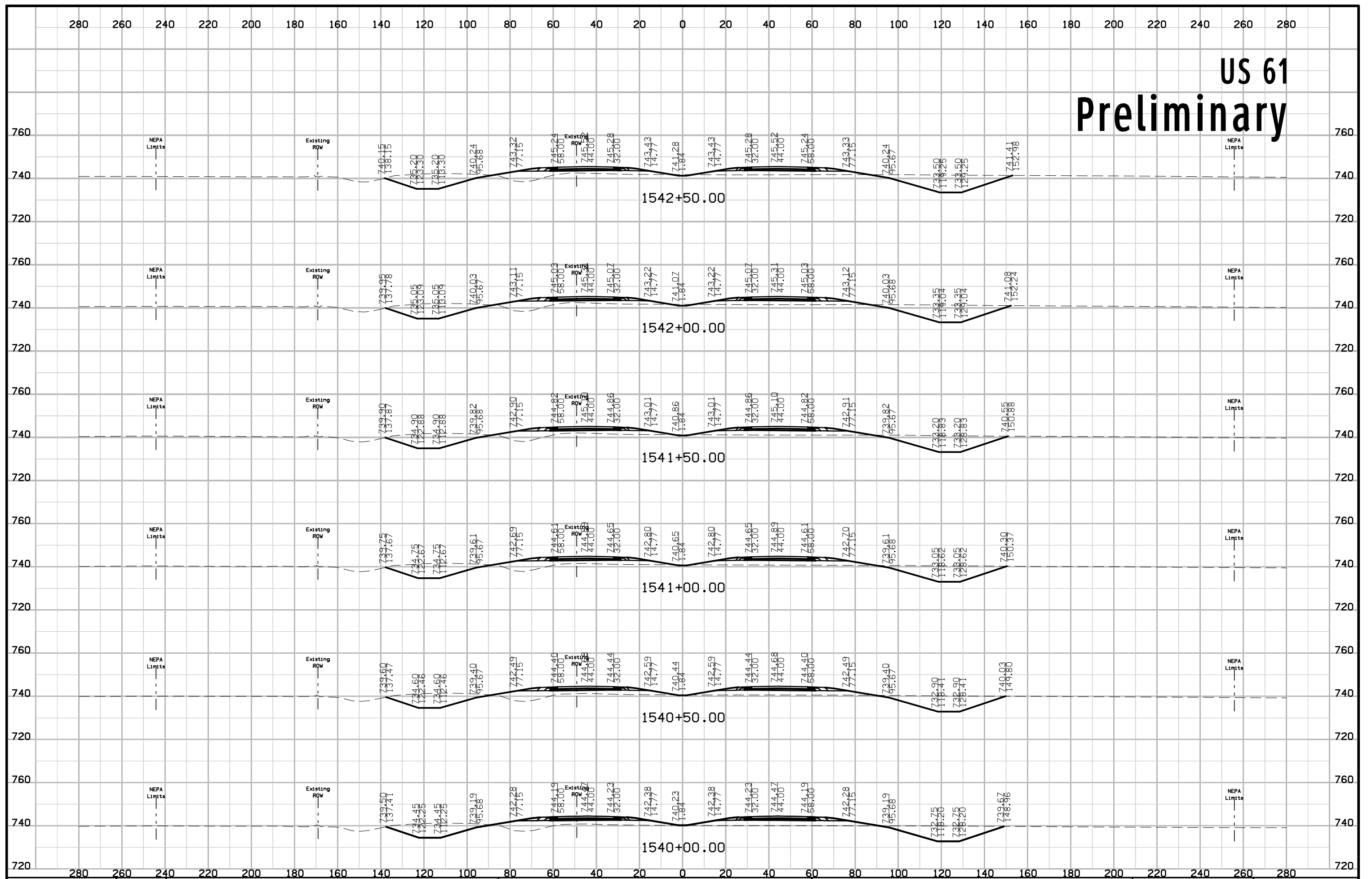

US 61 Preliminary

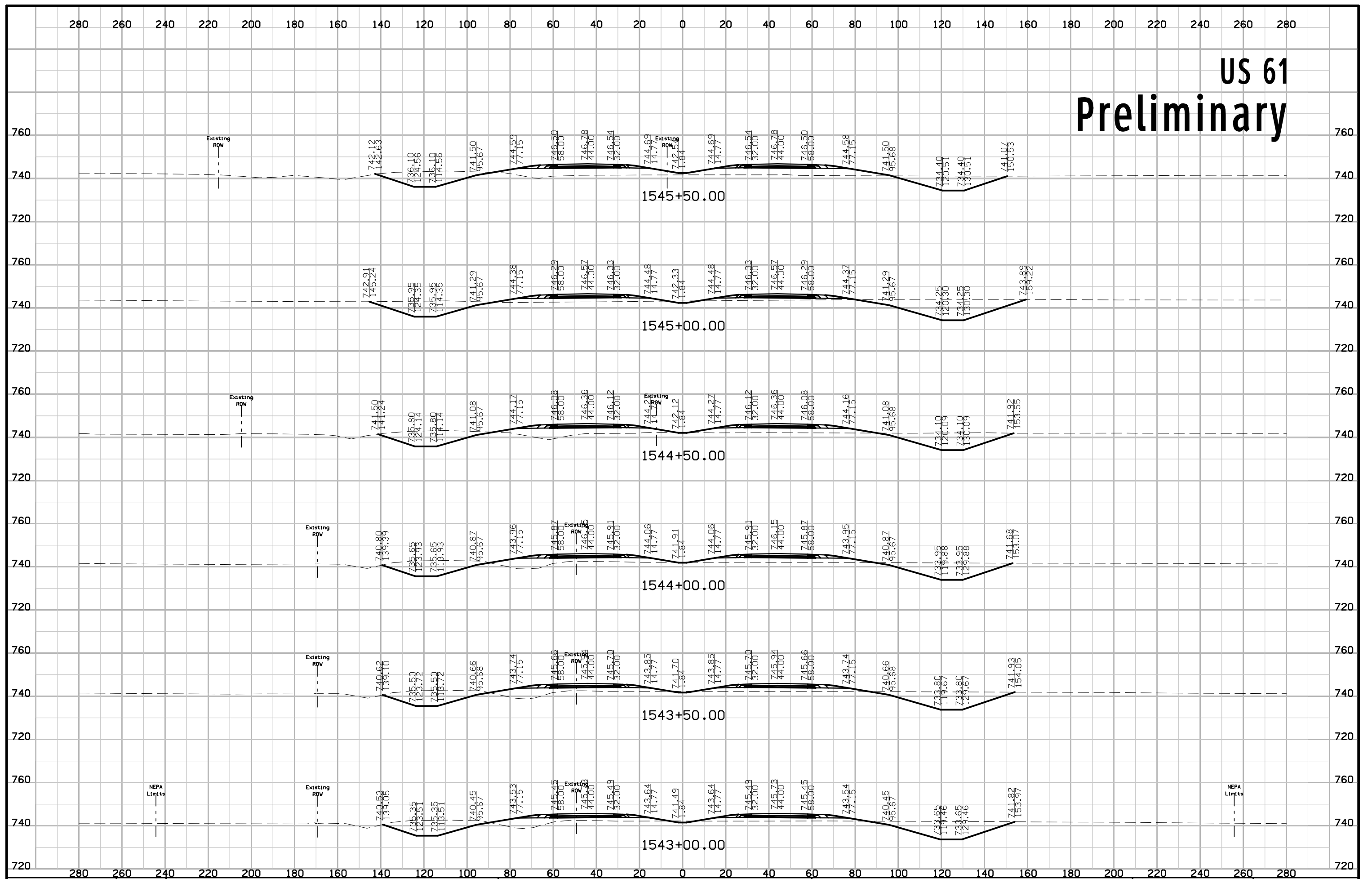

US 61 Preliminary

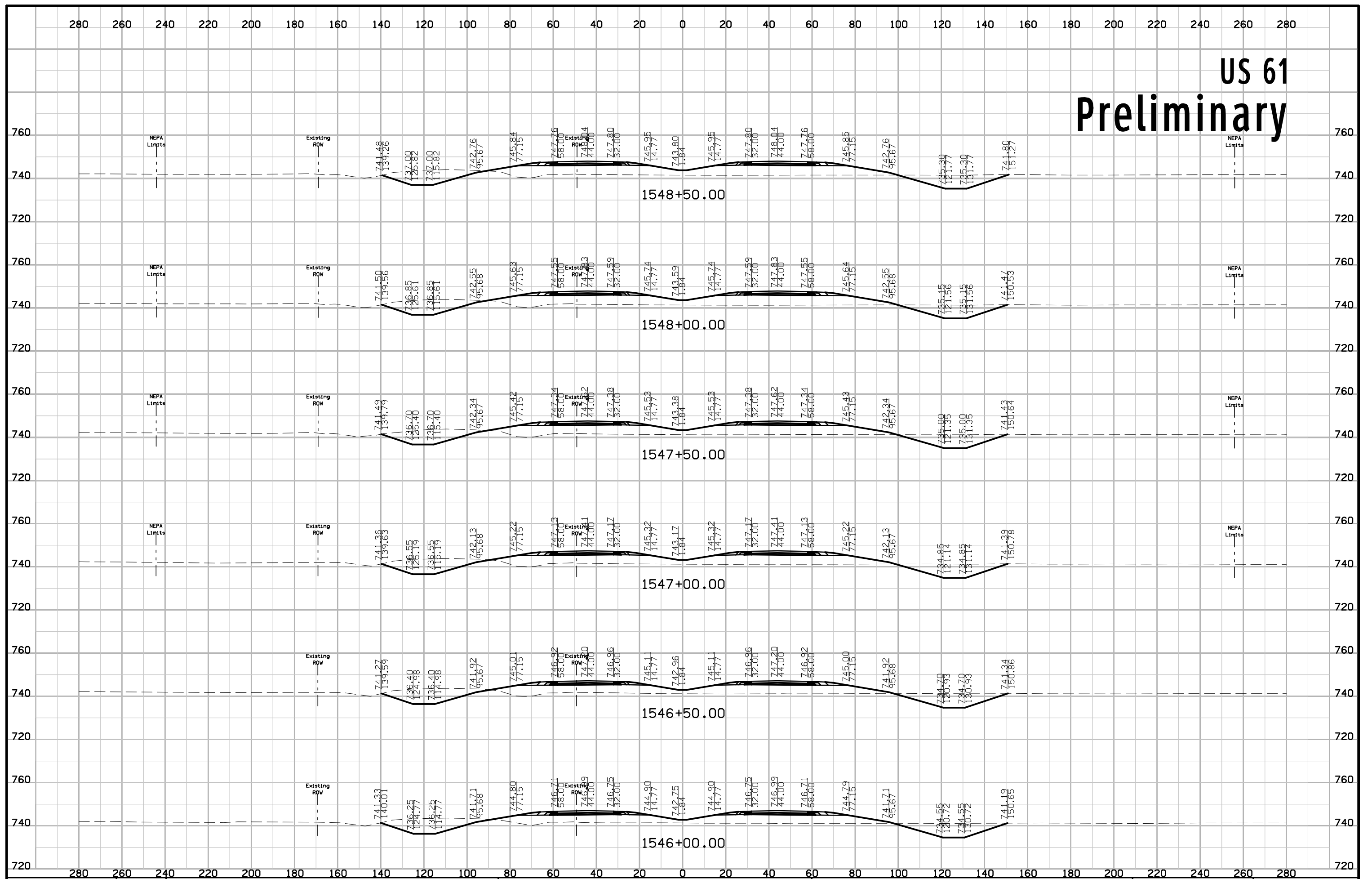

US 61 Preliminary

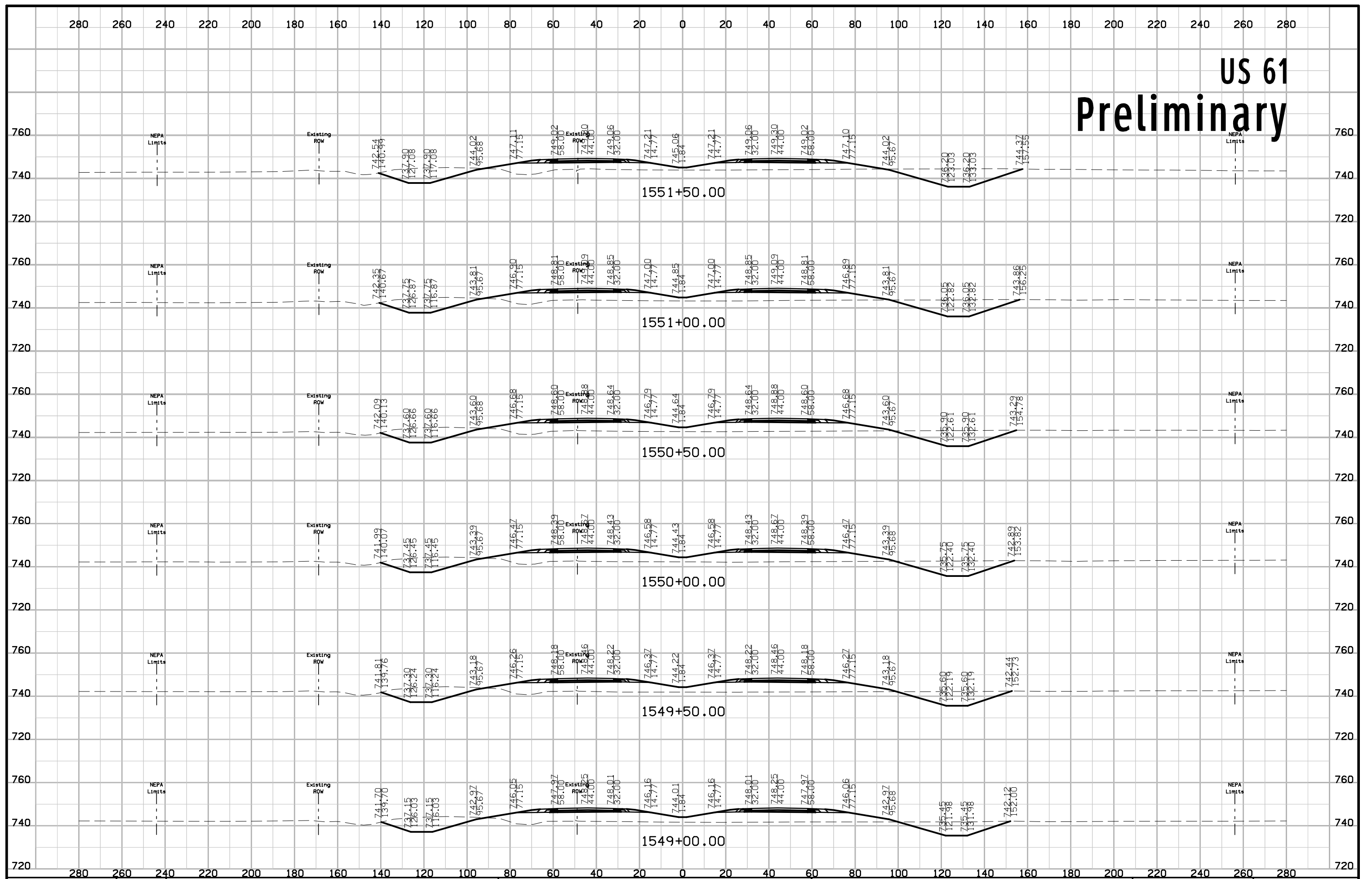

US 61 Preliminary

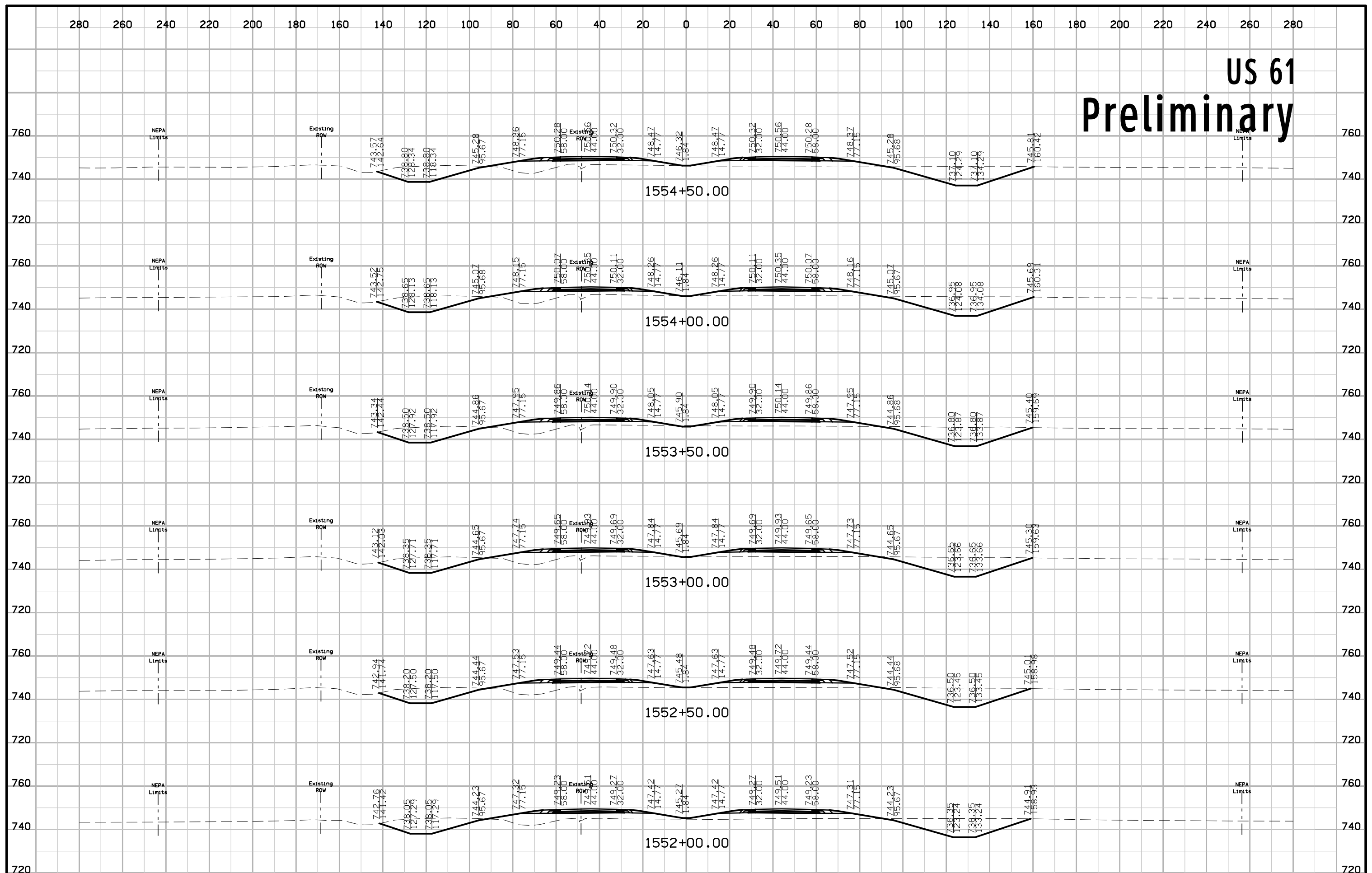

US 61 Preliminary

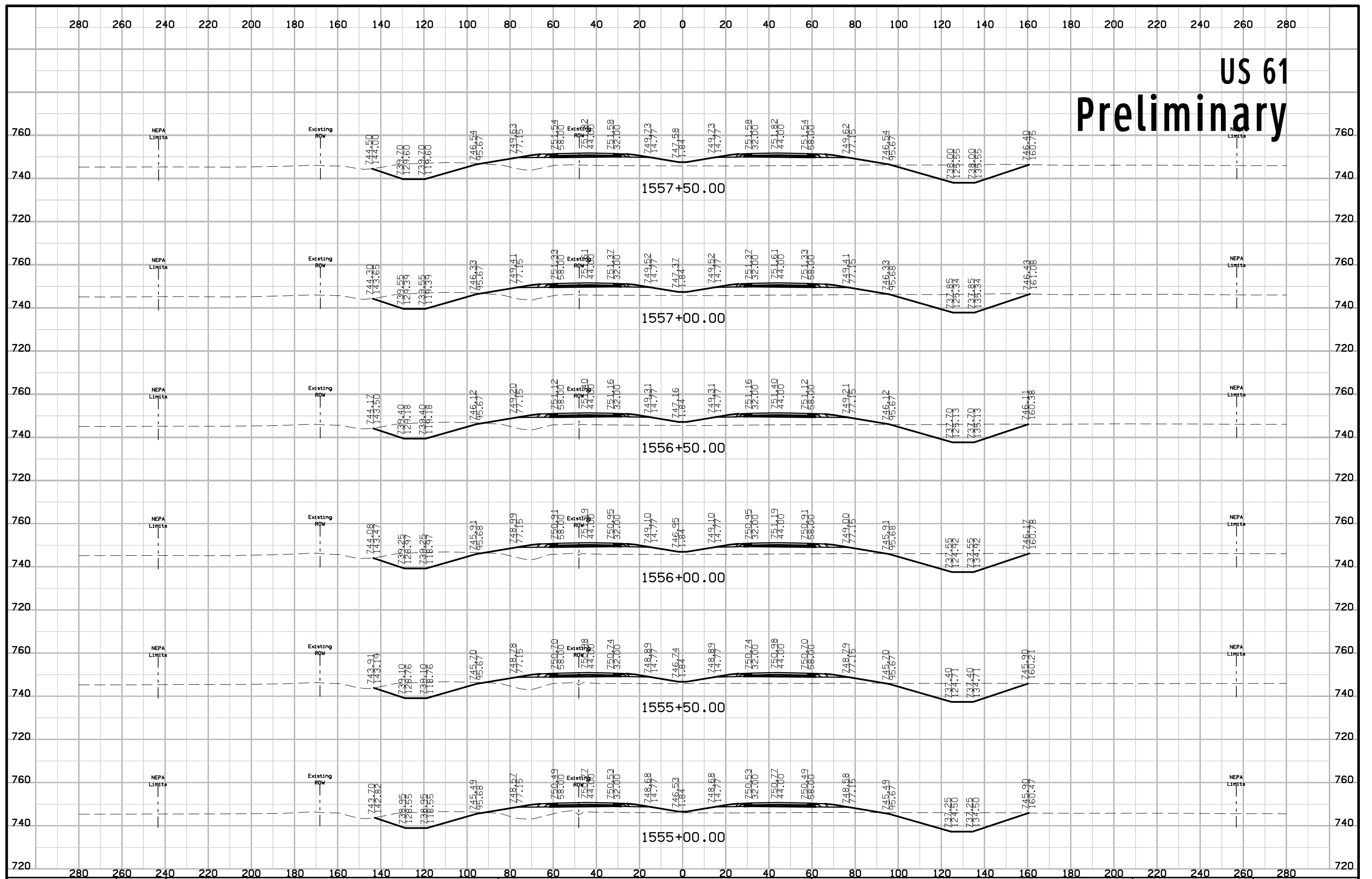

US 61 Preliminary

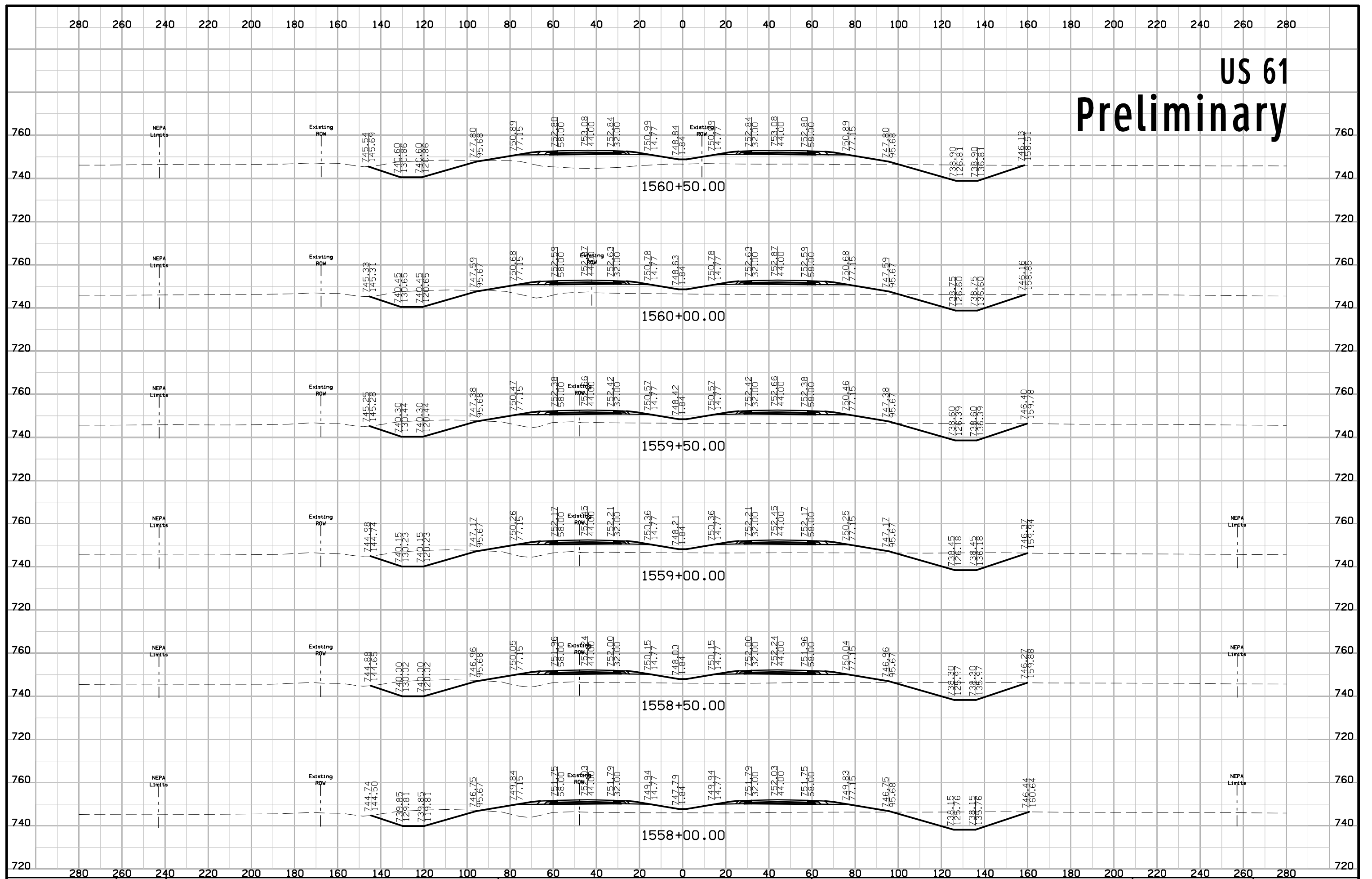

US 61 Preliminary

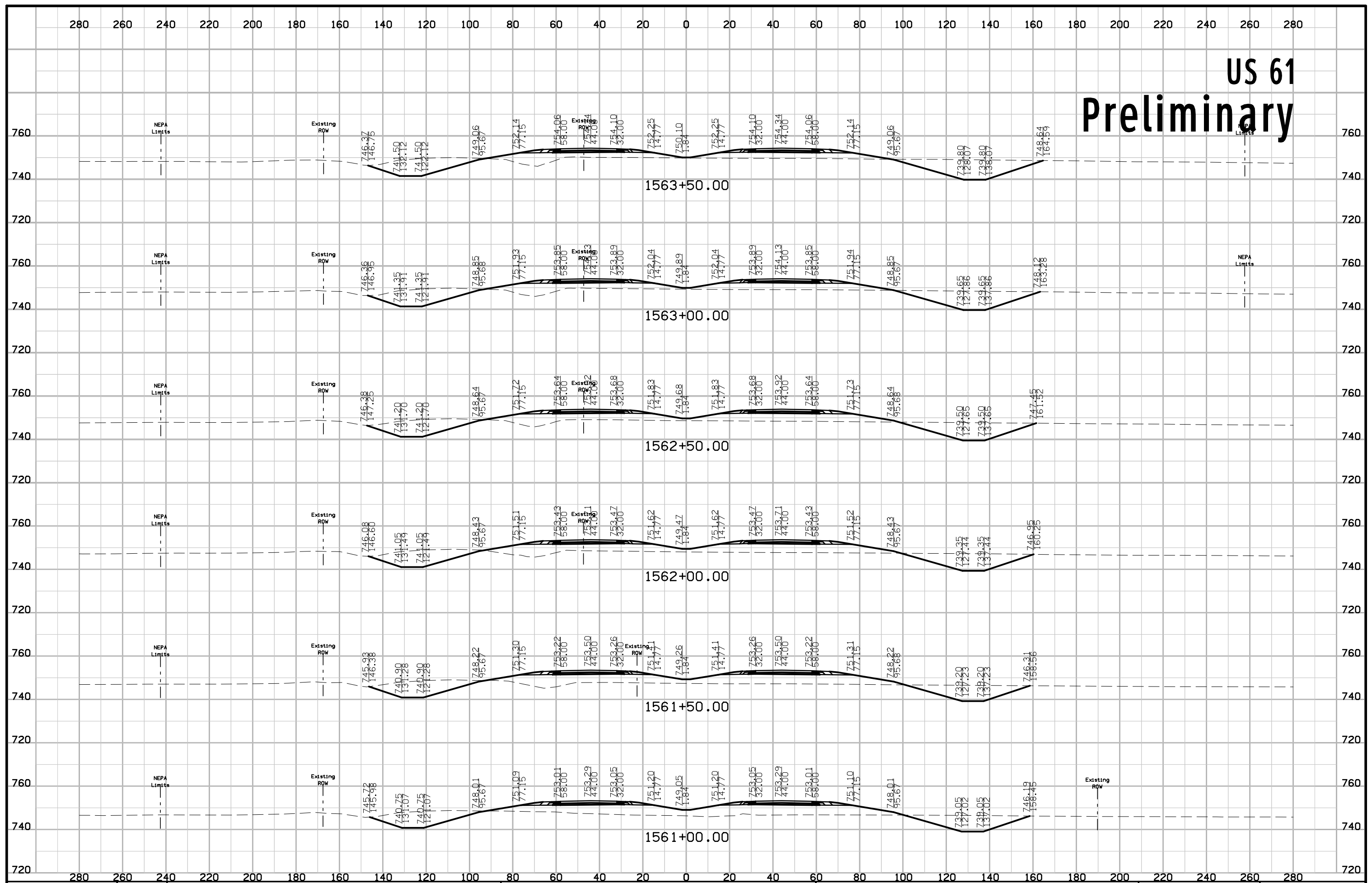

US 61 Preliminary

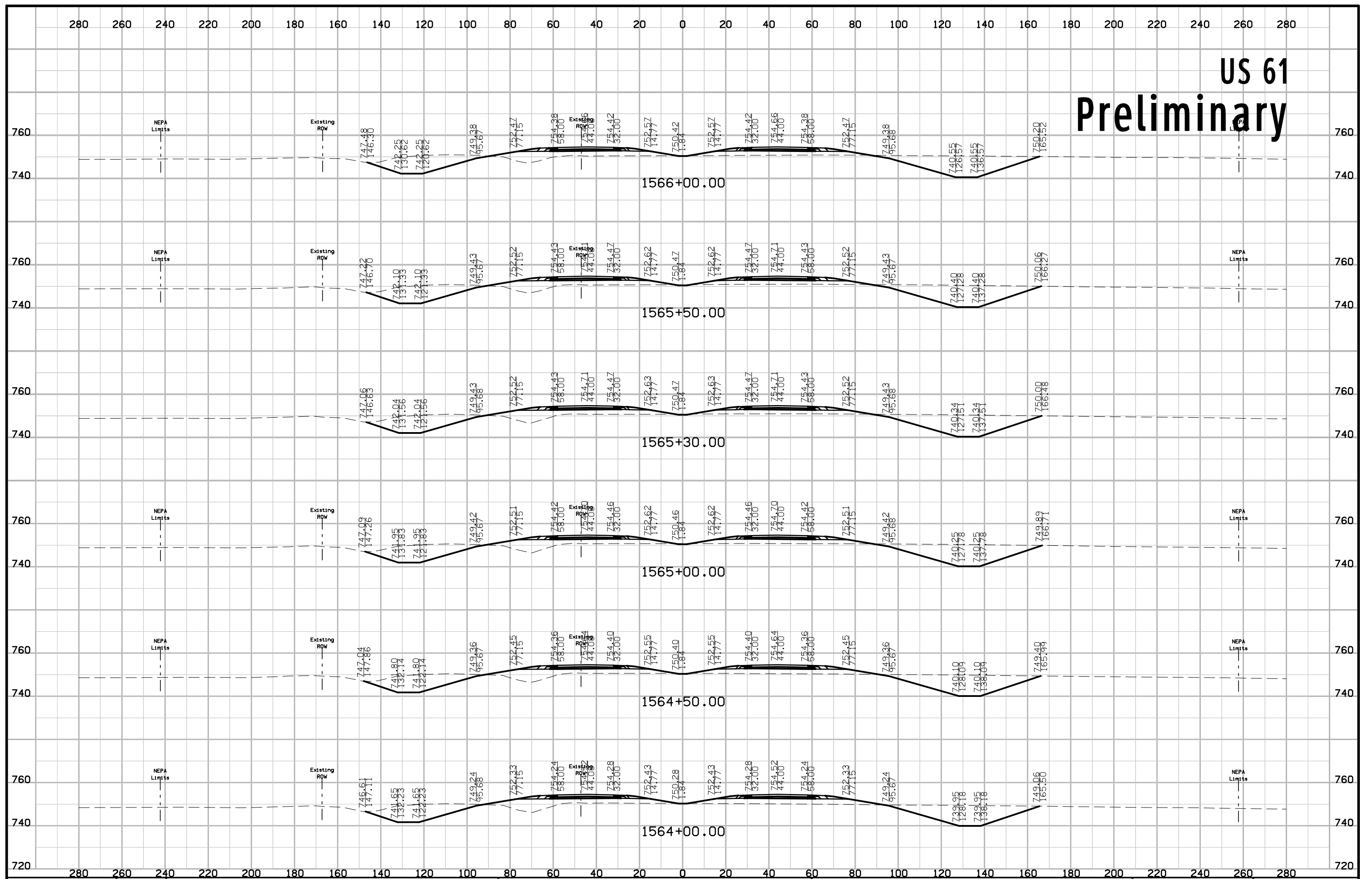

US 61 Preliminary

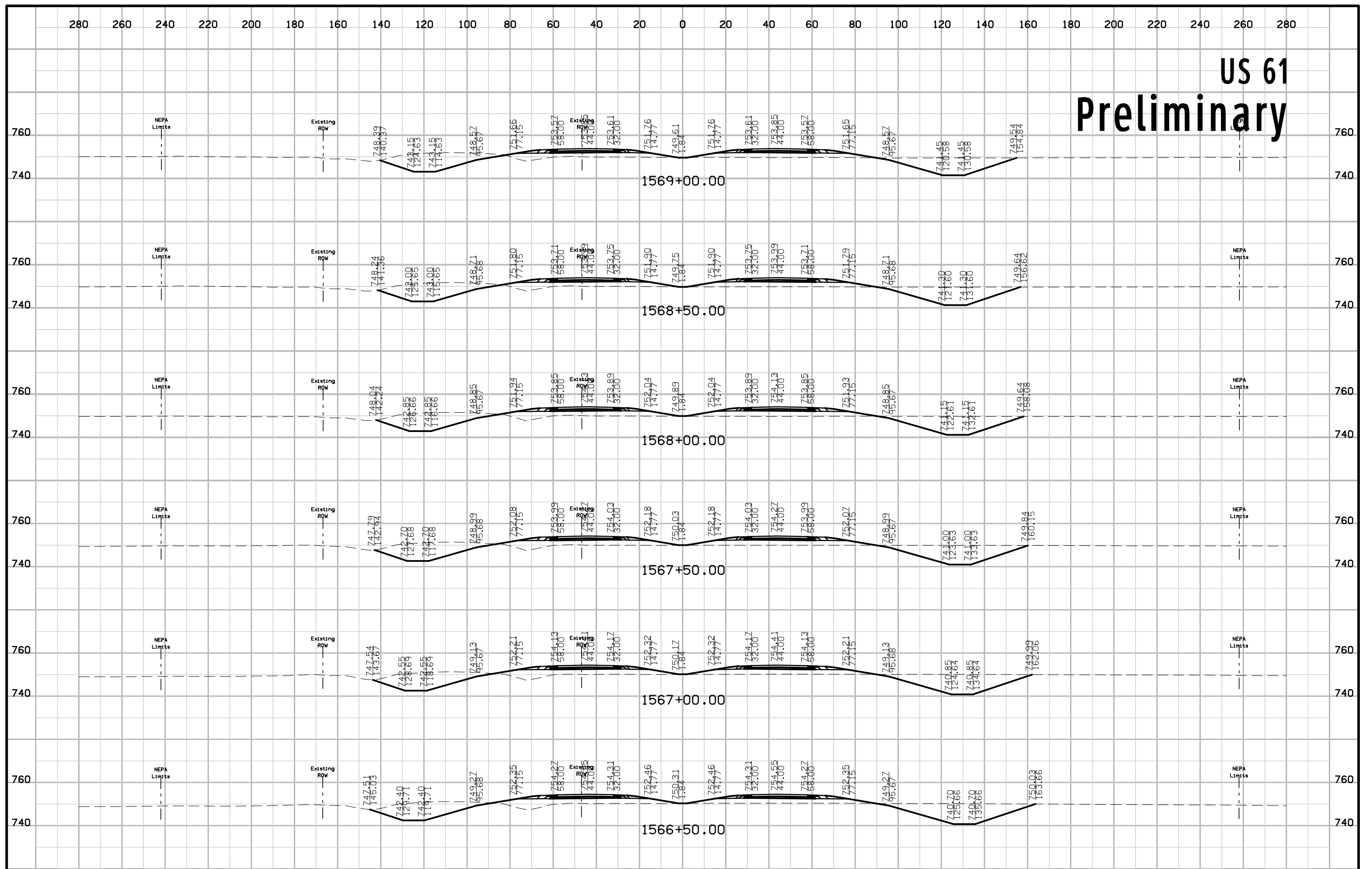

US 61 Preliminary

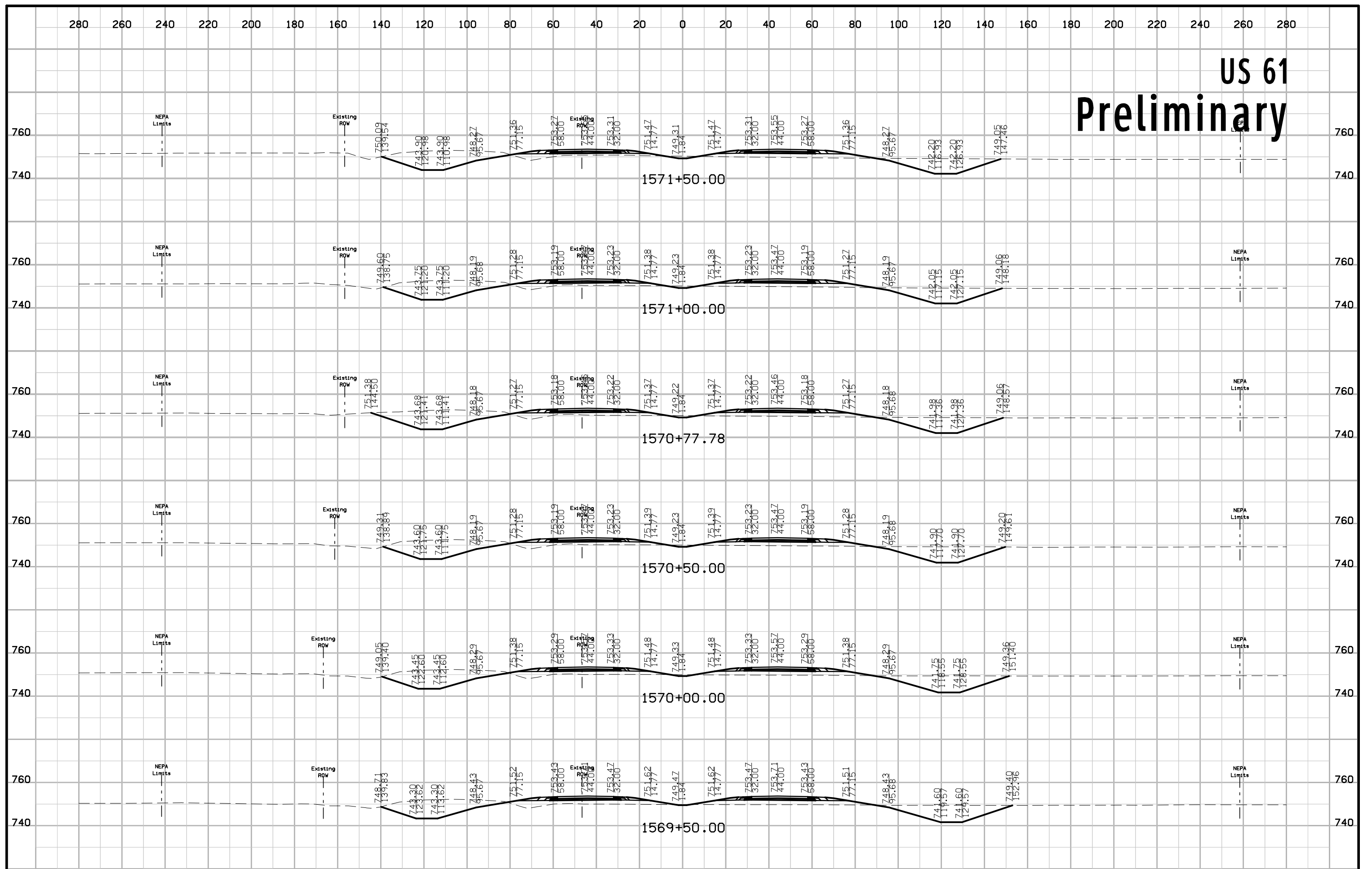

US 61 Preliminary

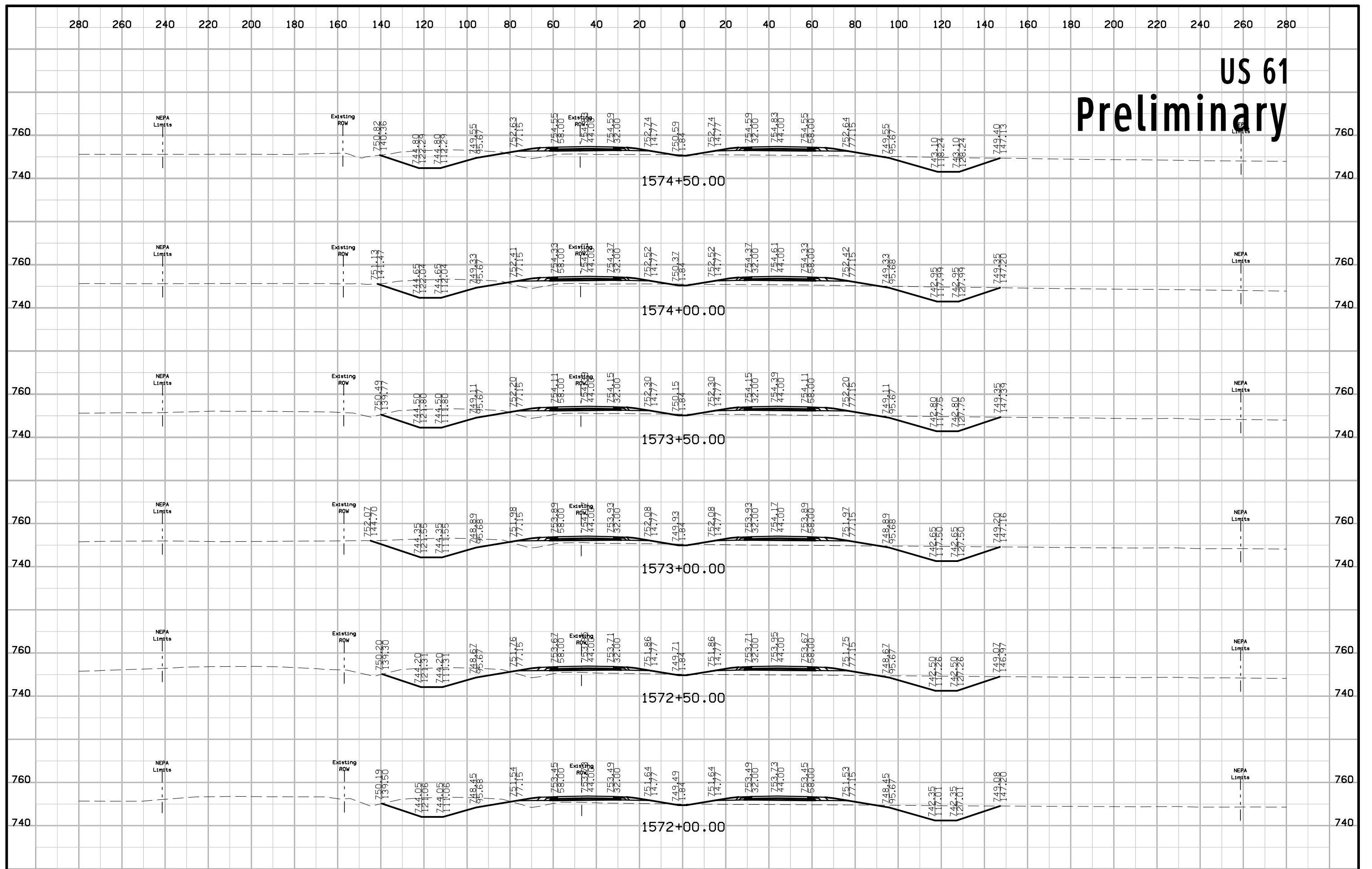

US 61 Preliminary

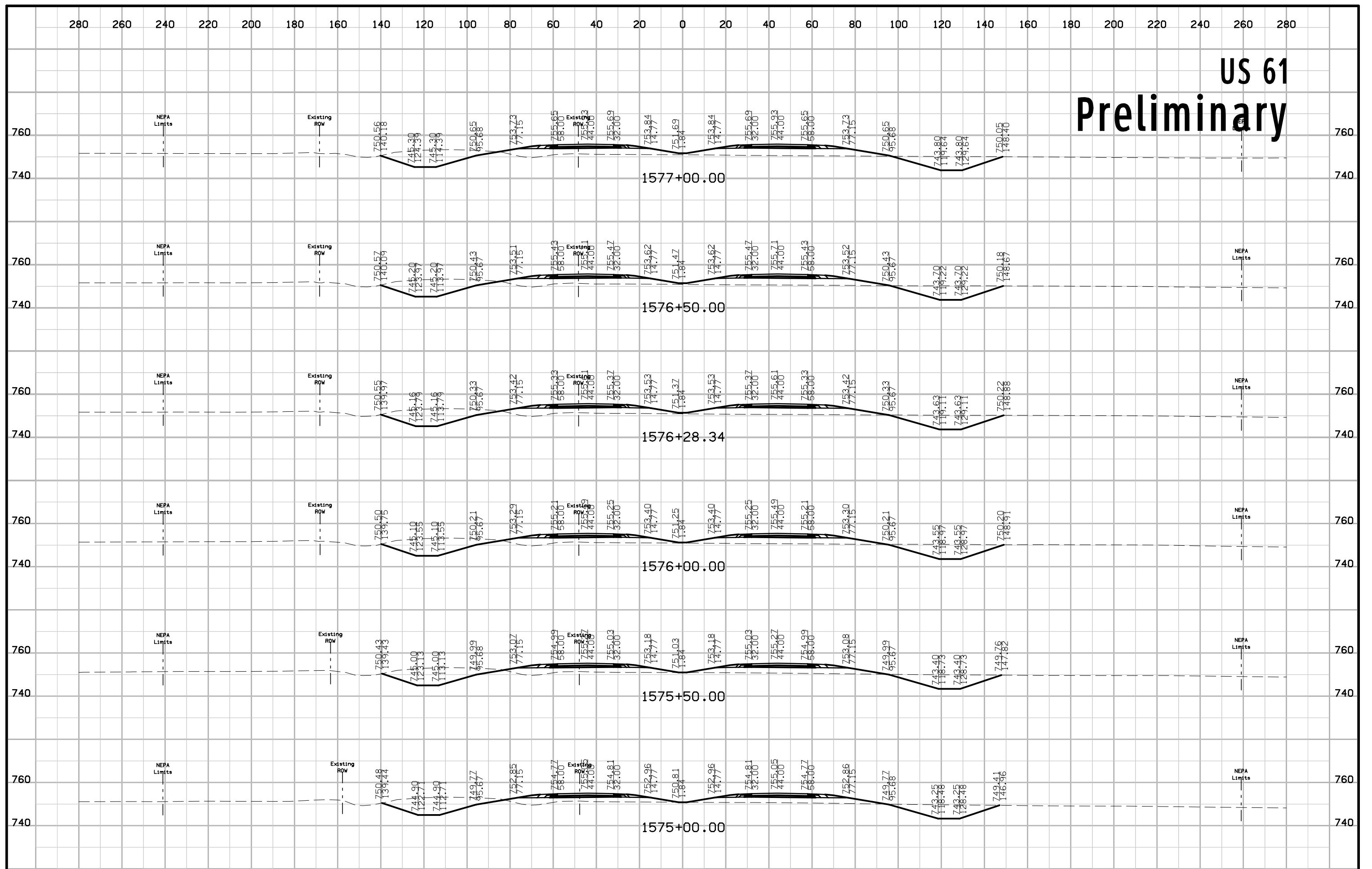

US 61 Preliminary

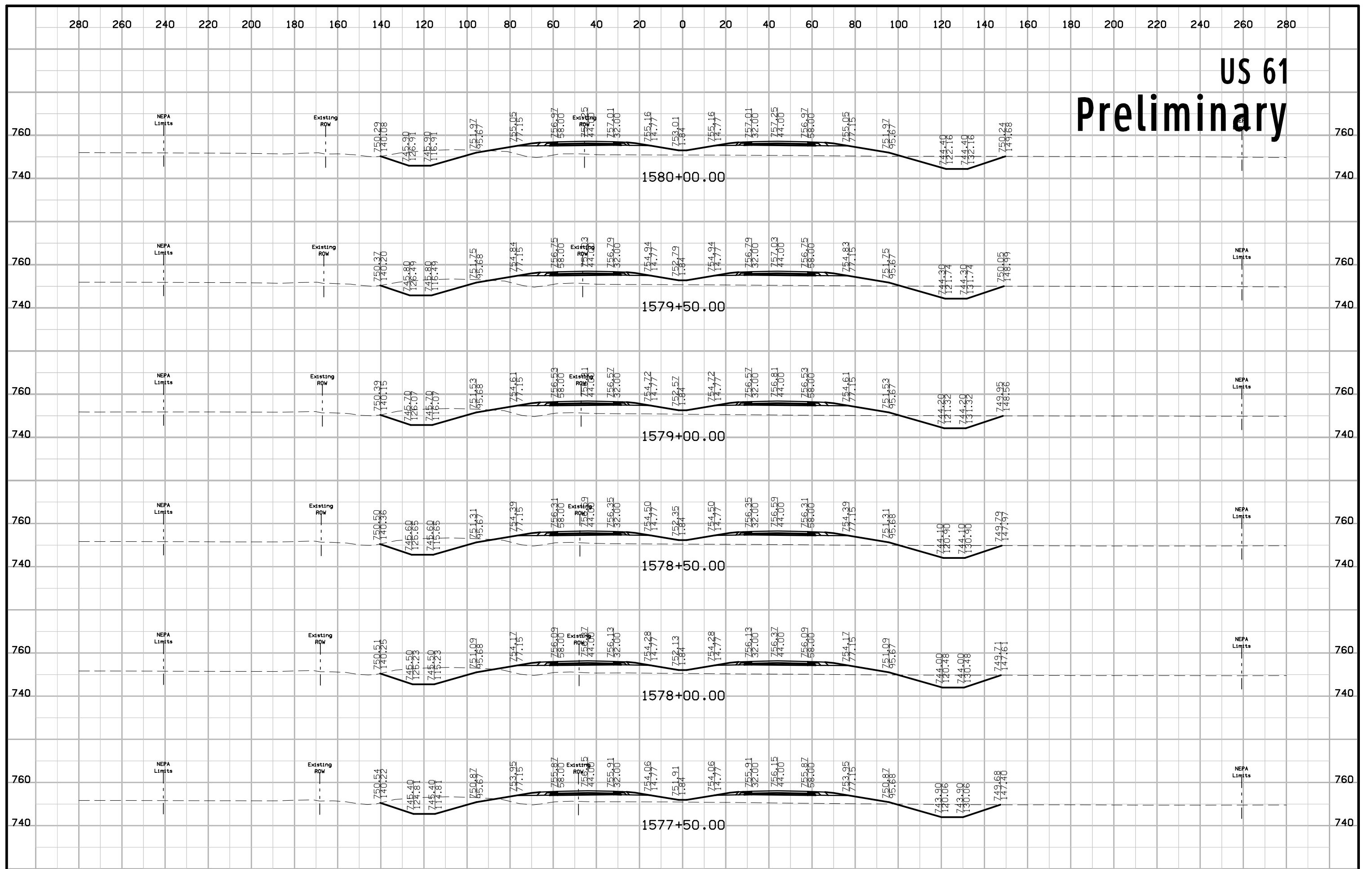

US 61 Preliminary

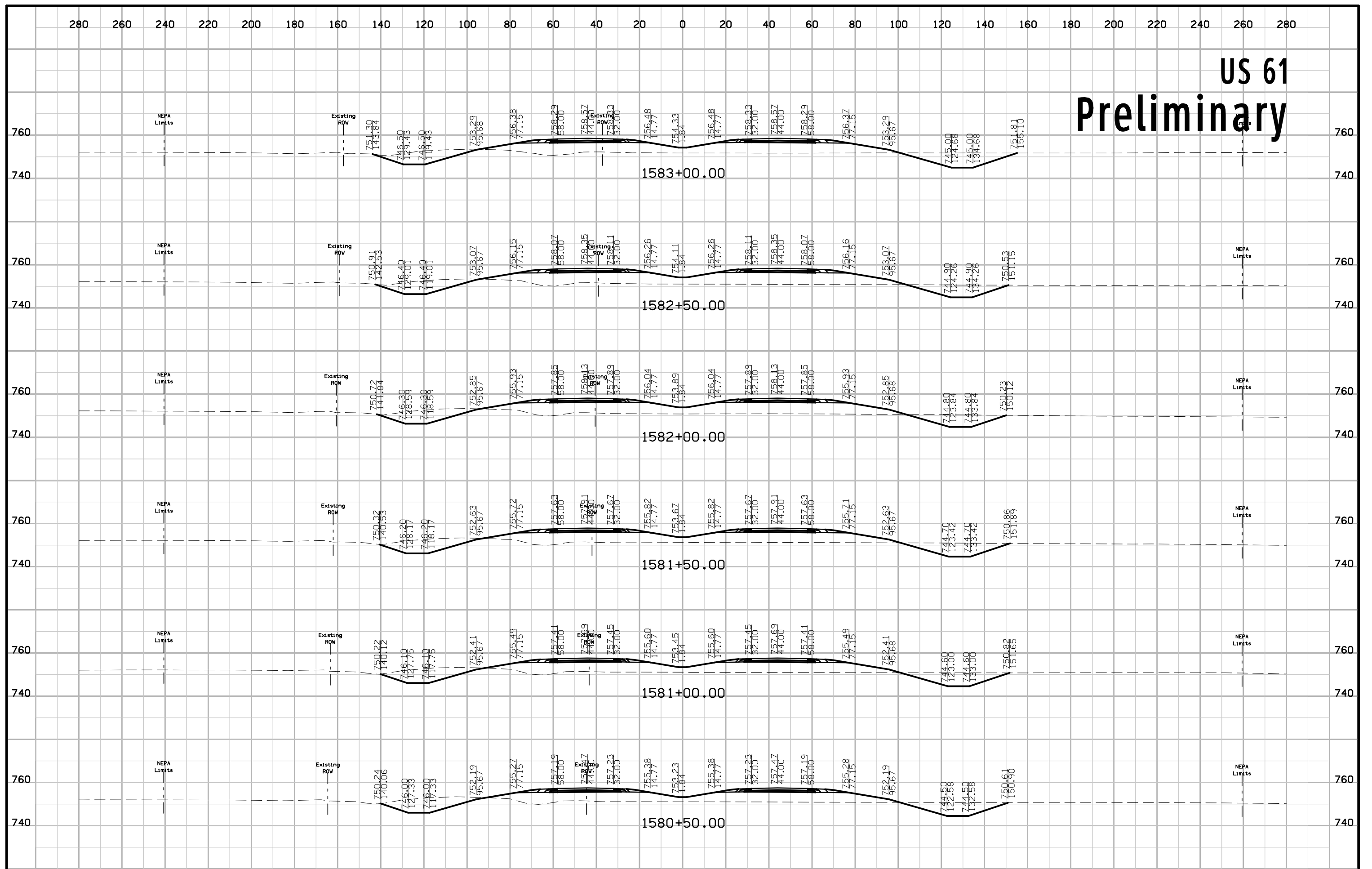

US 61 Preliminary

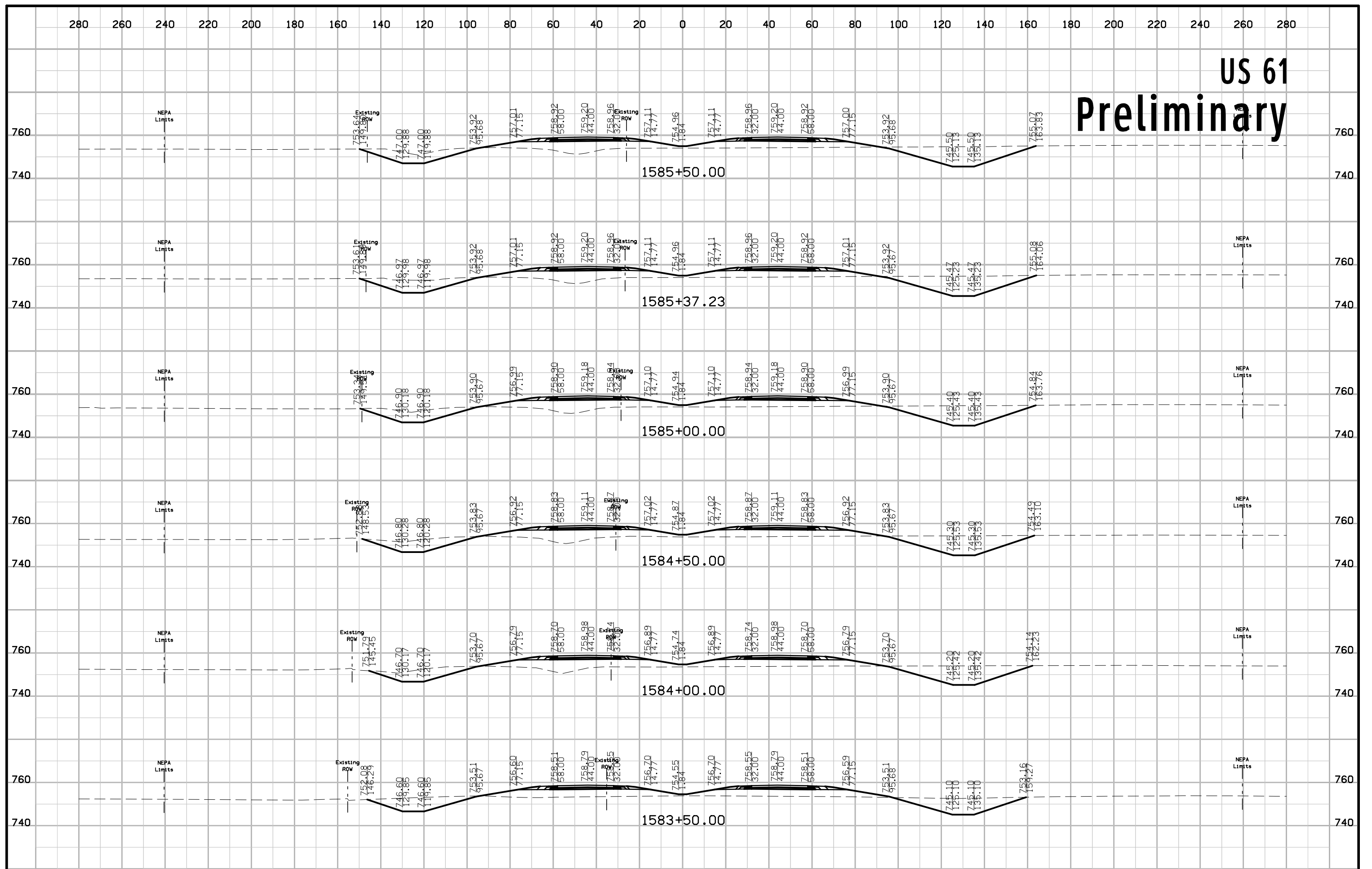

US 61 Preliminary

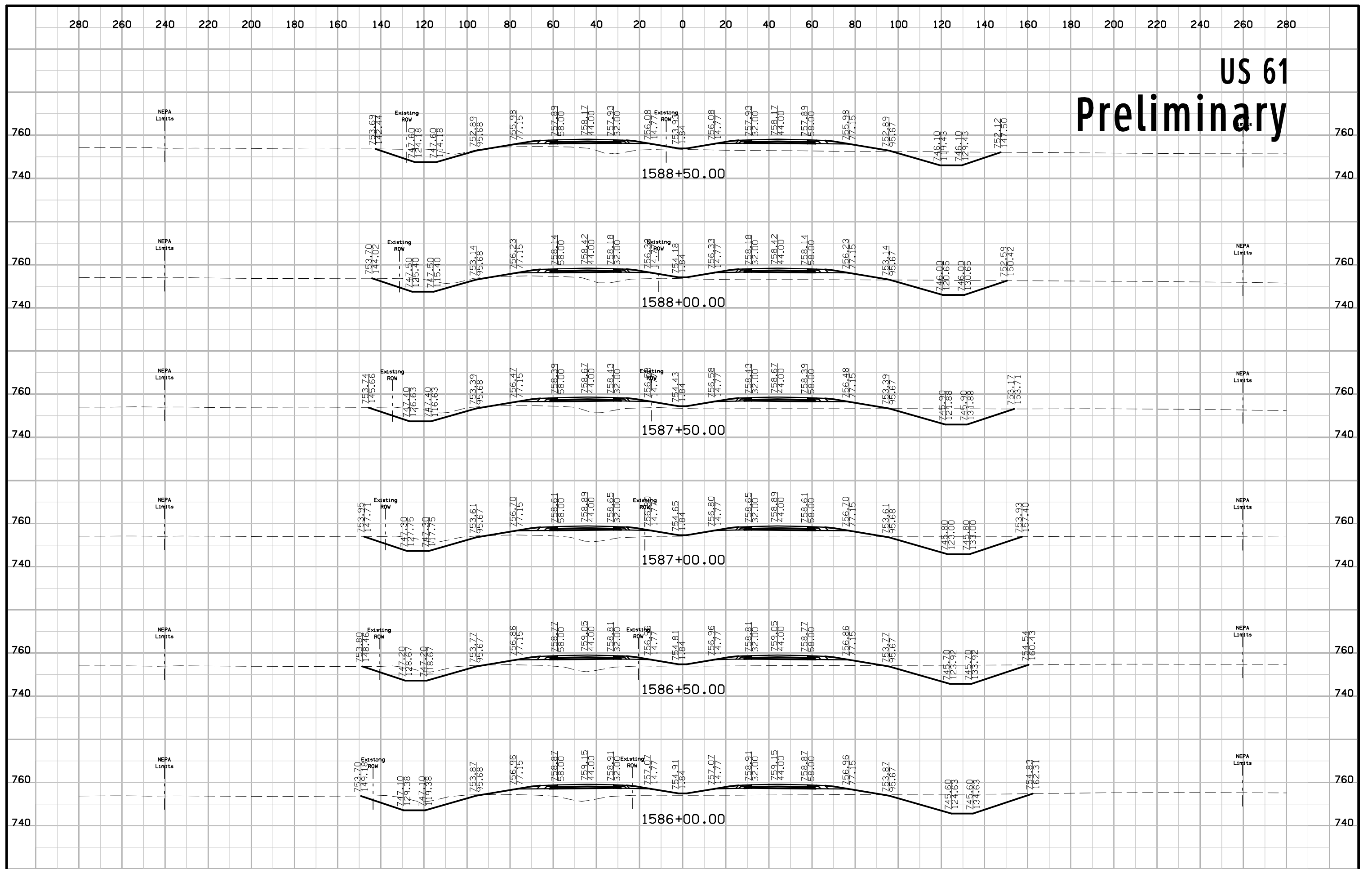

US 61 Preliminary

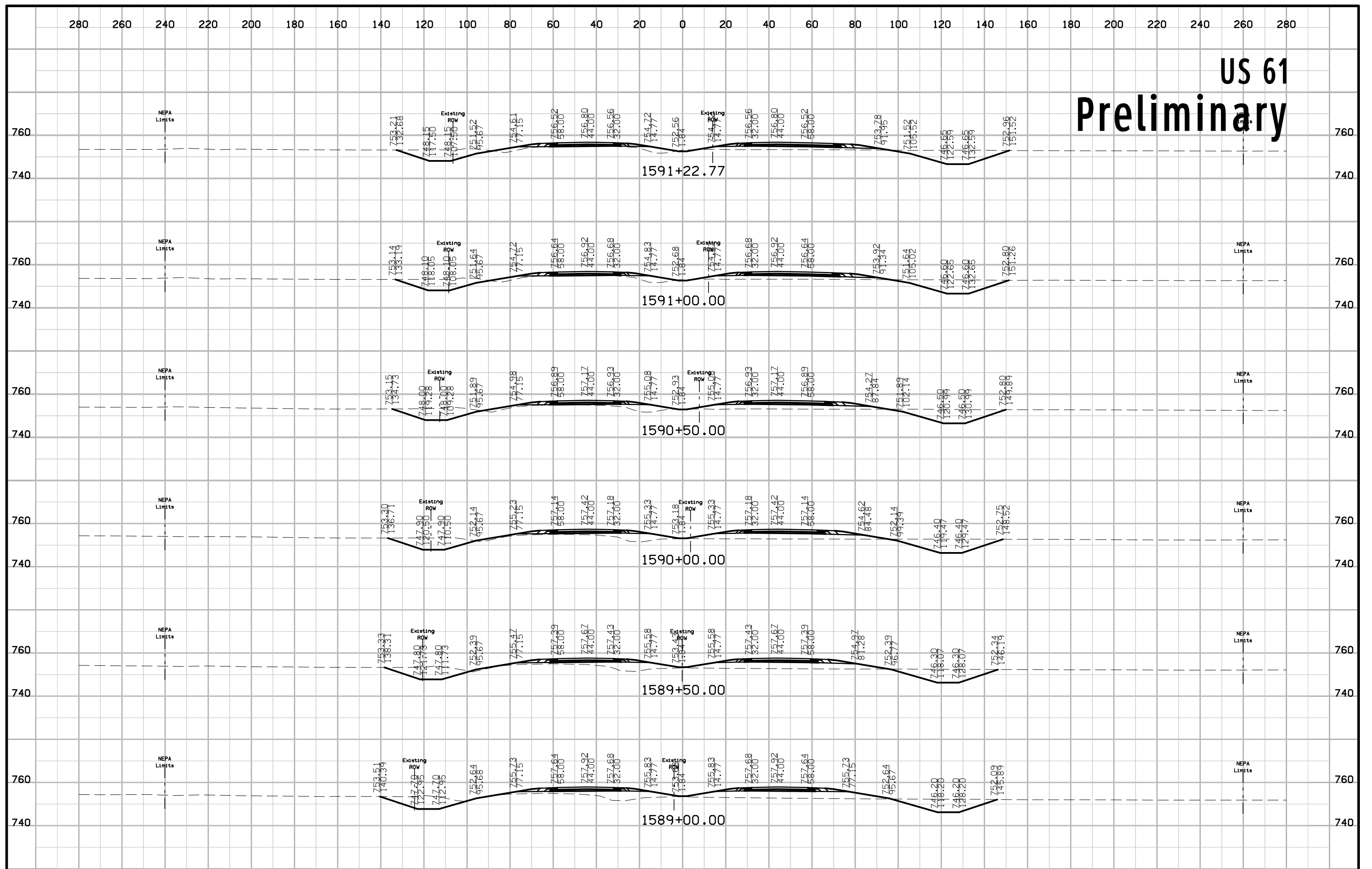

US 61 Preliminary

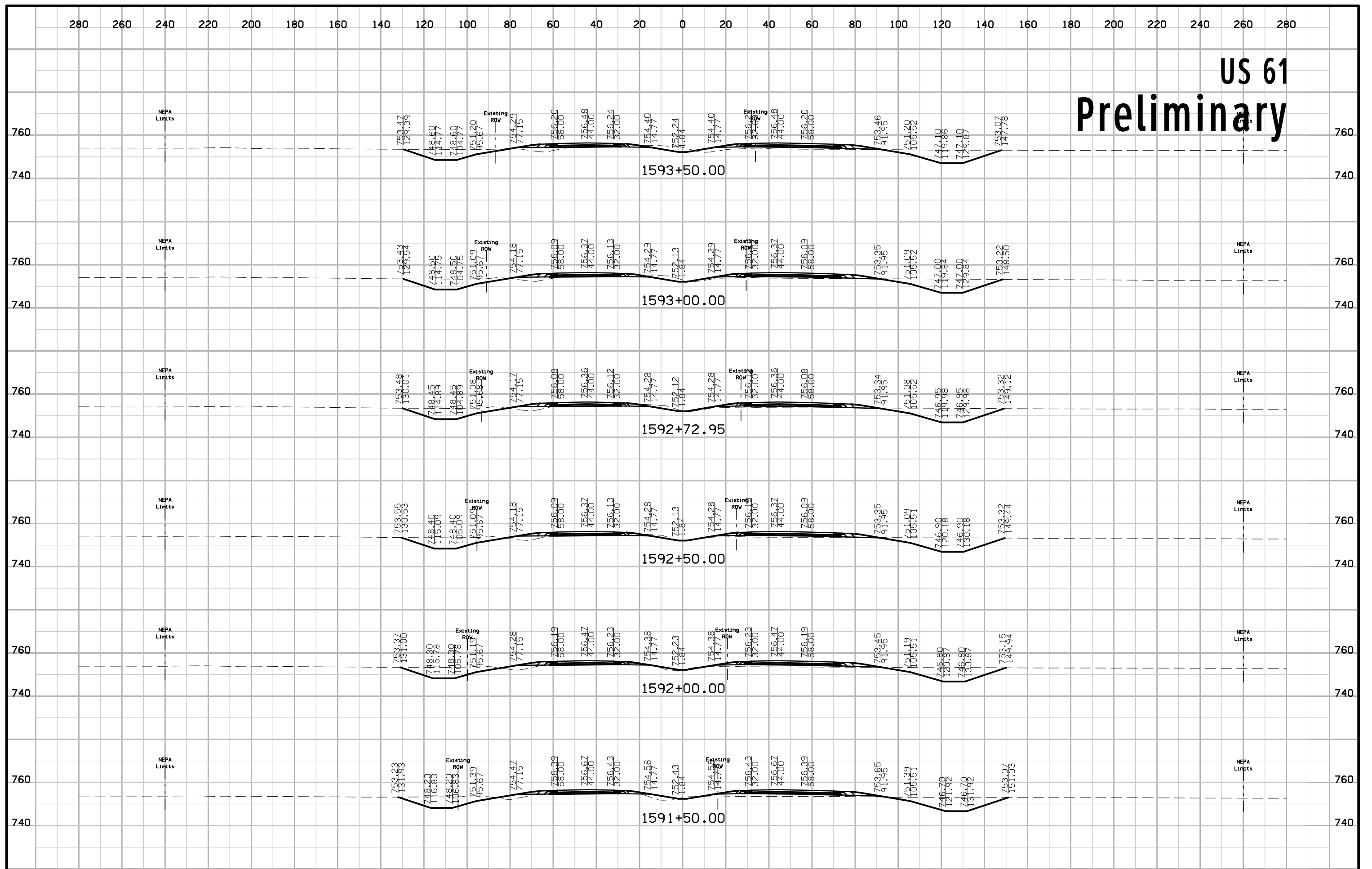

US 61 Preliminary

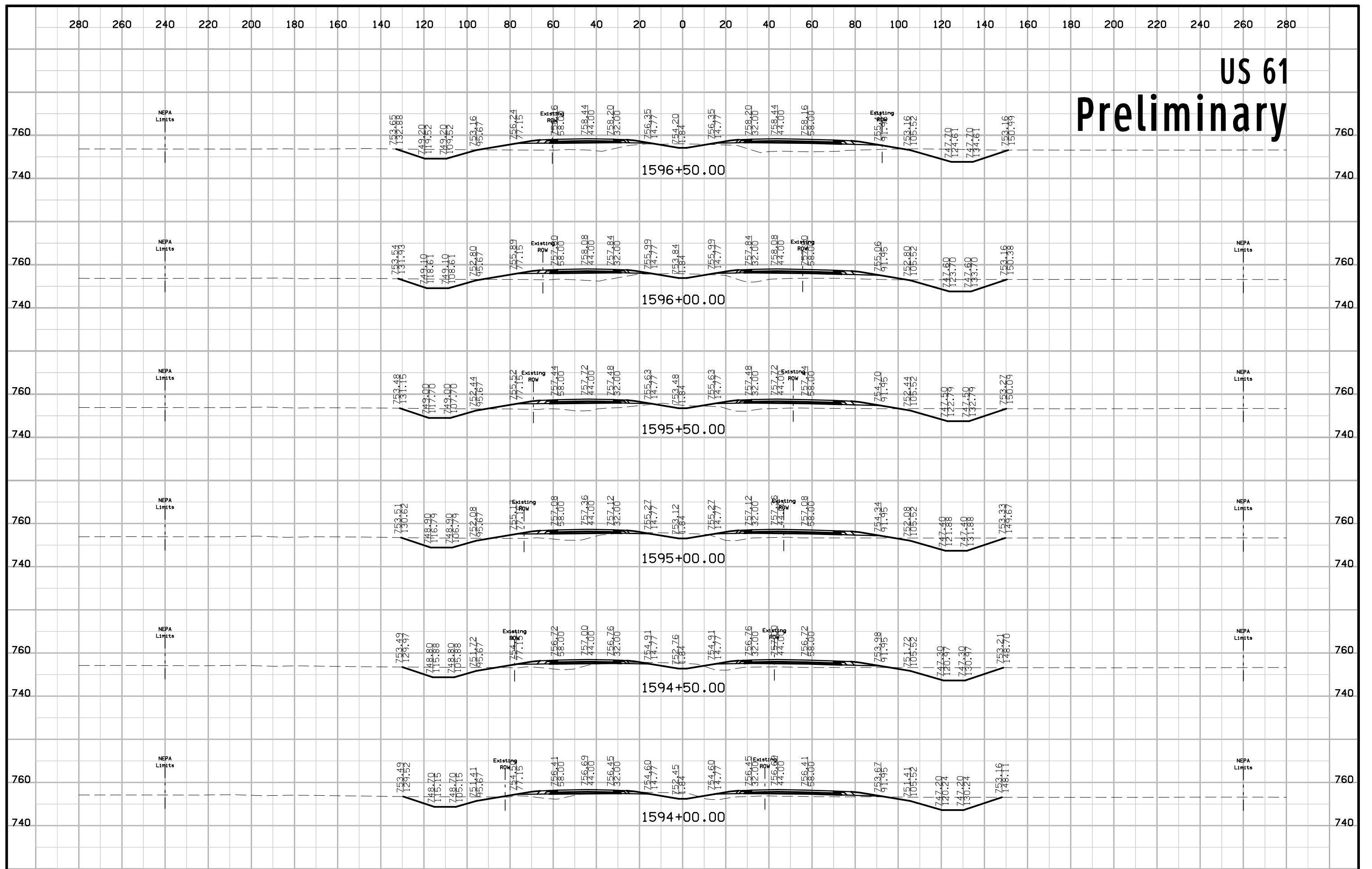

US 61 Preliminary

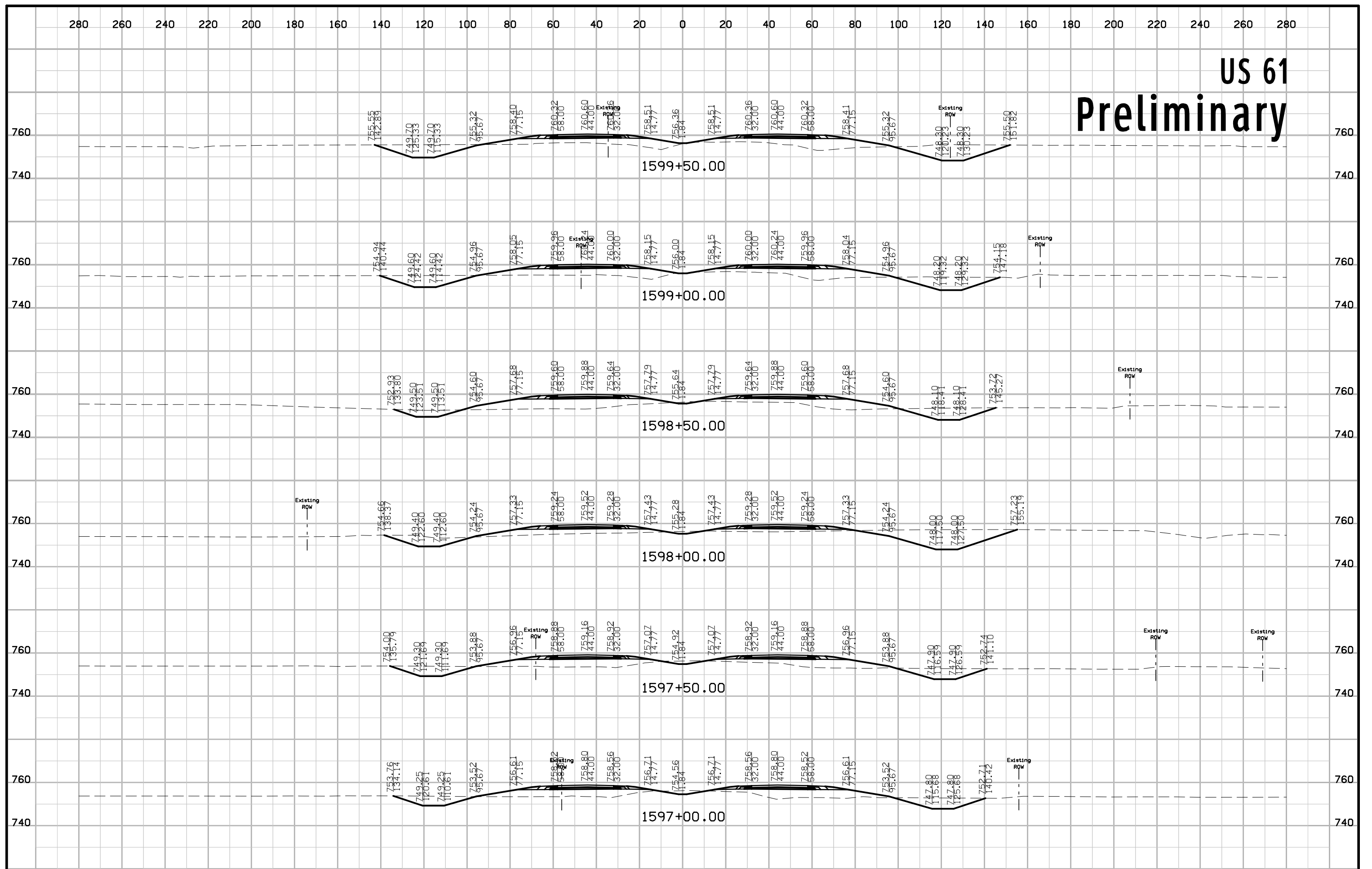

US 61 Preliminary

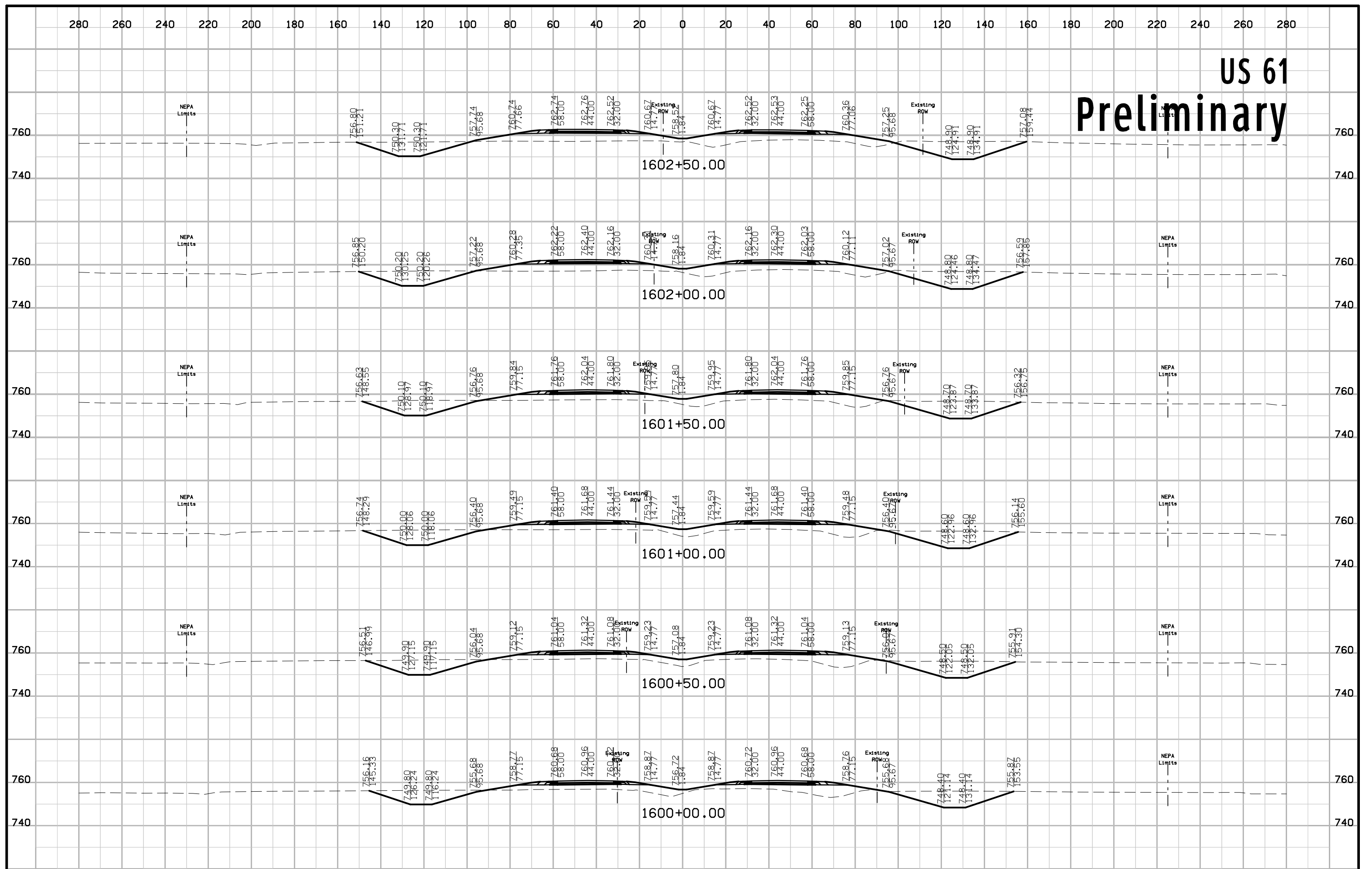

US 61 Preliminary

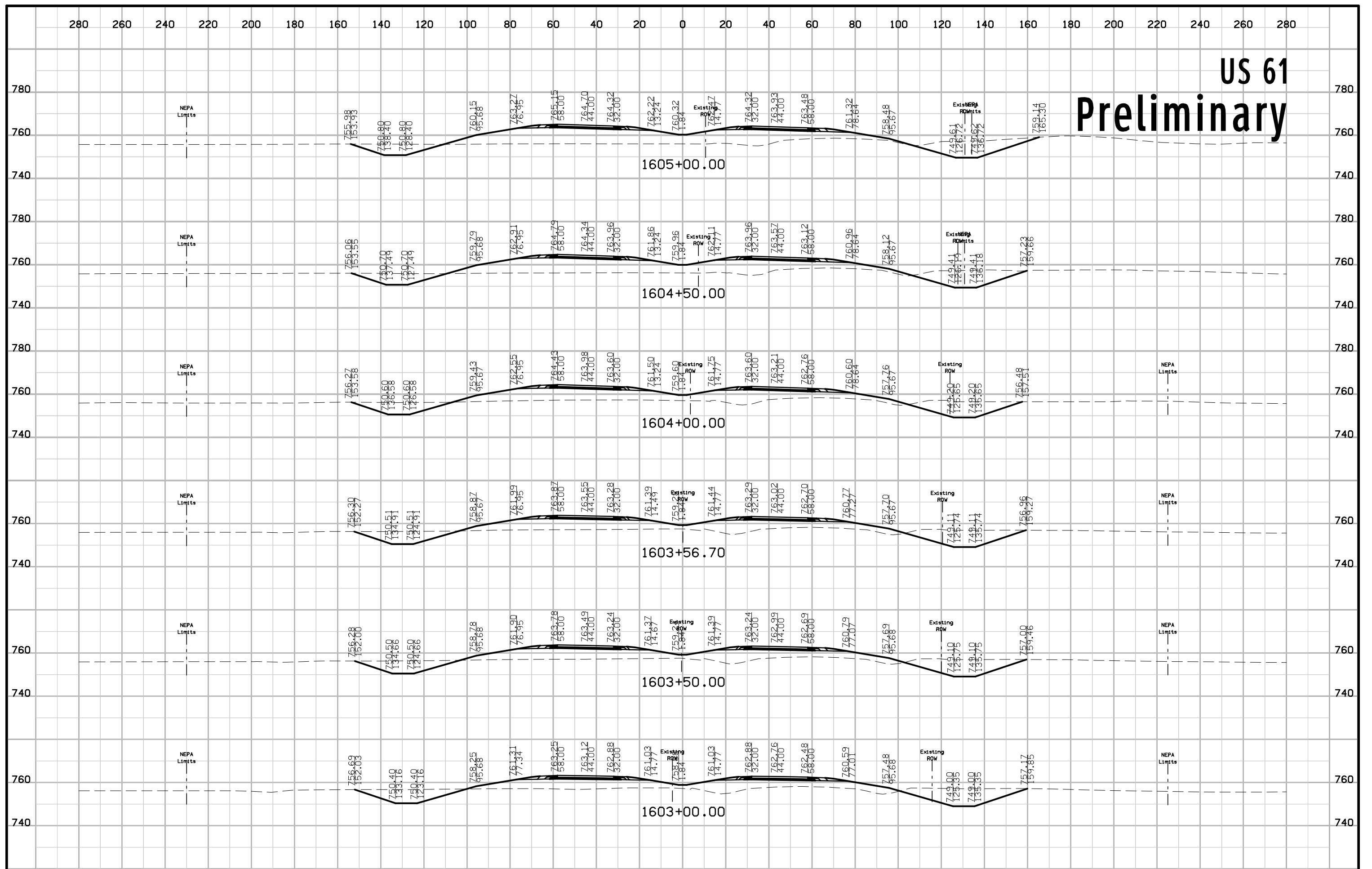

US 61 Preliminary

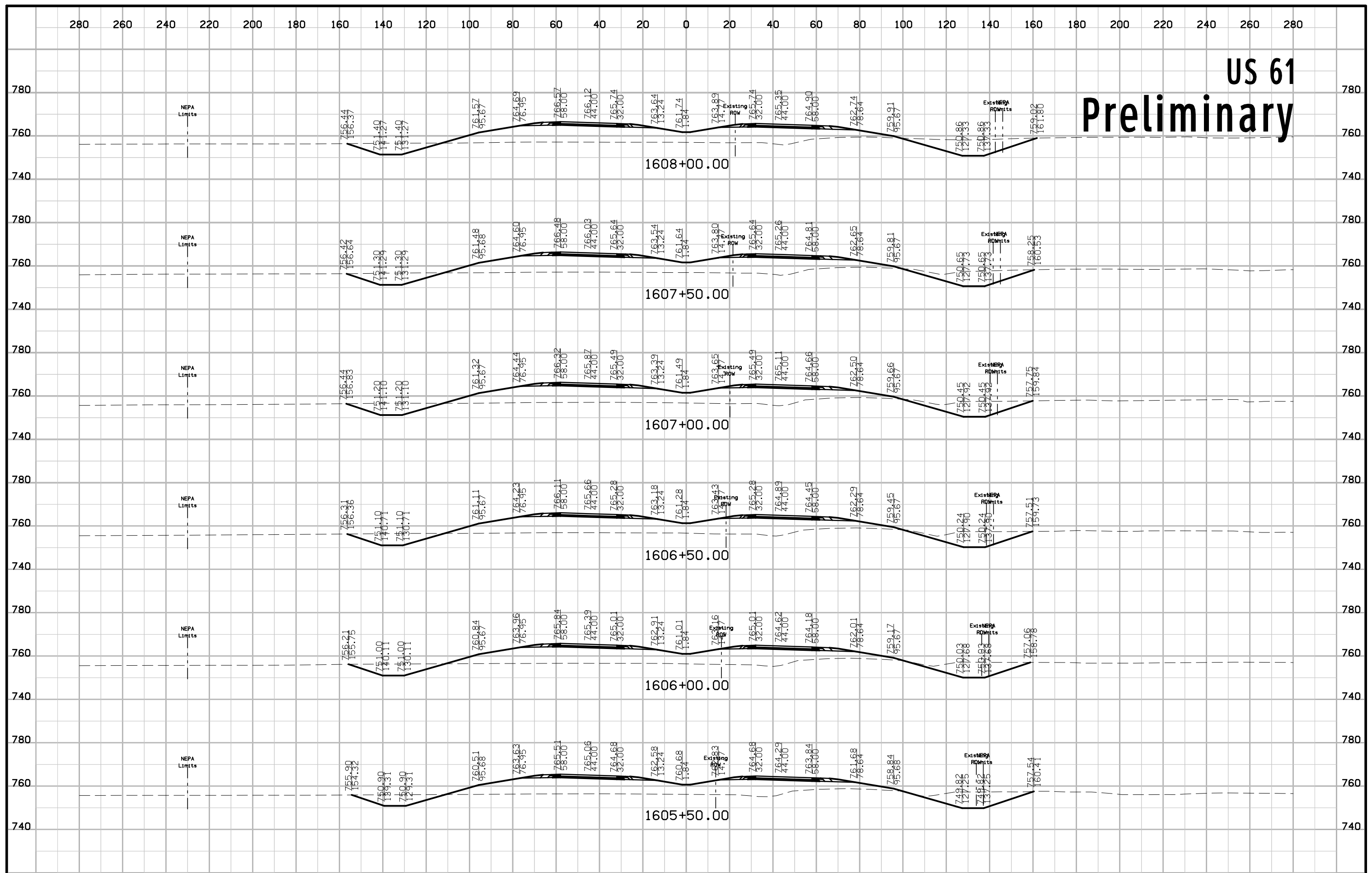

US 61 Preliminary

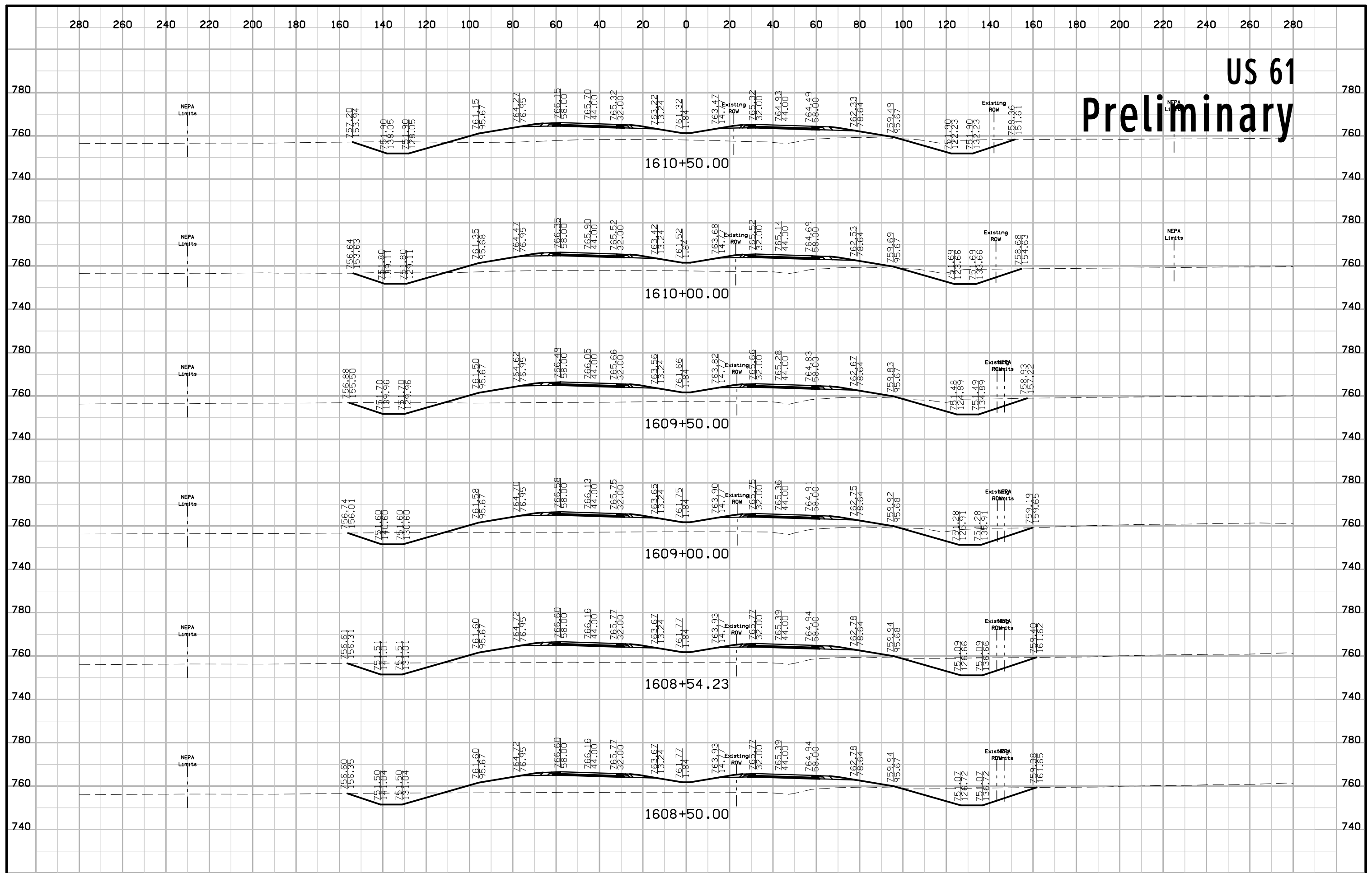

US 61 Preliminary

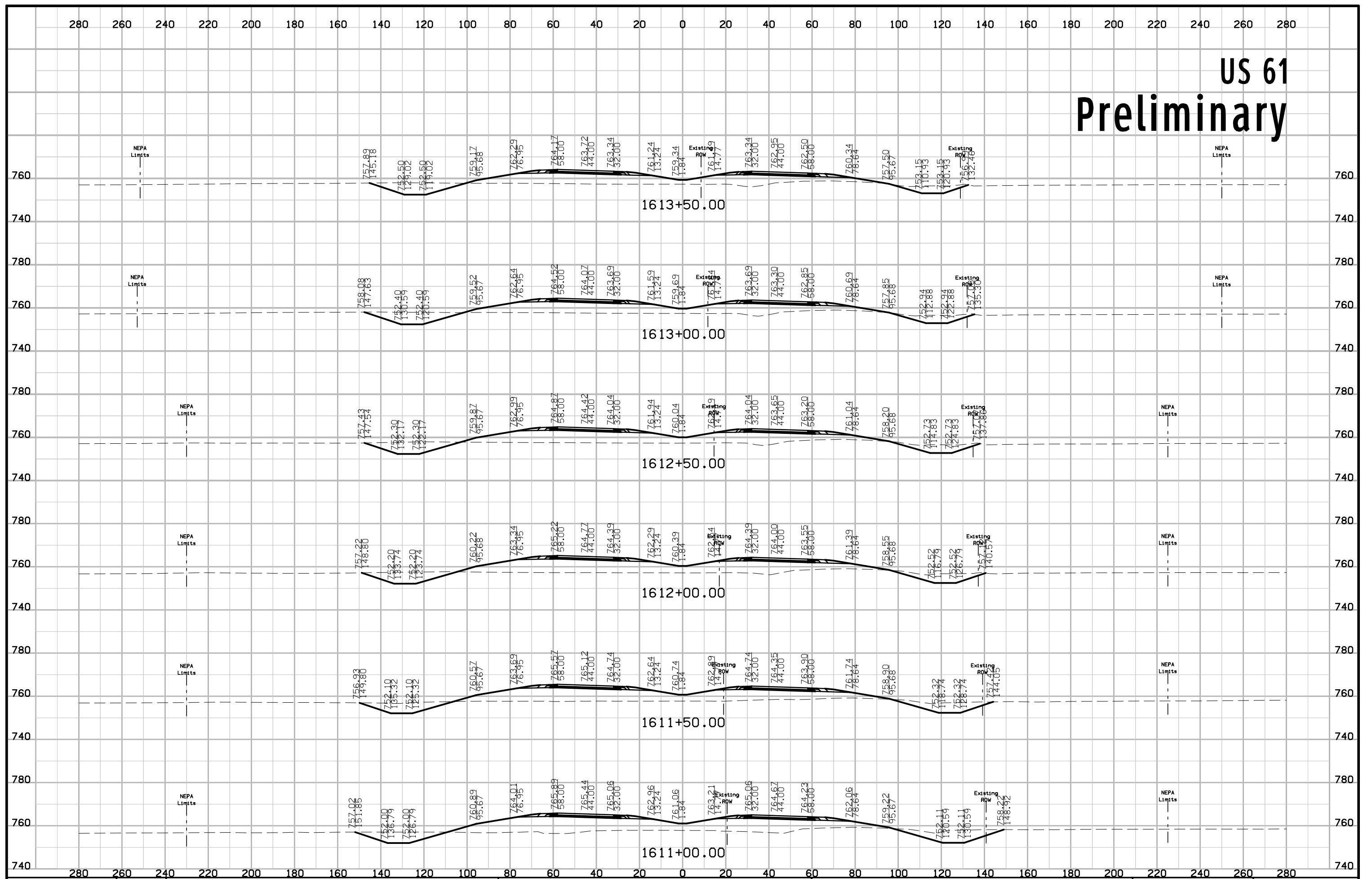

US 61 Preliminary

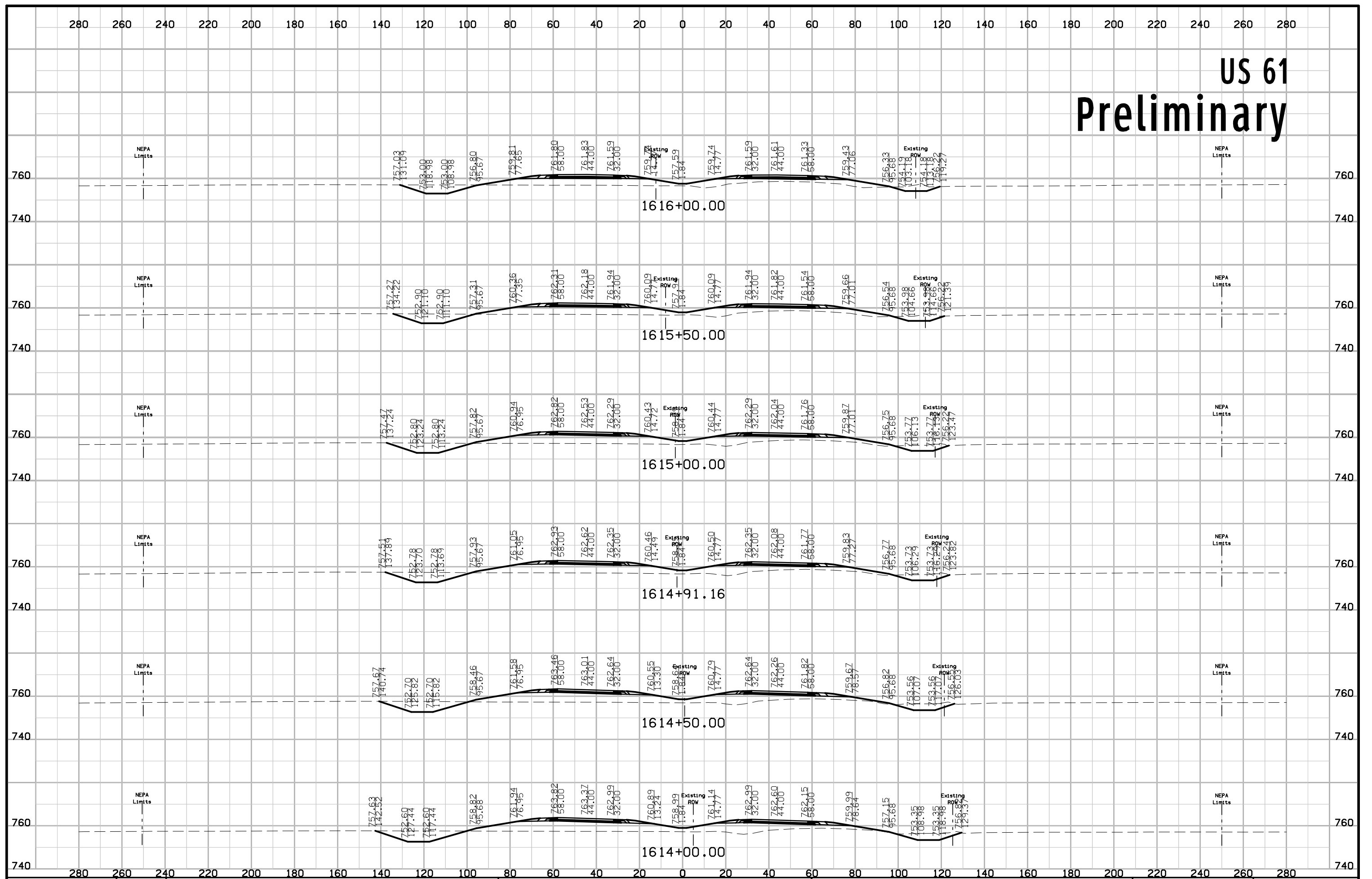

US 61 Preliminary

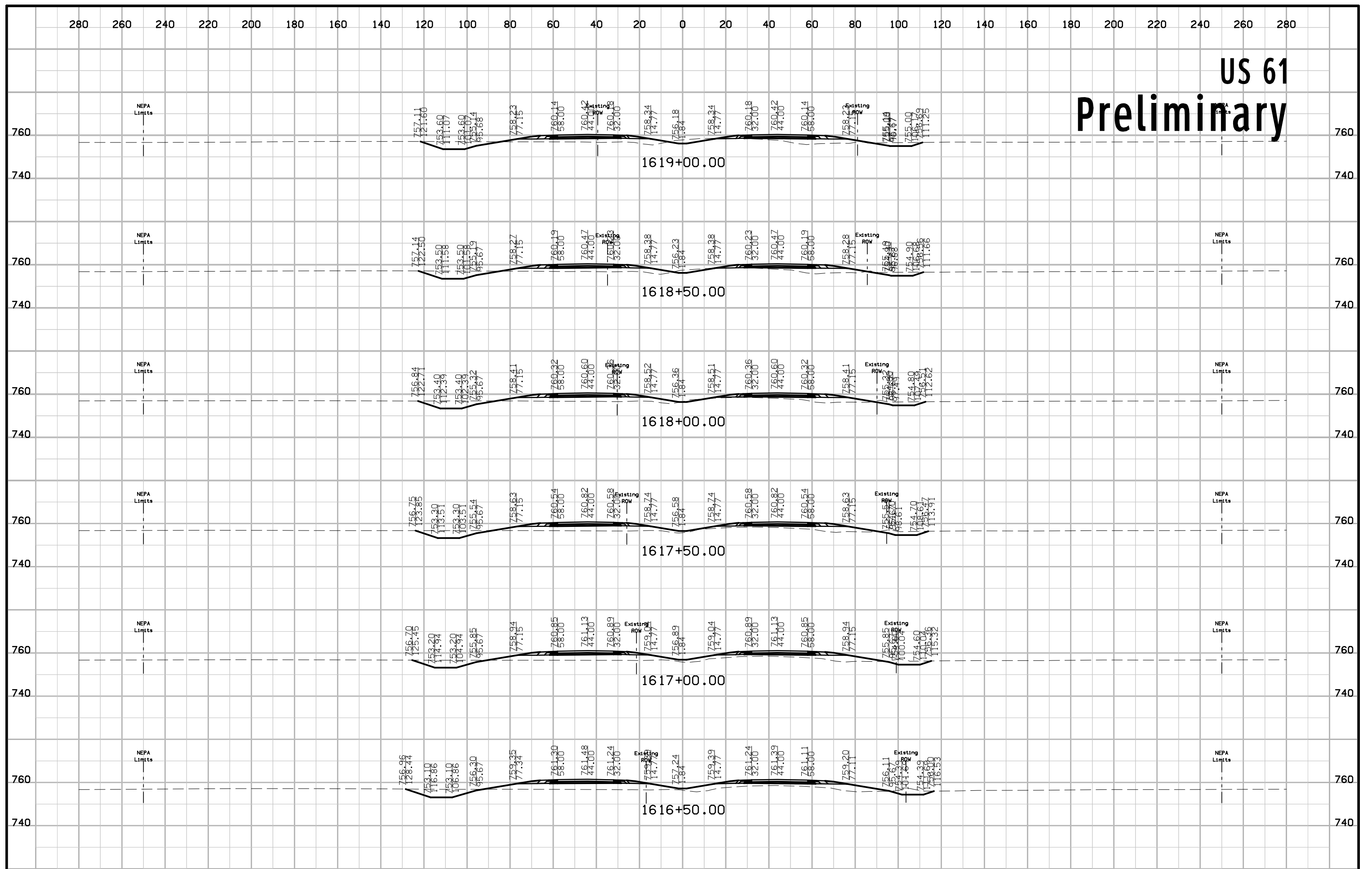

US 61 Preliminary

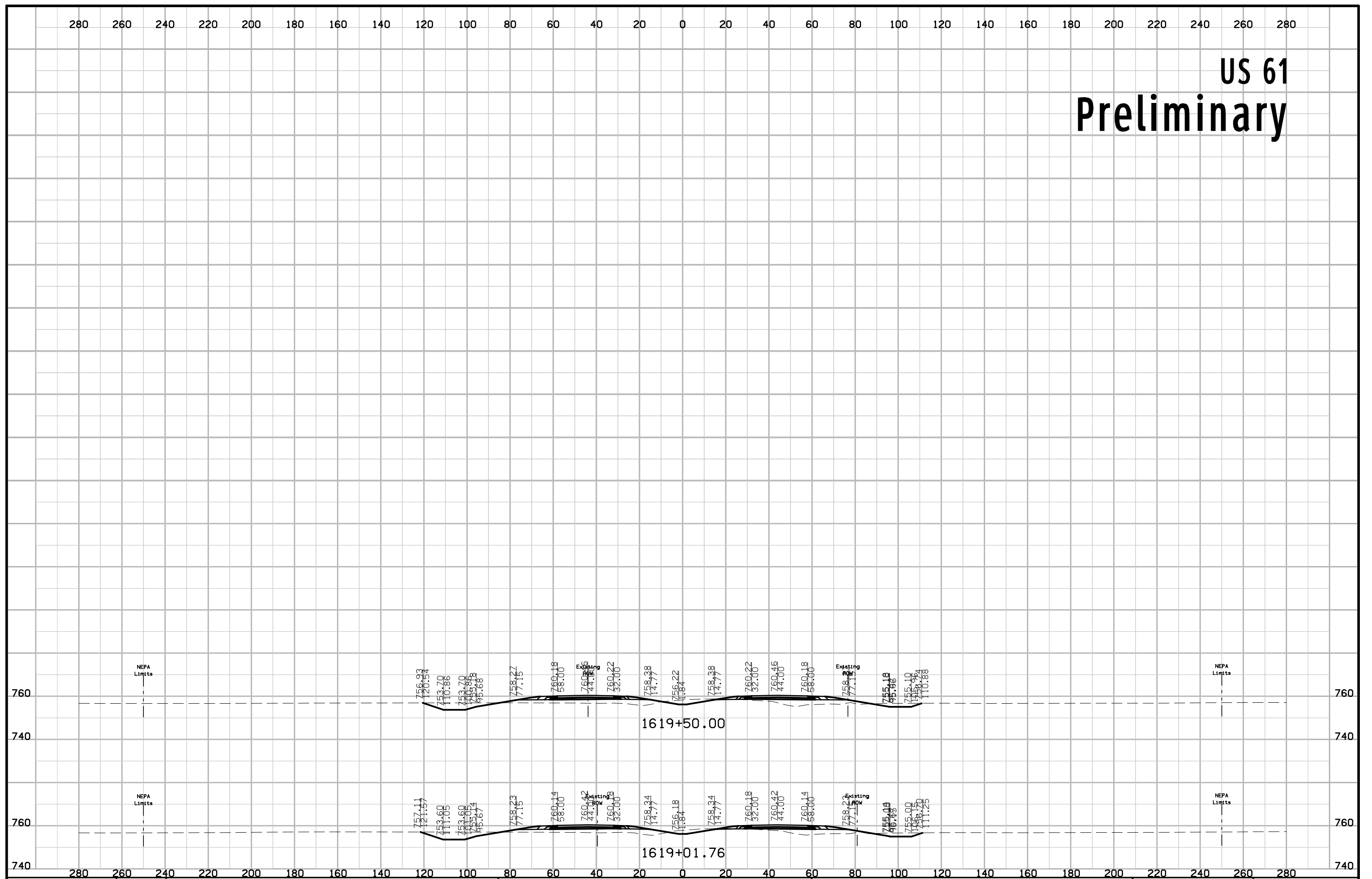

US 61 Preliminary

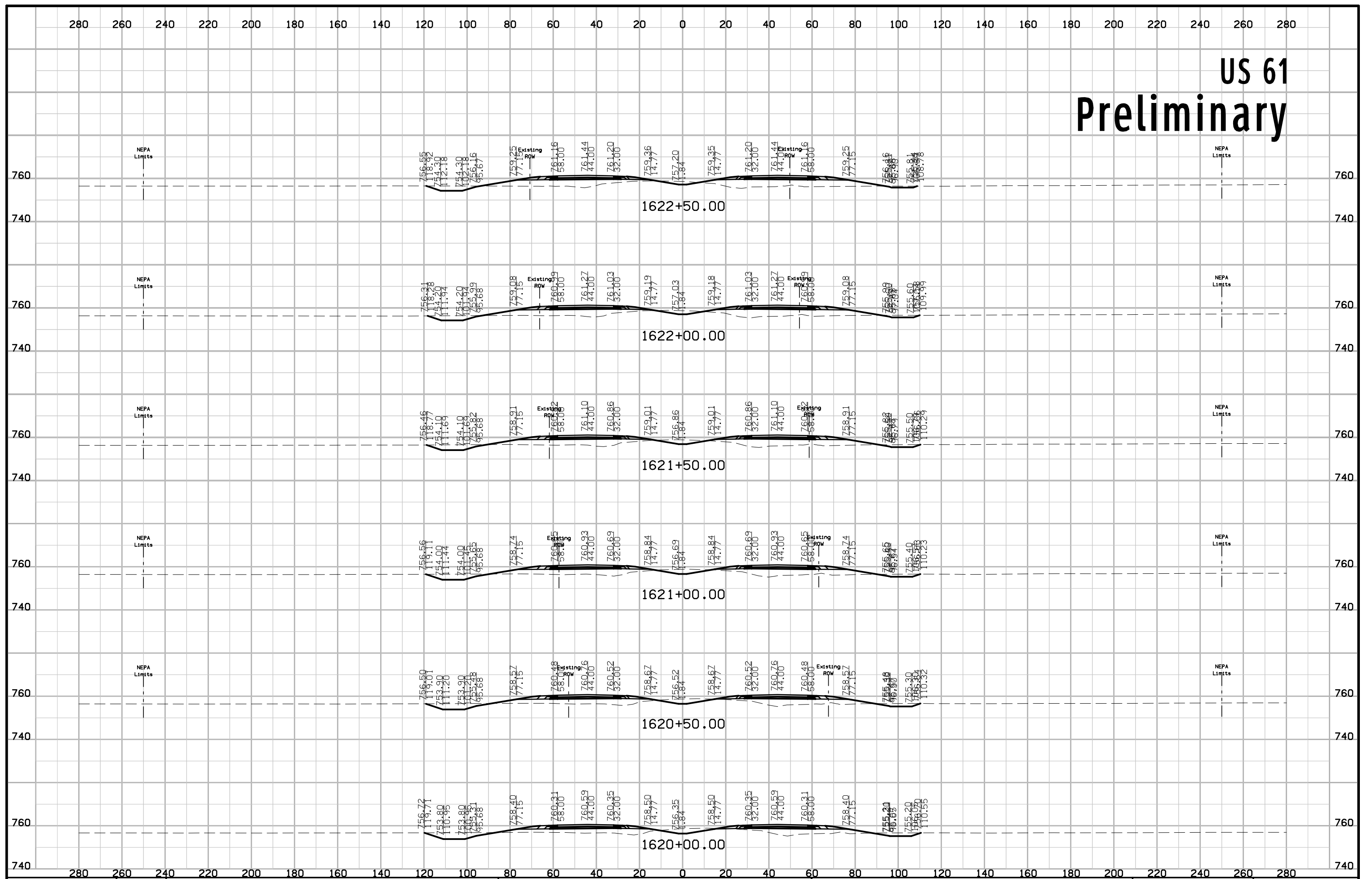

US 61 Preliminary

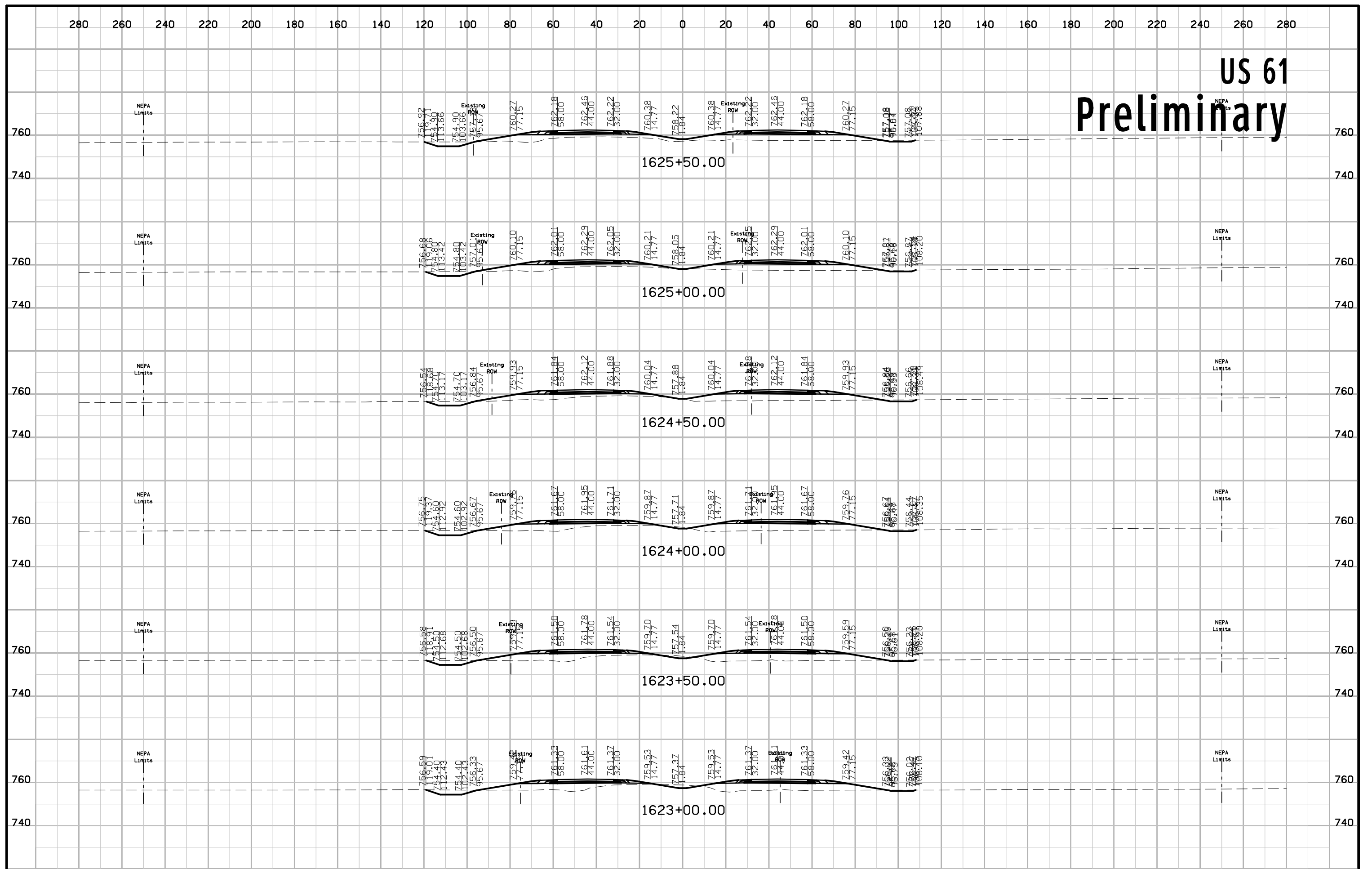

US 61 Preliminary

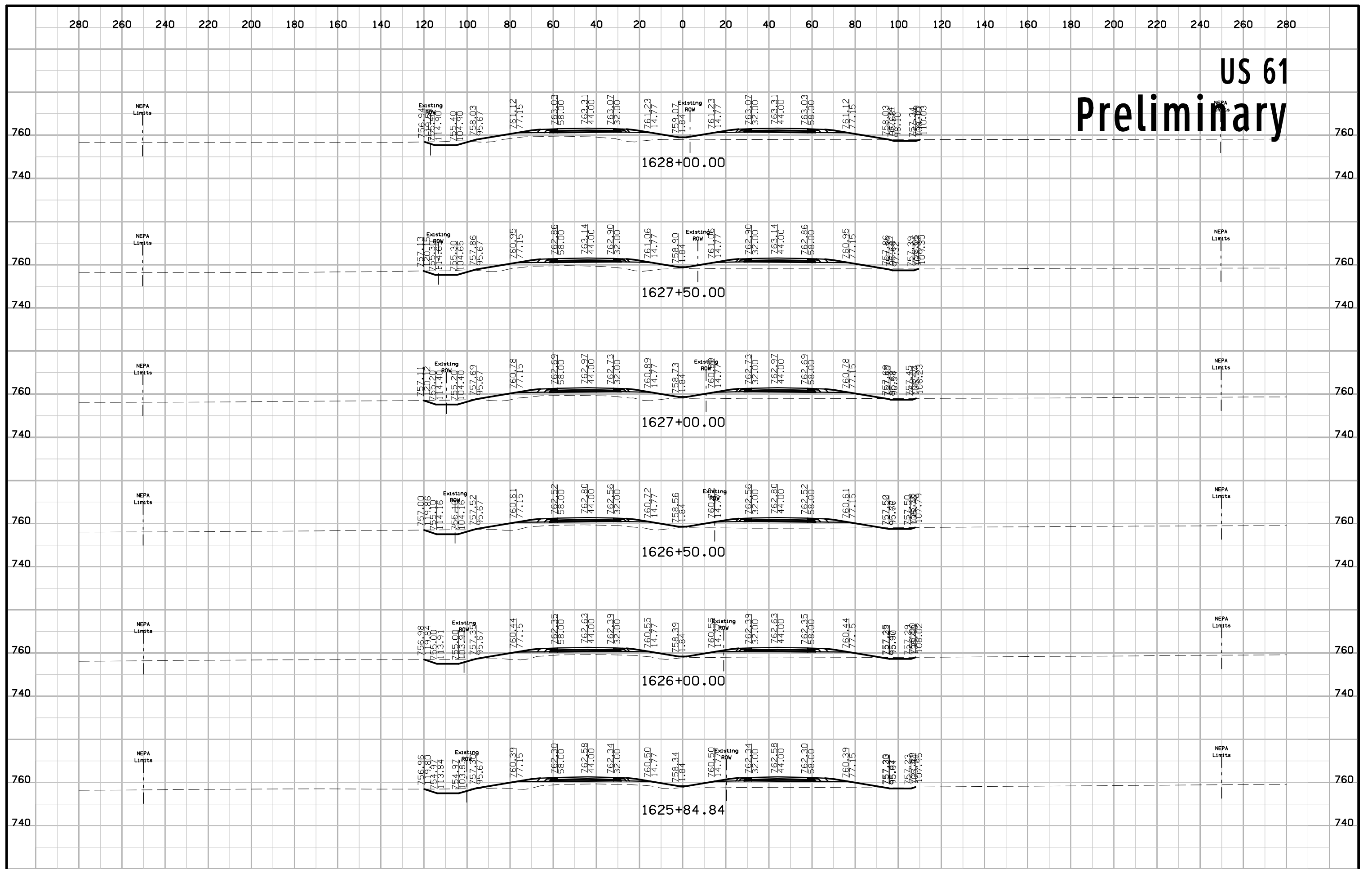

US 61 Preliminary

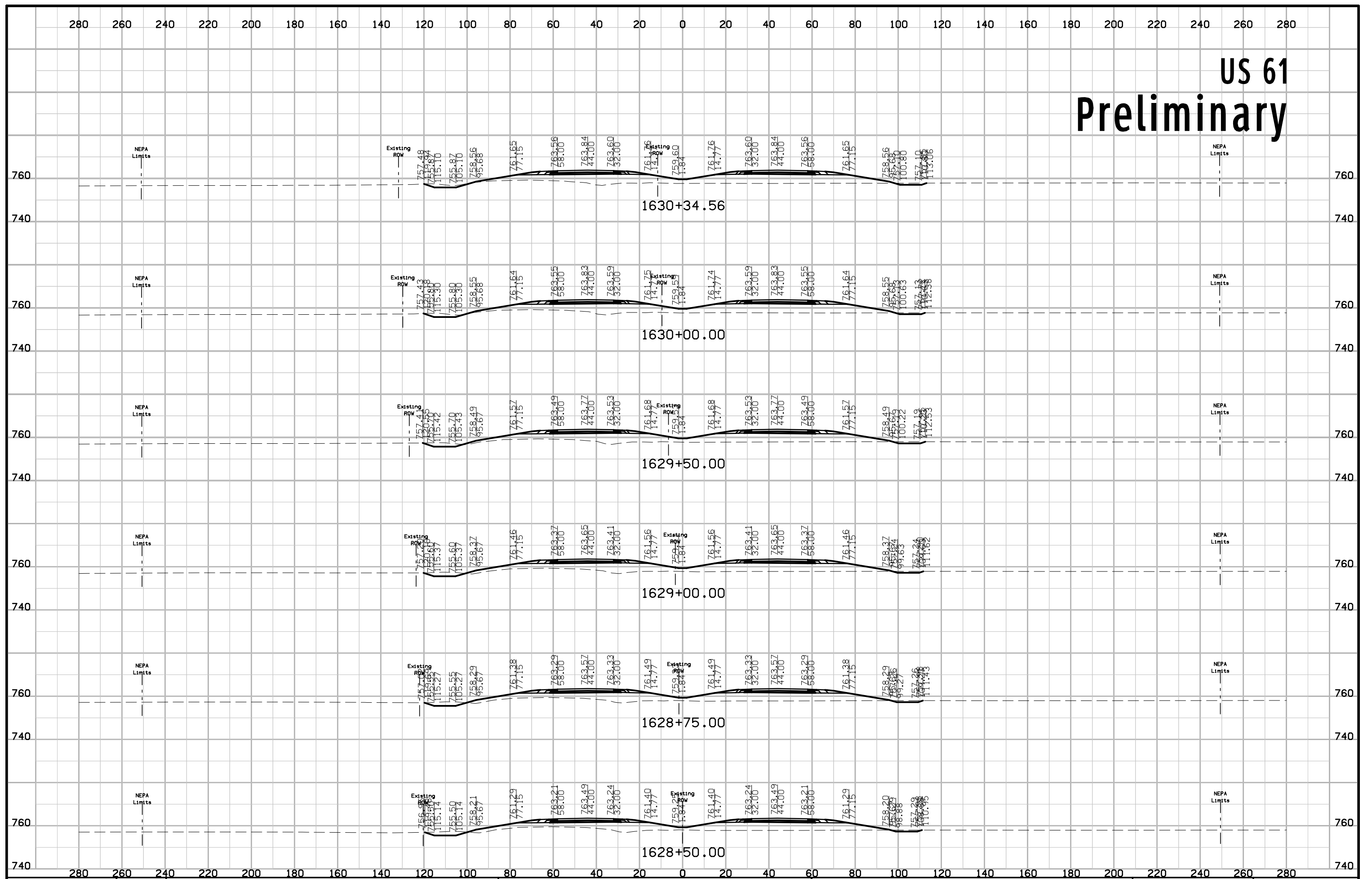

US 61 Preliminary

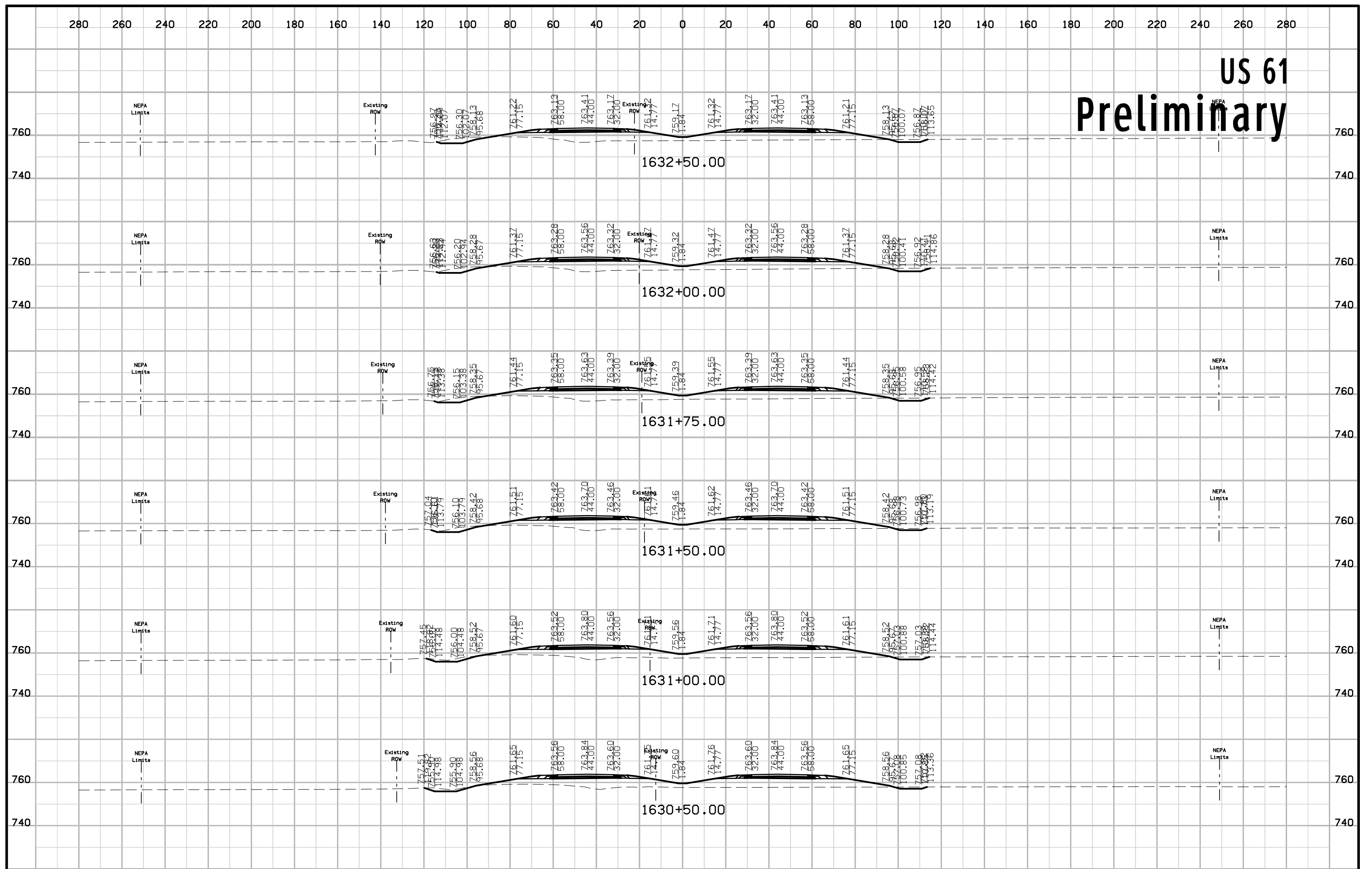

US 61 Preliminary

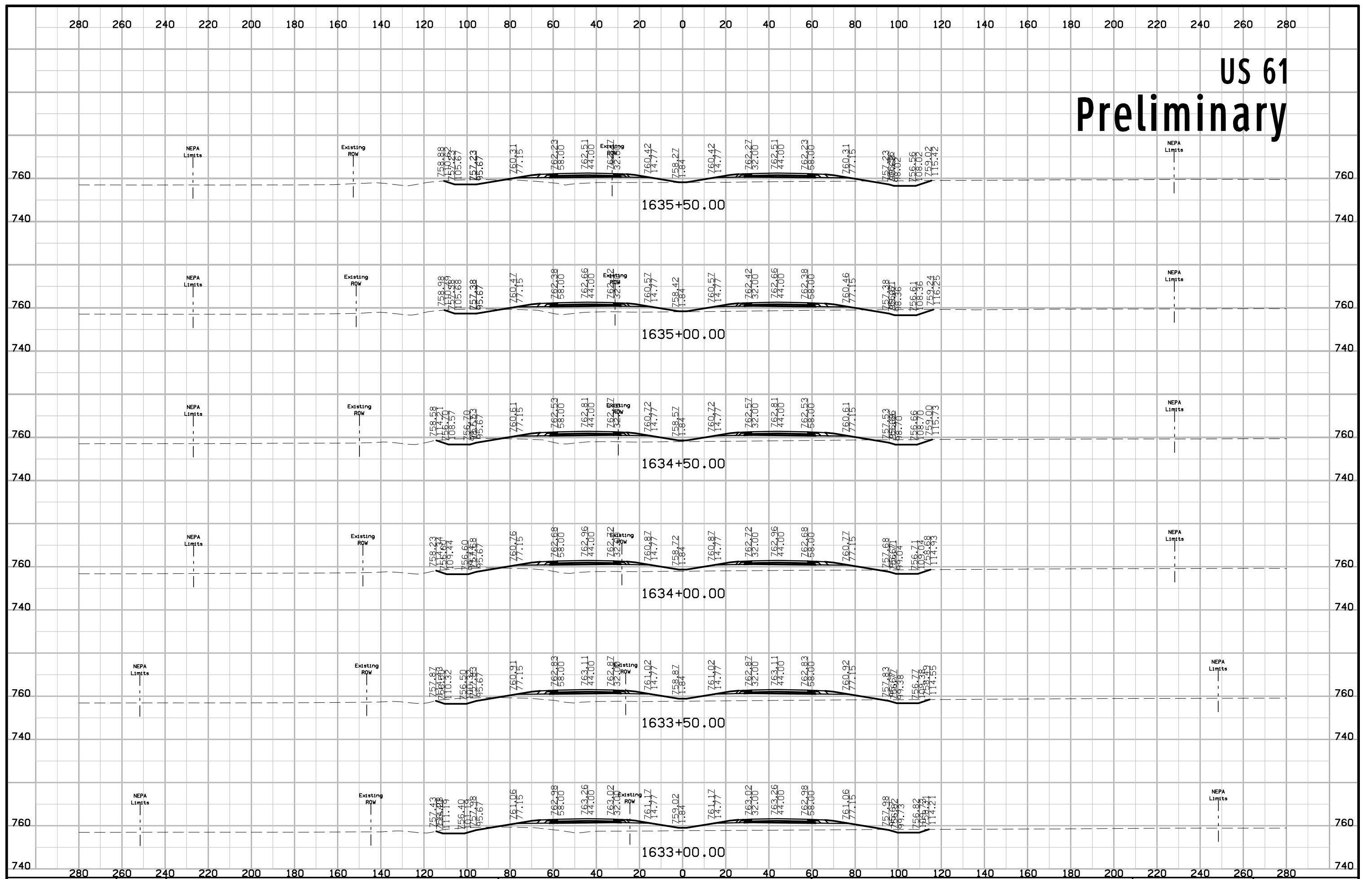

US 61 Preliminary

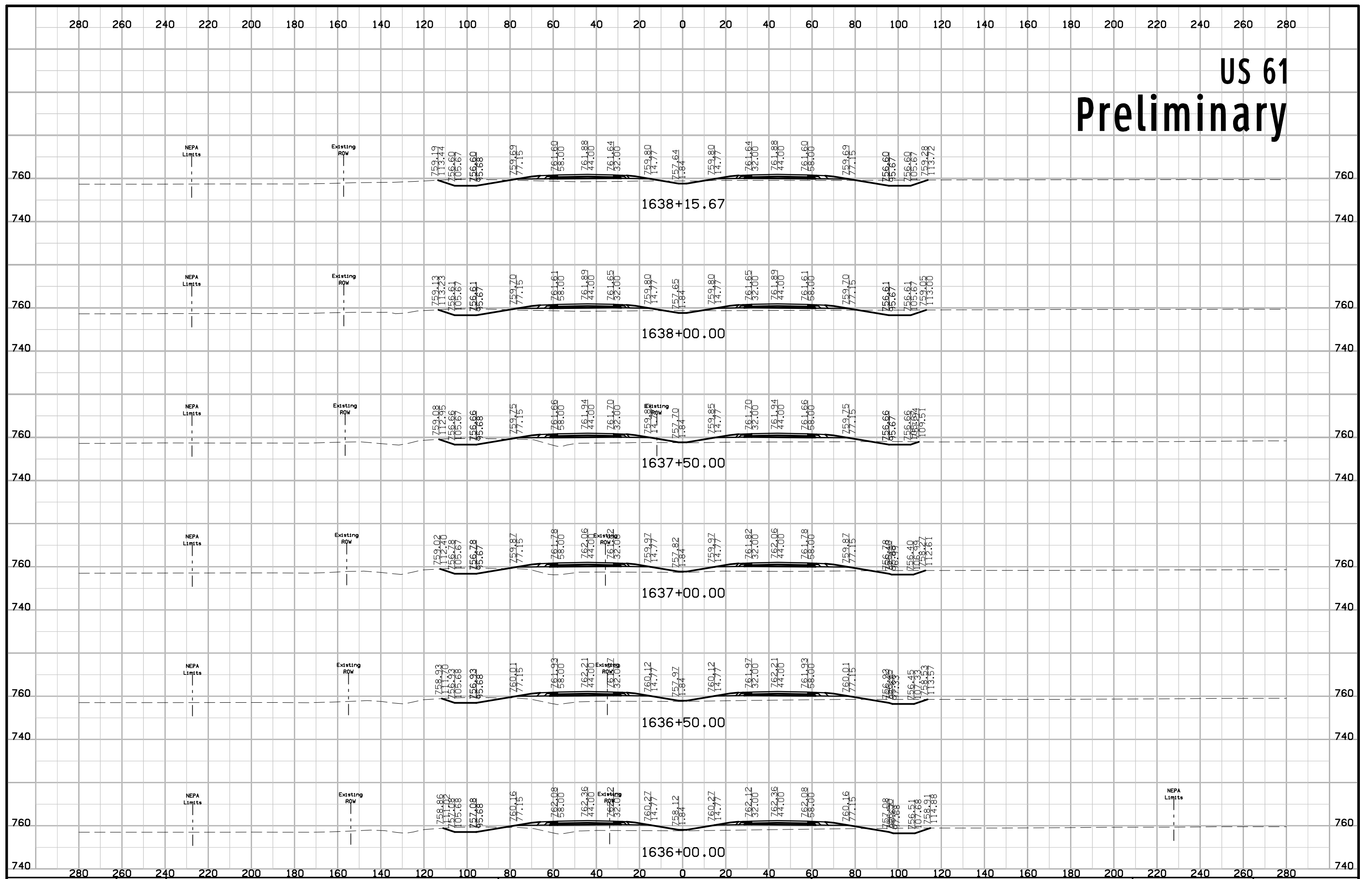

US 61 Preliminary

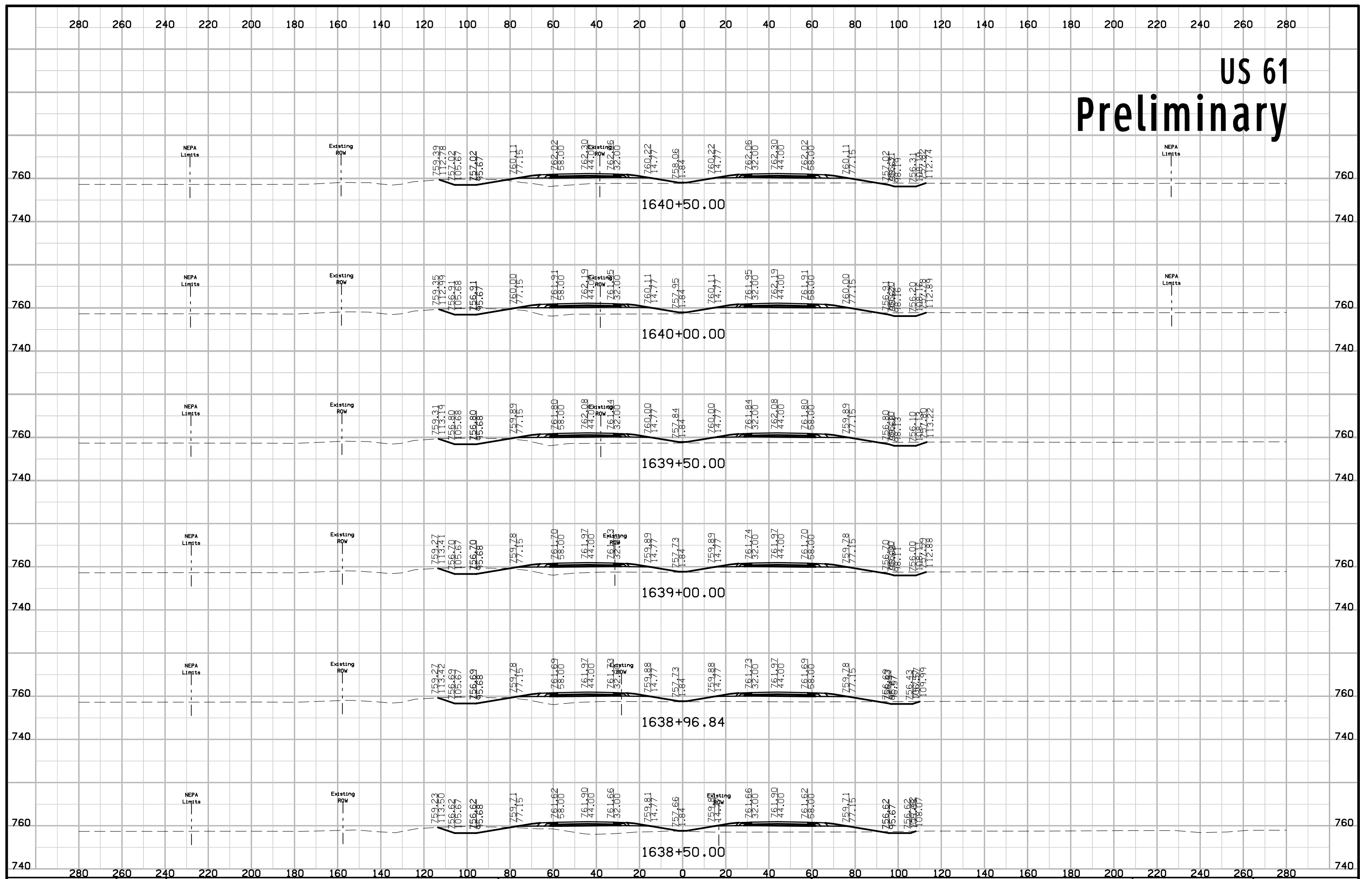

US 61 Preliminary

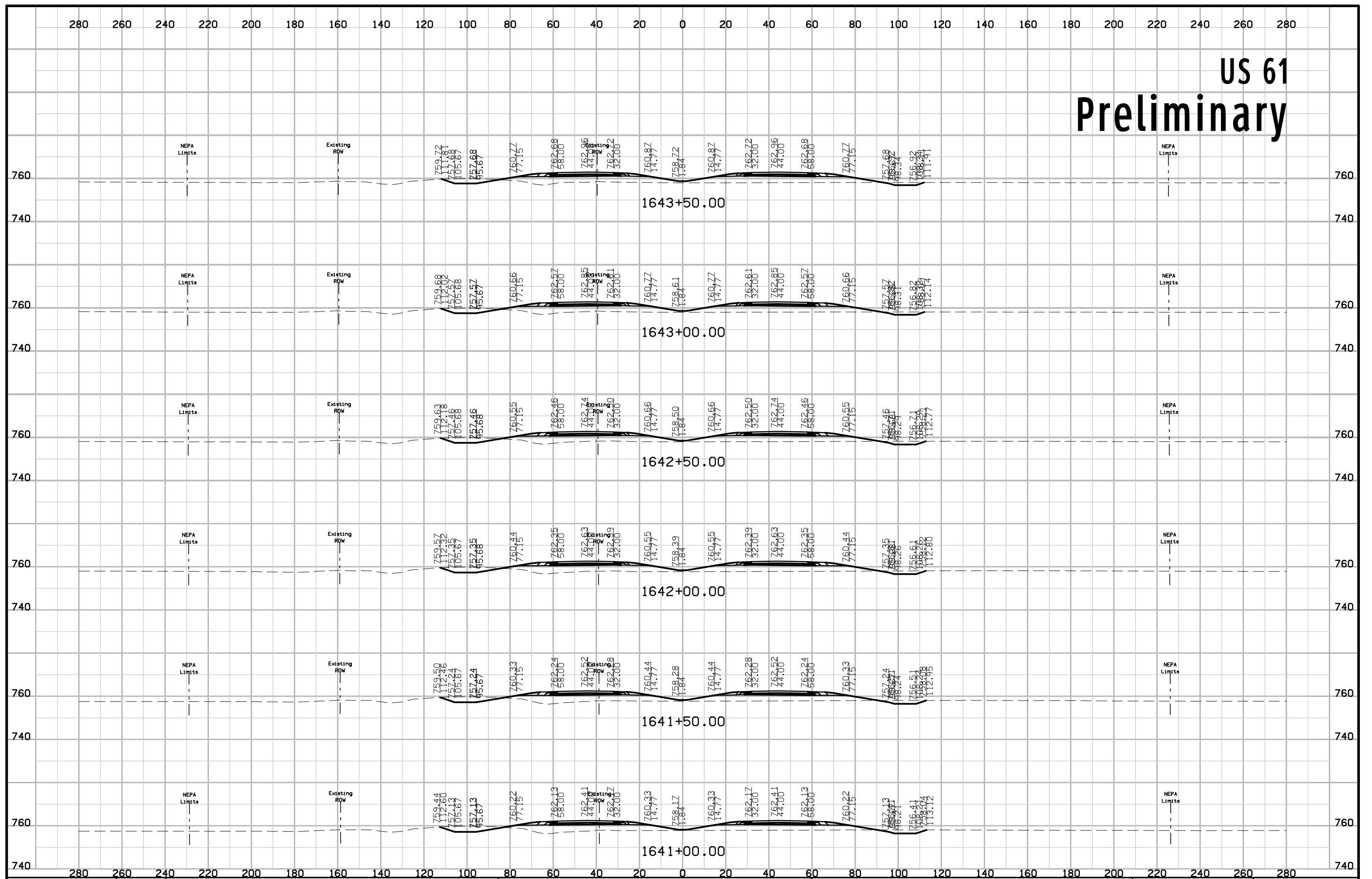

US 61 Preliminary

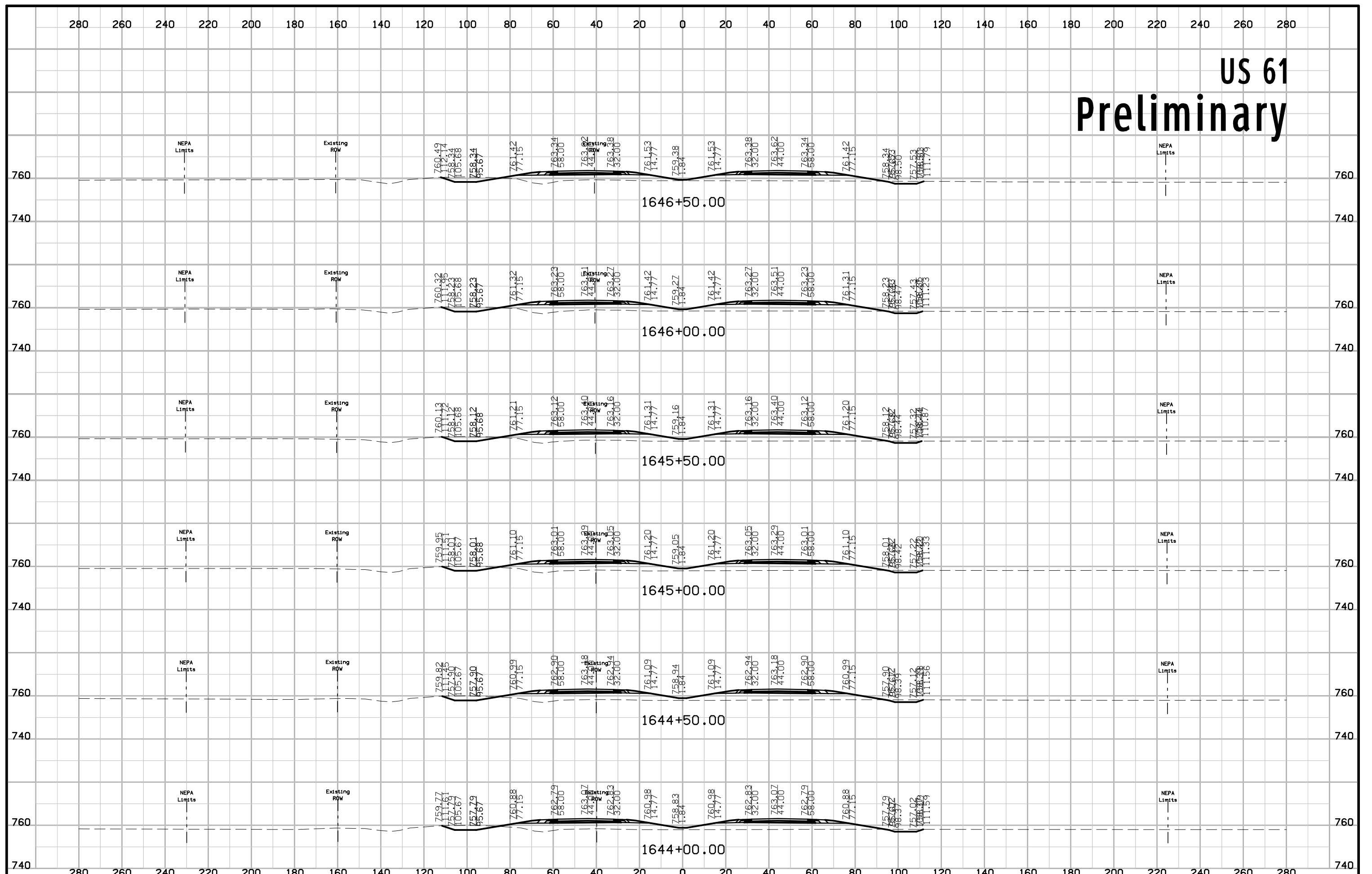

US 61 Preliminary

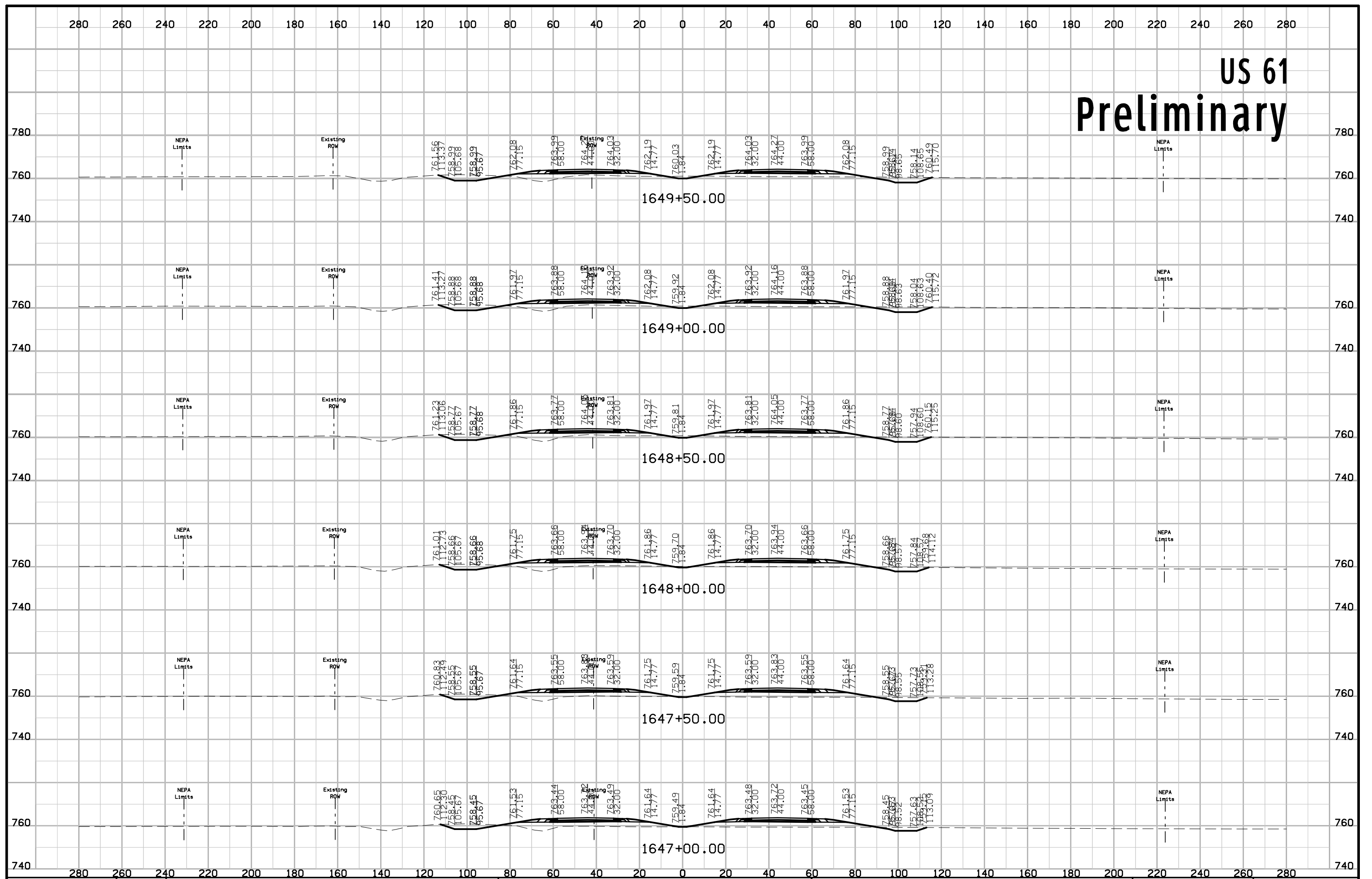

US 61 Preliminary

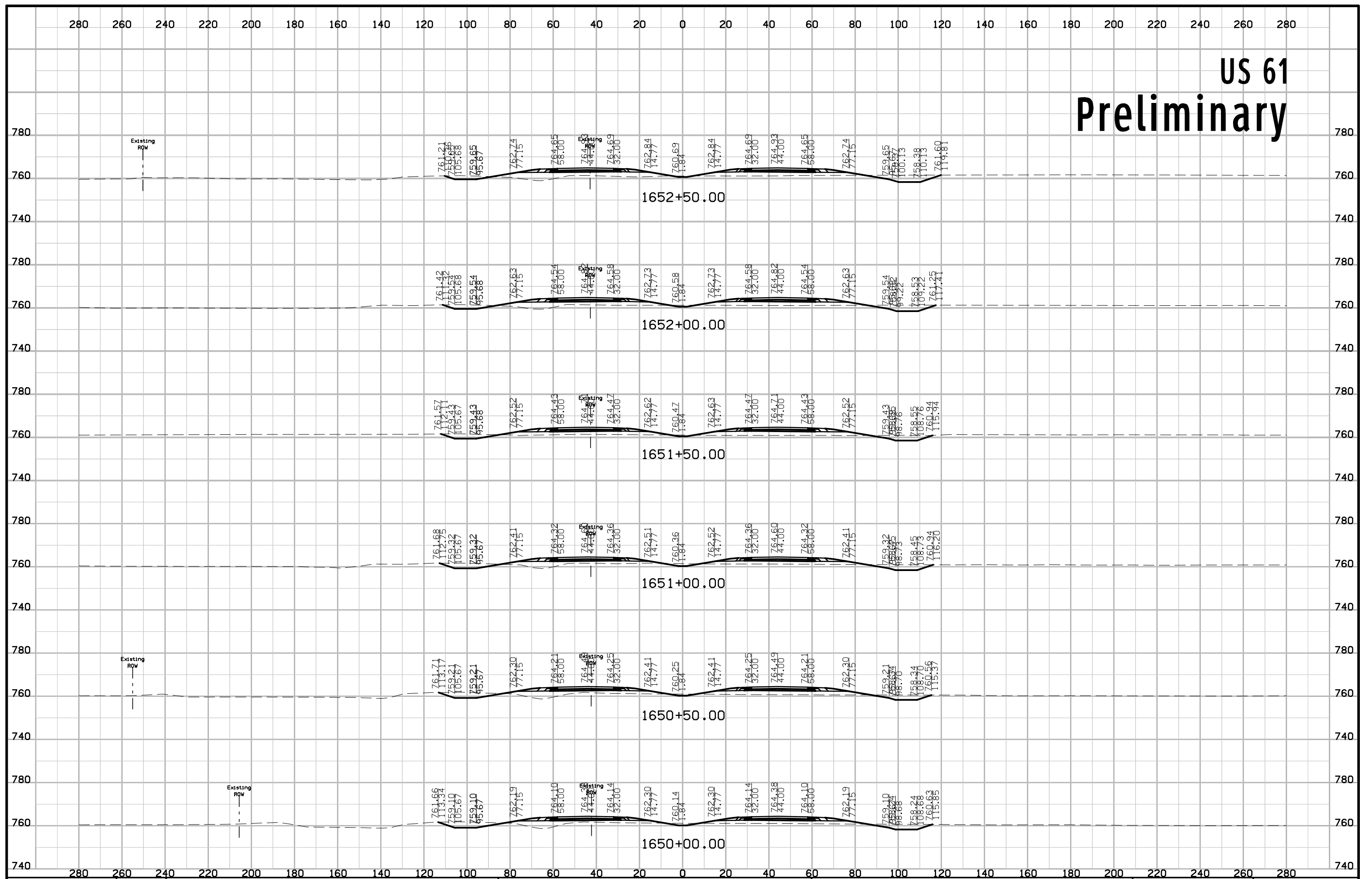

US 61 Preliminary

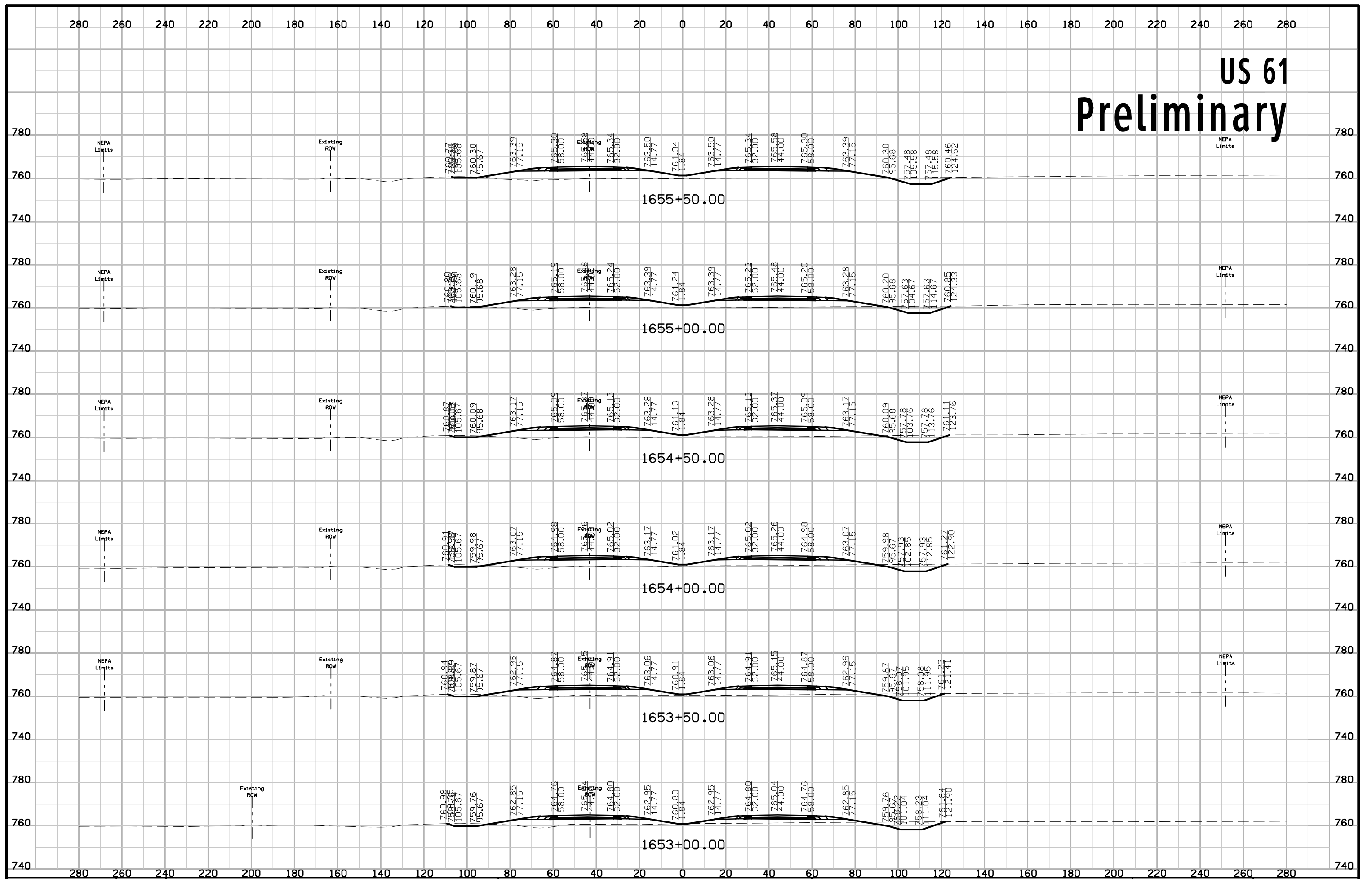

US 61 Preliminary

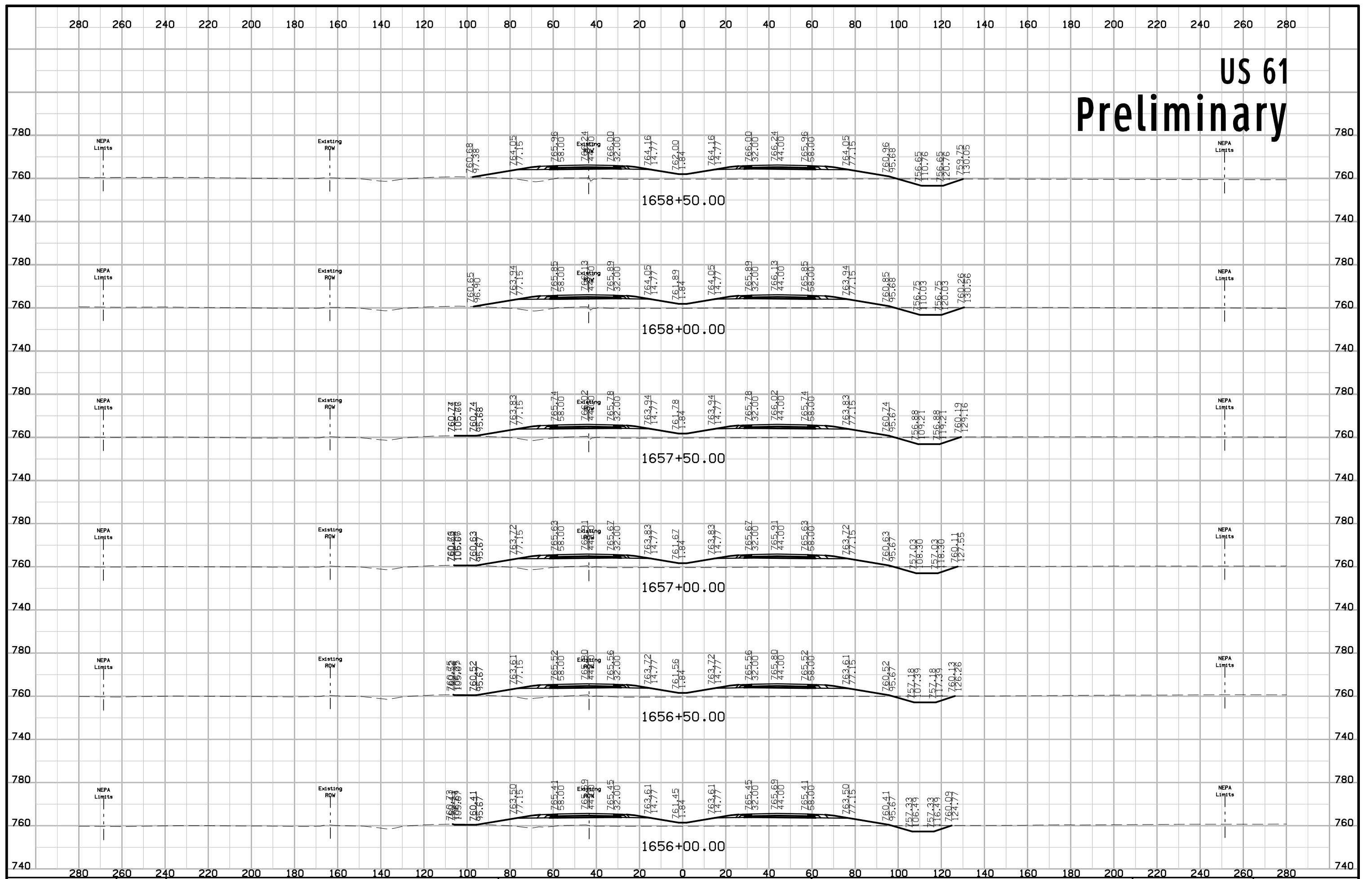

US 61 Preliminary

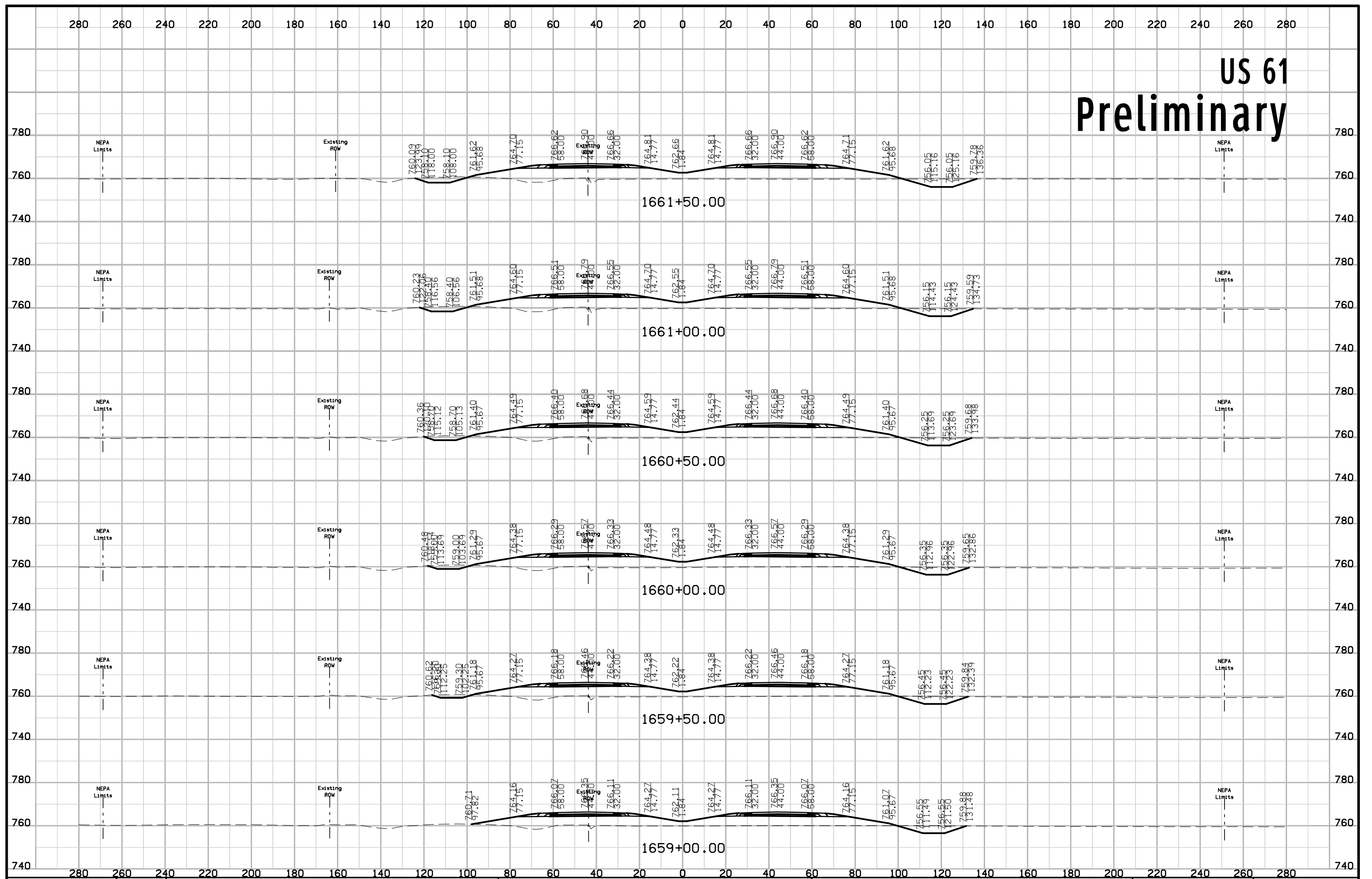

US 61 Preliminary

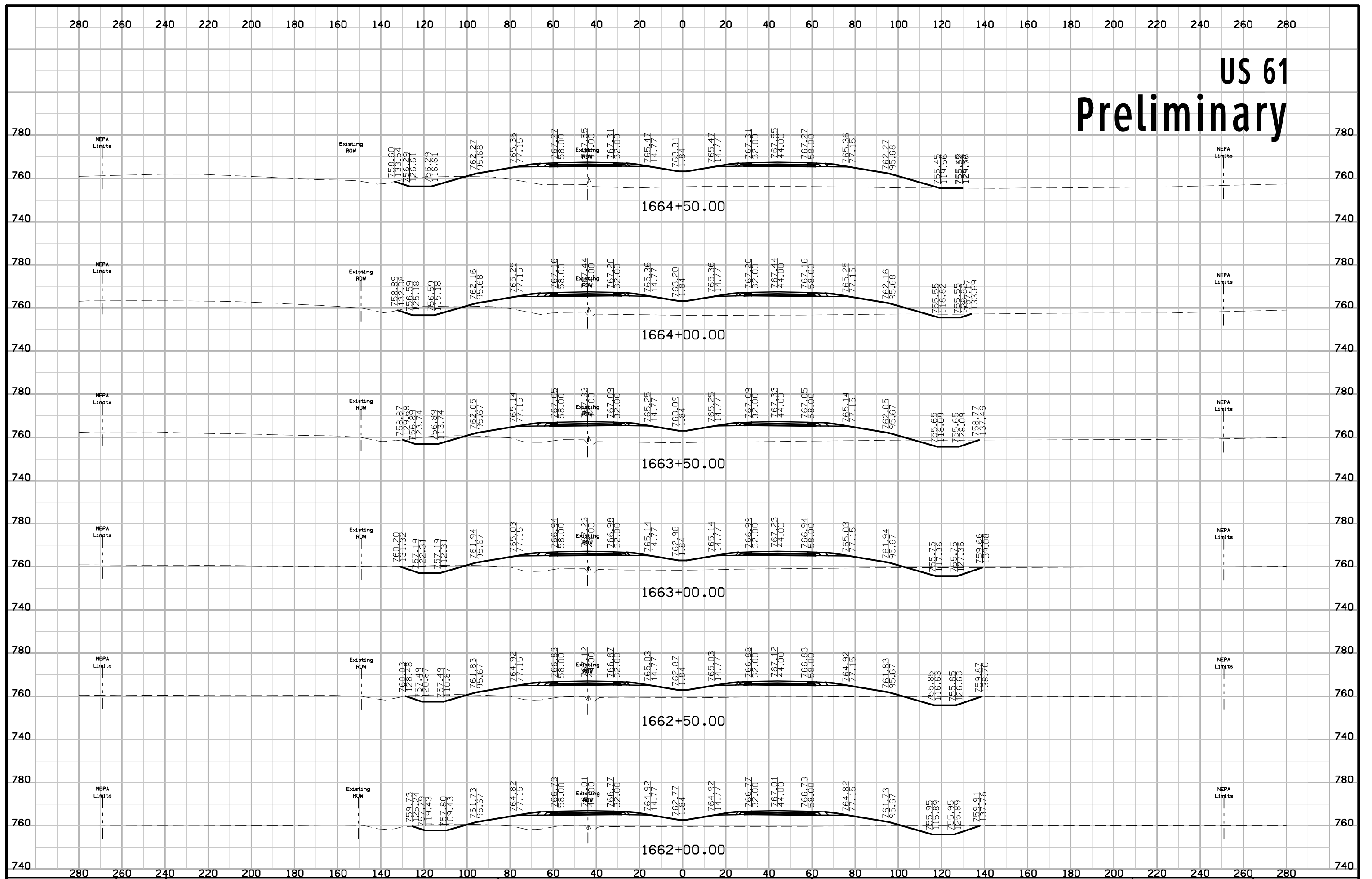

US 61 Preliminary

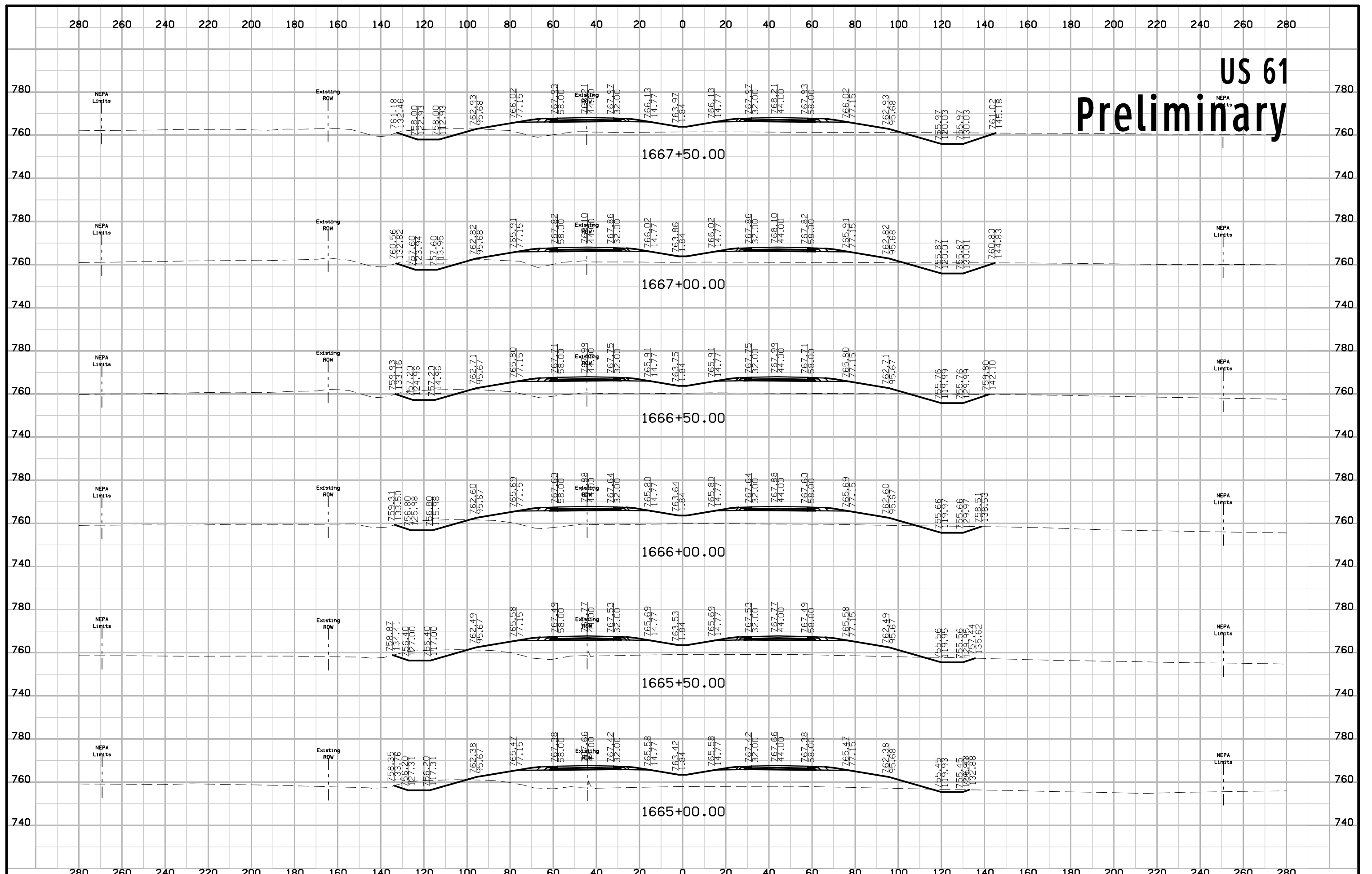

US 61 Preliminary

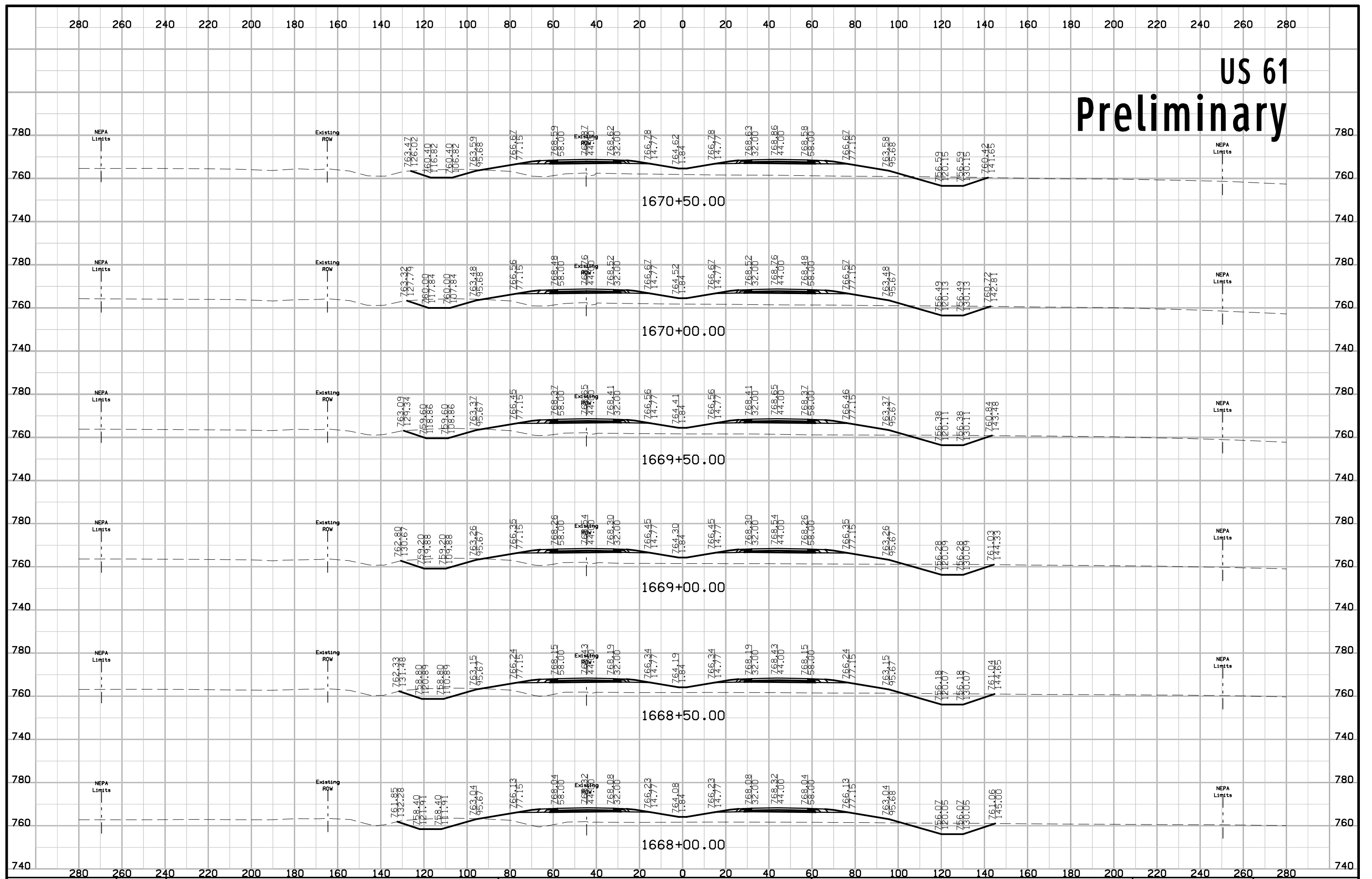

US 61 Preliminary

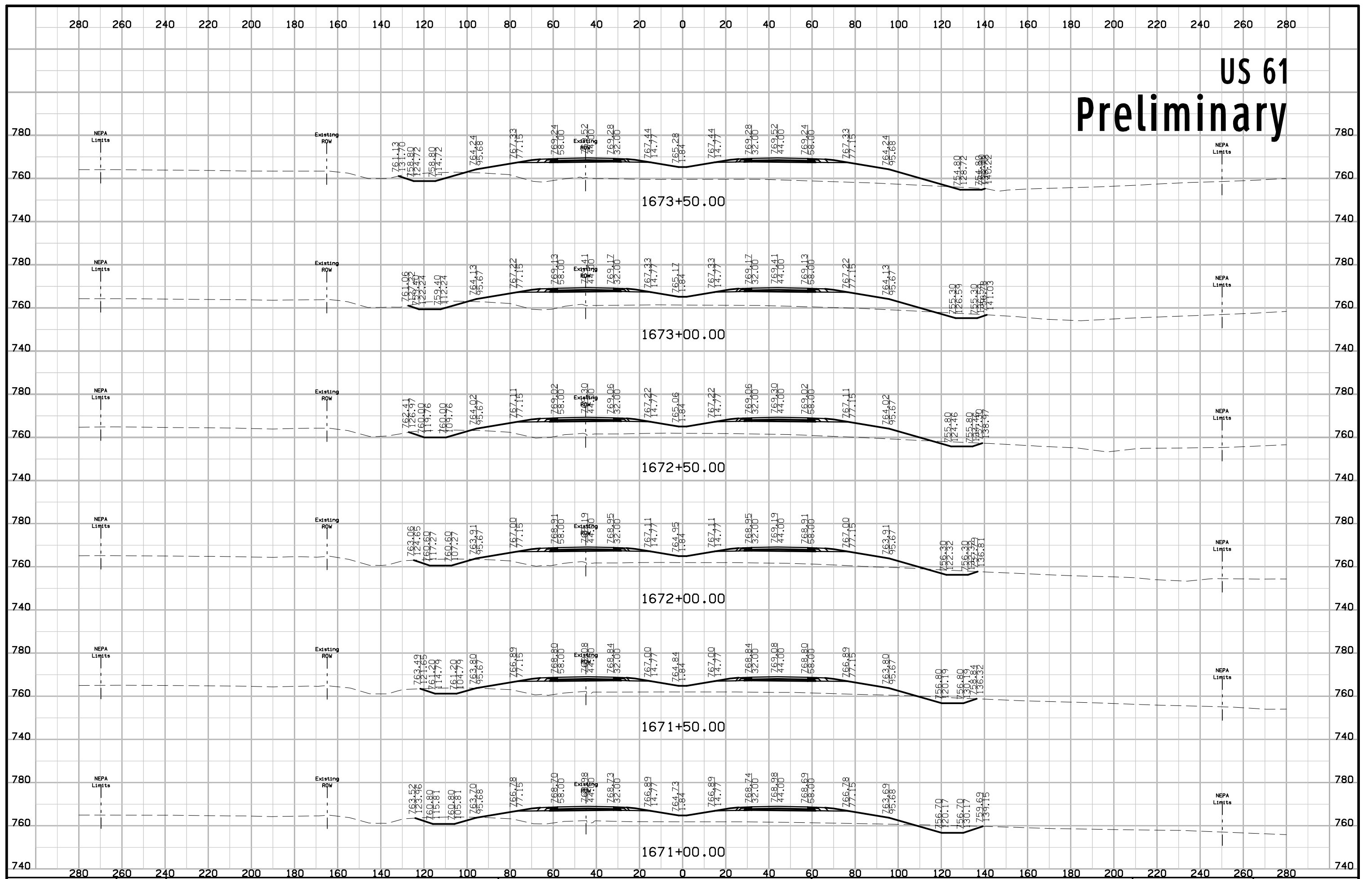

US 61 Preliminary

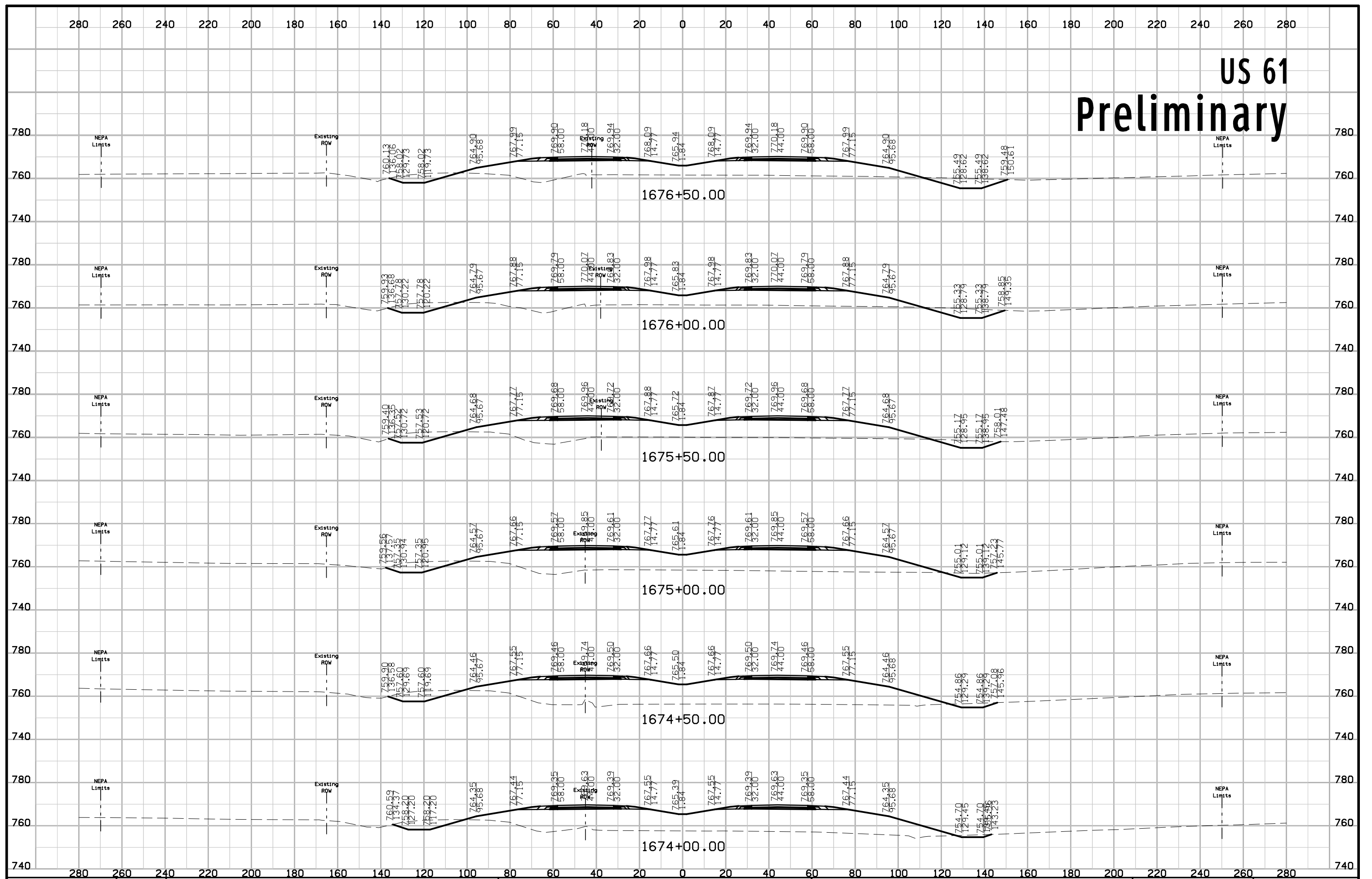

US 61 Preliminary

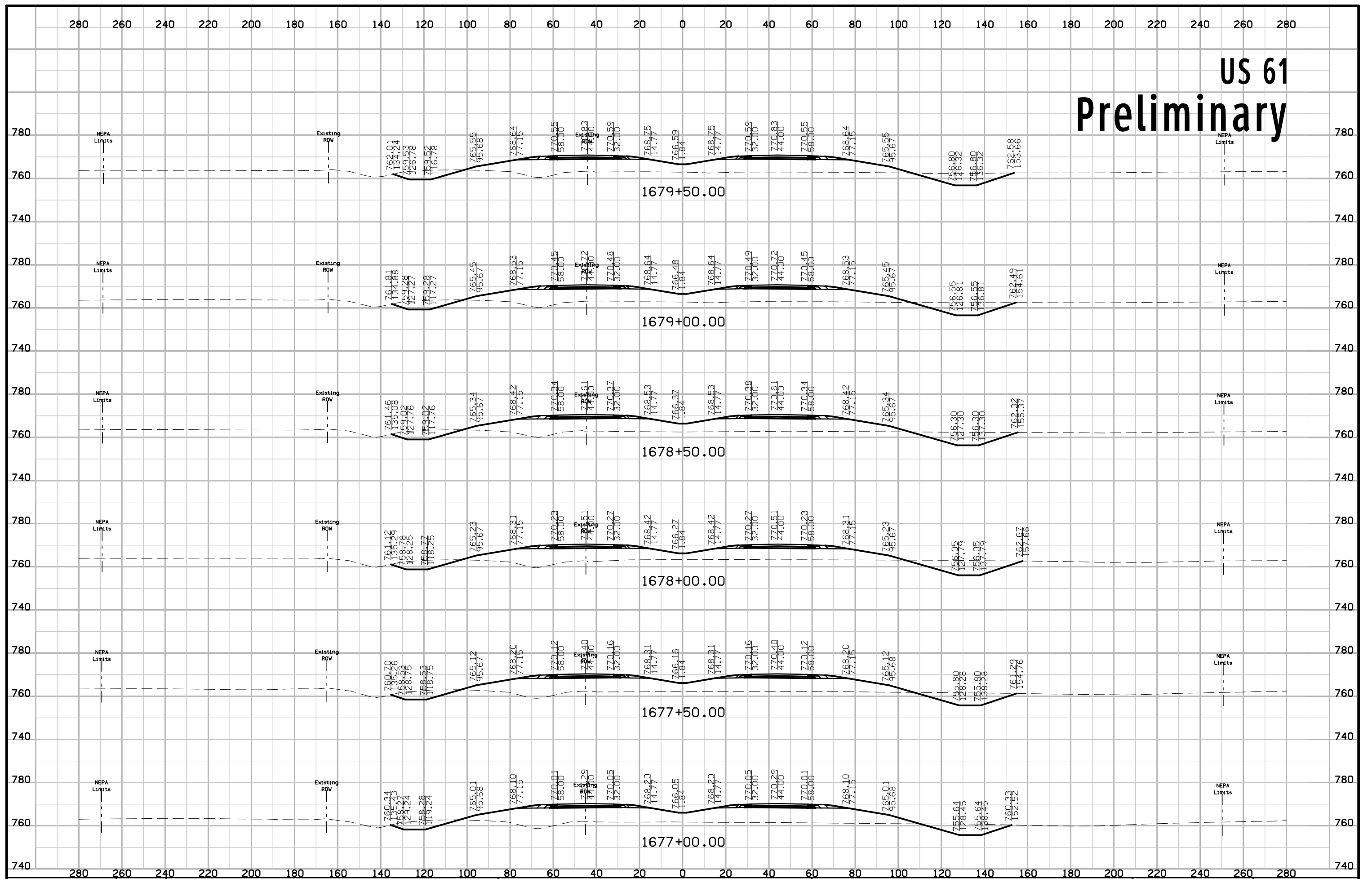

US 61 Preliminary

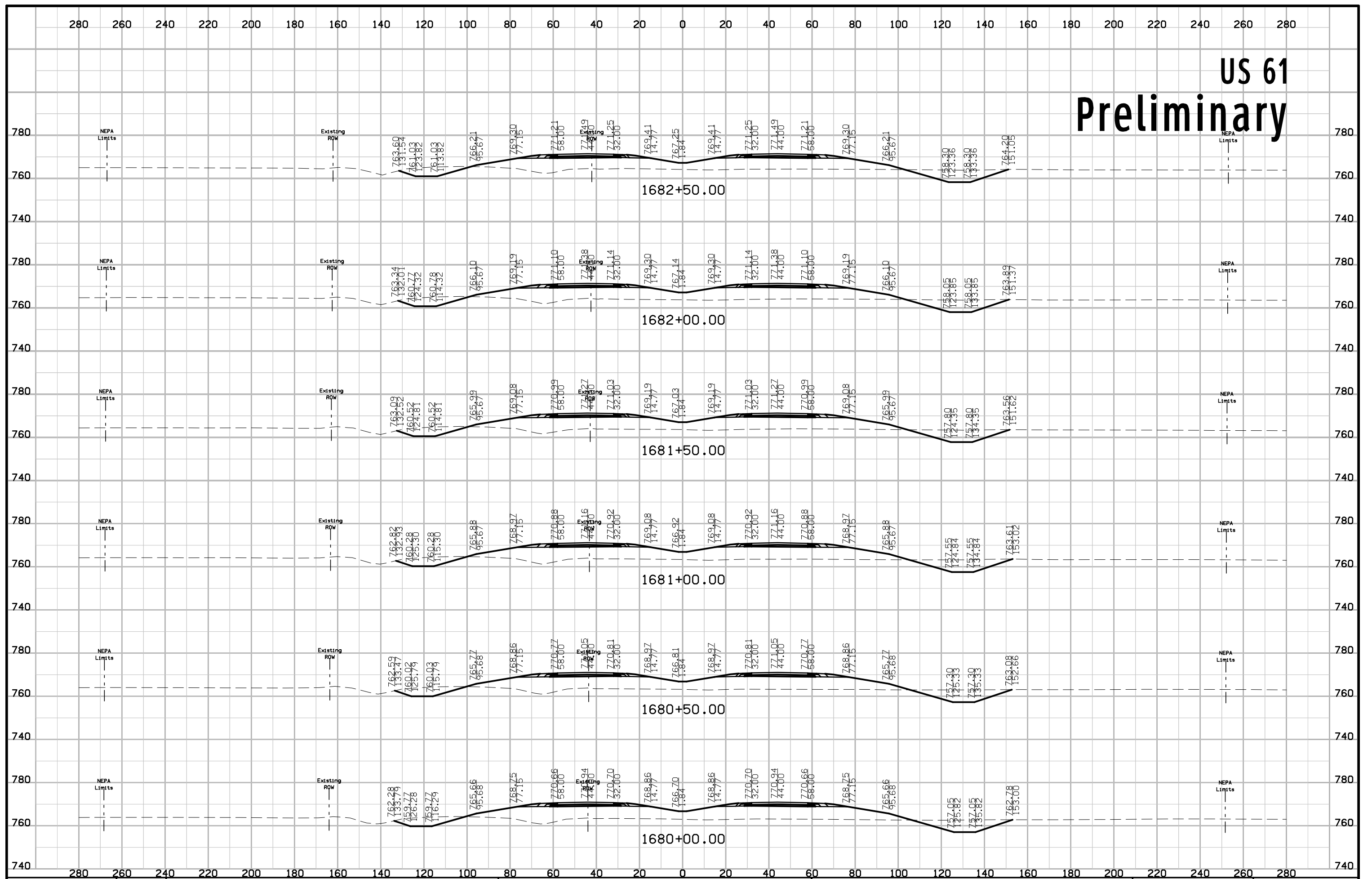

US 61 Preliminary

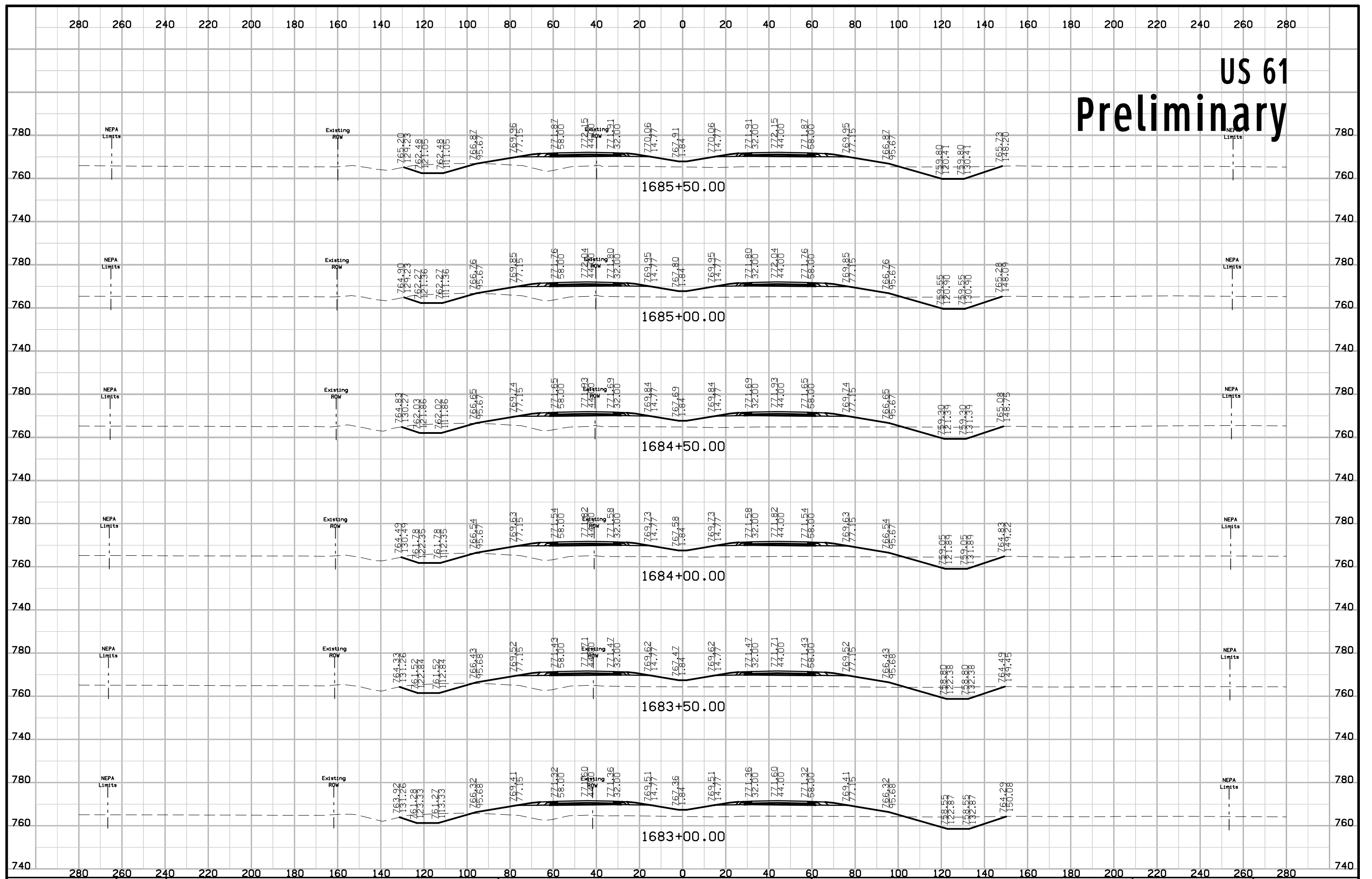

US 61 Preliminary

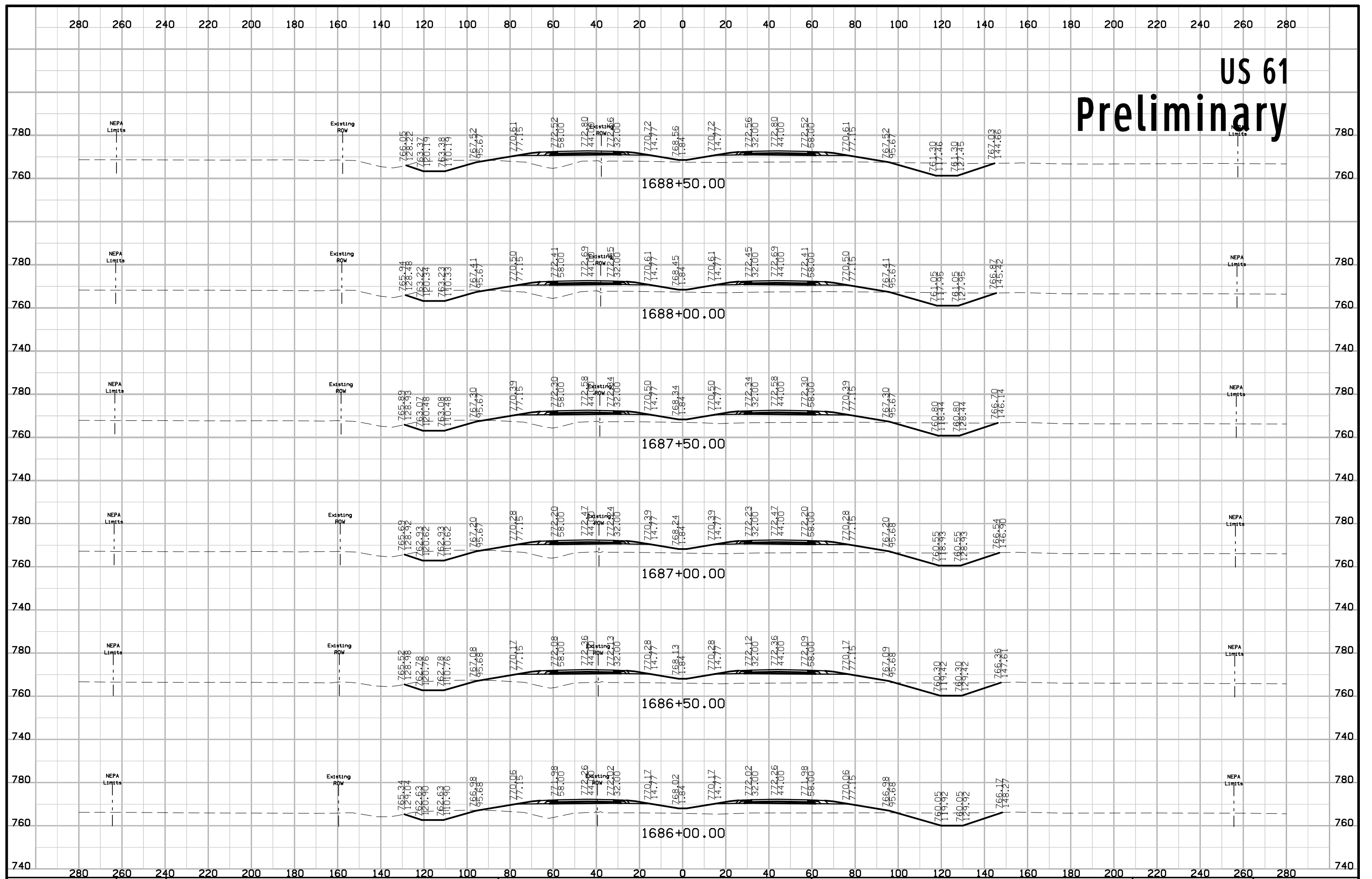

US 61 Preliminary

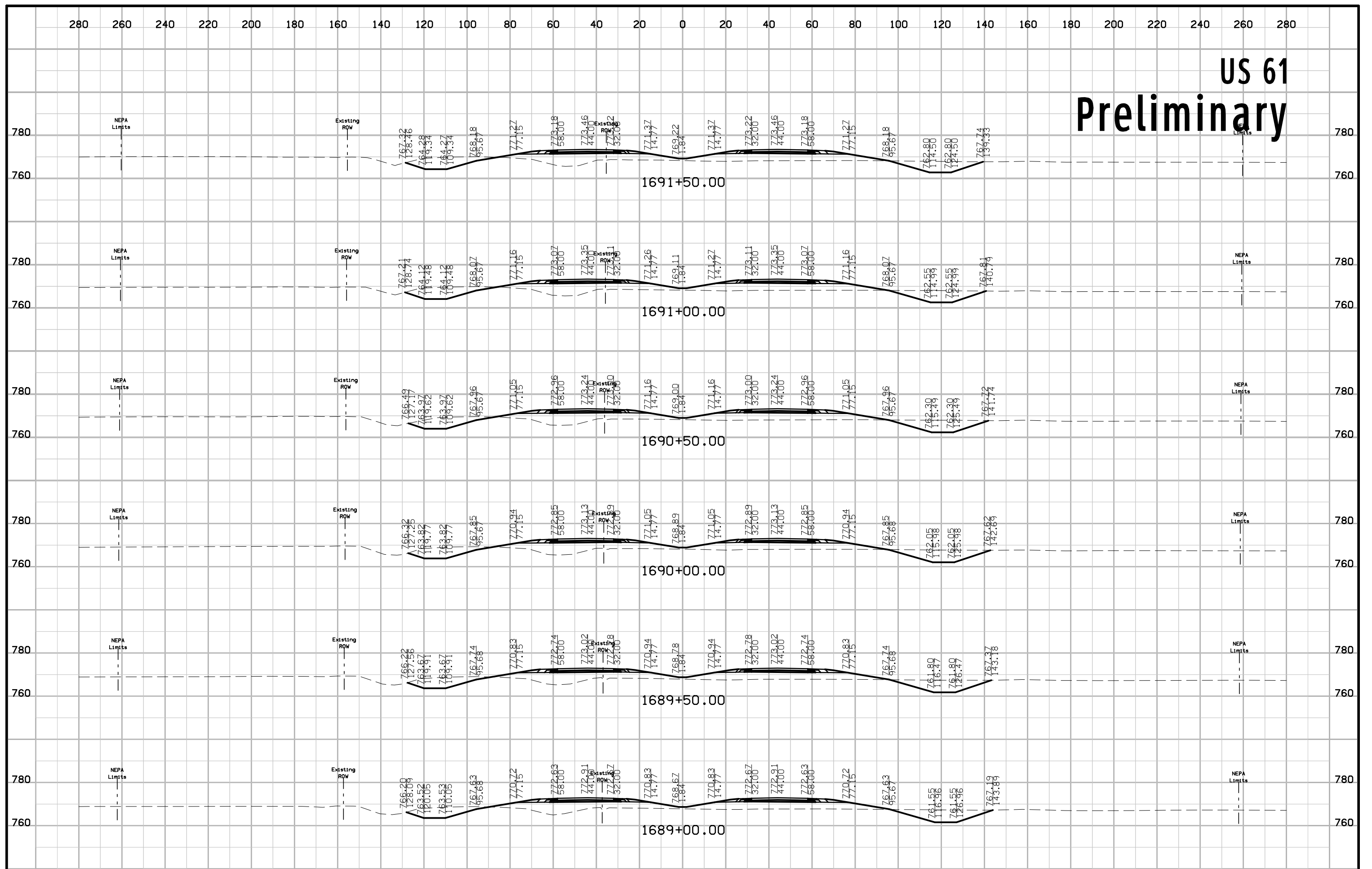

US 61 Preliminary

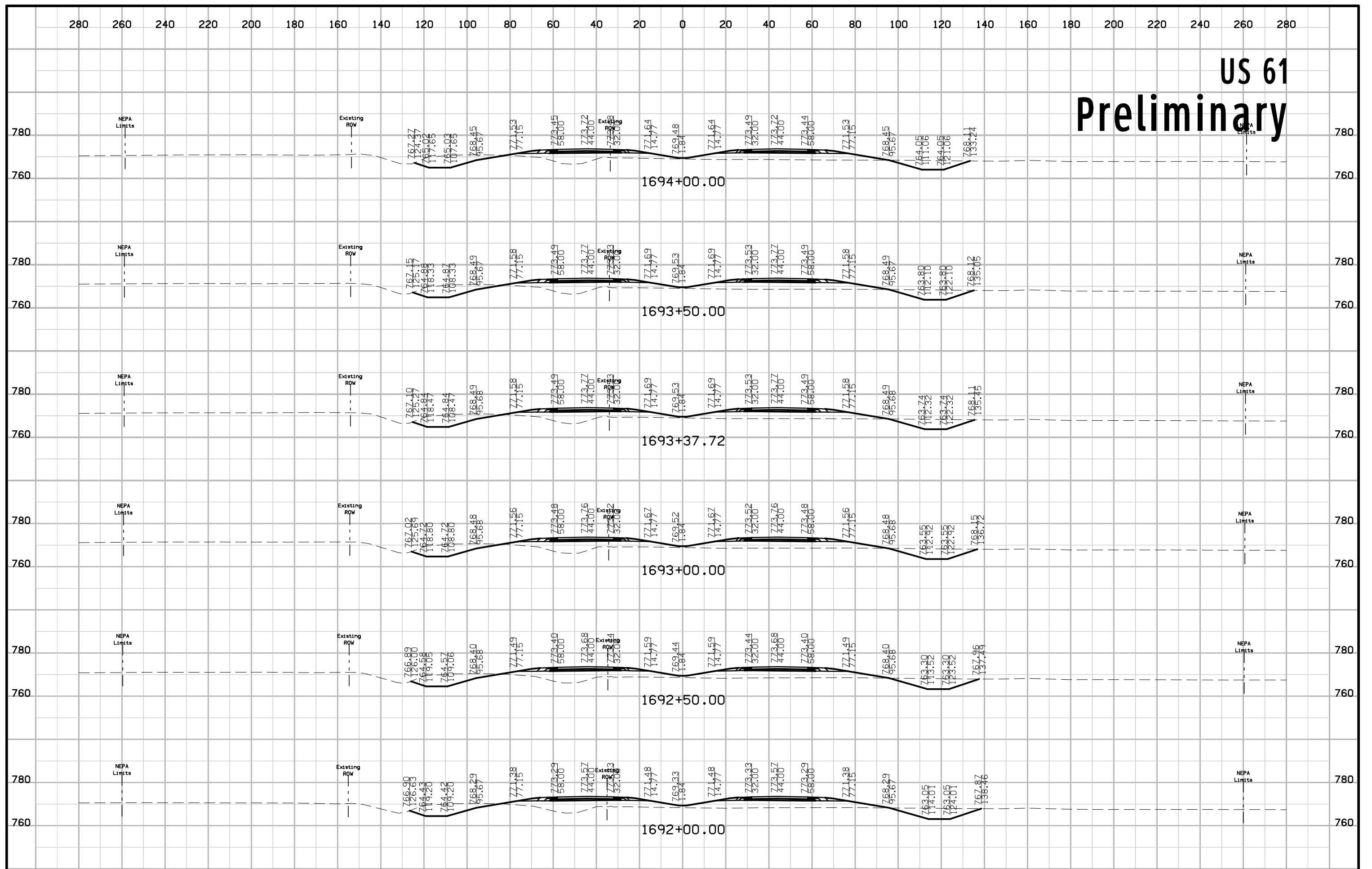

US 61 Preliminary

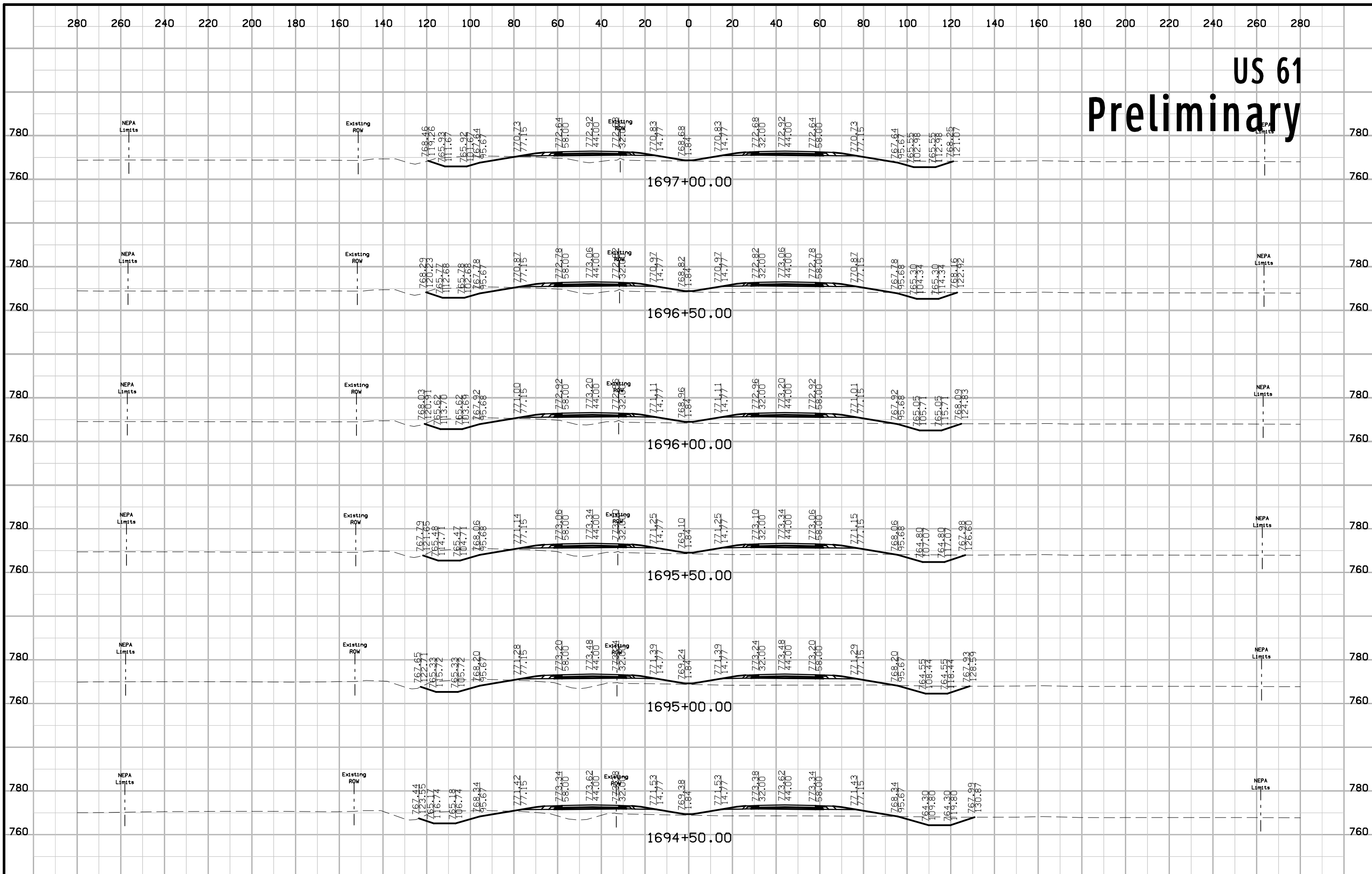

US 61 Preliminary

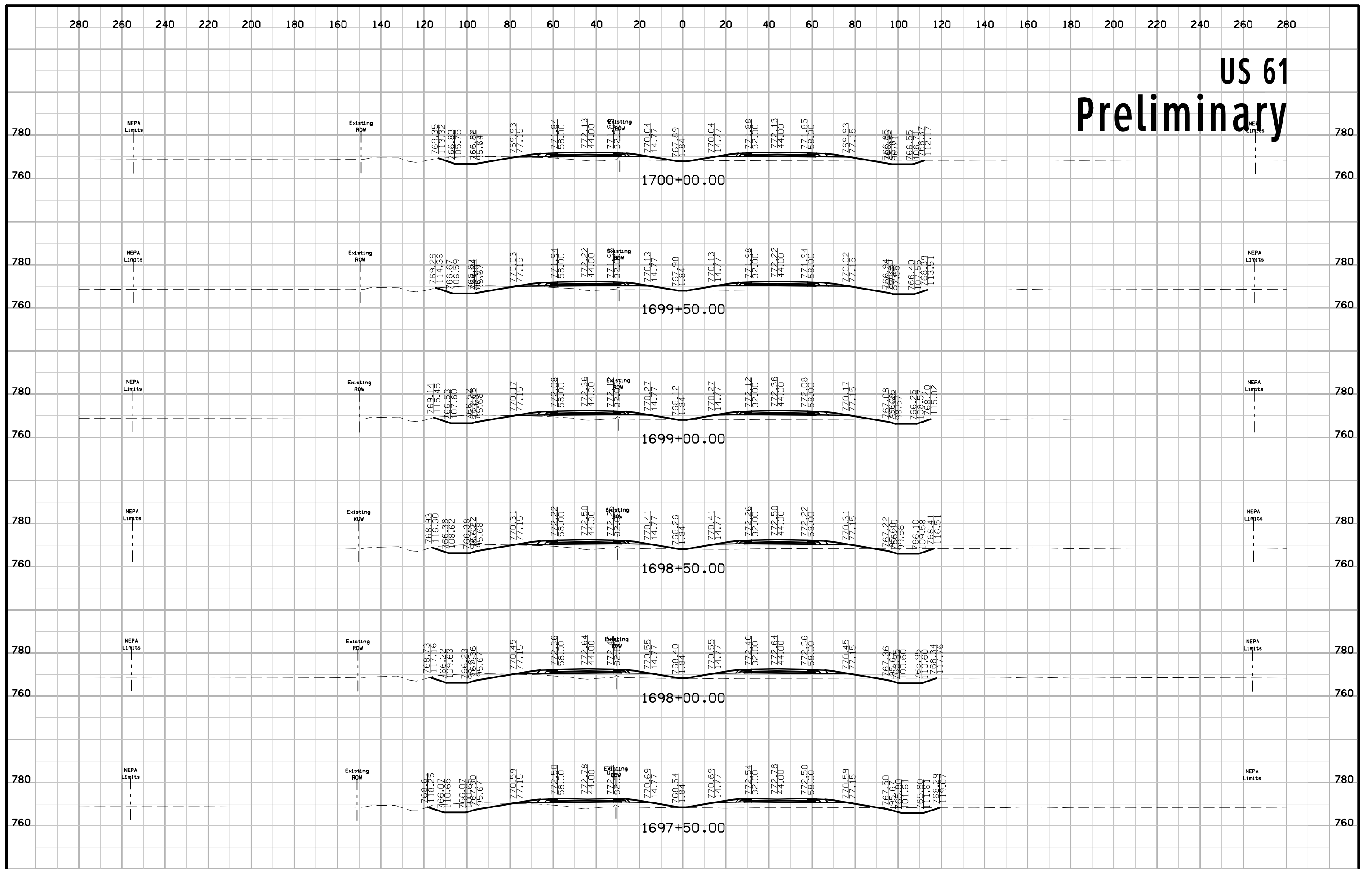

US 61 Preliminary

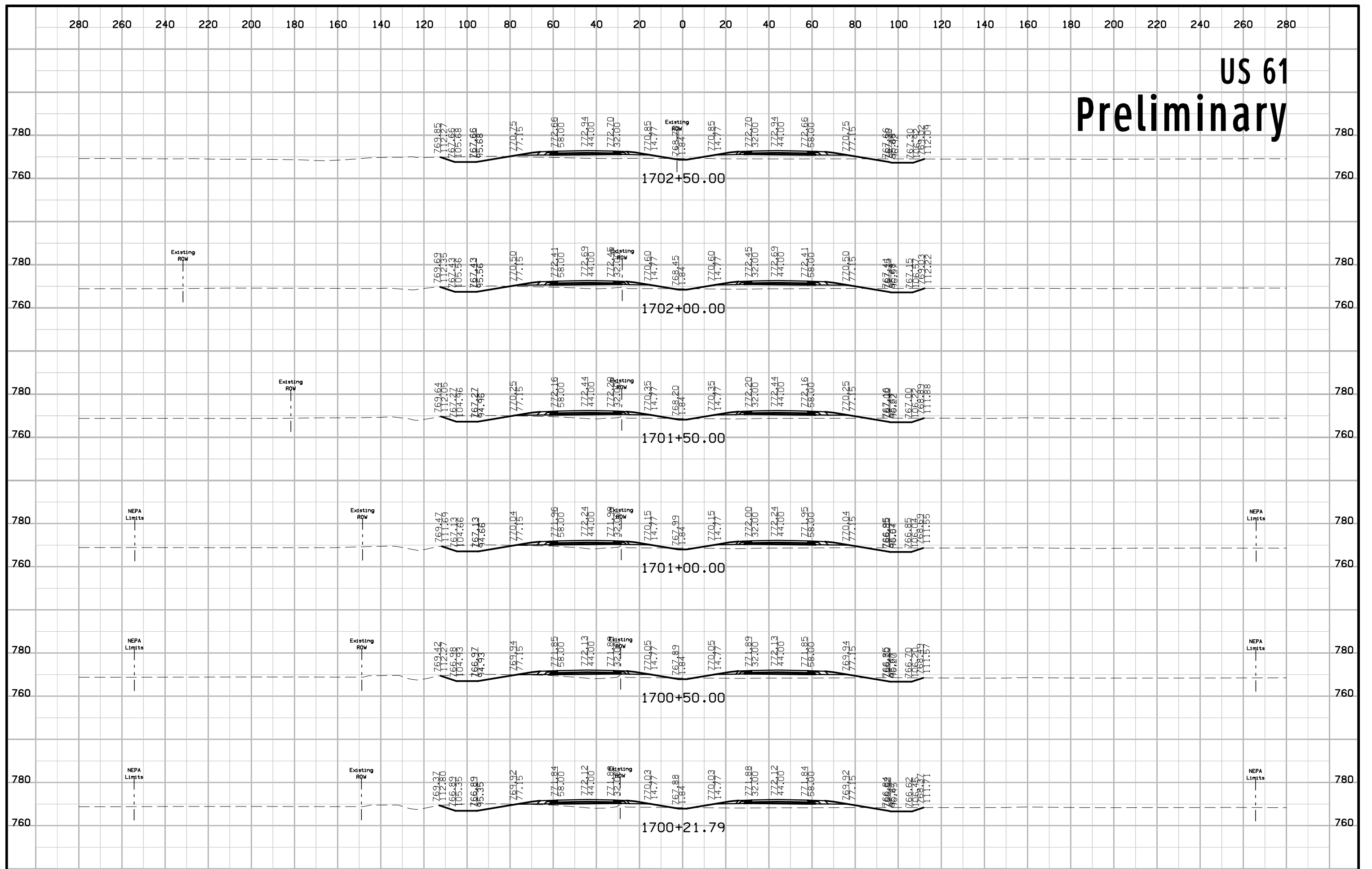

US 61 Preliminary

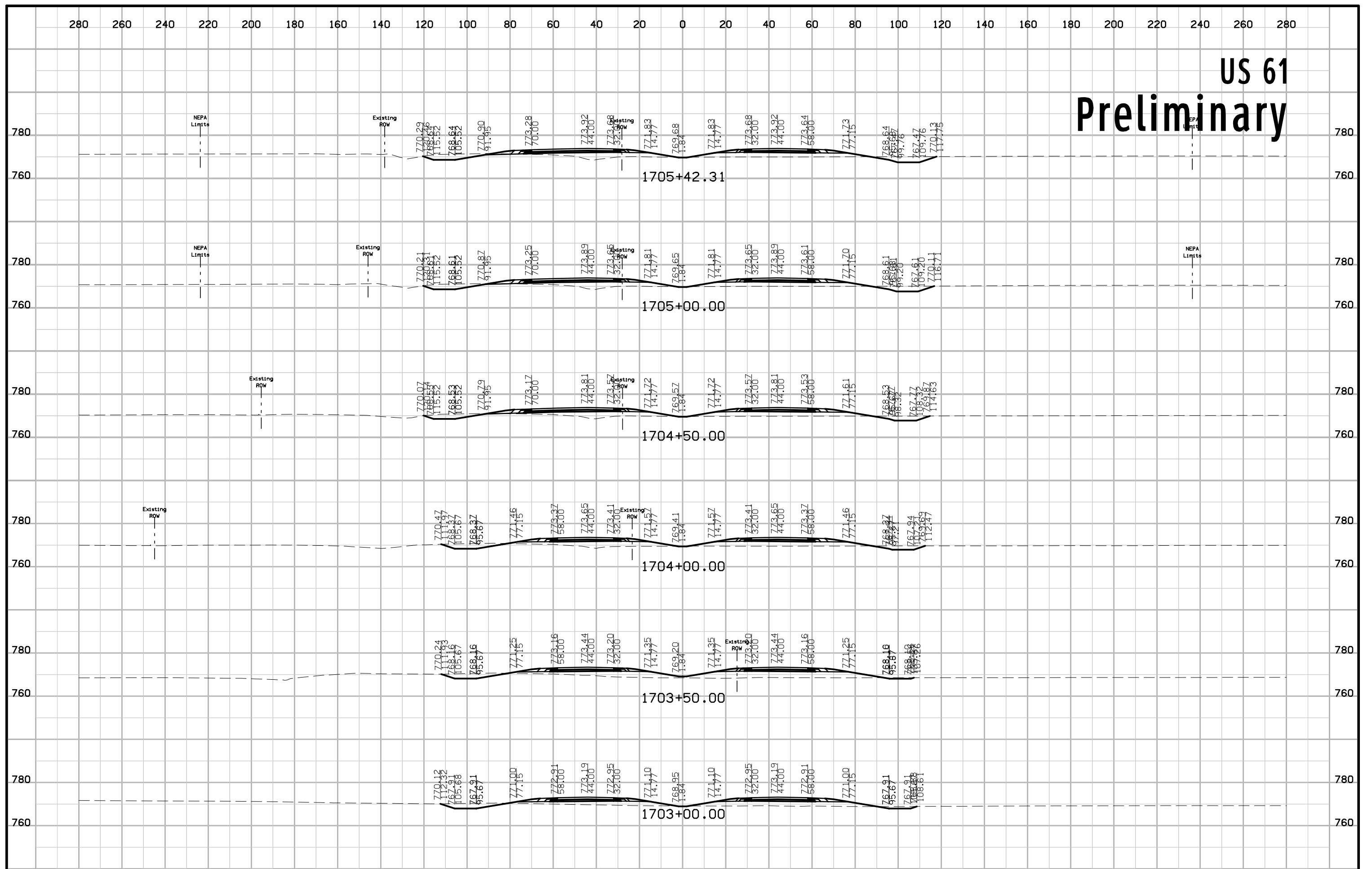

US 61 Preliminary

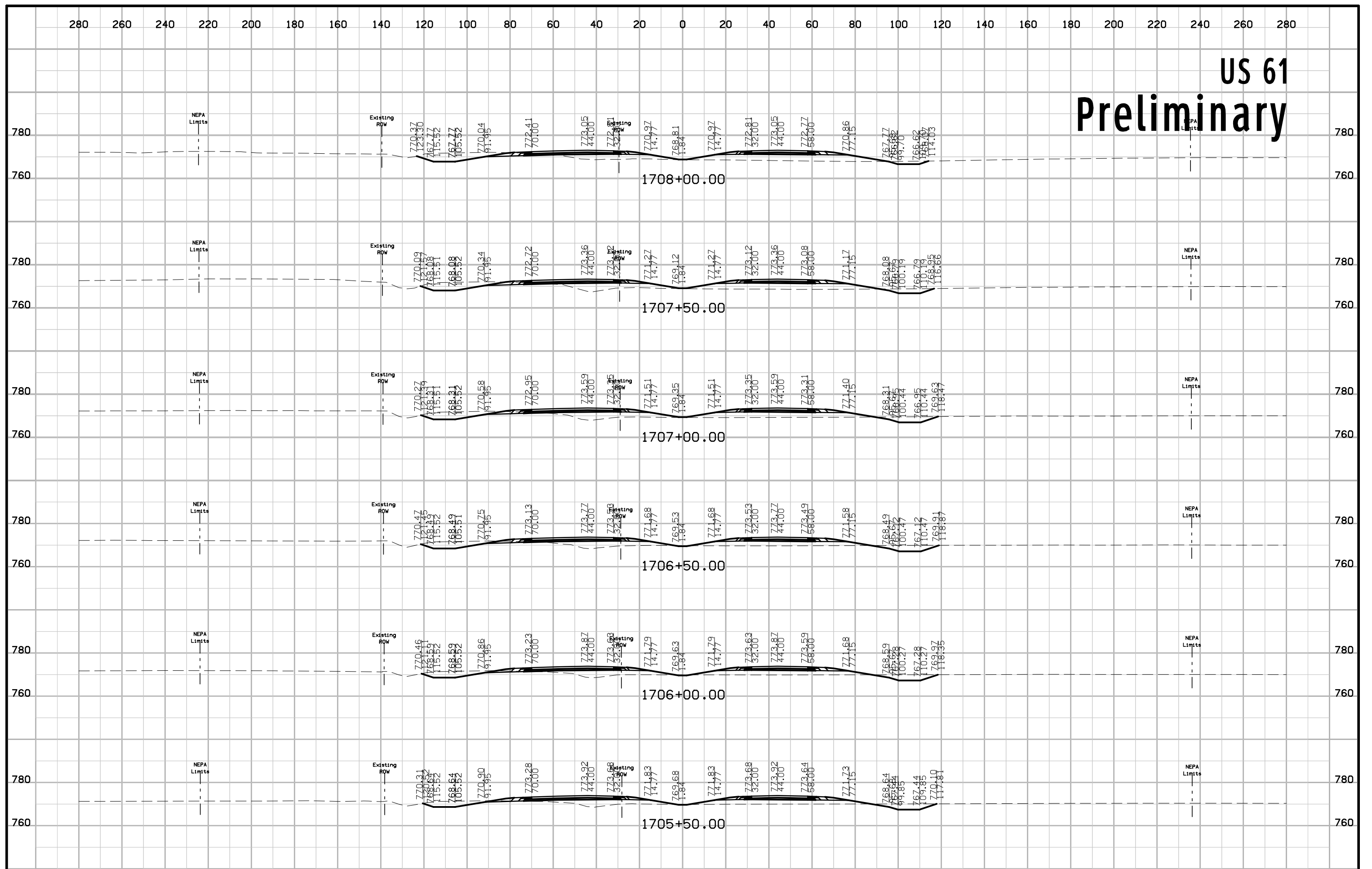

US 61 Preliminary

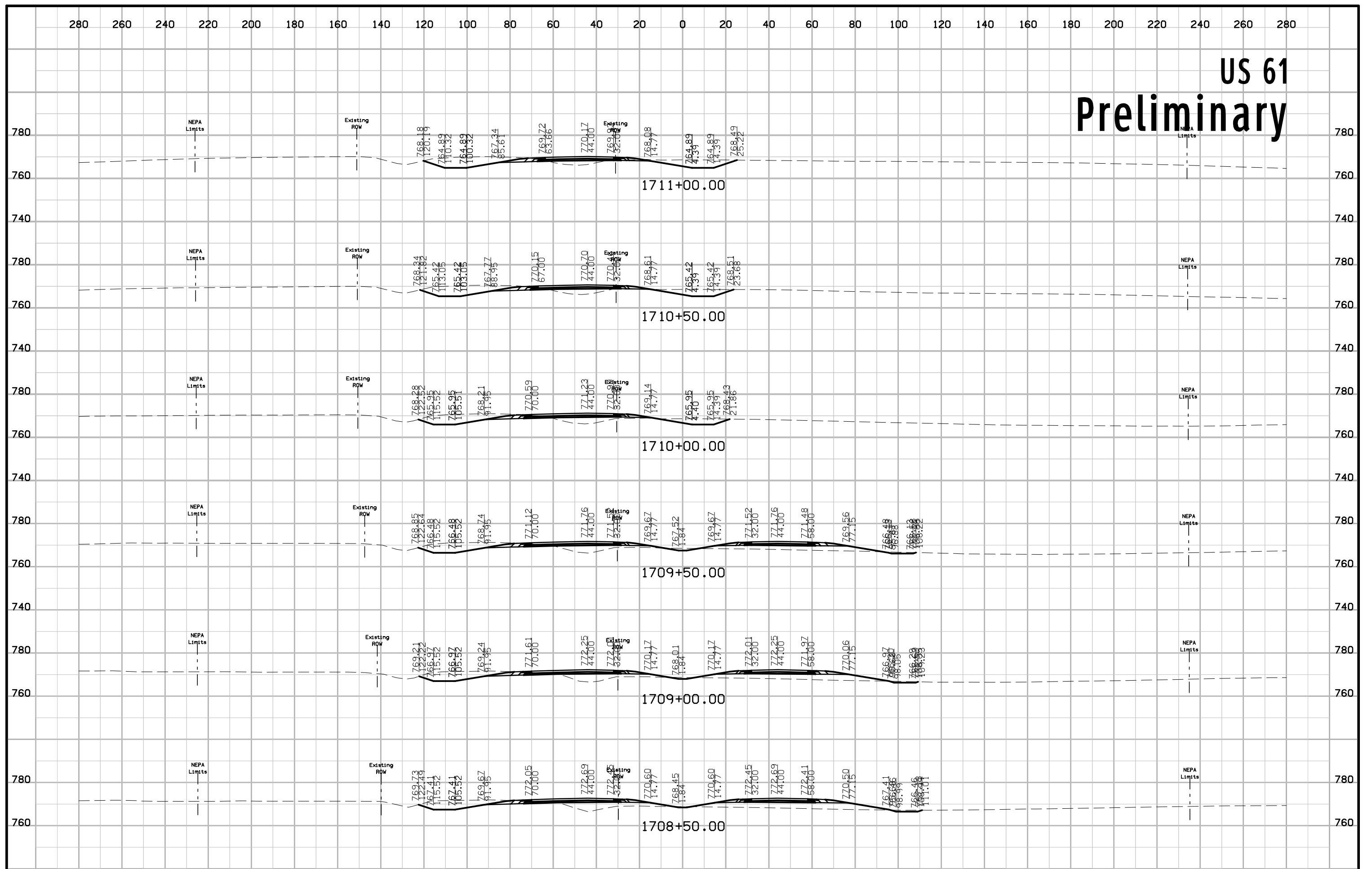

US 61 Preliminary

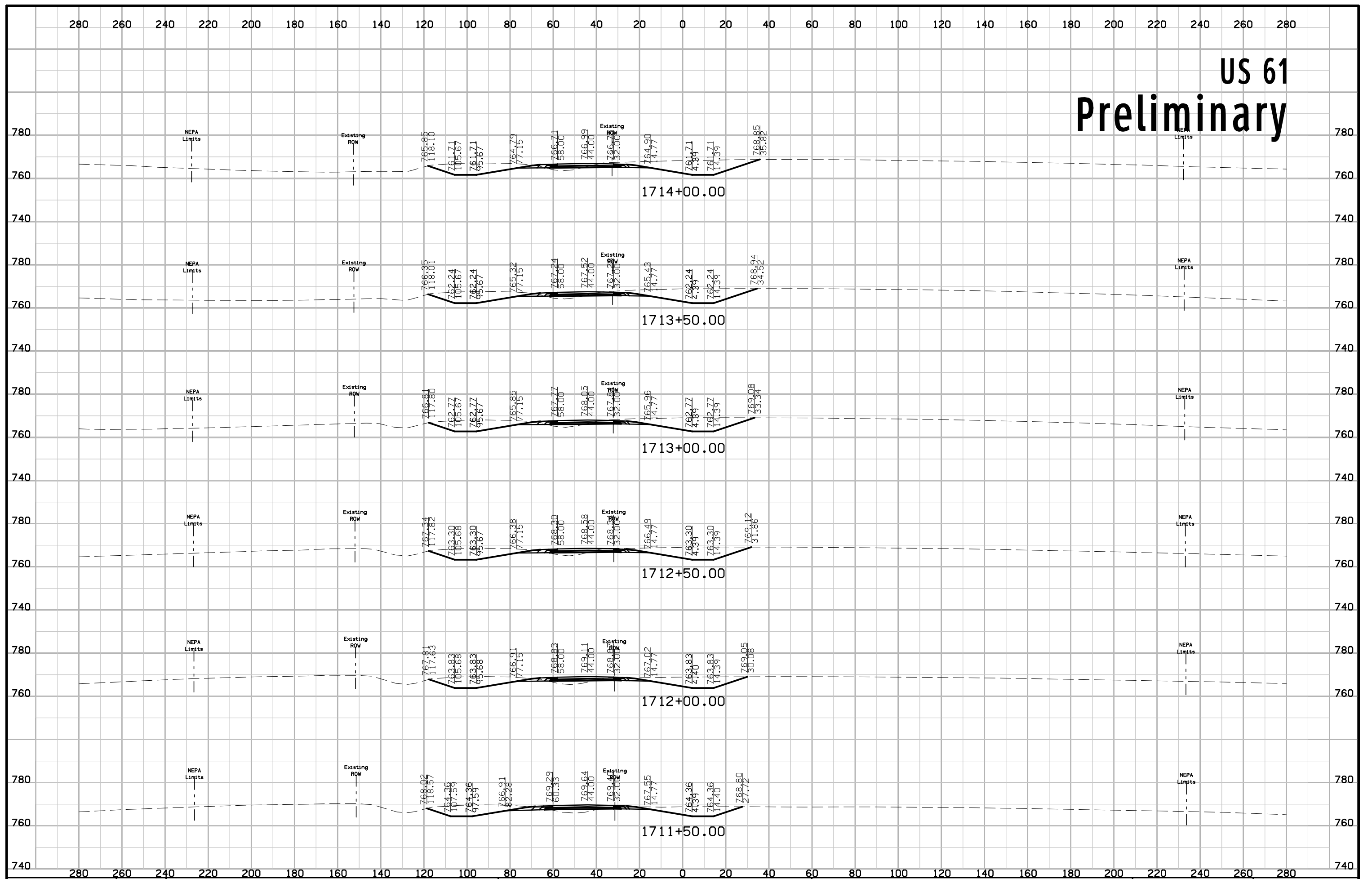

US 61 Preliminary

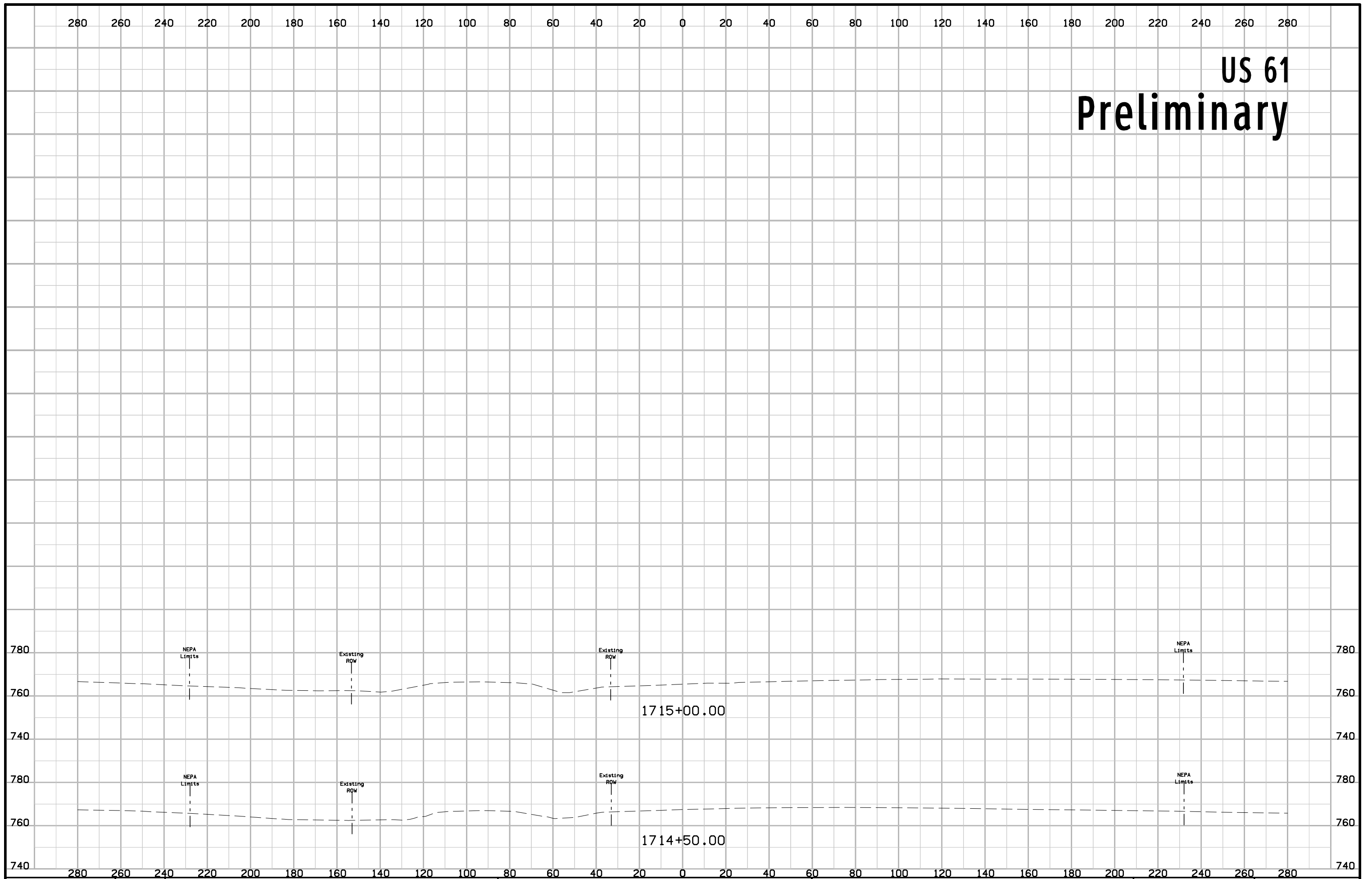

Mark Twain Dr Preliminary

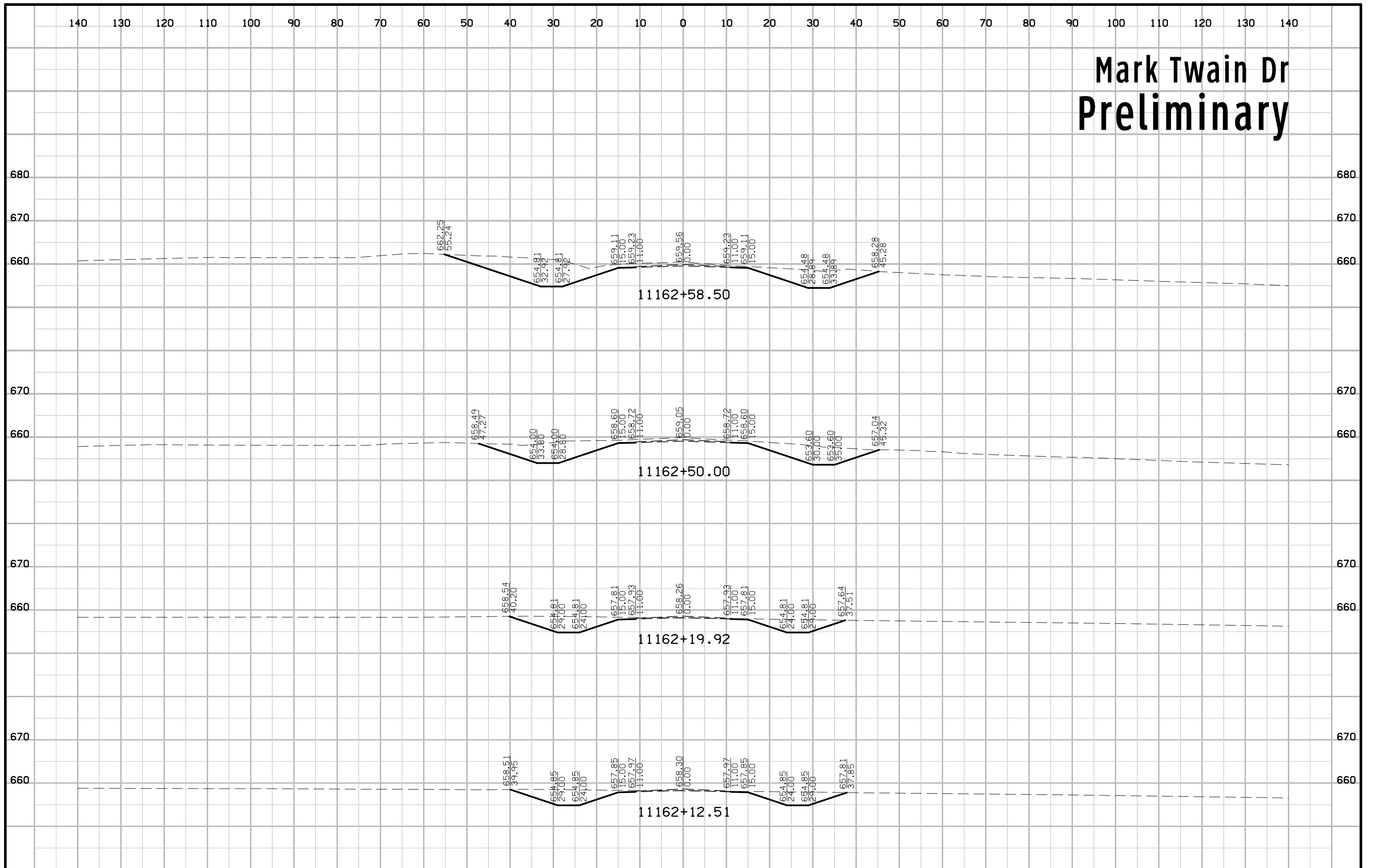

Mark Twain Dr Preliminary

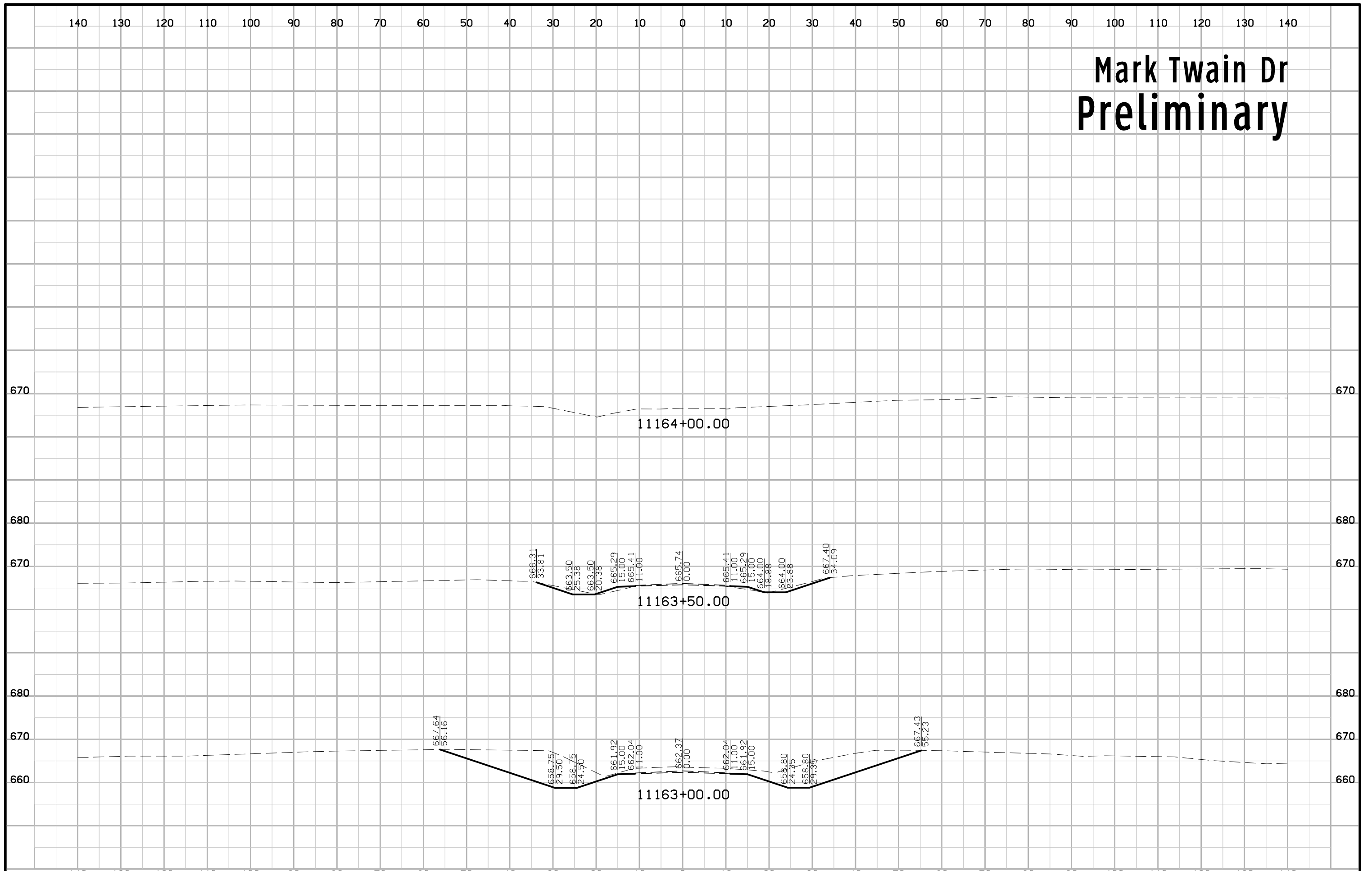

Memorial Park Rd / Lakeside Dr Preliminary

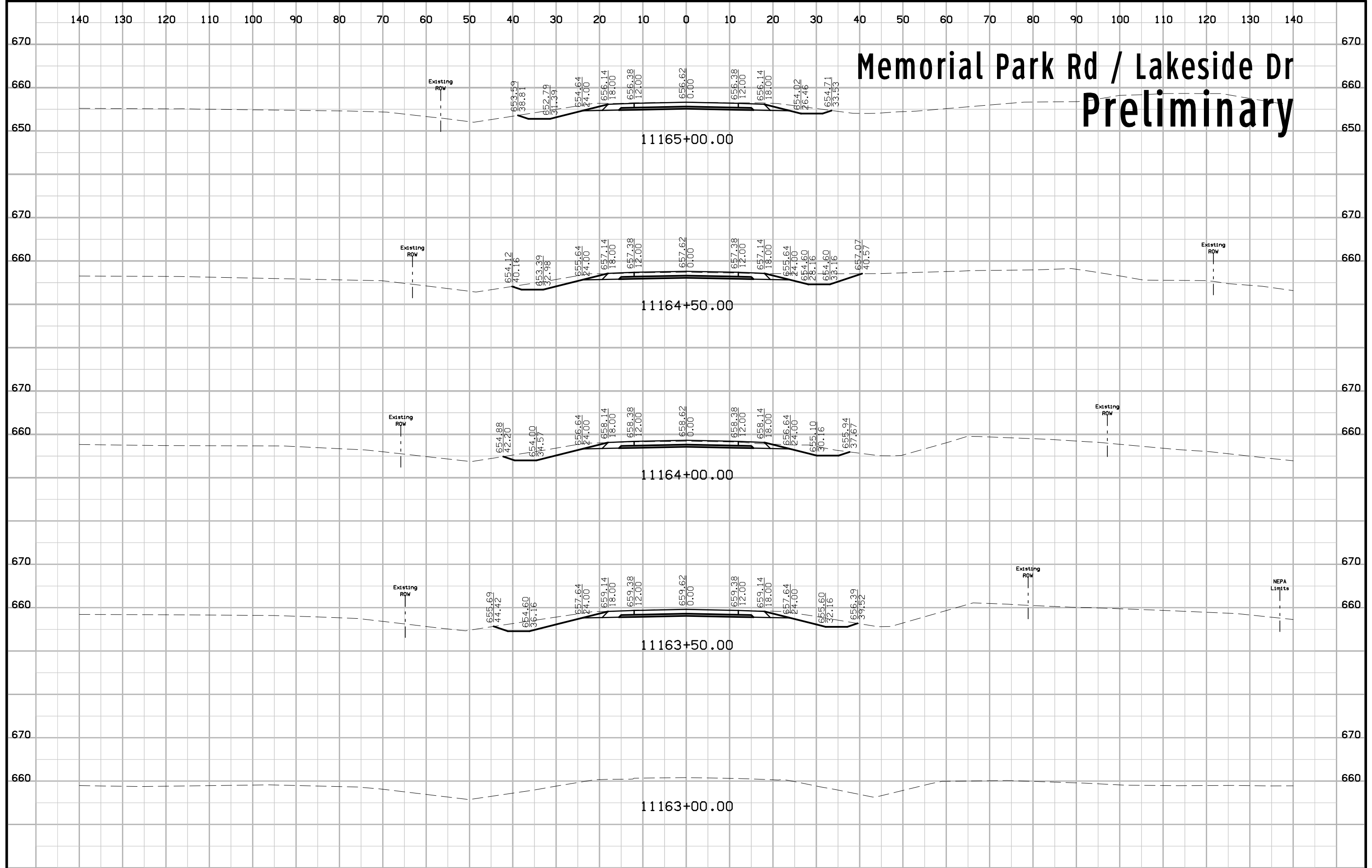

Memorial Park Rd / Lakeside Dr Preliminary

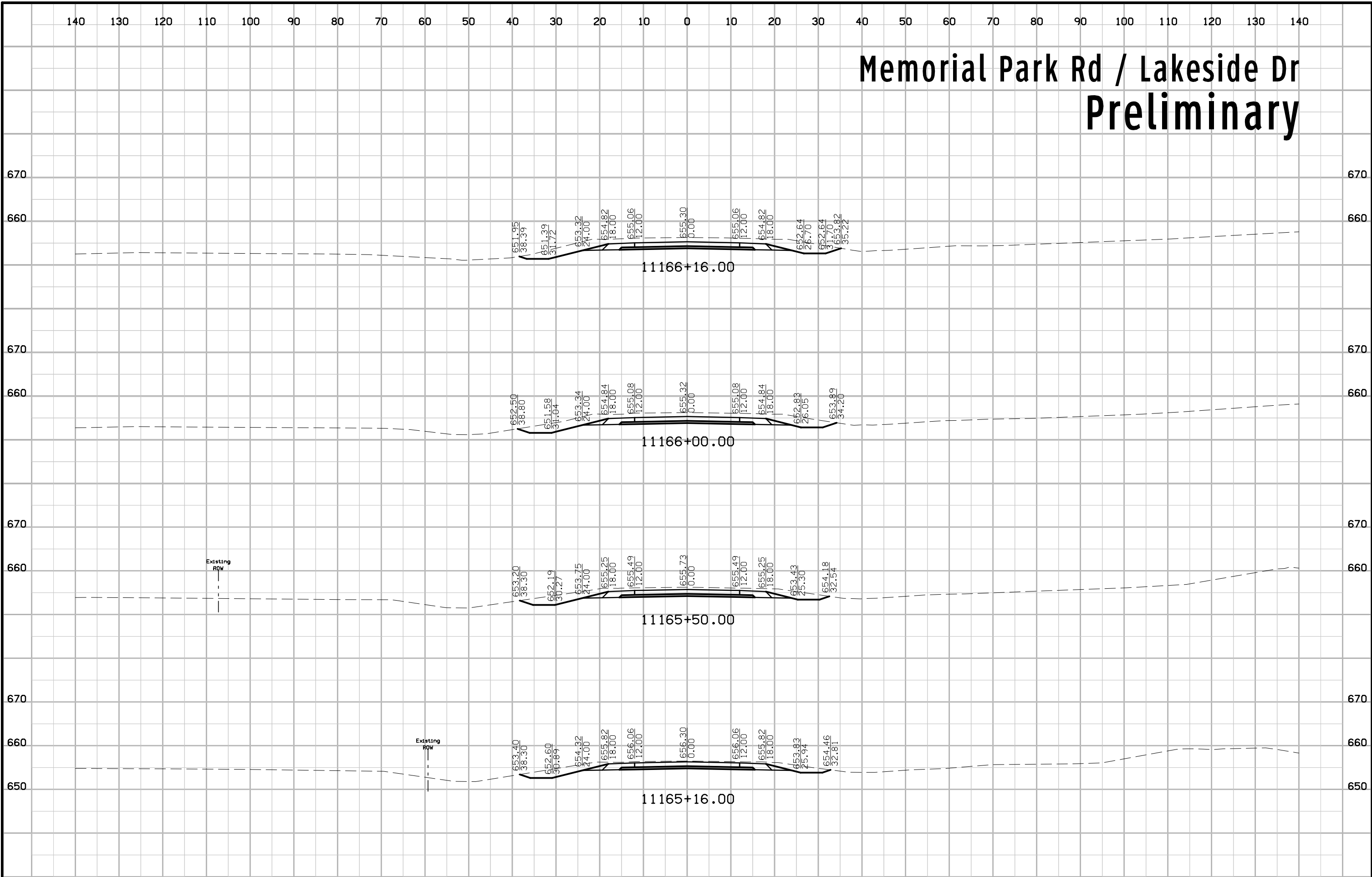

Memorial Park Rd / Lakeside Dr Preliminary

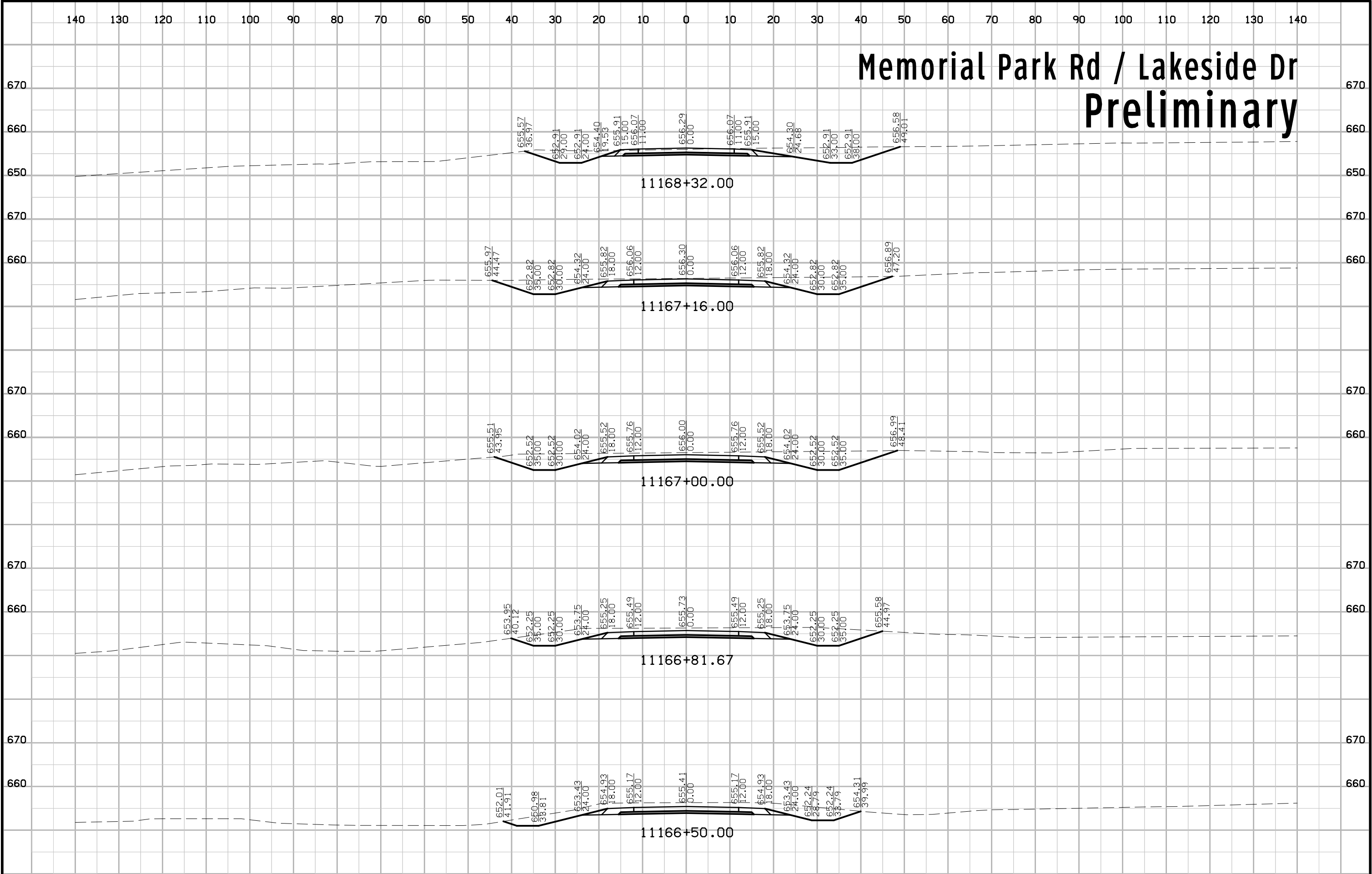

Memorial Park Rd / Lakeside Dr Preliminary

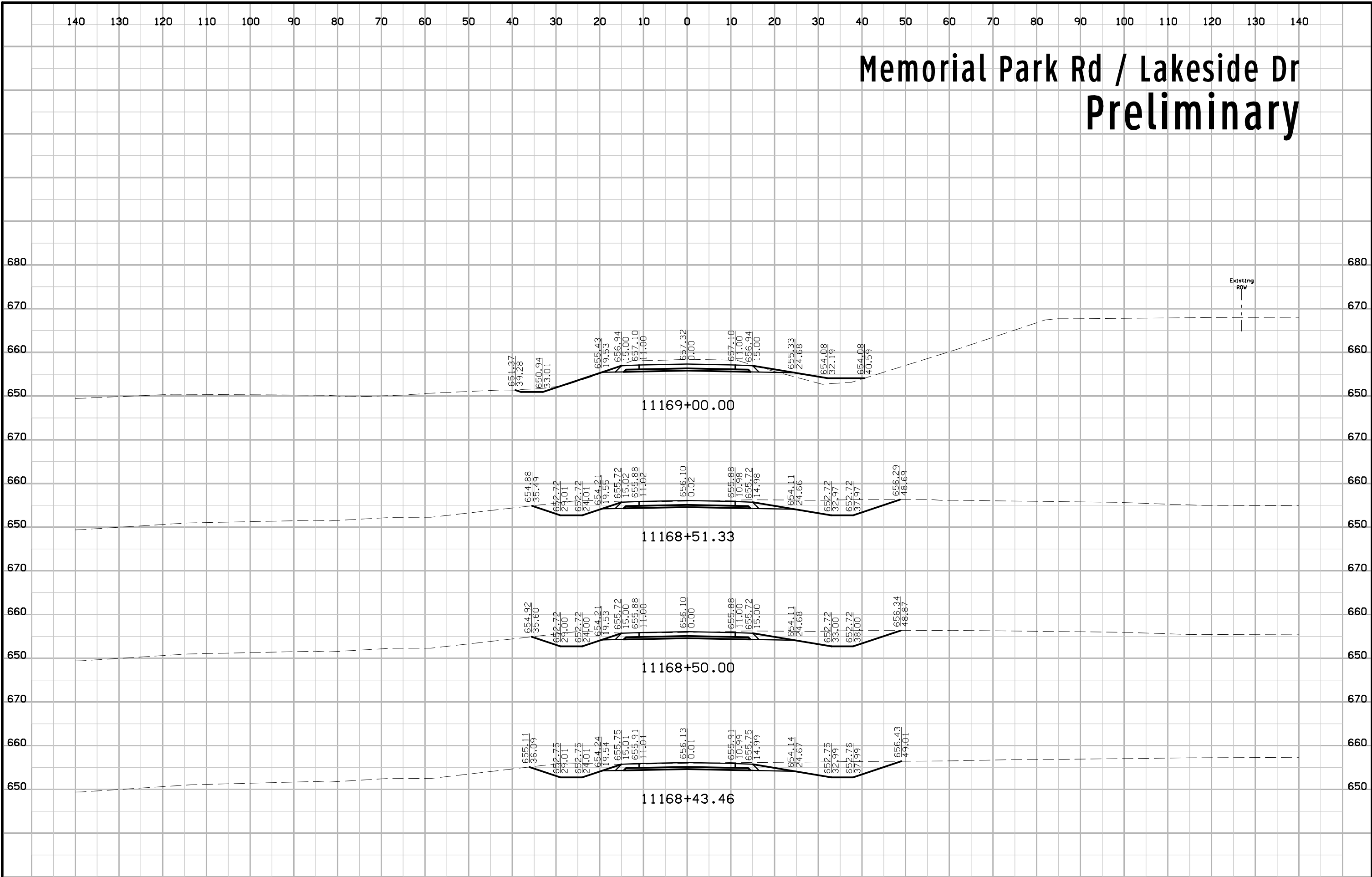

Memorial Park Rd / Lakeside Dr Preliminary

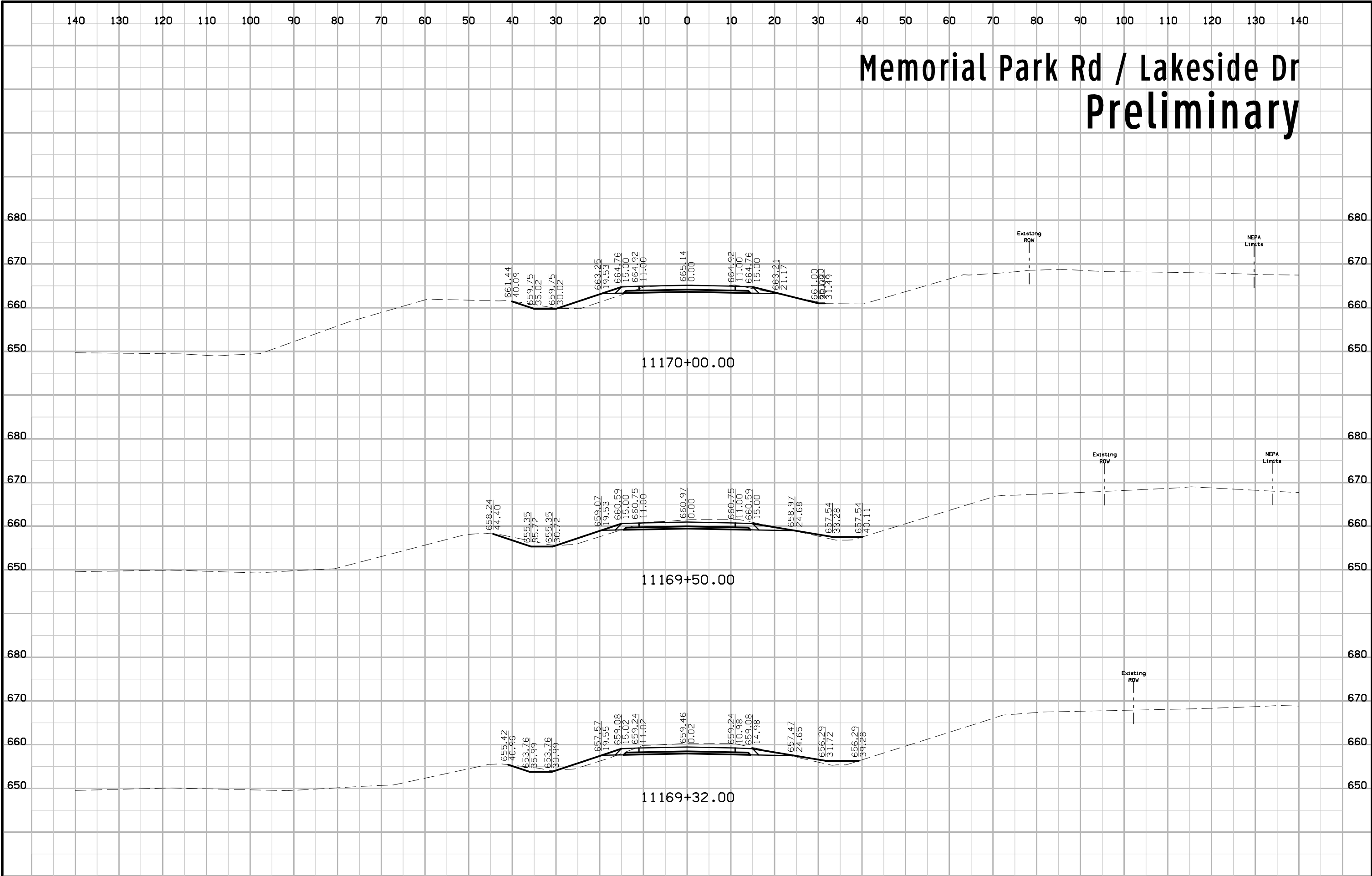

140 130 120 110 100 90 80 70 60 50 40 30 20 10 0 10 20 30 40 50 60 70 80 90 100 110 120 130 140

Memorial Park Rd / Lakeside Dr Preliminary

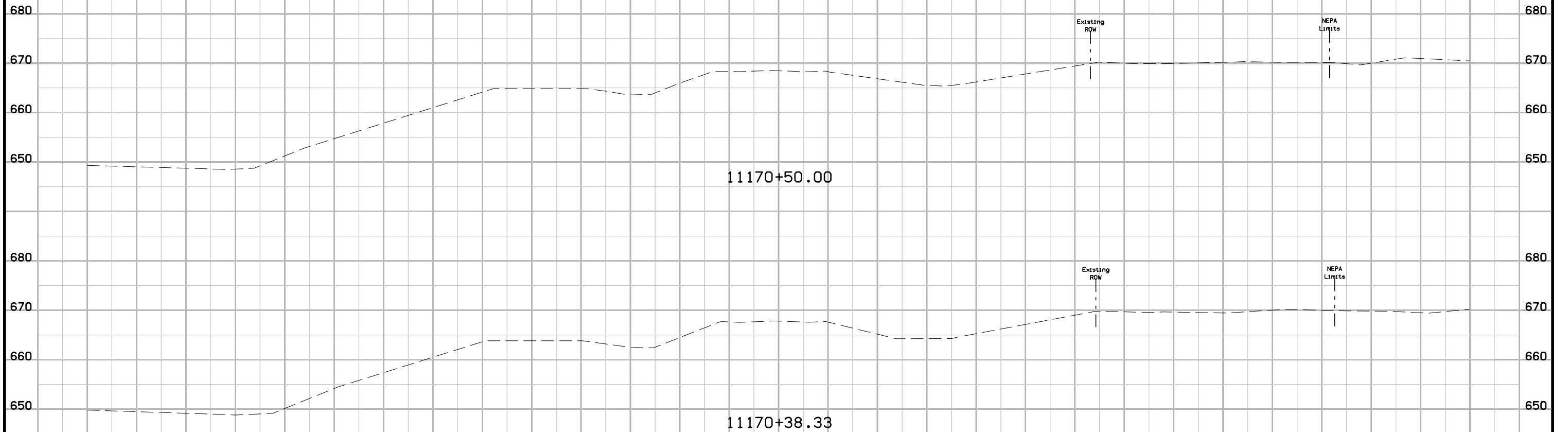

Plank Rd Preliminary

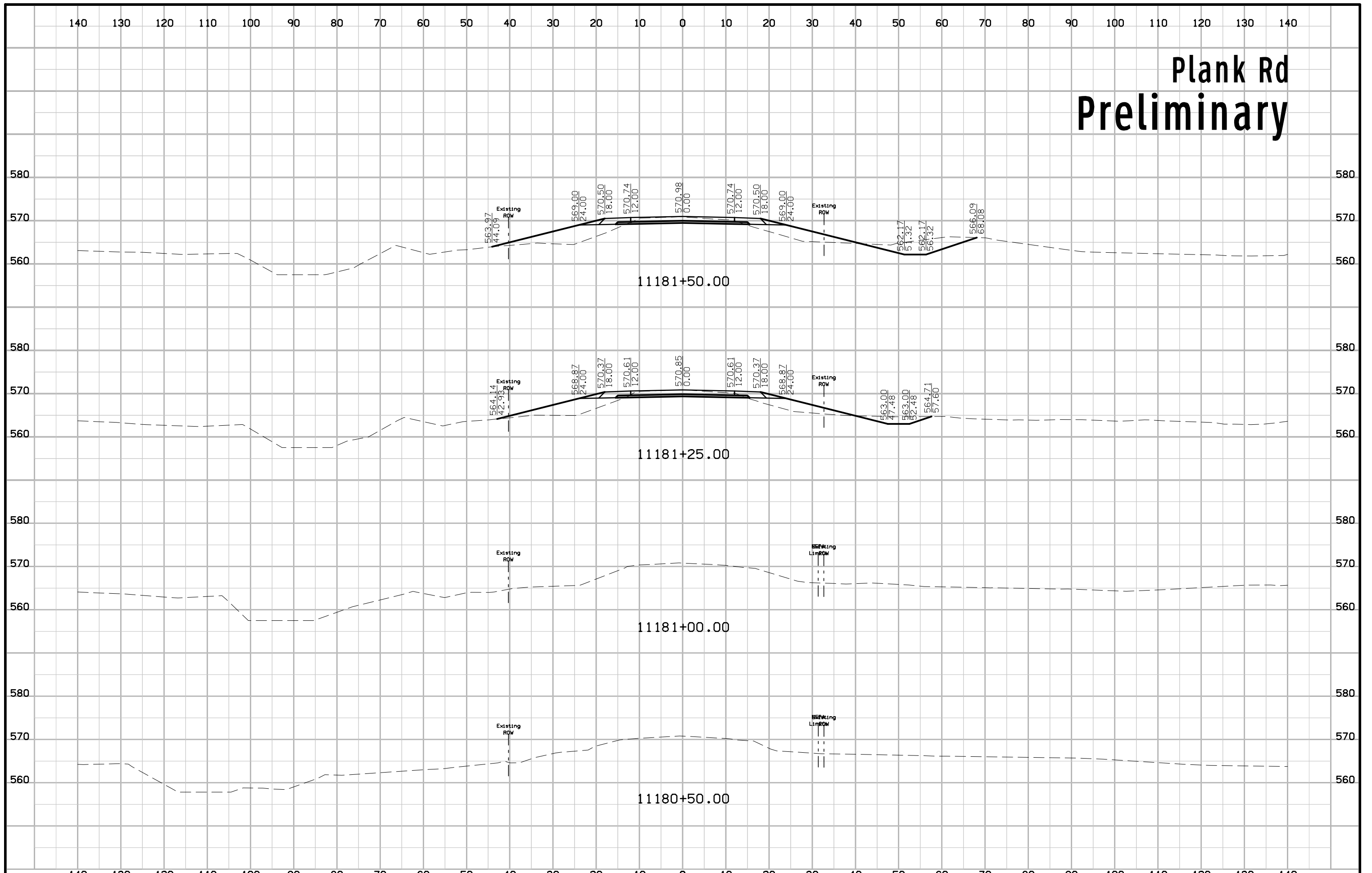

Plank Rd Preliminary

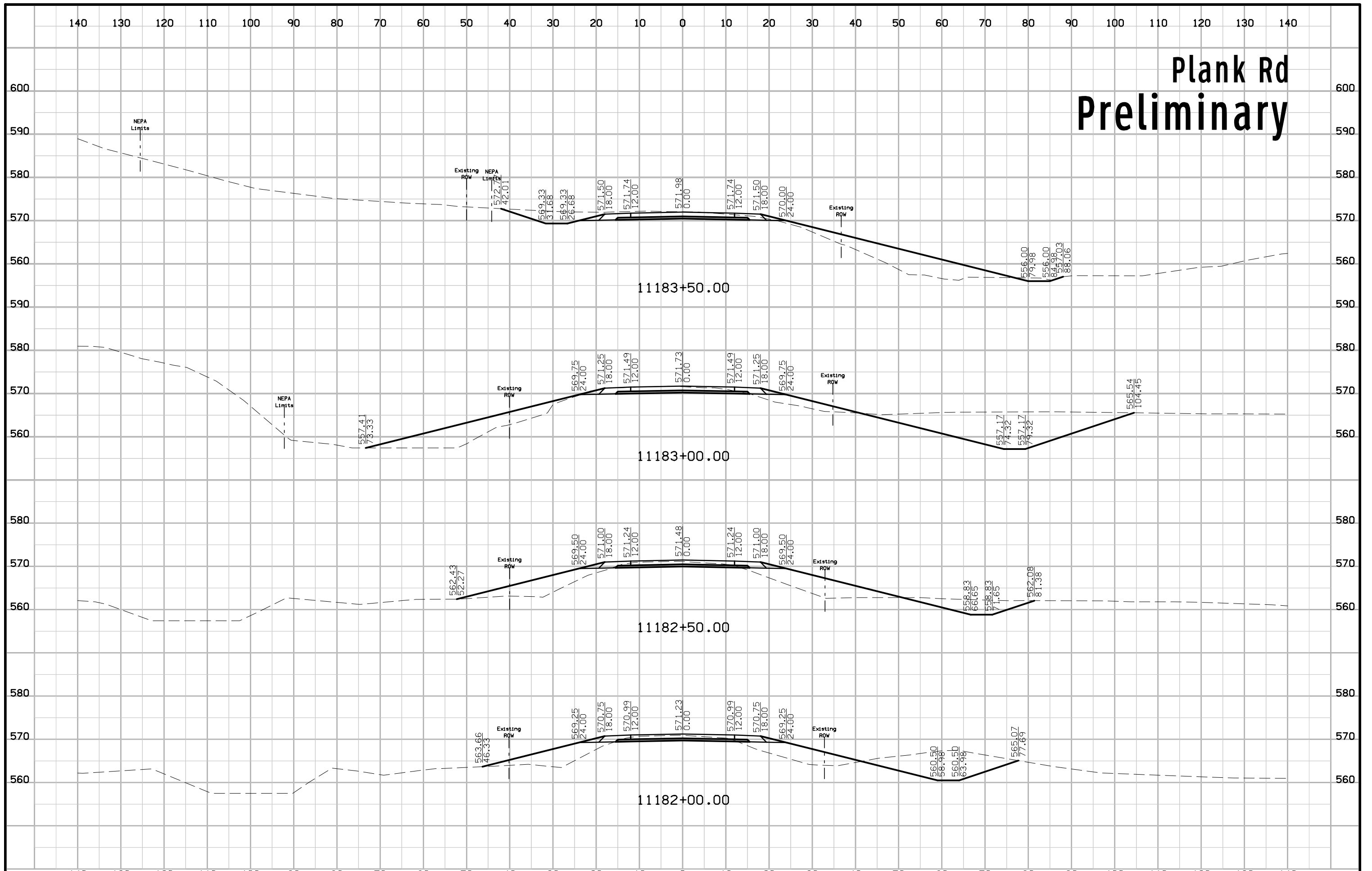

Plank Rd Preliminary

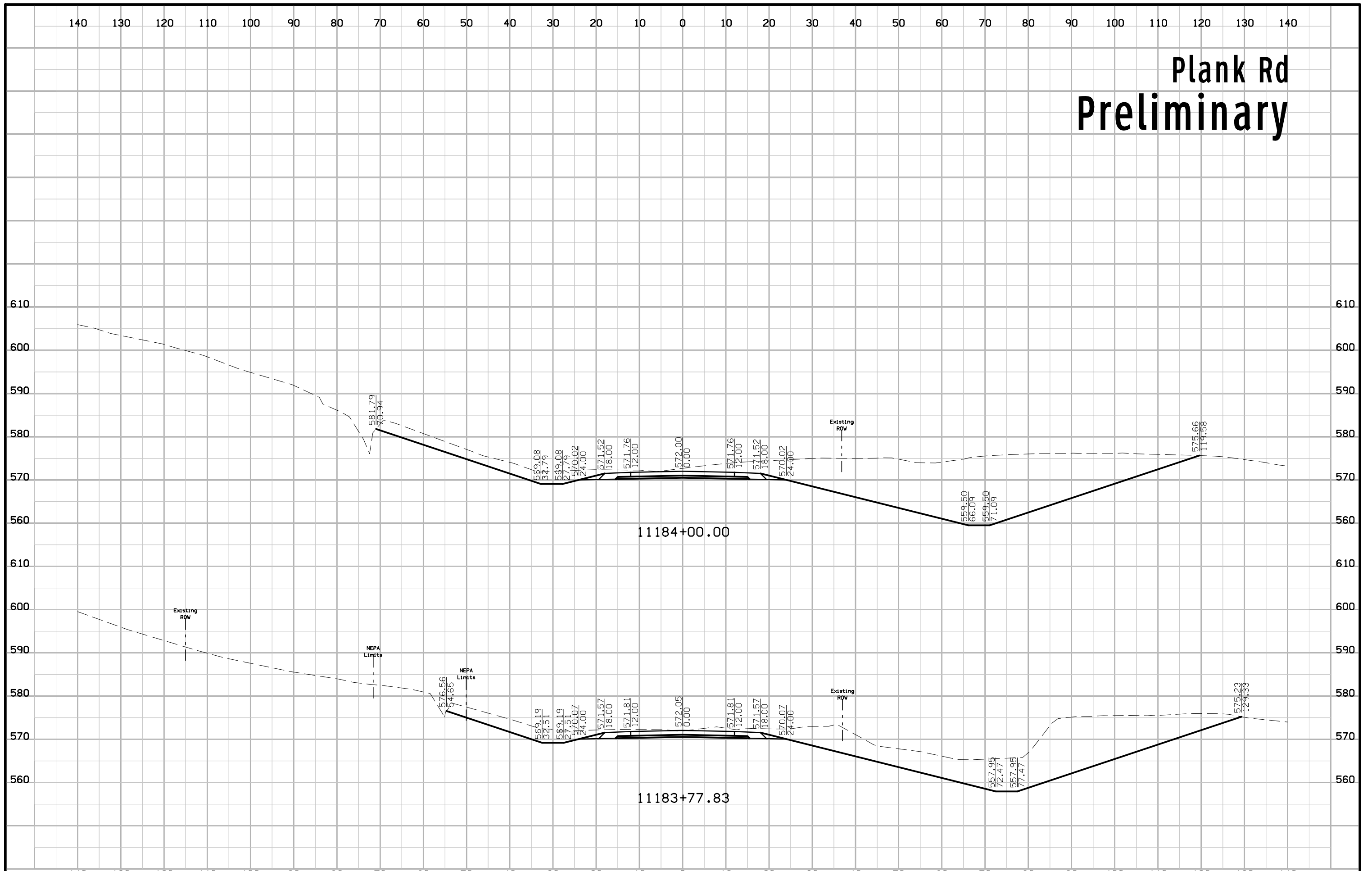

Plank Rd Preliminary

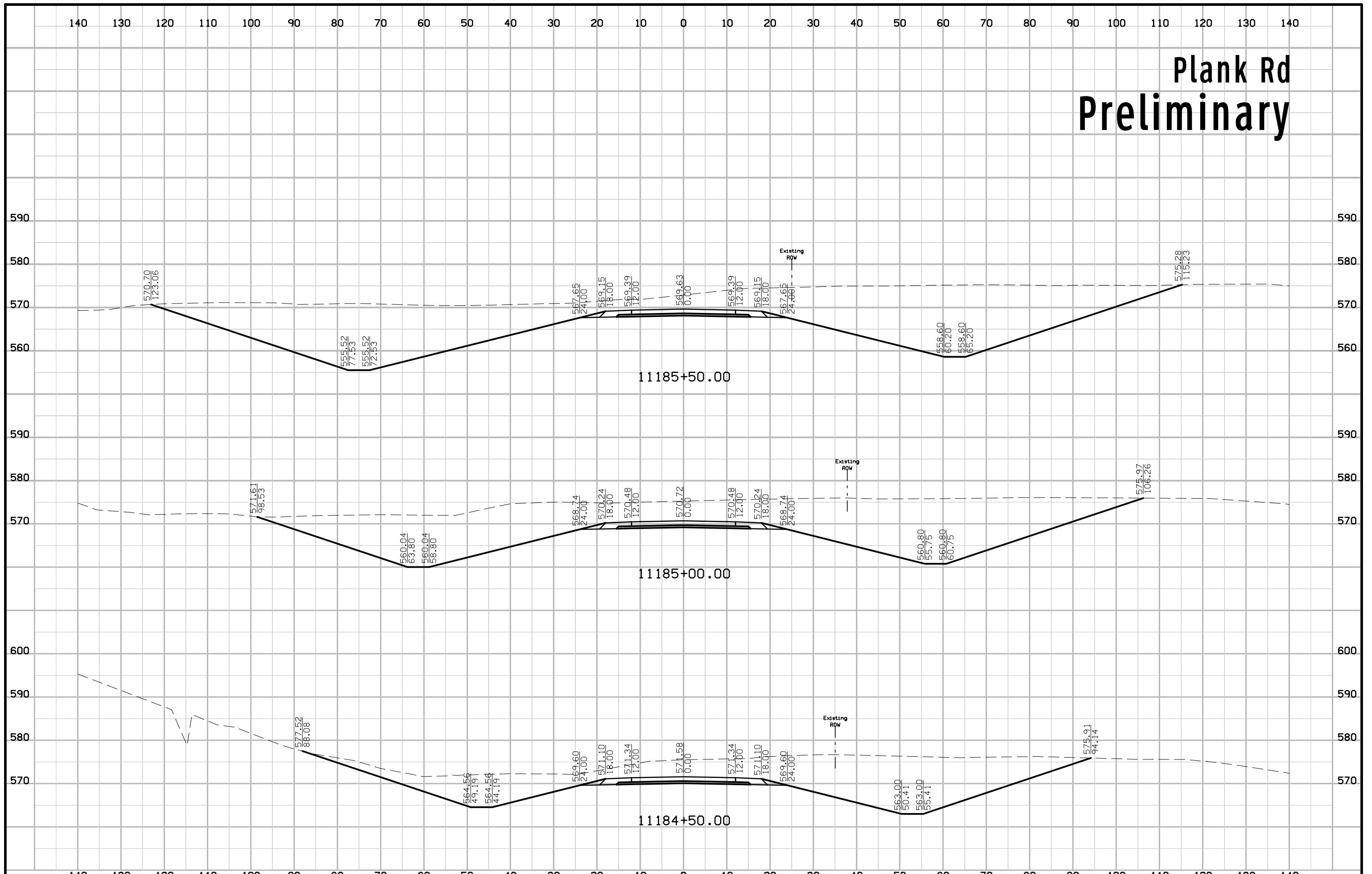

Plank Rd Preliminary

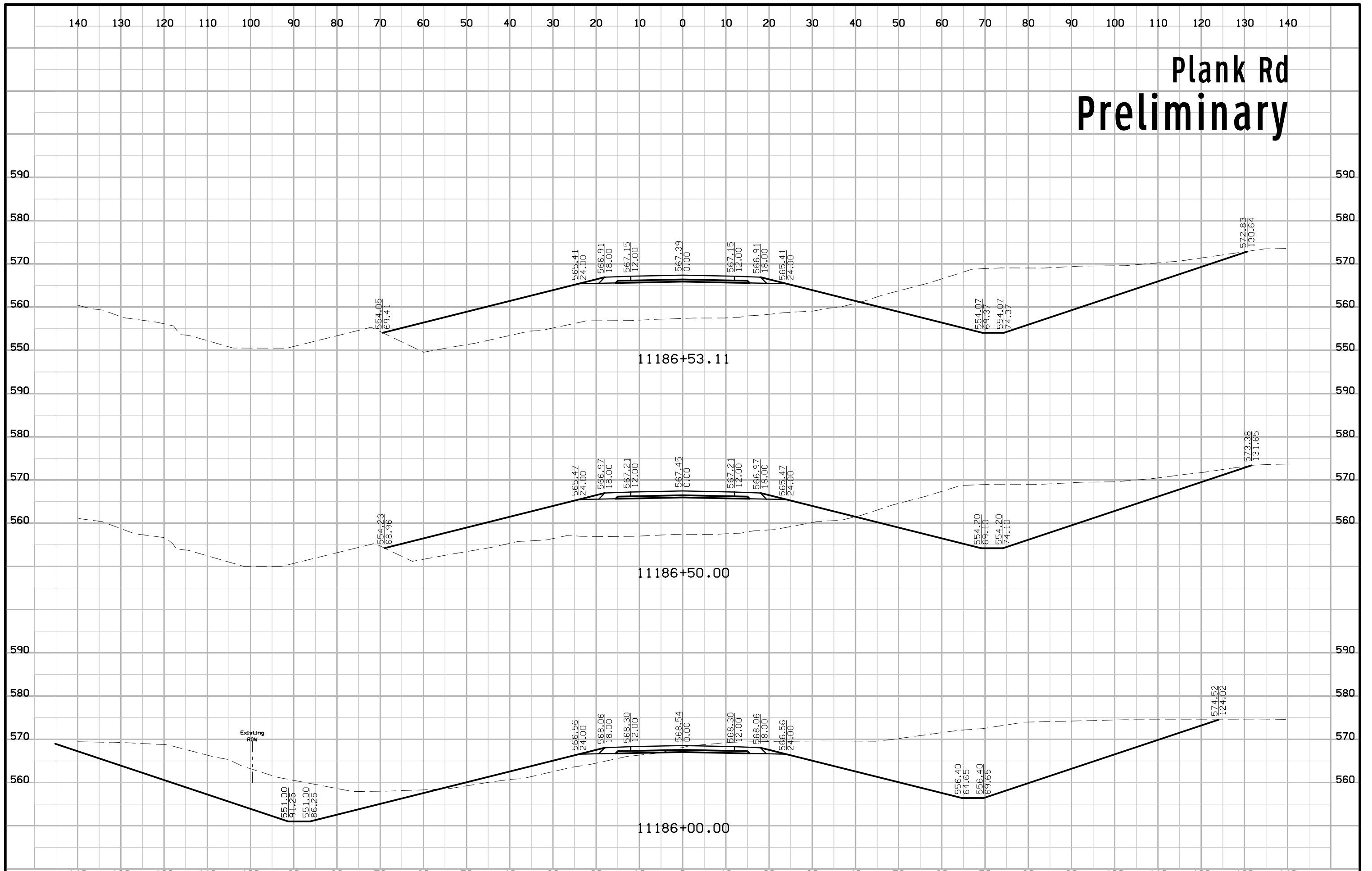

Plank Rd Preliminary

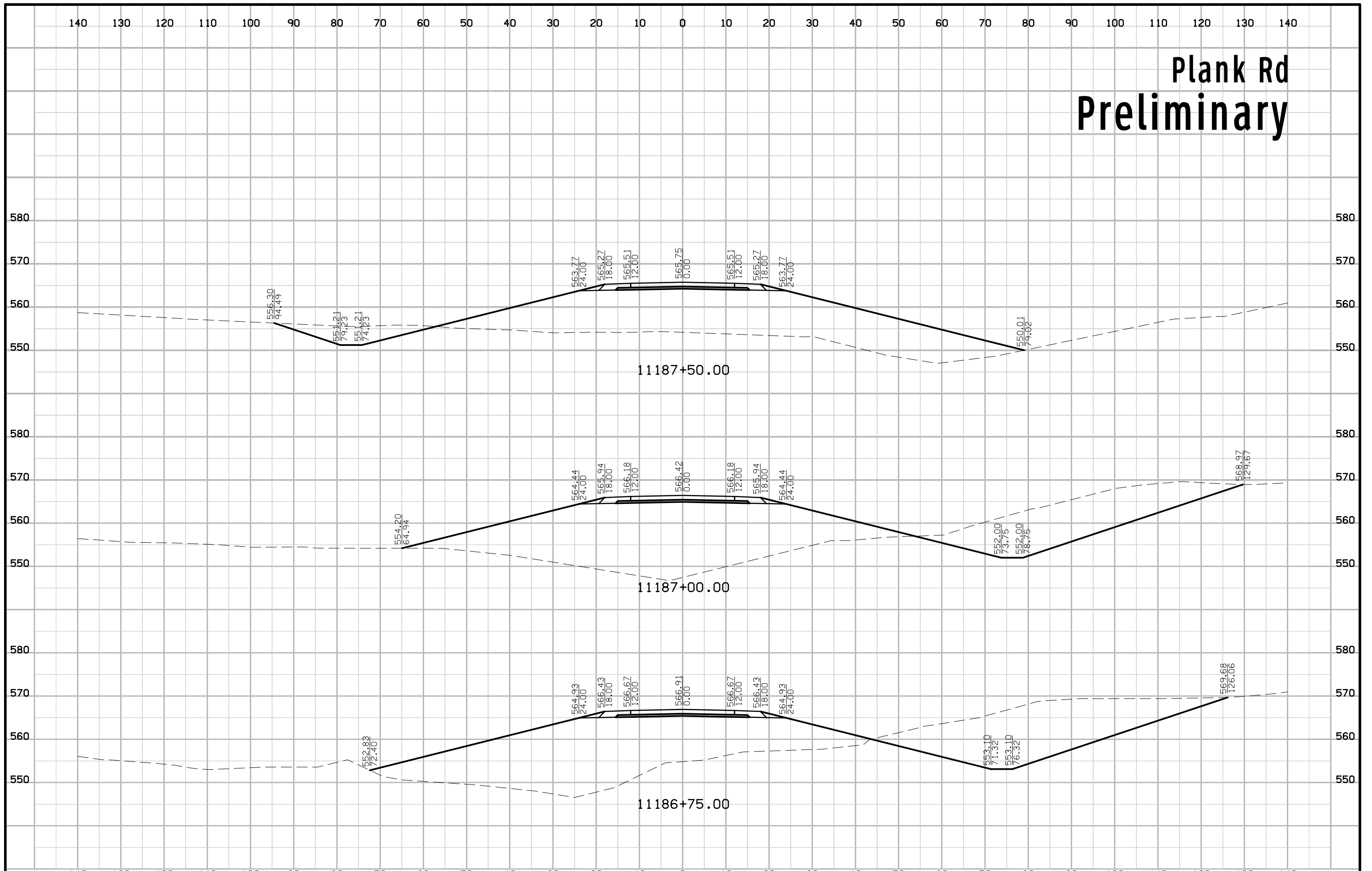

Plank Rd Preliminary

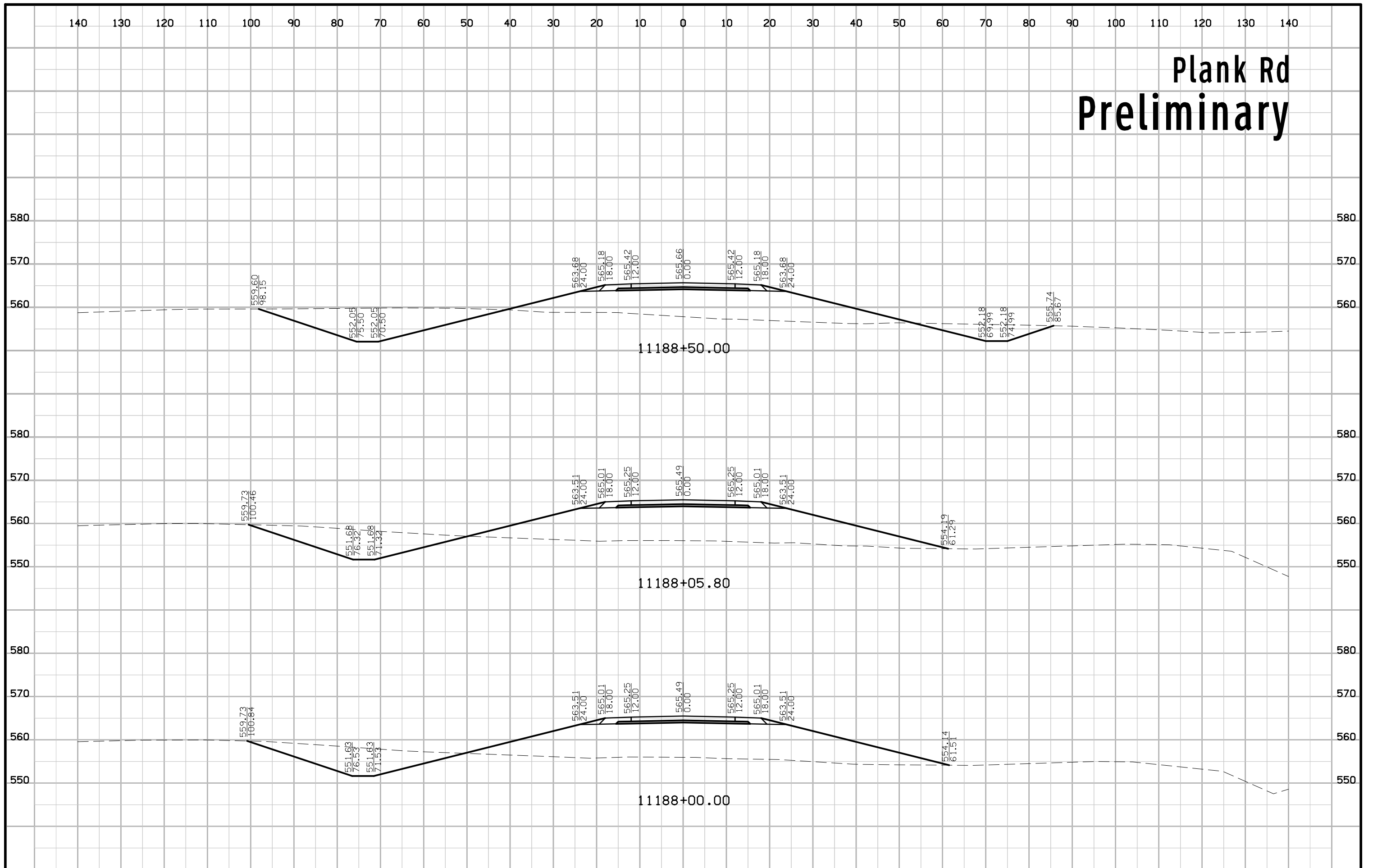

Plank Rd Preliminary

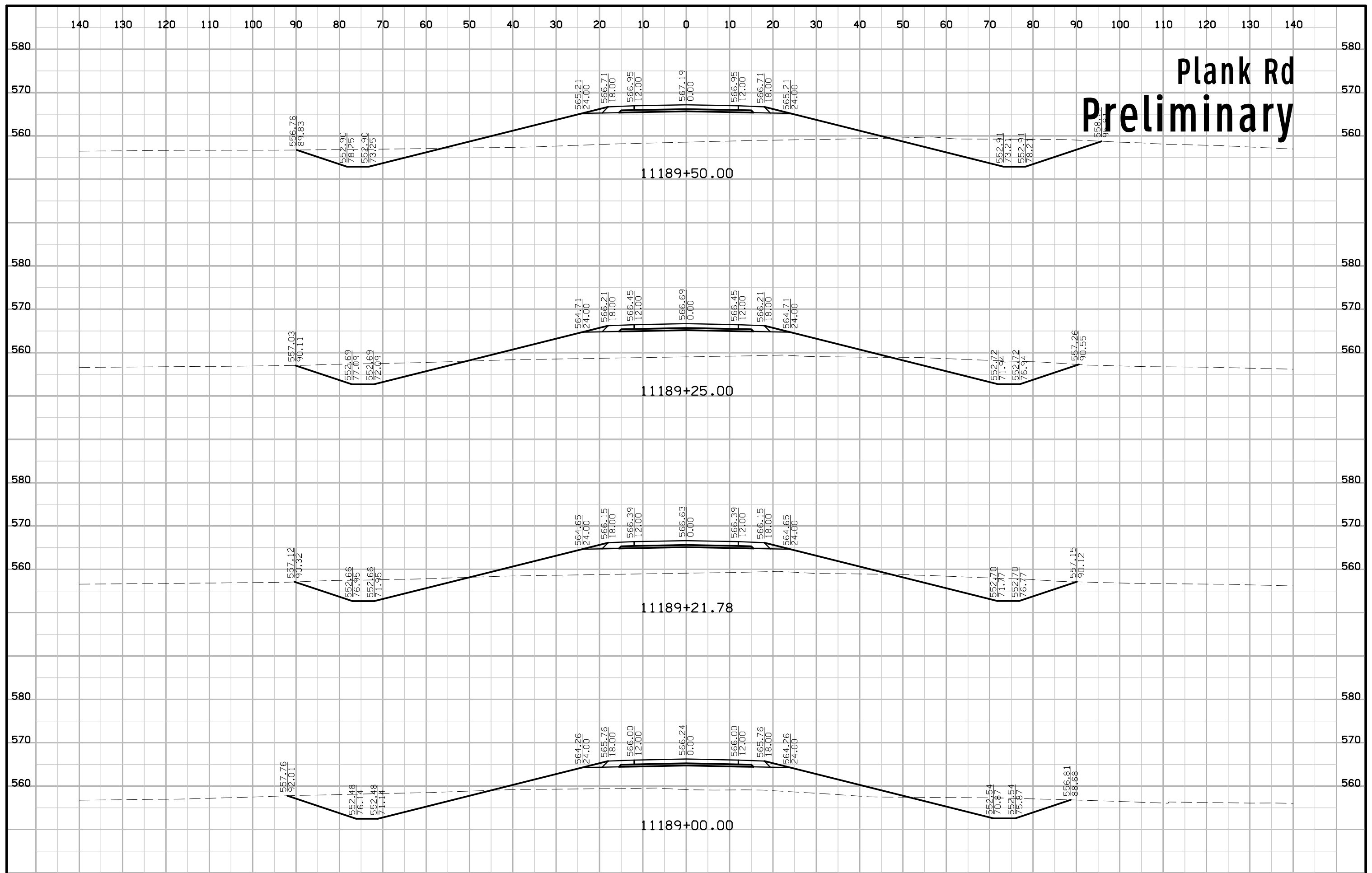

Plank Rd Preliminary

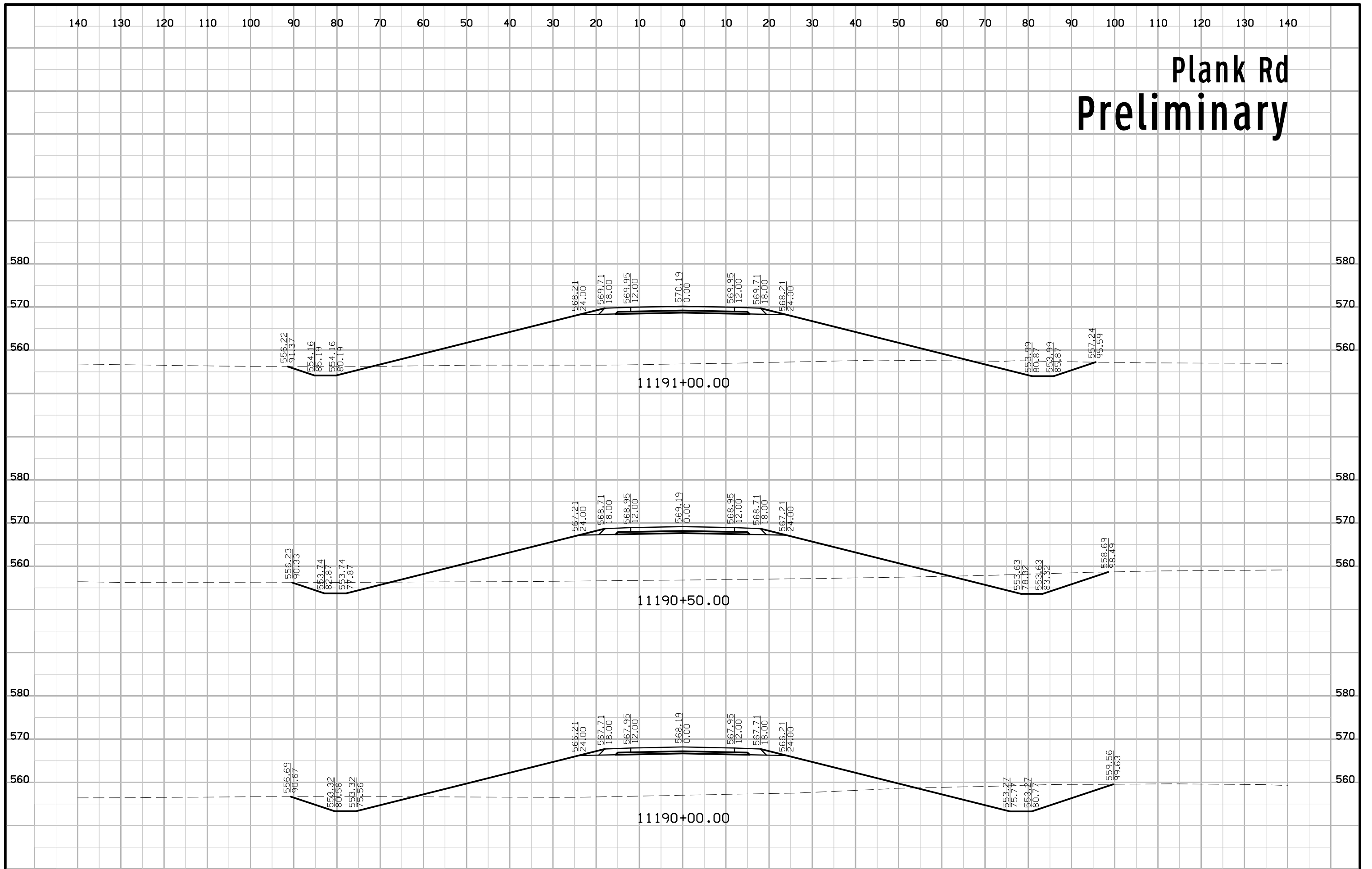

Plank Rd Preliminary

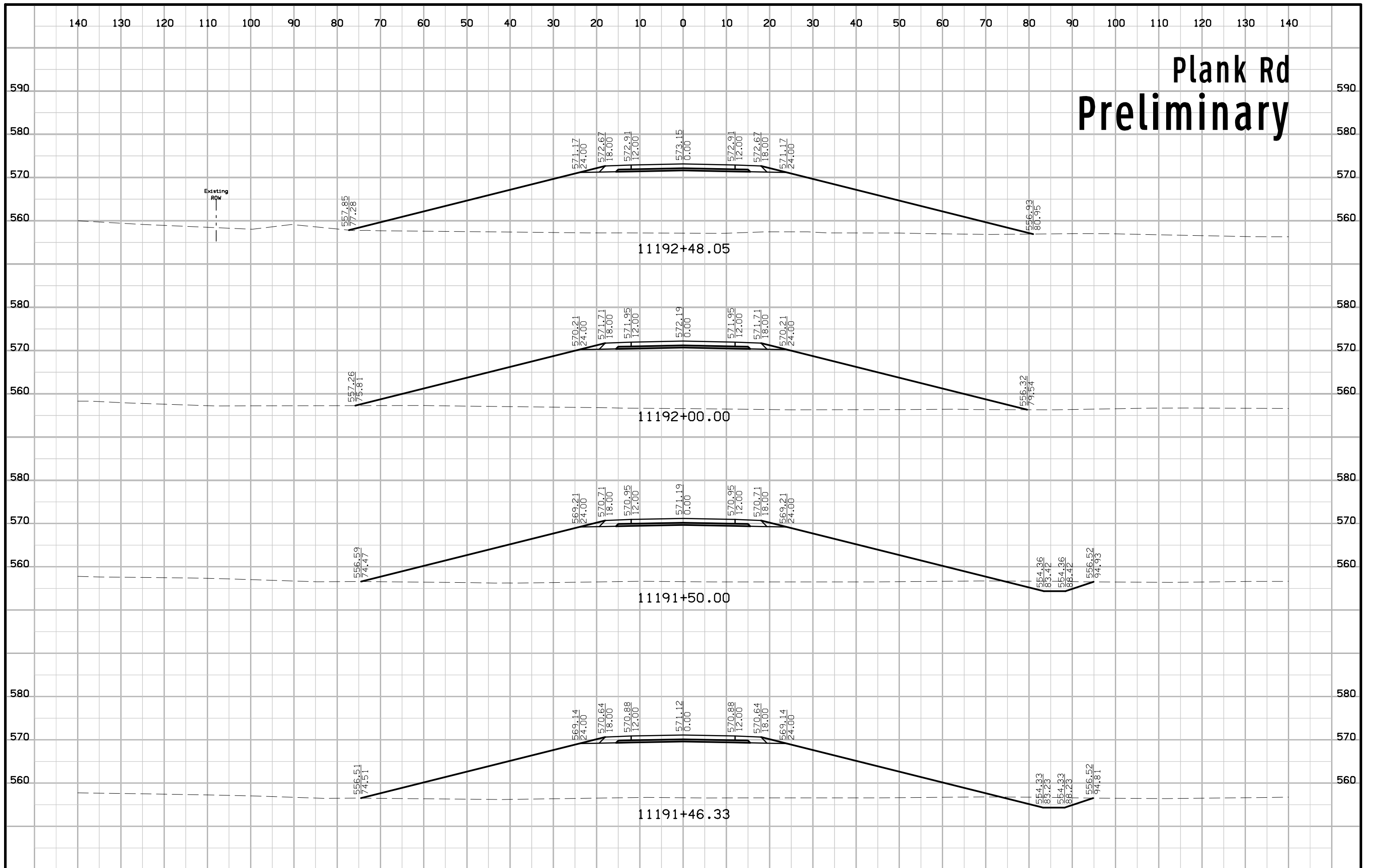

Flint Bottom Rd / Upper Flint Rd Preliminary

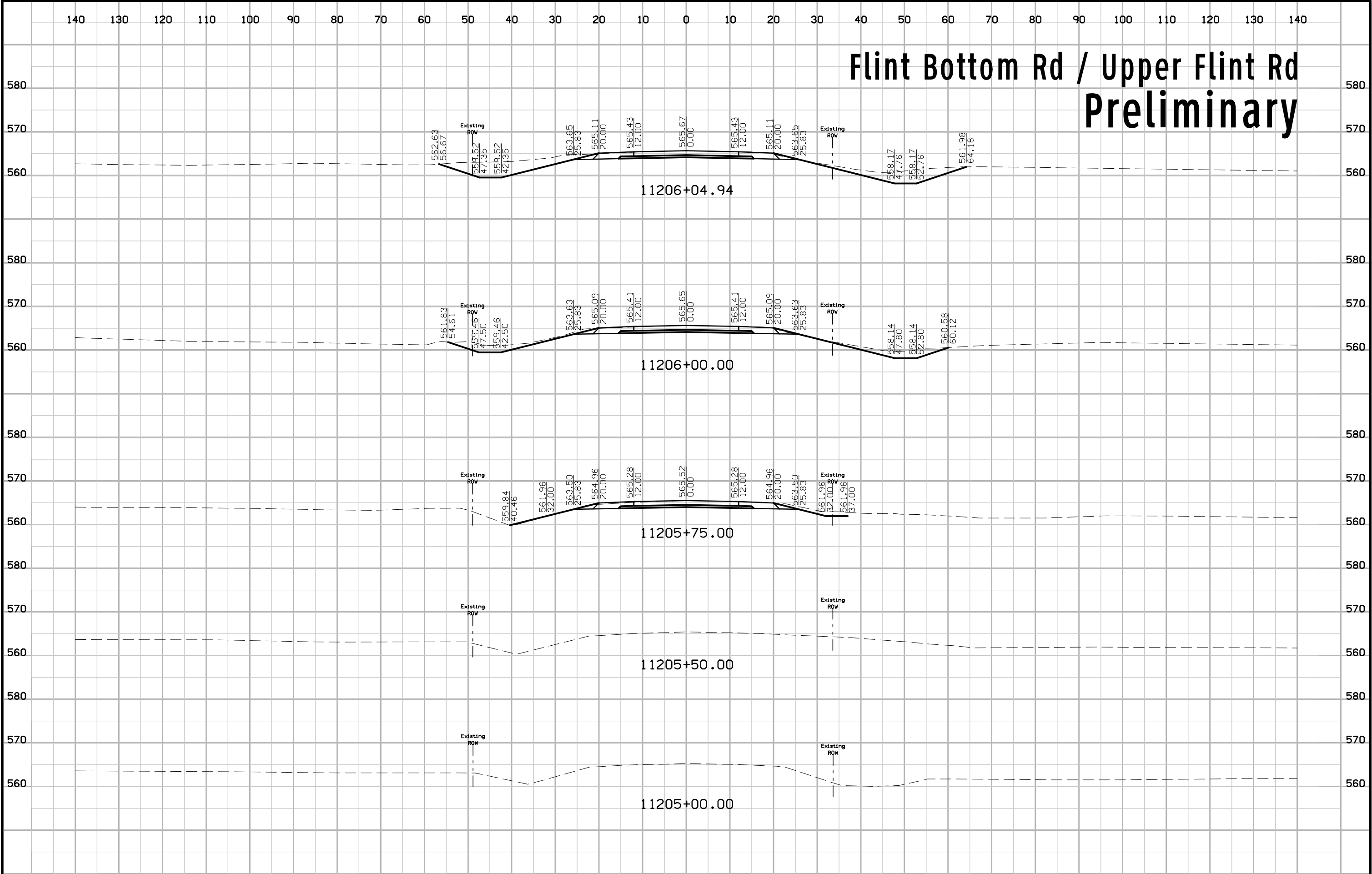

Flint Bottom Rd / Upper Flint Rd Preliminary

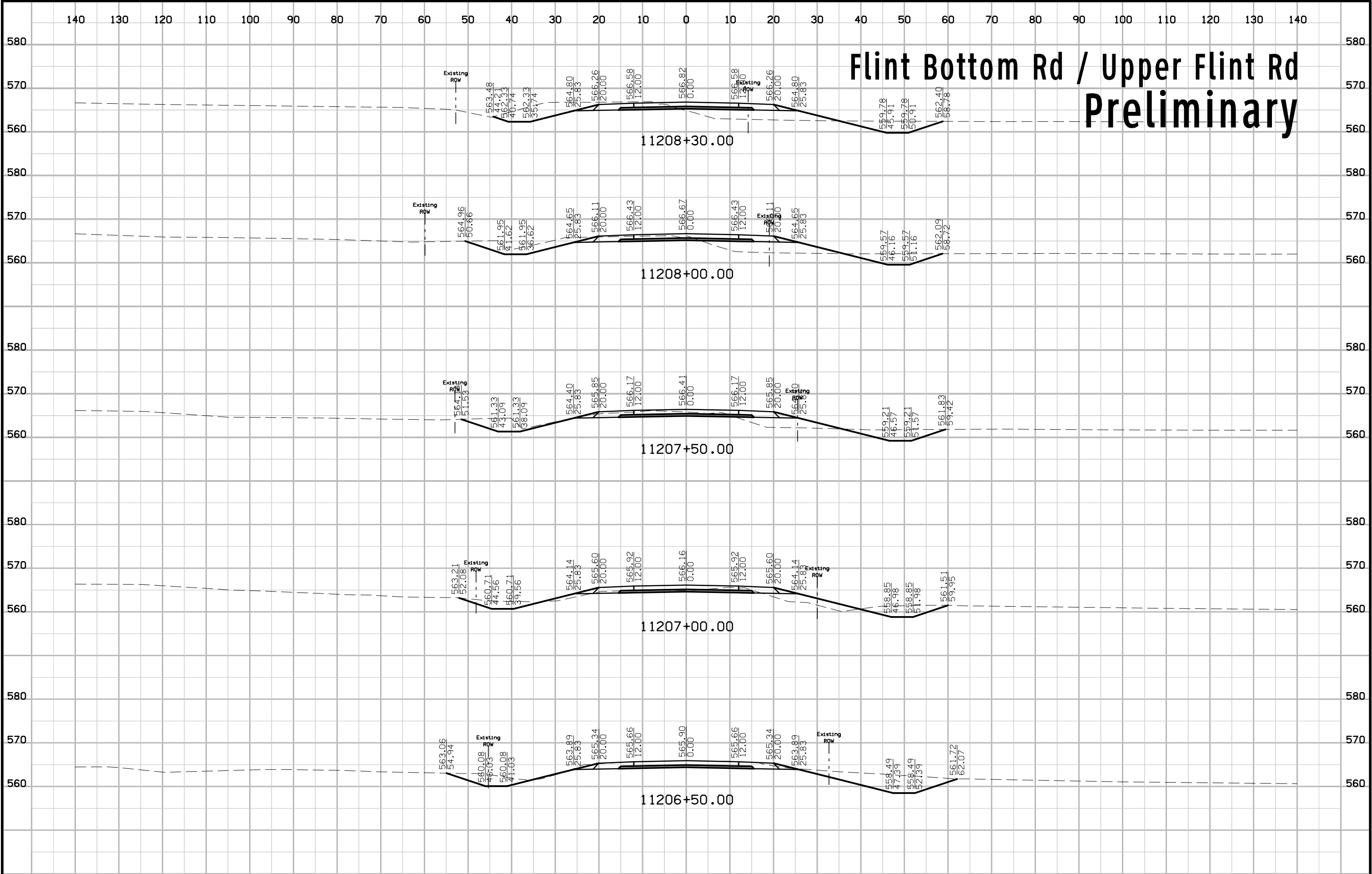

Flint Bottom Rd / Upper Flint Rd Preliminary

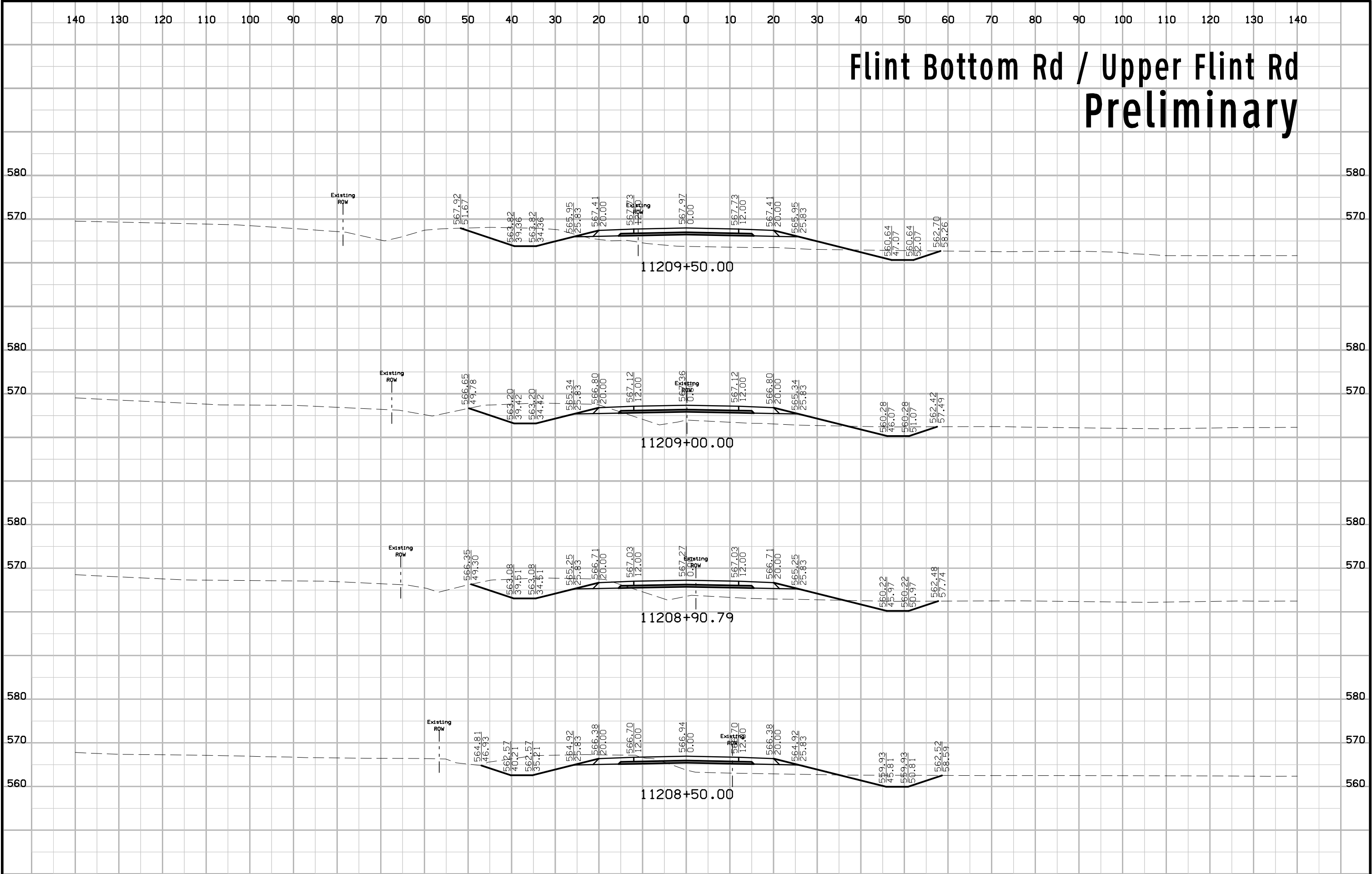

Flint Bottom Rd / Upper Flint Rd Preliminary

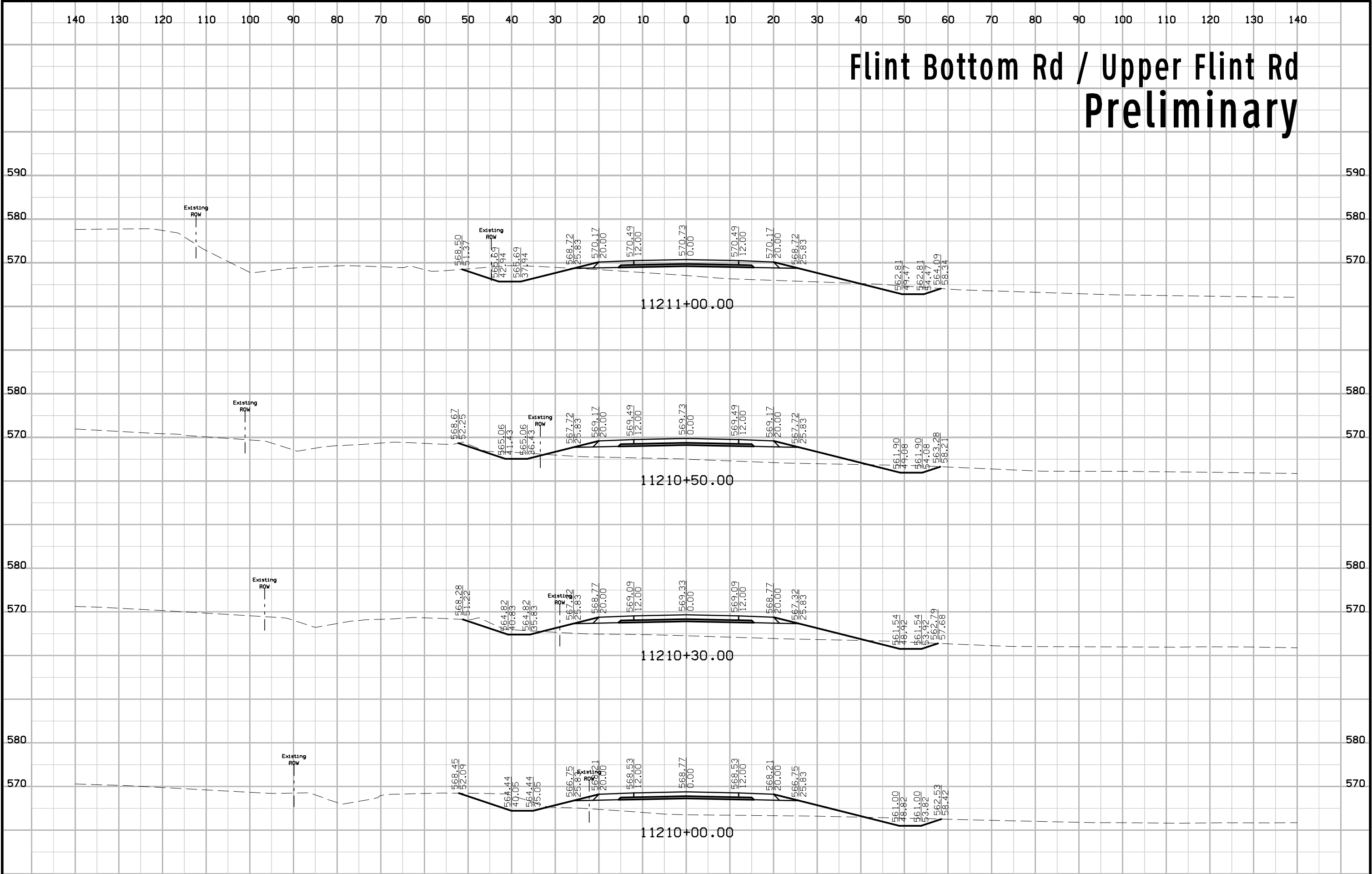

Flint Bottom Rd / Upper Flint Rd Preliminary

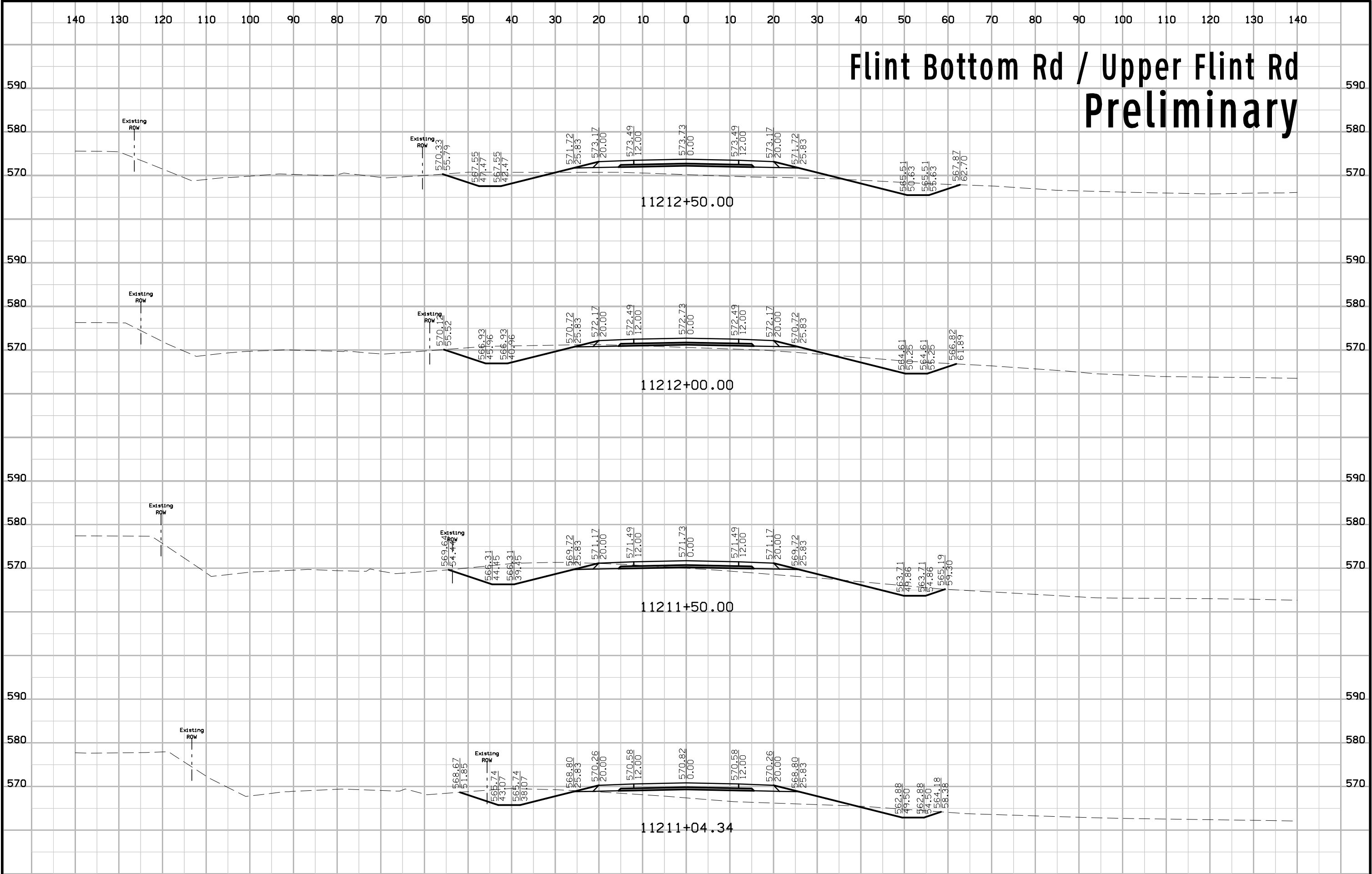

Flint Bottom Rd / Upper Flint Rd Preliminary

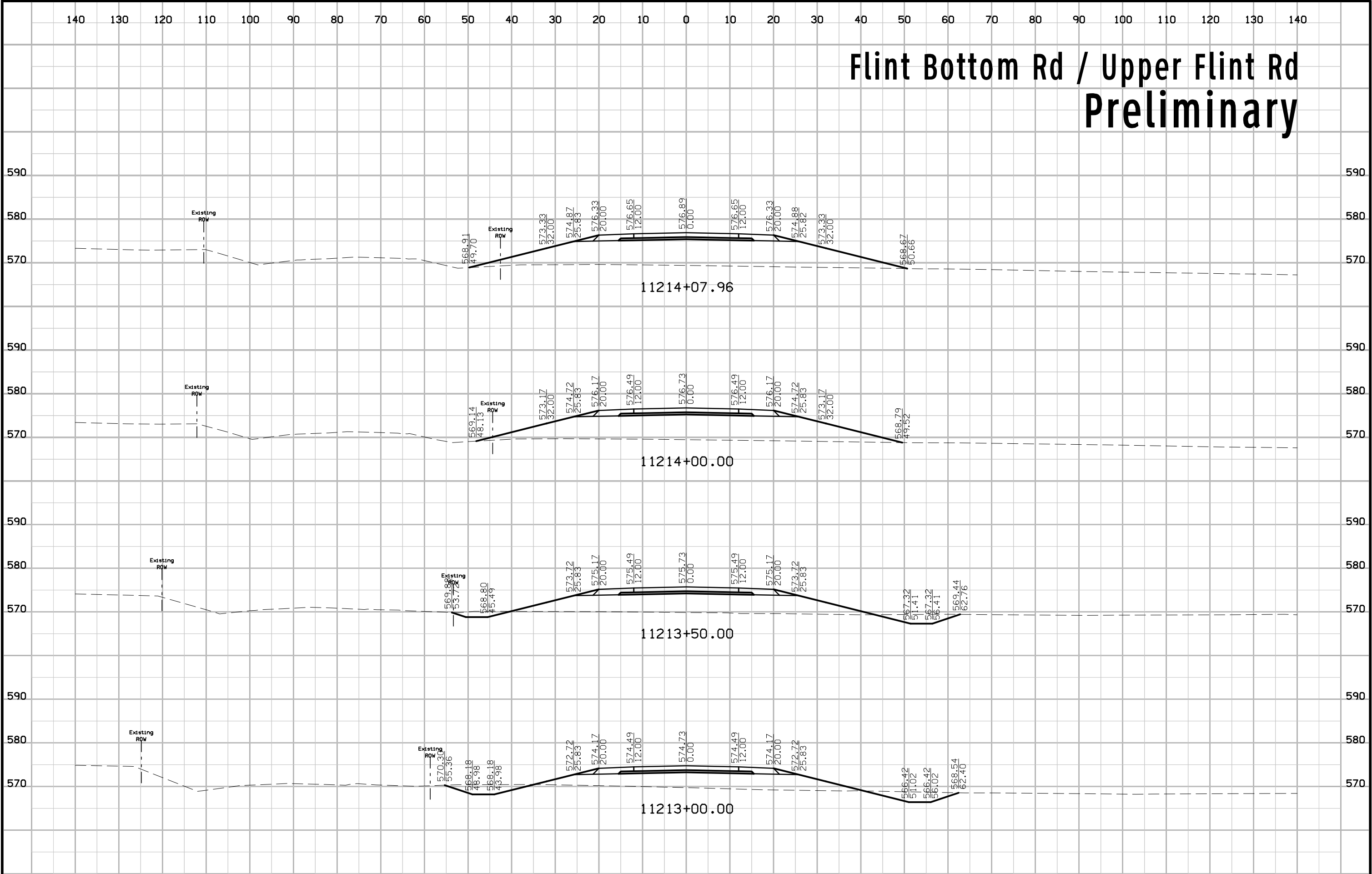

Flint Bottom Rd / Upper Flint Rd Preliminary

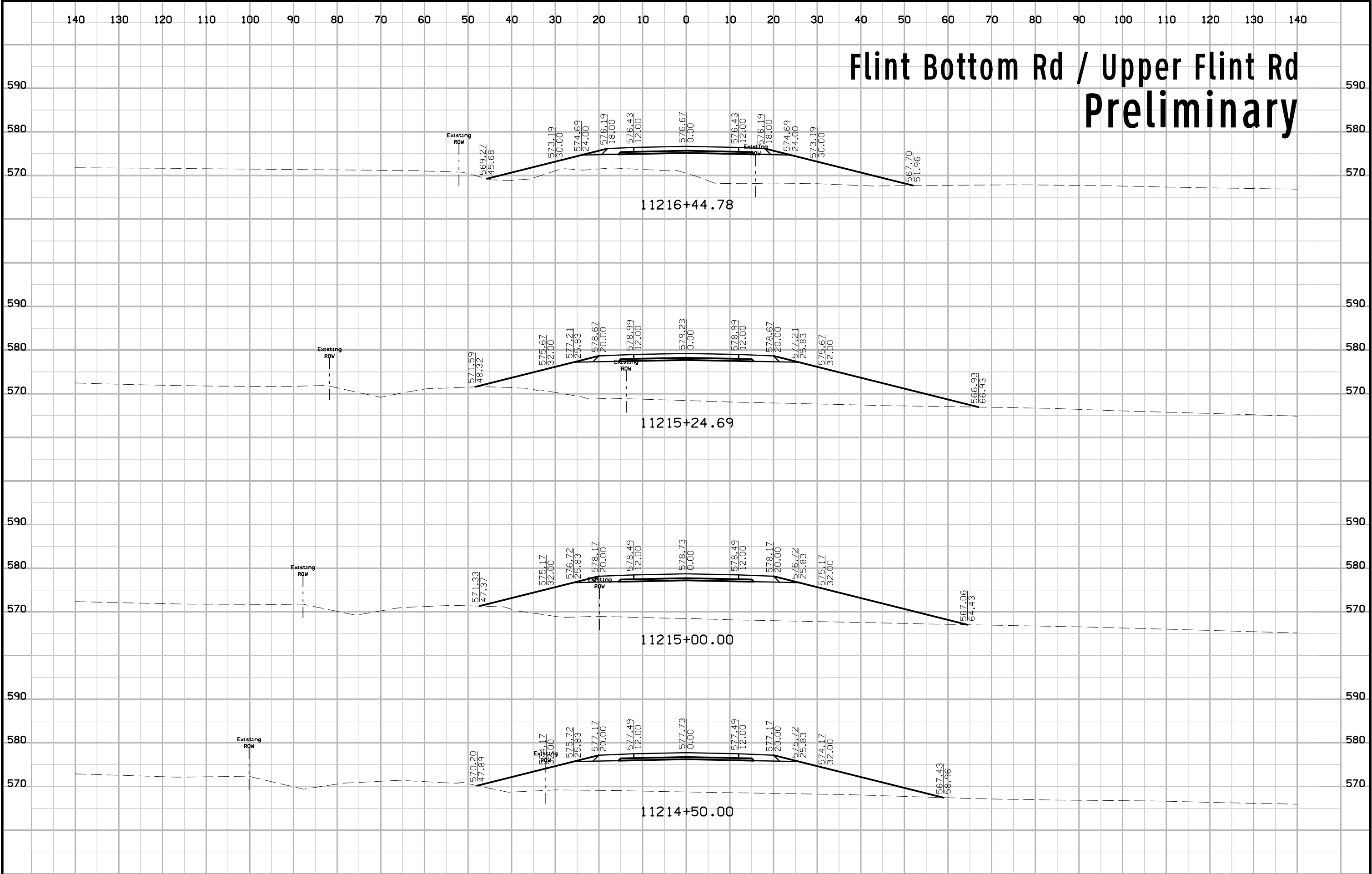

Flint Bottom Rd / Upper Flint Rd Preliminary

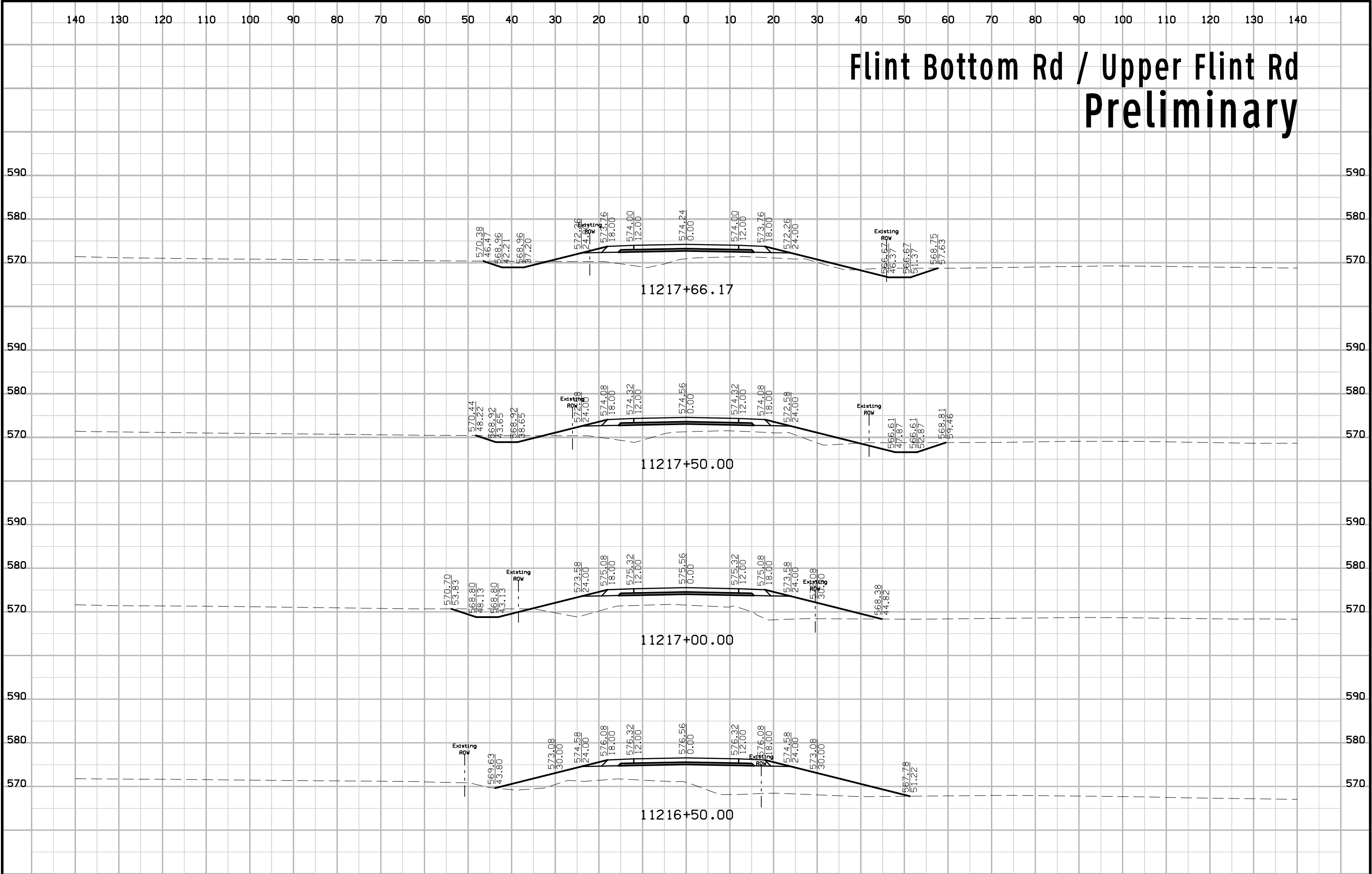

Flint Bottom Rd / Upper Flint Rd Preliminary

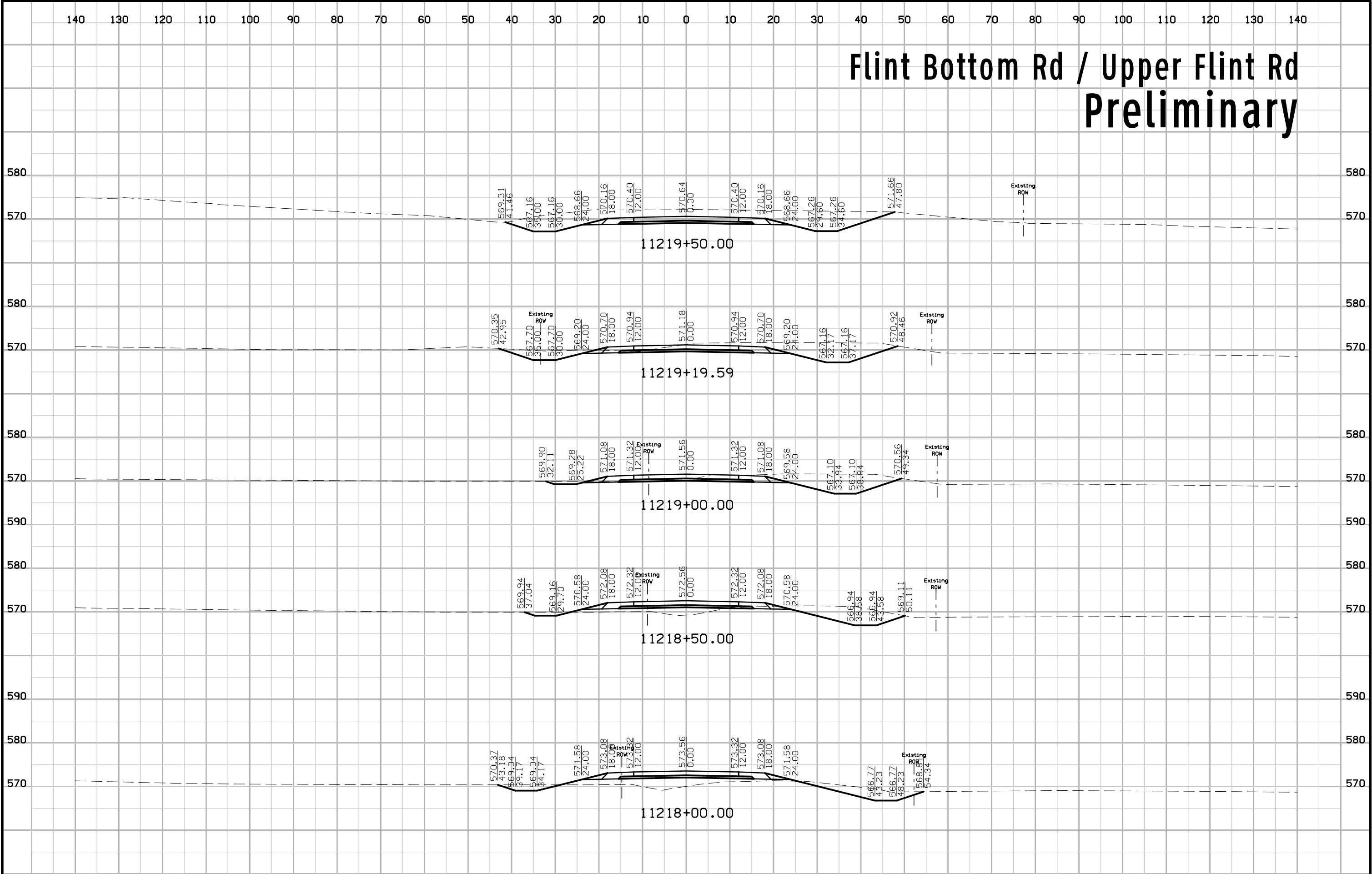

Flint Bottom Rd / Upper Flint Rd Preliminary

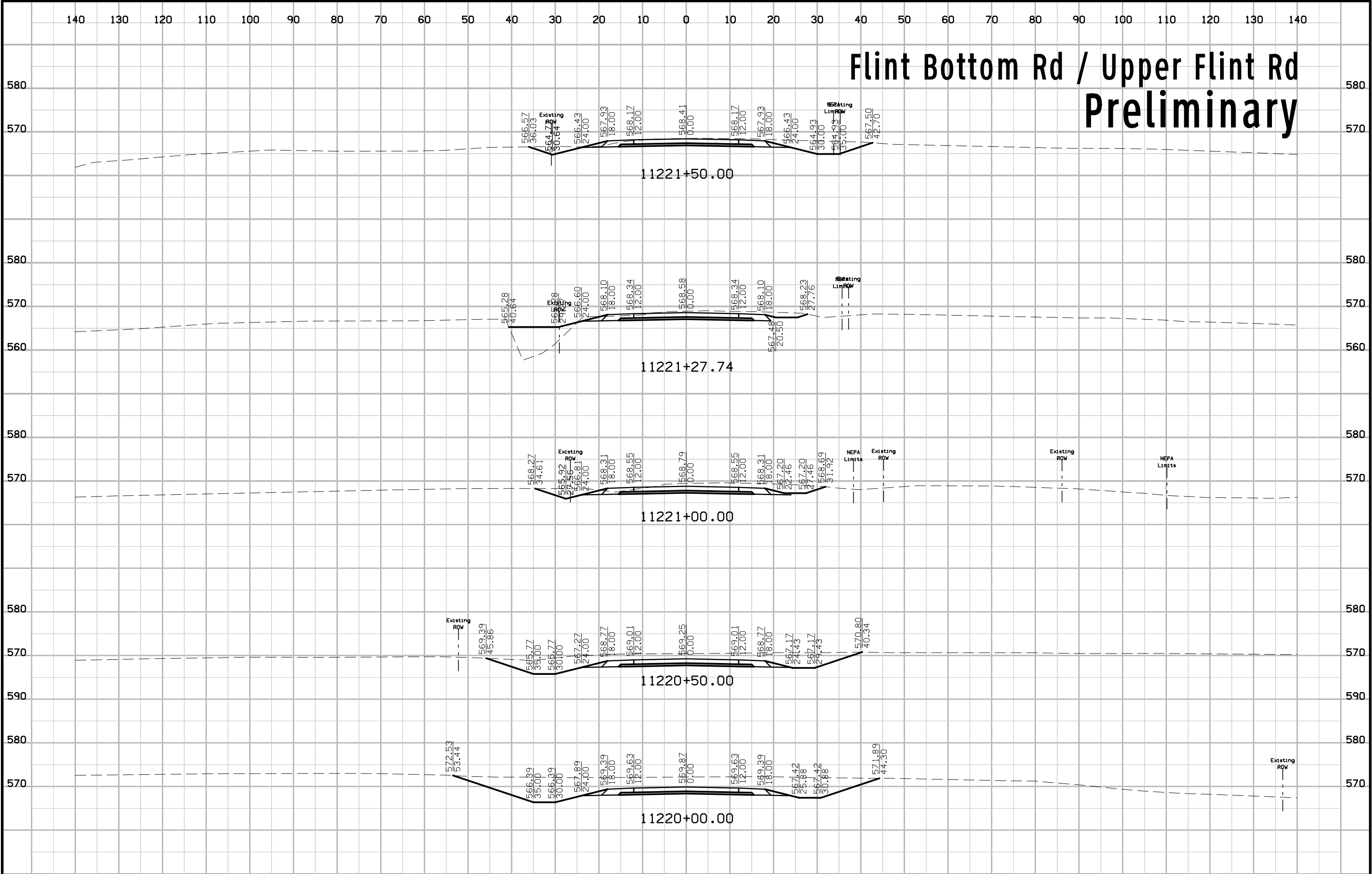

Flint Bottom Rd / Upper Flint Rd Preliminary

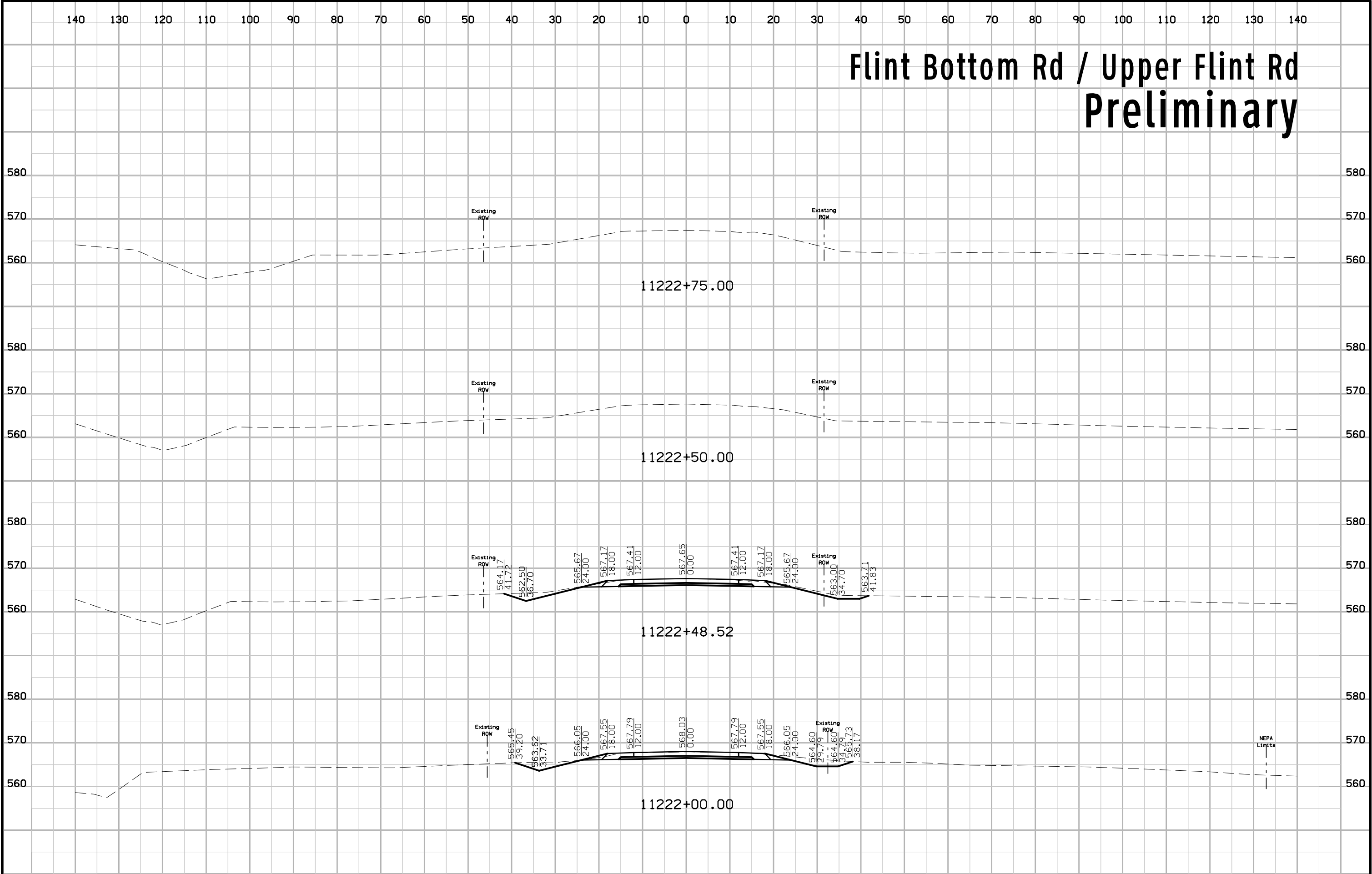

140 130 120 110 100 90 80 70 60 50 40 30 20 10 0 10 20 30 40 50 60 70 80 90 100 110 120 130 140

Flint Bottom Rd / Upper Flint Rd Preliminary

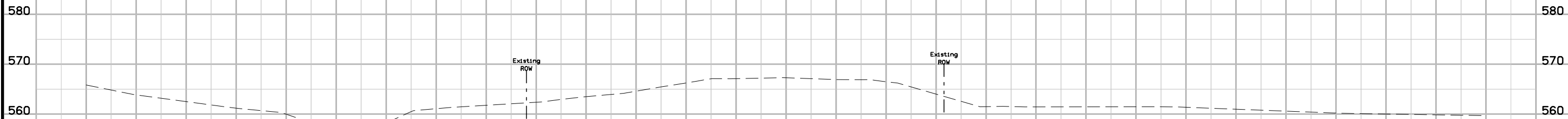

11223+00.00

140 130 120 110 100 90 80 70 60 50 40 30 20 10 0 10 20 30 40 50 60 70 80 90 100 110 120 130 140

Tanner Ln Preliminary

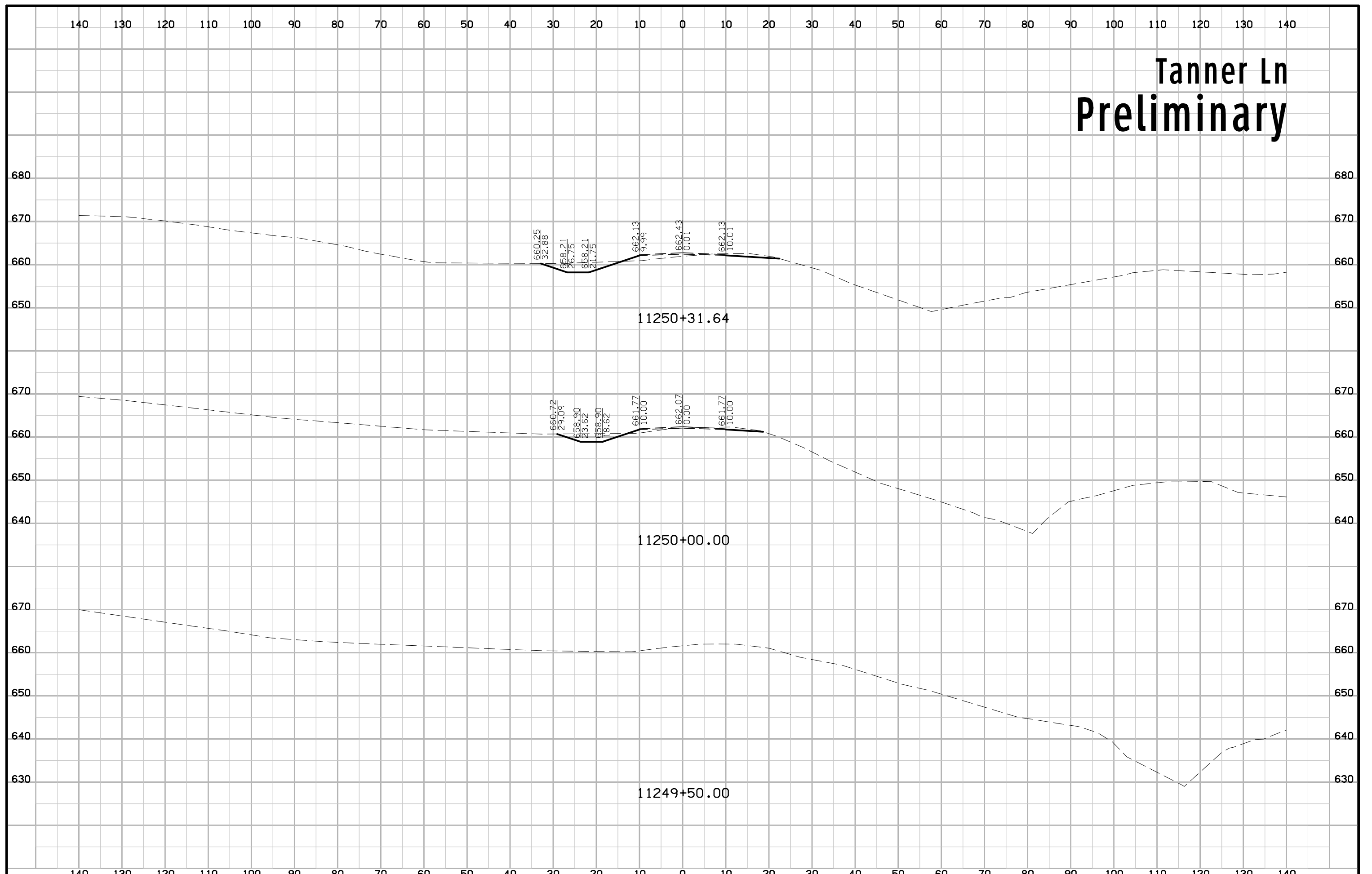

Tanner Ln Preliminary

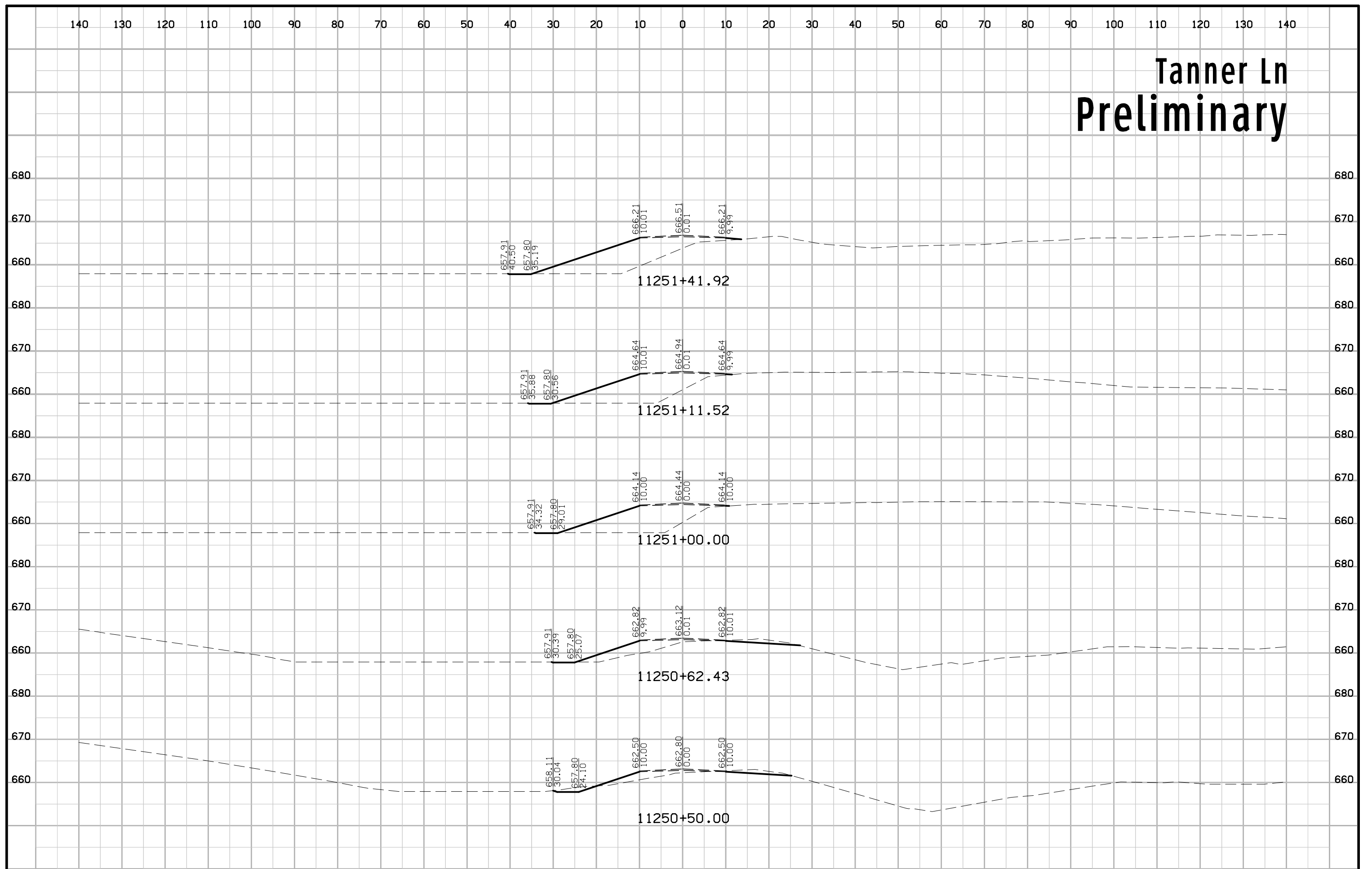

Tanner Ln Preliminary

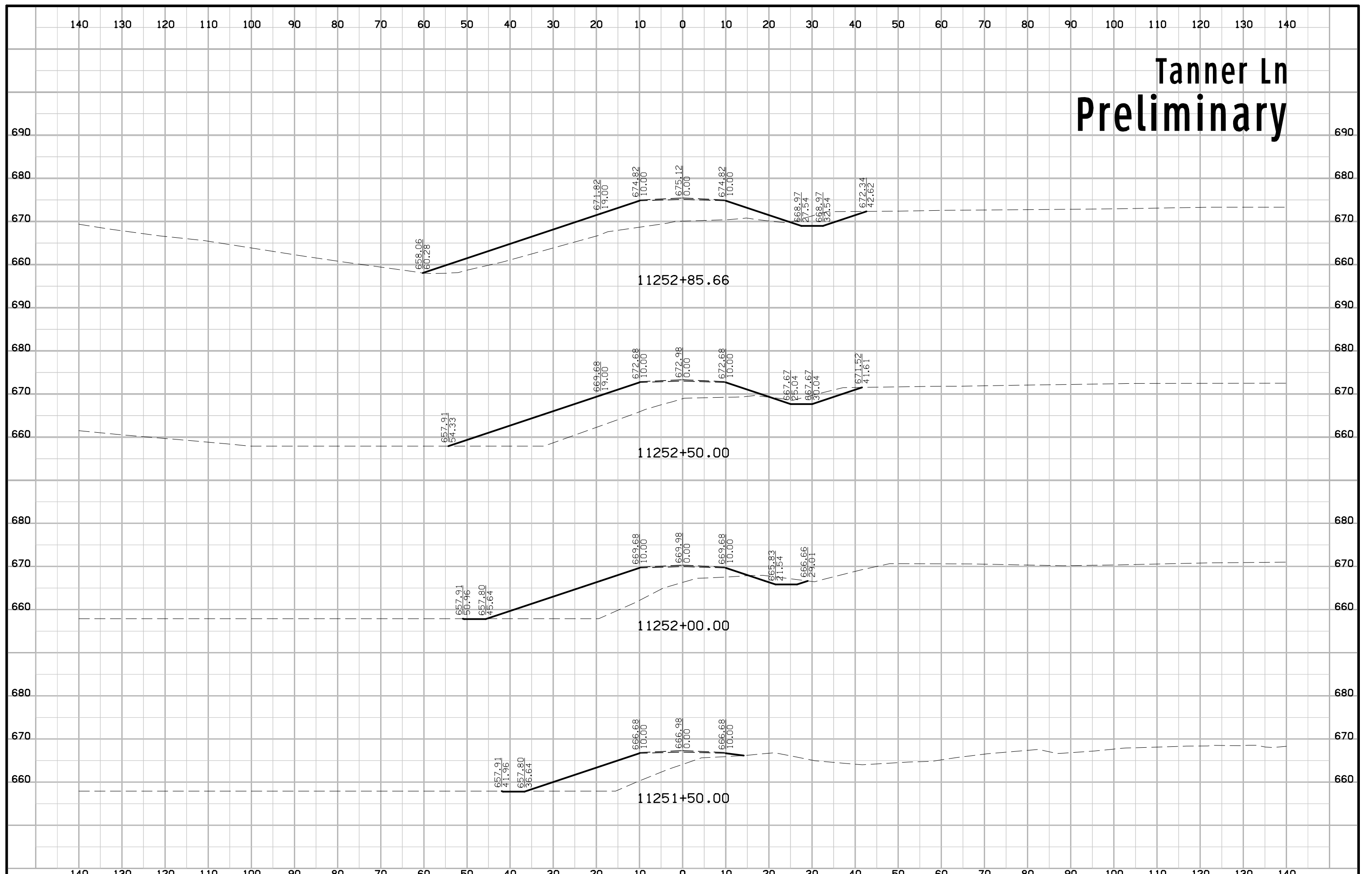

Tanner Ln Preliminary

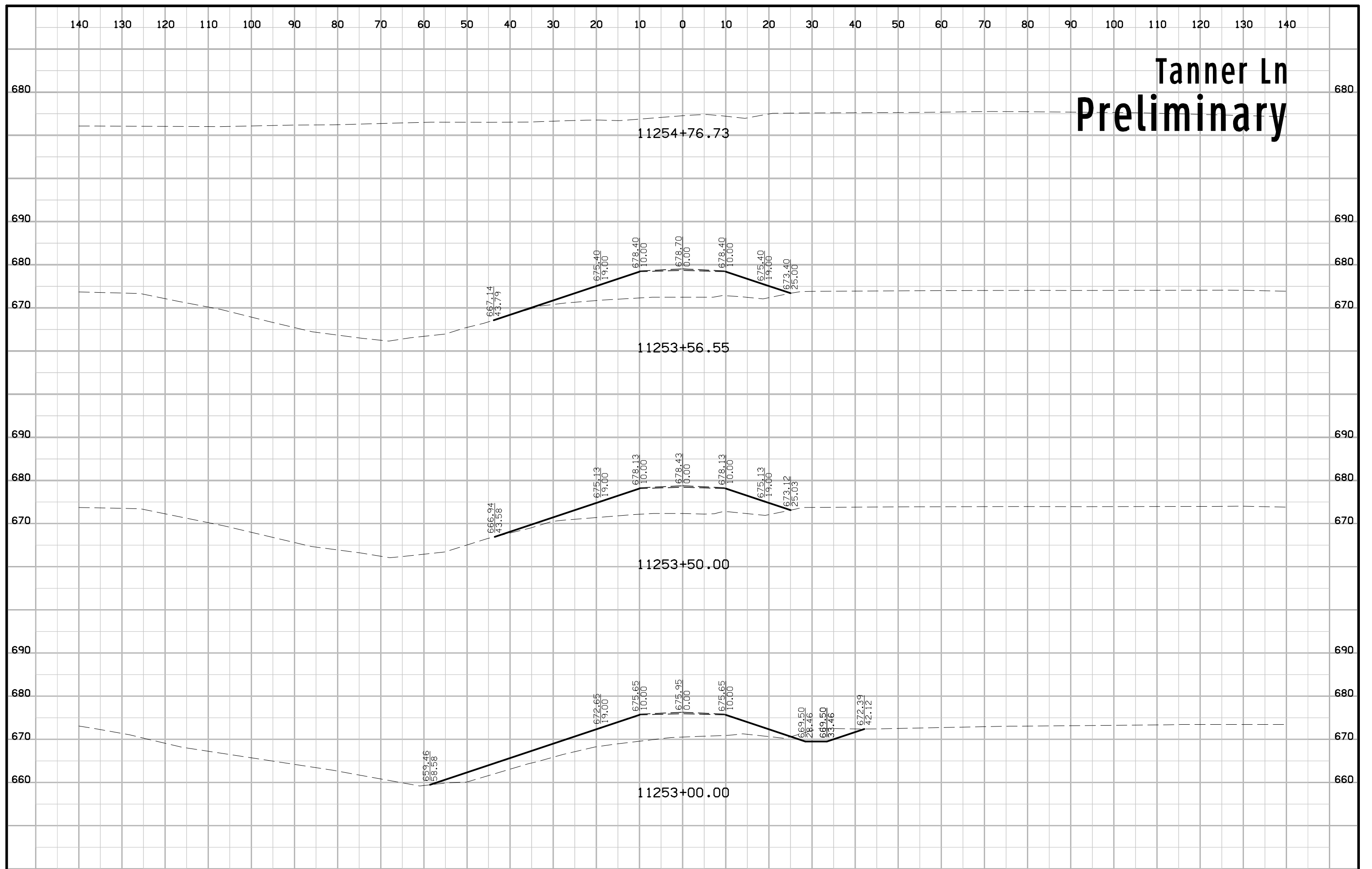

Tanner Ln Preliminary

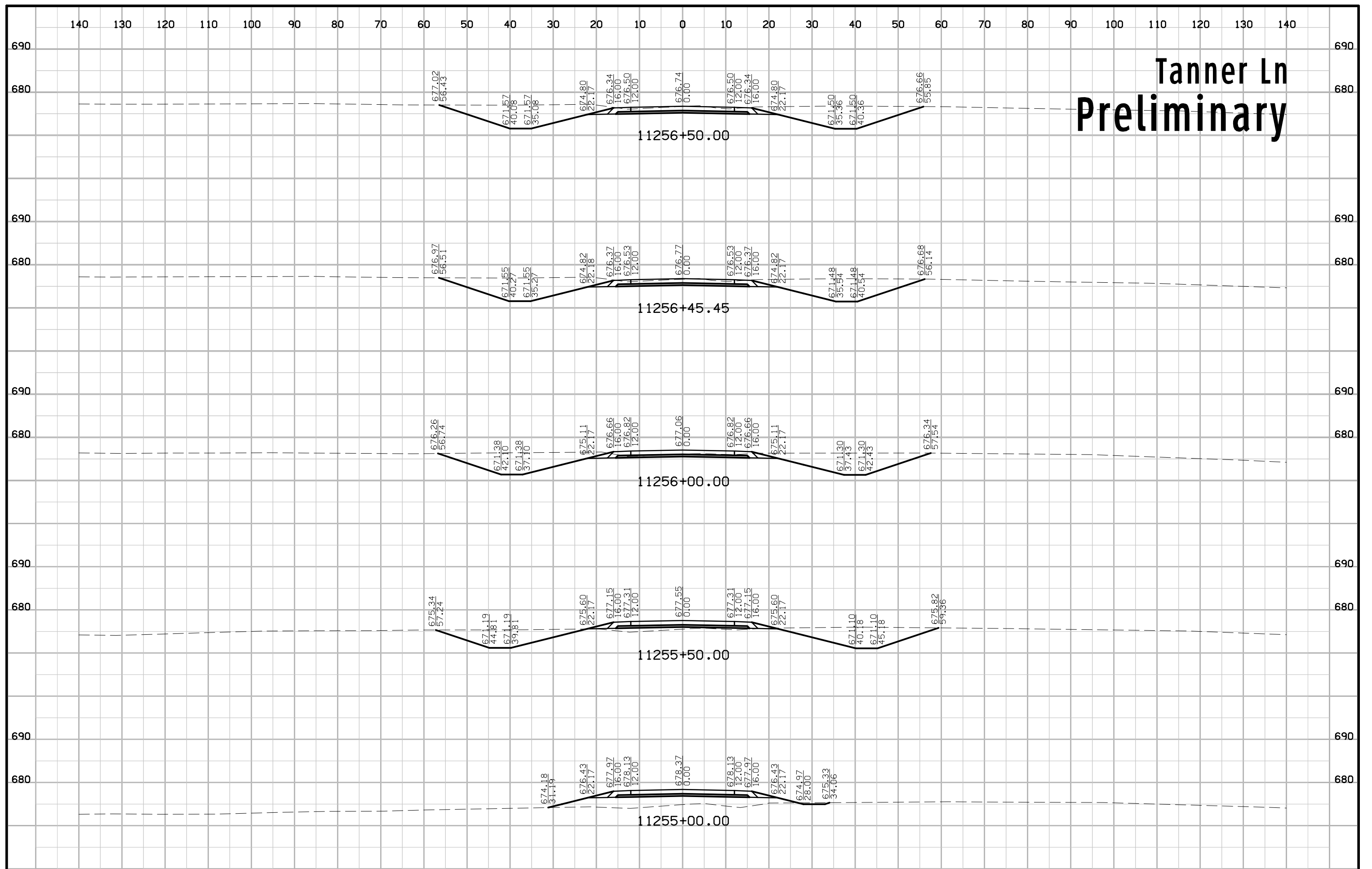

Tanner Ln Preliminary

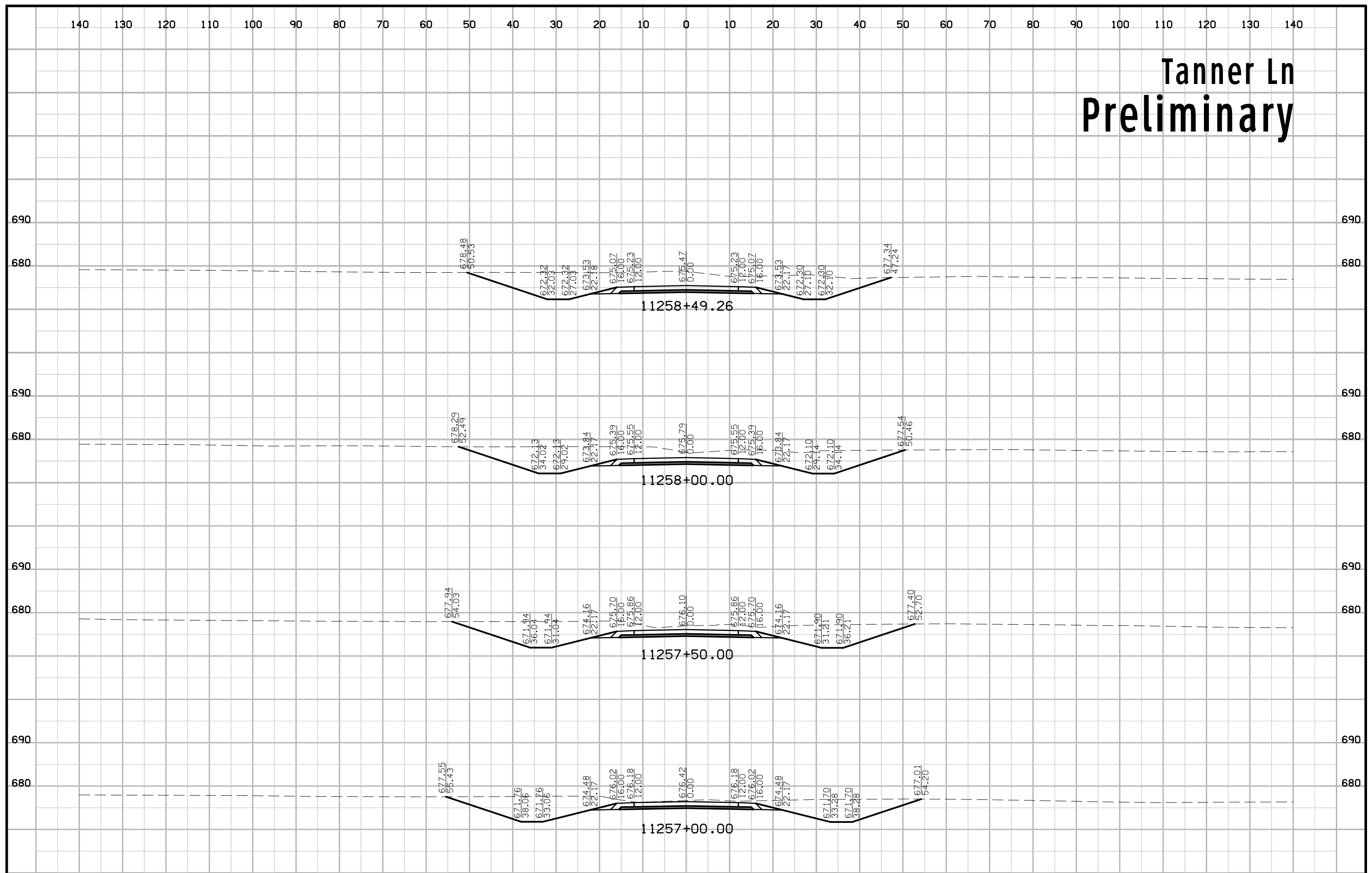

Tanner Ln Preliminary

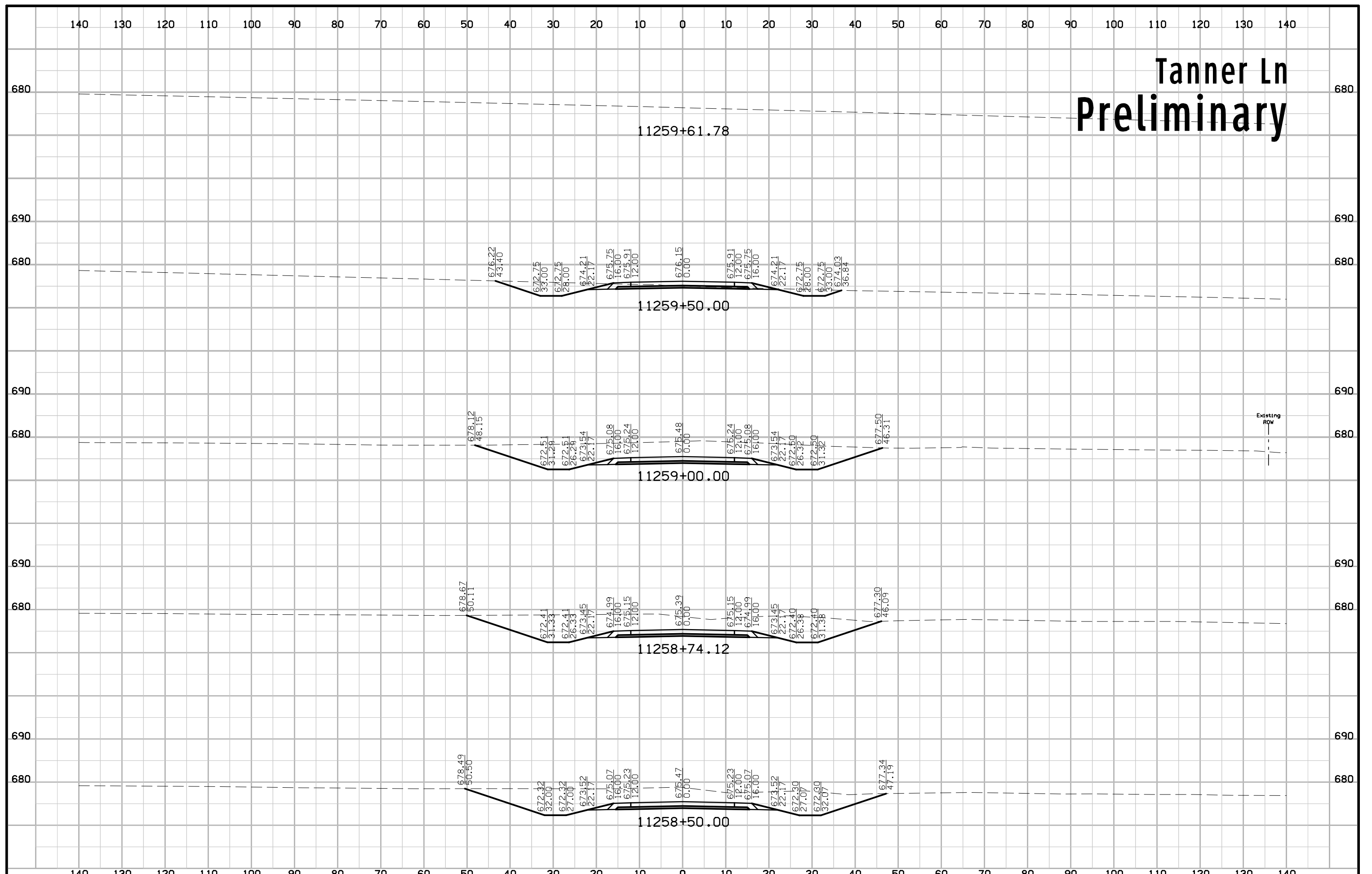

130th St Preliminary

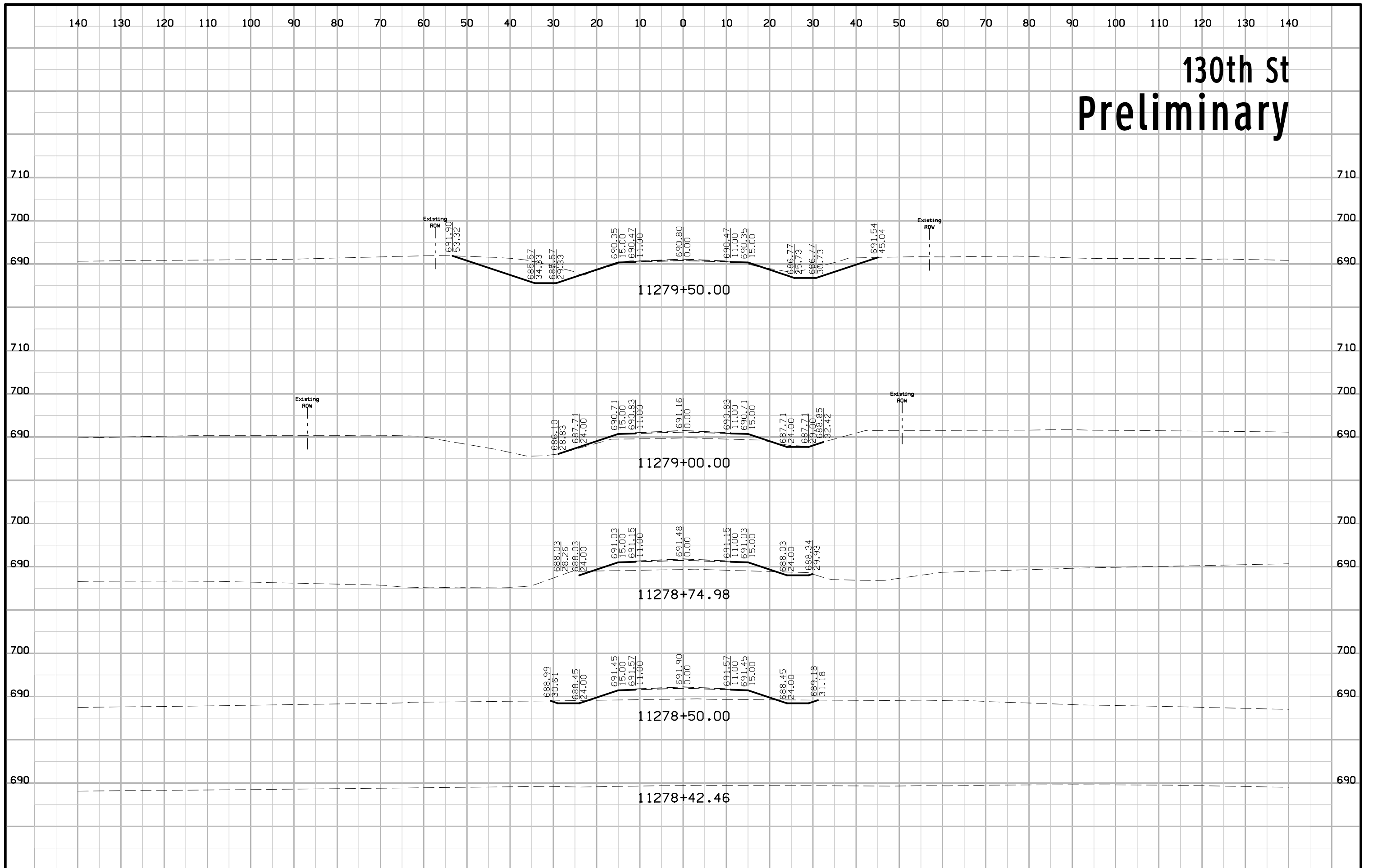

130th St Preliminary

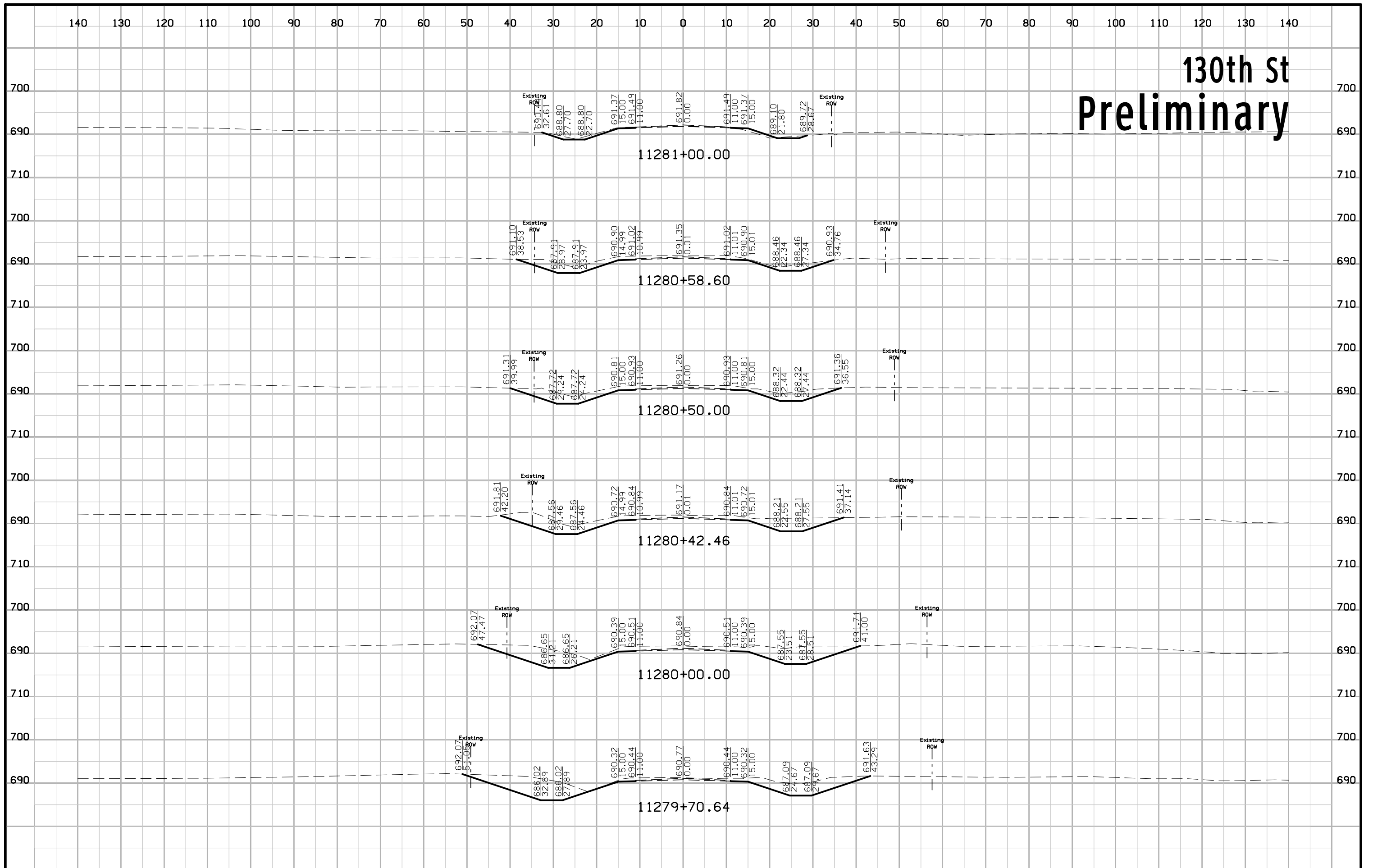

130th St Preliminary

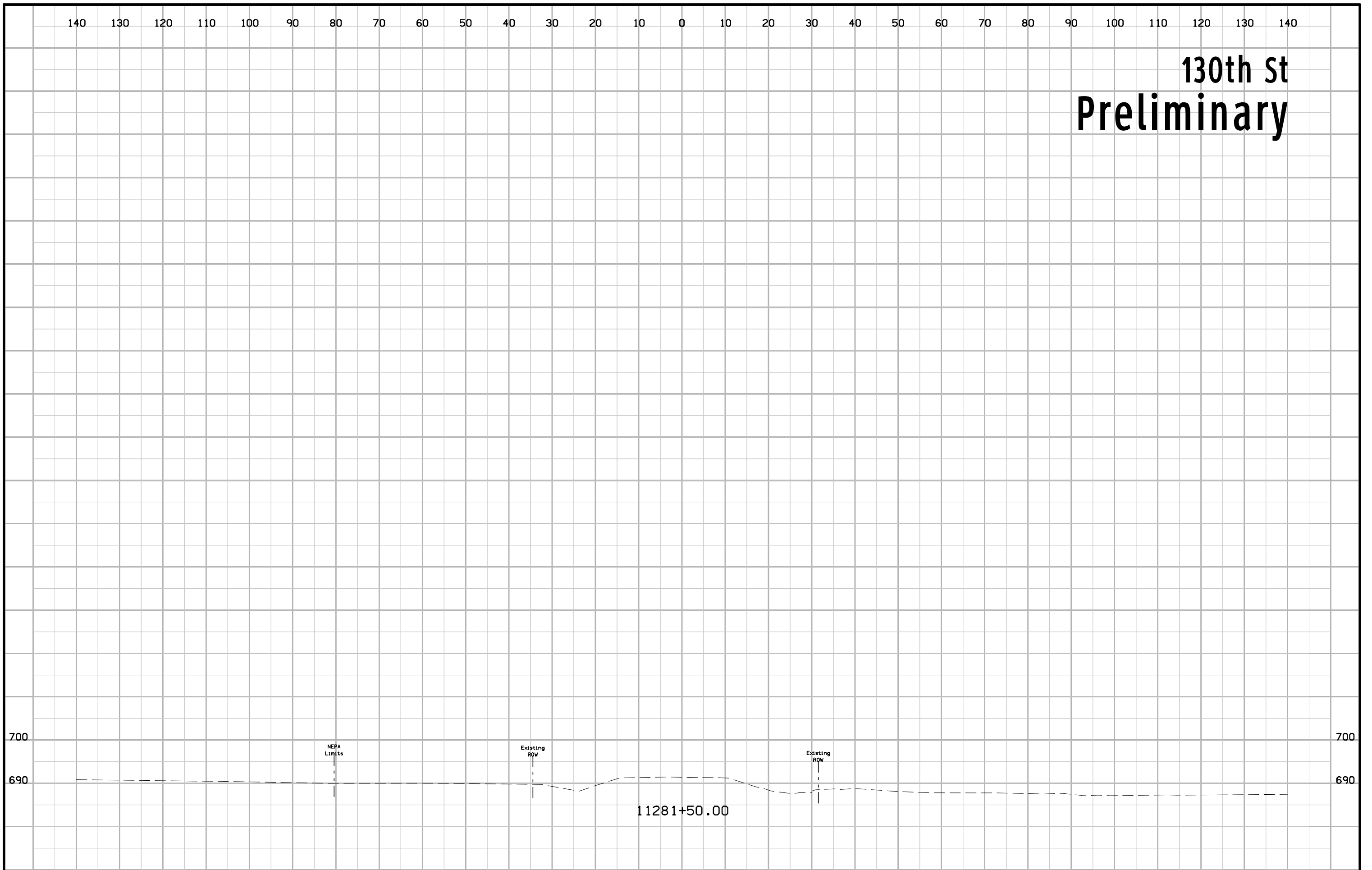

Pfeiff Rd / 124th Ave Preliminary

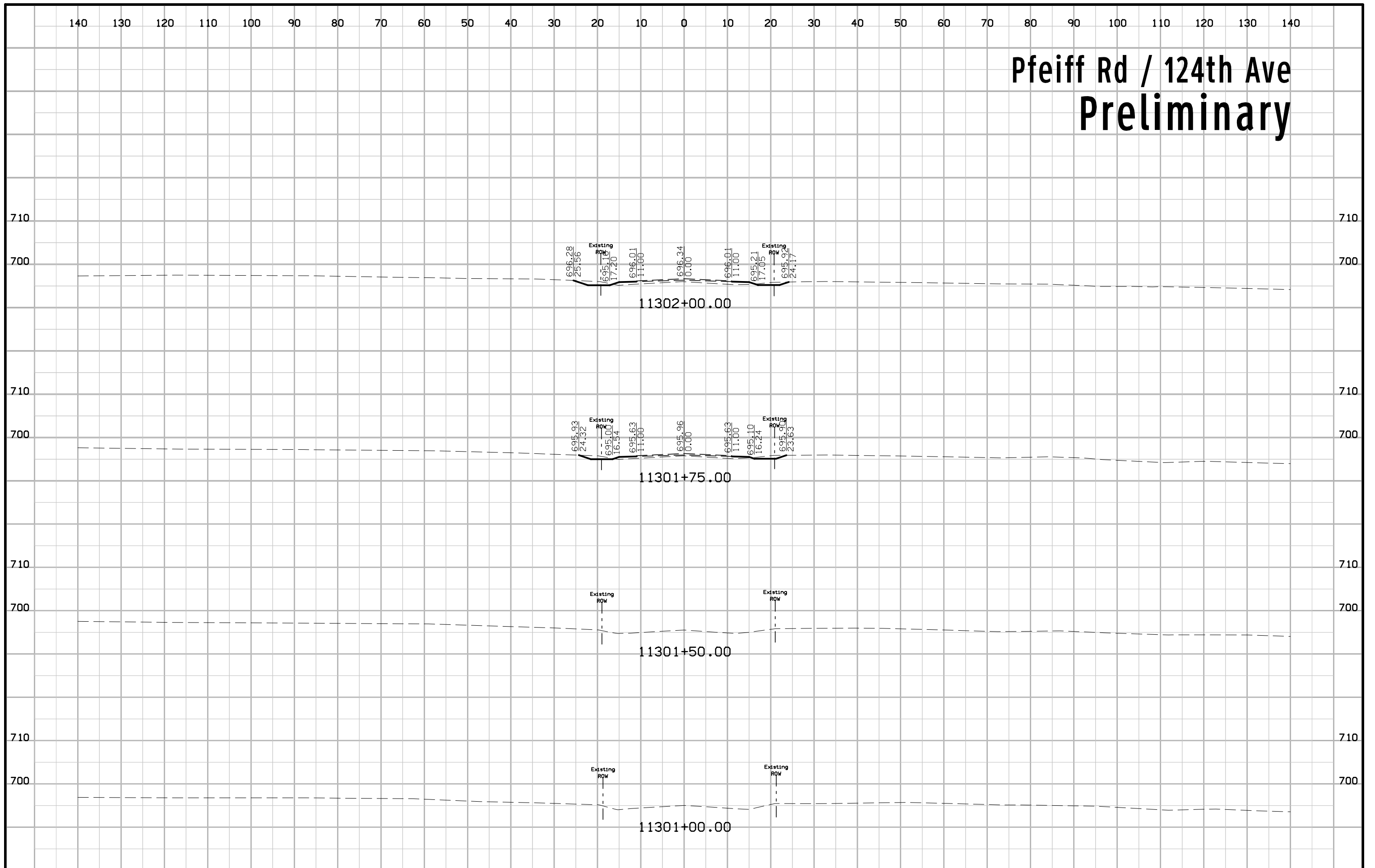

Pfeiff Rd / 124th Ave Preliminary

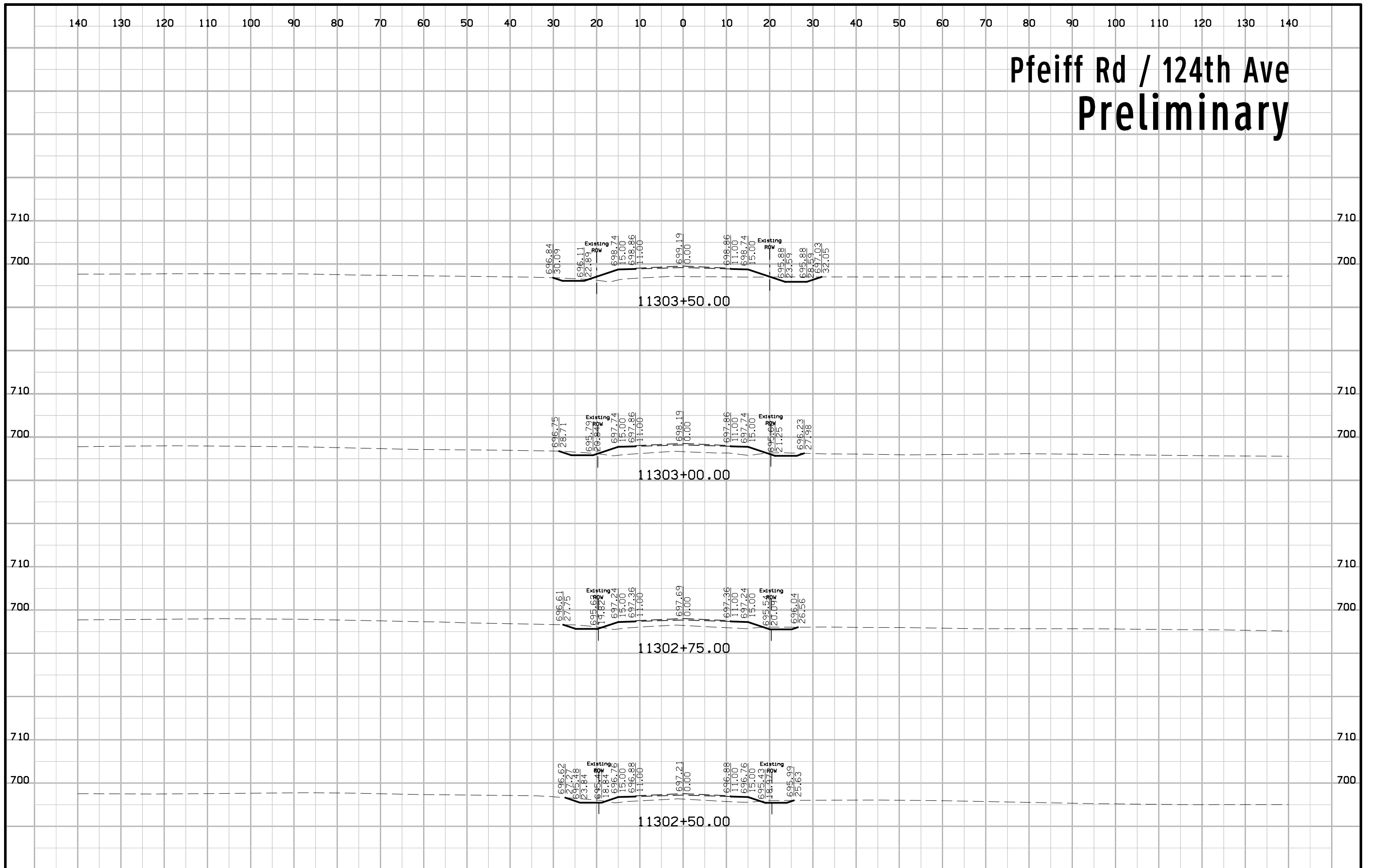

Pfeiff Rd / 124th Ave Preliminary

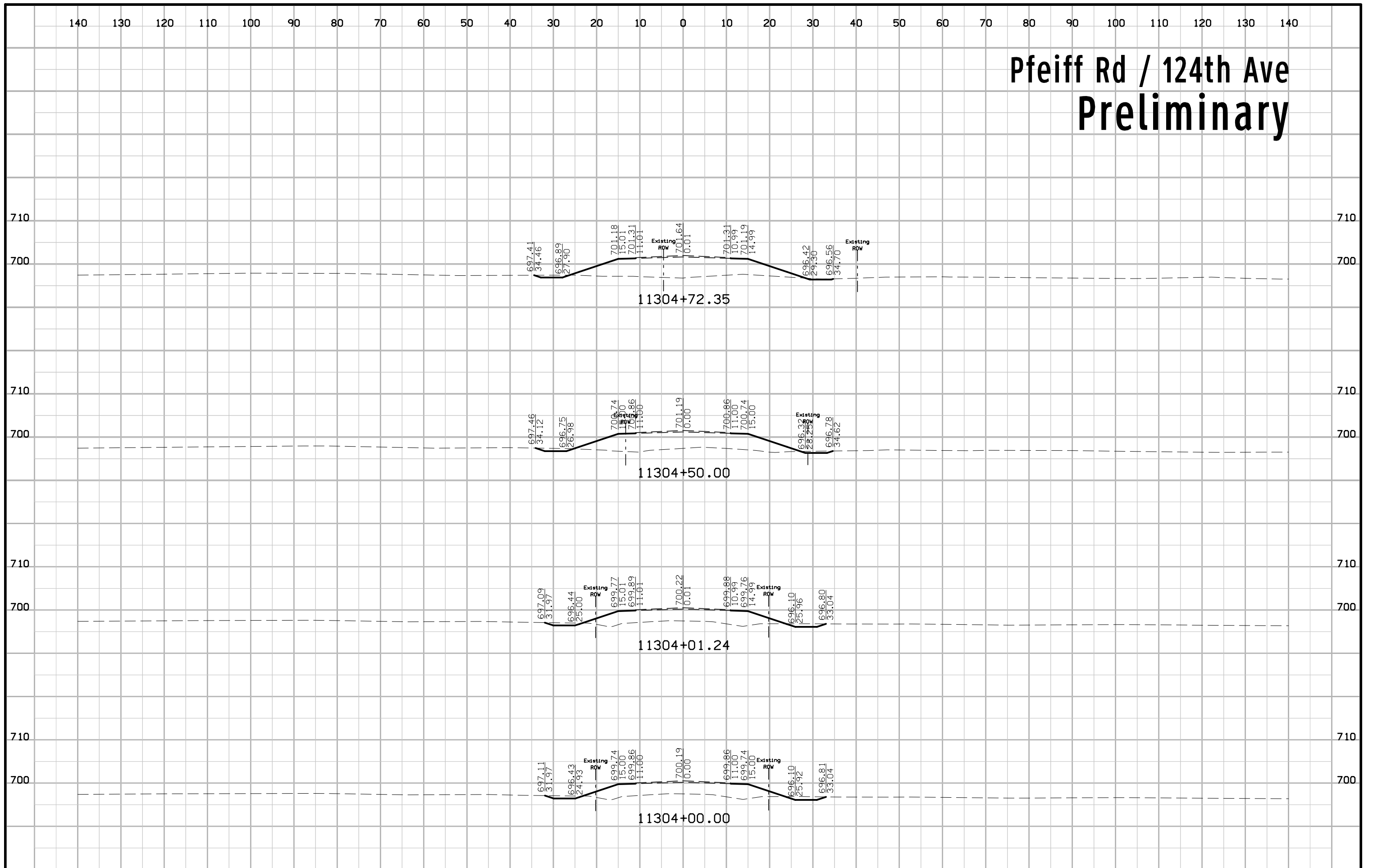

Pfeiff Rd / 124th Ave Preliminary

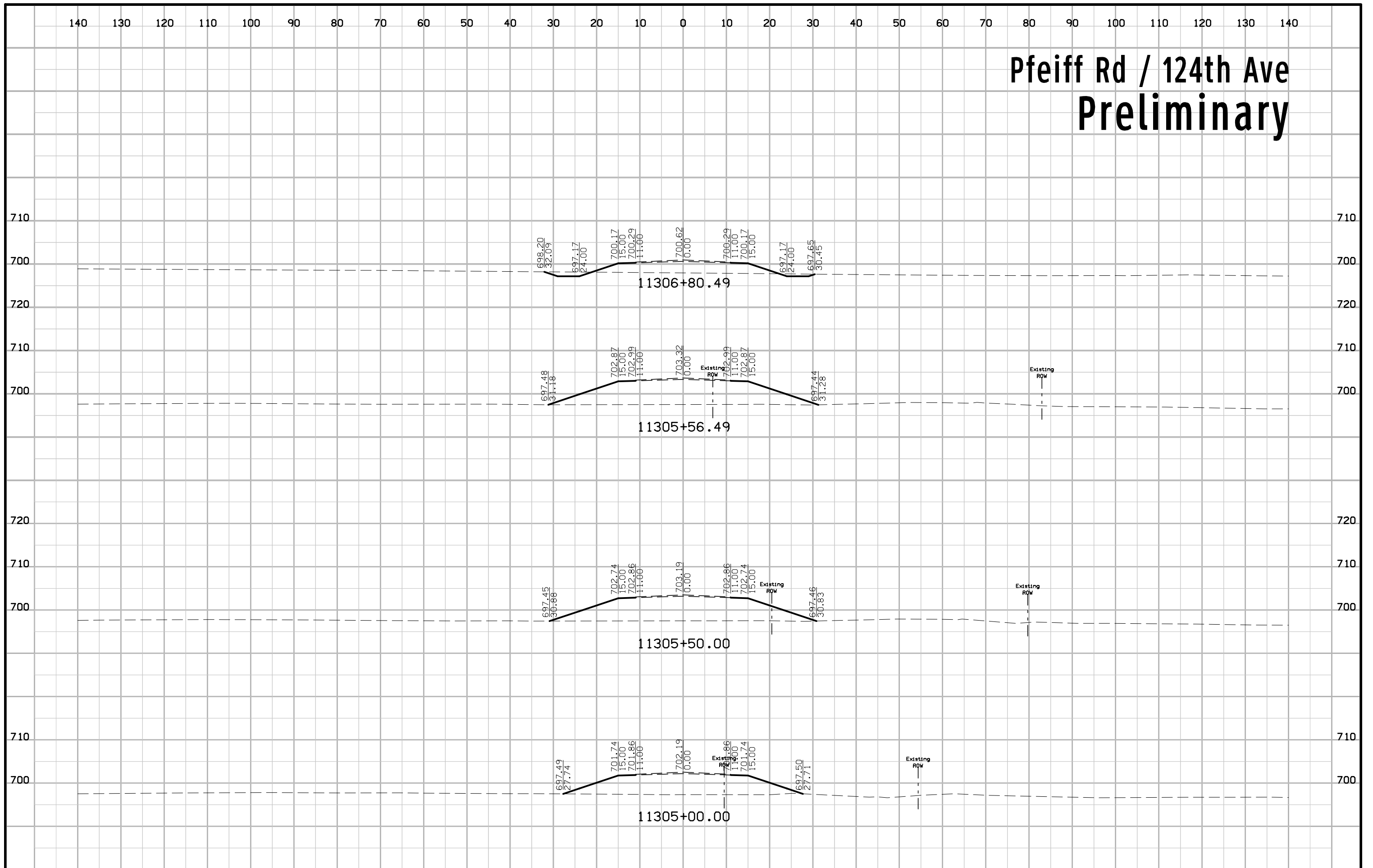

Pfeiff Rd / 124th Ave Preliminary

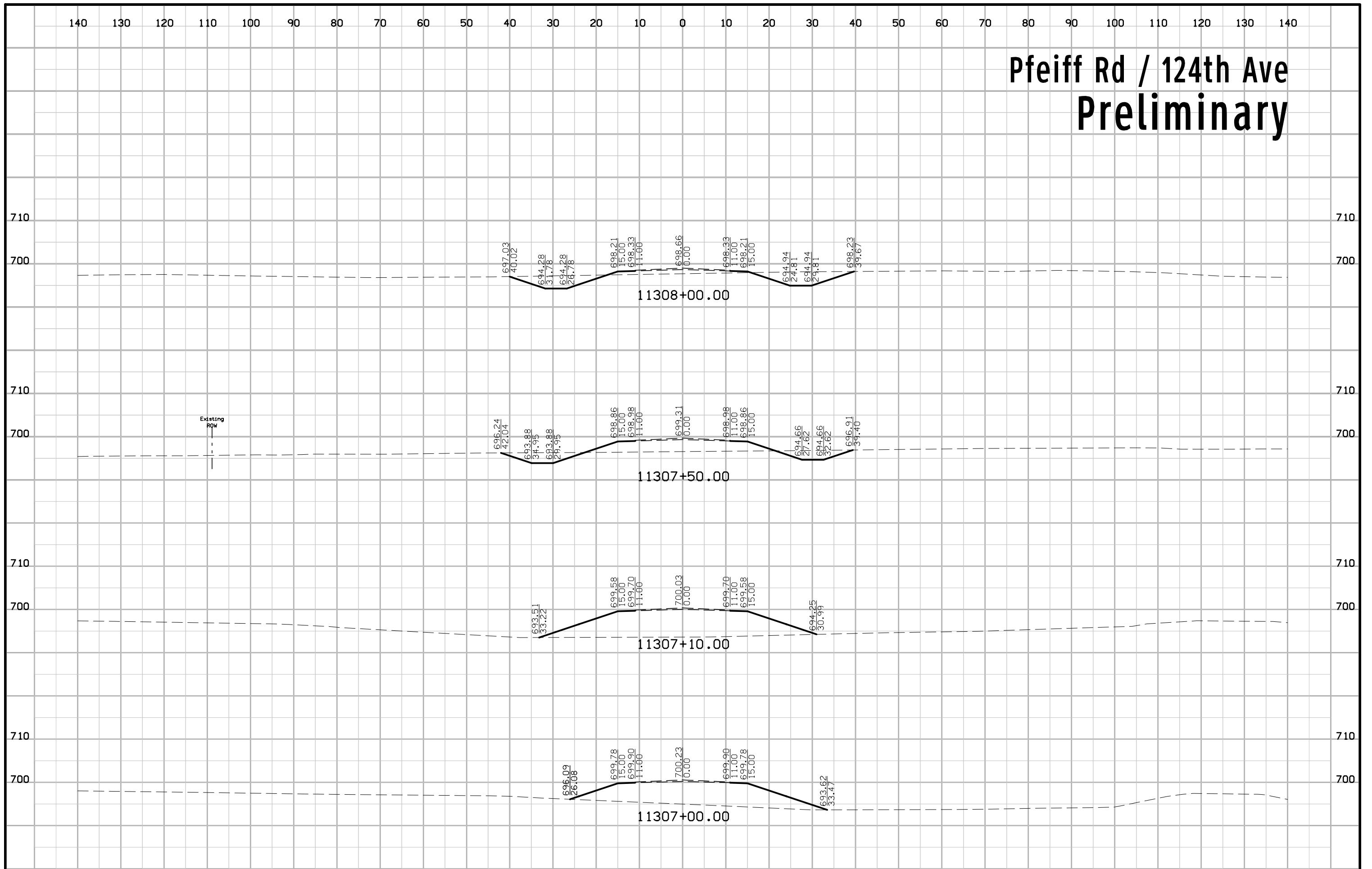

Pfeiff Rd / 124th Ave Preliminary

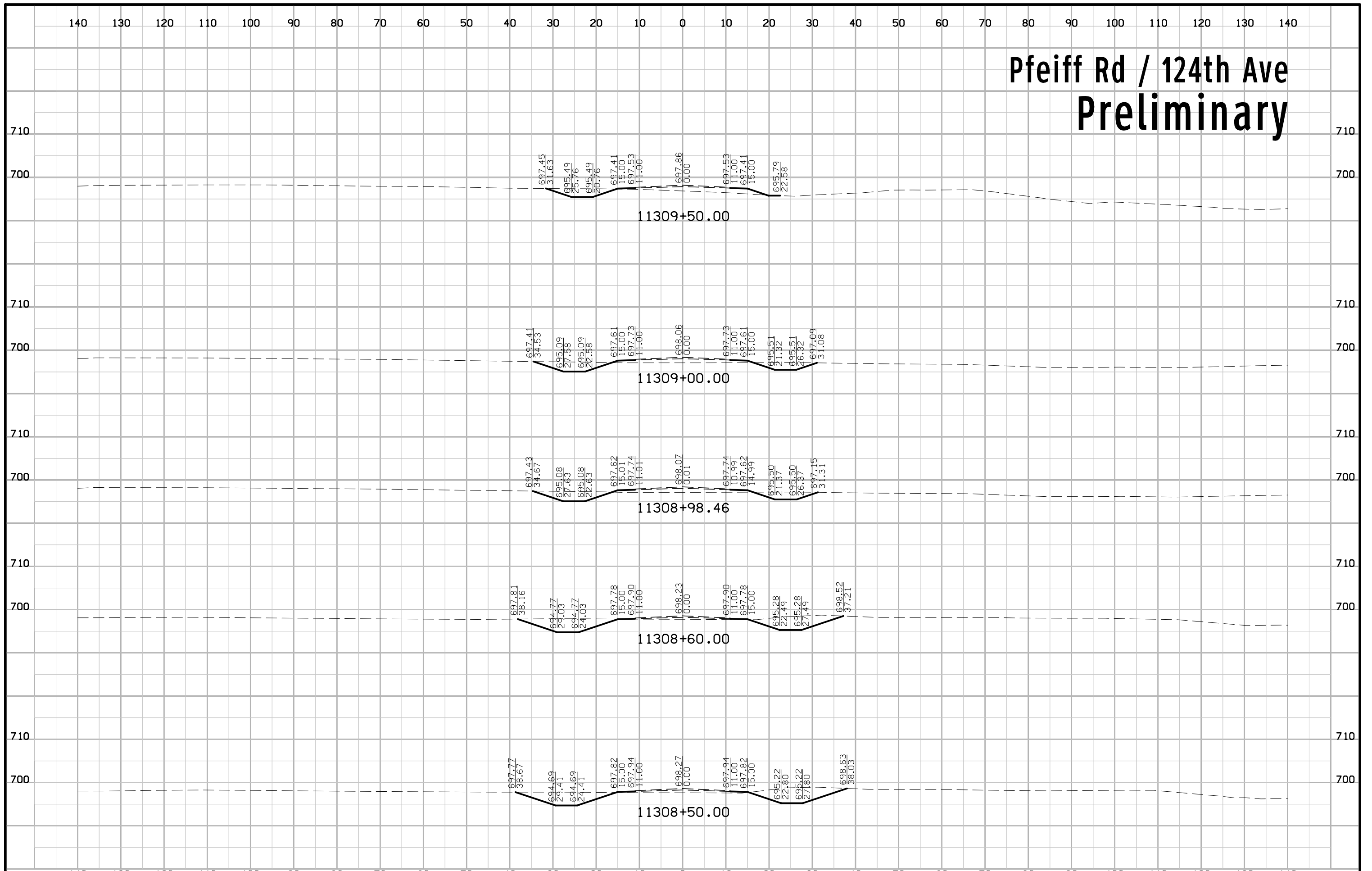

Pfeiff Rd / 124th Ave Preliminary

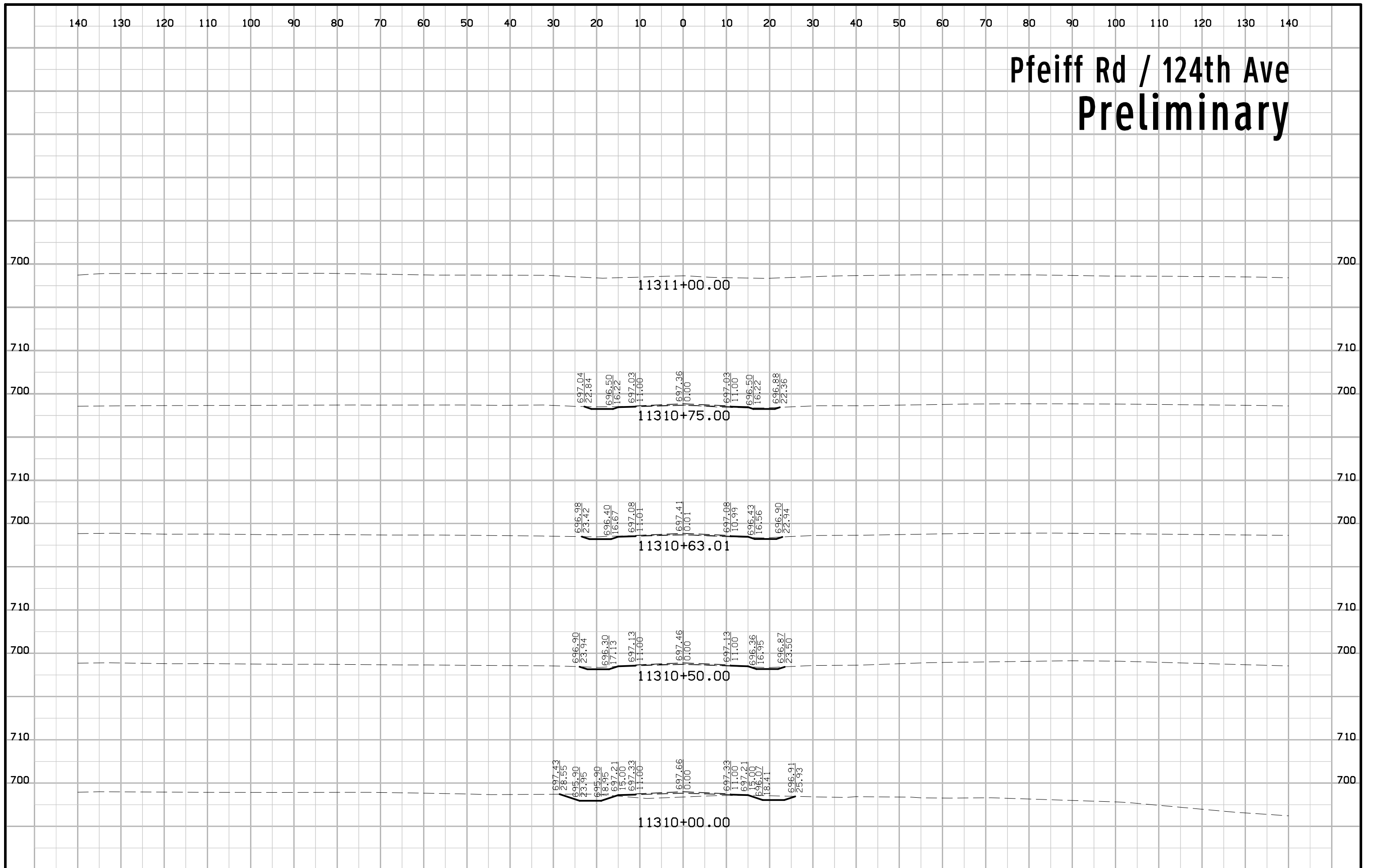

Iowa City Rd Preliminary

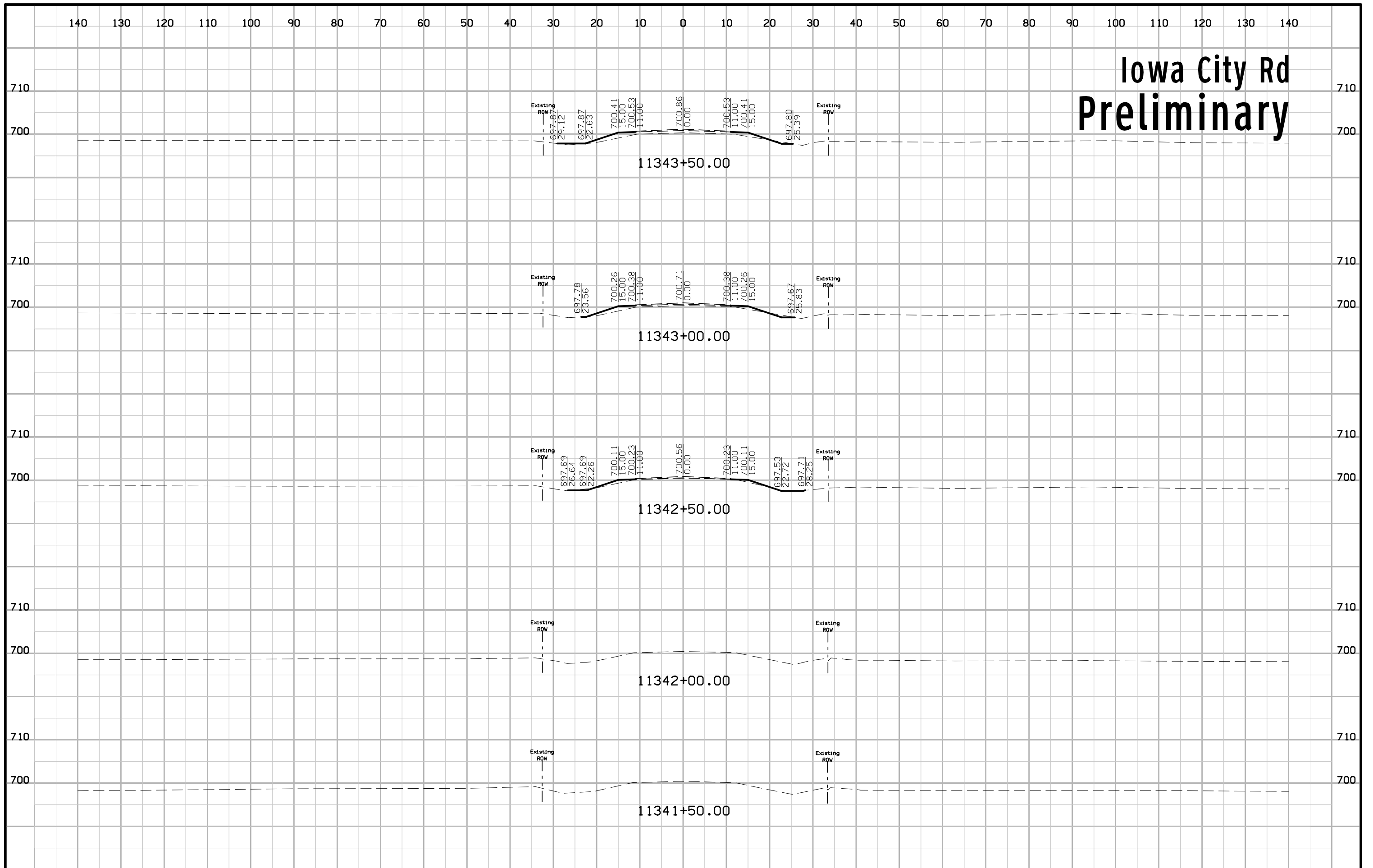

Iowa City Rd Preliminary

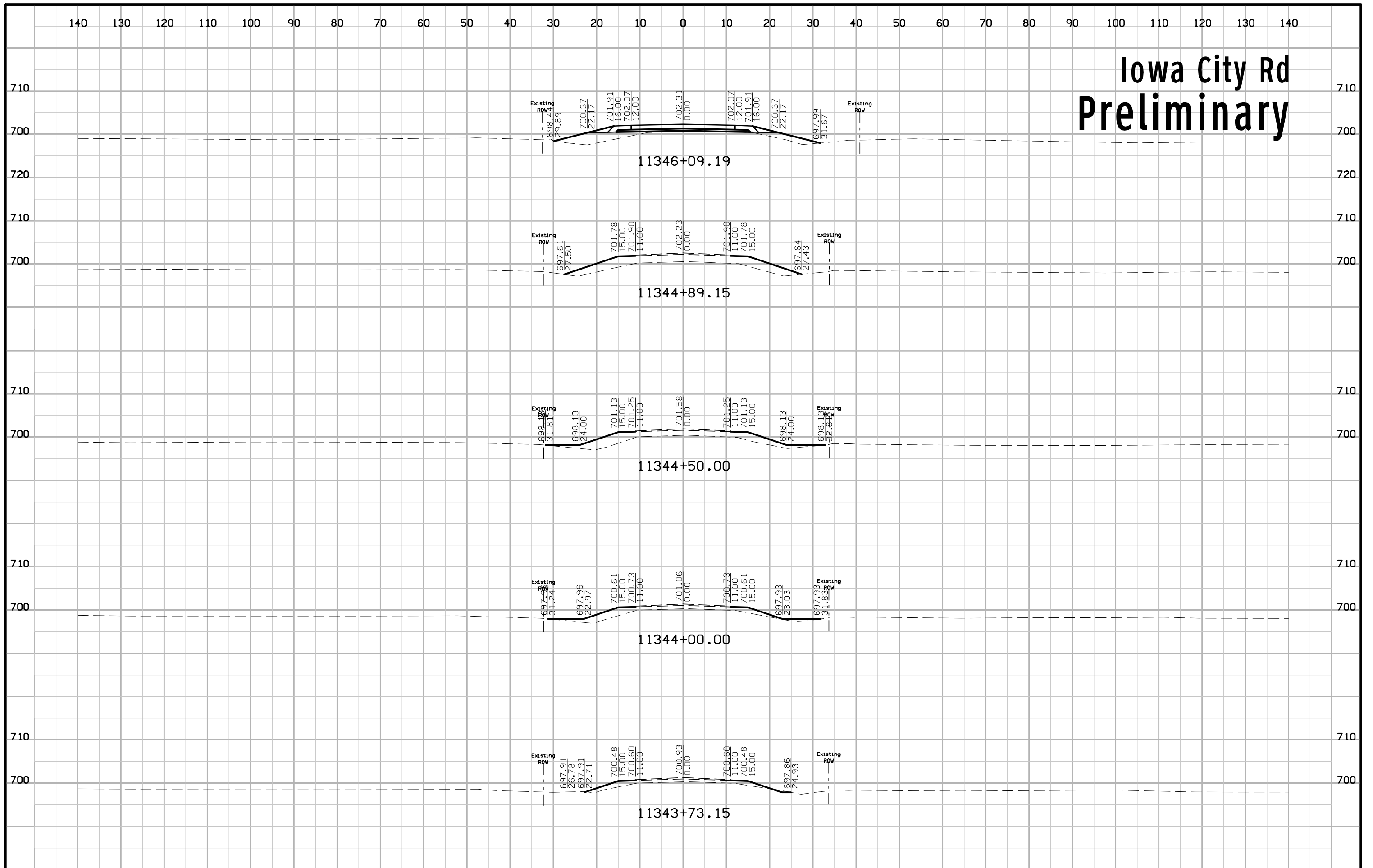

Iowa City Rd Preliminary

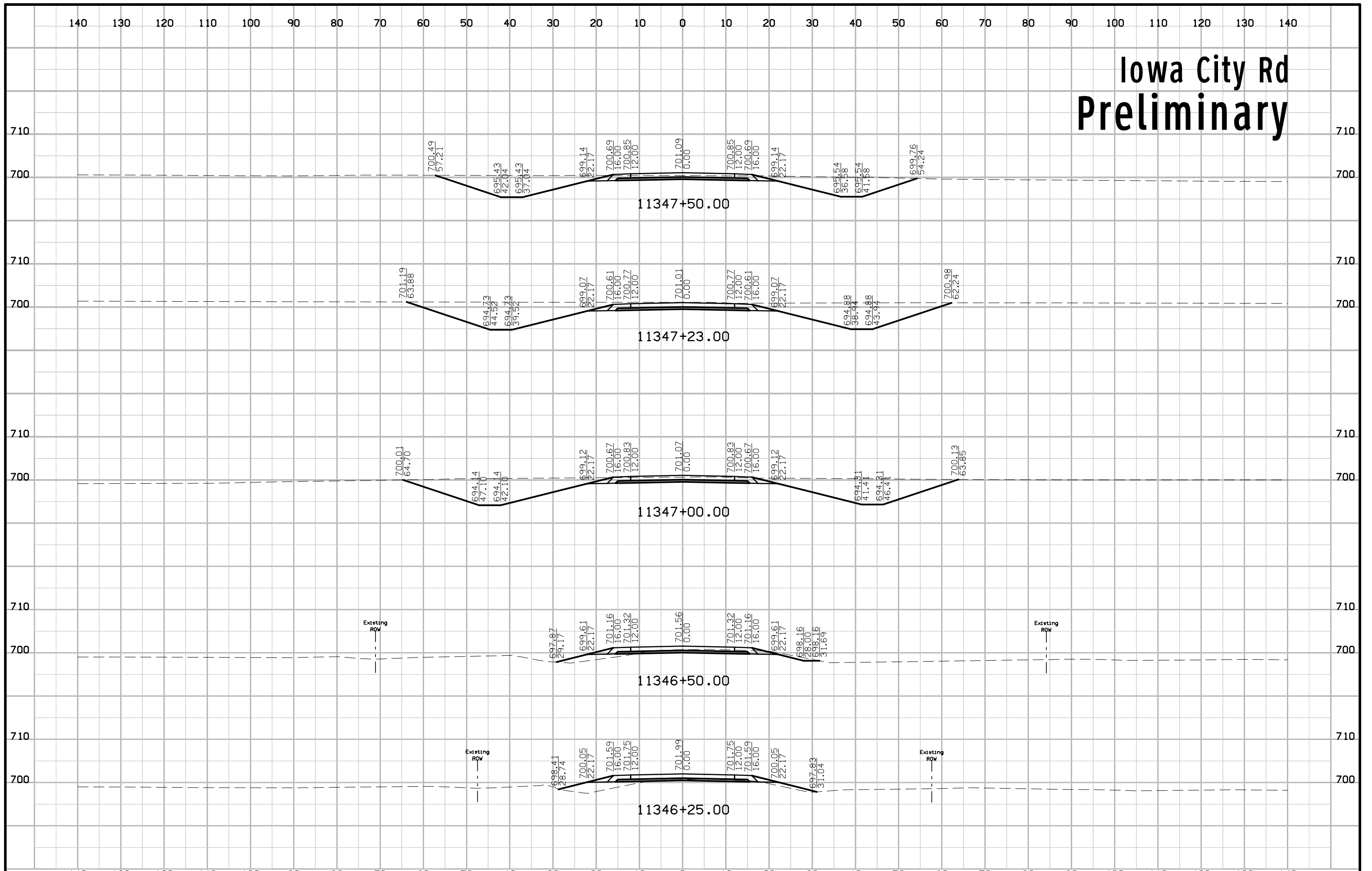

Iowa City Rd Preliminary

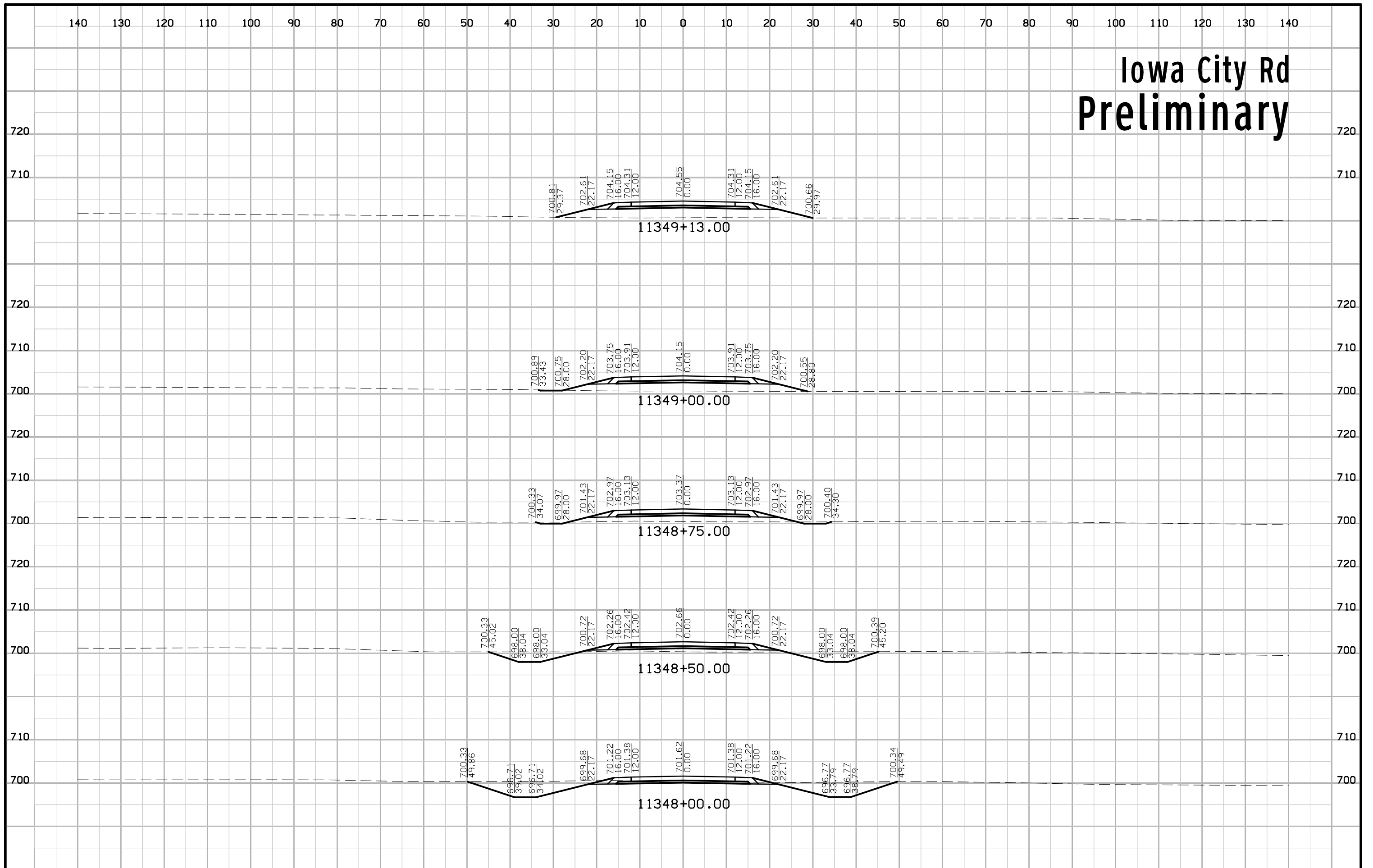

Existing US 61 Connection at Iowa City Rd Preliminary

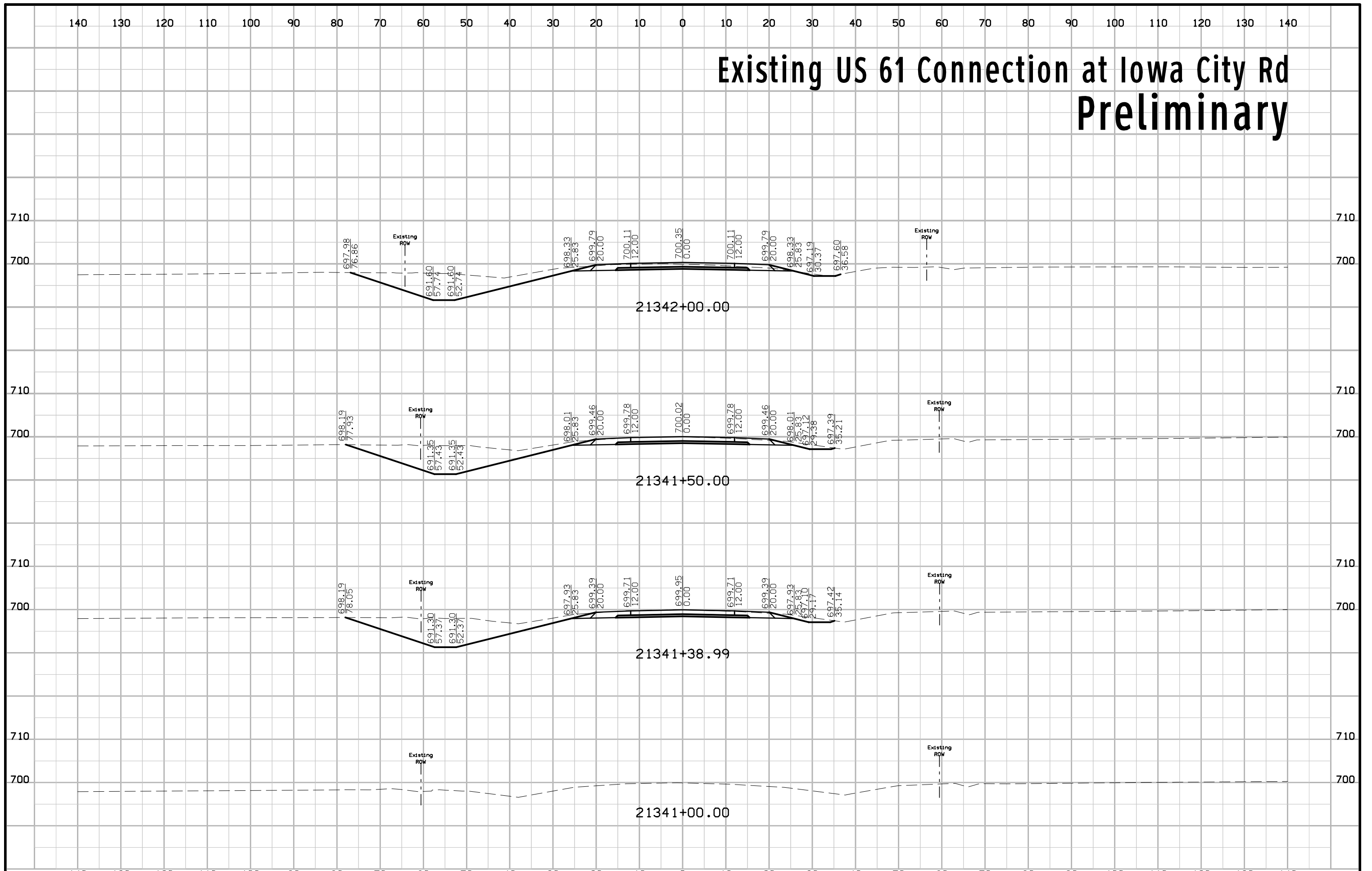

Existing US 61 Connection at Iowa City Rd Preliminary

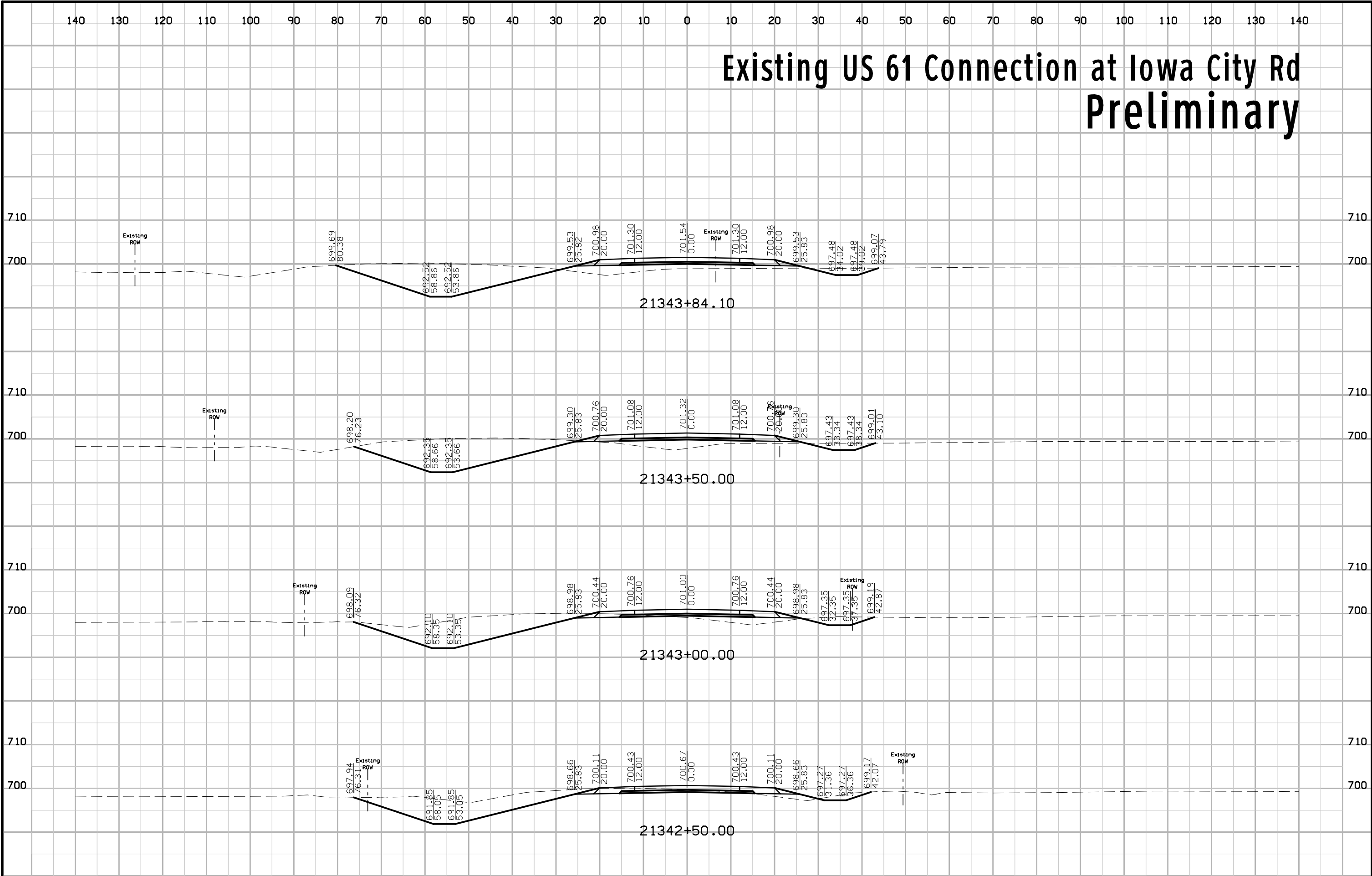

Existing US 61 Connection at Iowa City Rd Preliminary

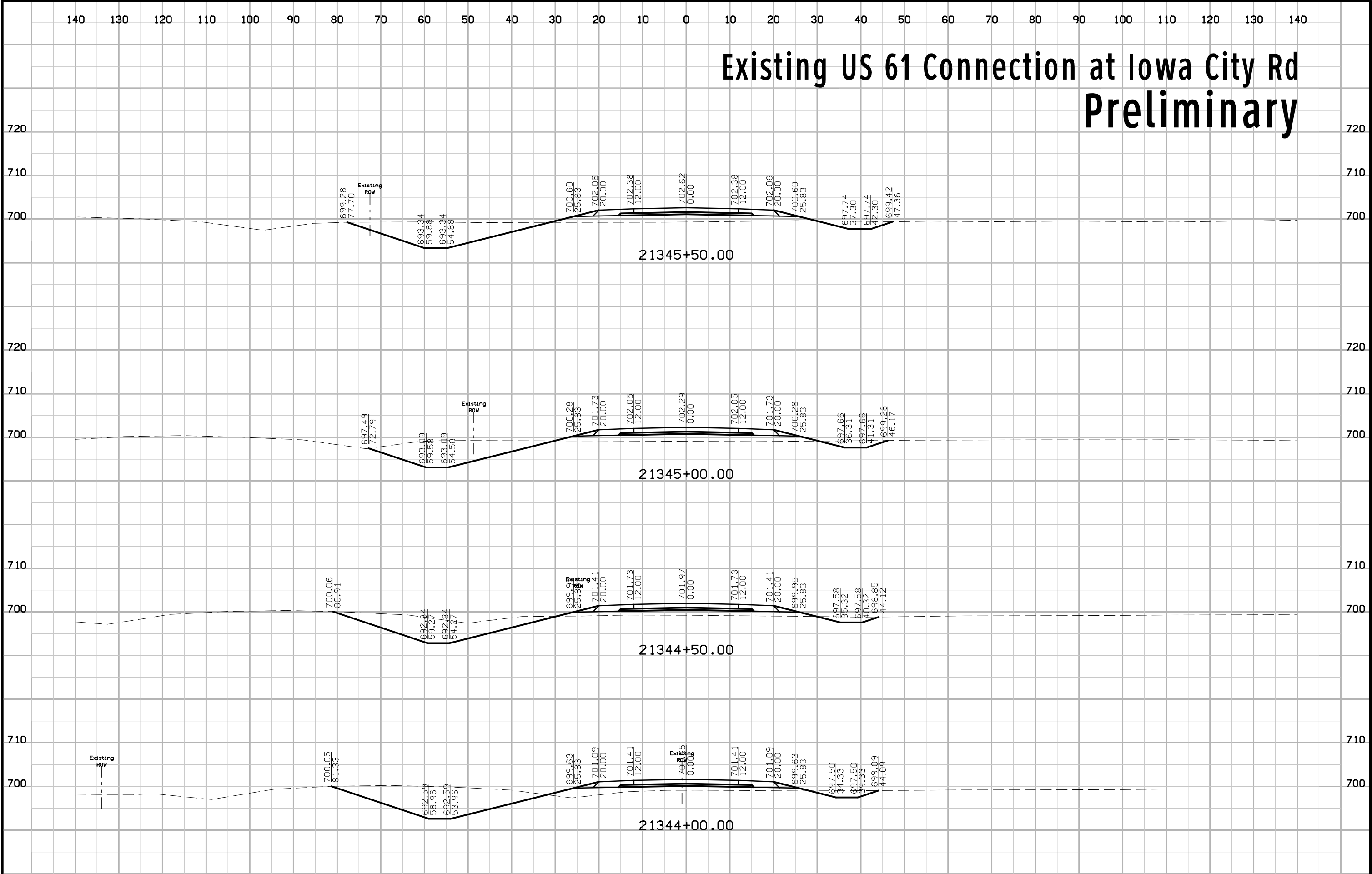

Existing US 61 Connection at Iowa City Rd Preliminary

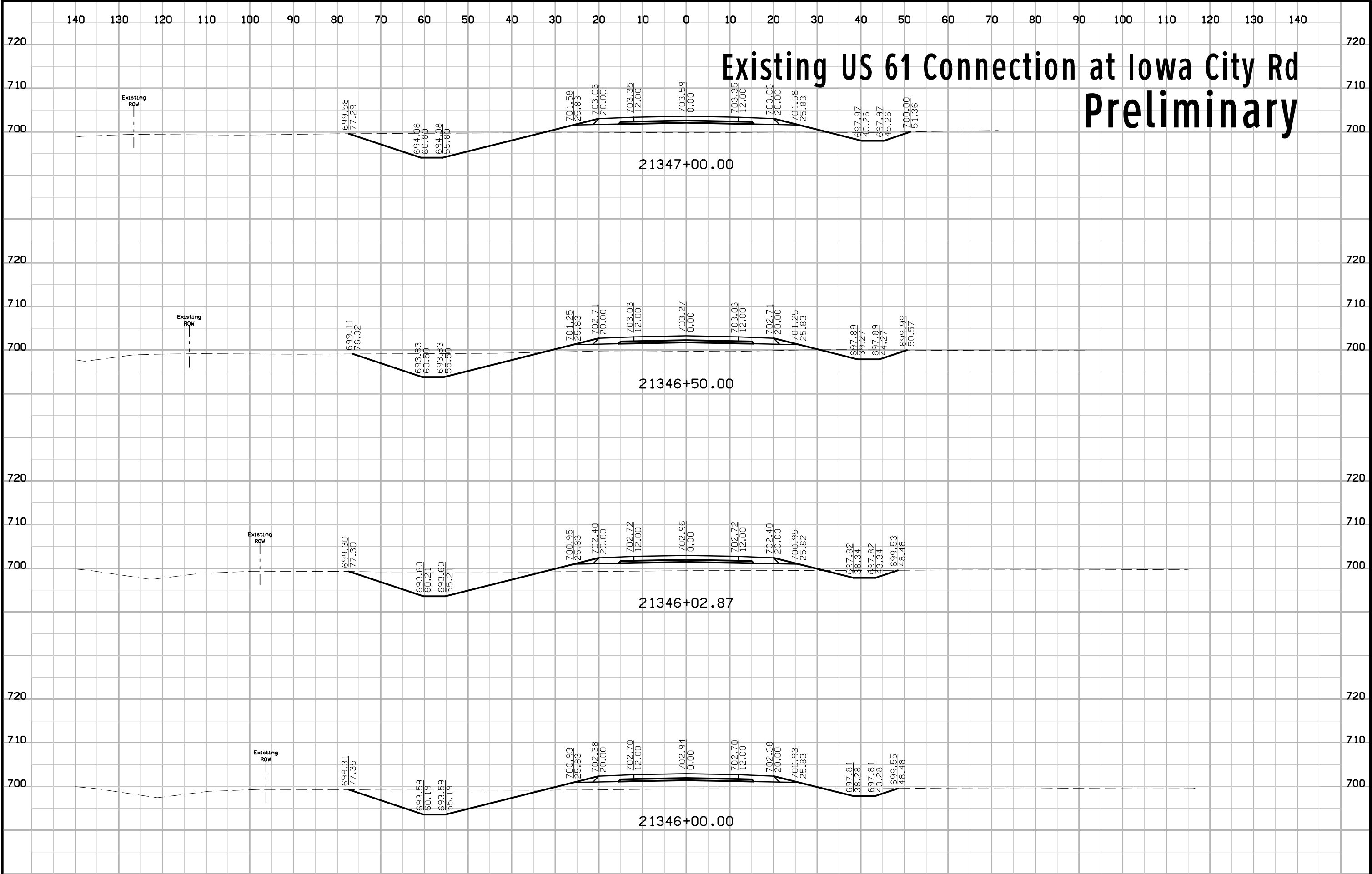

Existing US 61 Connection at Iowa City Rd Preliminary

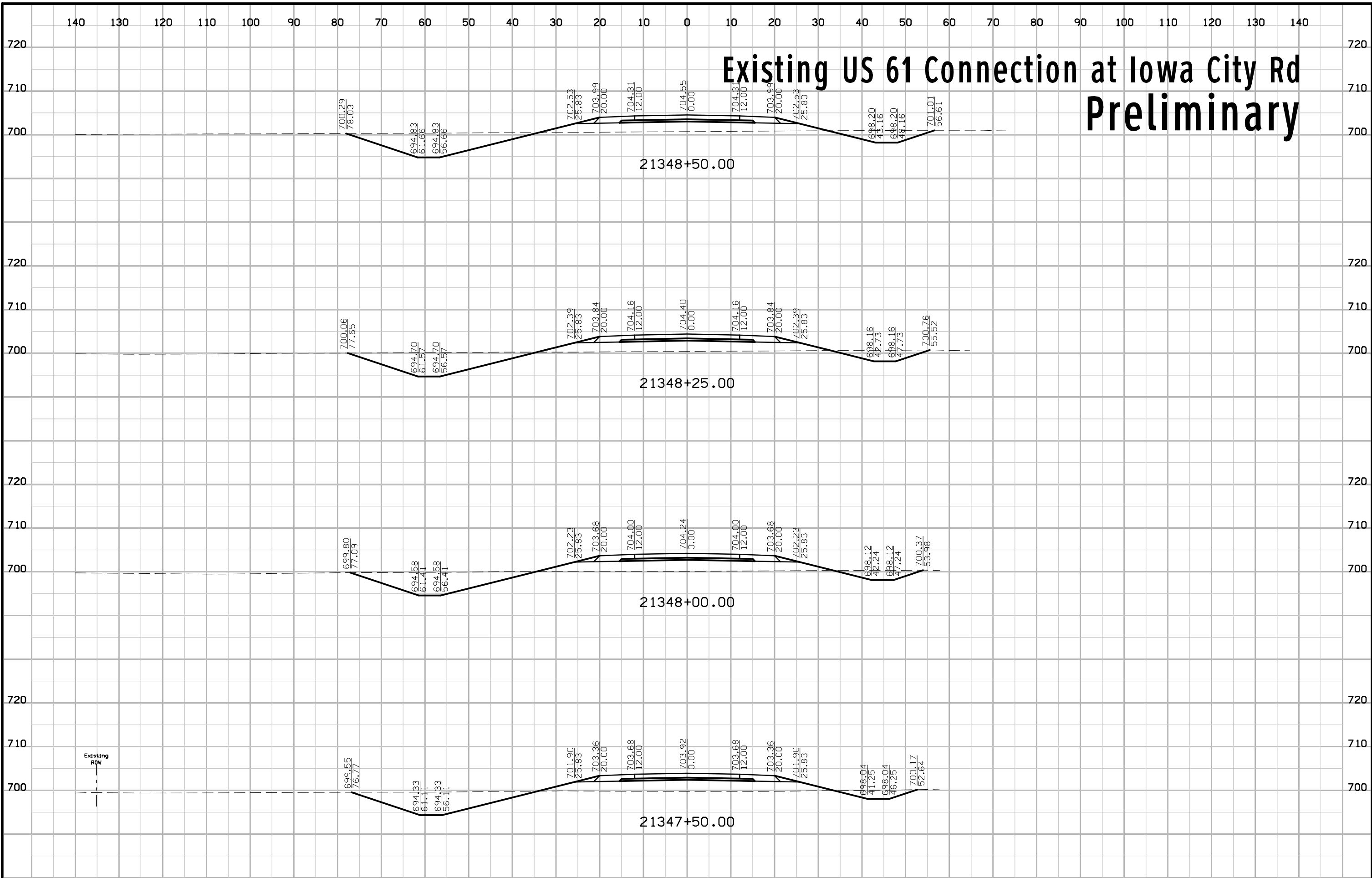

Existing US 61 Connection at Iowa City Rd Preliminary

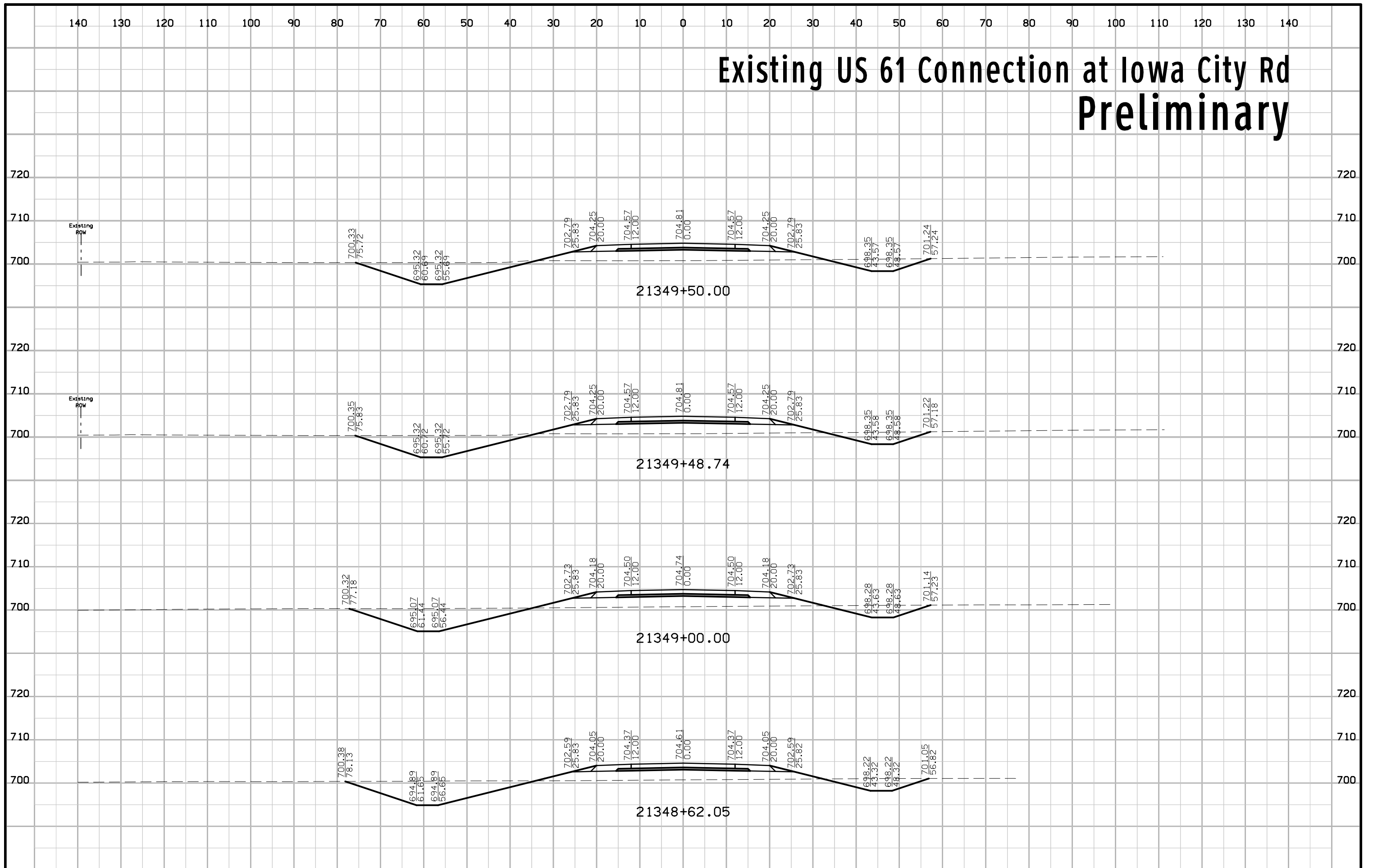

Existing US 61 Connection at Iowa City Rd Preliminary

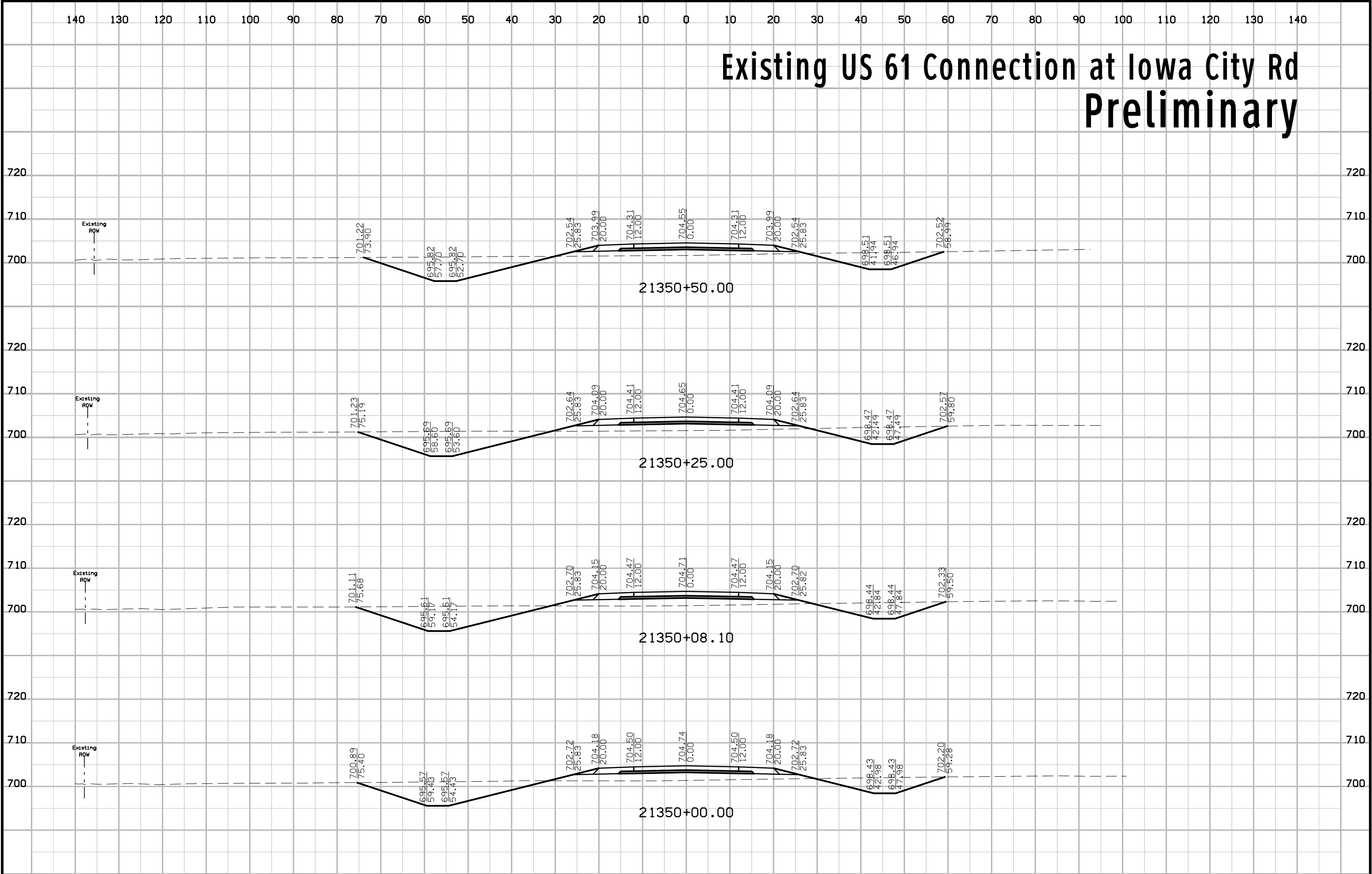

Existing US 61 Connection at Iowa City Rd Preliminary

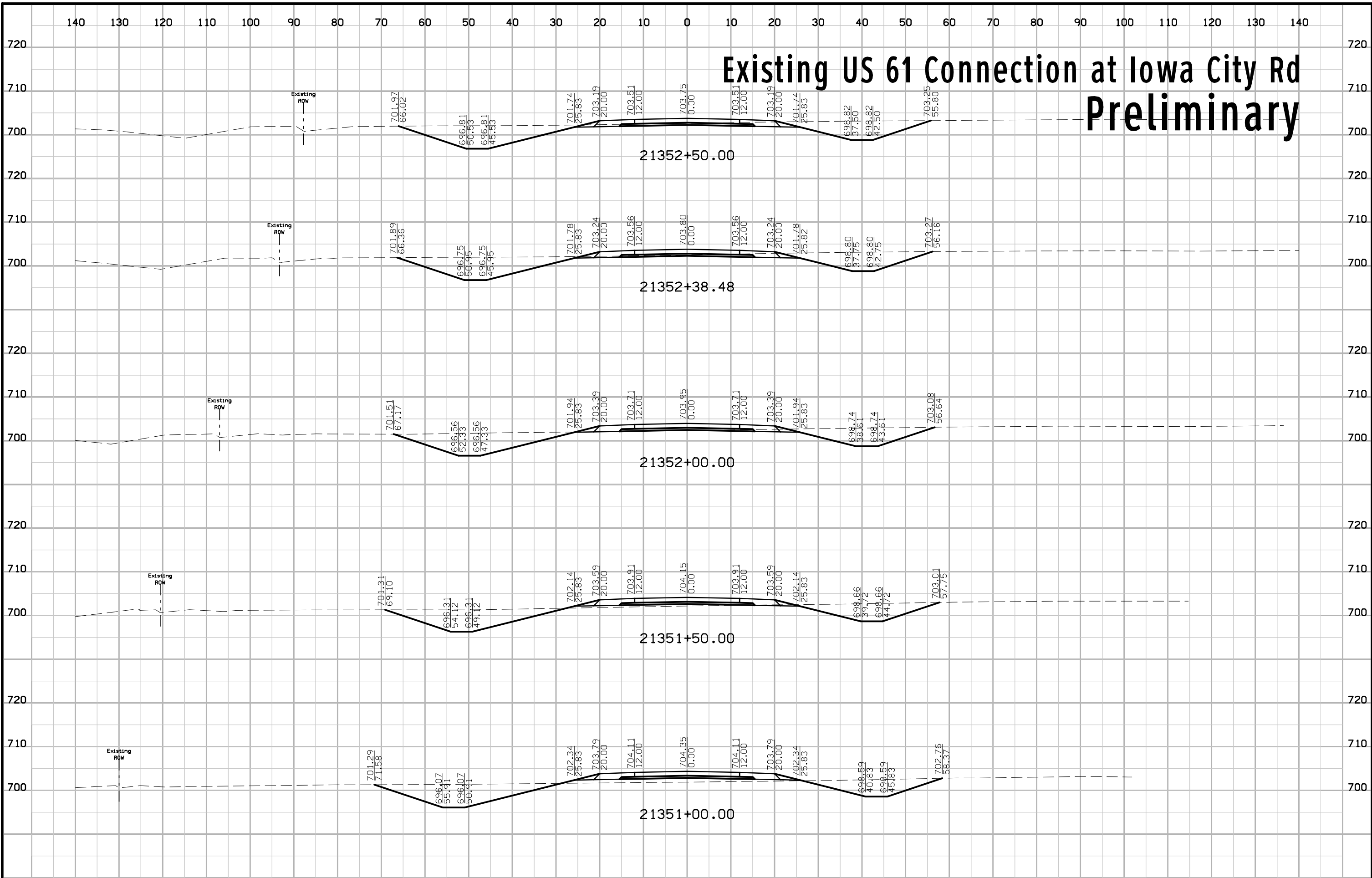

Existing US 61 Connection at Iowa City Rd Preliminary

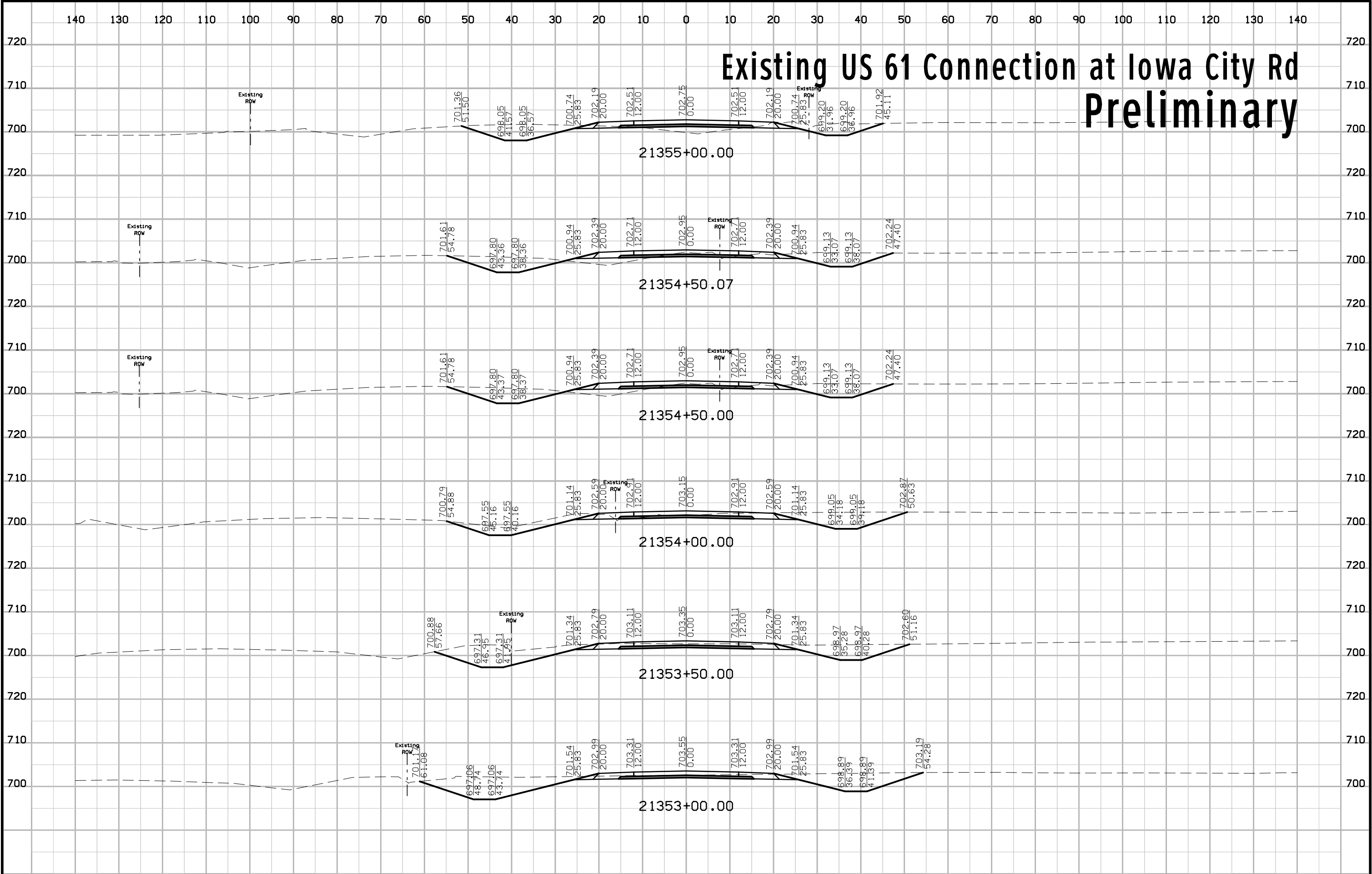

Existing US 61 Connection at Iowa City Rd Preliminary

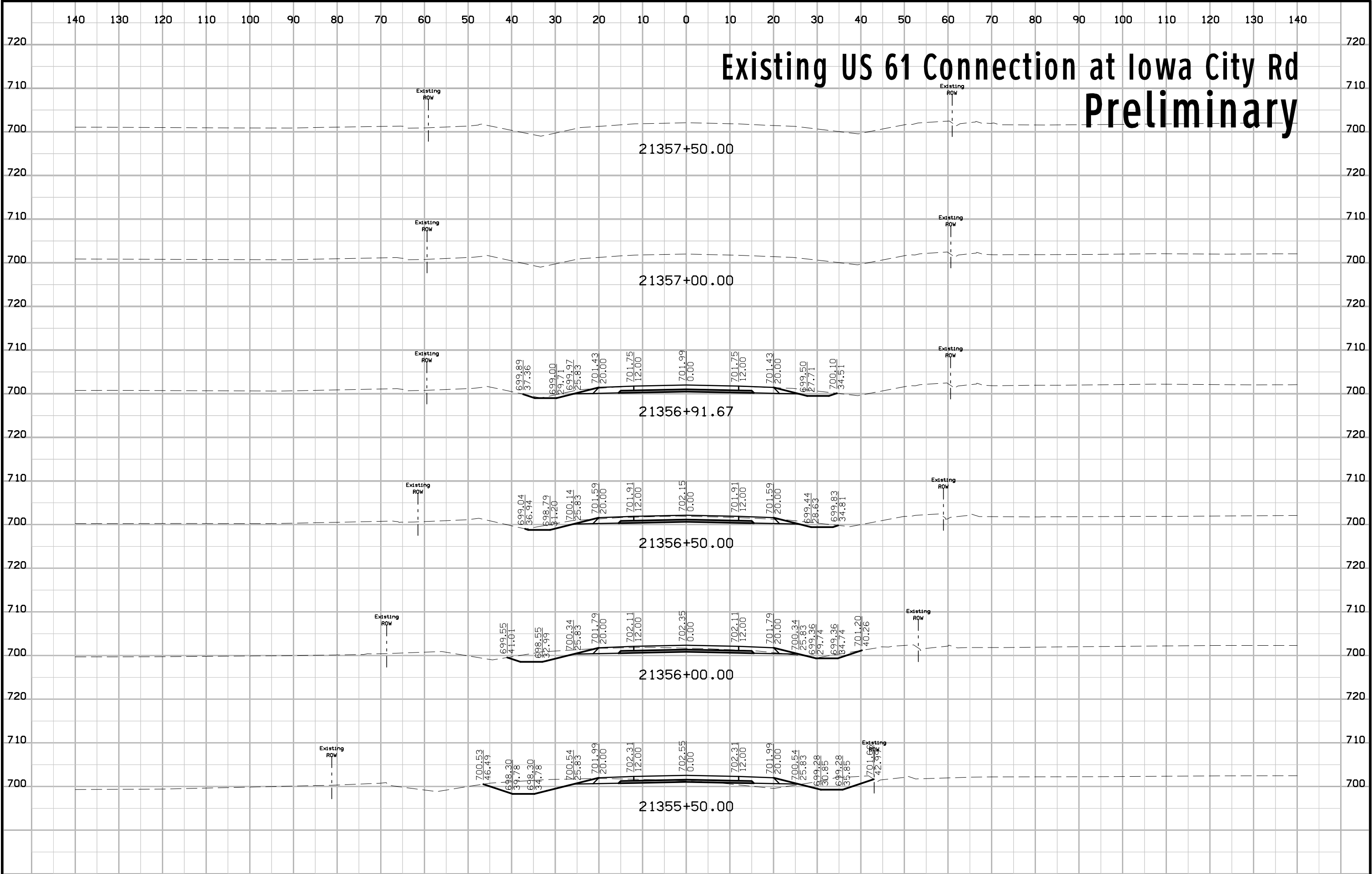

150th St / Center Ave Preliminary

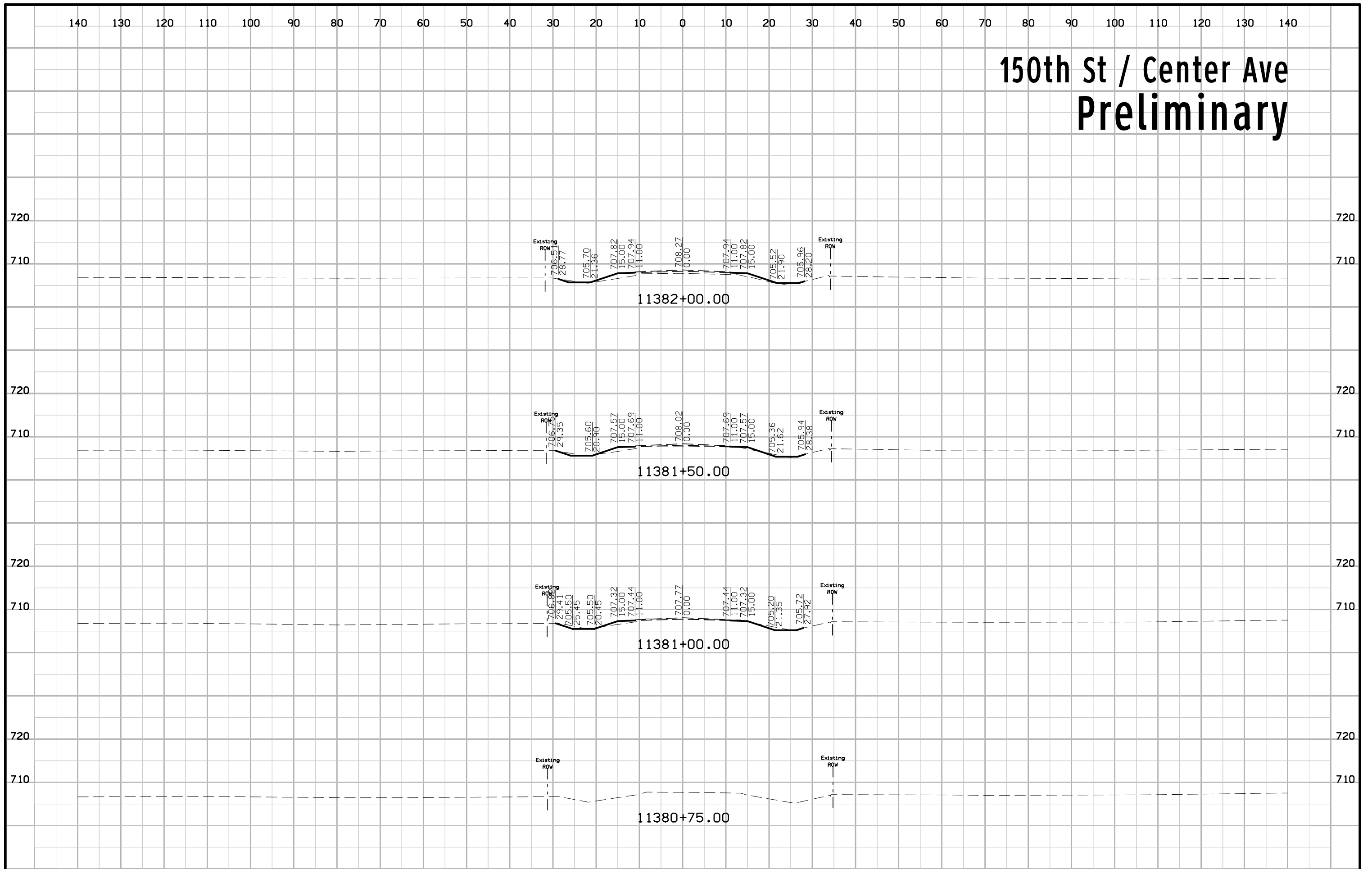

150th St / Center Ave Preliminary

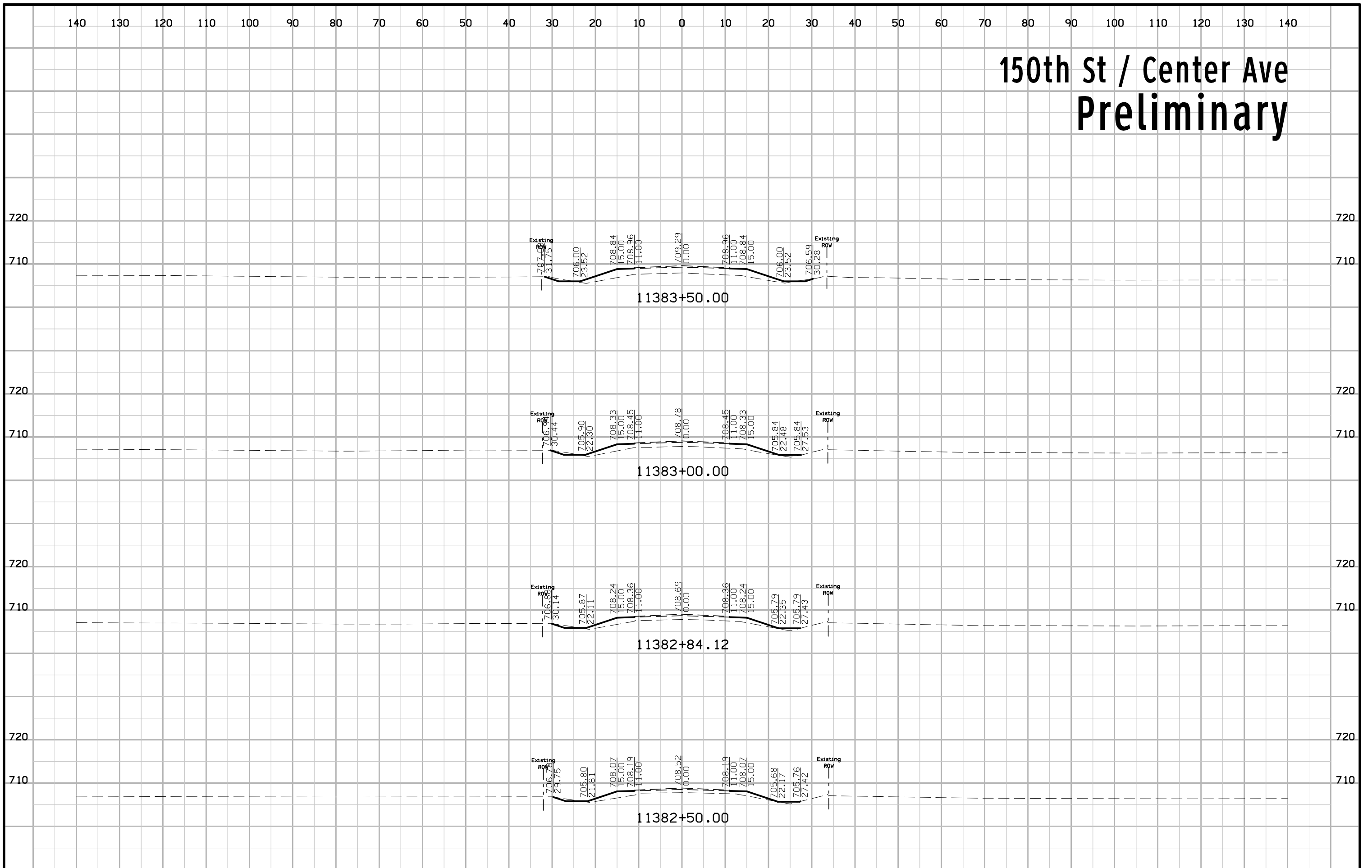

150th St / Center Ave Preliminary

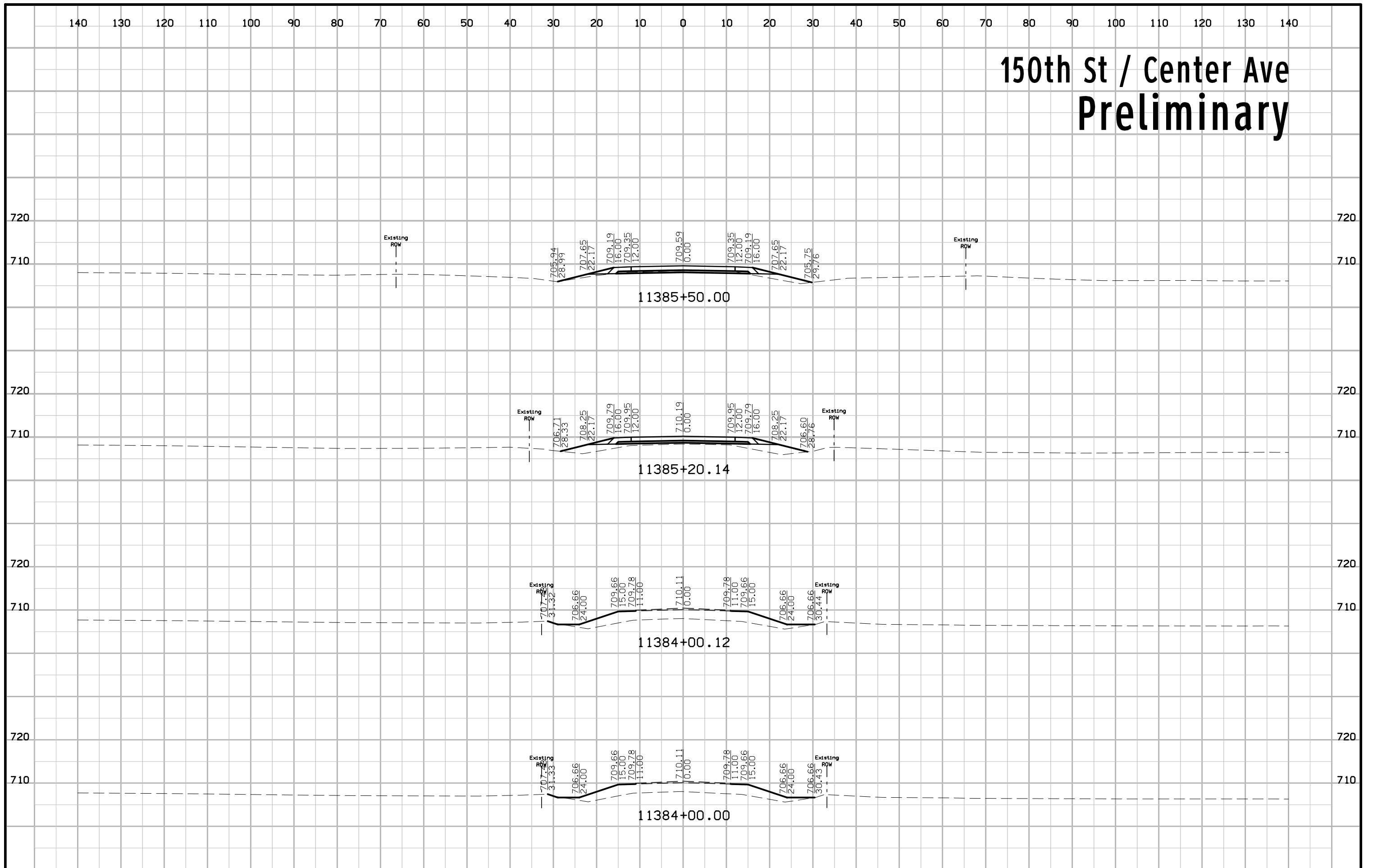

150th St / Center Ave Preliminary

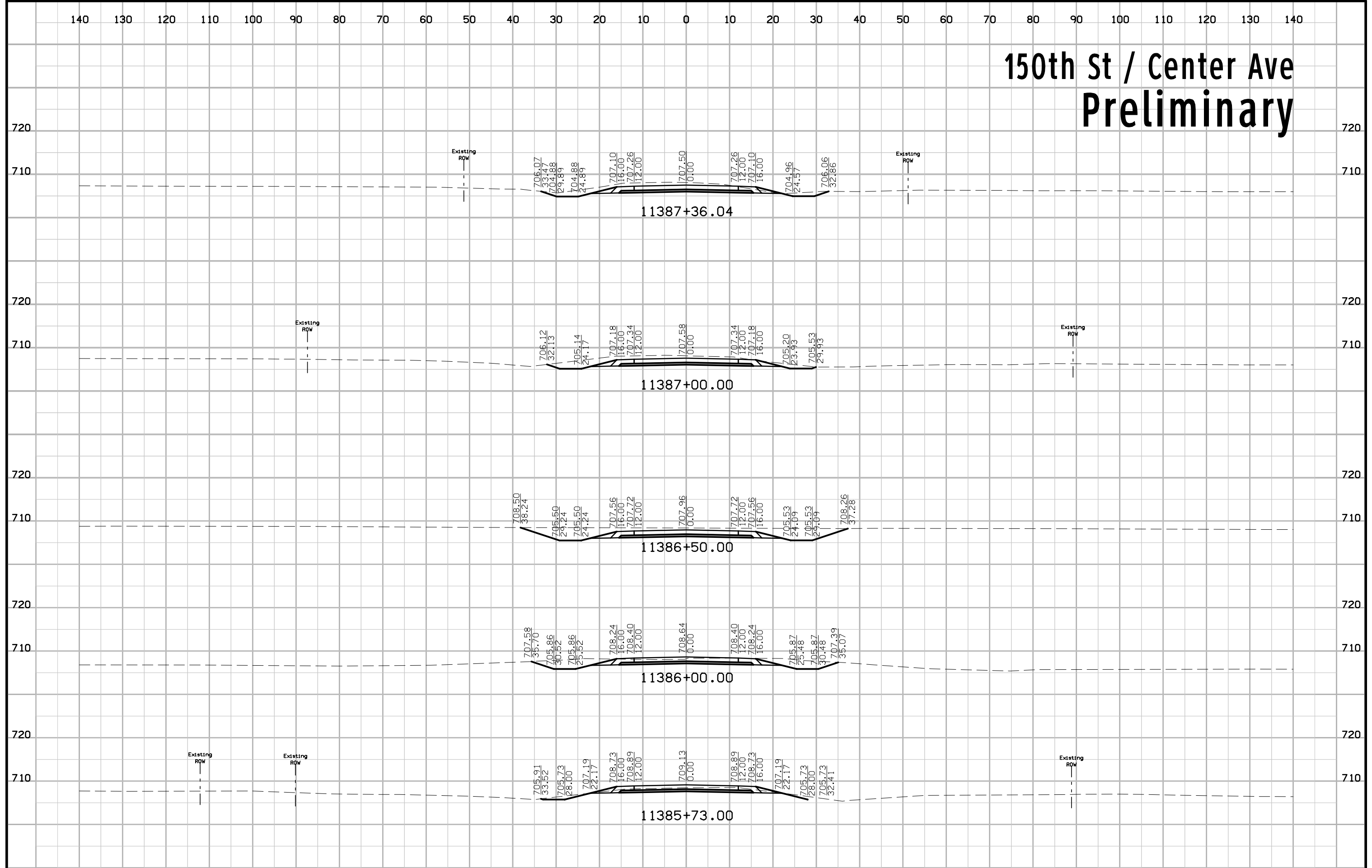

150th St / Center Ave Preliminary

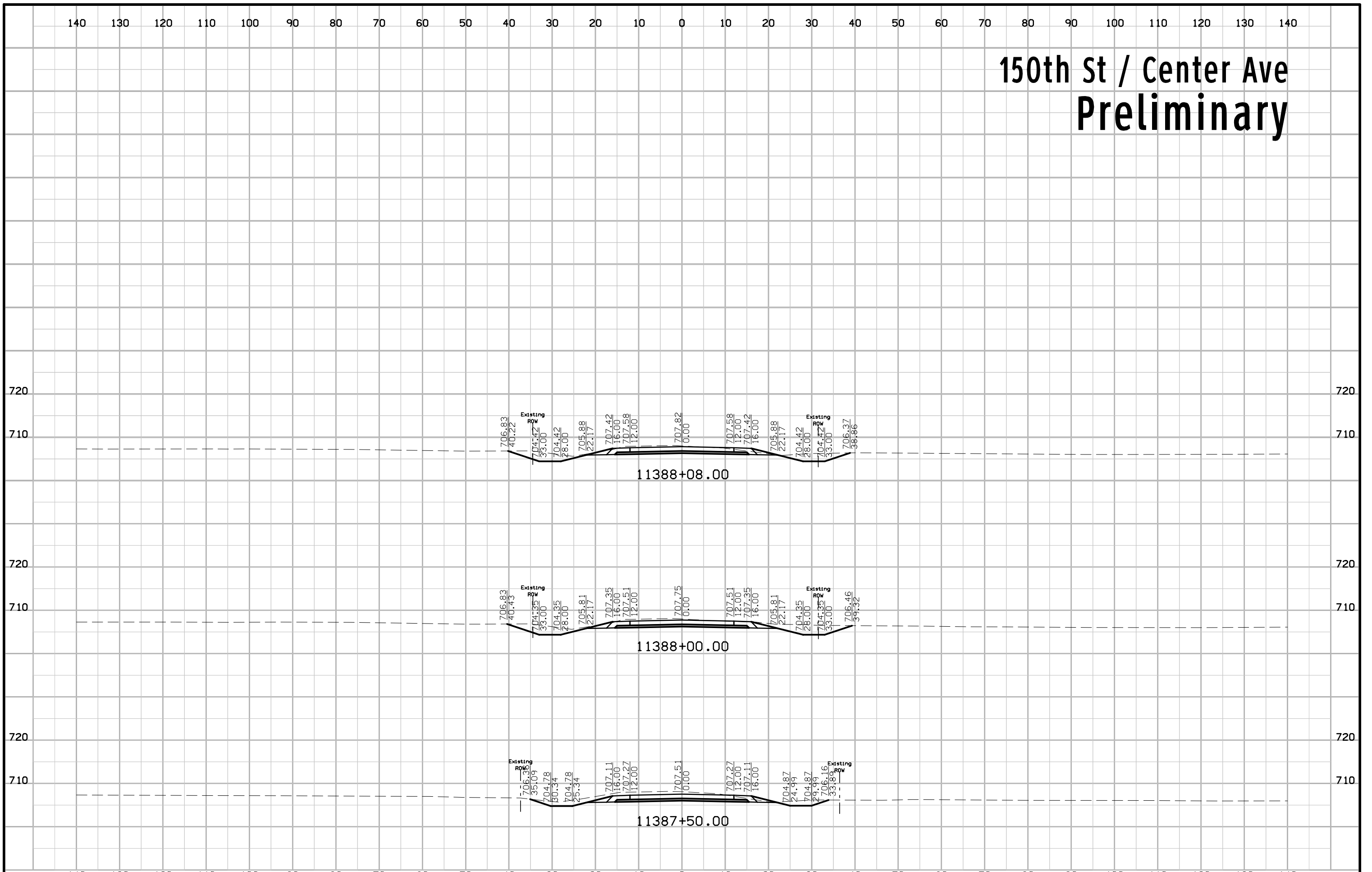

Existing US 61 Connection at 150th St Preliminary

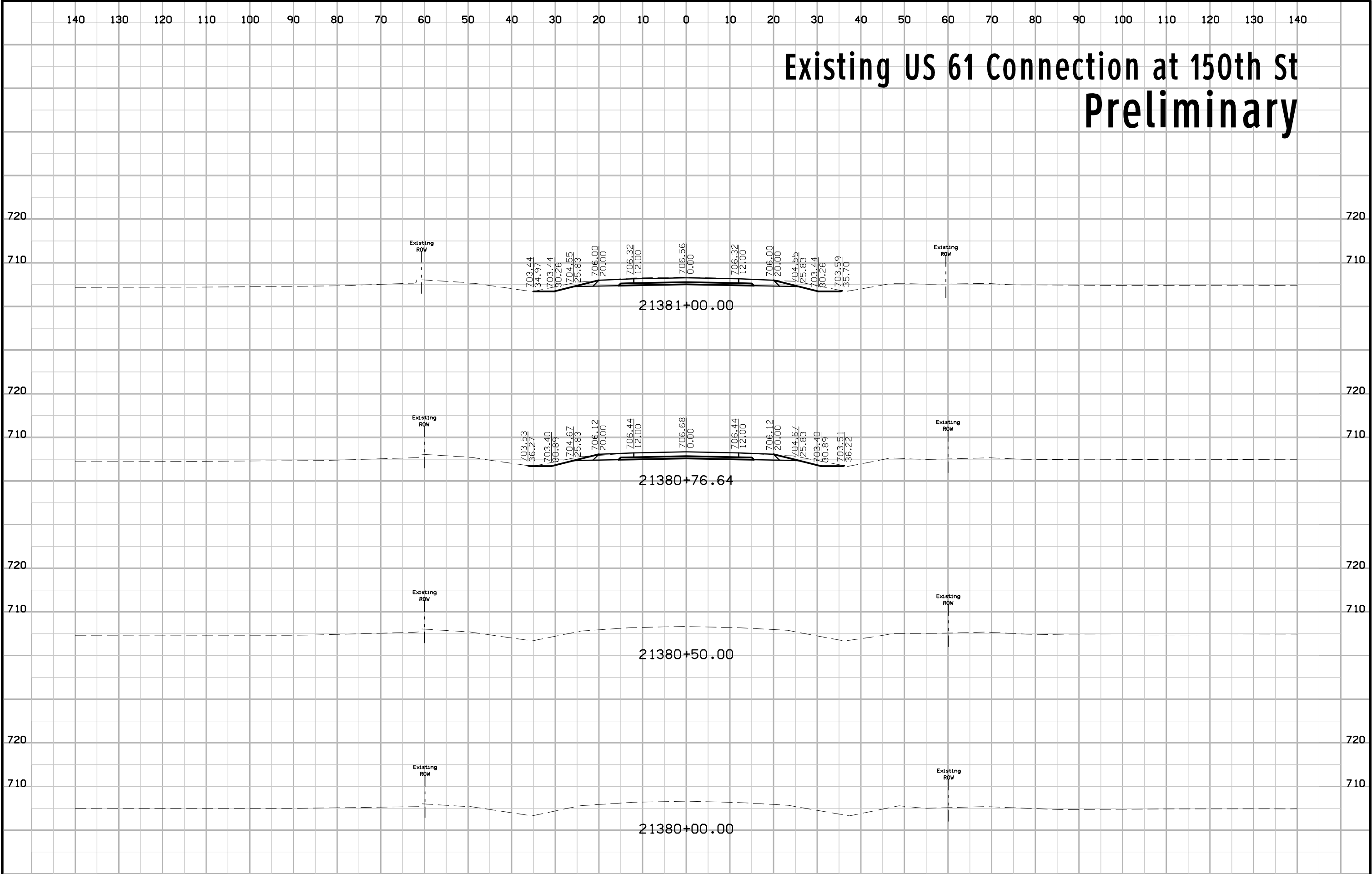

Existing US 61 Connection at 150th St Preliminary

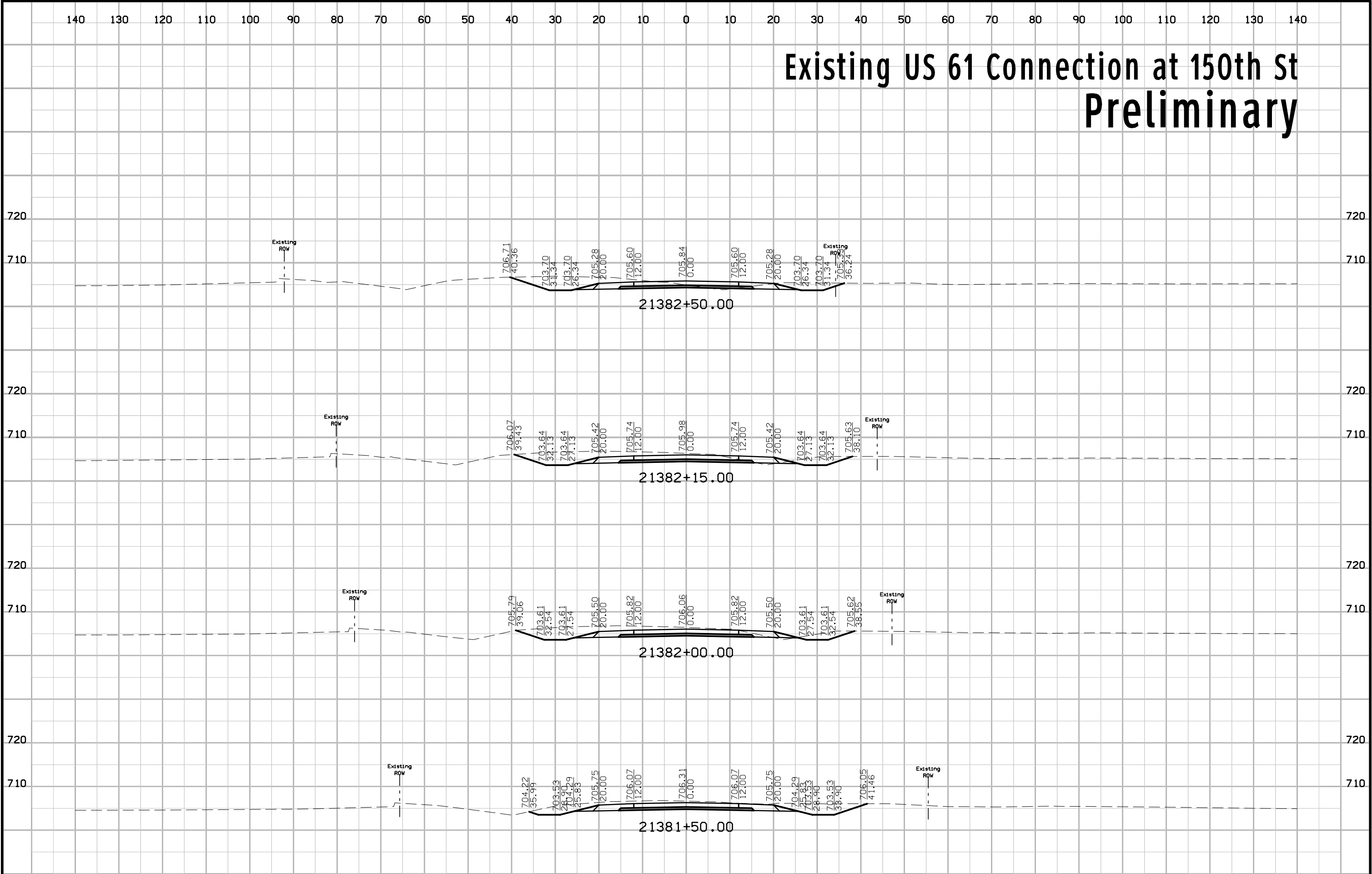

Existing US 61 Connection at 150th St Preliminary

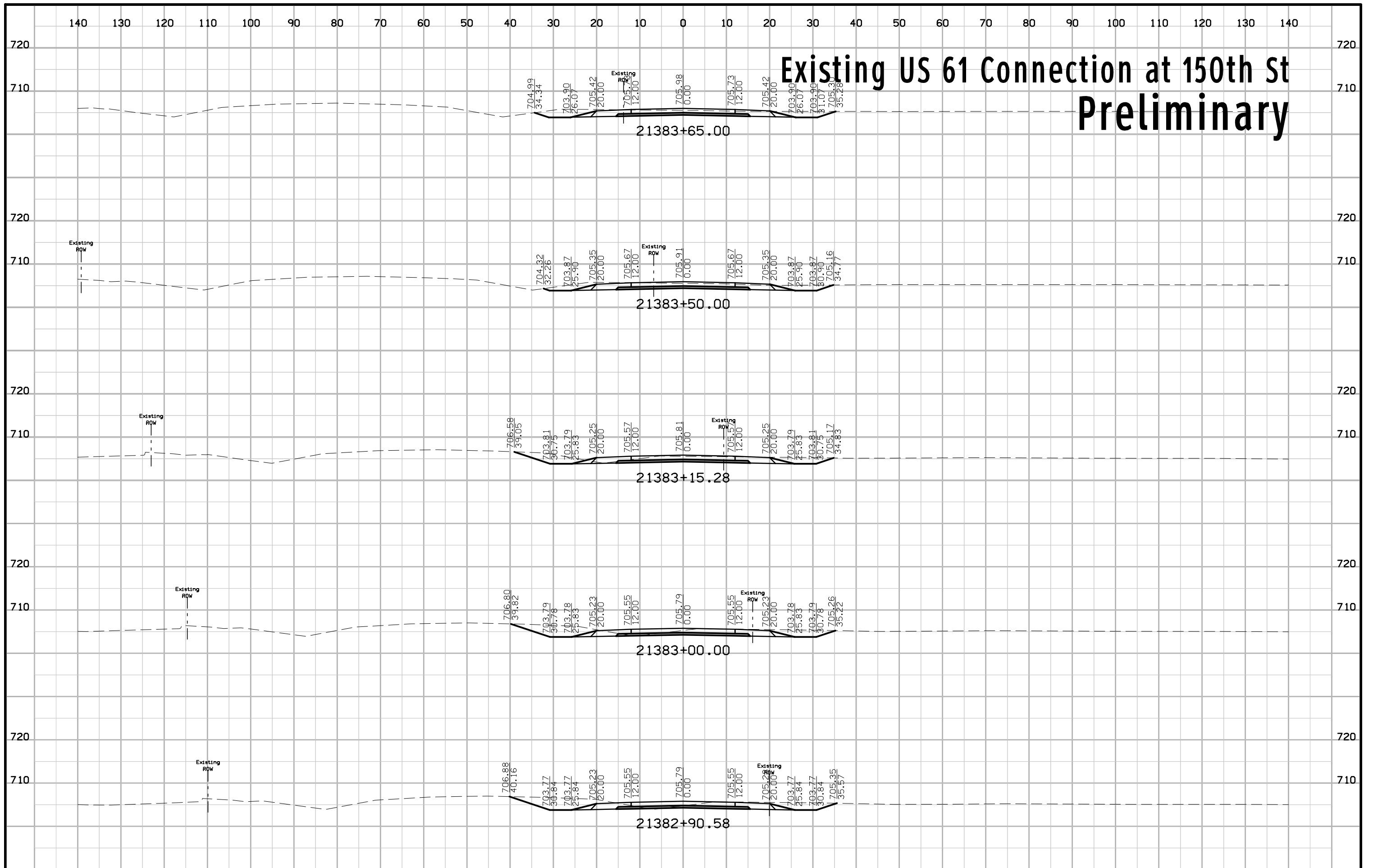

Existing US 61 Connection at 150th St Preliminary

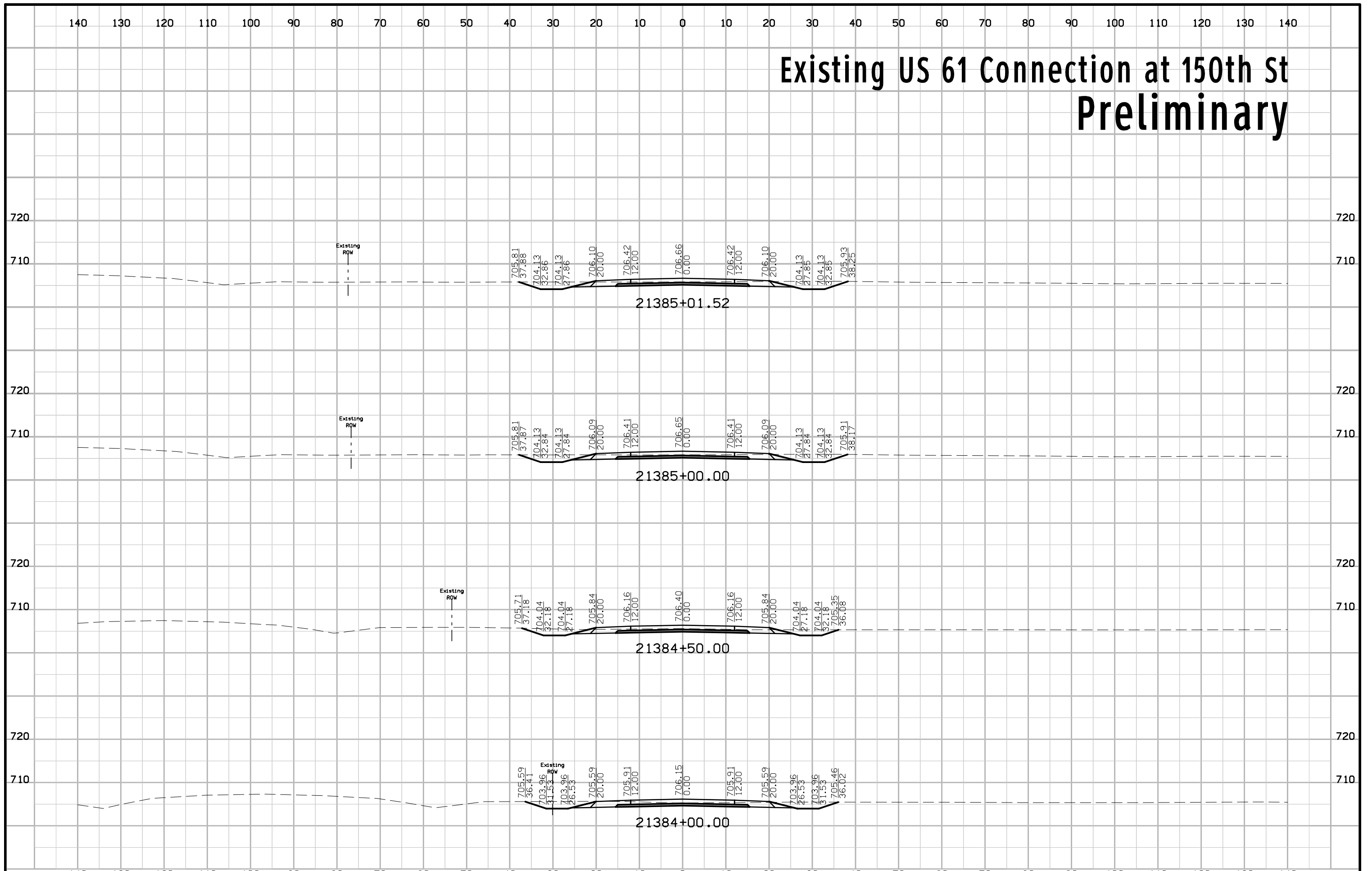

Existing US 61 Connection at 150th St Preliminary

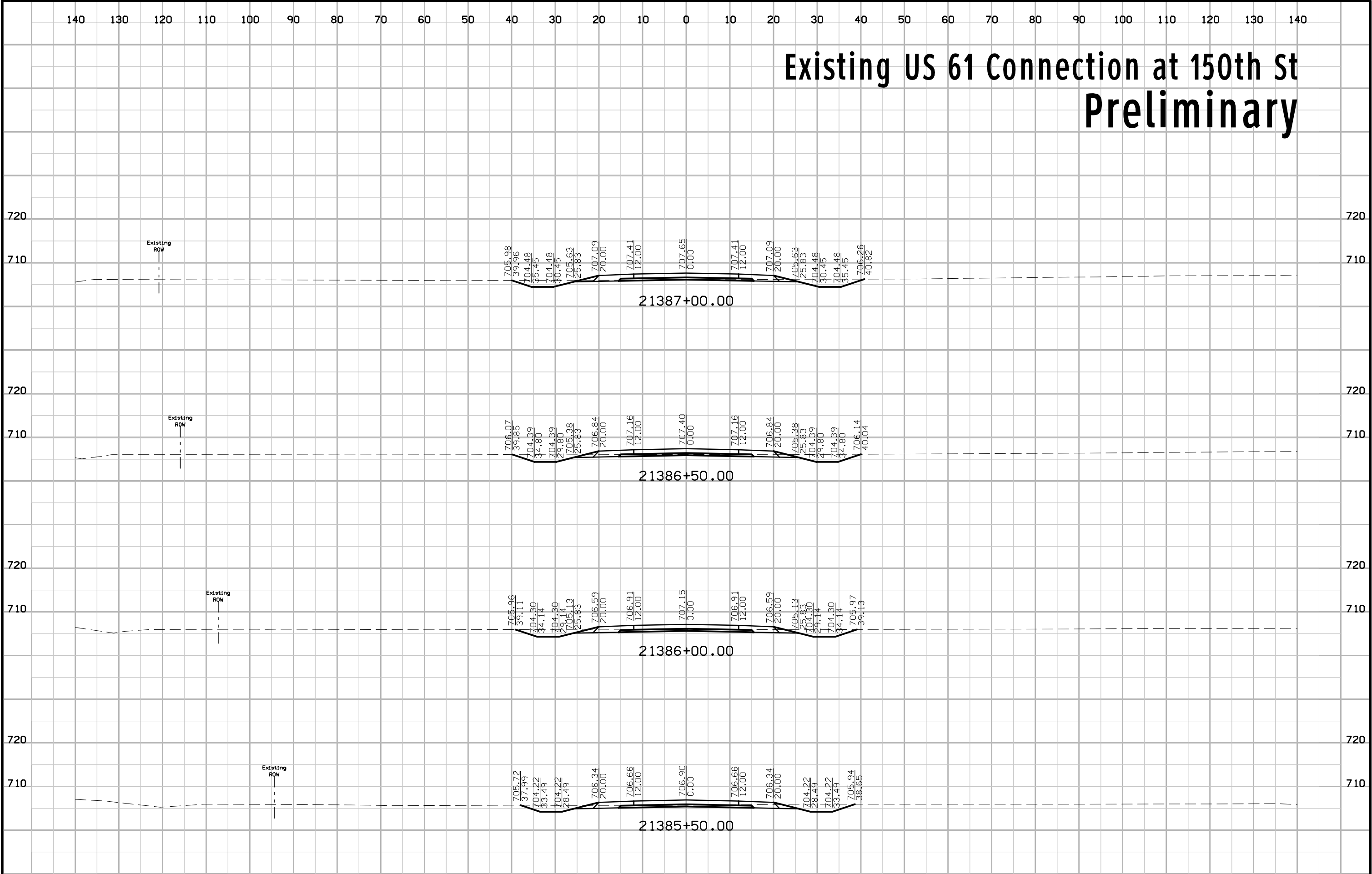

Existing US 61 Connection at 150th St Preliminary

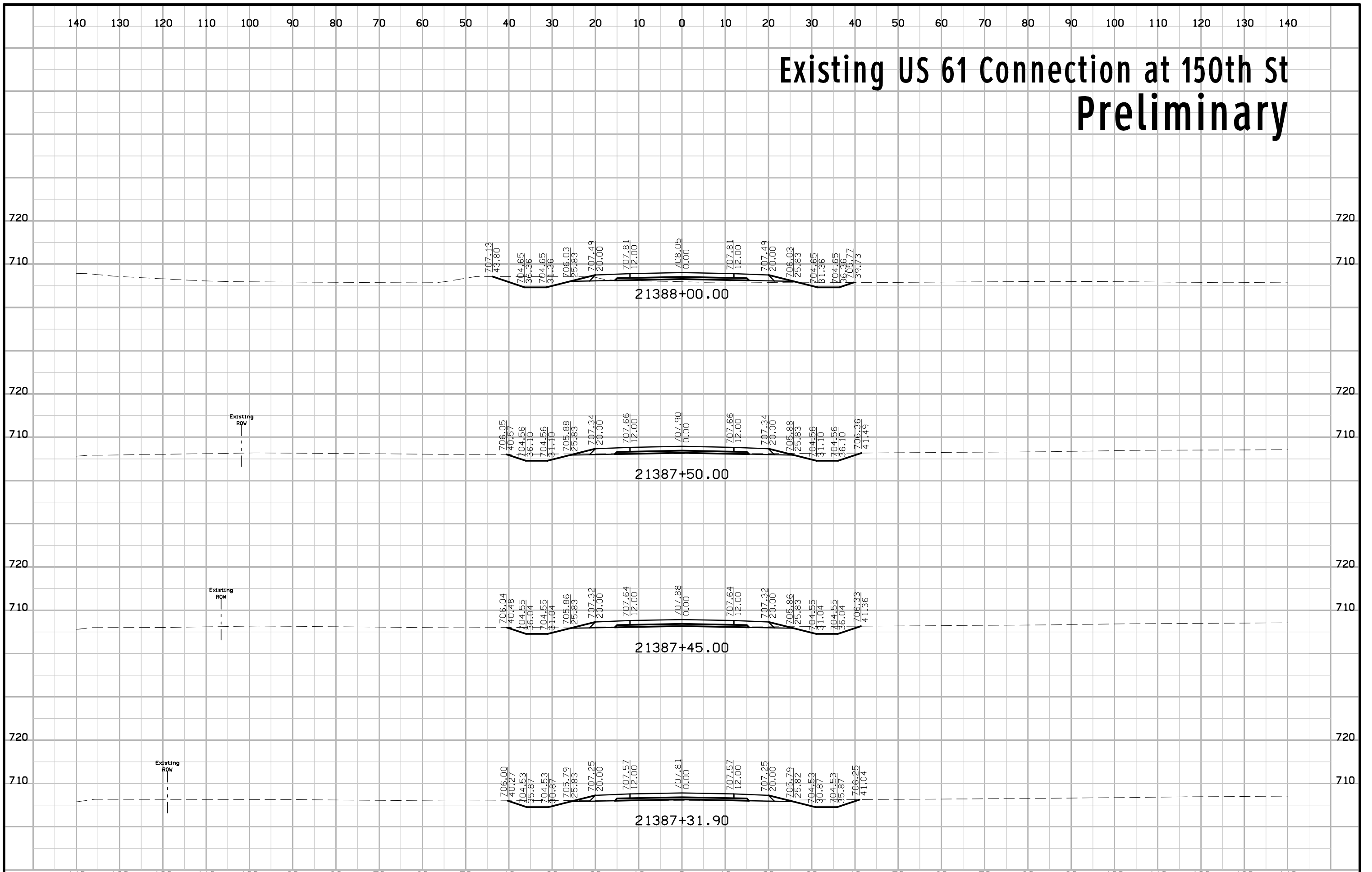

Existing US 61 Connection at 150th St Preliminary

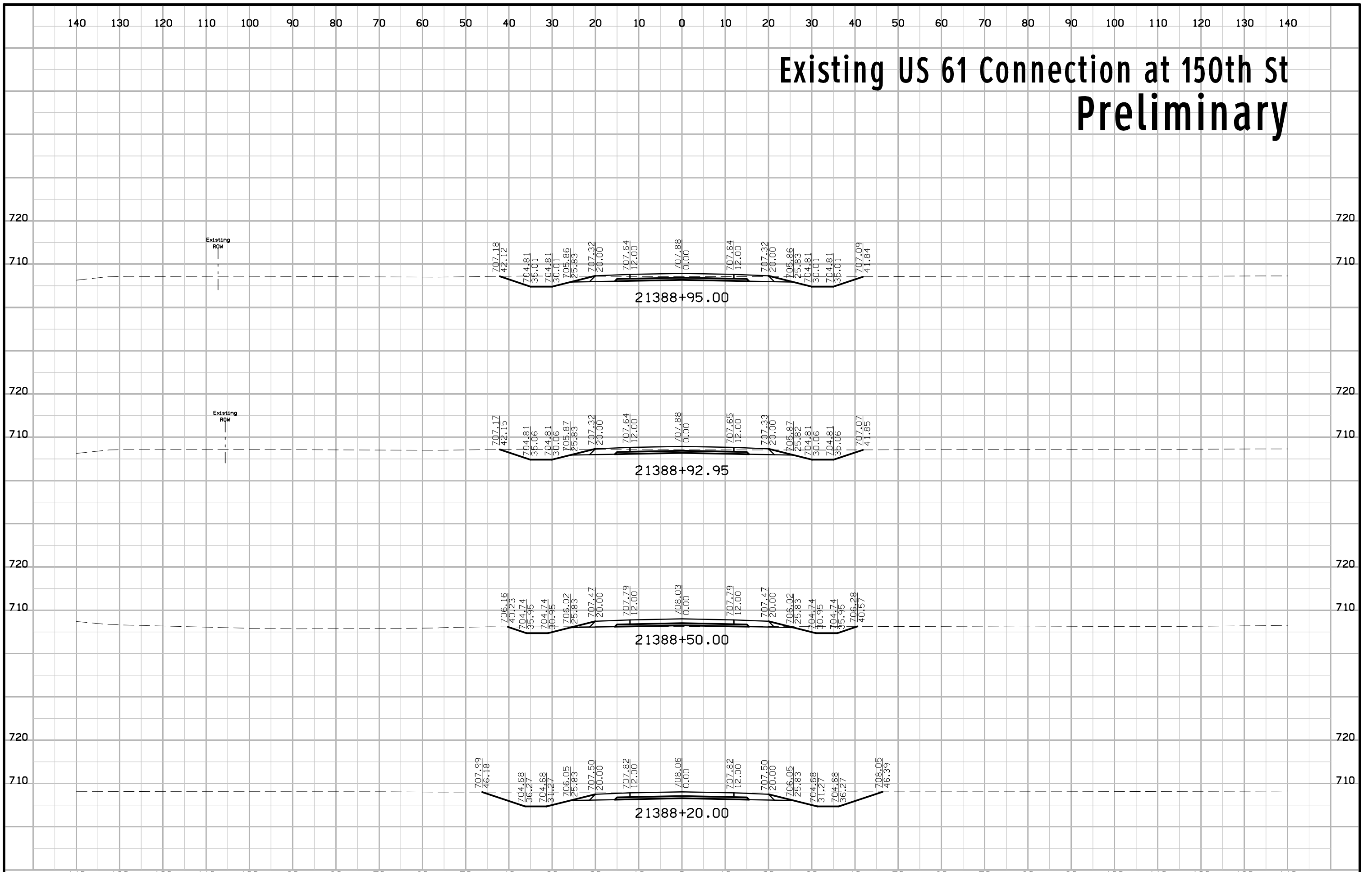

Existing US 61 Connection at 150th St Preliminary

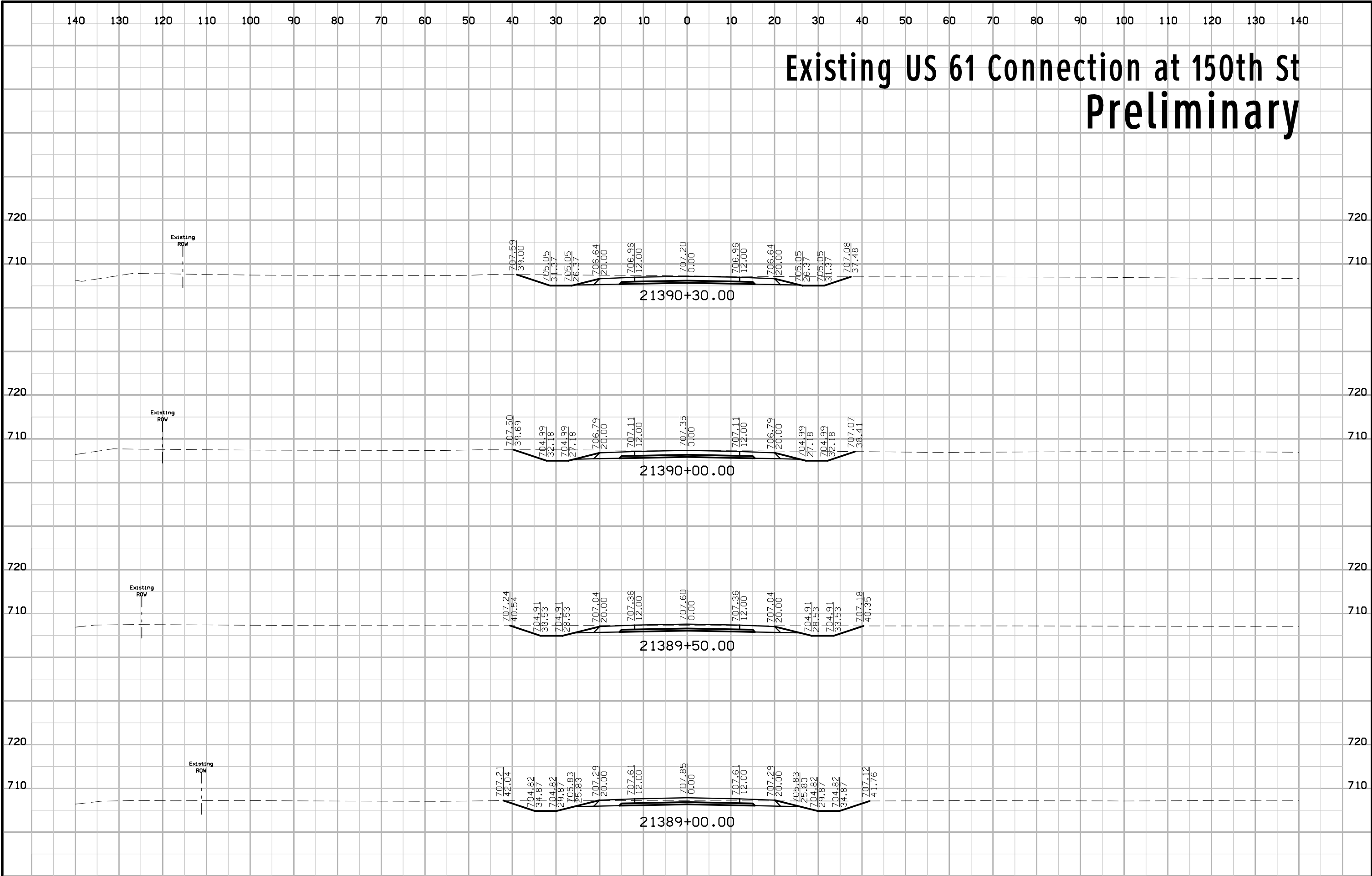

Existing US 61 Connection at 150th St Preliminary

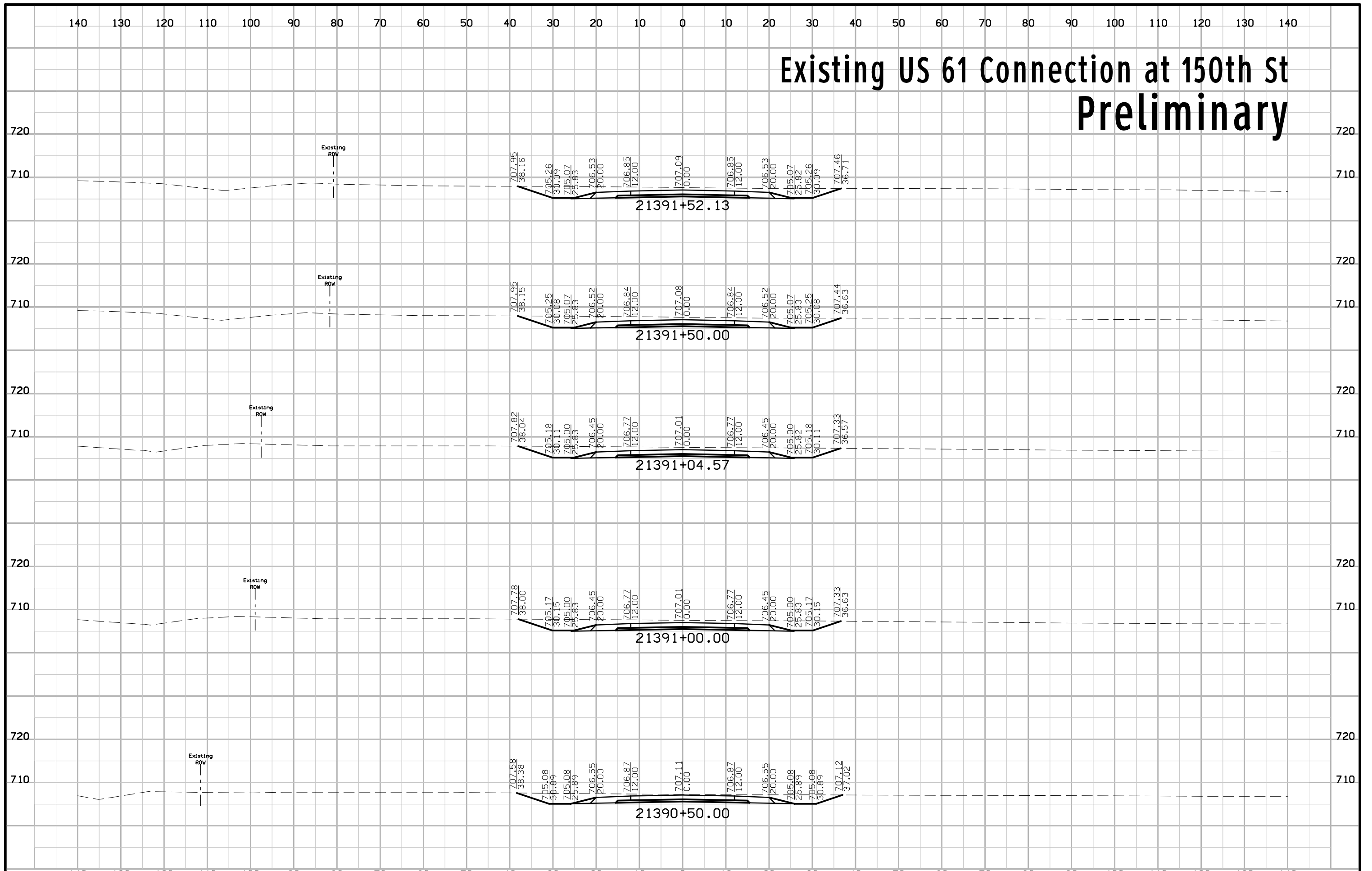

Existing US 61 Connection at 150th St Preliminary

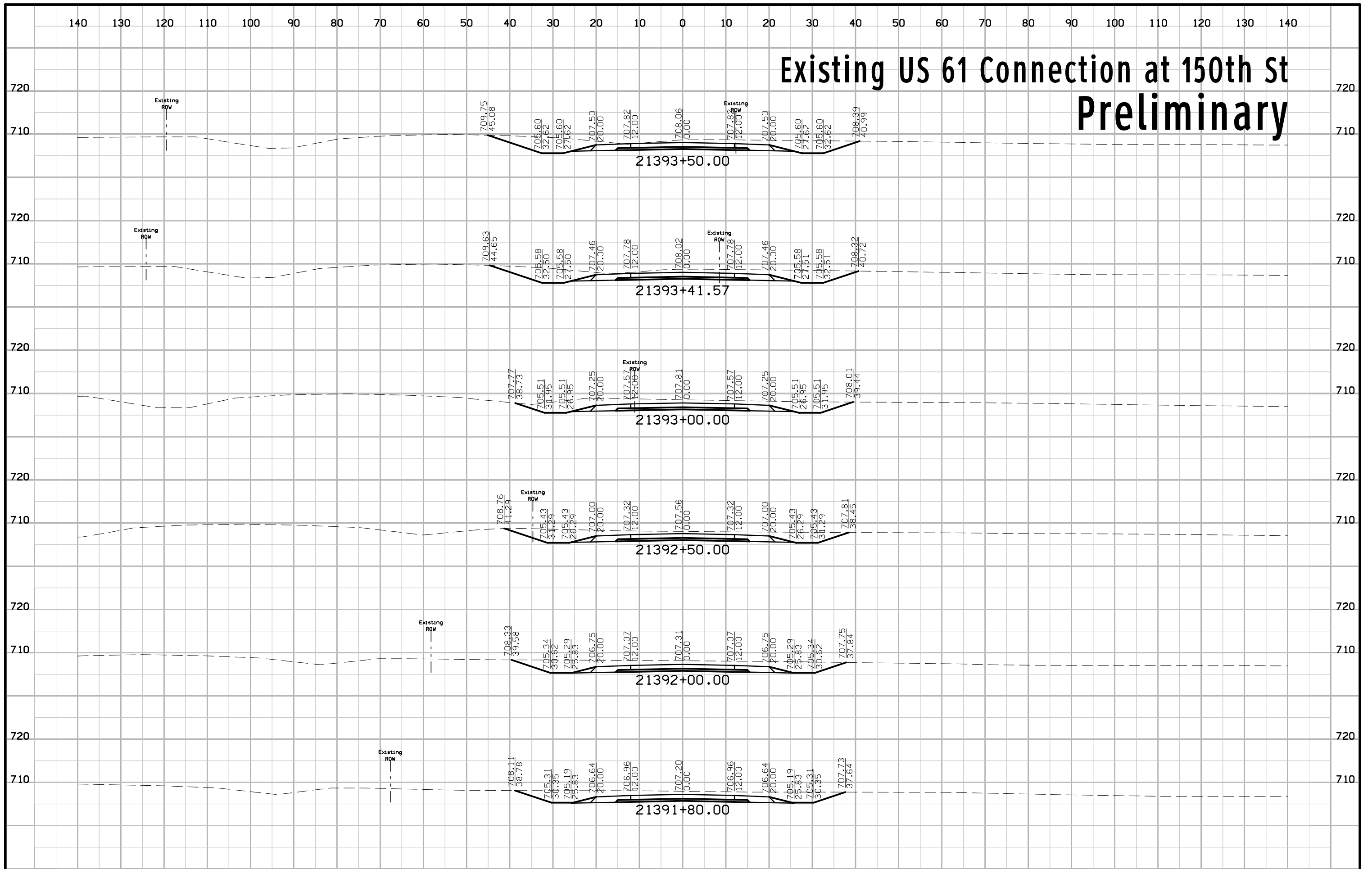

Existing US 61 Connection at 150th St Preliminary

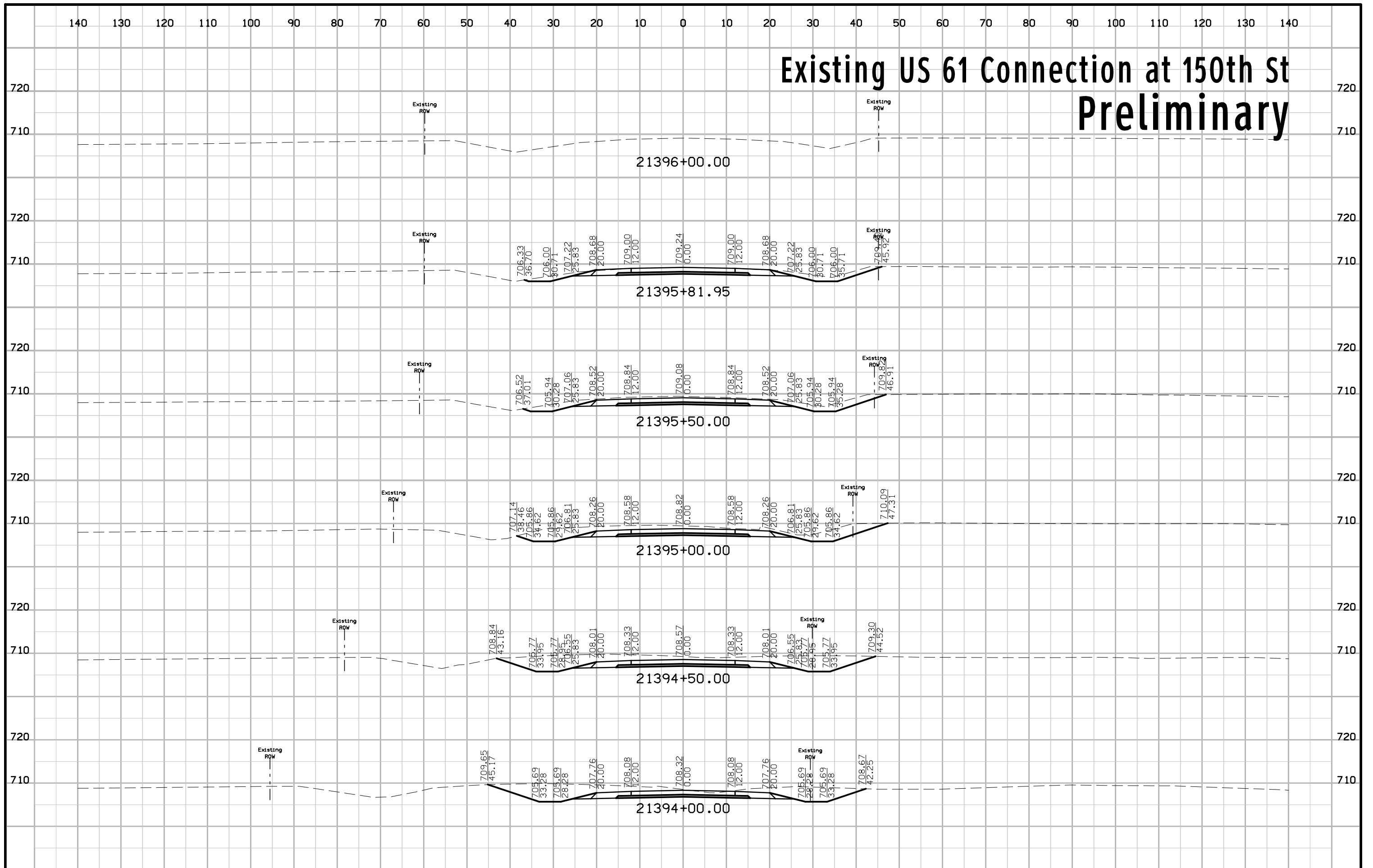

Existing US 61 Connection at 150th St Preliminary

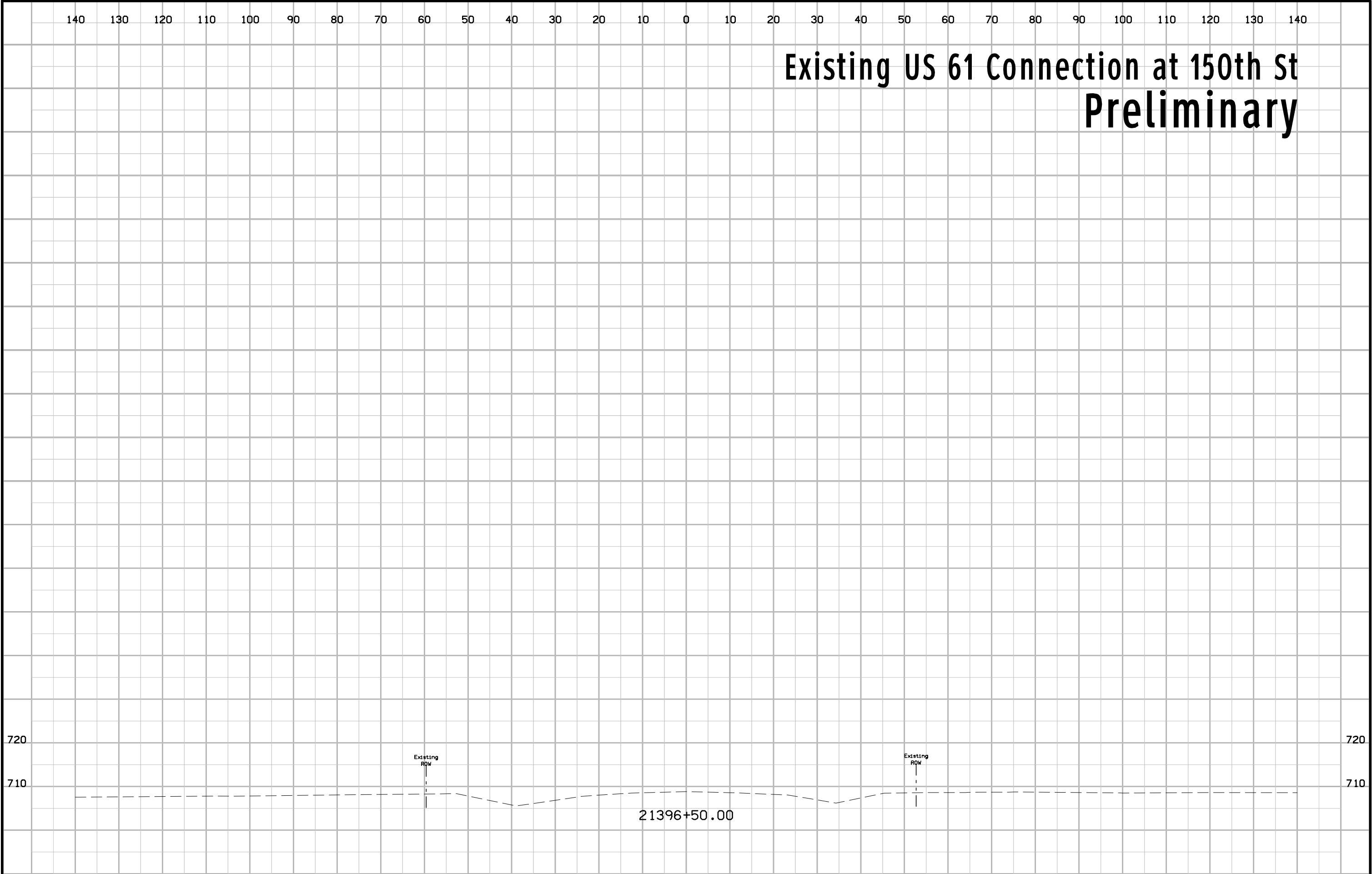

160th St Preliminary

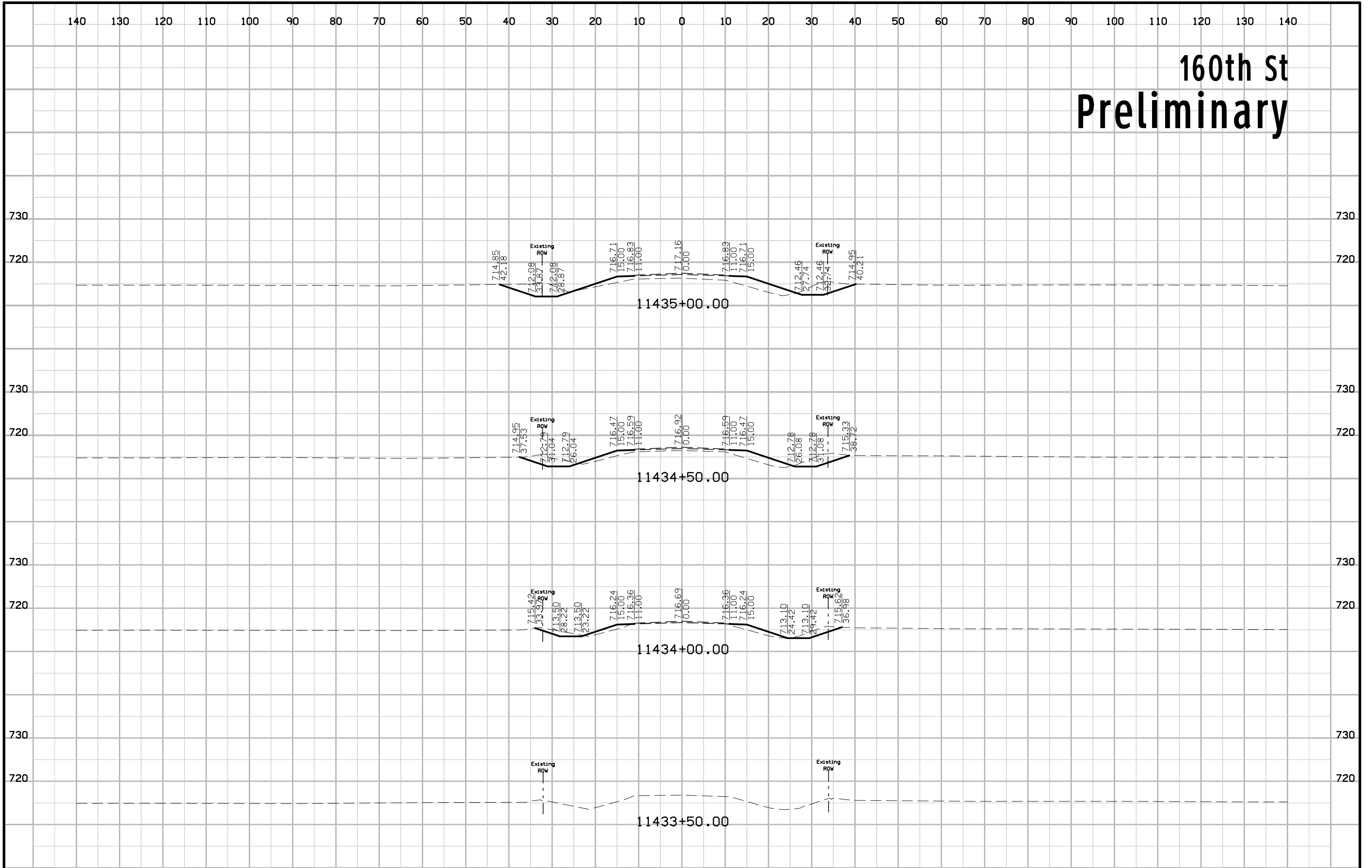

160th St Preliminary

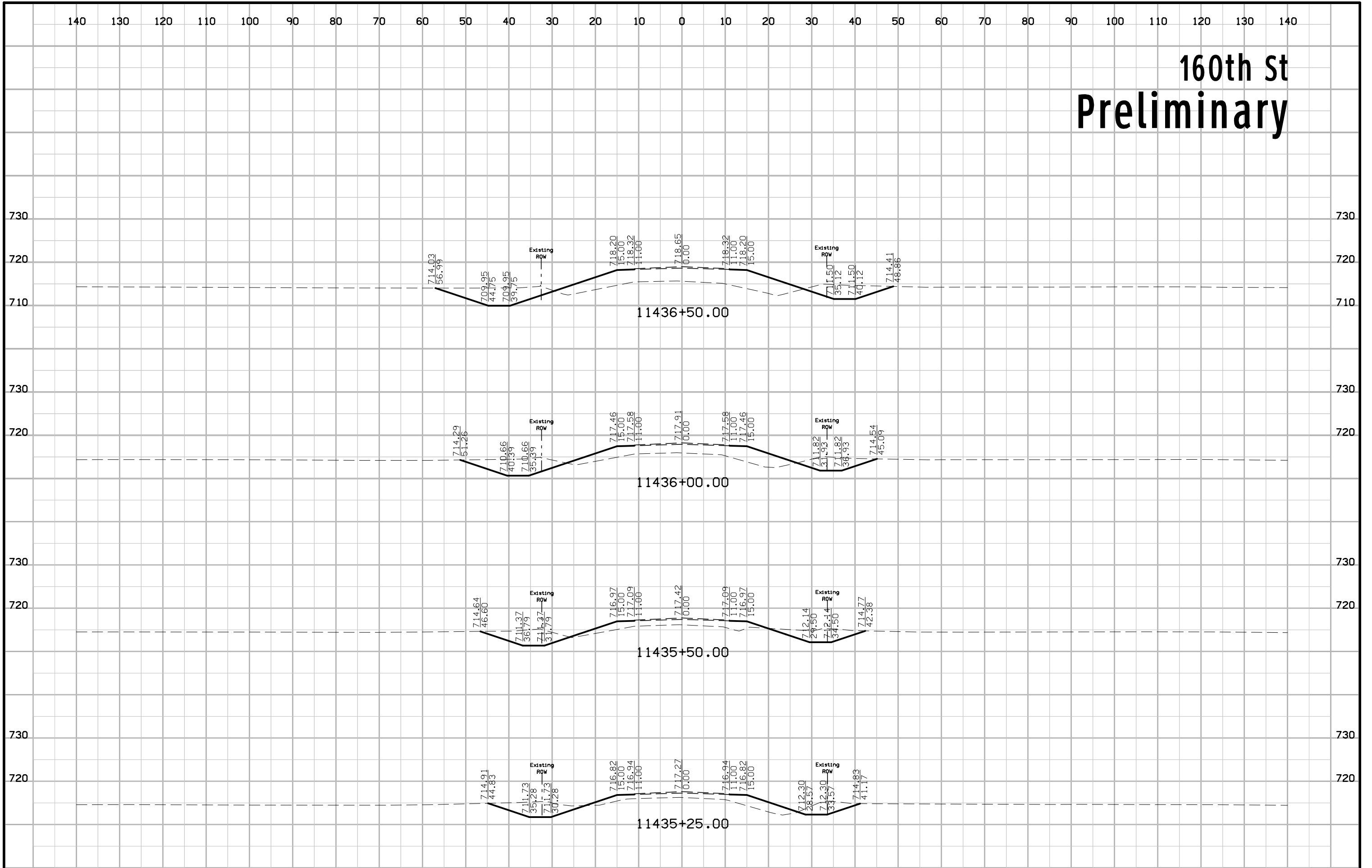

160th St Preliminary

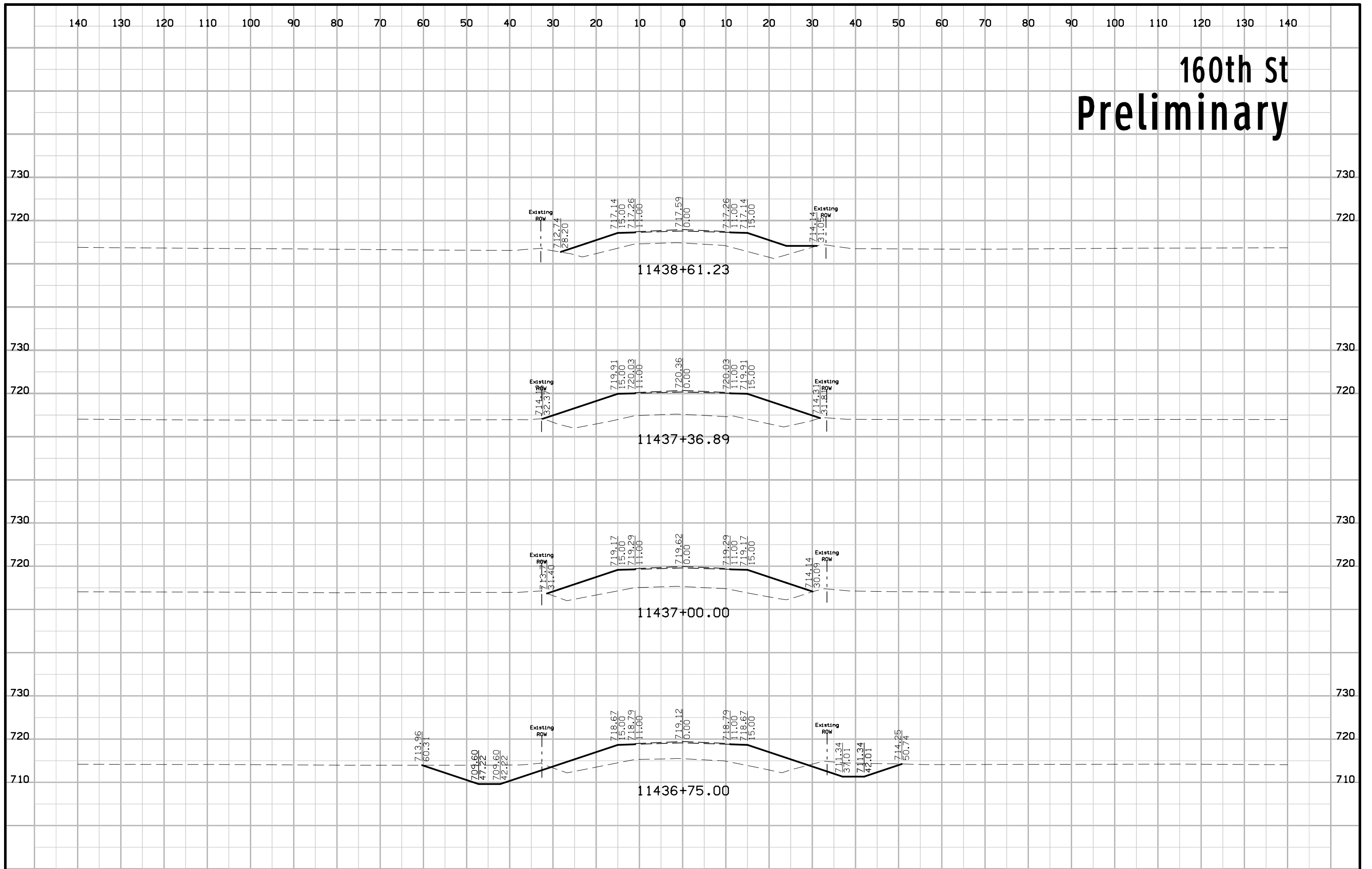

160th St Preliminary

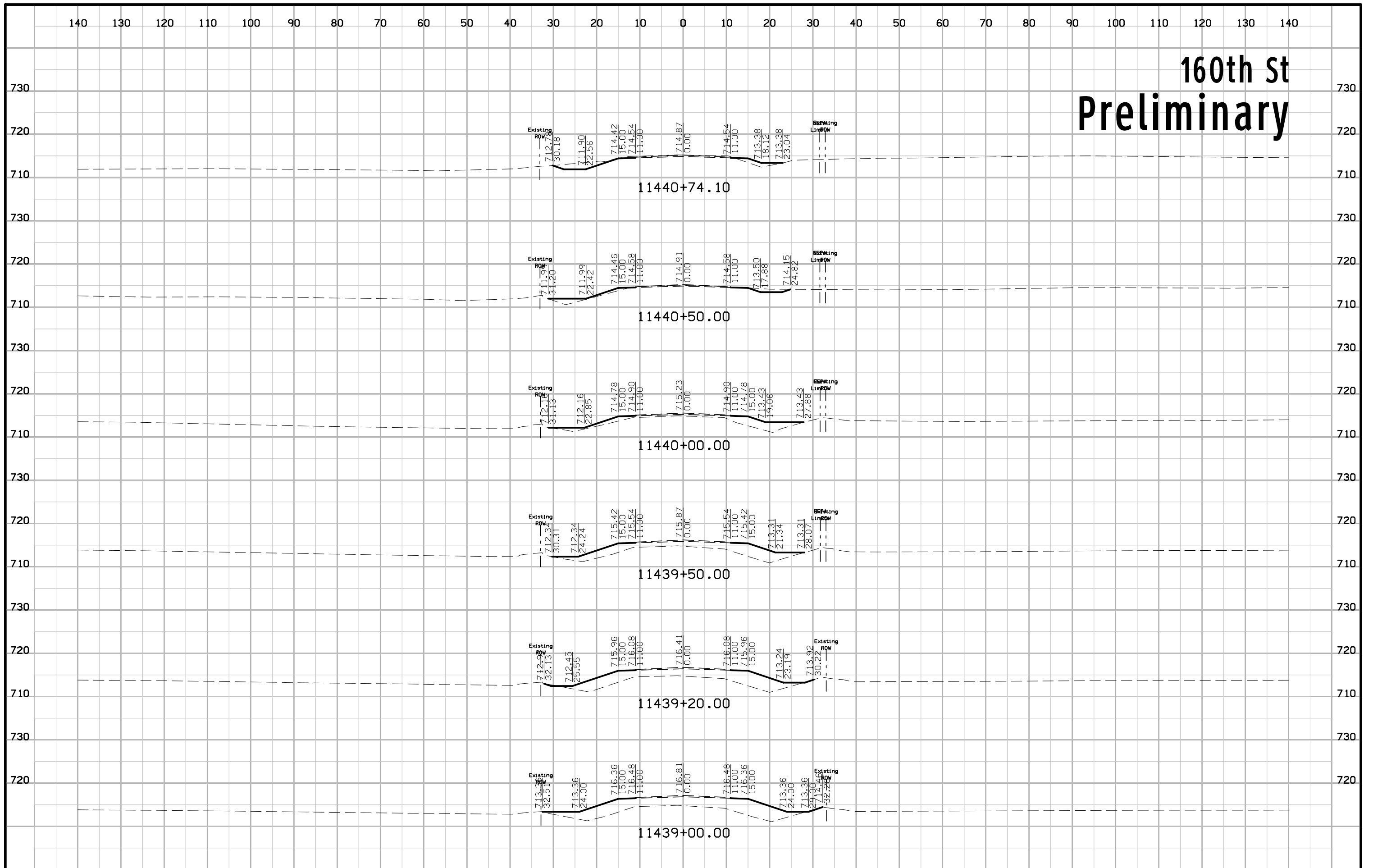

160th St Preliminary

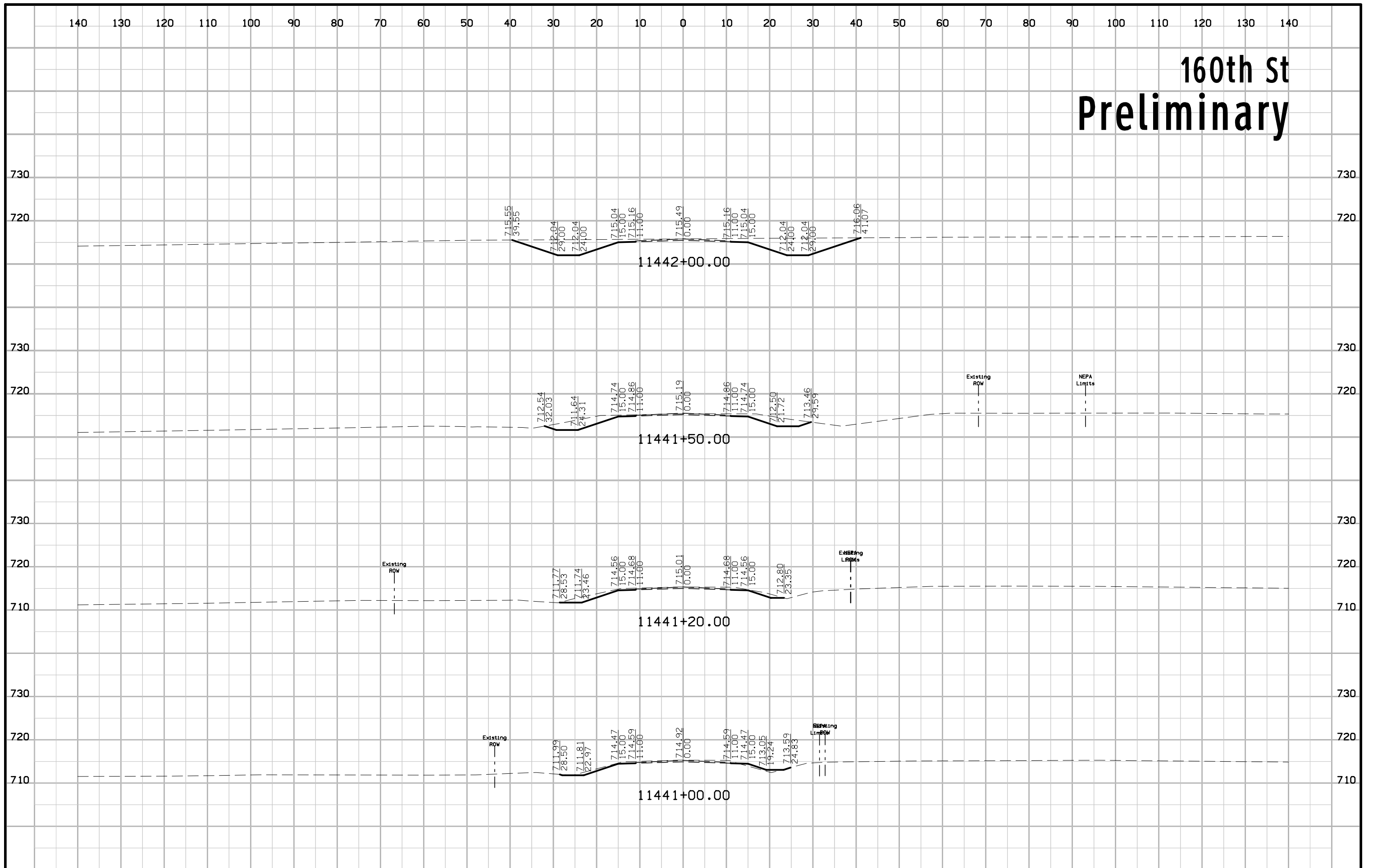

160th St Preliminary

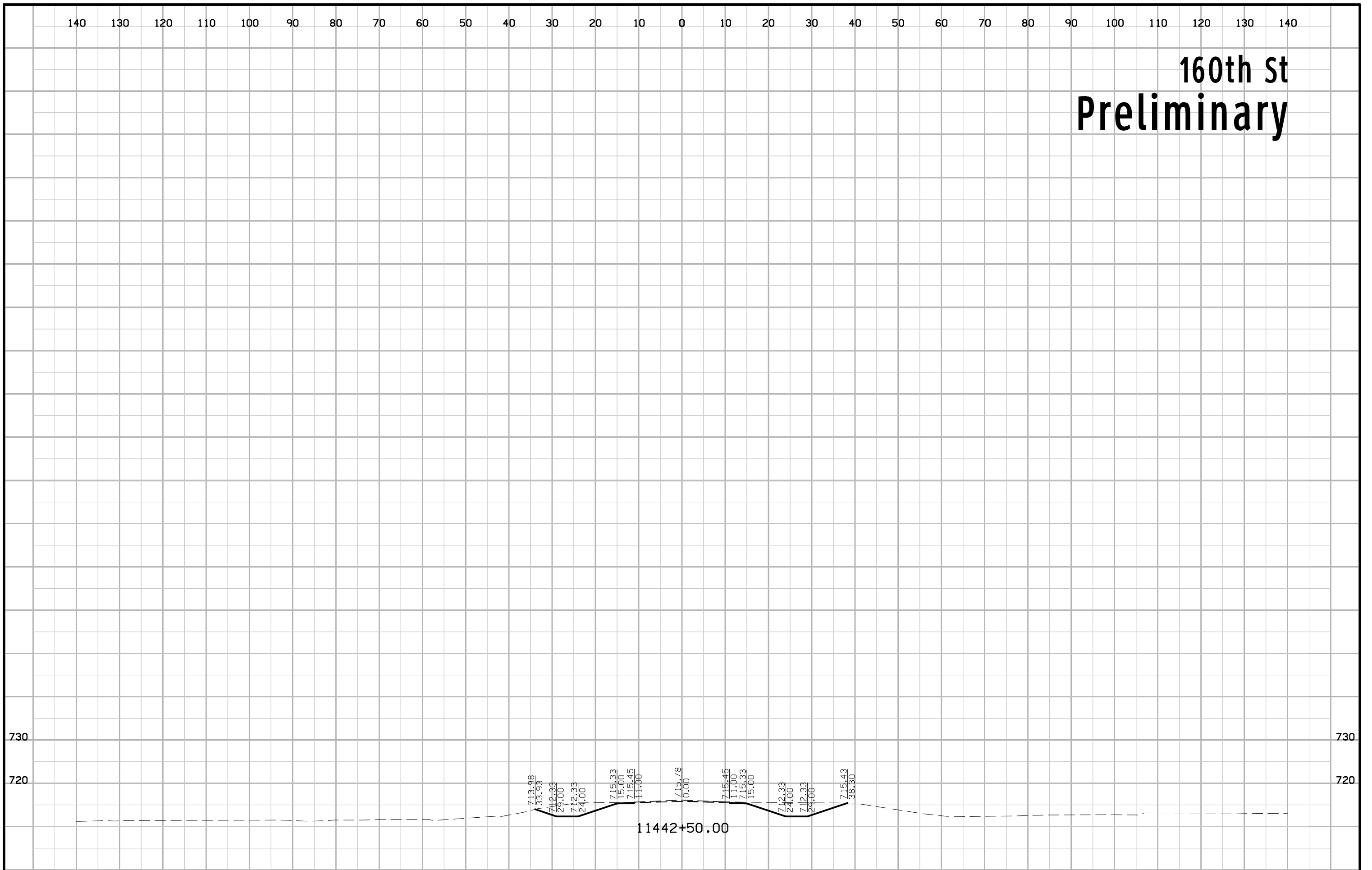

170th St / Stoney Hollow Rd Preliminary

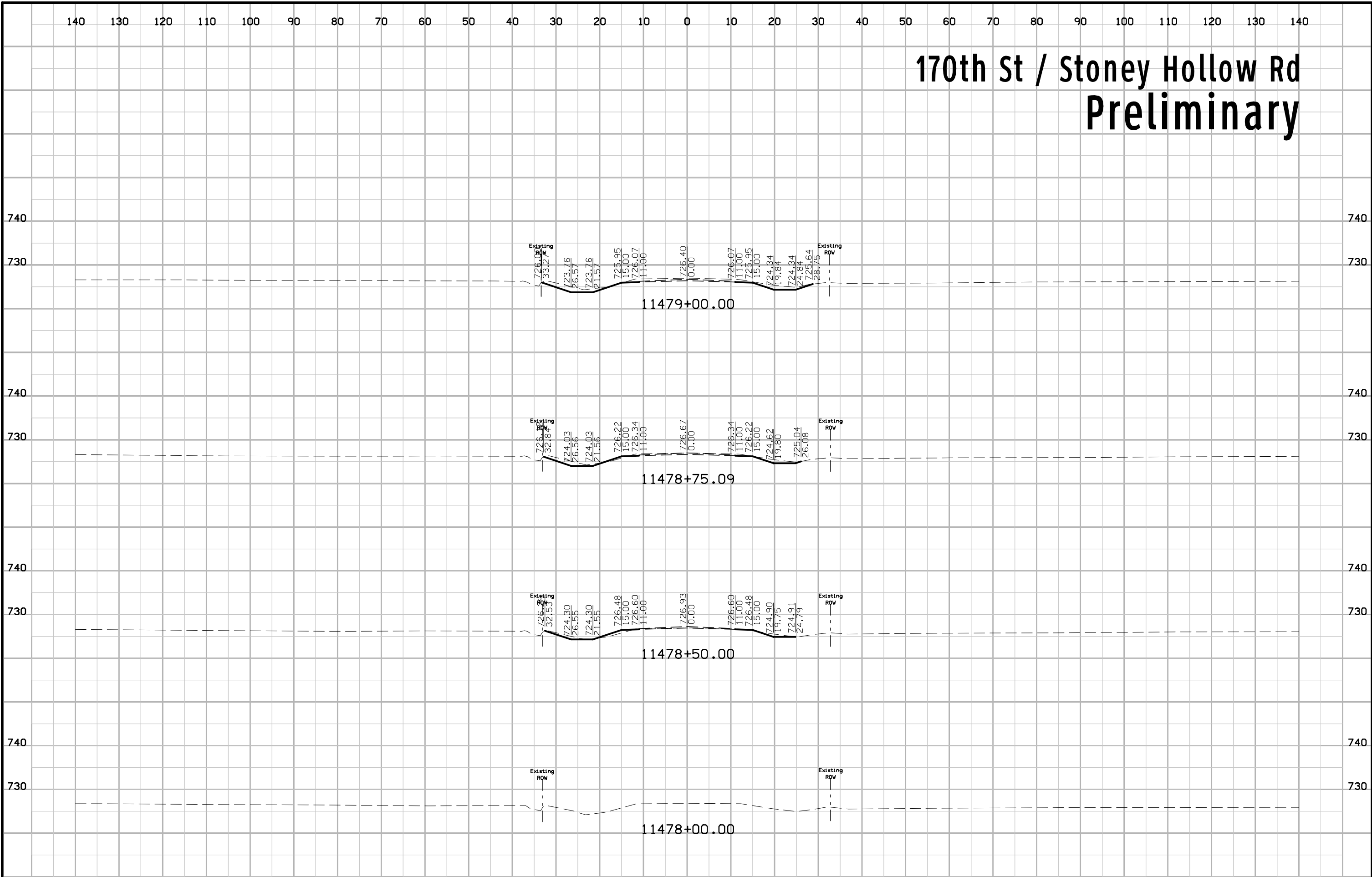

170th St / Stoney Hollow Rd Preliminary

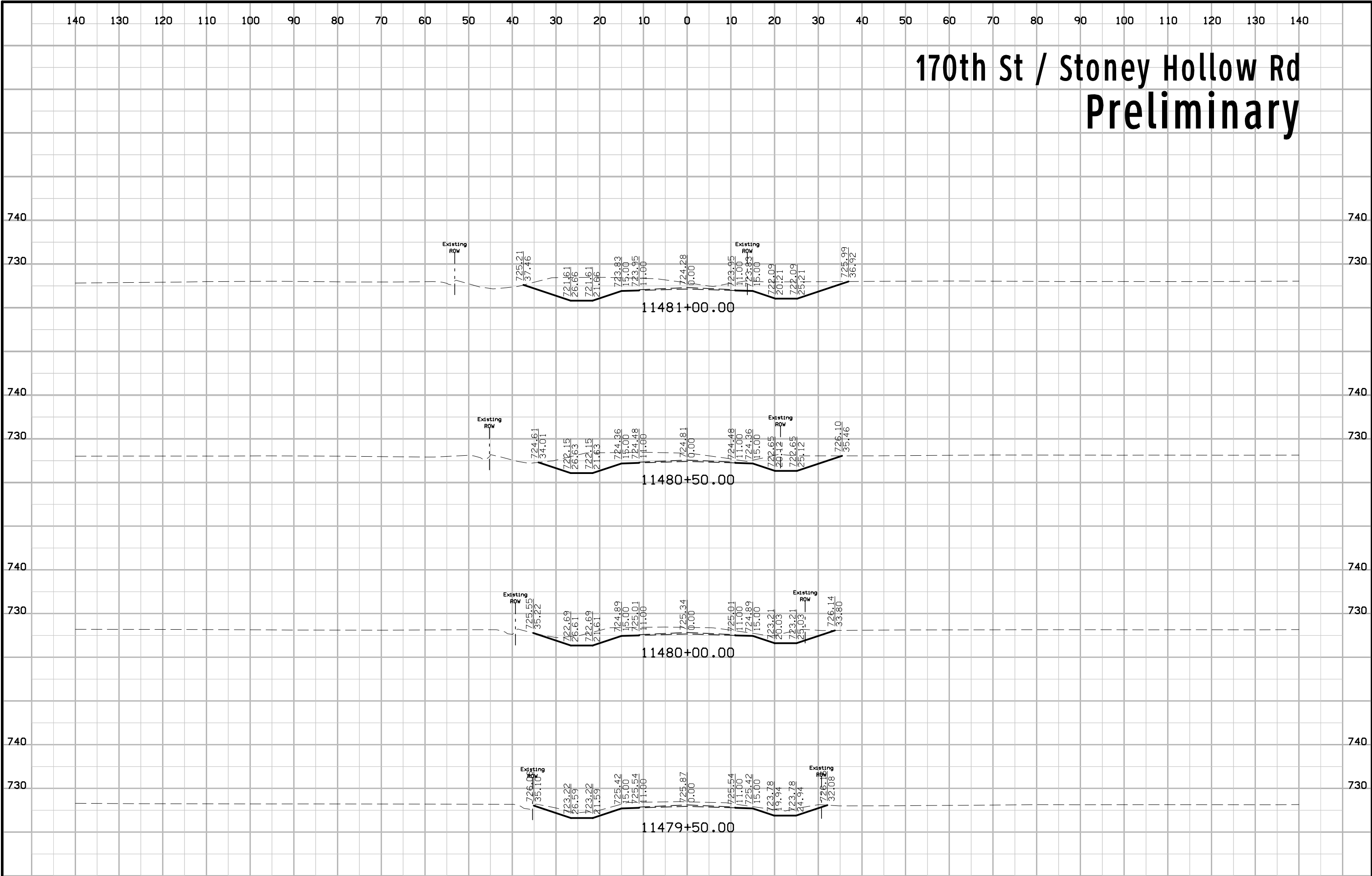

170th St / Stoney Hollow Rd Preliminary

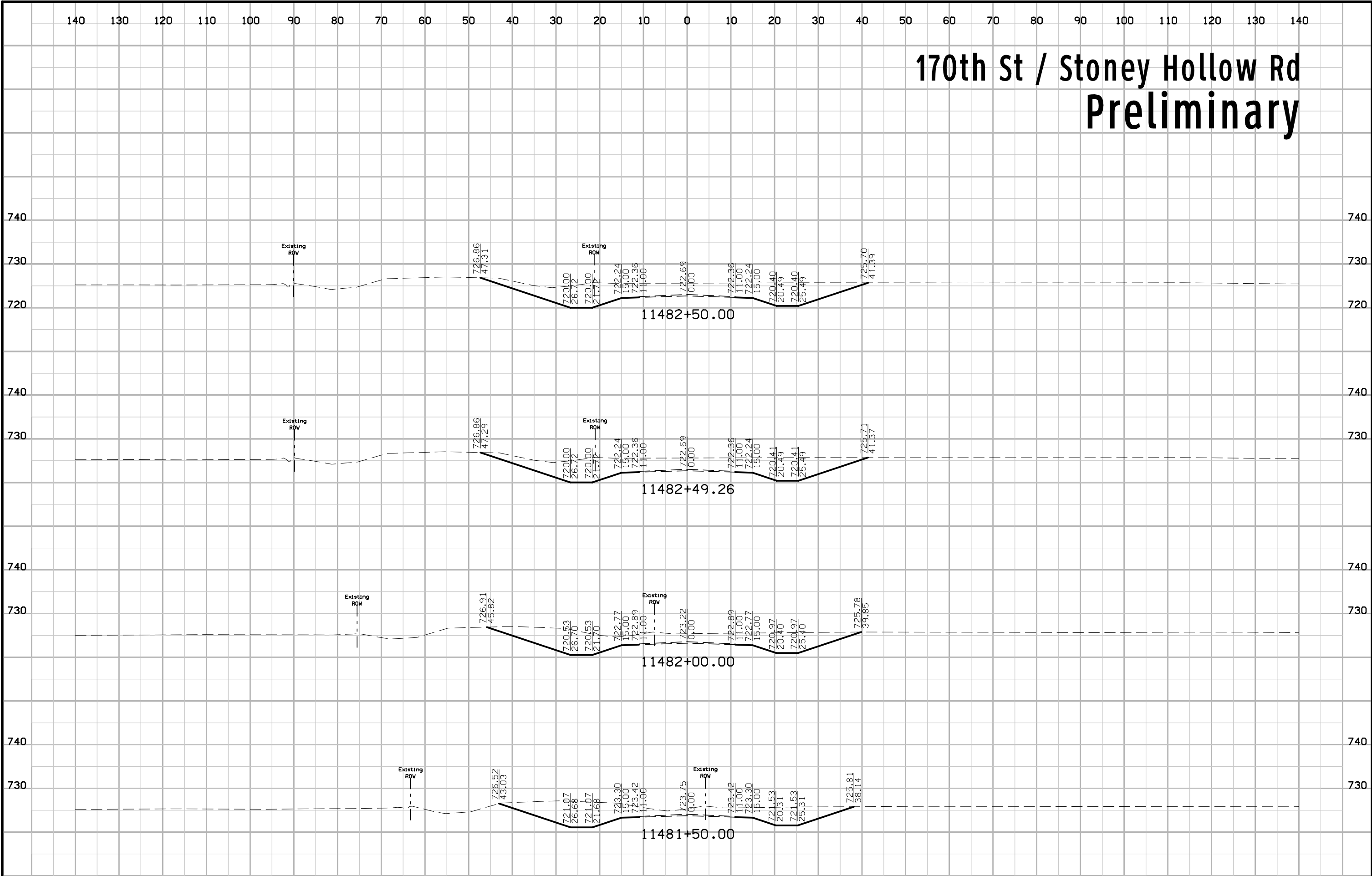

170th St / Stoney Hollow Rd Preliminary

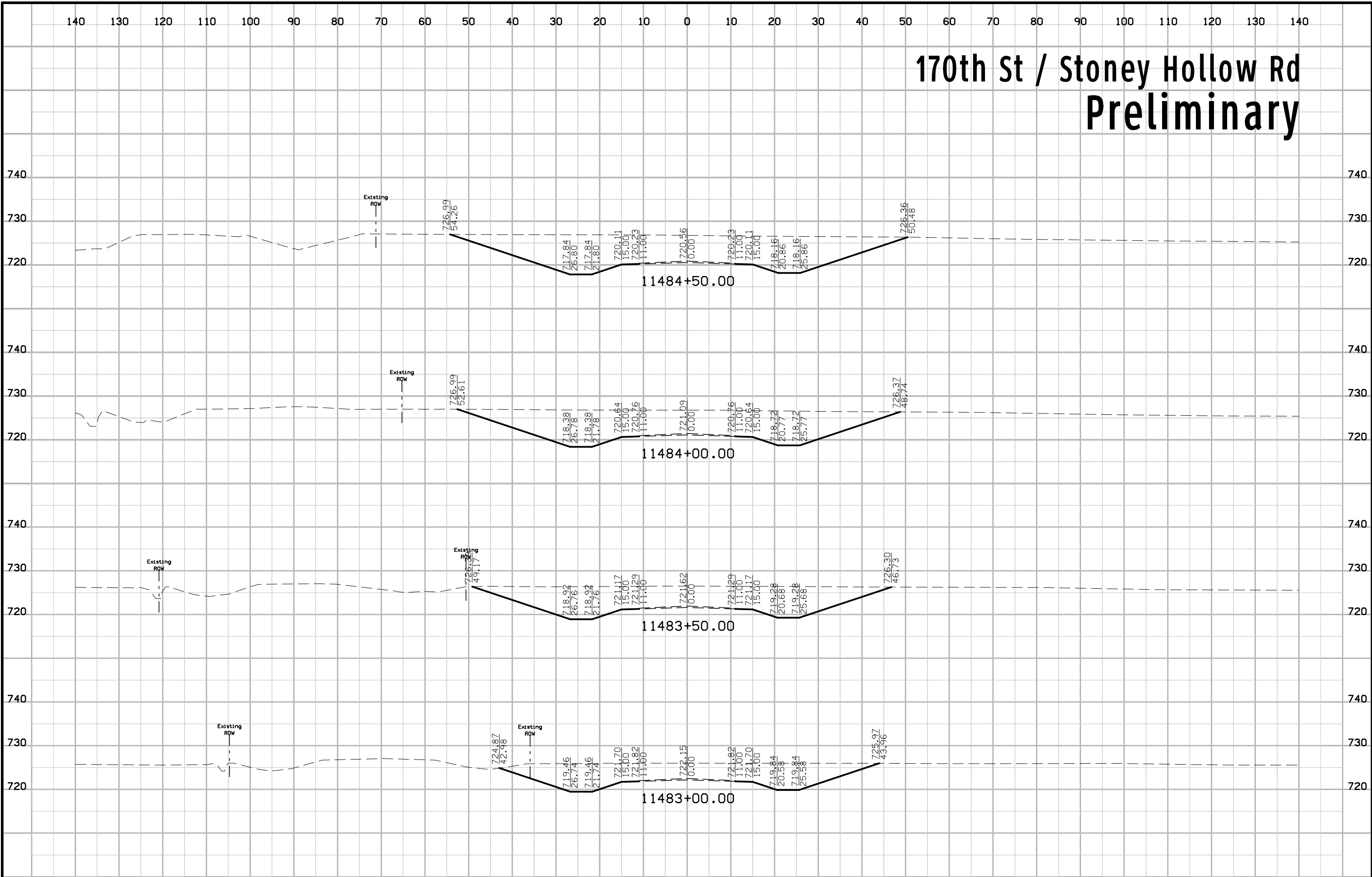

170th St / Stoney Hollow Rd Preliminary

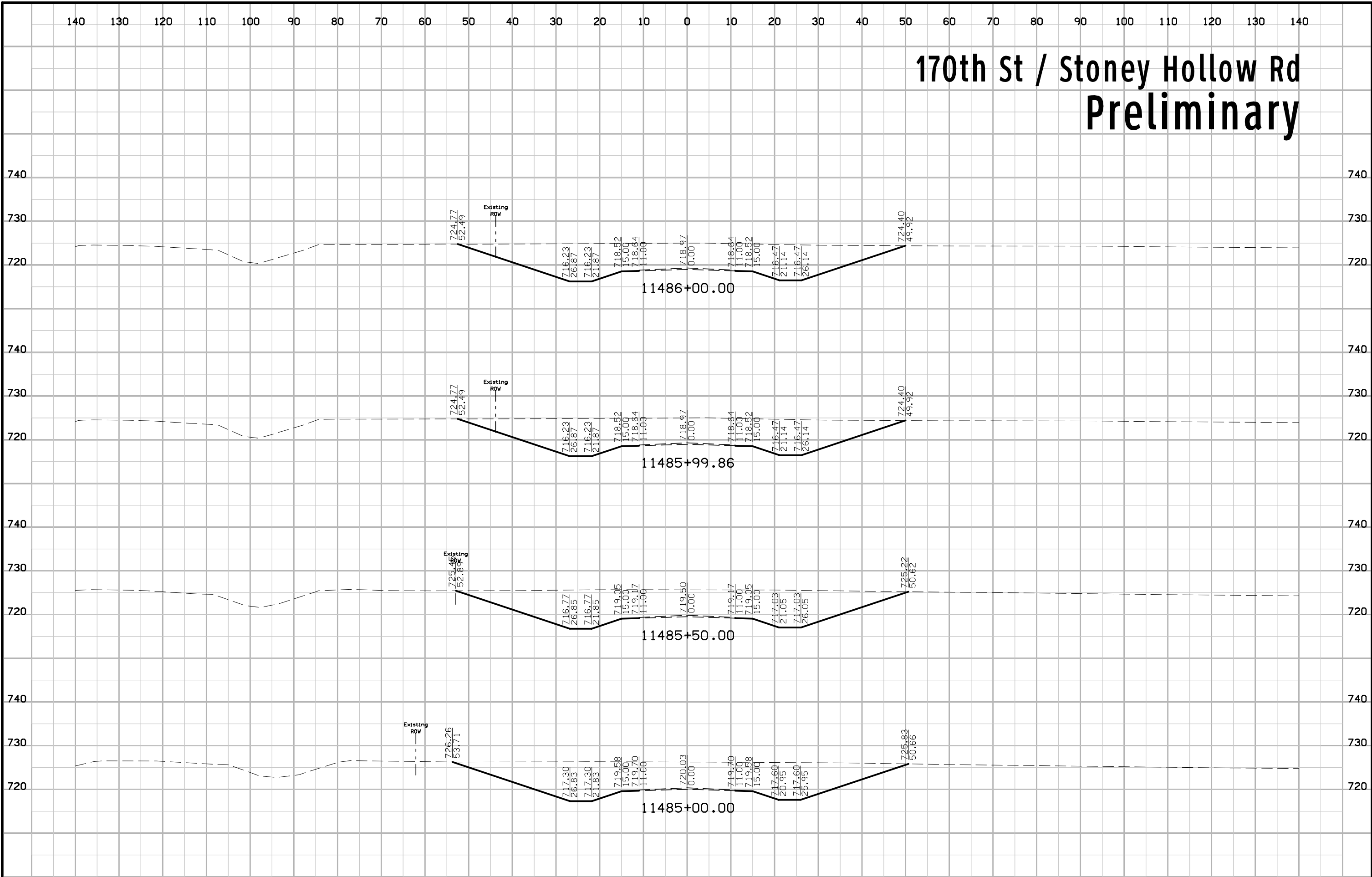

170th St / Stoney Hollow Rd Preliminary

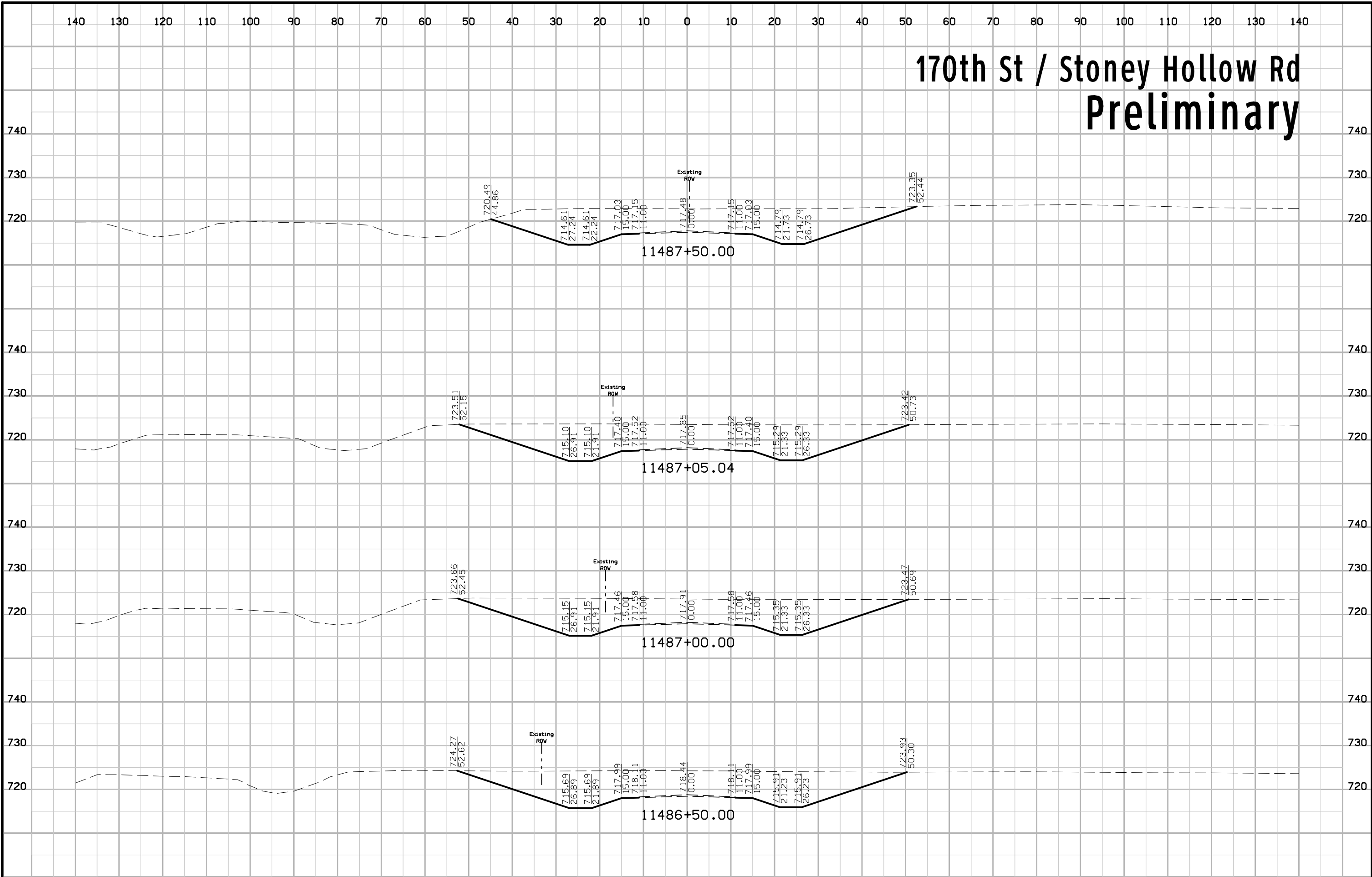

170th St / Stoney Hollow Rd Preliminary

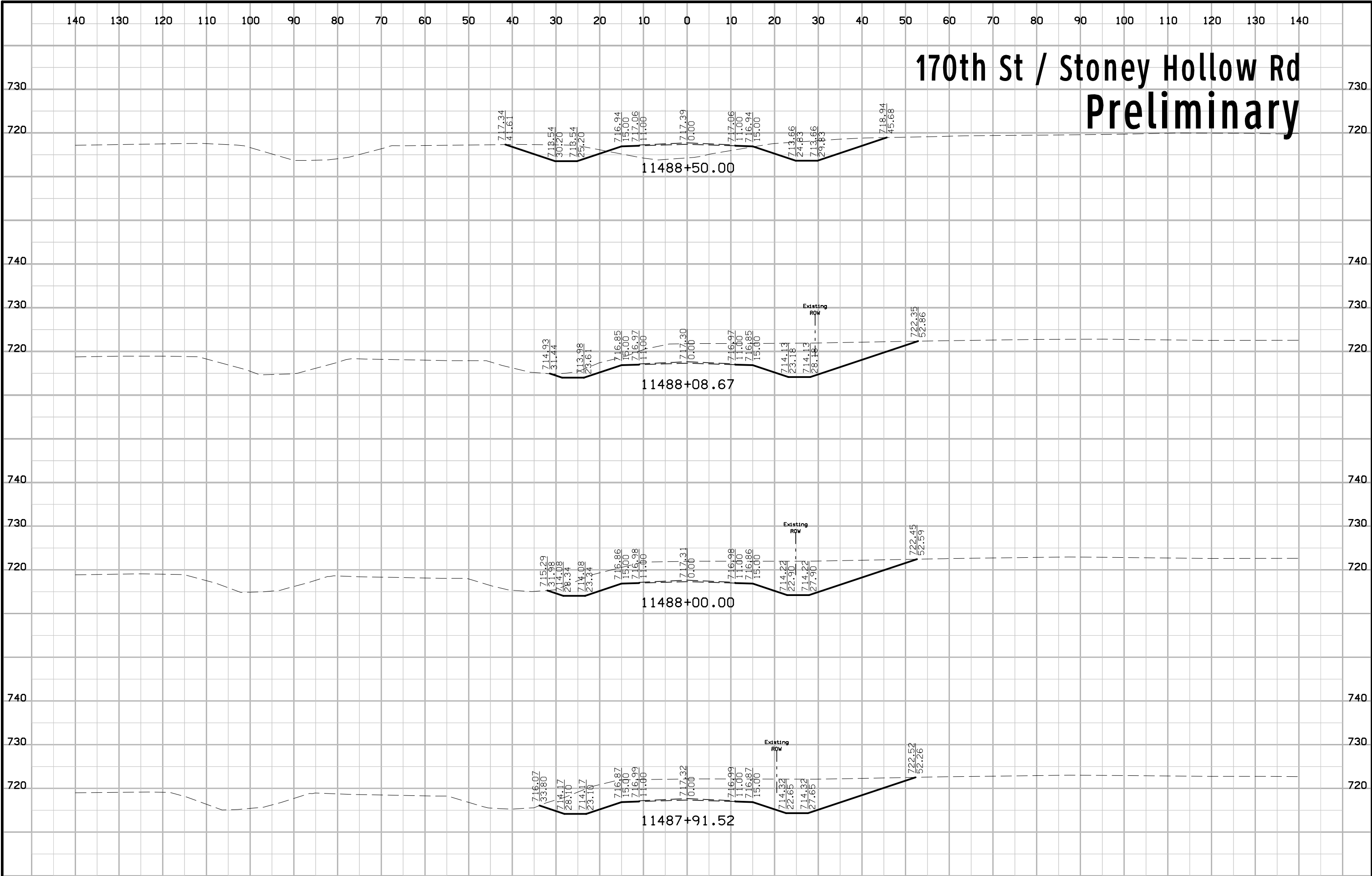

170th St / Stoney Hollow Rd Preliminary

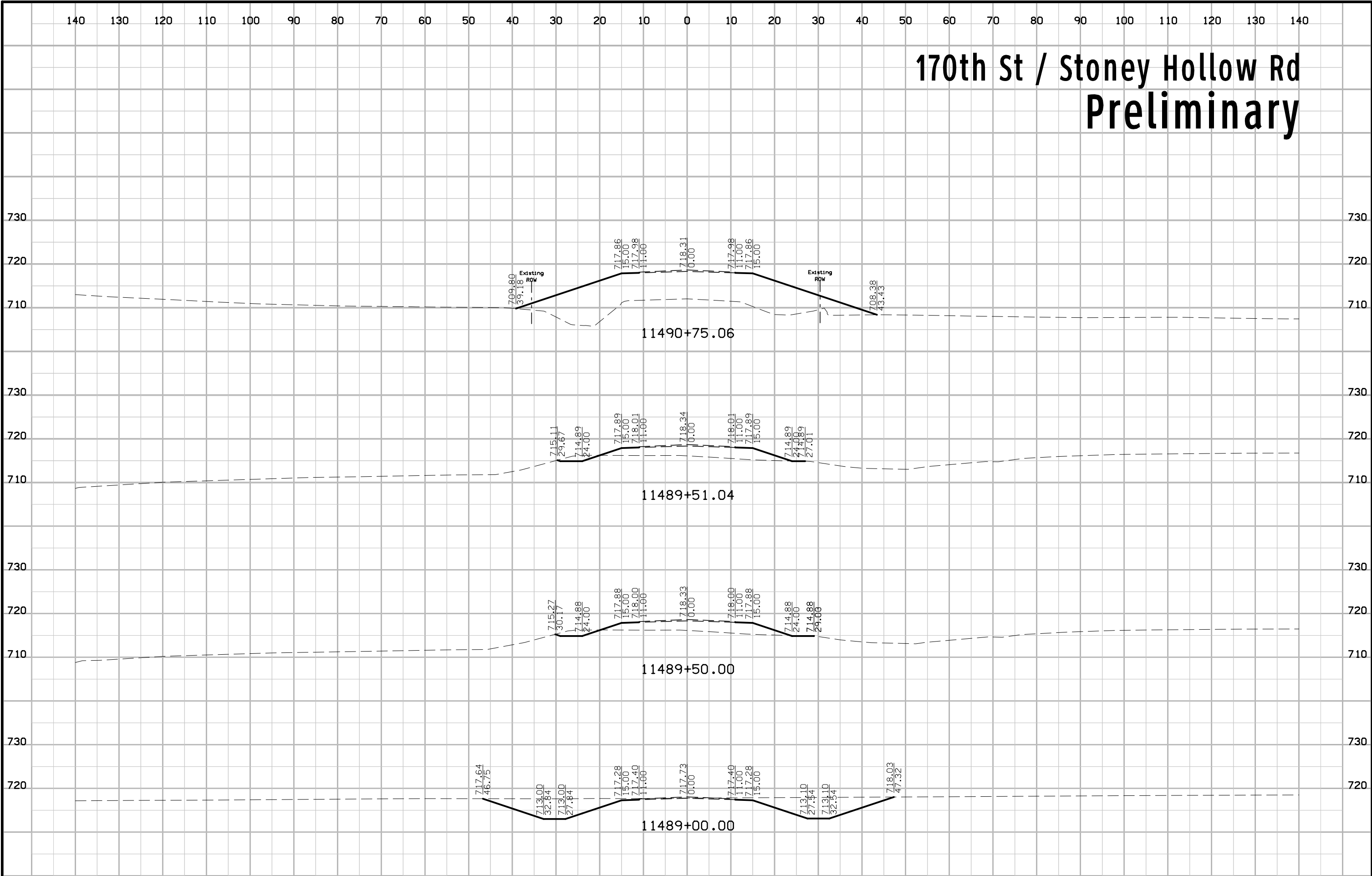

170th St / Stoney Hollow Rd Preliminary

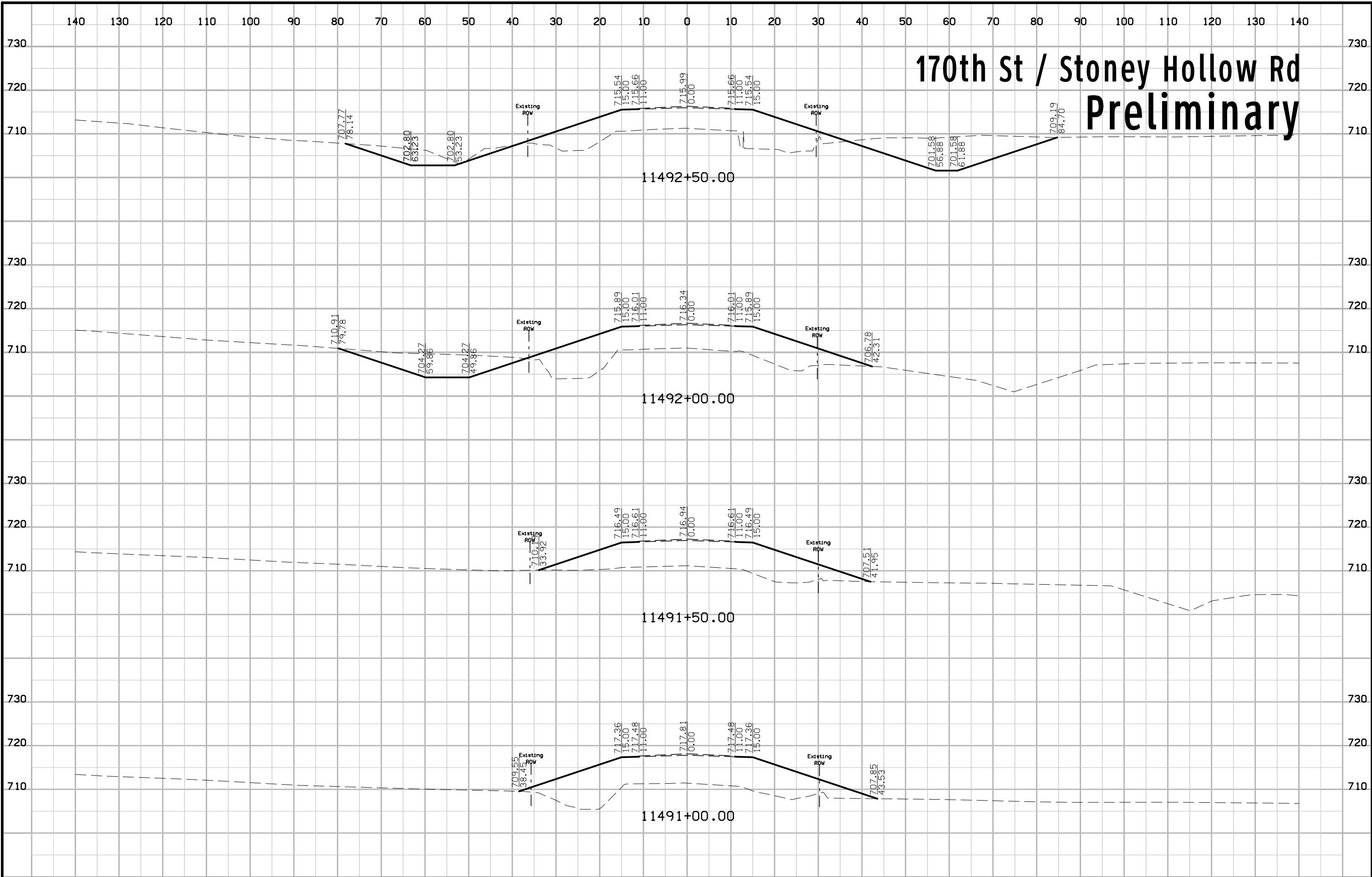

170th St / Stoney Hollow Rd Preliminary

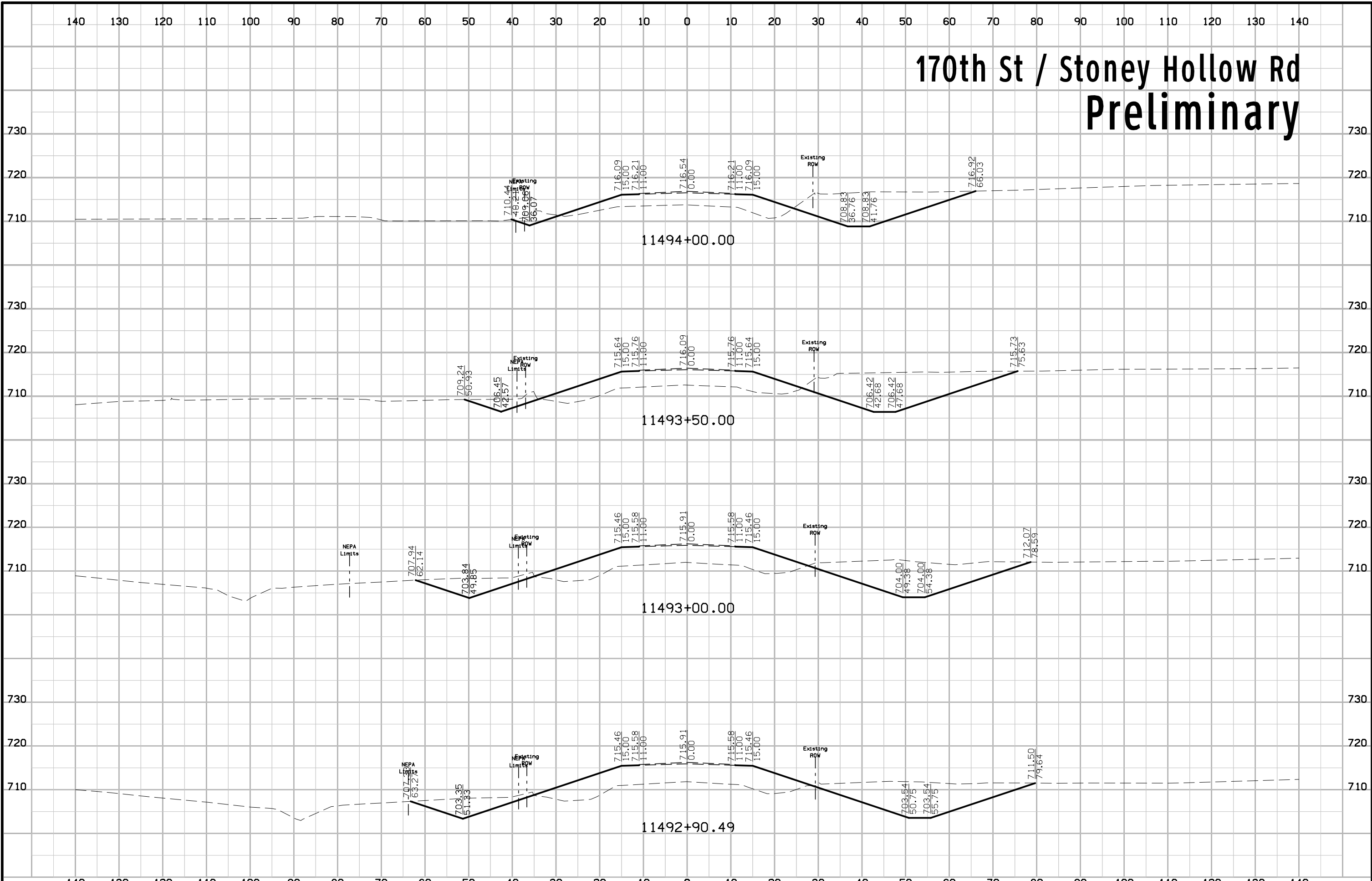

170th St / Stoney Hollow Rd Preliminary

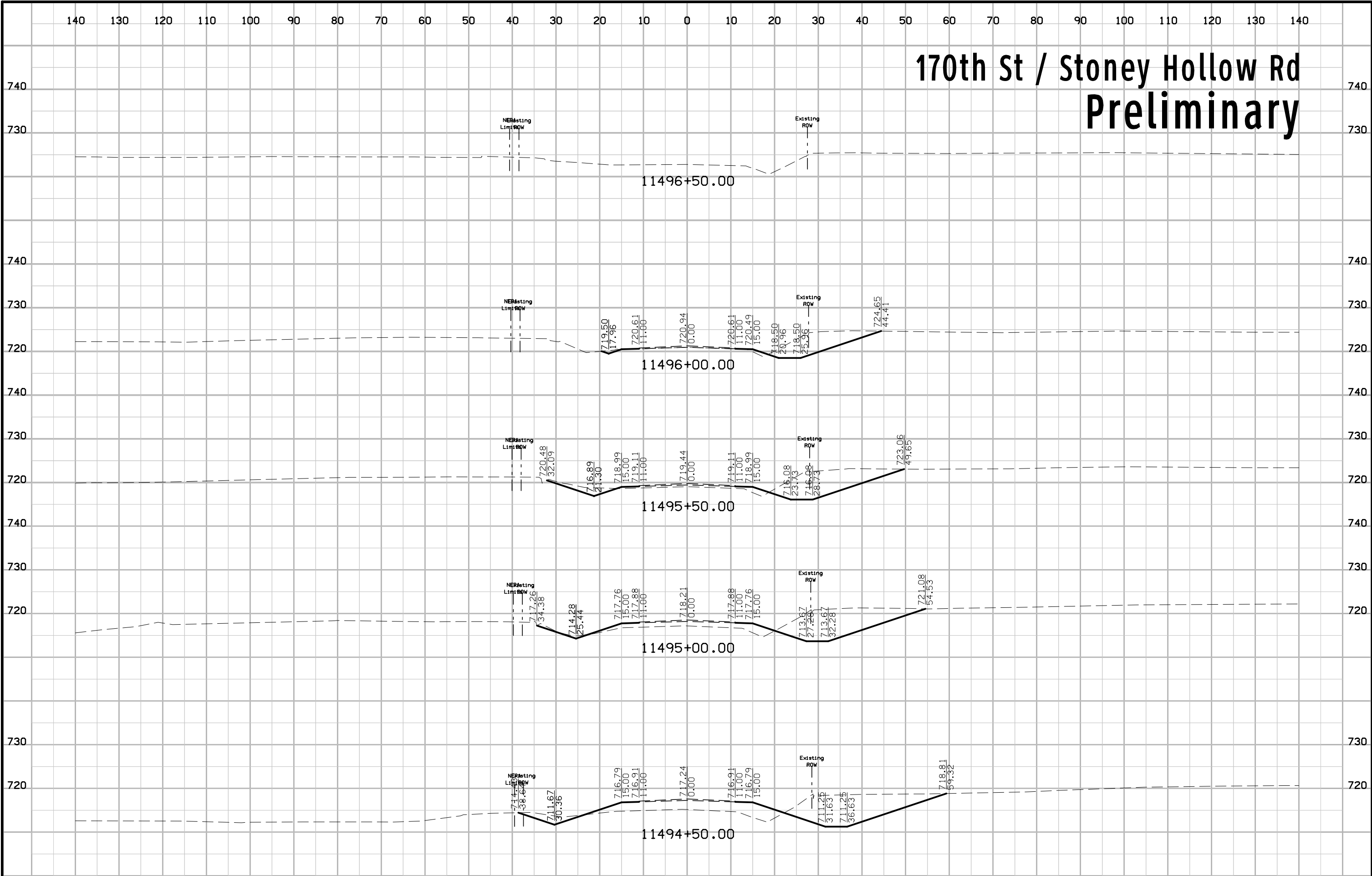

Dodgeville Rd / 180th St Preliminary

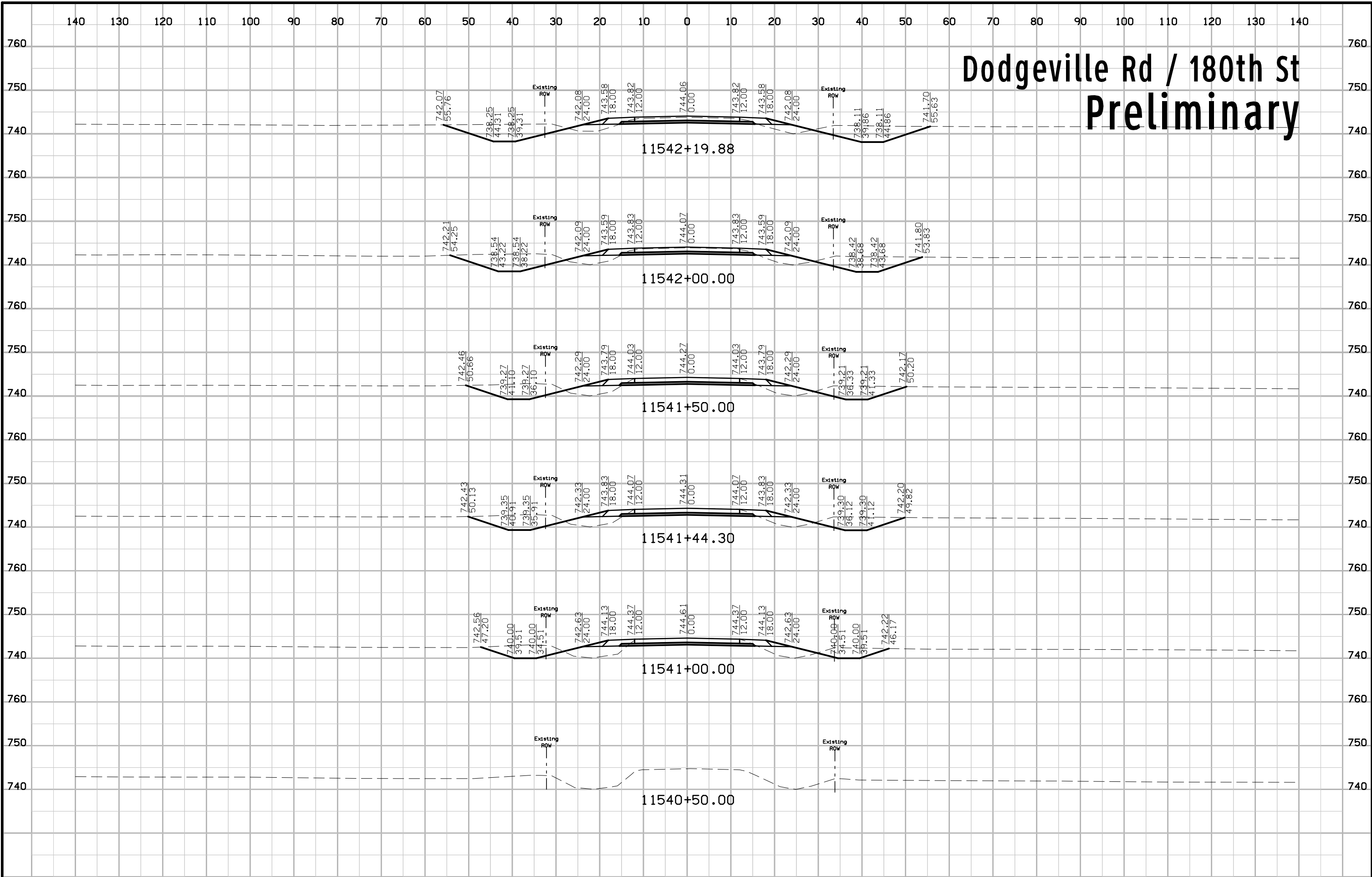

Dodgeville Rd / 180th St Preliminary

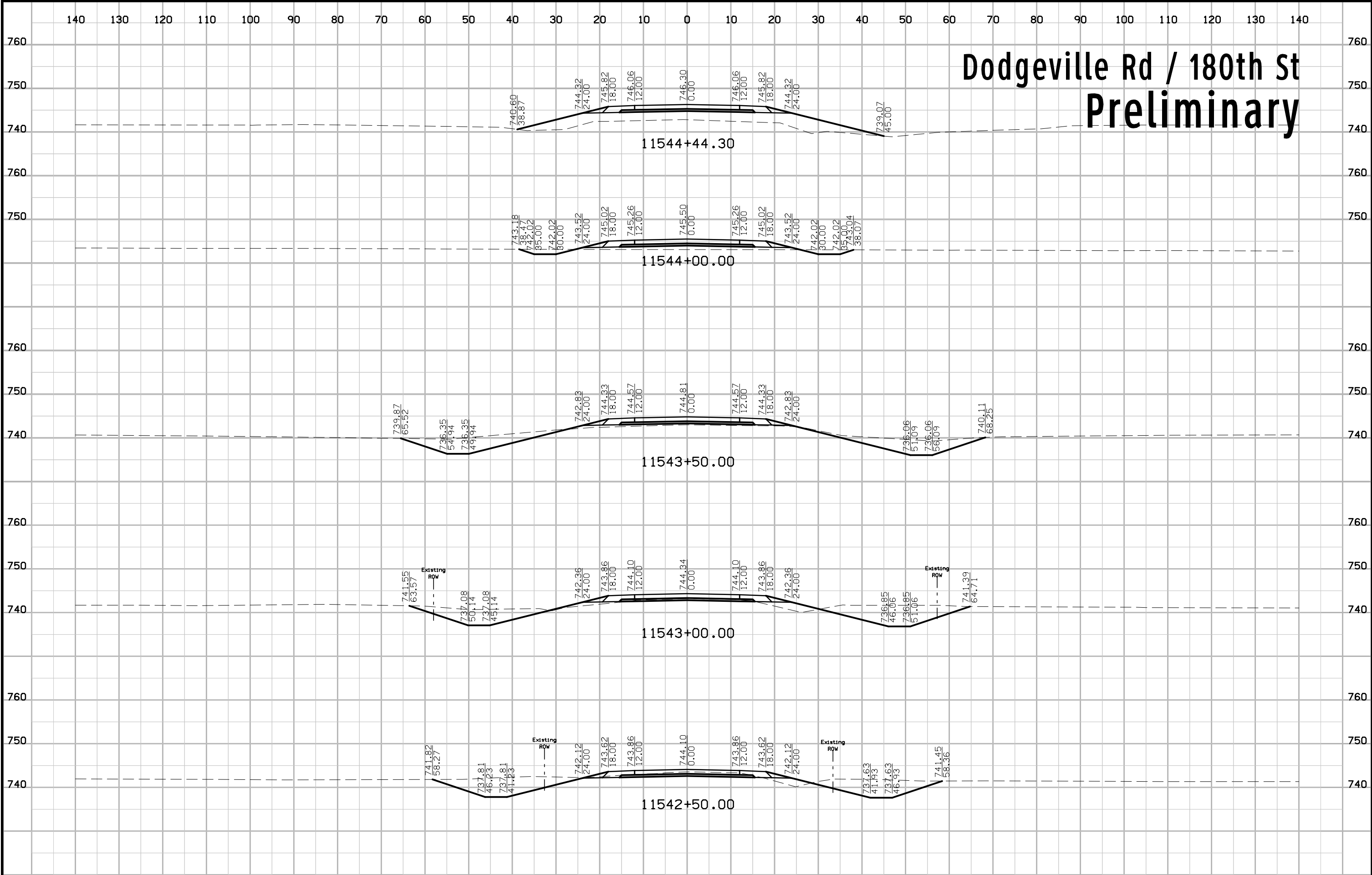

Dodgeville Rd / 180th St Preliminary

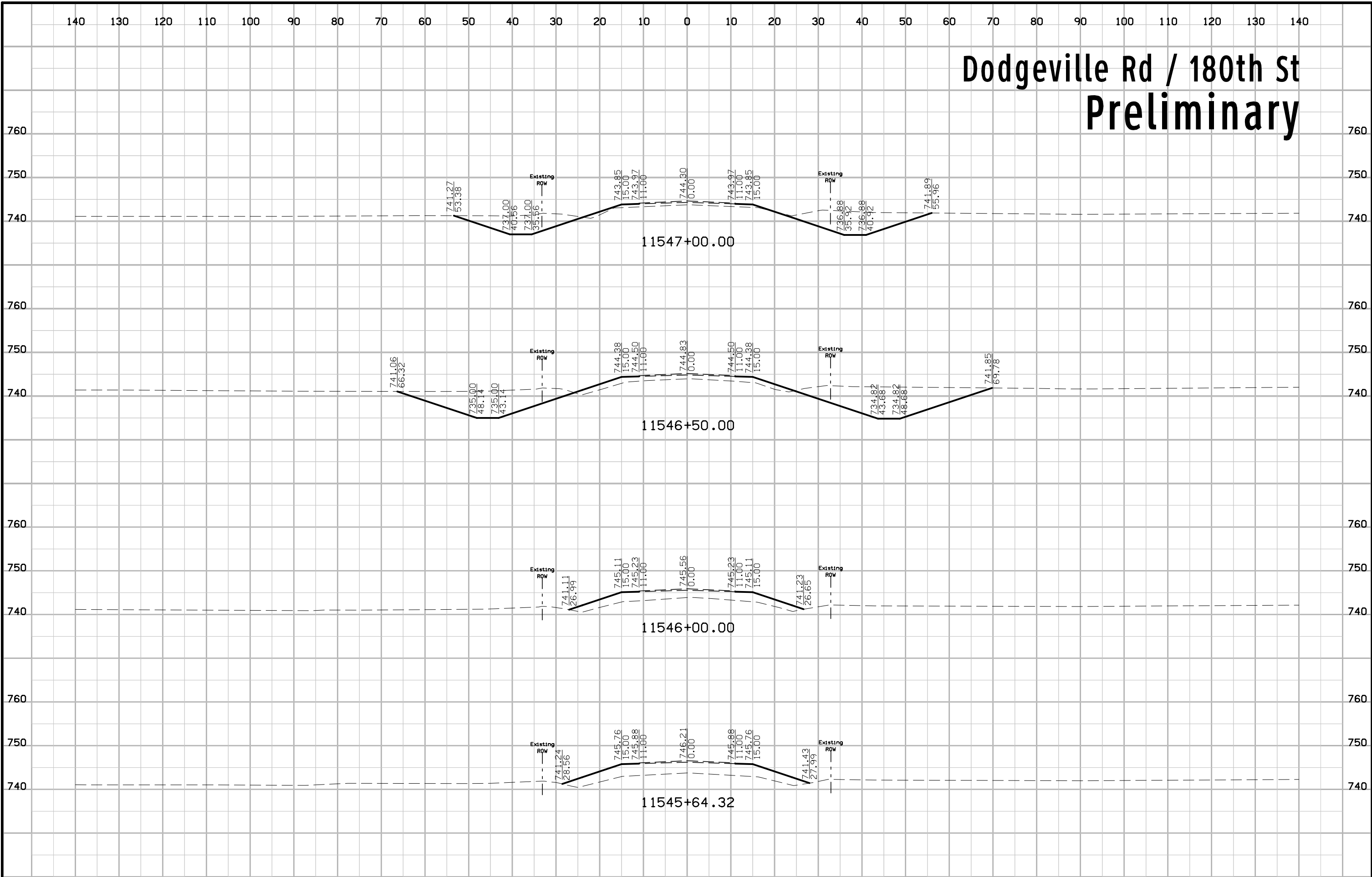

Dodgeville Rd / 180th St Preliminary

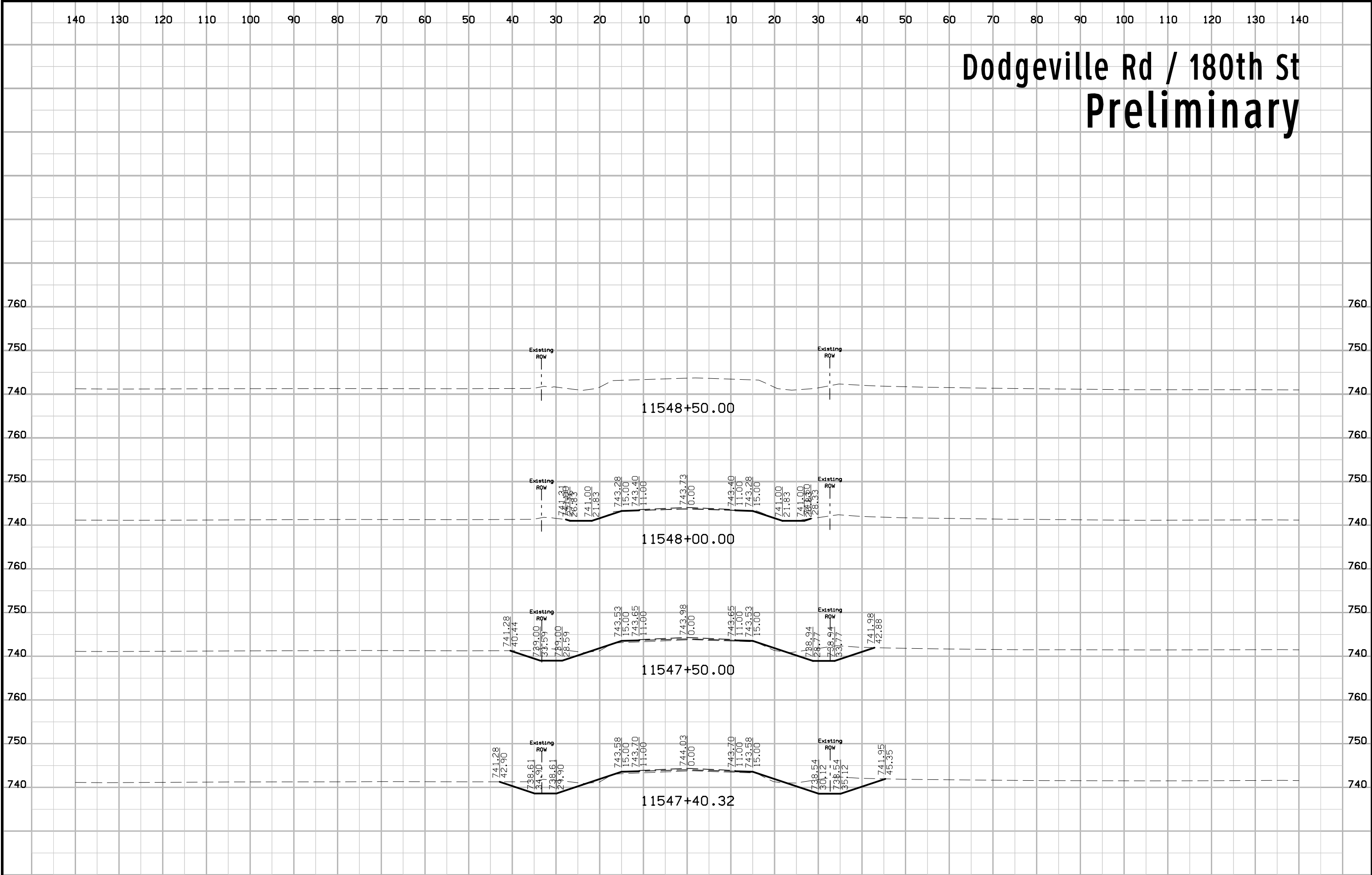

182nd St Preliminary

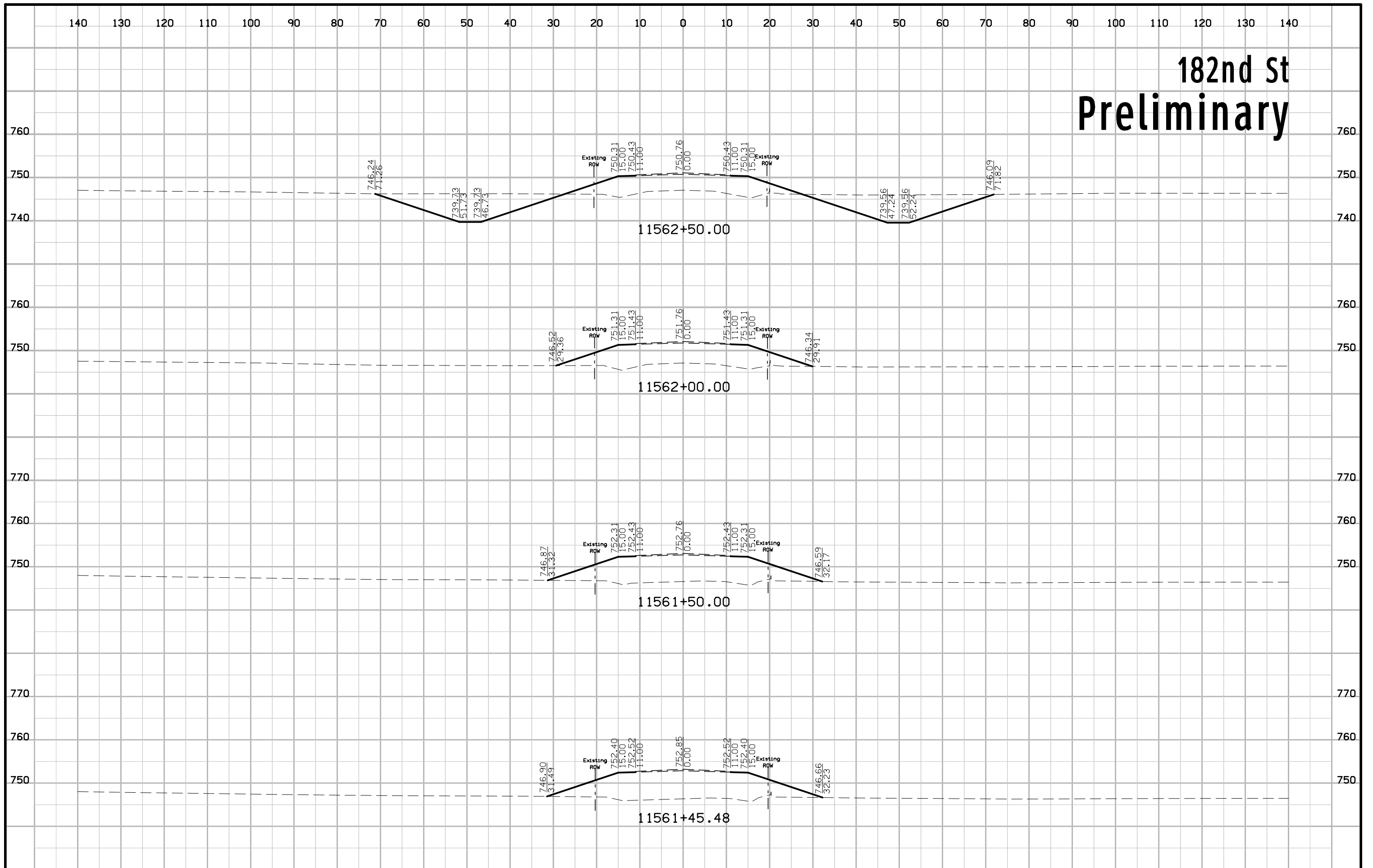

182nd St Preliminary

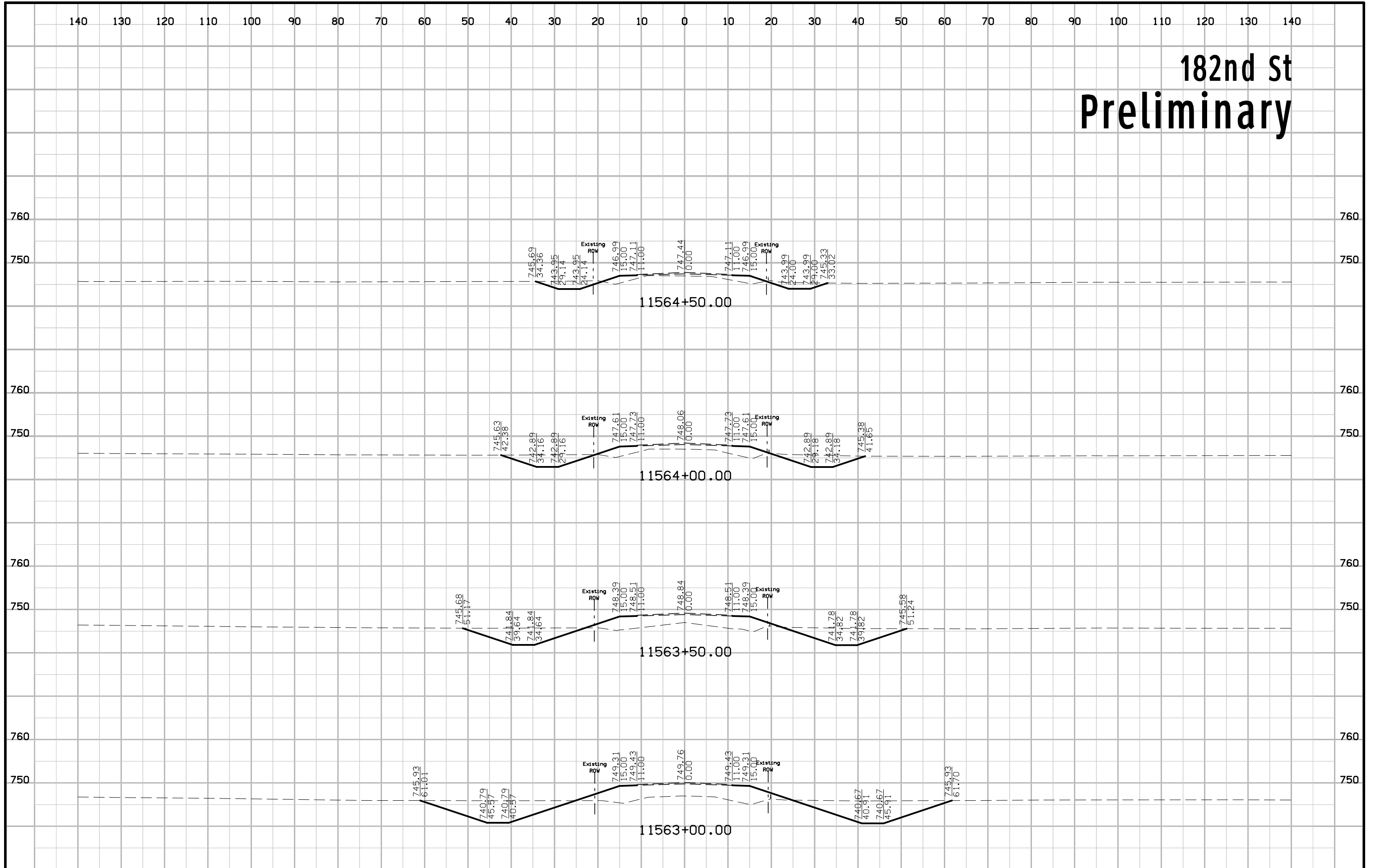

182nd St Preliminary

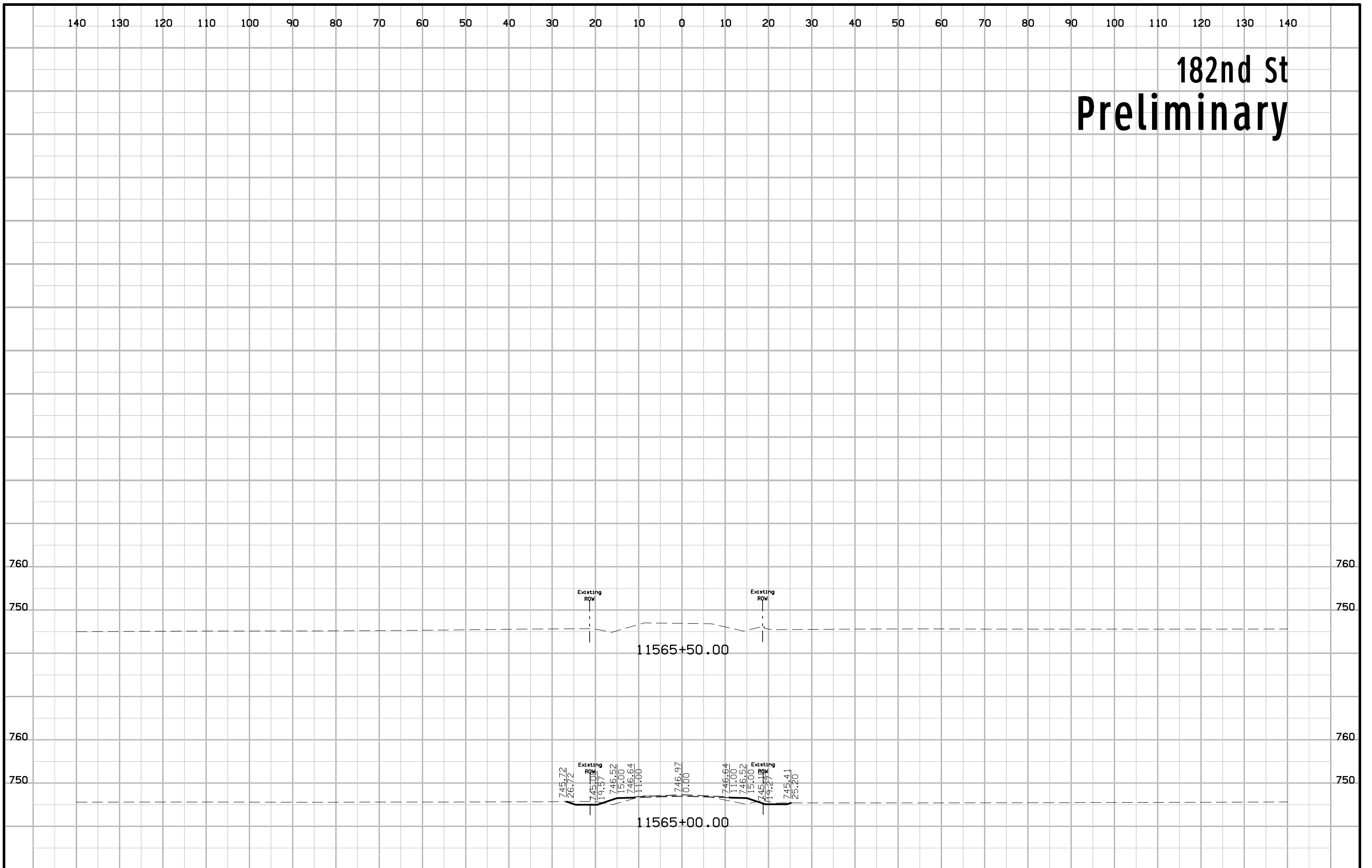

190th St / Sperry Rd Preliminary

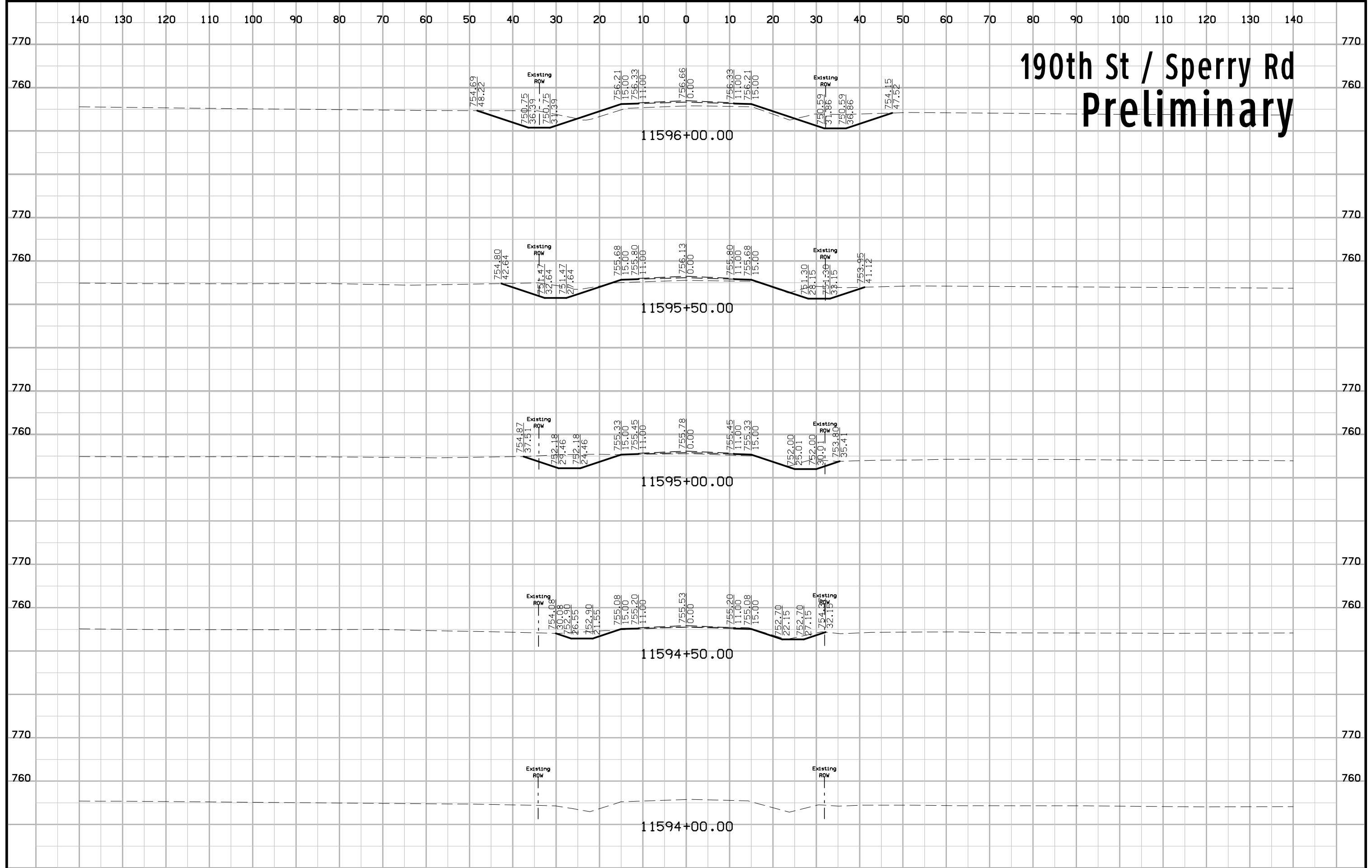

190th St / Sperry Rd Preliminary

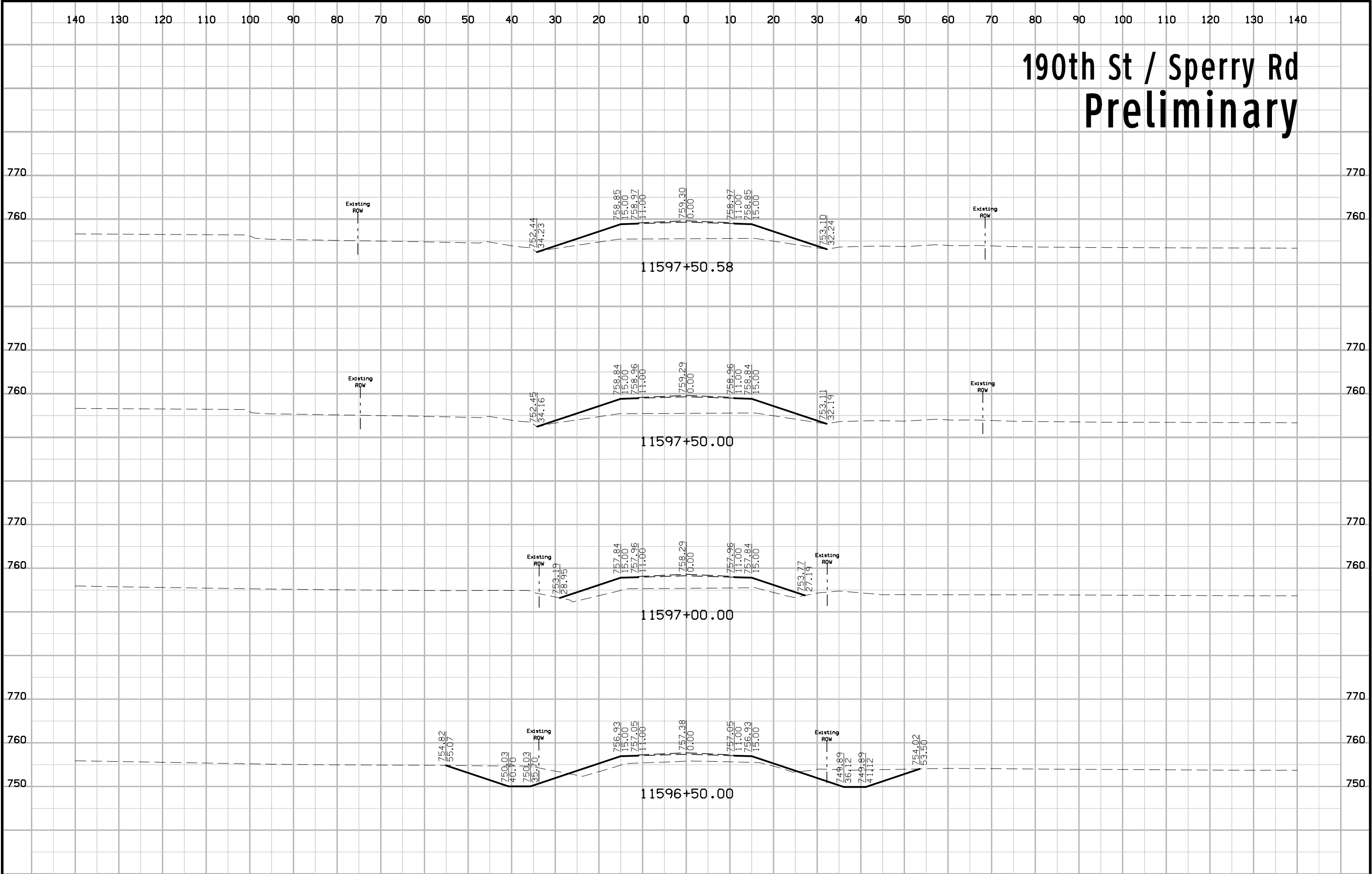

190th St / Sperry Rd Preliminary

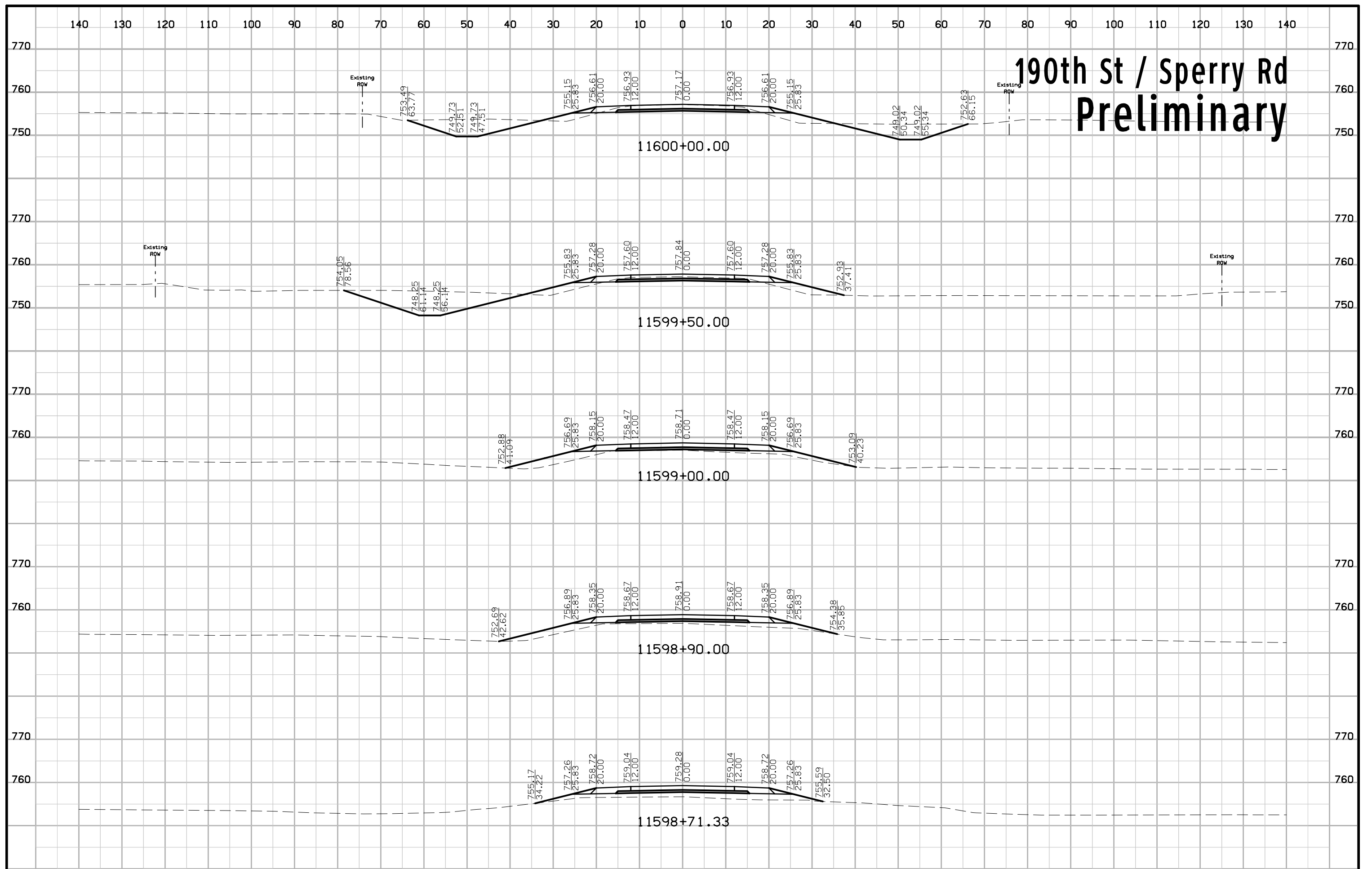

190th St / Sperry Rd Preliminary

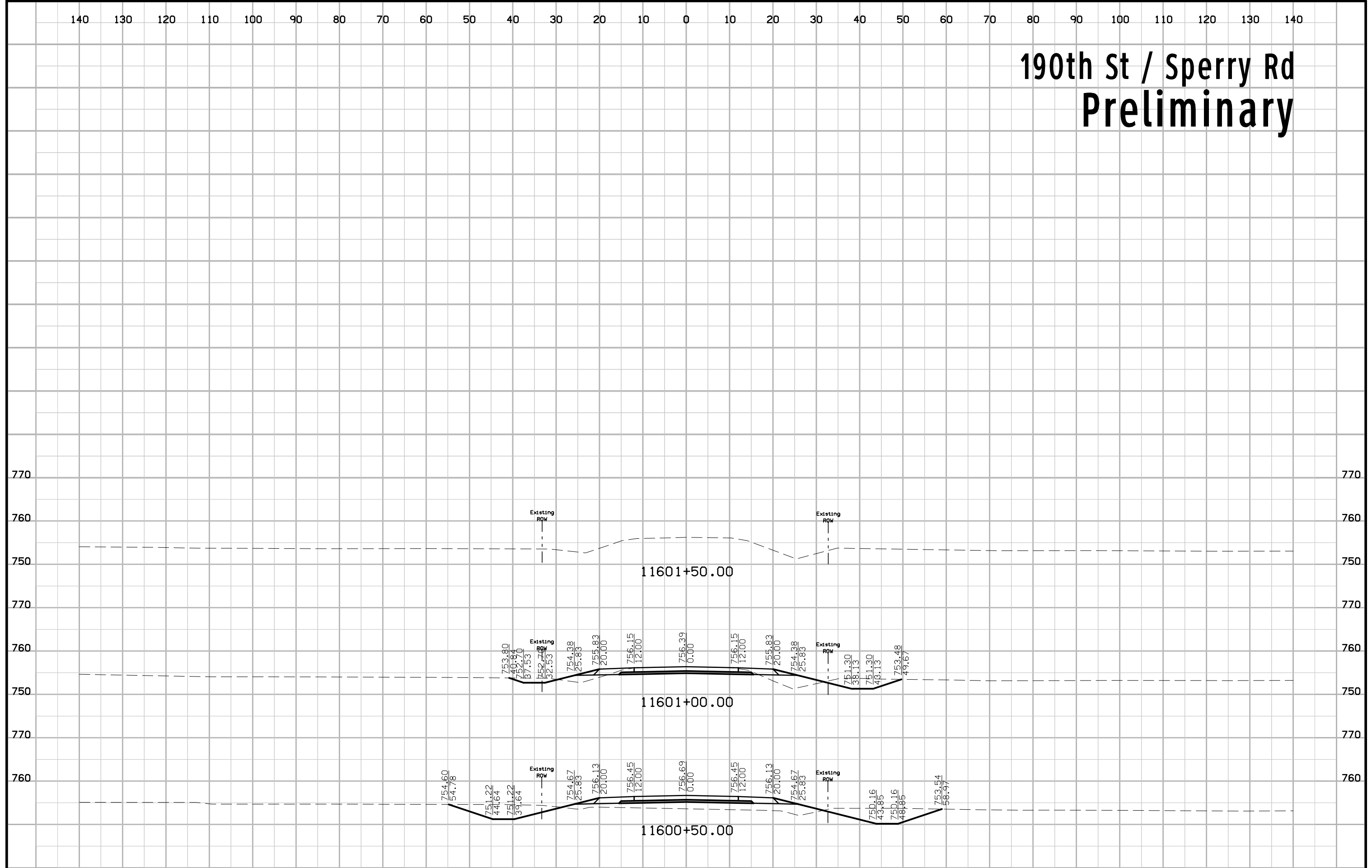

198th St Preliminary

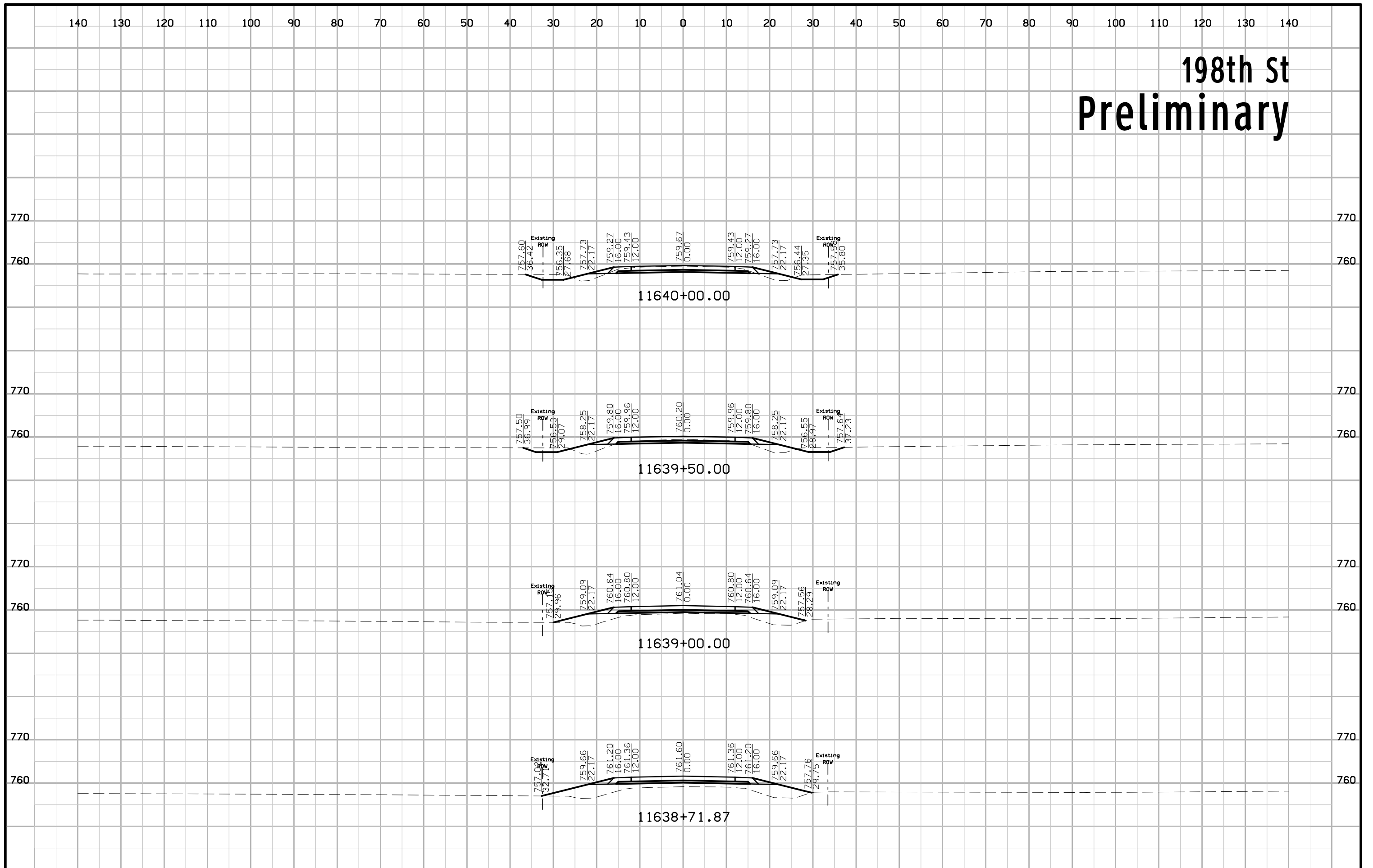

198th St Preliminary

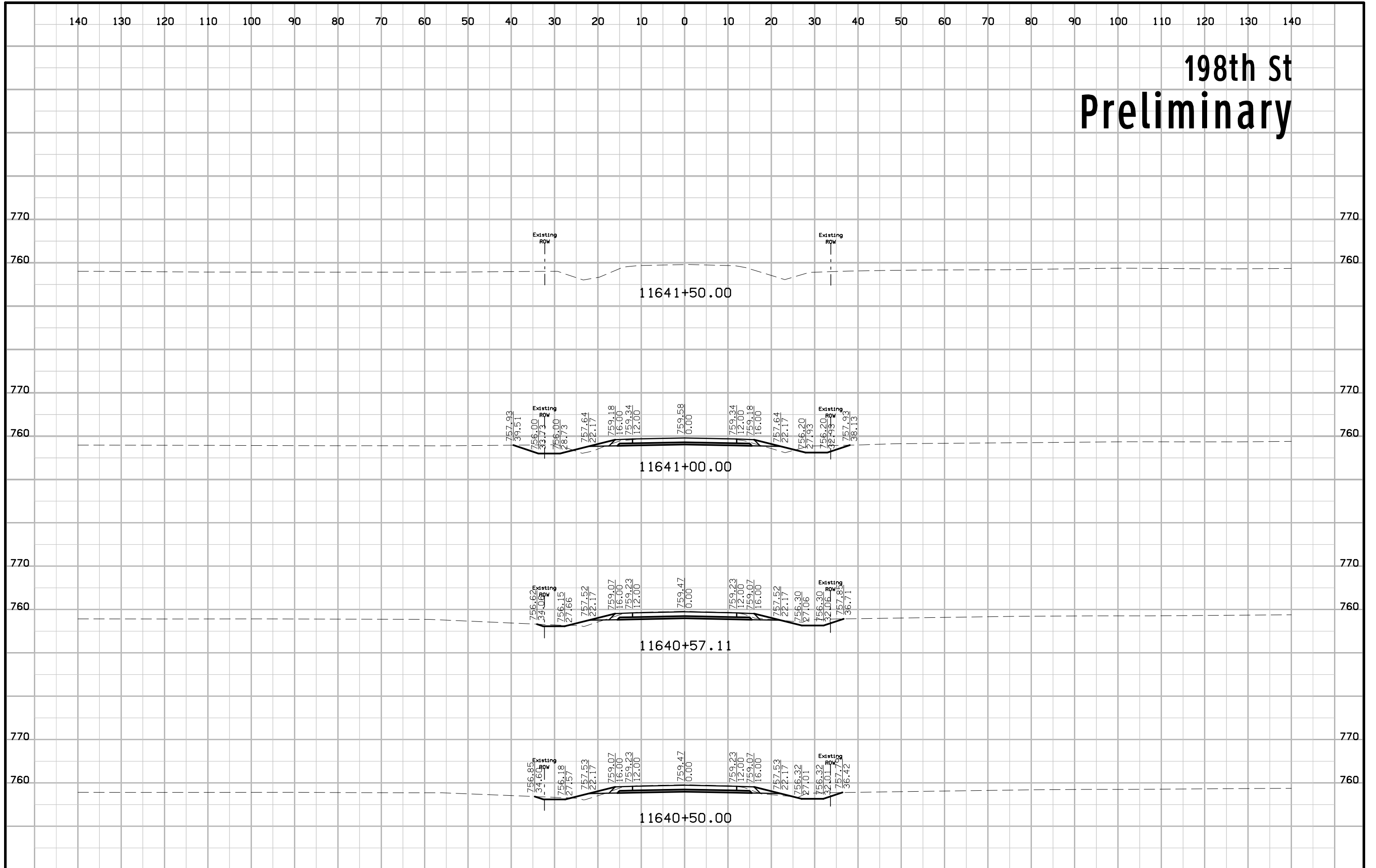

Pleasant Grove Rd Preliminary

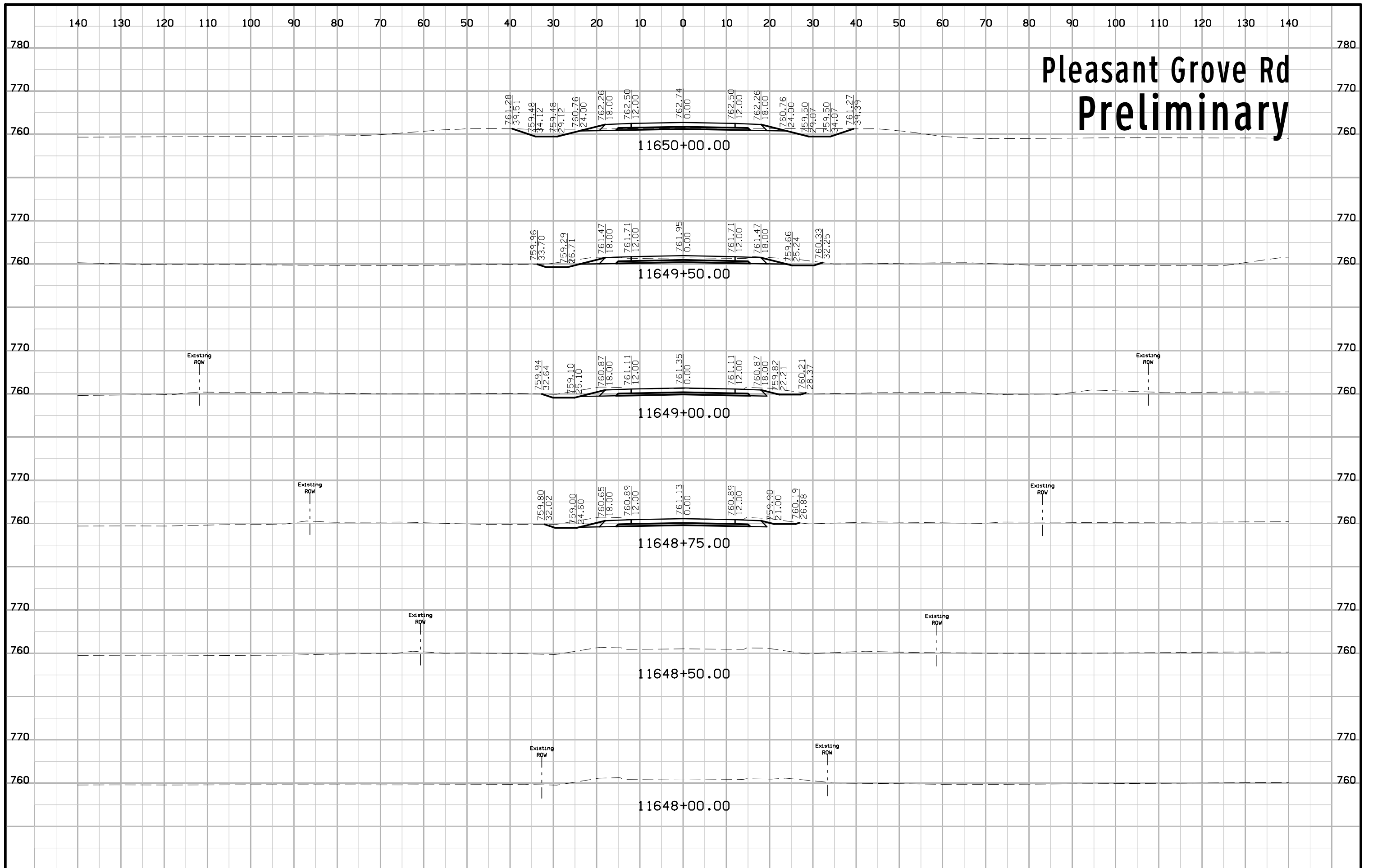

Pleasant Grove Rd Preliminary

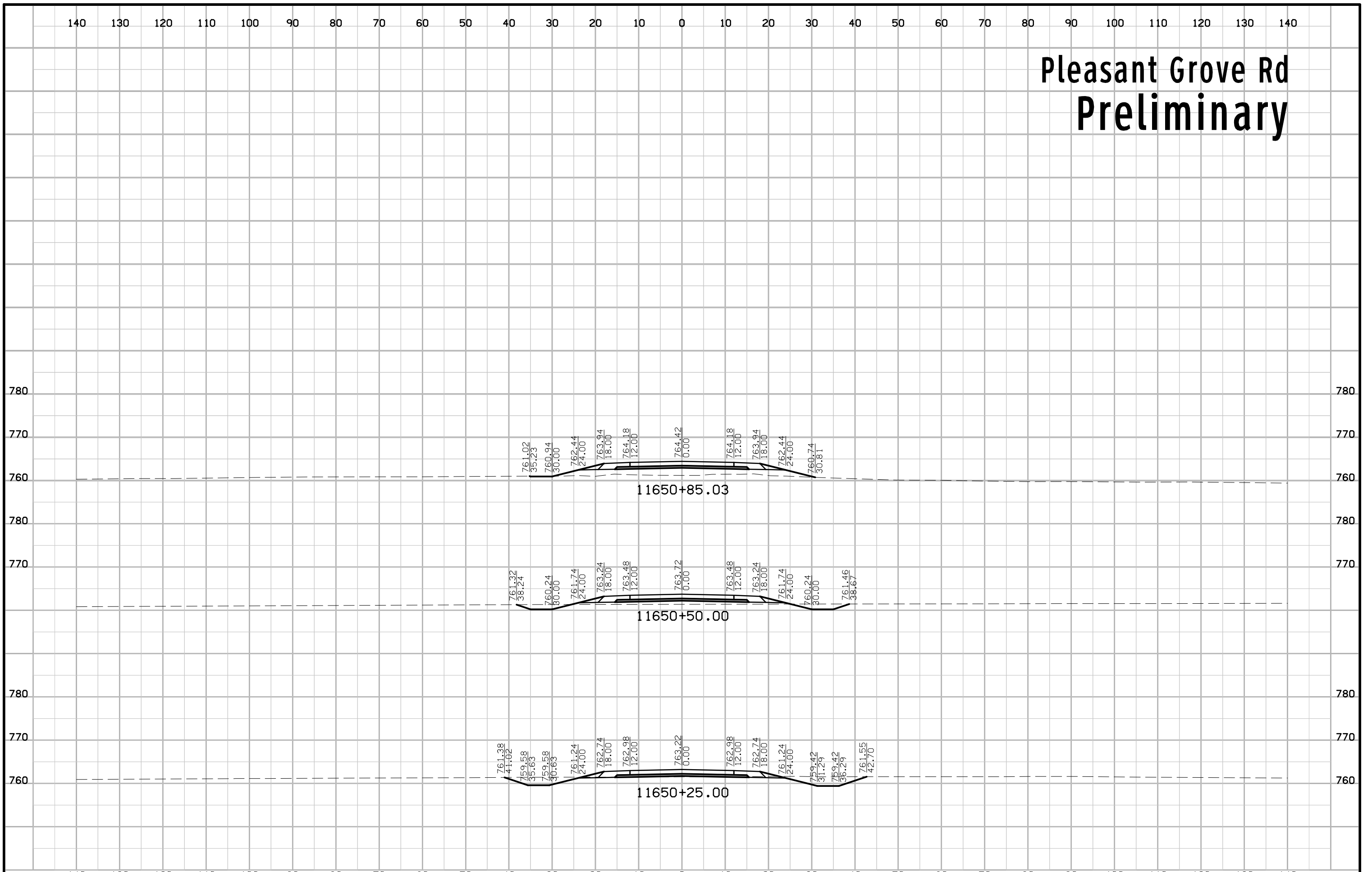

210th St (West) Preliminary

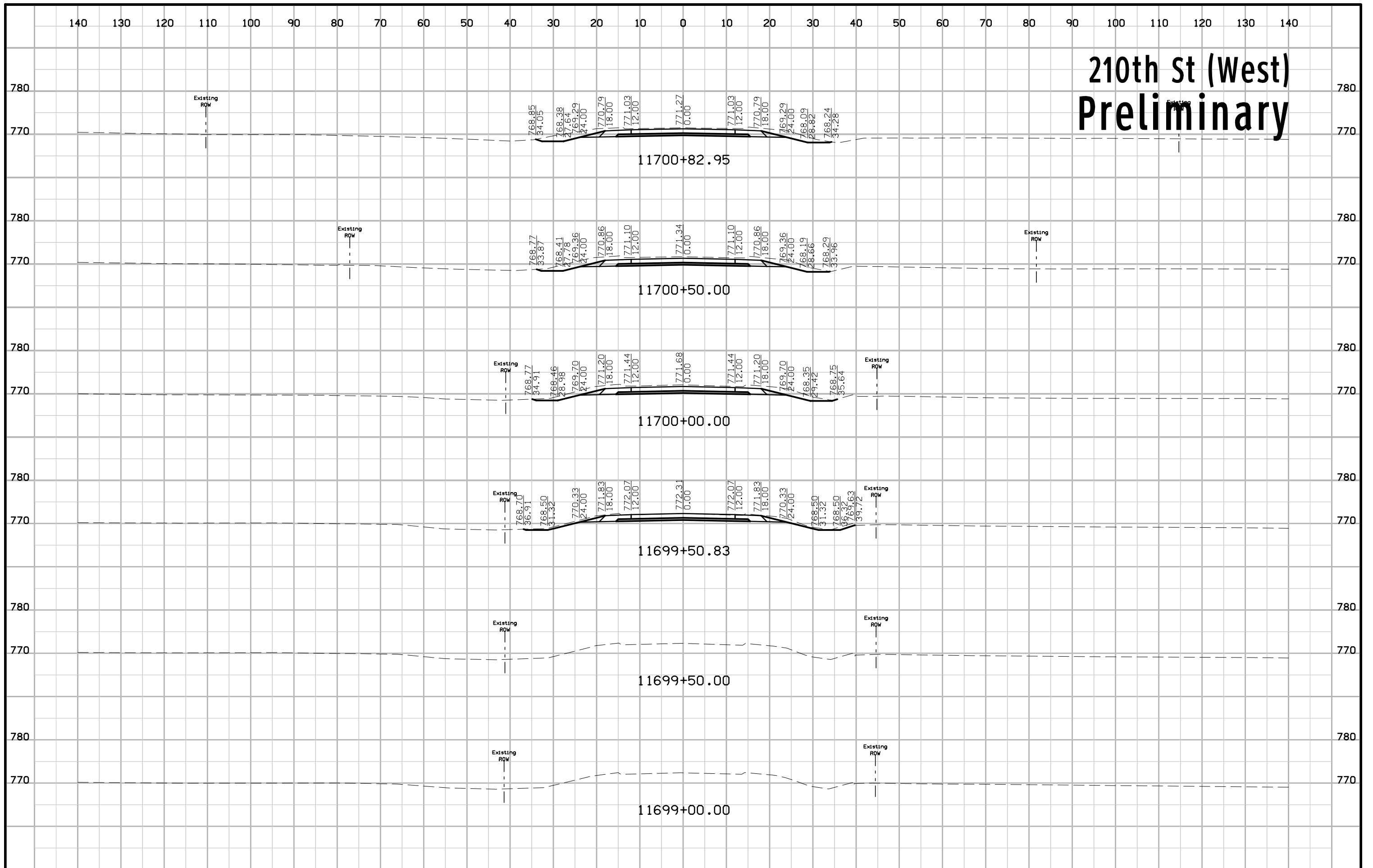

210th St (West) Preliminary

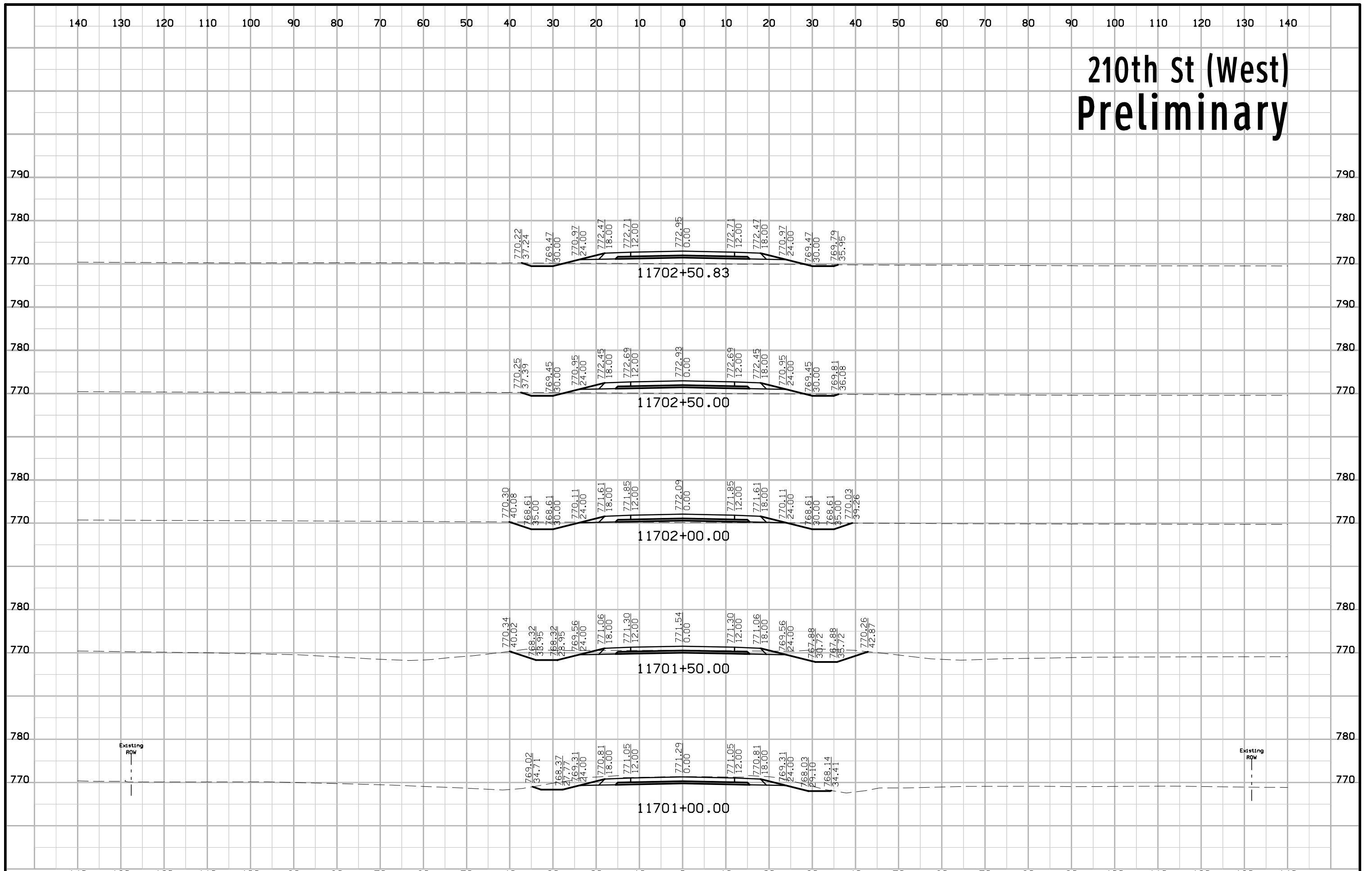

210th St (East) Preliminary

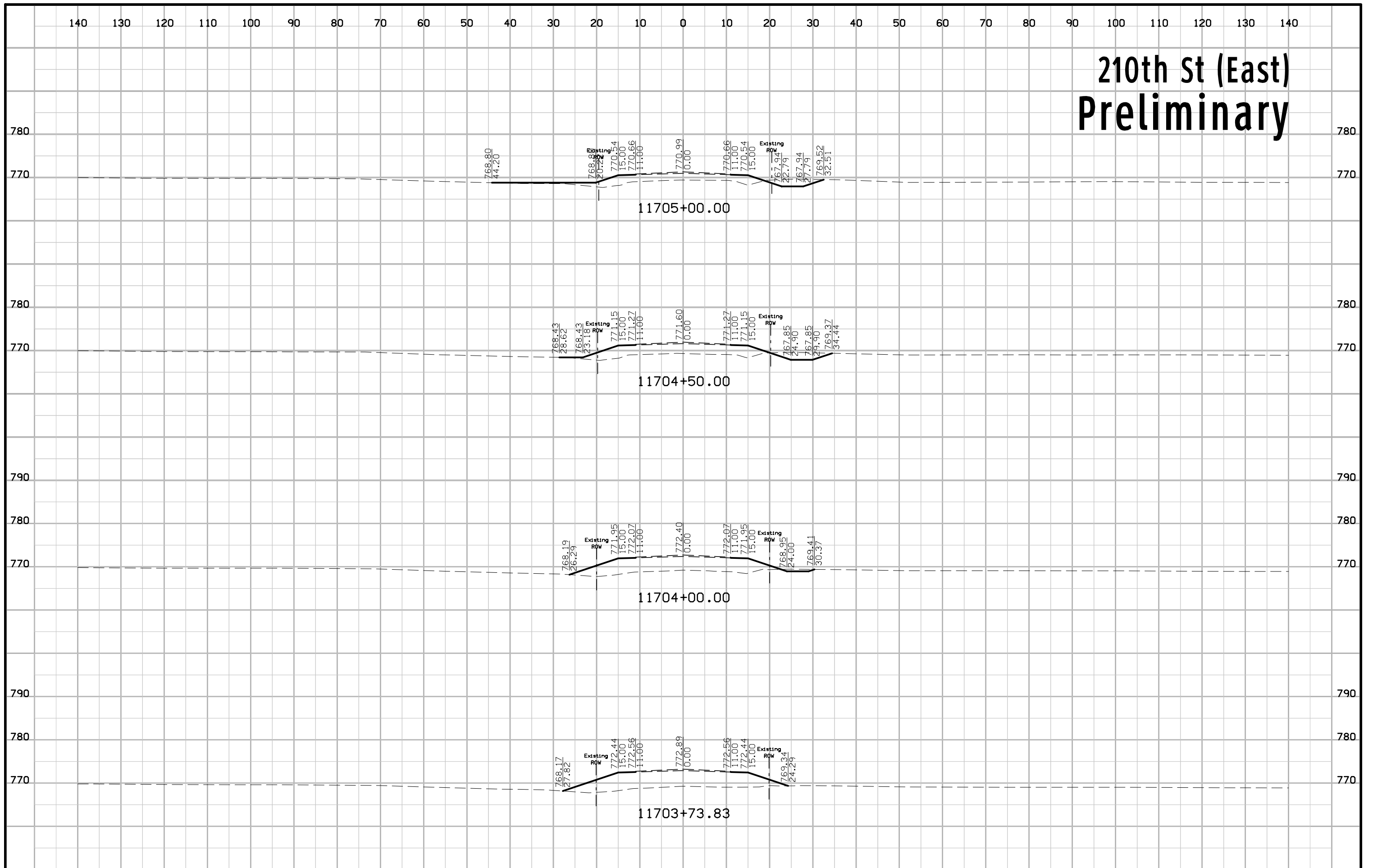

210th St (East) Preliminary

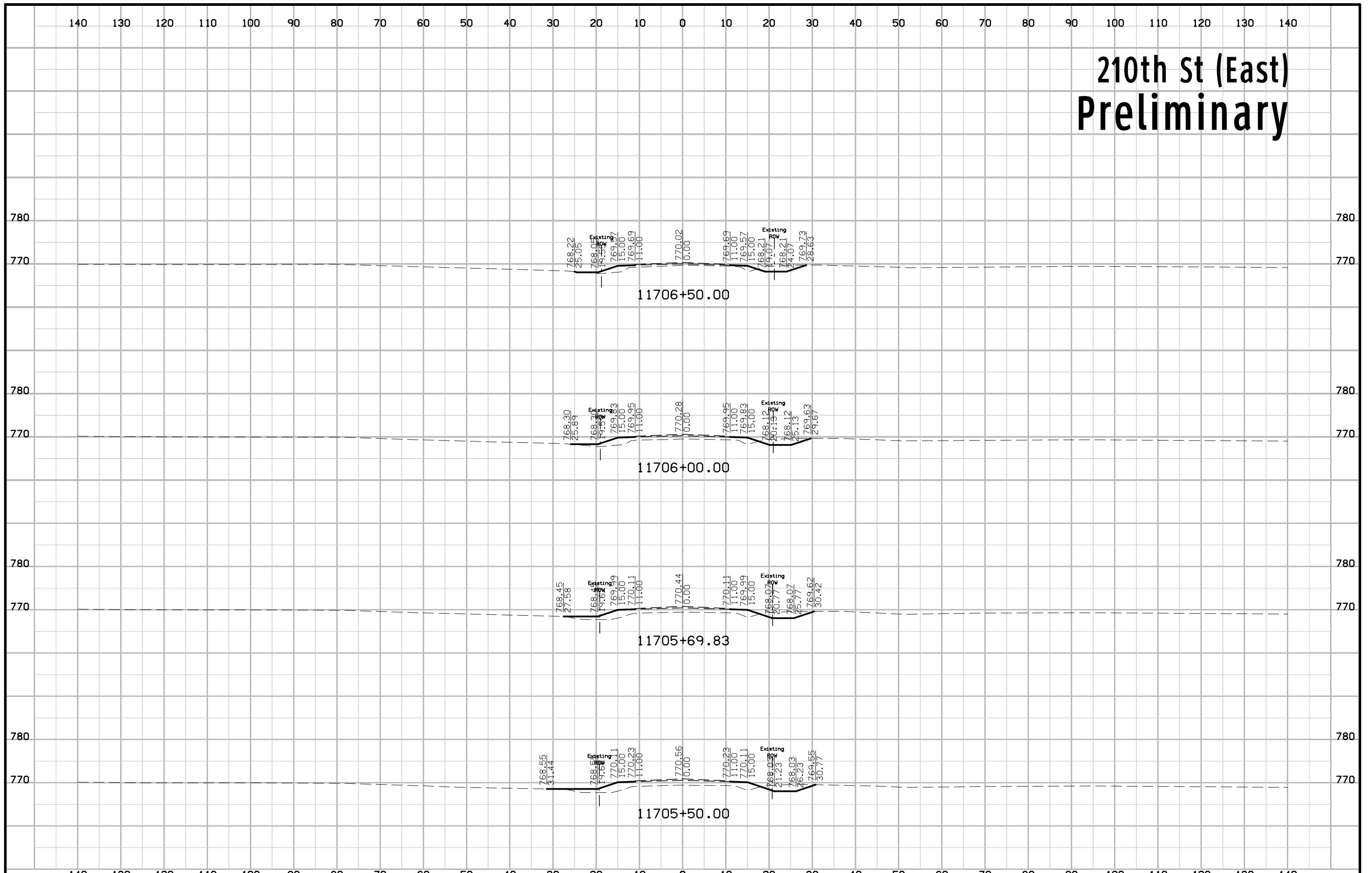

210th St (East) Preliminary

