

WAPELLO RECONSTRUCTION - BRIDGE DECK REPLACEMENT
GO.
 NHSX-063-2(137)--3H-90

LETTING DATE
 11-15-2022



Highway Division

PLANS OF PROPOSED IMPROVEMENT ON THE

PRIMARY ROAD SYSTEM
WAPELLO COUNTY

RECONSTRUCTION - BRIDGE DECK REPLACEMENT

Little Soap Creek 1.9 miles N of Davis Co

SCALES: As Noted

Refer to the Proposal Form for list of applicable specifications.

Value Engineering Saves. Refer to Article 1105.14 of the Specifications.



REVISIONS

TOTAL

PROJECT IDENTIFICATION NUMBER

10-90-063-010

PROJECT NUMBER

NHSX-063-2(137)--3H-90

R.O.W. PROJECT NUMBER

NHSX-063-2(137)--3H-90

INDEX OF SHEETS

No.	DESCRIPTION
A Sheets	Title Sheets
A.1	Title Sheet
A.2	Location Map Sheet
B Sheets	Typical Cross Sections and Details
B.1 - 3	Typical Cross Sections and Details
D Sheets	Mainline Plan and Profile Sheets
* D.1	Plan & Profile Legend & Symbol Information Sheet
* D.2	US 63
J Sheets	Traffic Control and Staging Sheets
J.1	Traffic Control Plan
V Sheets	Bridge and Culvert Situation Plans
V.1 - 3	Bridge and Culvert Situation Plans
W Sheets	Mainline Cross Sections
W.1 - 9	US 63 Cross Sections
	* Color Plan Sheets

DESIGN DATA RURAL

2019	AADT	6100	V.P.D.
2039	AADT	6800	V.P.D.
20--	DHV	--	V.P.H.
	TRUCKS	11	%
	Total		
	Design ESALs	--	

INDEX OF SEALS

SHEET NO.	NAME	TYPE
A.1	Paul W. Flattery	Primary Signature Block
X	X	X

PRELIMINARY PLANS

Subject to change by final design.

D5 PLAN - Date: 08-31-2020

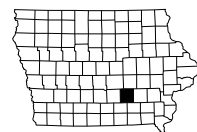

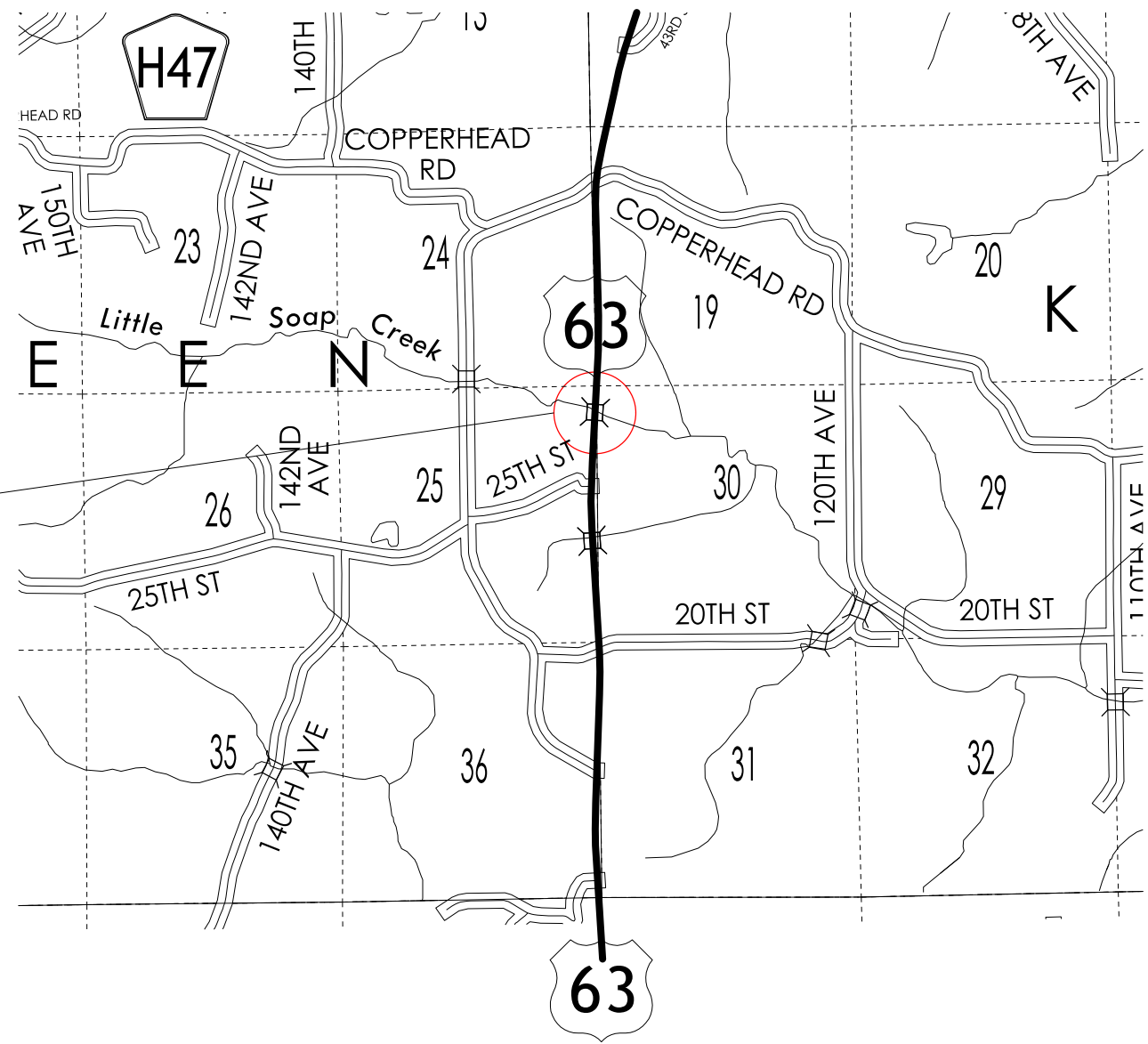

Project Location
 STA 100+34.67
 Ref. Loc. 28.64
 FHWA #50600
 Main, #9028.65063

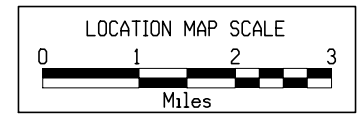
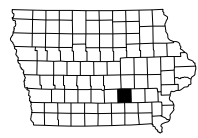

LOCATION		DIMENSIONS			
ROAD IDENTIFICATION	STATION TO STATION	(L) Feet	(R) Feet	(X) Inches	FS
US 63	97+46.72	97+66.86	30.7	21.5	3:1
US 63	97+66.86	98+16.72	30.7-28.7	21.5	3:1
US 63	98+16.72	98+41.87	28.7	21.5	3:1
US 63	98+41.87	98+54.30	28.7-27.4	21.5	3:1
US 63	98+54.30	99+06.57	27.4	21.5	3:1
Bridge	99+06.57	101+54.73			
US 63	101+54.73	101+94.66	27.3	21.5	3:1
US 63	101+94.66	102+44.52	27.3-29.3	21.5	3:1
US 63	102+44.52	102+79.21	29.3	21.5	3:1
US 63	98+01.95	98+25.30	28.9	21.5	3:1
US 63	98+25.30	98+74.64	28.9-27.4	21.5	3:1
US 63	98+74.64	99+14.56	27.4	21.5	3:1
Bridge	99+14.56	101+62.72			
US 63	101+62.72	102+14.99	27.4	21.5	3:1
US 63	102+14.99	102+27.42	27.4-28.6	21.5	3:1
US 63	102+27.42	102+52.57	28.6	21.5	3:1
US 63	102+52.57	103+02.43	28.6-30.7	21.5	3:1
US 63	103+02.43	103+22.57	30.7	21.5	3:1

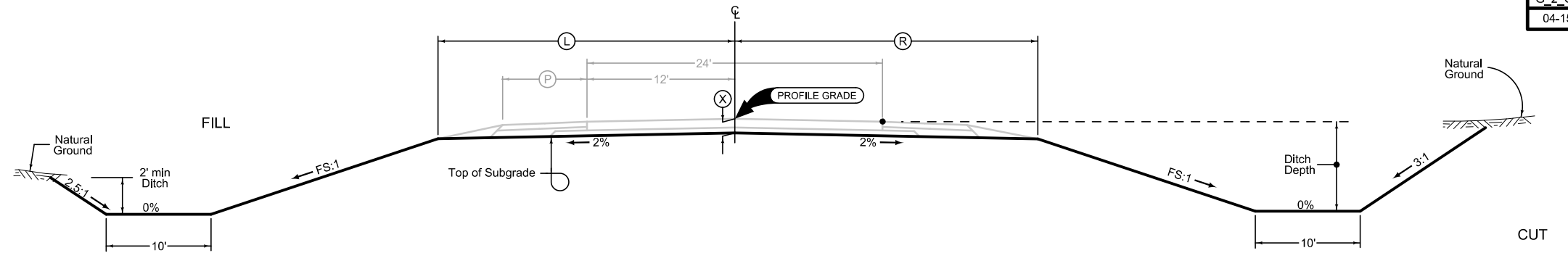

Normal section shown may be modified appropriately in areas of superelevated curves or other locations specifically designated by the Engineer.

See plan & profile sheets and cross sections for additional details of ditches and back-slopes.

2 LANE GRADING

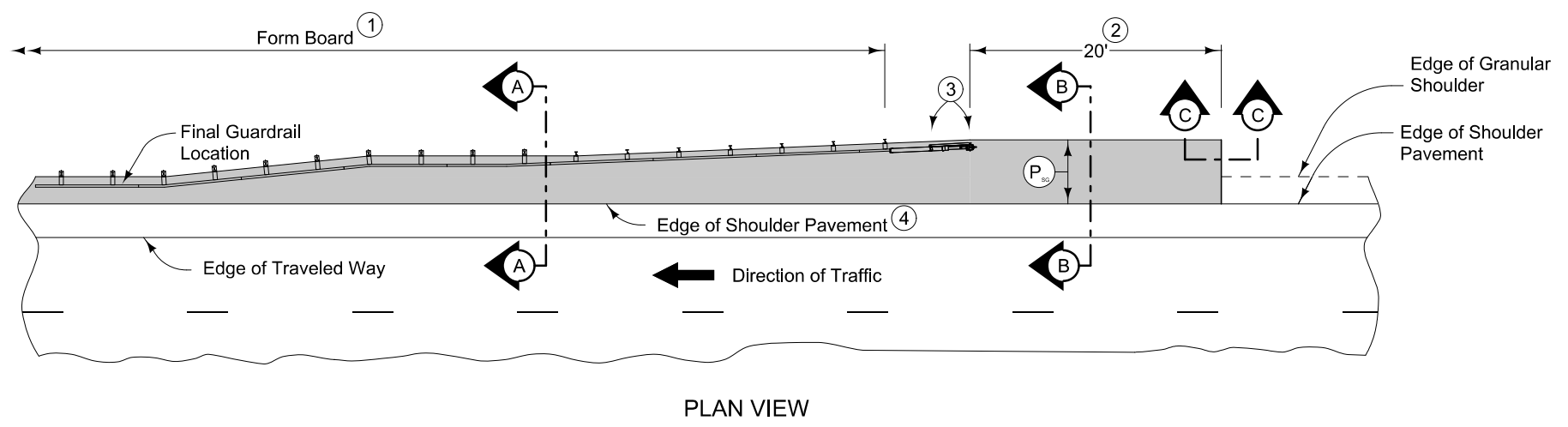

6" PCC Paved Shoulder at guardrail with following jointing layout:

Match mainline pavement joint spacing. When mainline pavement is 8" or greater in thickness, place additional transverse 'C' joints in shoulder at mid-panel of the mainline pavement. Place longitudinal 'C' joint at P/2 from edge of mainline pavement when P is greater than 10' wide. Terminate longitudinal joint at transverse joint less than 10' in length.

Refer to Tabulation 112-9 for shoulder quantities.

- ① When guardrail posts are installed prior to construction of PCC paved shoulder, fasten form board to the face of guardrail posts for the length shown.
- ② Continue paved shoulder 20 feet beyond the center of the first post.
- ③ Shoulder may be notched for first 2 posts or post sleeves may be installed through pavement. Do not drive posts through pavement.
- ④ 'KT-1 joint for PCC shoulder. 'B' joint for HMA shoulder.
- ⑤ Match shoulder slope.
- ⑥ The Contractor has the option to pave the paved shoulder at guardrail and the partial width paved shoulder as one operation.
- ⑦ Refer to other details in the plan.

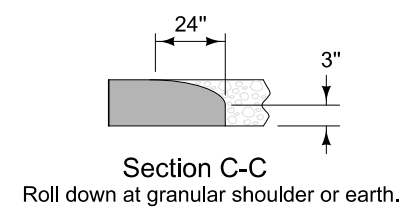
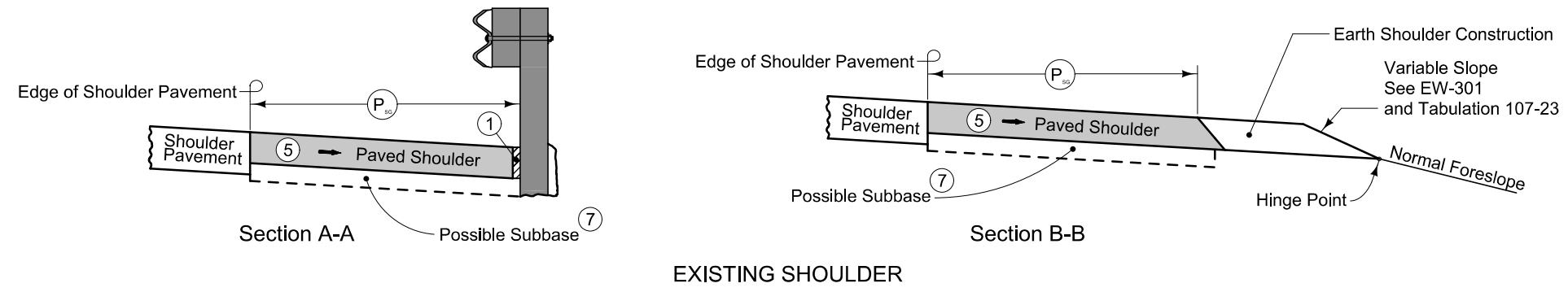
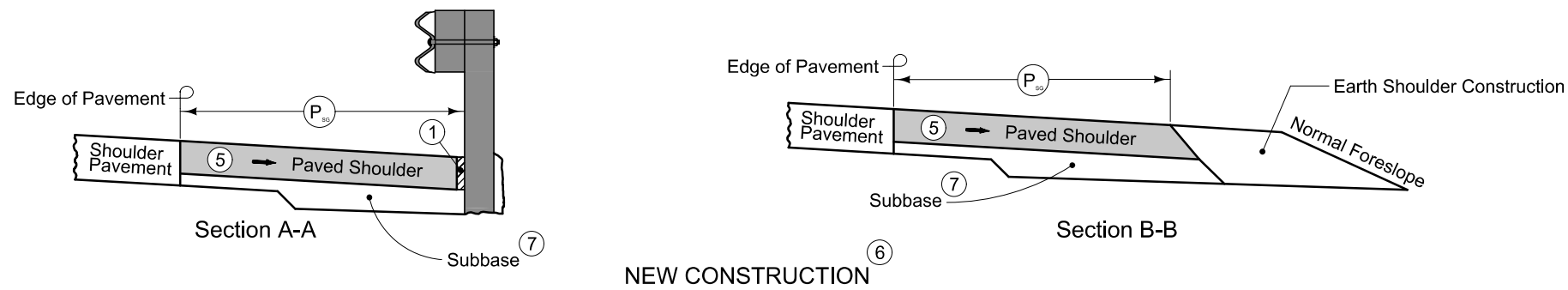

PAVED SHOULDER AT GUARDRAIL (ADJACENT TO PARTIAL WIDTH PAVED SHOULDER)

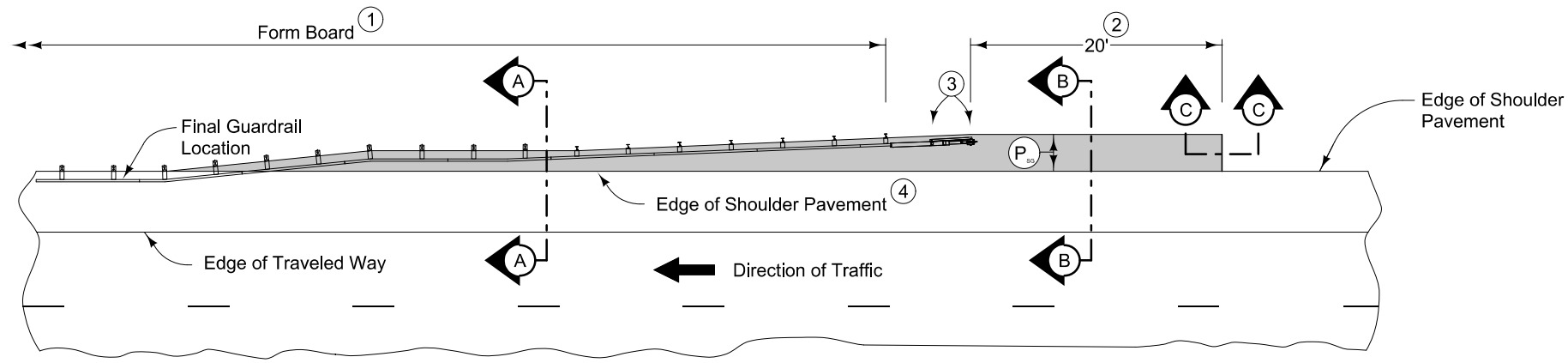

PLAN VIEW

6" PCC Paved Shoulder at guardrail with following jointing layout:
 Match mainline pavement joint spacing. When mainline pavement is 8" or greater in thickness, place additional transverse 'C' joints in shoulder at mid-panel of the mainline pavement. Place longitudinal 'C' joint at P/2 from edge of mainline pavement when P is greater than 10' wide. Terminate longitudinal joint at transverse joint less than 10' in length.

Refer to Tabulation 112-9 for shoulder quantities.

- ① When guardrail posts are installed prior to construction of PCC paved shoulder, fasten form board to the face of guardrail posts for the length shown.
- ② Continue paved shoulder 20 feet beyond the center of the first post.
- ③ Shoulder may be notched for first 2 posts or post sleeves may be installed through pavement. Do not drive posts through pavement.
- ④ 'KT-1 joint for PCC shoulder. 'B' joint for HMA shoulder.
- ⑤ Match shoulder slope.
- ⑥ The Contractor has the option to pave the paved shoulder at guardrail and the full width paved shoulder as one operation.
- ⑦ Refer to other details in the plan.

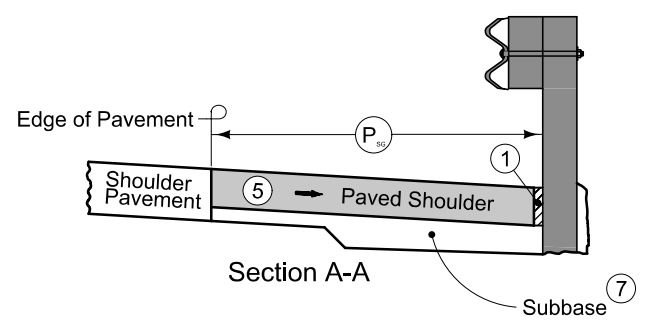

Section A-A

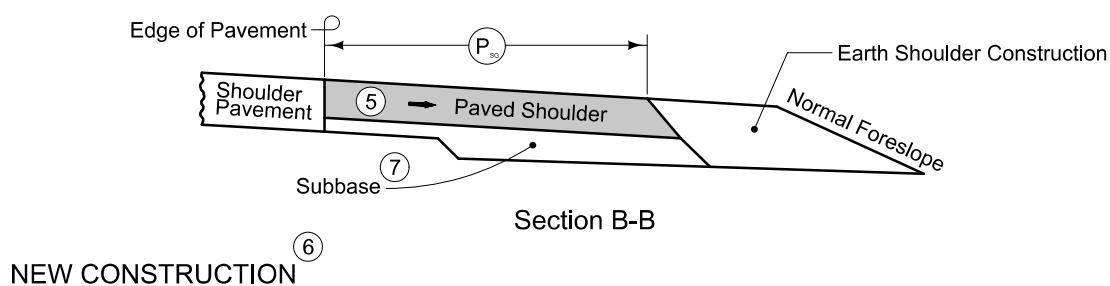

Section B-B

NEW CONSTRUCTION

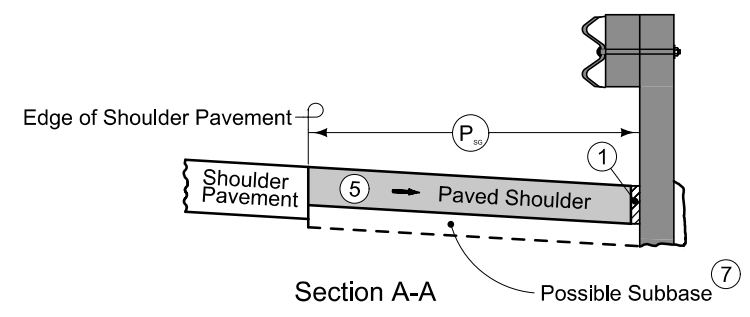

Section A-A

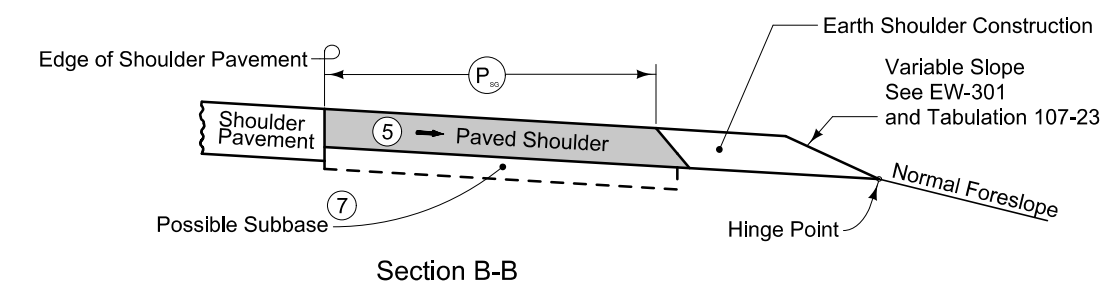

Section B-B



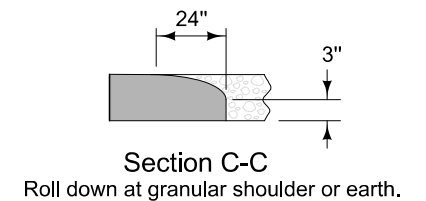



















EXISTING SHOULDER



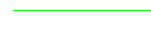
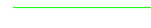

Section C-C

PAVED SHOULDER AT GUARDRAIL (ADJACENT TO FULL WIDTH PAVED SHOULDER)













SURVEY SYMBOLS

-  TEV Evergreen Tree
-  SI Sign
-  OUT Tile Outlet
-  TPD Telephone Pedestal
-  TDC Tree Deciduous
-  TSB Telephone Switch Box
-  EB Electrical Box
-  SEP Septic Tank
-  WEL Well
-  LP L.P. Tank
-  CIS Cistern
-  MH Utility Access (Manhole)
-  PR Electric Riser Pole
-  SHR Shrub
-  WHD Water Hydrant
-  STP Stump
-  FW Wire Fence
-  FCL Chain Link and Security Fence
-  D Centerline Draw or Stream (Down)
-  BNK Stream Bank
-  DU Centerline Draw or Stream (Up)
-  EW Edge of Water
-  Existing Guardrail







UTILITY LEGEND











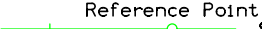

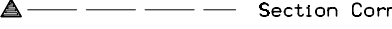
-  F0 Century Link Fiber Optic
-  F02 INC Fiber Optic
-  W Wapello Rural Water









PLAN VIEW COLOR LEGEND OF PLAN AND PROFILE SHEETS

LINEWORK		Design Color No.	
Green	(2)		Existing Topographic Features and Labels
Blue	(1)		Proposed Alignment, Stationing, Tic Marks, and Alignment Annotation
Magenta	(5)		Existing Utilities
SHADING		Design Color No.	
Yellow	(4)		Highlight for Critical Notes or Features
Red	(3)		Delineates Restricted Areas
Lavender	(9)		Temporary Pavement Shading
Gray, Light	(48)		Proposed Pavement Shading
Gray, Med	(80)		Proposed Granular Shading
Gray, Dark	(112)		Proposed Grade and Pave Shading "In conjunction with a paving project"
Brown, Light	(236)		Grading Shading
Tan	(8)		Proposed Sidewalk Shading
Blue, Light	(230)		Proposed Sidewalk Landing Shading
Pink	(11)		Proposed Sidewalk Ramp Shading

PROFILE VIEW COLOR LEGEND OF PLAN AND PROFILE SHEETS

LINEWORK		Design Color No.	
Green	(2)		Existing Ground Line Profile
Blue	(1)		Proposed Profile and Annotation
Magenta	(5)		Existing Utilities
Blue, Light	(230)		Proposed Ditch Grades, Left
Black	(0)		Proposed Ditch Grades, Median
Rust	(14)		Proposed Ditch Grades, Right

-  Reference Point
-  Station
-  Survey Line
-  Section Corner
-  Ground Line Intercept
-  Saw Cut
-  Guardrail
-  Trench Drain
-  HighTension Cable Guardrail
-  Sheet Pile
-  Pavement Removal
-  Clearing & Grubbing Area

- RIGHT-OF-WAY LEGEND**
-  Proposed Right-of-Way
 -  Existing Right of Way
 -  Existing and Proposed Right-of-Way
 -  Easement and Existing Right-of-Way
 -  Easement (Temporary)
 -  Easement
 -  Access Control
 -  Property Line

**PLAN AND PROFILE
LEGEND AND SYMBOL
INFORMATION SHEET**
(COVERS SHEET SERIES D, E, F, & K)

Green Twp.
T-71N R14W
Sec. 25

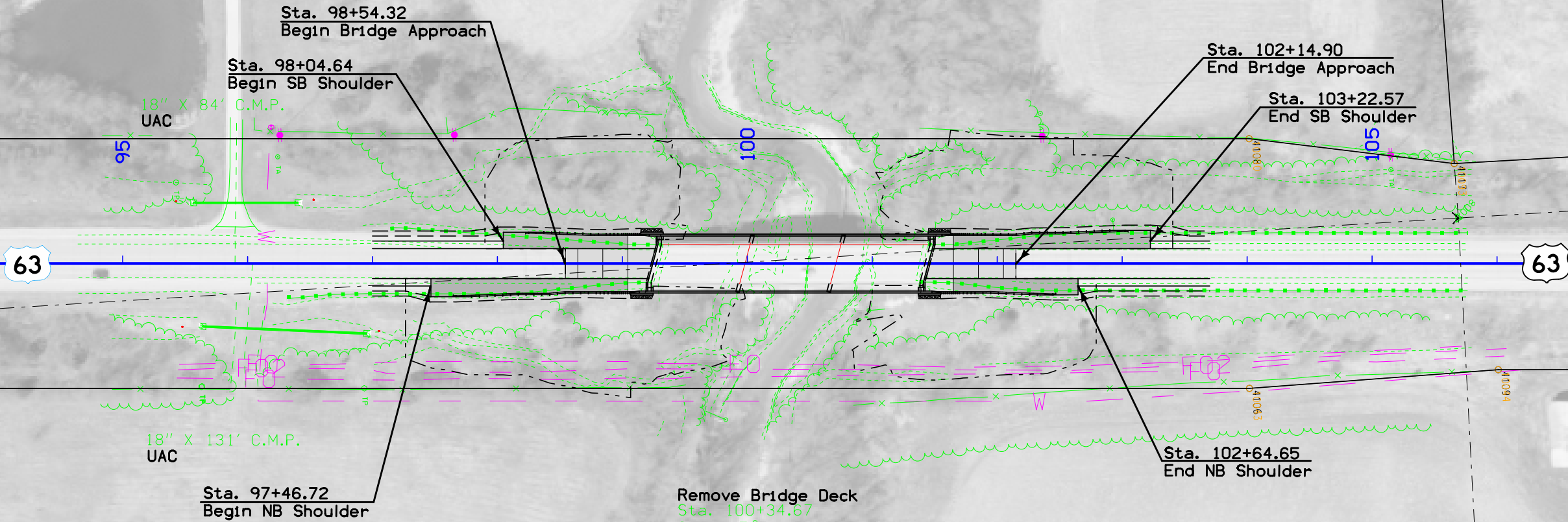
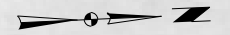

Remove Bridge Deck
 Sta. 100+34.67
 Skew 15° Lt. Ahead
 217'-6 X 30' Prestensioned
 Prestressed Concrete Beam Bridge
 D.A.=30 SQ Miles H

Build
 Sta. 100+34.67
 Skew 15° Lt. Ahead
 217'-6 X 44' Prestensioned
 Prestressed Concrete Beam Bridge

Keokuk Twp.
T-71N R13W
Sec. 30

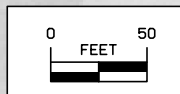

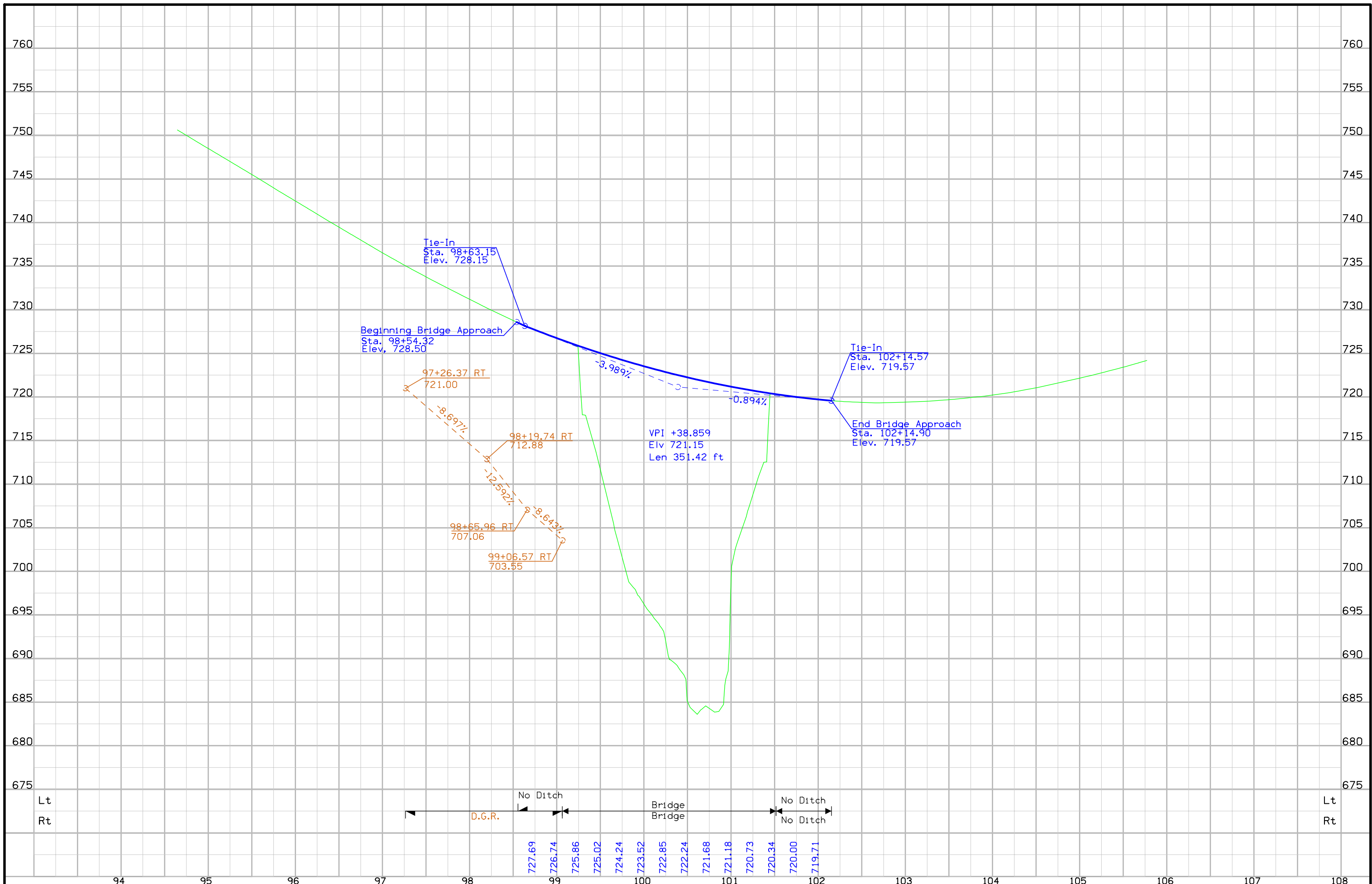

NO ACCESS RIGHTS ARE TO BE ACQUIRED ON THIS PROJECT.

ACCESS CONTROL PREVIOUSLY ACQUIRED.

Green Twp.
T-71N R14W
Sec. 25

①
DAVID V. ROTOLE AND
JENNIFER K. ROTOLE

99+30.00 (Ex.R/W COR)
⊘145.00'

97+89.00
⊘100.00'

104+00.00 (Ex.R/W COR)
⊘100.00'

100+70.00 (Ex.R/W COR)
⊘130.00'

93

94

95

96

97

98

99

102

103

104

105

106

107

63

63

98+15.00
⊘100.00'

98+80.00
⊘116.00'

TEMPORARY EASEMENT
TO SHAPE

102+15
⊘100'±R

101+00±Ex.R/W
⊘109'

②

RALPH P. AND LINDA L. OWEN
FAMILY REVOCABLE TRUST

Keokuk Twp.
T-71N R13W
Sec. 30

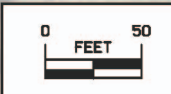

Right of Way Design Information
THIS SHEET INCLUDED FOR INFORMATION ONLY
ROW Team: CAGLE / LARSON
ROW #: NHSN-063-2(154)-2R-90
Plan Date: 12/17/2020
Color Legend:
Property Lines
Temporary Easement
Permanent Acquisition

CONTROL POINT NO. G040: N 6204899.980, E 22870300.750 FD REBAR 67' WEST OF CENTERLINE US HIGHWAY 63, 69 FEET NORTHWEST OF APRON INLET RCP, 15 FEET SOUTH OF PRIVATE ENTRANCE. ELEVATION 784.34

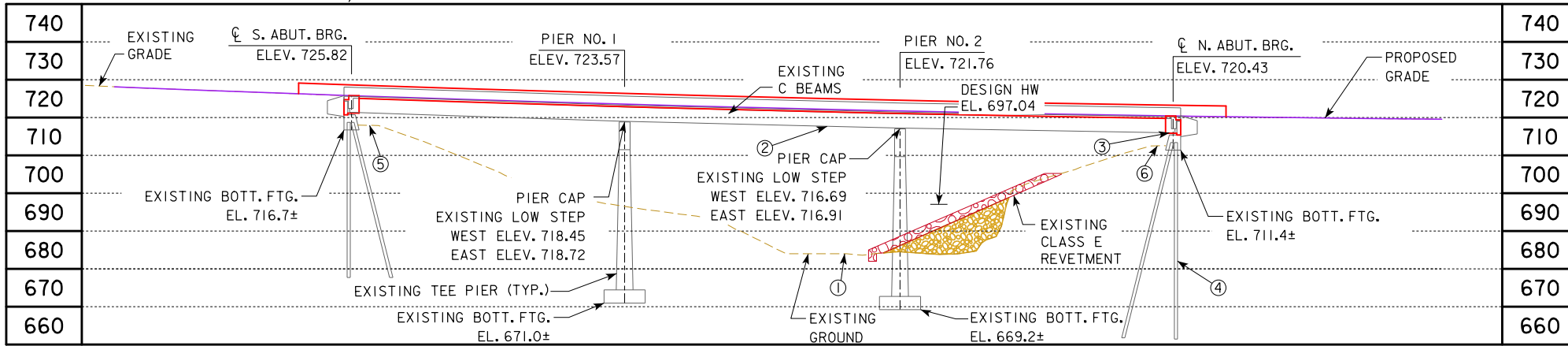

VPC STA = 98+63.15
VPC ELEV = 728.15
G1 = -3.99%
G2 = -0.89%
VPI STA = 100+38.86
VPI ELEV = 721.15
VC = 351.42'
VPT STA = 102+14.57
VPT ELEV = 719.57

PROPOSED PROFILE GRADE US 63

- ① STREAMBED EL. 683.6
- ② REGULATORY LOW BEAM
- ③ OPERATIONAL LOW BEAM
- ④ EXISTING BRIDGE
217'-6 x 30'-0 PPCB
STA. 100+34.67
DESIGN NO. 1662
- ⑤ EXISTING TOP OF BERM EL. 718.00
- ⑥ EXISTING TOP OF BERM EL. 712.50
- ⑦ EXISTING REVETMENT INSTALLED AS PART OF
PROJECT MB-063-5(500)29--77-90; DESIGN 120
- ⑧ IF EXISTING REVETMENT DISTURBED DUE TO BERM GRADING
REINSTALL TO EXTENTS PRESENT PRIOR TO CONSTRUCTION.
TOP OF REVETMENT SOUTH BANK EL. 701.0
TOP OF REVETMENT NORTH BANK EL. 705.0

LONGITUDINAL SECTION ALONG CL APPROACH ROADWAY

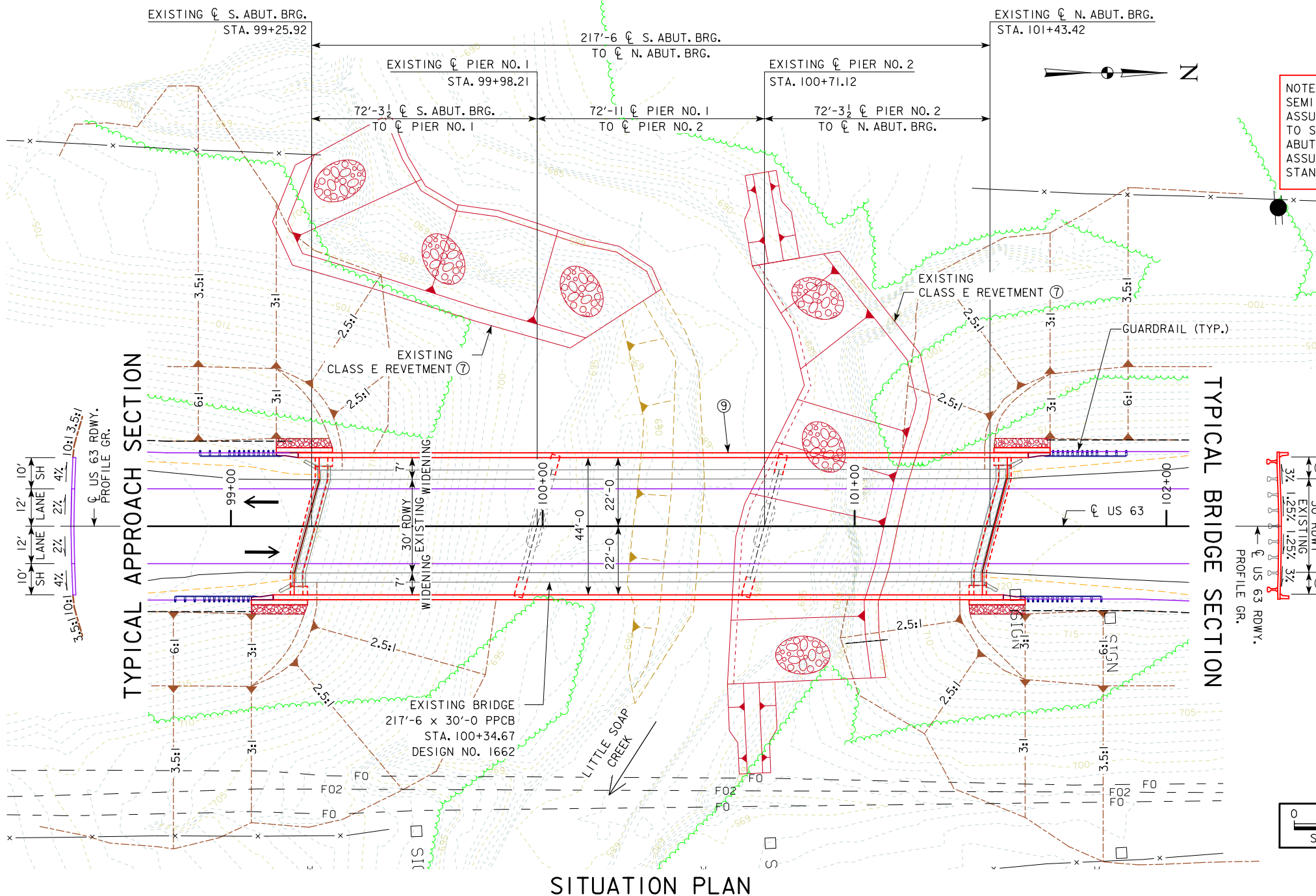

NOTE TO FINAL DESIGNER
SEMI INTEGRAL ABUTMENTS ASSUMED FOR WIDENING AND ASSUMED EXISTING STUB ABUTMENTS WILL BE CONVERTED TO SEMI INTEGRAL. INFORM PRELIM DESIGN IF FINAL ABUTMENT TYPE NOT SEMI INTEGRAL. ASSUMED LENGTH OF ABUTMENT WINGS BASED ON PRELIMINARY STANDARDS; INFORM PRELIM DESIGN IF LENGTH CHANGES.

- ⑨ PROPOSED BRIDGE
REPLACE EXISTING DECK AND WIDEN FROM 30'-0 TO 44'-0
- ⑩ TL-4 BRIDGE RAILING PROPOSED
- ⑪ UAC EXISTING BERM GRADE UNDER EXISTING BRIDGE
- ⑫ 7' WIDENING

HYDRAULIC DATA

DRAINAGE AREA = 28.9 SQ. MI.
STREAM SLOPE = 17.6 FT./MI.
AVG. LOW WATER STAGE = 687.0

Q₅₀ = 6,670 CFS
STAGE = 697.04
REGULATORY LOW BEAM = 717.26
BACKWATER = 0.13 FT.
AVG. BRIDGE VELOCITY = 8.0 FPS

Q₁₀₀ = 7,930 CFS
STAGE = 698.00
OPERATIONAL LOW BEAM = 715.45
BACKWATER = 0.17 FT.
AVG. BRIDGE VELOCITY = 8.5 FPS

Q₂₀₀ = 9,230 CFS
STAGE = 698.88
CALCULATED DESIGN SCOUR = 676.6

Q₅₀₀ = 10,800 CFS
STAGE = 699.78
AVG. BRIDGE VELOCITY = 9.5 FPS
CALCULATED CHECK SCOUR = 676.6

ROADWAY OVERTOP 719.31
STA. 102+65.56

UTILITIES LEGEND:

FO - FIBER OPTIC - CENTURY LINK
FO2 - FIBER OPTIC - ICN
W - WATER - WAPELLO RURAL WATER

UTILITIES SHOWN ON THIS SHEET ARE FOR INFORMATION ONLY, SEE ROAD DESIGN SHEETS FOR FINAL UTILITY INFORMATION.

TRAFFIC ESTIMATE

2019 AADT	6,100	V.P.D.
2039 AADT	6,800	V.P.D.
20-- DHV		V.P.H.
TRUCKS	11	%
TOTAL DESIGN ESALS		

LOCATION

US 63 OVER LITTLE SOAP CREEK
T-71N R-13W
SECTION 30
KEOKUK TOWNSHIP
WAPELLO COUNTY
FHWA NO. 50600
BRIDGE MAINT. NO. 9028.6S063
LATITUDE 40.926694°
LONGITUDE -92.409467°



PRELIMINARY

DESIGN FOR DECK REPLACEMENT AND WIDENING EXISTING 15° L.A. SKEW BRIDGE TO A

217'-6 X 44'-0 PRETENSIONED PRESTRESSED CONCRETE BEAM BRIDGE

72'-3½ END SPANS C BEAMS 72'-11 CENTER SPAN

SITUATION PLAN

STATION 100+34.67 AUGUST 2020

WAPELLO COUNTY

IOWA DEPARTMENT OF TRANSPORTATION - HIGHWAY DIVISION
DESIGN SHEET NO. 1 OF 3 FILE NO. 31997 DESIGN NO. 223

BERM SLOPE LOCATION TABLE						
SOUTH ABUTMENT			NORTH ABUTMENT			
STATION	OFFSET	ELEV	STATION	OFFSET	ELEV	
B1	99+34.85	28.17' LT	718.00	101+42.01	28.17' LT	712.50
B2	99+26.99	28.17' RT	718.00	101+33.88	28.17' RT	712.50
G1	99+14.56	50.56' LT	718.00	101+62.72	48.87' LT	712.50
G2	99+06.59	51.35' RT	718.00	101+54.73	49.17' RT	712.50
W1	99+14.56	28.17' LT	725.46	101+62.72	28.17' LT	719.40
W2	99+06.57	28.17' RT	725.75	101+54.73	28.17' RT	719.51

W - END WING / EROSION STONE
 BERM SLOPE TABLE ELEVATIONS REFLECT GRADING SURFACE

- ⑦ EXISTING REVETMENT INSTALLED AS PART OF PROJECT MB-063-5(500)29--77-90; DESIGN 120
- ⑧ IF EXISTING REVETMENT DISTURBED DUE TO BERM GRADING REINSTALL TO EXTENTS PRESENT PRIOR TO CONSTRUCTION. TOP OF REVETMENT SOUTH BANK EL. 701.0 TOP OF REVETMENT NORTH BANK EL. 705.0
- ⑨ PROPOSED BRIDGE REPLACE EXISTING DECK AND WIDEN FROM 30'-0 TO 44'-0

DO NOT GRADE BERMS UNDER EXISTING BRIDGE
 MATCH WIDTH OF EXISTING TOP OF BERM

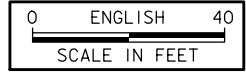
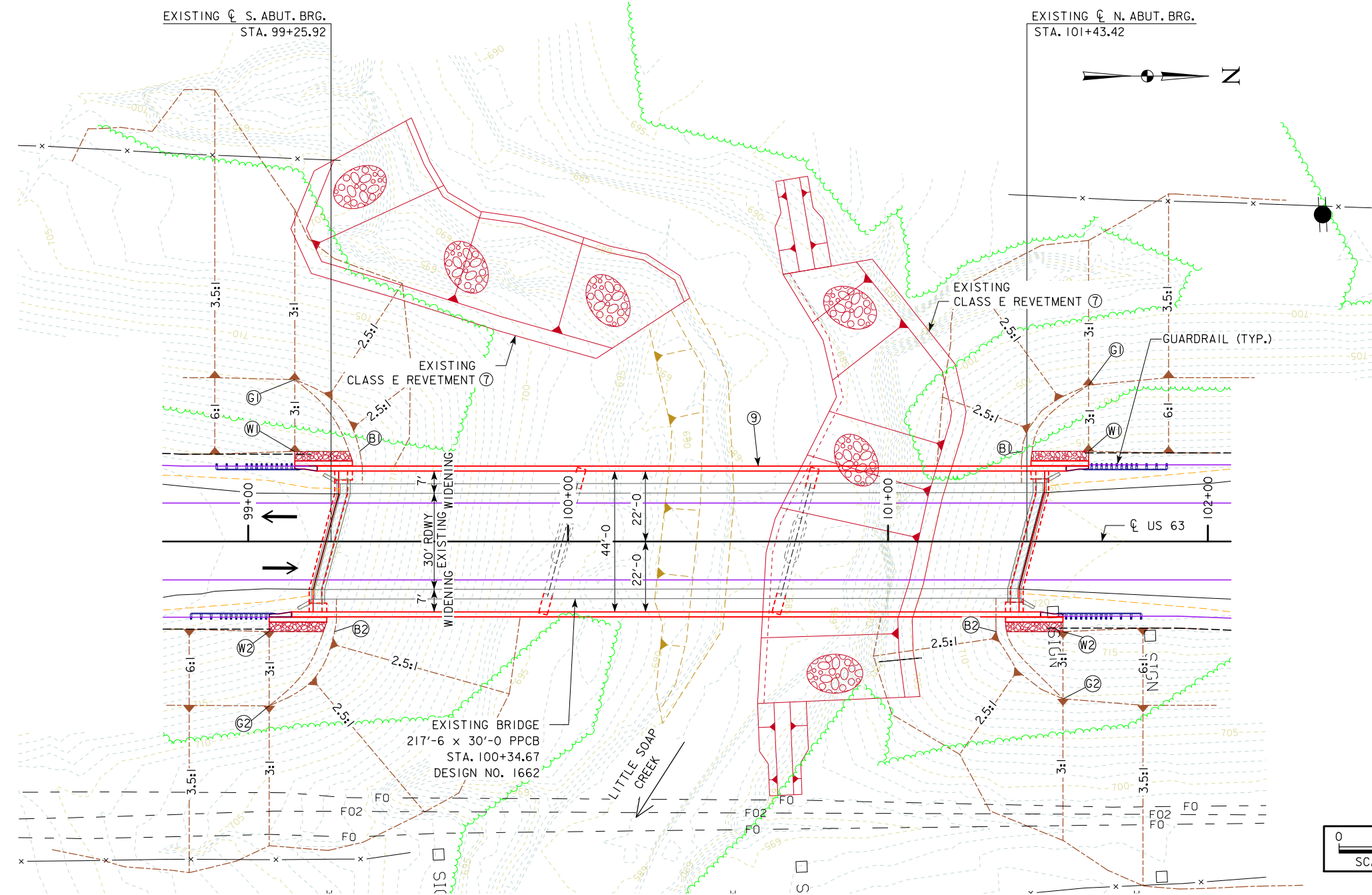

PRELIMINARY
 DESIGN FOR DECK REPLACEMENT AND WIDENING EXISTING 15° L.A. SKEW BRIDGE TO A
217'-6 X 44'-0 PRETENSIONED PRESTRESSED CONCRETE BEAM BRIDGE
 72'-3½ END SPANS C BEAMS 72'-11 CENTER SPAN
SITUATION PLAN - SITE
 STATION 100+34.67 AUGUST 2020
WAPELLO COUNTY
 IOWA DEPARTMENT OF TRANSPORTATION - HIGHWAY DIVISION
 DESIGN SHEET NO. 2 OF 3 FILE NO. 31997 DESIGN NO. 223

SITE PLAN

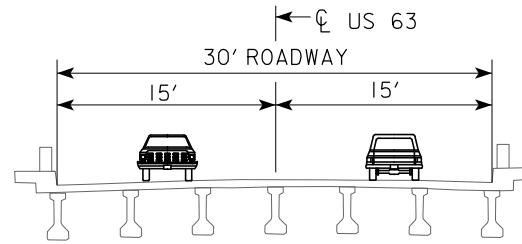

EXISTING SECTION

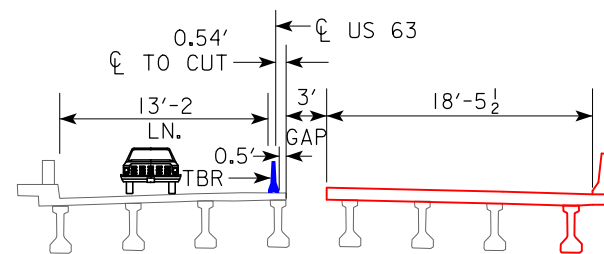

STAGE I

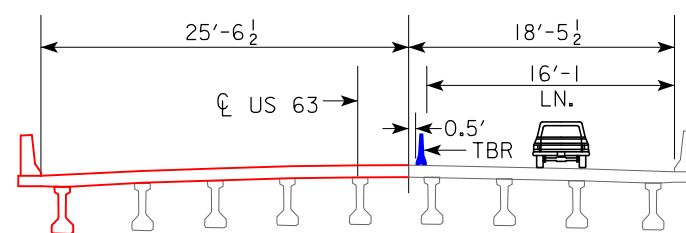

STAGE 2

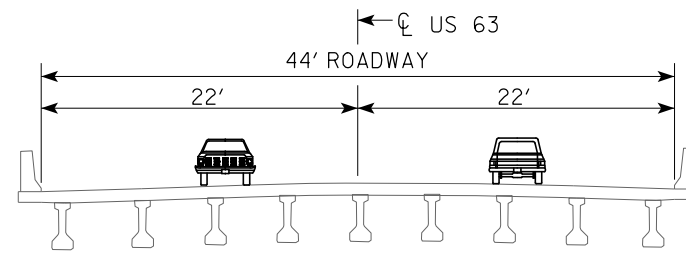

FINISHED SECTION

STAGING DETAILS
NOT TO SCALE

- DRIVING SURFACE
- UNDER CONSTRUCTION
- ALL SECTIONS LOOKING NORTH

PRELIMINARY

DESIGN FOR DECK REPLACEMENT AND WIDENING EXISTING 15° L.A. SKEW BRIDGE TO A

**217'-6 X 44'-0 PRETENSIONED
PRESTRESSED CONCRETE BEAM BRIDGE**

72'-3 1/2 END SPANS C BEAMS 72'-11 CENTER SPAN

STAGING DETAILS

STATION 100+34.67 AUGUST 2020

WAPELLO COUNTY

IOWA DEPARTMENT OF TRANSPORTATION - HIGHWAY DIVISION

DESIGN SHEET NO. 3 OF 3 FILE NO. 31997 DESIGN NO. 223

US 63 Preliminary

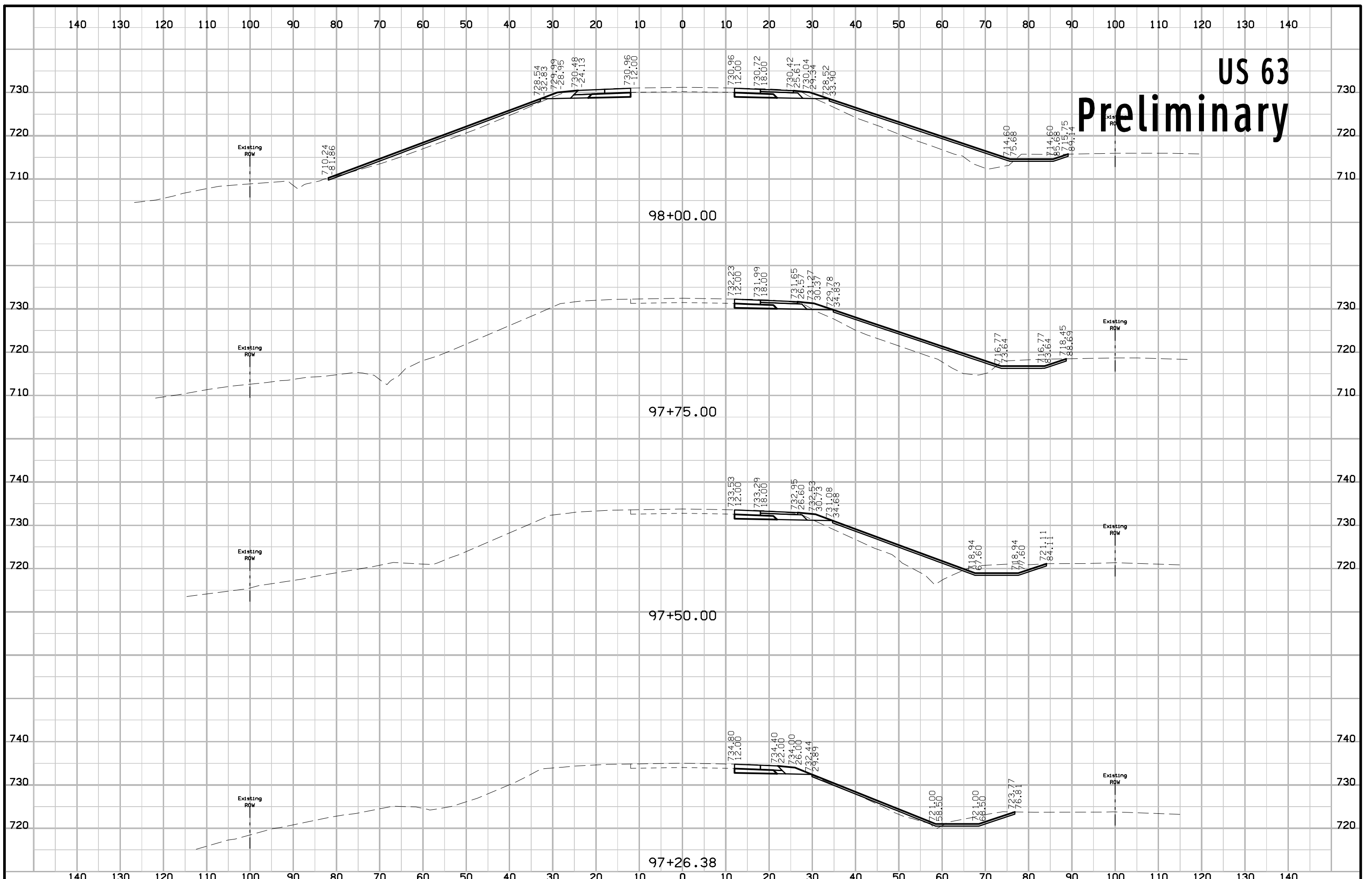

US 63 Preliminary

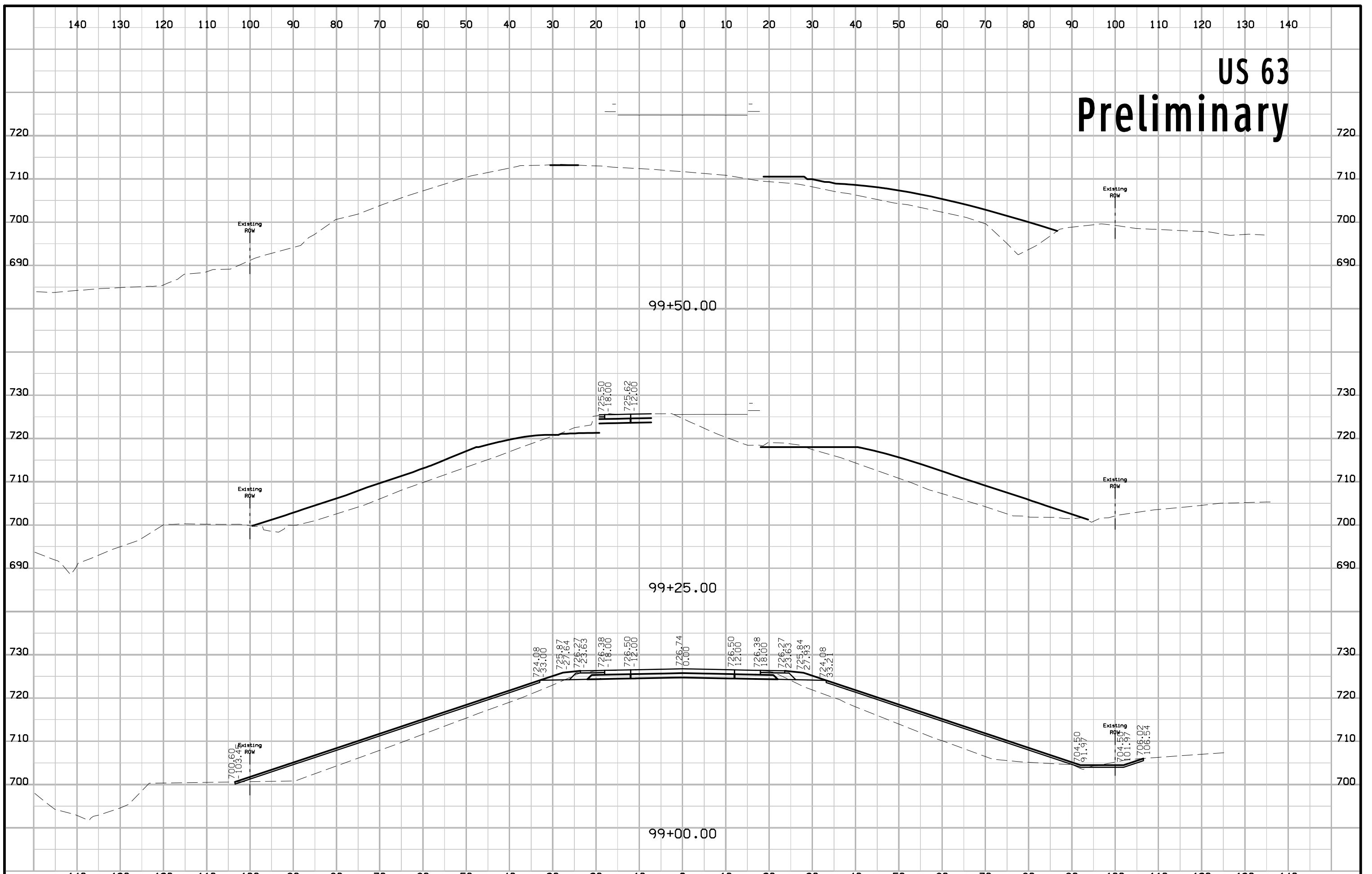

US 63 Preliminary

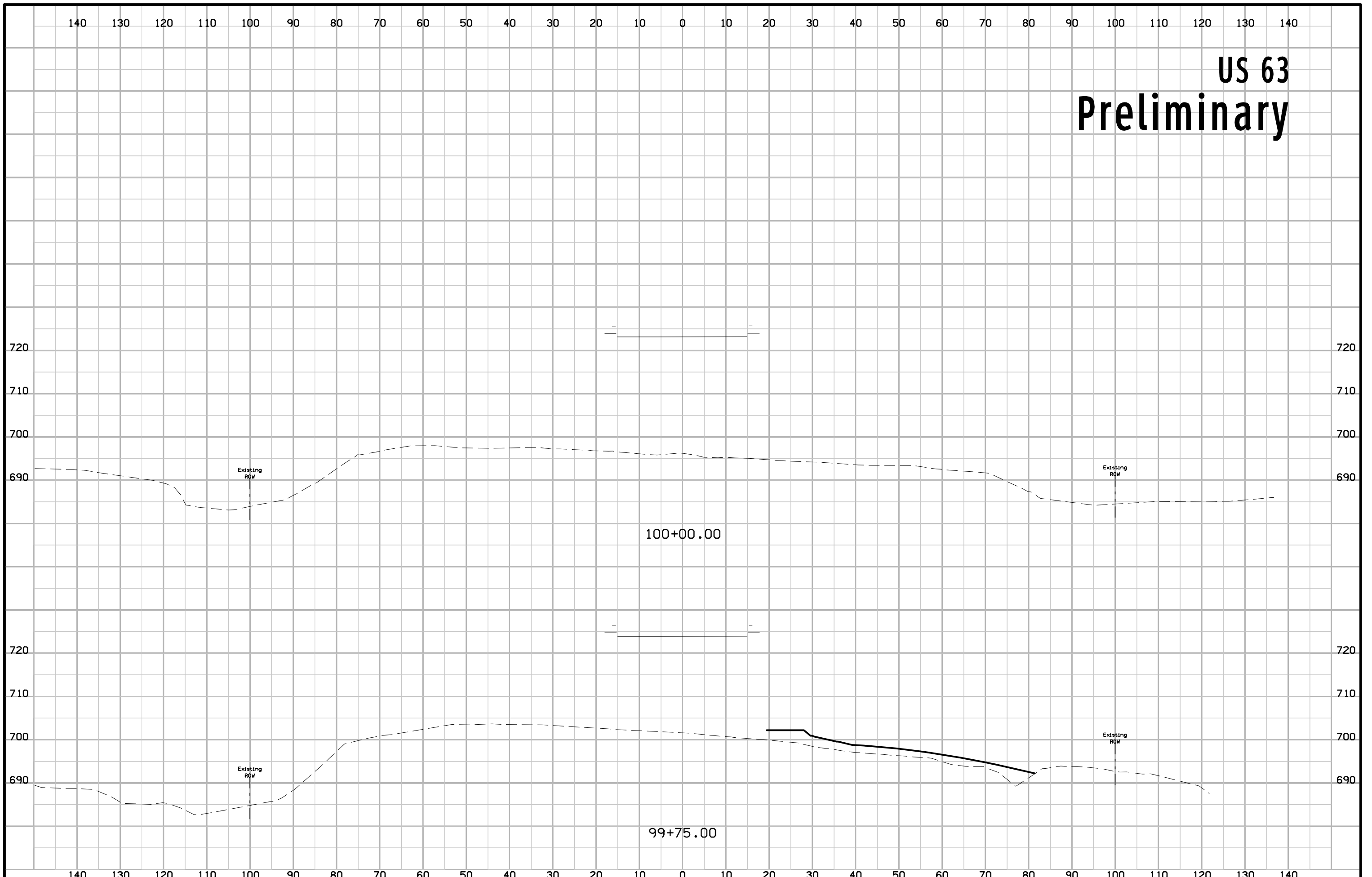

US 63 Preliminary

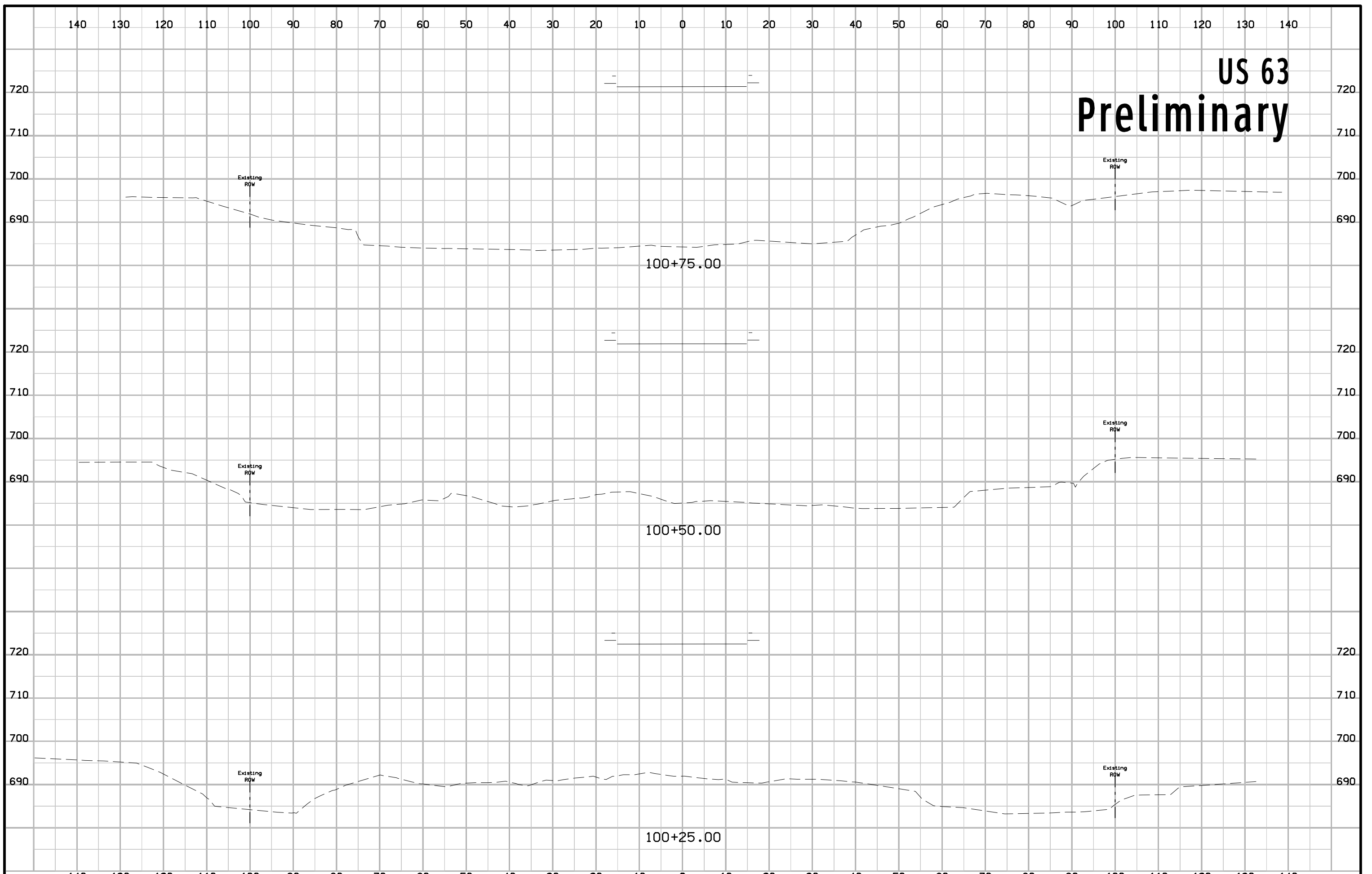

US 63 Preliminary

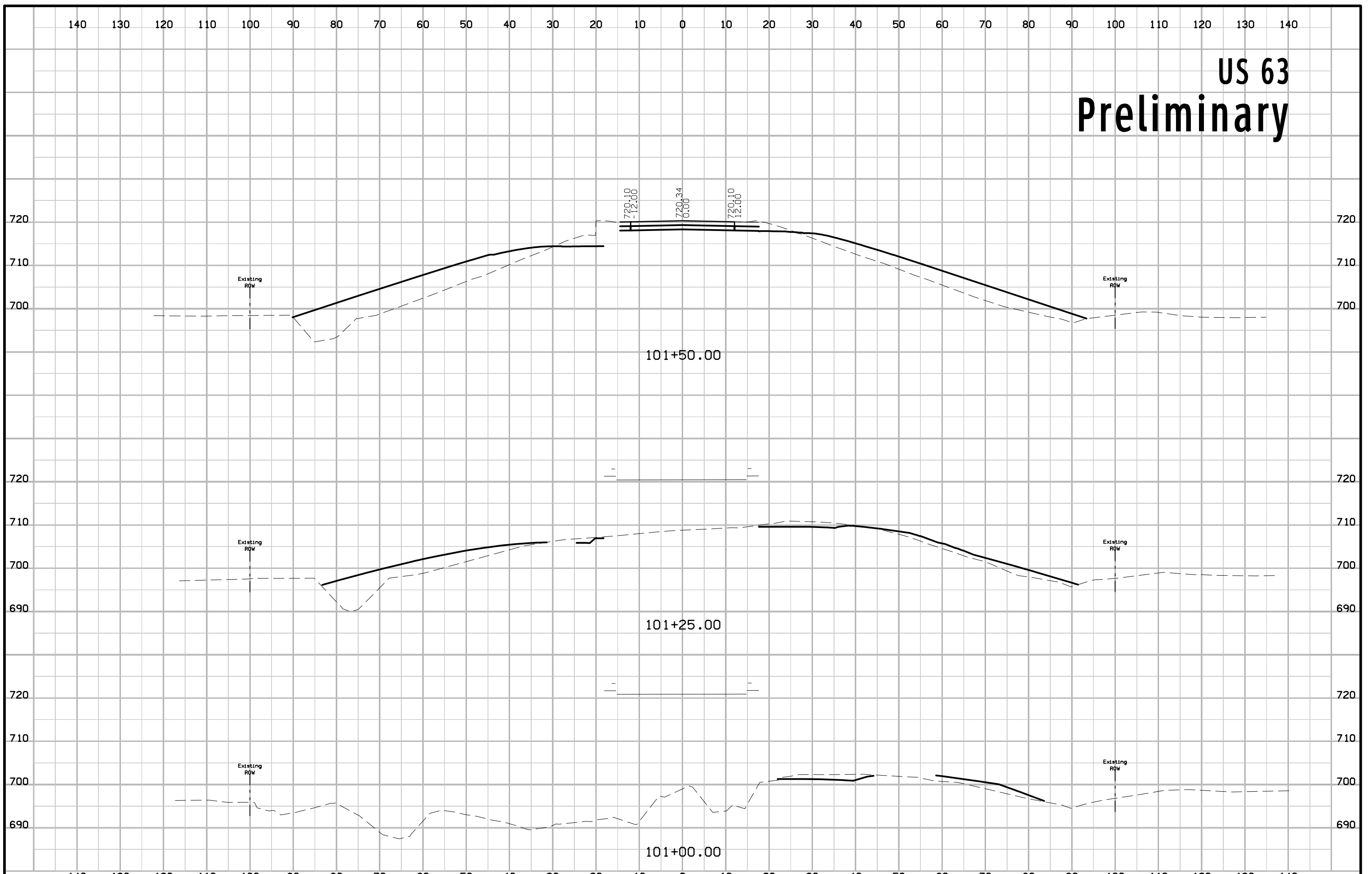

US 63 Preliminary

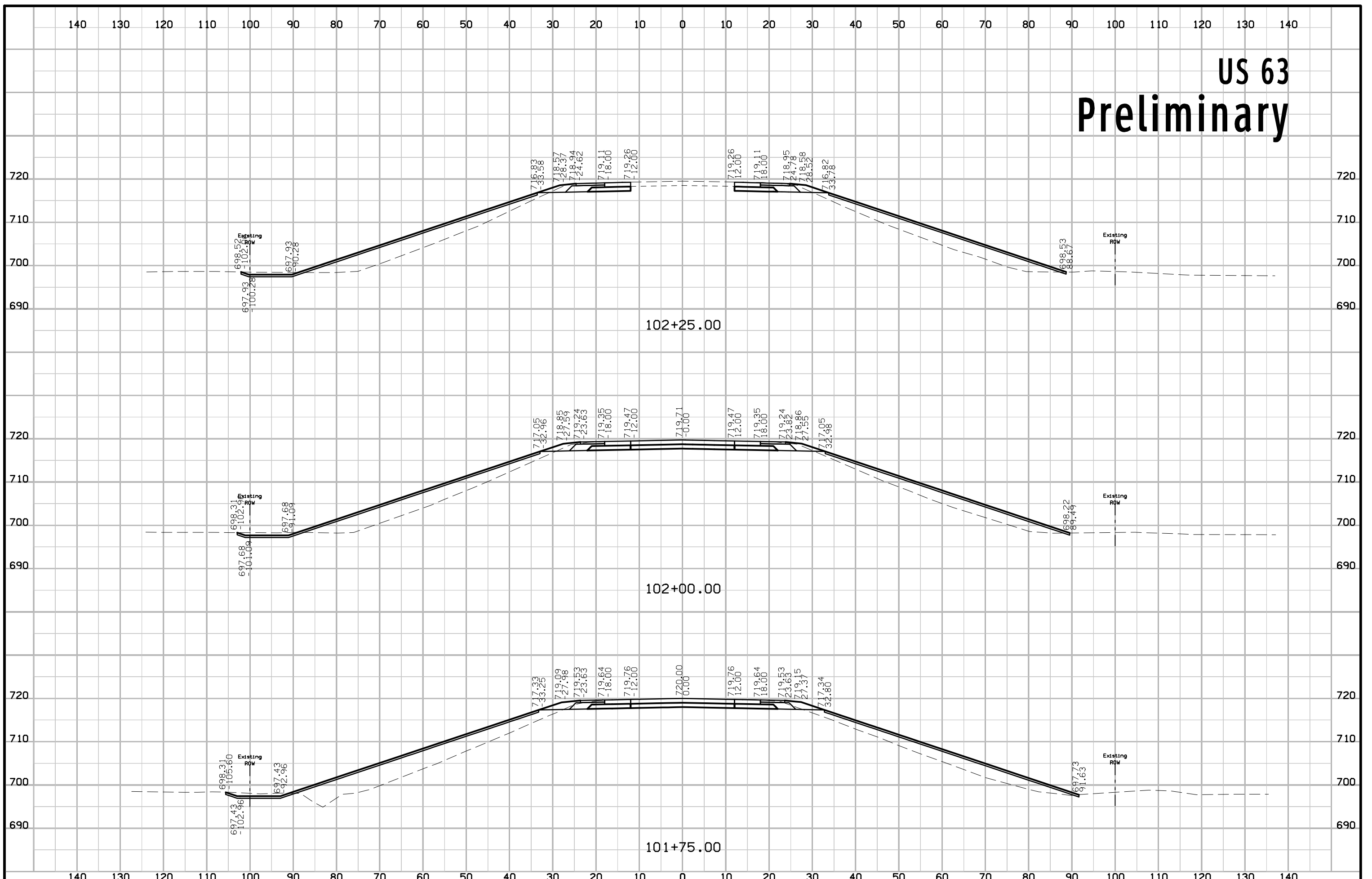

US 63 Preliminary

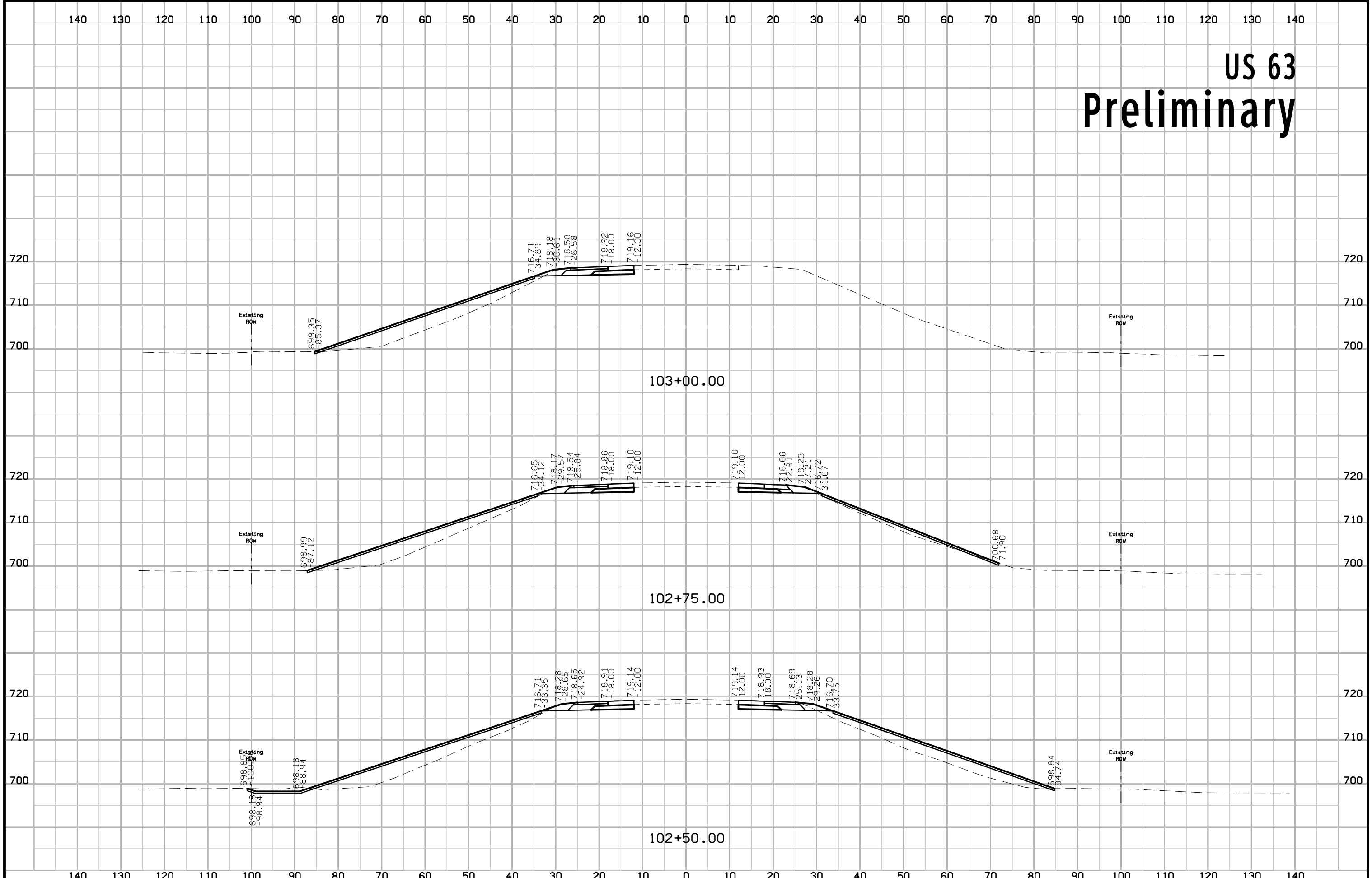

US 63 Preliminary

