

INDEX OF SHEETS	
No.	DESCRIPTION
A Sheets	Title Sheets
A.1	Title Sheet
A.2	Location Map Sheet
B Sheets	Typical Cross Sections and Details
B.1	Typical Cross Sections and Details
C Sheets	Quantities and General Information
C.1	Estimated Project Quantities and Reference Notes
C.2	Project Description
C.2 - 3	Tabulations
C.3	Standard Road Plans
D Sheets	Mainline Plan and Profile Sheets
D.1	Plan & Profile Legend & Symbol Information Sheet
F Sheets	Detour or Temporary Pavement Sheets
F.1 - 3	Detour Plan and Profile Sheets
G Sheets	Survey Sheets
G.1 - 3	Reference Ties and Bench Marks
G.4	Horizontal Control Tab. & Super for all Alignments
J Sheets	Traffic Control and Staging Sheets
J.1	Traffic Control Plan
J.1	511 Travel Restrictions
J.1	Coordinated Operations
L Sheets	Geometric, Staking and Jointing Sheets
L.1	Jointing & Geometrics Legend & Symbol Information Sheet
L.2 - 6	Jointing Sheets
R Sheets	Erosion Control Sheets
RC.1 - 5	Est. Quantities, PPP, General Notes and Tabulations
U Sheets	500 Series, Mod.Stds. and Detail Sheets
U.1	500 Series, Modified Standards and Detail Sheets
W Sheets	Mainline Cross Sections
W.1	Cross Sections Legend & Symbol Information Sheet
W.2 - 35	Mainline Cross Sections



PLANS OF PROPOSED IMPROVEMENT ON THE
PRIMARY ROAD SYSTEM
Mahaska COUNTY
 PCC Pavement - Grade and New
 N of Co Rd G63 to S of
 293rd St - Various Locations (Crossovers)

SCALES: As Noted

Refer to the Proposal Form for list of applicable specifications.

Value Engineering Saves. Refer to Article 1105.14 of the Specifications.



REVISIONS

TOTAL

62

PROJECT IDENTIFICATION NUMBER
25-62-063-010
PROJECT NUMBER
NHSN-063-3(110)--2R-62
R.O.W. PROJECT NUMBER

INDEX OF SEALS			
SHEET NO.	NAME	TYPE	BID QUANTITY SHEETS
A.1	Kyle Schrock	Roadway Design	C.1
RC.1	Rachel Harris	Landscape Design	RC.2

ROADWAY DESIGN



My license renewal date is December 31, 2025

Pages or sheets covered by this seal: A.1-2, B.1, C.1-3, D.1, F.1-3, G.1-4, L.1-6, U.1, W.1-34

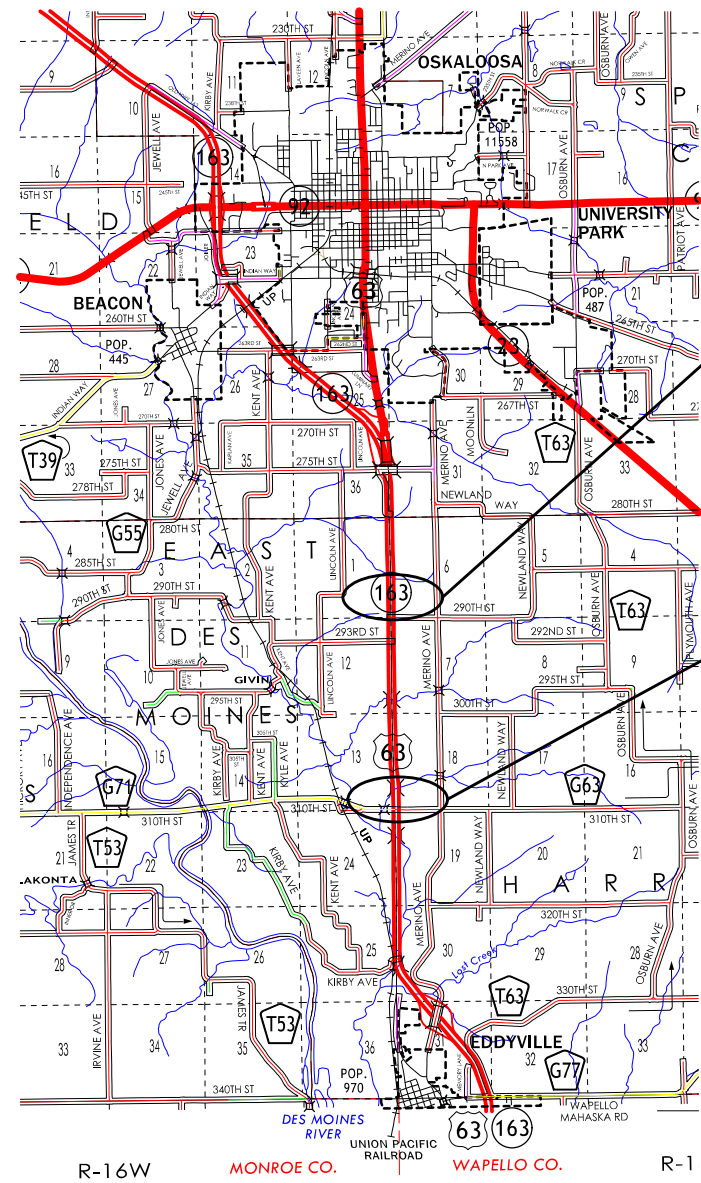

NORTH CROSSOVER
 Sta. 1384+66.45
 M.P. 59.45

SOUTH CROSSOVER
 Sta. 1267+73.87
 M.P. 57.20

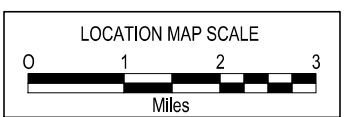
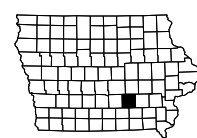

ESTIMATED PROJECT QUANTITIES AND REFERENCE NOTES

Roadway Items : Roadway Items

Item no.	Item Code	Item	Unit	Quantities		Estimate Reference Notes
				Estimated	Roadway Items	
1	2102-0425070	SPECIAL BACKFILL	TON	2,753.6		Refer to Typical on B-sheets and Tab. 112-8 on C-sheets.
2	2102-2710070	EXCAVATION, CLASS 10, ROADWAY AND BORROW	CY	2,270		Refer to Tab. 112-8 on C-sheets.
3	2102-2713090	EXCAVATION, CLASS 13, WASTE	CY	219		
4	2121-7425020	GRANULAR SHOULDERS, TYPE B	TON	290.1		Refer to Typical on B-sheets and Tab. 112-8 on C-sheets.
5	2304-0100000	DETOUR PAVEMENT	SY	6,907.5		Refer to Typical on B-sheets and Tab. 112-8 on C-sheets. Detour Pavement shall be 9" PCC.
6	2402-2720100	EXCAVATION, CLASS 20, FOR ROADWAY PIPE CULVERT	CY	7		Refer to Tab. 104-3 on C-sheets.
7	2417-2307036	DRAIN, CORRUGATED METAL SLOTTED PIPE, 36 IN., W/6 IN. GRATE	LF	96		Refer to Tab. 112-8 on C-sheets.
8	2417-5895018	BEVELED PIPE AND GUARD, 18 INCH	EACH	2		
9	2422-0360018	APRONS, UNCLASSIFIED, 18 IN. DIA.	EACH	4		Refer to Tab. 104-3 on C-sheets.
10	2422-1723018	CULVERT, UNCLASSIFIED ROADWAY PIPE, 18 IN. DIA.	LF	302		Refer Tab. 104-3 and 112-8 on C-sheets.
11	2510-6745850	REMOVAL OF PAVEMENT	SY	1,432.4		Refer to Tabs. 112-8 and 102-5 on C-sheets.
12	2526-8285000	CONSTRUCTION SURVEY	LS	1		
13	2528-2518005	CROSSOVER BARRICADE	EACH	2		Refer to U-sheets for Details of Barricade at Crossover.
14	2528-8445110	TRAFFIC CONTROL	LS	1		Refer to Traffic Control Plan on J-sheets.
15	2533-4980005	MOBILIZATION	LS	1		--

100-1D
10-18-05

PROJECT DESCRIPTION

This Project is to place crossovers for a future project on US 63 in Mahaska County south of Oskaloosa.

102-5
04-18-17

EXISTING PAVEMENT

No.	Location					Year	Type	Project Number	Surface		Base		Subbase		Removal		Coarse Aggregate			Reinforcement	Remarks			
	County	Route	Dir. of Travel	Begin Ref. Loc. Sign	End Ref. Loc. Sign				Type	Depth	Type	Depth	Type	Depth	Type	Depth	Type	Depth	Source			Type	Durability Class	Type
	Mahaska	US-63	SB	56.79	60.33	1998		NHS-137-3(19)--19-62	PCC	10	GSB	10					SULLY	C. LST.	1					
	Mahaska	US-63	NB	57.94	58.92	2017	M	MP-63-5(709)34--76-90	PCC	10.5											PCC Patching			
	Mahaska	US-63	NB	57.94	58.92	1995		NHS-137-3(22)--19-62	AAC	2	AAC	4.5					HARSCO/HECKETT	SLAG			WIDEN 1.1M			
	Mahaska	US-63	NB	57.94	58.92	1949		F-146(3)	PC8	8							EDDYVILLE	Gravel	2					
	Mahaska	US-63	NB	58.92	60.11	2021	M	MP-063-5(711)34--76-90													PCC Patching			
	Mahaska	US-63	NB	58.92	60.11	2019	M	MP-063-5(710)34--76-90													PCC Patching			
	Mahaska	US-63	NB	58.92	60.11	2017	M	MP-63-5(709)34--76-90	PCC	10.5											PCC Patching			
	Mahaska	US-63	NB	58.92	60.11	1995		NHS-137-3(22)--19-62	AAC	2	AAC	2					HARSCO/HECKETT	SLAG						
	Mahaska	US-63	NB	58.92	60.11	1963		F-146(7)	PCC	9							LANGSTRATT	C. LST.	3					

104-3
10-17-17

DRAINAGE STRUCTURE BY ROAD CONTRACTOR

Length of unclassified pipe calculated is based on using Reinforced Concrete Pipe.

- * Not a bid item
- ① Diameter or equivalent diameter
- ② UNCL = Unclassified Pipe CMP = Corrugated Metal Pipe RCP = Reinforced Concrete Pipe LCP = Arch or Elliptical Low Clearance Pipe SARC = Steel Arch Pipe
- ③ Backfill according to DR-101

Drainage Area	Location	Type	Size	Kind Of Pipe	Length New Const.	Bedding Class	Design Cover (H)		Apron No.	Apron Guard* (DR-213)	Elbow* (DR-141)	Diaphragm* (DR-501)	Tee Section* (DR-142)	"D" Section* (DR-141)	Reducer*	Type 'C' Connections* (DR-122)	Connected Pipe Joint* (DR-121)	4" Perforated Subdrain*	Flow Line Elevations				Dimensions Lin. Ft.		Skew Ahead Degrees		Dike			Class 20	Flowable Mortar	Floodable* Backfill	Porous* Backfill	Flooded Backfill	Remarks					
							FT	FT											Lt.	Rt.	Other	Other	Lt.	Rt.	Lt.	Rt.	Type	CY	CY							CY	CY			
							IN	OUT																														Total	Extensions	Rt.
ACRE			IN		LF				No.	No.	No.	No.	No.	No.	Type	No.	Type	FT	Lt.	Rt.	Other	Other	Lt.	Rt.	Lt.	Rt.	Lt.	Rt.	Lt.											
	3383+49.49	DR-651	18	UNCL	54	C	1.5	0.08	1	1									796.10	794.40			12.2	41.8			46													
	3386+75.36	DR-651	18	UNCL	76	C	1.0	0.08	1	1									790.80	791.10			12.0	64.0			63													

112-8
04-15-14

MEDIAN CROSSOVERS

Refer to PV-500 Series.

* Not a bid item

Road Ident.	Location Station	Standard Road Plan	Detour Pavement	Special Backfill	Granular Shoulder	Embankment in Place	Class 10 Excavation	Class 13 Waste	Removal of Pavement	Saw Cut*	18" Unclassified Roadway Pipe	36" CMP Slotted Drain/6" Grate	Beveled Pipe and Guard	Remarks
US 63	1267+73.87	See F.1	3011.4	1143.5	98.0		570.0	219.0	812.1	1638.0	172.0	96.0	2	
US 63	1384+66.45	See F.2	3896.1	1610.1	192.1		1700.0		620.3	1357.0	See Tab. 104-3 on C-sheets			
Totals			6907.5	2753.6	290.1	0.0	2270.0	219.0	1432.4	2995.0	172.0	96.0	2	

105-4
10-18-11

STANDARD ROAD PLANS

The following Standard Road Plans apply to construction work on this project.

Number	Date	Title
DR-101	04-18-17	Pipe Culvert (Bedding and Backfill)
DR-102	04-21-15	Pipe Culvert (Cover and Camber)
DR-103	04-21-15	Pipe Culvert (Installation Details)
DR-104	04-19-16	Depth of Cover Tables for Concrete and Corrugated Pipe
DR-121	04-18-23	Connected Pipe Joints
DR-203	04-21-20	Metal Pipe Aprons and Beveled Ends
DR-212	04-21-20	Beveled Pipe and Guard
DR-502	10-21-25	Slotted Drain for Median Crossovers
DR-651	04-18-17	Unclassified Pipe Culvert
PV-101	10-21-25	Joints
TC-1	10-15-19	Work Not Affecting Traffic (Two-Lane or Multi-Lane)
TC-402	04-18-23	Work Within 15 ft of Traveled Way
TC-418	04-18-23	Lane Closure on Divided Highway

262-6
10-18-05

UTILITIES (NOT A POINT 25 PROJECT)

This is NOT a POINT 25 project and is not subject to the provisions of IAC 761-115.25.

SURVEY SYMBOLS

- Interstate Highway Symbol
- U.S. Highway Symbol
- Iowa Highway Symbol
- County Road Highway Symbol
- Evergreen Tree
- Deciduous Tree
- Fruit Tree
- Shrub (Bushes)
- Timber
- Hedge
- Stump
- Swamp
- Rock Outcrop
- Broken Concrete
- Revetment (Rip Rap)
- Cemetery
- Grave
- Cave
- Sink Hole
- Board Fence
- Chain Link or Security Fence
- Wire Fence
- Terrace
- Earth Dam or Dike (Existing)
- Tile Outlet
- Edge of Water
- Existing Drainage
- Right of Way Rail or Lot Corner
- Concrete Monument
- Well
- Windmill
- Beehive Intake
- Existing Intake
- Existing Utility Access (Manhole)
- Fire Hydrant
- Water Hydrant (Rural)
- Septic Tank
- Cistern
- L.P. Gas Tank (No Footing)
- Underground Storage Tank
- Latrine
- Satellite TV Dish
- Water Hook Up
- Radio Tower
- Tower Anchor
- Guardrail (Beam or Cable)
- Guard Post (one or two)
- Guard Post (over two)
- Filler Pipe
- Gas Valve
- Water Valve
- Speed Limit Sign
- Mile Marker Post
- Sign
- Traffic Signal Control Box
- Rail Road Signal Control Box
- Telephone Switch Box
- Electric Box

UTILITY LEGEND

PLAN VIEW COLOR LEGEND OF PLAN AND PROFILE SHEETS

LINEWORK		Design Color No.		
Green	(2)		Existing Topographic Features and Labels	
Blue	(1)		Proposed Alignment, Stationing, Tic Marks, and Alignment Annotation	
Magenta	(5)		Existing Utilities	
SHADING		Design Color No.		Transparency
Pink, Dark	(13)		Temporary Pavement Shading	50%
Yellow	(4)		Proposed Pavement Shading	50%
Orange	(6)		Proposed Granular Shading	50%
Orange	(70)		Proposed Shoulder Granular Shading	50%
Yellow	(68)		Proposed Shoulder Paved Full Depth Shading	50%
Yellow	(132)		Proposed Shoulder Paved Partial Depth Shading	50%
Brown, Light	(236)		Grading Shading	50%
Orange, Light	(134)		Proposed Granular Entrance Shading	50%
Yellow	(220)		Proposed Paved Entrance Shading	50%
Tan	(8)		Proposed Sidewalk Shading	50%
Blue, Light	(230)		Proposed Sidewalk Landing Shading	50%
Pink	(11)		Proposed Sidewalk Ramp Shading	50%
Red	(3)		Proposed Structure Shading	50%
Red	(3)		Delineates Restricted Areas	0%

PROFILE VIEW COLOR LEGEND OF PLAN AND PROFILE SHEETS

LINEWORK		Design Color No.	
Green	(10)		Existing Ground Line Profile
Blue	(1)		Proposed Profile and Annotation
Magenta	(5)		Existing Utilities
Blue, Light	(230)		Proposed Ditch Grades, Left
Black	(0)		Proposed Ditch Grades, Median
Rust	(14)		Proposed Ditch Grades, Right

- Reference Point
- Station
- Survey Line
- Section Corner
- Ground Line Intercept
- Saw Cut
- Guardrail
- Trench Drain
- HighTension Cable Guardrail
- Sheet Pile
- Pavement Removal
- Clearing & Grubbing Area

RIGHT-OF-WAY LEGEND

- Proposed Right-of-Way Symbol
- Proposed Right-of-Way Line
- Existing Right of Way
- Existing and Proposed Right-of-Way
- Easement and Existing Right-of-Way
- Easement (Temporary) Symbol
- Easement (Temporary) Line
- Easement
- C/A Access Control
- Property Line Symbol
- Property Line

PLAN AND PROFILE LEGEND AND SYMBOL INFORMATION SHEET

(COVERS SHEET SERIES D, E, F, & K)

East Des Moines TWP.
T-74N R-16W
SEC. 13

Sta. 1271+26.62
Skew 15° RT AH
10'x10'x236' RCB
D.A.=2061 A-R Plans
U.A.C.



$\Delta = 05^{\circ}06'46.32''$ (LT)
T = 344.08'
L = 687.69'
R = 7706.43'
E = 7.68'

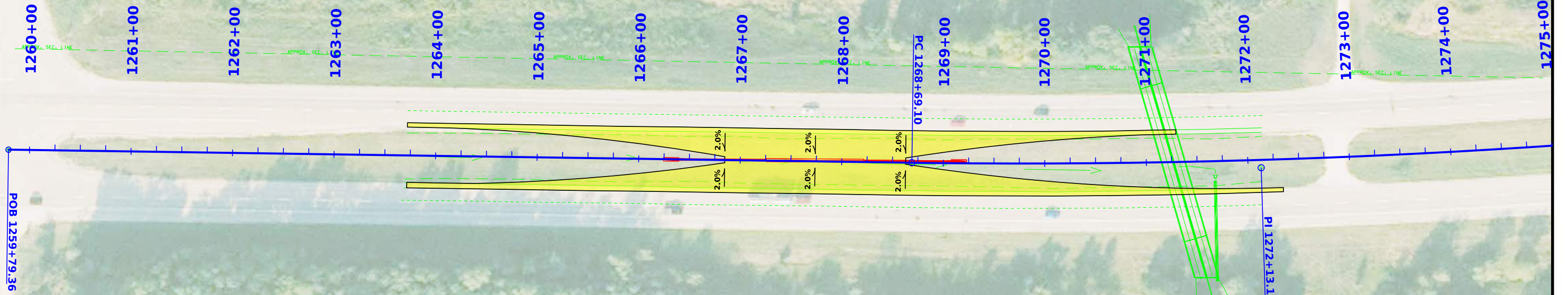

Harrison TWP.
T-74N R-15W
SEC. 18

Sta. 1271+67.57, 19.46 Rt.
24"x 98.6' RCP
D.A.=Median Only
U.A.C.

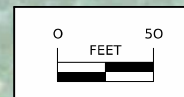

East Des Moines TWP.
T-74N R-16W
SEC. 1

Sta. 1388+59.77, 1.03 Lt.
24"x70' RCP W/ Plastic Ext.
D.A.=Median Only
U.A.C.



$\Delta = 14^{\circ}08'05.24''$ (LT)
T = 247.96'
L = 493.40'
R = 2000.00'
E = 15.31'

$\Delta = 13^{\circ}15'25.84''$ (LT)
T = 232.42'
L = 462.76'
R = 2000.00'
E = 13.46'

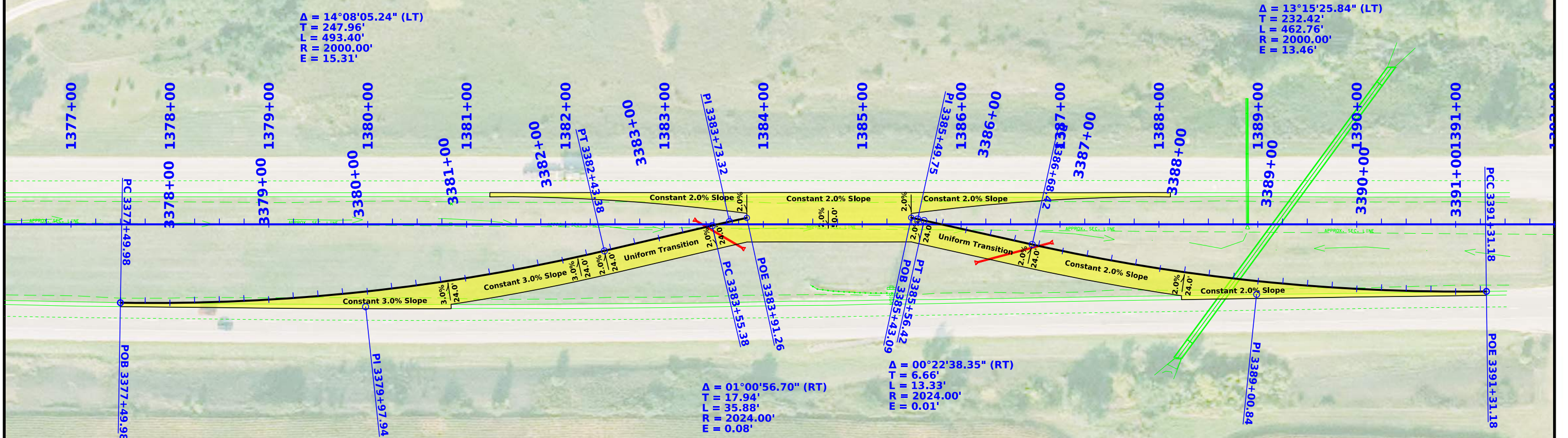

$\Delta = 01^{\circ}00'56.70''$ (RT)
T = 17.94'
L = 35.88'
R = 2024.00'
E = 0.08'

$\Delta = 00^{\circ}22'38.35''$ (RT)
T = 6.66'
L = 13.33'
R = 2024.00'
E = 0.01'

3383+49.49
Install 18"x54' UNCL
FL = Lt. 796.10
Rt. 794.40

3386+75.36
Install 18"x76' UNCL
FL = Lt. 790.80
Rt. 791.10

Harrison TWP.
T-74N R-15W
SEC. 6

Sta. 1388+88.69
Skew 36°11' LT AH
6'x8'x364.9' RCB
D.A.=243 A-H to R Plans
U.A.C.

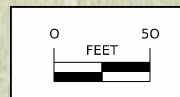



Survey Information

SURVEY INDEX

County : Mahaska
Project Code : 25-62-063-010
Phase Number : NHSX-063-3(108)--3H-62
Location : N of Co Rd G63 to S of 293rd St - Various Locations
Work Code : 1012-PCC Pavement - Replace
Project Directory : 6206301025

Survey Personnel

Clayton Henningsen – Survey Party Chief
Jason Arn – Survey Party Chief

Date(s) of Survey

Begin Date 03/12/2025
End Date 03/31/2025

General Information

This survey is for US Hwy 63 at locations N of Co Rd G63 to S of 293rd St. This survey request was for the US Hwy 63 corridor only. This project is a Full Field DTM survey.

Utility Information

For logging data and other utility details see Utility Survey and Ownership Report in the Utility folder of the PrelimSurvey project directory.

Project Control

Coordinates were determined for primary project control points by conducting concurrent six-hour static observations. Post processing is constrained to nearby Iowa Real Time Network reference stations. For additional details of the control survey, contact the Preliminary Survey department.

PROJECT DATUM: NAD83(2011) for EPOCH 2010.00 (IaRTN 2019 ADJUSTMENT)
COORDINATE SYSTEM: IOWA REGIONAL COORDINATE SYSTEM ZONE 09
(U.S. SURVEY FOOT)
VERTICAL DATUM: NAVD88
GEOID MODEL: 2018u3

Alignment Information

The horizontal alignments for U.S. Hwy 63 this survey is a retrace of PCC Plans No. NHS-137-3(19)—19-62. Survey stationing for SURMLA063 was equated to the plan POT at Sta. 1259+79.36 and carried ahead without equation throughout the south survey area. Survey stationing for SURMLB063 was equated to the plan POT at Sta. 1367+49.54 and carried ahead without equation throughout the south survey area. All points provided by district survey 5.

Survey stationing relates to as built plan stationing as follows:

SURMLA063

POT Sta. 1259+79.36 PCC Plans No. NHS-137-3(19)—19-62
Survey POT Sta. 1259+79.36

PC Sta. 1268+69.09 PCC Plans No. NHS-137-3(19)—19-62
Survey PC Sta. 1268+69.10

PT Sta. 1275+56.82 PCC Plans No. NHS-137-3(19)—19-62
Survey PT Sta. 1275+56.80

SURMLB063

POT Sta. 1367+49.54 PCC Plans No. NHS-137-3(19)—19-62
Survey POT Sta. 1367+49.54

POT Sta. 1401+05.21 PCC Plans No. NHS-137-3(19)—19-62
Survey POT Sta. 1401+05.13

CONTROL POINT VICINITY MAP

This map is a guide to the vicinity of the primary project control points. Primary control is for use with RTK base stations and for RTN validation. Future surveys will use primary project control to establish temporary control as needed for construction or other surveying applications.

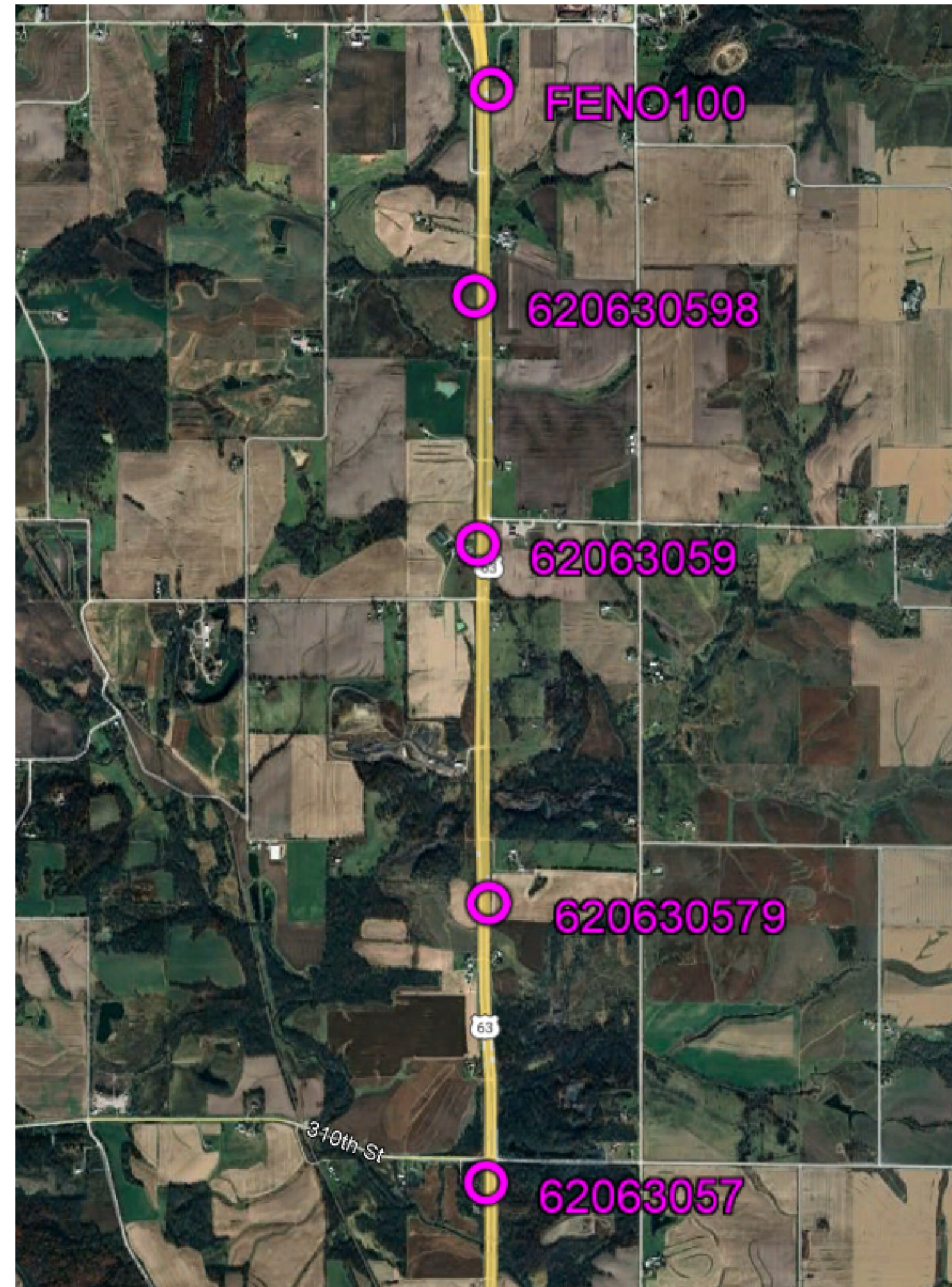

HORIZ. DATUM: NAD83(2011) for EPOCH 2010.00 (IaRTN 2019 Adjustment) - Iowa RCS Zone 09 (U.S. Survey Foot)

VERT. DATUM: NAVD88 - Geoid Model: 2018u3

Coordinate listing from next sheet will be used with IaRTN for monument recovery. No other reference ties are given.

HORIZONTAL AND VERTICAL PROJECT CONTROL COORDINATE LISTING
 HORIZ. DATUM: NAD83(2011) for EPOCH 2010.00 (IaRTN 2019 Adjustment)
 Ia. Regional Coordinate System Zone 09 (U.S. Survey Foot)
 VERT. DATUM: NAVD88
 Geoid Model: 2018u3

<u>Point Name</u>	<u>Northing</u>	<u>Easting</u>	<u>Elevation</u>	<u>Feature Definition-Description</u>
62063057	7547586.96	19548513.50	711.02	CP FENO MONUMENT
62063059	7558123.89	19548300.42	810.44	CP FENO MONUMENT
620630579	7552217.27	19548517.30	765.55	CP FENO MONUMENT
620630598	7562204.58	19548275.97	813.02	CP FENO MONUMENT
FENO100	7565613.06	19548466.78	816.87	CP FENO MONUMENT

ALIGNMENT COORDINATES

Name	Location	Point on Tangent			Begin Spiral			Begin Curve			Simple Curve PI or Master PI of SCS			End Curve			End Spiral		
		Station	Coordinates		Station	Coordinates		Station	Coordinates		Station	Coordinates		Station	Coordinates		Station	Coordinates	
			Y (Northing)	X (Easting)		Y (Northing)	X (Easting)		Y (Northing)	X (Easting)		Y (Northing)	X (Easting)		Y (Northing)	X (Easting)		Y (Northing)	X (Easting)
1	ML063_S	1259+79.36	7547985.31	19548594.62															
2	ML063_S						1268+69.10	7548875.05	19548590.44	1272+13.18	7549219.12	19548588.78	1275+56.80	7549561.67	19548556.47				
1	ML063_N	1367+79.36	7558748.41	19548386.51															
1	ML063_N	1401+34.95	7562103.90	19548360.68															
1	X03377						3377+49.98	7559719.61	19548458.39	3379+97.94	7559967.56	19548460.59	3382+43.38	7560208.54	19548402.17				
3	X03377						3383+55.38	7560317.39	19548375.79	3383+73.32	7560334.82	19548371.56	3383+91.26	7560352.33	19548367.64				
1	X03385						3385+43.09	7560518.48	19548366.21	3385+49.75	7560525.01	19548367.56	3385+56.42	7560531.53	19548368.96				
3	X03385						3386+68.42	7560641.04	19548392.42	3389+00.84	7560868.31	19548441.10	3391+31.18	7561100.68	19548436.36				

SPIRAL OR CIRCULAR CURVE DATA

Name	Location	ΔSCS	Horizontal Alignment Data												Remarks			
			Spiral Data						Curve Data									
			θS	Ls	Ts	Es	Xc	Yc	L.T.	S.T.	ΔC	T	L	R		E		
C1	ML063_S												5.113	344.075	687.694	7706.435	7.677	
C1	X03377												14.135	247.957	493.397	2000.000	15.312	
C2	X03377												1.016	17.941	35.882	2024.000	0.080	
C1	X03385												0.377	6.664	13.329	2024.000	0.011	
C2	X03385												13.257	232.419	462.763	2000.000	13.459	

PLAN VIEW COLOR LEGEND OF JOINTING SHEETS

Design Color No.	Feature
(1)	Proposed Alignment, Stationing, Tic Marks, and Alignment Annotation
(55)	B Joint
(71)	C Joint
(77)	CD Joint
(76)	CT Joint
(76)	DW Joint
(76)	HT Joint
(77)	RD Joint
(76)	RT Joint
(130)	CF-1 Joint
(130)	CF-2 Joint
(130)	CF-3 Joint
(130)	CF-4 Joint
(72)	E Joint
(142)	ED Joint
(142)	EE Joint
(142)	EF Joint
(72)	ES Joint
(64)	BT-1 Joint
(64)	BT-2 Joint
(128)	BT-3 Joint
(128)	BT-4 Joint
(128)	BT-5 Joint
(128)	BT-6 Joint
(79)	K Joint
(70)	KS-1 Joint
(70)	KS-2 Joint
(143)	KT-1 Joint
(143)	KT-2 Joint
(143)	KT-3 Joint
(138)	L-1 Joint
(138)	L-2 Joint
(138)	L-3 Joint

JOINTING NOTES:

All longitudinal joints shall be either KT-2 or L-2 unless indicated otherwise.
 All transverse joints shall be CD joints with a maximum 17' spacing unless indicated otherwise,
 If a joint length is 2', a C joint shall be used instead of a CD joint.
 Refer to Typical 7101 for details of paved header.
 Refer to Typical 7154A and 7154B for paved shoulder details.

GEOMETRICS AND STAKING NOTES:

Refer to Appropriate Standard Road Plans for Additional Information.
 Refer to G Sheets for Horizontal Alignment Information.

**JOINTING AND GEOMETRICS
 LEGEND AND INFORMATION SHEET**

(COVERS SHEET SERIES L)

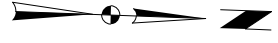

1268+00

1269+00

1270+00

1271+00

1272+00

1273+00

1274+00

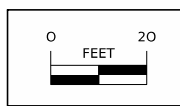
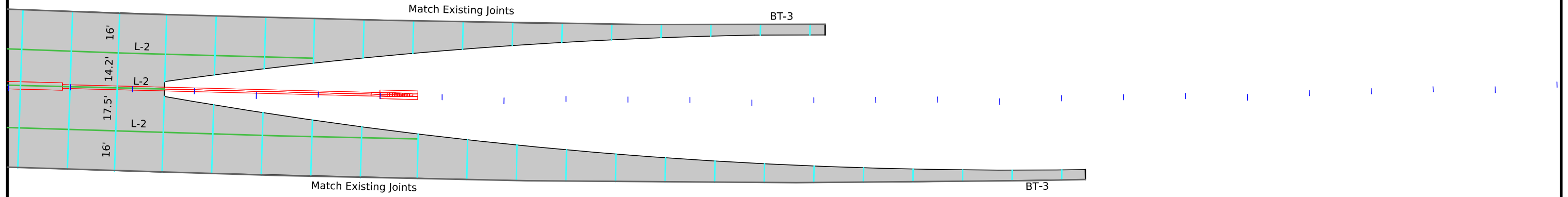



1376+00

1377+00

1378+00

1379+00

1380+00

1381+00

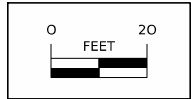
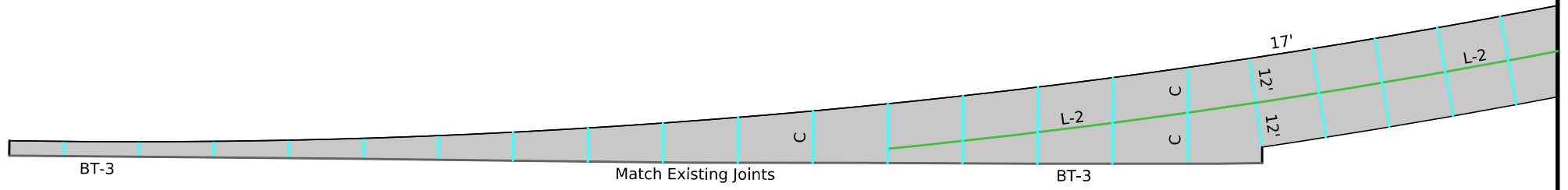

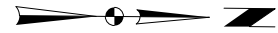

1382+00

1383+00

1384+00

1385+00

1386+00

1387+00

BT-3

Match Existing Joints

BT-3

BT-3

C

C

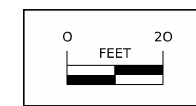
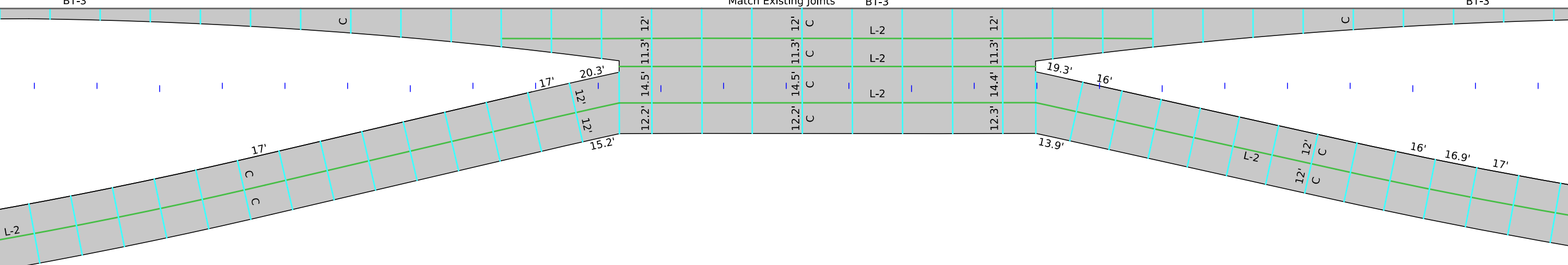

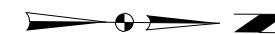

1388+00

1389+00

1390+00

1391+00

1392+00

1393+00

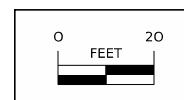
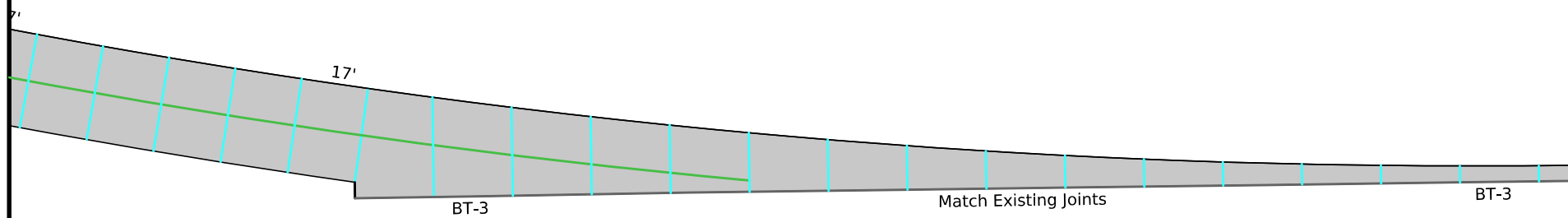

LANDSCAPE DESIGN	
	<p>I hereby certify that the portion of this technical submission described below was prepared by me or under my direct supervision and responsible charge. I am a duly licensed professional landscape architect under the laws of the state of Iowa.</p>
	<p> <i>Rachel Harris</i> _____ <small>Signature</small> <small>Date</small> Rachel A. Harris <small>Printed or Typed Name</small> My license renewal date is June 30, 2026 </p>
<p>Pages or sheets covered by this seal: RC.1 - 5</p>	

ESTIMATED PROJECT QUANTITIES AND REFERENCE NOTES

Roadside Items : Roadside Items

Item no.	Item Code	Item	Unit	Quantities		Estimate Reference Notes
				Estimated	Roadside Items	
1	2602-0000312	PERIMETER AND SLOPE SEDIMENT CONTROL DEVICE, 12 IN. DIA.	LF	2,500		<p>Refer to Standard Road Plan EC-204.</p> <p>Item is included for temporary perimeter sediment control, inlet protection, and water velocity reduction on slopes or ditches at locations to be determined during construction. Verify specific locations with the Engineer prior to beginning placement.</p>
2	2602-0000320	PERIMETER AND SLOPE SEDIMENT CONTROL DEVICE, 20 IN. DIA.	LF	2,500		<p>Refer to Standard Road Plan EC-204.</p> <p>Item is included for temporary perimeter sediment control, inlet protection, and water velocity reduction on slopes or ditches at locations to be determined during construction. Verify specific locations with the Engineer prior to beginning placement.</p> <p>Item may be used in addition to, or as a direct replacement for "Perimeter and Slope Sediment Control Device, 12 in. dia." upon Engineer approval.</p>
3	2602-0000351	REMOVAL OF PERIMETER AND SLOPE OR DITCH CHECK SEDIMENT CONTROL DEVICE	LF	5,000		

232_03A
9/28/22

EROSION CONTROL (RURAL SEEDING)

Area to be seeded is estimated to be less than 1 acre. If the contractor determines the area exceeds 2 acres, notify the Engineer. Approved quantity in excess of 2 acres will be paid for as extra work according to Article 1109.03,B of the Standard Specifications.

Following the completion of work in a disturbed area and according to the seeding dates in Section 2601 of the Standard Specifications, place seed, fertilizer, and mulch on the disturbed area lying 8 feet adjacent to shoulder and median as follows:

Place seed and fertilize according to the requirements of Article 2601.03,C,3 and Section 4169 of the Standard Specifications.

Place mulch according to the requirements of Articles 2601.03,E,2,a and 4169.07,A of the Standard Specifications.

Preparing the seedbed, furnishing and applying seed, fertilizer, and mulch are all incidental to mobilization and will not be paid for separately.

232_11
6/21/23

EROSION CONTROL (STABILIZING CROP SEEDING)

Area to be seeded is estimated to be less than 1 acre. If the contractor determines the area exceeds 2 acres, notify the Engineer. Approved quantity in excess of 2 acres will be paid for as extra work according to Article 1109.03,B of the Standard Specifications.

If outside of permanent seeding dates in Section 2601 of the Standard Specifications, or if required by a storm water permit, place stabilizing crop, fertilizer, and mulch on the disturbed area as follows:

Place seed and fertilize according to the requirements of Article 2601.03,C,1 and Section 4169 of the Standard Specifications.

Place mulch according to the requirements of Articles 2601.03,E,2,a and 4169.07,A of the Standard Specifications.

Preparing the seedbed, furnishing and applying seed, fertilizer, and mulch are incidental to mobilization and will not be paid for separately.

281_03
11/9/23

STORM WATER BEST MANAGEMENT PRACTICES

When the following best management practices are used, they are intended to account for disturbed areas where storage volume cannot be provided: Perimeter and Slope Sediment Control Device and Seeding.

INDEX OF TABULATIONS

111_25
10/23/24

Tabulation	Tabulation Title	Sheet No.
111_25	INDEX OF TABULATIONS	RC.4
105_04	STANDARD ROAD PLANS	RC.5

105_04
4/15/25

STANDARDS

The following Standards apply to construction work on this project.

Number	Date	Title
EC-204	10-19-21	Perimeter, Slope and Ditch Check Sediment Control Devices
EC-502	04-21-15	Seeding in Rural Areas

The price bid for "Crossover Barricade", each, is considered full compensation for furnishing all materials and work necessary to construct the barricade as detailed hereon.

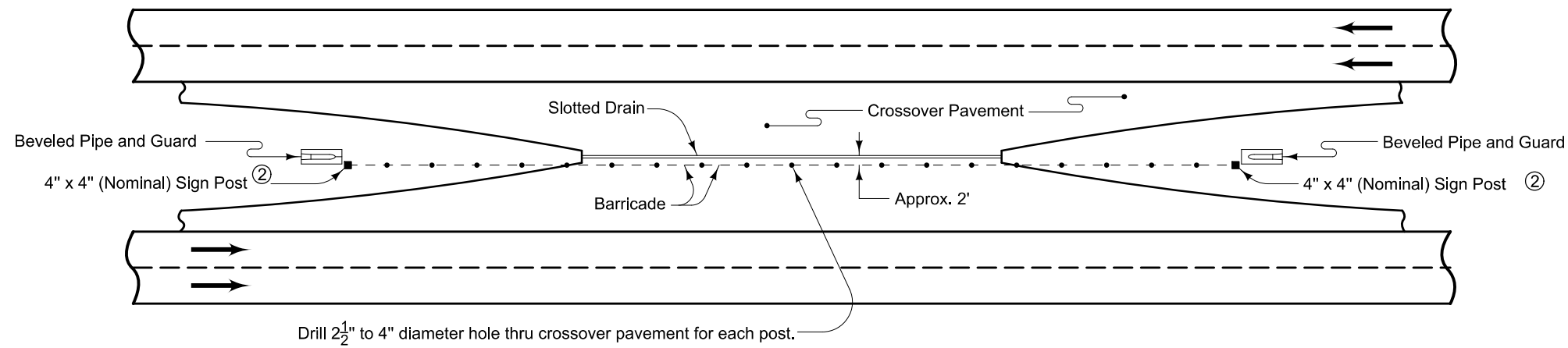

PLAN VIEW

- ① 3 1/4" center mount yellow reflector, attached to sign post with 0.190 x 1.25 slotted pan head screws.
- ② Extend the barricade to within 2 feet from the top end of the concrete collar.
- ③ 0.125 inch aluminum panel with Type III or IV retroreflective sheeting on both sides.
- ④ ReflectORIZED red stripes on both sides shall slope from upper left to lower right of panel.
- ⑤ Embed all delineator posts a minimum of 2'-6".
- ⑥ 1/4" inch diameter steel cable.

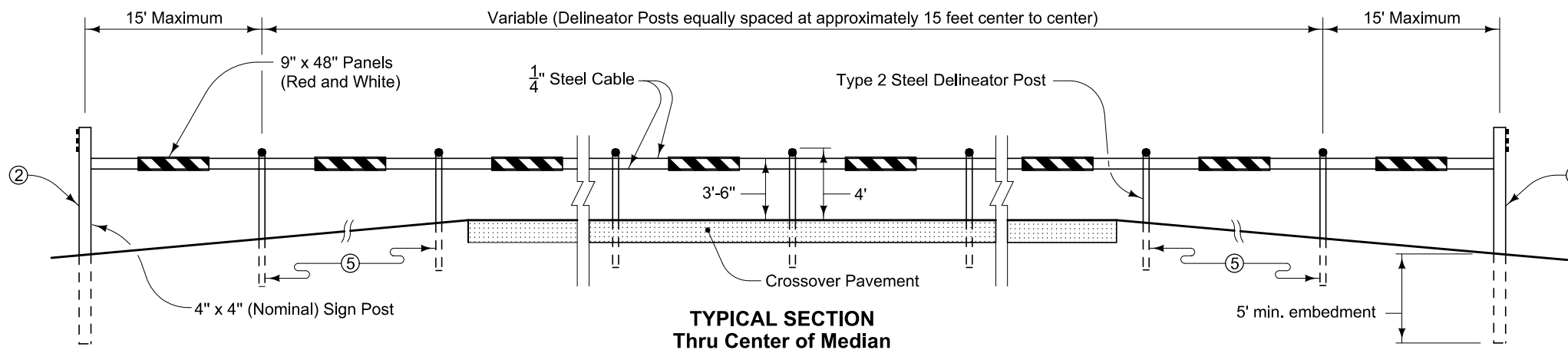

TYPICAL SECTION Thru Center of Median

List Of Materials For Barricading At Median Crossovers			
Quantities for Standard Road Plans			Items
PV-500	PV-503	PV-506	
25	19	18	Type 2 Steel Delineator Posts
2	2	2	4" x 4" (Nominal) Sign Post
56	44	42	3 1/4" Yellow Reflectors, center mounted
25	19	18	0.190 x 2.00 slotted pan head bolts and self-locking nuts
6	6	6	0.190 x 1.25 slotted pan head screws
26	20	19	9" x 48" Aluminum panels (red on white)
50	38	36	3/8" Cable clamps, lock washers and nuts
104	80	76	1/4" Cable clamps, neoprene washers and self-locking nuts
4	4	4	3/8" x 6" Eye bolts, washers and nuts
4	4	4	1/4" Cable clamps
820'	640'	610'	Approximate length of 1/4" diameter Steel Cable
405'	315'	300'	Distance from Sign Post to Sign Post based on Note ②

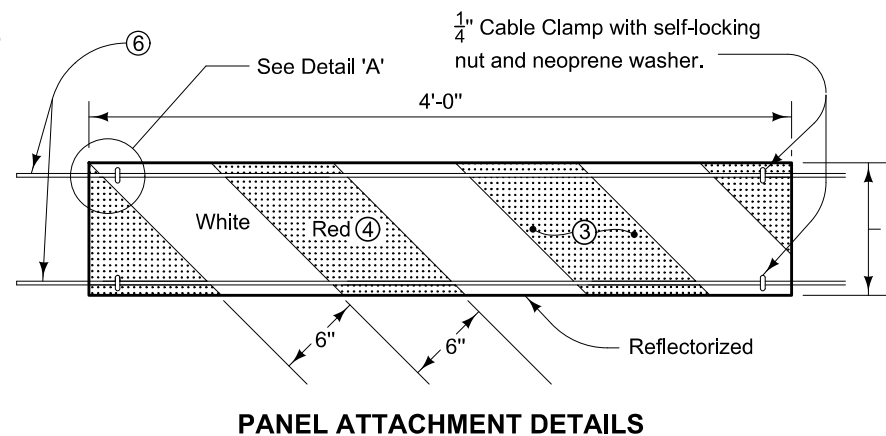
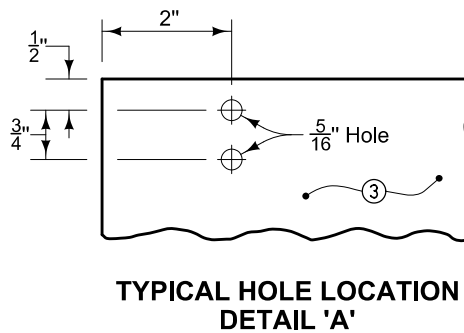
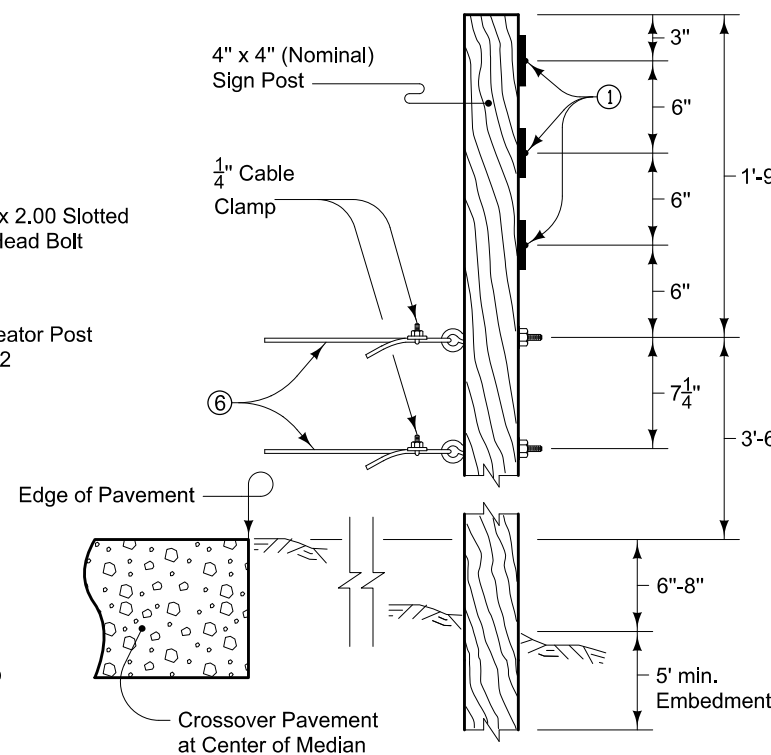
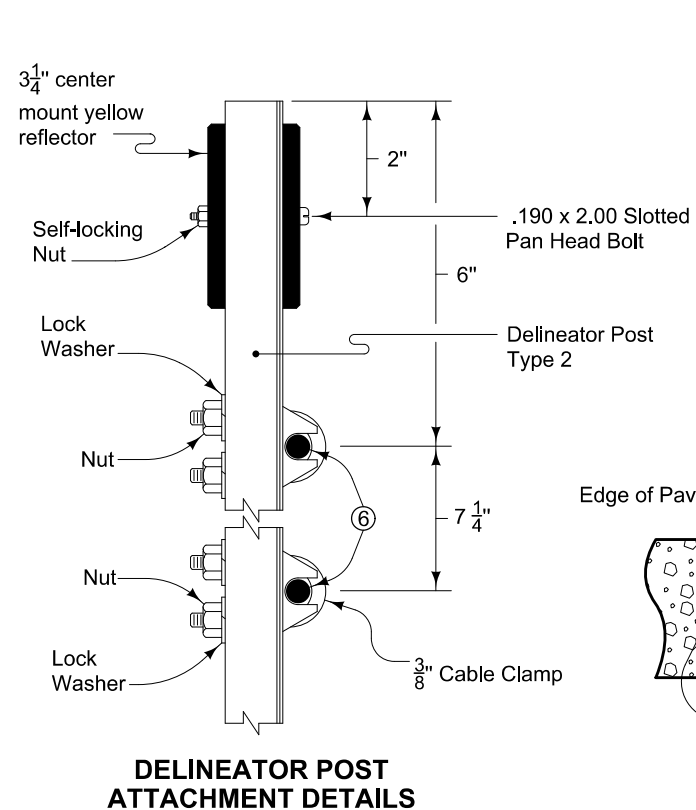

 ROAD DESIGN DETAIL	REVISION	
	9	10-19-10
	540-13	
SHEET 1 of 1		
REVISIONS: Changed RV designations to PV.		

DETAILS OF BARRICADE AT CROSSOVER

CROSS SECTION VIEW COLOR LEGEND

Design Color No.	Feature	Design Color No.	Feature
Aggregate			
(64)	Choke Stone	(8)	Behind Curb Cut
(42)	Engineering Fabric	(6)	Granular
(8)	Flooded Backfill	(13)	Granular Back Fill
(92)	Macadam Stone	(48)	Rock Undercut
(20)	Modified	(8)	Shoulder Earth Fill
(12)	Plowing Shaping	(2)	Side Slopes
(14)	Porous Backfill	(226)	Side Slopes Dressing
(8)	Revetment Class A	Substrata	
(6)	Revetment Class B	(128)	Boulder
(62)	Revetment Class C	(209)	Boulder Removed
(188)	Revetment Class D	(48)	Broken Weathered
(28)	Revetment Class E	(210)	Broken Weathered Removed
(12)	Shoulder Special Backfill	(3)	Core Out
(12)	Special Backfill	(115)	Core Out Remove Only
(20)	Subbase	(195)	Core Out Remove and Replace
(20)	Subbase Lower	(203)	Existing Pavement
(20)	Subbase Upper	(184)	Existing Pavement Remove Only
(118)	Subgrade Treatment	(200)	Existing Pavement Remove and Replace
Asphalt			
(207)	HMA Base Course	(6)	Loam
(207)	HMA Interim Course	(211)	Loam Removed
(207)	HMA Surface Course	(80)	Rock
Bridge			
(0)	Bridge	(212)	Rock Removed
Concrete			
(0)	Barrier Concrete	(4)	Select Sand
(0)	Barrier Concrete Footing	(214)	Select Sand Removed
(0)	Curb Gutter	(3)	Shale
(48)	Flowable Mortar	(215)	Shale Removed
(0)	Median Concrete	(10)	Topsoil
(0)	PCC Pavement	(2)	Topsoil Remove Only
(0)	Sidewalk	(4)	Topsoil Remove and Replace
Unsuitable / Waste			
(0)	Existing Pavement	(3)	Unsuitable Type A
Shoulder			
(209)	Shoulder HMA	(216)	Unsuitable Type A Removed
(0)	Shoulder PCC	(13)	Unsuitable Type B
(6)	Shoulder Granular	(217)	Unsuitable Type B Removed
Structural			
(112)	Noise Wall	(11)	Unsuitable Type C
(112)	Noise Wall Footing	(218)	Unsuitable Type C Removed
(112)	Retaining Wall Back	(3)	Waste
(112)	Retaining Wall Back Excavate	(219)	Waste Removed
(112)	Retaining Wall Face		
(112)	Retaining Wall Front Excavate		
(112)	Retaining Wall Front Footing		
(112)	Retaining Wall MSE Gutter		
(112)	Retaining Wall Reinforced Earth		

NOTES:

Text

NOTES:

Text

CROSS SECTIONS LEGEND AND INFORMATION SHEET

(COVERS SHEET SERIES W, X, Y, & Z)

ML063

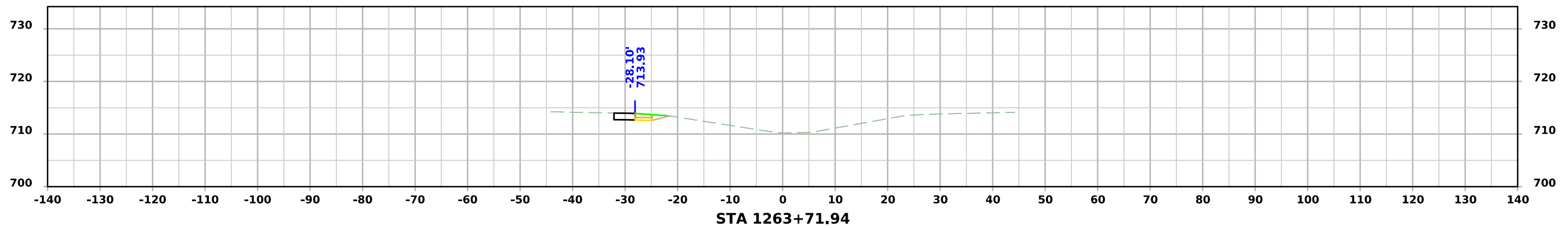
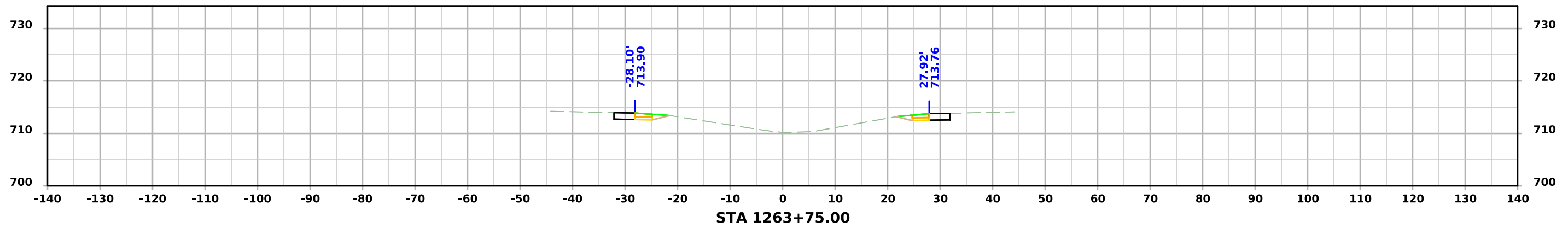
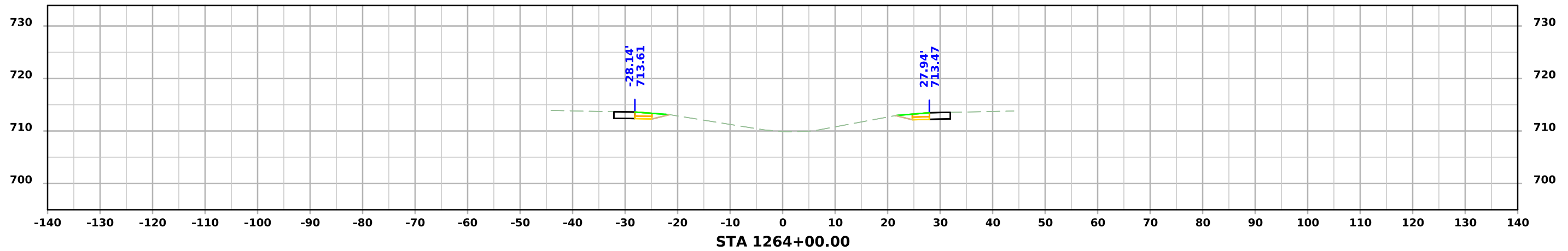

ML063

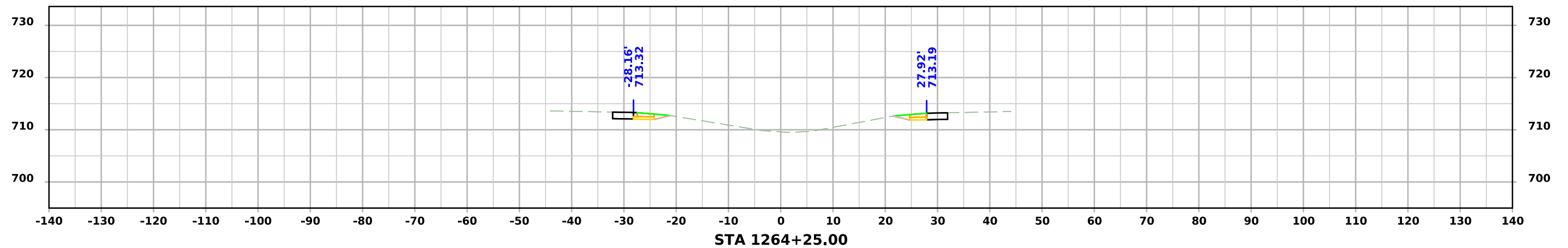
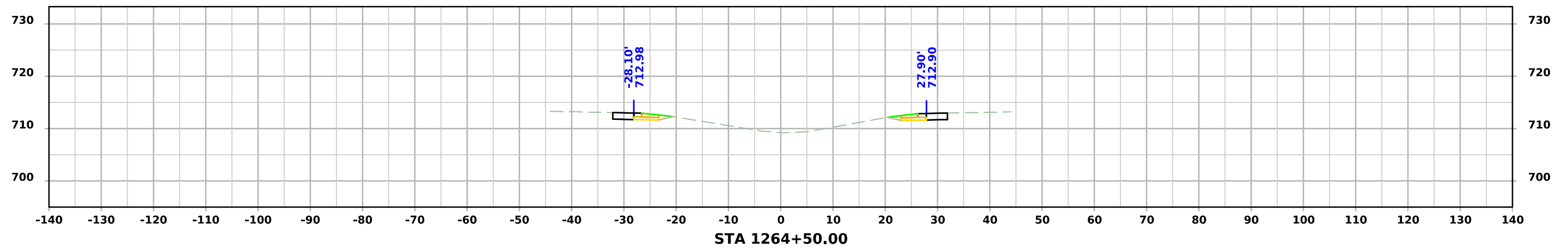
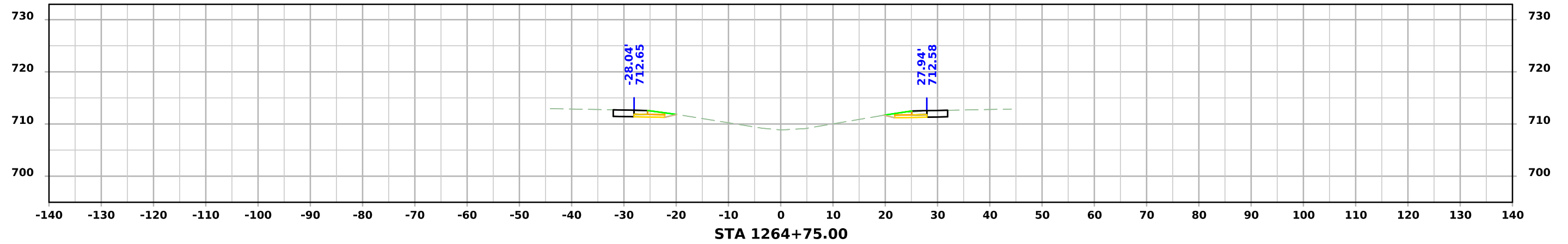

ML063

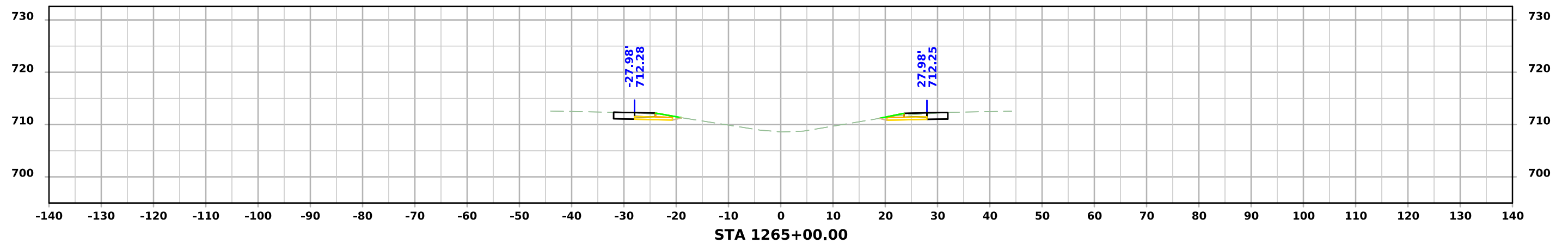
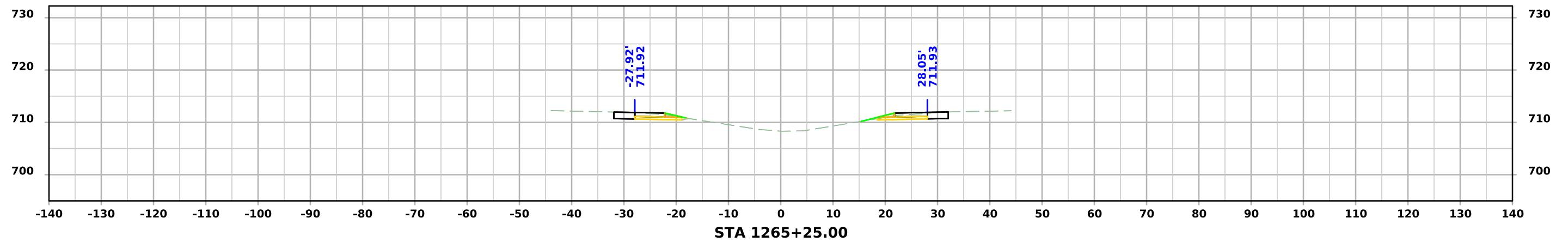
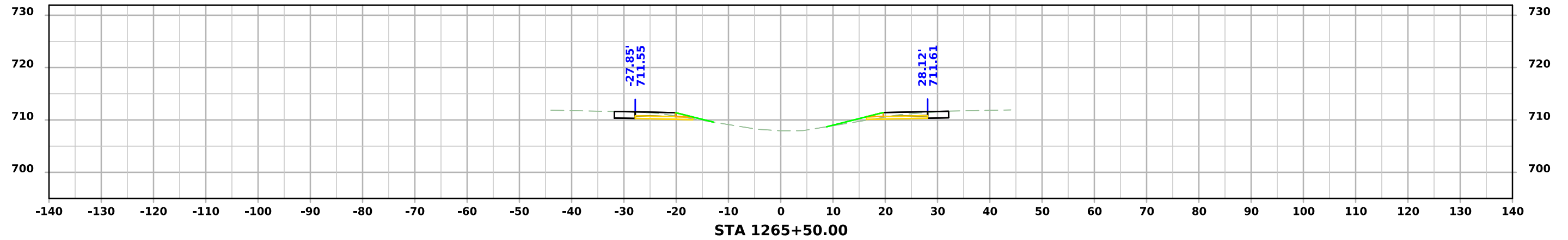

ML063

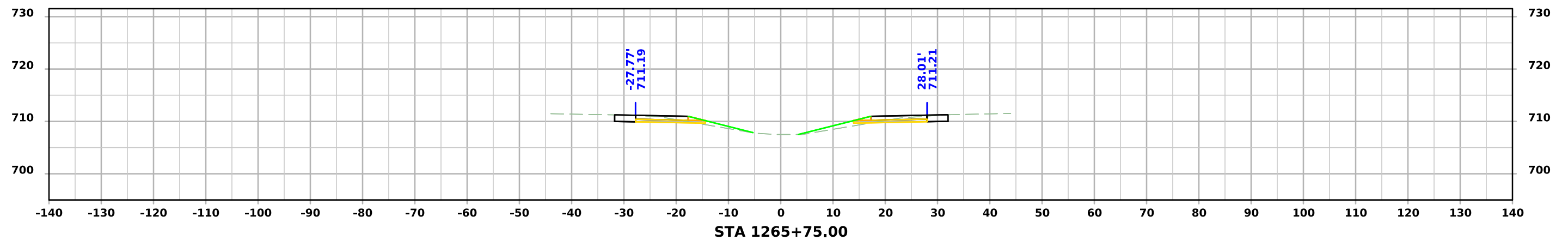
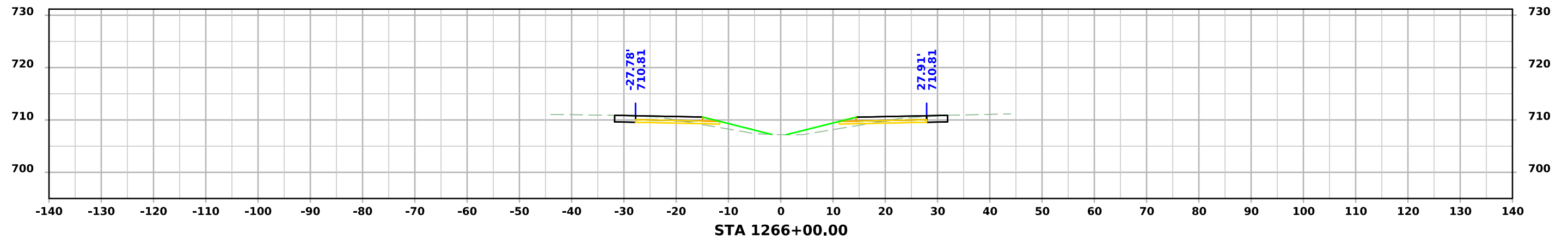
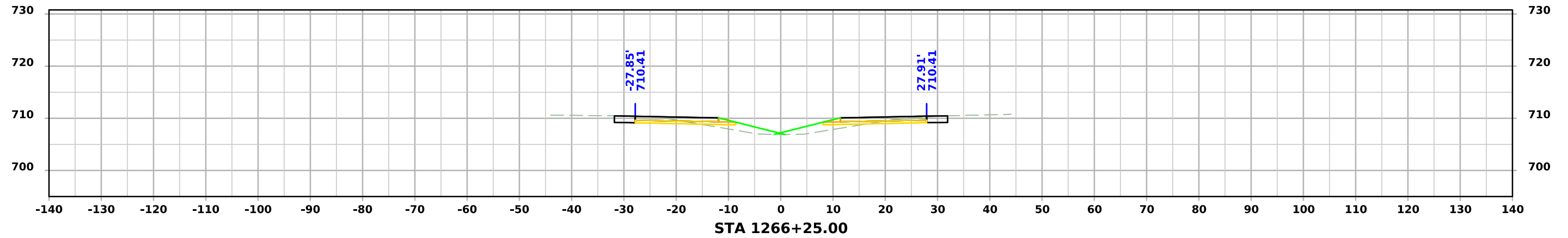

ML063

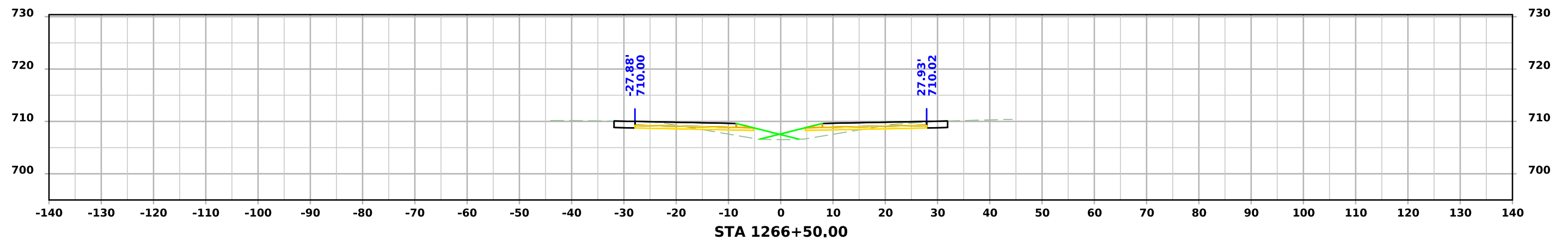
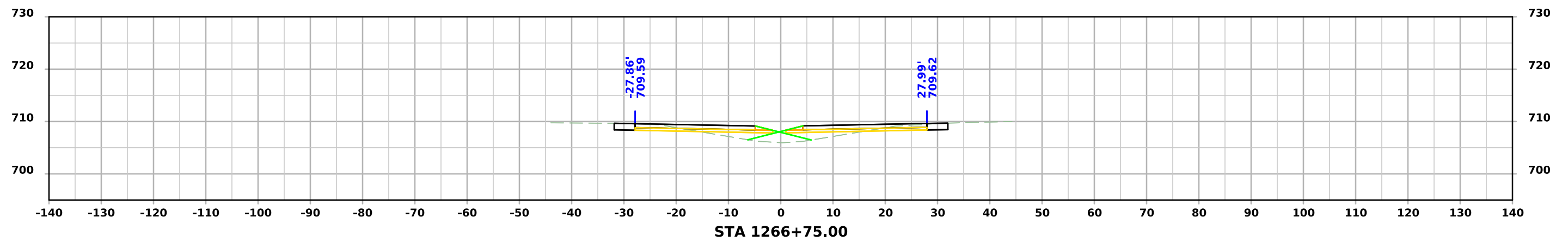
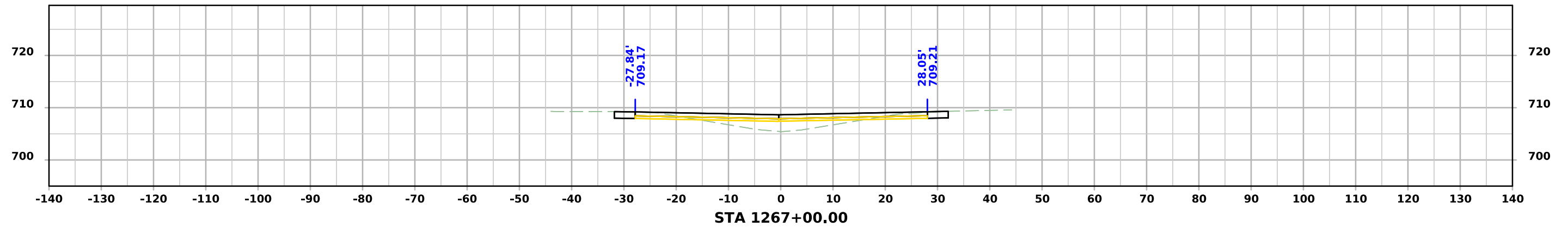

ML063

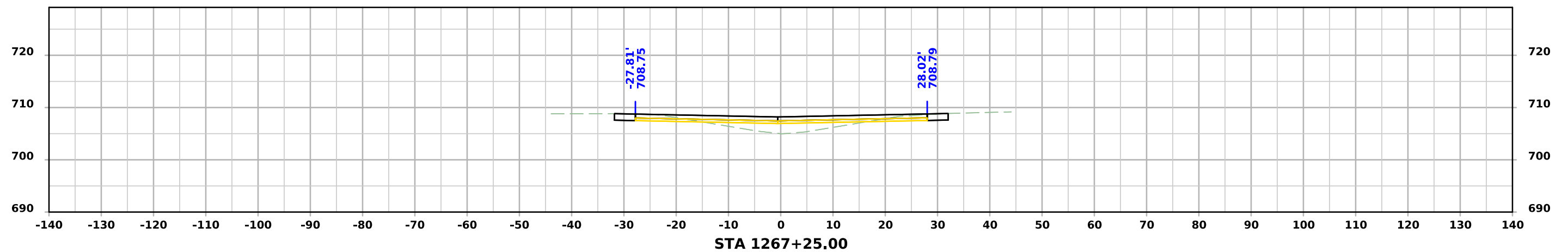
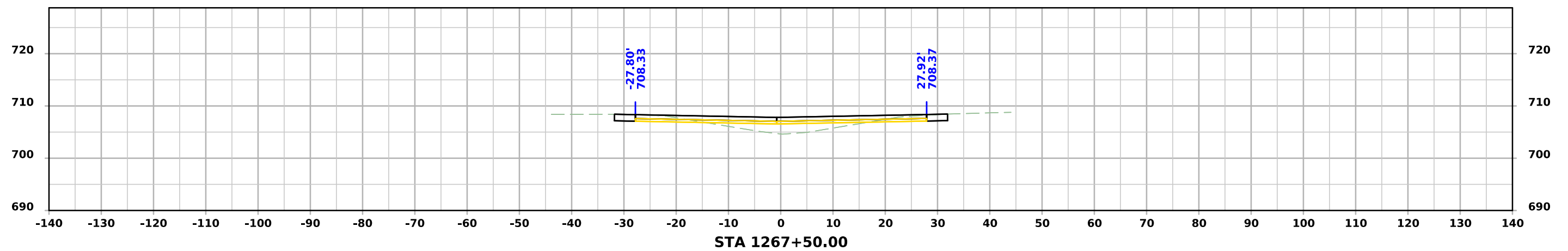
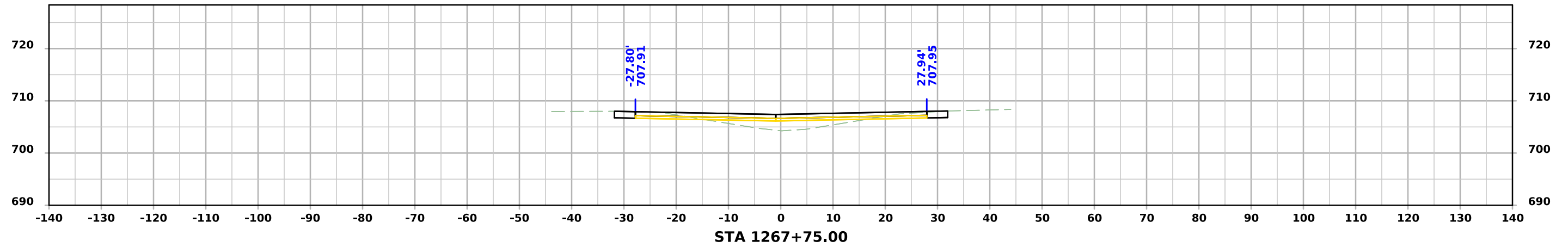

ML063

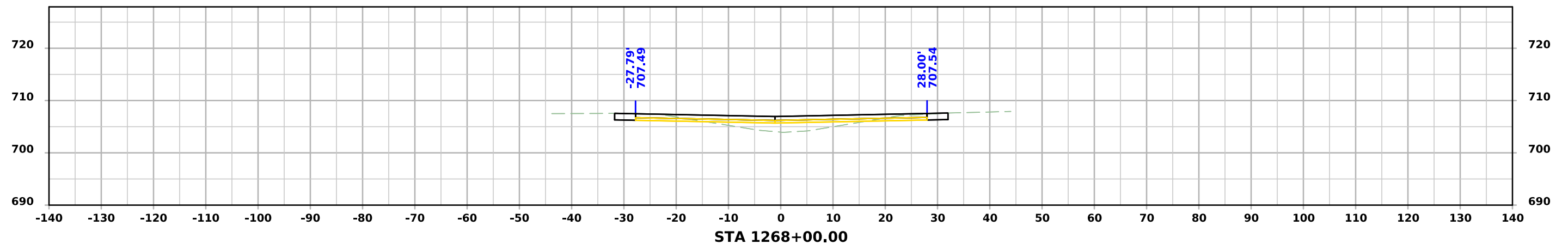
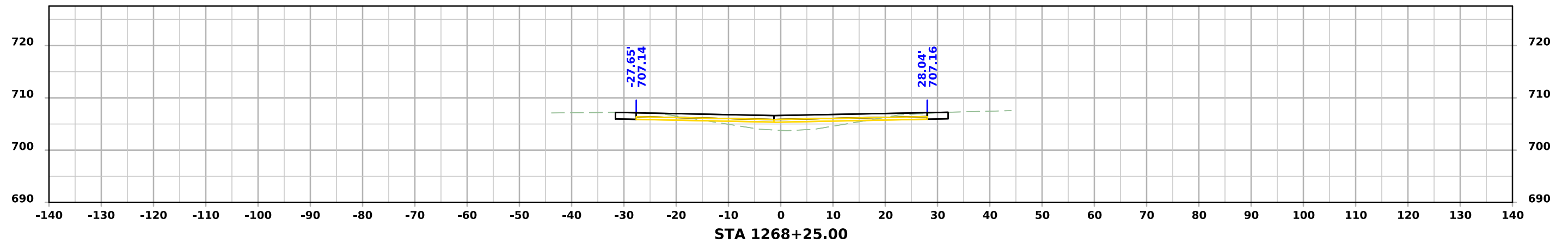
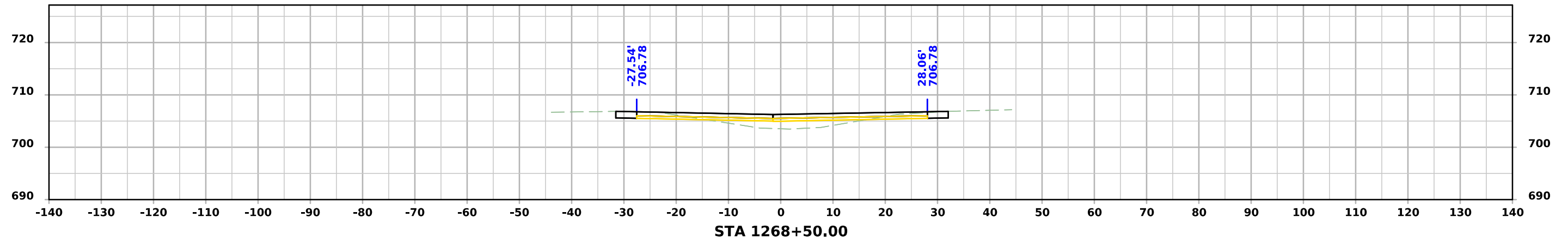

ML063

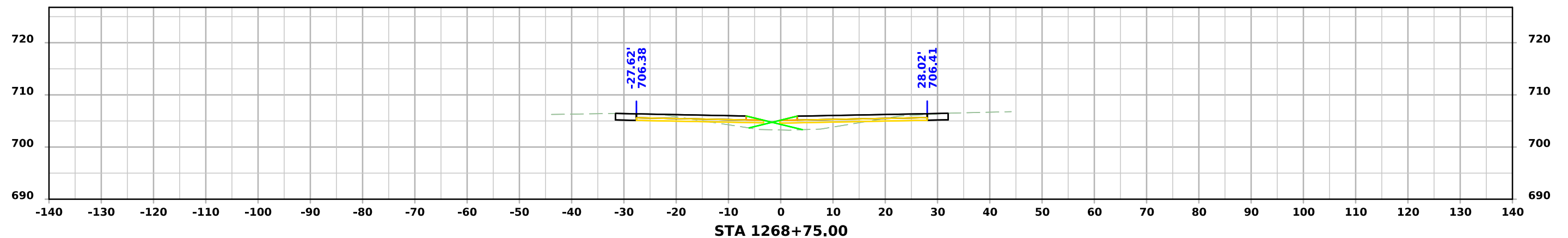
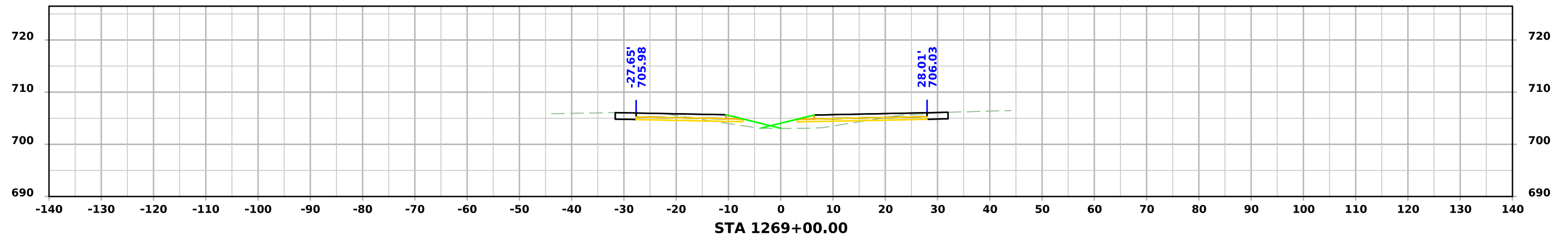
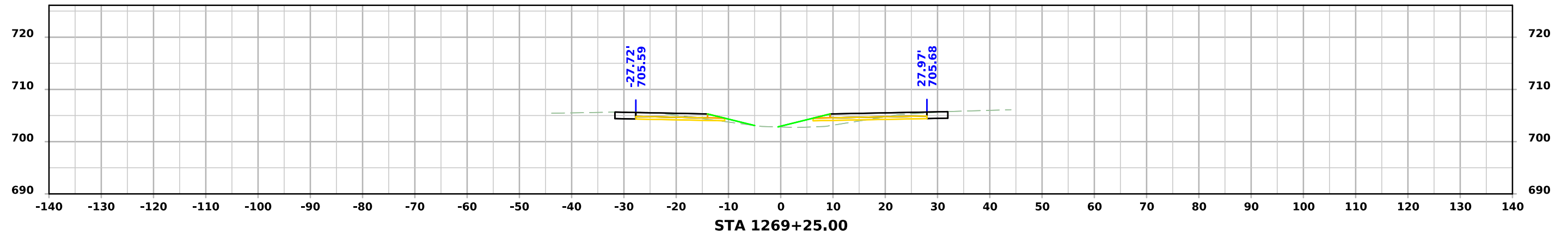

ML063

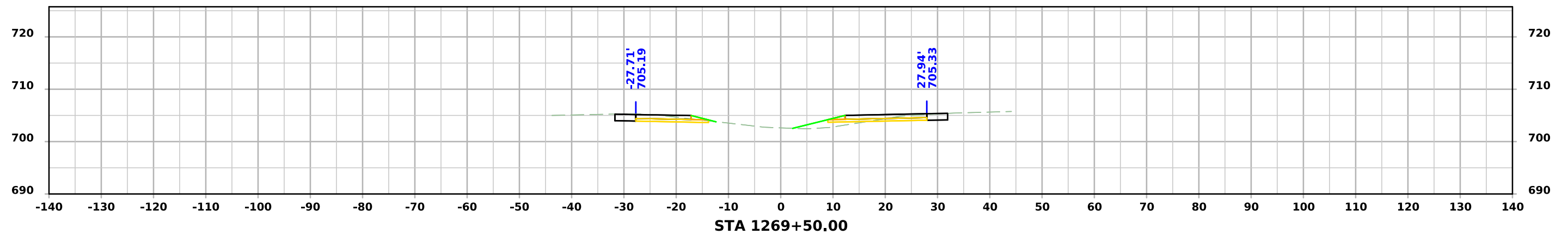
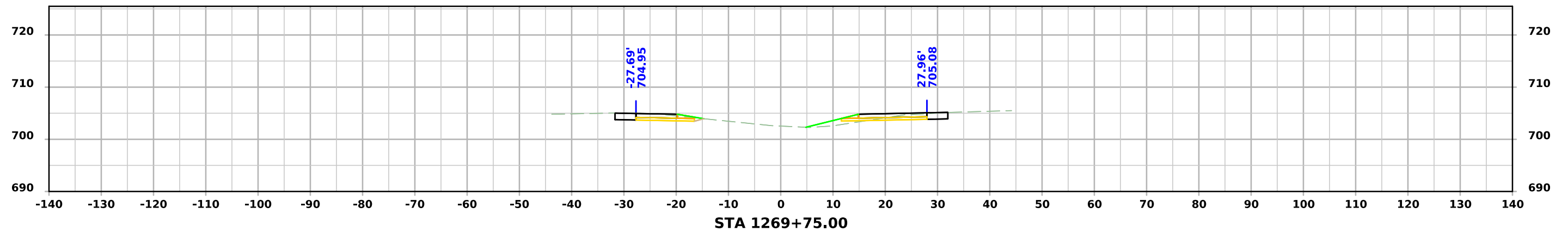
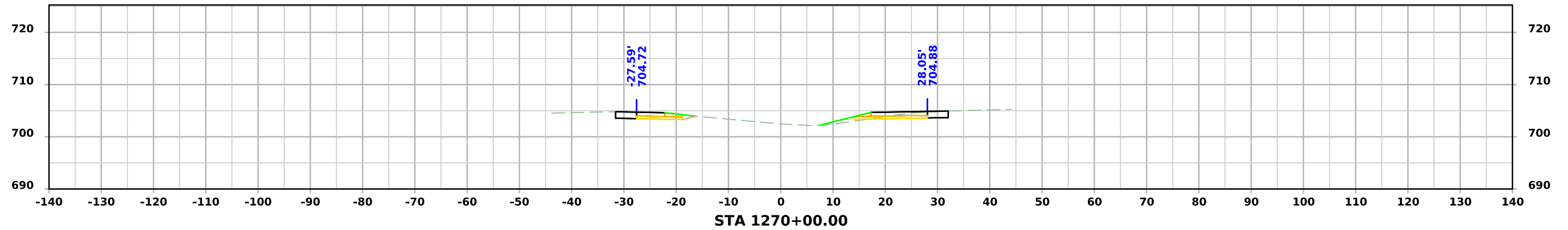

ML063

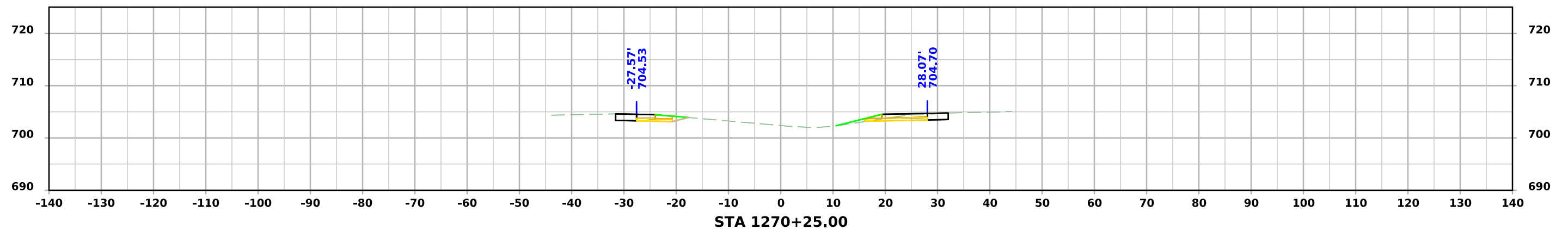
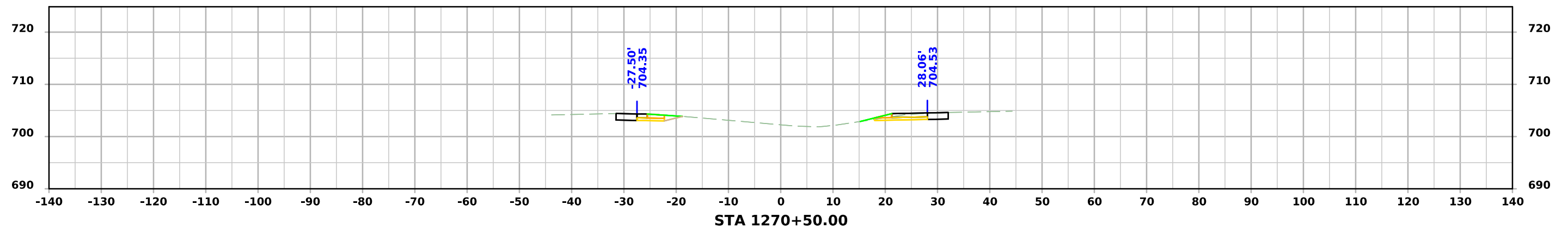
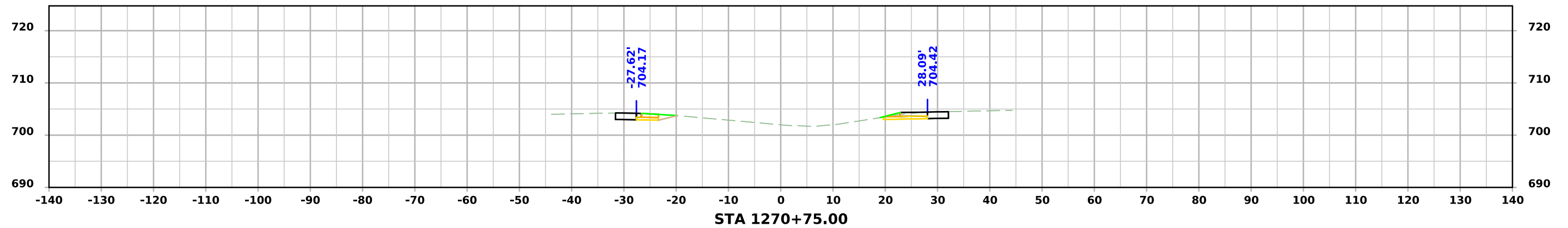

ML063

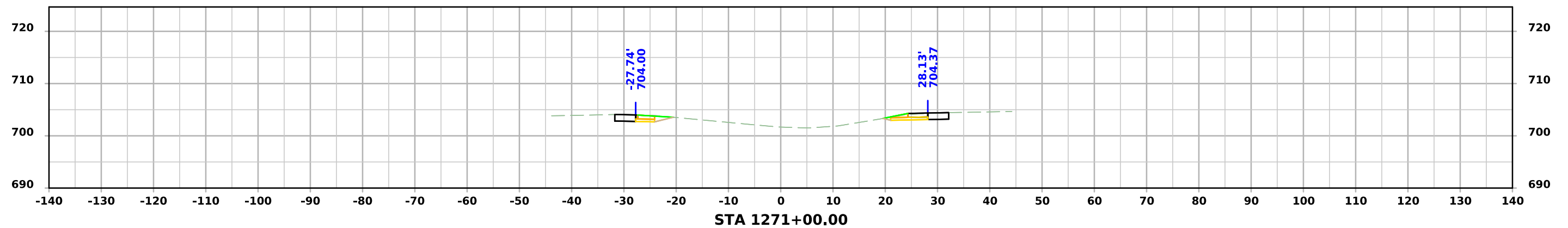
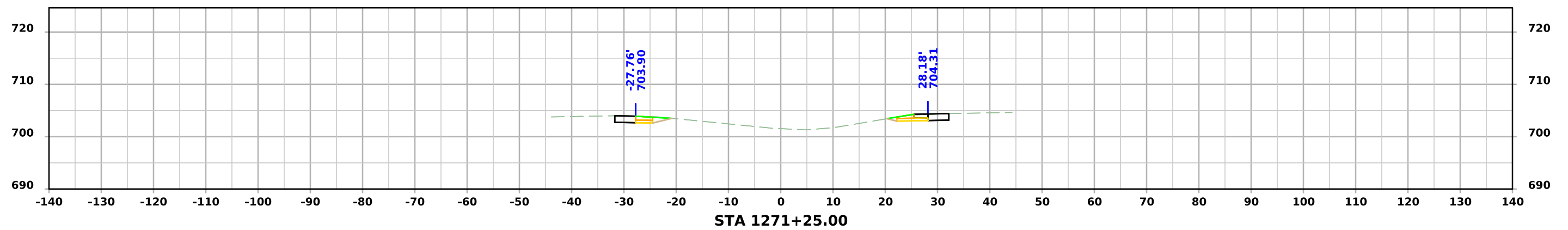
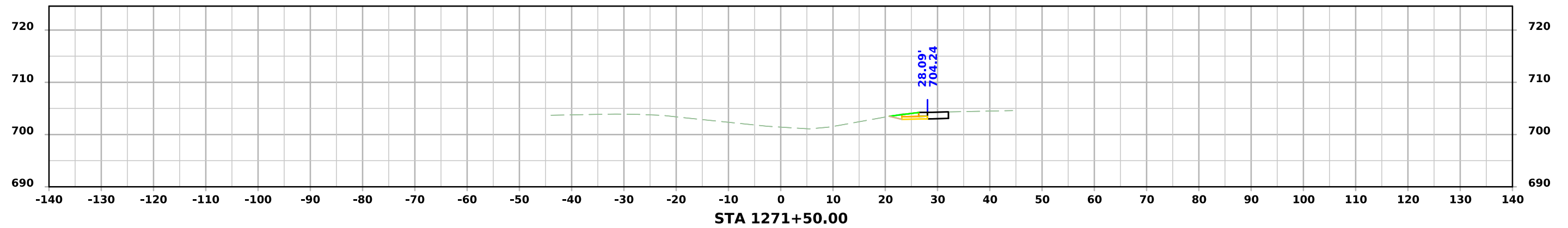

ML063

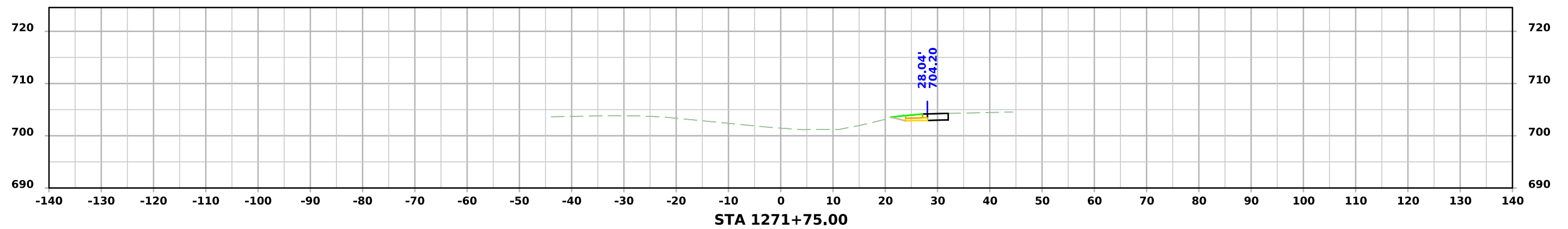
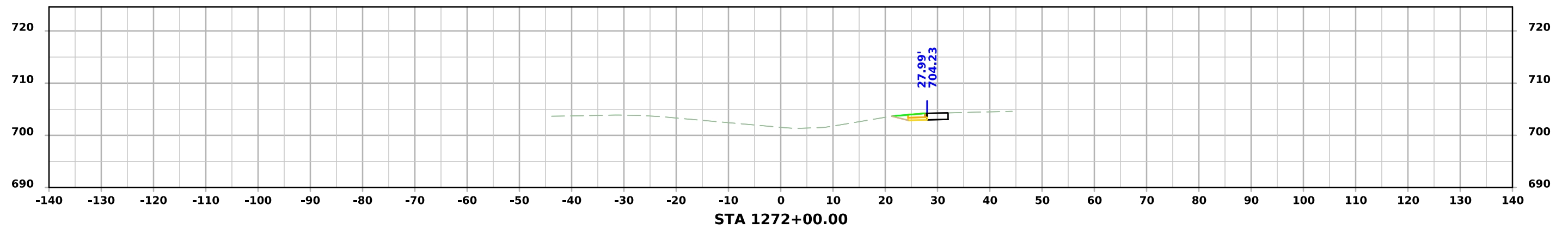
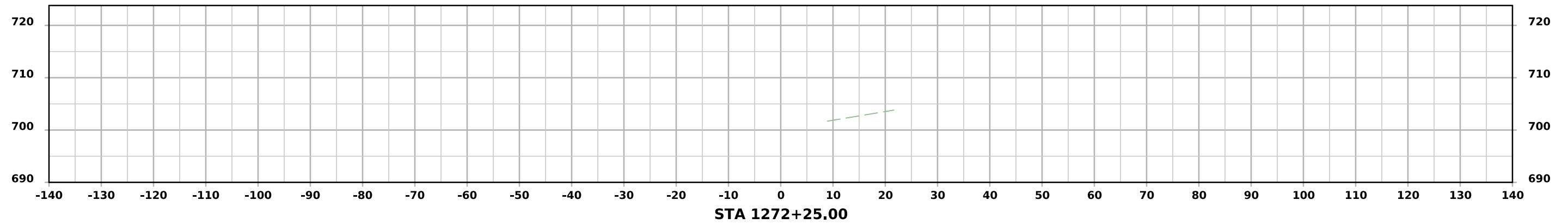

ML063

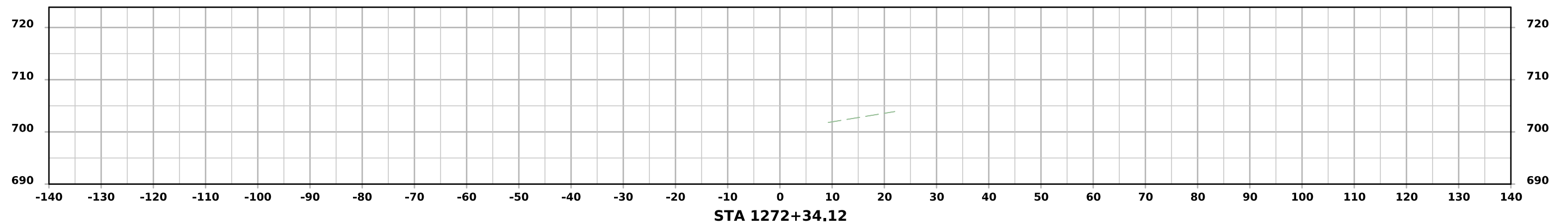

ML063

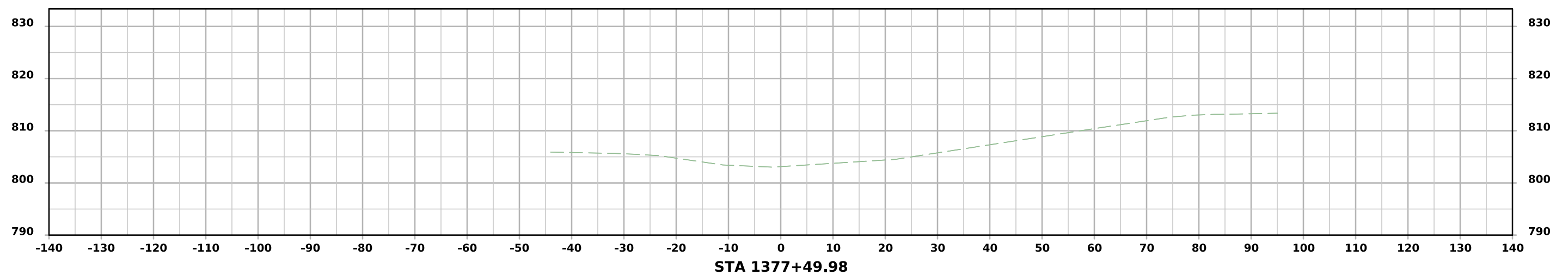
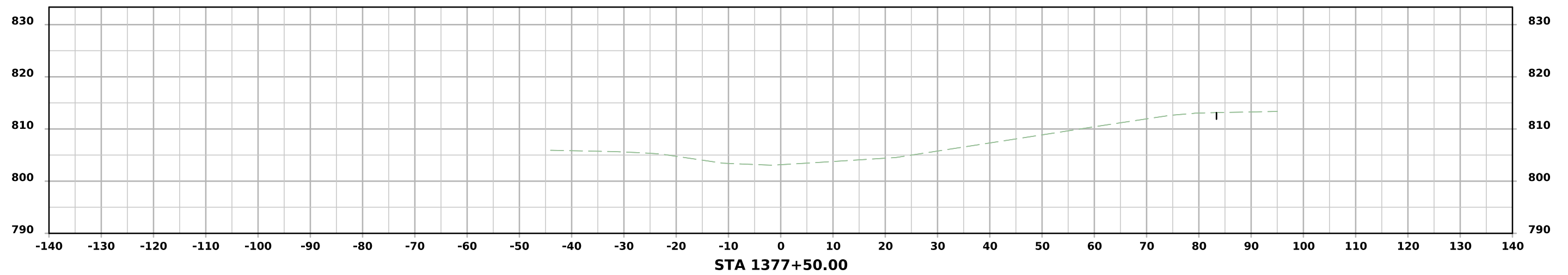
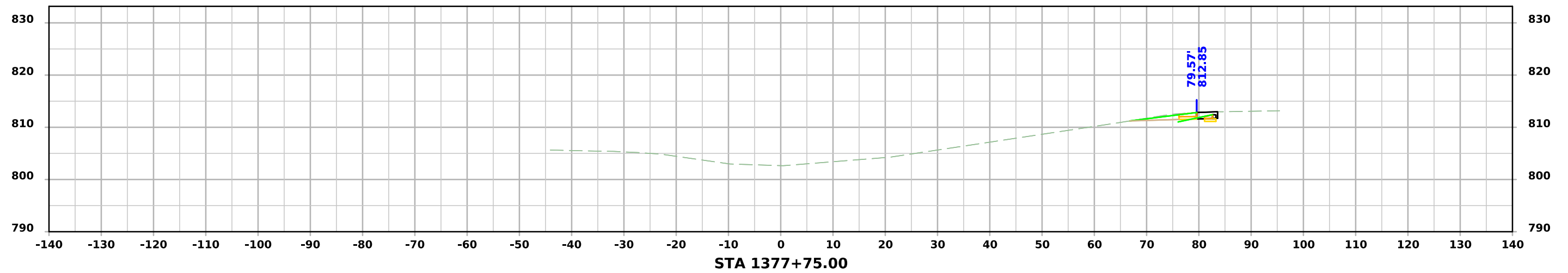

ML063

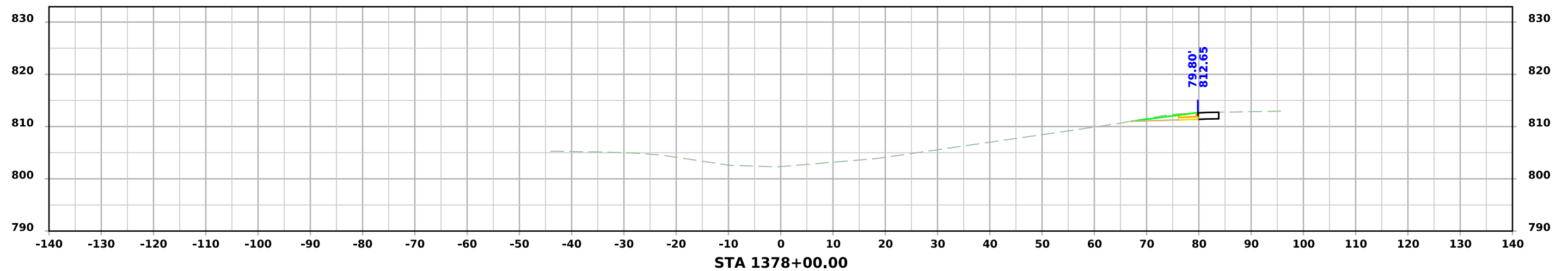
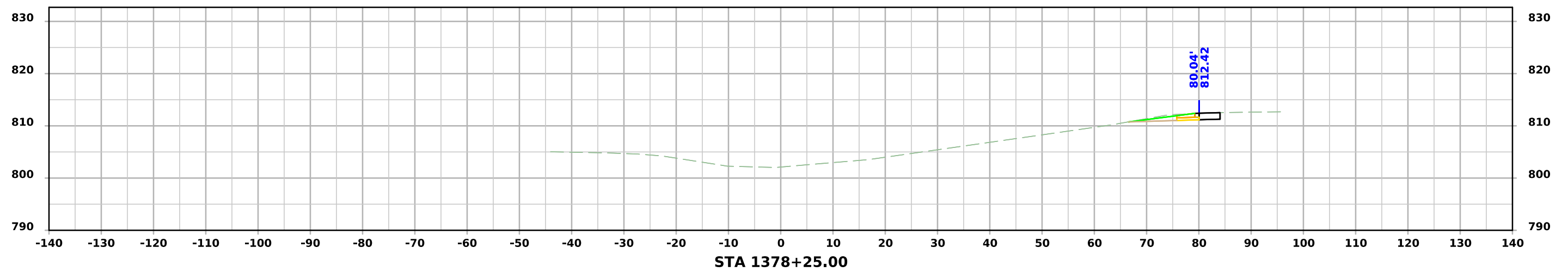
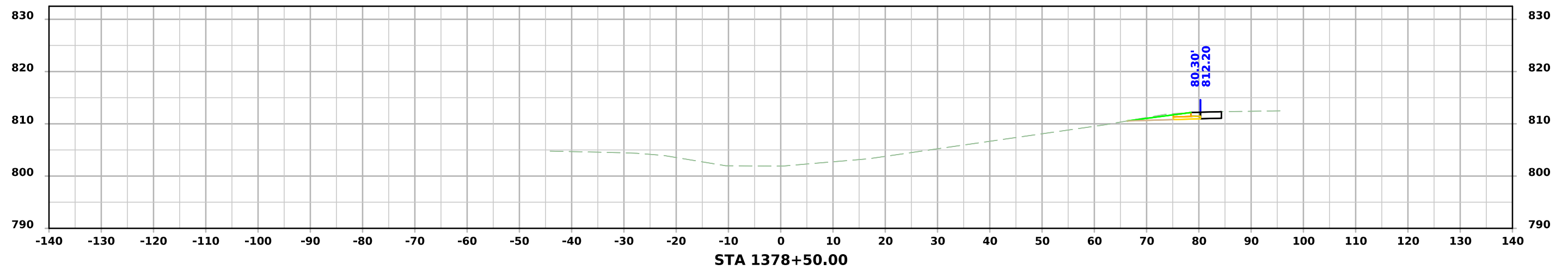

ML063

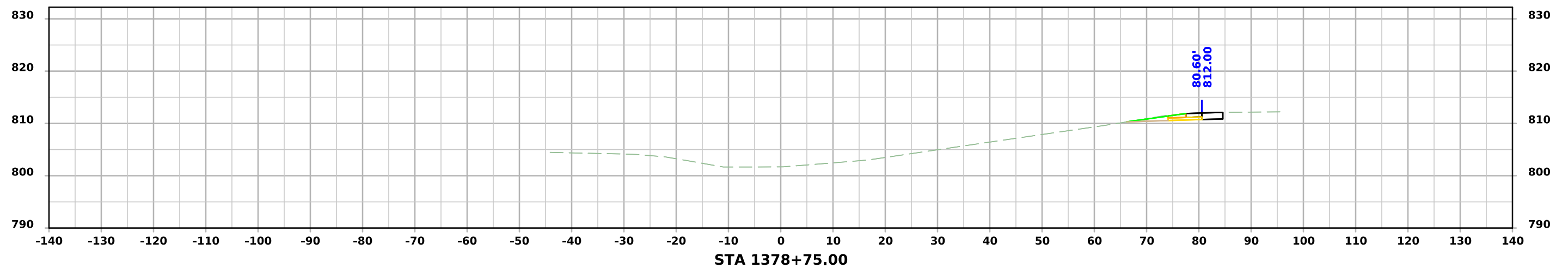
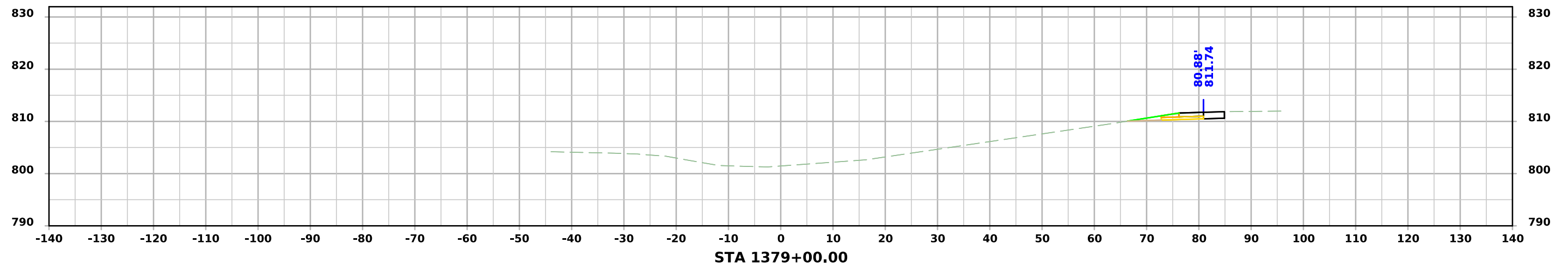
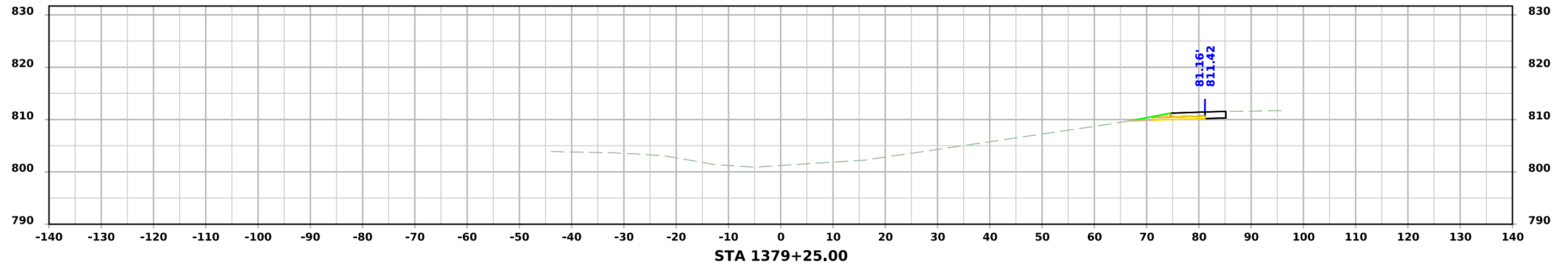

ML063

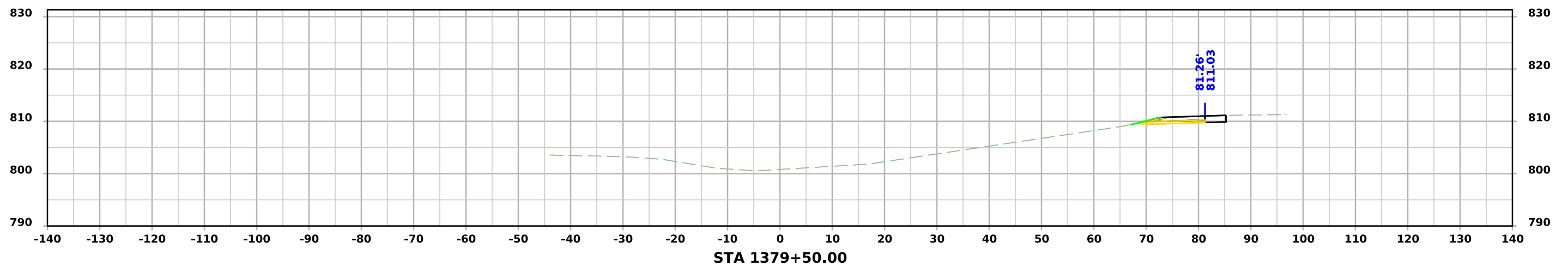
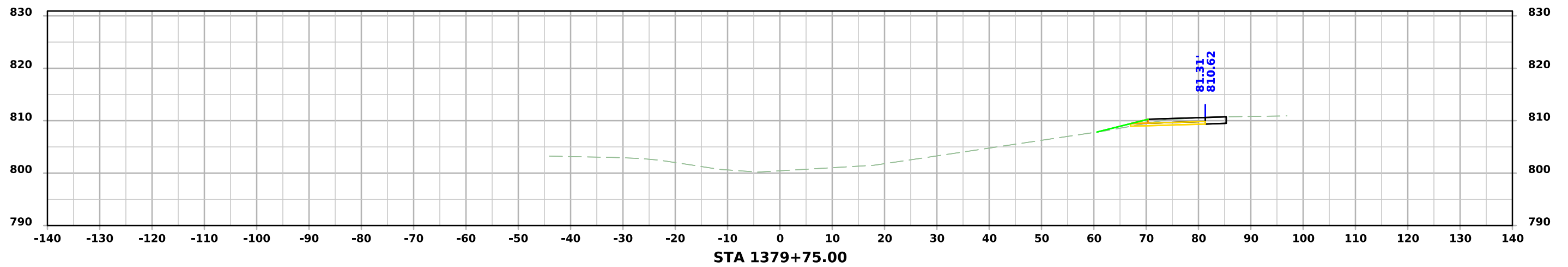
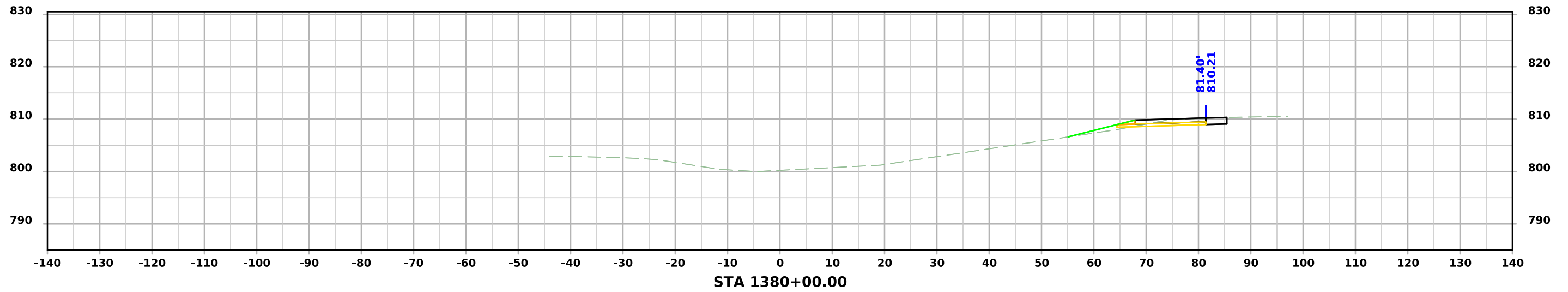

ML063

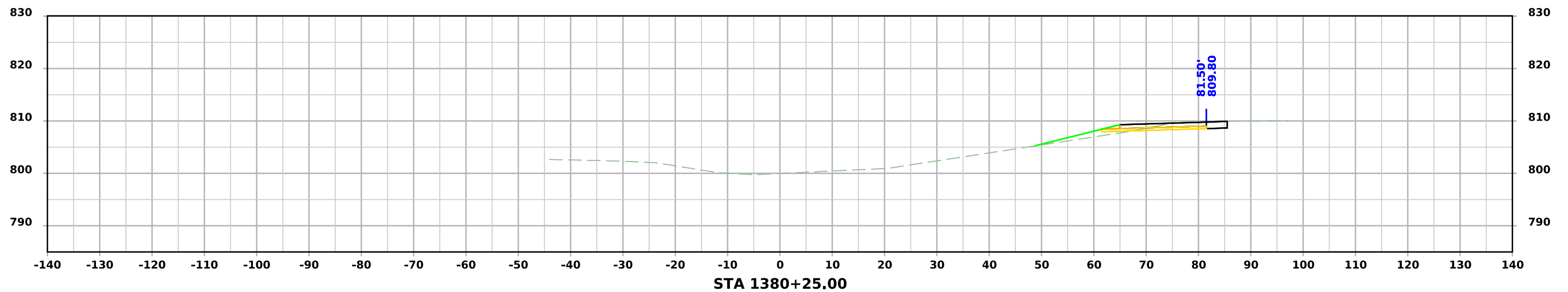
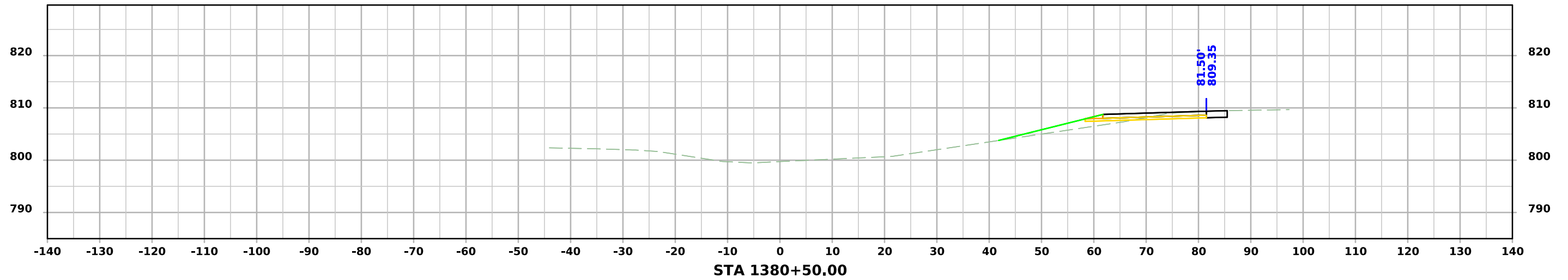
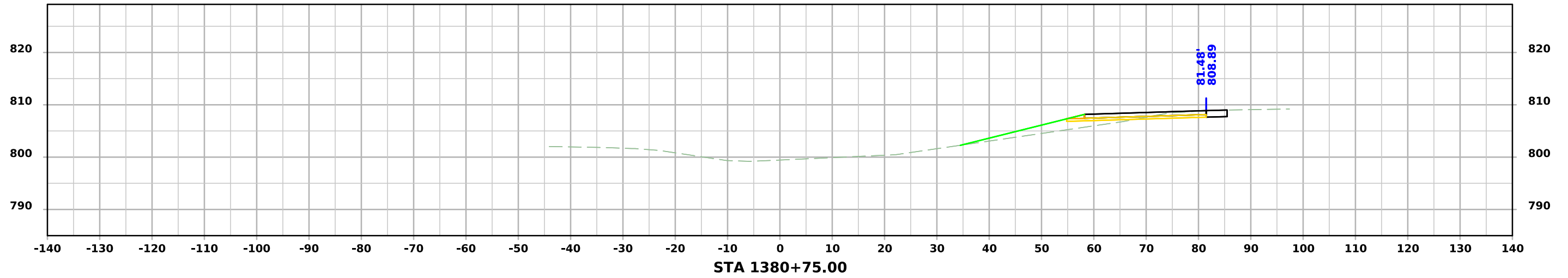

ML063

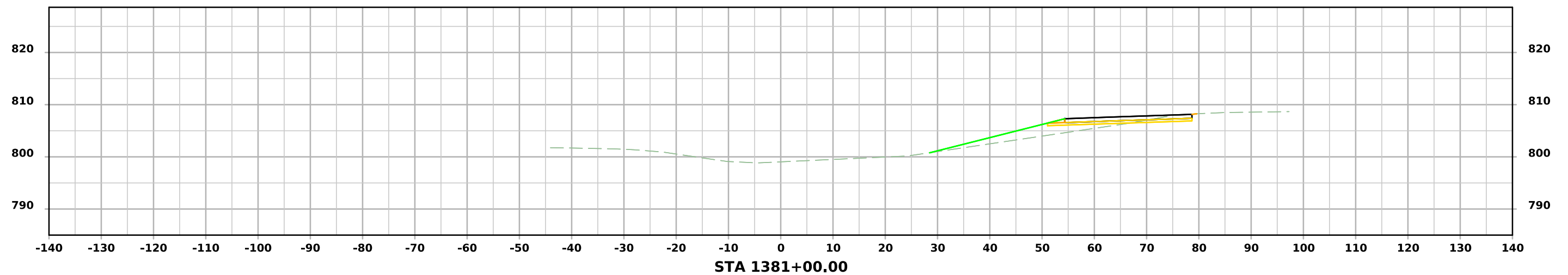
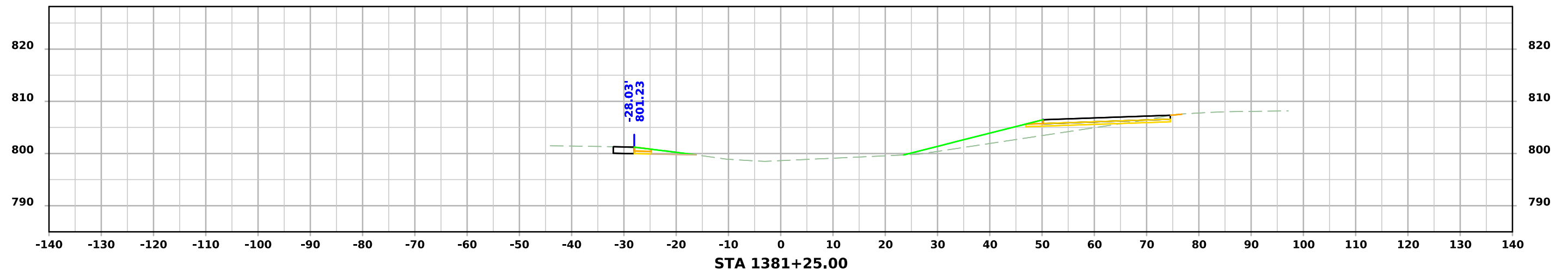
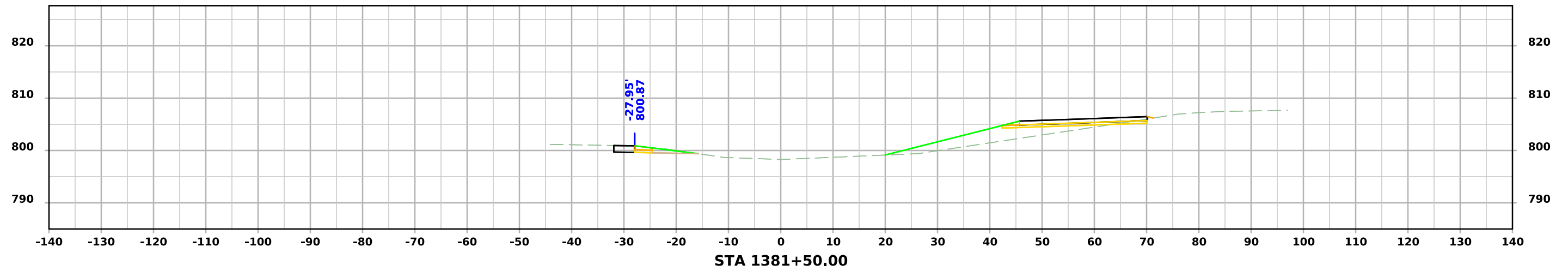

ML063

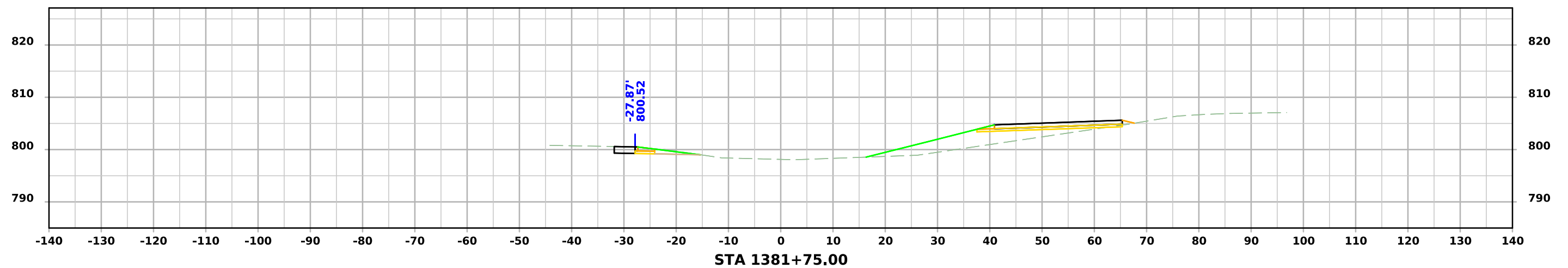
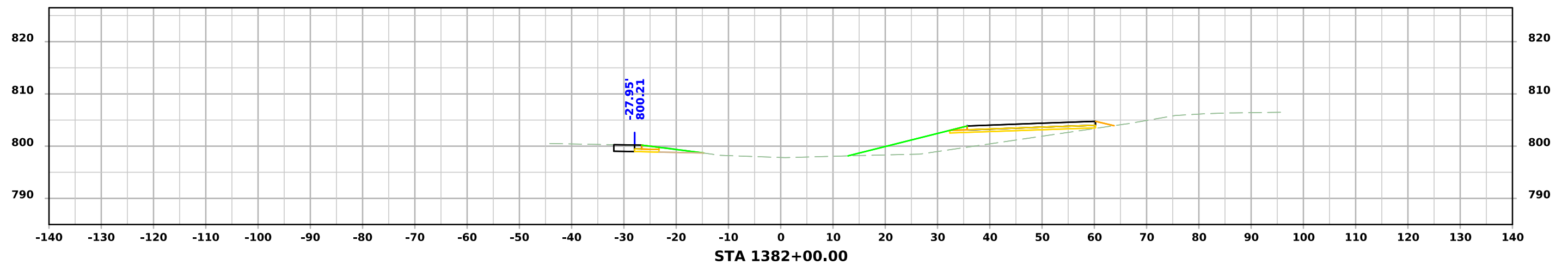
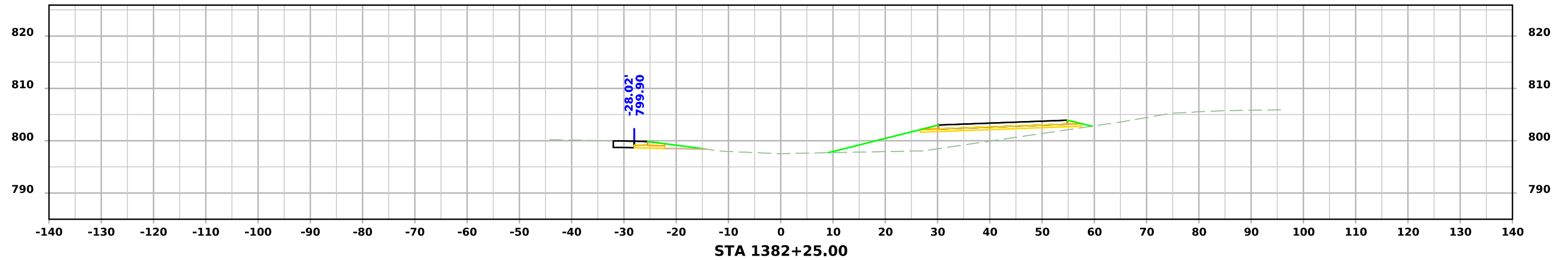

ML063

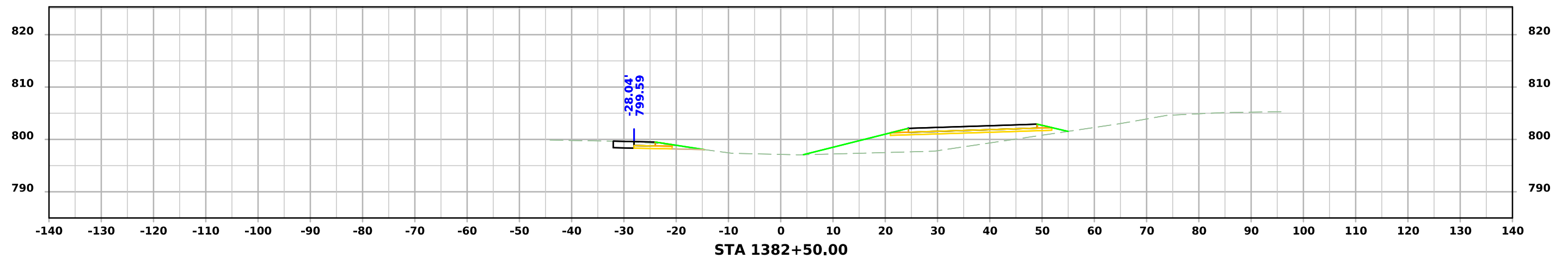
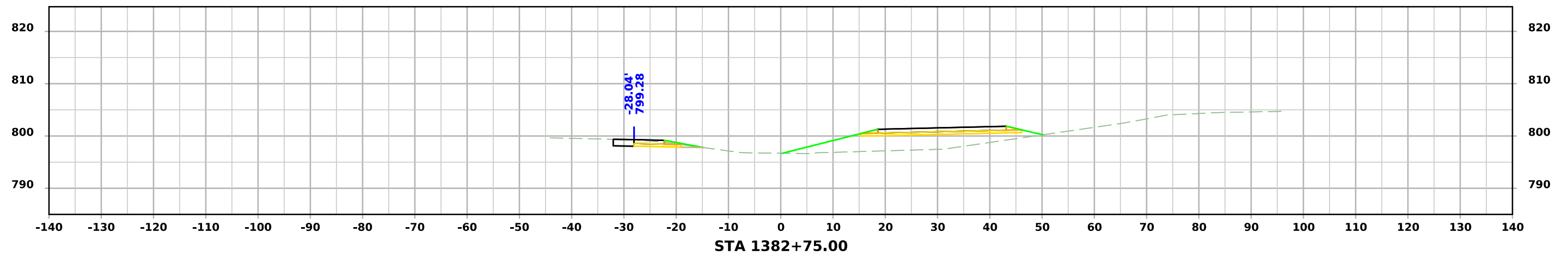
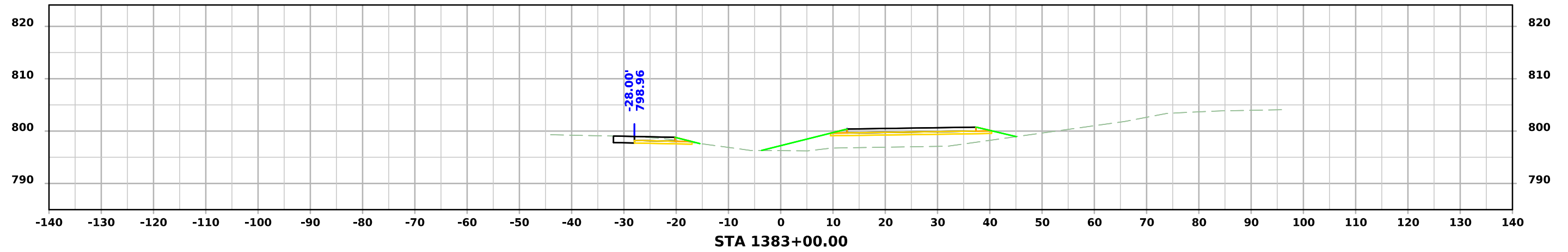

ML063

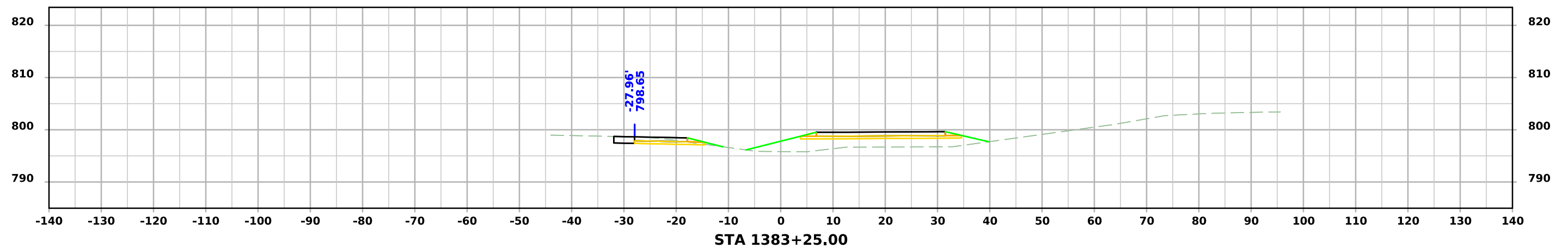
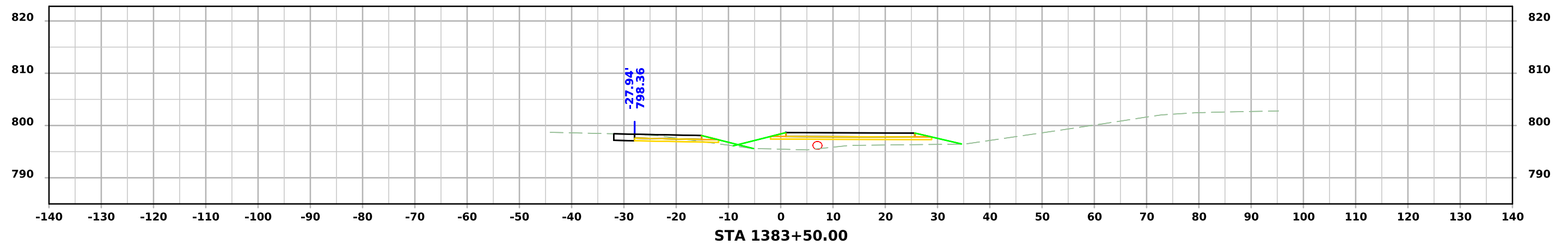
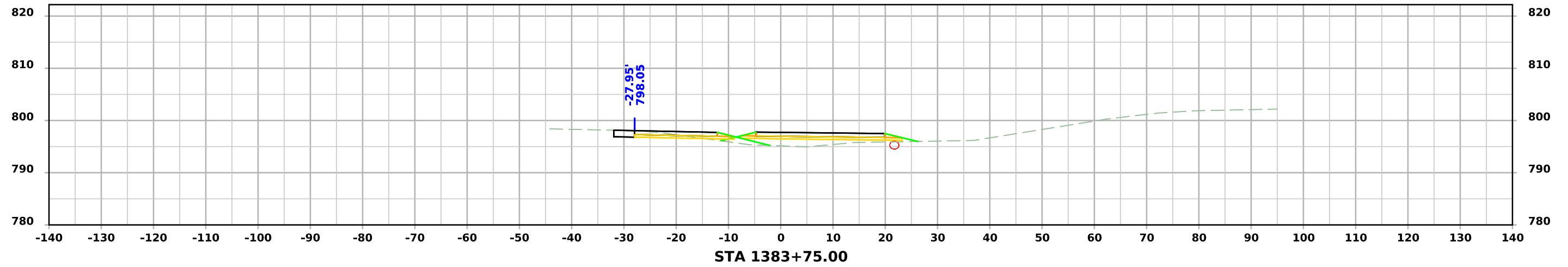

ML063

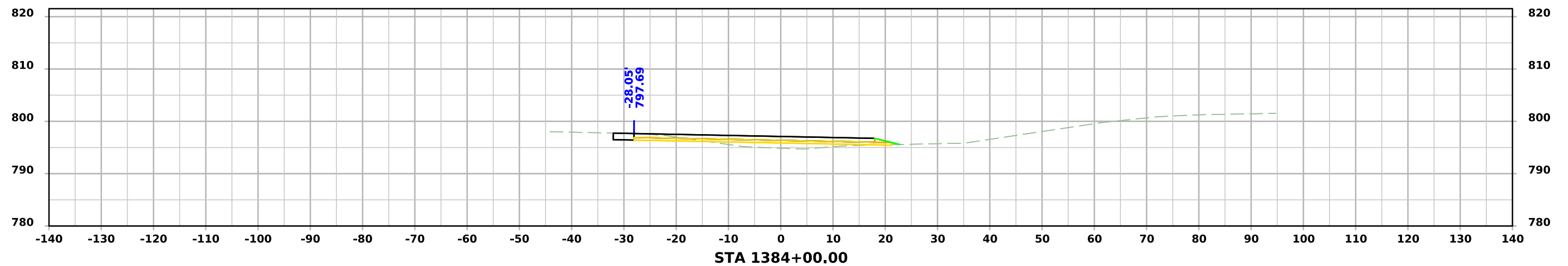
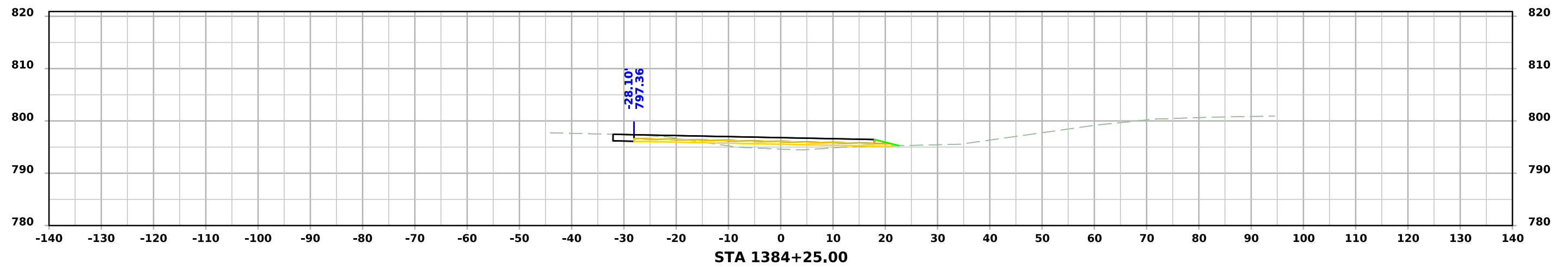
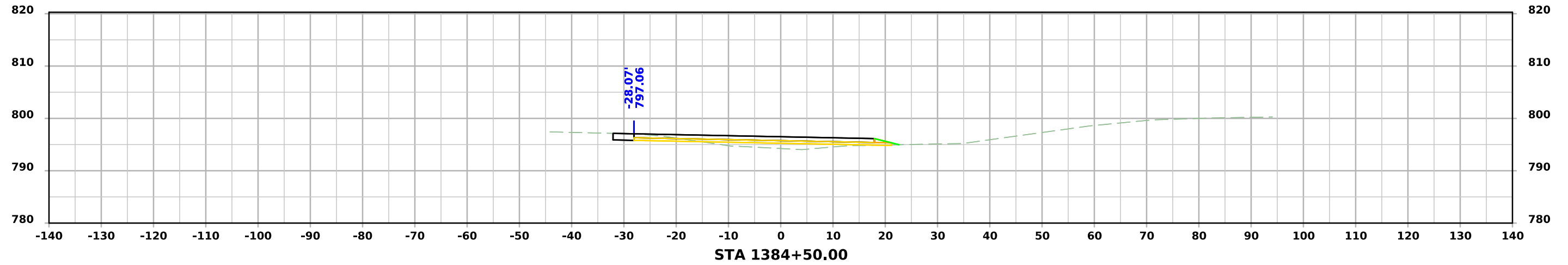

ML063

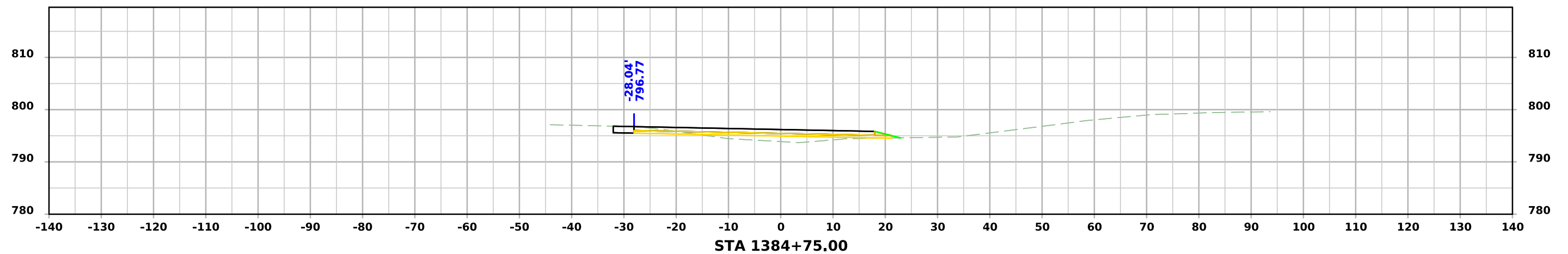
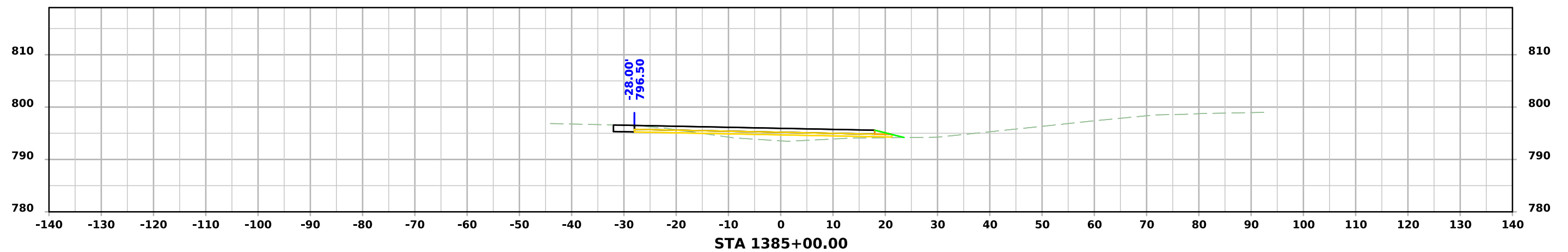
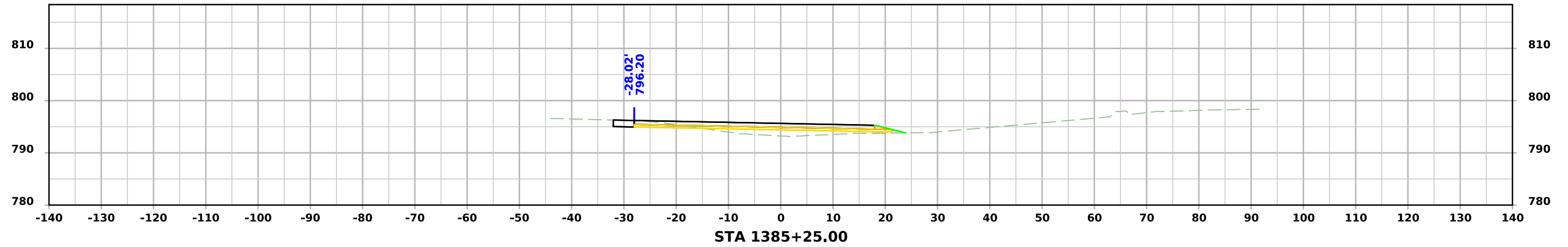

ML063

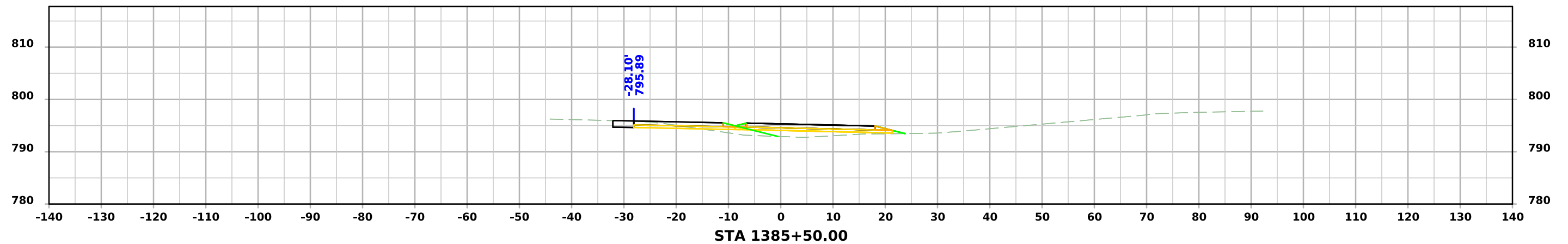
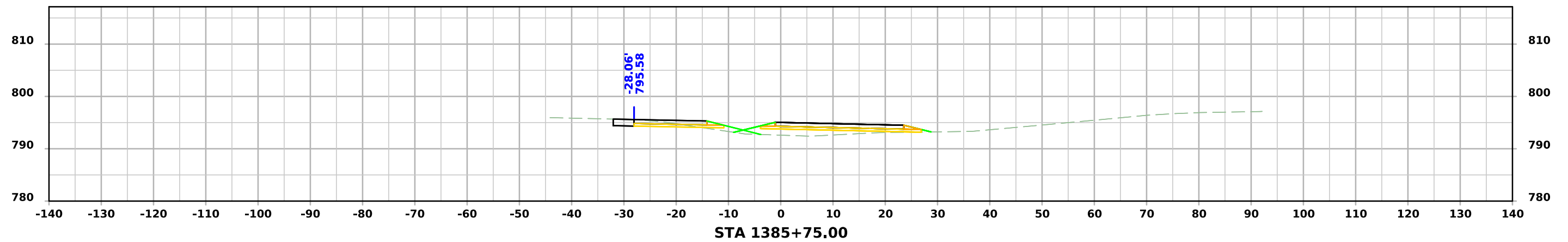
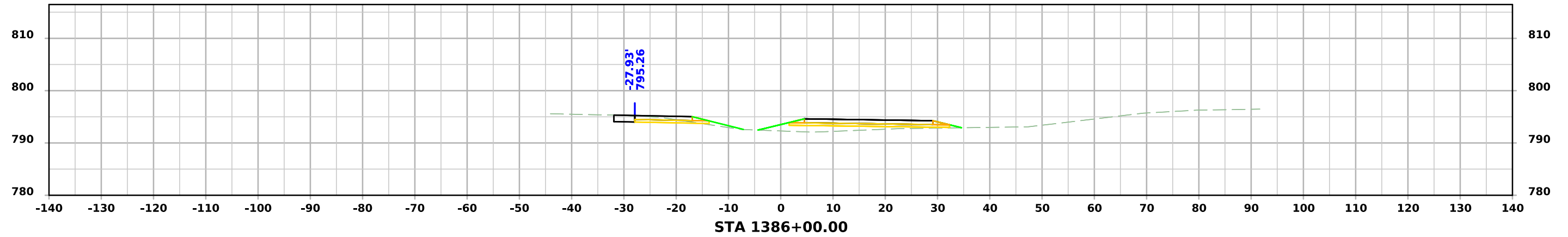

ML063

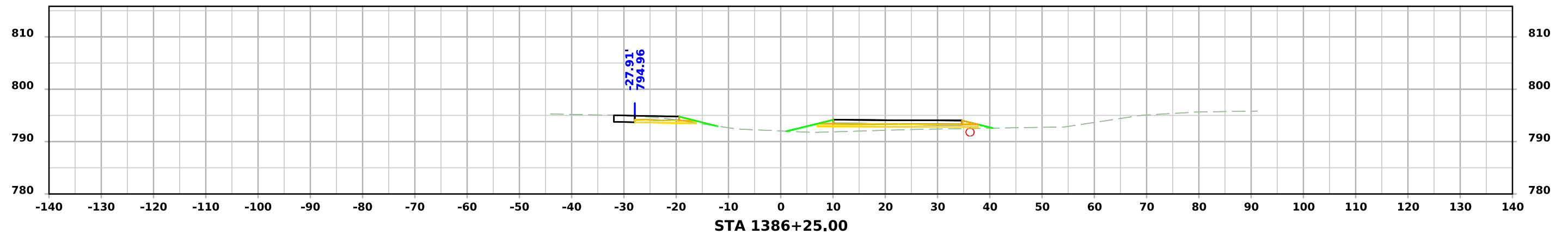
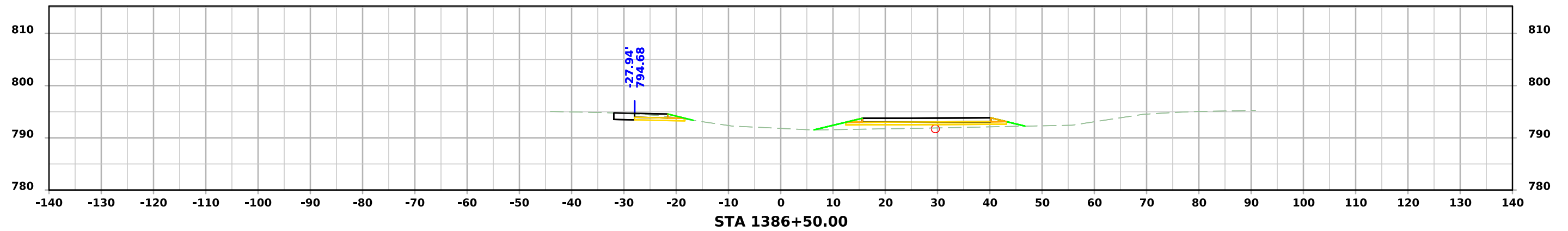
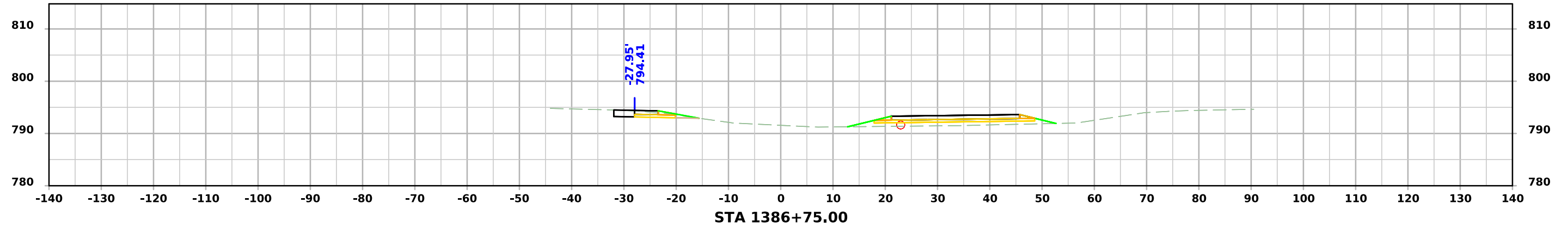

ML063

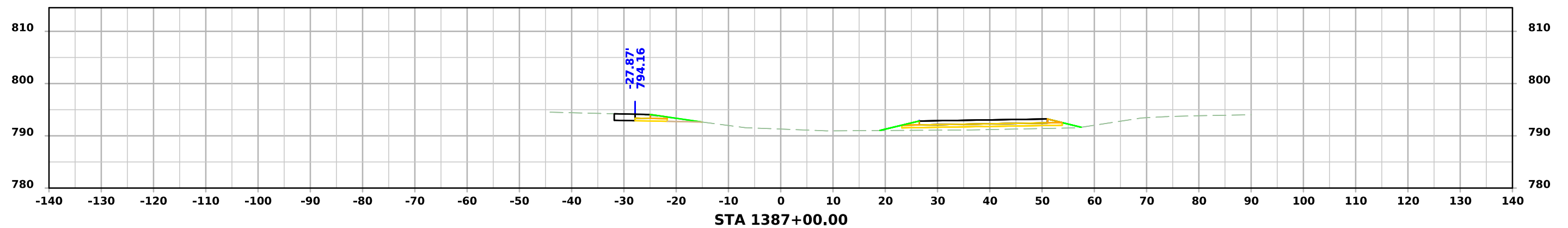
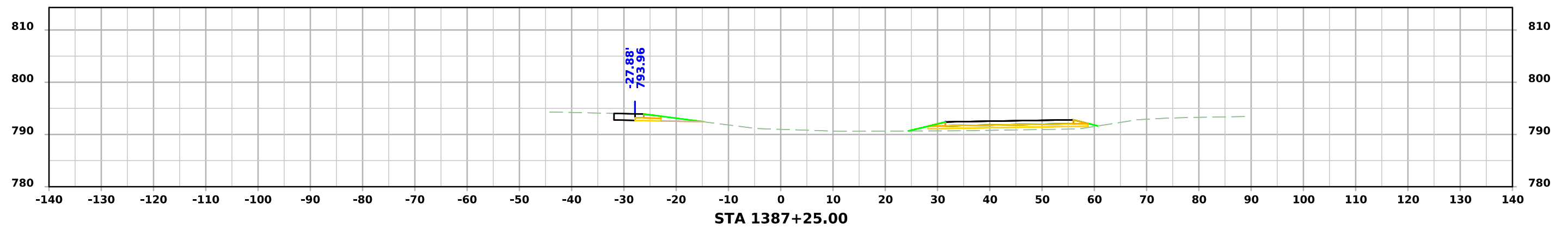
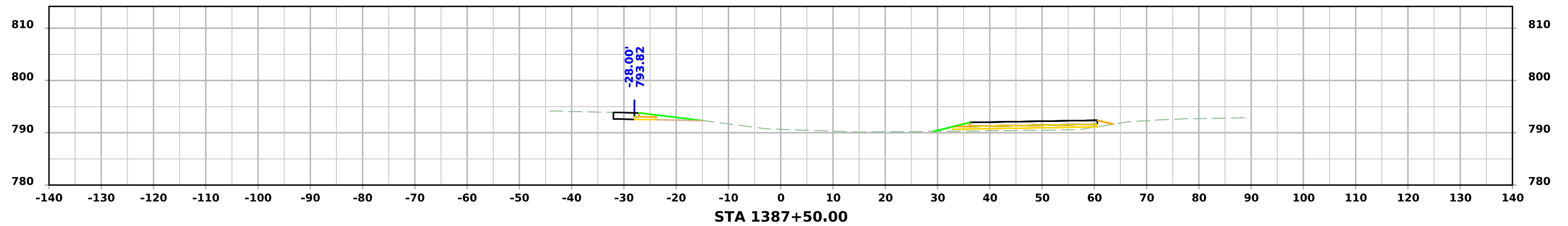

ML063

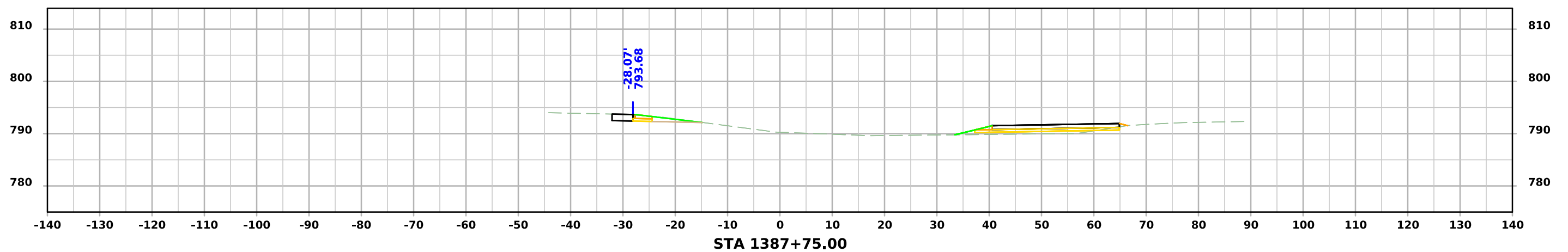
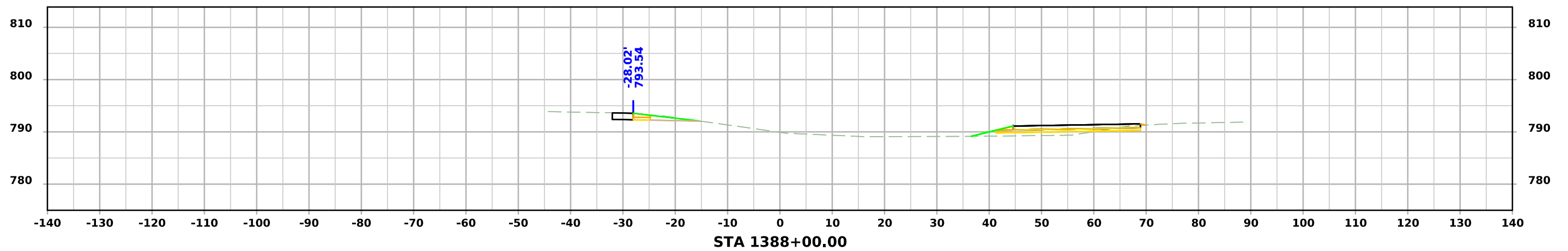
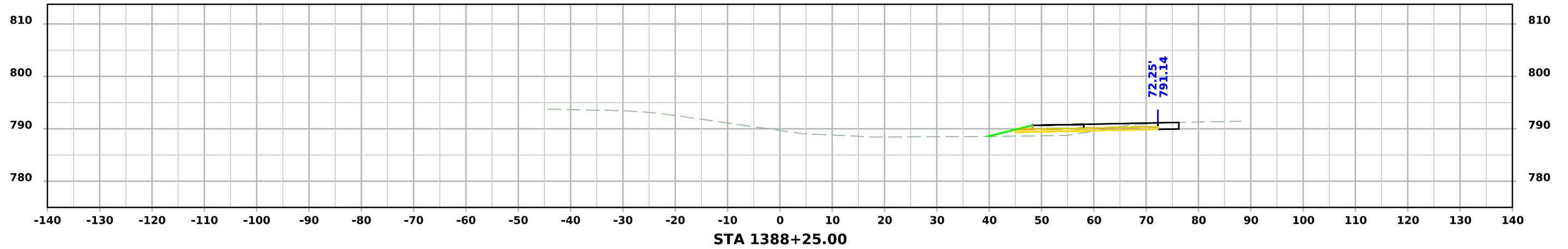

ML063

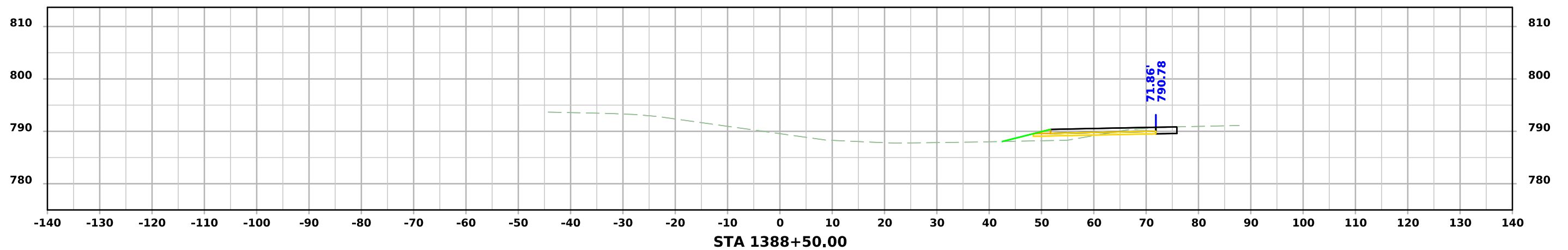
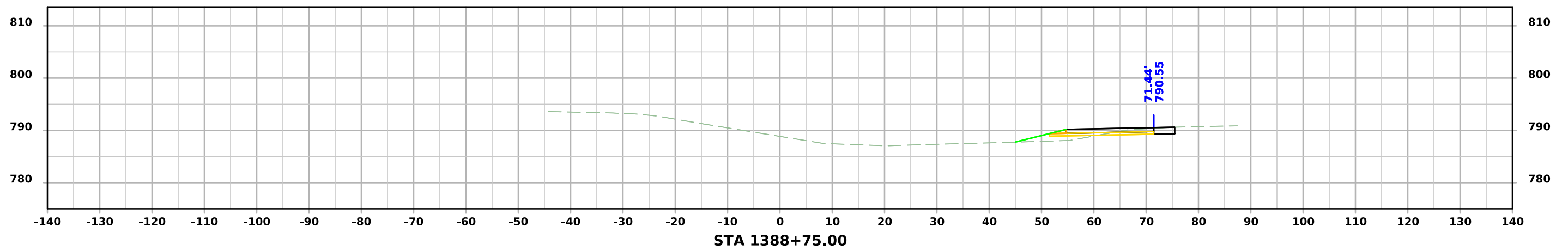
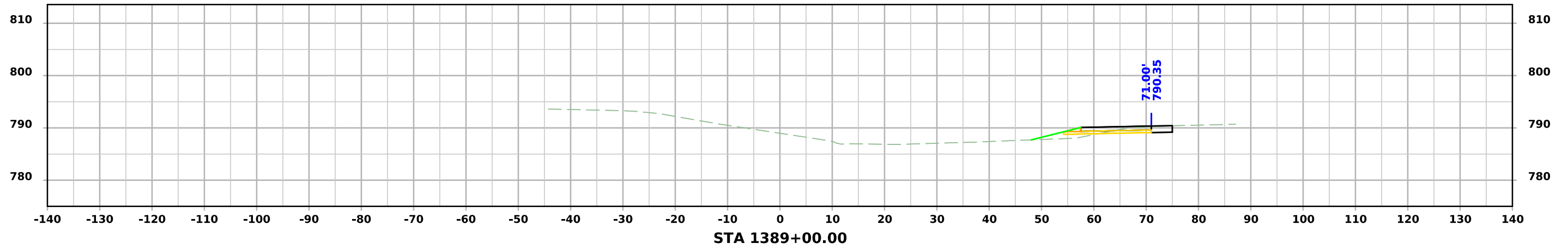

ML063

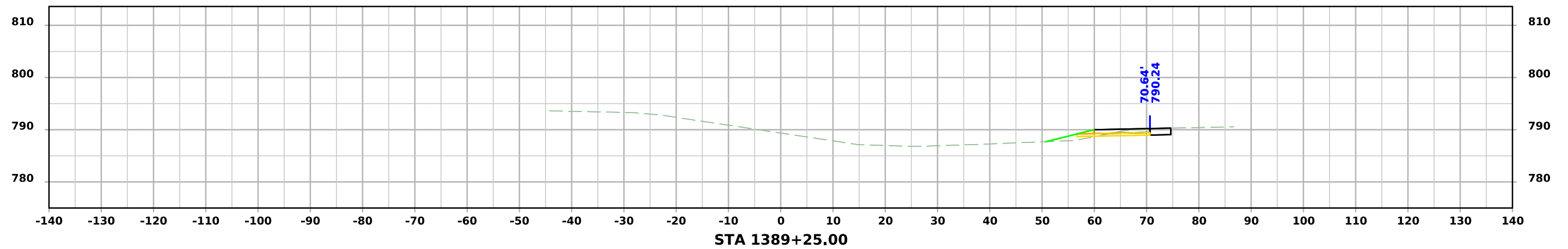
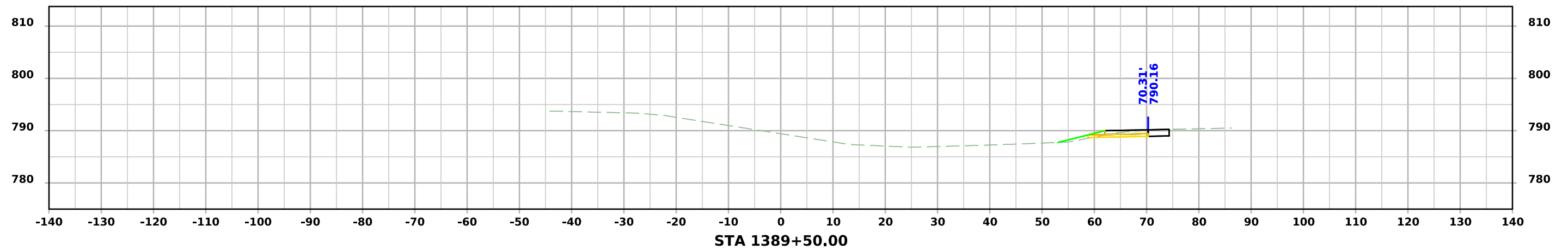
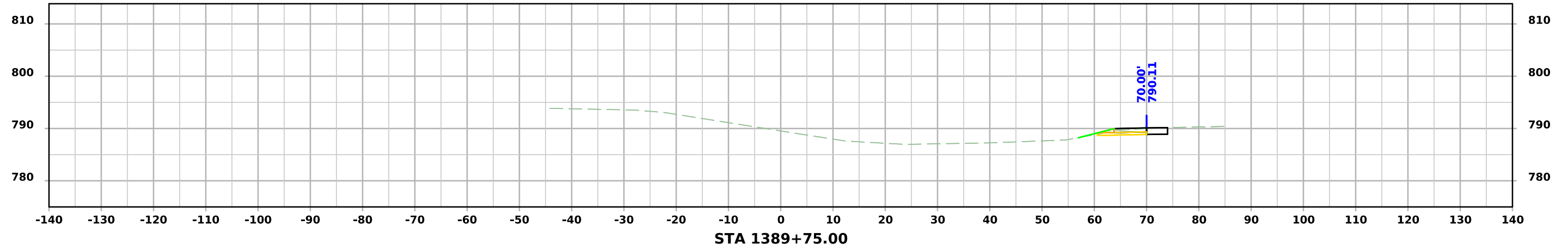

ML063

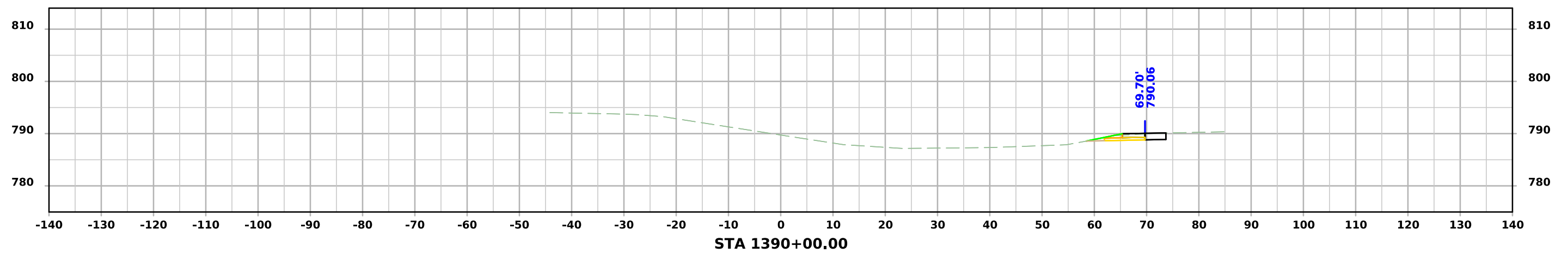
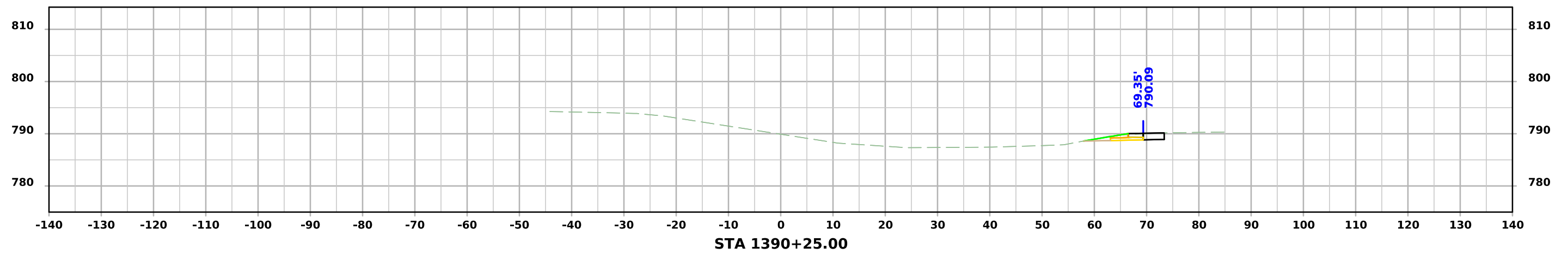
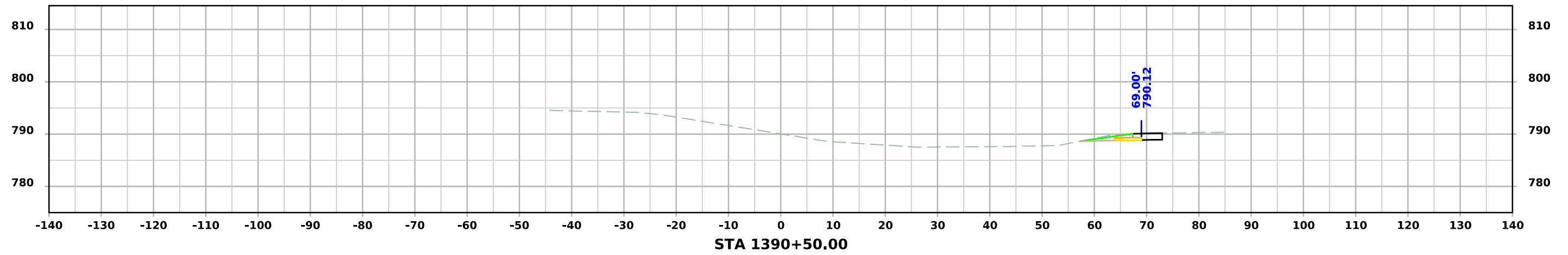

ML063

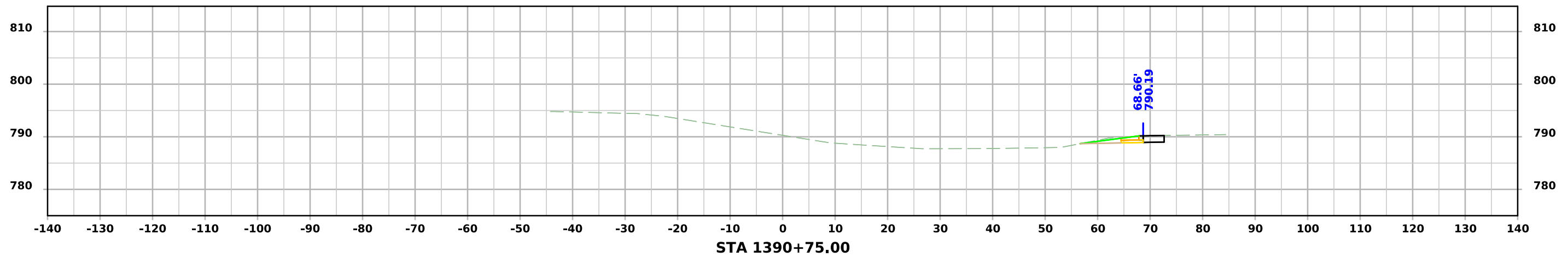
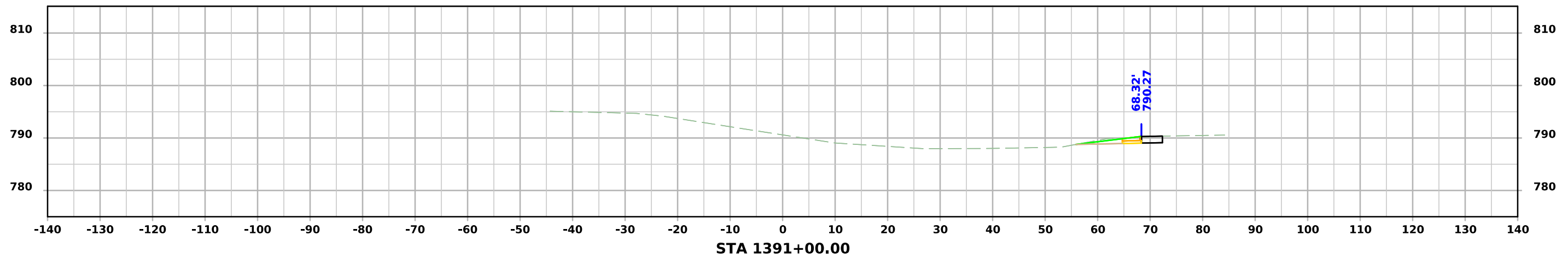
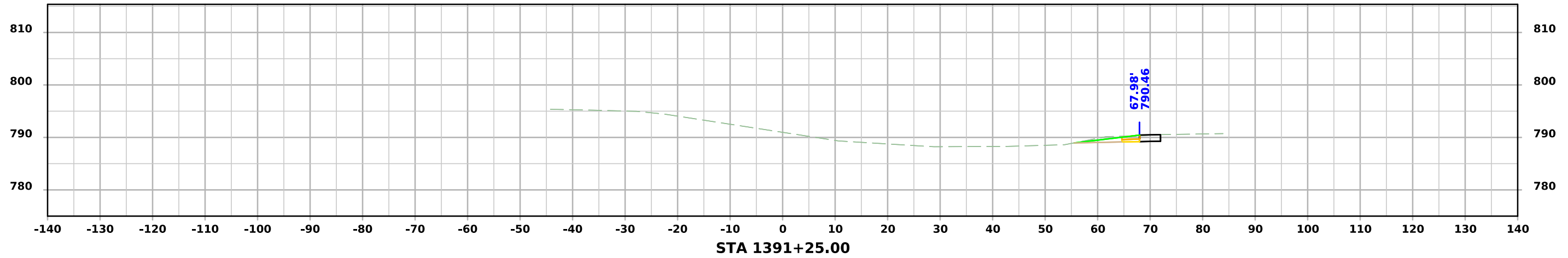

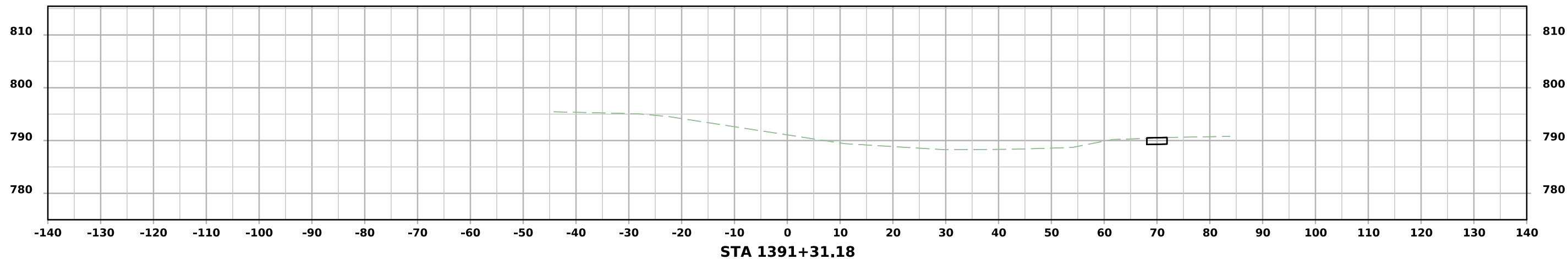

ML063 Culverts

