

US75 SB Preliminary

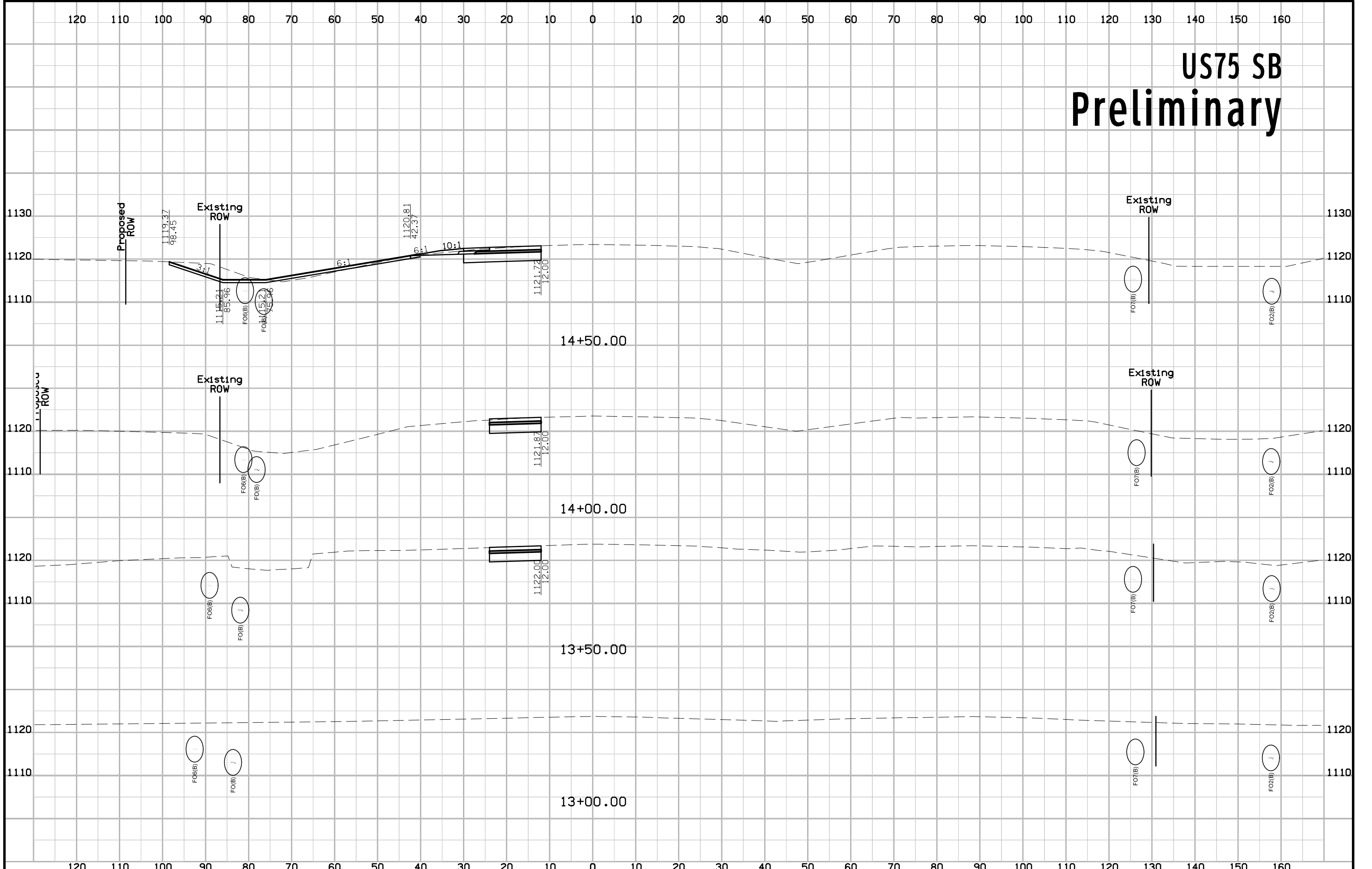

US75 SB Preliminary

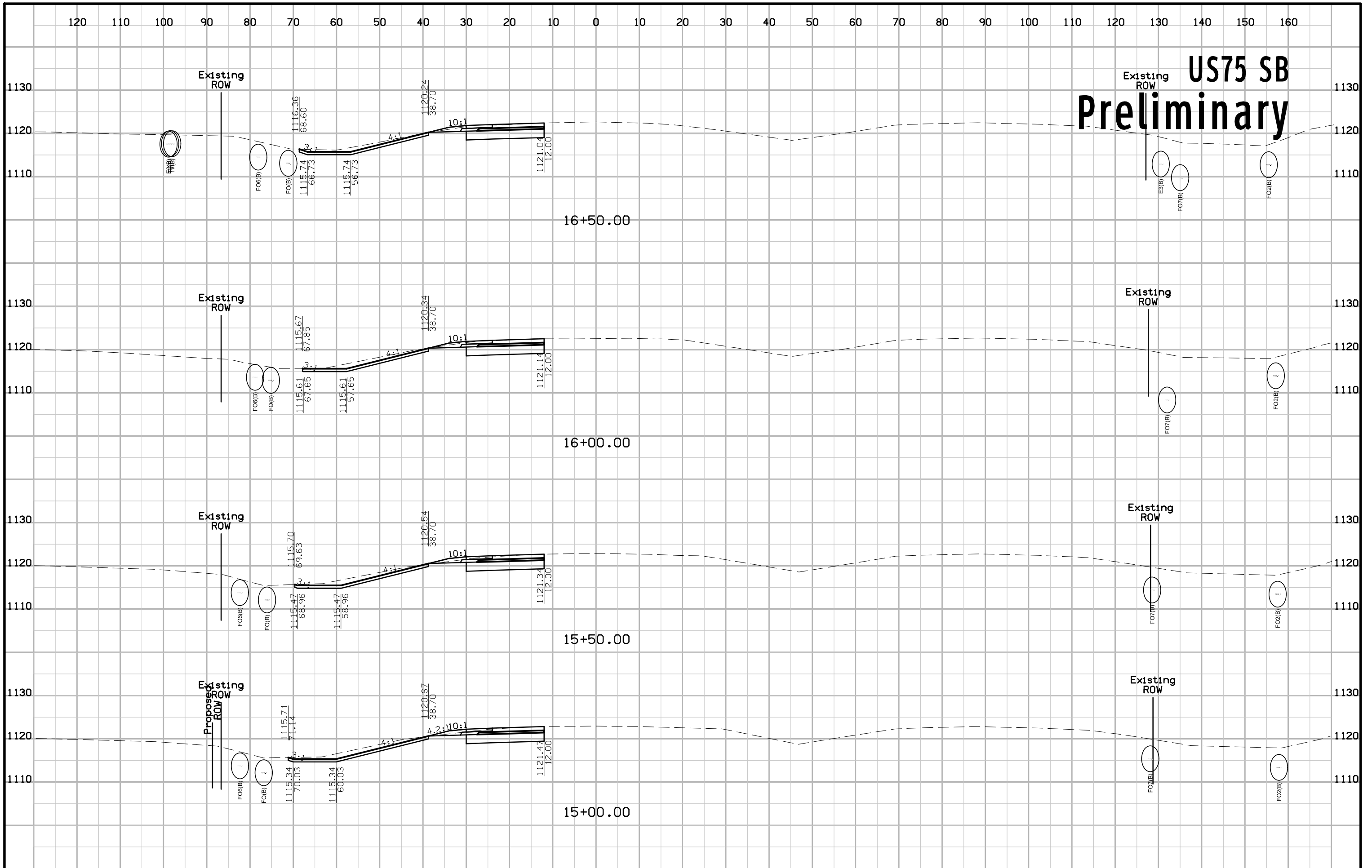

US75 SB Preliminary

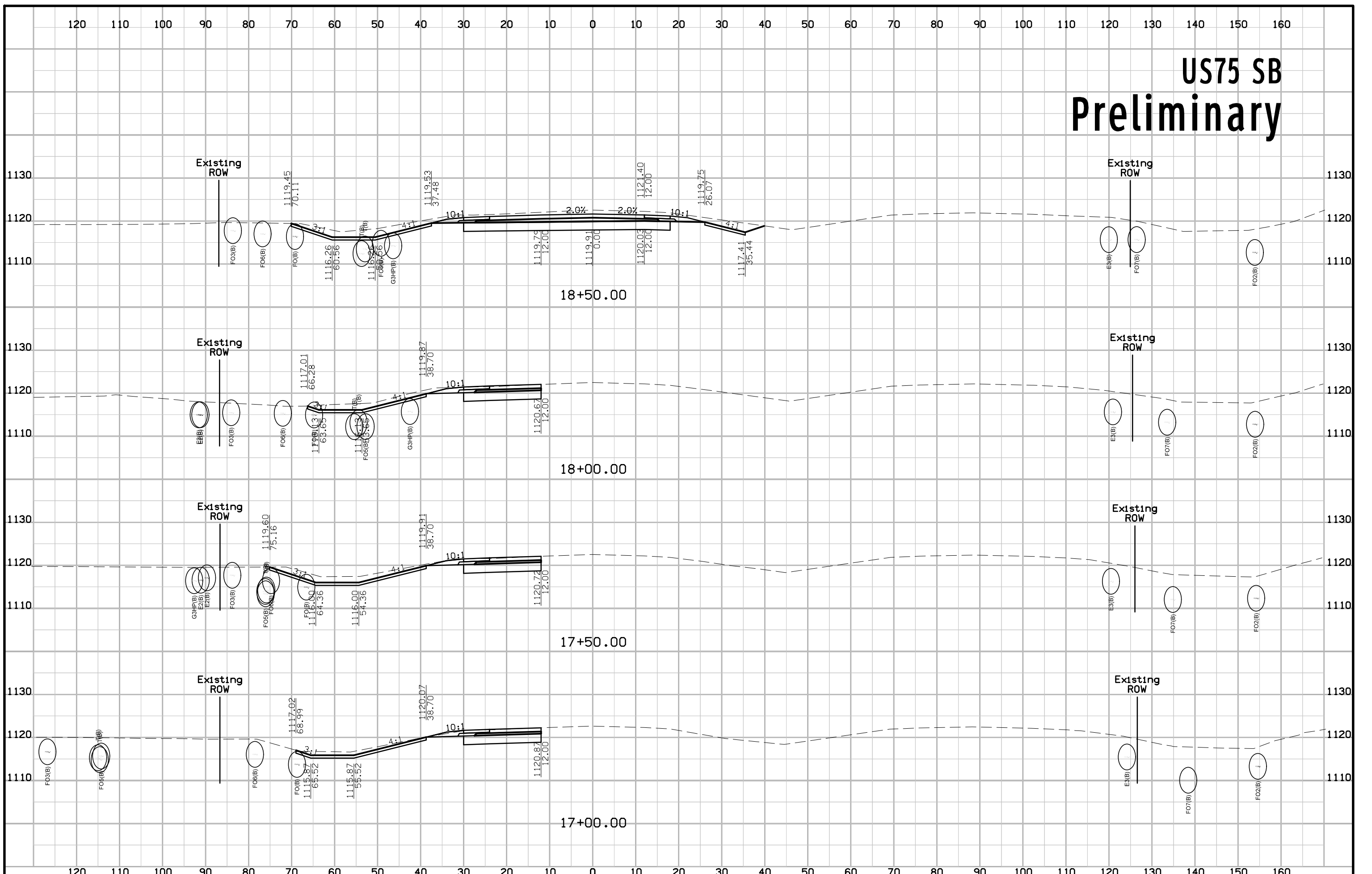

US75 SB Preliminary

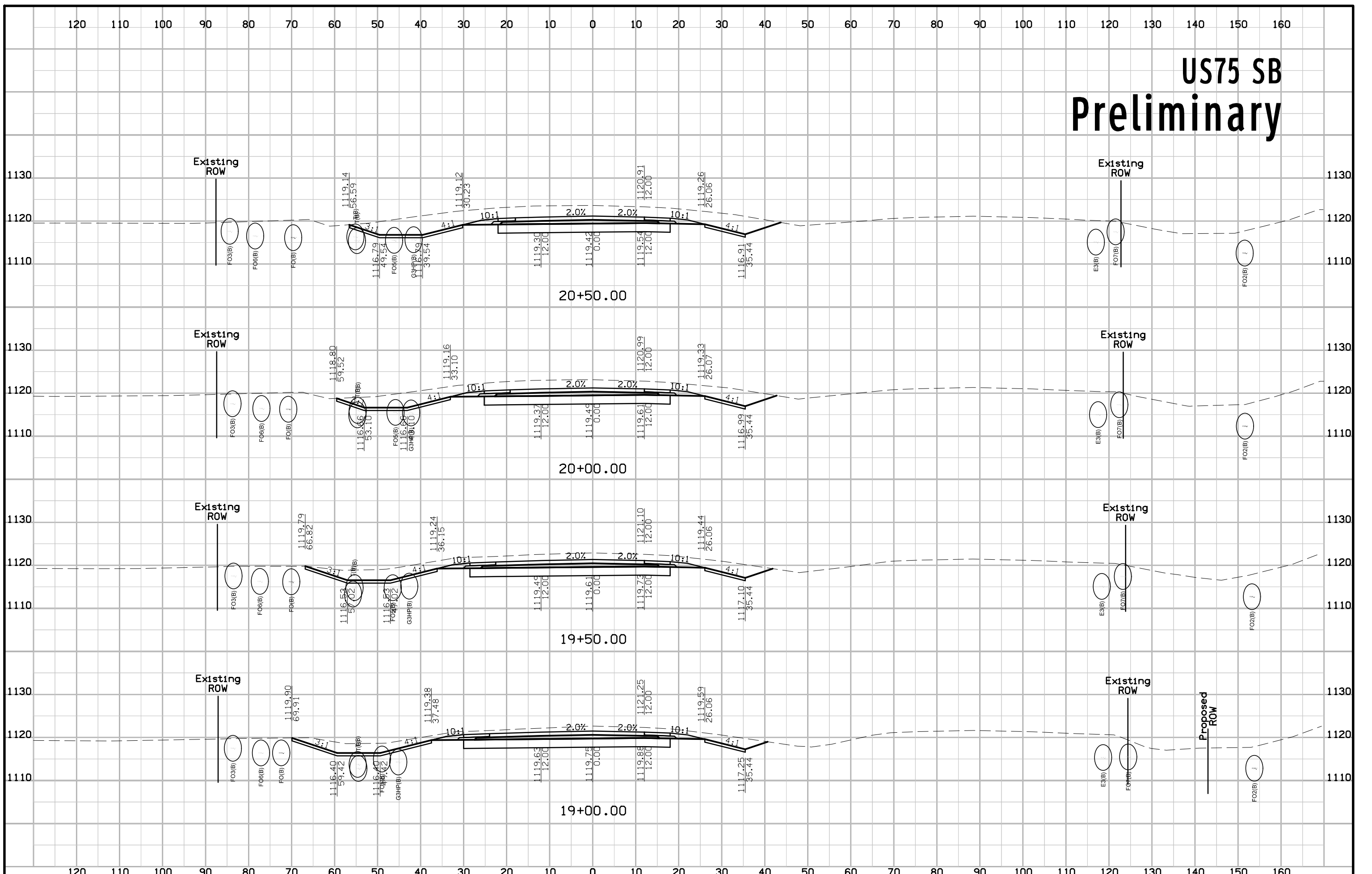

US75 SB Preliminary

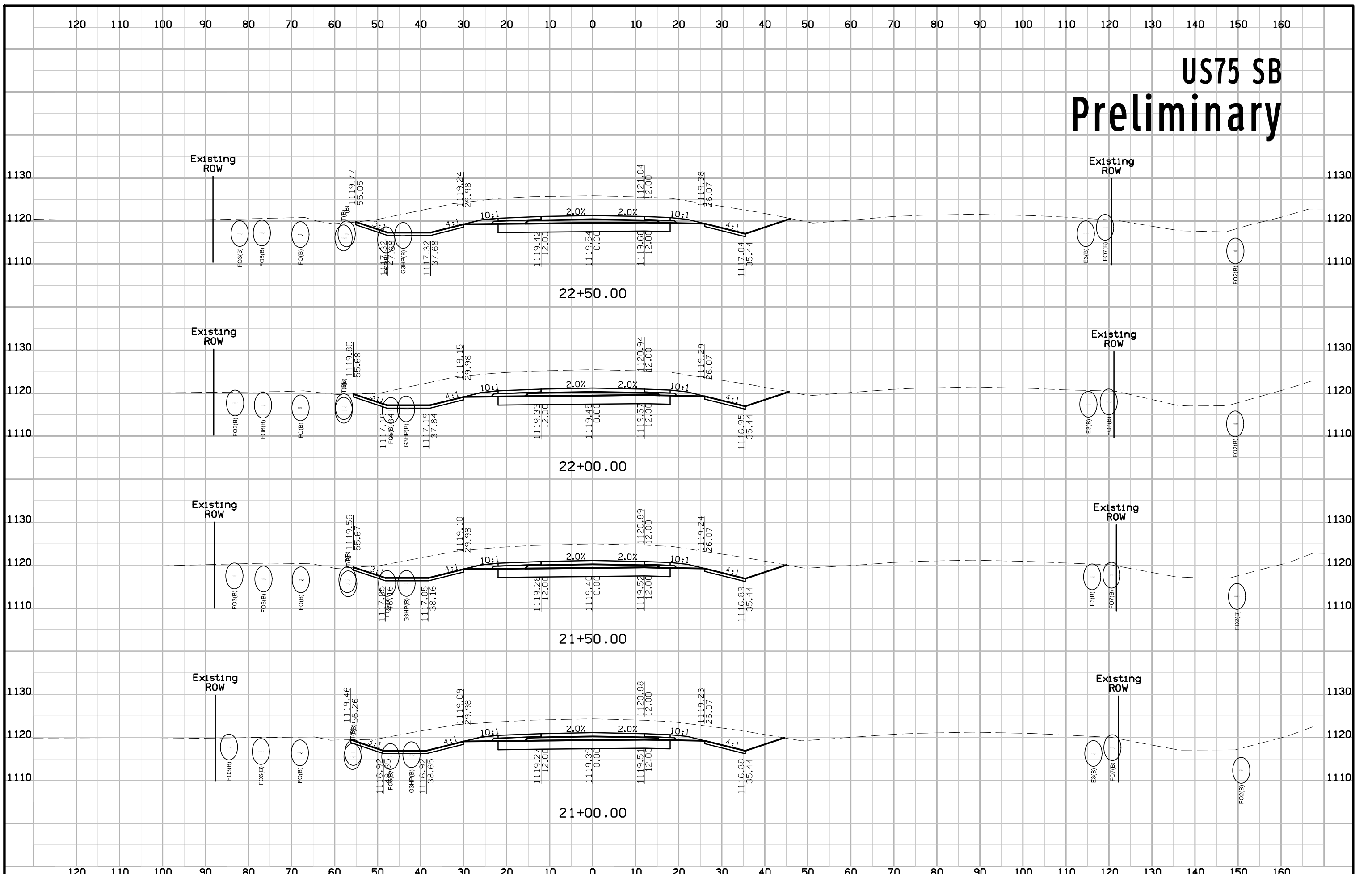

US75 SB Preliminary

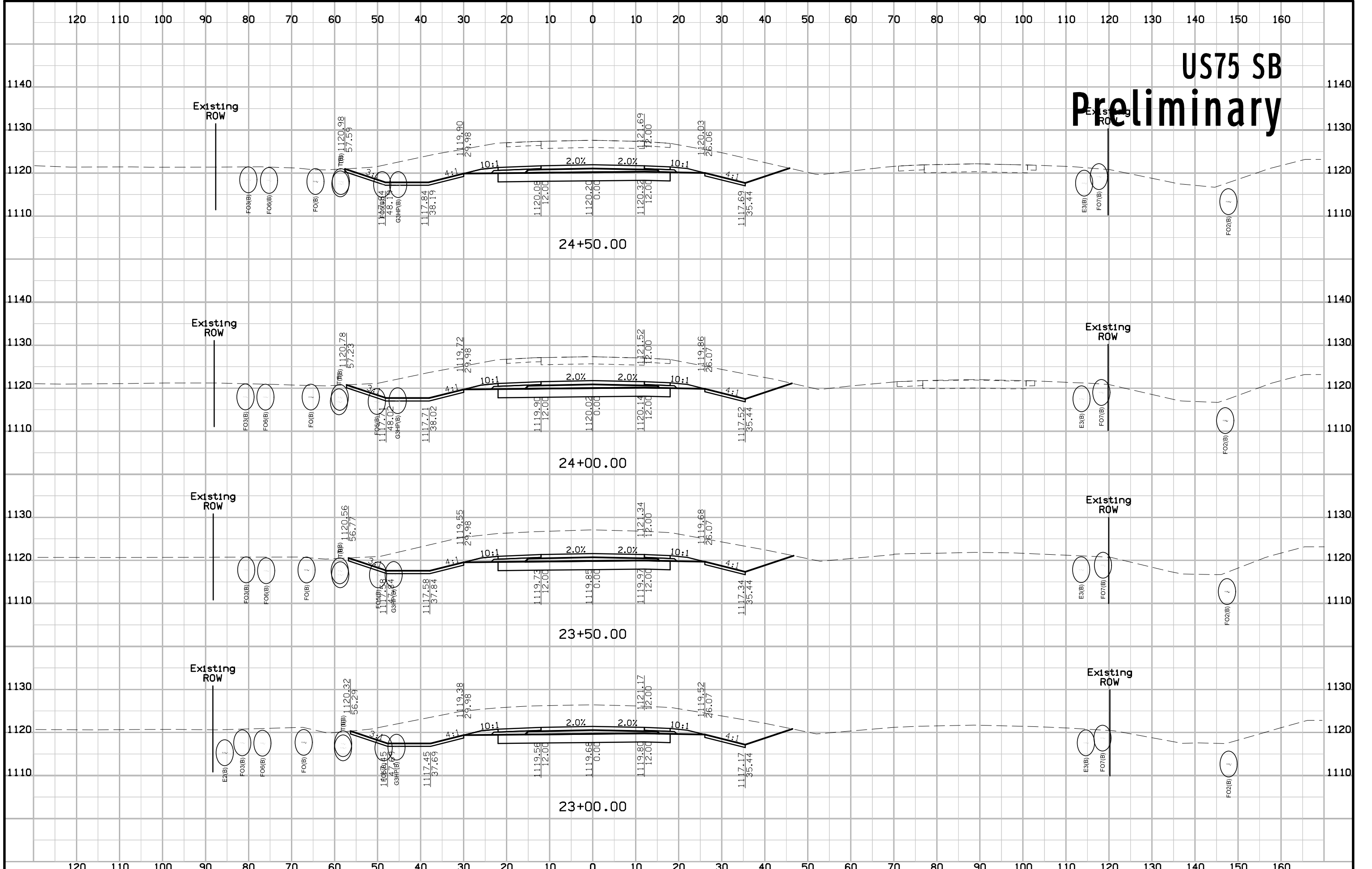

US75 SB Preliminary

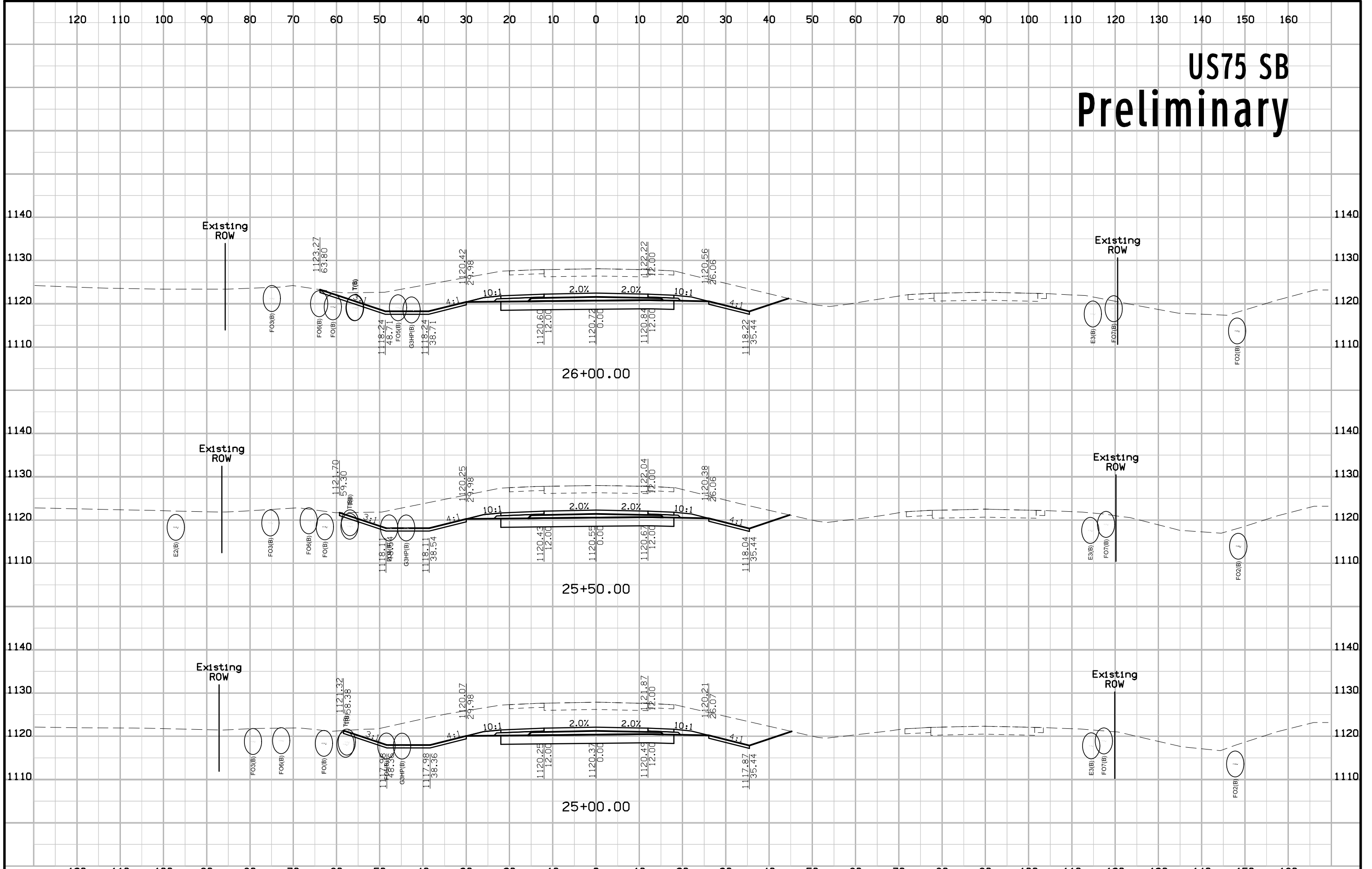

US75 SB Preliminary

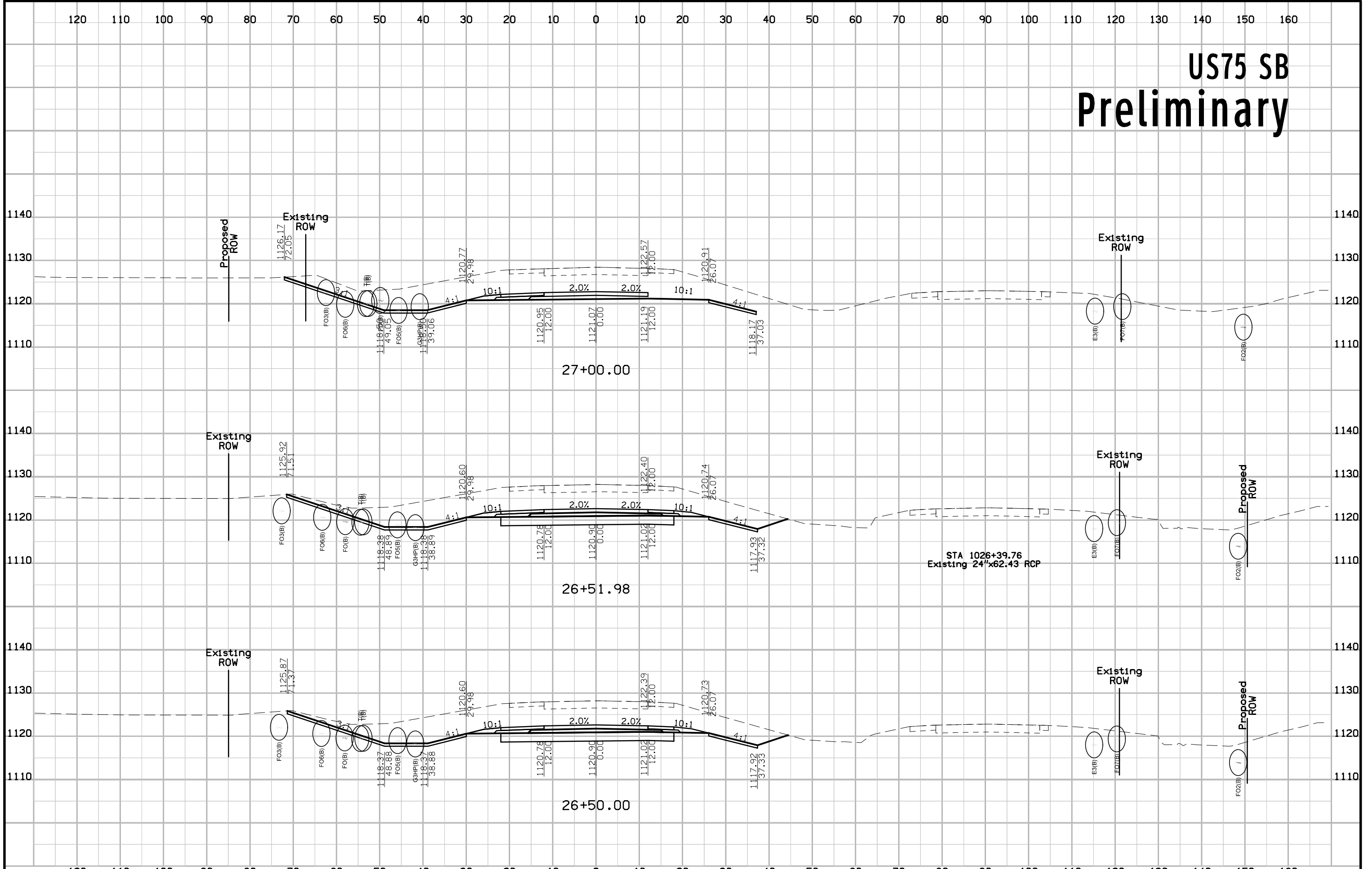

US75 SB Preliminary

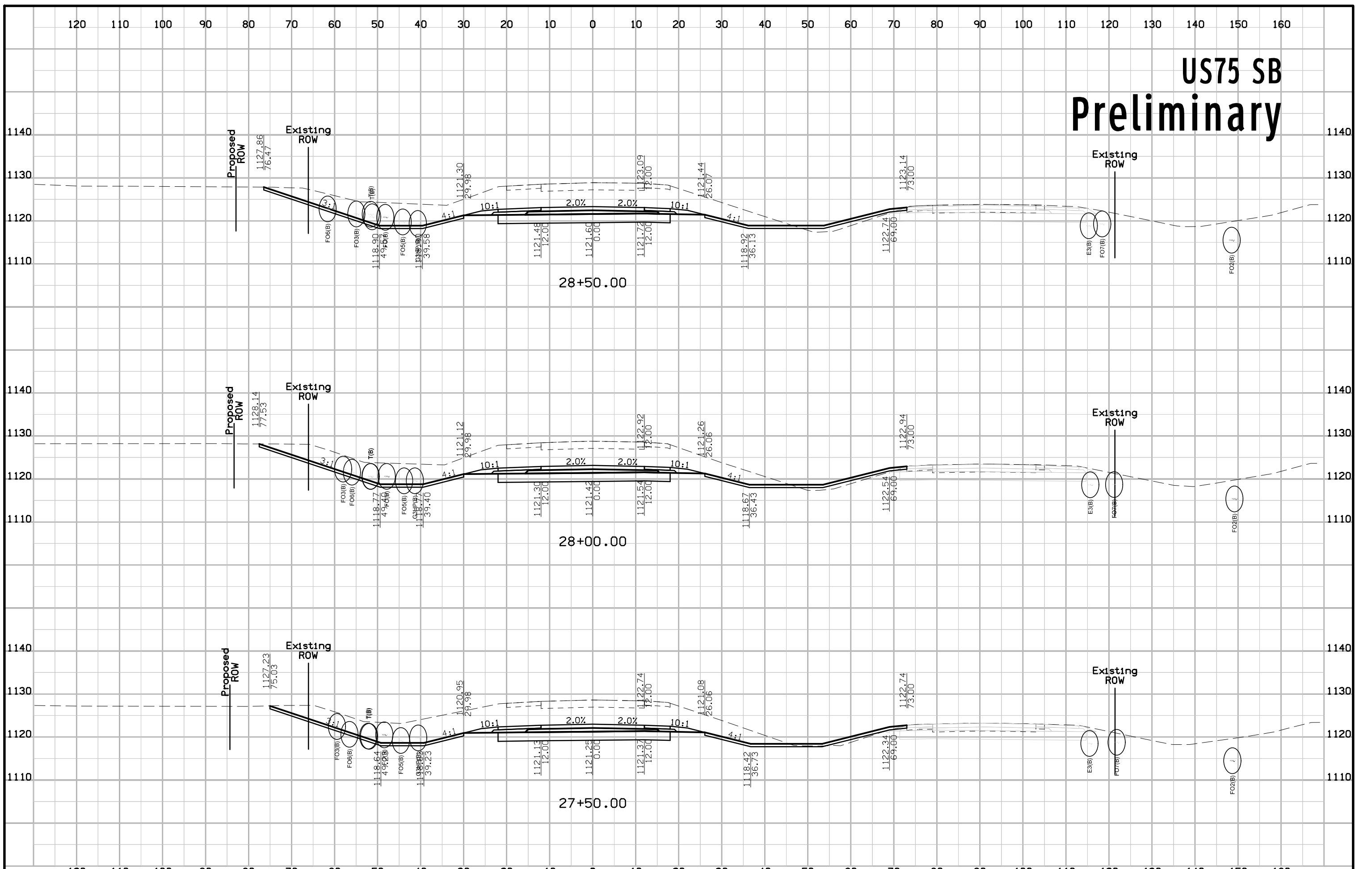

US75 SB Preliminary

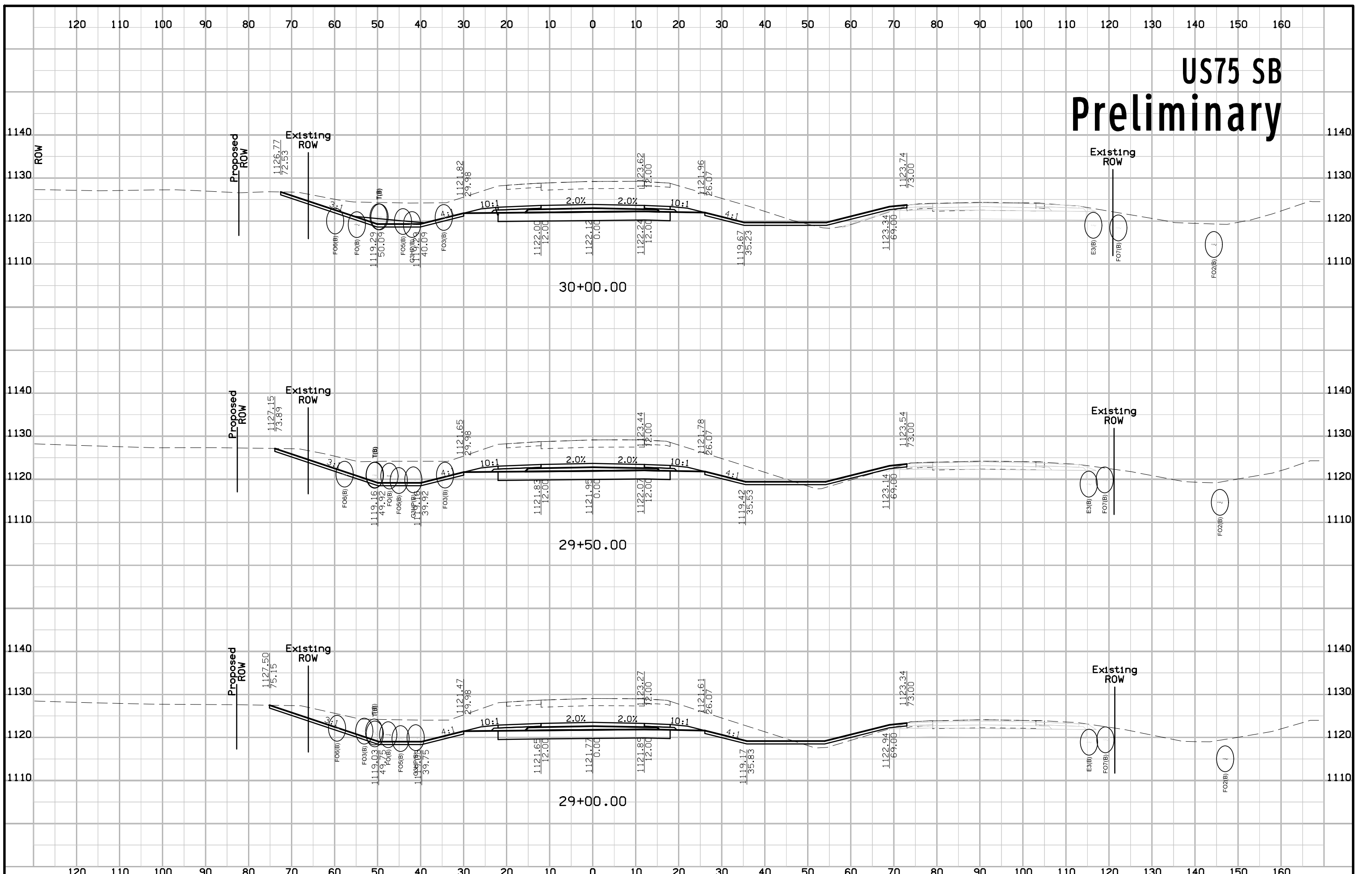

US75 SB Preliminary

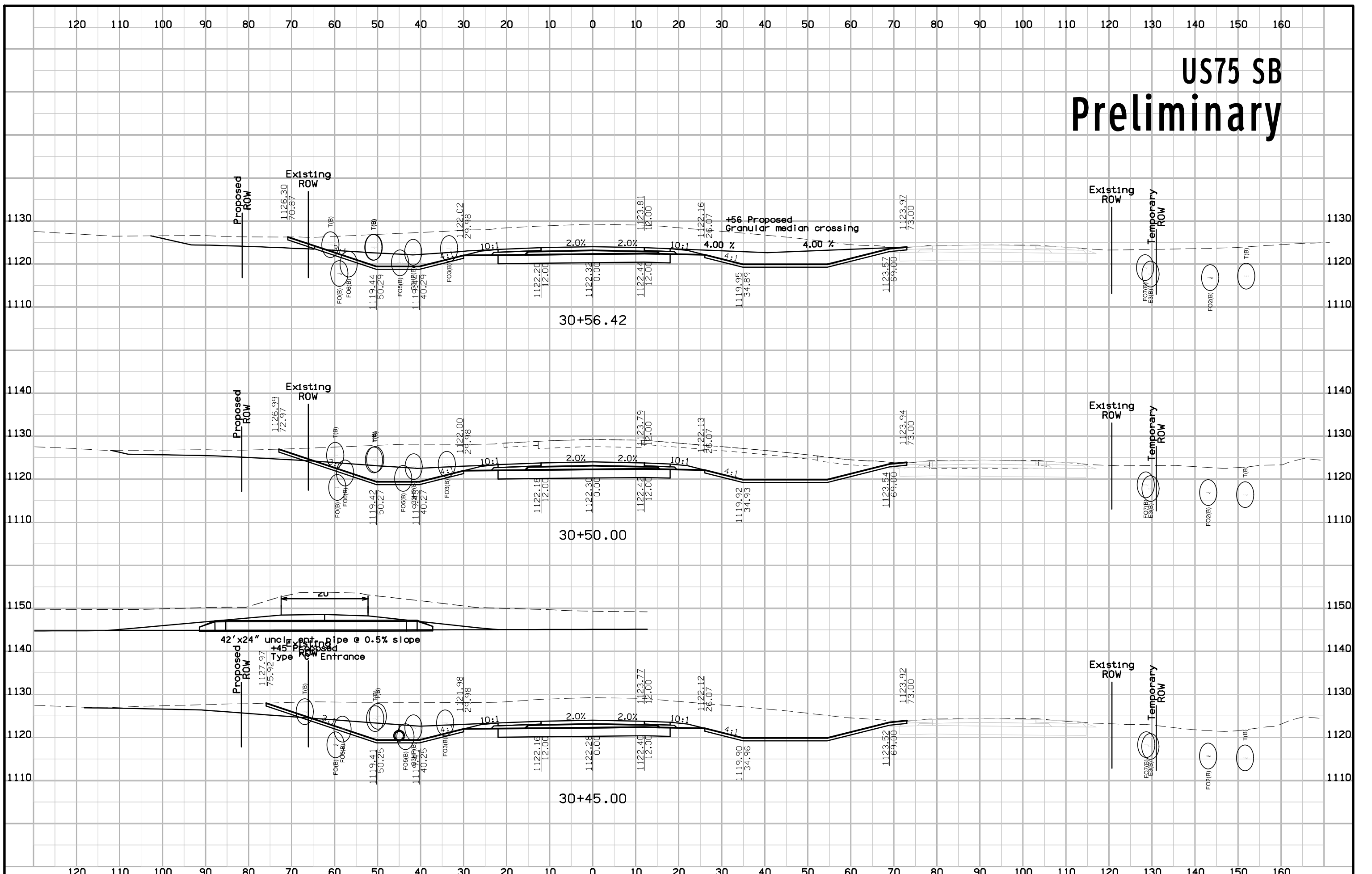

US75 SB Preliminary

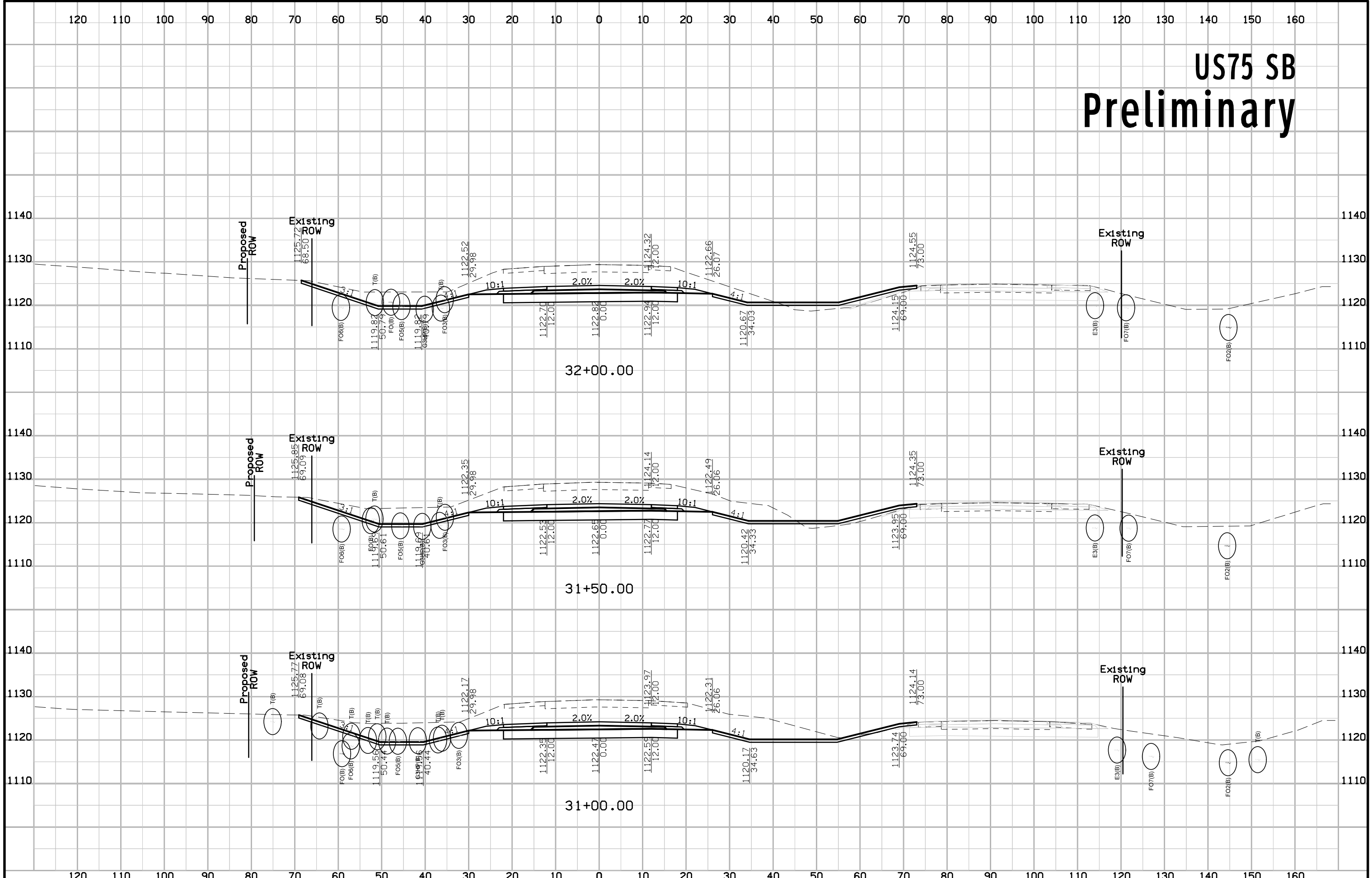

US75 SB Preliminary

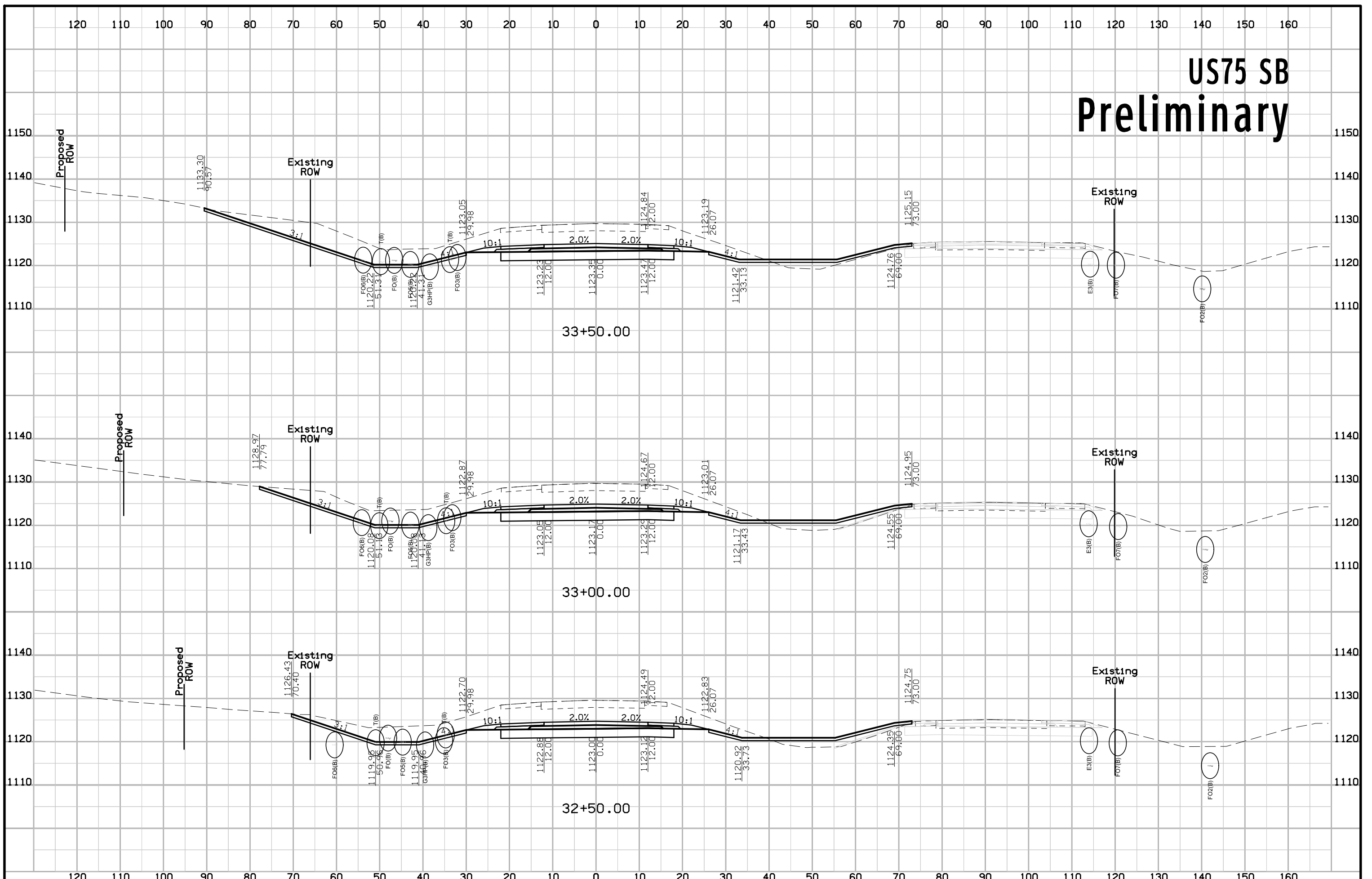

US75 SB Preliminary

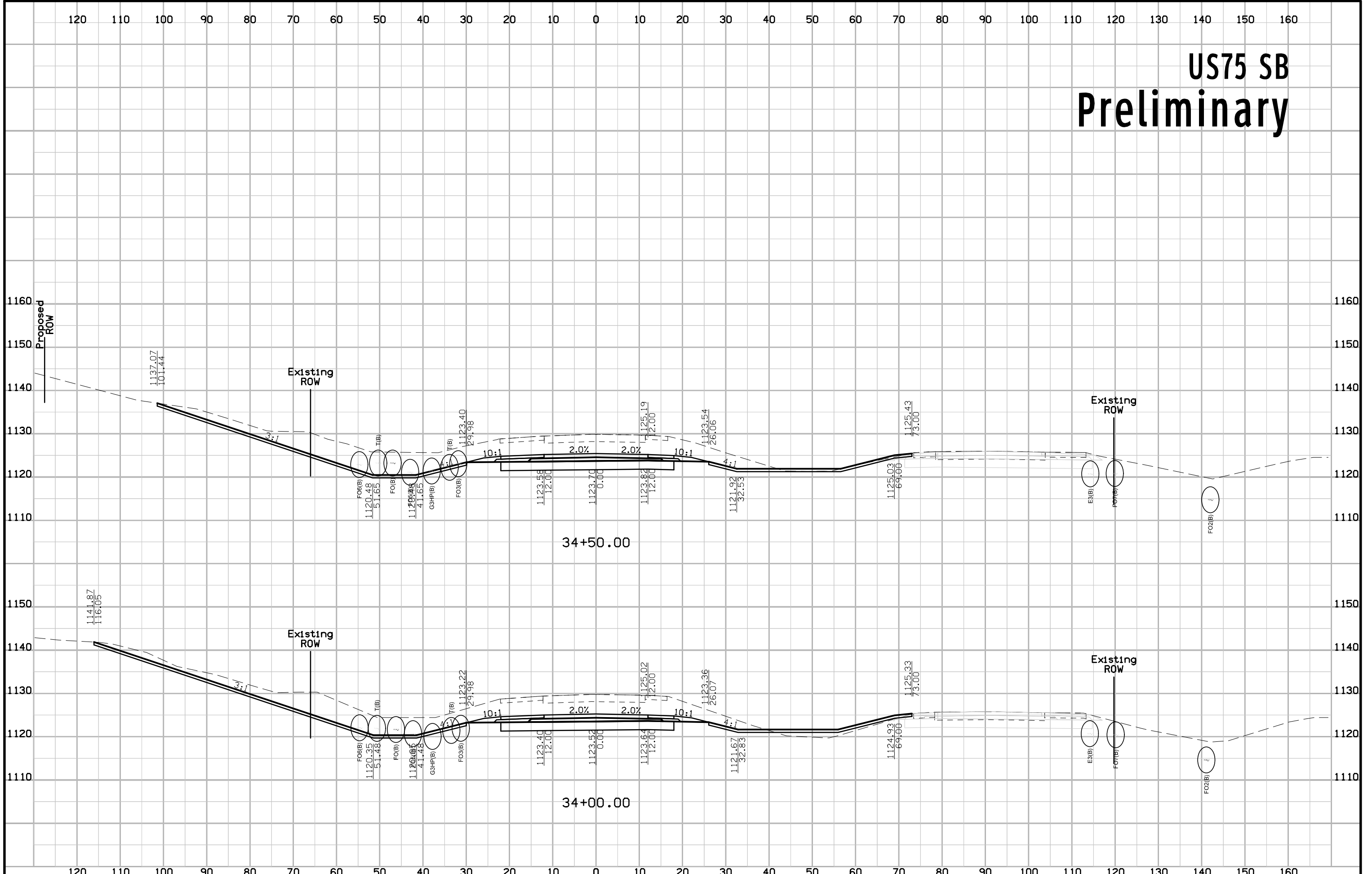

US75 SB Preliminary

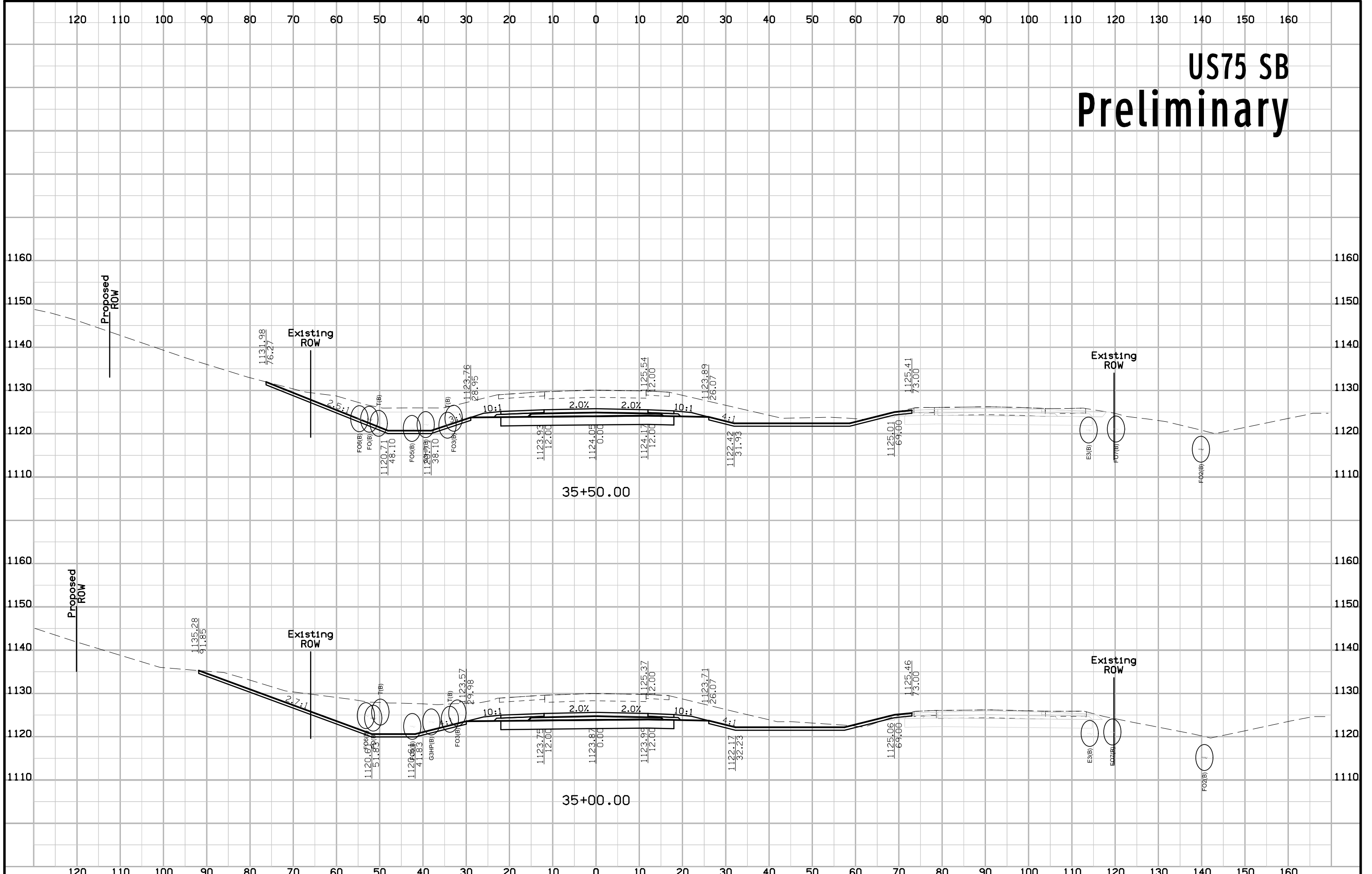

US75 SB Preliminary

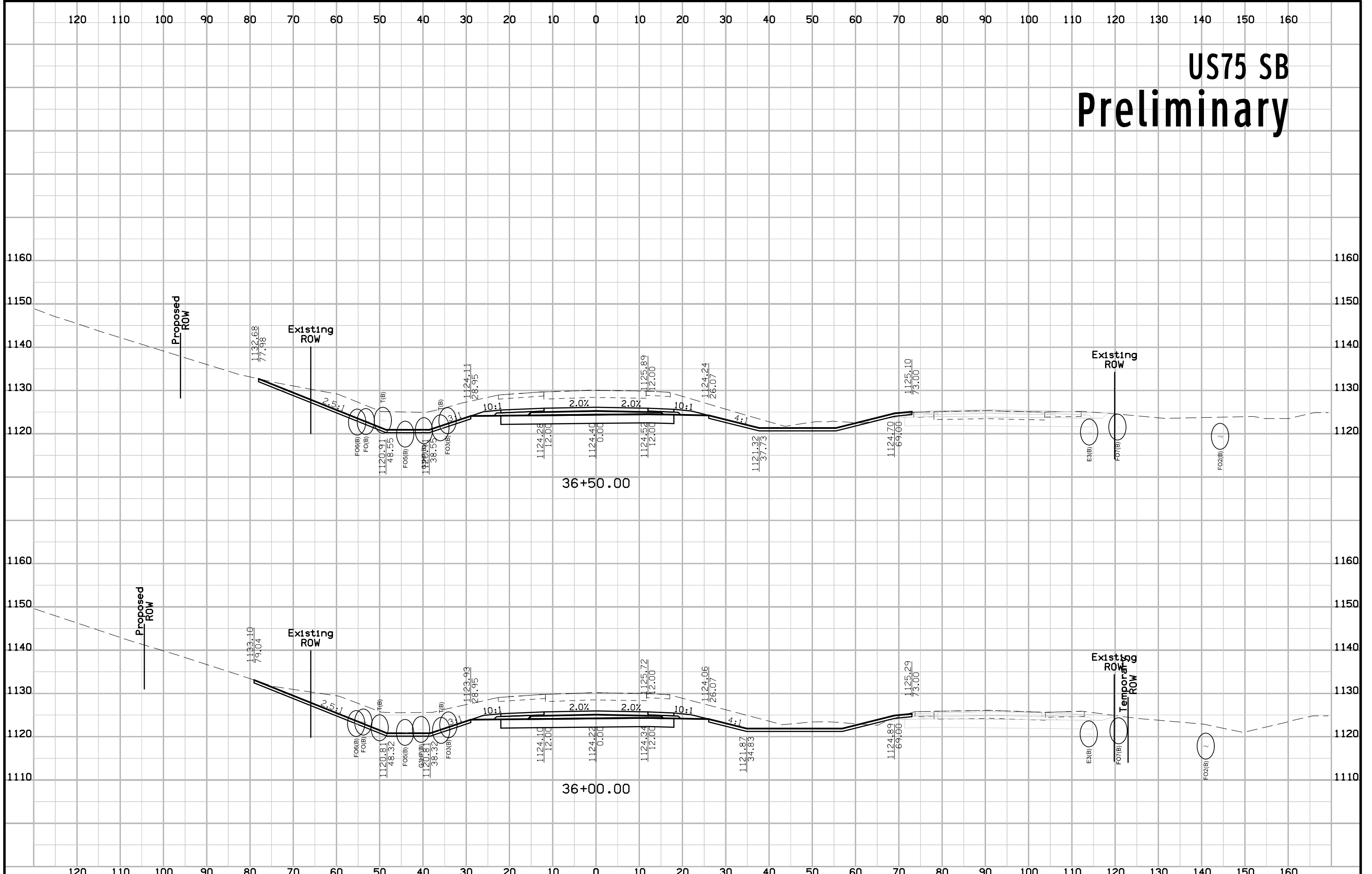

US75 SB Preliminary

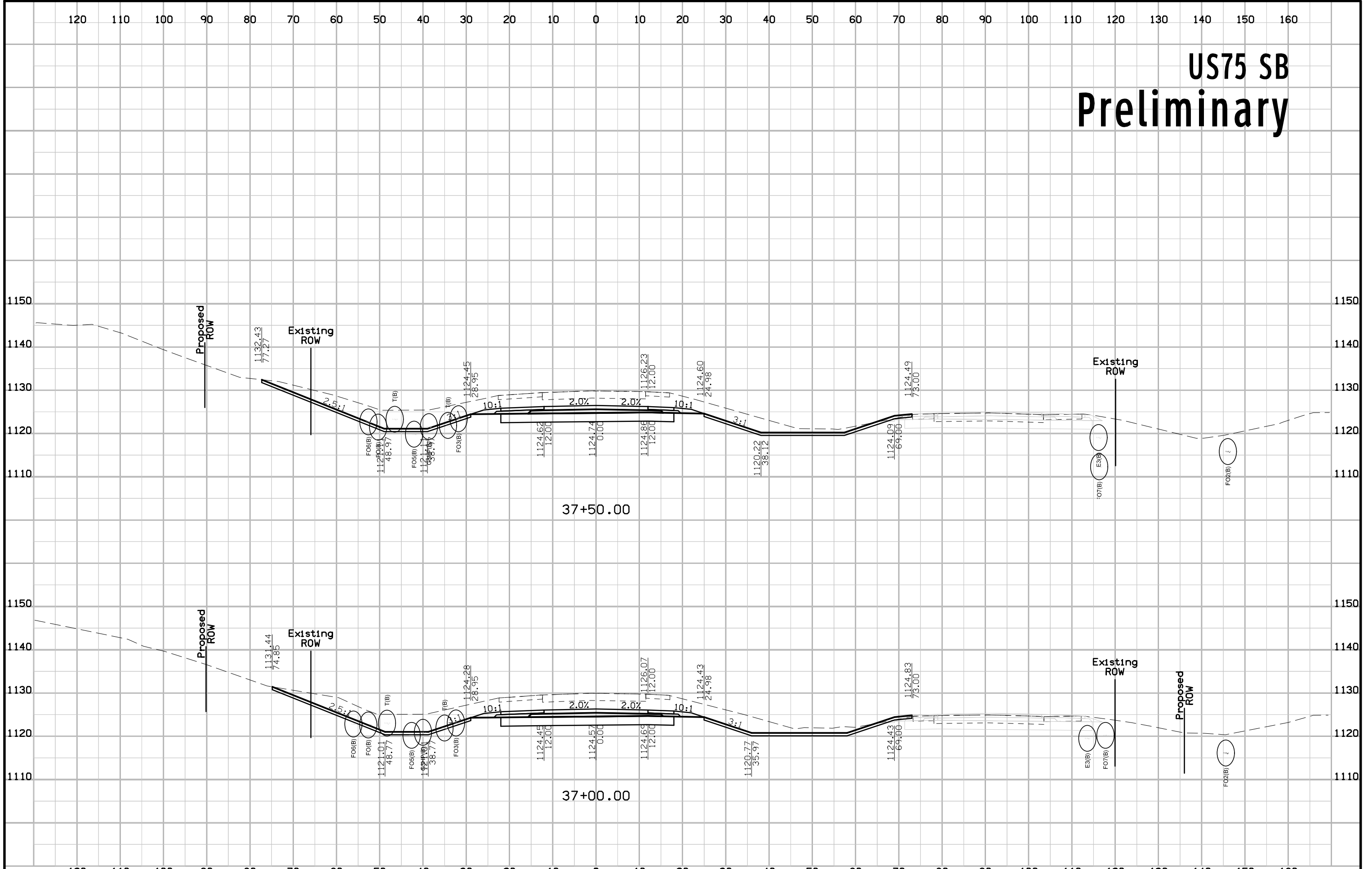

US75 SB Preliminary

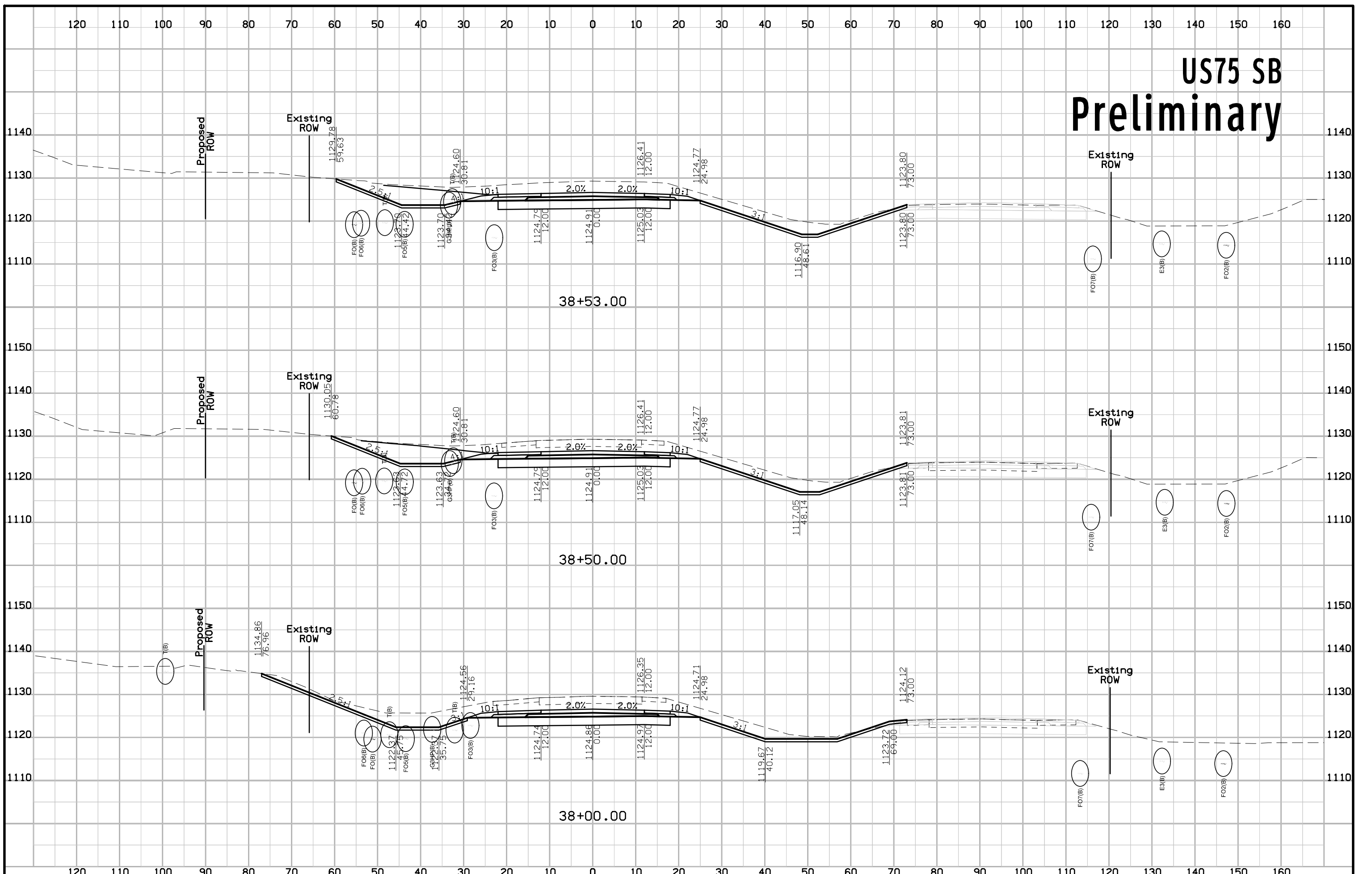

US75 SB Preliminary

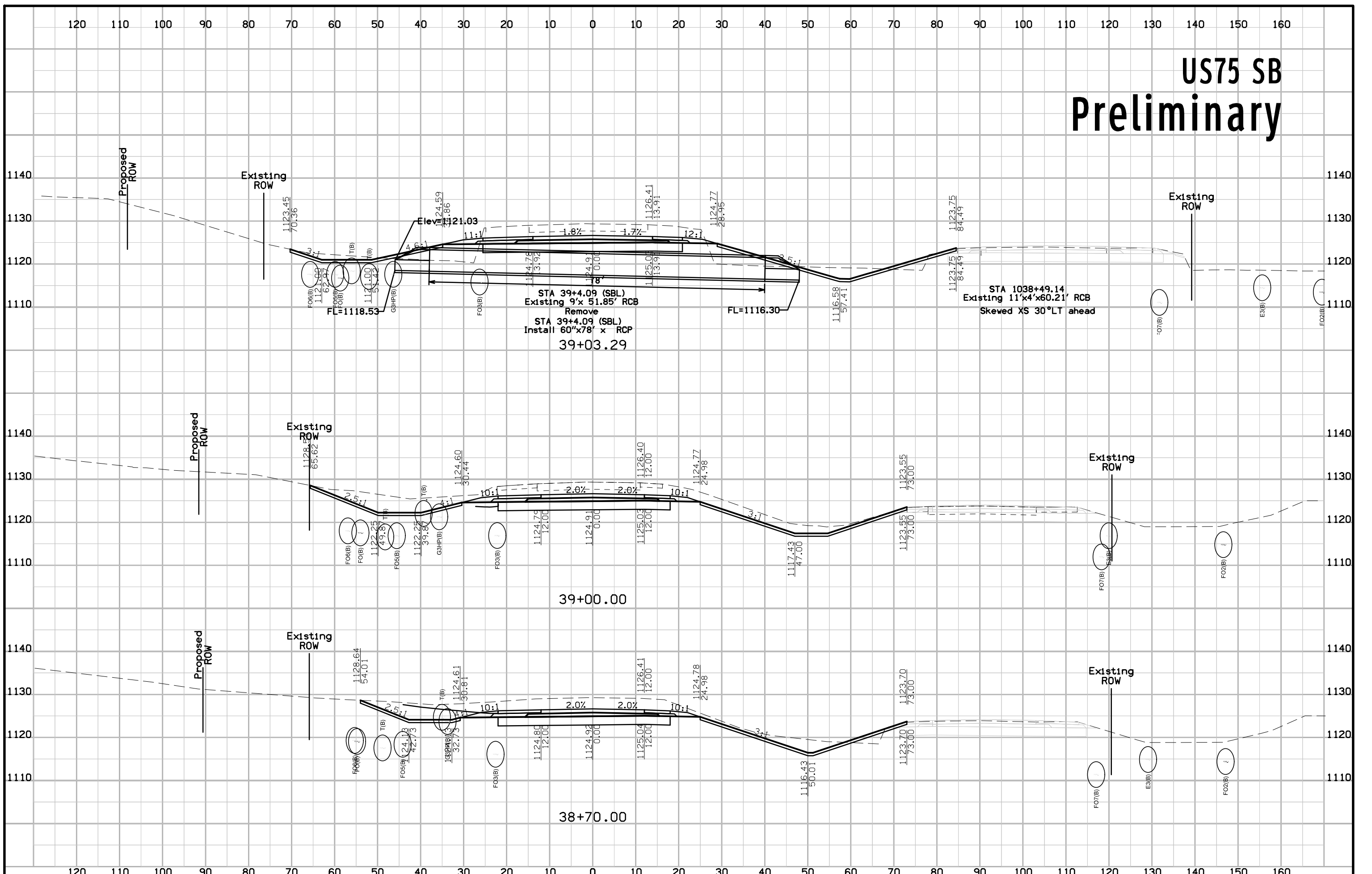

US75 SB Preliminary

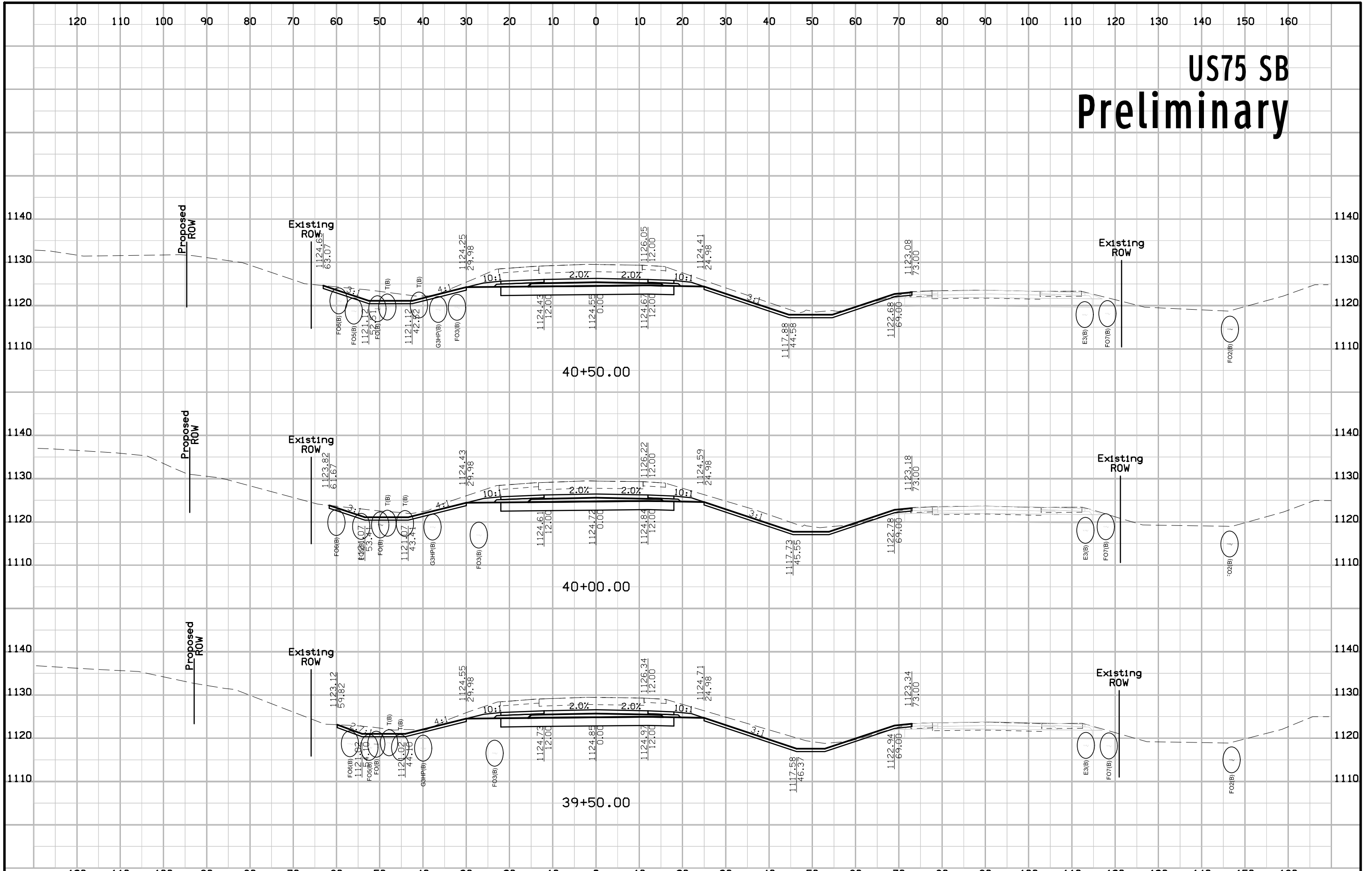

US75 SB Preliminary

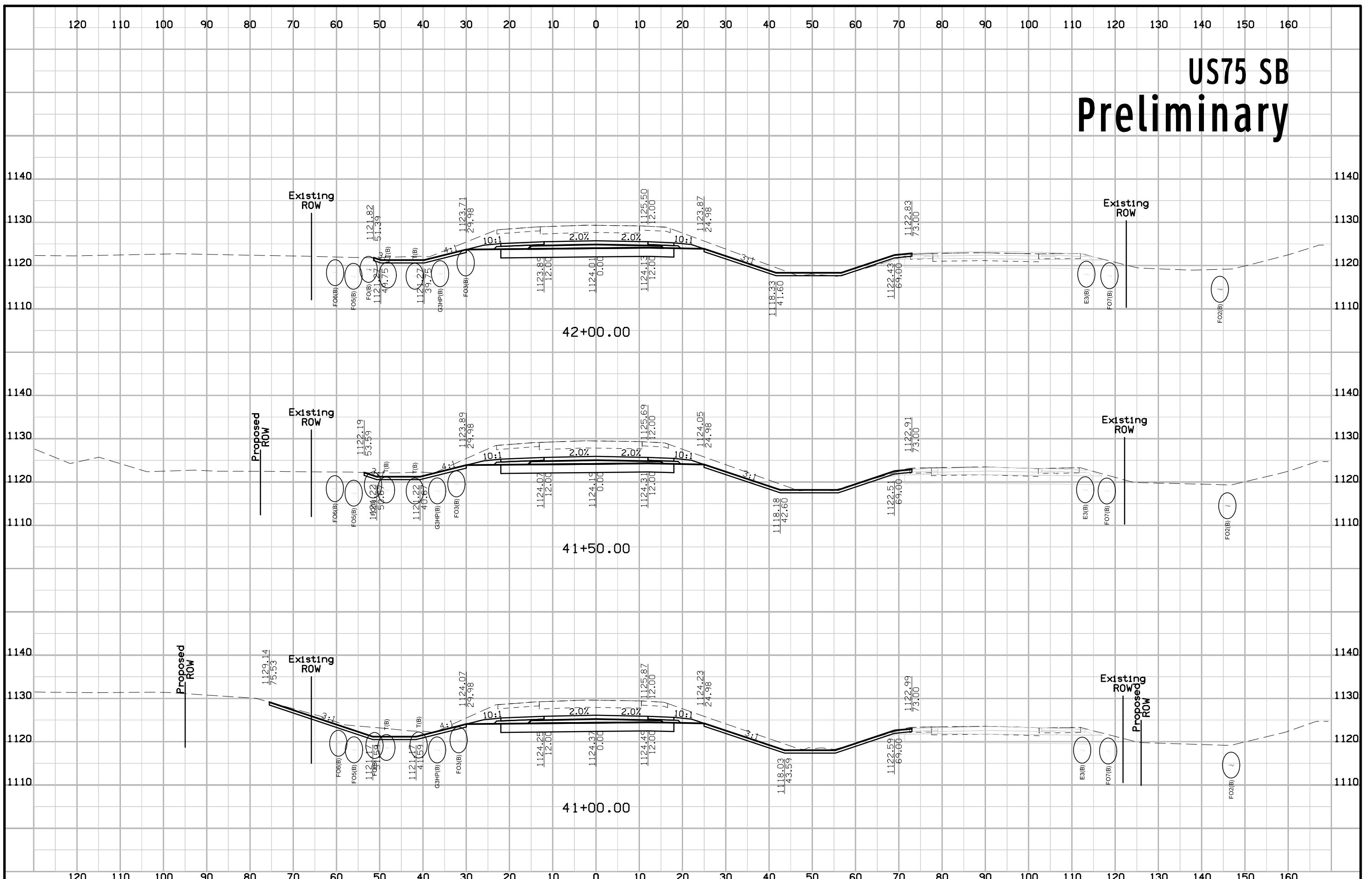

US75 SB Preliminary

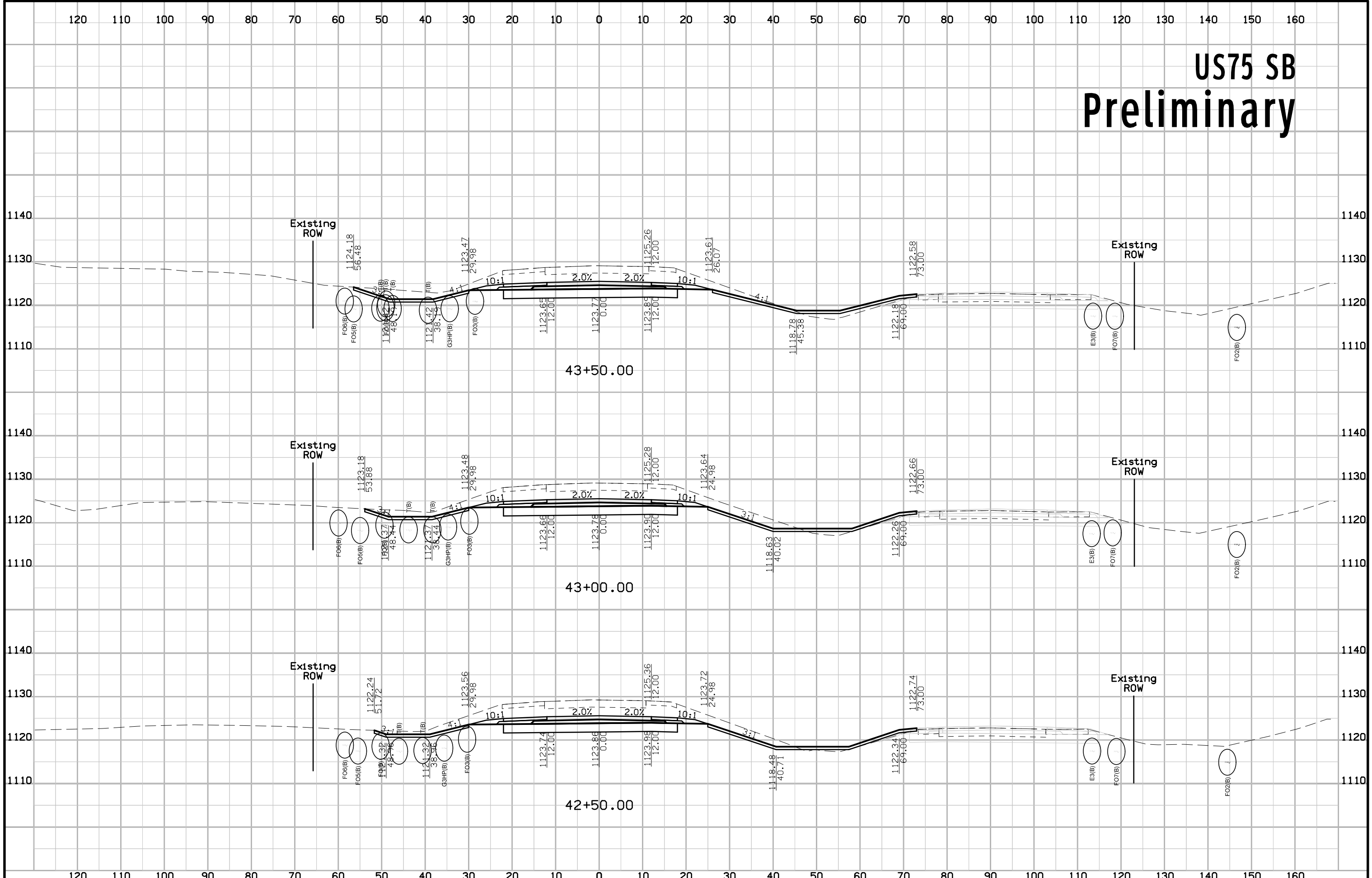

US75 SB Preliminary

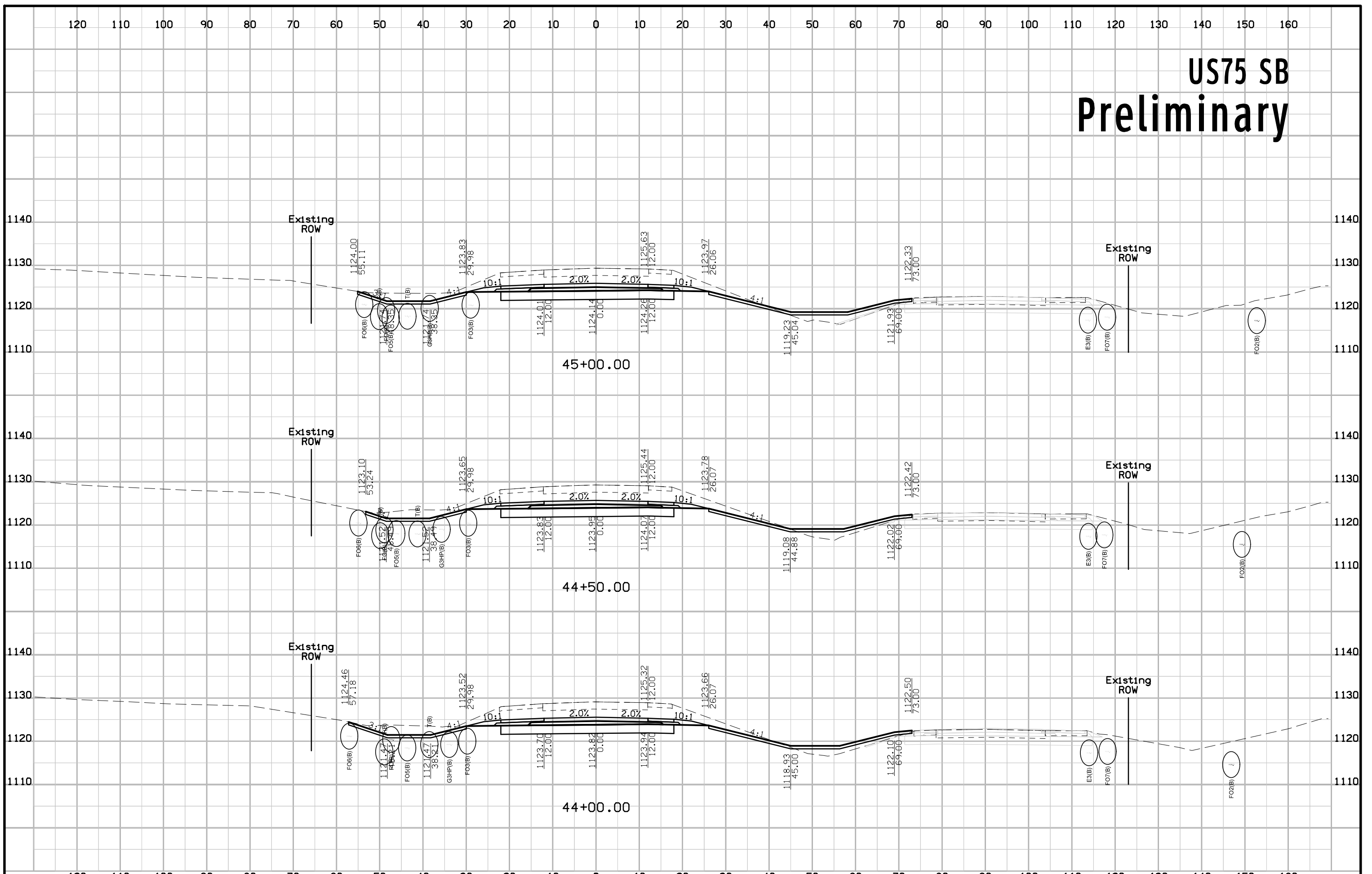

US75 SB Preliminary

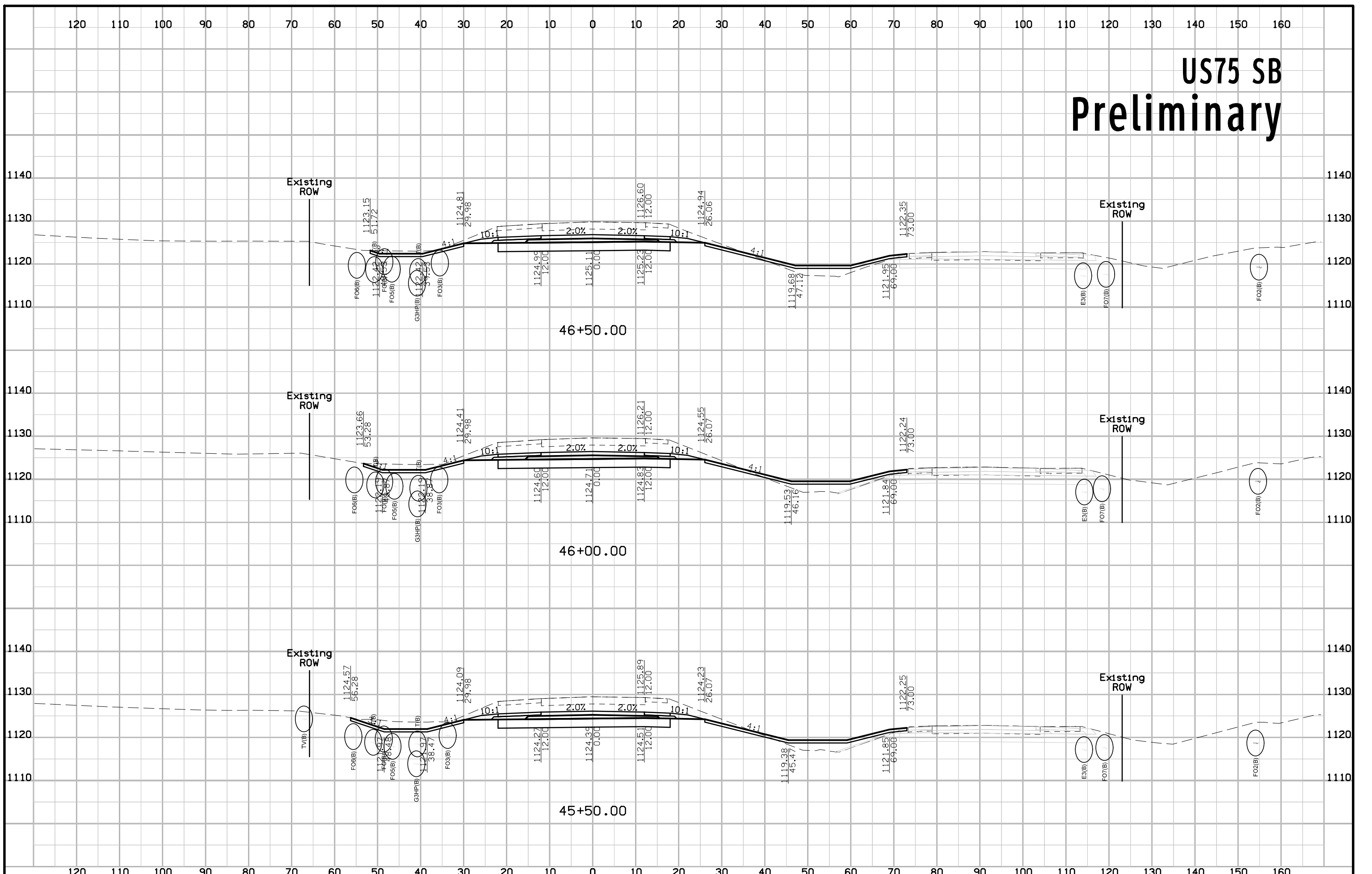

US75 SB Preliminary

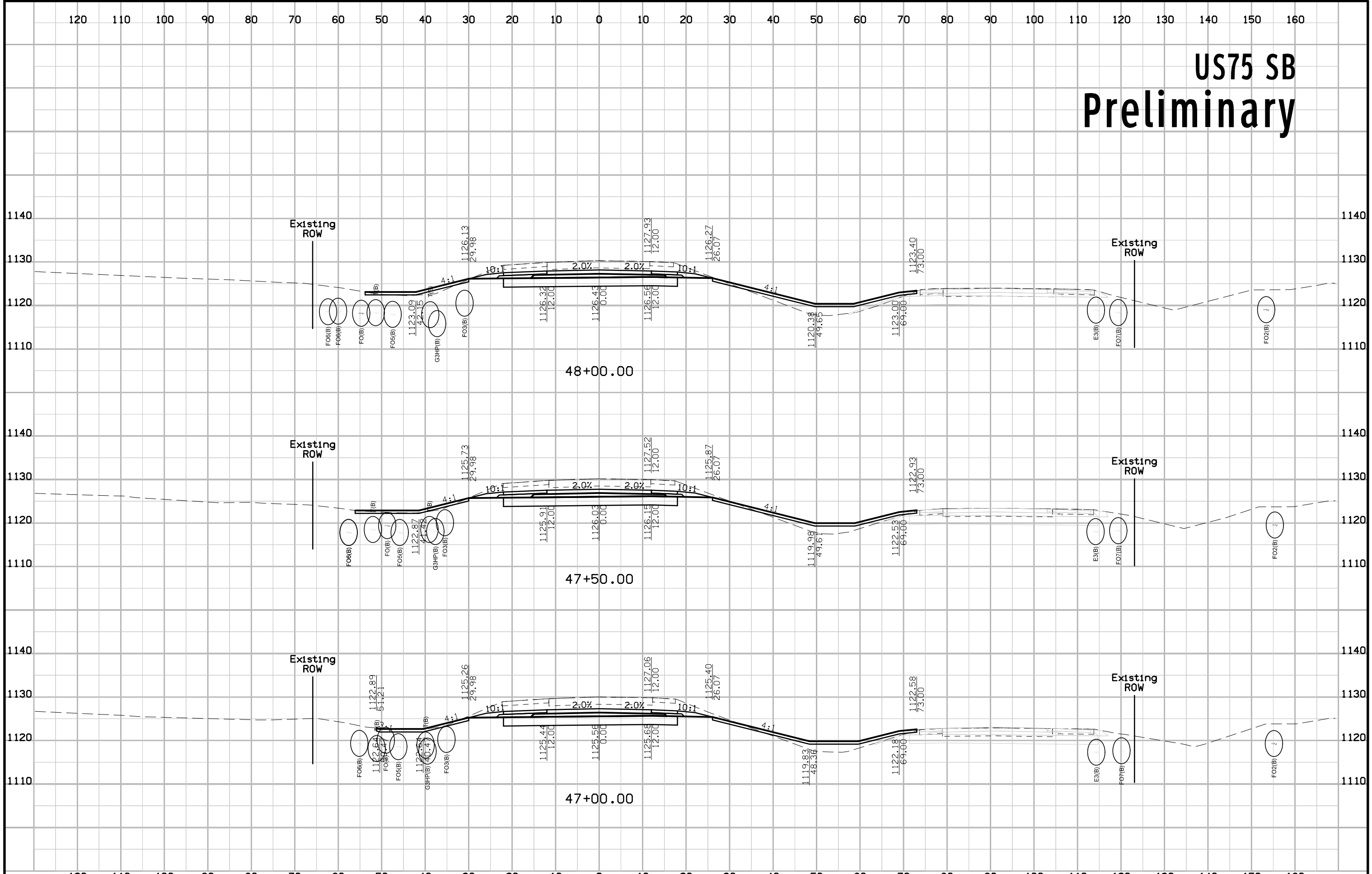

US75 SB Preliminary

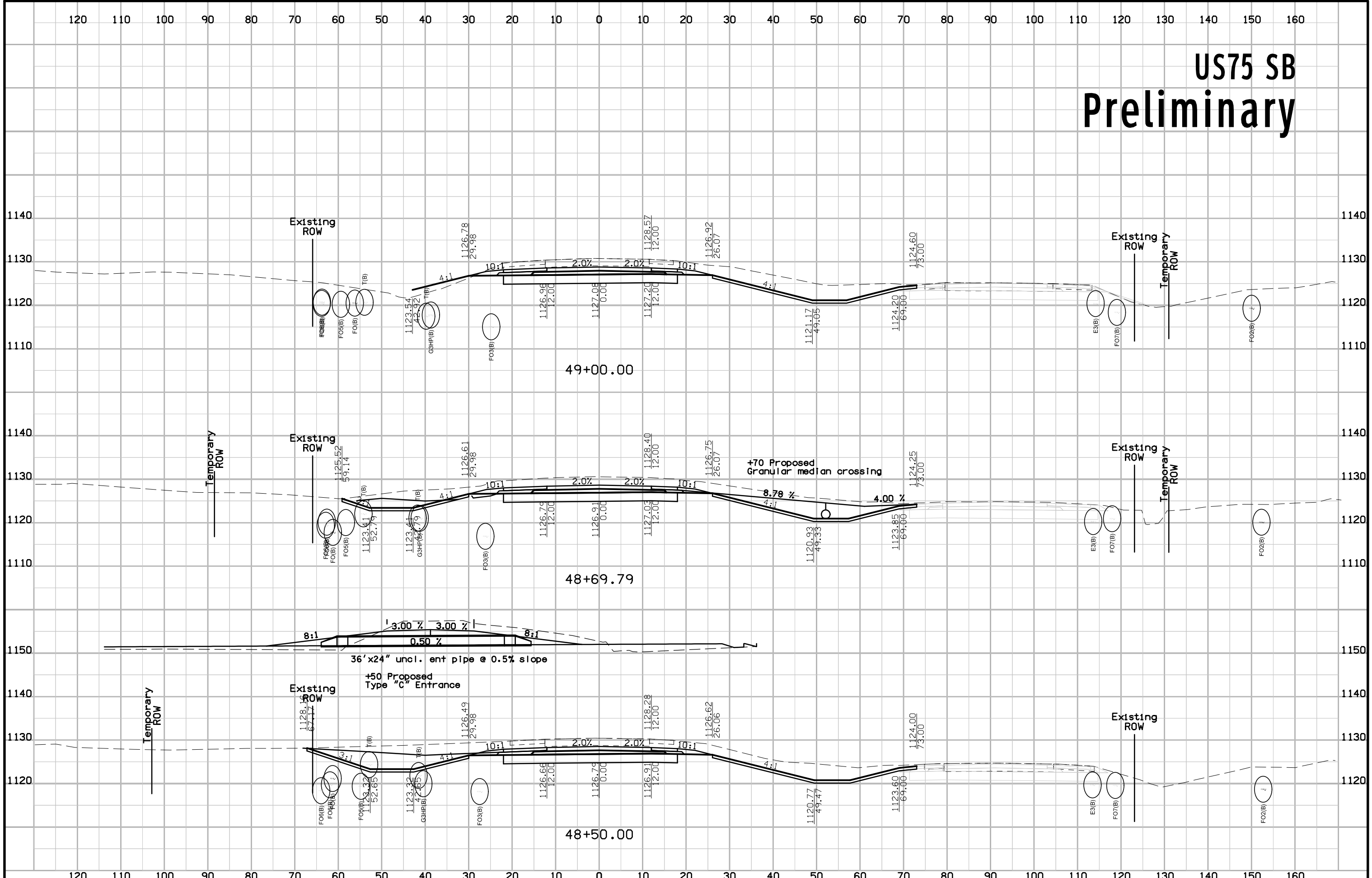

US75 SB Preliminary

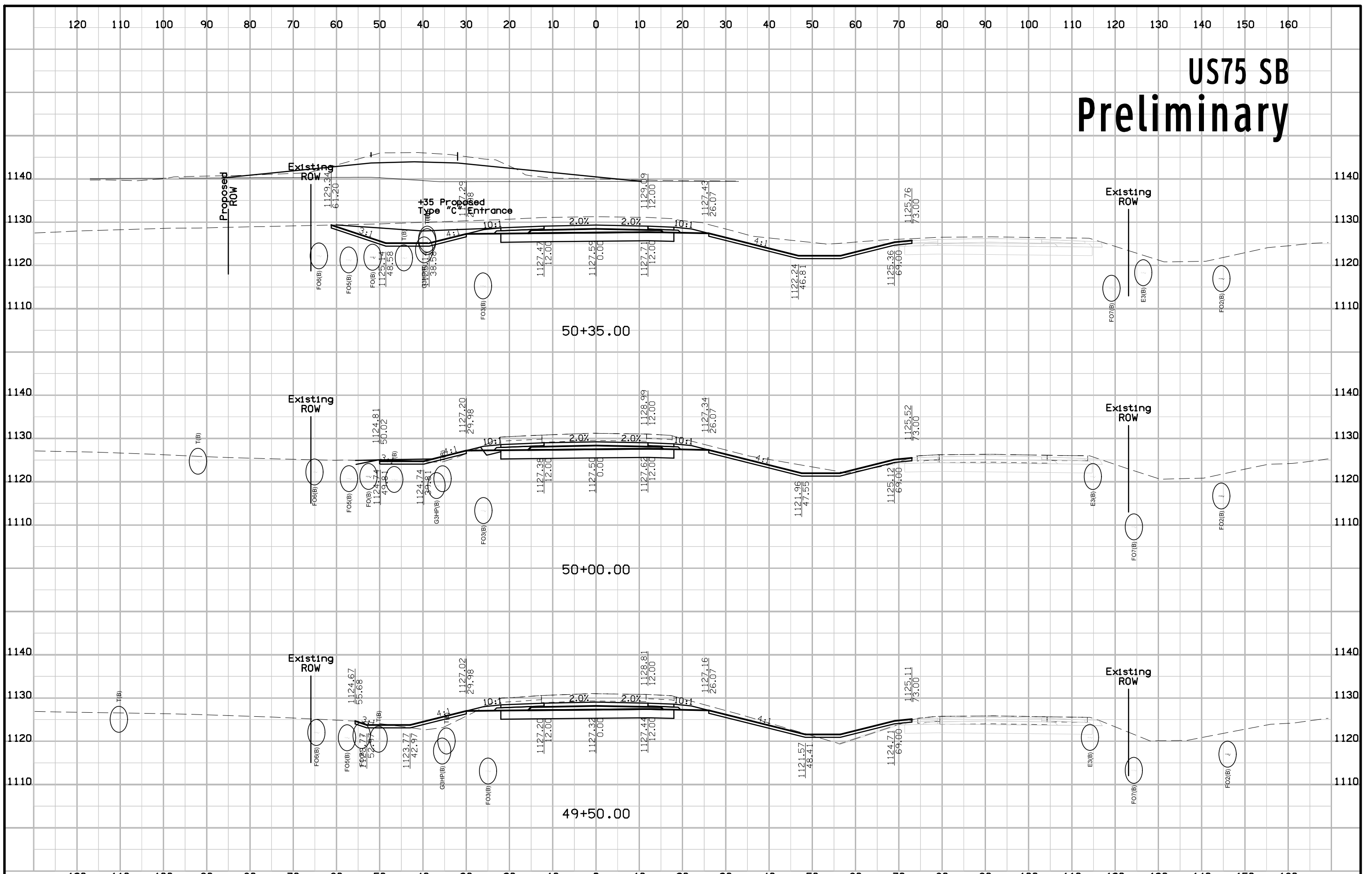

US75 SB Preliminary

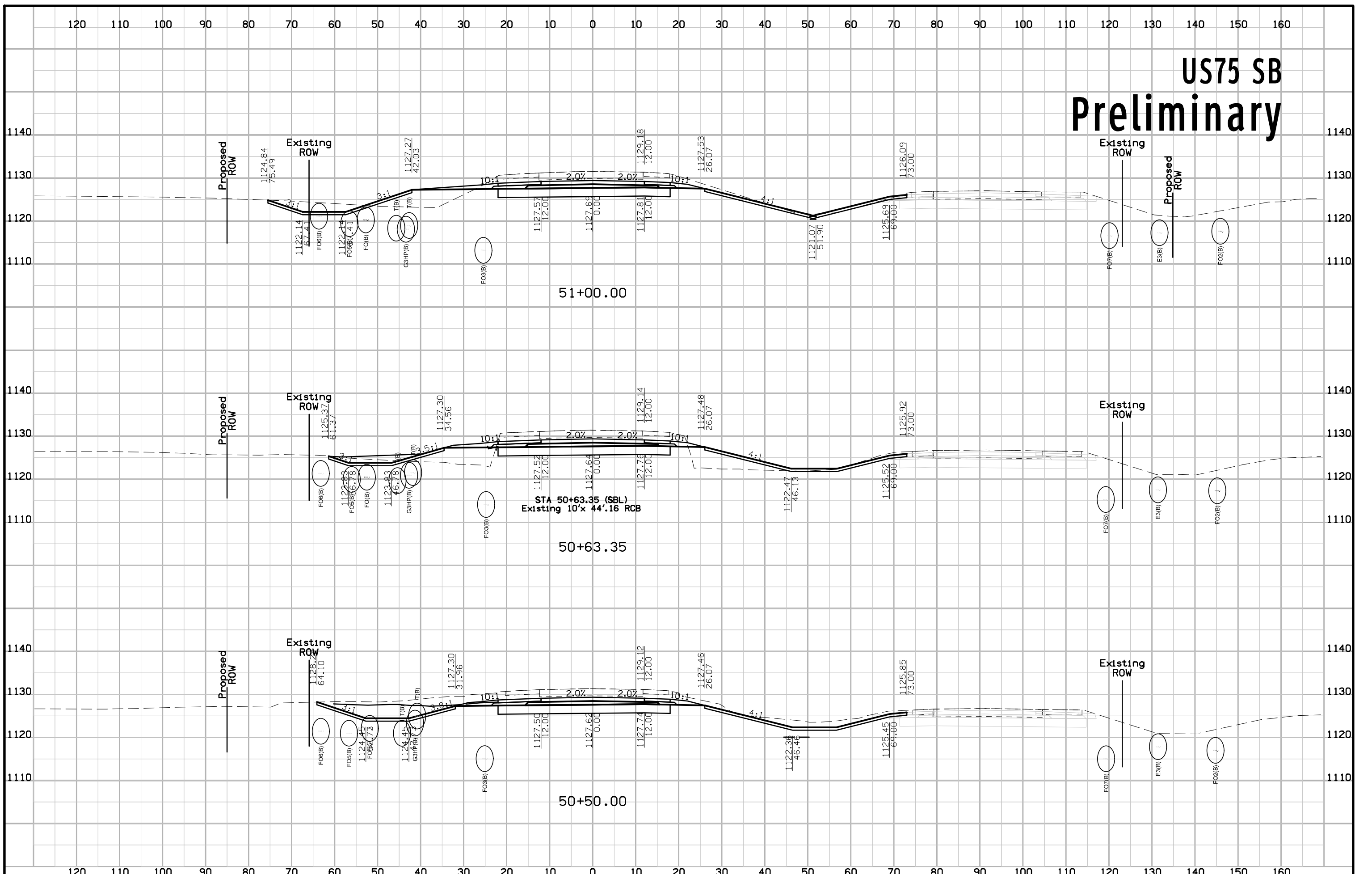

US75 SB Preliminary

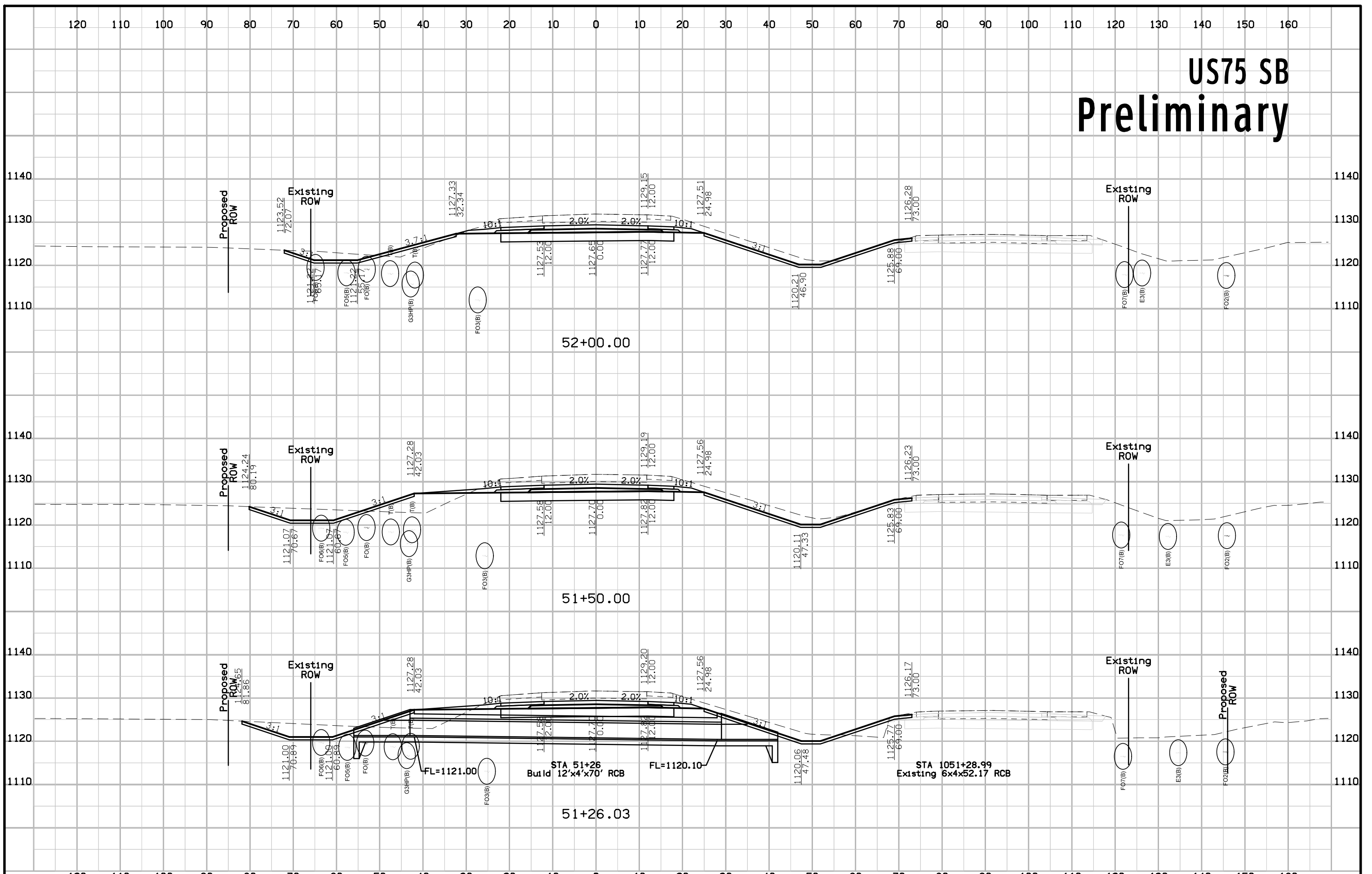

US75 SB Preliminary

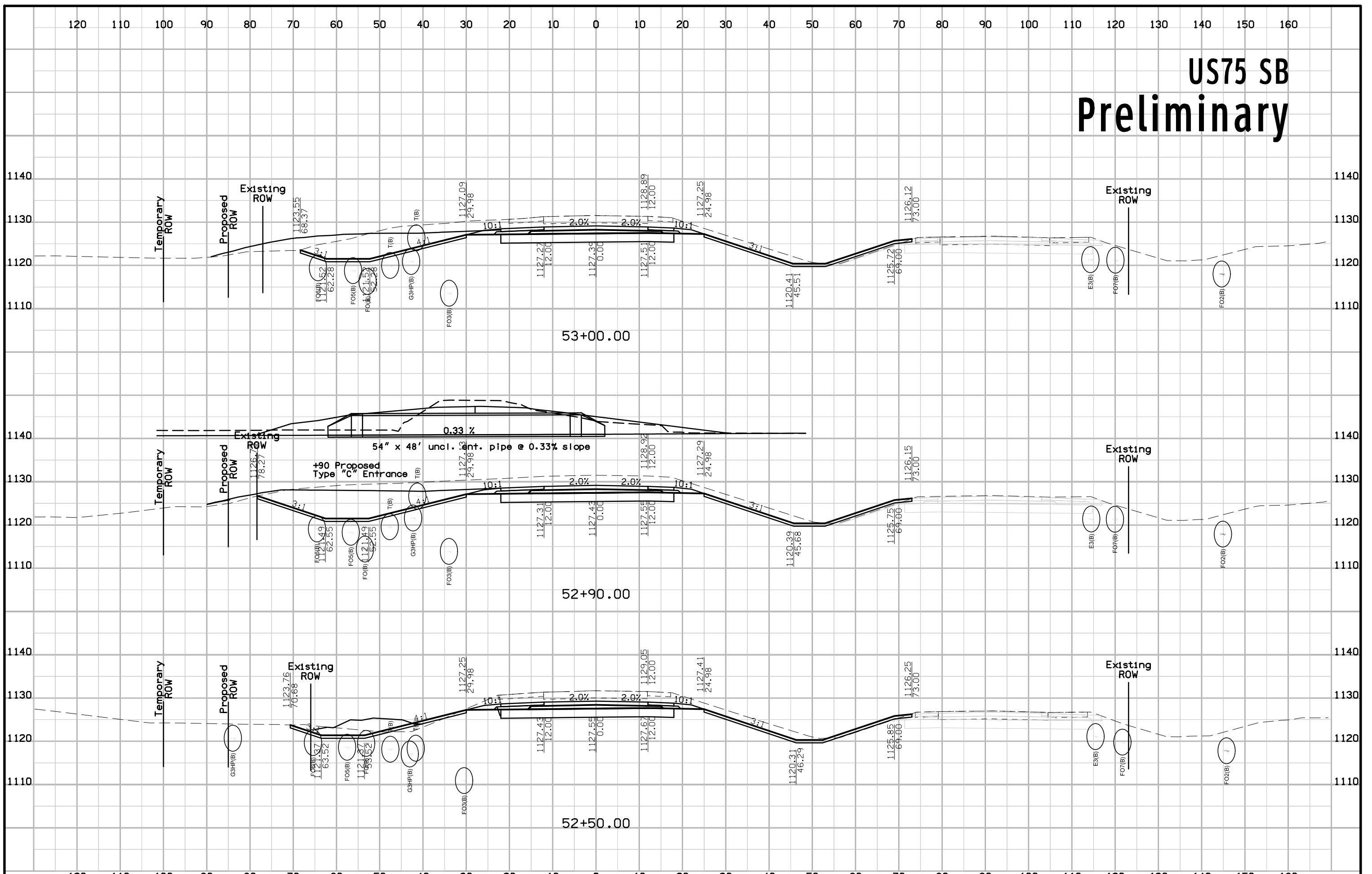

US75 SB Preliminary

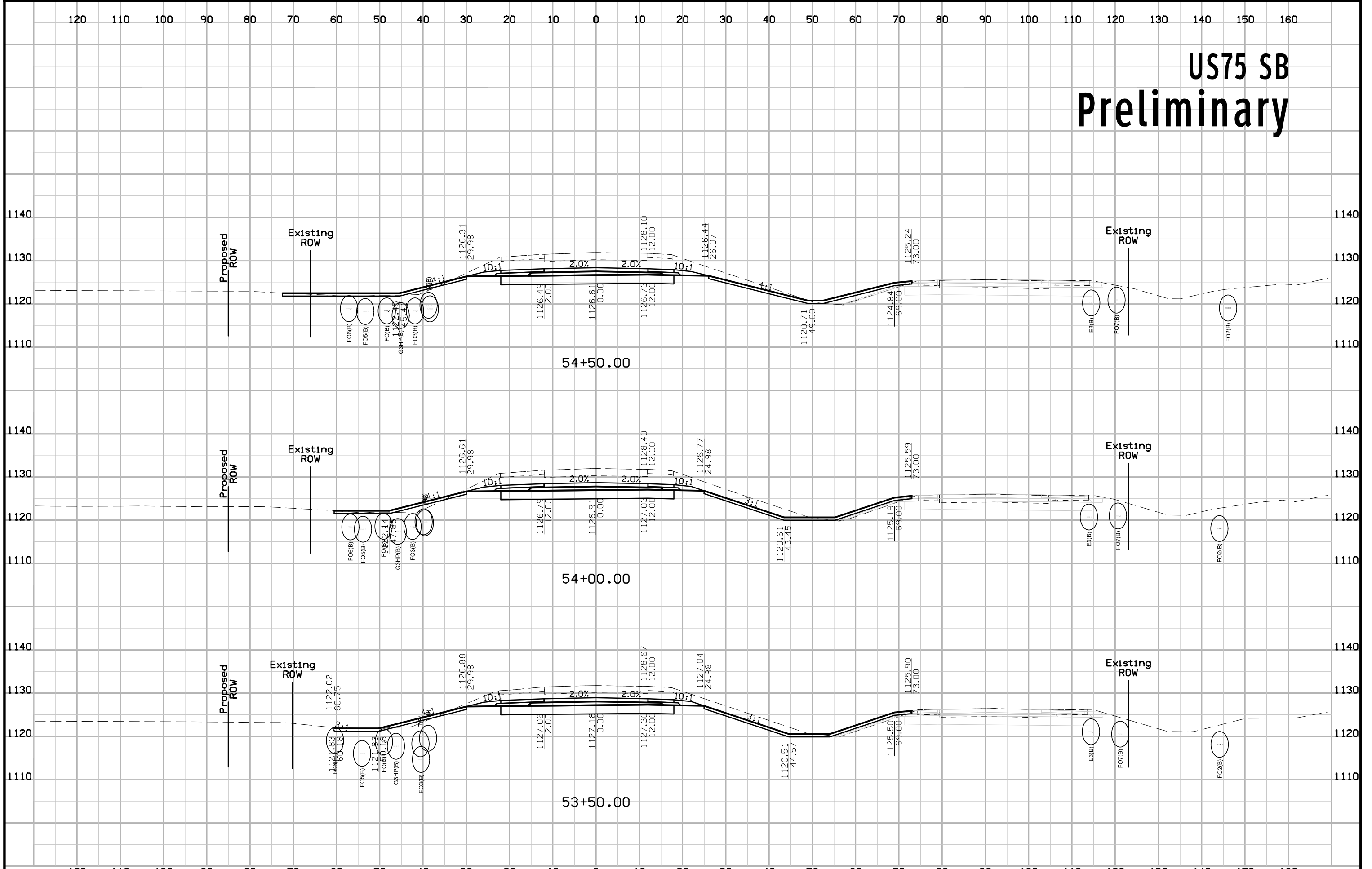

US75 SB Preliminary

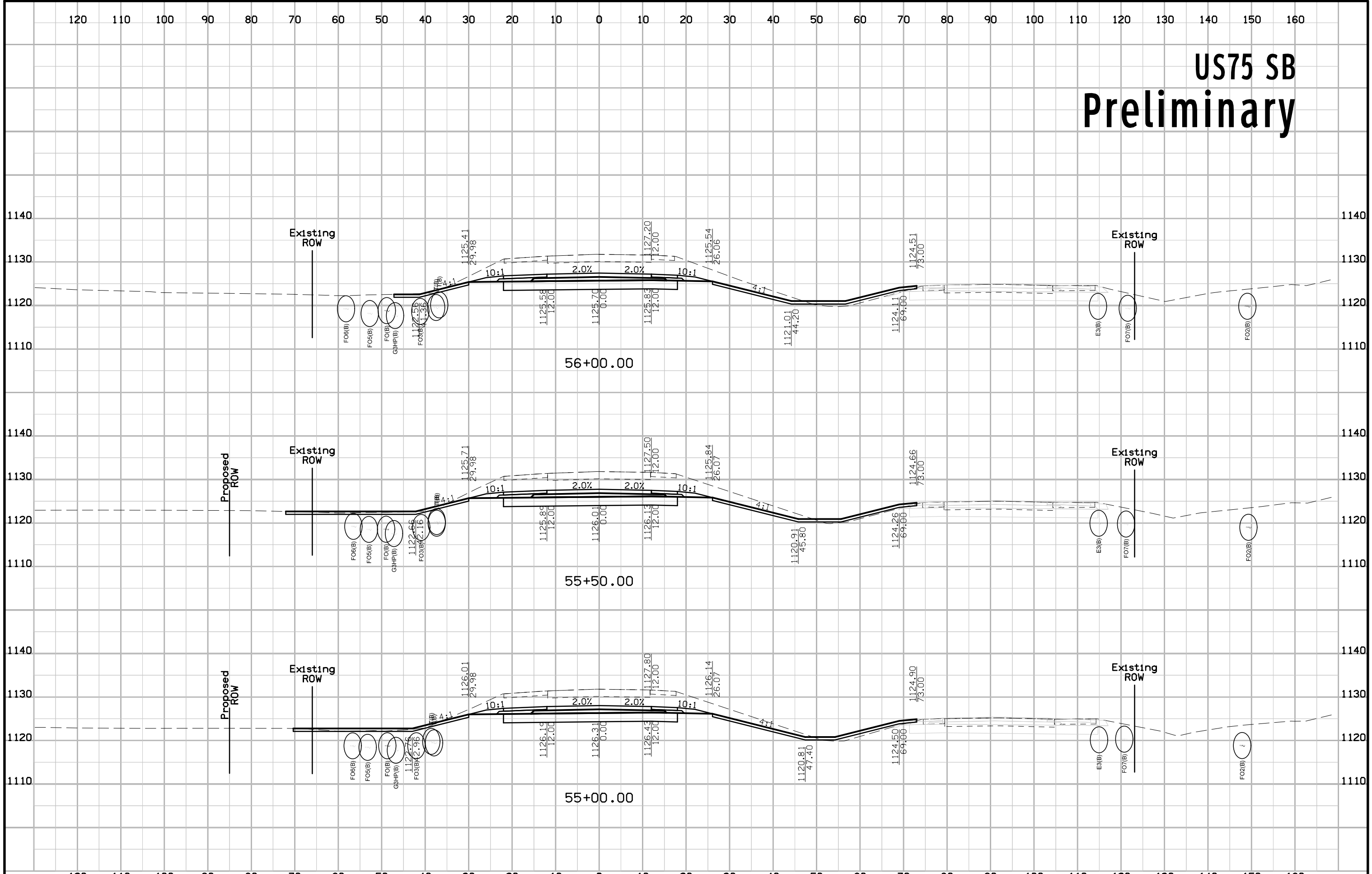

US75 SB Preliminary

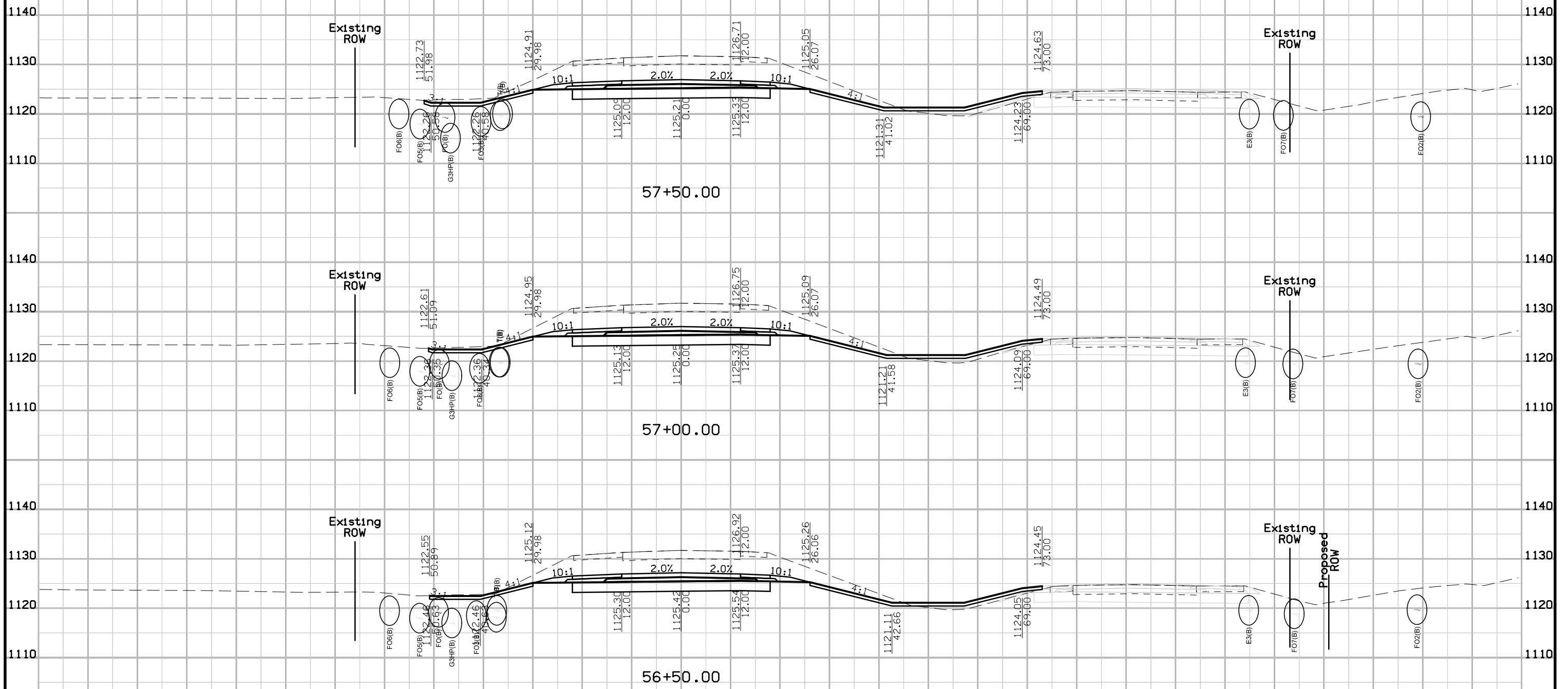

US75 SB Preliminary

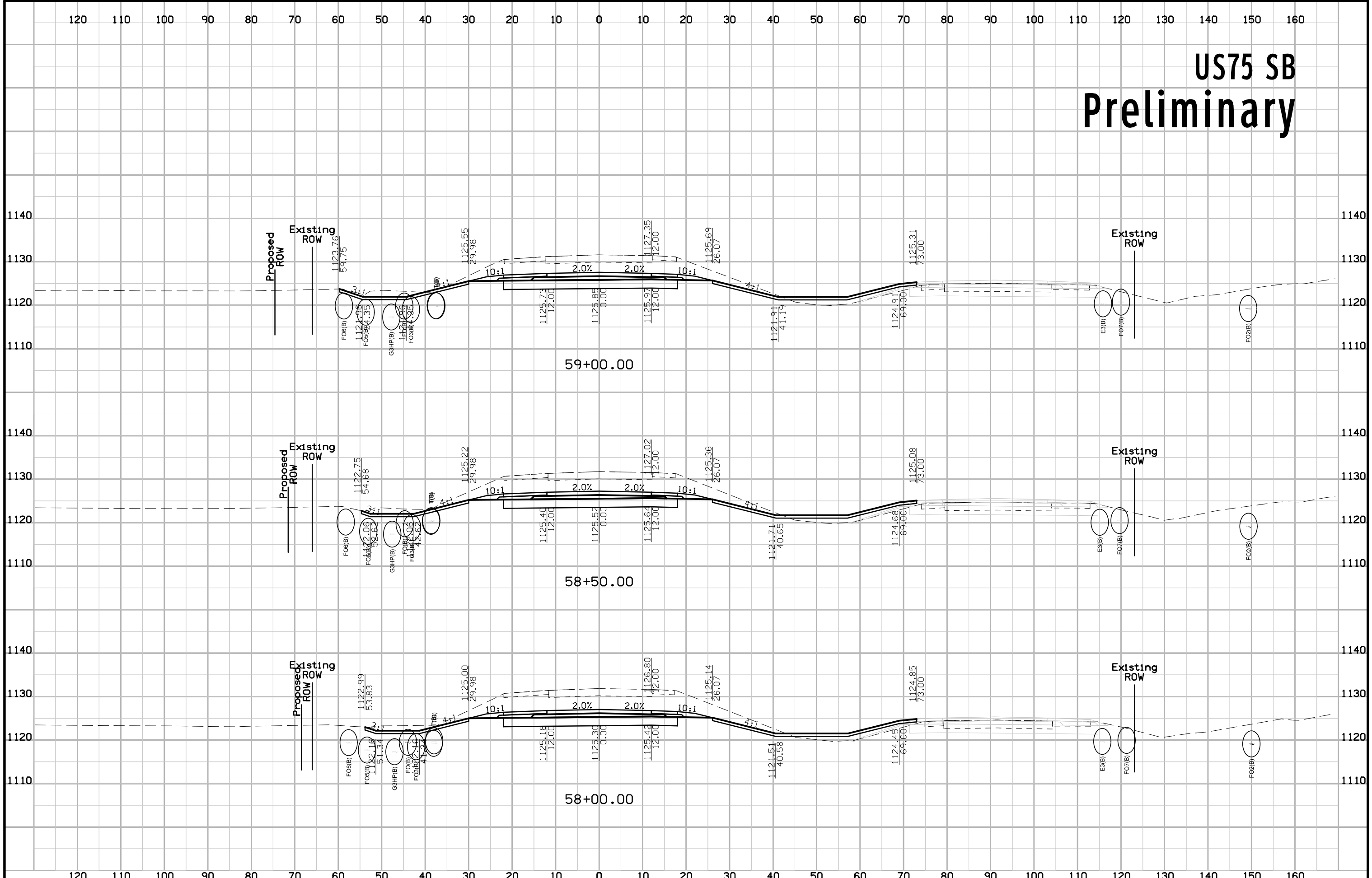

US75 SB Preliminary

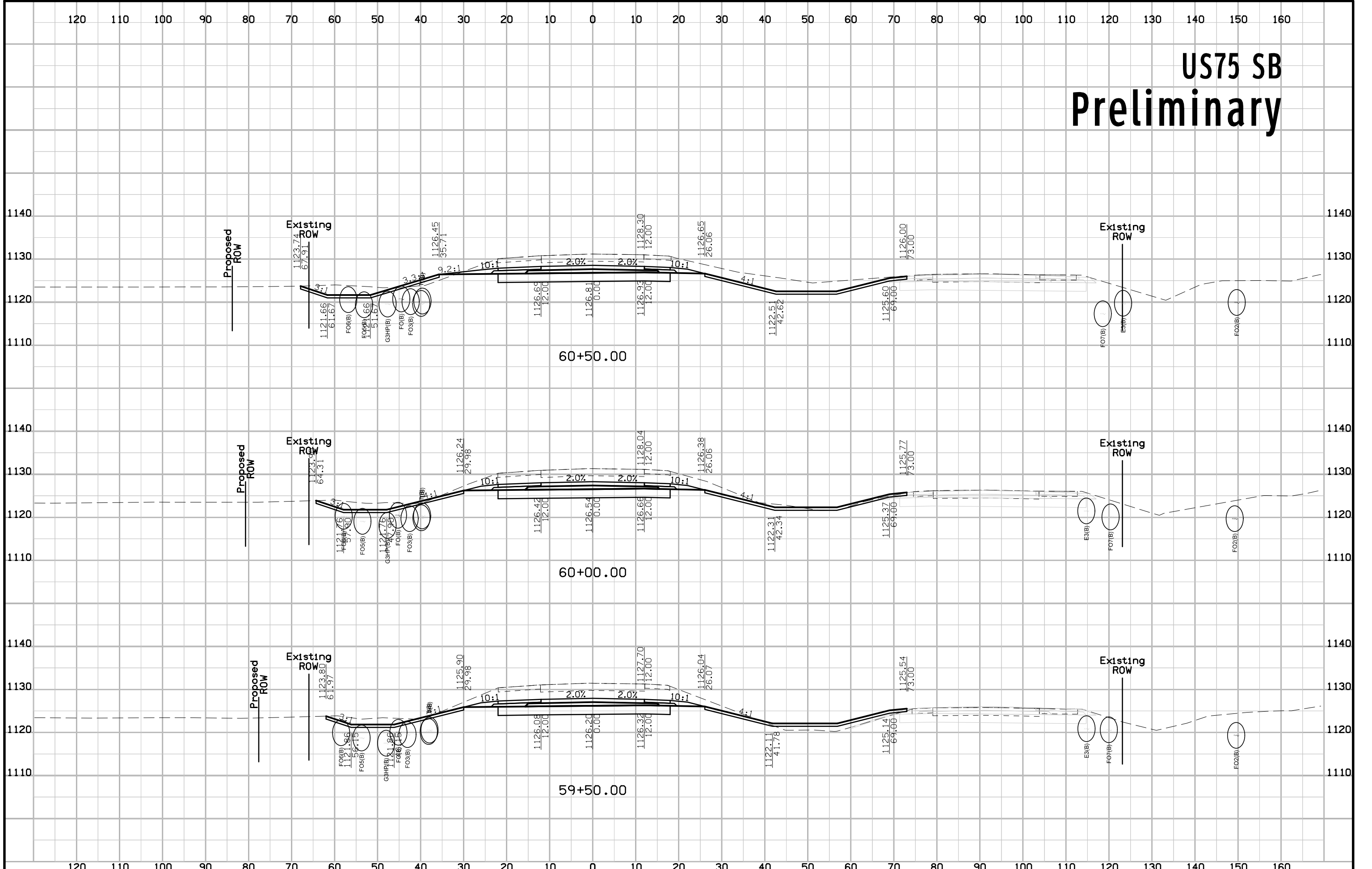

US75 SB Preliminary

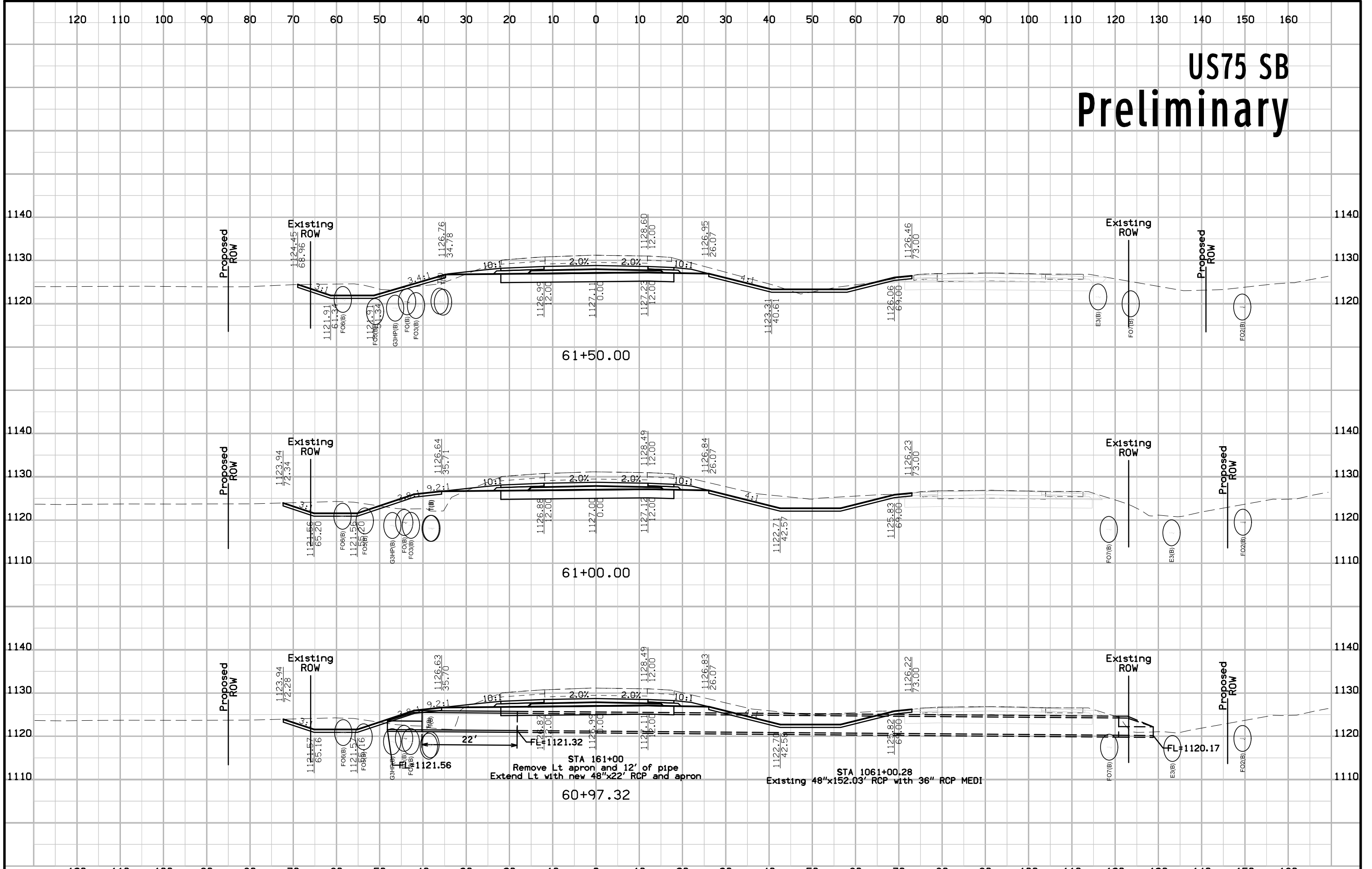

US75 SB Preliminary

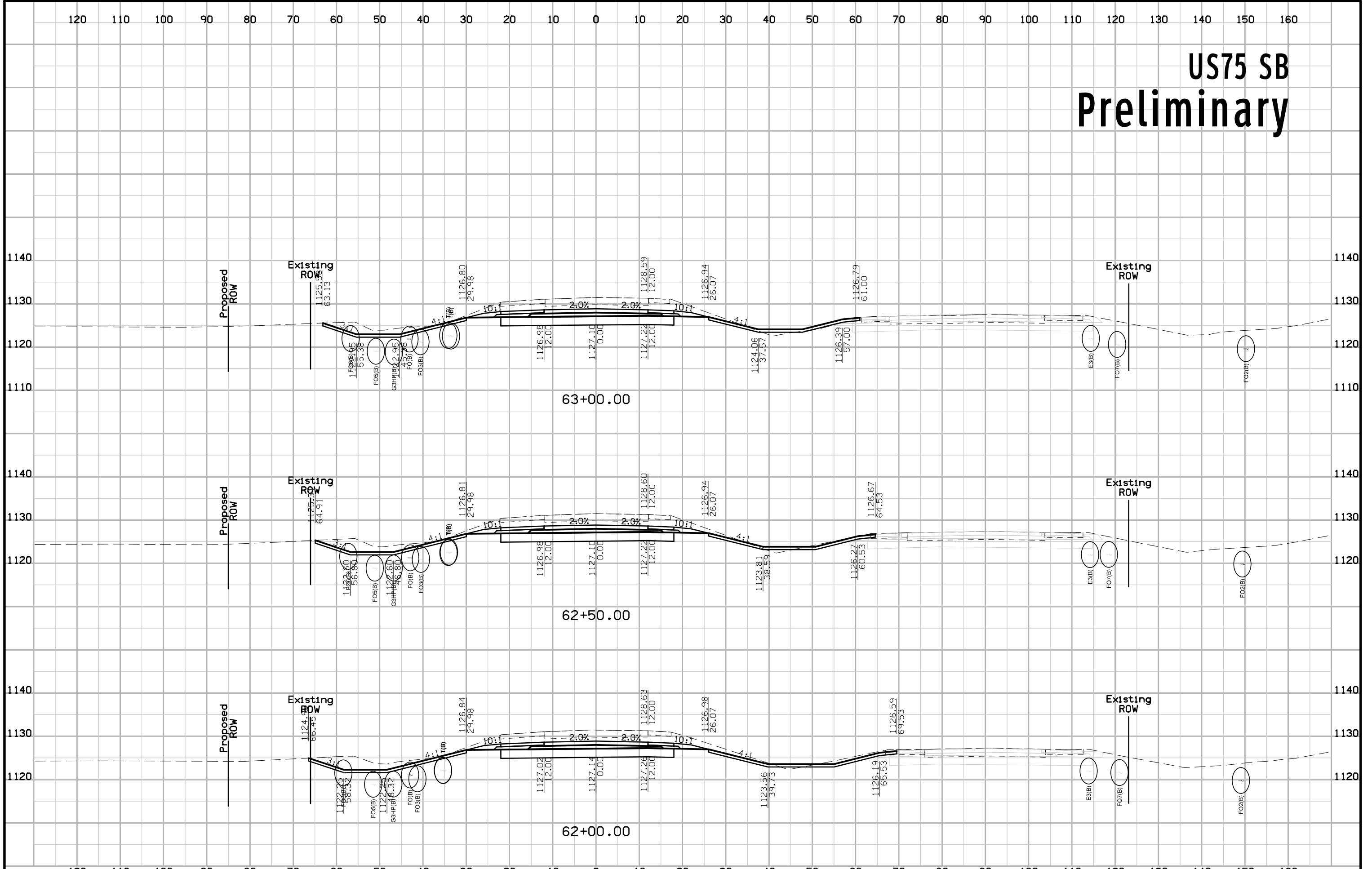

US75 SB Preliminary

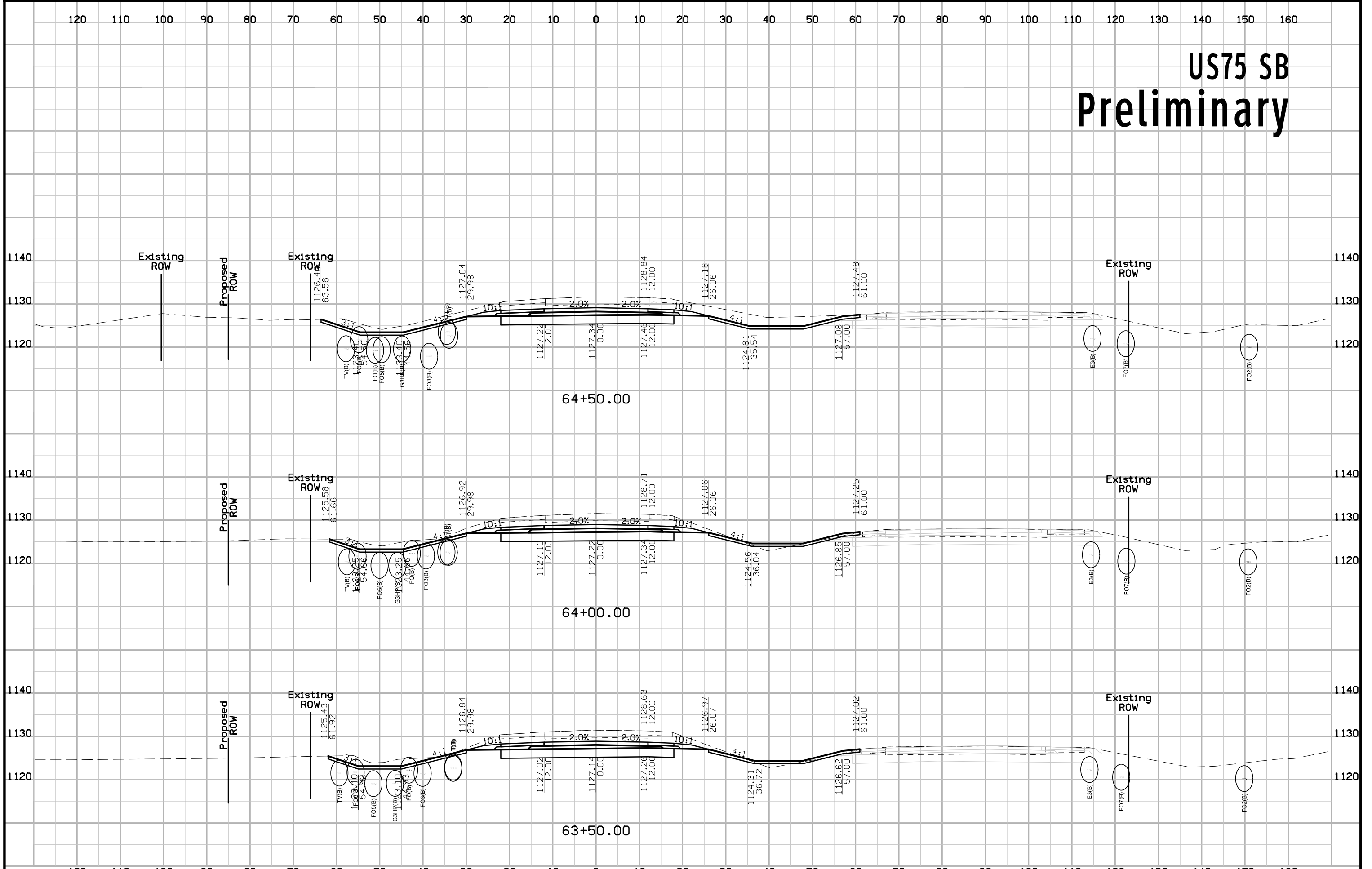

US75 SB Preliminary

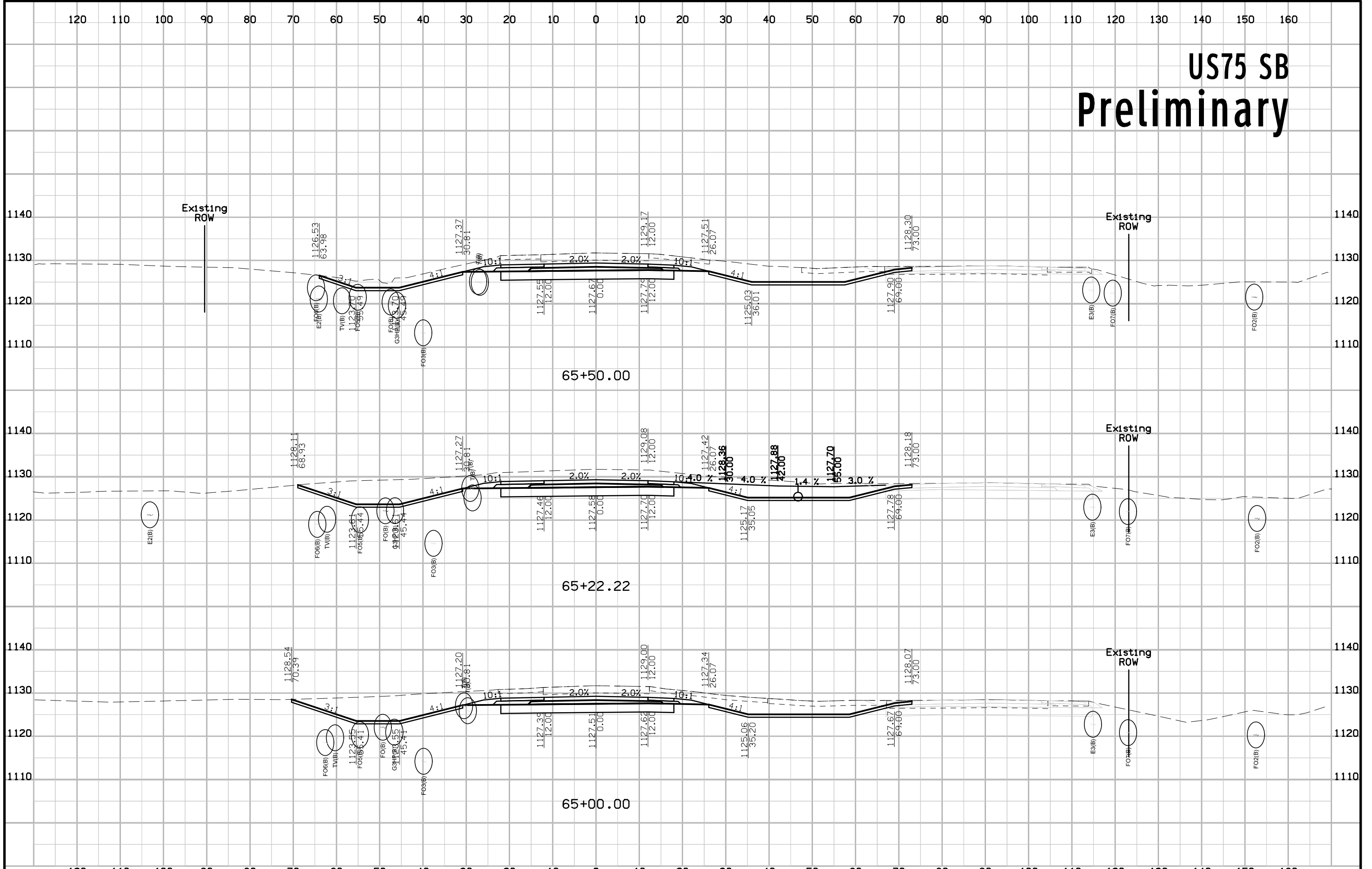

US75 SB Preliminary

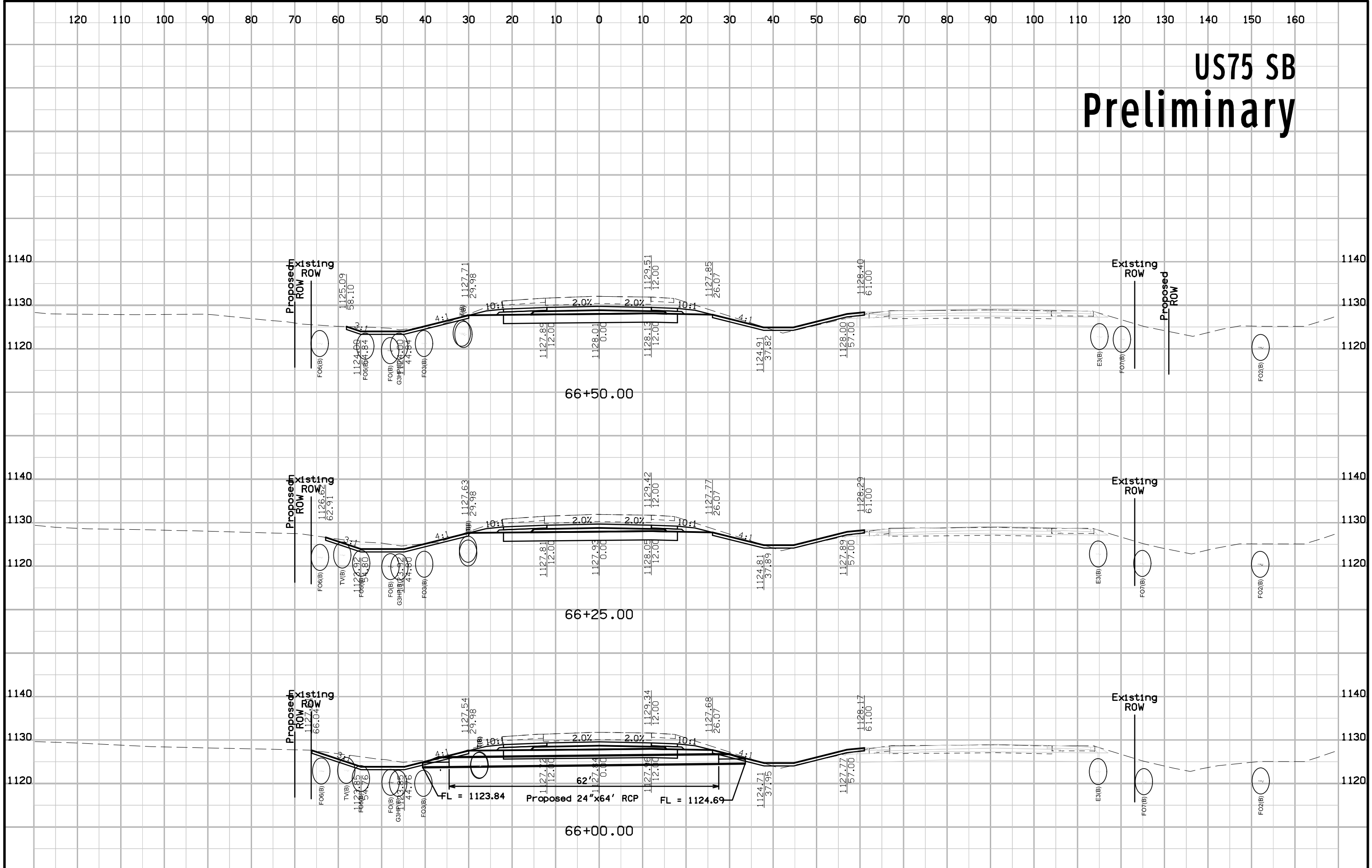

US75 SB Preliminary

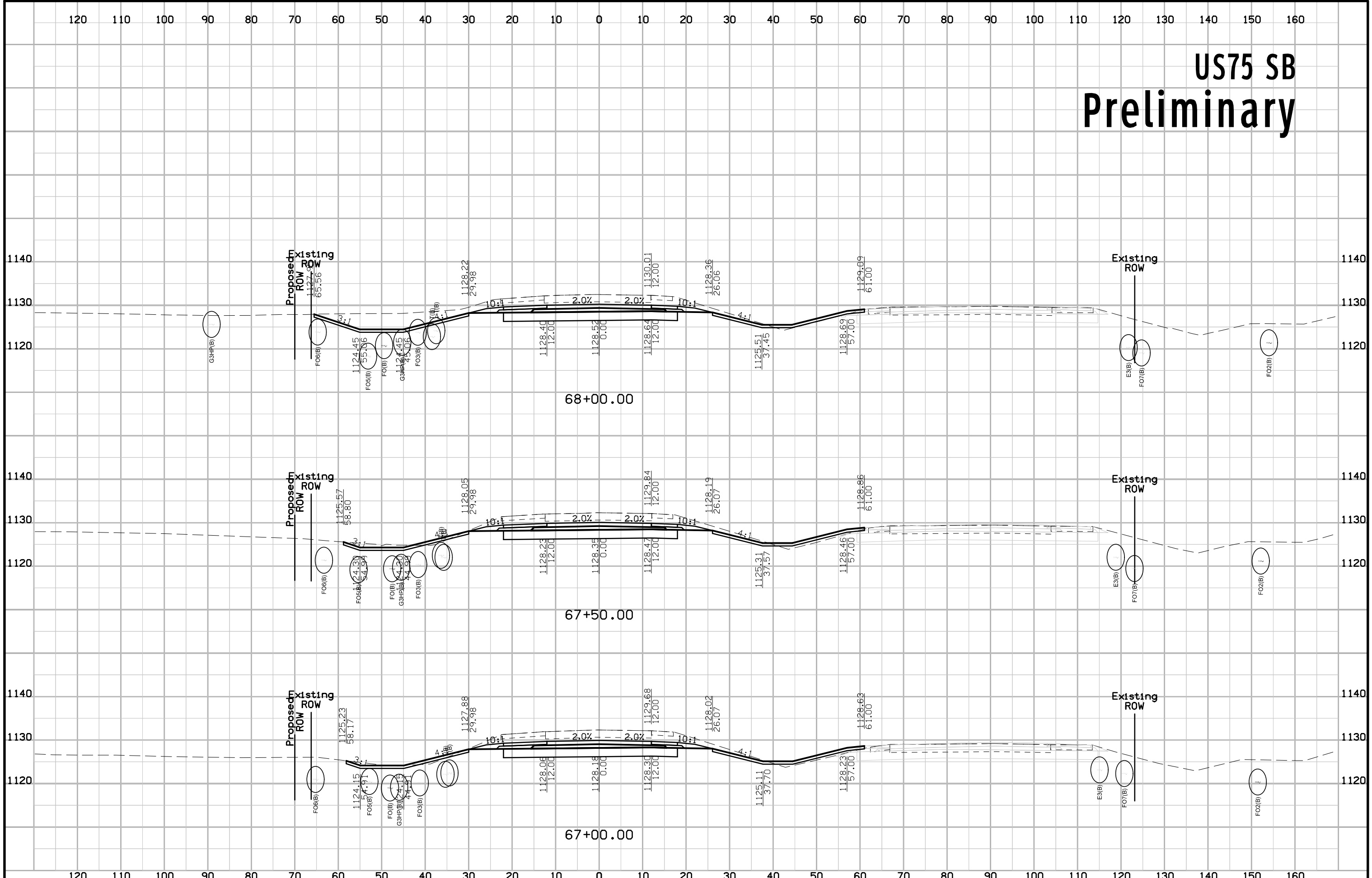

US75 SB Preliminary

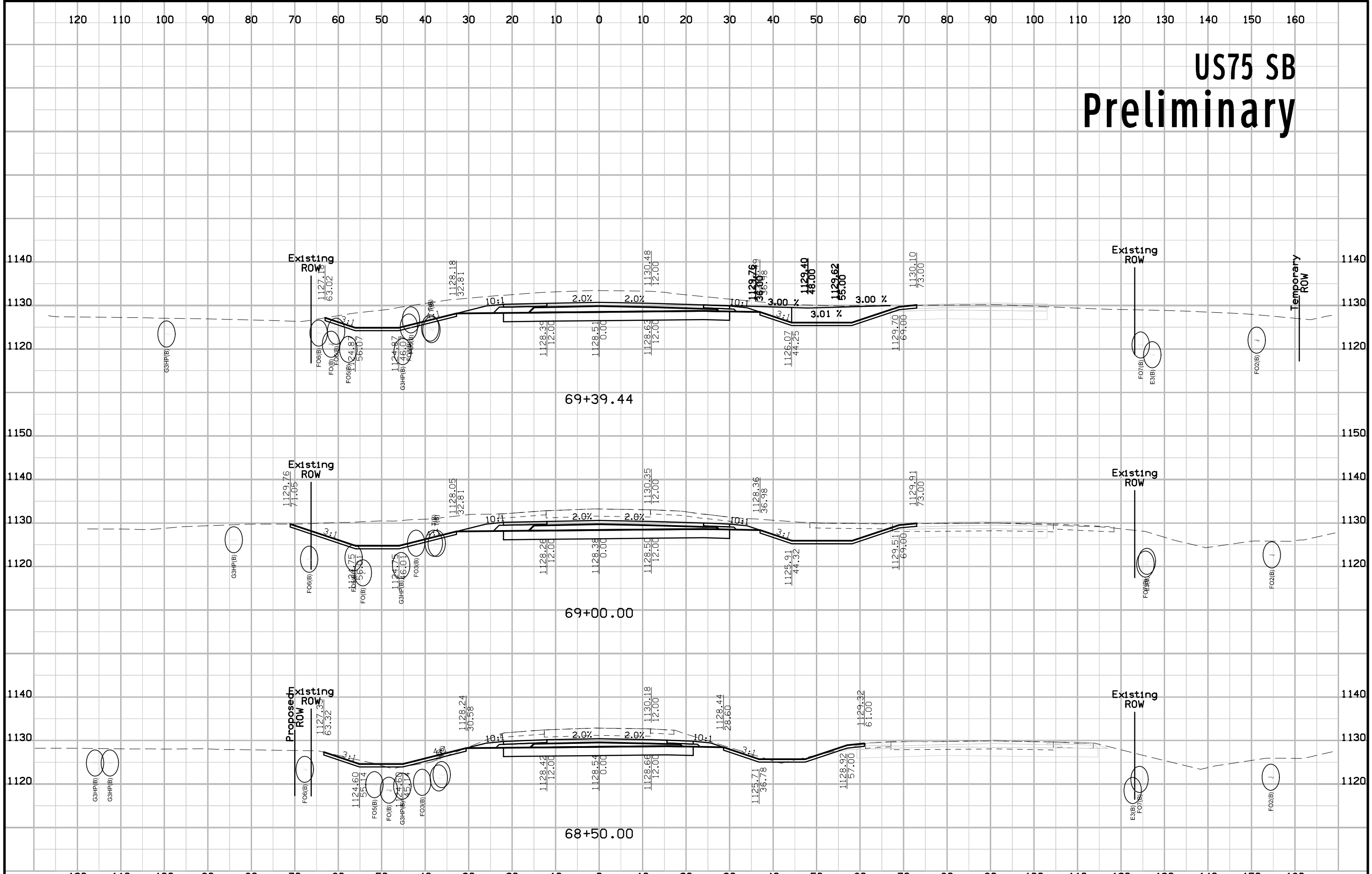

US75 SB Preliminary

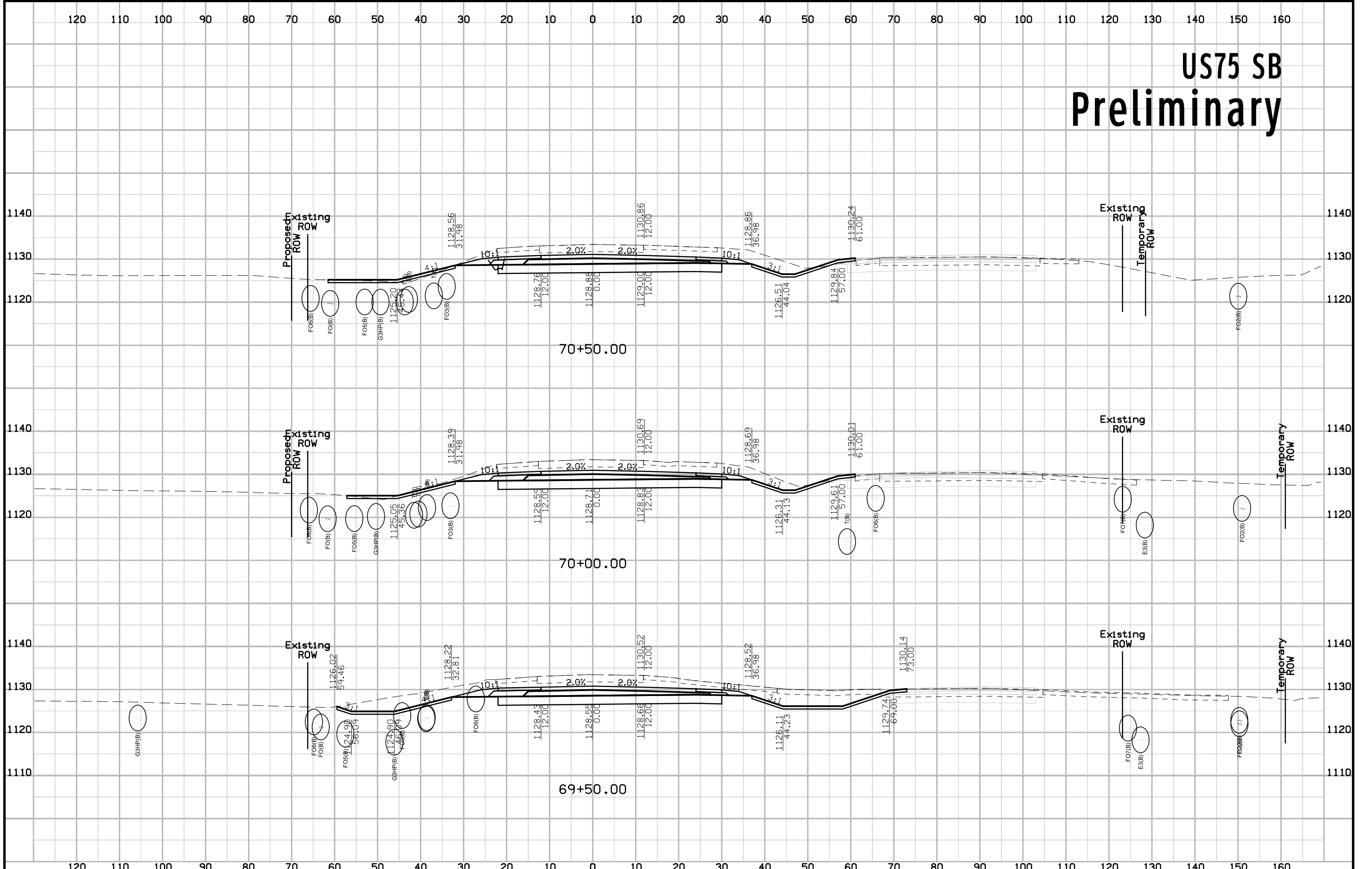

US75 SB Preliminary

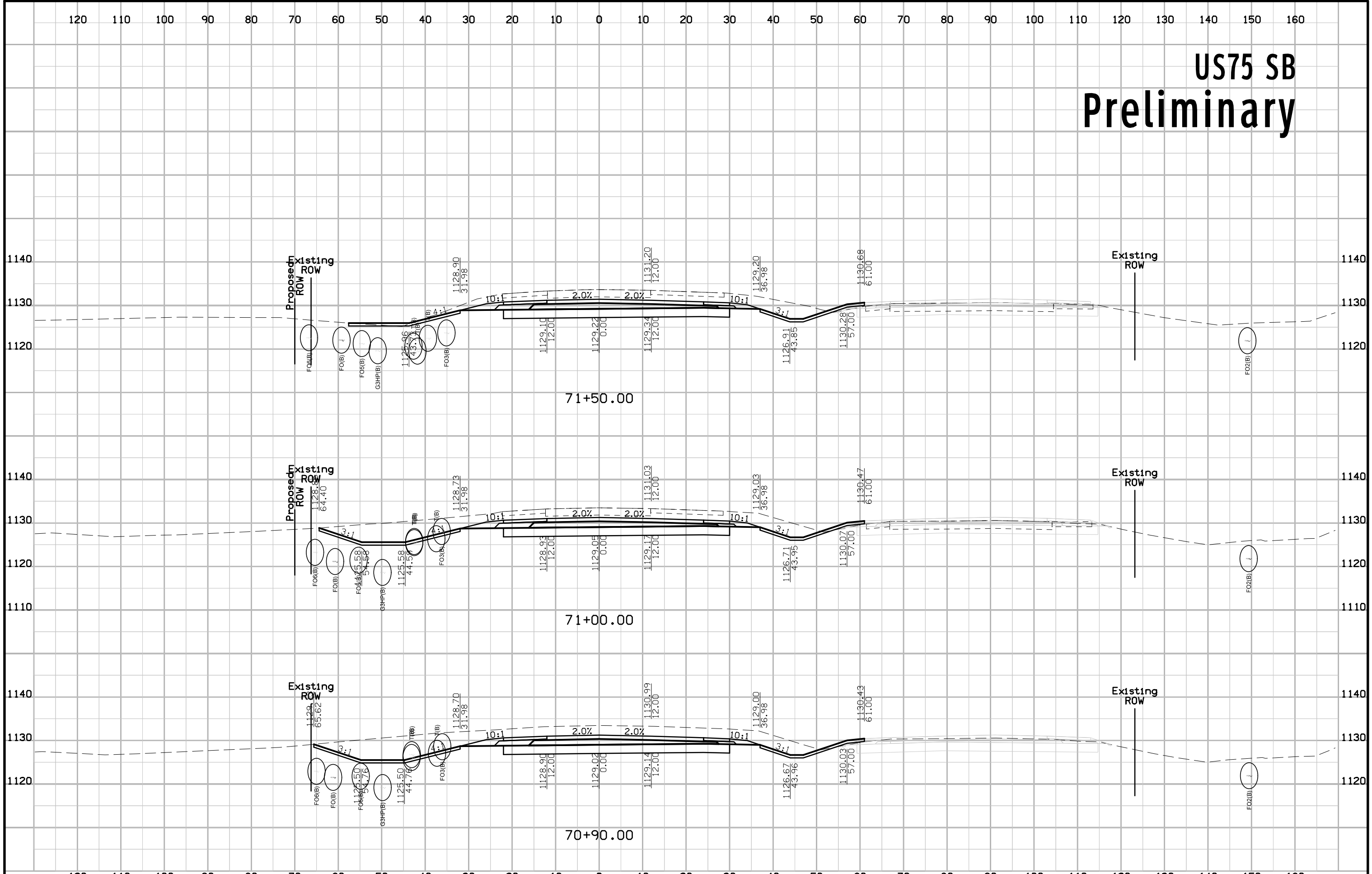

US75 SB Preliminary

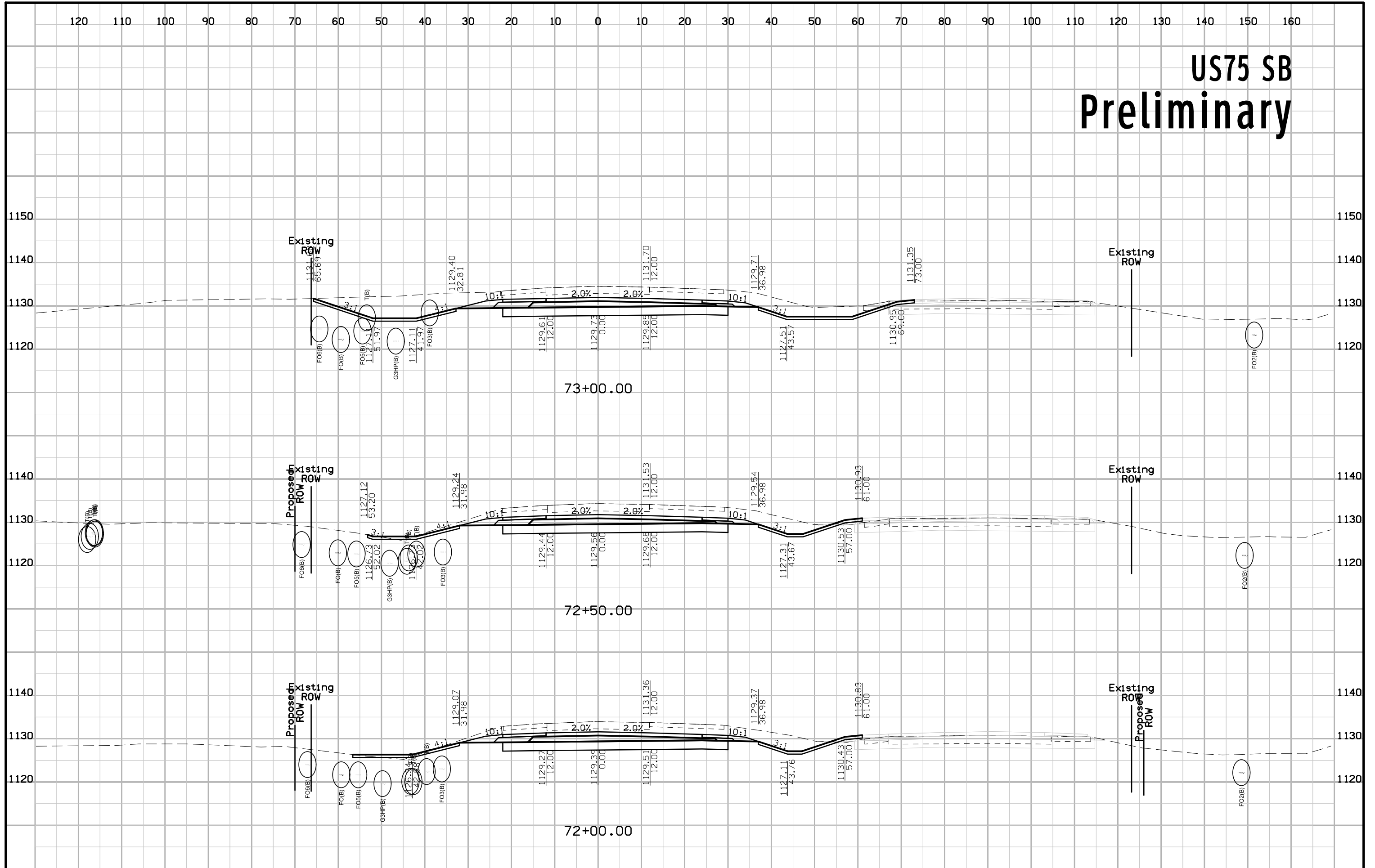

US75 SB Preliminary

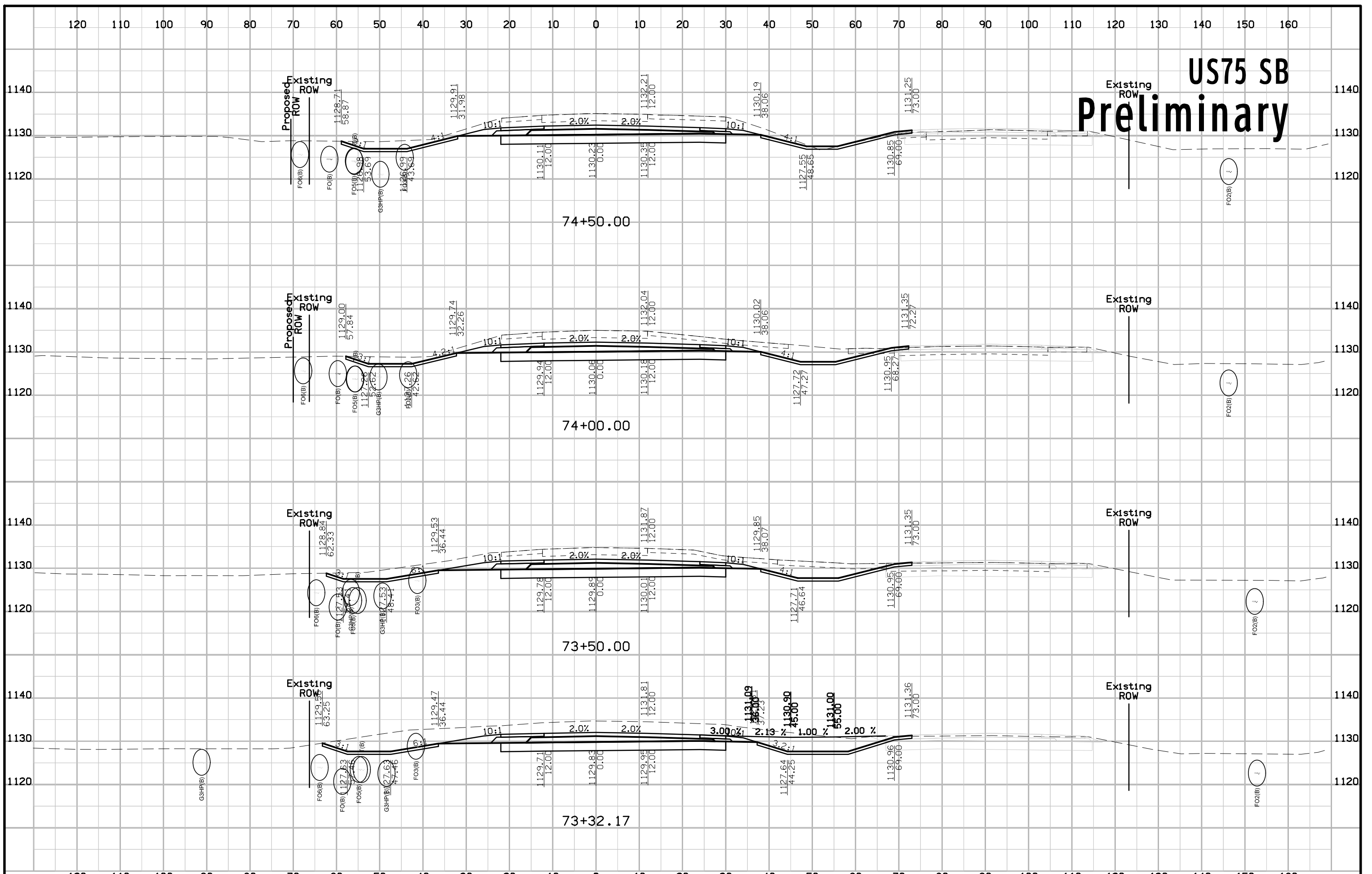

US75 SB Preliminary

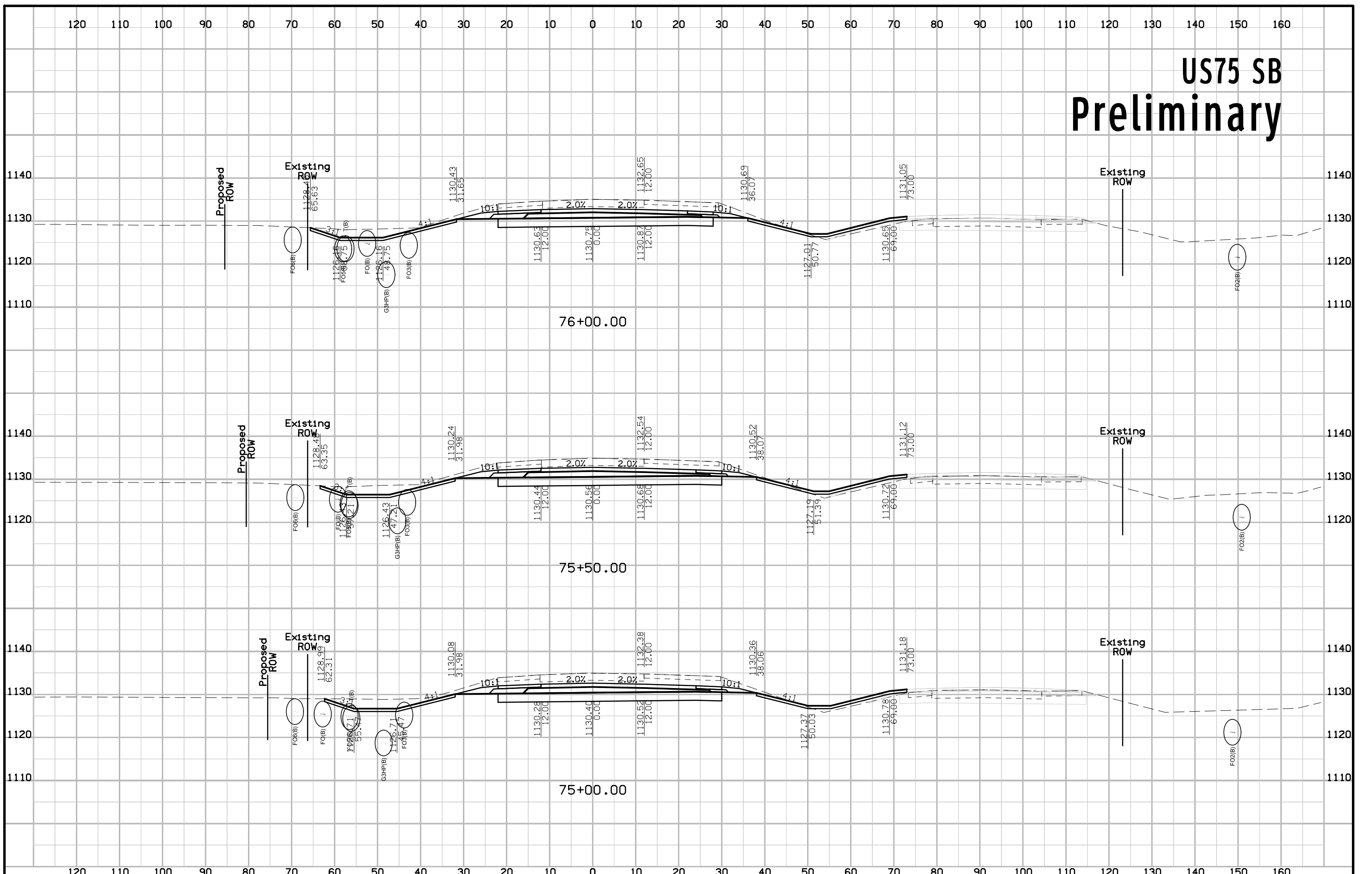

US75 SB Preliminary

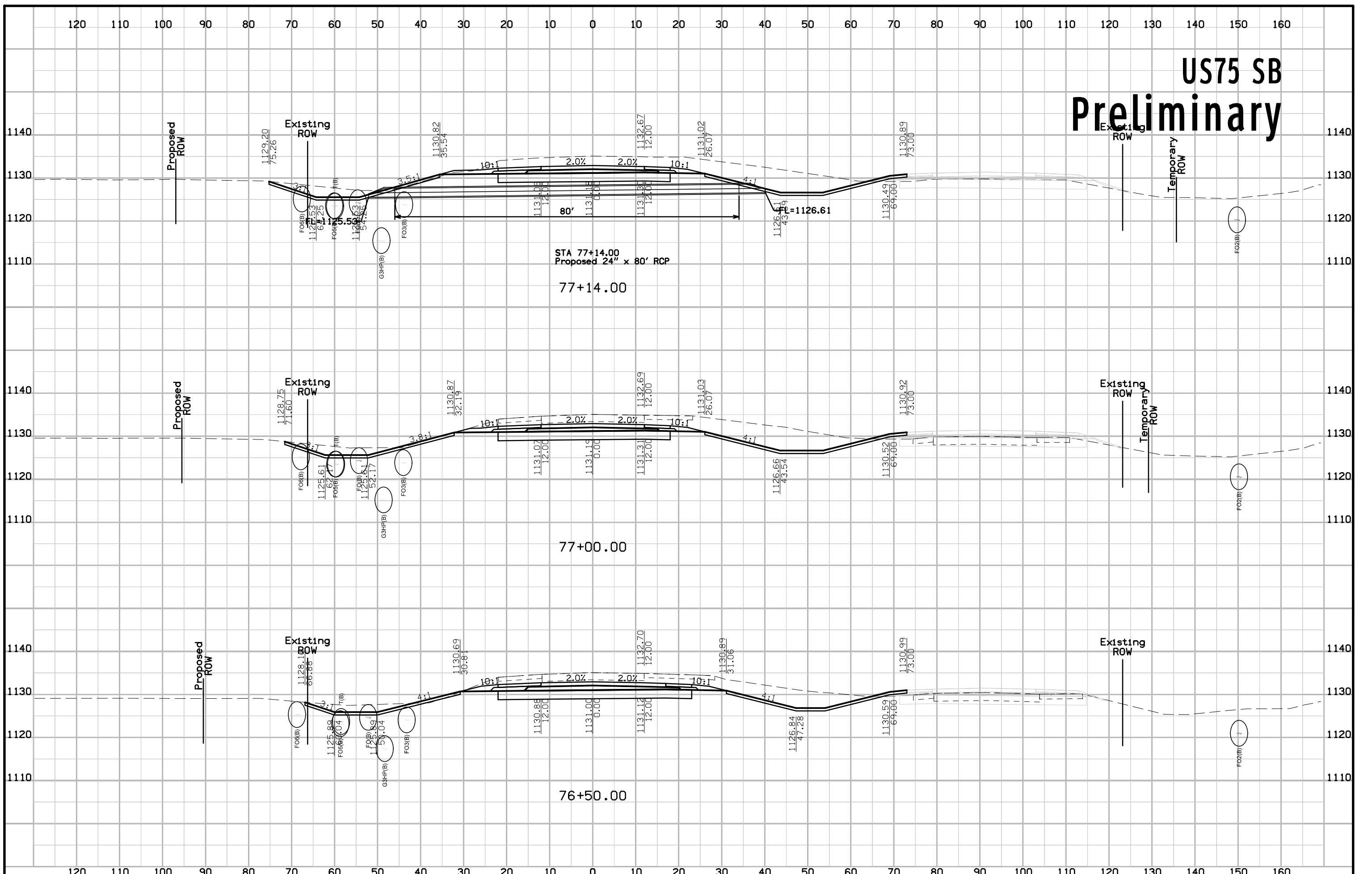

US75 SB Preliminary

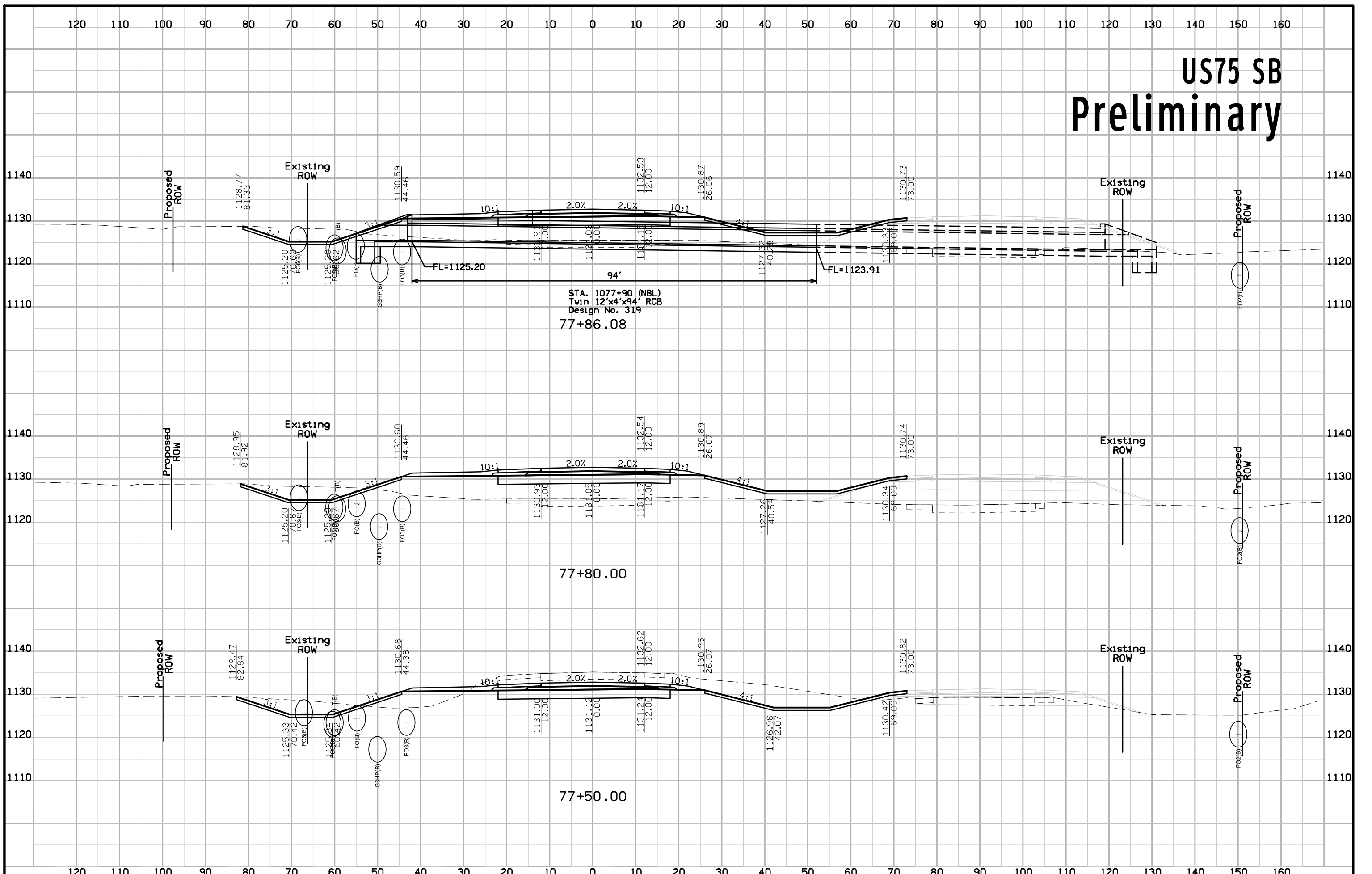

STA. 1077+90 (NBL)
Twin 12'x4'x94' RCB
Design No. 319
77+86.08

77+80.00

77+50.00

US75 SB Preliminary

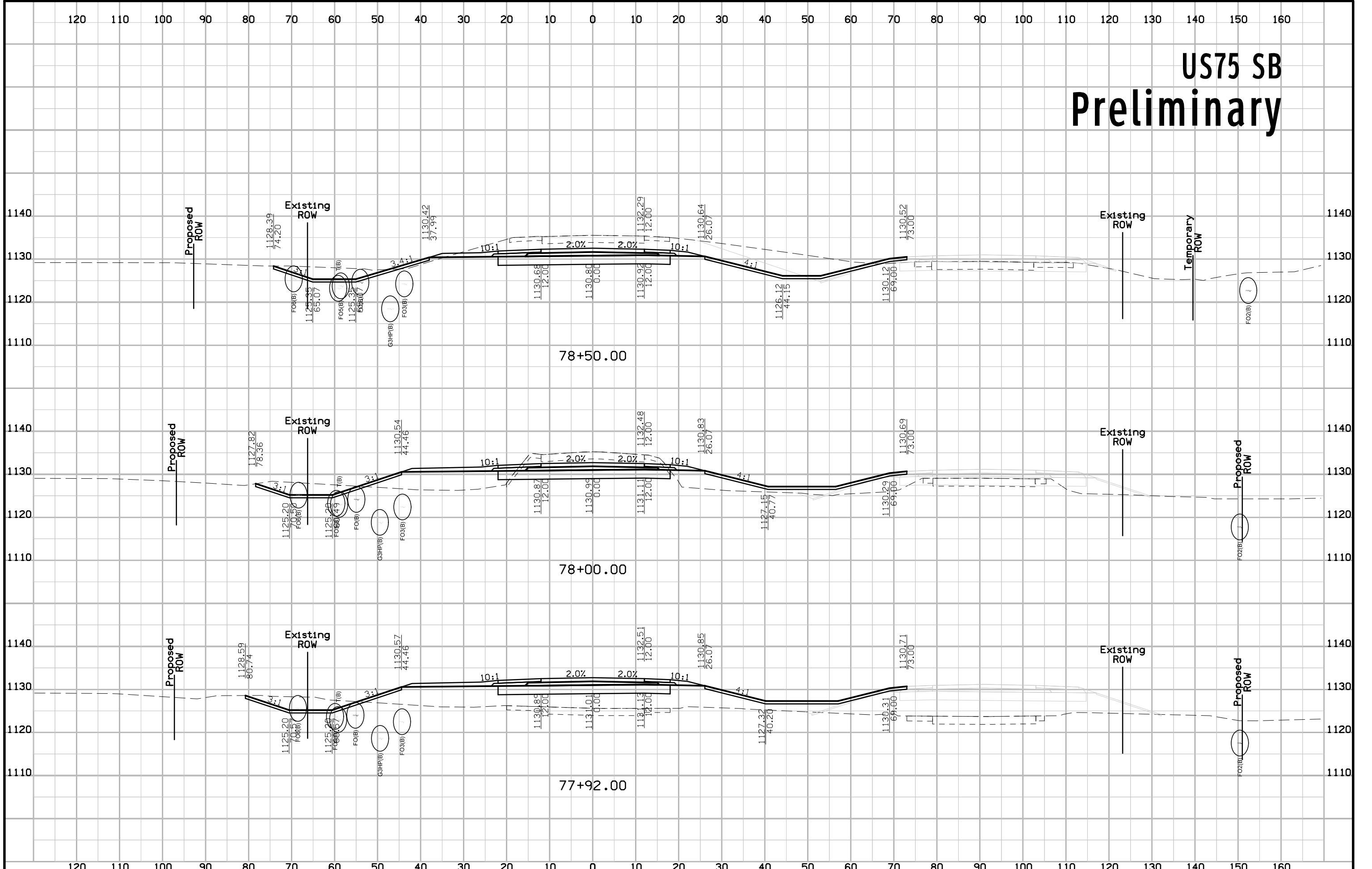

US75 SB Preliminary

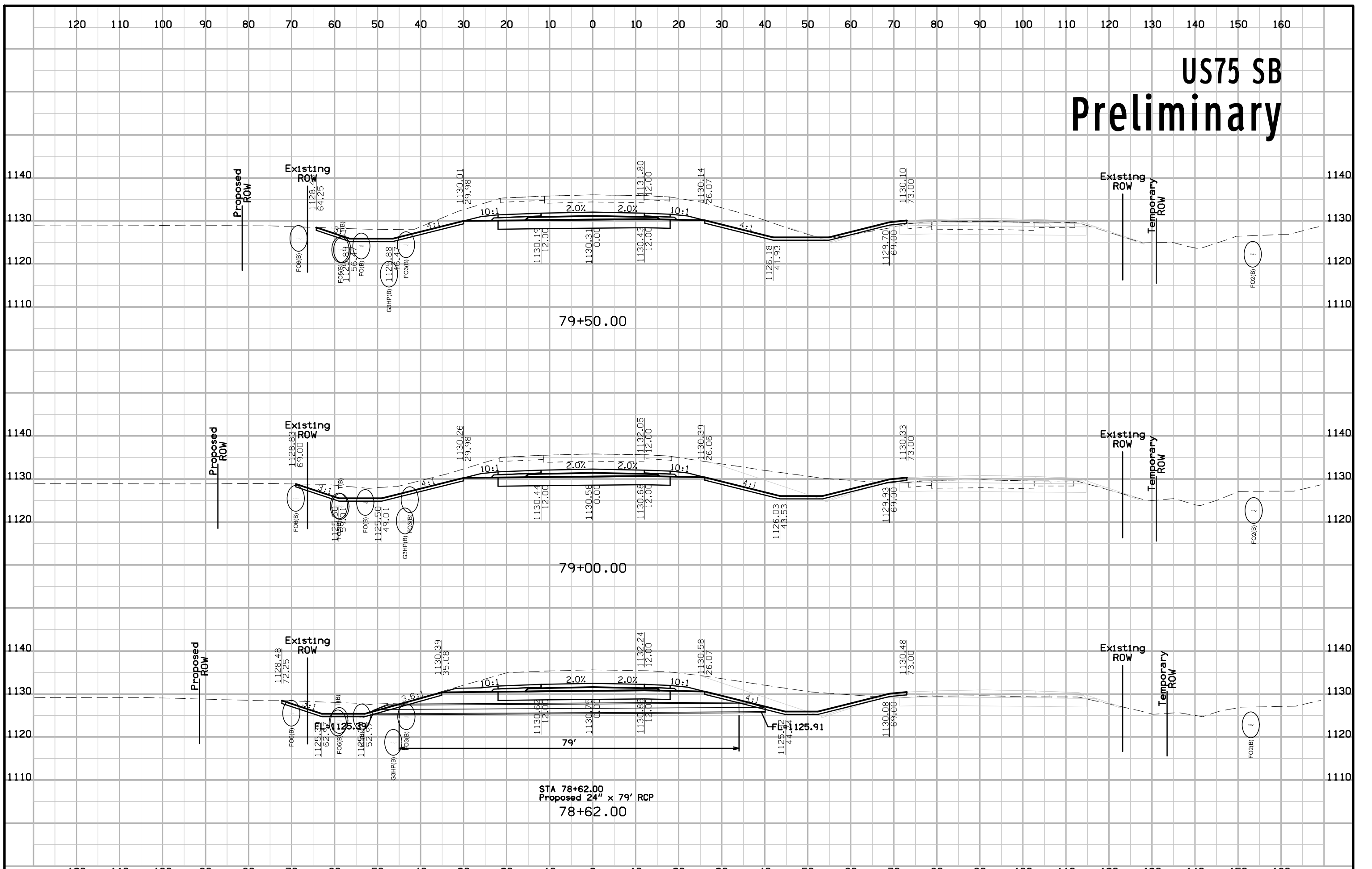

STA 78+62.00
Proposed 24" x 79' RCP
78+62.00

US75 SB Preliminary

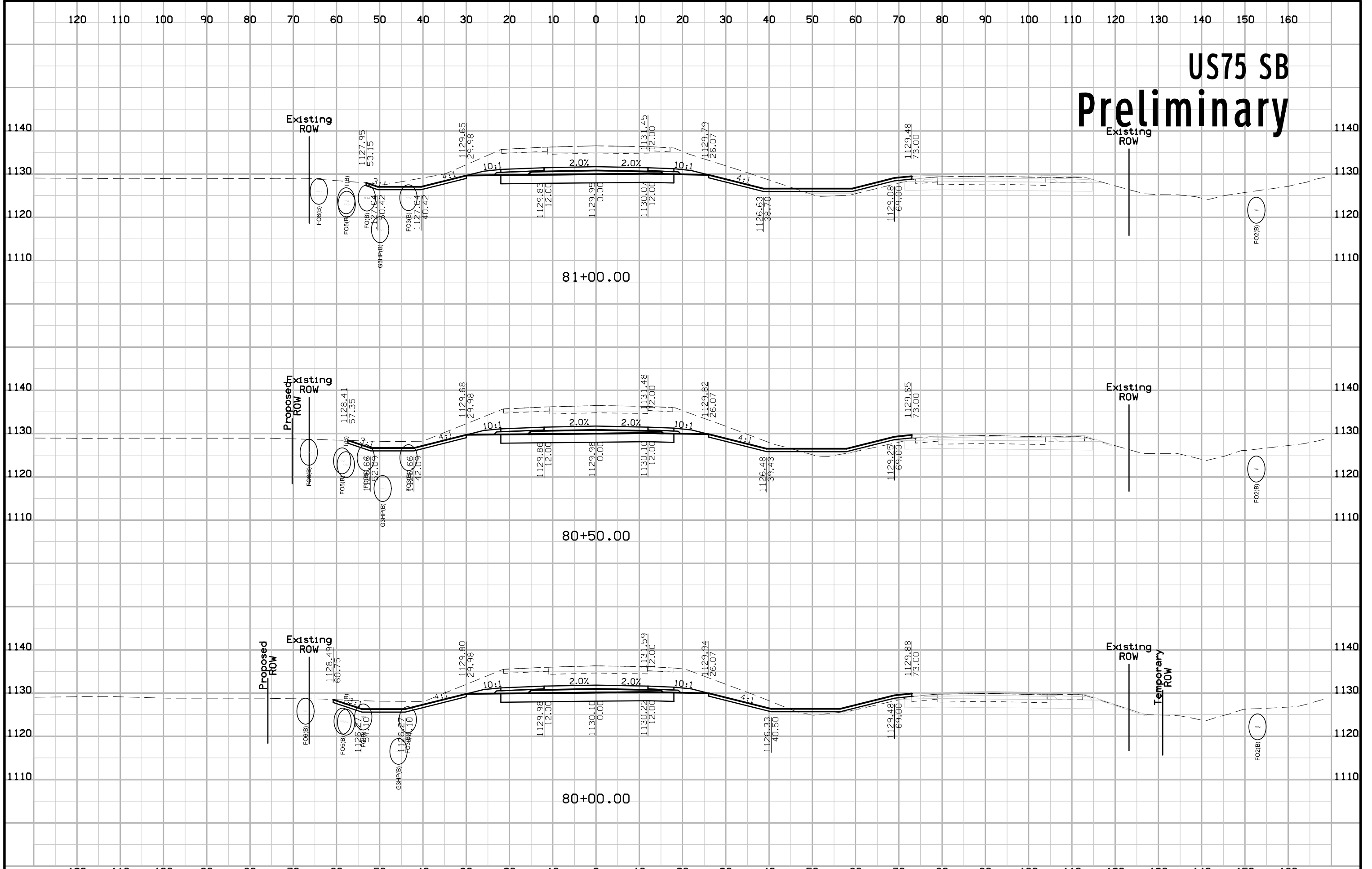

US75 SB Preliminary

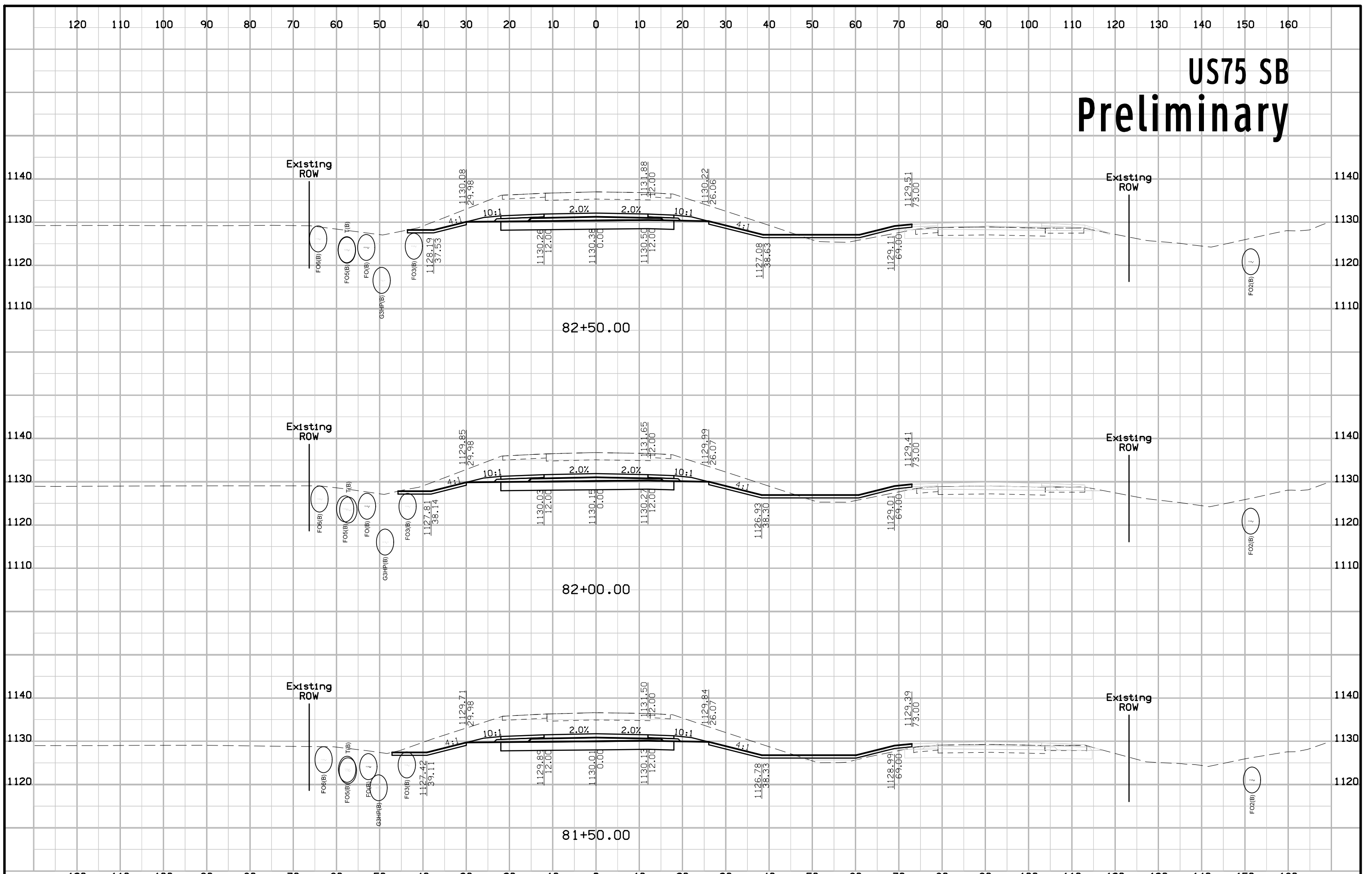

US75 SB Preliminary

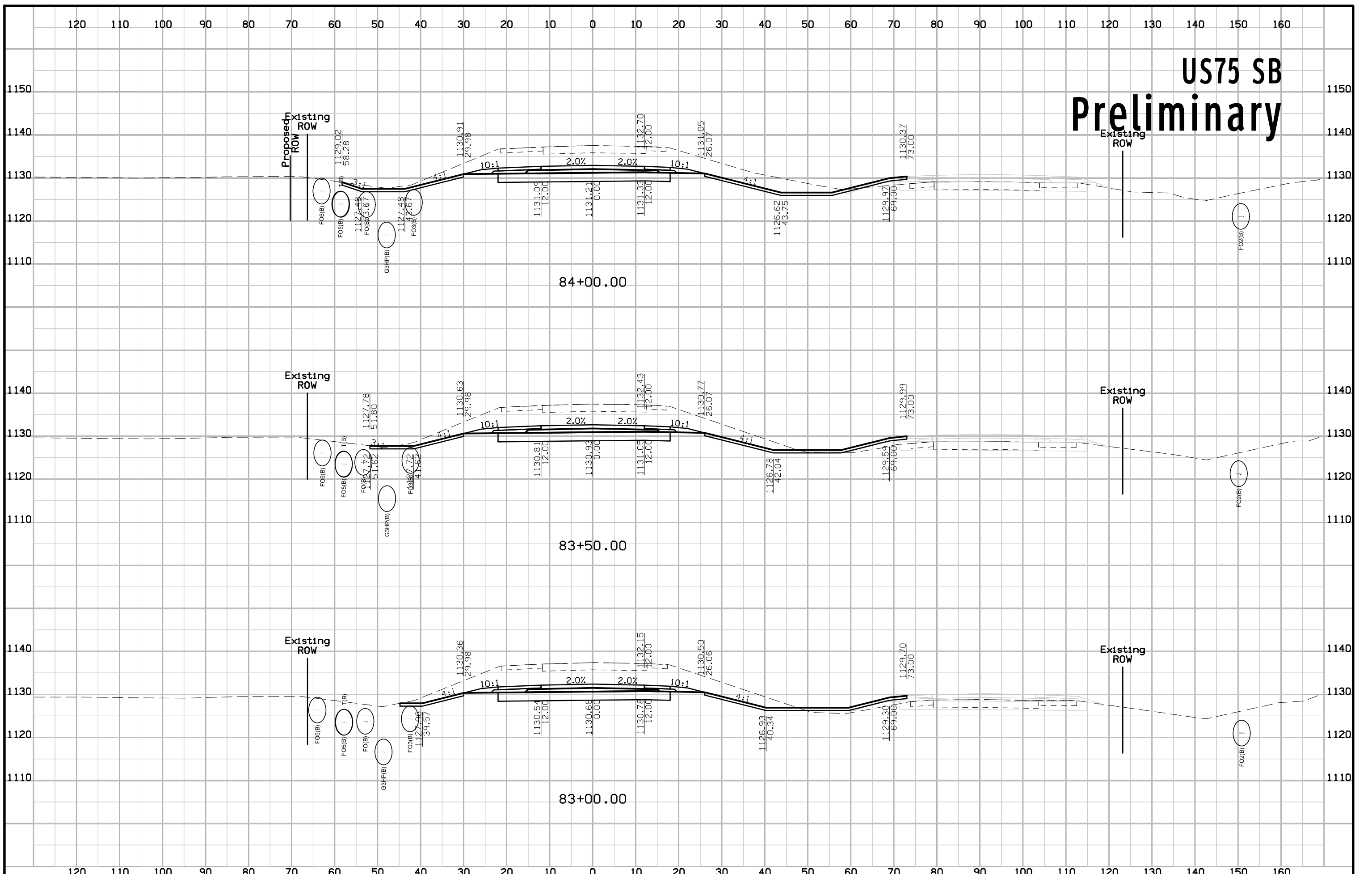

US75 SB Preliminary

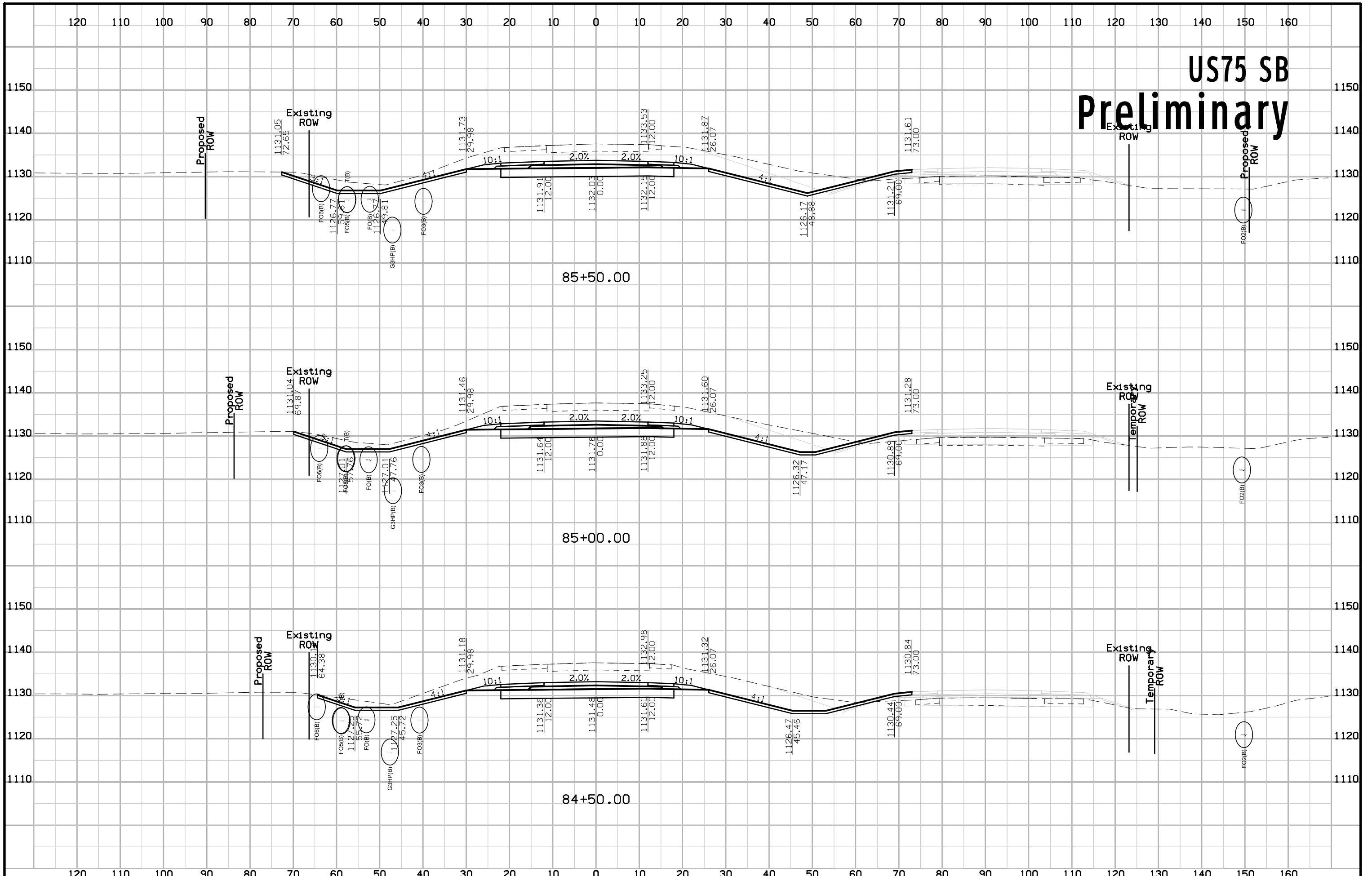

US75 SB Preliminary

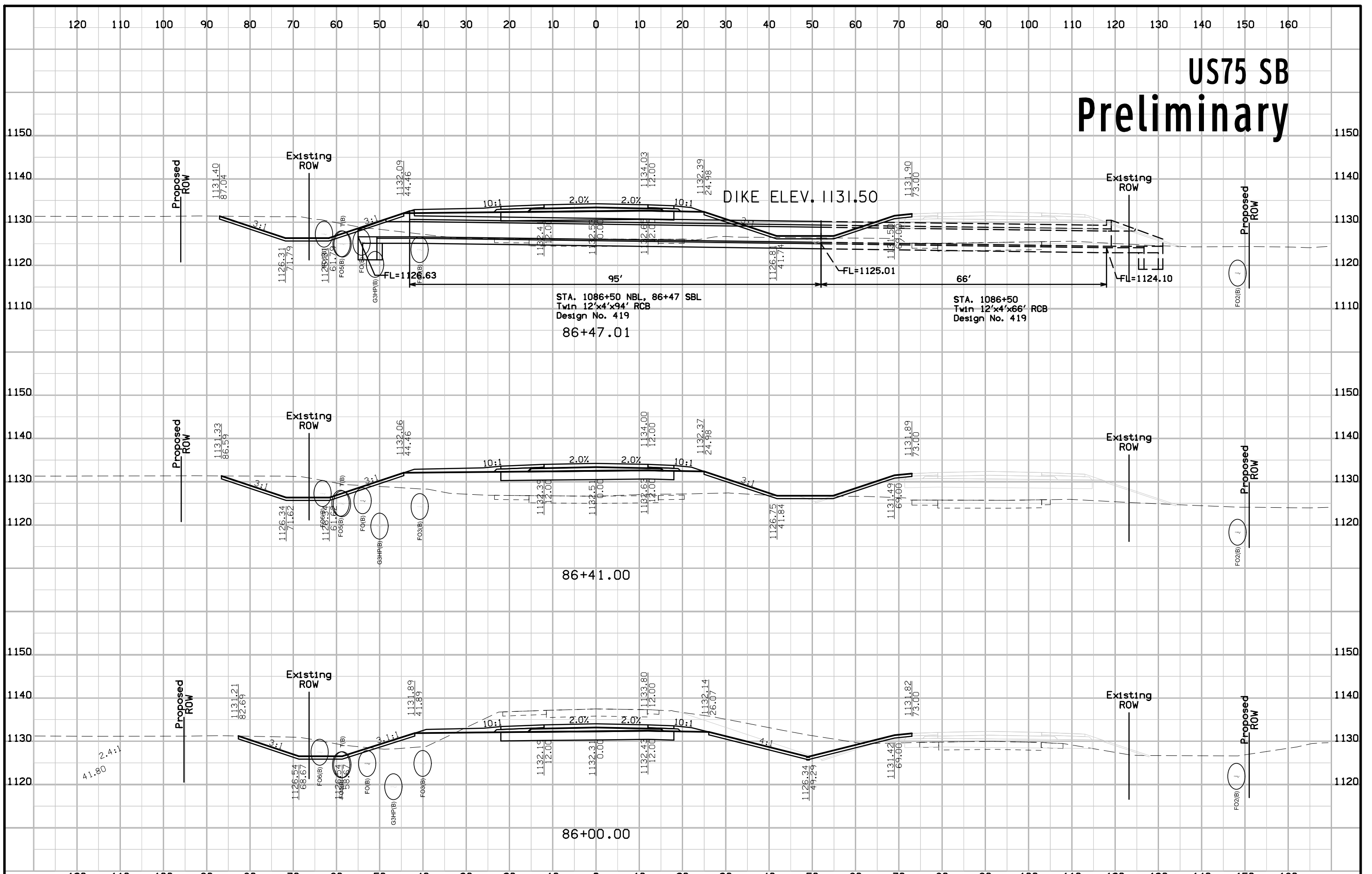

US75 SB Preliminary

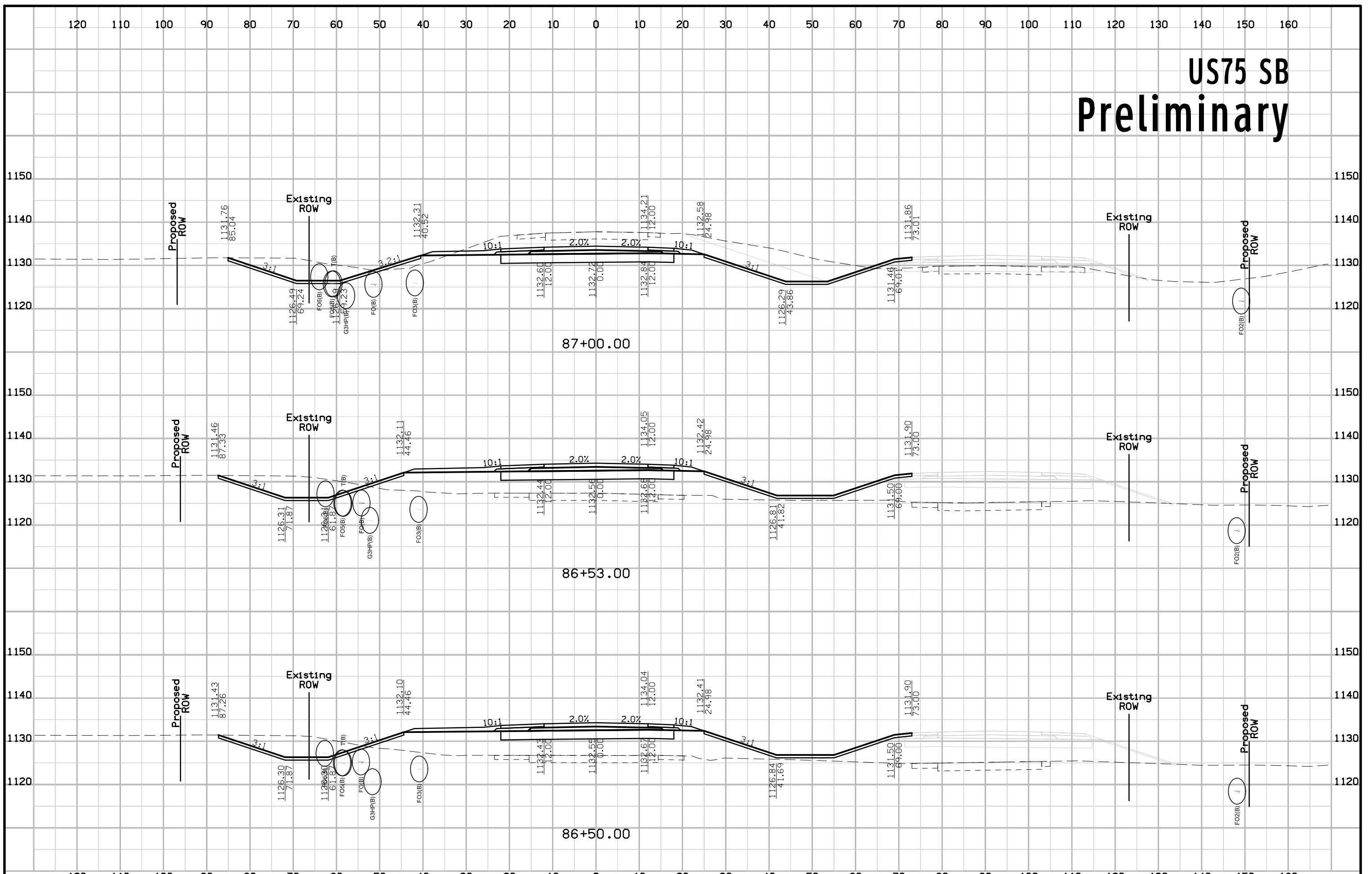

US75 SB Preliminary

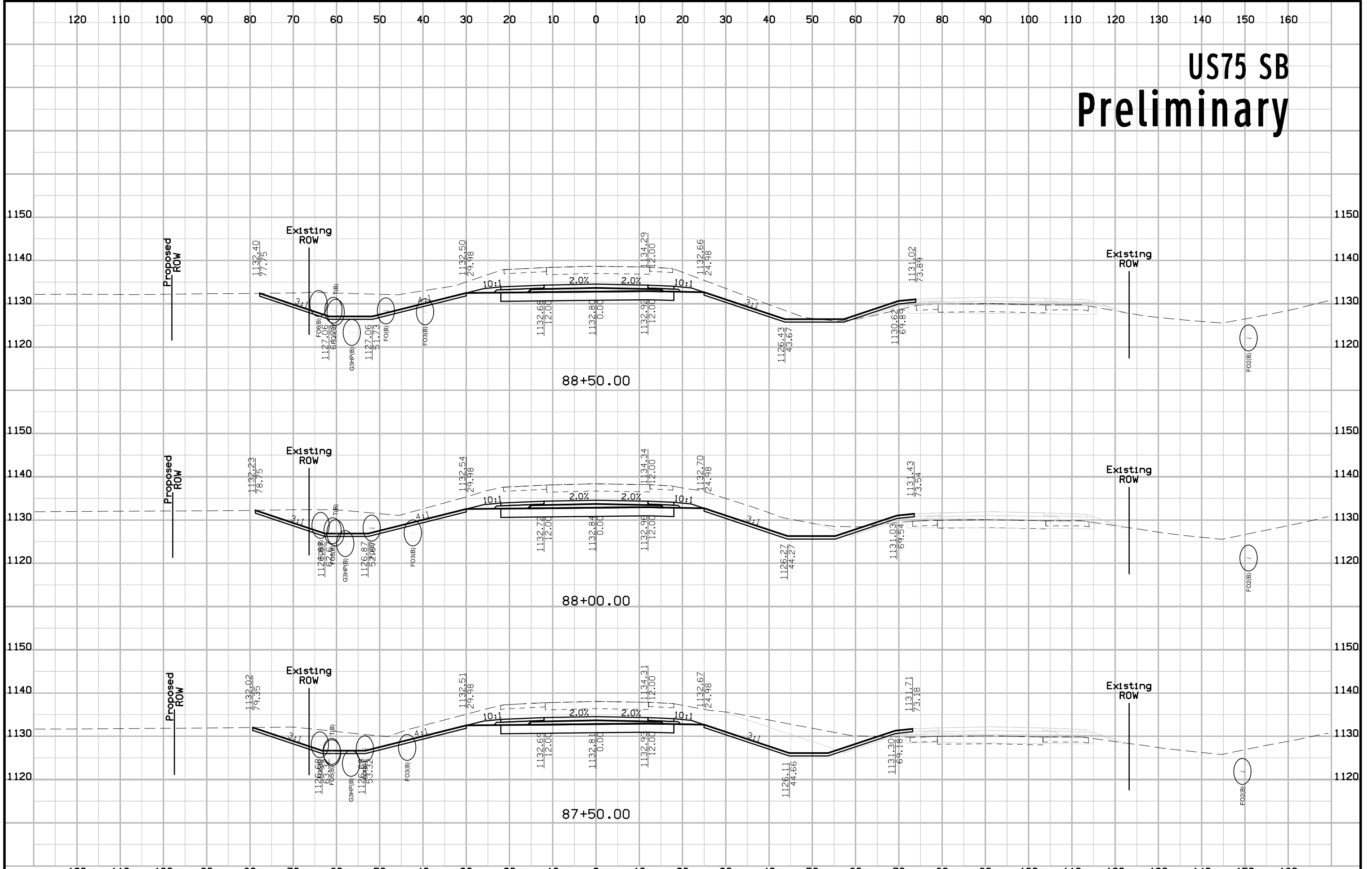

US75 SB Preliminary

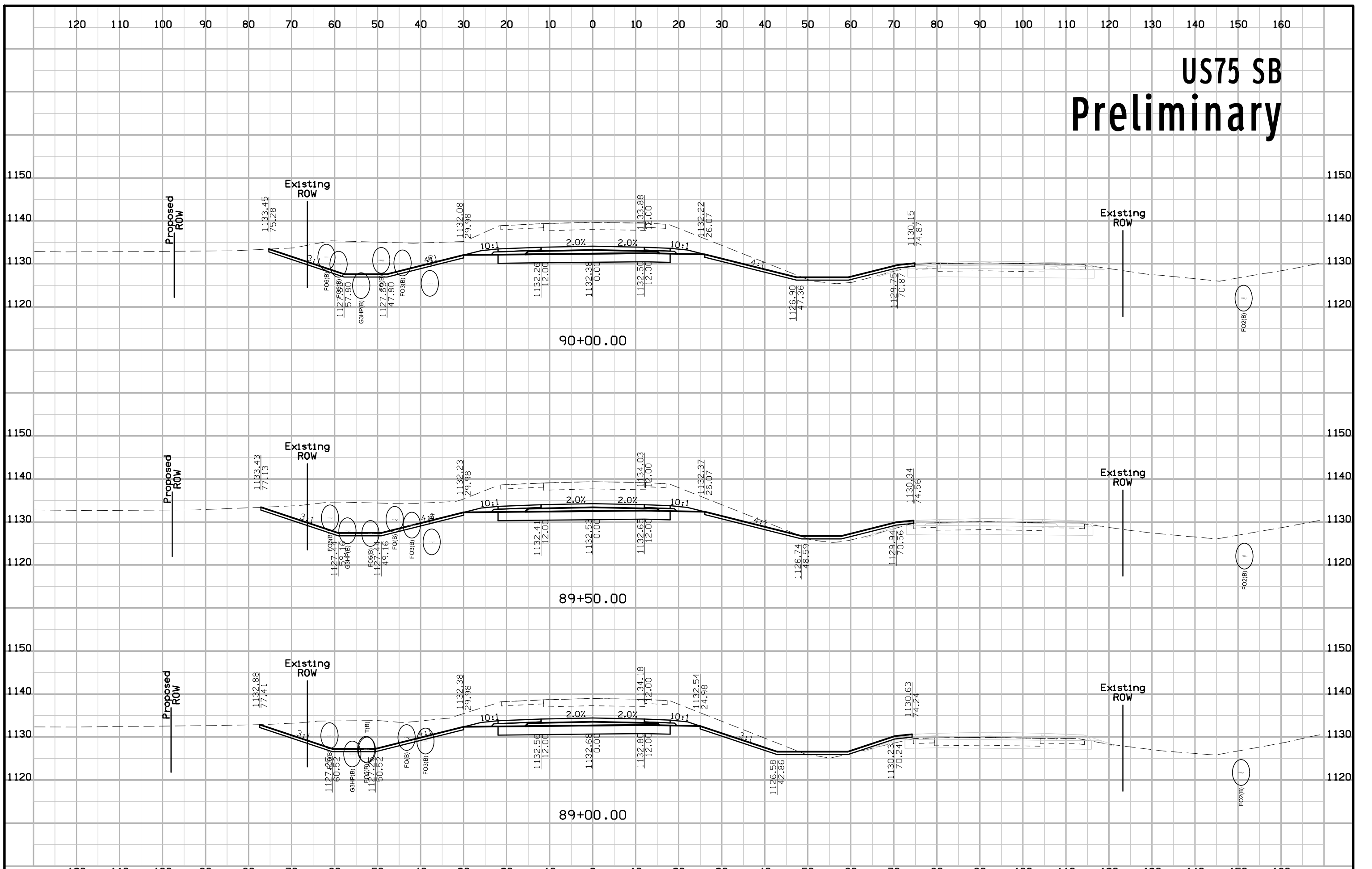

US75 SB Preliminary

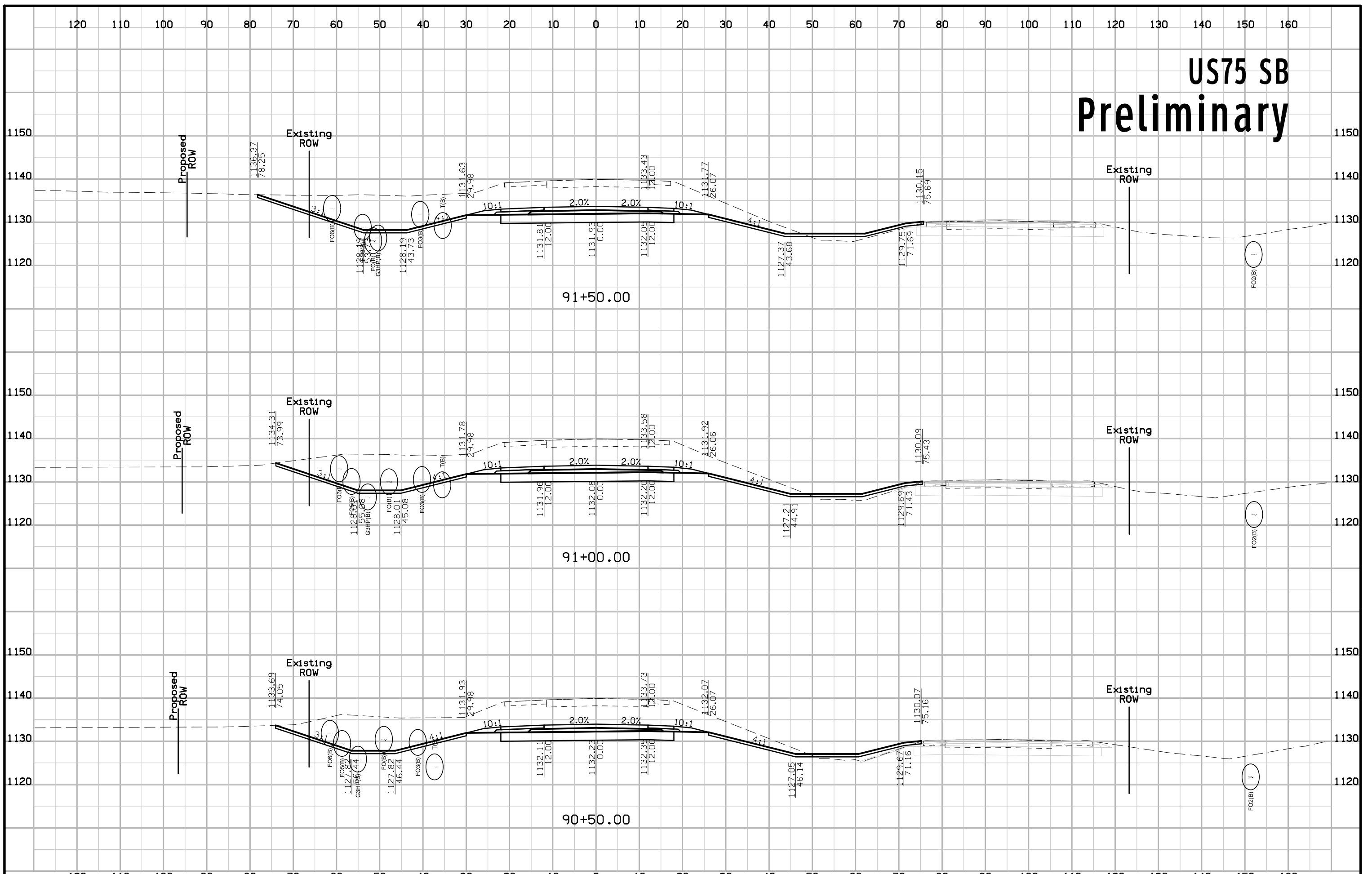

US75 SB Preliminary

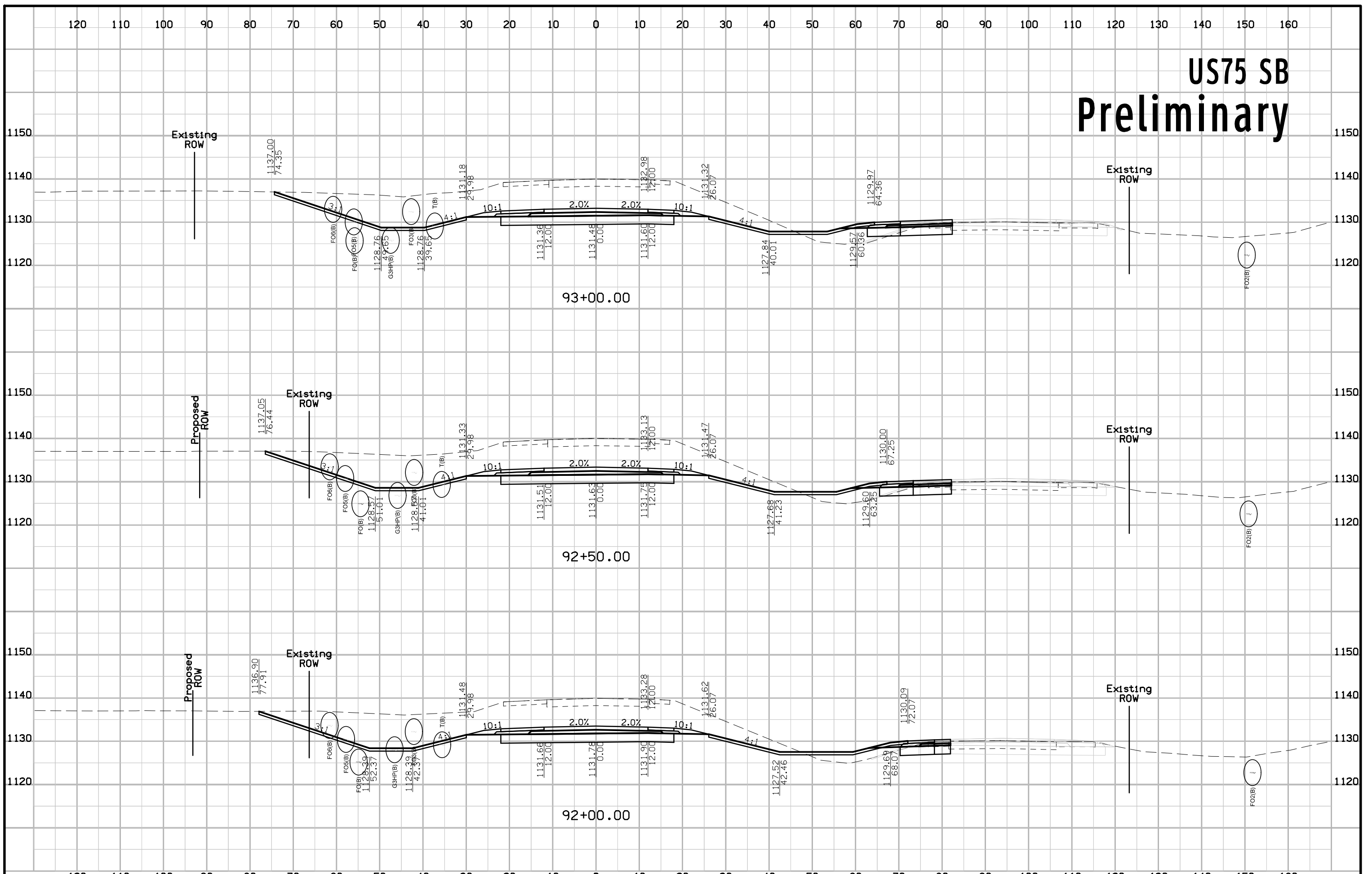

US75 SB Preliminary

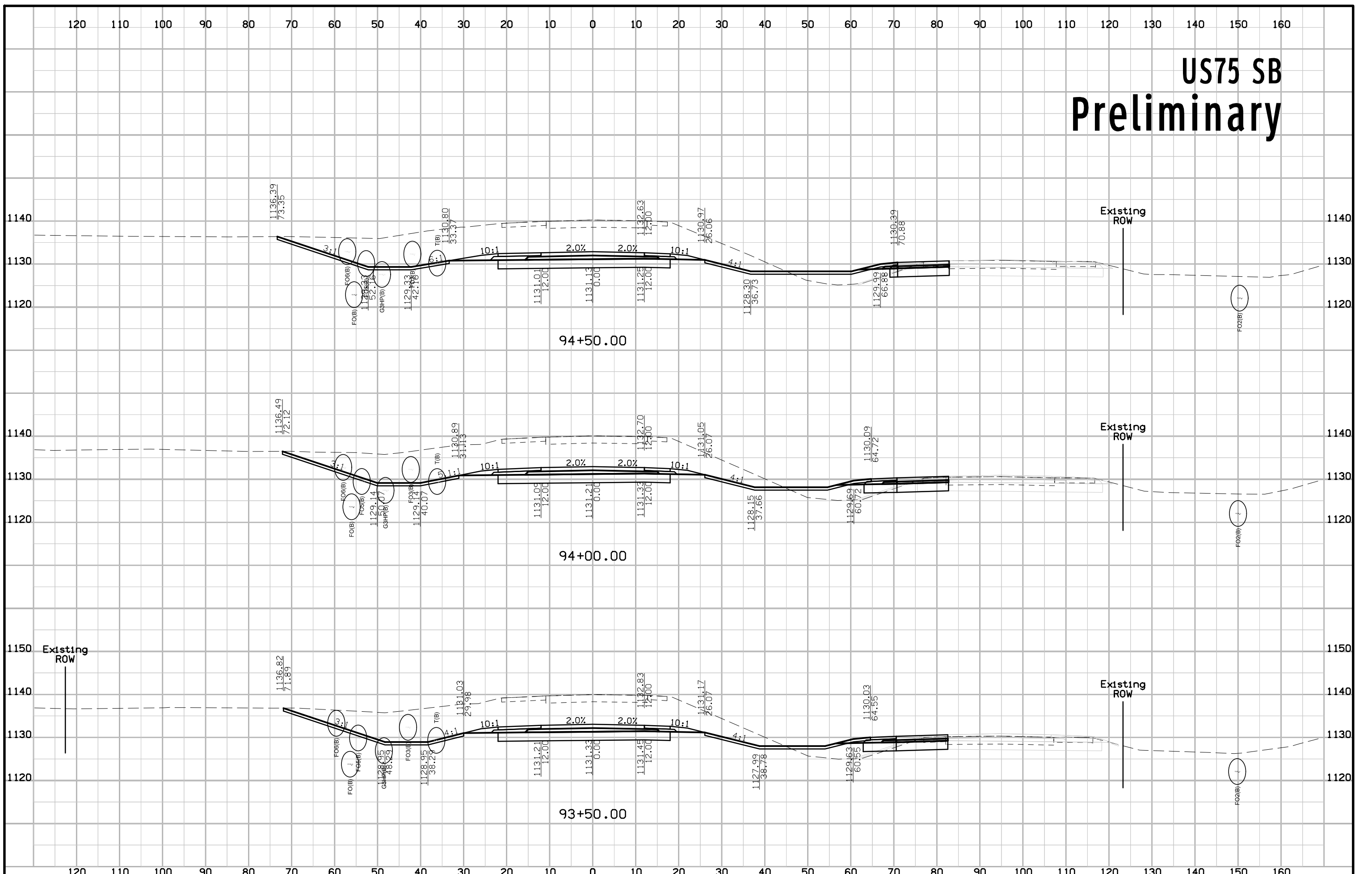

US75 SB Preliminary

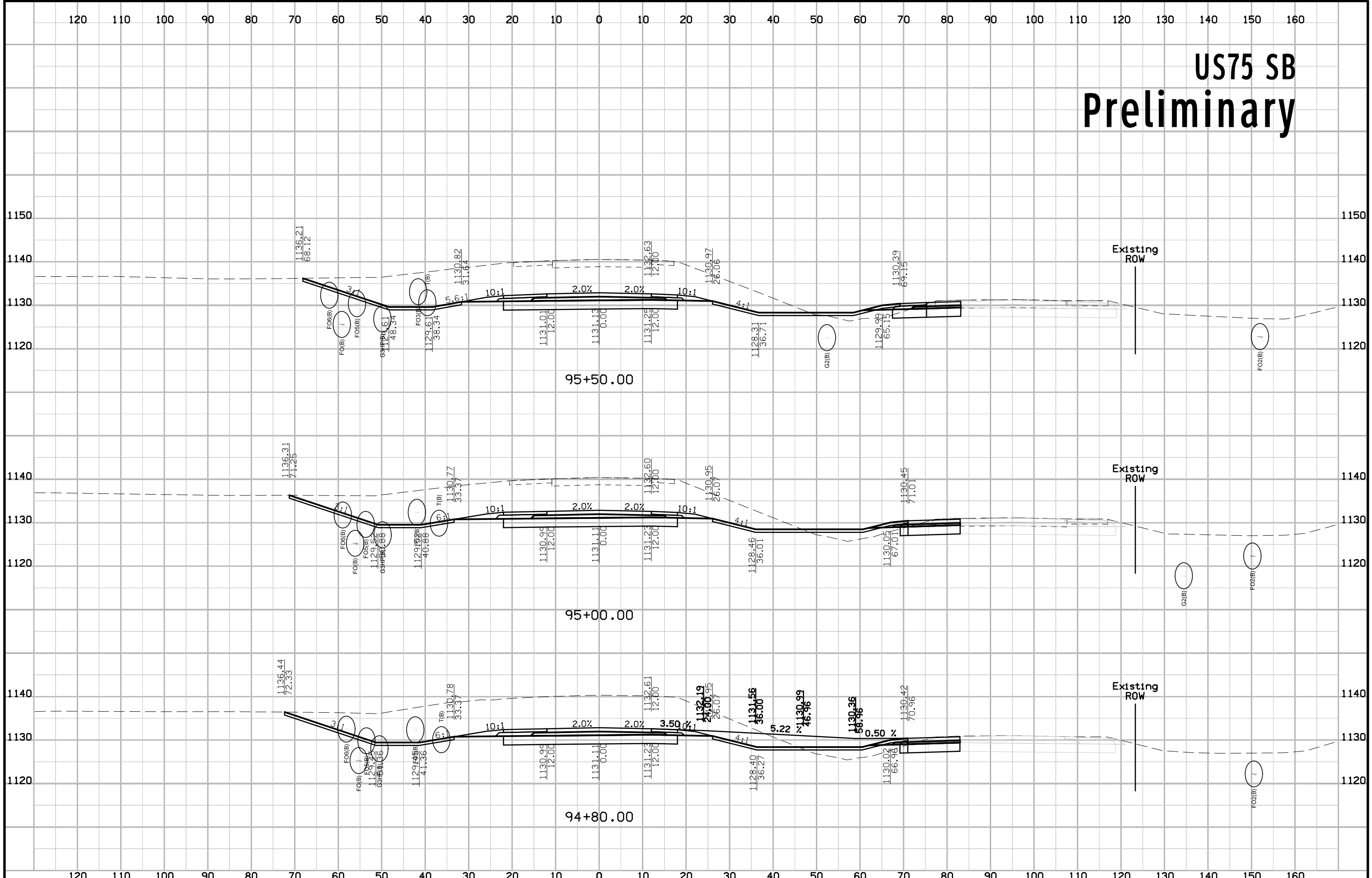

US75 SB Preliminary

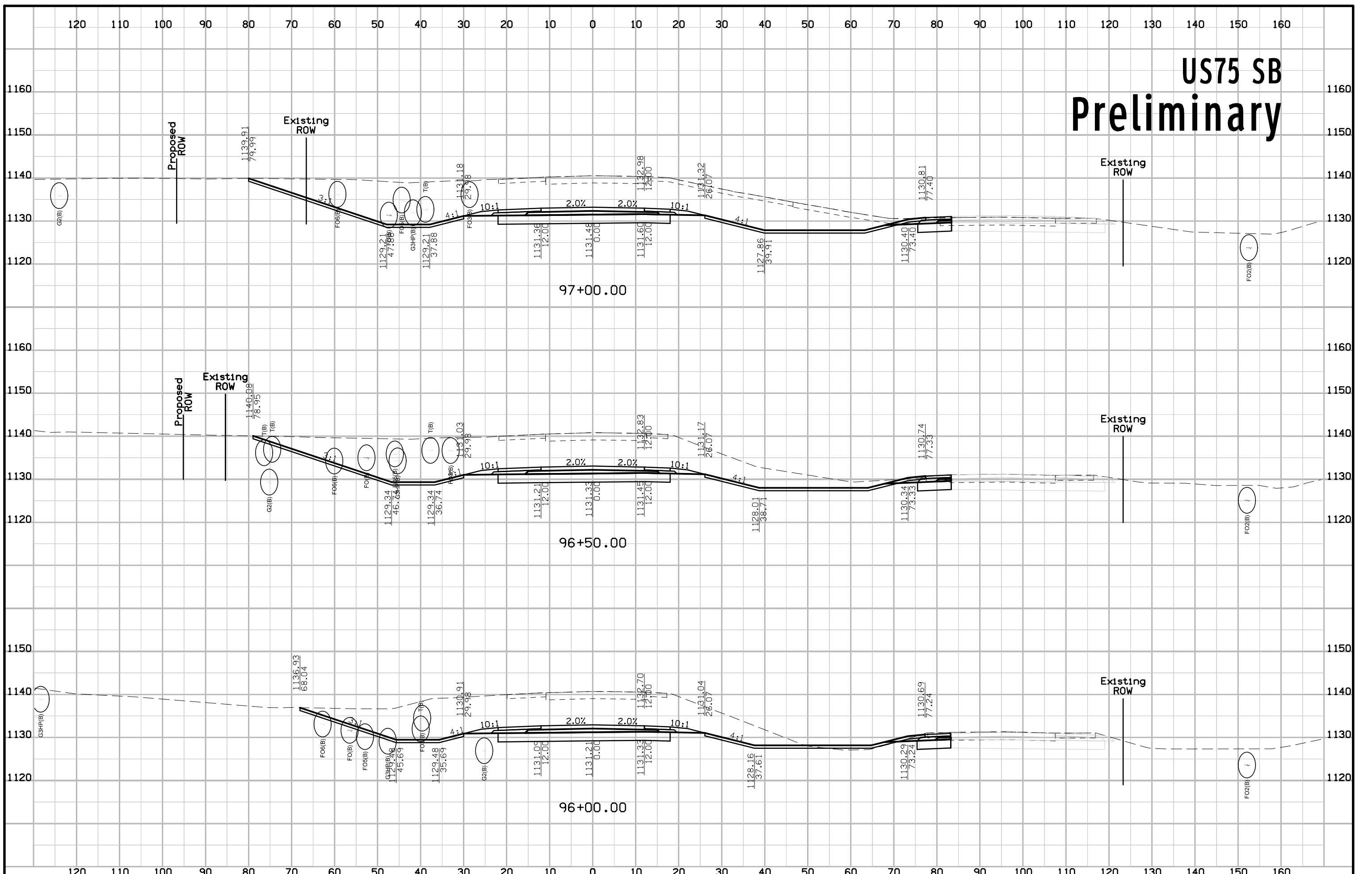

US75 SB Preliminary

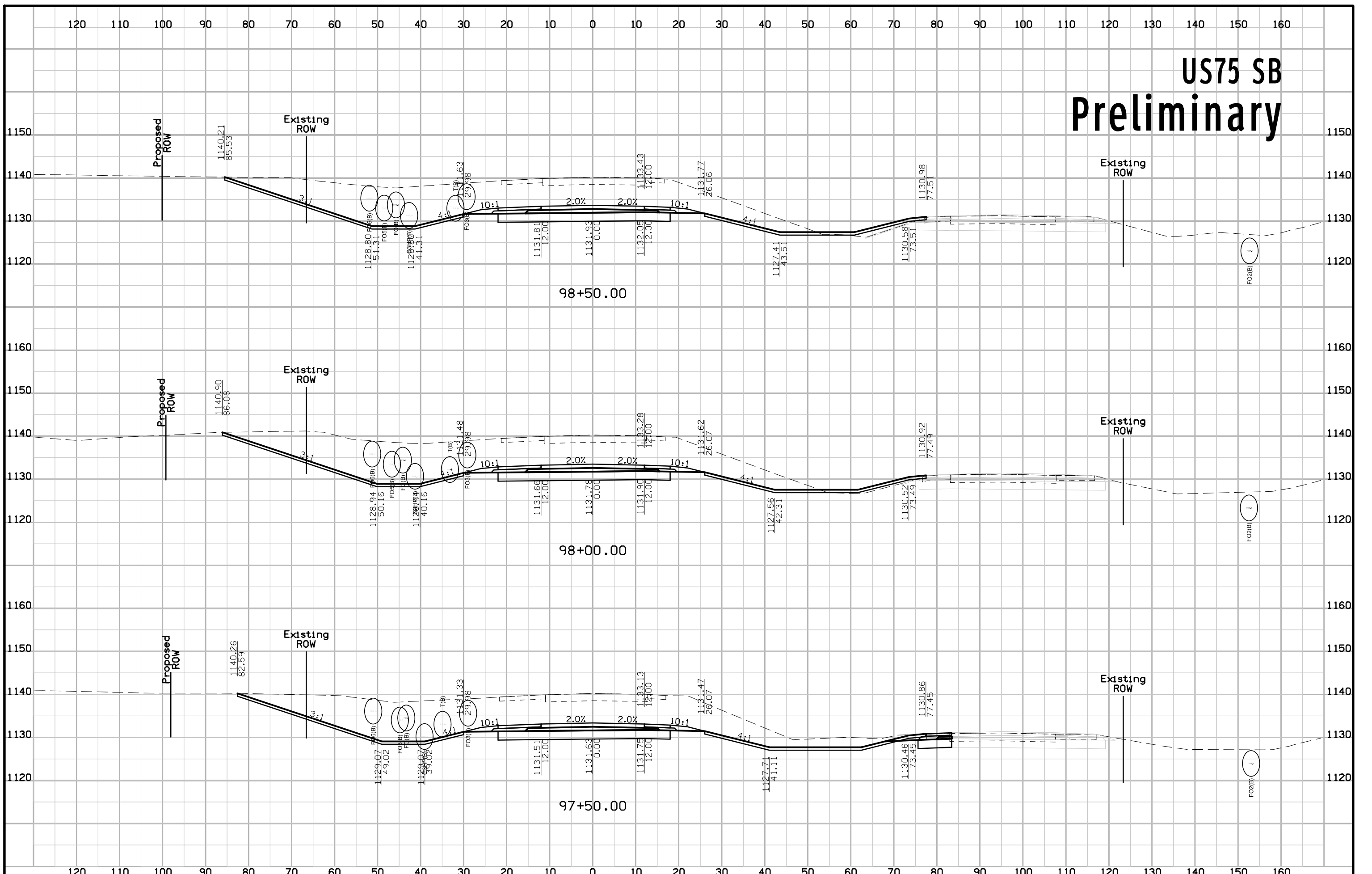

US75 SB Preliminary

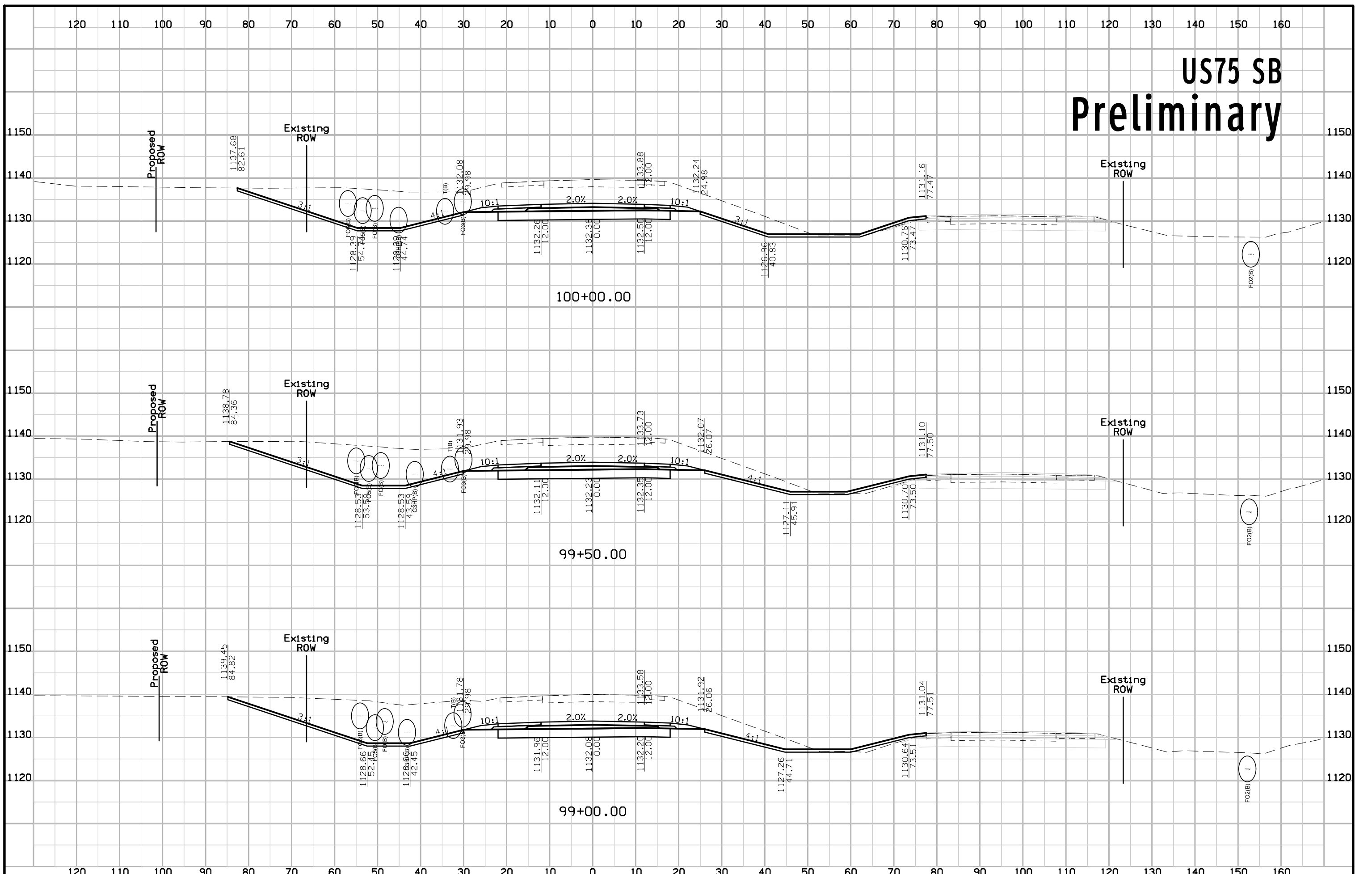

US75 SB Preliminary

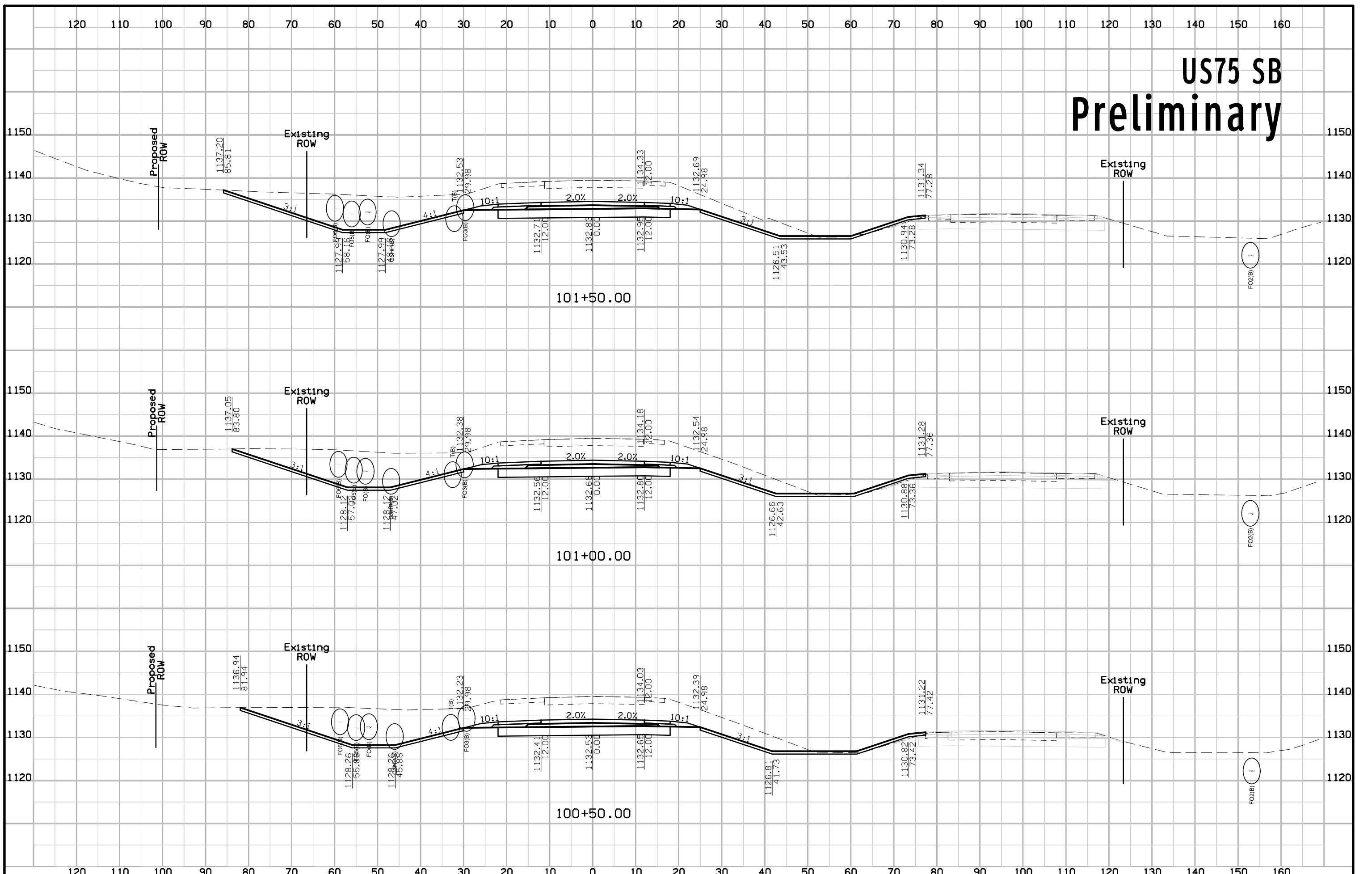

US75 SB Preliminary

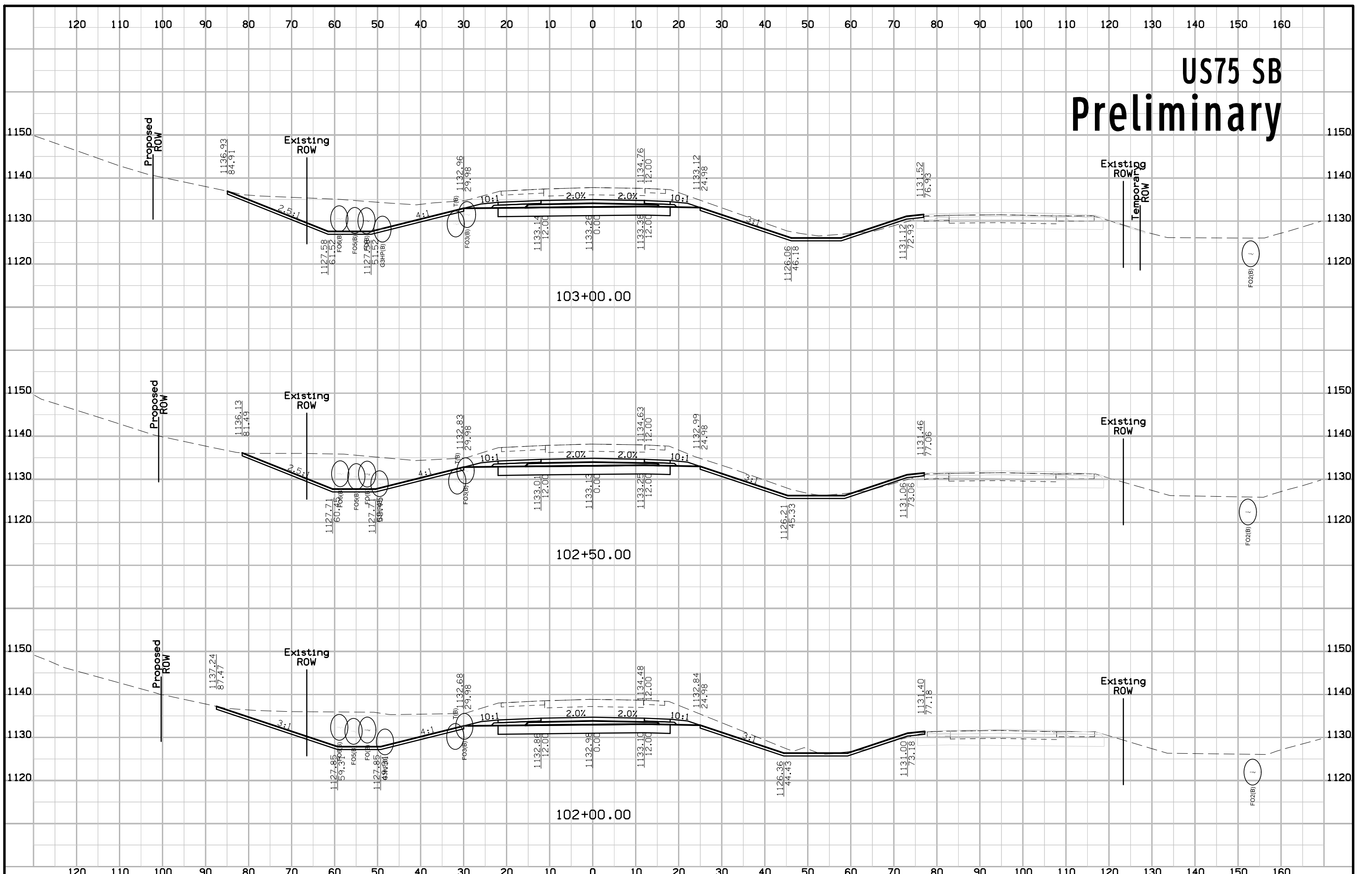

US75 SB Preliminary

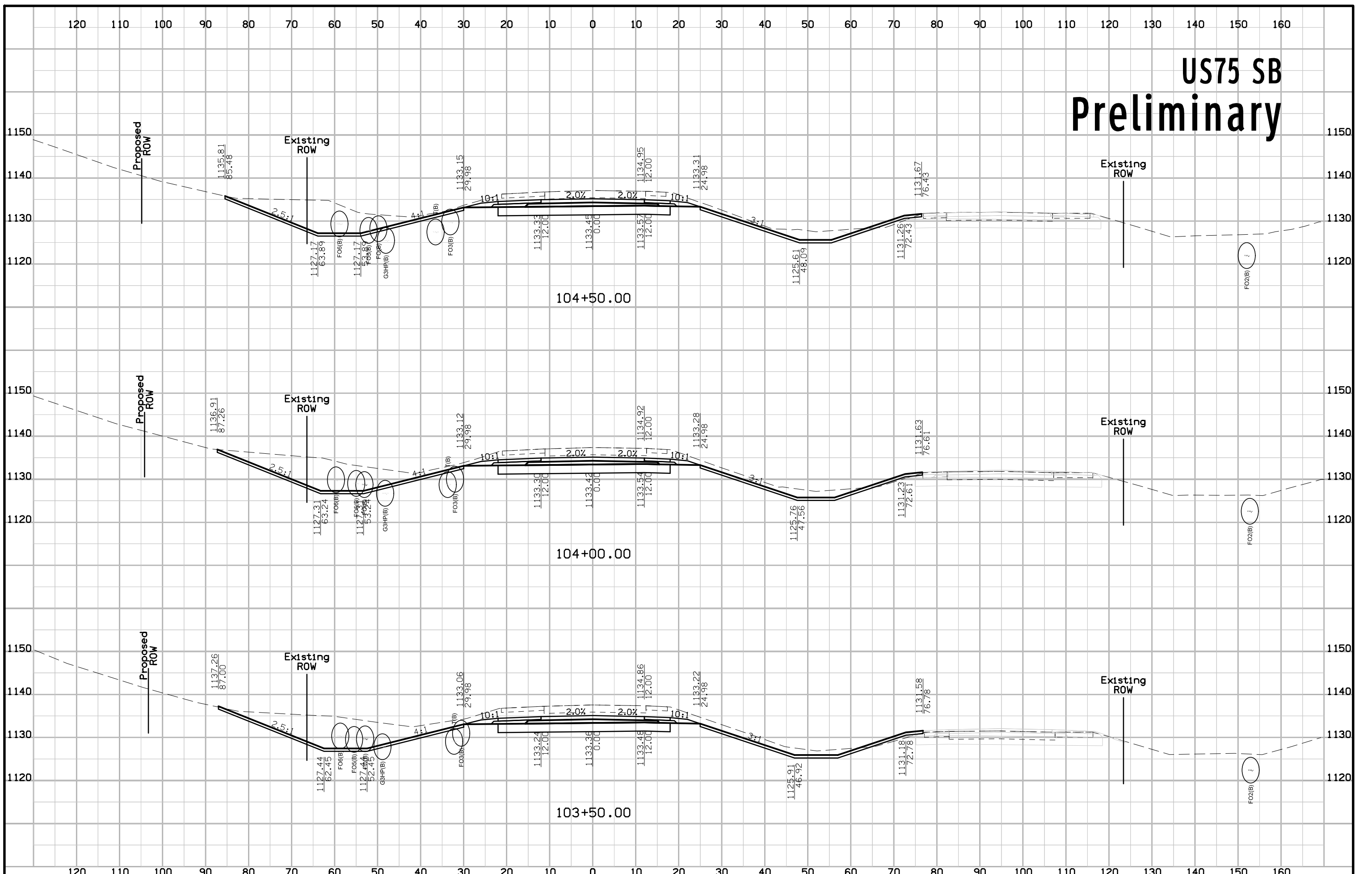

US75 SB Preliminary

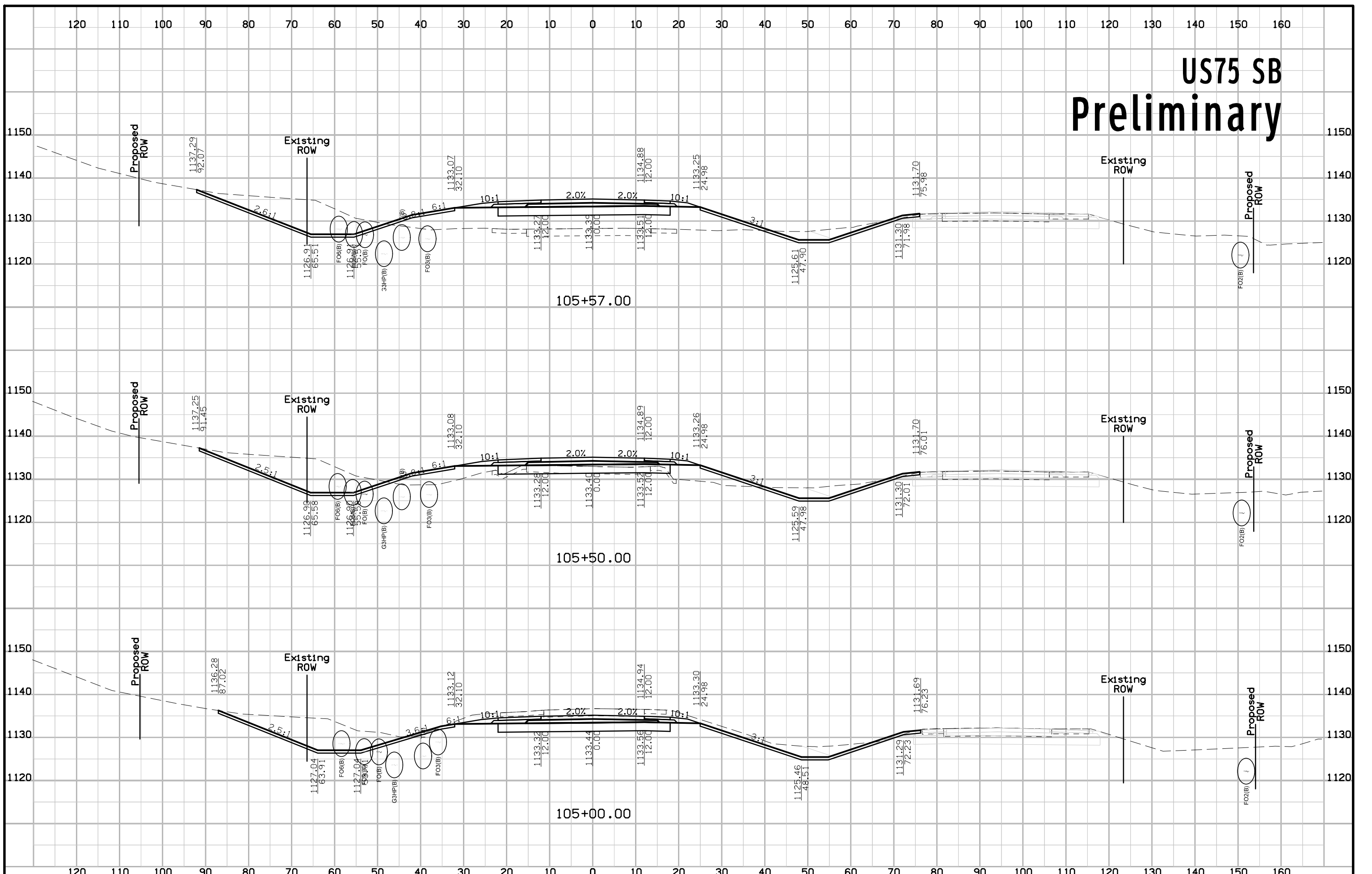

US75 SB Preliminary

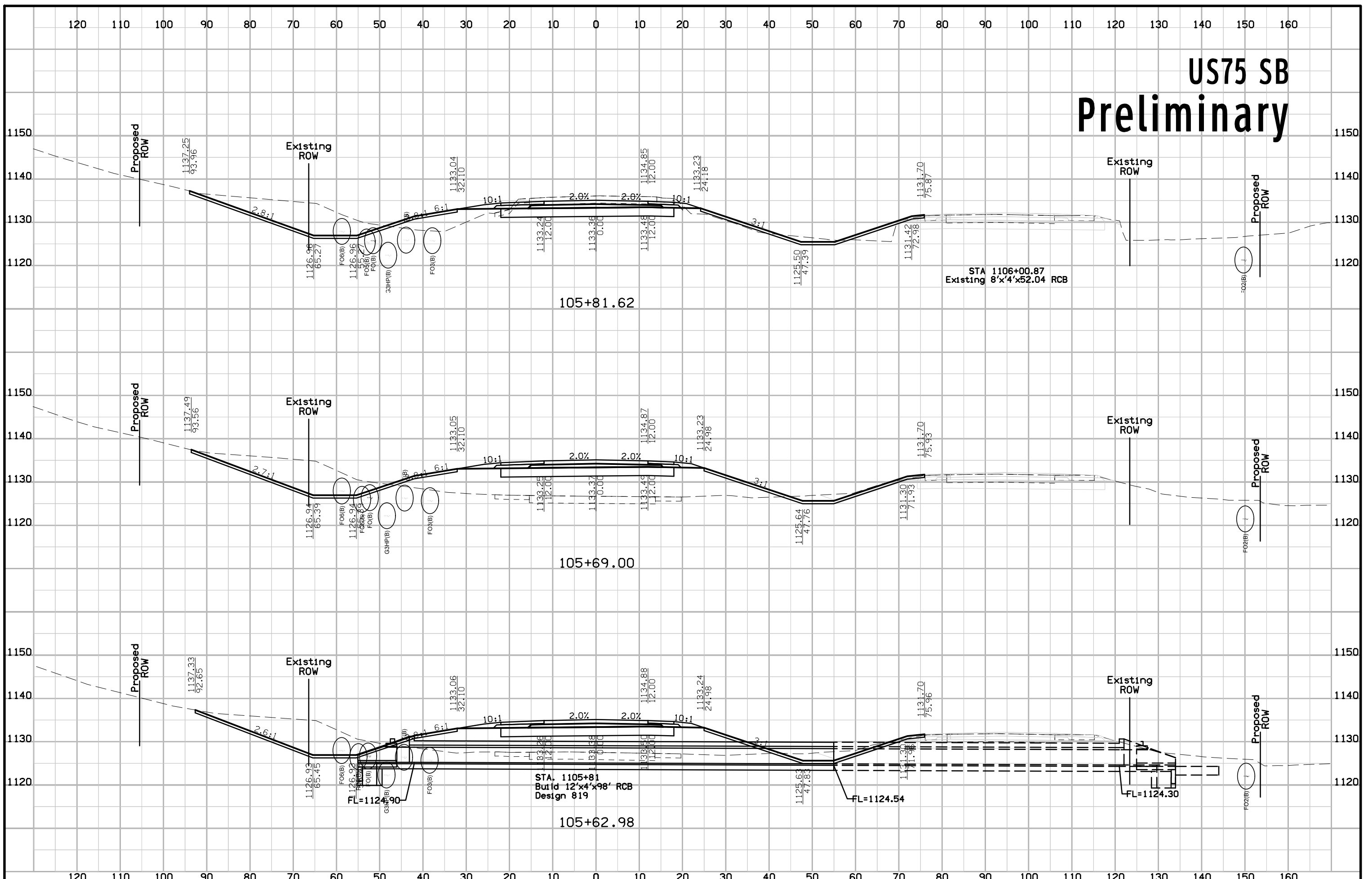

US75 SB Preliminary

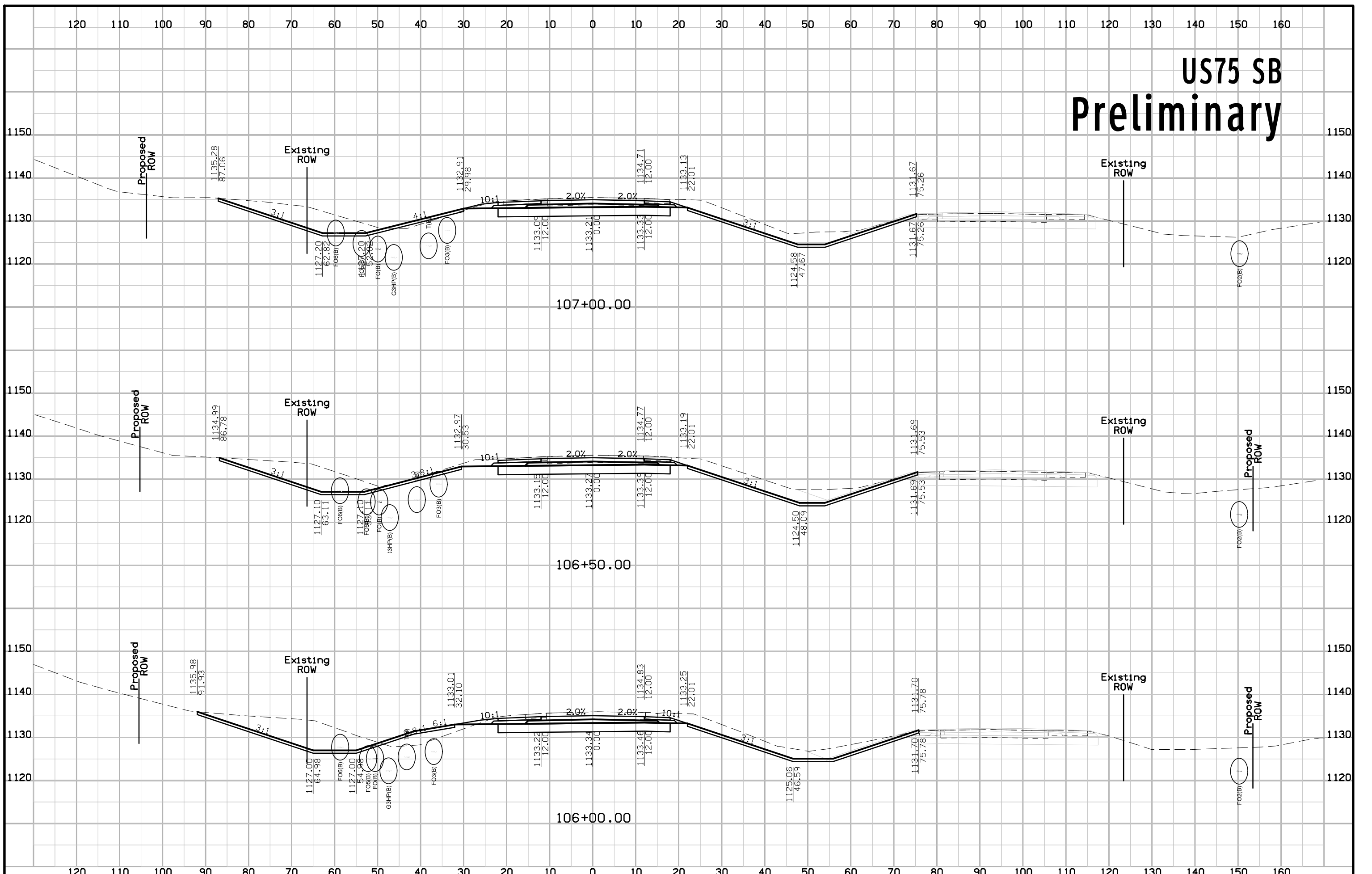

US75 SB Preliminary

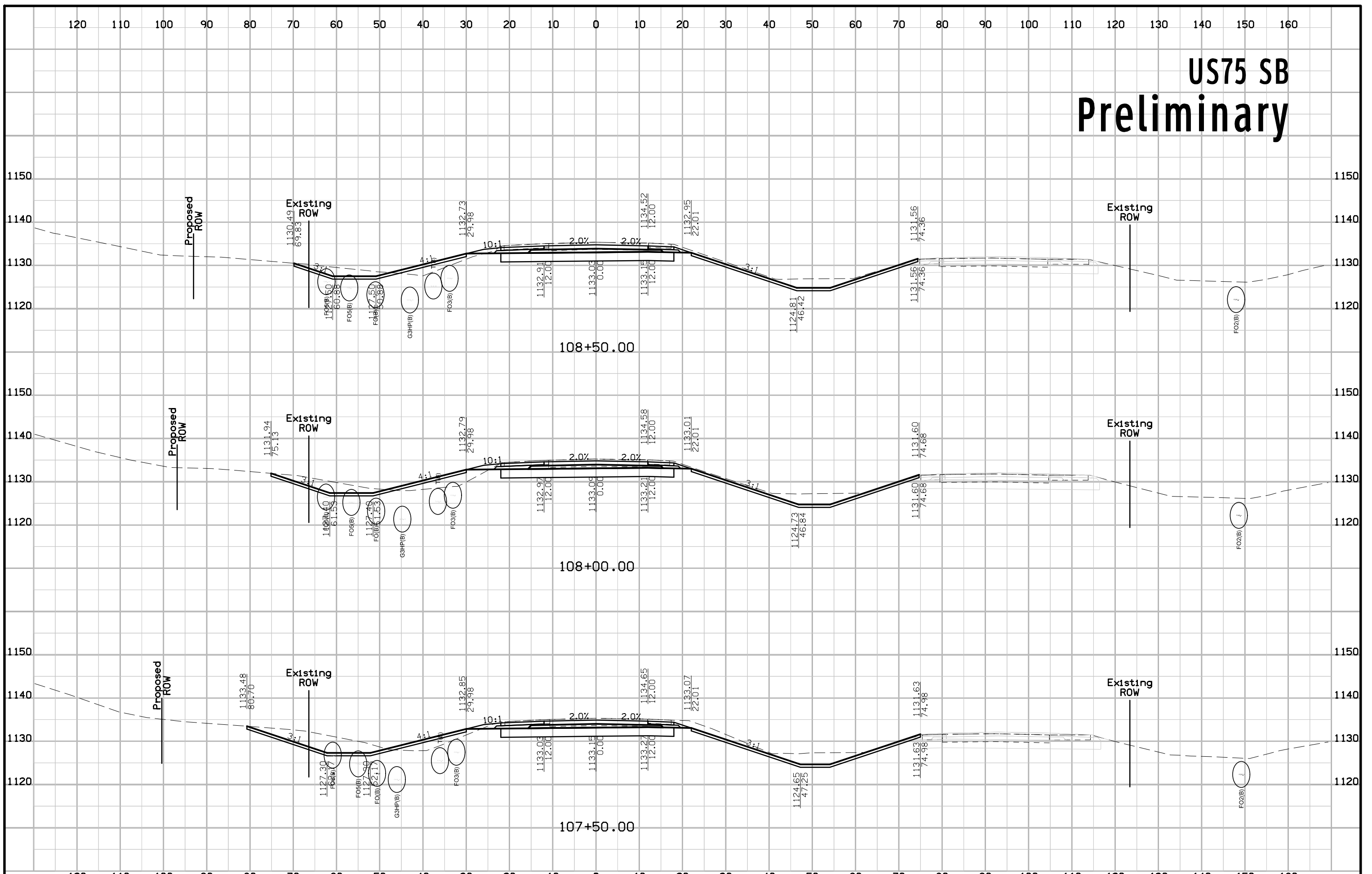

US75 SB Preliminary

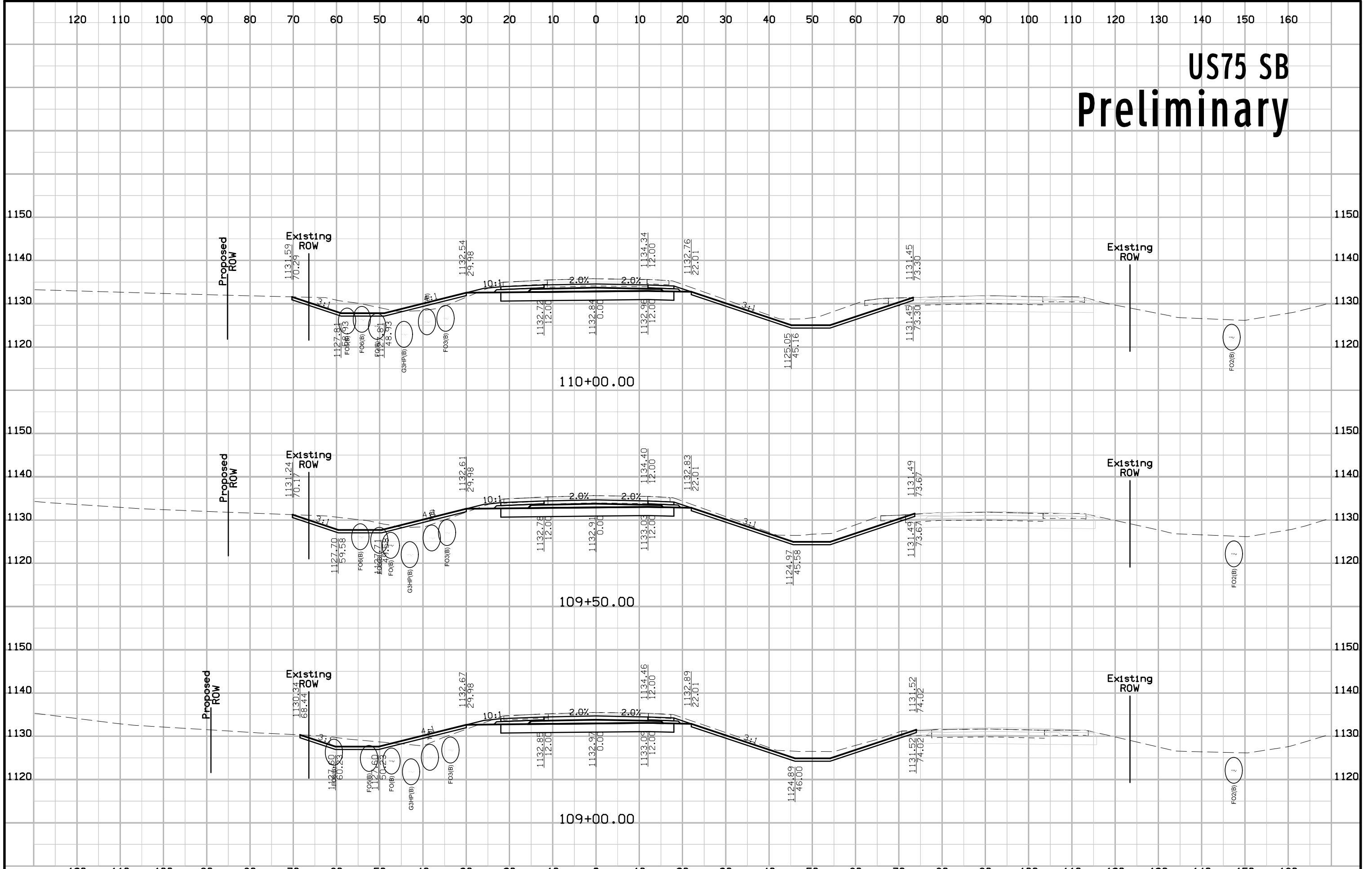

US75 SB Preliminary

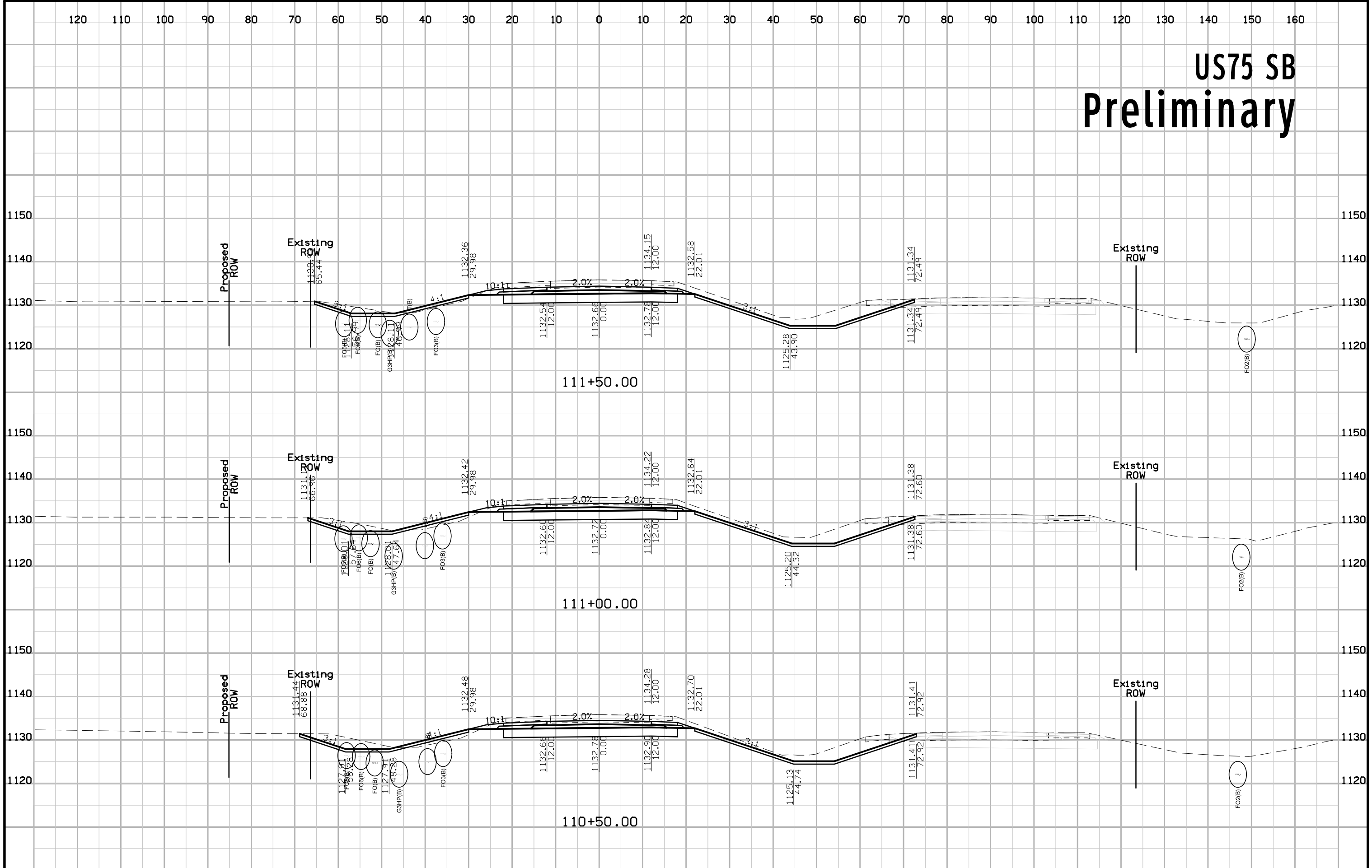

US75 SB Preliminary

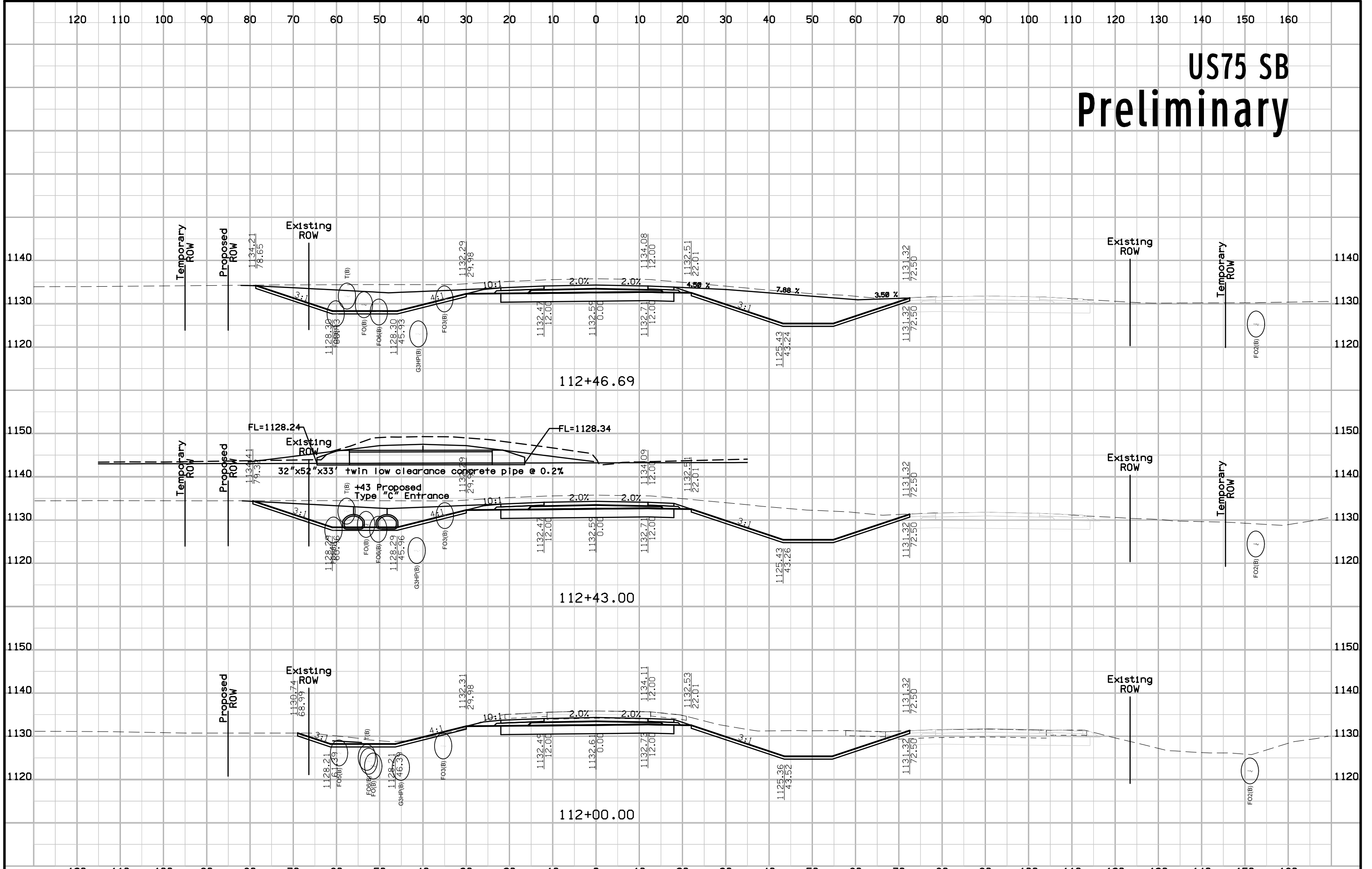

US75 SB Preliminary

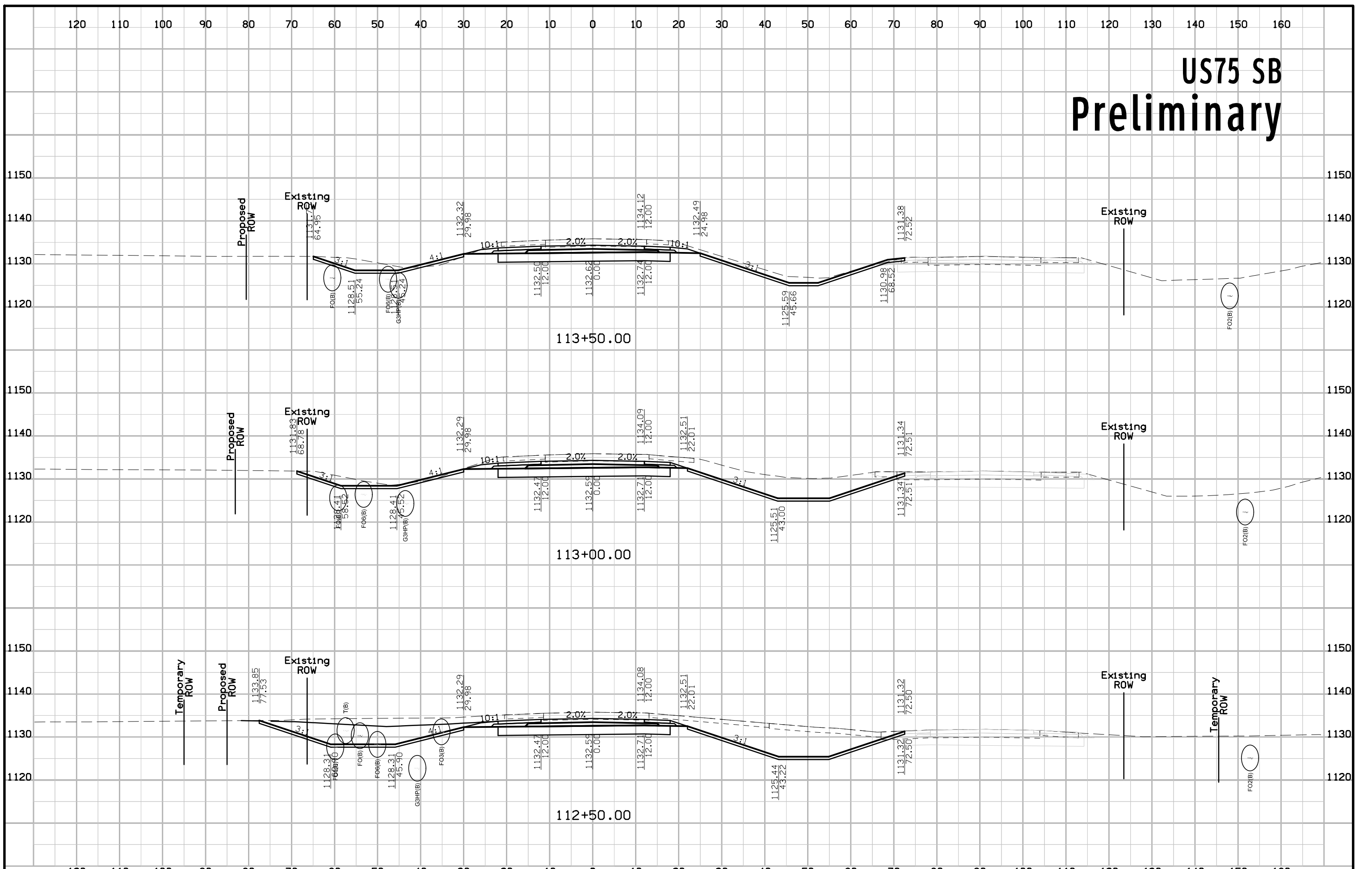

US75 SB Preliminary

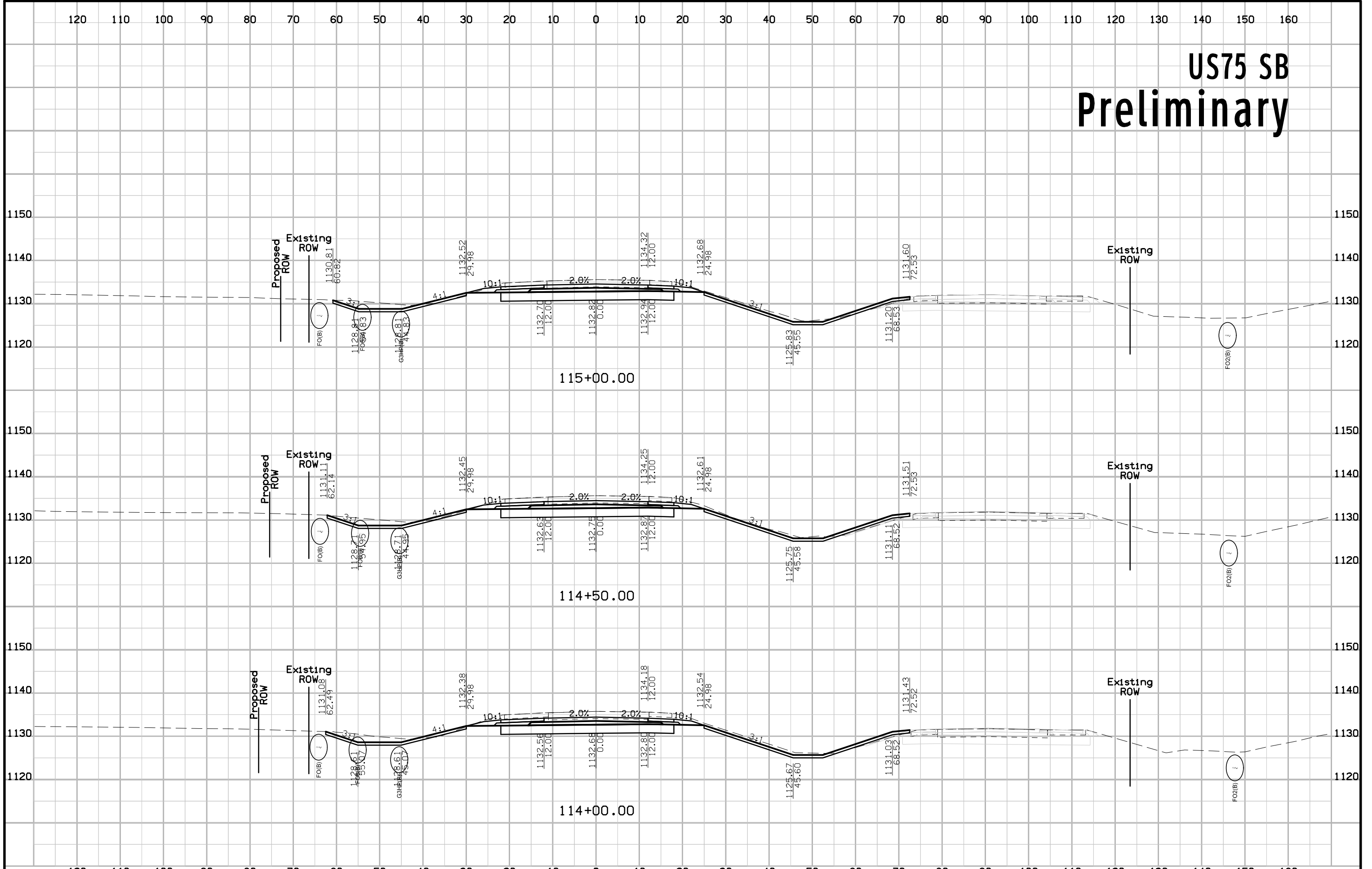

US75 SB Preliminary

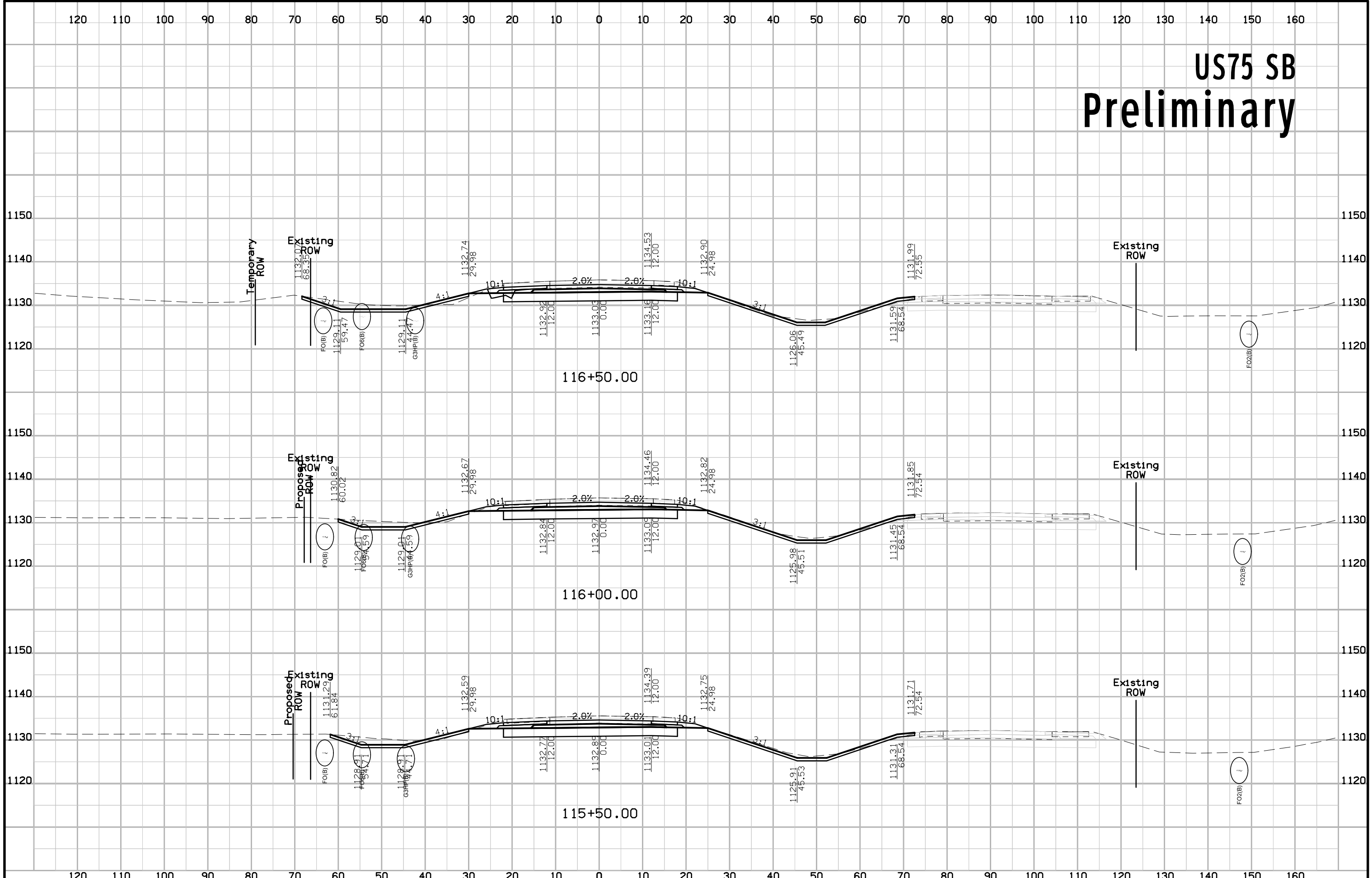

US75 SB Preliminary

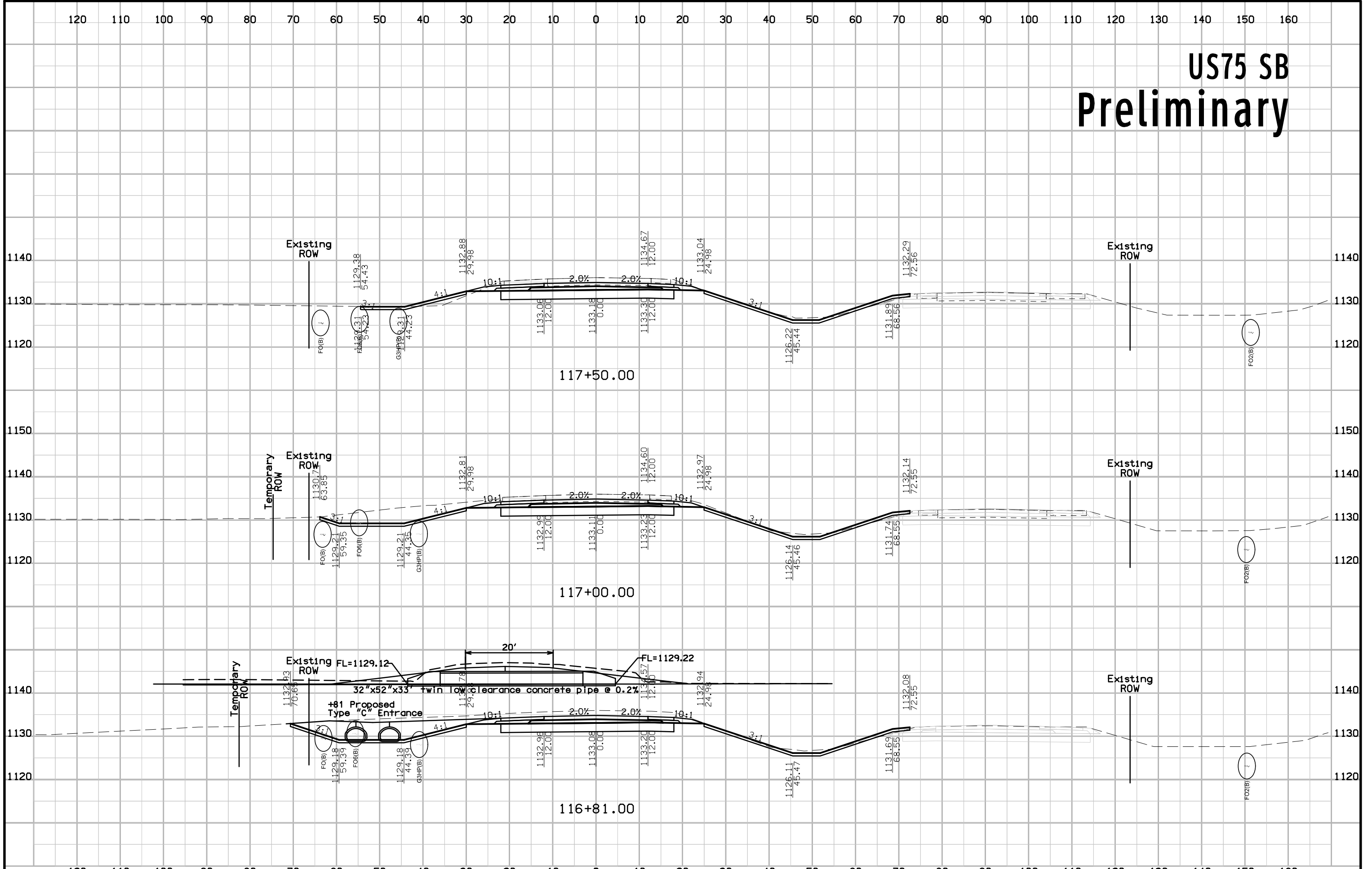

US75 SB Preliminary

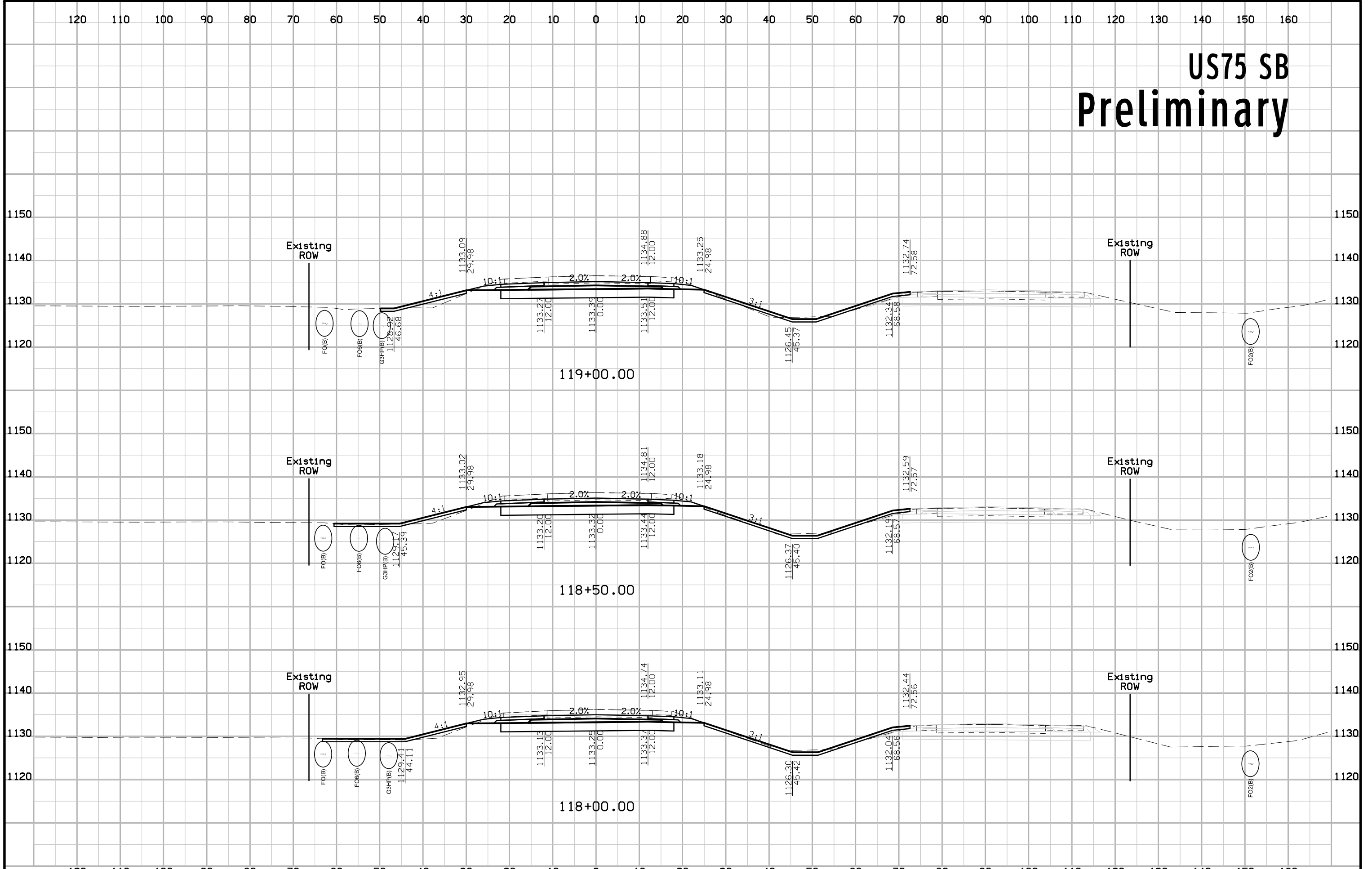

US75 SB Preliminary

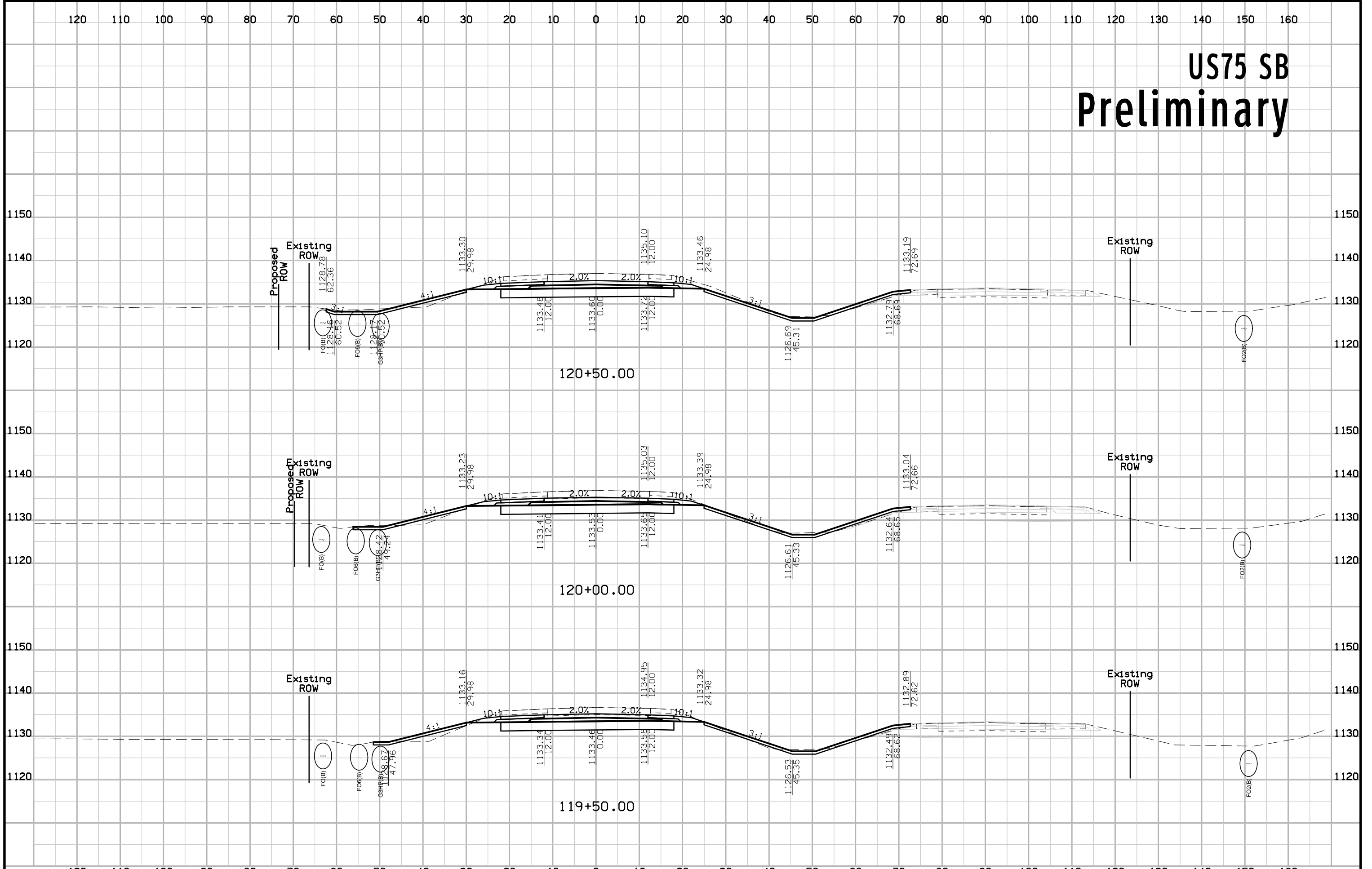

US75 SB Preliminary

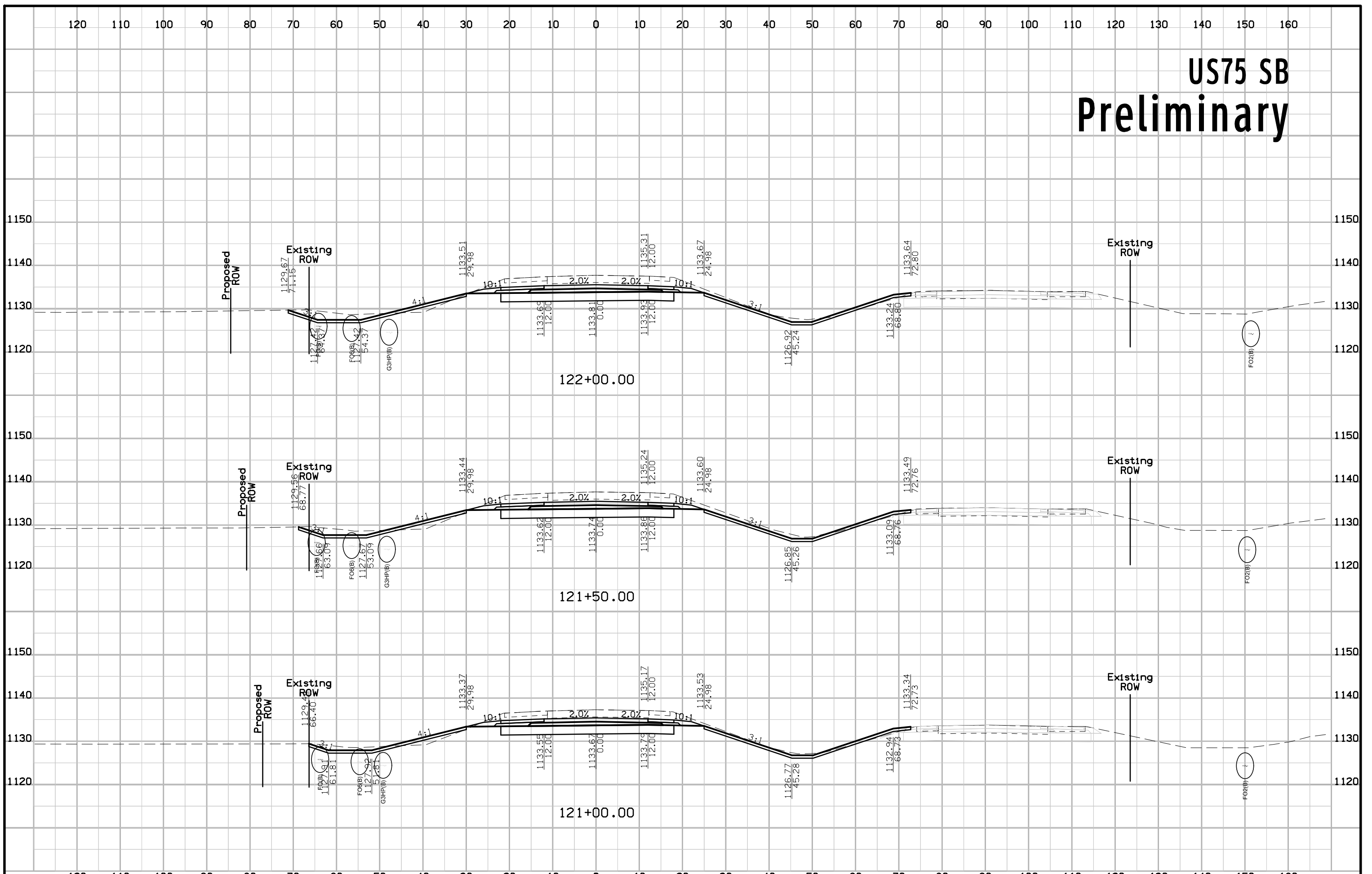

US75 SB Preliminary

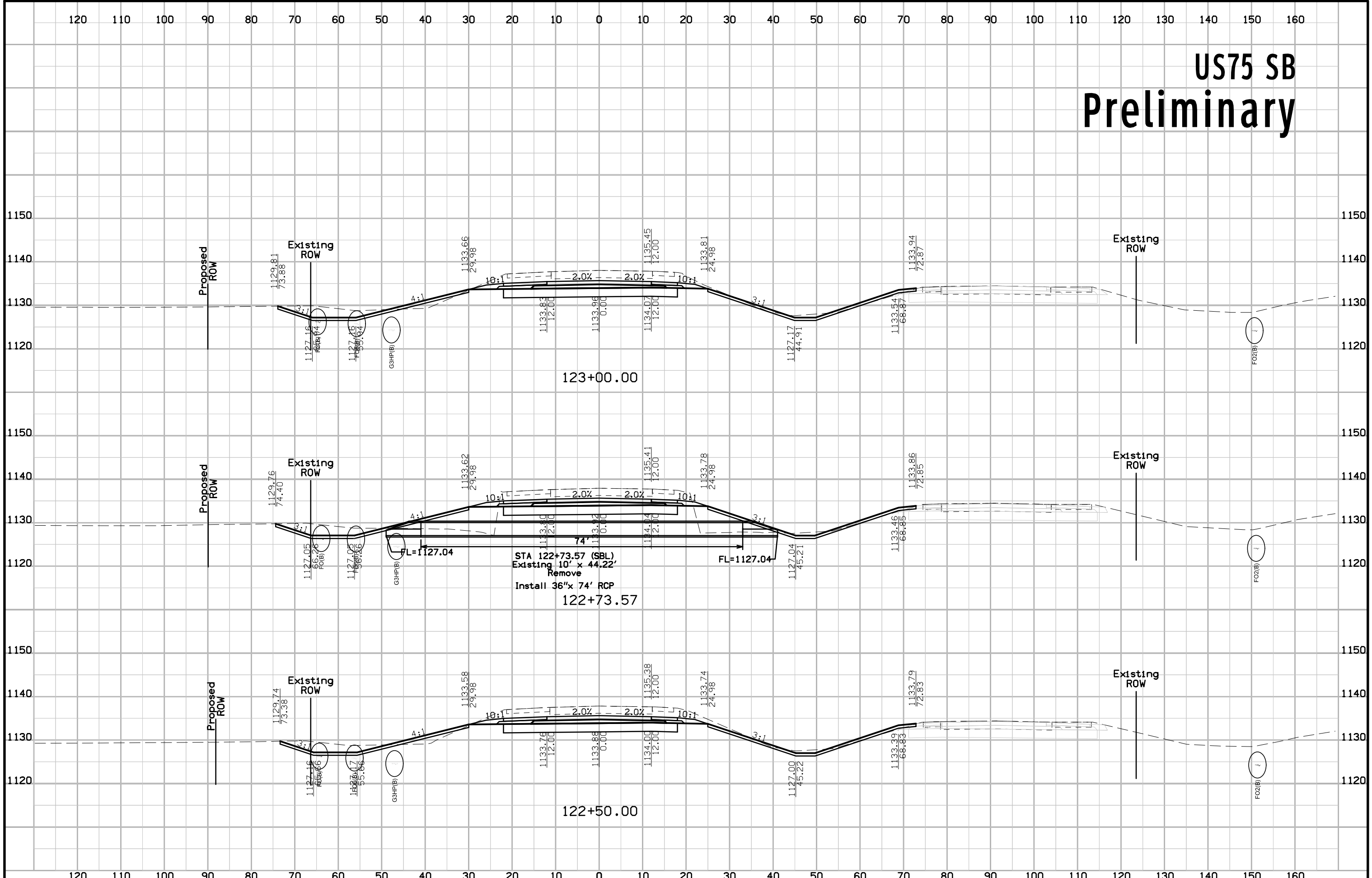

US75 SB Preliminary

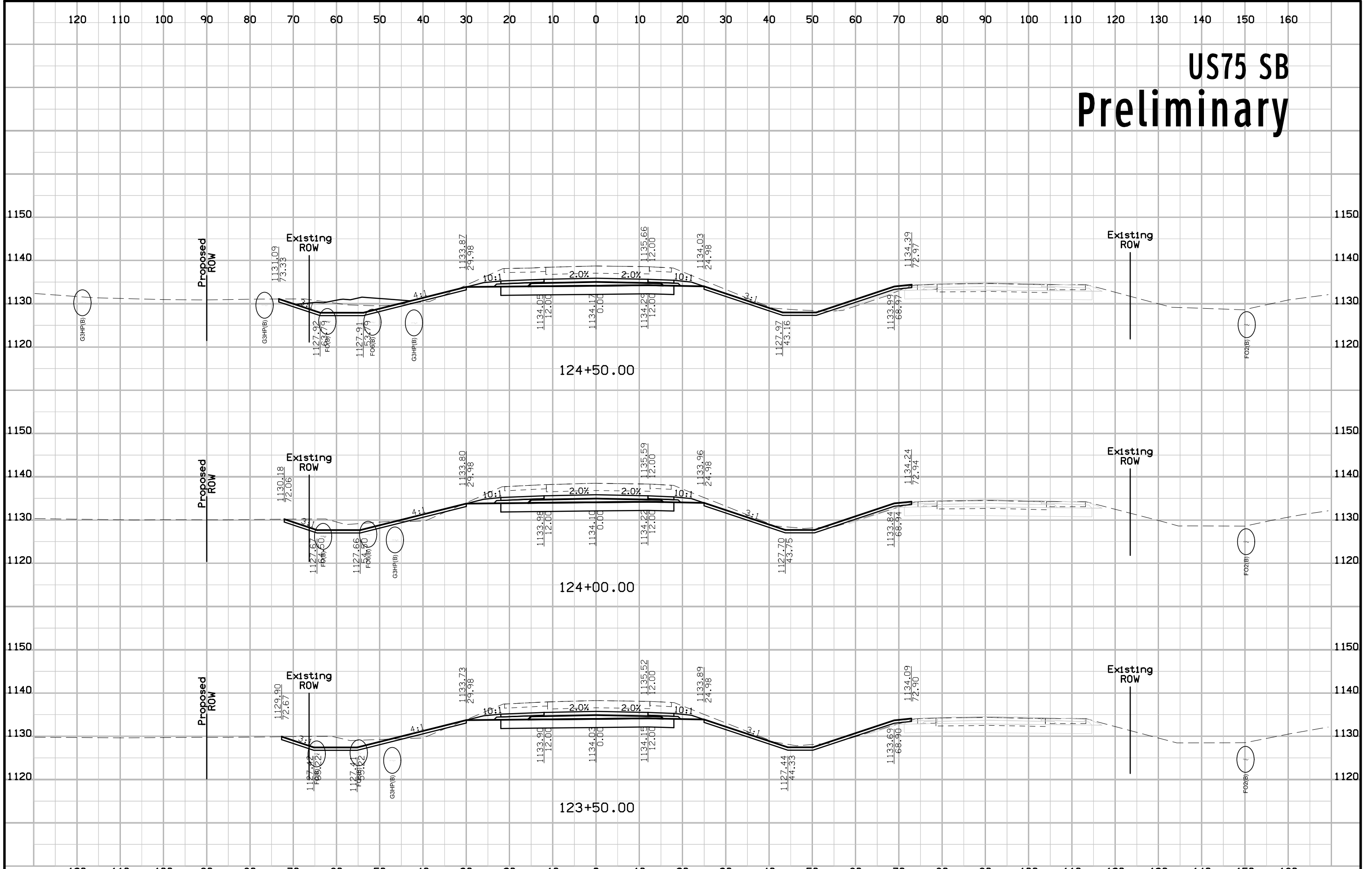

US75 SB Preliminary

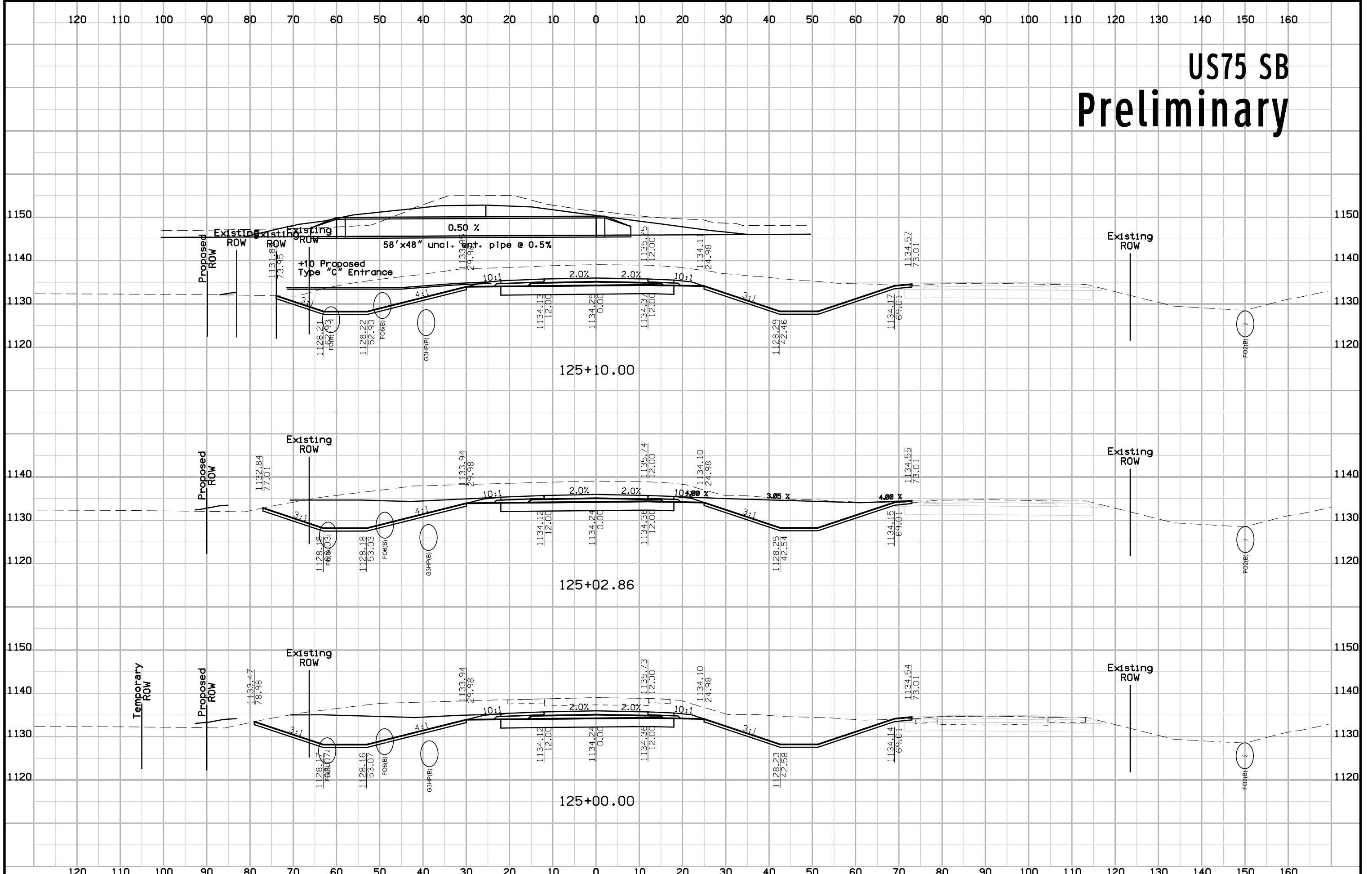

US75 SB Preliminary

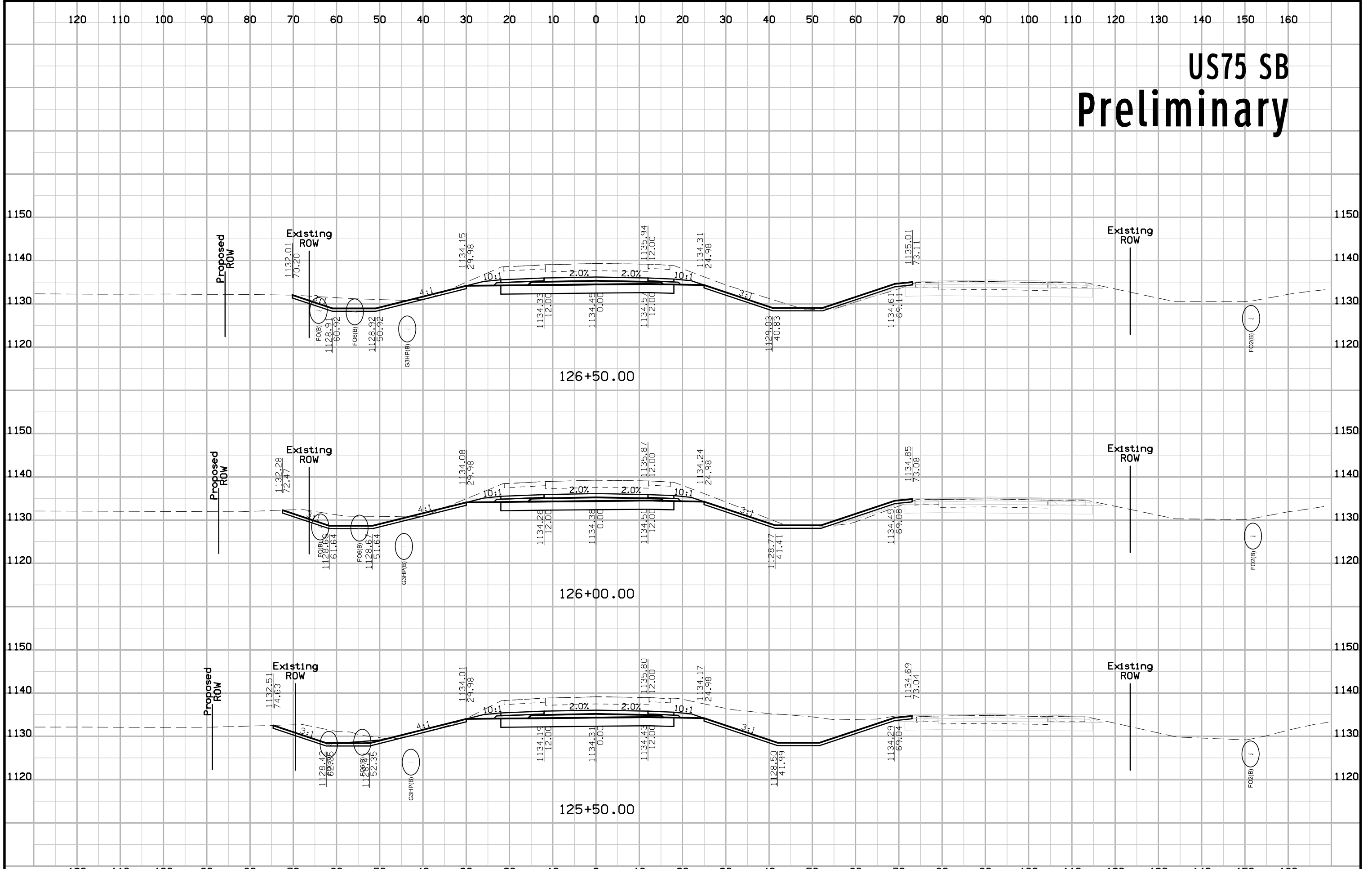

US75 SB Preliminary

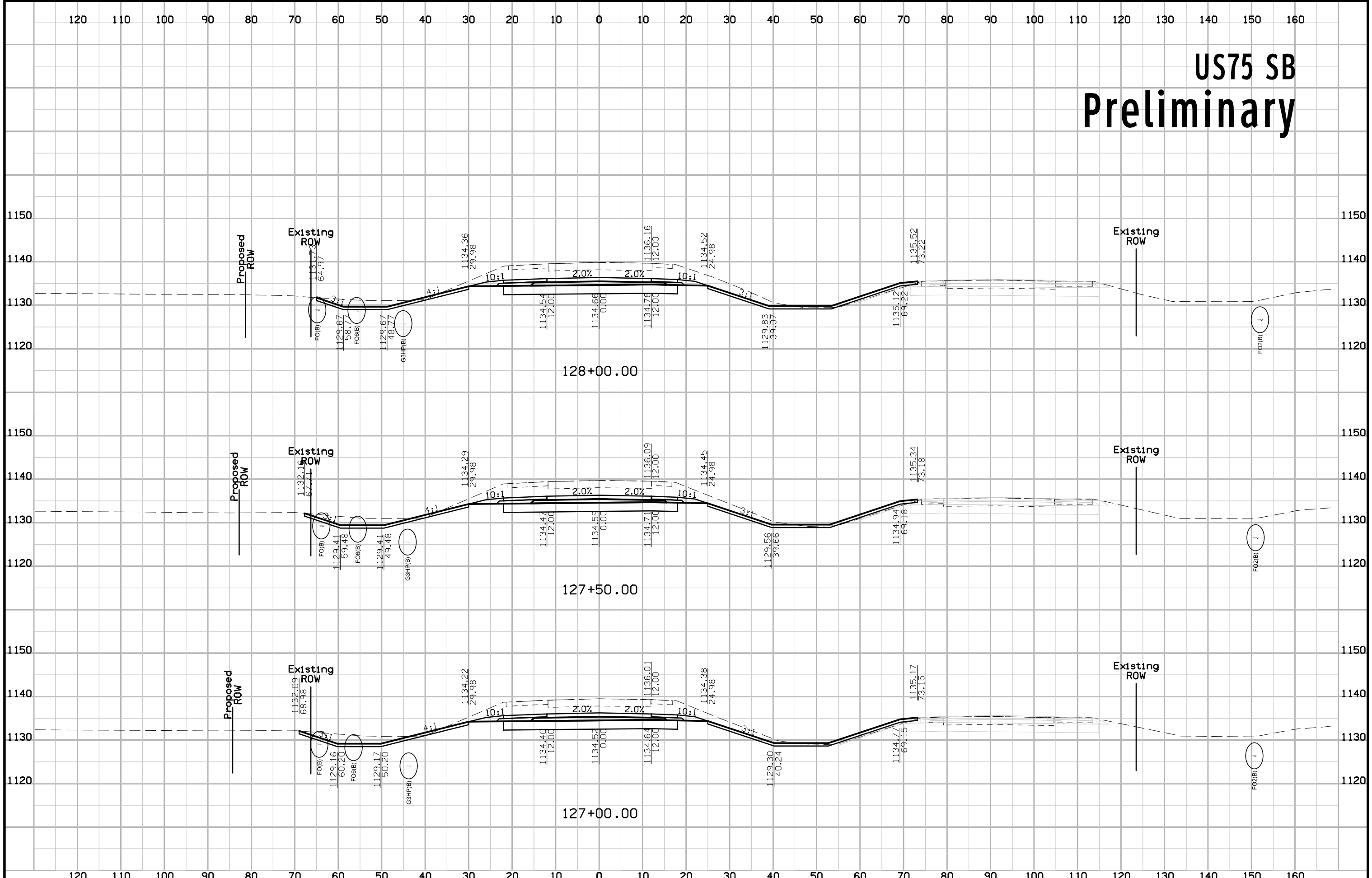

US75 SB Preliminary

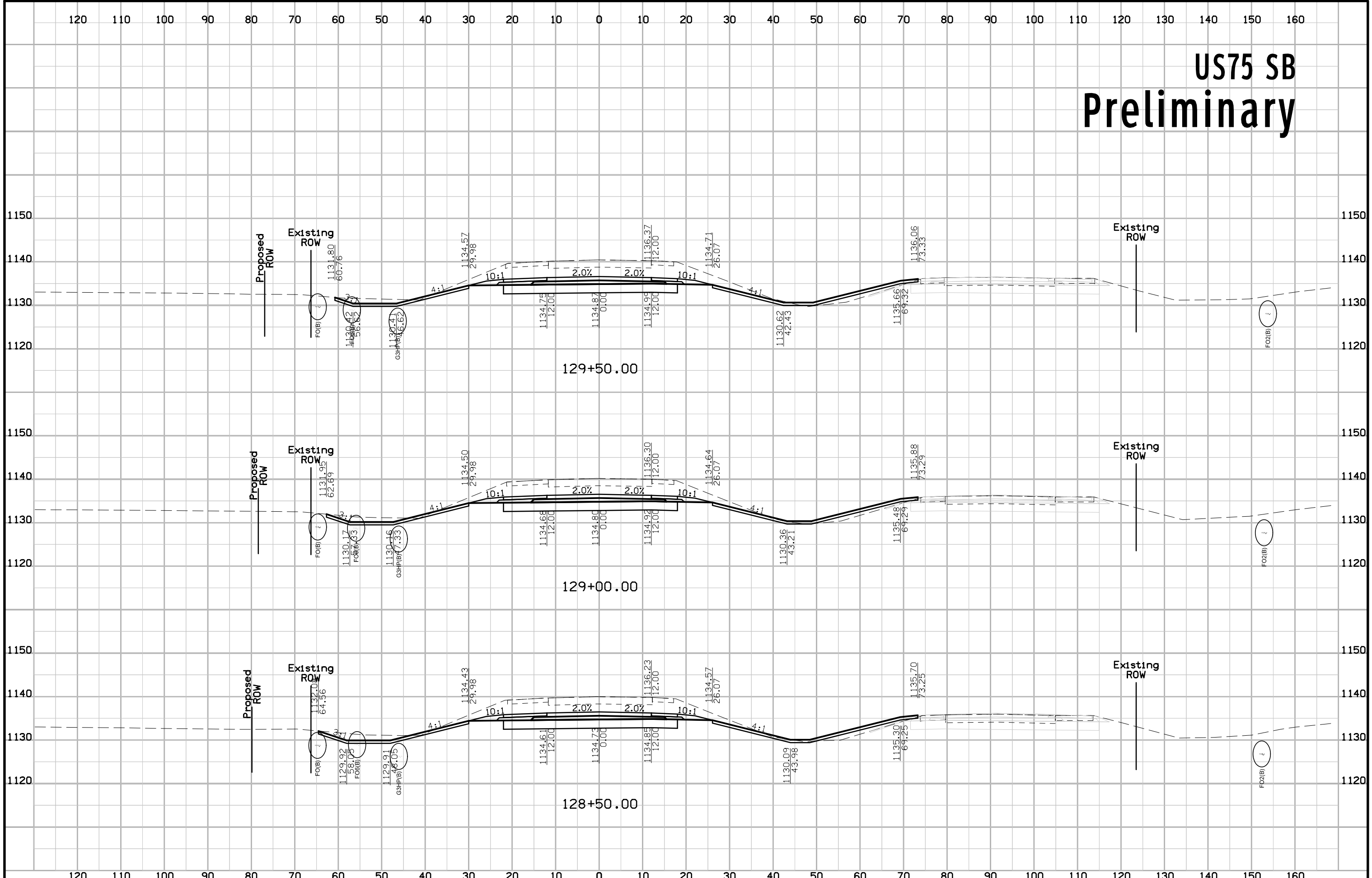

US75 SB Preliminary

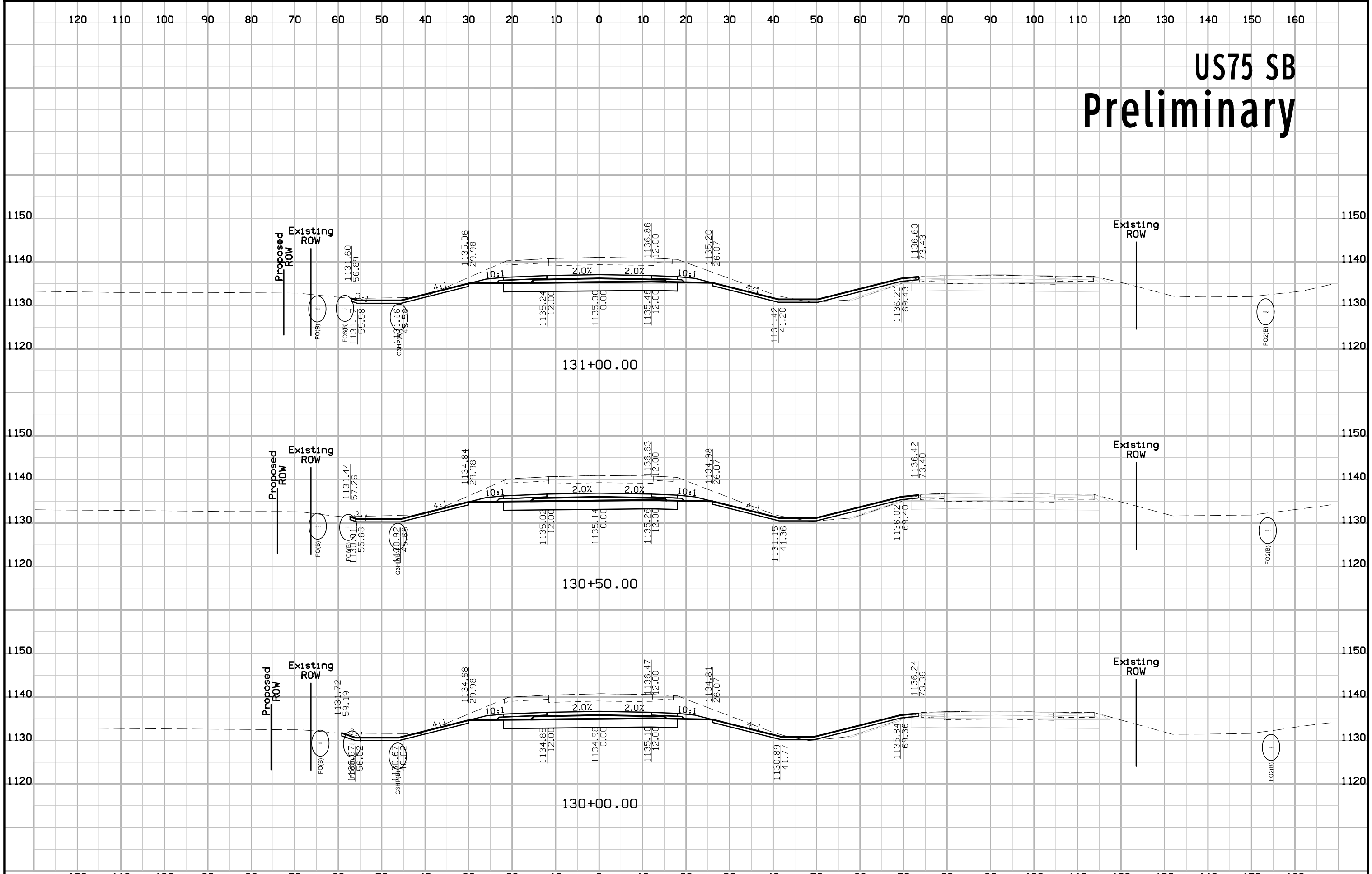

US75 SB Preliminary

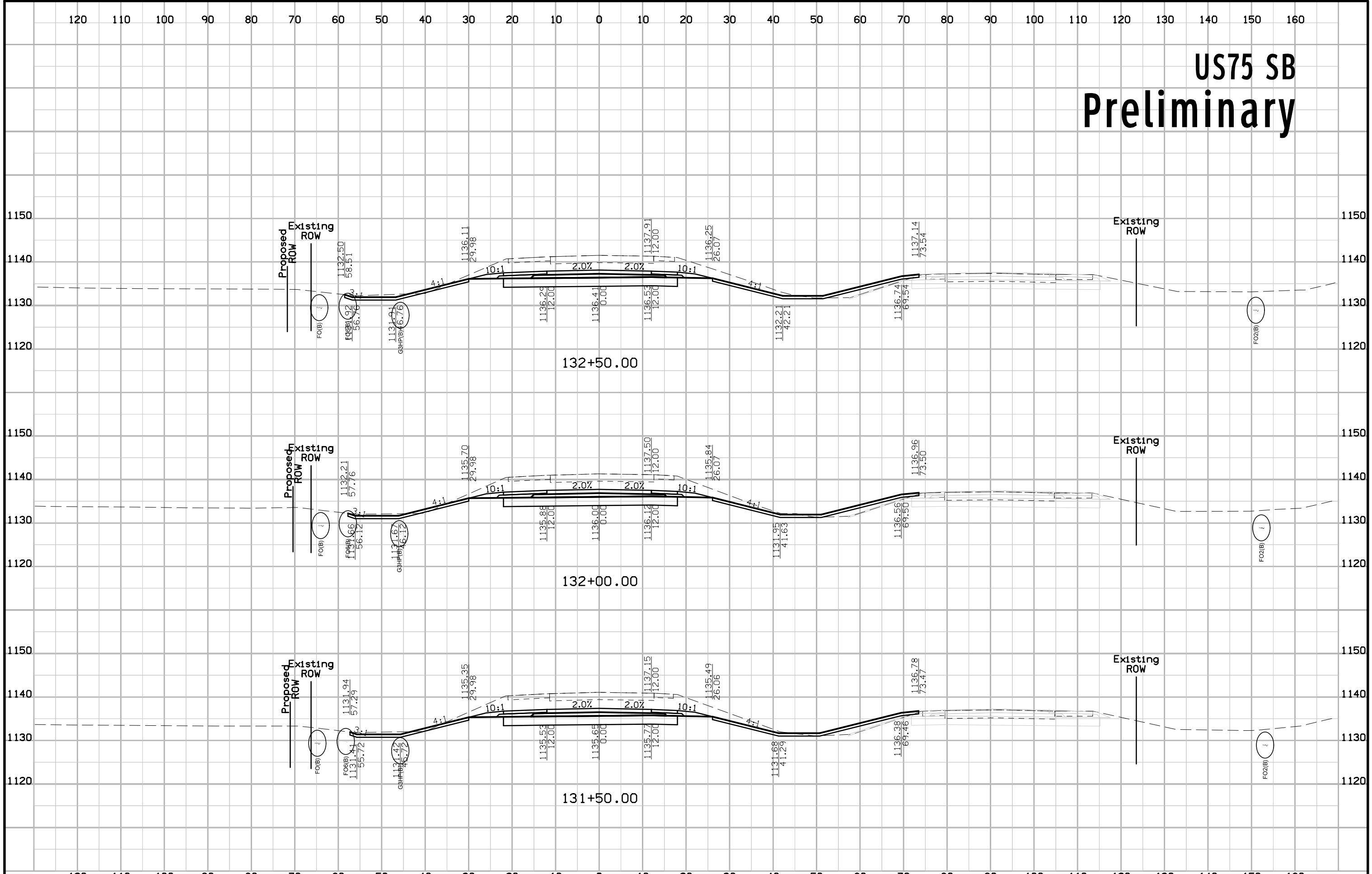

US75 SB Preliminary

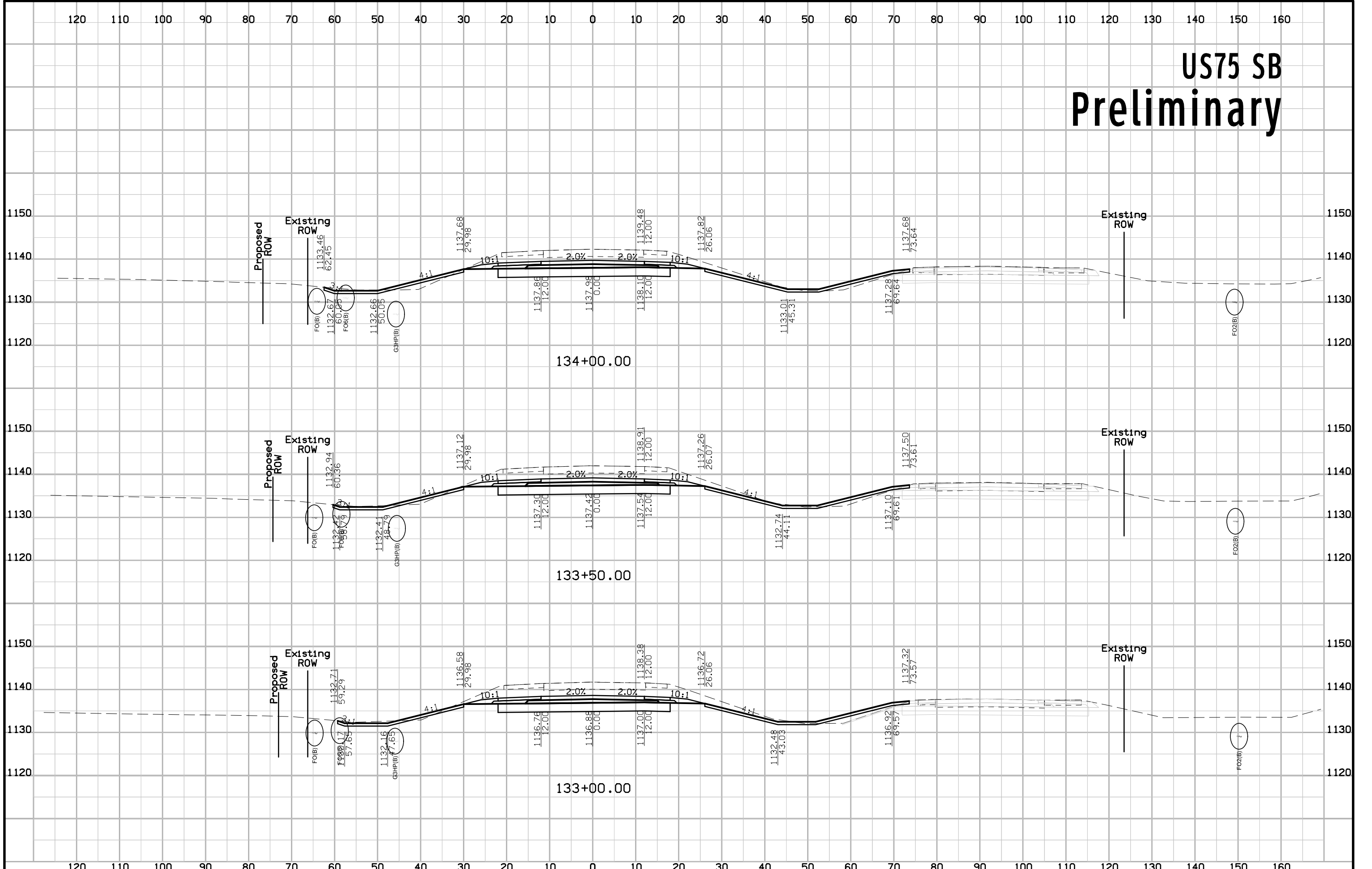

US75 SB Preliminary

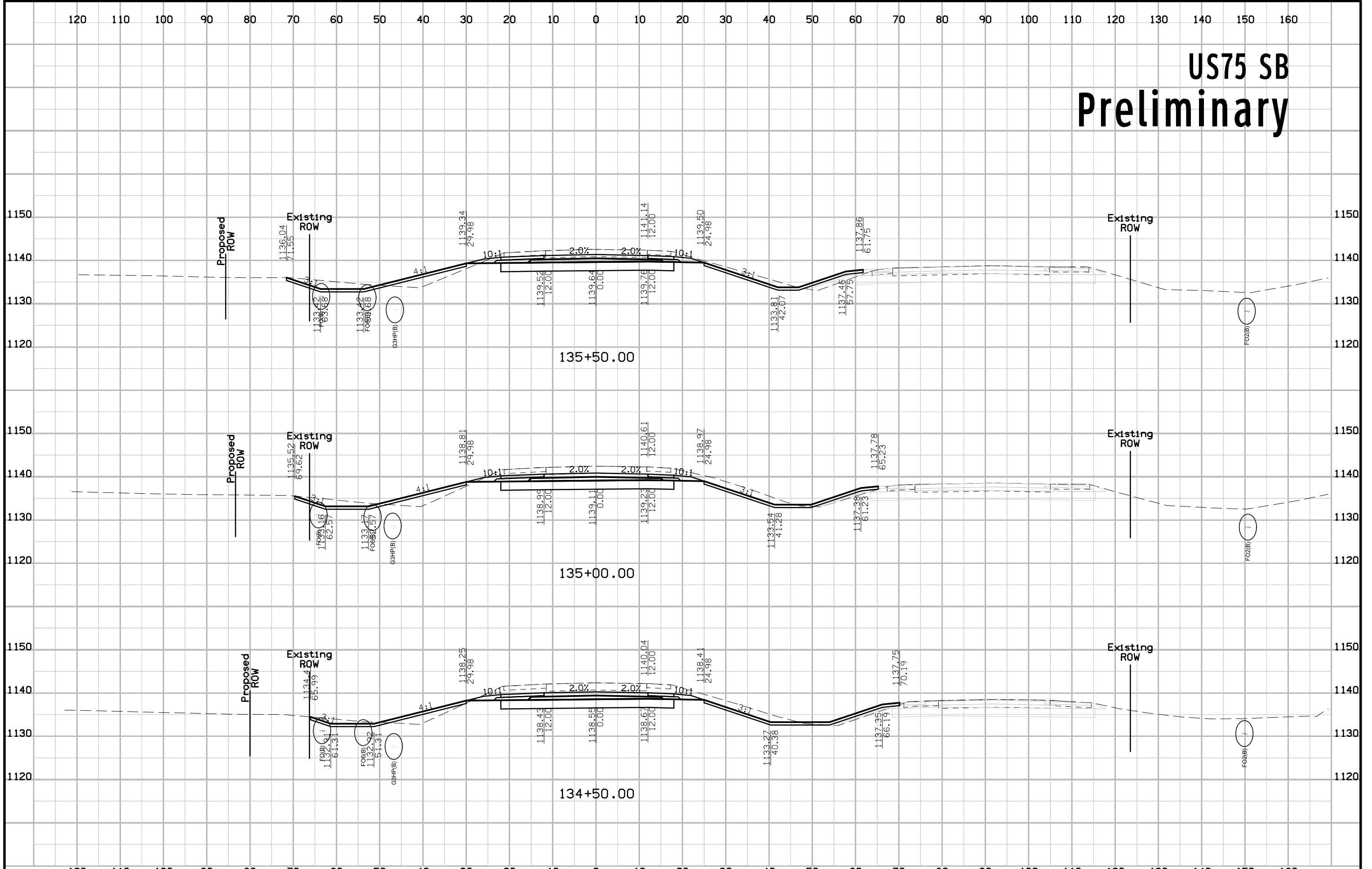

US75 SB Preliminary

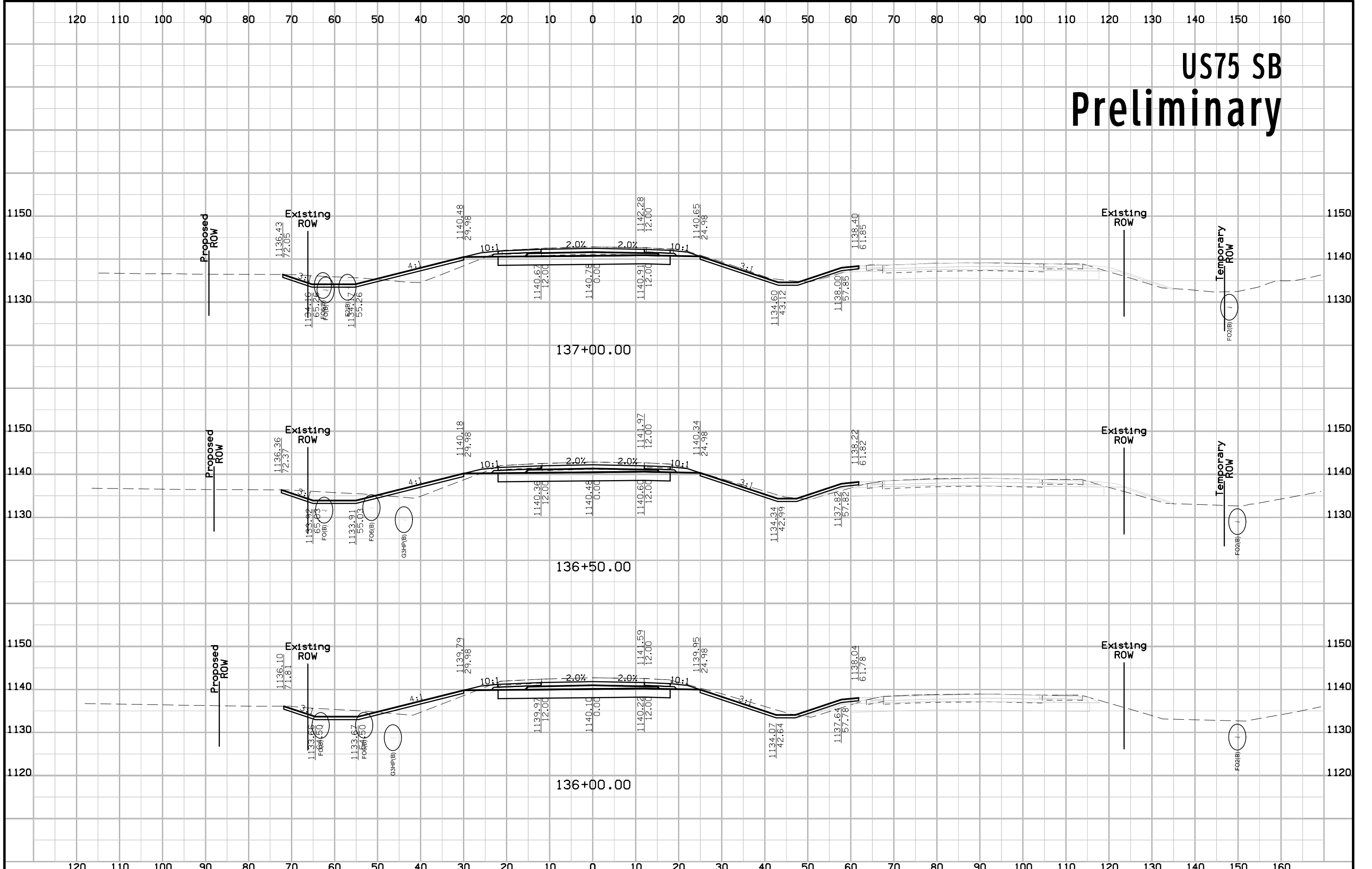

US75 SB Preliminary

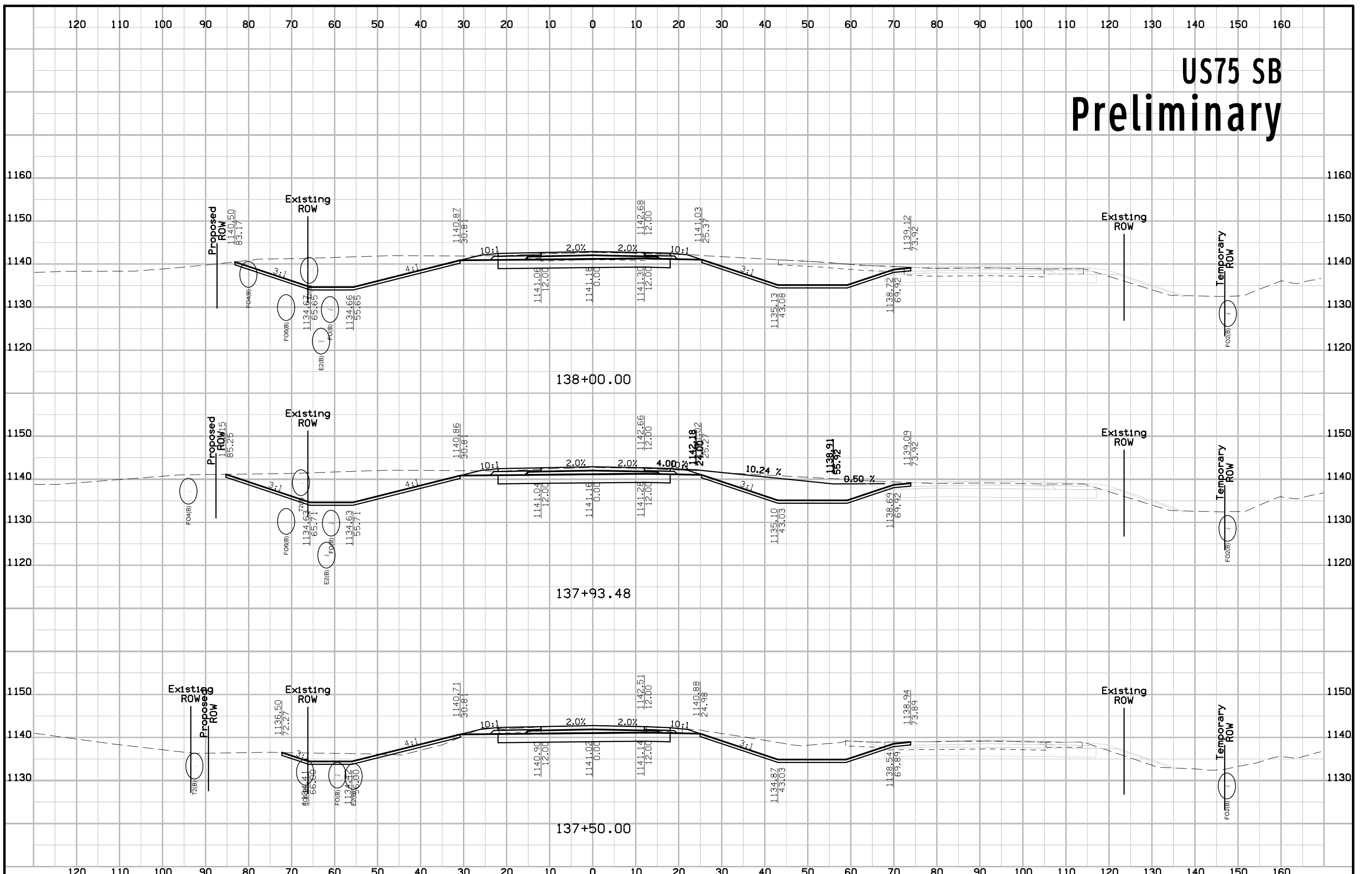

US75 SB Preliminary

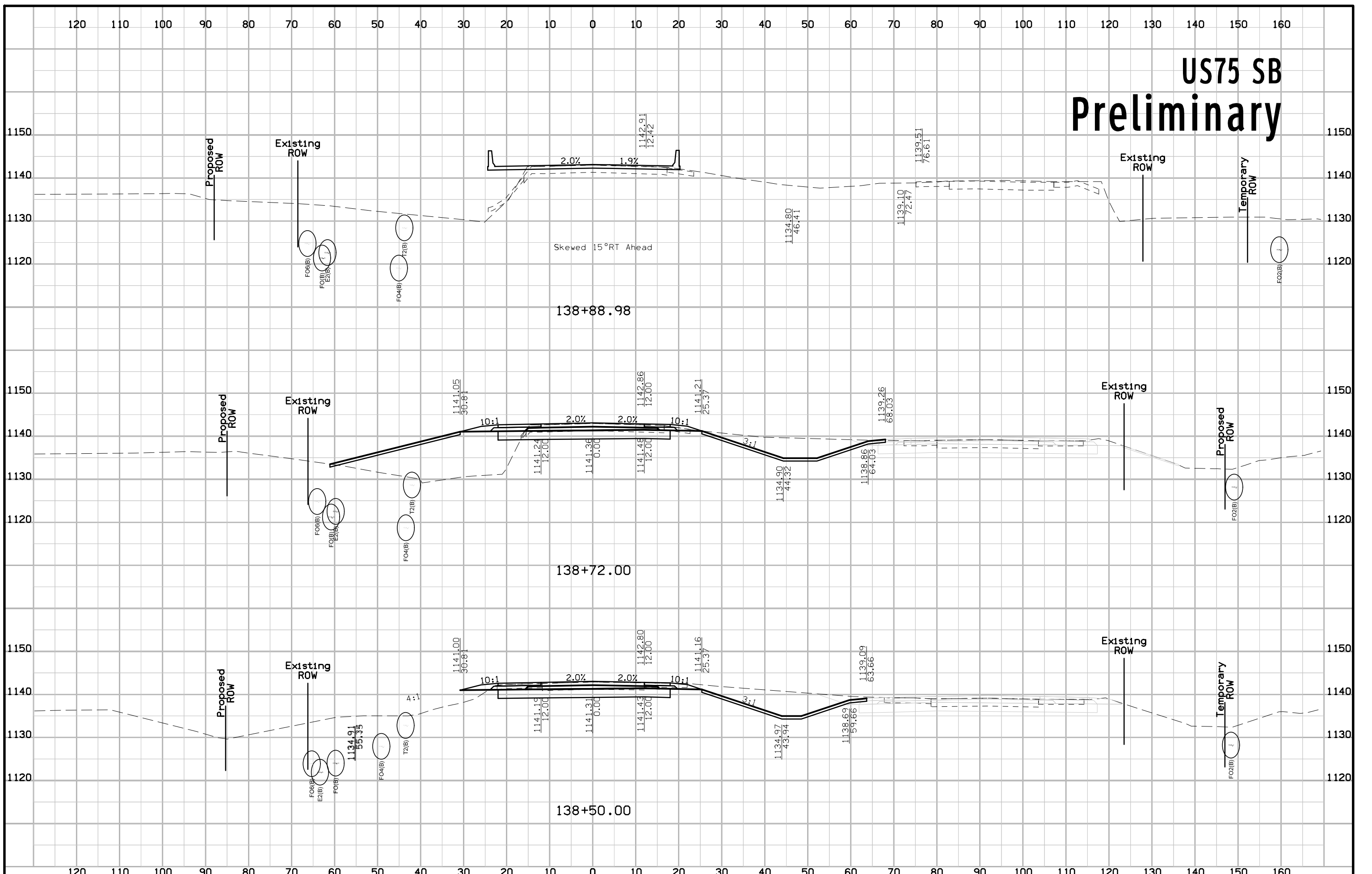

US75 SB Preliminary

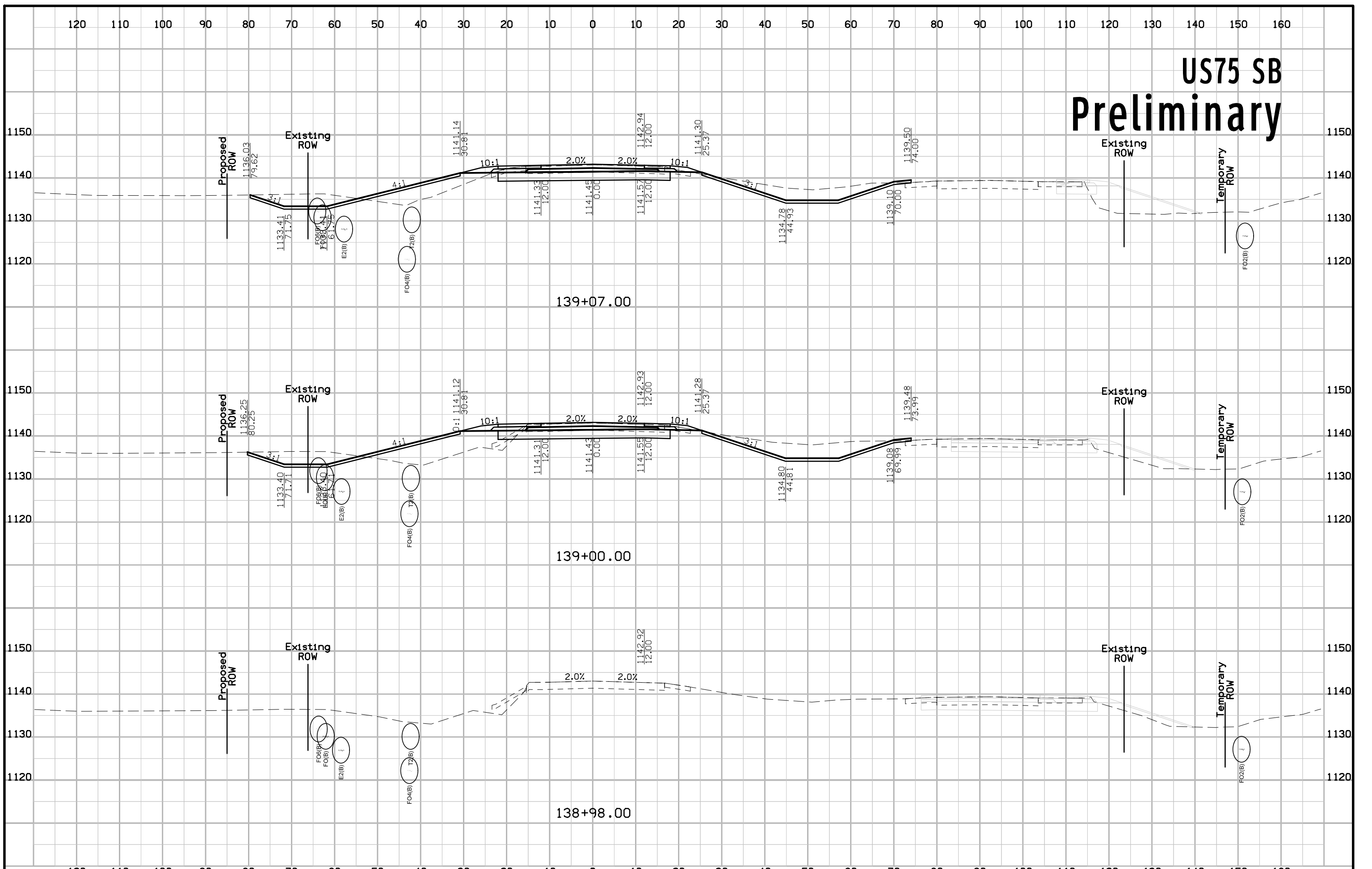

US75 SB Preliminary

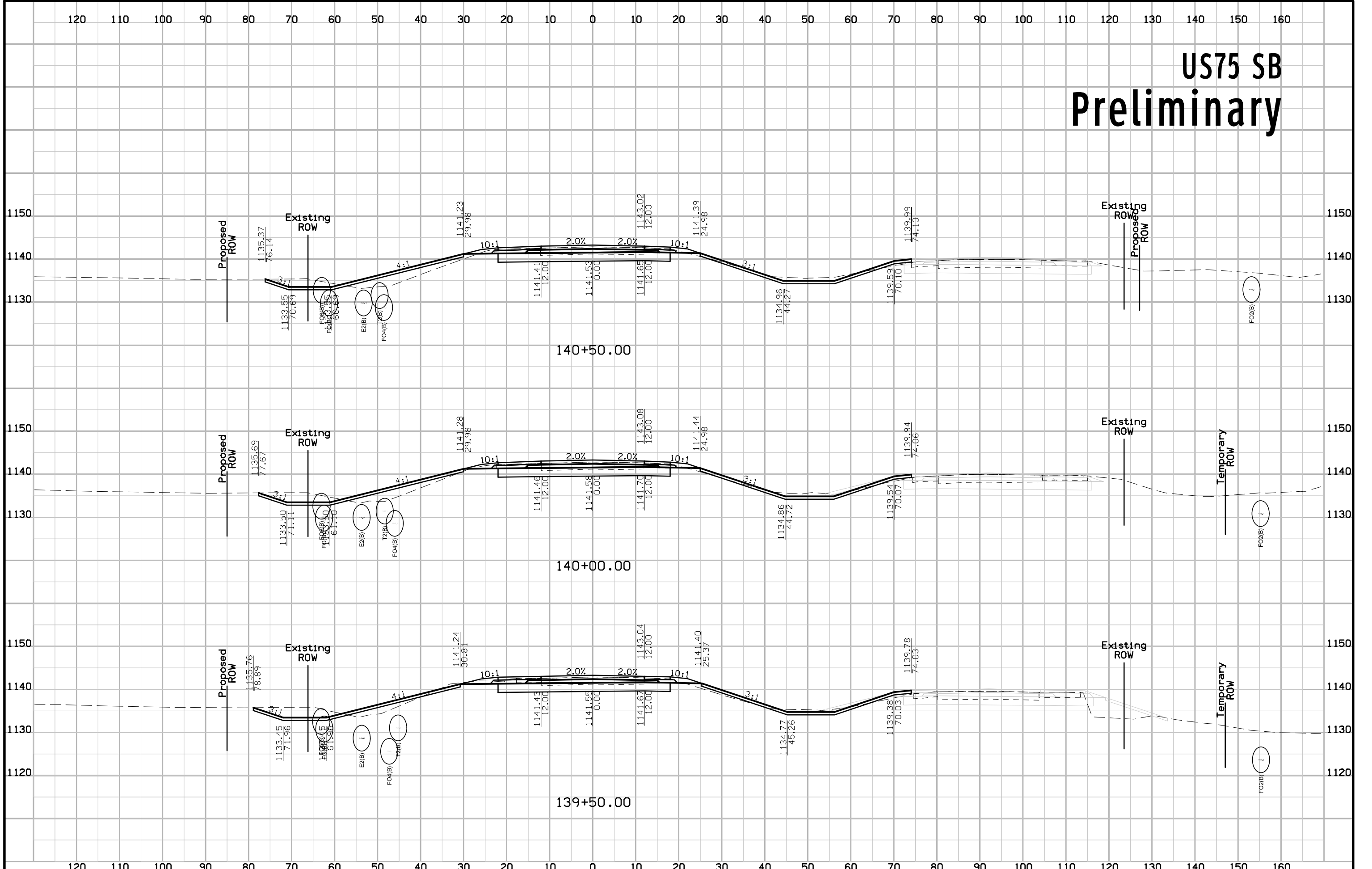

US75 SB Preliminary

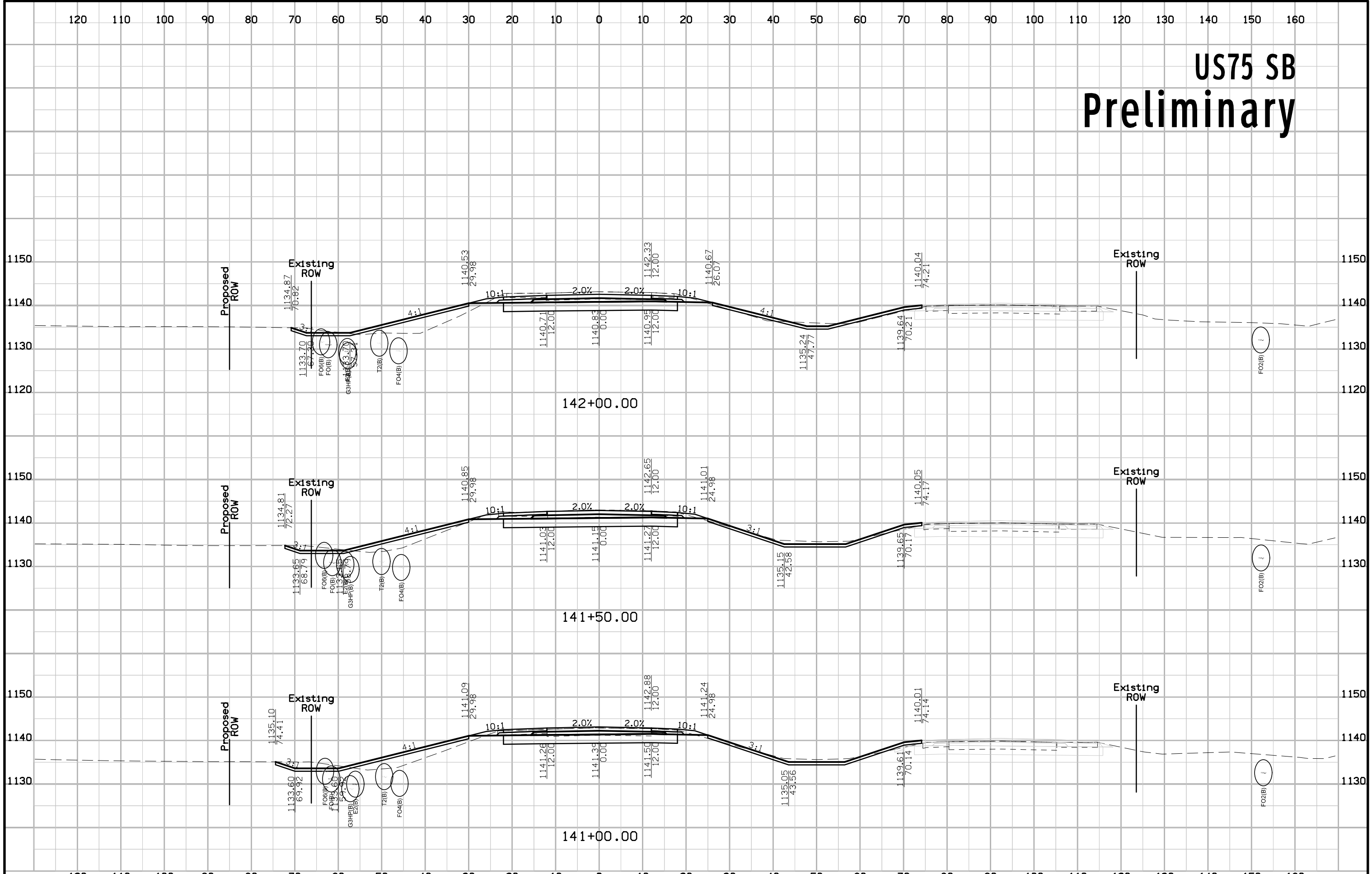

US75 SB Preliminary

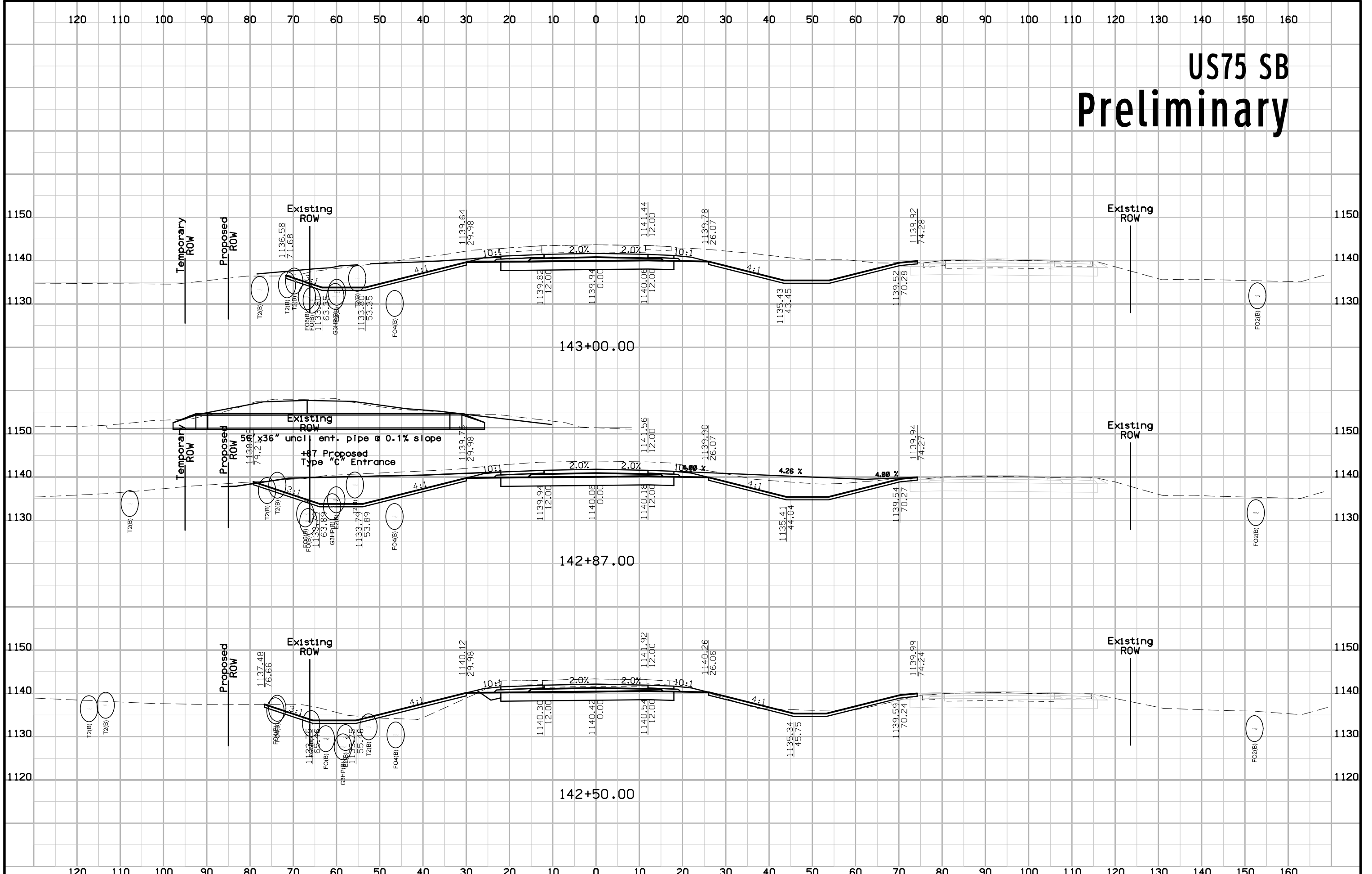

US75 SB Preliminary

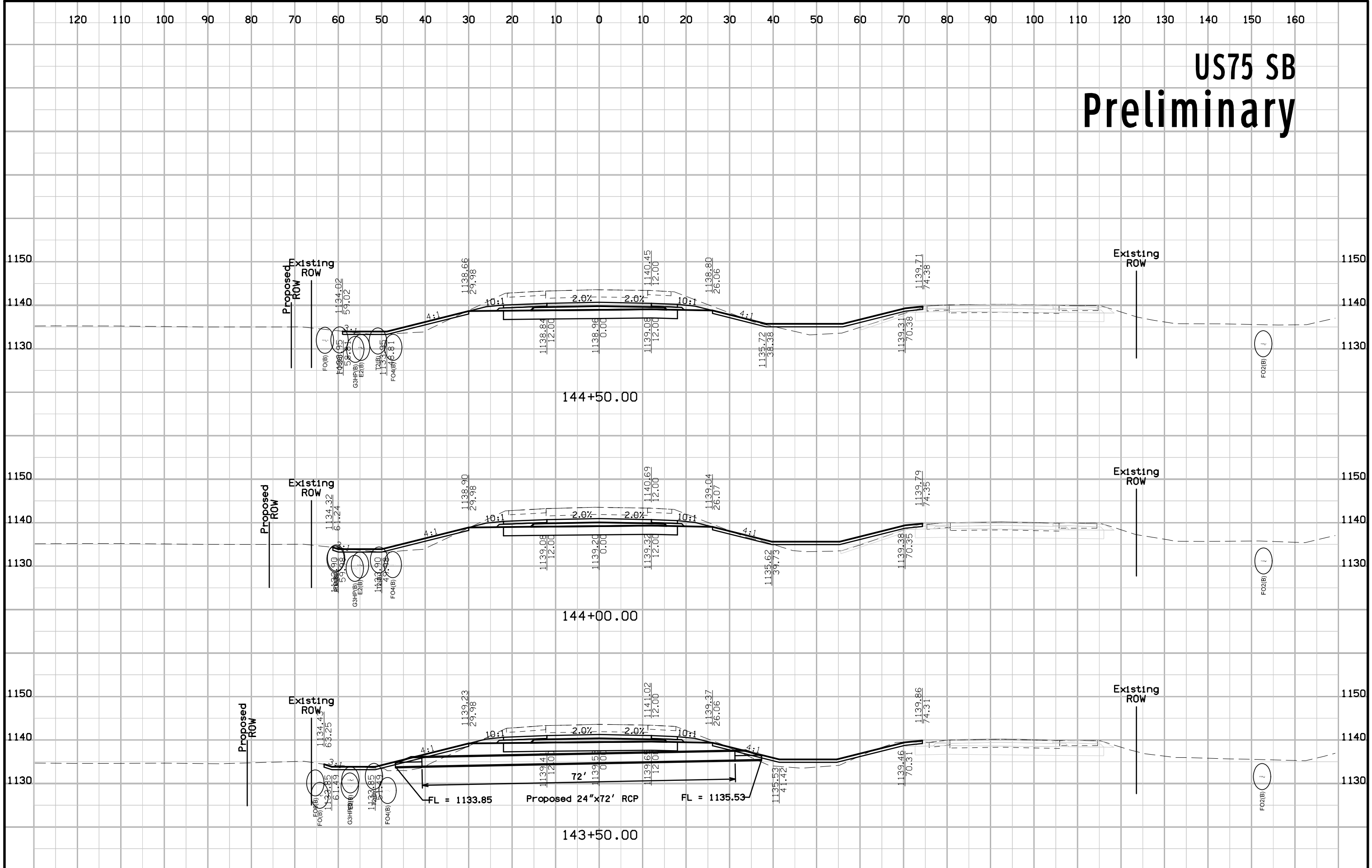

US75 SB Preliminary

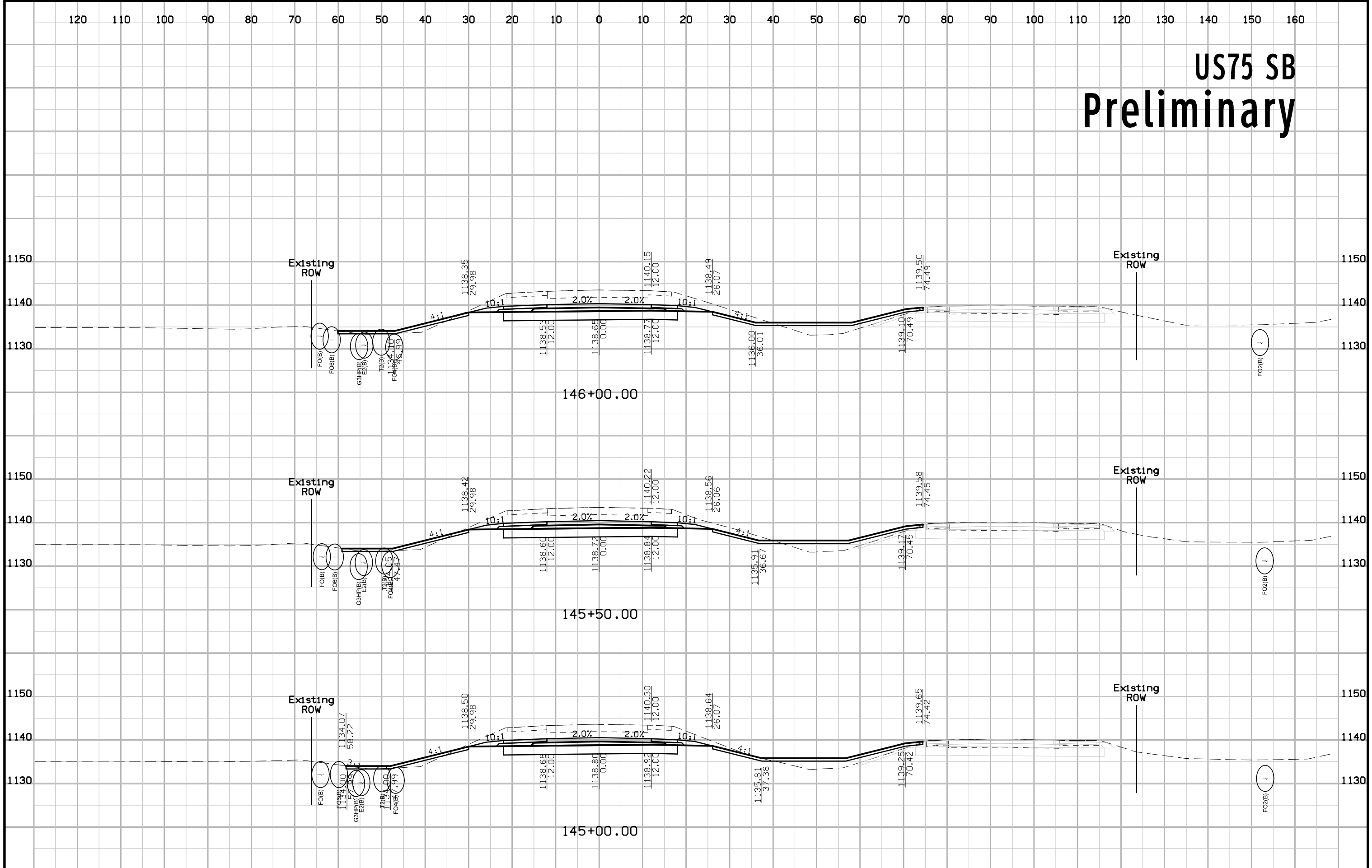

US75 SB Preliminary

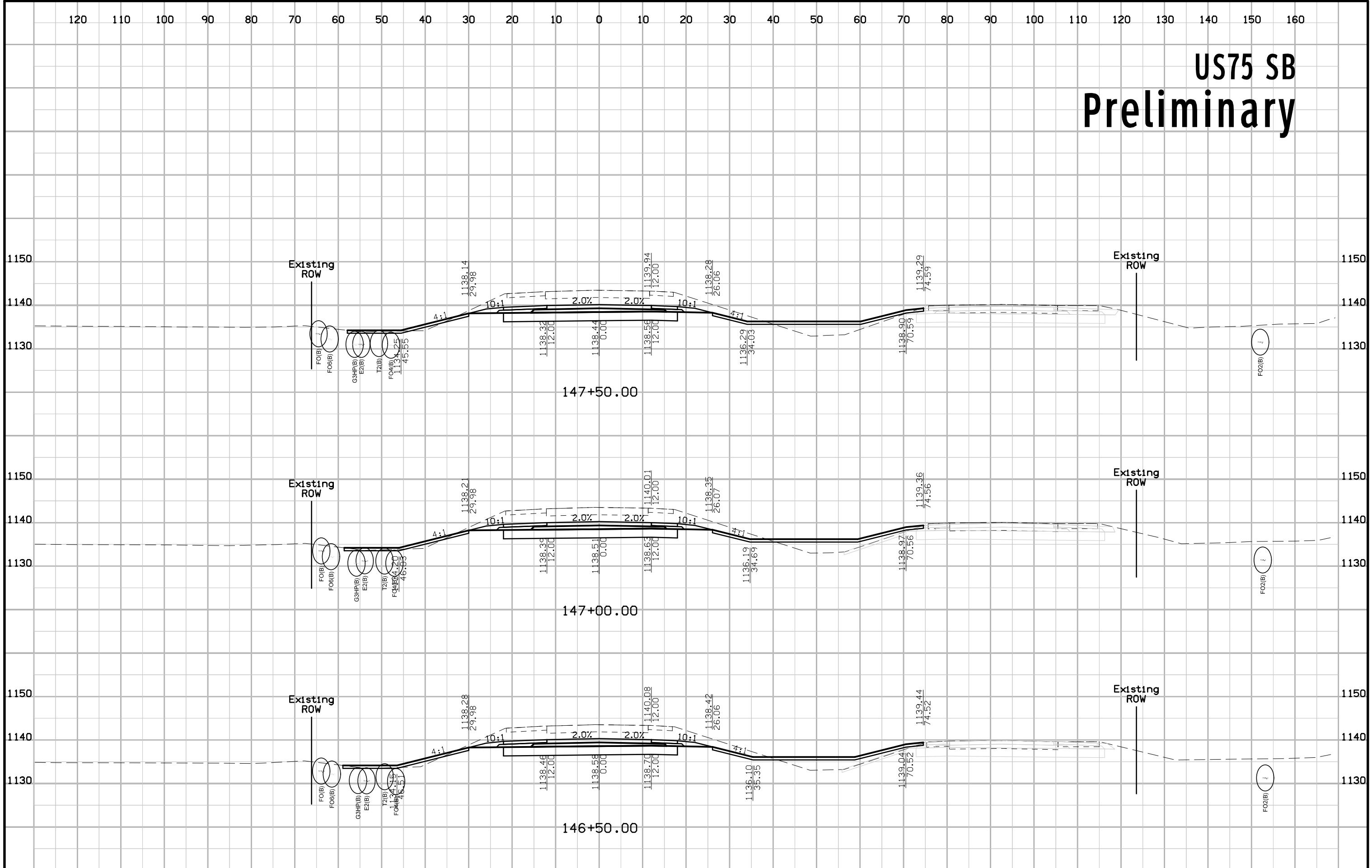

US75 SB Preliminary

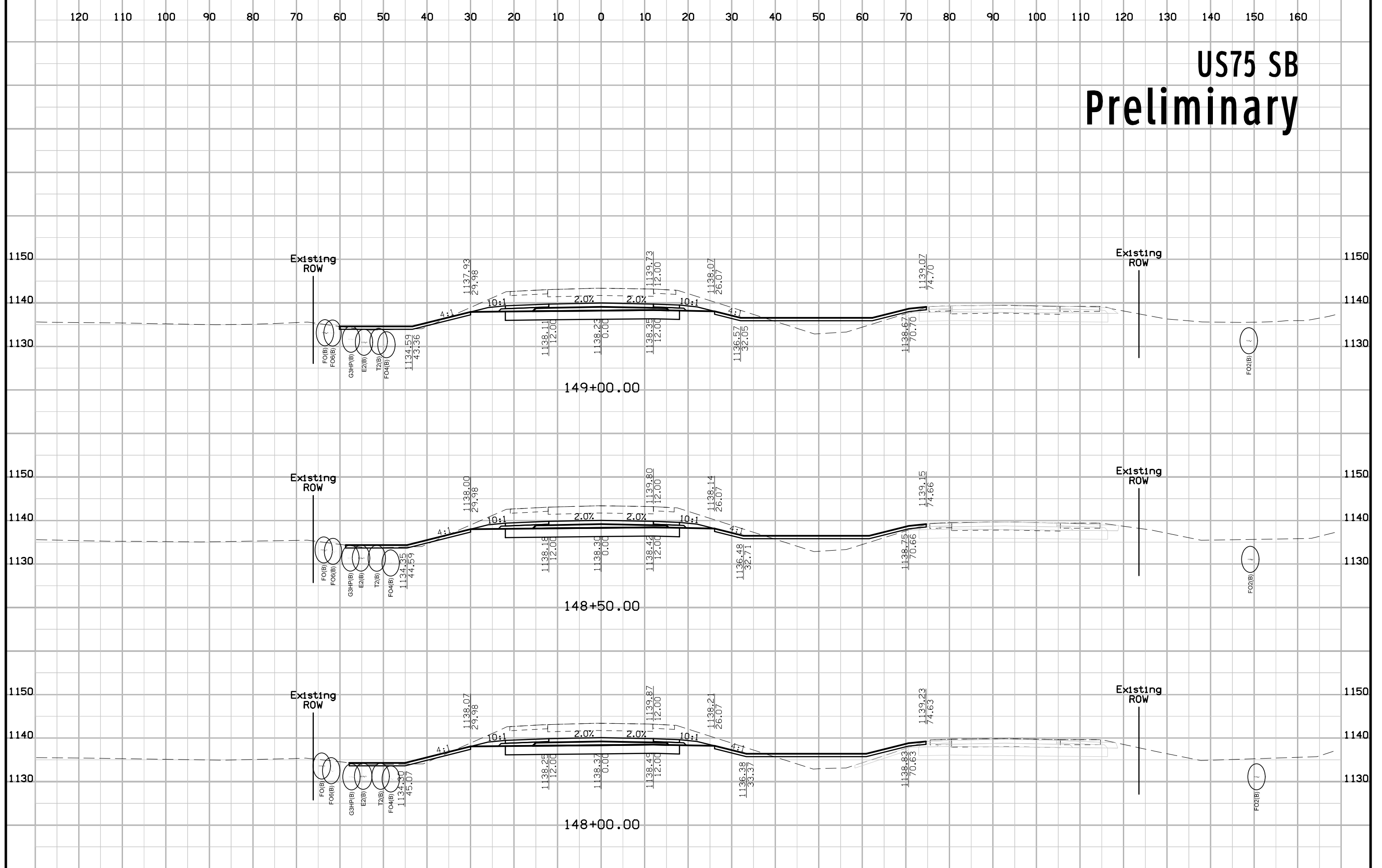

US75 SB Preliminary

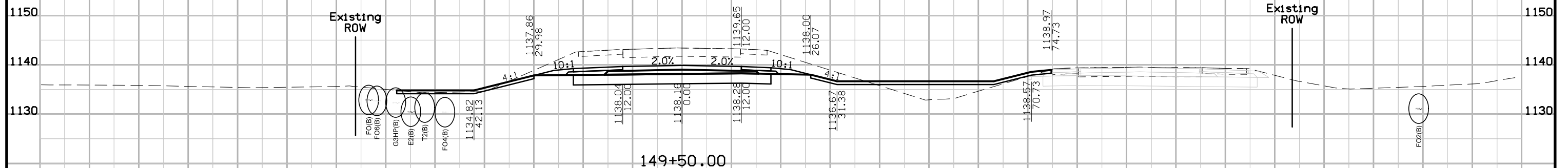
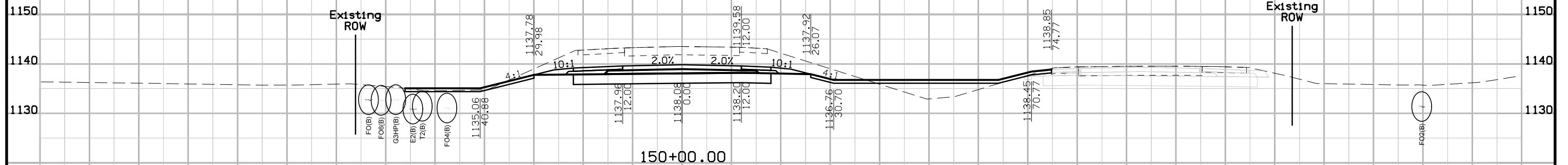
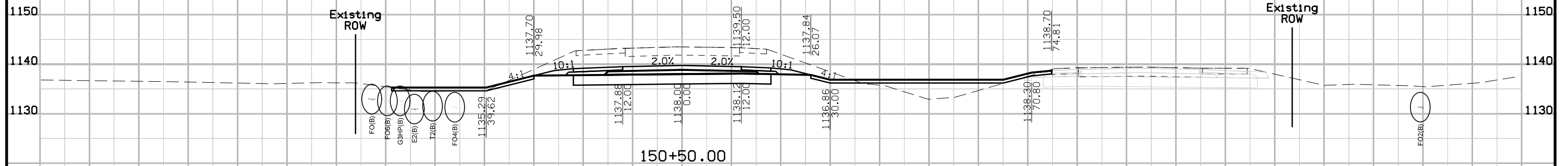

US75 SB Preliminary

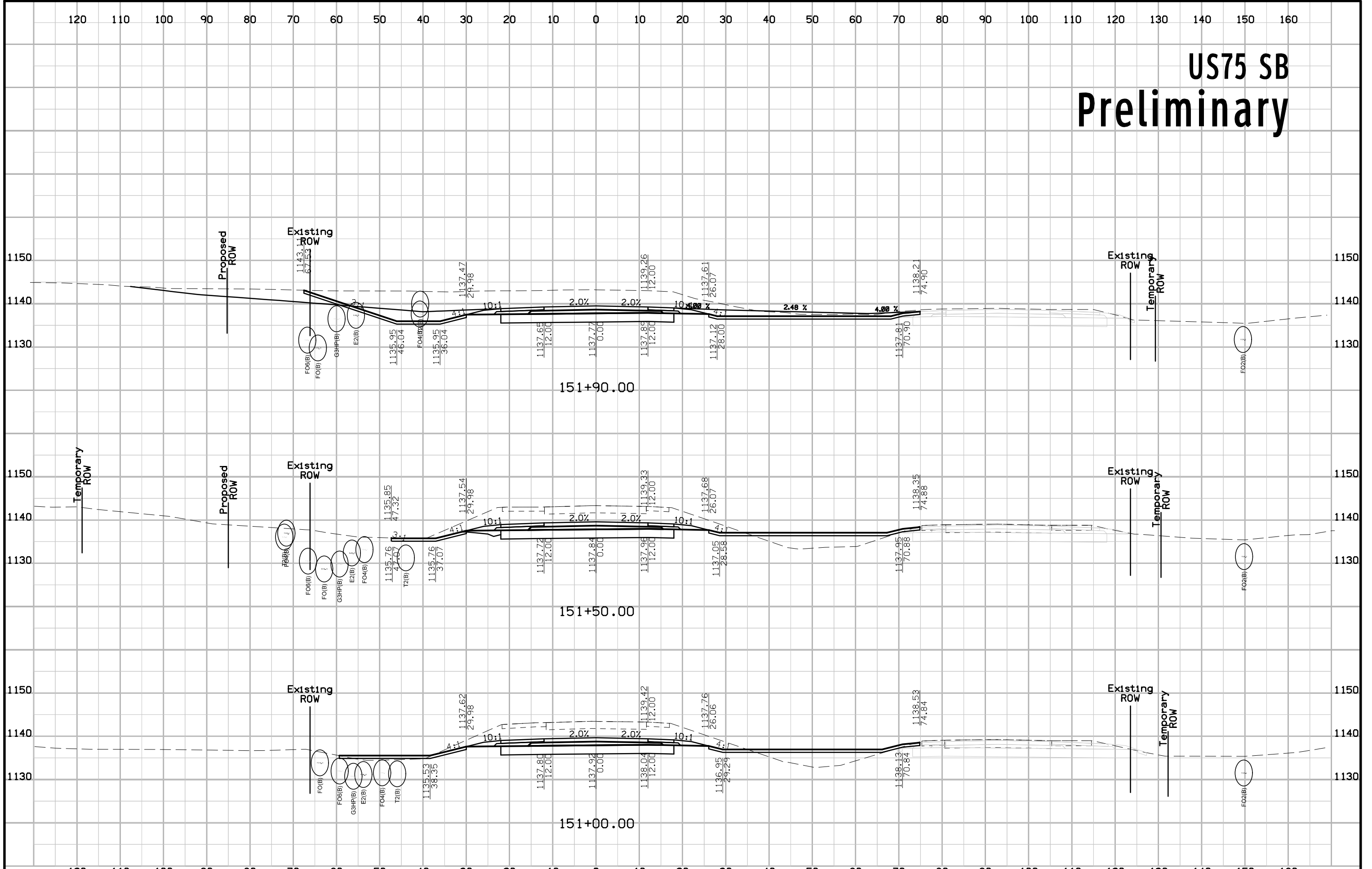

US75 SB Preliminary

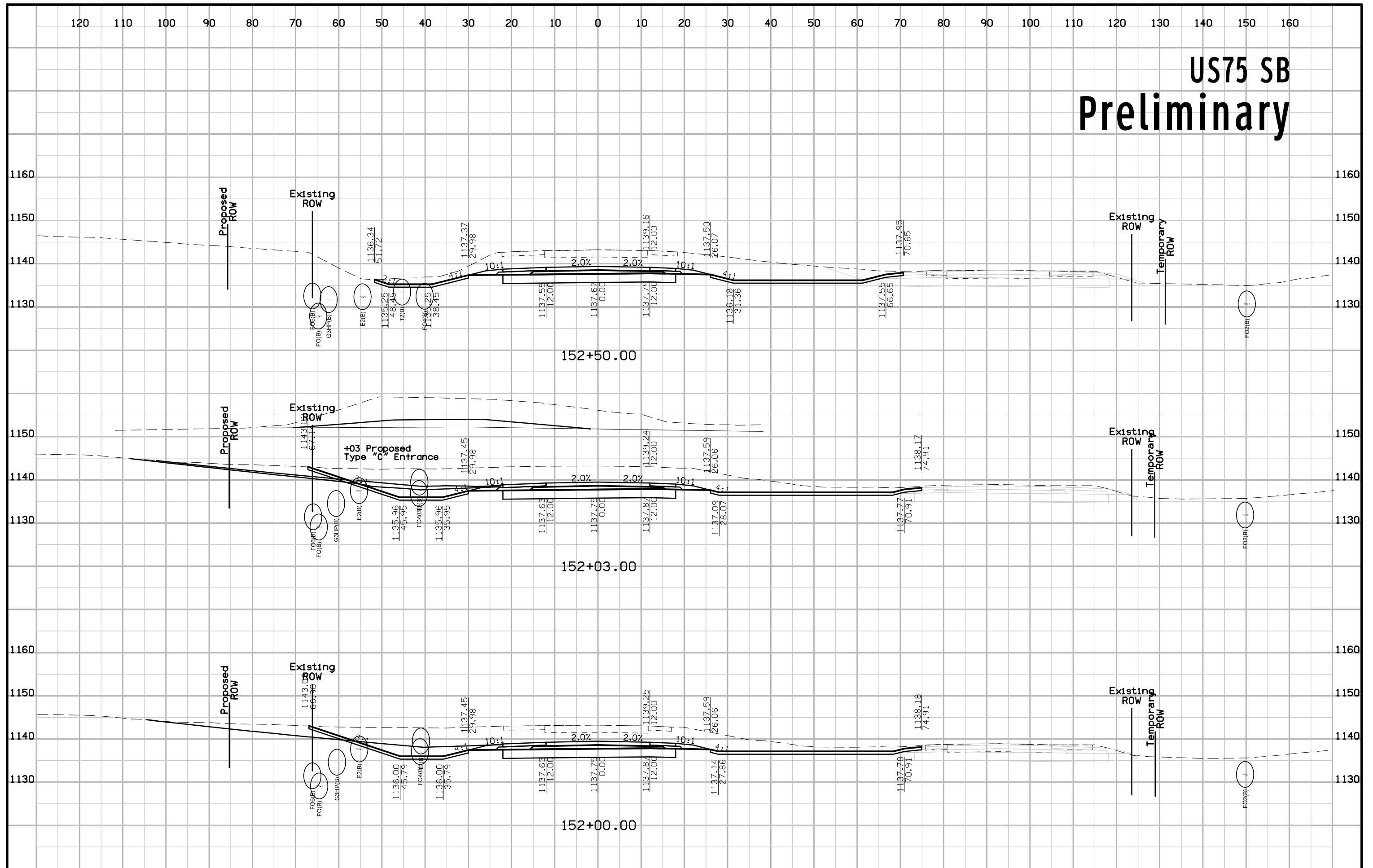

US75 SB Preliminary

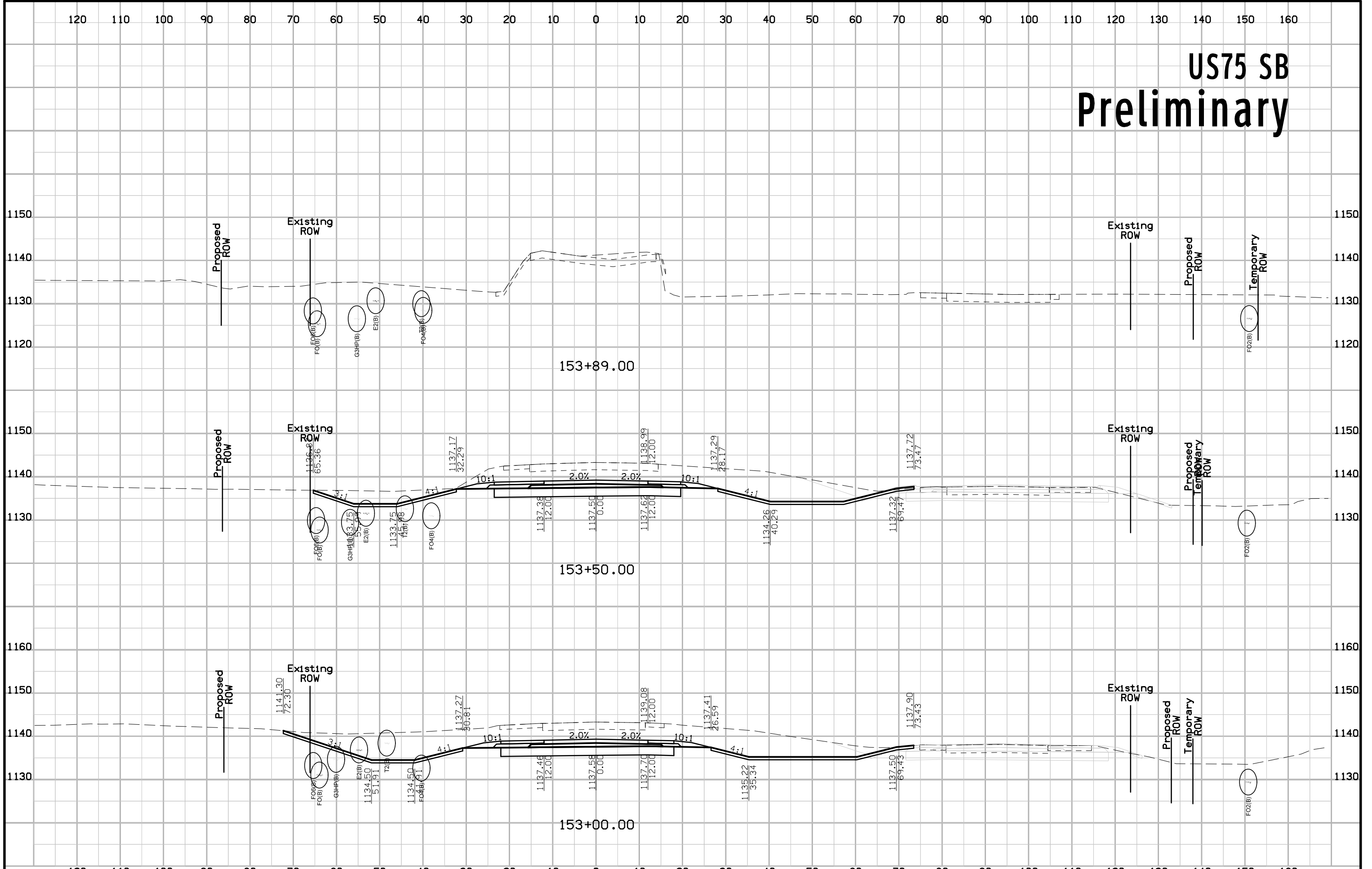

US75 SB Preliminary

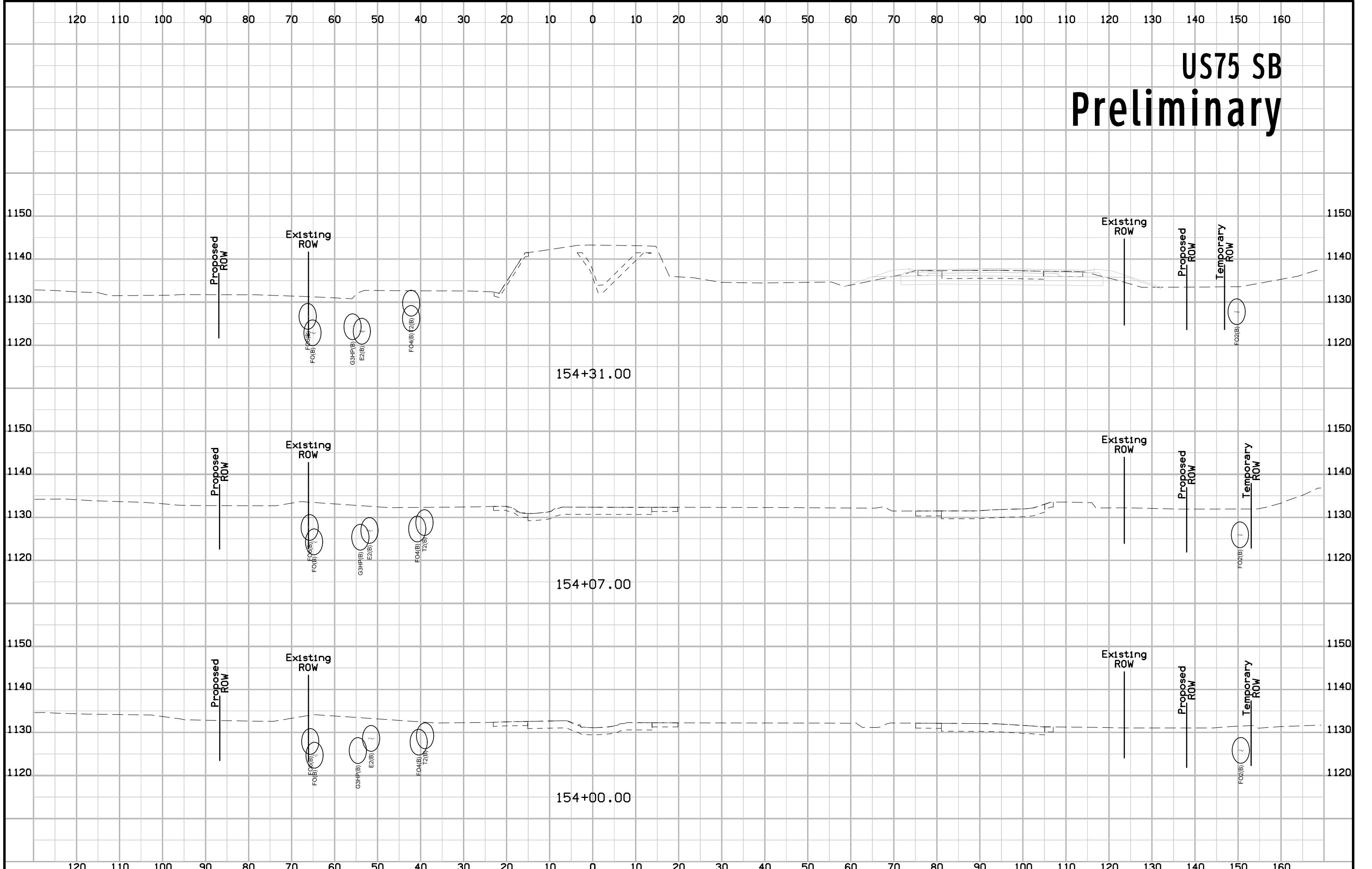

US75 SB Preliminary

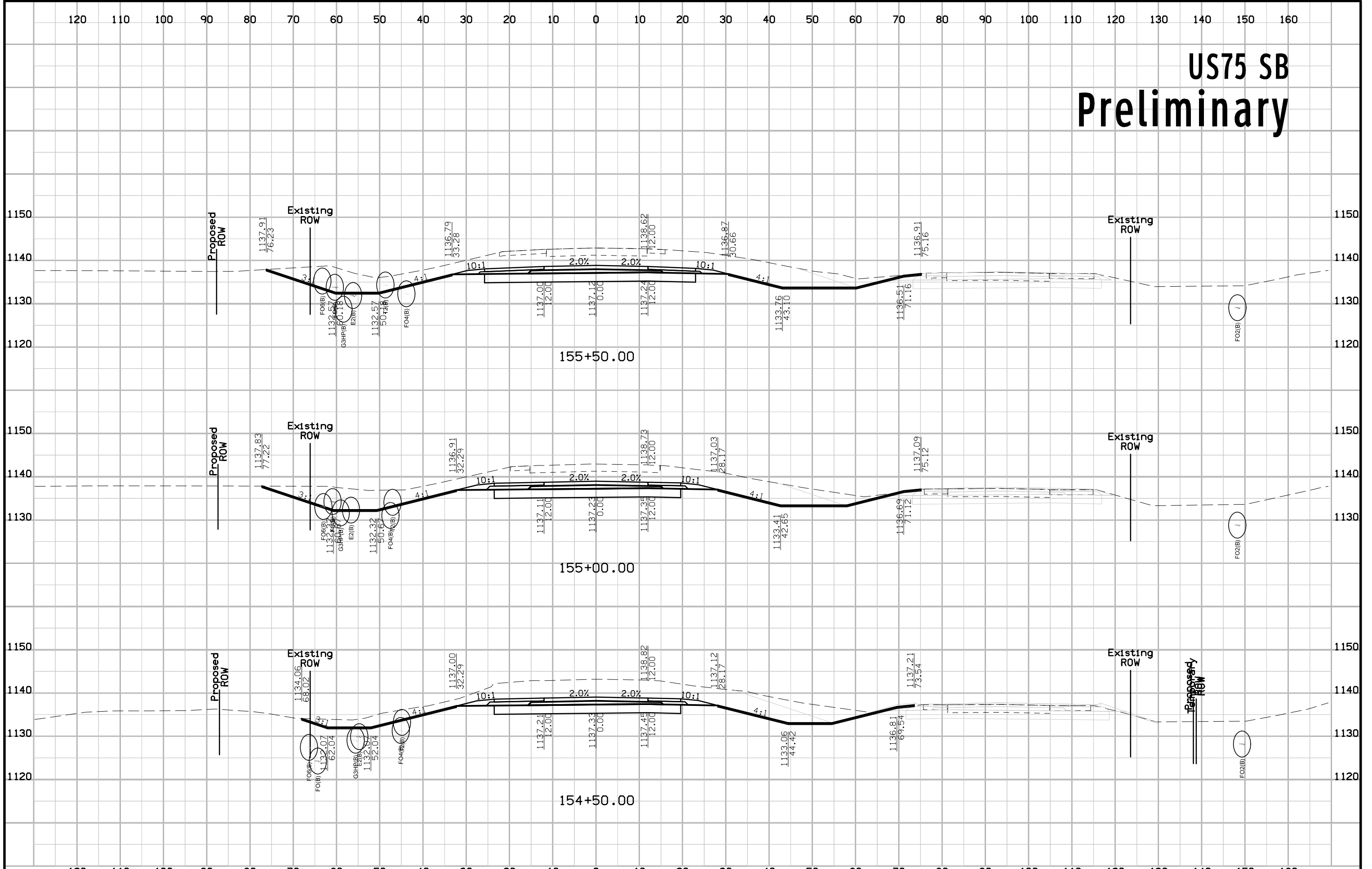

US75 SB Preliminary

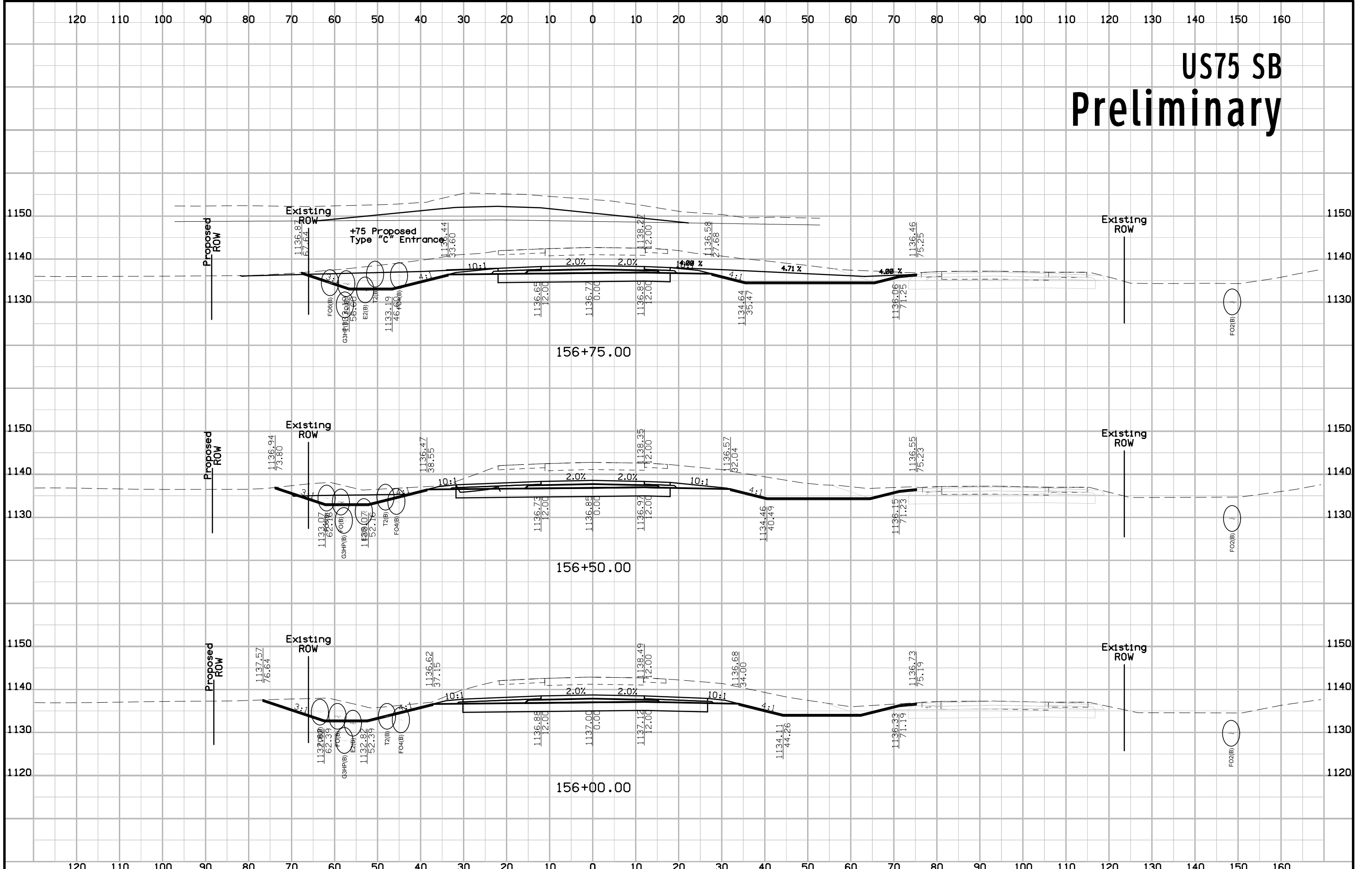

US75 SB Preliminary

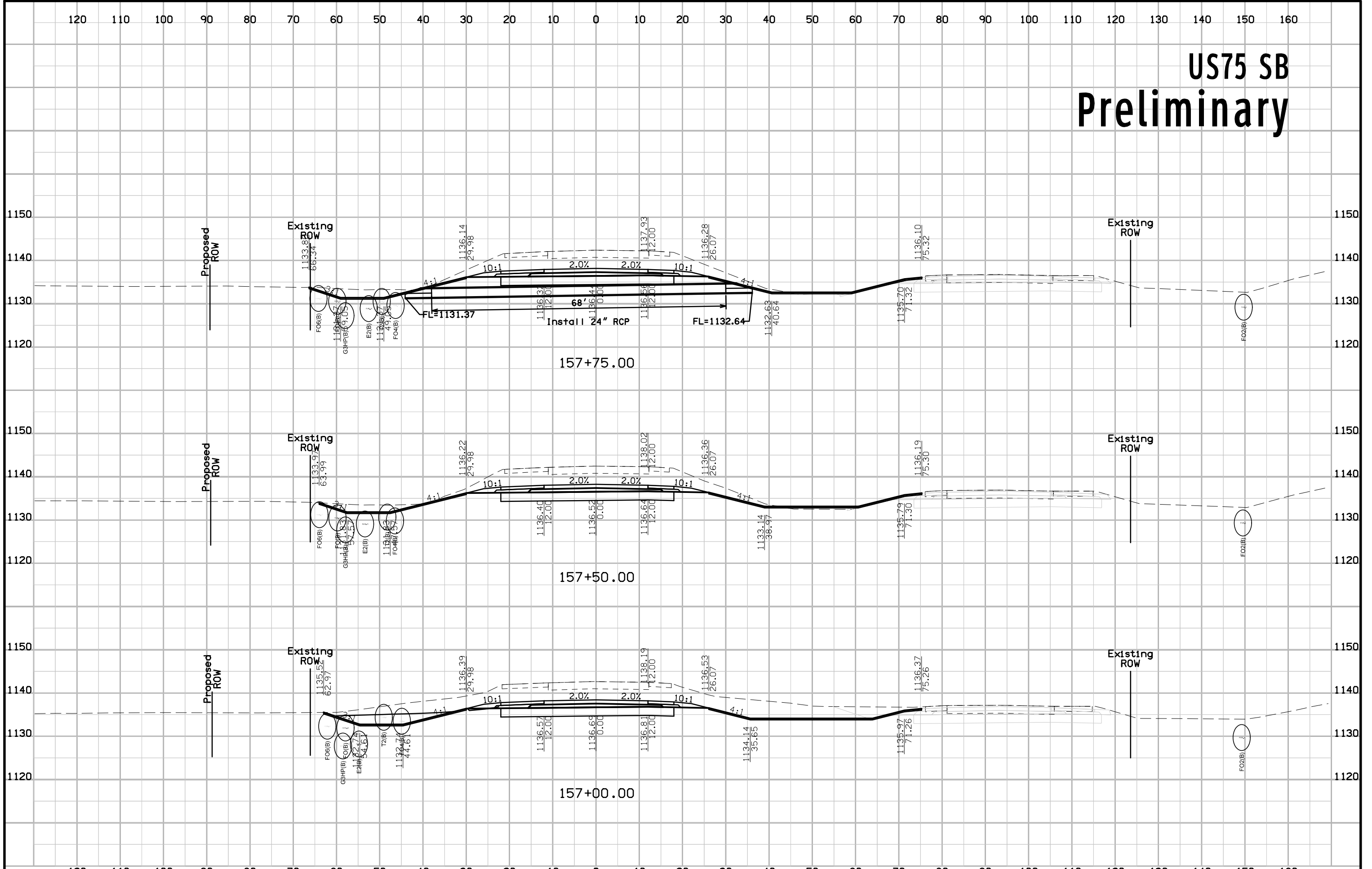

US75 SB Preliminary

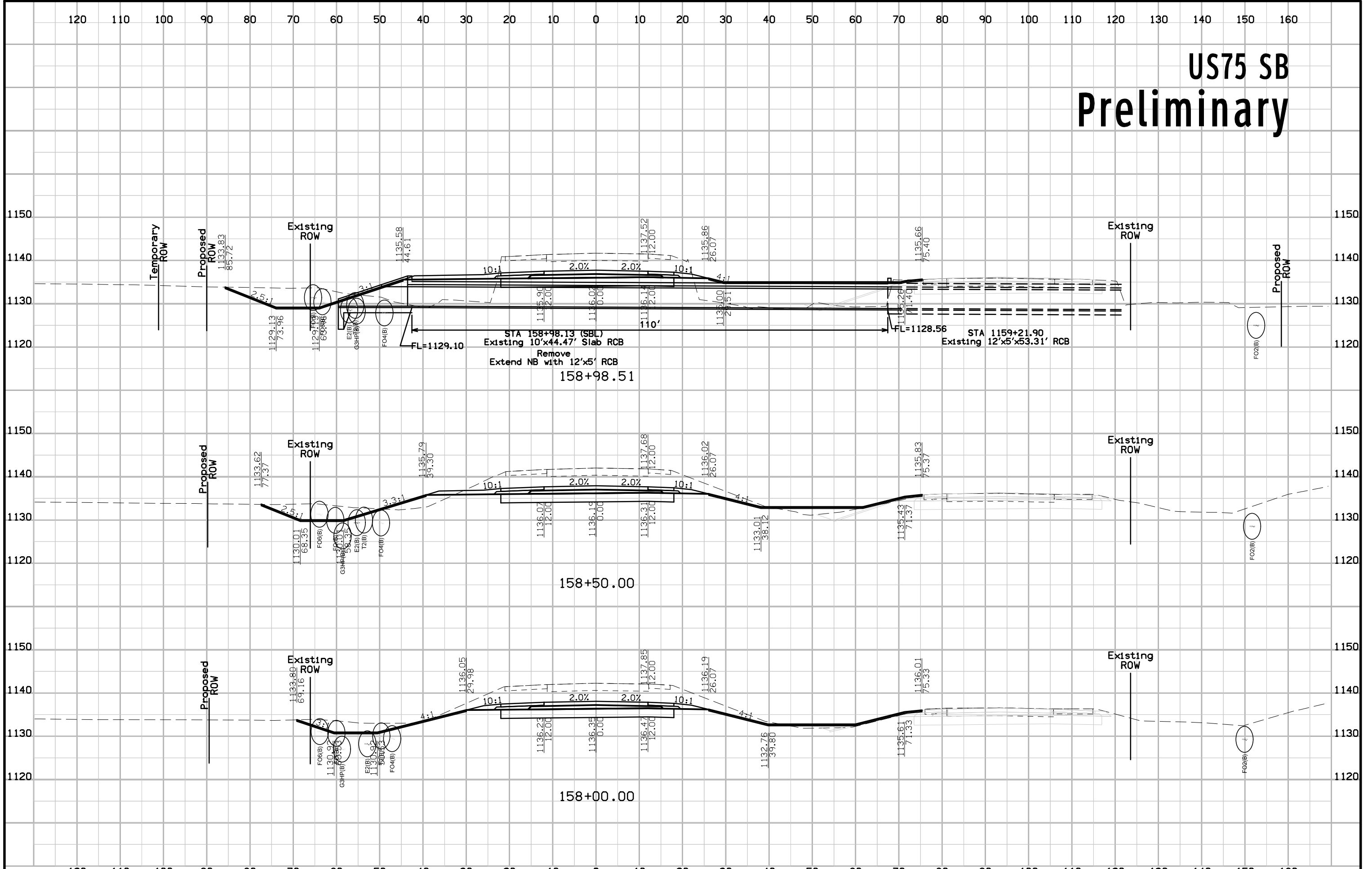

US75 SB Preliminary

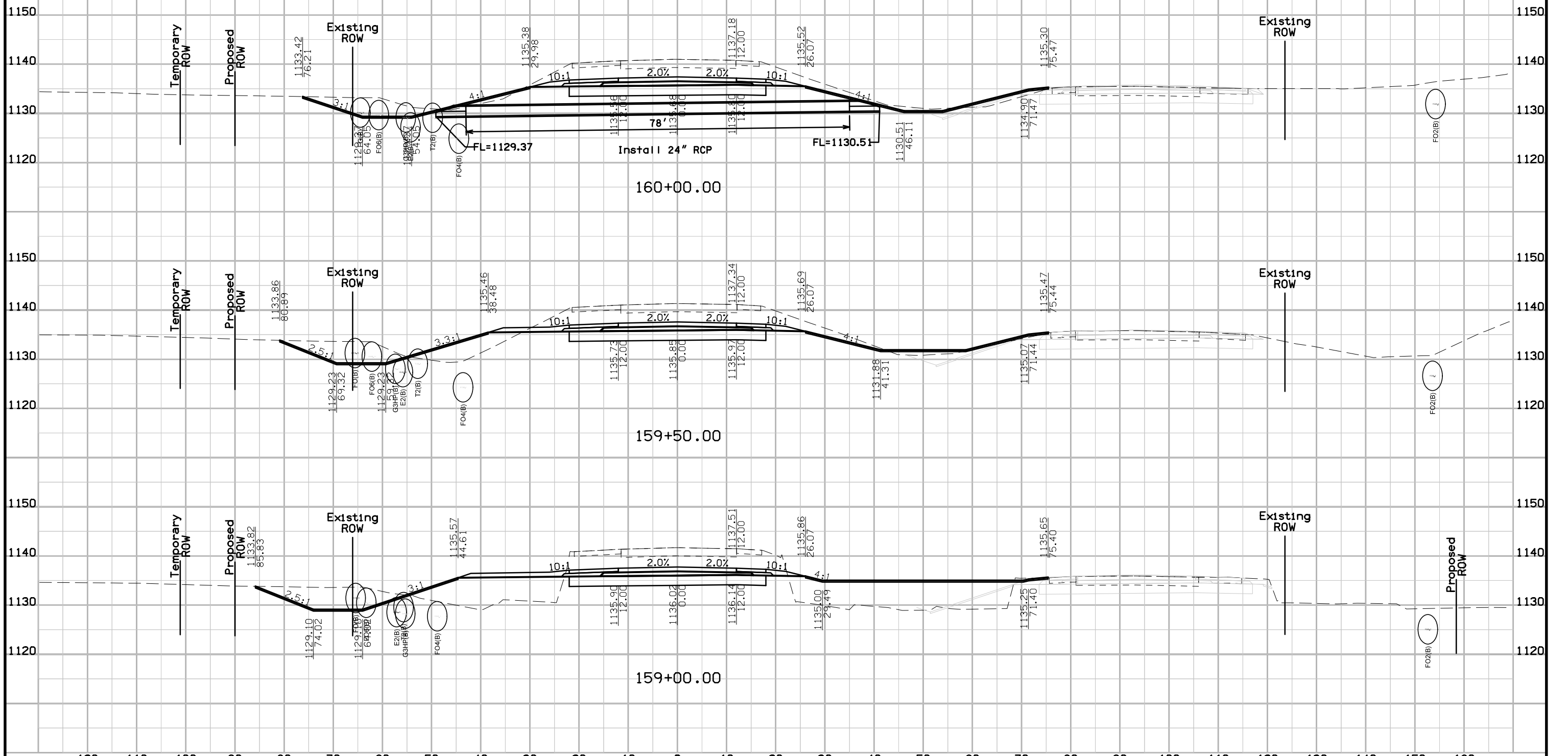

US75 SB Preliminary

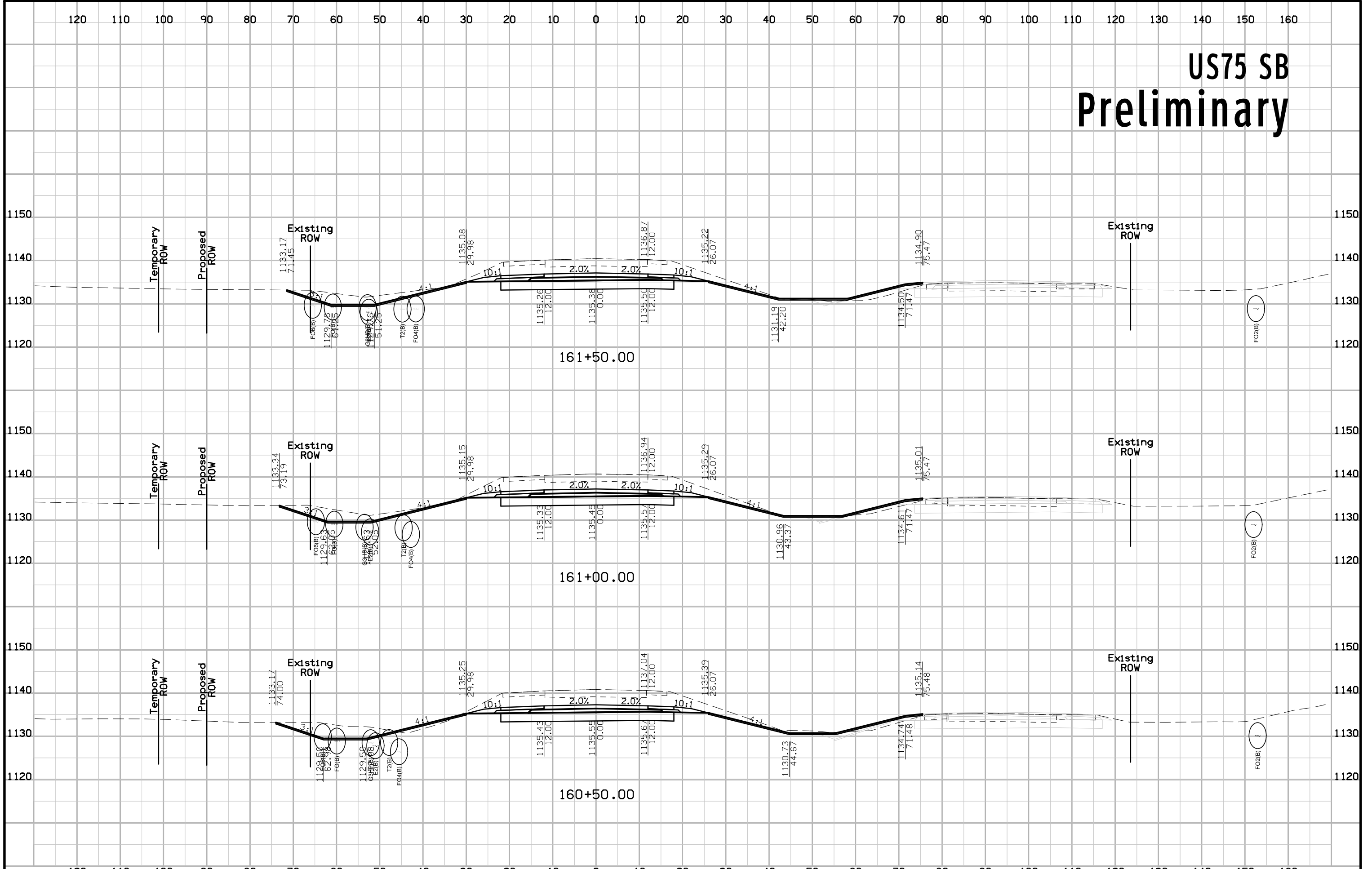

US75 SB Preliminary

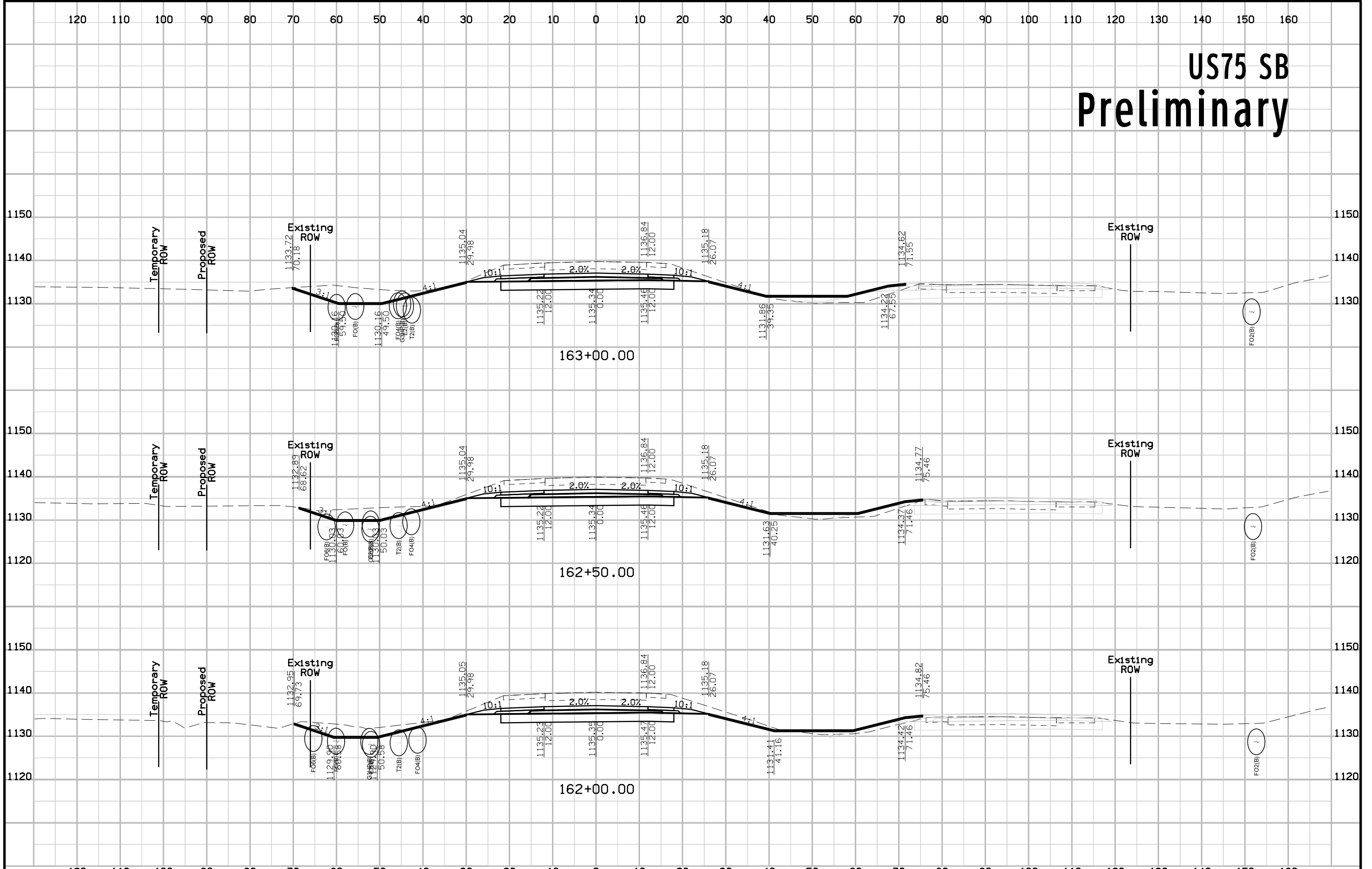

US75 SB Preliminary

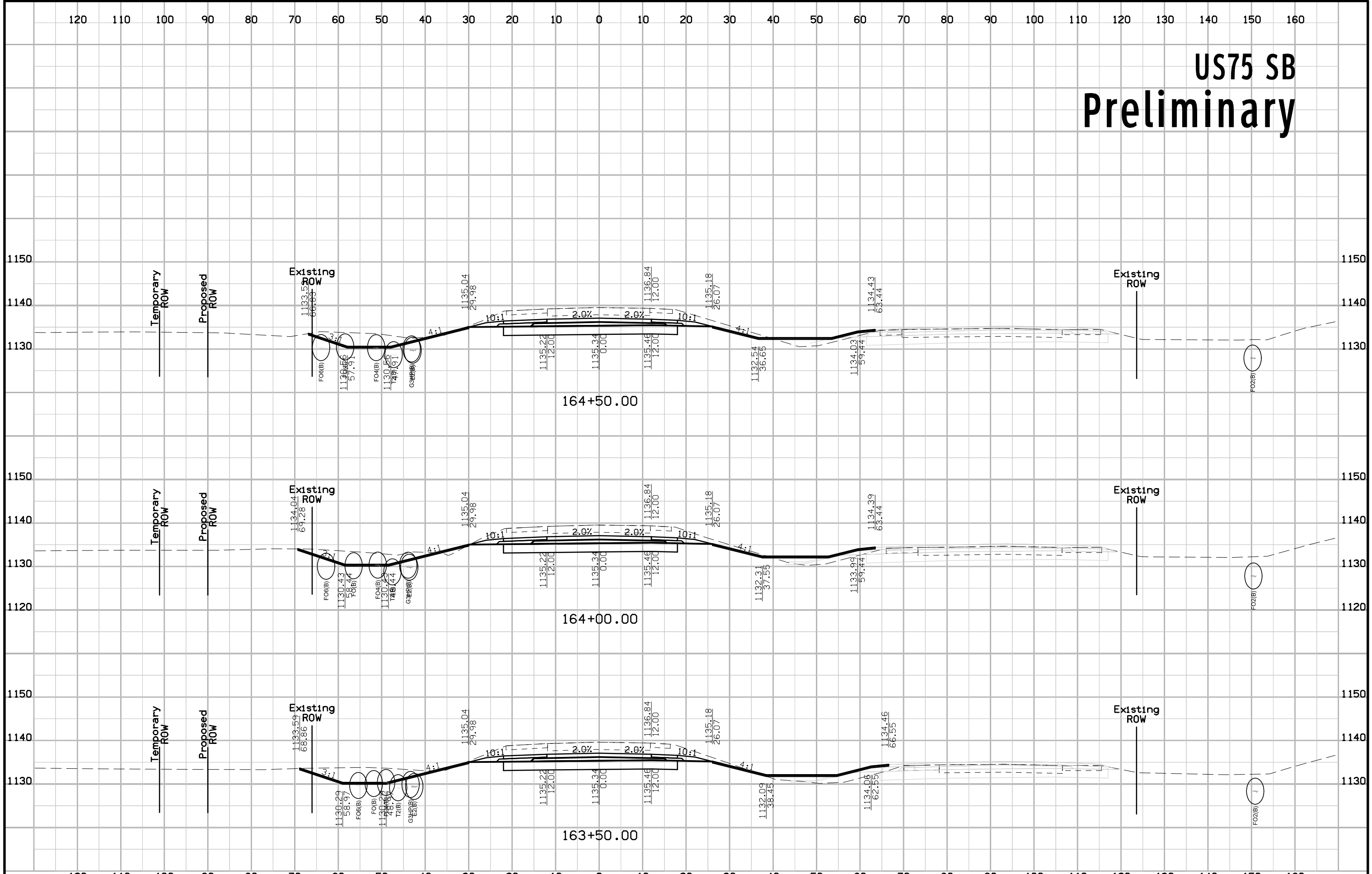

US75 SB Preliminary

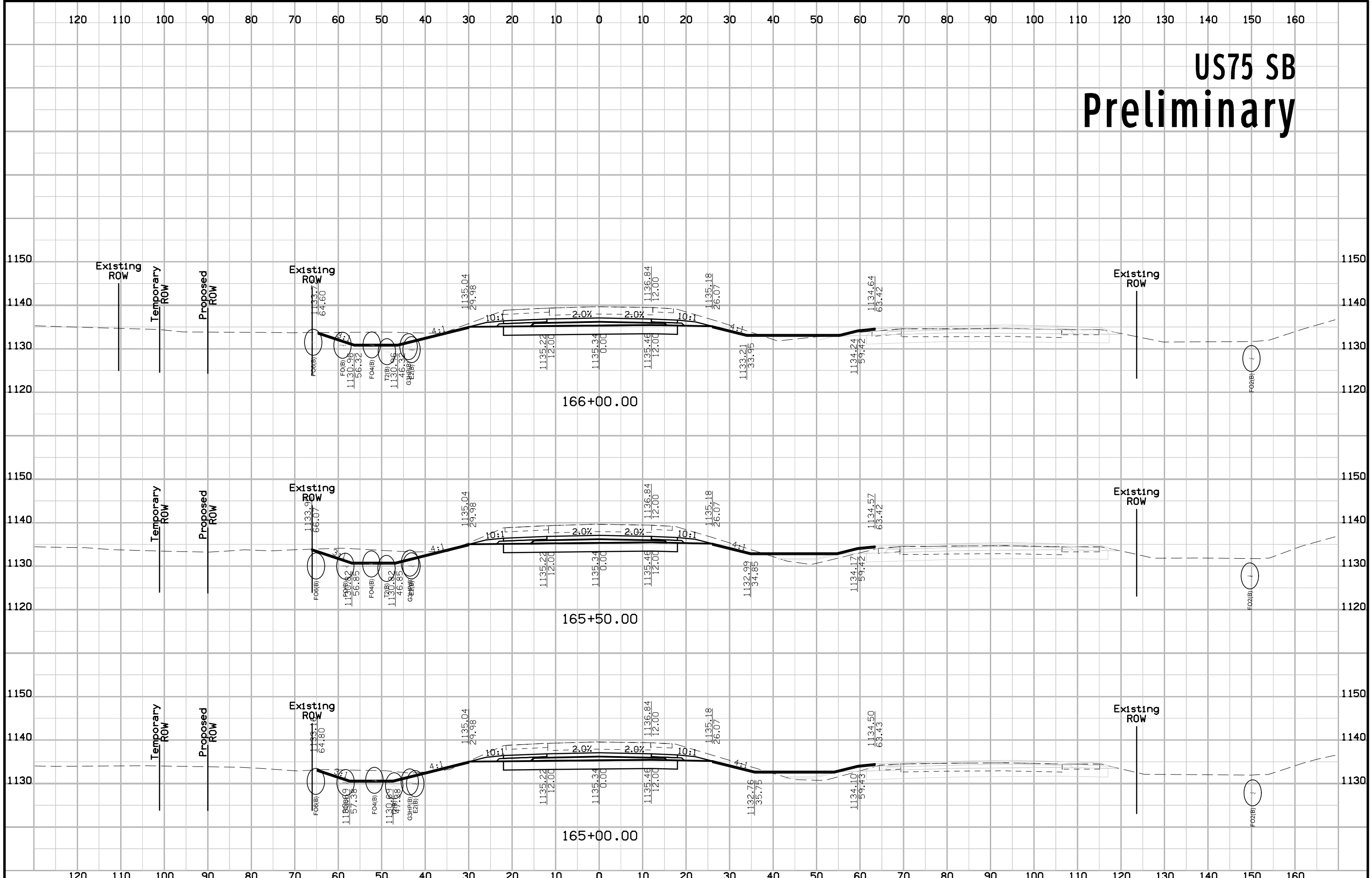

US75 SB Preliminary

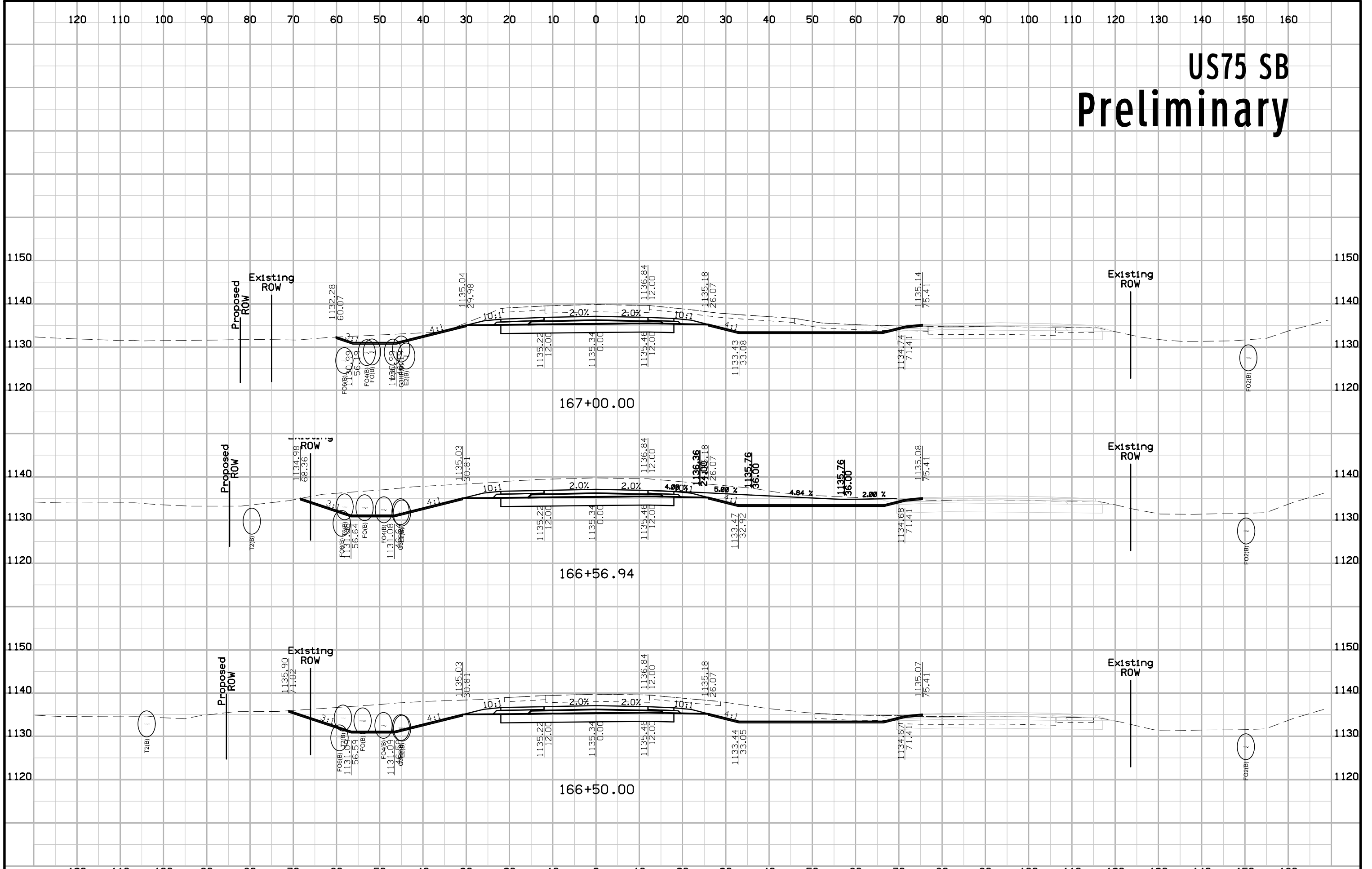

US75 SB Preliminary

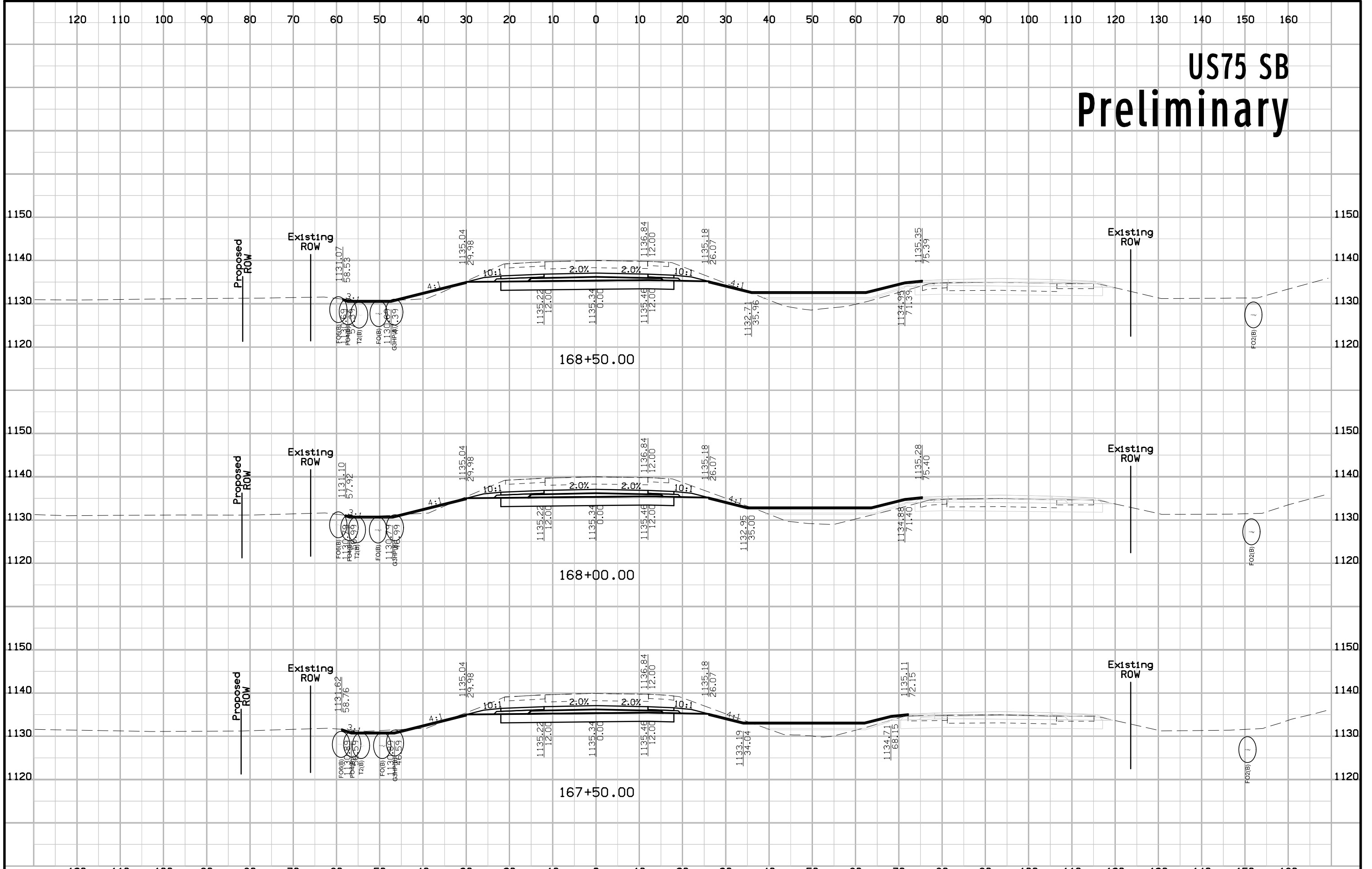

US75 SB Preliminary

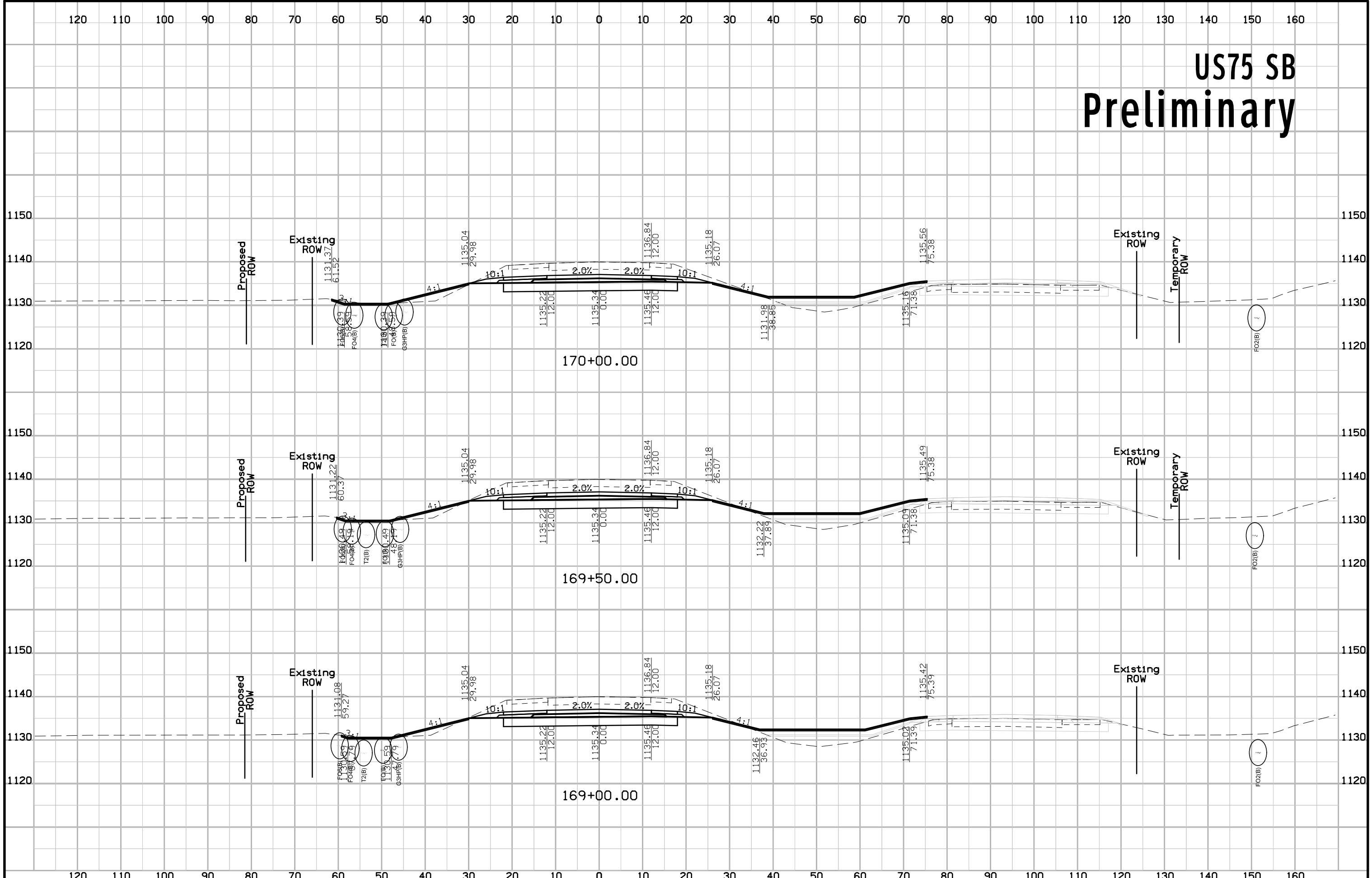

US75 SB Preliminary

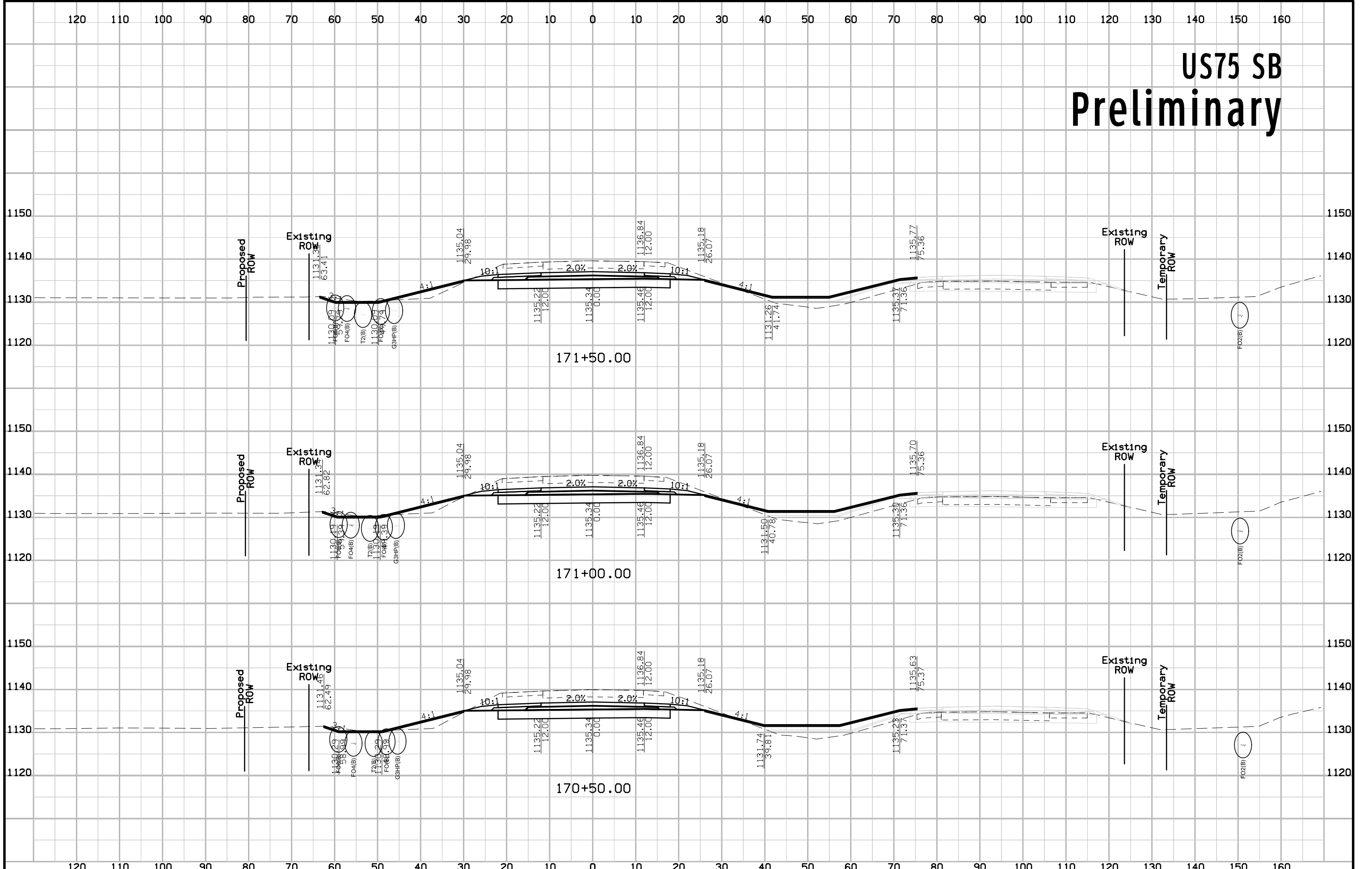

US75 SB Preliminary

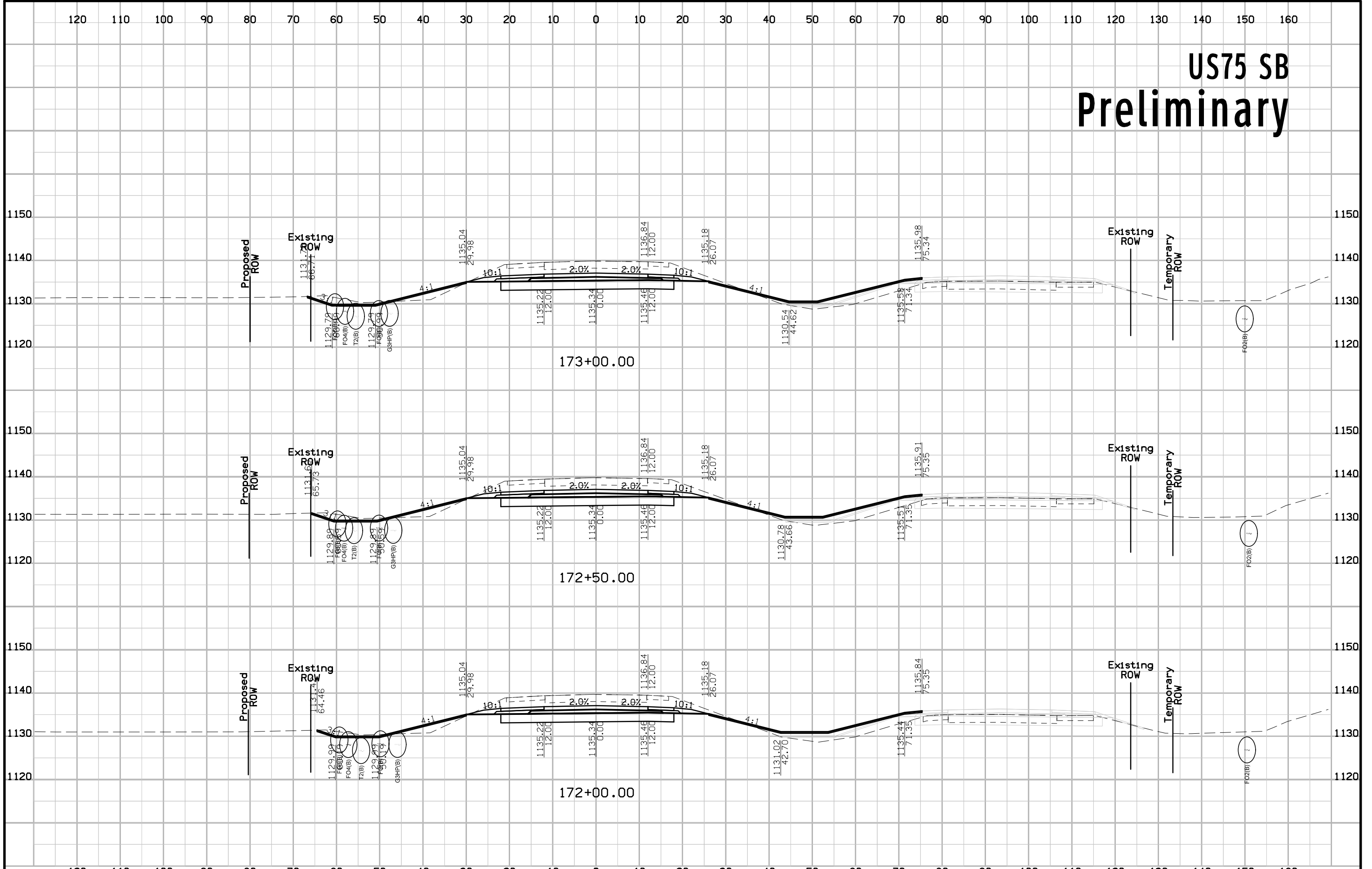

US75 SB Preliminary

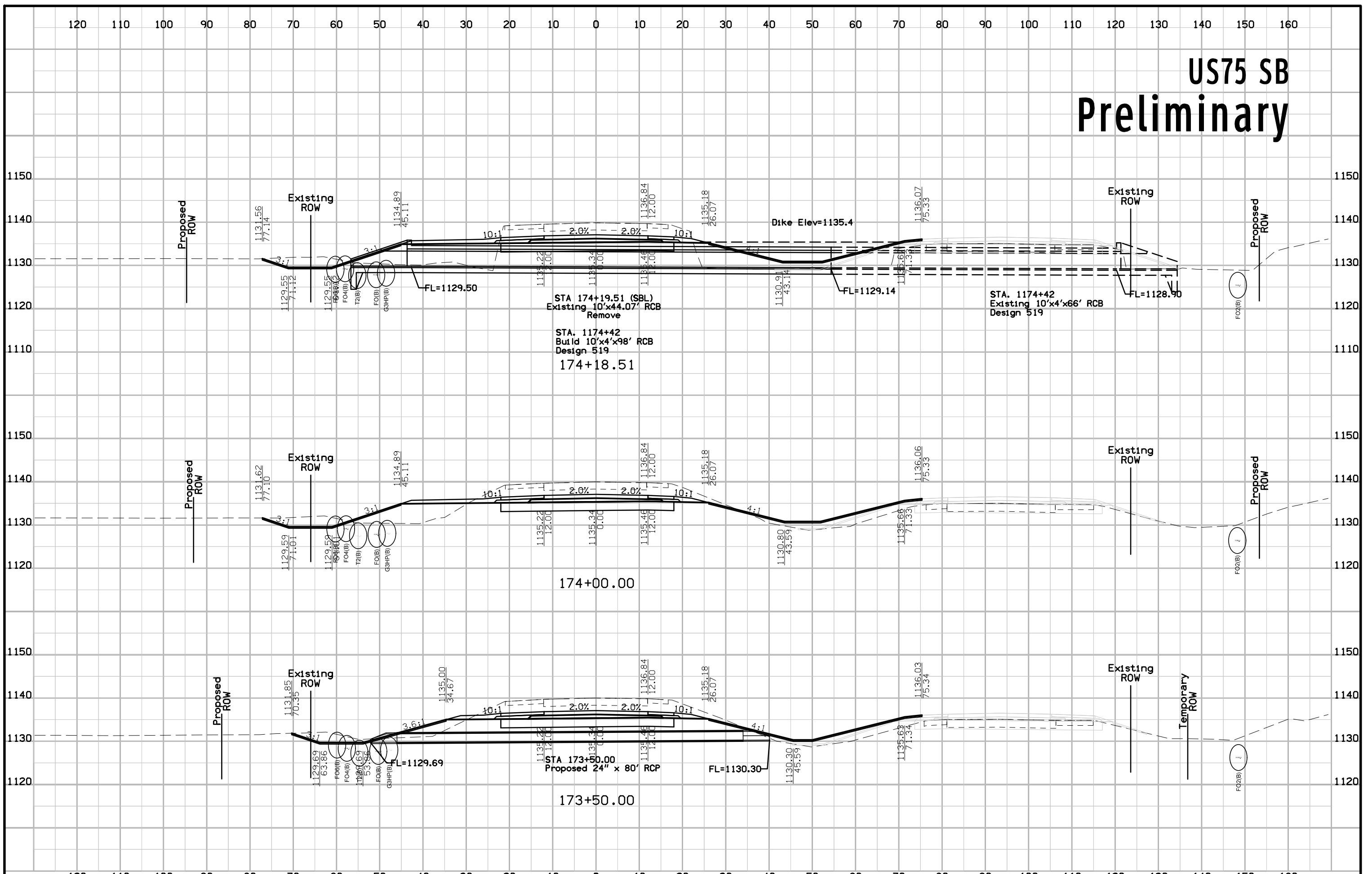

US75 SB Preliminary

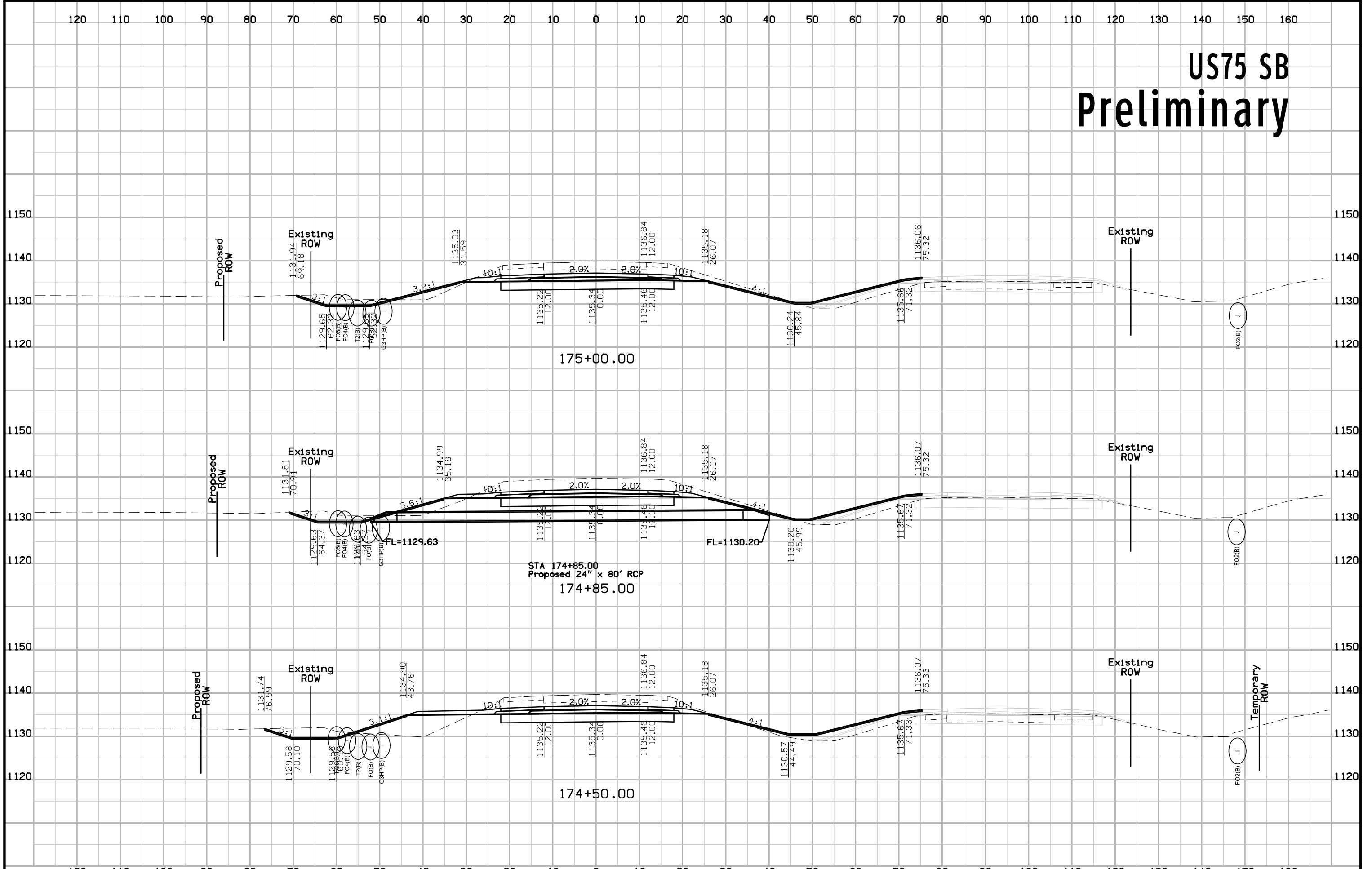

US75 SB Preliminary

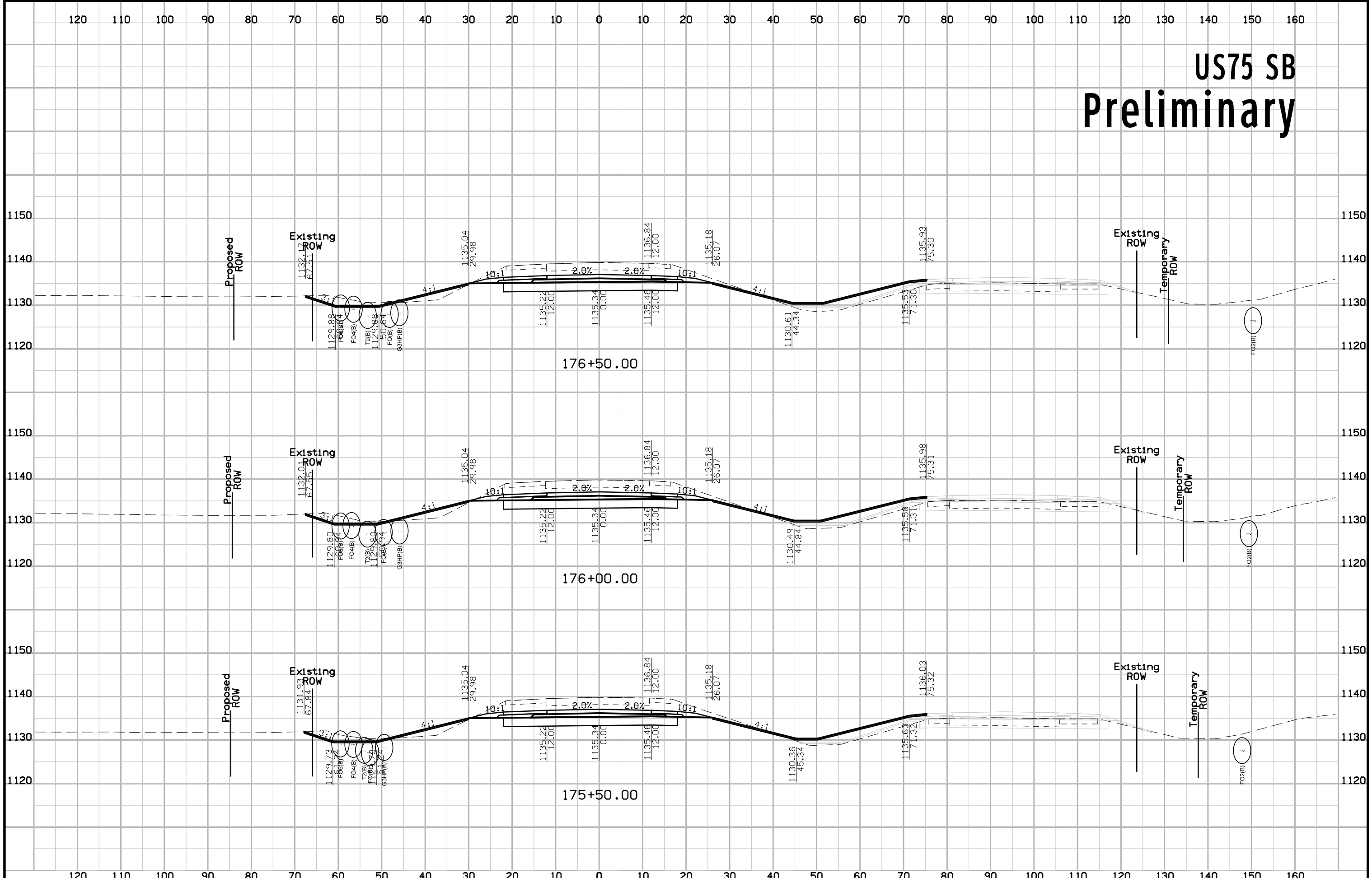

US75 SB Preliminary

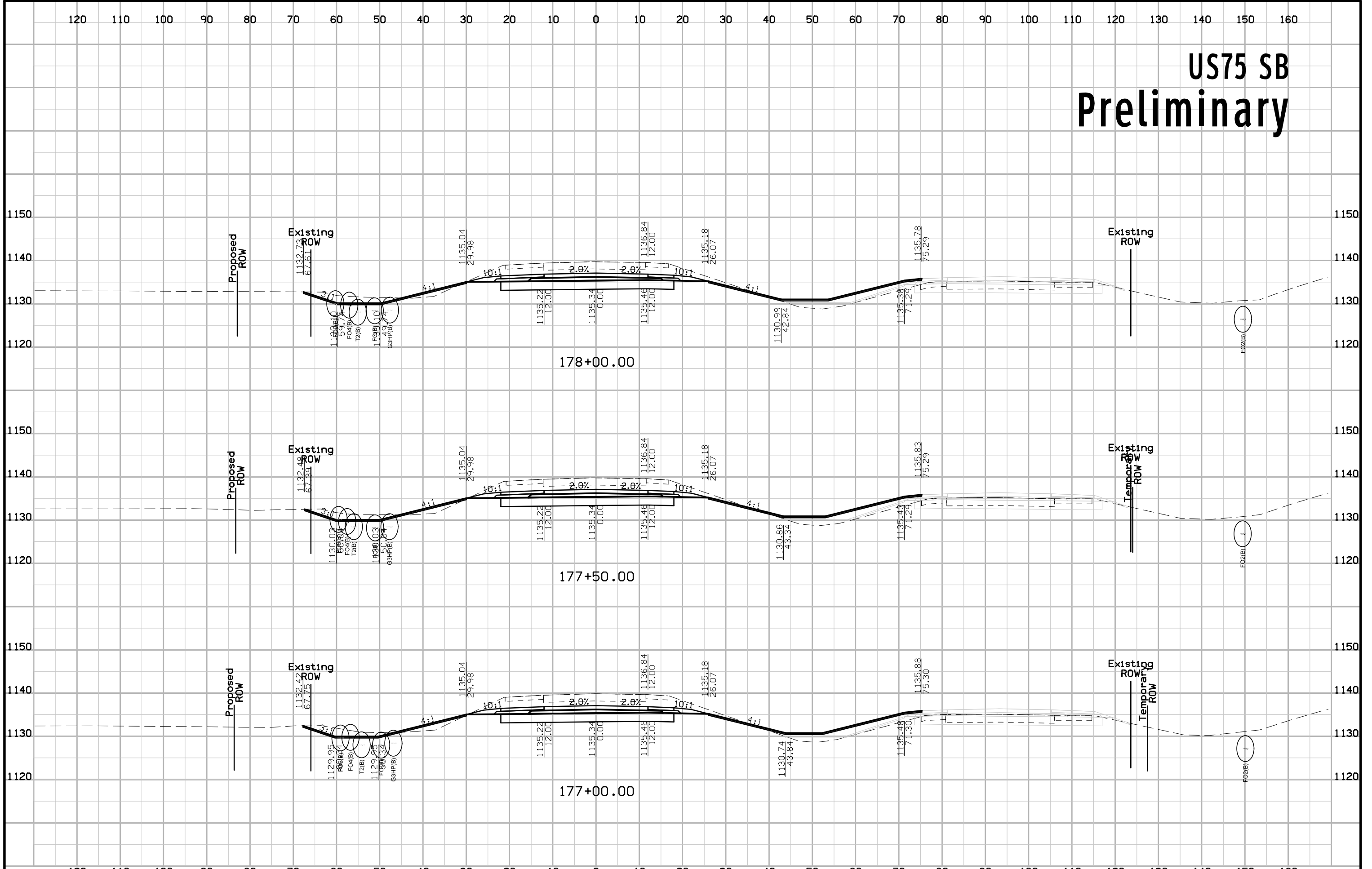

US75 SB Preliminary

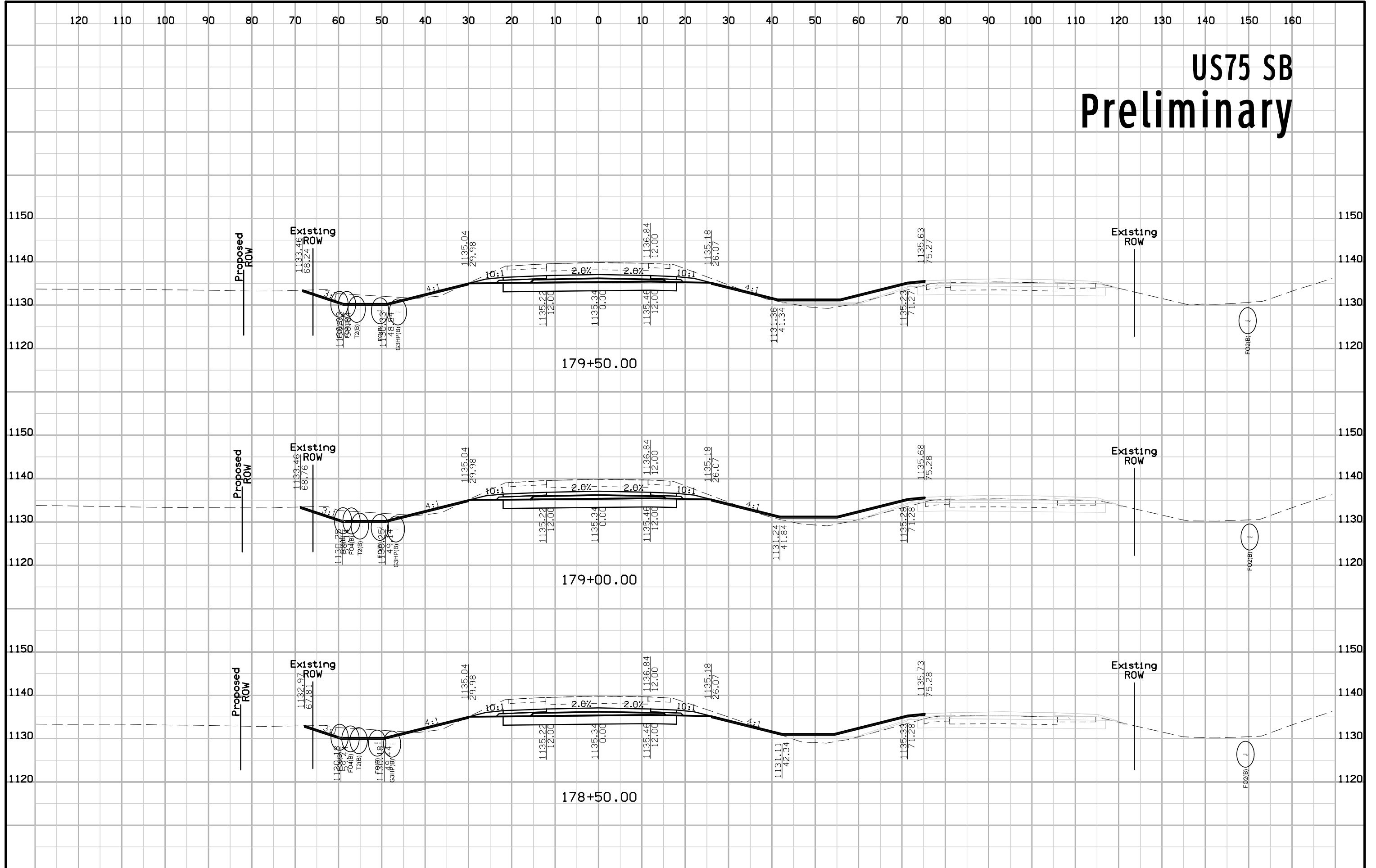

US75 SB Preliminary

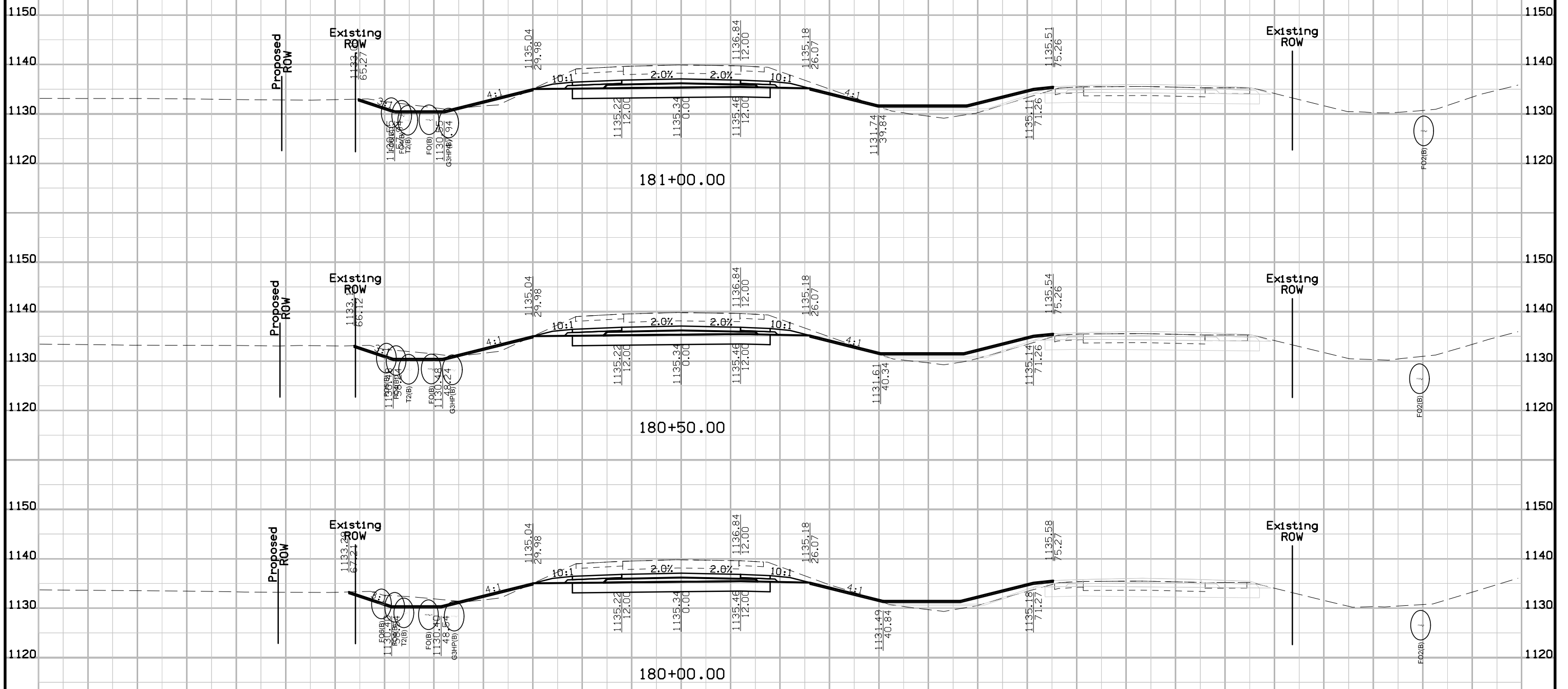

US75 SB Preliminary

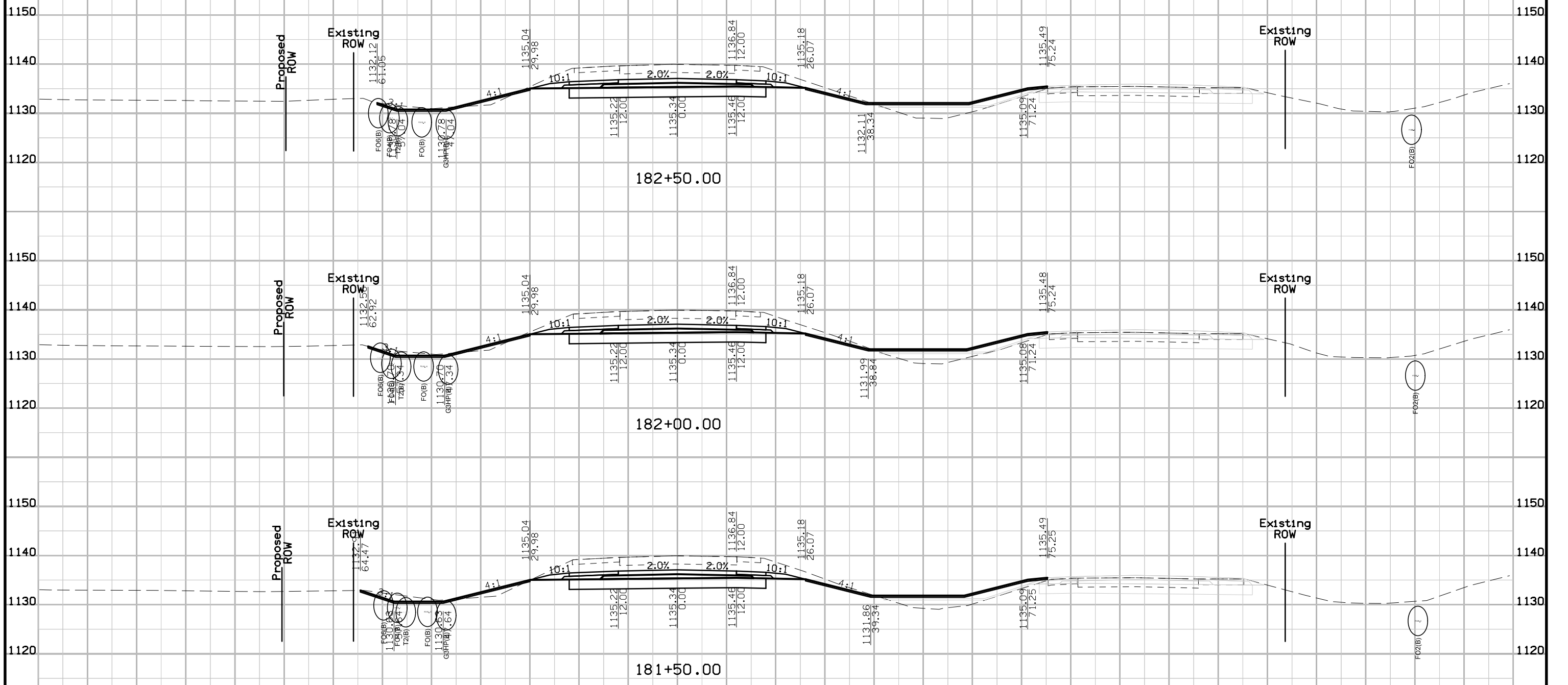

US75 SB Preliminary

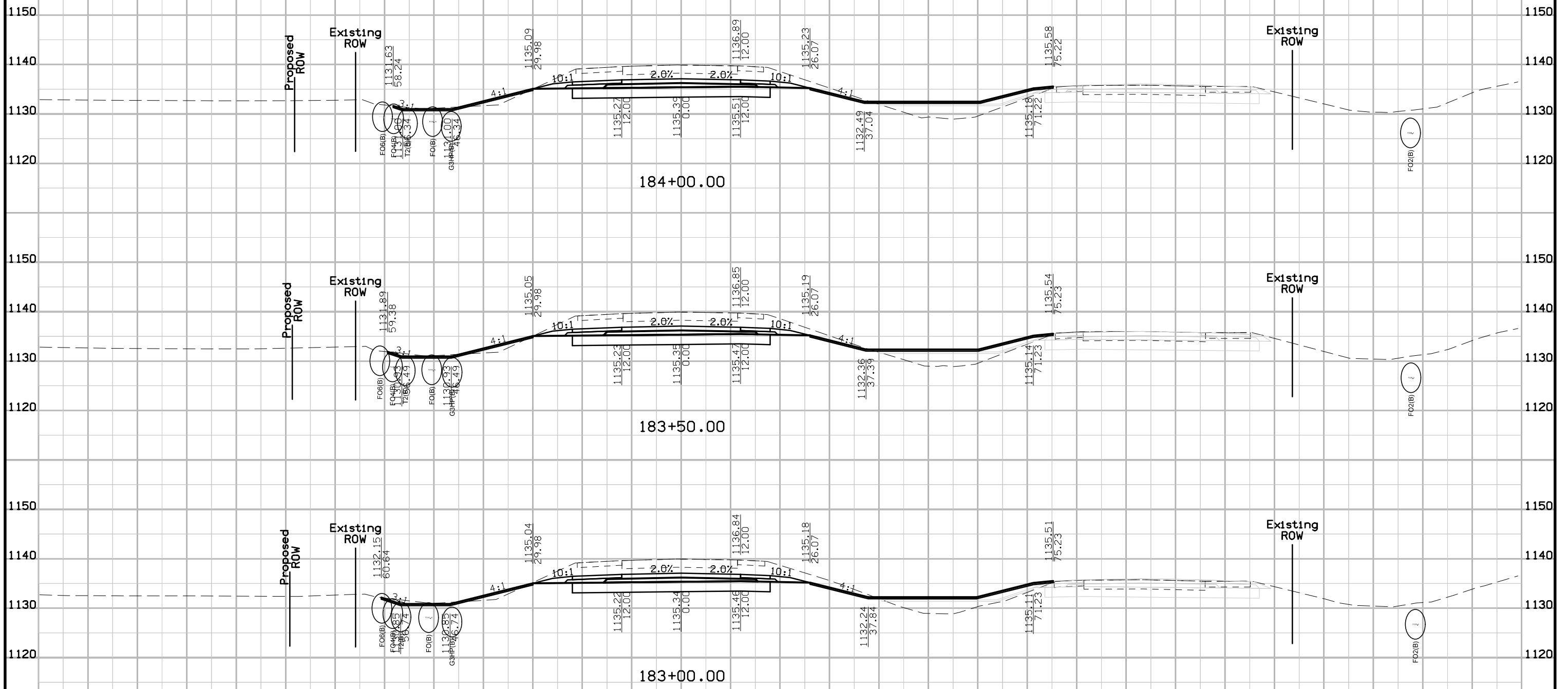

US75 SB Preliminary

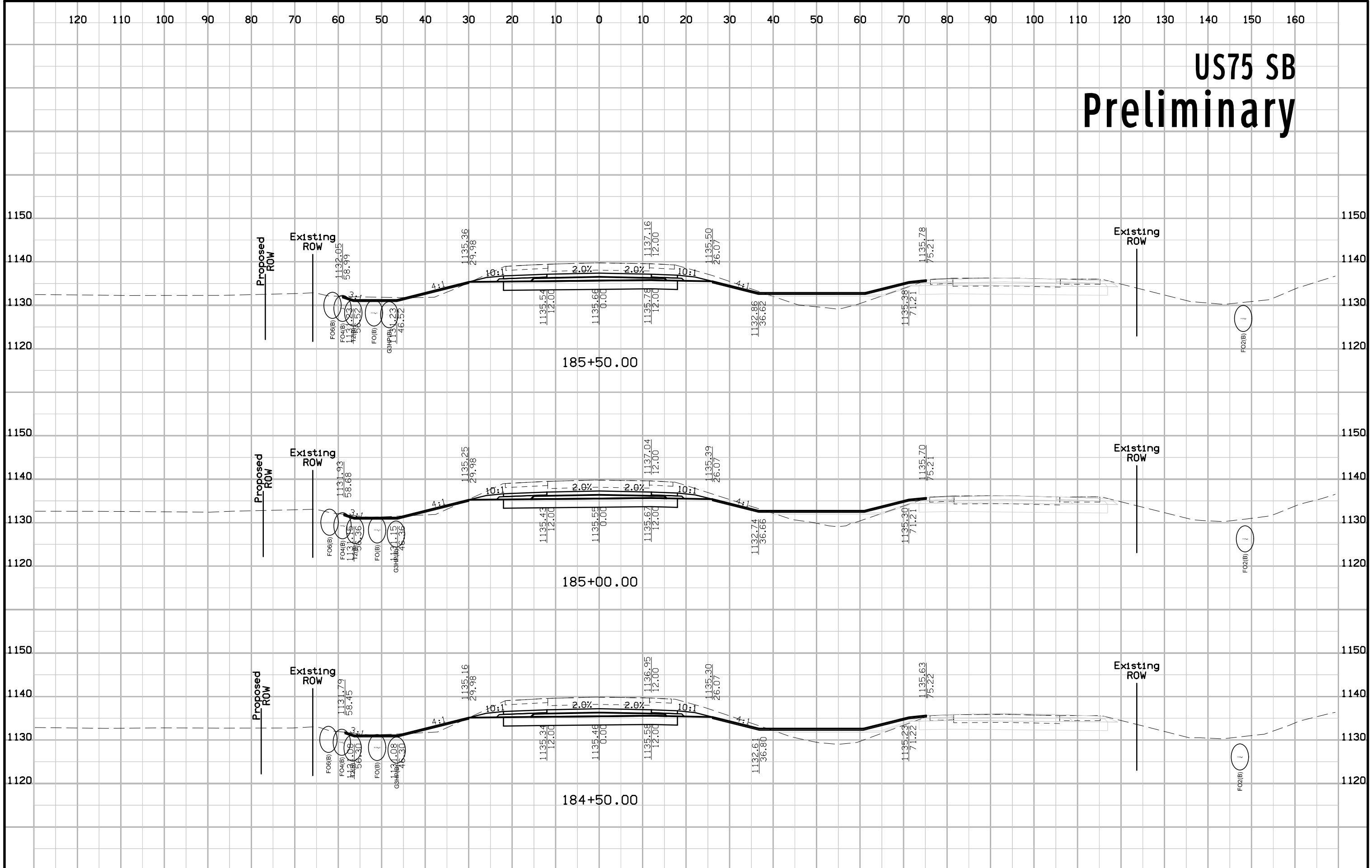

US75 SB Preliminary

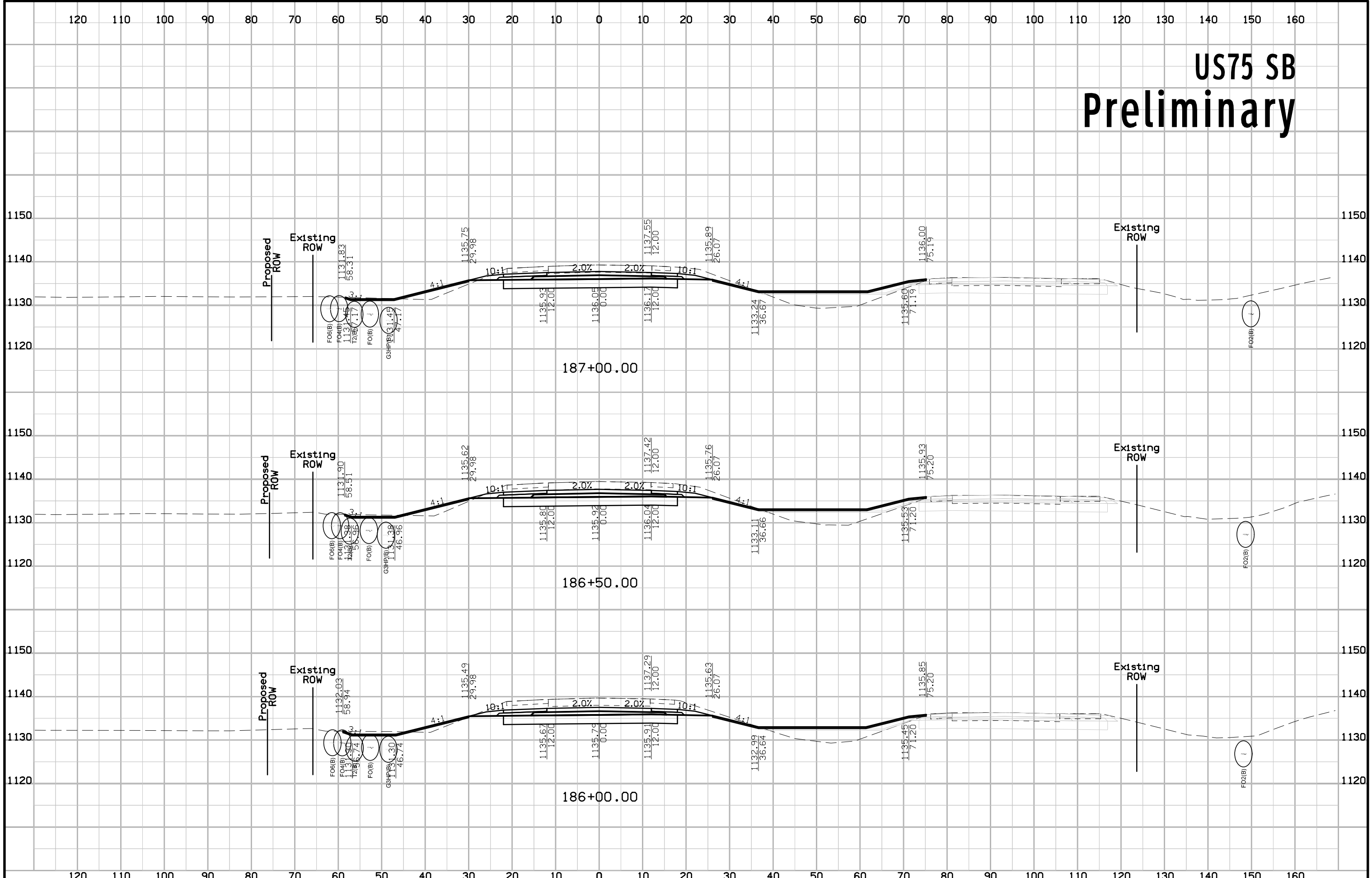

US75 SB Preliminary

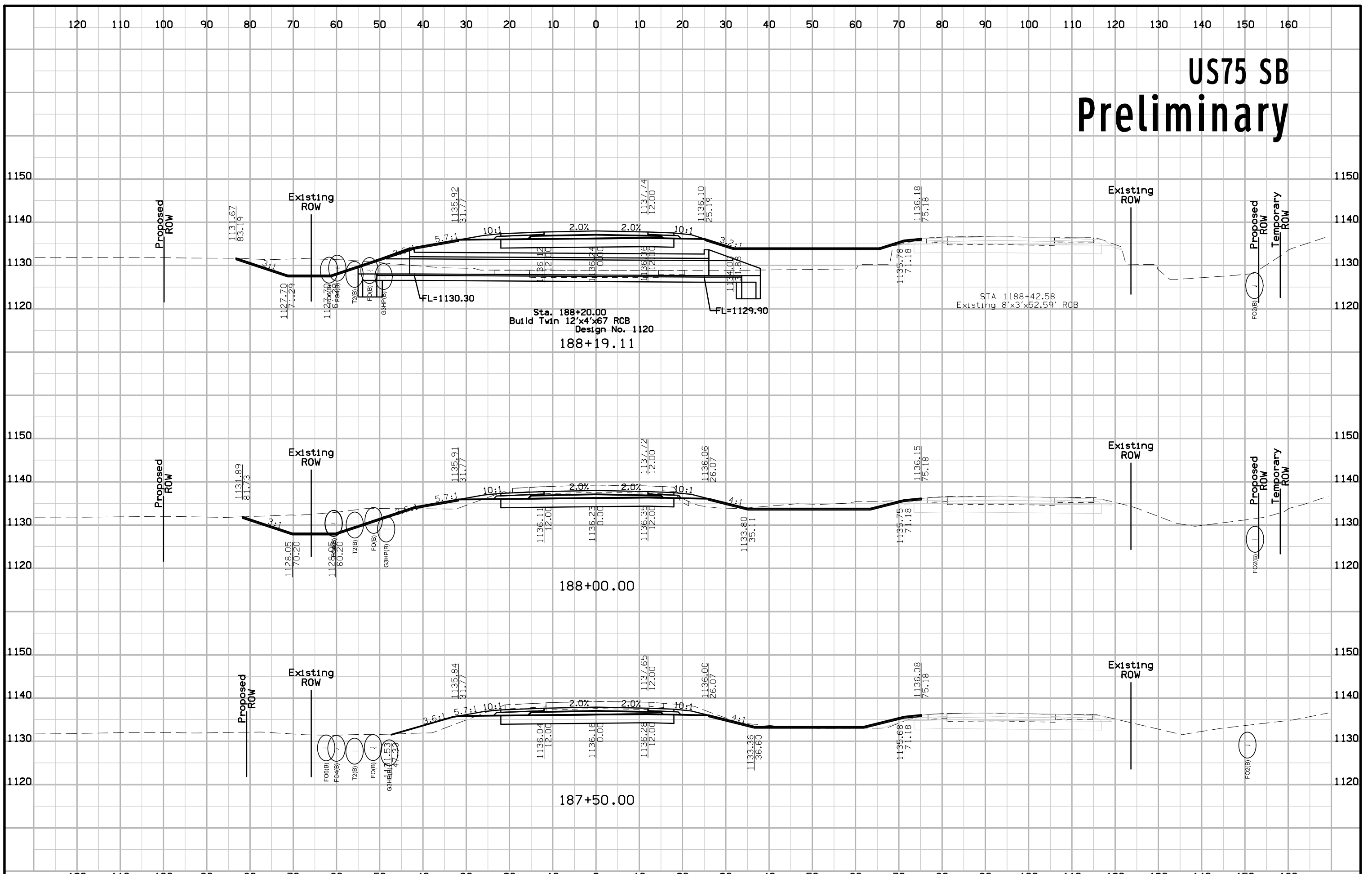

US75 SB Preliminary

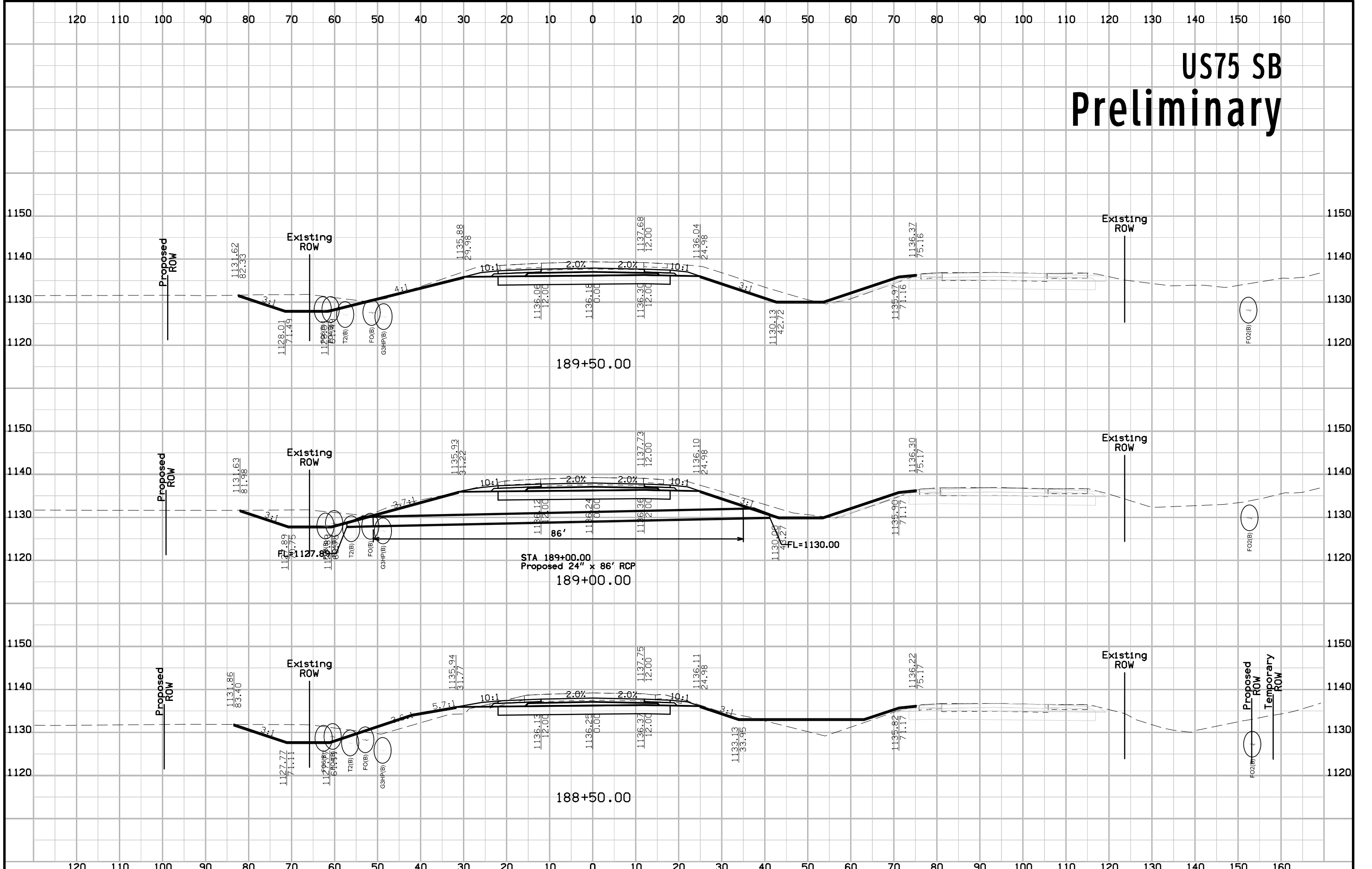

US75 SB Preliminary

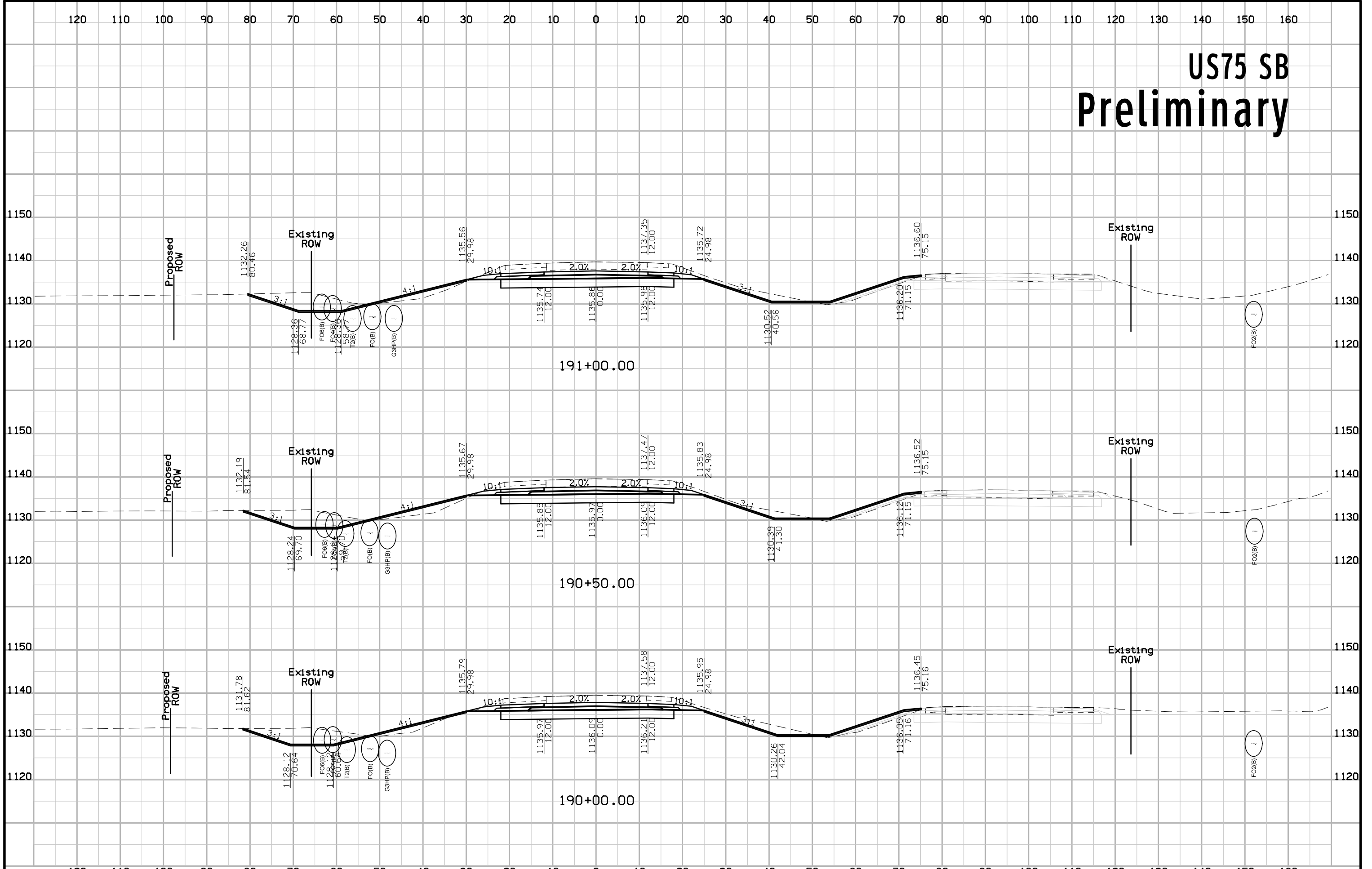

US75 SB Preliminary

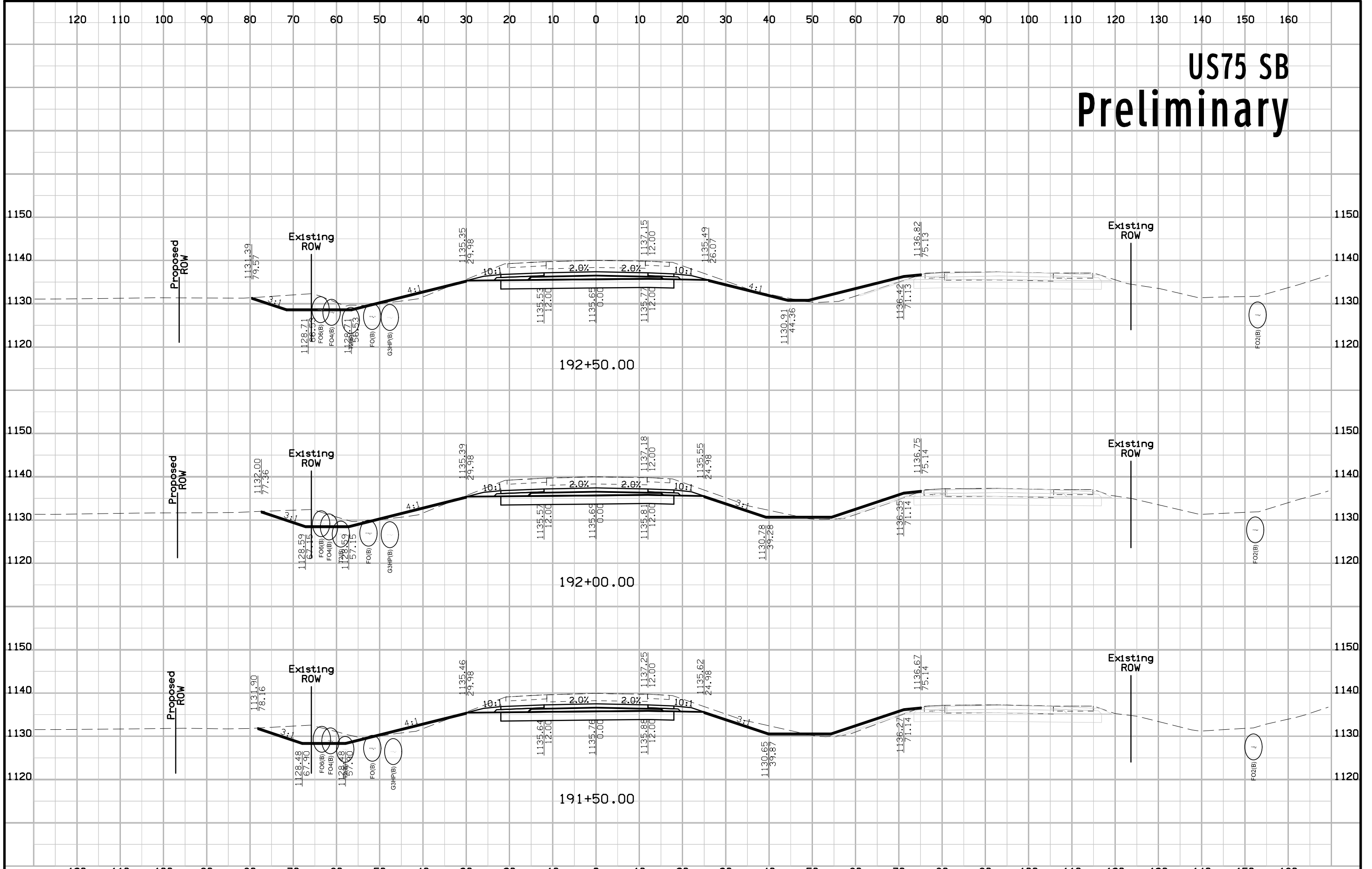

US75 SB Preliminary

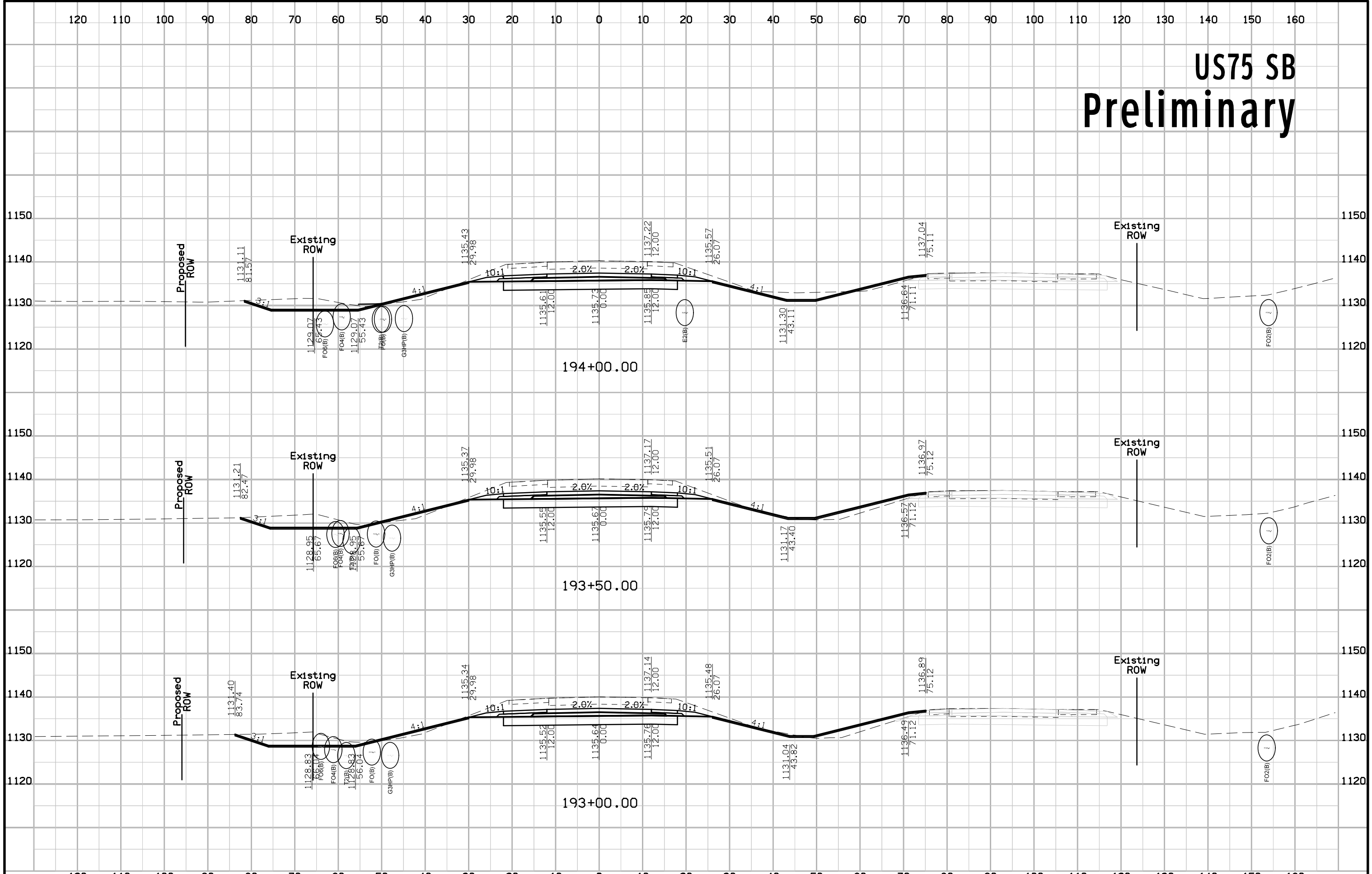

US75 SB Preliminary

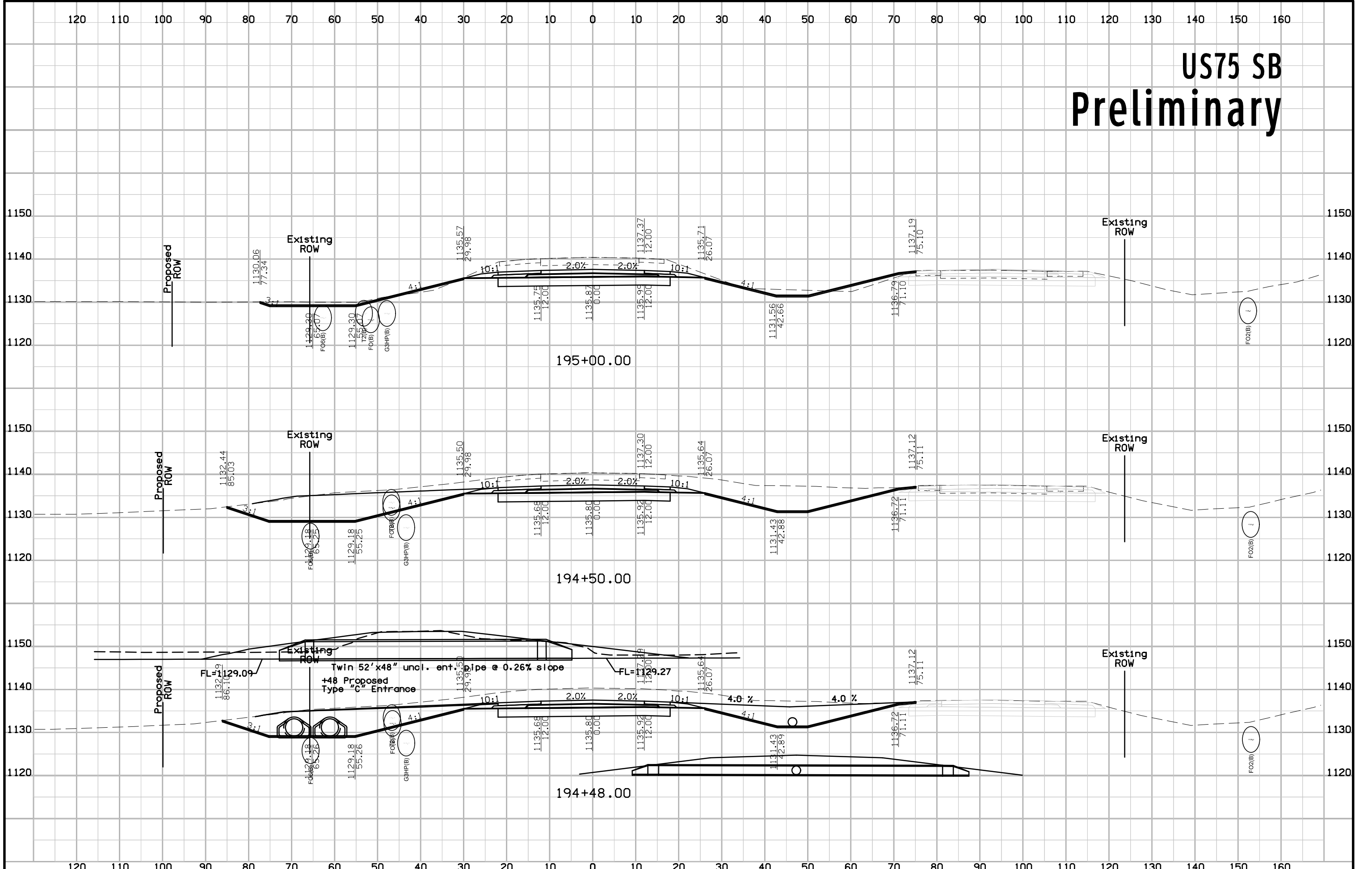

US75 SB Preliminary

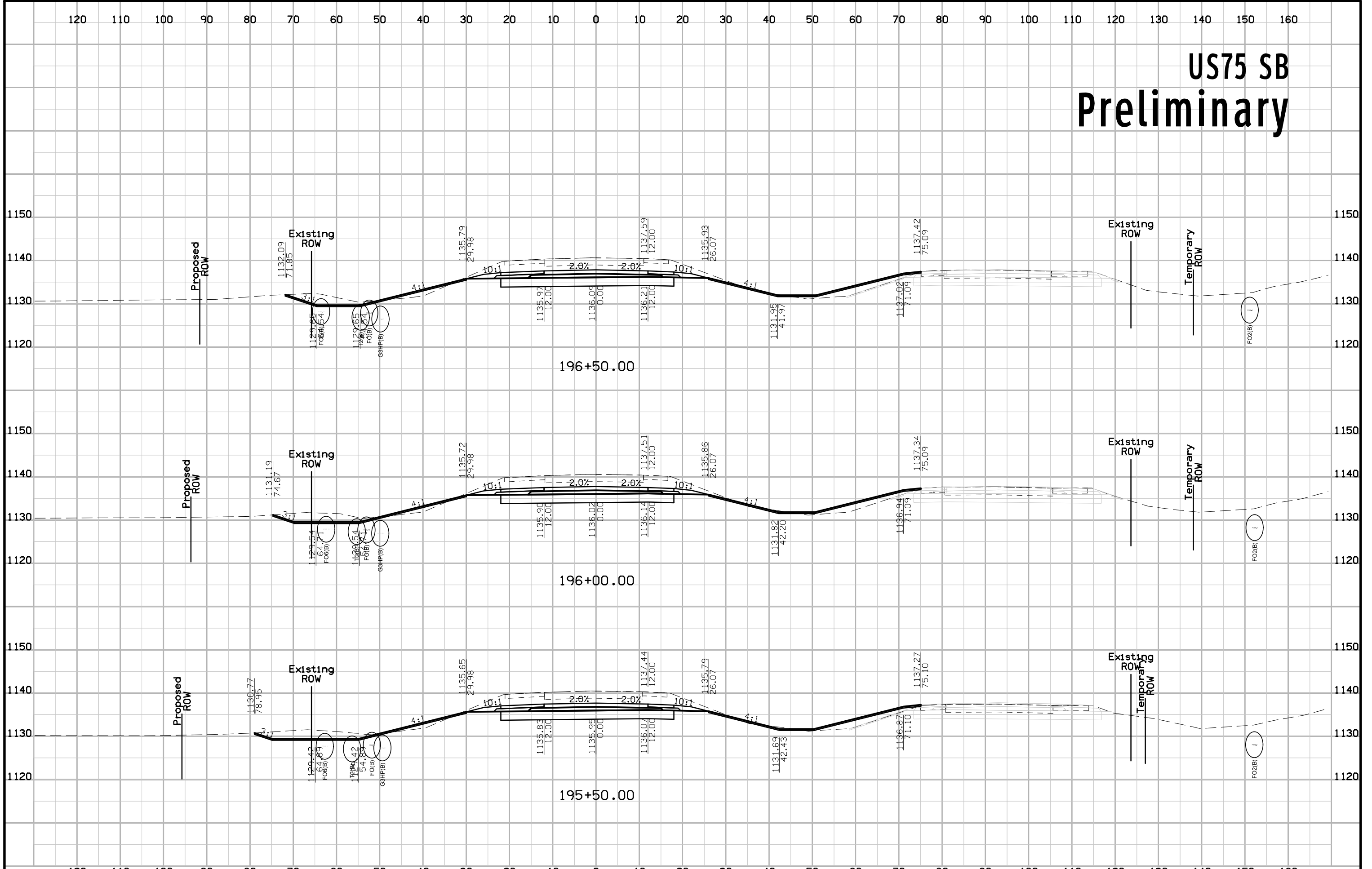

US75 SB Preliminary

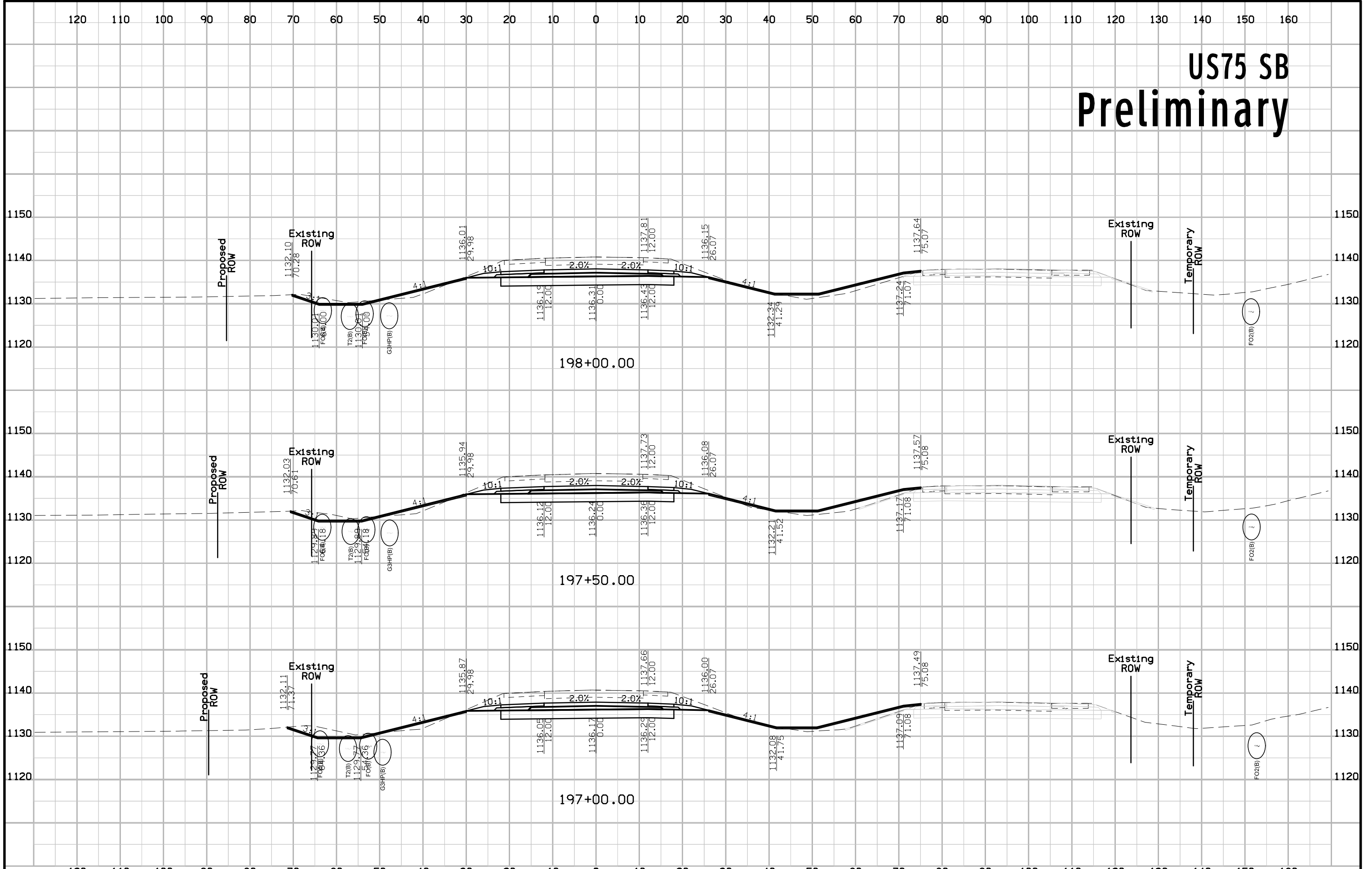

US75 SB Preliminary

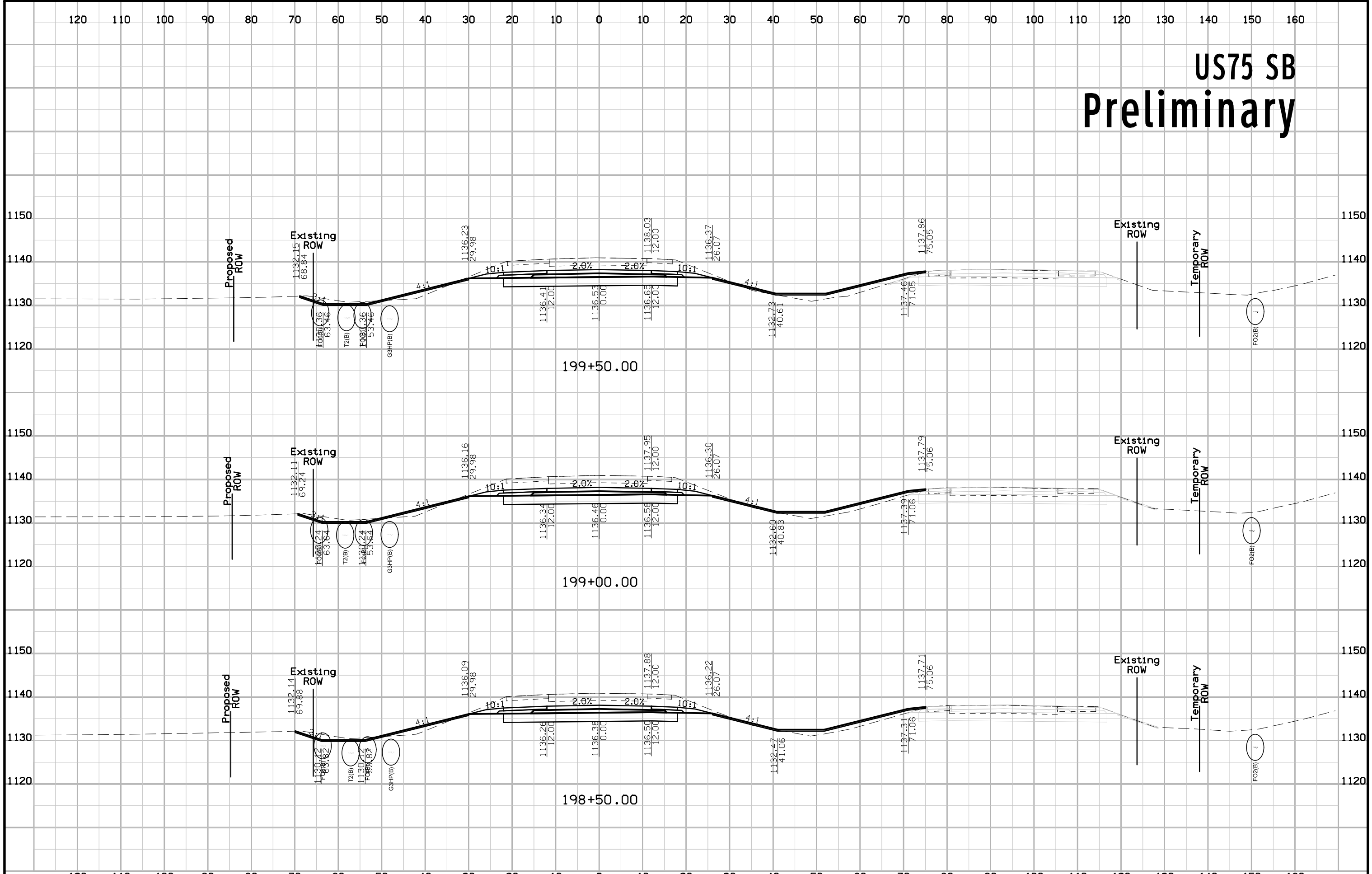

US75 SB Preliminary

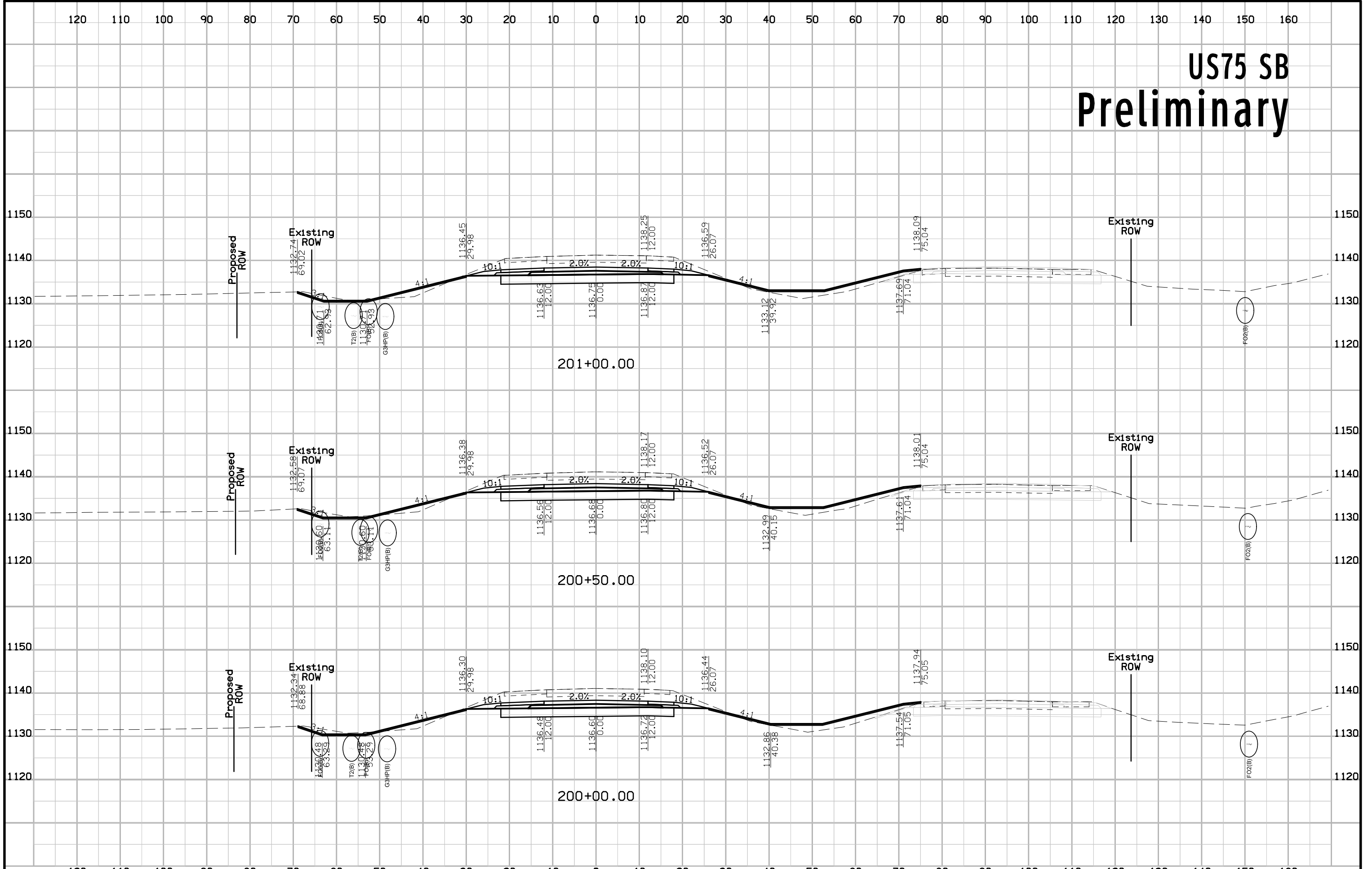

US75 SB Preliminary

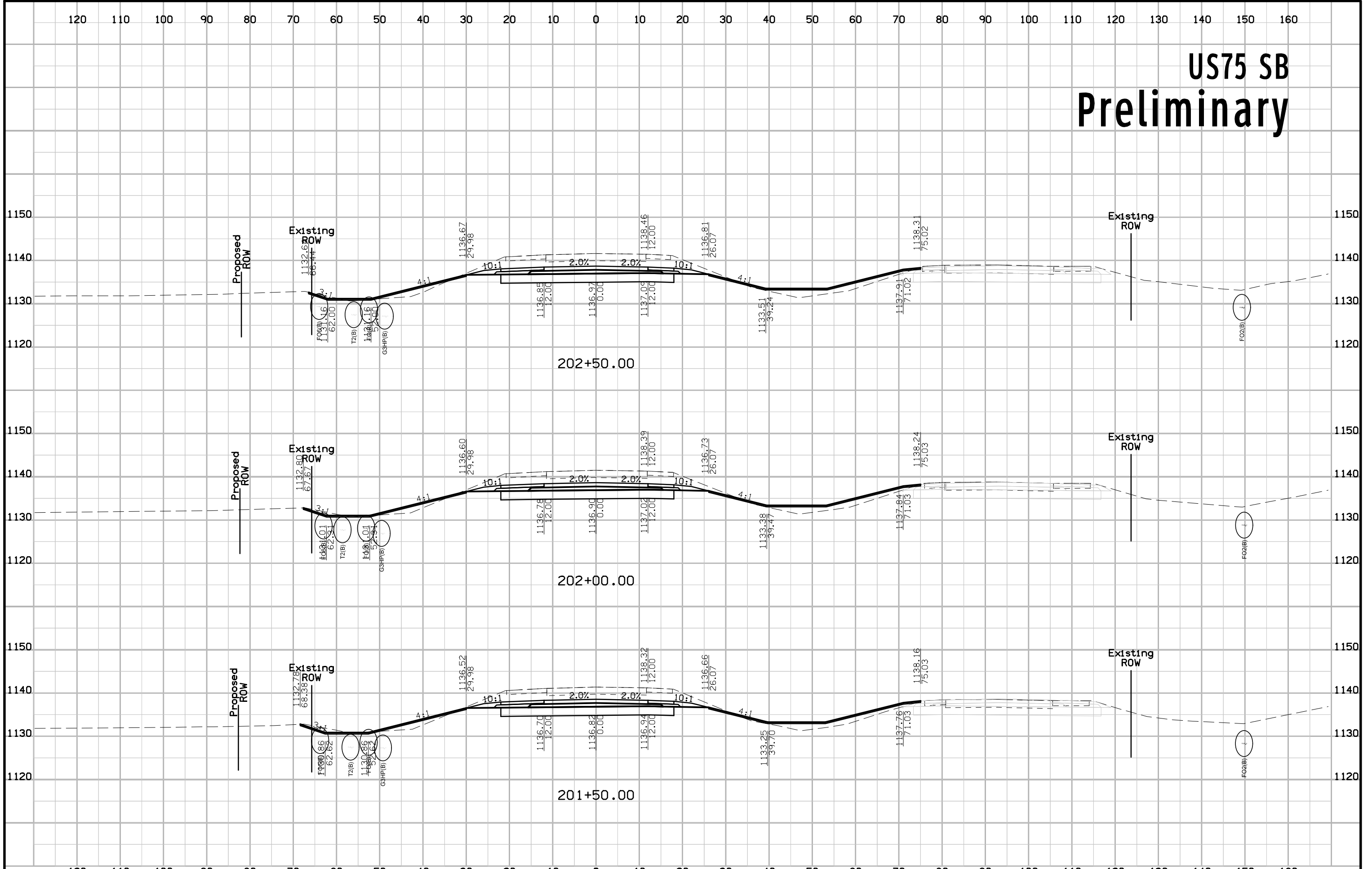

US75 SB Preliminary

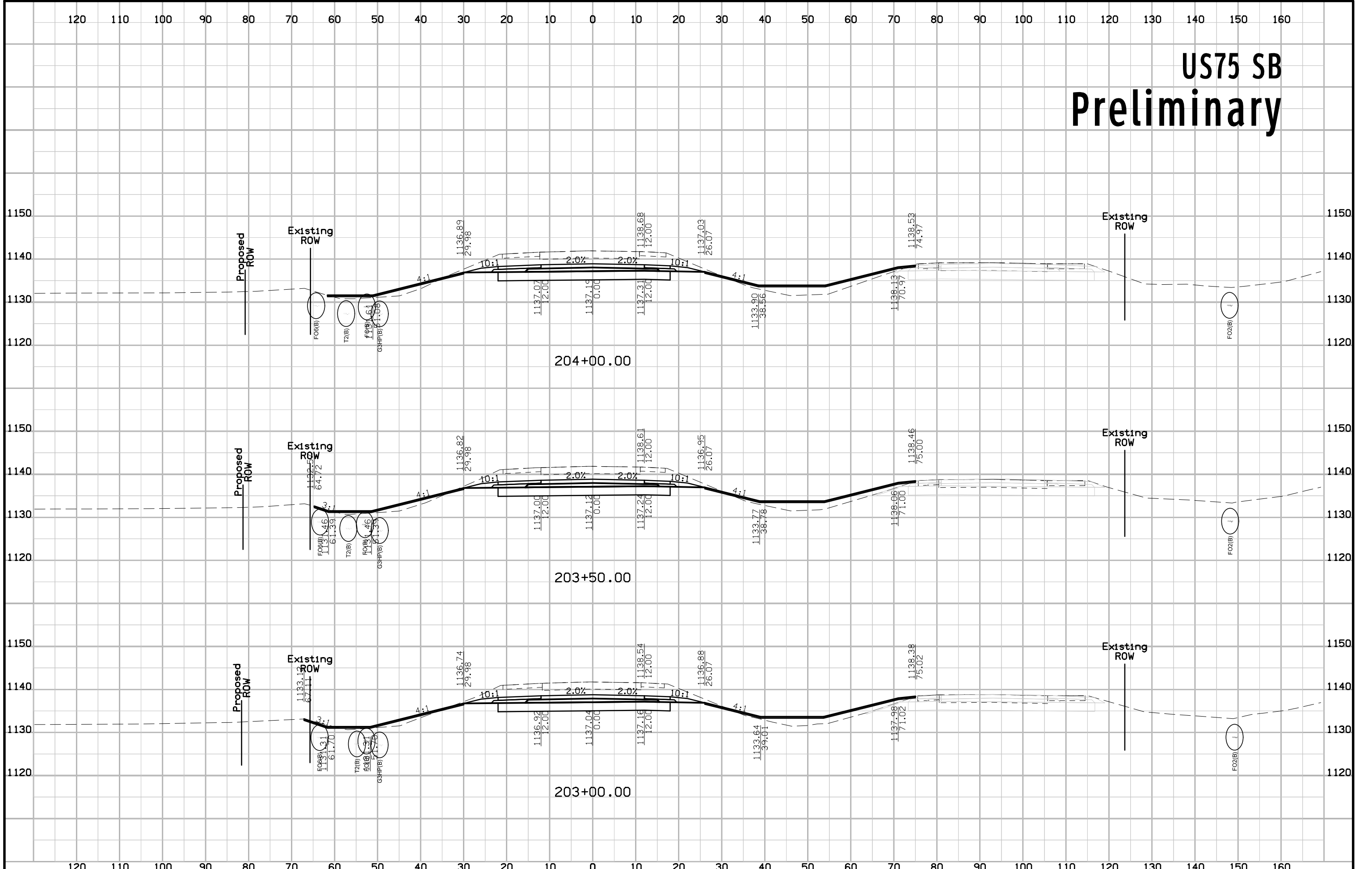

US75 SB Preliminary

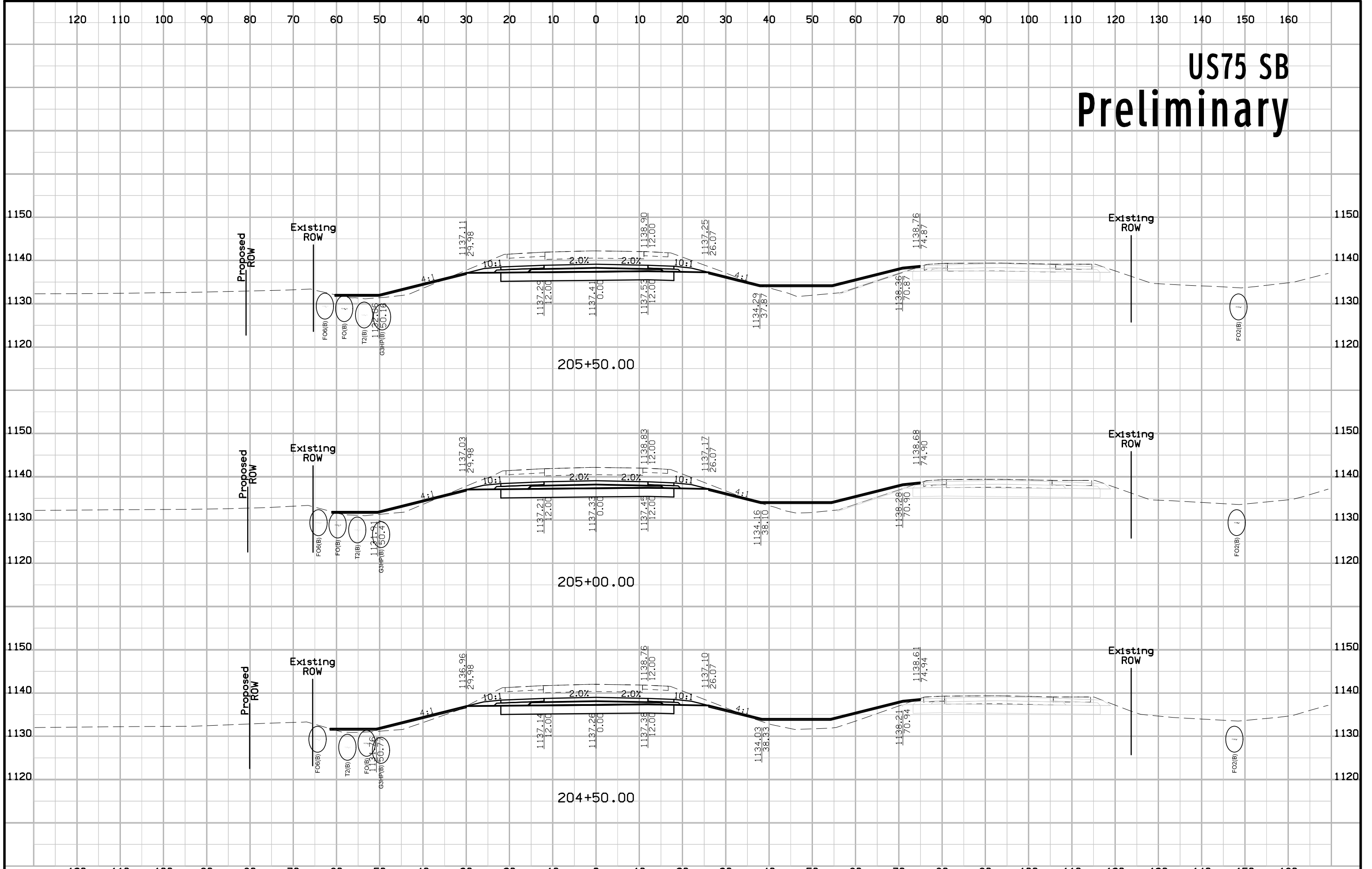

US75 SB Preliminary

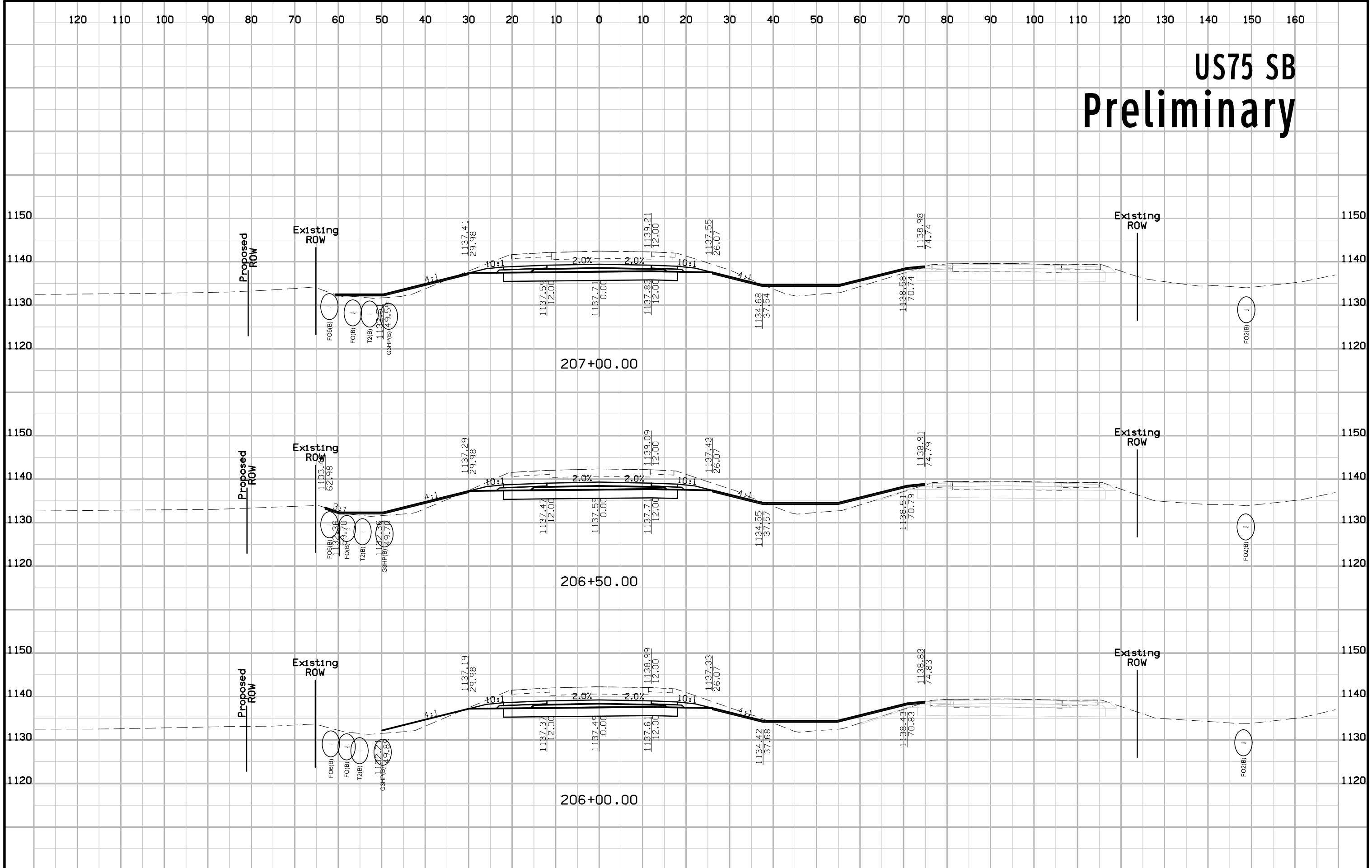

US75 SB Preliminary

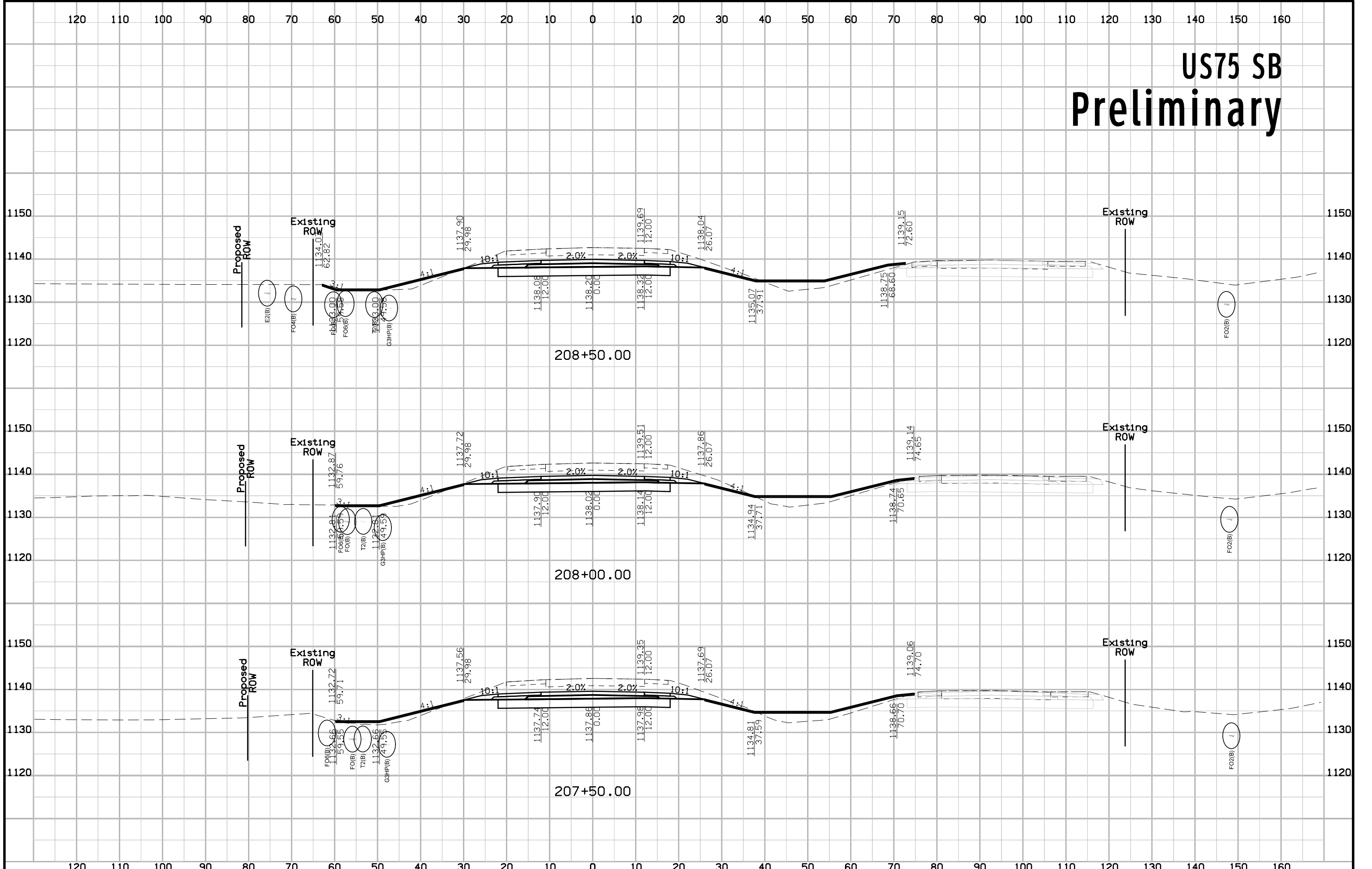

US75 SB Preliminary

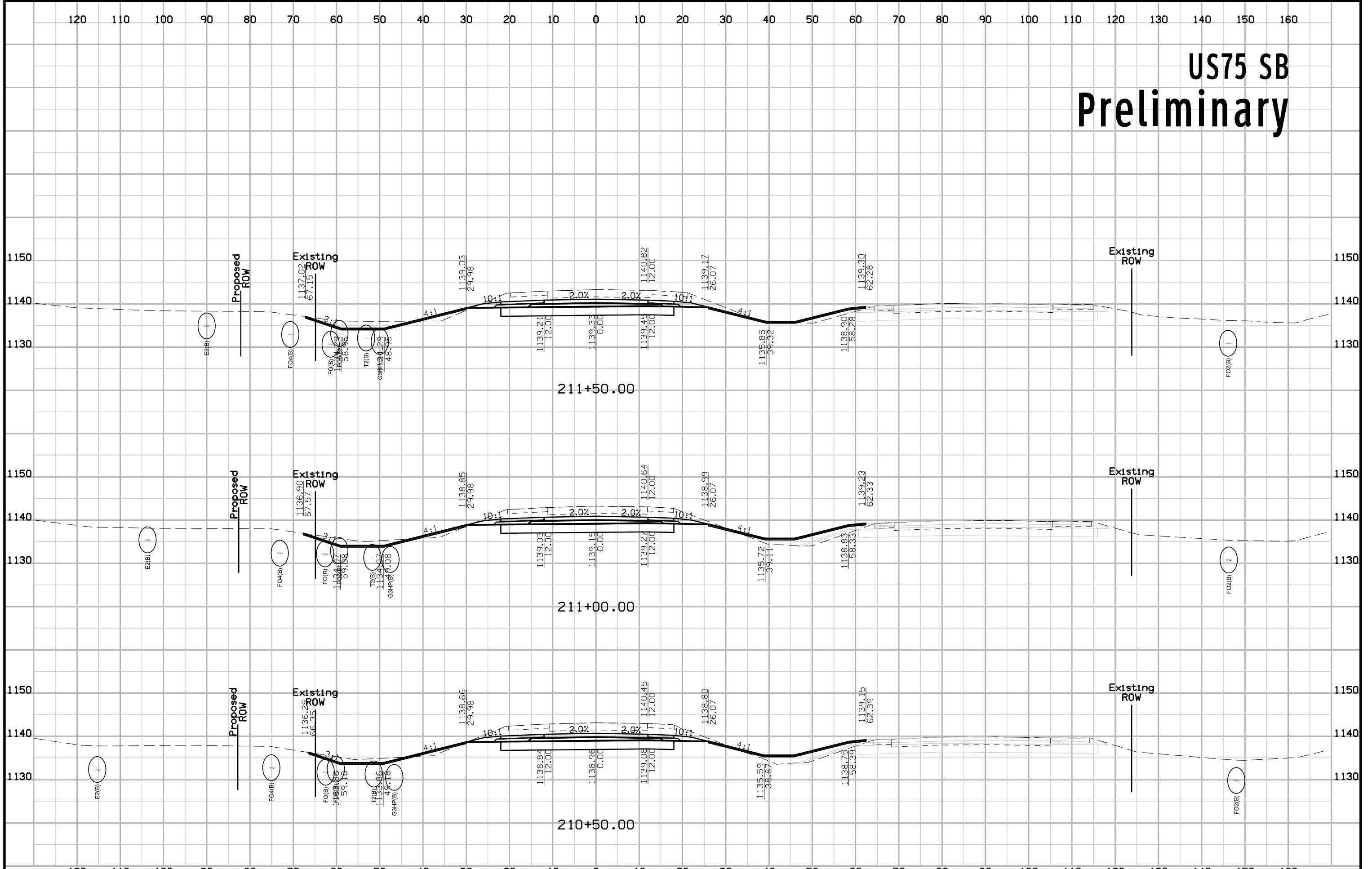

US75 SB Preliminary

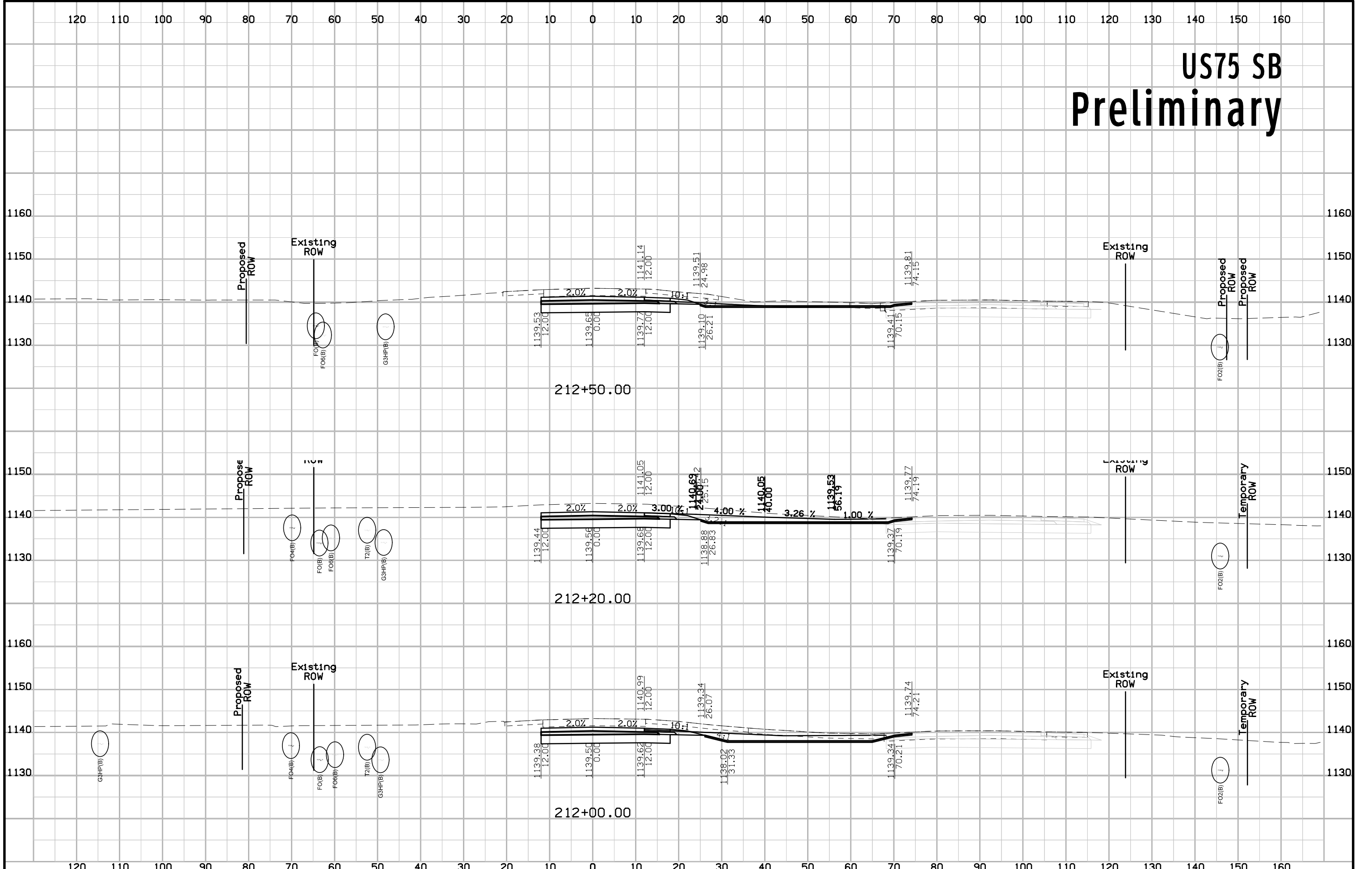

US75 SB Preliminary

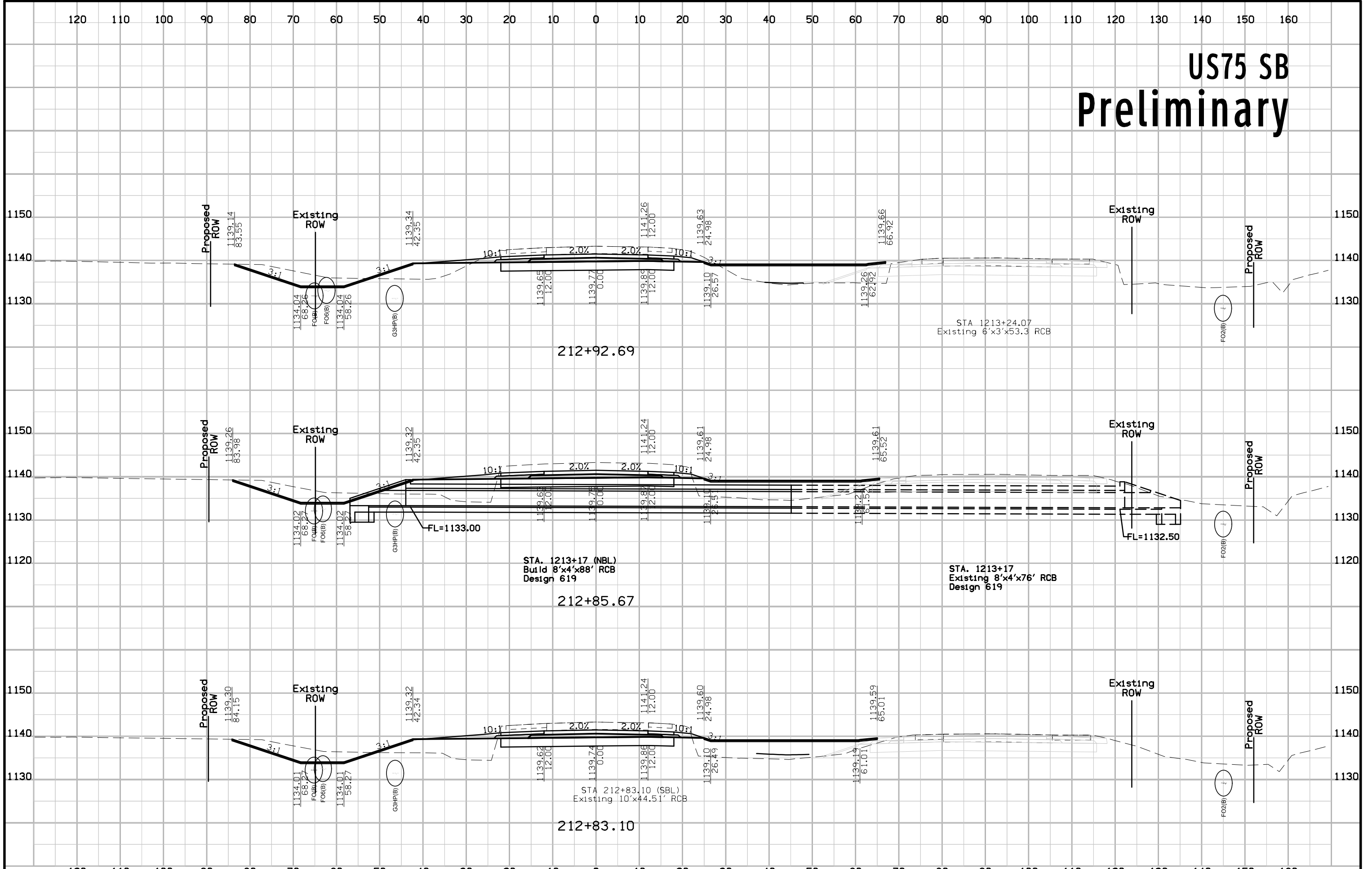

US75 SB Preliminary

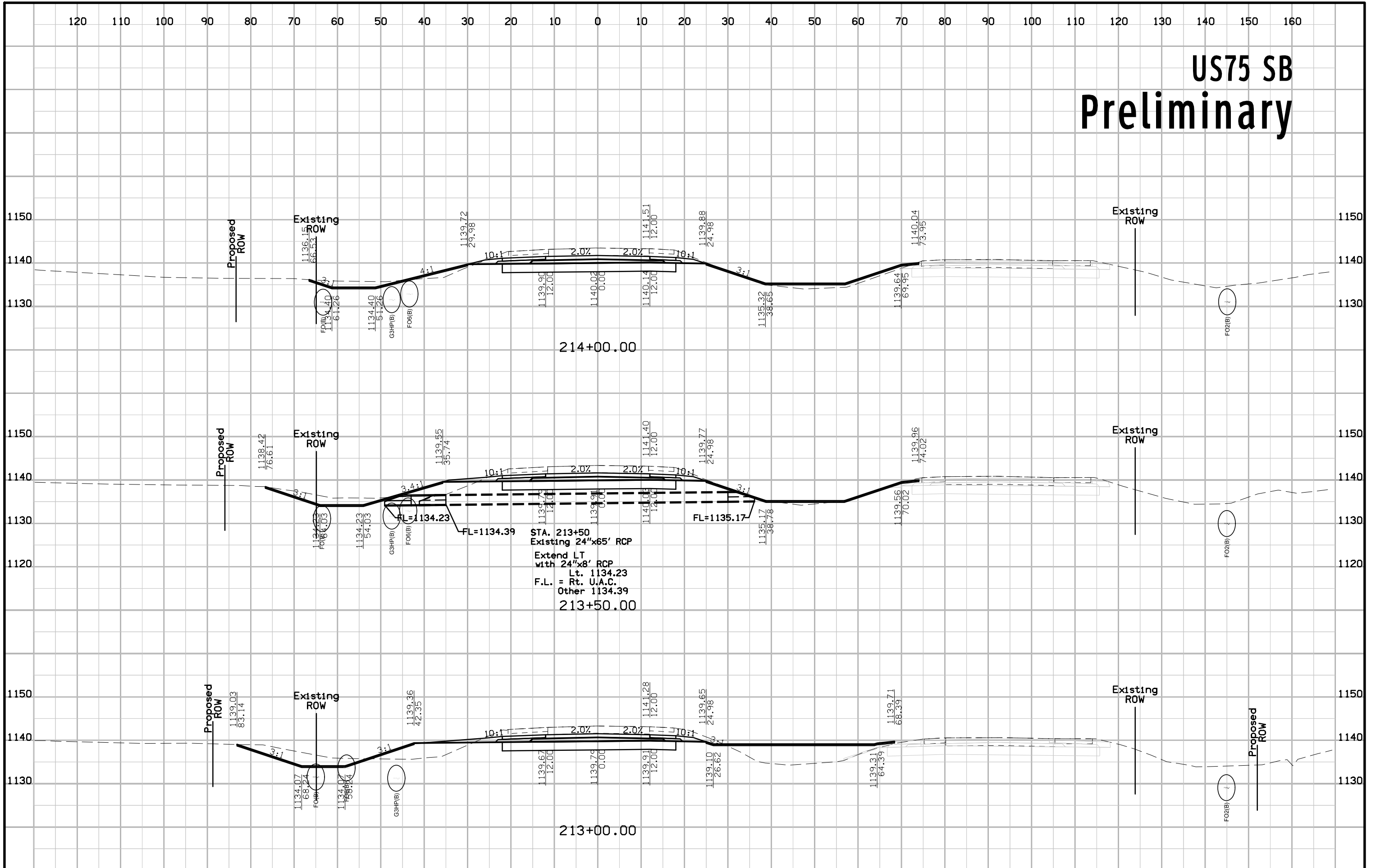

US75 SB Preliminary

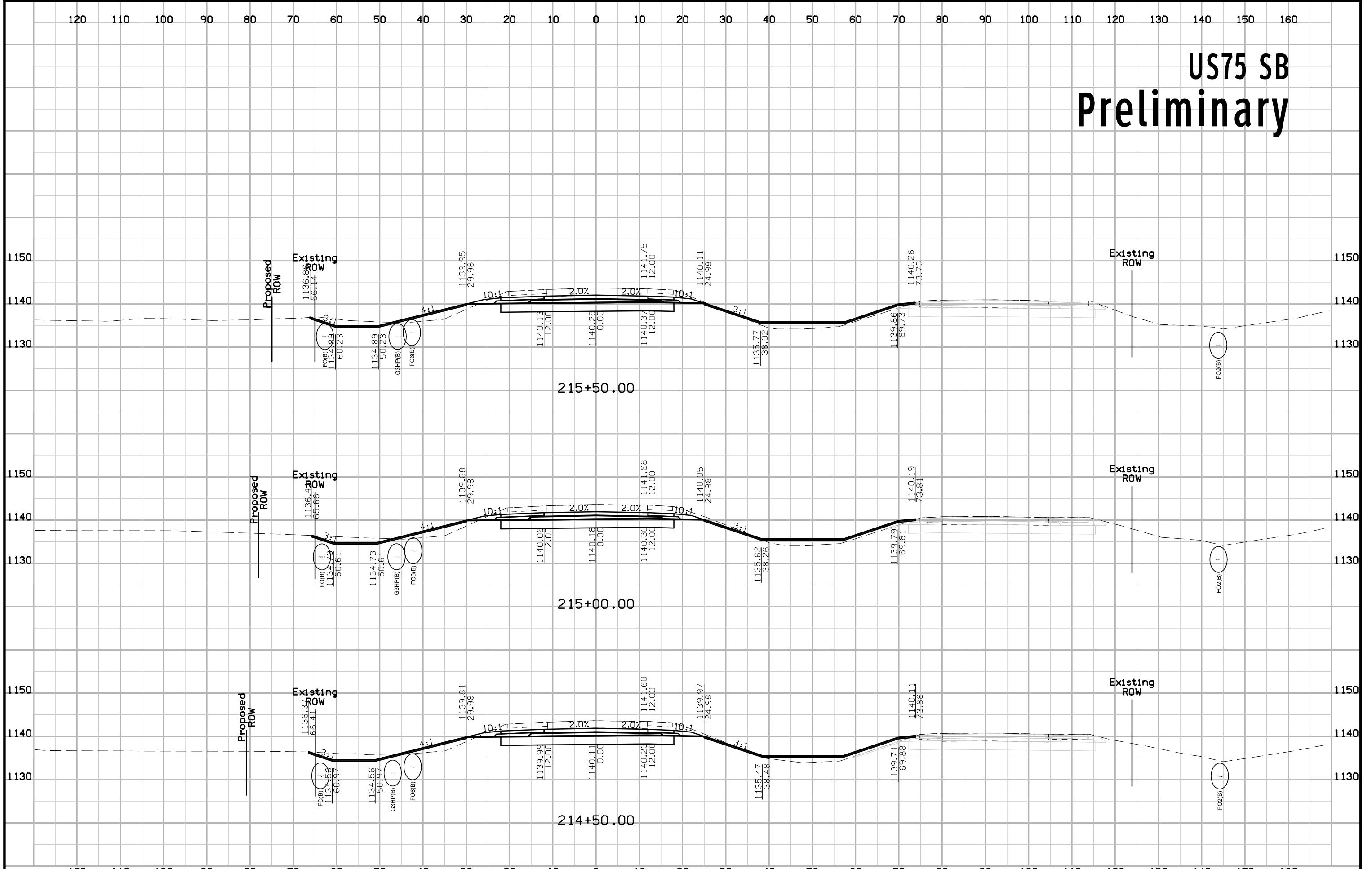

US75 SB Preliminary

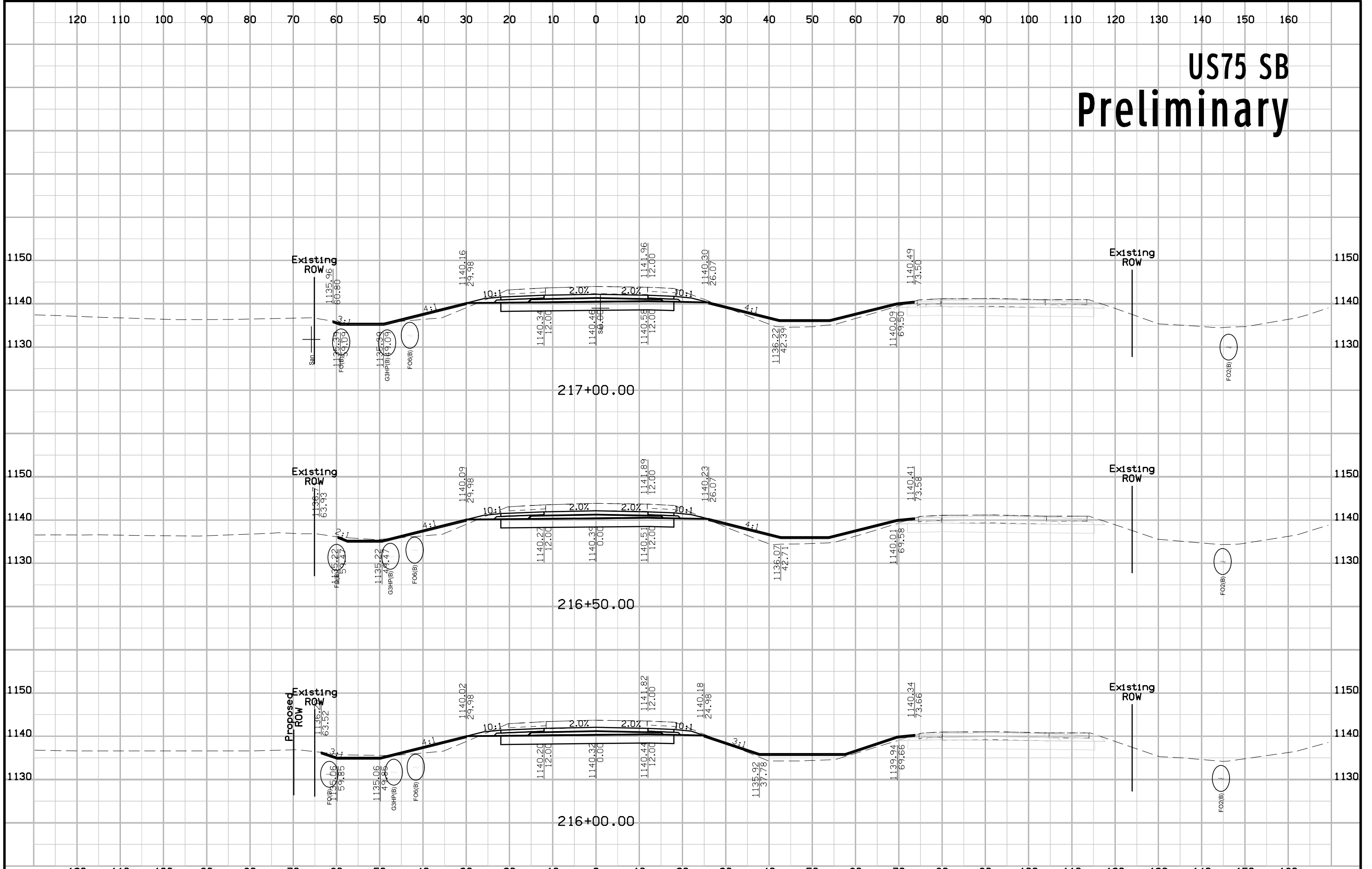

US75 SB Preliminary

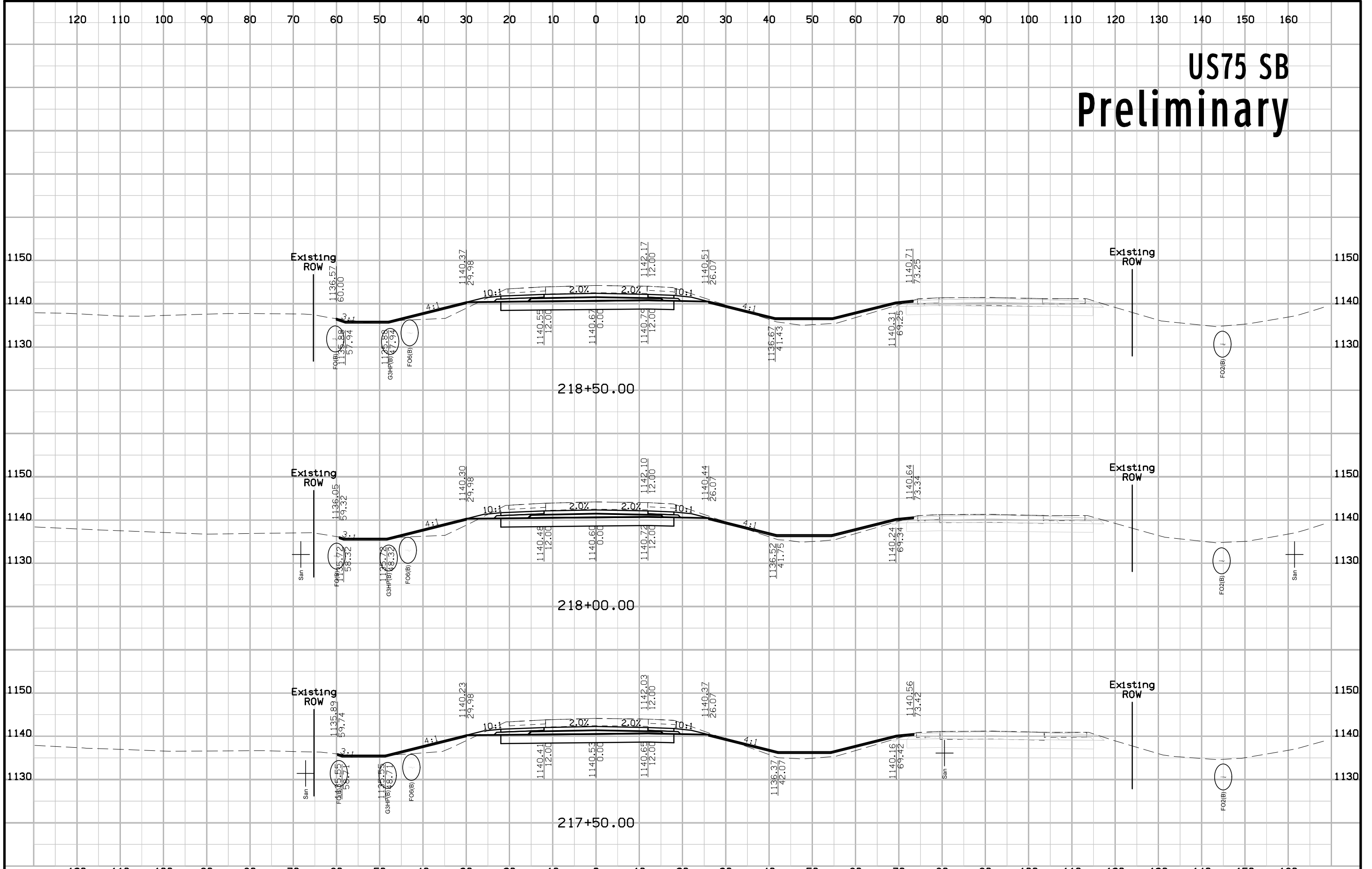

US75 SB Preliminary

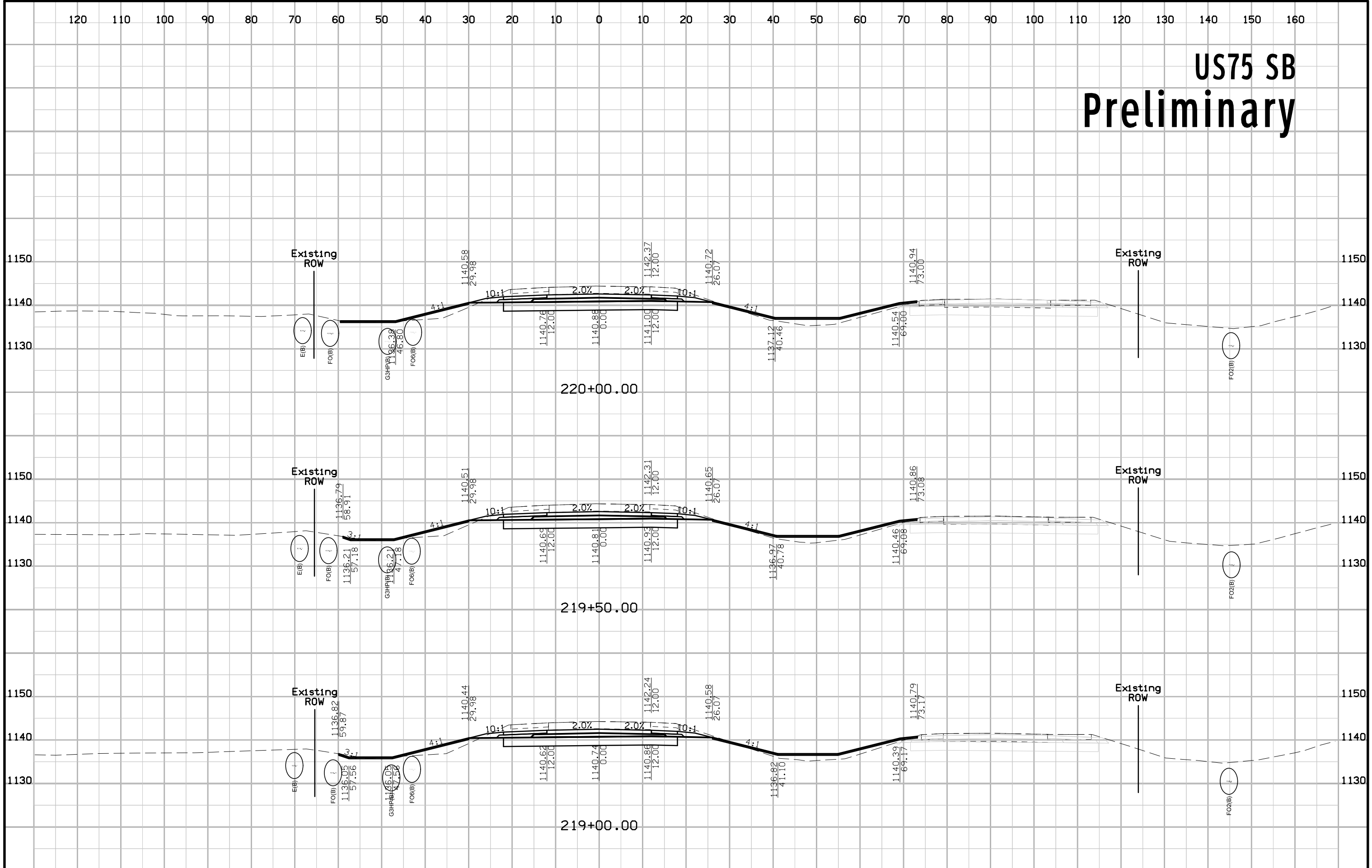

US75 SB Preliminary

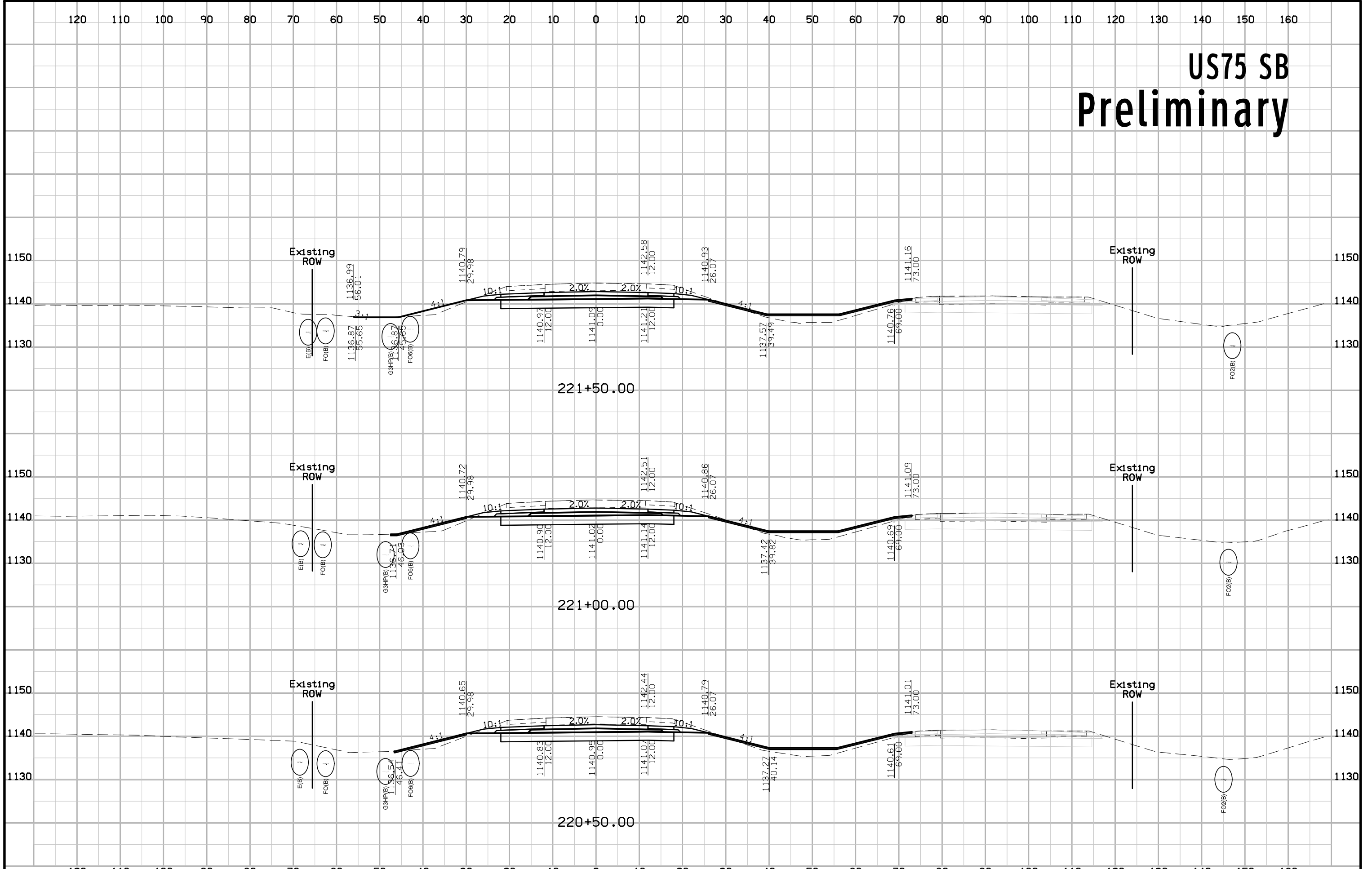

US75 SB Preliminary

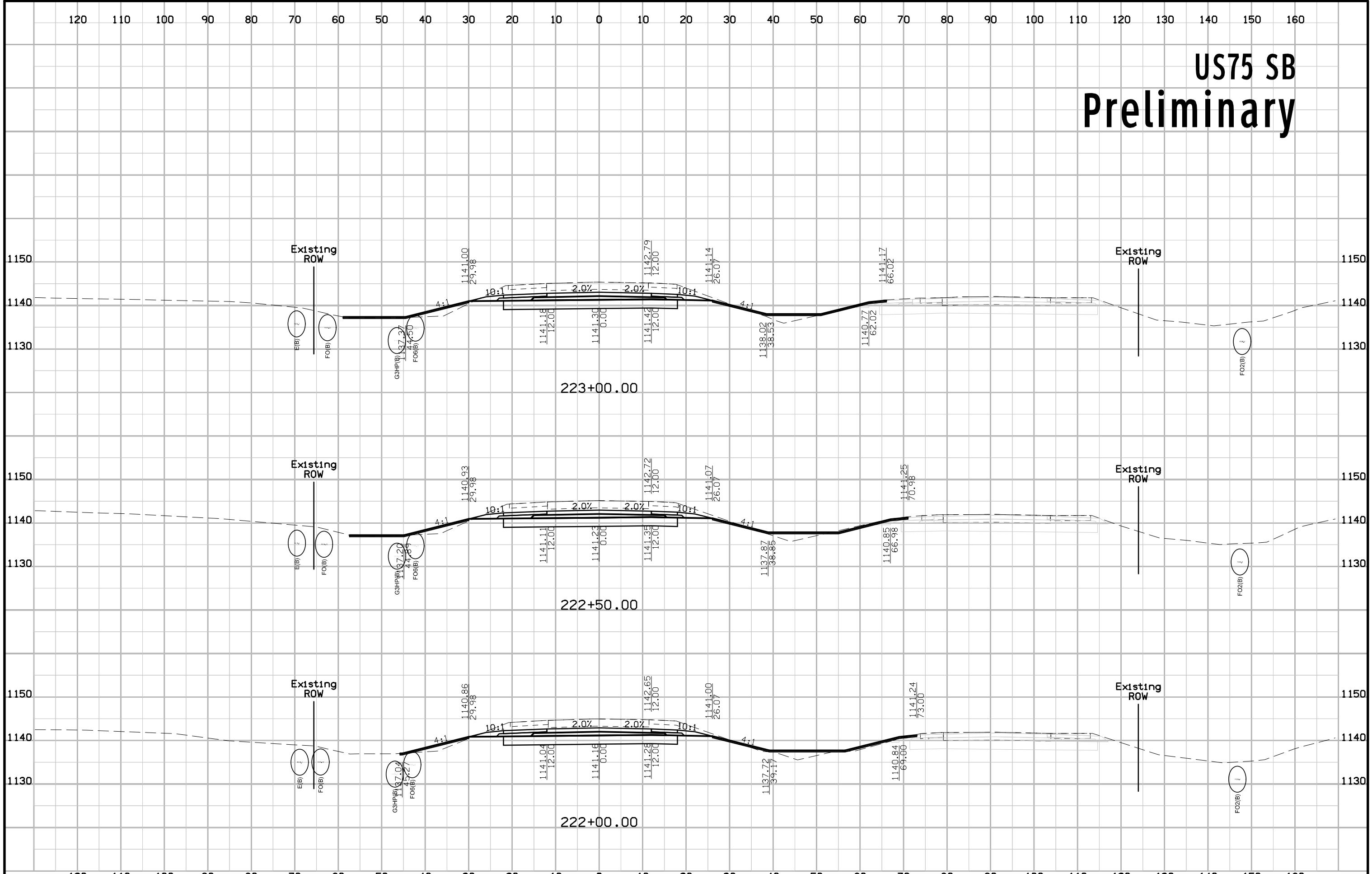

US75 SB Preliminary

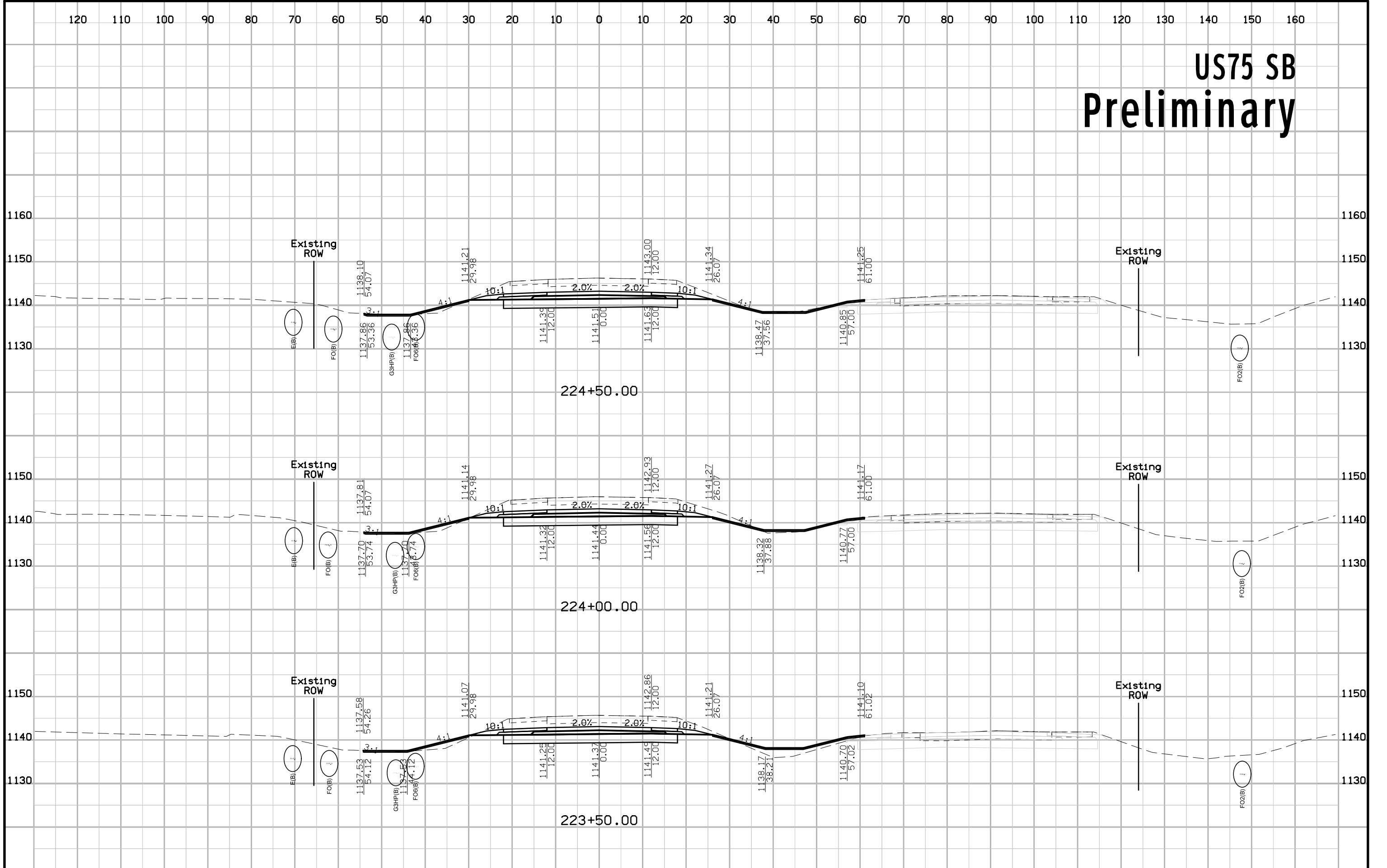

US75 SB Preliminary

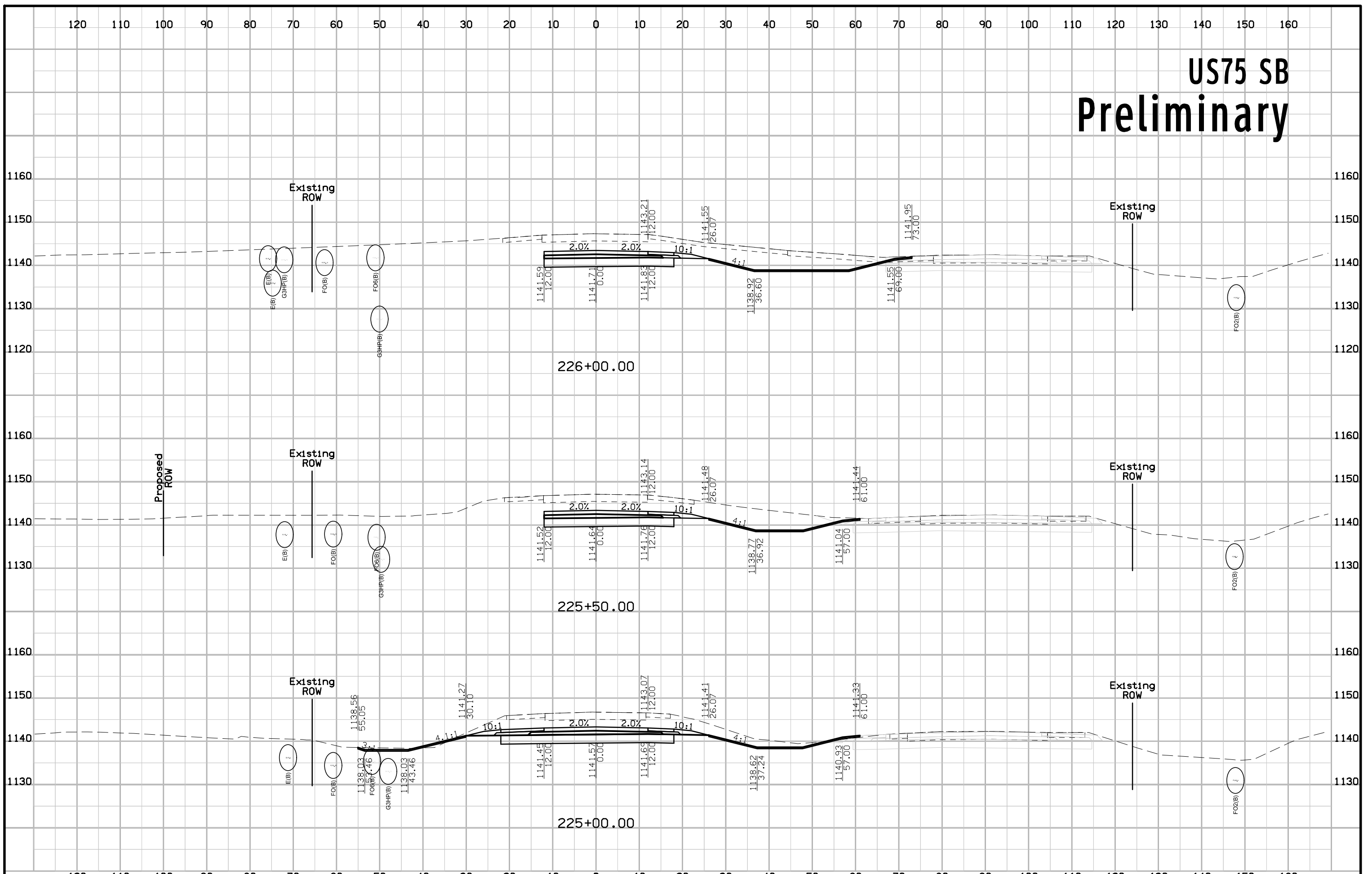

US75 SB Preliminary

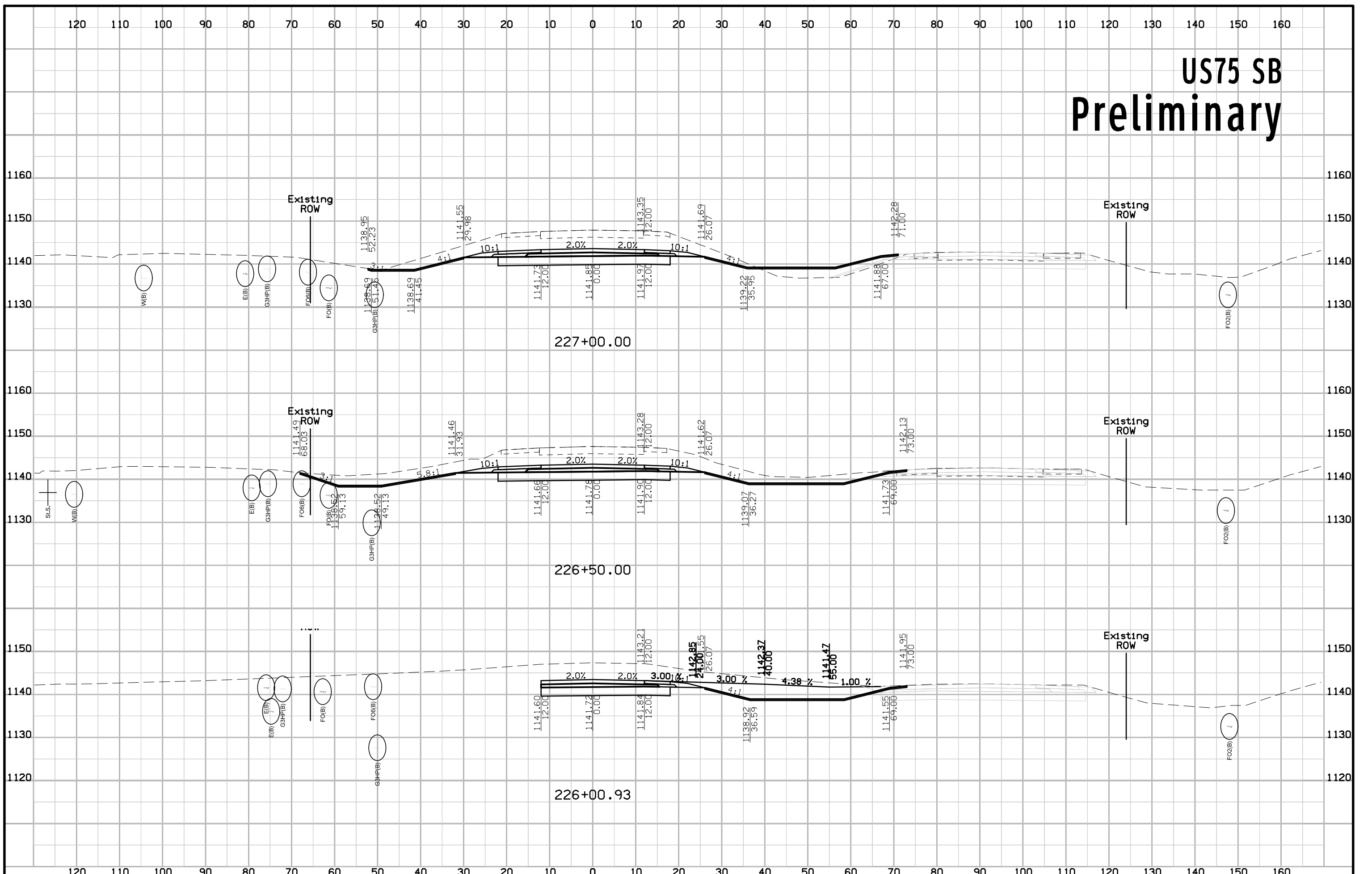

US75 SB Preliminary

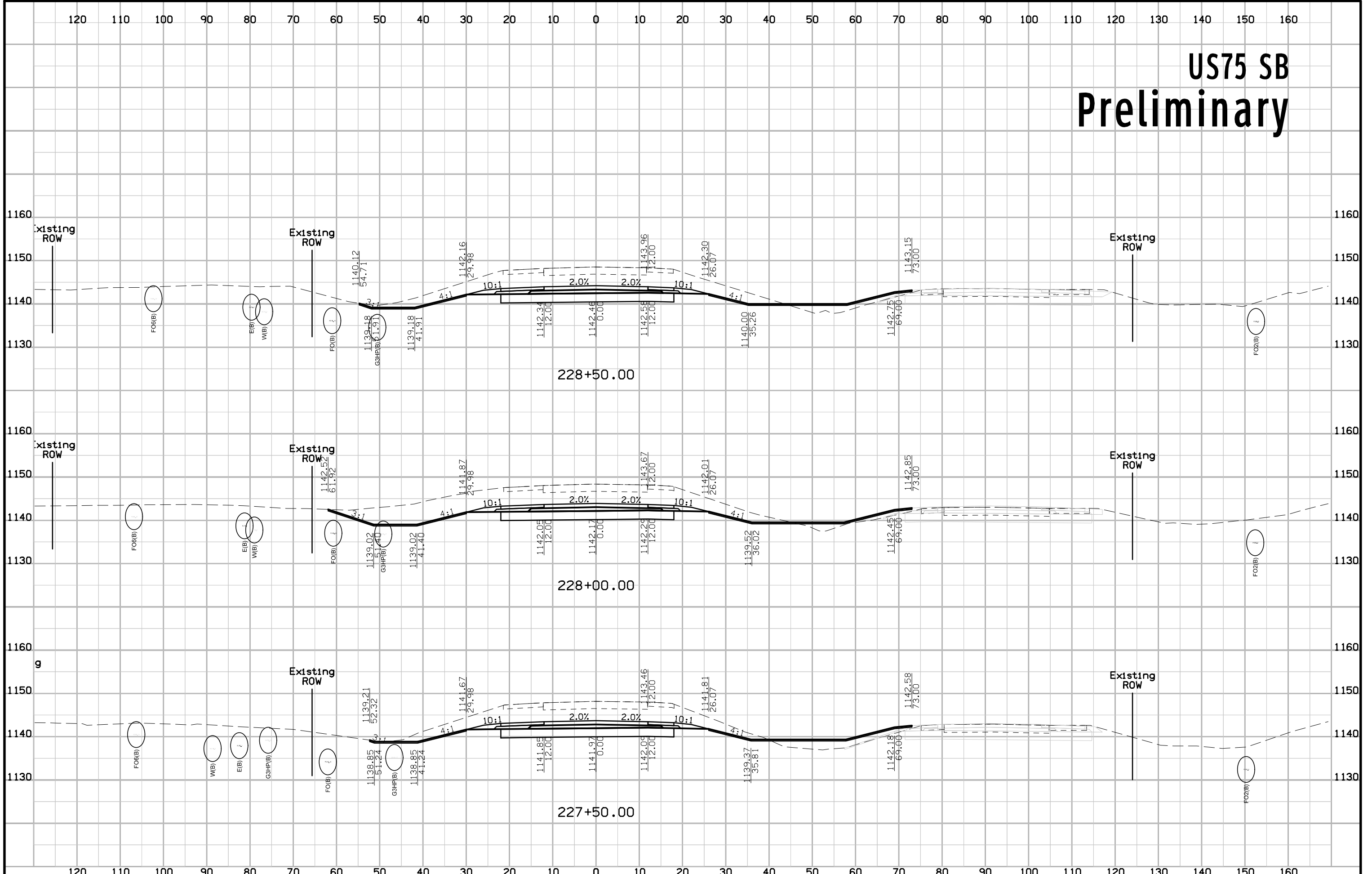

US75 SB Preliminary

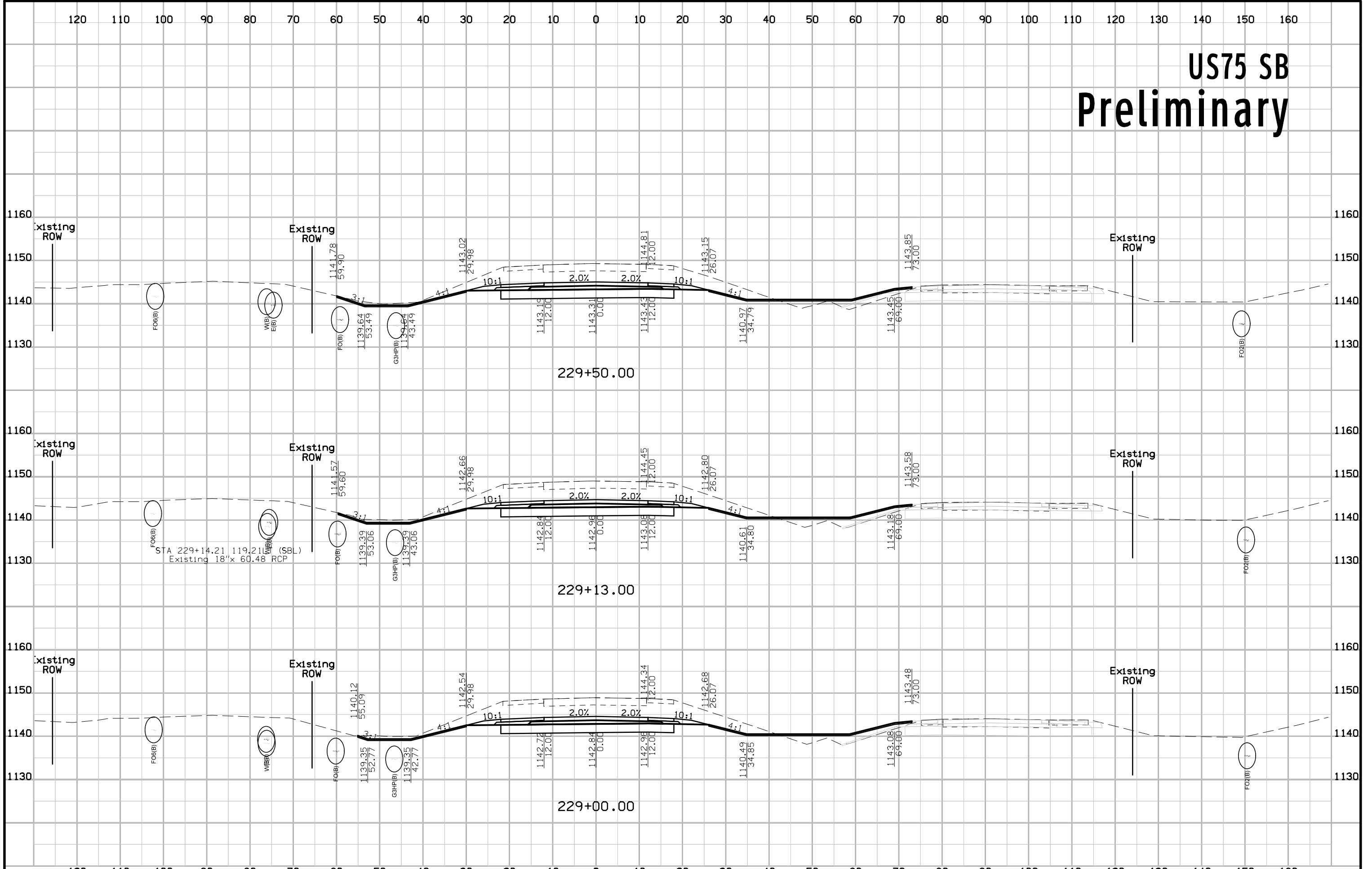

US75 SB Preliminary

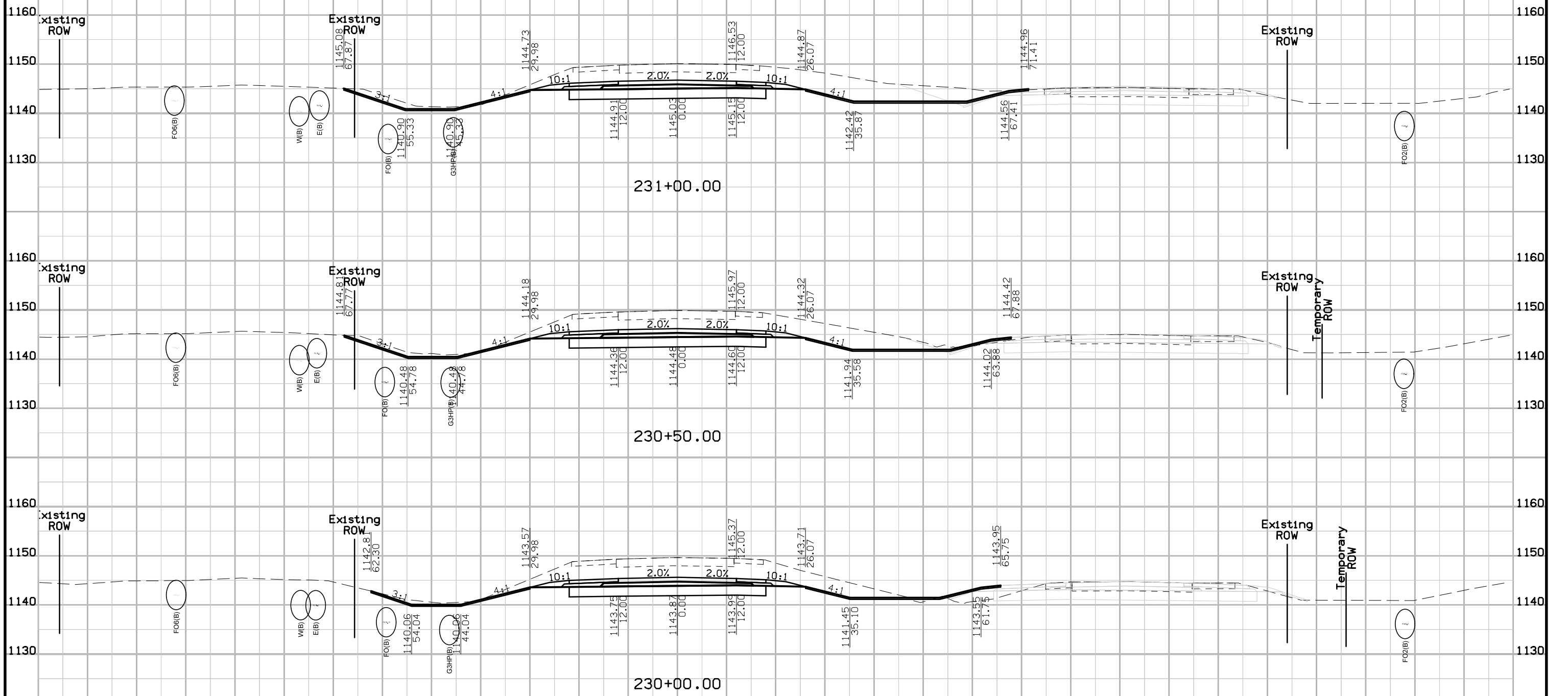

US75 SB Preliminary

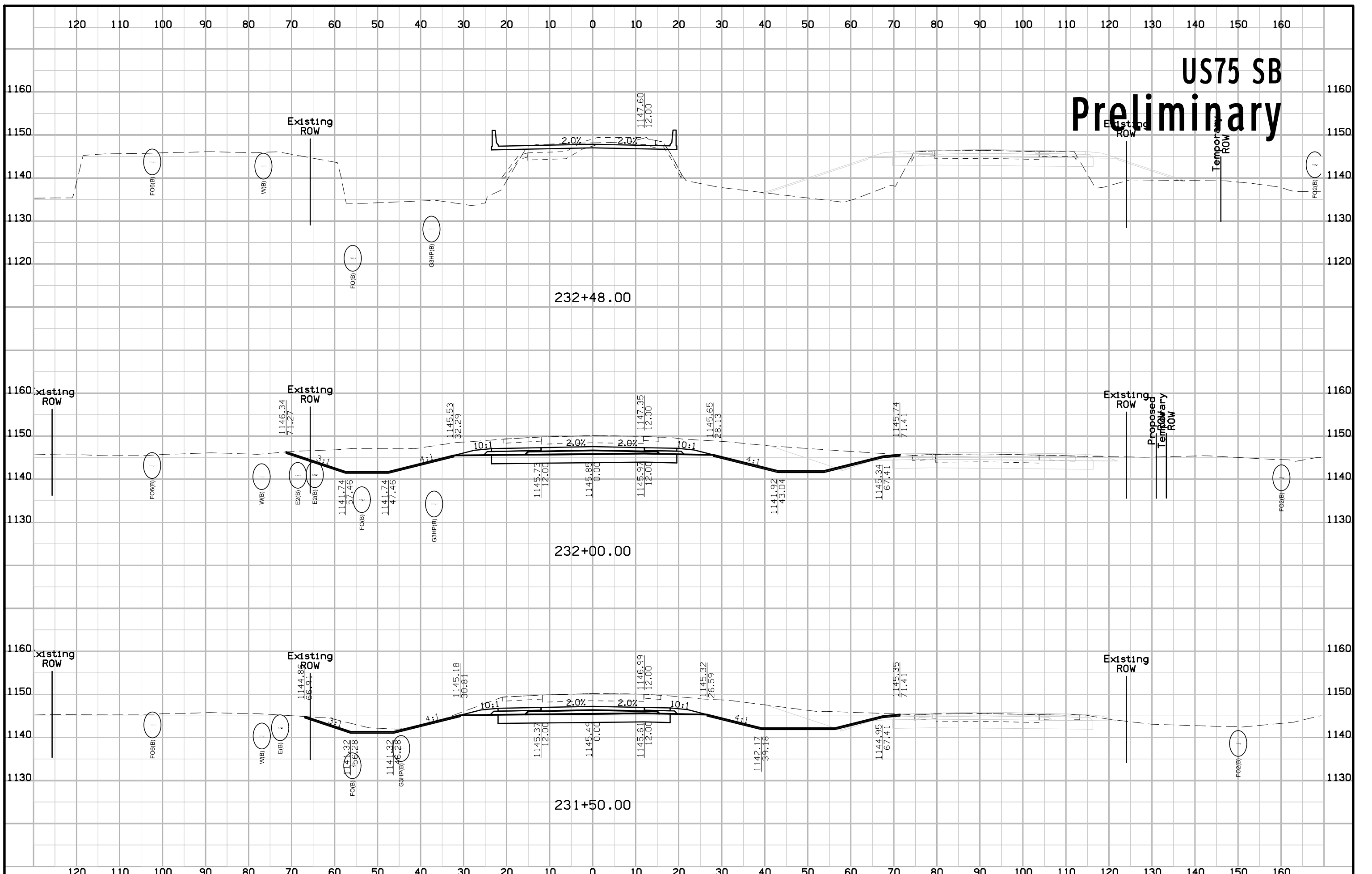

US75 SB Preliminary

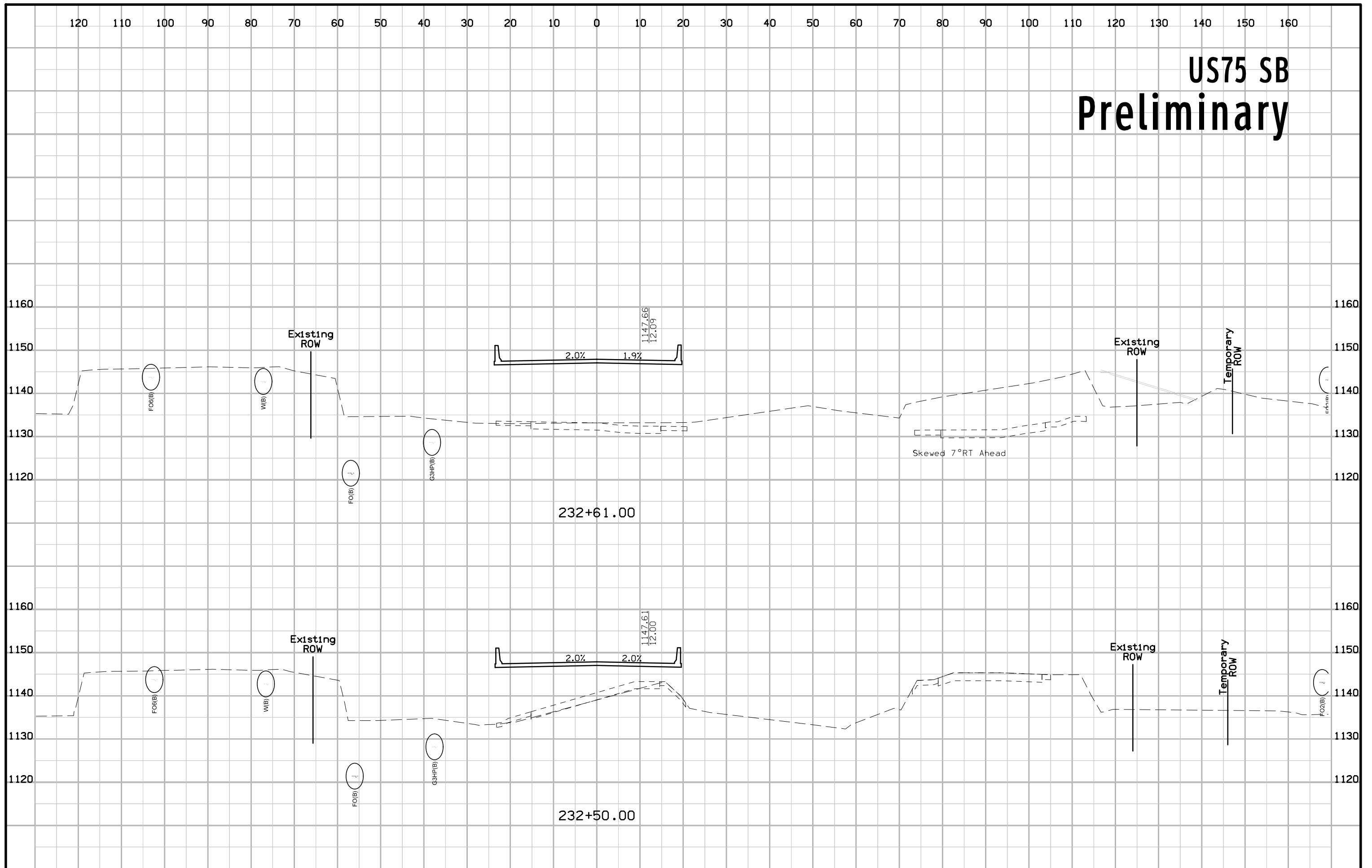

US75 SB Preliminary

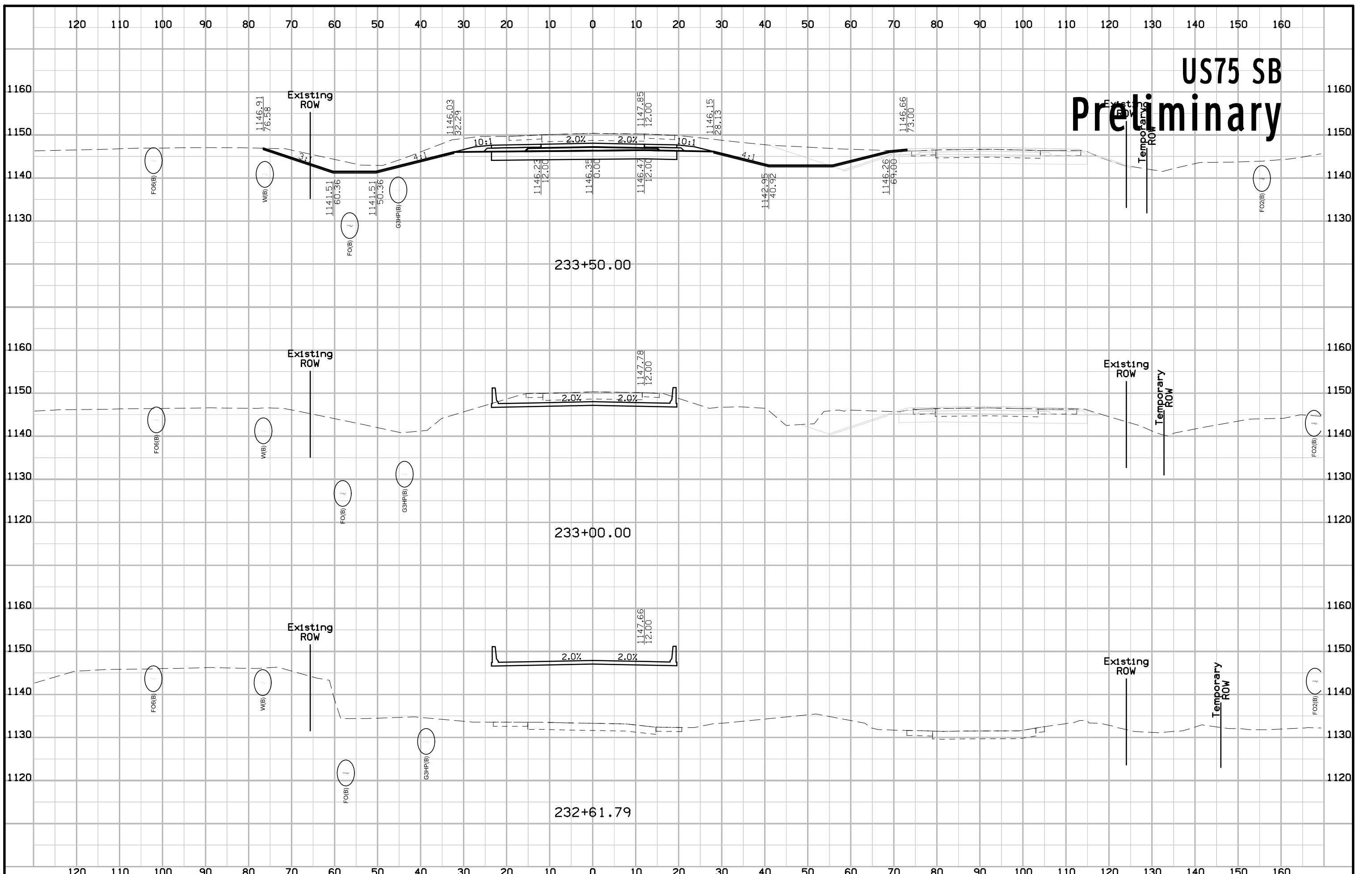

US75 SB Preliminary

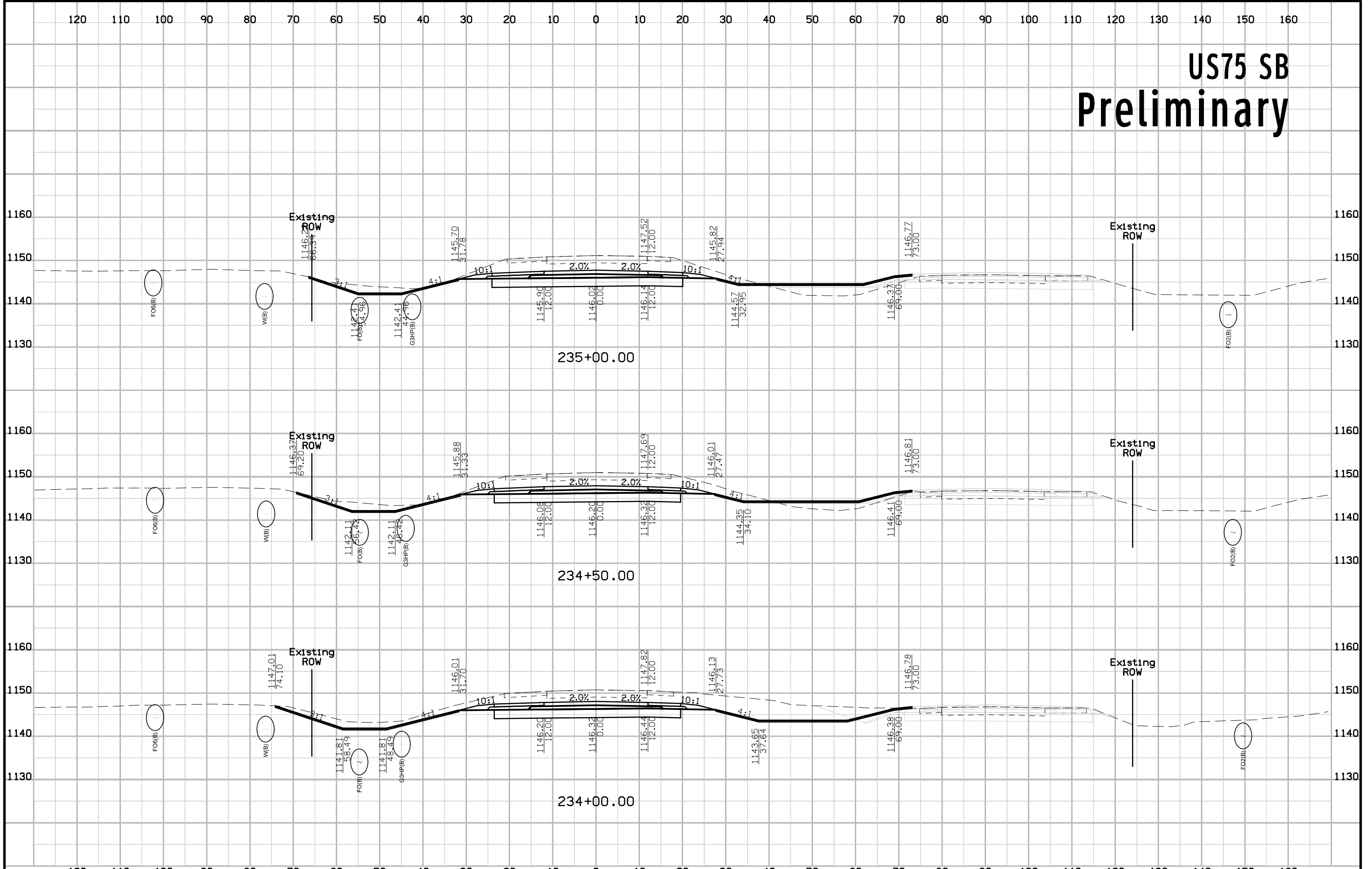

US75 SB Preliminary

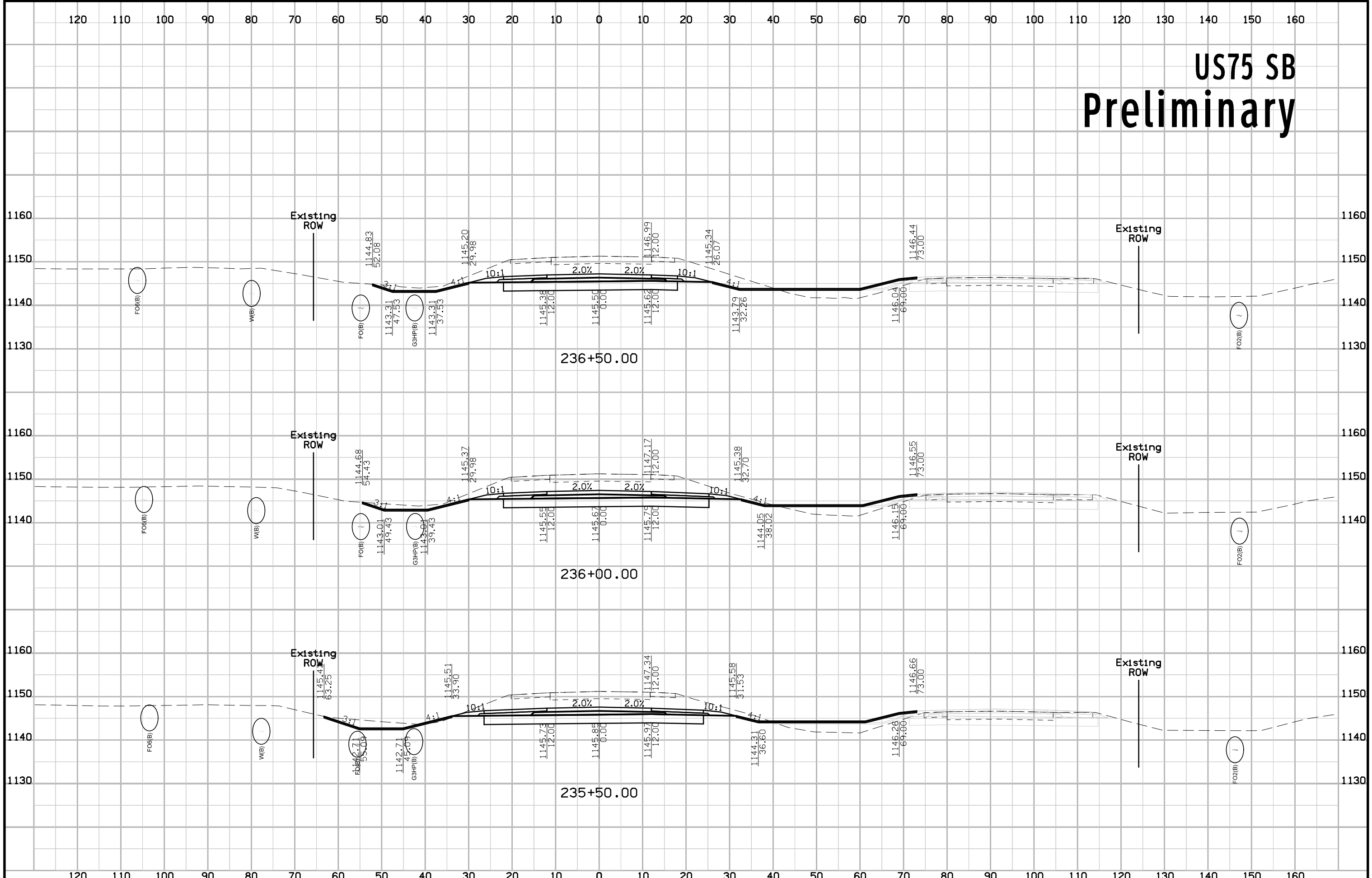

US75 SB Preliminary

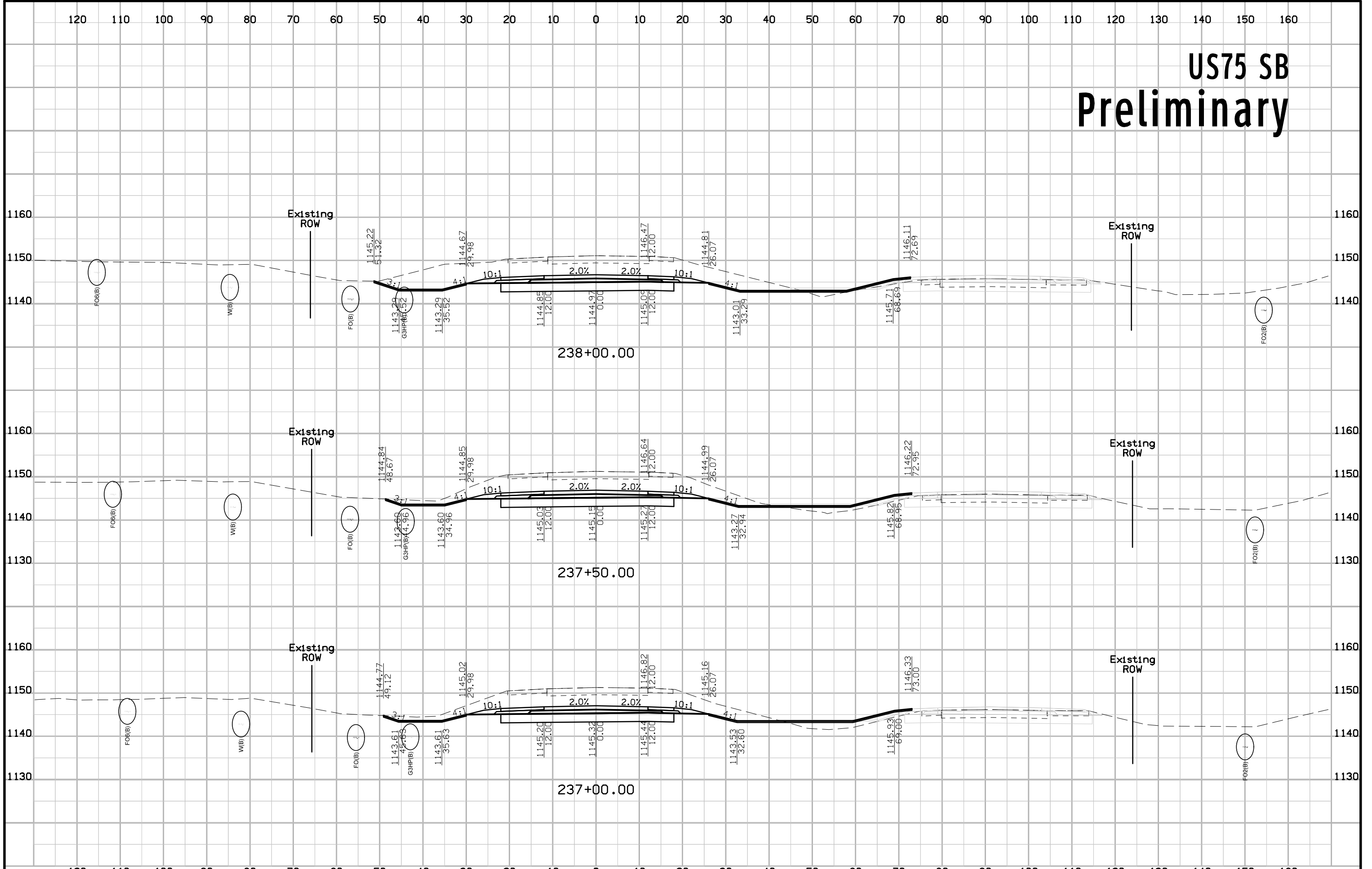

US75 SB Preliminary

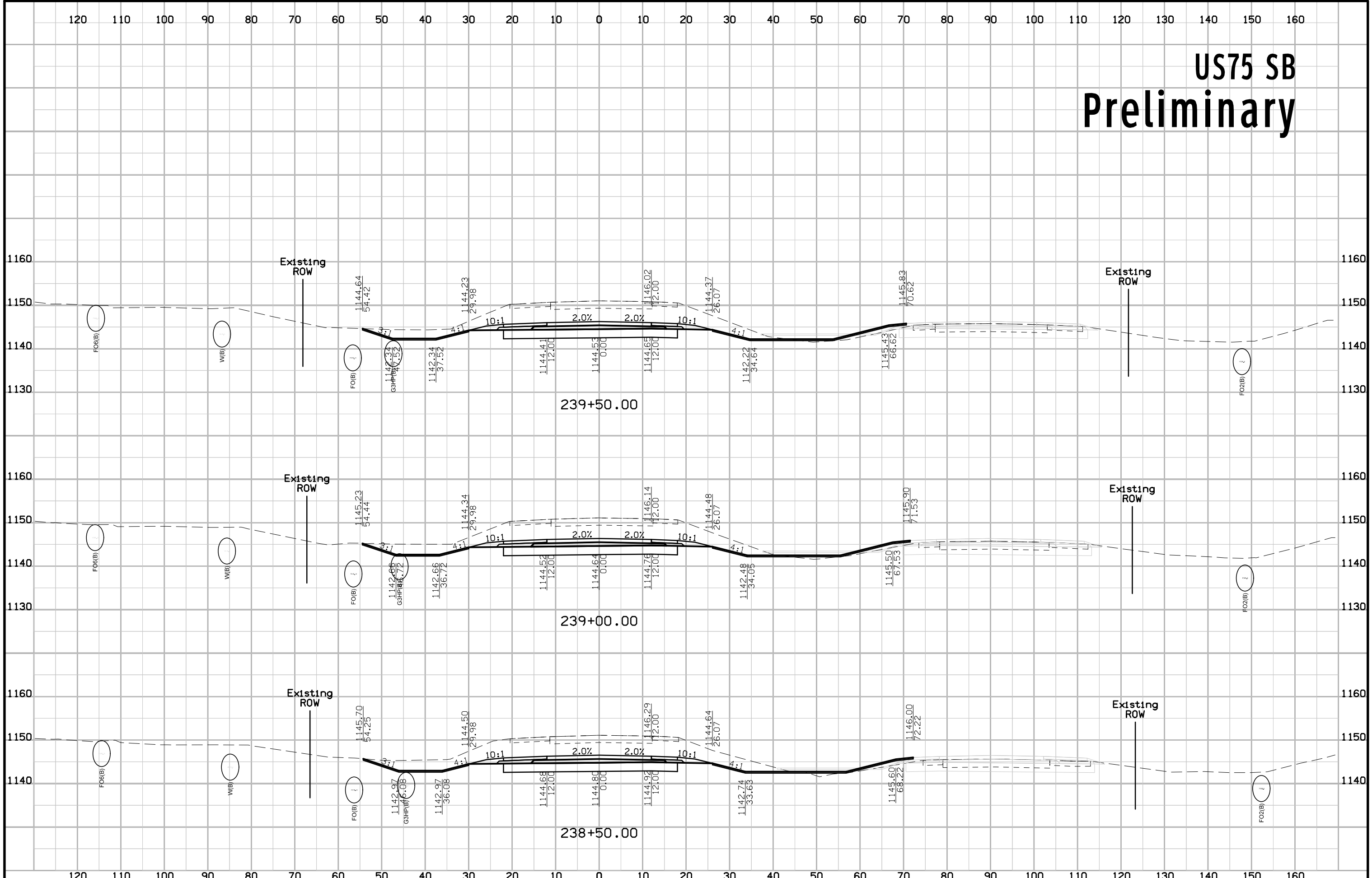

US75 SB Preliminary

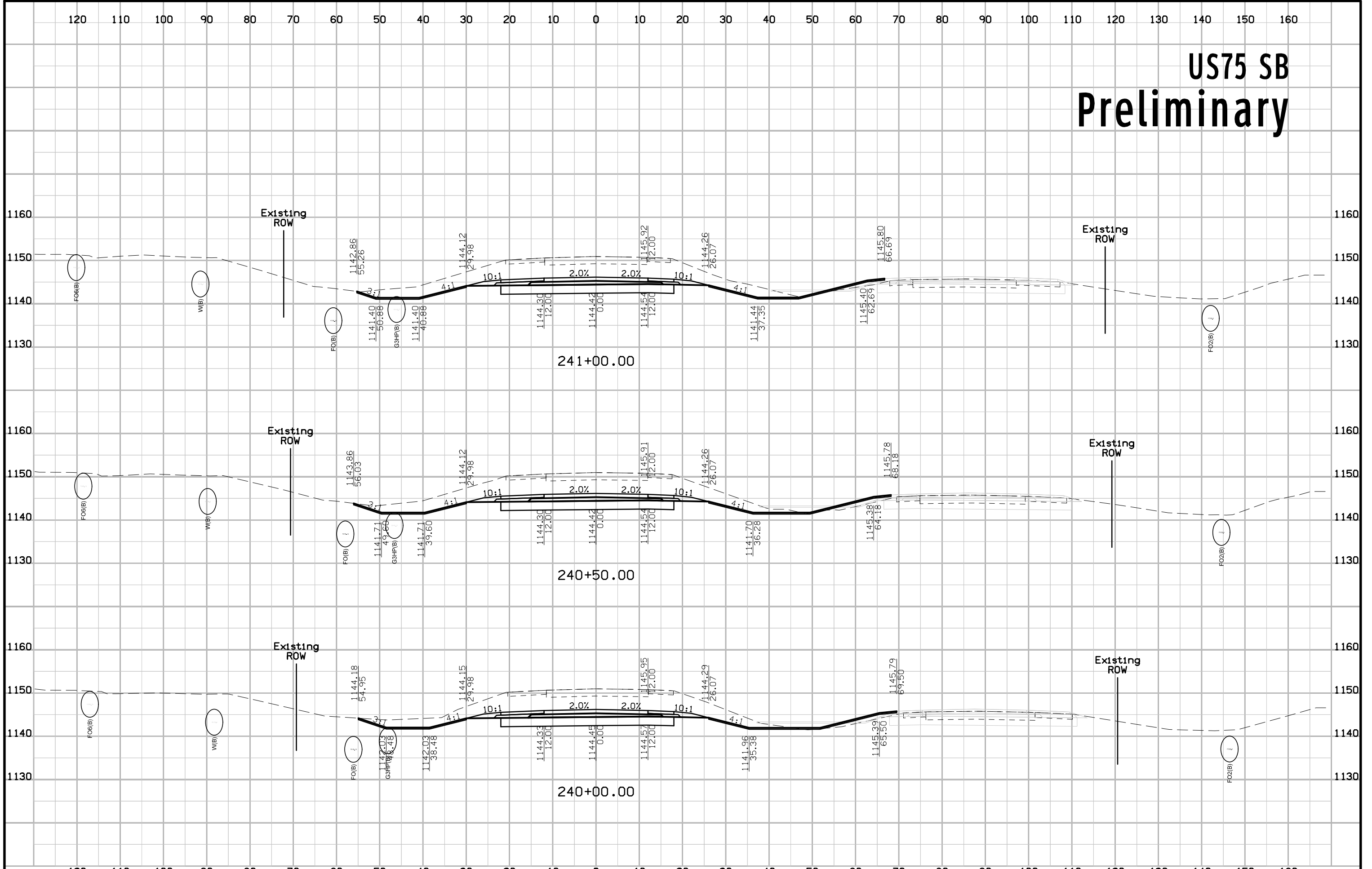

US75 SB Preliminary

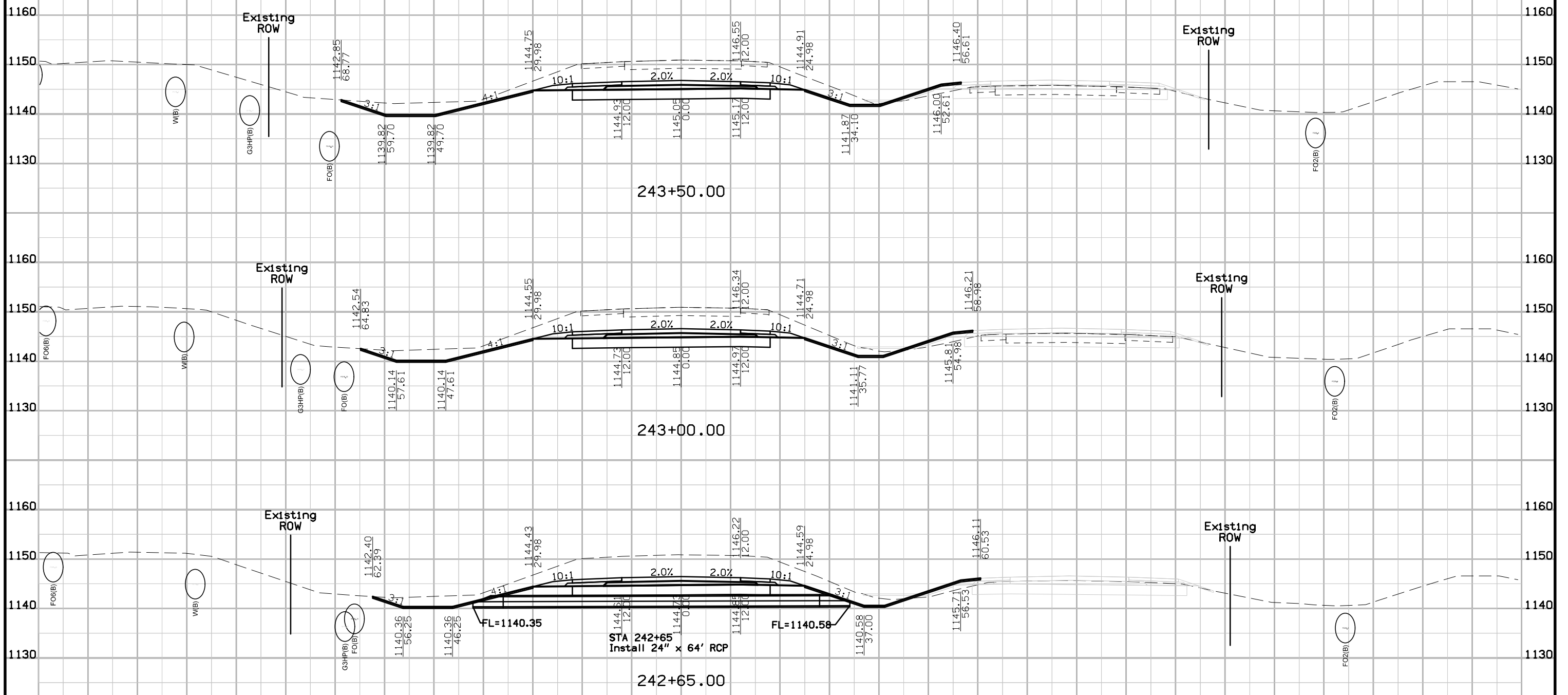

US75 SB Preliminary

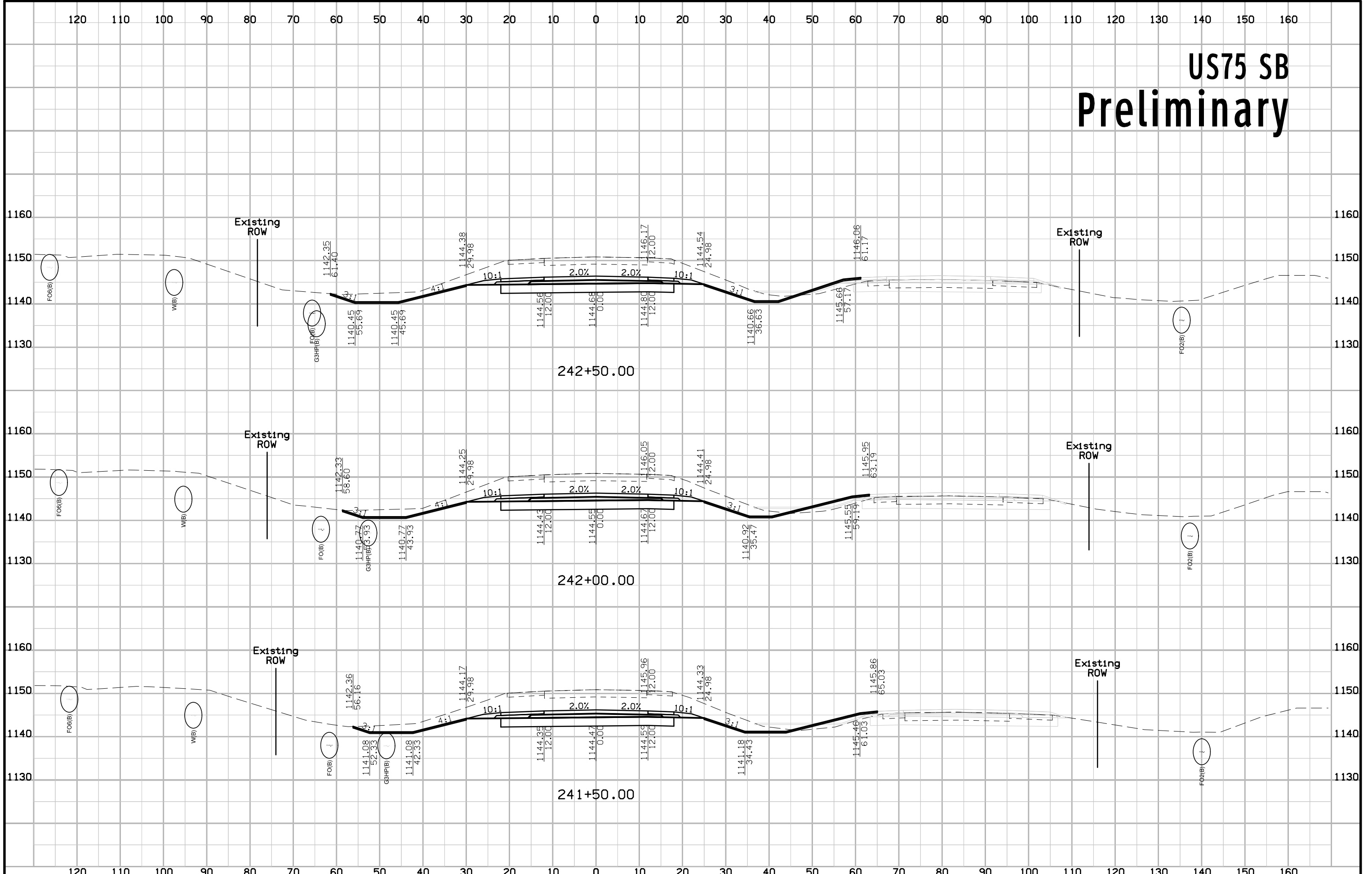

US75 SB Preliminary

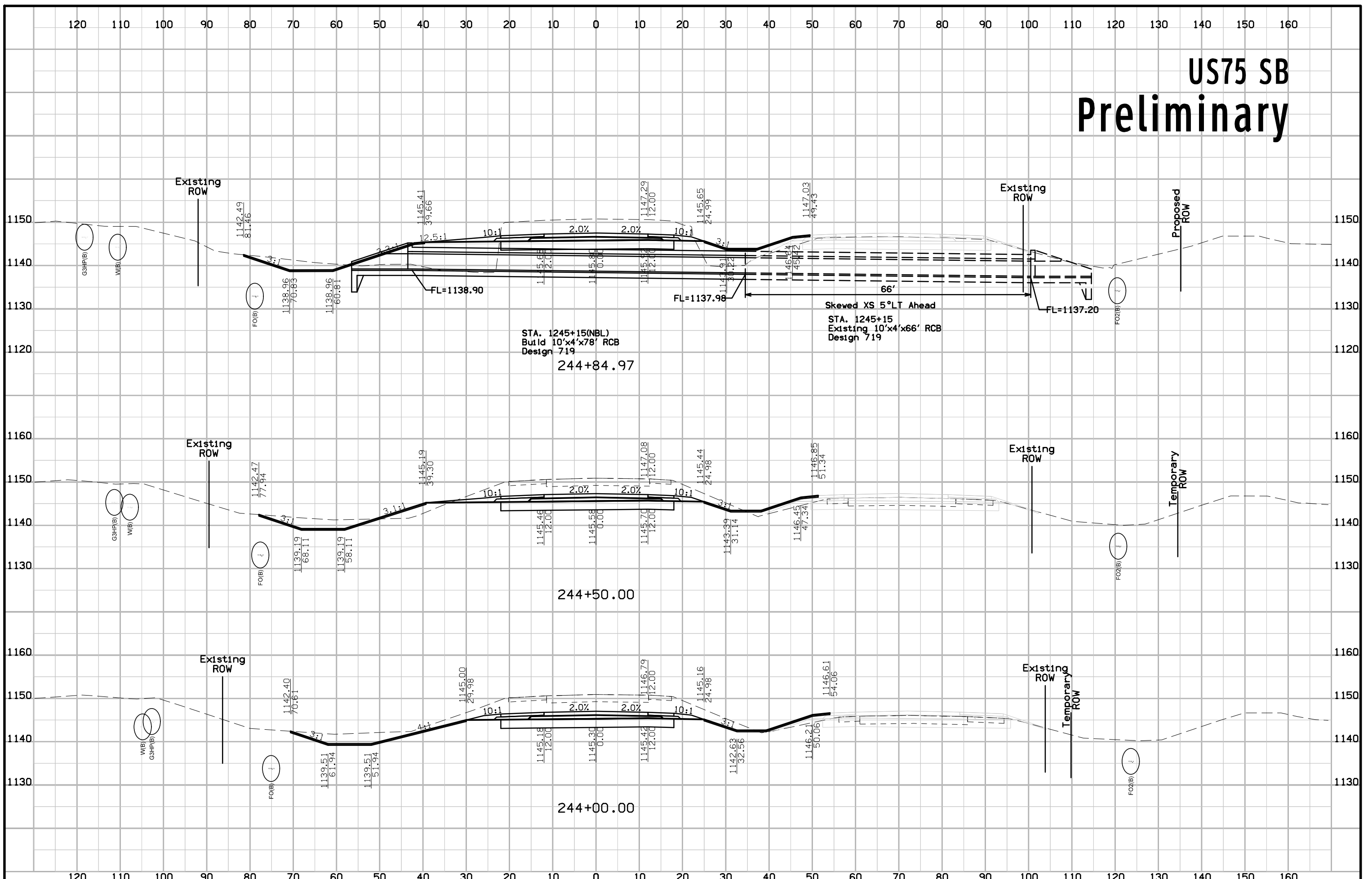

US75 SB Preliminary

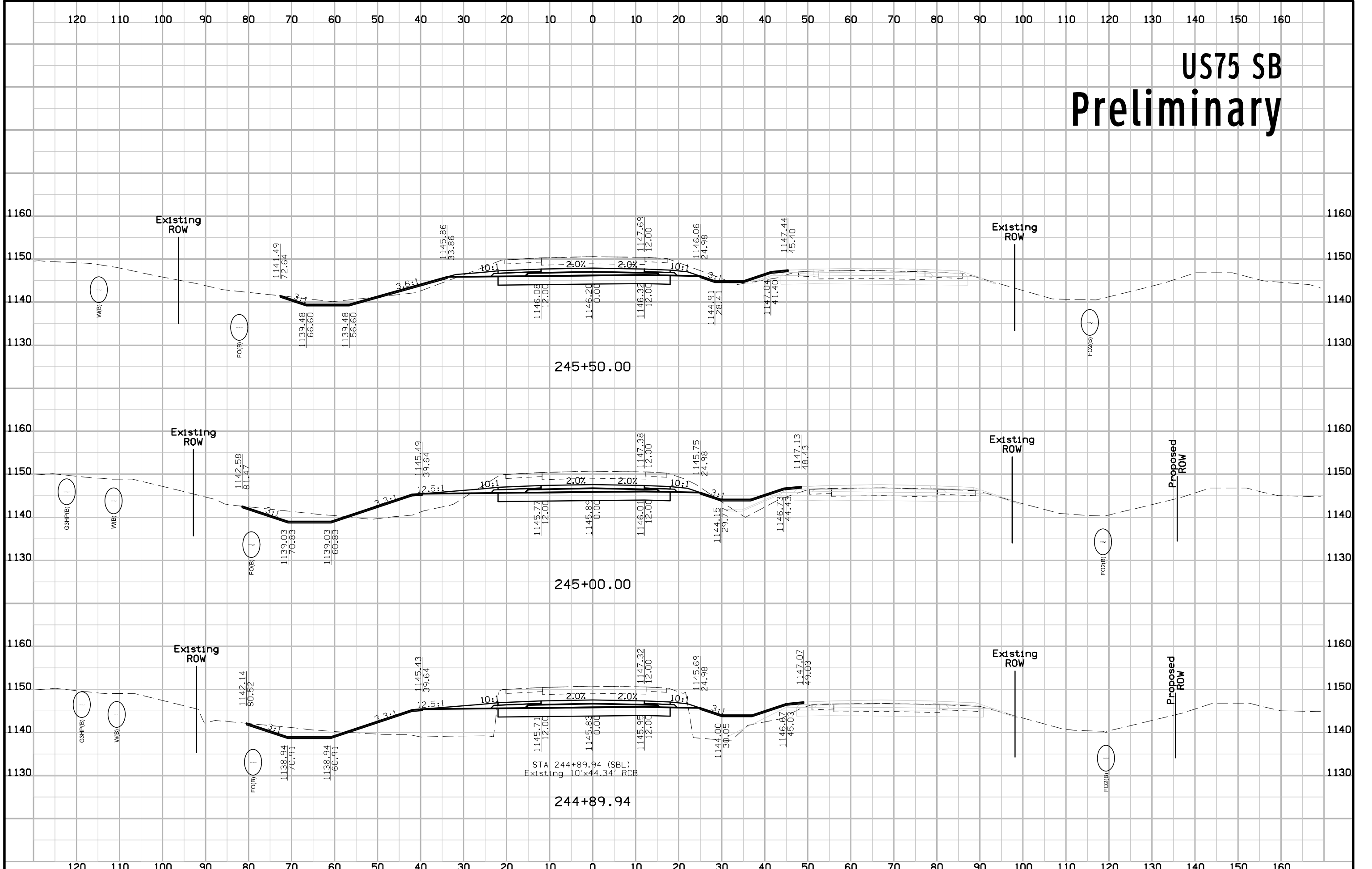

US75 SB Preliminary

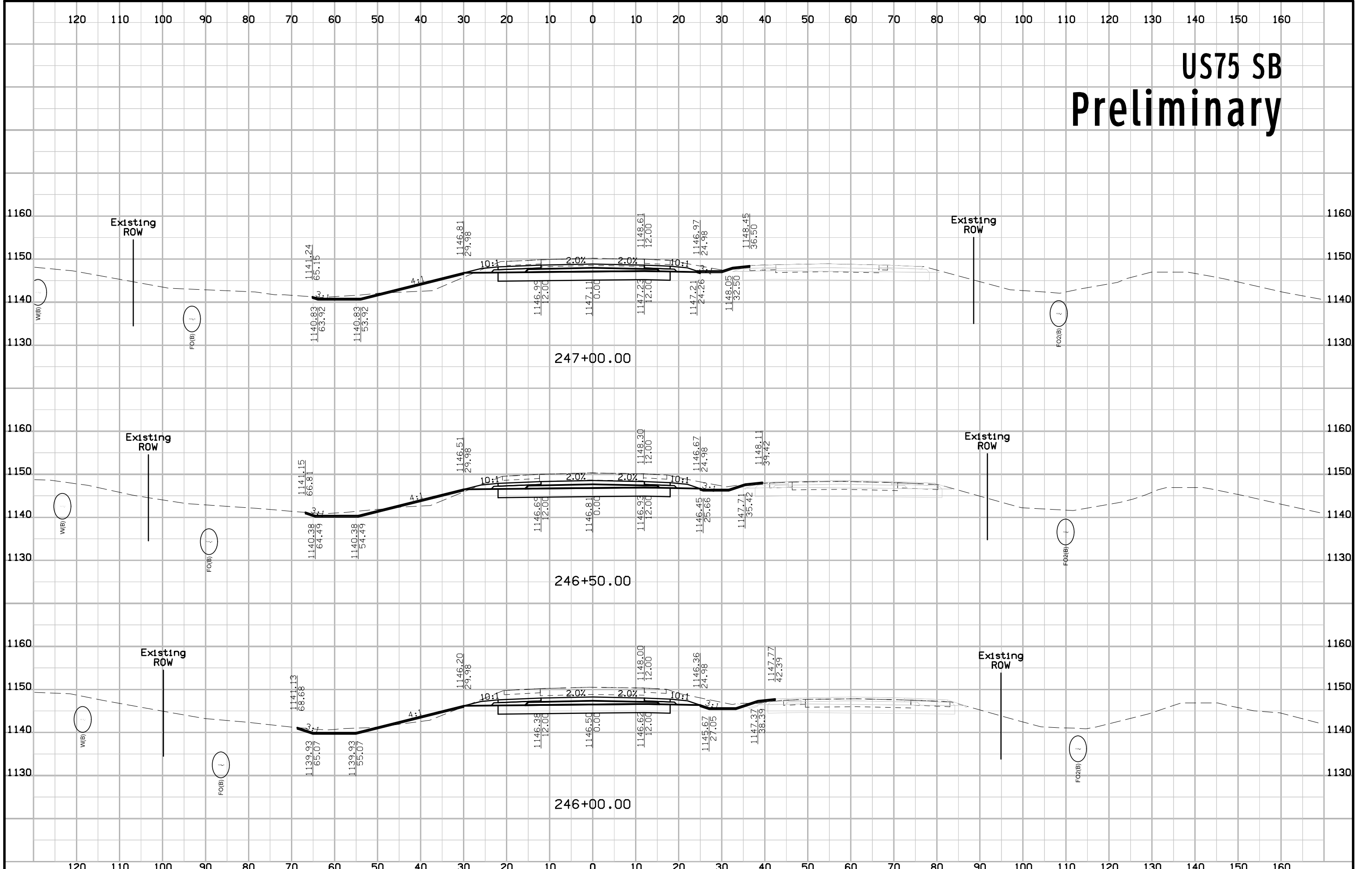

US75 SB Preliminary

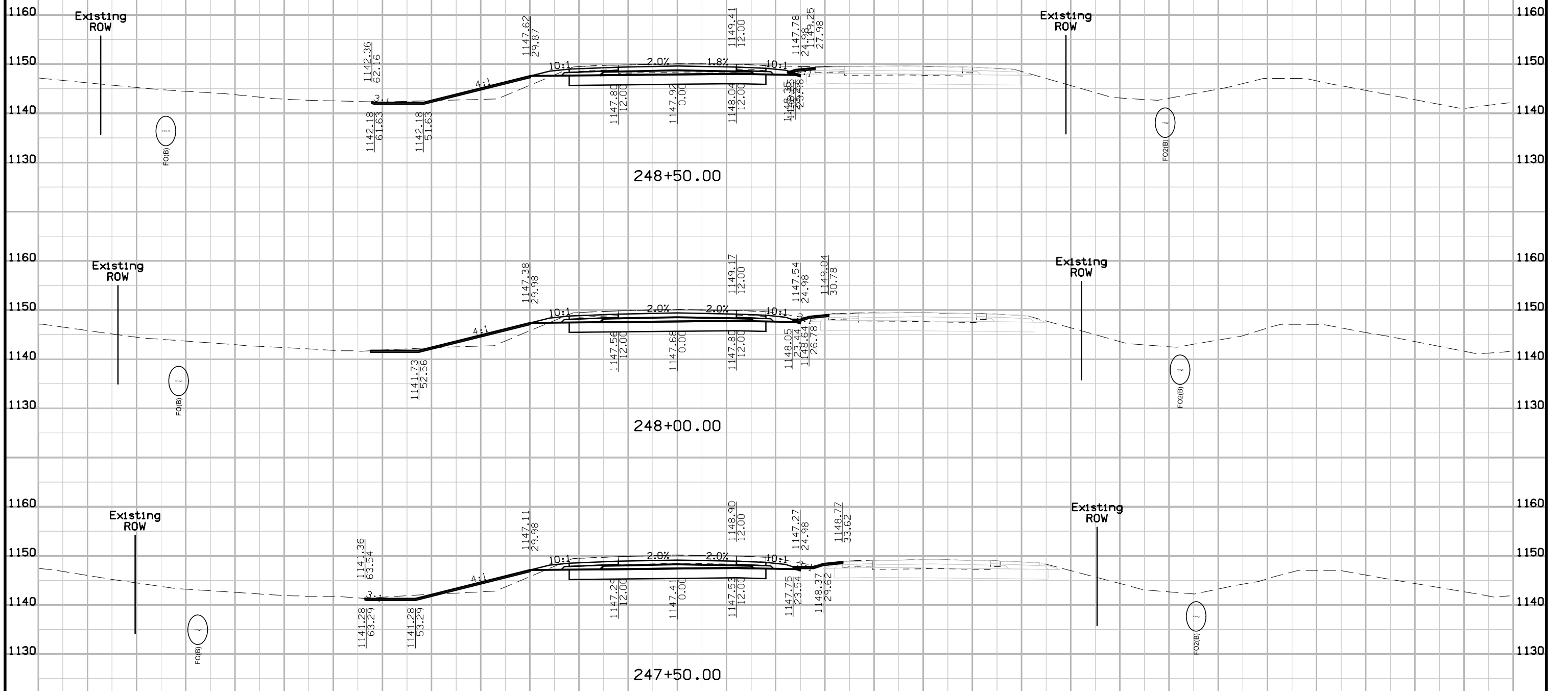

US75 SB Preliminary

