



PLANS OF PROPOSED IMPROVEMENT ON THE
**PRIMARY ROAD SYSTEM
MONONA COUNTY**
PCC Pavement - Grade and Replace
I-29/IA 175 Interchange Near Onawa

SCALES: As Noted

Refer to the Proposal Form for list of applicable specifications.

Value Engineering Saves. Refer to Article 1105.14 of the Specifications.



REVISIONS

TOTAL	354
PROJECT IDENTIFICATION NUMBER	21-67-175-020
PROJECT NUMBER	STP-175-1(95)--2C-67
R.O.W. PROJECT NUMBER	STPN -175-1(100)--2J-67

No.	DESCRIPTION
A Sheets	Title Sheets
* A.1	Title Sheet
* A.2	Location Map Sheet
B Sheets	Typical Cross Sections and Details
B.1 - 10	Typical Cross Sections and Details
D Sheets	Mainline Plan and Profile Sheets
* D.1	Plan & Profile Legend & Symbol Information Sheet
* D.2 - 4	I-29
E Sheets	Side Road Plan and Profile Sheets
* E.1 - 4	IA 175
F Sheets	Detour or Temporary Pavement Sheets
* F.1	Detour Ramp A
* F.2	Detour Ramp B
* F.3 - 4	Detour Widening Ramp C
* F.5 - 6	Detour Widening Ramp D
* F.7 - 8	Detour Widening IA 175 East
* F.9 - 10	Detour Widening IA 175 West
* F.11	Detour Ramp D
* F.12	Detour 28th St.
* F.13	Detour 28th St. Frontage Road
G Sheets	Survey Sheets
G.1 - 3	Reference Ties and Bench Marks
G.4	Alignment Coordinates
G.5	Horizontal Control Tab. & Super for all Alignments
J Sheets	Traffic Control and Staging Sheets
J.1 - 4	Traffic Control Plan & Staging Tabulations and Notes
* J.5	Traffic Control & Staging Legend & Symbol Info. Sheet
* J.6 - 11	Staging Typical Sections
* J.12 - 91	Traffic Control Plan & Staging Sheets
* J.92 - 95	Detour Sheets
K Sheets	Interchange Sheets
* K.1 - 3	Interchange Layout Sheets
* K.4	IA 175 Ramp A
* K.5	IA 175 Ramp B
* K.6	IA 175 Ramp C
* K.7	IA 175 Ramp D
U Sheets	500 Series, Mod.Stds. and Detail Sheets
* U.1 - 8	Acceleration and Deceleration Lanes for Ramps
V Sheets	Bridge and Culvert Situation Plans
* V.1 - 2	Bridge Situation Plans
* V.3 - 8	RCB Culvert Situation Plans
W Sheets	Mainline Cross Sections
* W.1	Cross Sections Legend & Symbol Information Sheet
* W.2 - 36	I-29 Cross Sections
* W.37 - 38	I-29 Culvert Cross Sections
X Sheets	Side Road Cross Sections
* X.1 - 46	IA 175 Cross Sections
* X.47	IA 175 Culvert Cross Sections
Y Sheets	Ramp Cross Sections
* Y.1 - 25	IA 175 Ramp A Cross Sections
* Y.26 - 49	IA 175 Ramp B Cross Sections
* Y.50 - 82	IA 175 Ramp C Cross Sections
* Y.83 - 110	IA 175 Ramp D Cross Sections
* Y.111	Ramp A Culvert Cross Sections
* Y.112	Ramp D Culvert Cross Sections
	* Color Plan Sheets

H Sheets

**For Project Location Map
Refer to Sheet No. A.2**

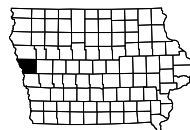

DESIGN DATA RURAL

2026	AADT	3700	V.P.D.
2046	AADT	4600	V.P.D.
2056	AADT	5200	V.P.D.
2046	DHV	480	V.P.H.
	TRUCKS	16	%
	Total		
	Design ESALs	--	

INDEX OF SEALS

SHEET NO.	NAME	TYPE	BID QUANTITY SHEETS
A.1	X	Primary Signature Block	X
X	X	X	X

PRELIMINARY PLANS

Subject to change by final design.

U03 1st Plan Submittal to Utilities
Date: February 16, 2024

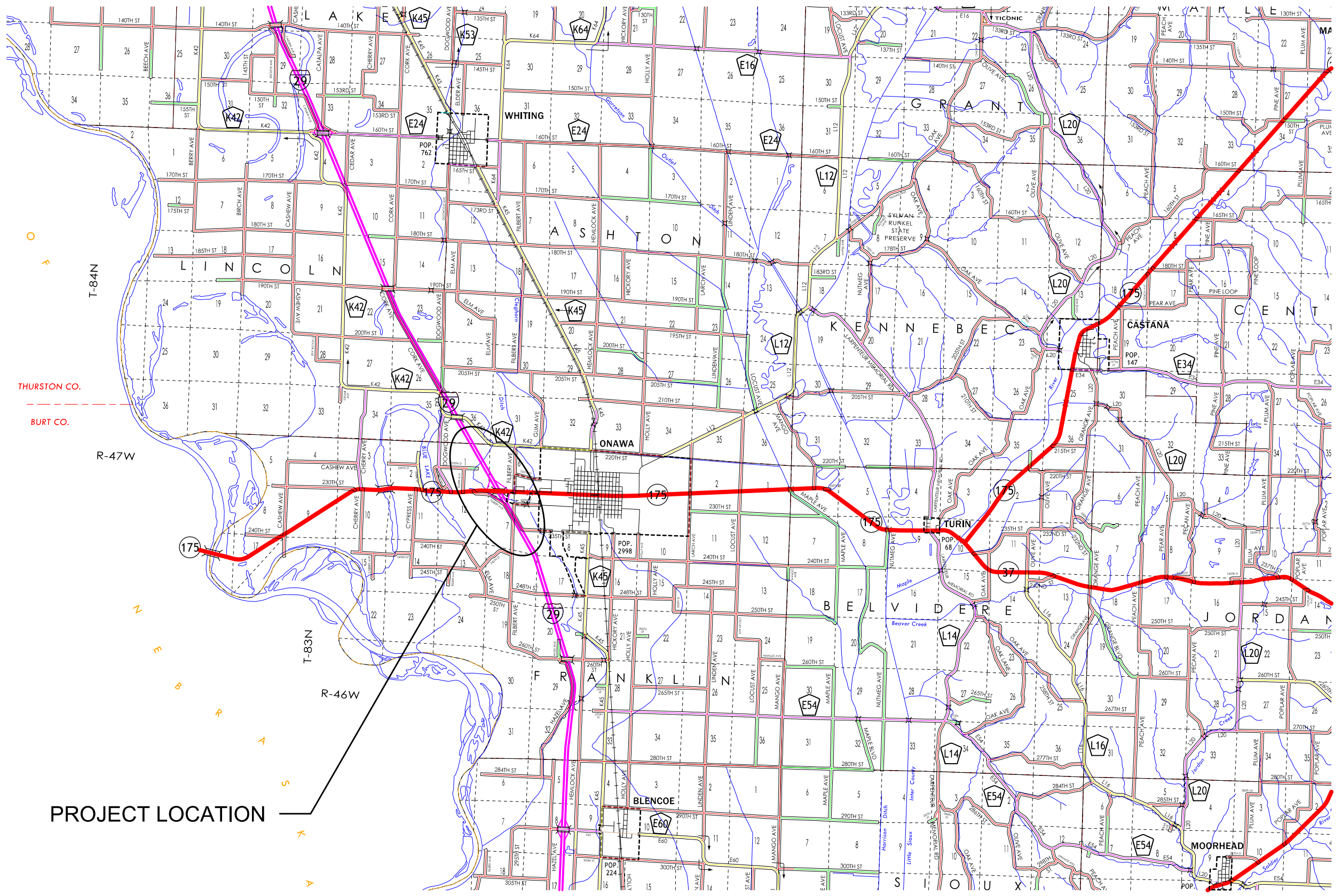

PROJECT LOCATION

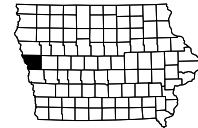

Normal section shown may be modified appropriately in areas of super-elevated curves or other locations specifically designated by the Engineer.

See Plan & Profile sheets and cross sections for additional details of ditches and backslopes.

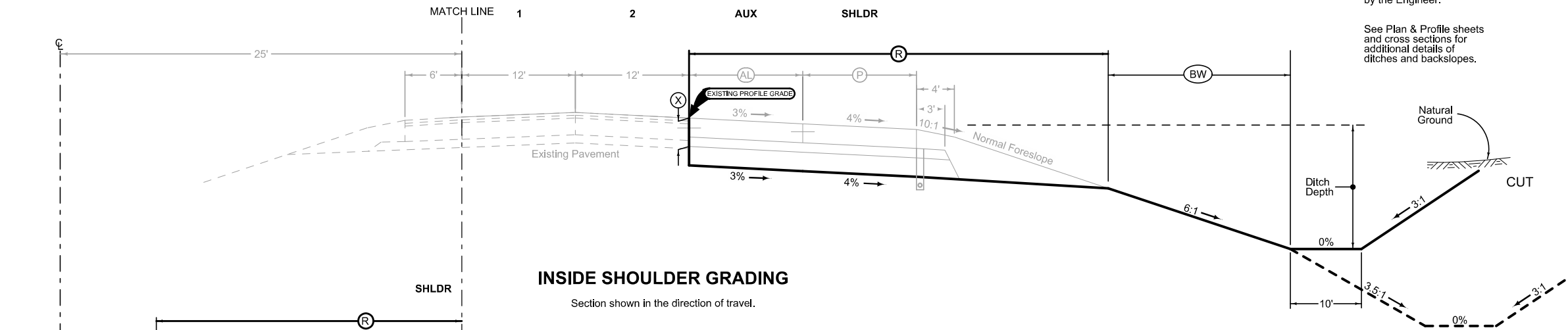

INSIDE SHOULDER GRADING

Section shown in the direction of travel.

LOCATION			DIMENSIONS	
ROAD IDENTIFICATION	STATION TO STATION		(R) Feet	(BW) Feet
I-29 NB	744+00.00	747+65.00	VARIES	VARIES
I-29 SB	745+00.00	749+25.00	VARIES	VARIES

WIDENING GRADING

Section shown in the direction of travel.

LOCATION			DIMENSIONS		
ROAD IDENTIFICATION	STATION TO STATION		(R) Feet	(X) Inches	(BW) Feet
I-29 NB	715+50.00	718+30.00	VARIES	34.5	VARIES
I-29 NB	718+30.00	728+30.00	42	34.5	4.4
I-29 NB	728+30.00	734+50.00	42 - 70	34.5	4.4
I-29 NB	747+65.00	750+50.00	0	0	4.4
I-29 NB	757+93.23	761+00.00	66 - 42	34.5	4.4
I-29 NB	761+00.00	771+00.00	42	34.5	4.4
I-29 NB	771+00.00	777+00.00	VARIES	34.5	VARIES
I-29 SB	715+50.00	721+50.00	42	34.5	4.4
I-29 SB	721+50.00	731+50.00	VARIES	34.5	VARIES
I-29 SB	731+50.00	734+50.00	42 - 66	34.5	4.4
I-29 SB	749+25.00	751+25.00	0	0	4.4
I-29 SB	762+26.50	766+45.00	70 - 42	34.5	4.4
I-29 SB	766+45.00	776+45.00	42	34.5	4.4
I-29 SB	776+45.00	779+45.00	42	34.5	4.4

MEDIAN DITCH GRADING

Section shown in the direction of travel.

LOCATION		
ROAD IDENTIFICATION	STATION TO STATION	
I-29 NB	749+00.00	750+50.00
I-29 SB	750+00.00	750+50.00

INSIDE SHOULDER & MEDIAN DITCH GRADING

Section shown in the direction of travel.

LOCATION			DIMENSIONS	
ROAD IDENTIFICATION	STATION TO STATION		(R) Feet	(BW) Feet
I-29 NB	748+40.00	749+00.00	VARIES	VARIES
I-29 SB	749+25.00	750+00.00	VARIES	VARIES

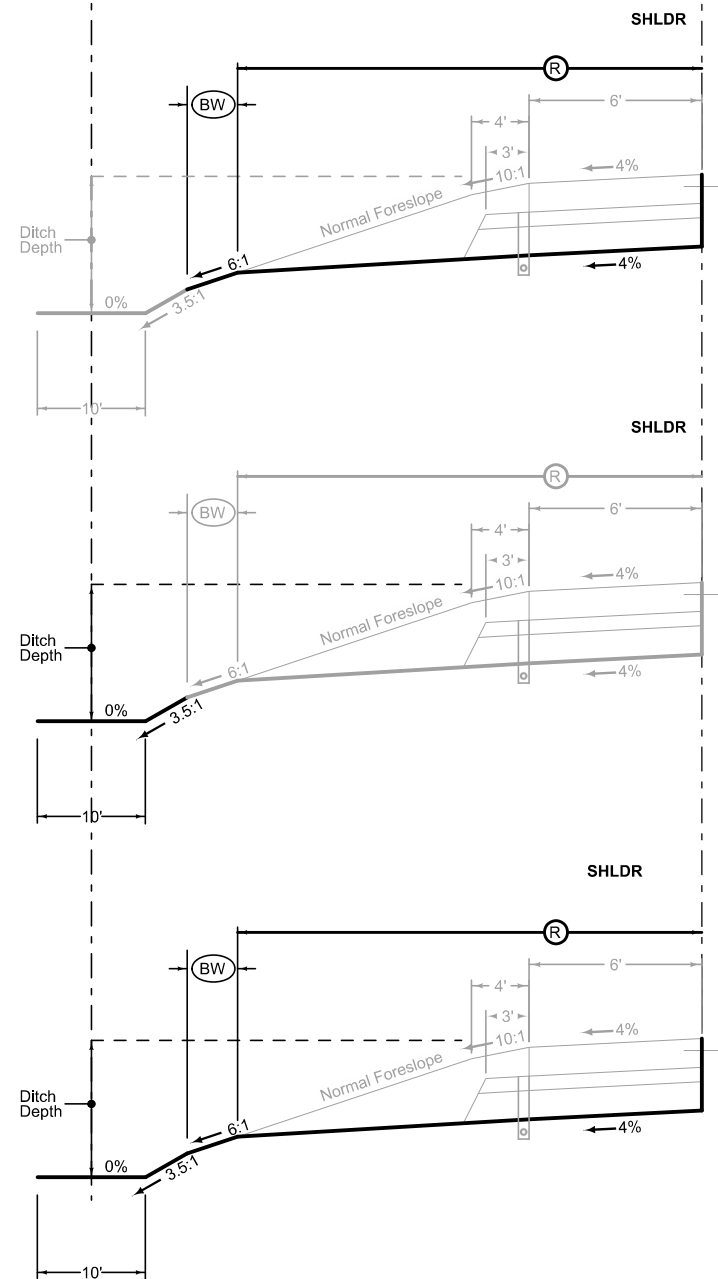

I-29

Normal section shown may be modified appropriately in areas of superelevated curves or other locations specifically designated by the Engineer.

See Plan & Profile sheets and cross sections for additional details of ditches and backslopes.

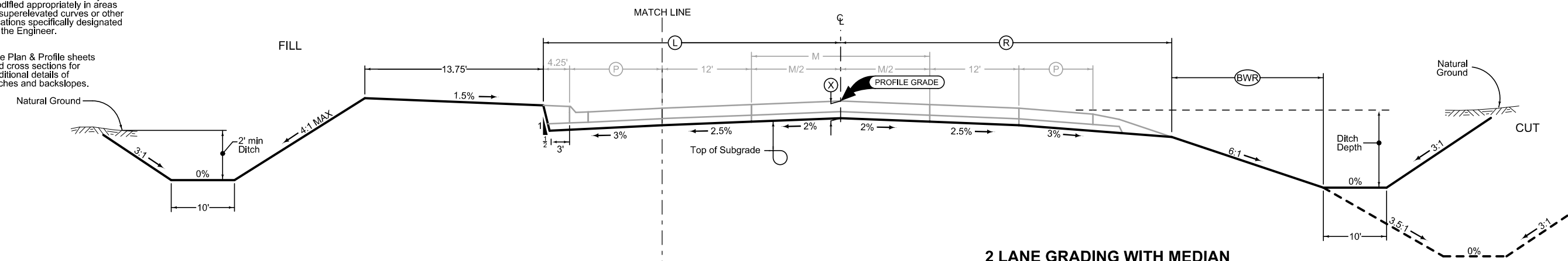

**2 LANE GRADING WITH MEDIAN
(Barnroof Section)**

LOCATION		DIMENSIONS			
ROAD IDENTIFICATION	STATION TO STATION	Ⓛ Feet	Ⓡ Feet	ⓧ Inches	Ⓟ Feet
IA 175	1725+00.00 - 1726+80.00	40.0	37.1	21.5	6.9
IA 175	1726+80.00 - 1736+40.86	40.0 - 47.0	37.1 - 44.1	21.5	6.9
IA 175	1736+40.86 - 1738+60.00	47.0	44.1	21.5	6.9
IA 175	1740+25.00 - 1744+62.73	47.0	44.1	21.5	6.9
IA 175	1747+00.00 - 1750+00.00	47.0	44.1	21.5	6.9
IA 175	1752+50.00 - 1757+03.77	55.0 - 47.0	44.1	21.5	6.9
IA 175	1757+03.77 - 1758+20.00	47.0	44.1	21.5	6.9
IA 175	1758+20.00 - 1761+80.00	47.0	44.1	21.5	6.9
IA 175	1763+40.00 - 1766+76.70	49.0 - 51.0	44.1	21.5	6.9
IA 175	1766+76.70 - 1771+49.11	51.0 - 44.1	44.1 - 37.1	21.5	6.9

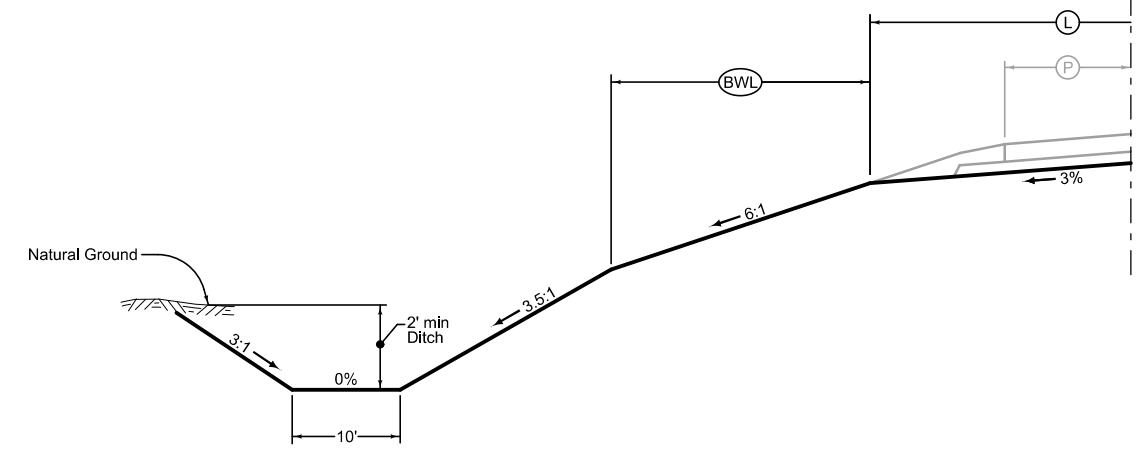

OPEN SHOULDER GRADING

LOCATION		DIMENSIONS	
ROAD IDENTIFICATION	STATION TO STATION	ⓧ Inches	Ⓟ Feet
IA 175	1722+00.00 - 1725+00.00	21.5	0
IA 175	1763+40.00 - 1765+60.00	21.5	0 - 1.6
IA 175	1765+60.00 - 1766+76.70	21.5	1.6 - 7.6
IA 175	1766+76.70 - 1771+49.11	21.5	7.6 - 5

IA 175

LOCATION				DIMENSIONS					
INTERCHANGE	RAMP	STATION TO STATION		(L) Feet	(R) Feet	(C) Feet	(X) Inches	(BW) Feet	(BW) Feet
IA 175	A	1549+34.61	1562+26.06	34.3	25.7	16	22.5	40.1	39.2
IA 175	B	2532+49.07	2544+57.44	36.6	22.6	16	22.5	49.7	52.2
IA 175	C	3534+58.92	3550+79.14	36.6	22.6	16	22.5	34.8	33.1
IA 175	D	4543+72.26	4557+91.09	36.6	22.6	16	22.5	32.3	29.4

Section view is in direction of traffic.
Normal sections shown may be appropriately modified for areas specifically designated by the Engineer such as intersections or superelevated curves.

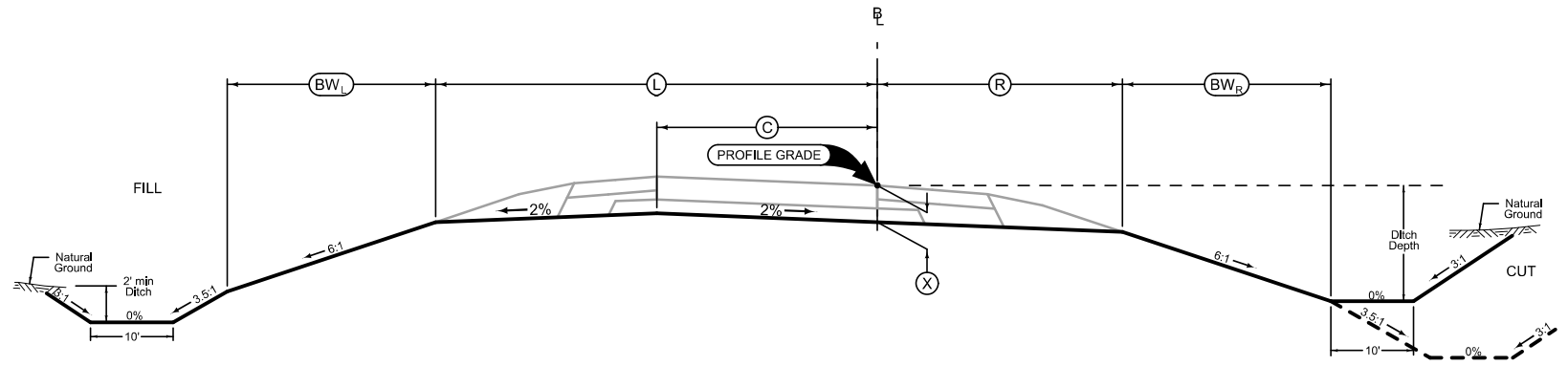

RAMP GRADING

IA 175 Ramps

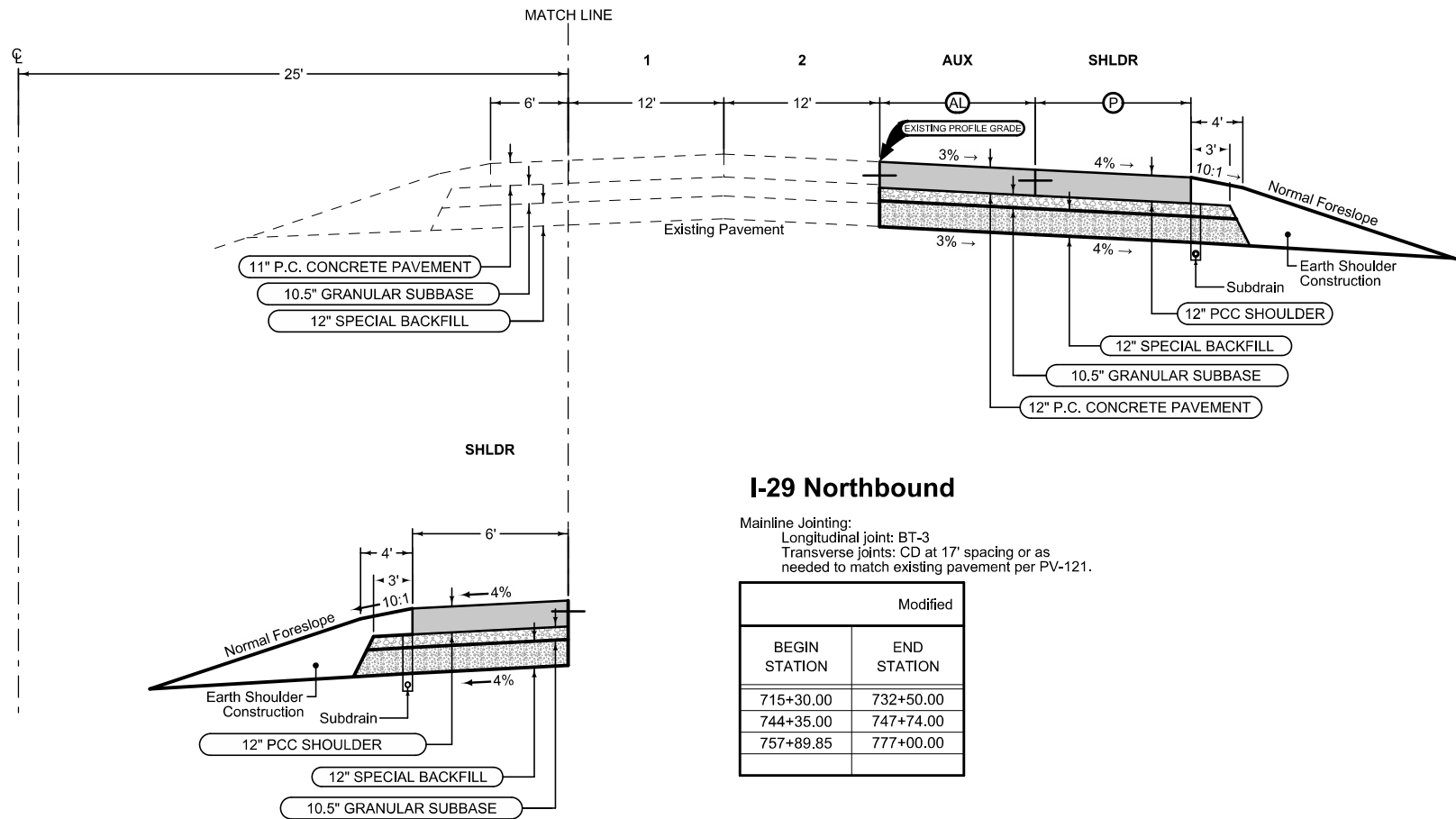

Full Depth PCC Shoulder

Shoulder Jointing:
 Longitudinal joint: L-2 or KT-2
 Transverse joints: CD at 17' spacing or as needed to match existing pavement per PV-121.

Direction of Travel	BEGIN STATION	END STATION	Modified	
			AL FEET	P FEET
NB	715+30.00	716+79.88	0 - 6	12 - 6
NB	716+79.88	718+29.88	6 - 12	6
NB	718+29.88	728+30.00	12	6
NB	728+30.00	732+50.00	12 - 40	6
NB	744+35.00	745+56.42	0	12
NB	745+56.42	747+74.00	0	17
NB	757+89.85	761+00.00	42.3 - 12	6
NB	761+00.00	771+00.00	12	6
NB	771+00.00	774+00.00	12 - 6	6
NB	774+00.00	777+00.00	6 - 0	6 - 1 2

I-29 Northbound

Mainline Jointing:
 Longitudinal joint: BT-3
 Transverse joints: CD at 17' spacing or as needed to match existing pavement per PV-121.

Modified	
BEGIN STATION	END STATION
715+30.00	732+50.00
744+35.00	747+74.00
757+89.85	777+00.00

Full Depth PCC Shoulder

Shoulder Jointing:
 Longitudinal joint: L-2 or KT-2
 Transverse joints: CD at 17' spacing or as needed to match existing pavement per PV-121.

LOCATION		
Direction of Travel	BEGIN STATION	END STATION
NB	744+00.00	749+00.00

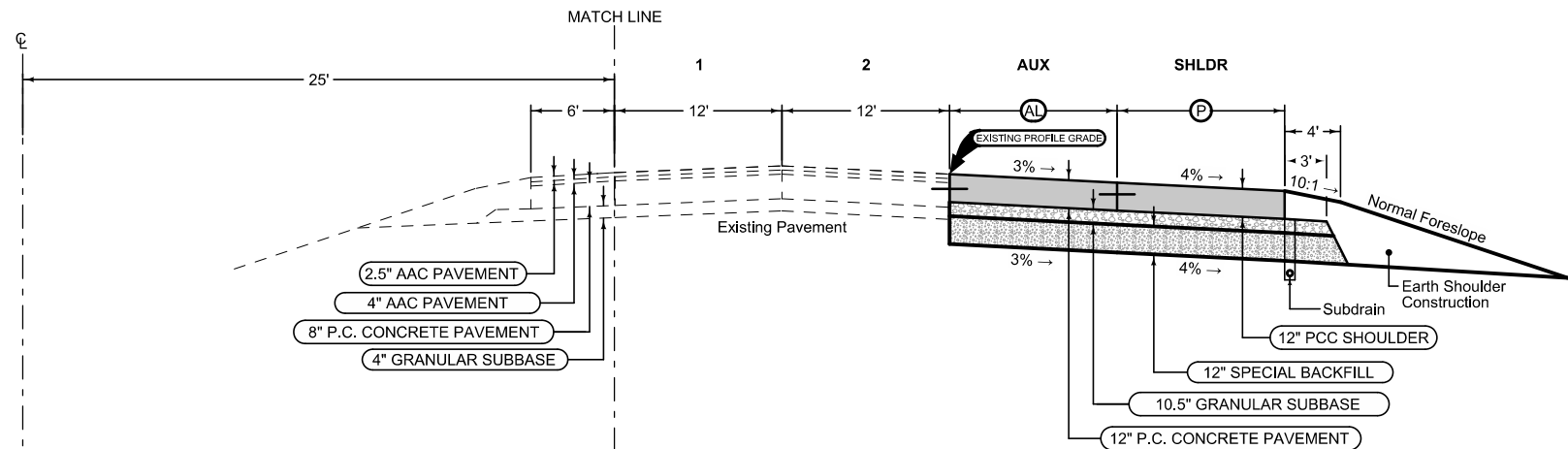

Full Depth PCC Shoulder

Shoulder Jointing:
 Longitudinal joint: L-2 or KT-2
 Transverse joints: CD at 17' spacing or as needed to match existing pavement per PV-121.

Modified				
Direction of Travel	BEGIN STATION	END STATION	AL FEET	P FEET
SB	715+50.00	718+50.00	0 - 6	12 - 6
SB	718+50.00	721+50.00	6 - 12	6
SB	721+50.00	731+50.00	12	6
SB	731+50.00	734+60.15	12 - 36	6
SB	746+24.00	748+43.00	0	17

Full Depth PCC Shoulder

Shoulder Jointing:
 Longitudinal joint: L-2 or KT-2
 Transverse joints: CD at 17' spacing or as needed to match existing pavement per PV-121.

LOCATION		
Direction of Travel	BEGIN STATION	END STATION
SB	745+00.00	750+00.00

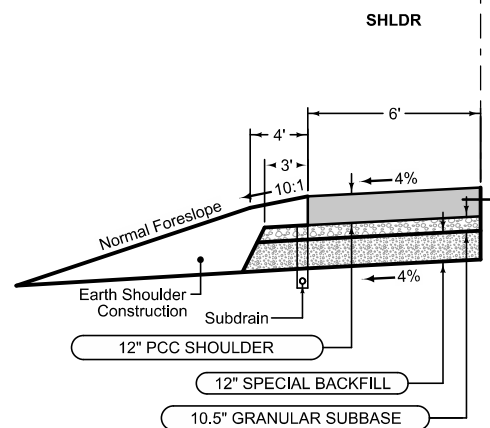

I-29 Southbound

Section shown in the direction of traffic.

Mainline Jointing:
 Longitudinal joint: BT-3
 Transverse joints: CD at 17' spacing or as needed to match existing pavement per PV-121.

Modified	
BEGIN STATION	END STATION
715+50.00	734+60.15
745+00.00	750+00.00

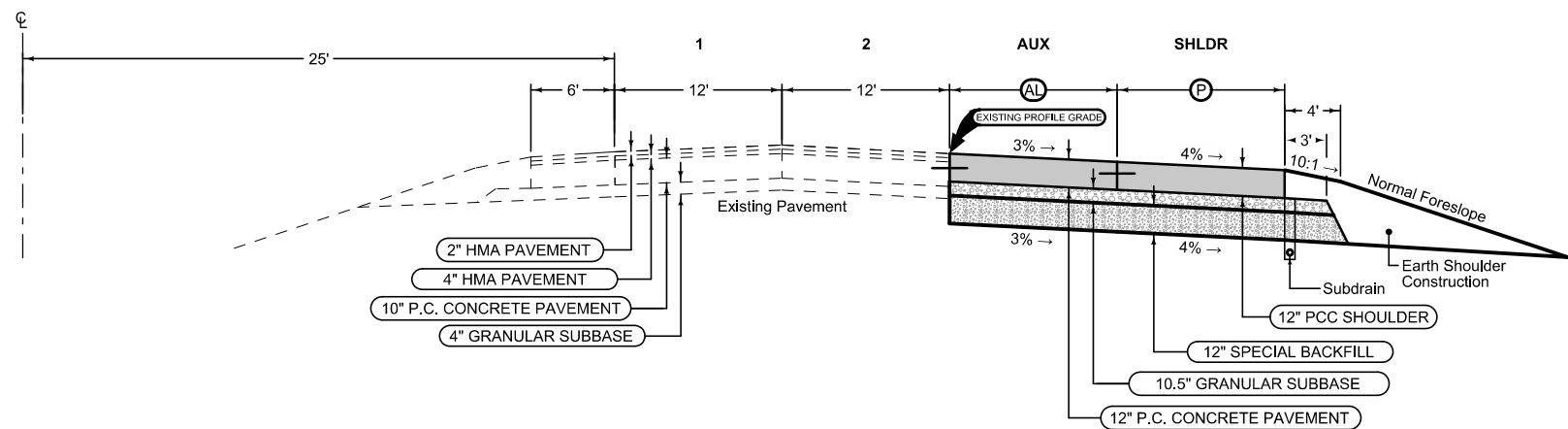

Full Depth PCC Shoulder

Shoulder Jointing:
 Longitudinal joint: L-2 or KT-2
 Transverse joints: CD at 17' spacing or as needed to match existing pavement per PV-121.

Modified				
Direction of Travel	BEGIN STATION	END STATION	AL FEET	P FEET
SB	762+25.00	766+45.00	40 - 12	6
SB	766+45.00	776+45.00	12	6
SB	776+45.00	777+95.00	12 - 6	6
SB	777+95.00	779+45.00	6 - 0	6 - 1 2

I-29 Southbound

Section shown in the direction of traffic.

Mainline Jointing:
 Longitudinal joint: BT-3
 Transverse joints: CD at 17' spacing or as needed to match existing pavement per PV-121.

Modified	
BEGIN STATION	END STATION
762+25.00	779+45.00

Full Depth PCC Shoulder

Shoulder Jointing:
 Longitudinal joint: BT-2, L-2 or KT-2
 Transverse joints: C at 17' spacing

2_P_FullPCC_ Modified		
BEGIN STATION	END STATION	(P) FEET
1723+38.08	1738+65.29	10
1740+75.03	1744+56.02	10
1747+53.02	1750+67.73	10
1753+15.69	1761+76.04	10
1763+39.93	1771+49.11	10

Curbed Shoulder

Shoulder Jointing:
 Longitudinal joint not required when distance from back of curb to nearest joint is less than 15':

Single pour: L-2
 Staged : KT-2
 Transverse: C at 17' spacing

2_Curb_ Modified				
STATION TO STATION	(L) Feet	(P) Feet	(S) Feet	Curb Type See PV-102
1725+00.00	1725+75.00	0 - 6	10 - 11	4" Sloped
1725+75.00	1738+02.92	6	11	4" Sloped
1758+83.77	1761+86.90	6	11	4" Sloped
1740+27.93	1743+29.55	6	11	4" Sloped
1743+29.55	1743+79.55	6 - 0	11	4" Sloped
1743+79.55	1744+29.49	0	11	4" Sloped
1747+06.03	1747+56.02	0	11	4" Sloped
1747+56.02	1748+06.30	0 - 6	11	4" Sloped
1748+06.30	1749+98.75	6	11	4" Sloped

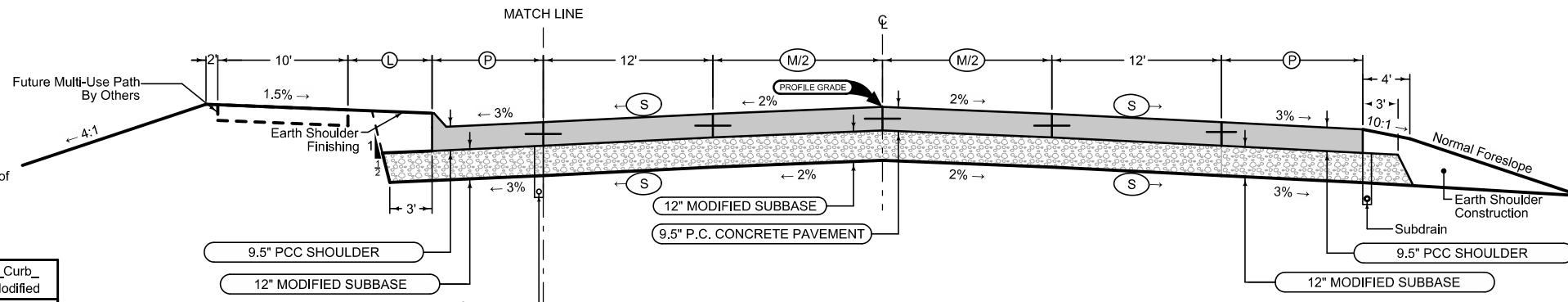

Mainline Jointing:
 Transverse joints: CD at 17' spacing
 Longitudinal joint: L-2

2P_TWLTL_ Modified				
DIR OF TRAV	STATION TO STATION	(M/2) Feet	(S) Percent	
WB	1722+00.00	1725+82.80	0	2
WB	1725+82.80	1737+36.74	0 - 7	2 - 2.5
WB	1737+36.74	1744+48.22	7	2.5
WB	1747+24.70	1761+90.33	7	2.5
EB	1723+38.08	1725+82.80	0	2
EB	1725+82.80	1736+27.60	0 - 6.1	2 - 2.5
EB	1736+27.60	1737+36.74	6.1 - 7	2.5
EB	1737+36.74	1744+48.22	7	2.5
EB	1747+24.70	1761+90.72	7	2.5

Added Lane Shoulder

Shoulder Jointing:
 Longitudinal joint not required when distance from back of curb to nearest joint is less than 15':

Single pour: L-2
 Staged : KT-2
 Transverse: C at 17' spacing

2_Curb_ Modified					
STATION TO STATION	(L) Feet	(P) Feet	(AL) Feet	Curb Type See PV-102	
1752+04.15	1757+03.75	6	7	12	4" Sloped
1757+03.75	1758+18.42	6	7	12 - 4.8	4" Sloped
1758+18.42	1758+83.77	6	7 - 11	4.8 - 0	4" Sloped

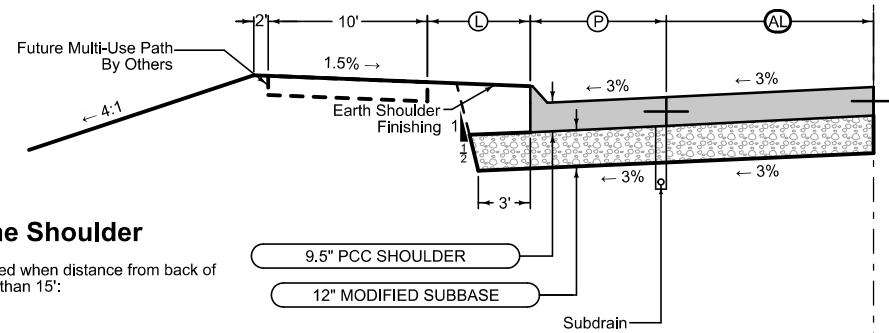

Full Depth PCC Shoulder

Shoulder Jointing:
 Longitudinal joint: L-2 or KT-2
 Transverse joints: CD at 17' spacing or as needed to match existing pavement per PV-121.

Modified		
STATION TO STATION	(P) Feet	
1722+00.00	1725+00.00	10
1763+09.45	1771+49.11	10

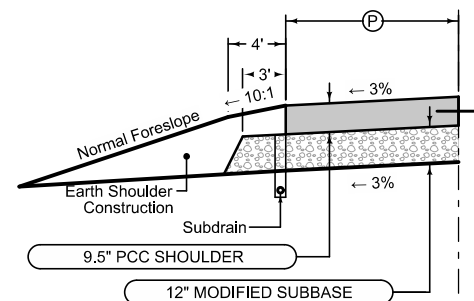

IA 175

Paved Shoulder Alternates

PCC Shoulder Jointing:
 Longitudinal Joint: BT-1 or BT-5
 Transverse joints: C at 15' spacing
 HMA Shoulder Jointing:
 Longitudinal Joints: B

INTERCHANGE	RAMP	BEGIN STATION	END STATION
IA 175	A	1549+34.61	1562+26.06
IA 175	B	2532+49.07	2544+57.44
IA 175	C	3534+58.92	3550+79.14
IA 175	D	4543+72.26	4557+91.09

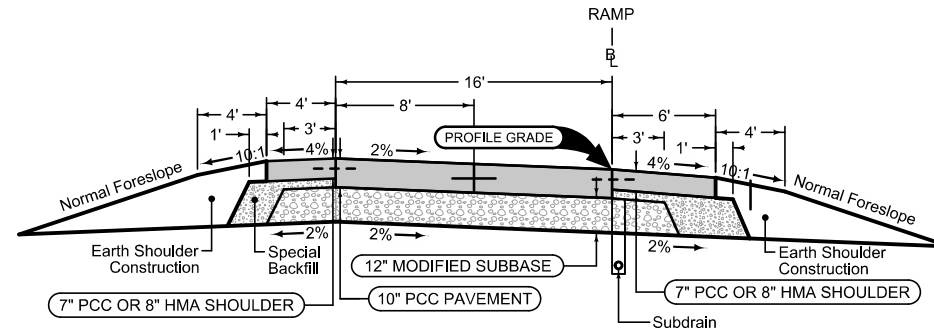

Section shown in the direction of traffic.

Ramp Jointing:
 Transverse joints: CD at 15' spacing.
 Longitudinal joints: L-2

INTERCHANGE	RAMP	BEGIN STATION	END STATION
IA 175	A	1549+34.61	1562+26.06
IA 175	B	2532+49.07	2544+57.44
IA 175	C	3534+58.92	3550+79.14
IA 175	D	4543+72.26	4557+91.09

Paved Shoulder Alternates

PCC Shoulder Jointing:
 Longitudinal Joint: BT-1 or BT-5
 Transverse joints: C at 15' spacing
 HMA Shoulder Jointing:
 Longitudinal Joints: B

INTERCHANGE	RAMP	BEGIN STATION	END STATION
IA 175	A	1549+34.61	1562+26.06
IA 175	B	2532+49.07	2544+57.44
IA 175	C	3534+58.92	3550+79.14
IA 175	D	4543+72.26	4557+91.09

IA 175 Ramps

LOCATION			DIMENSIONS										6" Special Backfill Tons/Station	Earth Shoulder Construction Station
ROAD IDENTIFICATION	STATION TO STATION		HMA					PCC						
			L Feet	R Feet	LANE Feet	T Inches	SGW Feet	L Feet	R Feet	LANE Feet	T Inches	SGW Feet	S Percent	FS Ratio
Detour Ramp A	11551+48.46	11563+20.71	18.0	4.0	16.0		18.0	4.0	16.0			Var.	3:1	
Detour Ramp B	12540+92.35	12531+78.72	18.0	4.0	16.0		18.0	4.0	16.0			Var.	2:1-3:1	
Detour Ramp D	11760+80.18	11771+17.35	20.0	2.0	16.0		20.0	2.0	16.0			Var.	3:1	
Detour 28th St. [1]	21000+60.50	21001+51.00	14.0	14.0	12.0		14.0	14.0	12.0			Var.	3:1	
Detour 28th St. Frontage Road [1]	31000+35.62	31003+91.32	11.0	11.0	11.0		11.0	11.0	11.0			Var.	3:1	
Notes:														
[1] Two-lane temporary access														

Quantity calculations based on vertical pavement edges.
Normal section shown may be modified appropriately in areas of super-elevated curves or other locations specifically designated by the Engineer.

① Possible HMA 1:1 slope

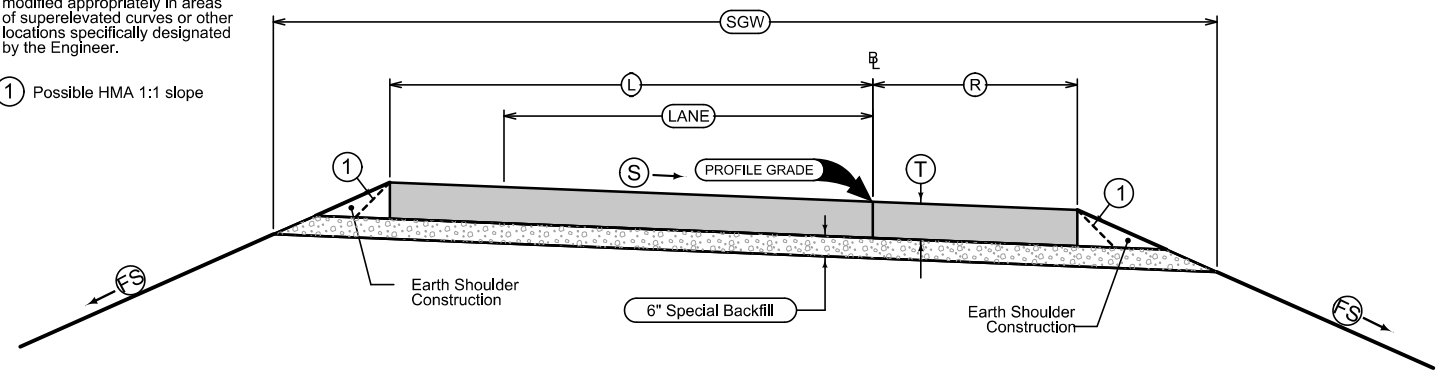

DETOUR PAVING

D_Detour
Modified

Detours

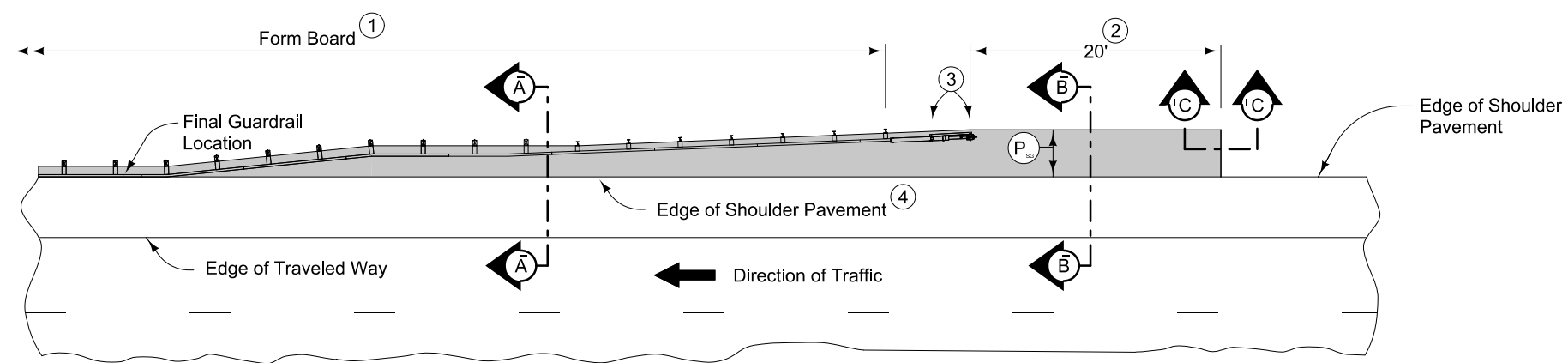

PLAN VIEW

9" HMA Paved Shoulder at guardrail. 8" PCC may be substituted with the following jointing layout:

Match mainline pavement joint spacing. When mainline pavement is 8" or greater in thickness, place additional transverse 'C' joints in shoulder at mid-panel of the mainline pavement. Place longitudinal 'C' joint at P/2 from edge of mainline pavement when P is greater than 10' wide. Terminate longitudinal joint at transverse joint less than 10' in length.

Compaction of HMA is required to face of guardrail post. Hand compaction will be allowed under guardrail. Removal and reinstallation of guardrail will be allowed with no additional payment.

Refer to Tabulation 112-9 for shoulder quantities.

- ① PCC option only: When guardrail posts are installed prior to construction of PCC paved shoulder, fasten form board to the face of guardrail posts for the length shown.
- ② Continue paved shoulder 20 feet beyond the center of the first post.
- ③ Shoulder may be notched for first 2 posts or post sleeves may be installed through pavement. Do not drive posts through pavement.
- ④ 'KT' (per PV-101) joint for PCC shoulder. 'B' (per PV-101) joint for HMA shoulder.
- ⑤ Match shoulder slope.
- ⑥ The Contractor has the option to pave the paved shoulder at guardrail and the full width paved shoulder as one operation.
- ⑦ Refer to other details in the plan.

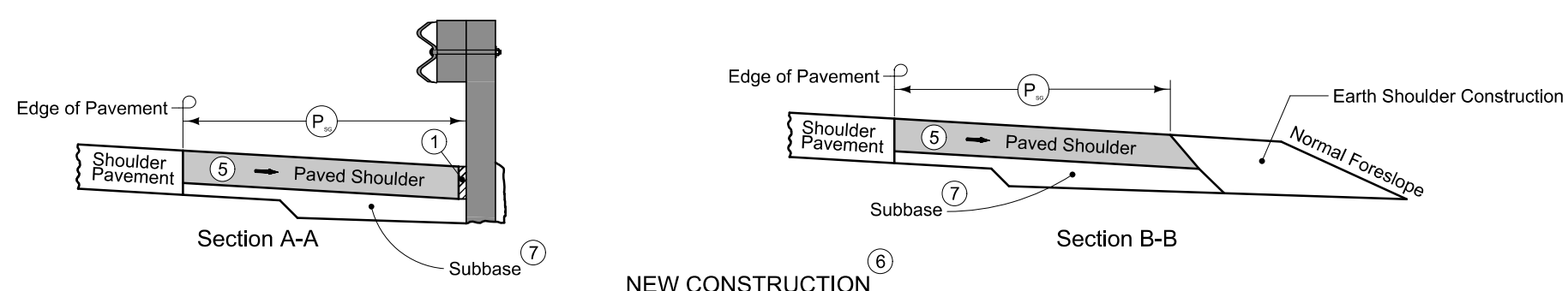

NEW CONSTRUCTION

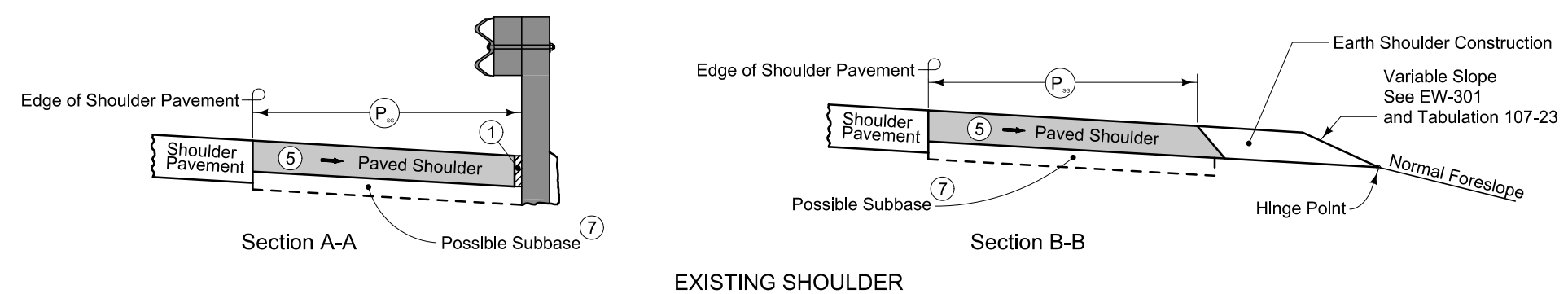

EXISTING SHOULDER

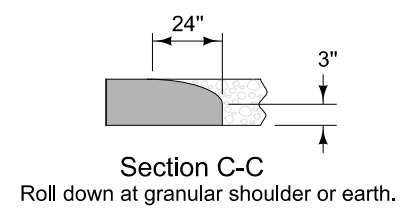

PAVED SHOULDER AT GUARDRAIL (ADJACENT TO FULL WIDTH PAVED SHOULDER)

6147
10-20-15

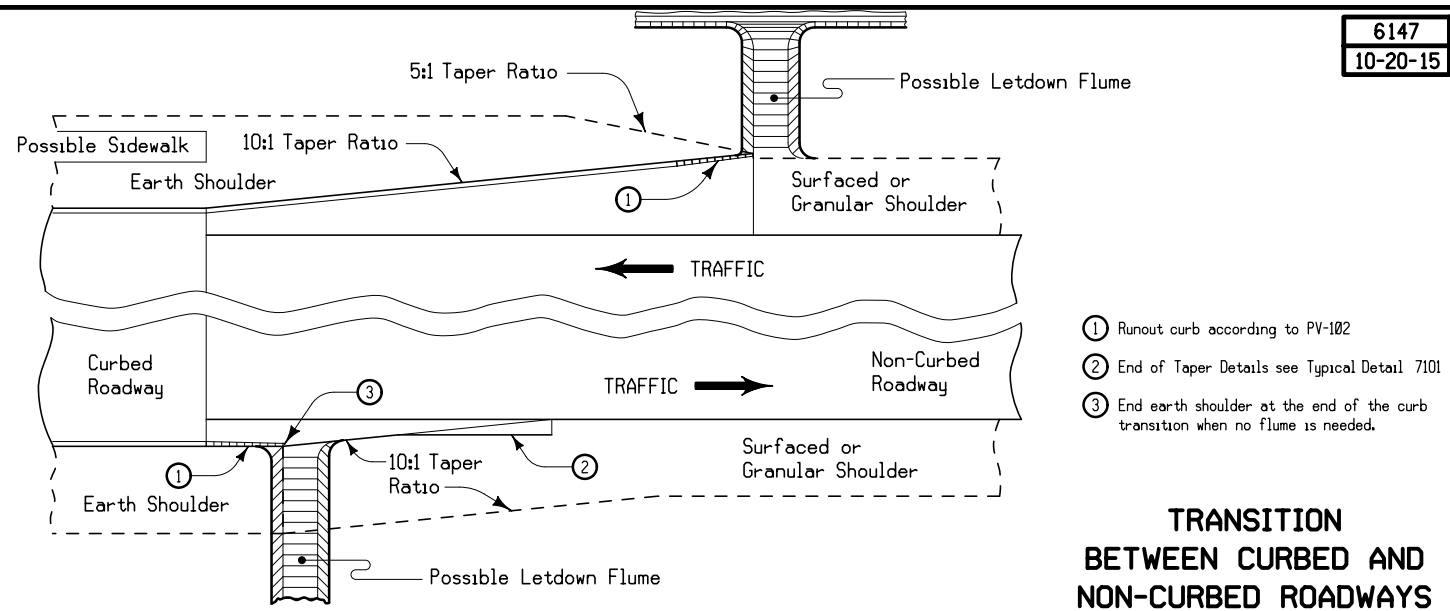

- ① Runout curb according to PV-102
- ② End of Taper Details see Typical Detail 7101
- ③ End earth shoulder at the end of the curb transition when no flume is needed.

**TRANSITION
BETWEEN CURBED AND
NON-CURBED ROADWAYS**

7101
10-19-10

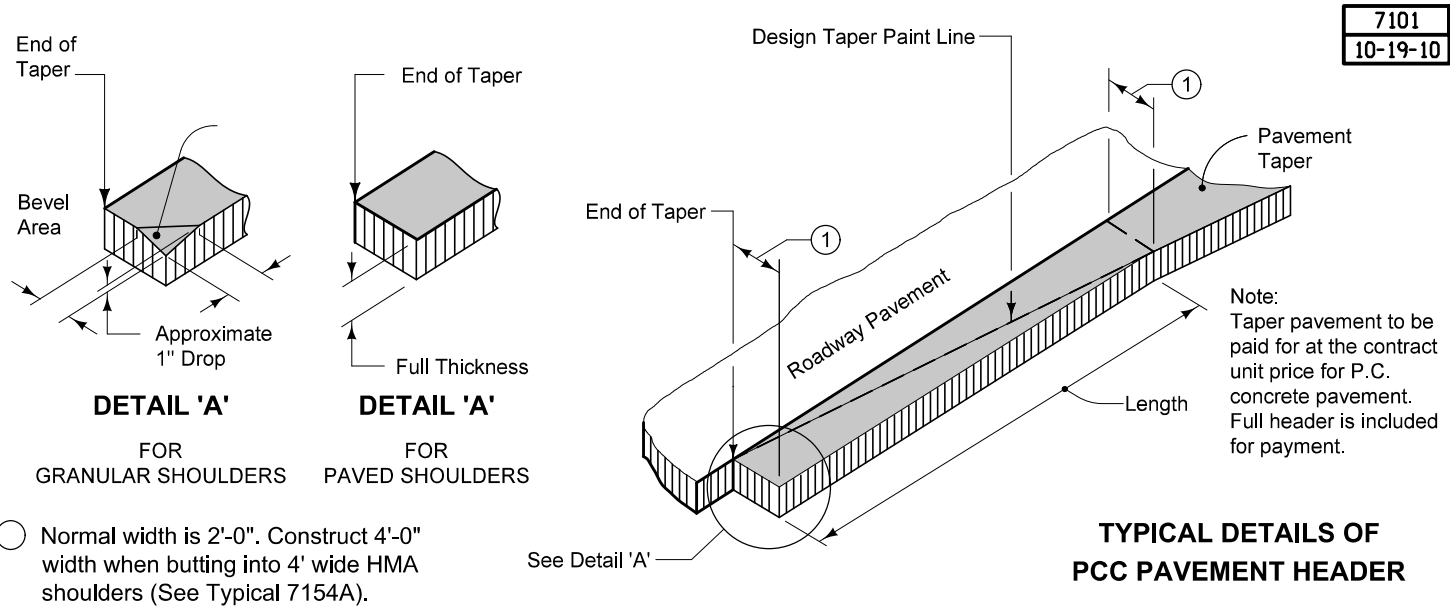

Note:
Taper pavement to be paid for at the contract unit price for P.C. concrete pavement. Full header is included for payment.

**TYPICAL DETAILS OF
PCC PAVEMENT HEADER**

7154A
10-20-09

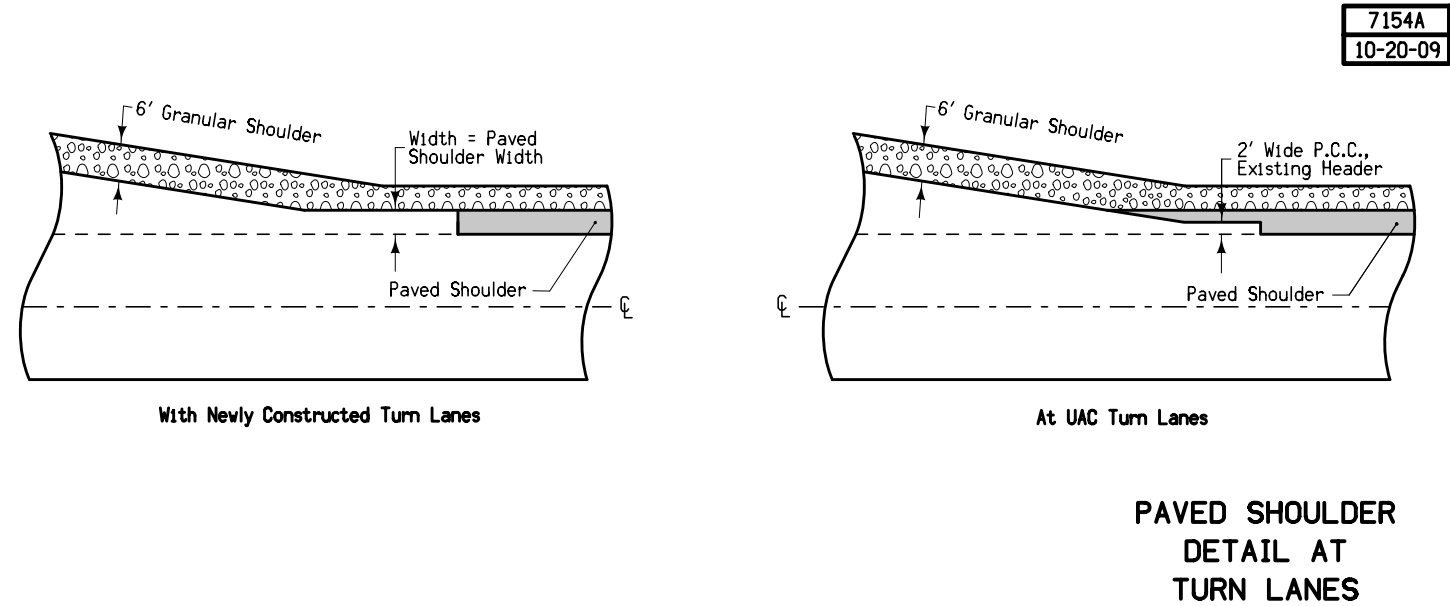

**PAVED SHOULDER
DETAIL AT
TURN LANES**

7154B
10-19-21

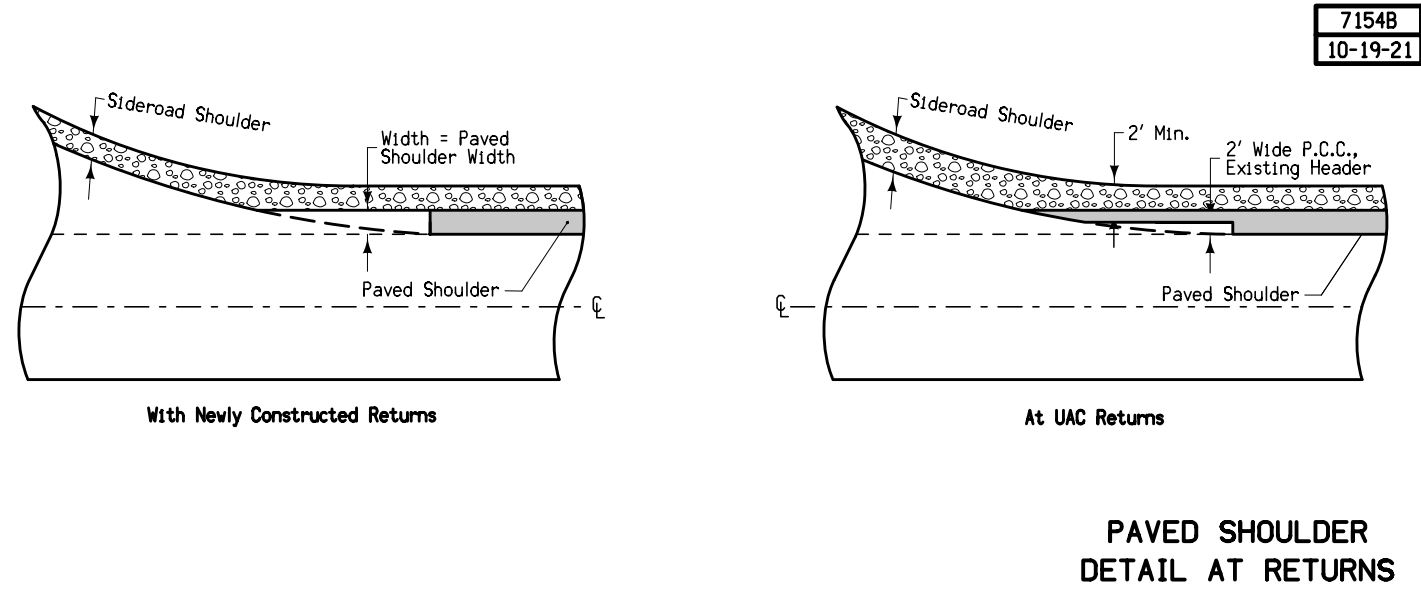

**PAVED SHOULDER
DETAIL AT RETURNS**

DRAINAGE STRUCTURE BY ROAD CONTRACTOR

Length of unclassified pipe calculated is based on using Reinforced Concrete Pipe.

- * Not a bid item
- ① Diameter or equivalent diameter
- ② UNCL = Unclassified Pipe CMP = Corrugated Metal Pipe RCP = Reinforced Concrete Pipe LCP = Arch or Elliptical Low Clearance Pipe SARC = Steel Arch Pipe
- ③ Backfill according to DR-101

Drainage Area ACRE	Location	Type	Size ① IN	Kind Of Pipe ②	Length New Const. LF	Bedding Class	Design Cover (H)		Apron No.		Apron Guard* (DR-213) No.	Elbow* (DR-141) No.	Diaphragm* (DR-501) No.	Tee Section* (DR-142) No.	"D" Section* (DR-141) No.	Reducer* No.	Type 'C' Connections* (DR-122) Type No.	Connected Pipe Joint* (DR-121) Type	4" Perforated Subdrain* FT	Flow Line Elevations				Dimensions Lin. Ft.				Skew Ahead Degrees		Dike			Class 20 CY	Flowable Mortar CY	Floodable* Backfill (A) CY	Porous* Backfill (B) CY	Flooded Backfill (A+B) CY	Remarks				
							FT	FT	IN	OUT										Lt.	Rt.	Other	Other	Lt.	Rt.	Lt.	Rt.	Lt.	Rt.	Lt.	Rt.	Lt.							Rt.	Location Station	Top Elevation	Type
	ML029																																									
2.9	722+49.78	DR-621	24	RCP	18	B	2.1	0.08		1	2										1046.14		1046.14																			
10.7	750+00.00	DR-601	30	RCP	158	B	2.2	0.08		1											1046.74	1047.51				88.9	81.4													Trenchless		
2.1	763+99.64	DR-621	24	RCP	24	B	2.2	0.08		1	2																															
5.0	772+56.80	DR-621	30	RCP	54	B	3.6	0.08		1											1046.42	1046.14	1046.41	1046.15																		
1.7	777+48.90	DR-621	24	RCP	20	B	3.1	0.08		1											1047.65		1047.92																			
	RPA175																																									
19.5	1552+00.00	DR-601	30	RCP	168	B	17.0	0.33		1	1										1044.80	1045.74				83.6	96.7														3000D	
	RPD175																																									
4.1	4549+50.00	DR-601	24	RCP	116	B	10.0	0.17		1	1										1047.60	1048.05				73.0	55.3															
	SR175																																									
75.4	1761+51.96	DR-601	30	LCP	96	B	2.0	0.08		1	1	2									1047.08	1046.92				63.6	48.4															Twin LCP 1/2
75.4	1761+58.04	DR-601	30	LCP	96	B	2.0	0.08		1	1	2									1047.08	1046.92				63.6	48.4															Twin LCP 2/2
1.6	1763+50.00	DR-601	24	LCP	82	B	1.8	0.08		1	1	2									1047.23	1047.18				47.3	46.7															

110-2
04-16-13

REMOVAL OF EXISTING STRUCTURES

Location	Description	Remarks
722+49.78	24" x 6' RCP	Apron removal incidental to culvert removal, ML029, partial
763+99.64	24" x 14' RCP	Apron removal incidental to culvert removal, ML029, partial
772+56.80	30" x 6' RCP	Apron removal incidental to culvert removal, ML029, partial
772+56.80	30" x 6' RCP	Apron removal incidental to culvert removal, ML029, partial
777+48.90	24" x 6' RCP	Apron removal incidental to culvert removal, ML029, partial
1734+99.30	Remove headwall left	Headwall removal, SR175, partial
1762+03.40	36" x 61' RCP	Apron removal incidental to culvert removal, SR175
1763+02.30	24" x 67' RCP	Apron removal incidental to culvert removal, SR175
1549+75.00	30" x 73' RCP	Apron removal incidental to culvert removal, RPA175
2537+25.00	112" x 75" x 72' LCP	Headwall removal incidental to box culvert removal, RPB175
3539+95.00	6' x 8' x 51' RCB	Headwall removal incidental to box culvert removal, RPC175

SURVEY SYMBOLS

- Interstate Highway Symbol
- U.S. Highway Symbol
- Iowa Highway Symbol
- County Road Highway Symbol
- Evergreen Tree
- Deciduous Tree
- Fruit Tree
- Shrub (Bushes)
- Timber
- Hedge
- Stump
- Swamp
- Rock Outcrop
- Broken Concrete
- Revetment (Rip Rap)
- Cemetery
- Grave
- Cave
- Sink Hole
- Board Fence
- Chain Link or Security Fence
- Wire Fence
- Terrace
- Earth Dam or Dike (Existing)
- Tile Outlet
- Edge of Water
- Existing Drainage
- Right of Way Rail or Lot Corner
- Concrete Monument
- Well
- Windmill
- Beehive Intake
- Existing Intake
- Existing Utility Access (Manhole)
- Fire Hydrant
- Water Hydrant (Rural)
- Septic Tank
- SIGN Sign
- TCB Traffic Signal Control Box
- RRB Rail Road Signal Control Box
- TSB Telephone Switch Box
- EB Electric Box

- Cistern
- L.P. Gas Tank (No Footing)
- Underground Storage Tank
- Latrine
- Satellite TV Dish
- Water Hook Up
- Radio Tower
- Tower Anchor
- Guardrail (Beam or Cable)
- Guard Post (one or two)
- Guard Post (over two)
- Filler Pipe
- Gas Valve
- Water Valve
- Speed Limit Sign
- Mile Marker Post

UTILITY LEGEND

- F0** — Midwest Fiber Networks
Contact Name: Cory Schmuki
Contact Phone: (414) 349-2764
Contact Email: cschmuki@midwestfibernetworks.com
- F02** — Long Lines Ltd.
Contact Name: Tom Connors
Contact Phone: (712) 333-5526
Contact Email: tom.connors@longlines.biz
- W** — City Of Onawa
Contact Name: John Casady
Contact Phone: (712) 420-0941
Contact Email: jcasady@onawa.com
- TV** — Long Lines Ltd.
Contact Name: Tom Connors
Contact Phone: (712) 333-5526
Contact Email: tom.connors@longlines.biz
- T1** — Lumen Centurylink
Contact Name: Steve Parker
Contact Phone: (507) 358-1978
Contact Email: Steve.Parker4@lumen.com
- T2** — Long Lines Ltd.
Contact Name: Tom Connors
Contact Phone: (712) 333-5526
Contact Email: tom.connors@longlines.biz
- E1** — Western Iowa Power Cooperative
Contact Name: Jeremy Kreger
Contact Phone: (712) 420-1126
Contact Email: jeremy.kreger@wipco.com
- E2** — Iowa Department Of Transportation
Contact Name: Jason Dale
Contact Phone: (515) 239-1995
Contact Email: Jason.Dale@iowadot.us
- G** — Black Hills Energy
Contact Name: Brad Fleming
Contact Phone: (402) 660-0812
Contact Email: brad.fleming@blackhillscorp.com
- SAN. (B) -** City Of Onawa
Contact Name: John Casady
Contact Phone: (712) 420-0941
Contact Email: jcasady@onawa.com

PLAN VIEW COLOR LEGEND OF PLAN AND PROFILE SHEETS

LINEWORK		Design Color No.
Green	(2)	Existing Topographic Features and Labels
Blue	(1)	Proposed Alignment, Stationing, Tic Marks, and Alignment Annotation
Magenta	(5)	Existing Utilities
SHADING		Design Color No.
Lavender	(9)	Temporary Pavement Shading
Yellow	(4)	Proposed Pavement Shading
Orange	(6)	Proposed Granular Shading
Orange	(70)	Proposed Shoulder Granular Shading
Yellow	(68)	Proposed Shoulder Paved Full Depth Shading
Yellow	(132)	Proposed Shoulder Paved Partial Depth Shading
Brown, Light	(112)	Proposed Roadway Grading Shading
Brown, Light	(236)	Proposed Grading Shading
Brown	(238)	Previously Constructed Grading Shading
Orange, Light	(134)	Proposed Granular Entrance Shading
Yellow	(220)	Proposed Paved Entrance Shading
Tan	(8)	Proposed Sidewalk Shading
Blue, Light	(230)	Proposed Sidewalk Landing Shading
Pink	(11)	Proposed Sidewalk Ramp Shading
Green, Light	(225)	Existing Pavement Shading
Red	(131)	Proposed Structure Shading (50% Transparency)
Red	(3)	Delineates Restricted Areas

PROFILE VIEW COLOR LEGEND OF PLAN AND PROFILE SHEETS

LINEWORK		Design Color No.
Green	(10)	Existing Ground Line Profile
Blue	(1)	Proposed Profile and Annotation
Magenta	(5)	Existing Utilities
Blue, Light	(230)	Proposed Ditch Grades, Left
Black	(0)	Proposed Ditch Grades, Median
Rust	(14)	Proposed Ditch Grades, Right

- Reference Point
- Station
- Survey Line
- Section Corner
- Ground Line Intercept (Permanent)
- Ground Line Intercept (Temporary)
- Saw Cut
- Guardrail
- Trench Drain
- HighTension Cable Guardrail
- Sheet Pile
- Pavement Removal
- Clearing & Grubbing Area

RIGHT-OF-WAY LEGEND

- Proposed Right-of-Way
- Existing Right of Way
- Existing and Proposed Right-of-Way
- Easement and Existing Right-of-Way
- Easement (Temporary)
- Easement
- Access Control
- Property Line

PLAN AND PROFILE LEGEND AND SYMBOL INFORMATION SHEET

(COVERS SHEET SERIES D, E, F, & K)

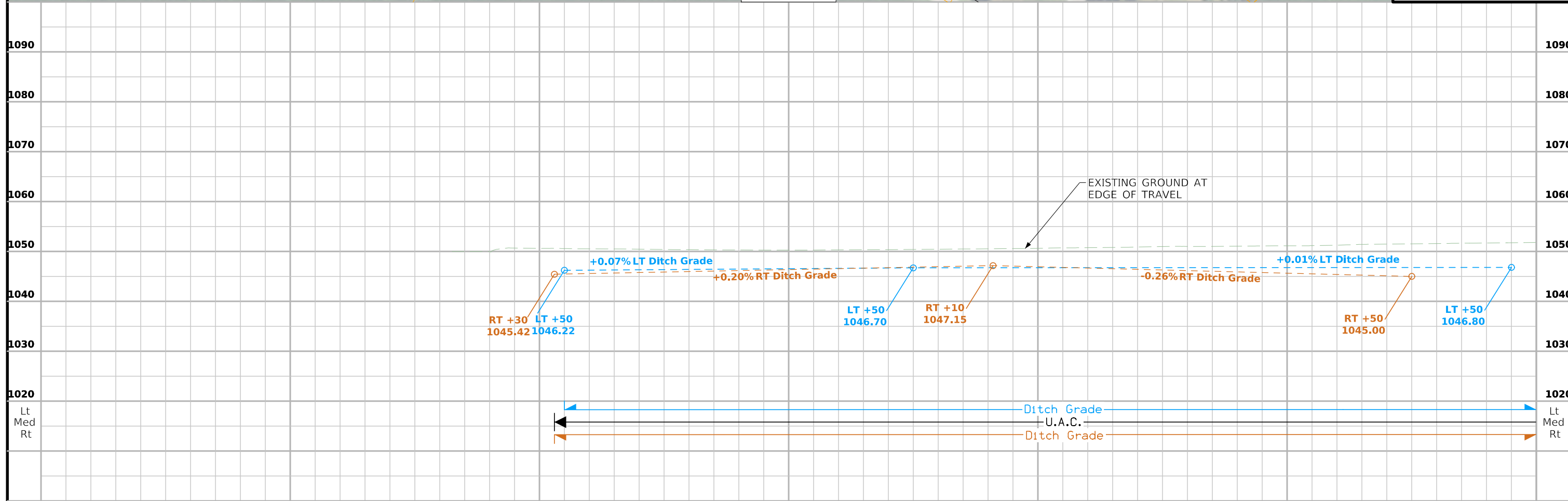
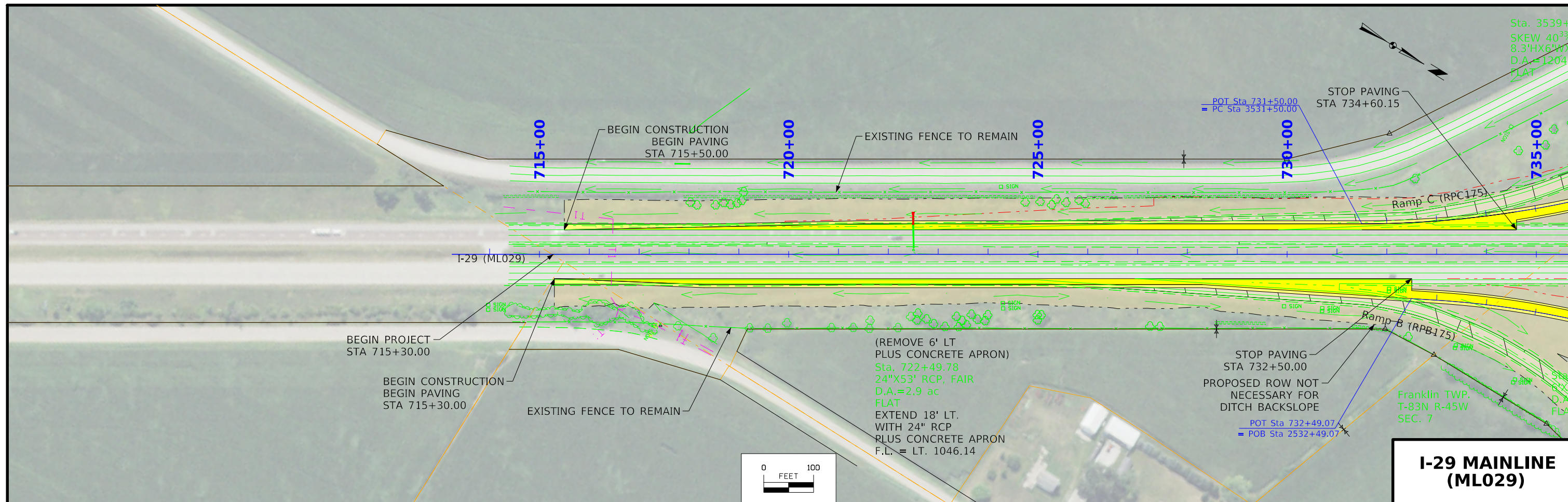

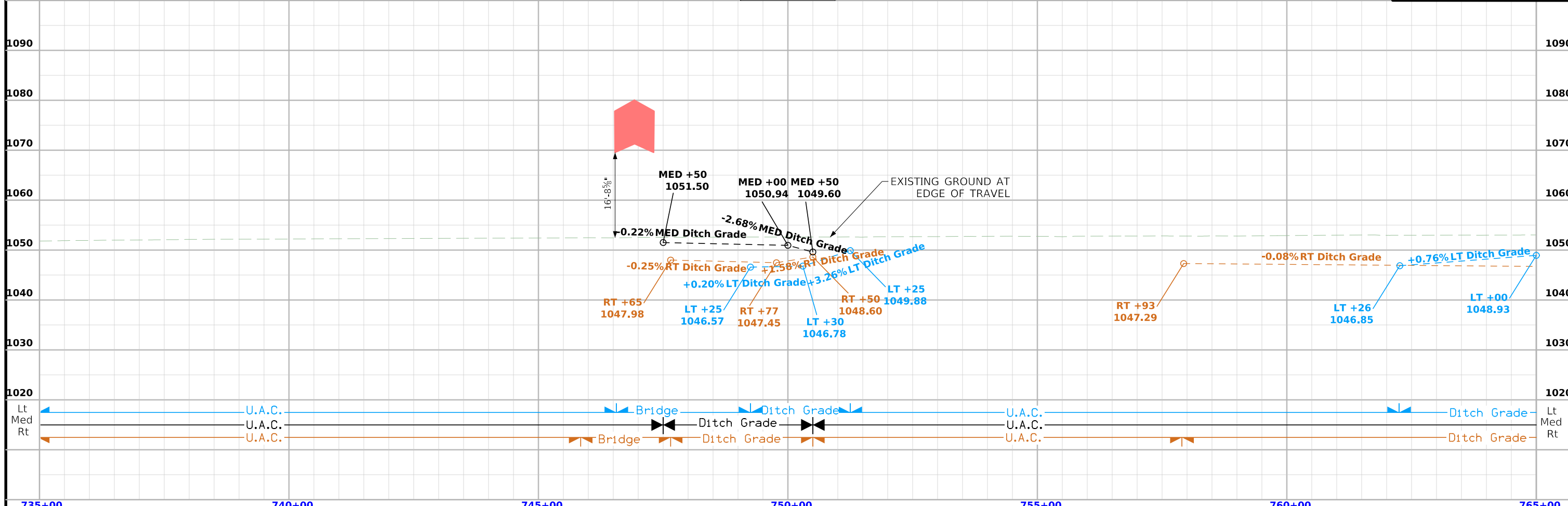
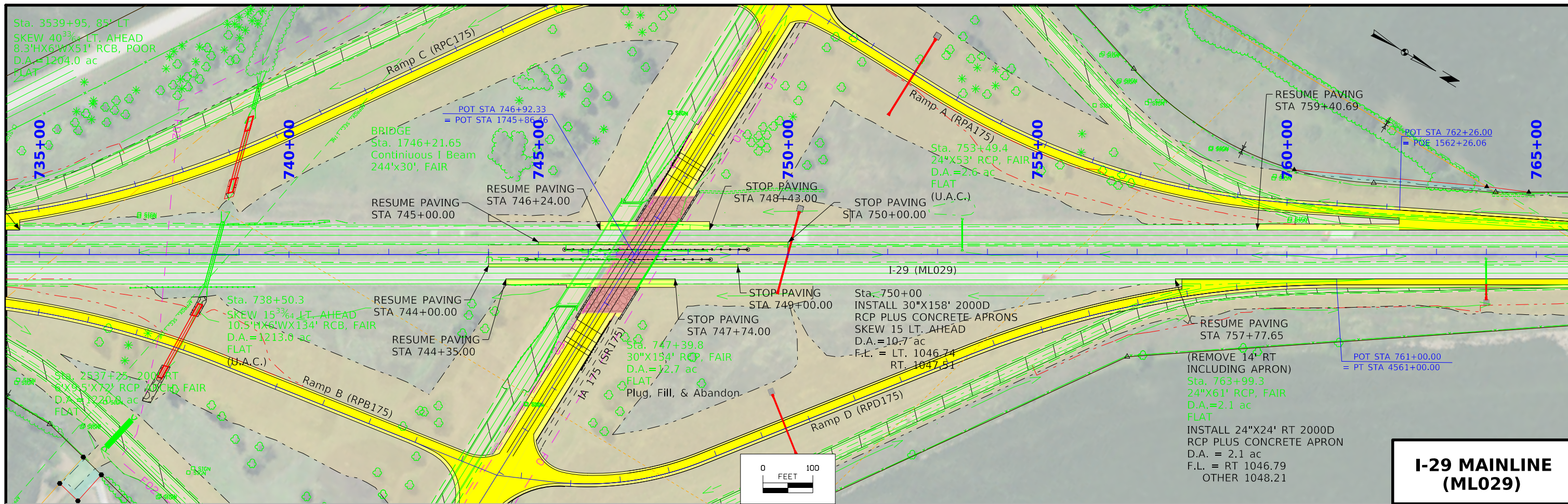

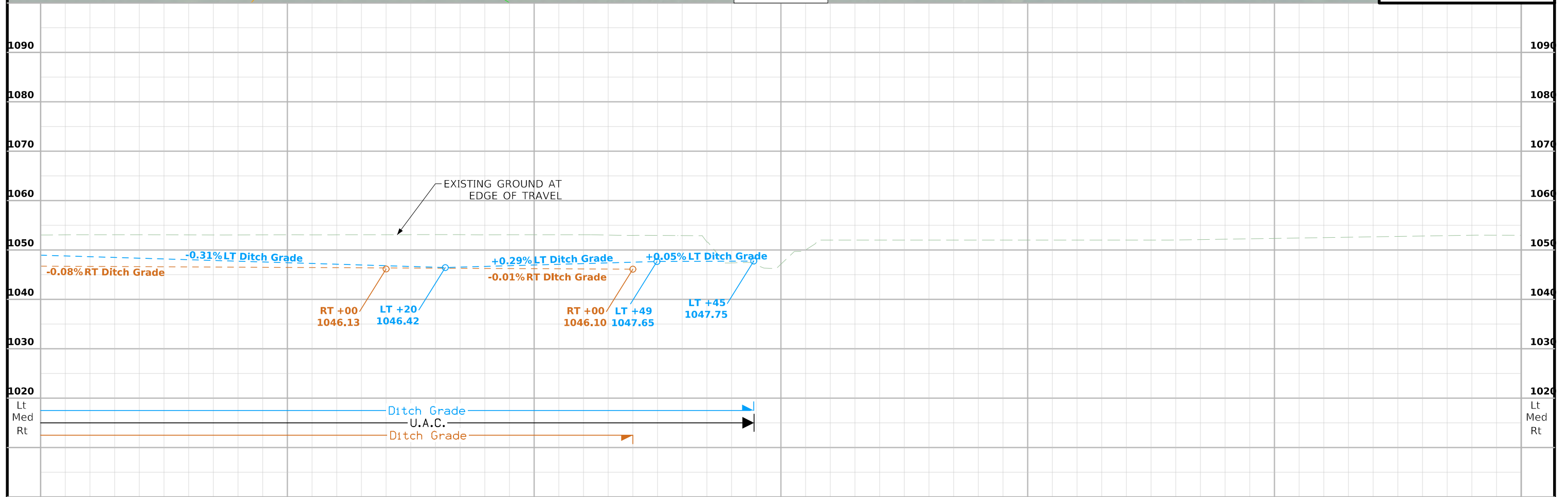
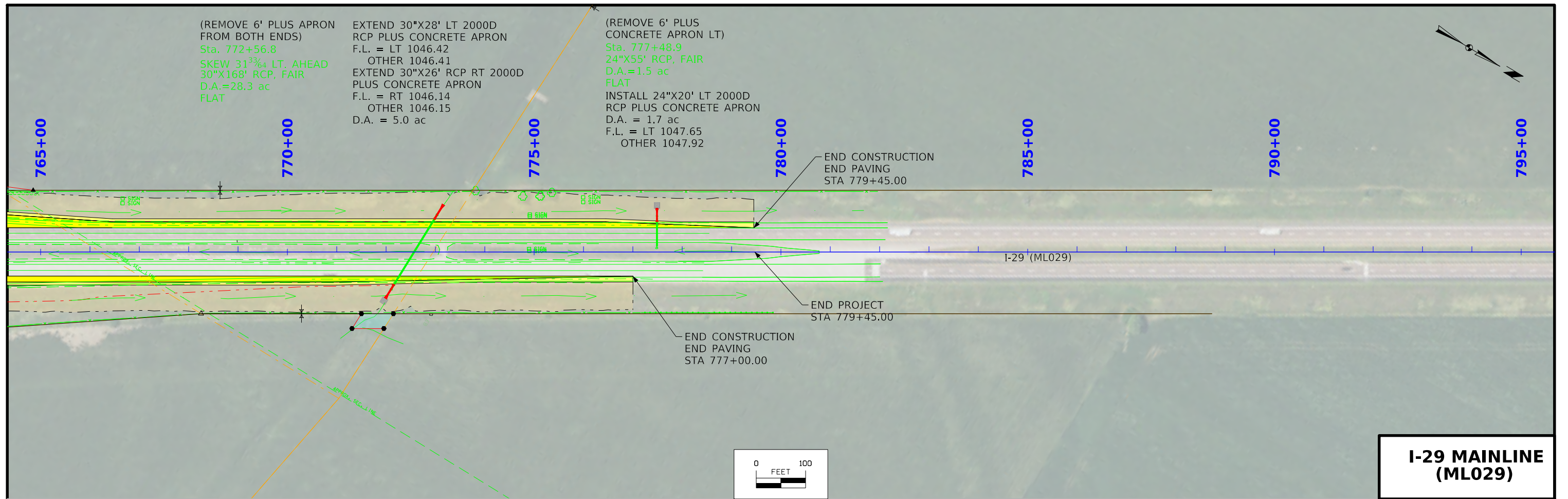

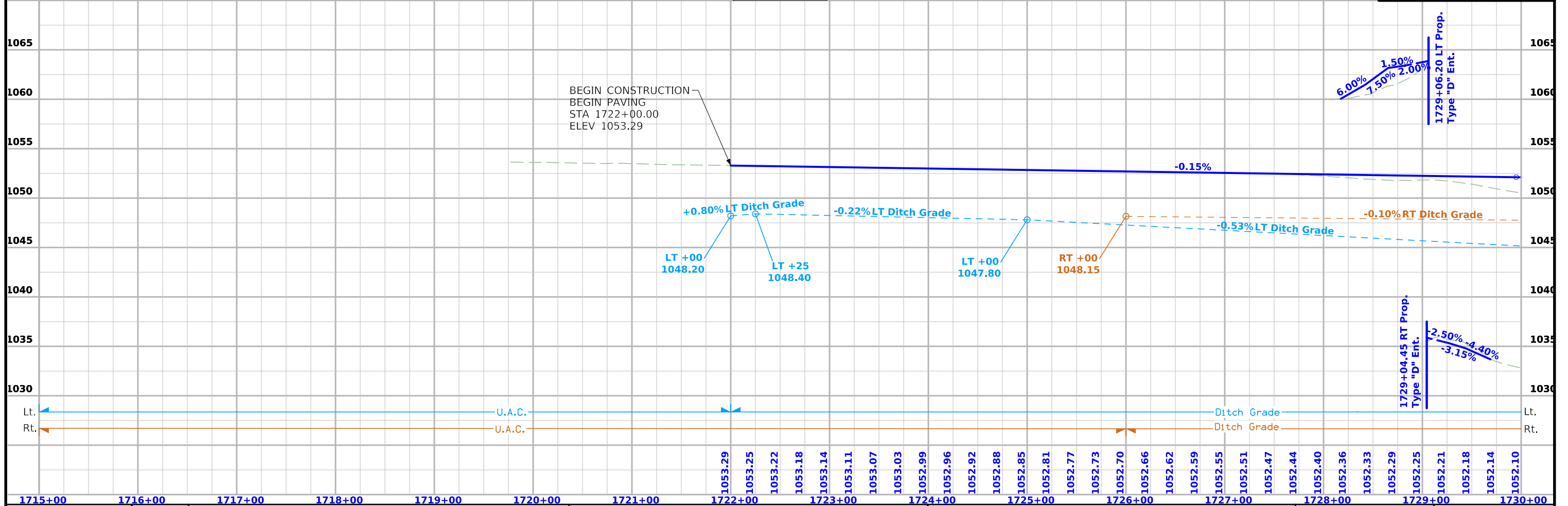
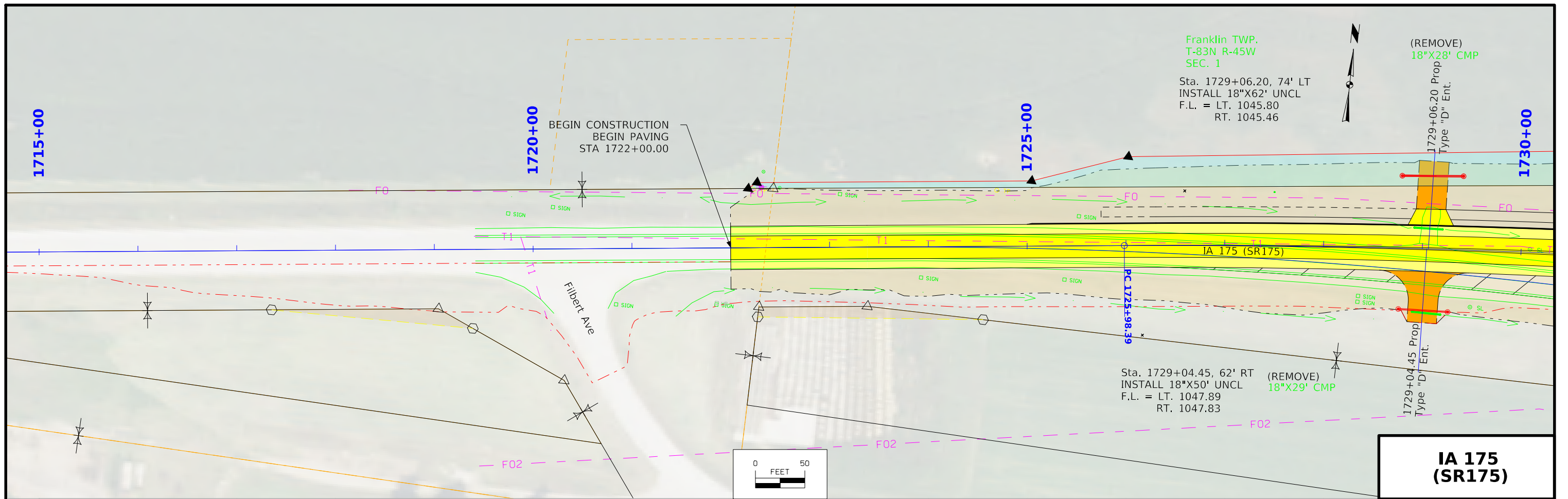

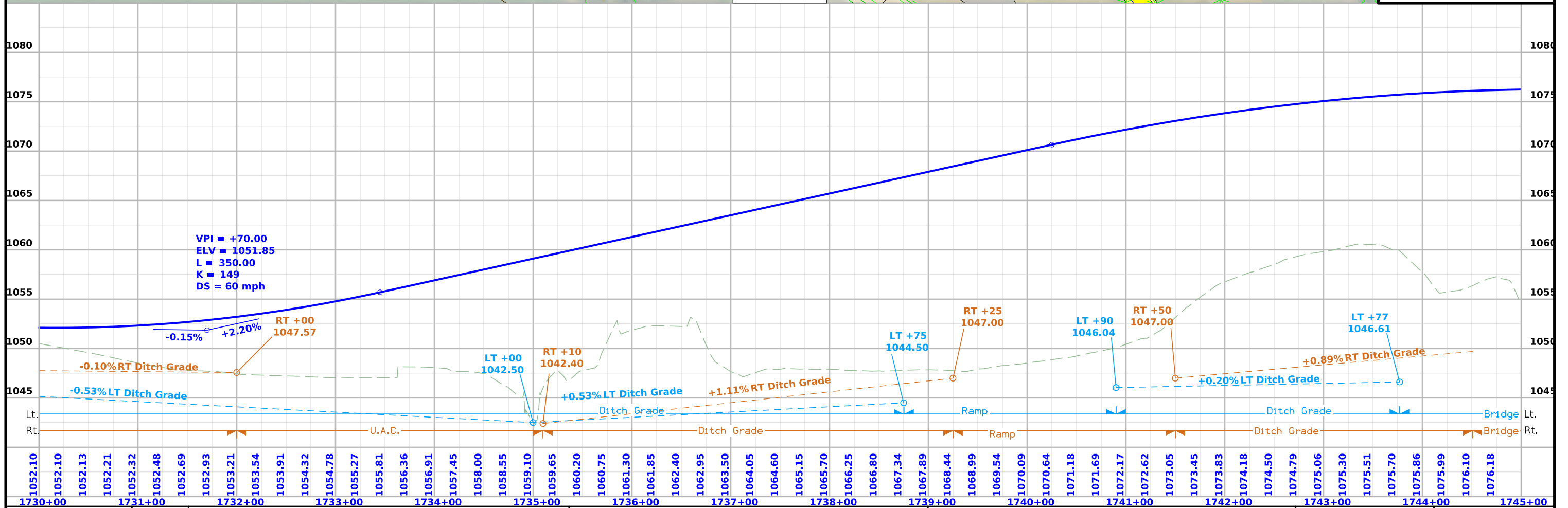
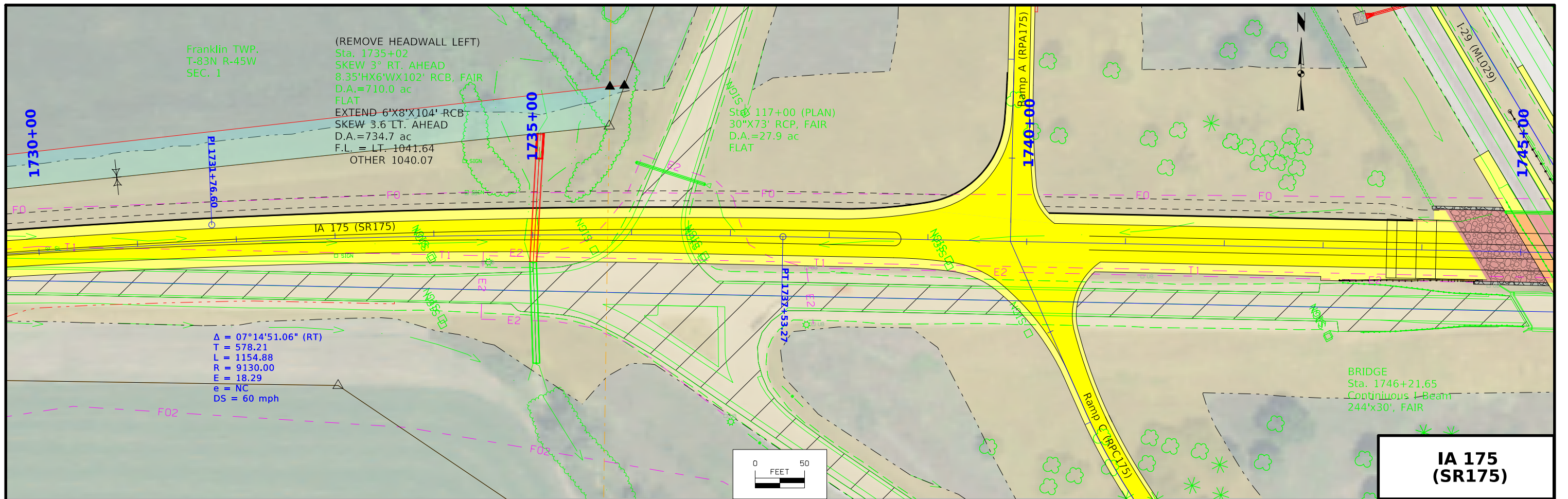

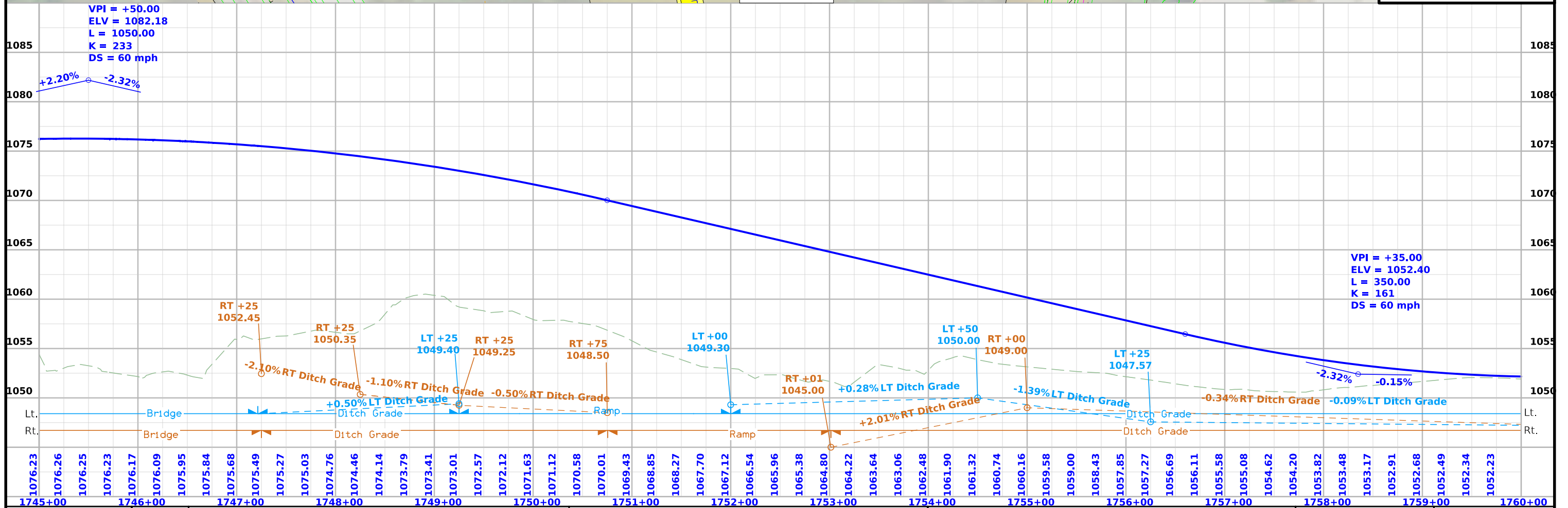
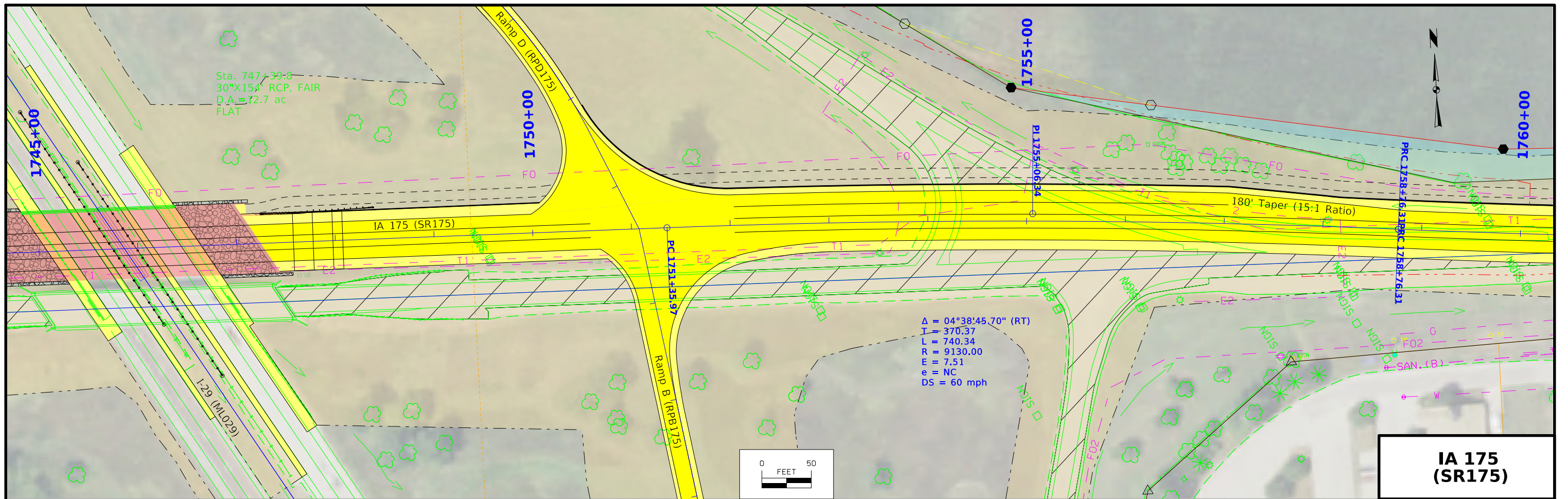

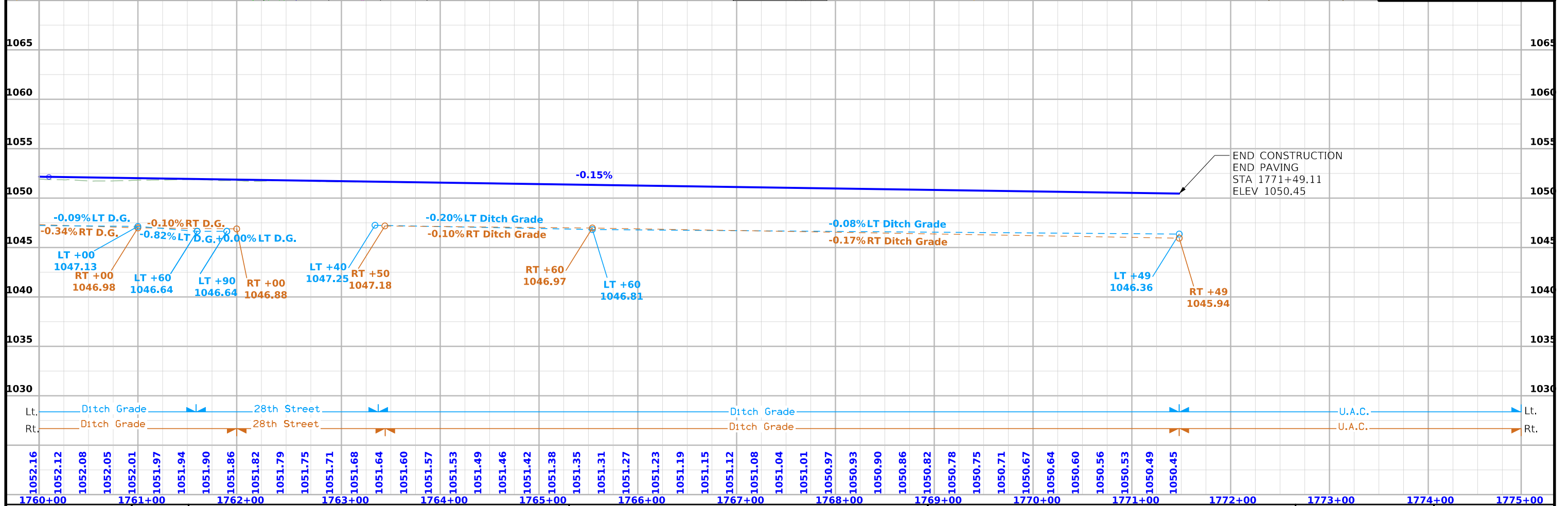
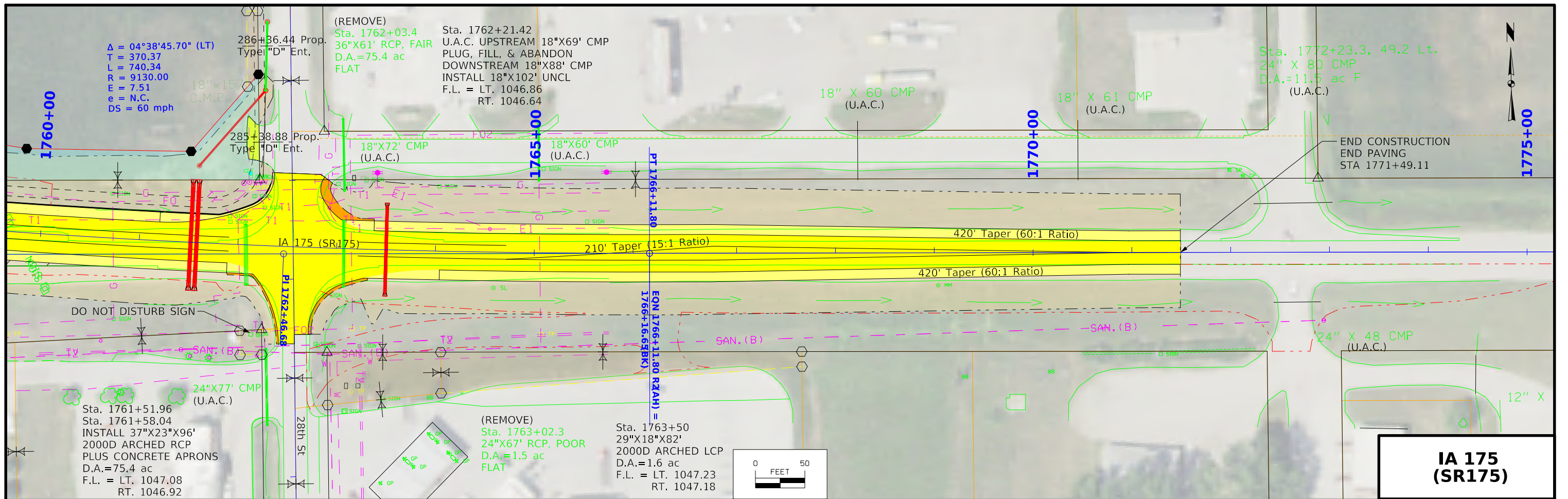

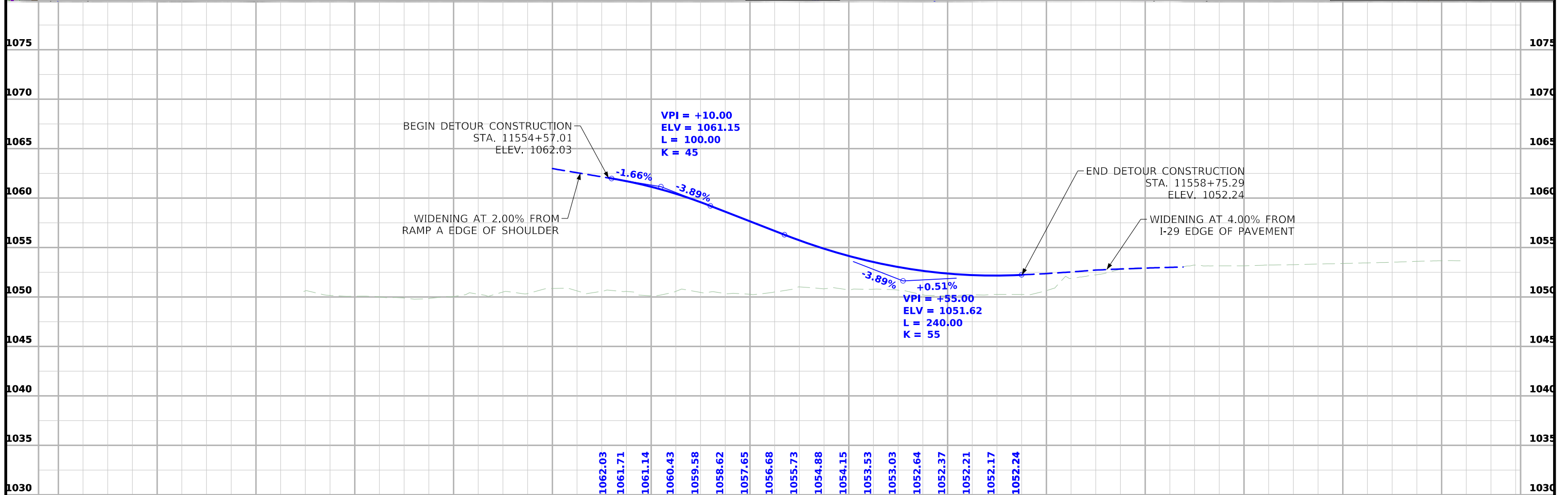
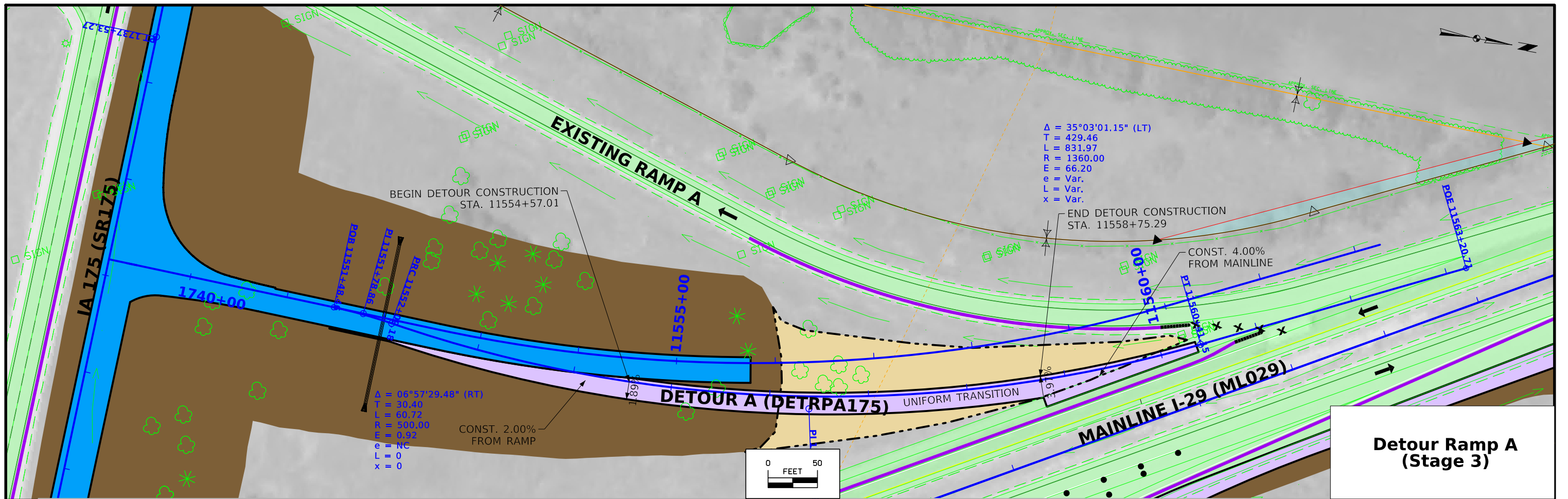

FILE NO.	ENGLISH	DESIGN TEAM	Iowa DOT / HR Green	MONONA COUNTY	PROJECT NUMBER	STP-175-1(95)--2C-67	SHEET NUMBER	F.1
----------	---------	-------------	---------------------	---------------	----------------	----------------------	--------------	-----

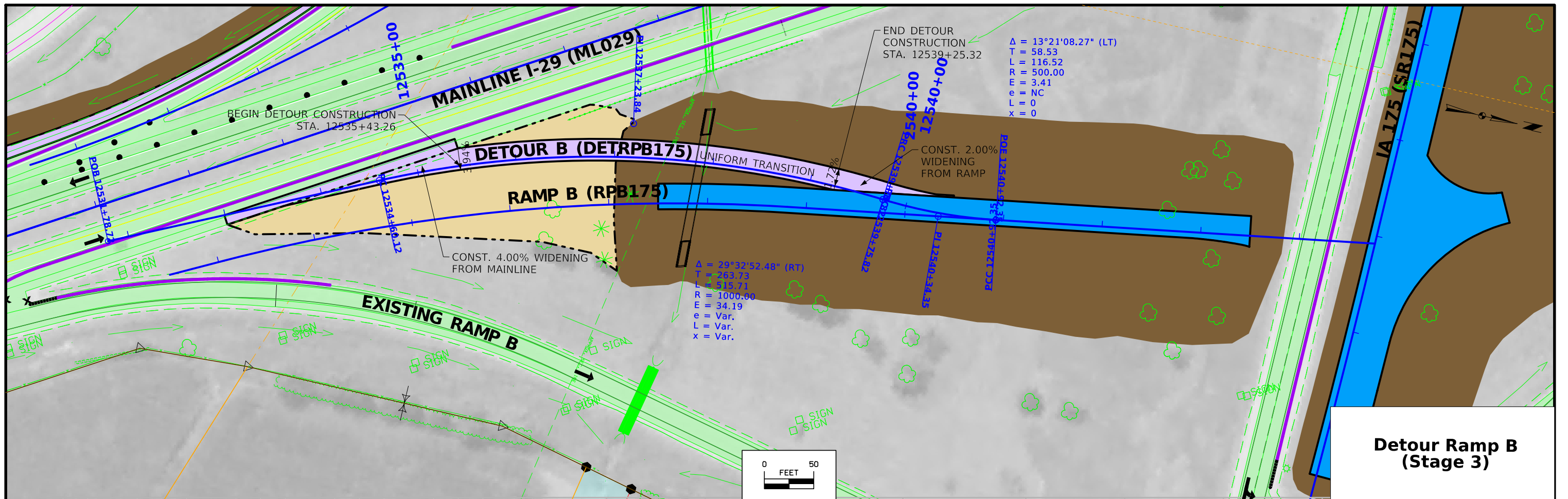

Detour Ramp B (Stage 3)

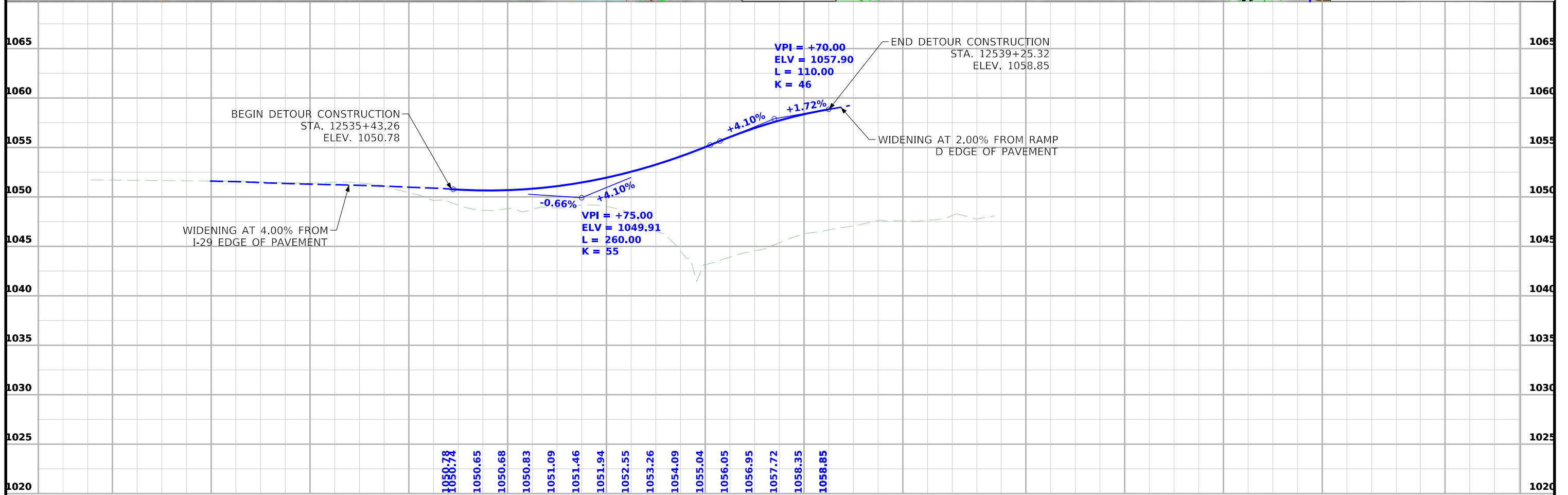



**Detour Widening
Ramp C
(Stage 3)**

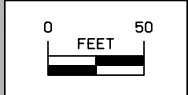

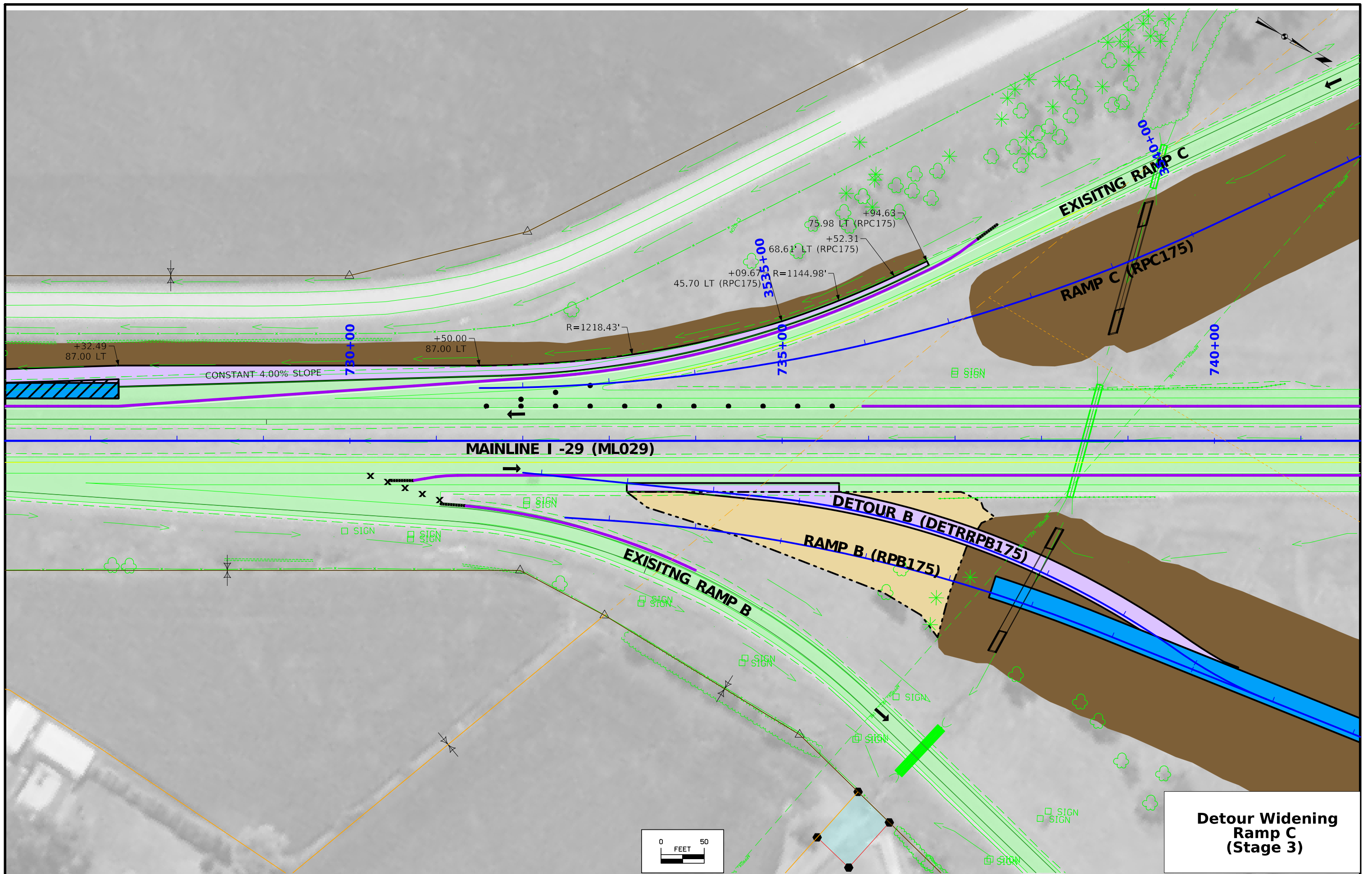

**Detour Widening
Ramp C
(Stage 3)**

FILE NO.	ENGLISH	DESIGN TEAM Iowa DOT / HR Green	MONONA COUNTY	PROJECT NUMBER STP-175-1(95)--2C-67	SHEET NUMBER F.4
1:32:17 PM	2/9/2024	rtyrrel	pw:\projectwise.dot.int.lan:PWMain\Documents\Projects\6717502021\Design\CADD_Files\Sheet_Files\SHT_6717502021_F03_Z06.dgn		

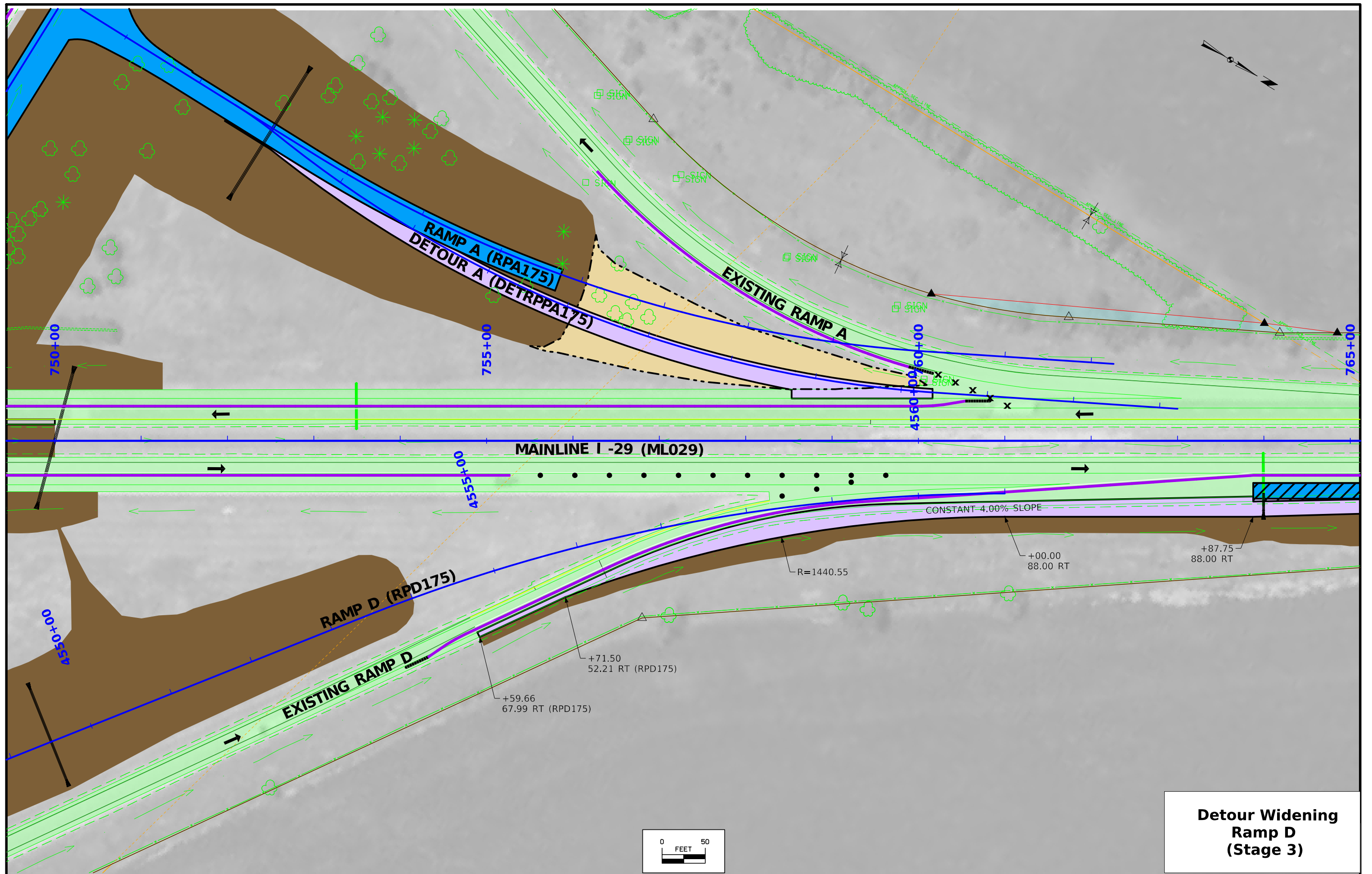

**Detour Widening
Ramp D
(Stage 3)**



**Detour Widening
Ramp D
(Stage 3)**

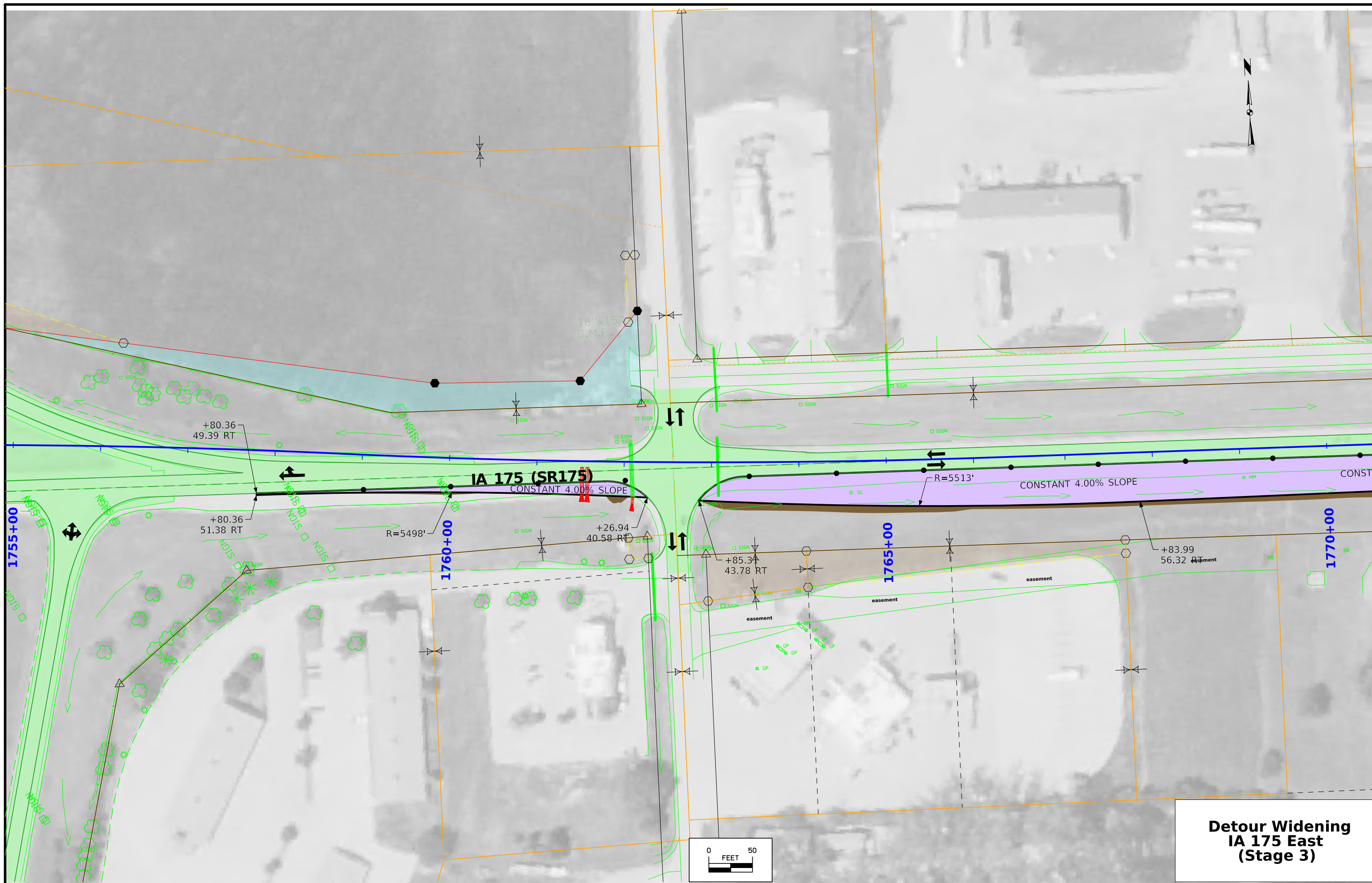

**Detour Widening
IA 175 East
(Stage 3)**

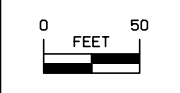

FILE NO.	ENGLISH	DESIGN TEAM Iowa DOT / HR Green	MONONA COUNTY	PROJECT NUMBER STP-175-1(95)--2C-67	SHEET NUMBER F.7
1:33:19 PM	2/9/2024	rtyrrel	pw:\projectwise.dot.int\lan:PWM\Main\Documents\Projects\6717502021\Design\CADD_Files\Sheet_Files\SHT_6717502021_F05_Z06.dgn		

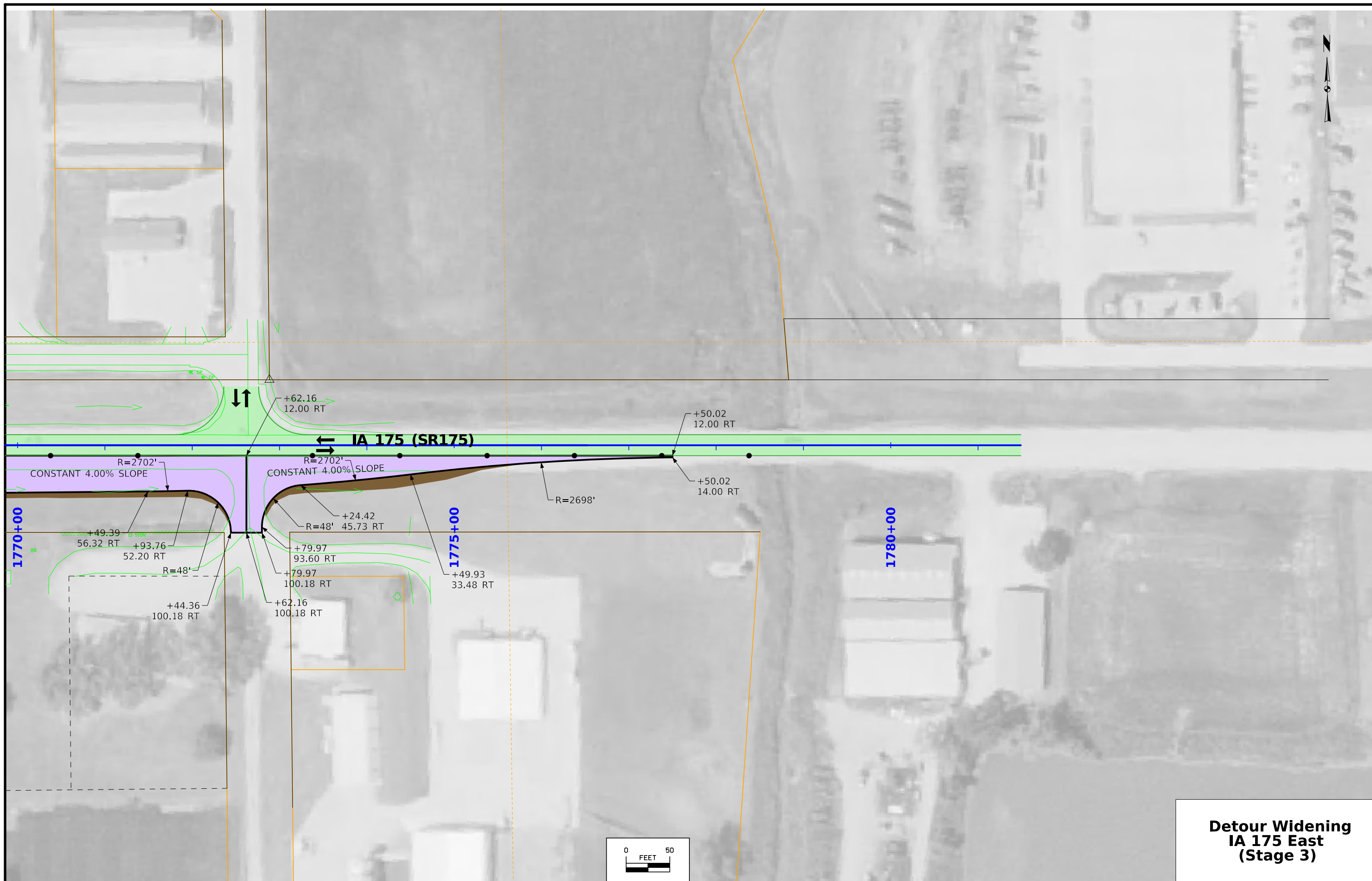

**Detour Widening
IA 175 East
(Stage 3)**

Franklin TWP.
T-83N R-45W
SEC. 1

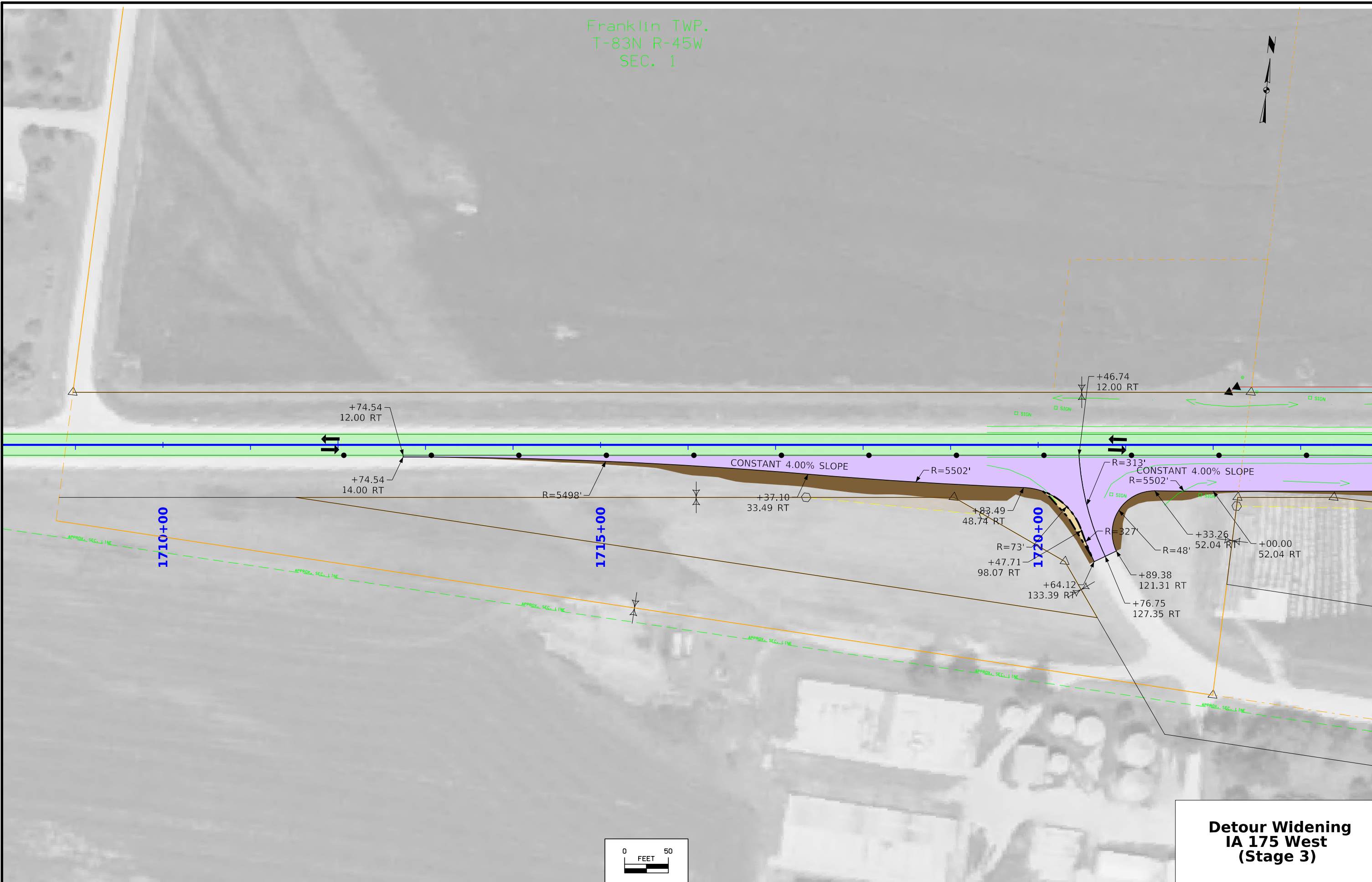

**Detour Widening
IA 175 West
(Stage 3)**

Franklin TWP.
T-83N R-45W
SEC. 1

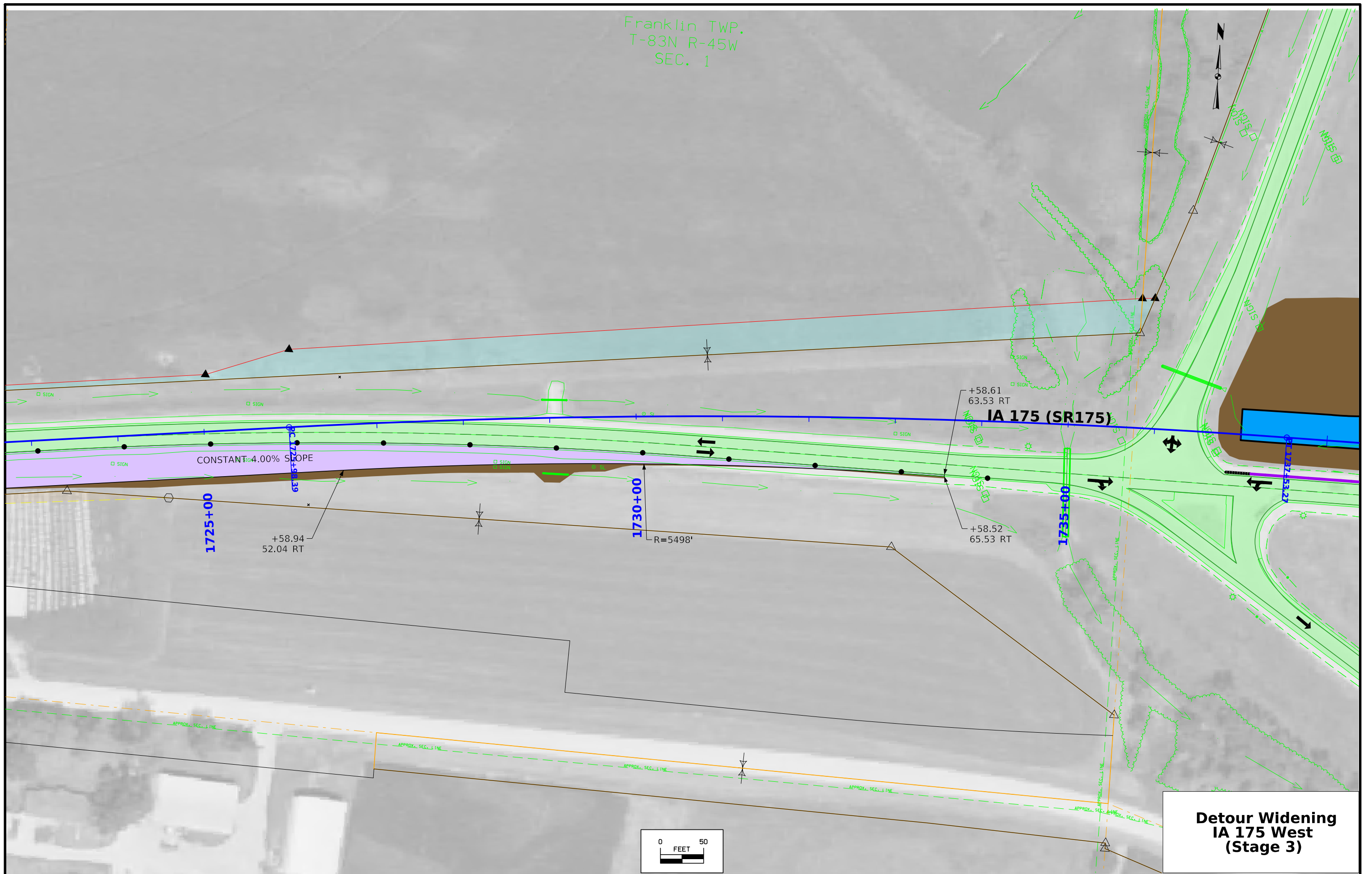

**Detour Widening
IA 175 West
(Stage 3)**

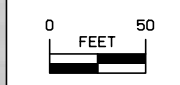

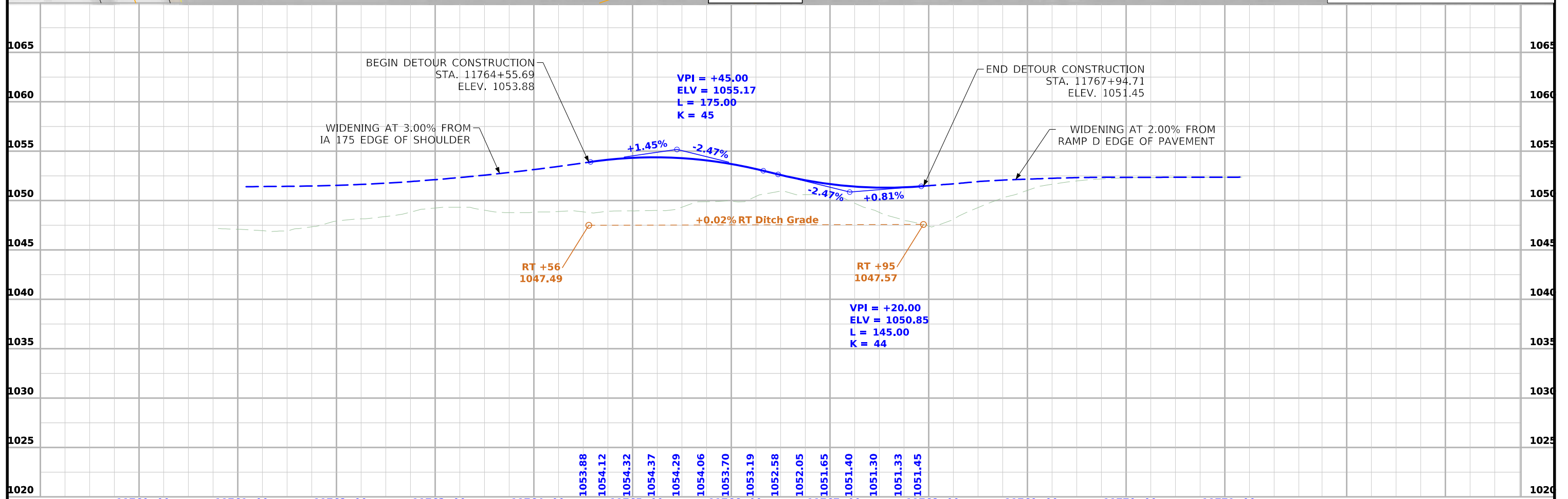
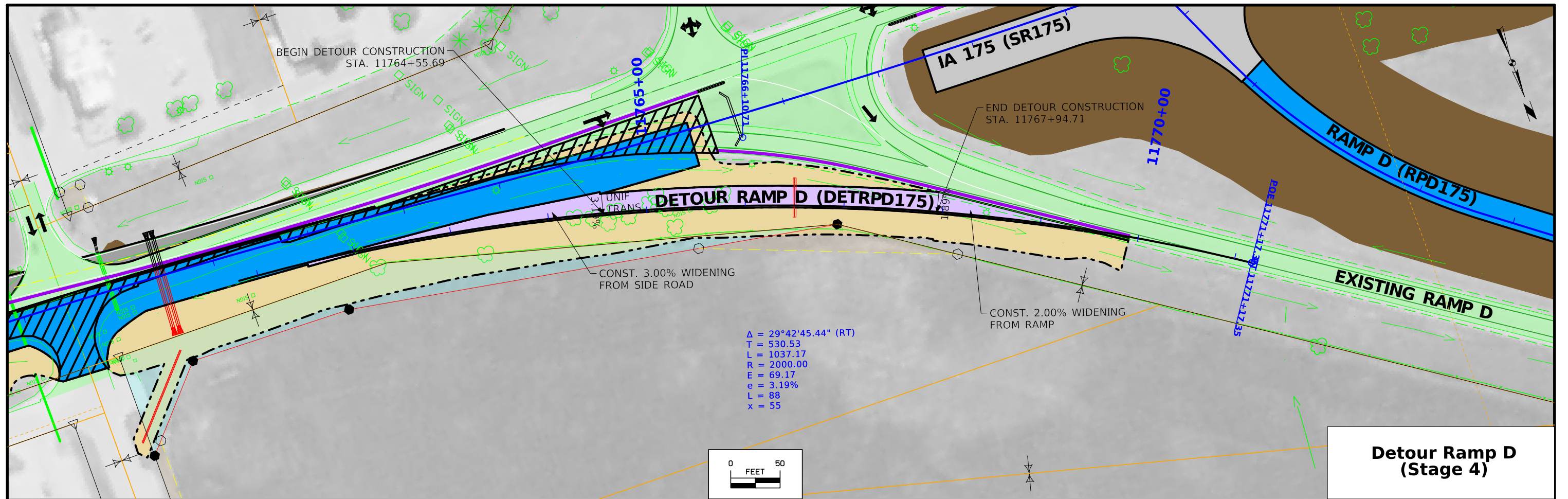

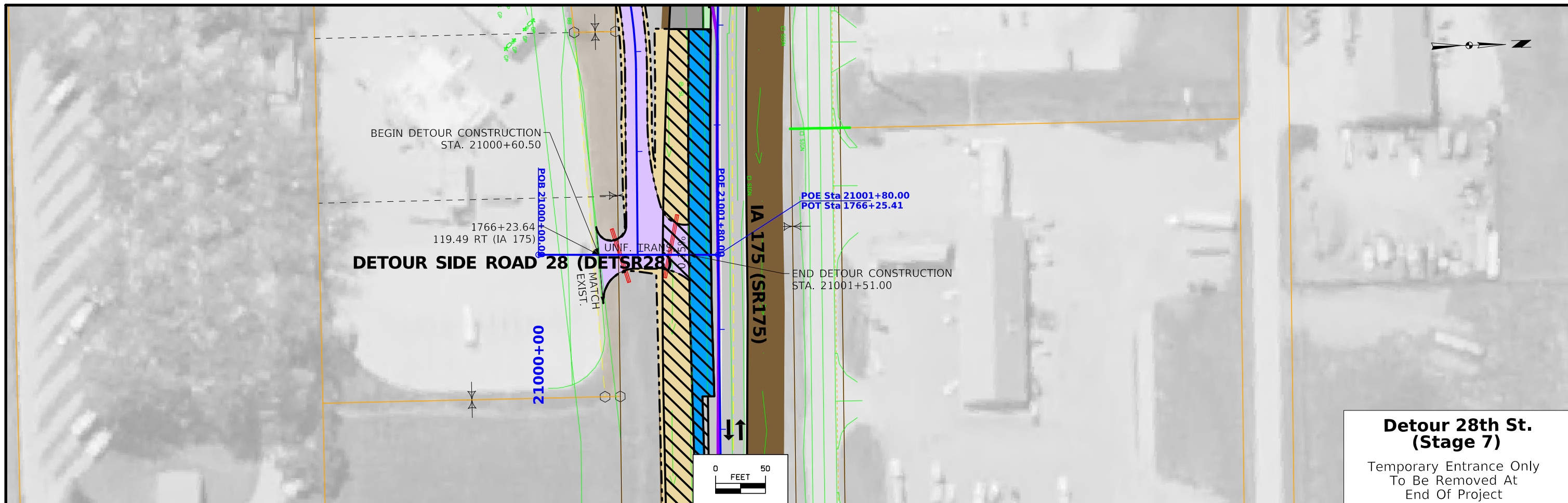

**Detour 28th St.
(Stage 7)**
Temporary Entrance Only
To Be Removed At
End Of Project

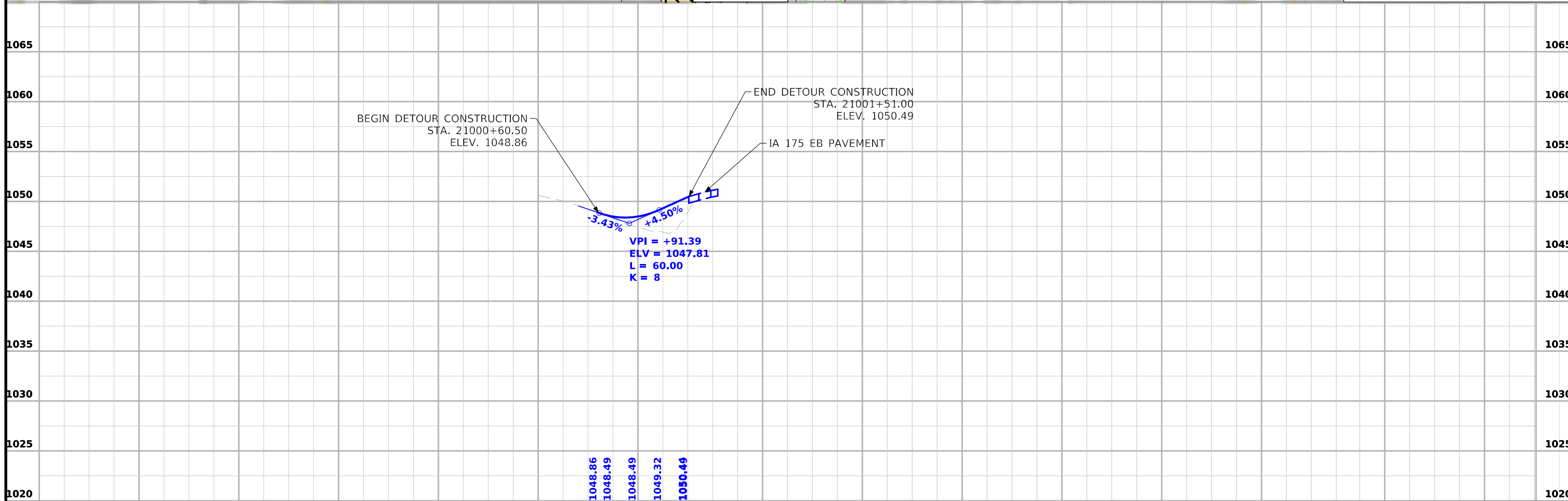

FILE NO.	ENGLISH	DESIGN TEAM Iowa DOT / HR Green	MONONA COUNTY	PROJECT NUMBER STP-175-1(95)--2C-67	SHEET NUMBER F.12
----------	---------	--	----------------------	--	--------------------------

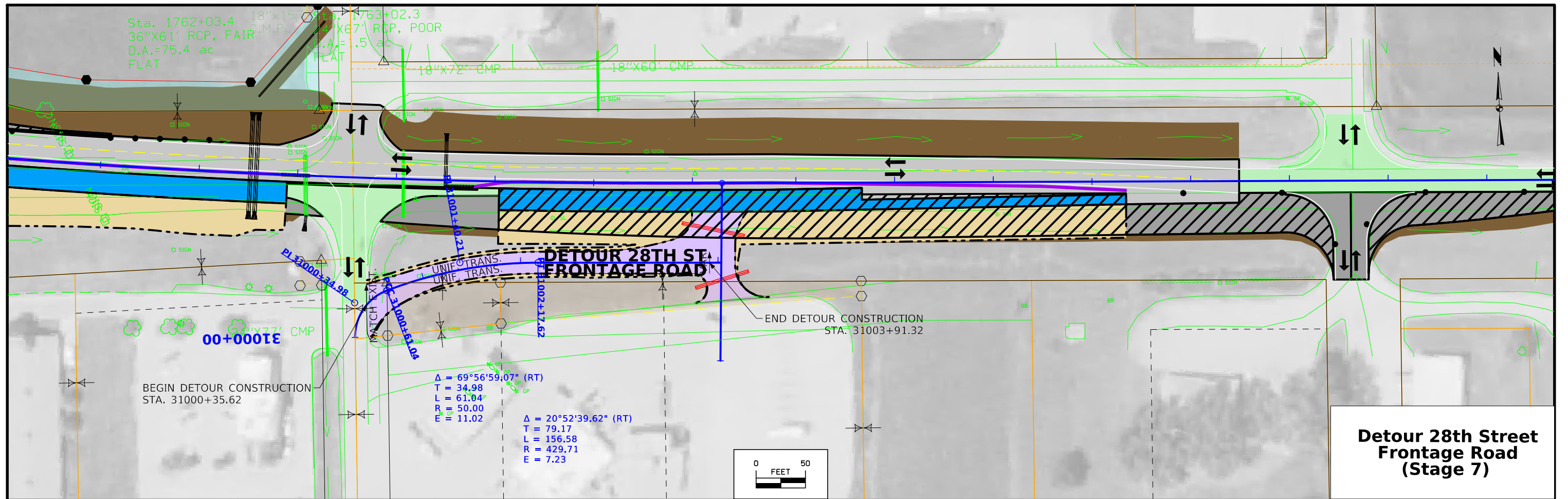

**Detour 28th Street
Frontage Road
(Stage 7)**

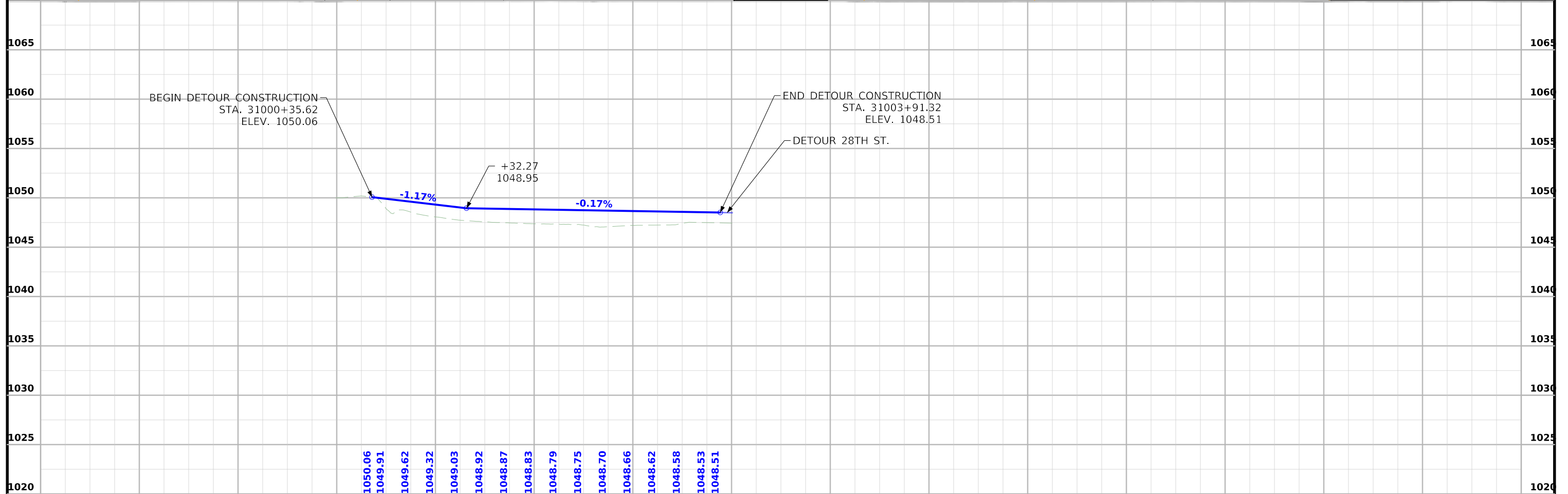

FILE NO.	ENGLISH	DESIGN TEAM	Iowa DOT / HR Green	MONONA COUNTY	PROJECT NUMBER	STP-175-1(95)--2C-67	SHEET NUMBER	F.13
----------	---------	-------------	----------------------------	---------------	----------------	-----------------------------	--------------	-------------

Survey Information

SURVEY INDEX

County: Monona
PIN: 21-67-175-020
Project Number: STP-175-1(95)—2C-67
Location: I-29 and IA 175 interchange
Type of Work: PCC pavement grade and replace
Project Directory: 6717502021

Survey Personnel

Tom Hoyle – Lead Survey Technician
Brad Duffy – Survey Technician
Max Phillips - Survey Technician
Dave Ciskowski – Survey Technician

Date(s) of Survey

Begin Date 10/10/2022
End Date 12/09/2022

General Information

This survey is for the I-29 and IA 175 interchange west of Onawa. This project is a partial and Full Field DTM survey with Photo control. Measurement units for this survey are US survey feet.

Utility Information

For logging data and other utility details see Utility Survey and Ownership Report in the Utility folder of the PrelimSurvey project directory.

Project Control

Coordinates were determined for primary project control points 1, 2, and 3 by conducting multiple 30-minute static observations. Post processing is constrained to nearby Iowa Real Time Network reference stations.

The RTN position of reference station Onawa (IAOA) was held fixed horizontally and vertically, Sloan (IASN) was held horizontally. NGS mark Q 181 (NM1907) was tied it's record orthometric height of 1051.06 is 0.177' higher than the elevation derived by this survey of 1050.883.

A double run level loop was run through control points 1-9 and benchmarks 500-505. The GPS derived elevations of control points 1 and 2 were held fixed. The estimated standard error of the observed height differences from the network adjustment was 0.0069 ft/mile.

PROJECT DATUM: NAD83(2011) for EPOCH 2010.00 (IaRTN 2019 ADJUSTMENT)
COORDINATE SYSTEM: IOWA REGIONAL COORDINATE SYSTEM ZONE 6
(U.S. SURVEY FOOT)
VERTICAL DATUM: NAVD88
GEOID MODEL: 2018

Alignment Information

The horizontal alignment for I-29 in this survey is a retrace of As-built Plans No. I-29_6(7)114. Several monuments were found along the tangent of I-29 and used to create the tangent of I-29 in this project area. This tangent was intersected with the tangent of IA 175 and the Survey stationing was equated to the IA 175 and I-29 intersection plan Sta. of 746+21.65 and run back and ahead without equation throughout the survey.

Survey stationing relates to as built plan stationing as follows:

PI Sta. 746+21.65 As-built Plans Project No. I-29_6(7)114
Survey POT Sta. 746+21.65.

The horizontal alignment for IA 175 this survey is a retrace of As-built Plans No. F-993(1) and I-29_6(7)114. Survey stationing was equated to the plan PI at Sta. 1727+01.00 and run back and ahead without equation throughout the survey.

Survey stationing relates to as built plan stationing as follows:

PI Sta. 1727+01.00 As-built Plans Project No. F-993(1) and I-29_6(7)114.
Survey PI Sta. 1727+01.00.

CONTROL POINT VICINITY MAP

This map is a guide to the vicinity of the primary project control points. Primary control is for use with RTK base stations and for RTN validation. Future surveys will use primary project control to establish temporary control as needed for construction or other surveying applications.



HORIZ. DATUM: NAD83(2011) for EPOCH 2010.00 (IaRTN 2019 Adjustment) - Iowa RCS Zone 6 (U.S. Survey Foot)

VERT. DATUM: NAVD88 - Geoid Model: 2018

Coordinate listing from next sheet will be used with IaRTN for monument recovery. No other reference ties are given.

HORIZONTAL AND VERTICAL PROJECT CONTROL COORDINATE LISTING
 HORIZ. DATUM: NAD83(2011) for EPOCH 2010.00 (IaRTN 2019 Adjustment)
 Ia. Regional Coordinate System Zone 6 (U.S. Survey Foot)
 VERT. DATUM: NAVD88
 Geoid Model: 2018

Point Name	Northing	Easting	Elevation	Feature Definition- Description
1	7246812.8146	16392085.3359	1047.760	CP FD 1/2" REBAR 20" DEEP 1080' SOUTH OF IA 175 IN THE MEDIAN OF I29
2	7250024.4466	16390151.0886	1050.287	CP FD 5/8" REBAR 15" DEEP 2670' NORTH OF IA 175 IN THE MEDIAN OF I29
3	7247826.5308	16389650.3128	1049.455	CP CONCRETE MONUMENT 1880'WEST OF I29 68' NORTH OF IA 175

ALIGNMENT COORDINATES

Name	Location	Point on Tangent			Begin Spiral			Begin Curve			Simple Curve PI or Master PI of SCS			End Curve			End Spiral		
		Station	Coordinates		Station	Coordinates		Station	Coordinates		Station	Coordinates		Station	Coordinates		Station	Coordinates	
			Y (Northing)	X (Easting)		Y (Northing)	X (Easting)		Y (Northing)	X (Easting)		Y (Northing)	X (Easting)		Y (Northing)	X (Easting)		Y (Northing)	X (Easting)
1	ML029	713+24.54	7244915.24	16393228.23															
1	ML029	803+33.31	7252632.46	16388580.40															
1	SR175	1707+00.26	7247545.01	16387618.55															
2	SR175						1725+98.39	7247756.61	16389504.85	1731+76.60	7247821.07	16390079.46	1737+53.27	7247812.52	16390657.61				
4	SR175						1751+35.97	7247792.08	16392040.16	1755+06.35	7247786.60	16392410.49	1758+76.31	7247751.15	16392779.16				
5	SR175						1758+76.31	7247751.15	16392779.16	1762+46.68	7247715.70	16393147.83	1766+11.80	7247710.22	16393518.16				
7	SR175	1771+49.11	7247702.28	16394055.41															
7	SR175	1781+49.11	7247687.49	16395055.30															
1	RPA175	1549+15.61	7247809.12	16390887.82															
2	RPA175						1552+57.34	7248150.81	16390892.87	1556+40.12	7248533.55	16390898.53	1560+07.50	7248873.86	16390723.30				
3	RPA175	1562+26.06	7249068.17	16390623.24															
1	RPB175	2532+48.94	7246609.74	16392311.51															
2	RPB175						2533+05.77	7246660.27	16392285.49	2535+95.53	7246917.88	16392152.84	2538+80.47	7247203.95	16392106.75				
1	RPC175						3531+50.00	7246447.52	16392234.18	3535+95.02	7246828.74	16392004.58	3540+25.77	7247076.64	16391635.00				
3	RPC175						3545+69.08	7247379.28	16391183.79	3547+46.84	7247478.30	16391036.17	3549+15.30	7247640.49	16390963.44				
4	RPC175	3551+00.11	7247809.12	16390887.82															
1	RPD175	4543+51.30	7247792.50	16392011.92															
2	RPD175						4544+58.36	7247890.18	16391968.11	4546+16.89	7248034.84	16391903.25	4547+68.77	7248130.60	16391776.90				
4	RPD175						4553+39.74	7248475.49	16391321.88	4557+24.52	7248707.92	16391015.23	4561+00.00	7249037.53	16390816.71				

SPIRAL OR CIRCULAR CURVE DATA

Horizontal Alignment Data

Name	Location	ΔSCS	Horizontal Alignment Data												Remarks			
			Spiral Data						Curve Data									
			θS	Ls	Ts	Es	Xc	Yc	L.T.	S.T.	ΔC	T	L	R		E		
C1	SR175												07° 14' 51.06"	578.212	1154.881	9130	18.291	
C2	SR175												04° 38' 45.70"	370.372	740.338	9130	7.509	
C3	SR175												04° 38' 45.70"	370.372	740.338	9130	7.509	
C1	RPA175												28° 05' 31.67"	382.779	750.159	1530	47.156	
C1	RPB175												18° 05' 31.67"	289.760	574.696	1820	22.922	
C1	RPC175												25° 05' 20.61'	445.020	875.773	2000	48.913	
C2	RPC175												31° 59' 42.95"	177.754	346.222	620	24.978	
C1	RPD175												28° 41' 10.69"	158.533	310.416	620	19.948	
C2	RPD175												21° 46' 48.17"	384.778	760.267	2000	36.677	

SUPERELEVATION DATA

See PV-300 Series

Road Identification	Circular Curve or Spiral Curve Name	Radius	Superelevation Data			Standard Road Plan	Section A-A	Section B-B	Section C-C	Section D-D	Section E-E	Section F-F	Case A	Case B	Case C	Case S	Case T	Case U	Remarks
			e	L	x														
Ramp A	RPA175	1530	6.0	186	62	PV-303	1551+89.14		1552+57.34	1553+13.14						1552+51.14	1552+51.14		
Ramp B	RPB175	1820	5.8	180	62	PV-303	1560+75.70		1560+07.50	1559+51.70						1560+13.70	1560+13.70		
Ramp C	RPC175	2000	5.4	168	62	PV-303	2532+41.90		2533+05.90	2533+59.90						2533+04.04	2533+04.04		Trans. begins 8.9' into gore
Ramp C	RPC175	2000	5.4	168	62	PV-303	2539+44.60		2538+80.60	2538+26.60						2538+82.46	2538+82.46		
Ramp C	RPC175	620	5.8	140	48	PV-303	3530+94.40		3531+50.00	3532+00.40						3531+56.84	3531+56.84		
Ramp C	RPC175	620	5.8	140	48	PV-303	3540+81.37		3540+25.77	3539+75.37						3540+18.93	3540+18.93		
Ramp D	RPD175	620	5.8	140	48	PV-303	3544+23.08	3544+71.08	3545+69.08	3546+11.08						3545+67.63	3545+67.63		
Ramp D	RPD175	620	5.8	140	48	PV-303	3550+61.30	3550+13.30	3549+15.30	3548+73.30						3549+16.75	3549+16.75		
Ramp D	RPD175	2000	5.4	168	62	PV-303	4543+12.36	4543+60.36	4544+58.36	4545+00.36						4544+56.91	4544+56.91		
Ramp D	RPD175	2000	5.4	168	62	PV-303	4549+14.77	4548+66.77	4547+68.77	4547+26.77						4547+70.22	4547+70.22		
Ramp D	RPD175	2000	5.4	168	62	PV-303	4552+84.14		4553+39.74	4553+90.14						4553+46.58	4553+46.58		
Ramp D	RPD175	2000	5.4	168	62	PV-303	4561+55.60		4561+00.00	4560+49.60						4560+93.16	4560+93.16		



To: Nikki Cuva/Jeff Larson
Right of Way Design

Final Draft: December 6th, 2023

District 3: Jessica Felix
Shane Tymkowicz

Project Details:
PIN: 21-67-175-020
Project #: STP-175-1(95)—2C-67
ROW #: STPN-175-1(100)—2J-67

TAS: Jan Laaser-Webb
Traffic & Safety Bureau

From: Leilah Armstrong
Traffic & Safety Bureau

MONONA COUNTY
IA 175 Interchange

SUBJECT: Access Review

PROJECT LOCATION AND DESCRIPTION:

This project is the reconstruction of the I-29/IA 175 interchange into a tight diamond interchange from a standard diamond interchange.

ACCESS CATEGORY CLASSIFICATION:

I-29
Interstate/Freeway facilities provide for full access control with access allowed at interchanges.

IA 175
IA 175 to the east of the I-29 interchange is the Municipal 600 category and to the west the Rural Safety and Need Category.

ACCESS RIGHTS ACQUISITION:

Access rights were previously acquired from Sta. 1722+23 to Sta. 1787+47 on both sides as a part of project I-29-6(2)114. There are Type C entrances at Sta. 1729+00 on both sides which were granted on 9-14-61. These were within the access control limits and in 1971 FHWA was credited, and the access control limits moved to Sta. 1729+00 on both sides of IA 175.

No additional access rights will be acquired as a part of this project.

ADMINISTRATIVE RULES:

In accordance with Chapter 112.5(5)(f) *Interchange and intersection access control*, "For any new interchange or interchange reconstruction, access rights should be acquired and extend a minimum of 600 feet away from the ramp bifurcation point. If the AADT will exceed 10,000 within 20 years, a minimum of 1,000 feet of access rights should be acquired."

(d) "When the interchange crossroad AADT will be between 3,000 and 10,000 within 20 years, the first full movement should be at least 1,000 feet away from the ramp. All access types may have a restricted right-in and right-out access at a minimum of 600 feet from the ramp bifurcation point."

ACCESS CONTROL LIMITS:

IA 175

The access control line extends from Sta. 1729+00 to Sta. 1787+47 since access rights were previously acquired. Existing entrances were permitted via a special access connection permit (SAC) and the table below lists which entrances will still be authorized for use.

ACCESS LOCATION DETAILS:

Location	Access	Comments
1723+38	IA175	Begin Project Construction
1729+08 RT	Type D Entrance	Proposed – Access rights dissolved and FHWA credited in 1971
1729+08 LT	Type D Entrance	Proposed - Access rights dissolved and FHWA credited in 1971
1762+50 LT	28th Street	UAC – SPRC
1762+50 RT	28th Street	UAC – SPRC
1771+50	IA175	End Project Construction

ACCESS CONTROL DIAGRAM:

*Please note that access rights were previously acquired, and the access control line is longer than the entire length of the project. The entrances that were previously authorized above via a special access connection permit shall remain in place across the access control line.

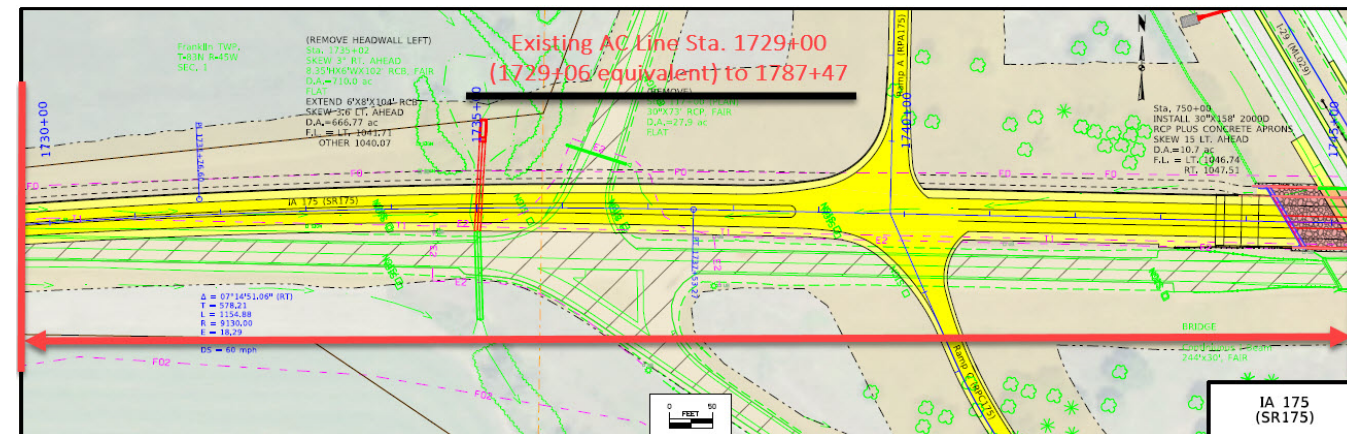
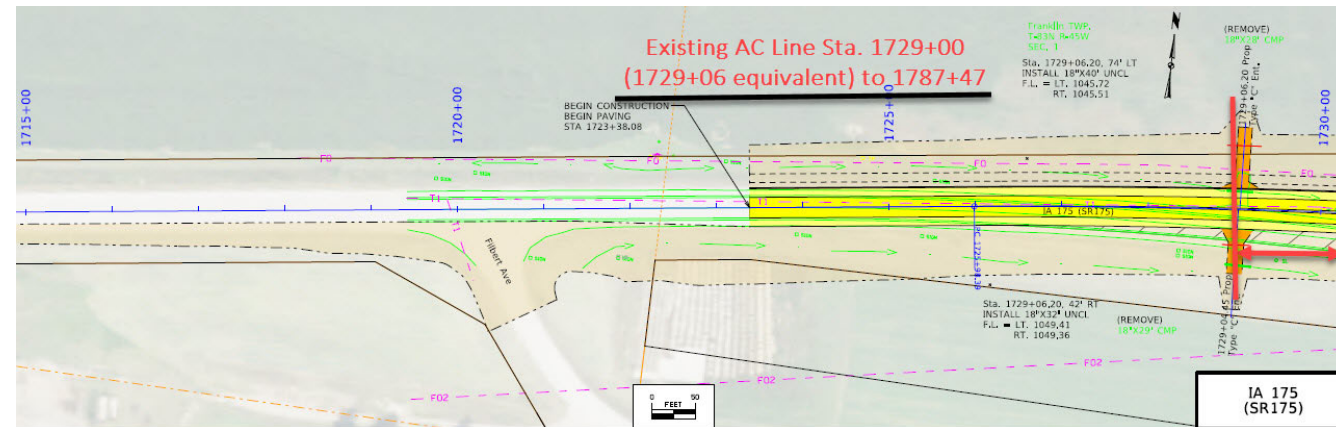

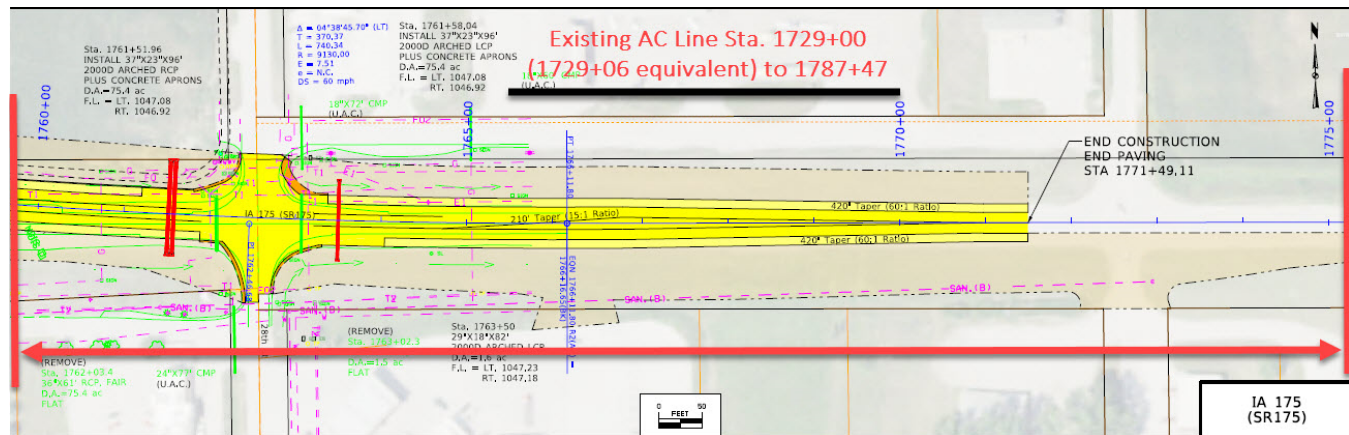
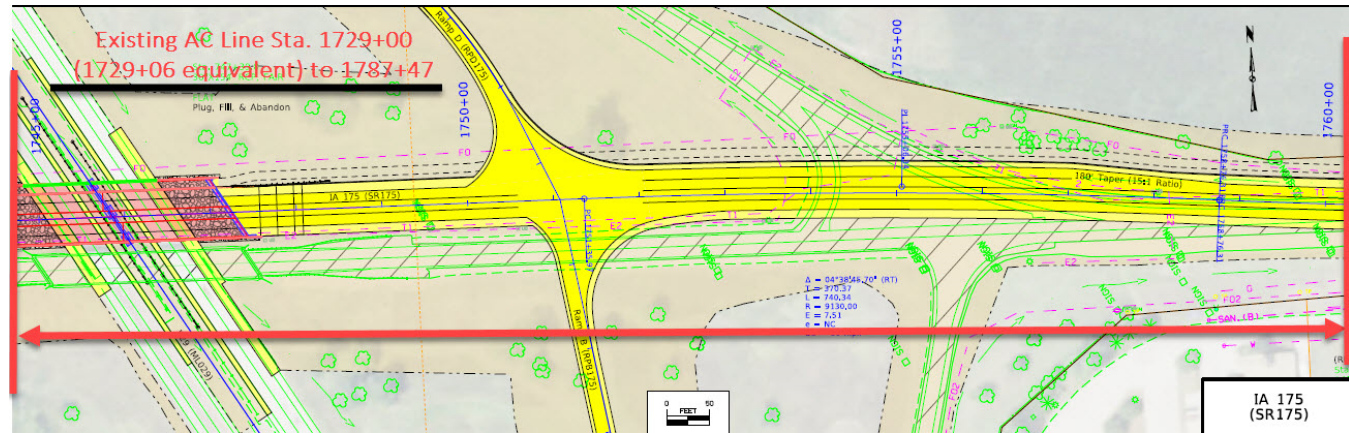



Right of Way Design Information	
THIS SHEET INCLUDED FOR INFORMATION ONLY	
ROW Team:	FREDRICKSON / CUVA
ROW #:	STPN-175-1(100)-2J-67
Plan Date:	01/23/2024
Color Legend:	
	Property Lines
	Temporary Easement
	Permanent Acquisition

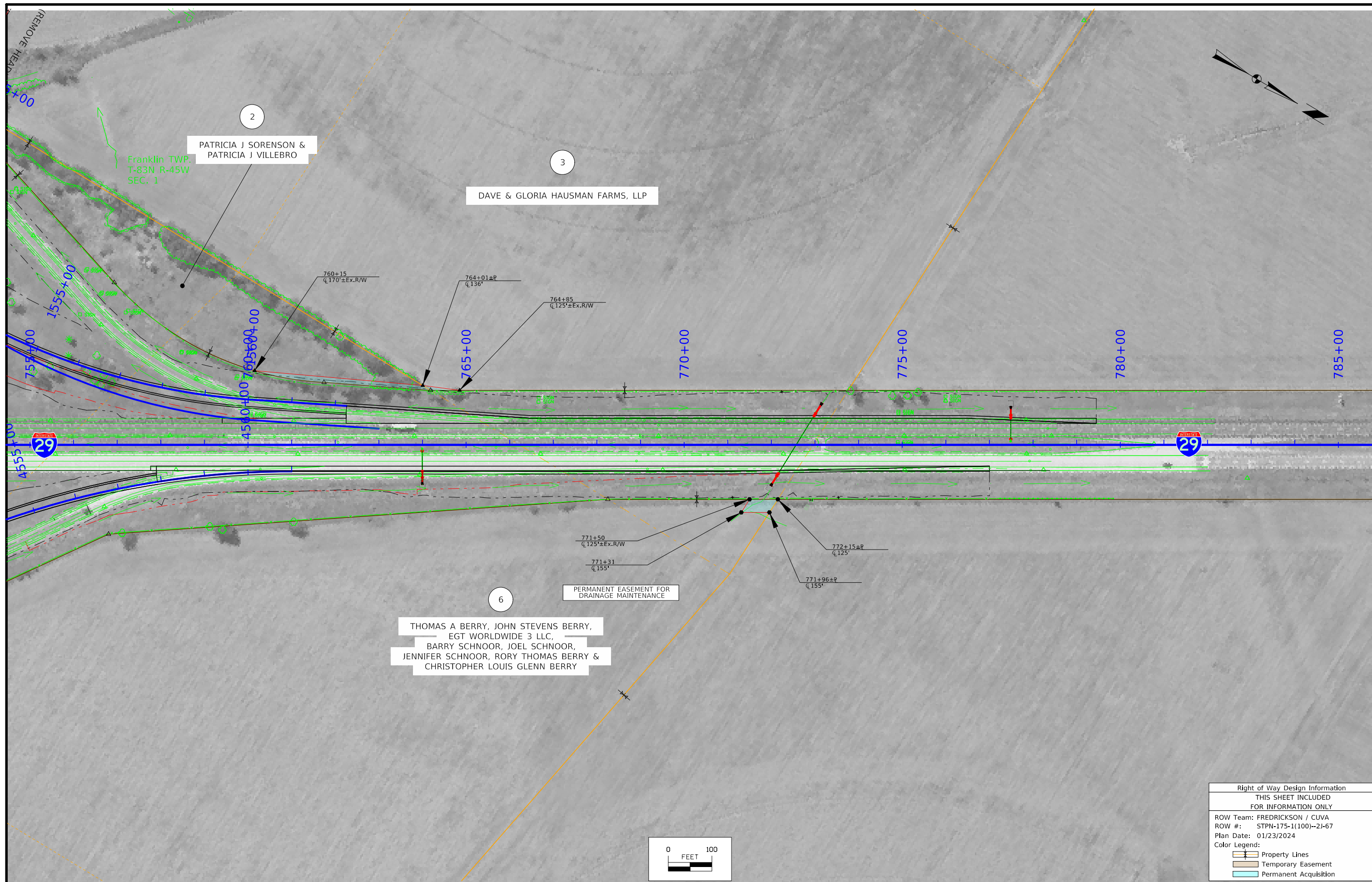

Right of Way Design Information	
THIS SHEET INCLUDED FOR INFORMATION ONLY	
ROW Team:	FREDRICKSON / CUVA
ROW #:	STPN-175-1(100)-2J-67
Plan Date:	01/23/2024
Color Legend:	
	Property Lines
	Temporary Easement
	Permanent Acquisition



3

DAVE & GLORIA HAUSMAN FARMS LLP

1715+00

1720+00

1725+00

175

4

JOYCE E BENTLEY REVOCABLE TRUST

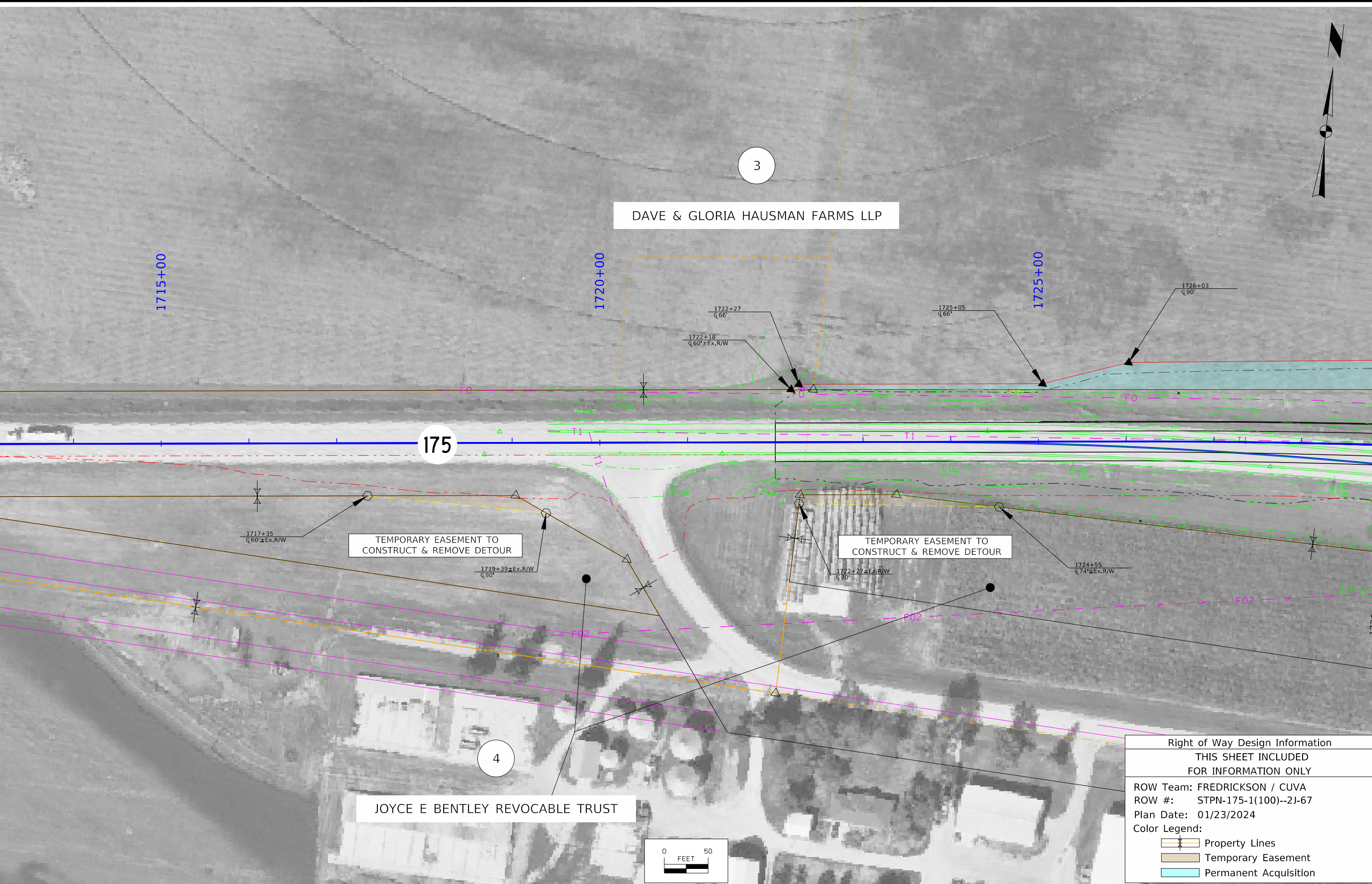

Right of Way Design Information	
THIS SHEET INCLUDED FOR INFORMATION ONLY	
ROW Team:	FREDRICKSON / CUVA
ROW #:	STPN-175-1(100)--2J-67
Plan Date:	01/23/2024
Color Legend:	
	Property Lines
	Temporary Easement
	Permanent Acquisition

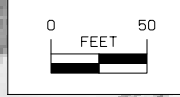

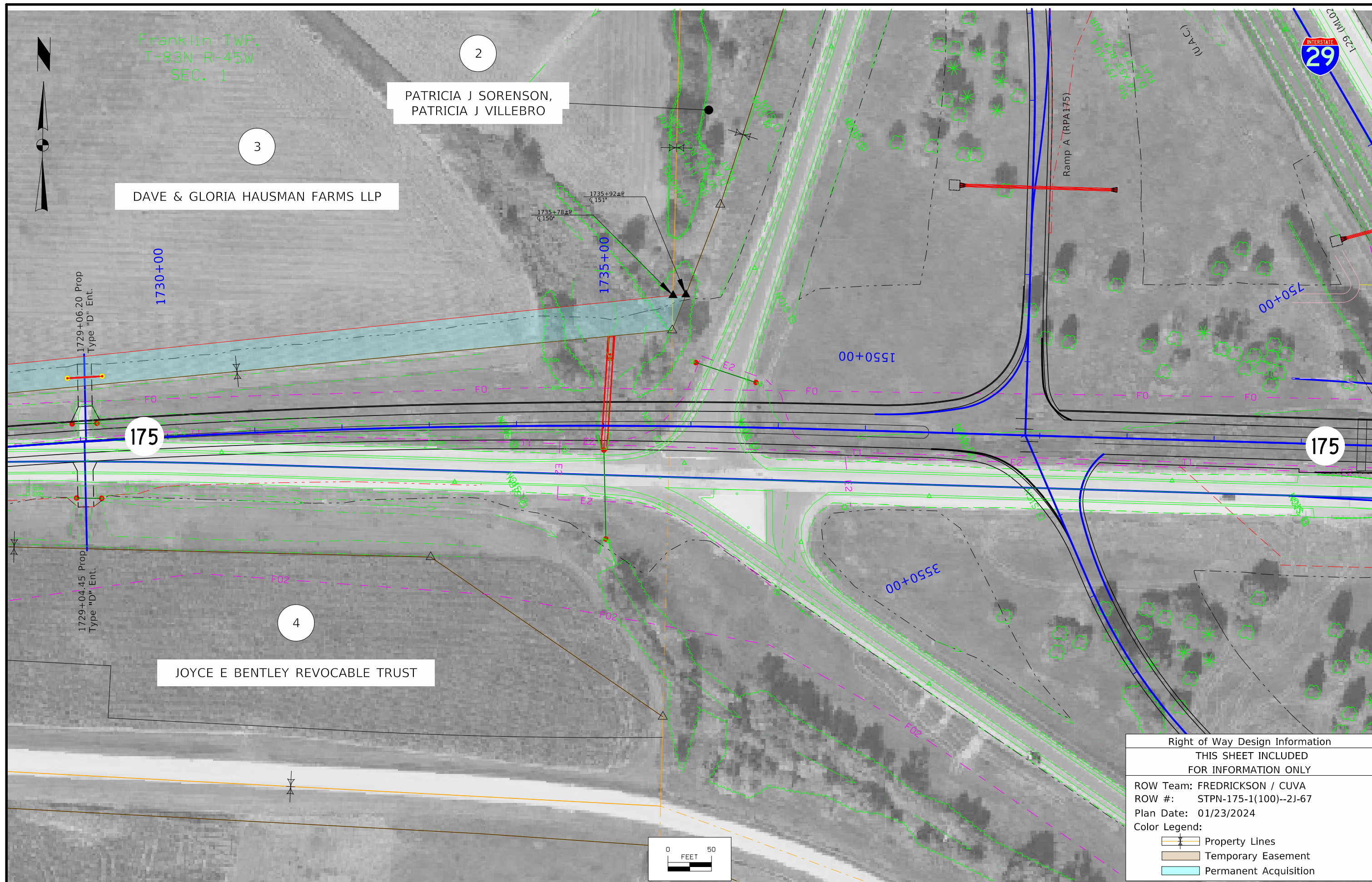

Franklin TWP.
T-83N R-45W
SEC. 1

PATRICIA J SORENSON,
PATRICIA J VILLEBRO

DAVE & GLORIA HAUSMAN FARMS LLP

JOYCE E BENTLEY REVOCABLE TRUST

Right of Way Design Information	
THIS SHEET INCLUDED FOR INFORMATION ONLY	
ROW Team:	FREDRICKSON / CUVA
ROW #:	STPN-175-1(100)--2J-67
Plan Date:	01/23/2024
Color Legend:	
	Property Lines
	Temporary Easement
	Permanent Acquisition

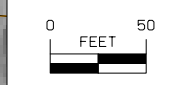

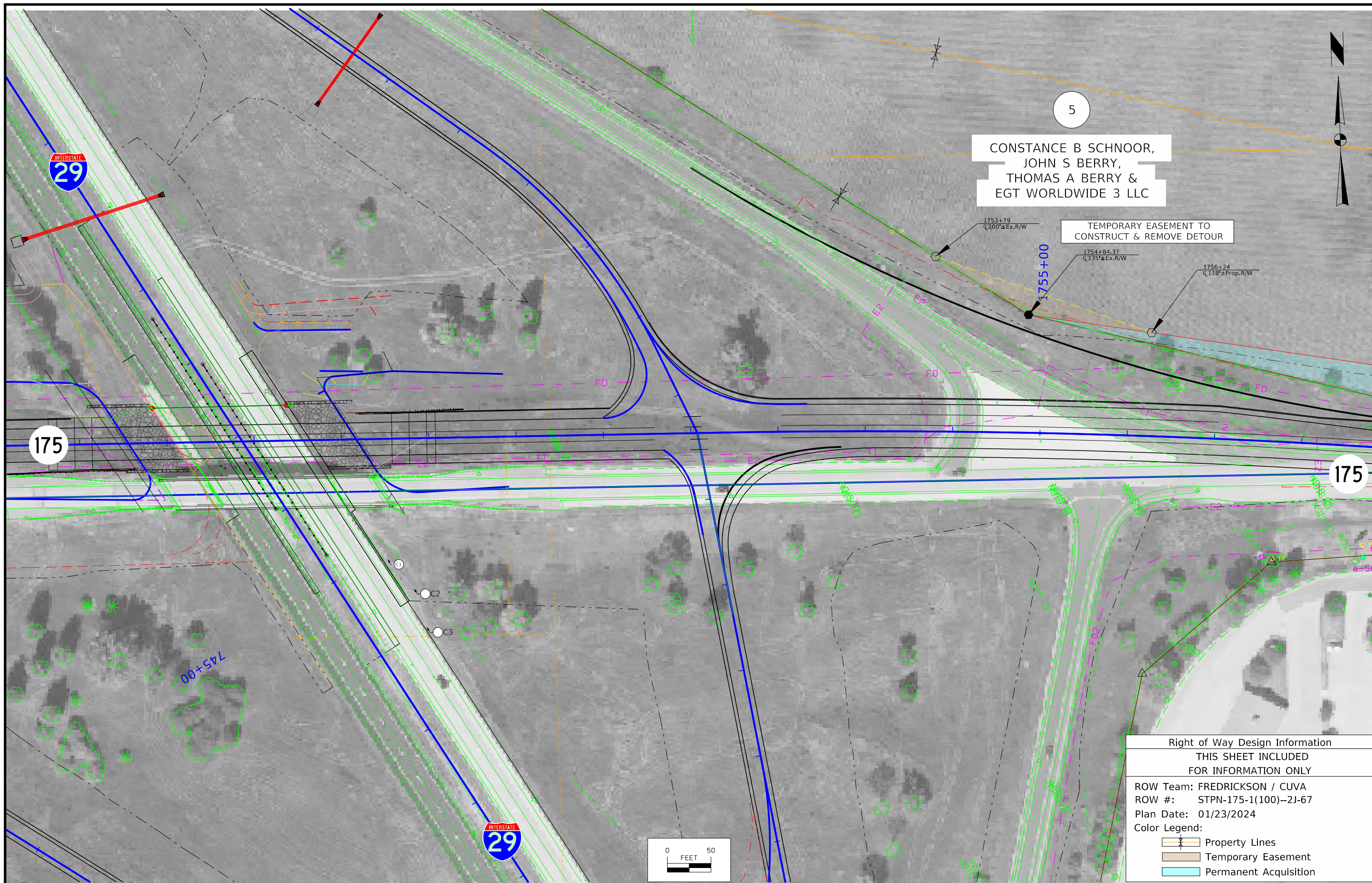

5
 CONSTANCE B SCHNOOR,
 JOHN S BERRY,
 THOMAS A BERRY &
 EGT WORLDWIDE 3 LLC

TEMPORARY EASEMENT TO
 CONSTRUCT & REMOVE DETOUR

1753+79
 ±200'±Ex.R/W

1754+84.37
 ±135'±Ex.R/W

1756+24
 ±118'±Prop.R/W

1755+00

745+00

C2

C3

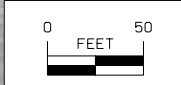

Right of Way Design Information	
THIS SHEET INCLUDED FOR INFORMATION ONLY	
ROW Team: FREDRICKSON / CUVA	
ROW #: STPN-175-1(100)--2J-67	
Plan Date: 01/23/2024	
Color Legend:	
	Property Lines
	Temporary Easement
	Permanent Acquisition

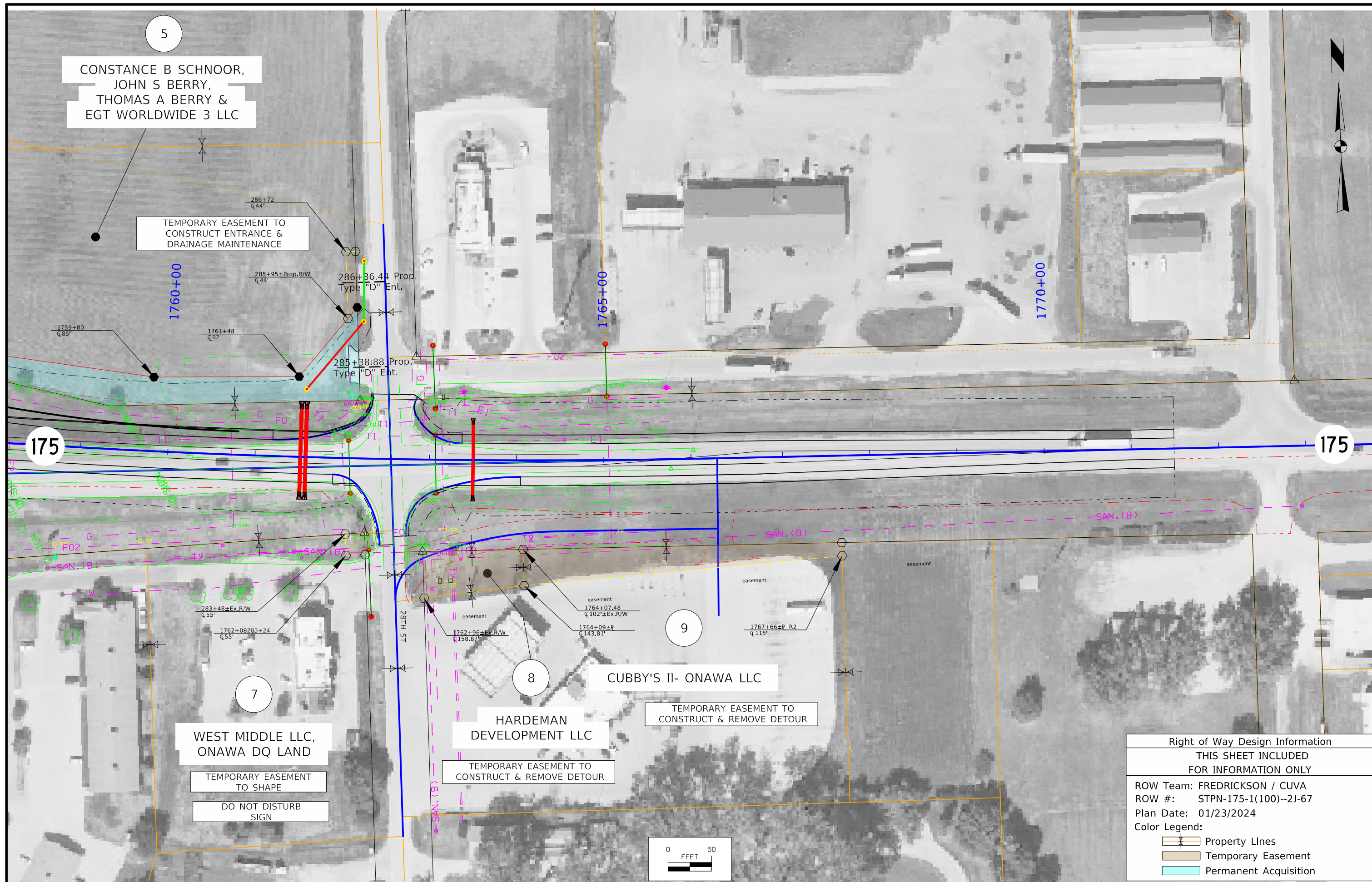

Right of Way Design Information	
THIS SHEET INCLUDED FOR INFORMATION ONLY	
ROW Team: FREDRICKSON / CUVA	
ROW #: STPN-175-1(100)--2J-67	
Plan Date: 01/23/2024	
Color Legend:	
	Property Lines
	Temporary Easement
	Permanent Acquisition

TRAFFIC CONTROL PLAN

Traffic control on this project shall be in accordance with the standard road plans shown in tabulation 105-4 and the specific layouts show in the plans. For additional complementary information, refer to Part 6 of the Manual on Uniform Traffic Control Devices (MUTCD) and the current standard specifications and supplemental specifications.

Maintain a minimum of one lane of traffic in each direction on I-29 at all times. In Stage 1, outside shoulder closures on I-29 in both directions are not allowed.

Maintain two-way traffic along IA 175 at all times.

Maintain traffic on all adjacent local roadways at all times.

I-29 mainline posted speed limit through the work zones shall be marked as 55 mph. Remove or cover all existing signs that conflict with 55 mph speed limit while the 55 mph speed limit is in effect.

Unused TBR to be stored at least 15' away from the travel lanes at a location approved by the Engineer.

511 TRAVEL RESTRICTIONS

Line No.	Route	Direction	County	Location Description	Feature Crossed	Object Type	Maint. Bridge No., Structure ID, or FHWA No.	Type of Restriction	Existing Measurement	Construction Measurement	Construction Measurement as Signed	Projected As Built Measurement	Remarks
	I-29	NB	Monona	At IA 175 over I-29 bridge		Barrier	N/A	Horizontal	N/A	23'	N/A	N/A	
	I-29	SB	Monona	At IA 175 over I-29 bridge		Barrier	N/A	Horizontal	N/A	23'	N/A	N/A	
								None					
								None					

STAGING NOTES

STAGE 1

Traffic:

- Maintain existing traffic along IA 175 and interchange ramps
- Close inside lane of I-29 in both directions at proposed IA 175 over I-29 bridge median pier. Refer to IaDOT Standard Road Plan TC-421.

Construction:

- Install proposed culvert beneath I-29 just north of IA 175 with bore pits and trenchless installation in substage prior to bridge pier construction. Protect work area as shown on IaDOT Standard Road Plan TC-402 and TBR.
- Construct proposed IA 175 over I-29 bridge median pier
- Grade and pave permanent inside shoulder along both directions of I-29 at IA 175
- Grade portions of IA 175, Ramp A, and Ramp D

STAGE 2

Traffic:

- Maintain existing traffic along IA 175 and Ramps
- Close outside lane of I-29 in both directions through interchange. Refer to IaDOT Standard Road Plan TC-418 and TC-421.

Construction:

- Construct remaining portions of proposed IA 175 over I-29 bridge
- Grade portions of Ramp B and Ramp C
- Grade portion of acceleration lanes along I-29
- Grade Detour Ramp A and Detour Ramp B
- Grade temporary widening pavement along IA 175 at east and west ends
- Grade temporary widening pavement along Ramps C and D and acceleration lanes

STAGE 3

Traffic:

- Maintain traffic in the same configuration as in the previous stage

Construction:

- Pave previously-graded portion of acceleration lanes along I-29
- Pave previously-graded portion of IA 175, Ramp A, and Ramp B
- Pave previously-graded Detour Ramp A and Detour Ramp B
- Pave previously-graded temporary widening pavement along IA 175 at east and west ends. Stage construct across Filbert St. west of I-29 and 26th St. to provide continual access.
- Pave previously-graded temporary widening pavement along Ramps C and D and acceleration lanes
- Acceleration lanes and temporary widening pavement along Ramp C to be separate site
- Acceleration lanes and temporary widening pavement along Ramp D to be separate site

STAGE 4

Traffic:

- Maintain traffic in the same configuration as in the previous stage along I-29 and Ramps A and B
- Shift IA 175 traffic onto temporary widening pavement along IA 175 at east and west ends
- Shift Ramp C and Ramp D traffic onto temporary widening pavement along Ramps C and D and acceleration lanes
- Close north leg of IA 175 and 28th St. intersection

Construction:

- Grade and pave remaining portion of acceleration lanes along I-29
- Pave previously-graded portion of Ramp C and Ramp D
- Grade and pave remaining portion of Ramp C and Ramp D
- Grade and pave portions of IA 175
- Grade and pave Detour Ramp D

STAGE 5

Traffic:

- Maintain traffic in the same configuration as in the previous stage along I-29, IA 175, and Ramps B and C
- Detour I-29 Southbound exit ramp (Ramp A) traffic via the E60 (Blencoe) interchange (see Detour Sheets)
- Detour IA 175 Eastbound to I-29 Northbound (Ramp D) traffic via the E60 (Blencoe) interchange (see Detour Sheets)
- Shift Ramp D traffic onto Detour Ramp D
- Maintain closure of north leg of IA 175 and 28th St. intersection

Construction:

- Grade and pave portions of IA 175

STAGE 6

Traffic:

- Maintain traffic in the same configuration as in the previous stage along I-29 and Ramps B and C

STAGING NOTES

- Detour I-29 Northbound to IA 175 Westbound (Ramp B) traffic via the E24 (Whiting) interchange (see Detour Sheets)
- Detour IA 175 Westbound to I-29 Southbound (Ramp C) traffic via the E24 (Whiting) interchange (see Detour Sheets)
- Shift Ramp A traffic onto Detour Ramp A
- Shift Ramp D traffic onto permanent Ramp D
- Shift IA 175 traffic onto permanent IA 175
- Shift Ramp B traffic onto temporary widening pavement along IA 175 east end
- Shift Ramp C traffic onto temporary widening pavement along IA 175 west end
- Open north leg of IA 175 and 28th St. intersection to traffic

Construction:

- Grade and pave portion of Ramp B
- Grade and pave remaining portion of Ramp C

STAGE 7

Traffic:

- Maintain traffic in the same configuration as in the previous stage along I-29, IA 175, and Ramps A and D
- Shift Ramp B traffic onto Detour Ramp B
- Shift Ramp C traffic onto permanent Ramp C

Construction:

- Remove existing IA 175 over I-29 bridge
- Grade and pave permanent outside shoulder along both directions of I-29 at IA 175
- Grade and pave portions of IA 175
- Grade and pave Detour 28th St. Frontage Road
- Grade and pave Detour 28th St. south access

STAGE 8

Traffic:

- Maintain traffic in the same configuration as in the previous stage along IA 175 and Ramps C and D
- Open both lanes of I-29 Northbound to traffic
- Open both lanes of I-29 Southbound to traffic just north of the IA 175 over I-29 bridge
- Shift Ramp A traffic onto permanent Ramp A
- Shift Ramp B traffic onto permanent Ramp B
- Close south leg of IA 175 and 28th St. intersection
- Detour south leg of IA 175 and 28th St. intersection traffic to Detour 28th St. Frontage Road and Detour 28th St. south access

Construction:

- Grade and pave permanent outside shoulder along I-29 Southbound at Ramp A gore
- Grade and pave remaining portion of IA 175 at 28th St. (to be separate site)

STAGE 9

Traffic:

- Traffic in final configuration on all roadways

Construction:

- Remove Detour 28th St. Frontage Road and Detour 28th St. south access

111_01
10/14/22

COORDINATED OPERATIONS

Other work in progress during the same period of time will include the construction of the projects listed. Coordinate operations with those of other contractors working within the same area.

Project	Type of Work

CROSS SECTION VIEW COLOR LEGEND OF TRAFFIC CONTROL AND STAGING SHEETS

SHADING	Design Color No.	
Green, Light	(225)	Existing Pavement Shading
Gray, Light	(48)	Previously Constructed Pavement Shading
Gray, Med	(80)	Previously Constructed Temporary Pavement
Blue, Light	(230)	Proposed Pavement Shading
Lavender	(9)	Temporary Pavement Shading
Brown, Med	(237)	Future Proposed Pavement Shading

CROSS SECTION VIEW PATTERN AND SYMBOL LEGEND OF TRAFFIC CONTROL AND STAGING SHEETS

	Pavement Removal		Proposed Granular Shoulder
	Proposed Granular Subbase		Temporary Shoulder
	Proposed Special Backfill		Existing Shoulder Strengthening
	Temporary Barrier Rail, Unpinned		Temporary Barrier Rail, Pinned
			Channelizing Device

PLAN VIEW COLOR LEGEND OF TRAFFIC CONTROL AND STAGING SHEETS

LINEWORK	Design Color No.	
Green	(2)	Existing Topographic Features and Labels
Magenta	(5)	Pavement Marking Call Outs
Blue	(1)	Proposed Alignment, Stationing, Tic Marks, and Alignment Annotation
Yellow	(4)	Pavement Markings, Yellow
Off White	(254)	Pavement Markings, White
Violet	(15)	Temporary barrier rail, Unpinned
Flush Orange	(228)	Temporary barrier rail, Pinned

SHADING	Design Color No.	
Green, Light	(225)	Existing Pavement Shading
Gray, Light	(48)	Previously Constructed Pavement Shading
Brown	(238)	Previously Constructed Grading Limits Shading
Blue, Light	(230)	Proposed Pavement Shading
Lavender	(9)	Temporary Pavement Shading
Brown, Light	(236)	Proposed Grading Limits Shading
Gray, Med	(80)	Previously Constructed Temporary Pavement Shading
Red	(3)	Proposed Structures
White	(0)	Pavement Removal Hatching

PLAN VIEW PATTERN AND SYMBOL LEGEND OF TRAFFIC CONTROL AND STAGING SHEETS

	Channelizing Device		Crash Cushion (Temp or Perm)
	Drum		Traffic Signal
	Temporary Lane Separator		Flagger
	Tubular Marker		Temporary Floodlighting
	Channelizer Marker		Traffic Sign
	Concrete Barrier Marker		Type III Barricade
	Delineator		Type A Warning Light
	Temporary Barrier Rail		Direction of Traffic
	Pavement Removal		Safety Closure
	Sand Barrel Layout		Lane Identification

NOTE: Device spacing according to Standard Road Plans unless specifically dimensioned.

TRAFFIC CONTROL AND STAGING LEGEND AND SYMBOL INFORMATION SHEET

(COVERS SHEET SERIES J)

Stage 3

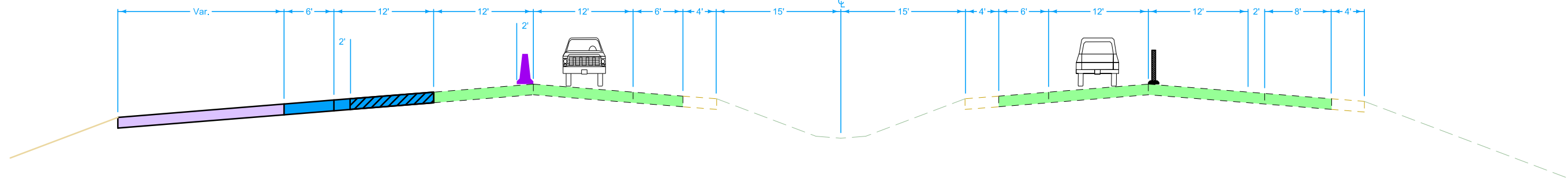

Stage 4

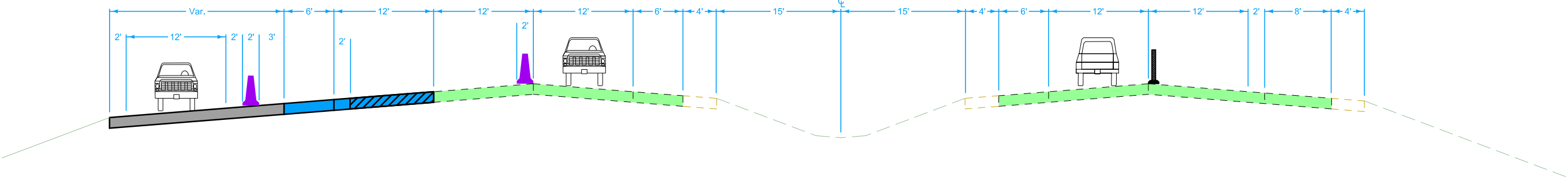

Stage 7

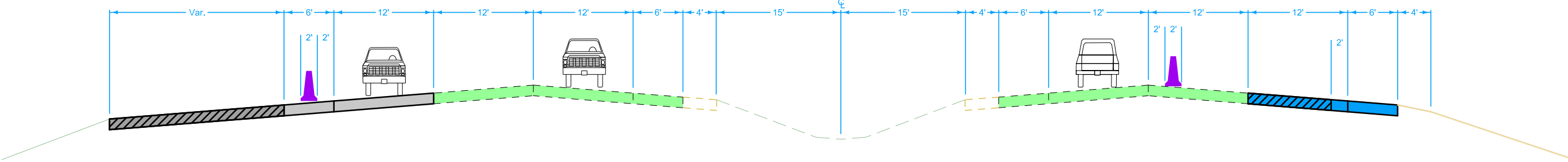

I-29
 South of IA 175
 (looking north)

Stage 1

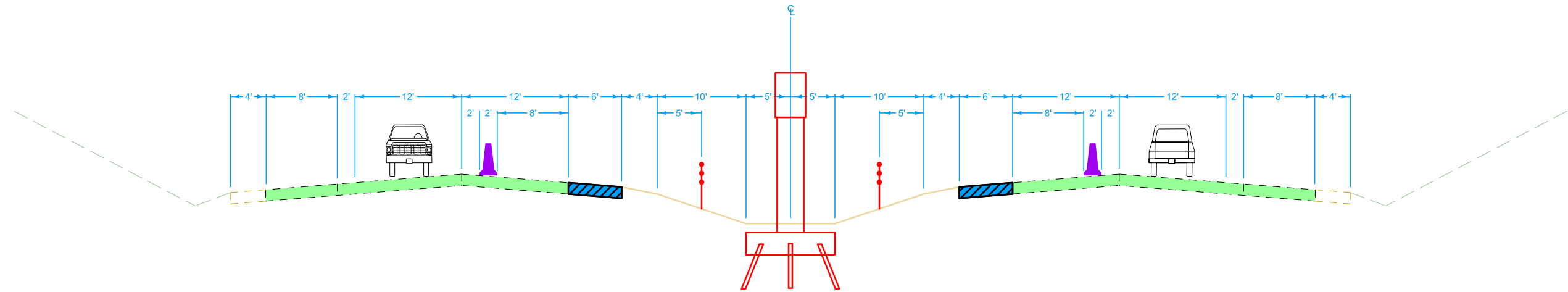

Stage 2

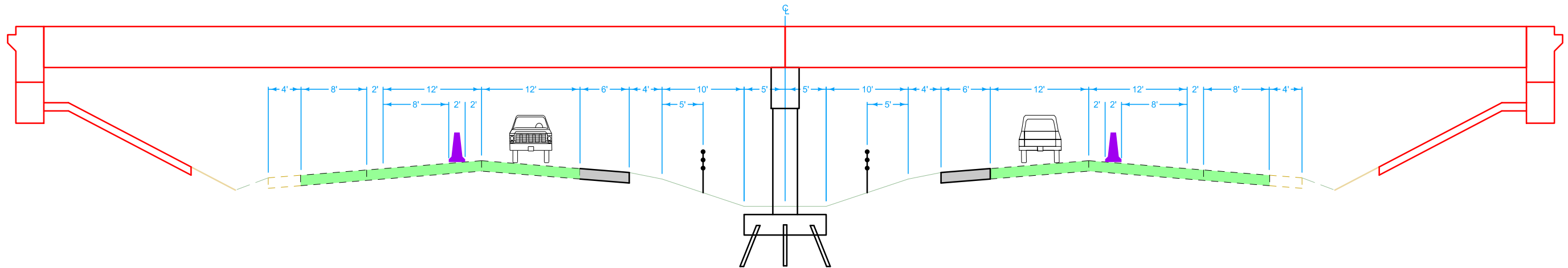

Stage 7

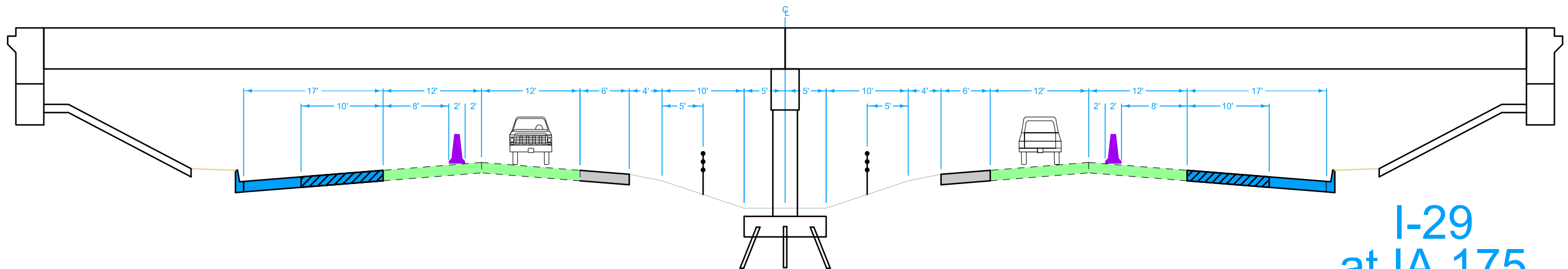

I-29
at IA 175
(looking north)

Stage 3

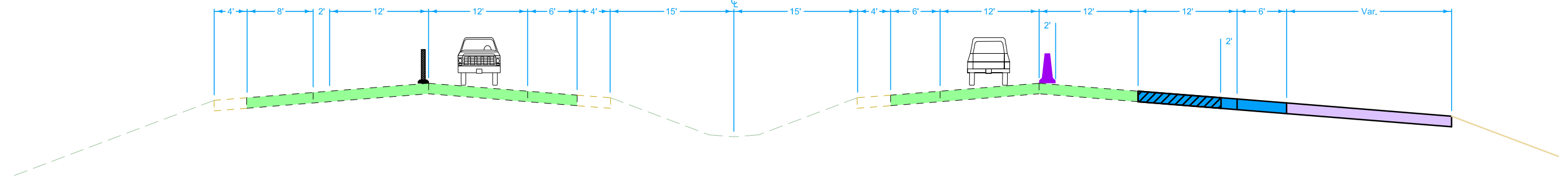

Stage 4

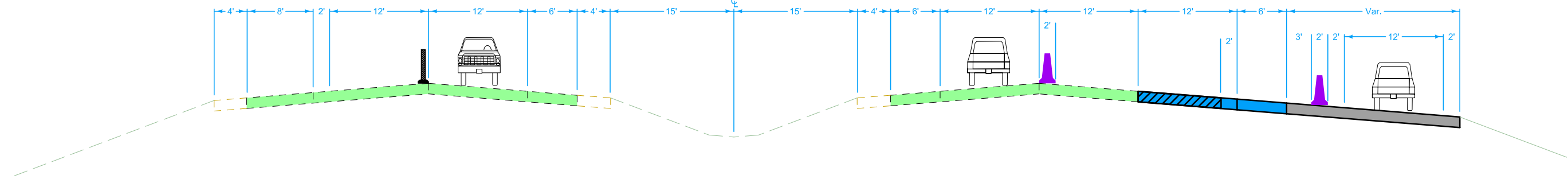

Stage 6

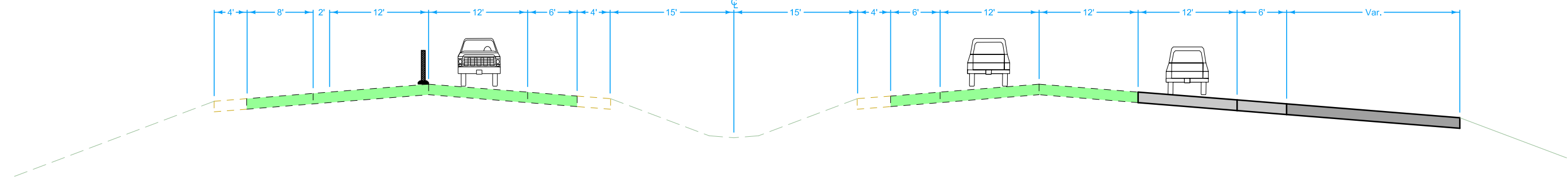

Stage 7

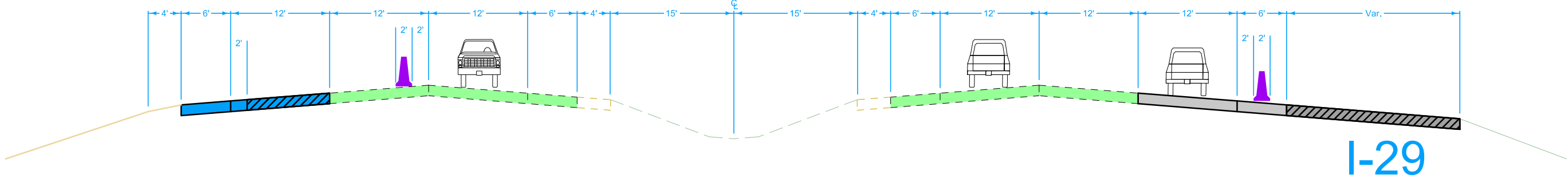

I-29
North of IA 175
(looking north)

Stage 3

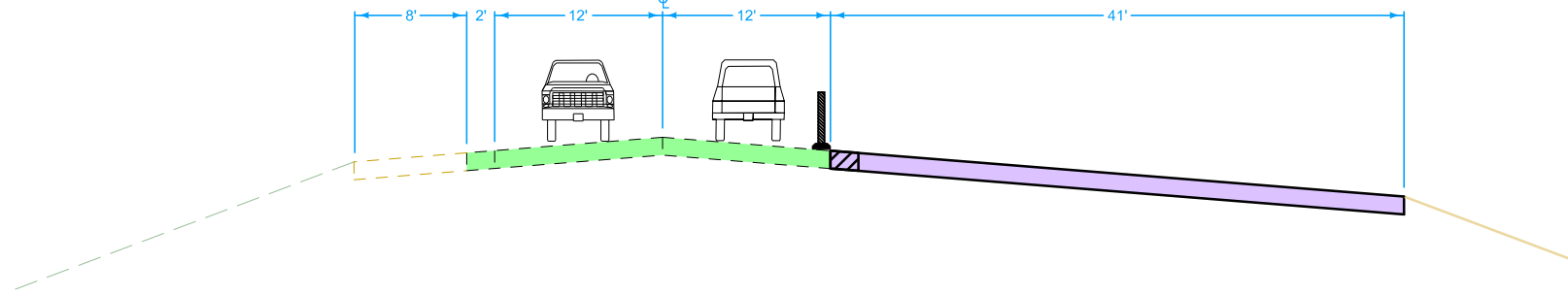

Stage 4

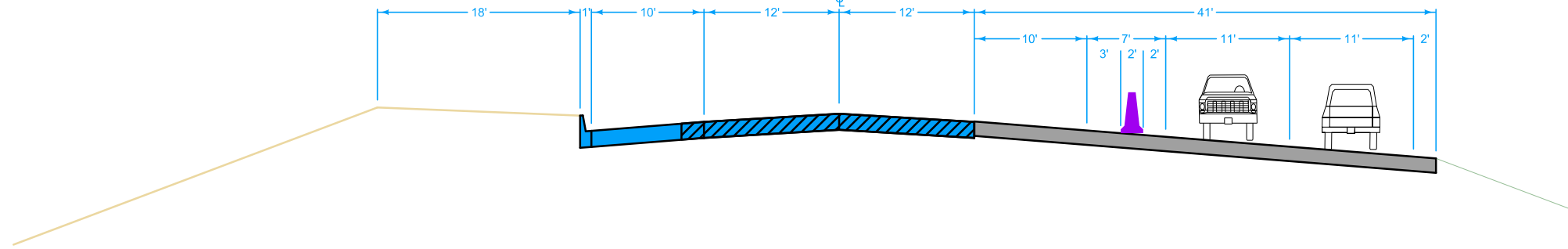

Stage 6

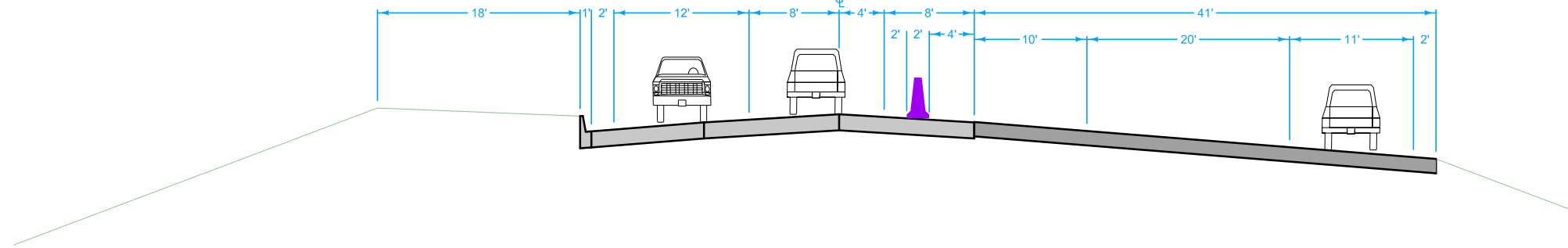

Stage 7

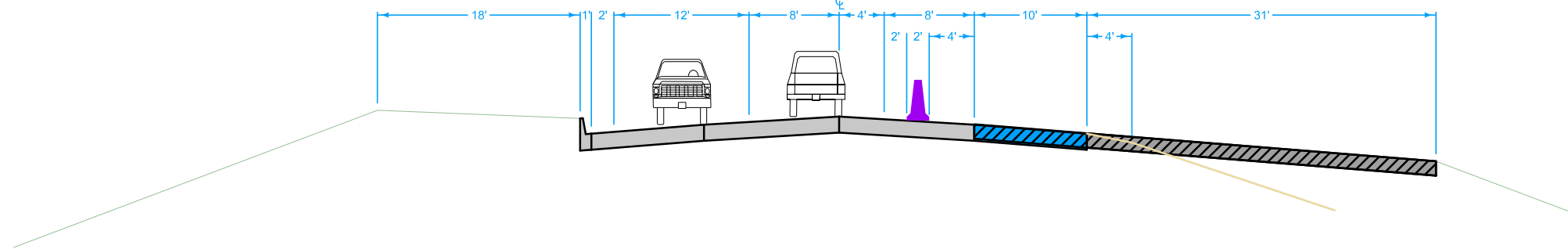

IA 175
West of I-29
Ramp Terminals
(looking east)

Stage 1

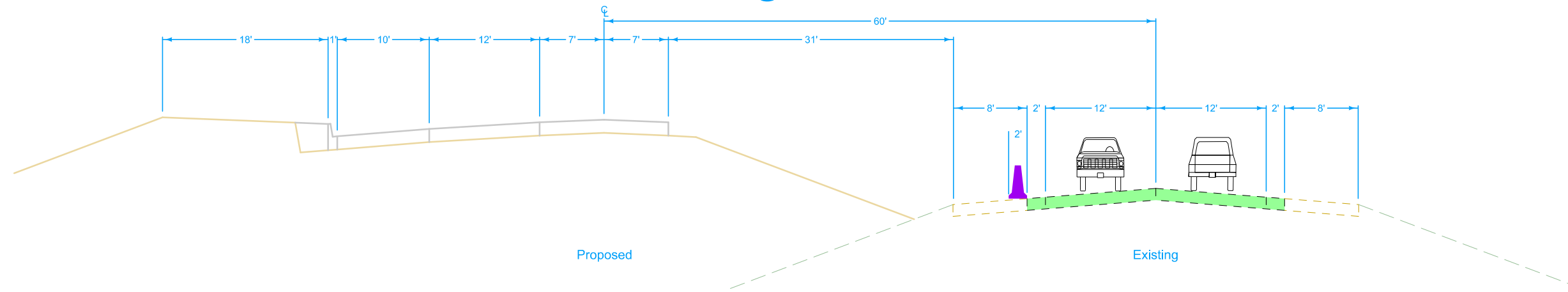

Stage 3

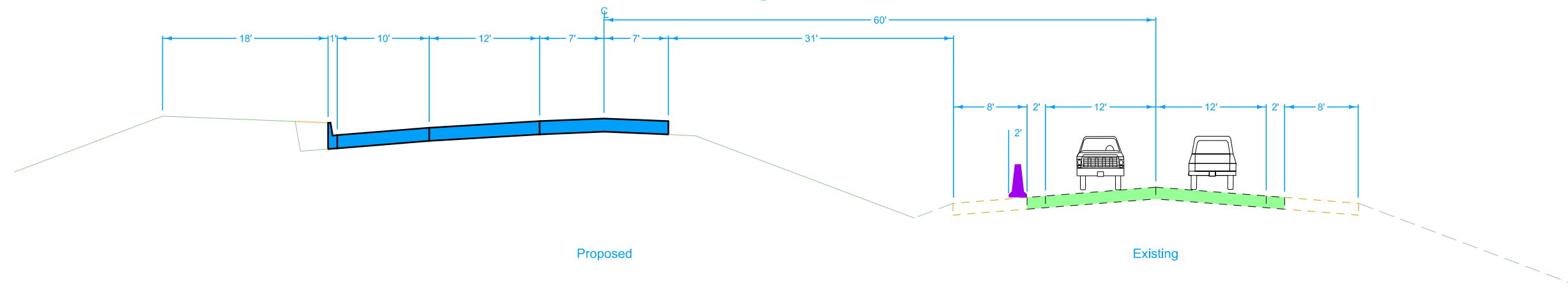

Stage 6

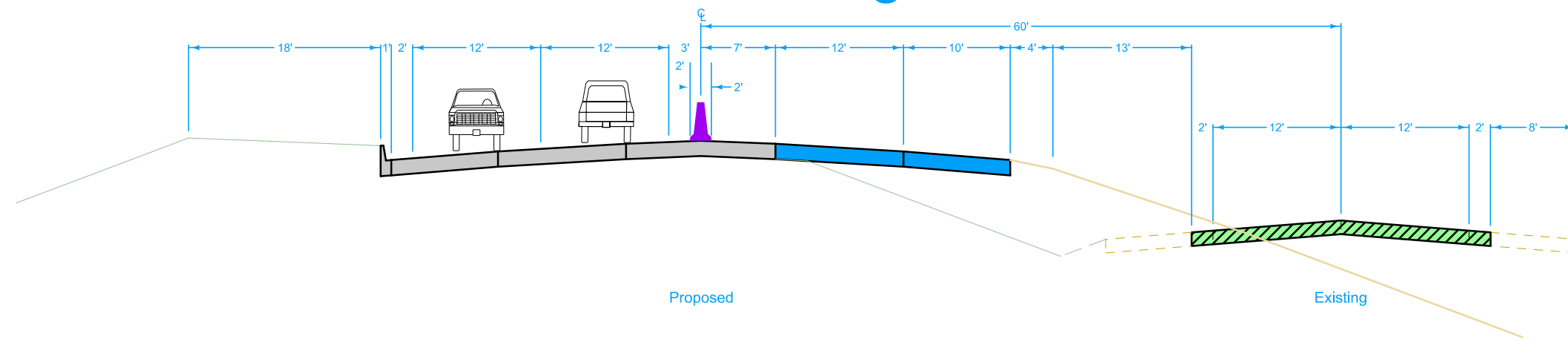

IA 175
Between I-29
Ramp Terminals
 (looking east)

Stage 3

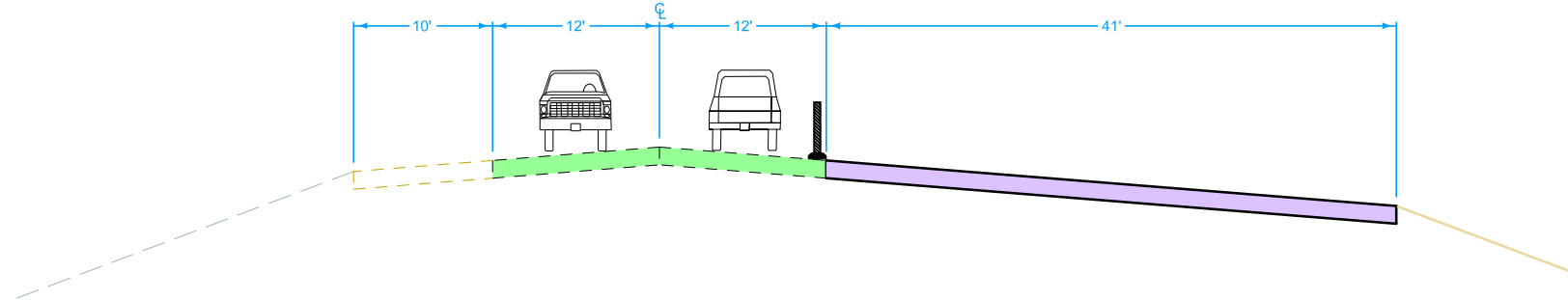

Stage 4

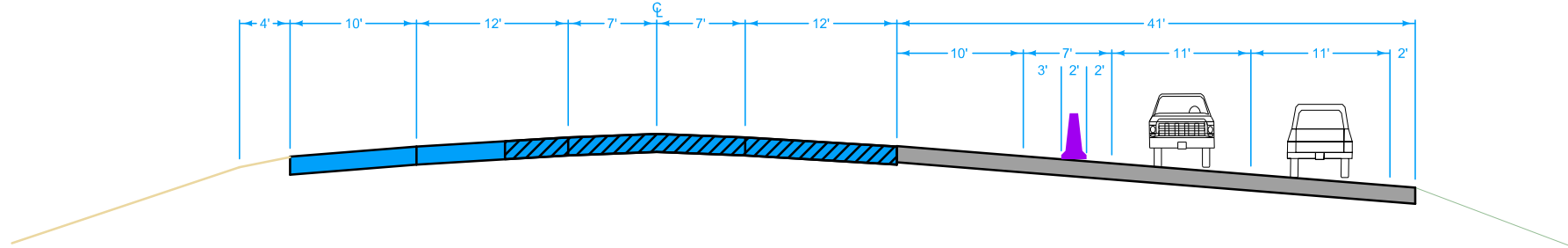

Stage 6

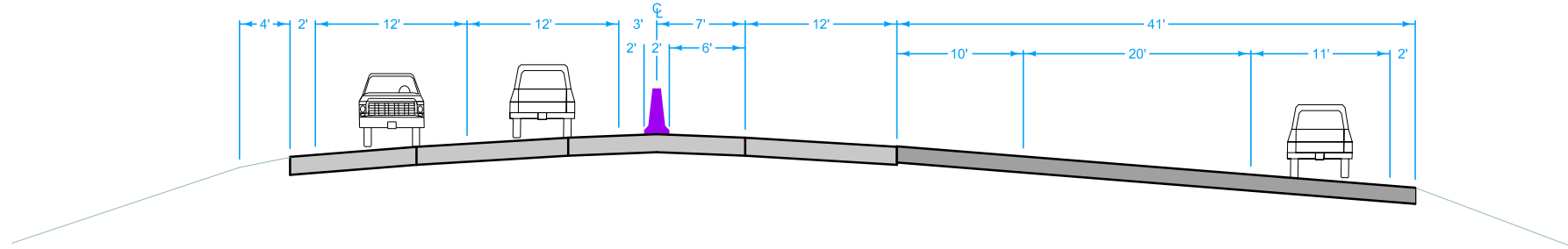

Stage 7/8

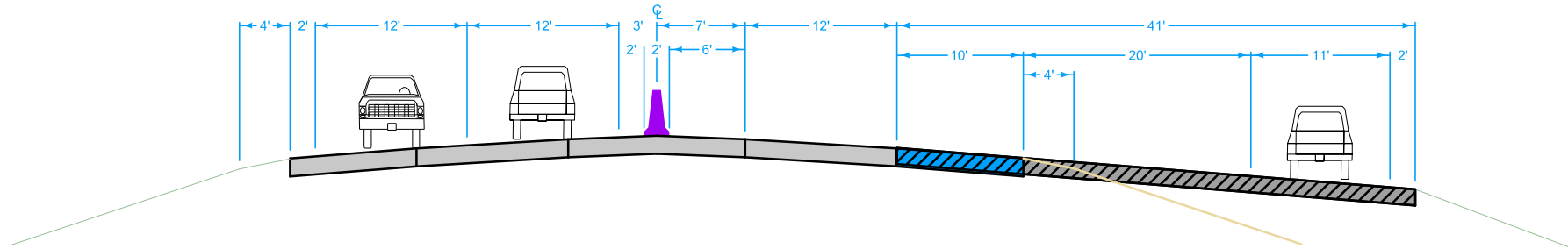

IA 175
East of I-29
Ramp Terminals
(looking east)

Franklin TWP.
T-83N R-45W
SEC. 7



FILBERT AVENUE

715+00

720+00

725+00

MAINLINE I-29 (ML029)

SIGN
SIGN

SIGN
SIGN

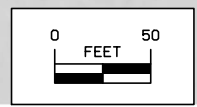

I-29 MAINLINE STAGE 1

Franklin TWP.
T-83N R-45W
SEC. 7

FILBERT AVENUE

RAMP C

MAINLINE I-29 (ML029)

RAMP B

I-29 MAINLINE STAGE 1

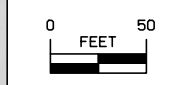

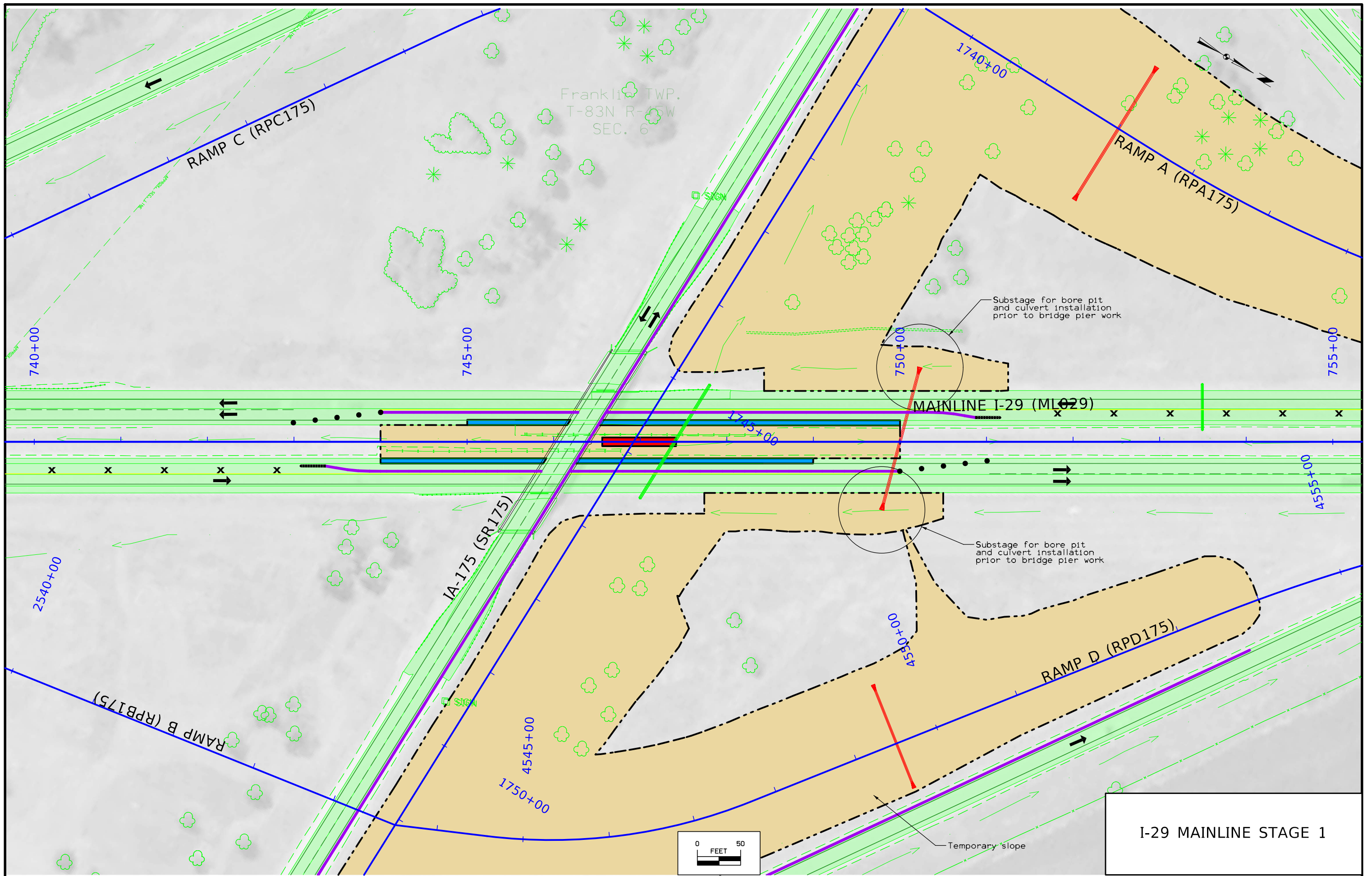

I-29 MAINLINE STAGE 1

Franklin TWP.
T-83N R-45W
SEC. 1

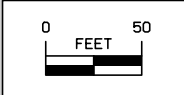
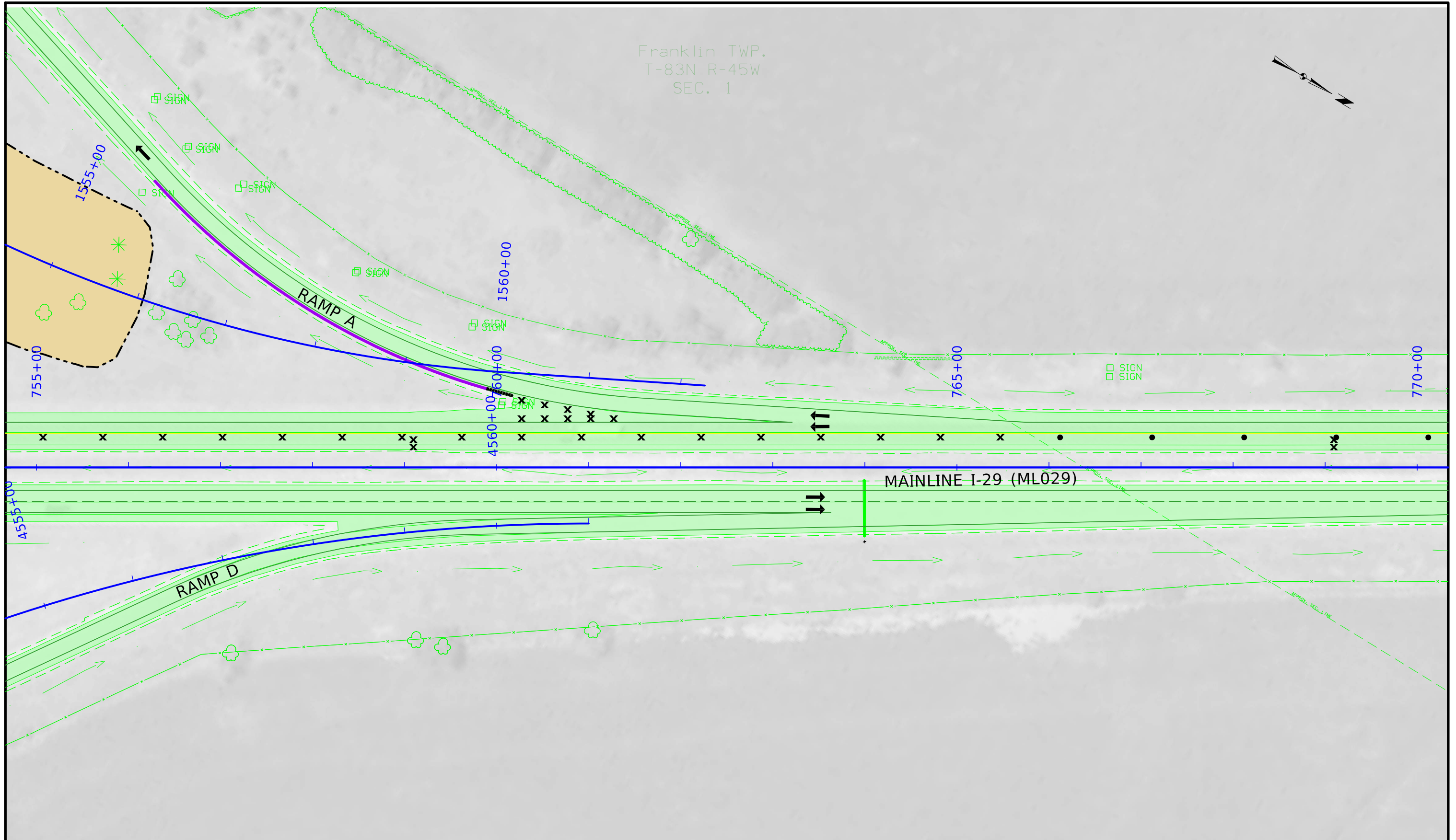
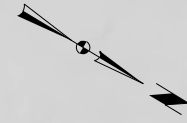

I-29 MAINLINE STAGE 1

Franklin TWP.
T-83N R-45W
SEC. 1

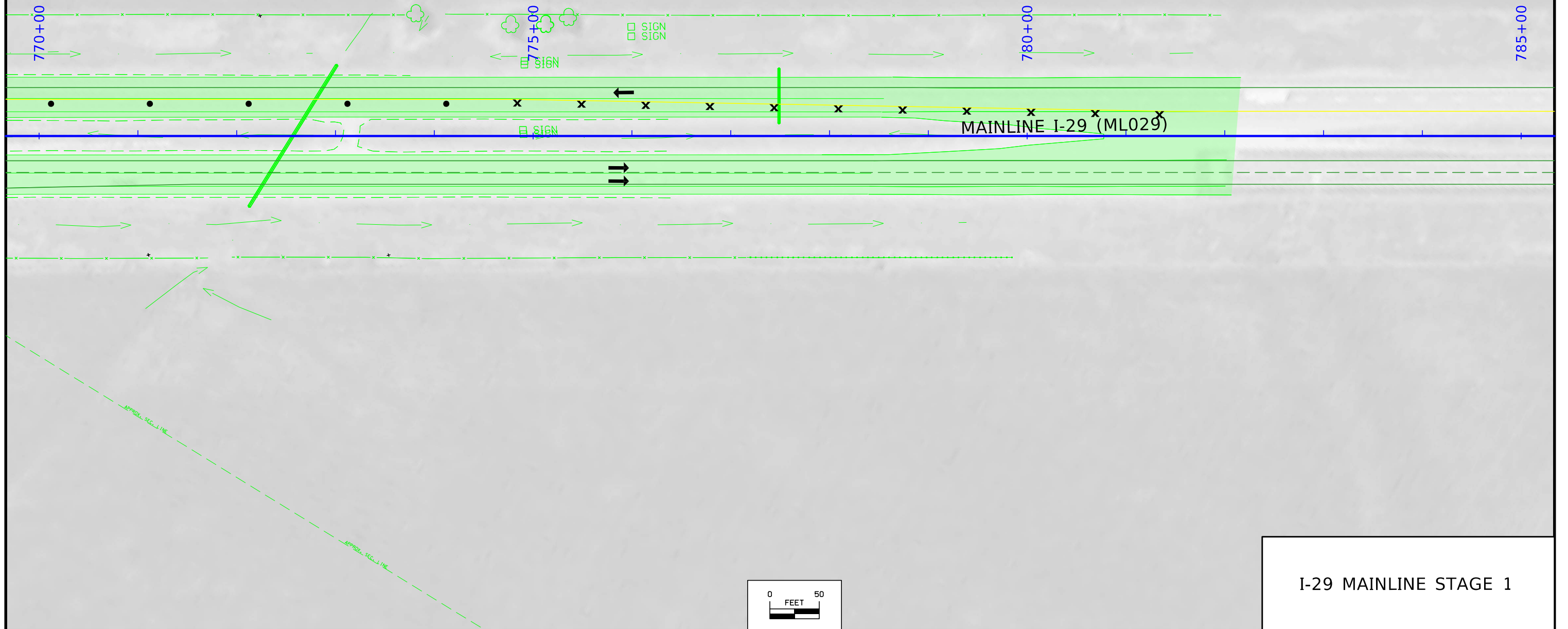

I-29 MAINLINE STAGE 1

Franklin TWP.
T-83N R-45W
SEC. 1



ELDER AVENUE

1710+00

1715+00

1720+00

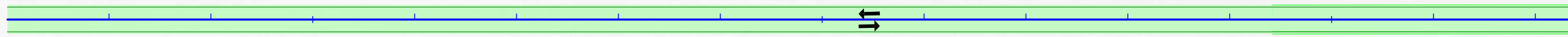

IA-175 (SR175)



FILBERT AVENUE

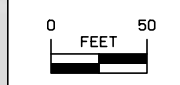
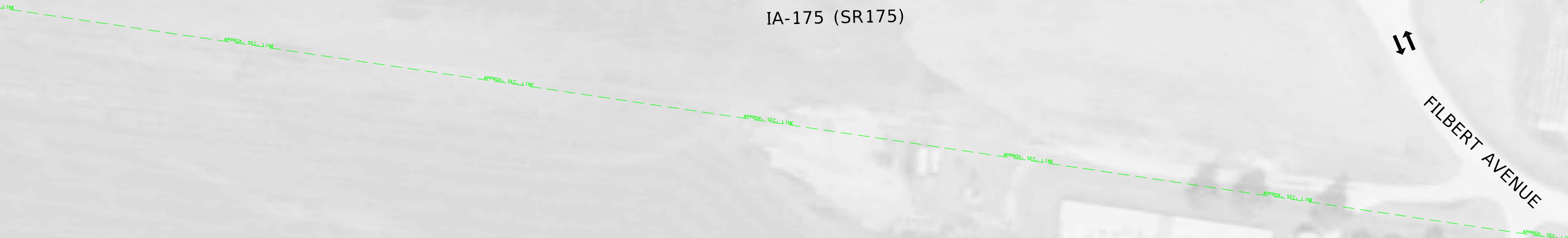

SR175 STAGE 1

Franklin TWP.
T-83N R-45W
SEC. 1



1725+00

1730+00

1735+00

IA-175 (SR175)

RAMP A

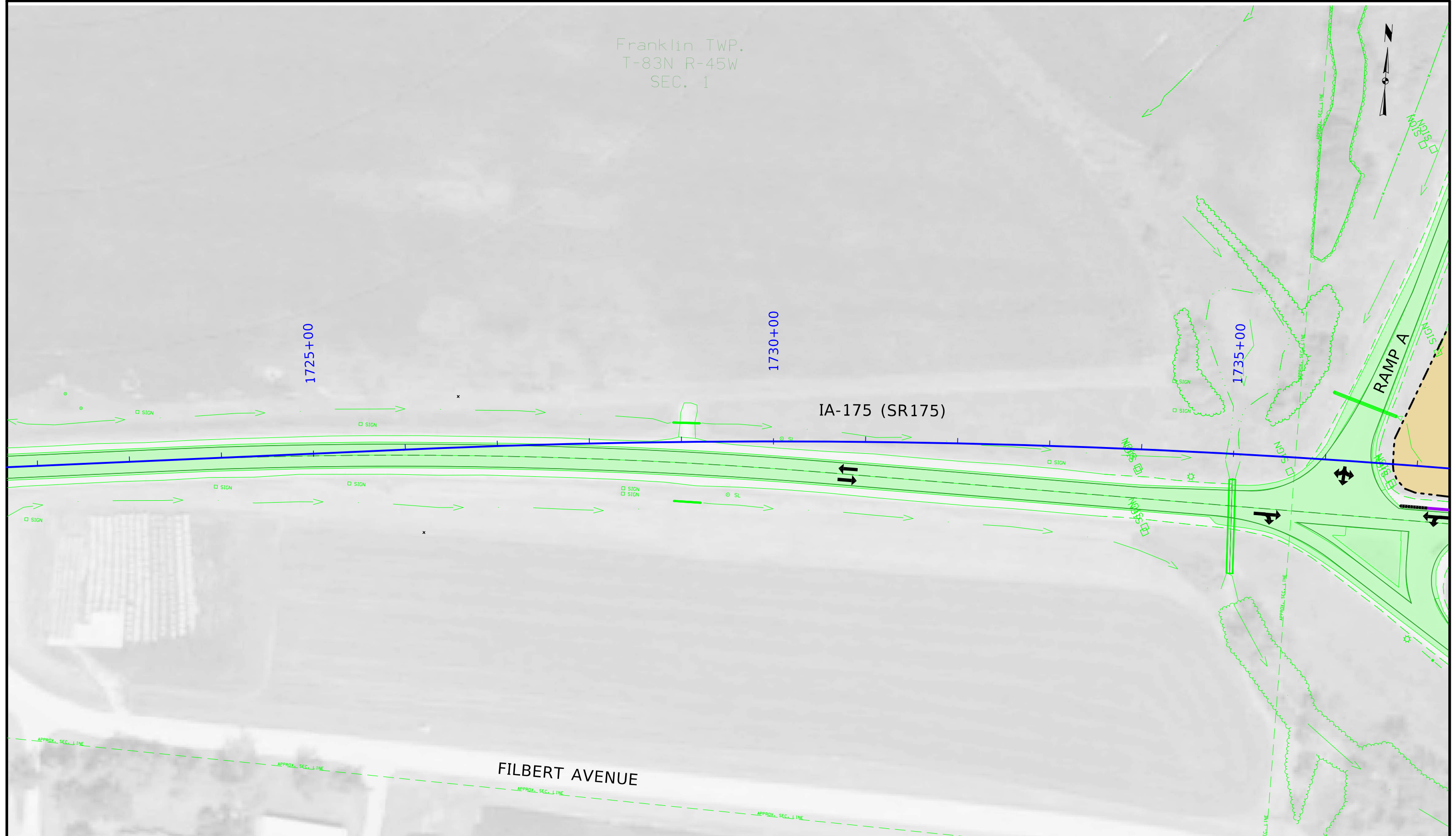

FILBERT AVENUE

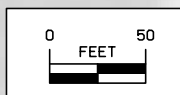

SR175 STAGE 1

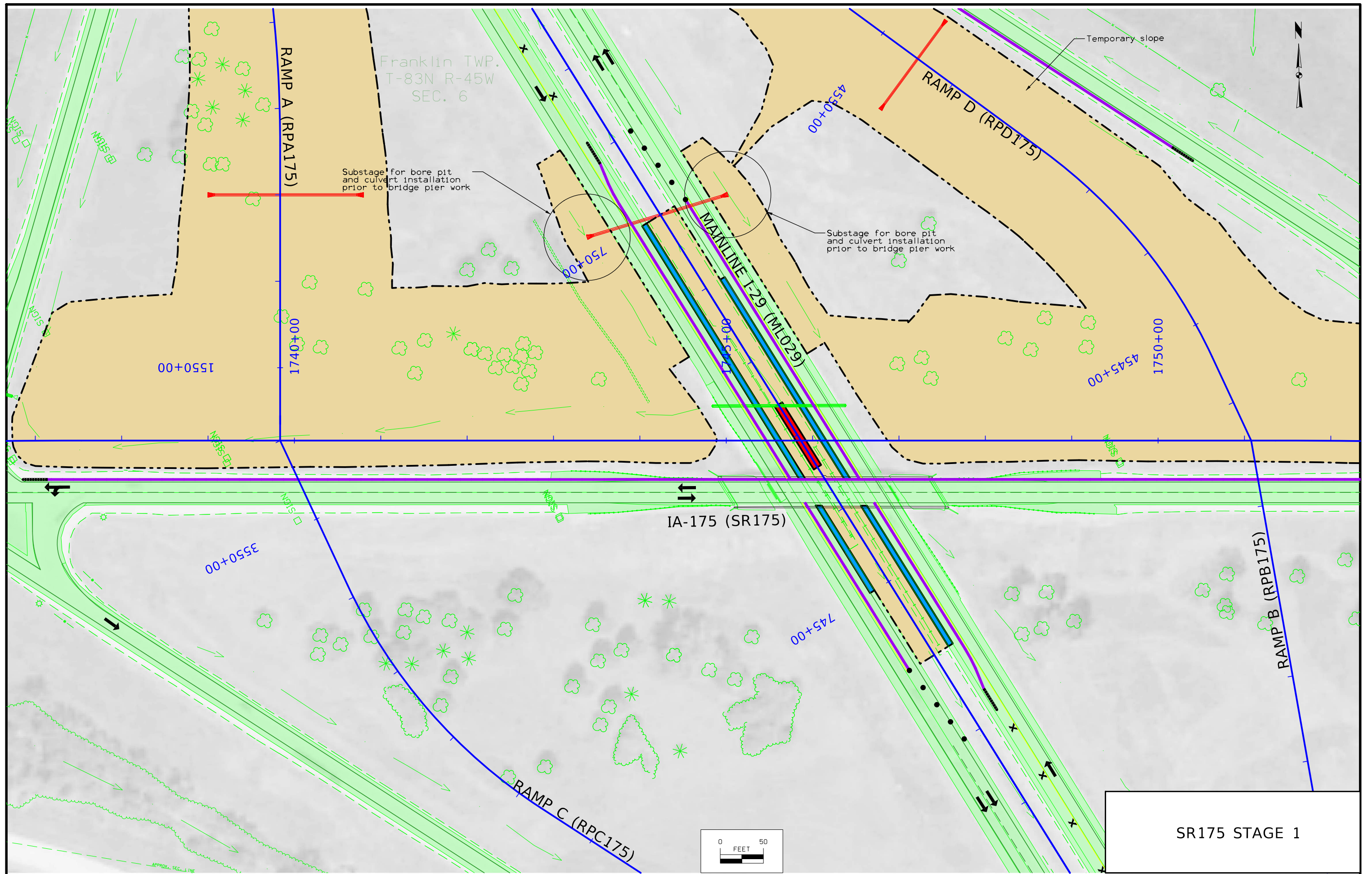

SR175 STAGE 1

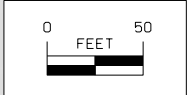

Franklin TWP.
T-83N R-45W
SEC. 6

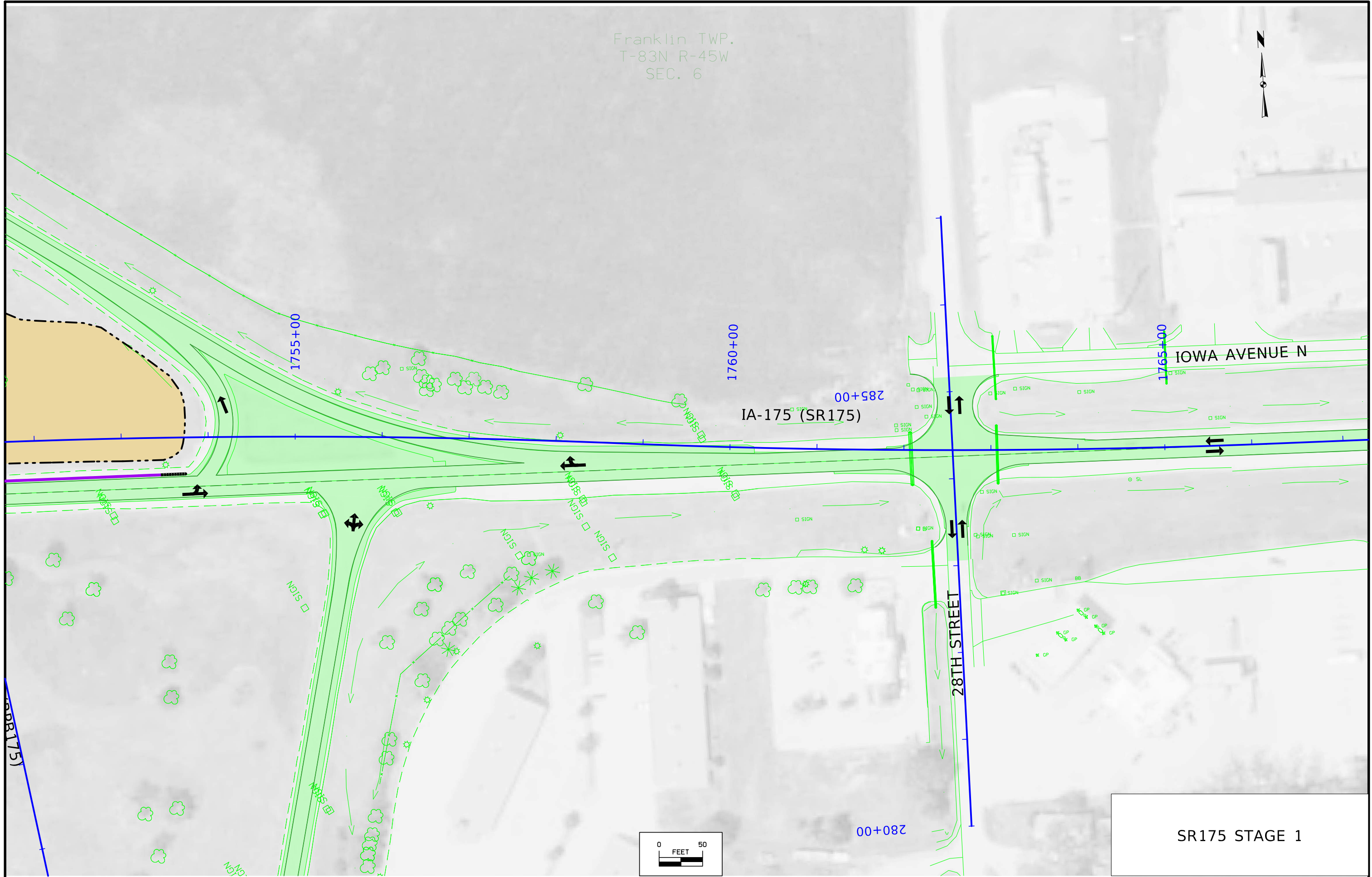

SR175 STAGE 1

Franklin TWP.
T-83N R-45W
SEC. 6



26TH STREET

IOWA AVENUE N

1770+00

1775+00

1780+00

IA-175 (SR175)

SR175 STAGE 1

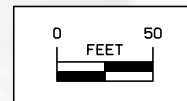

Franklin TWP.
T-83N R-45W
SEC. 7

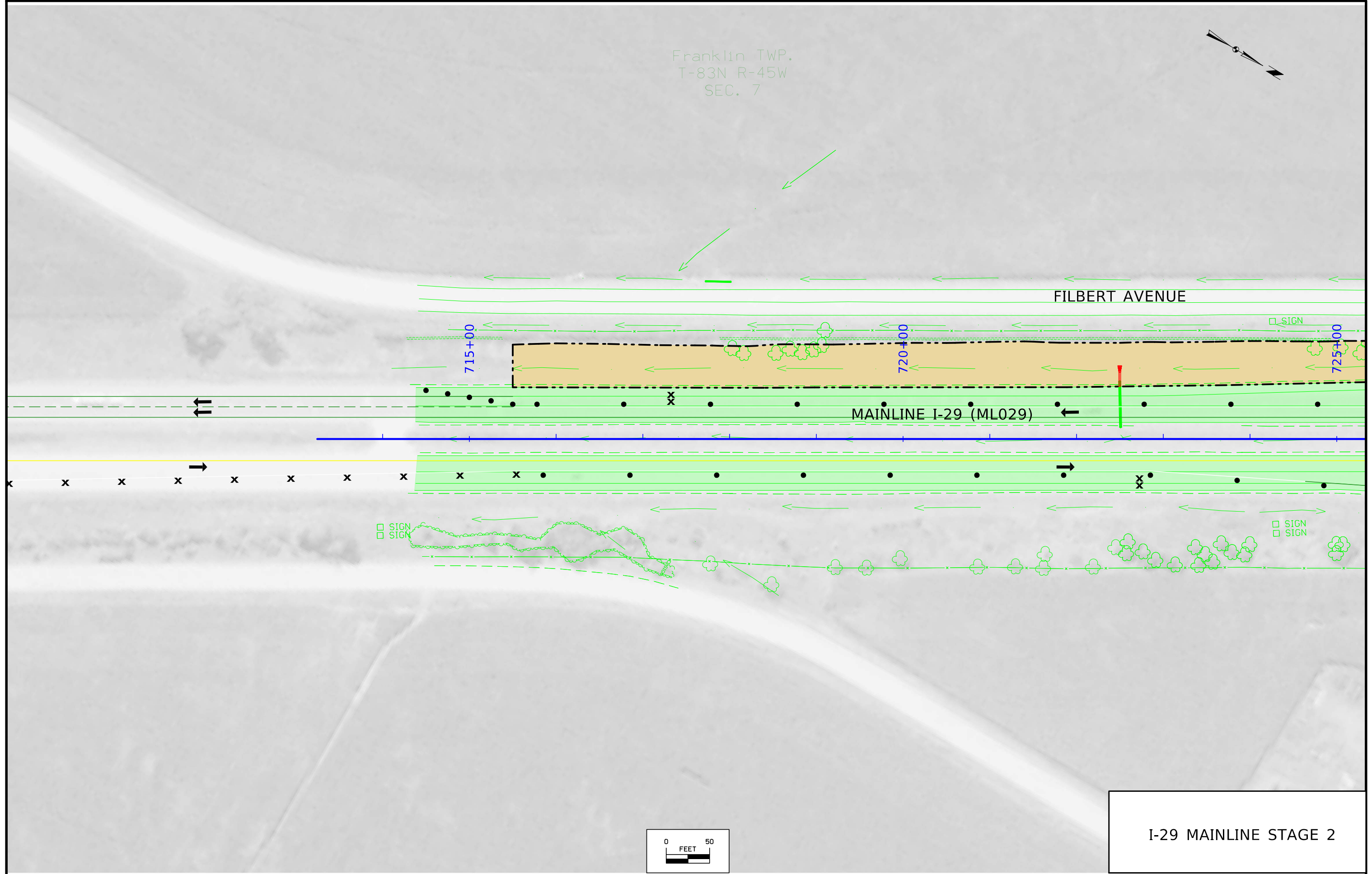

FILBERT AVENUE

MAINLINE I-29 (ML029)

715+00

720+00

725+00

SIGN

SIGN
SIGN

SIGN
SIGN

I-29 MAINLINE STAGE 2

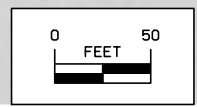

Franklin TWP.
T-83N R-45W
SEC. 7

FILBERT AVENUE

RAMP C

Temporary slope

MAINLINE I-29 (ML029)

RAMP B

I-29 MAINLINE STAGE 2

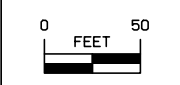

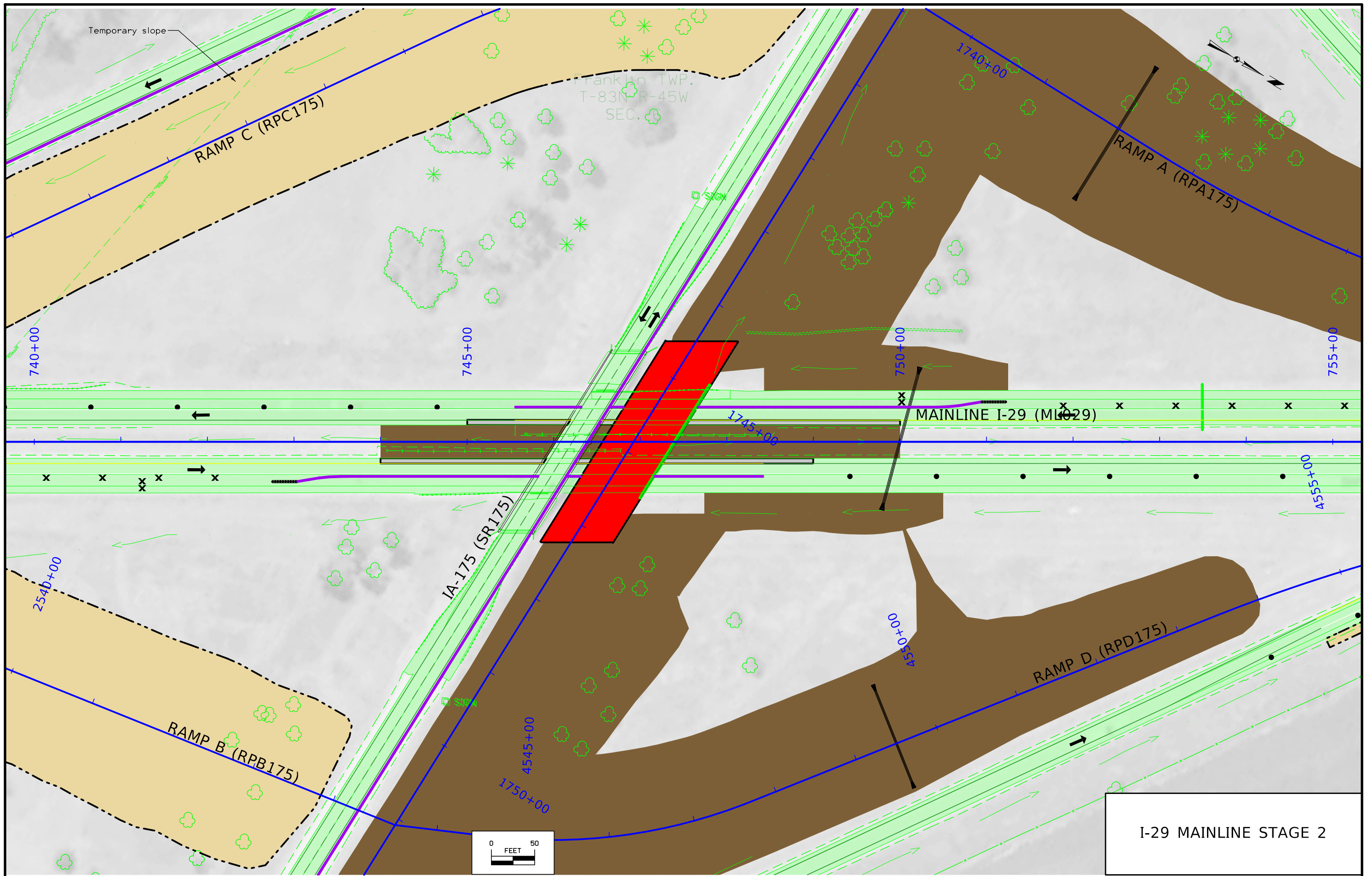

I-29 MAINLINE STAGE 2

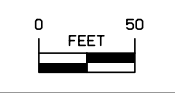

Franklin TWP.
T-83N R-45W
SEC. 1

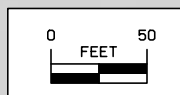
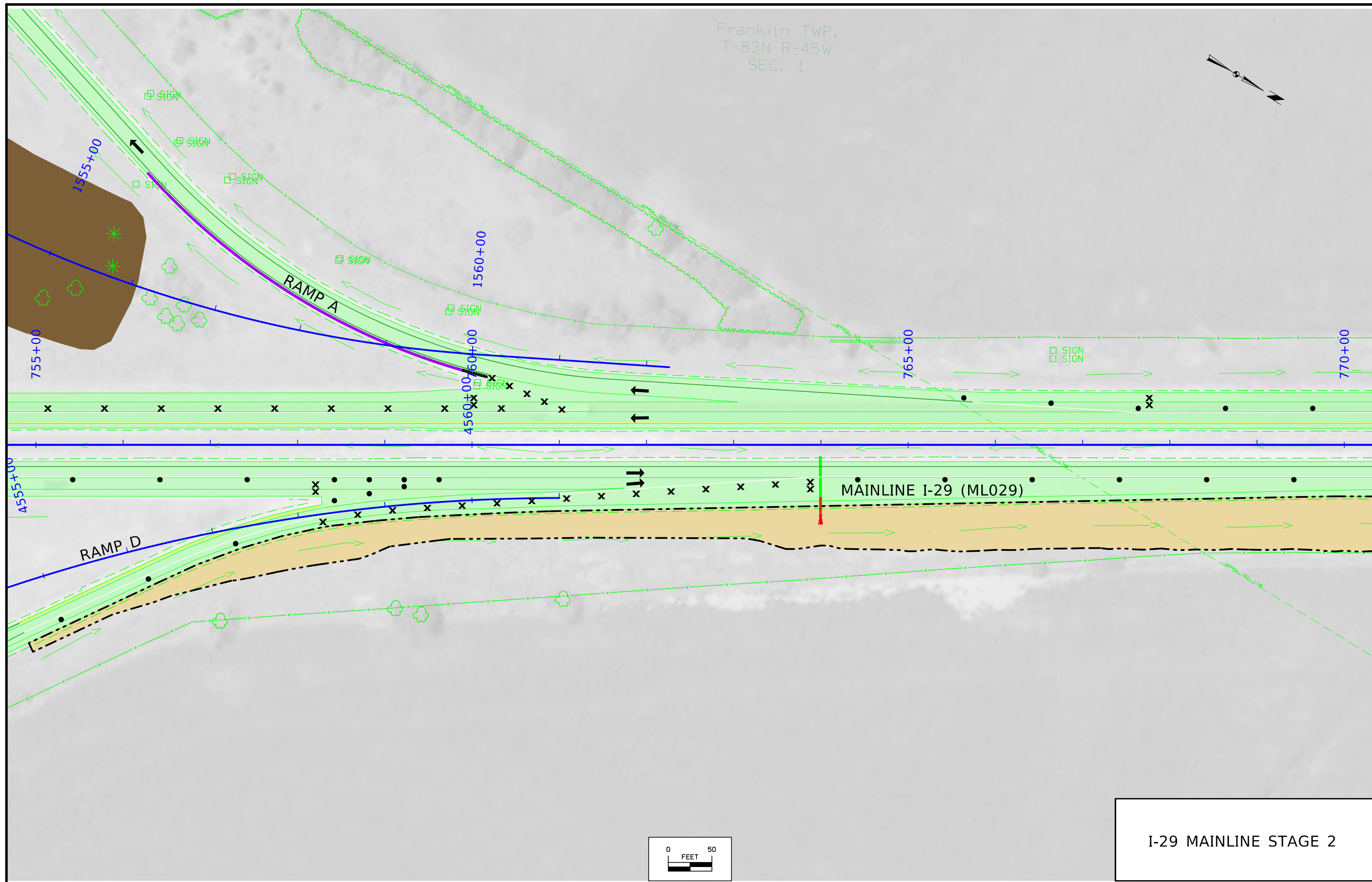

I-29 MAINLINE STAGE 2

Franklin TWP.
T-83N R-45W
SEC. 1

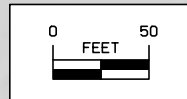
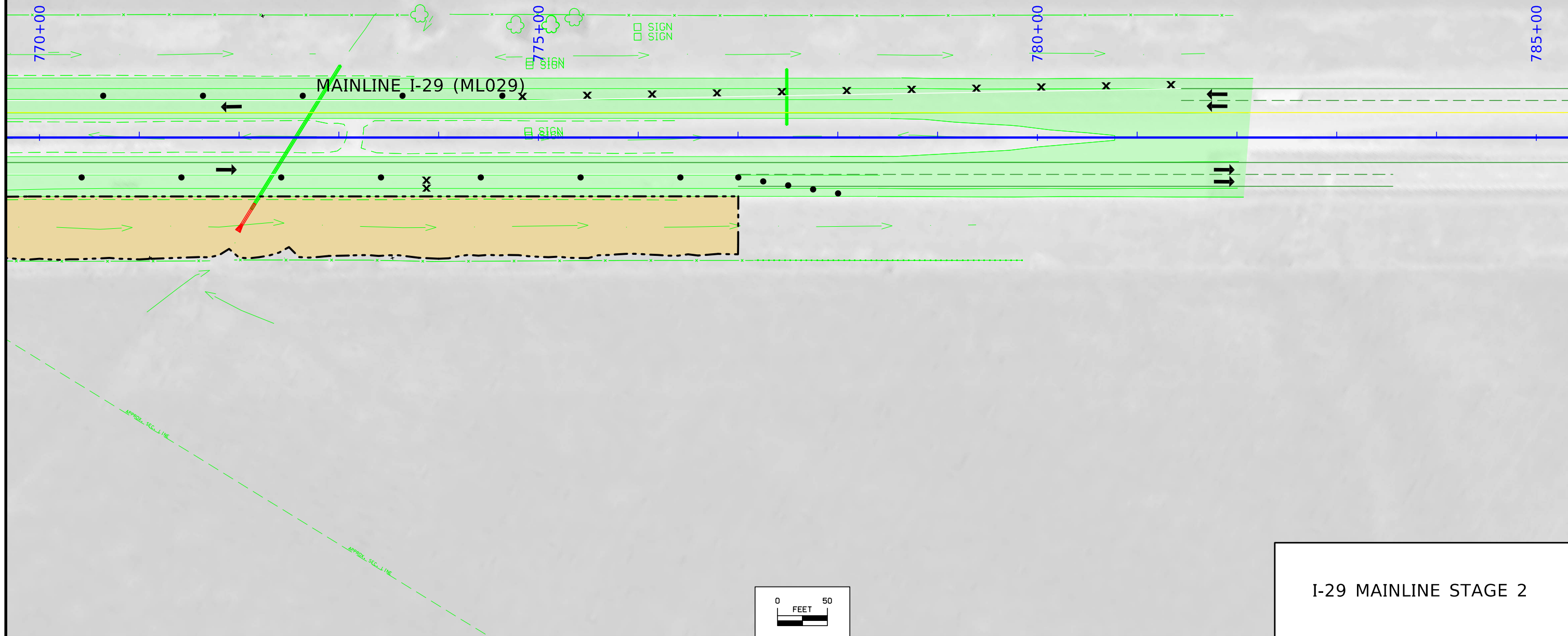

I-29 MAINLINE STAGE 2

Franklin TWP.
T-83N R-45W
SEC. 1



ELDER AVENUE

1710+00

1715+00

1720+00

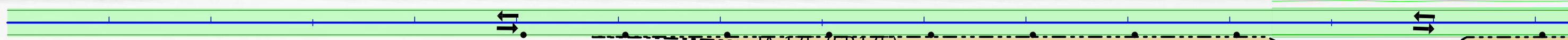

SR 175 (SR 175)

SIGN

SIGN

FILBERT AVENUE

APPROX. SEC. LINE

APPROX. SEC. LINE

APPROX. SEC. LINE

APPROX. SEC. LINE

APPROX. SEC. LINE

APPROX. SEC. LINE

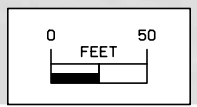

SR175 STAGE 2

Franklin TWP.
T-83N R-45W
SEC. 1



1725+00

1730+00

1735+00

IA-175 (SR175)

RAMP A

FILBERT AVENUE

SR175 STAGE 2

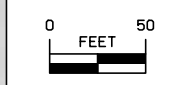

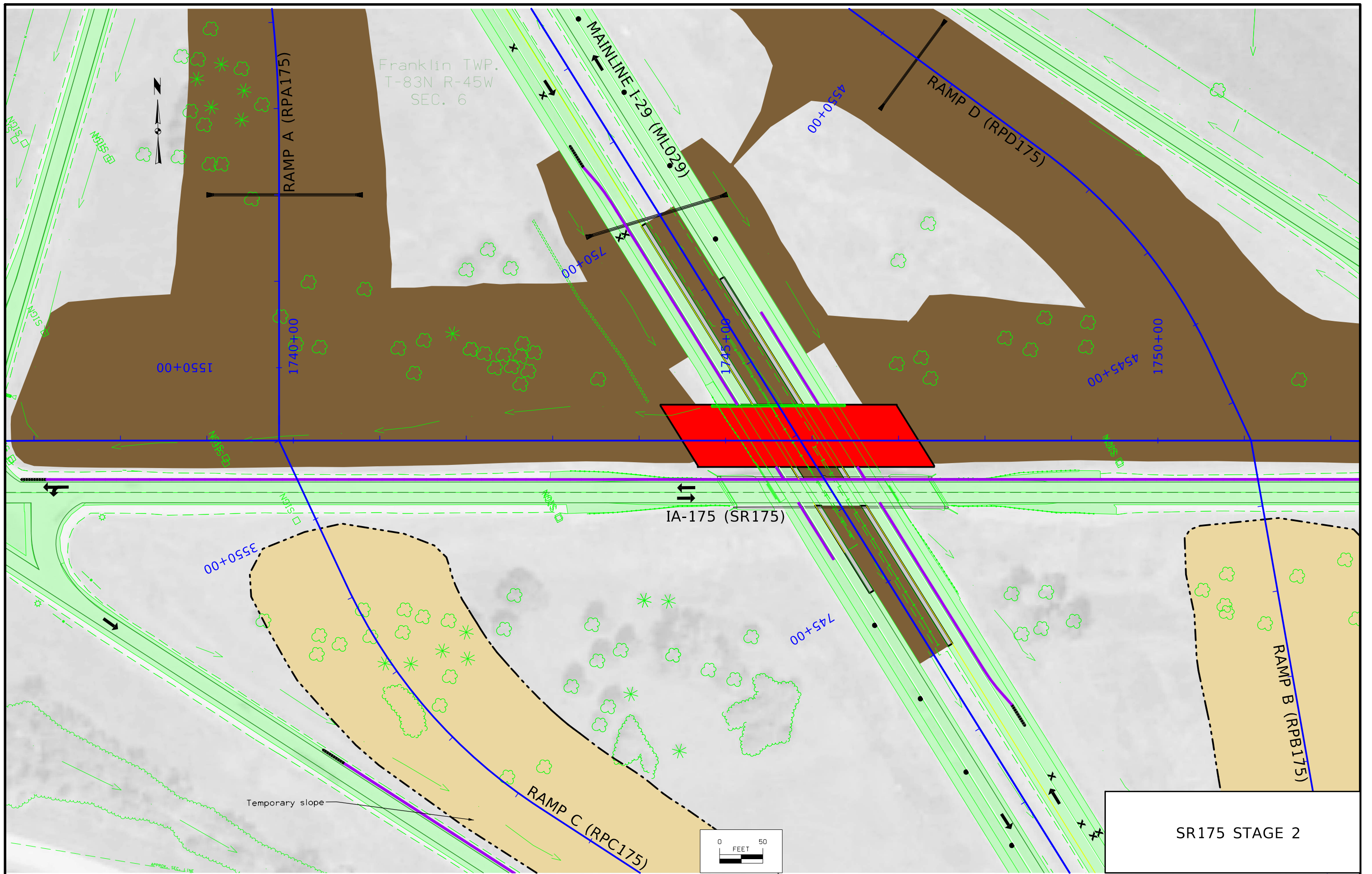

SR175 STAGE 2

Franklin TWP.
T-83N R-45W
SEC. 6

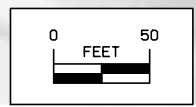
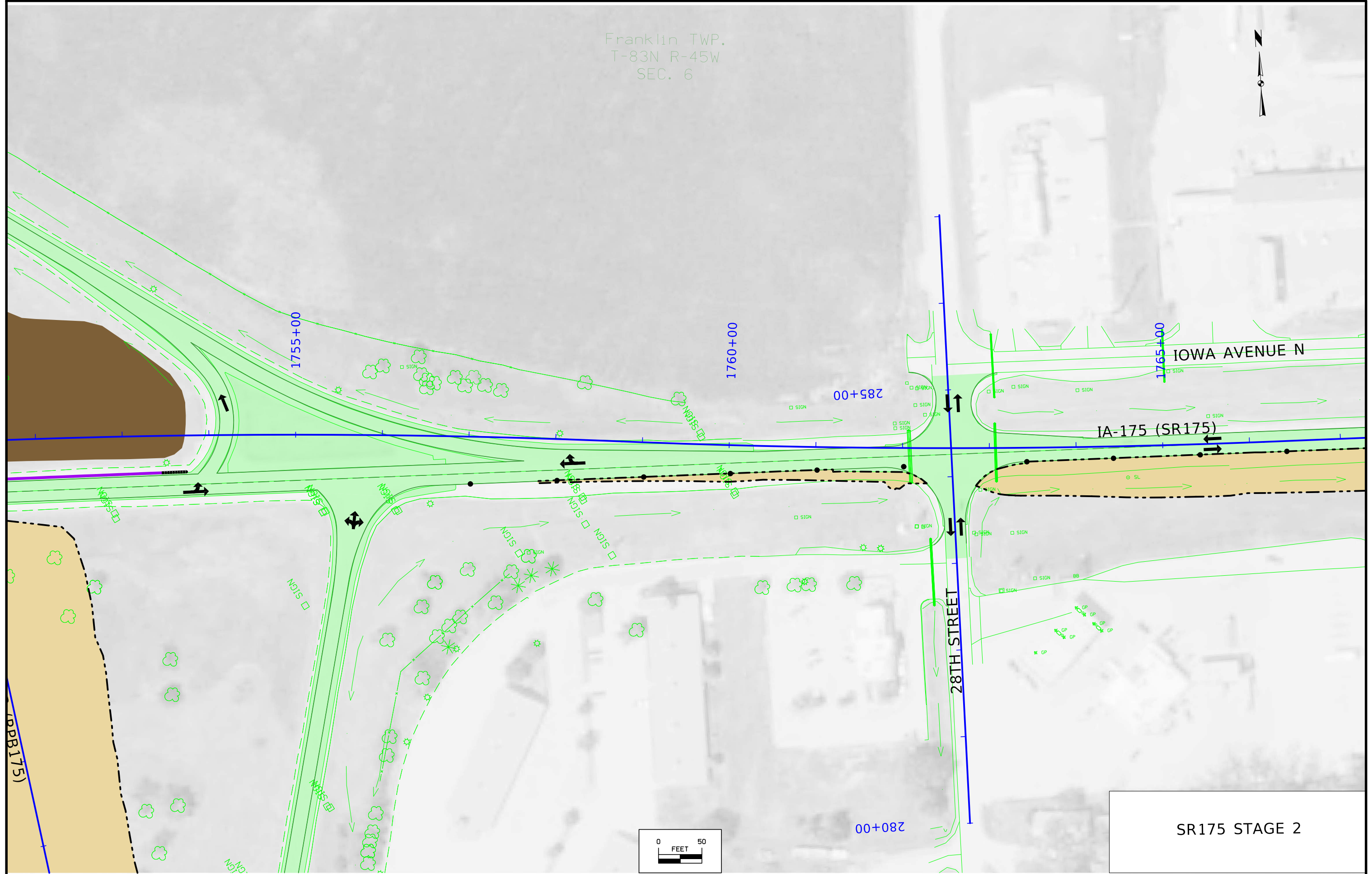

SR175 STAGE 2

Franklin TWP.
T-83N R-45W
SEC. 6



26TH STREET

IOWA AVENUE N

IA-175 (SR175)

1770+00

1775+00

1780+00

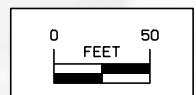
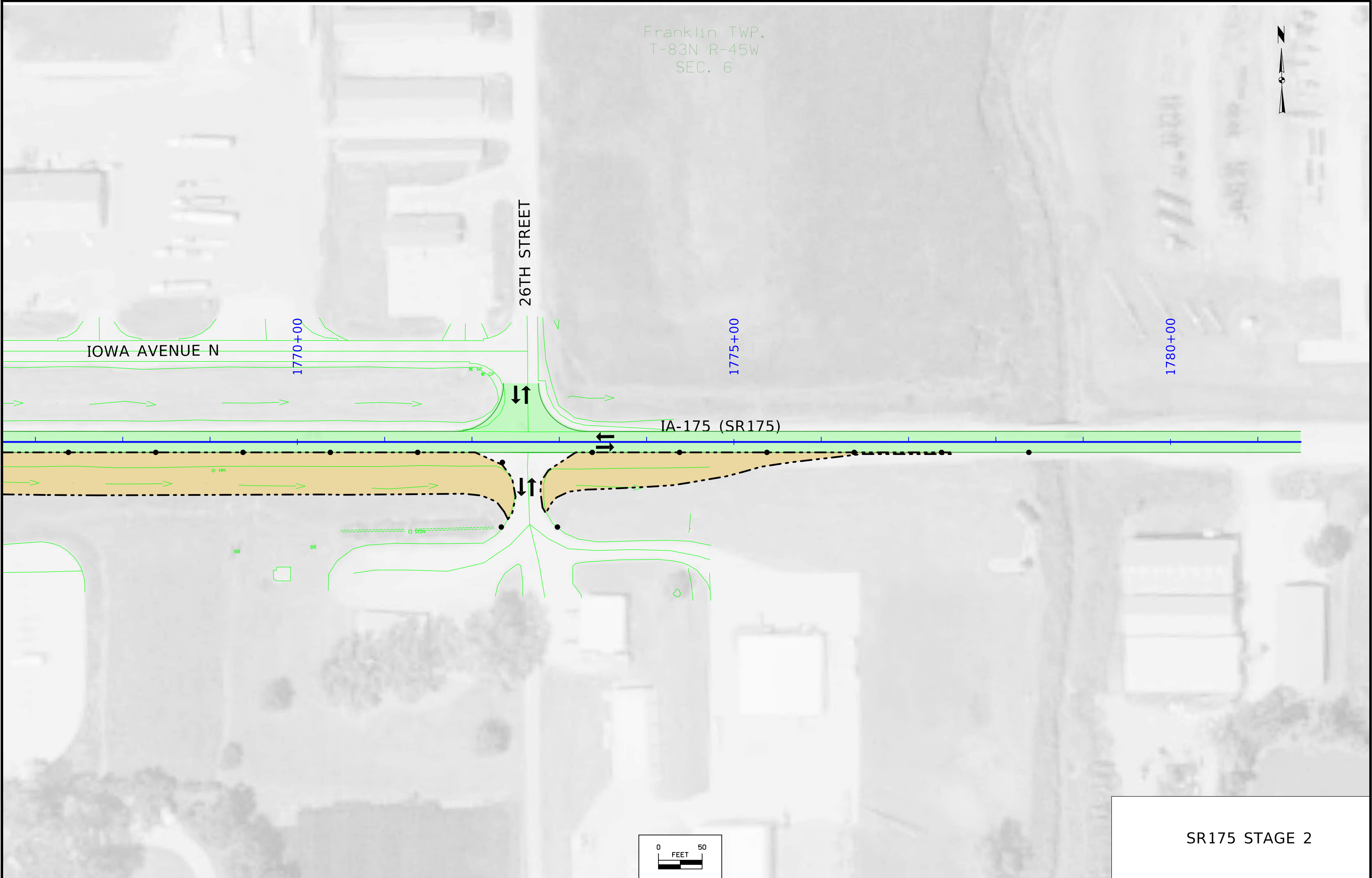

SR175 STAGE 2

Franklin TWP.
T-83N R-45W
SEC. 7



Permanent pavement and temporary
widening pavement to be separate site

FILBERT AVENUE

715+00

720+00

725+00

MAINLINE I-29 (ML029)

SIGN
SIGN

SIGN
SIGN

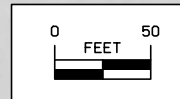

I-29 MAINLINE STAGE 3

Franklin TWP.
T-83N R-45W
SEC. 7

FILBERT AVENUE

RAMP C

RAMP C (RPC175)

MAINLINE I-29 (ML029)

DETOUR RAMP B

RAMP B

I-29 MAINLINE STAGE 3

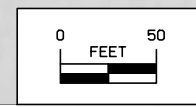

Permanent pavement and temporary widening pavement to be separate site

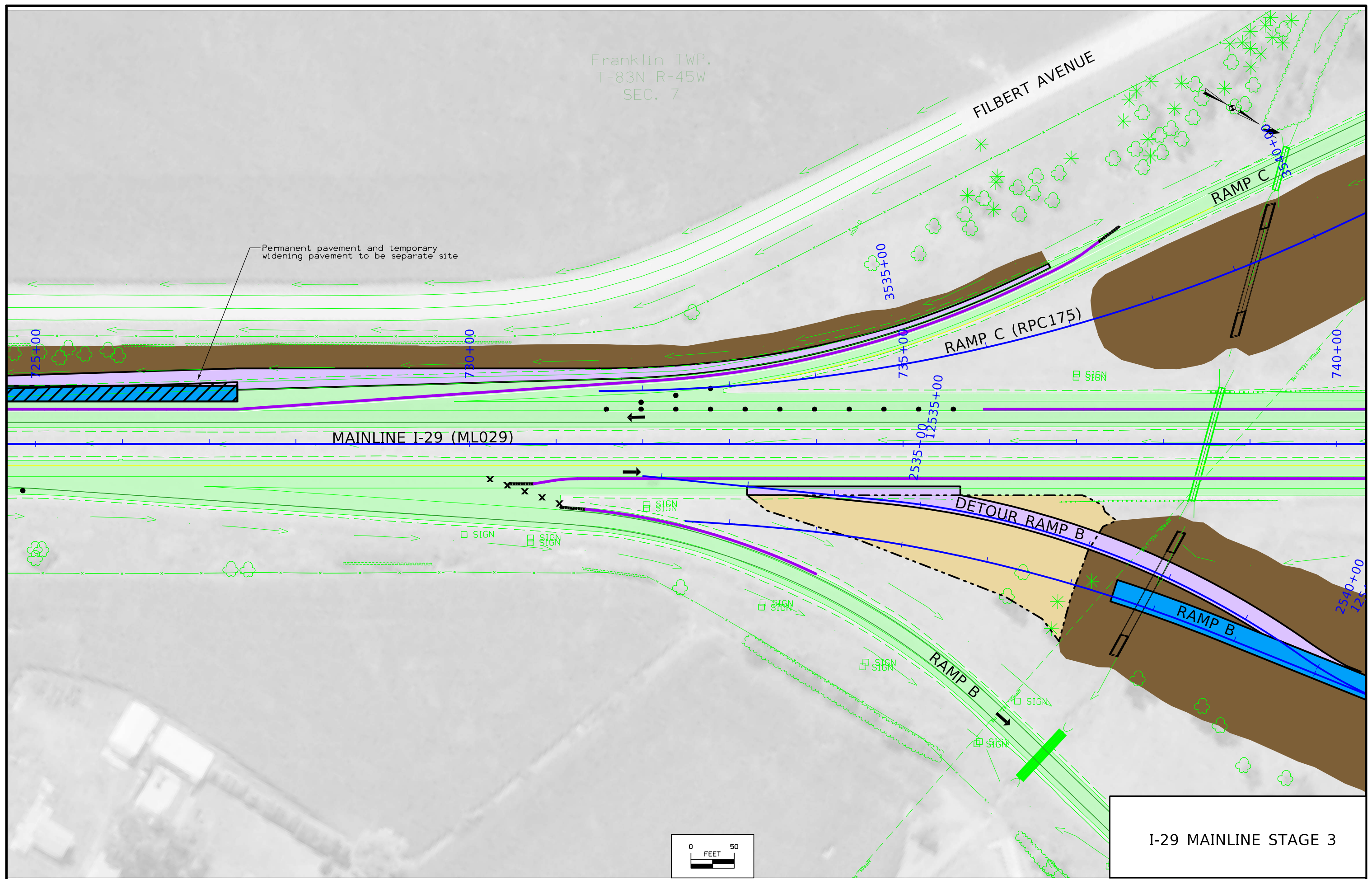

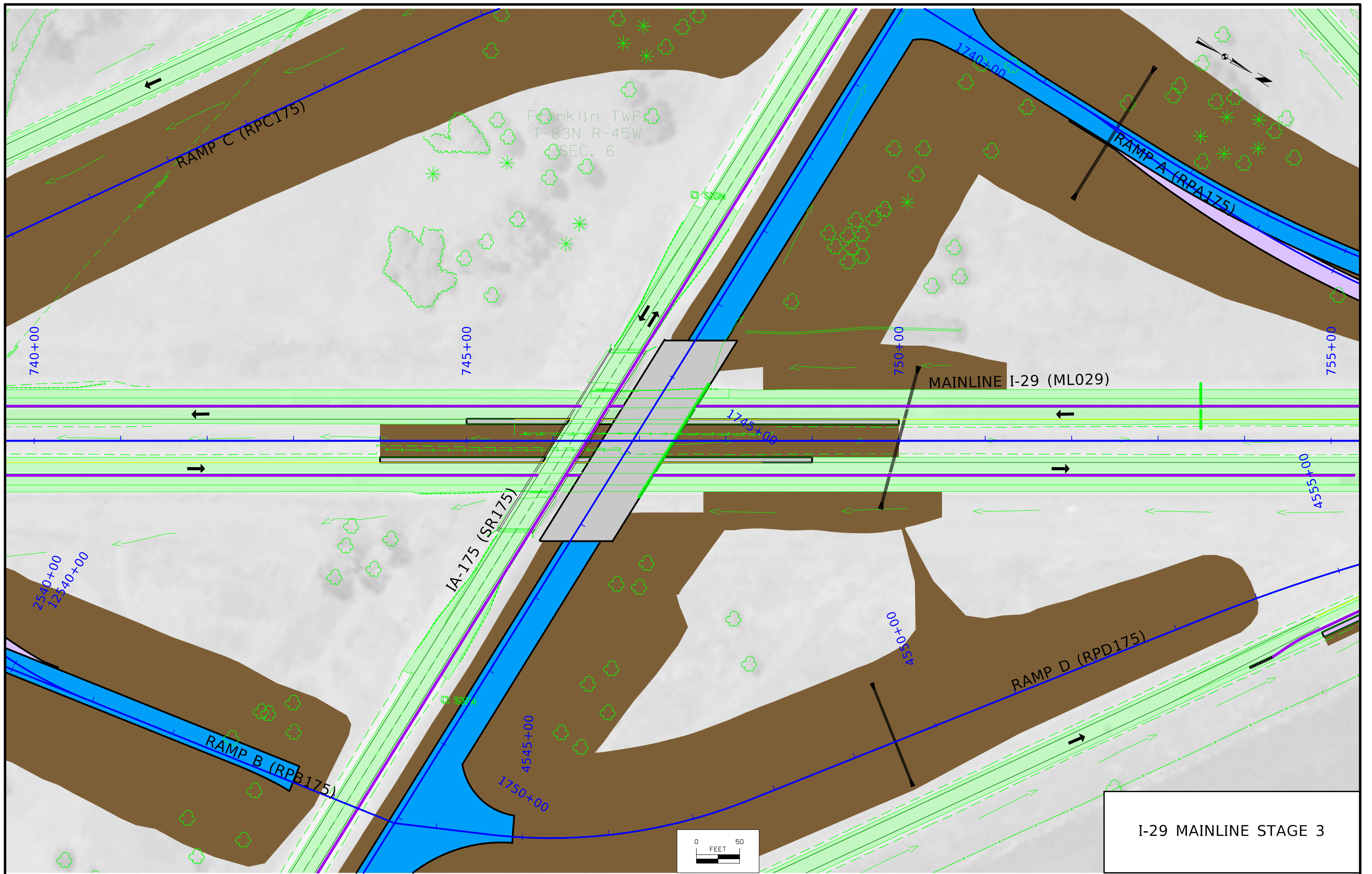

Franklin TWP.
T-83N R-45W
SEC. 1

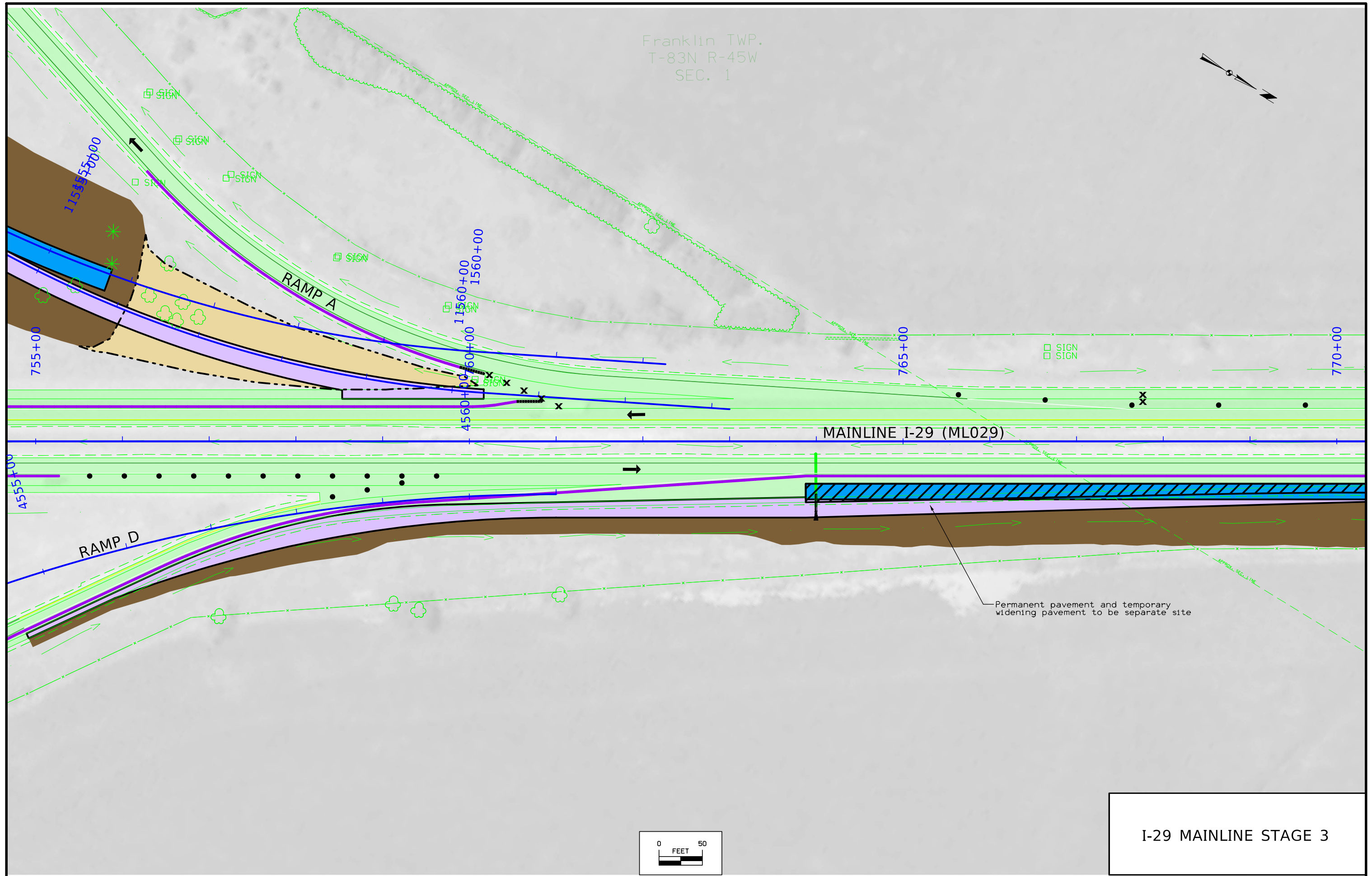
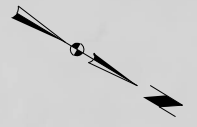

Permanent pavement and temporary widening pavement to be separate site

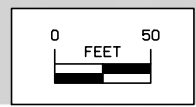

I-29 MAINLINE STAGE 3

Franklin TWP.
T-83N R-45W
SEC. 1

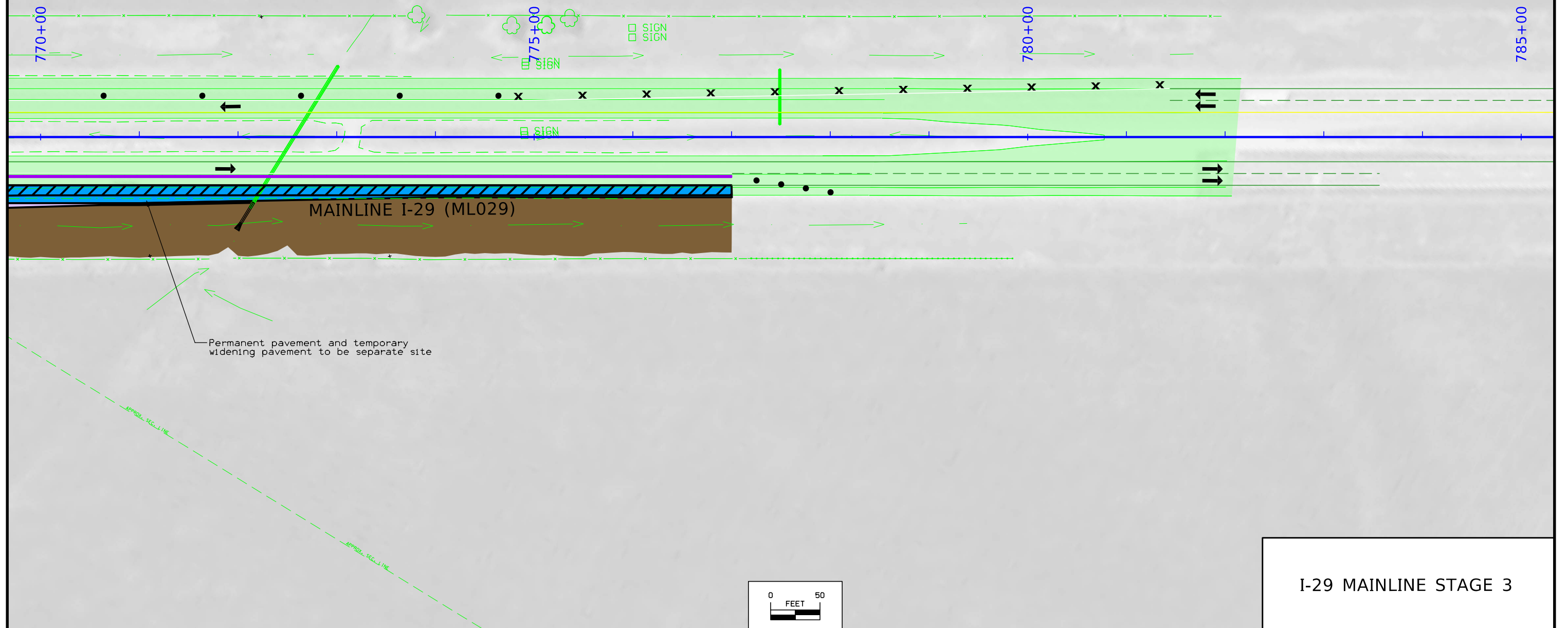

Permanent pavement and temporary widening pavement to be separate site

MAINLINE I-29 (ML029)

I-29 MAINLINE STAGE 3

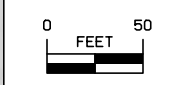

Franklin TWP.
T-83N R-45W
SEC. 1



ELDER AVENUE

1710+00

1715+00

1720+00

IA-175 (SR175)



SIGN

SIGN

SIGN

SIGN

Stage construct across Filbert St.
to provide continual access

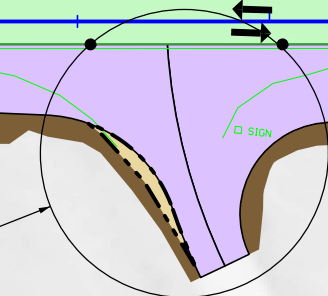

FILBERT AVENUE

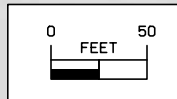

SR175 STAGE 3

Franklin TWP.
T-83N R-45W
SEC. 1

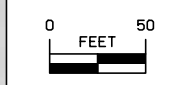

SR175 STAGE 3

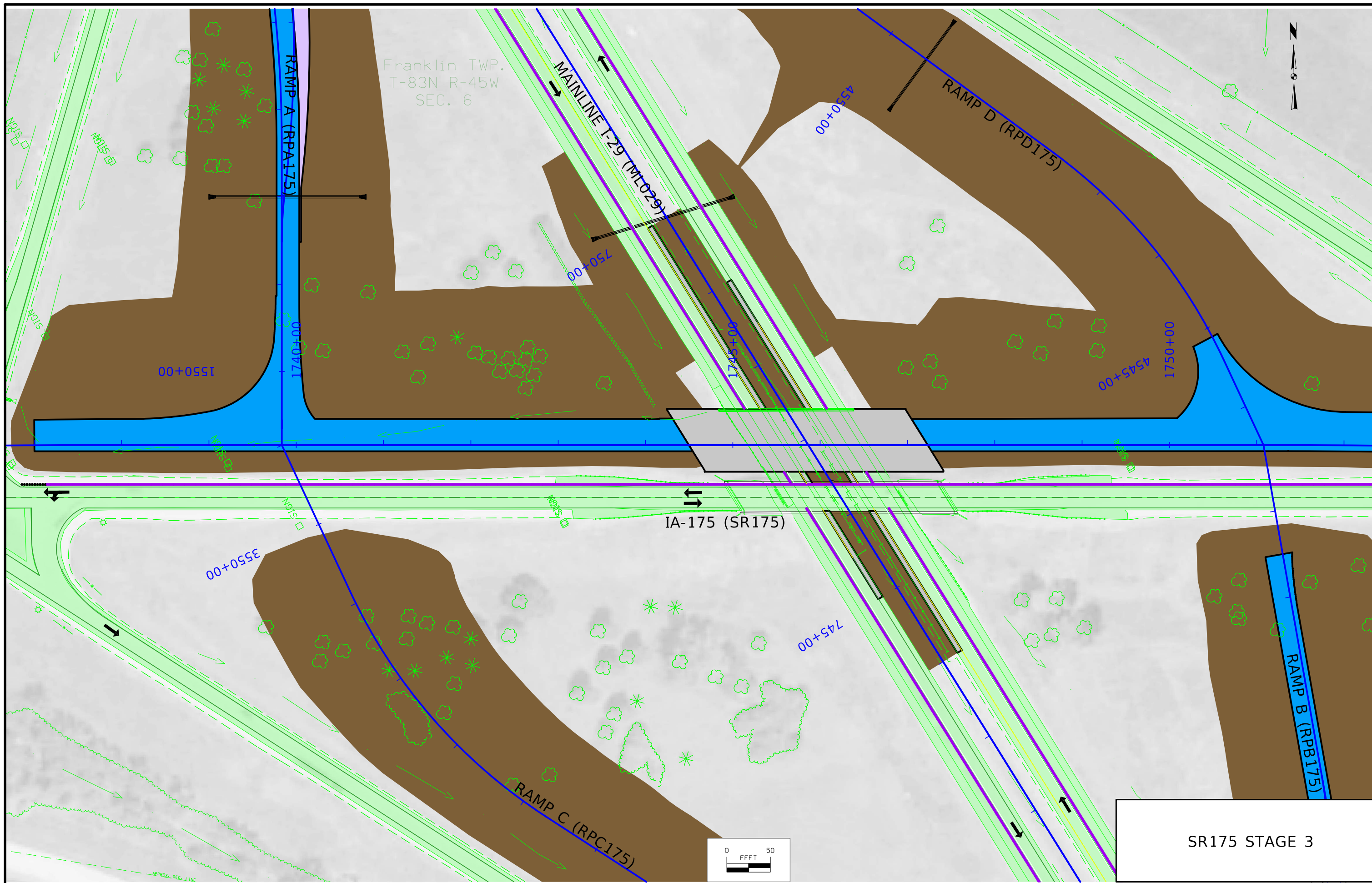

SR175 STAGE 3

FILE NO.	ENGLISH	DESIGN TEAM Iowa DOT/HR Green	MONONA COUNTY	PROJECT NUMBER STP-175-1(95)--2C-67	SHEET NUMBER J.39
----------	---------	-------------------------------	---------------	-------------------------------------	-------------------

Franklin TWP.
T-83N R-45W
SEC. 6

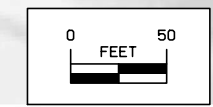
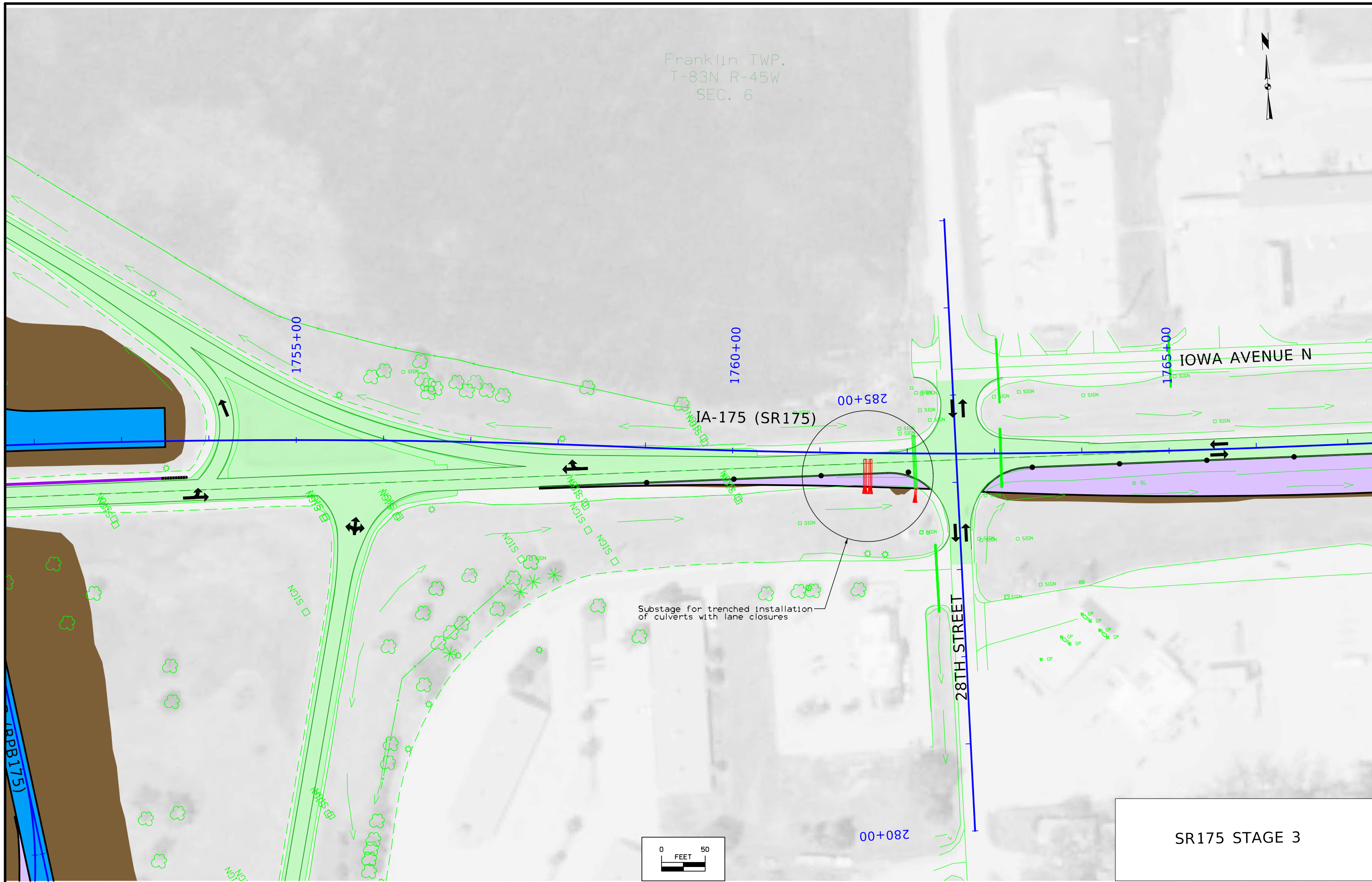

SR175 STAGE 3

Franklin TWP.
T-83N R-45W
SEC. 6



26TH STREET

IOWA AVENUE N

1770+00

1775+00

1780+00

IA-175 (SR175)

Stage construct across 26th St.
to provide continual access

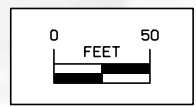

SR175 STAGE 3

Franklin TWP.
T-83N R-45W
SEC. 7

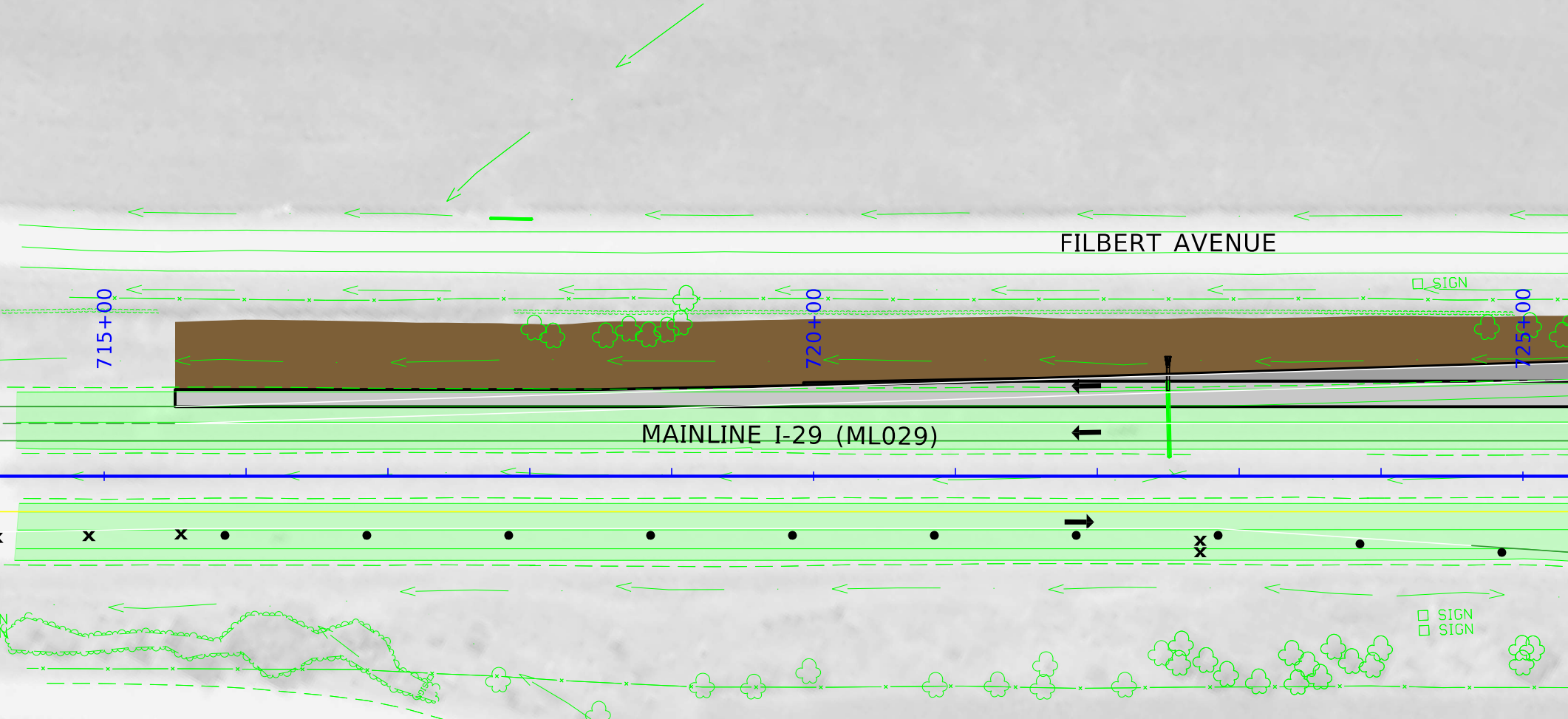

FILBERT AVENUE

MAINLINE I-29 (ML029)

715+00

720+00

725+00

□ SIGN

□ SIGN
□ SIGN

□ SIGN
□ SIGN

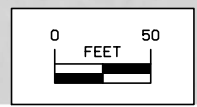

I-29 MAINLINE STAGE 4

Franklin TWP.
T-83N R-45W
SEC. 7

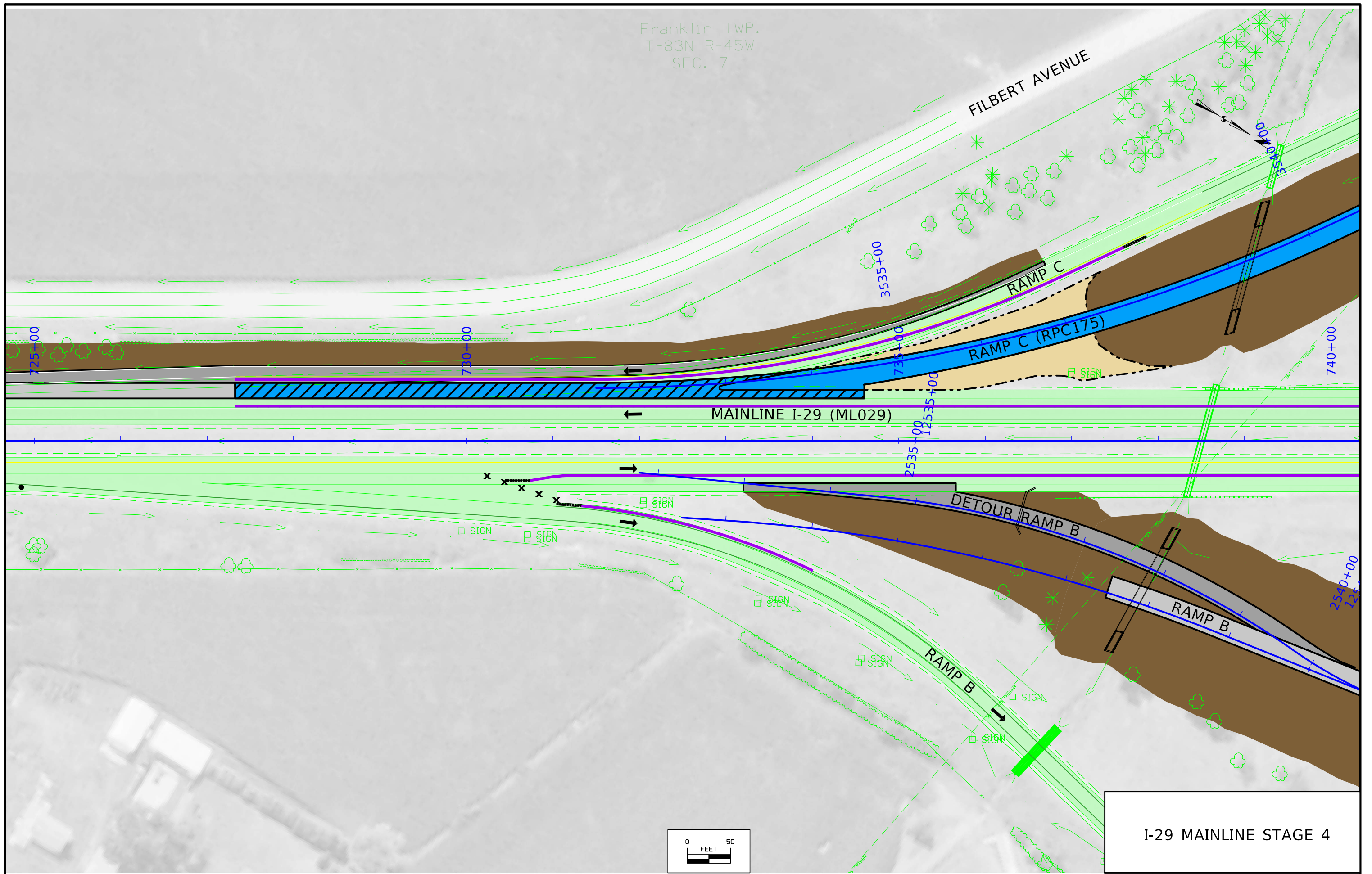

I-29 MAINLINE STAGE 4

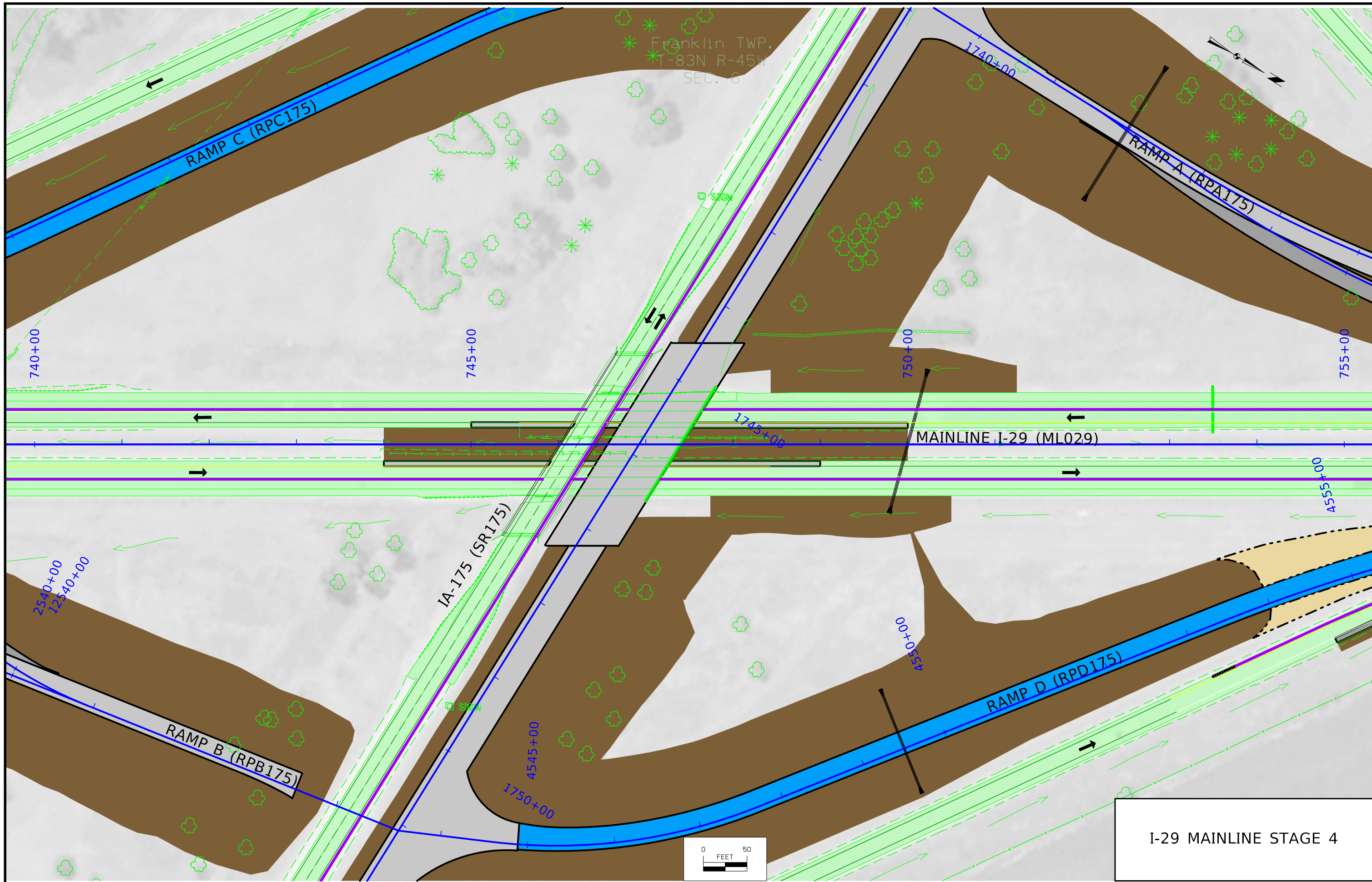

Franklin TWP.
T-83N R-45W
SEC. 1

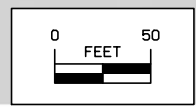
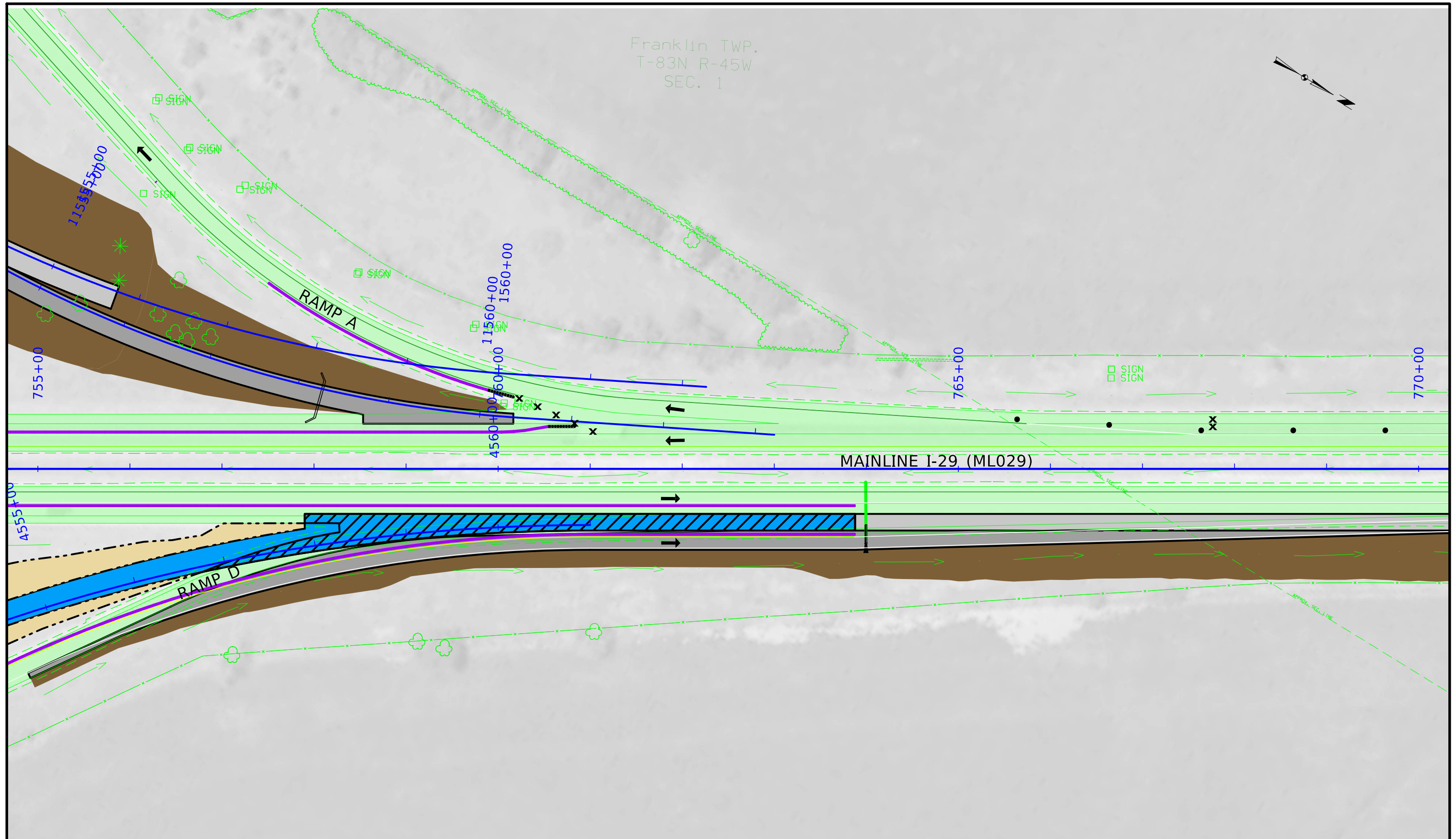
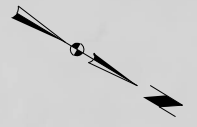

I-29 MAINLINE STAGE 4

Franklin TWP.
T-83N R-45W
SEC. 1

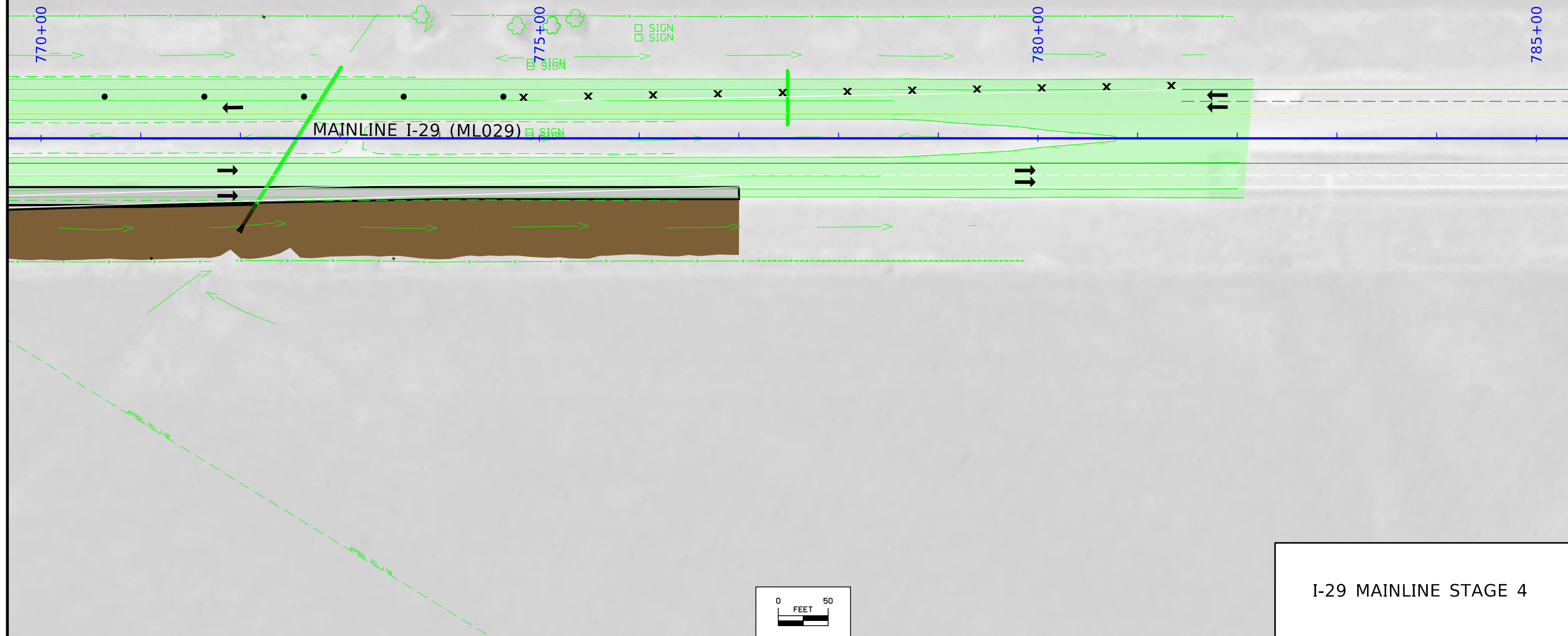

I-29 MAINLINE STAGE 4

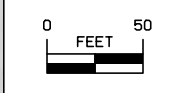

Franklin TWP.
T-83N R-45W
SEC. 1



ELDER AVENUE

1710+00

1715+00

1720+00

IA-175 (SR175)

FILBERT AVENUE

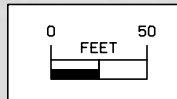

SR175 STAGE 4

Franklin TWP.
T-83N R-45W
SEC. 1

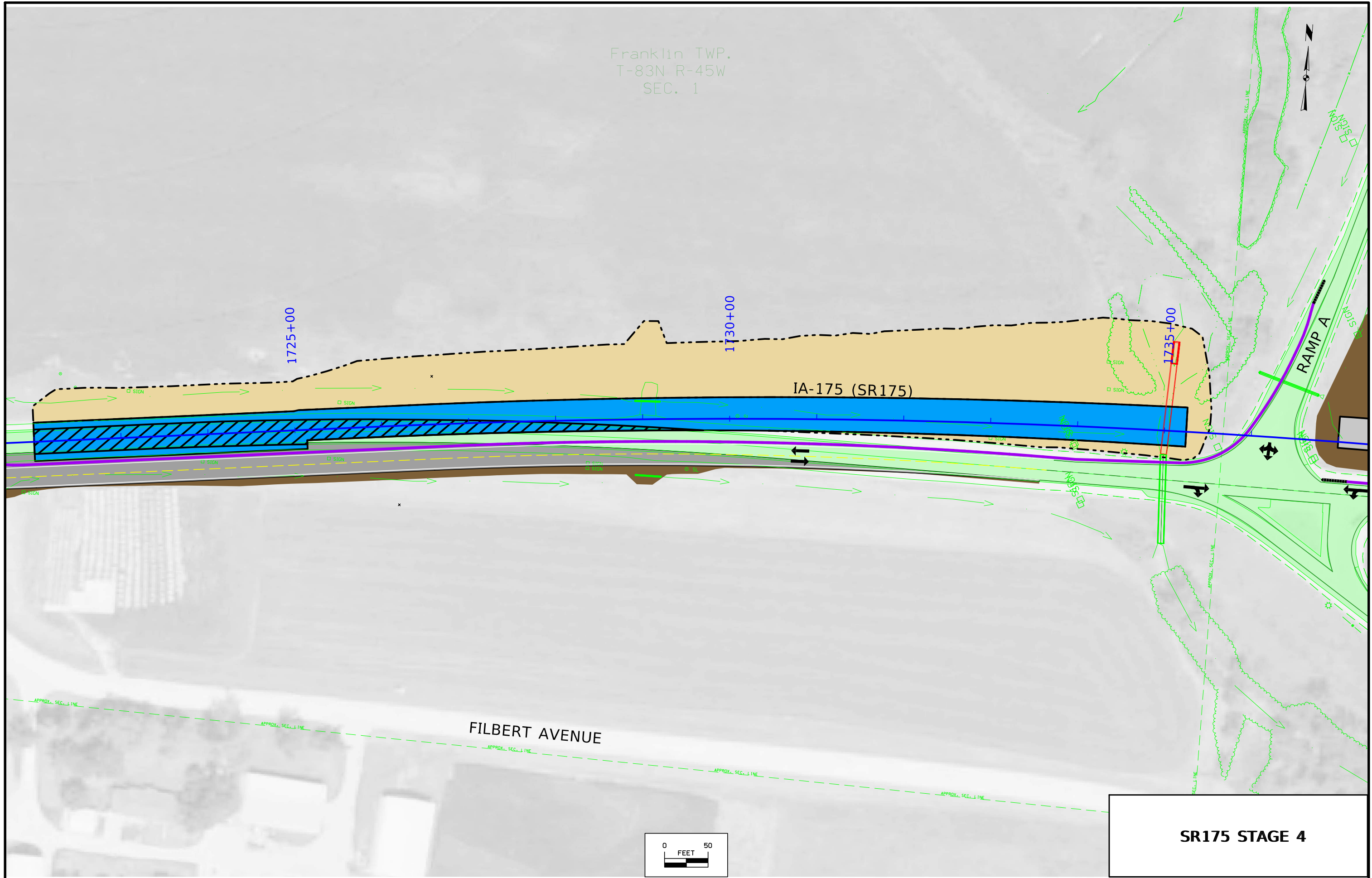

SR175 STAGE 4

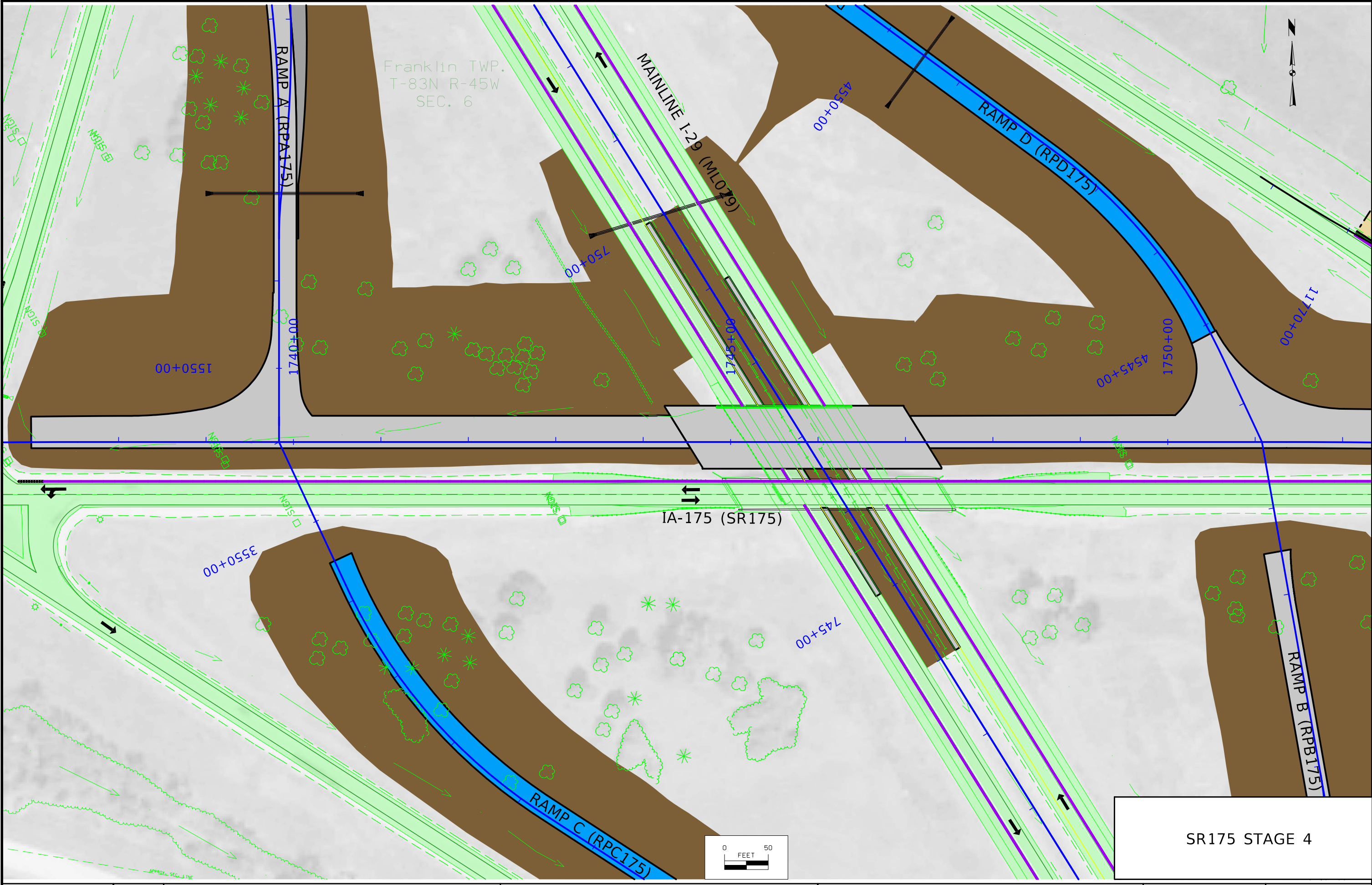

SR175 STAGE 4

FILE NO.	ENGLISH	DESIGN TEAM Iowa DOT/HR Green	MONONA COUNTY	PROJECT NUMBER STP-175-1(95)--2C-67	SHEET NUMBER J.49
----------	---------	-------------------------------	---------------	-------------------------------------	-------------------

Franklin TWP.
T-83N R-45W
SEC. 6



Narrow area of temporary pavement
tying between existing and proposed

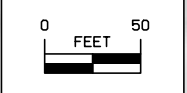
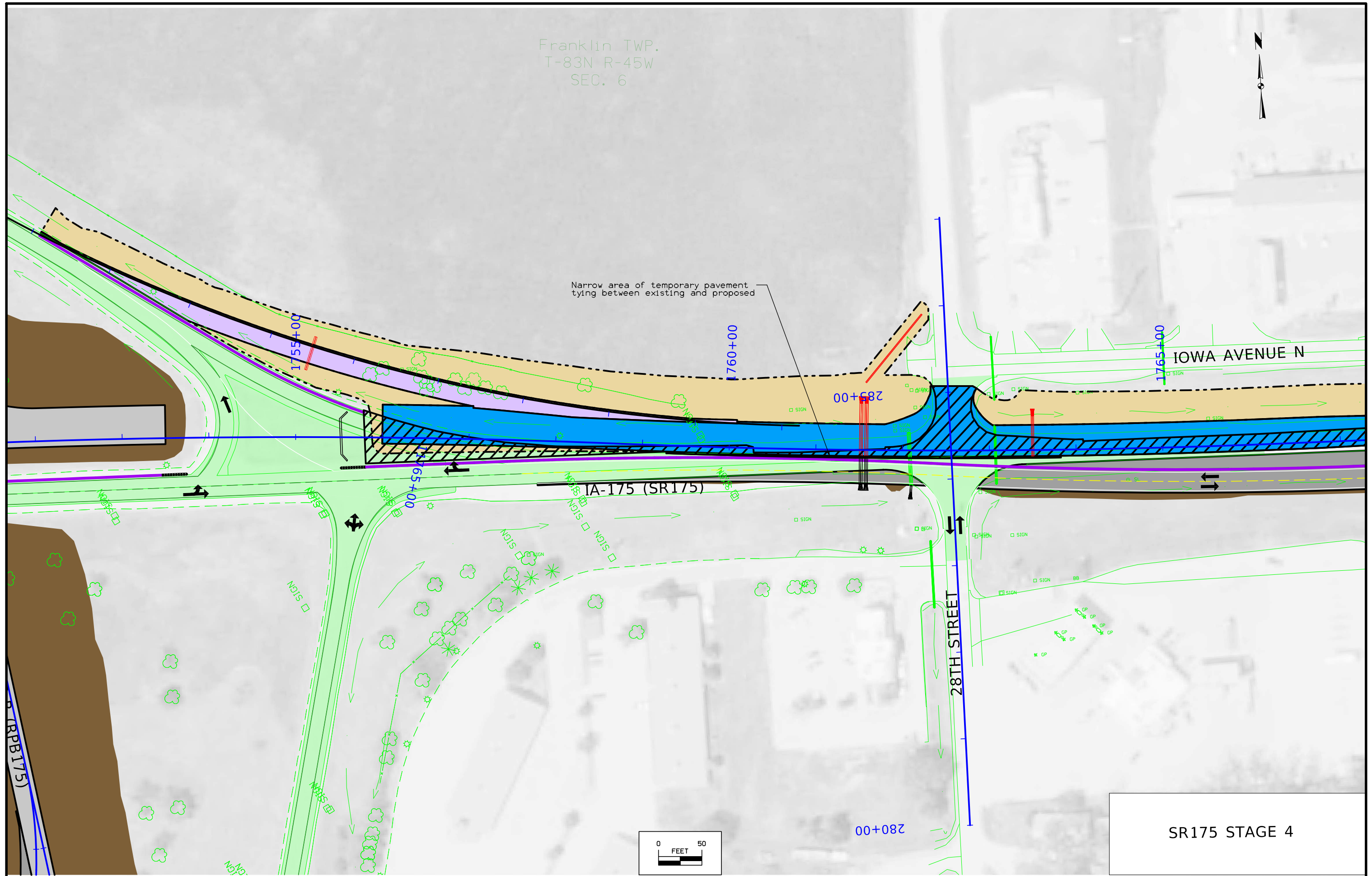

SR175 STAGE 4

FILE NO.	ENGLISH	DESIGN TEAM Iowa DOT/HR Green	MONONA COUNTY	PROJECT NUMBER STP-175-1(95)--2C-67	SHEET NUMBER J.50
----------	---------	-------------------------------	---------------	-------------------------------------	-------------------

Franklin TWP.
T-83N R-45W
SEC. 6



26TH STREET

IOWA AVENUE N

1770+00

1775+00

1780+00

IA-175 (SR175)

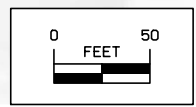

SR175 STAGE 4

Franklin TWP.
T-83N R-45W
SEC. 7

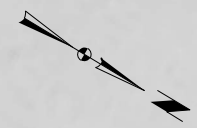

FILBERT AVENUE

715+00

720+00

725+00

MAINLINE I-29 (ML029)

SIGN
SIGN

SIGN
SIGN

I-29 MAINLINE STAGE 5

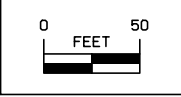

Franklin TWP.
T-83N R-45W
SEC. 7

FILBERT AVENUE

RAMP C

RAMP C (RPC175)

MAINLINE I-29 (ML029)

DETOUR RAMP B

RAMP B

RAMP B

I-29 MAINLINE STAGE 5

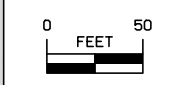

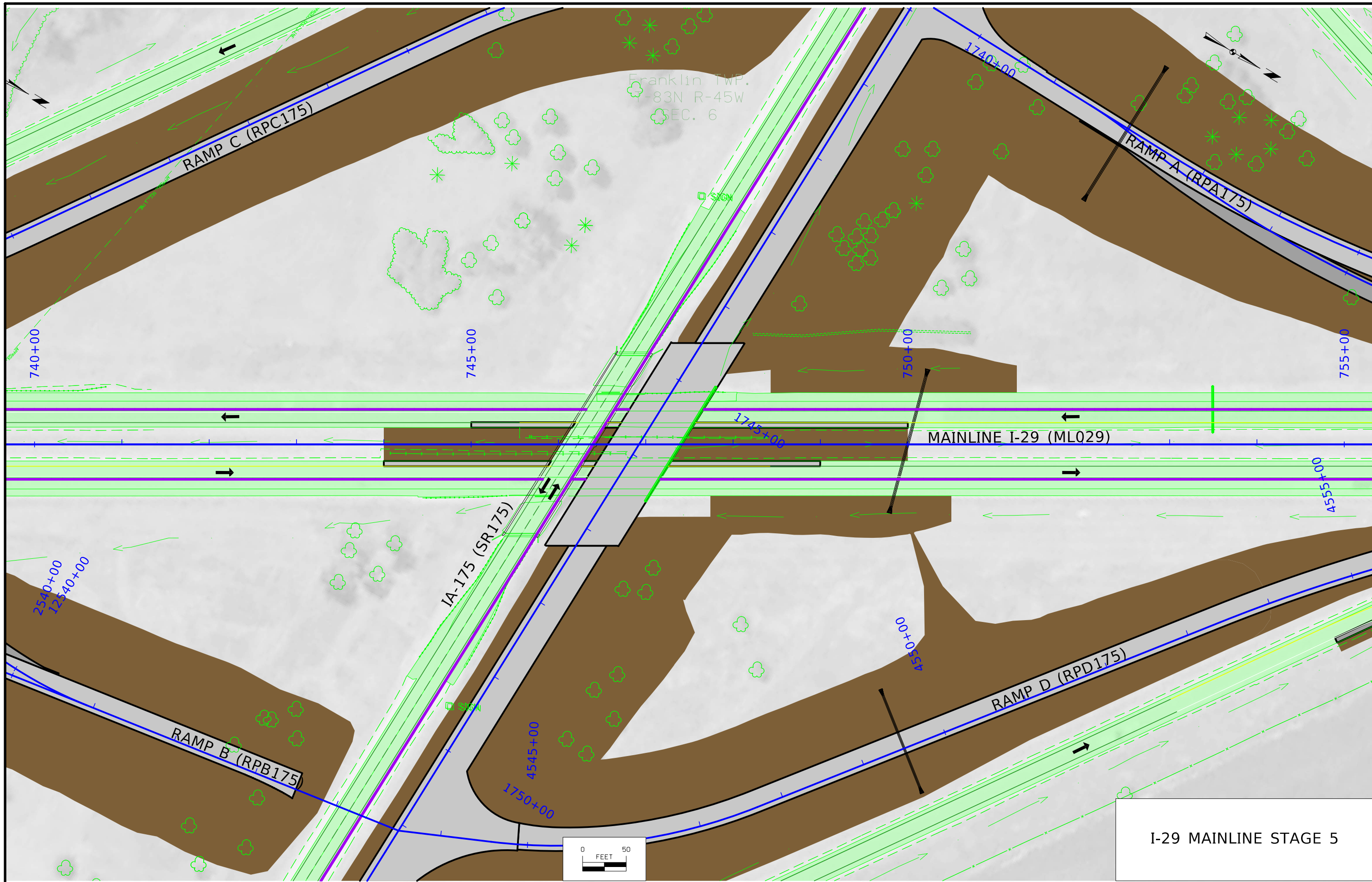

Franklin TWP.
T-83N R-45W
SEC. 6

RAMP C (RPC175)

RAMP A (RPA175)

MAINLINE I-29 (ML029)

IA-175 (SR175)

RAMP B (RPB175)

RAMP D (RPD175)

I-29 MAINLINE STAGE 5

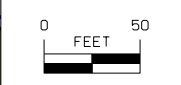

Franklin TWP.
T-83N R-45W
SEC. 1

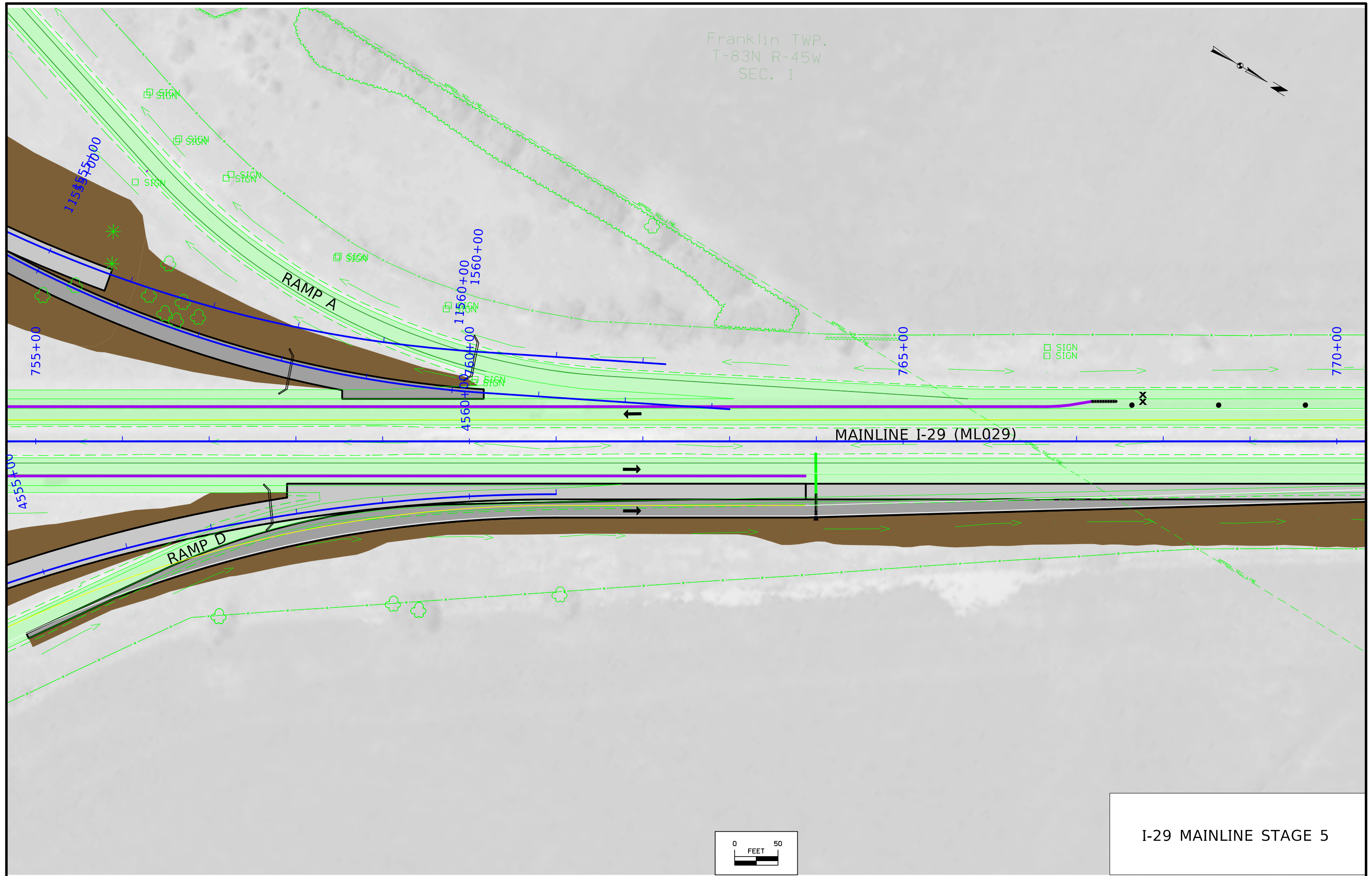
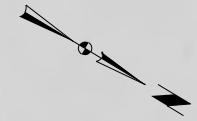

I-29 MAINLINE STAGE 5

Franklin TWP.
T-83N R-45W
SEC. 1

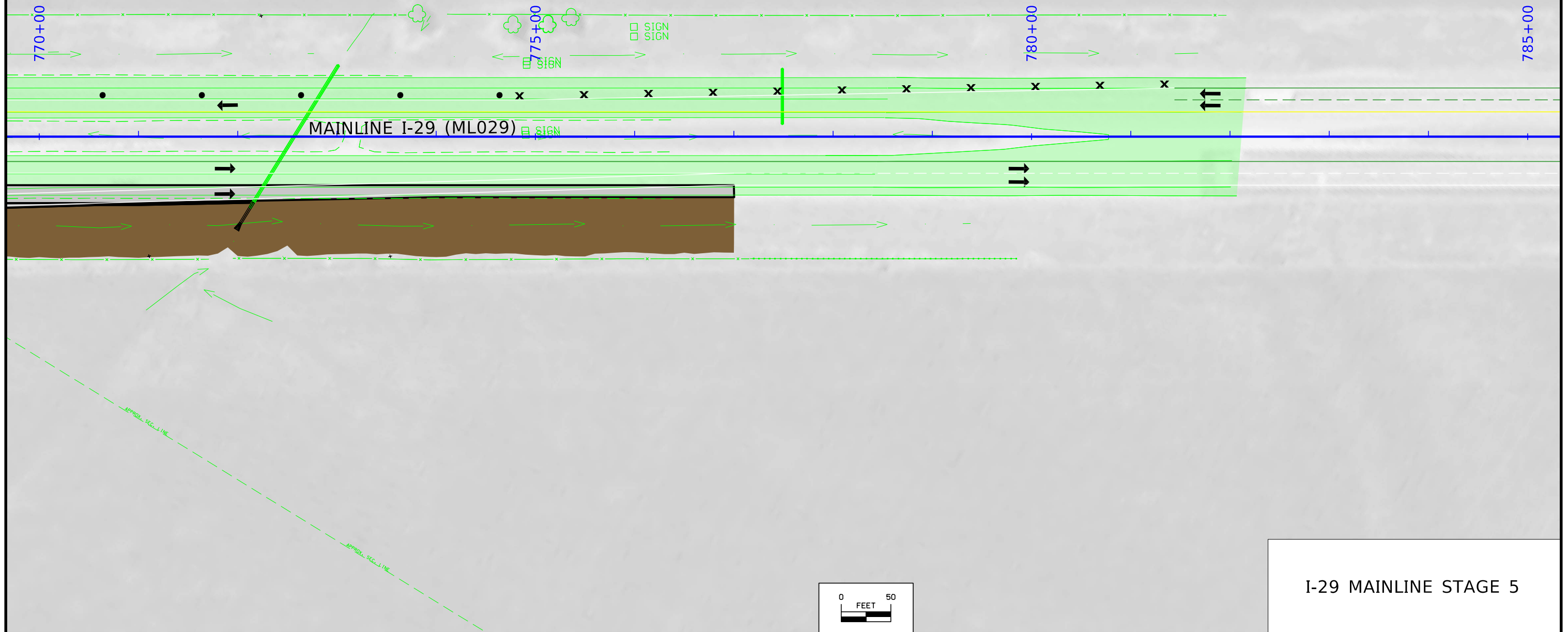

I-29 MAINLINE STAGE 5

Franklin TWP.
T-83N R-45W
SEC. 1



ELDER AVENUE

1710+00

1715+00

1720+00

IA-175 (SR175)

FILBERT AVENUE

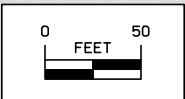

SR175 STAGE 5

Franklin TWP.
T-83N R-45W
SEC. 1



1725+00

1730+00

1735+00

RAMP A

IA-175 (SR175)

FILBERT AVENUE

SR175 STAGE 5

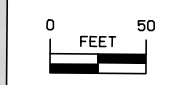

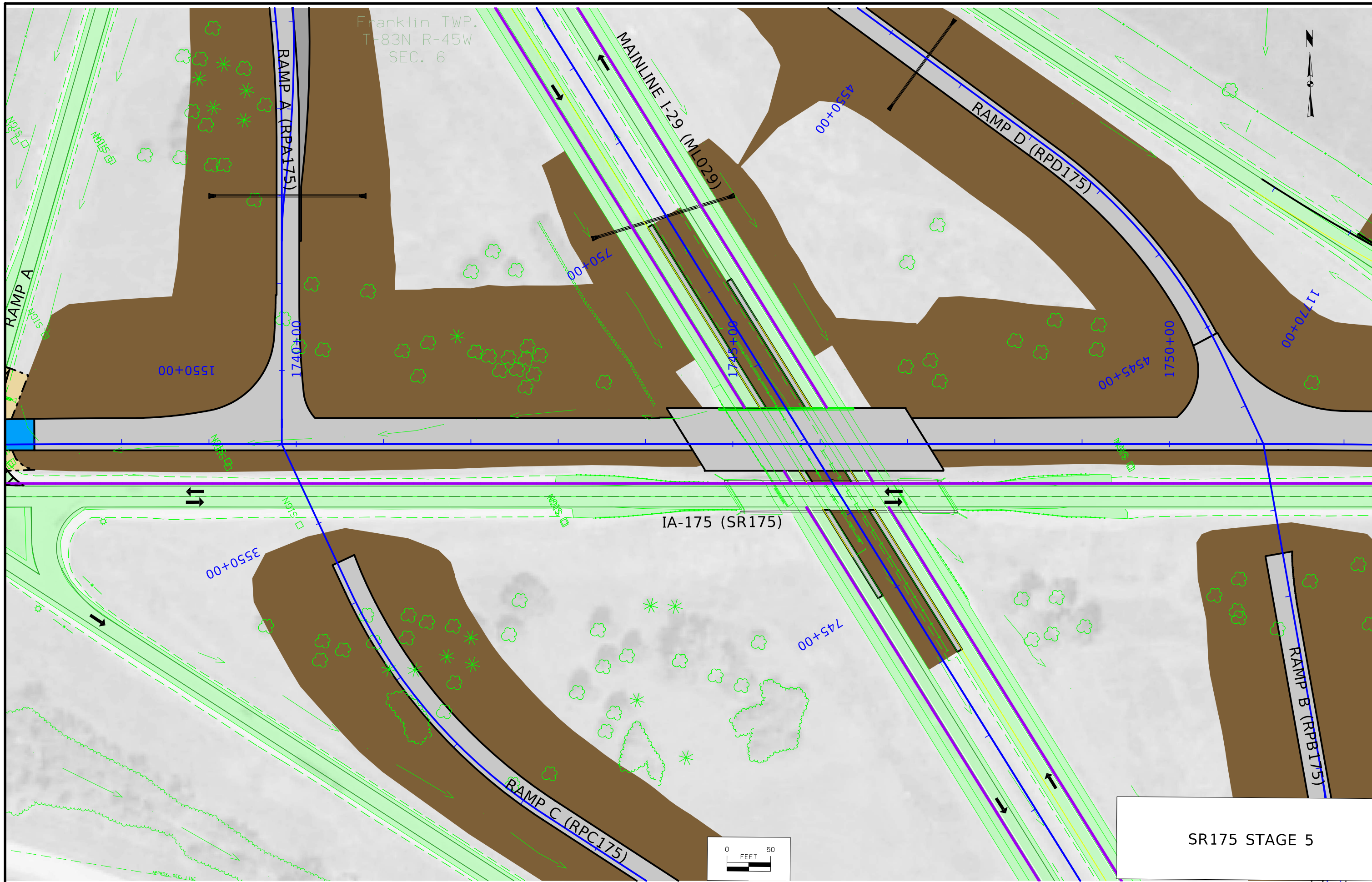

SR175 STAGE 5

FILE NO.	ENGLISH	DESIGN TEAM Iowa DOT/HR Green	MONONA COUNTY	PROJECT NUMBER STP-175-1(95)--2C-67	SHEET NUMBER J.59
----------	---------	-------------------------------	---------------	-------------------------------------	-------------------

Franklin TWP.
T-83N R-45W
SEC. 6

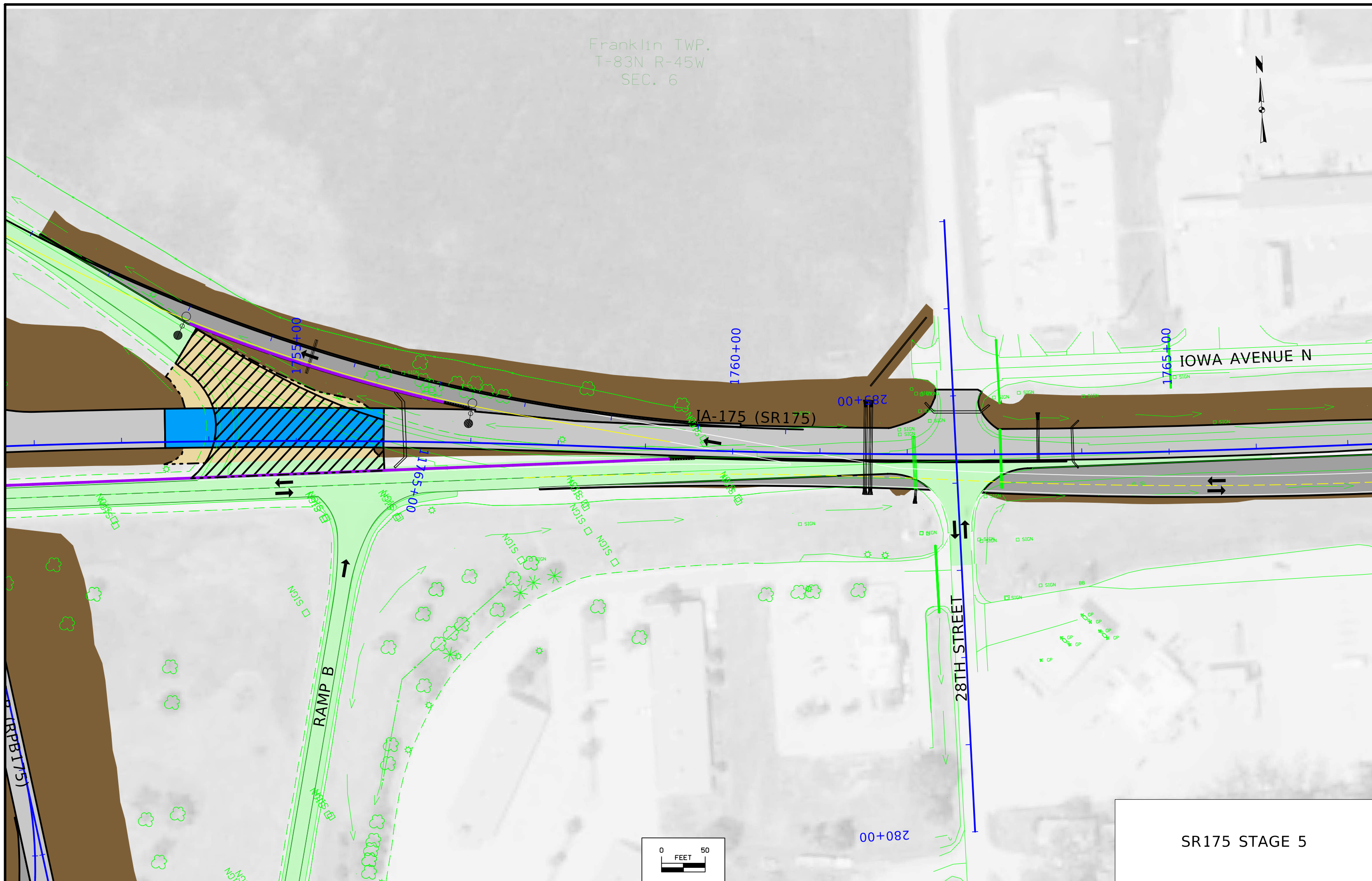

SR175 STAGE 5

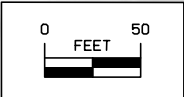

Franklin TWP.
T-83N R-45W
SEC. 6

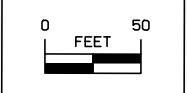
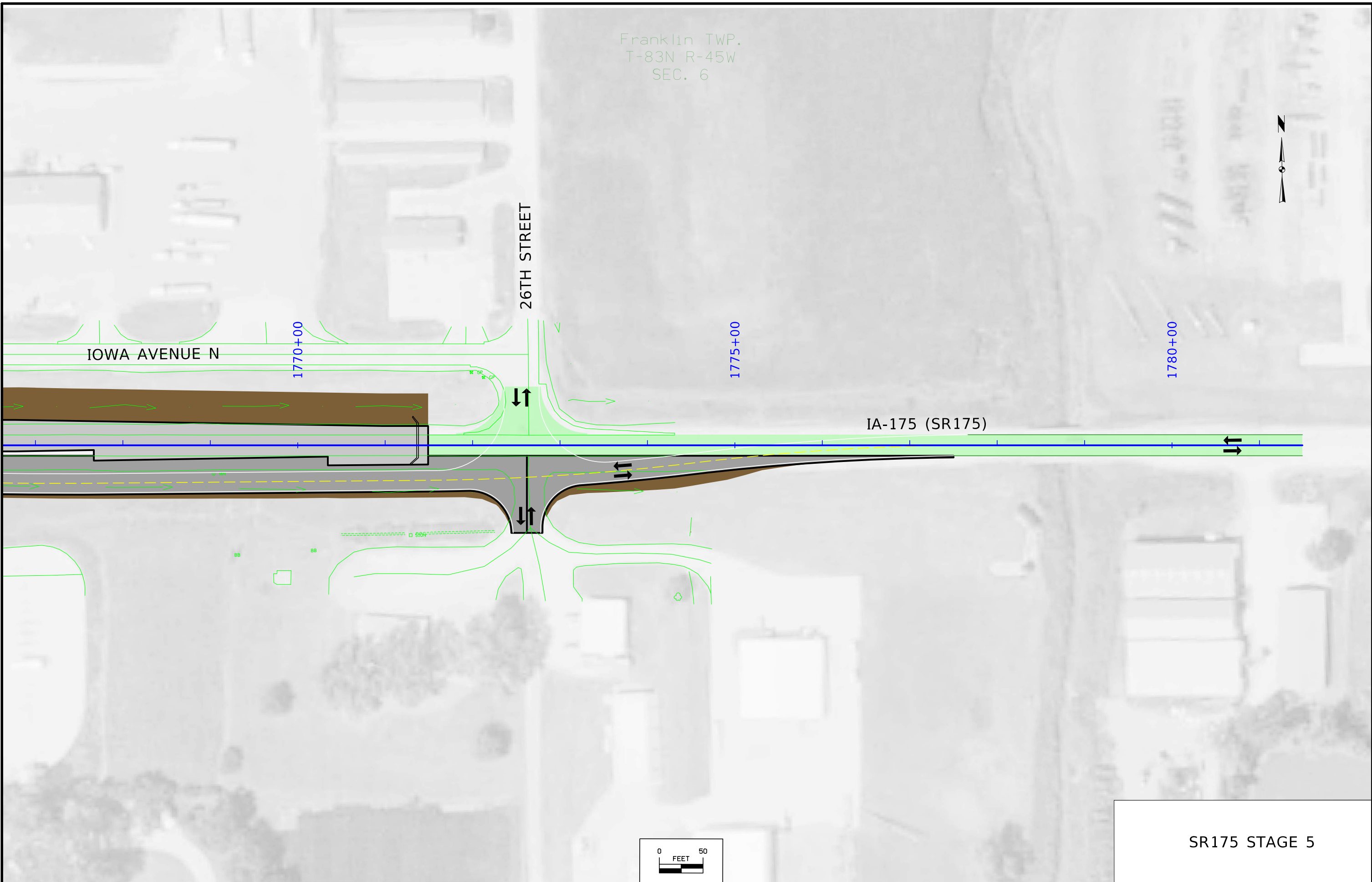

SR175 STAGE 5

Franklin TWP.
T-83N R-45W
SEC. 7

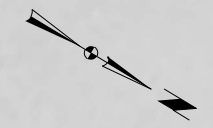

FILBERT AVENUE

715+00

720+00

725+00

MAINLINE I-29 (ML029)

SIGN
SIGN

SIGN
SIGN

I-29 MAINLINE STAGE 6

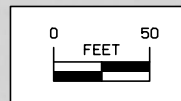

Franklin TWP.
T-83N R-45W
SEC. 7

FILBERT AVENUE

RAMP C

RAMP C (RPC175)

MAINLINE I-29 (ML029)

DETOUR RAMP B

RAMP B

RAMP B

I-29 MAINLINE STAGE 6

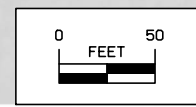

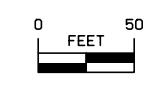
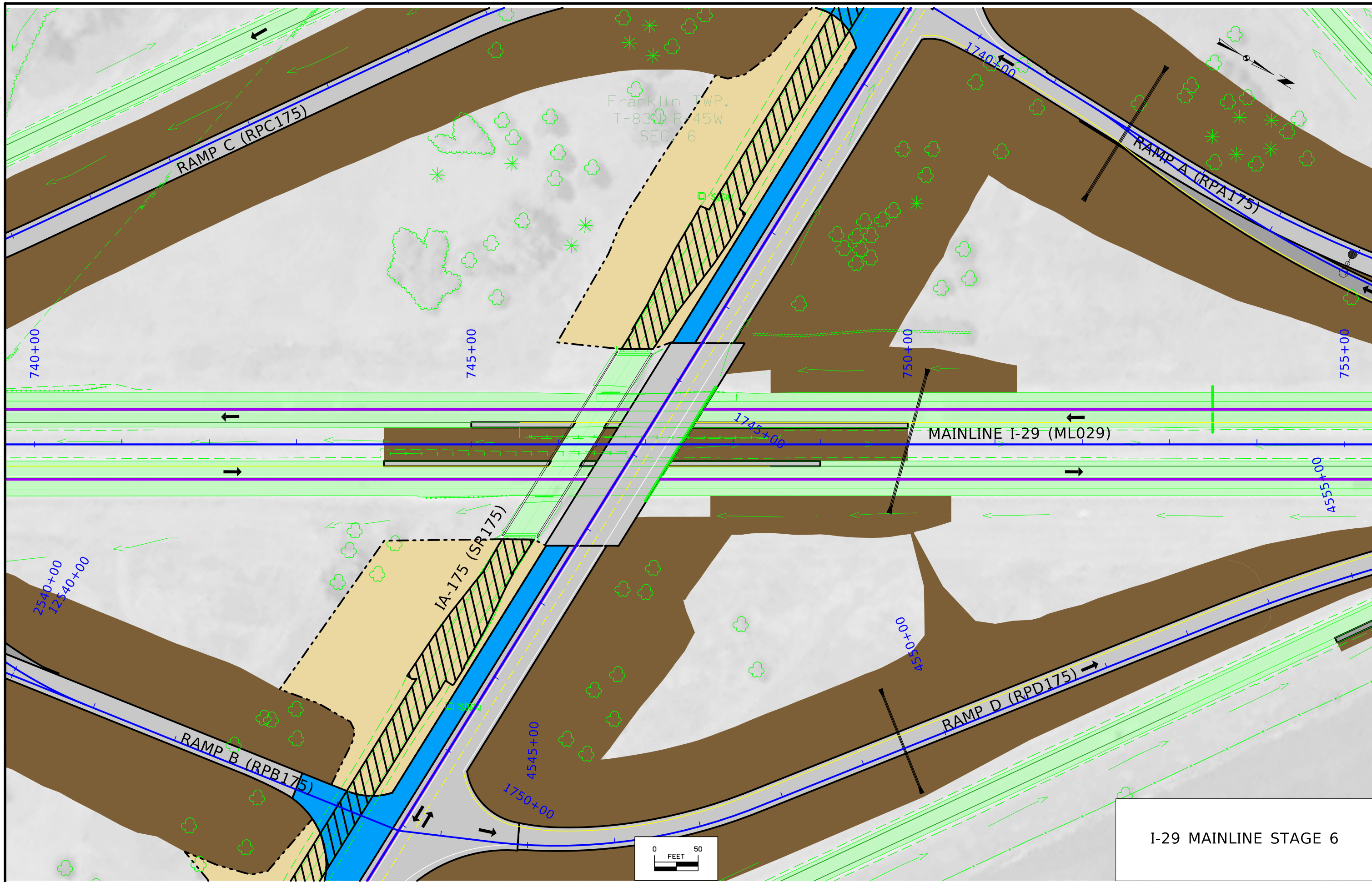

I-29 MAINLINE STAGE 6

Franklin TWP.
T-83N R-45W
SEC. 1

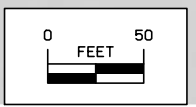
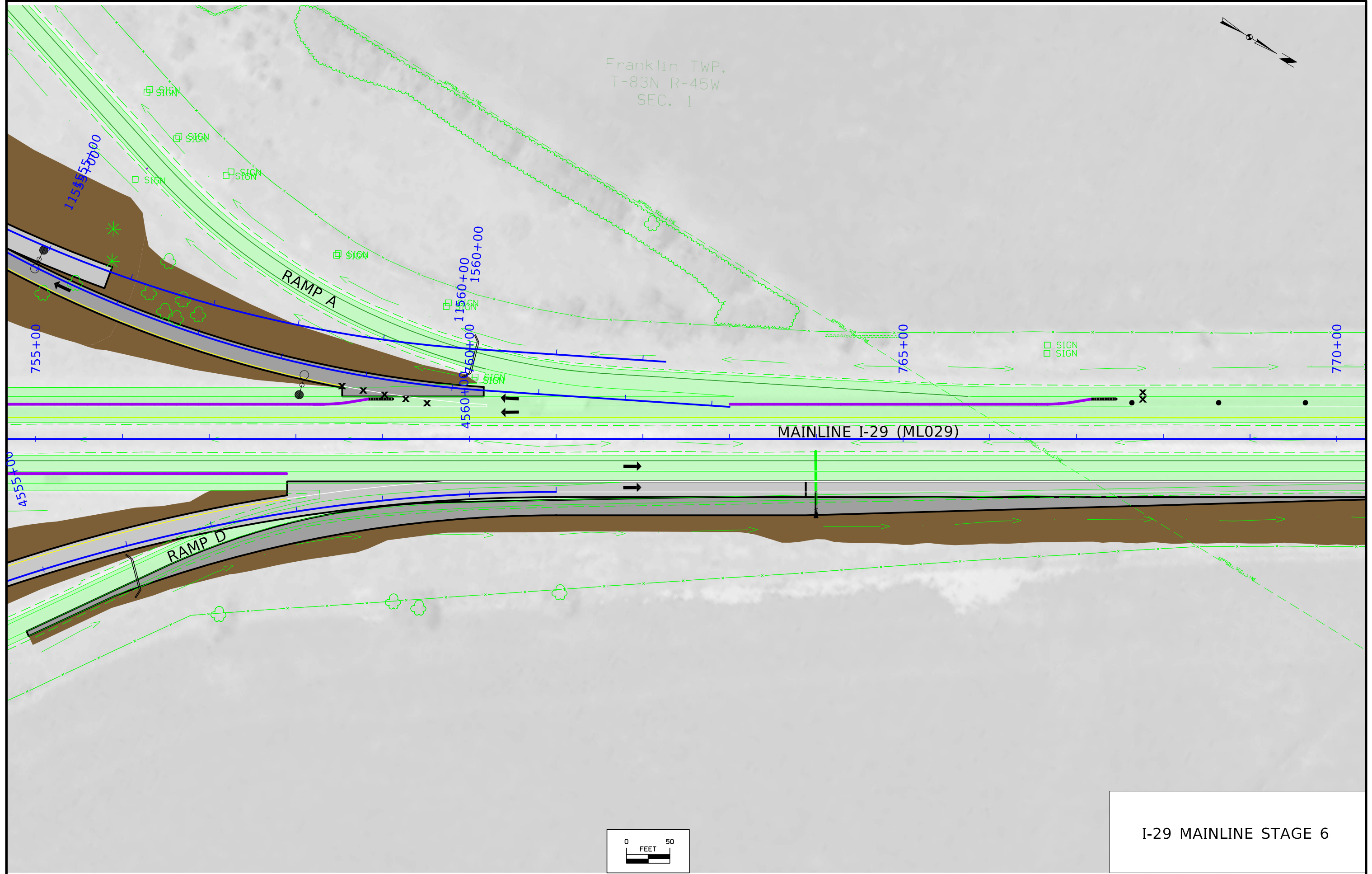

I-29 MAINLINE STAGE 6

Franklin TWP.
T-83N R-45W
SEC. 1

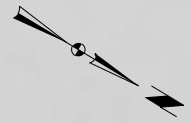

I-29 MAINLINE STAGE 6

Franklin TWP.
T-83N R-45W
SEC. 1



ELDER AVENUE

1710+00

1715+00

1720+00

IA-175 (SR175)

FILBERT AVENUE

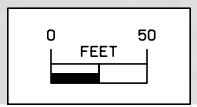

SR175 STAGE 6

Franklin TWP.
T-83N R-45W
SEC. 1



1725+00

1730+00

1735+00

IA-175 (SR175)

RAMP A

FILBERT AVENUE

SR175 STAGE 6

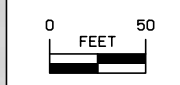

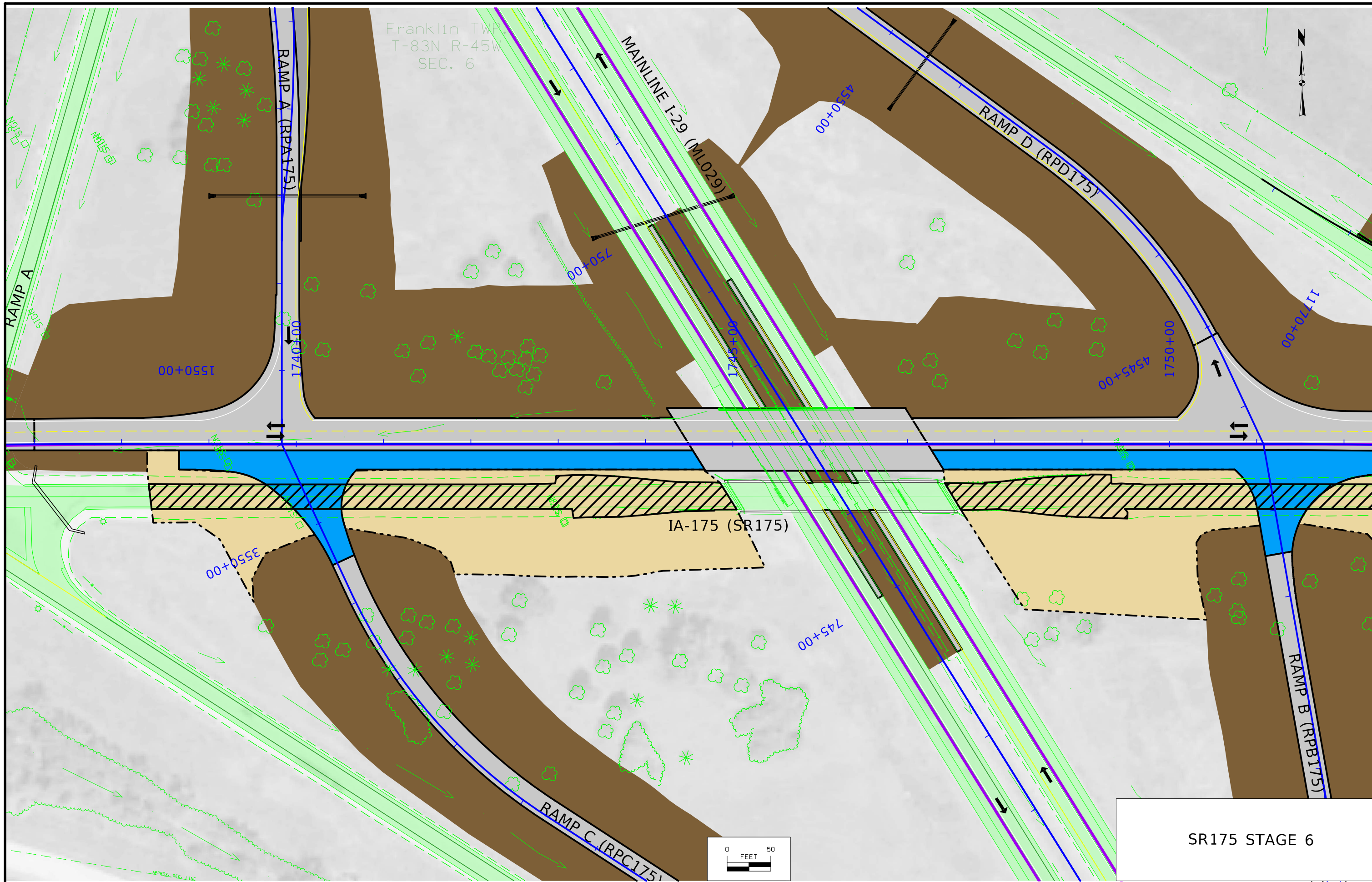

Franklin TWP.
T-83N R-45W
SEC. 6

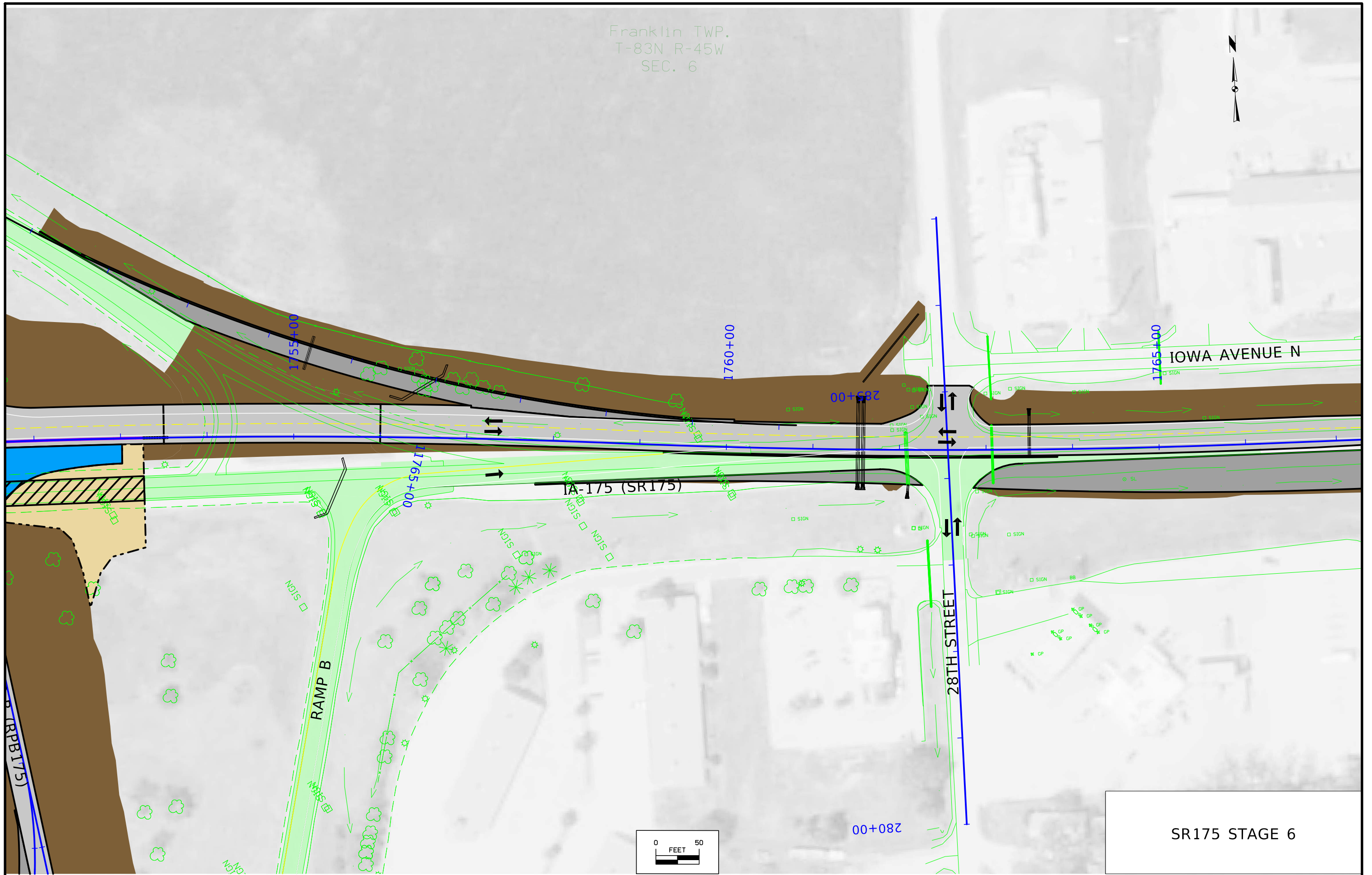

SR175 STAGE 6

Franklin TWP.
T-83N R-45W
SEC. 6

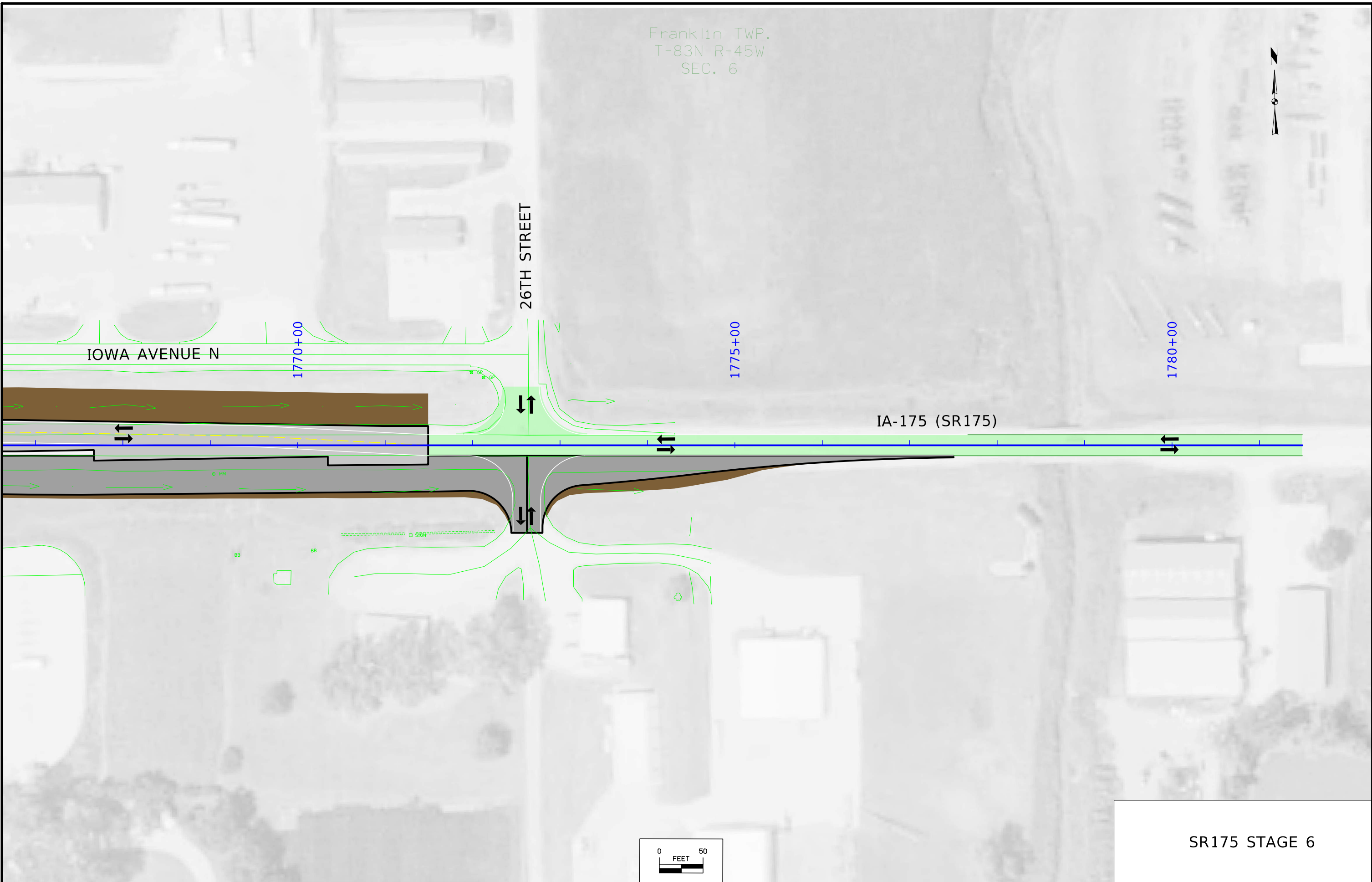

SR175 STAGE 6

Franklin TWP.
T-83N R-45W
SEC. 7

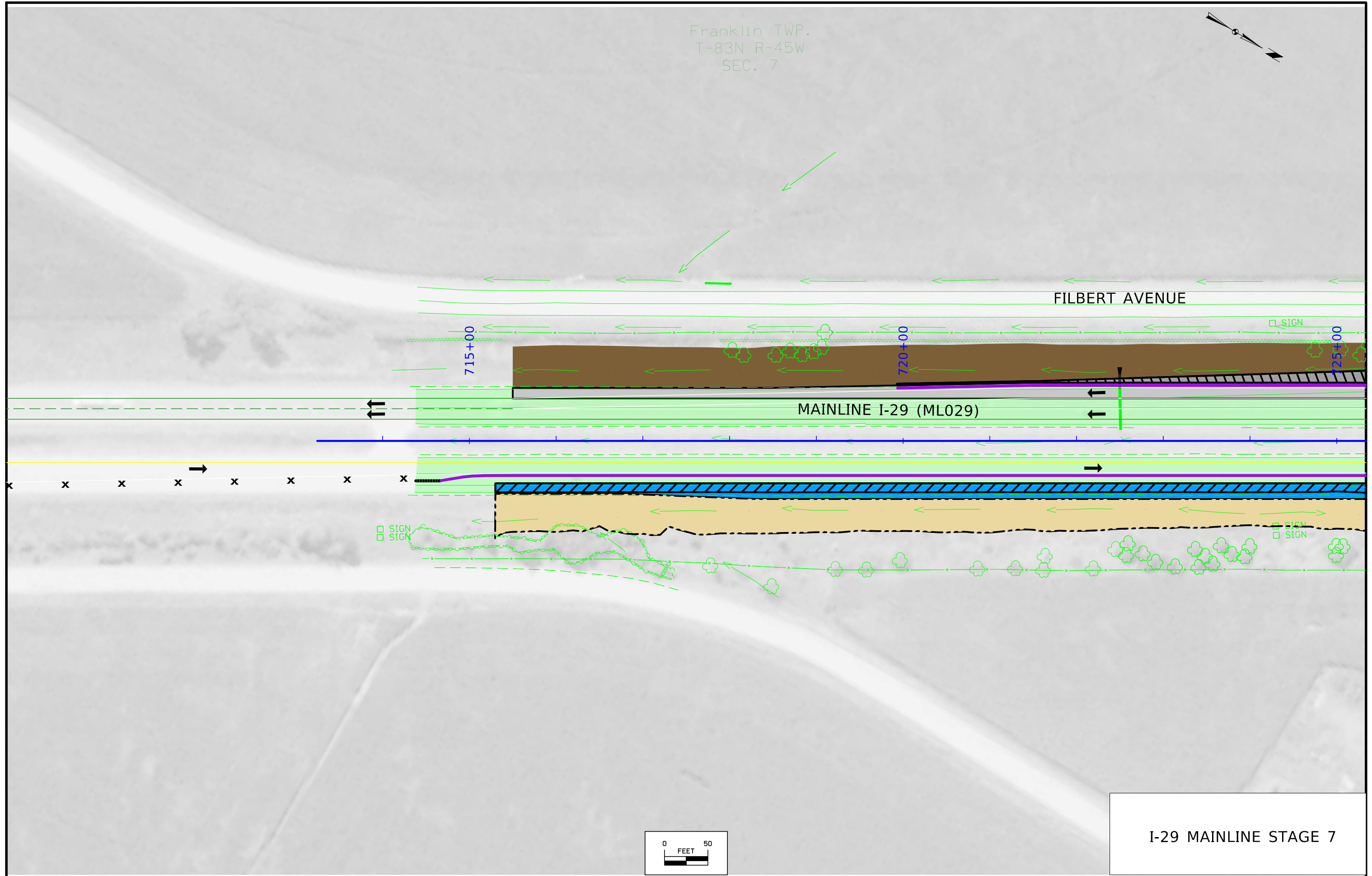
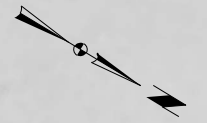

FILBERT AVENUE

MAINLINE I-29 (ML029)

715+00

720+00

725+00

SIGN

SIGN
SIGN

SIGN
SIGN

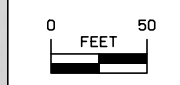

I-29 MAINLINE STAGE 7

Franklin TWP.
T-83N R-45W
SEC. 7

FILBERT AVENUE

Final slope grading

RAMP C (RPC175)

MAINLINE I-29 (ML029)

DETOUR RAMP B

RAMP B

I-29 MAINLINE STAGE 7

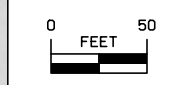

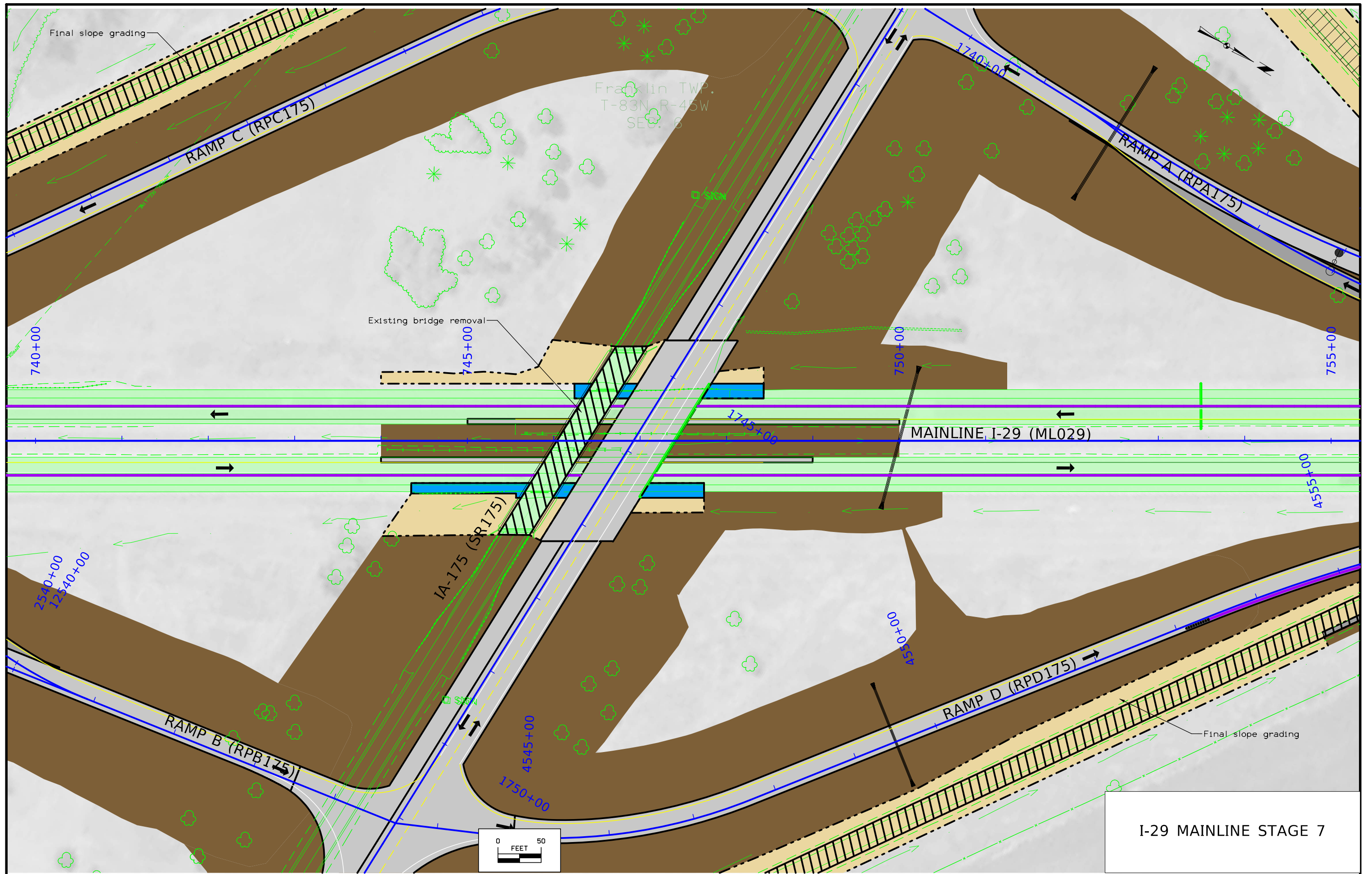

Franklin TWP.
T-83N, R-45W
SEC. 6

I-29 MAINLINE STAGE 7

Franklin TWP.
T-83N R-45W
SEC. 1

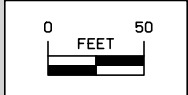
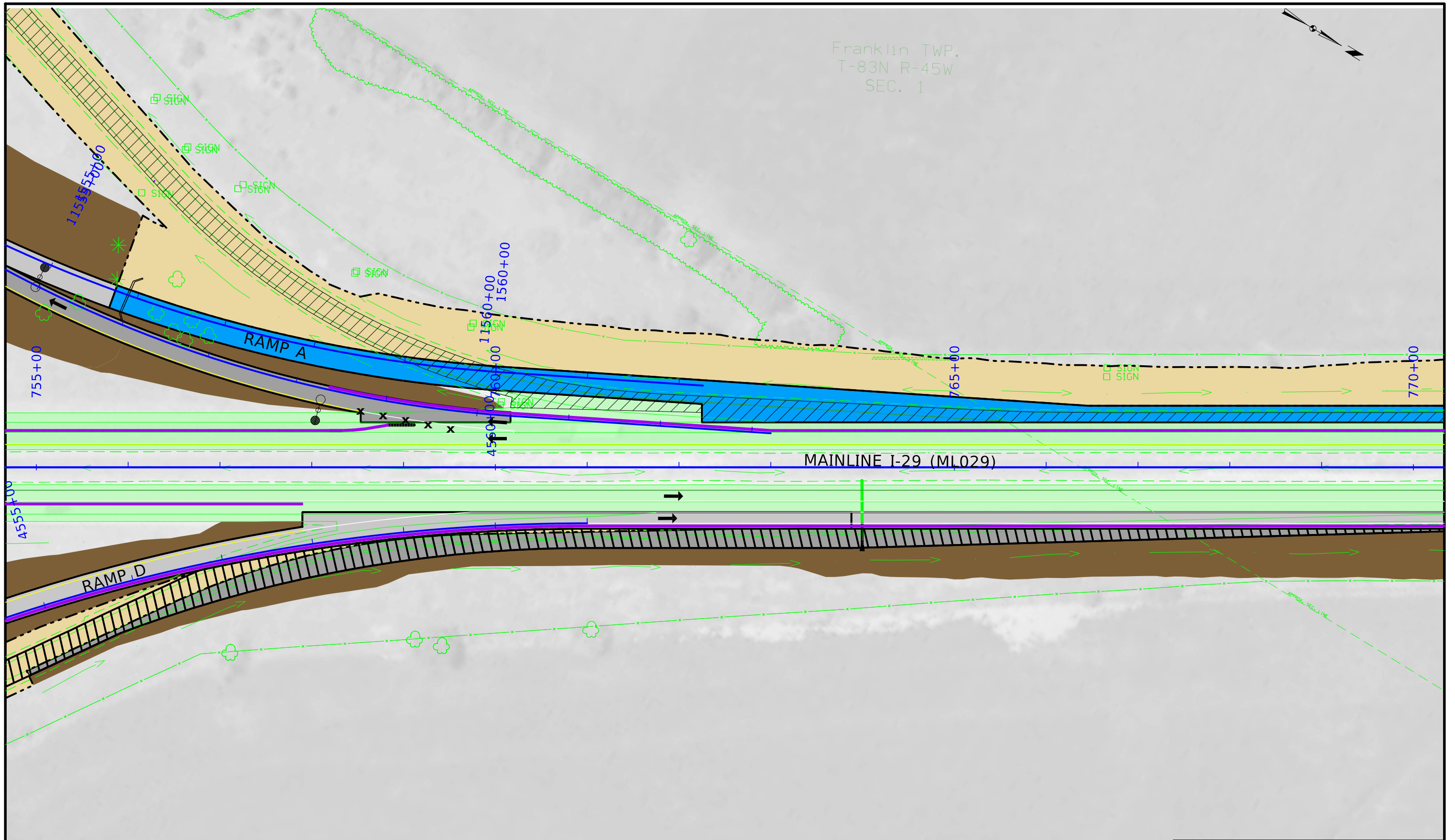
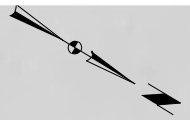

I-29 MAINLINE STAGE 7

Franklin TWP.
T-83N R-45W
SEC. 1

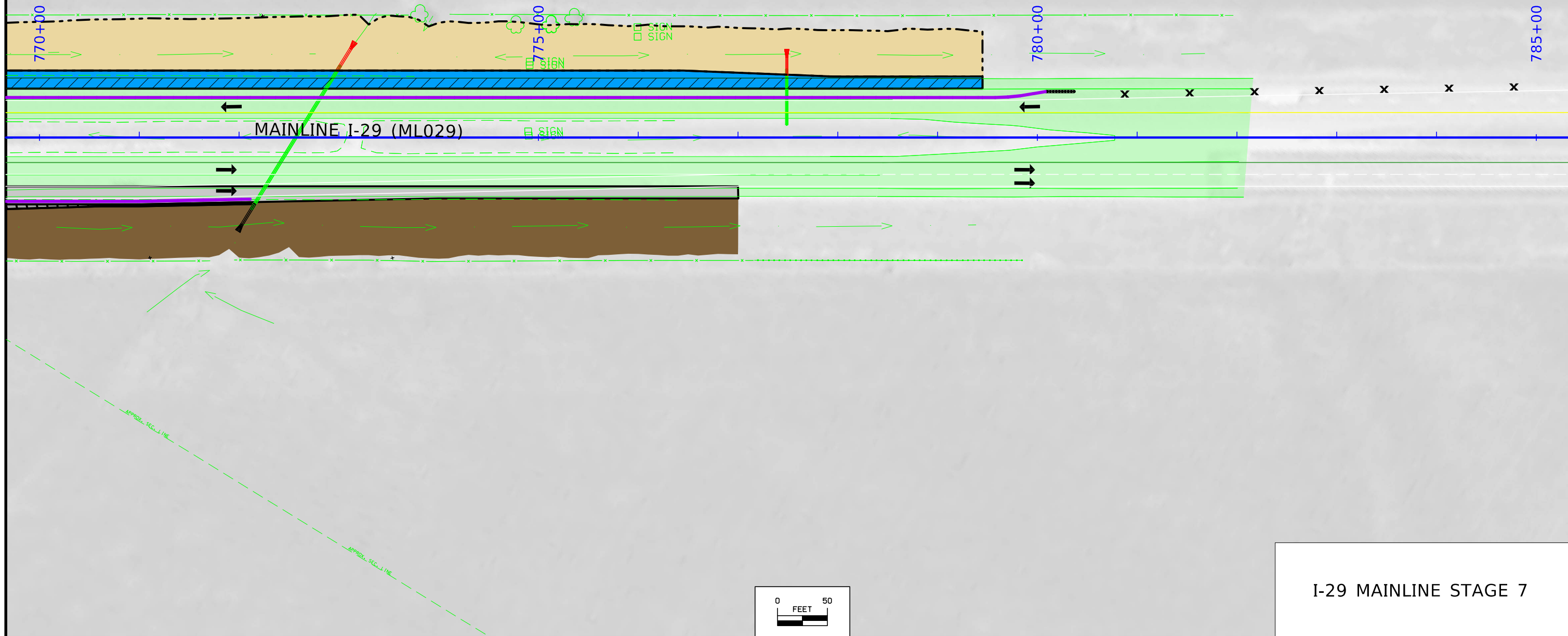
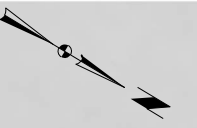

MAINLINE I-29 (ML029)

I-29 MAINLINE STAGE 7

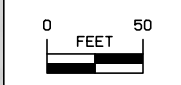

Franklin TWP.
T-83N R-45W
SEC. 1



ELDER AVENUE

1710+00

1715+00

1720+00

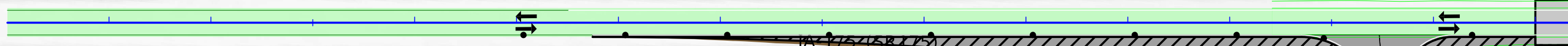

SIGN

SIGN

SR 175 (SR 175)

FILBERT AVENUE

APPROX. SEC. LINE

APPROX. SEC. LINE

APPROX. SEC. LINE

APPROX. SEC. LINE

APPROX. SEC. LINE

APPROX. SEC. LINE

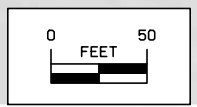

SR175 STAGE 7

Franklin TWP.
T-83N R-45W
SEC. 1



1725+00

1730+00

1735+00

IA-175 (SR175)

FILBERT AVENUE

SR175 STAGE 7

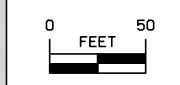

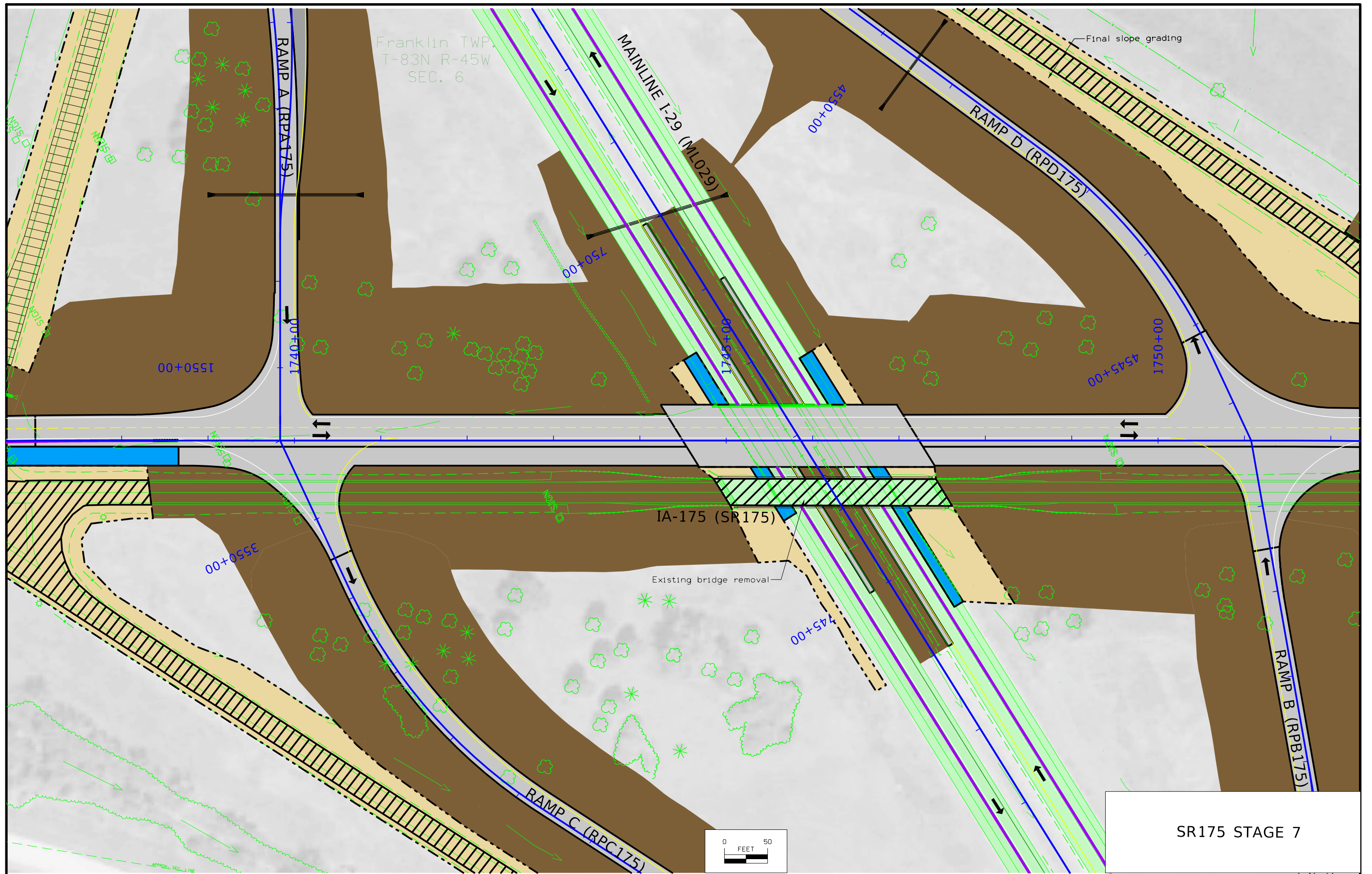

Franklin TWP.
T-83N R-45W
SEC. 6

Final slope grading

IA-175 (SR175)

Existing bridge removal

SR175 STAGE 7

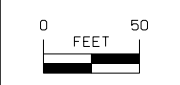

FILE NO.	ENGLISH	DESIGN TEAM Iowa DOT/HR Green	MONONA COUNTY	PROJECT NUMBER STP-175-1(95)--2C-67	SHEET NUMBER J.79
----------	---------	-------------------------------	---------------	-------------------------------------	-------------------

Franklin TWP.
T-83N R-45W
SEC. 6

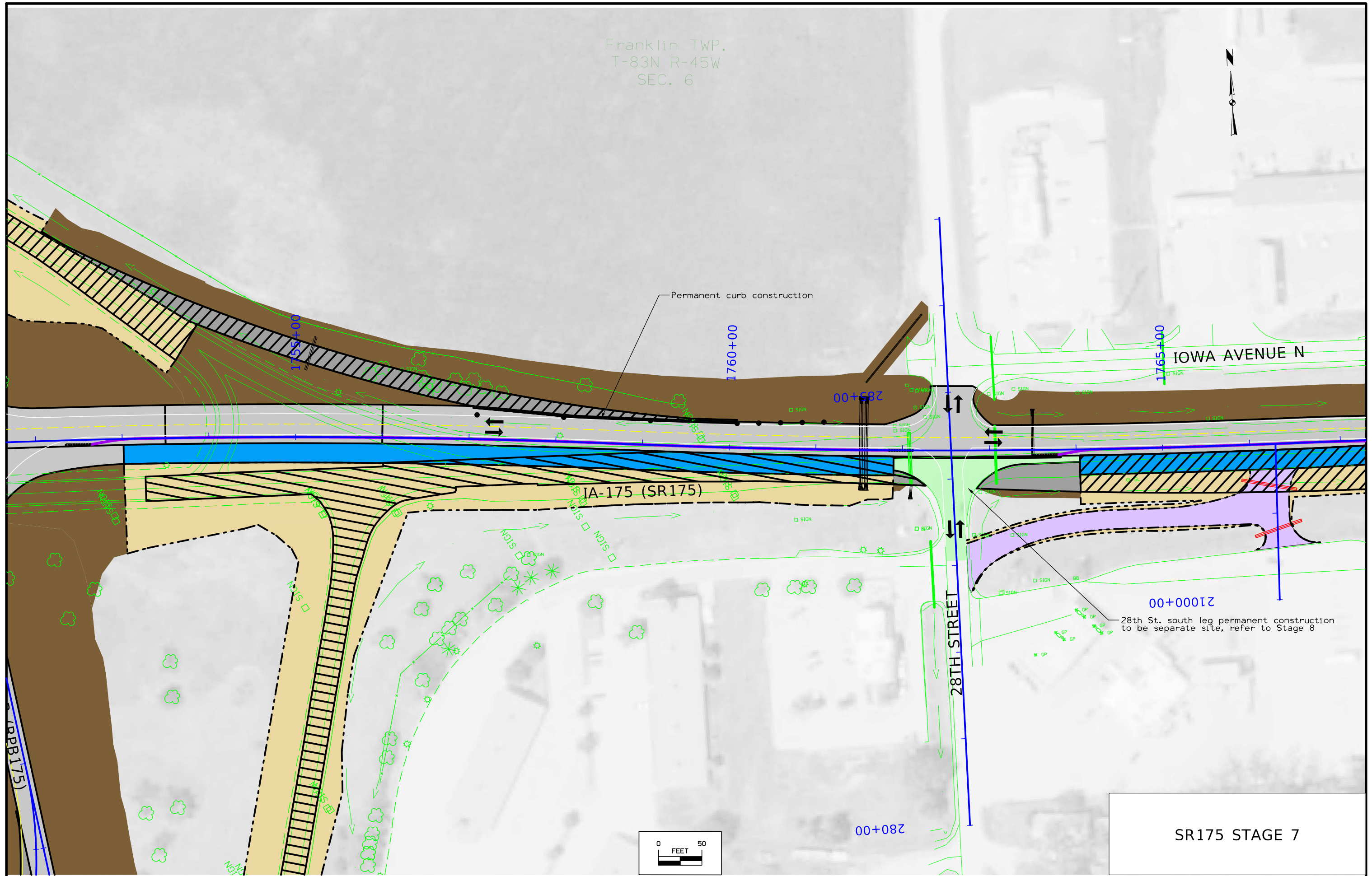

SR175 STAGE 7

Franklin TWP.
T-83N R-45W
SEC. 6



26TH STREET

IOWA AVENUE N

1770+00

1775+00

1780+00

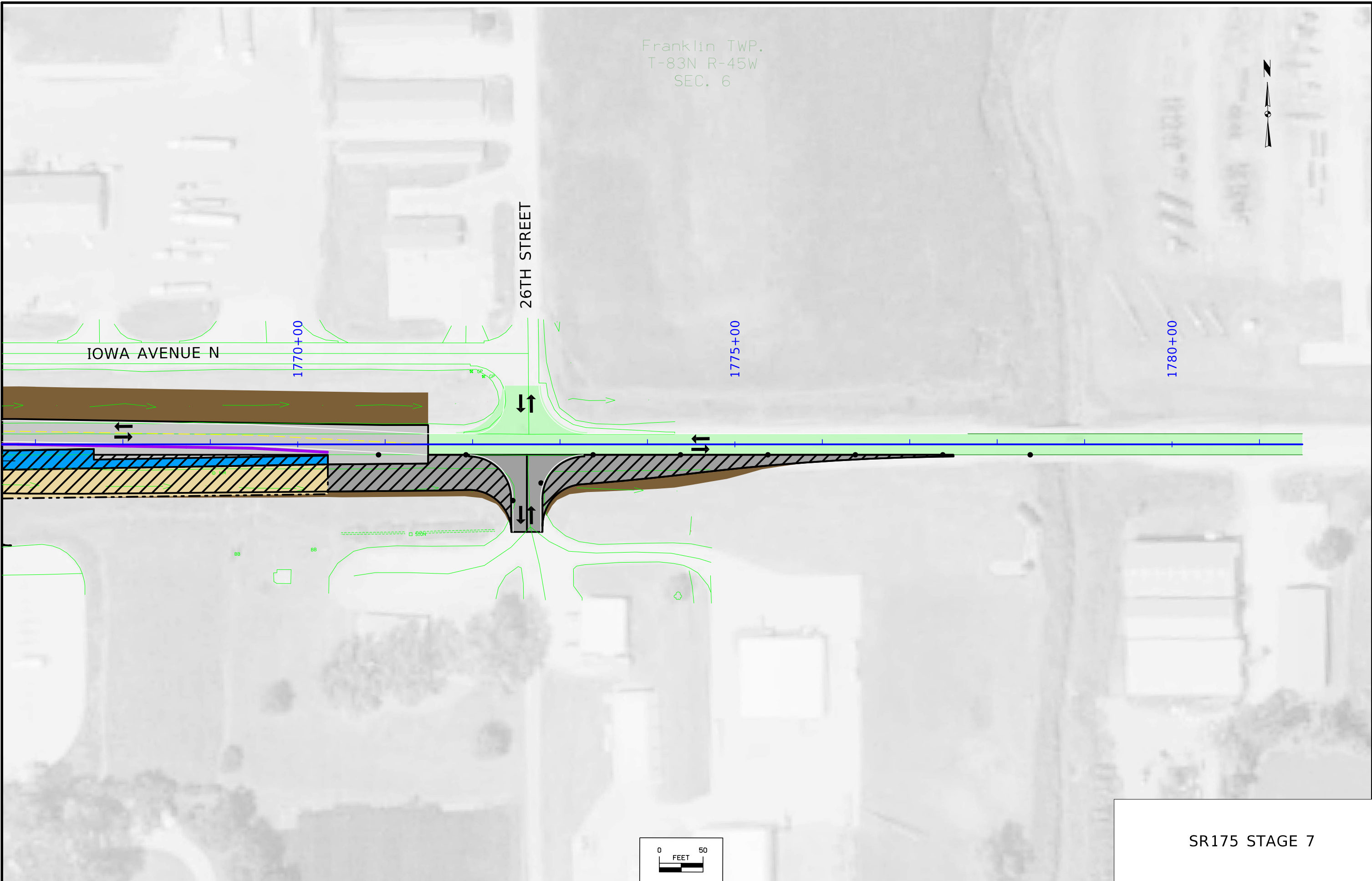

SR175 STAGE 7

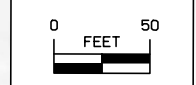

Franklin TWP.
T-83N R-45W
SEC. 7

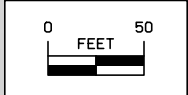
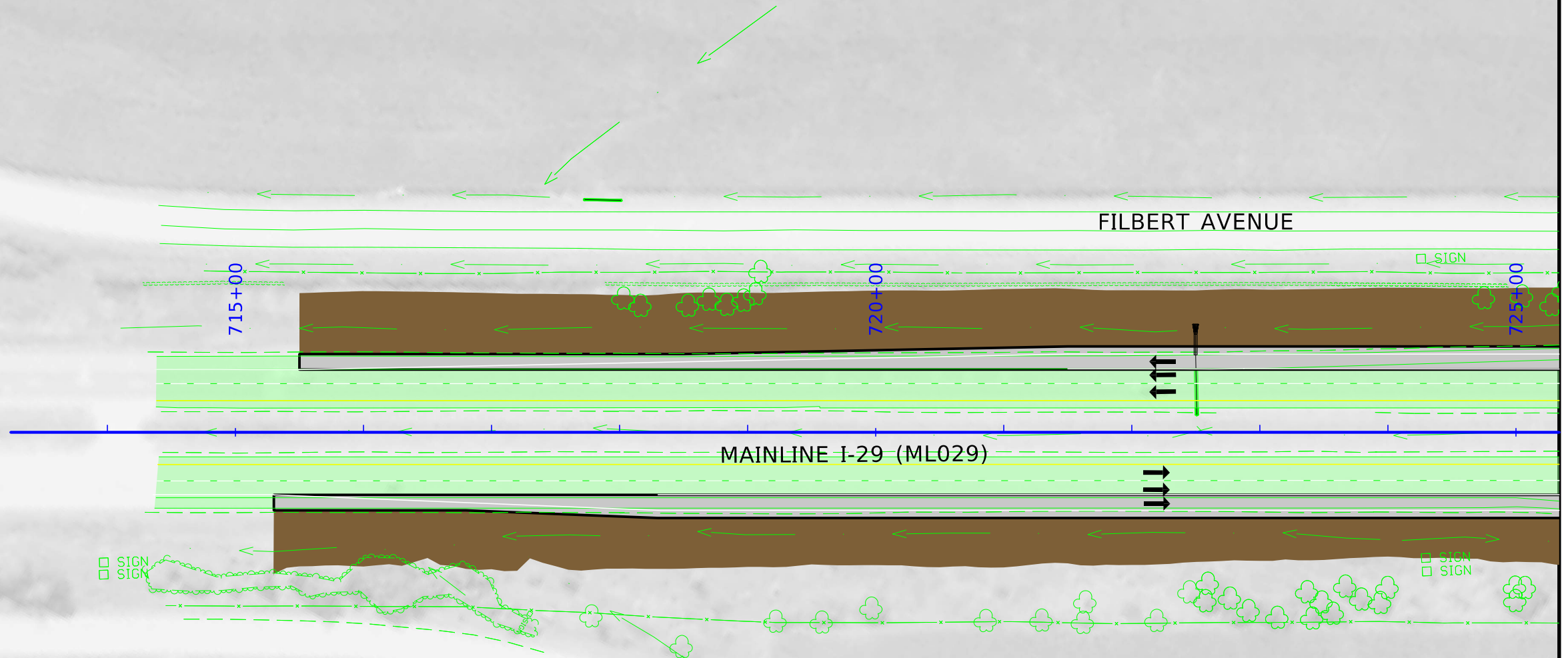
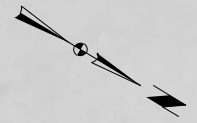

I-29 MAINLINE STAGE 8

Franklin TWP.
T-83N R-45W
SEC. 7

FILBERT AVENUE

RAMP C

MAINLINE I-29 (MI 029)

RAMP D

I-29 MAINLINE STAGE 8

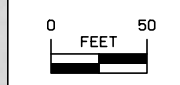

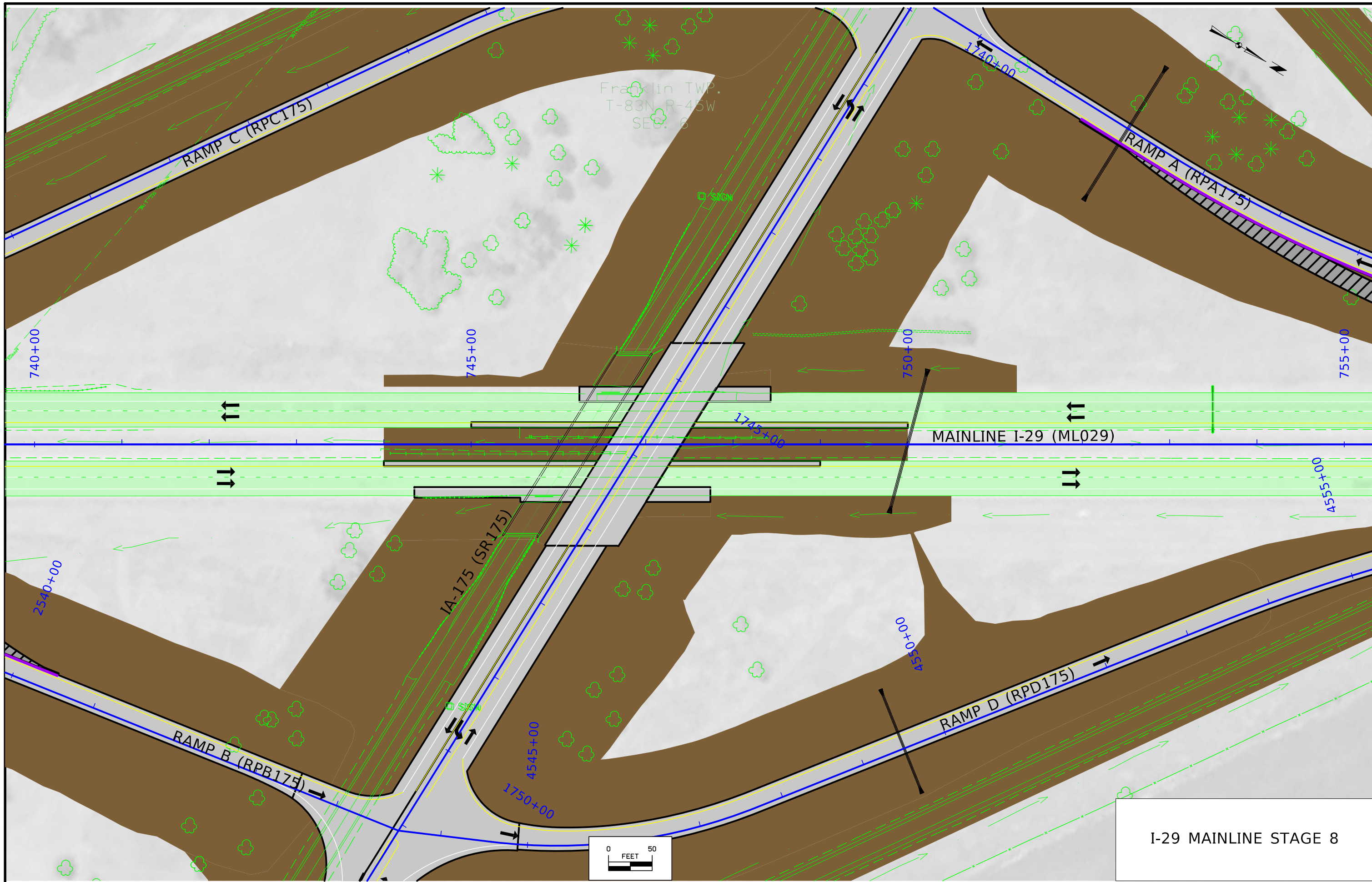

I-29 MAINLINE STAGE 8

Franklin TWP.
T-83N R-45W
SEC. 1

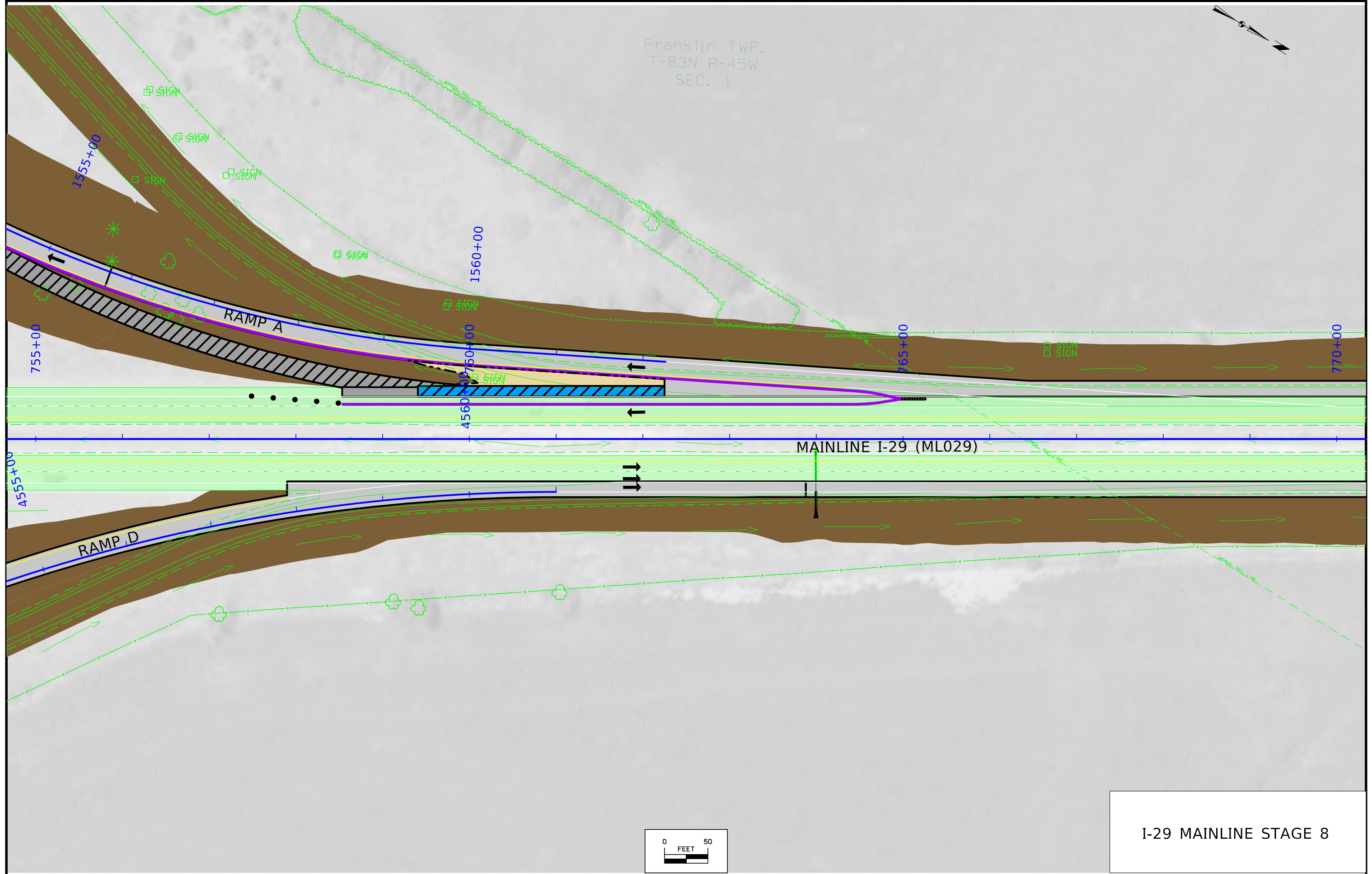
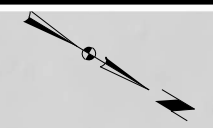

MAINLINE I-29 (ML029)

RAMP A

RAMP D

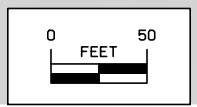

I-29 MAINLINE STAGE 8

Franklin TWP.
T-83N R-45W
SEC. 1

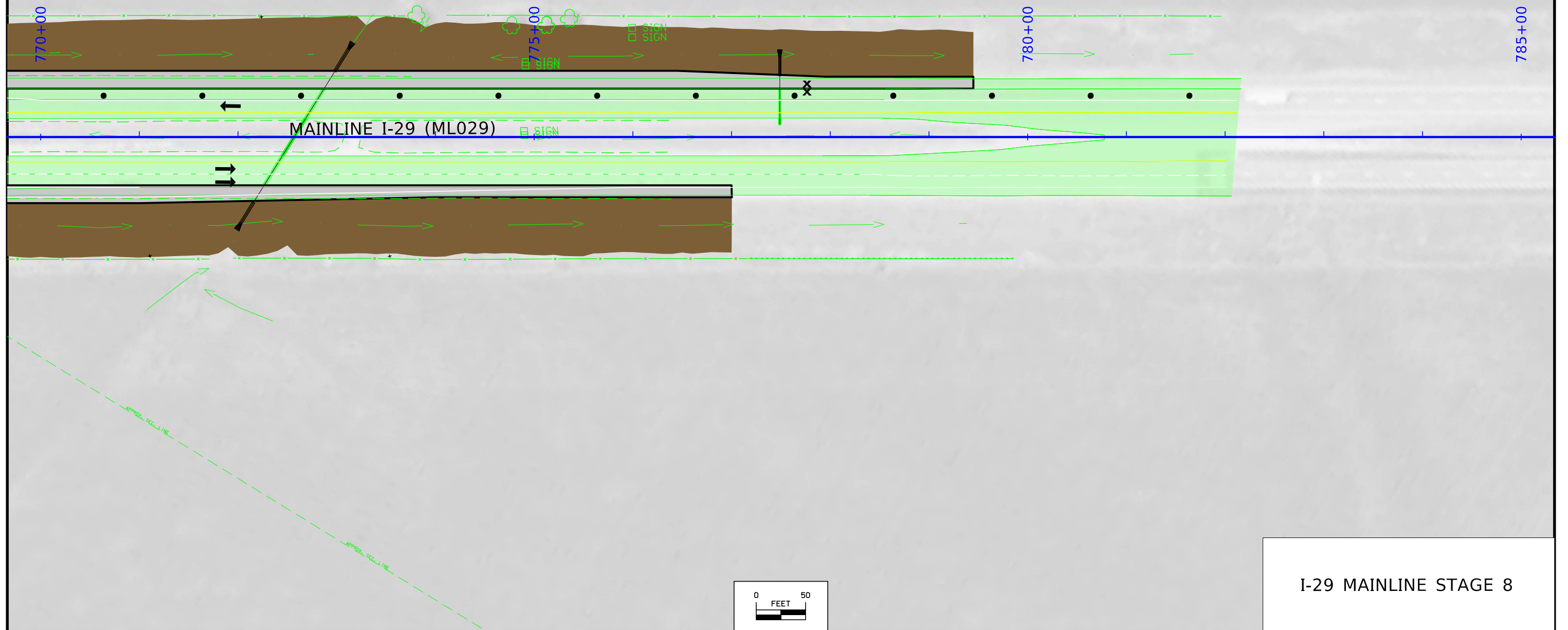
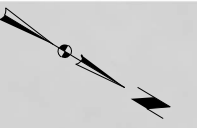

Franklin TWP.
T-83N R-45W
SEC. 1



ELDER AVENUE

1710+00

1715+00

1720+00

IA 175 (SR175)



SIGN

SIGN

SIGN

SIGN

APPROX. SEC. LINE

APPROX. SEC. LINE

APPROX. SEC. LINE

APPROX. SEC. LINE

APPROX. SEC. LINE

APPROX. SEC. LINE

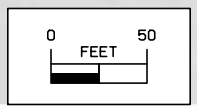

SR175 STAGE 8

Franklin TWP.
T-83N R-45W
SEC. 1



1725+00

1730+00

1735+00

IA-175 (SR175)

FILBERT AVENUE

SR175 STAGE 8

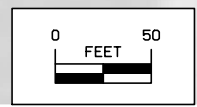

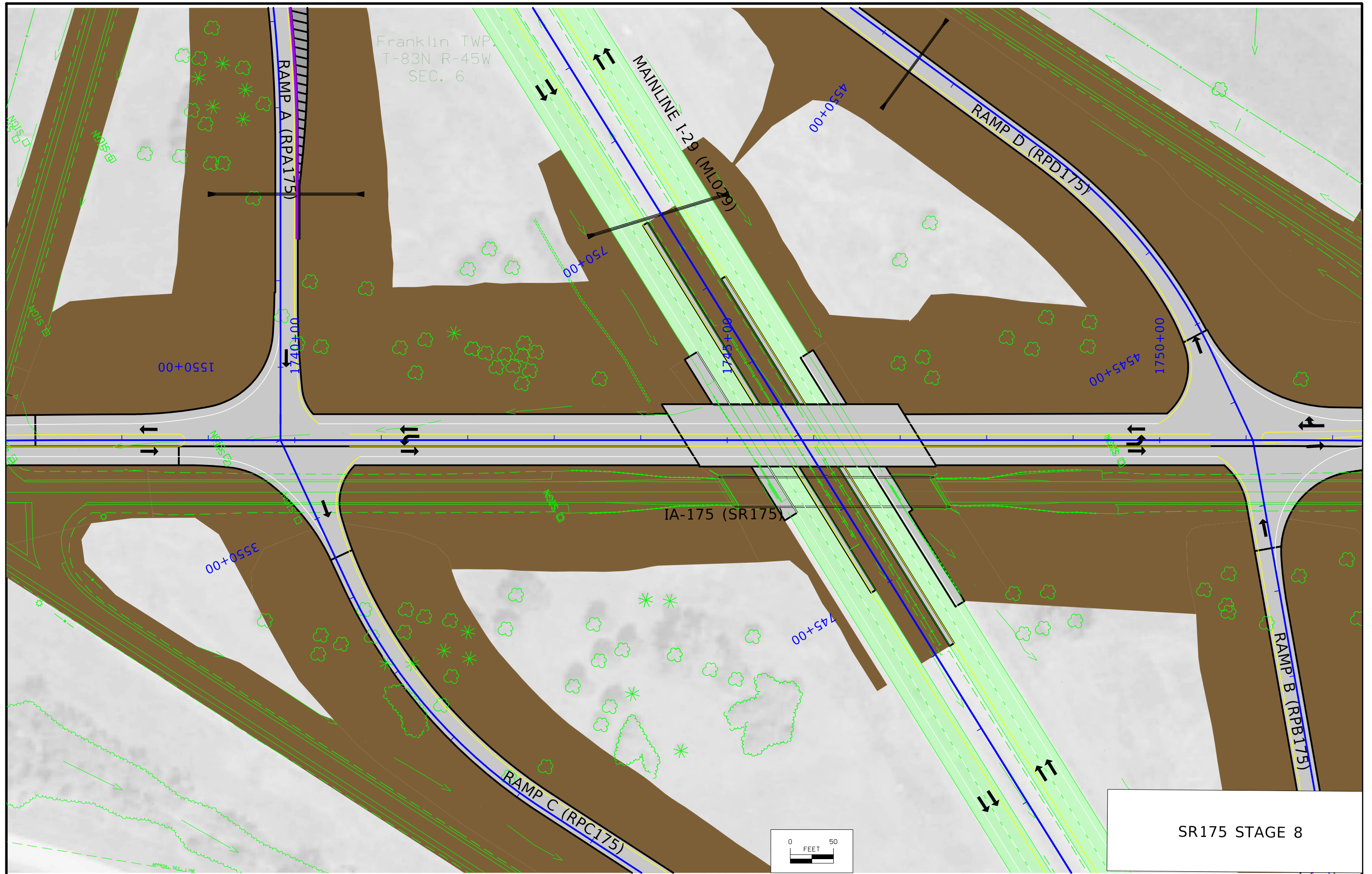

SR175 STAGE 8

Franklin TWP.
T-83N R-45W
SEC. 6

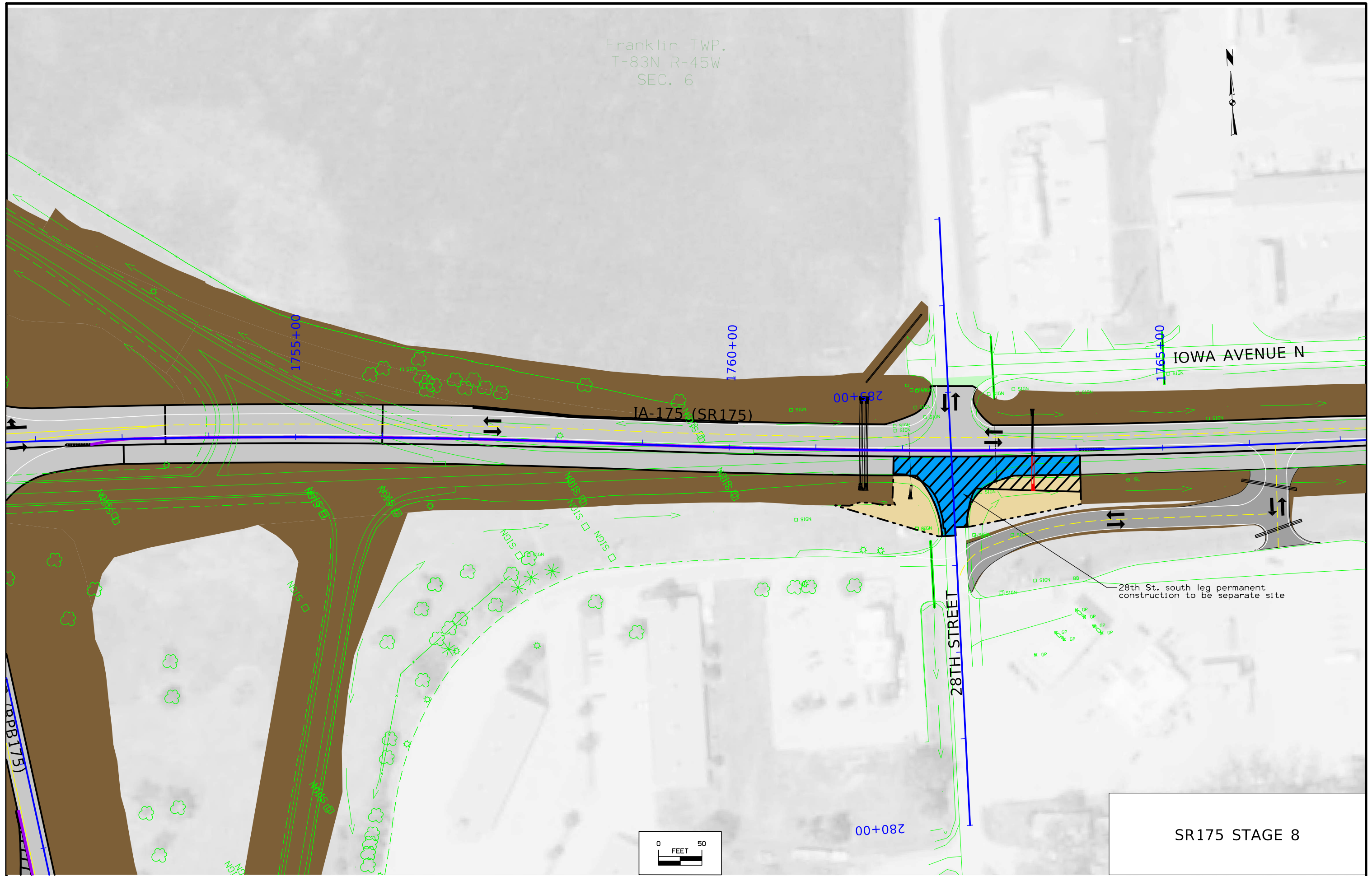

SR175 STAGE 8

Franklin TWP.
T-83N R-45W
SEC. 6



26TH STREET

IOWA AVENUE N

1770+00

1775+00

1780+00

IA-175 (SR175)

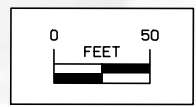
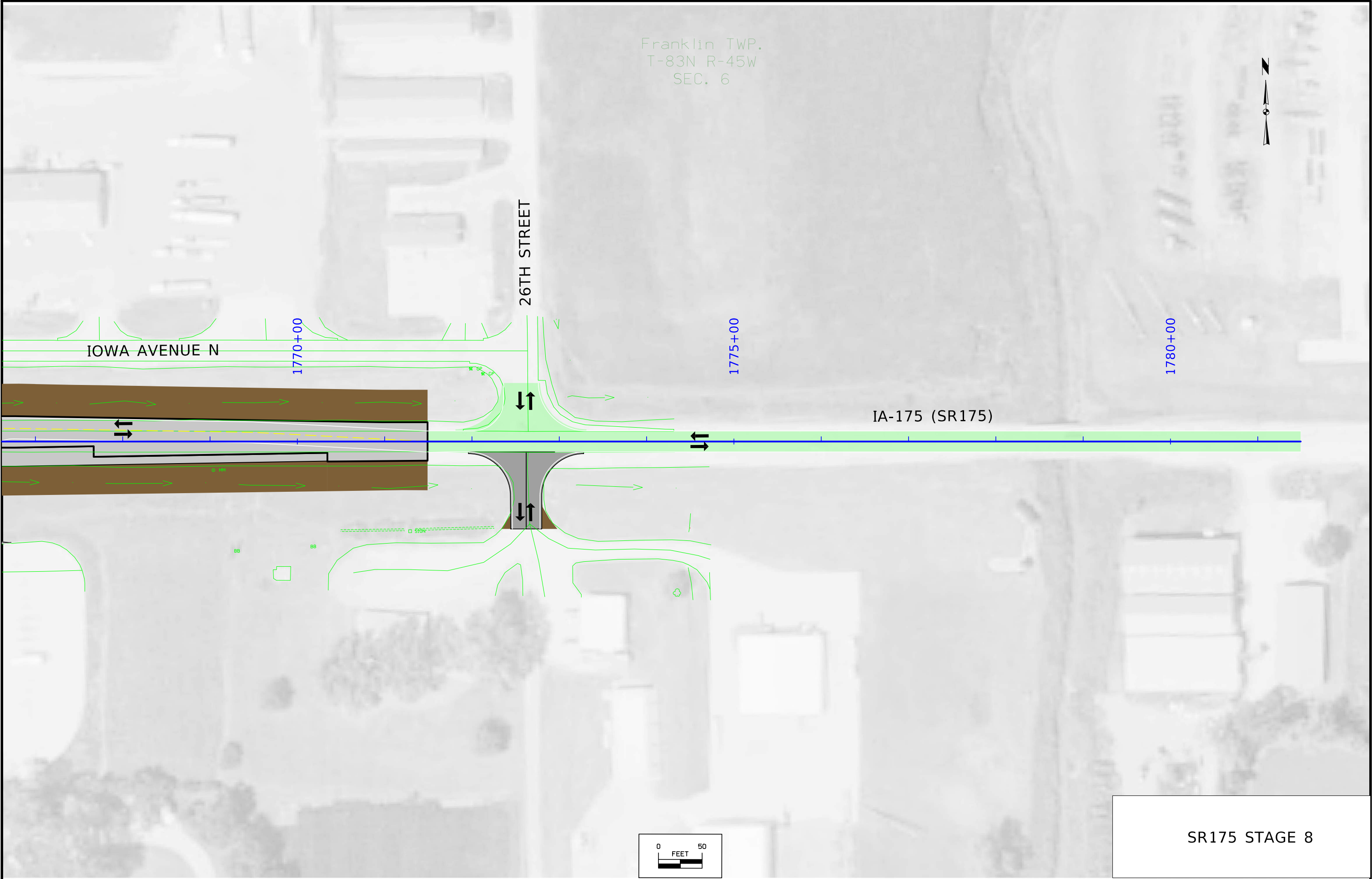

SR175 STAGE 8

Stage 5
Detour from I-29 Southbound to IA 175

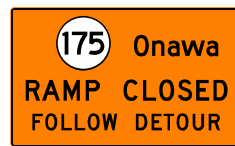

SPECIAL

①



E5-2a

②



M4-8
M1-5
M6-3

③



M4-8
M1-5
M5-2R

④



M4-8
M1-5
M6-2L

⑤



M4-8
M1-5
M6-1L

⑥



M4-8A

⑦

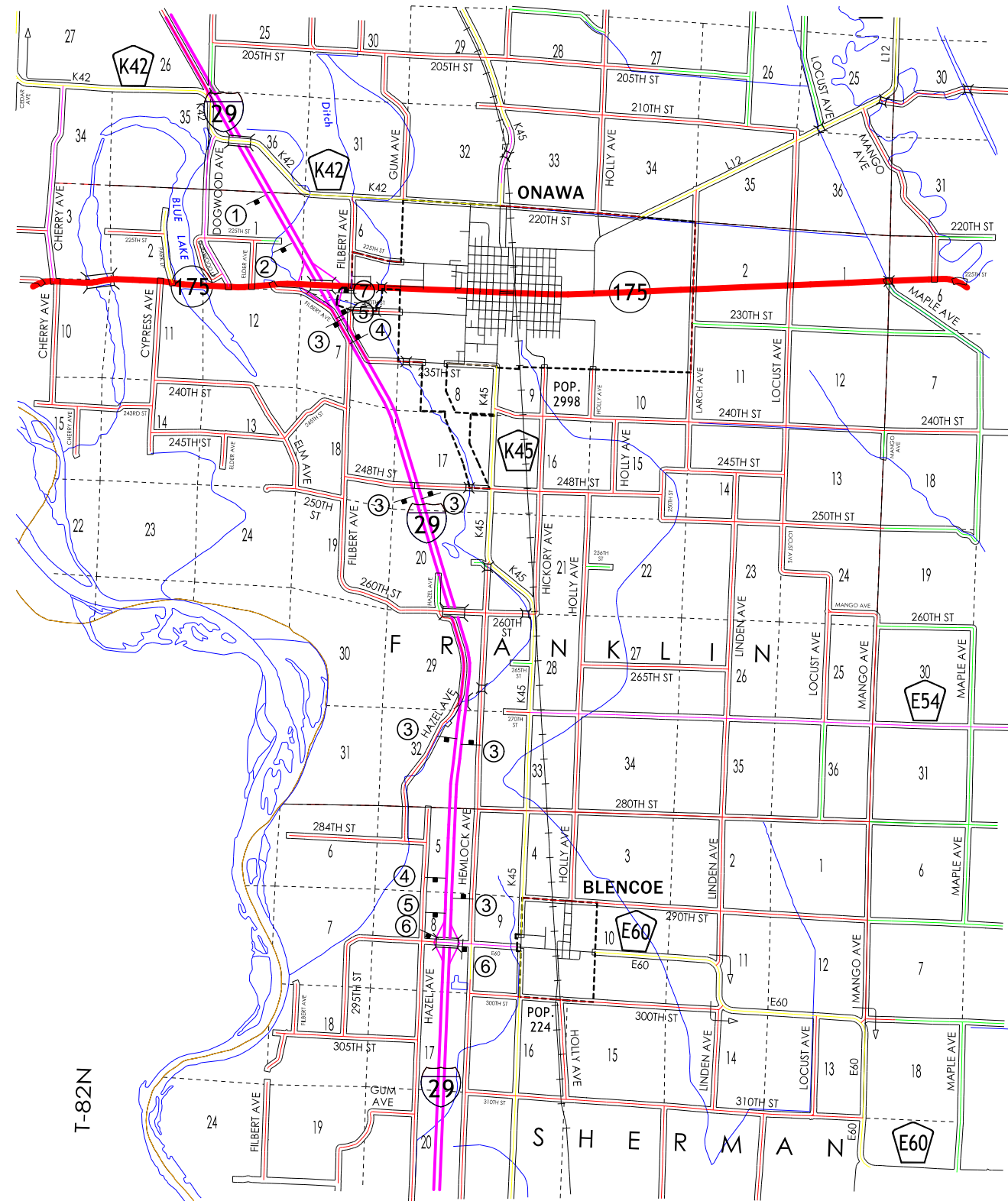

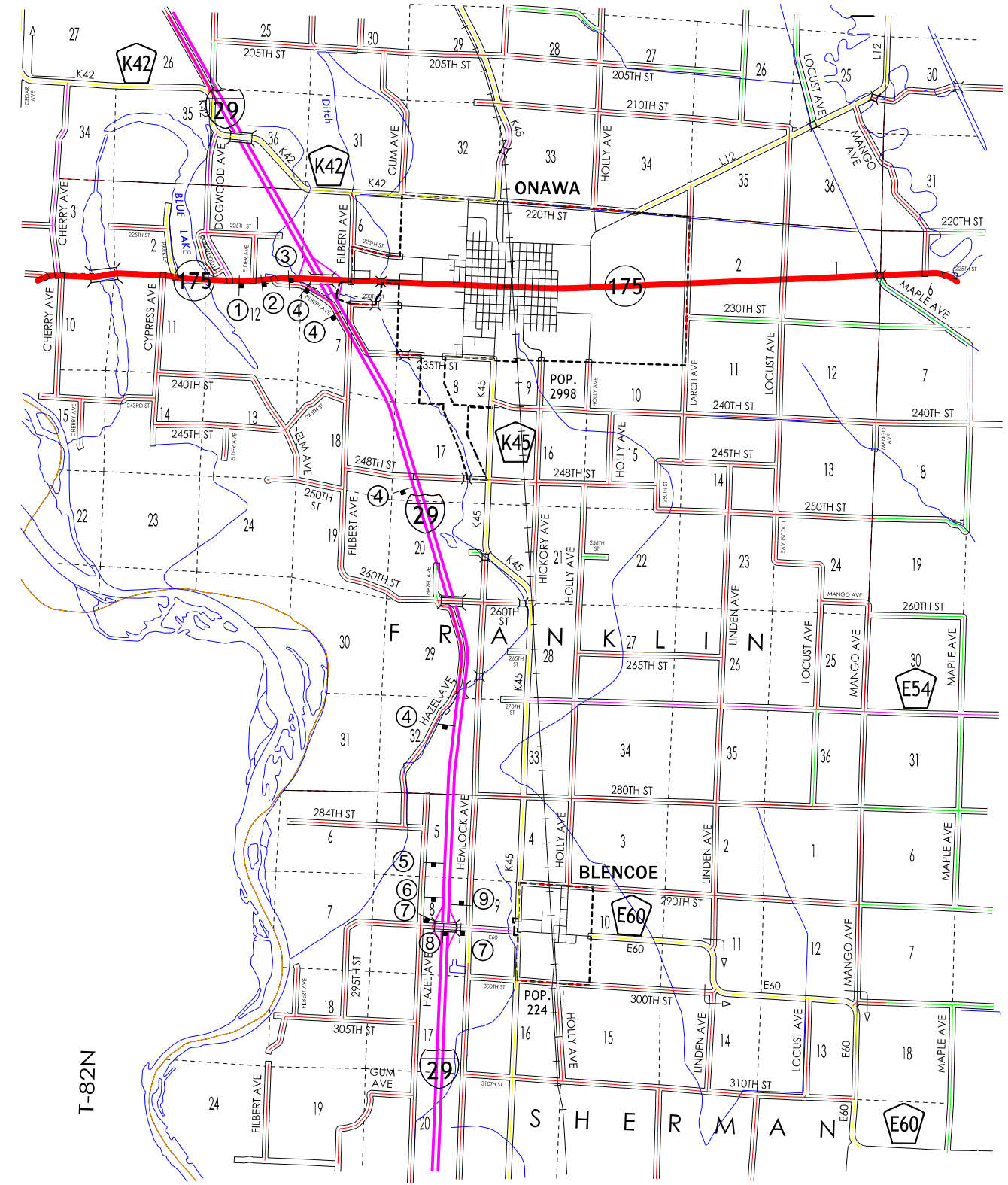
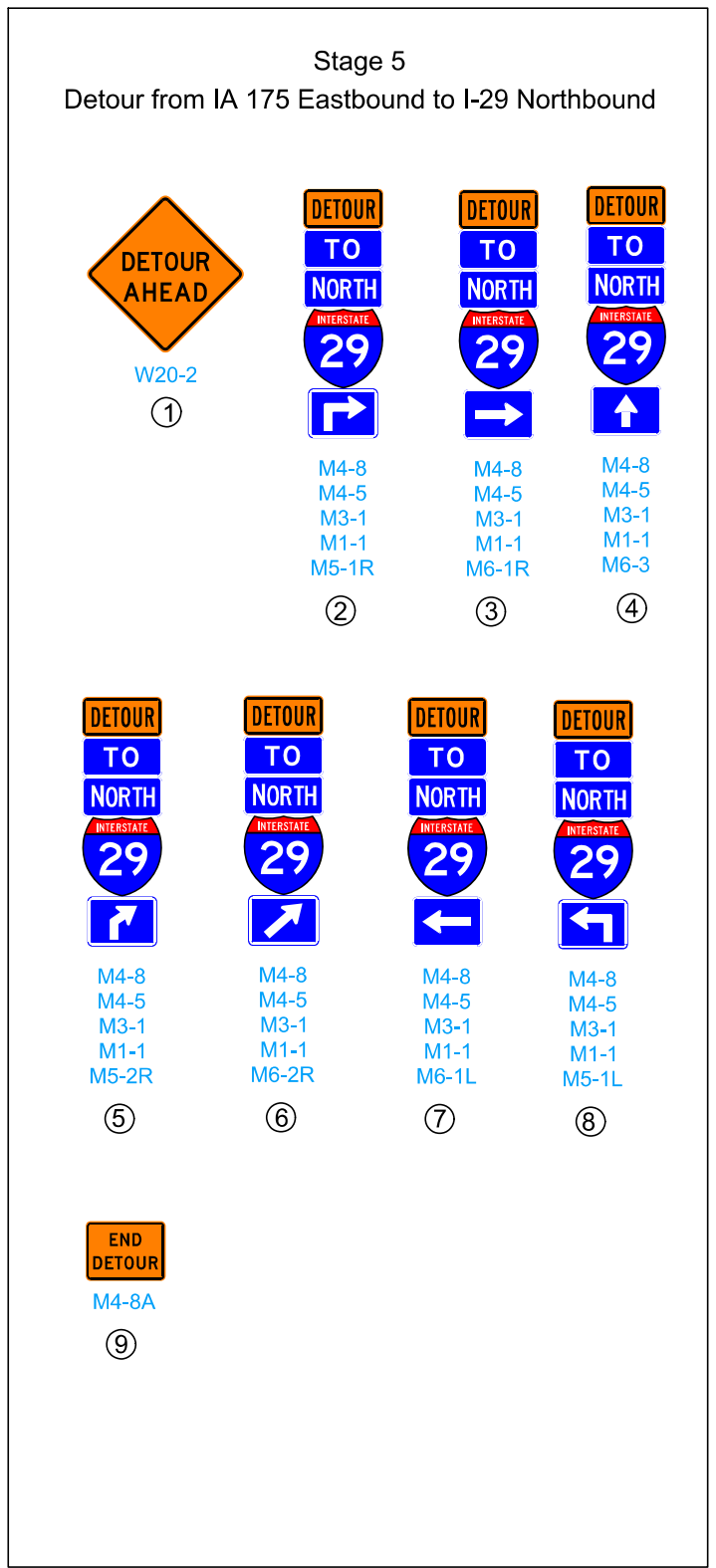

Stage 6
 Detour from I-29 Northbound to IA 175 Westbound

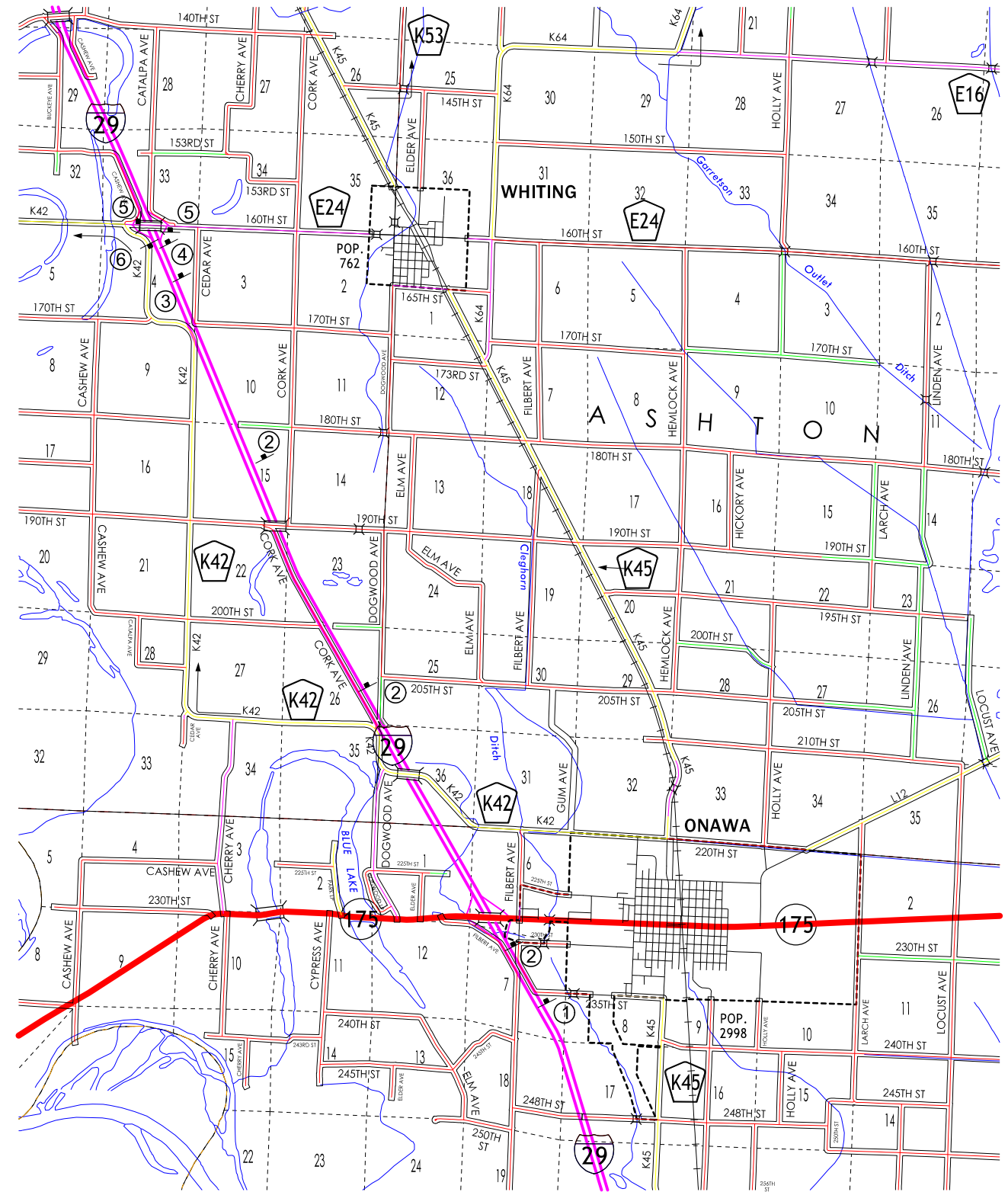
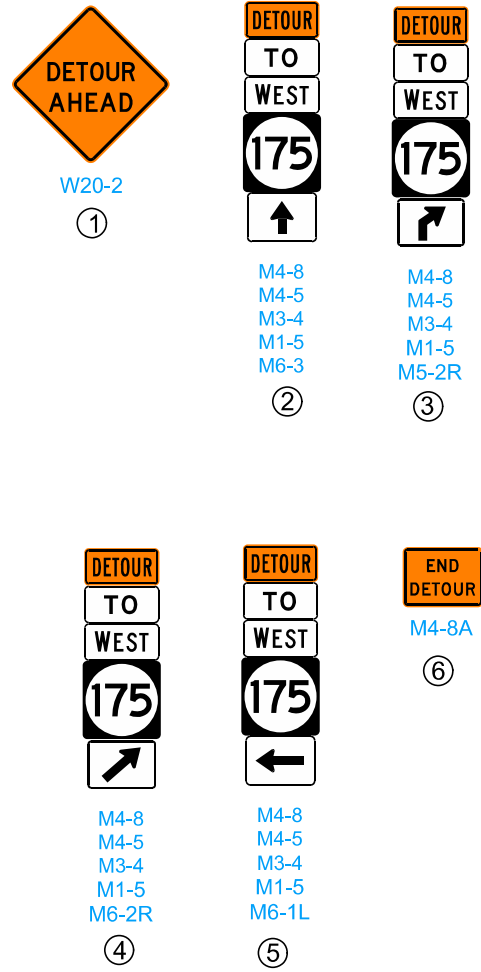

Stage 6
 Detour from IA 175 Westbound to I-29 Southbound

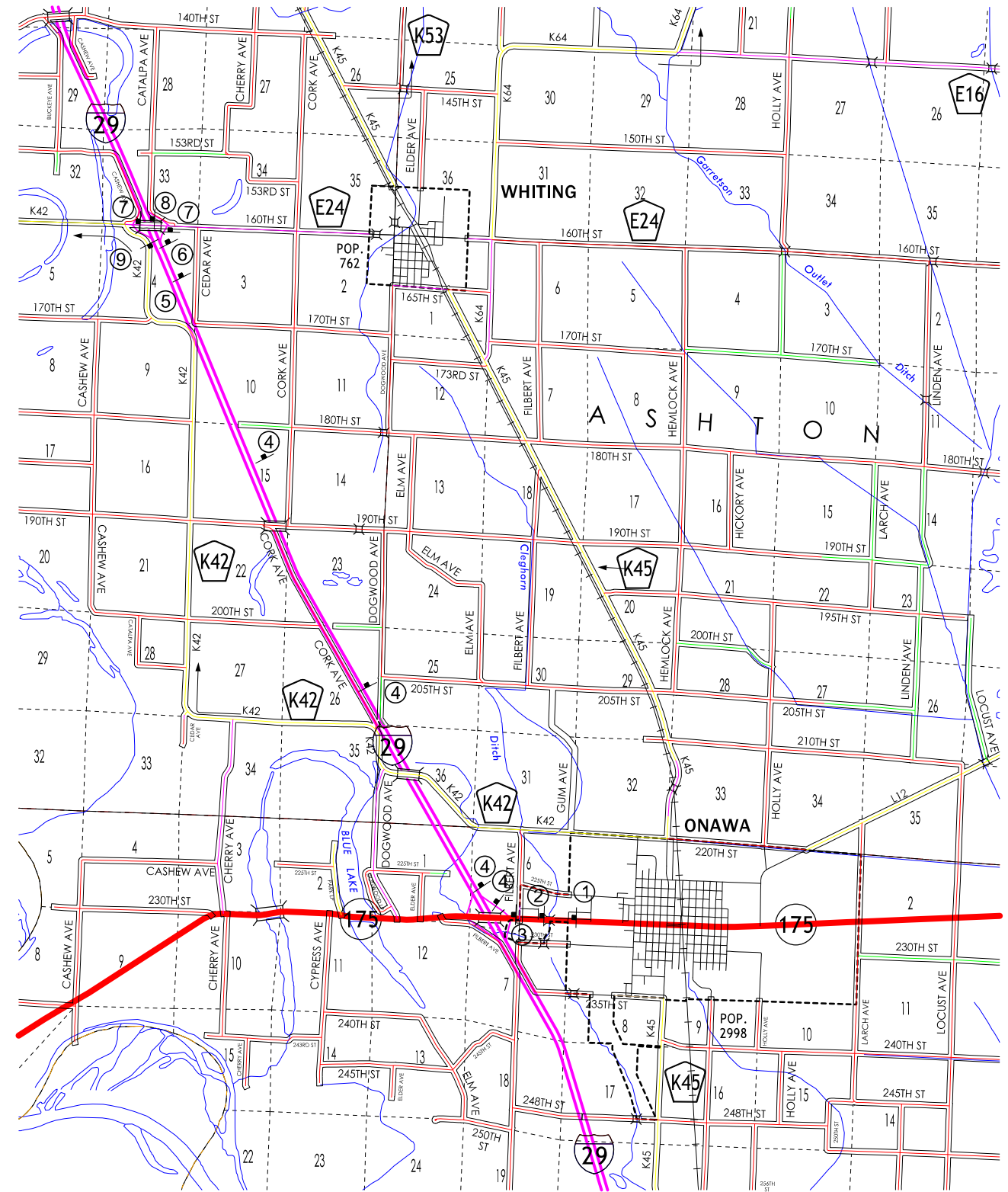
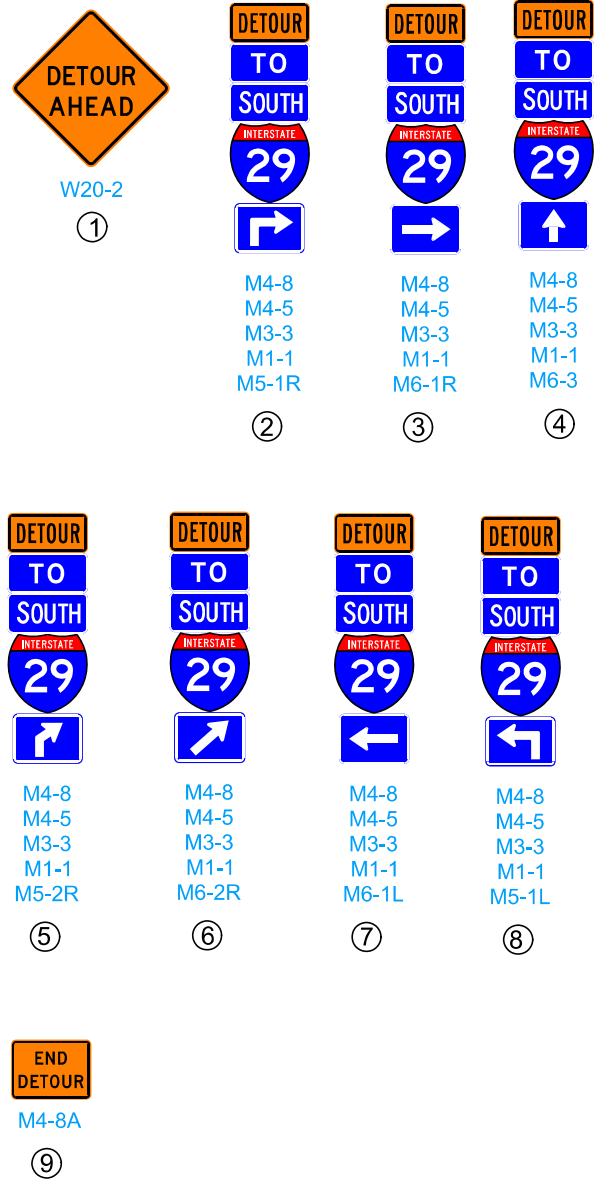

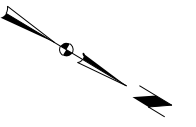

$\Delta = 25^\circ 05' 20.61''$ (LT)
 T = 445.02
 L = 875.77
 R = 2000.00
 E = 48.91
 e = 5.4
 L = 168
 x = 62
 DS = 60 mph

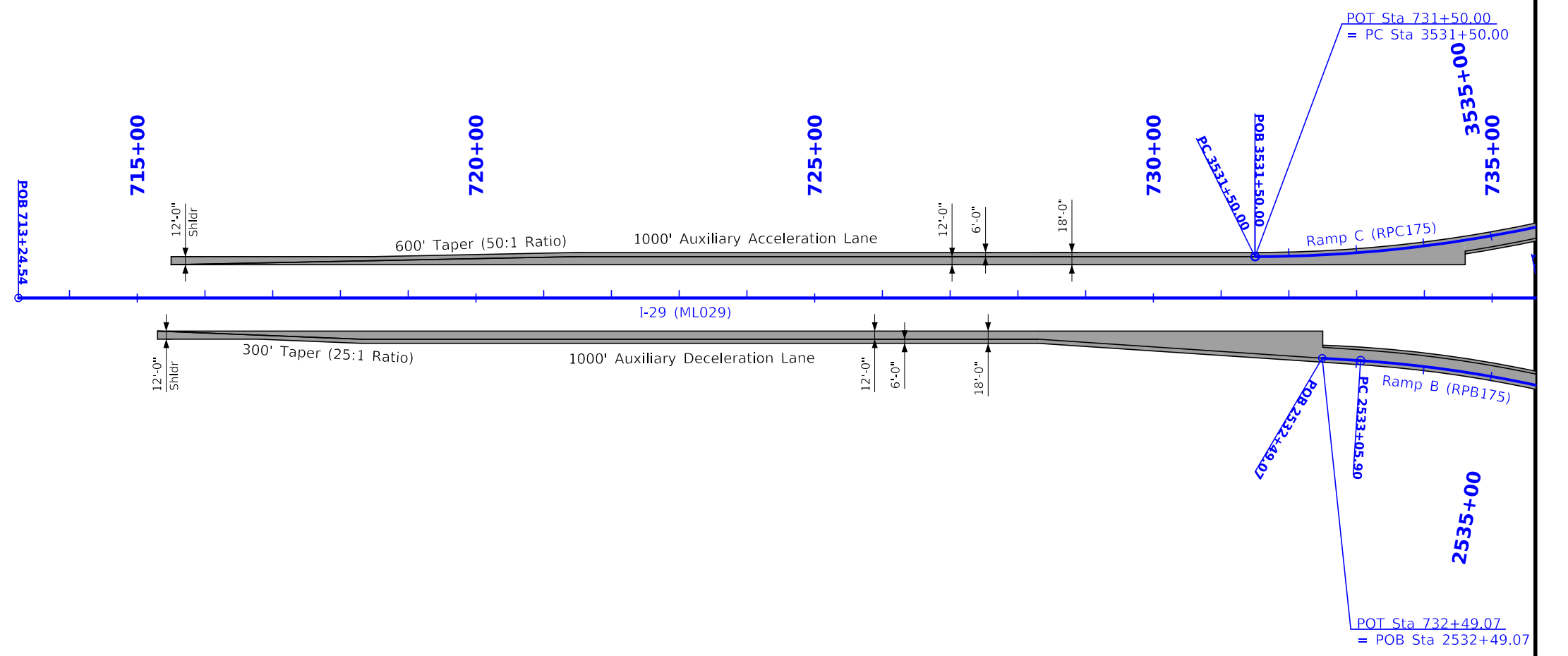

Geometric Plan
Proposed Interchange of
I-29 and IA Highway 175

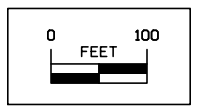

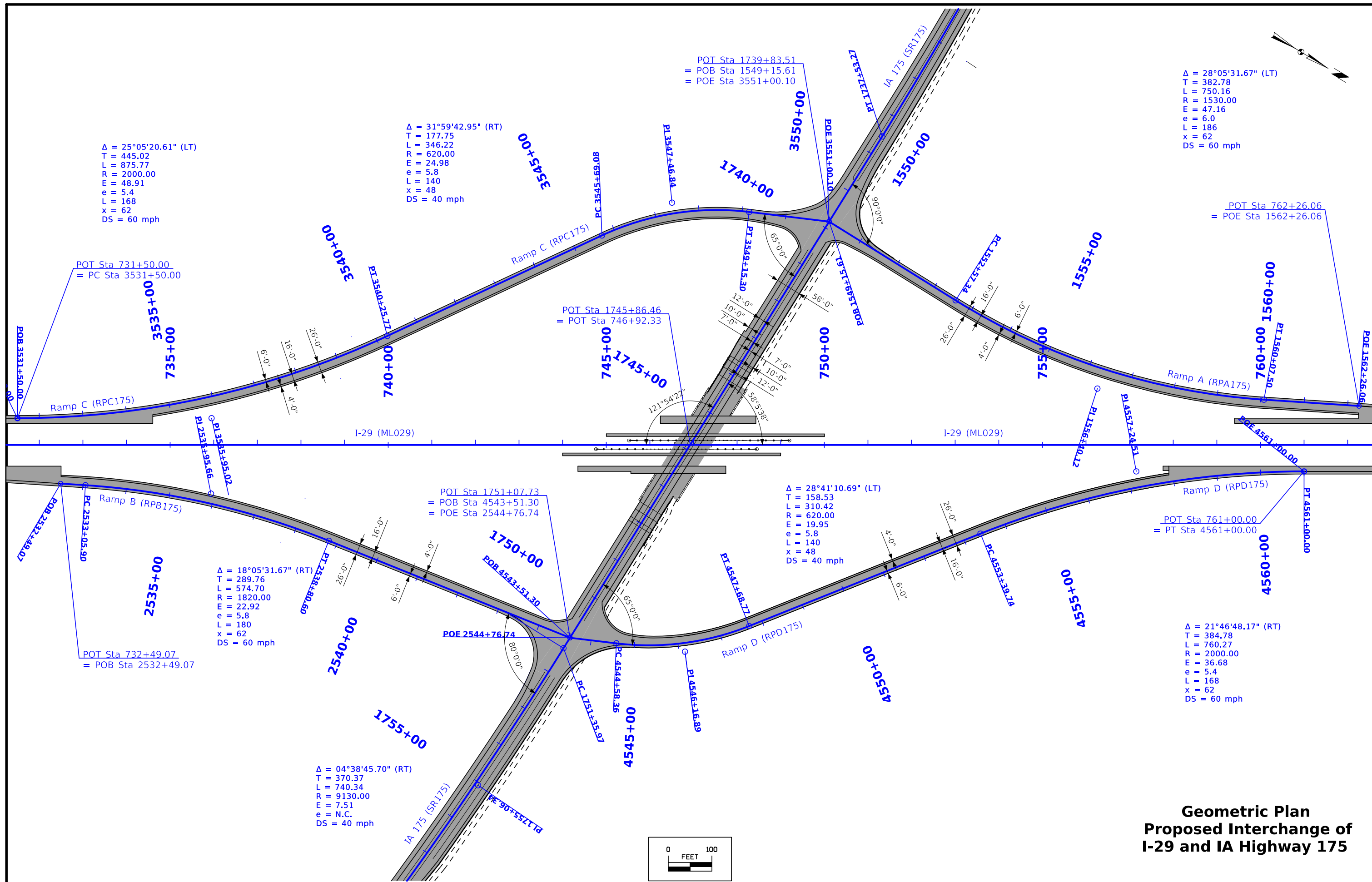

**Geometric Plan
Proposed Interchange of
I-29 and IA Highway 175**

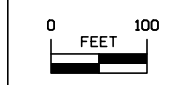

$\Delta = 28^{\circ}05'31.67''$ (LT)
 T = 382.78
 L = 750.16
 R = 1530.00
 E = 47.16
 e = 6.0
 L = 186
 x = 62
 DS = 60 mph

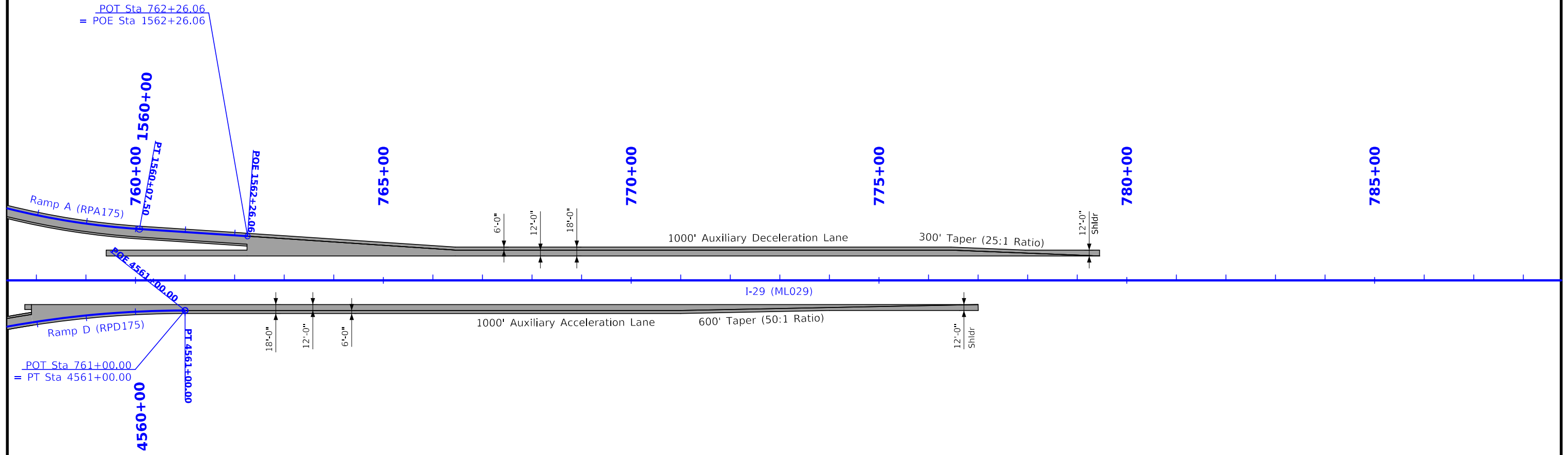
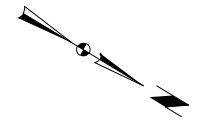

$\Delta = 21^{\circ}46'48.17''$ (RT)
 T = 384.78
 L = 760.27
 R = 2000.00
 E = 36.68
 e = 5.4
 L = 168
 x = 62
 DS = 60 mph

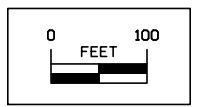

Geometric Plan
Proposed Interchange of
I-29 and IA Highway 175

FILE NO.	ENGLISH	DESIGN TEAM Iowa DOT / HR Green	MONONA COUNTY	PROJECT NUMBER STP-175-1(95)--2C-67	SHEET NUMBER K.3
----------	---------	--	----------------------	--	-------------------------

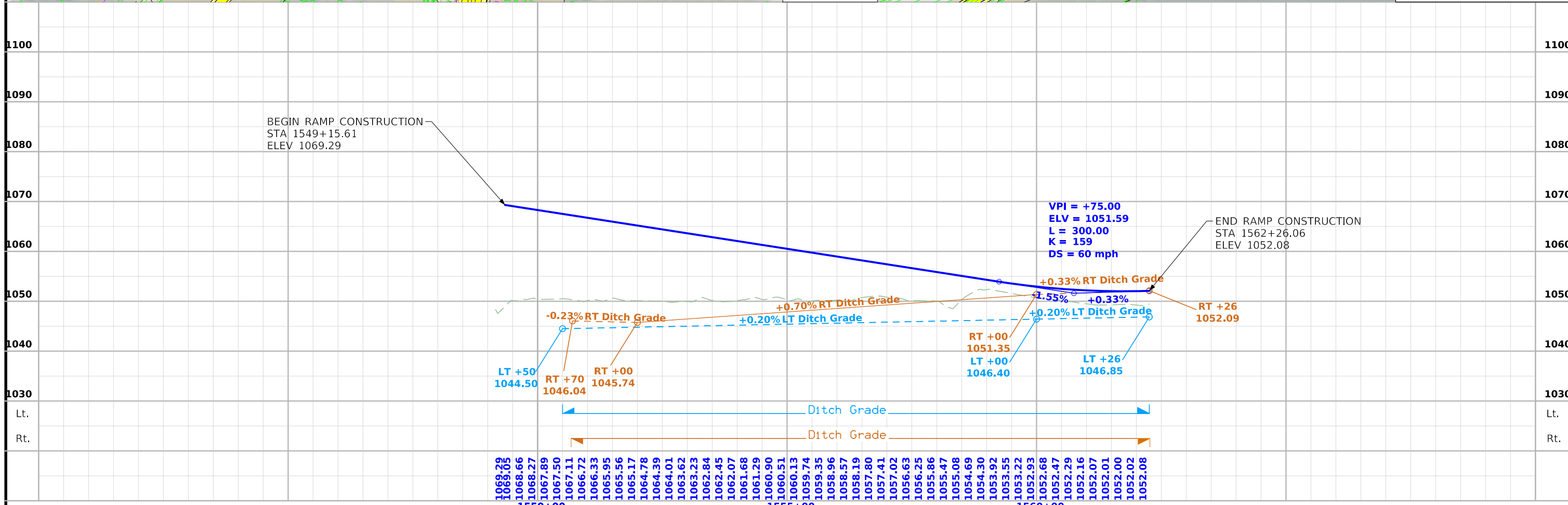
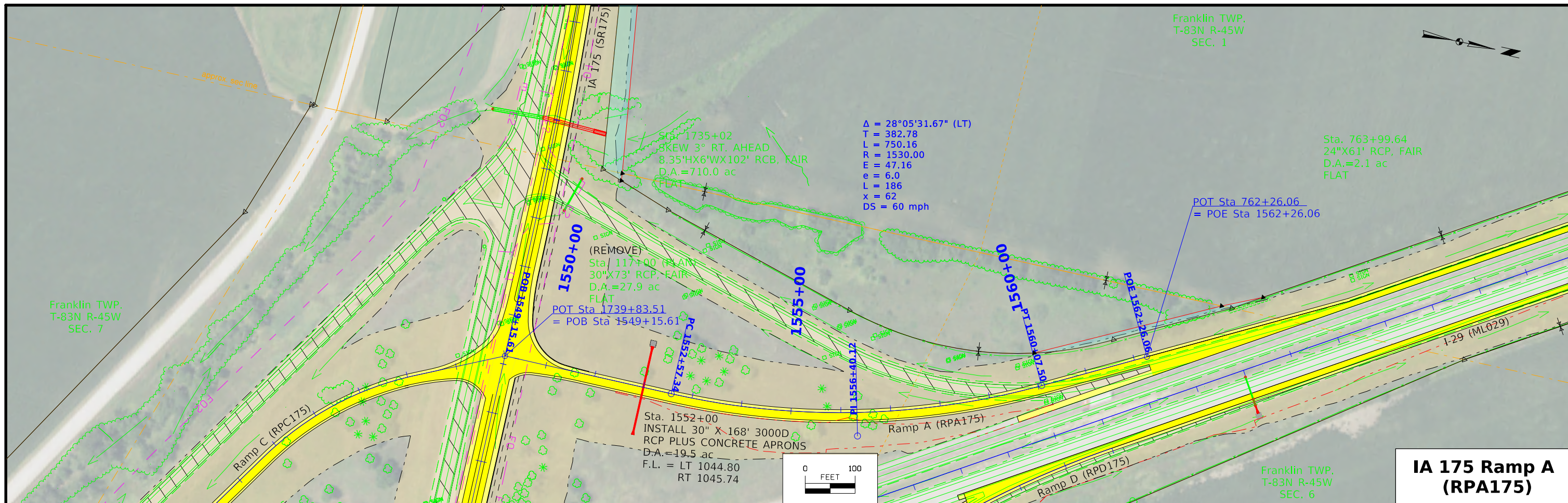

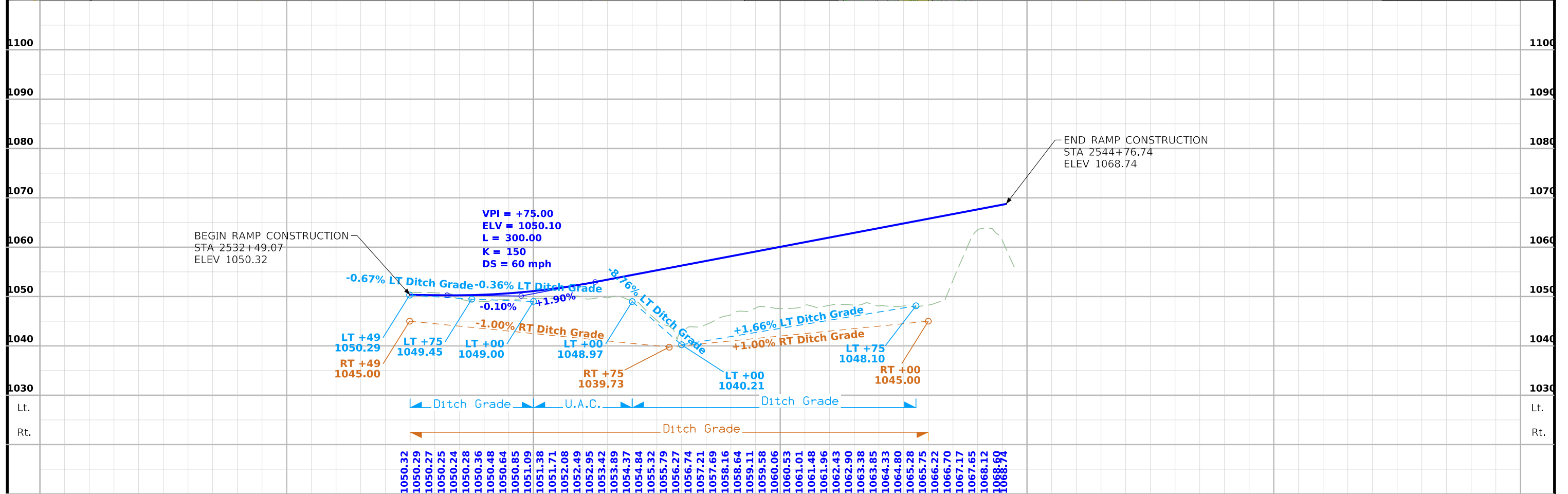
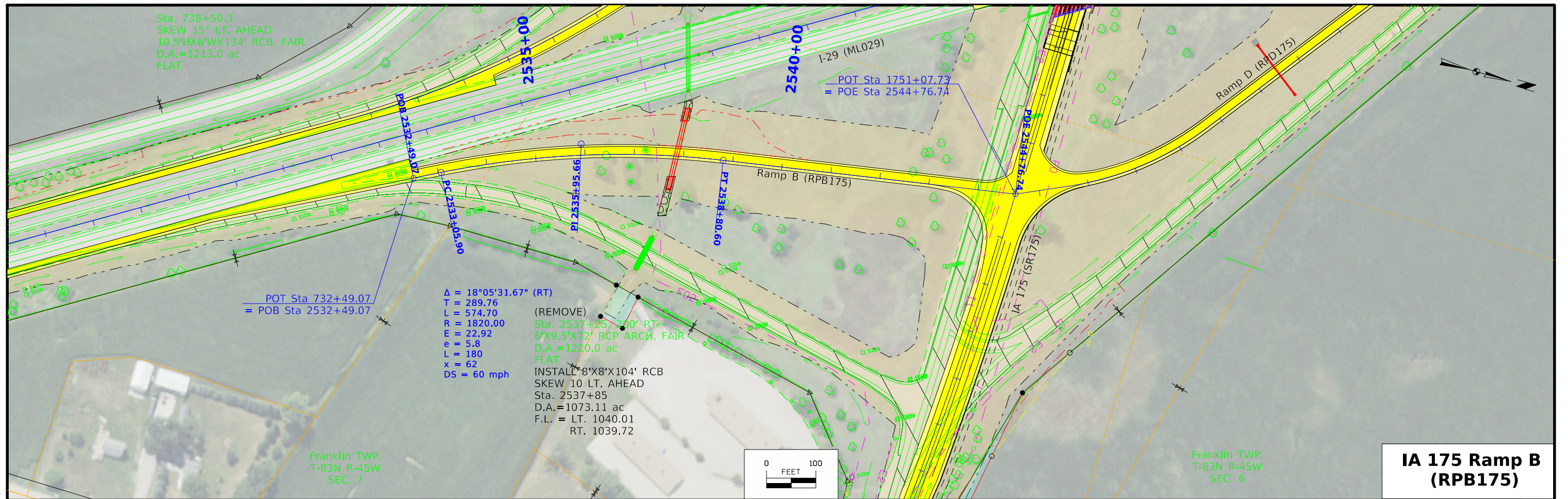

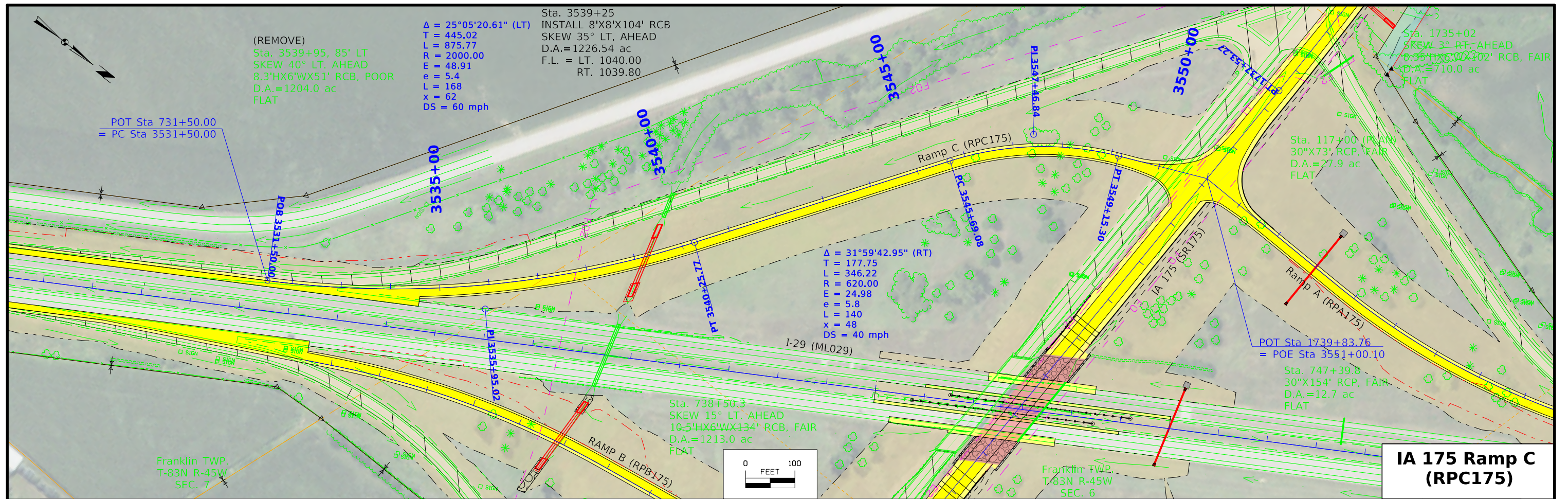

IA 175 Ramp C (RPC175)

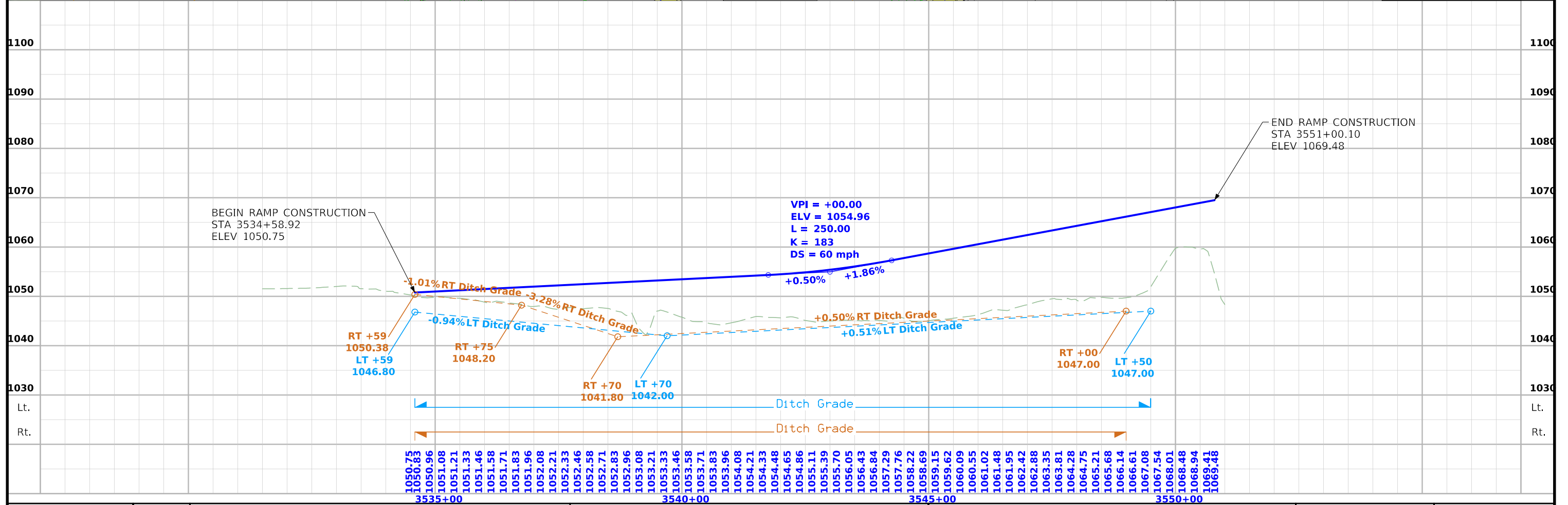

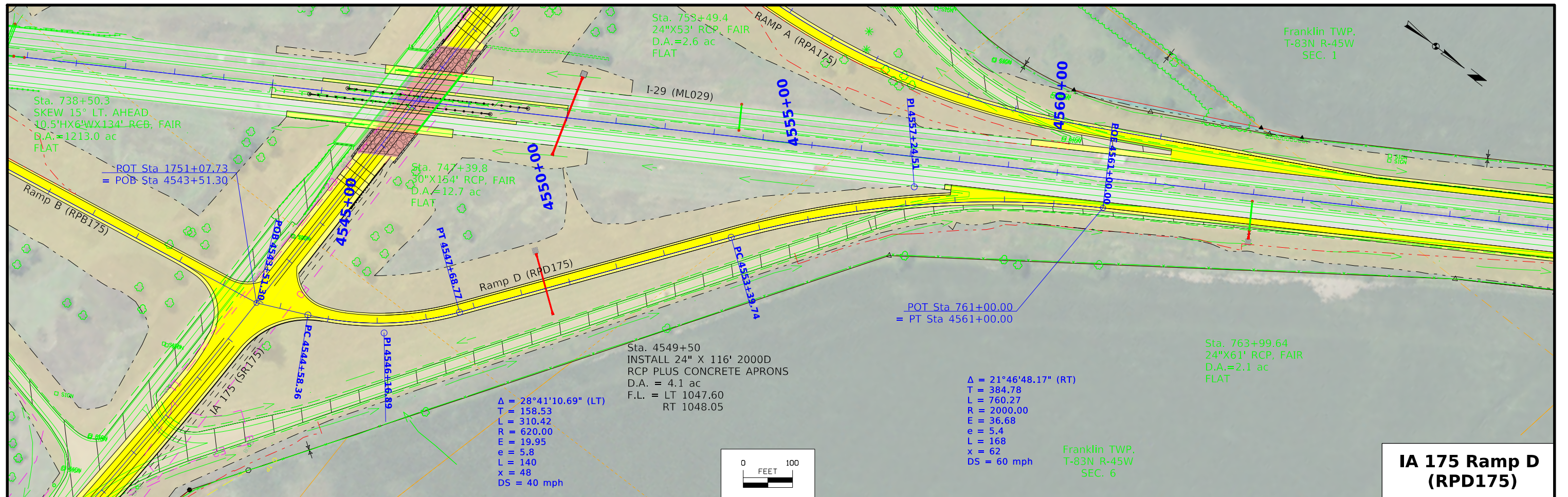

IA 175 Ramp D (RPD175)

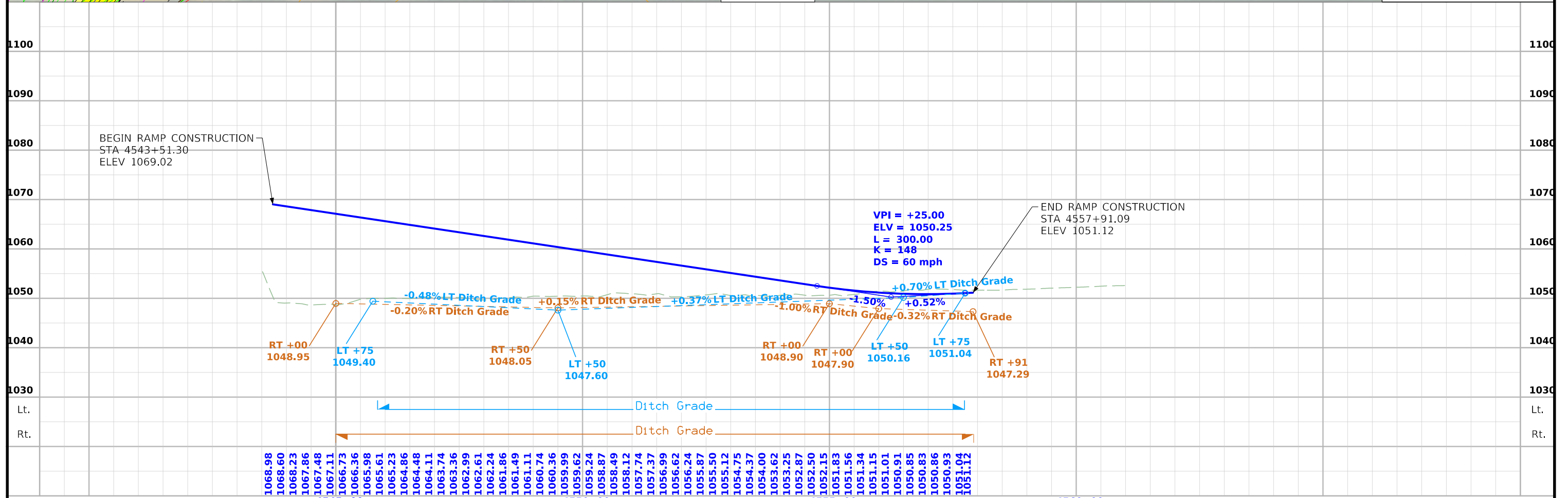

FILE NO.	ENGLISH	DESIGN TEAM	Iowa DOT / HR Green	COUNTY	MONONA	PROJECT NUMBER	STP-175-1(95)--2C-67	SHEET NUMBER	K.7
----------	---------	-------------	----------------------------	--------	---------------	----------------	-----------------------------	--------------	------------

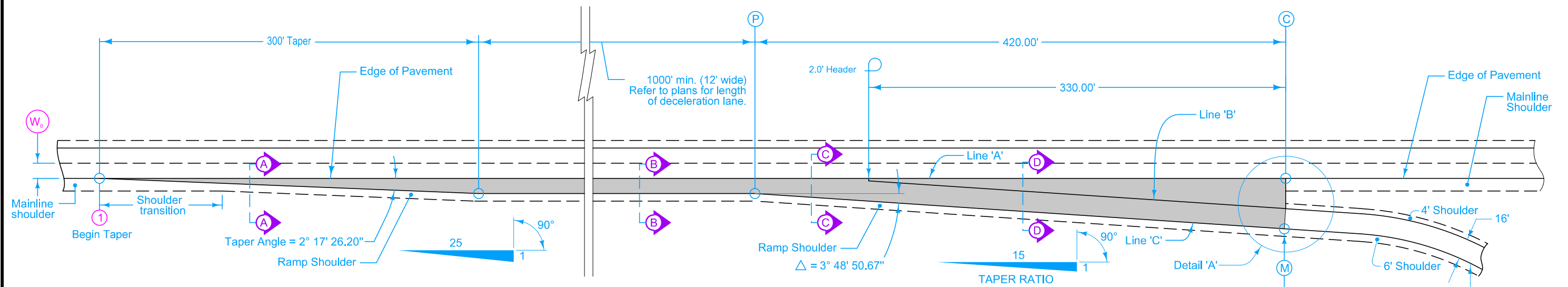

PLAN

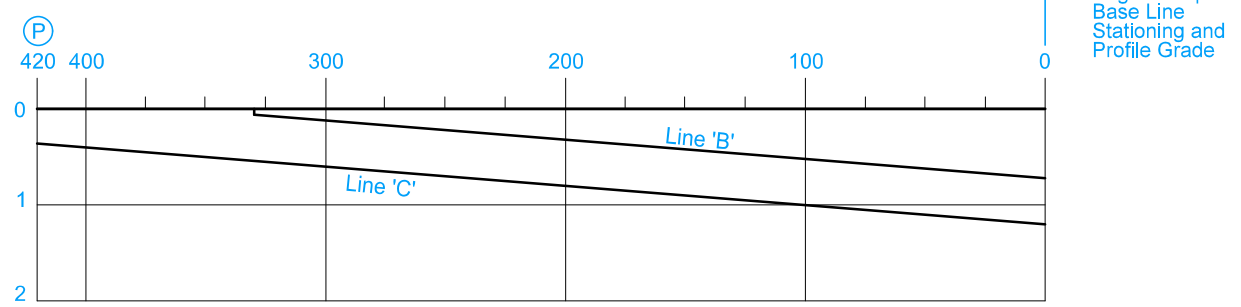

Note: The algebraic difference between the profile grade for ramp base line at (M) and realtive profile grade of mainline at (C) is 0.20%

PROFILE

DISTANCE (Ft.)	420	400	375	350	330	325	300	275	250	225	200	175	150	125	100	75	50	25	0
OFFSET (Ft.)	12.00	13.33	15.00	16.67	18.00	18.33	20.00	21.67	23.33	25.00	26.67	28.33	30.00	31.67	33.33	35.00	36.67	38.33	40.00
DROP (Ft.)	0.36	0.40	0.45	0.50	0.54	0.55	0.60	0.65	0.70	0.75	0.80	0.85	0.90	0.95	1.00	1.05	1.10	1.16	1.20

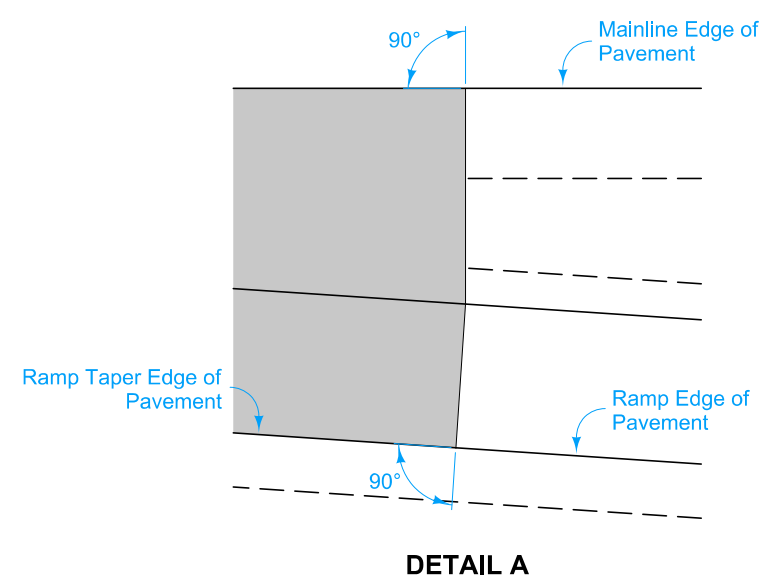

DETAIL A

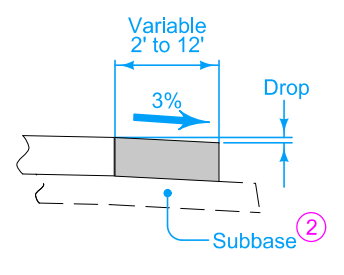

SECTION A-A

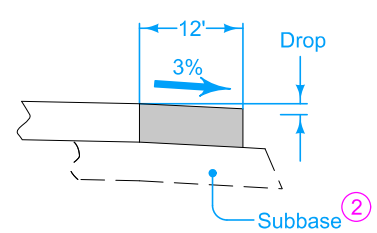

SECTION B-B

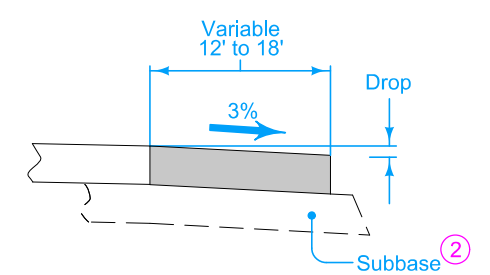

SECTION C-C

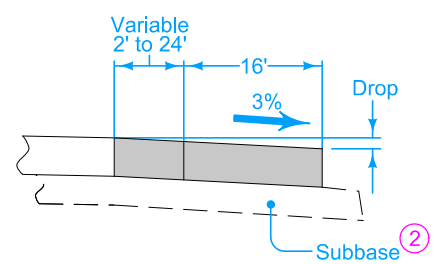

SECTION D-D

W_o	Shoulder Width beyond Edge of Mainline Pavement		
	8'	10'	12'
12'	NA	100'	150'

NOTE: W_o is the width of the outside lane to the Edge of Pavement.

- Construct ramp exit pavement the same thickness as mainline pavement.
- For joint detail, see PV-101.
- ① For header construction detail at the end of taper, see Typical 7101 or Typical 7102.
- ② Construct subbase for ramp exit pavement the same thickness as mainline subbase.

MODIFIED ROAD DESIGN DETAIL	REVISION
	2 04-21-20
	533-01
SHEET 1 of 2	

MODIFICATIONS:

PARALLEL DECELERATION TAPER FOR 16' RAMP A (60 MPH DESIGN SPEED)

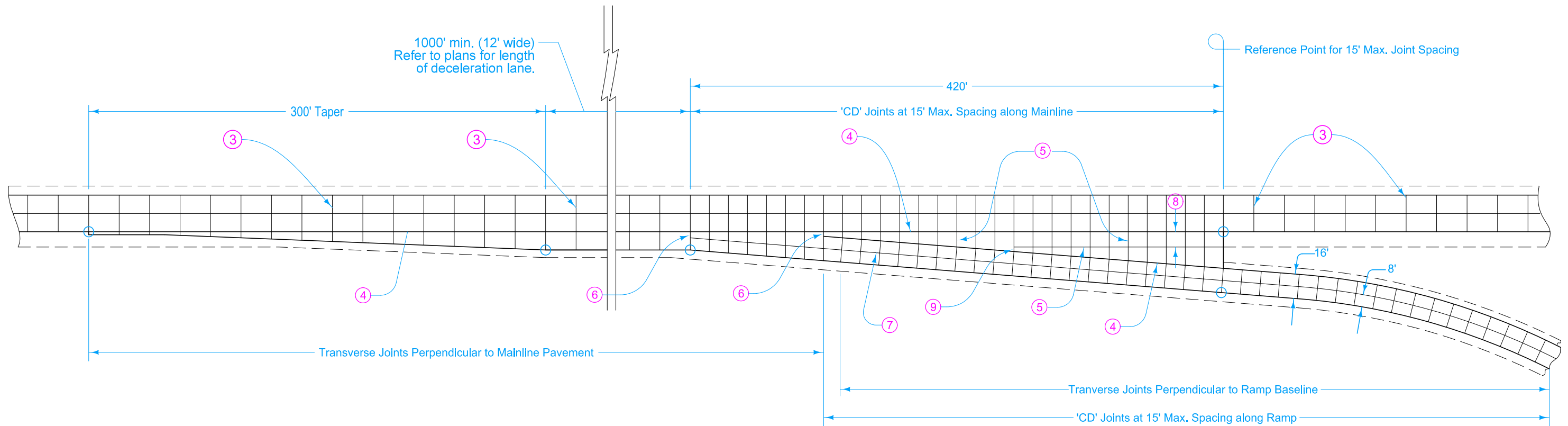

16' EXIT RAMP WITH PARALLEL DECELERATION LANE

- ③ 'CD' Joints at 17' spacing.
- ④ 'BT-2' or 'KT-2' Joint.
- ⑤ 'C' Joint.
- ⑥ 'B' Joint. 2' minimum, 4' maximum.
- ⑦ 'L-2' Joint.
- ⑧ 10' minimum or equal to mainline shoulder width.
- ⑨ 'B' or 'C' Joint. 2' minimum. 4' maximum.

MODIFIED	REVISION	
	2	04-21-20
ROAD DESIGN DETAIL		533-01
		SHEET 2 of 2
MODIFICATIONS:		
PARALLEL DECELERATION TAPER FOR 16' RAMP A (60 MPH DESIGN SPEED)		

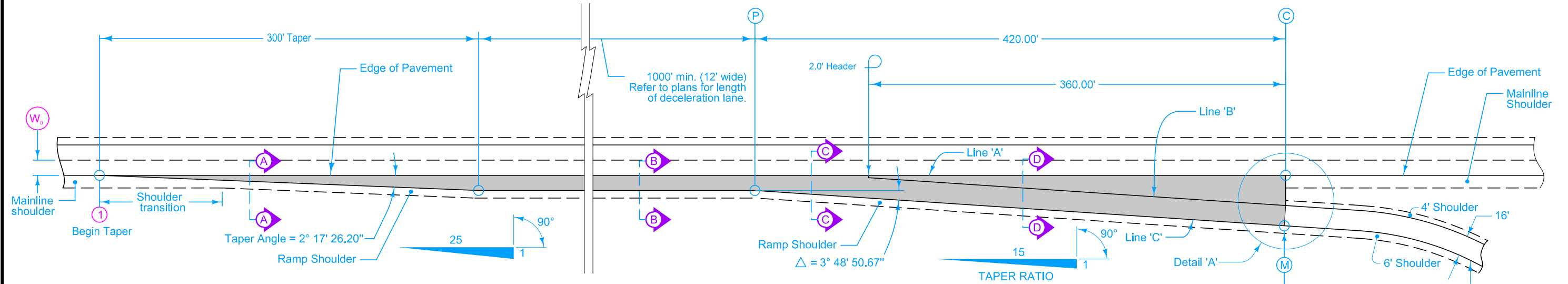

PLAN

TABLE OF OFFSETS AND DROPS FOR 16' RAMP TAPER

DISTANCE (Ft.)	420	400	375	350	330	325	300	275	250	225	200	175	150	125	100	75	50	25	8.9	0
OFFSET (Ft.)	12.00	13.33	15.00	16.67	18.00	18.33	20.00	21.67	23.33	25.00	26.67	28.33	30.00	31.67	33.33	35.00	36.67	38.33	39.38	40.00
SLOPE (%)	Constant 3.0% Slope																			3.08
DROP (Ft.)	0.36	0.40	0.45	0.50	0.54	0.55	0.60	0.65	0.70	0.75	0.80	0.85	0.90	0.95	1.00	1.05	1.10	1.15	1.18	1.23

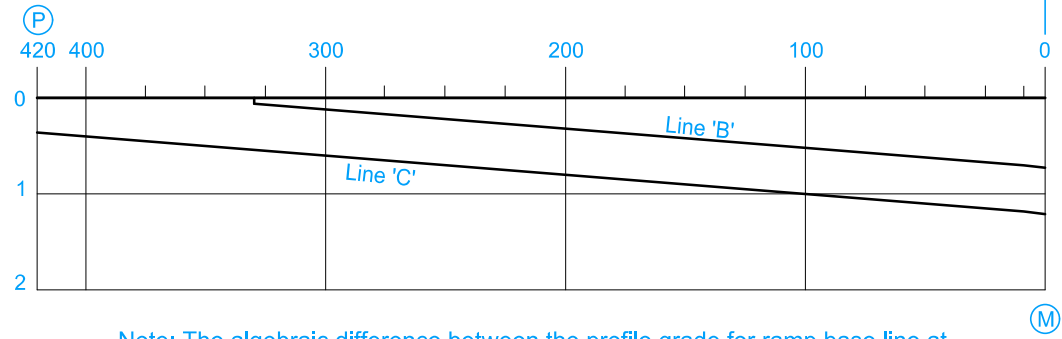

Note: The algebraic difference between the profile grade for ramp base line at (M) and relative profile grade of mainline at (C) is 0.20%

PROFILE

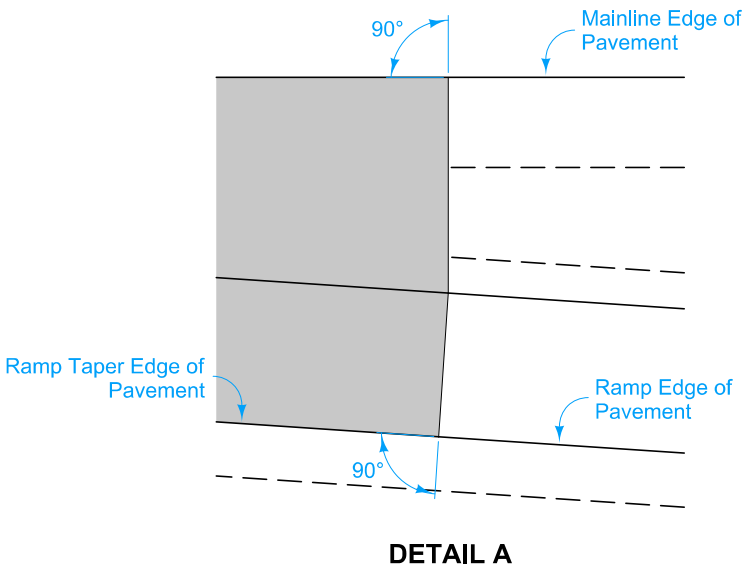

DETAIL A

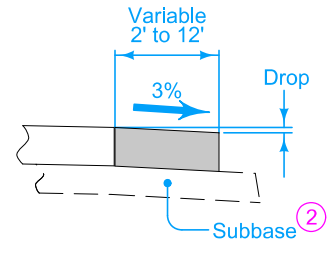

SECTION A-A

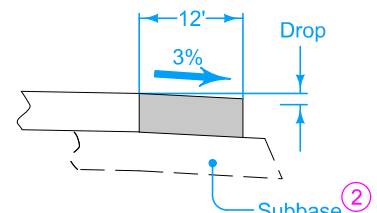

SECTION B-B

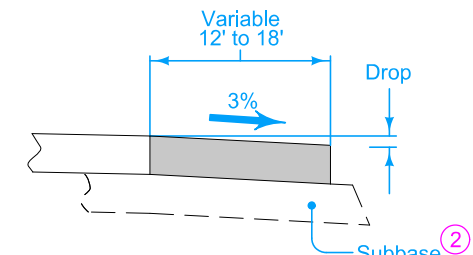

SECTION C-C

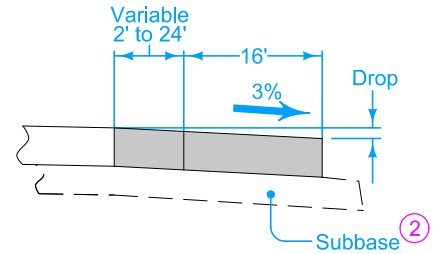

SECTION D-D

TABLE OF SHOULDER TRANSITION LENGTHS WITH 6' SHOULDER ON RAMP

W _o	Shoulder Width beyond Edge of Mainline Pavement		
	8'	10'	12'
12'	NA	100'	150'

NOTE: W_o is the width of the outside lane to the Edge of Pavement.

- Construct ramp exit pavement the same thickness as mainline pavement.
- For joint detail, see PV-101.
- ① For header construction detail at the end of taper, see Typical 7101 or Typical 7102.
- ② Construct subbase for ramp exit pavement the same thickness as mainline subbase.

MODIFIED ROAD DESIGN DETAIL	REVISION	
	2	04-21-20
	533-01	
		SHEET 1 of 2
MODIFICATIONS: Added superelevation transition to Table of Offsets and Drops		
PARALLEL DECELERATION TAPER FOR 16' RAMP B (60 MPH DESIGN SPEED)		

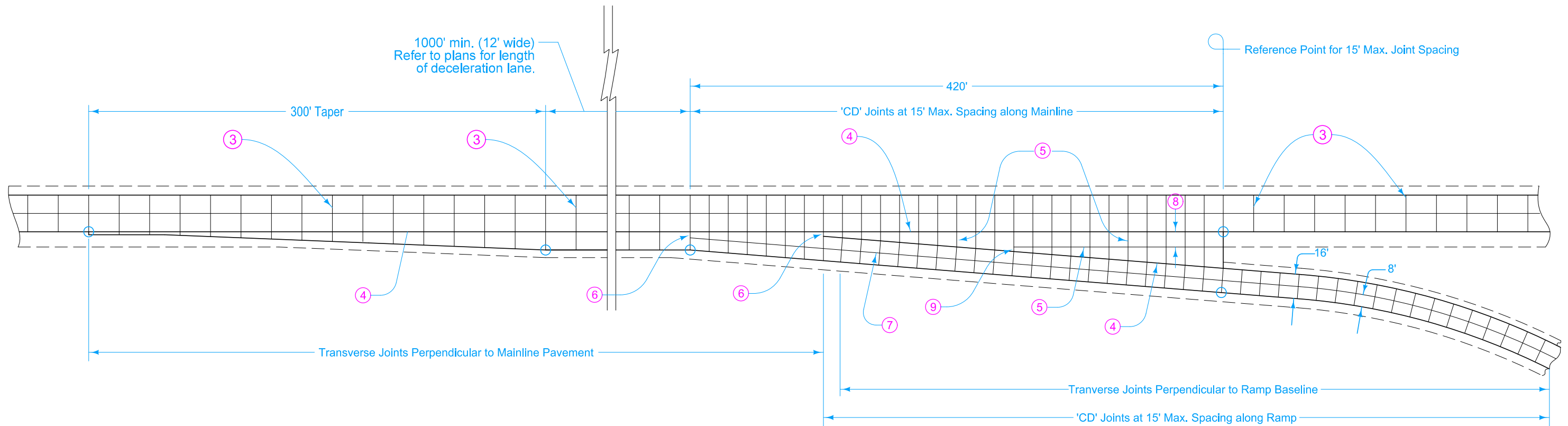

16' EXIT RAMP WITH PARALLEL DECELERATION LANE

- ③ 'CD' Joints at 17' spacing.
- ④ 'BT-2' or 'KT-2' Joint.
- ⑤ 'C' Joint.
- ⑥ 'B' Joint. 2' minimum, 4' maximum.
- ⑦ 'L-2' Joint.
- ⑧ 10' minimum or equal to mainline shoulder width.
- ⑨ 'B' or 'C' Joint. 2' minimum. 4' maximum.

MODIFIED	REVISION	
	2	04-21-20
ROAD DESIGN DETAIL		533-01
		SHEET 2 of 2
MODIFICATIONS: Added superelevation transition to Table of Offsets and Drops		
PARALLEL DECELERATION TAPER FOR 16' RAMP B (60 MPH DESIGN SPEED)		

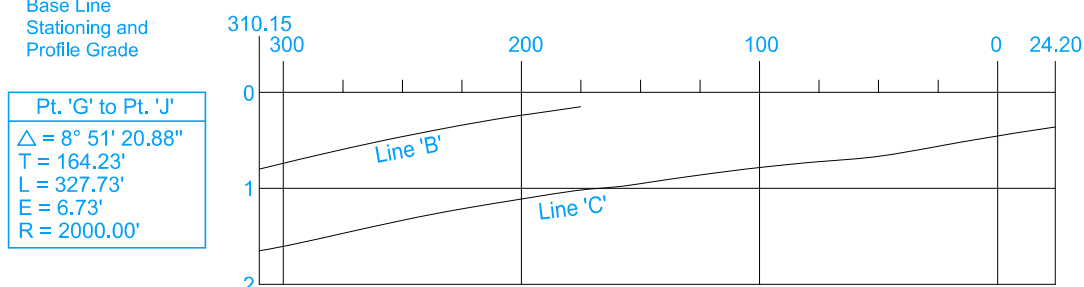
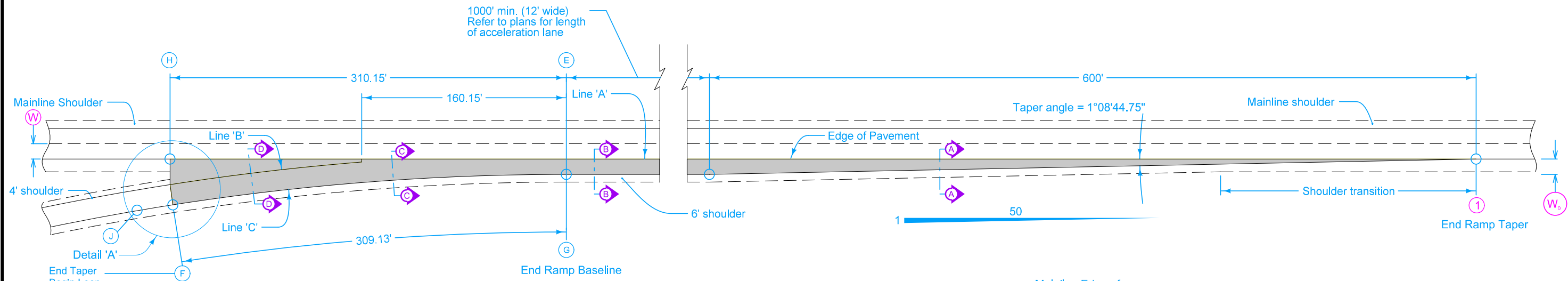

Pt. 'G' to Pt. 'J'
$\Delta = 8^\circ 51' 20.88''$
$T = 164.23'$
$L = 327.73'$
$E = 6.73'$
$R = 2000.00'$

W ₀	Shoulder Width beyond Edge of Mainline Pavement		
	8'	10'	12'
12'	NA	100'	150'

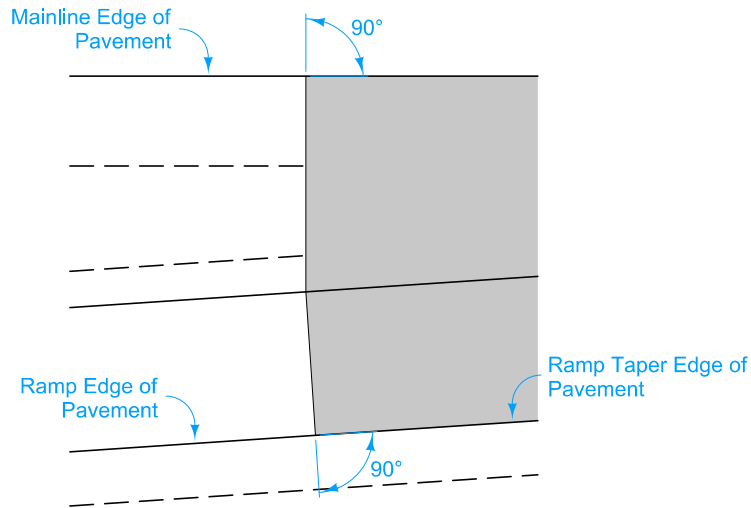

NOTE: The algebraic difference between ramp profile grade at point (F) and relative profile grade of mainline at point (H) is 0.62%

DISTANCE FROM POINT (E) ALONG LINE 'A' (Ft.)		310.15	300	275	250	225	204	200	175	160.15	150	125	100	75	50	25	0	24.2
From Line 'A' To Line 'B'	OFFSET (Ft.)	20.00	18.44	14.85	11.56	8.60	6.35	5.95	3.61	2.41								
	SLOPE (%)	Constant 4.0% Slope								4.11	4.0	5.40						
	DROP (Ft.)	0.80	0.74	0.59	0.46	0.34	0.25	0.24	0.15	0.13								
From Line 'B' To Line 'C'	OFFSET (Ft.)	Constant 16' Offset																
	SLOPE (%)	Constant 5.4% Slope																
	DROP (Ft.)	0.86	0.86	0.86	0.86	0.86	0.86	0.86	0.86	0.86								
From Line 'A' To Line 'C'	OFFSET (Ft.)										17.62	15.91	14.50	13.41	12.62	12.16	12.00	12.00
	SLOPE (%)										5.40	5.40	5.40	5.40	5.40	4.59	3.78	3.00
	DROP (Ft.)	1.65	1.61	1.47	1.33	1.21	1.13	1.11	1.01	0.99	0.95	0.86	0.78	0.72	0.68	0.56	0.45	0.36
DISTANCE FROM POINT (G) ALONG LINE 'C' (Ft.)		309.13	298.73	273.67	248.66	223.68	202.73	198.74	173.83	159.04	150.14	125.08	100.04	75.02	50.01	25.00	0.00	

DETAIL A

Construct ramp exit pavement the same thickness as mainline pavement.

For joint detail, see PV-101.

① For header construction detail at the end of taper, see Typical 7101 or Typical 7102.

② Construct subbase for ramp exit pavement the same thickness as mainline subbase.

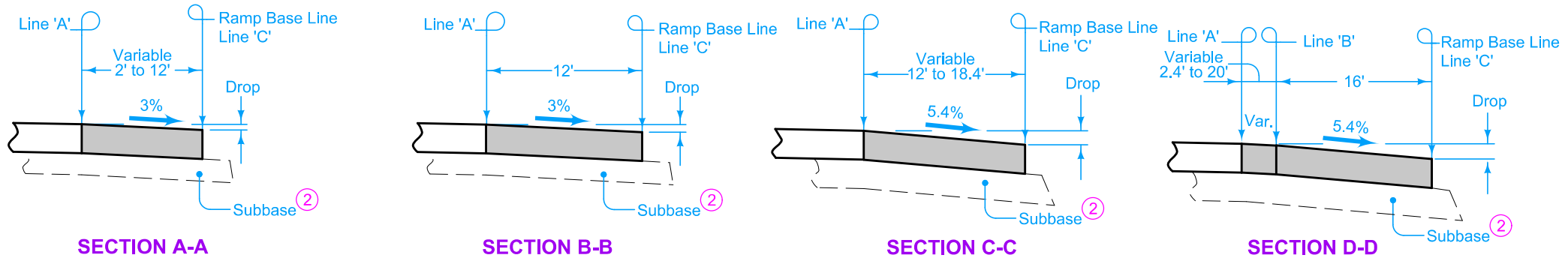

MODIFIED ROAD DESIGN DETAIL	REVISION
	3 04-20-21
	533-02
SHEET 1 of 2	
MODIFICATIONS: Added Point J and Ramp Profile note.	
PARALLEL ACCELERATION TAPER FOR 16' RAMP C (60 MPH DESIGN SPEED)	

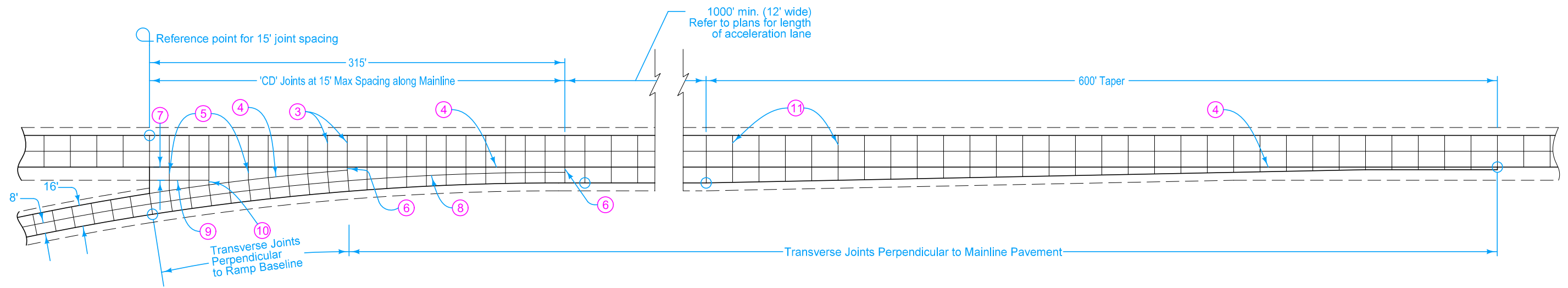

- ③ 'CD' Joints at 15' spacing.
- ④ 'BT-2' or 'KT-2' Joint.
- ⑤ 'C' Joint.
- ⑥ 'B' Joint. 2' minimum, 4' maximum.
- ⑦ 10' minimum or equal to mainline shoulder width.
- ⑧ 'L-2' Joint.
- ⑨ 'C' Joint parallel to mainline pavement.
- ⑩ 'B' or 'C' Joint. 2' minimum, 4' maximum.
- ⑪ 'CD' Joints at 17' spacing.

MODIFIED	REVISION	
	3	04-20-21
ROAD DESIGN DETAIL		533-02
		SHEET 2 of 2
MODIFICATIONS: Added Point J and Ramp Profile note.		
PARALLEL ACCELERATION TAPER FOR 16' RAMP C (60 MPH DESIGN SPEED)		

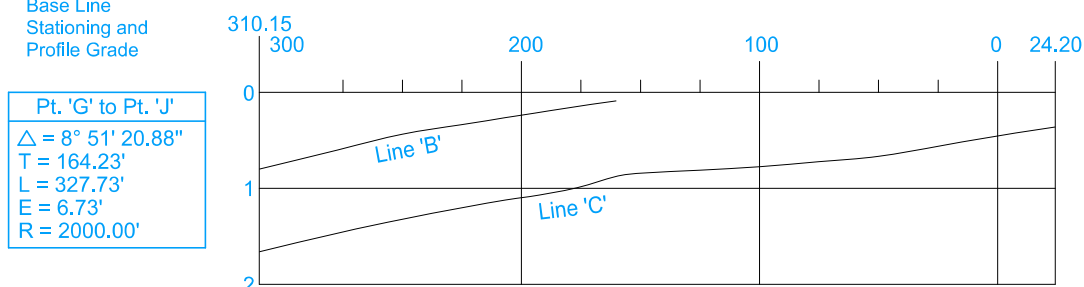
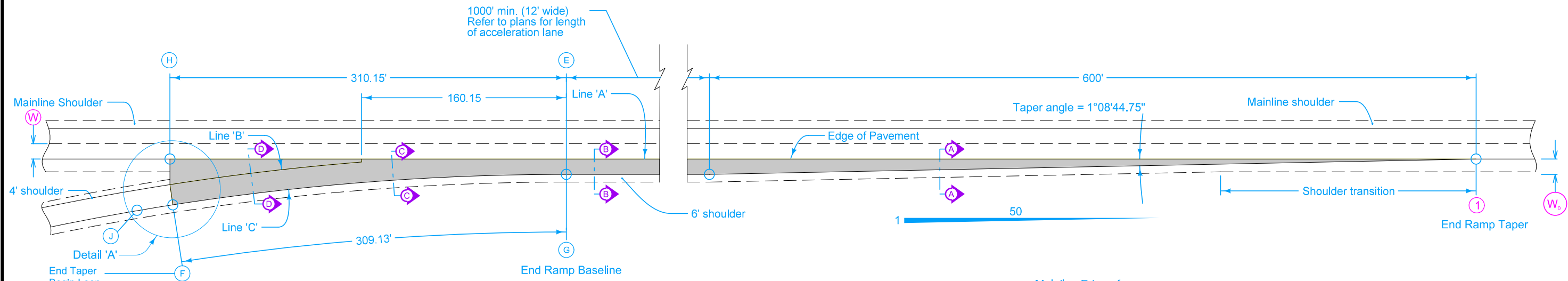

Pt. 'G' to Pt. 'J'
 $\Delta = 8^\circ 51' 20.88''$
 $T = 164.23'$
 $L = 327.73'$
 $E = 6.73'$
 $R = 2000.00'$

NOTE: The algebraic difference between ramp profile grade at point (F) and relative profile grade of mainline at point (H) is 0.59%

W ₀	Shoulder Width beyond Edge of Mainline Pavement		
	8'	10'	12'
12'	NA	100'	150'

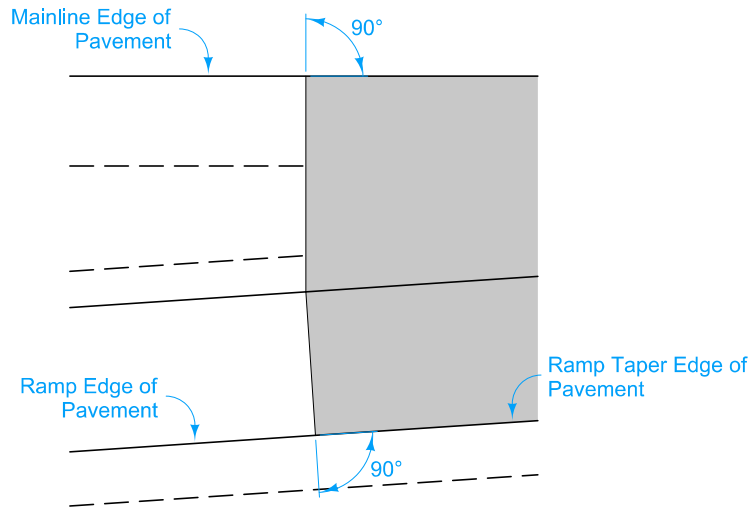

DETAIL A

Construct ramp exit pavement the same thickness as mainline pavement.

For joint detail, see PV-101.

① For header construction detail at the end of taper, see Typical 7101 or Typical 7102.

② Construct subbase for ramp exit pavement the same thickness as mainline subbase.

DISTANCE FROM POINT (E) ALONG LINE 'A' (Ft.)		310.15	300	275	250	225	204	200	175	160.15	120	110	100	75	50	25	0	24.2	
From Line 'A' To Line 'B'	OFFSET (Ft.)	20.00	18.45	14.85	11.56	8.60	6.35	5.95	3.62	2.30									
	SLOPE (%)	4.00	4.00	3.96	3.63	3.95	3.94	4.03	3.87	3.91									
	DROP (Ft.)	0.80	0.74	0.59	0.42	0.34	0.25	0.24	0.14	0.09									
From Line 'B' To Line 'C'	OFFSET (Ft.)	Constant 16' Offset																	
	SLOPE (%)	Constant 5.4% Slope																	
	DROP (Ft.)	0.86	0.86	0.86	0.86	0.86	0.86	0.86	0.86	0.86	0.86								
From Line 'A' To Line 'C'	OFFSET (Ft.)										15.60	15.03	14.50	13.41	12.63	12.16	12.00	12.00	
	SLOPE (%)										5.38	5.38	5.38	5.37	5.38	4.61	3.75	3.00	
	DROP (Ft.)	1.66	1.6	1.45	1.32	1.20	1.11	1.10	1.00	0.86	0.84	0.81	0.78	0.72	0.68	0.56	0.45	0.36	
DISTANCE FROM POINT (G) ALONG LINE 'C' (Ft.)		309.13	298.73	273.67	248.66	223.68	202.73	198.74	173.83	159.04	150.14	125.08	100.04	75.02	50.01	25.00	0.00		

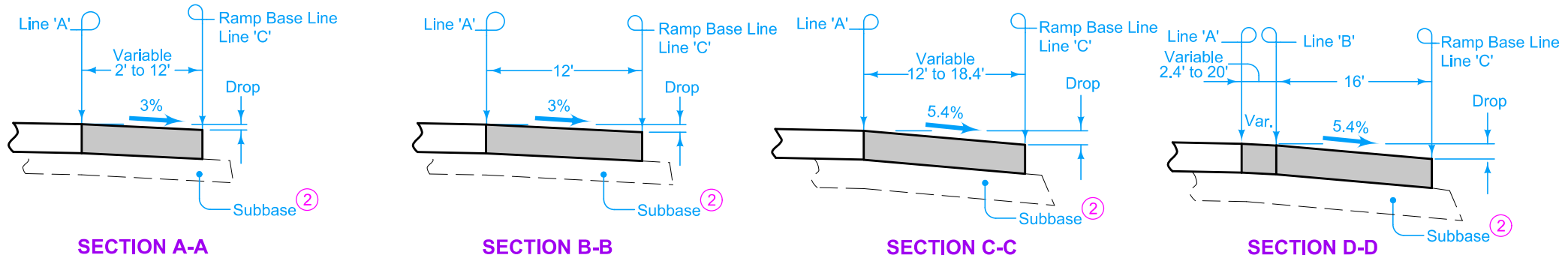

MODIFIED ROAD DESIGN DETAIL	REVISION	
	3	04-20-21
	533-02	
SHEET 1 of 2		
MODIFICATIONS: Added Point J and Ramp Profile note.		
PARALLEL ACCELERATION TAPER FOR 16' RAMP D (60 MPH DESIGN SPEED)		

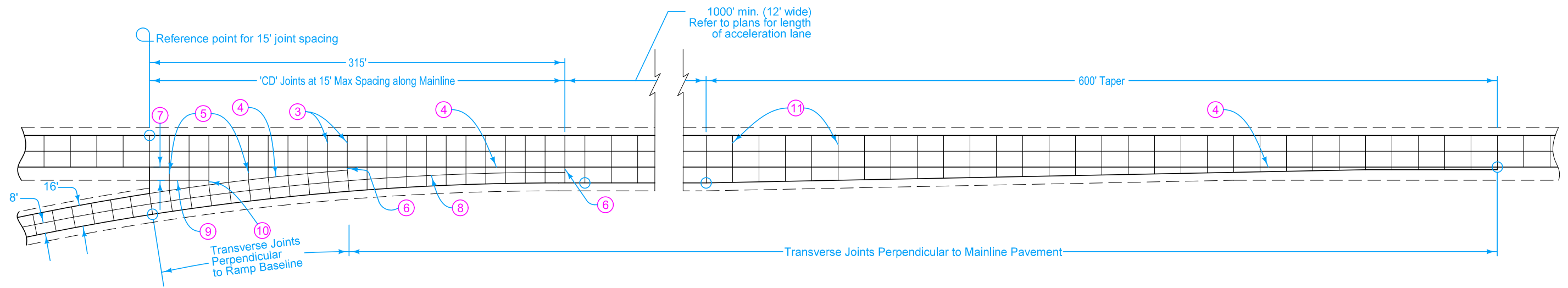

- ③ 'CD' Joints at 15' spacing.
- ④ 'BT-2' or 'KT-2' Joint.
- ⑤ 'C' Joint.
- ⑥ 'B' Joint. 2' minimum, 4' maximum.
- ⑦ 10' minimum or equal to mainline shoulder width.
- ⑧ 'L-2' Joint.
- ⑨ 'C' Joint parallel to mainline pavement.
- ⑩ 'B' or 'C' Joint. 2' minimum, 4' maximum.
- ⑪ 'CD' Joints at 17' spacing.

MODIFIED	REVISION	
	3	04-20-21
ROAD DESIGN DETAIL		533-02
		SHEET 2 of 2
MODIFICATIONS: Added Point J and Ramp Profile note.		
PARALLEL ACCELERATION TAPER FOR 16' RAMP D (60 MPH DESIGN SPEED)		

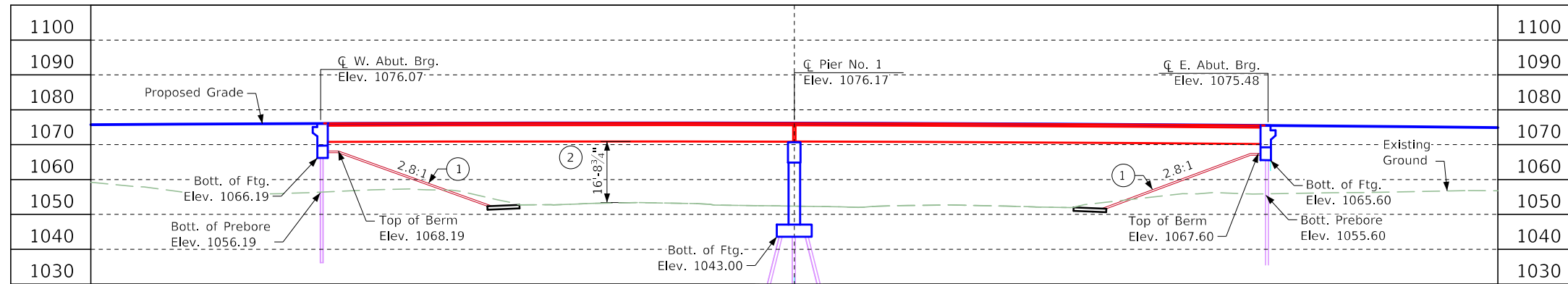

Section A - A (Longitudinal Section Along Centerline Approach Roadway)

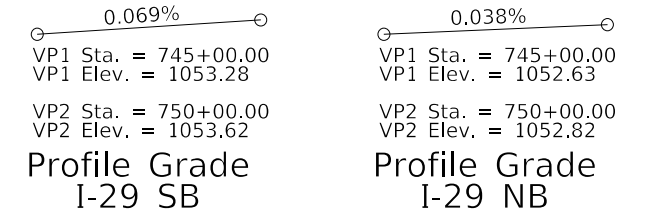
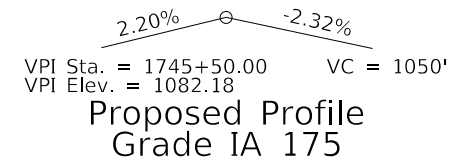

Minimum Vertical Clearance

S.B. I-29
 Overhead Station = 1745+19.16, 38.08' Lt.
 Overhead Elevation = 1075.56
 Depth of Superstructure = 5.38' (8.5" deck, 2" haunch, 4.5' beam)
 Underpass Station = 747+60.23, 0' Lt.
 Underpass Elevation 1053.46
 Minimum Vertical Clearance = 16.73'

N.B. I-29
 Overhead Station = 1746+46.91, 27.08' Rt.
 Overhead Elevation = 1075.35
 Depth of Superstructure = 5.38' (8.5" deck, 2" haunch, 4.5' beam)
 Underpass Station = 746+37.39, 0' Lt.
 Underpass Elevation 1052.68
 Minimum Vertical Clearance = 17.30'

Utilities Note:

Utilities shown on this sheet are for information only. See Road Design sheets for final utility information.

Utility Symbols:

- FO - Fiber Optic Line
- T1 - Telephone Line
- E2 - Electric Line

Location

IA 175 Over I-29
 T-83N R-45W
 Sections 6
 Franklin Township
 Monona County
 FHWA No. 036831
 Latitude 42.027171°
 Longitude -96.132711°

General Notes:

This design is for the replacement of the existing 244' x 30' Continuous I-Beam Bridge, Monona Design No. 4458, FHWA No. 036830, Maint. No. 6705.5S175.

Design Notes:

1. TSS TL-5 Bridge Railing Proposed
2. Pier type - frame pier - 4'-0" width assumed
3. Collision requirements shall be evaluated during final design
4. Bridge aesthetics to be incorporated during Final design
5. Non-Standard 3'-6" integral abutment width may be required
6. Non-Standard Abutment Wing Walls (NW & SE)
7. I-29 profile grades created using survey
8. 10' Multi-use path is the min. clear width
9. Final Design shall consider the need for temporary shoring to accommodate staging of bridge construction and include in the final plans as necessary.

Plan Notes:

2-Span Grading Shown (see EW 204 - 5' offset)
 Top of bridge deck at centerline roadway is 0.03' below the profile grade to account for parabolic crown.

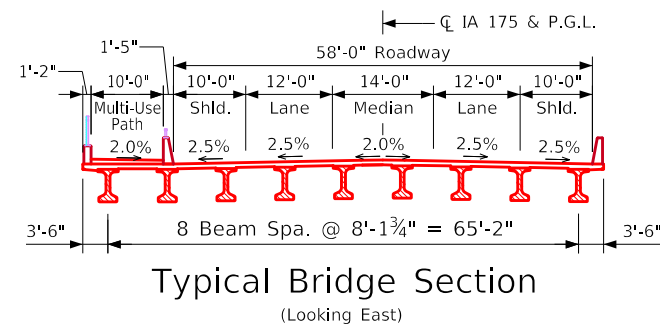

Typical Bridge Section (Looking East)

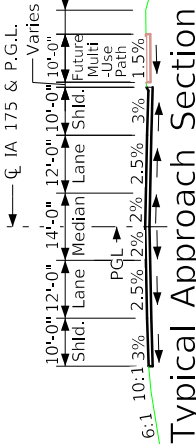

Typical Approach Section

IA 175 Traffic Est.

2026 AADT	3,700	V.P.D.
2046 AADT	4,600	V.P.D.
2056 AADT	5,200	V.P.D.
2046 DHV	480	V.P.H.
Trucks	16	%
Total Design ESALs	---	

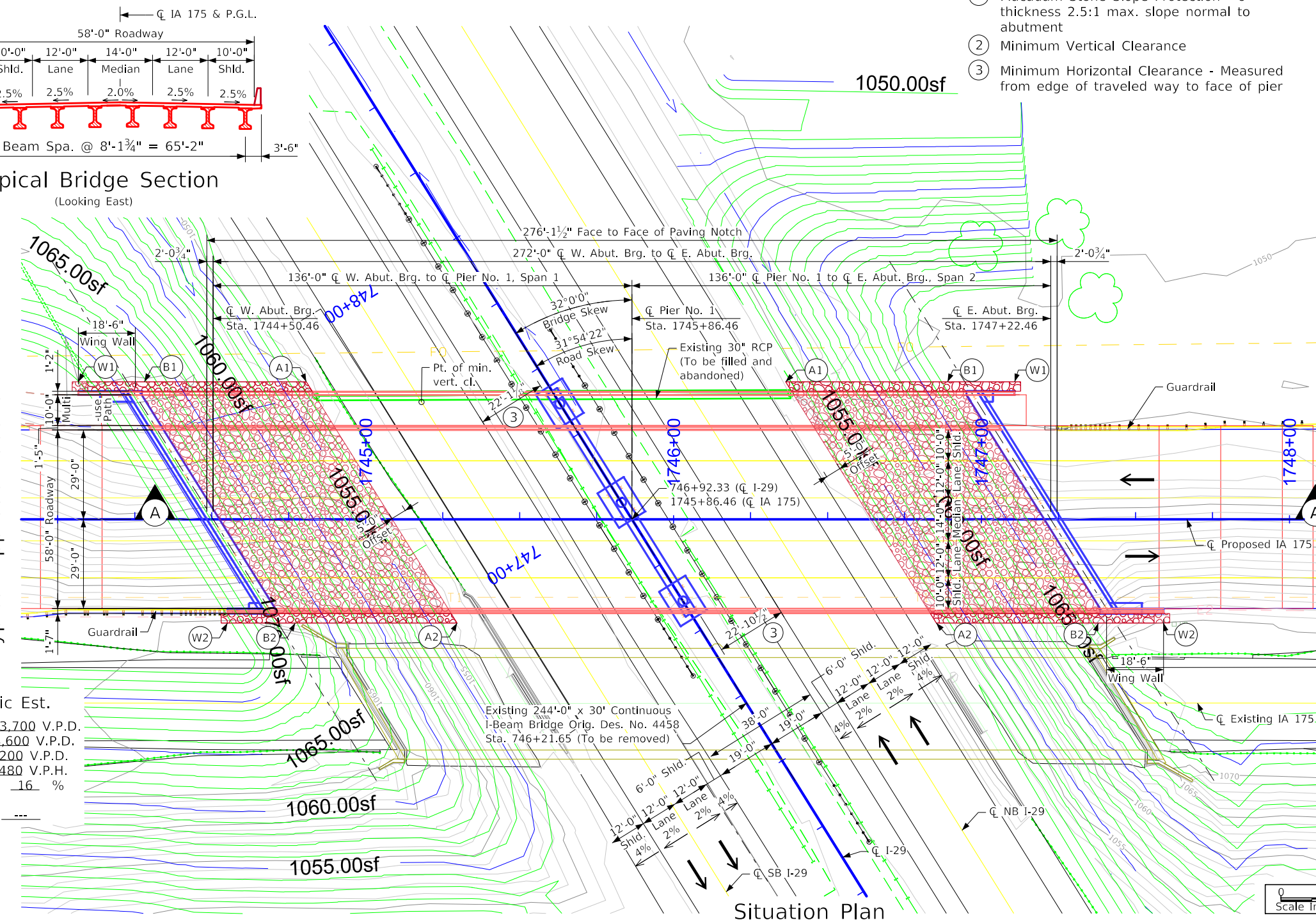

Situation Plan

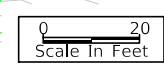

Preliminary

Design For 32° Skew (R.A.)

272'-0" x 58'-0" P.P.C.B. Bridge

w/ 10' Multi-Use Path

(BTD Beams)

Situation Plan

136'-0" End Spans

STA. 1745+86.46 (IA 175)

Turn-in Date: November 2023

Monona County

IOWA DEPARTMENT OF TRANSPORTATION

Design No. 0126 Design Sheet No. 1 of 2 FHWA No. 036831

Control Point: CP-1; N=7246812.81, E=16392085.34, Elev. 1047.76,
 CP FD 1/2" Rebar 20" Deep 1080' S. of IA 175 in Median of I-29

Berm Slope Location Table						
Points	West Abutment			East Abutment		
	Station	Offset	Elev.	Station	Offset	Elev.
A1	1744+80.96	44.58' LT.	1052.56	1746+36.45	44.58' LT.	1051.79
A2	1745+29.62	33.58' RT.	1052.49	1746+85.12	33.58' RT.	1051.75
B1	1744+28.20	44.58' LT.	1068.19	1746+89.00	44.58' LT.	1067.60
B2	1744+77.05	33.58' RT.	1068.19	1747+37.84	33.58' RT.	1067.60
W1	1744+06.70	44.58' LT.	1075.71	1747+10.70	44.58' LT.	1075.41
W2	1744+55.08	33.58' RT.	1075.28	1747+59.08	33.58' RT.	1074.35

Recoverable Berm Location Table						
Points	West Abutment			East Abutment		
	Station	Offset	Elev.	Station	Offset	Elev.
C1	1744+15.36	149.94' LT.	1052.64	1747+50.66	138.86' RT.	1051.70
C2	1743+85.75	184.26' LT.	1052.39	1747+80.27	173.18' RT.	1051.41
C3	1743+72.27	228.62' LT.	1052.90	1747+93.76	217.54' RT.	1051.87
B	1744+28.20	44.58' LT.	1068.19	1747+37.84	33.58' RT.	1067.60

Berm slope elevations reflect the grading surface.

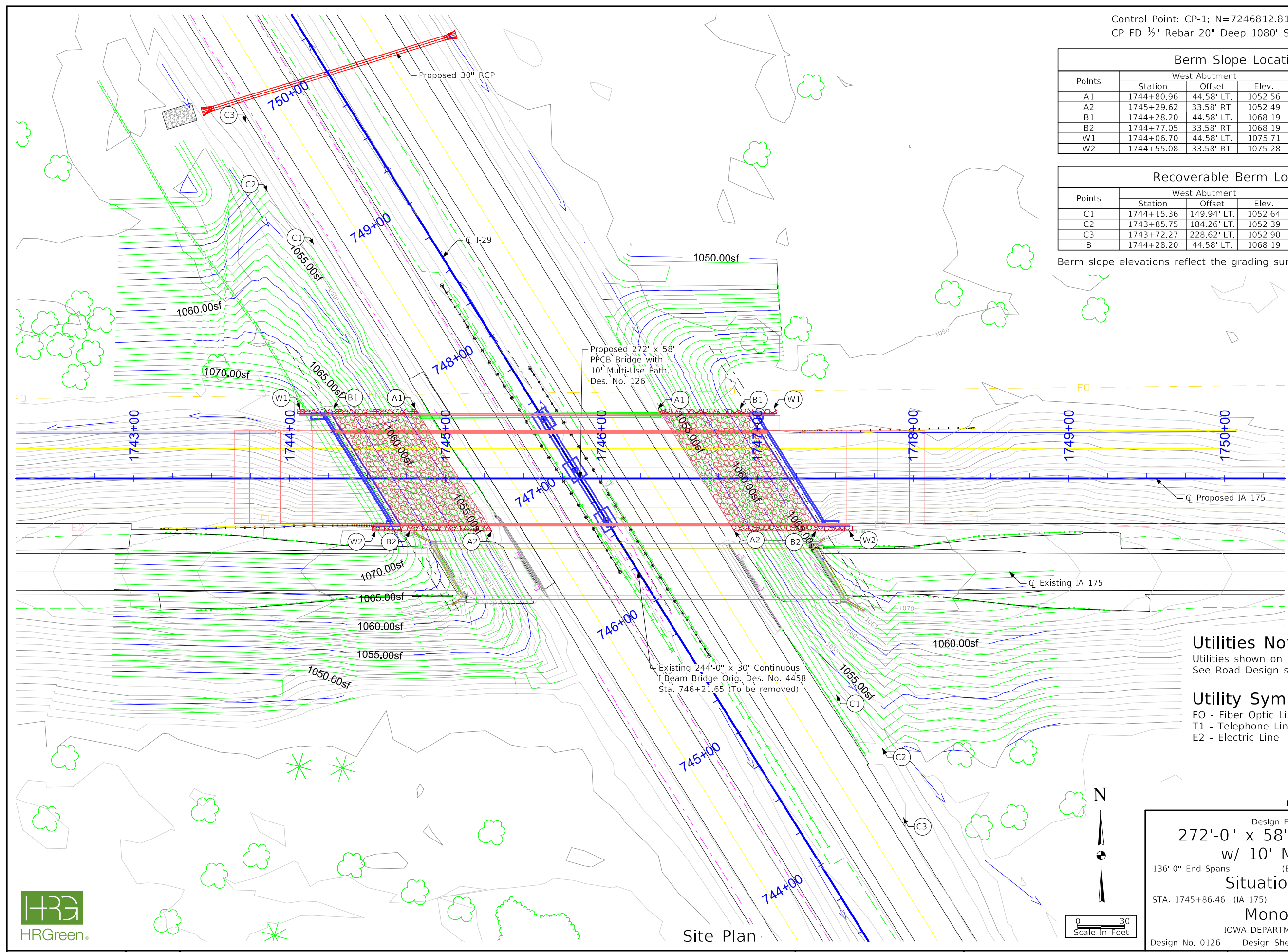

Utilities Note:
 Utilities shown on this sheet are for information only.
 See Road Design sheets for final utility information.

Utility Symbols:
 FO - Fiber Optic Line
 T1 - Telephone Line
 E2 - Electric Line

Preliminary

Design For 32° Skew (R.A.)
272'-0" x 58'-0" P.P.C.B. Bridge
 w/ 10' Multi-Use Path
 (BTD Beams)
Situation Plan - Site
 STA. 1745+86.46 (IA 175) Turn-In Date: November 2023
Monona County
 IOWA DEPARTMENT OF TRANSPORTATION
 Design No. 0126 Design Sheet No. 2 of 2 FHWA No. 036831



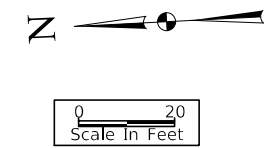
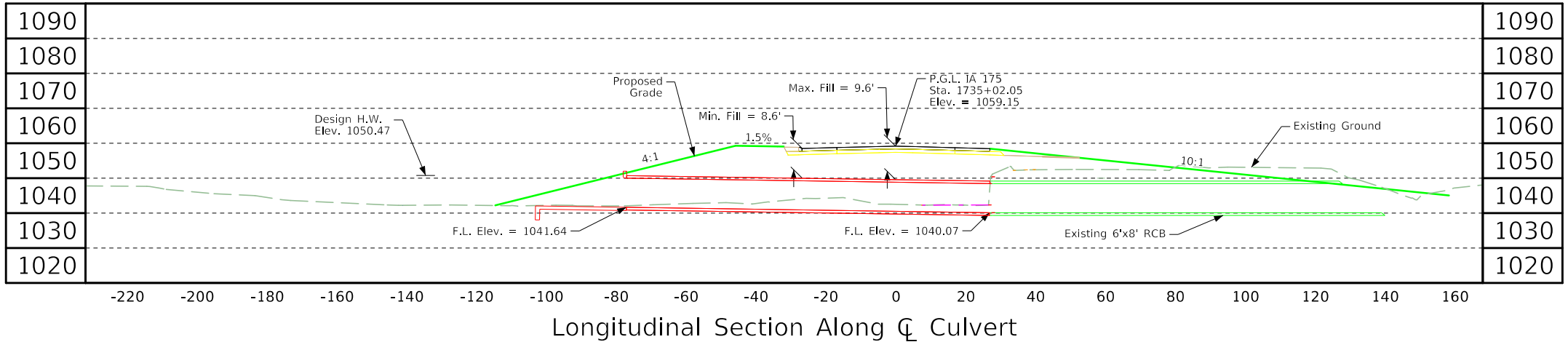

General Notes:
 This design is for the extension of the existing 6'x8'x102' box culvert with a 6'x8'x104' cast-in-place reinforced concrete box. Design No. 0226, Asset ID No. 900625.

Design Notes:
 1. Design Fill - 10'
 2. Fill height increased on existing RCB.

Longitudinal Section Along Centerline of Culvert

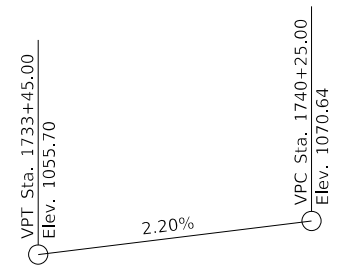

Proposed Profile Grade IA 175

Location
 IA 175 over Ditch
 T-83N R-45W
 Section 1
 Franklin Township
 Monona County
 Asset ID No. 900625
 Latitude 42.027323°
 Longitude -96.136702°

Hydraulic Data
 Drainage Area = 734.7 Acres
 Design Discharge = 213.24 CFS
 HW Elev. = 1050.47
 Exit Velocity = 4.26 FPS
 Stream Slope = 4.74 Ft./Mi.

IA 175 Traffic Est.

2023 AADT	3,700	V.P.D.
2046 AADT	4,600	V.P.D.
2046 DHV	480	V.P.H.
Trucks	16	%
Total Design ESALs		

Curve Data (IA 175)
 PI Sta. 1731+76.60
 Δ = 7°14'52.80" (RT)
 T = 578.21
 L = 1154.88
 E = 18.29
 R = 9130.00'
 PC Sta. 1725+98.39
 PT Sta. 1737+53.27

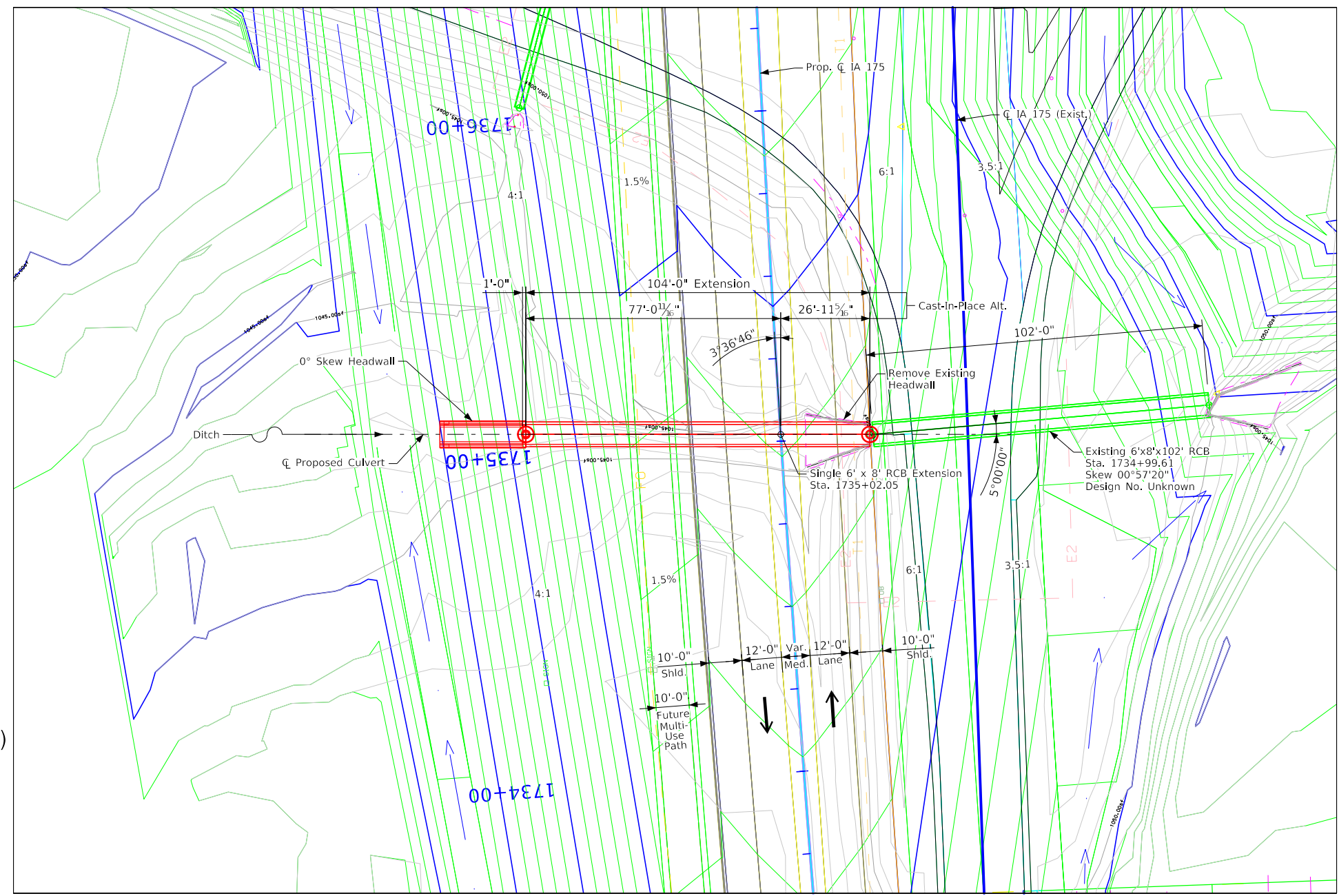

Situation Plan

Hydraulic Design

I hereby certify that this engineering document was prepared by me or under my direct personal supervision and that I am a duly licensed Professional Engineer under the laws of the State of Iowa.

Signature: Jason A. Lastovica Date: 12-21-23
 Printed or Typed Name: Jason A. Lastovica
 My license renewal date is December 31, 2024

Pages or sheets covered by this seal: Sheets V.3 - V.4

Design History At This Site

Des. No.	Type of Work
Unknown	Original Design, 6'x8'x102' RCB
226	RCB Ext. 6'x8'x104'

Utilities Note:
 Utilities shown on this sheet are for information only. See Road Design sheets for utility information.

General Utility Symbols:
 FO - Fiber Optic Line - Unknown
 T1 - Telephone Line - Unknown
 E2 - Electric Line - Unknown

Preliminary

Design For 3°36'46" Skew (L.A.)
**Single 6'-0" x 8'-0" C.I.P
 Concrete Box Culvert Extension**

Situation Plan
 STA. 1735+02.05 (IA 175) Turn-In Date: December 2023
Monona County
 IOWA DEPARTMENT OF TRANSPORTATION
 Design No. 0226 Design Sheet No. 1 of 2 ASSET 900625



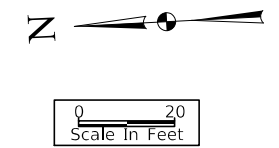
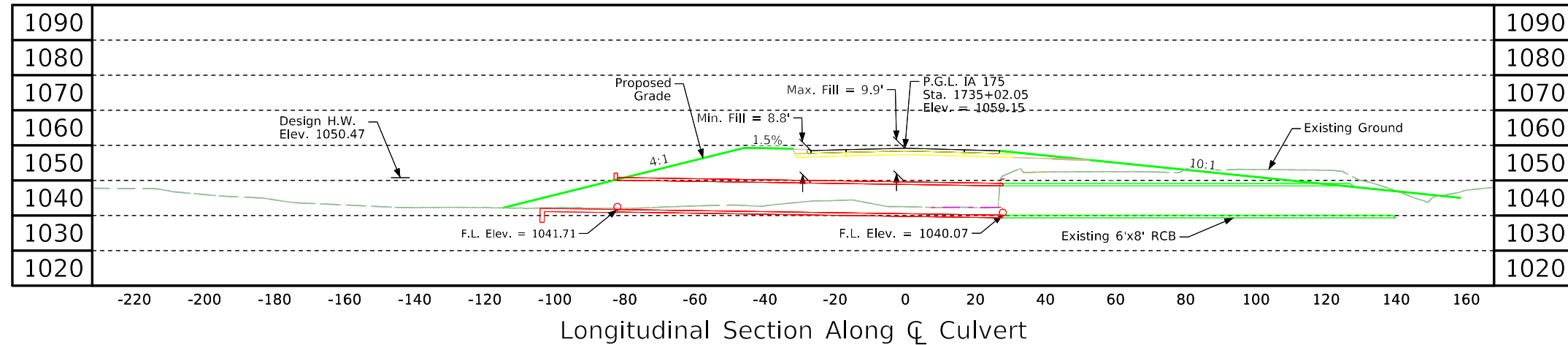

General Notes:
 This design is for the extension of the existing 6'x8'x102' box culvert with a 6'x8'x110'-6" precast reinforced concrete box. Design No. 0226, Asset ID No. 900625.

Design Notes:
 1. Design Fill - 10'
 2. Fill height increased on existing RCB.

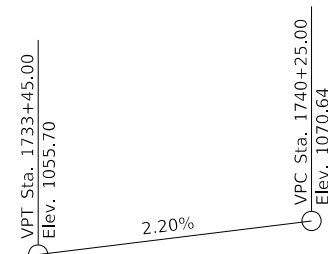

Proposed Profile Grade IA 175

Location
 IA 175 over Ditch
 T-83N R-45W
 Section 1
 Franklin Township
 Monona County
 Asset ID No. 900625
 Latitude 42.027323°
 Longitude -96.136702°

Hydraulic Data
 Drainage Area = 734.7 Acres
 Design Discharge = 213.24 CFS
 HW Elev. = 1050.47
 Exit Velocity = 4.26 FPS
 Stream Slope = 4.74 Ft./Mi.

IA 175 Traffic Est.

2023 AADT	3,700	V.P.D.
2046 AADT	4,600	V.P.D.
2046 DHV	480	V.P.H.
Trucks	16	%
Total Design ESALs		

Curve Data (IA 175)
 PI Sta. 1731+76.60
 Δ = 7°14'52.80" (RT)
 T = 578.21
 L = 1154.88
 E = 18.29
 R = 9130.00'
 PC Sta. 1725+98.39
 PT Sta. 1737+53.27

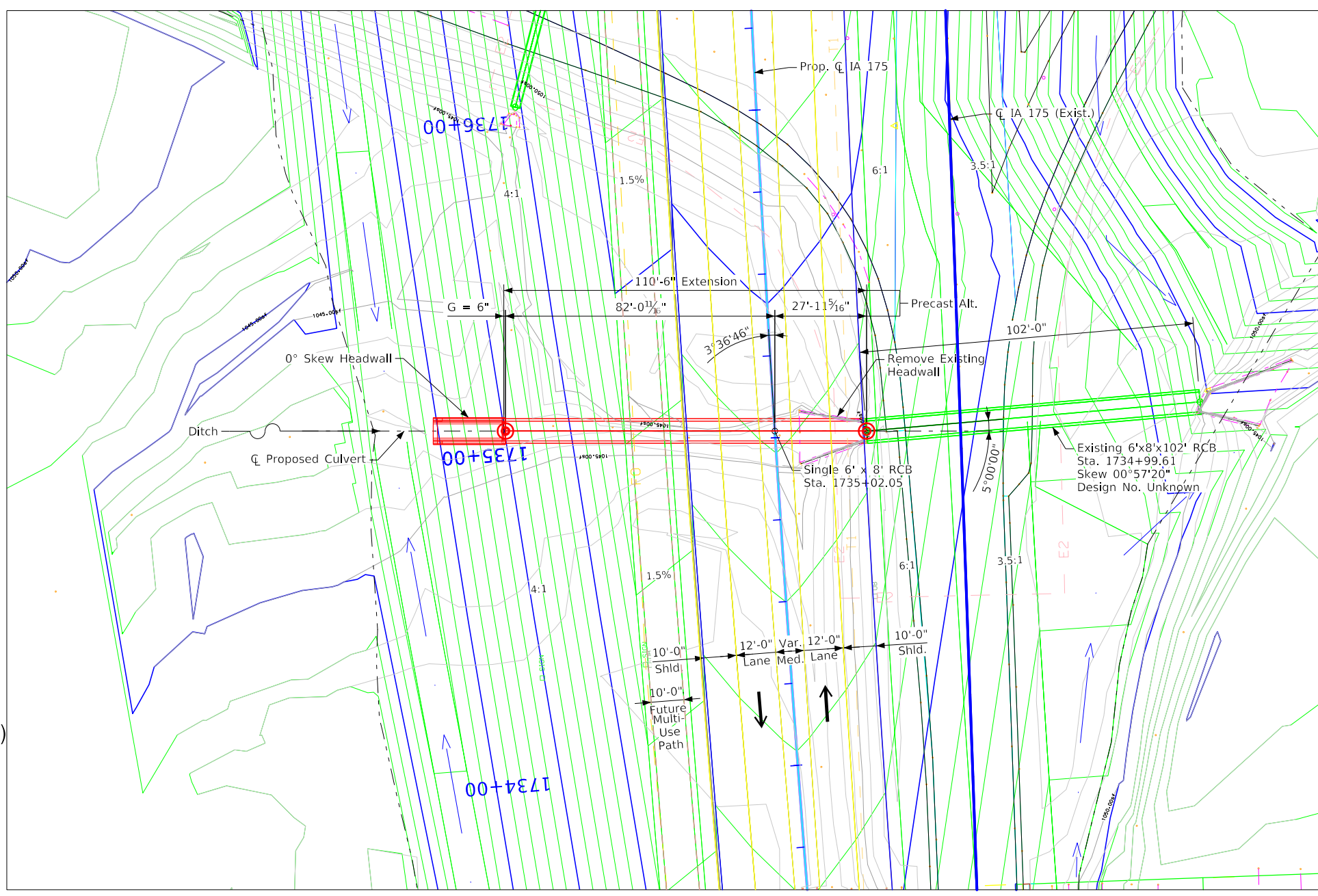

Situation Plan

Design History At This Site

Des. No.	Type of Work
Unknown	Original Design, 6'x8'x102' RCB
226	RCB Ext. 6'x8'x110'-6"

Utilities Note:
 Utilities shown on this sheet are for information only. See Road Design sheets for utility information.

General Utility Symbols:
 FO - Fiber Optic Line - Unknown
 T1 - Telephone Line - Unknown
 E2 - Electric Line - Unknown

Preliminary

Design For 3°36'46" Skew (L.A.)
Single 6'-0" x 8'-0" Precast Concrete Box Culvert Extension

Situation Plan
 STA. 1735+02.05 (IA 175) Turn-In Date: December 2023
Monona County
 IOWA DEPARTMENT OF TRANSPORTATION
 Design No. 0226 Design Sheet No. 2 of 2 ASSET 900625



Location

I-29 / IA 175 Ramp B
over Ditch
T-83N R-45W
Section 6
Franklin Township
Monona County
Asset ID No. 900630
Latitude 42.025275°
Longitude -96.130265°

Curve Data

I-29 / IA 175 Ramp B
PI Sta. 2535+95.66 (RT)
Δ = 18°02'31.67"
T = 289.76
L = 574.70
E = 22.92
R = 1820.00'
PC Sta. 2533+05.90
PT Sta. 2538+80.60

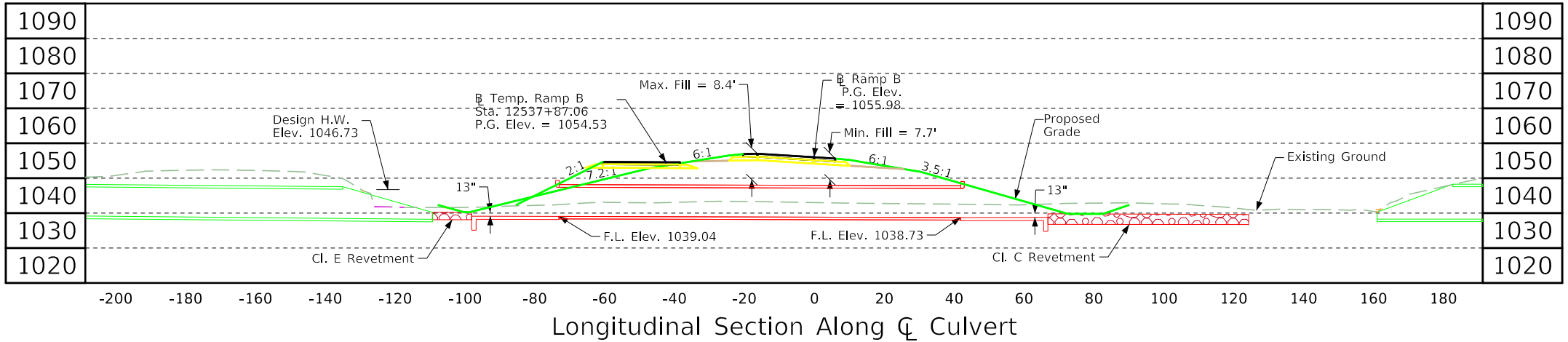

General Notes:
This design is for new Single 8'x8'x115' Cast-In-Place RCB, Monona Design No. 0326, Asset ID No. 900630.

Design Notes:
1. Design Fill - 9'
2. Revetment is proposed at the culvert inlet due to proximity to existing culvert and at the outlet due to the outlet velocity exceeding policy limits.
3. Inlet revetment grading assumes adjacent existing box culvert under I-29 outlet lowered to Elev. 1040.75. Excavation quantity to be included in final design.

Plan Notes:
Flow Line of the culvert has been set 13" below streambed.

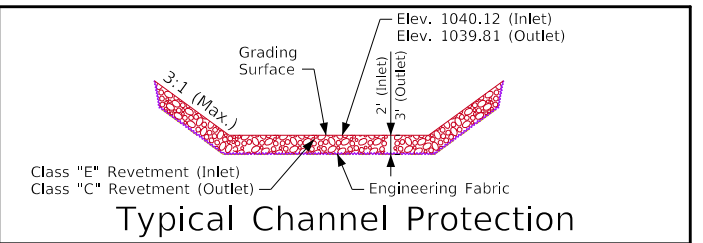
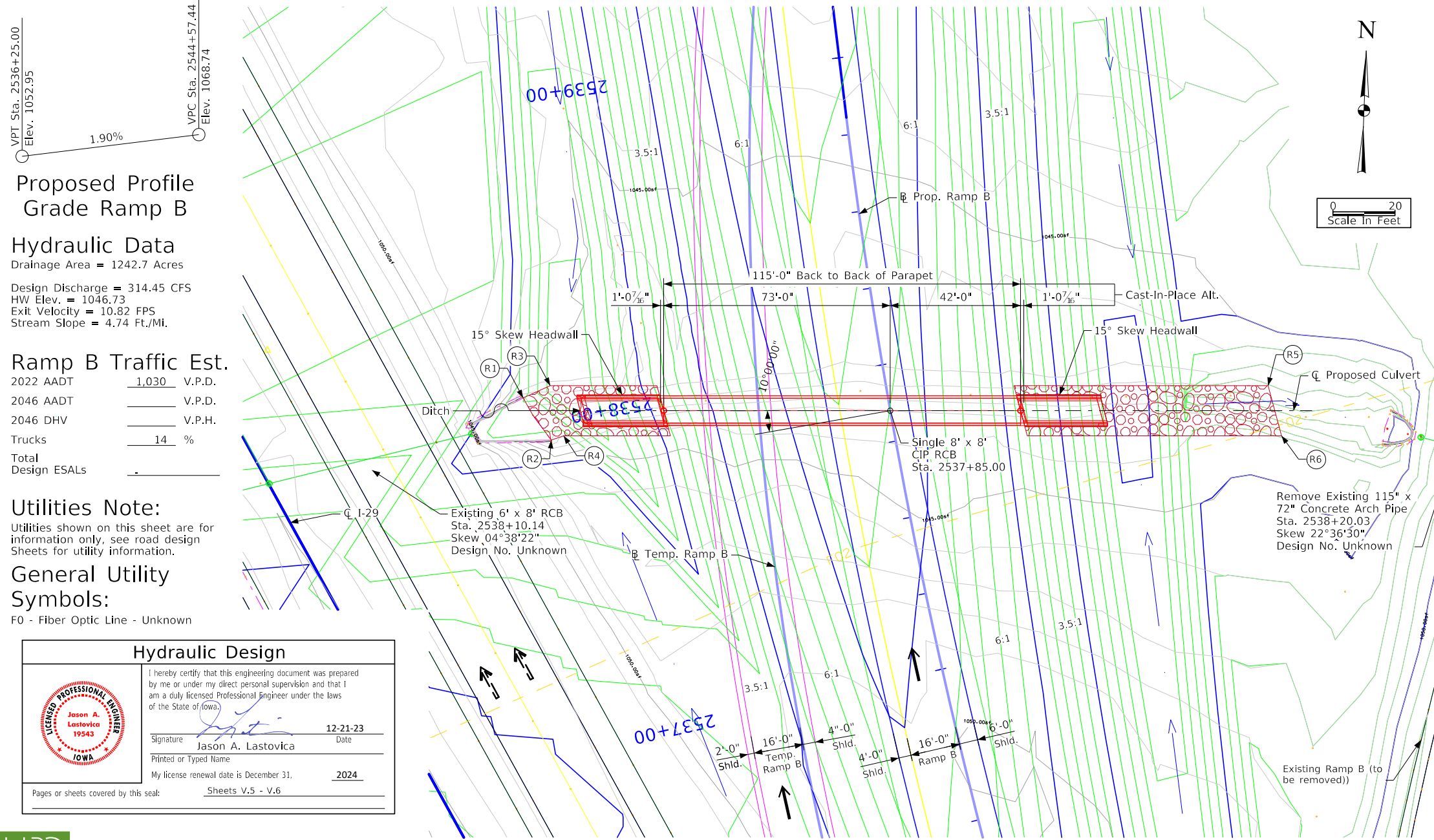

Estimated Revetment Quantities				
Location	Revetment CL. "C" (Ton)	Revetment CL. "E" (Ton)	Engineering Fabric (SY)	Excavation CL. 10 (CY)
Inlet	-	50.4	64.0	31.5
Outlet	186.6	-	170.1	116.6
Totals	186.6	50.4	234.1	148.1

Excavation quantity calculated from grading surface. Excavation quantity is for embedded revetment core out only, and does not include excavation to the grading surface. Excavation quantity to the grading surface is determined by Road Design and included in the Road Plans.

- Revetment Layout:**
- (R1) 2538+08.14, 115.96' LT., Revetment Limits, Elev. 1040.75
 - (R2) 2537+94.05, 109.24' LT., Revetment Limits, Elev. 1040.75
 - (R3) 2538+09.83, 105.50' LT., Revetment Limits, Elev. 1040.31
 - (R4) 2537+95.48, 104.34' LT., Revetment Limits, Elev. 1040.31
 - (R5) 2537+70.88, 121.25' RT., Revetment Limits, Elev. 1040.47
 - (R6) 2537+52.99, 122.50' RT., Revetment Limits, Elev. 1040.47

Design History At This Site	
Des. No.	Type of Work
326	Original Design, 8'x8'x115' RCB

Design For 10° Skew (L.A.)
Single 8'-0" x 8'-0" x 115'-0"
Cast-In-Place Concrete Box Culvert
Situation Plan
STA. 2537+85.00 (Ramp B) Turn-In Date: December 2023
Monona County
IOWA DEPARTMENT OF TRANSPORTATION
Design No. 0326 Design Sheet No. 1 of 2 ASSET 900630

Proposed Profile Grade Ramp B

Hydraulic Data

Drainage Area = 1242.7 Acres
Design Discharge = 314.45 CFS
HW Elev. = 1046.73
Exit Velocity = 10.82 FPS
Stream Slope = 4.74 Ft./MI.

Ramp B Traffic Est.

2022 AADT	1,030	V.P.D.
2046 AADT		V.P.D.
2046 DHV		V.P.H.
Trucks	14	%
Total Design ESALS		

Utilities Note:

Utilities shown on this sheet are for information only, see road design sheets for utility information.

General Utility Symbols:

F0 - Fiber Optic Line - Unknown

Hydraulic Design

I hereby certify that this engineering document was prepared by me or under my direct personal supervision and that I am a duly licensed Professional Engineer under the laws of the State of Iowa.

Signature: *Jason A. Lastovica* Date: 12-21-23
Printed or Typed Name: Jason A. Lastovica
My license renewal date is December 31, 2024

Pages or sheets covered by this seal: Sheets V.5 - V.6



Location

I-29 / IA 175 Ramp B over Ditch
 T-83N R-45W
 Section 6
 Franklin Township
 Monona County
 Asset ID No. 900630
 Latitude 42.025275°
 Longitude -96.130265°

Curve Data

I-29 / IA 175 Ramp B
 PI Sta. 2535+95.66 (RT)
 $\Delta = 18^{\circ}02'31.67''$
 T = 289.76
 L = 574.70
 E = 22.92
 R = 1820.00'
 PC Sta. 2533+05.90
 PT Sta. 2538+80.60

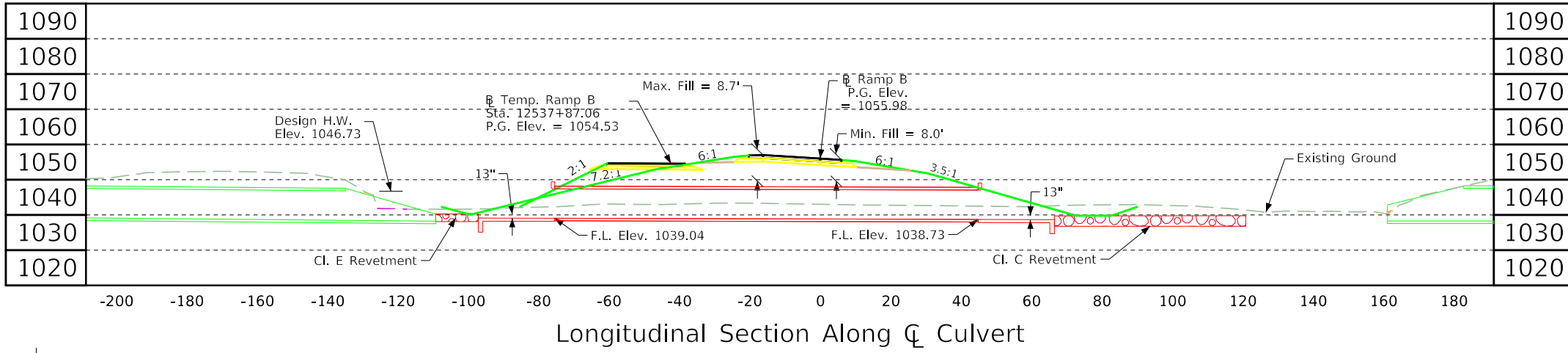

General Notes:
 This design is for new Single 8'x8'x120'-4³/₈" Precast RCB, Monona Design No. 0326, Asset ID No. 900630.

Design Notes:
 1. Design Fill - 9'
 2. Revetment is proposed at the culvert inlet due to proximity to existing culvert and at the outlet due to the outlet velocity exceeding policy limits.
 3. Inlet revetment grading assumes adjacent existing box culvert under I-29 outlet lowered to Elev. 1040.75. Excavation quantity to be included in final design.

Plan Notes:
 Flow Line of the culvert has been set 13" below streambed.

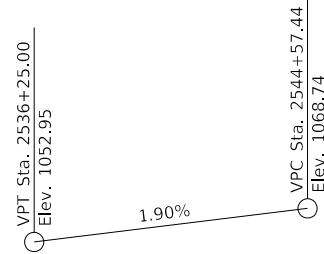

Hydraulic Data

Drainage Area = 1242.7 Acres
 Design Discharge = 314.45 CFS
 HW Elev. = 1046.73
 Exit Velocity = 10.82 FPS
 Stream Slope = 4.74 Ft./Mi.

Ramp B Traffic Est.

2022 AADT	1,030	V.P.D.
2046 AADT		V.P.D.
2046 DHV		V.P.H.
Trucks	14	%
Total Design ESALS		

Utilities Note:

Utilities shown on this sheet are for information only, see road design sheets for utility information.

General Utility Symbols:

F0 - Fiber Optic Line - Unknown

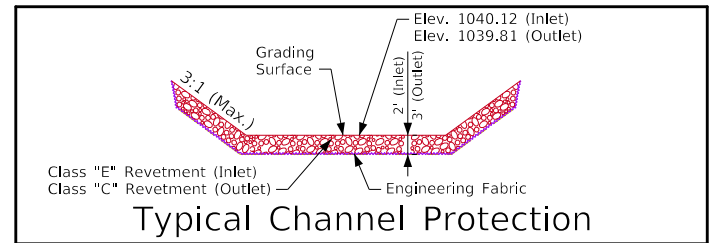
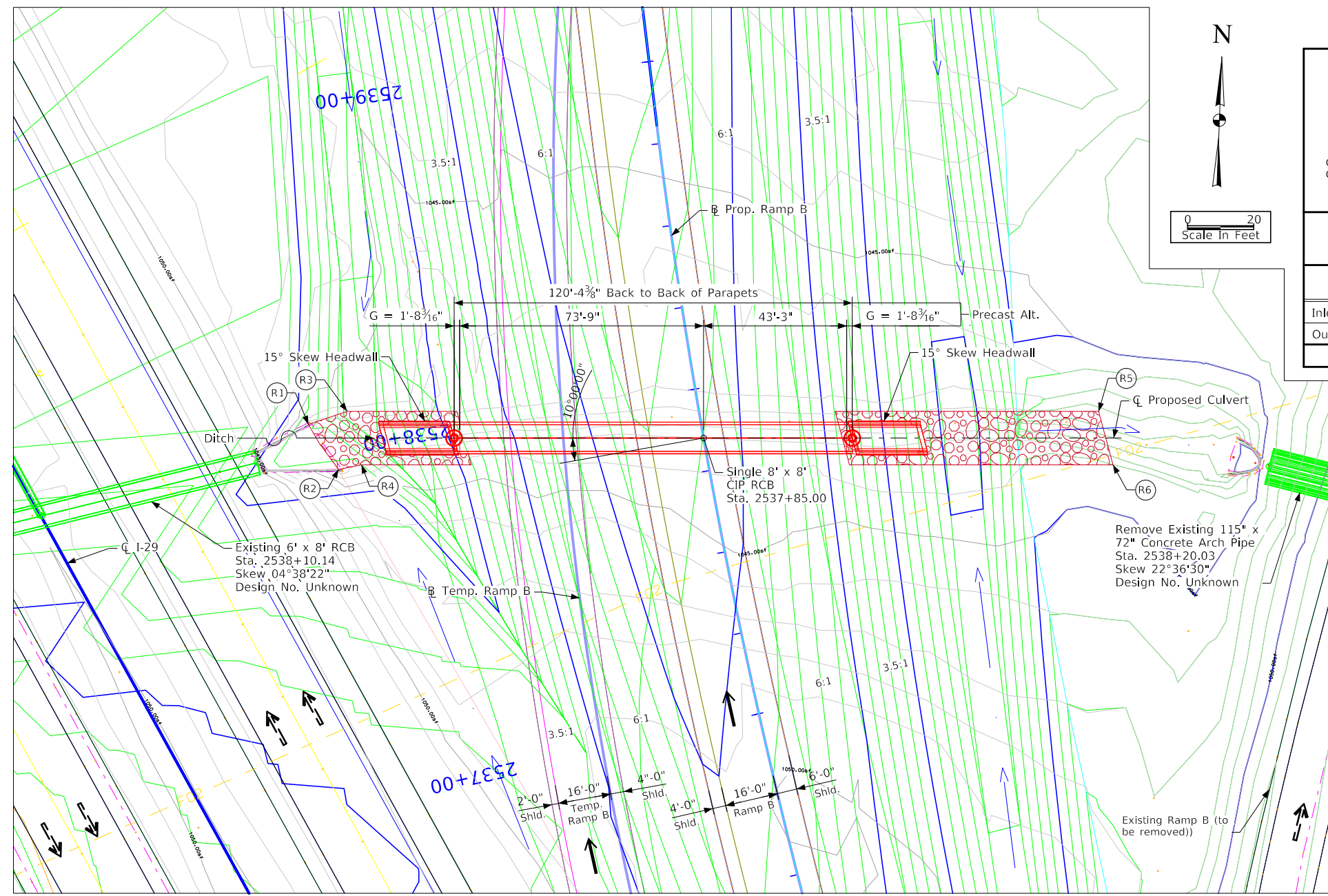

Estimated Revetment Quantities

Location	Revetment CL. "C" (Ton)	Revetment CL. "E" (Ton)	Engineering Fabric (SY)	Excavation CL. 10 (CY)
Inlet	-	56.5	72.2	35.3
Outlet	189.8	-	206.3	118.6
Totals	189.8	56.5	278.5	153.9

Excavation quantity calculated from grading surface. Excavation quantity is for embedded revetment core out only, and does not include excavation to the grading surface. Excavation quantity to the grading surface is determined by Road Design and included in the Road Plans.

- Revetment Layout:**
- (R1) 2538+08.14, 115.96' LT., Revetment Limits, Elev. 1040.75
 - (R2) 2537+94.05, 109.24' LT., Revetment Limits, Elev. 1040.75
 - (R3) 2538+09.83, 105.50' LT., Revetment Limits, Elev. 1040.31
 - (R4) 2537+95.48, 104.34' LT., Revetment Limits, Elev. 1040.31
 - (R5) 2537+71.33, 118.97' RT., Revetment Limits, Elev. 1040.47
 - (R6) 2537+53.46, 120.23' RT., Revetment Limits, Elev. 1040.47

Design History At This Site

Des. No.	Type of Work
326	Original Design, 8'x8'x120'-4 ³ / ₈ " RCB

Preliminary

Design For 10° Skew (L.A.)
Single 8'-0" x 8'-0" x 120'-4³/₈" Precast Concrete Box Culvert
Situation Plan
 STA. 2537+85.00 (Ramp B) Turn-In Date: December 2023
Monona County
 IOWA DEPARTMENT OF TRANSPORTATION
 Design No. 0326 Design Sheet No. 2 of 2 ASSET 900630



Location

I-29 / IA 175 Ramp C
 over Ditch
 T-83N R-45W
 Section 7
 Franklin Township
 Monona County
 Asset ID No. 900635
 Latitude 42.025065°
 Longitude -96.131753°

Curve Data

I-29 / IA 175 Ramp C
 PI Sta. 3535+95.02 (LT)
 $\Delta = 25^{\circ}05'20.40''$
 T = 445.02
 L = 875.77
 E = 48.91
 R = 2000.00'
 PC Sta. 3531+50.00
 PT Sta. 3540+25.77

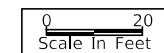
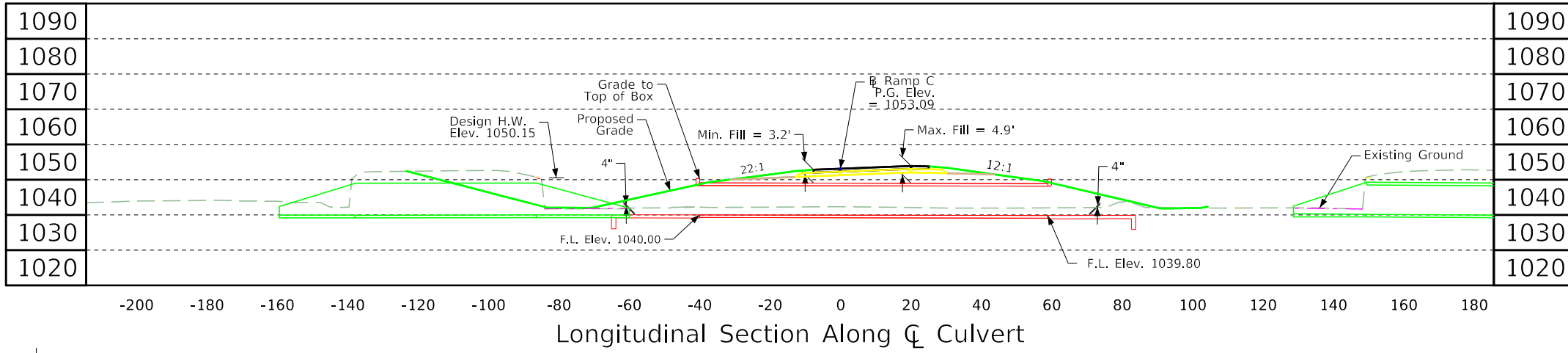

General Notes:
 This design is for new Single 8'x8'x99' cast-in-place reinforced concrete box. Design No. 0426, Asset ID No. 900635.

Design Notes:
 1. Design Fill - 5'
 2. Erosion Control Blanket is proposed at the culvert outlet. See roadway erosion control plans for details.
 3. RCB length controlled by clear zone.

Plan Notes:
 Flow Line of the culvert has been set 4" below streambed.

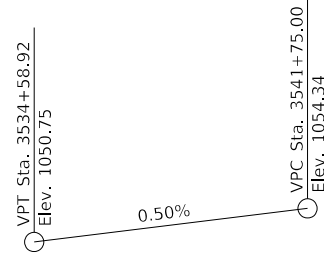

Proposed Profile Grade Ramp C

Hydraulic Data

Drainage Area = 1226.5 Acres
 Design Discharge = 311.41 CFS
 HW Elev. = 1050.15
 Exit Velocity = 5.08 FPS
 Stream Slope = 4.74 Ft./Mi.

Ramp C Traffic Est.

2022 AADT	950	V.P.D.
2046 AADT		V.P.D.
2046 DHV		V.P.H.
Trucks	13	%
Total Design ESALS		

Utilities Note:

Utilities shown on this sheet are for information only, see road design Sheets for utility information.

General Utility Symbols:

F0 - Fiber Optic Line - Unknown

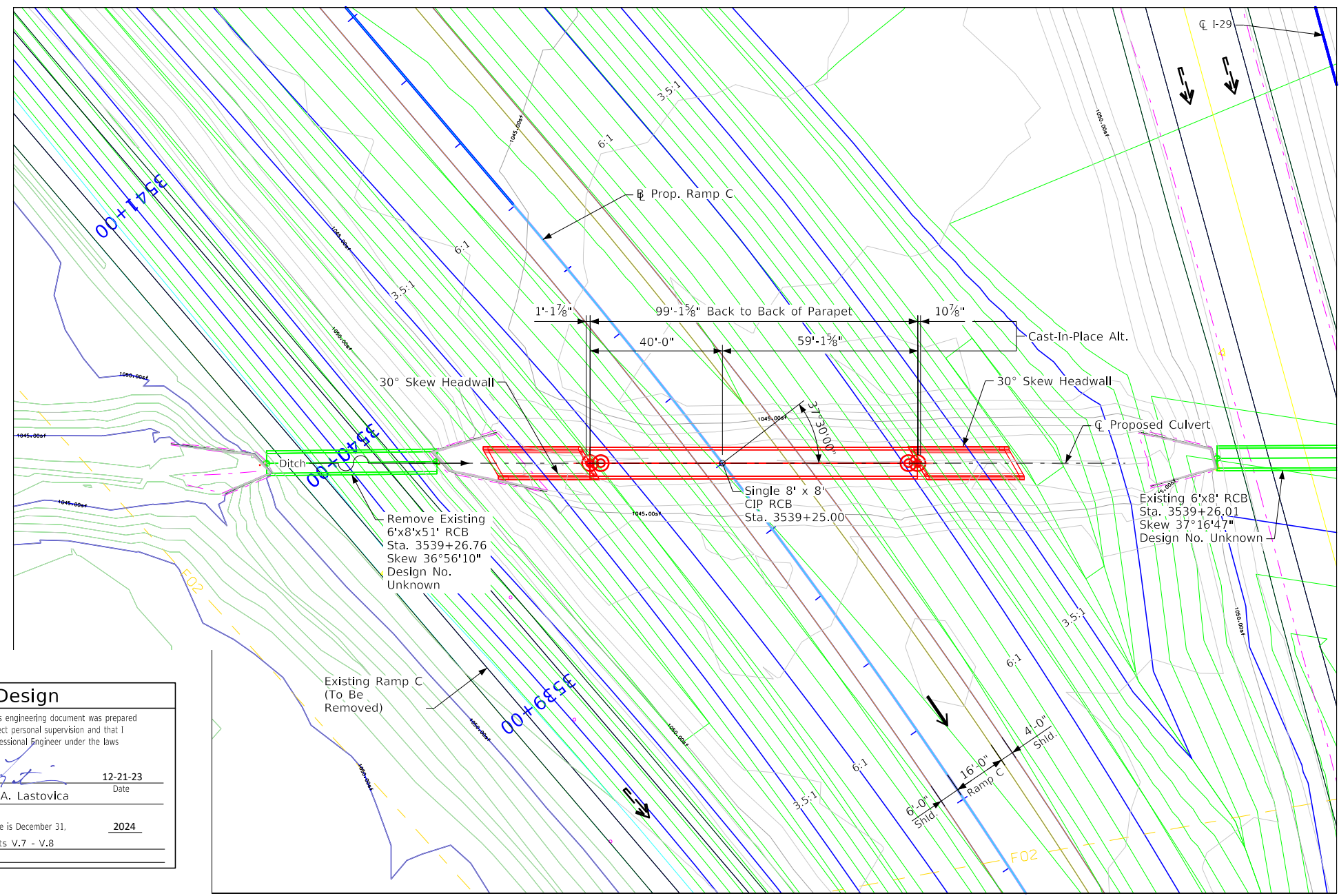

Situation Plan

Design History At This Site	
Des. No.	Type of Work
426	Original Design, 8'x8'x99' RCB

Hydraulic Design

I hereby certify that this engineering document was prepared by me or under my direct personal supervision and that I am a duly licensed Professional Engineer under the laws of the State of Iowa.

Signature: *Jason A. Lastovica* Date: 12-21-23
 Printed or Typed Name: Jason A. Lastovica
 My license renewal date is December 31, 2024

Pages or sheets covered by this seal: Sheets V.7 - V.8

Preliminary

Design For 37°30'00" Skew (L.A.)
Single 8'-0" x 8'-0" x 99'-0"
Cast-In-Place Concrete Box Culvert

Situation Plan
 STA. 3539+25.00 (Ramp C) Turn-In Date: December 2023
Monona County
 IOWA DEPARTMENT OF TRANSPORTATION
 Design No. 0426 Design Sheet No. 1 of 2 ASSET 900635

Location

I-29 / IA 175 Ramp C
 over Ditch
 T-83N R-45W
 Section 7
 Franklin Township
 Monona County
 Asset ID No. 900635
 Latitude 42.025065°
 Longitude -96.131753°

Curve Data

I-29 / IA 175 Ramp C
 PI Sta. 3535+95.02 (LT)
 $\Delta = 25^{\circ}05'20.40''$
 T = 445.02
 L = 875.77
 E = 48.91
 R = 2000.00'
 PC Sta. 3531+50.00
 PT Sta. 3540+25.77

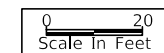
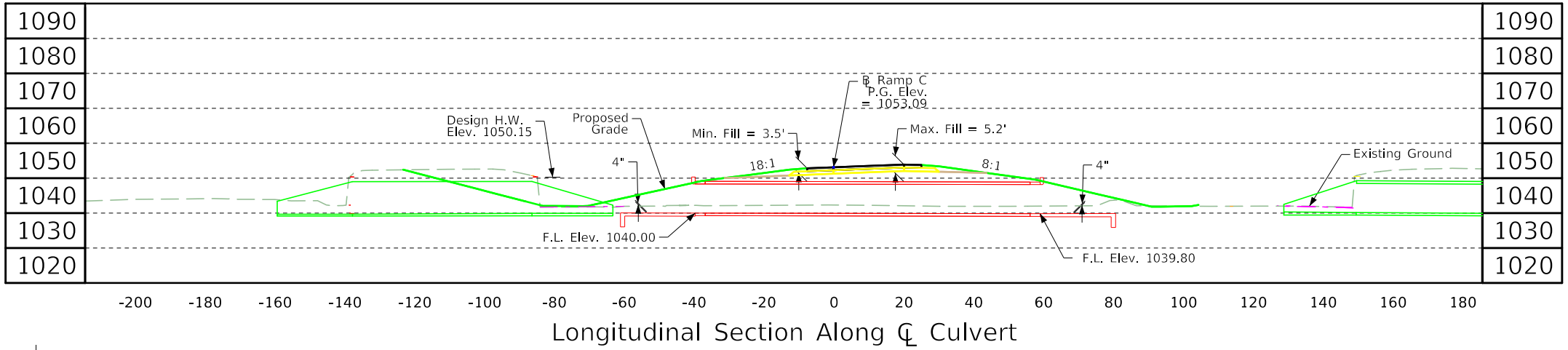

General Notes:
 This design is for new Single 8'x8'x98'-9 1/4" precast reinforced concrete box. Design No. 0426, Asset ID No. 900635.

- Design Notes:**
1. Design Fill - 5'
 2. Erosion Control Blanket is proposed at the culvert outlet. See roadway erosion control plans for details.
 3. RCB length controlled by clear zone.

Plan Notes:
 Flow Line of the culvert has been set 4" below streambed.

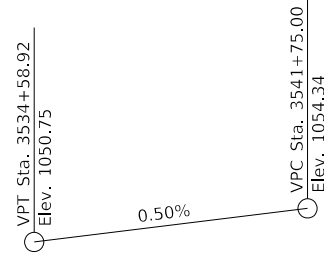

Proposed Profile Grade Ramp C

Hydraulic Data

Drainage Area = 1242.7 Acres
 Design Discharge = 314.45 CFS
 HW Elev. = 1046.73
 Exit Velocity = 5.08 FPS
 Stream Slope = 4.74 Ft./MI.

Ramp C Traffic Est.

2022 AADT	950	V.P.D.
2046 AADT		V.P.D.
2046 DHV		V.P.H.
Trucks	13	%
Total Design ESALS		

Utilities Note:

Utilities shown on this sheet are for information only, see road design Sheets for utility information.

General Utility Symbols:

F0 - Fiber Optic Line - Unknown

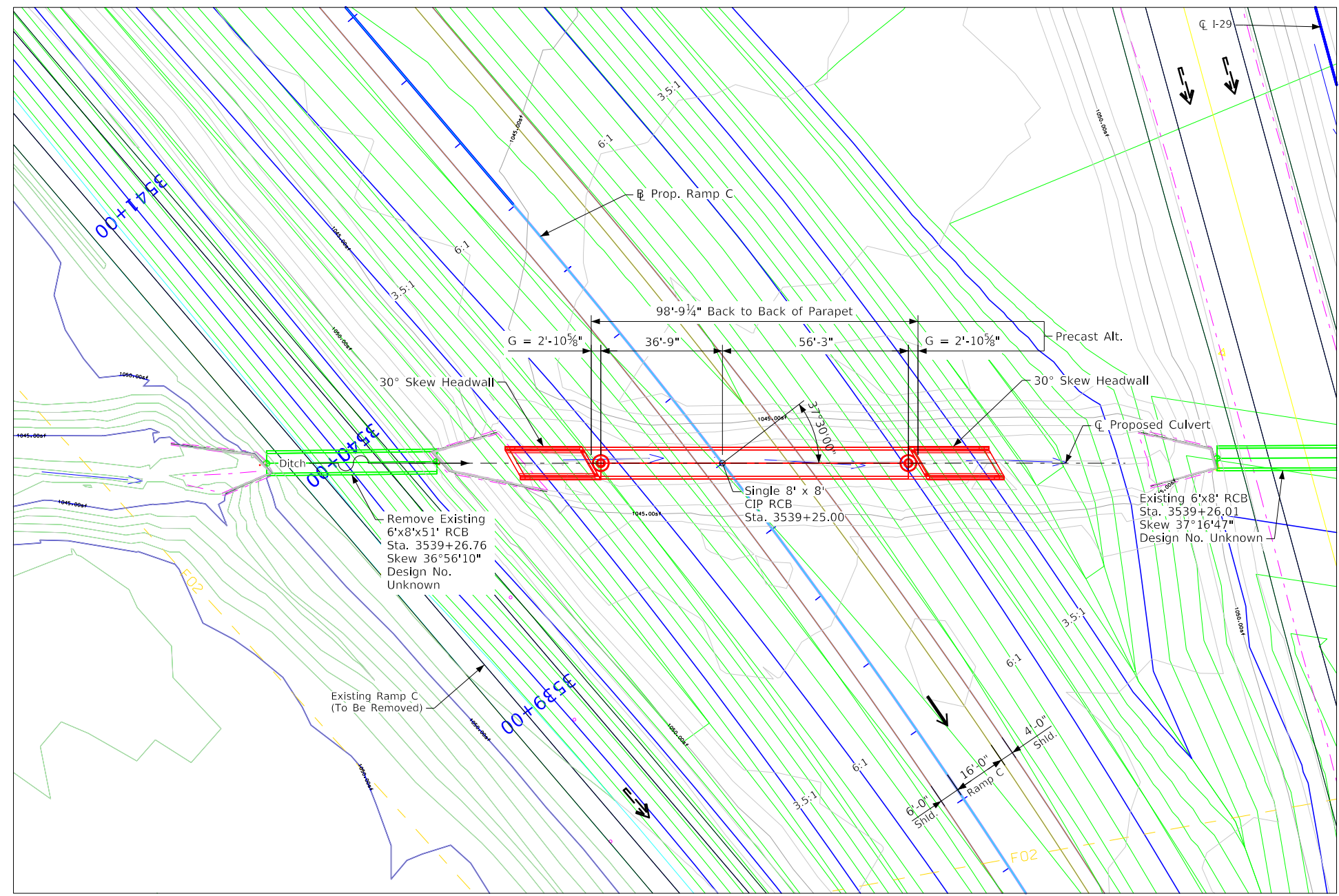

Situation Plan

Design History At This Site	
Des. No.	Type of Work
426	Original Design, 8'x8'x98'-9 1/4" RCB

Preliminary

Design For 37°30'00" Skew (L.A.)

Single 8'-0" x 8'-0" x 98'-9 1/4" Precast Concrete Box Culvert

Situation Plan

STA. 3539+25.00 (Ramp C) Turn-In Date: December 2023

Monona County

IOWA DEPARTMENT OF TRANSPORTATION

Design No. 0426 Design Sheet No. 2 of 2 ASSET 900635



CROSS SECTION VIEW COLOR LEGEND

Design Color No.	Feature	Design Color No.	Feature
Aggregate			
(64)	Choke Stone	(112)	Noise Wall
(42)	Engineering Fabric	(112)	Noise Wall Footing
(8)	Flooded Backfill	(112)	Retaining Wall Back
(92)	Macadam Stone	(112)	Retaining Wall Back Excavate
(20)	Modified	(112)	Retaining Wall Face
(12)	Plowing Shaping	(112)	Retaining Wall Front Excavate
(14)	Porous Backfill	(112)	Retaining Wall Front Footing
(8)	Revetment Class A	(112)	Retaining Wall MSE Gutter
(6)	Revetment Class B	(112)	Retaining Wall Reinforced Earth
(62)	Revetment Class C		
(188)	Revetment Class D	Grading	
(28)	Revetment Class E	(8)	Behind Curb Cut
(12)	Shoulder Special Backfill	(6)	Granular
(12)	Special Backfill	(13)	Granular Back Fill
(20)	Subbase	(48)	Rock Undercut
(20)	Subbase Lower	(8)	Shoulder Earth Fill
(20)	Subbase Upper	(2)	Side Slopes
(118)	Subgrade Treatment	(226)	Side Slopes Dressing
Asphalt			
(207)	HMA Base Course	Substrata	
(207)	HMA Interim Course	(128)	Boulder Substrata
(207)	HMA Surface Course	(48)	Broken Weathered Substrata
Concrete			
(0)	Barrier Concrete	(3)	Core Out Substrata
(0)	Barrier Concrete Footing	(203)	Existing Pavement Substrata
(0)	Curb Gutter	(6)	Loam Substrata
(48)	Flowable Mortar	(80)	Rock Substrata
(0)	Median Concrete	(4)	Select Sand Substrata
(0)	PCC Pavement	(3)	Shale Substrata
(0)	Sidewalk	(10)	Topsoil Substrata
Shoulder			
(209)	Shoulder HMA	Unsuitable / Waste	
(0)	Shoulder PCC	(3)	Unsuitable Type A
(6)	Shoulder Granular	(13)	Unsuitable Type B
Existing			
(0)	Existing Pavement	(11)	Unsuitable Type C
		(3)	Waste

CROSS SECTIONS LEGEND AND INFORMATION SHEET

(COVERS SHEET SERIES W, X, Y, & Z)

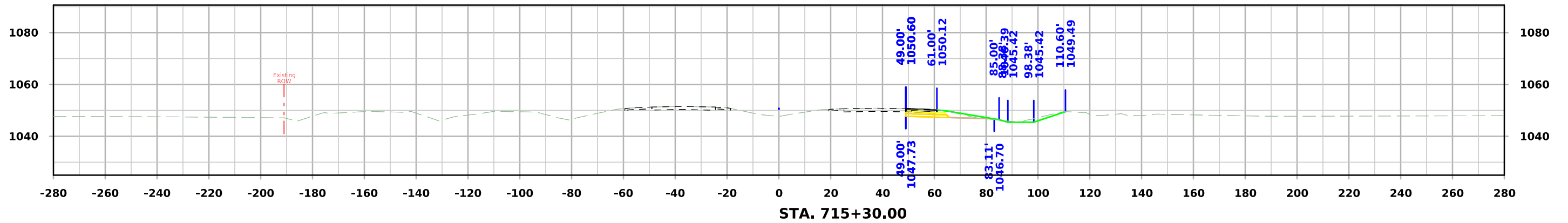
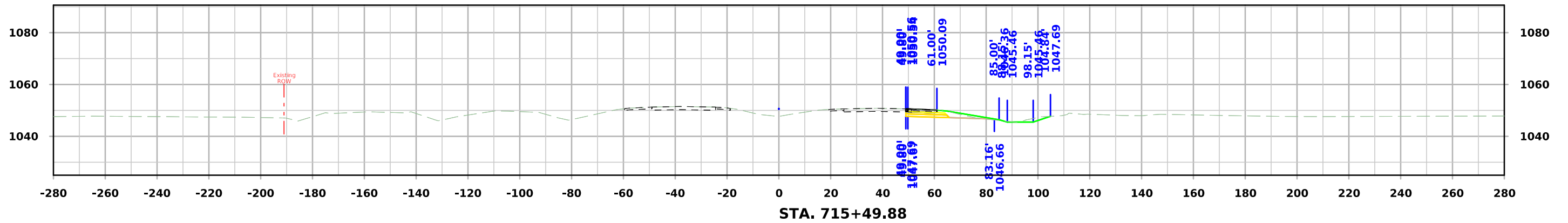
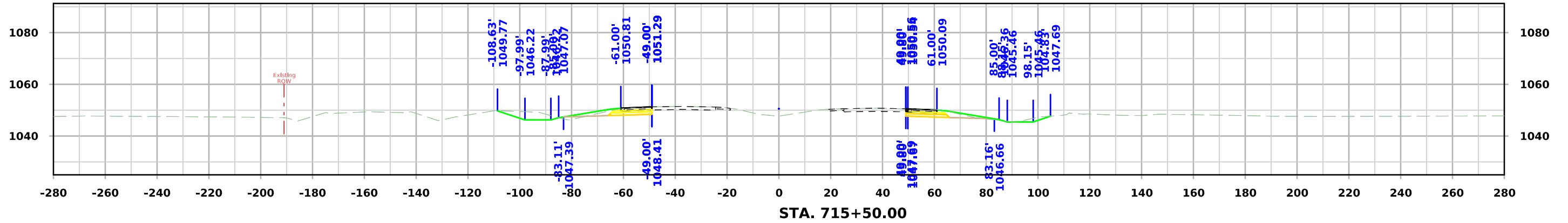

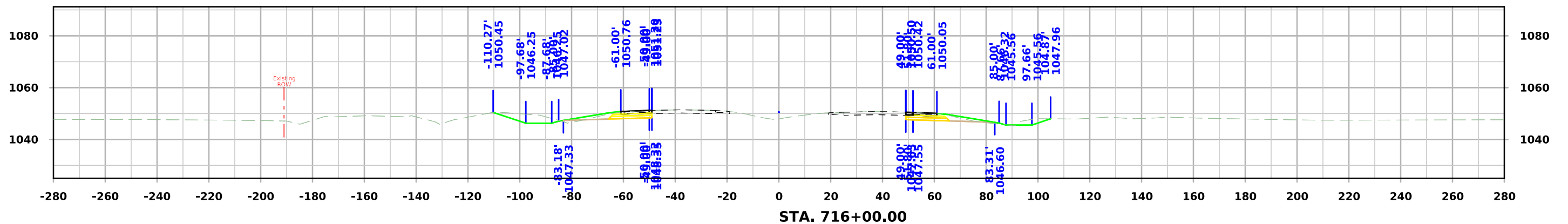
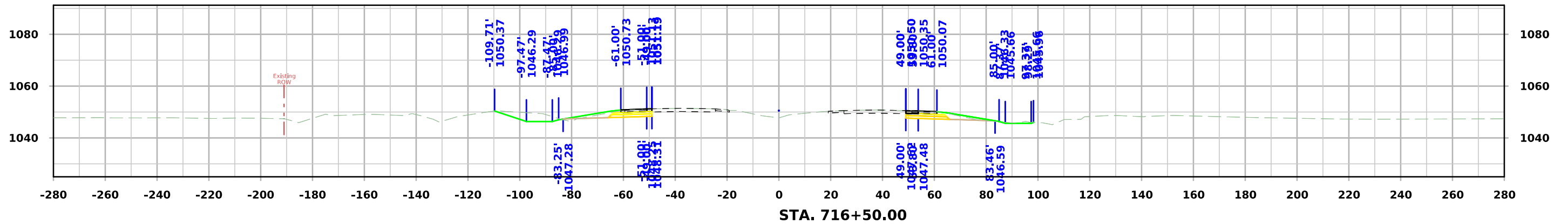
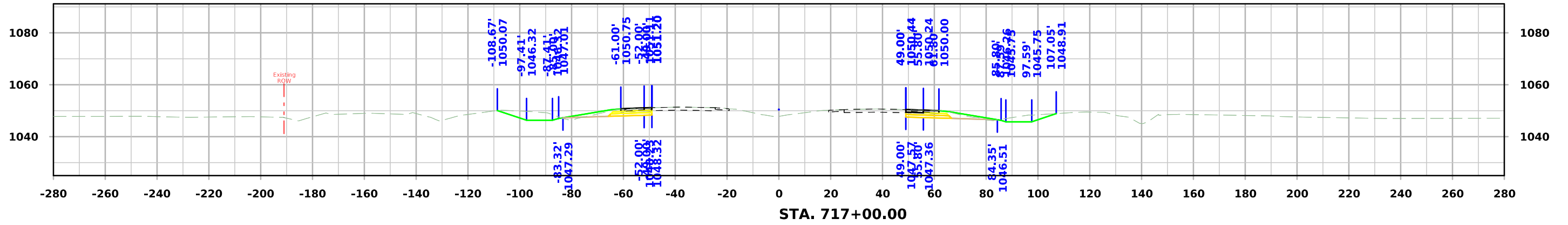

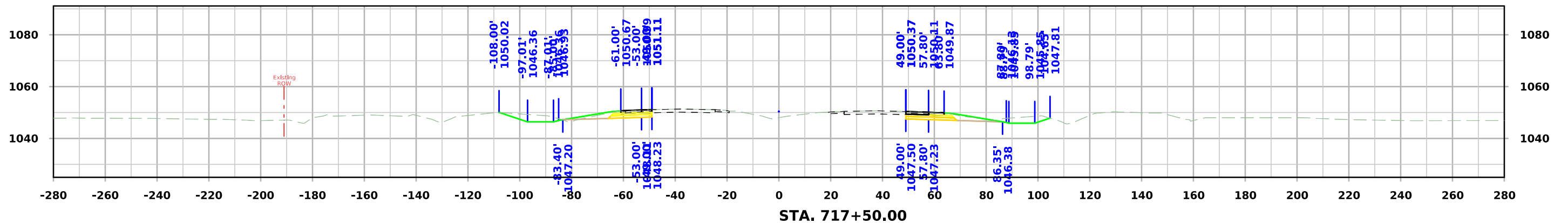
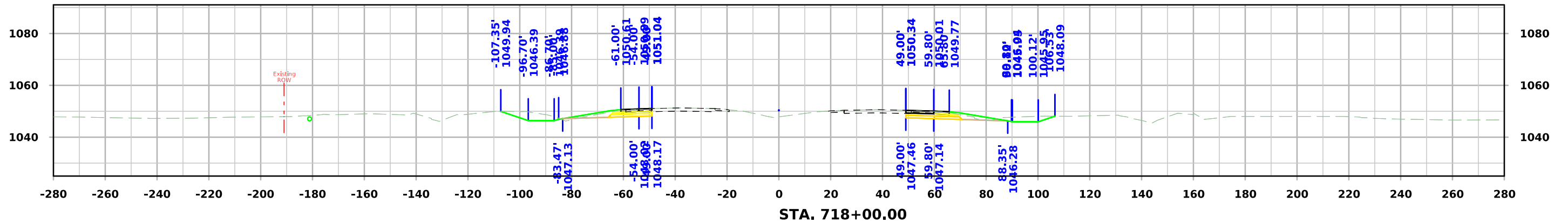
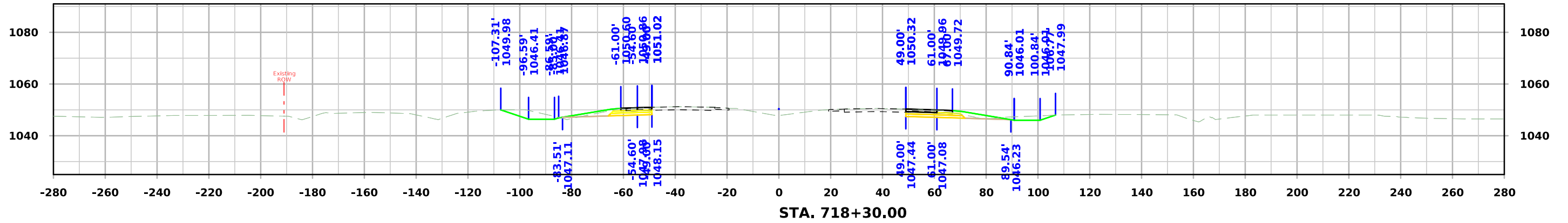

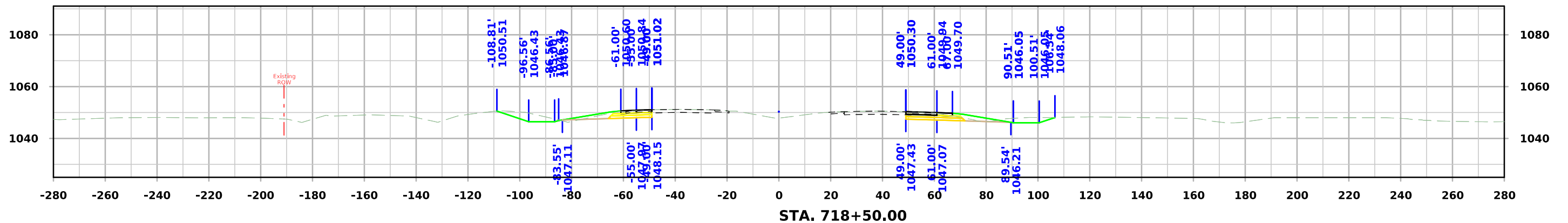
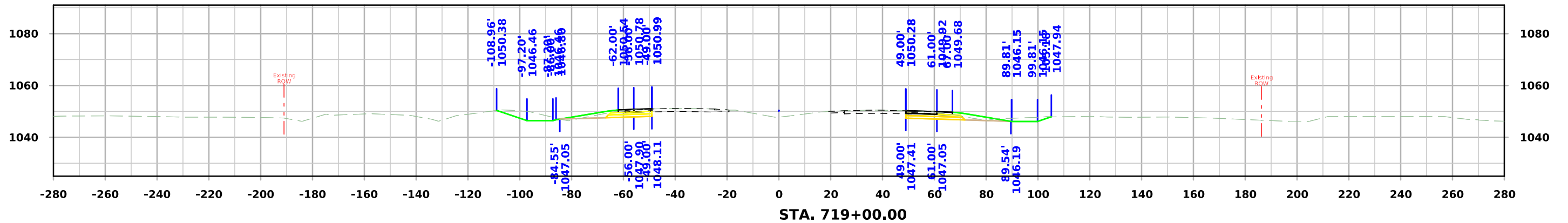
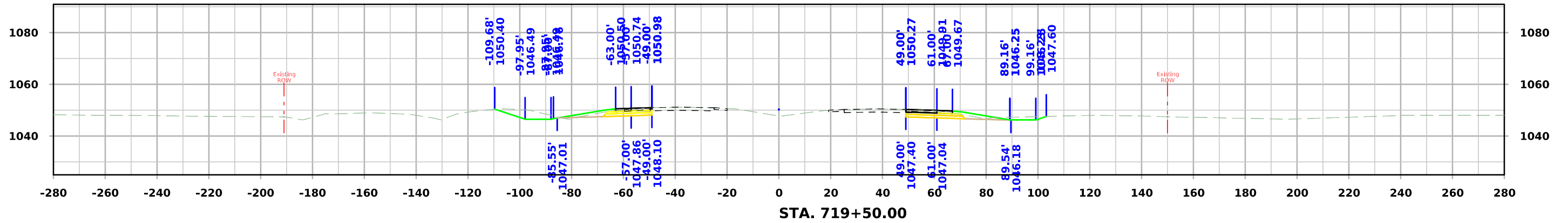

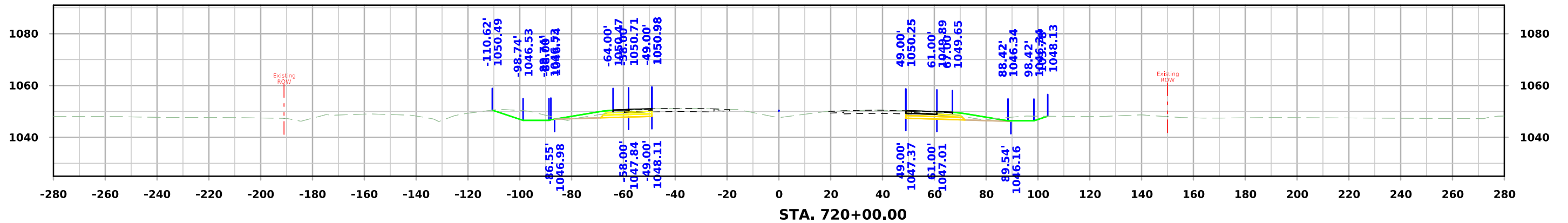
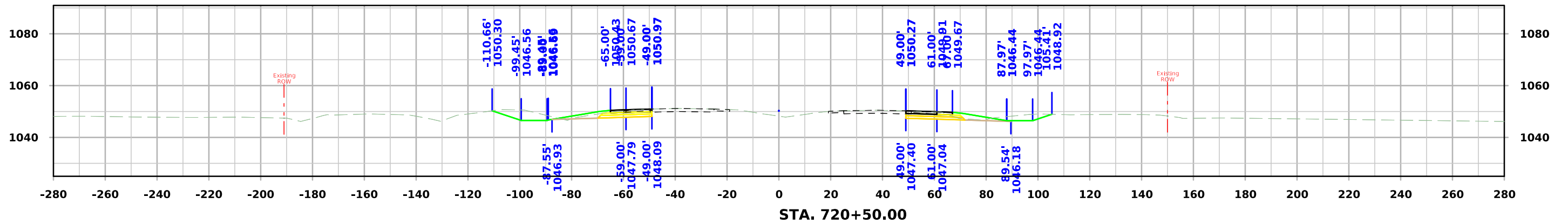
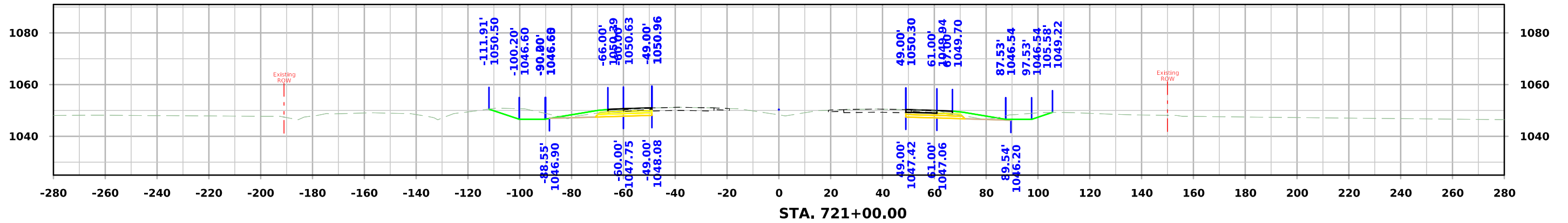

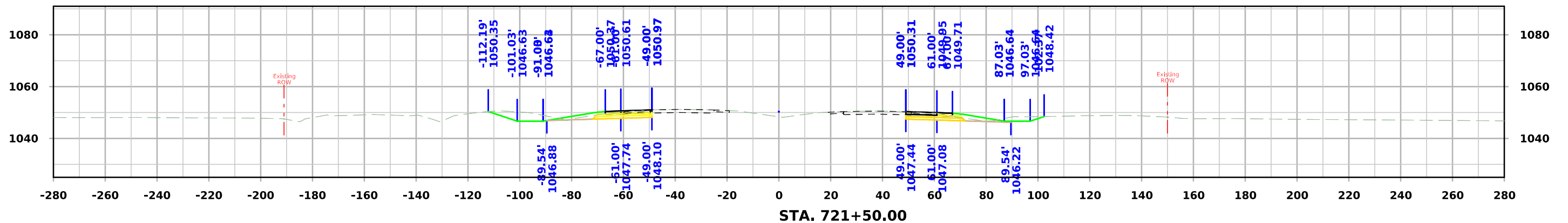
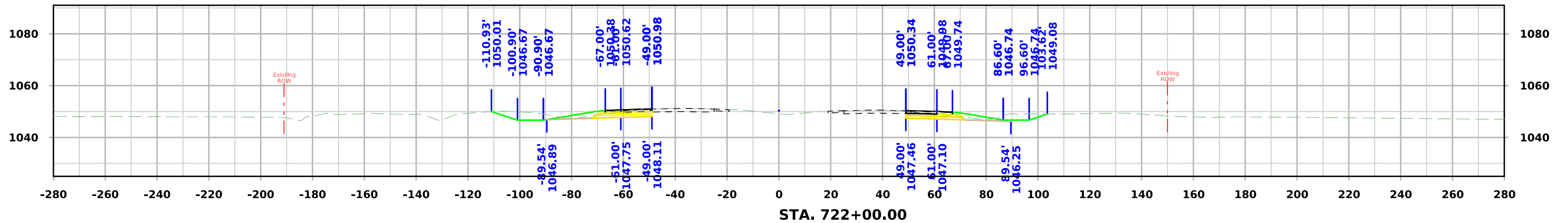
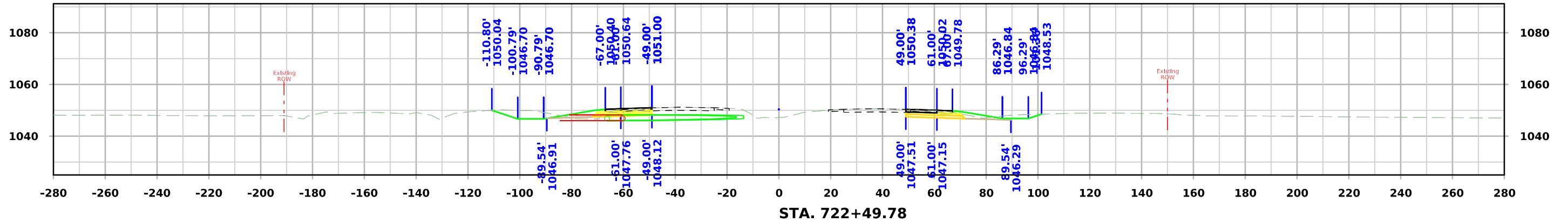

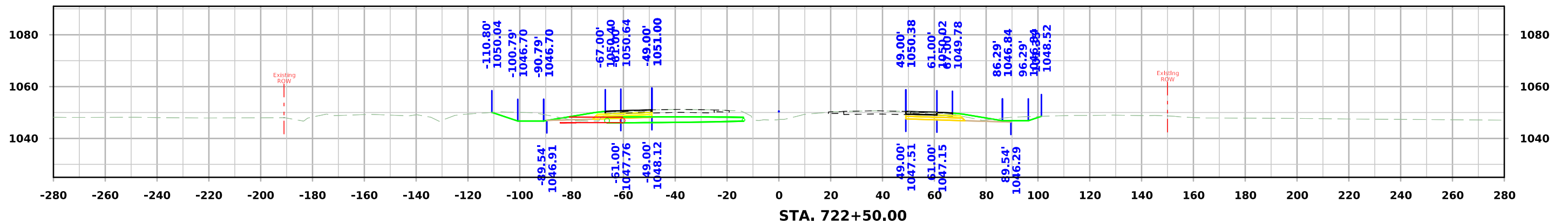
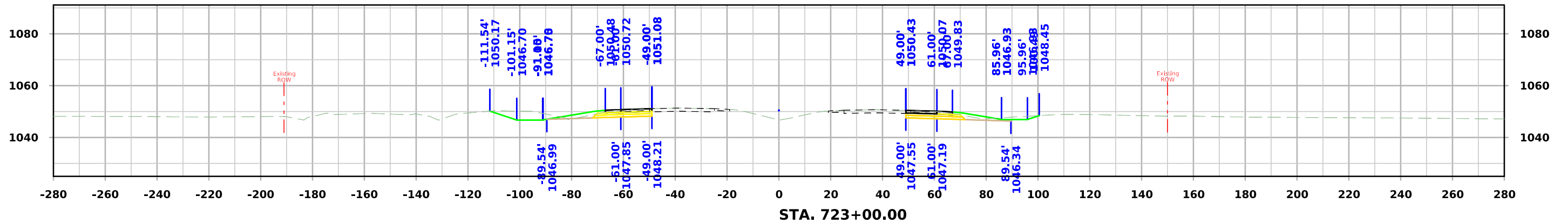
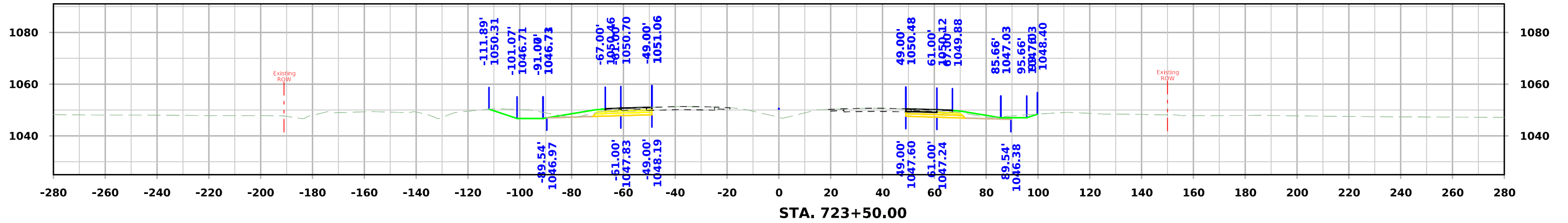

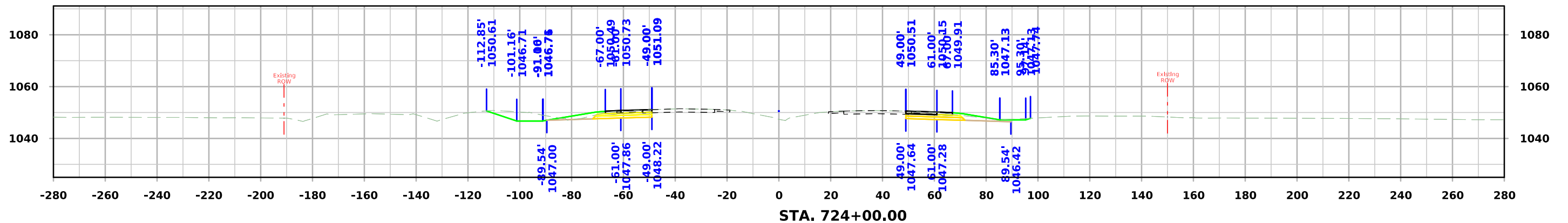
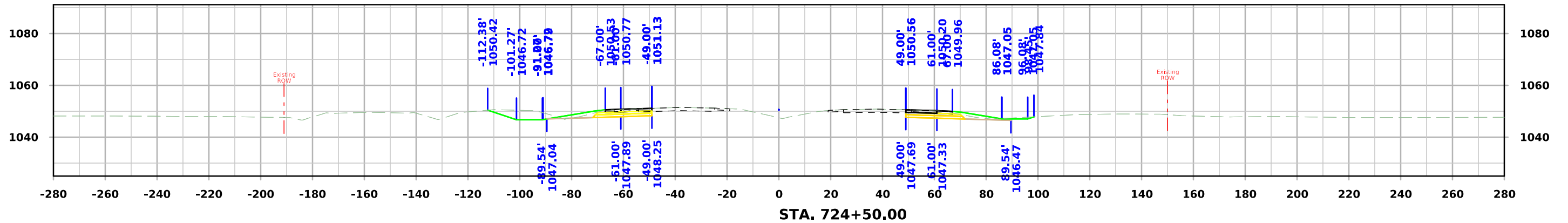
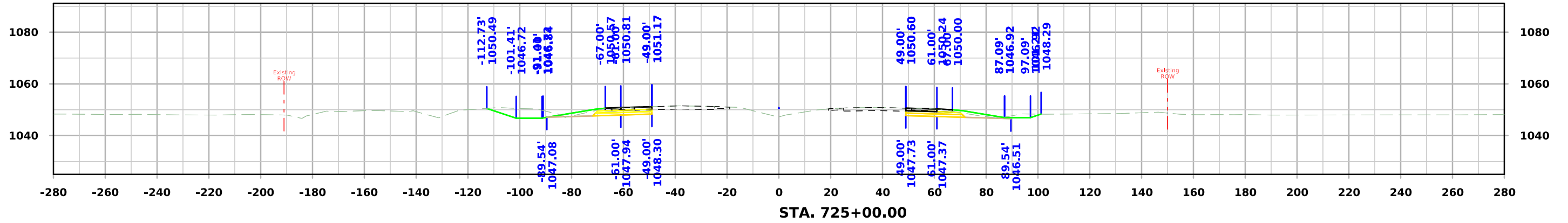

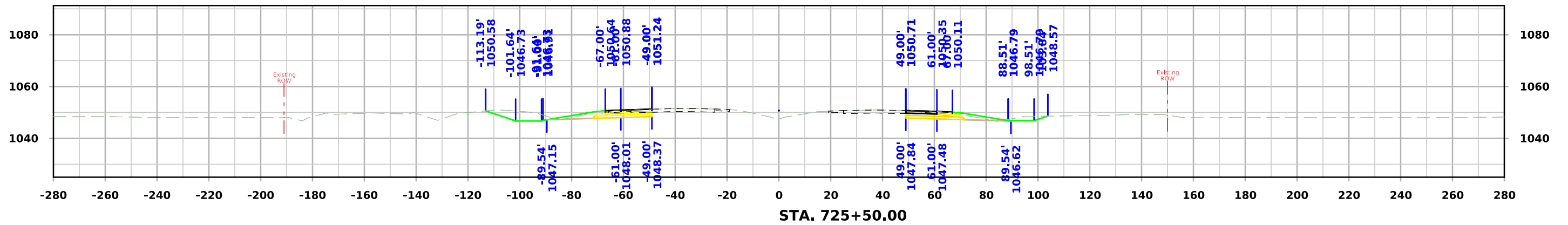
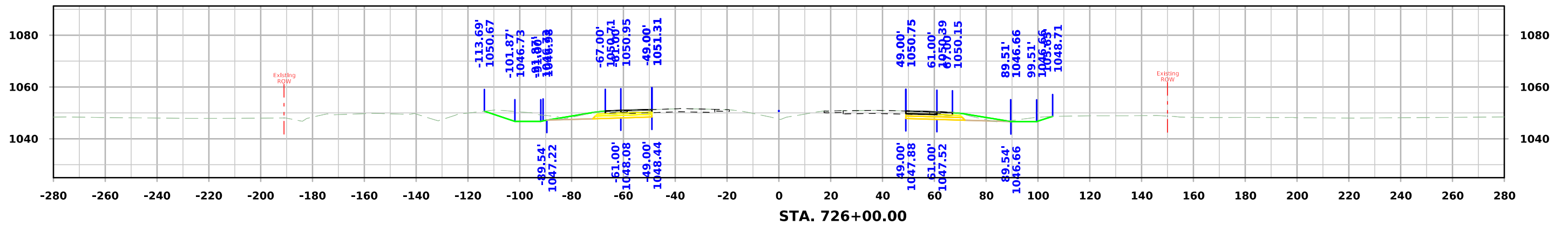
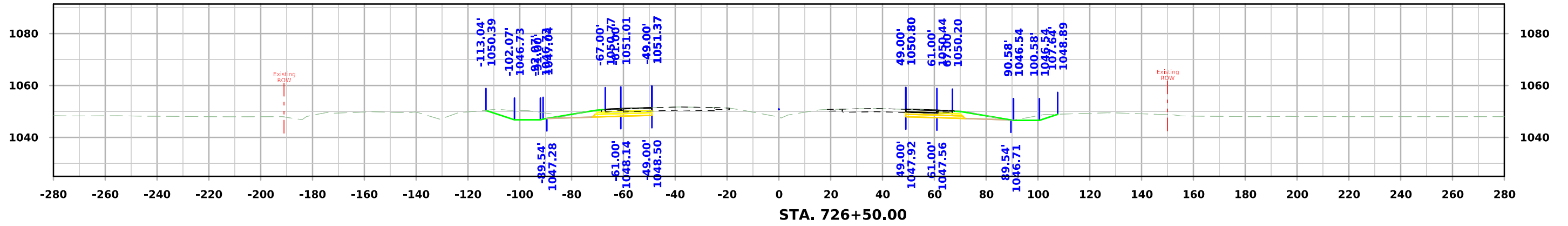

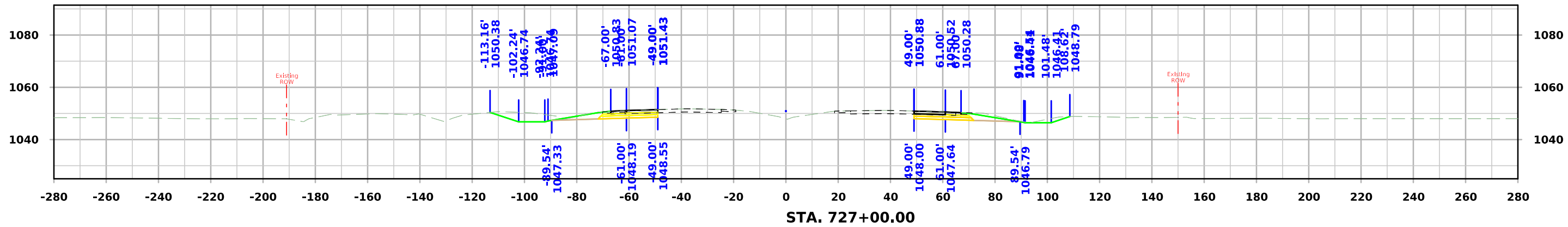
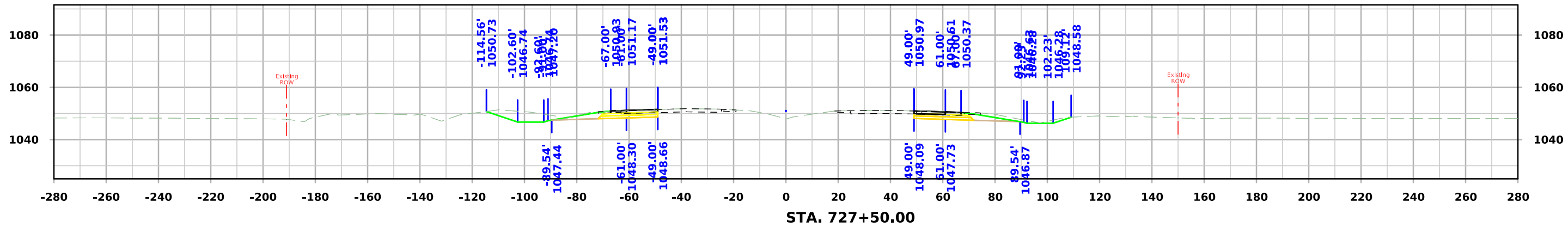
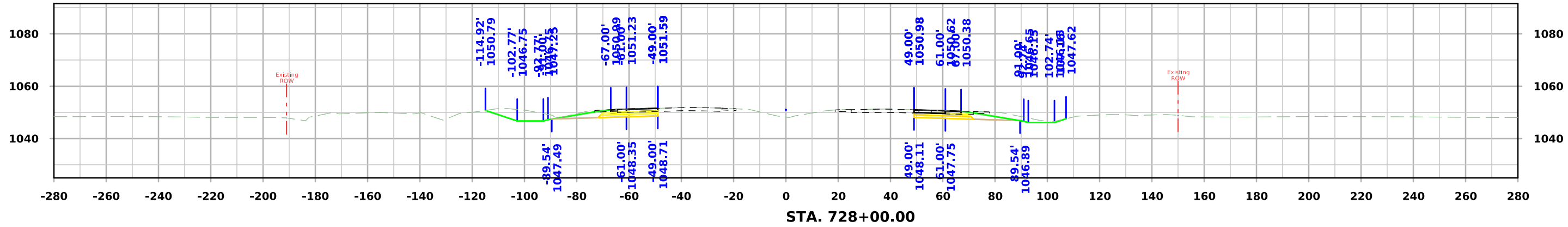

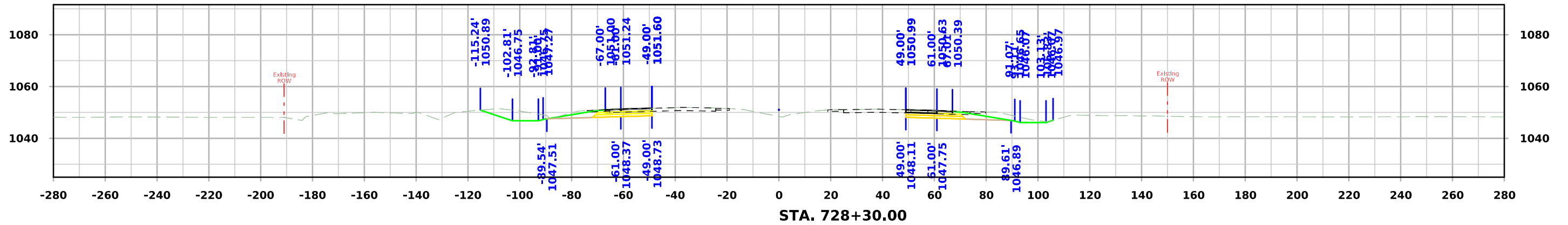
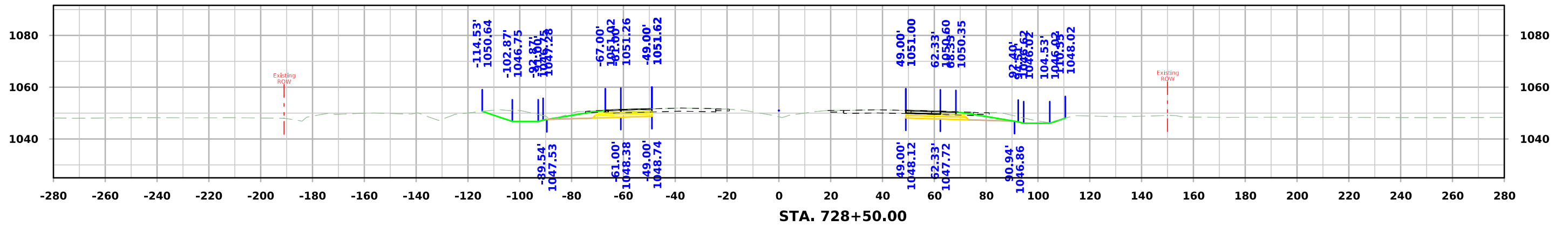
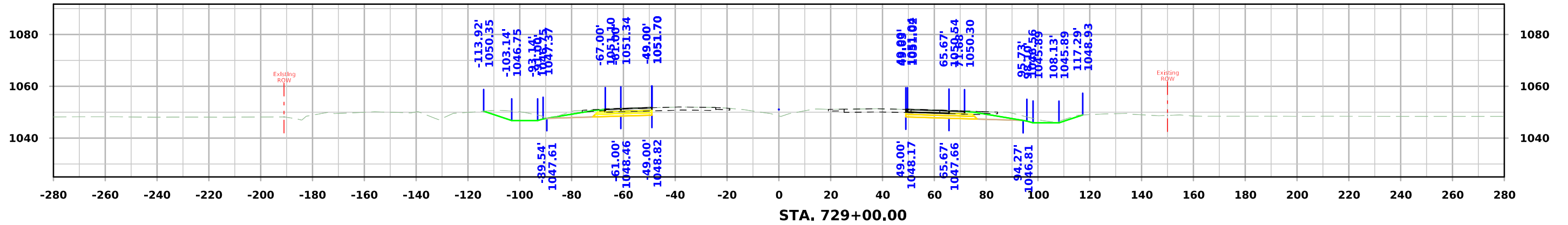

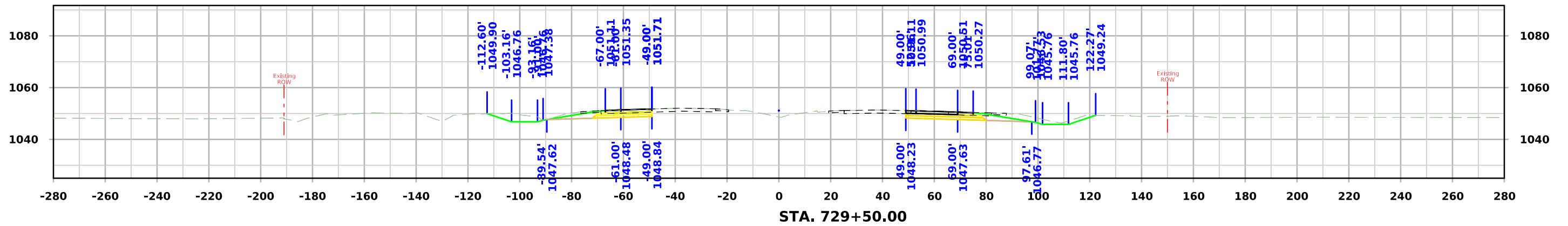
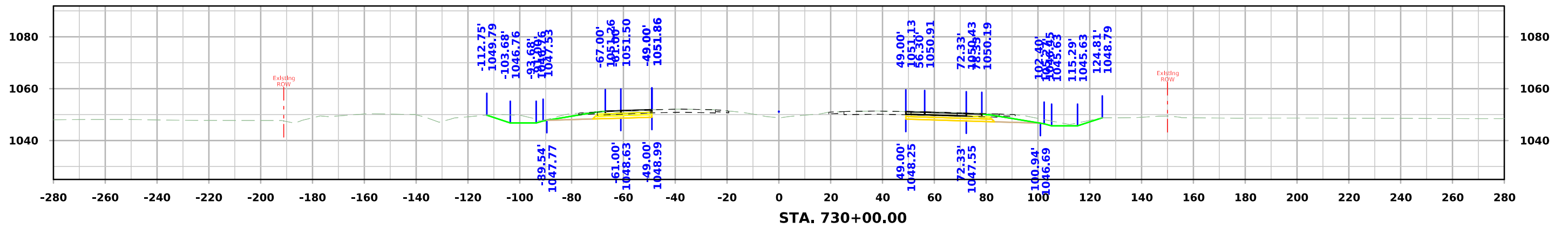
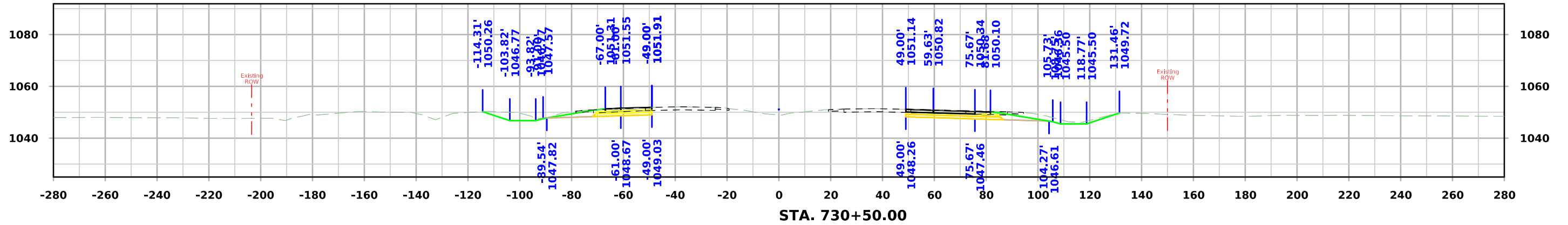

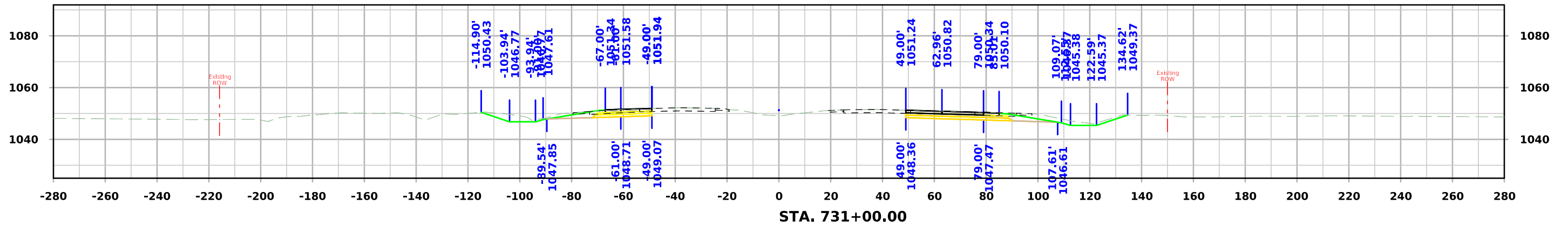
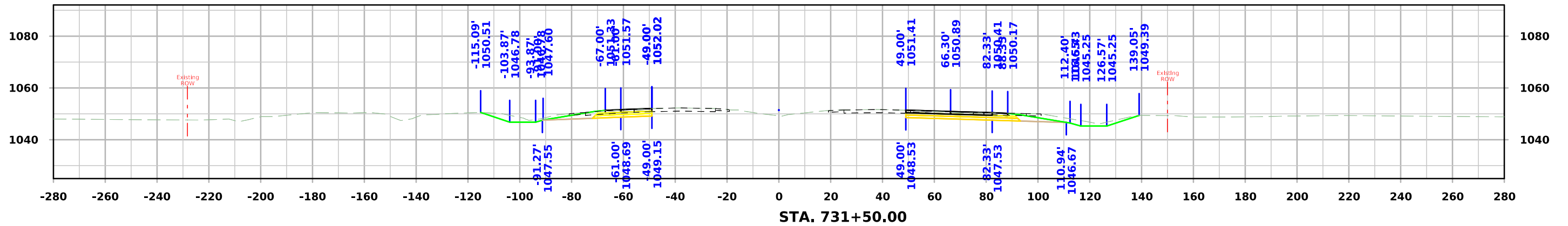
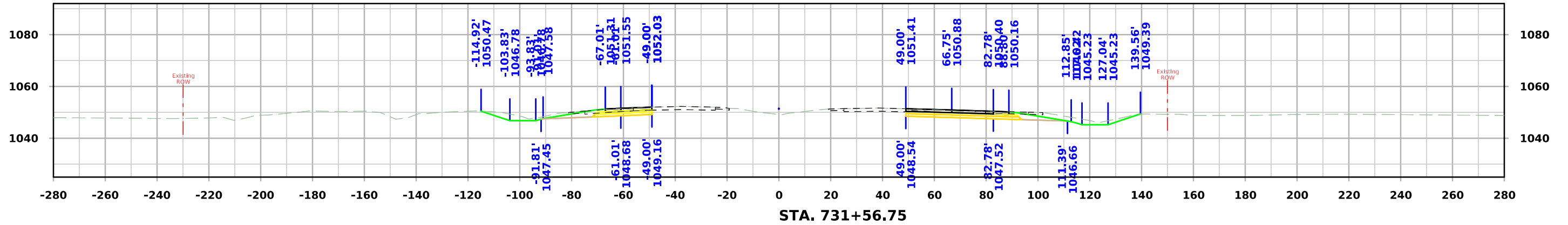

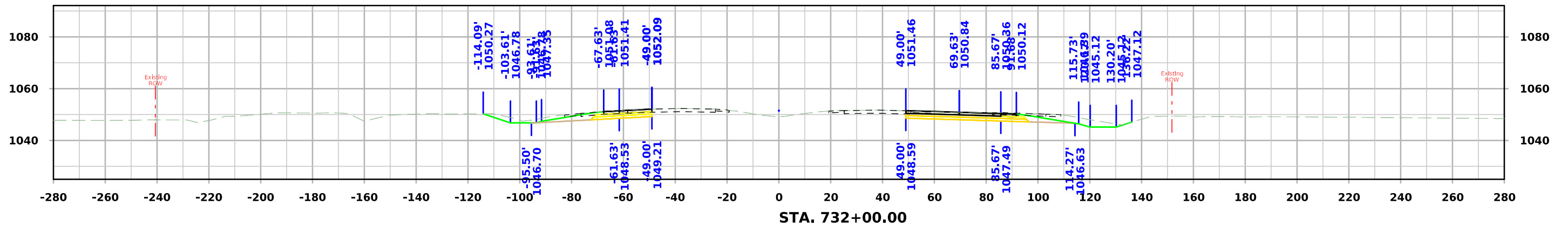
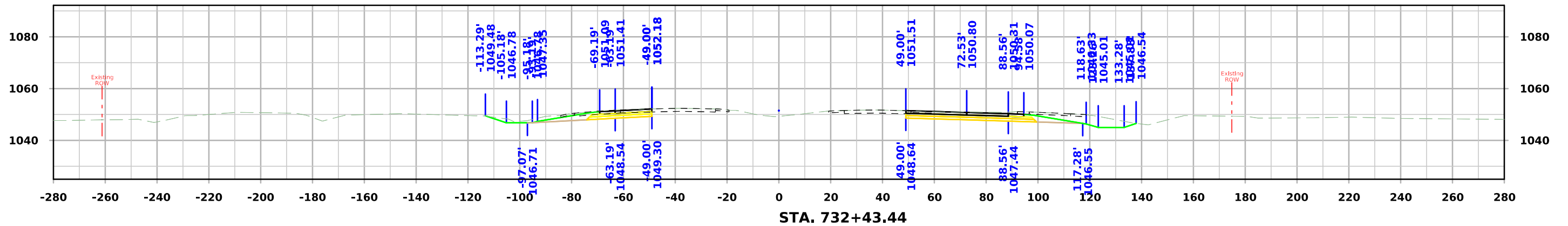
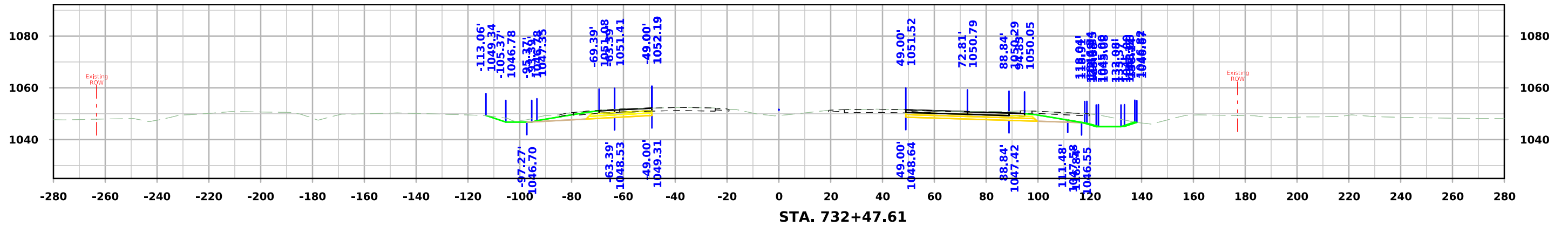

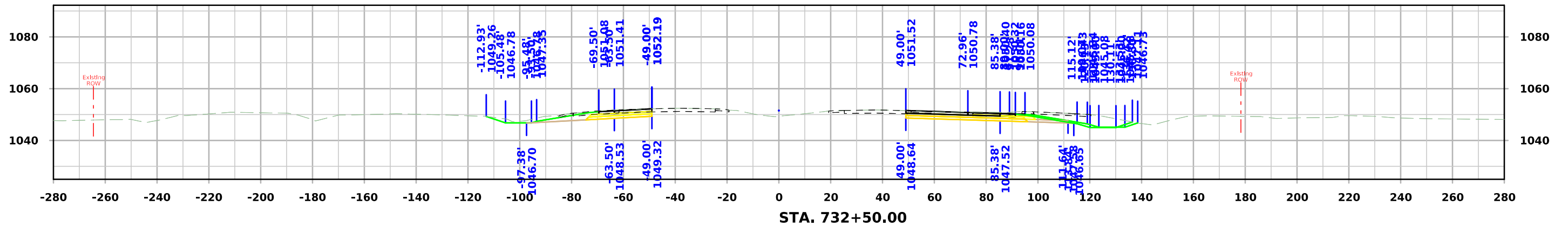
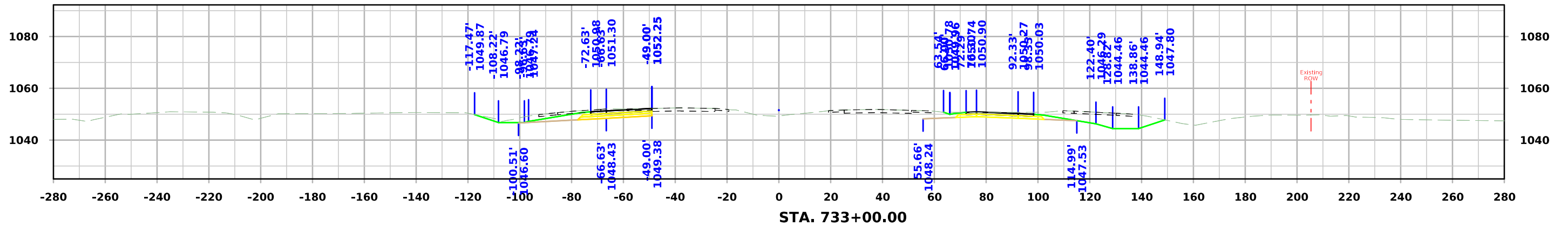
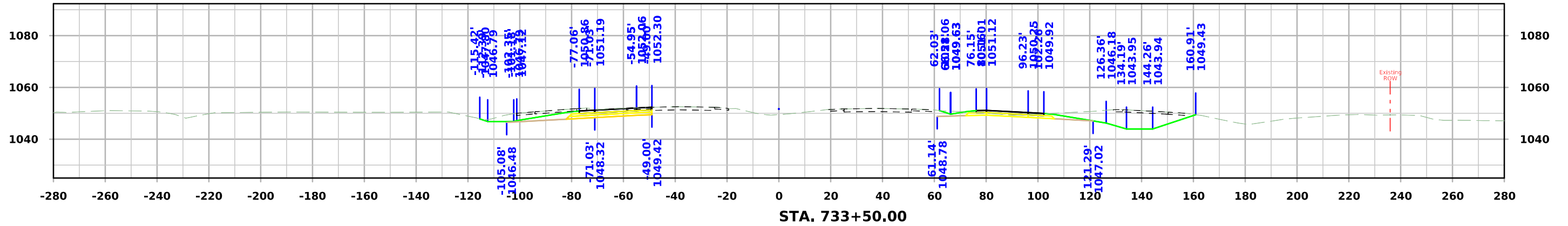

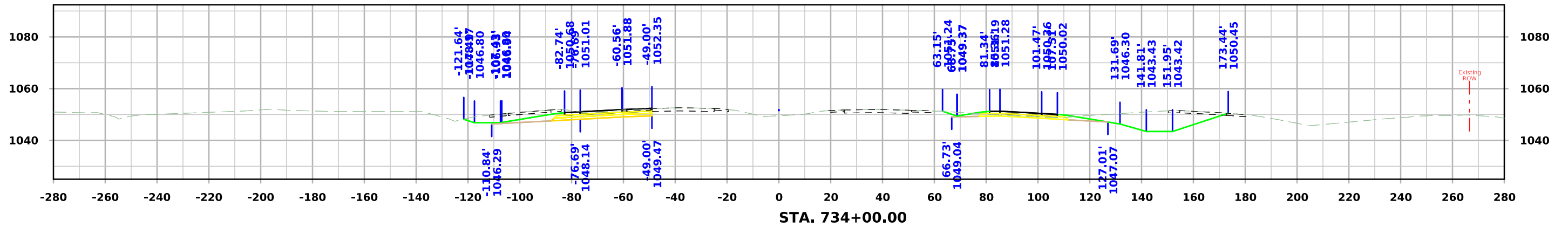
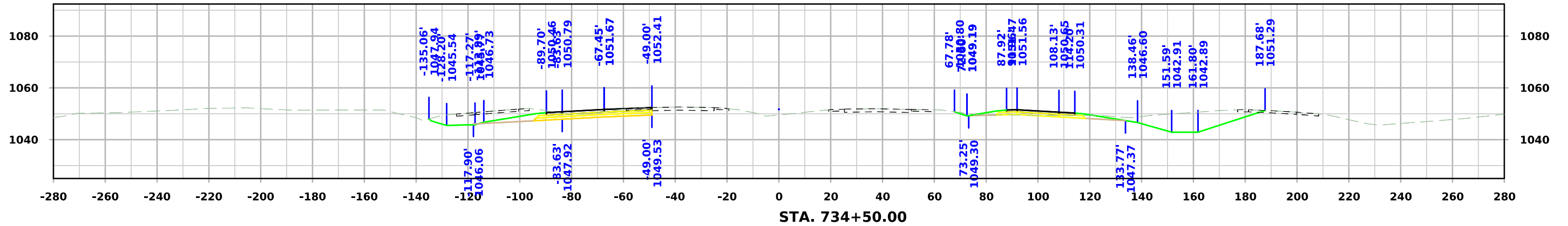
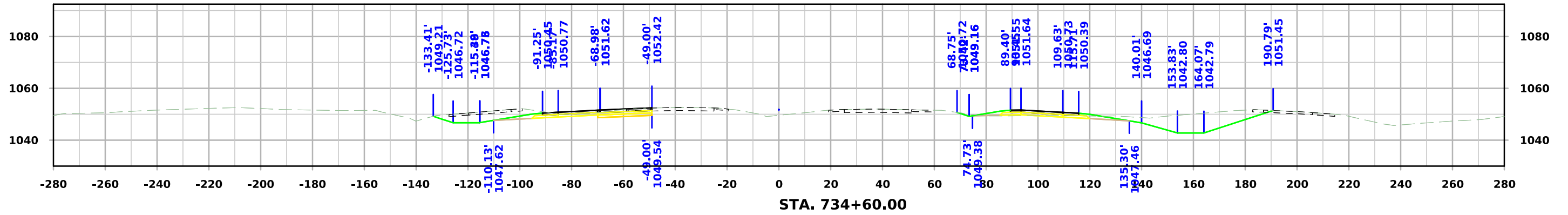

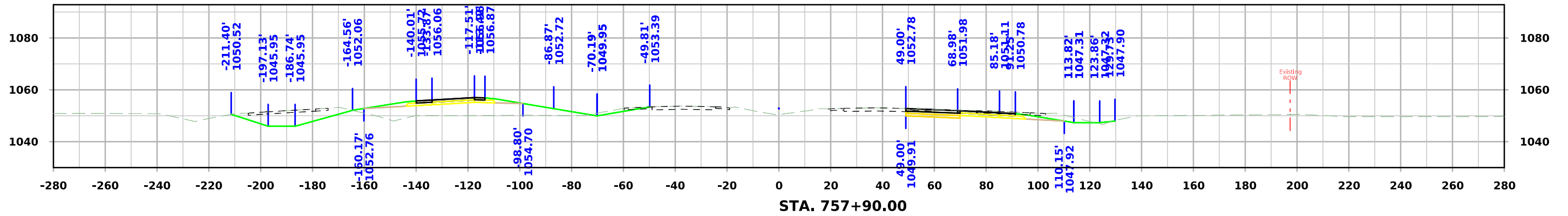

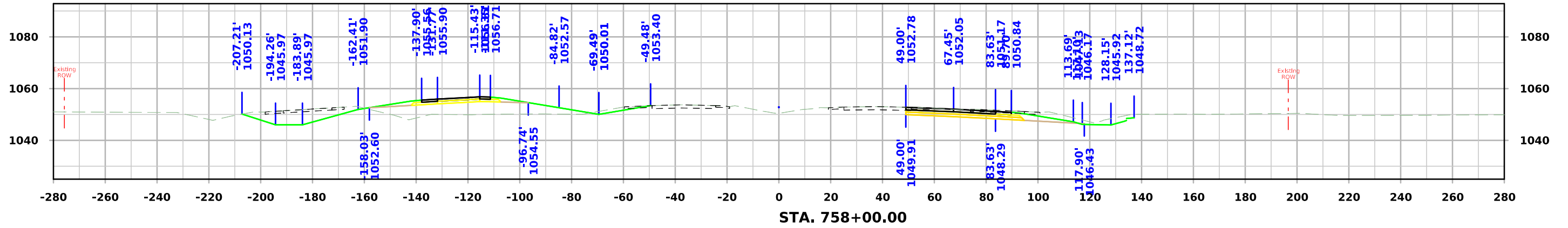
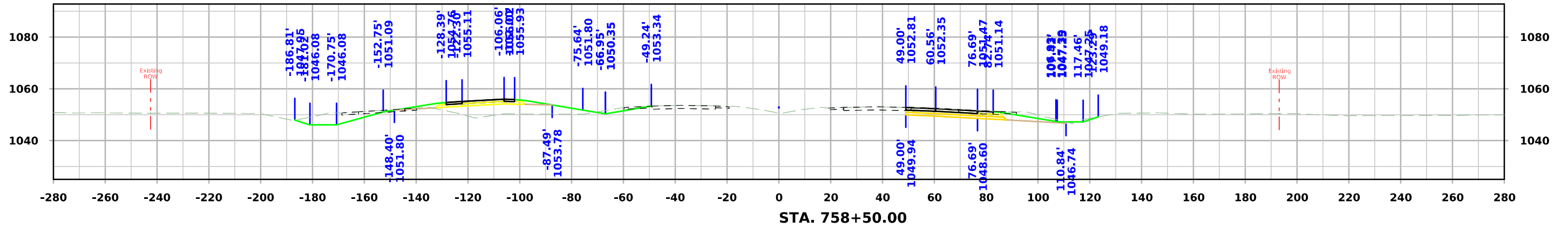
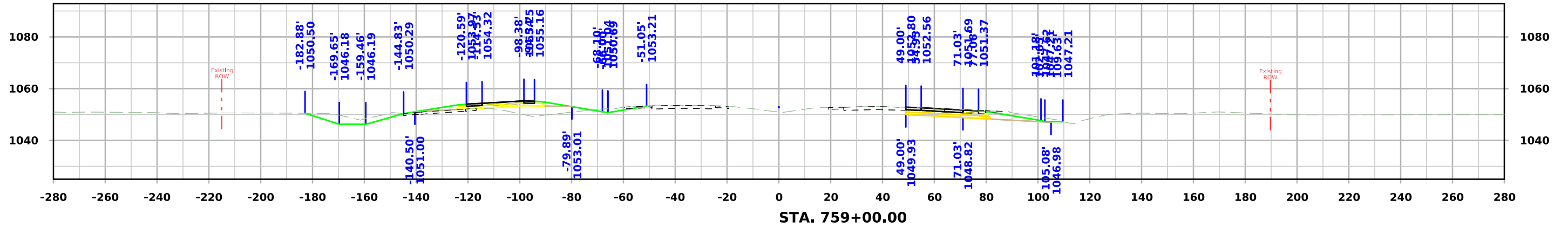

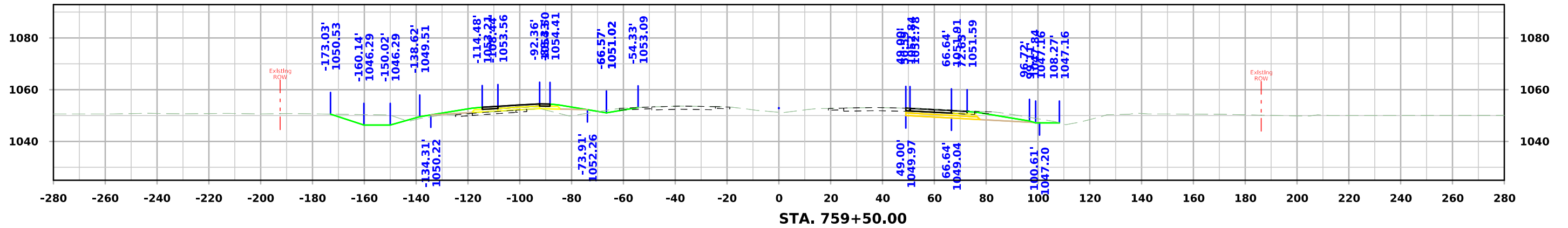
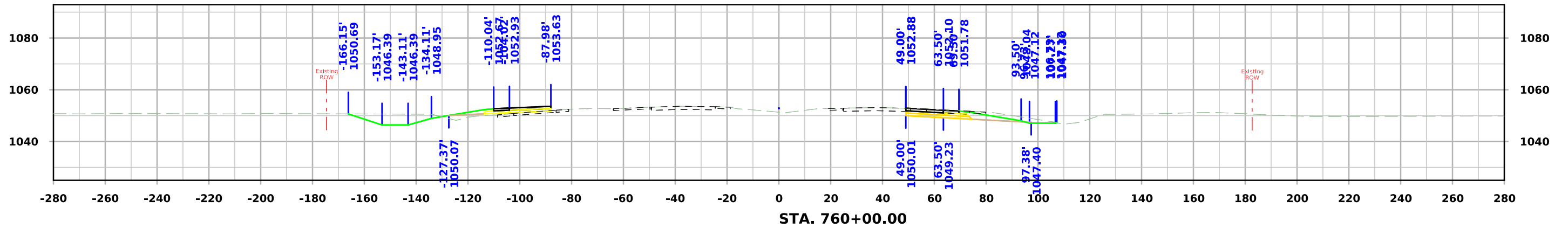
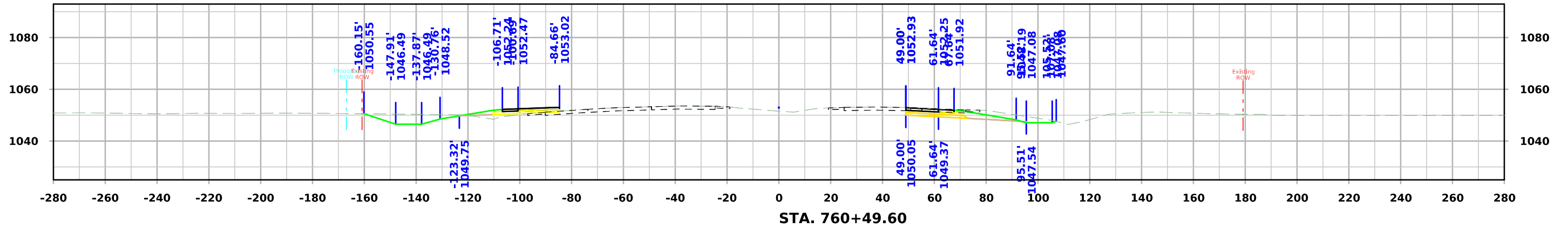

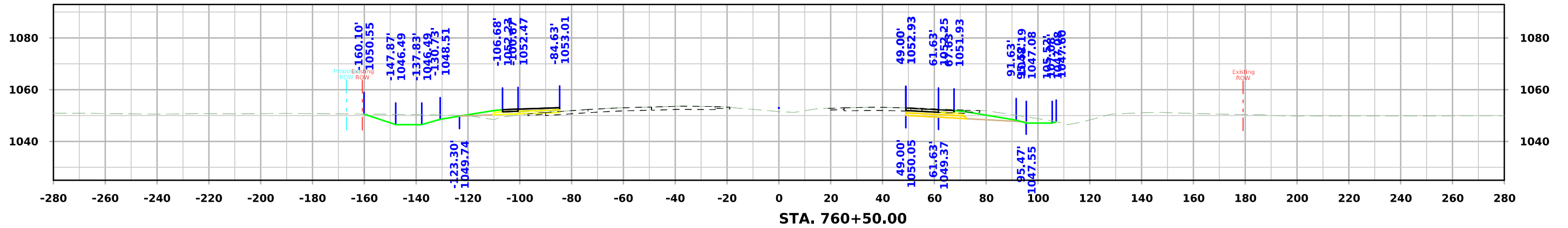
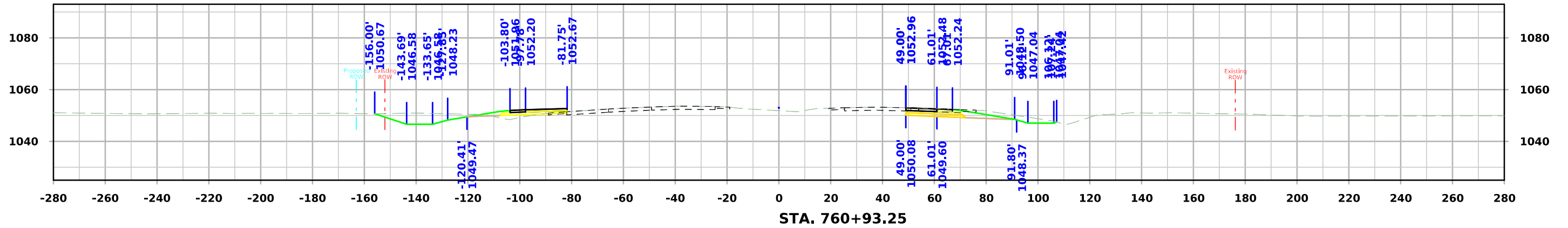
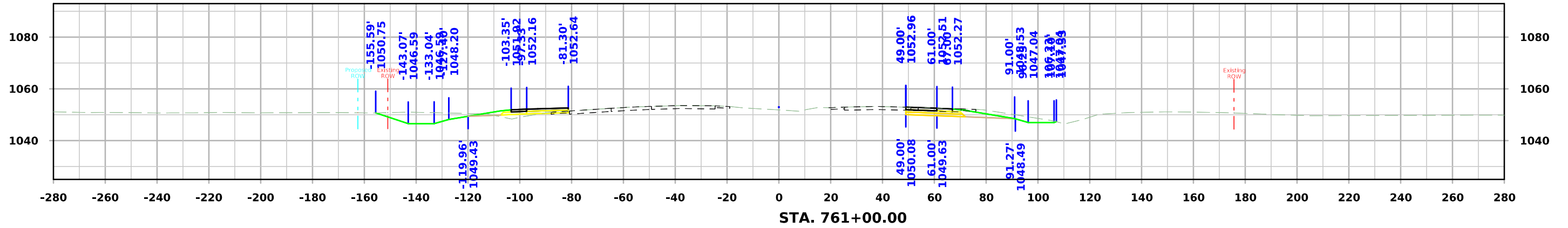

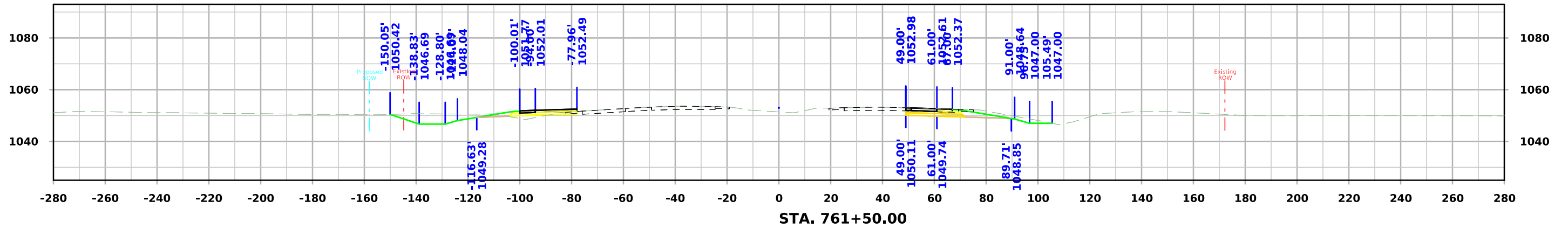
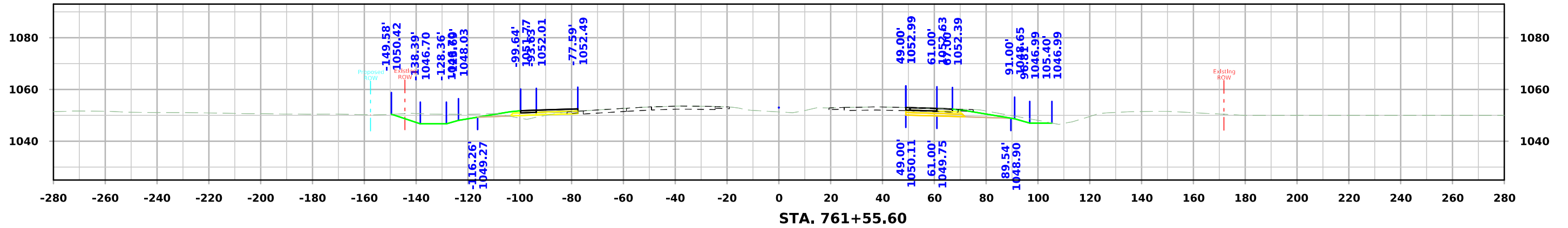
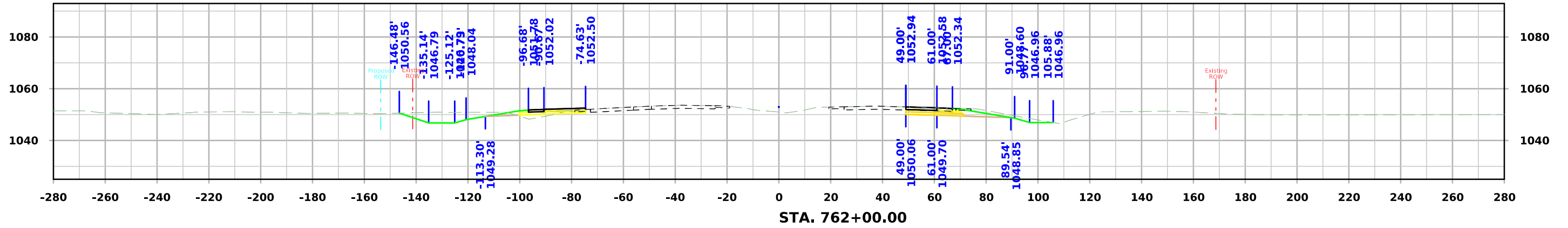

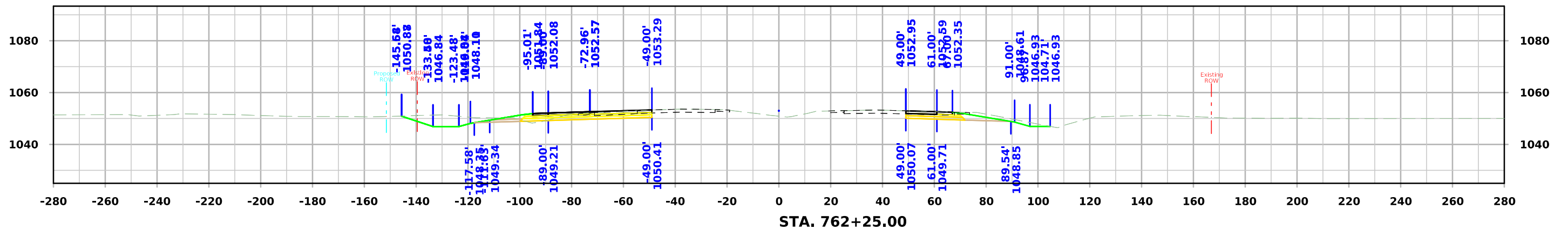
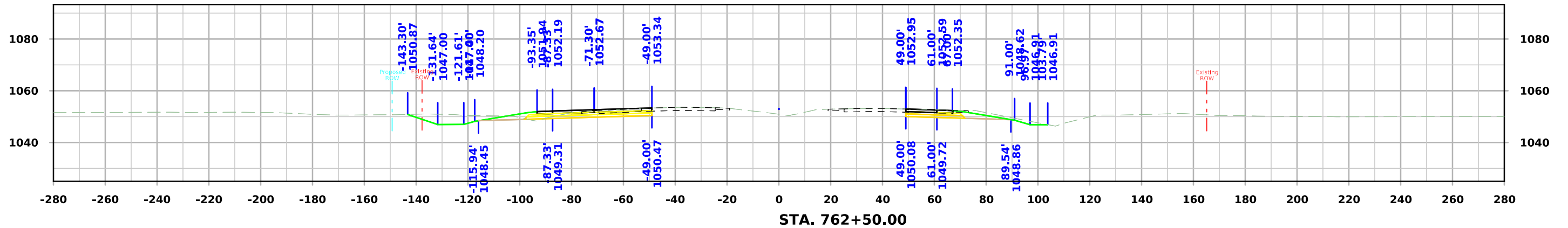
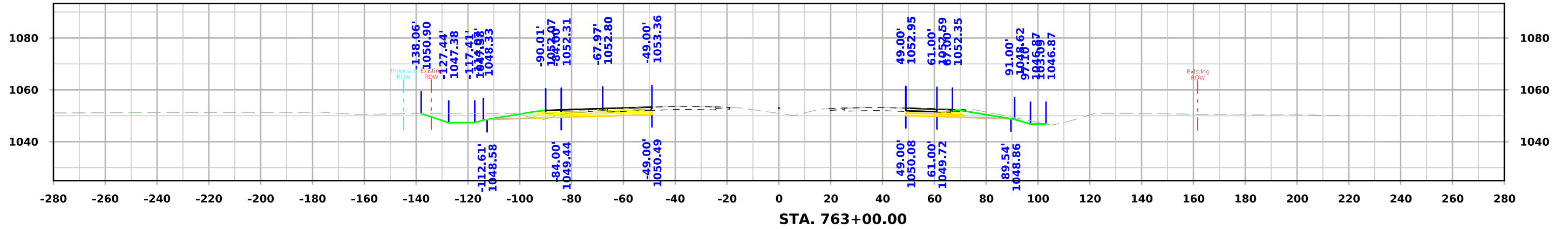

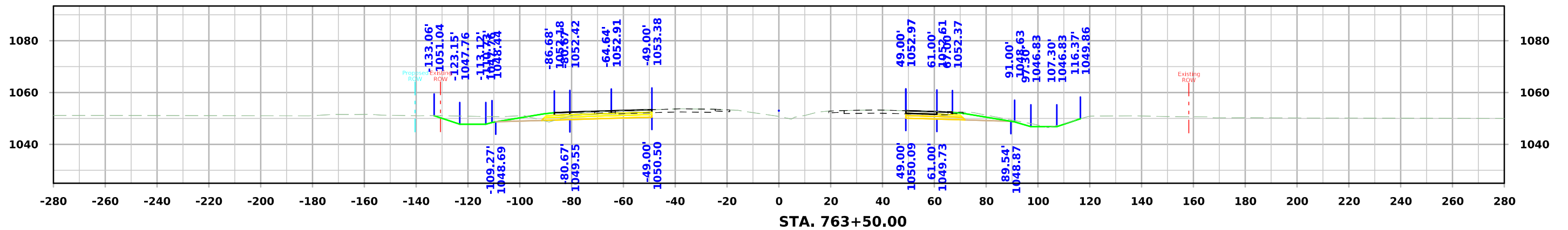
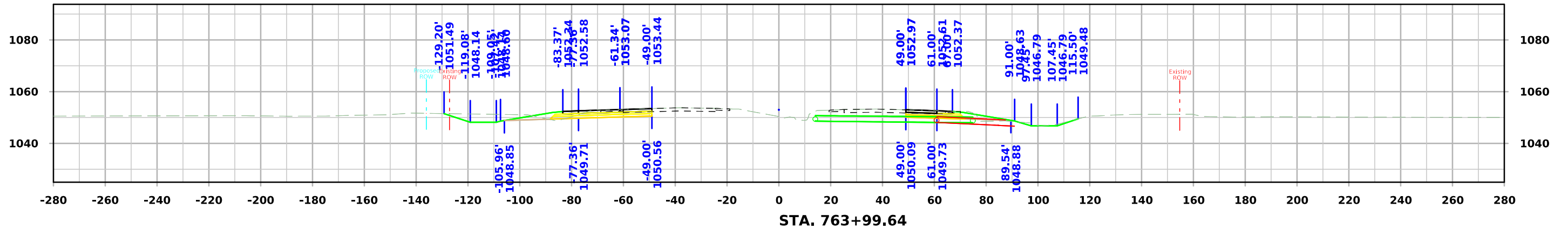
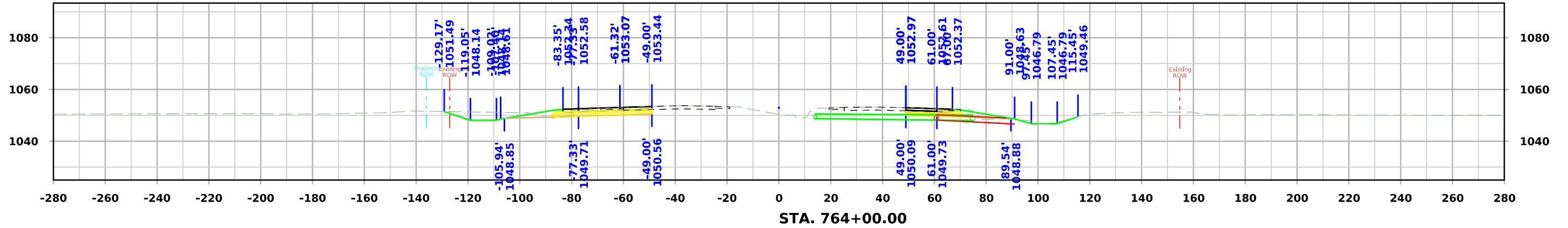

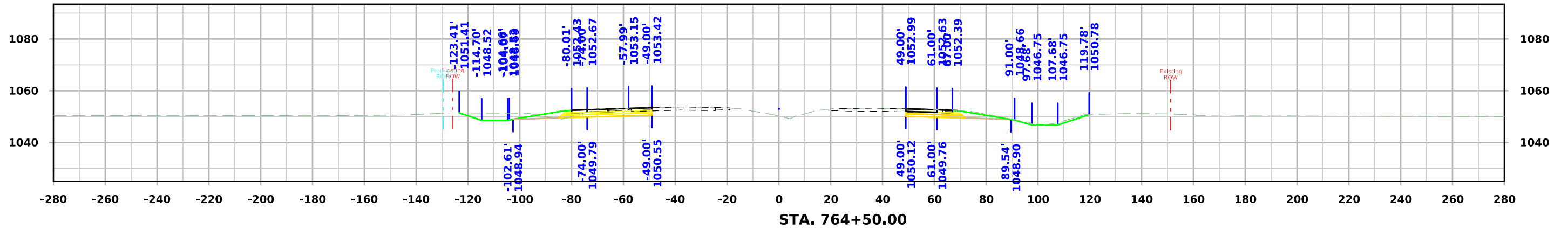
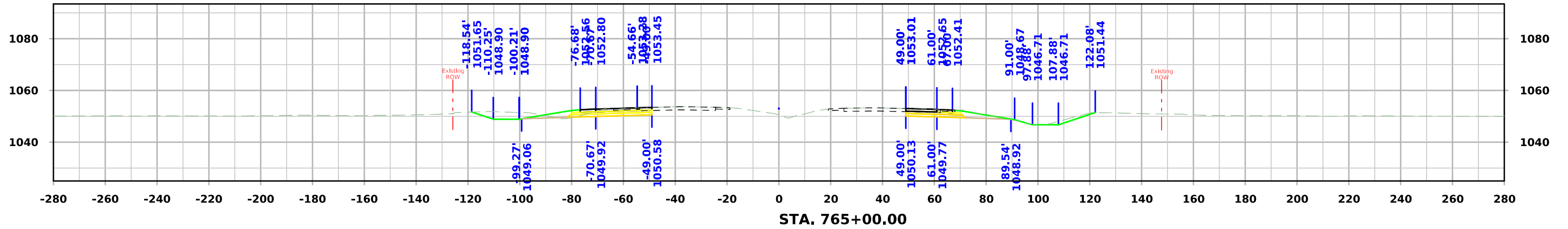
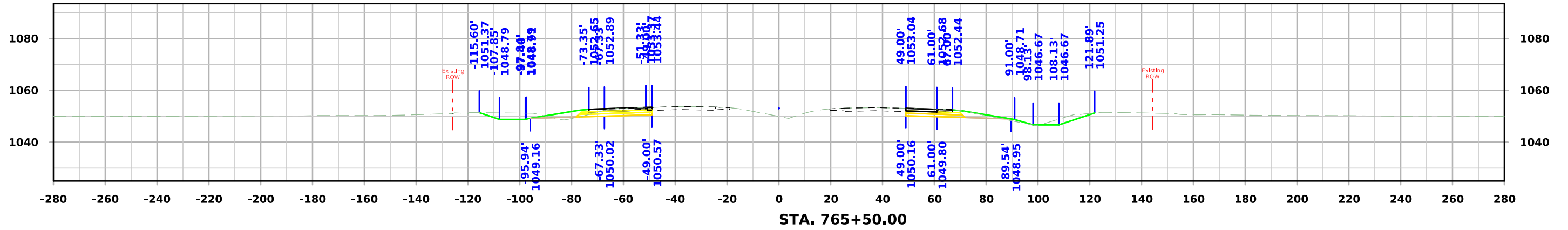

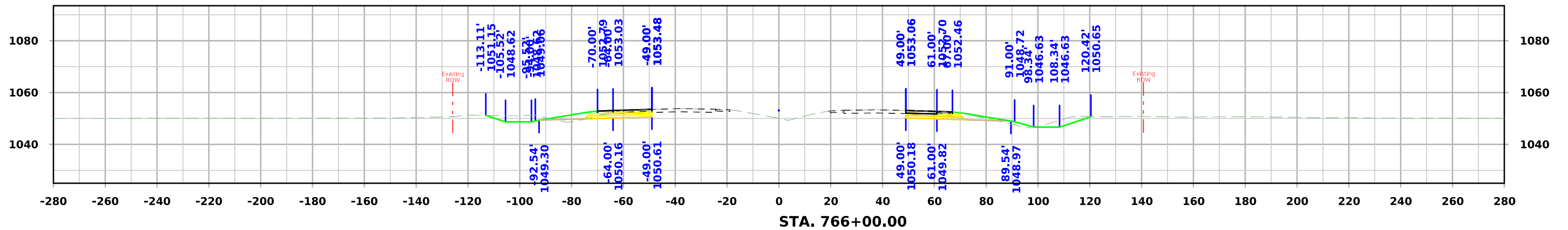
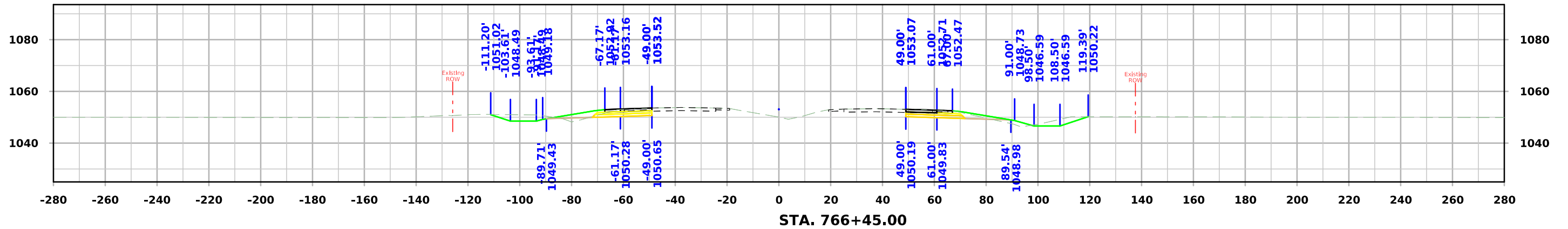
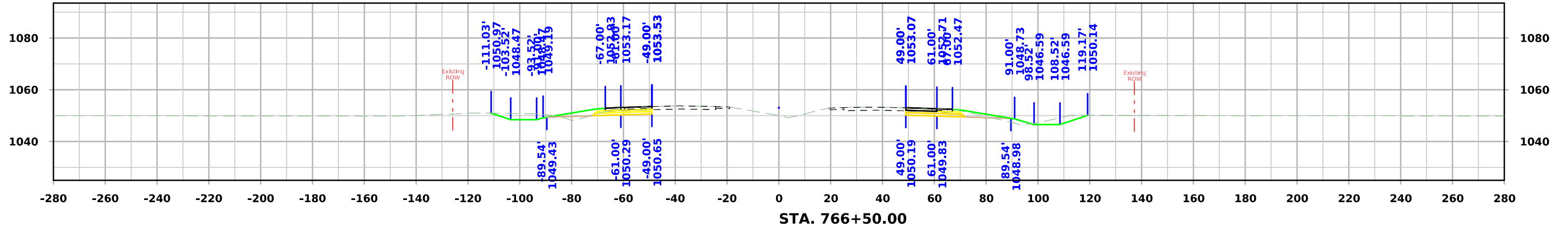

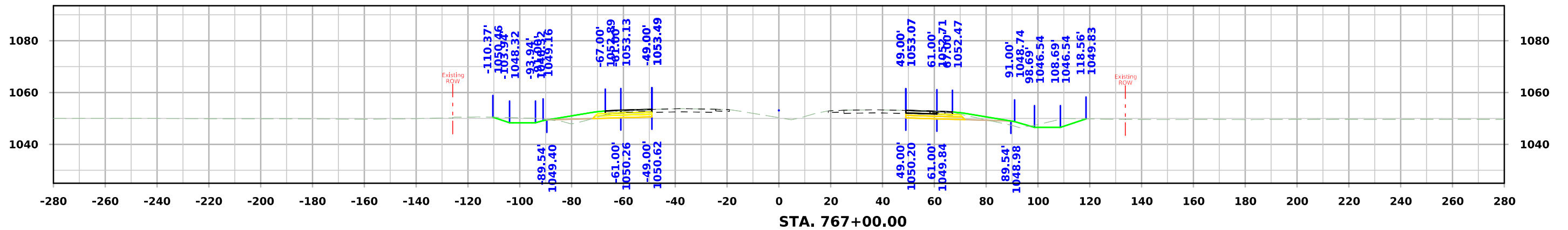
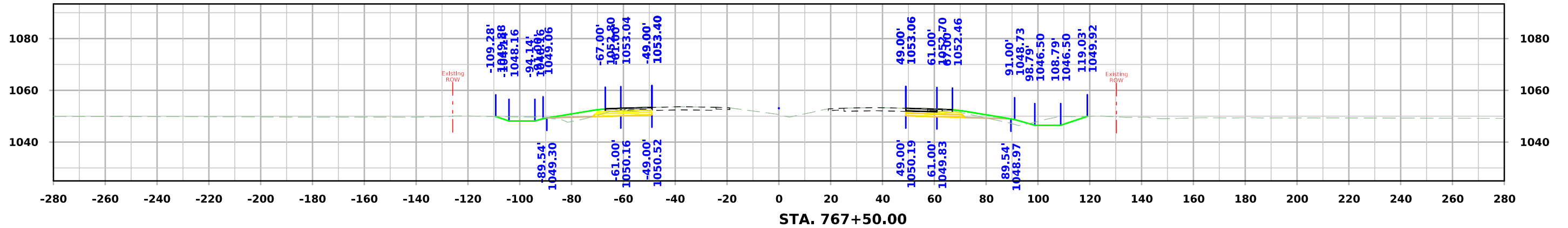
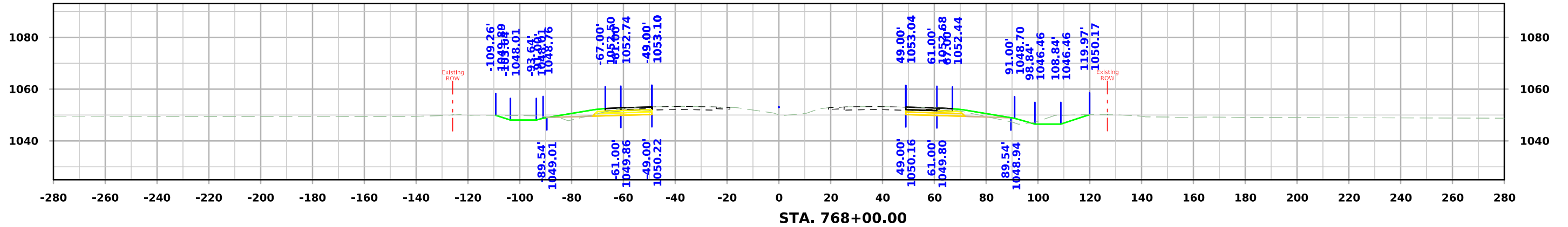

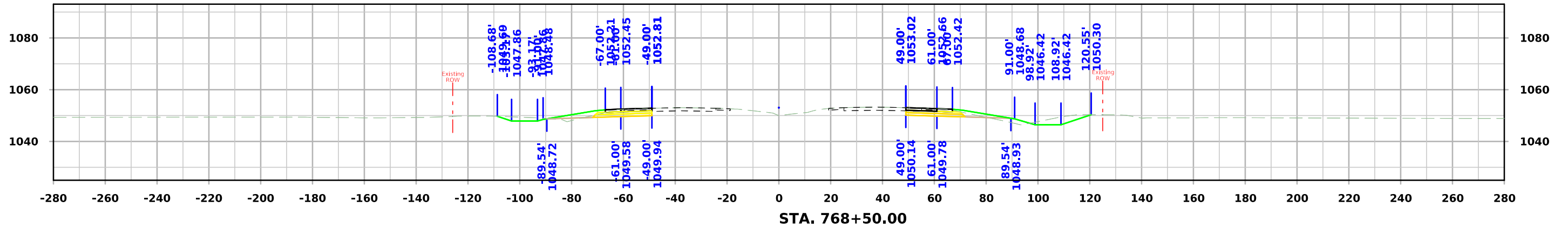
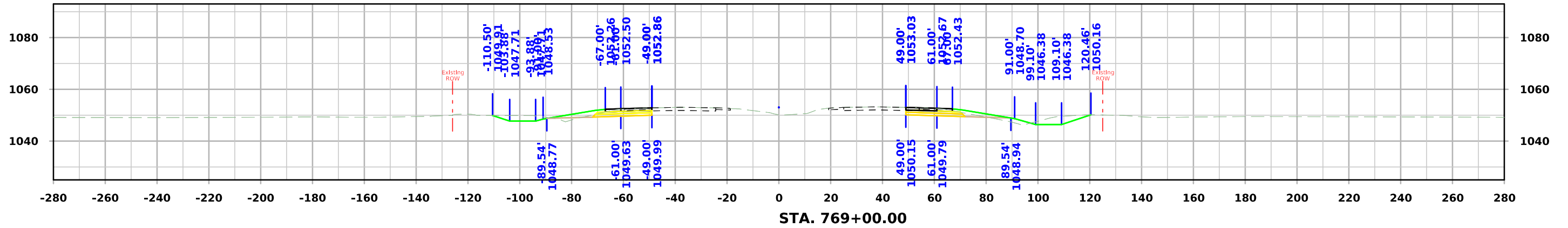
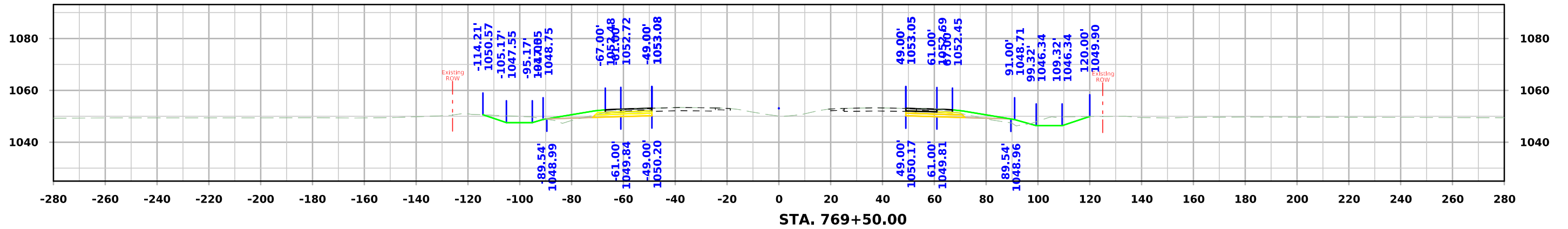

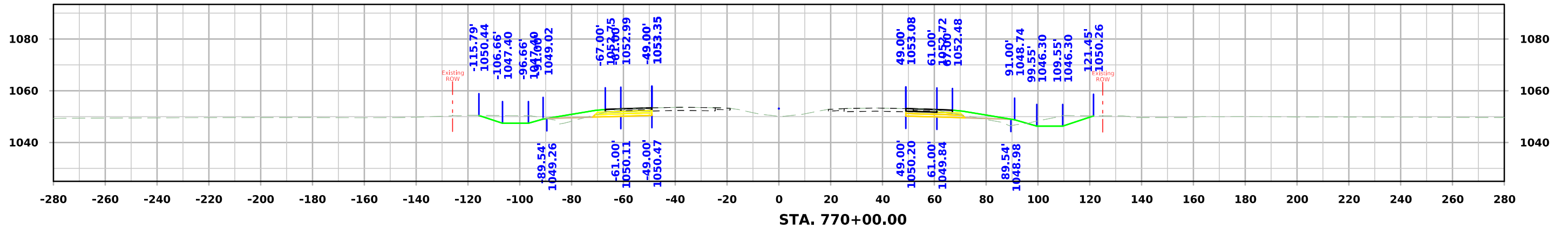
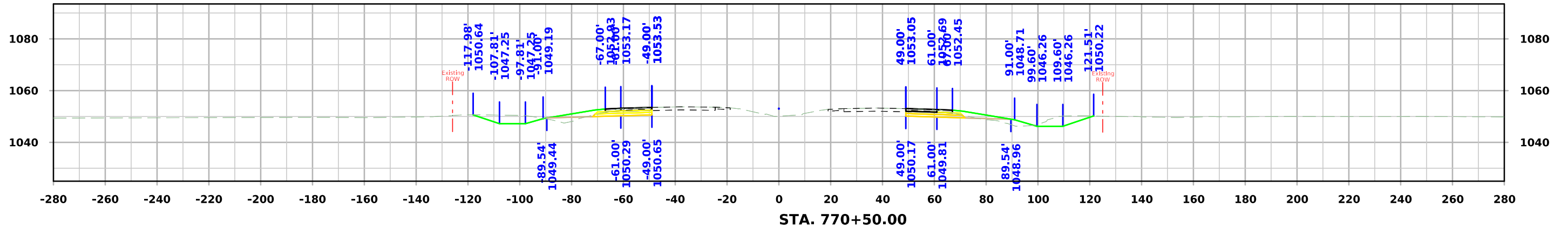
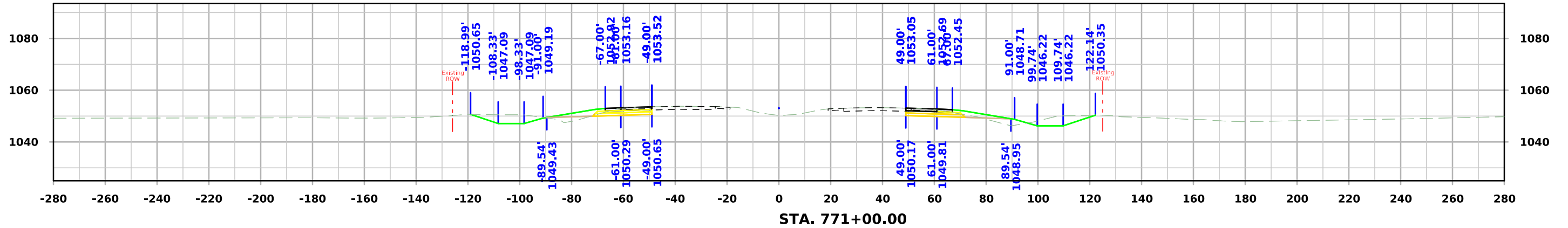

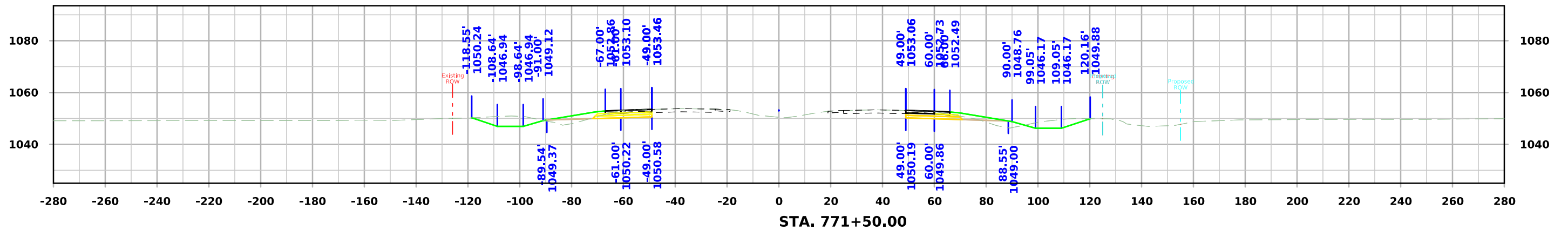
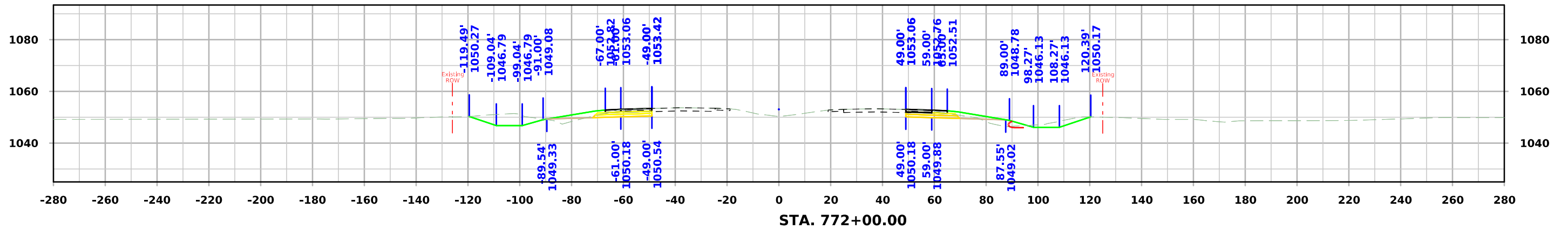
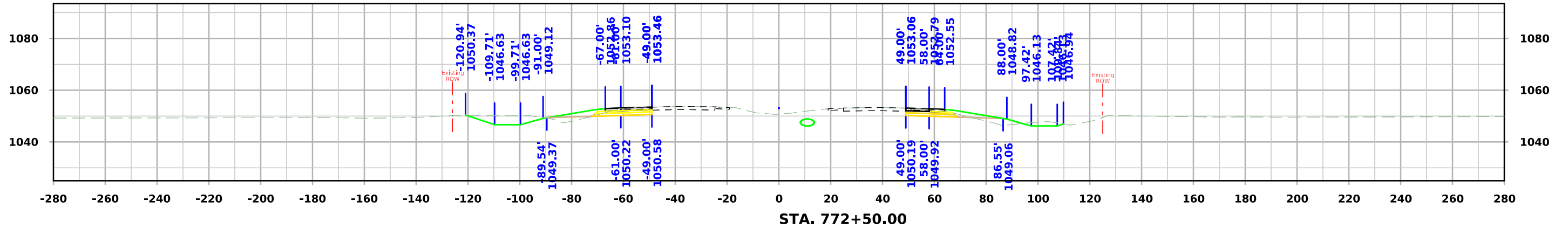

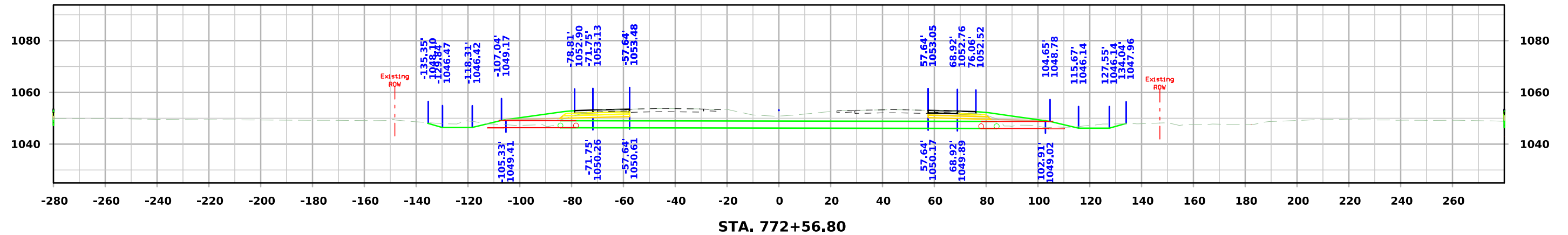
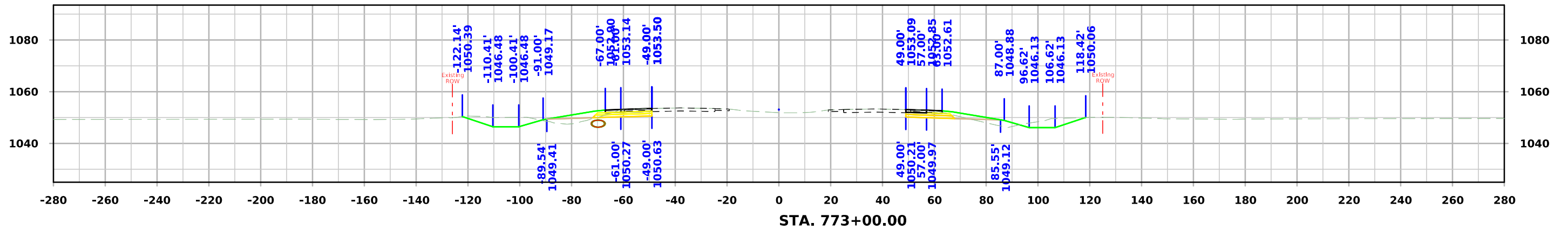
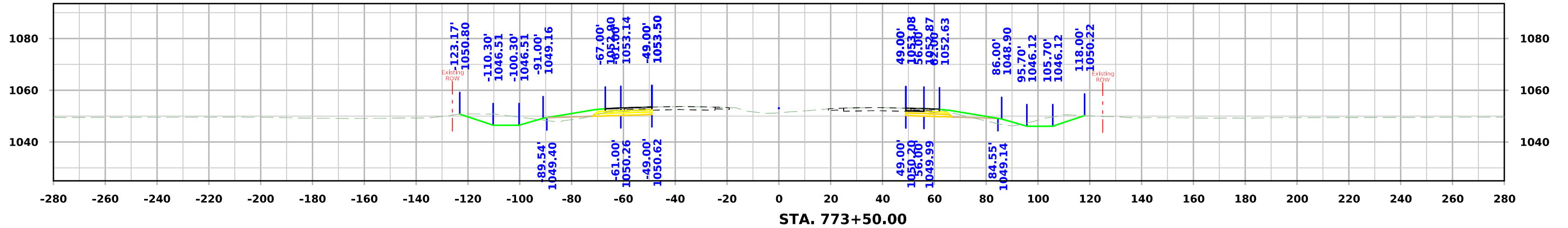

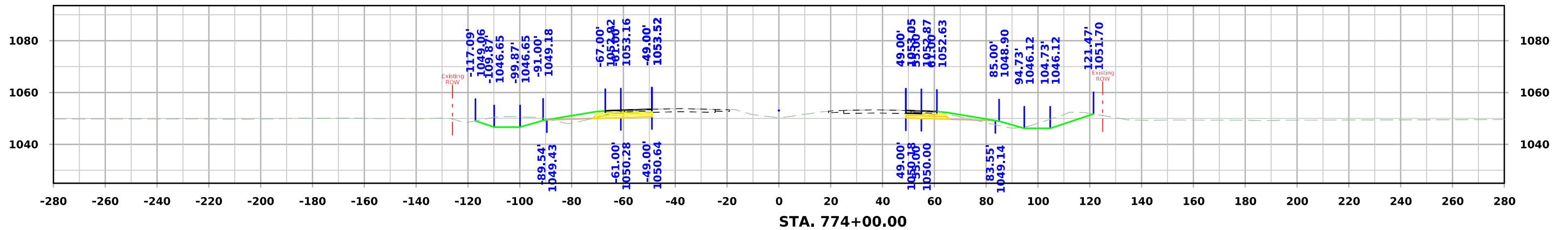
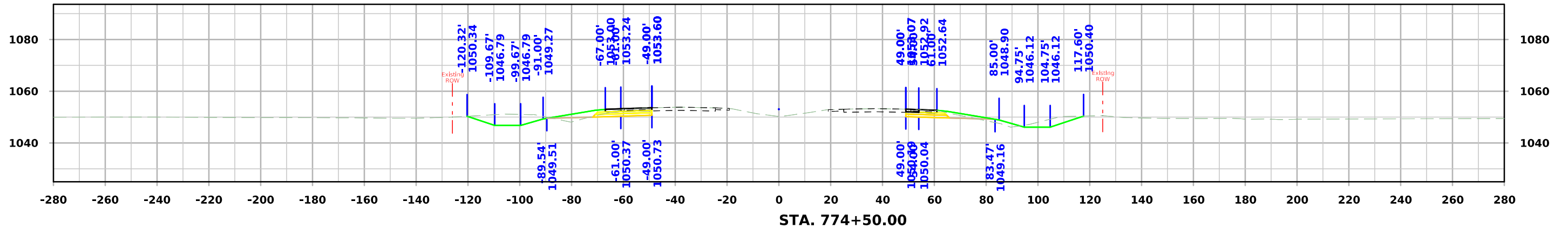
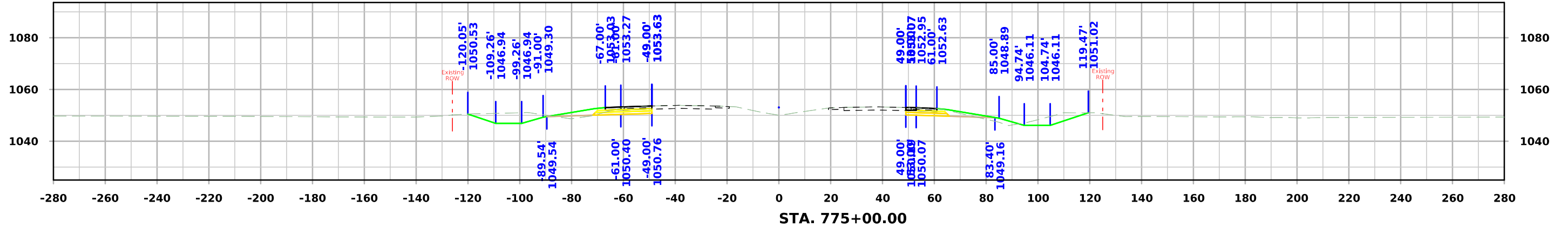

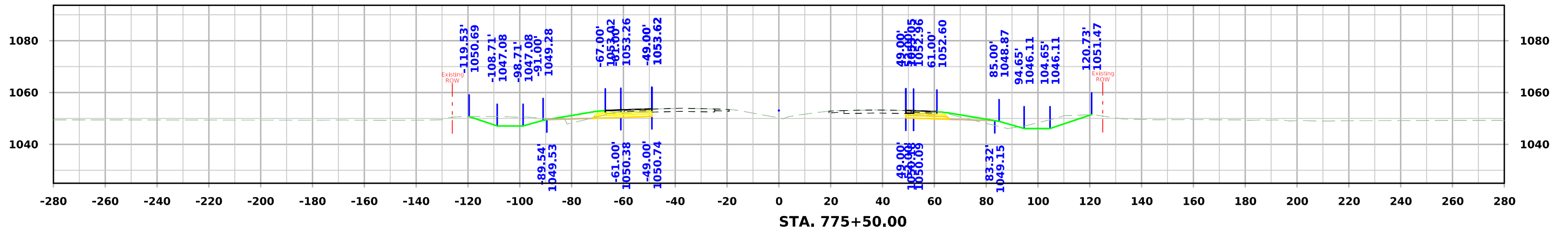
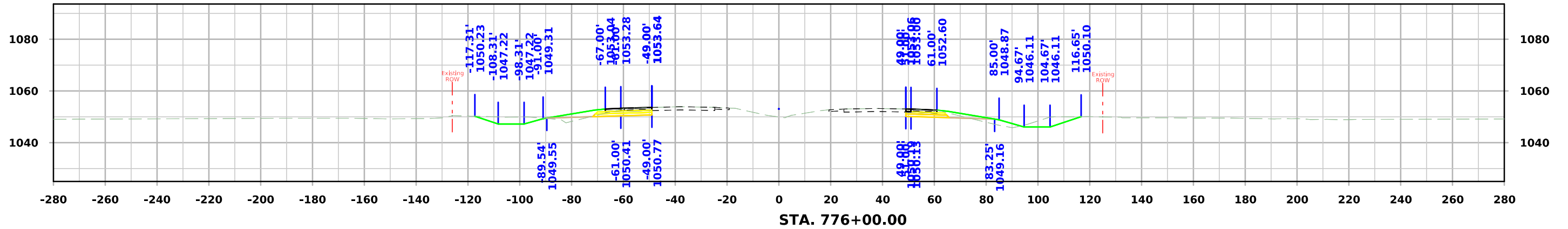
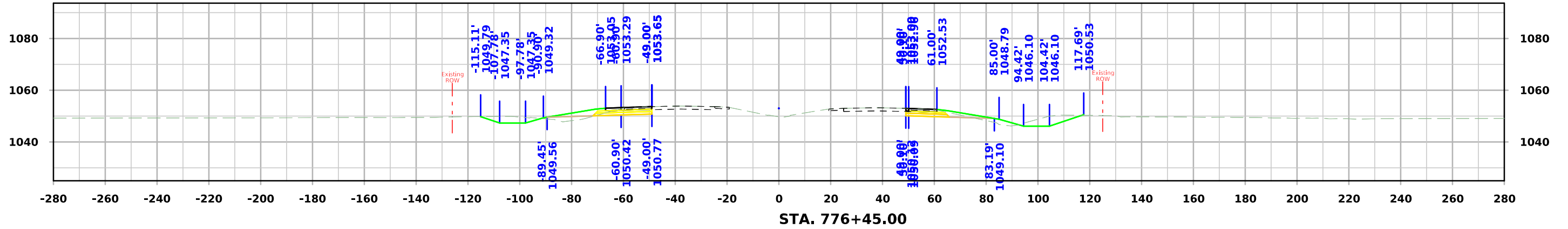

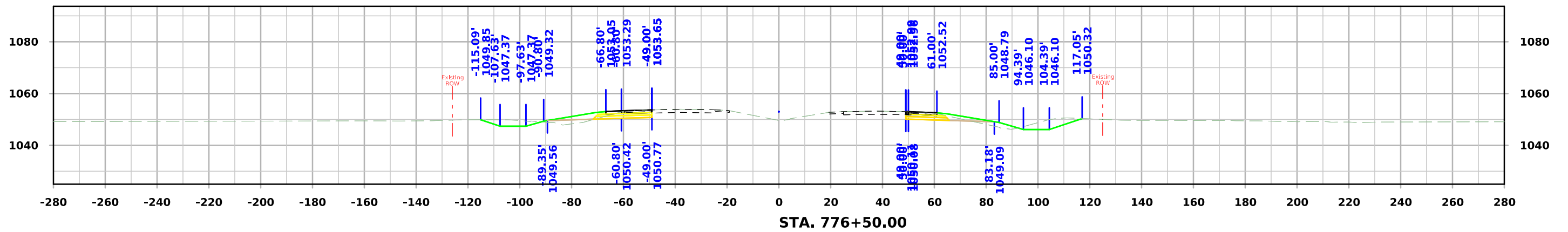
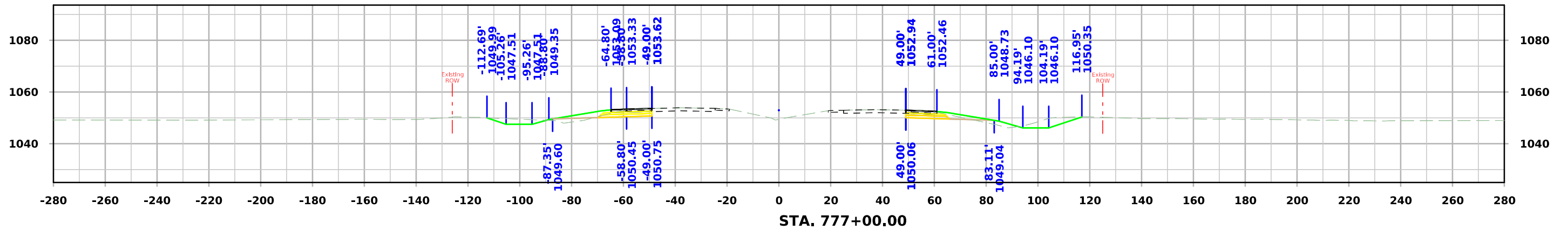
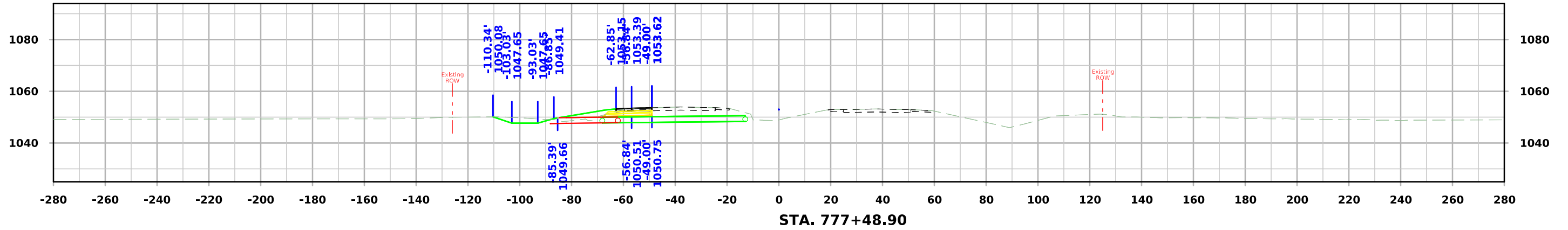

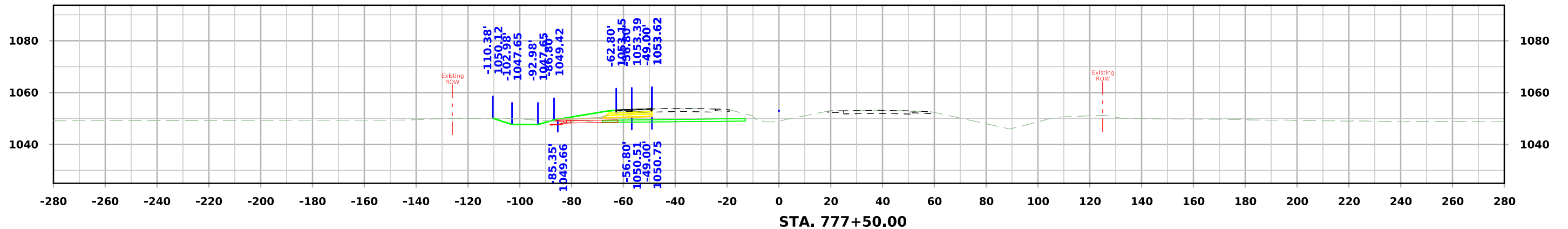
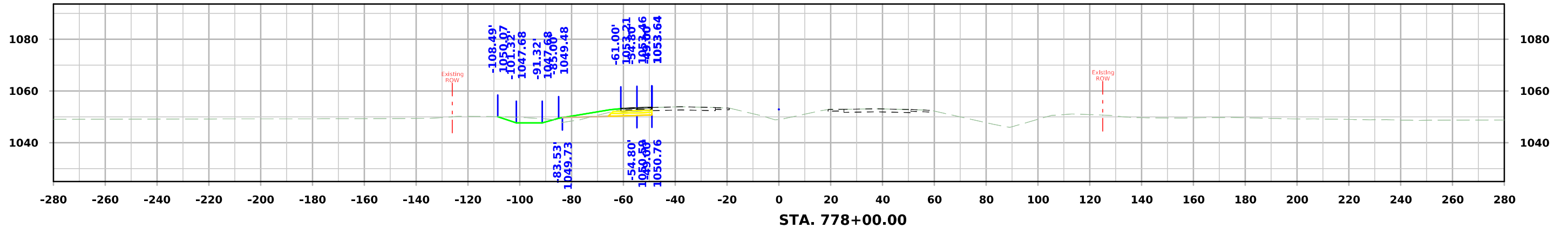
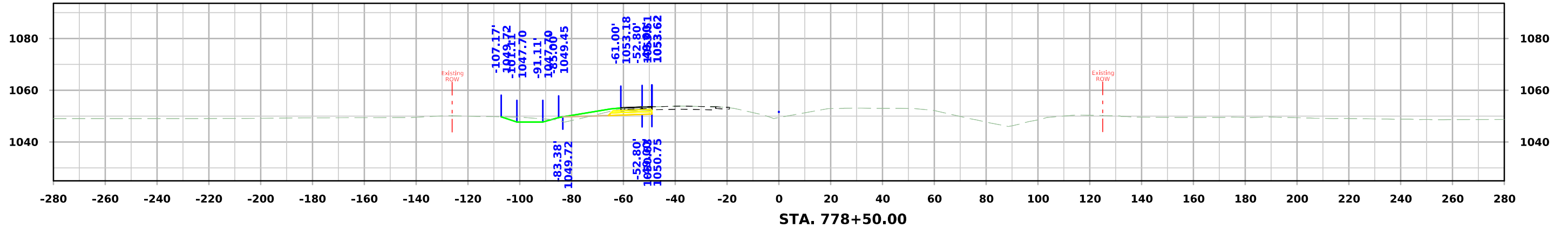

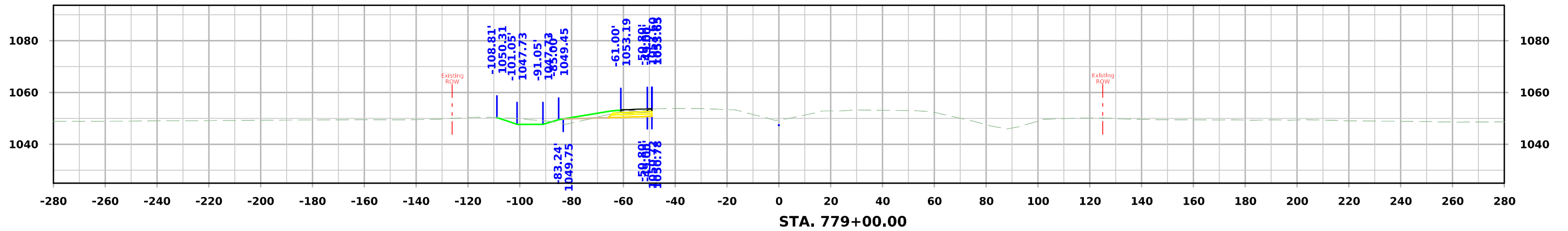
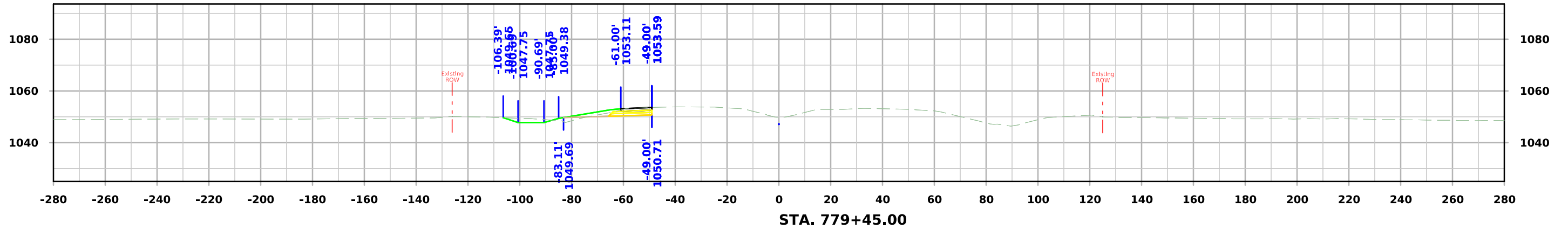

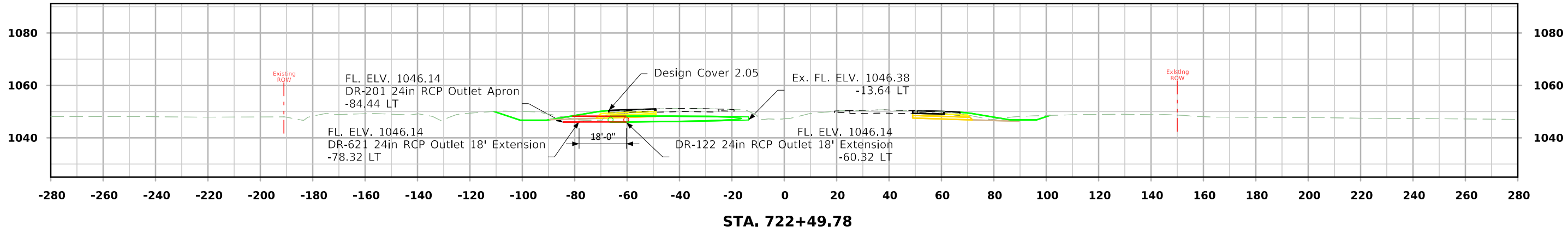
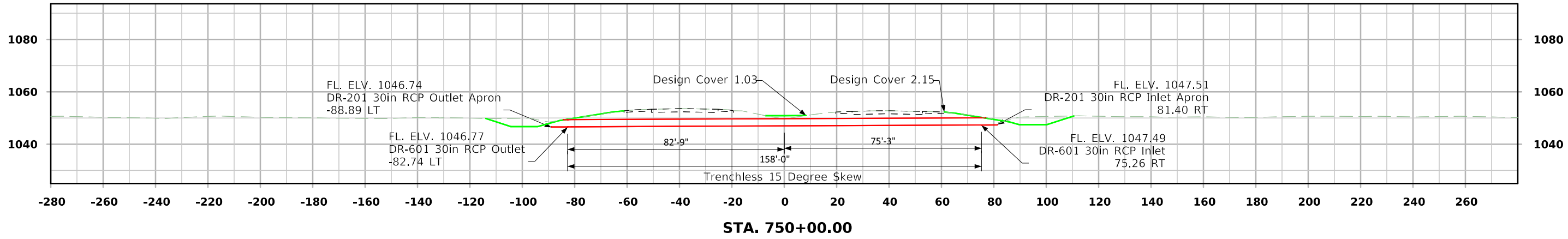
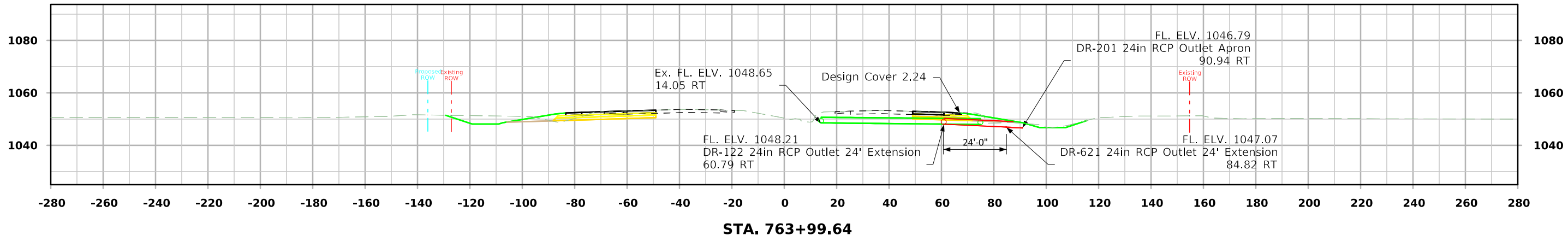

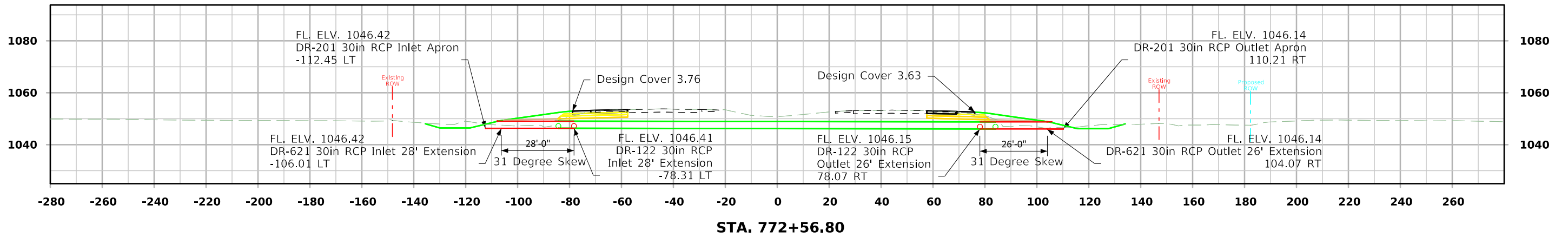
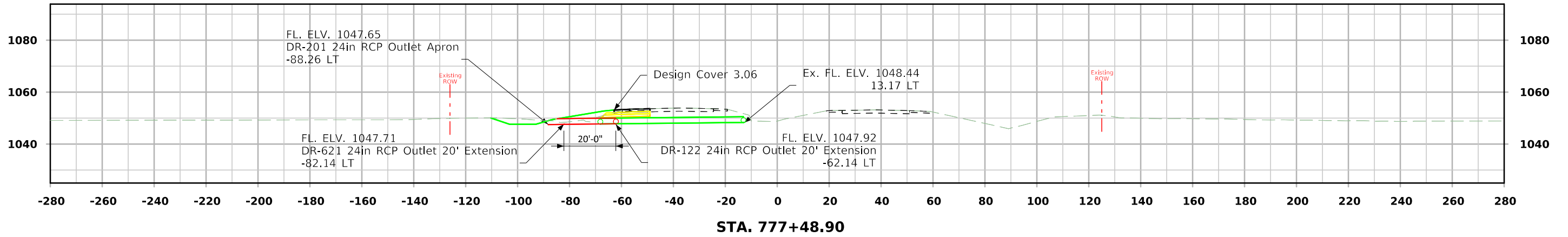

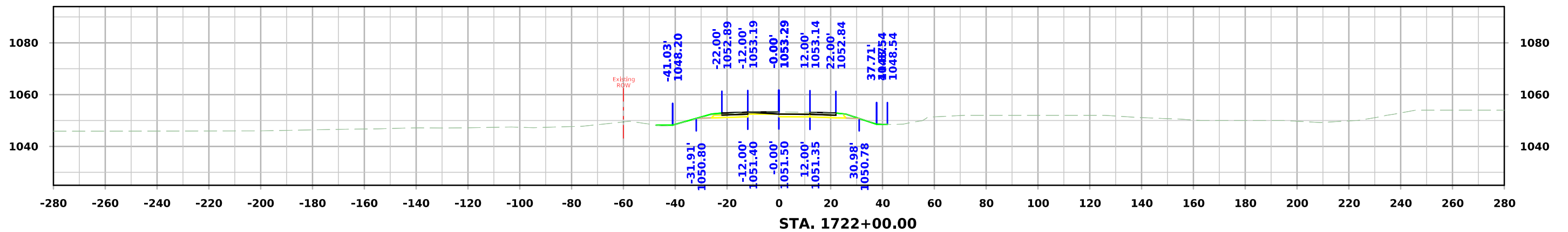
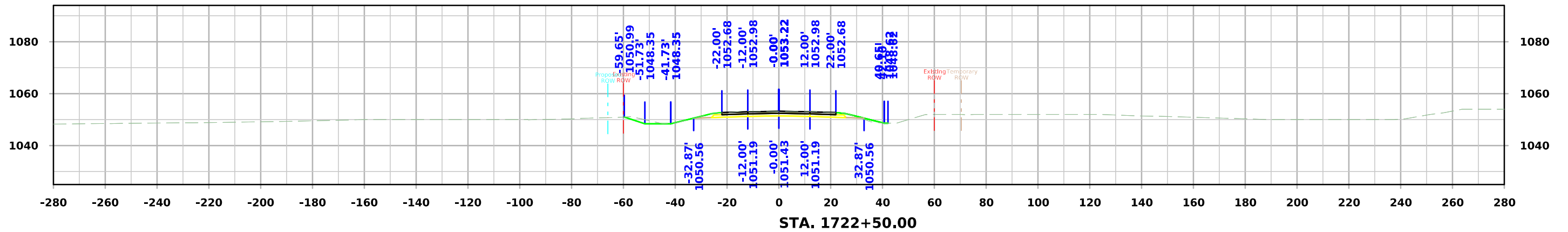
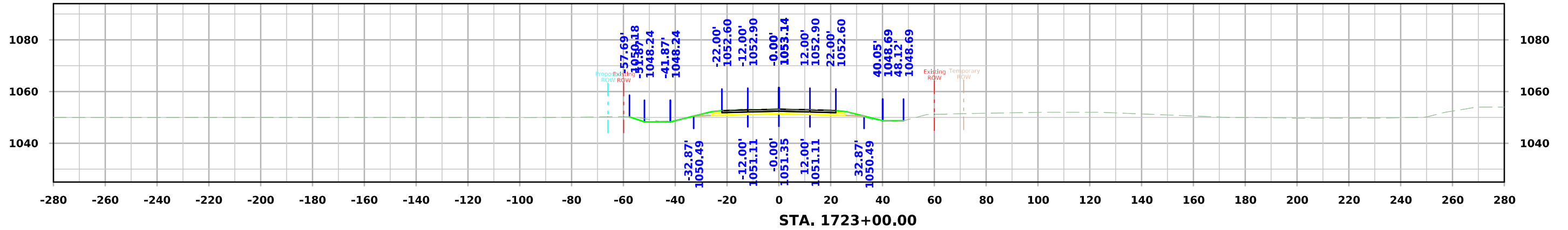

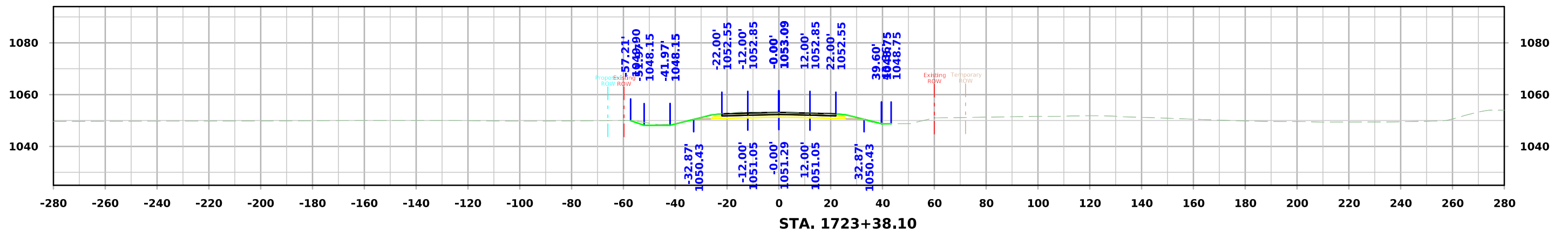
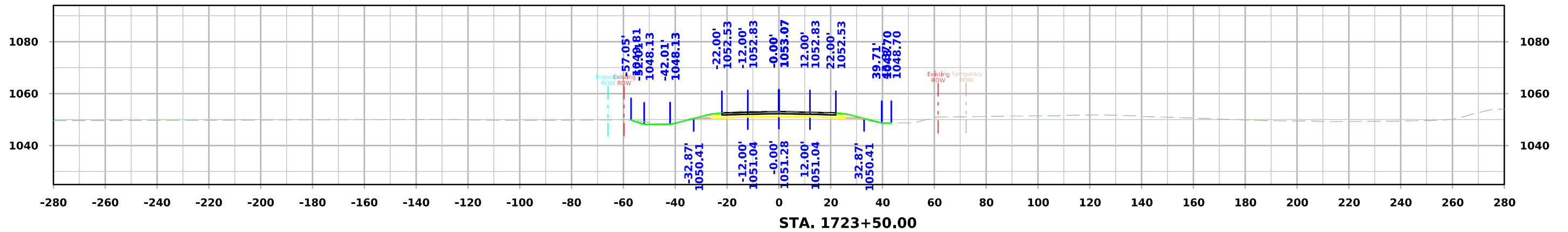
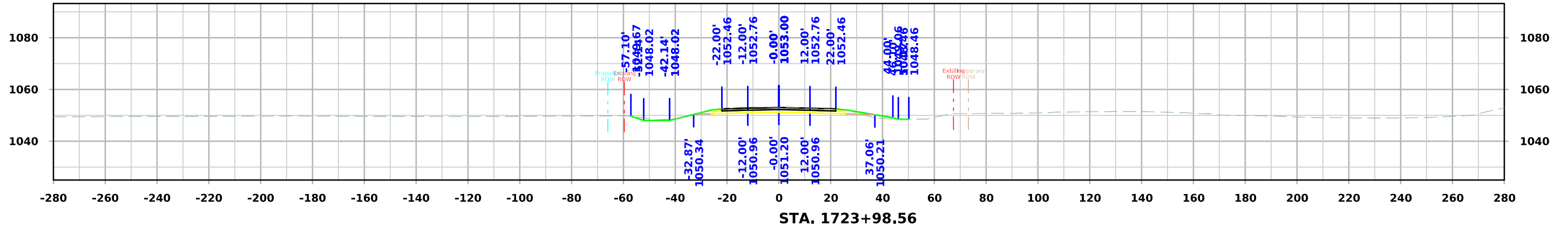

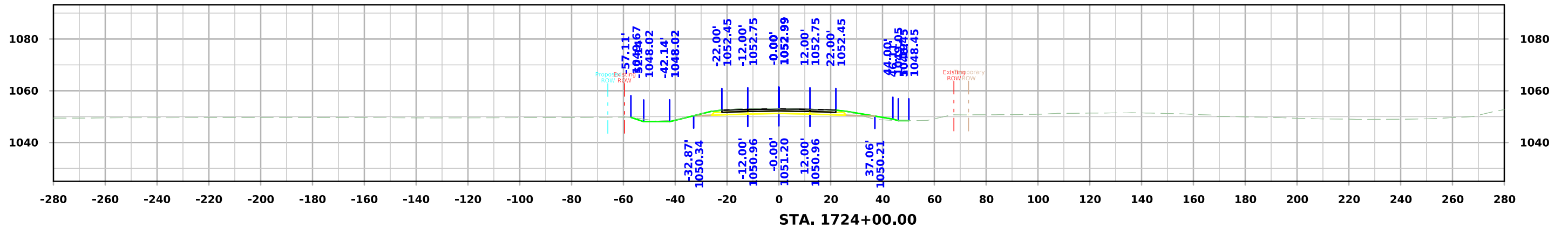
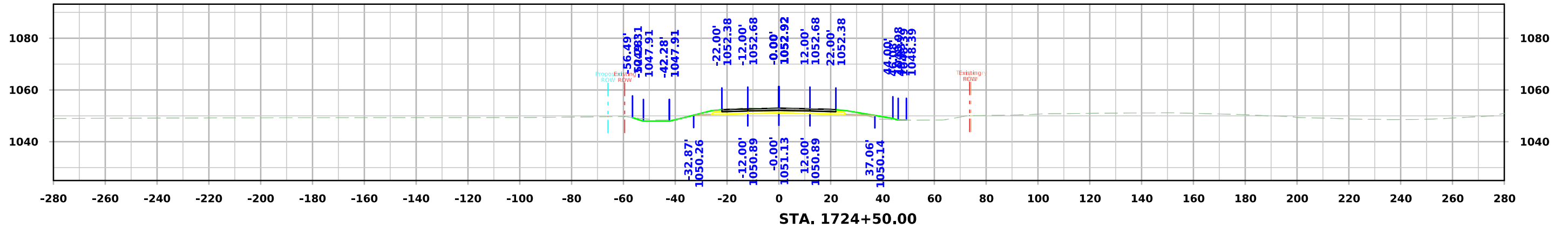
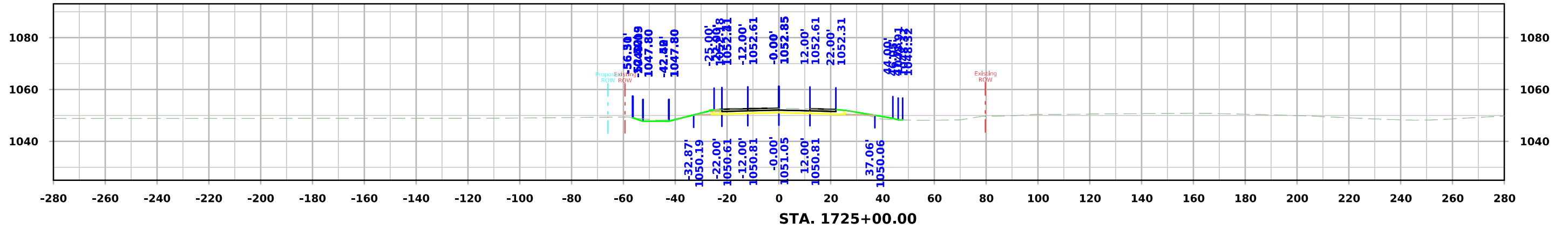

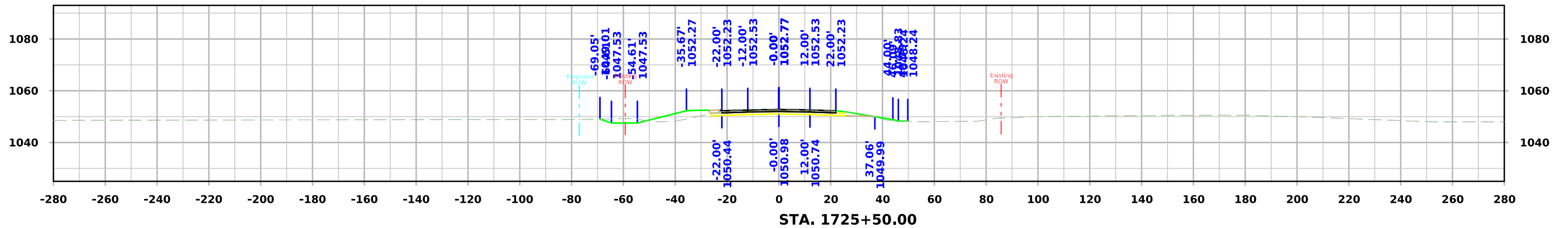
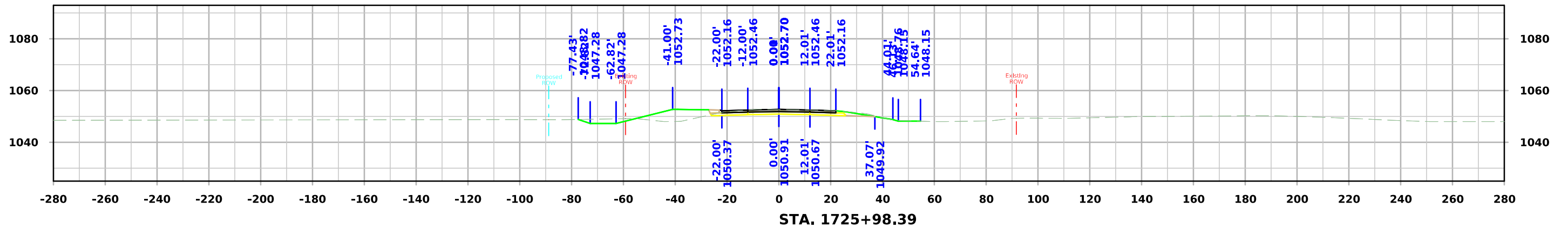
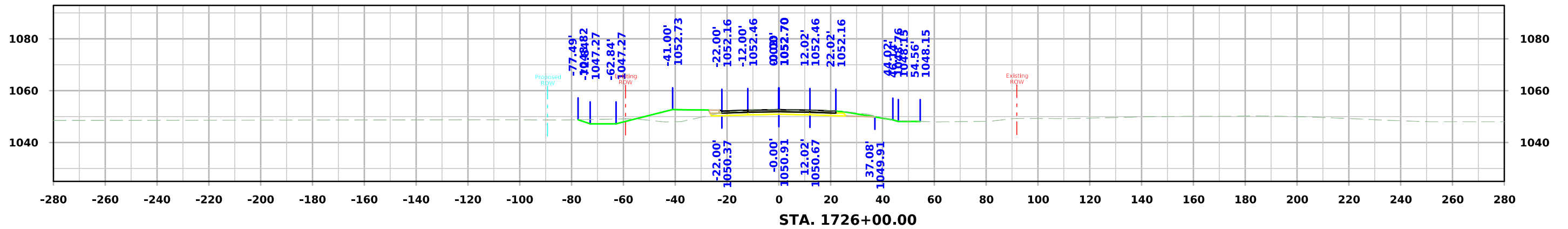

IA 175

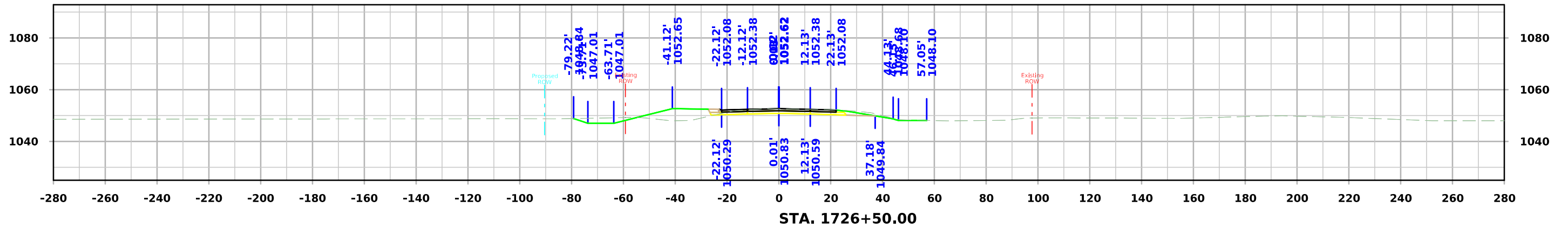
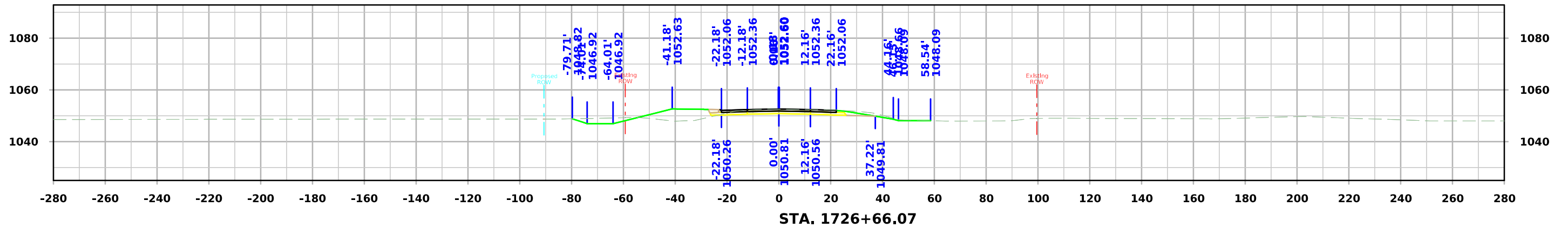
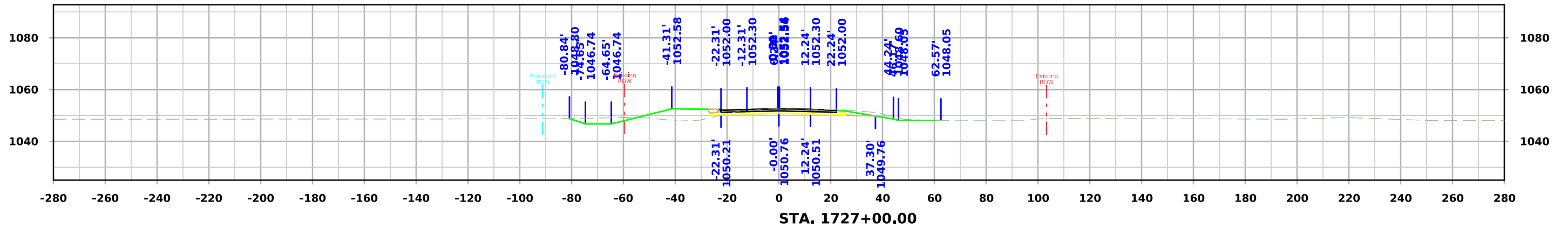

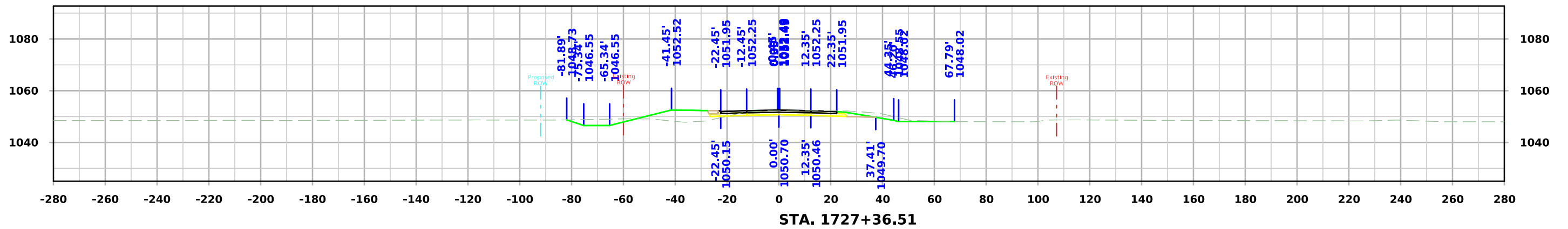
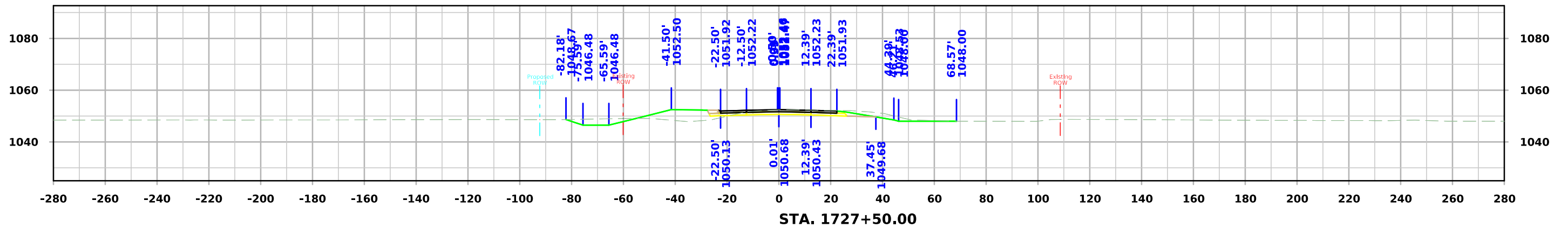
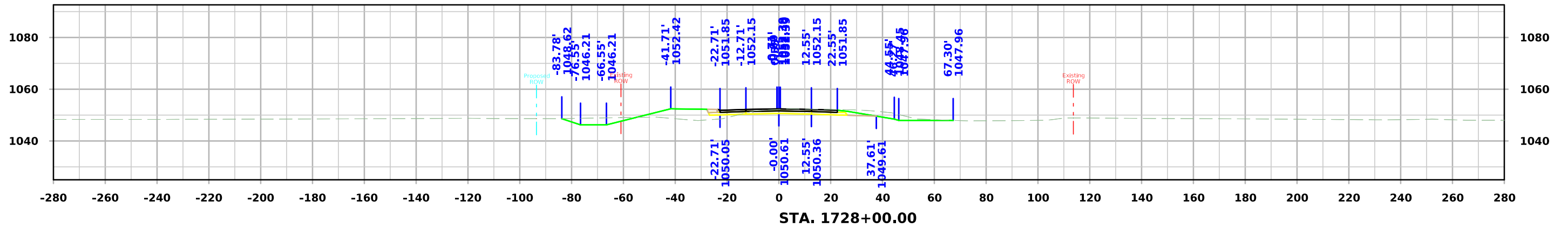

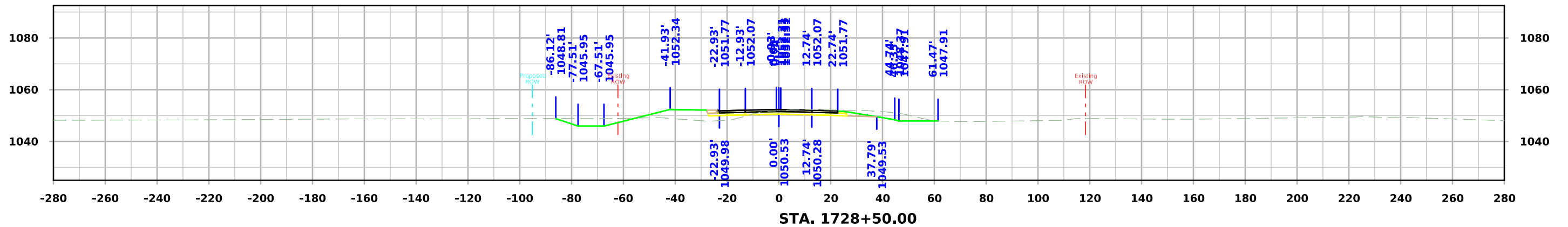
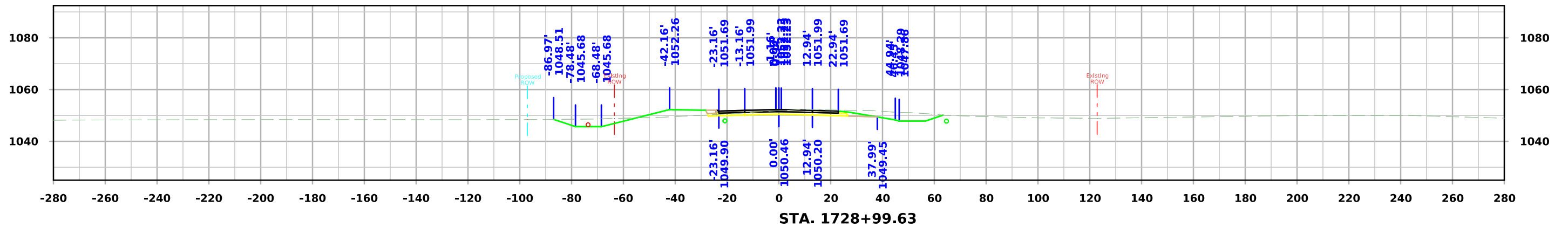
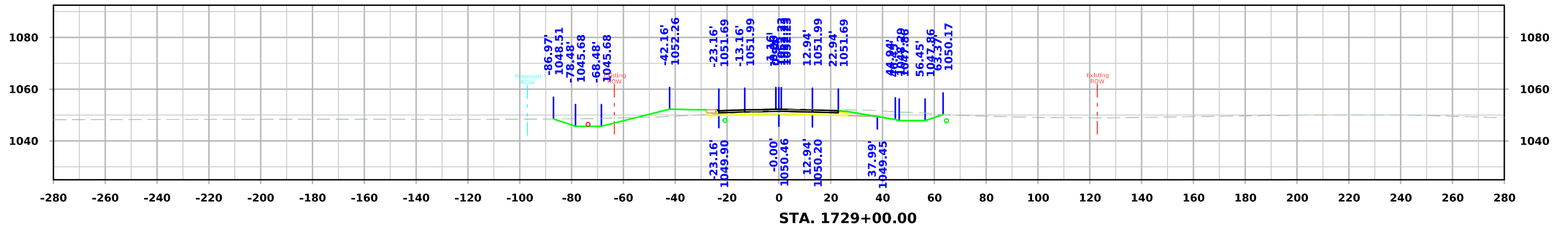

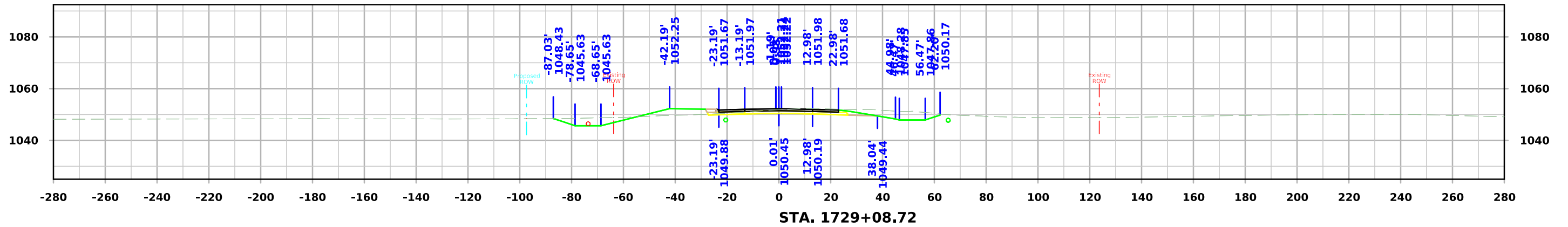
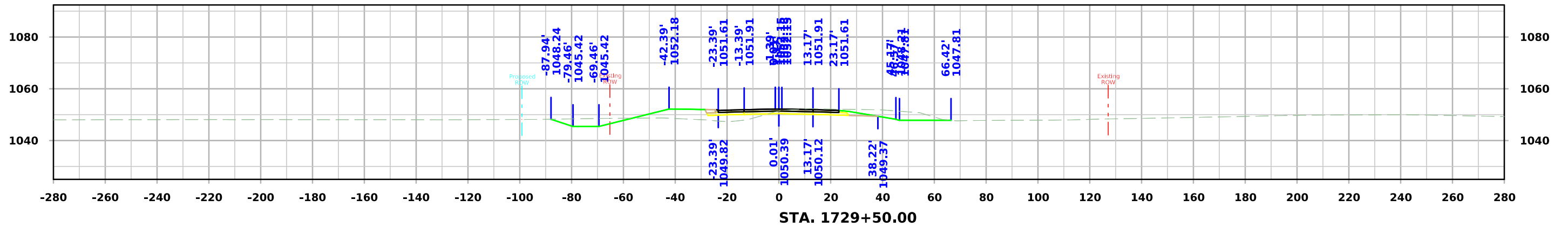
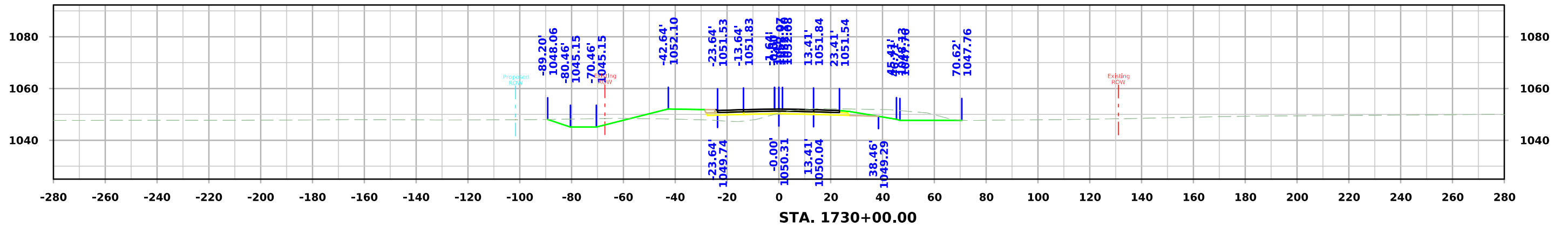

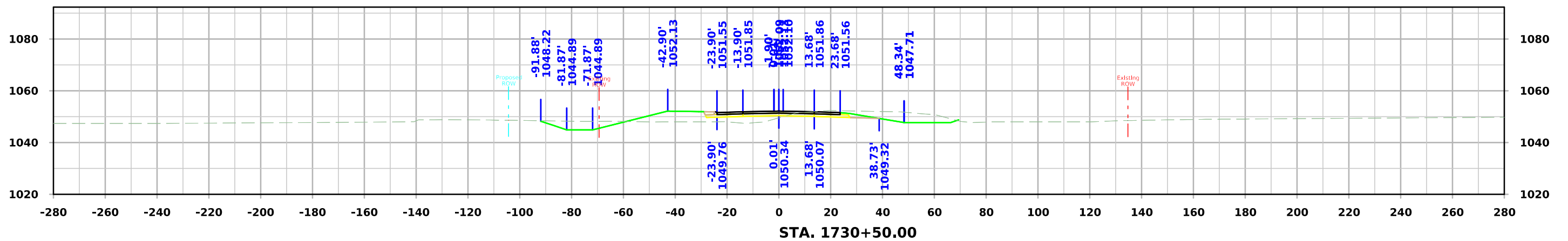
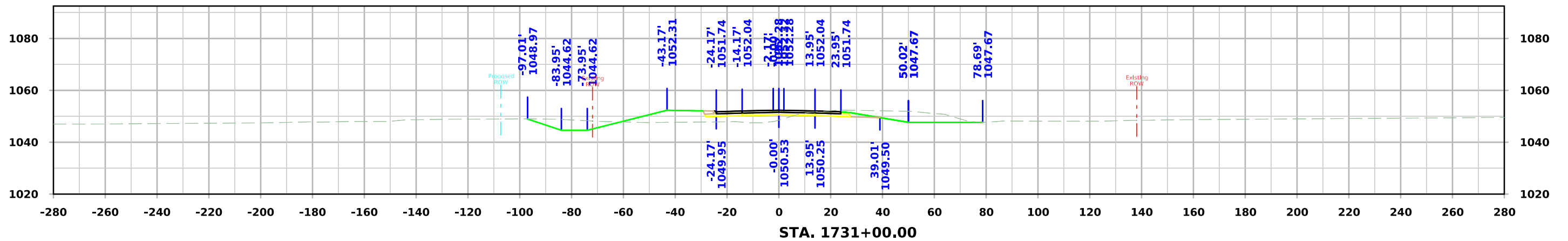
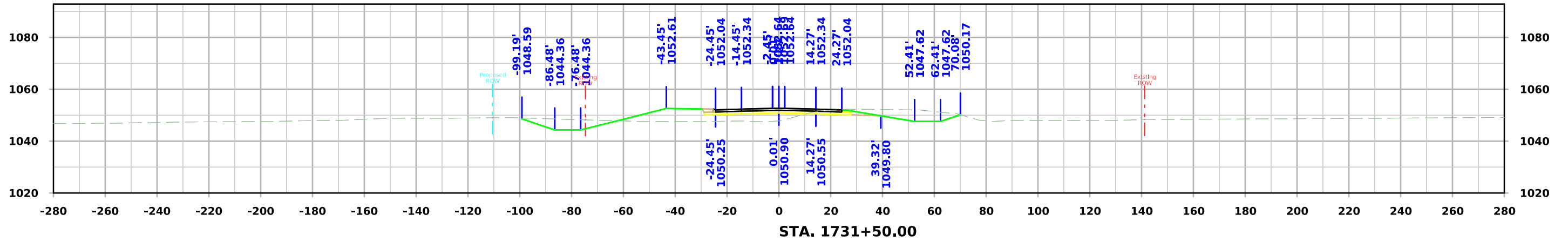

IA 175

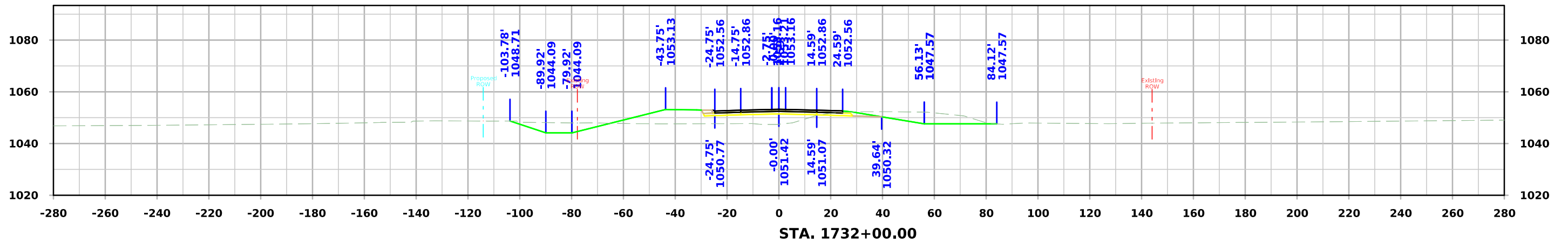
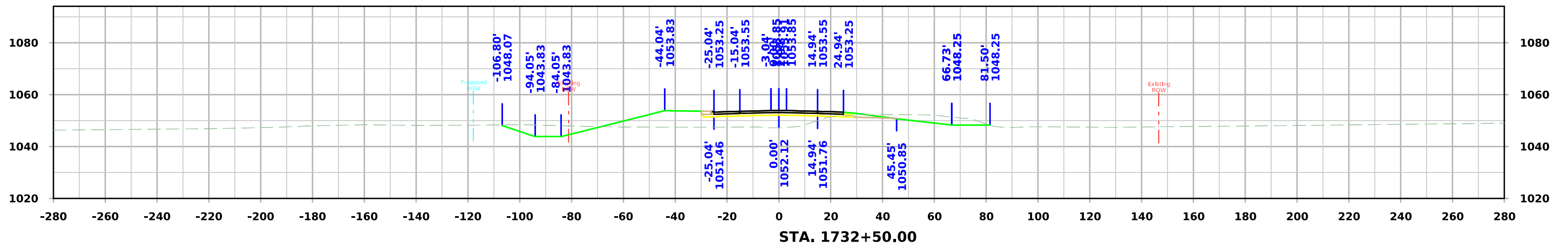
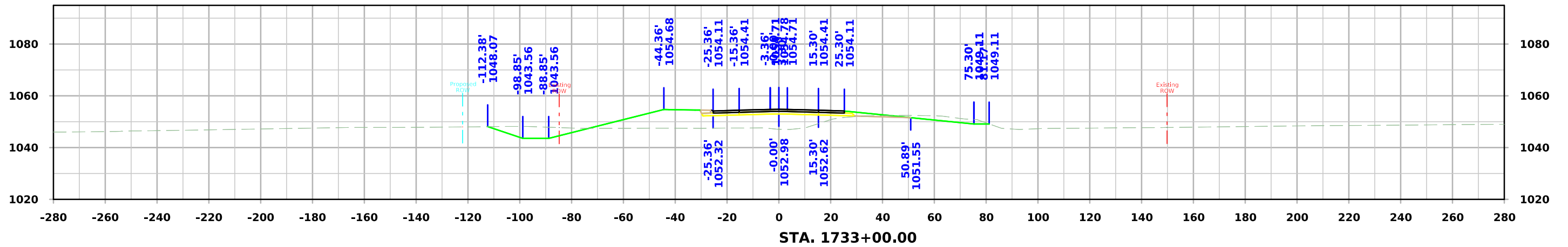

IA 175

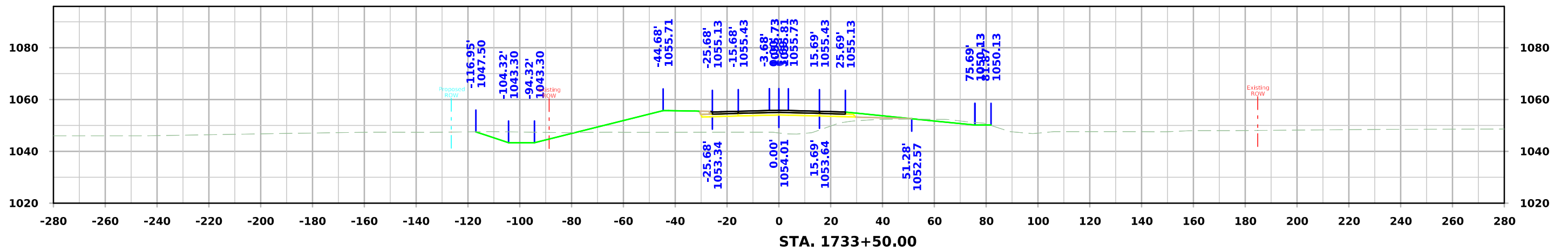
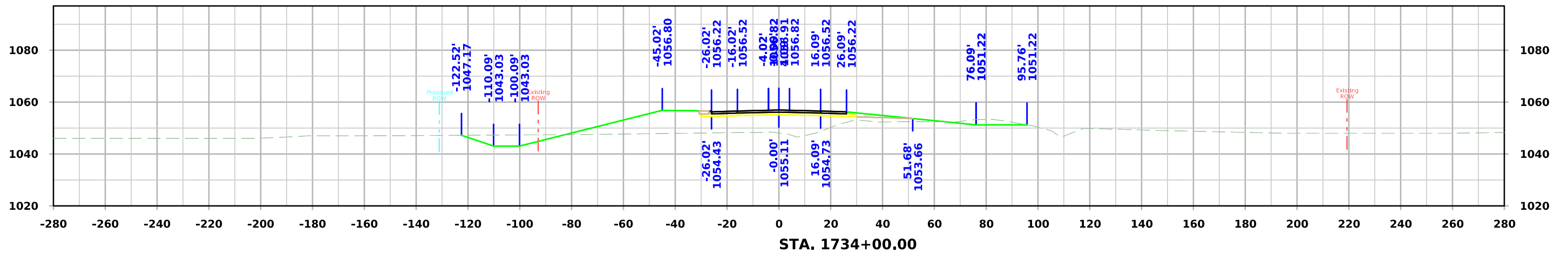
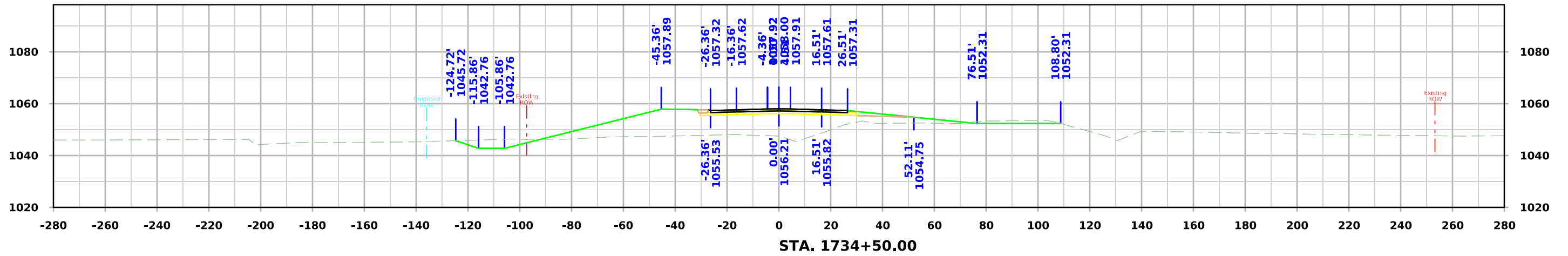

IA 175

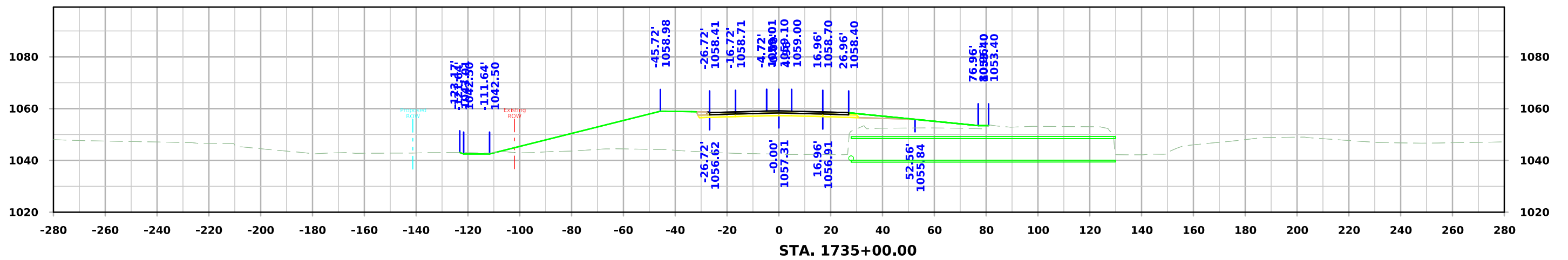
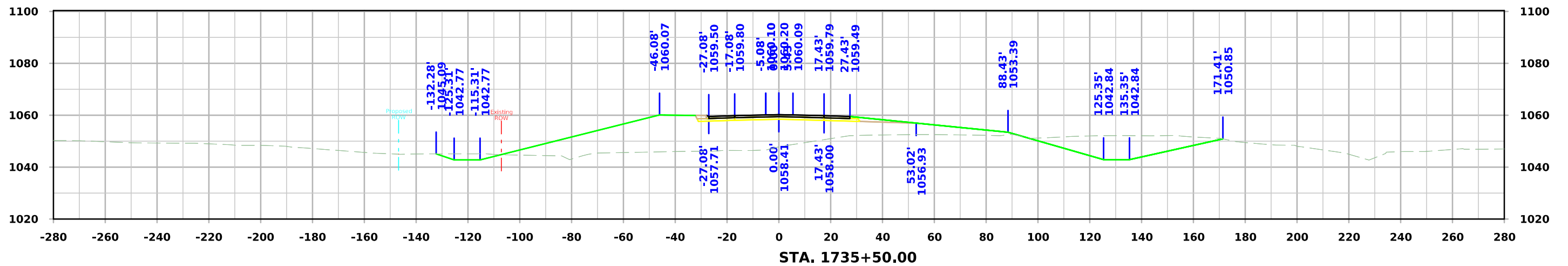
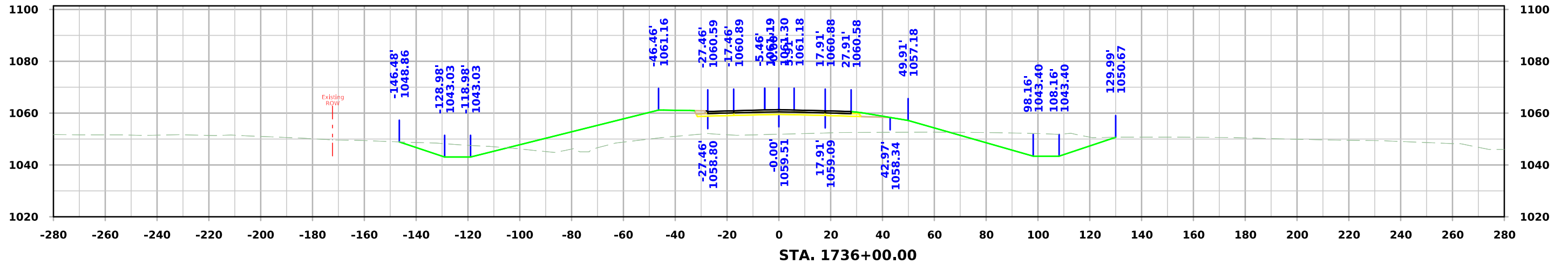

IA 175

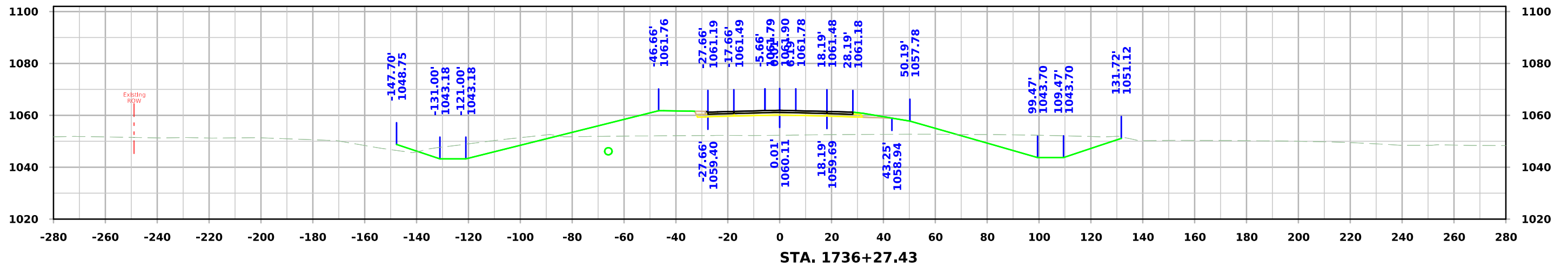
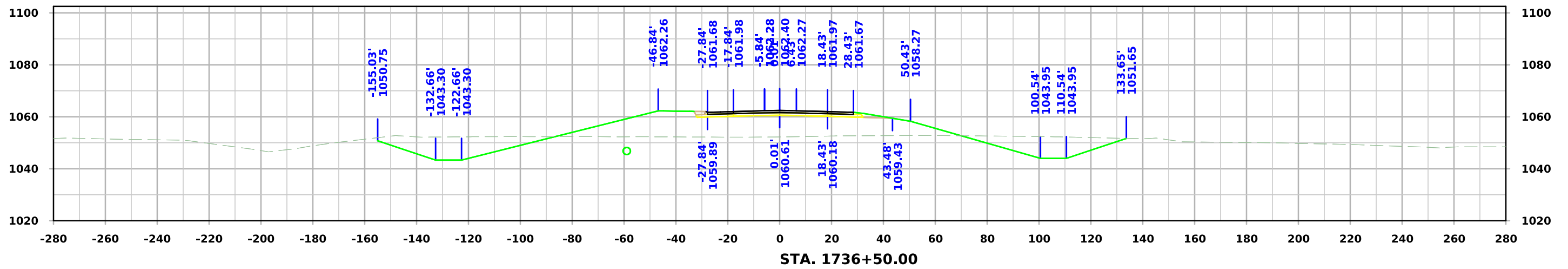
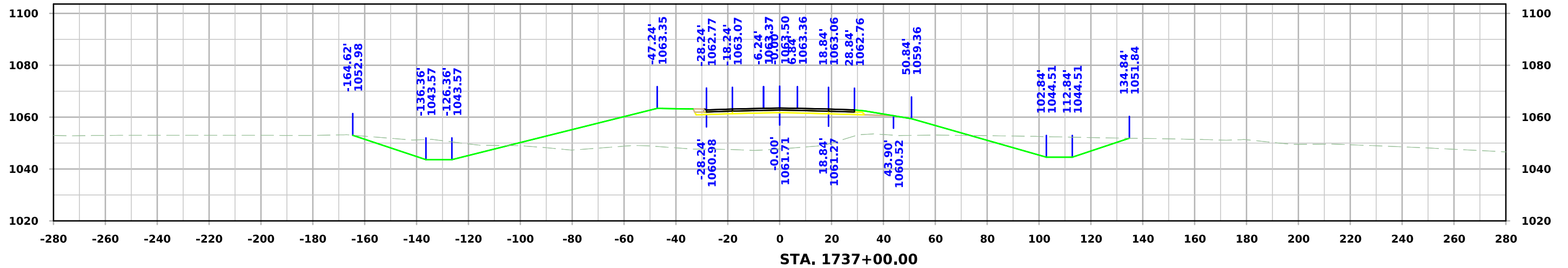

IA 175

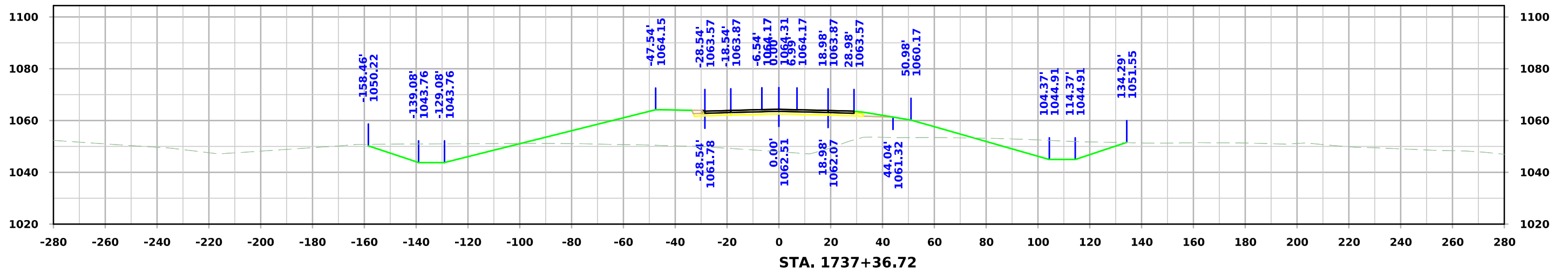
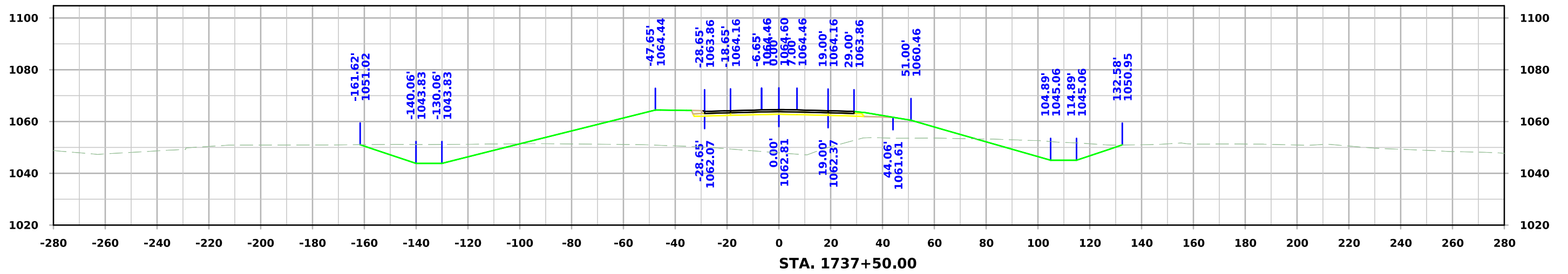
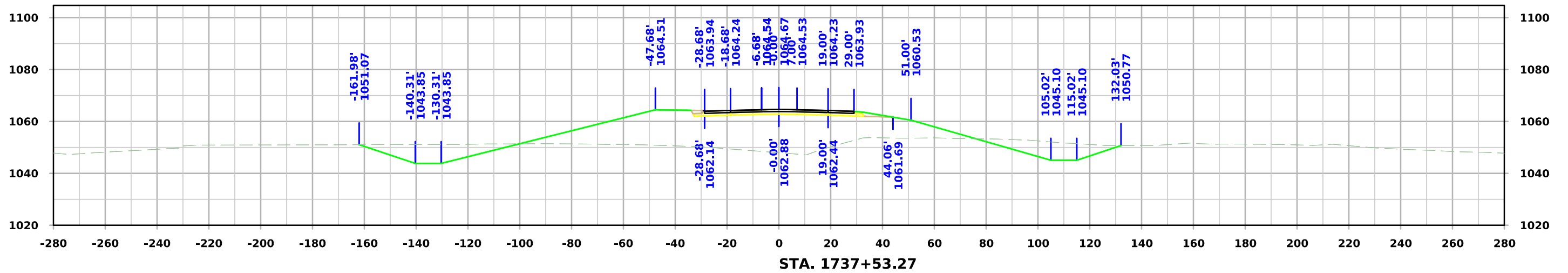

IA 175

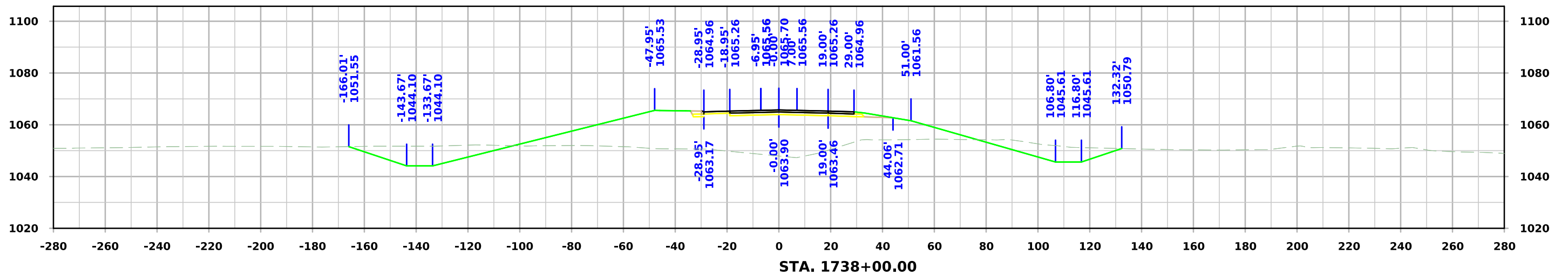
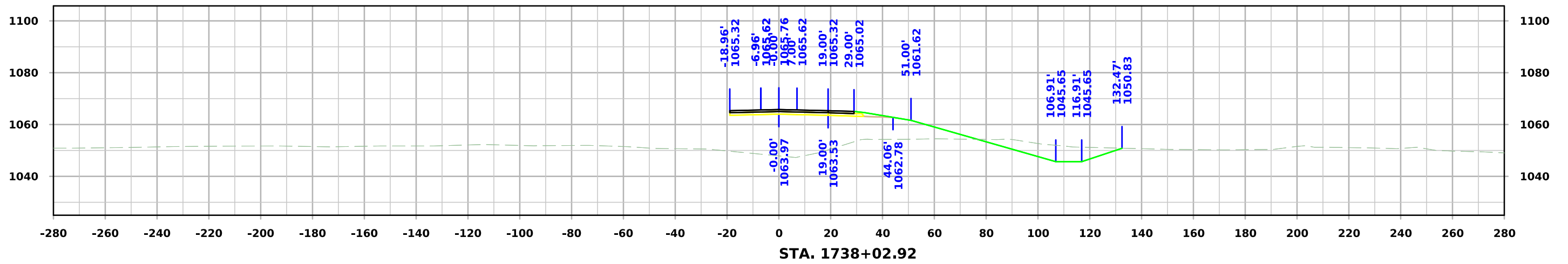
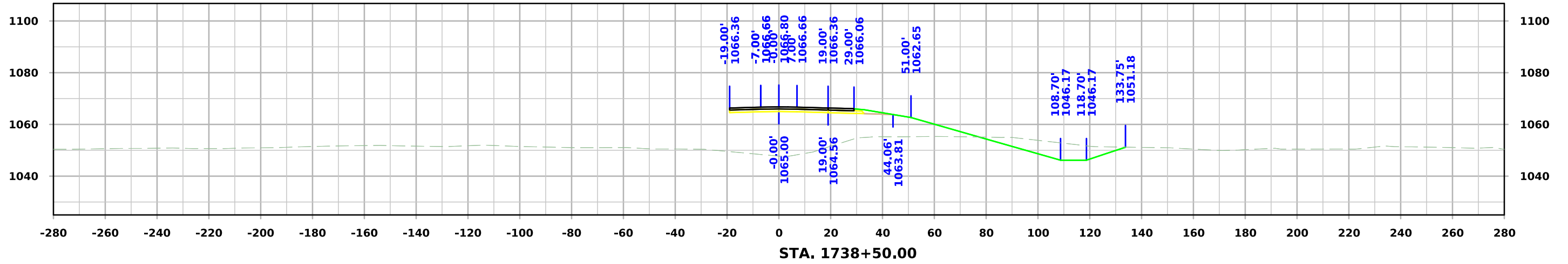

IA 175

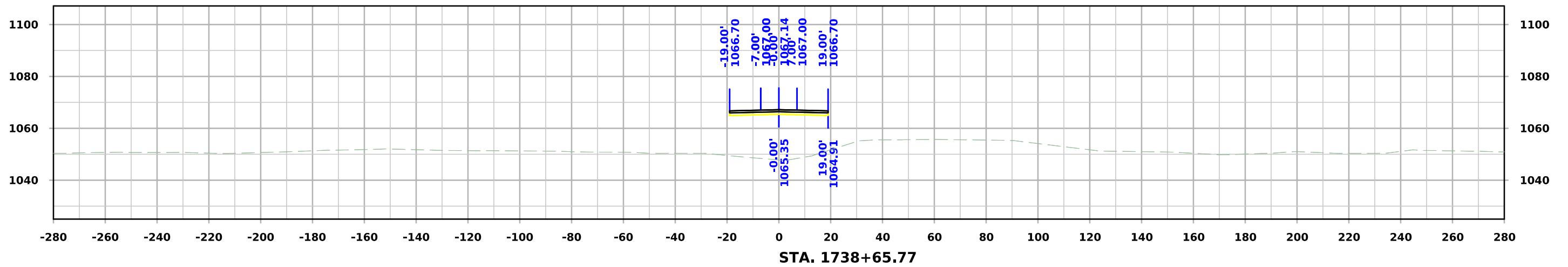
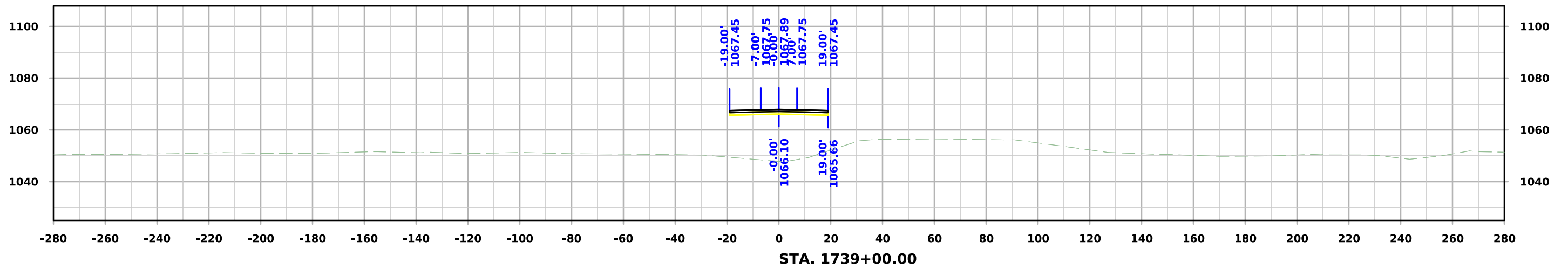
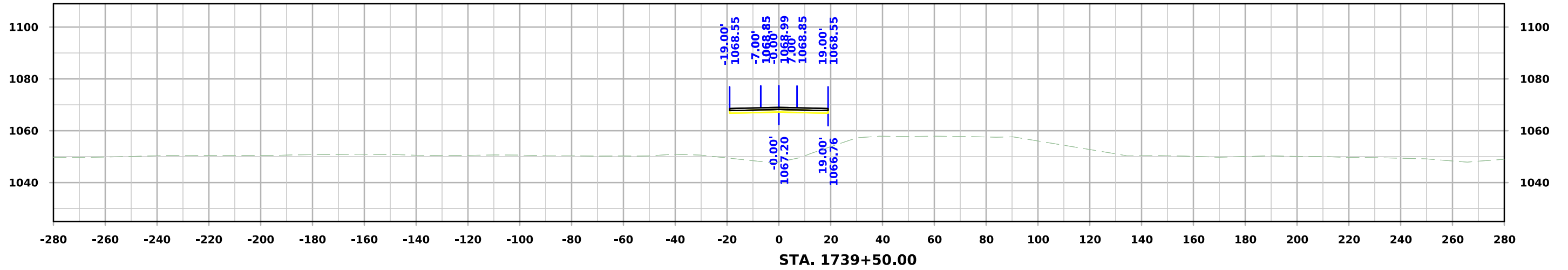

IA 175

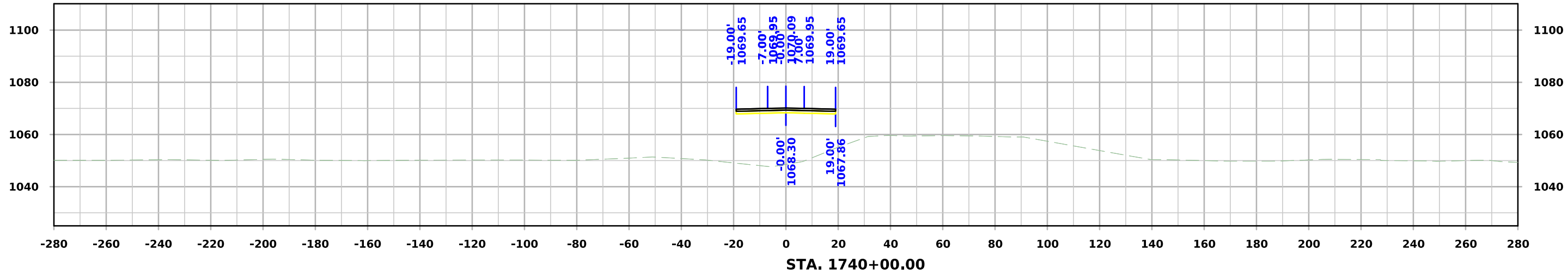
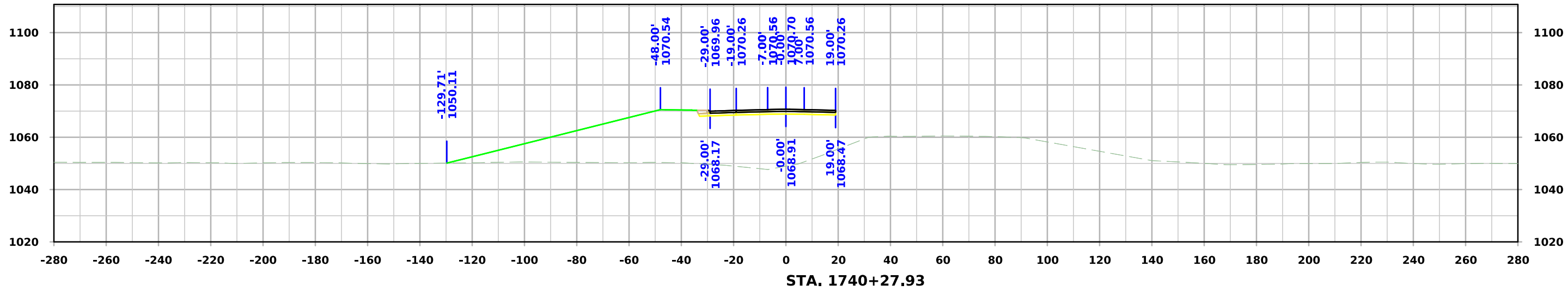
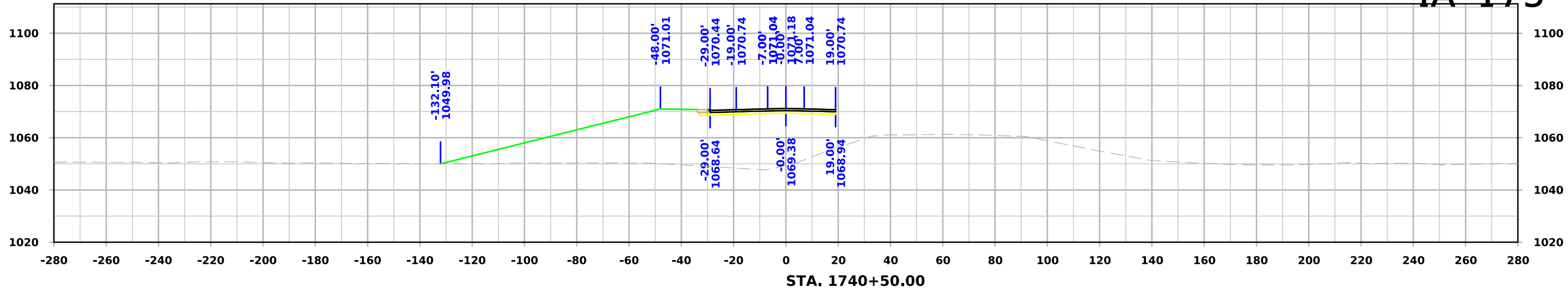

IA 175

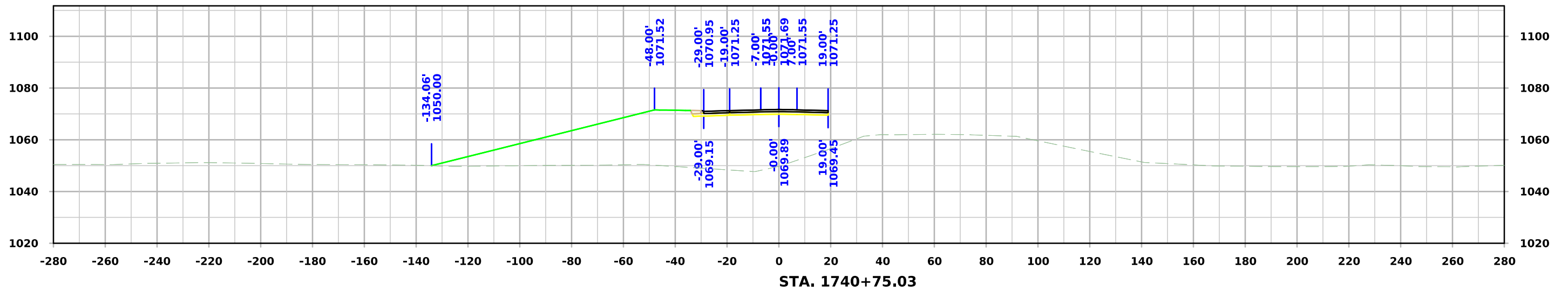
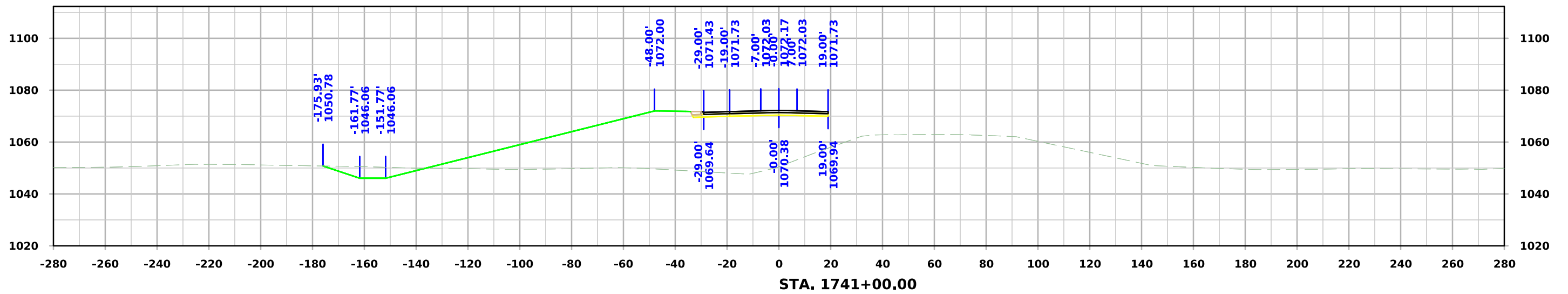
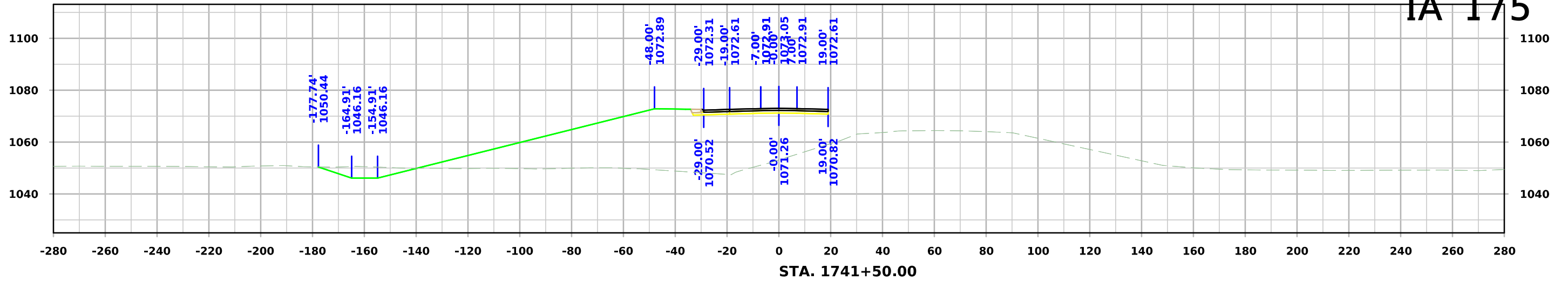

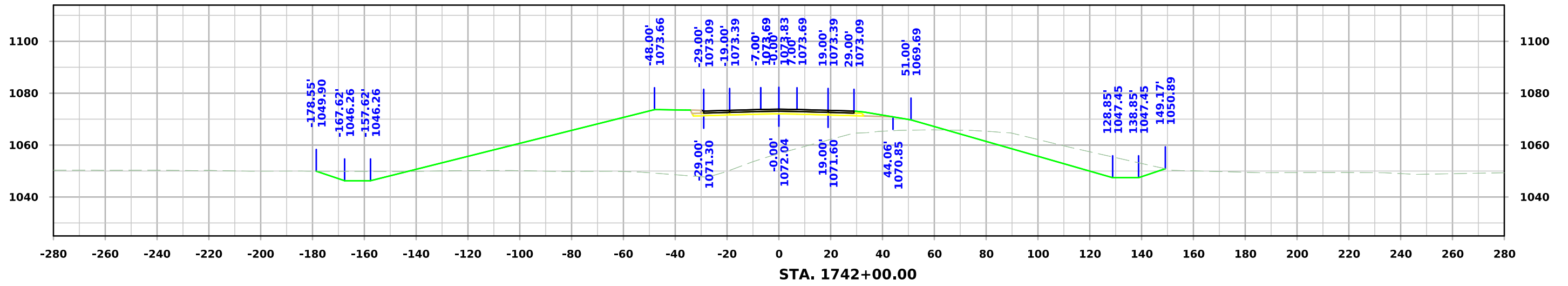
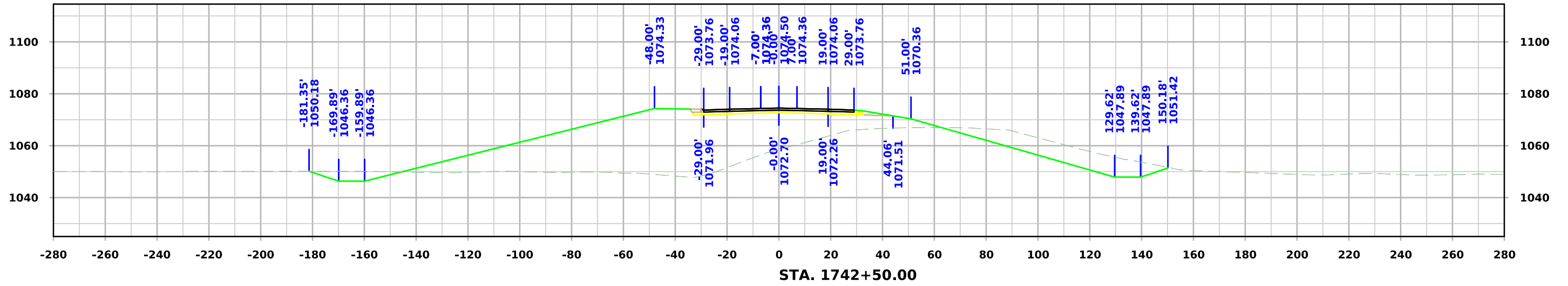
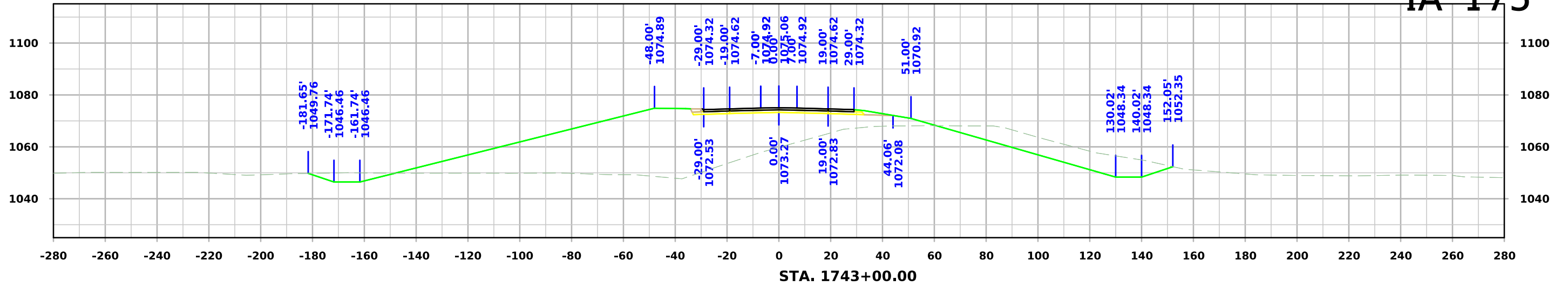

IA 175

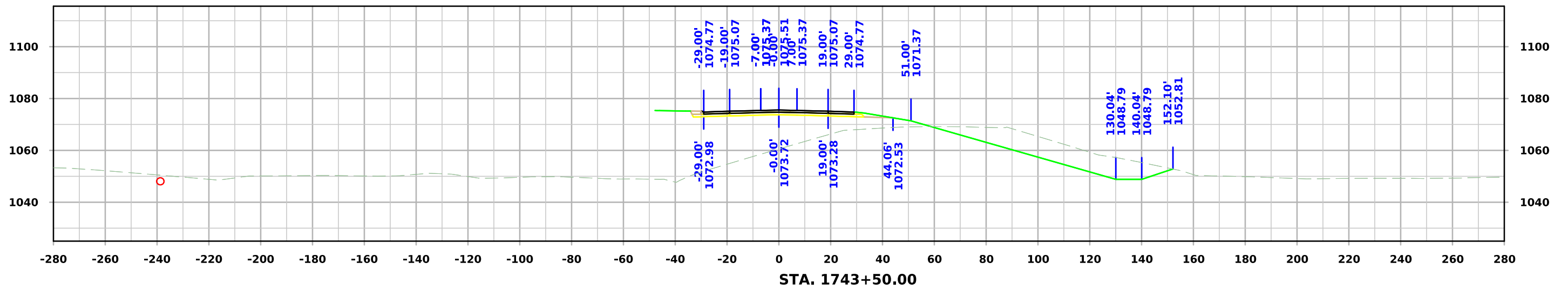
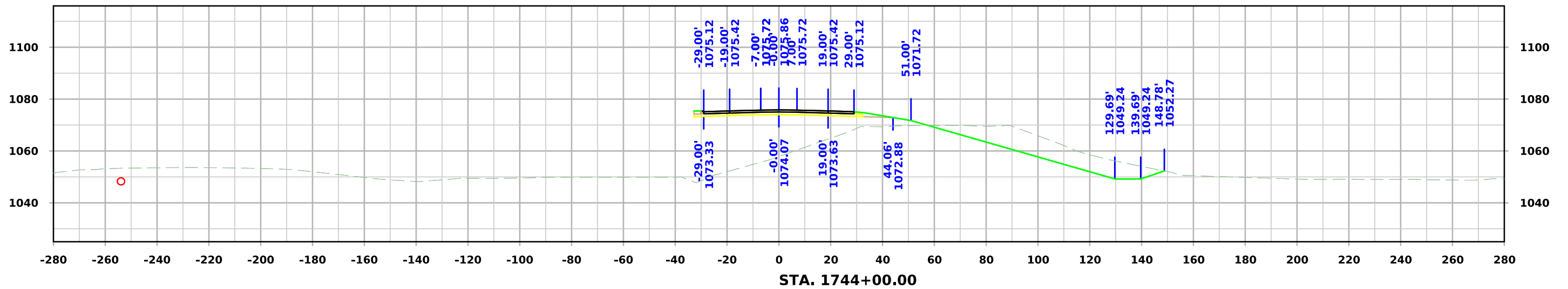
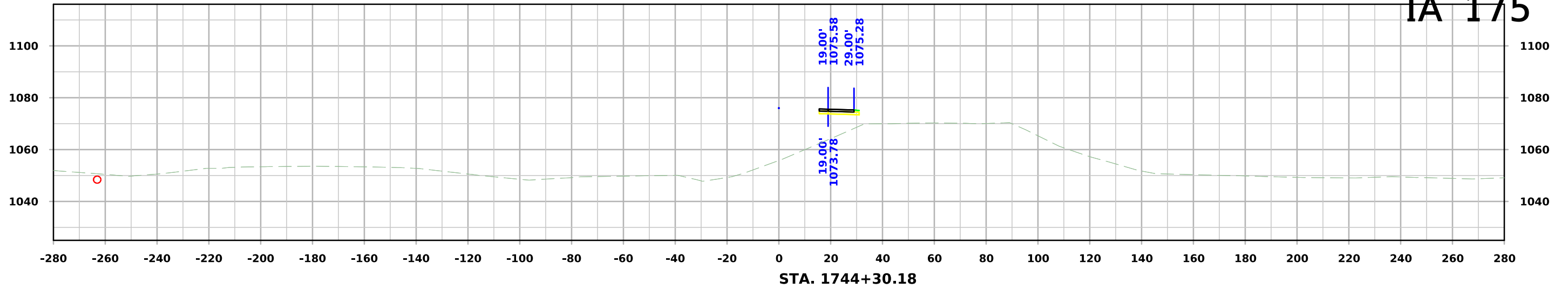

IA 175

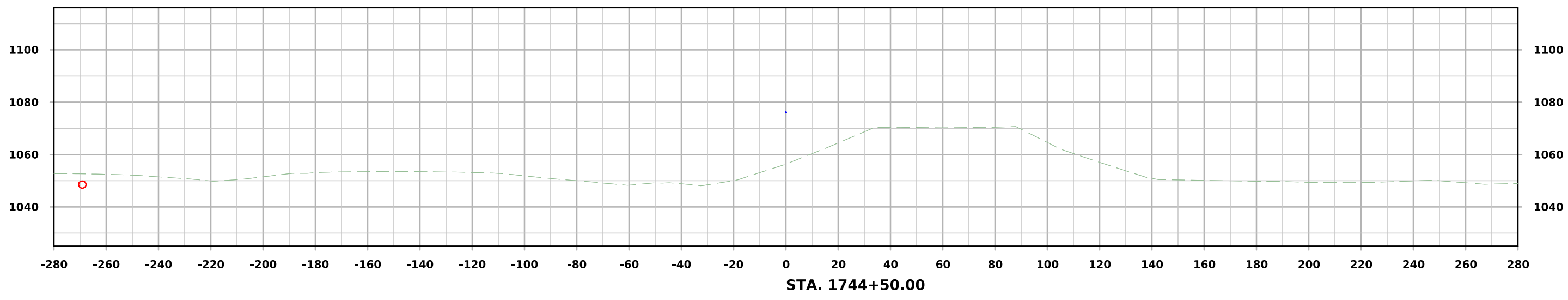
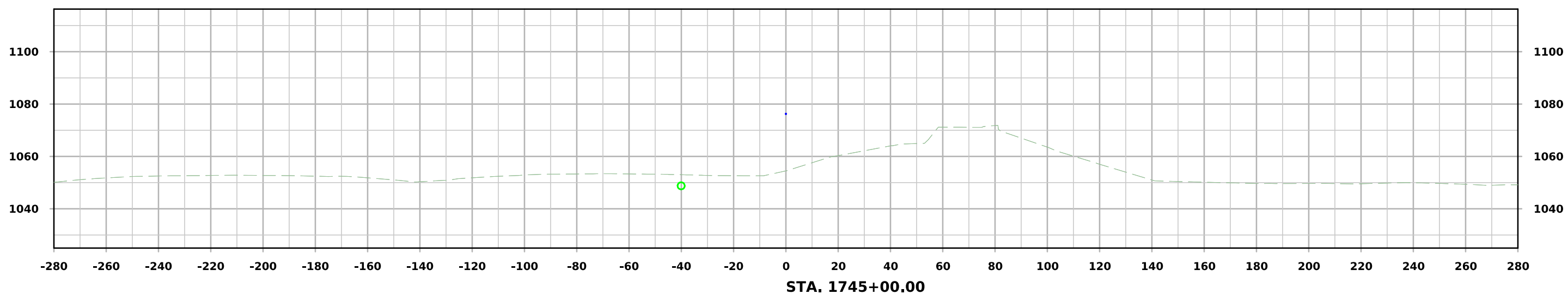
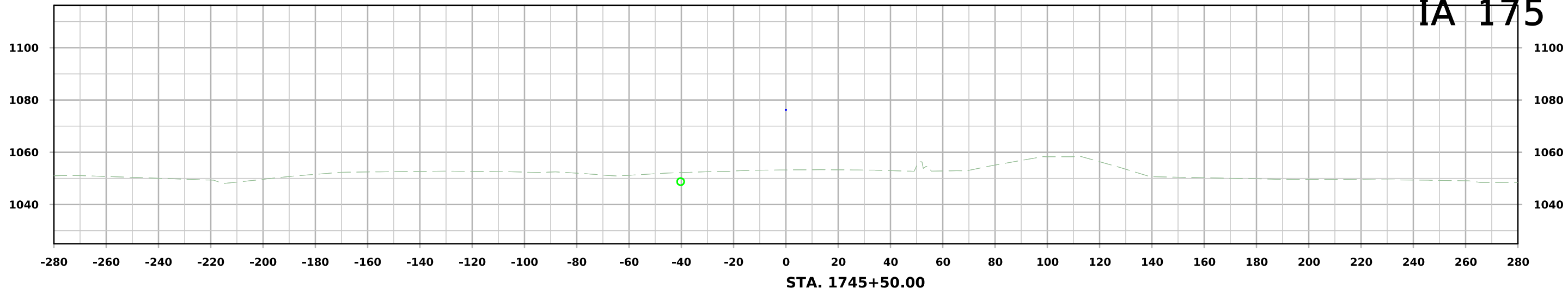

IA 175

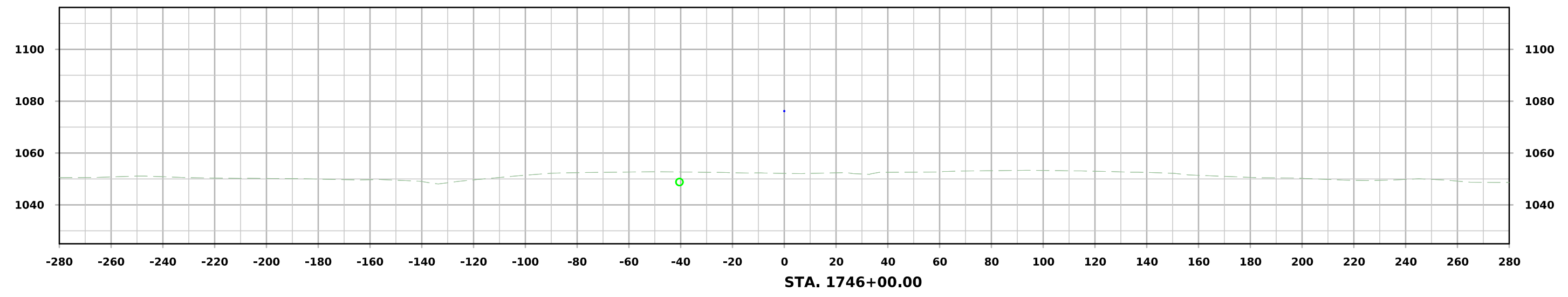
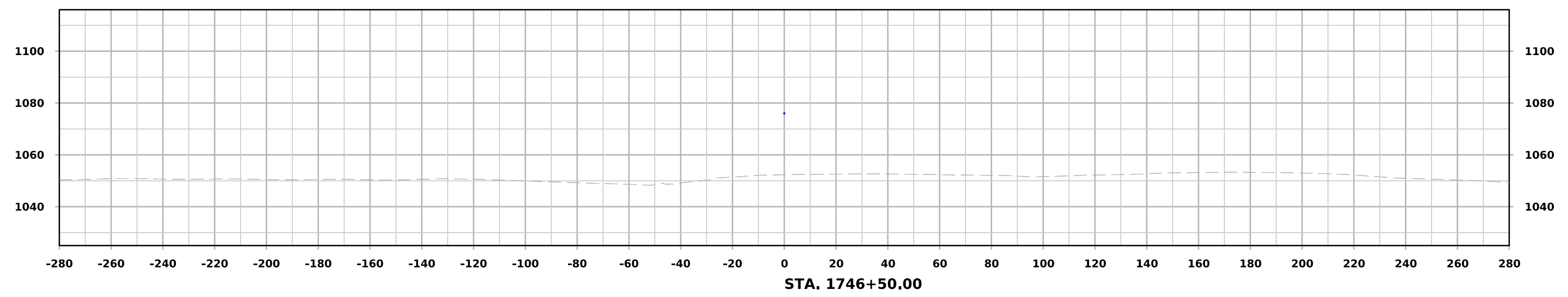
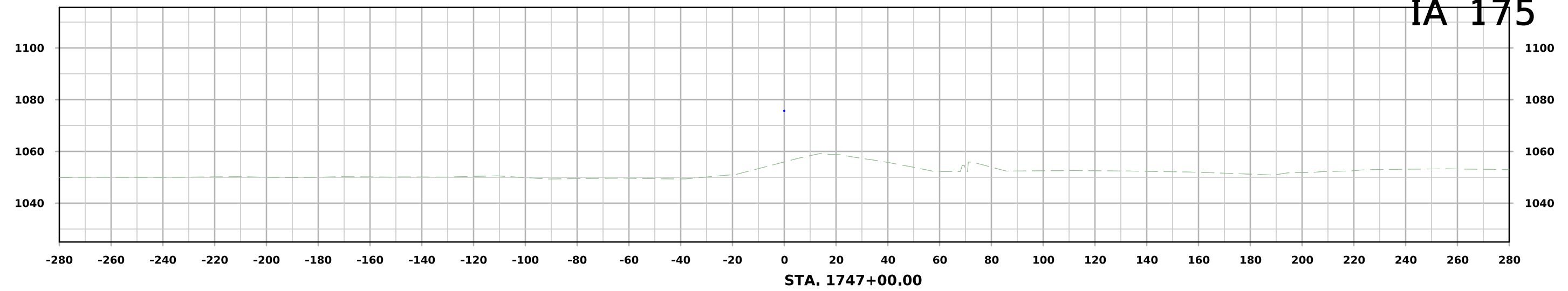

IA 175

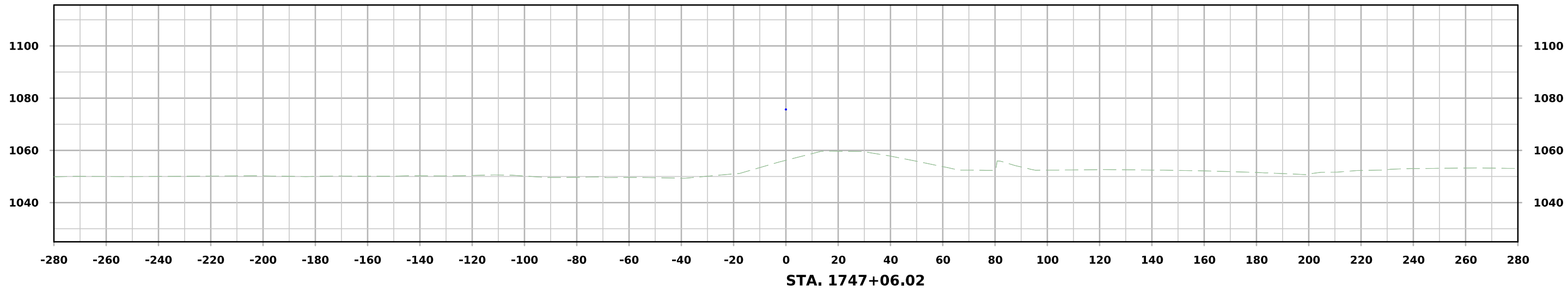
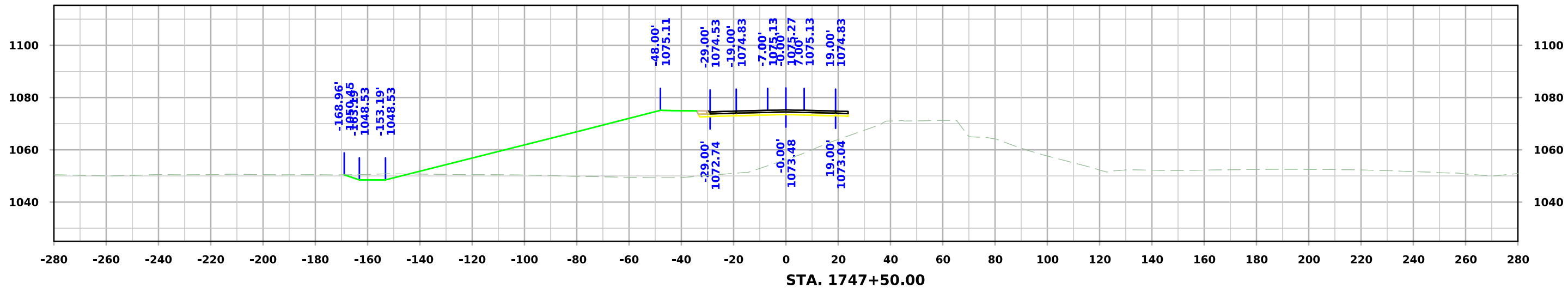
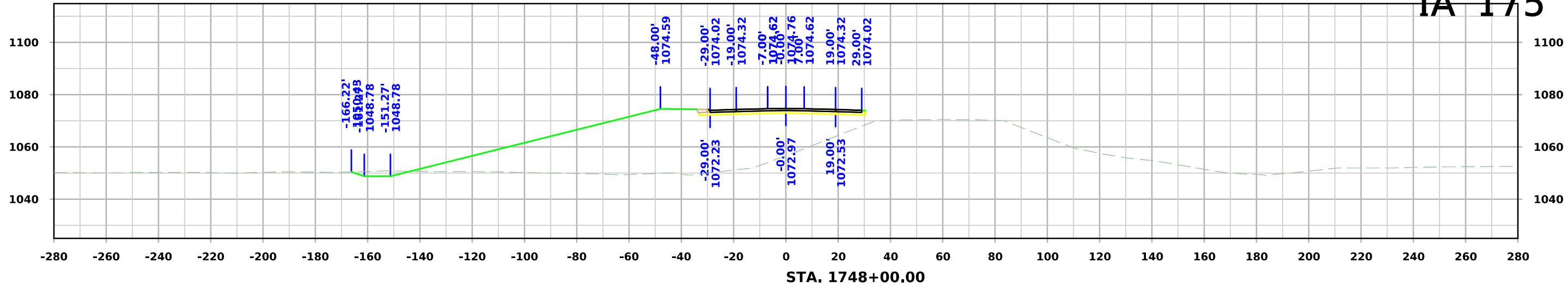

IA 175

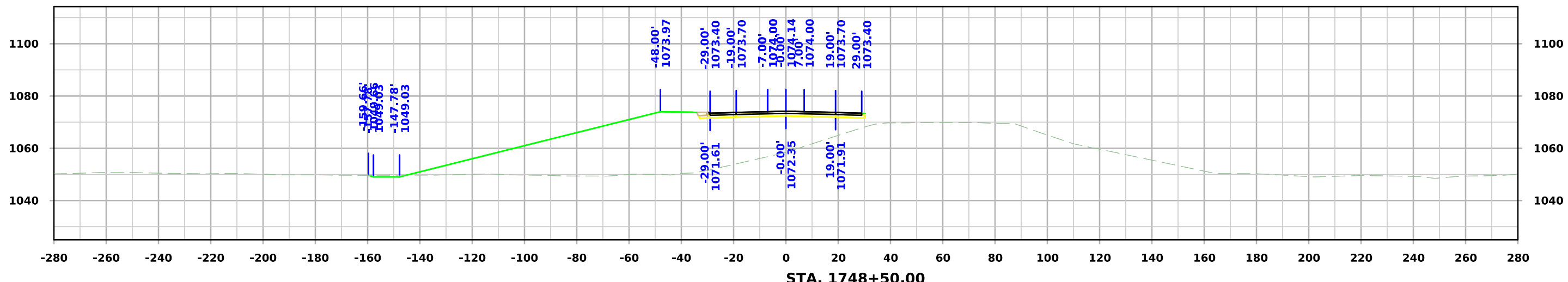
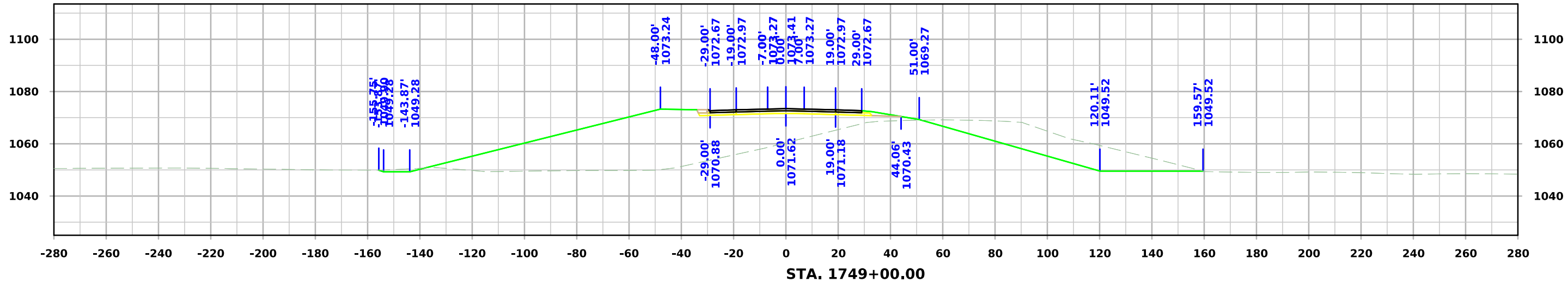
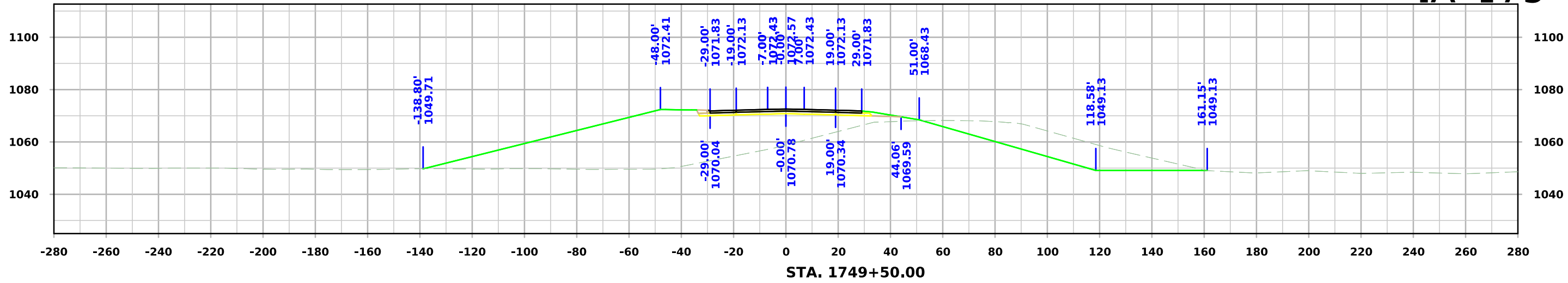

IA 175

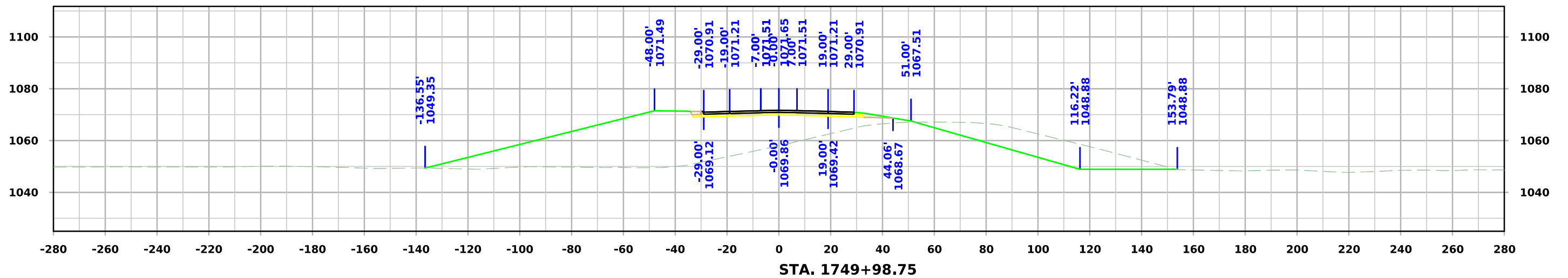
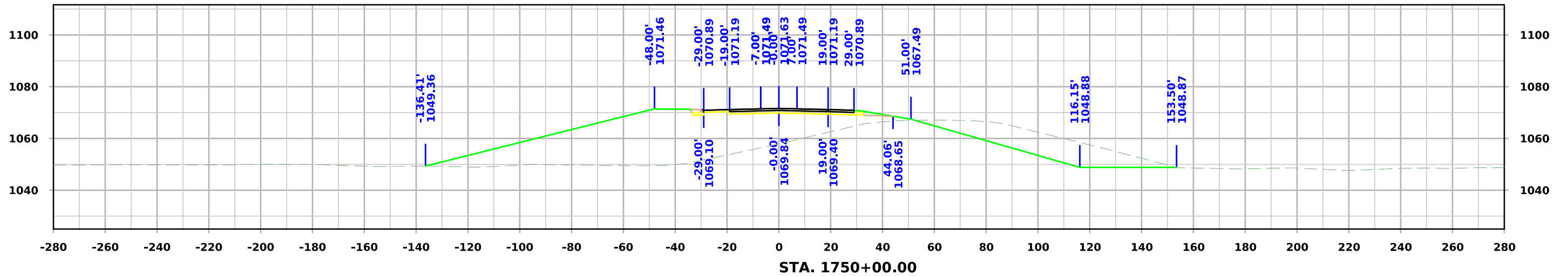
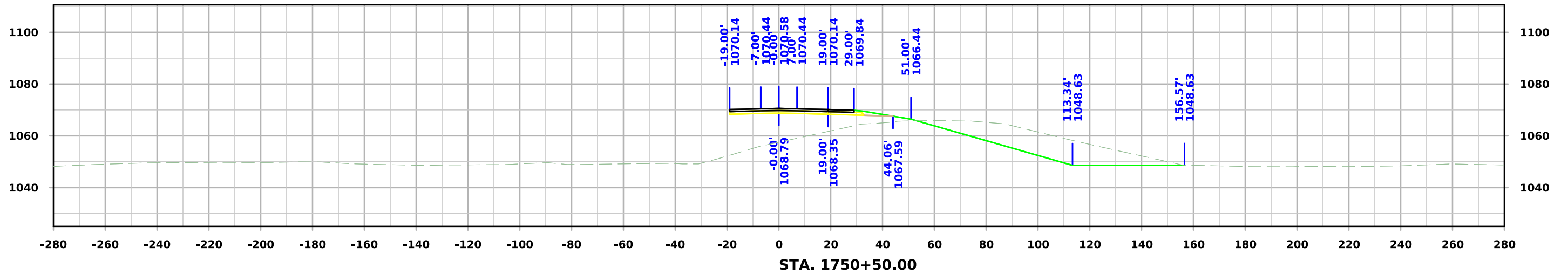

IA 175

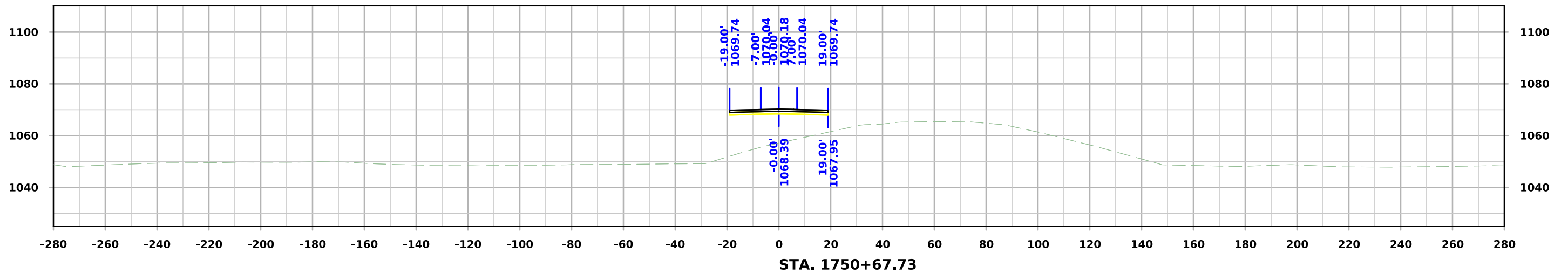
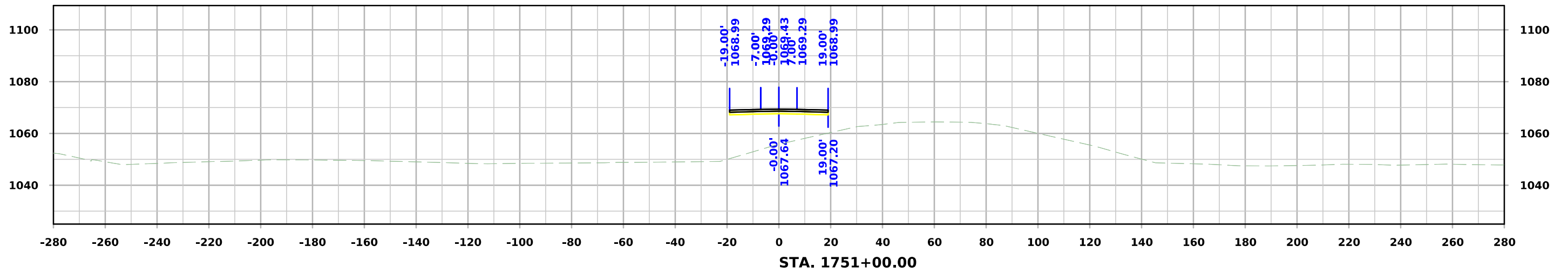
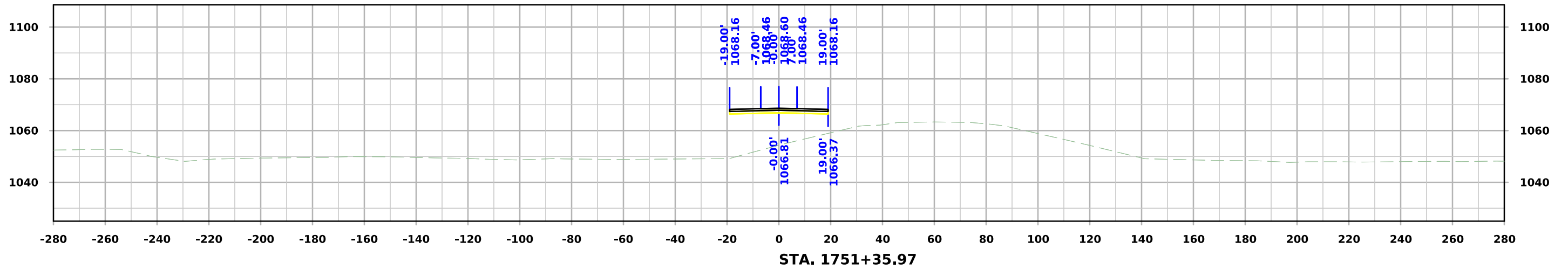

IA 175

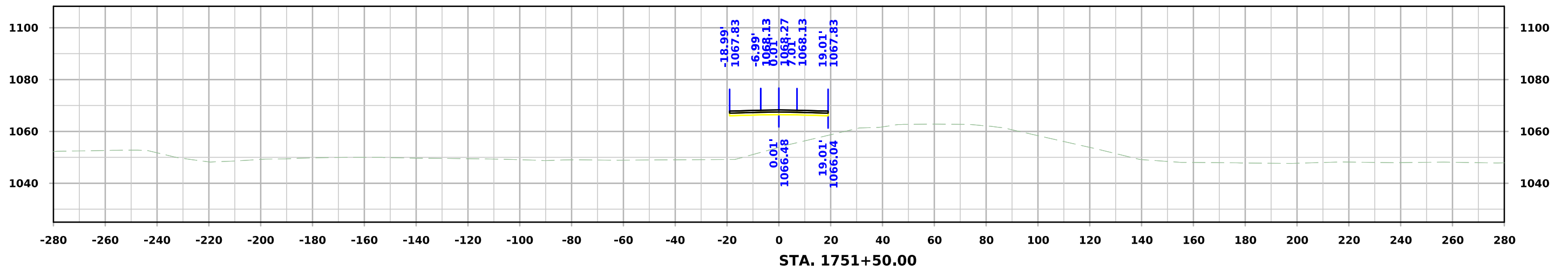
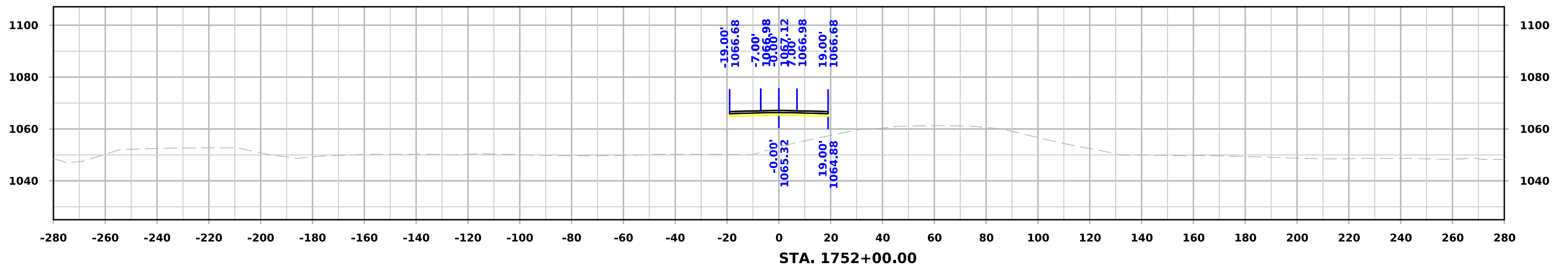
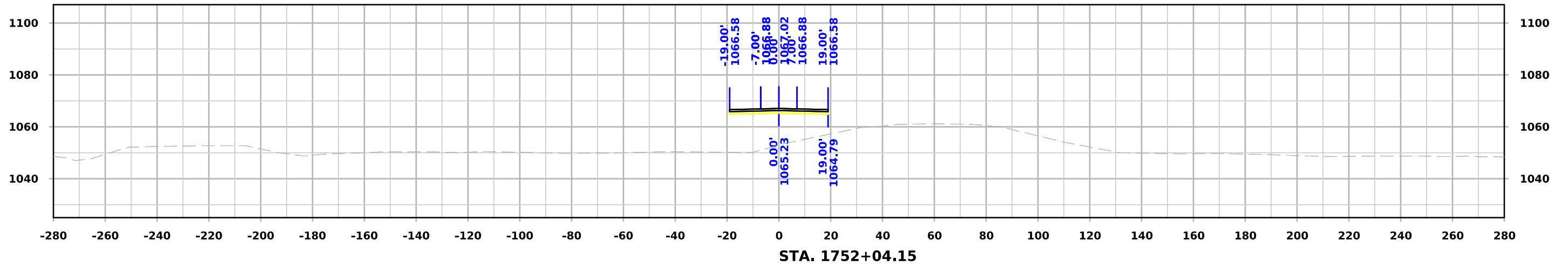

IA 175

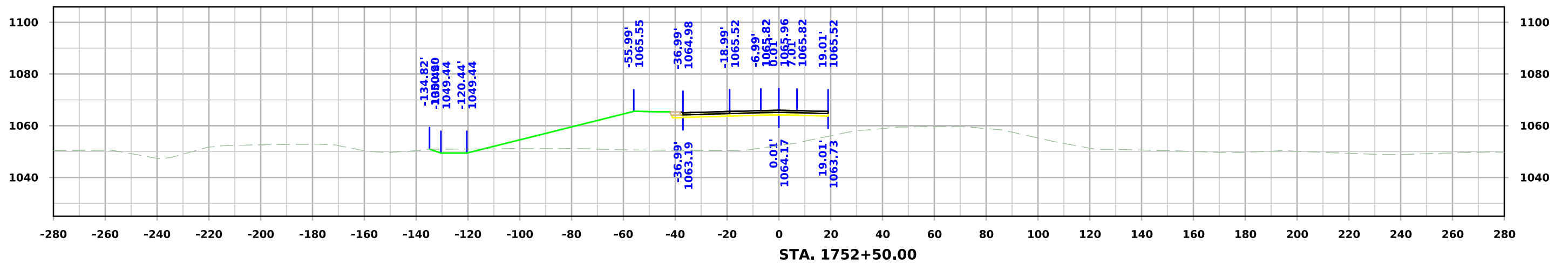
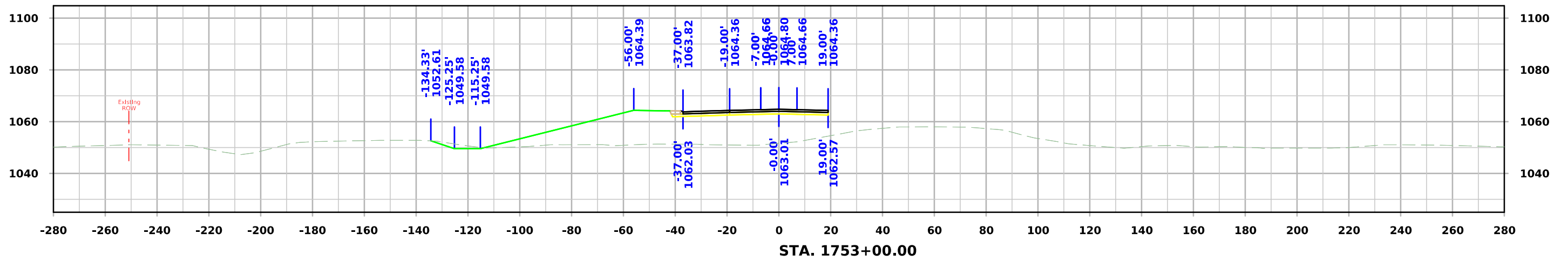
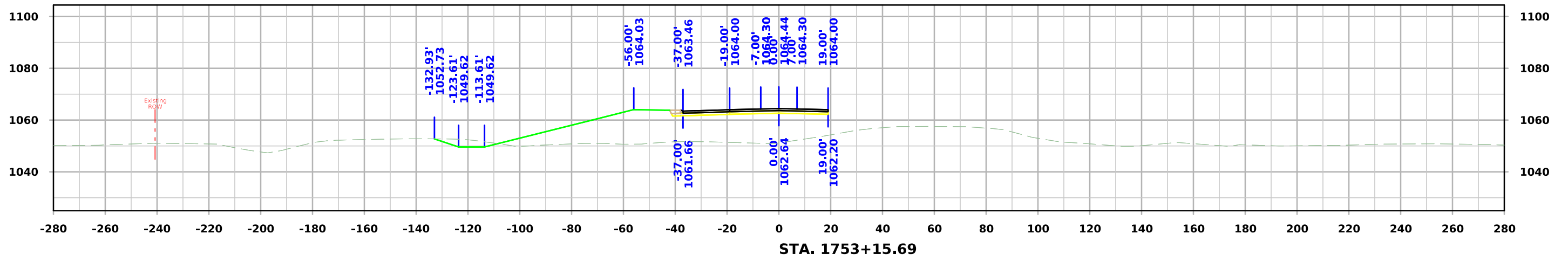

IA 175

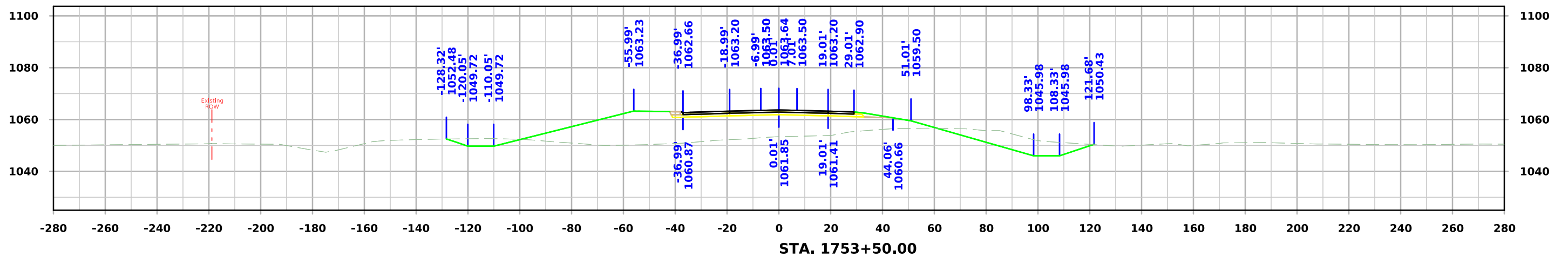
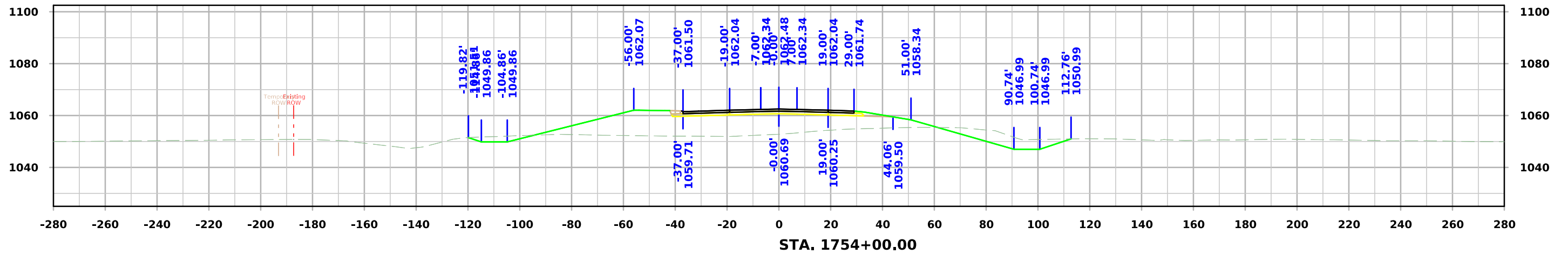
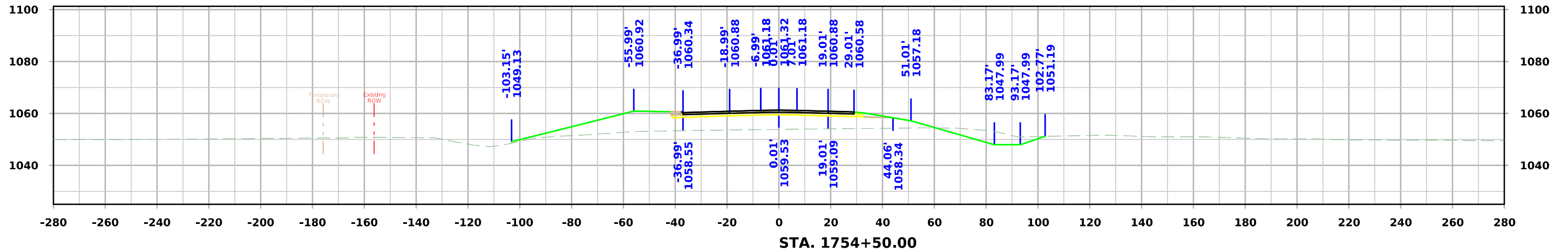

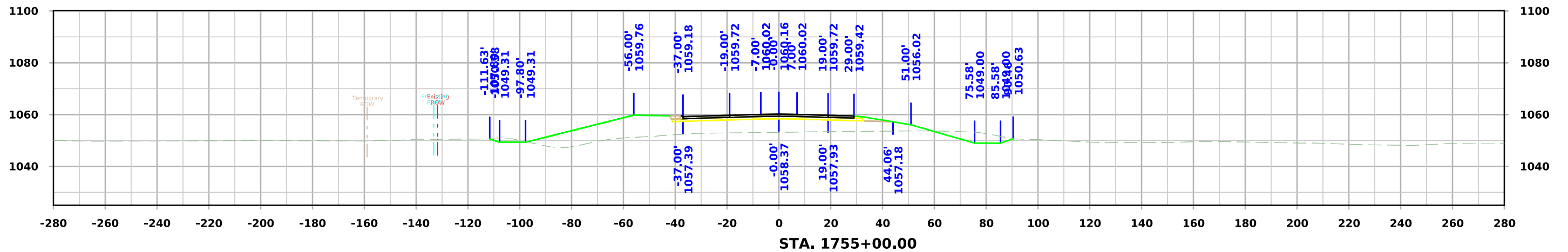
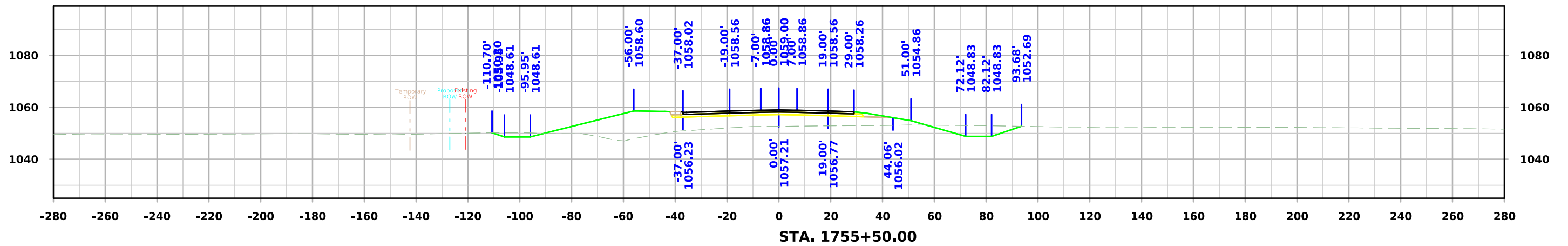
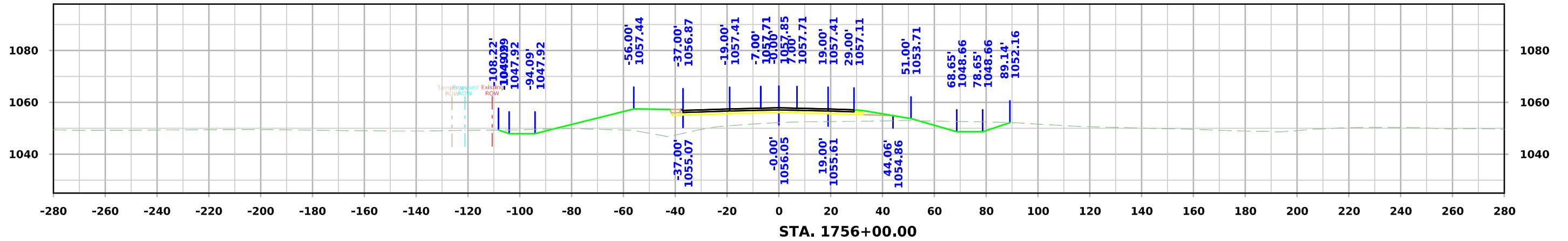

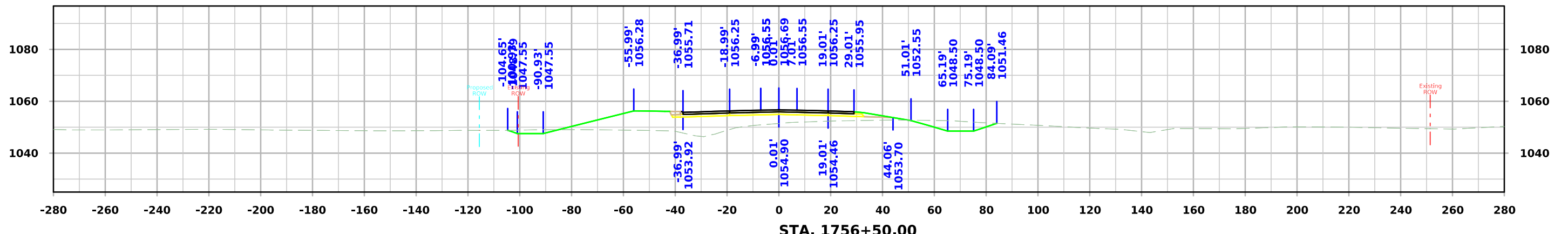
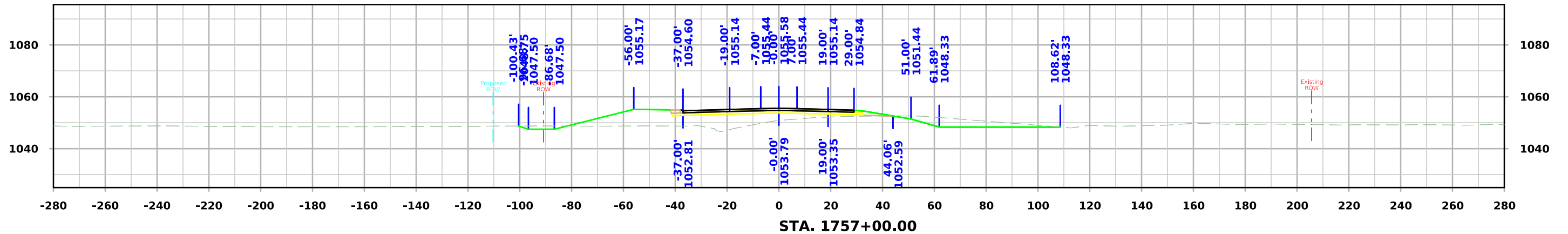
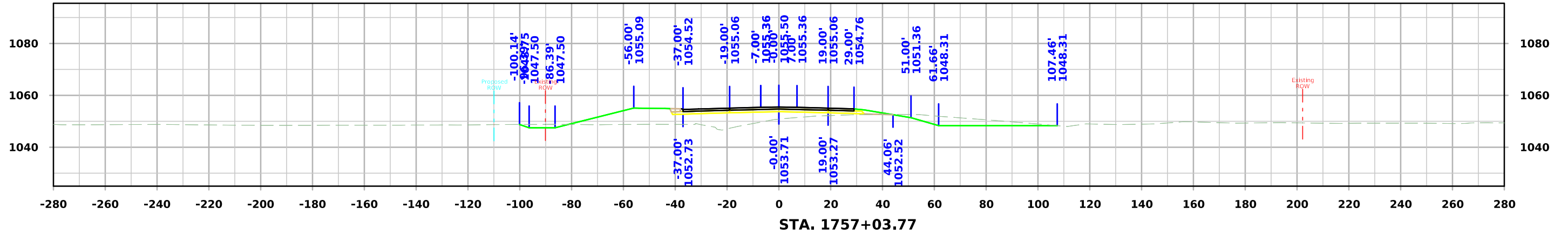

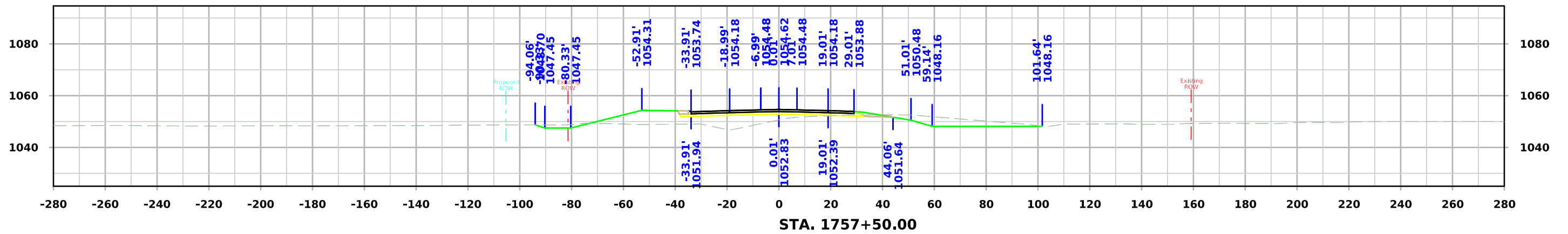
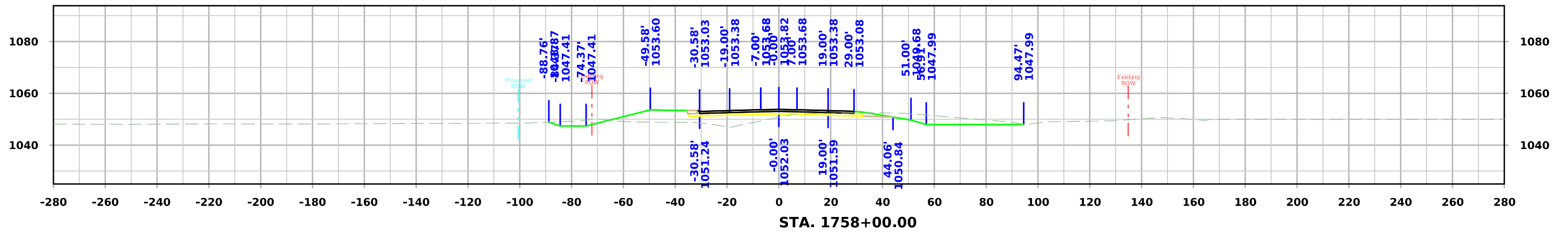
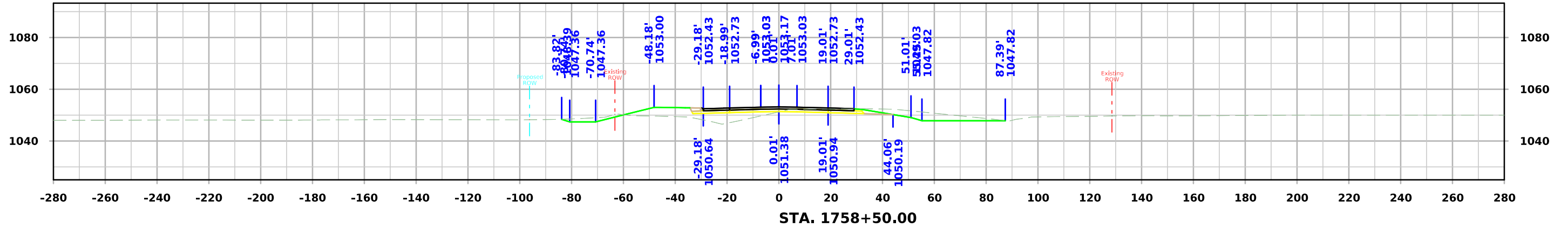

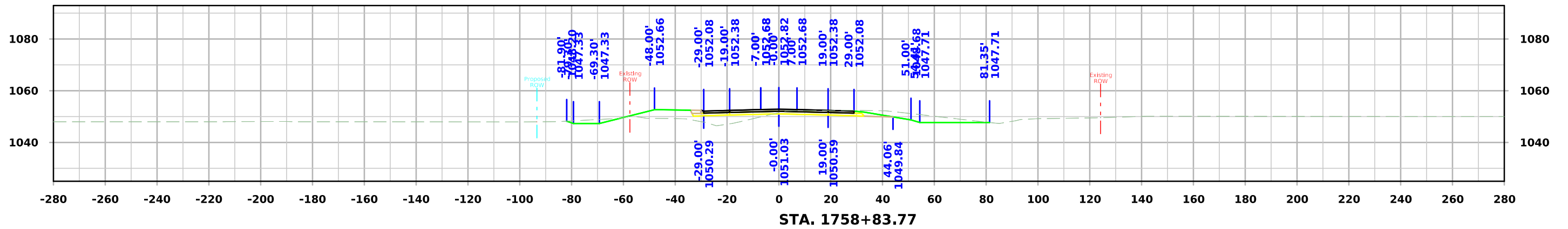
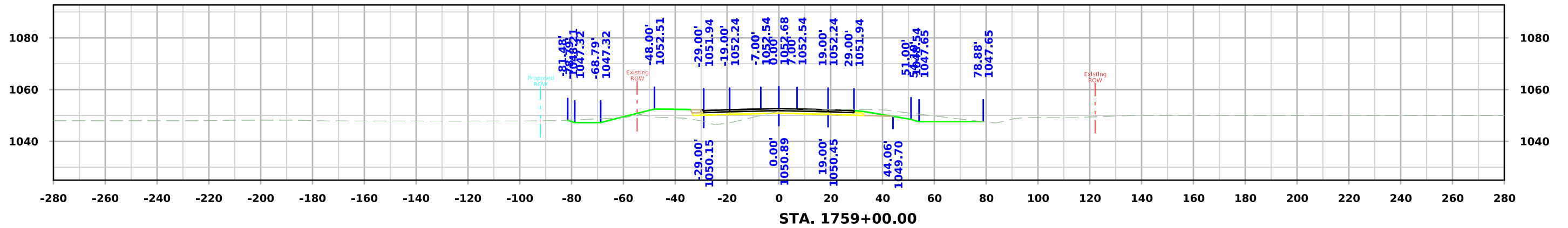
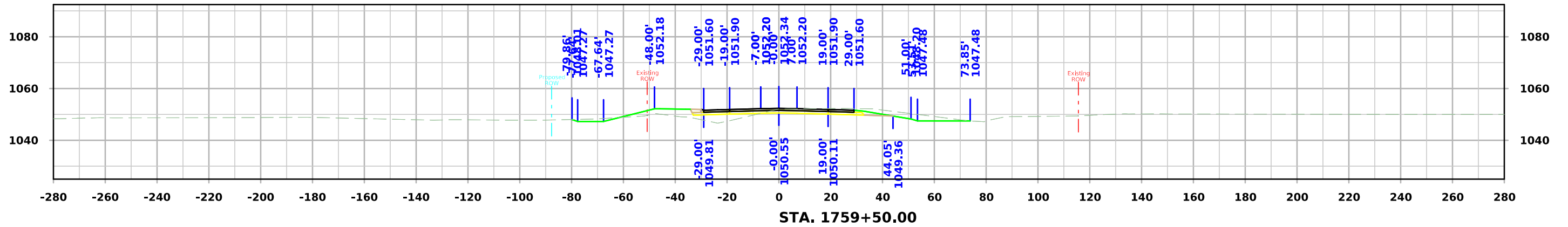

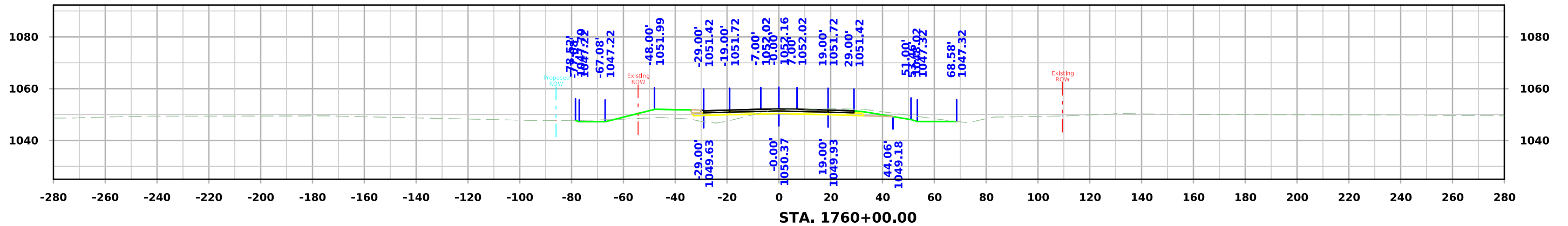
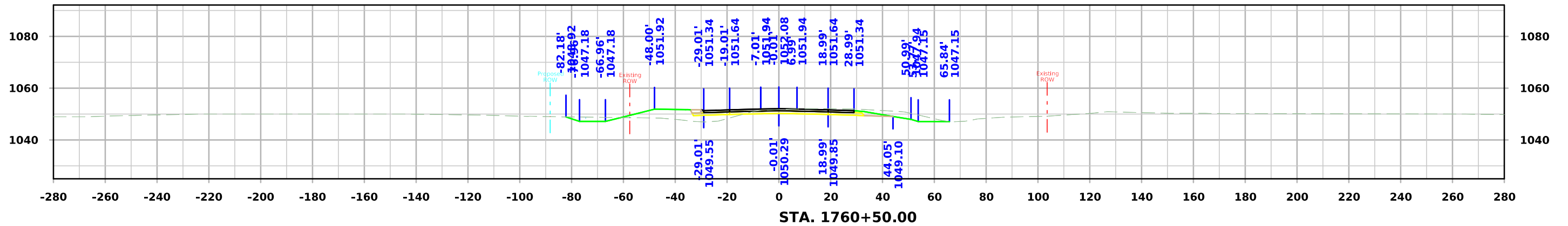
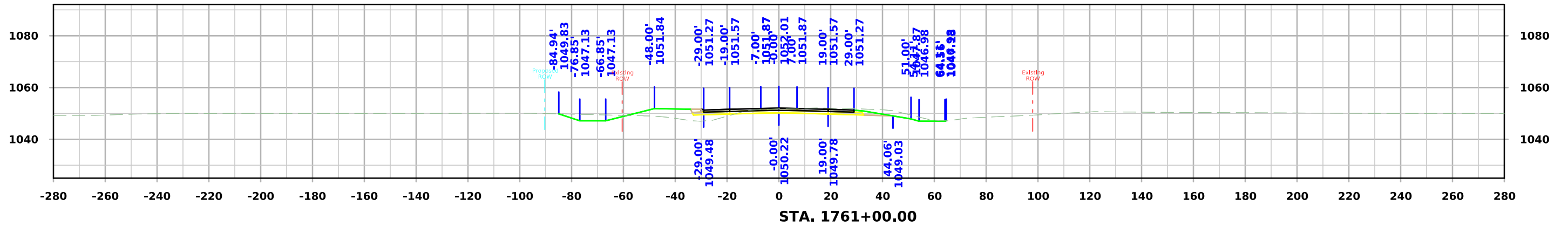

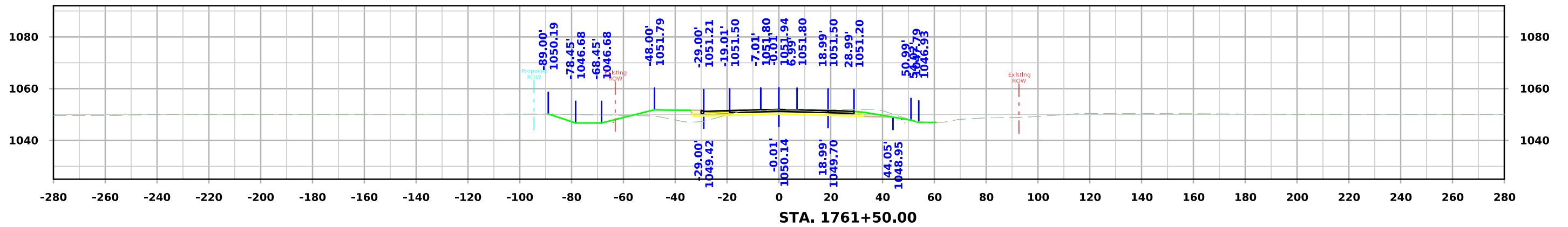
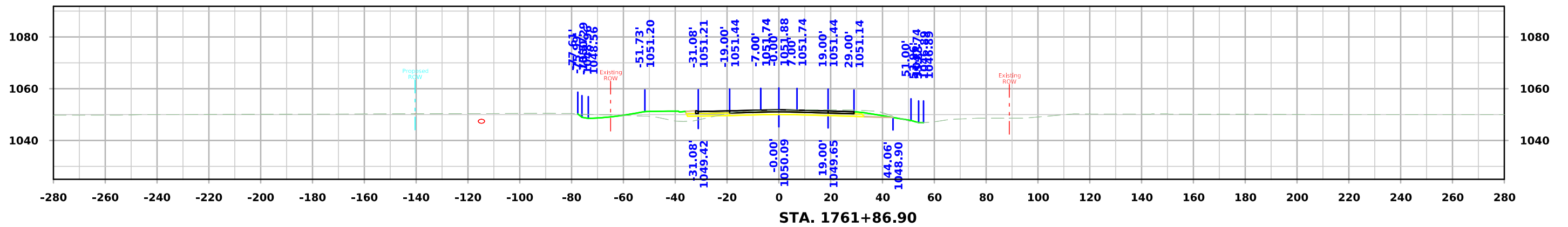
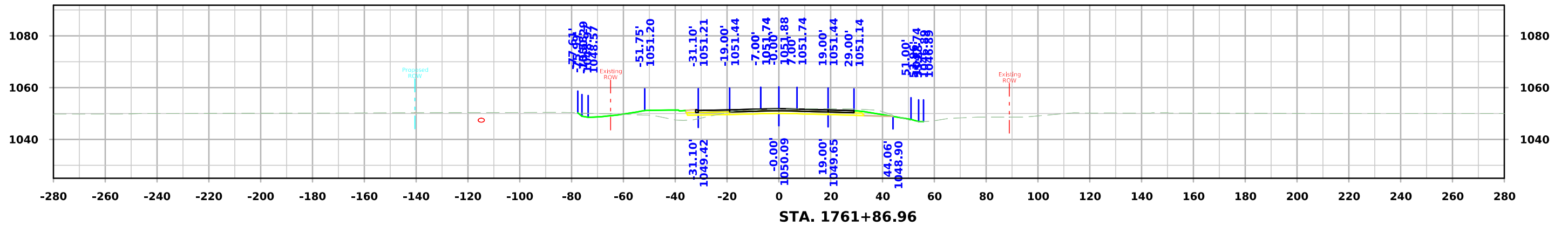

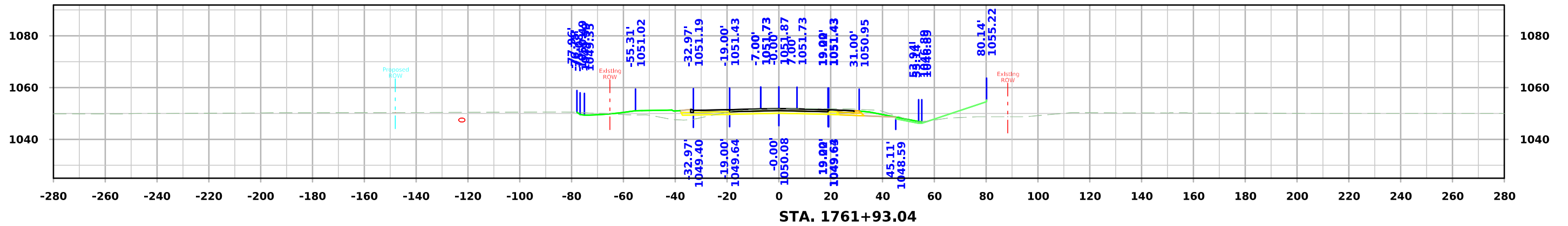
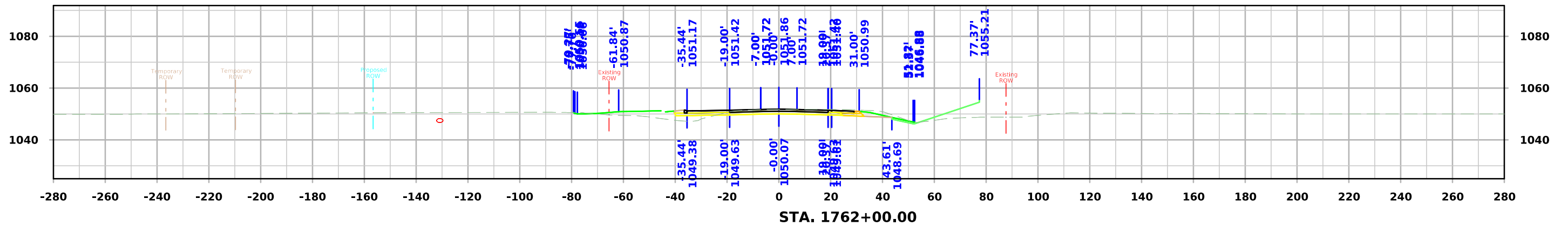
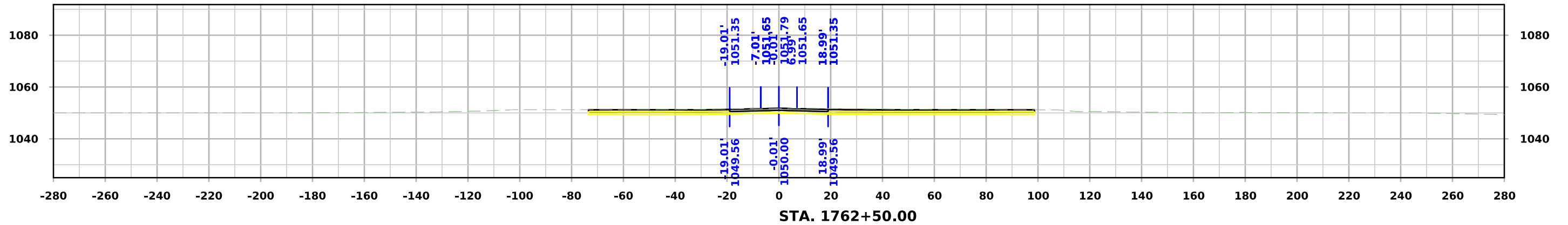

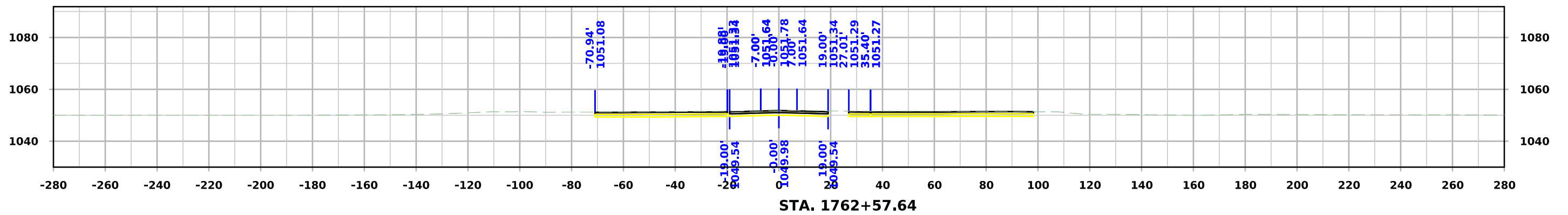
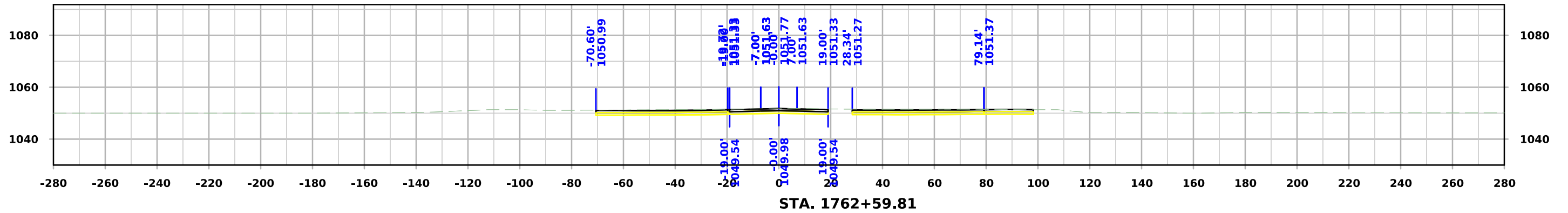
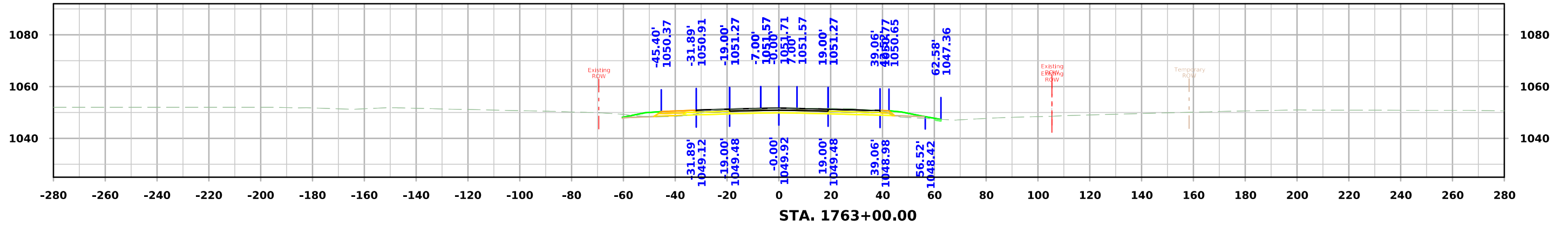

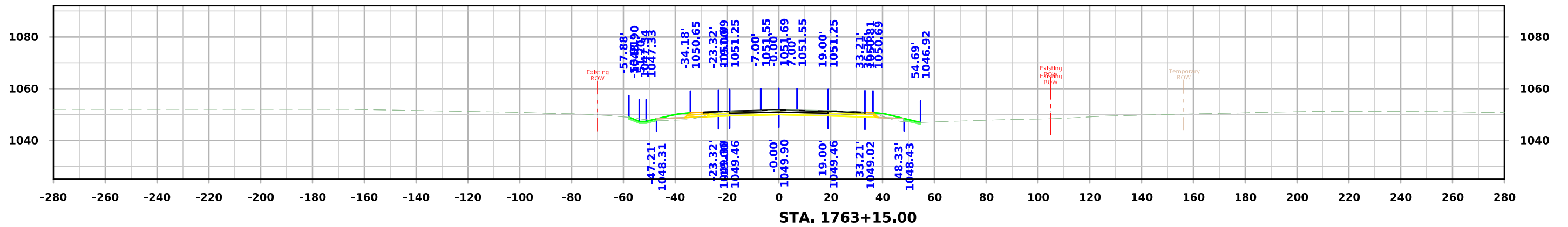
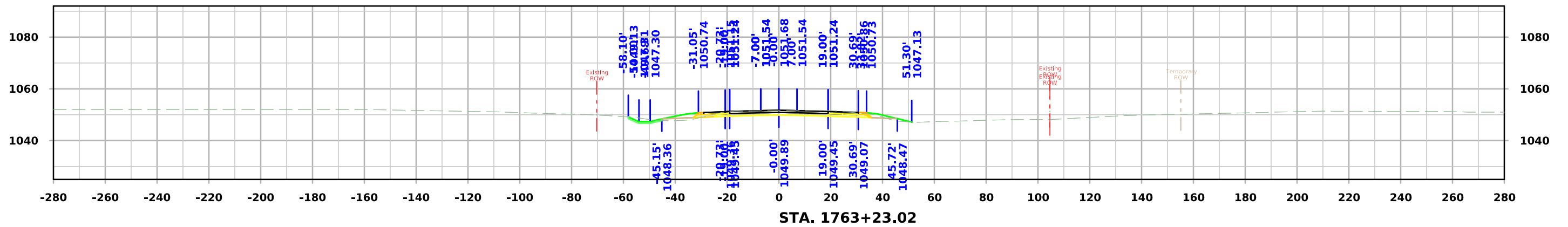
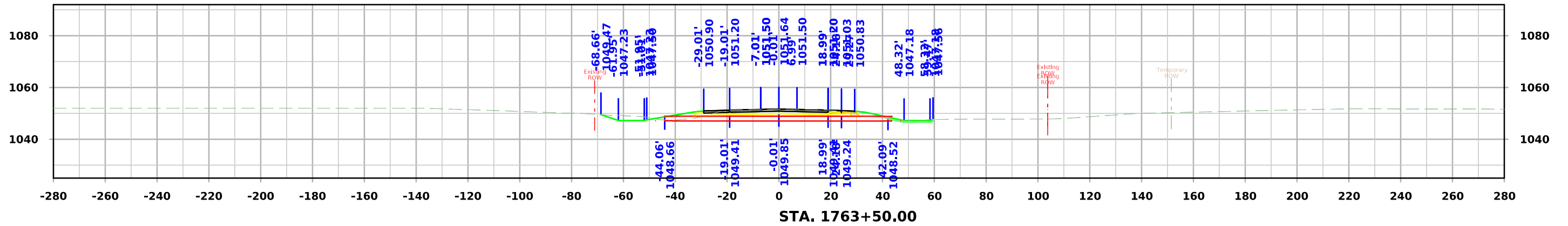

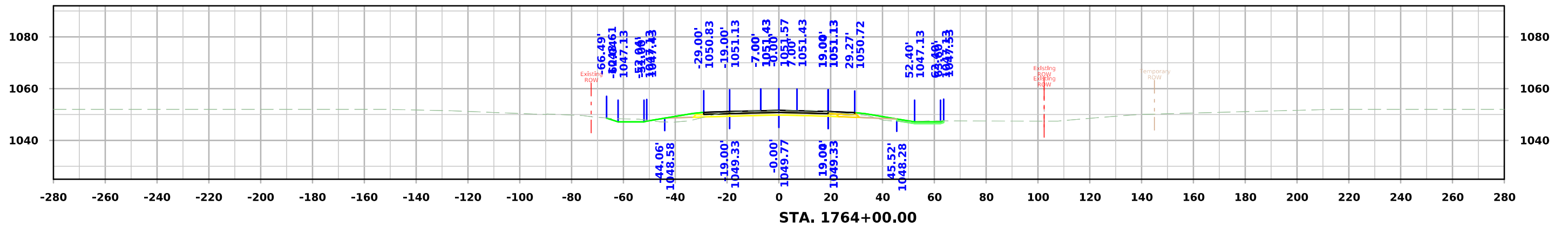
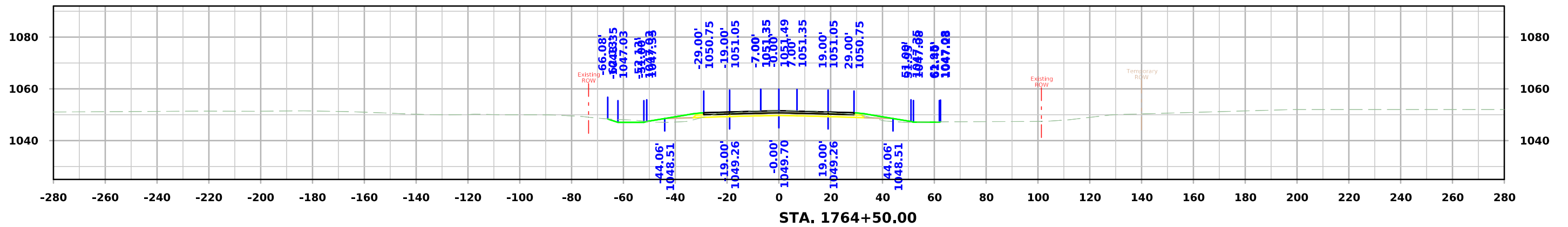
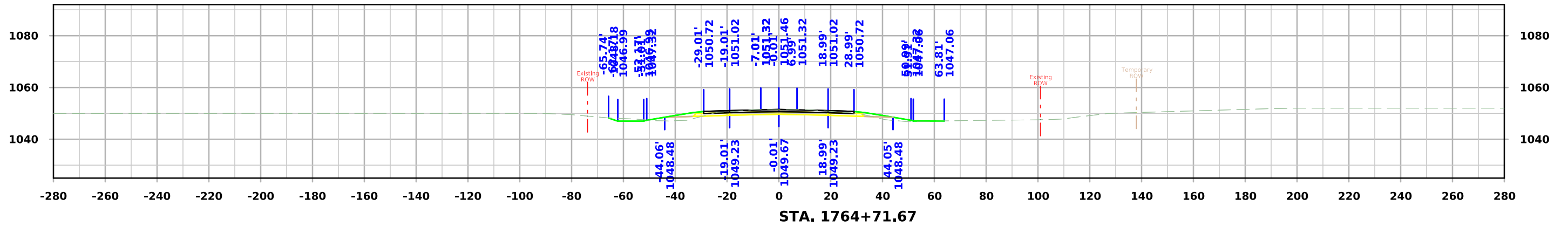

IA 175

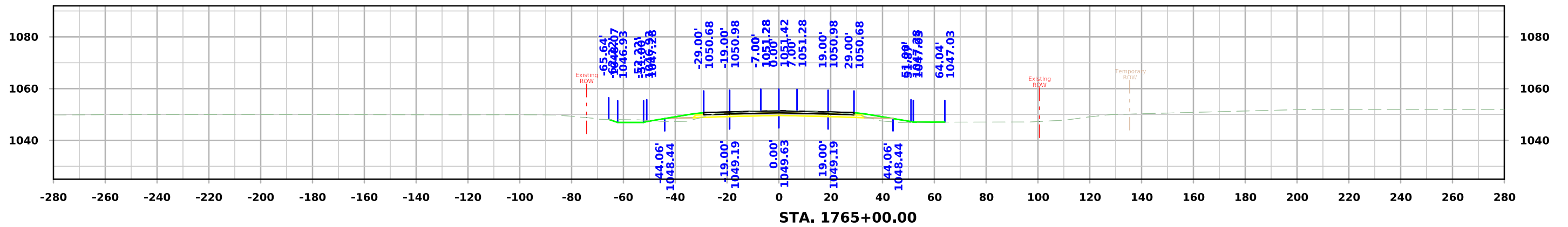
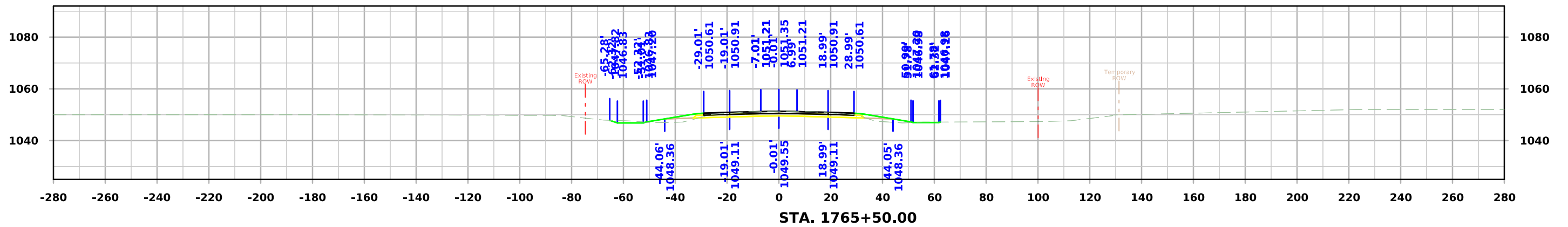
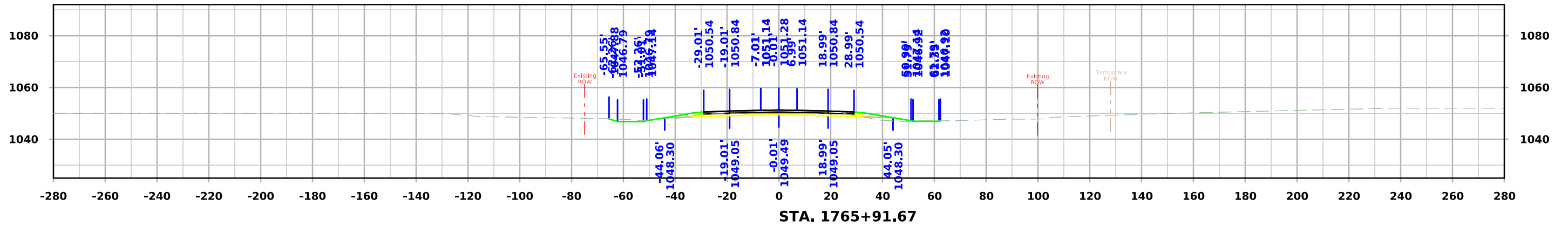

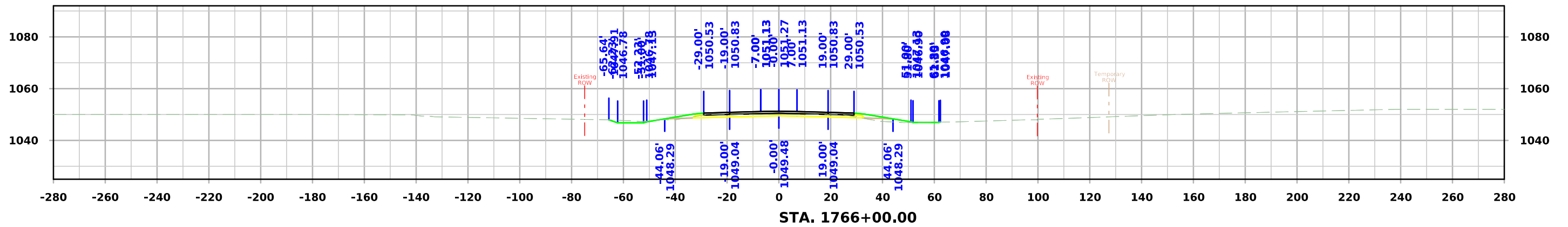
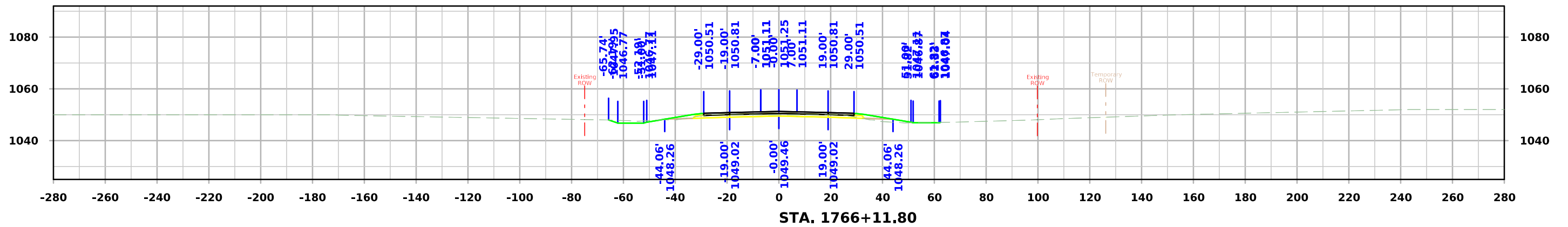
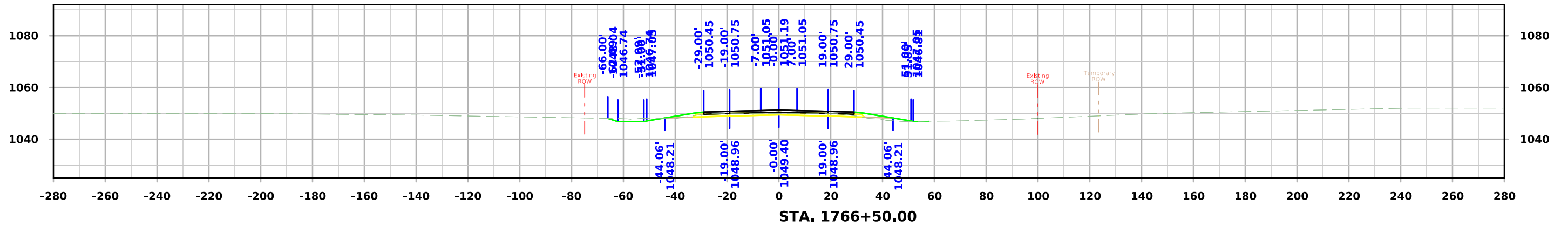

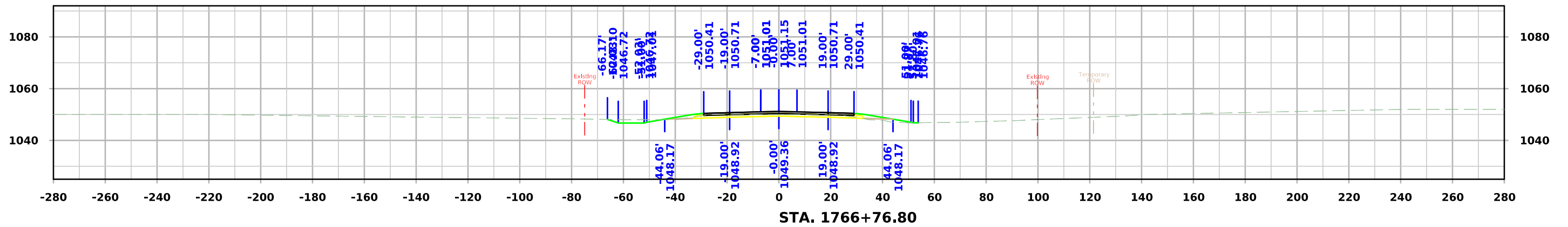
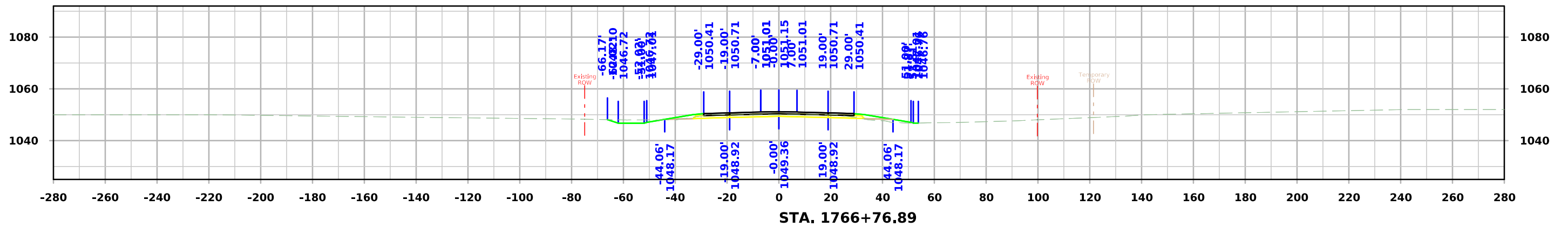
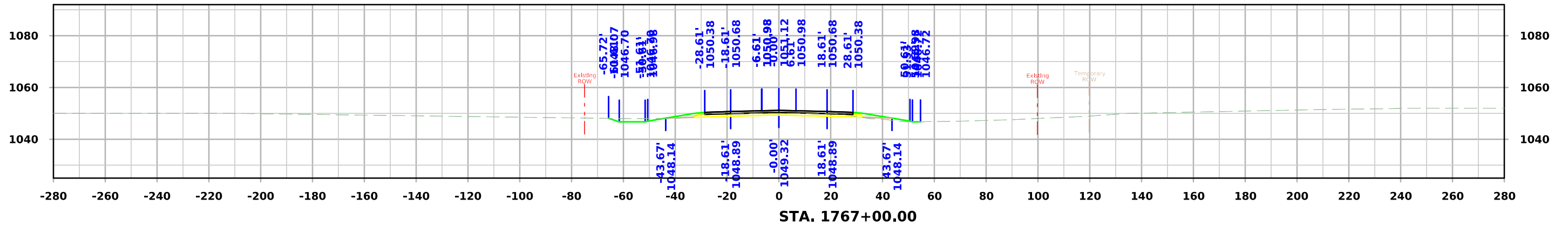

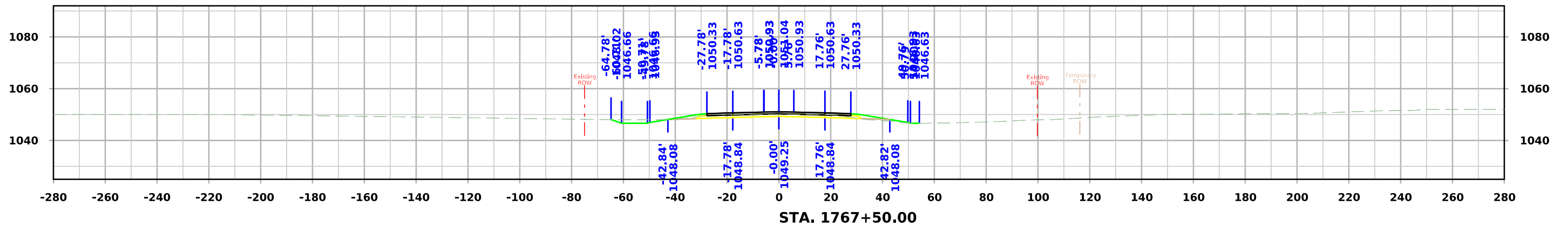
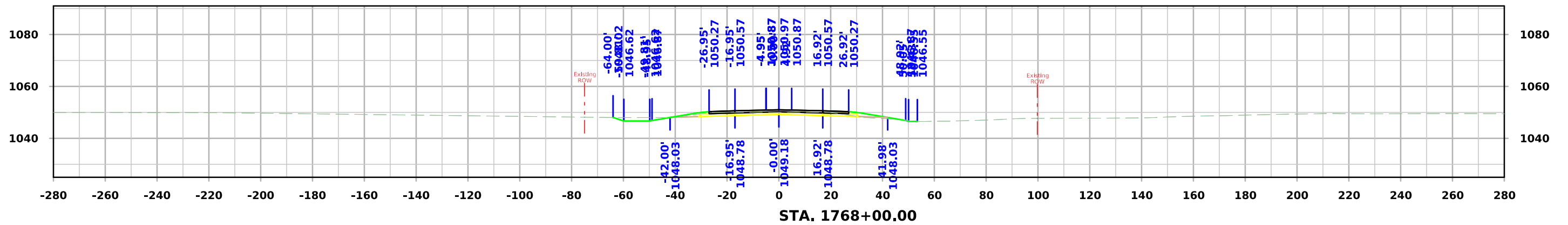
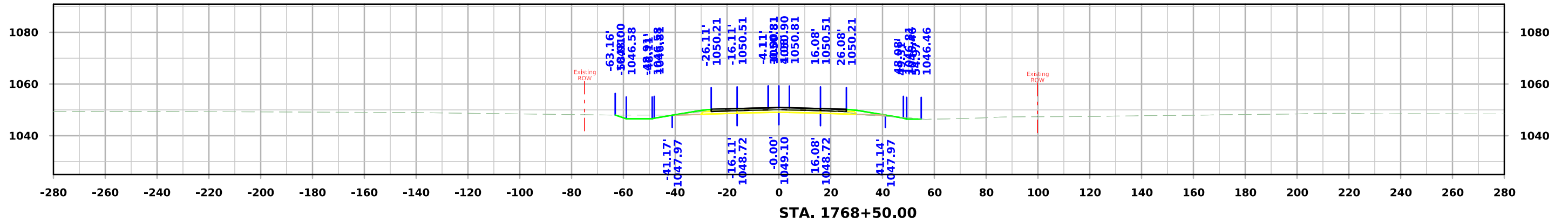

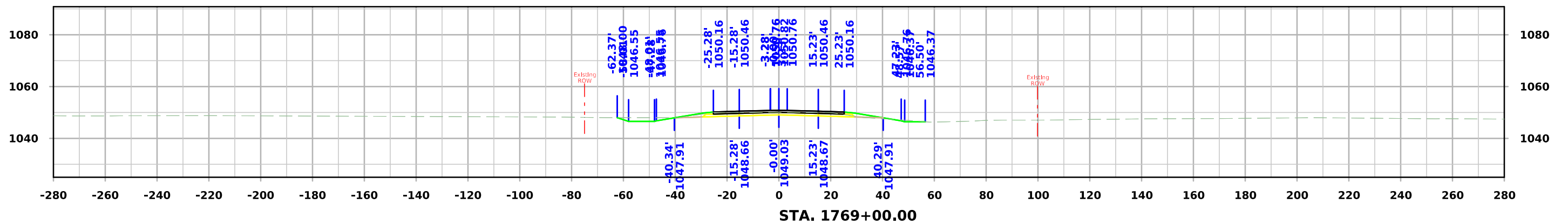
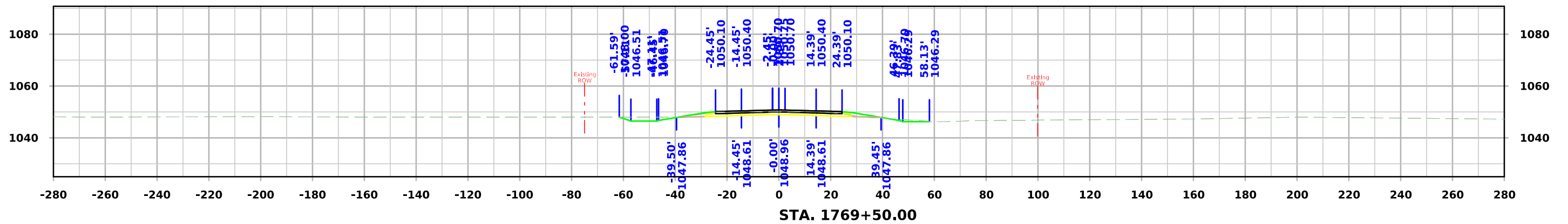
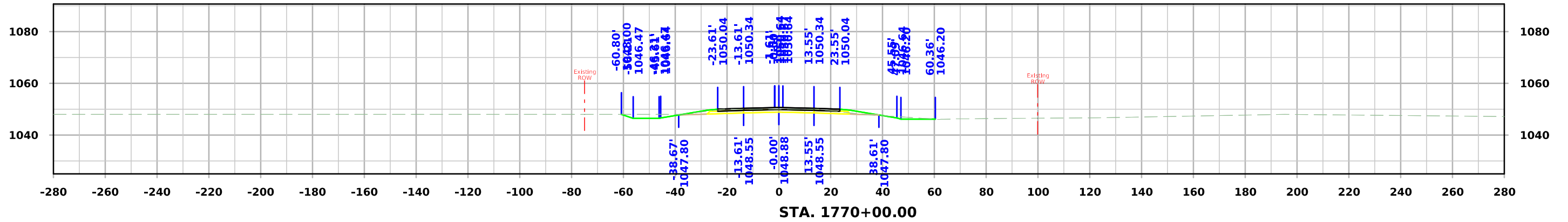

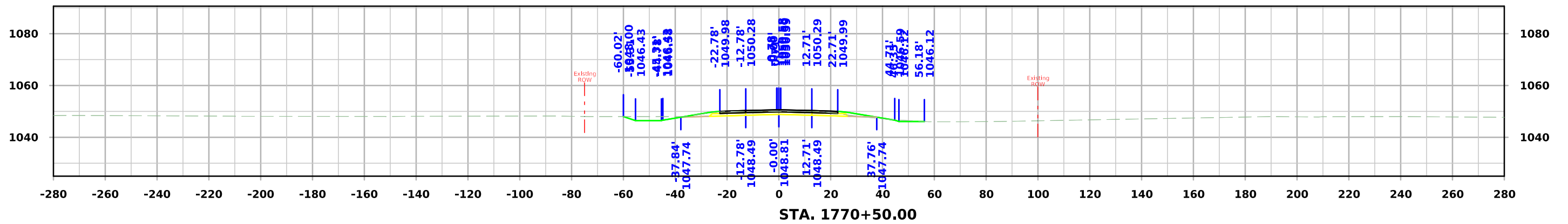
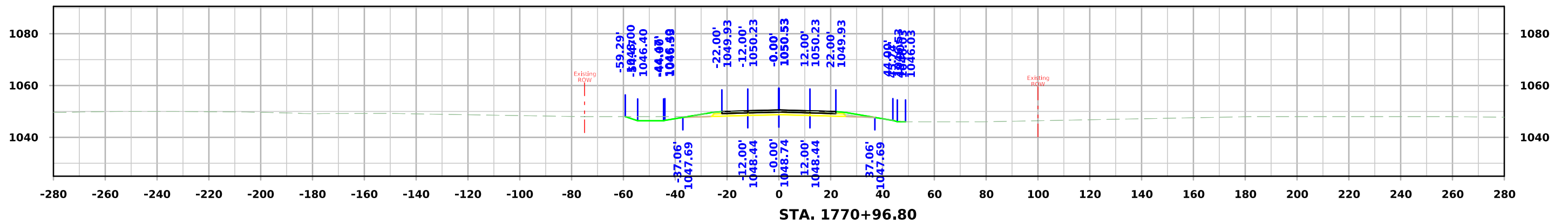
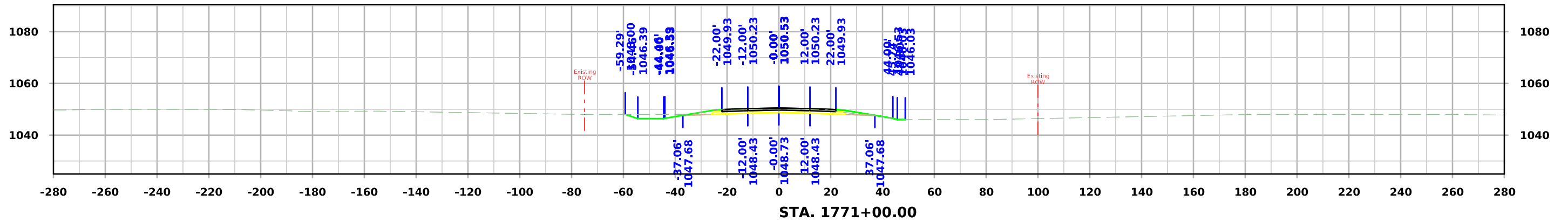

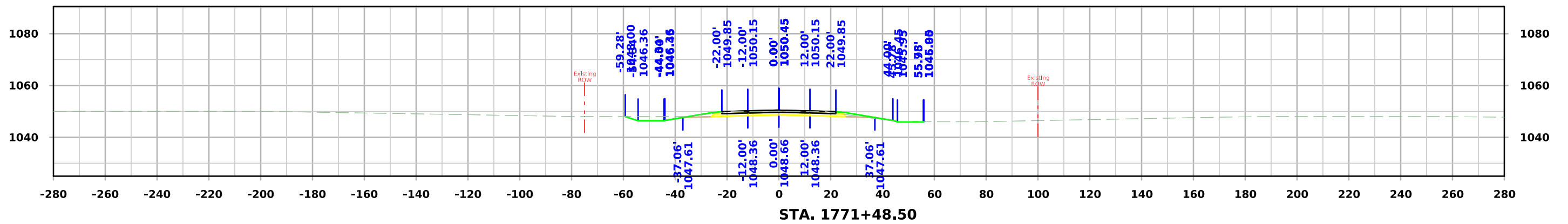

STA. 1771+48.50

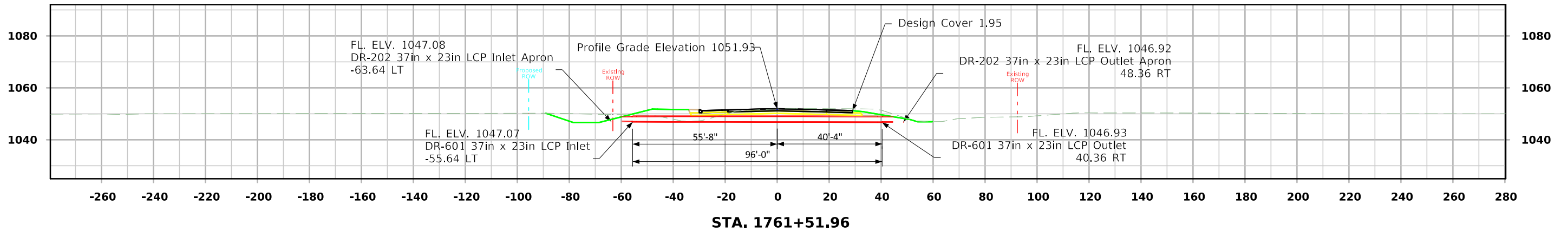
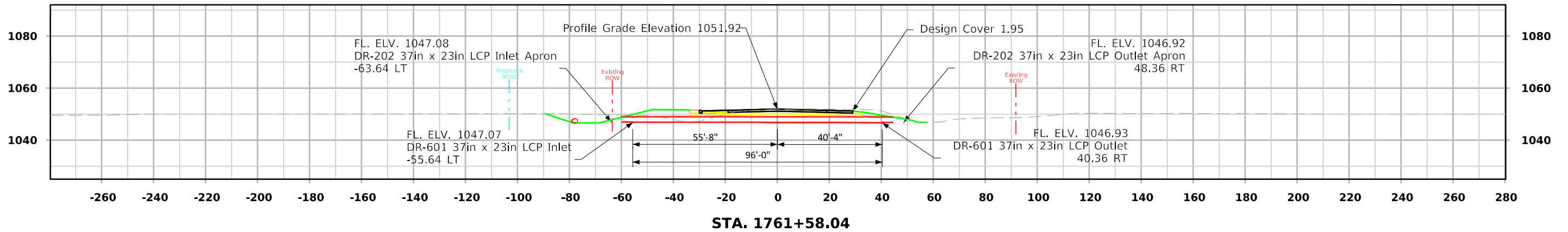
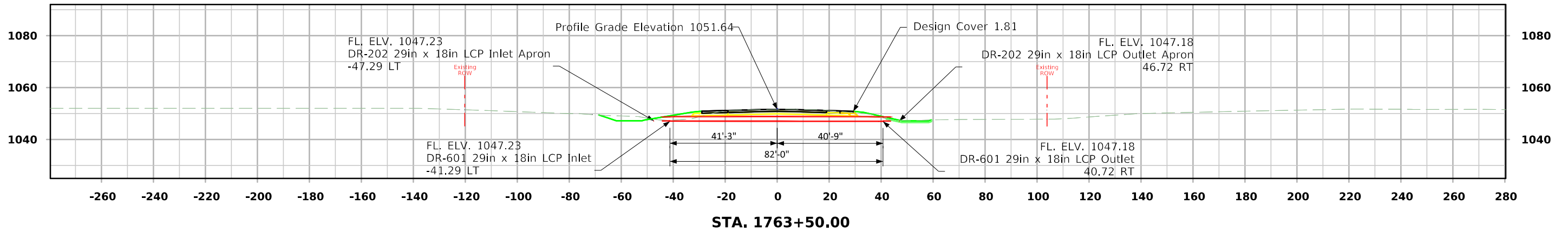

IA 175 Ramp A

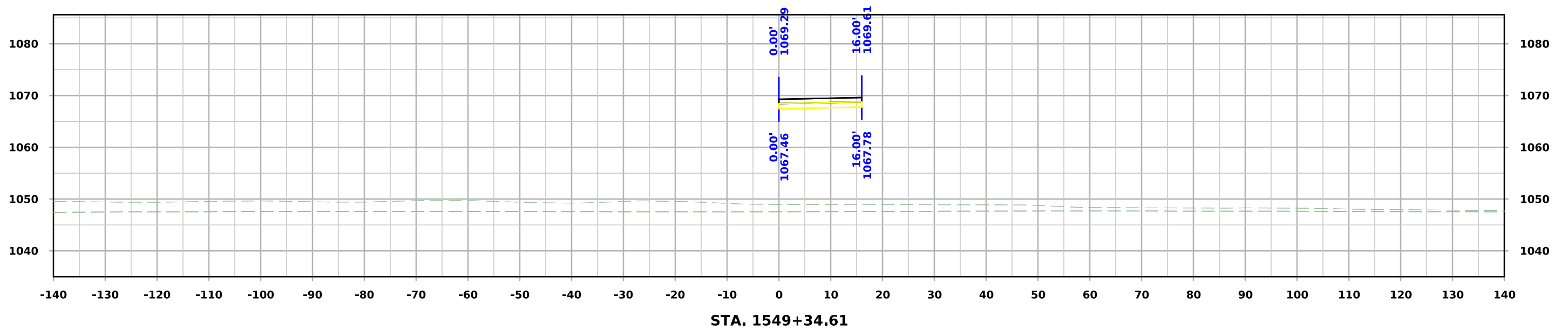
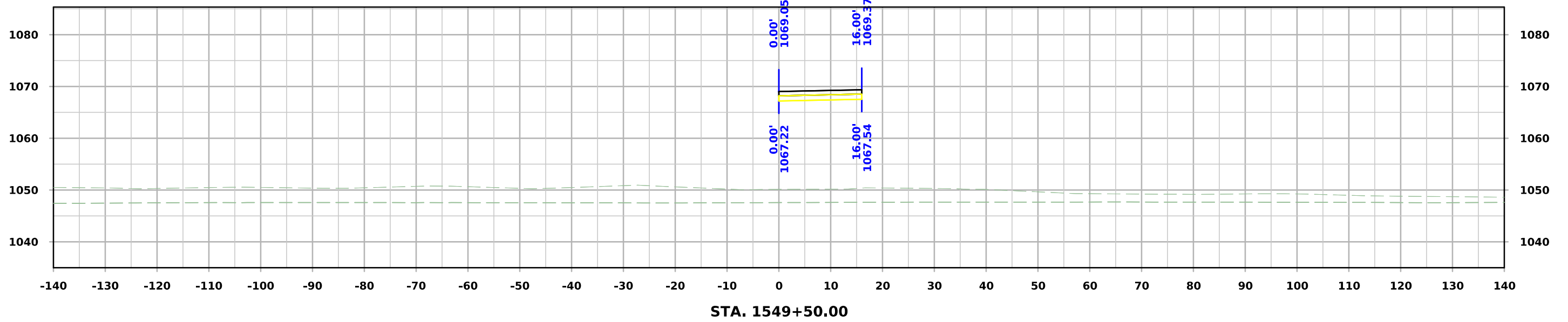

IA 175 Ramp A

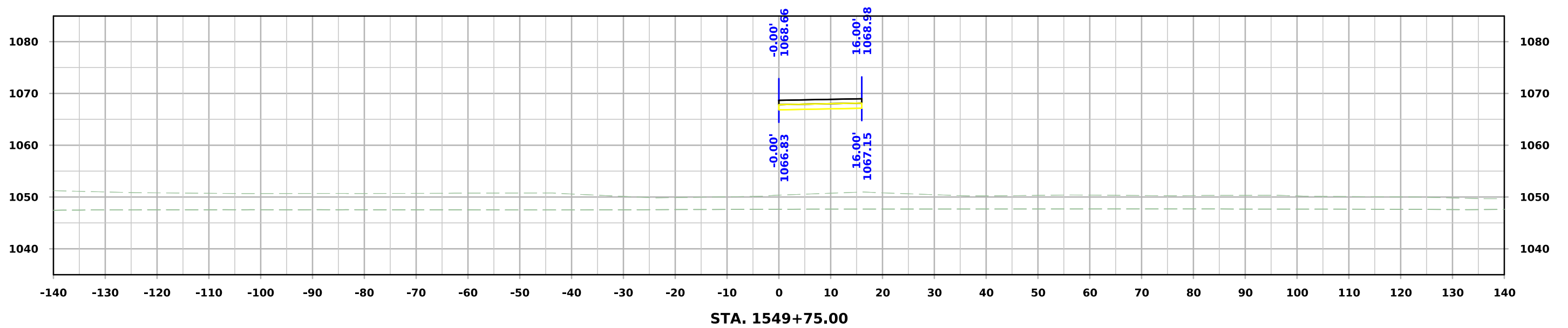
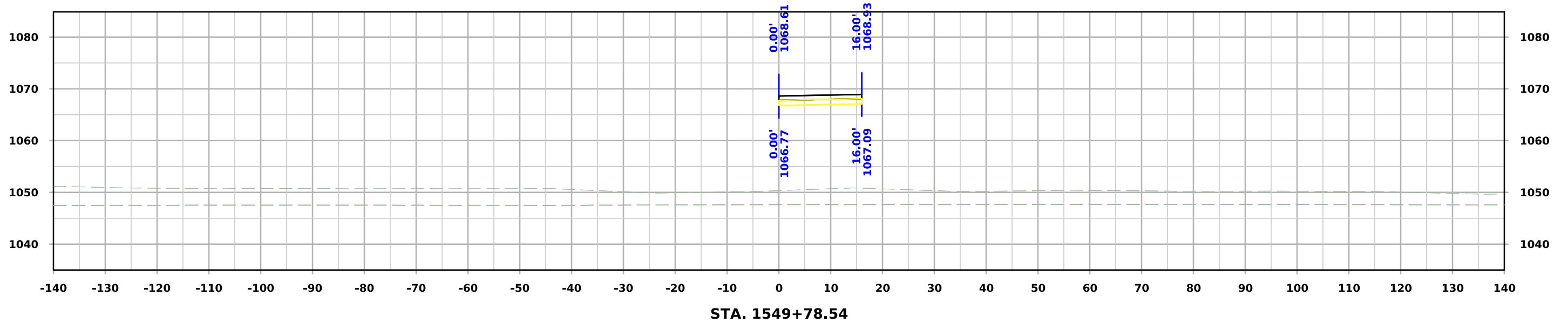

IA 175 Ramp A

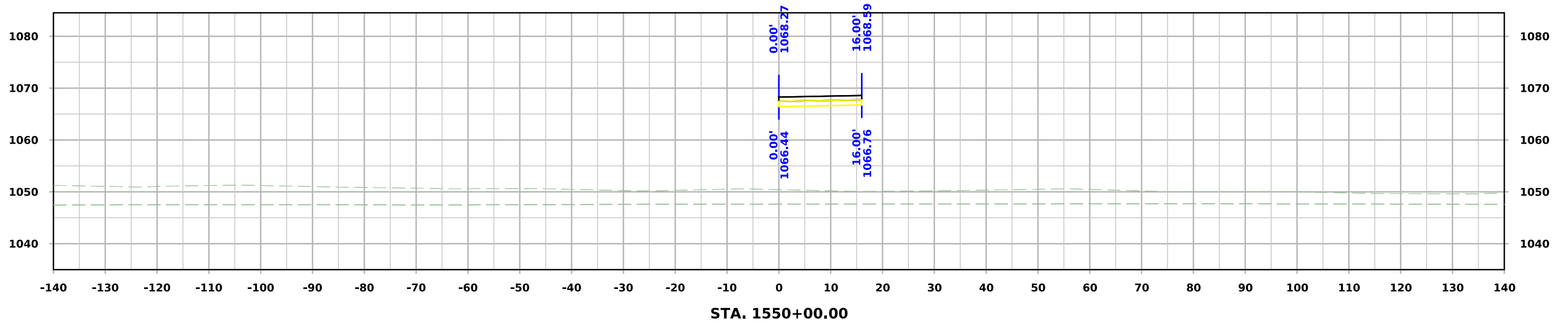
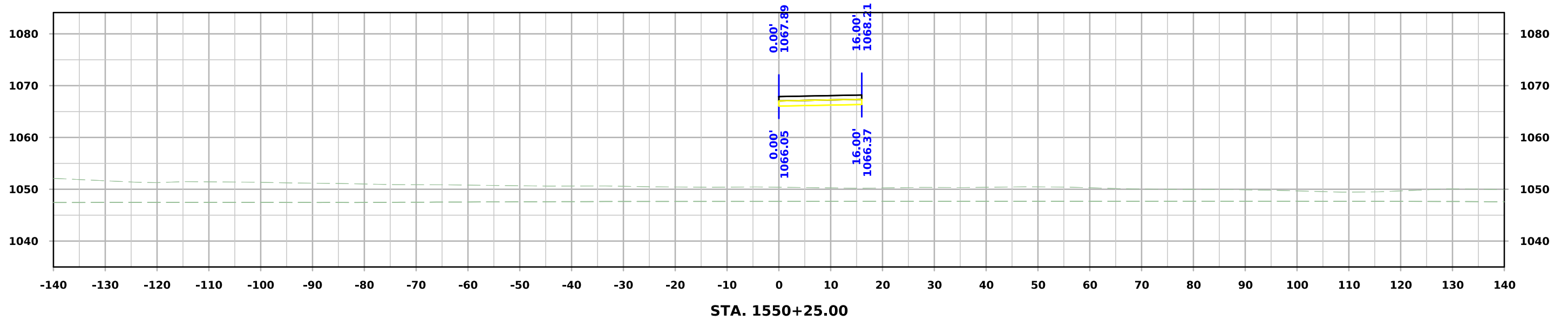

IA 175 Ramp A

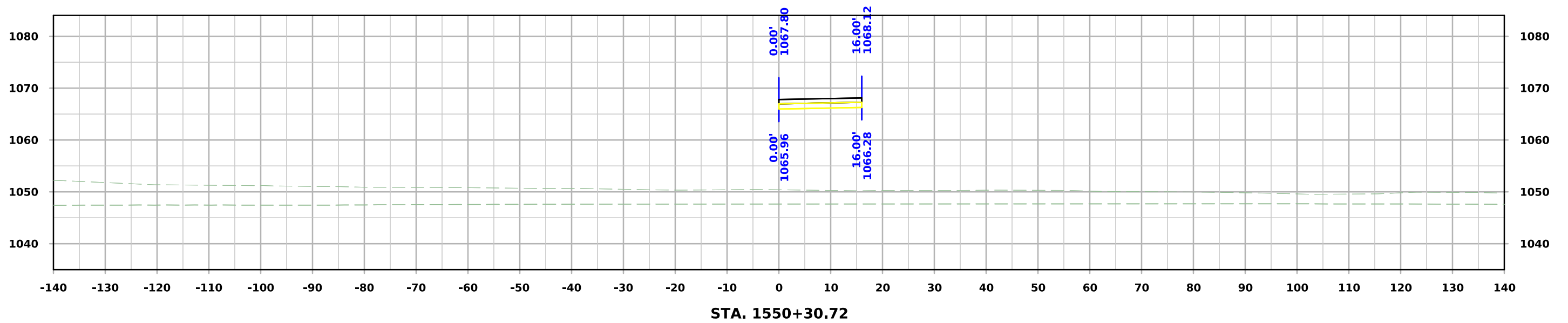
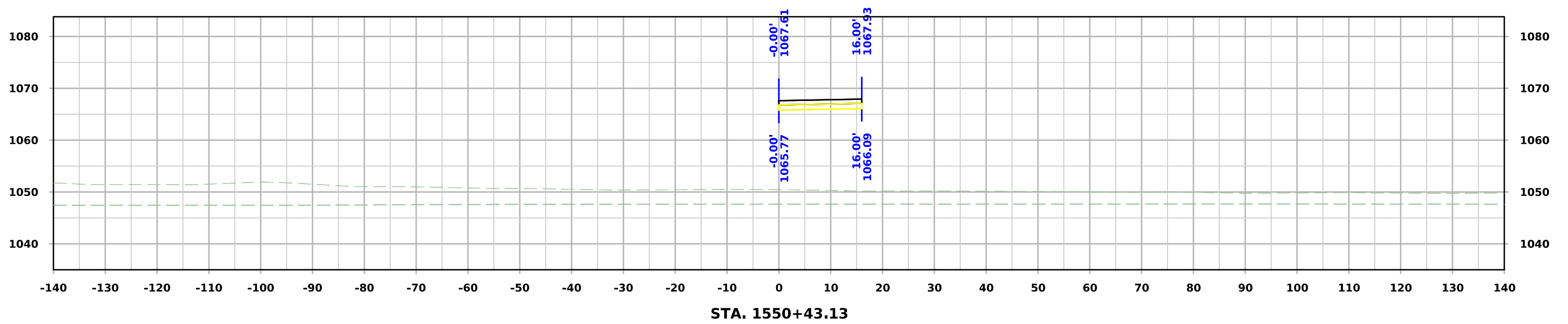

IA 175 Ramp A

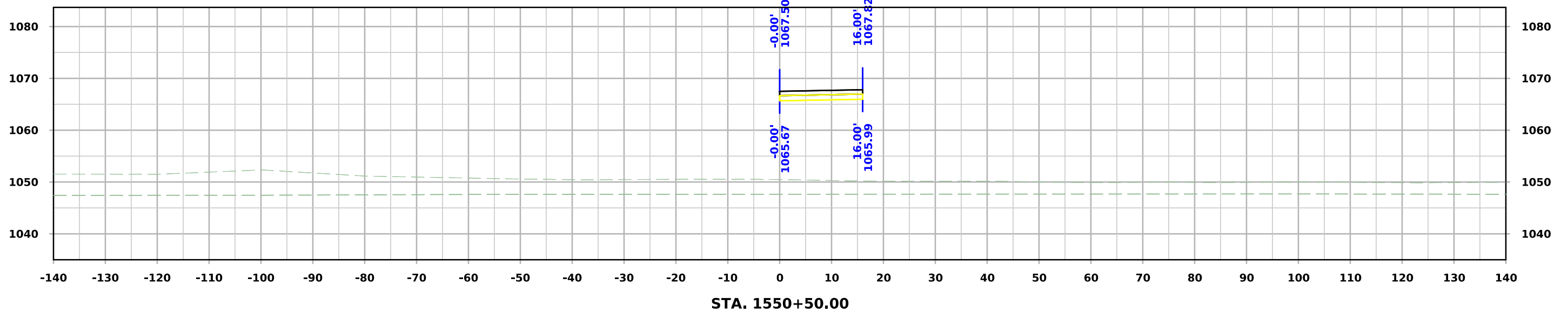
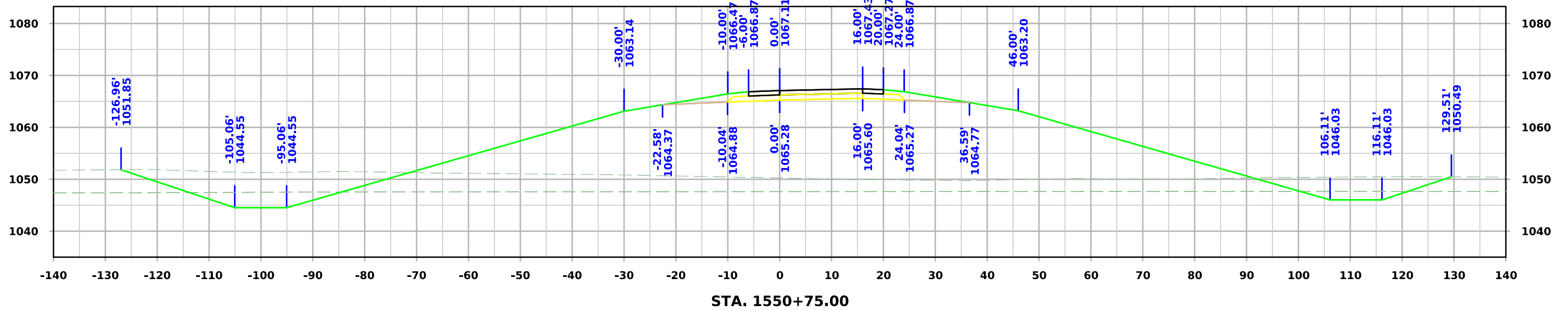

IA 175 Ramp A

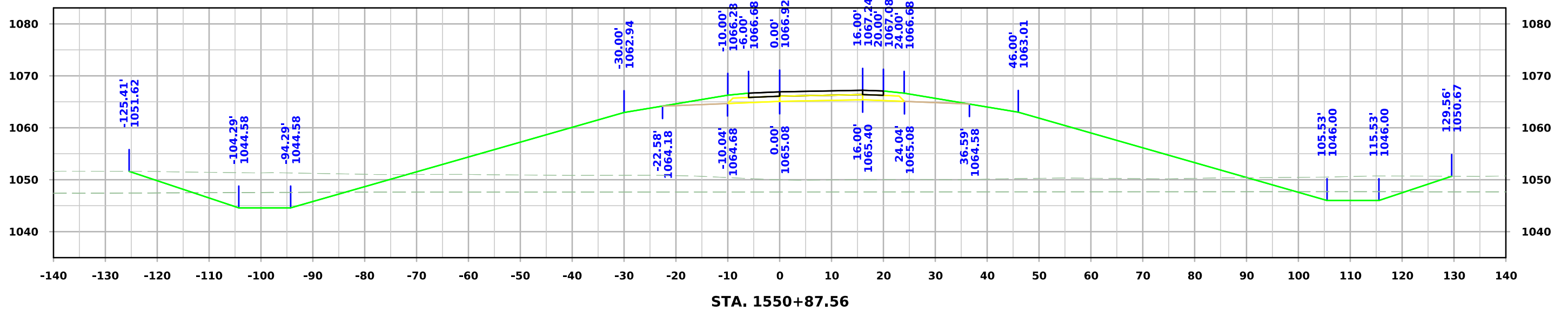
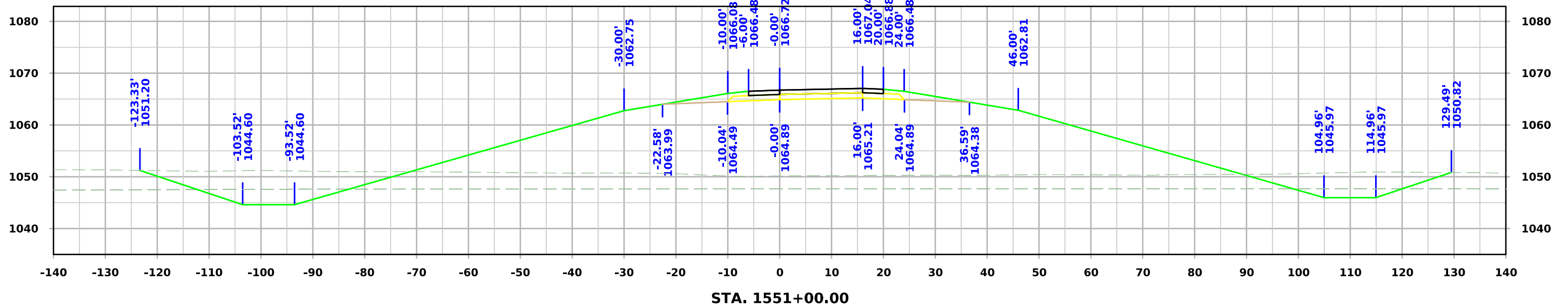

IA 175 Ramp A

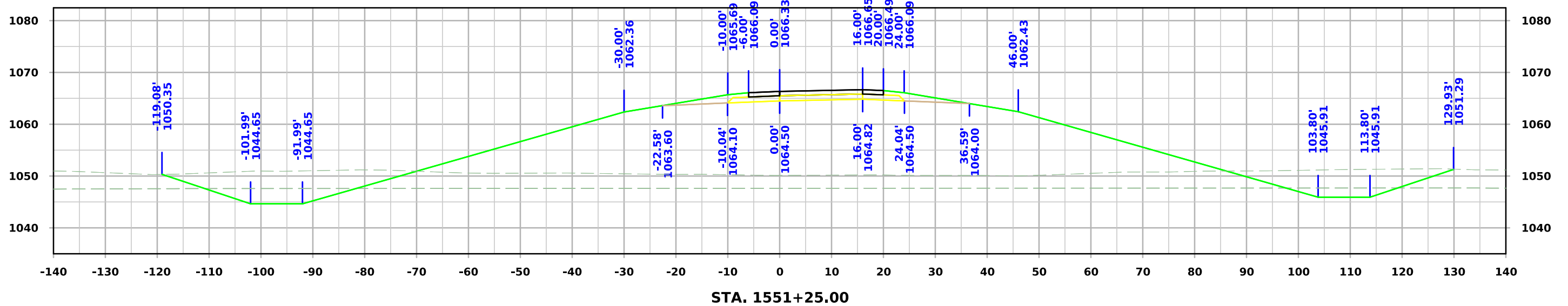
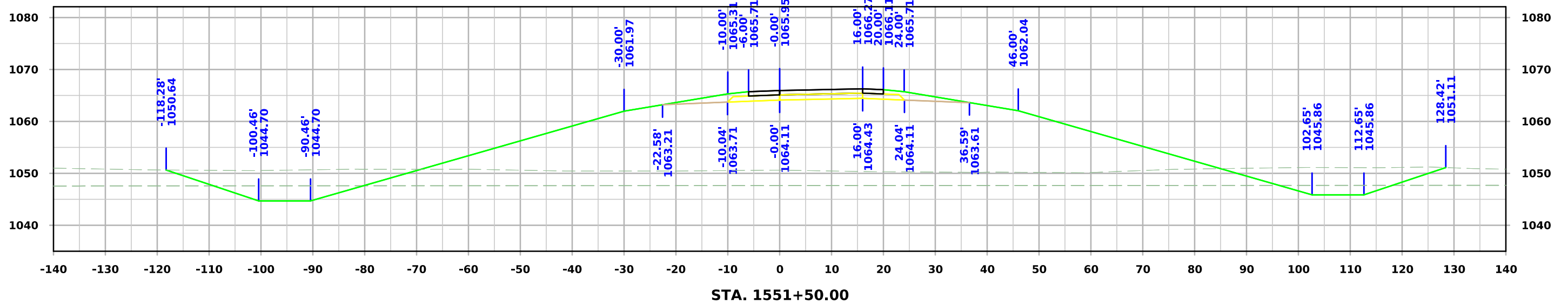

IA 175 Ramp A

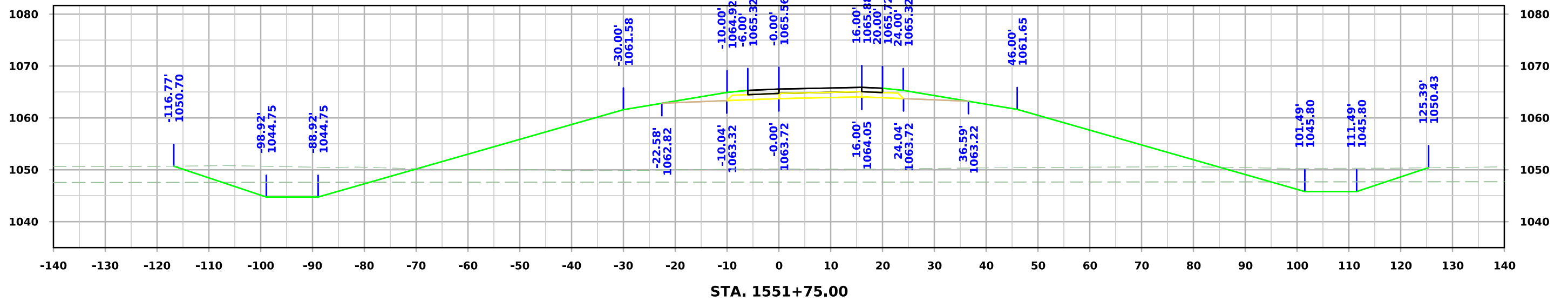
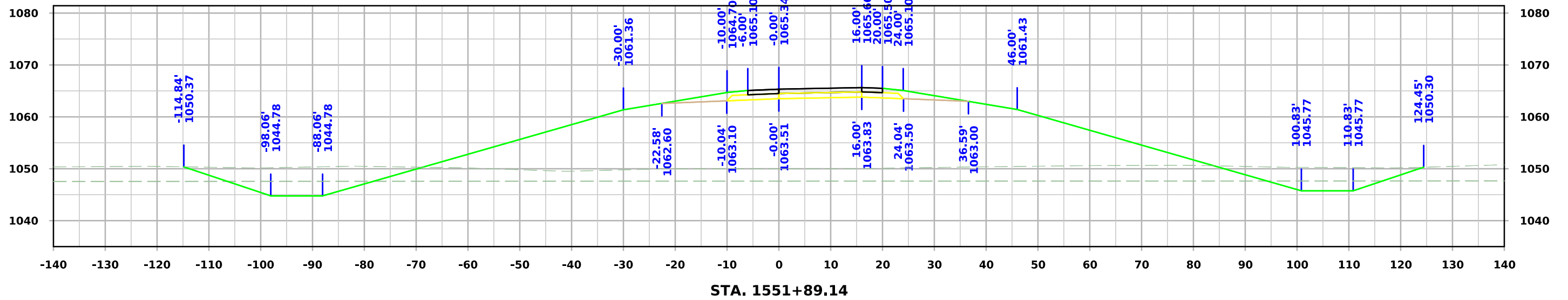

IA 175 Ramp A

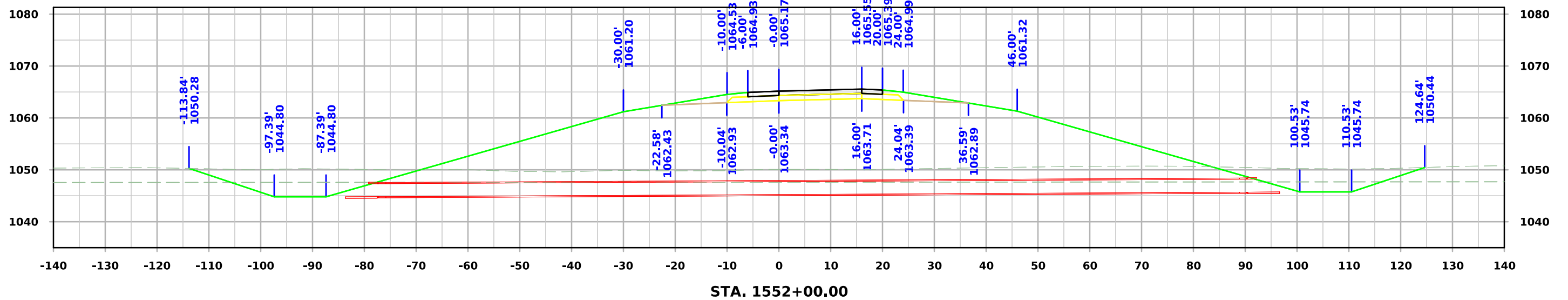
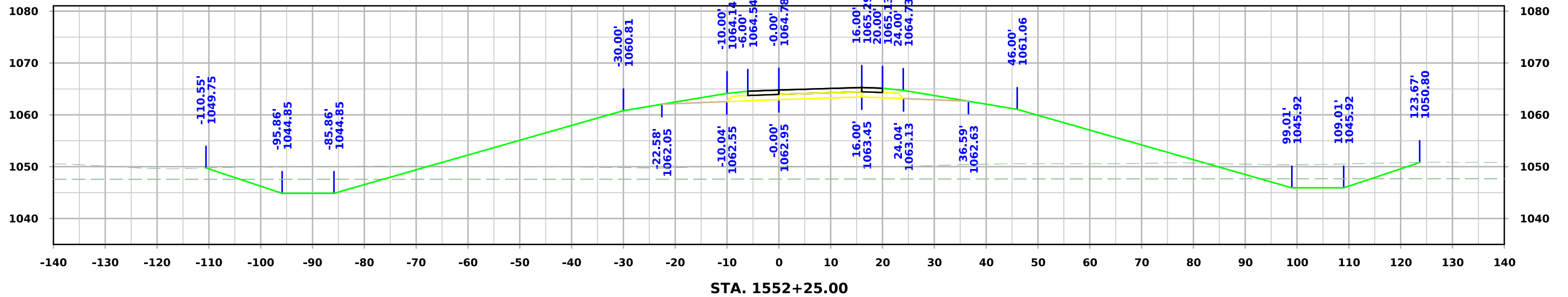

IA 175 Ramp A

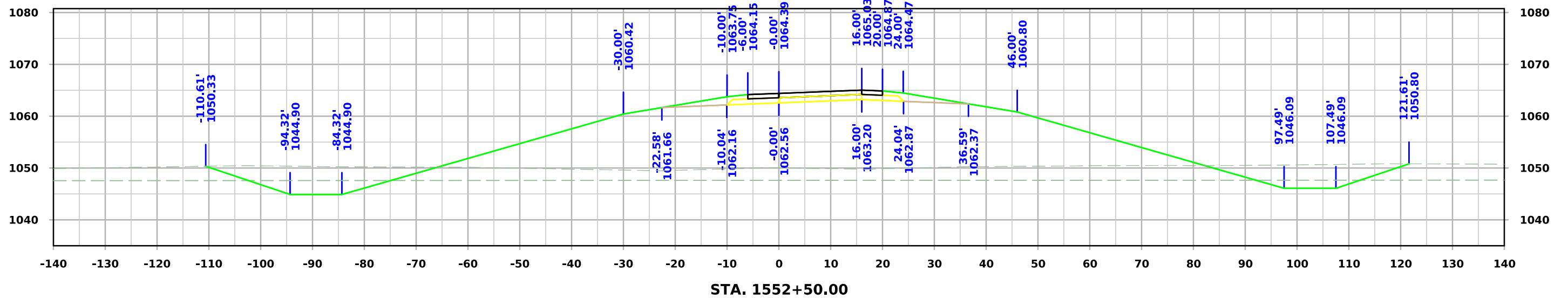
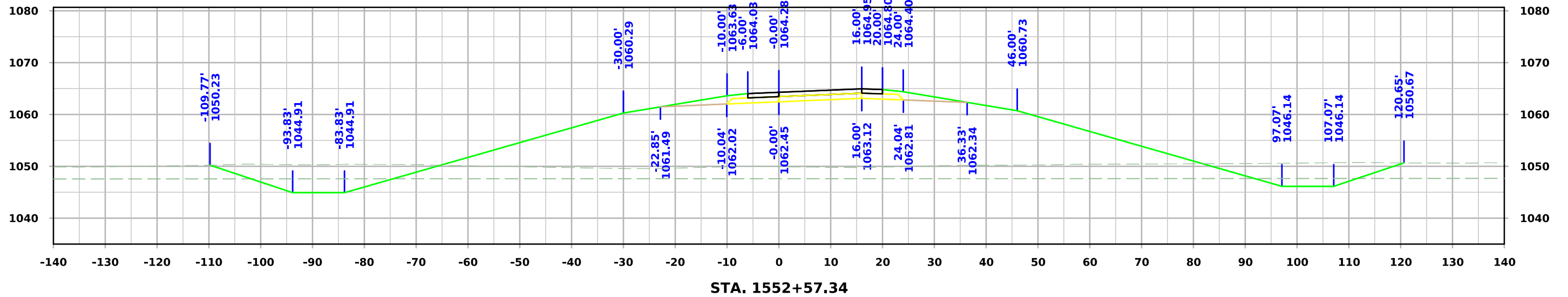

IA 175 Ramp A

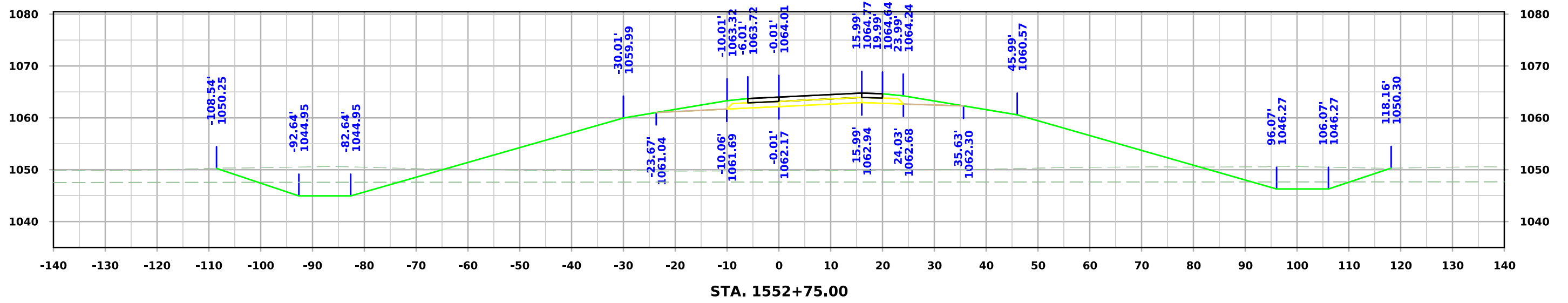
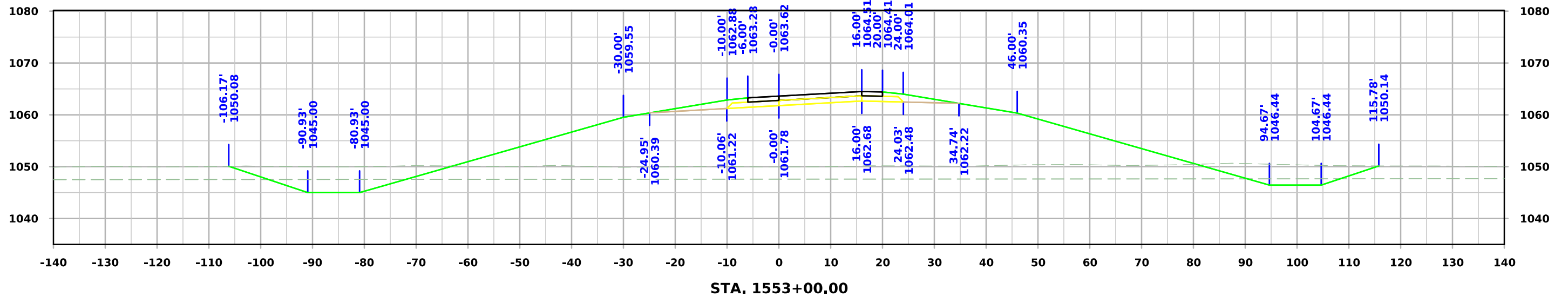

IA 175 Ramp A

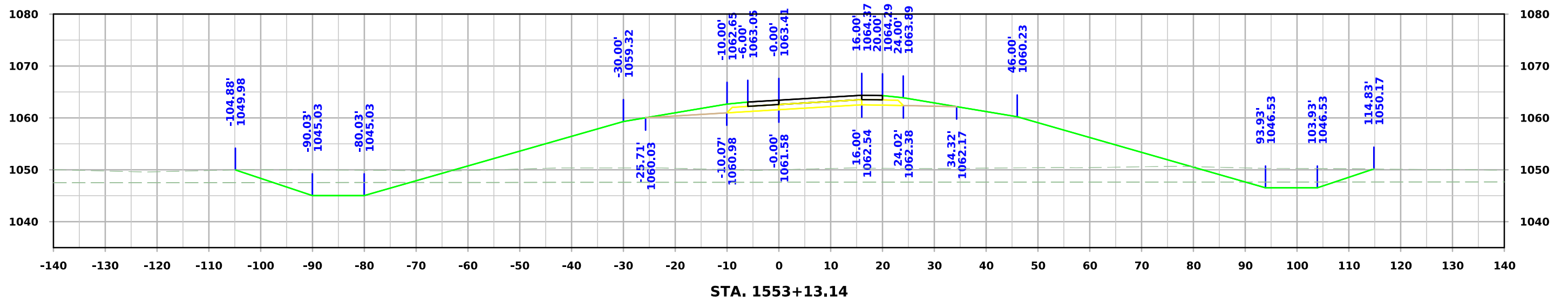
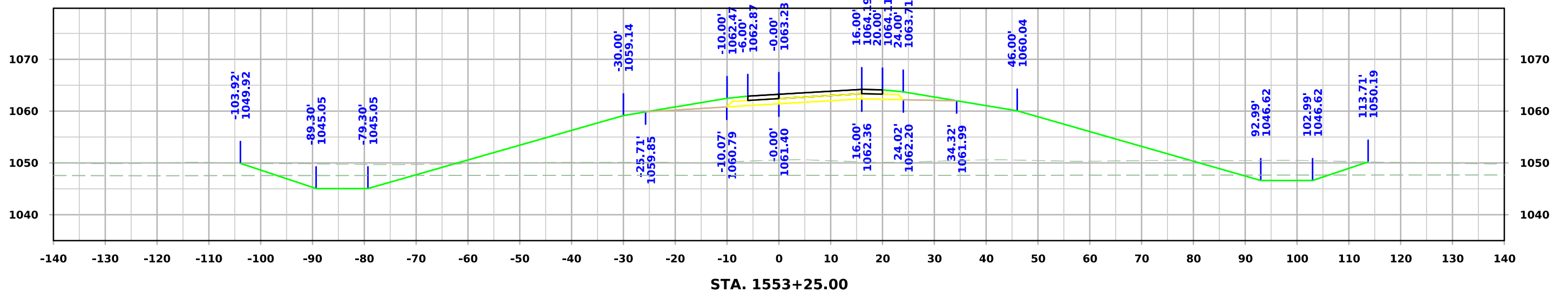
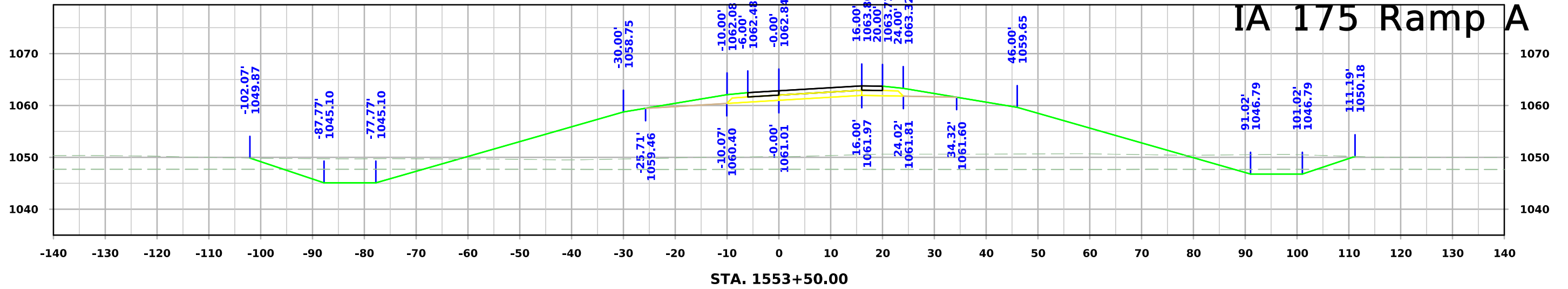

IA 175 Ramp A

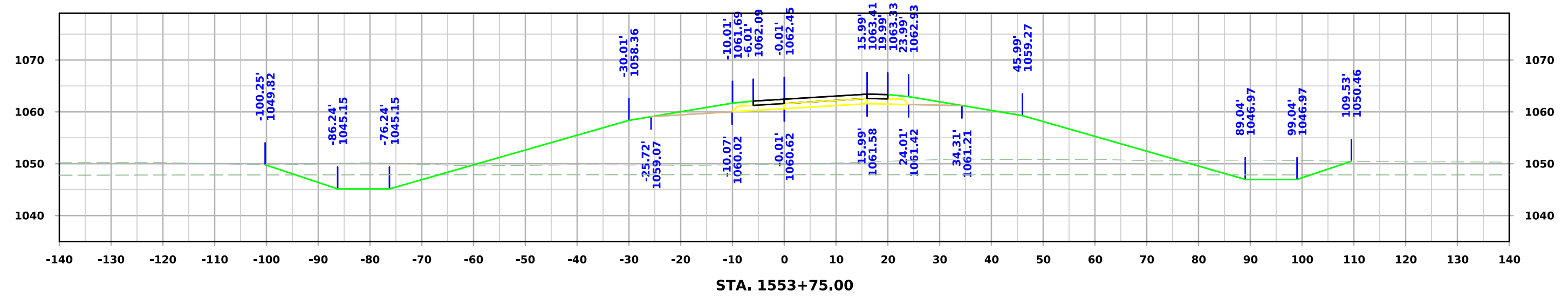
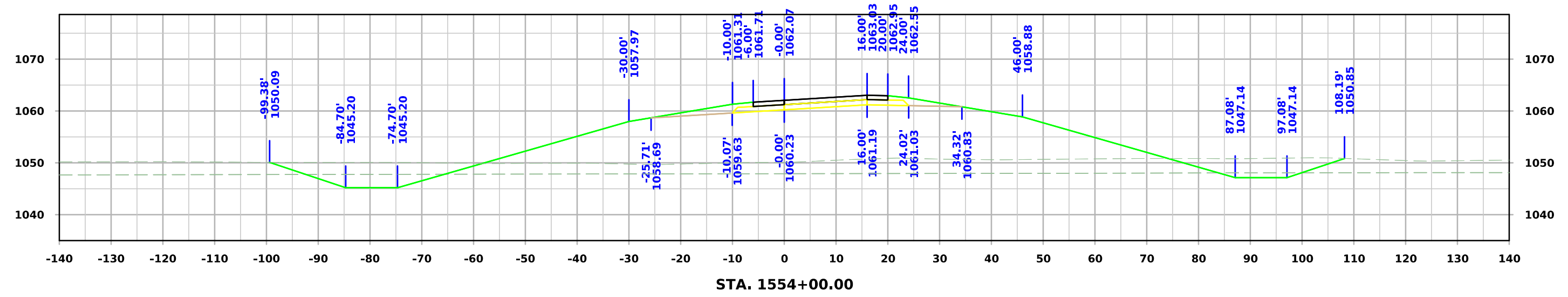
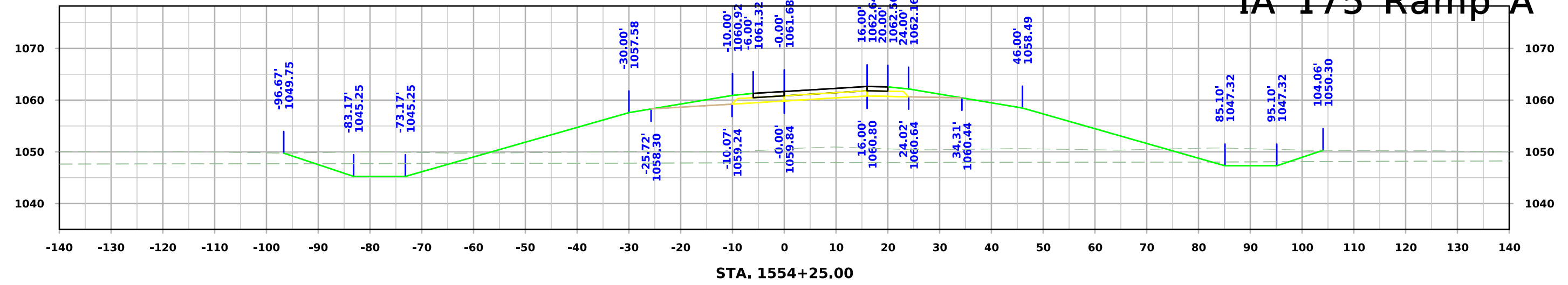

IA 175 Ramp A

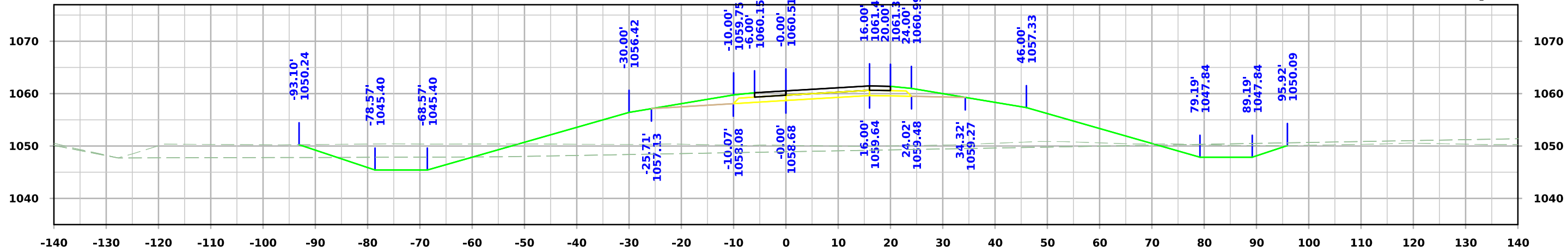

STA. 1555+00.00

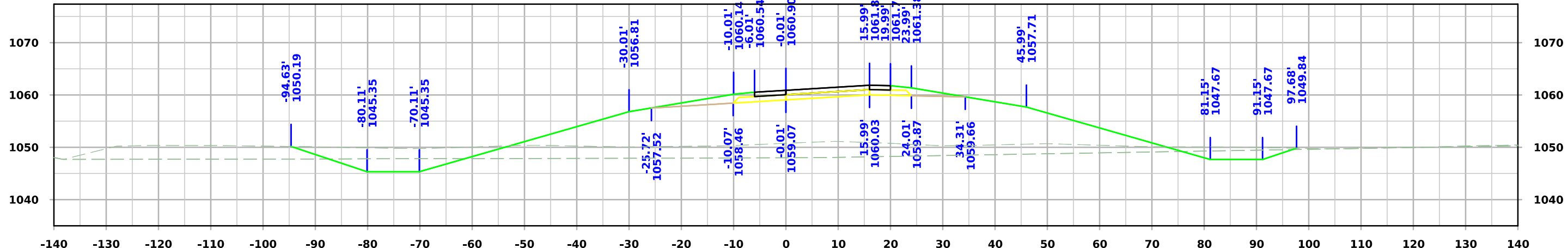

STA. 1554+75.00

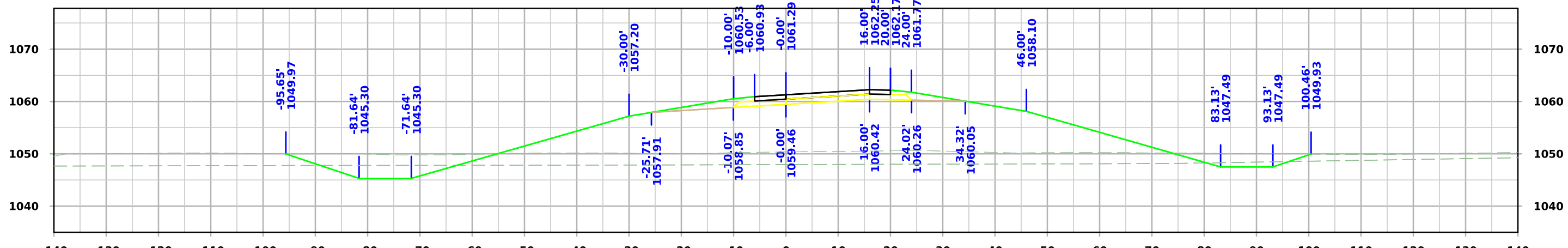

STA. 1554+50.00

IA 175 Ramp A

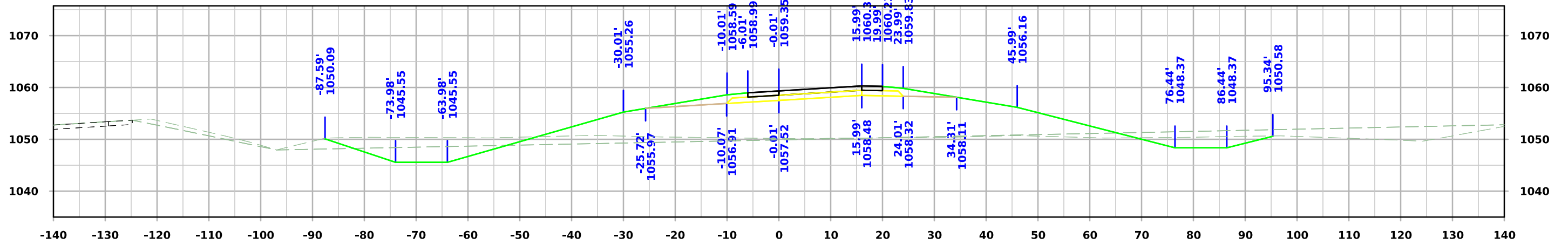

STA. 1555+75.00

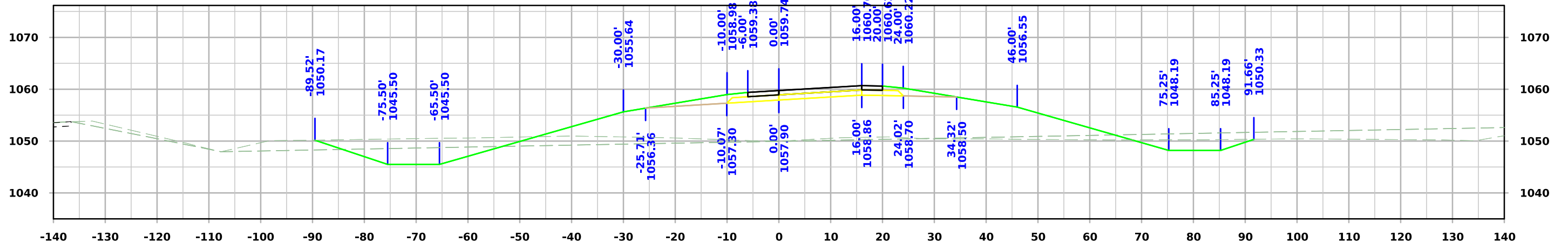

STA. 1555+50.00

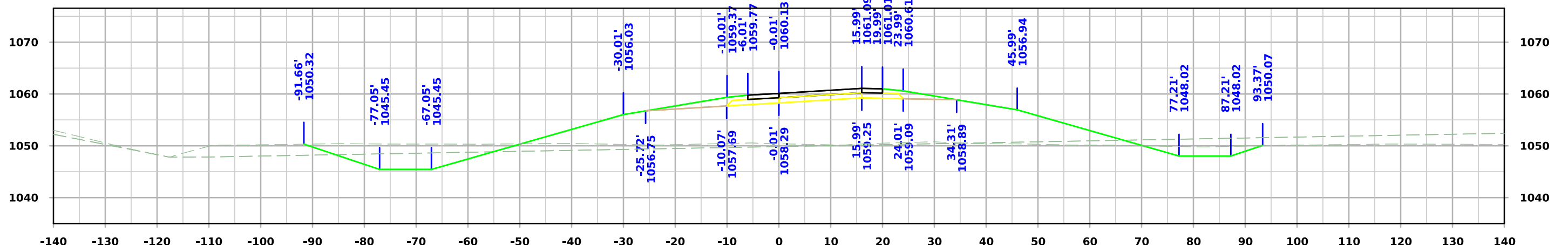

STA. 1555+25.00

IA 175 Ramp A

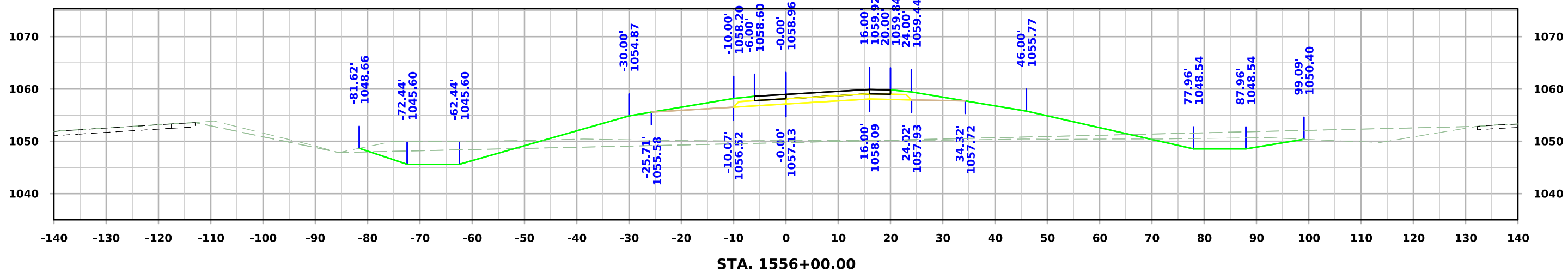
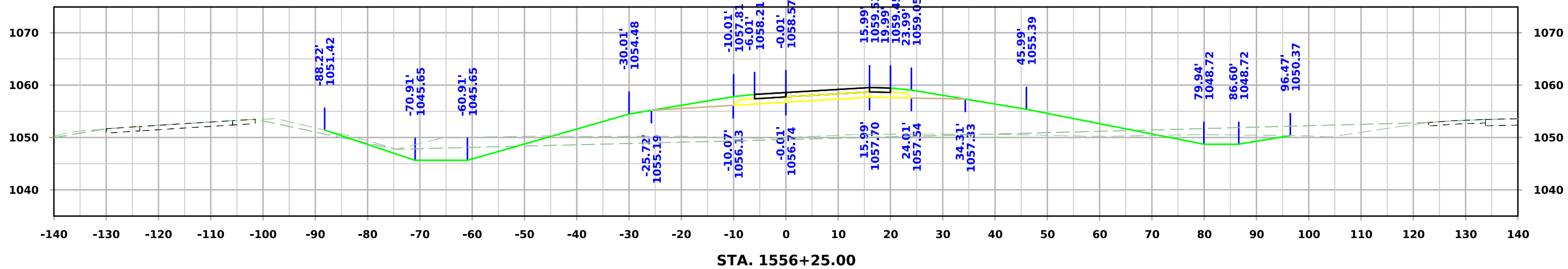
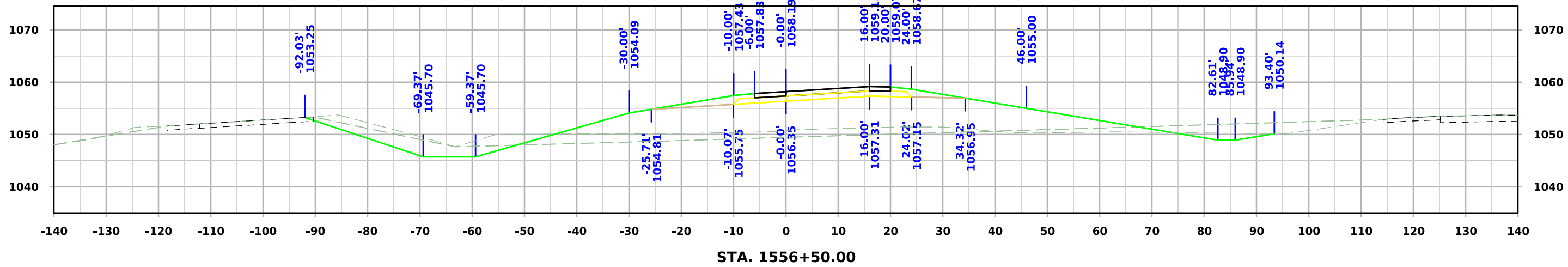

IA 175 Ramp A

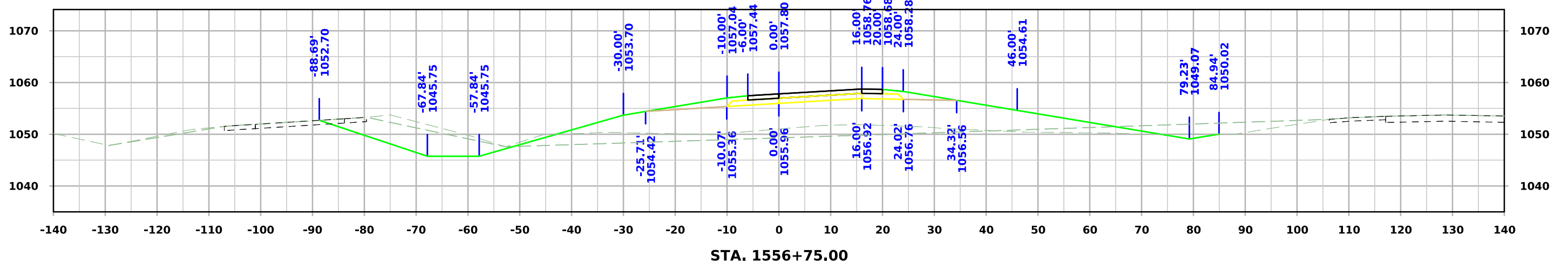
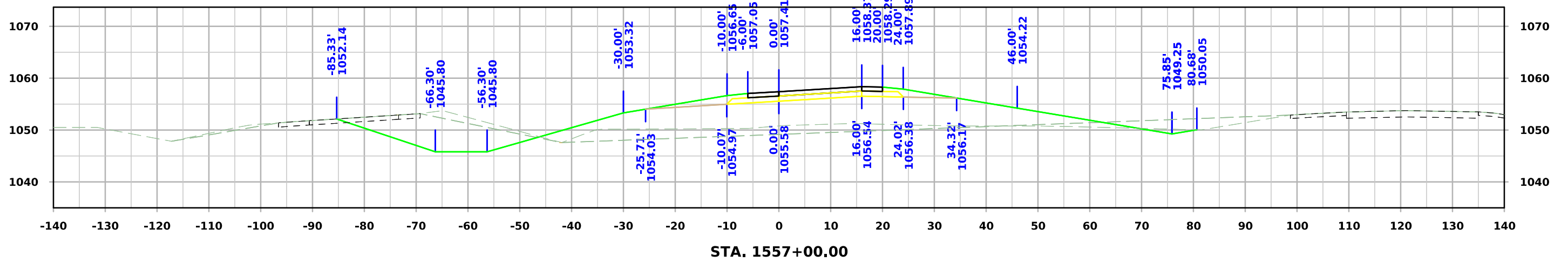
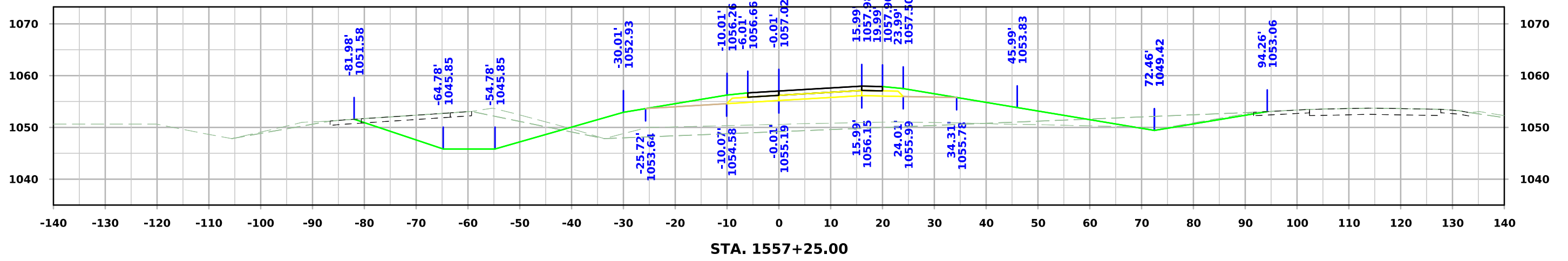

IA 175 Ramp A

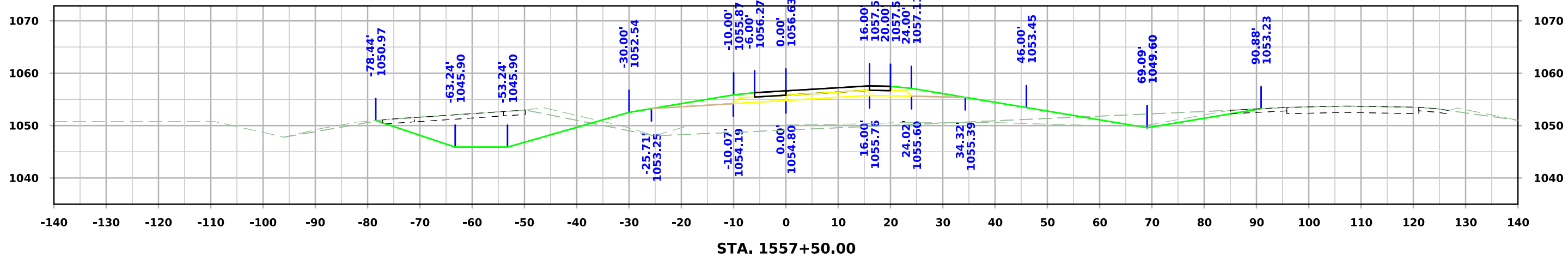
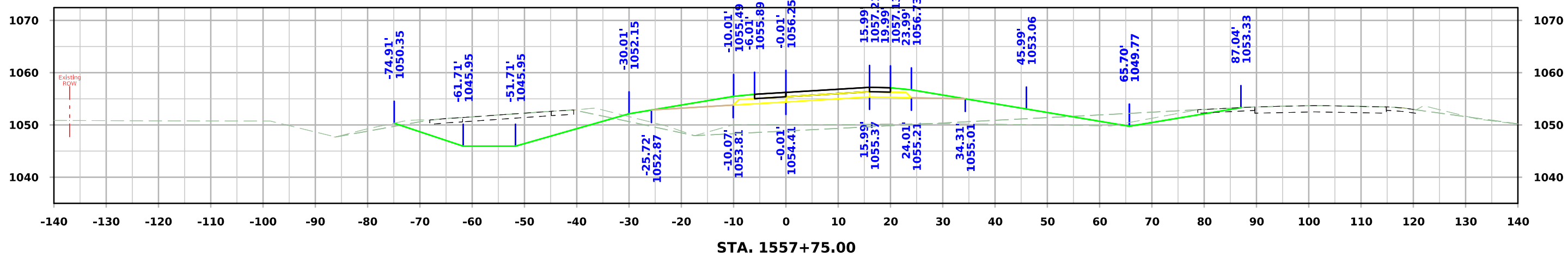
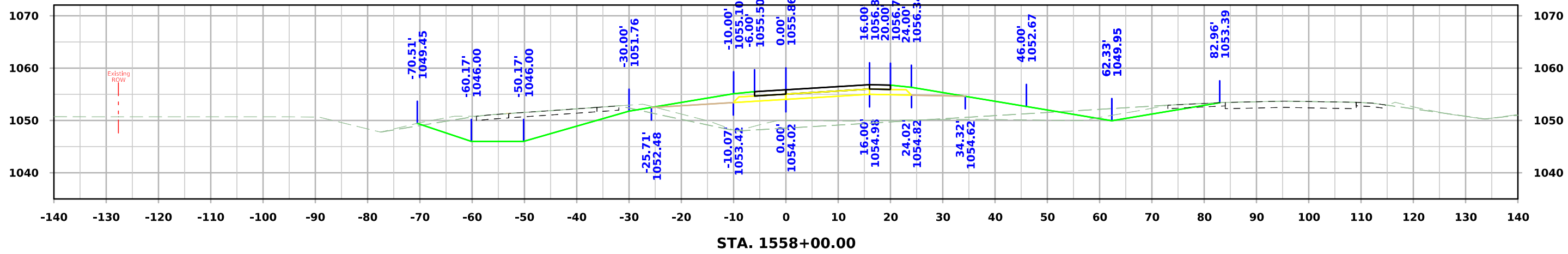

IA 175 Ramp A

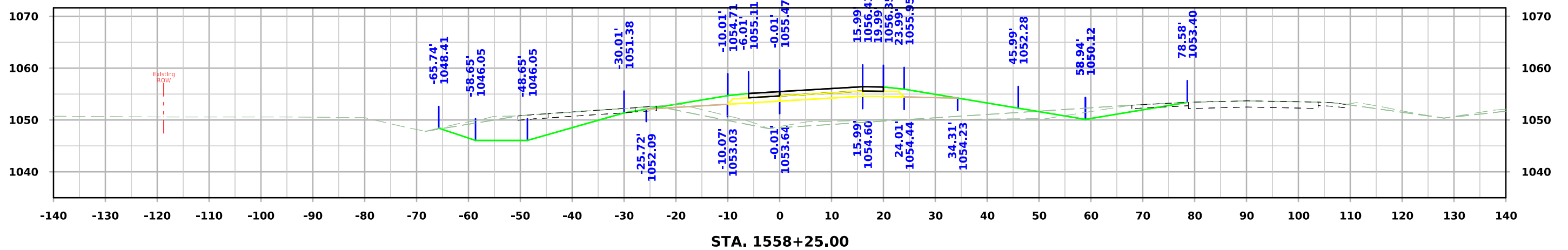
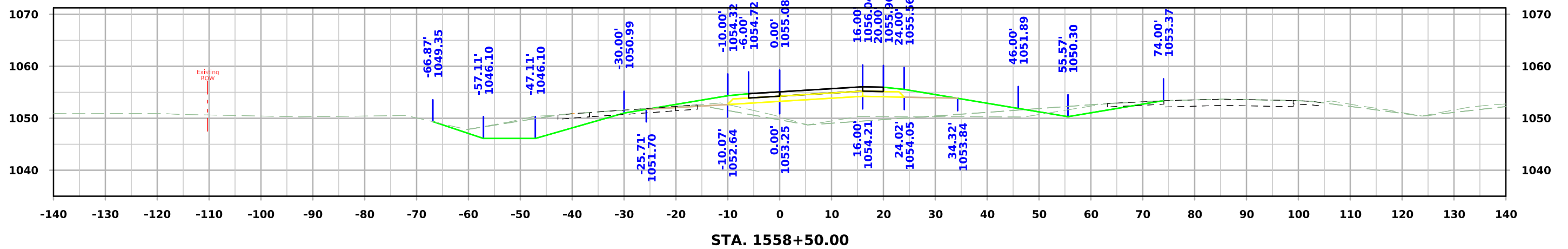
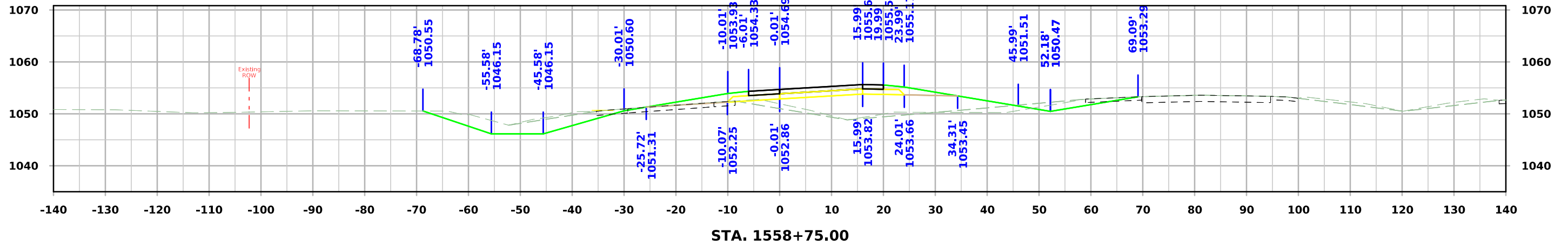

IA 175 Ramp A

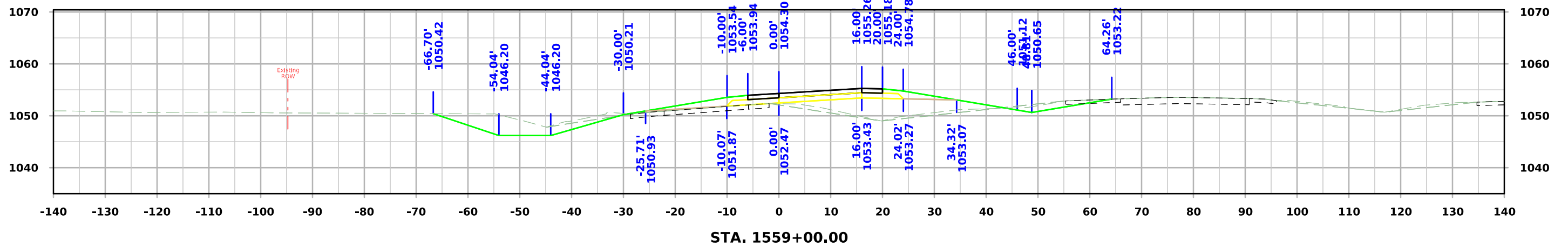
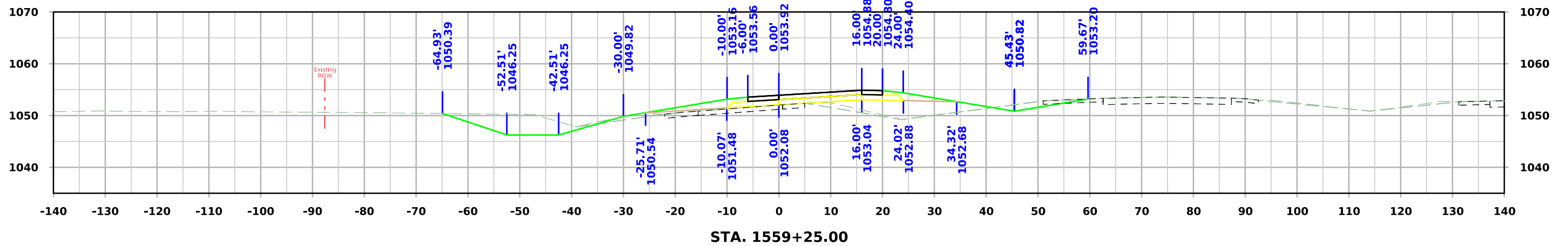
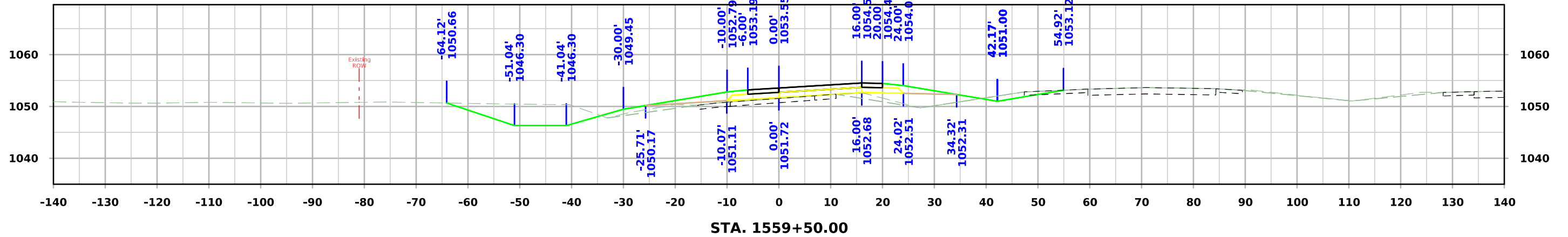

IA 175 Ramp A

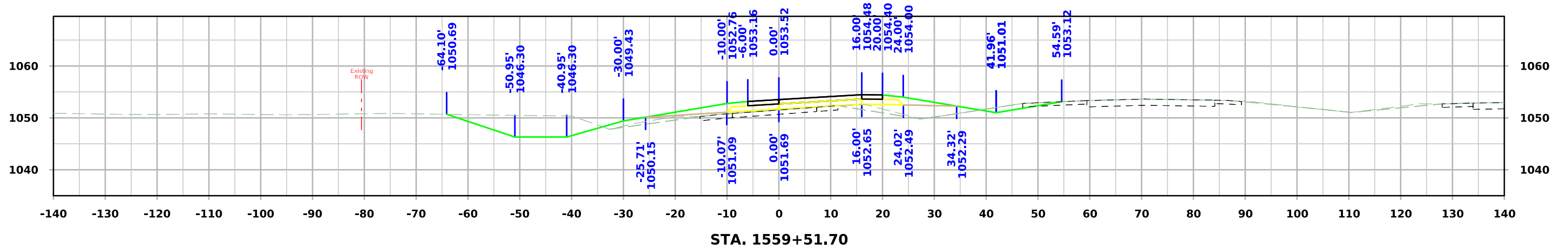
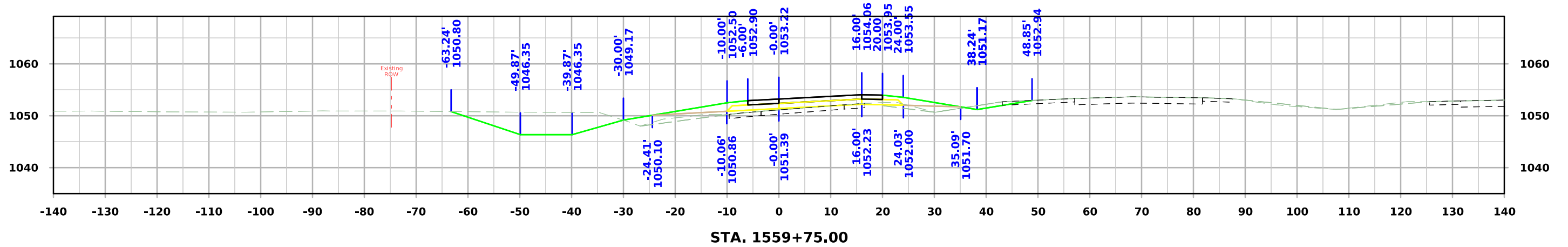
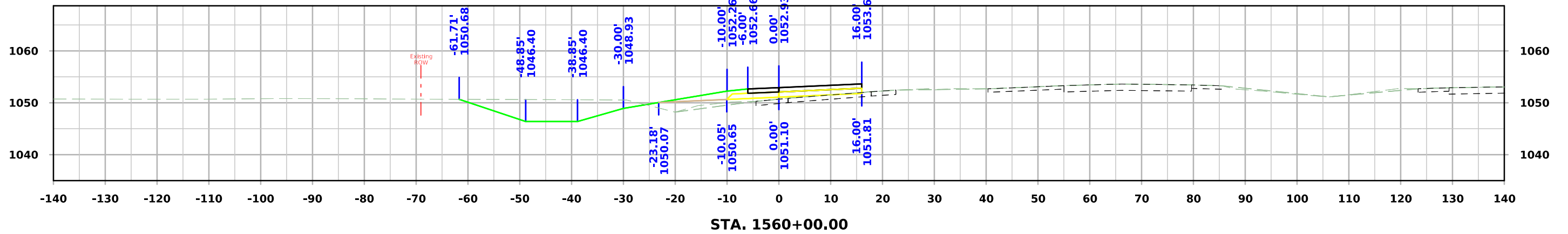

IA 175 Ramp A

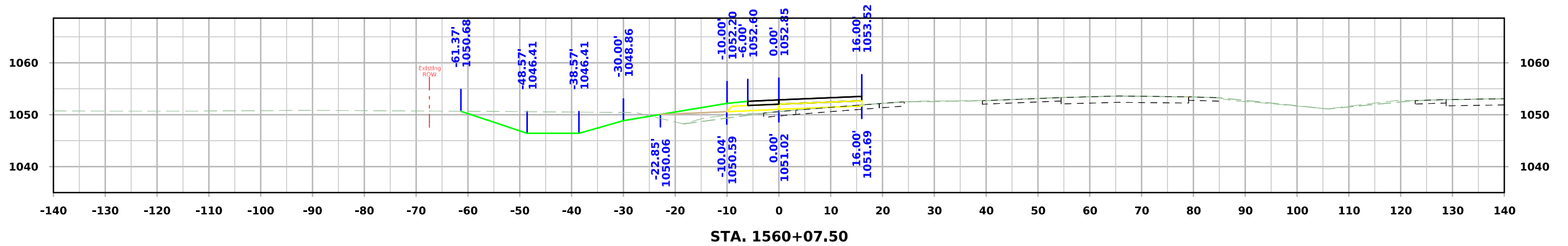
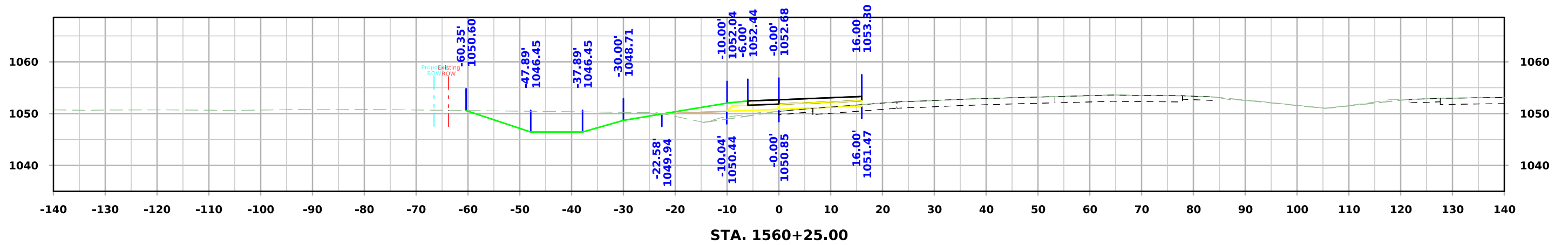
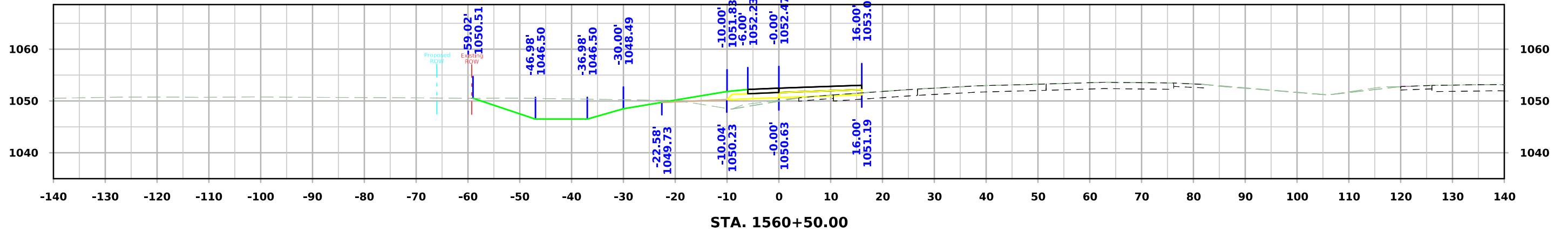

IA 175 Ramp A

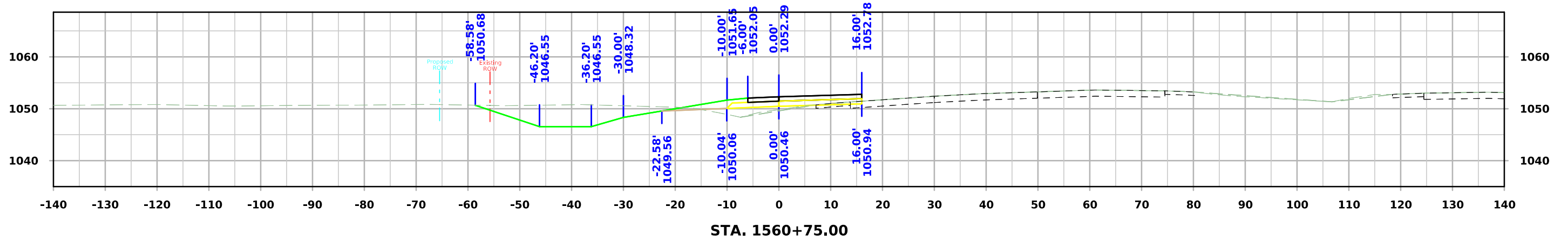
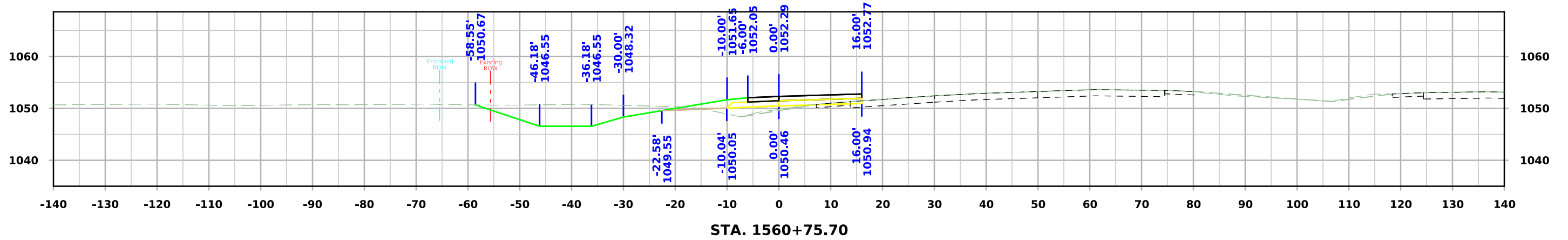
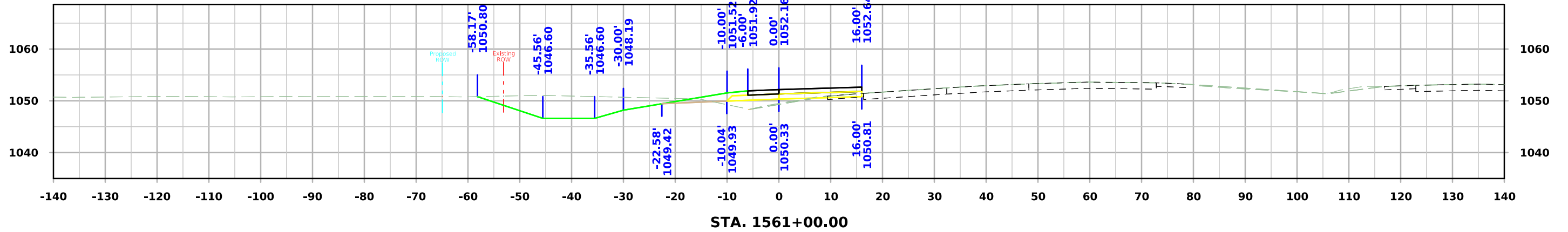

IA 175 Ramp A

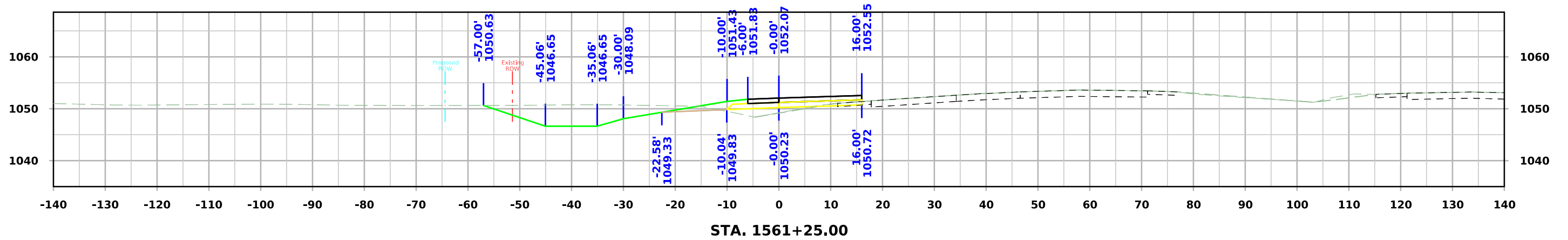
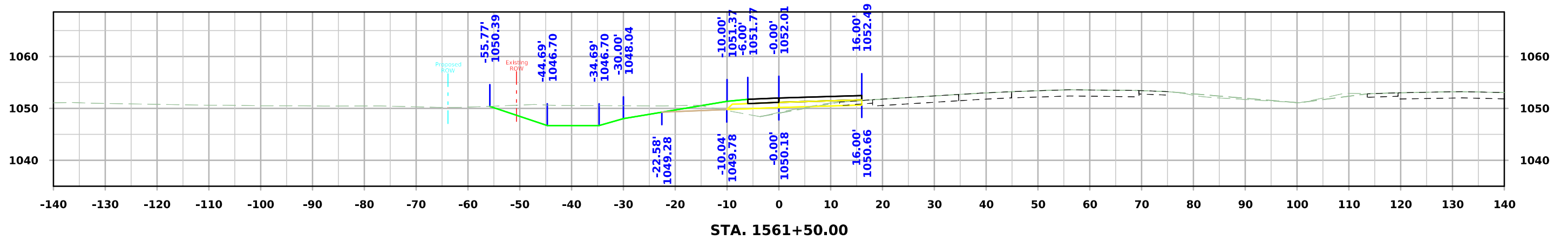
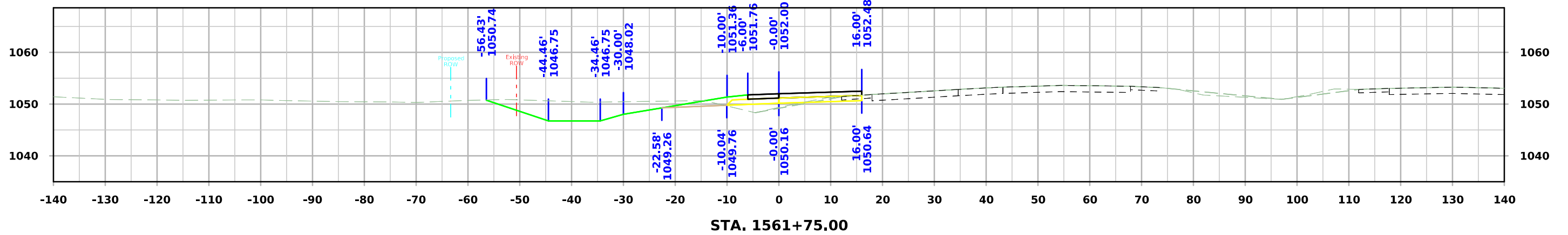

IA 175 Ramp A

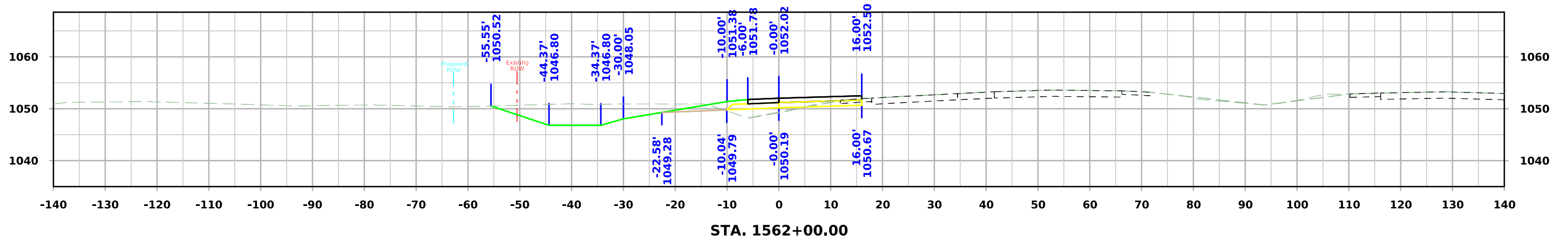
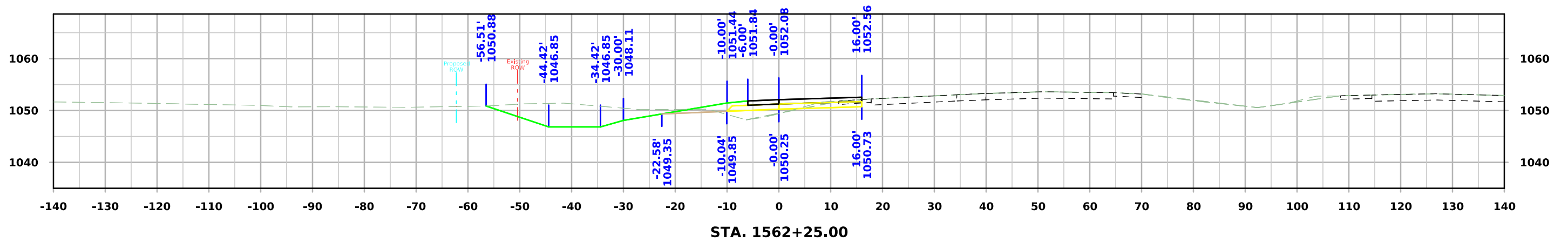
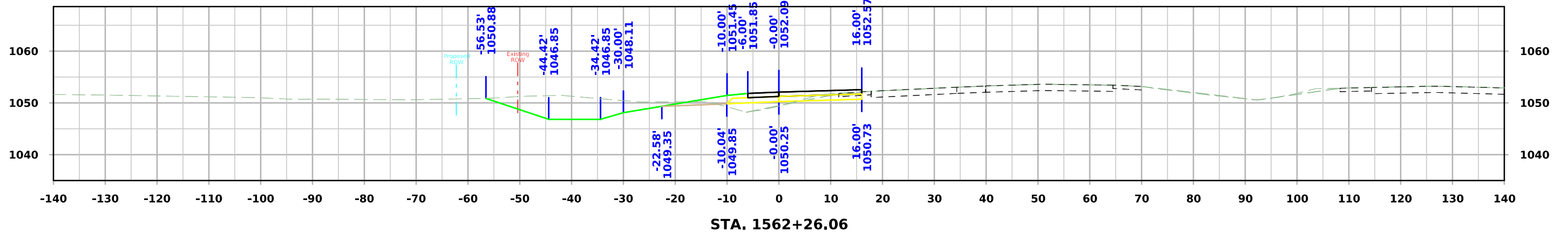

IA 175 Ramp B

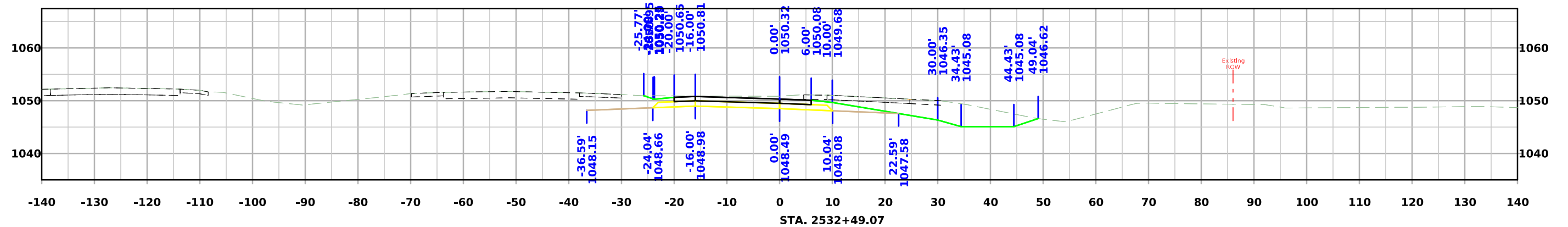
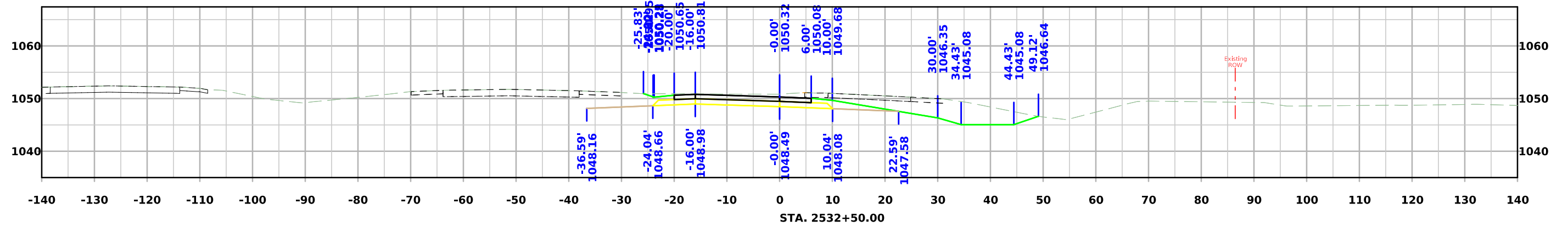
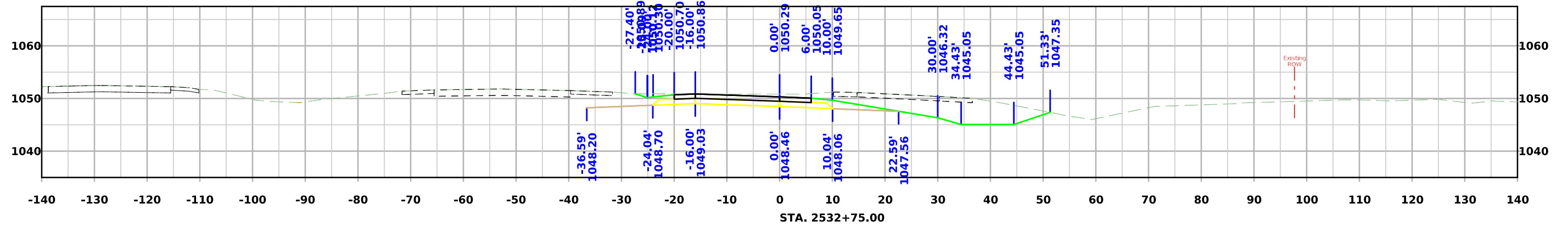

IA 175 Ramp B

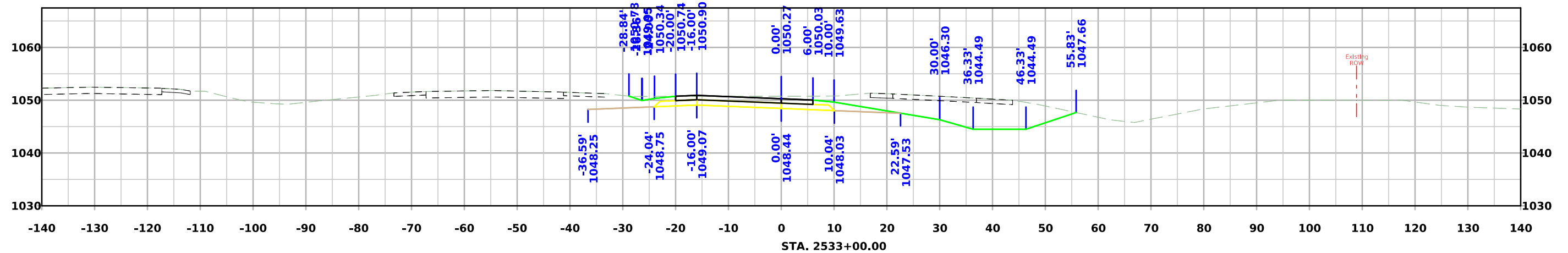
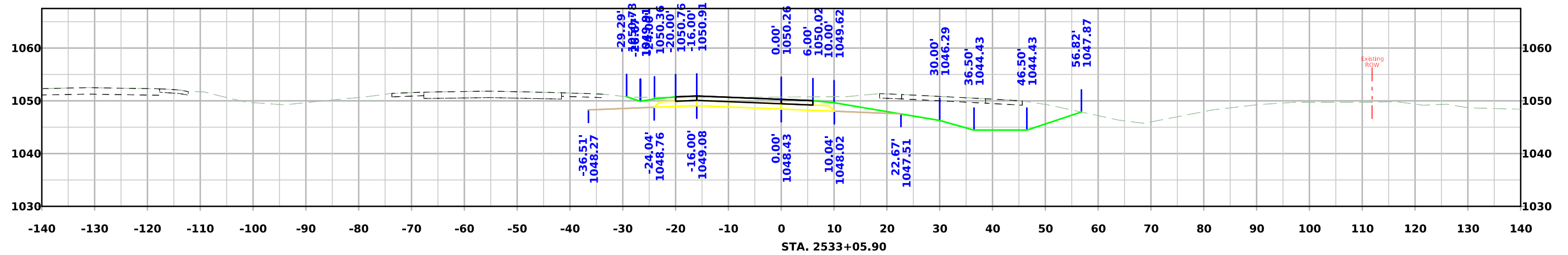
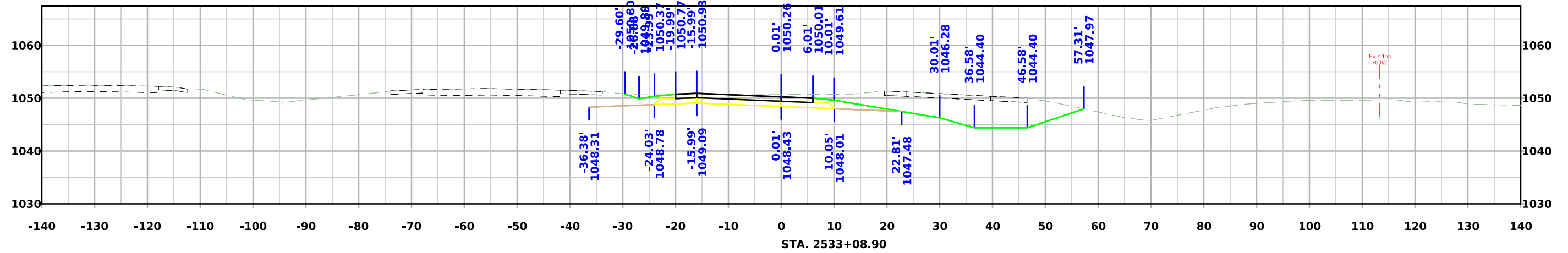

IA 175 Ramp B

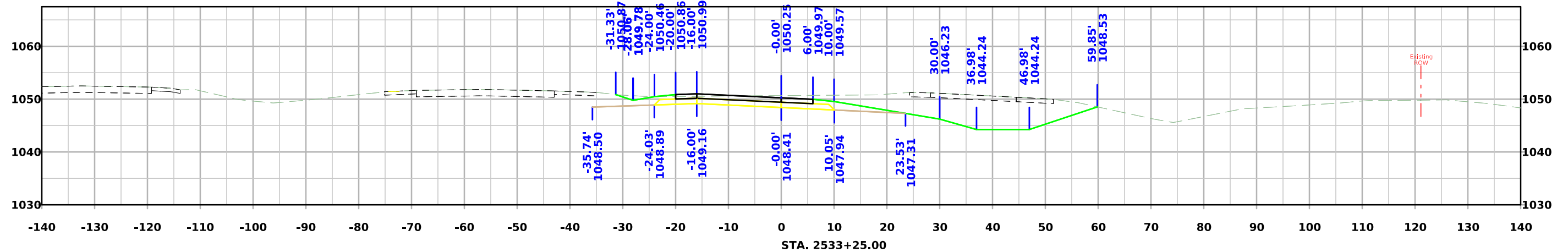
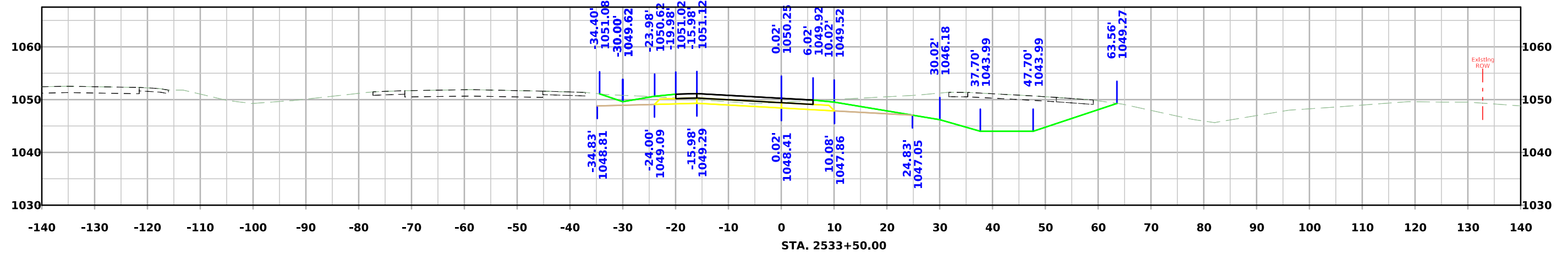
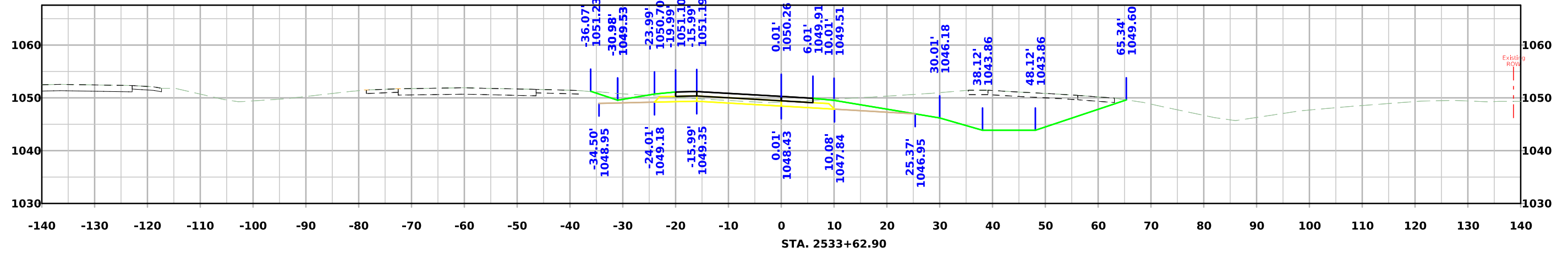

IA 175 Ramp B

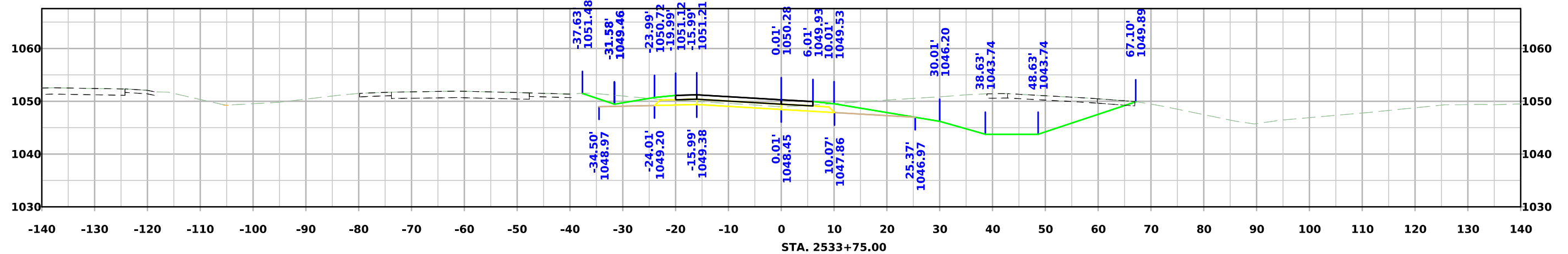
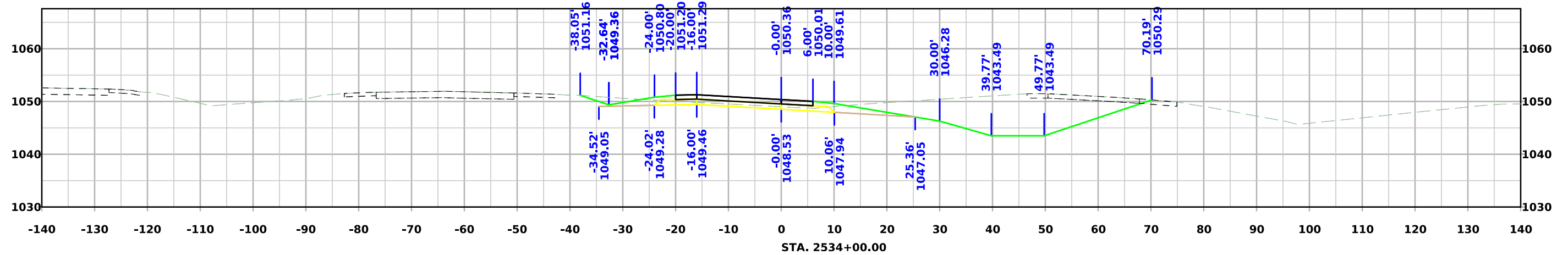
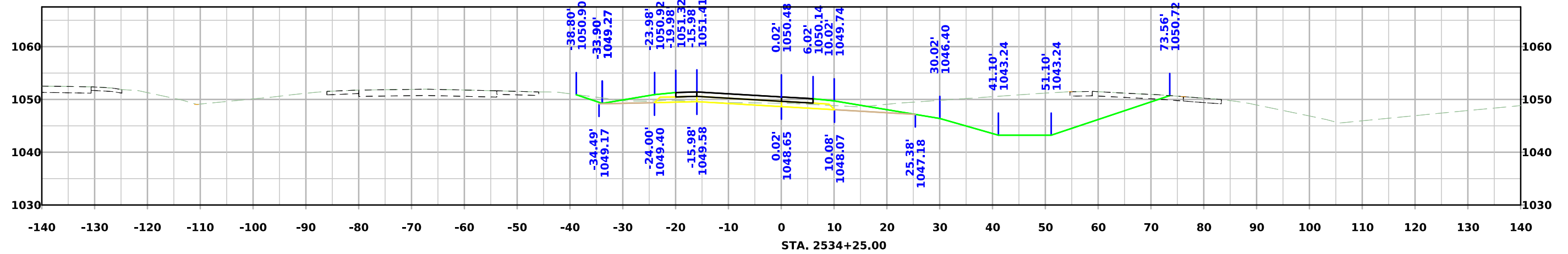

IA 175 Ramp B

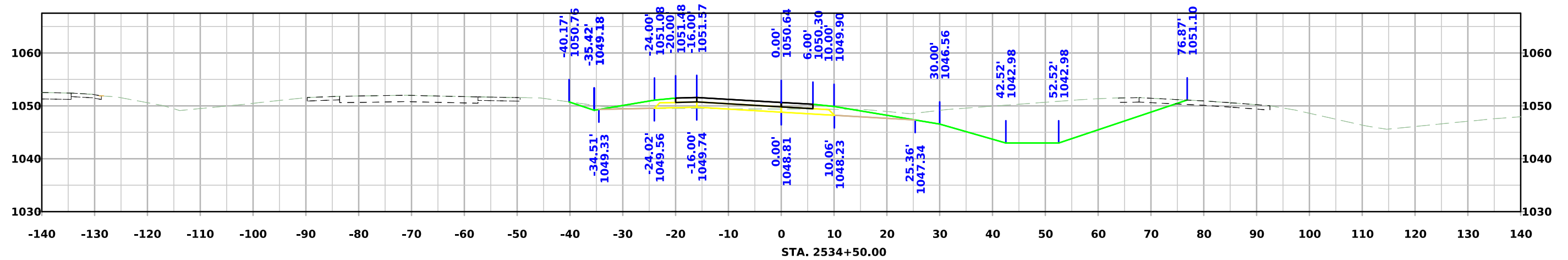
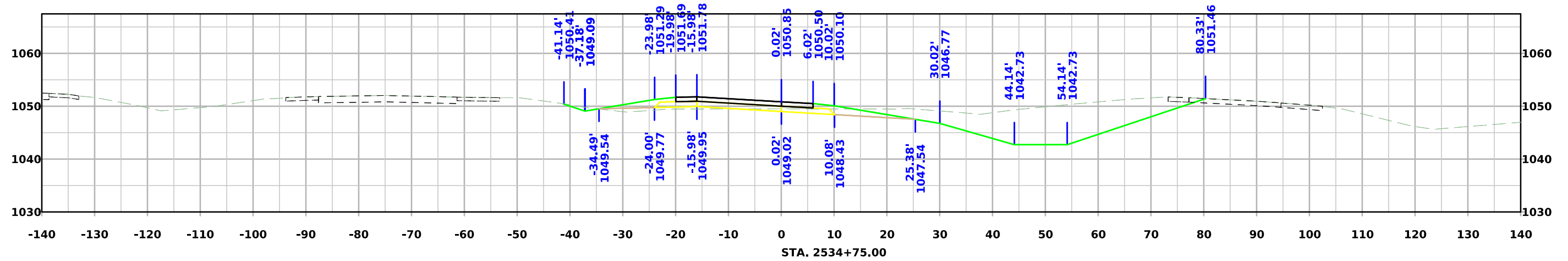
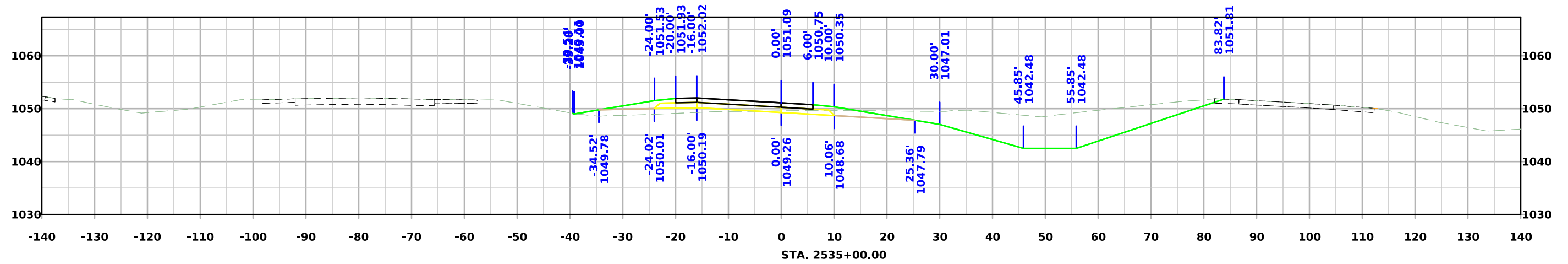

IA 175 Ramp B

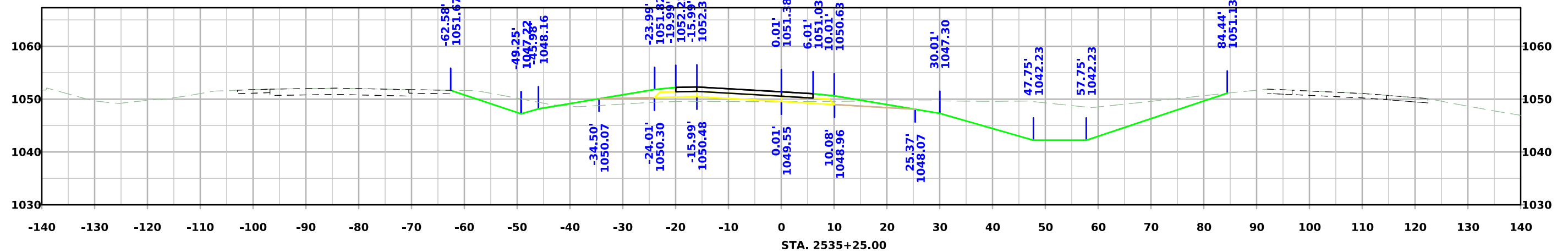
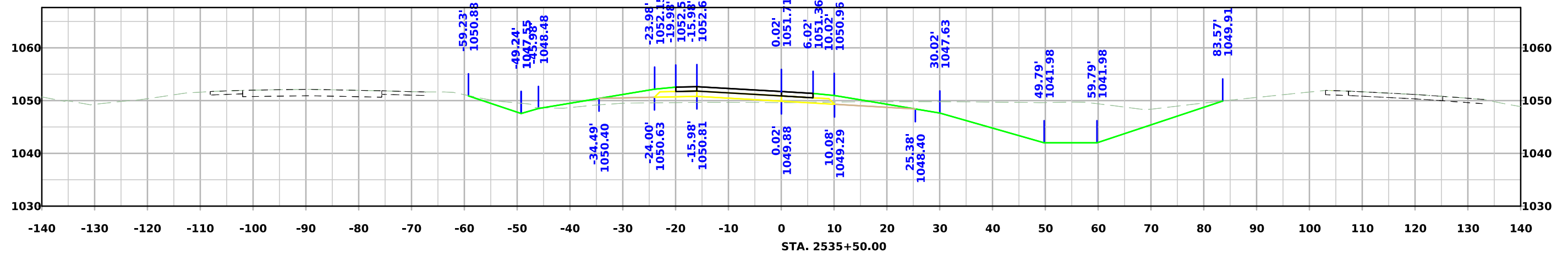
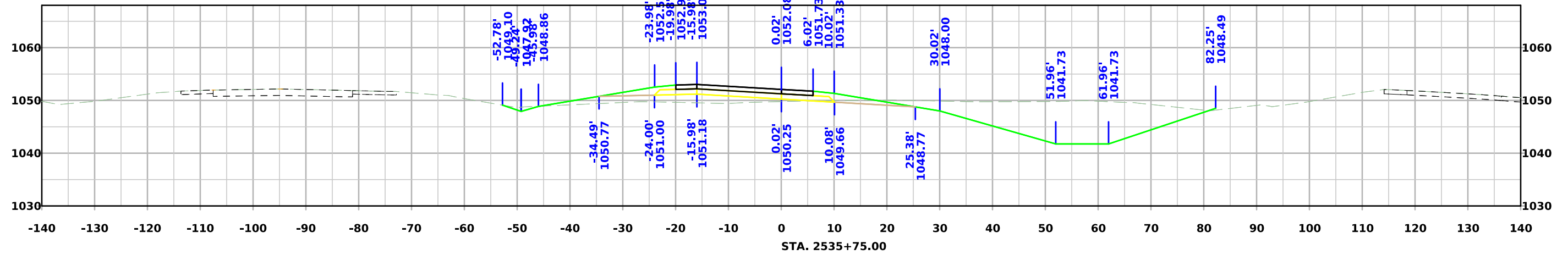

IA 175 Ramp B

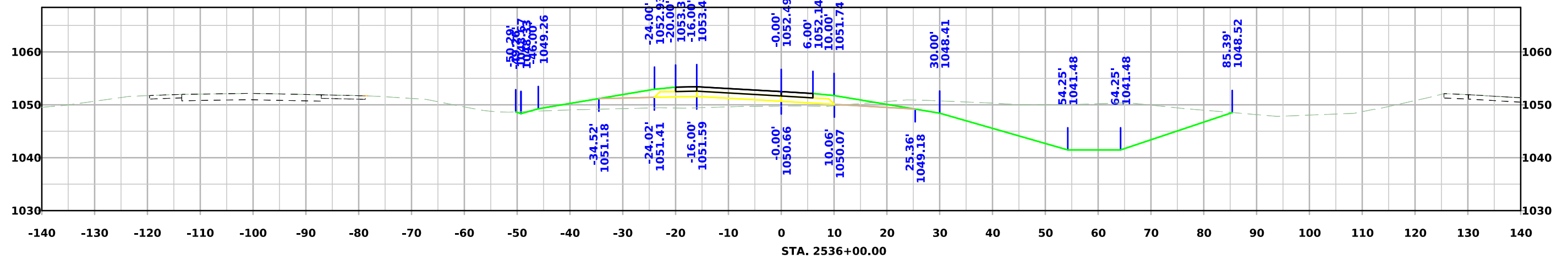
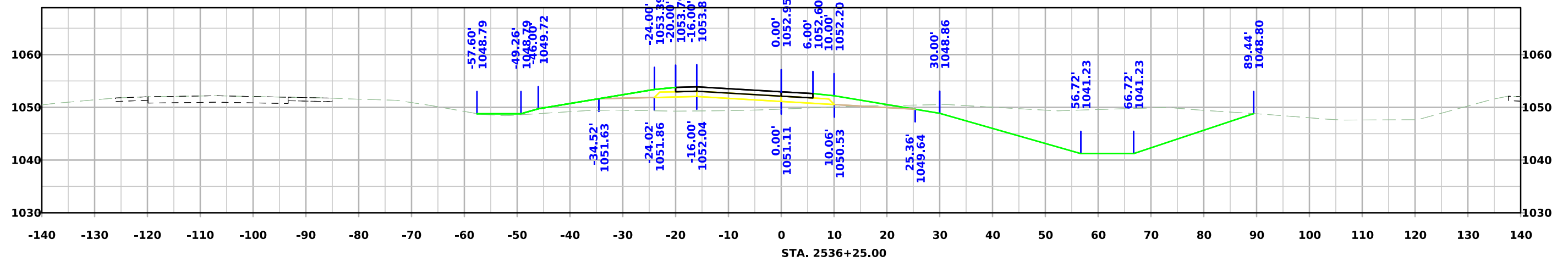
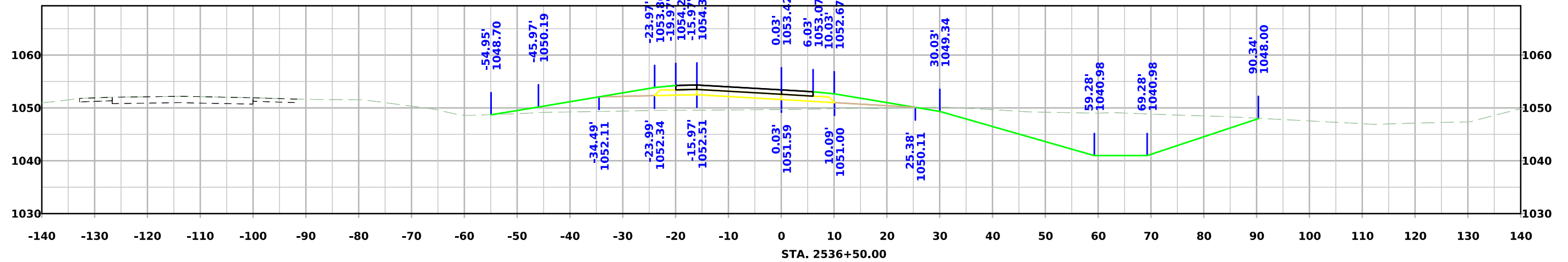

IA 175 Ramp B

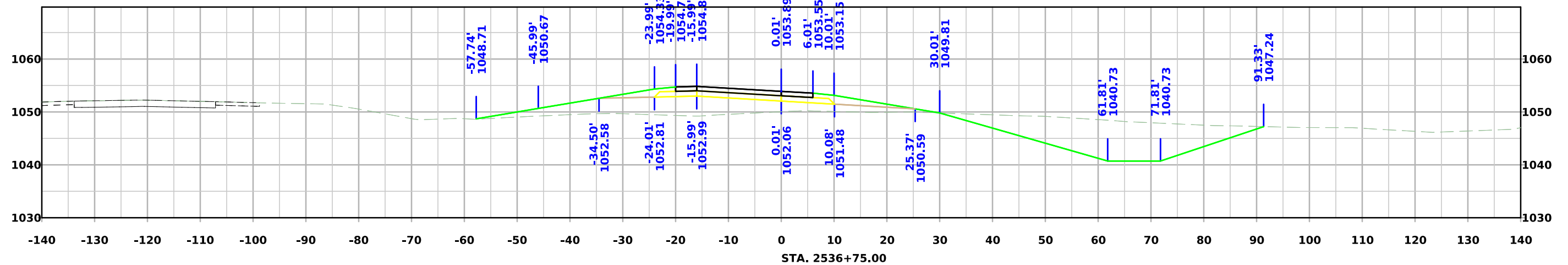
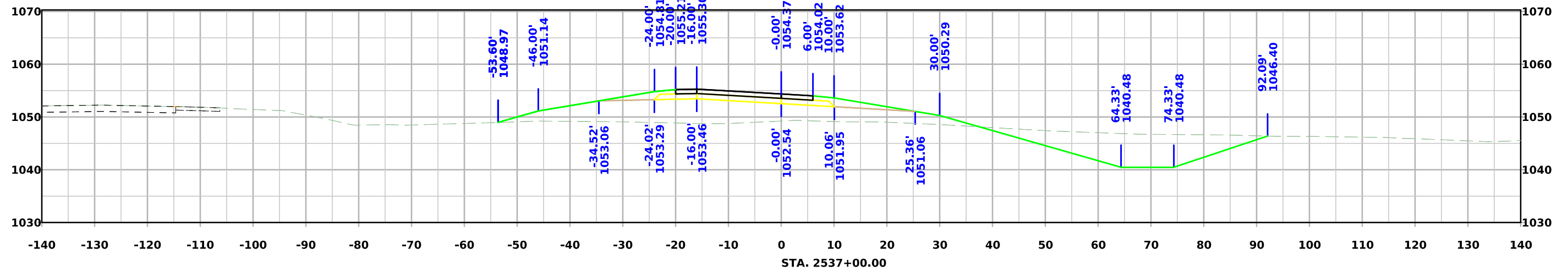
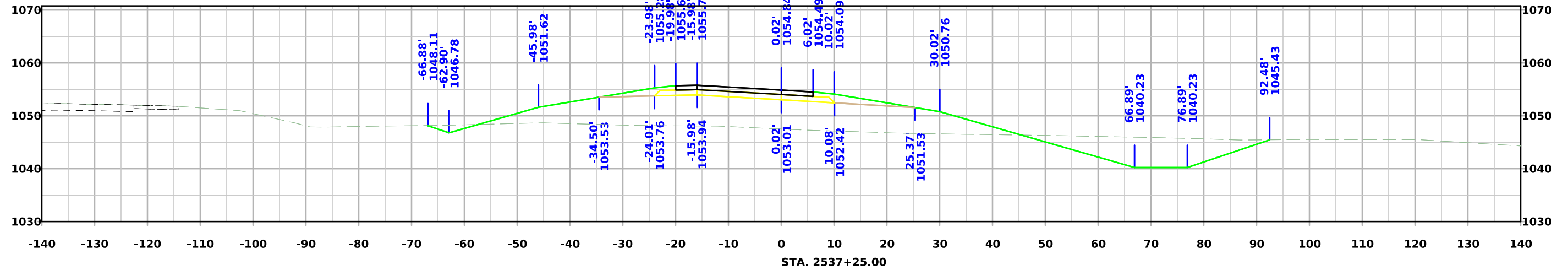

IA 175 Ramp B

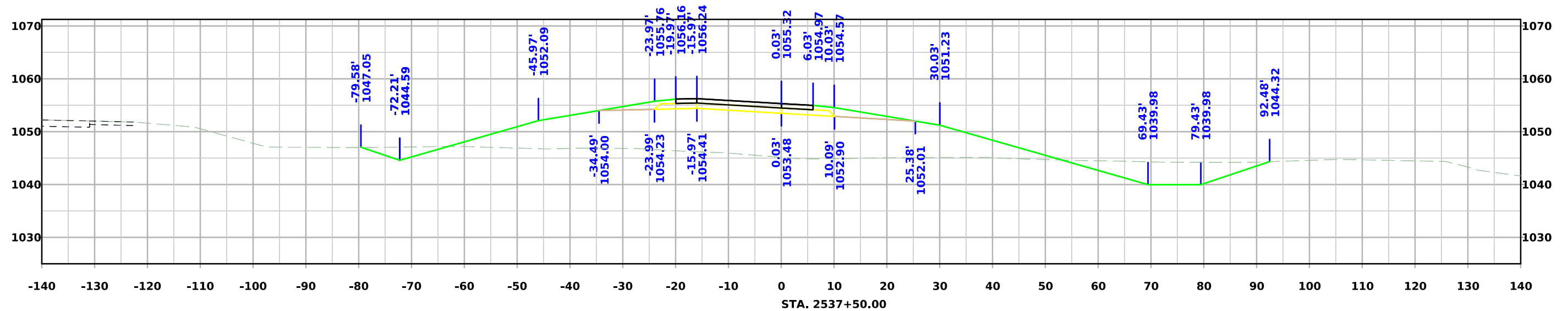
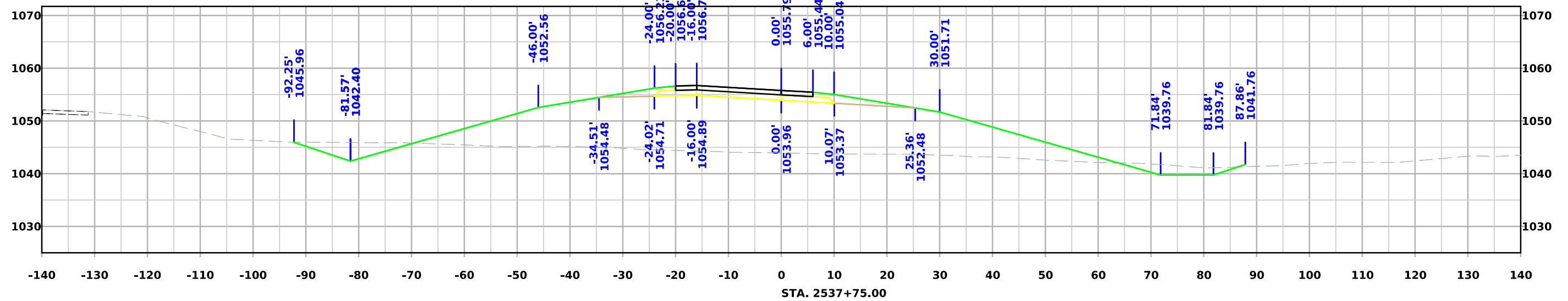

IA 175 Ramp B

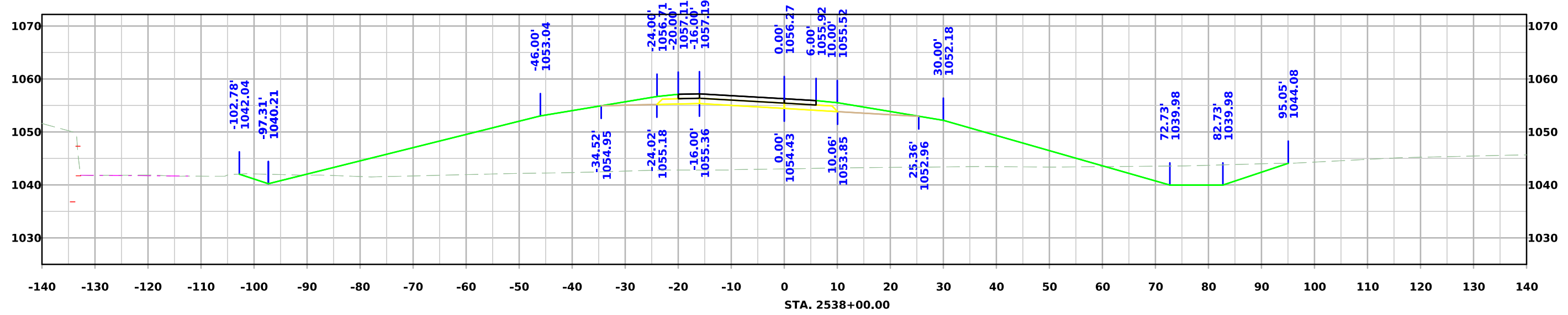
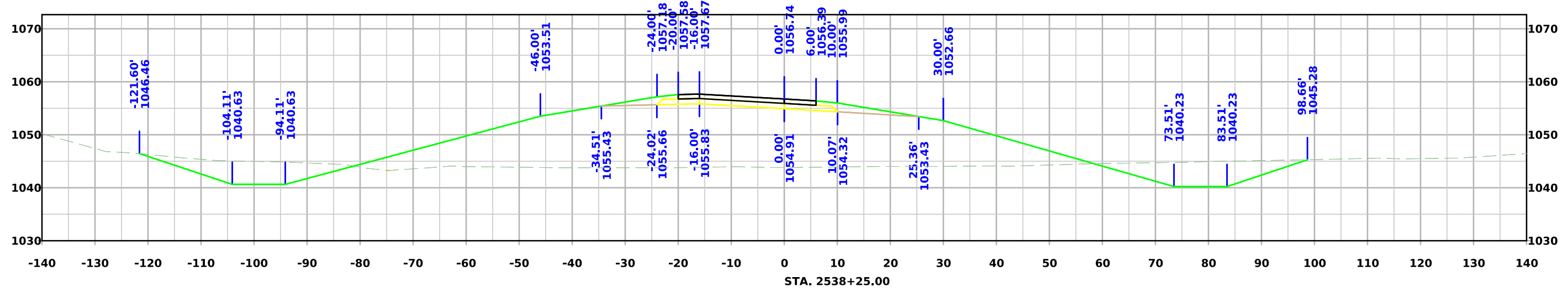
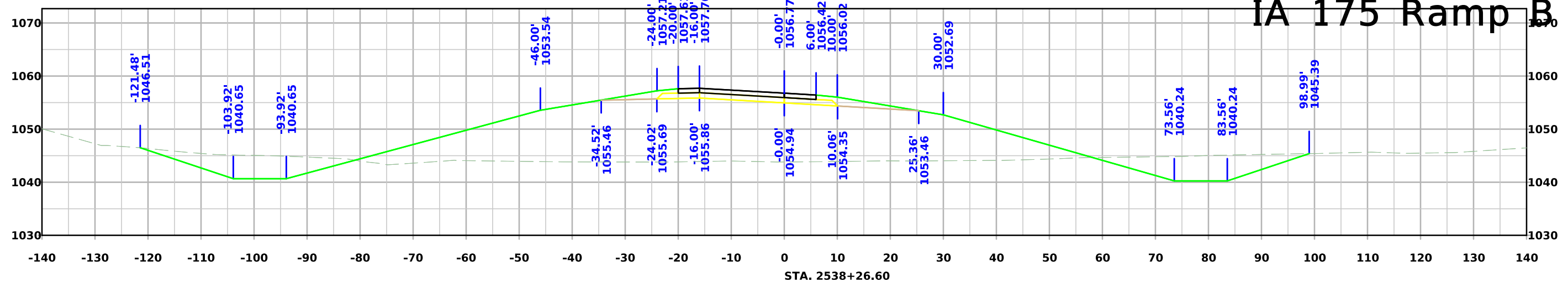

IA 175 Ramp B

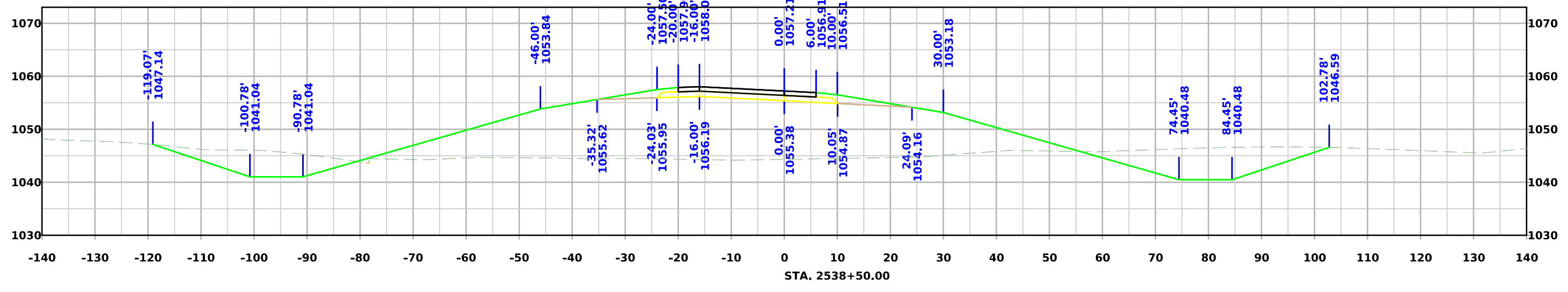
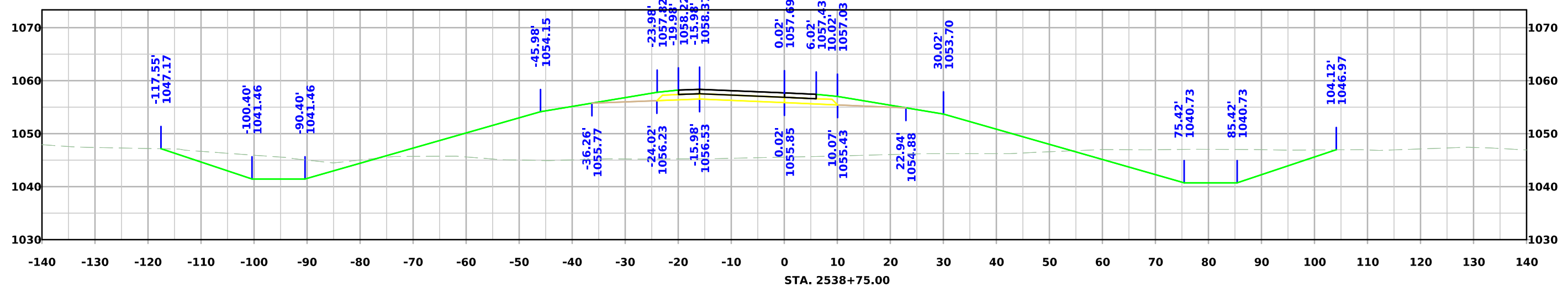
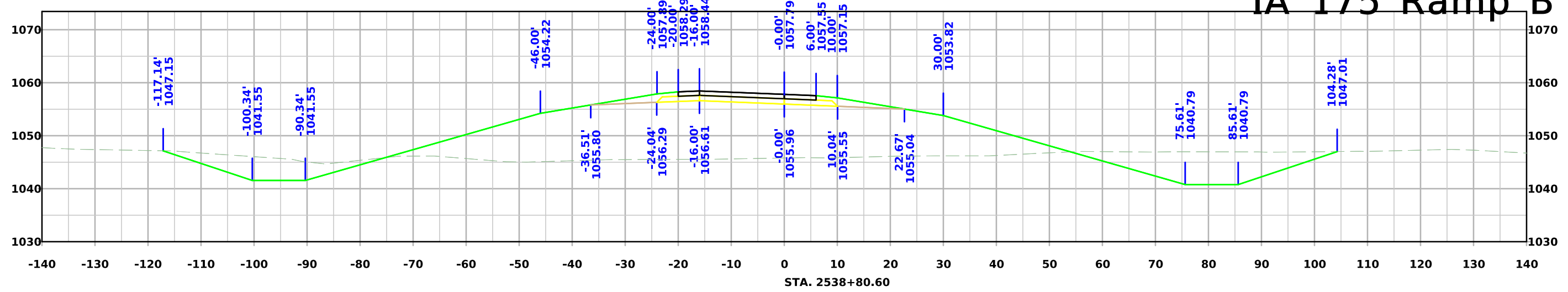

IA 175 Ramp B

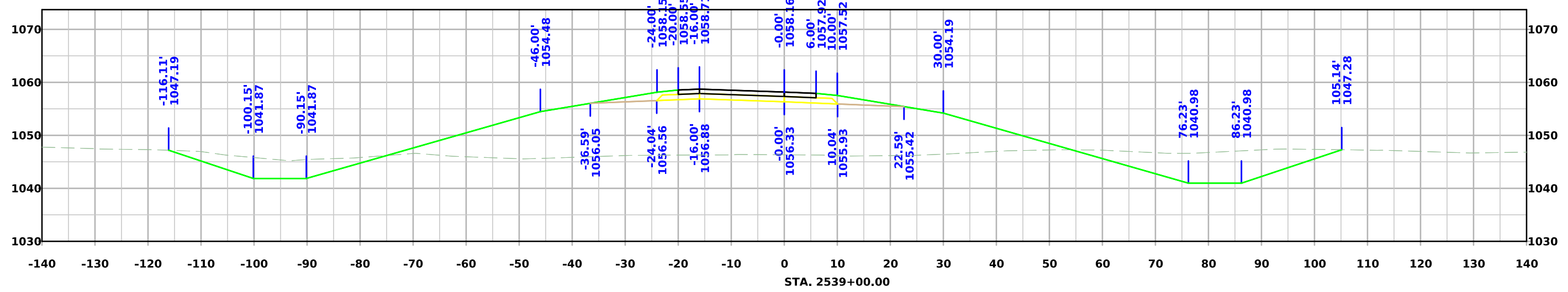
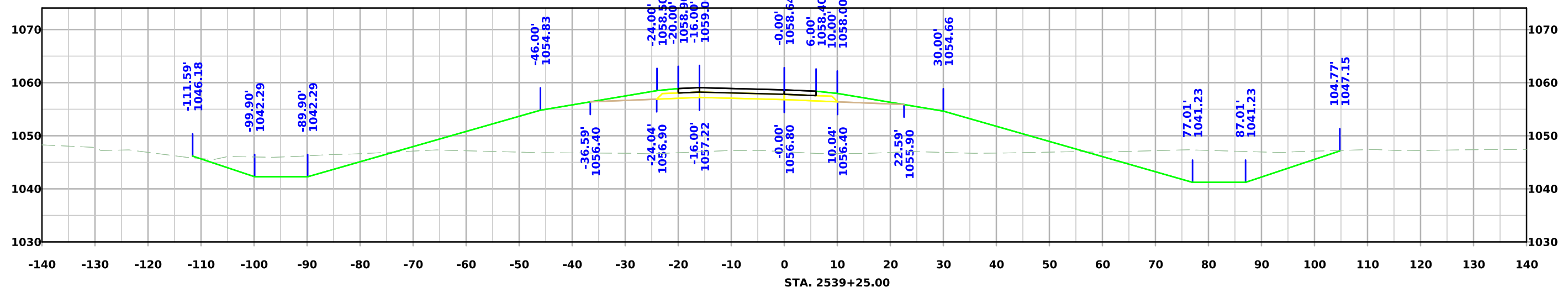
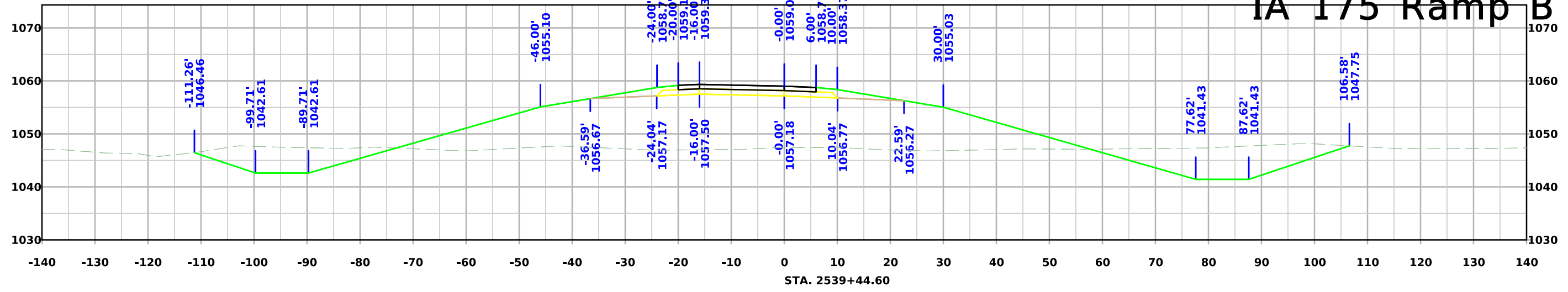

IA 175 Ramp B

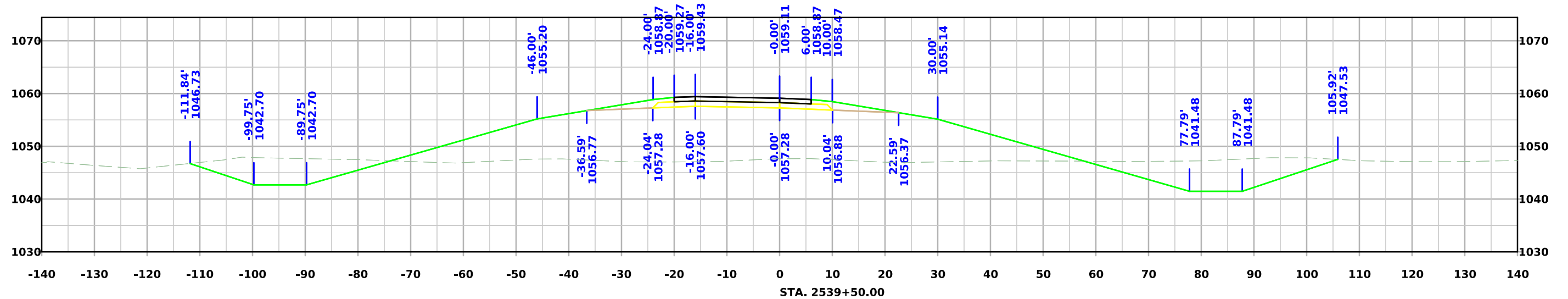
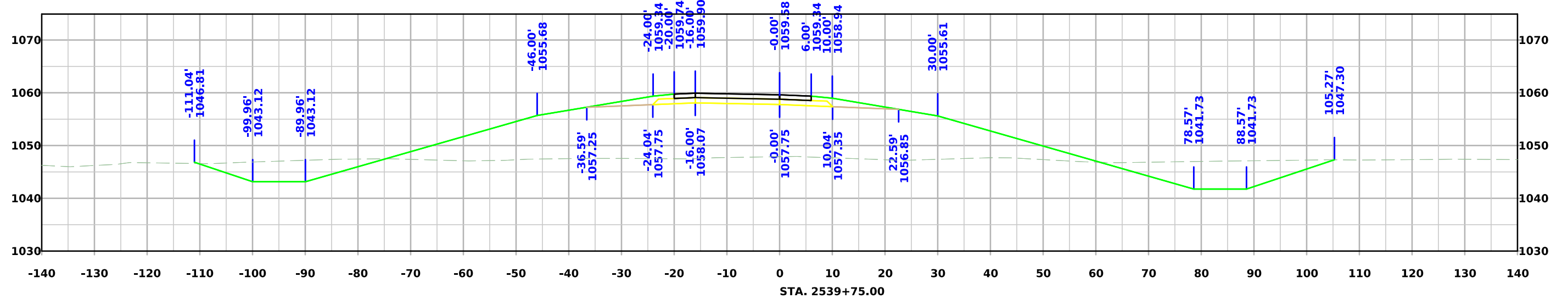

IA 175 Ramp B

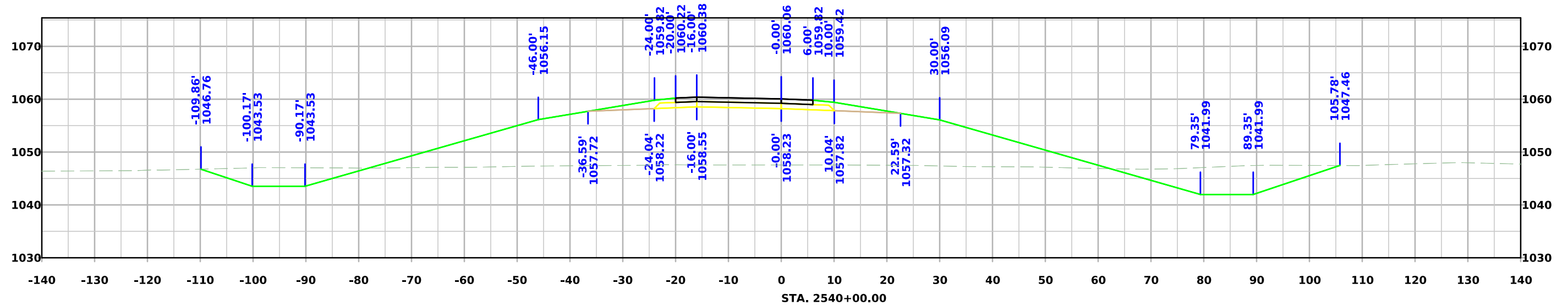
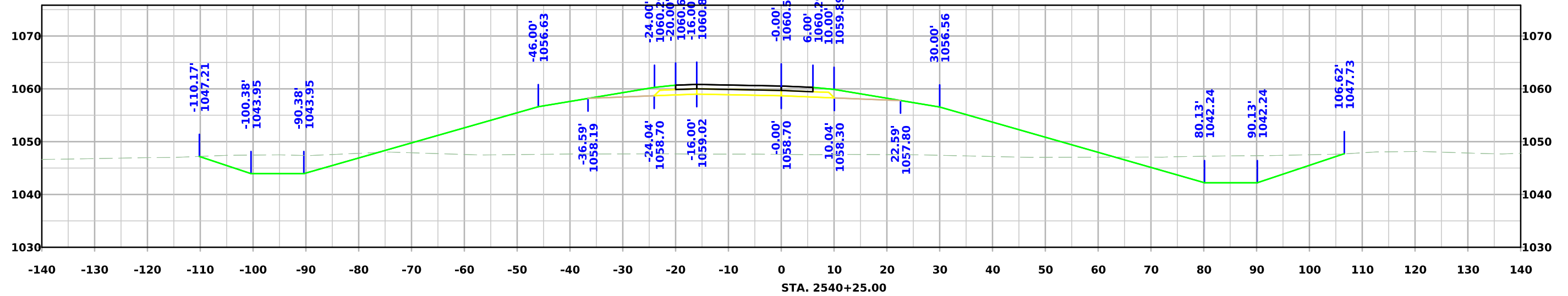

IA 175 Ramp B

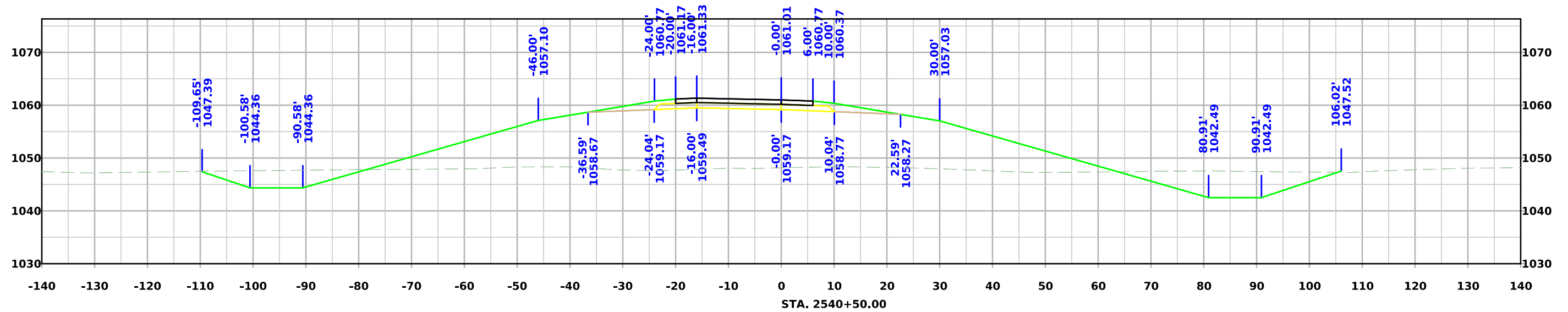
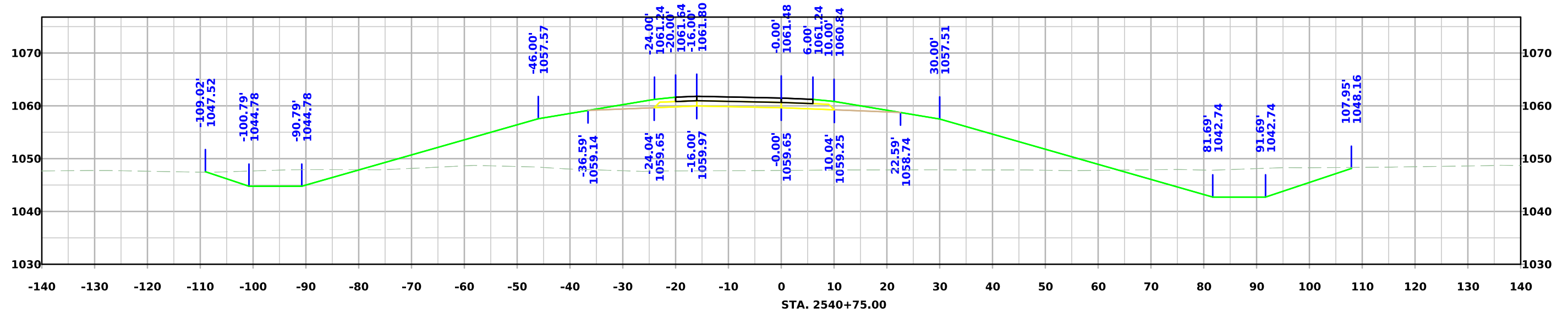

IA 175 Ramp B

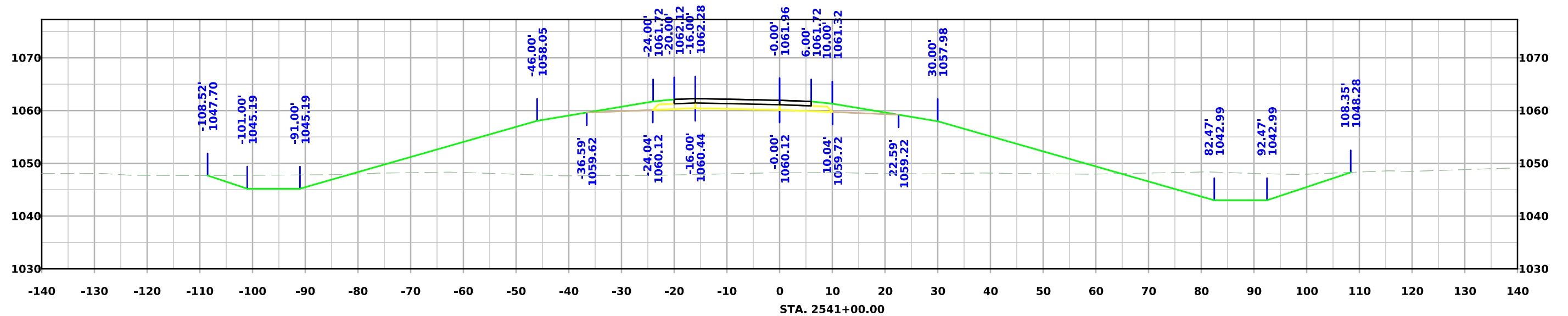
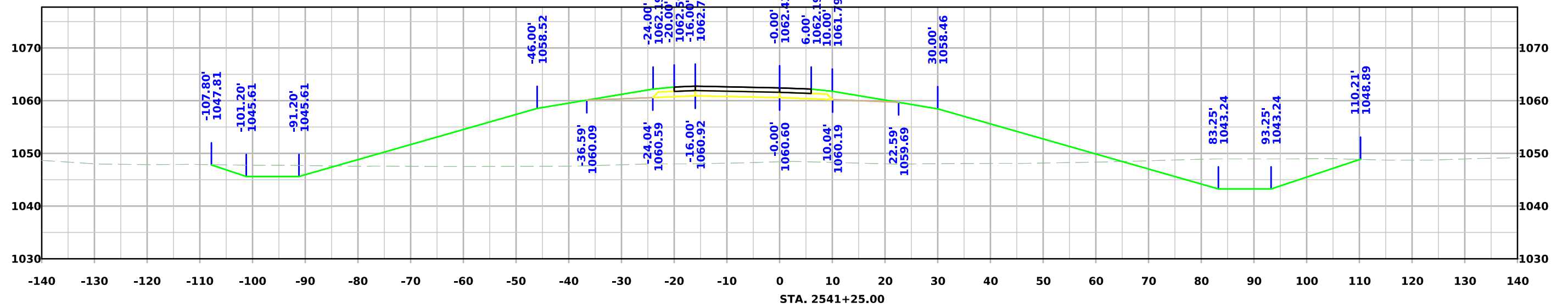

IA 175 Ramp B

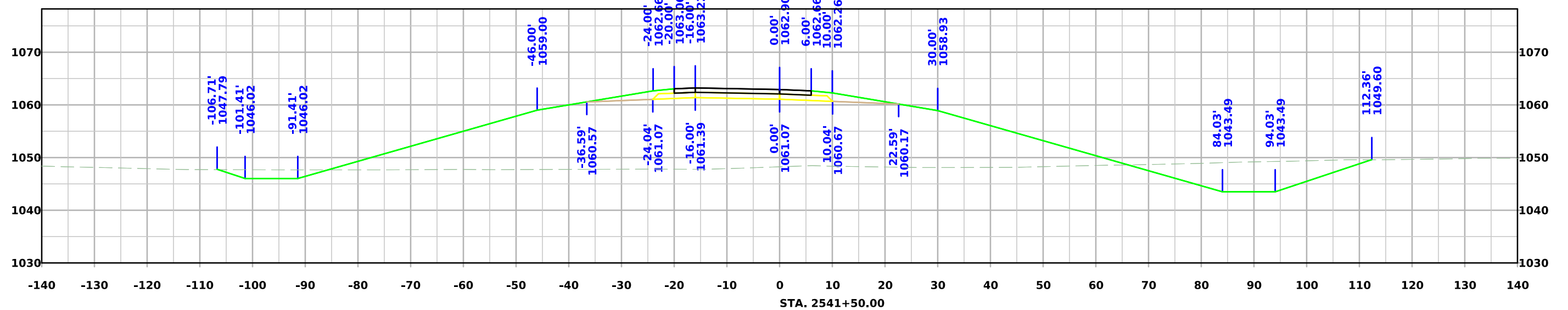
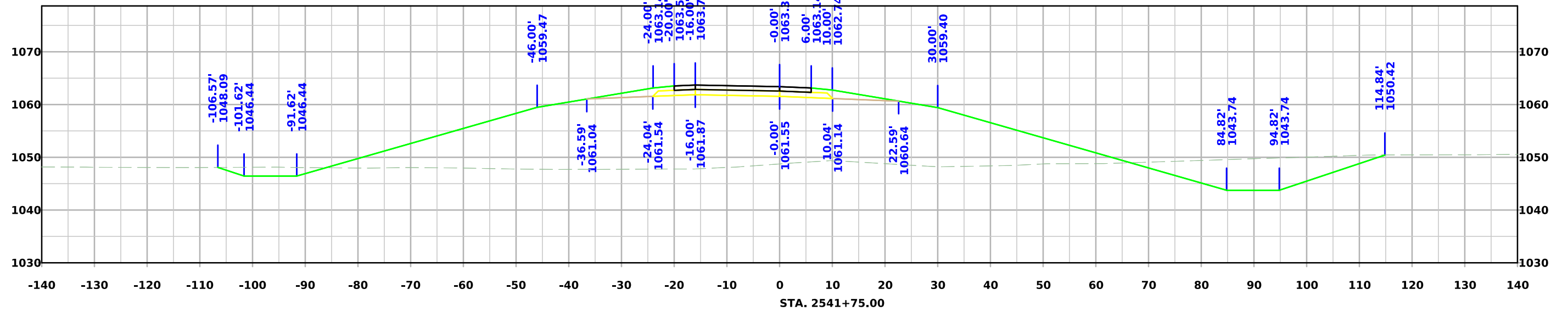

IA 175 Ramp B

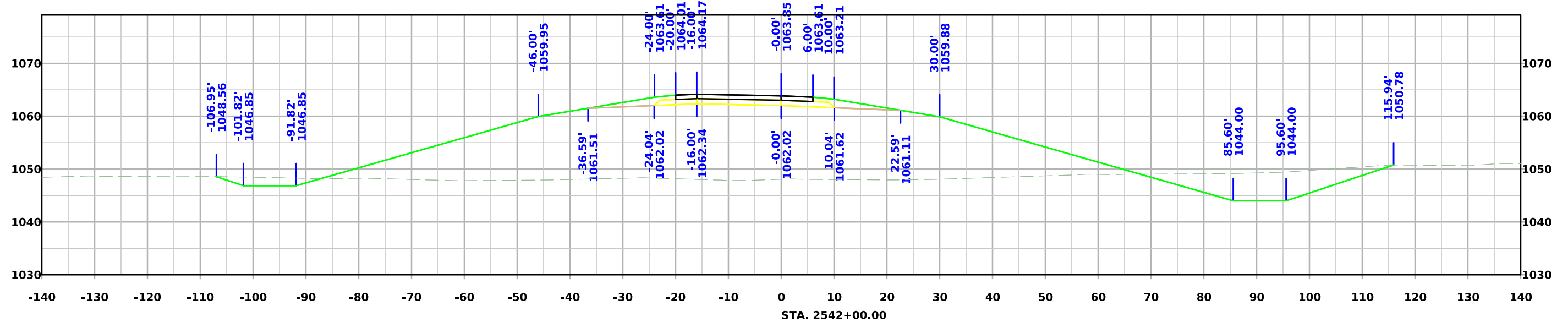
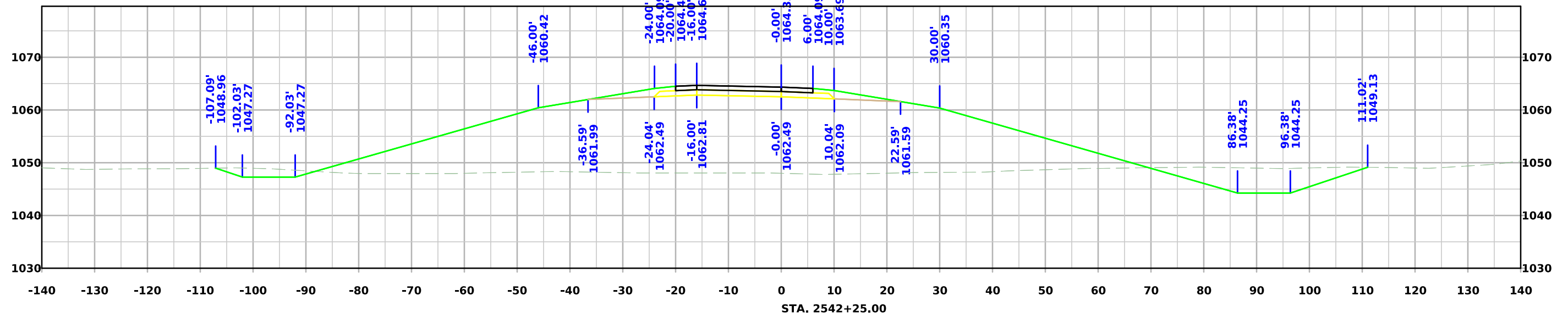

IA 175 Ramp B

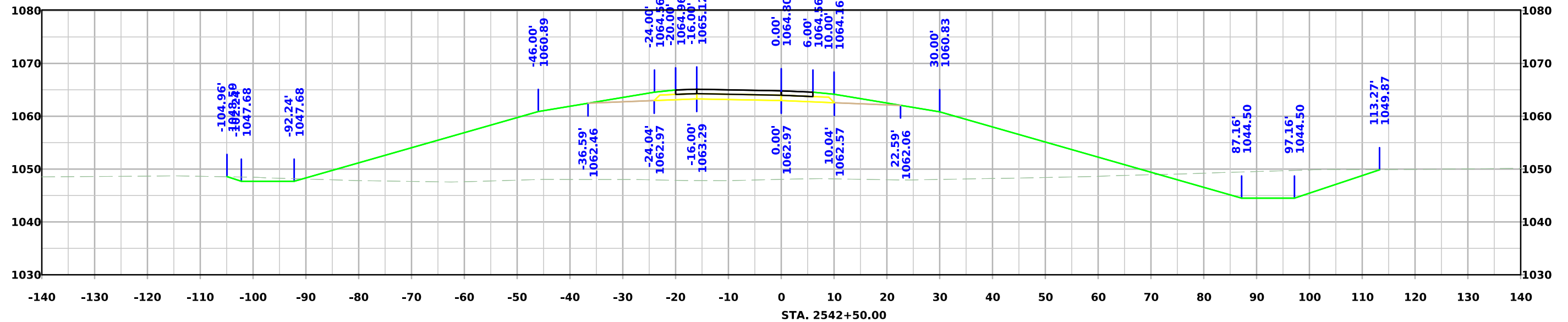
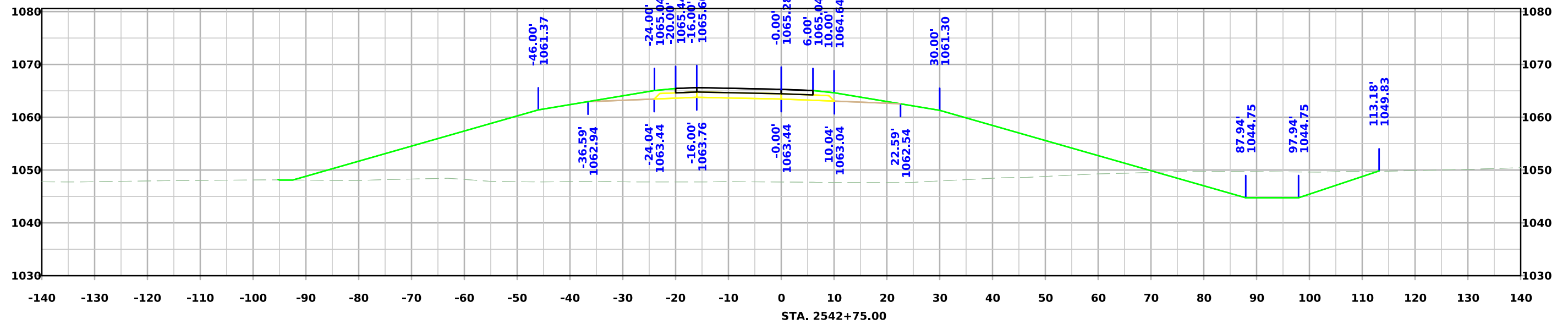

IA 175 Ramp B

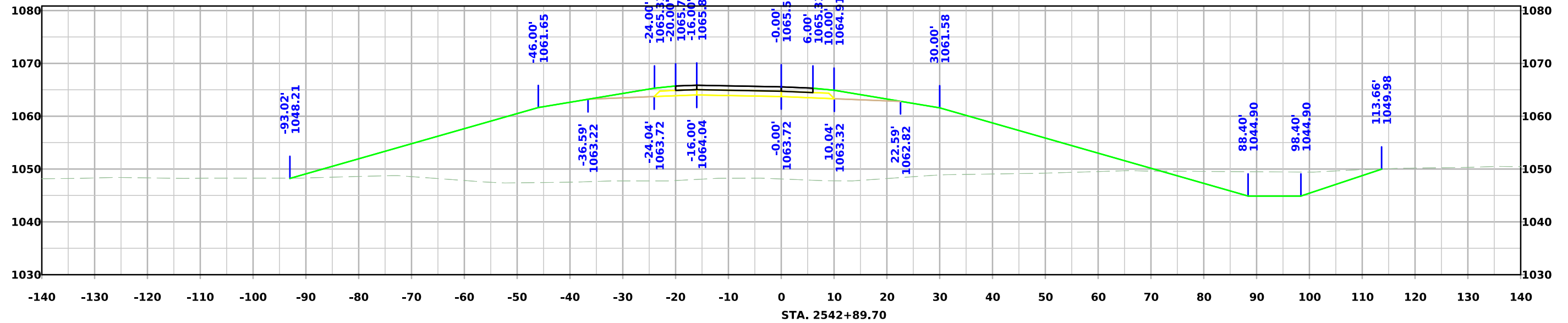
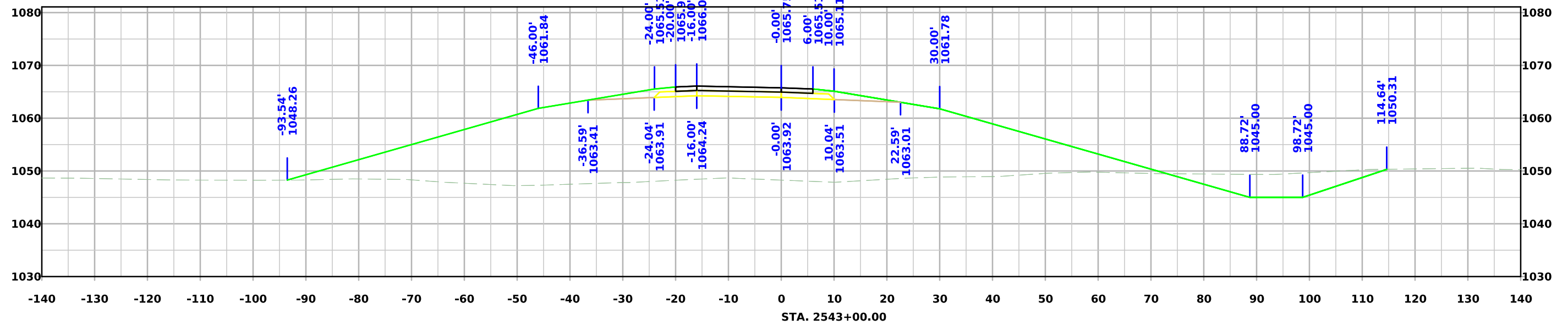

IA 175 Ramp B

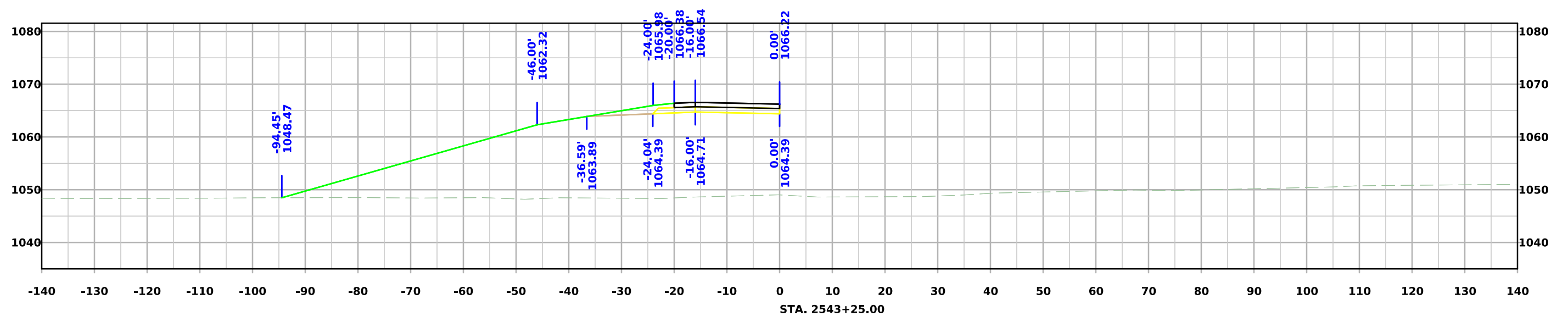
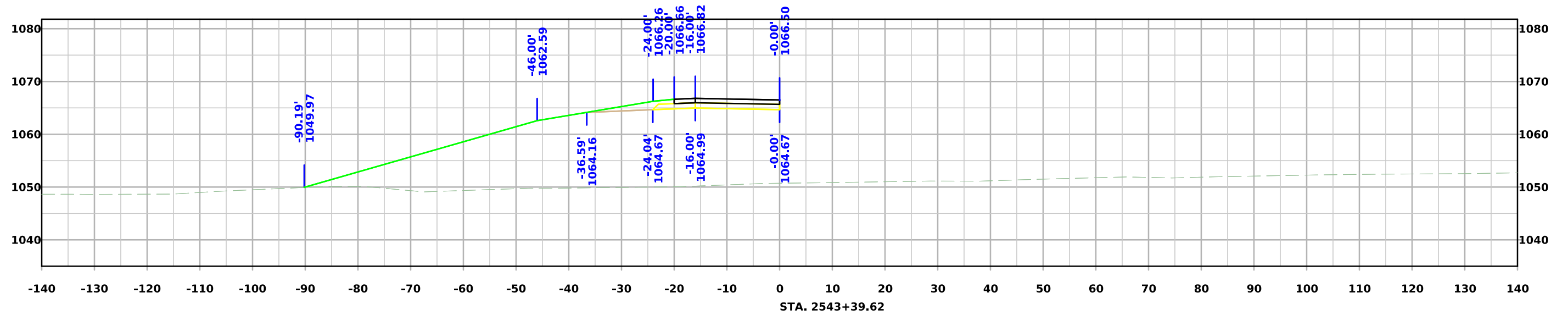

IA 175 Ramp B

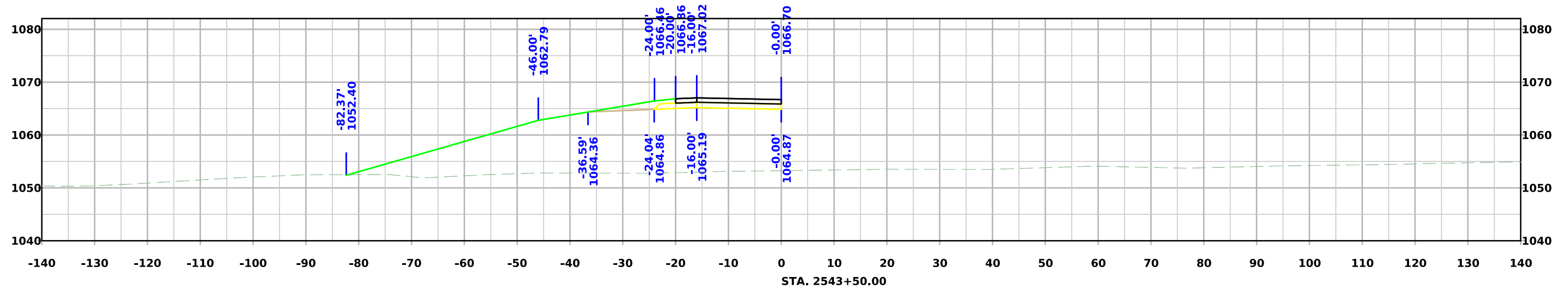
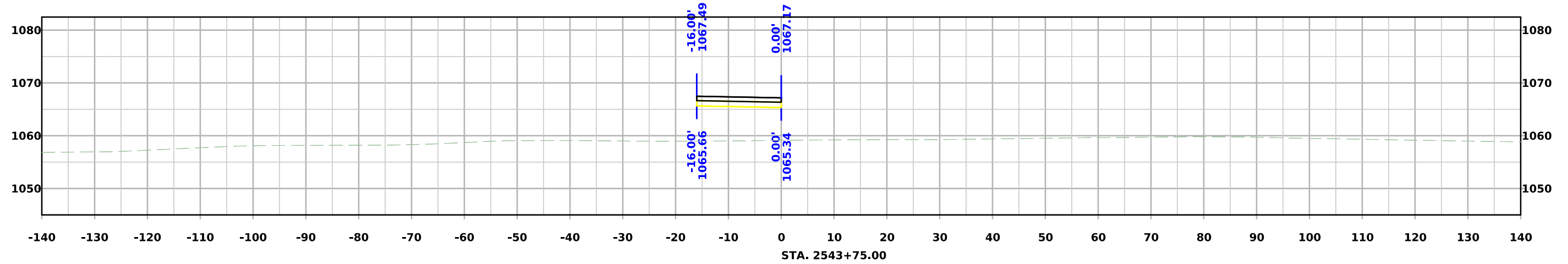
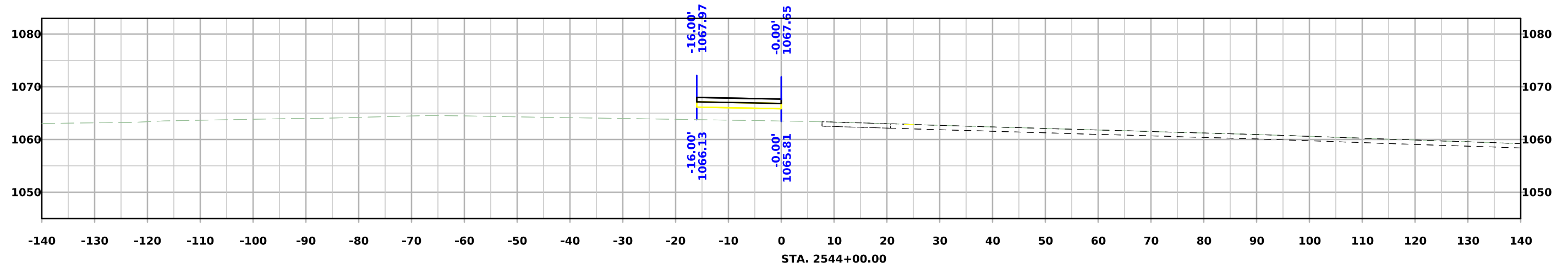

IA 175 Ramp B

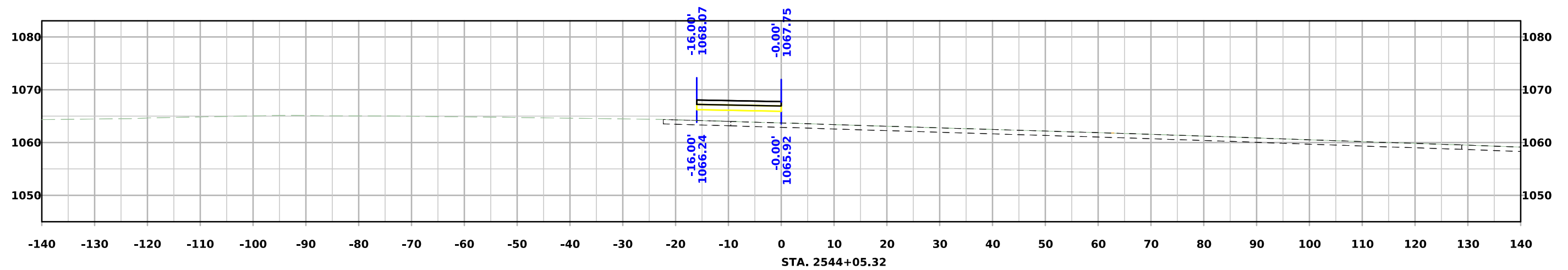
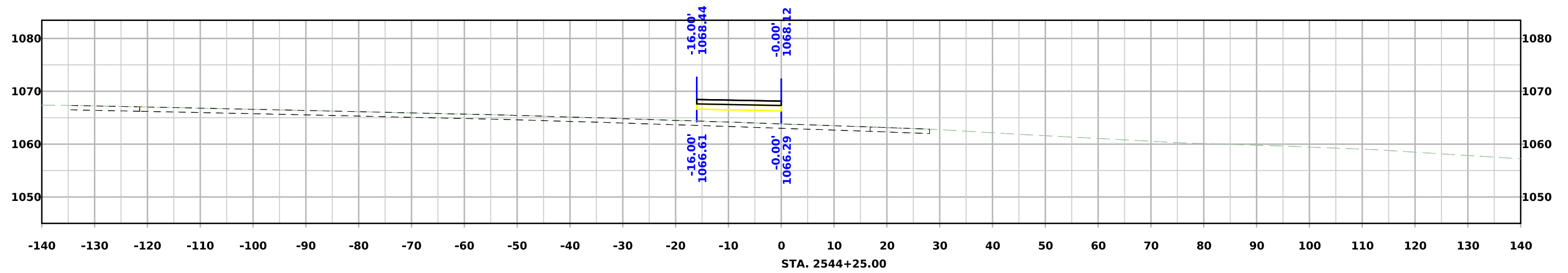
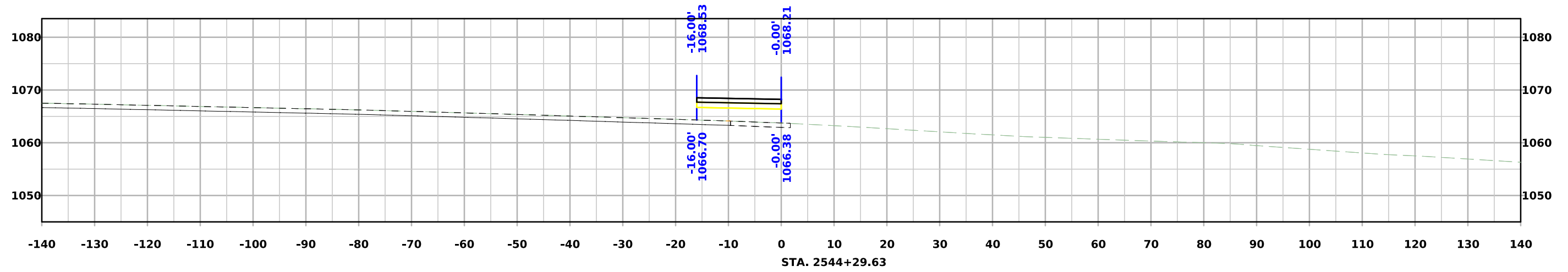

IA 175 Ramp B

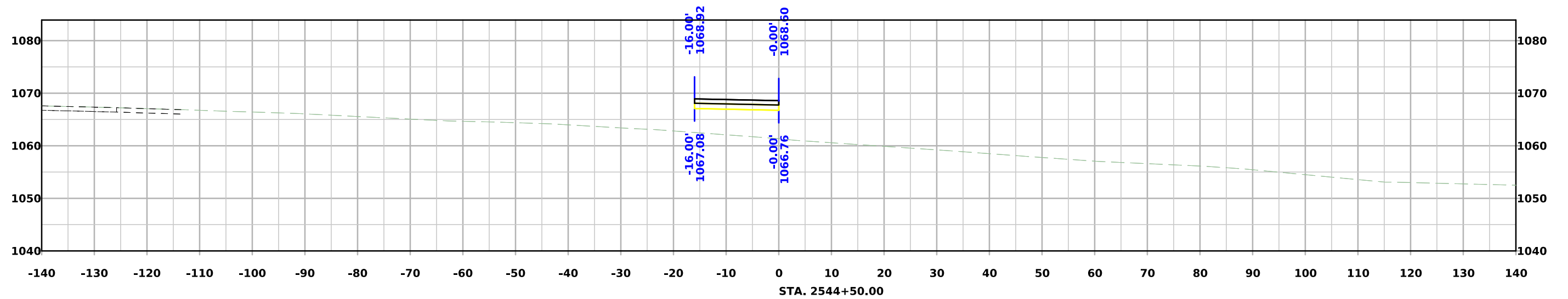
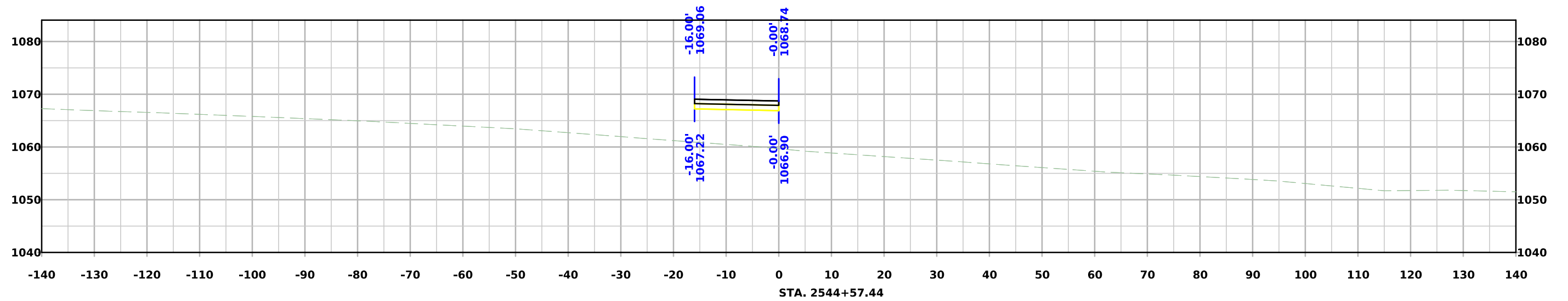

IA 175 Ramp C

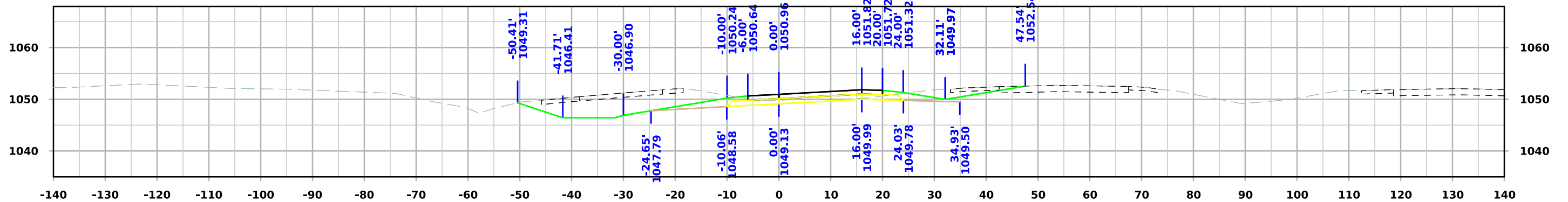

STA. 3535+00.00

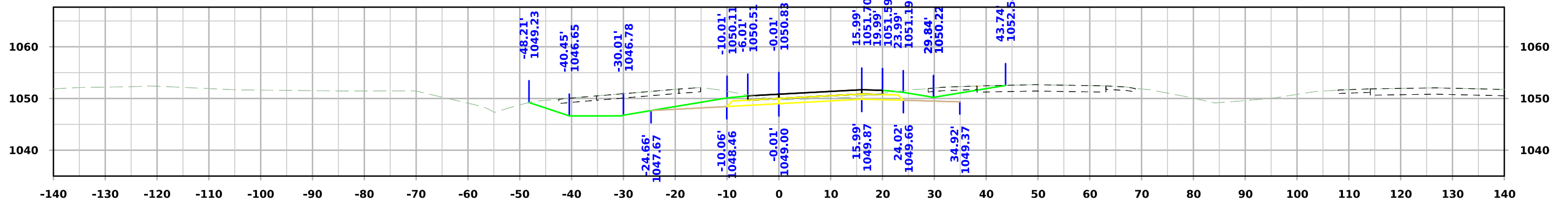

STA. 3534+75.00

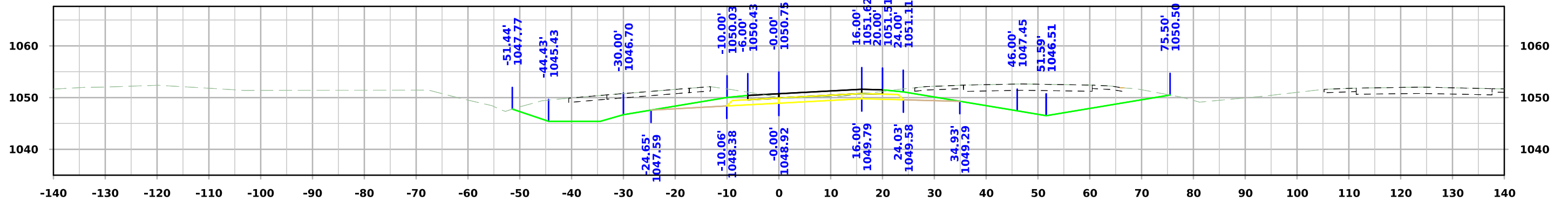

STA. 3534+58.92

IA 175 Ramp C

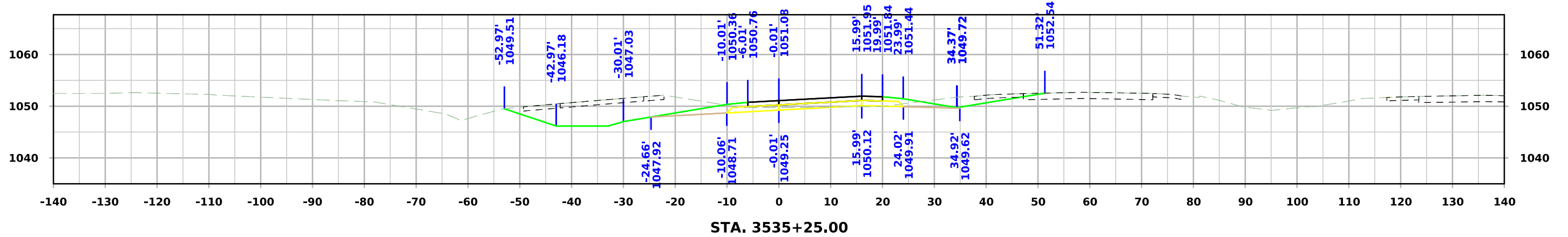
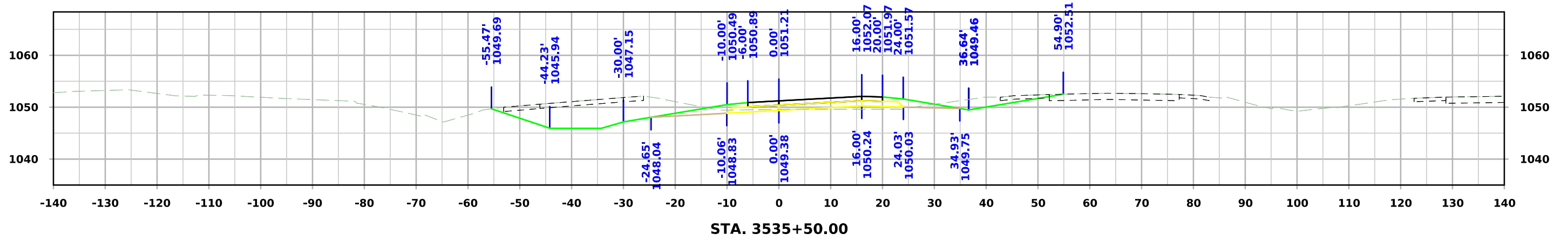
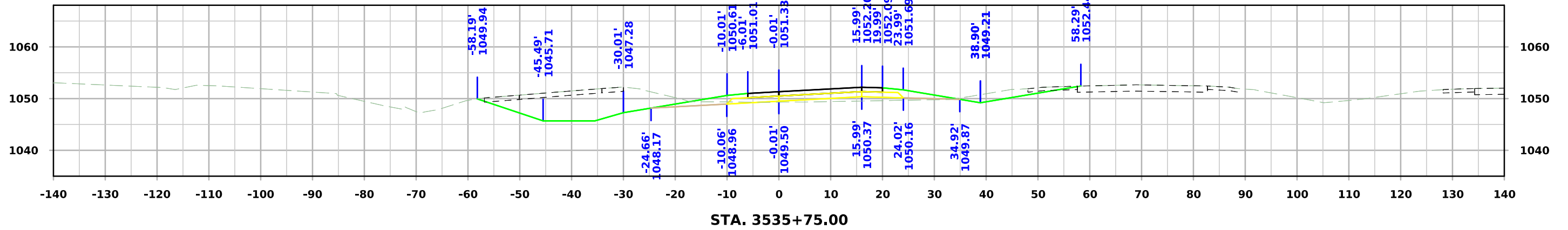

IA 175 Ramp C

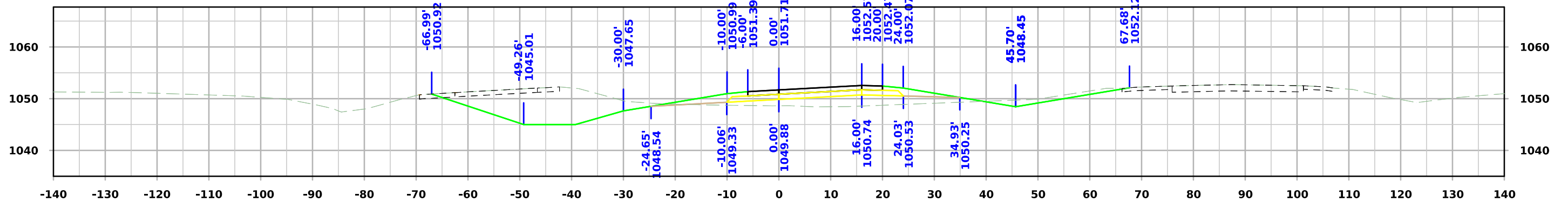

STA. 3536+50.00

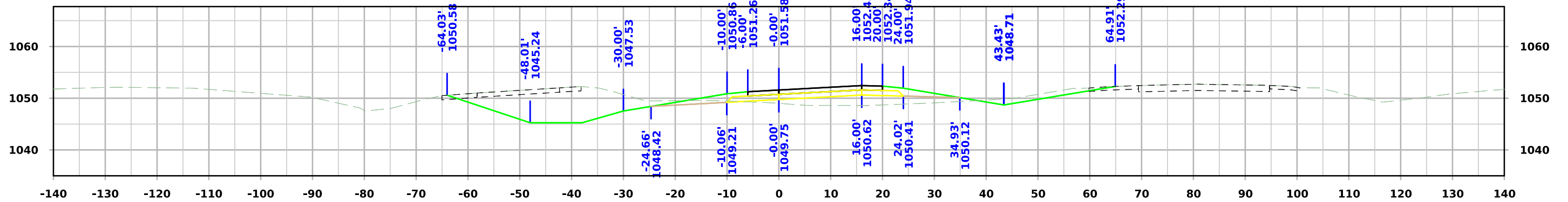

STA. 3536+25.00

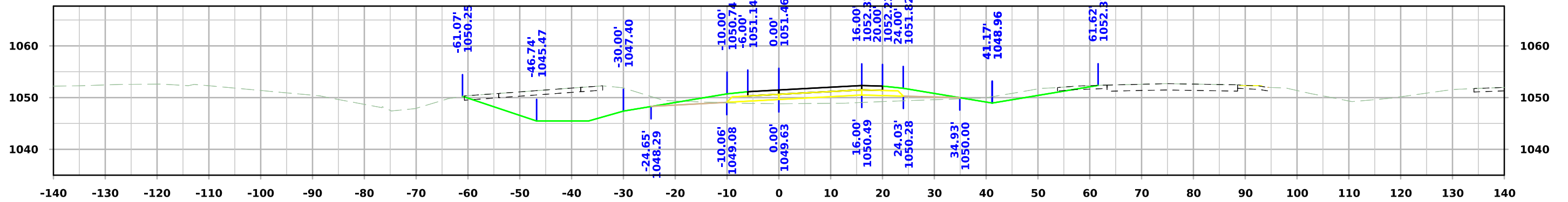

STA. 3536+00.00

IA 175 Ramp C

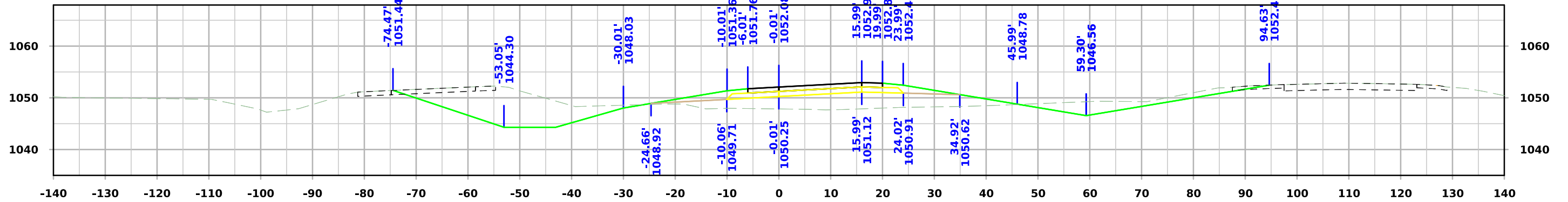

STA. 3537+25.00

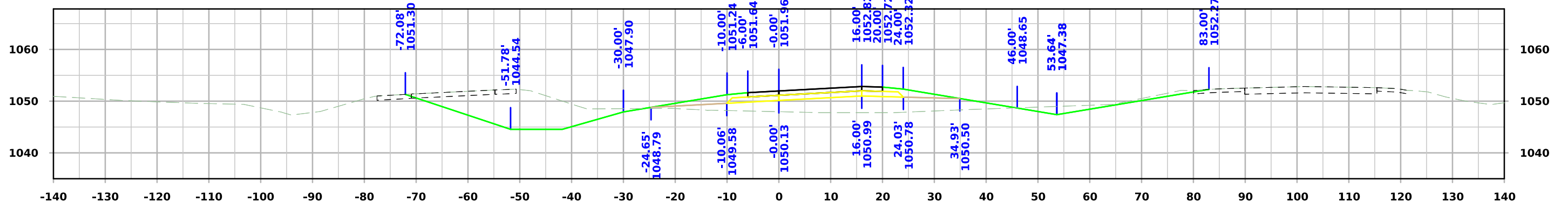

STA. 3537+00.00

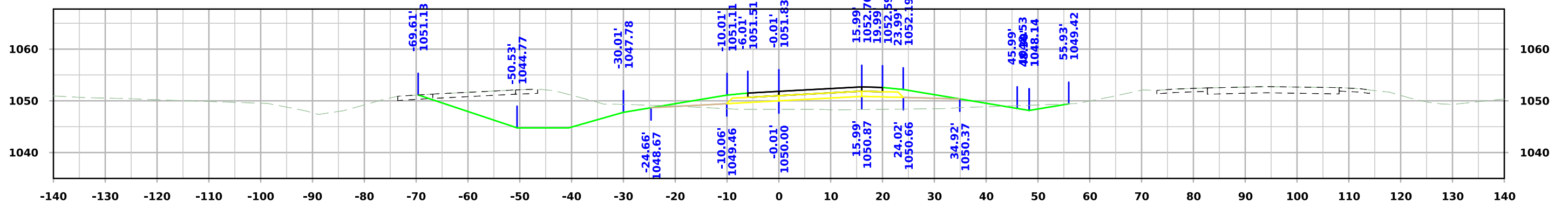

STA. 3536+75.00

IA 175 Ramp C

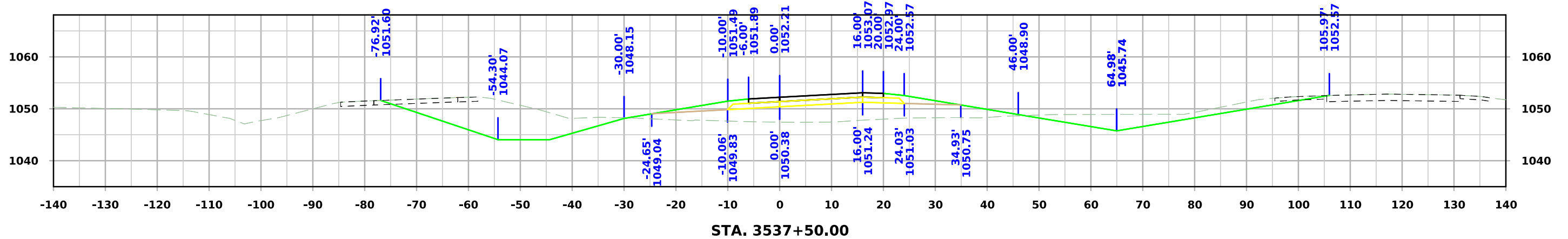
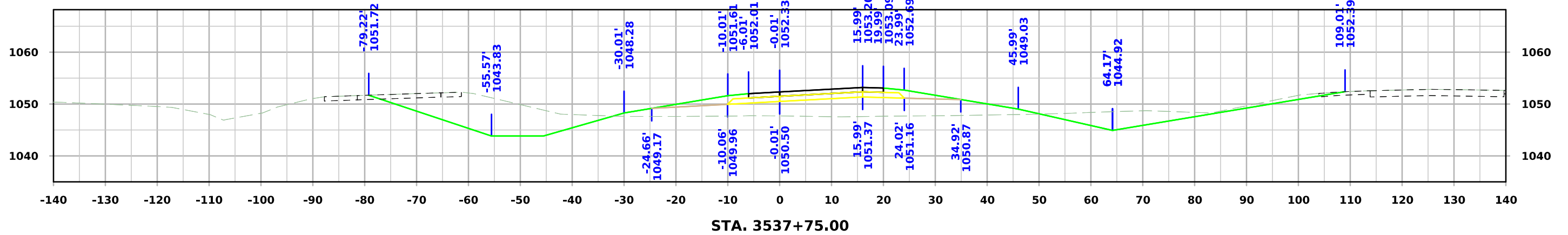
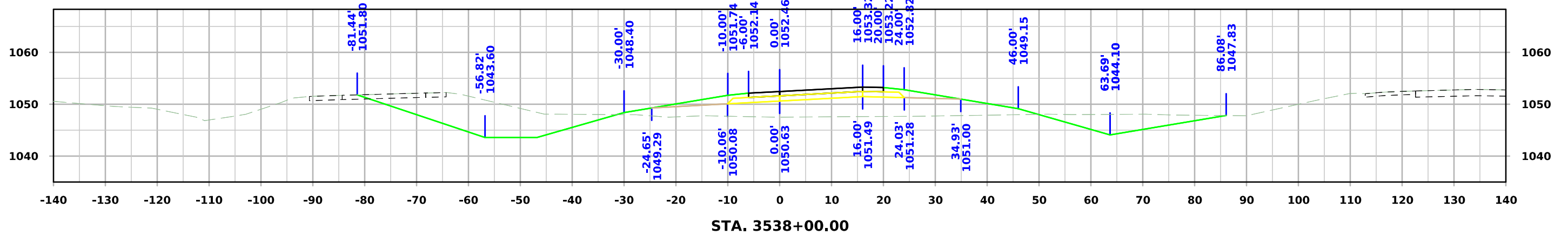

IA 175 Ramp C

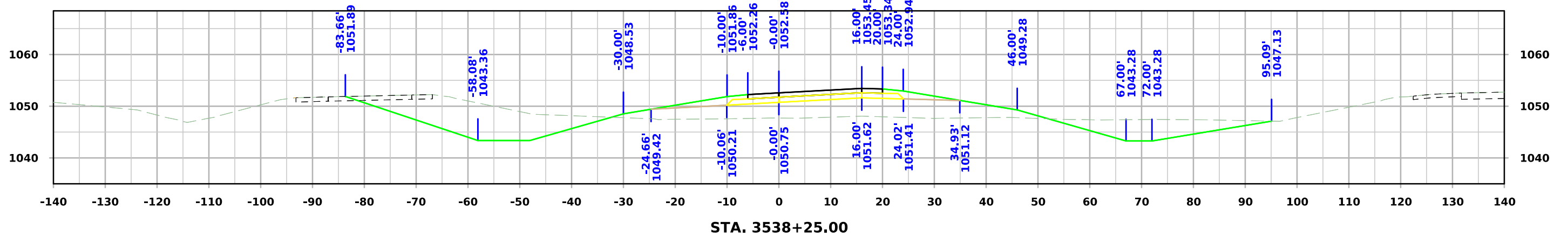
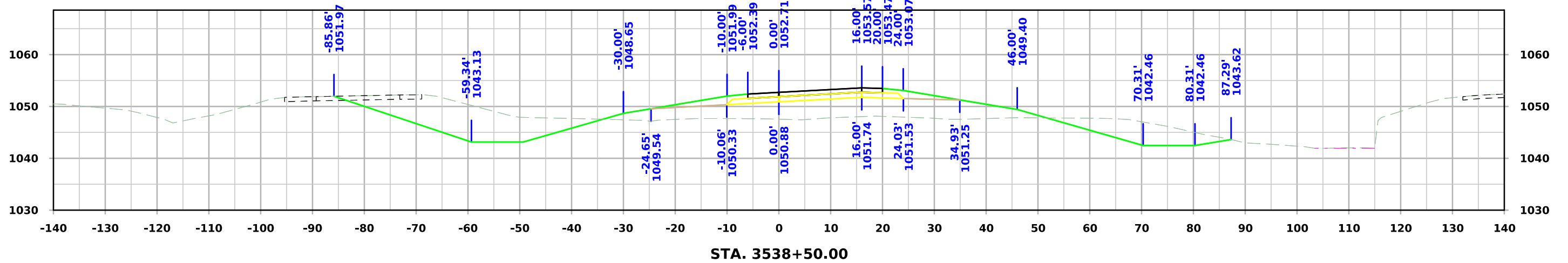
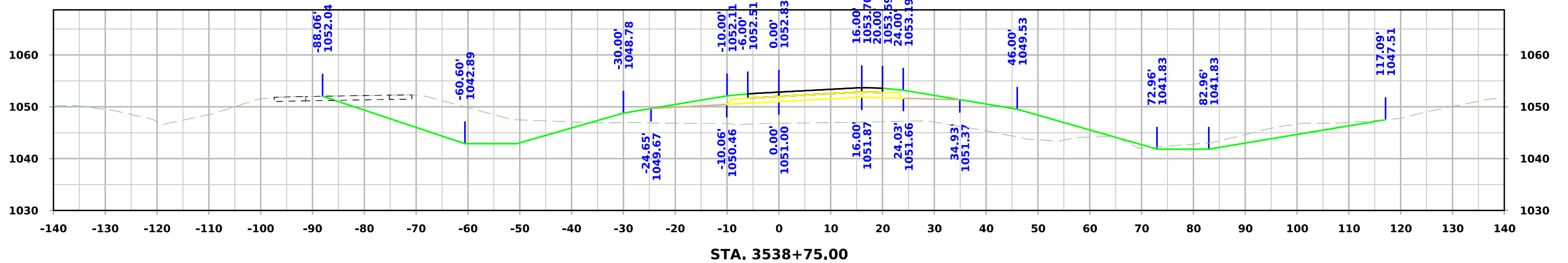

IA 175 Ramp C

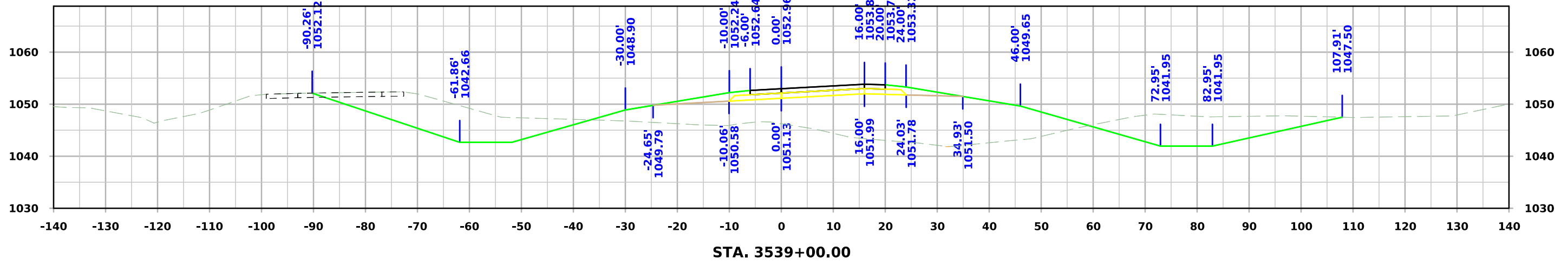
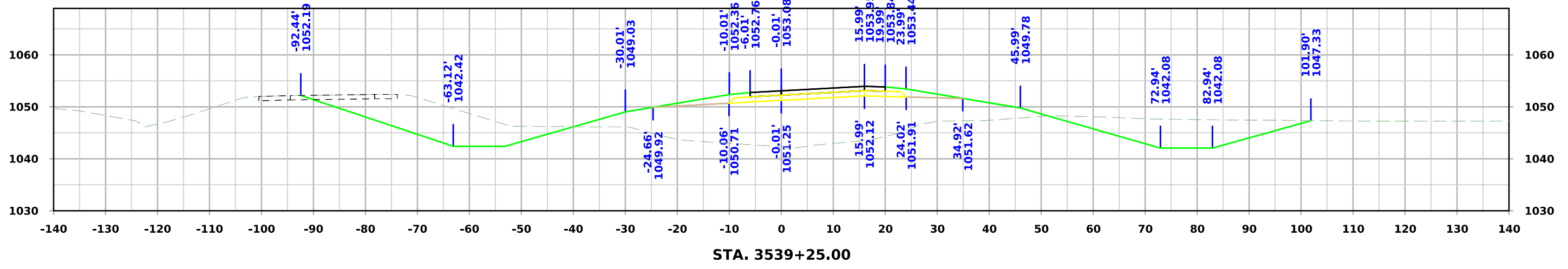
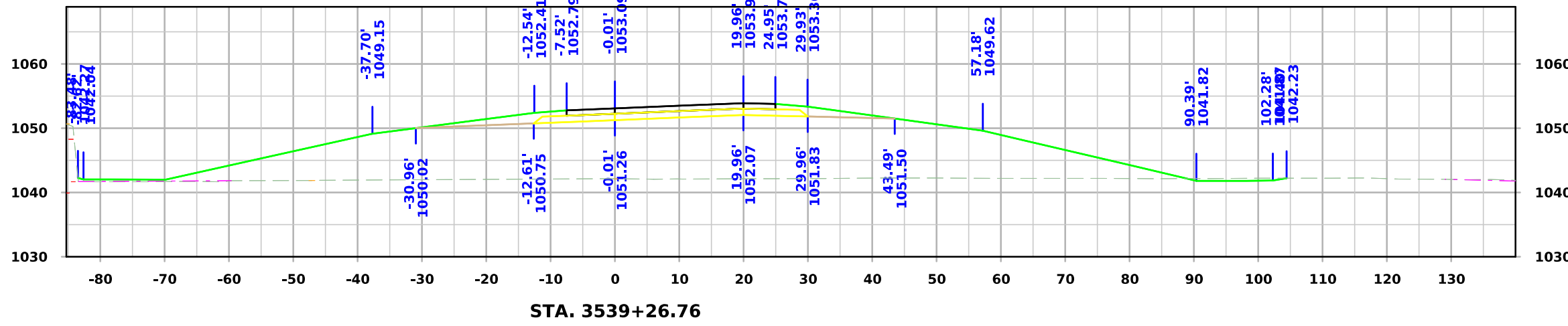

IA 175 Ramp C

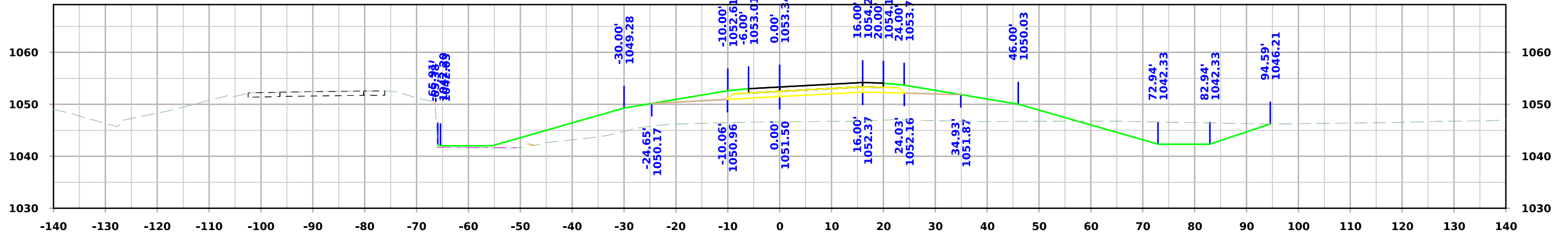

STA. 3539+75.37

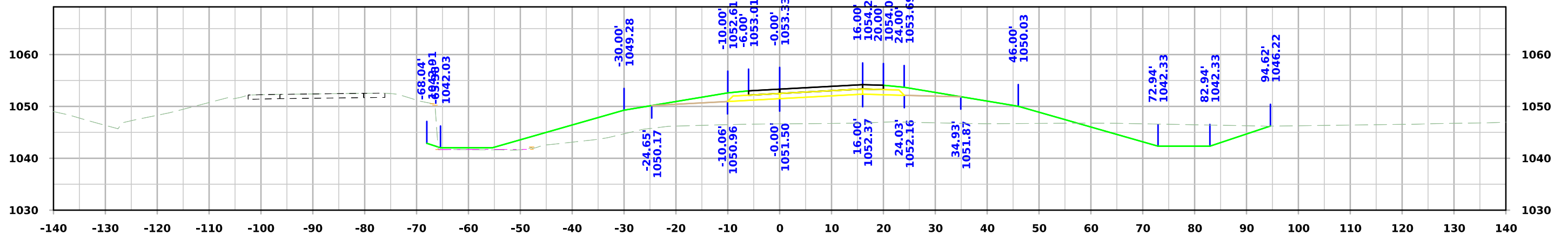

STA. 3539+75.00

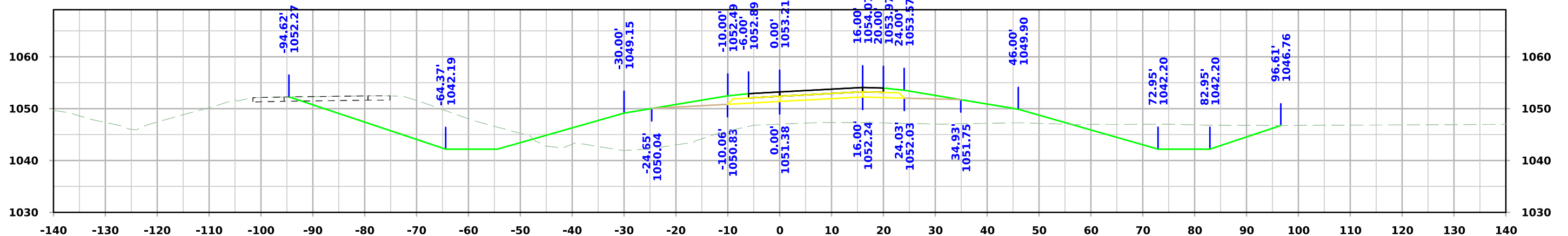

STA. 3539+50.00

IA 175 Ramp C

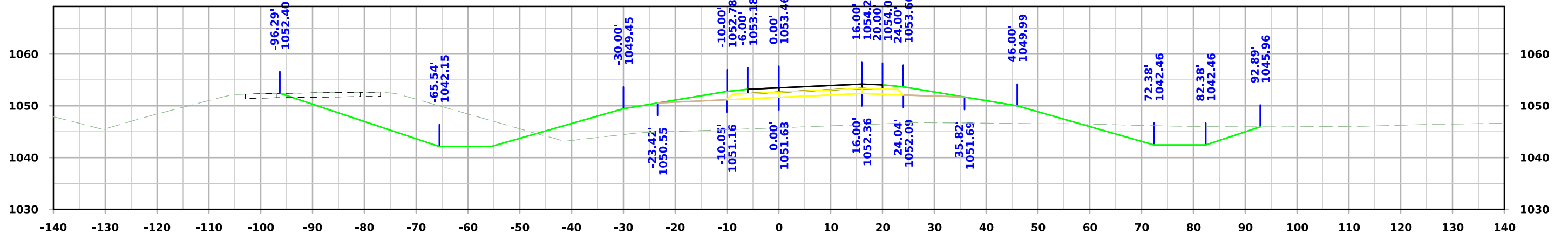
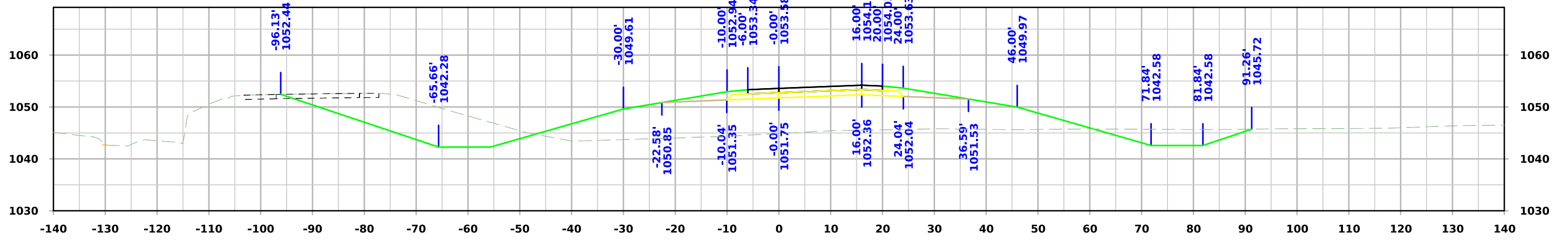
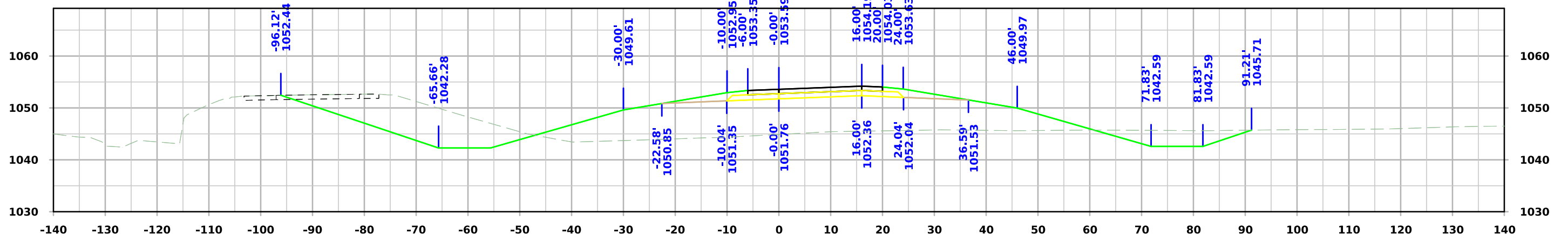

IA 175 Ramp C

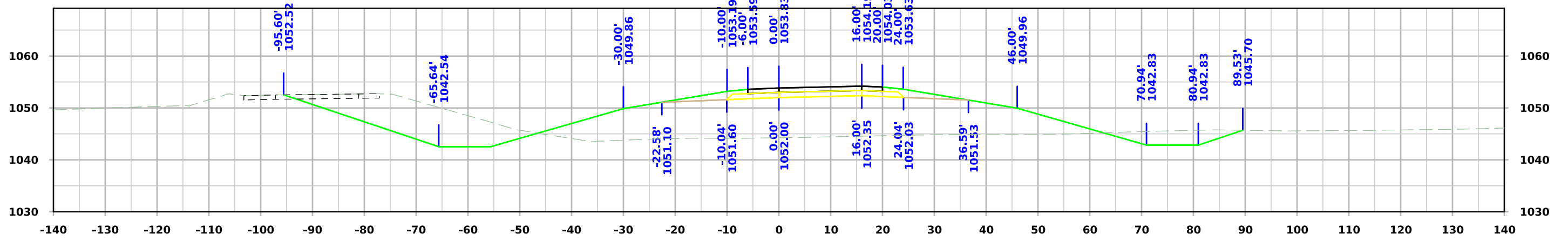

STA. 3540+75.00

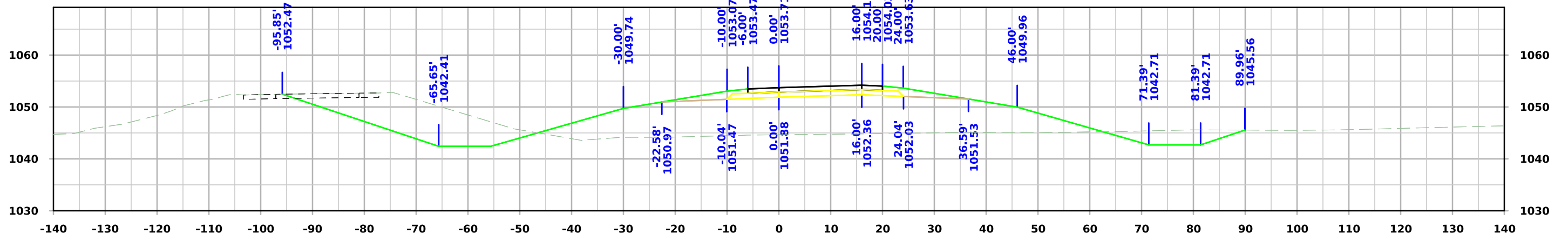

STA. 3540+50.00

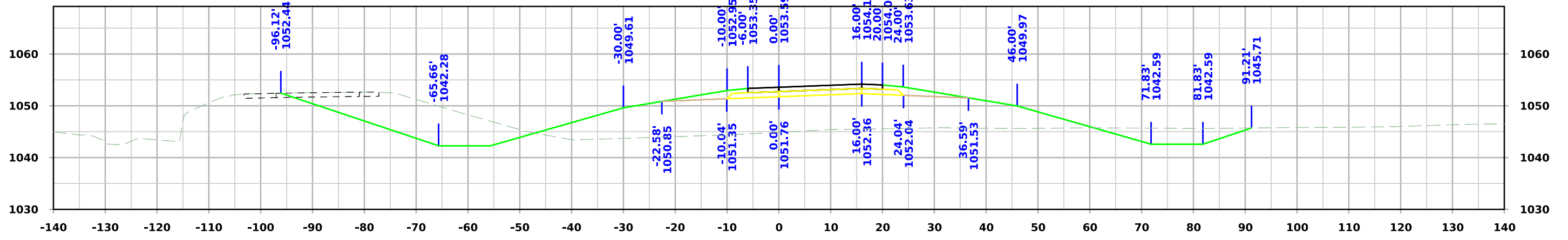

STA. 3540+25.77

IA 175 Ramp C

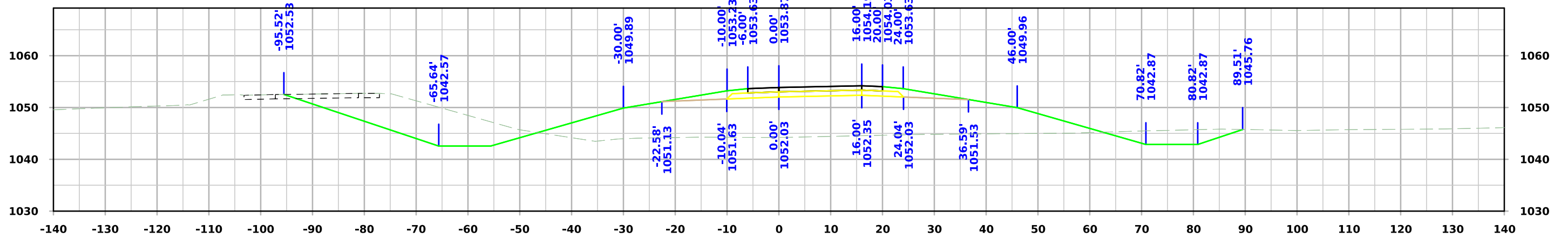
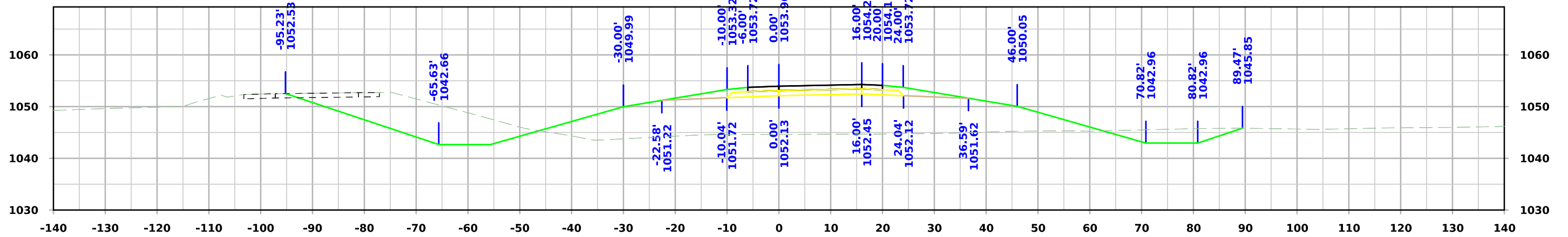
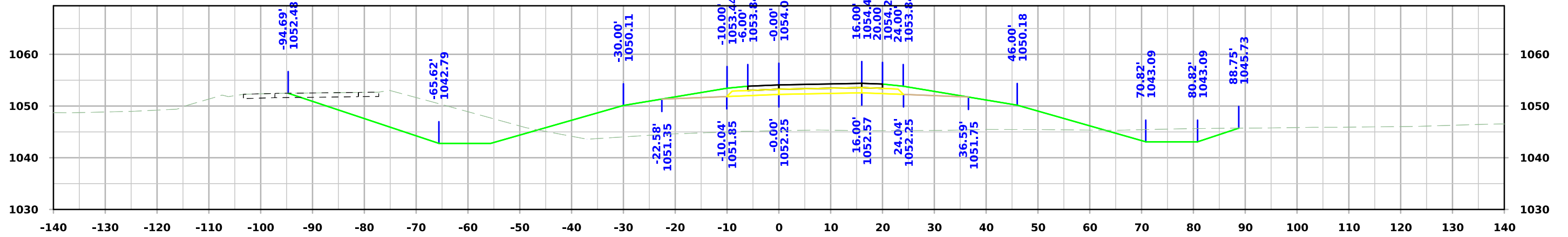

IA 175 Ramp C

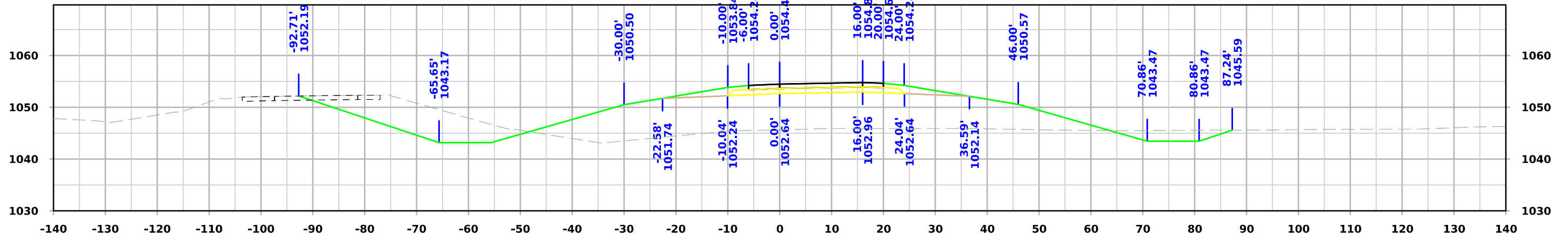

STA. 3542+00.00

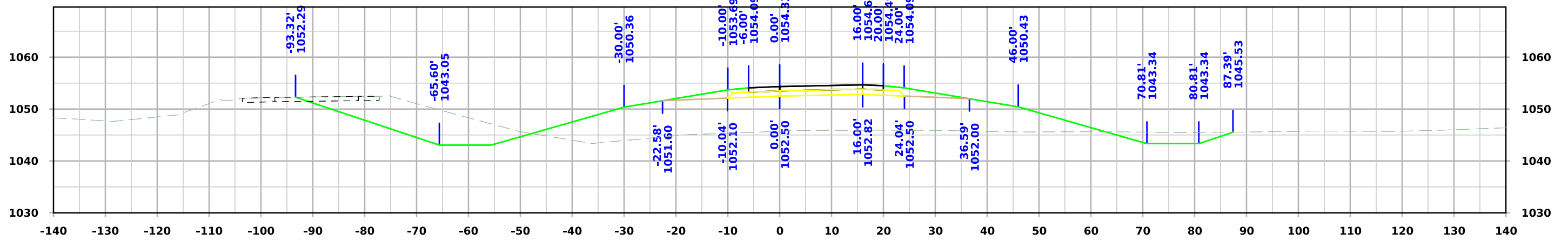

STA. 3541+75.00

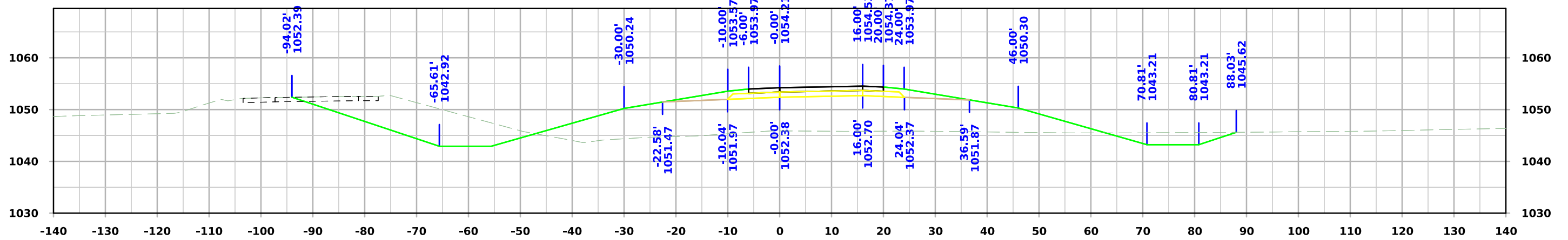

STA. 3541+50.00

IA 175 Ramp C

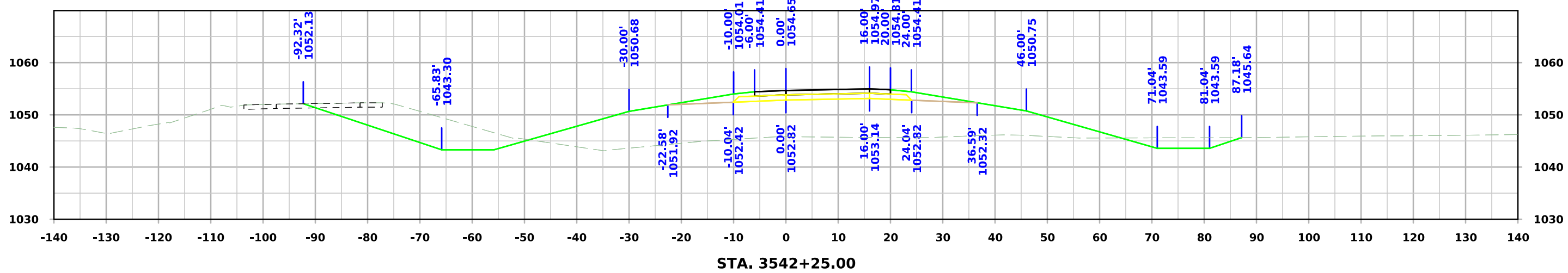
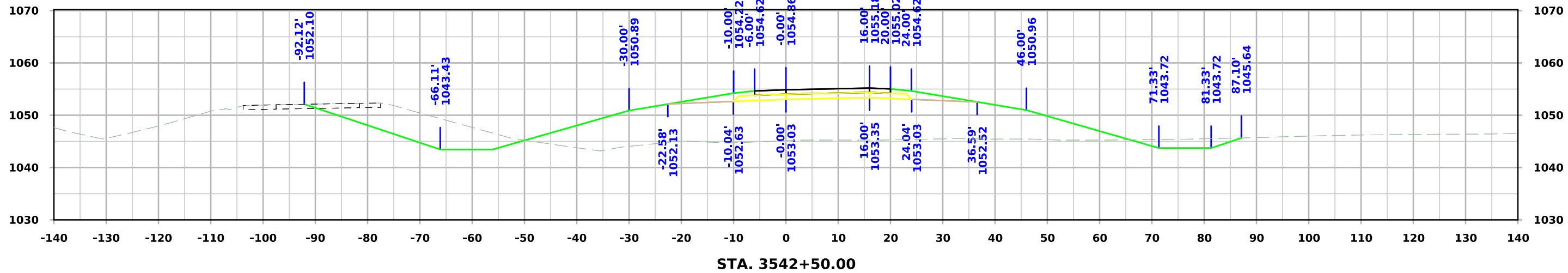
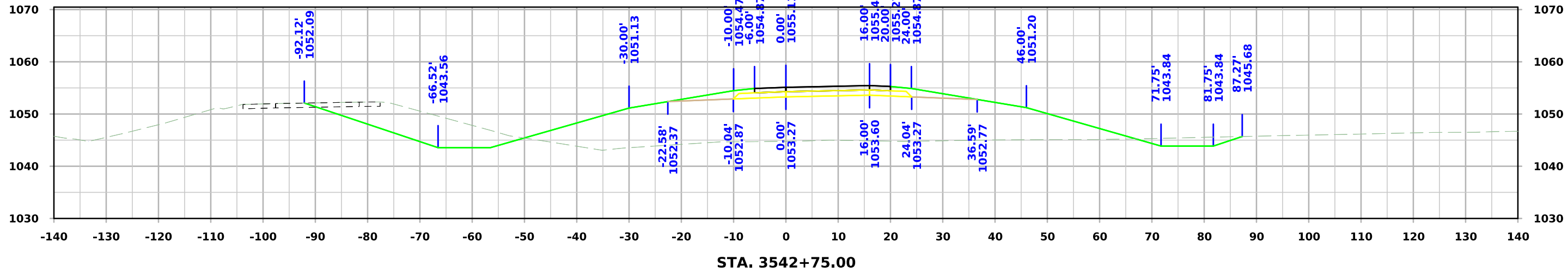

IA 175 Ramp C

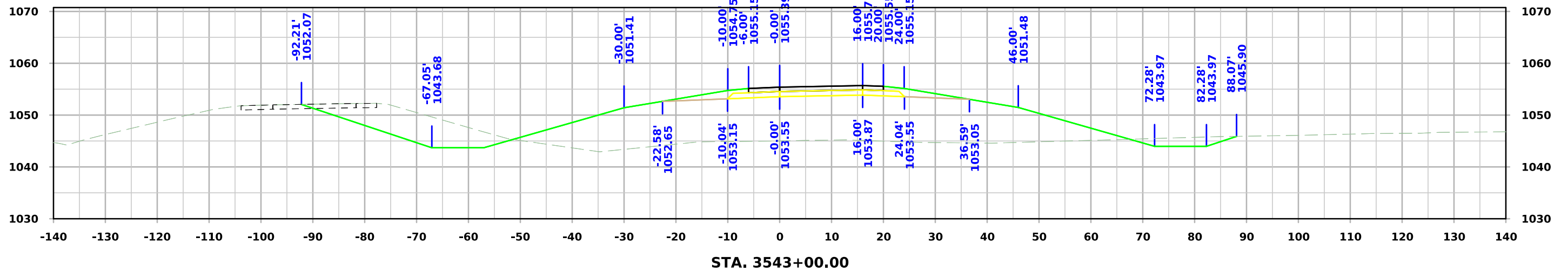
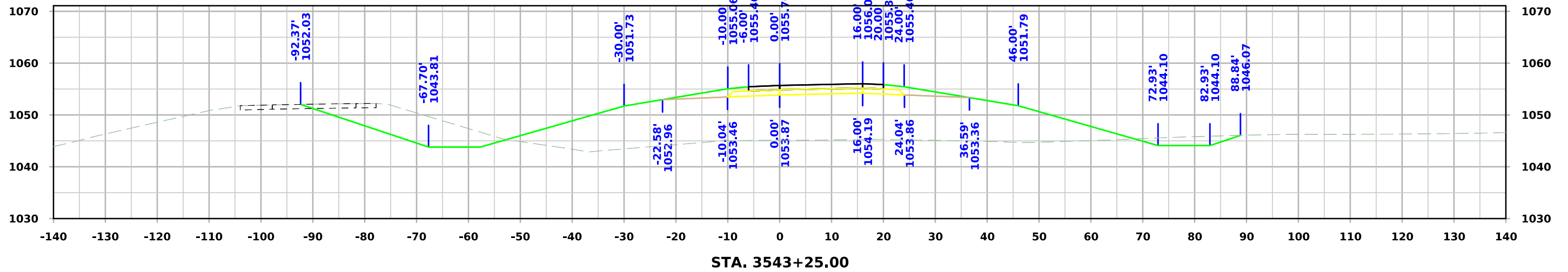
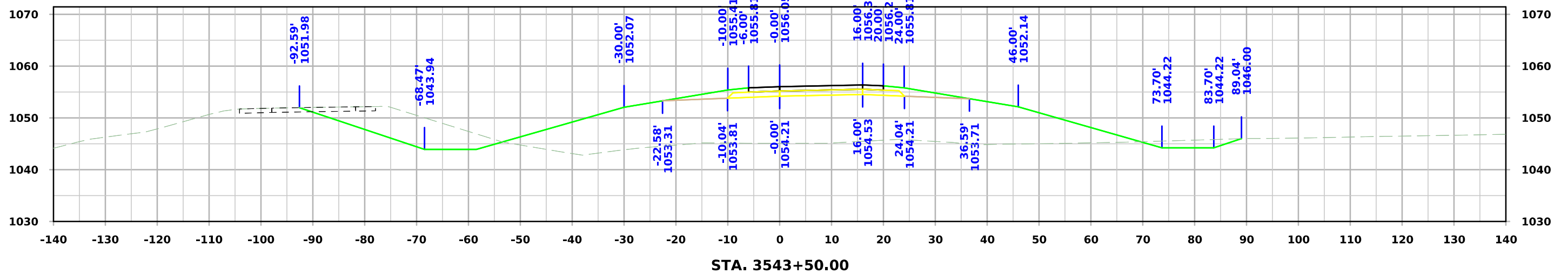

IA 175 Ramp C

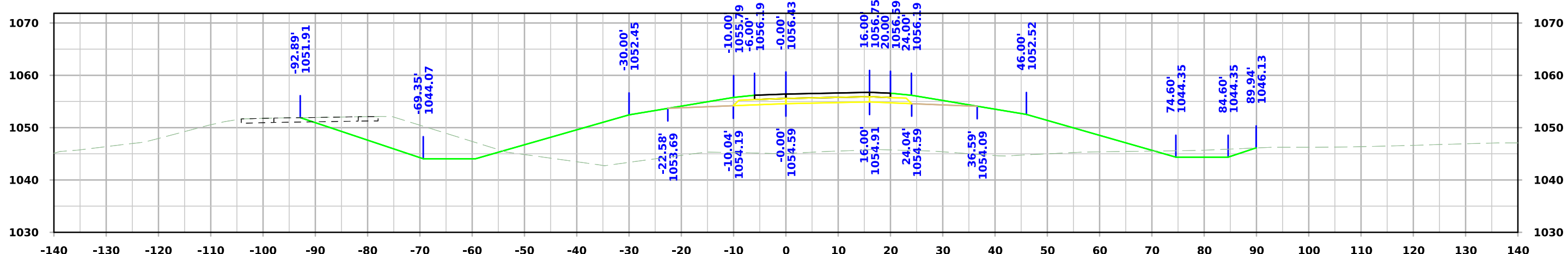
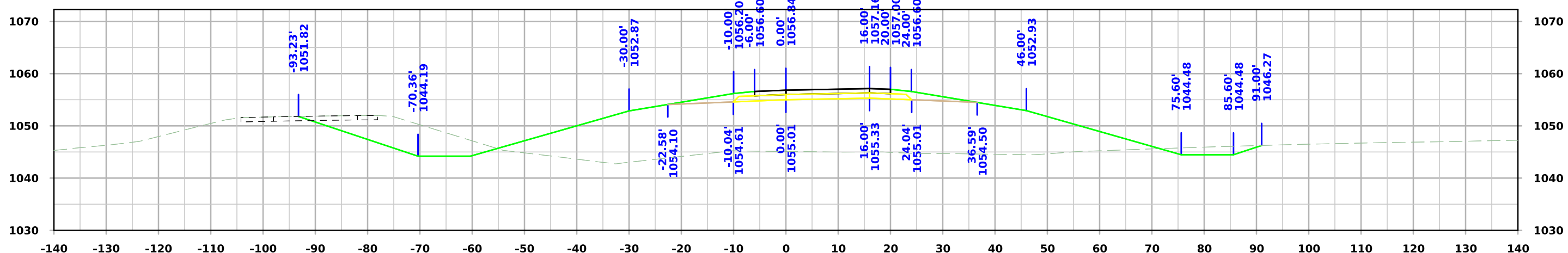
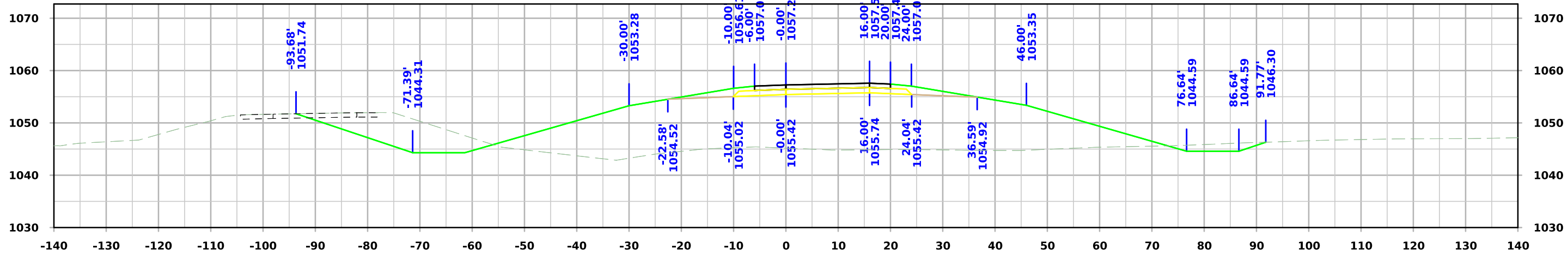

IA 175 Ramp C

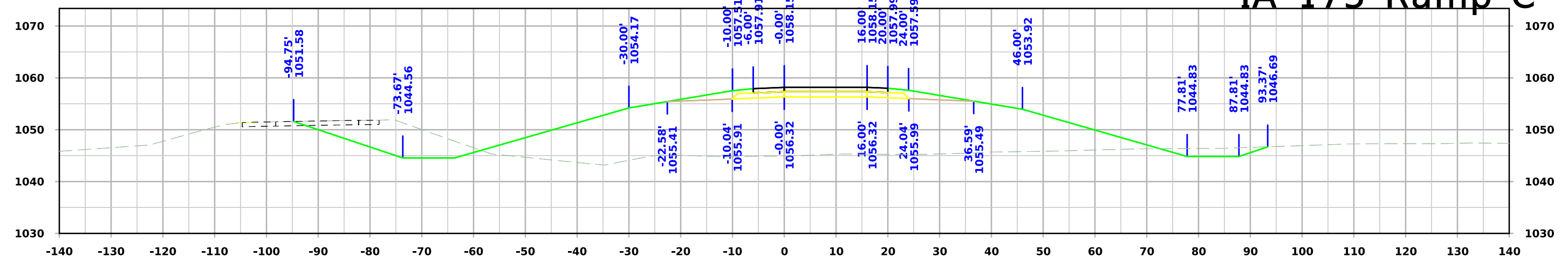

STA. 3544+71.08

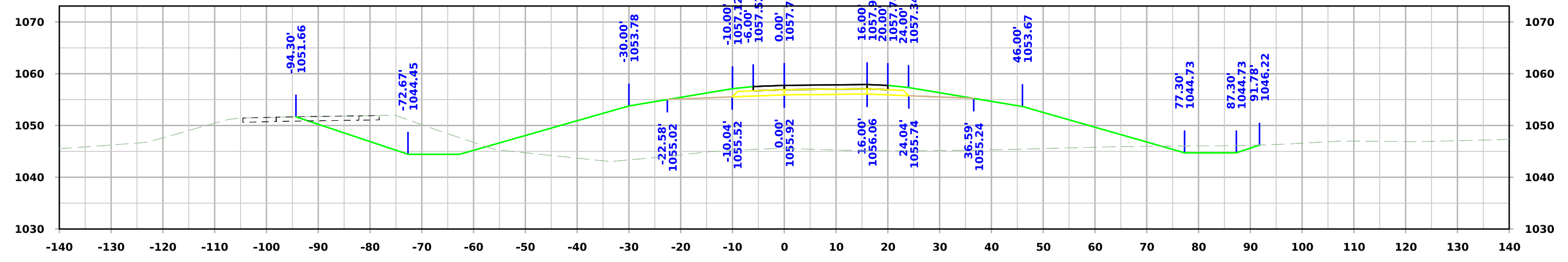

STA. 3544+50.00

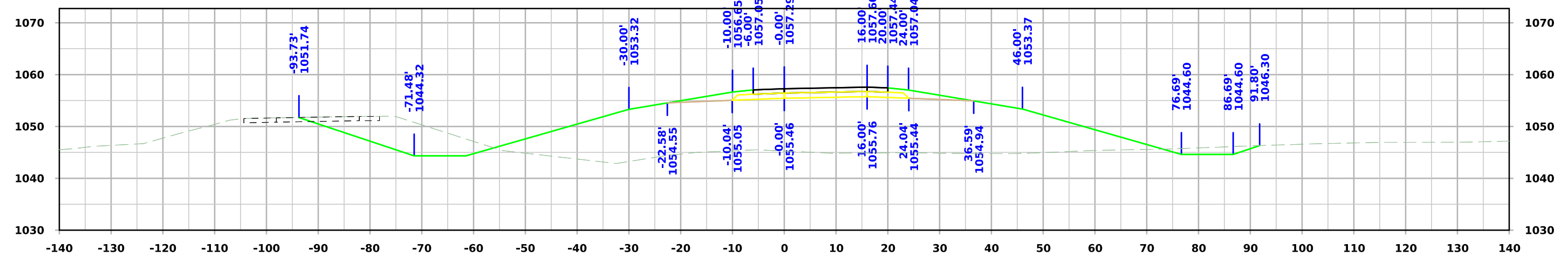

STA. 3544+25.00

IA 175 Ramp C

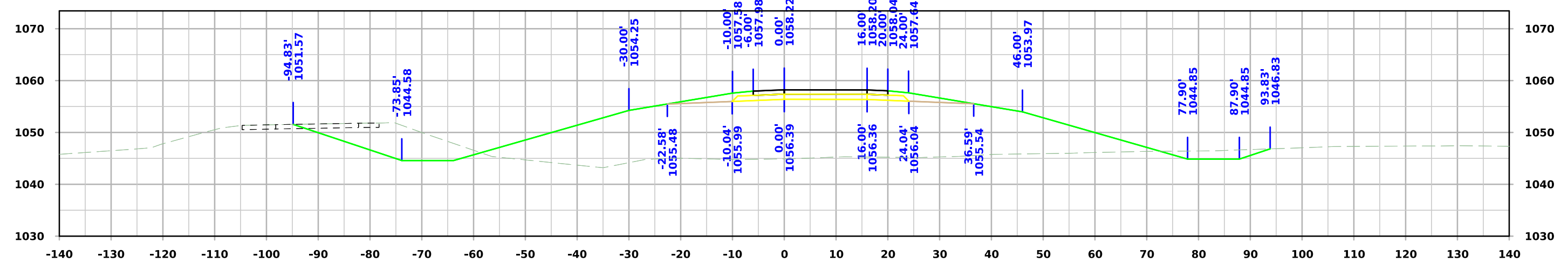
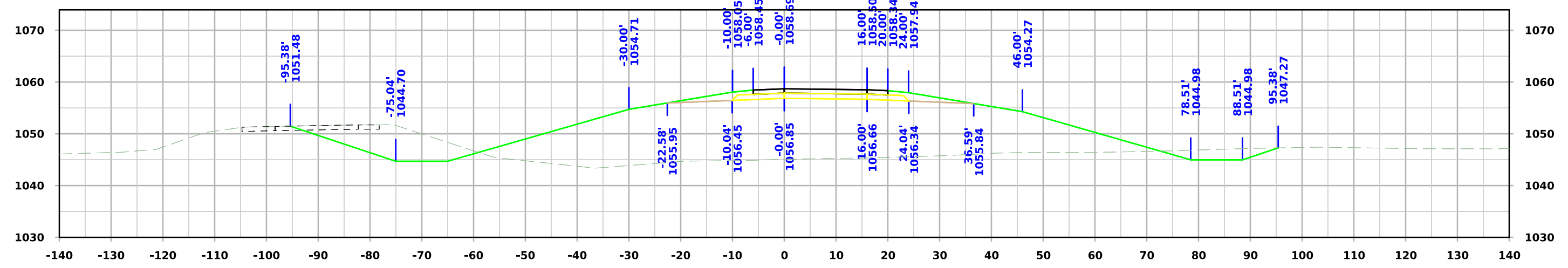
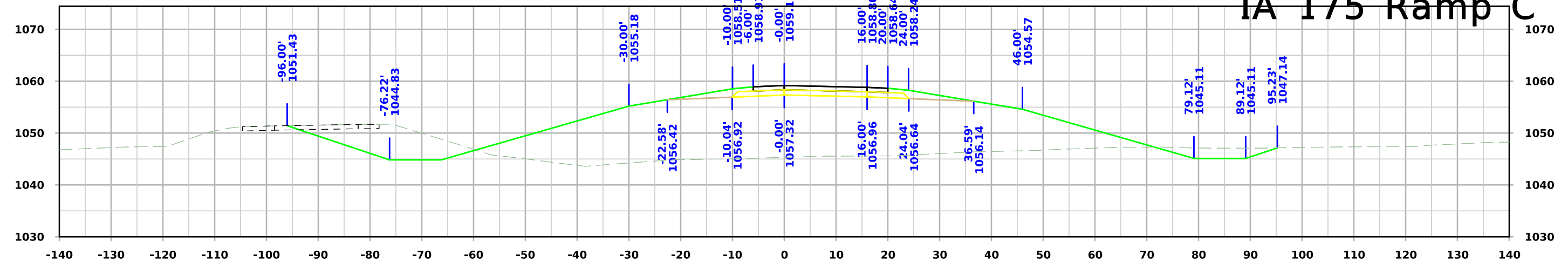

IA 175 Ramp C

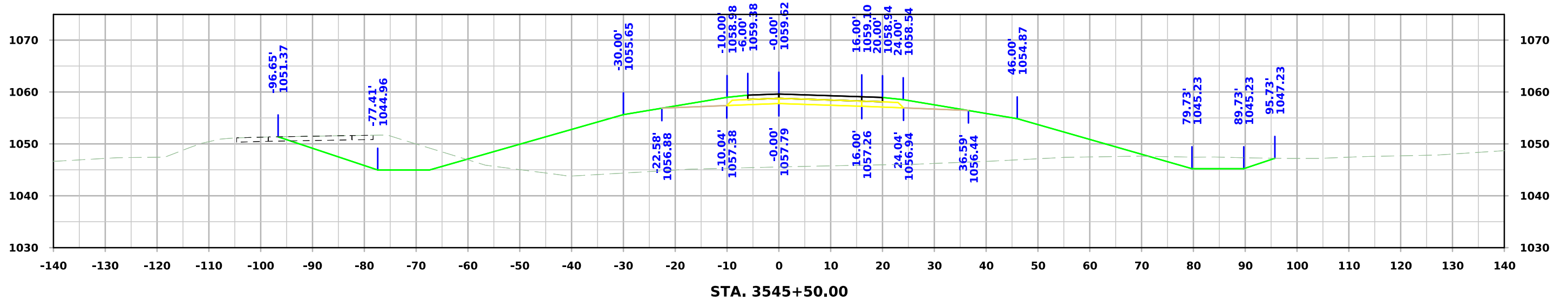
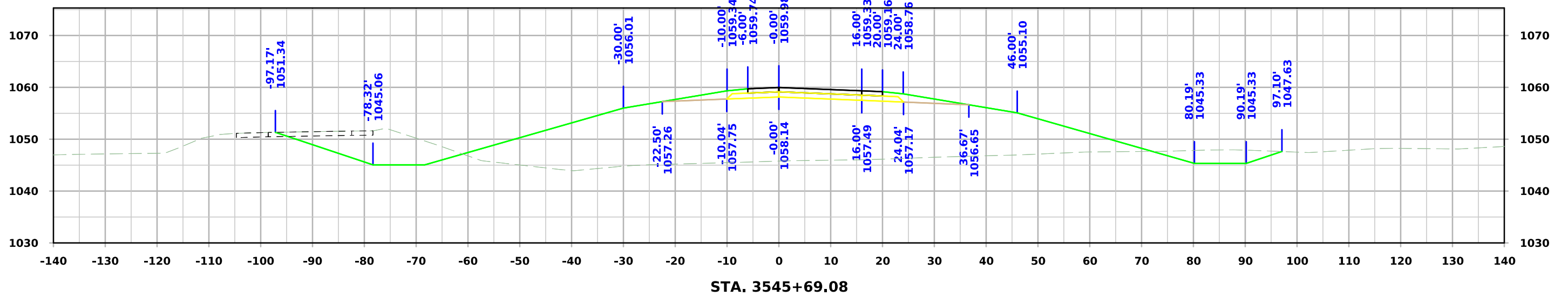

IA 175 Ramp C

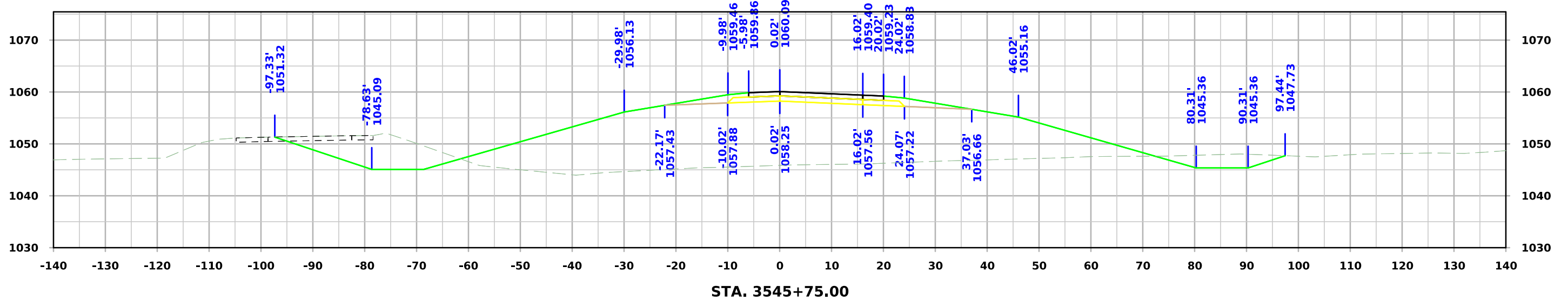
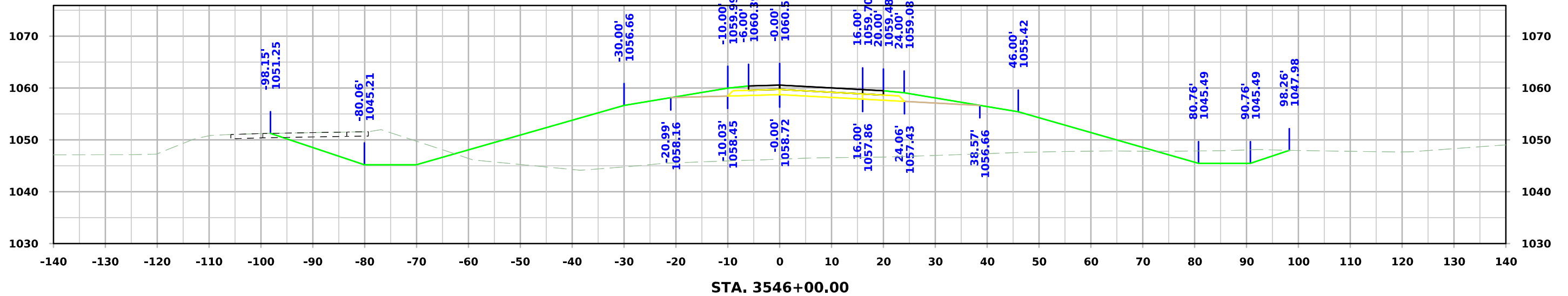

IA 175 Ramp C

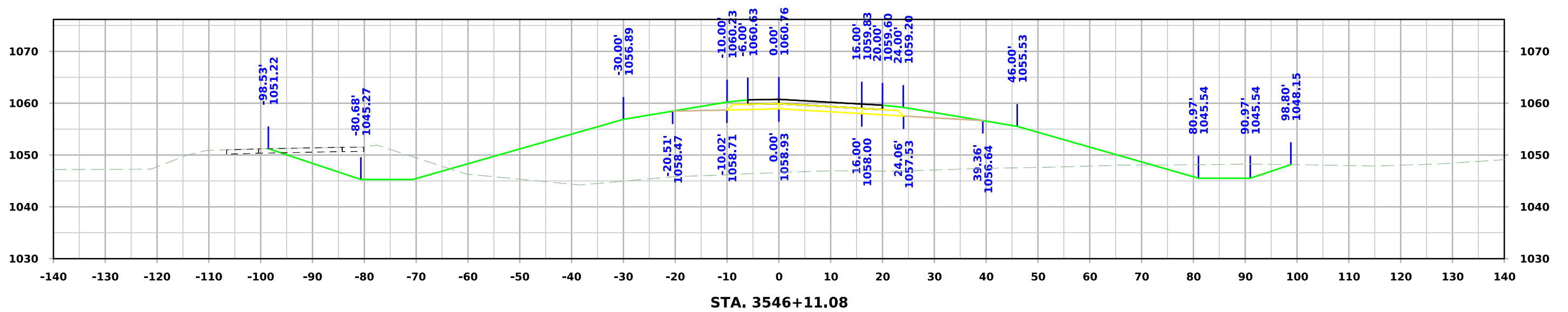
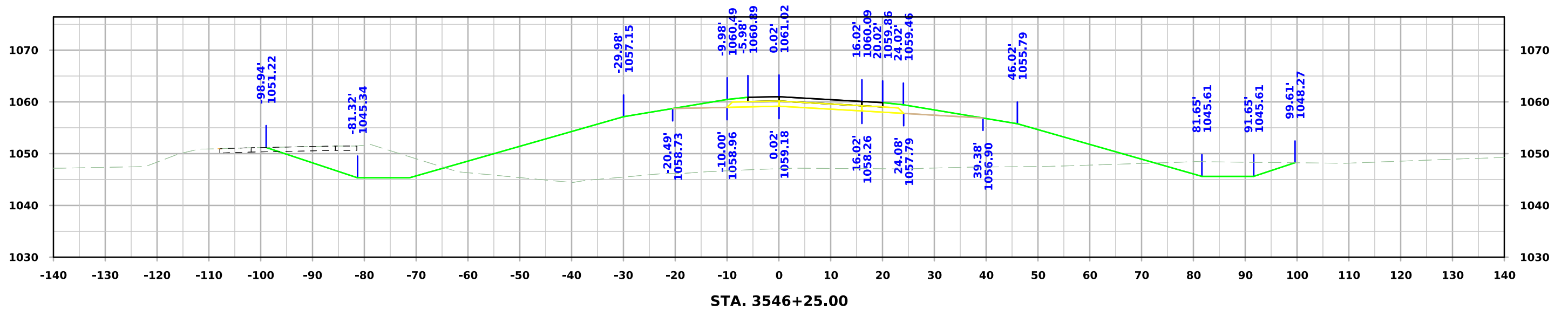

IA 175 Ramp C

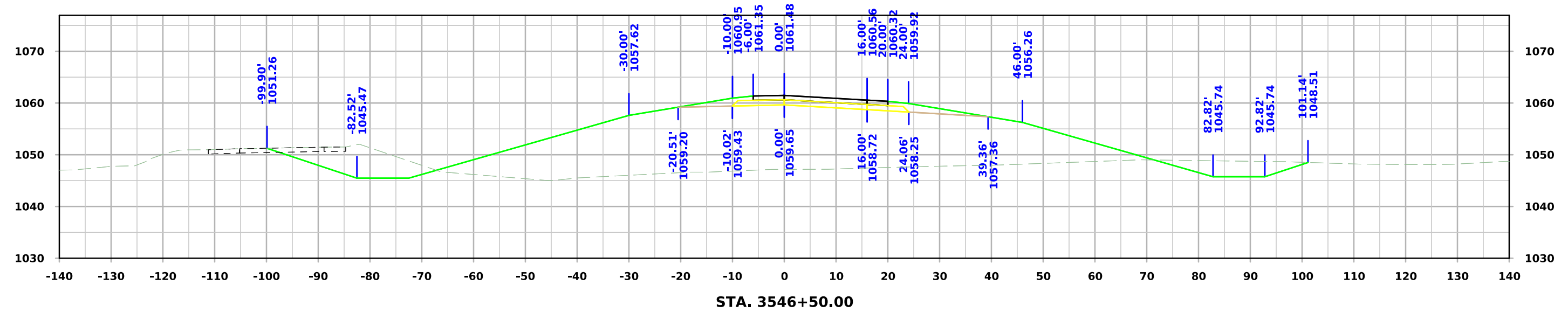
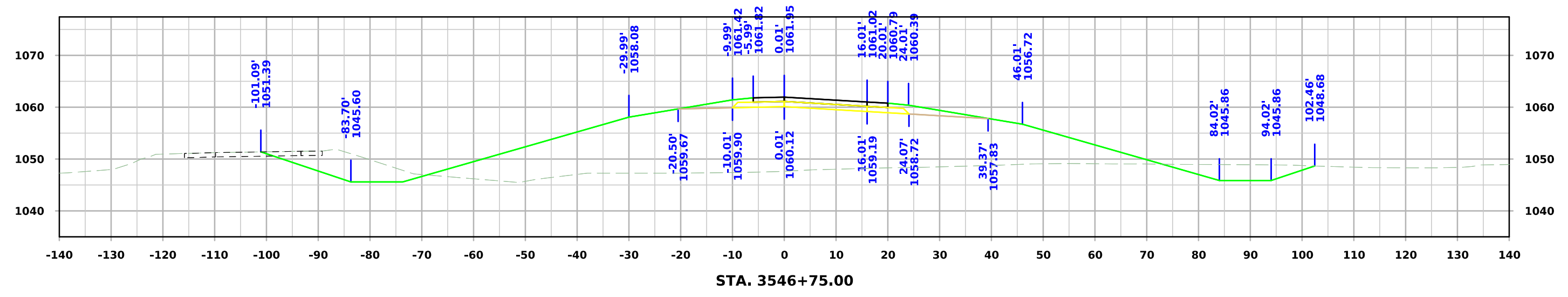
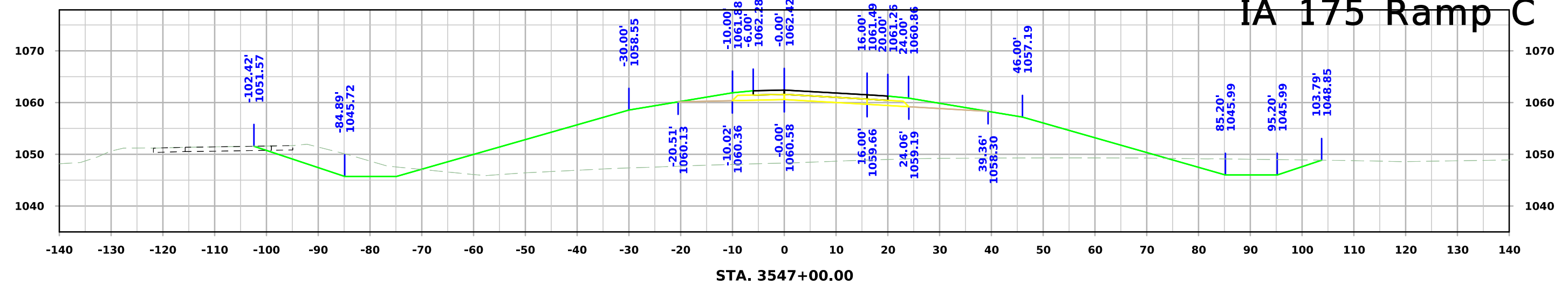

IA 175 Ramp C

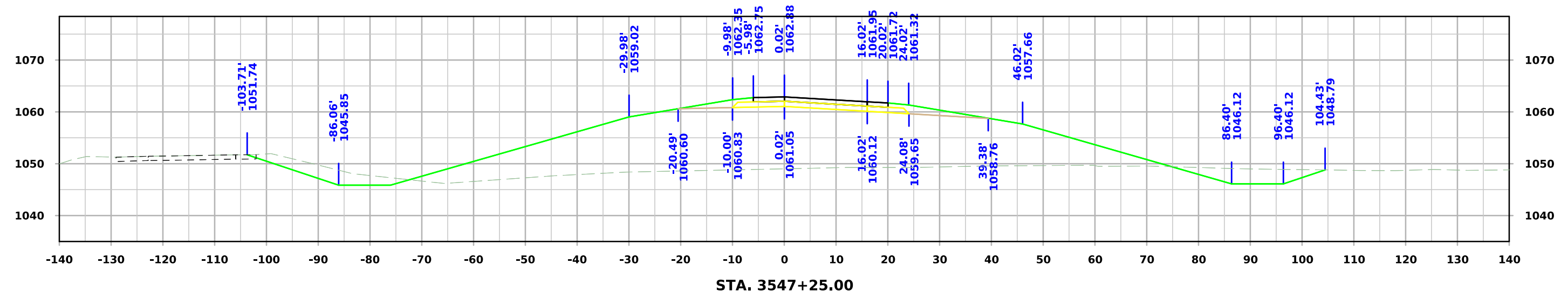
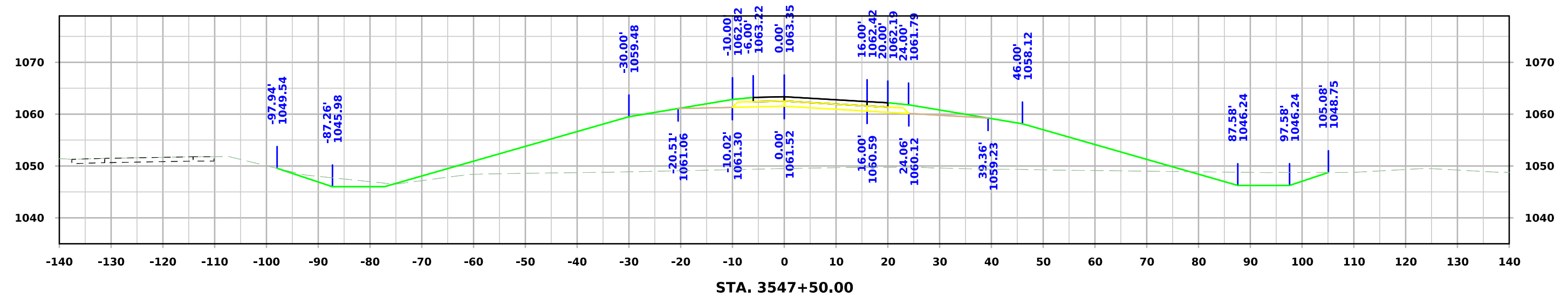
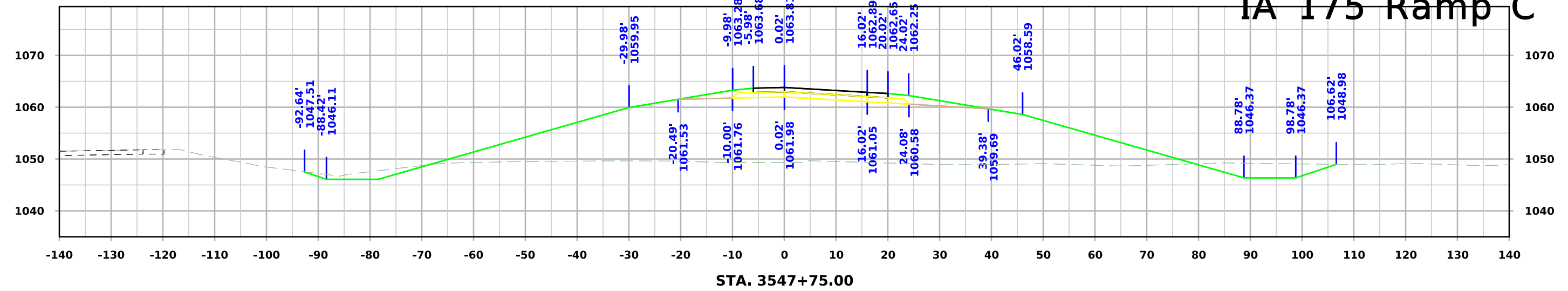

IA 175 Ramp C

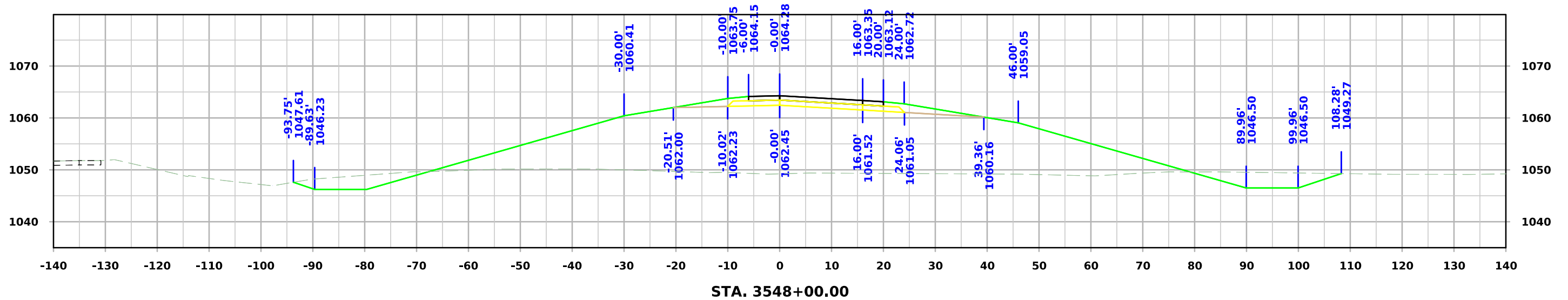
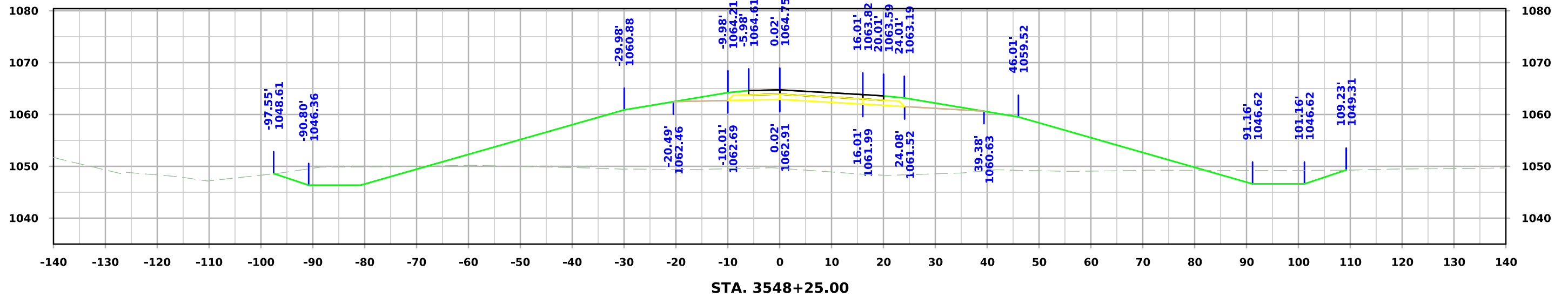

IA 175 Ramp C

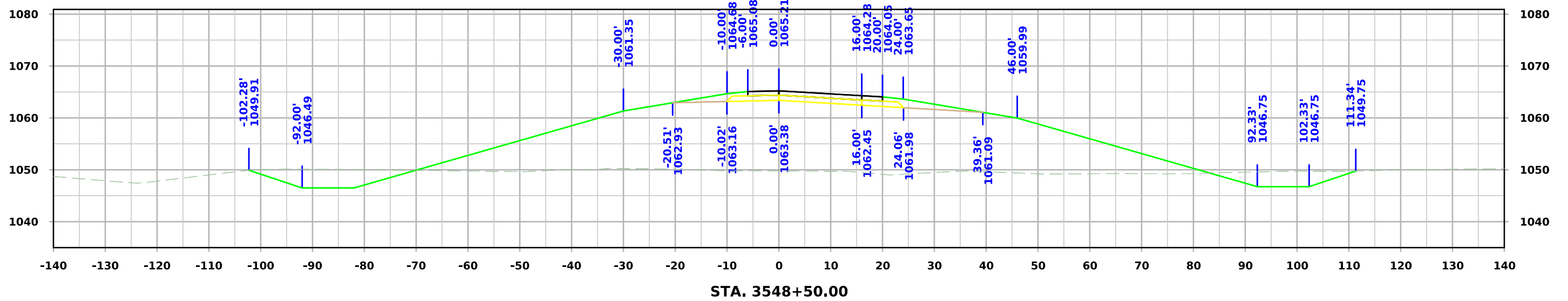
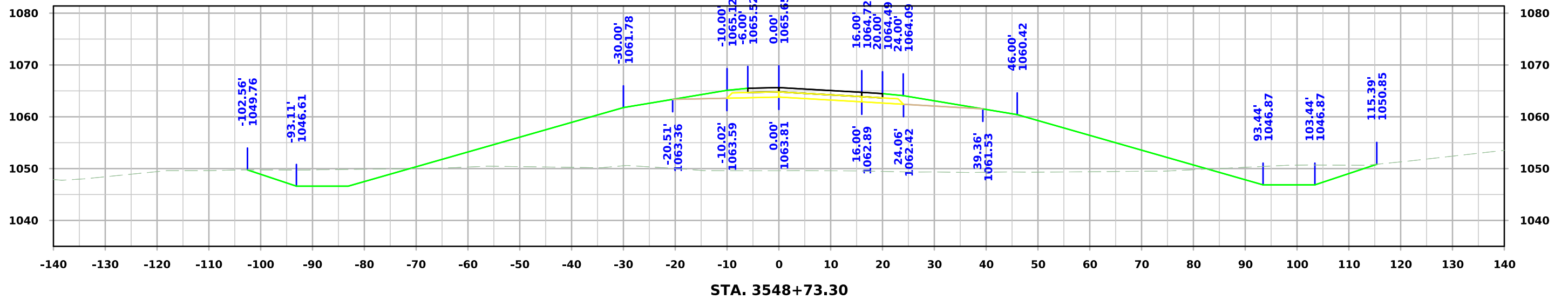

IA 175 Ramp C

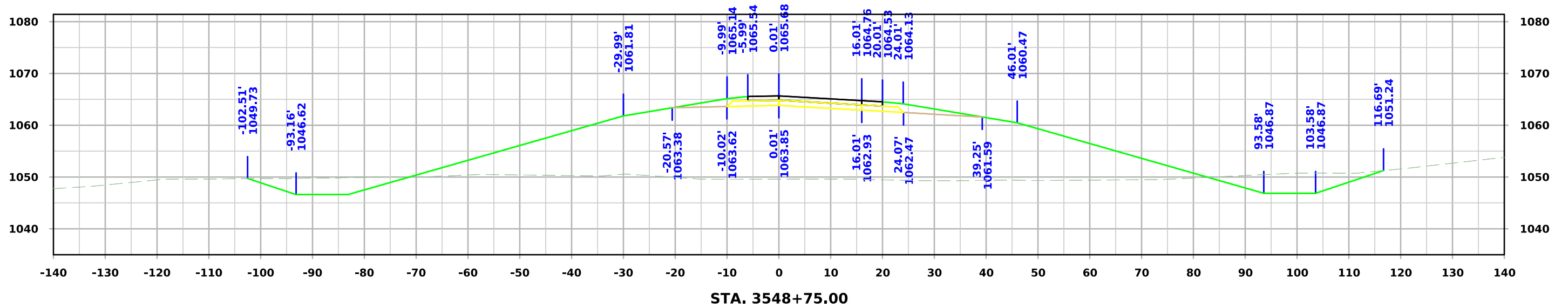
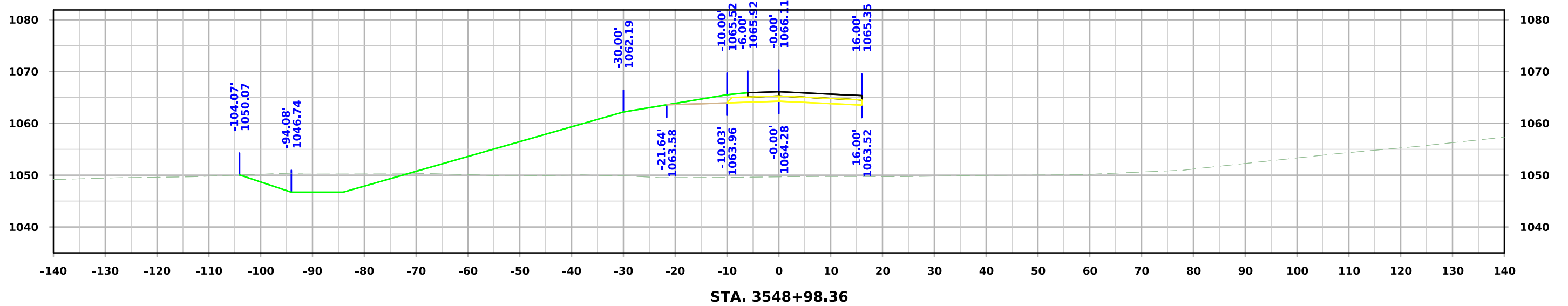

IA 175 Ramp C

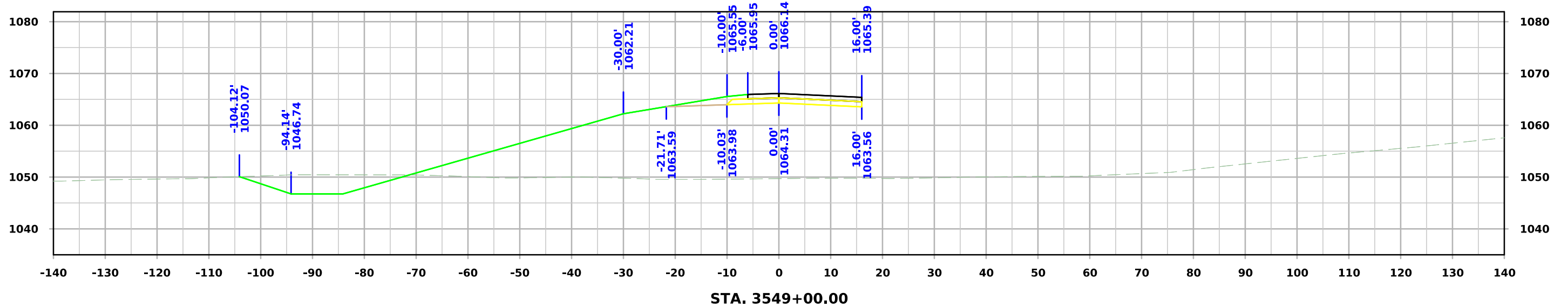
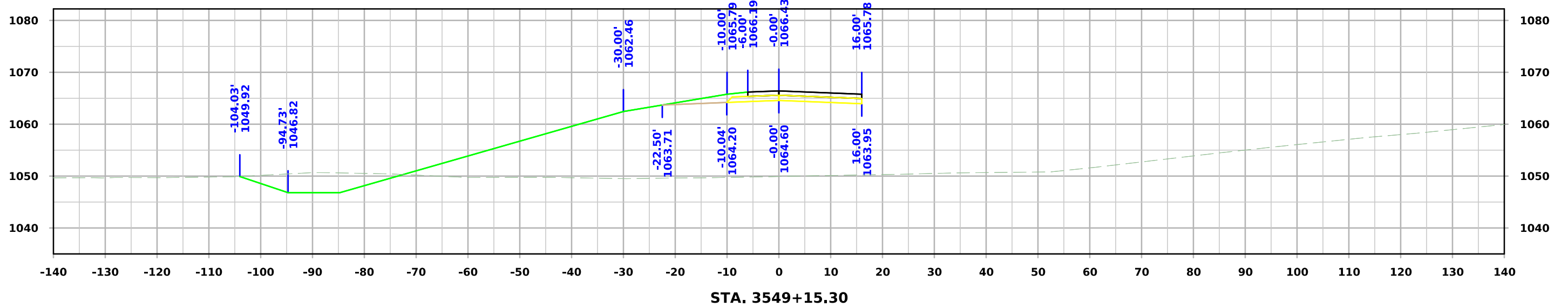

IA 175 Ramp C

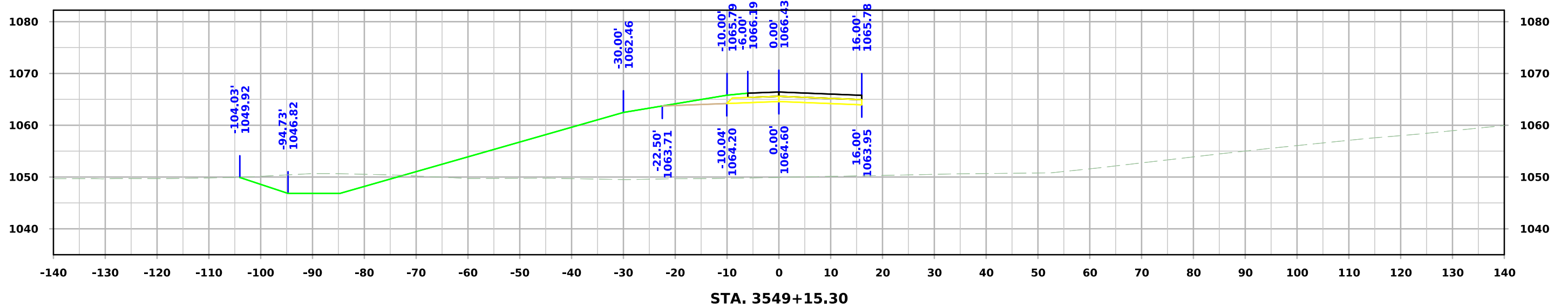
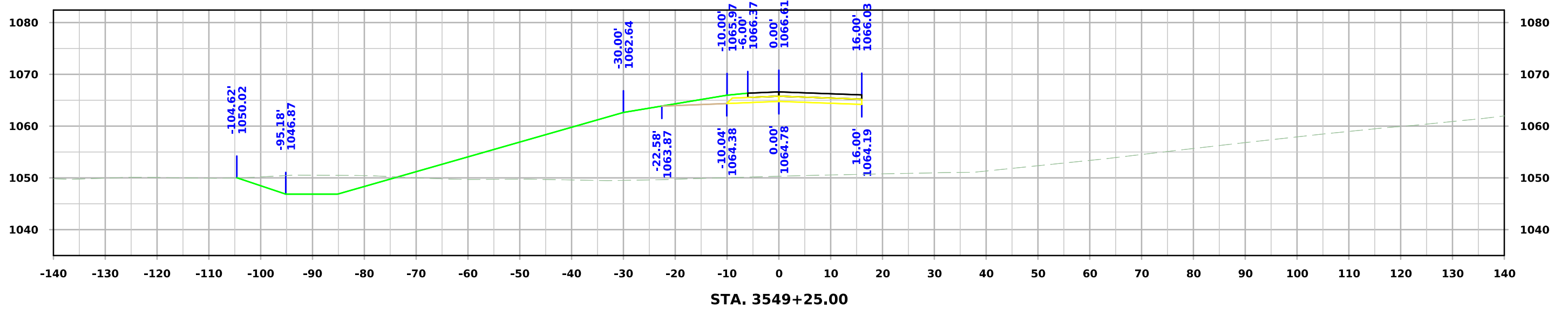

IA 175 Ramp C

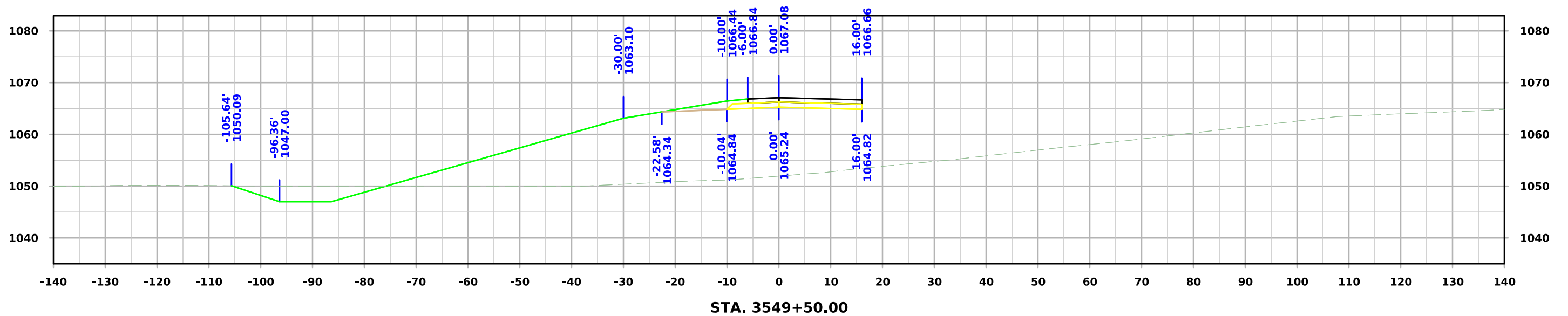
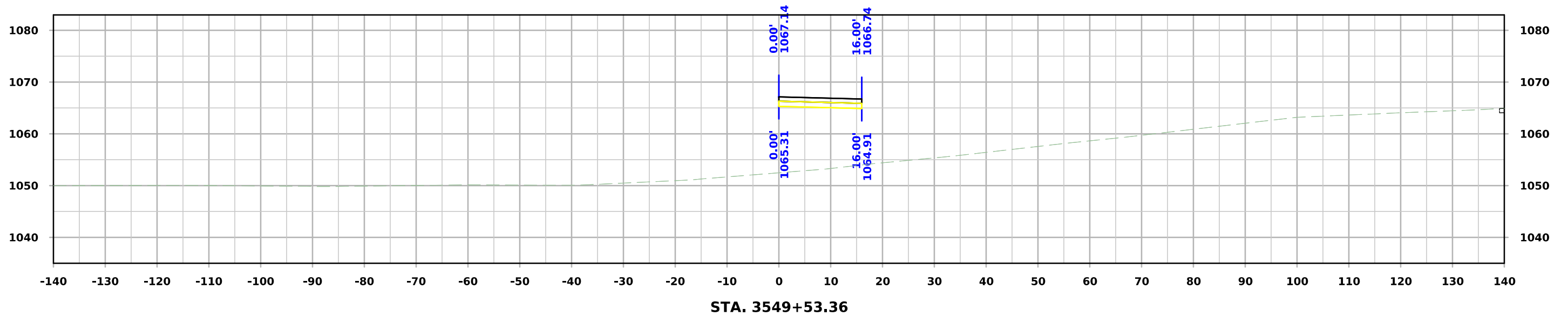

IA 175 Ramp C

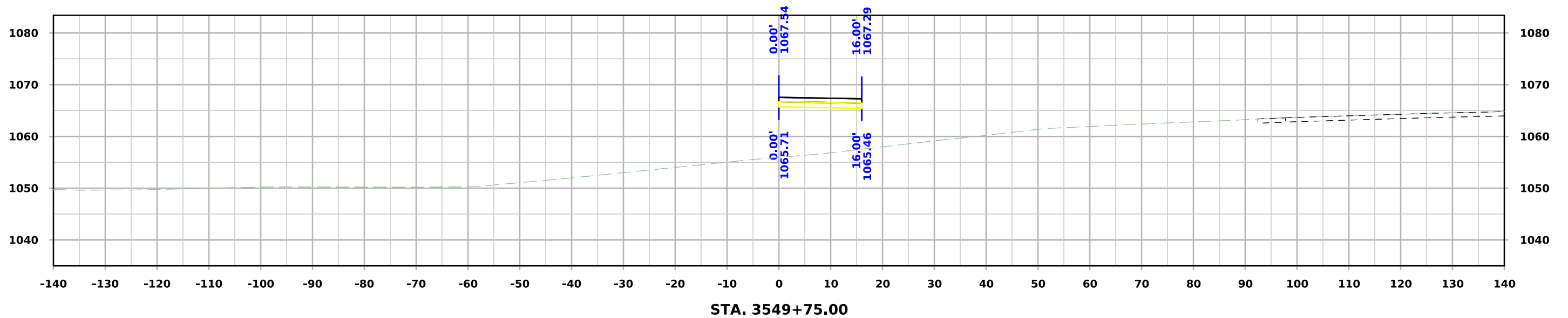
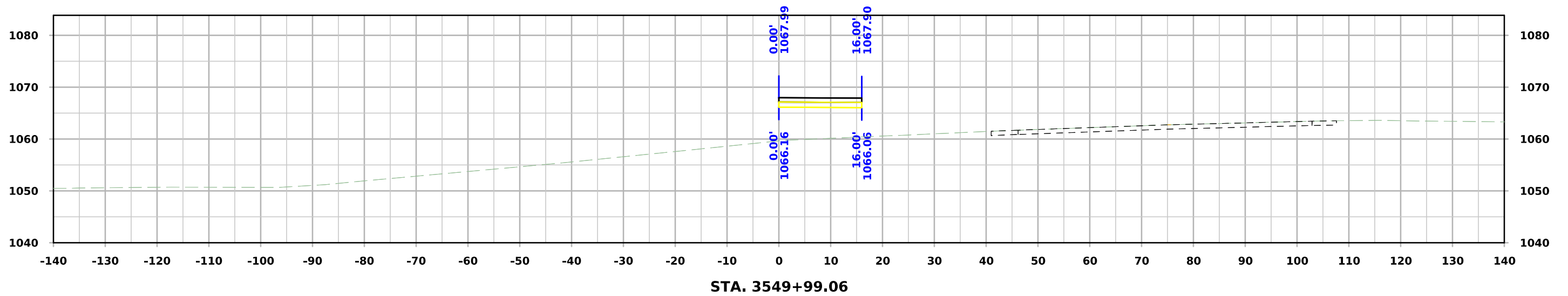

IA 175 Ramp C

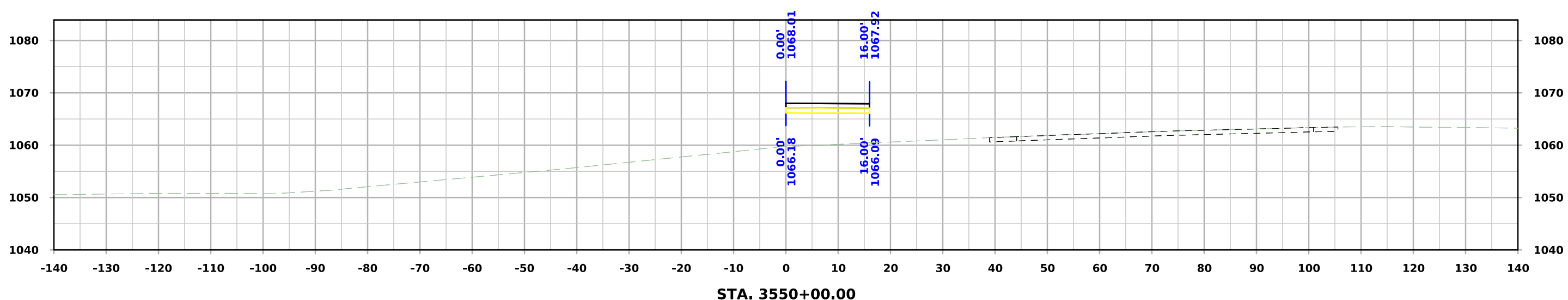
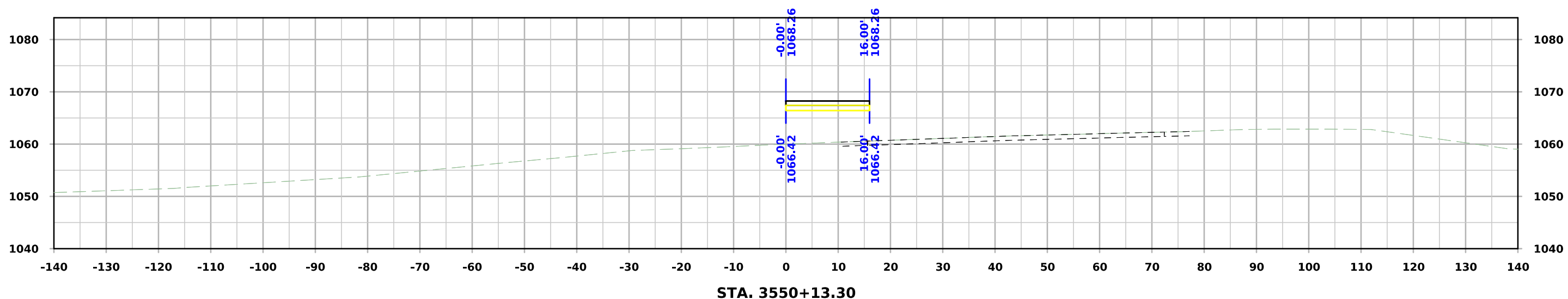
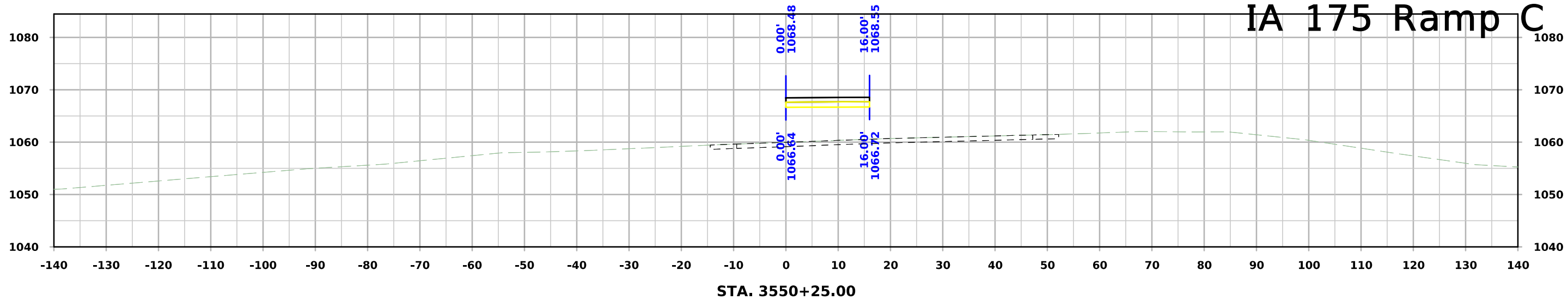

IA 175 Ramp C

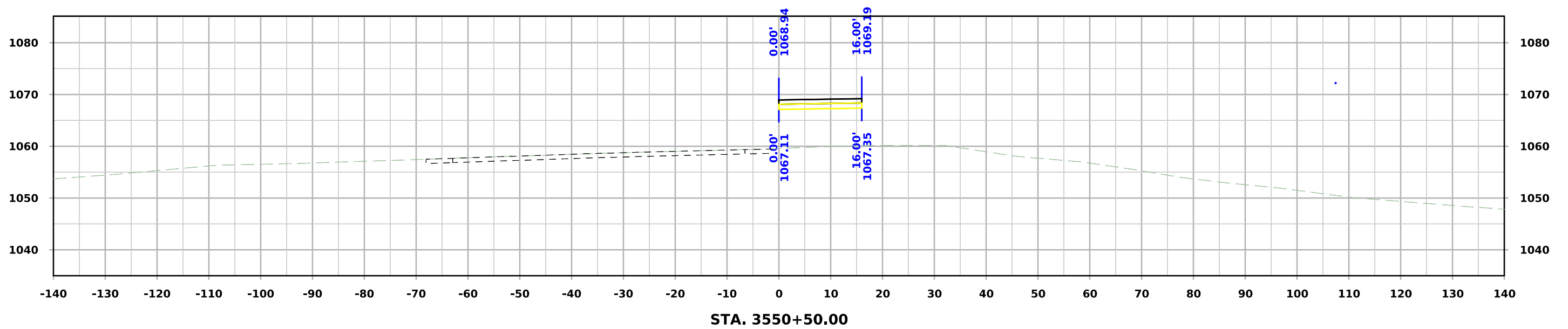
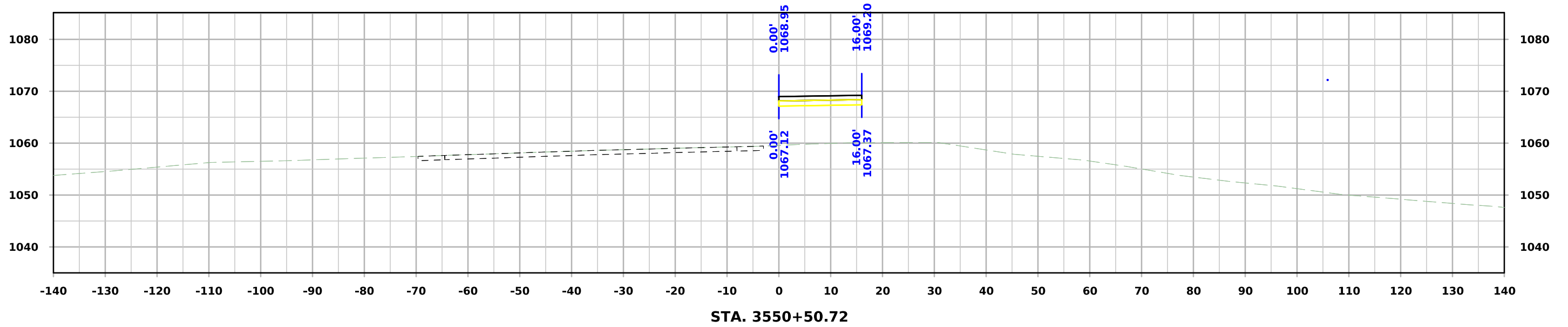

IA 175 Ramp C

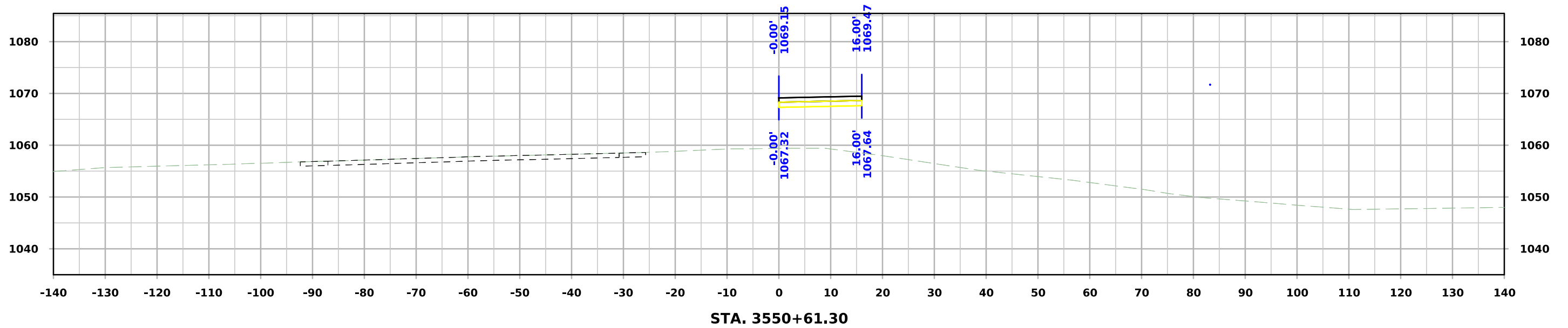
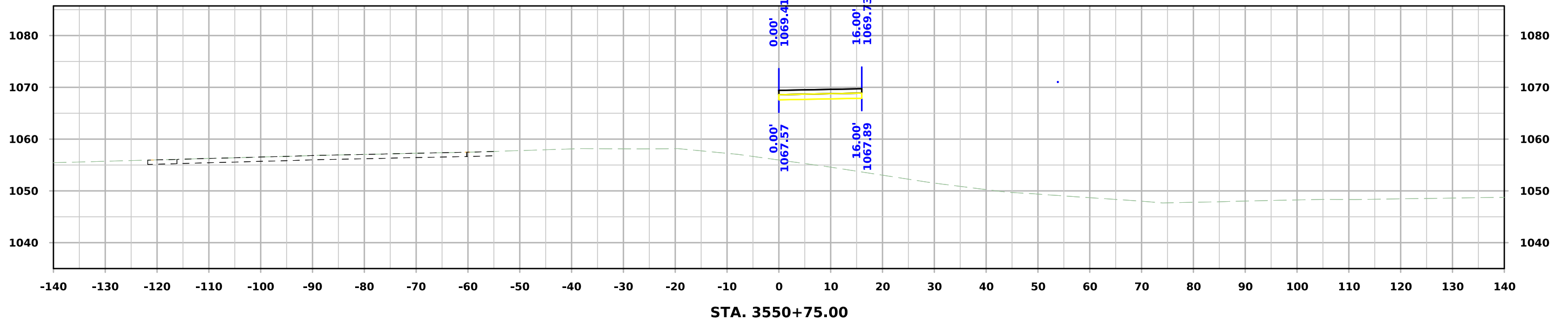

IA 175 Ramp C

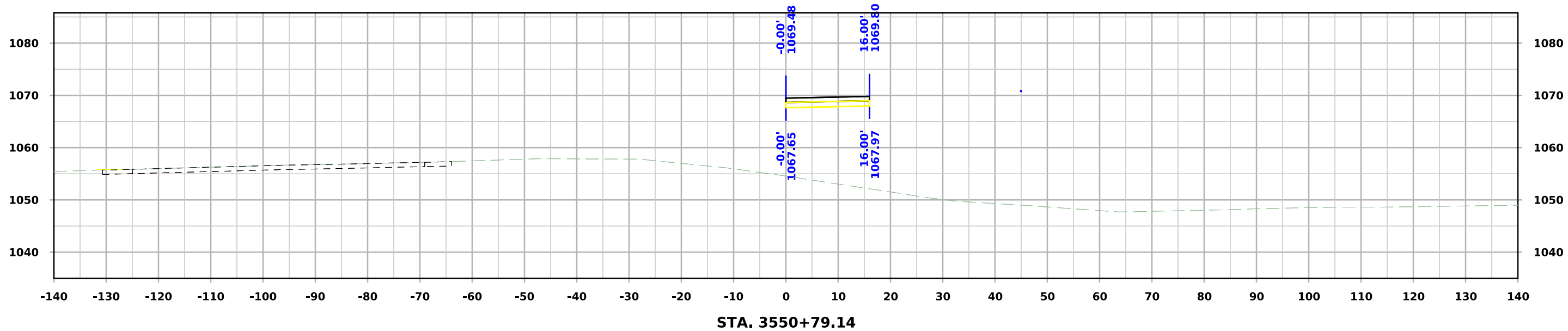

IA 175 Ramp D

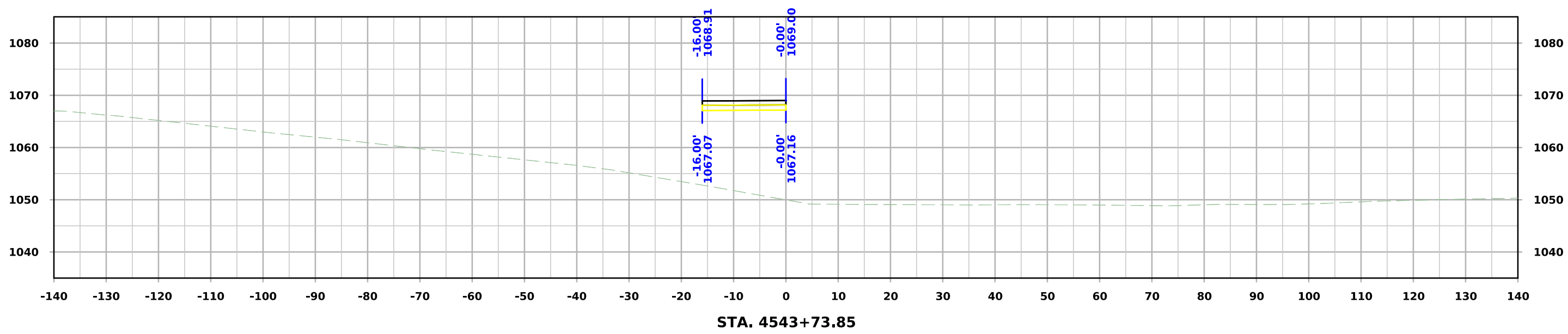
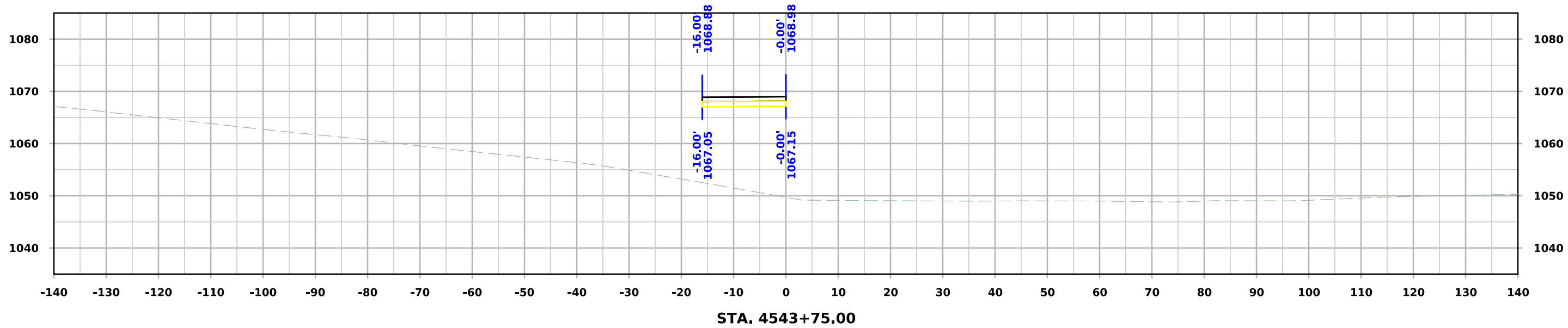

IA 175 Ramp D

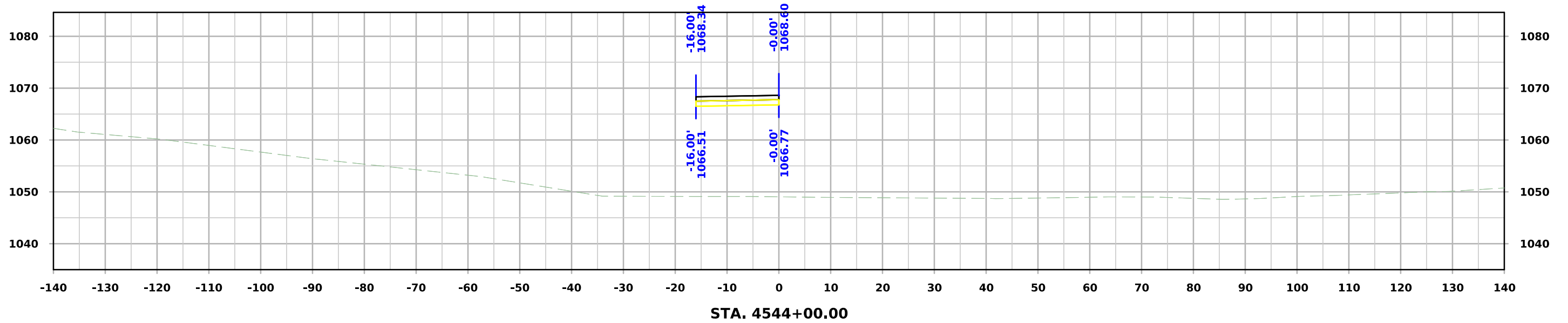
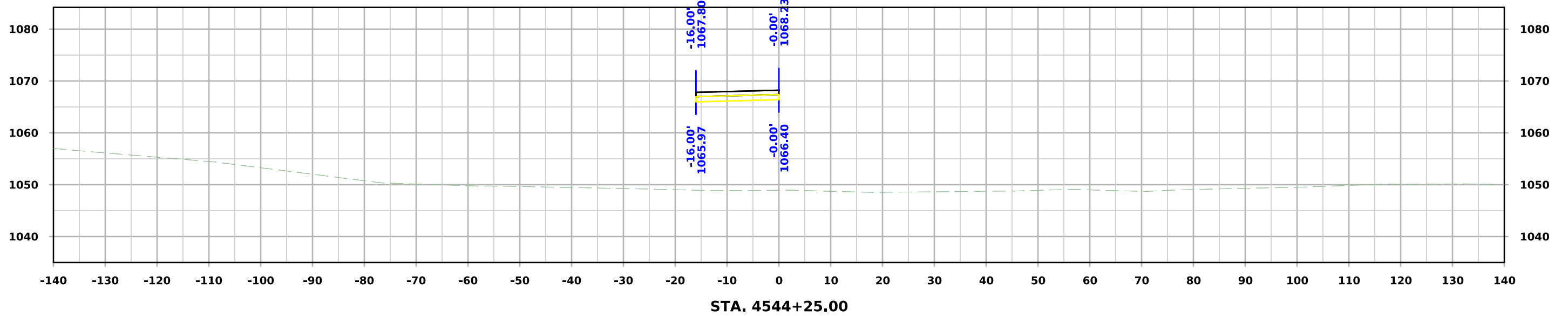

IA 175 Ramp D

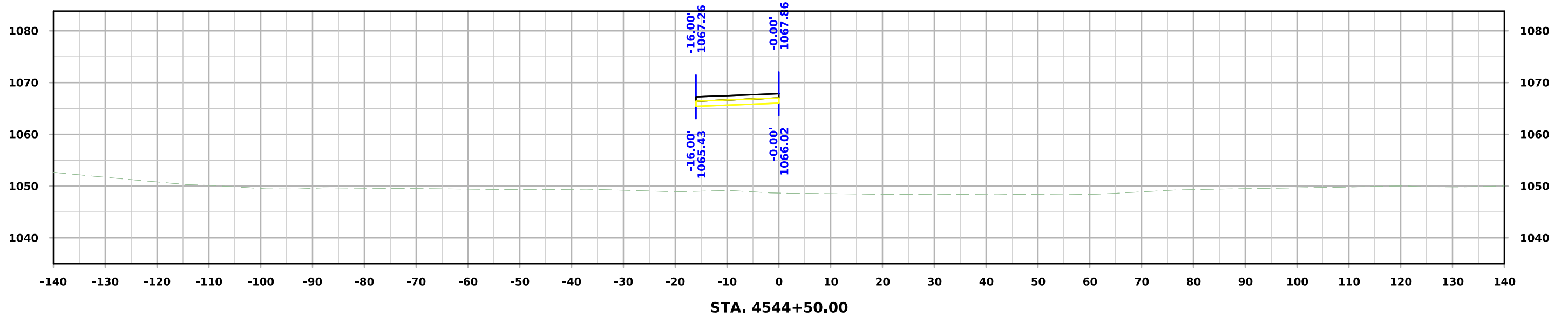
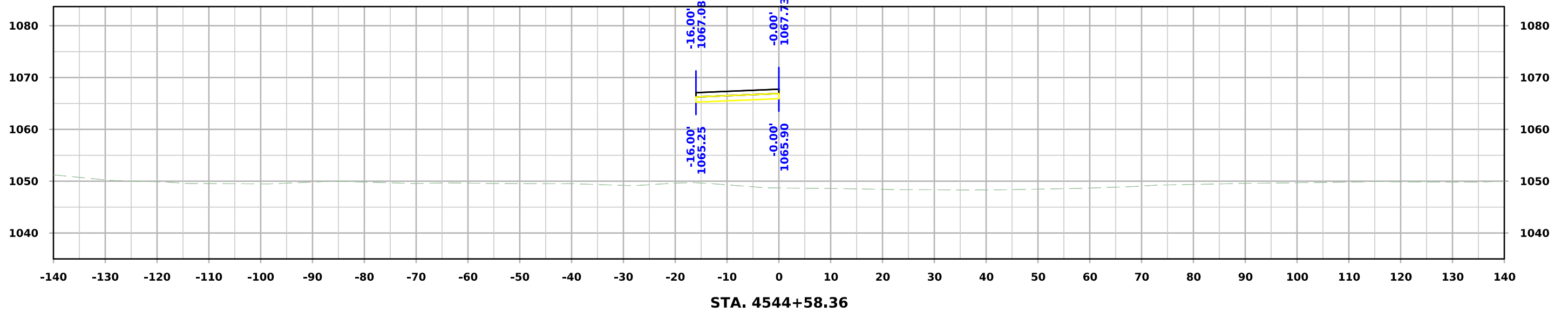

IA 175 Ramp D

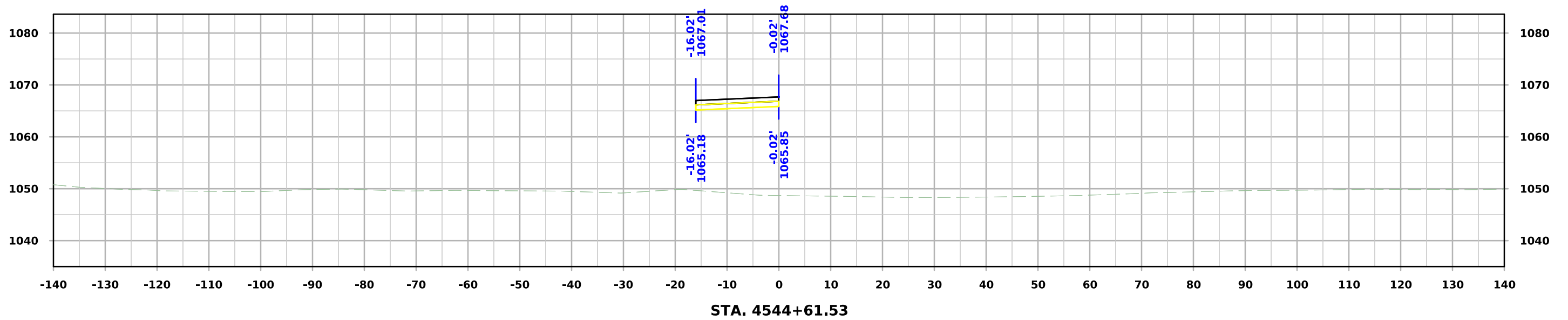
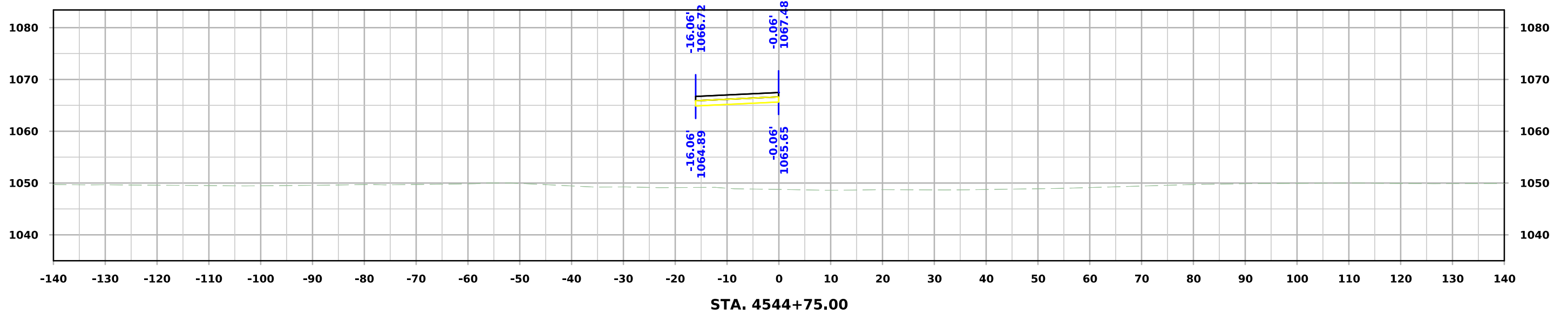

IA 175 Ramp D

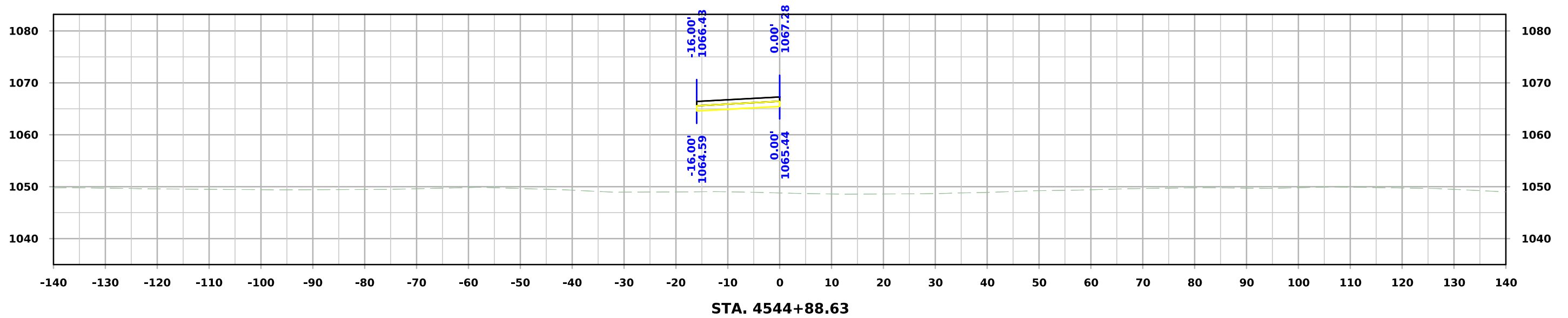
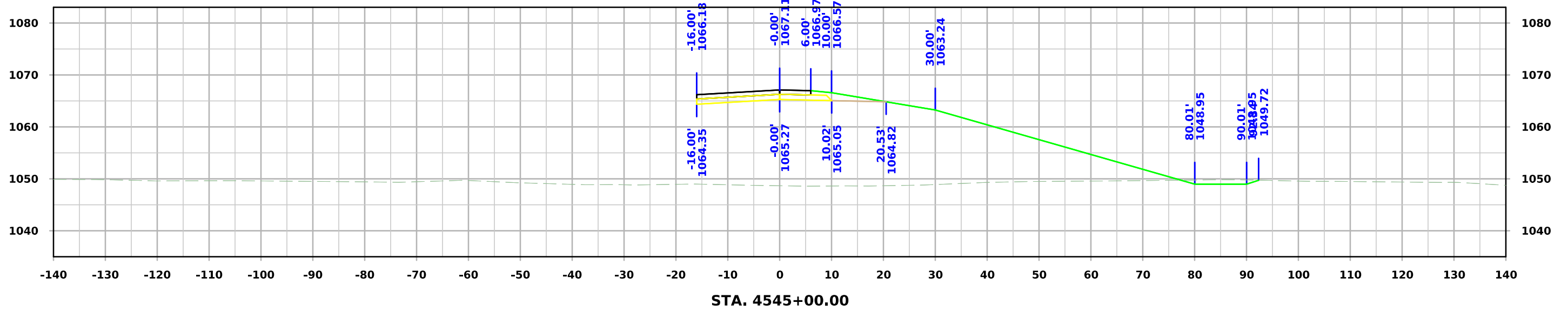

IA 175 Ramp D

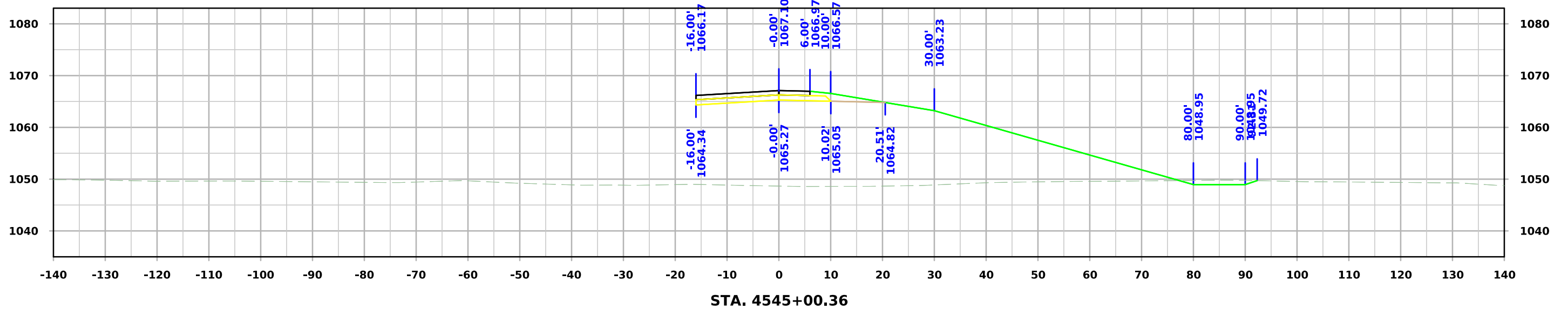
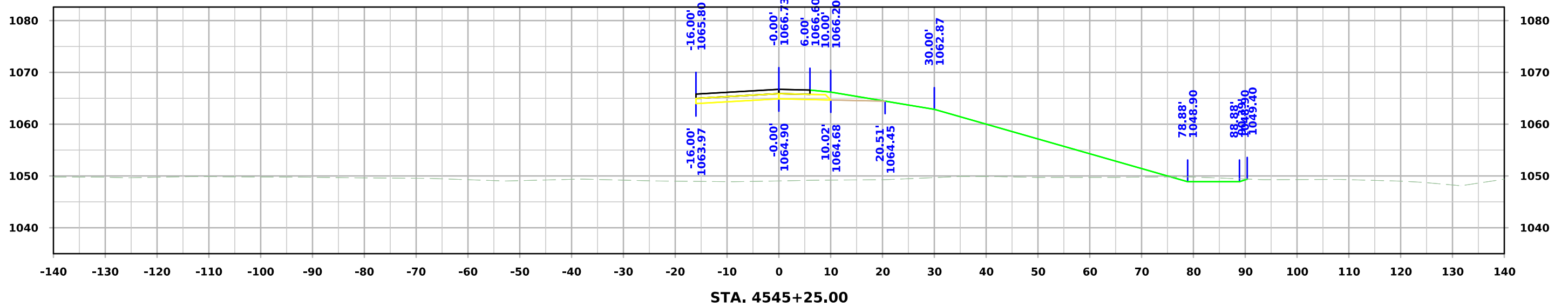

IA 175 Ramp D

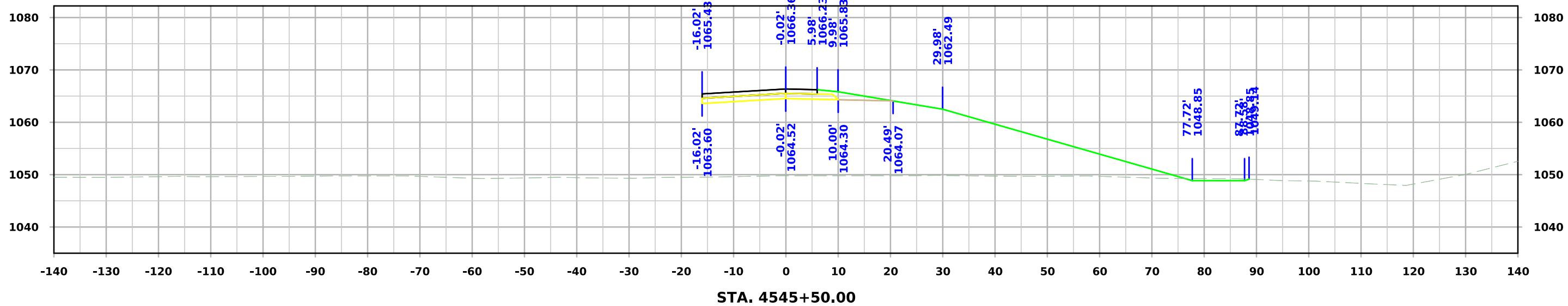
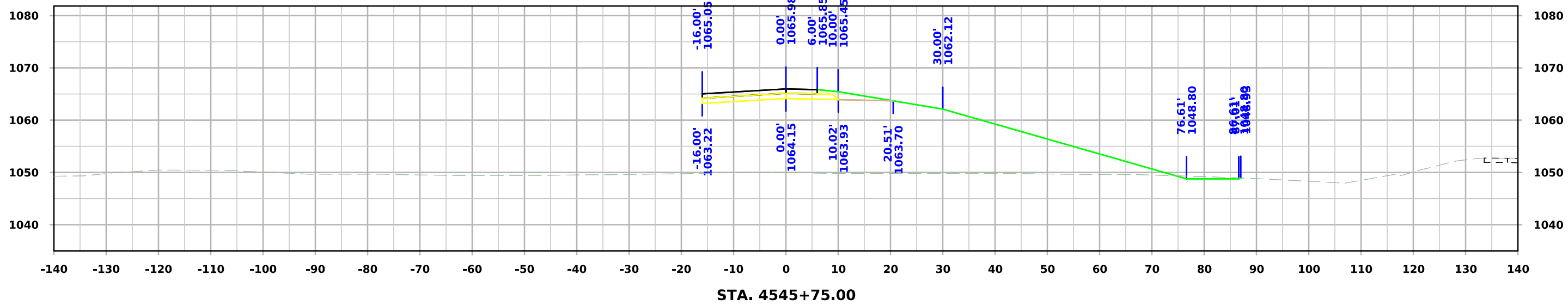

IA 175 Ramp D

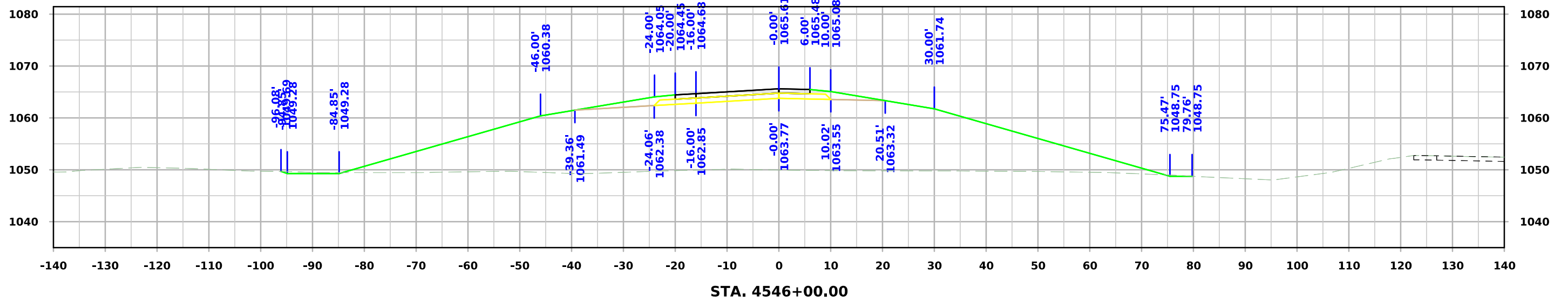
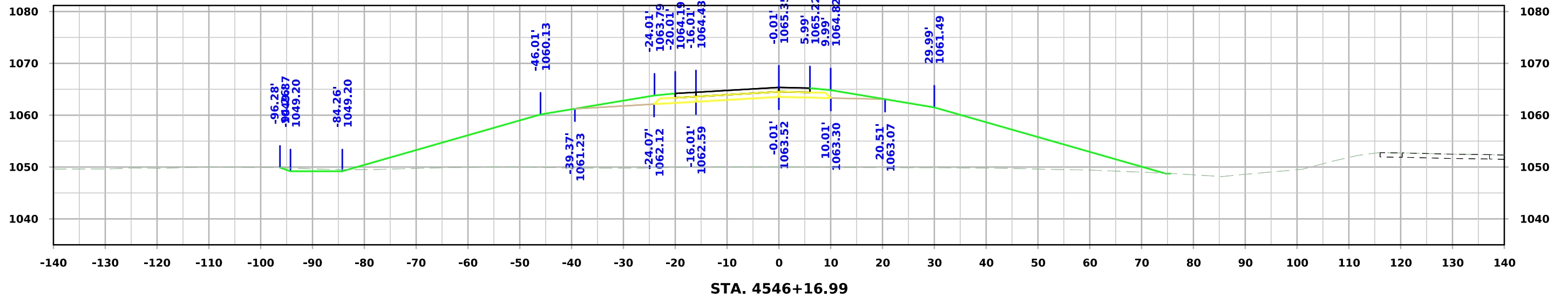

IA 175 Ramp D

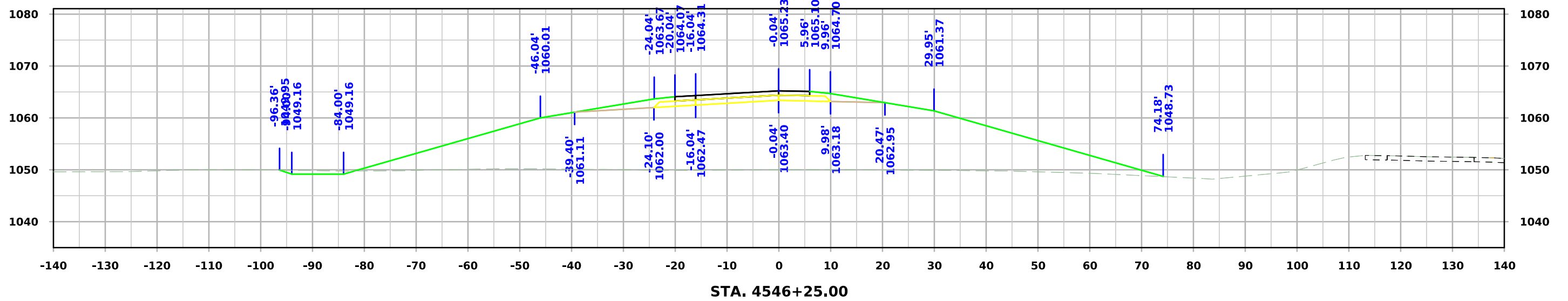
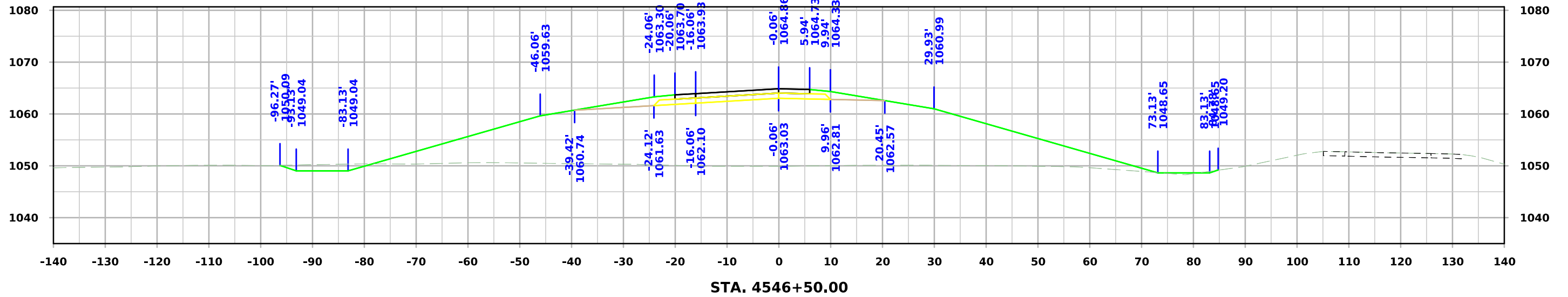

IA 175 Ramp D

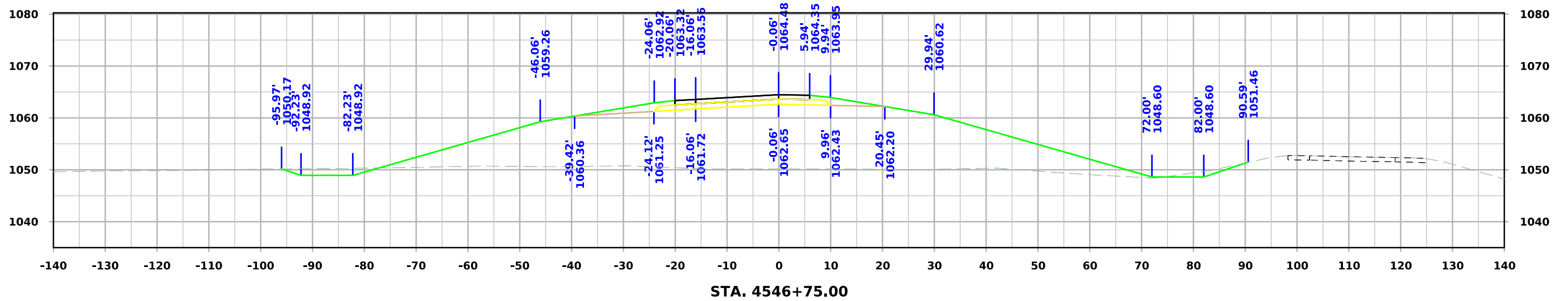
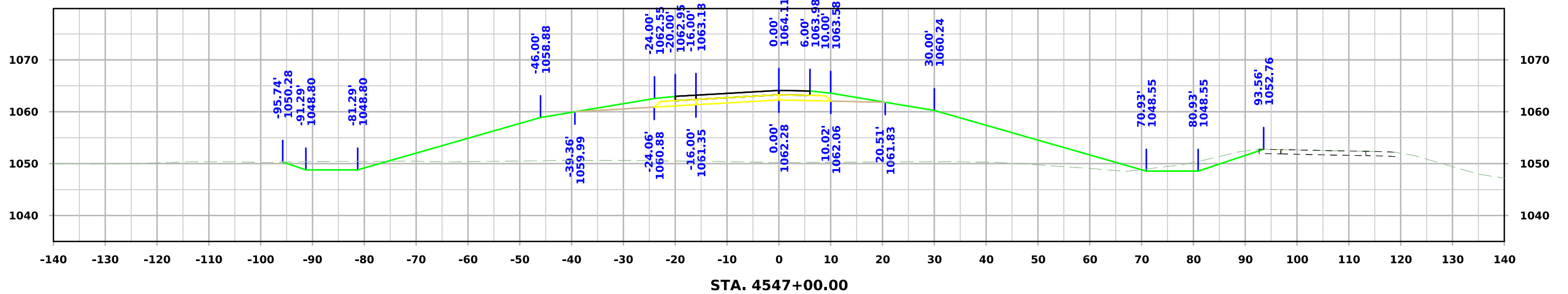

IA 175 Ramp D

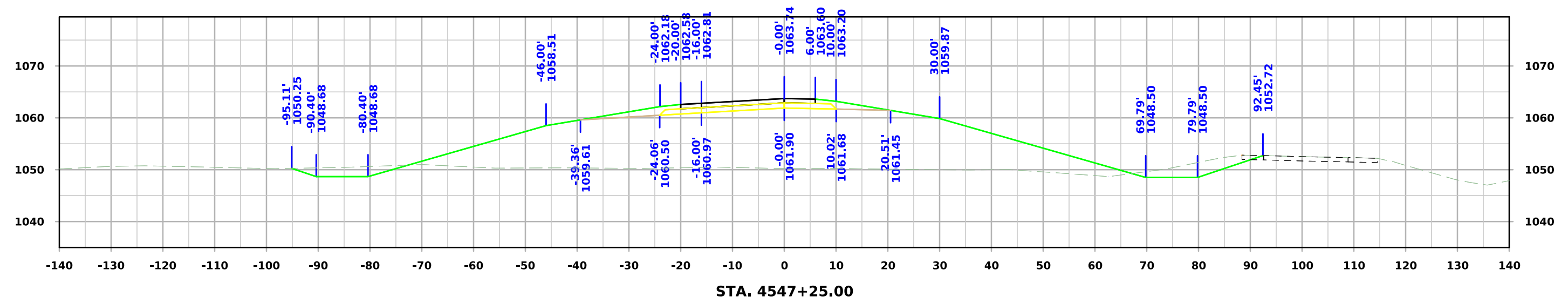
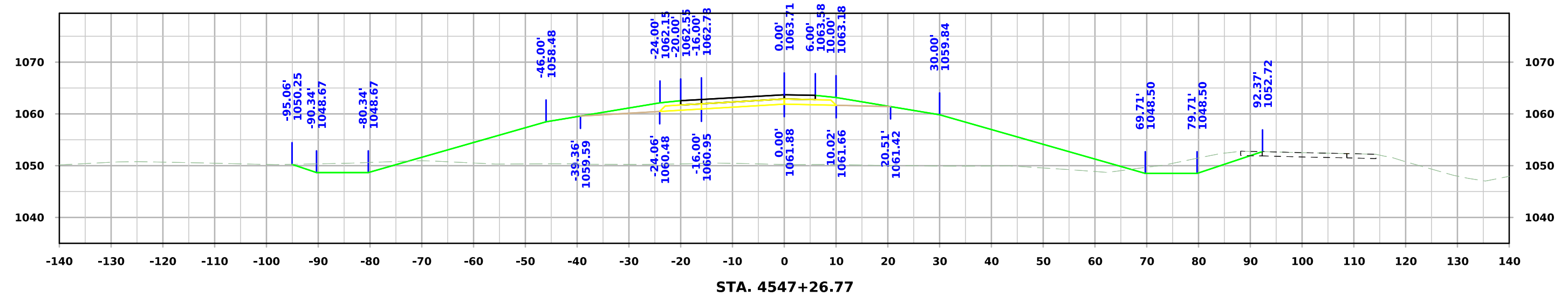
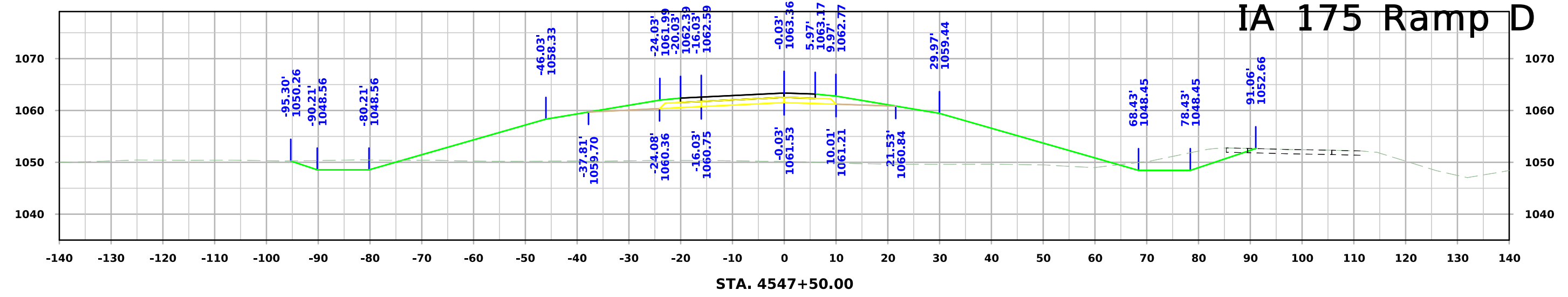

IA 175 Ramp D

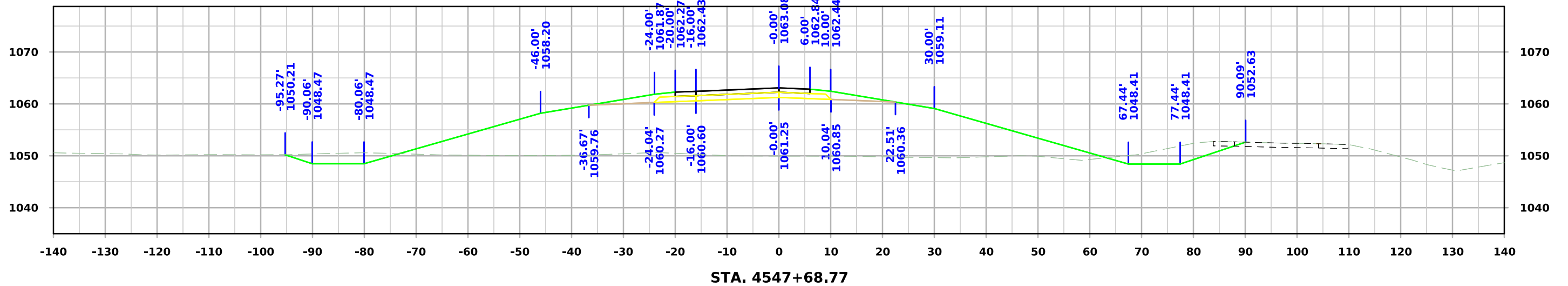
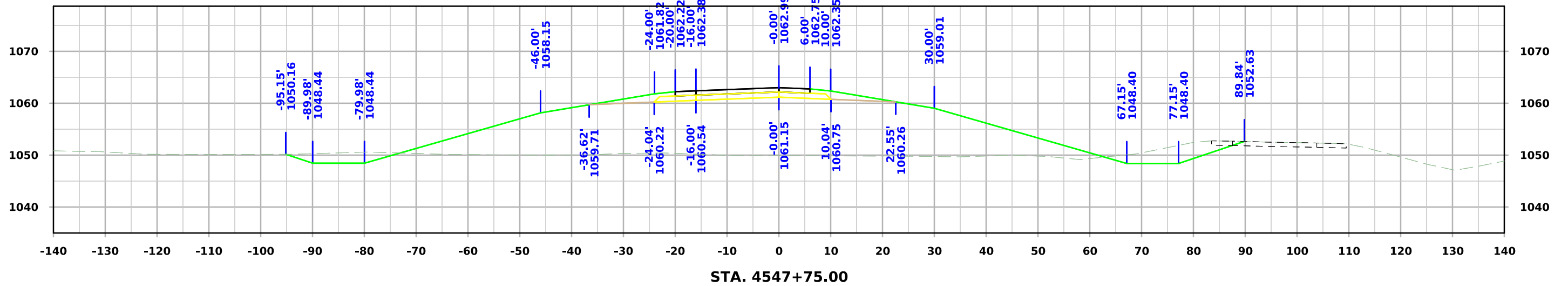
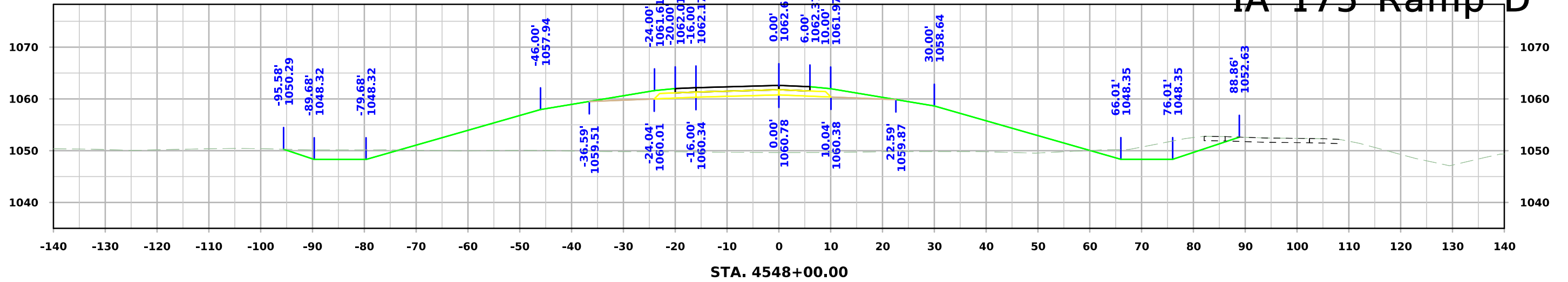

IA 175 Ramp D

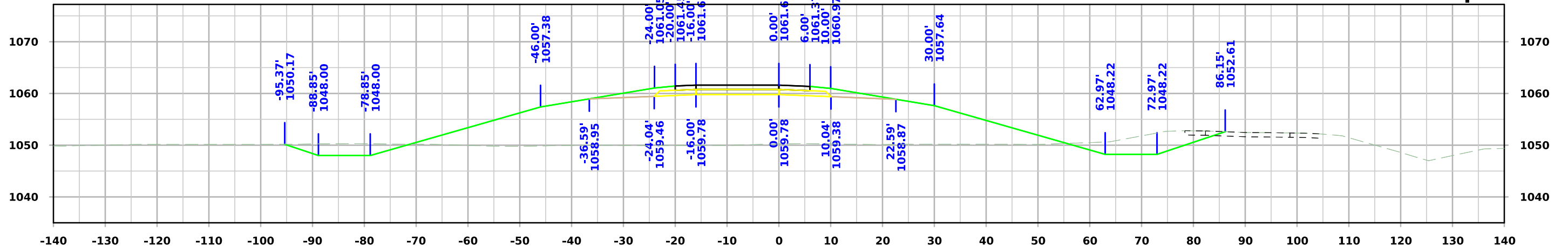

STA. 4548+66.77

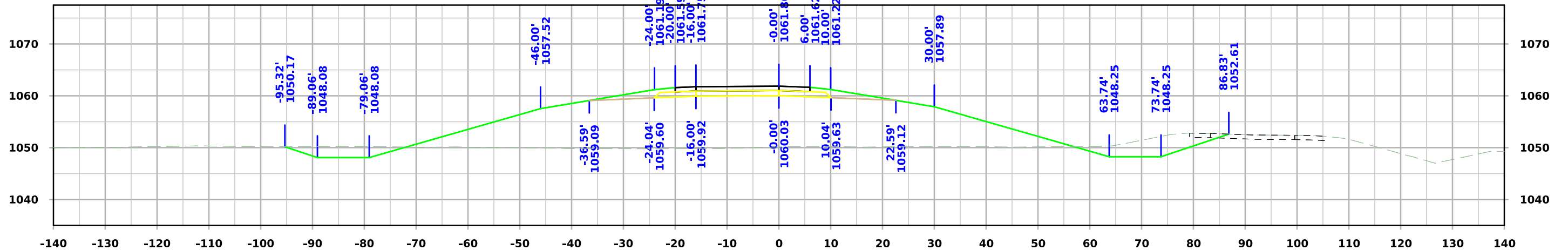

STA. 4548+50.00

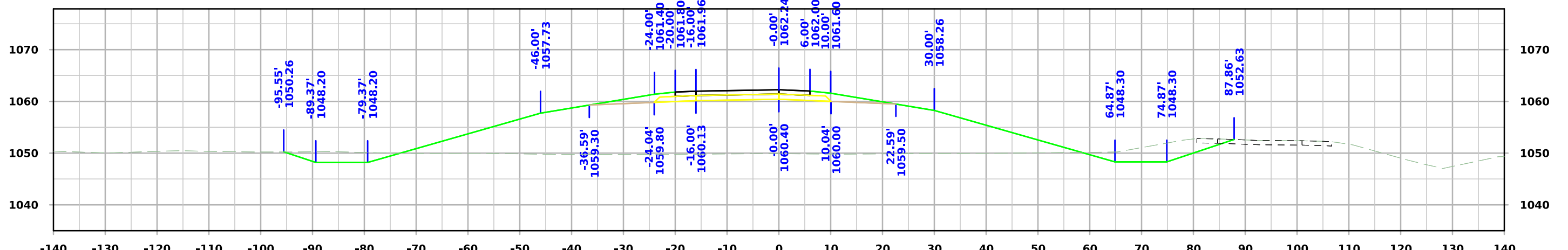

STA. 4548+25.00

IA 175 Ramp D

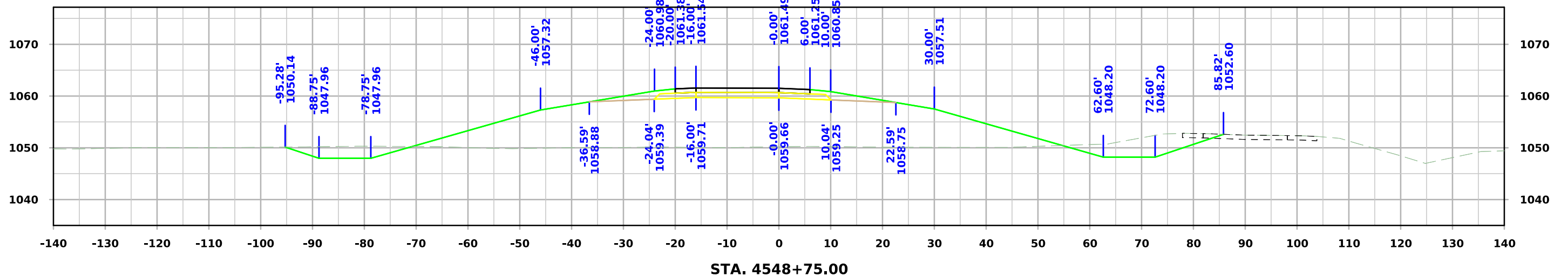
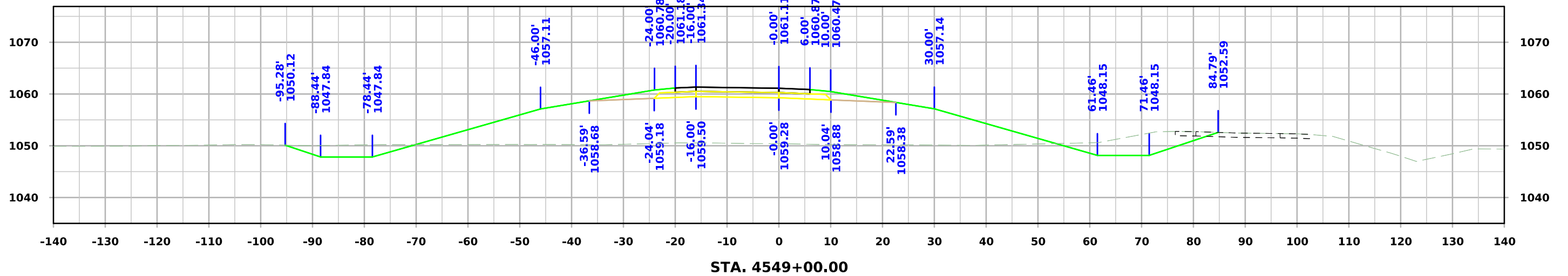
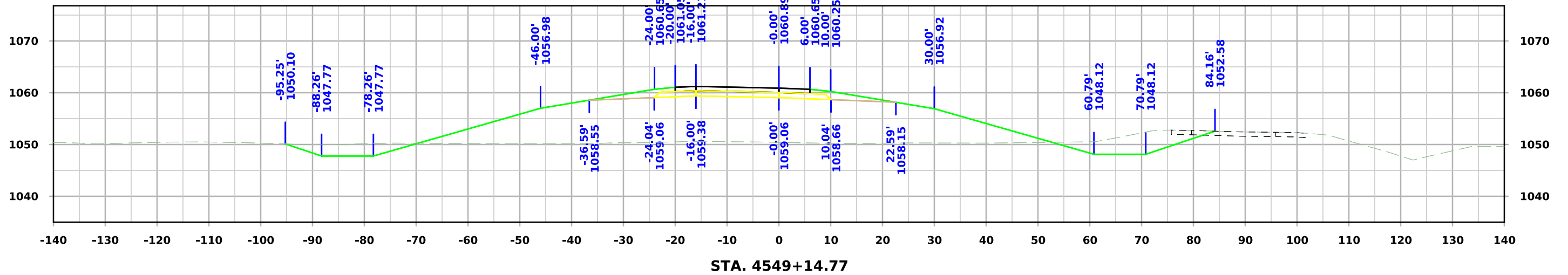

IA 175 Ramp D

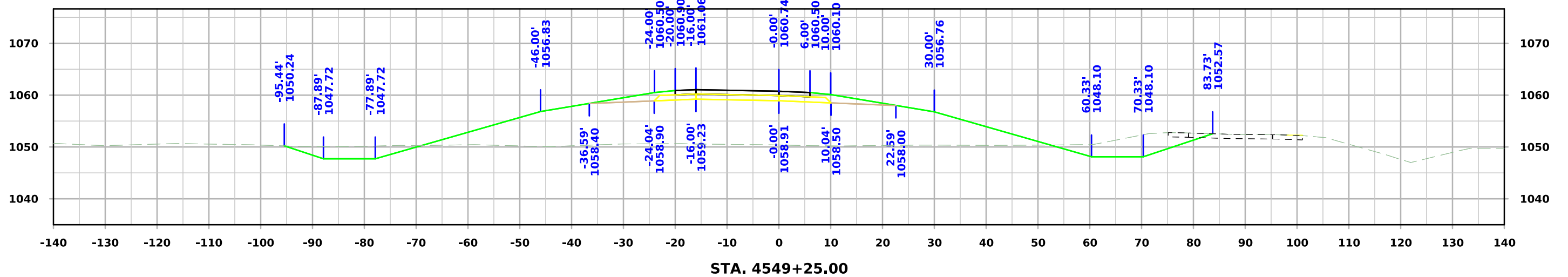
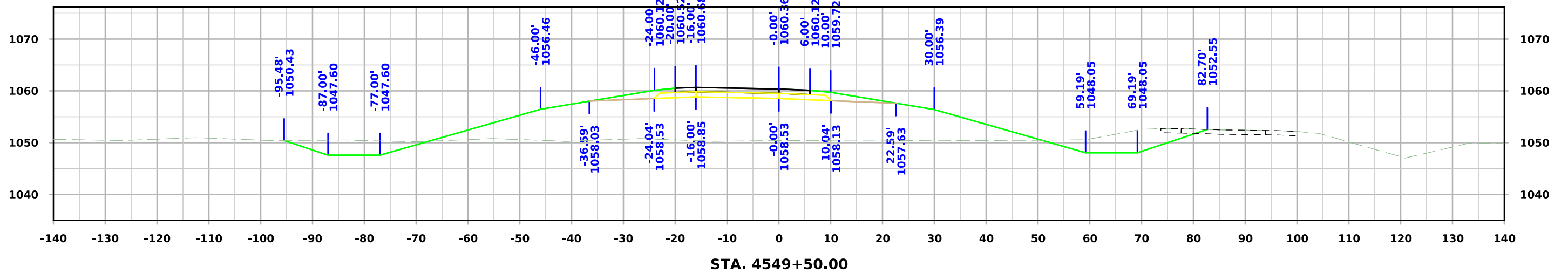
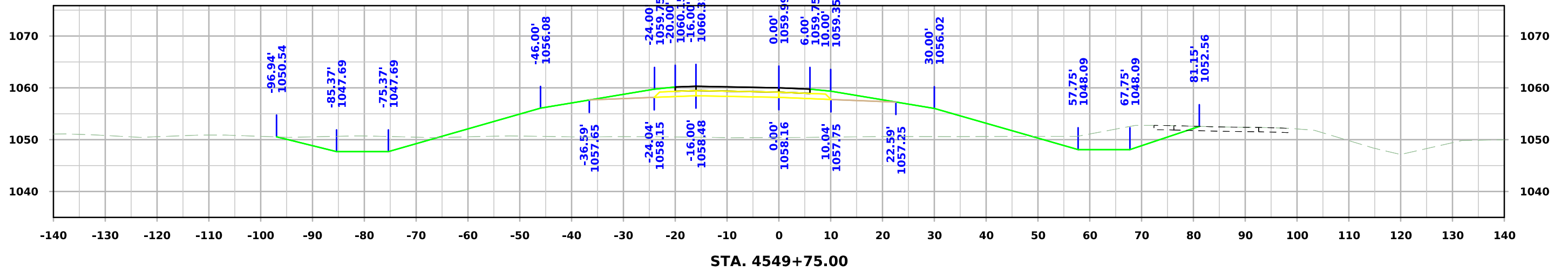

IA 175 Ramp D

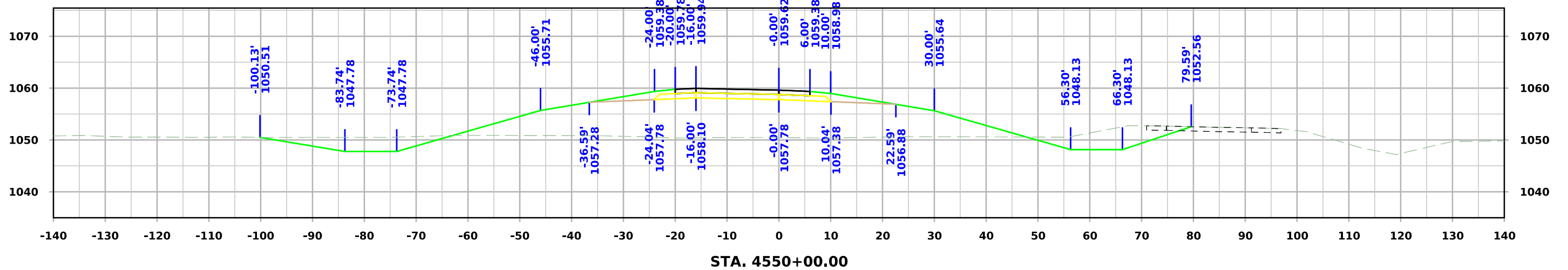
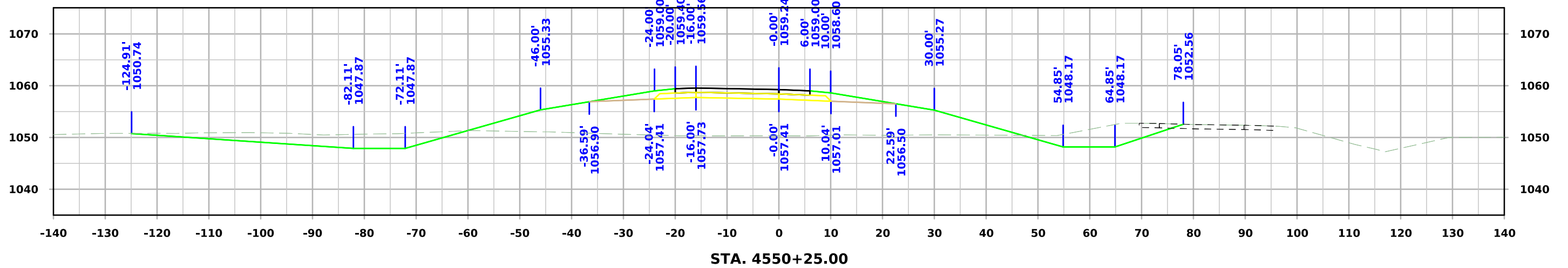
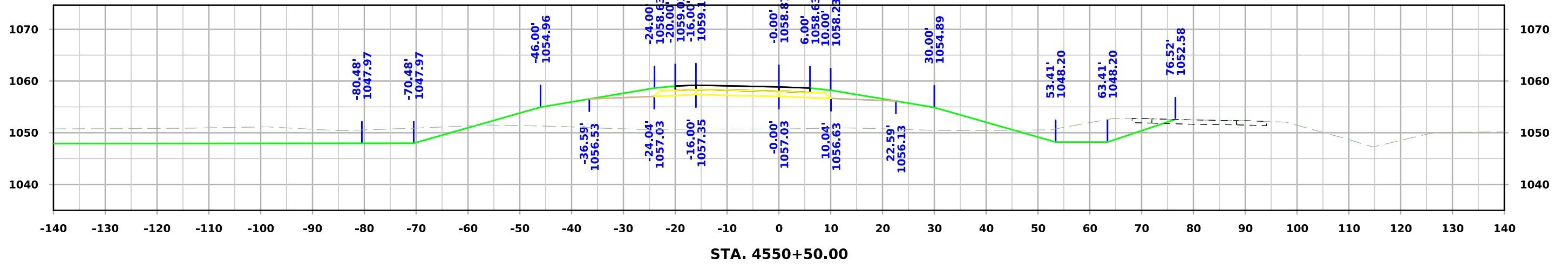

IA 175 Ramp D

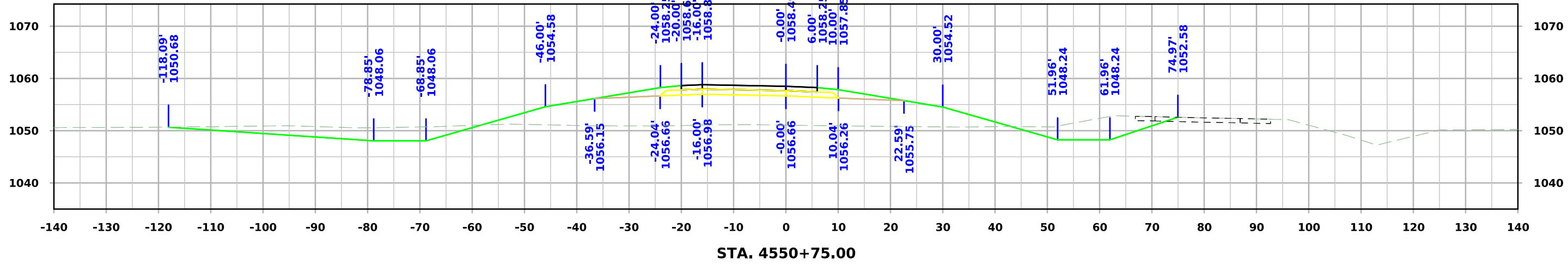
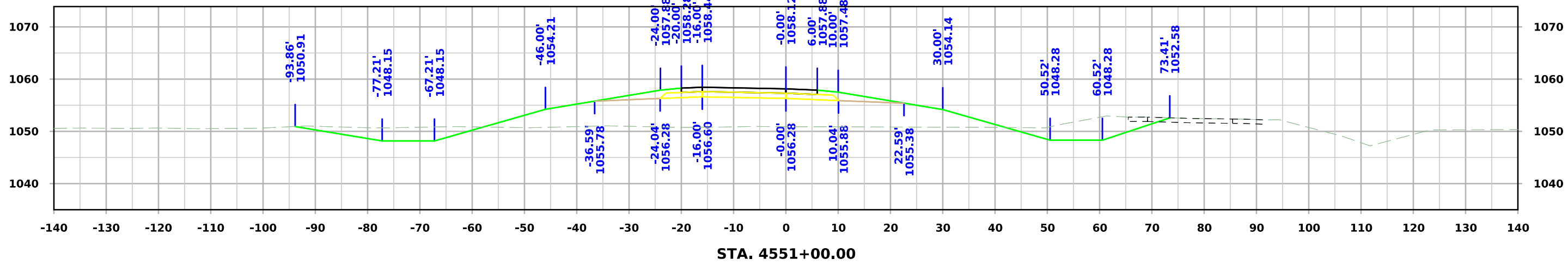
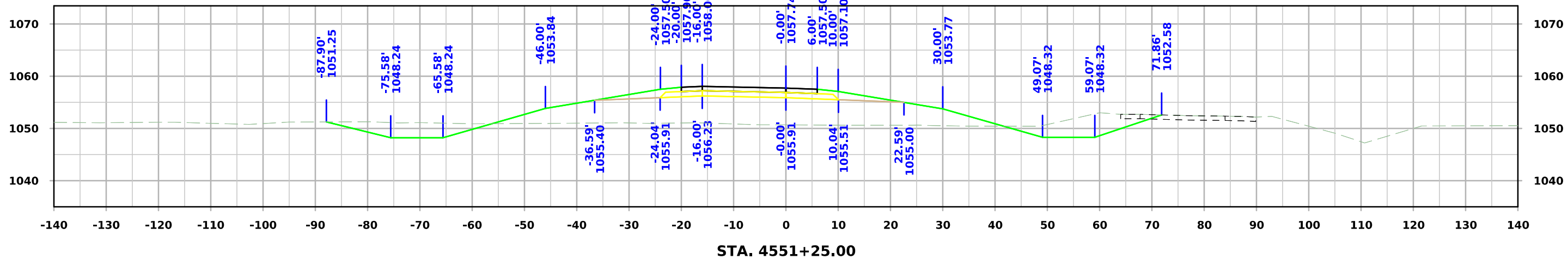

IA 175 Ramp D

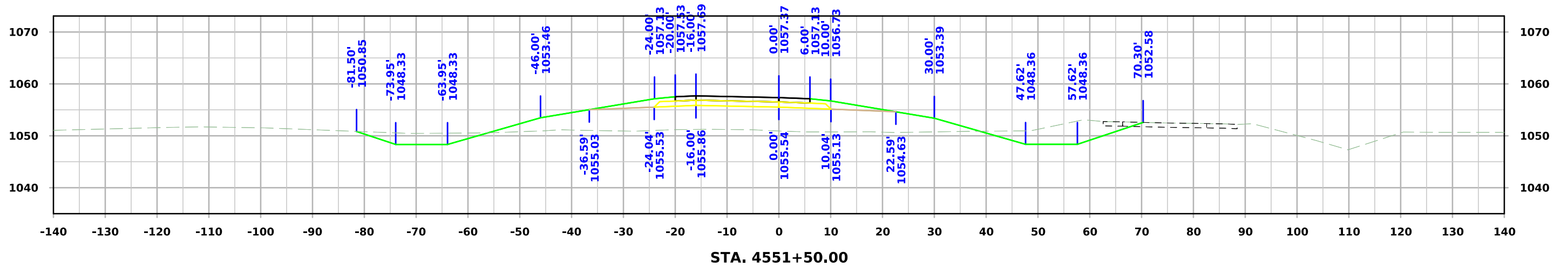
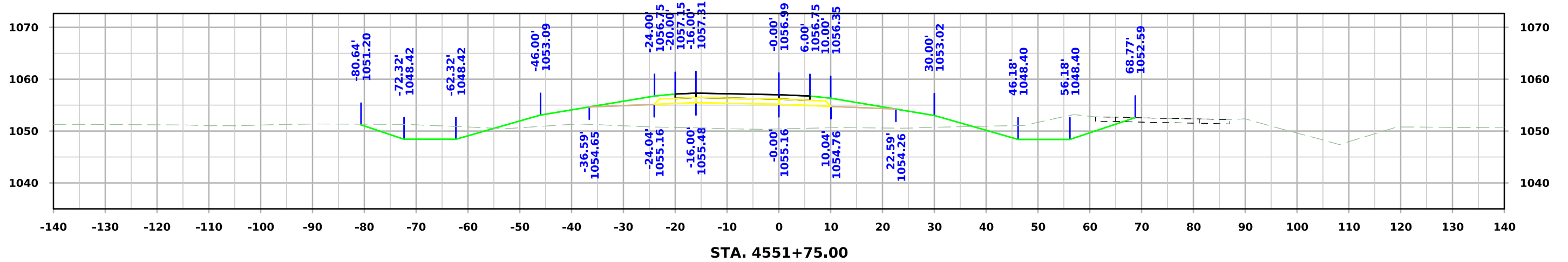
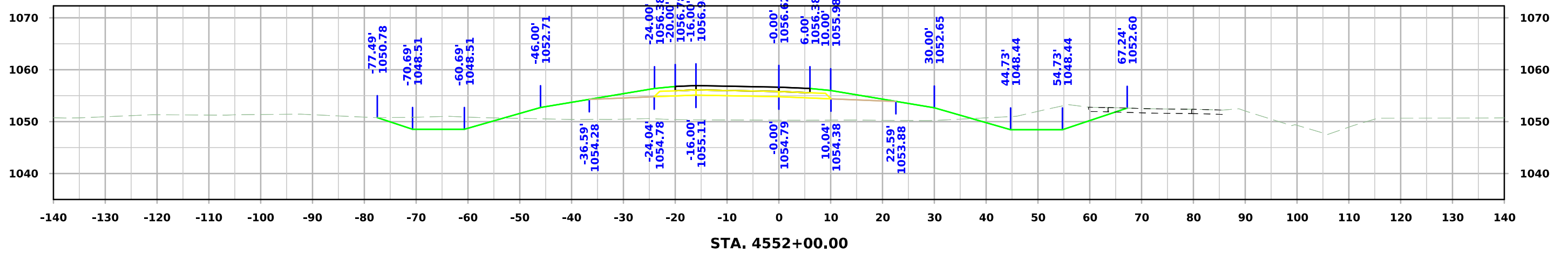

IA 175 Ramp D

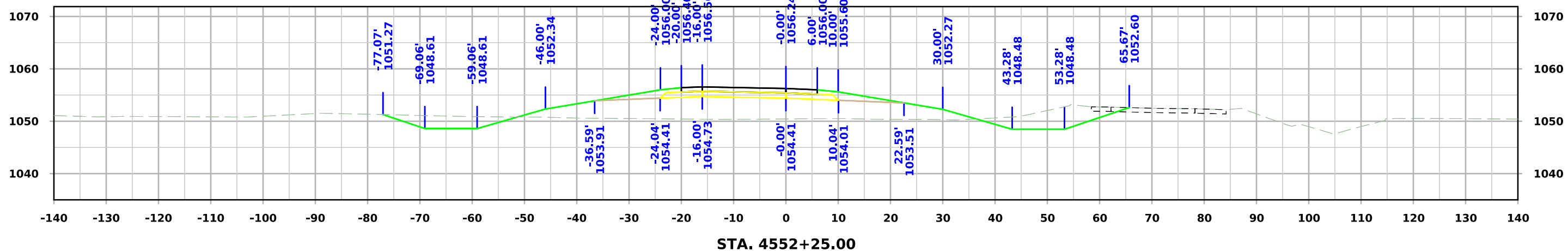
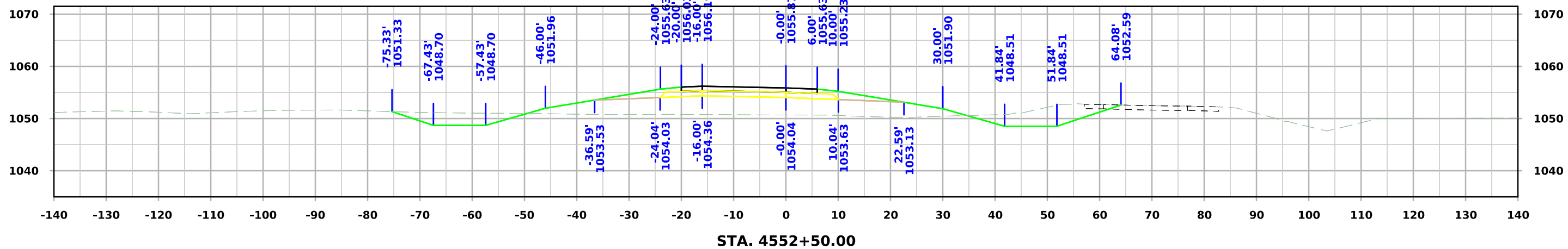
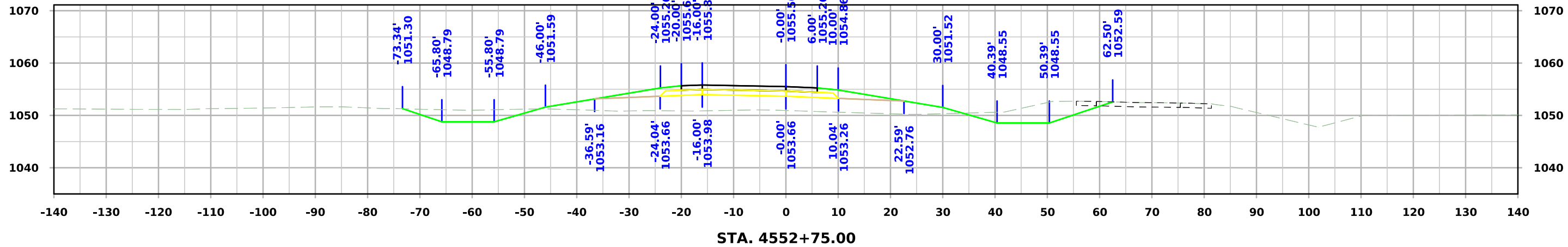

IA 175 Ramp D

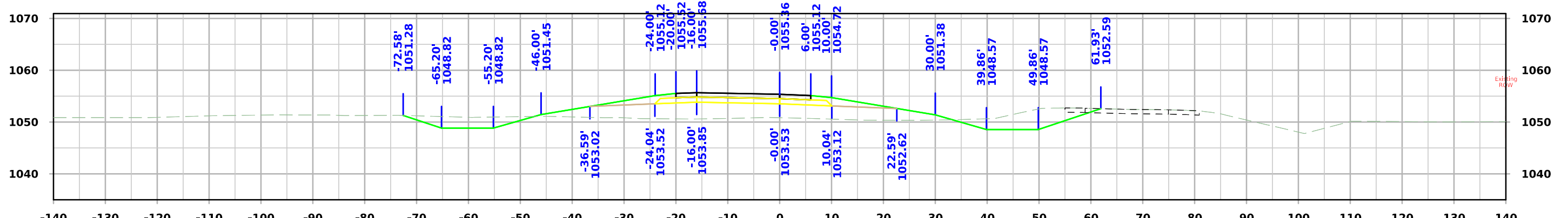
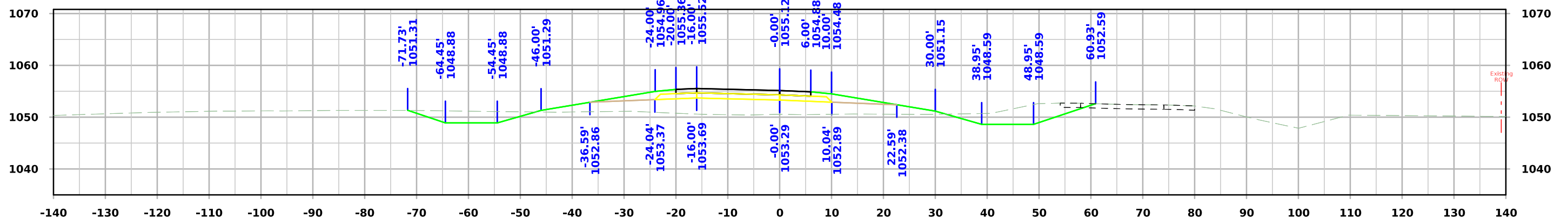
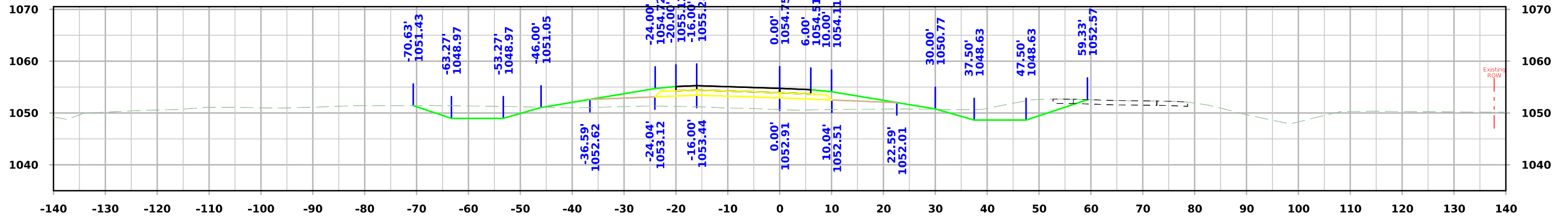

IA 175 Ramp D

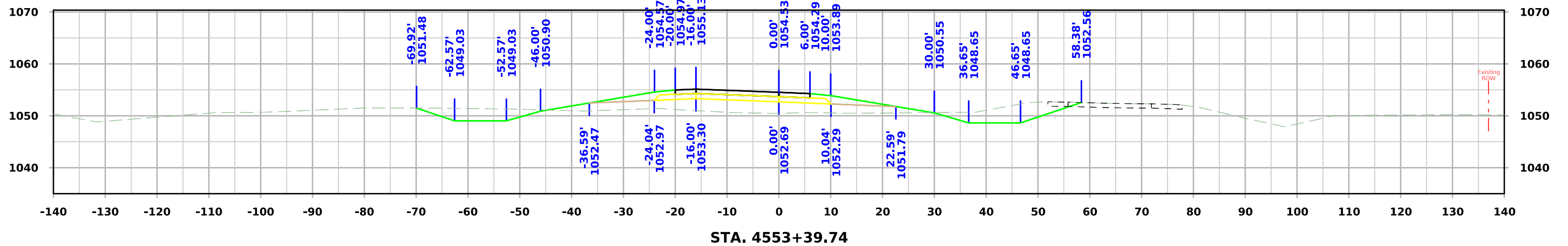
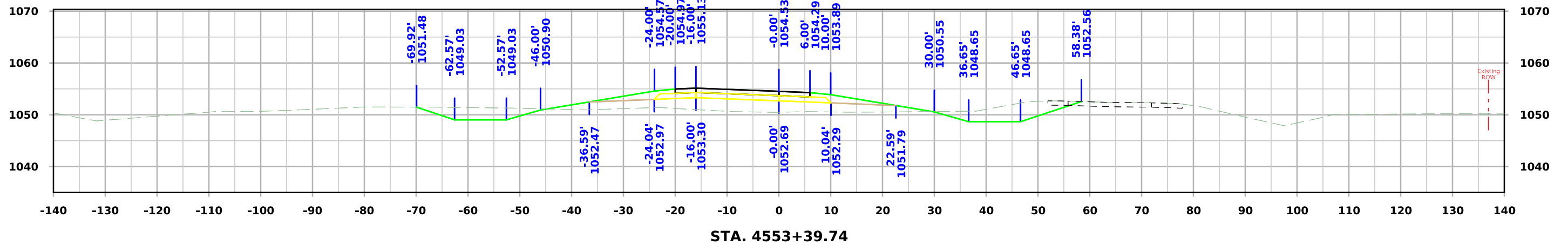
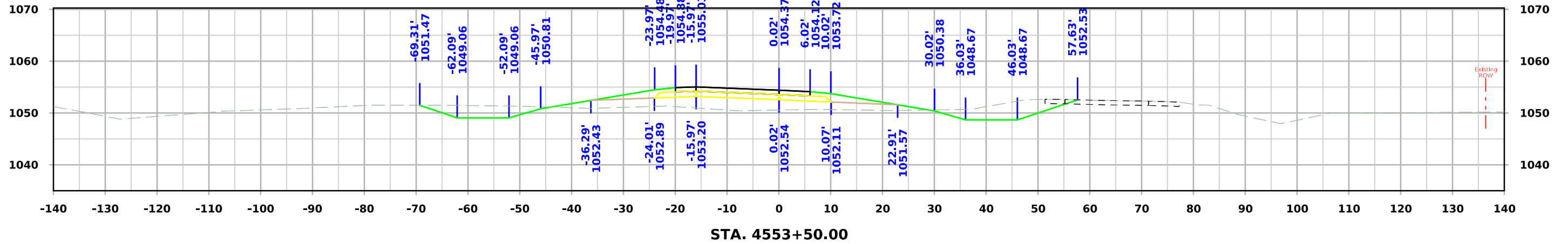

IA 175 Ramp D

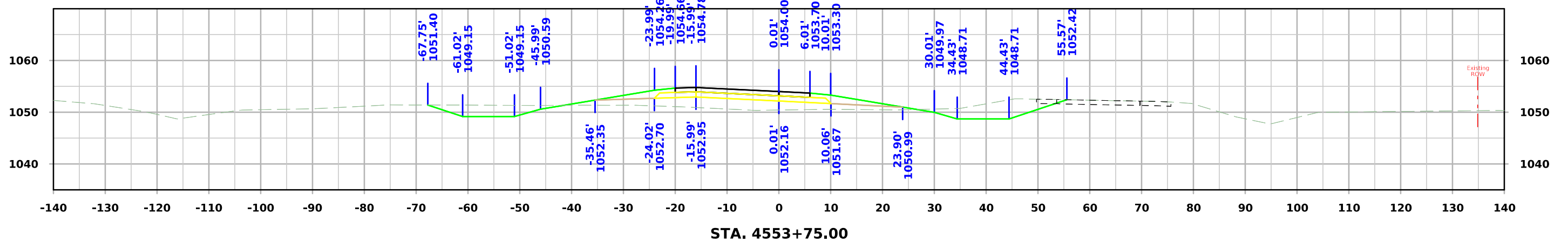
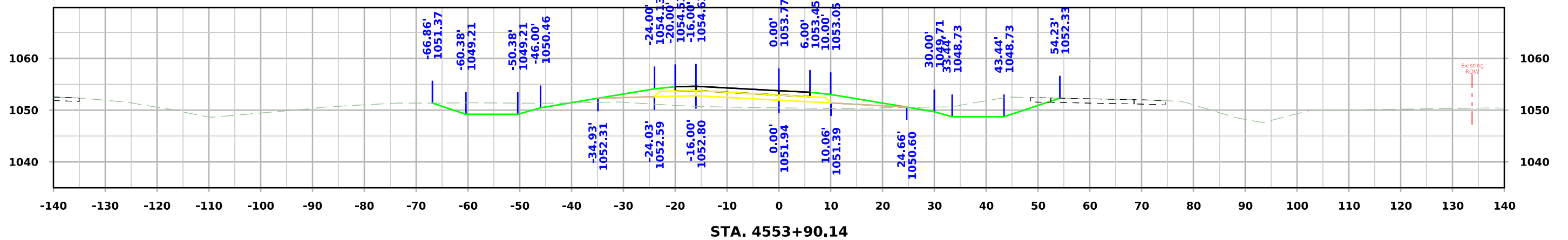
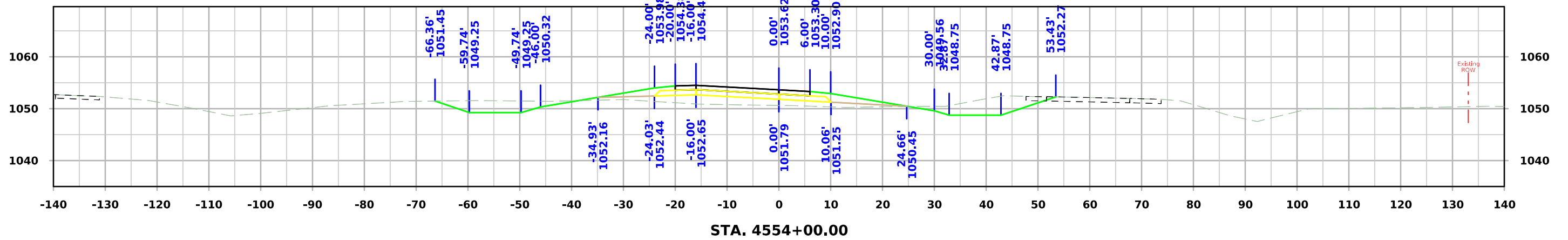

IA 175 Ramp D

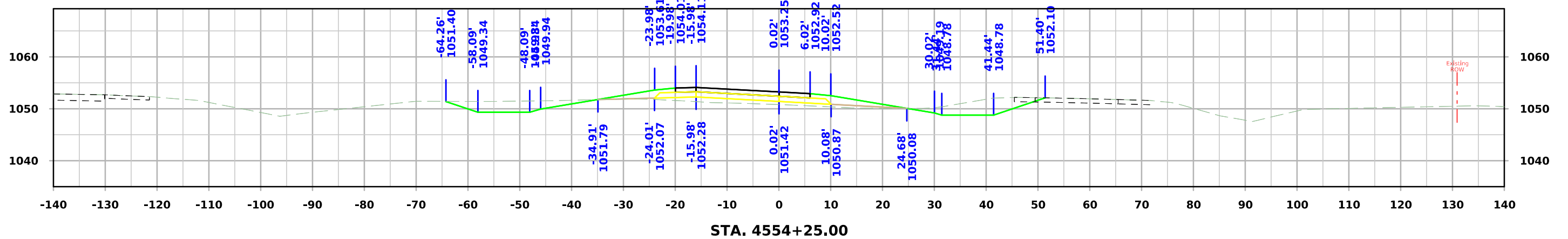
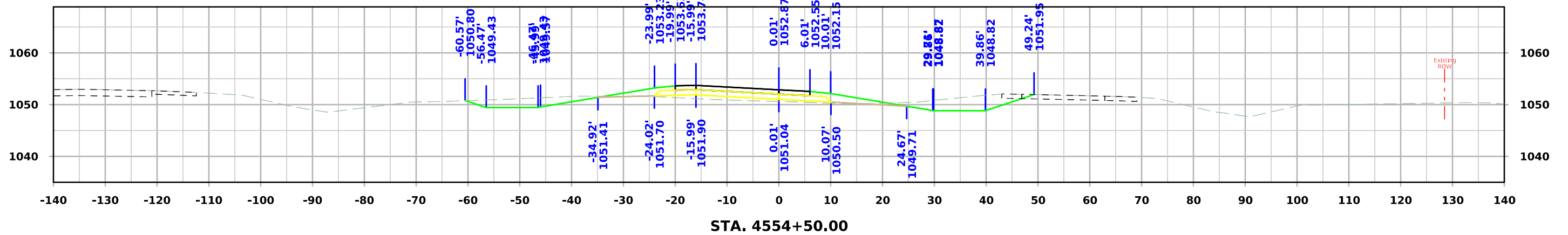
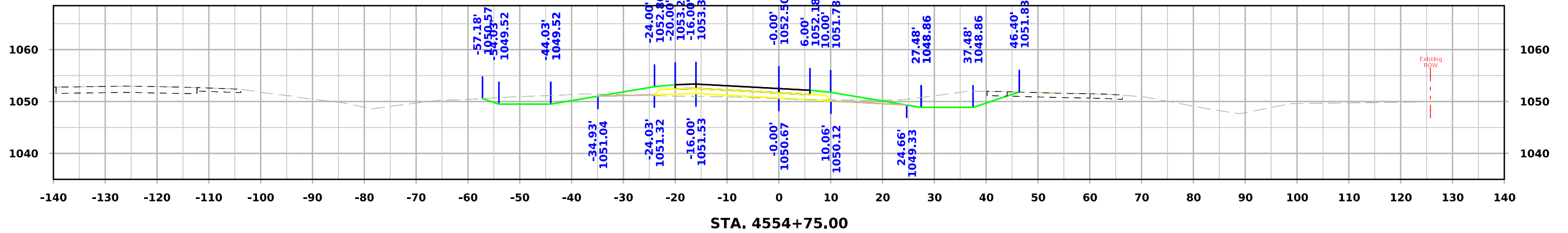

IA 175 Ramp D

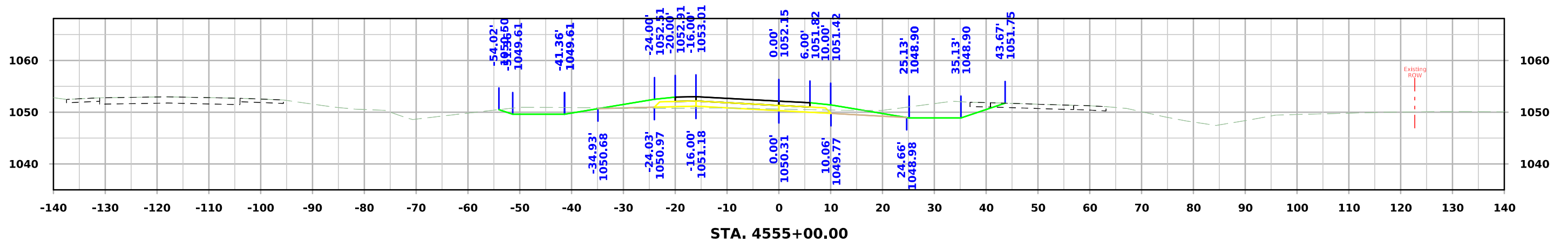
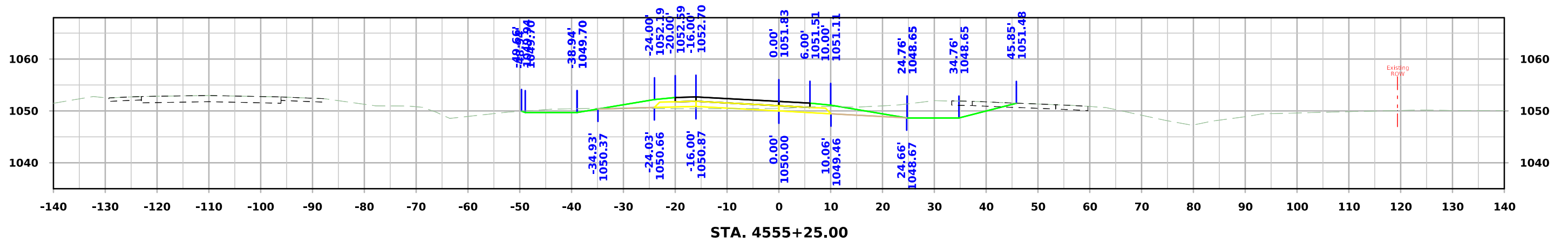
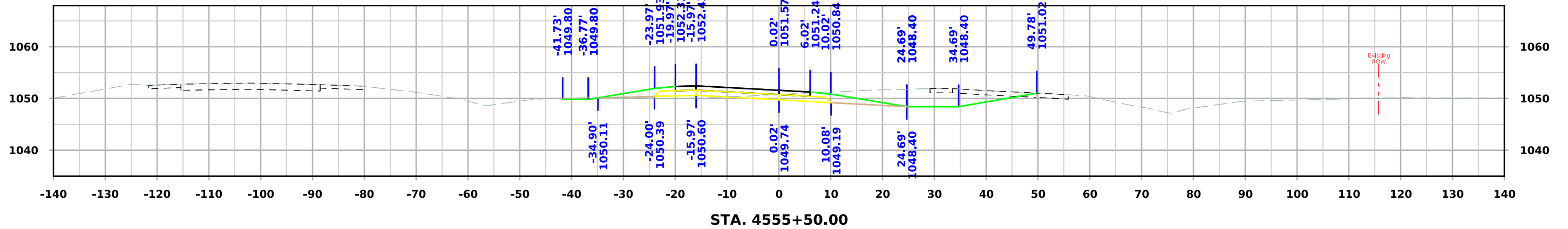

IA 175 Ramp D

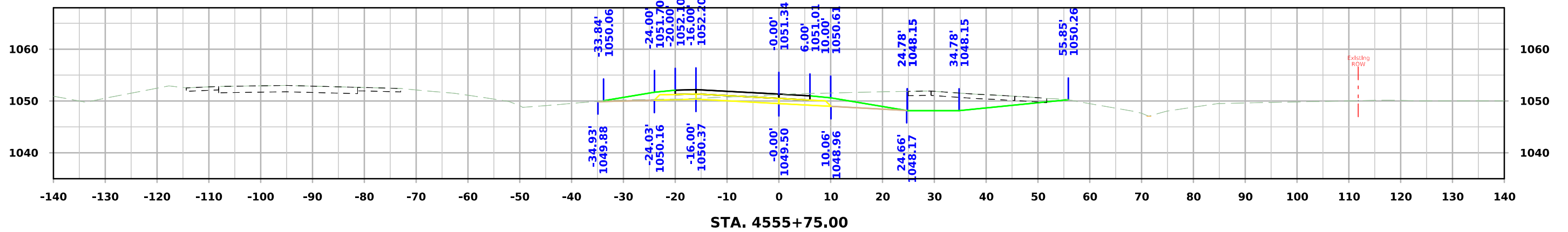
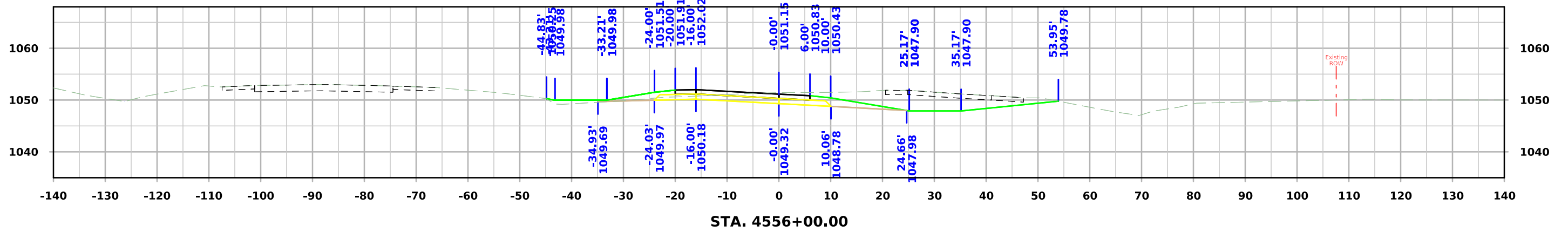
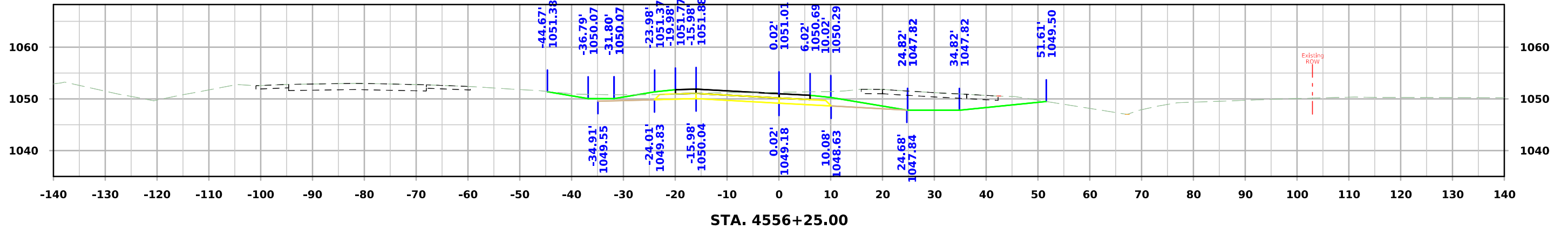

IA 175 Ramp D

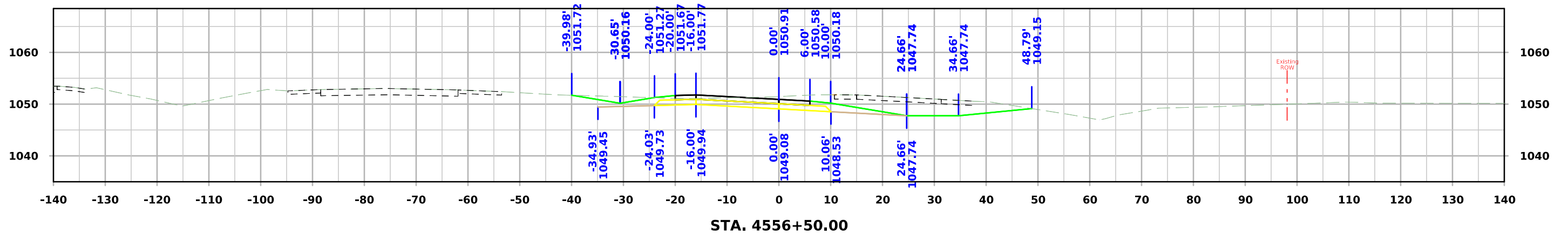
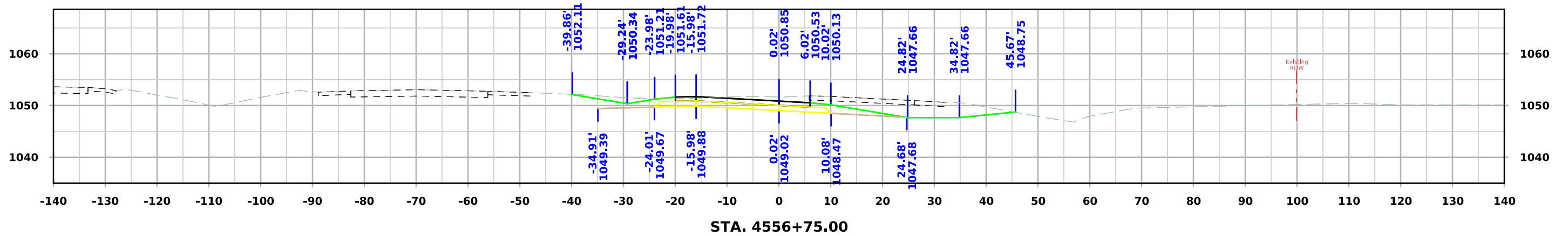
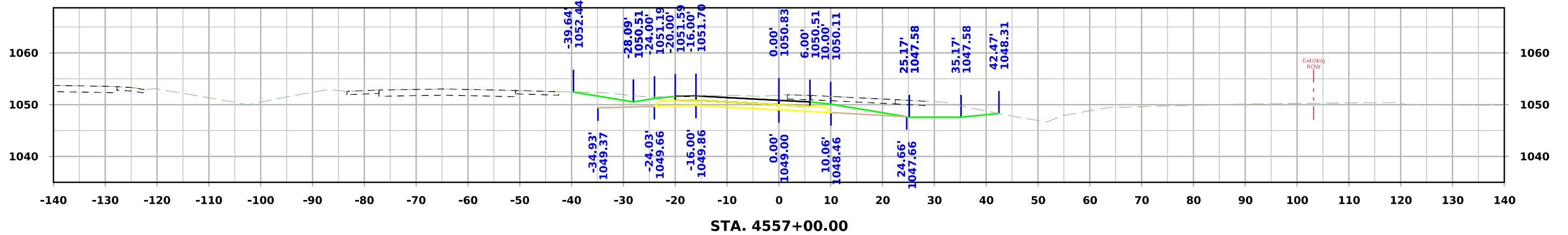

IA 175 Ramp D

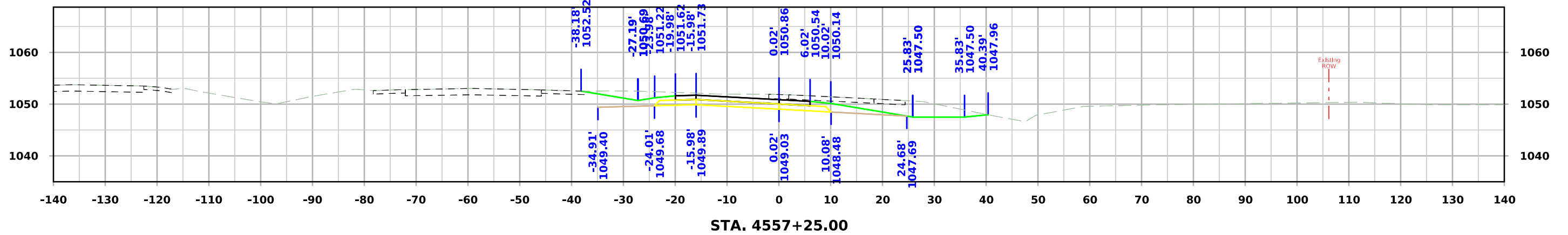
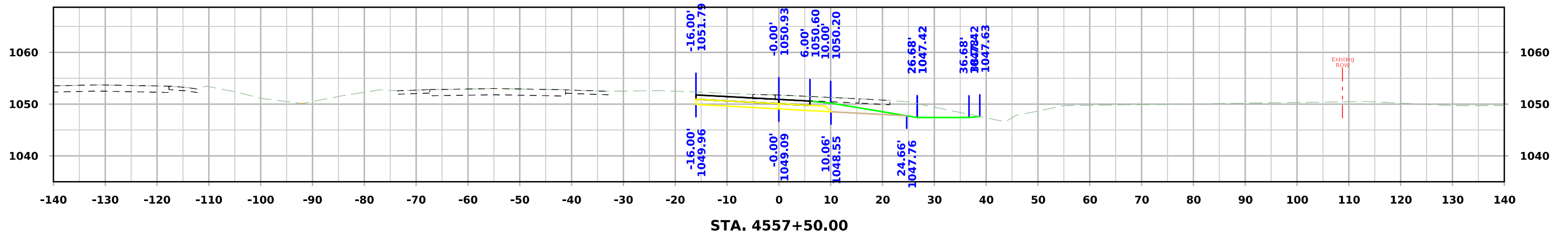
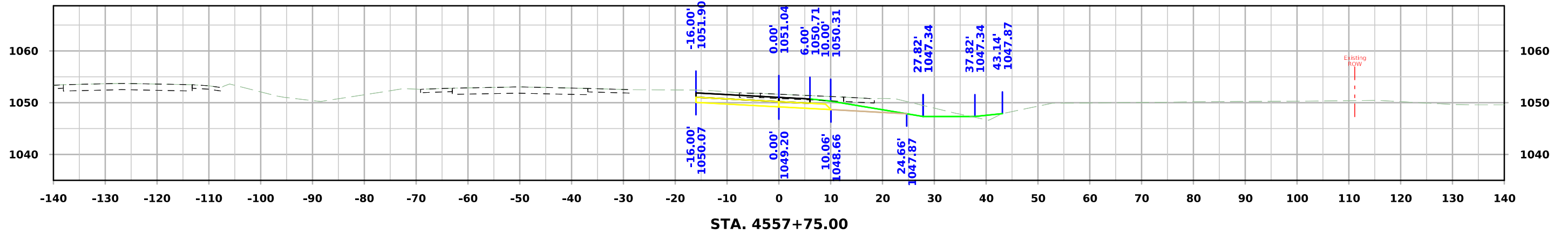

IA 175 Ramp D

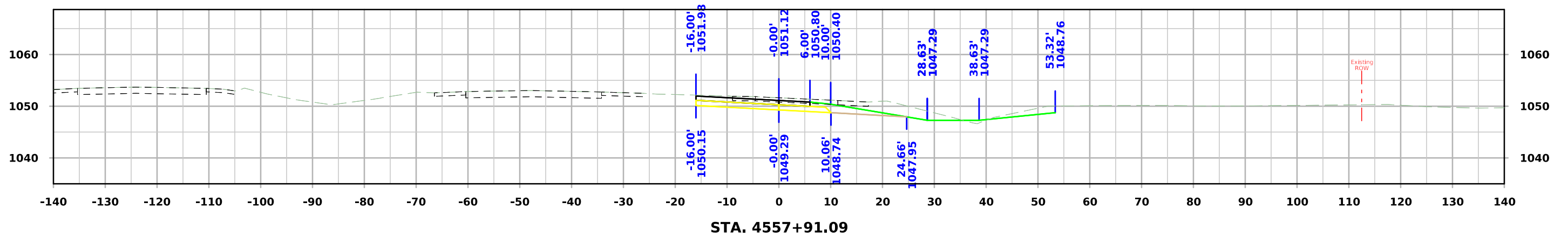

STA. 4557+91.09

Ramp A

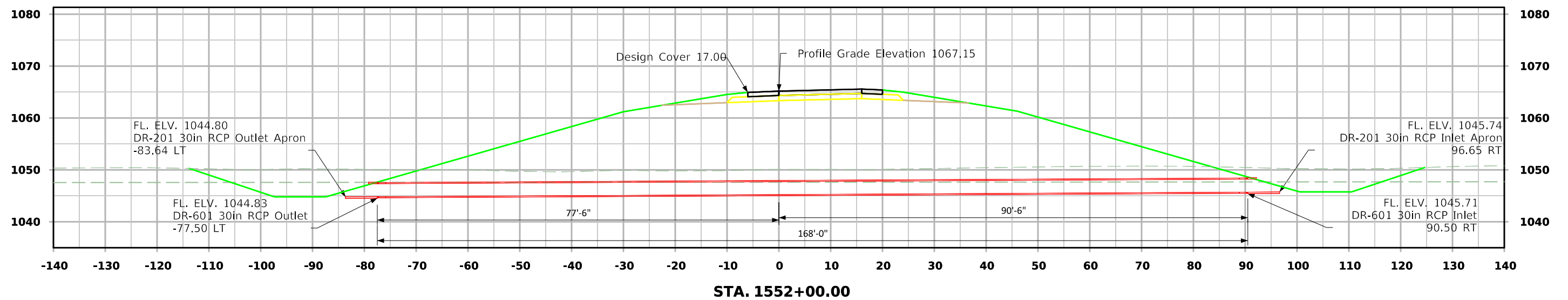

Ramp D

