

No.	DESCRIPTION
<b>INDEX OF SHEETS</b>	
<b>A Sheets</b>	<b>Title Sheets</b>
A.1	Title Sheet
A.2	Location Map Sheet
<b>B Sheets</b>	<b>Typical Cross Sections and Details</b>
B.1 - 2	Typical Cross Sections and Details
<b>D Sheets</b>	<b>Mainline Plan and Profile Sheets</b>
* D.1	Plan & Profile Legend & Symbol Information Sheet
* D.2 - 3	IA 333
<b>G Sheets</b>	<b>Survey Sheets</b>
G.1 - 3	Reference Ties and Bench Marks
G.4 - 5	Horizontal Control Tab. for Roadway Alignments
<b>J Sheets</b>	<b>Traffic Control and Staging Sheets</b>
J.1	Traffic Control Plan
<b>M Sheets</b>	<b>Levee Sheets</b>
<b>MB Sheets</b>	<b>Levee Typical Cross Sections and Details</b>
MB.1 - 6	Levee Typical Cross Sections and Details
<b>ME Sheets</b>	<b>Levee Plan and Profile Sheets</b>
* ME.1	Levee Plan & Profile Legend & Symbol Information Sheet
* ME.2 - 3	Ditch 6 Levee Plan and Profile
<b>MG Sheets</b>	<b>Levee Survey Sheets</b>
MG.1 - 2	Horizontal Control Tab. for Levee Alignments
<b>MU Sheets</b>	<b>Levee Detail Sheets</b>
* MU.1 - 3	Levee Entrance Plan and Profile
* MU.4 - 5	Temporary Ring Levee Plan and Profile
<b>MX Sheets</b>	<b>Levee Cross Sections</b>
* MX.1	Levee Cross Sections Legend & Symbol Information Sheet
* MX.2 - 8	Ditch 6 Levee Cross Sections
* MX.9 - 17	Ditch 6 Levee Entrance Cross Sections
* MX.18 - 24	Temporary Ring Levee Cross Sections
<b>V Sheets</b>	<b>Culvert Plat Plans</b>
V.1 - 2	Culvert Plat Plans
<b>W Sheets</b>	<b>Mainline Cross Sections</b>
* W.1	Cross Sections Legend and Symbol Information Sheet
* W.2 - 15	Mainline Cross Sections
	* Color Plan Sheets

H Sheets



PLANS OF PROPOSED IMPROVEMENT ON THE  
**PRIMARY ROAD SYSTEM**  
**FREMONT COUNTY**  
**PCC Pavement - Grade and Pave**  
IA-333 from BNSF RR to 0.6 mi East of I-29

SCALES: As Noted

Refer to the Proposal Form for list of applicable specifications.

Value Engineering Saves. Refer to Article 1105.14 of the Specifications.



For Project Location Map  
Refer to Sheet A.2

DESIGN DATA RURAL			
2019	AADT	1460	V.P.D.
20	--	AADT	-- V.P.D.
20	--	DHV	-- V.P.H.
	TRUCKS	11.1	%
	Total		
	Design ESALs	--	

INDEX OF SEALS		
SHEET NO.	NAME	TYPE
A.1	William Wegner	Primary Signature Block

# PRELIMINARY PLANS

Subject to change by final design.

## D5 PLAN - Date: July 13, 2022

REVISIONS

TOTAL

70

PROJECT IDENTIFICATION NUMBER

22-36-333-010

PROJECT NUMBER

STP-333-1(030)--2C-36

R.O.W. PROJECT NUMBER

STPN-333-1(030)--2J-36

STA 12+00.00  
BEGIN CONSTRUCTION  
MP 0.41

STA 26+50.00  
END CONSTRUCTION  
MP 0.68

FREMONT CO.  
(IOWA)

OTOE CO.  
(NEBRASKA)

ATCHISON CO.  
(MISSOURI)

MISSOURI  
RIVER

T-67N

R-42W

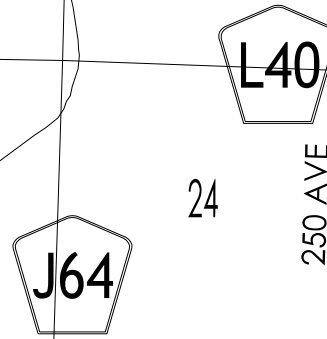

333

HAMBURG

POP.  
1187

BNSF RAILWAY

BLUFF RD

SWEDISH RD

Nishnabotna

300 ST

310 ST

300 ST

297 ST

305 ST

287 AVE

308 ST

26

25

30

29

28

27

26

35 240 AVE

36 250 AVE

31 322 ST

315 ST

265 AVE

33

34

35

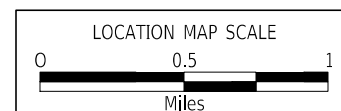
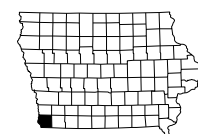

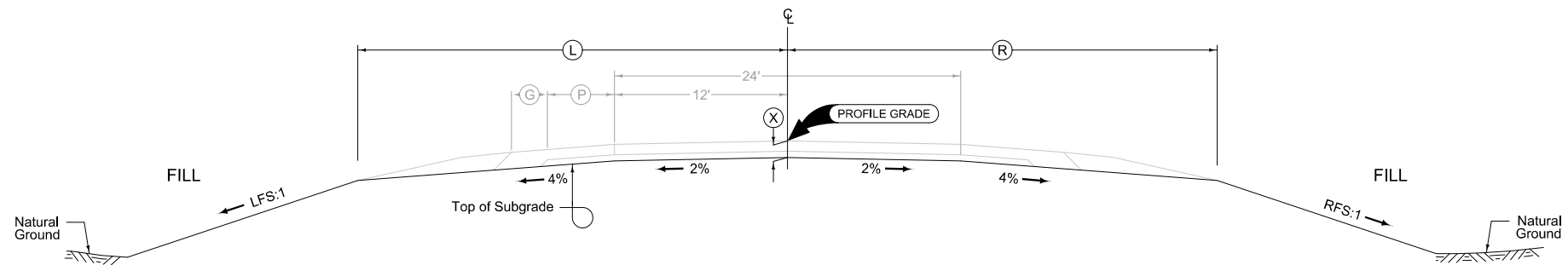

**2 LANE GRADING  
STA 12+00.00 TO STA 21+00.00**

Normal section shown may be modified appropriately in areas of super-elevated curves or other locations specifically designated by the Engineer.

See plan & profile sheets and cross sections for additional details of ditches and backslopes.

LOCATION		DIMENSIONS					
ROAD IDENTIFICATION	STATION TO STATION		(L) Feet	(R) Feet	(X) Inches	LFS	RFS
IA-333	12+00.00	14+00.00	23.97 - 34.83	23.97 - 30.55	21	①	①
IA-333	14+00.00	24+80.00	23.97	23.97	21	3	3
IA-333	24+80.00	25+30.00	23.97 - 26.58	23.97	21	3 - 4	3
IA-333	25+30.00	26+50.00	26.58 - 34.50	23.97	21	①	3

① Refer to Cross Sections for additional details of varying foreslopes and subgrade widths.

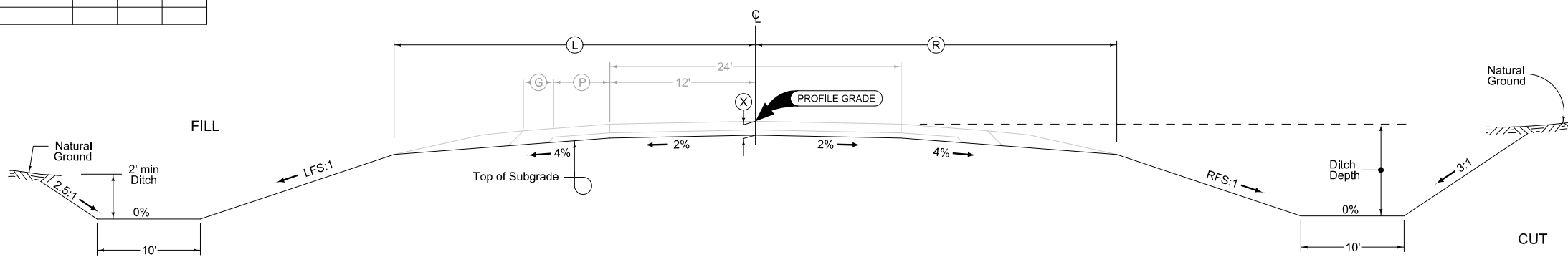

**2 LANE GRADING  
STA 21+00.00 TO STA 26+50.00**

Normal section shown may be modified appropriately in areas of super-elevated curves or other locations specifically designated by the Engineer.

See plan & profile sheets and cross sections for additional details of ditches and backslopes.

**IA-333 GRADING**

**Full Depth PCC Combination Shoulder**

Shoulder Jointing:  
 Longitudinal joint: L-2 or KT-2  
 Transverse joints: C at 17' spacing

		2_C_FullPCC_04-21-20	
STATION TO STATION		(P) Feet	(G) Feet
12+00.00	26+50.00	4	2

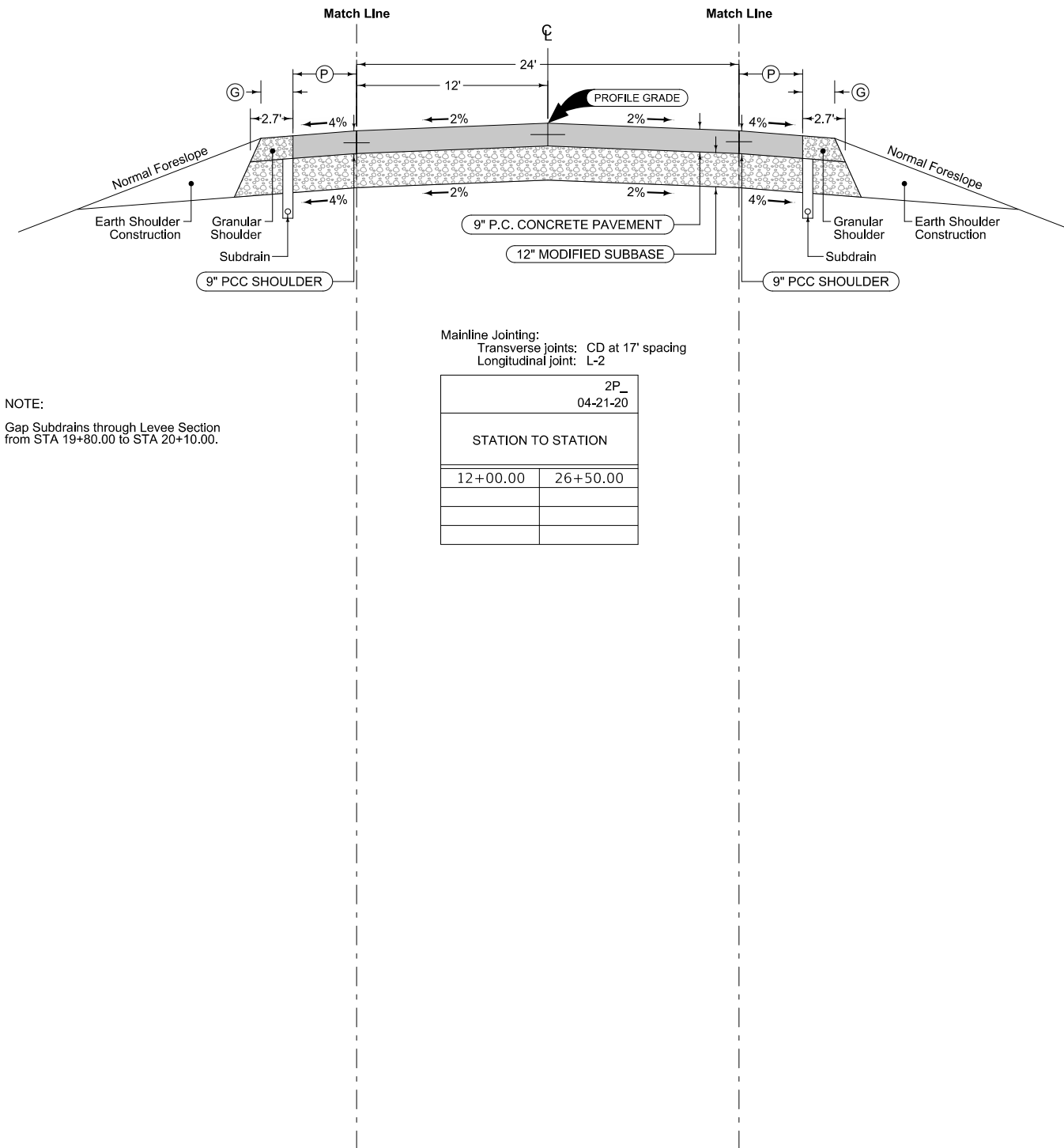

Mainline Jointing:  
 Transverse joints: CD at 17' spacing  
 Longitudinal joint: L-2

2P_04-21-20	
STATION TO STATION	
12+00.00	26+50.00

NOTE:  
 Gap Subdrains through Levee Section  
 from STA 19+80.00 to STA 20+10.00.

**Full Depth PCC Combination Shoulder**

Shoulder Jointing:  
 Longitudinal joint: L-2 or KT-2  
 Transverse joints: C at 17' spacing

		2_C_FullPCC_04-21-20	
STATION TO STATION		(P) Feet	(G) Feet
12+00.00	26+50.00	4	2

Refer to Plan and Profile sheets and Cross Sections  
 for additional details on sideroad returns.

See Tab 100-24 or 100-25 for pavement quantities.  
 See Tab 112-9 for shoulder quantities.

**IA-333 PAVING**

### SURVEY SYMBOLS

- Interstate Highway Symbol
- U.S. Highway Symbol
- Iowa Highway Symbol
- County Road Highway Symbol
- Evergreen Tree
- Deciduous Tree
- Fruit Tree
- Shrub (Bushes)
- Timber
- Hedge
- Stump
- Swamp
- Rock Outcrop
- Broken Concrete
- Revetment (Rip Rap)
- Cemetery
- Grave
- Cave
- Sink Hole
- Board Fence
- Chain Link or Security Fence
- Wire Fence
- Terrace
- Earth Dam or Dike (Existing)
- Tile Outlet
- Edge of Water
- Existing Drainage
- Right of Way Rail or Lot Corner
- Concrete Monument
- Well
- Windmill
- Beehive Intake
- Existing Intake
- Existing Utility Access (Manhole)
- Fire Hydrant
- Water Hydrant (Rural)

- Septic Tank
- Cistern
- L.P. Gas Tank (No Footing)
- Underground Storage Tank
- Latrine
- Satellite TV Dish
- Water Hook Up
- Radio Tower
- Tower Anchor
- Guardrail (Beam or Cable)
- Guard Post (one or two)
- Guard Post (over two)
- Filler Pipe
- Gas Valve
- Water Valve
- Speed Limit Sign
- Mile Marker Post
- Sign
- Traffic Signal Control Box
- Rail Road Signal Control Box
- Telephone Switch Box
- Electric Box

### UTILITY LEGEND

#### SURVEYED UTILITY OWNER SYMBOLS

Sub-Surface Utility Mapping Quality Level is in accordance with CI/ASCE 38-02 Standard Guidelines for the Collection and Depiction of Existing Subsurface Utility Data.

Remark Abbreviations  
 QLA Quality Level A Highest guideline quality level  
 QLD Quality Level D Lowest guideline quality level

- FOID, Fiber Optic CenturyLink - Quality D
- GLID, Gas Line Black Hills Energy - Quality D
- PPA, Power Pole MidAmerican Electric

### PLAN VIEW COLOR LEGEND OF PLAN AND PROFILE SHEETS

LINEWORK		Design Color No.	
Green	(2)		Existing Topographic Features and Labels
Blue	(1)		Proposed Alignment, Stationing, Tic Marks, and Alignment Annotation
Magenta	(5)		Existing Utilities
SHADING		Design Color No.	
Lavender	(9)		Temporary Pavement Shading
Yellow	(4)		Proposed Pavement Shading
Orange	(6)		Proposed Granular Shading
Yellow	(68)		Proposed Shoulder, Paved Full Depth
Yellow	(132)		Proposed Shoulder, Paved Partial Depth
Orange	(70)		Proposed Shoulder, Granular
Yellow	(220)		Proposed Entrance, Paved
Orange	(134)		Proposed Entrance, Granular
Red	(3)		Proposed Structures

### PROFILE VIEW COLOR LEGEND OF PLAN AND PROFILE SHEETS

LINEWORK		Design Color No.	
Green	(2)		Existing Ground Line Profile
Blue	(1)		Proposed Profile and Annotation
Magenta	(5)		Existing Utilities
Blue, Light	(230)		Proposed Ditch Grades, Left
Black	(0)		Proposed Ditch Grades, Median
Rust	(14)		Proposed Ditch Grades, Right

- Reference Point
- Station
- Survey Line
- Section Corner
- Ground Line Intercept
- Saw Cut
- Guardrail
- Trench Drain
- HighTension Cable Guardrail
- Sheet Pile

### RIGHT-OF-WAY LEGEND

- Proposed Right-of-Way
- Existing Right of Way
- Existing and Proposed Right-of-Way
- Easement and Existing Right-of-Way
- Easement (Temporary)
- Easement
- Access Control
- Property Line

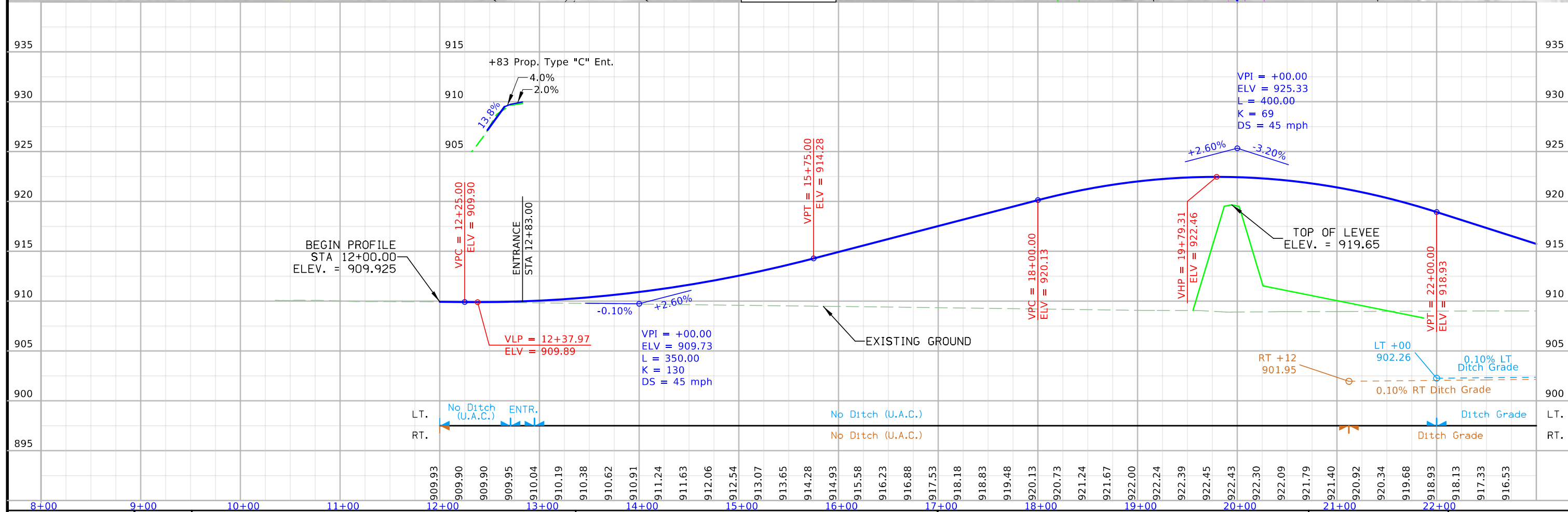
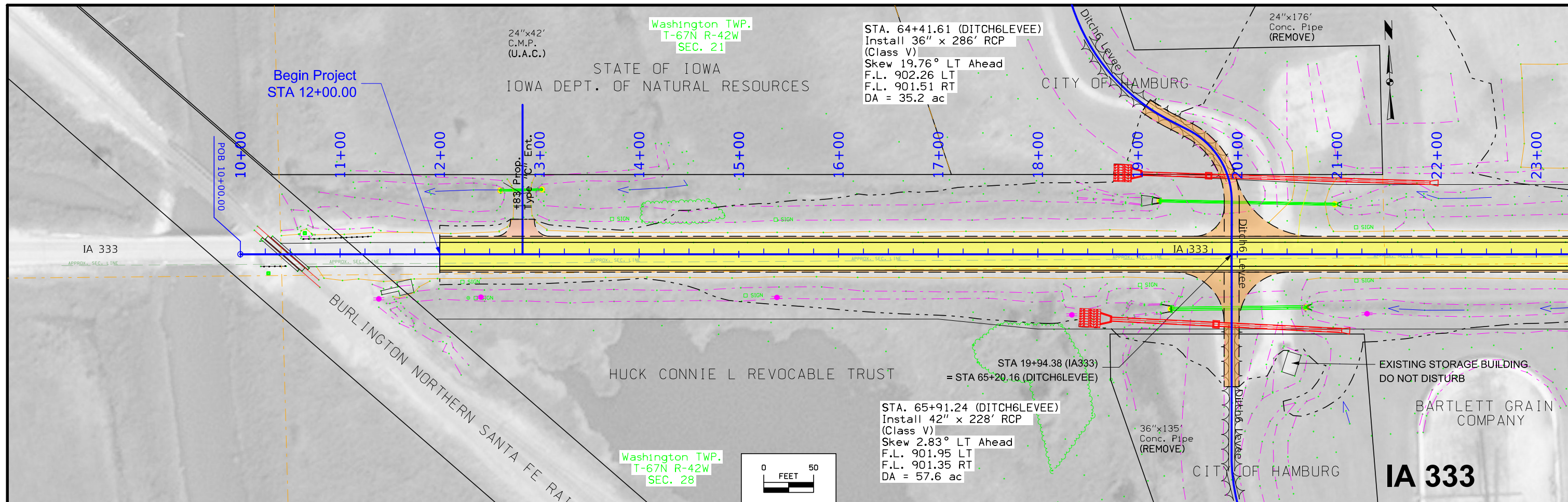

FILE NO.	ENGLISH	DESIGN TEAM IOWA DOT / HDR	FREMONT COUNTY	PROJECT NUMBER	STP-333-1(030)--2C-36	SHEET NUMBER	D.2
----------	---------	----------------------------	----------------	----------------	-----------------------	--------------	-----



Survey Information

**SURVEY INDEX**

**County: Fremont**  
**PIN: 22-36-333-010**  
**Project Number: STP-333-1(30)—2C-36**  
**Location: BNSF RR to 0.6 mi E of I-29**  
**Type of Work: Grade and Pavement- Unspecified**  
**Project Directory: 3633301022**

**Alignment Information**

Alignment was provided by the District 4 ROW office

**Utility Information**

For logging data and other utility details see Utility Survey and Ownership Report in the Utility folder of the PrelimSurvey project directory.

**Survey Personnel**

Paul Harry – Survey Party Chief  
Scott Liddell – Survey Party Chief  
Brett Lausen – Assistant Survey Party Chief

**Date(s) of Survey**

Begin Date 10/18/2021  
End Date 11/08/2021

**General Information**

Measurement units for this survey are US survey feet. This survey is for Hwy 333 at the city of Hamburg levee system.

**Project Control**

(RTN Example)  
Nearby Iowa Real Time Network reference stations were utilized to obtain horizontal and vertical control on primary project control points. Two or more five-minute observations were taken with appropriate time spans between and used in a weighted average to obtain final coordinate values. For additional details of the control survey, contact the Preliminary Survey department.

**PROJECT DATUM: NAD83(2011) EPOCH 2010.00**  
**VERTICAL DATUM: NAVD88**  
**COORDINATE SYSTEM: IOWA REGIONAL COORDINATE SYSTEM ZONE 6**  
**GEOID MODEL: 2012bu2**



## CONTROL POINT VICINITY MAP

This map is a guide to the vicinity of the primary project control points. Primary control is for use with RTK base stations and for RTN validation. Future surveys will use primary project control to establish temporary control as needed for construction or other surveying applications.



HORIZ. DATUM: NAD83(2011) EPOCH 2010.00

VERT. DATUM: NAVD88

1a. Regional Coordinate System Zone 06

Coordinate listing from next sheet will be used with 1aRTN for monument recovery. No other reference ties are given.

HORIZONTAL AND VERTICAL PROJECT CONTROL COORDINATE LISTING

HORIZ. DATUM: NAD83(2011) EPOCH 2010.00

VERT. DATUM: NAVD88

1a. Regional Coordinate System Zone 06  
Project Control Marks are Bench Marks

Point Name	Northing	Easting	Elevation	Feature Definition-Description
HAM2	6731388.421	16512874.37	908.284	CP FD NGS MON 1.0 MILES NW ALONG RR RD FROM THE INTERSECTION OF RR RD AND HWY 333 MONUMENT IS 42FT SW OF CL RR RD AND 38FT NE OF CL RR TRACKS
27B	6727795.404	16515152.65	931.84	FENO FD FENO MONUMENT 290FT W OF THE INTERSECTION OF I-29 AND HWY 333 MONUMENT IS 107FT W OF NW COR BRG 25FT N OF CL 333 AND 4FT N OF WITNESS POST
36333008	6727752.983	16519267.35	905.121	CP FD IP WITH RED PLASTIC CAP 0.1 MILES W ALONG HWY 333 FROM THE INTERSECTION OF HWY 333 AND A ST IN HAMBURG MONUMENT IS 54FT N OF CL 333 AND 87 FT N OF STATION MARKER 35

**NOTE:**

The first two digits in the control point name refer to the county number.  
The next 3 digits refer to the highway number.  
The next 3 digits refer to the highway milepost.  
The last digit refers to the distance from the referenced milepost to the nearest tenth of a mile.





NO ACCESS RIGHTS ARE TO BE ACQUIRED ON THIS PROJECT.

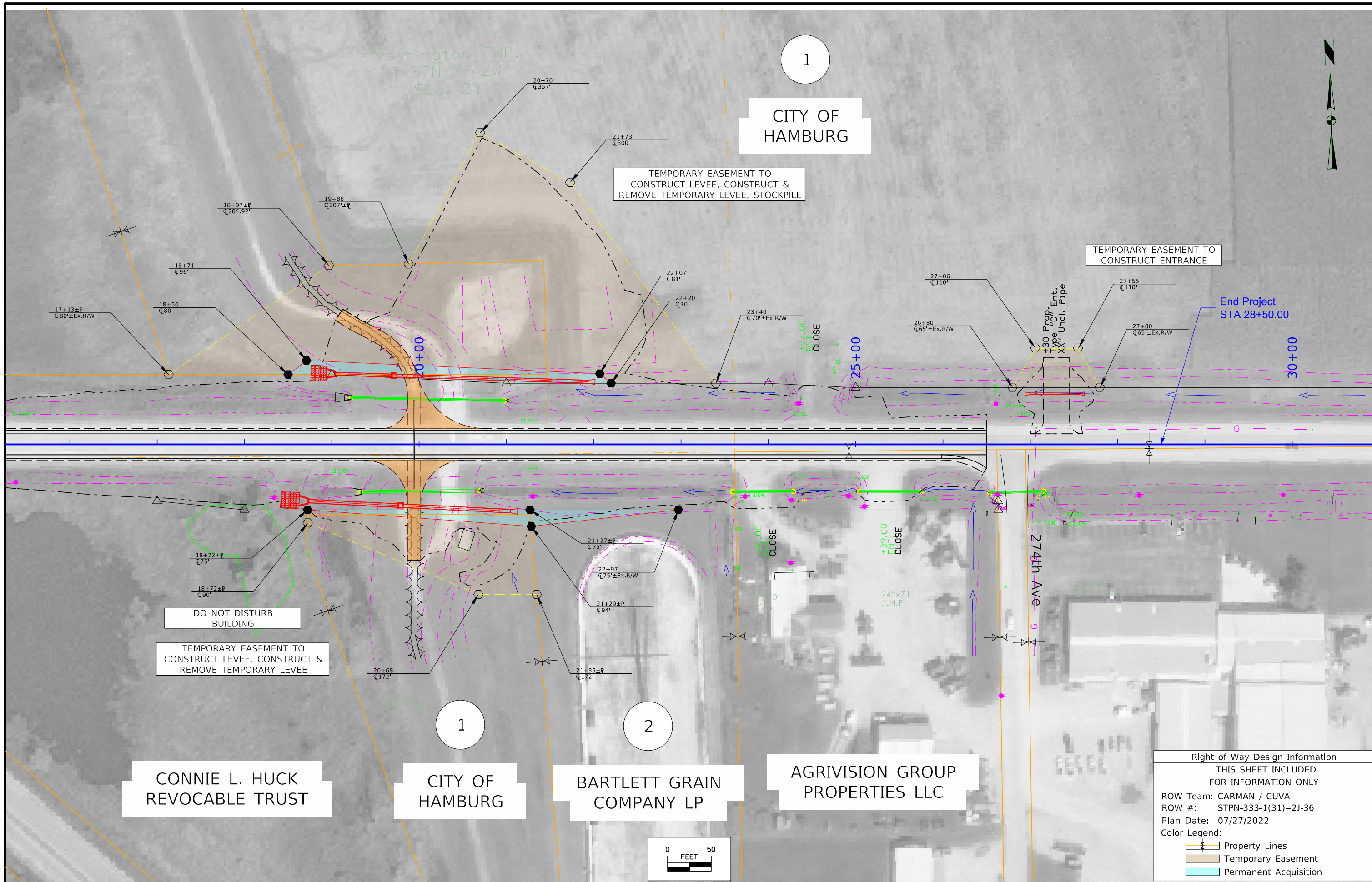

Washington TWP.  
T-67N R-42W  
SEC. 21

1  
CITY OF  
HAMBURG

TEMPORARY EASEMENT TO  
CONSTRUCT LEVEE, CONSTRUCT &  
REMOVE TEMPORARY LEVEE, STOCKPILE

TEMPORARY EASEMENT TO  
CONSTRUCT ENTRANCE

End Project  
STA 28+50.00

DO NOT DISTURB  
BUILDING

TEMPORARY EASEMENT TO  
CONSTRUCT LEVEE, CONSTRUCT &  
REMOVE TEMPORARY LEVEE

CONNIE L. HUCK  
REVOCABLE TRUST

1  
CITY OF  
HAMBURG

2  
BARTLETT GRAIN  
COMPANY LP

AGRIVISION GROUP  
PROPERTIES LLC

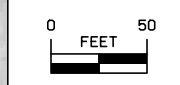

Right of Way Design Information	
THIS SHEET INCLUDED FOR INFORMATION ONLY	
ROW Team:	CARMAN / CUVA
ROW #:	STPN-333-1(31)--21-36
Plan Date:	07/27/2022
Color Legend:	
	Property Lines
	Temporary Easement
	Permanent Acquisition

108-23A  
08-01-08

**TRAFFIC CONTROL PLAN**

Contractor shall not encroach into BNSF Railroad Right of Way.  
Iowa 333 traffic shall be maintained via an off-site detour.

Local Traffic intended for IA-333 westbound or Interstate I-29 access will be detoured using Iowa 333 through the City of Hamburg and northbound using US-275. Traffic will then use Iowa 2 westbound to access I-29. Traffic intended for IA-333 westbound will use I-29 SB and exit at Iowa 333 for westbound access.

Traffic intended for IA-333 eastbound or access to the City of Hamburg from Interstate I-29 will need to exit at the Iowa 2 interchange and travel eastbound. Traffic will then travel southbound on US-275 to the City of Hamburg.

108-26A  
08-01-08

**STAGING NOTES**

STAGE 1:  
Iowa 333 will be closed, and traffic will use an off-site detour.  
Contractor shall construct the temporary ring levee to a height elevation of 911.00.

STAGE 2:  
Once the temporary ring levee is constructed, the contractor shall begin excavating into the existing levee for partial removal of both existing culverts and partial construction of both proposed culverts and their perspective flap gates and sluice gate riser structures. Contractor will then construct the full height compacted cohesive fill Levee to an elevation of 919.65.

STAGE 3:  
Once the full height levee is constructed, the contractor shall remove the temporary ring levee in order to finish the construction of the proposed culverts and removal of the existing culverts. When the proposed culverts are installed, the contractor shall construct the levee seepage berm.

STAGE 4:  
Contractor shall begin construction of Iowa 333 and levee entrances.

STAGE 5:  
End off-site detour and maintain traffic on Iowa 333.

108-25  
10-21-14

**511 TRAVEL RESTRICTIONS**

Route	Direction	County	Location Description	Feature Crossed	Object Type	Maint. Bridge No., Structure ID, or FHWA No.	Type of Restriction	Existing Measurement	Construction Measurement	Construction Measurement as Signed	Projected As Built Measurement	Remarks
			No Travel Restrictions Expected.									

111-01  
04-17-12

**COORDINATED OPERATIONS**

Other work in progress during the same period of time will include the construction of the projects listed. Coordinate operations with those of other contractors working within the same area.

Project	Type of Work
None Provided.	

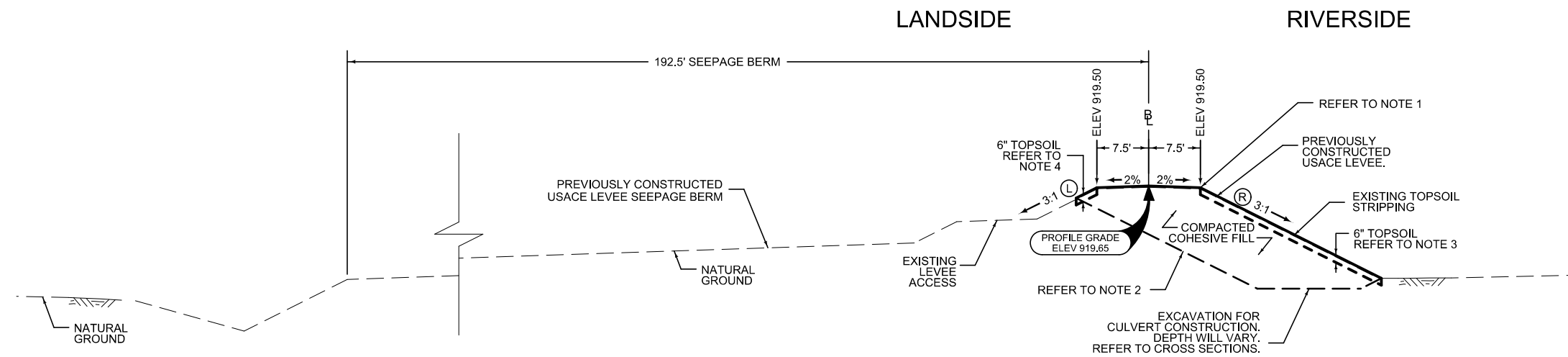

**LEVEE RECONSTRUCTION FOR CULVERT CONSTRUCTION  
(STA 63+30.00 - STA 63+80.00)**

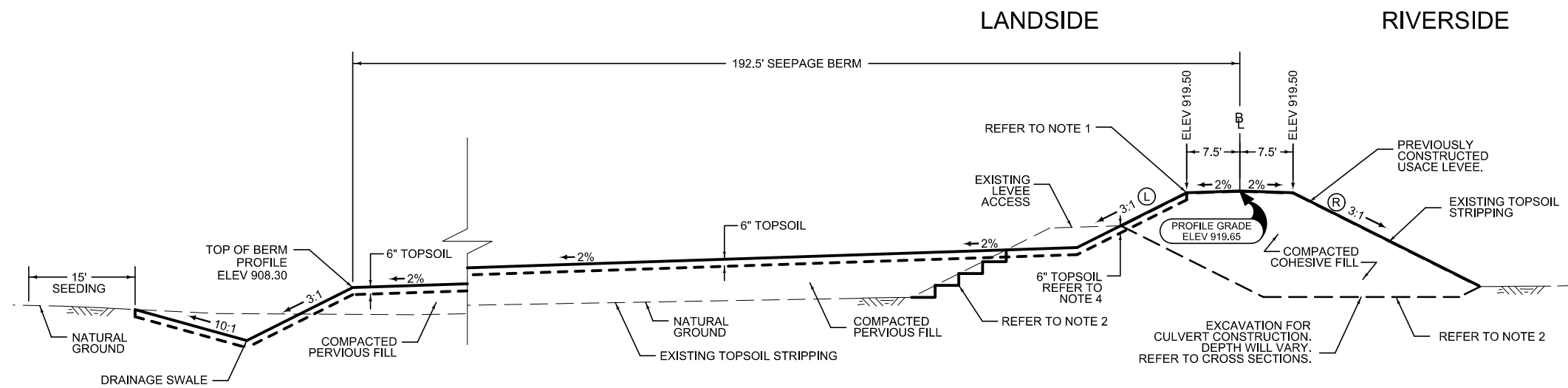

**LEVEE RECONSTRUCTION WITH SEEPAGE BERM  
(STA 63+80.00 - STA 64+44.44)**

**NOTES:**

- 1.) PROPOSED LEVEE ENTRANCE AND LEVEE SURFACING NOT SHOWN. REFER TO LEVEE ENTRANCE TYPICALS FOR GRADING AND LEVEE SURFACING DETAILS.
- 2.) BENCH EXISTING COMPACTED LEVEE EMBANKMENT WITH 1 FOOT MAXIMUM VERTICAL BENCHES.
- 3.) TOPSOIL RIGHT LEVEE FORESLOPE FROM STA 63+30.00 TO STA 63+50.00. REFER TO LEVEE ENTRANCE TYPICALS ON SHEET MB.4 FOR OTHER TOPSOIL LOCATIONS.
- 4.) TOPSOIL LEFT LEVEE FORESLOPE FROM STA 63+30.00 TO STA 64+20.00. REFER TO LEVEE ENTRANCE TYPICALS ON SHEETS MB.4 AND MB.5 FOR OTHER TOPSOIL LOCATIONS.

**DITCH 6 LEVEE  
GRADING**



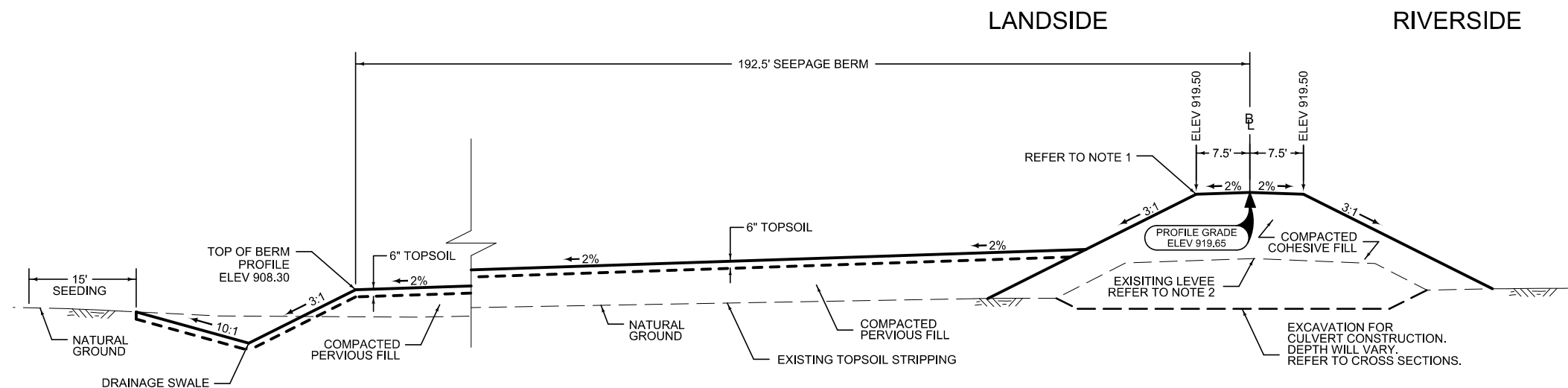

**LEVEE TYPICAL**  
**(STA 64+44.44 - STA 64+70.00)**

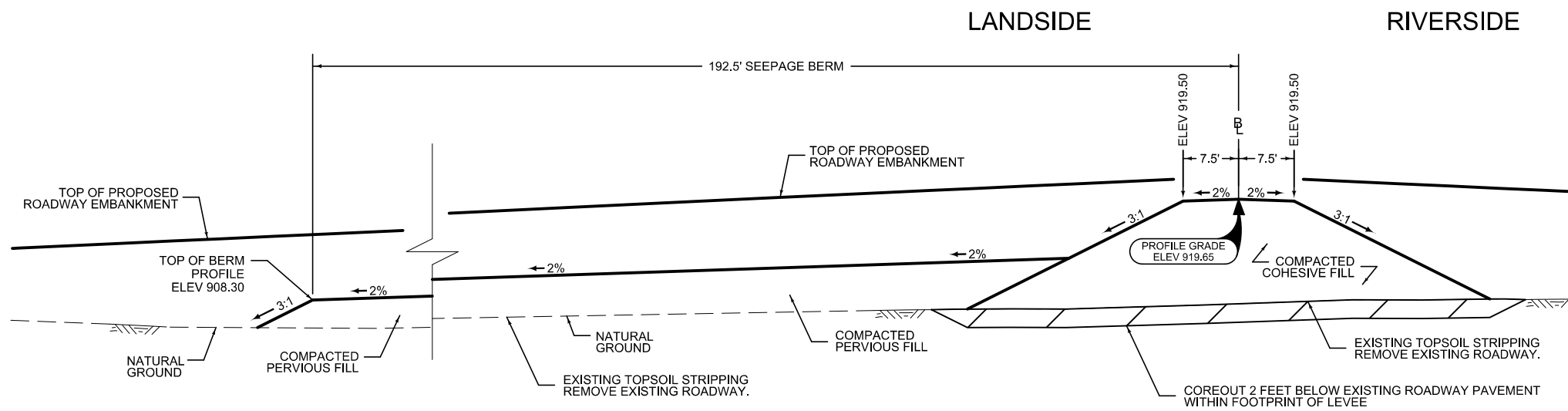

**LEVEE TYPICAL AT ROADWAY EMBANKMENT**  
**(STA 64+70.00 - STA 65+70.00)**

**NOTES:**

- 1.) PROPOSED LEVEE ENTRANCE AND LEVEE SURFACING NOT SHOWN. REFER TO LEVEE ENTRANCE TYPICALS FOR GRADING AND LEVEE SURFACING DETAILS.
- 2.) BENCH EXISTING COMPACTED LEVEE EMBANKMENT WITH 1 FOOT MAXIMUM VERTICAL BENCHES.

**DITCH 6 LEVEE  
 GRADING**

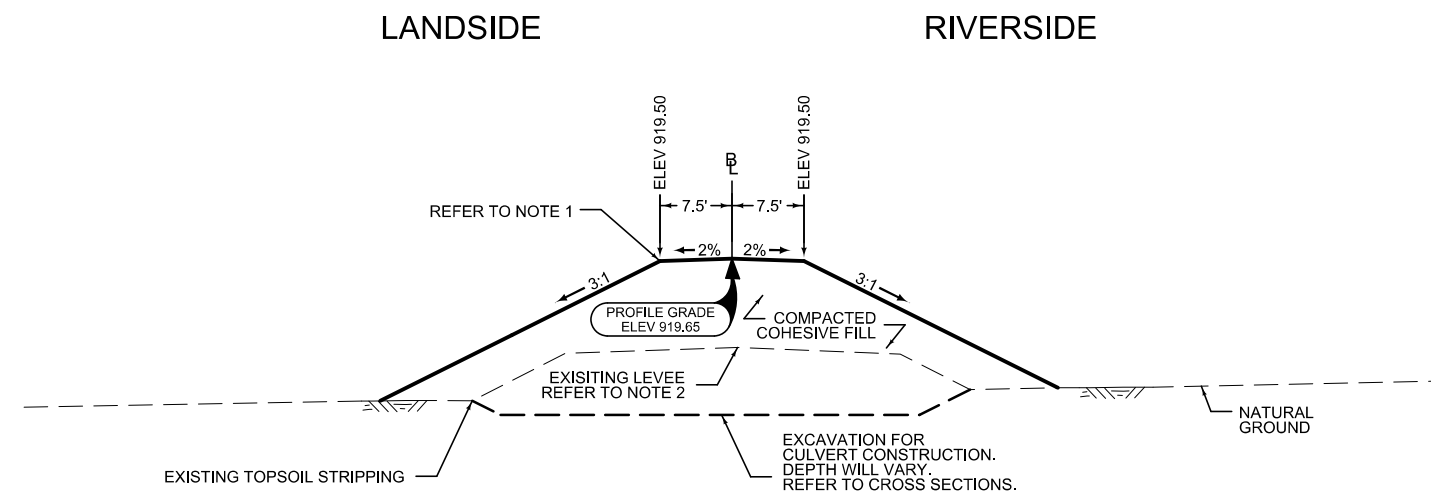

**LEVEE TYPICAL**  
**(STA 65+70.00 - STA 65+95.16)**

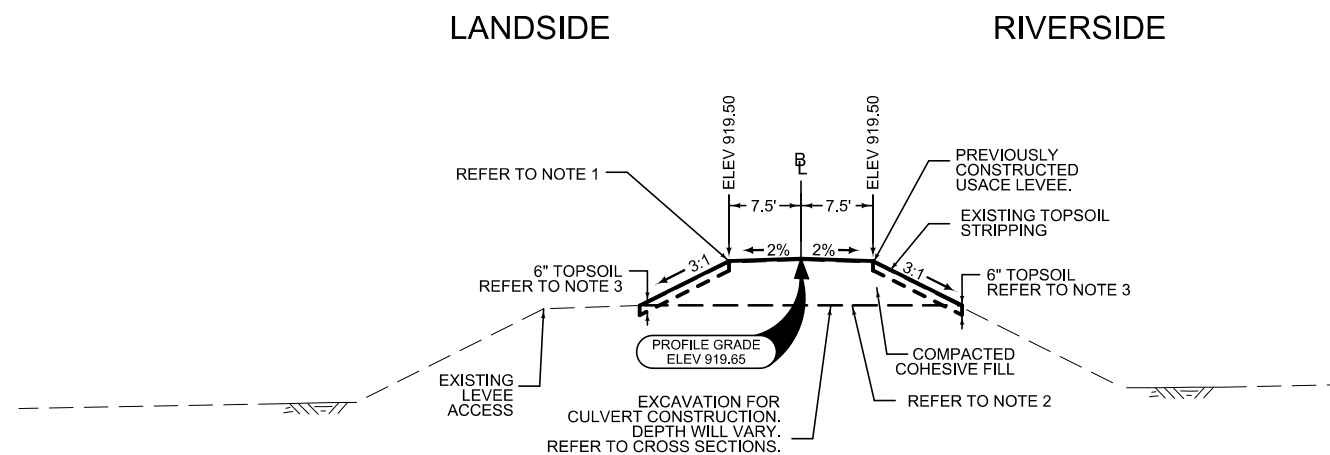

**LEVEE RECONSTRUCTION FOR CULVERT CONSTRUCTION**  
**(STA 65+95.16 - STA 66+53.00)**

NOTES:

- 1.) PROPOSED LEVEE ENTRANCE AND LEVEE SURFACING NOT SHOWN. REFER TO LEVEE ENTRANCE TYPICALS FOR GRADING AND LEVEE SURFACING DETAILS.
- 2.) BENCH EXISTING COMPACTED LEVEE EMBANKMENT WITH 1 FOOT MAXIMUM VERTICAL BENCHES.
- 3.) TOPSOIL RIGHT AND LEFT LEVEE FORESLOPE FROM STA 66+25.00 TO STA 66+53.00. REFER TO LEVEE ENTRANCE TYPICALS ON SHEET MB.6 FOR OTHER TOPSOIL LOCATIONS.

**DITCH 6 LEVEE  
 GRADING**

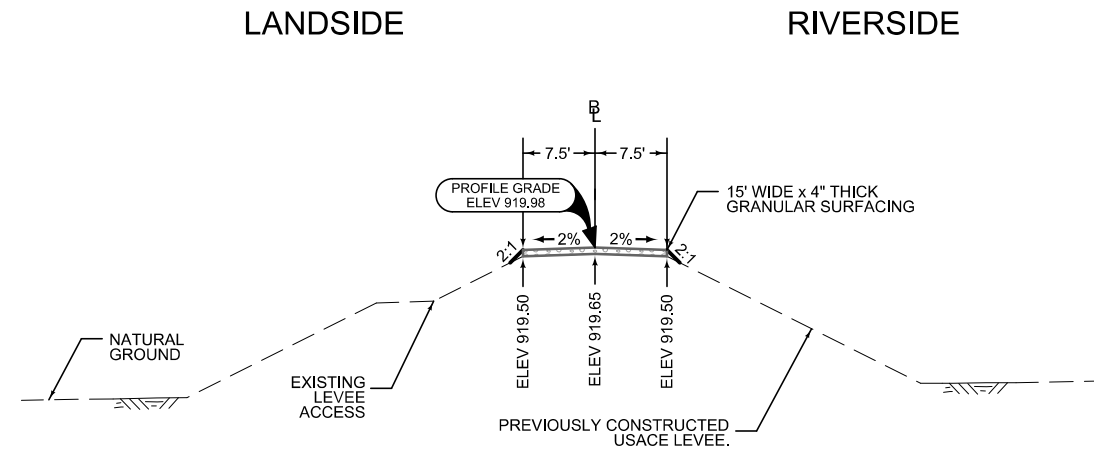

**LEVEE ENTRANCE SURFACING  
(STA 63+30.00 - STA 63+50.00)  
(STA 66+25.00 - STA 66+53.00)**

**DITCH 6 LEVEE ENTRANCE SURFACING**

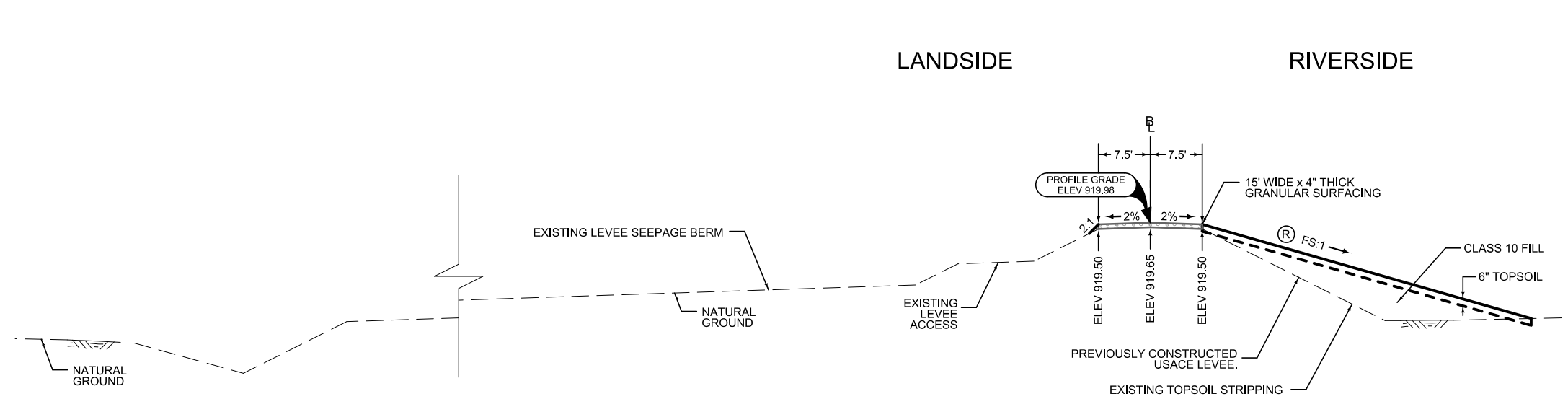

**LEVEE ENTRANCE GRADING AT EXISTING LEVEE  
(STA 63+50.00 - STA 64+20.00)**

**LEVEE ENTRANCE FORESLOPE GRADING**

STATION TO STATION		Ⓡ FS
63+50.00	63+75.00	3 - 8
63+75.00	64+20.00	8

**DITCH 6 LEVEE ENTRANCE GRADING**

**LEEVE ENTRANCE  
FORESLOPE GRADING**

STATION TO STATION		Ⓛ FS
64+20.00	64+44.44	3 - 8

**LEEVE ENTRANCE  
FORESLOPE GRADING**

STATION TO STATION		Ⓡ FS
64+20.00	64+44.44	8

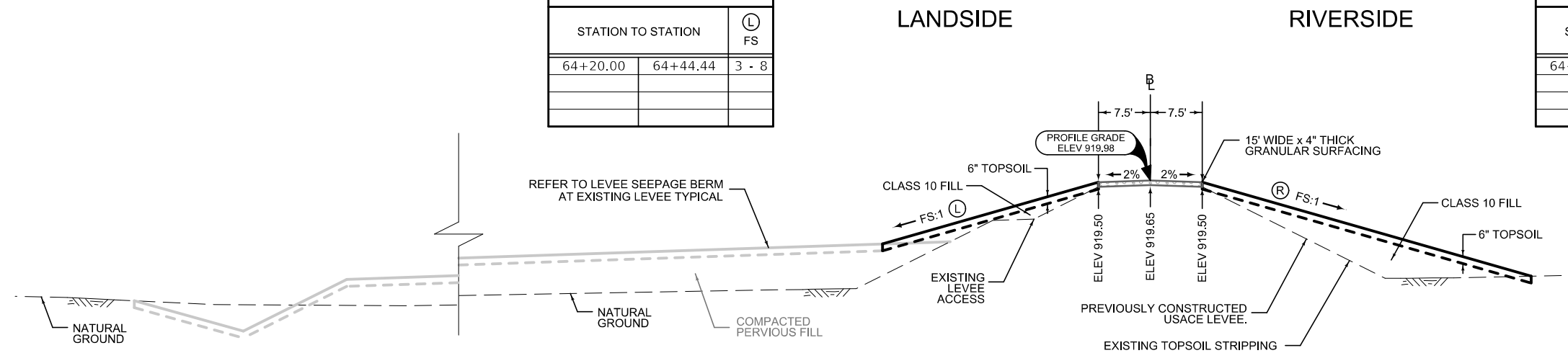

**LEEVE ENTRANCE GRADING AT EXISTING LEEVE  
(STA 64+20.00 - STA 64+44.44)**

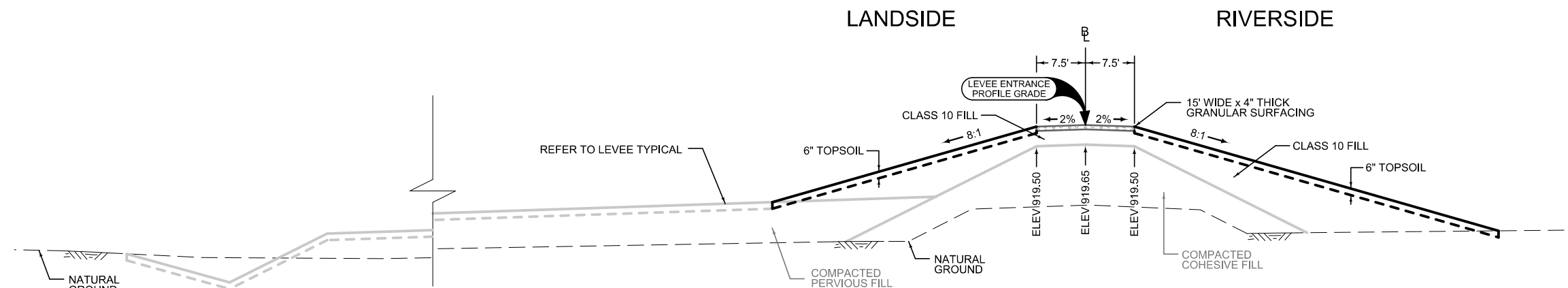

**LEEVE ENTRANCE TYPICAL  
(STA 64+44.44 - STA 65+02.16)  
(STA 65+38.16 - STA 65+95.16)**

- NOTES:  
1.) PROFILE GRADE AT TOP OF LEEVE GRANULAR SURFACING.  
2.) REFER TO PLANS FOR LEEVE ENTRANCE RETURN DETAILS.

**DITCH 6 LEEVE ENTRANCE  
GRADING**

**LEVEE ENTRANCE  
FORESLOPE GRADING**

STATION TO STATION		Ⓛ FS
65+95.16	66+25.00	8 - 3

**LEVEE ENTRANCE  
FORESLOPE GRADING**

STATION TO STATION		Ⓡ FS
65+95.16	66+25.00	8 - 3

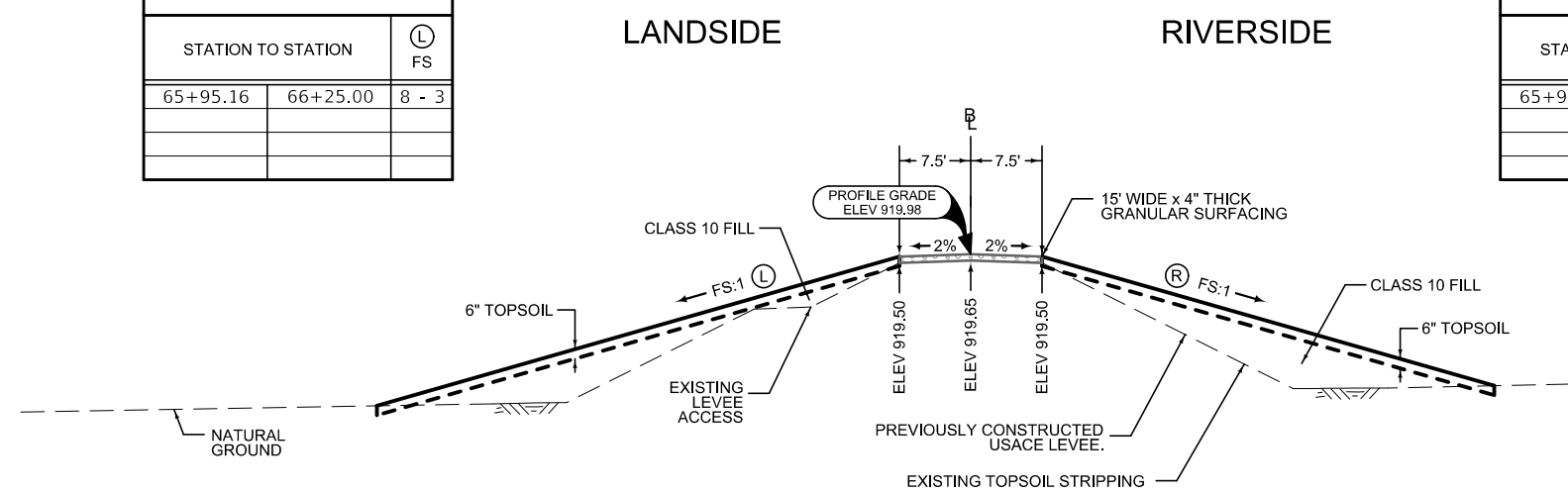

**LEVEE ENTRANCE GRADING AT EXISTING LEVEE  
(STA 65+95.16 - STA 66+25.00)**

**DITCH 6 LEVEE ENTRANCE  
GRADING**

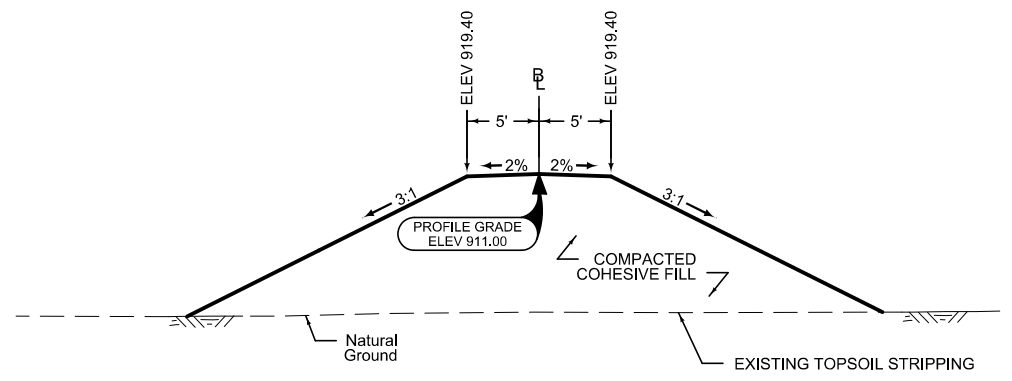

**TEMPORARY RING LEVEE  
(STA 0+90.00 - STA 5+05.00)**

**TEMPORARY RING LEVEE  
GRADING**

- NOTES:
- A TEMPORARY RING LEVEE IS REQUIRED FOR THE OPEN CUT TRENCH EXCAVATION OPERATION NEEDED FOR THE REMOVAL OF THE EXISTING CULVERTS AND INSTALLATION OF NEW CULVERTS THROUGH THE LEVEE.
  - 1.) CONSTRUCT RING LEVEE TO ELEVATION 911.00' PRIOR TO REMOVAL OF EXISTING CULVERTS OR INSTALLATION OF NEW CULVERTS.
  - 2.) IF A HIGH WATER EVENT IS IMMINENT, AS DETERMINED BY THE STATE, CONSTRUCT THE RING LEVEE AS SHOWN TO ELEVATION 919.65'.
  - 3.) THE RING LEVEE CAN BE REMOVED ONCE THE NEW LEVEE HAS BEEN CONSTRUCTED TO A HEIGHT THAT EXCEEDS THE RING LEVEE.

### SURVEY SYMBOLS

- Interstate Highway Symbol
- U.S. Highway Symbol
- Iowa Highway Symbol
- County Road Highway Symbol
- Evergreen Tree
- Deciduous Tree
- Fruit Tree
- Shrub (Bushes)
- Timber
- Hedge
- Stump
- Swamp
- Rock Outcrop
- Broken Concrete
- Revetment (Rip Rap)
- Cemetery
- Grave
- Cave
- Sink Hole
- Board Fence
- Chain Link or Security Fence
- Wire Fence
- Terrace
- Earth Dam or Dike (Existing)
- Tile Outlet
- Edge of Water
- Existing Drainage
- Right of Way Rail or Lot Corner
- Concrete Monument
- Well
- Windmill
- Beehive Intake
- Existing Intake
- Existing Utility Access (Manhole)
- Fire Hydrant
- Water Hydrant (Rural)

- Septic Tank
- Cistern
- L.P. Gas Tank (No Footing)
- Underground Storage Tank
- Latrine
- Satellite TV Dish
- Water Hook Up
- Radio Tower
- Tower Anchor
- Guardrail (Beam or Cable)
- Guard Post (one or two)
- Guard Post (over two)
- Filler Pipe
- Gas Valve
- Water Valve
- Speed Limit Sign
- Mile Marker Post
- Sign
- Traffic Signal Control Box
- Rail Road Signal Control Box
- Telephone Switch Box
- Electric Box

### UTILITY LEGEND

#### SURVEYED UTILITY OWNER SYMBOLS

Sub-Surface Utility Mapping Quality Level is in accordance with C/ASCE 38-02 Standard Guidelines for the Collection and Depiction of Existing Subsurface Utility Data.

Remark Abbreviations  
 QLA Quality Level A Highest guideline quality level  
 QLD Quality Level D Lowest guideline quality level

- FOID, Fiber Optic CenturyLink - Quality D
- GLID, Gas Line Black Hills Energy - Quality D
- PPA, Power Pole MidAmerican Electric

### PLAN VIEW COLOR LEGEND OF PLAN AND PROFILE SHEETS

LINEWORK		Design Color No.	
Green	(2)		Existing Topographic Features and Labels
Blue	(1)		Proposed Alignment, Stationing, Tic Marks, and Alignment Annotation
Magenta	(5)		Existing Utilities
SHADING		Design Color No.	
Lavender	(9)		Temporary Pavement Shading
Gray, Light	(48)		Proposed Pavement Shading
Gray, Med	(80)		Proposed Granular Shading
Gray, Dark	(112)		Proposed Grade and Pave Shading "In conjunction with a paving project"
Brown, Light	(236)		Grading Shading
Tan	(8)		Proposed Sidewalk Shading
Blue, Light	(230)		Proposed Sidewalk Landing Shading
Pink	(11)		Proposed Sidewalk Ramp Shading
Orange	(70)		Proposed Entrance Granular Surfacing

### PROFILE VIEW COLOR LEGEND OF PLAN AND PROFILE SHEETS

LINEWORK		Design Color No.	
Green	(2)		Existing Ground Line Profile
Blue	(1)		Proposed Profile and Annotation
Magenta	(5)		Existing Utilities
Blue, Light	(230)		Proposed Ditch Grades, Left
Black	(0)		Proposed Ditch Grades, Median
Rust	(14)		Proposed Ditch Grades, Right

- Reference Point
- Station
- Survey Line
- Section Corner
- Ground Line Intercept
- Saw Cut
- Guardrail
- Trench Drain
- HighTension Cable Guardrail
- Road Removal

- #### RIGHT-OF-WAY LEGEND
- Proposed Right-of-Way
  - Existing Right of Way
  - Existing and Proposed Right-of-Way
  - Easement and Existing Right-of-Way
  - Easement (Temporary)
  - Easement
  - Access Control
  - Property Line

## PLAN AND PROFILE LEGEND AND SYMBOL INFORMATION SHEET

(COVERS SHEET SERIES ME & MU)



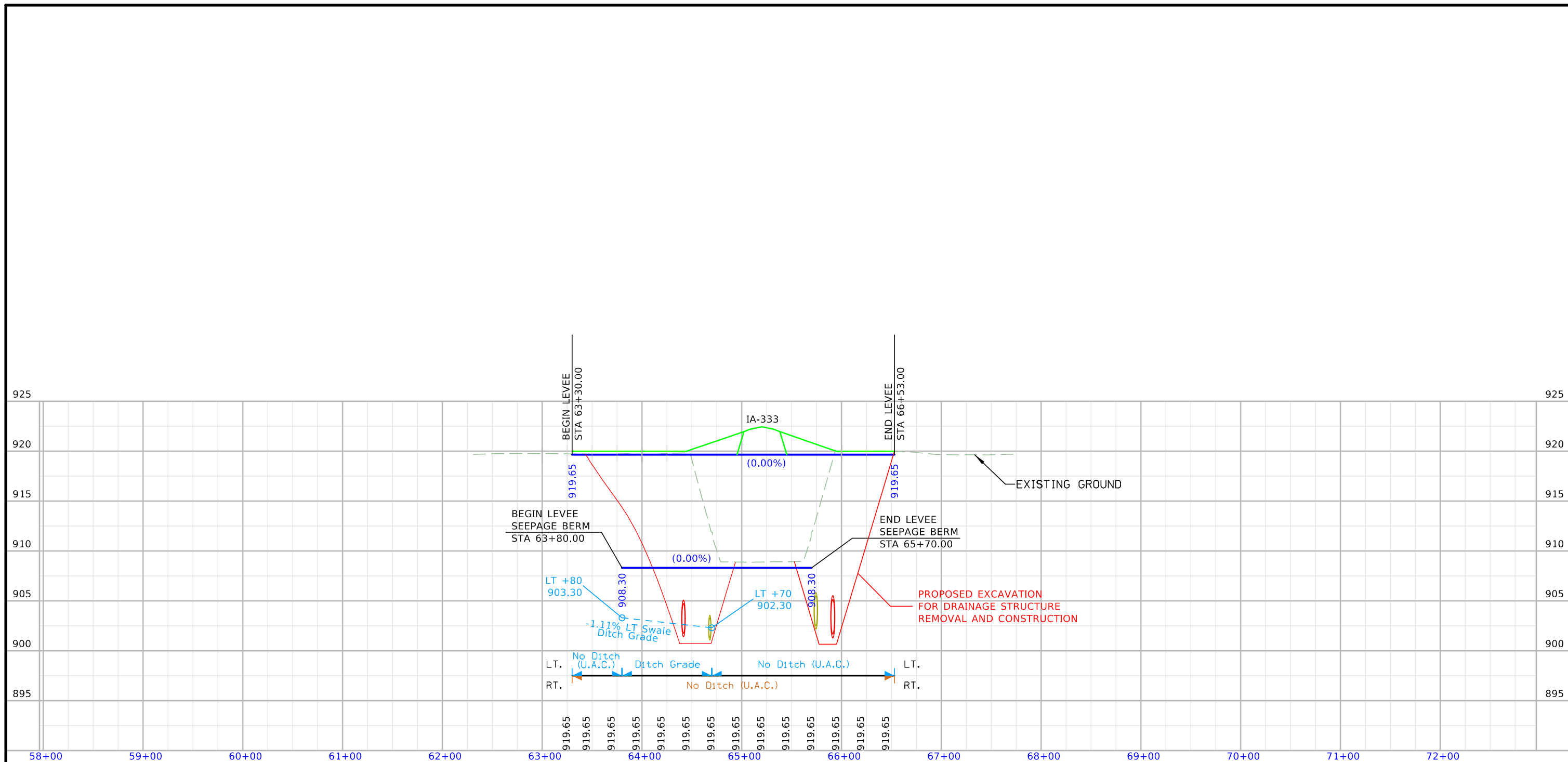

DITCH 6 LEVEE



**ALIGNMENT COORDINATES**

101-16  
10-20-09

Name	Location	Point on Tangent		Begin Spiral		Begin Curve		Simple Curve PI or Master PI of SCS			End Curve		End Spiral			
		Station	Coordinates		Station	Coordinates		Station	Coordinates		Station	Coordinates		Station	Coordinates	
			Y (Northing)	X (Easting)		Y (Northing)	X (Easting)		Y (Northing)	X (Easting)		Y (Northing)	X (Easting)		Y (Northing)	X (Easting)
<b>LEVEE</b>																
<b>DITCH#6 LEVEE</b>																
L01		10+00.00	6,731,186.72	16,519,044.08												
DITCH6LEVEE-1						15+96.73	6,730,837.87	16,518,559.94	16+55.94	6,730,803.26	16,518,511.90	17+07.32	6,730,818.50	16,518,454.68		
DITCH6LEVEE-2						20+09.70	6,730,896.34	16,518,162.49	21+14.47	6,730,923.30	16,518,061.26	22+02.71	6,730,855.44	16,517,981.45		
DITCH6LEVEE-3						23+92.69	6,730,732.36	16,517,836.72	24+62.17	6,730,687.36	16,517,783.80	25+27.46	6,730,680.03	16,517,714.71		
DITCH6LEVEE-4						27+07.25	6,730,661.05	16,517,535.92	27+42.50	6,730,657.33	16,517,500.87	27+77.17	6,730,664.50	16,517,466.37		
DITCH6LEVEE-5						31+57.01	6,730,741.83	16,517,094.49	35+37.06	6,730,819.19	16,516,722.39	36+23.33	6,730,455.75	16,516,833.52		
DITCH6LEVEE-6						62+03.65	6,727,988.19	16,517,587.98	62+85.74	6,727,909.68	16,517,611.98	63+59.45	6,727,870.68	16,517,684.23		
DITCH6LEVEE-7						63+78.68	6,727,861.54	16,517,701.15	64+27.76	6,727,838.23	16,517,744.33	64+66.73	6,727,789.17	16,517,743.12		
DITCH6LEVEE-8						67+21.64	6,727,534.33	16,517,736.81	67+45.48	6,727,510.50	16,517,736.22	67+69.10	6,727,487.19	16,517,741.24		
DITCH6LEVEE-9						71+99.85	6,727,066.13	16,517,832.10	72+43.85	6,727,023.12	16,517,841.38	72+86.47	6,726,987.98	16,517,867.85		
DITCH6LEVEE-10						73+19.81	6,726,961.35	16,517,887.91	74+02.72	6,726,895.12	16,517,937.80	74+58.26	6,726,833.83	16,517,881.96		
DITCH6LEVEE-11						75+33.17	6,726,778.45	16,517,831.51	76+28.88	6,726,707.71	16,517,767.05	76+85.87	6,726,640.21	16,517,834.90		
DITCH6LEVEE-12						79+08.23	6,726,483.39	16,517,992.55	79+39.66	6,726,461.23	16,518,014.84	79+67.76	6,726,429.79	16,518,014.66		
DITCH6LEVEE-13						94+39.85	6,724,957.73	16,518,006.20	94+73.77	6,724,923.80	16,518,006.00	95+05.97	6,724,895.00	16,517,988.08		
L02		95+12.61	6,724,889.37	16,517,984.57												
<b>LEVEE ENTRANCE RETURNS</b>																
<b>ENTR.RET1</b>																
ENTR.RET1-1						0+00.00	6,727,751.76	16,517,823.73	0+60.39	6,727,753.21	16,517,763.36	1+03.45	6,727,811.67	16,517,748.21		
E11		1+04.92	6,727,813.09	16,517,747.85												
<b>ENTR.RET2</b>																
ENTR.RET2-1						0+00.00	6,727,754.63	16,517,704.77	0+29.98	6,727,753.90	16,517,734.74	0+47.10	6,727,783.87	16,517,735.49		
<b>ENTR.RET3</b>																
ENTR.RET3-1						0+00.00	6,727,719.12	16,517,683.83	0+50.03	6,727,717.92	16,517,733.85	0+78.57	6,727,667.90	16,517,732.61		
<b>ENTR.RET4</b>																
ENTR.RET4-1						0+00.00	6,727,716.35	16,517,798.80	0+49.97	6,727,717.55	16,517,748.85	0+78.51	6,727,667.60	16,517,747.61		
<b>TEMPORARY RING LEVEE</b>																
<b>T10</b>		0+00.00	6,727,884.64	16,517,661.99												
TEMPRING-1						1+38.47	6,727,881.21	16,517,800.42	1+98.47	6,727,879.73	16,517,860.40	2+32.71	6,727,819.75	16,517,858.91		
TEMPRING-2						4+02.45	6,727,650.06	16,517,854.71	4+72.45	6,727,580.09	16,517,852.98	5+12.40	6,727,581.82	16,517,783.00		
T11		5+57.31	6,727,582.93	16,517,738.11												

**SPIRAL OR CIRCULAR CURVE DATA**

101-17  
04-19-11

Name	Location	Δ <sub>SCS</sub>	Horizontal Alignment Data													Remarks	
			Spiral Data								Curve Data						
			θs	Ls	Ts	Es	Xc	Yc	L.T.	S.T.	Δ <sub>c</sub>	T	L	R	E		
<b>LEVEE</b>																	
<b>DITCH#6 LEVEE</b>																	
DITCH6LEVEE-1											50° 41' 27.46" RT	59.21'	110.59'	125.00'	13.31'		
DITCH6LEVEE-2											55° 17' 34.97" LT	104.76'	193.01'	200.00'	25.78'		
DITCH6LEVEE-3											34° 19' 01.97" RT	69.47'	134.76'	225.00'	10.48'		
DITCH6LEVEE-4											17° 48' 17.54" RT	35.24'	69.92'	225.00'	2.74'		
DITCH6LEVEE-5											118° 44' 48.91" LT	380.05'	466.32'	225.00'	216.66'		
DITCH6LEVEE-6											44° 38' 06.15" LT	82.10'	155.81'	200.00'	16.19'		
DITCH6LEVEE-7											53° 03' 18.45" RT	49.08'	88.04'	80.00'	13.85'		
DITCH6LEVEE-8											13° 35' 42.17" LT	23.84'	47.46'	200.00'	1.42'		
DITCH6LEVEE-9											24° 48' 53.84" LT	44.00'	86.62'	200.00'	4.78'		
DITCH6LEVEE-10											79° 19' 35.38" RT	82.91'	138.45'	100.00'	29.90'		
DITCH6LEVEE-11											87° 29' 13.64" LT	95.71'	152.69'	100.00'	38.42'		
DITCH6LEVEE-12											45° 28' 51.36" RT	31.44'	59.53'	75.00'	6.32'		
DITCH6LEVEE-13											31° 34' 26.07" RT	33.93'	66.13'	120.00'	4.70'		
<b>LEVEE ENTRANCE RETURNS</b>																	
<b>ENTR_RET1</b>																	
ENTR_RET1-1											74° 05' 37.46" RT	60.39'	103.45'	80.00'	20.23'		
<b>ENTR_RET2</b>																	
ENTR_RET2-1											89° 57' 39.95" LT	29.98'	47.10'	30.00'	12.41'		
<b>ENTR_RET3</b>																	
ENTR_RET3-1											90° 02' 20.05" RT	50.03'	78.57'	50.00'	20.73'		
<b>ENTR_RET4</b>																	
ENTR_RET4-1											89° 57' 39.95" LT	49.97'	78.51'	50.00'	20.69'		
<b>TEMPORARY RING LEVEE</b>																	
TEMPRING-1											90° 00' 00.00" RT	60.00'	94.25'	60.00'	24.85'		
TEMPRING-2											90° 00' 00.00" RT	70.00'	109.96'	70.00'	28.99'		

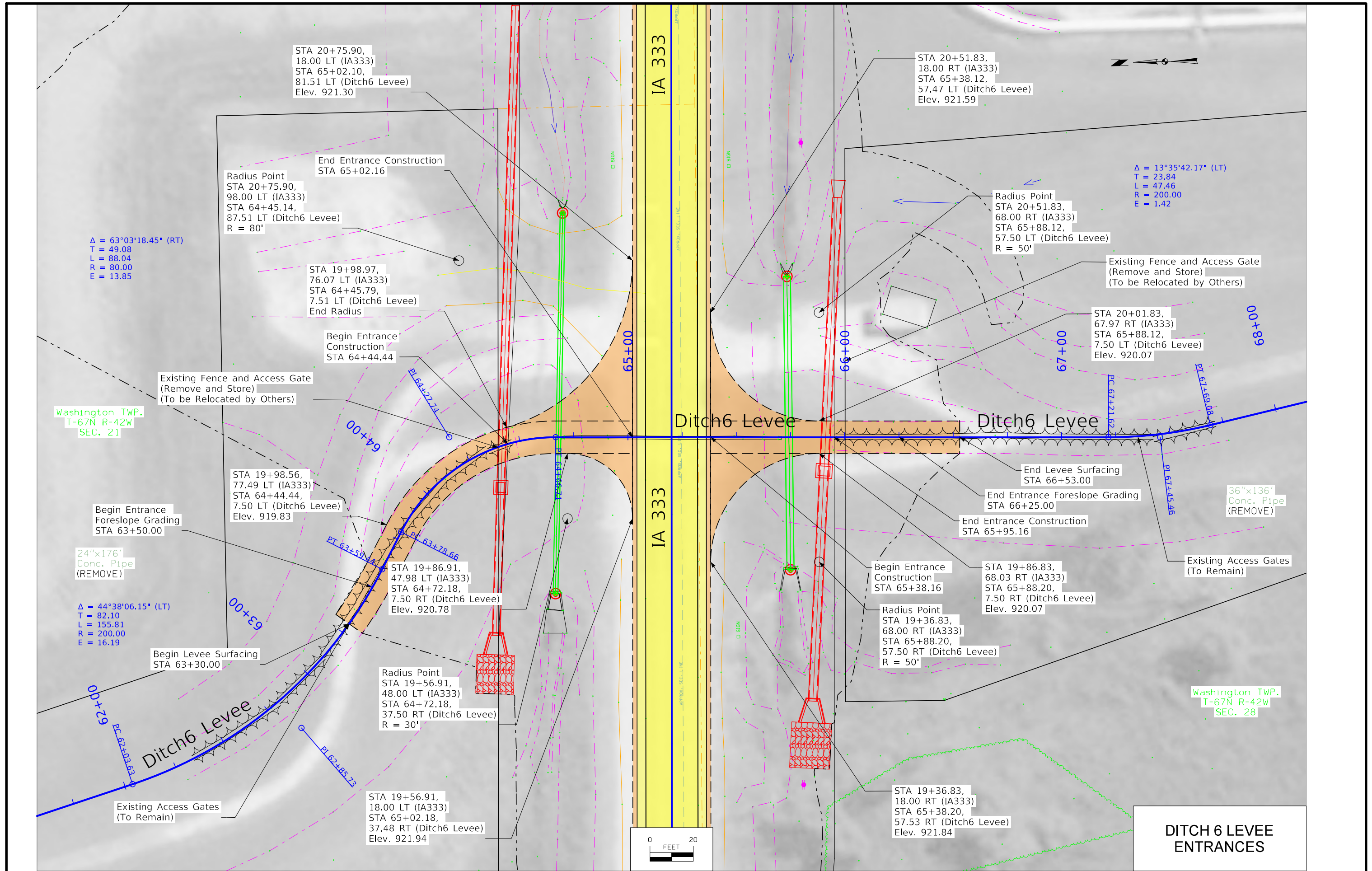

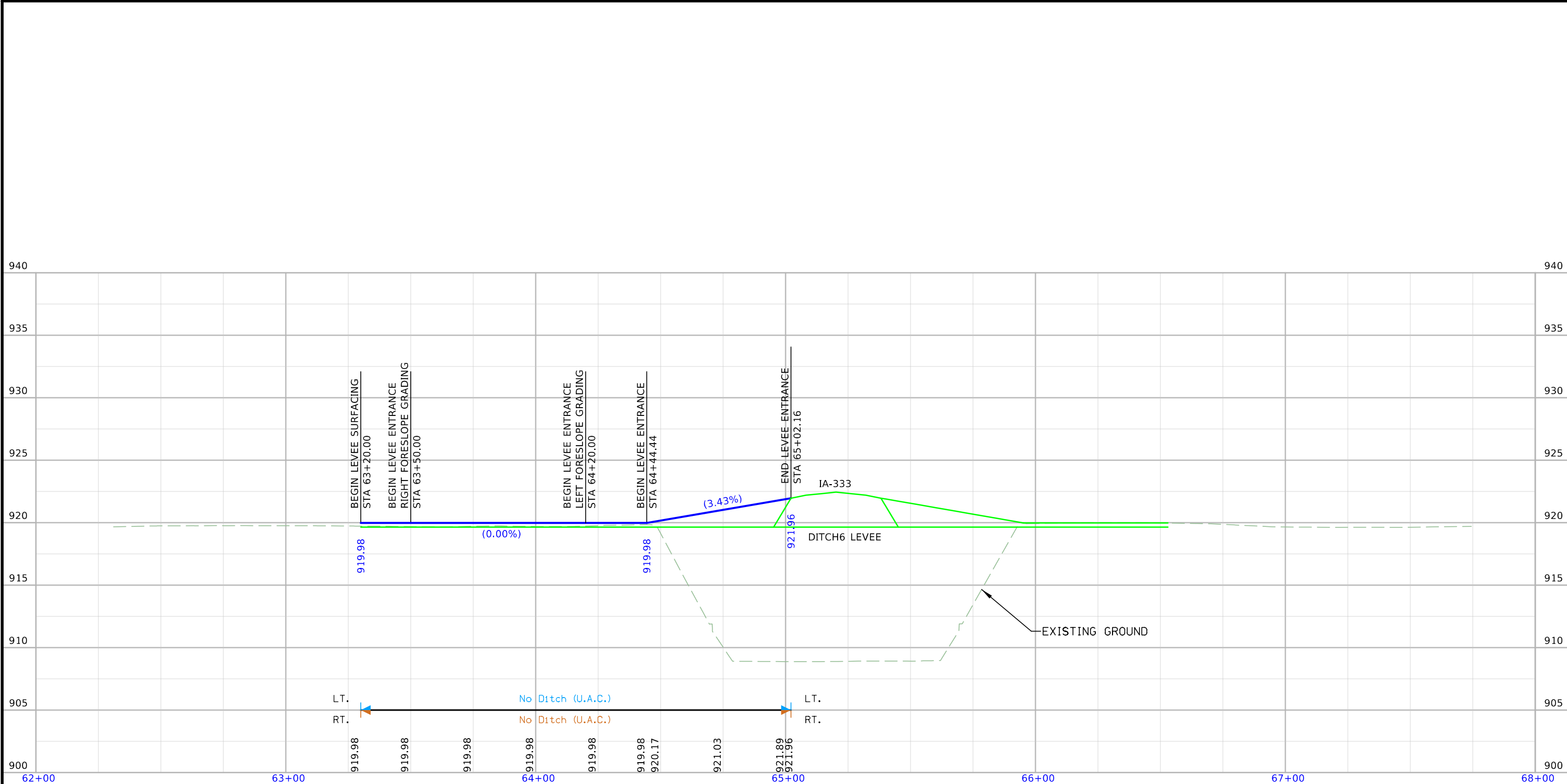

DITCH 6 LEVEE ENTRANCES

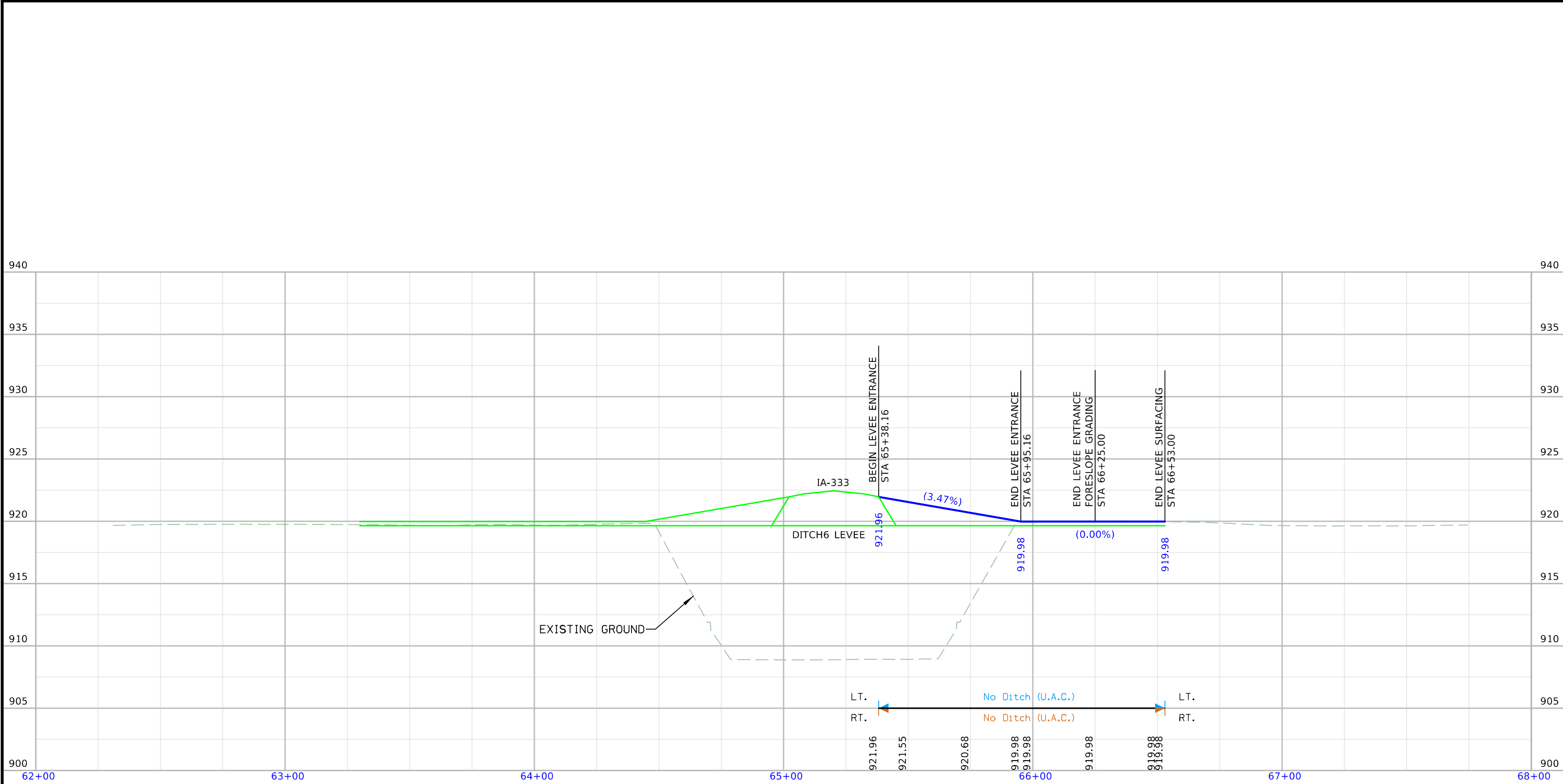

DITCH 6 LEVEE ENTRANCES



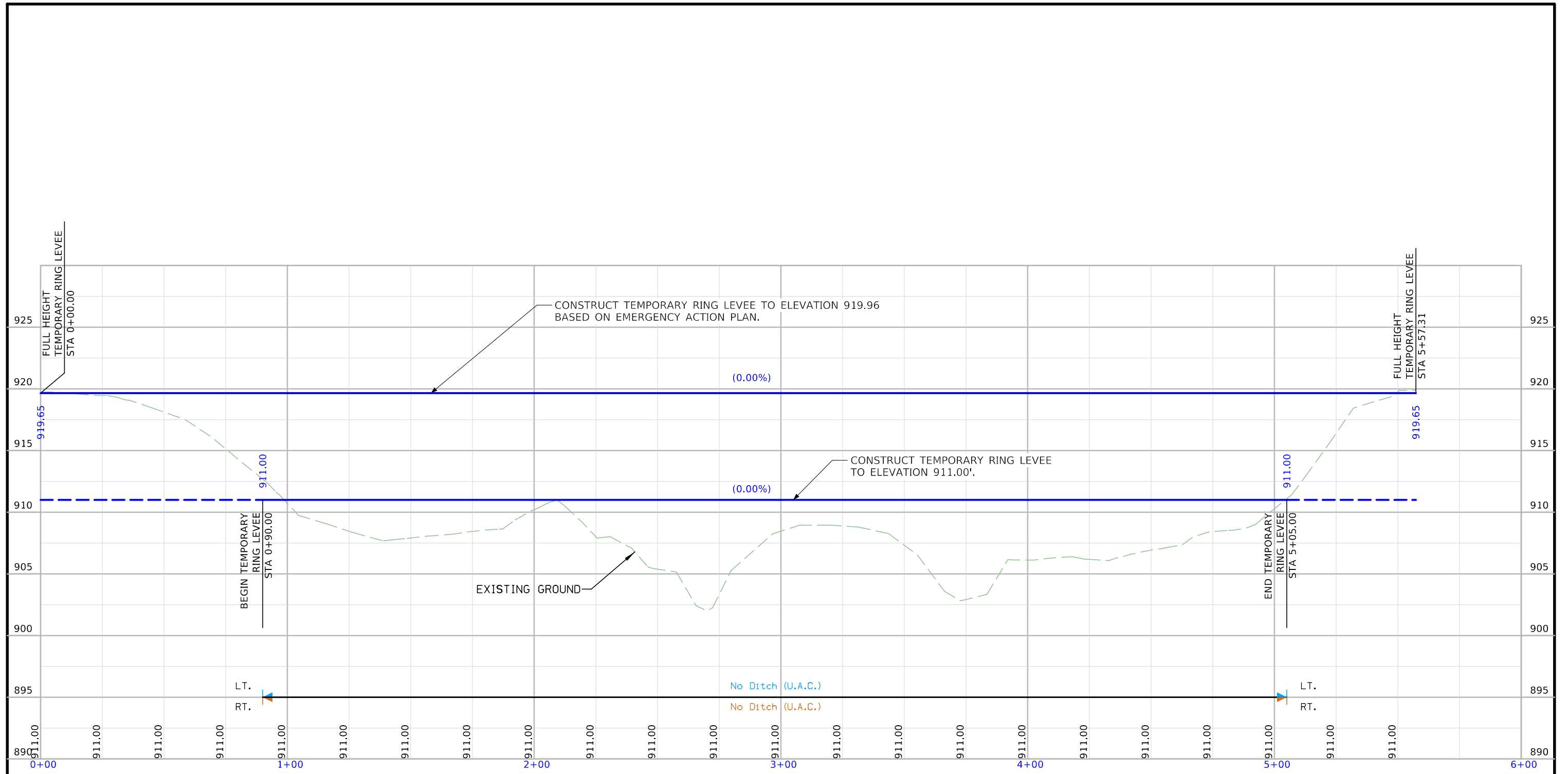

DITCH 6 LEVEE

**LINE STYLE LEGEND OF CROSS SECTION SHEETS (ROAD)**

- Existing Ground Line
- ===== Proposed Template
- ===== Proposed Topsoil Placement
- Additional Topsoil Removal
- Subgrade Treatment
- Granular Shoulder
- ===== Pavement
- Existing Pipe\RCB
- ===== Proposed Pipe\RCB
- ===== Proposed Dike
- All Elements Associated with Proposed Entrances

**LINE STYLE LEGEND OF CROSS SECTION SHEETS (SOILS)**

- Topsoil (Class 10)
- Slope Dressing Only
- Class 10 Materials
- Select Loams And Clay-Loams
- Select Sand
- Unsuitable Type A Disposal
- Unsuitable Type B Disposal
- Unsuitable Type C Disposal
- Shale
- Waste
- Broken and Weathered Rock
- Solid Rock
- Boulders

Note: All layer lines and descriptions identify layers above the line.

Note: Vertical or near vertical lines connecting soil layers at edges of cross sections are only for the purpose of calculating template quantities and do not depict soil stratification.

**SYMBOL LEGEND OF CROSS SECTION SHEETS**

- Existing ROW  
| Existing Right-of-Way Limit
- Proposed ROW  
| Proposed Right-of-Way Limit
- Temporary ROW  
| Temporary Right-of-Way Limit

**CROSS SECTION VIEW SUBSTRATA COLOR LEGEND**

Design Color No.	Feature
(128)	Boulder Substrata
(3)	Core out Substrata
(203)	Existing Pavement
(6)	Loam Substrata
(80)	Rock Substrata
(4)	Select Sand Substrata
(3)	Shale Substrata
(10)	Existing Topsoil Substrata
(3)	Unsuitable Type A Substrata
(13)	Unsuitable Type B Substrata
(11)	Unsuitable Type C Substrata
(3)	Waste Substrata

**NOTES:**

Text

**NOTES:**

Text

**CROSS SECTIONS  
LEGEND AND INFORMATION SHEET**

(COVERS SHEET SERIES MX)



# DITCH 6 LEVEE

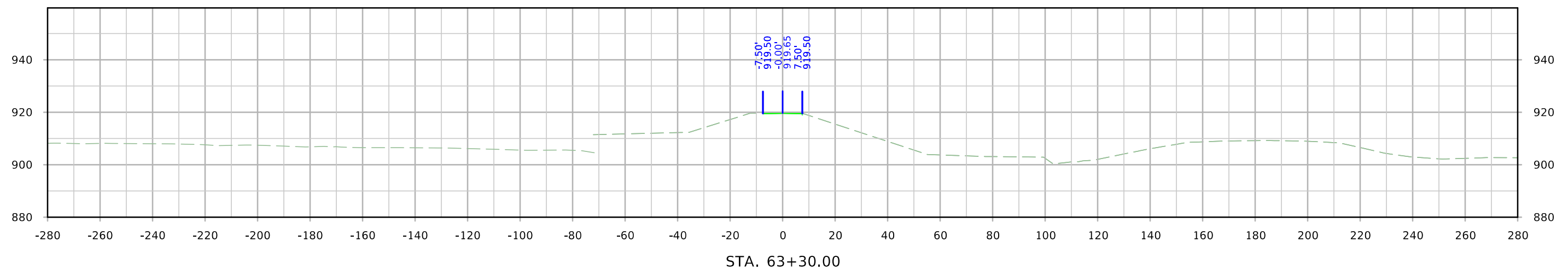
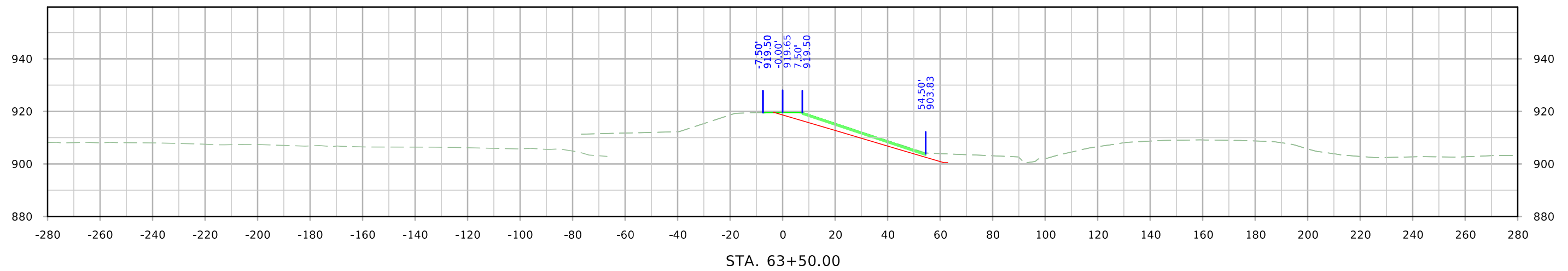
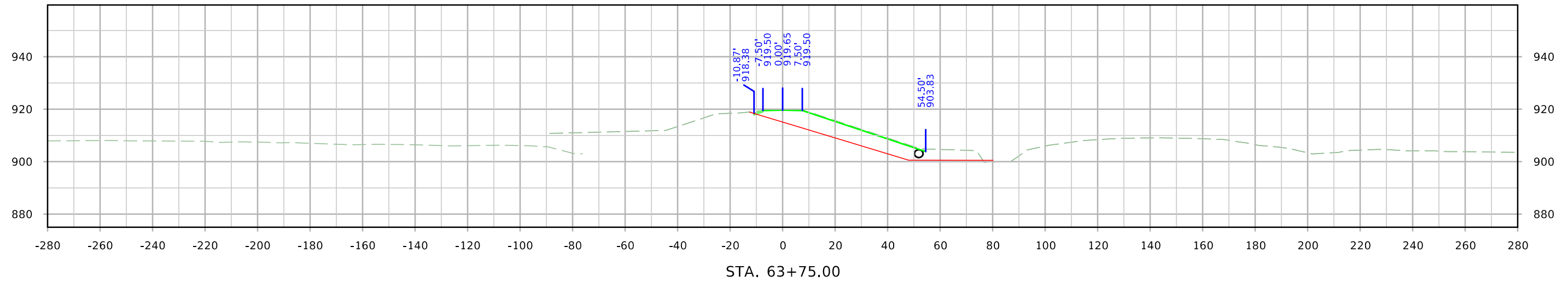

# DITCH 6 LEVEE

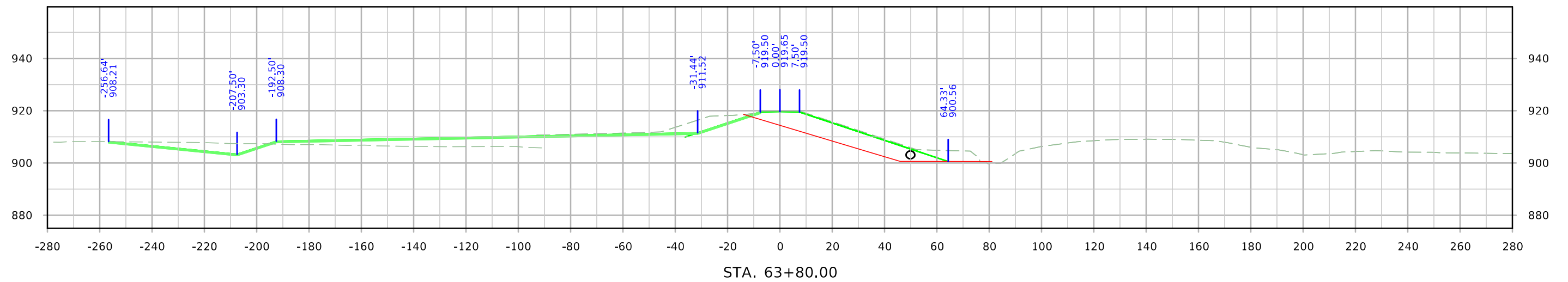
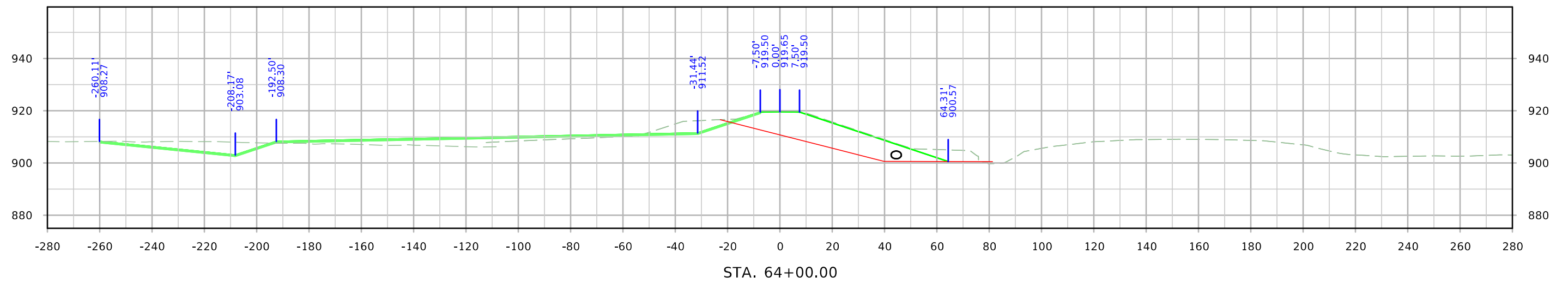
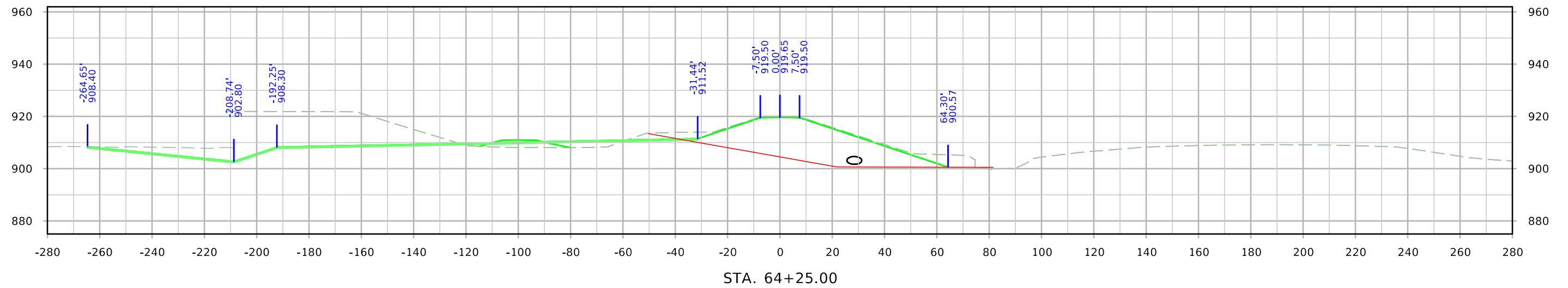

# DITCH 6 LEVEE

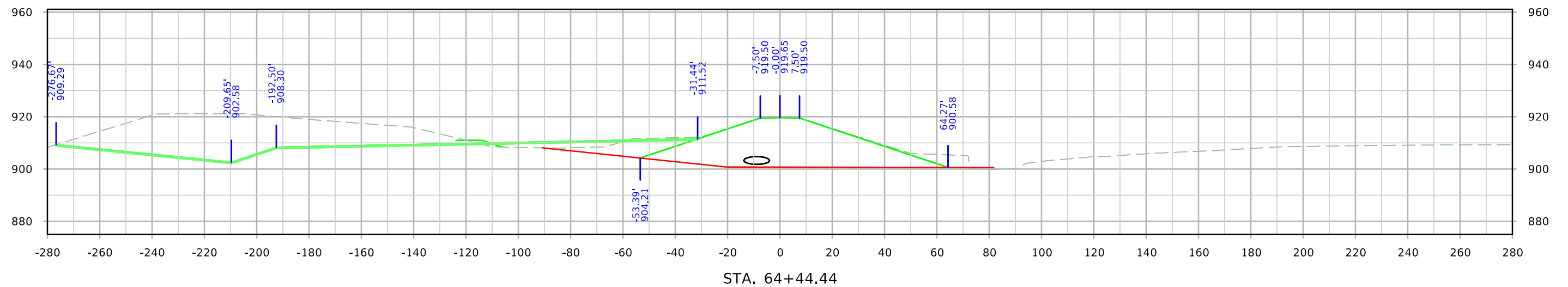
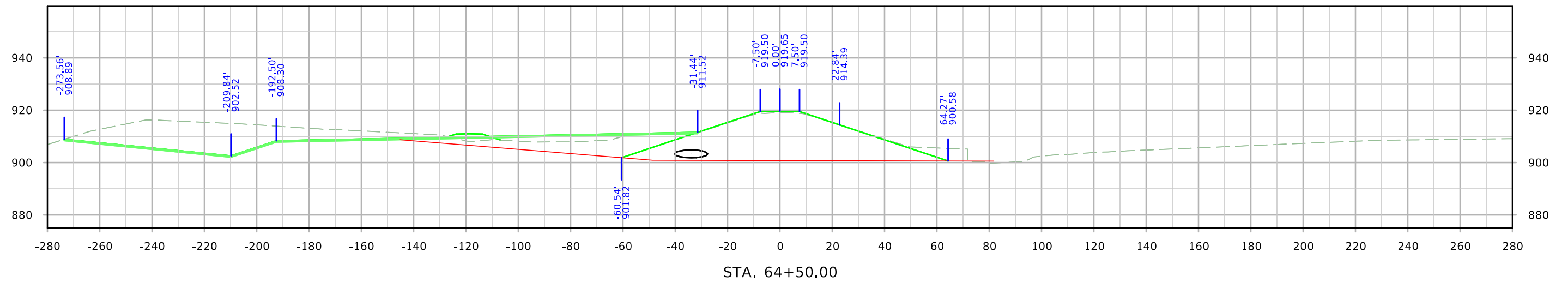
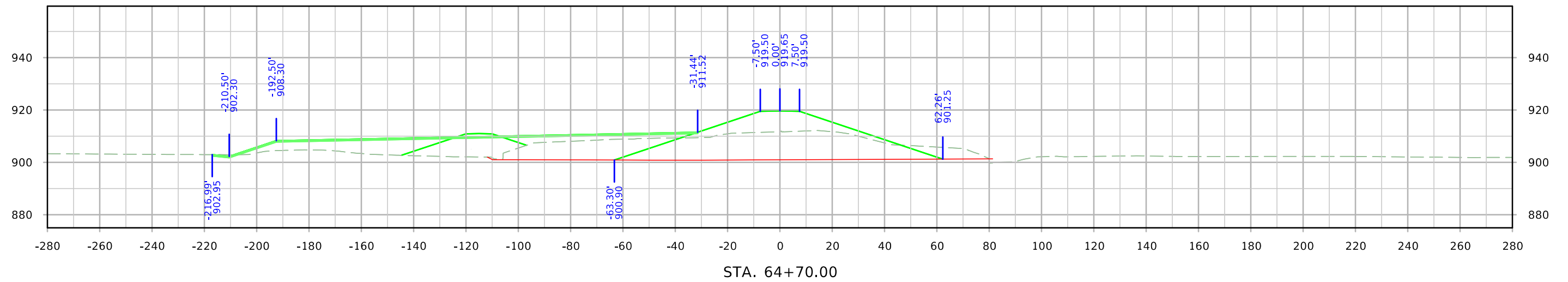

# DITCH 6 LEVEE

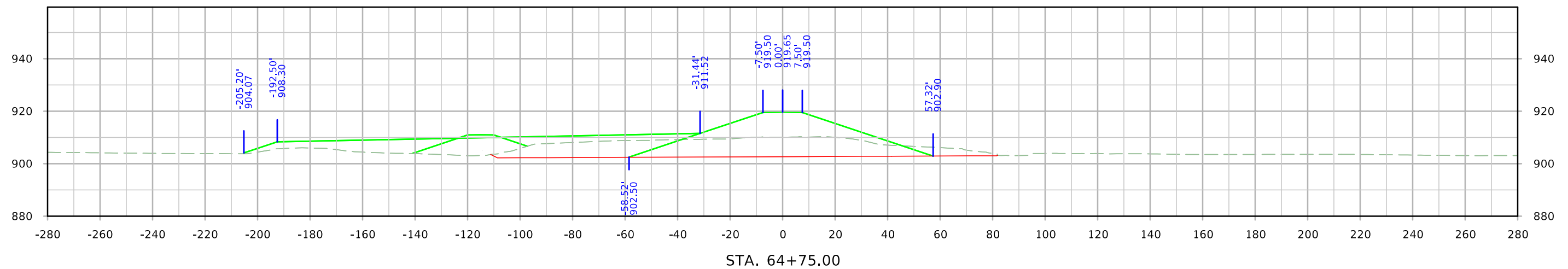
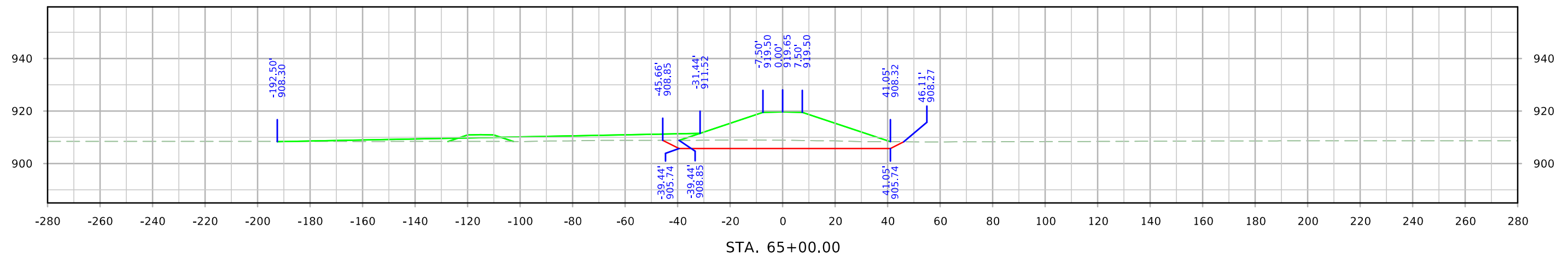
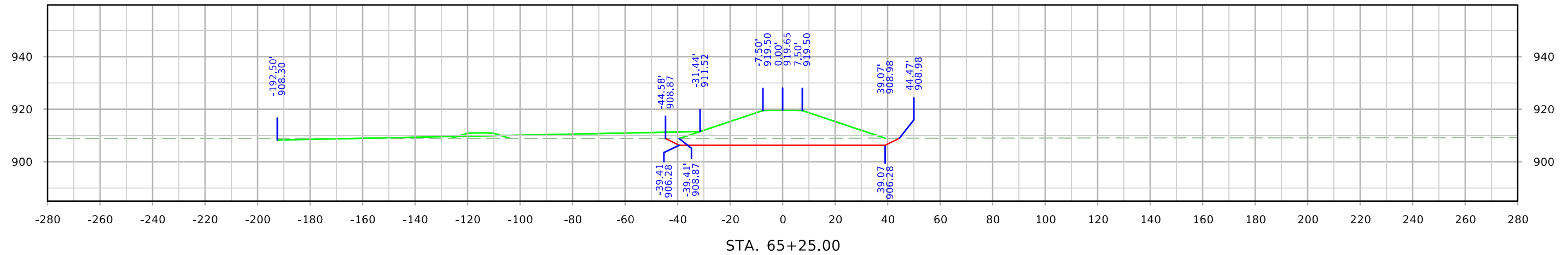

# DITCH 6 LEVEE

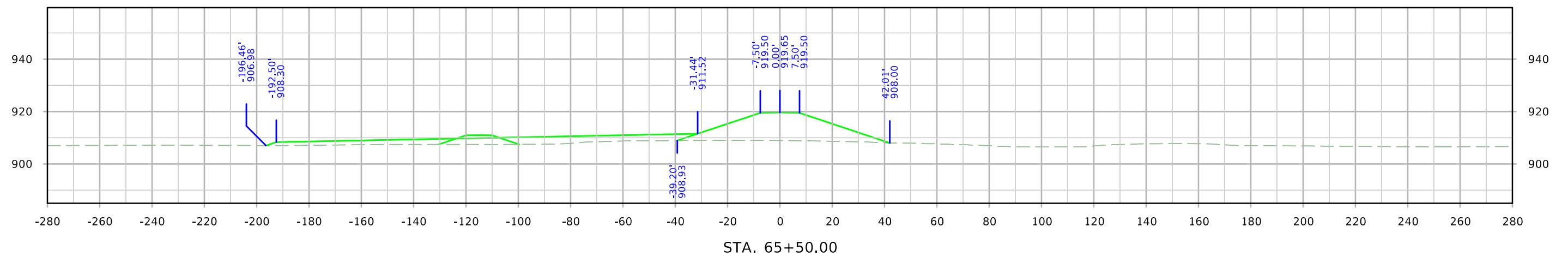
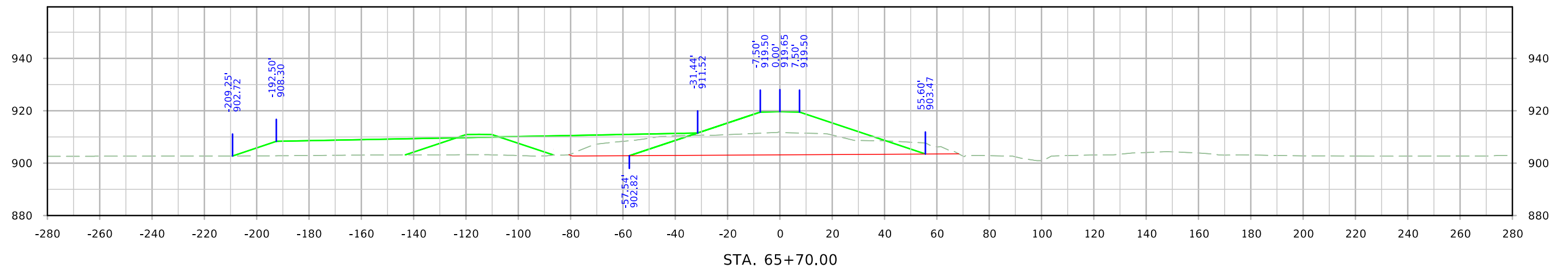
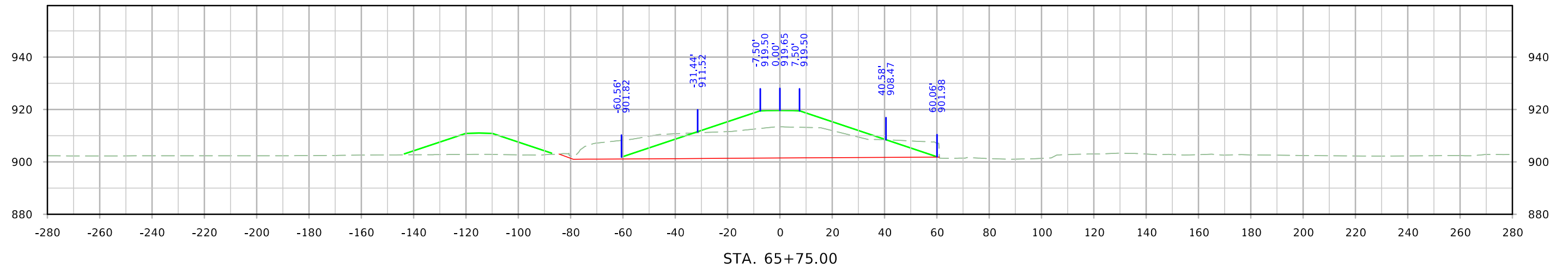

# DITCH 6 LEVEE

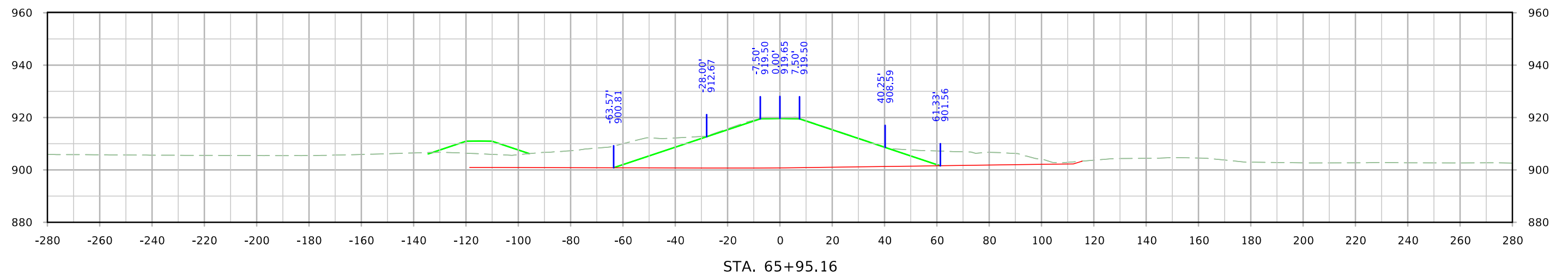
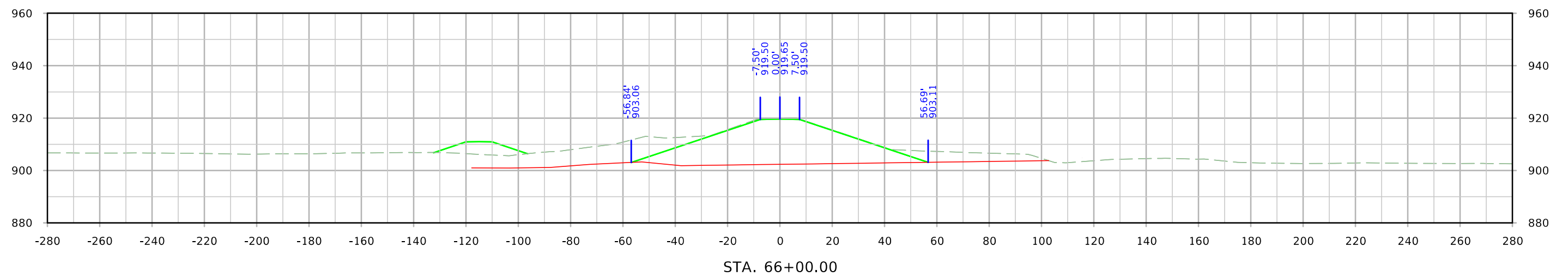
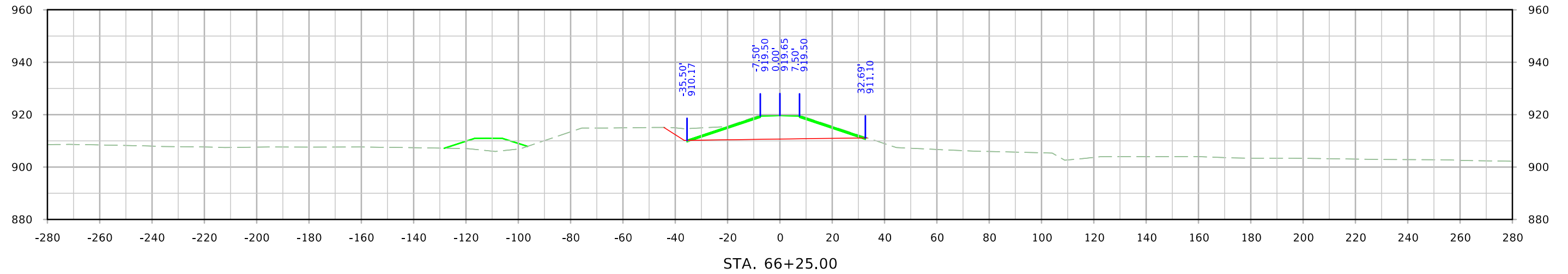

# DITCH 6 LEVEE

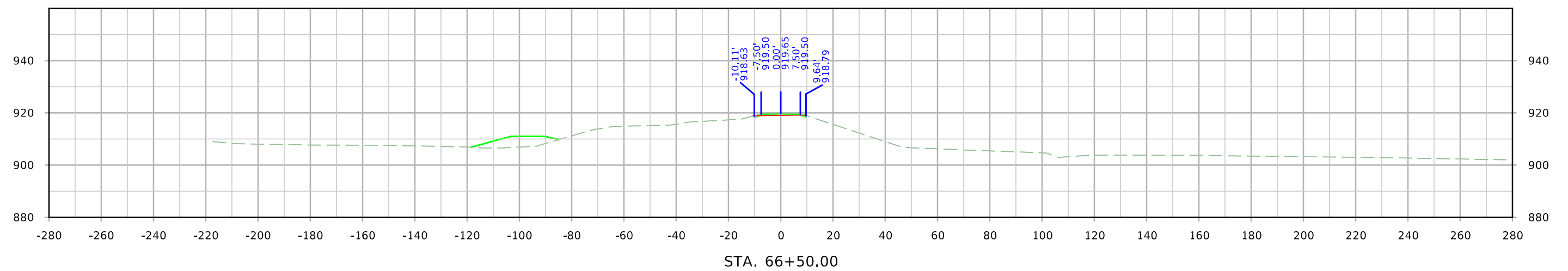
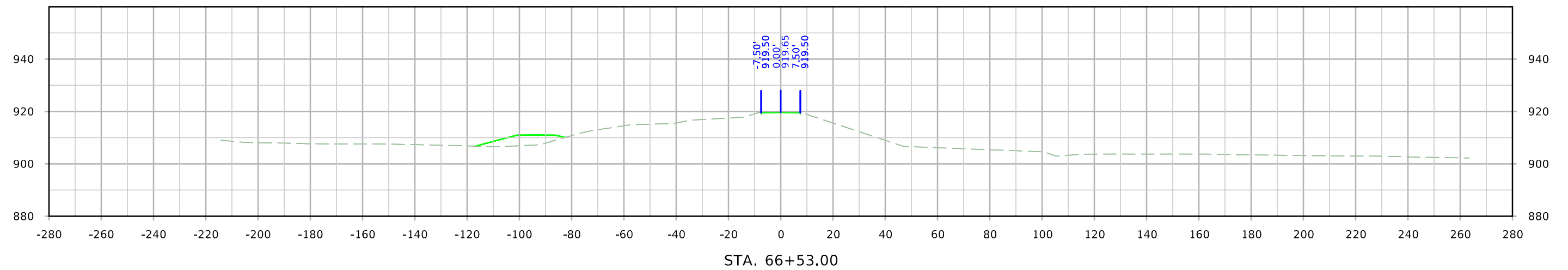

# DITCH 6 LEVEE - NORTH ENTRANCE

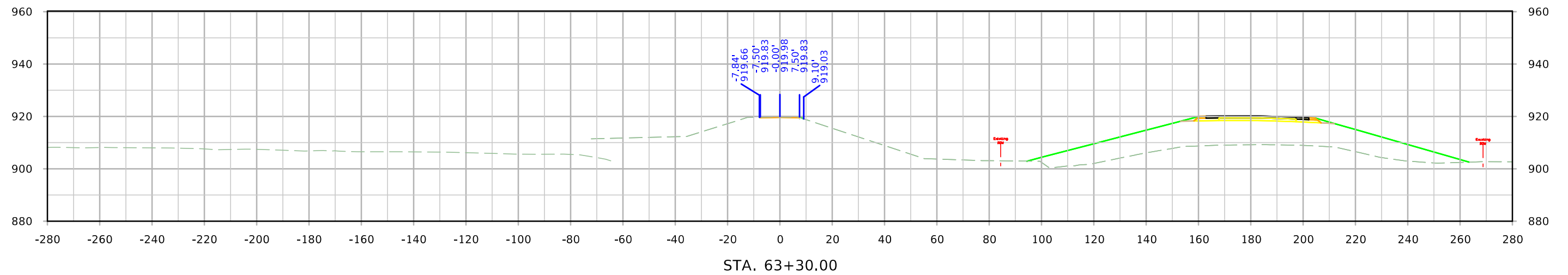
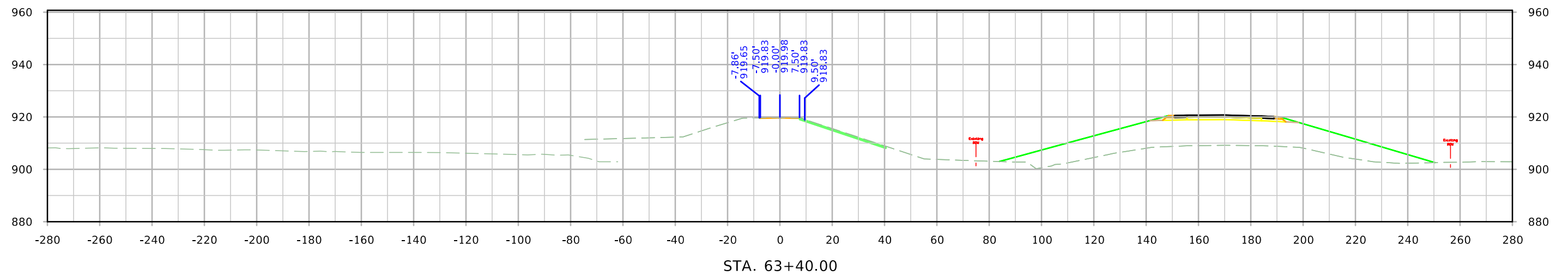



# DITCH 6 LEVEE - NORTH ENTRANCE

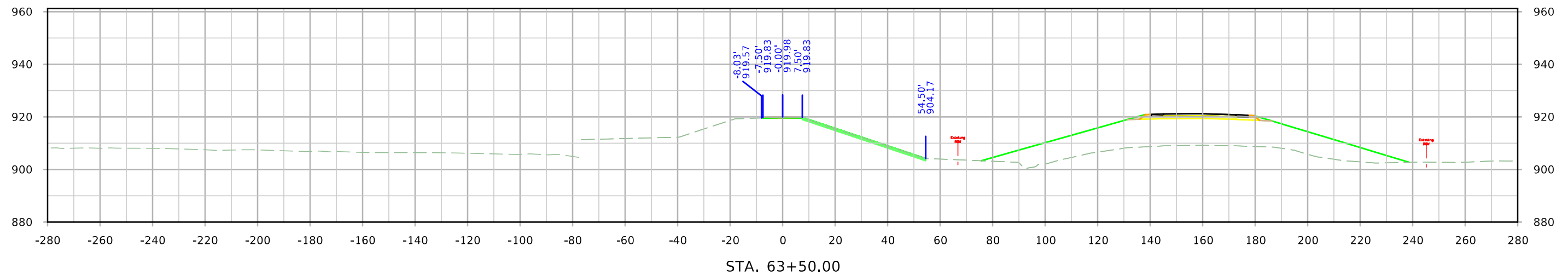
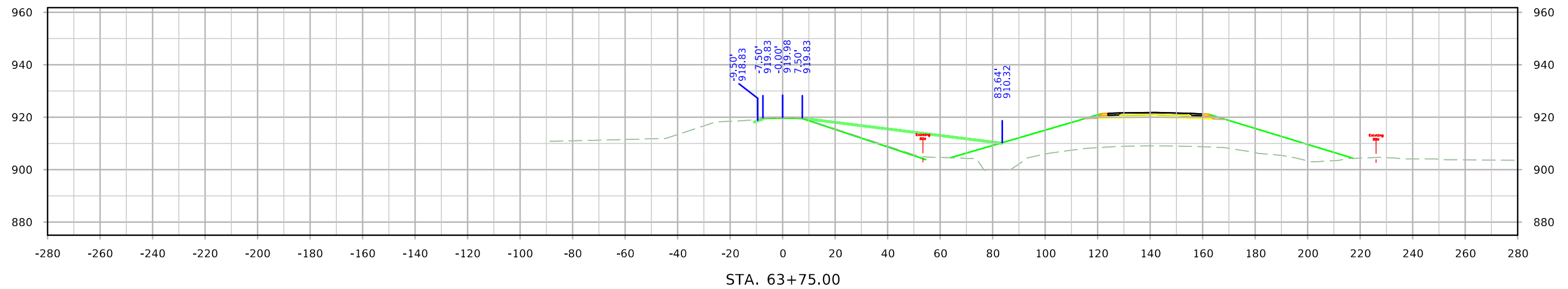
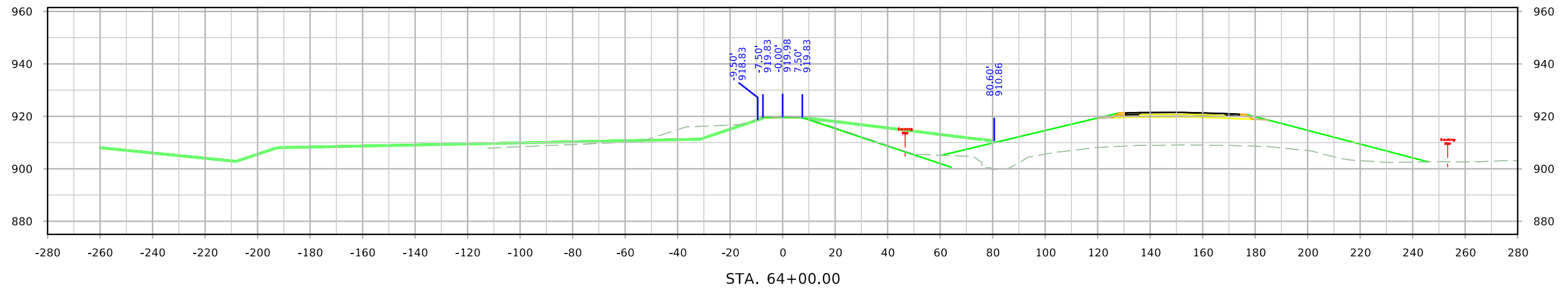

# DITCH 6 LEVEE - NORTH ENTRANCE

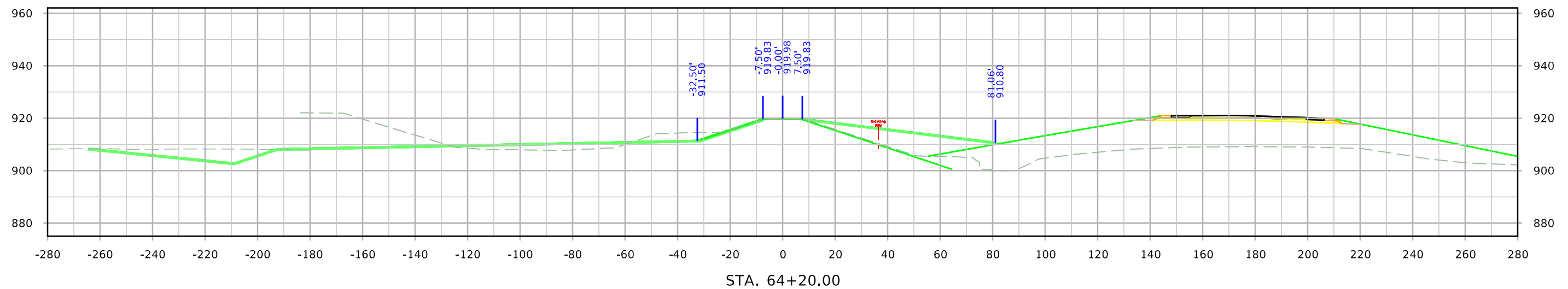
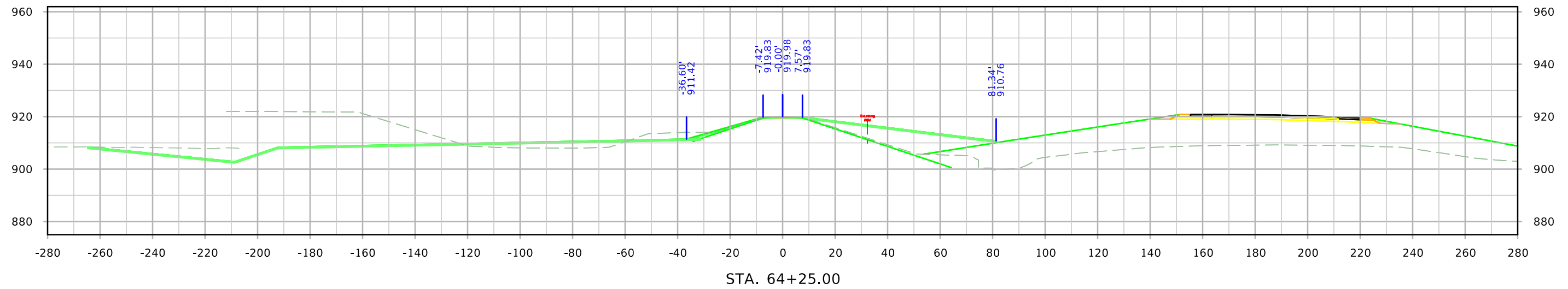
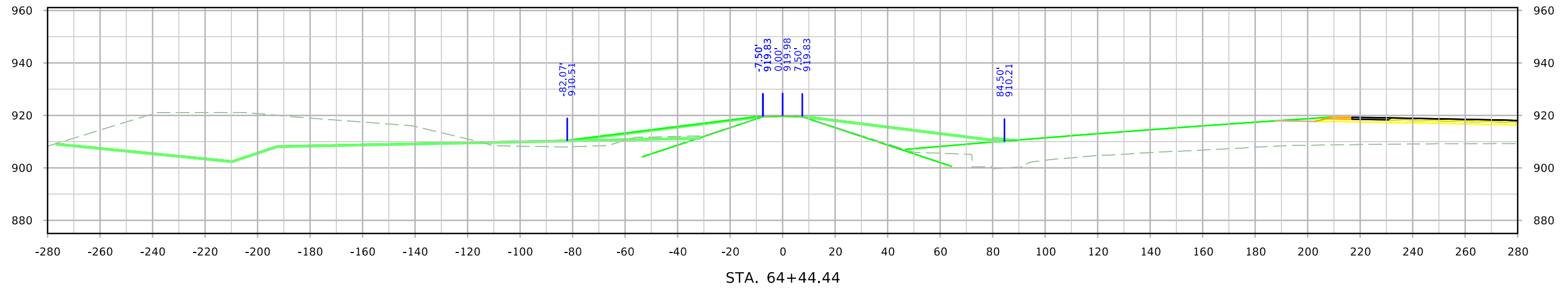

# DITCH 6 LEVEE - NORTH ENTRANCE

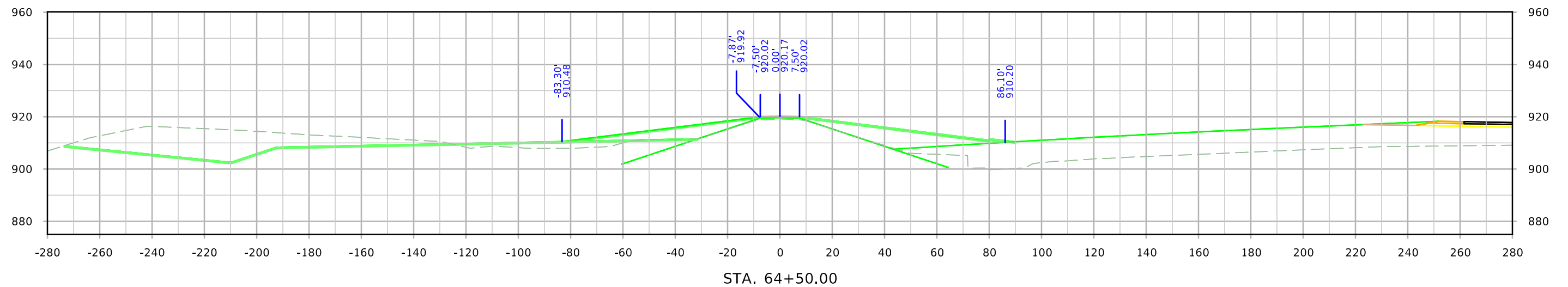
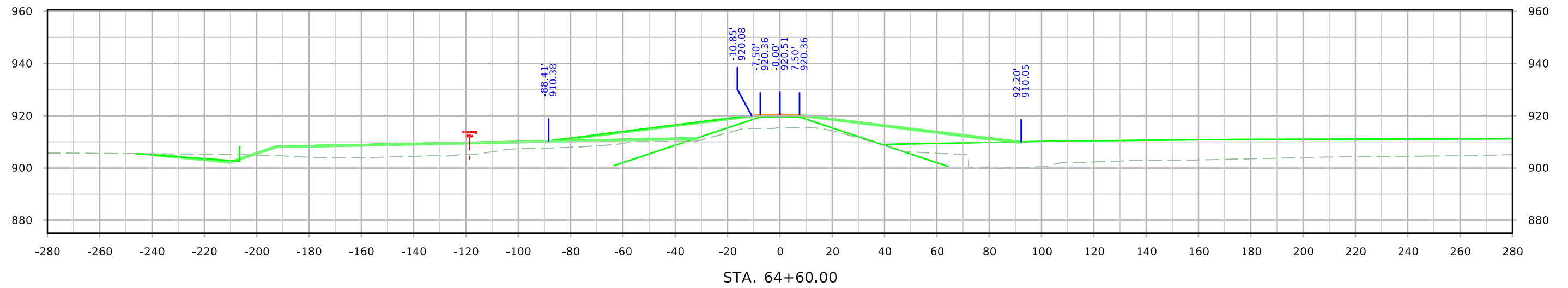
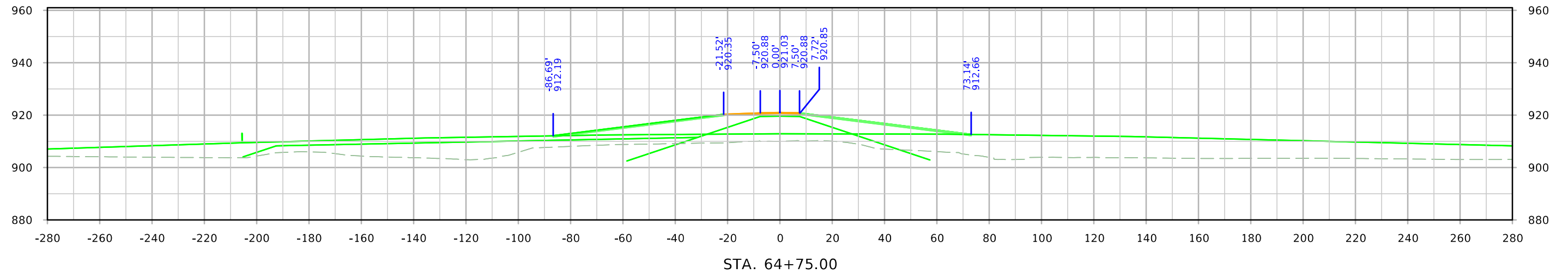

# DITCH 6 LEVEE - NORTH ENTRANCE

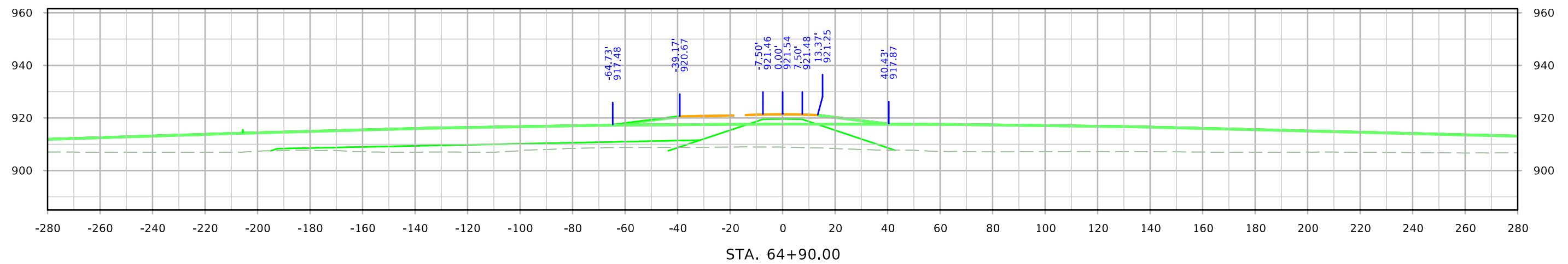
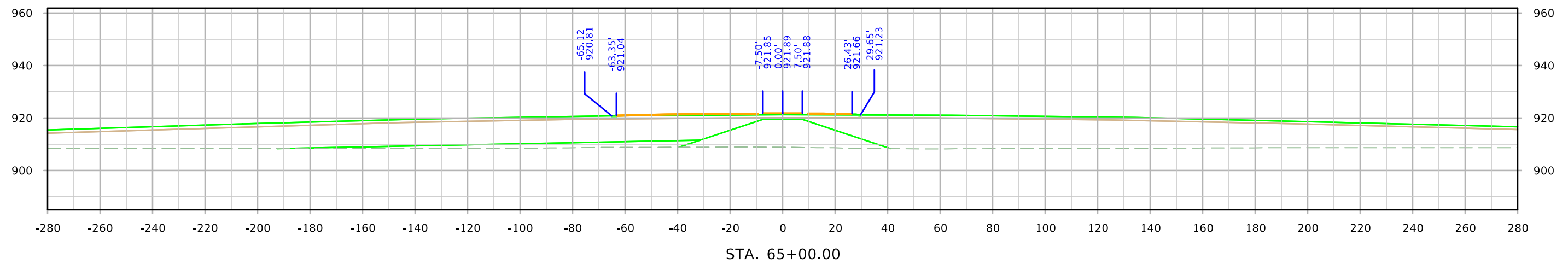
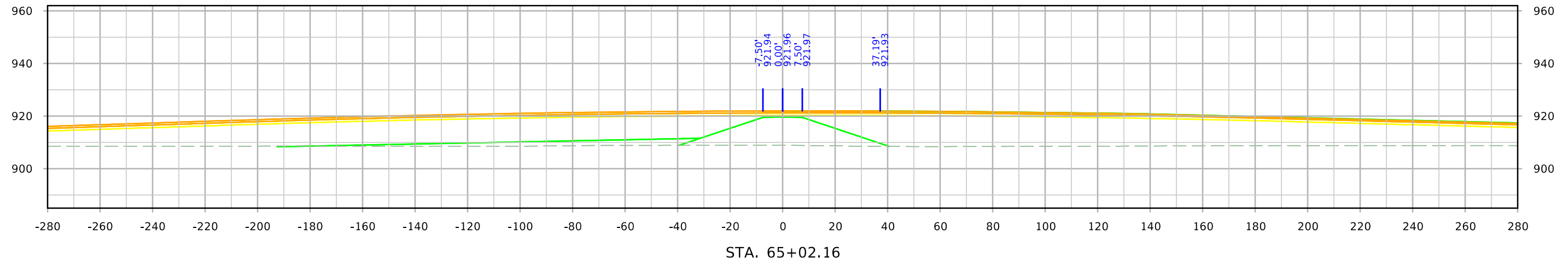

# DITCH 6 LEVEE - SOUTH ENTRANCE

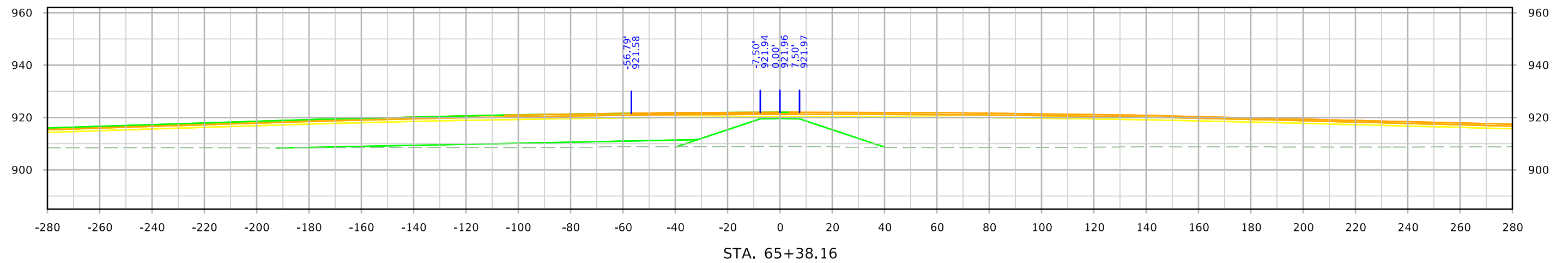
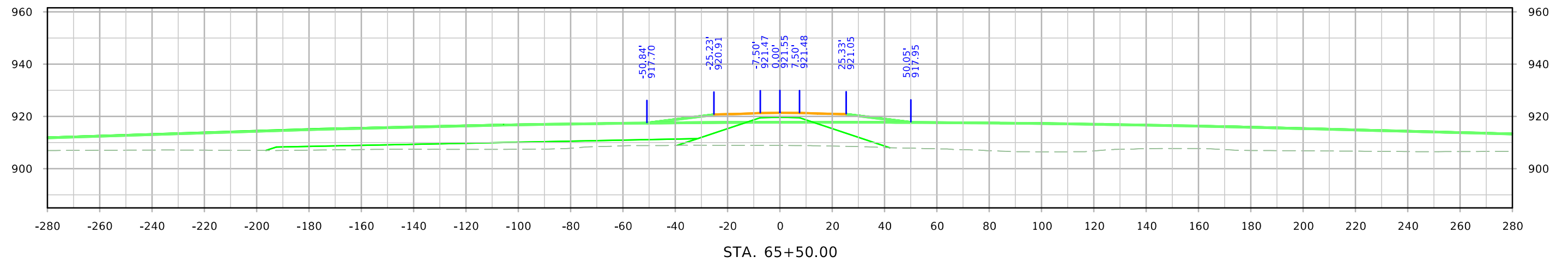
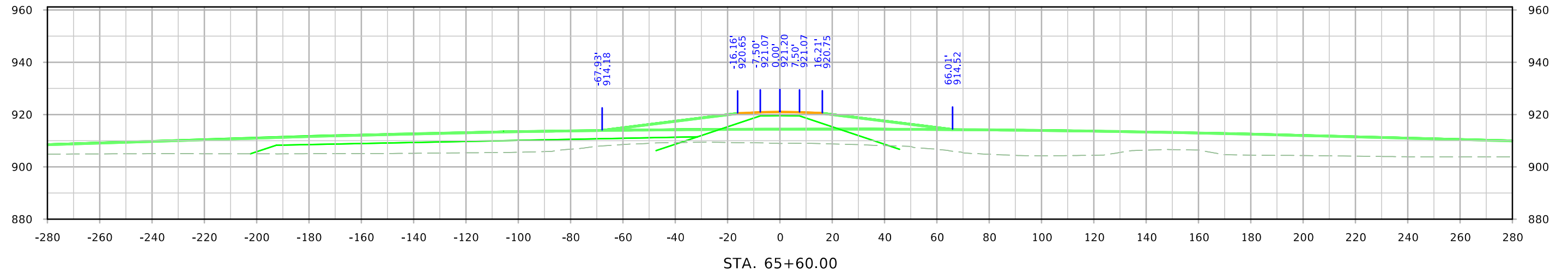

# DITCH 6 LEVEE - SOUTH ENTRANCE

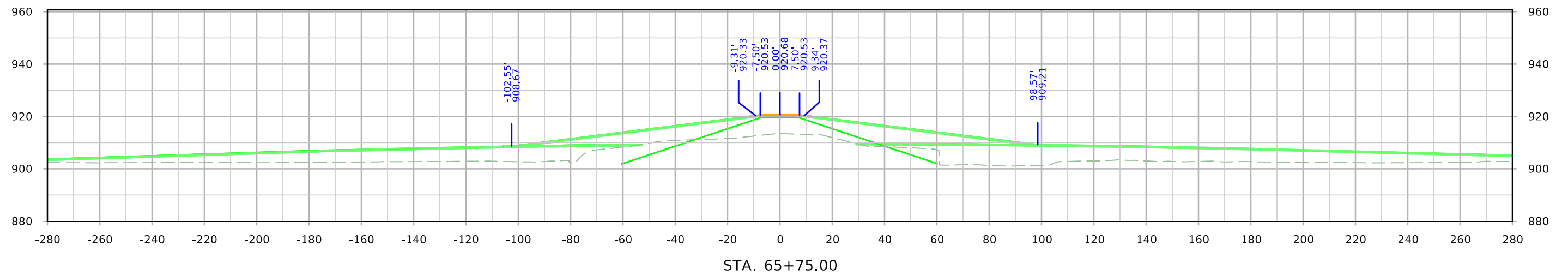
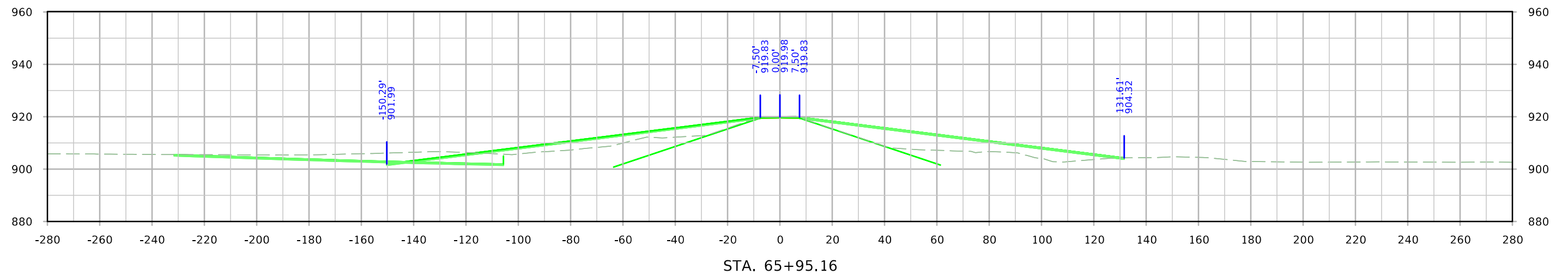
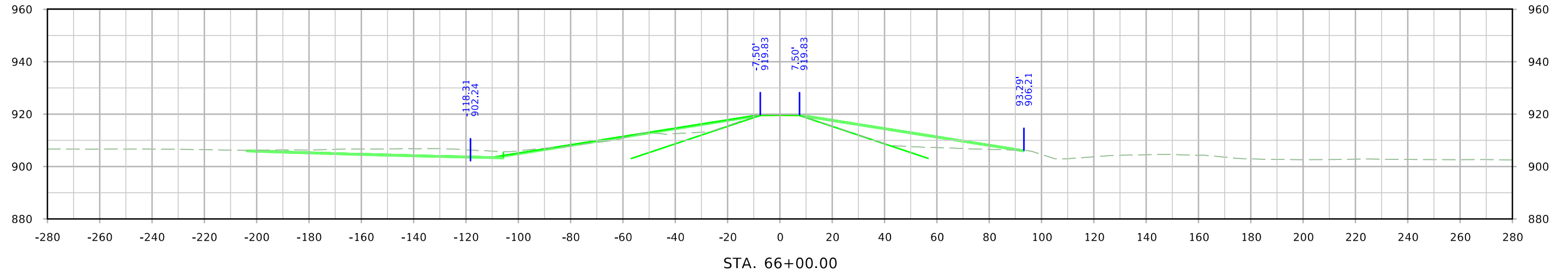

# DITCH 6 LEVEE - SOUTH ENTRANCE

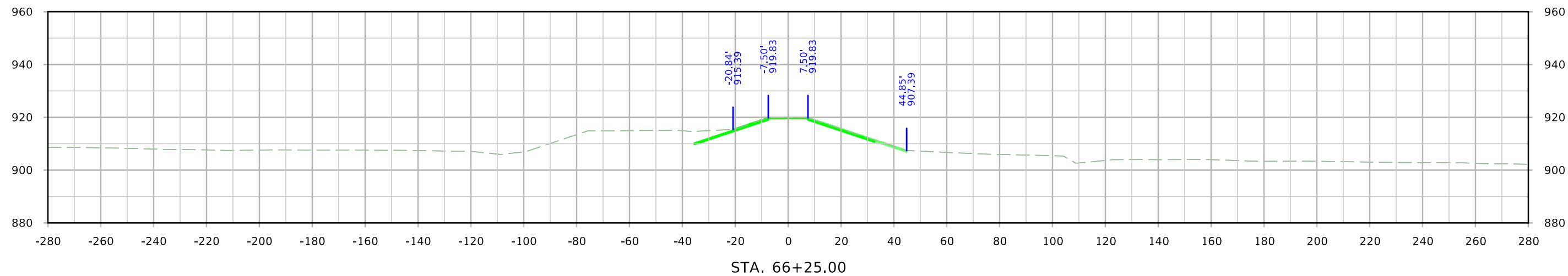

STA. 66+25.00

# DITCH 6 LEVEE - SOUTH ENTRANCE

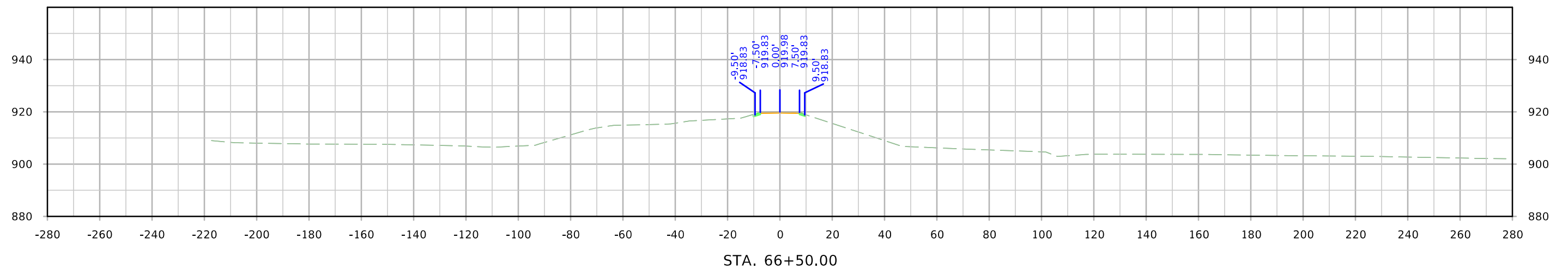
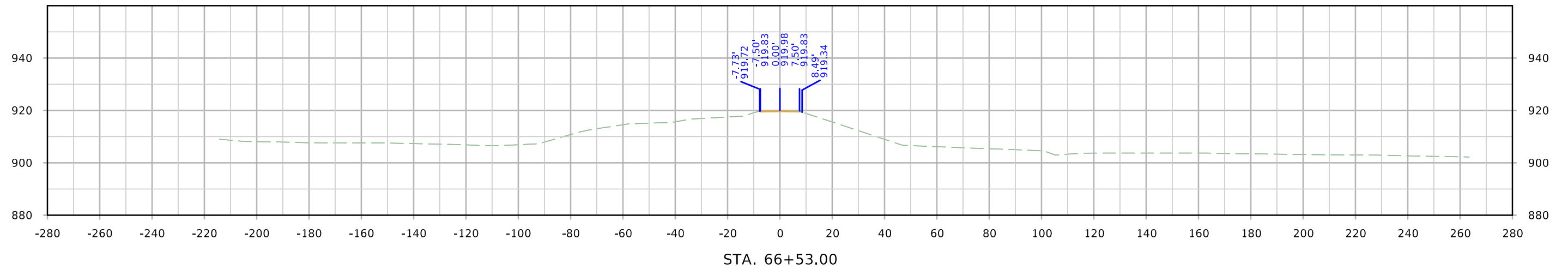



# Temporary Ring Levee

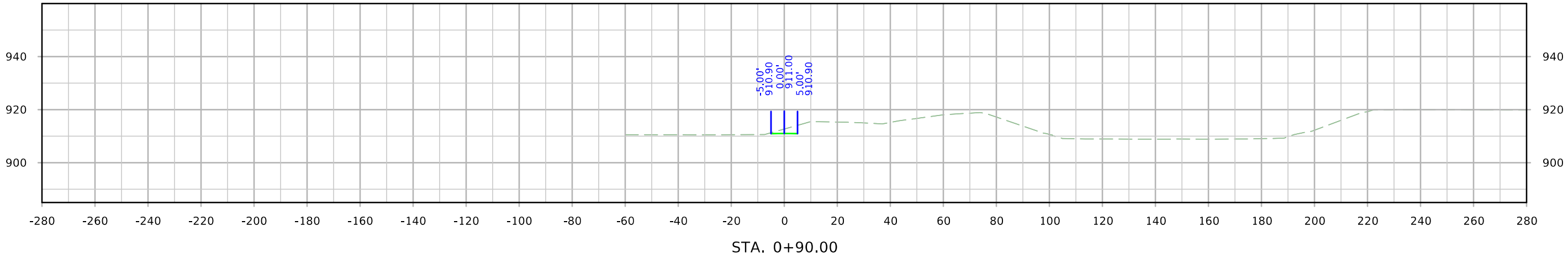
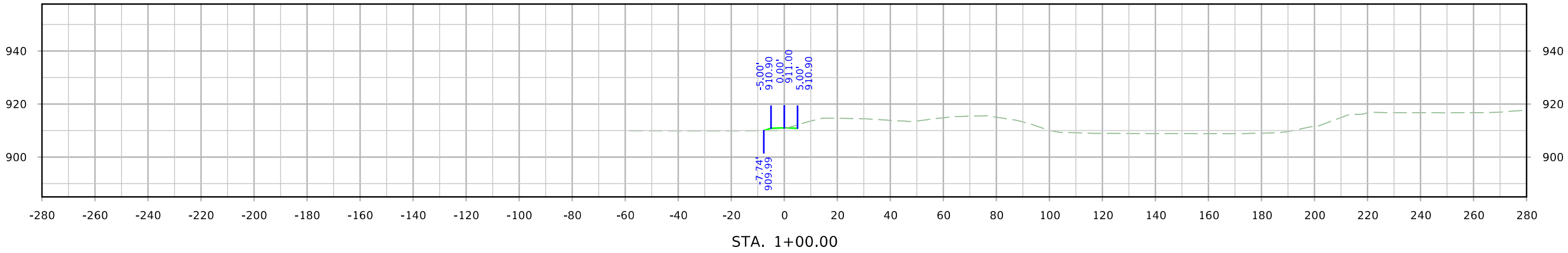
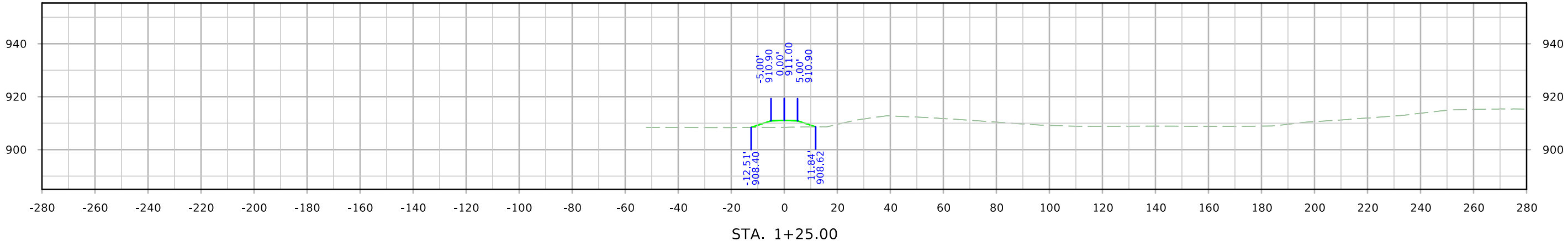

# Temporary Ring Levee

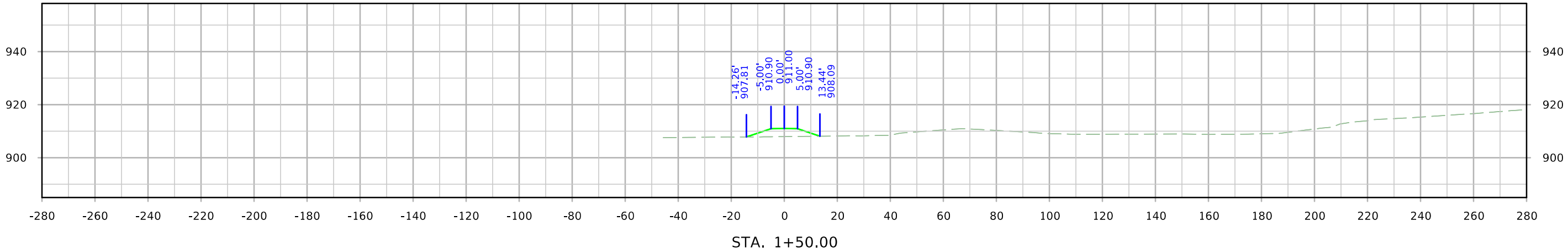
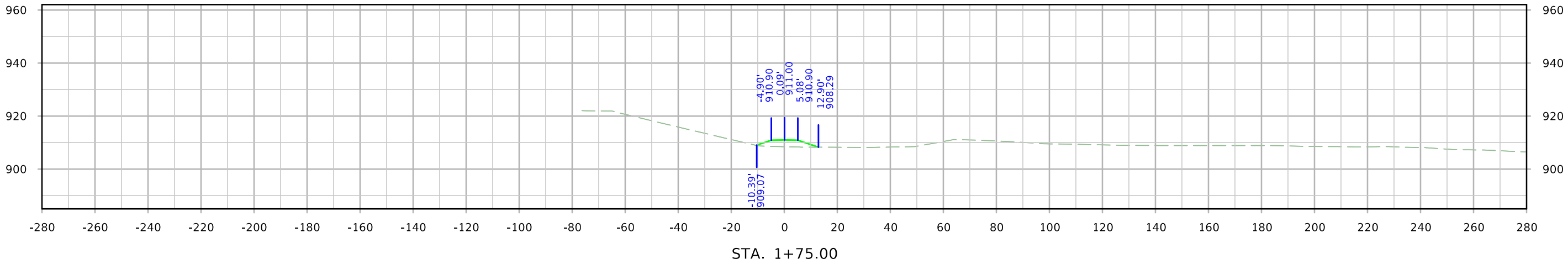
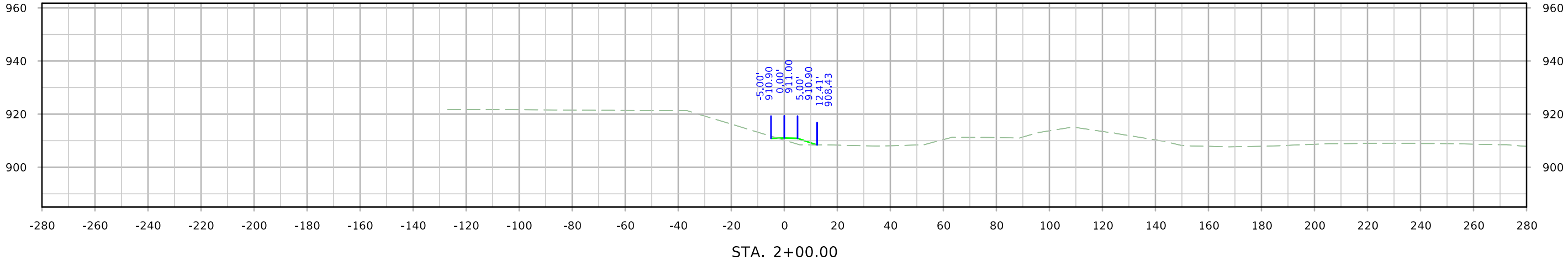

# Temporary Ring Levee

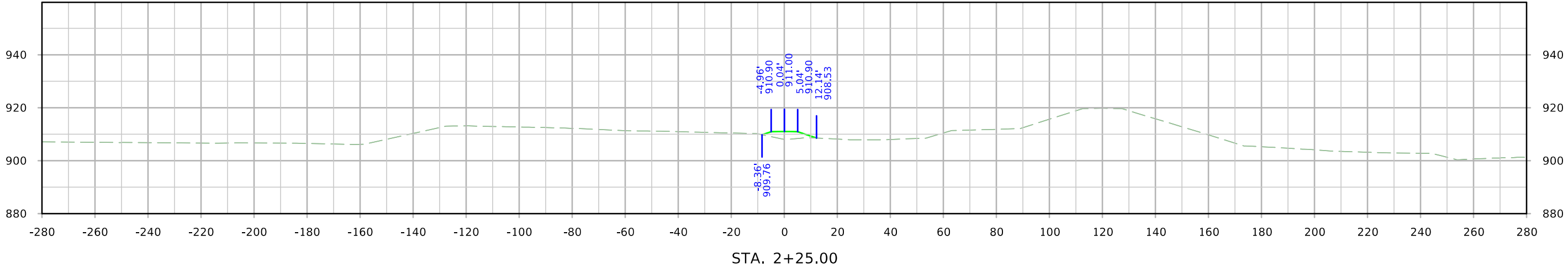
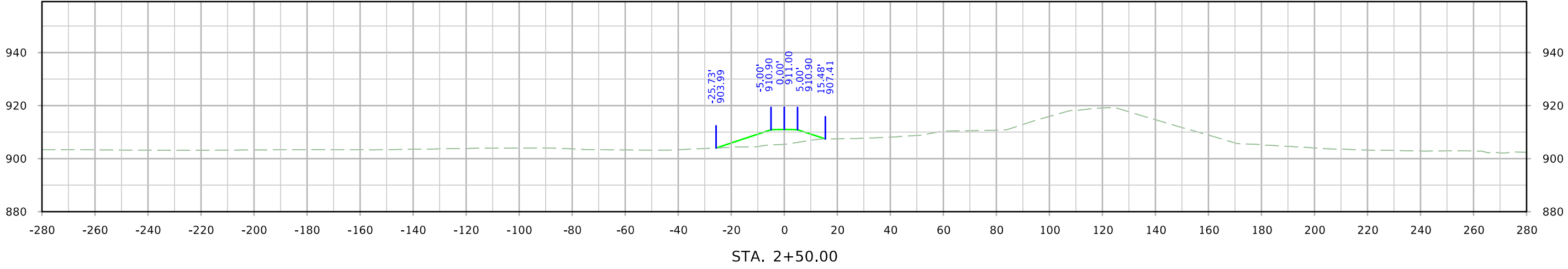
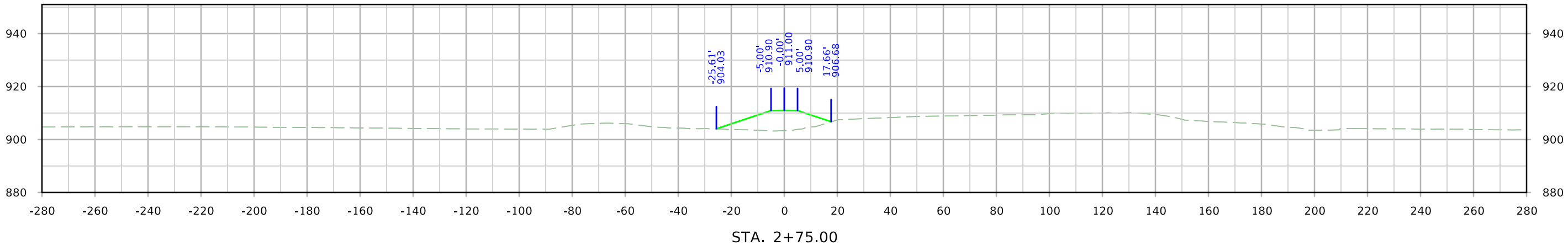

# Temporary Ring Levee

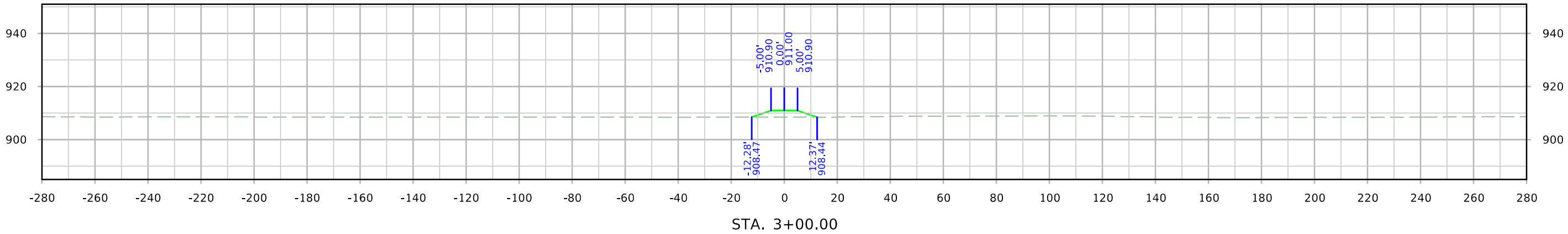
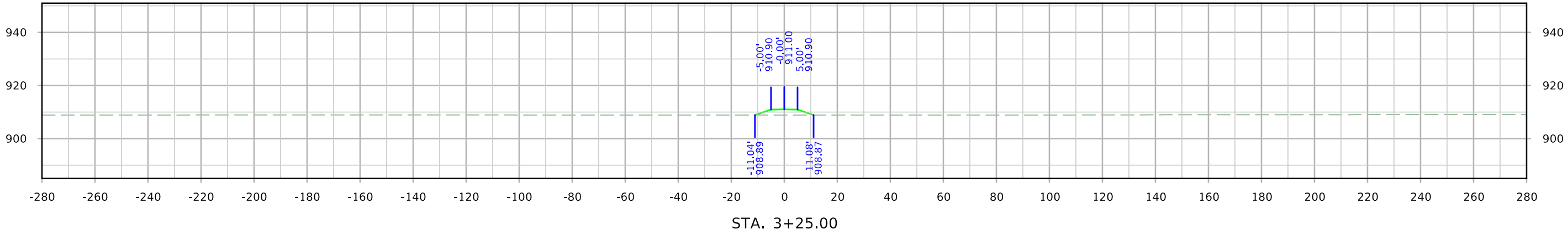
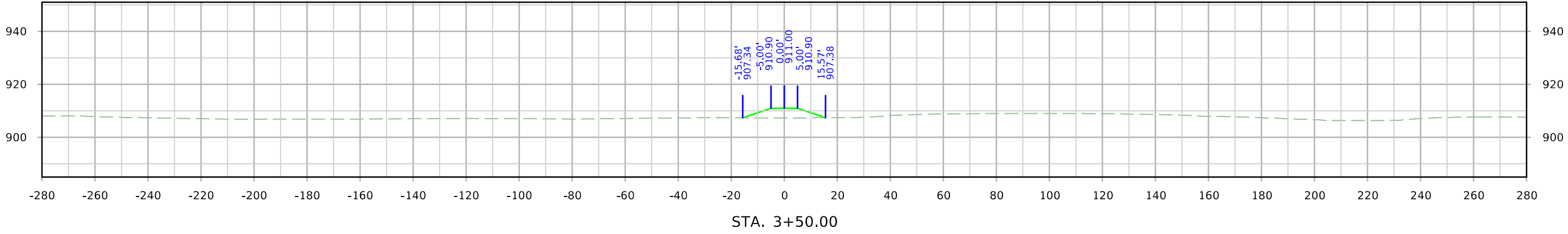

# Temporary Ring Levee

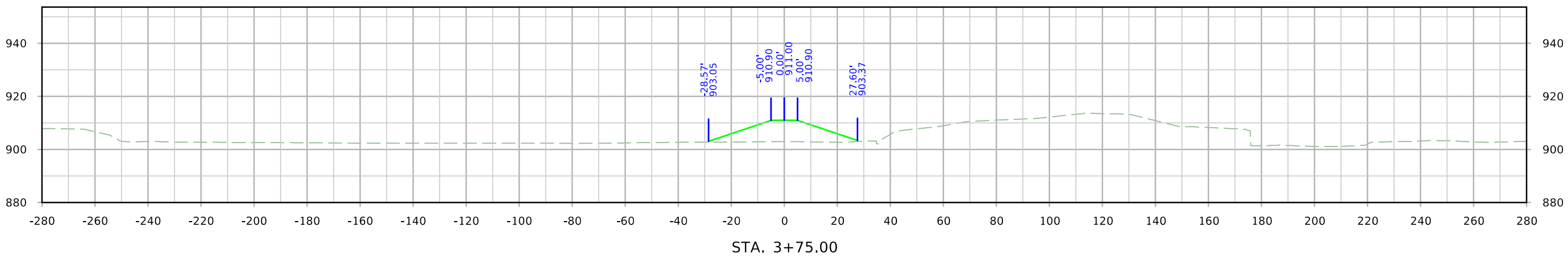
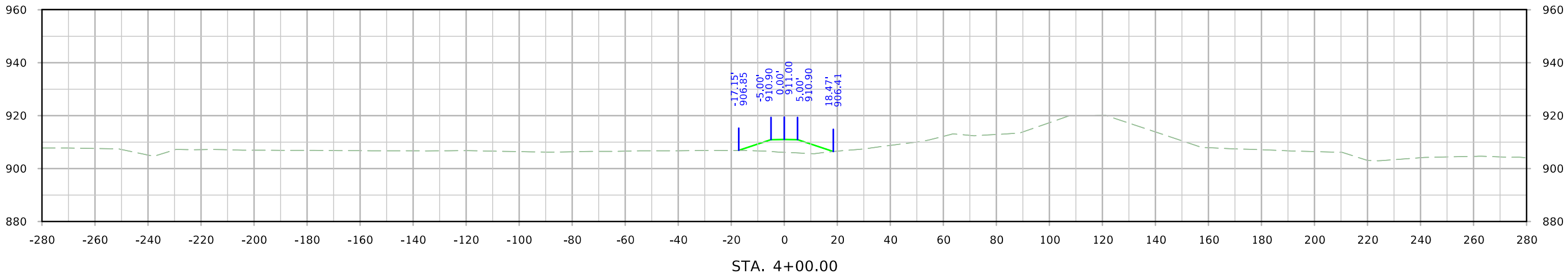
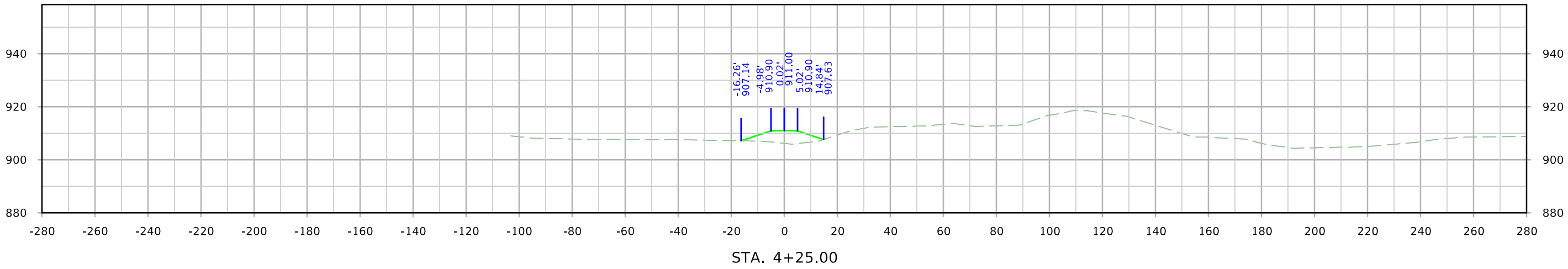

# Temporary Ring Levee

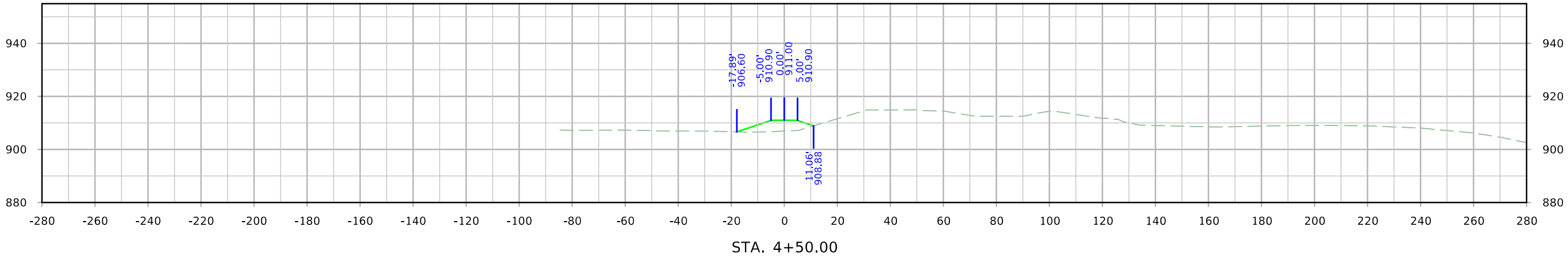
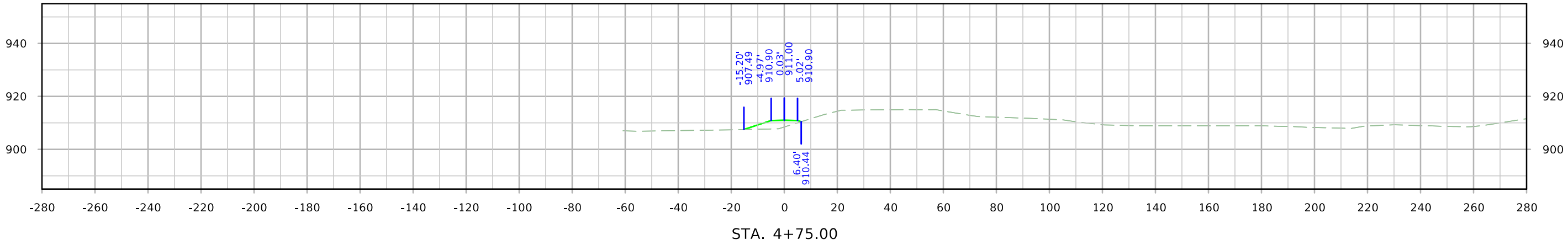
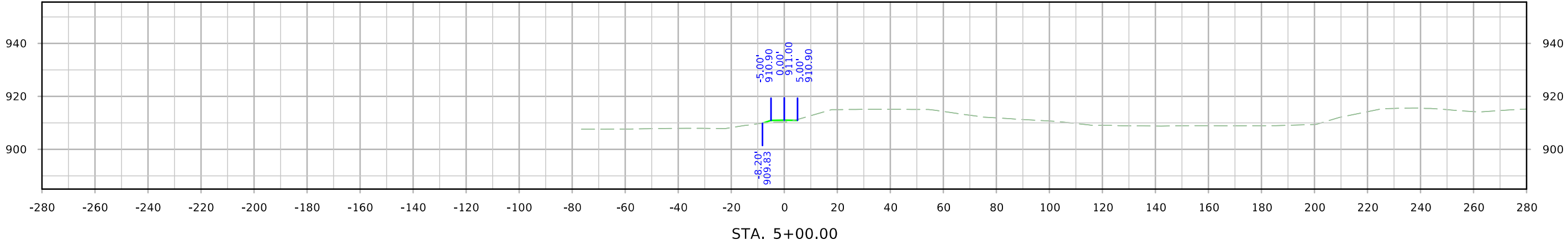

# Temporary Ring Levee

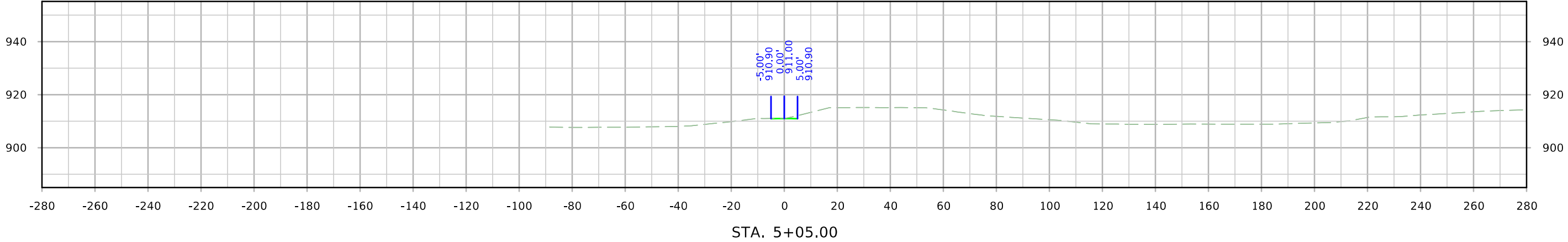

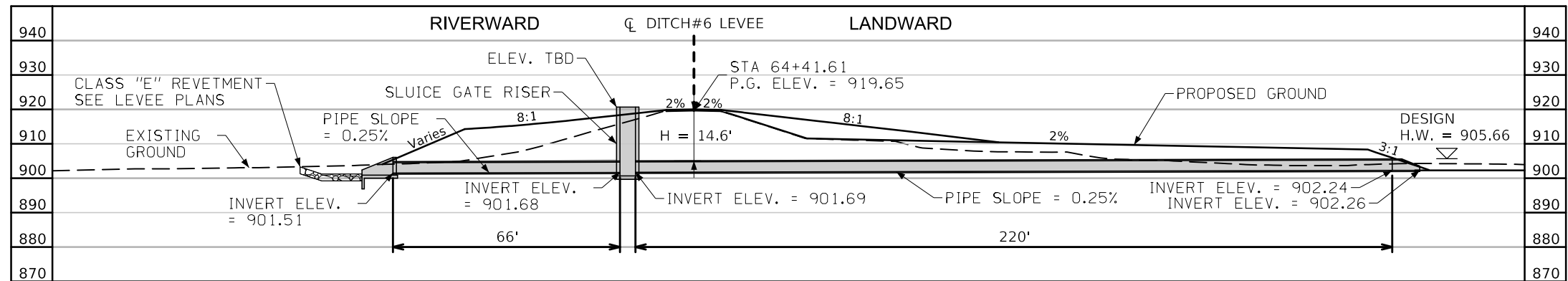

LONGITUDINAL SECTION ALONG CL CULVERT

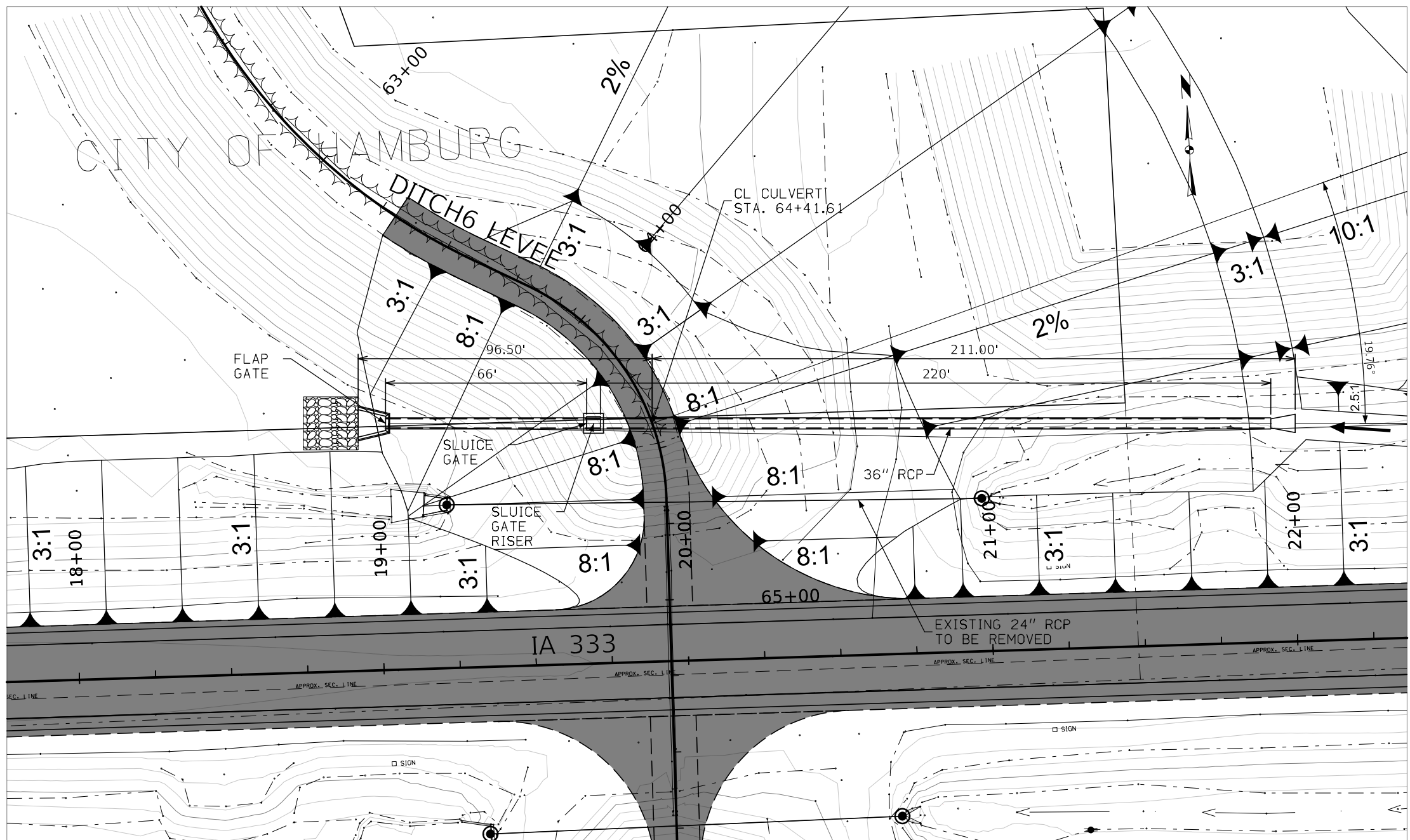

PLAT PLAN

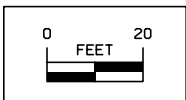

**Traffic Estimate**

IA-333  
 2019 AADT = 1460 A.P.D.  
 TRUCK = 11.1%

**Location**

LEVEE DITCH #6  
 T-67 N R-42 W  
 SECTION 21  
 WASHINGTON TOWNSHIP  
 FREMONT COUNTY

**Hydraulic Data**

DRAINAGE AREA = 35.2 acres  
 Q50 = 45 CFS  
 Q100 = 54 CFS  
 HW ELEV. = 905.66

Design For 19.76° Skew ( LA )  
**36" X 286'**  
**REINFORCED CONCRETE PIPE**  
**PLAT PLAN**  
 STA. 64+41.61 (DITCH6LEVEE) Letting Date: APRIL 18, 2023  
**FREMONT COUNTY**  
 IOWA DEPARTMENT OF TRANSPORTATION



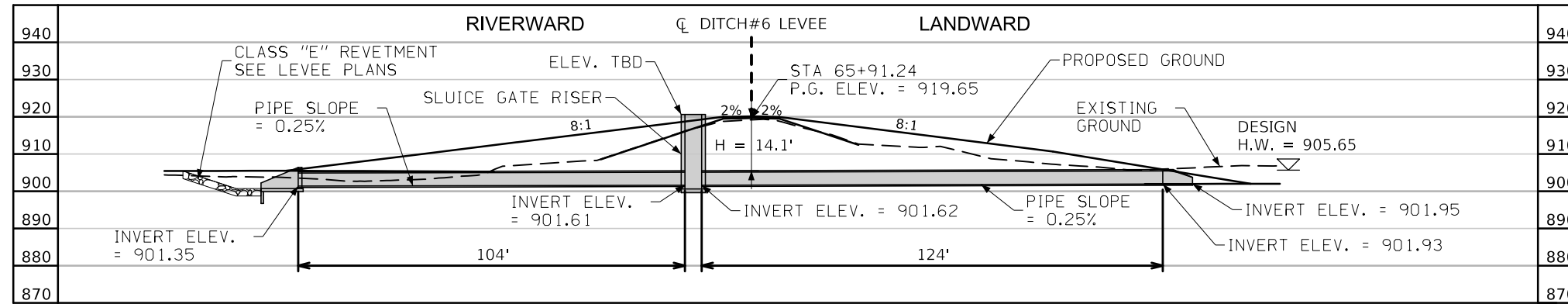

LONGITUDINAL SECTION ALONG CL CULVERT

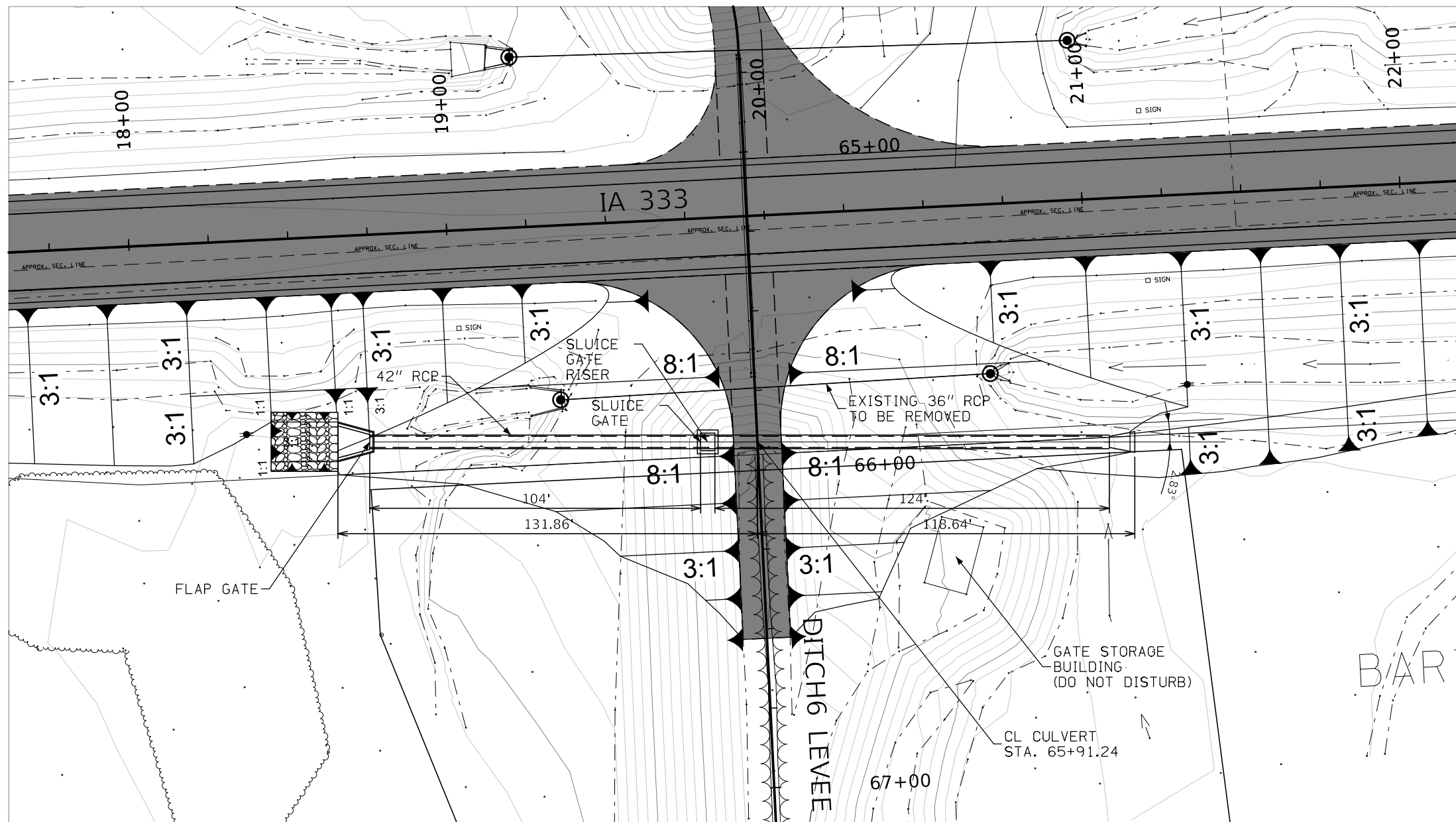

PLAT PLAN

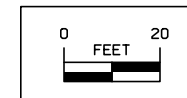

**Traffic Estimate**

IA-333  
 2019 AADT = 1460 A.P.D.  
 TRUCK = 11.1%

**Location**

LEVEE DITCH #6  
 T-67 N R-42 W  
 SECTION 28  
 WASHINGTON TOWNSHIP  
 FREMONT COUNTY

**Hydraulic Data**

DRAINAGE AREA = 57.6 acres  
 Q50 = 53 CFS  
 Q100 = 70 CFS  
 HW ELEV. = 905.65

Design For 2.83° Skew ( LA )  
**42" X 228'**  
**REINFORCED CONCRETE PIPE**  
**PLAT PLAN**  
 STA. 65+91.24 (DITCH6LEVEE) Letting Date: APRIL 18, 2023  
**FREMONT COUNTY**  
 IOWA DEPARTMENT OF TRANSPORTATION  
 Design No. TBD Design Sheet No. X of X FHWA No. TBD  
 SHEET NUMBER **V.2**

**LINE STYLE LEGEND OF CROSS SECTION SHEETS (ROAD)**

- Existing Ground Line
- ===== Proposed Template
- ===== Proposed Topsoil Placement
- Additional Topsoil Removal
- Subgrade Treatment
- Granular Shoulder
- ===== Pavement
- Existing Pipe\RCB
- ===== Proposed Pipe\RCB
- ===== Proposed Dike
- All Elements Associated with Proposed Entrances

**LINE STYLE LEGEND OF CROSS SECTION SHEETS (SOILS)**

- Topsoil (Class 10)
- Slope Dressing Only
- Class 10 Materials
- Select Loams And Clay-Loams
- Select Sand
- Unsuitable Type A Disposal
- Unsuitable Type B Disposal
- Unsuitable Type C Disposal
- Shale
- Waste
- Broken and Weathered Rock
- Solid Rock
- Boulders

Note: All layer lines and descriptions identify layers above the line.

Note: Vertical or near vertical lines connecting soil layers at edges of cross sections are only for the purpose of calculating template quantities and do not depict soil stratification.

**SYMBOL LEGEND OF CROSS SECTION SHEETS**

- Existing ROW  
| Existing Right-of-Way Limit
- Proposed ROW  
| Proposed Right-of-Way Limit
- Temporary ROW  
| Temporary Right-of-Way Limit

**CROSS SECTION VIEW SUBSTRATA COLOR LEGEND**

Design Color No.	Feature
(128)	Boulder Substrata
(3)	Core out Substrata
(203)	Existing Pavement
(6)	Loam Substrata
(80)	Rock Substrata
(4)	Select Sand Substrata
(3)	Shale Substrata
(10)	Existing Topsoil Substrata
(3)	Unsuitable Type A Substrata
(13)	Unsuitable Type B Substrata
(11)	Unsuitable Type C Substrata
(3)	Waste Substrata

**NOTES:**

Text

**NOTES:**

Text

**CROSS SECTIONS  
LEGEND AND INFORMATION SHEET**

(COVERS SHEET SERIES W, X, Y, & Z)

# ML - IA333

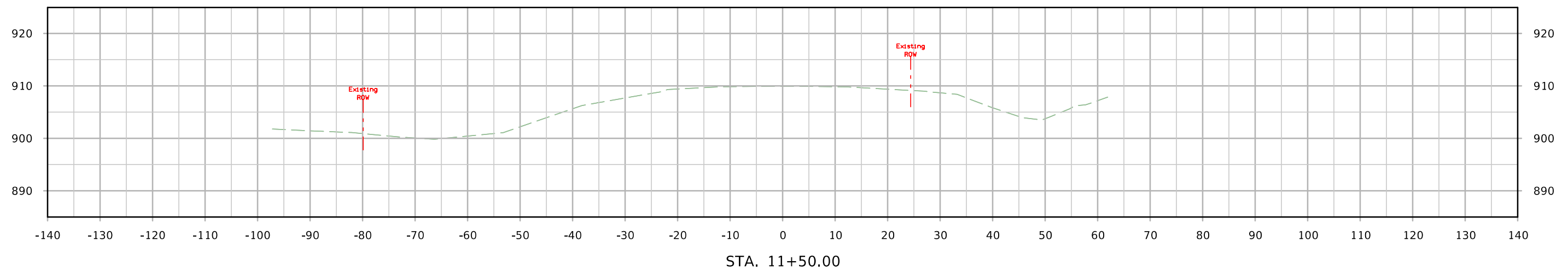
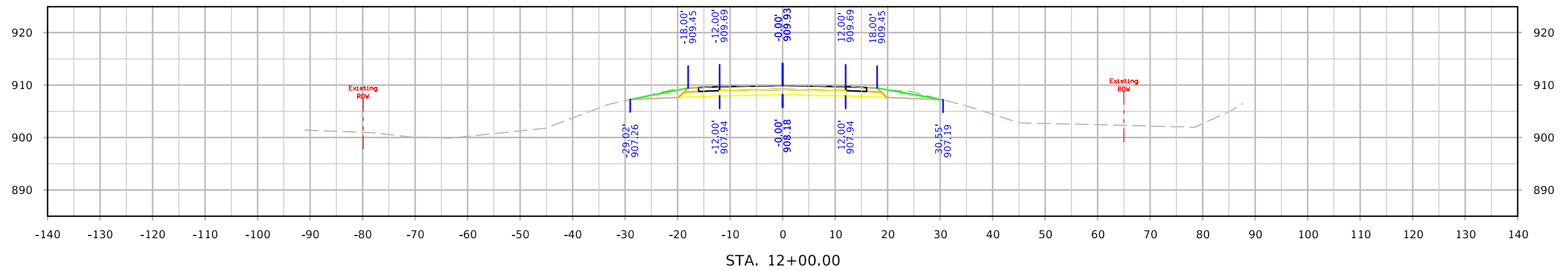
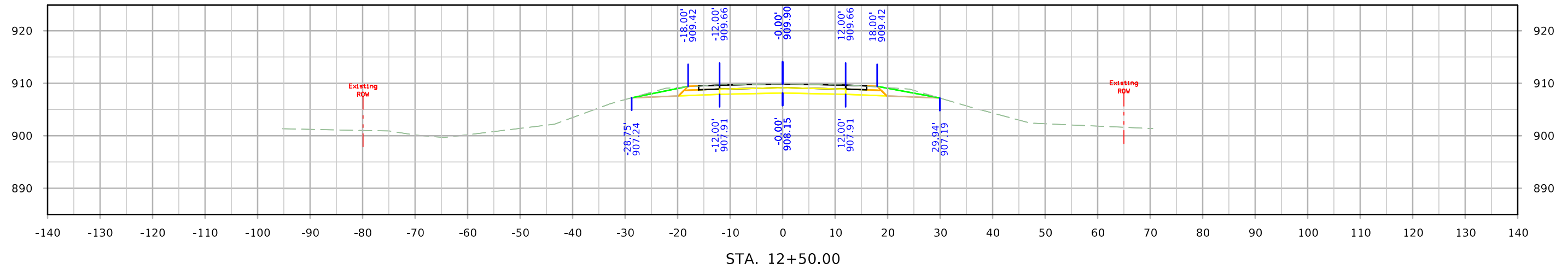

# ML - IA333

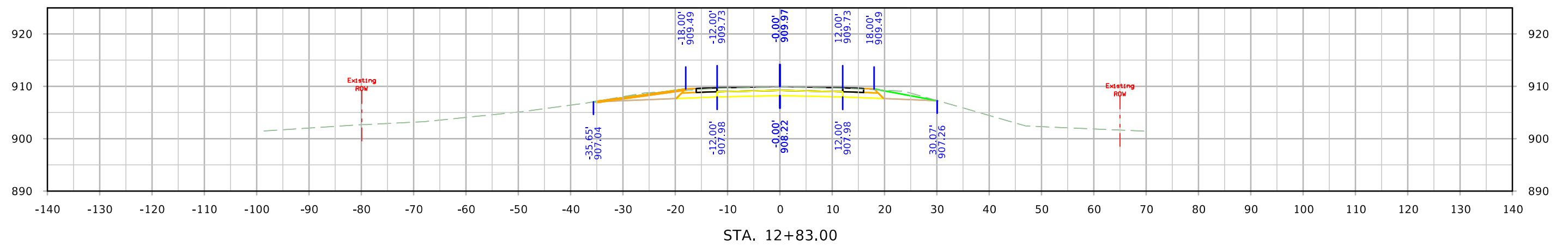
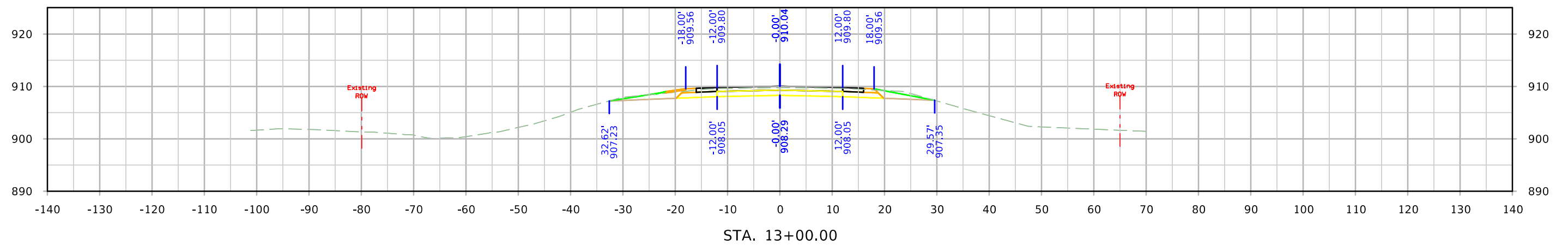
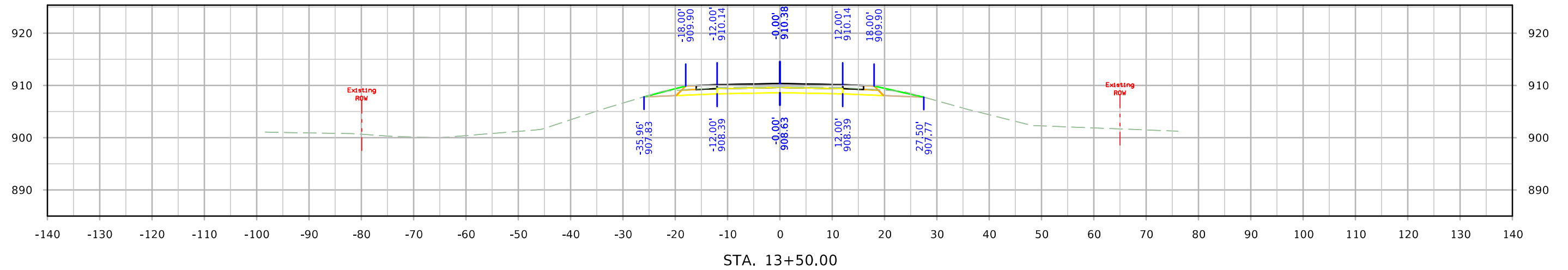

# ML - IA333

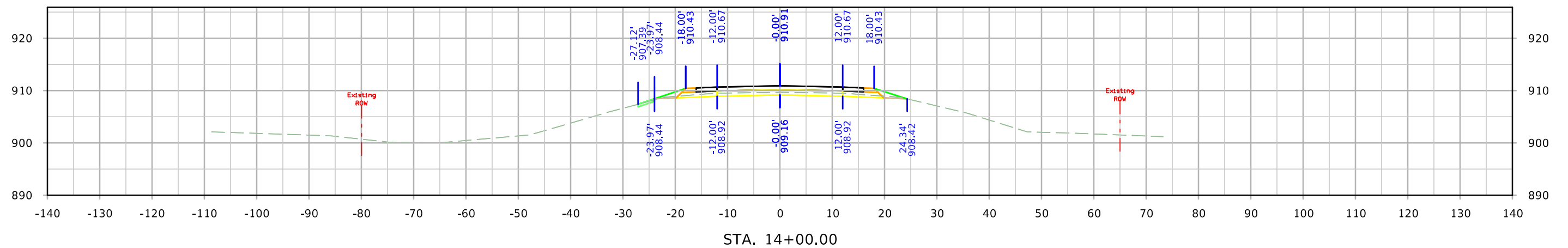
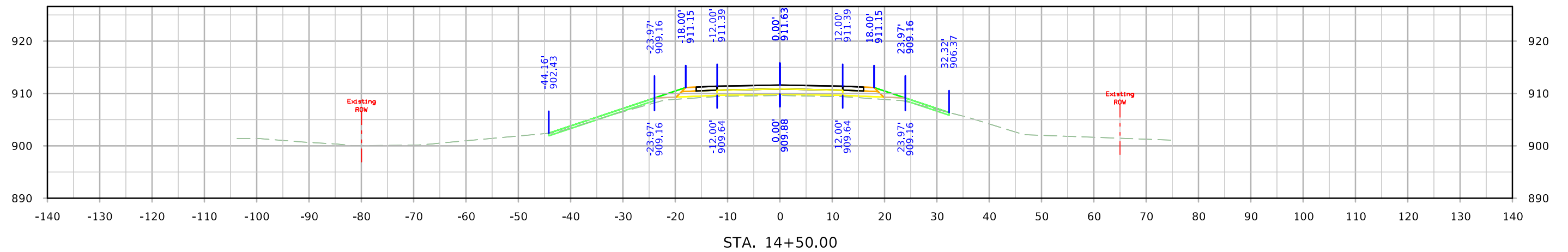
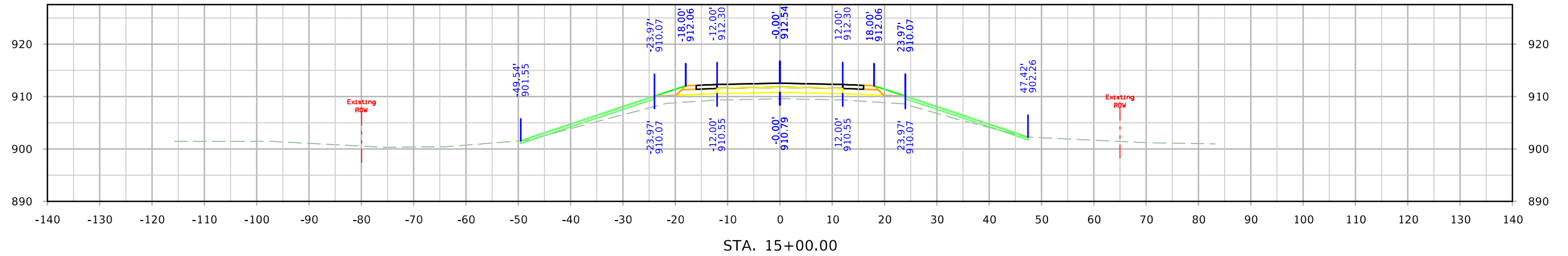

# ML - IA333

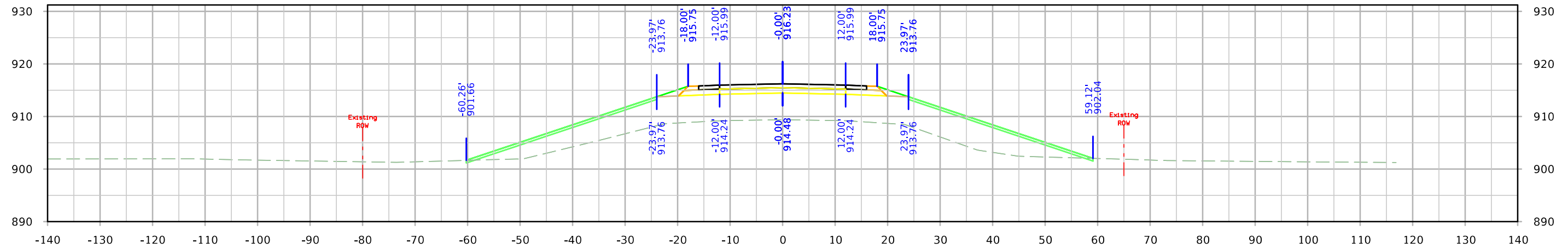

STA. 16+50.00

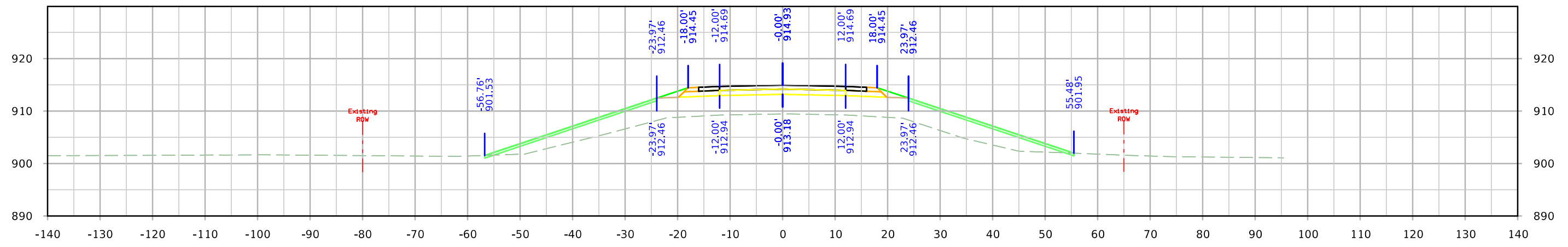

STA. 16+00.00

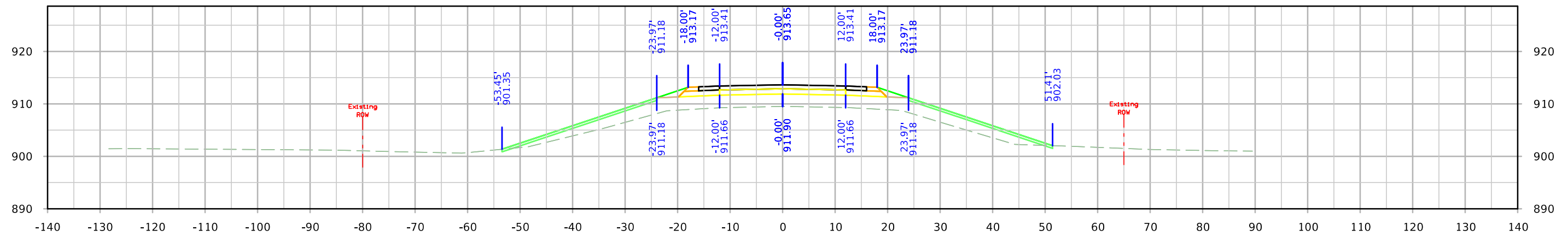

STA. 15+50.00

# ML - IA333

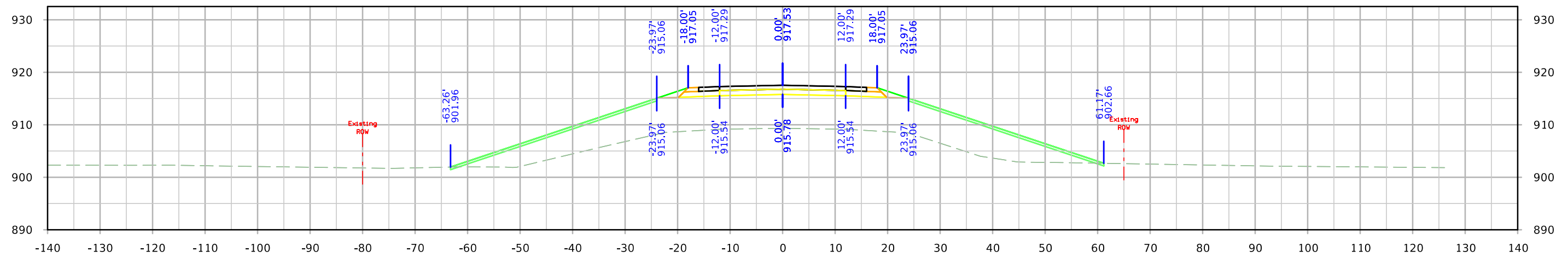
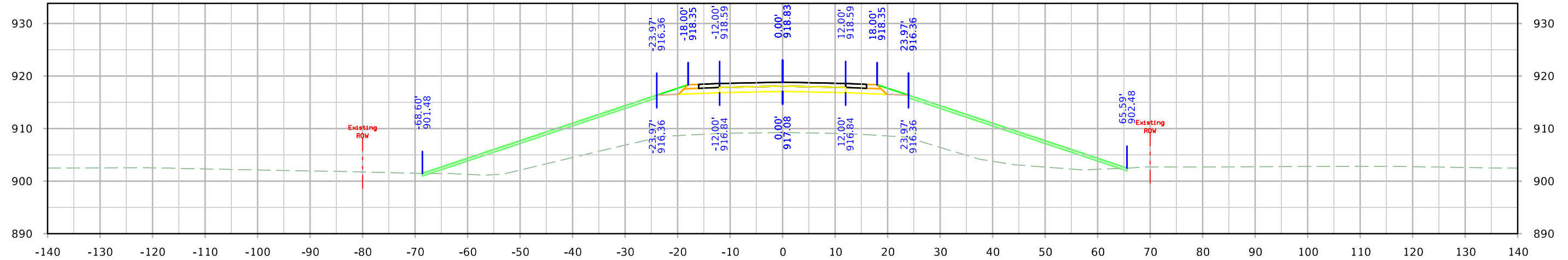
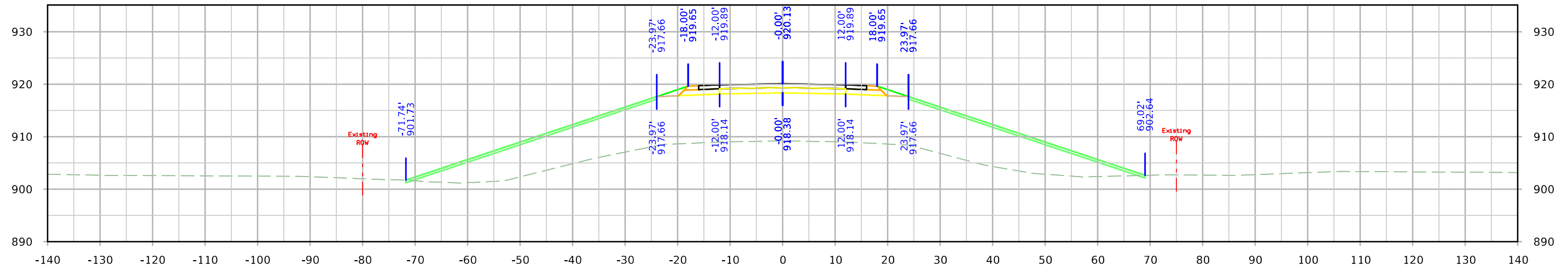

# ML - IA333

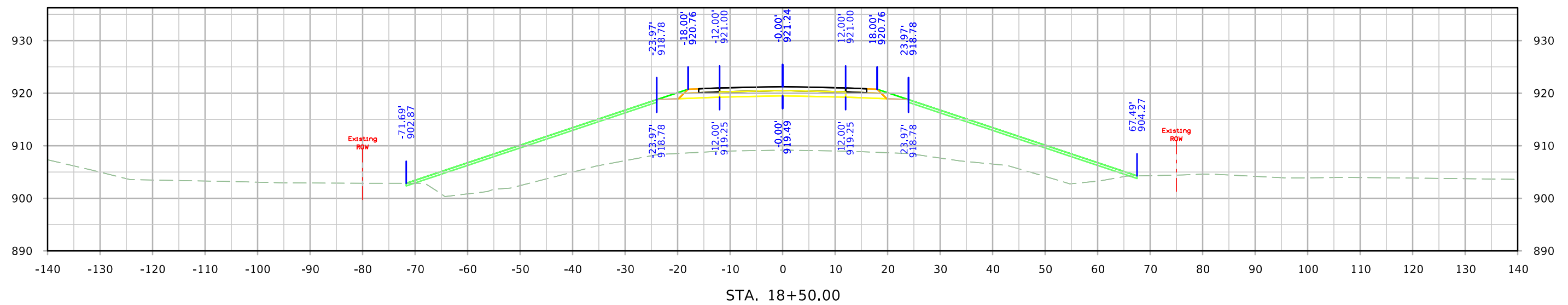
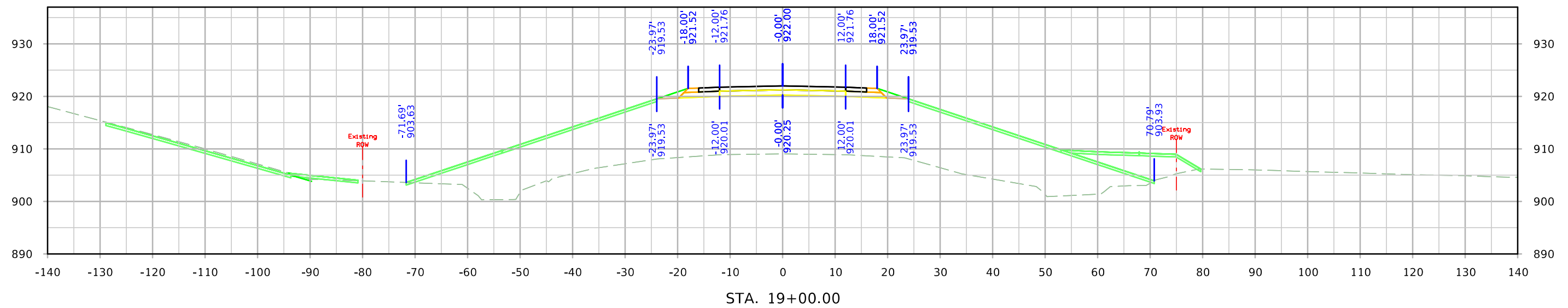



# ML - IA333

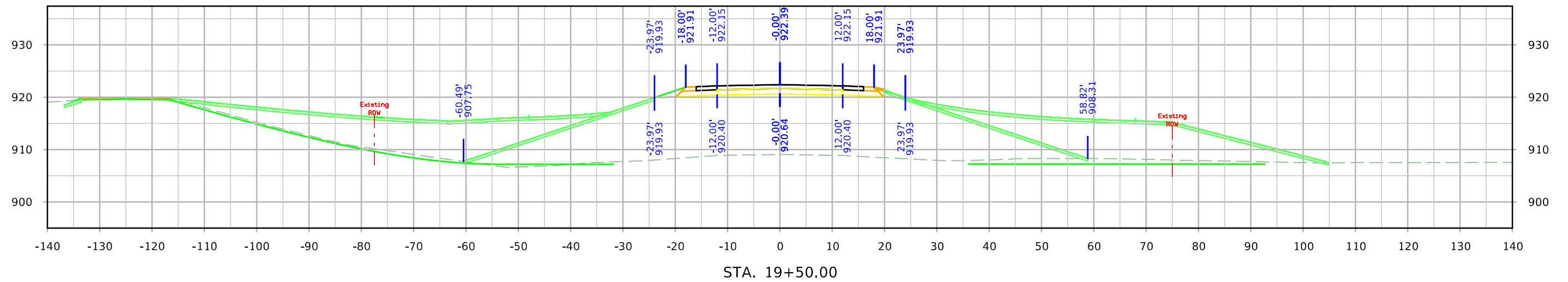
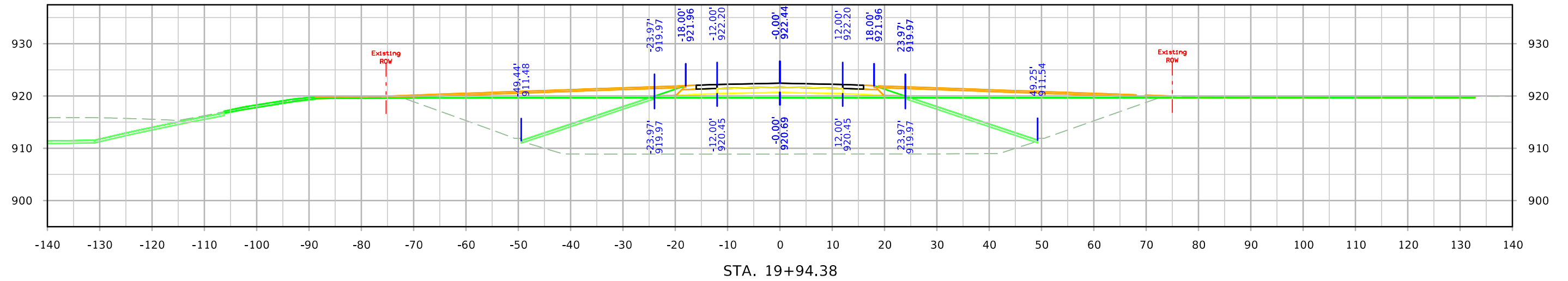
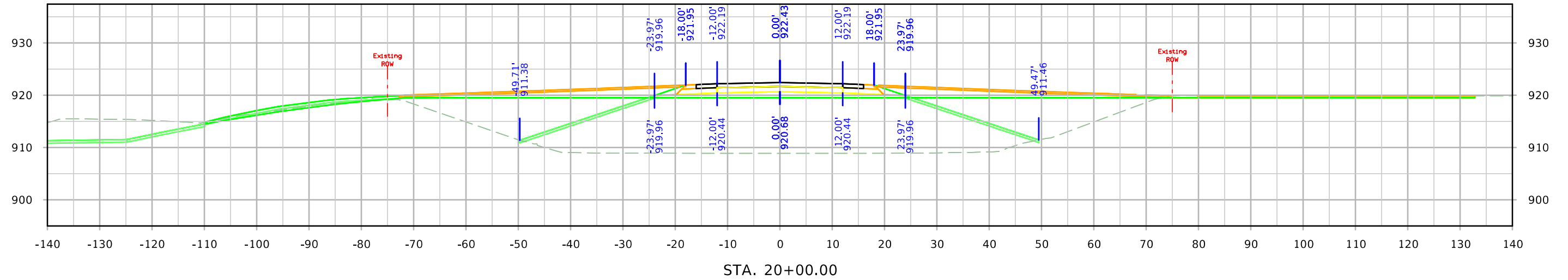

# ML - IA333

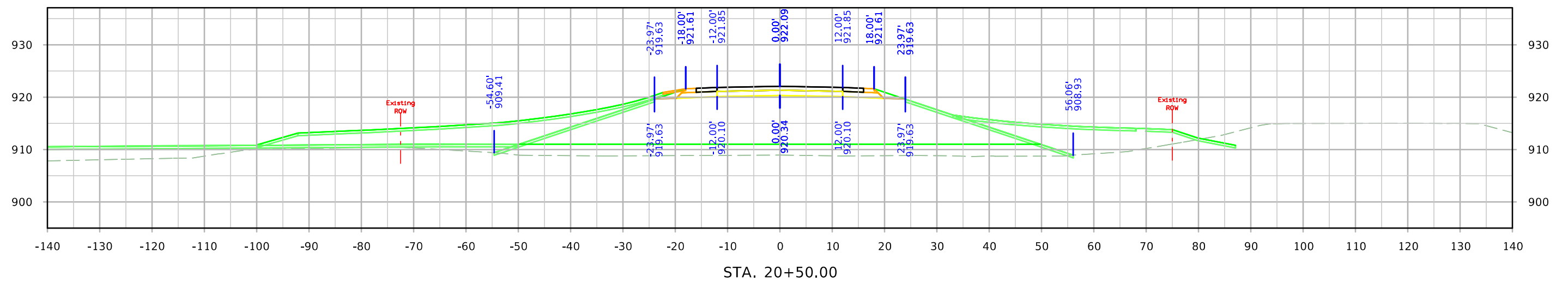
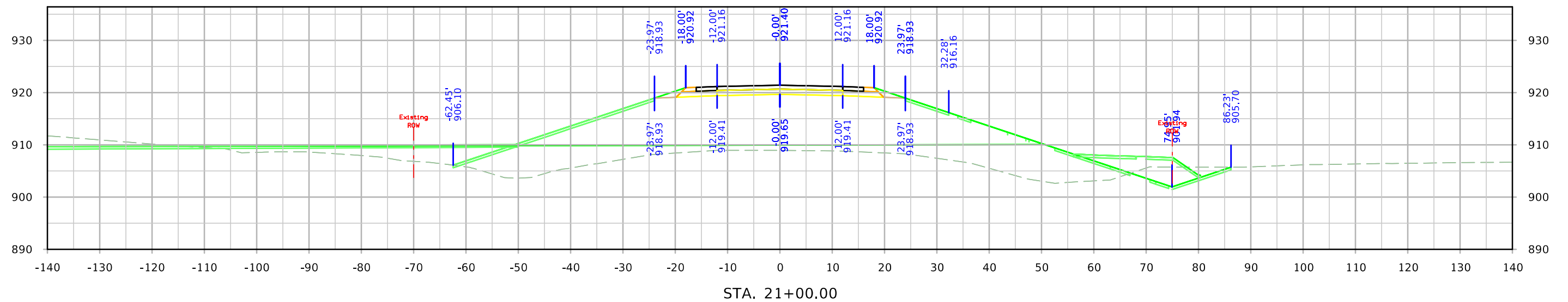

# ML - IA333

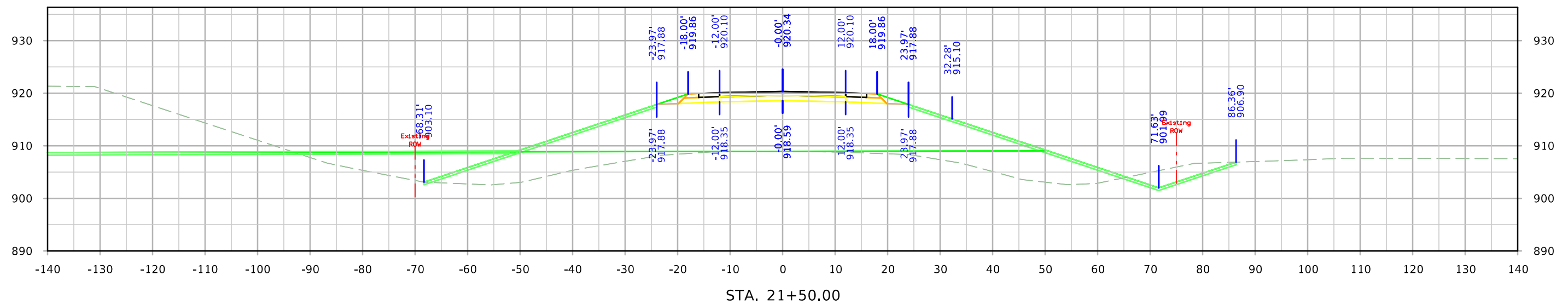
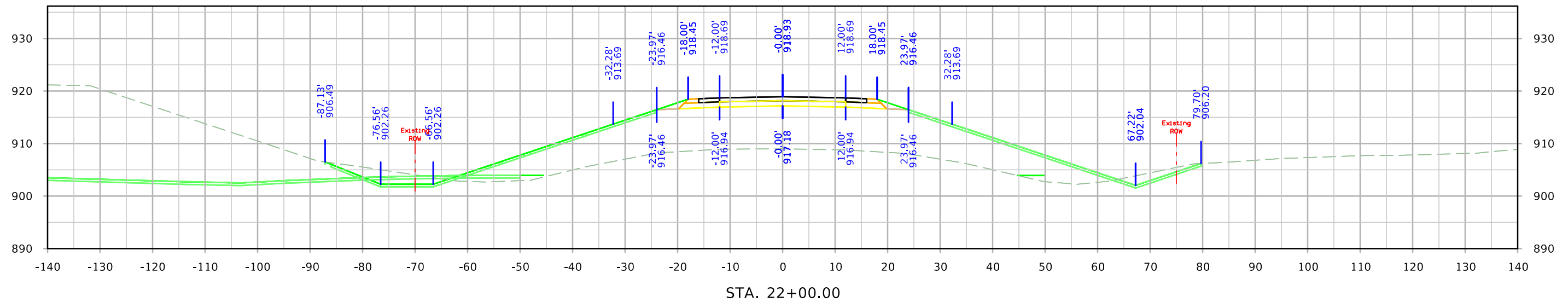

# ML - IA333

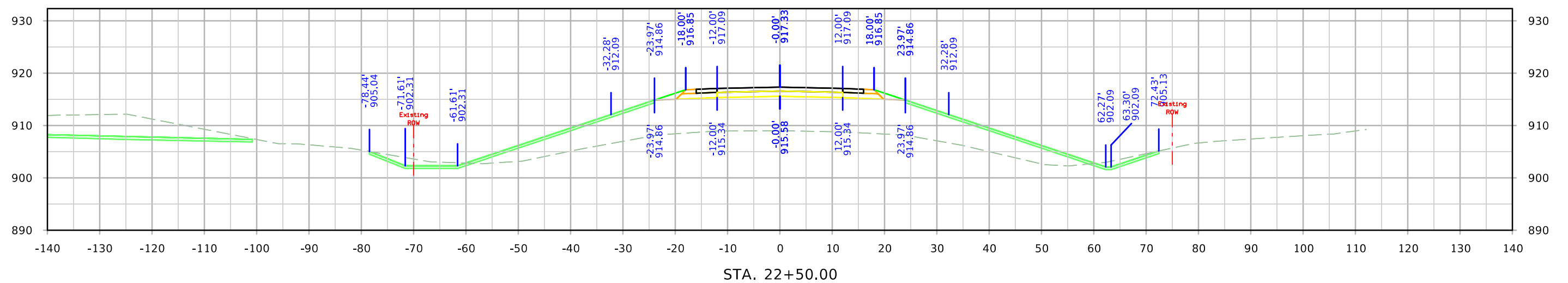
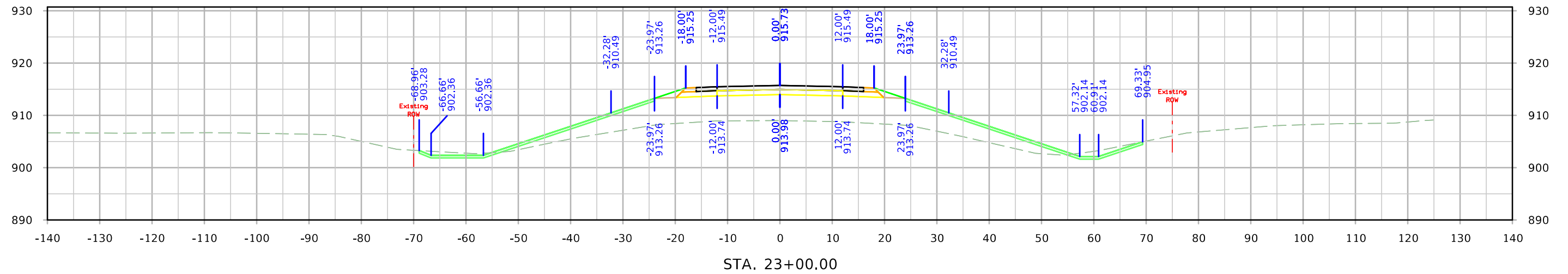
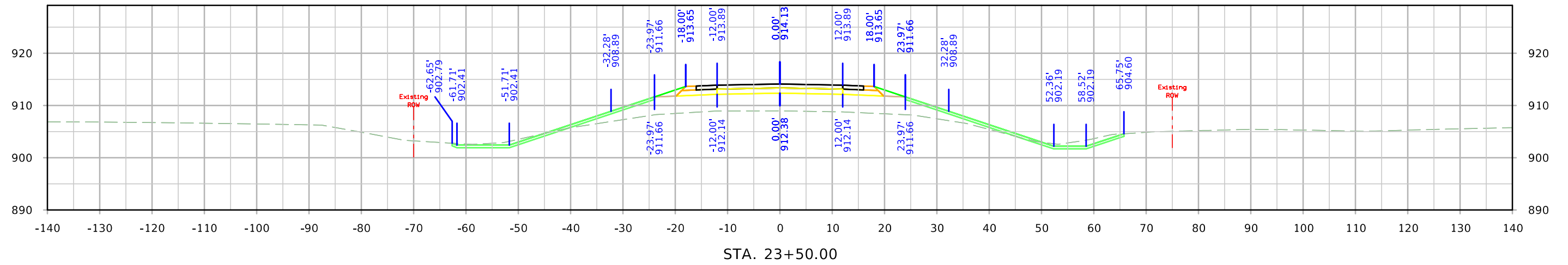

# ML - IA333

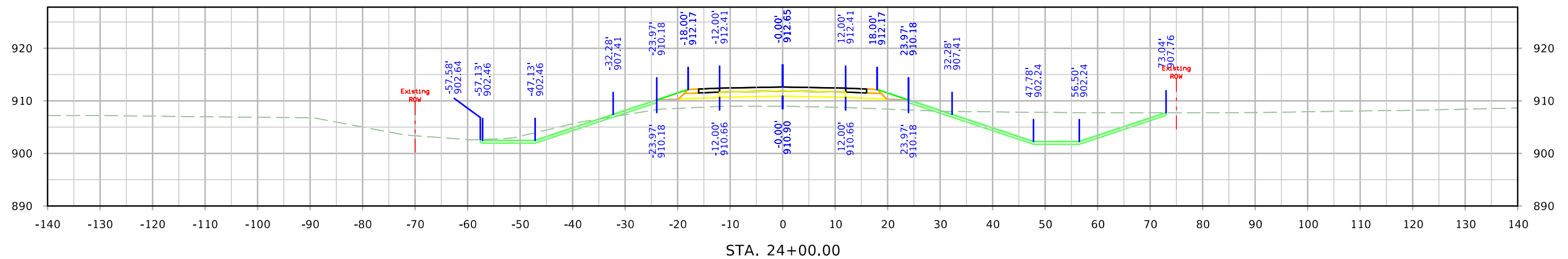
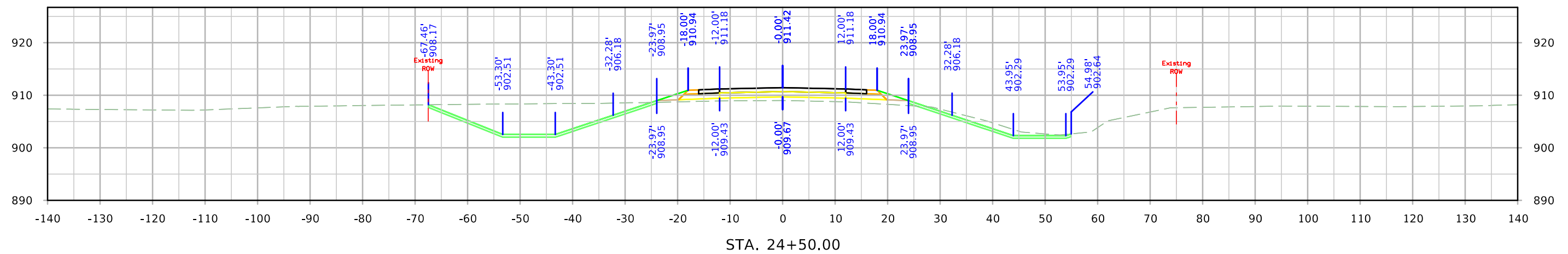
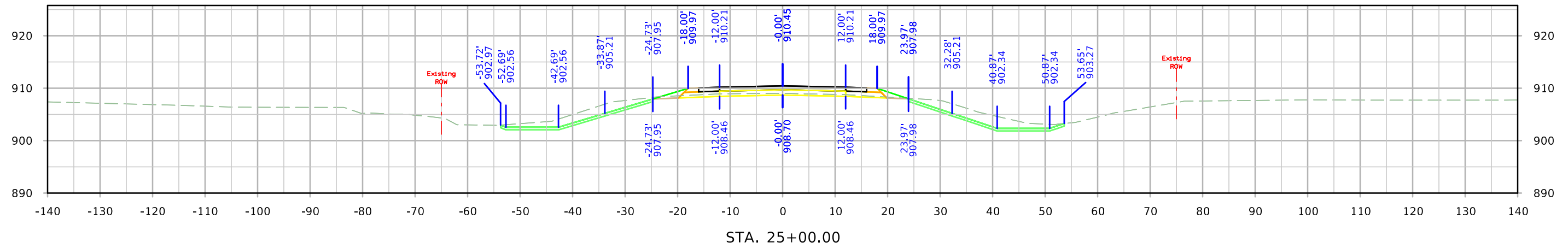

# ML - IA333

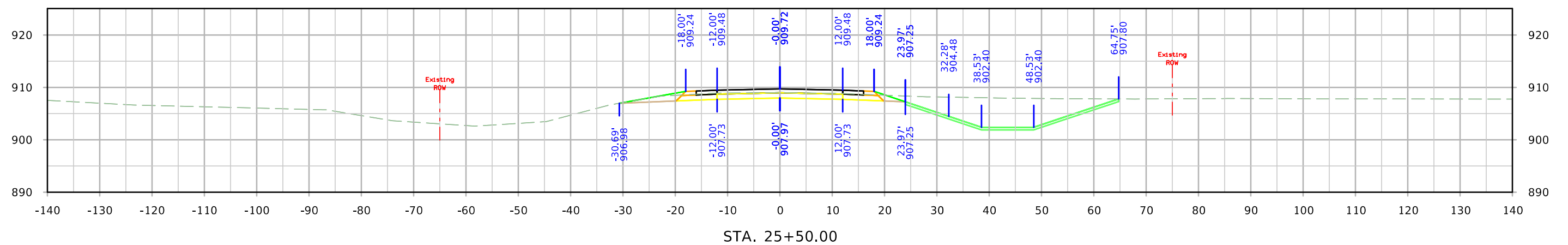
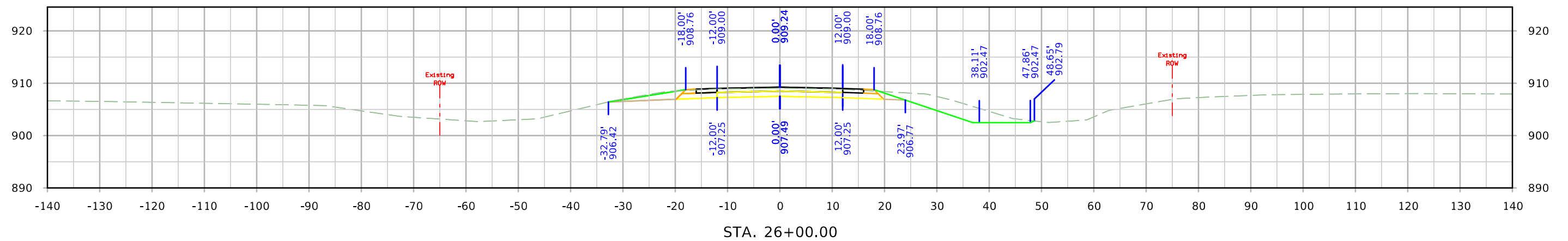
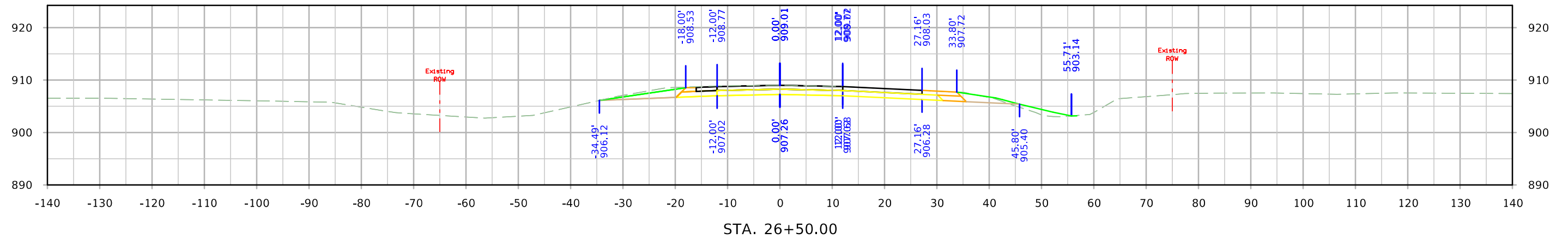

# ML - IA333

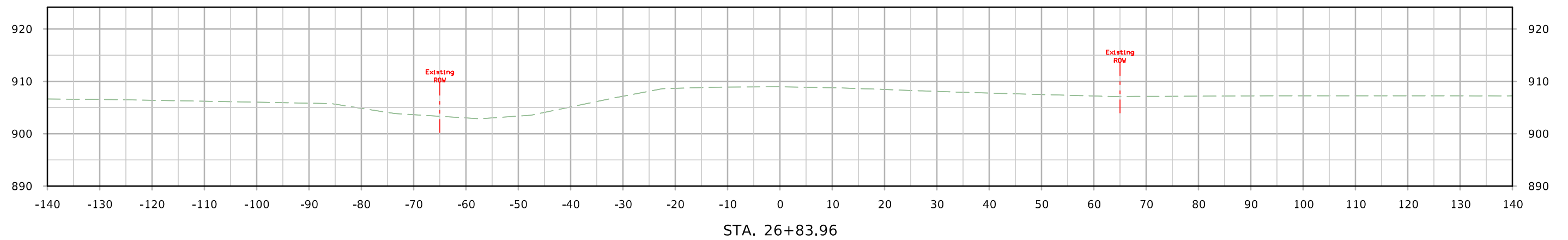
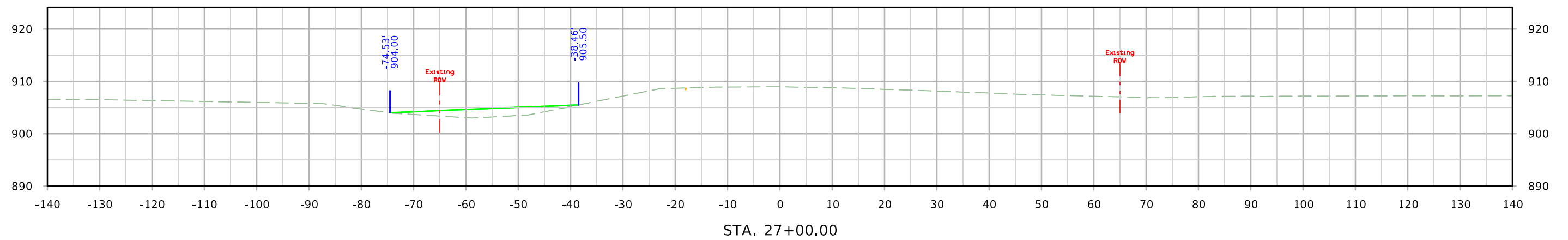
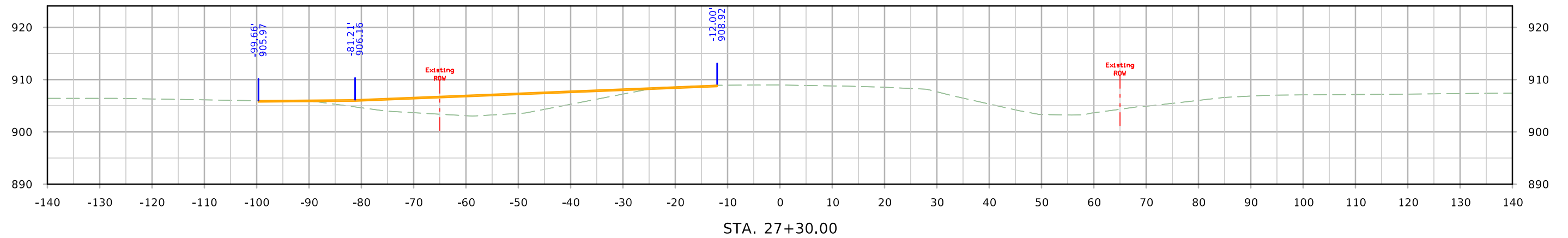

# ML - IA333

