

PLAN FOR SILT FENCE (1)

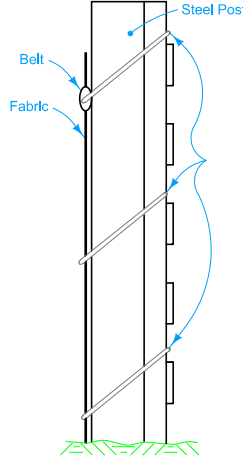

**PROFILE VIEW
ATTACHMENT TO POST**

Install all silt fence using a silt fence machine. Use manual (trench) installation if physical conditions prohibit machine installation.

For machine installation, compact by driving over each side of silt fence at least two times with a rubber-tired vehicle.

For manual installation, compact with a mechanical or pneumatic tamper.

Place silt fence continuously up to a maximum length of 200 feet. For every segment of silt fence that is placed, flare up the slope the last 20 feet of the segment to contain runoff as shown.

- ① Secure top of engineering fabric to steel posts using cable ties (50 lb.) or wire passing through or encompassing the belt. See attachment to post.
- ② For manual installation only, fold engineering fabric along bottom of trench.
- ③ Embed all posts 28 inches below the ground line.
- ④ Refer to Tab. 100-17

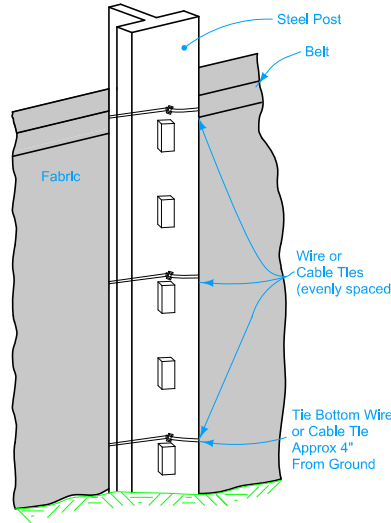
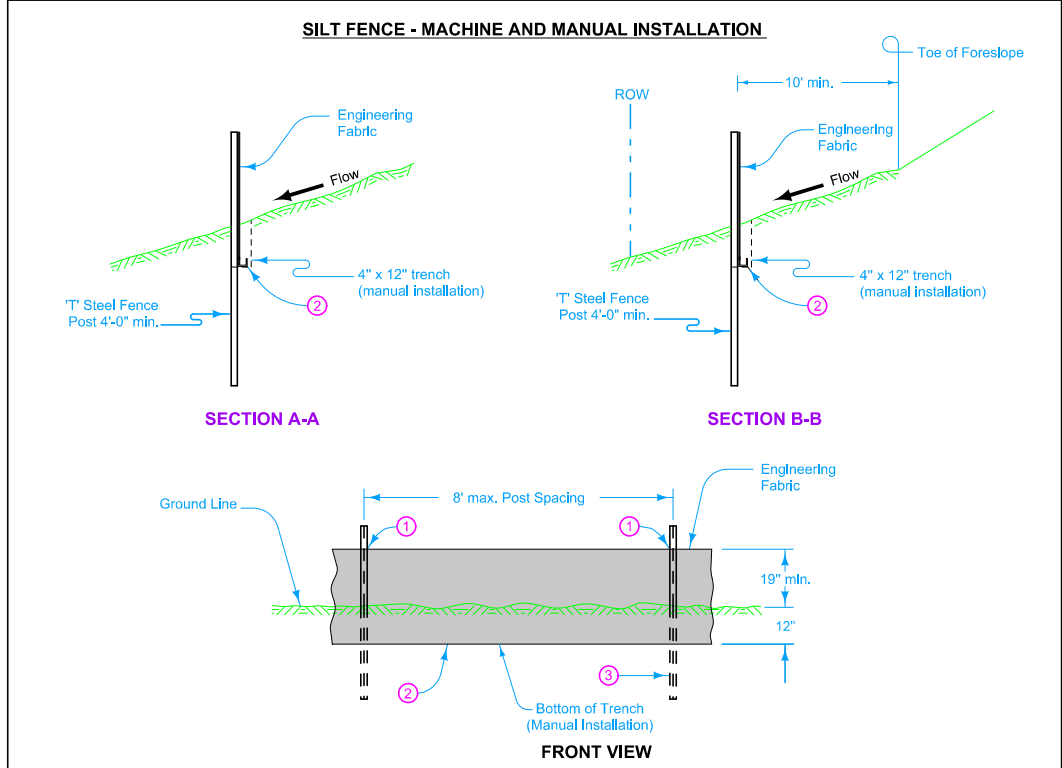

**BACK VIEW
ATTACHMENT TO POST**

Possible Contract Items:
Silt Fence
Silt Fence for Ditch Checks

Possible Tabulations:
100-17
100-18

IOWA DOT	REVISION	5	10-15-19
	STANDARD ROAD PLAN	EC-201	
	SHEET 1 of 6		

REVISIONS: Modified circle note 1.

Steve Miller
APPROVED BY DESIGN METHODS ENGINEER

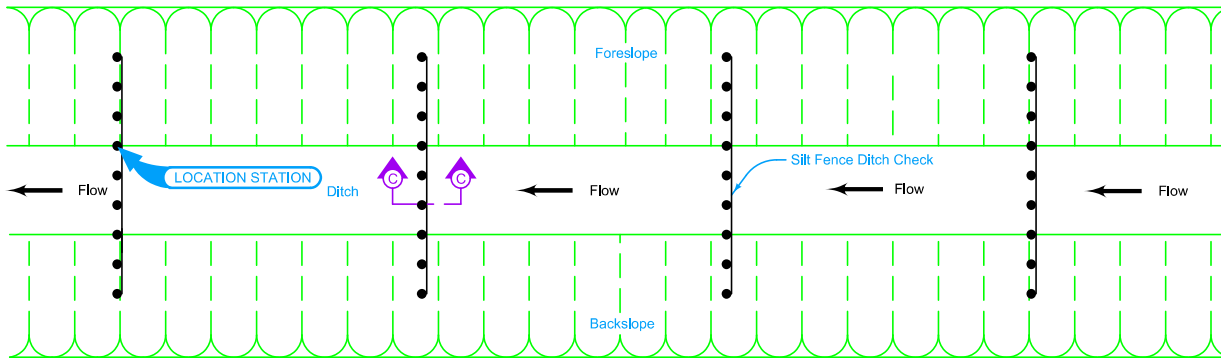

PLAN FOR DITCH CHECK (TYPE 1) ¹²

- ① Secure top of engineering fabric to steel posts using cable ties (50 lb.) or wire passing through or encompassing the belt. See attachment to post.
- ② For manual installation only, fold engineering fabric along bottom of trench.
- ③ Embed all posts 28 inches below the ground line.
- ④ Locate posts at toe of foreslope and toe of backslope and space remaining posts equally.
- ⑤ Minimum end span (in feet) = 2 X Foreslope (H:V).
- ⑥ Minimum end span (in feet) = 2 X Backslope (H:V).
- ⑫ Refer to Tab. 100-18

DITCH CHECK - MACHINE INSTALLATION

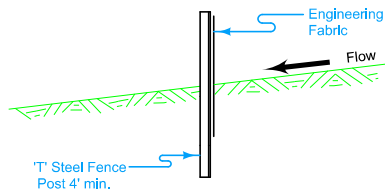

SECTION C-C

DITCH CHECK - MANUAL INSTALLATION

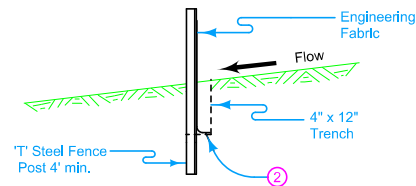

SECTION C-C

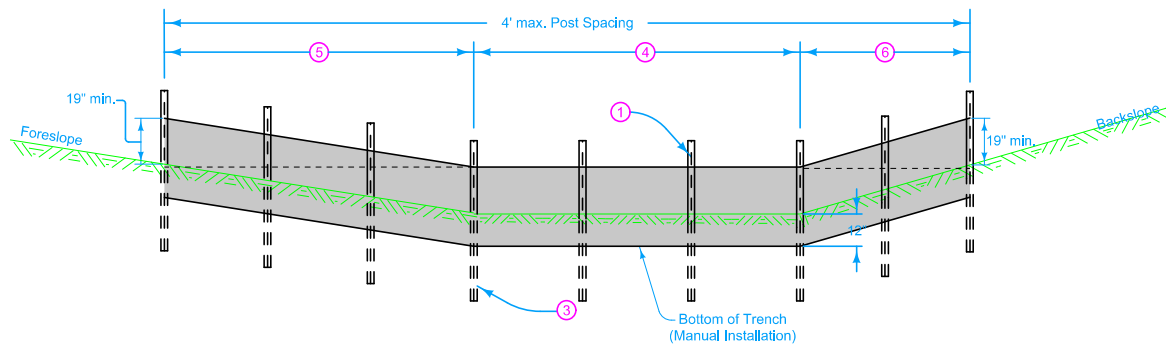

FRONT VIEW

IOWA DOT	REVISION	
	5	10-15-19
STANDARD ROAD PLAN		EC-201
		SHEET 2 of 6

REVISIONS: Modified circle note 1.

Handwritten Signature
APPROVED BY DESIGN METHODS ENGINEER

SILT FENCE

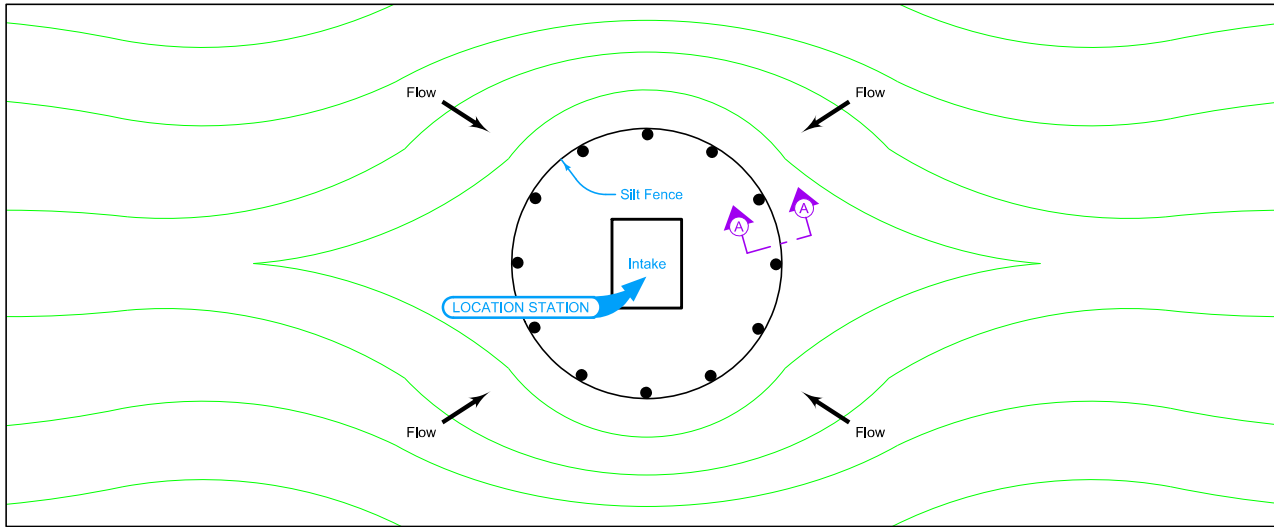

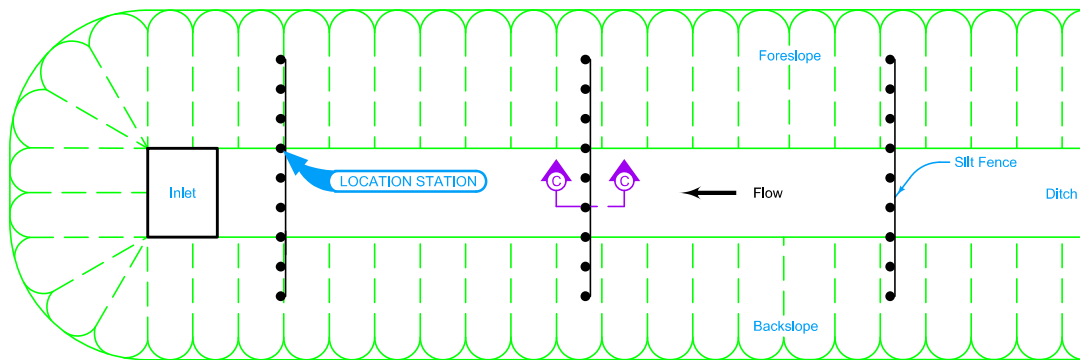

PLAN FOR SILT FENCE AT INTAKE (TYPE 2) ¹²

¹² Refer to Tab. 100-18



PLAN FOR SILT FENCE DITCH CHECK AT INLET (TYPE 3) ¹²

 Contour Lines

 STANDARD ROAD PLAN	REVISION	
	5	10-15-19
EC-201 SHEET 3 of 6		
REVISIONS: Modified circle note 1.		
APPROVED BY DESIGN METHODS ENGINEER 		
SILT FENCE		

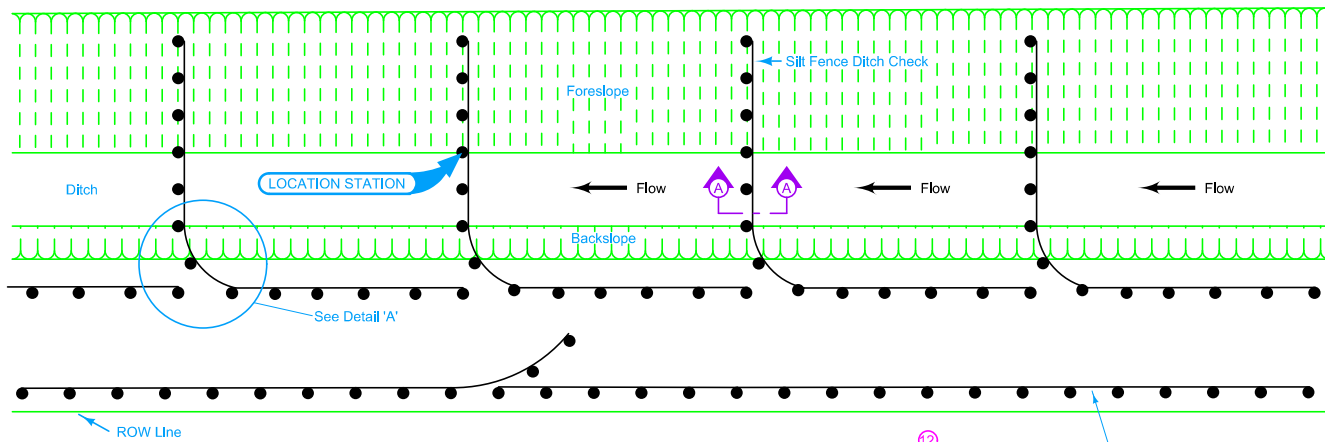

PLAN FOR SILT DITCH (SHALLOW DITCH SECTION-TYPE 4) ⑫

- ① Secure top of engineering fabric to steel posts using cable ties (50 lb.) or wire passing through or encompassing the belt. See attachment to post..
- ③ Embed all posts 28 inches below the ground line.
- ④ Locate posts at toe of foreslope and toe of backslope and space remaining posts equally.
- ⑤ Minimum end span (in feet) = 2 X Foreslope (H:V).
- ⑧ Place posts shown in Detail 'A' to transition from transverse to parallel installation. Place one post at the back slope intercept and the other beyond the intercept.
- ⑫ Refer to Tab. 100-18

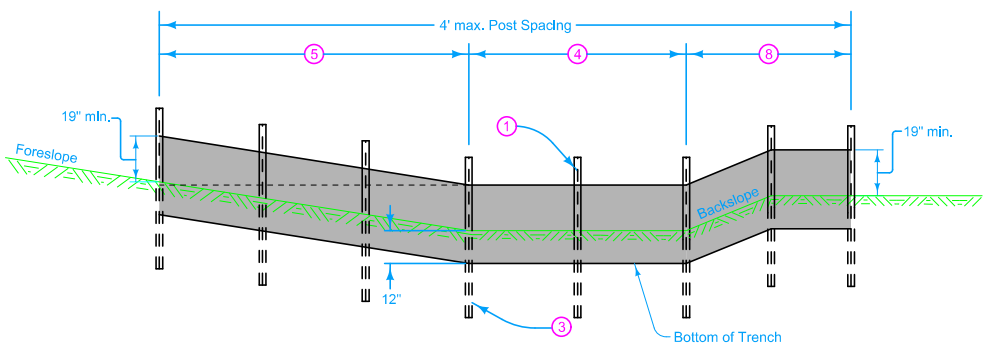

FRONT VIEW

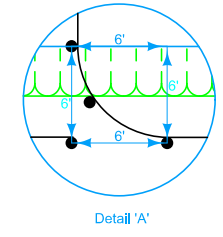

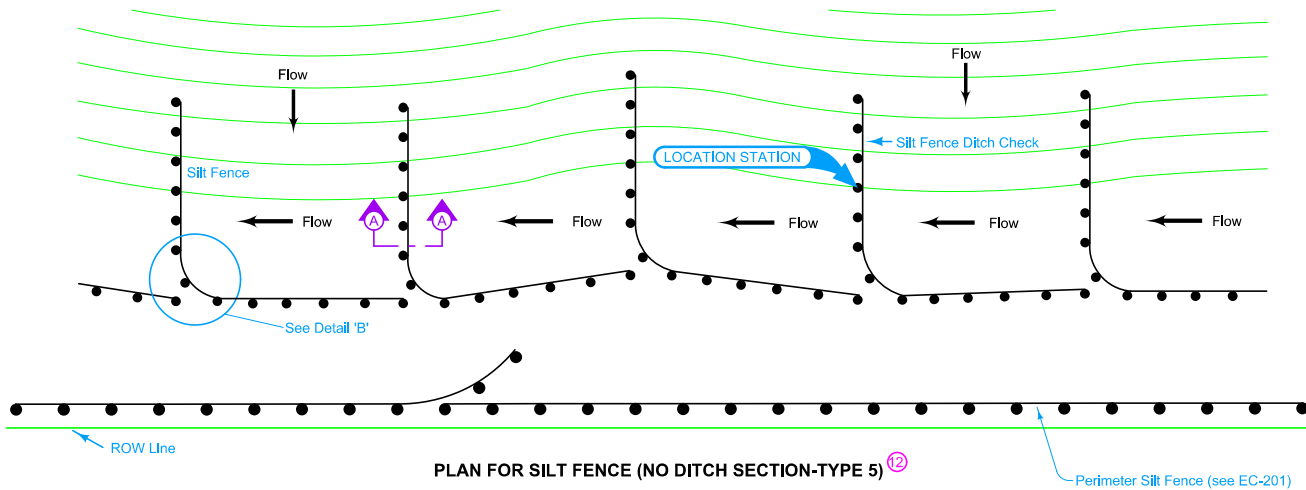

Detail 'A'

 STANDARD ROAD PLAN	REVISION
	5 10-15-19
EC-201	
SHEET 4 of 6	
REVISIONS: Modified circle note 1.	
 <small>APPROVED BY DESIGN METHODS ENGINEER</small>	
SILT FENCE	

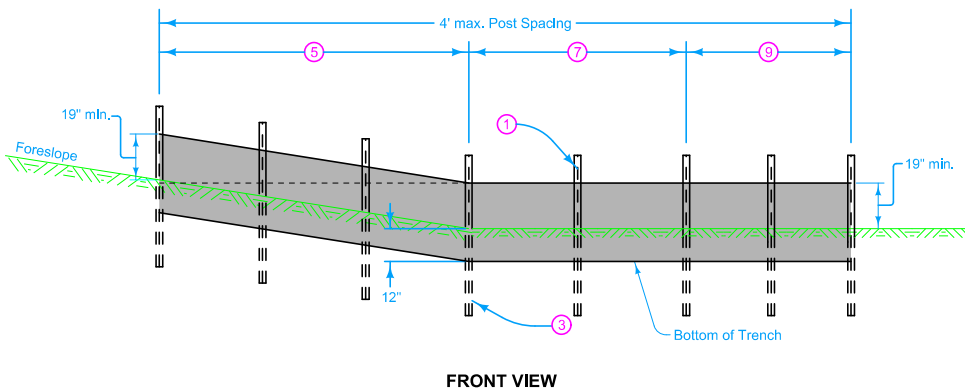

- ① Secure top of engineering fabric to steel posts using cable ties (50 lb.) or wire passing through or encompassing the belt. See attachment to post..
- ③ Embed all posts 28 inches below the ground line.
- ⑤ Minimum end span (in feet) = 2 X Foreslope (H:V).
- ⑦ Locate posts at toe of foreslope. Locate posts at 4 foot spacing
- ⑨ Place posts as shown in Detail 'B' to transition from transverse to parallel installation. The parallel portion of the installation should approximately parallel the intercept of the foreslope.
- ⑫ Refer to Tab. 100-18



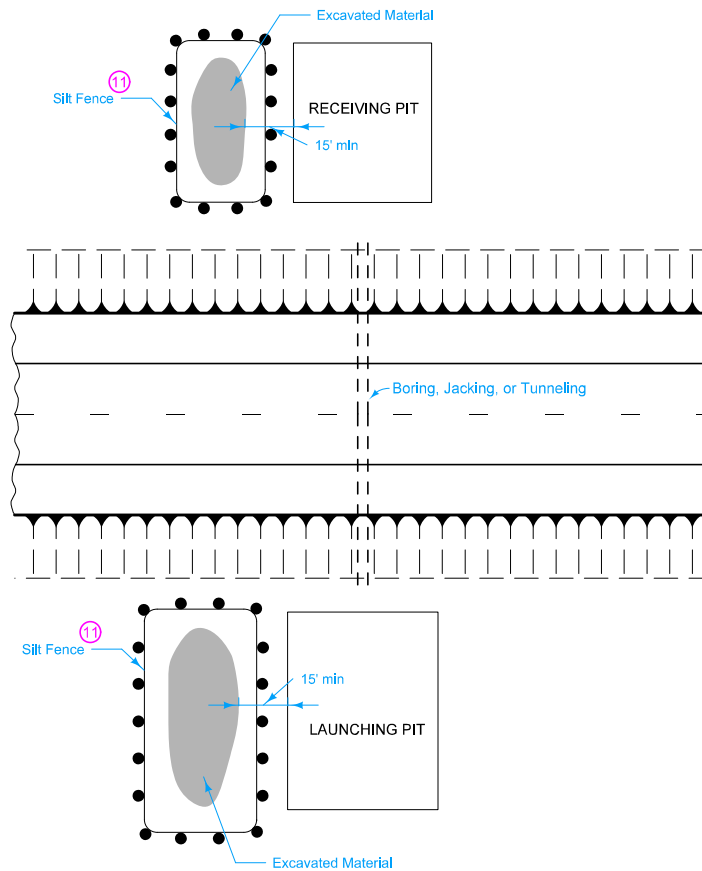

IOWA DOT	REVISION	
	5	10-15-19
STANDARD ROAD PLAN		EC-201
		SHEET 5 of 6
REVISIONS: Modified circle note 1.		
 APPROVED BY DESIGN METHODS ENGINEER		
SILT FENCE		

11 Refer to Tab. 100-17



PLAN FOR SILT FENCE FOR TRENCHLESS CONSTRUCTION

	REVISION	
	5	10-15-19
STANDARD ROAD PLAN	EC-201	
	SHEET 6 of 6	
REVISIONS: Modified circle note 1.		
		
APPROVED BY DESIGN METHODS ENGINEER		
SILT FENCE		