

**SNOW BORROW IMPROVEMENT**  
**STPN-141-2(56)--2J-67**

**MONONA CO.**

LETTING DATE  
 12/18/18

INDEX OF SHEETS	
No.	DESCRIPTION
<b>A Sheets</b>	<b>Title Sheets</b>
A.1	Title Sheet
A.2	Location Map Sheet
<b>B Sheets</b>	<b>Typical Cross Sections and Details</b>
B.1 - 3	Typical Cross Sections and Details
<b>C Sheets</b>	<b>Quantities and General Information</b>
C.1 - 8	Erosion Control
<b>D Sheets</b>	<b>Mainline Plan and Profile Sheets</b>
* D.1	Plan & Profile Legend & Symbol Information Sheet
* D.2 - 6	IA 141 Mainline
<b>J Sheets</b>	<b>Traffic Control and Staging Sheets</b>
J.1	Traffic Control Plan
<b>W Sheets</b>	<b>Mainline Cross Sections</b>
W.1	Cross Sections Legend & Symbol Information Sheet
W.2 - 6	Mainline 141 Cross Sections (Waste Area)
<b>X Sheets</b>	<b>Mainline Cross Sections</b>
X.1 - 54	Mainline 141 Cross Sections
<b>Y Sheets</b>	<b>Sideroad Cross Sections</b>
Y.1 - 3	Spruce Avenue Cross Sections
<b>Z Sheets</b>	<b>Sideroad Cross Sections</b>
Z.1	Sumac Avenue Cross Sections
* Color Plan Sheets	



## Highway Division

PLANS OF PROPOSED IMPROVEMENT ON THE

# PRIMARY ROAD SYSTEM MONONA COUNTY SNOW BORROW IMPROVEMENT

Approximately 2.5 Miles East of County Road L32 to  
Approximately 0.4 Miles West of County Road L37

SCALES: As Noted

Refer to the Proposal Form for list of applicable specifications.

Value Engineering Saves. Refer to Article 1105.14 of the Specifications.

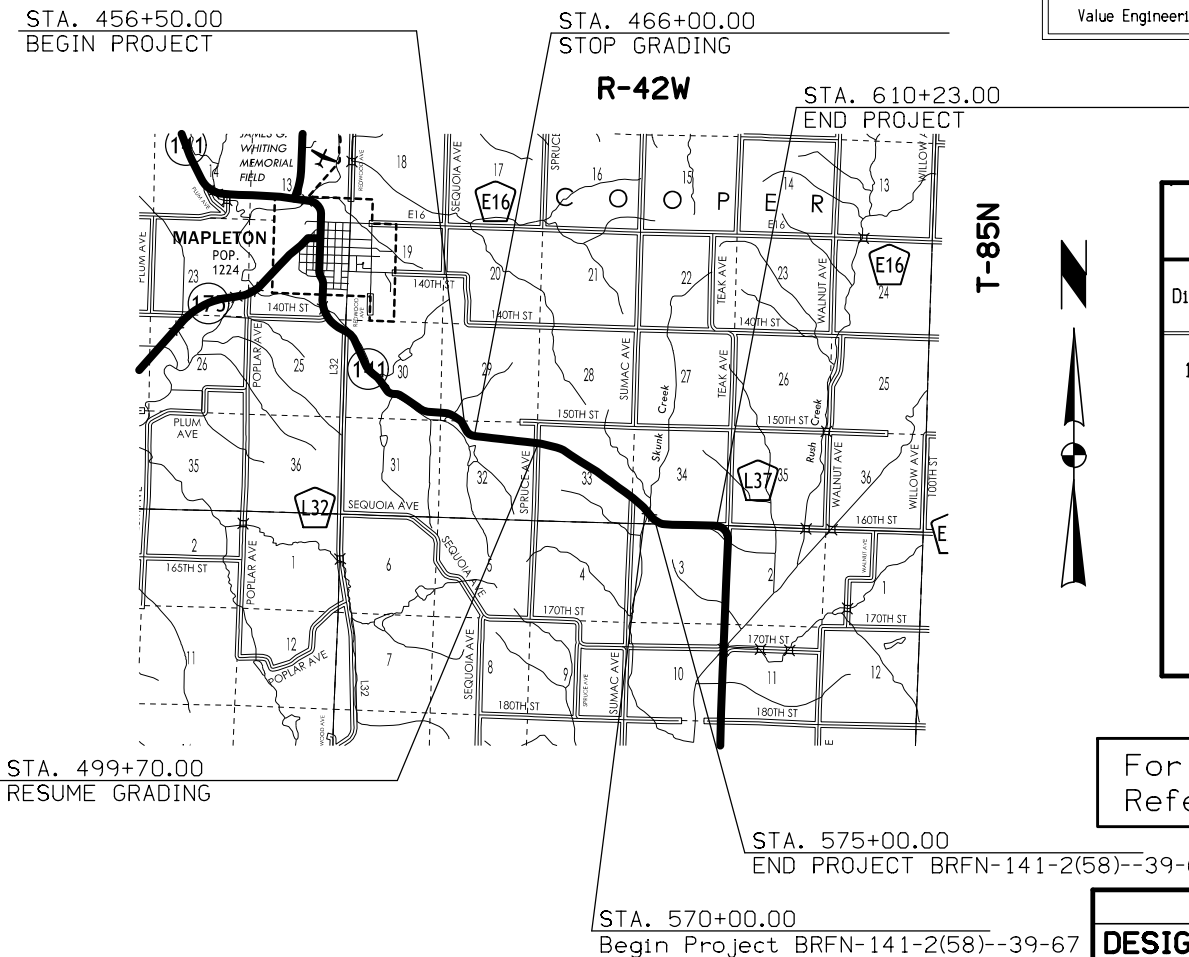

MILEAGE SUMMARY			
			105-1 09-27-94
Div.	Location	Lin. Ft.	Miles
1	Rural:		
	Sta. 456+50.00 to Sta. 610+23.00	15,373.00	2.911
	Omit Sta. 466+00.00 to Sta. 499+70.00	3,370.00	0.638
	RCB (By Others) Sta. 570+00 to 575+00	500.00	0.095
	<b>Total Net Length of Roadway in Project</b>	<b>11,503.00</b>	<b>2.178</b>
	Total Net Length Omitted	3,370.00	0.638
	Total Net Length By Others	500.00	0.095
	<b>Total Net Length of Project</b>	<b>15,373.00</b>	<b>2.911</b>

For Project Location Map  
Refer to Sheet A.2

### DESIGN DATA RURAL

2019 AADT	1033	V.P.D.
2039 AADT	1220	V.P.D.
2039 DHV	126	V.P.H.
TRUCKS	19	%
Total Design ESALs	--	

INDEX OF SEALS		
SHEET NO.	NAME	TYPE
A.1	Brian T. Higginbotham	Primary Signature Block

## PRELIMINARY PLANS

Subject to change by final design.

D5 - Date: 2/19/2017 (REV.)

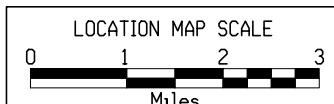
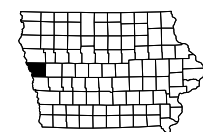

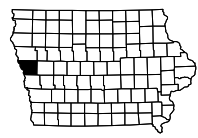
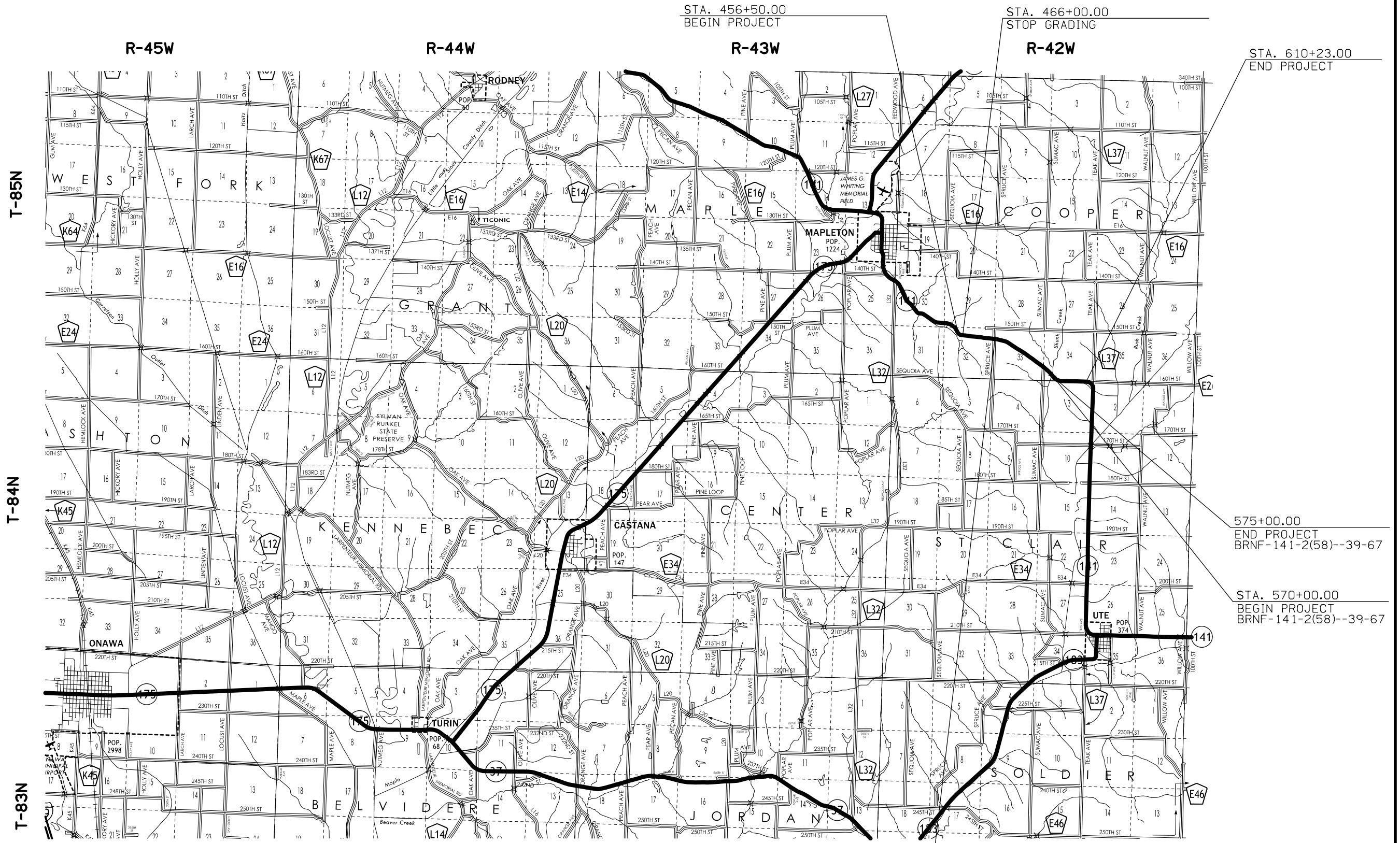

G\_2\_Grade  
Modified

LOCATION		DIMENSIONS				
ROAD IDENTIFICATION	STATION TO STATION	(L) Feet	(R) Feet	(X) Inches	FS	
IA 141	456+50.00	466+00.00	26	26	12	4
IA 141	499+70.00	610+23.00	26	26	12	4

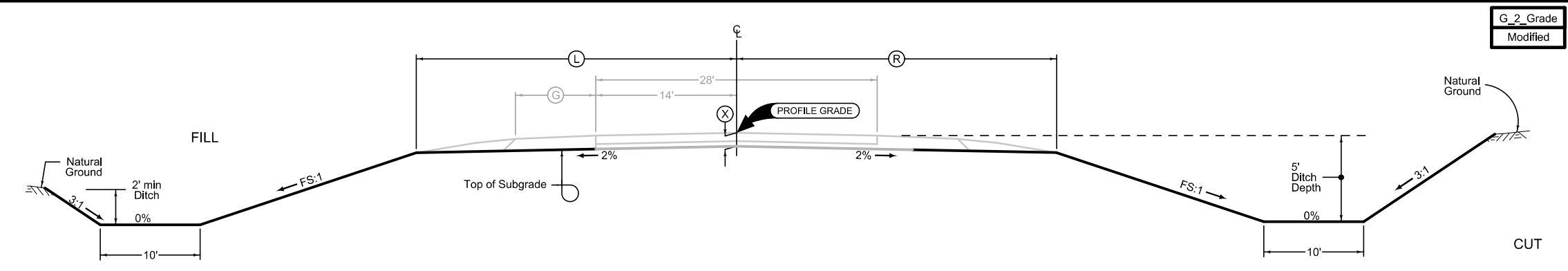

Normal section shown may be modified appropriately in areas of superelevated curves or other locations specifically designated by the Engineer.

See plan & profile sheets and cross sections for additional details of ditches and backslopes.

2 LANE GRADING

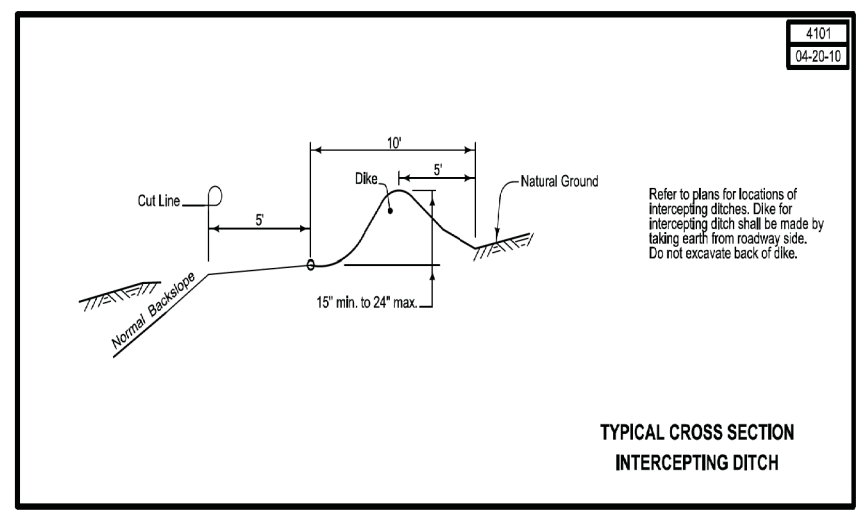

TYPICAL CROSS SECTION  
INTERCEPTING DITCH

4101  
04-20-10

**Granular Shoulder**

STATION TO STATION		Ⓞ Feet
456+50.00	466+00.00	6
499+70.00	610+23.00	6

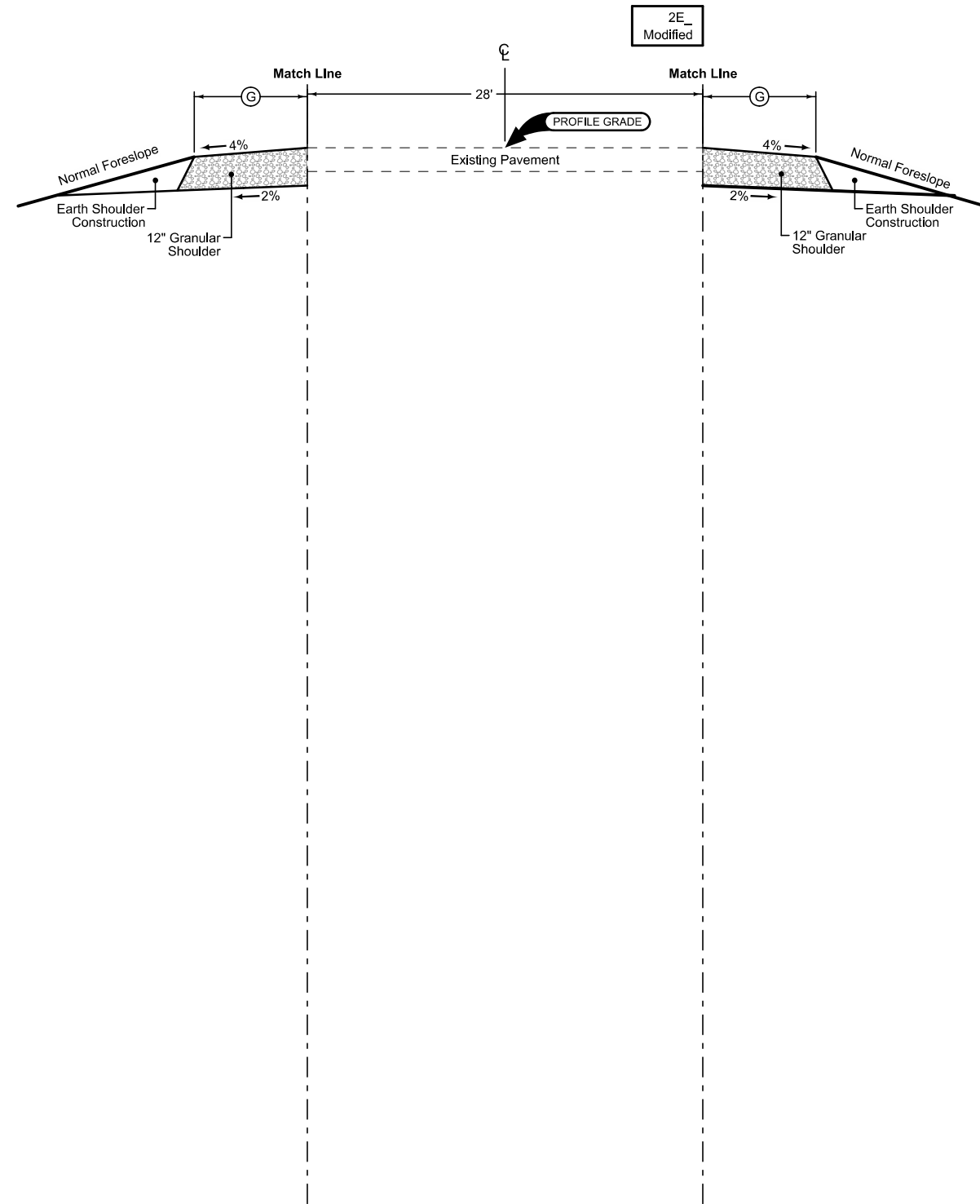

**Granular Shoulder**

STATION TO STATION		Ⓞ Feet
499+70.00	510+84.00	6
526+68.00	542+50.00	6

See Tab 100-24 or 100-25 for pavement quantities.  
See Tab 112-9 for shoulder quantities.

**IA HWY 141**



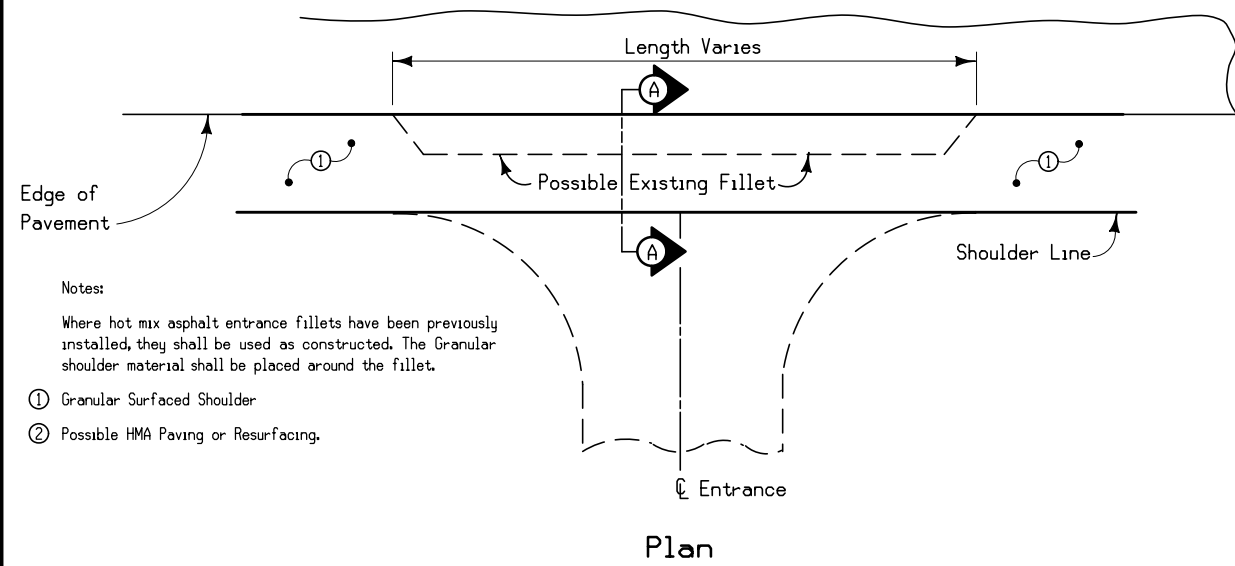

Notes:  
Where hot mix asphalt entrance fillets have been previously installed, they shall be used as constructed. The Granular shoulder material shall be placed around the fillet.

① Granular Surfaced Shoulder  
② Possible HMA Paving or Resurfacing.

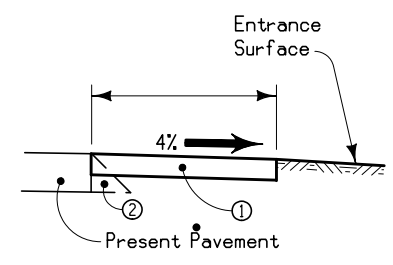

Section A-A  
Without Fillet

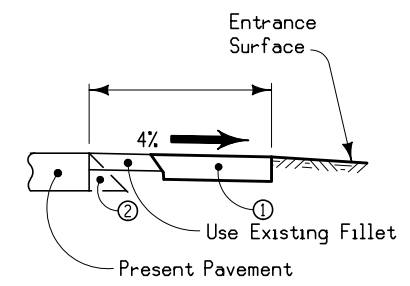

Section A-A  
With Previous Fillet

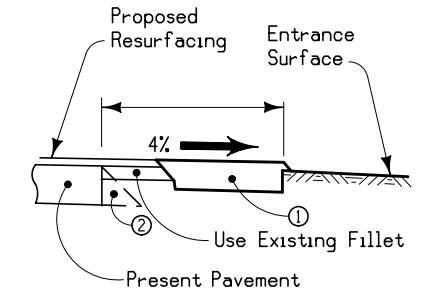

Section A-A  
With Previous Fillet  
And Resurfacing Less than 1/2"

GRANULAR SHOULDER CONSTRUCTION THRU ENTRANCES

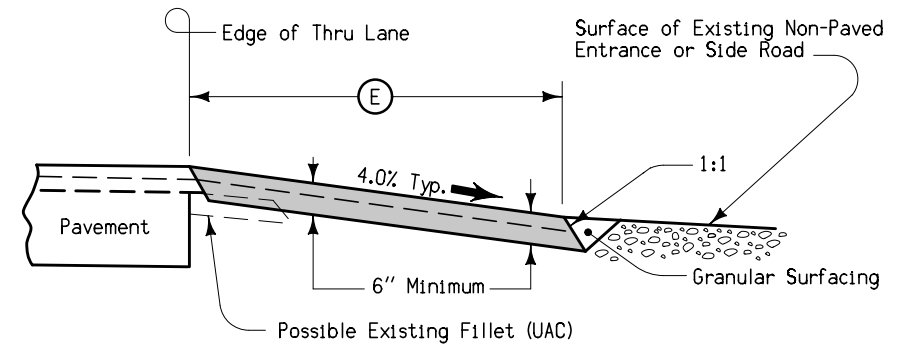
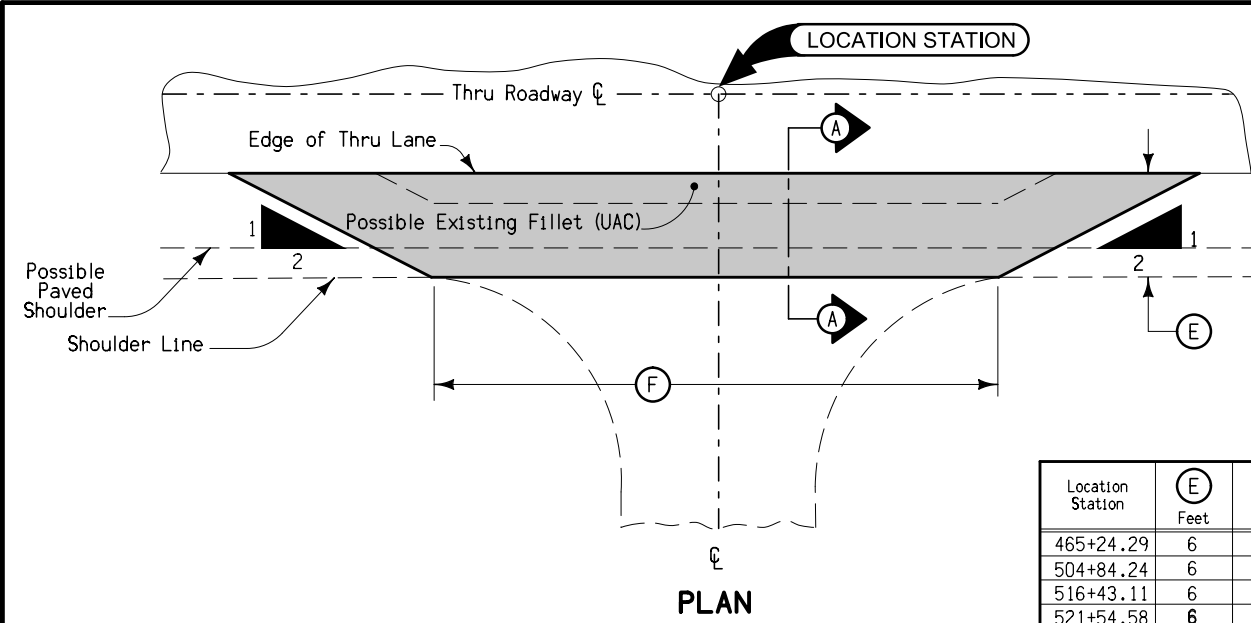

SECTION A-A

Special shaping of existing surface prior to placement of fillet may be required by the Engineer and is incidental to other work on the project.

Quantities included with mainline quantities.

FILLET FOR NON-PAVED ENTRANCES OR SIDE ROADS

Location Station	(E) Feet	(F) Feet
465+24.29	6	40
504+84.24	6	40
516+43.11	6	40
521+54.58	6	40
538+24.55	6	40
539+67.37	6	40
560+01.77	10	100
560+60.95	6	40
561+10.88	6	40
564+67.53	6	40
581+17.25	6	40
605+32.79	6	40

100-14  
10-18-16

### SILT BASINS

Possible Standard: EW-403

\* The functional height used in the volume equation is 95% of effective height. Effective height is 3 feet as shown in EW-403.  
 \* Volume equation:  $(0.5 * \text{Length} * (\text{Width} * \text{Height} + \text{Width} * (\text{Height} - \text{Length} * \text{Avg} \% \text{Slope})))$

Basin No.	Location		Bid Items			Stormwater Storage Volume Summary				Remarks
	Station	Side	Installation EACH	Removal EACH	Basin Width FT	Basin Length FT	Height FT	Avg. % Slope	Volume* CF	
3	503+70	LT	1		10.0	50.0	2.85	0.5%	1362.5	
4	520+95	LT	1		10.0	50.0	2.85	0.9%	1315.0	
6	549+50	LT	1		10.0	50.0	2.85	1.0%	1300.0	
11	513+00	RT	1		10.0	50.0	2.85	2.0%	1175.0	
13	533+25	RT	1		10.0	50.0	2.85	0.4%	1380.0	

100-16  
10-19-10

### TABULATION OF INTERCEPTING DITCHES

Location		Side	Length	Remarks
Station to Station			LF	
504+50	509+00	LT	450.0	
546+00	552+50	RT	650.0	
554+50	558+00	LT	350.0	
575+00	586+50	LT	1150.0	

100-18  
10-18-16

### SILT FENCES FOR DITCH CHECKS

Possible Standard: EC-201 Possible Detail: 570-4

\* The functional height used in the volume equation is 85% of effective height. Effective height is 1.58 feet as shown on EC-201.  
 \* Volume equation:  $[0.5 * \text{Spacing} * (0.5 * H^2 * FS + DW * H + 0.5 * H^2 * BS)]$

Basin No.	Type	Location		Bid Items			Stormwater Storage Volume Summary				Remarks	
		Station	Side	Installation LF	Maintenance LF	Removal LF	Foreslope FS:1	Backslope BS:1	Ditch Width FT	Avg. % Slope		Volume* CF
1	1	457+30	RT	24.0	2.4	12.0	4.0	3.0	10.0	3.8%	394.9	
1	1	457+70	RT	24.0	2.4	12.0	4.0	3.0	10.0	3.8%	394.9	
1	1	458+10	RT	24.0	2.4	12.0	4.0	3.0	10.0	3.8%	394.9	
1	1	458+50	RT	24.0	2.4	12.0	4.0	3.0	10.0	3.8%	394.9	
1	1	460+25	RT	24.0	2.4	12.0	4.0	3.0	10.0	6.0%	246.8	
1	1	460+50	RT	24.0	2.4	12.0	4.0	3.0	10.0	6.0%	246.8	
1	1	460+75	RT	24.0	2.4	12.0	4.0	3.0	10.0	6.0%	246.8	
1	1	461+00	RT	24.0	2.4	12.0	4.0	3.0	10.0	0.5%	1382.0	
1	1	462+40	RT	24.0	2.4	12.0	4.0	3.0	10.0	6.0%	246.8	
1	1	462+65	RT	24.0	2.4	12.0	4.0	3.0	10.0	6.0%	246.8	
1	1	462+90	RT	24.0	2.4	12.0	4.0	3.0	10.0	6.0%	246.8	
1	1	463+15	RT	24.0	2.4	12.0	4.0	3.0	10.0	6.0%	246.8	
1	1	463+40	RT	24.0	2.4	12.0	4.0	3.0	10.0	6.0%	246.8	
1	1	463+65	RT	24.0	2.4	12.0	4.0	3.0	10.0	6.0%	246.8	
1	1	463+90	RT	24.0	2.4	12.0	4.0	3.0	10.0	6.0%	246.8	
1	1	464+15	RT	24.0	2.4	12.0	4.0	3.0	10.0	6.0%	246.8	
2	1	501+10	LT	24.0	2.4	12.0	4.0	3.0	10.0	0.5%	2764.0	
3	1	502+65	LT	24.0	2.4	12.0	4.0	3.0	10.0	4.9%	345.5	
3	1	503+00	LT	24.0	2.4	12.0	4.0	3.0	10.0	4.9%	345.5	
3	1	503+35	LT	24.0	2.4	12.0	4.0	3.0	10.0	4.9%	345.5	
3	1	509+10	LT	24.0	2.4	12.0	4.0	3.0	10.0	1.4%	987.1	

100-18  
10-18-16

### SILT FENCES FOR DITCH CHECKS

Possible Standard: EC-201 Possible Detail: 570-4

\* The functional height used in the volume equation is 85% of effective height. Effective height is 1.58 feet as shown on EC-201.  
 \* Volume equation:  $[0.5 * \text{Spacing} * (0.5 * H^2 * FS + DW * H + 0.5 * H^2 * BS)]$

Basin No.	Type	Location		Bid Items			Stormwater Storage Volume Summary				Remarks	
		Station	Side	Installation LF	Maintenance LF	Removal LF	Foreslope FS:1	Backslope BS:1	Ditch Width FT	Avg. % Slope		Volume* CF
3	1	510+10	LT	24.0	2.4	12.0	4.0	3.0	10.0	1.4%	987.1	
3	1	511+30	LT	24.0	2.4	12.0	4.0	3.0	10.0	2.6%	493.6	
3	1	511+80	LT	24.0	2.4	12.0	4.0	3.0	10.0	2.6%	493.6	
3	1	512+30	LT	24.0	2.4	12.0	4.0	3.0	10.0	2.6%	493.6	
4	1	513+00	LT	24.0	2.4	12.0	4.0	3.0	10.0	2.5%	493.6	
4	1	513+50	LT	24.0	2.4	12.0	4.0	3.0	10.0	2.5%	493.6	
4	1	514+00	LT	24.0	2.4	12.0	4.0	3.0	10.0	2.5%	493.6	
4	1	514+50	LT	24.0	2.4	12.0	4.0	3.0	10.0	2.5%	493.6	
4	1	514+95	LT	24.0	2.4	12.0	4.0	3.0	10.0	2.5%	493.6	
4	1	515+30	LT	24.0	2.4	12.0	4.0	3.0	10.0	4.8%	345.5	
4	1	515+65	LT	24.0	2.4	12.0	4.0	3.0	10.0	4.8%	345.5	
4	1	516+00	LT	24.0	2.4	12.0	4.0	3.0	10.0	4.8%	345.5	
4	1	519+55	LT	24.0	2.4	12.0	4.0	3.0	10.0	4.9%	345.5	
4	1	519+90	LT	24.0	2.4	12.0	4.0	3.0	10.0	4.9%	345.5	
4	1	520+25	LT	24.0	2.4	12.0	4.0	3.0	10.0	4.9%	345.5	
4	1	520+60	LT	24.0	2.4	12.0	4.0	3.0	10.0	4.9%	345.5	
4	1	522+50	LT	24.0	2.4	12.0	4.0	3.0	10.0	0.9%	1530.1	
4	1	524+05	LT	24.0	2.4	12.0	4.0	3.0	10.0	0.9%	1530.1	
4	1	528+00	LT	24.0	2.4	12.0	4.0	3.0	10.0	2.3%	592.3	
4	1	528+60	LT	24.0	2.4	12.0	4.0	3.0	10.0	2.3%	592.3	
5	1	529+45	LT	24.0	2.4	12.0	4.0	3.0	10.0	3.0%	444.2	







### SILT FENCES FOR DITCH CHECKS

Possible Standard: EC-201 Possible Detail: 570-4

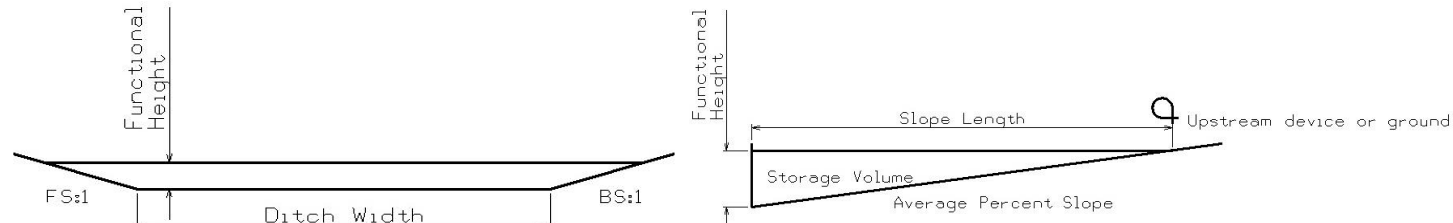

\* The functional height used in the volume equation is 85% of effective height. Effective height is 1.58 feet as shown on EC-201.  
\* Volume equation:  $[0.5 * Spacing * (0.5 * H^2 * FS + DW * H + 0.5 * H^2 * BS)]$

Basin No.	Type	Location		Bid Items			Stormwater Storage Volume Summary					Remarks
		Station	Side	Installation LF	Maintenance LF	Removal LF	Foreslope FS:1	Backslope BS:1	Ditch Width FT	Avg. % Slope	Volume* CF	
16	1	593+25	RT	24.0	2.4	12.0	4.0	3.0	10.0	7.4%	246.8	
16	1	593+50	RT	24.0	2.4	12.0	4.0	3.0	10.0	7.4%	246.8	
16	1	593+75	RT	24.0	2.4	12.0	4.0	3.0	10.0	7.4%	246.8	
16	1	594+00	RT	24.0	2.4	12.0	4.0	3.0	10.0	7.4%	246.8	
16	1	594+25	RT	24.0	2.4	12.0	4.0	3.0	10.0	7.4%	246.8	
16	1	594+50	RT	24.0	2.4	12.0	4.0	3.0	10.0	7.4%	246.8	
16	1	594+75	RT	24.0	2.4	12.0	4.0	3.0	10.0	7.4%	246.8	
16	1	597+95	RT	24.0	2.4	12.0	4.0	3.0	10.0	3.3%	444.2	
16	1	598+40	RT	24.0	2.4	12.0	4.0	3.0	10.0	3.3%	444.2	
16	1	598+70	RT	24.0	2.4	12.0	4.0	3.0	10.0	4.6%	345.5	
16	1	599+05	RT	24.0	2.4	12.0	4.0	3.0	10.0	4.6%	345.5	
16	1	599+40	RT	24.0	2.4	12.0	4.0	3.0	10.0	4.6%	345.5	
16	1	599+75	RT	24.0	2.4	12.0	4.0	3.0	10.0	4.6%	345.5	
16	1	600+10	RT	24.0	2.4	12.0	4.0	3.0	10.0	4.6%	345.5	
16	1	600+45	RT	24.0	2.4	12.0	4.0	3.0	10.0	4.6%	345.5	
16	1	601+15	RT	24.0	2.4	12.0	4.0	3.0	10.0	3.1%	493.6	
16	1	601+60	RT	24.0	2.4	12.0	4.0	3.0	10.0	3.1%	493.6	
16	1	603+00	RT	24.0	2.4	12.0	4.0	3.0	10.0	1.0%	1530.1	
16	1	604+60	RT	24.0	2.4	12.0	4.0	3.0	10.0	2.2%	592.3	
16	1	605+20	RT	24.0	2.4	12.0	4.0	3.0	10.0	2.2%	592.3	
16	1	605+80	RT	24.0	2.4	12.0	4.0	3.0	10.0	3.1%	444.2	

### ROCK CHECK DAM

Possible Detail: 570-2

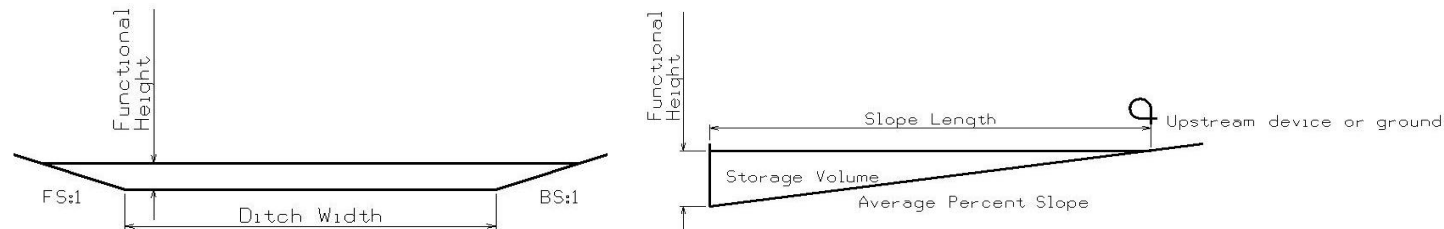

\* The functional height used in the volume equation is 90% of effective height. Effective height is 2 feet as shown in 570-2.  
\* Volume equation:  $[0.5 * Spacing * (0.5 * H^2 * FS + DW * H + 0.5 * H^2 * BS)]$

Basin No.	Location		Offset FT	Bid Items			Stormwater Storage Volume Summary					Remarks
	Station	Side		Installation LF	Maintenance Each	Removal Each	Foreslope FS:1	Backslope BS:1	Ditch Width FT	Avg. % Slope	Volume* CF	
1	459+06.25	RT	74.6	7.5	3	3	4.0	3.0	10.0	10.0%	293.4	
1	459+26.25	RT	82.9	7.5	3	3	4.0	3.0	10.0	10.0%	293.4	
1	459+46.25	RT	91.3	7.5	3	3	4.0	3.0	10.0	10.0%	293.4	
1	464+35	RT	80.8	7.5	3	3	4.0	3.0	10.0	10.0%	293.4	
1	464+55	RT	76.3	7.5	3	3	4.0	3.0	10.0	10.0%	293.4	
1	464+75	RT	71.5	7.5	3	3	4.0	3.0	10.0	10.0%	293.4	
3	504+93	LT	132.2	7.5	3	3	4.0	3.0	10.0	10.0%	293.4	
3	505+13	LT	128.6	7.5	3	3	4.0	3.0	10.0	10.0%	293.4	
3	505+33	LT	123.1	7.5	3	3	4.0	3.0	10.0	10.0%	293.4	
3	505+53	LT	117.1	7.5	3	3	4.0	3.0	10.0	10.0%	293.4	
3	505+73	LT	111.3	7.5	3	3	4.0	3.0	10.0	10.0%	293.4	
3	505+93	LT	105.4	7.5	3	3	4.0	3.0	10.0	10.0%	293.4	
3	506+13	LT	99.6	7.5	3	3	4.0	3.0	10.0	10.0%	293.4	
3	506+33	LT	94.2	7.5	3	3	4.0	3.0	10.0	10.0%	293.4	
3	506+53	LT	88.8	7.5	3	3	4.0	3.0	10.0	10.0%	293.4	
3	506+73	LT	83.3	7.5	3	3	4.0	3.0	10.0	10.0%	293.4	
3	506+93	LT	77.9	7.5	3	3	4.0	3.0	10.0	10.0%	293.4	
3	507+13	LT	72.3	7.5	3	3	4.0	3.0	10.0	10.0%	293.4	

### ROCK CHECK DAM

Possible Detail: 570-2

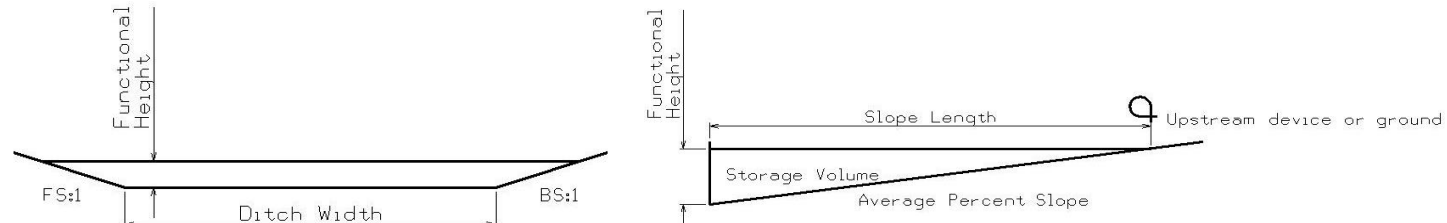

\* The functional height used in the volume equation is 90% of effective height. Effective height is 2 feet as shown in 570-2.

\* Volume equation:  $[0.5 * Spacing * (0.5 * H^2 * FS + DW * H + 0.5 * H^2 * BS)]$

Basin No.	Location			Bid Items			Stormwater Storage Volume Summary					Remarks
	Station	Side	Offset FT	Installation LF	Maintenance Each	Removal Each	Foreslope FS:1	Backslope BS:1	Ditch Width FT	Avg. % Slope	Volume* CF	
3	507+33	LT	66.5	7.5	3	3	4.0	3.0	10.0	10.0%	293.4	
3	507+53	LT	60.8	7.5	3	3	4.0	3.0	10.0	10.0%	293.4	
3	507+73	LT	55.1	7.5	3	3	4.0	3.0	10.0	10.0%	293.4	
3	507+93	LT	49.2	7.5	3	3	4.0	3.0	10.0	10.0%	293.4	
4	525+66	LT	138.6	7.5	3	3	4.0	3.0	10.0	10.0%	293.4	
4	525+86	LT	132.5	7.5	3	3	4.0	3.0	10.0	10.0%	293.4	
4	526+06	LT	126.4	7.5	3	3	4.0	3.0	10.0	10.0%	293.4	
4	526+26	LT	120.0	7.5	3	3	4.0	3.0	10.0	10.0%	293.4	
4	526+46	LT	113.6	7.5	3	3	4.0	3.0	10.0	10.0%	293.4	
4	526+66	LT	106.8	7.5	3	3	4.0	3.0	10.0	10.0%	293.4	
4	526+86	LT	99.5	7.5	3	3	4.0	3.0	10.0	10.0%	293.4	
4	527+06	LT	92.1	7.5	3	3	4.0	3.0	10.0	10.0%	293.4	
4	527+26	LT	84.5	7.5	3	3	4.0	3.0	10.0	10.0%	293.4	
4	527+46	LT	76.5	7.5	3	3	4.0	3.0	10.0	10.0%	293.4	
6	545+26	LT	173.9	7.5	3	3	4.0	3.0	10.0	9.6%	293.4	
6	454+46	LT	169.5	7.5	3	3	4.0	3.0	10.0	9.6%	293.4	
6	545+66	LT	165.2	7.5	3	3	4.0	3.0	10.0	9.6%	293.4	
6	545+86	LT	161.0	7.5	3	3	4.0	3.0	10.0	9.6%	293.4	
6	546+06	LT	156.7	7.5	3	3	4.0	3.0	10.0	9.6%	293.4	
6	546+26	LT	152.3	7.5	3	3	4.0	3.0	10.0	9.6%	293.4	
6	546+46	LT	147.9	7.5	3	3	4.0	3.0	10.0	9.6%	293.4	
6	546+66	LT	143.5	7.5	3	3	4.0	3.0	10.0	9.6%	293.4	
6	546+86	LT	139.1	7.5	3	3	4.0	3.0	10.0	9.6%	293.4	
6	547+06	LT	134.7	7.5	3	3	4.0	3.0	10.0	9.6%	293.4	
6	547+26	LT	130.1	7.5	3	3	4.0	3.0	10.0	9.6%	293.4	
6	547+46	LT	125.5	7.5	3	3	4.0	3.0	10.0	9.6%	293.4	
6	547+66	LT	121.1	7.5	3	3	4.0	3.0	10.0	9.6%	293.4	
6	547+86	LT	116.6	7.5	3	3	4.0	3.0	10.0	9.6%	293.4	
6	548+06	LT	112.1	7.5	3	3	4.0	3.0	10.0	9.6%	293.4	
6	548+26	LT	107.6	7.5	3	3	4.0	3.0	10.0	9.6%	293.4	
9	595+76	LT	57.6	7.5	3	3	4.0	3.0	10.0	9.3%	293.4	
9	595+96	LT	60.2	7.5	3	3	4.0	3.0	10.0	9.3%	293.4	
9	596+16	LT	62.8	7.5	3	3	4.0	3.0	10.0	9.3%	293.4	
9	596+36	LT	65.6	7.5	3	3	4.0	3.0	10.0	9.3%	293.4	
9	596+56	LT	68.5	7.5	3	3	4.0	3.0	10.0	9.3%	293.4	
9	596+76	LT	71.5	7.5	3	3	4.0	3.0	10.0	9.3%	293.4	
11	511+23	RT	72.3	7.5	3	3	4.0	3.0	10.0	10.0%	293.4	
11	511+43	RT	79.6	7.5	3	3	4.0	3.0	10.0	10.0%	293.4	
11	511+63	RT	86.9	7.5	3	3	4.0	3.0	10.0	10.0%	293.4	
11	511+83	RT	93.8	7.5	3	3	4.0	3.0	10.0	10.0%	293.4	
11	512+03	RT	100.7	7.5	3	3	4.0	3.0	10.0	10.0%	293.4	
11	512+23	RT	108.0	7.5	3	3	4.0	3.0	10.0	10.0%	293.4	
11	512+43	RT	115.4	7.5	3	3	4.0	3.0	10.0	10.0%	293.4	
11	513+54	RT	117.5	7.5	3	3	4.0	3.0	10.0	10.0%	293.4	
11	513+74	RT	109.7	7.5	3	3	4.0	3.0	10.0	10.0%	293.4	
11	513+94	RT	101.7	7.5	3	3	4.0	3.0	10.0	10.0%	293.4	
11	514+14	RT	93.6	7.5	3	3	4.0	3.0	10.0	10.0%	293.4	
11	514+34	RT	85.1	7.5	3	3	4.0	3.0	10.0	10.0%	293.4	

### ROCK CHECK DAM

Possible Detail: 570-2

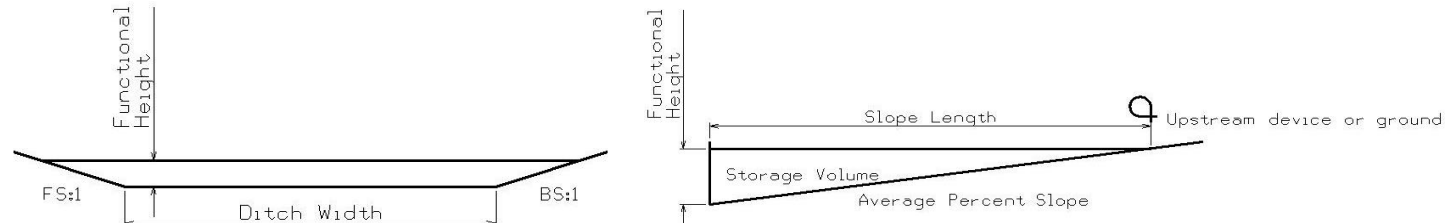

\* The functional height used in the volume equation is 90% of effective height. Effective height is 2 feet as shown in 570-2.

\* Volume equation:  $[0.5 * Spacing * (0.5 * H^2 * FS + DW * H + 0.5 * H^2 * BS)]$

Basin No.	Location			Bid Items			Stormwater Storage Volume Summary					Remarks
	Station	Side	Offset FT	Installation LF	Maintenance Each	Removal Each	Foreslope FS:1	Backslope BS:1	Ditch Width FT	Avg. % Slope	Volume* CF	
13	529+96	RT	51.9	7.5	3	3	4.0	3.0	10.0	9.9%	293.4	
13	530+16	RT	56.9	7.5	3	3	4.0	3.0	10.0	9.9%	293.4	
13	530+36	RT	62.1	7.5	3	3	4.0	3.0	10.0	9.9%	293.4	
13	530+56	RT	67.3	7.5	3	3	4.0	3.0	10.0	9.9%	293.4	
13	530+76	RT	72.4	7.5	3	3	4.0	3.0	10.0	9.9%	293.4	
13	530+96	RT	77.5	7.5	3	3	4.0	3.0	10.0	9.9%	293.4	
13	531+16	RT	82.6	7.5	3	3	4.0	3.0	10.0	9.9%	293.4	
13	531+36	RT	87.8	7.5	3	3	4.0	3.0	10.0	9.9%	293.4	
13	531+56	RT	92.9	7.5	3	3	4.0	3.0	10.0	9.9%	293.4	
13	531+76	RT	97.9	7.5	3	3	4.0	3.0	10.0	9.9%	293.4	
13	531+96	RT	102.9	7.5	3	3	4.0	3.0	10.0	9.9%	293.4	
13	532+16	RT	108.1	7.5	3	3	4.0	3.0	10.0	9.9%	293.4	
13	532+36	RT	113.3	7.5	3	3	4.0	3.0	10.0	9.9%	293.4	
13	532+56	RT	118.6	7.5	3	3	4.0	3.0	10.0	9.9%	293.4	
13	532+76	RT	124.5	7.5	3	3	4.0	3.0	10.0	9.9%	293.4	
13	534+74	RT	108.3	7.5	3	3	4.0	3.0	10.0	10.0%	293.4	
13	534+94	RT	101.9	7.5	3	3	4.0	3.0	10.0	10.0%	293.4	
13	535+14	RT	95.5	7.5	3	3	4.0	3.0	10.0	10.0%	293.4	
13	535+34	RT	89.8	7.5	3	3	4.0	3.0	10.0	10.0%	293.4	
13	535+54	RT	83.9	7.5	3	3	4.0	3.0	10.0	10.0%	293.4	
13	535+74	RT	78.0	7.5	3	3	4.0	3.0	10.0	10.0%	293.4	
13	535+94	RT	72.4	7.5	3	3	4.0	3.0	10.0	10.0%	293.4	
13	536+14	RT	66.8	7.5	3	3	4.0	3.0	10.0	10.0%	293.4	
13	536+34	RT	31.3	7.5	3	3	4.0	3.0	10.0	10.0%	293.4	
13	536+54	RT	55.9	7.5	3	3	4.0	3.0	10.0	10.0%	293.4	
13	536+74	RT	50.2	7.5	3	3	4.0	3.0	10.0	10.0%	293.4	
15	575+04	RT	86.6	7.5	3	3	4.0	3.0	10.0	10.0%	293.4	
15	575+24	RT	83.4	7.5	3	3	4.0	3.0	10.0	10.0%	293.4	
15	575+44	RT	80.1	7.5	3	3	4.0	3.0	10.0	10.0%	293.4	
15	575+64	RT	76.8	7.5	3	3	4.0	3.0	10.0	10.0%	293.4	
15	575+84	RT	73.5	7.5	3	3	4.0	3.0	10.0	10.0%	293.4	
15	576+04	RT	70.4	7.5	3	3	4.0	3.0	10.0	10.0%	293.4	
15	576+24	RT	67.2	7.5	3	3	4.0	3.0	10.0	10.0%	293.4	
15	576+44	RT	64.0	7.5	3	3	4.0	3.0	10.0	10.0%	293.4	
15	576+64	RT	60.7	7.5	3	3	4.0	3.0	10.0	10.0%	293.4	
15	576+84	RT	57.4	7.5	3	3	4.0	3.0	10.0	10.0%	293.4	
15	577+04	RT	54.1	7.5	3	3	4.0	3.0	10.0	10.0%	293.4	
16	595+26	RT	70.4	7.5	3	3	4.0	3.0	10.0	9.8%	293.4	
16	595+46	RT	73.7	7.5	3	3	4.0	3.0	10.0	9.8%	293.4	
16	595+66	RT	76.8	7.5	3	3	4.0	3.0	10.0	9.8%	293.4	
16	595+86	RT	79.8	7.5	3	3	4.0	3.0	10.0	9.8%	293.4	
16	596+06	RT	82.8	7.5	3	3	4.0	3.0	10.0	9.8%	293.4	
16	596+26	RT	85.9	7.5	3	3	4.0	3.0	10.0	9.8%	293.4	
16	596+46	RT	89.2	7.5	3	3	4.0	3.0	10.0	9.8%	293.4	
16	596+66	RT	92.5	7.5	3	3	4.0	3.0	10.0	9.8%	293.4	
16	596+86	RT	95.9	7.5	3	3	4.0	3.0	10.0	9.8%	293.4	
16	597+06	RT	99.3	7.5	3	3	4.0	3.0	10.0	9.8%	293.4	
16	597+26	RT	102.9	7.5	3	3	4.0	3.0	10.0	9.8%	293.4	



**STORMWATER DRAINAGE BASIN**

Basin No.	Station to Station		Side	Disturbed Area Acres	Discharge Point		Required Storage Volume CF	Remarks
					Station	Side		
1	456+50	466+00	RT	1.7	459+90	RT	6084.0	Sharp Curve up-station from project
2	499+70	502+50	LT	0.7	499+70	LT	2592.0	
3	502+50	512+50	LT	2.3	503+70	LT	8136.0	
4	512+50	529+00	LT	3.5	520+95	LT	12492.0	
5	529+00	538+25	LT	1.3	532+94	LT	4680.0	Water drains through pipe to other side
6	538+25	552+70	LT	3.5	549+50	LT	12528.0	
7	552+70	570+00	LT	3.4	570+00	LT	12276.0	Start Skunk Creek Project
8	575+00	590+40	LT	3.4	575+00	LT	12276.0	End Skunk Creek Project
9	590+40	610+23	LT	2.9	608+65	LT	10404.0	Water drains through pipe to other side
10	499+70	509+75	RT	1.1	499+70	RT	3996.0	
11	509+75	515+80	RT	1.0	513+00	RT	3564.0	
12	515+80	526+50	RT	1.3	521+00	RT	4752.0	Water drains through pipe to other side
13	526+50	539+70	RT	1.3	532+94	RT	4680.0	
14	539+70	570+00	RT	3.4	570+00	RT	12276.0	Start Skunk Creek Project
15	575+00	590+40	RT	2.7	575+00	RT	9828.0	End Skunk Creek Project
16	590+40	608+50	RT	2.8	608+50	RT	10152.0	

**SUMMARY OF STORMWATER STORAGE**

Basin No.	Item	Total Storage Volume Provided	Total Storage Volume Required	Remarks
		CF	CF	
1	Silt Fences for Ditch Checks	5676.0		
	Rock Check Dam	1760.4		
		<b>7436.4</b>	<b>6084.0</b>	
2	Silt Fences for Ditch Checks	2764.0		
		<b>2592.0</b>	<b>2592.0</b>	
3	Silt Fences for Ditch Checks	4491.5		
	Rock Check Dam	4694.4		
	Silt Basins	1362.5		
		<b>10548.4</b>	<b>8136.0</b>	
4	Silt Fences for Ditch Checks	9131.0		
	Rock Check Dam	2934.0		
	Silt Basins	1315.0		
		<b>13380.0</b>	<b>12492.0</b>	
5	Silt Fences for Ditch Checks	8390.7		
		<b>8390.7</b>	<b>4680.0</b>	
6	Silt Fences for Ditch Checks	9279.1		
	Rock Check Dam	4694.4		
	Silt Basins	1300.0		
		<b>15273.5</b>	<b>12528.0</b>	
7	Silt Fences for Ditch Checks	14708.4		
		<b>14708.4</b>	<b>12276.0</b>	
8	Silt Fences for Ditch Checks	15053.9		
		<b>15053.9</b>	<b>12276.0</b>	
9	Silt Fences for Ditch Checks	15251.3		
	Rock Check Dam	1760.4		
		<b>17011.7</b>	<b>10404.0</b>	
10	Silt Fences for Ditch Checks	8143.9		
		<b>8143.9</b>	<b>3996.0</b>	
11	Silt Fences for Ditch Checks	1974.3		
	Rock Check Dam	3520.8		
	Silt Basin	1175.0		
		<b>6670.1</b>	<b>3564.0</b>	
12	Silt Fences for Ditch Checks	9377.8		
		<b>9377.8</b>	<b>4752.0</b>	
13	Silt Fences for Ditch Checks	5281.2		
	Rock Check Dam	7628.4		
	Silt Basin	1380.0		
		<b>14289.6</b>	<b>4680.0</b>	
14	Silt Fences for Ditch Checks	26800.8		
		<b>26800.8</b>	<b>12276.0</b>	
15	Silt Fences for Ditch Checks	11648.2		
	Rock Check Dam	3227.4		
		<b>14875.6</b>	<b>9828.0</b>	
16	Silt Fences for Ditch Checks	11204.0		
	Rock Check Dam	3227.4		
		<b>14431.4</b>	<b>10152.0</b>	

**SURVEY SYMBOLS**

- CUL Culvert**
- FW Wire Fence**
- PIP Pipe Culvert**
- TFR Tree Fruit**
- MM Mile Marker Post**
- TLNL Tree Line Left**
- GDG Guard Rail Steel**
- OUT Tile Outlet**
- SI Sign**
- D Centerline Draw or Stream (Down)**
- SNP Unpaved Shoulder**
- DU Centerline Draw or Stream (Up)**
- SH Paved Shoulder**
- EP Edge of Paved Roads (ML or SR)**
- EG Edge of Gravel Road**
- CON Concrete or A/C Slab**
- BNK Stream Bank**
- EW Edge of Water**
- SP Stream Profile**
- GR Ground Shot**
- BL Topo Breakline**
- C Centerline BL of Road (ML or SR)**

**UTILITY LEGEND**  
Survey Information

SUB-SURFACE MAPPING QUALITY LEVEL  
 LEVEL (A) POT HOLE LOCATION OR ACTUAL XYZ Location  
 LEVEL (B) UTILITY FLAG LOCATION  
 LEVEL (C) PLOTTED FROM REFERENCE TO GROUND FEATURES  
 LEVEL (D) PLOTTED FROM UTILITY MAPS OR HEARSAY

- TPD Telephone Pedestal**
- PR Electric Riser Pole**
- PPA Power Pole Co. 1**
- TR Telephone Riser Pole**
- TL1D Telephone Line Co. 1 - Quality D**

**PLAN VIEW COLOR LEGEND OF PLAN AND PROFILE SHEETS**

LINEWORK	Design Color No.	
Green	(2)	Existing Topographic Features and Labels
Blue	(1)	Proposed Alignment, Stationing, Tic Marks, and Alignment Annotation
Magenta	(5)	Existing Utilities
SHADING	Design Color No.	
Yellow	(4)	Highlight for Critical Notes or Features
Red	(3)	Delineates Restricted Areas
Lavender	(9)	Temporary Pavement Shading
Gray, Light	(48)	Proposed Pavement Shading
Gray, Med	(80)	Proposed Granular Shading
Gray, Dark	(112)	Proposed Grade and Pave Shading "In conjunction with a paving project"
Brown, Light	(236)	Grading Shading
Tan	(8)	Proposed Sidewalk Shading
Blue, Light	(230)	Proposed Sidewalk Landing Shading
Pink	(11)	Proposed Sidewalk Ramp Shading

**PROFILE VIEW COLOR LEGEND OF PLAN AND PROFILE SHEETS**

LINEWORK	Design Color No.	
Green	(2)	Existing Ground Line Profile
Blue	(1)	Proposed Profile and Annotation
Magenta	(5)	Existing Utilities
Blue, Light	(230)	Proposed Ditch Grades, Left
Black	(0)	Proposed Ditch Grades, Median
Rust	(14)	Proposed Ditch Grades, Right

- Reference Point
- Station
  - Survey Line
  - Section Corner
  - Ground Line Intercept
  - Saw Cut
  - Guardrail
  - Trench Drain
  - HighTension Cable Guardrail
  - Sheet Pile
  - Pavement Removal
  - Clearing & Grubbing Area

- RIGHT-OF-WAY LEGEND**
- Proposed Right-of-Way
  - Existing Right of Way
  - Existing and Proposed Right-of-Way
  - Easement and Existing Right-of-Way
  - Easement (Temporary)
  - Easement
  - Access Control
  - Property Line

**VERTICAL CONTROL**

- Rock Ditch and Rock Dam Check
- Silt Fence

**PLAN AND PROFILE  
LEGEND AND SYMBOL  
INFORMATION SHEET**

(COVERS SHEET SERIES D, E, F, & K)

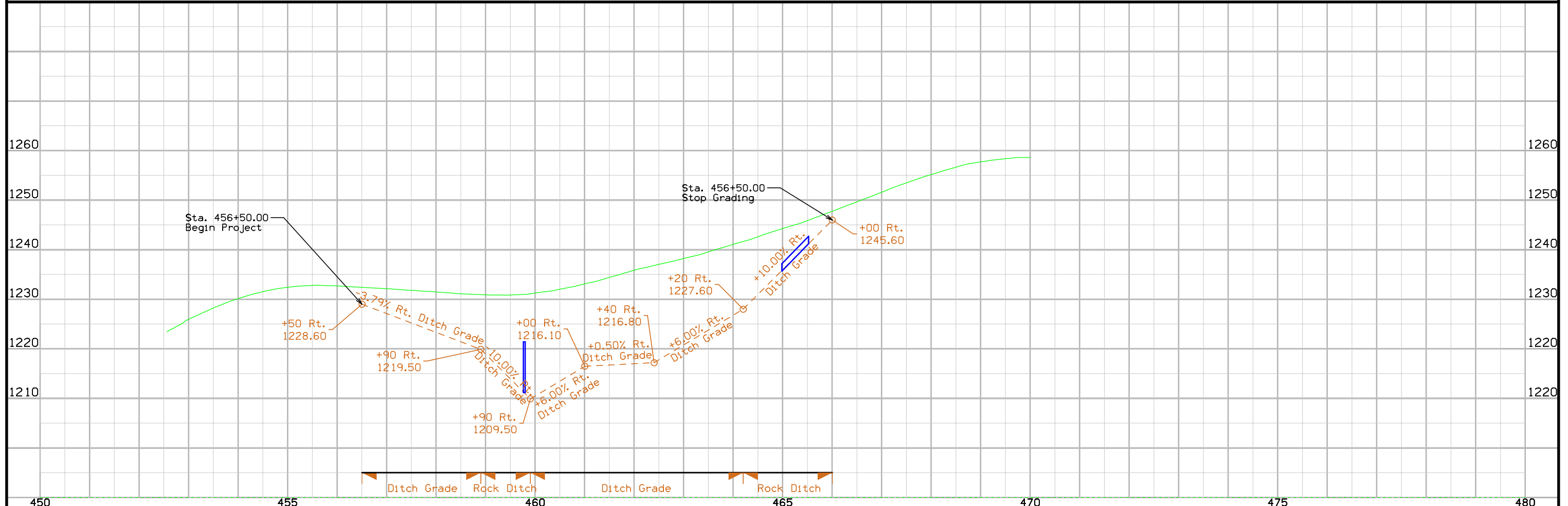
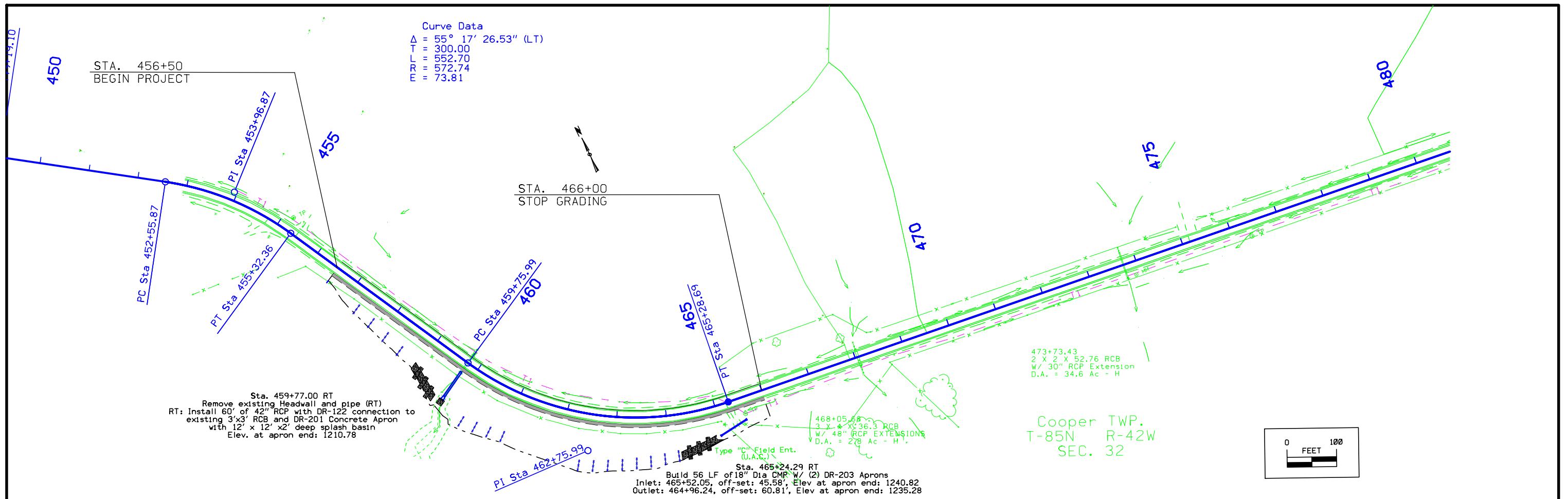

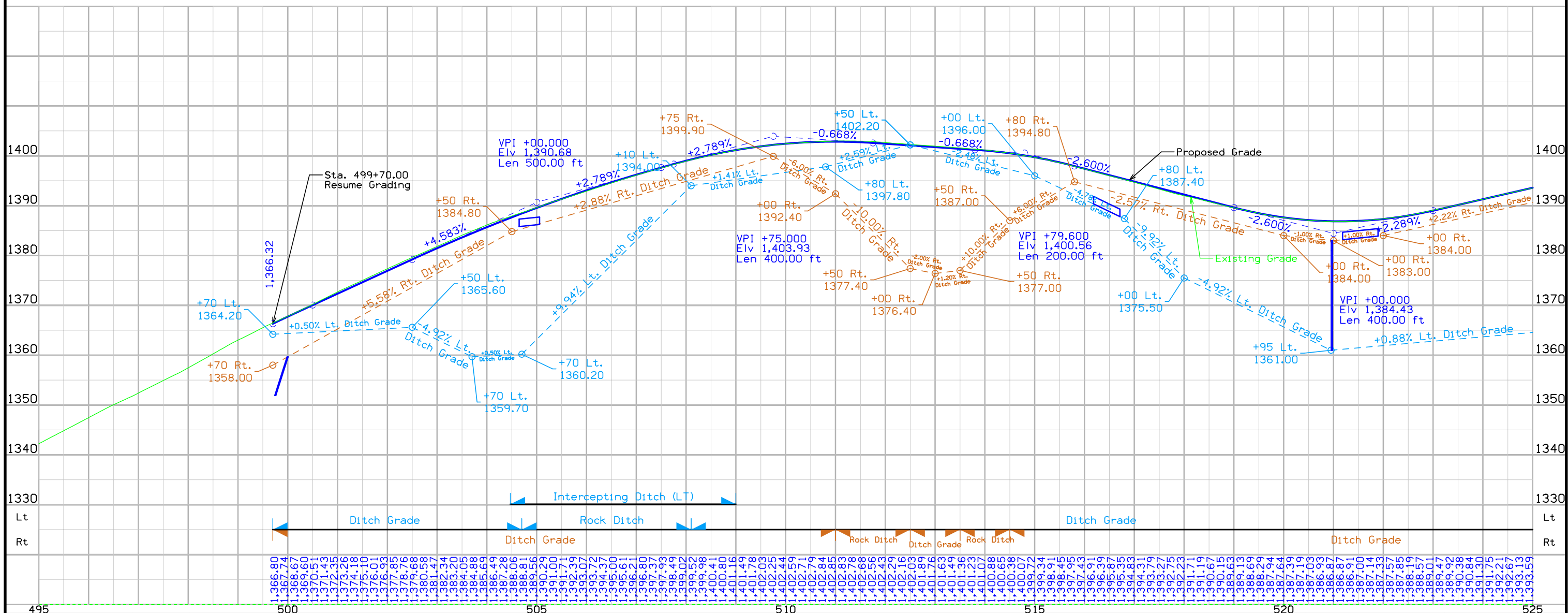
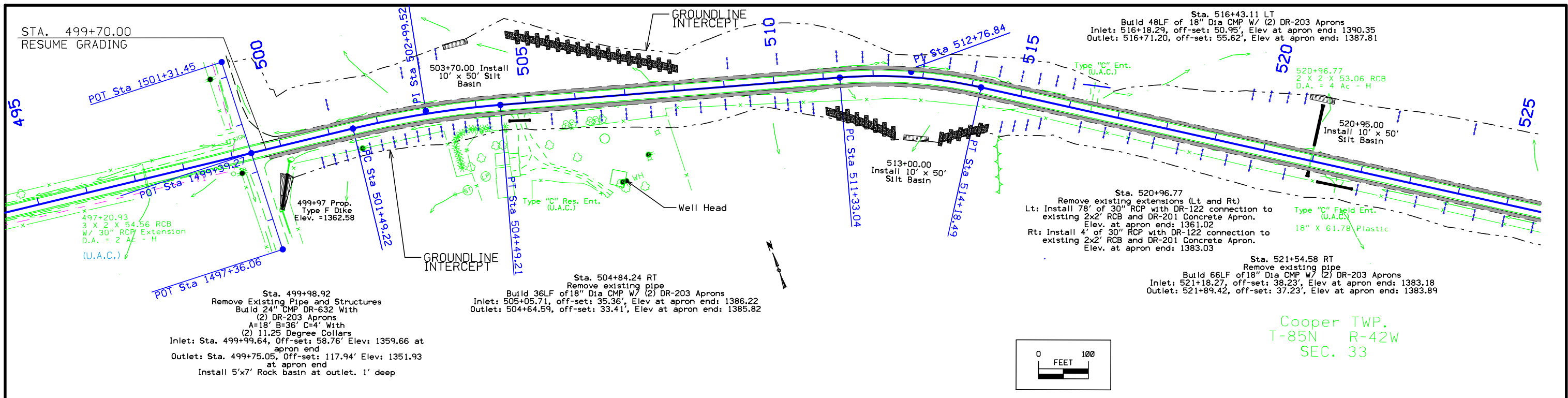

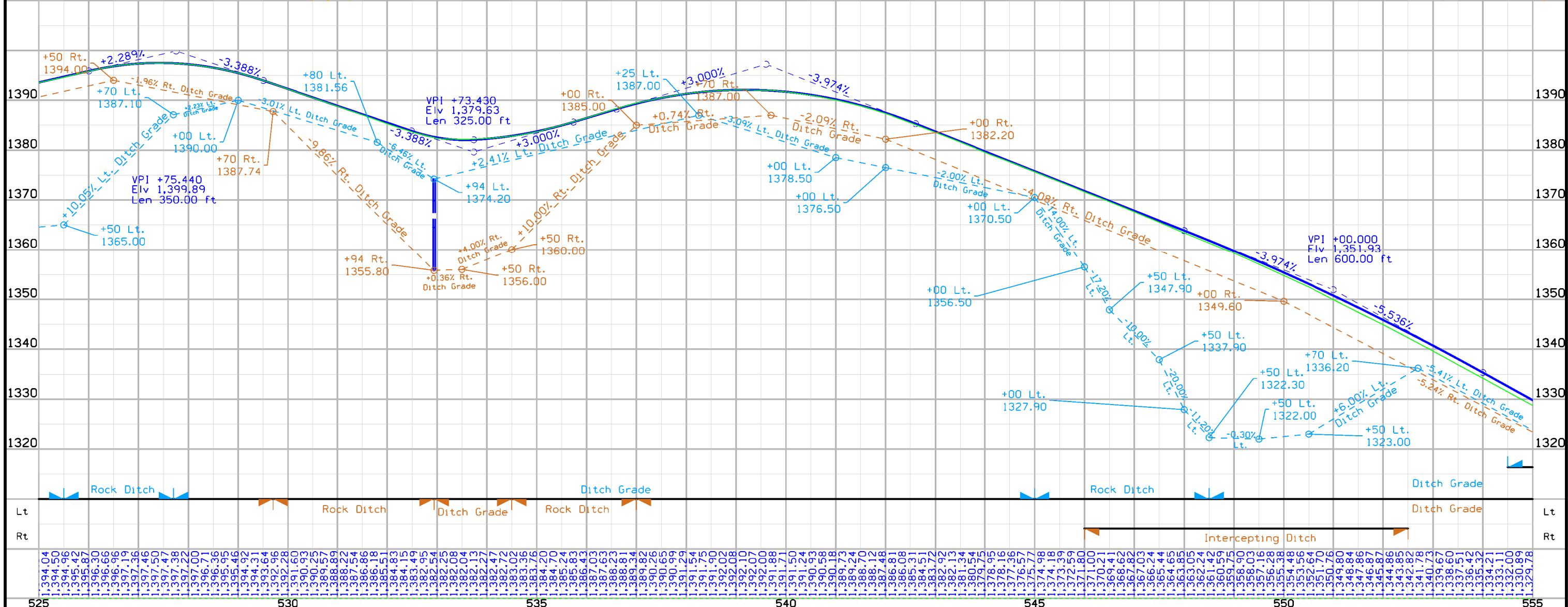
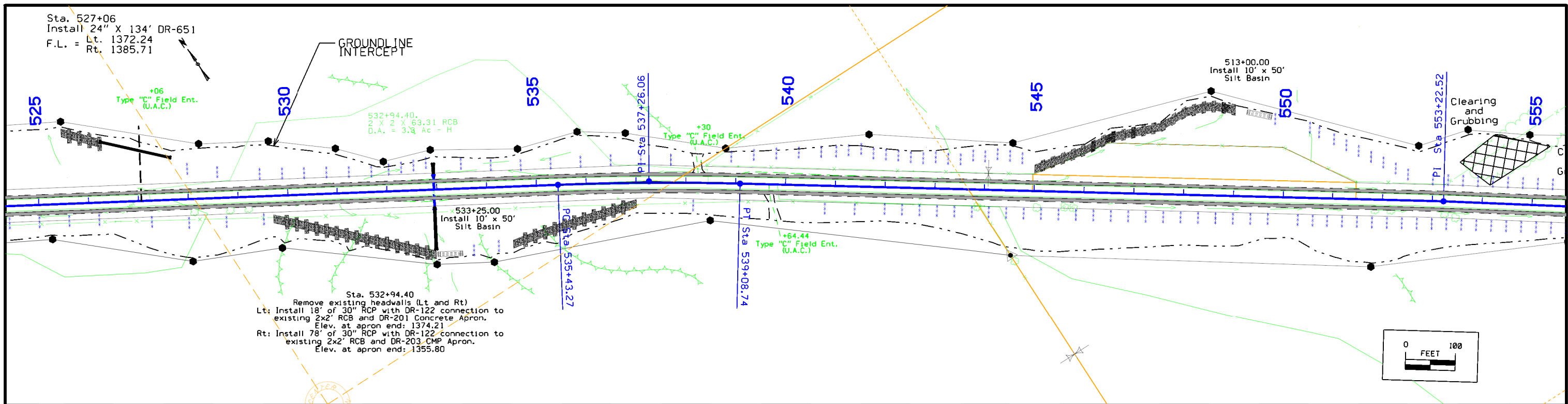



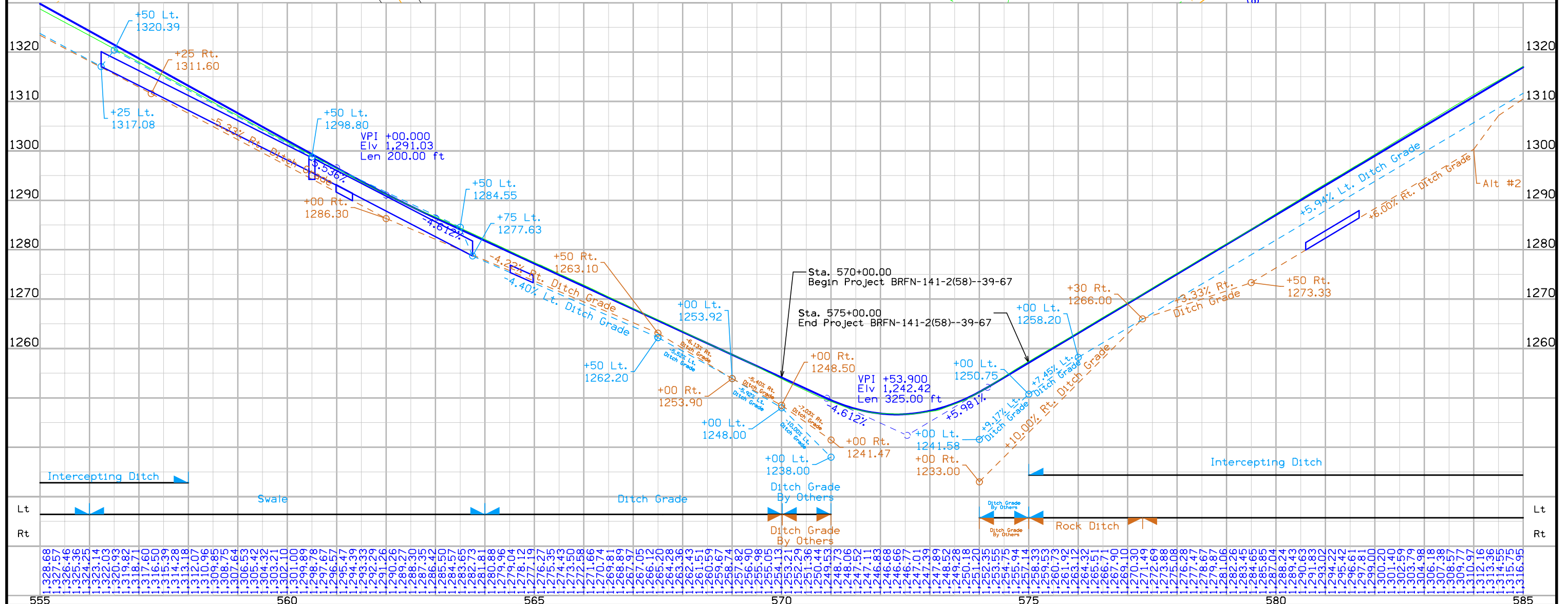
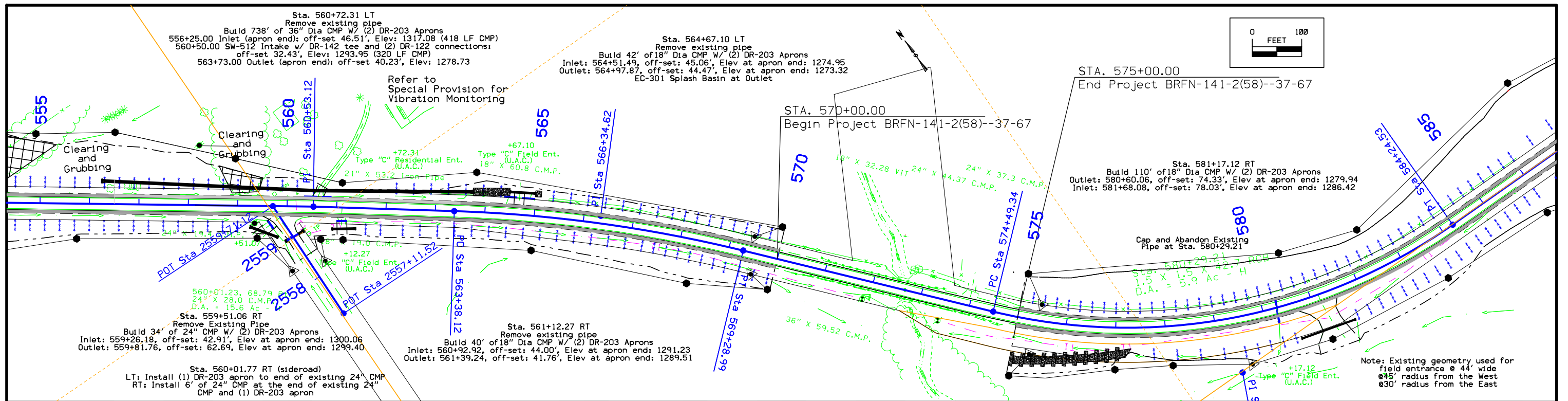

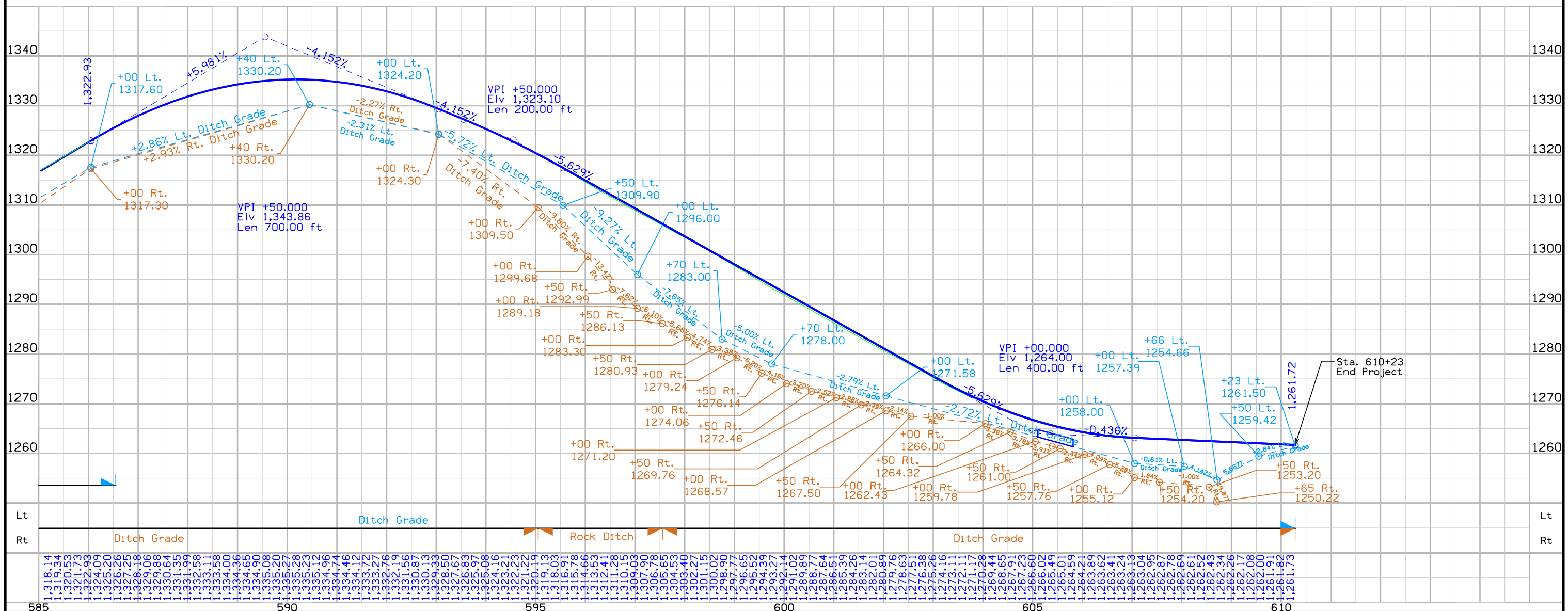
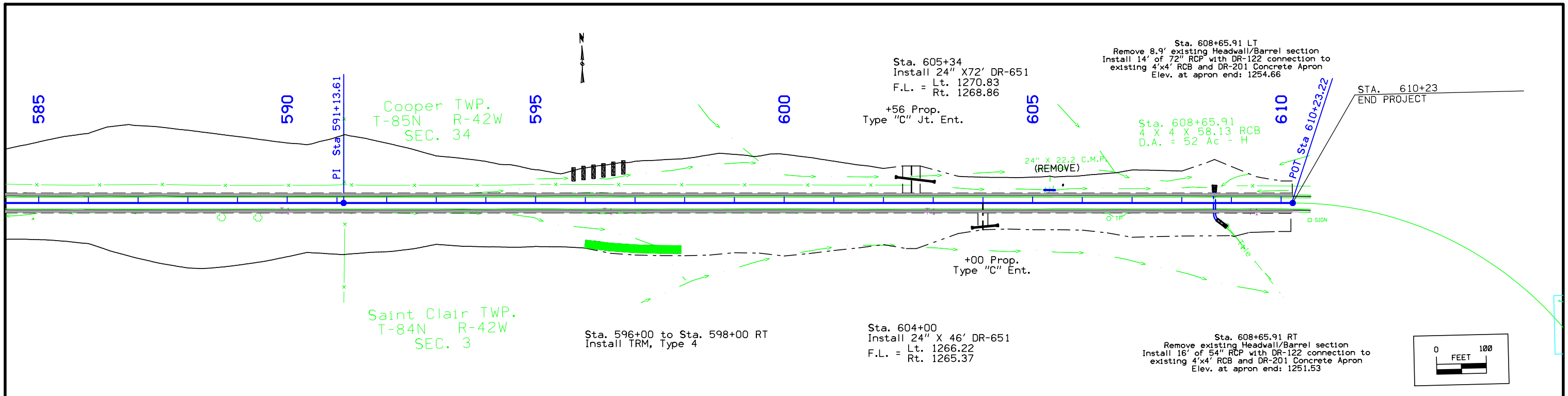

FILE NO.	ENGLISH	DESIGN TEAM	Tymkowicz \ hgm	MONONA COUNTY	PROJECT NUMBER	STPN-141-2(56)--2J-67	SHEET NUMBER	D.6
----------	---------	-------------	-----------------	---------------	----------------	-----------------------	--------------	-----

NO ACCESS RIGHTS ARE TO BE ACQUIRED ON THIS PROJECT.



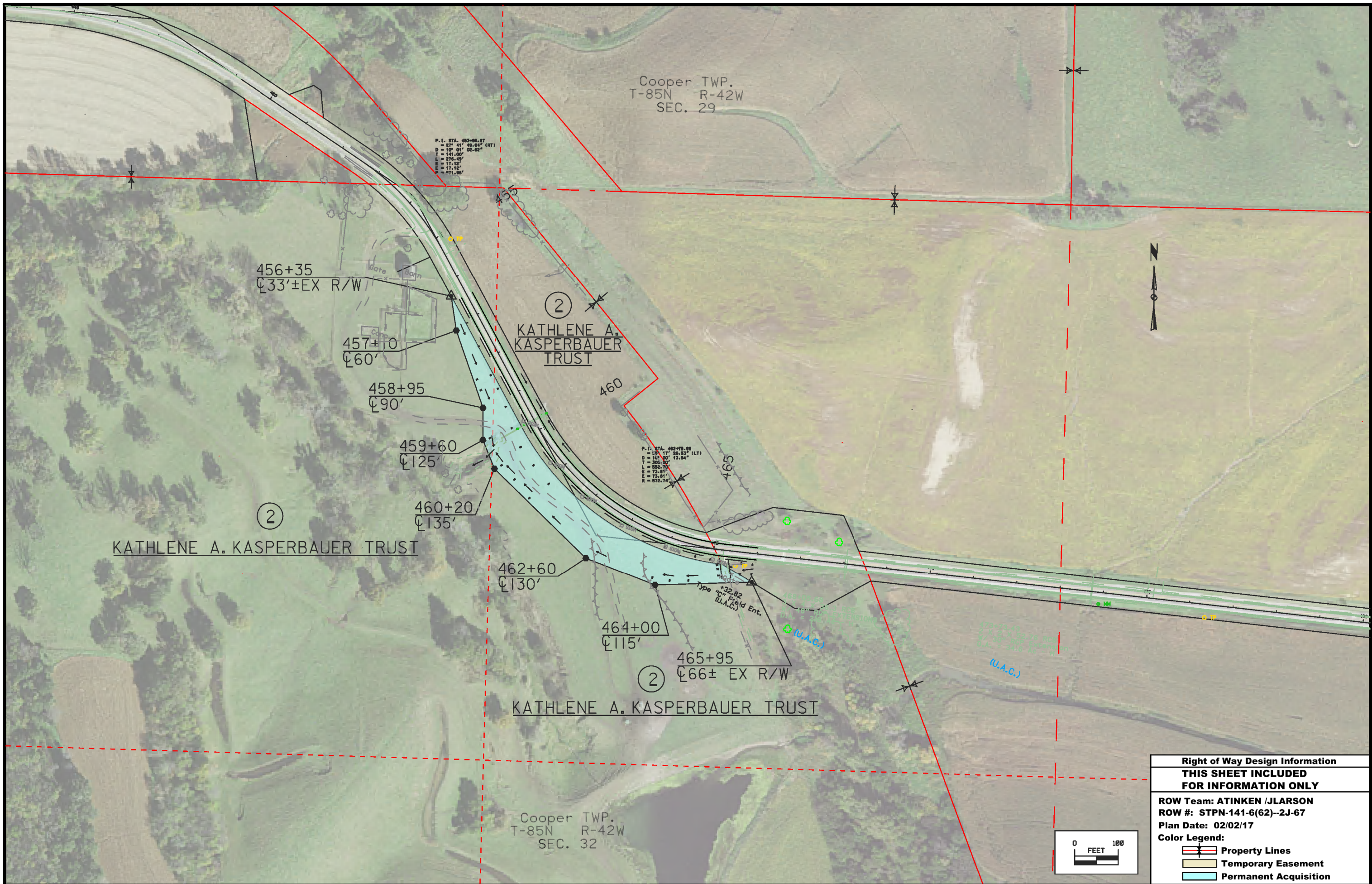

P.I. STA. 453+96.87  
 Δ = 27° 41' 48.04" (RT)  
 D = 10° 01' 02.82"  
 L = 141.00'  
 T = 276.49'  
 E = 171.12'  
 R = 871.96'

Cooper TWP.  
 T-85N R-42W  
 SEC. 29

P.I. STA. 462+78.99  
 Δ = 17° 17' 28.83" (LT)  
 D = 10° 00' 13.54"  
 L = 306.00'  
 T = 282.78'  
 E = 73.81'  
 R = 878.74'

②  
 KATHLENE A. KASPERBAUER TRUST

②  
 KATHLENE A. KASPERBAUER TRUST

Cooper TWP.  
 T-85N R-42W  
 SEC. 32

<b>Right of Way Design Information</b>	
<b>THIS SHEET INCLUDED FOR INFORMATION ONLY</b>	
ROW Team: ATINKEN /JLARSON	
ROW #: STPN-141-6(62)--2J-67	
Plan Date: 02/02/17	
Color Legend:	
	Property Lines
	Temporary Easement
	Permanent Acquisition

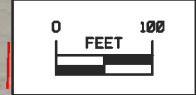



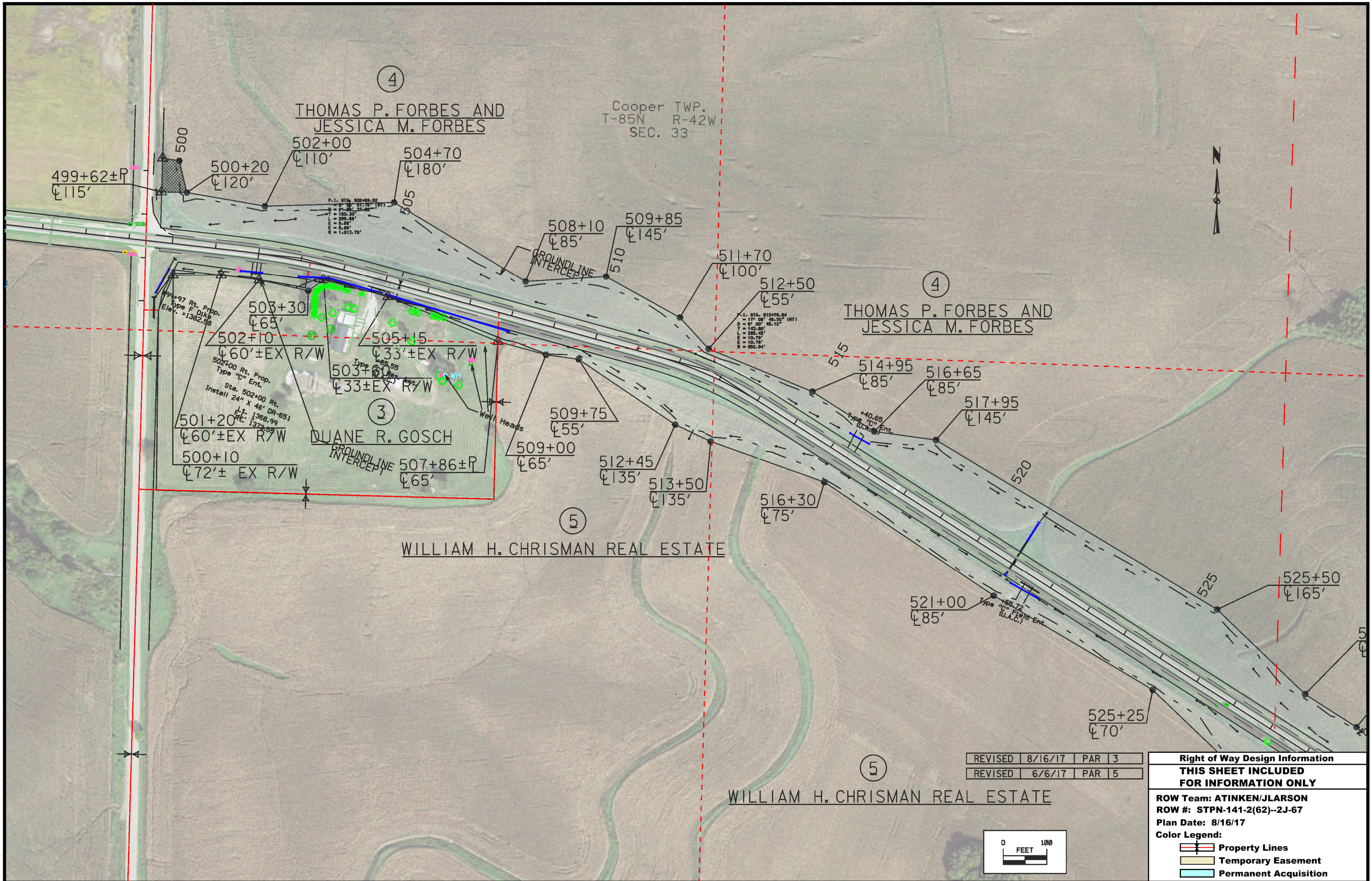

Cooper TWP.  
T-85N R-42W  
SEC. 33

THOMAS P. FORBES AND  
JESSICA M. FORBES

THOMAS P. FORBES AND  
JESSICA M. FORBES

DUANE R. GOSCH

WILLIAM H. CHRISMAN REAL ESTATE

WILLIAM H. CHRISMAN REAL ESTATE

REVISED	8/16/17	PAR	3
REVISED	6/6/17	PAR	5

<b>Right of Way Design Information</b>	
<b>THIS SHEET INCLUDED FOR INFORMATION ONLY</b>	
ROW Team: ATINKEN/JLARSON	
ROW #: STPN-141-2(62)--2J-67	
Plan Date: 8/16/17	
Color Legend:	
	Property Lines
	Temporary Easement
	Permanent Acquisition

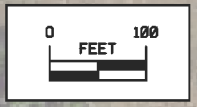



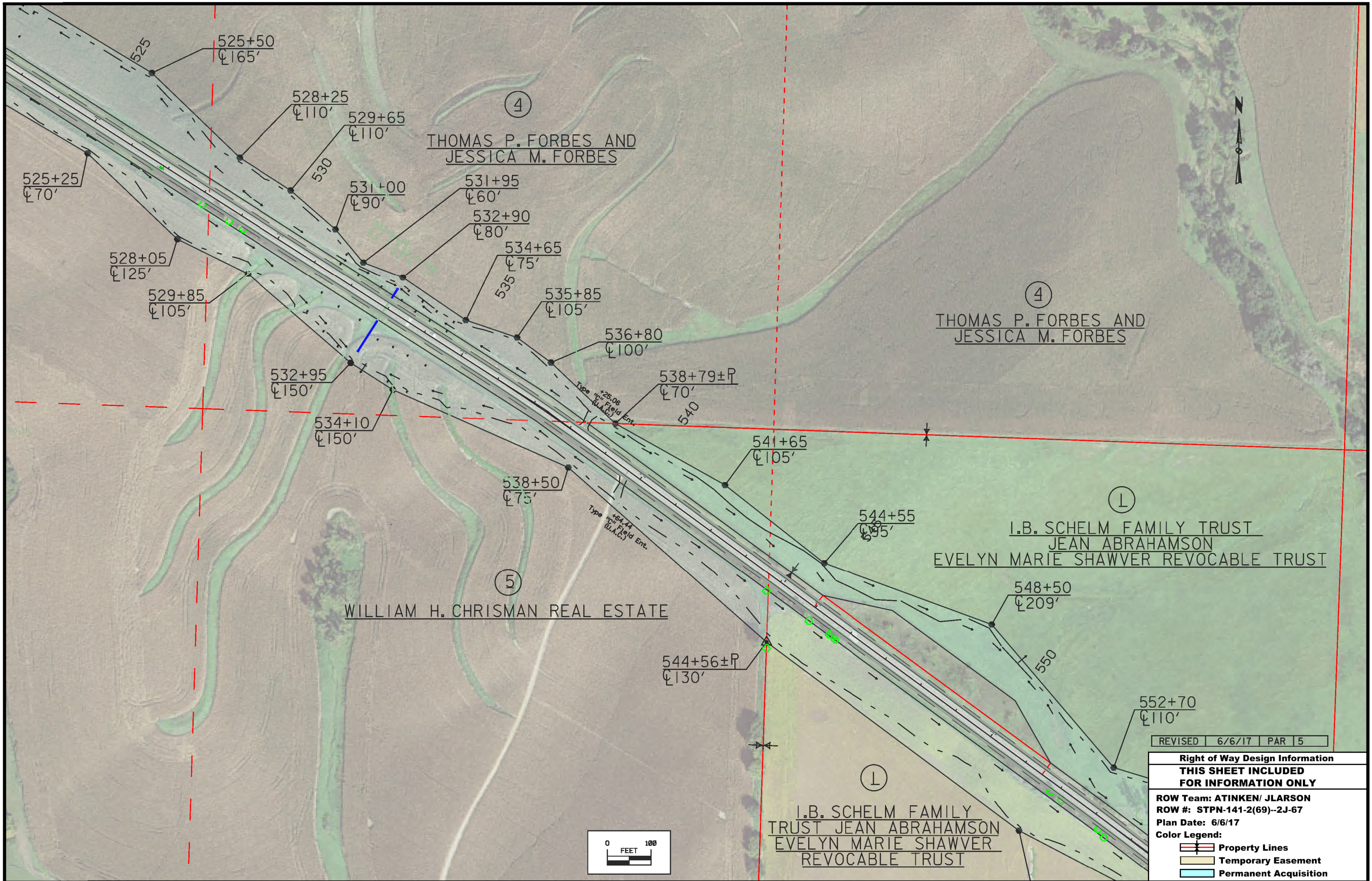

REVISED 6/6/17 PAR 5

**Right of Way Design Information**  
**THIS SHEET INCLUDED**  
**FOR INFORMATION ONLY**

ROW Team: ATINKEN/ JLARSON  
 ROW #: STPN-141-2(69)--2J-67  
 Plan Date: 6/6/17

**Color Legend:**  
 [Red dashed line] Property Lines  
 [Yellow shaded area] Temporary Easement  
 [Blue shaded area] Permanent Acquisition



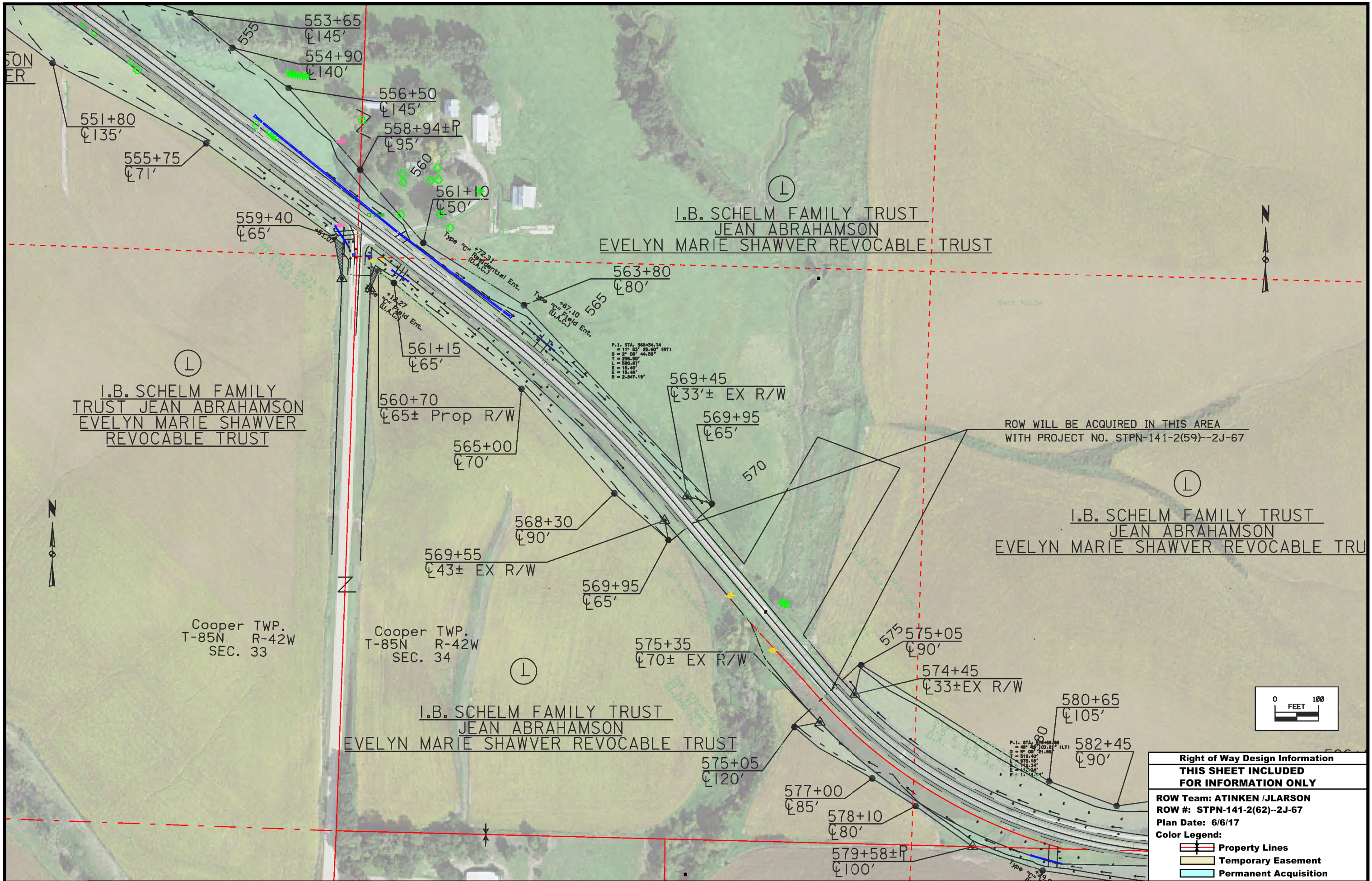

Right of Way Design Information	
<b>THIS SHEET INCLUDED FOR INFORMATION ONLY</b>	
ROW Team: ATINKEN /JLARSON	
ROW #: STPN-141-2(62)--2J-67	
Plan Date: 6/6/17	
Color Legend:	
	Property Lines
	Temporary Easement
	Permanent Acquisition



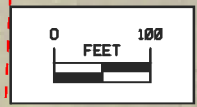
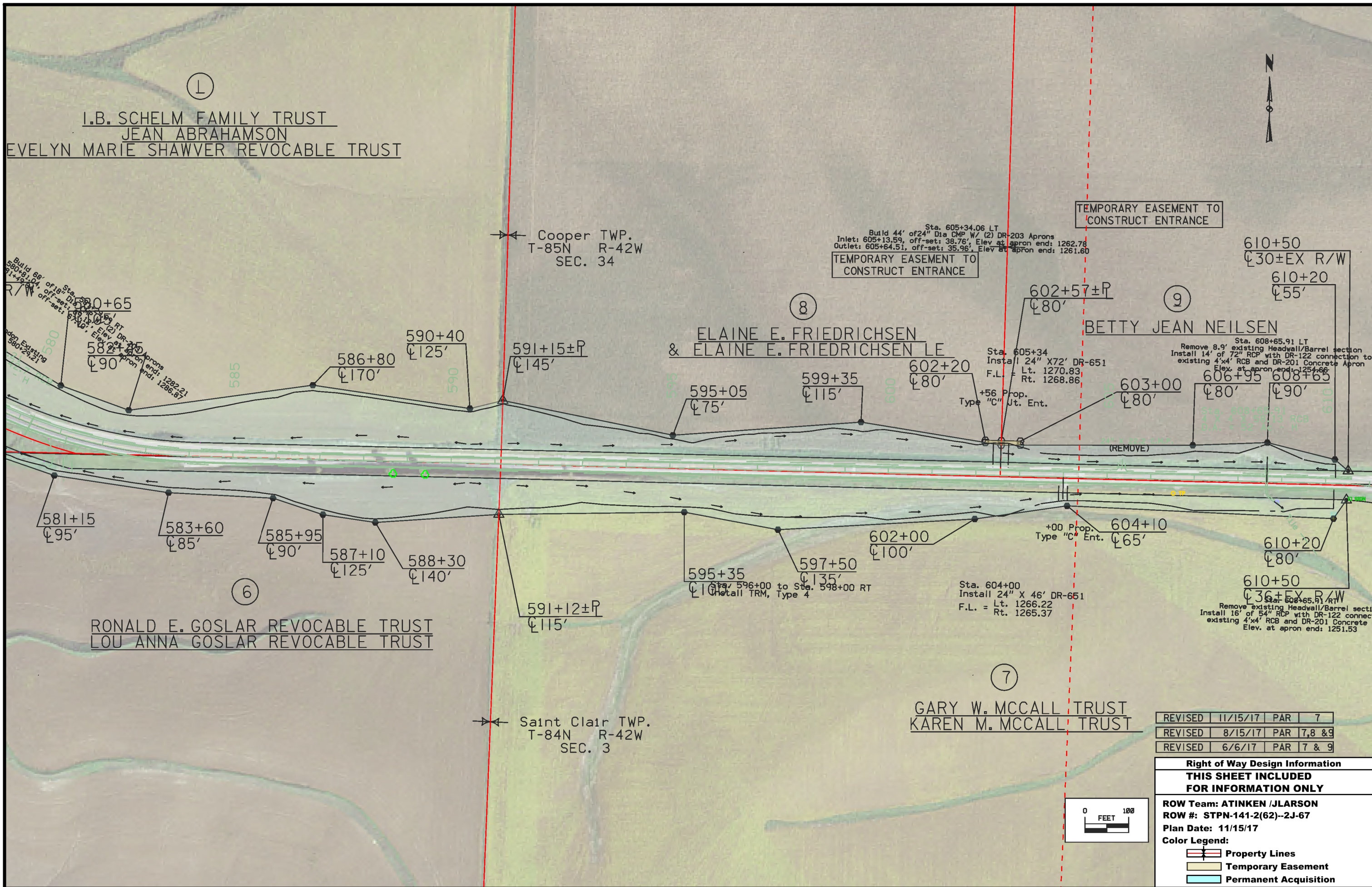

REVISED	11/15/17	PAR	7
REVISED	8/15/17	PAR	7,8 & 9
REVISED	6/6/17	PAR	7 & 9

**Right of Way Design Information**  
**THIS SHEET INCLUDED FOR INFORMATION ONLY**

**ROW Team:** ATINKEN /JLARSON  
**ROW #:** STPN-141-2(62)--2J-67  
**Plan Date:** 11/15/17  
**Color Legend:**  
▬ Property Lines  
▬ Temporary Easement  
▬ Permanent Acquisition



Cooper TWP.  
T-85N R-42W  
SEC. 32

Cooper TWP.  
T-85N R-42W  
SEC. 33

③  
DUANE R. OSCH  
Type 695 SS  
(L) 17' Ent.

④  
THOMAS P. FORBES AND  
JESSICA M. FORBES



⑤  
WILLIAM H. CHRISMAN REAL ESTATE

1501+30  
±32± EX R/W

500  
1501+25  
±70'

505

REVISED 6/6/17 PAR 3 & 5

<b>Right of Way Design Information</b>	
<b>THIS SHEET INCLUDED FOR INFORMATION ONLY</b>	
ROW Team: ATINKEN/JLARSON	
ROW #: STPN-141-2(62)--2J-67	
Plan Date: 6/6/17	
Color Legend:	
	Property Lines
	Temporary Easement
	Permanent Acquisition

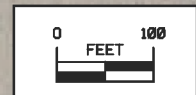



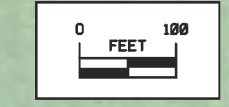
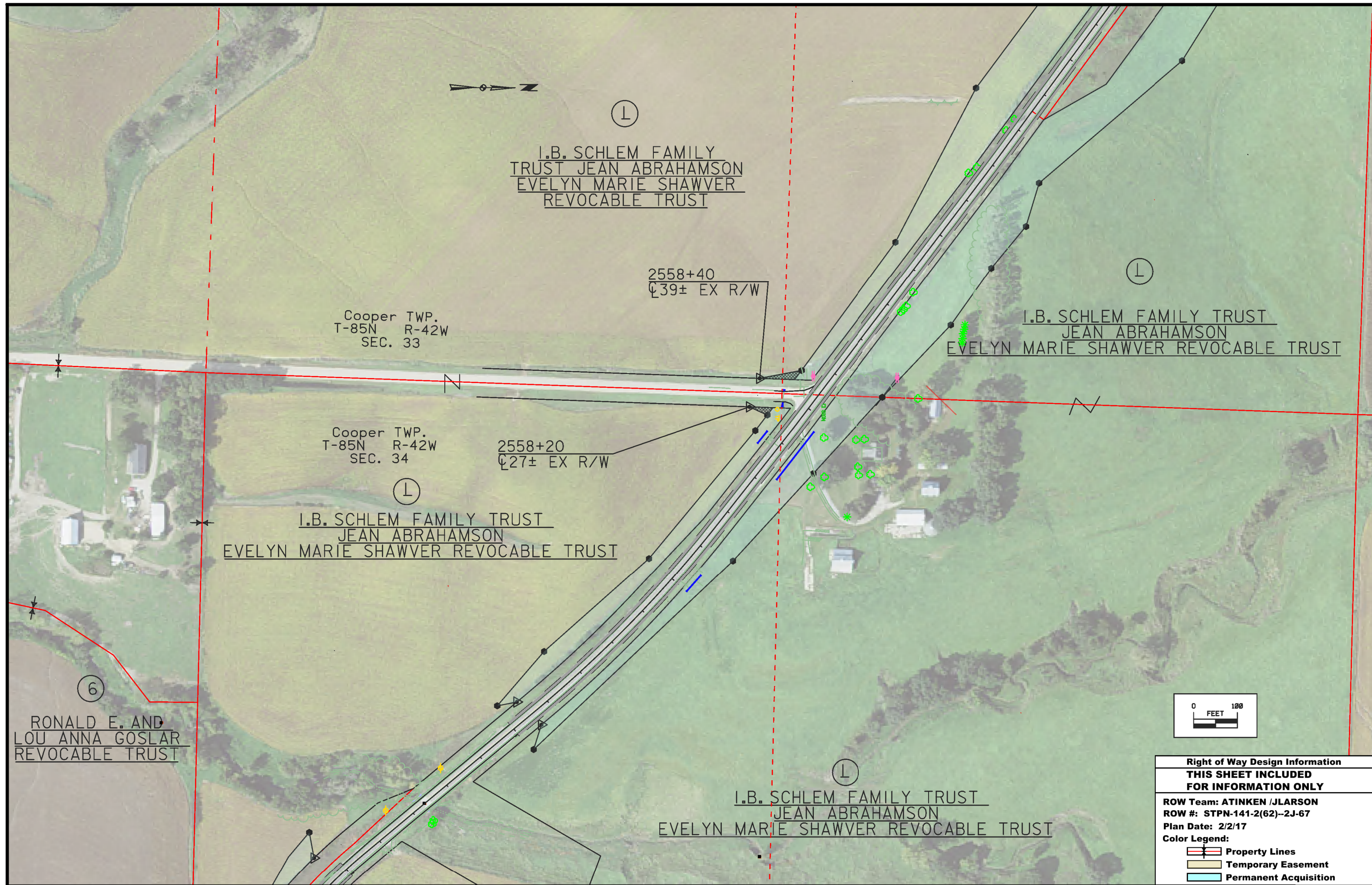

<b>Right of Way Design Information</b>	
<b>THIS SHEET INCLUDED FOR INFORMATION ONLY</b>	
ROW Team: ATINKEN /JLARSON	
ROW #: STPN-141-2(62)--2J-67	
Plan Date: 2/2/17	
Color Legend:	
	Property Lines
	Temporary Easement
	Permanent Acquisition

108-23A  
08-01-08

### TRAFFIC CONTROL PLAN

Iowa 141 will be open to traffic during construction.

Construction staging during shouldering and grading operations will require the utilization of the TC-214 Standard Road Plan. One Lane of traffic will be closed during the shouldering and grading operations while utilizing a pilot car and flaggers. Contractor shall maintain access to all properties and all sideroads at all times during construction. Two-way, two-lane traffic shall be re-established at the end of each day.

111-01  
04-17-12

### COORDINATED OPERATIONS

Other work in progress during the same period of time will include the construction of the projects listed. Coordinate operations with those of other contractors working within the same area.

Project	Type of Work
BRFN-141-2(58)--39-67	RCB Culvert Replacement



**LINE STYLE LEGEND OF CROSS SECTION SHEETS (ROAD)**

- - - - - - Existing Ground Line
- Proposed Template
- Proposed Topsoil Placement
- - - - - Additional Topsoil Removal
- Subgrade Treatment
- - - - - Granular Shoulder
- Pavement
- - - - - Existing Pipe\RCB
- Proposed Pipe\RCB
- Proposed Dike
- All Elements Associated with Proposed Entrances

**LINE STYLE LEGEND OF CROSS SECTION SHEETS (SOILS)**

- TS————— Topsoil (Class 10)
- SLOPE DRESSING — Slope Dressing Only
- CL 10————— Class 10 Materials
- SEL L0————— Select Loams And Clay-Loams
- SEL SA————— Select Sand
- UNS A————— Unsuitable Type A Disposal
- UNS B————— Unsuitable Type B Disposal
- UNS C————— Unsuitable Type C Disposal
- SHALE————— Shale
- WASTE————— Waste
- B&W LS————— Broken and Weathered Rock
- ROCK————— Solid Rock
- BLDRS————— Boulders

Note: All layer lines and descriptions identify layers above the line.

Note: Vertical or near vertical lines connecting soil layers at edges of cross sections are only for the purpose of calculating template quantities and do not depict soil stratification.

**SYMBOL LEGEND OF CROSS SECTION SHEETS**

- Existing ROW  
|  
Existing Right-of-Way Limit
- Proposed ROW  
|  
Proposed Right-of-Way Limit
- Temporary ROW  
|  
Temporary Right-of-Way Limit

**CROSS SECTION  
LEGEND AND SYMBOL  
INFORMATION SHEET**

(COVERS SHEET SERIES W, X, Y, & Z)

# WASTE AREA Preliminary

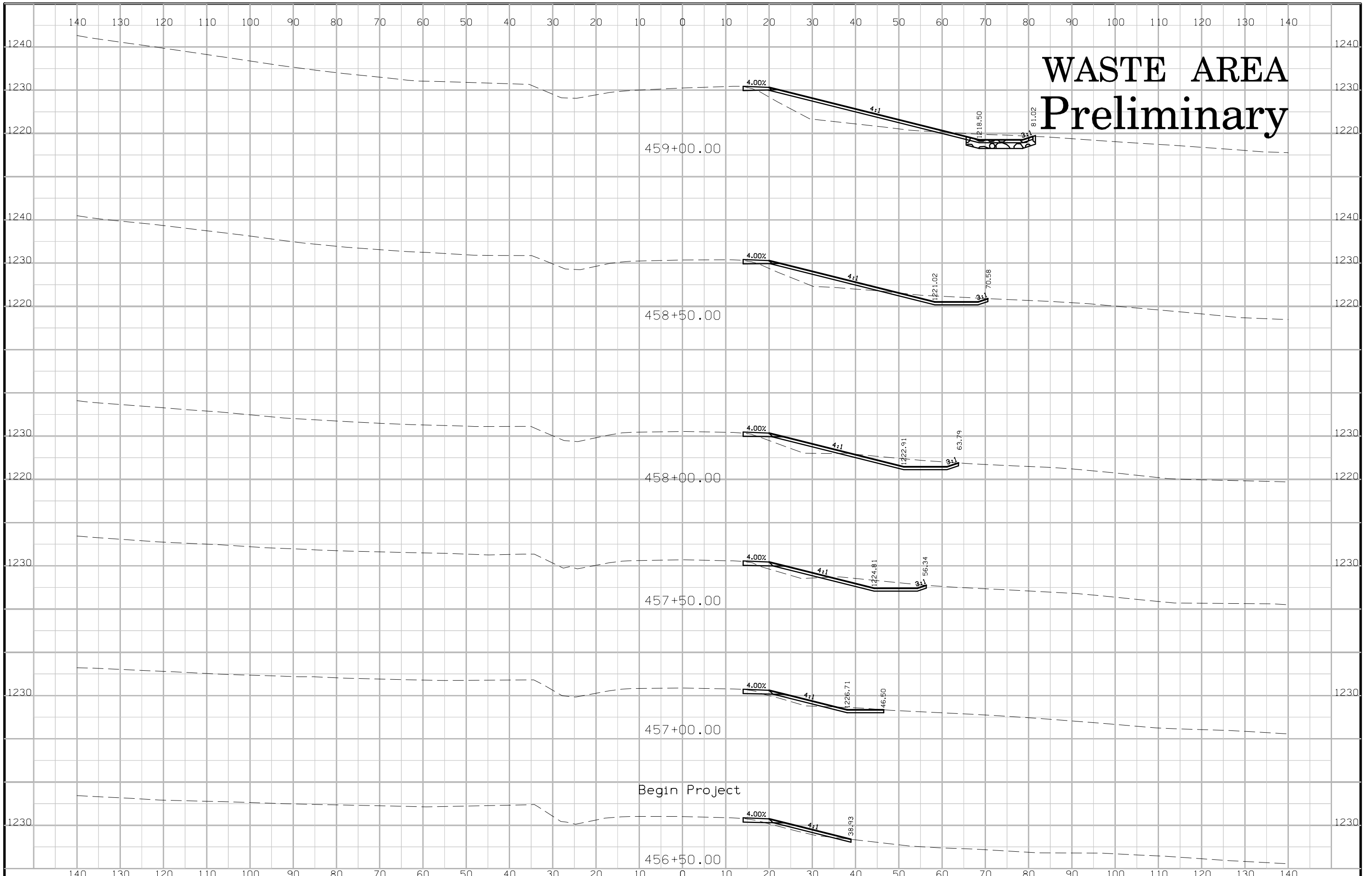

# WASTE AREA Preliminary

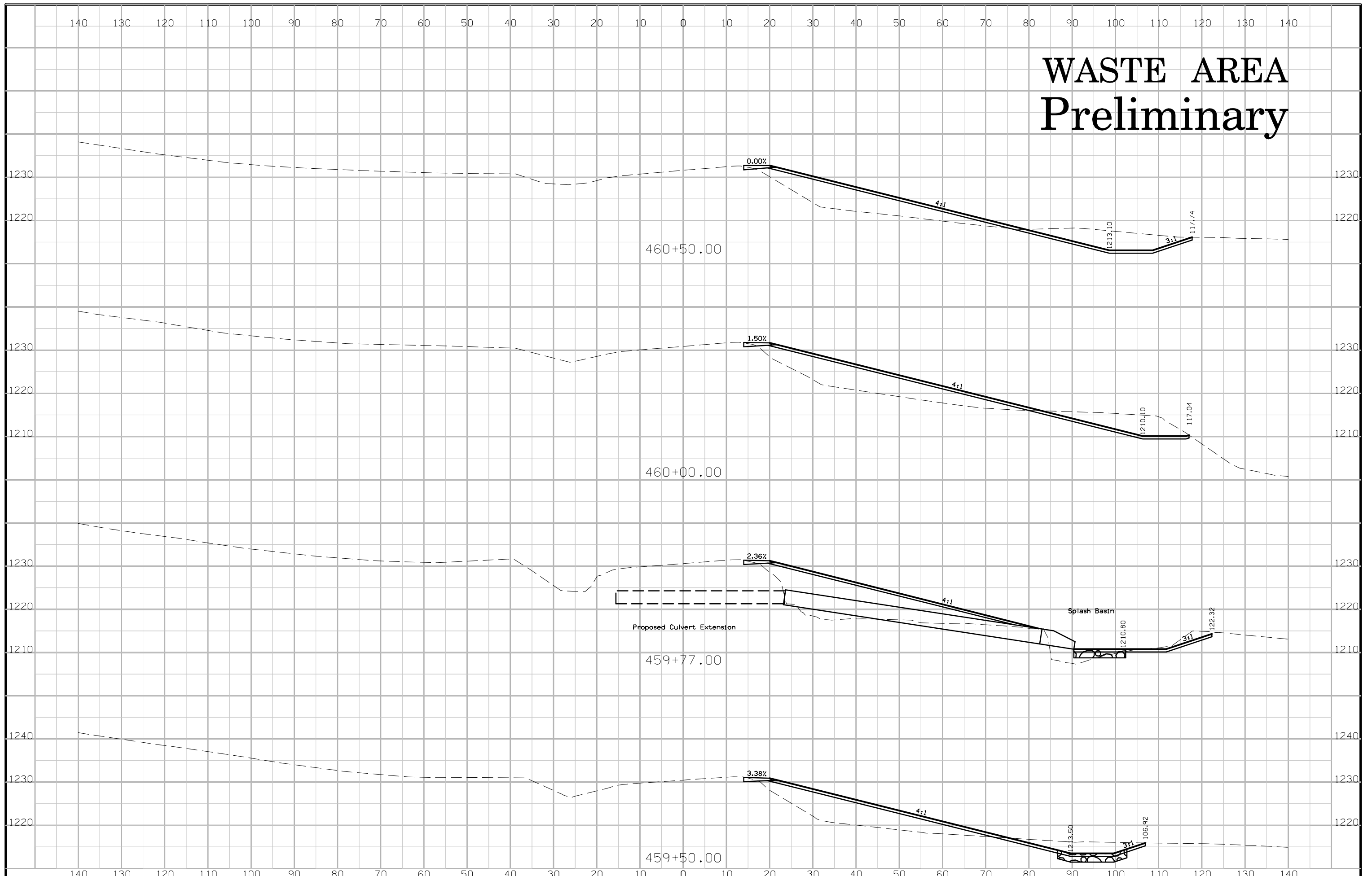

# WASTE AREA Preliminary

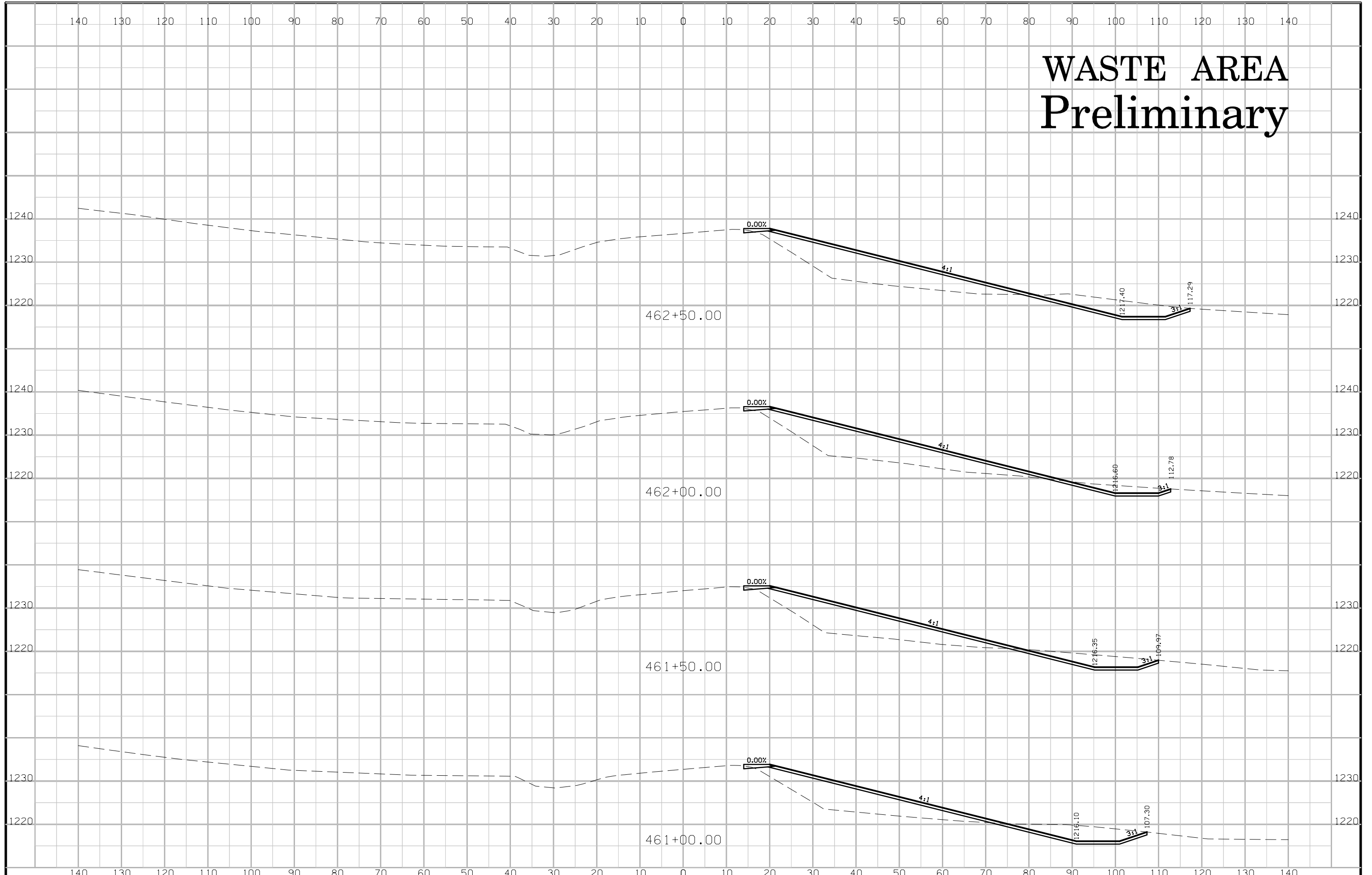

# WASTE AREA Preliminary

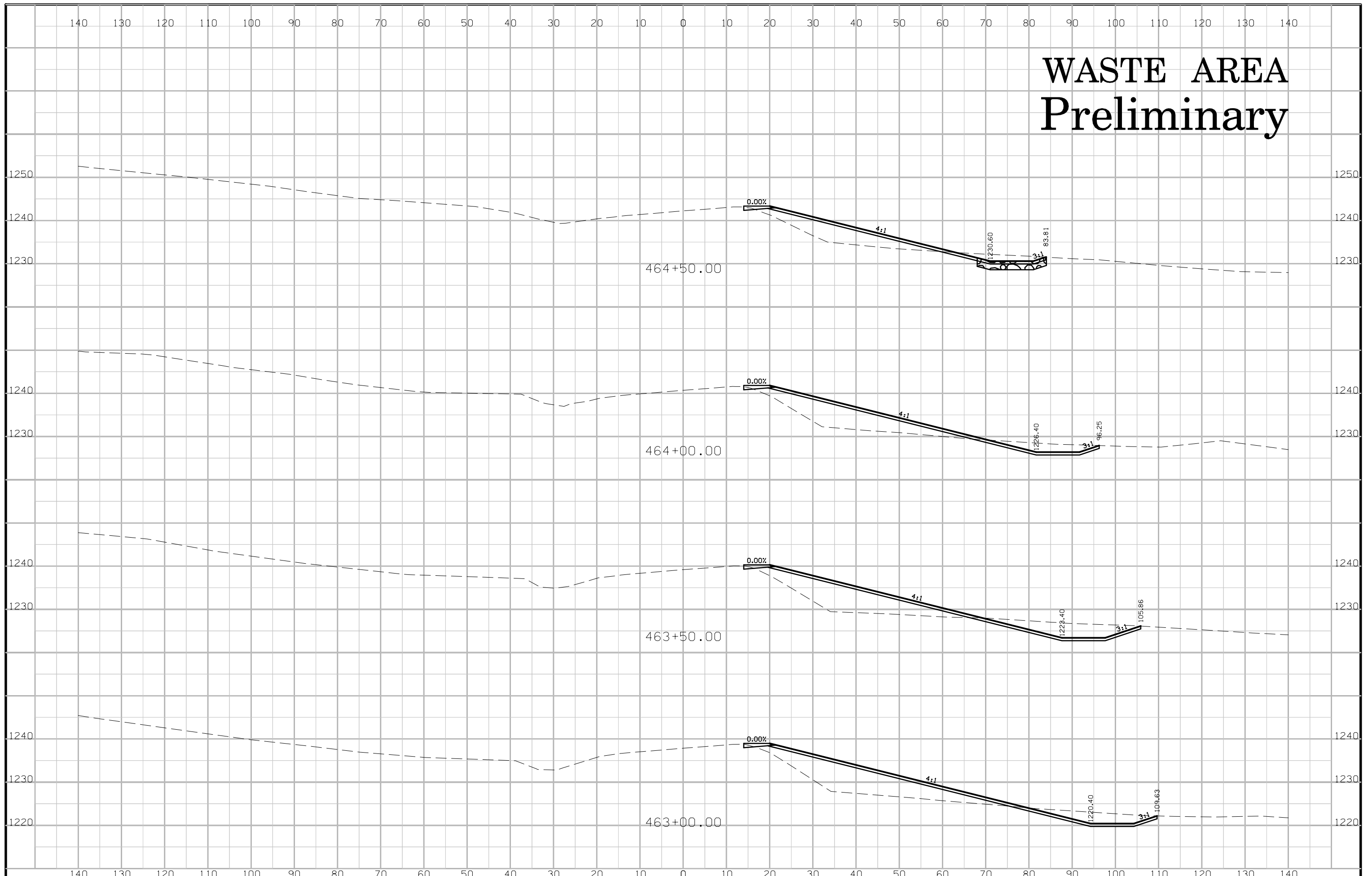

# WASTE AREA Preliminary

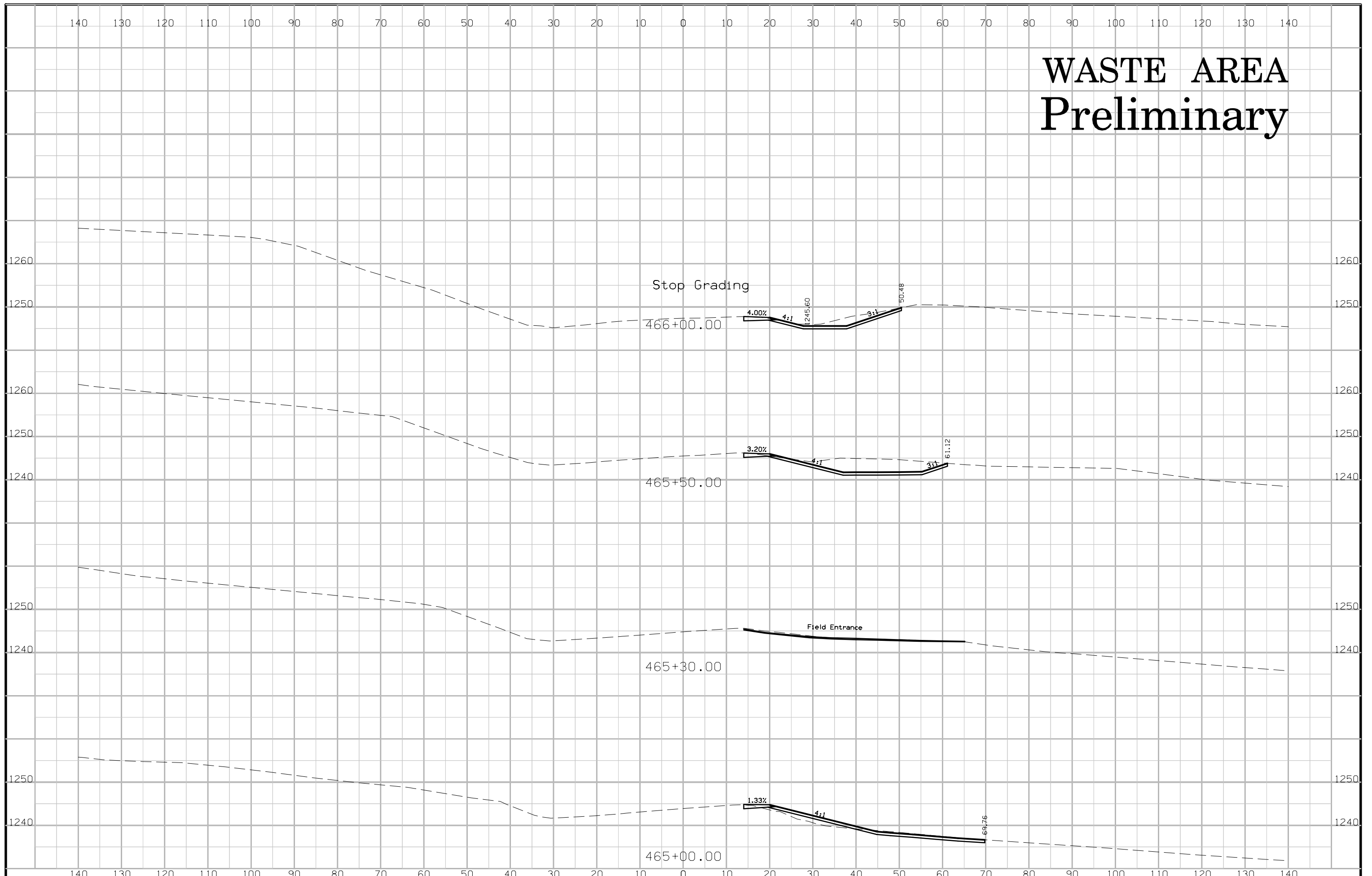

# IA 141 Preliminary

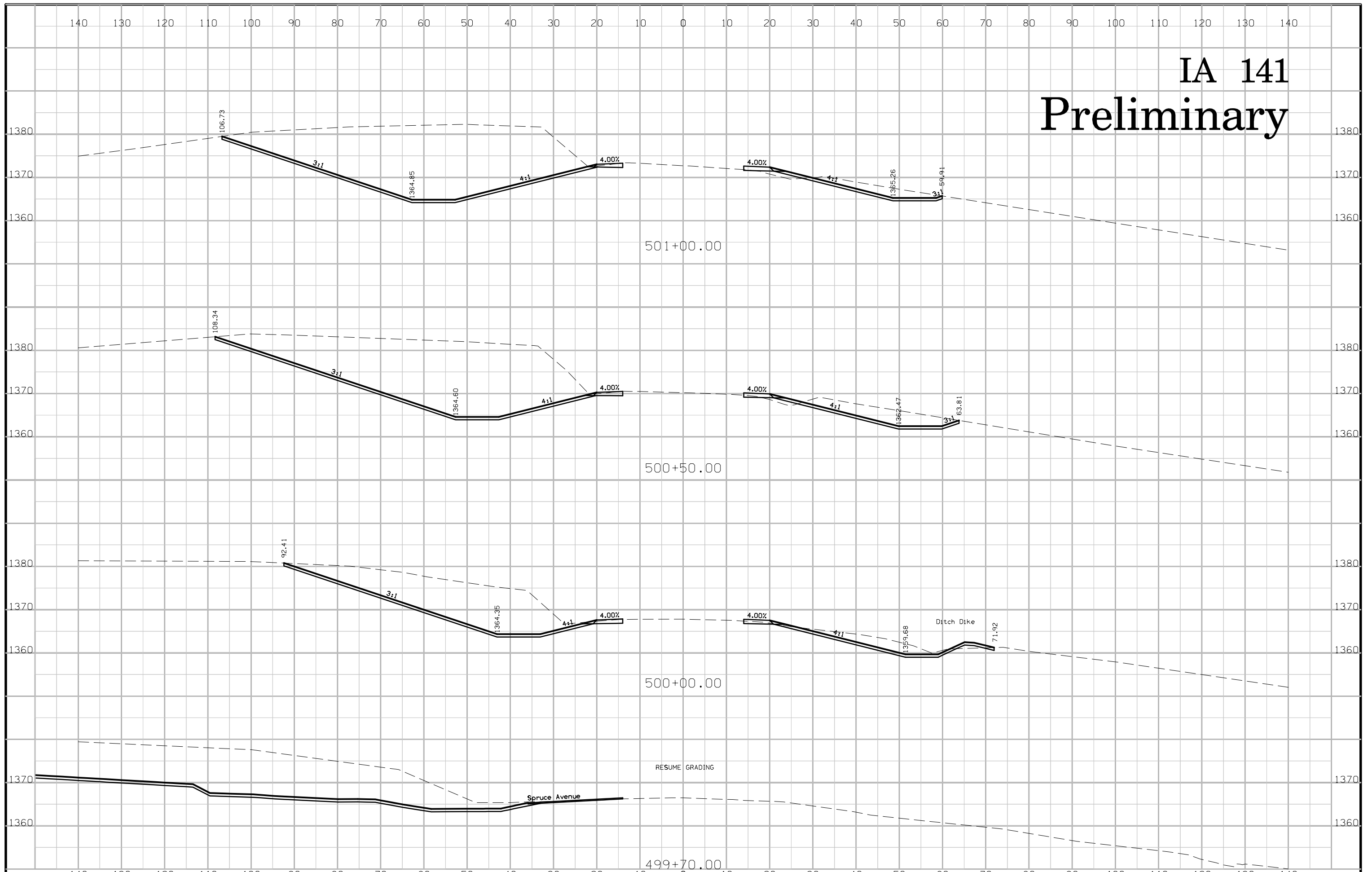

IA 141

Preliminary

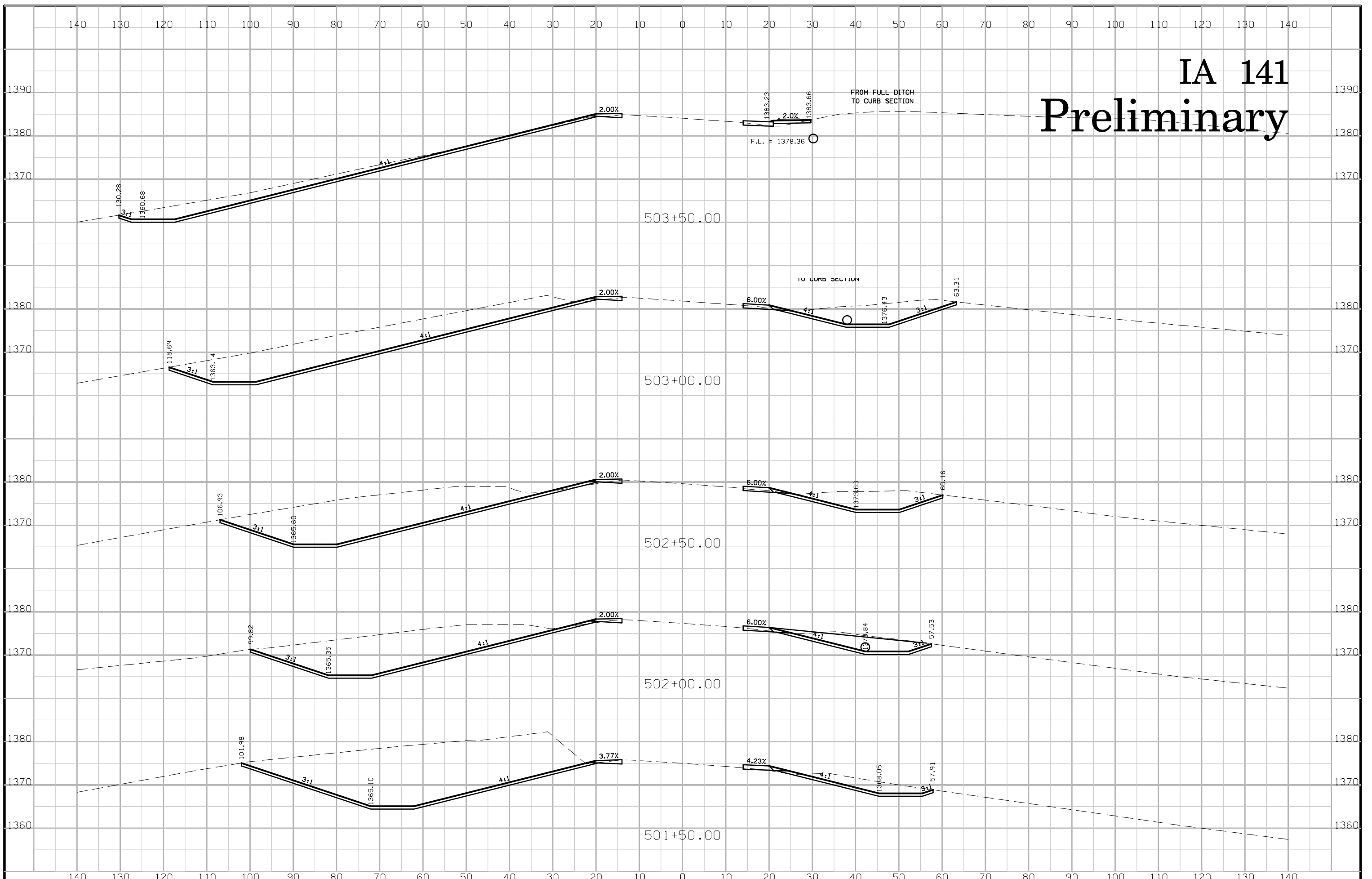



# IA 141 Preliminary

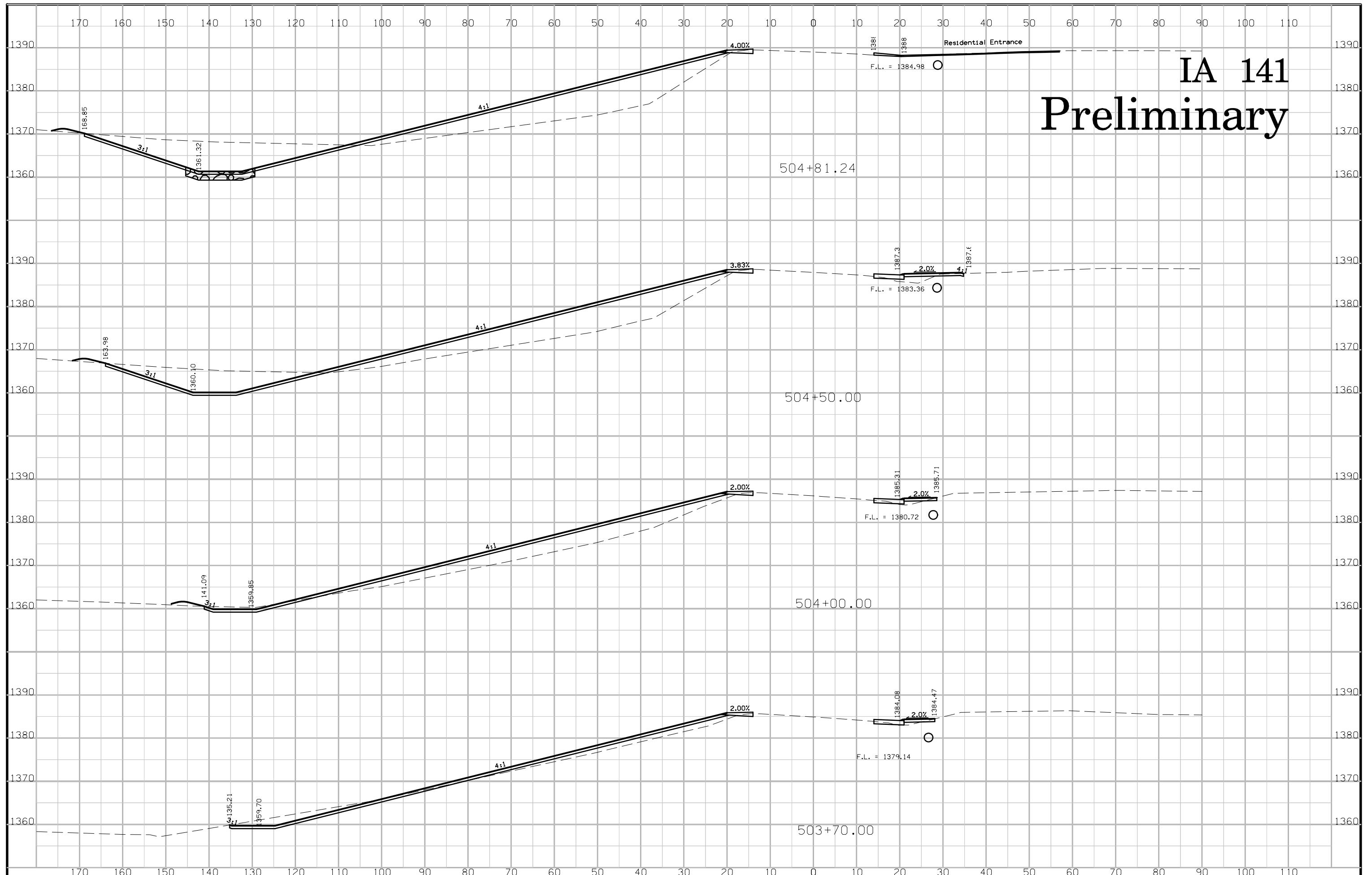

# IA 141 Preliminary

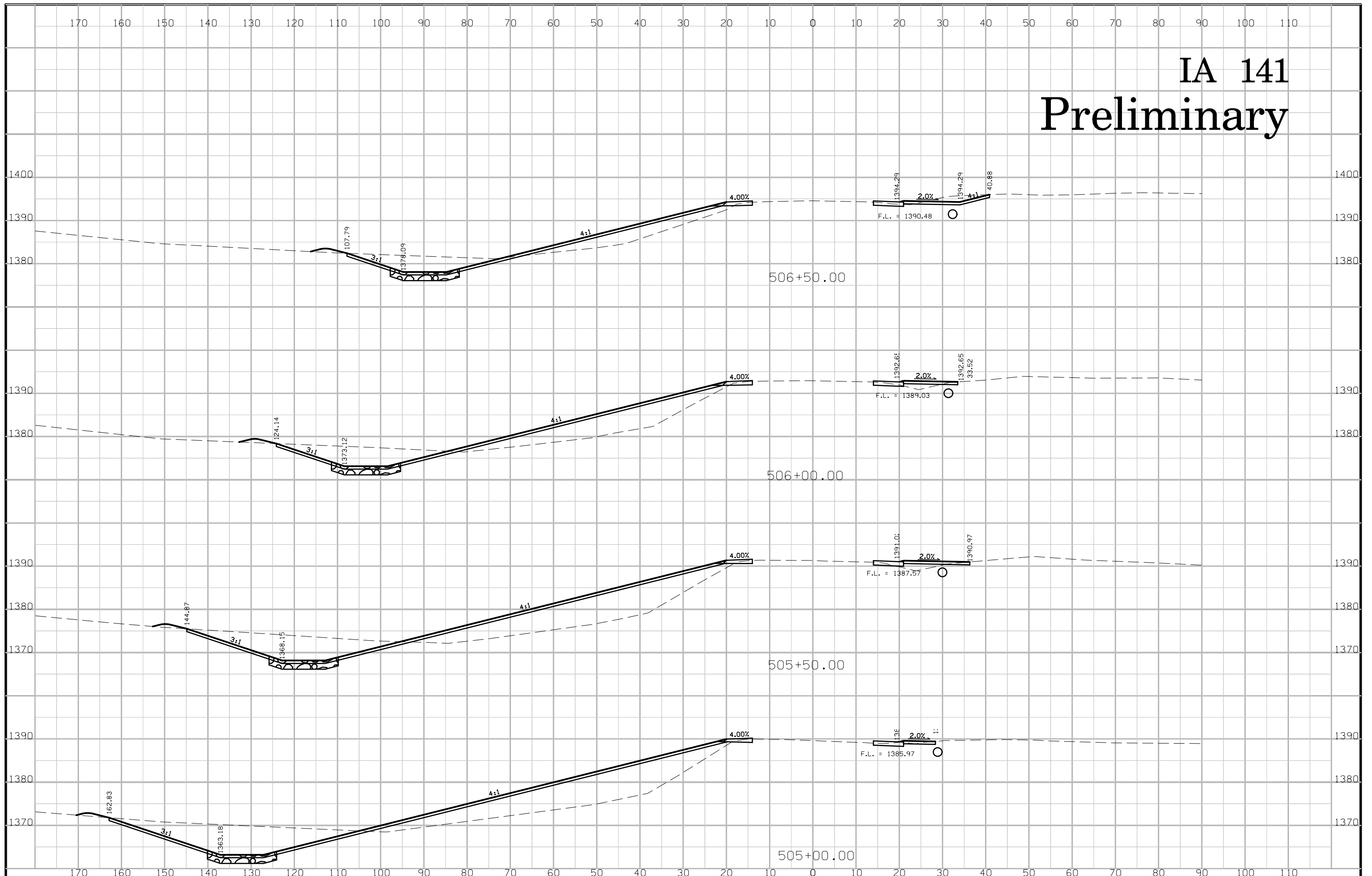

# IA 141 Preliminary

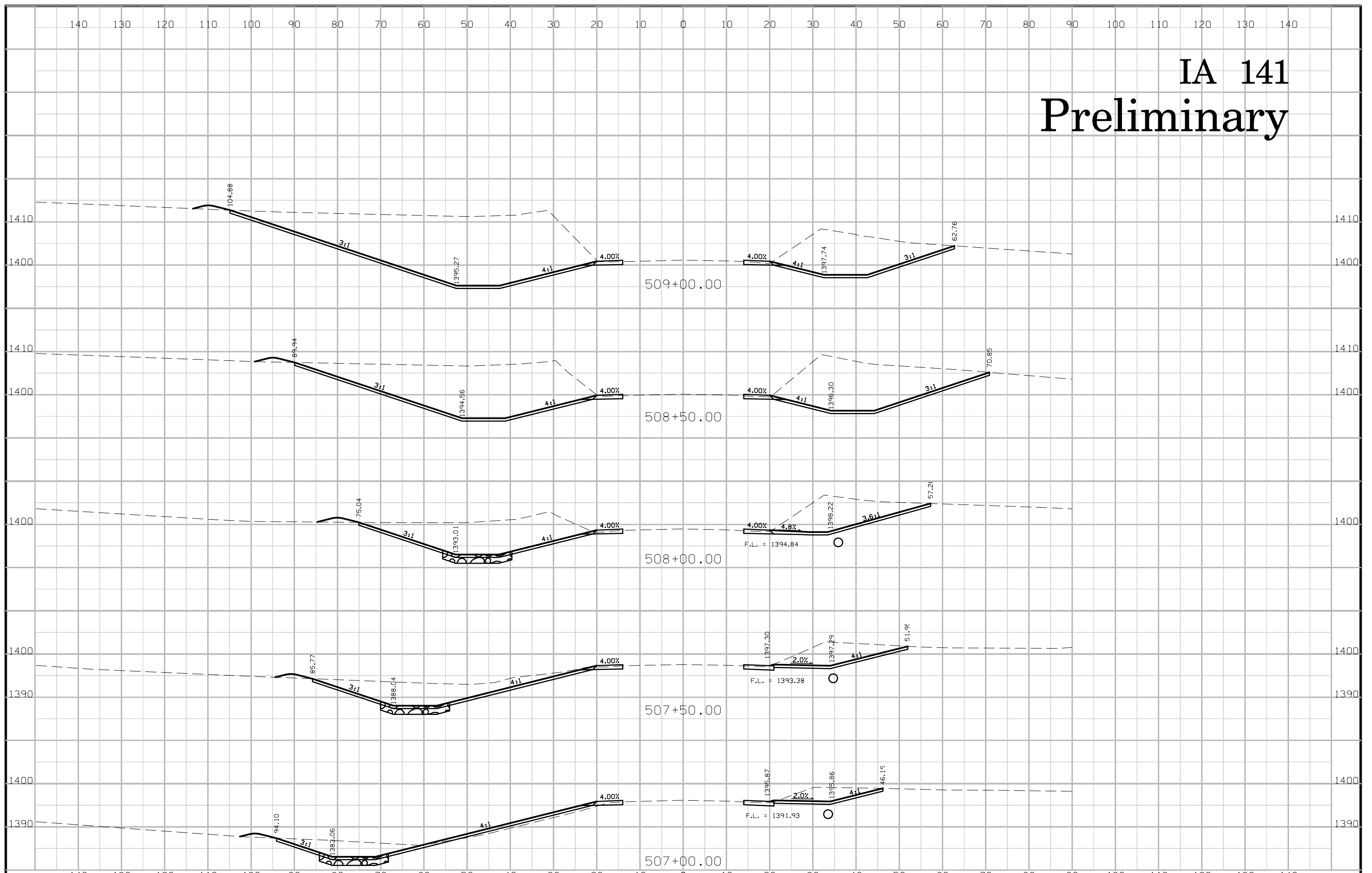

# IA 141 Preliminary

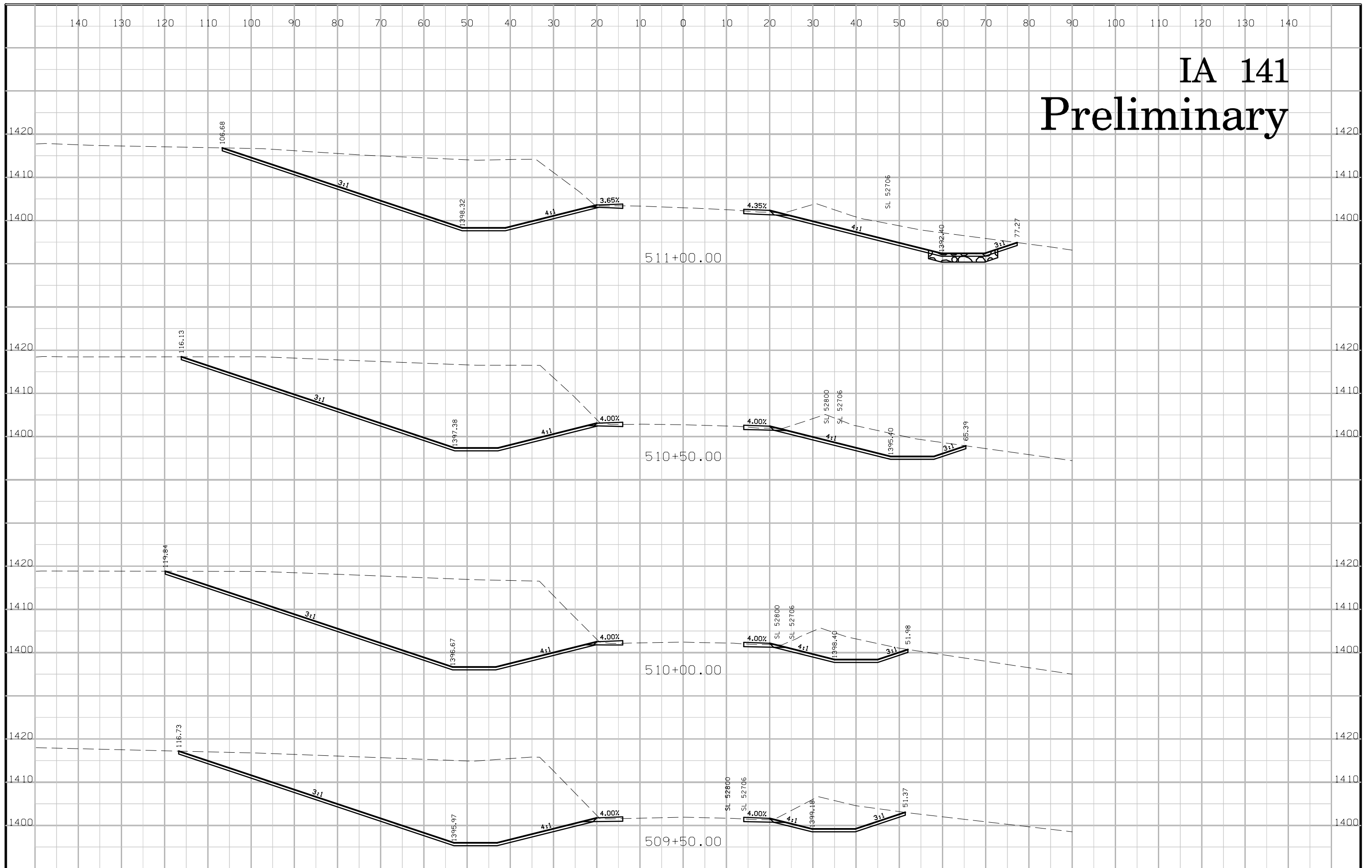

# IA 141 Preliminary

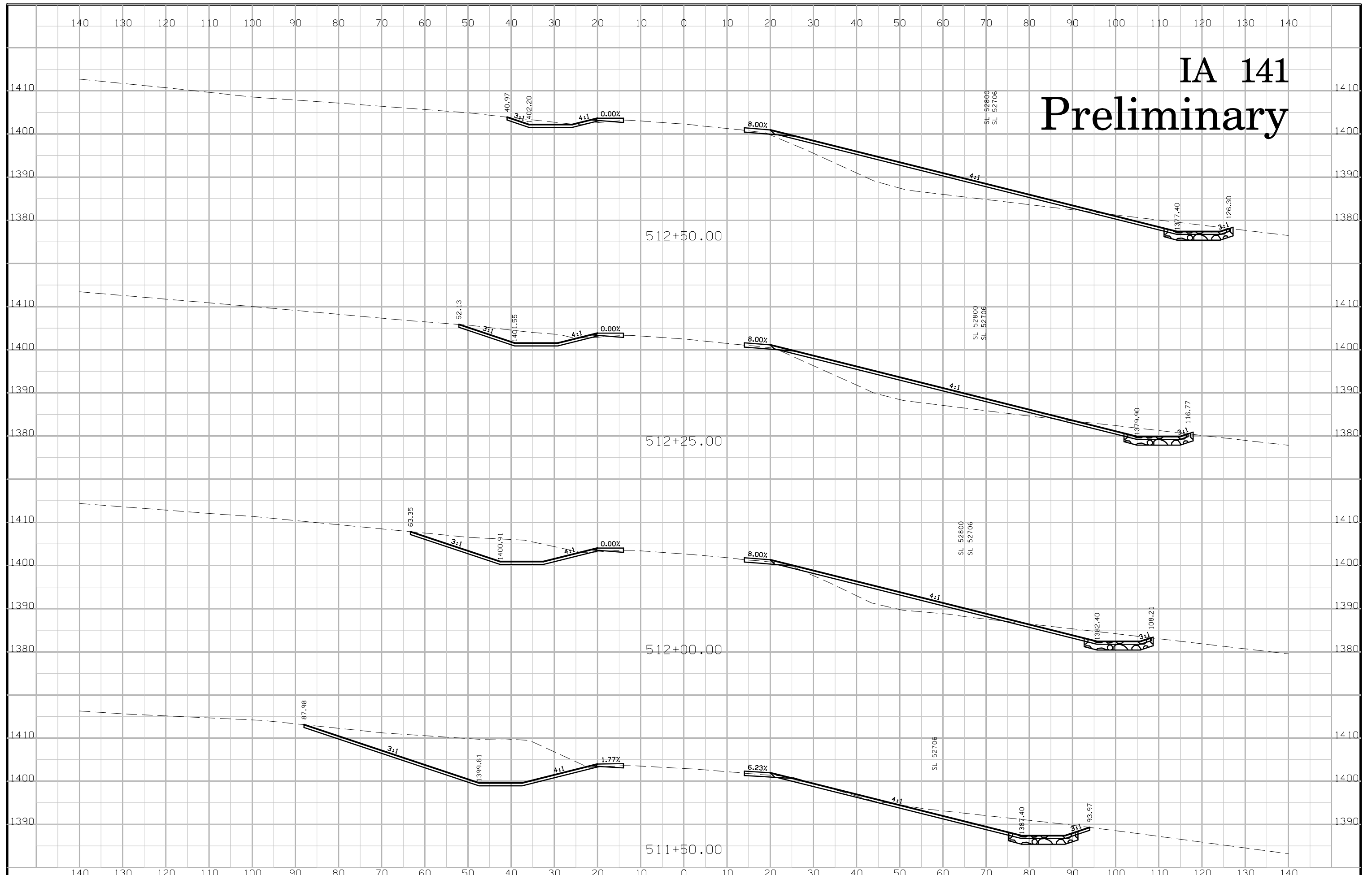

# IA 141 Preliminary

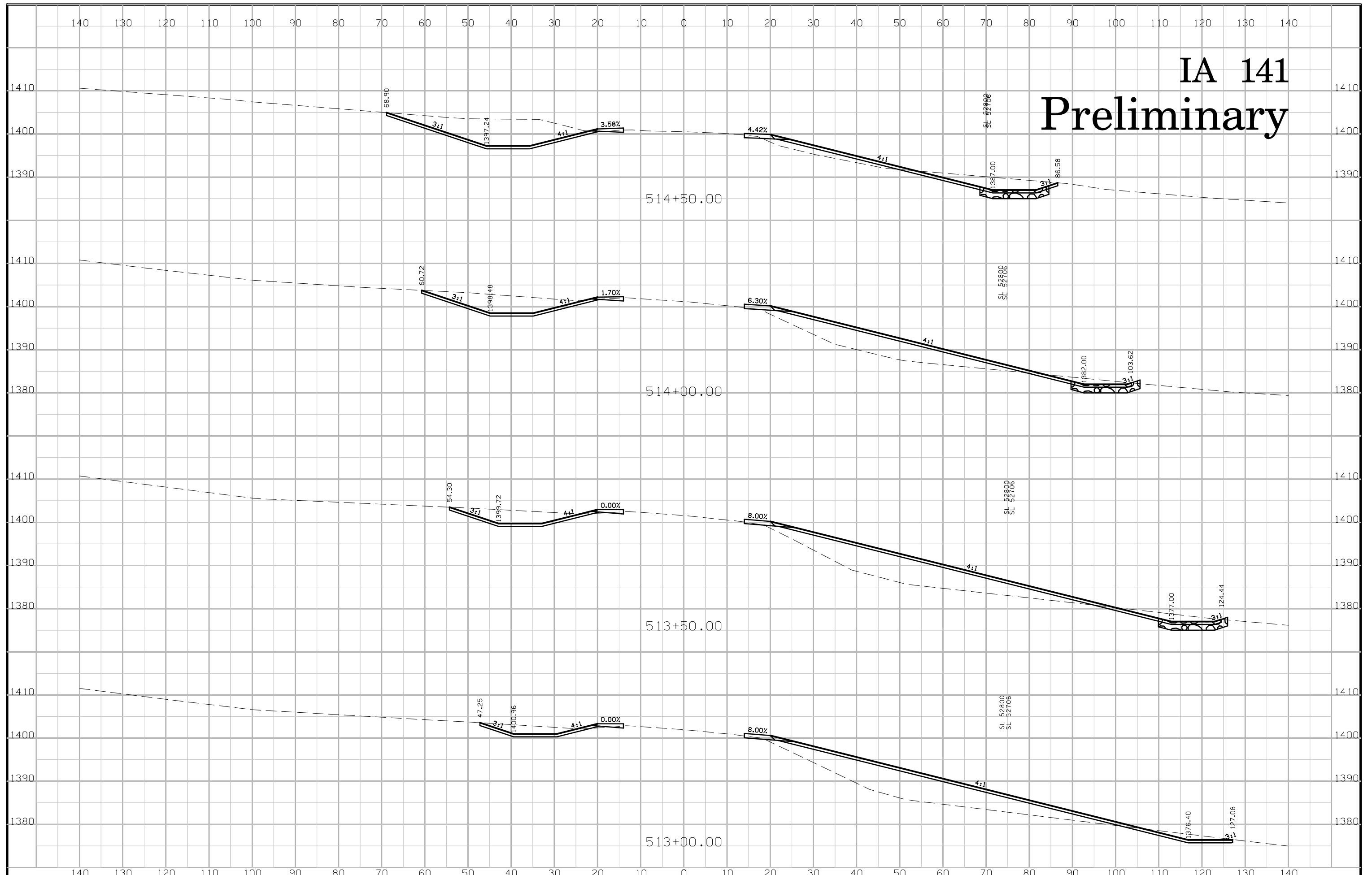

# IA 141 Preliminary

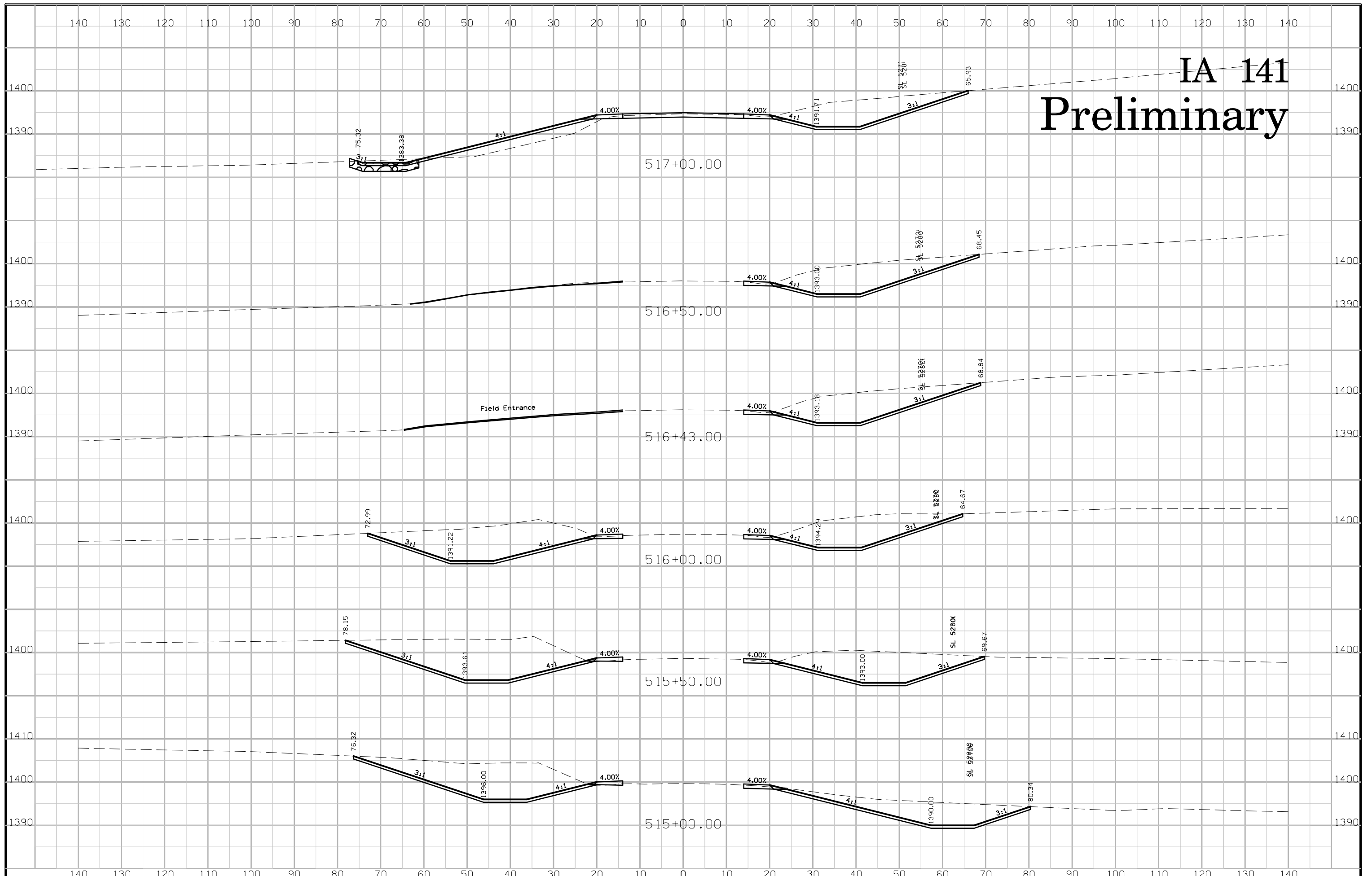

# IA 141 Preliminary

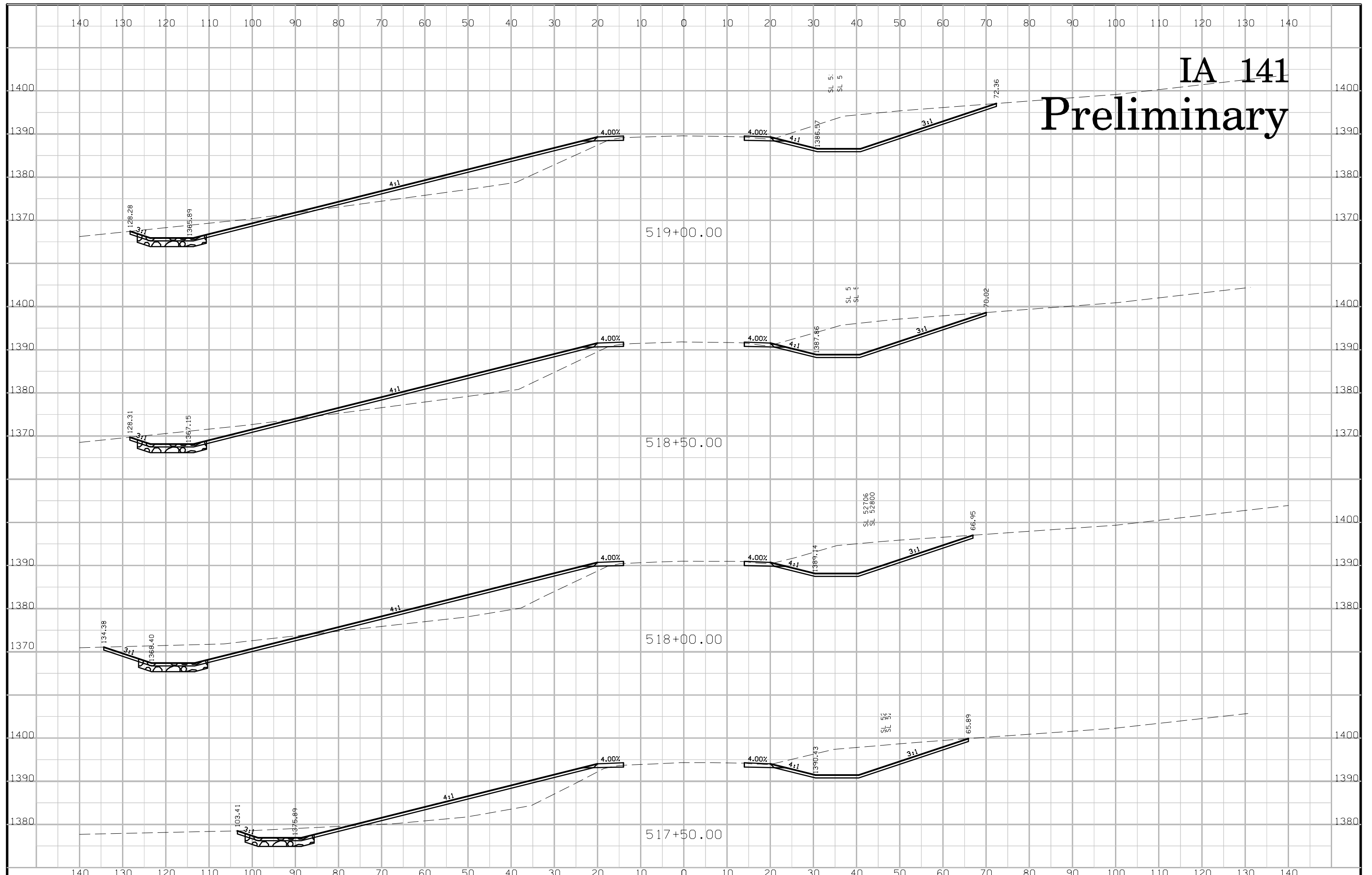



# IA 141 Preliminary

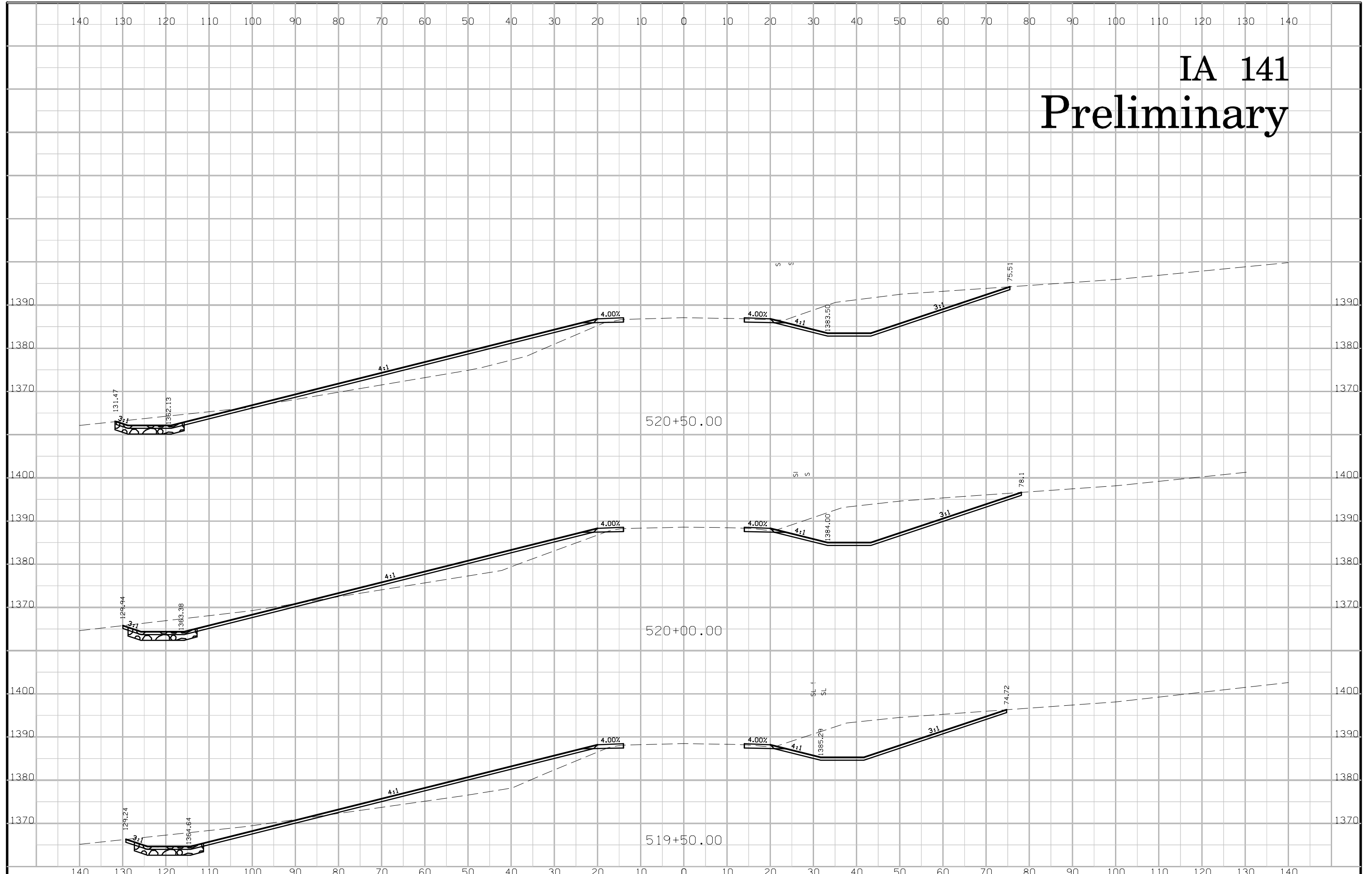

# IA 141 Preliminary

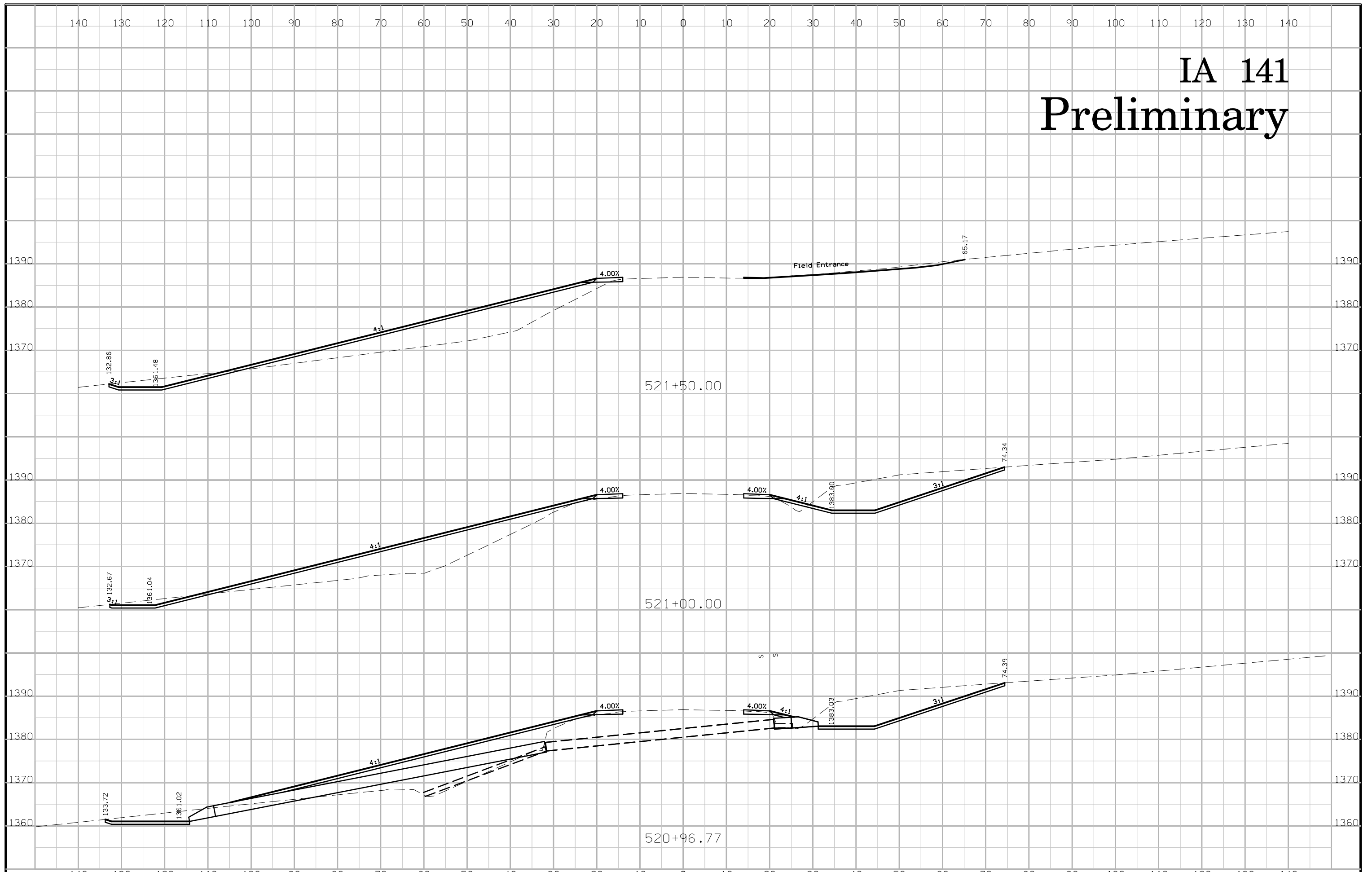

# IA 141 Preliminary

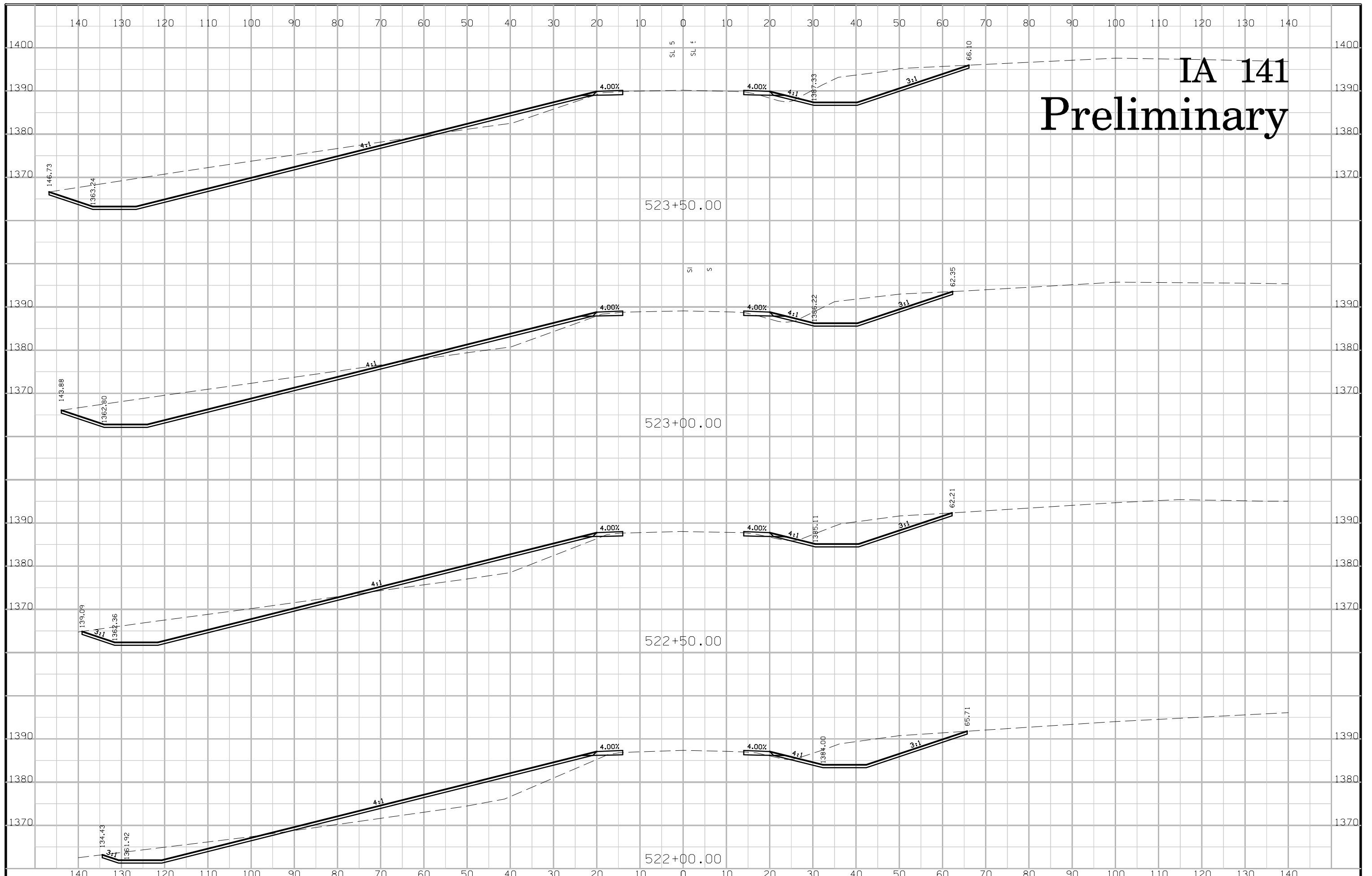

# IA 141 Preliminary

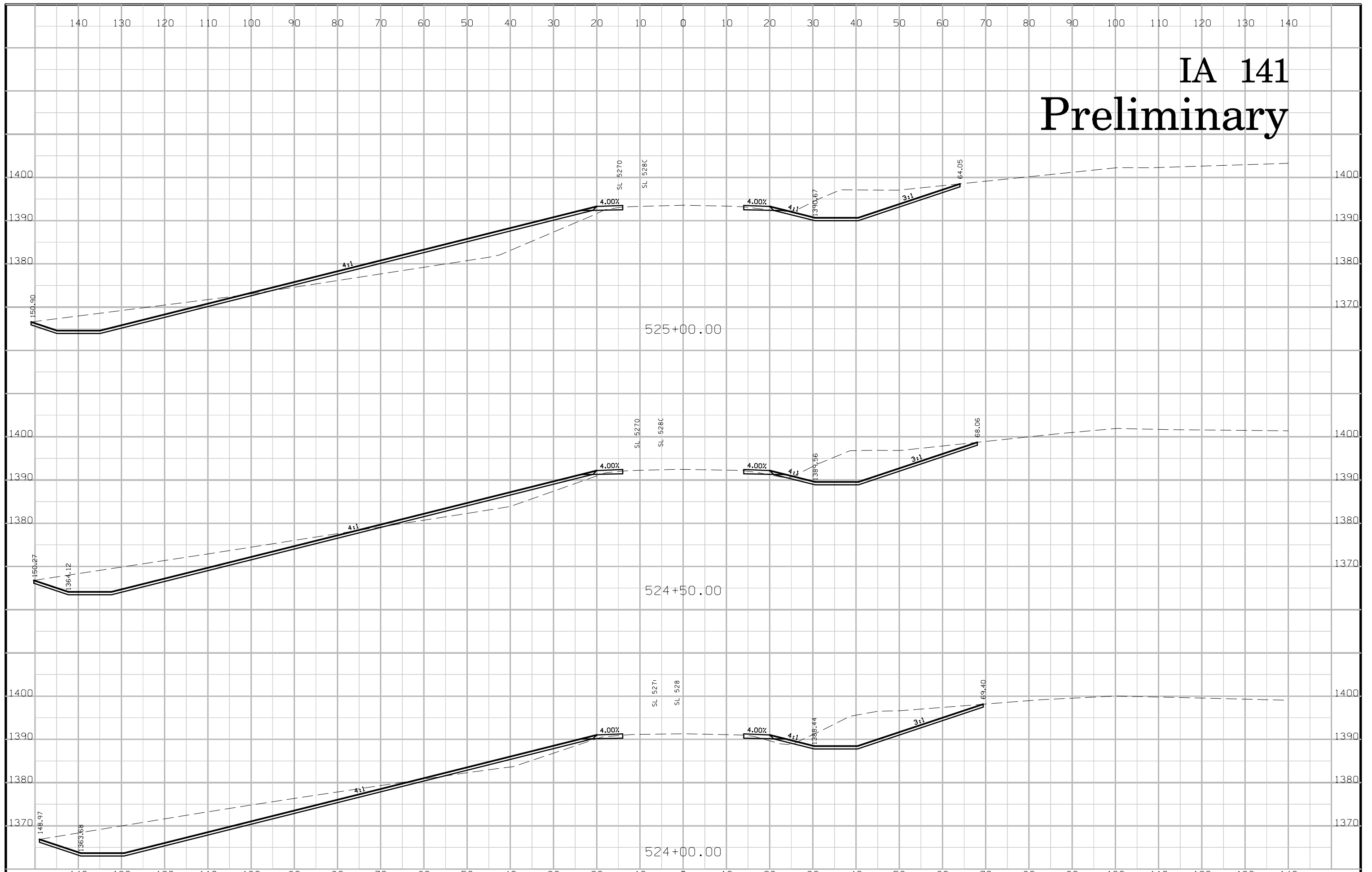

# IA 141 Preliminary

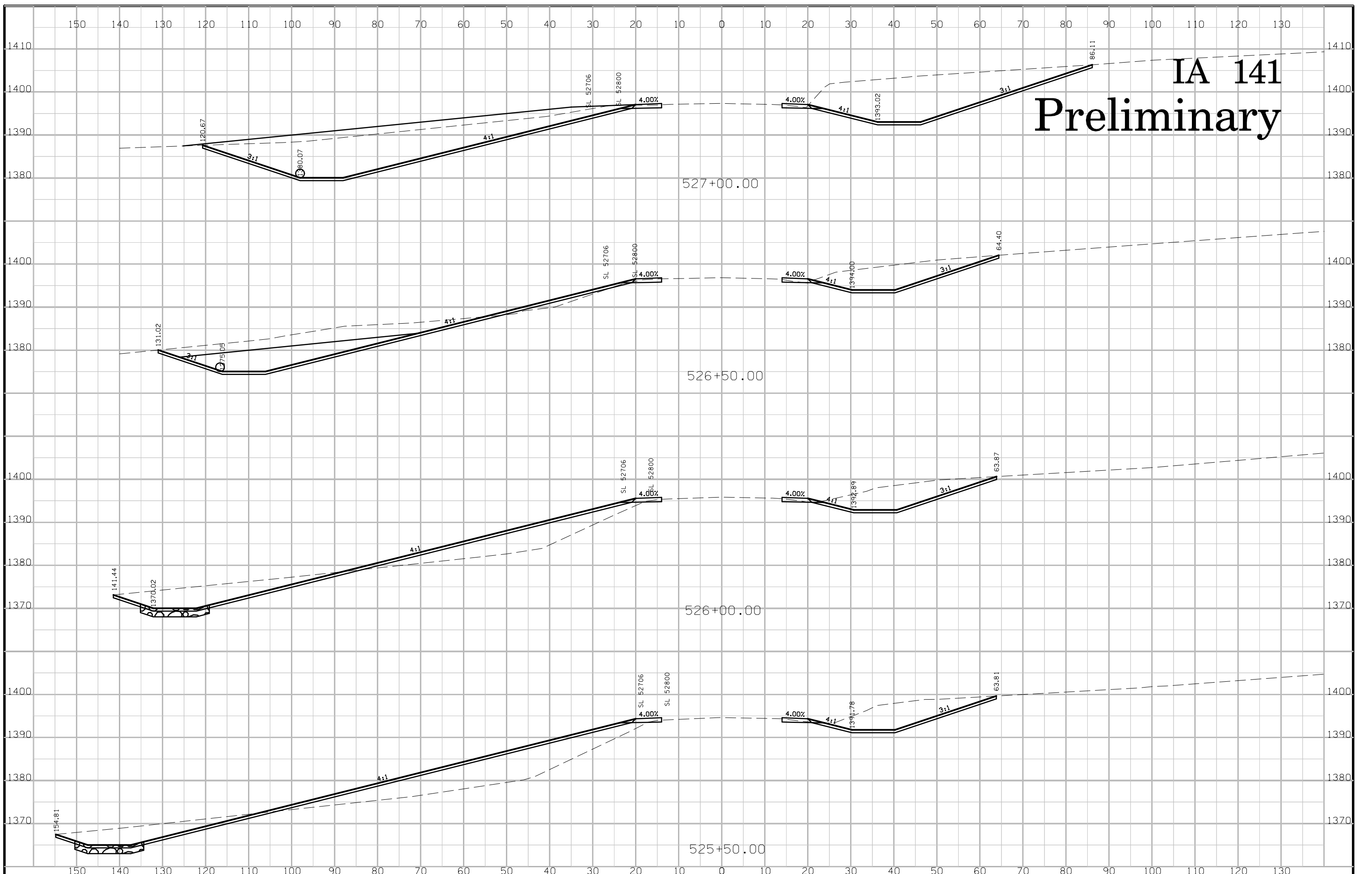

# IA 141 Preliminary

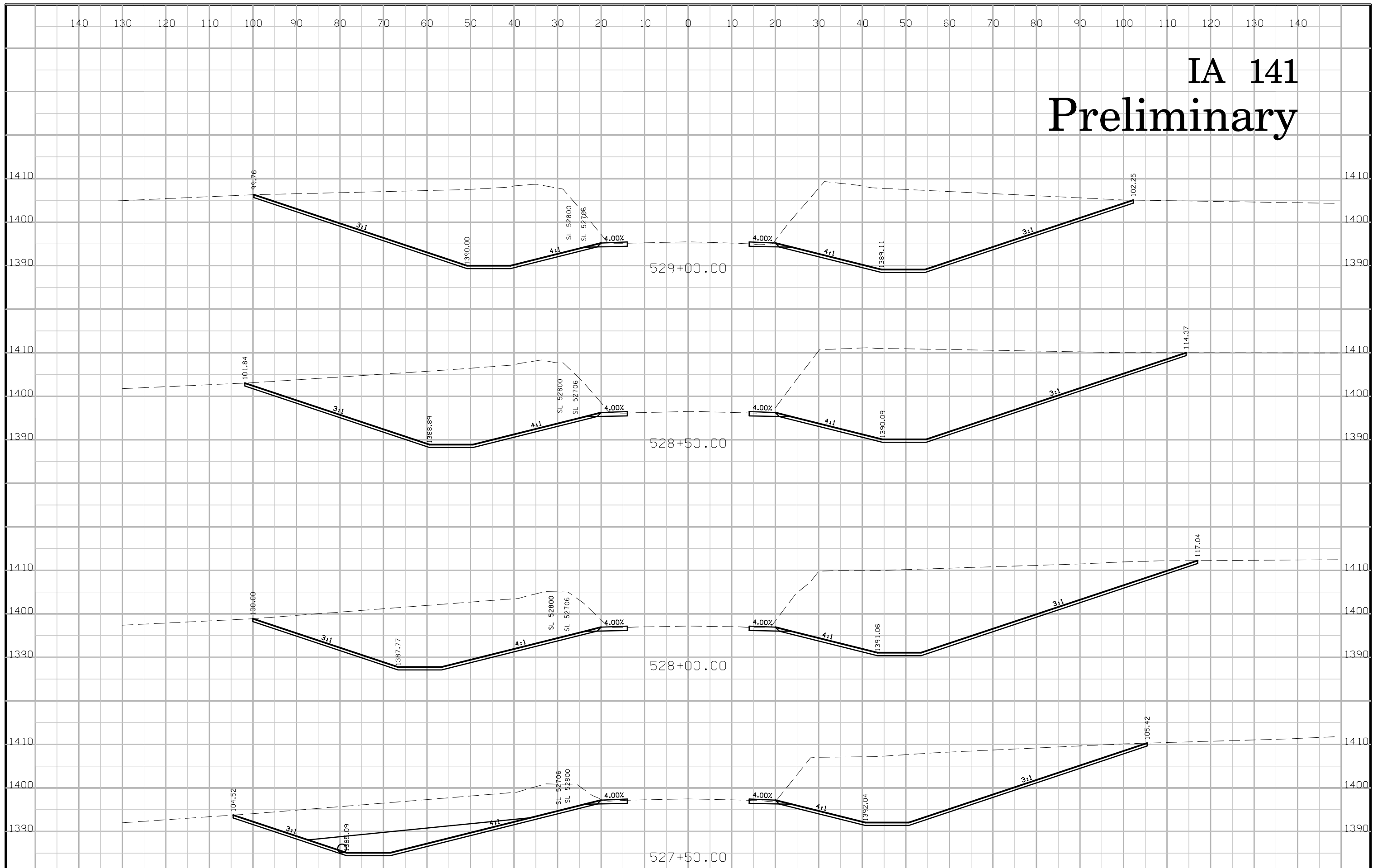

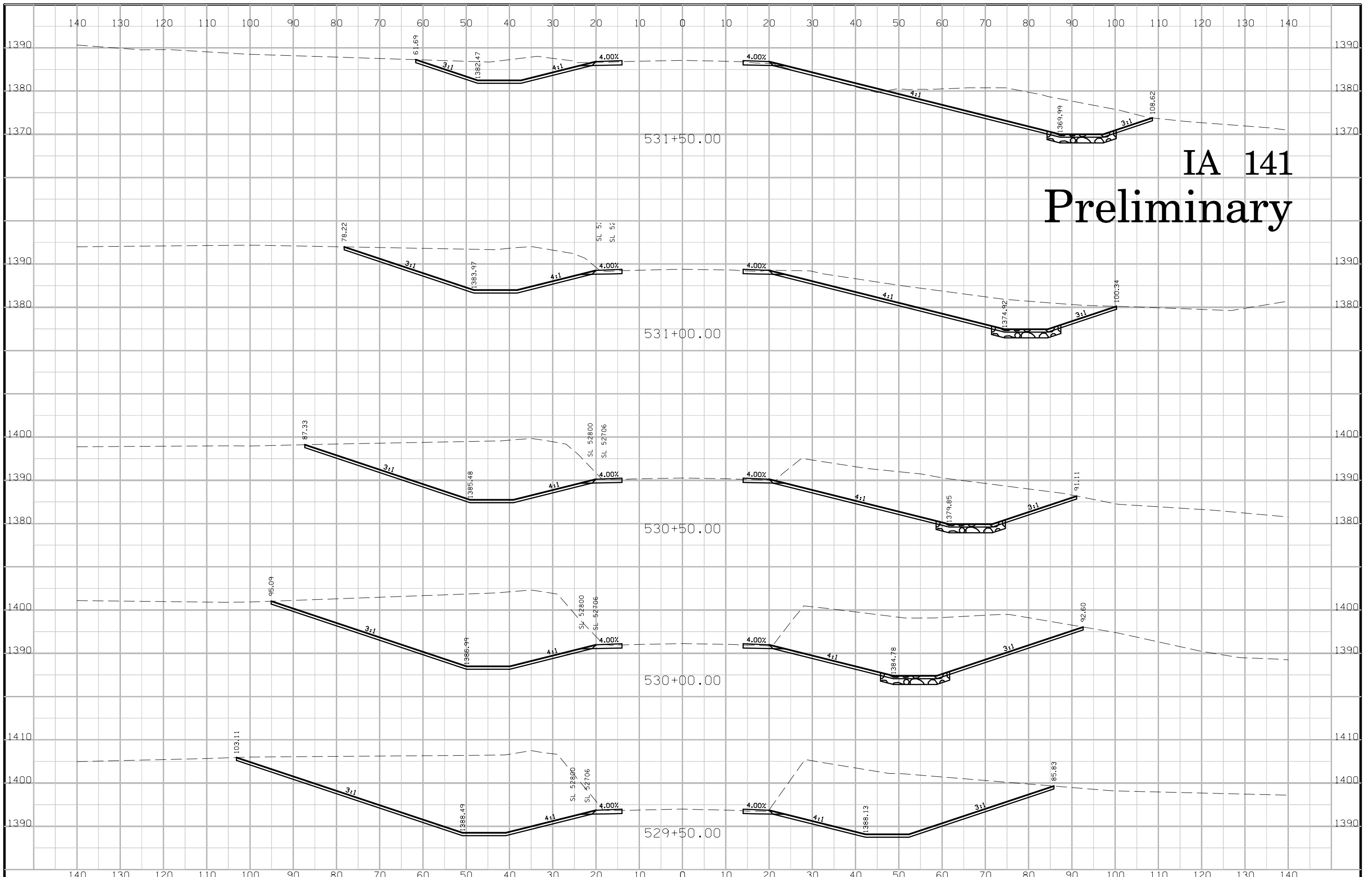

# IA 141 Preliminary

# IA 141 Preliminary

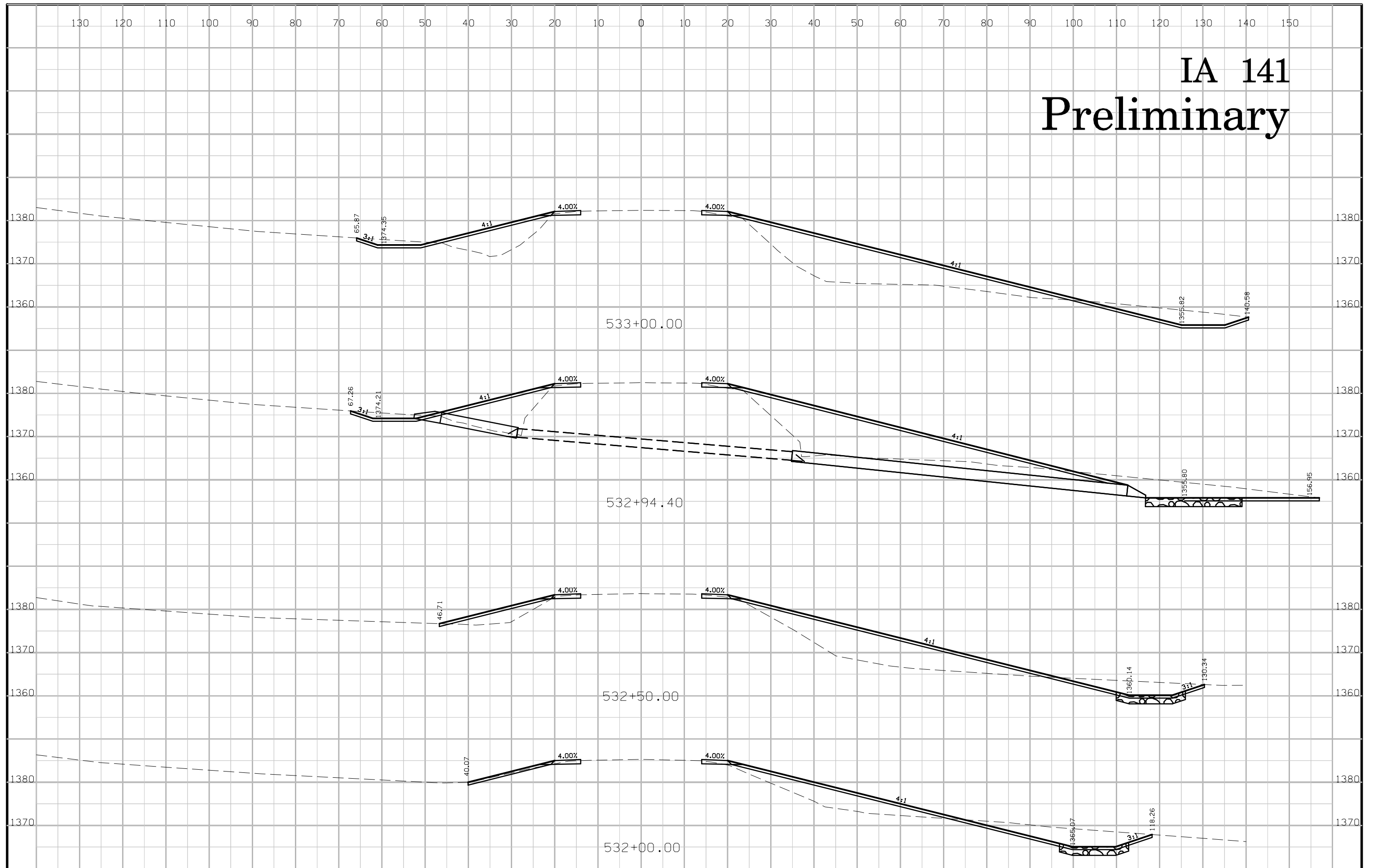



# IA 141 Preliminary

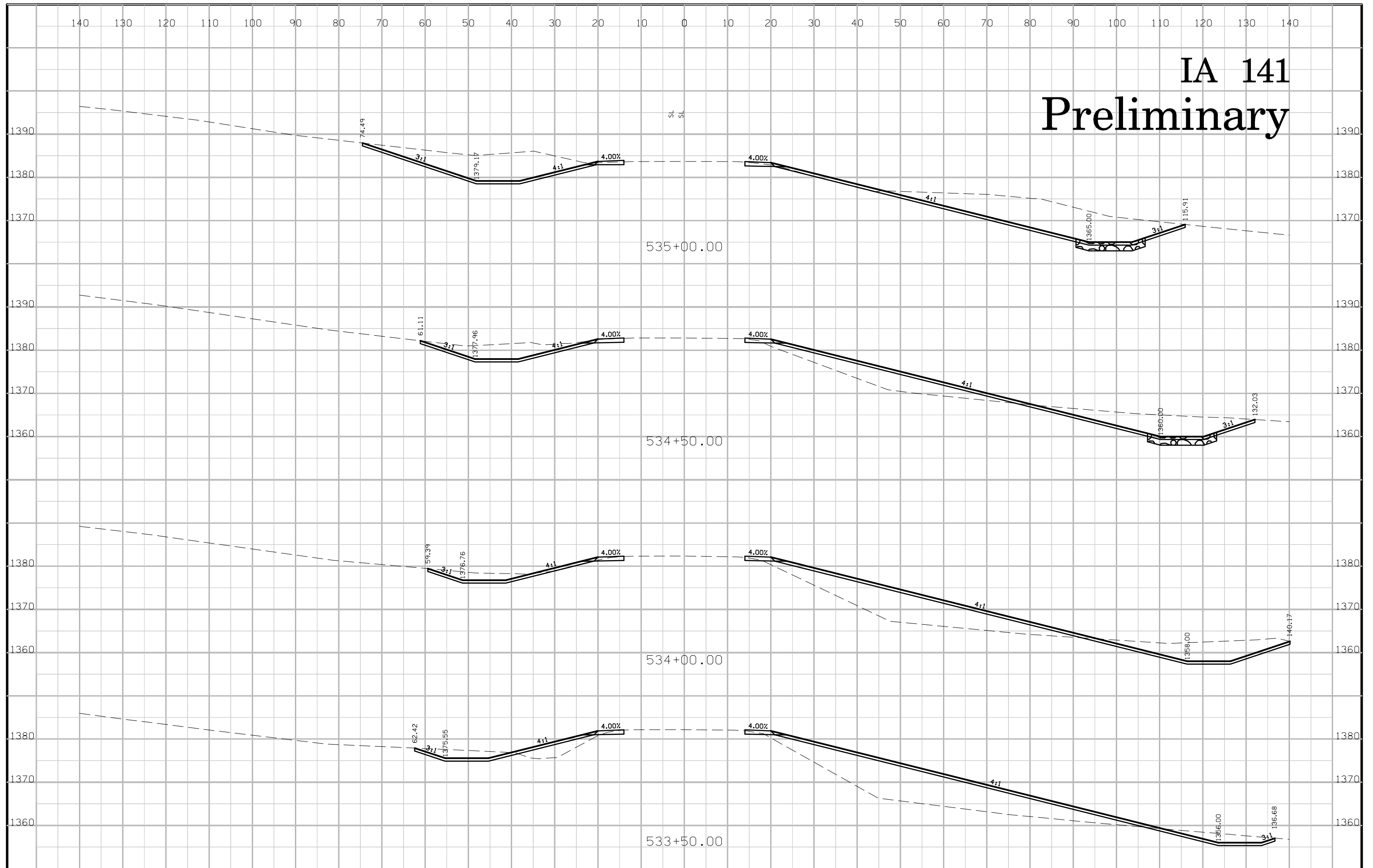

# IA 141 Preliminary

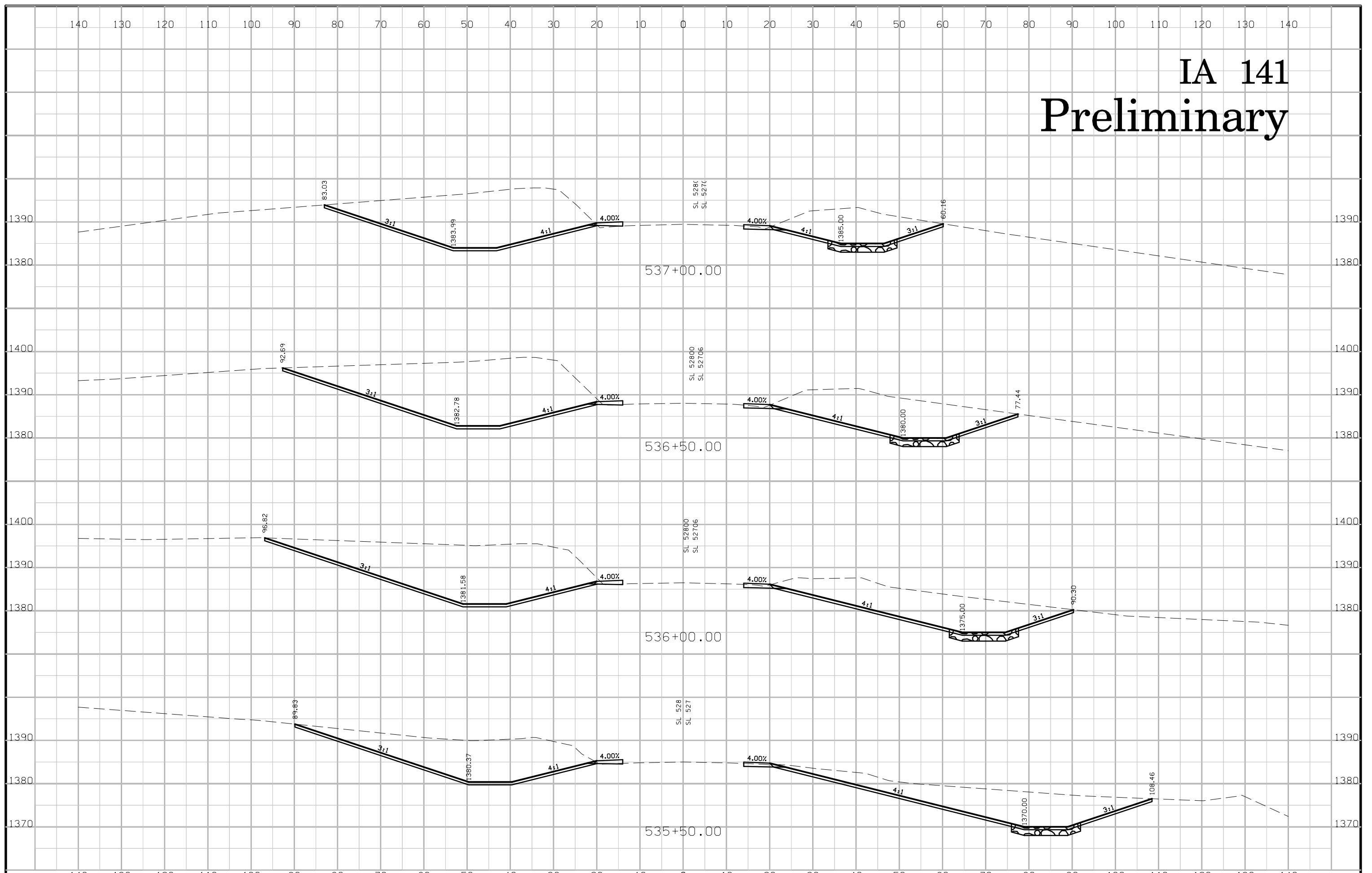

# IA 141 Preliminary

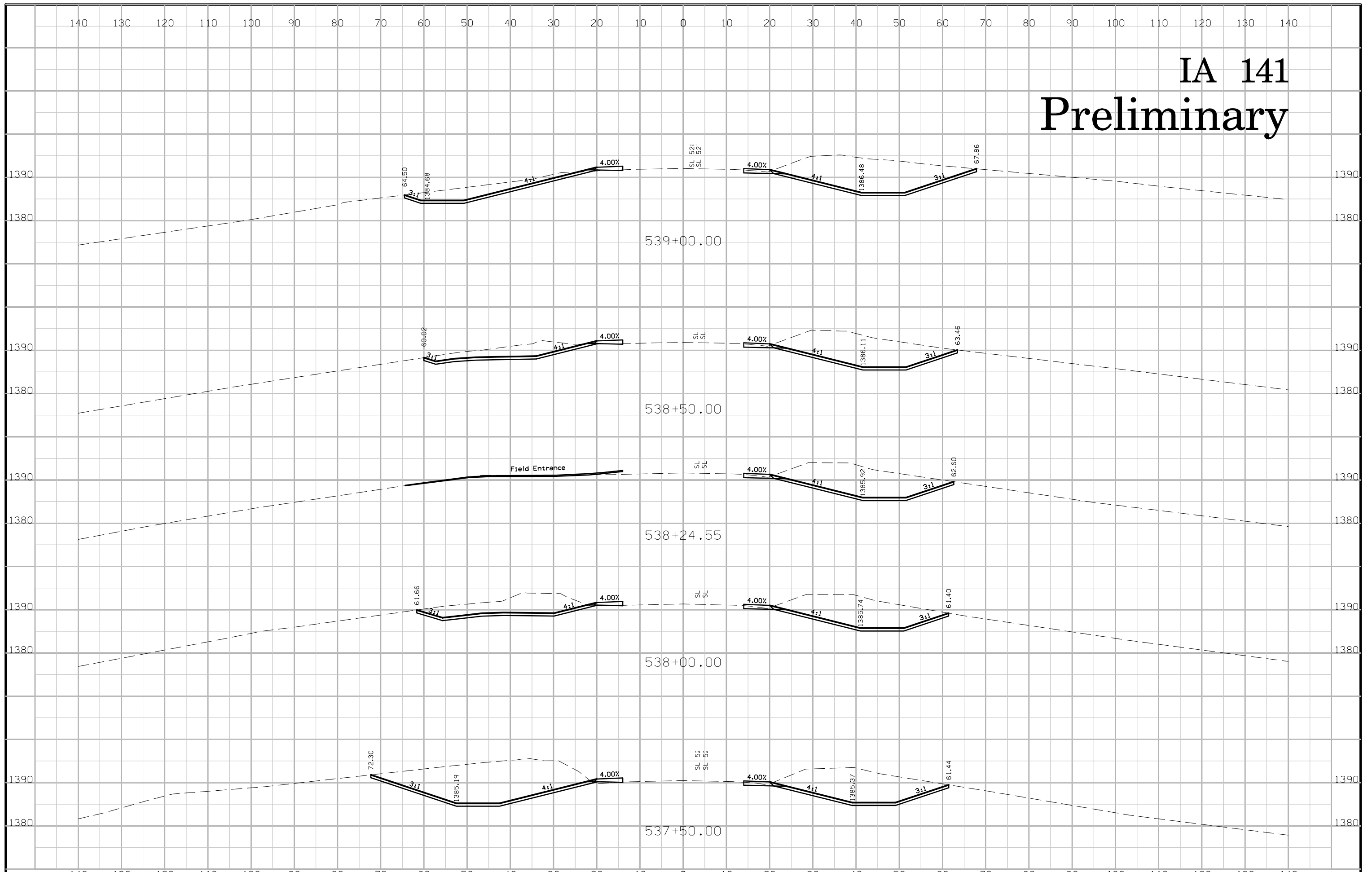

# IA 141 Preliminary

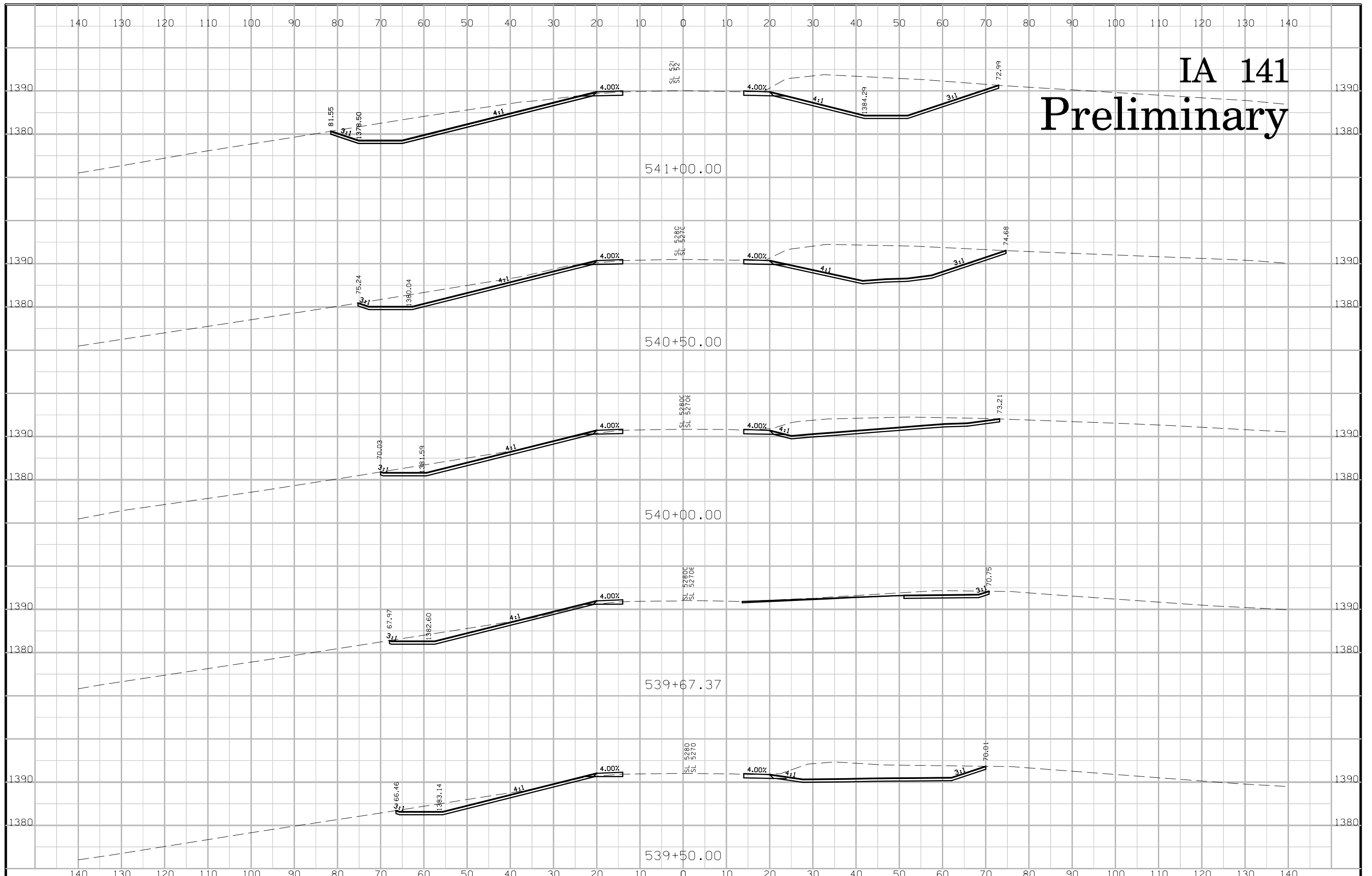

# IA 141 Preliminary

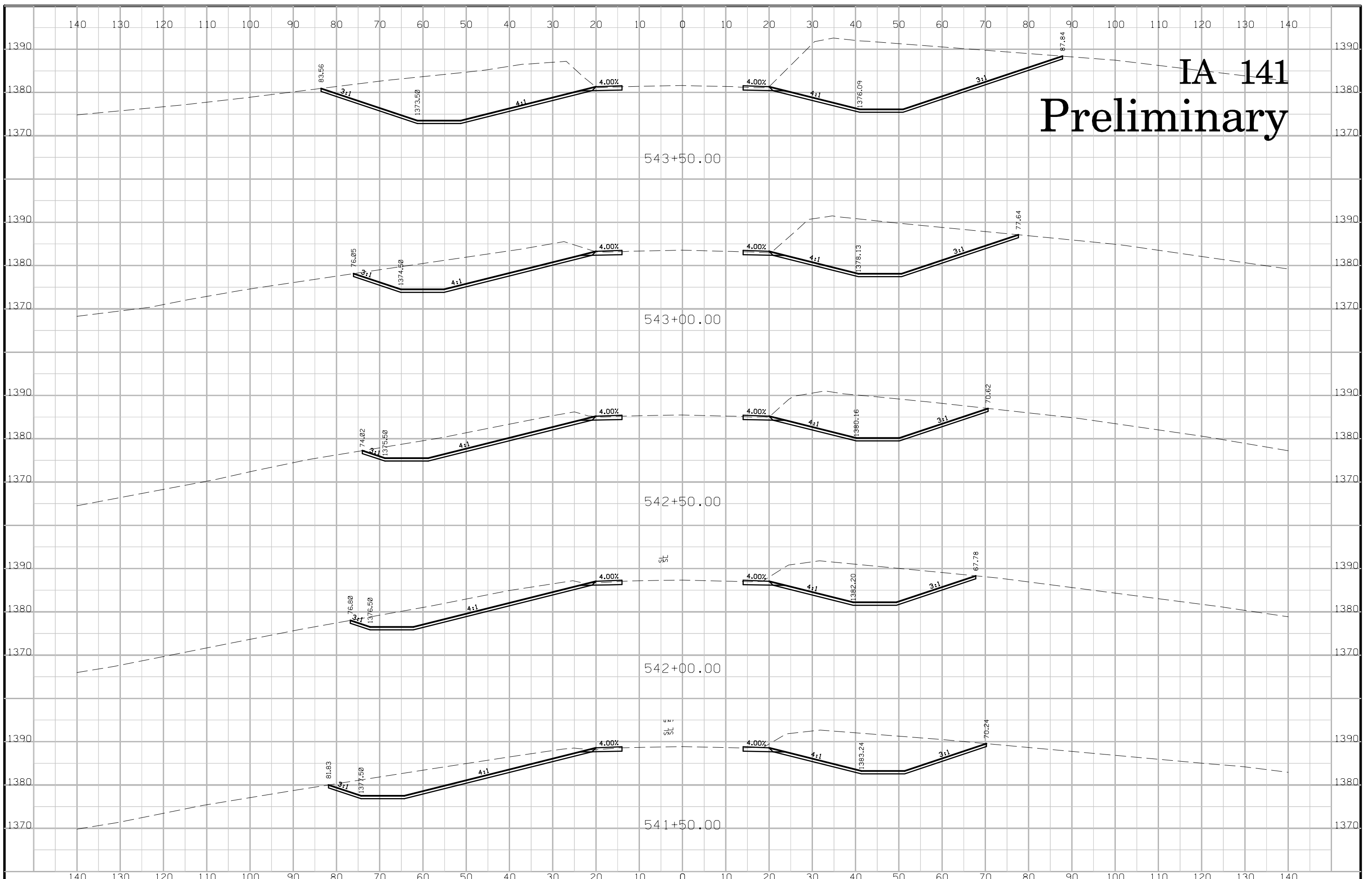

# IA 141 Preliminary

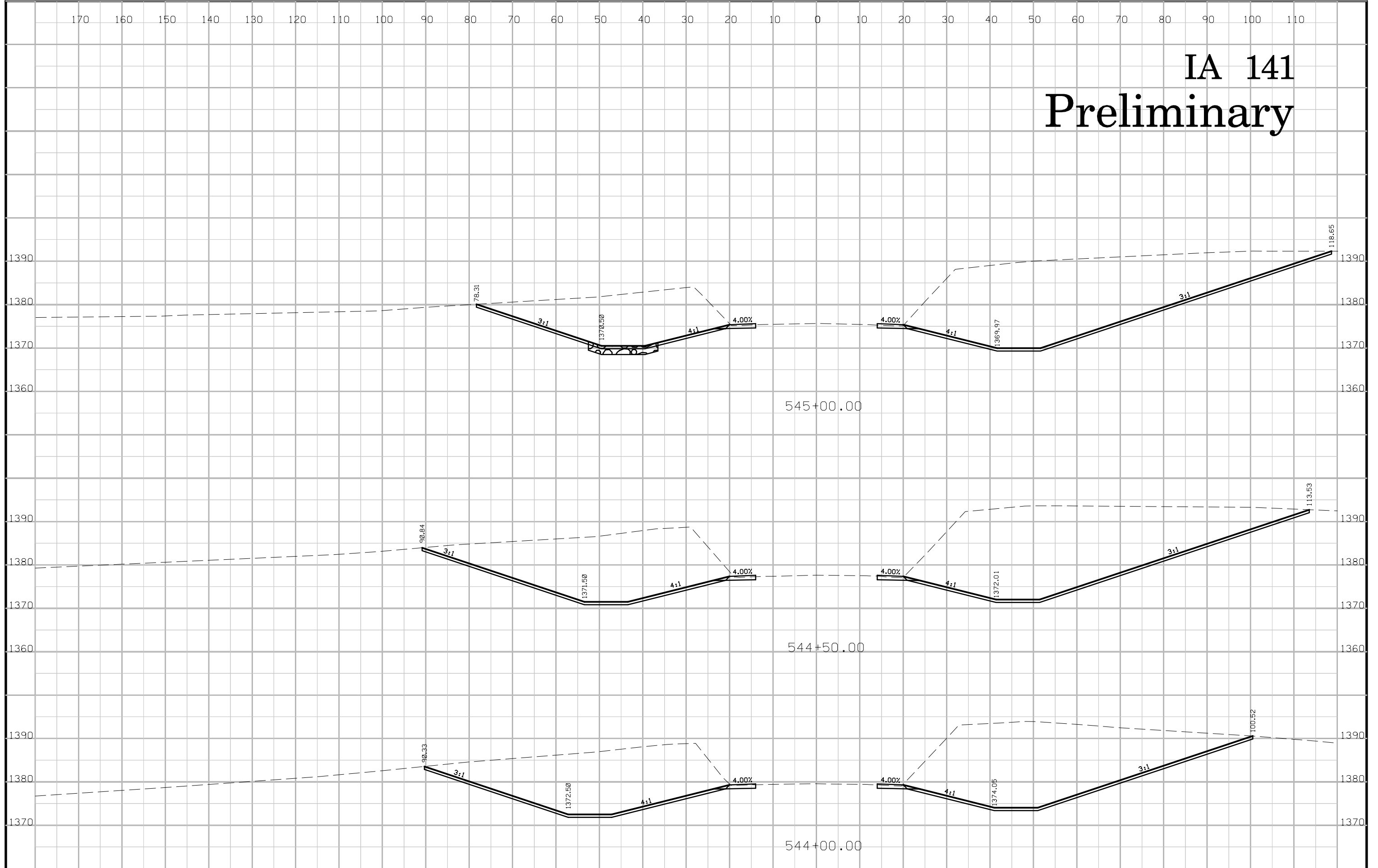

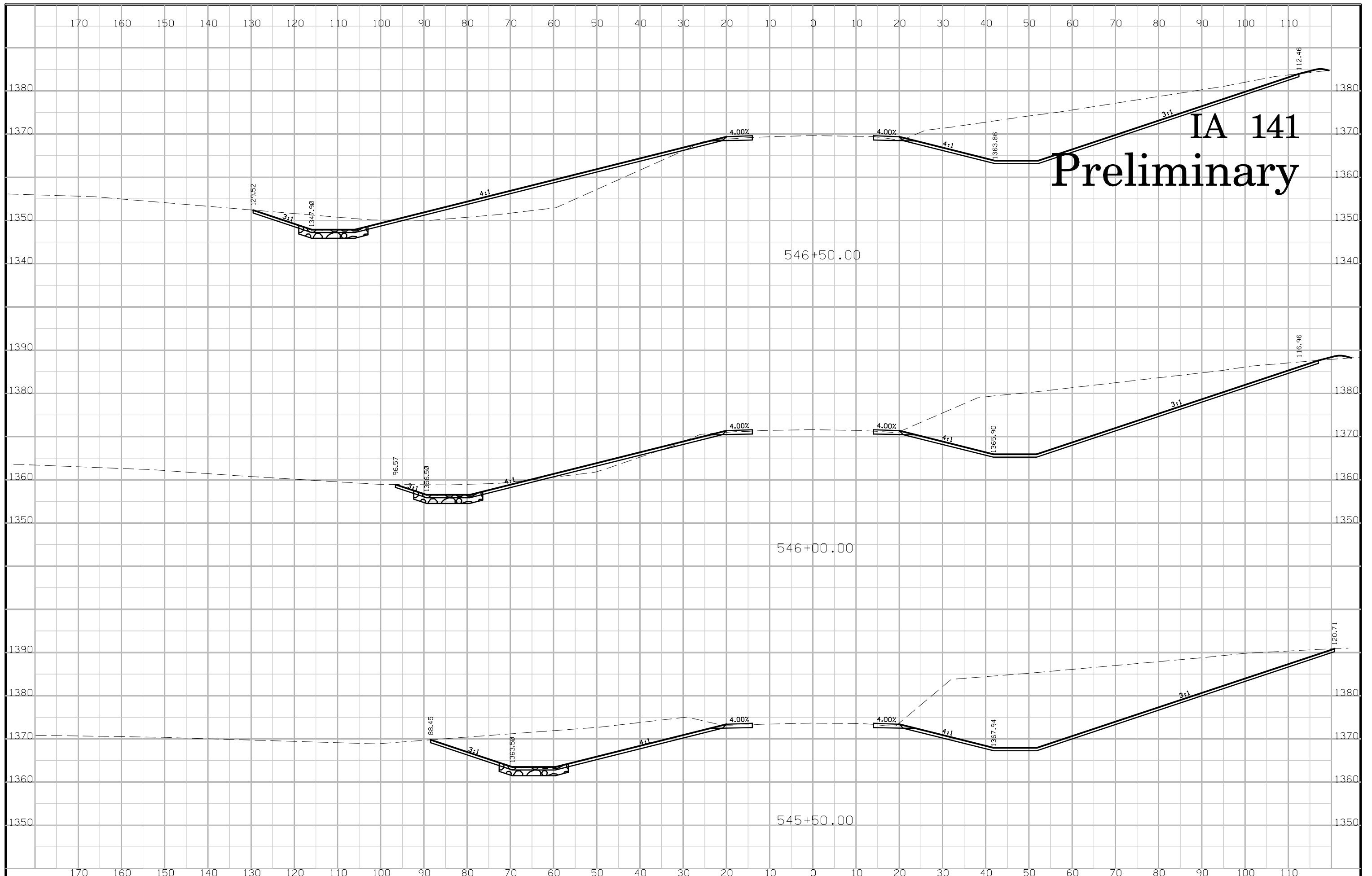

# IA 141 Preliminary

# IA 141 Preliminary

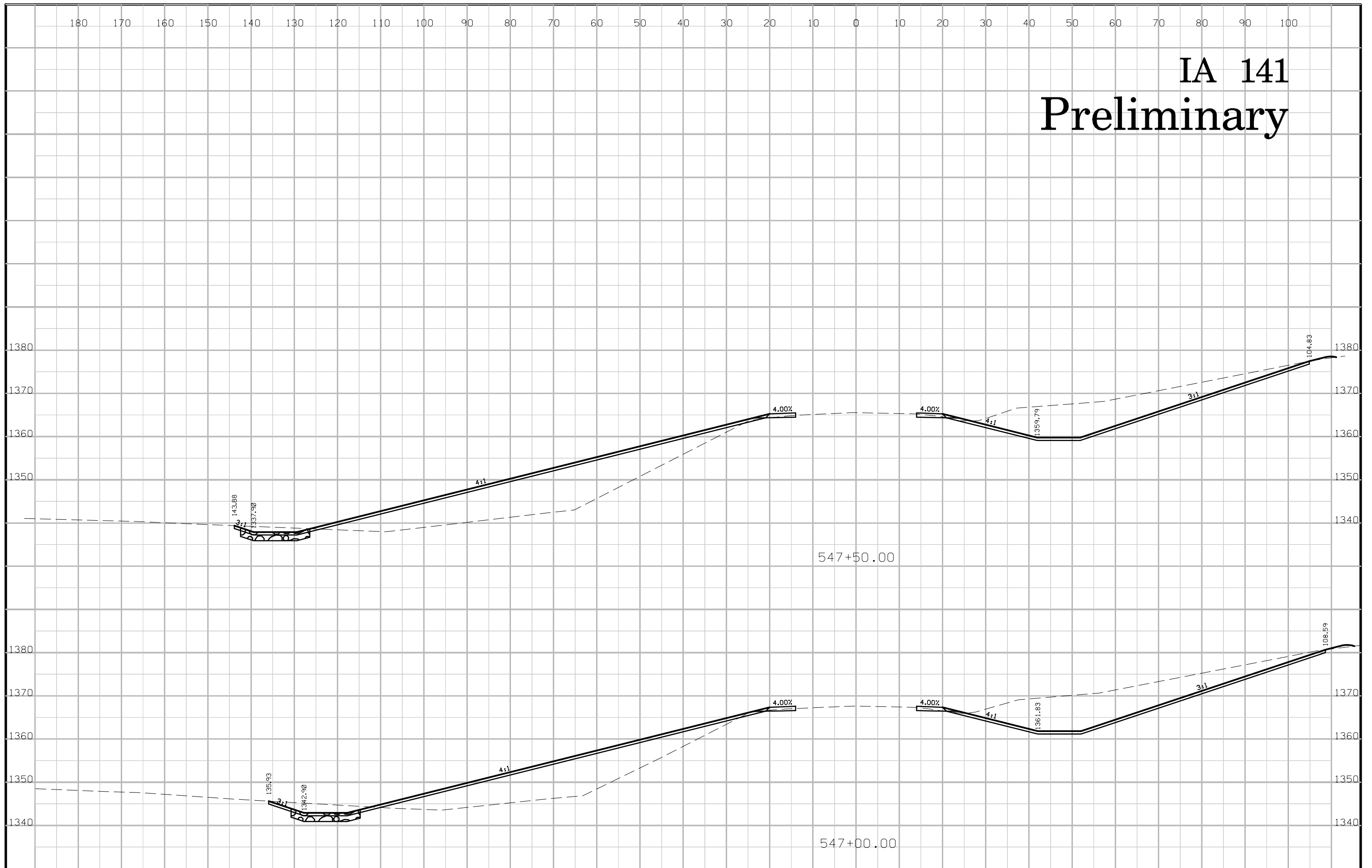



# IA 141 Preliminary

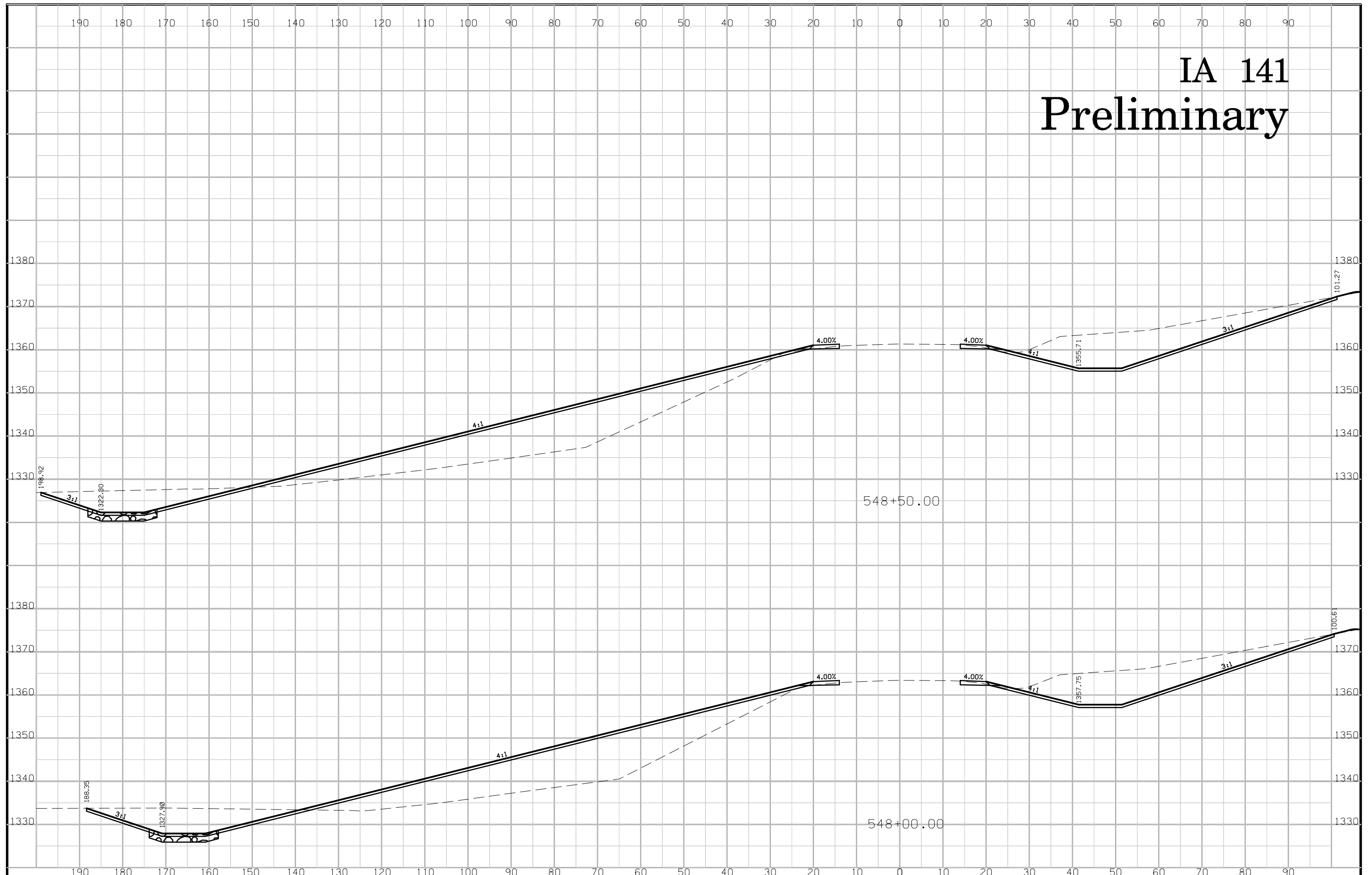

# IA 141 Preliminary

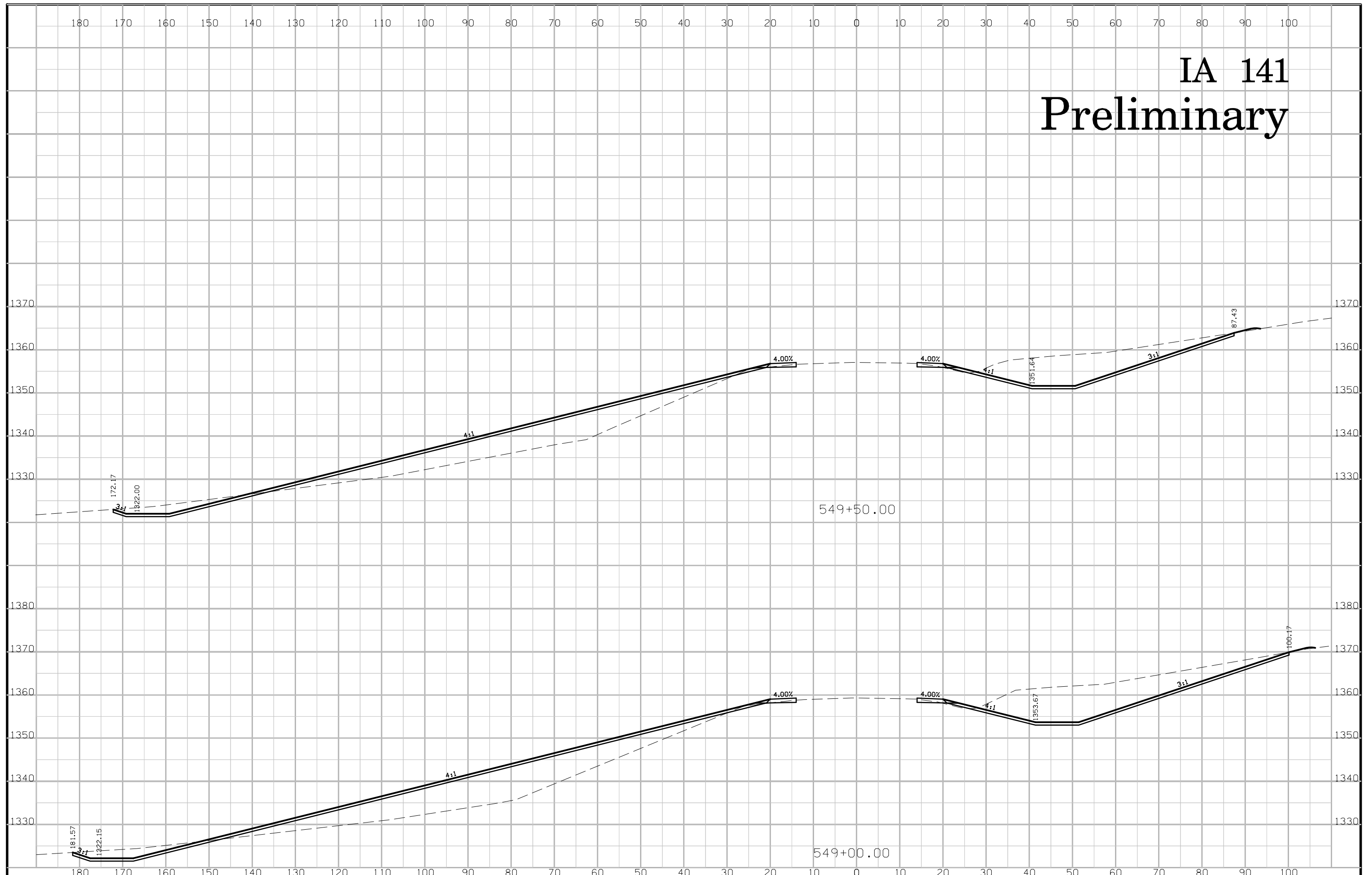

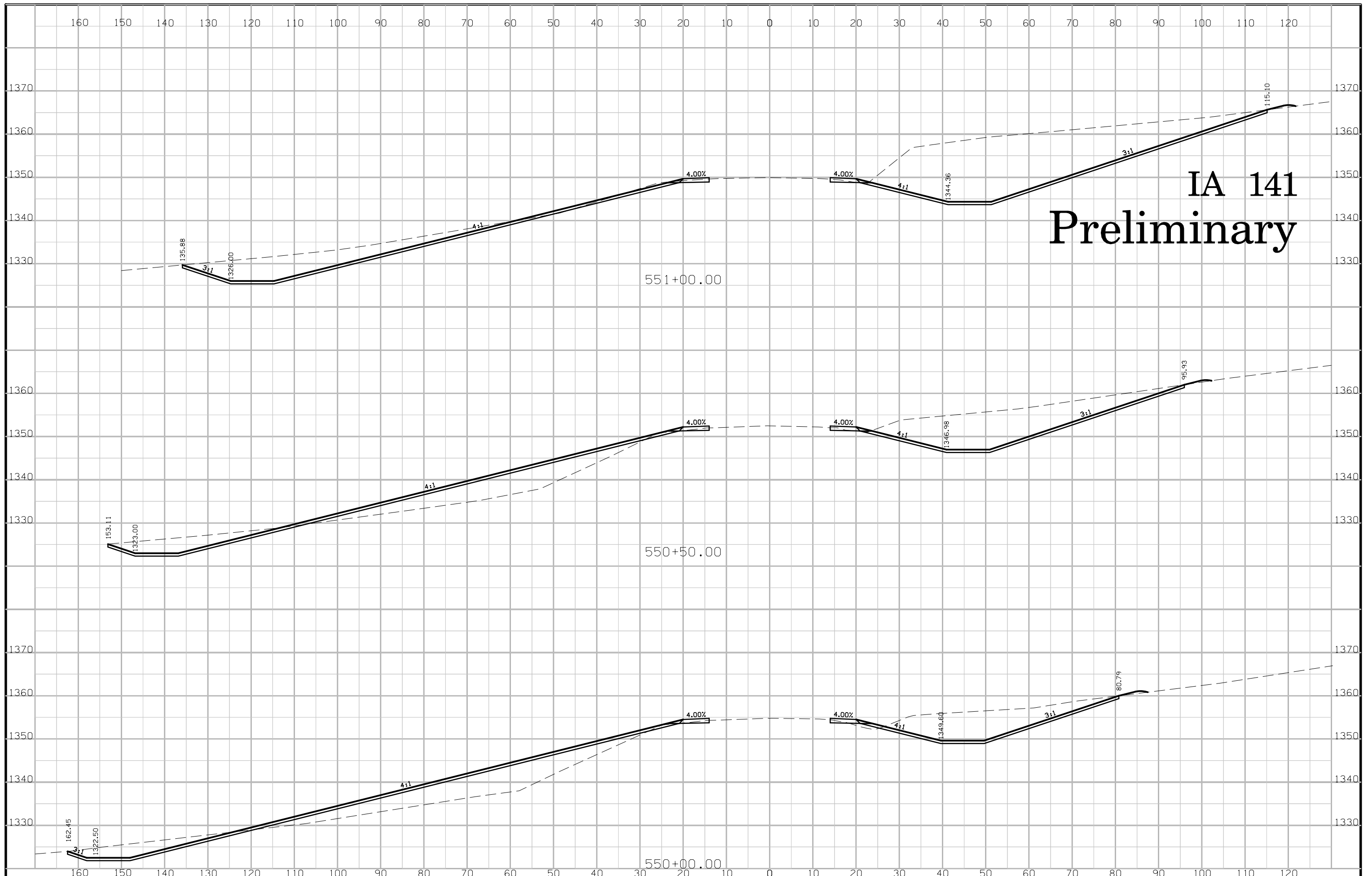

# IA 141 Preliminary

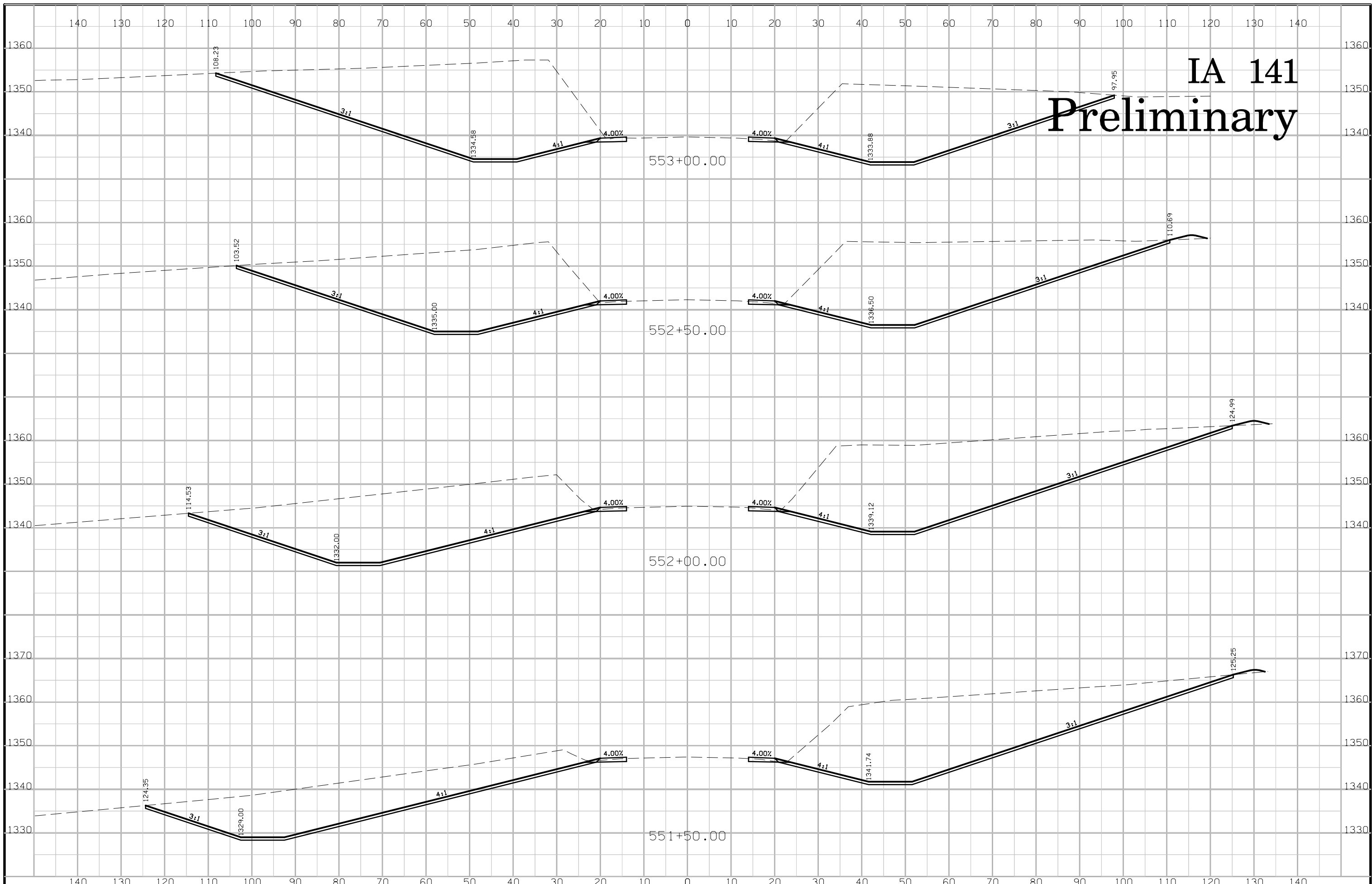

# IA 141 Preliminary

# IA 141 Preliminary

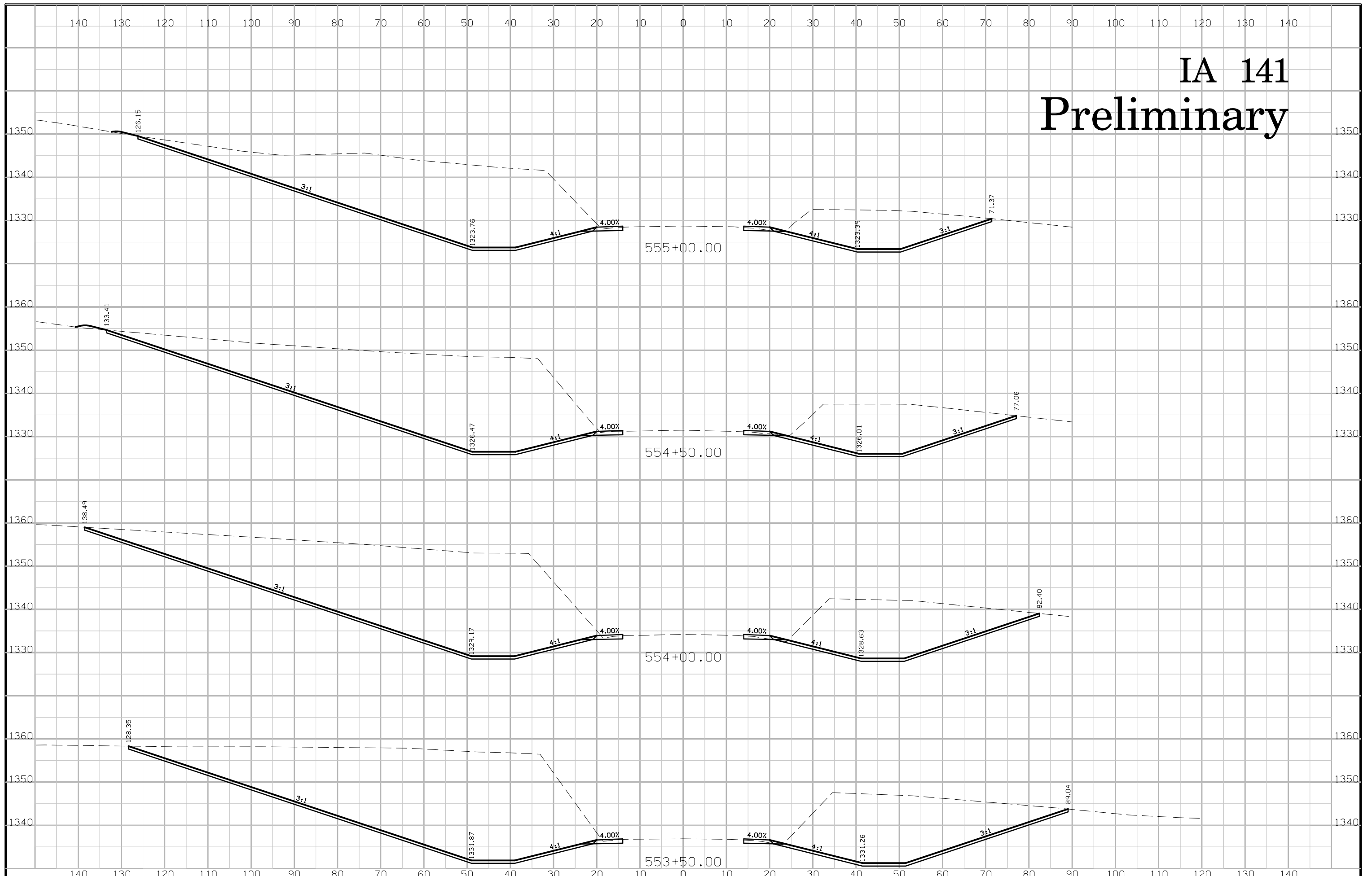

# IA 141 Preliminary

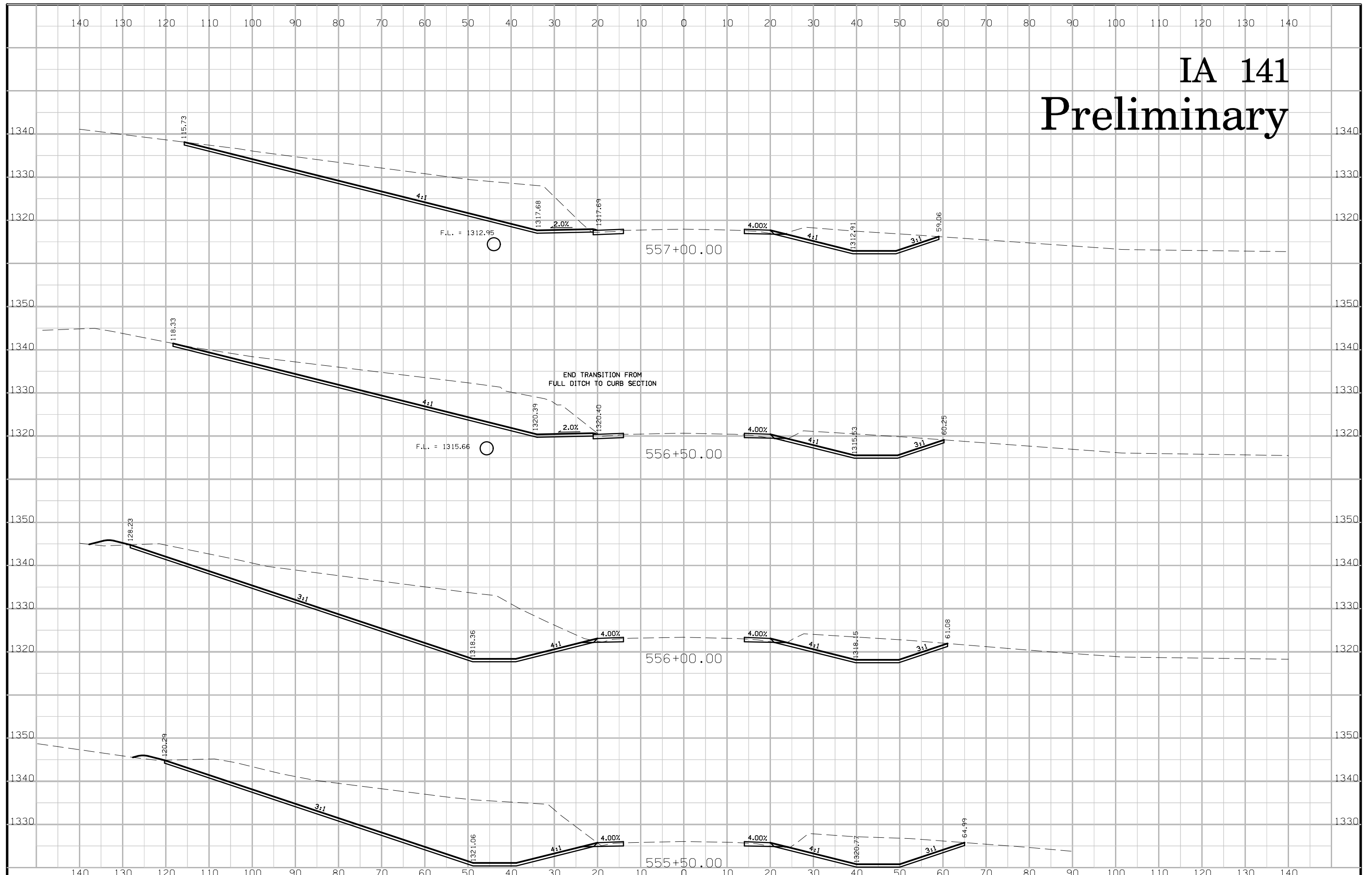

# IA 141 Preliminary

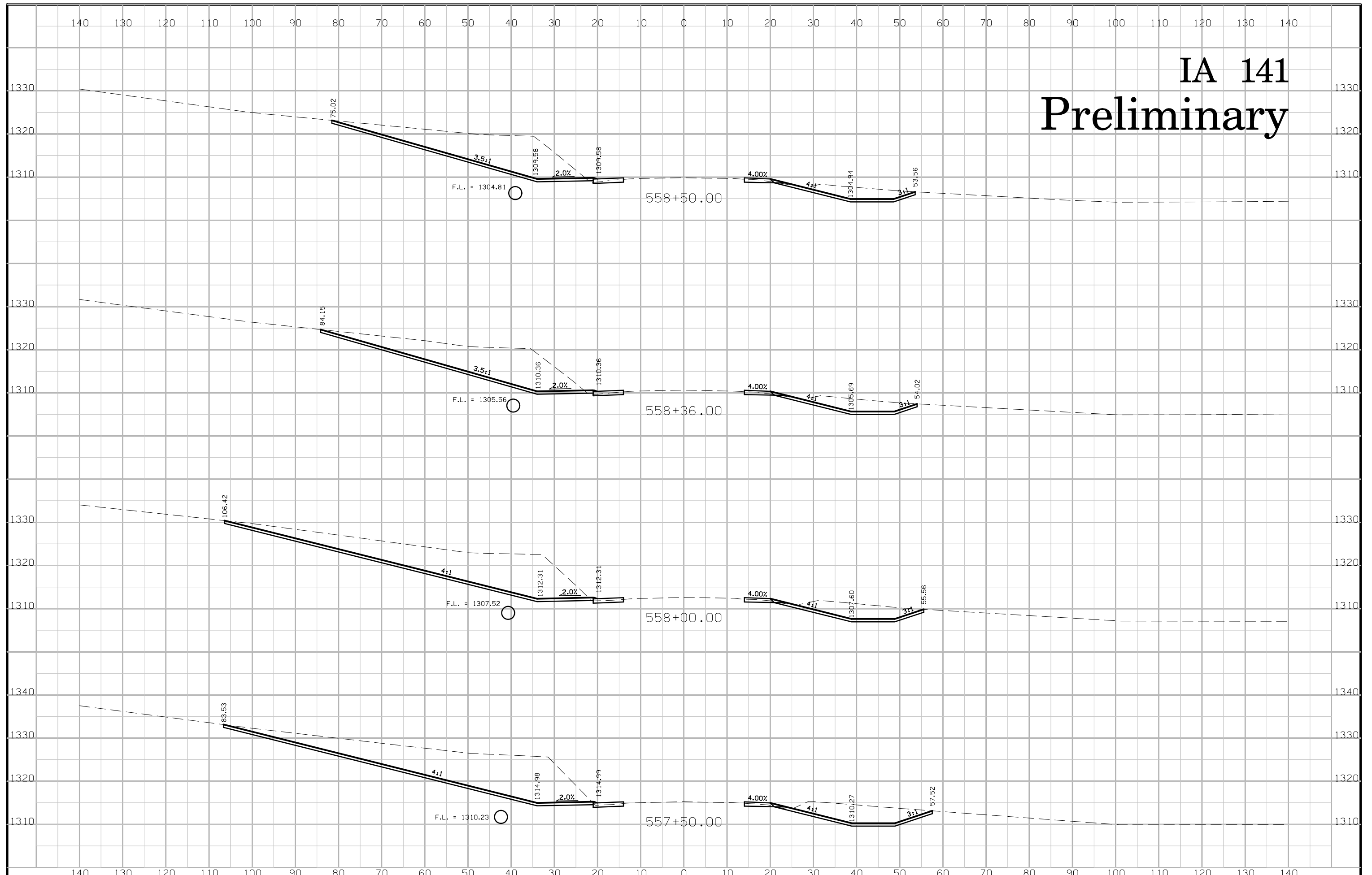

# IA 141 Preliminary

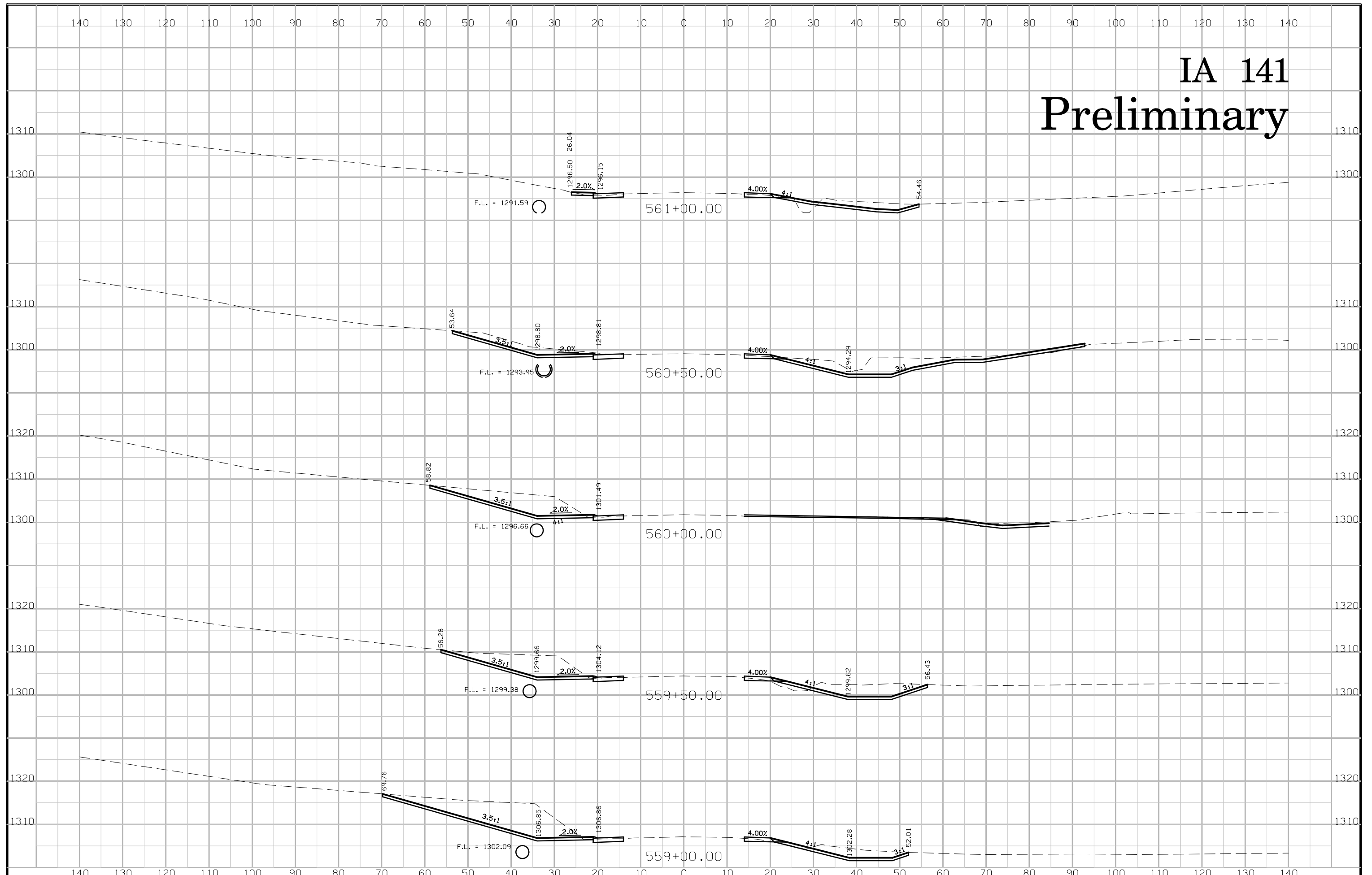



IA 141

Preliminary

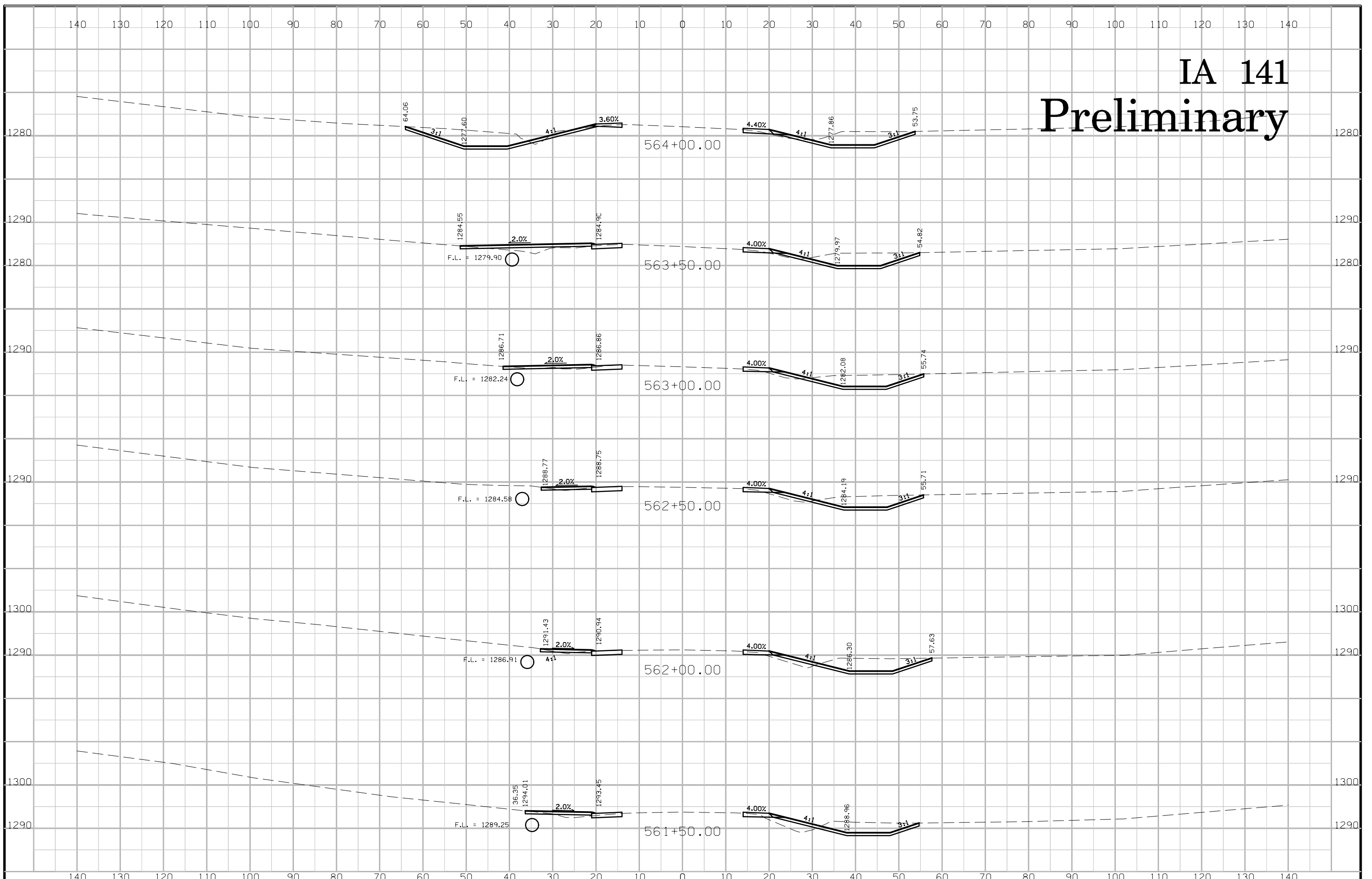

# IA 141 Preliminary

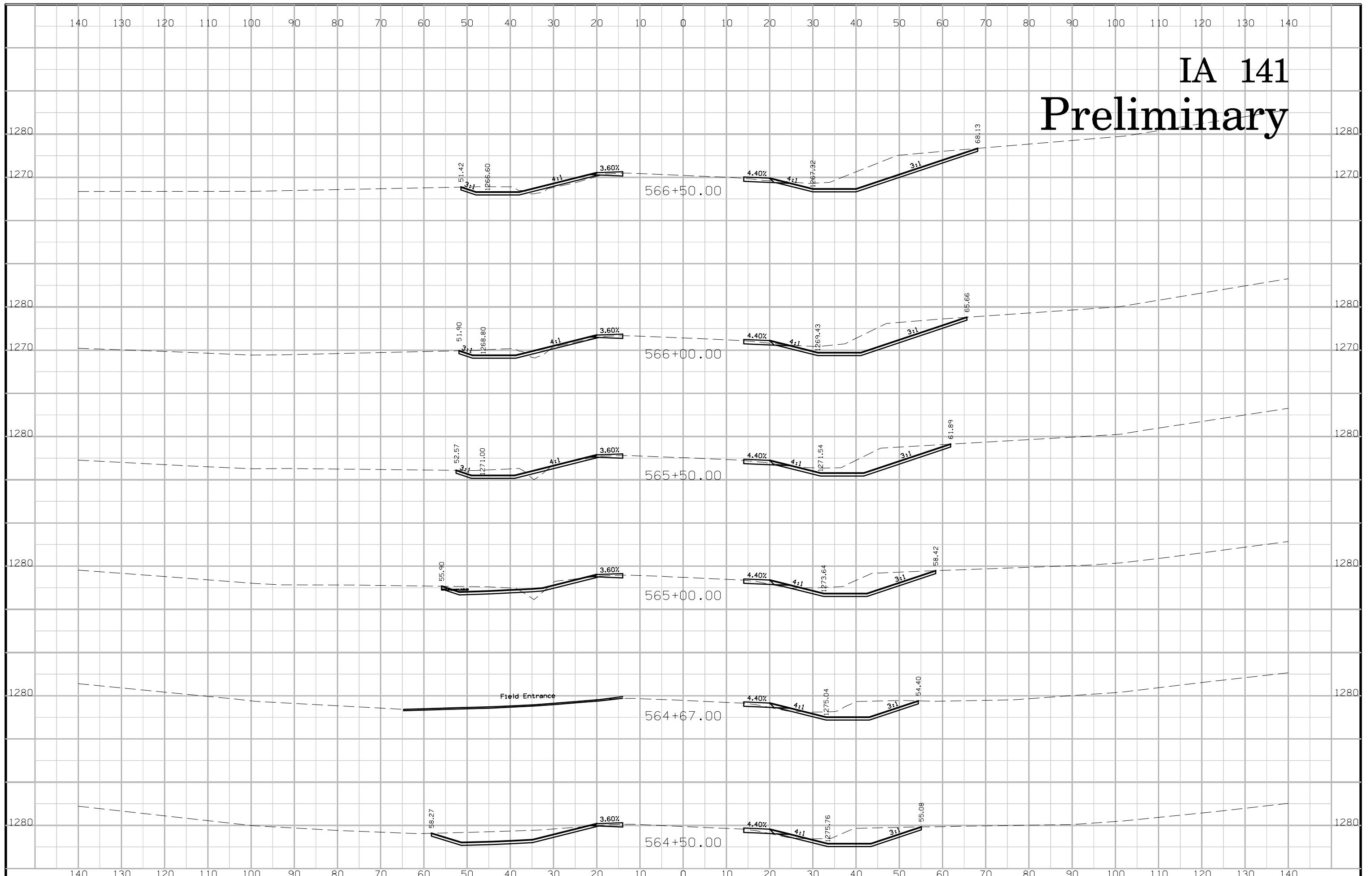

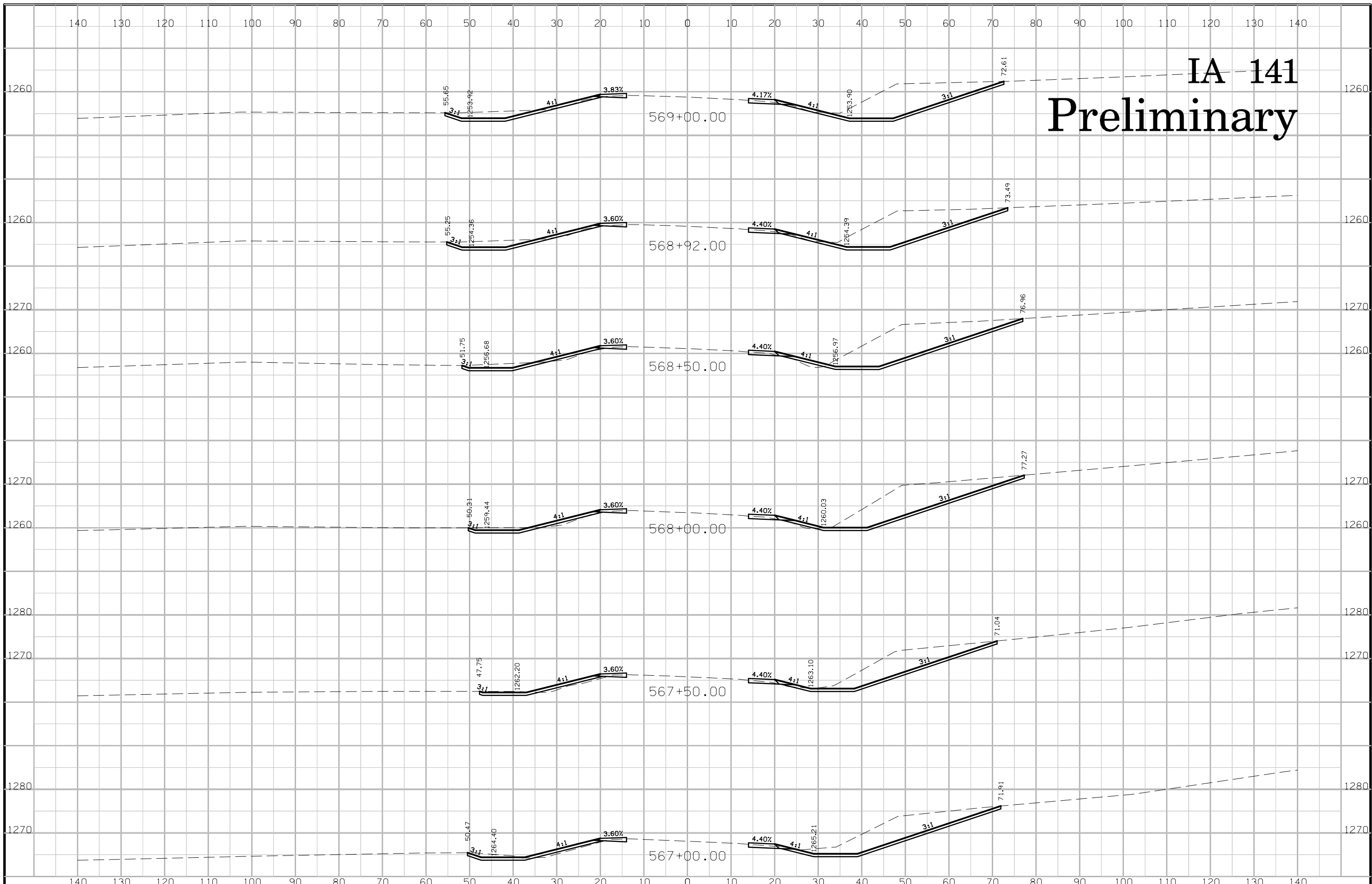

# IA-141 Preliminary

# IA 141 Preliminary

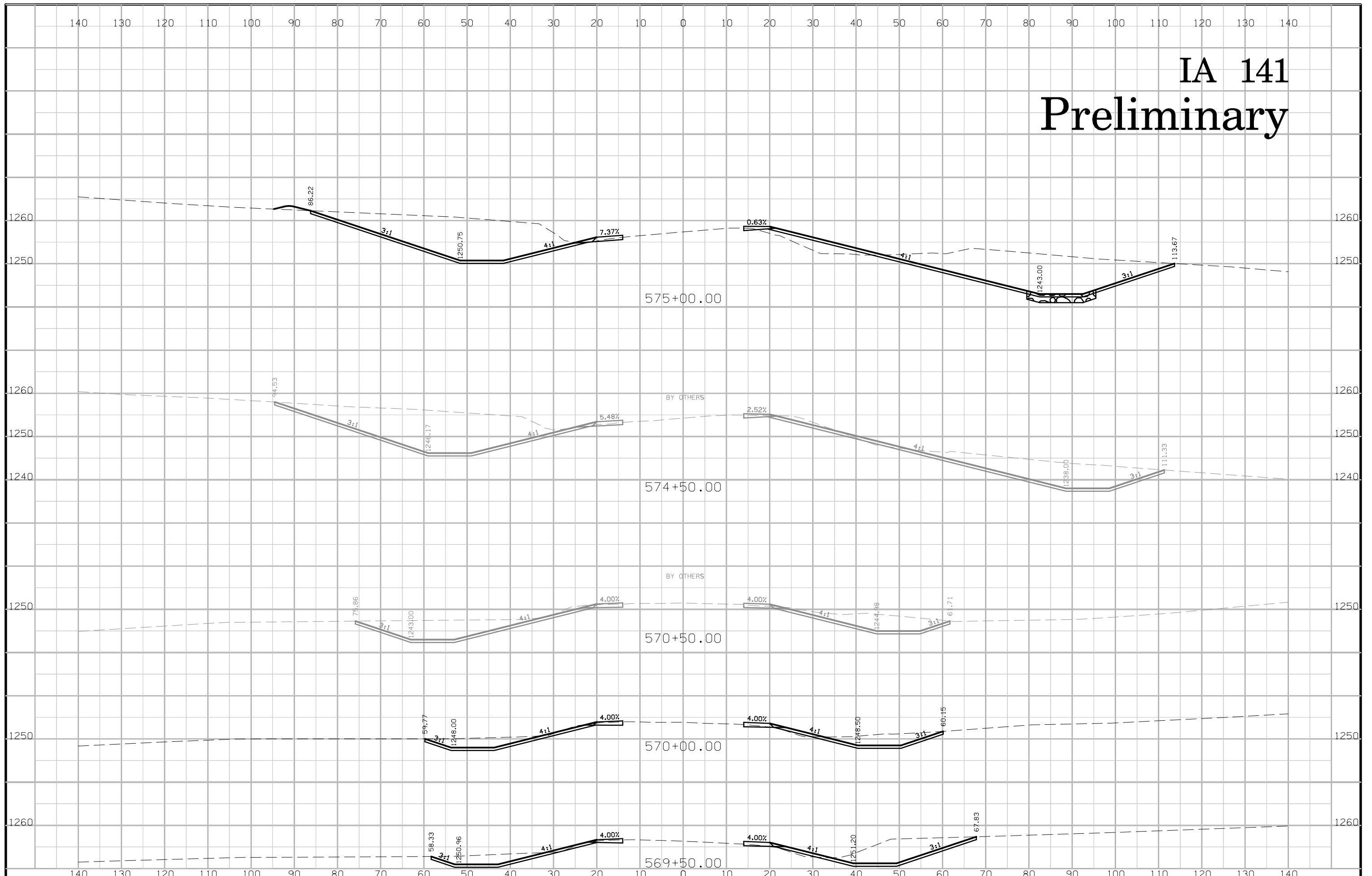

# IA 141 Preliminary

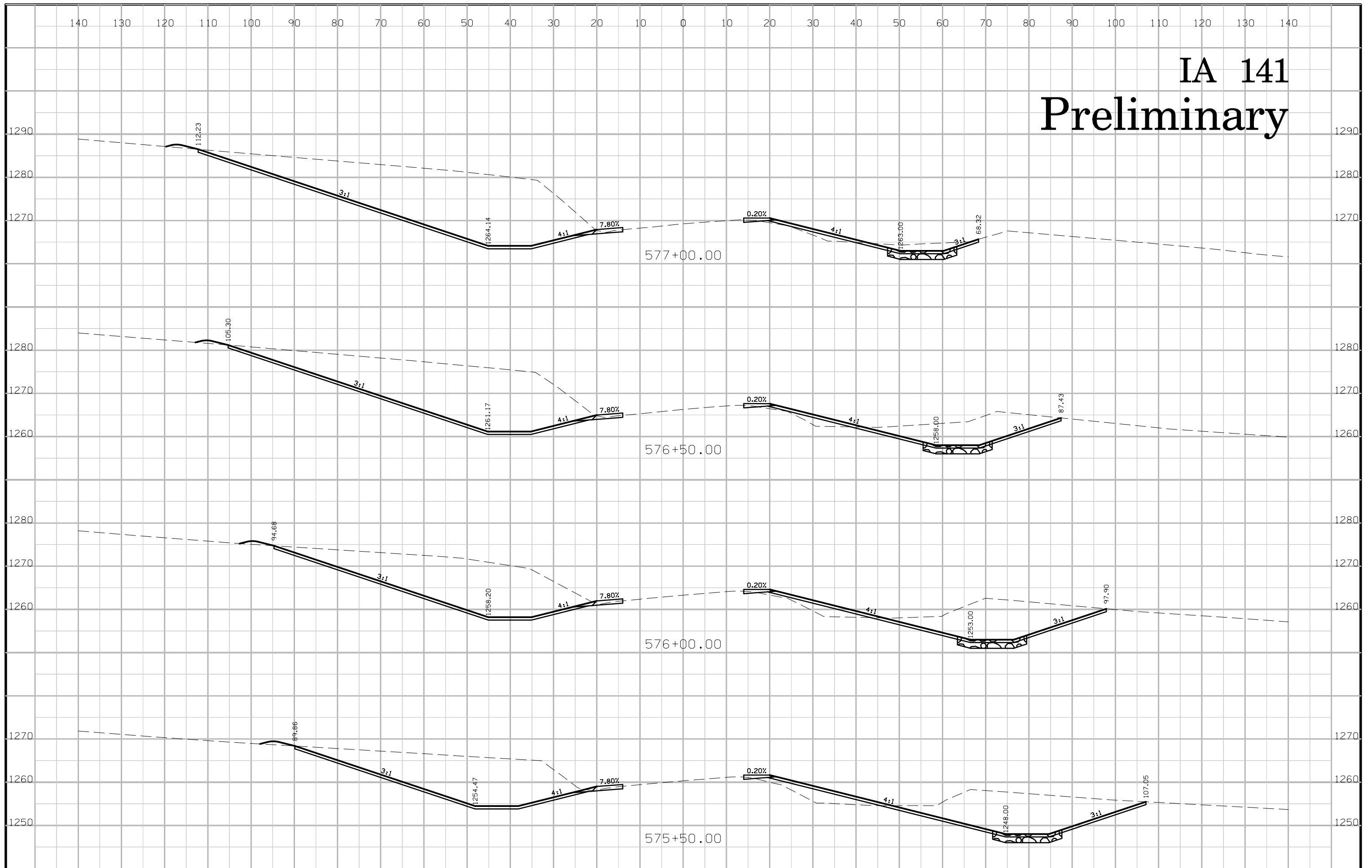



# IA 141 Preliminary

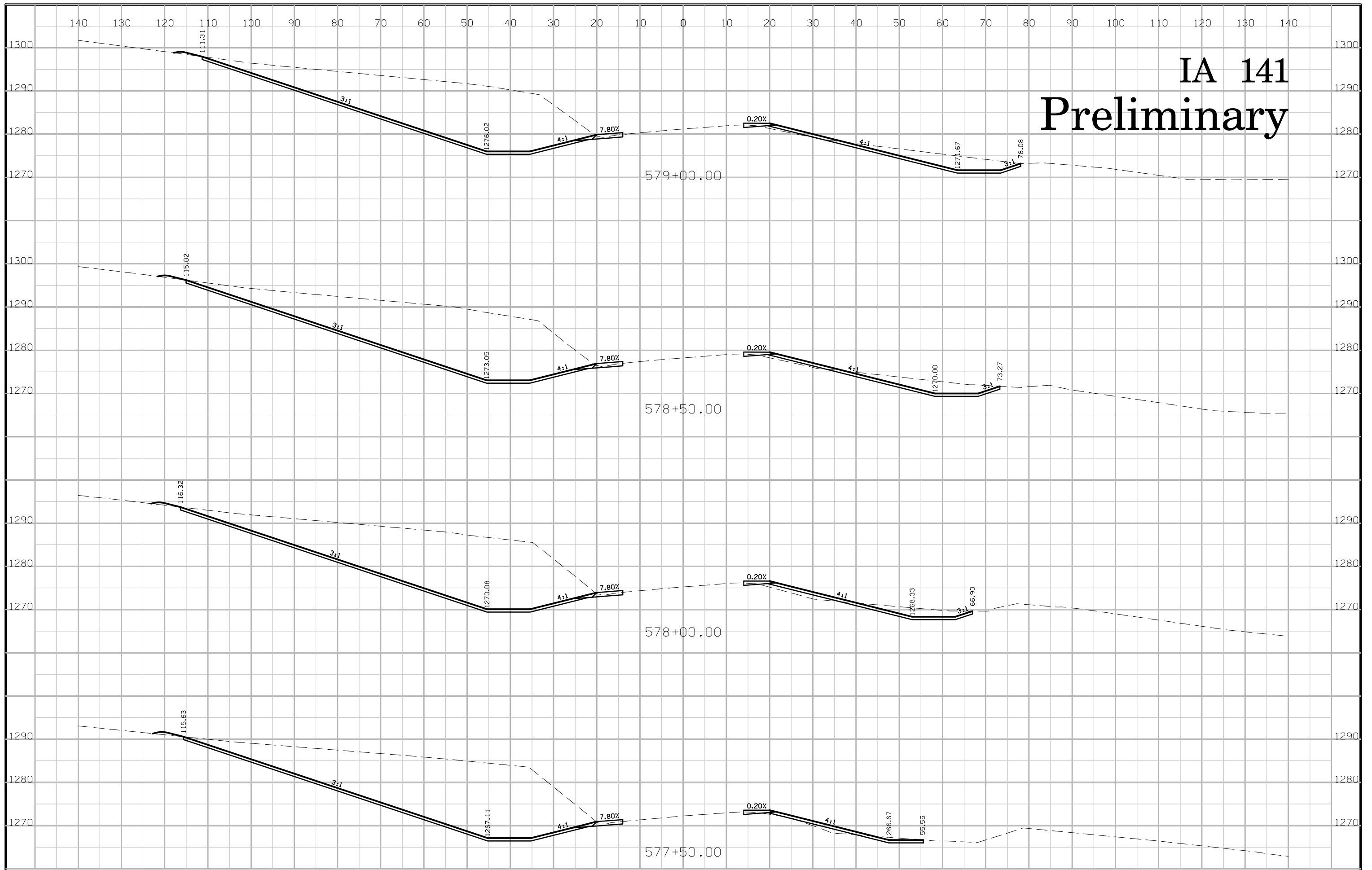

# IA 141 Preliminary

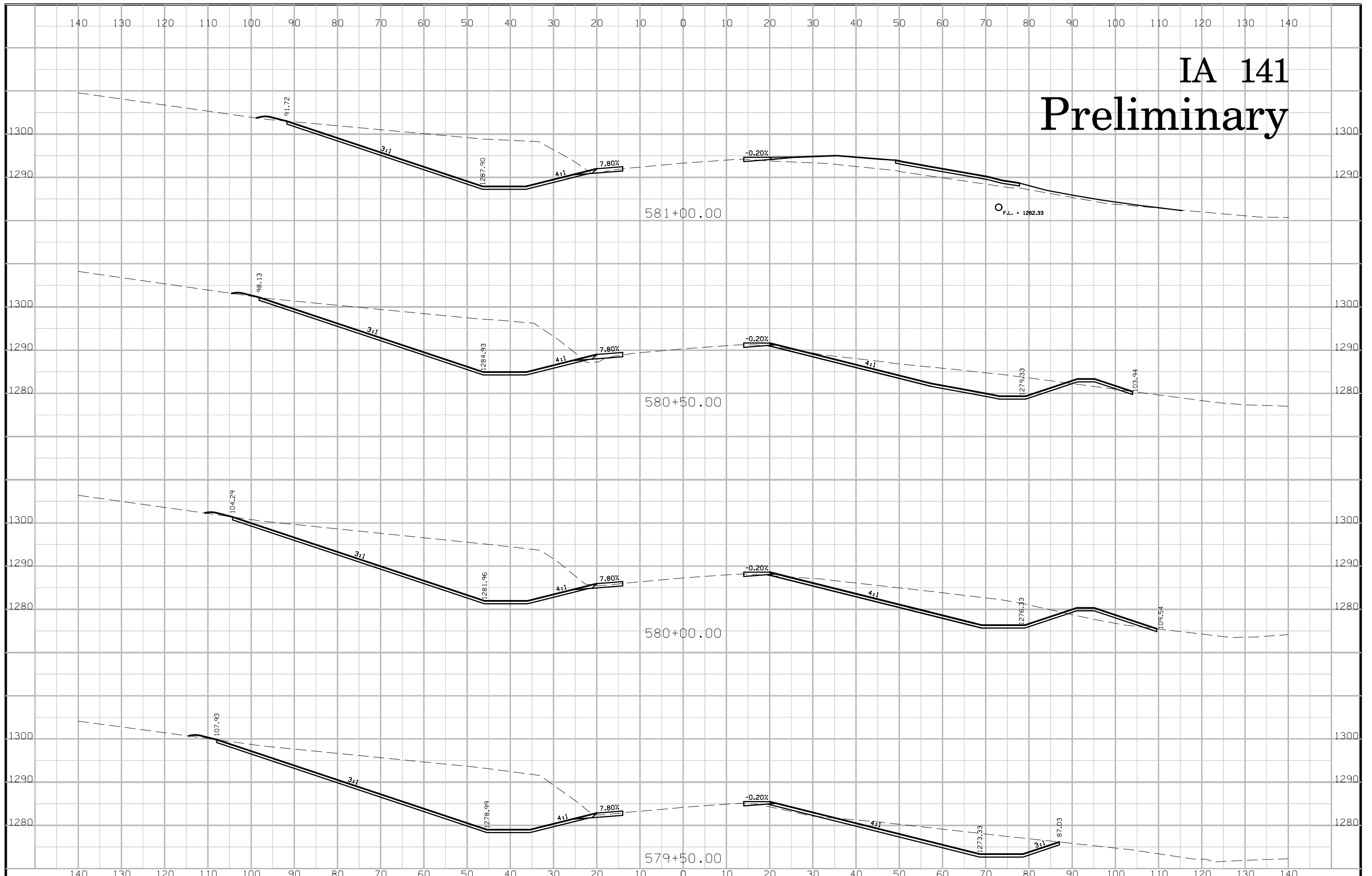

# IA 141 Preliminary

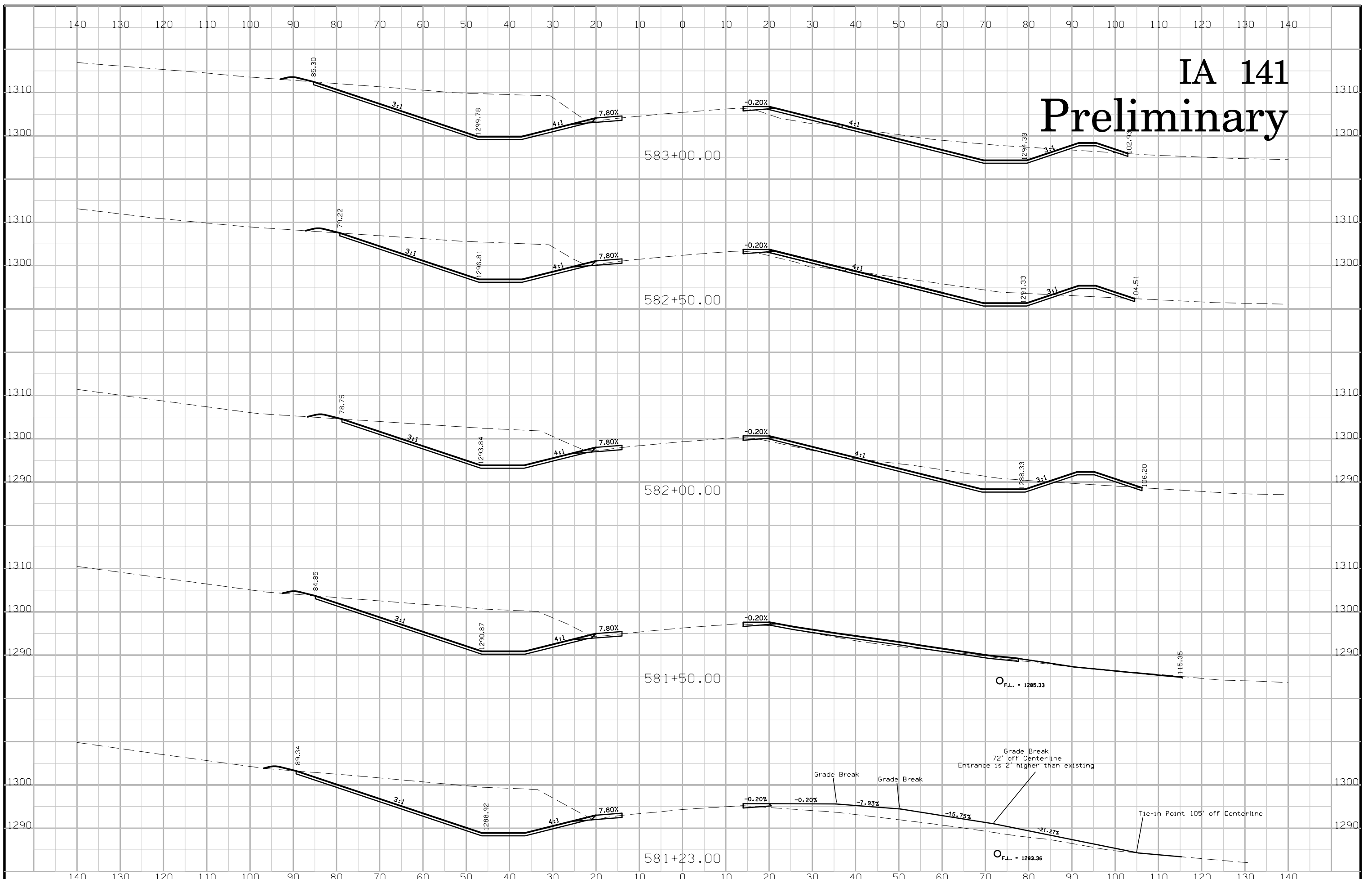

# IA 141 Preliminary

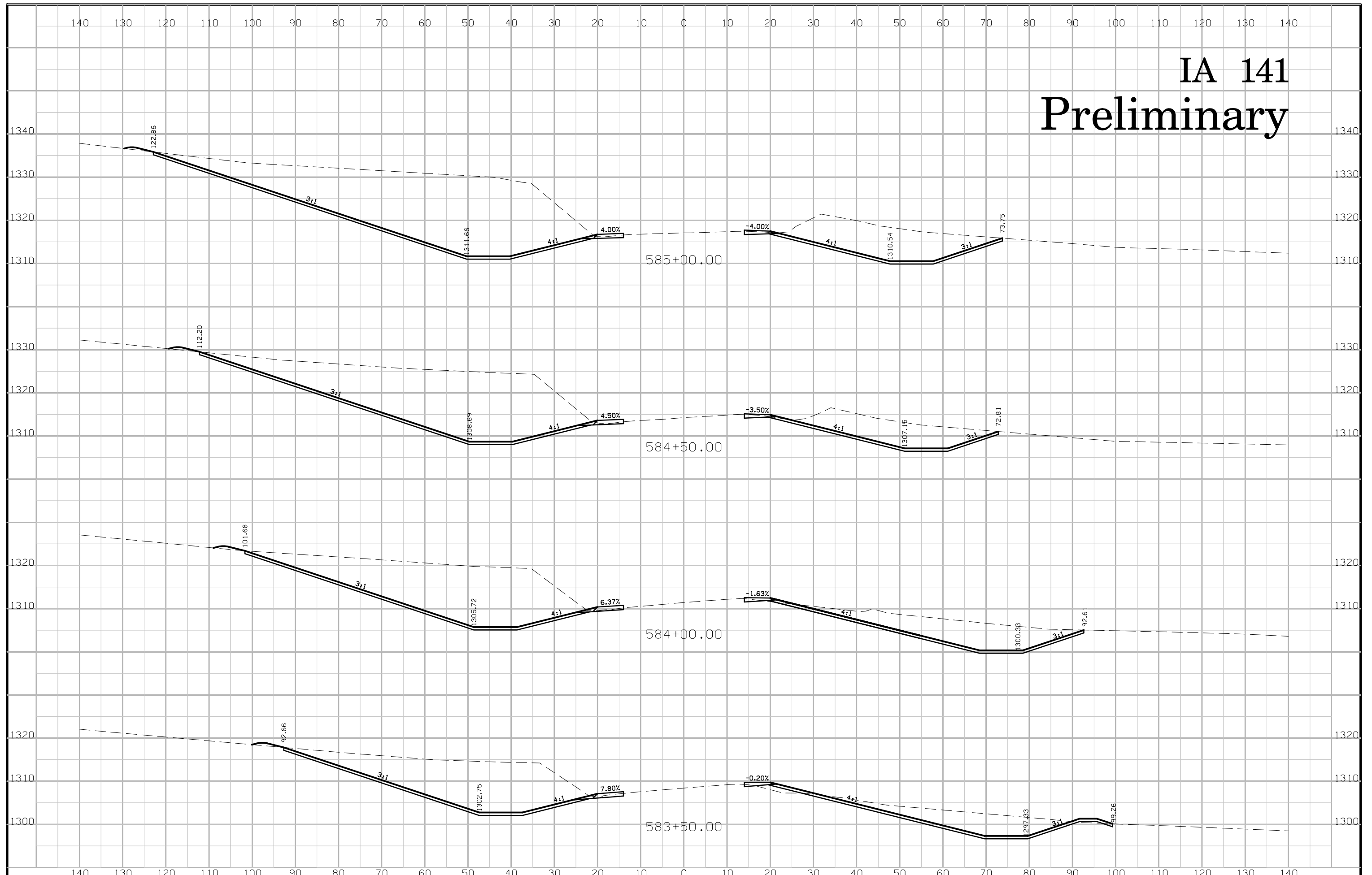

# IA 141 Preliminary

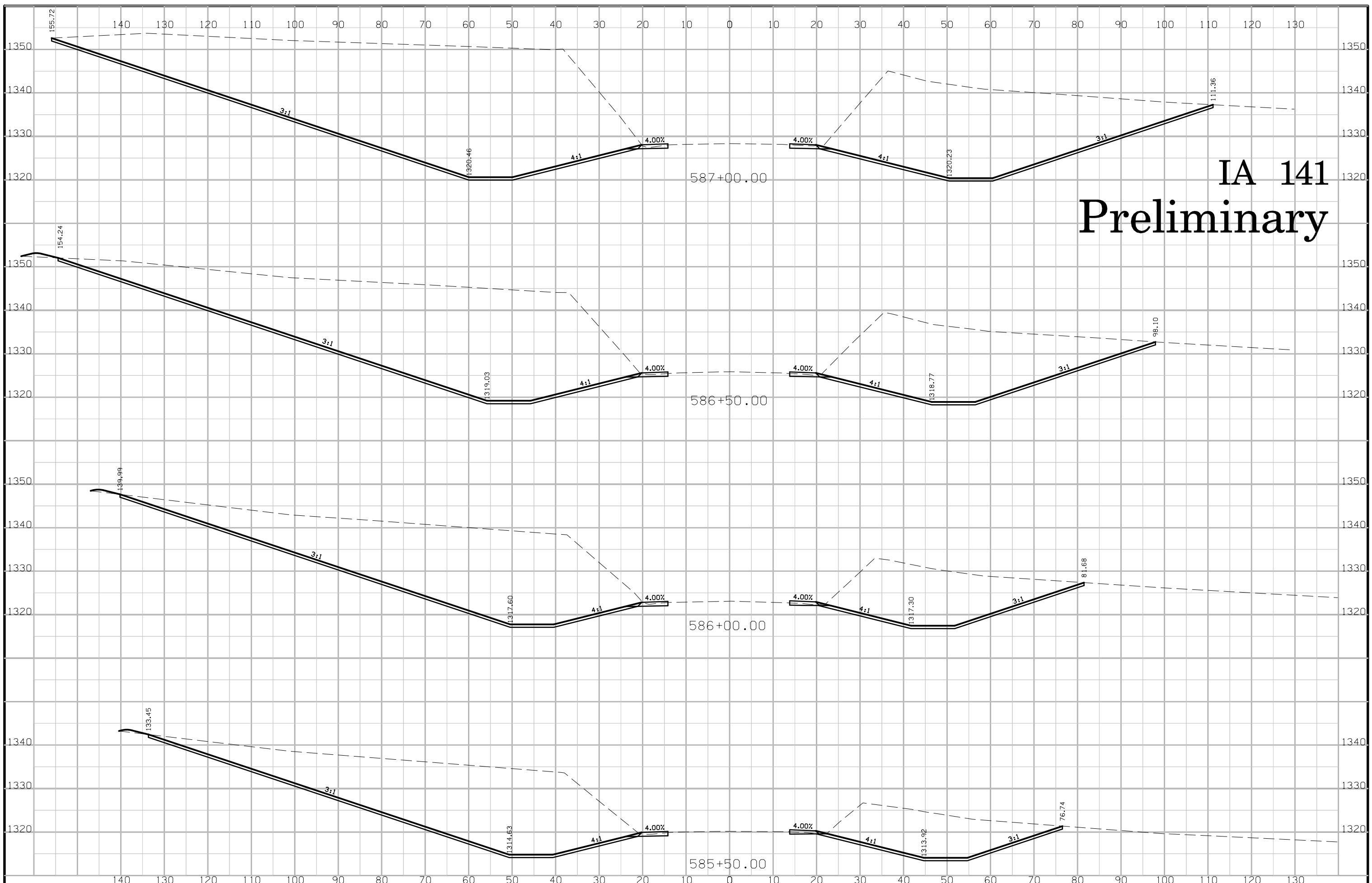

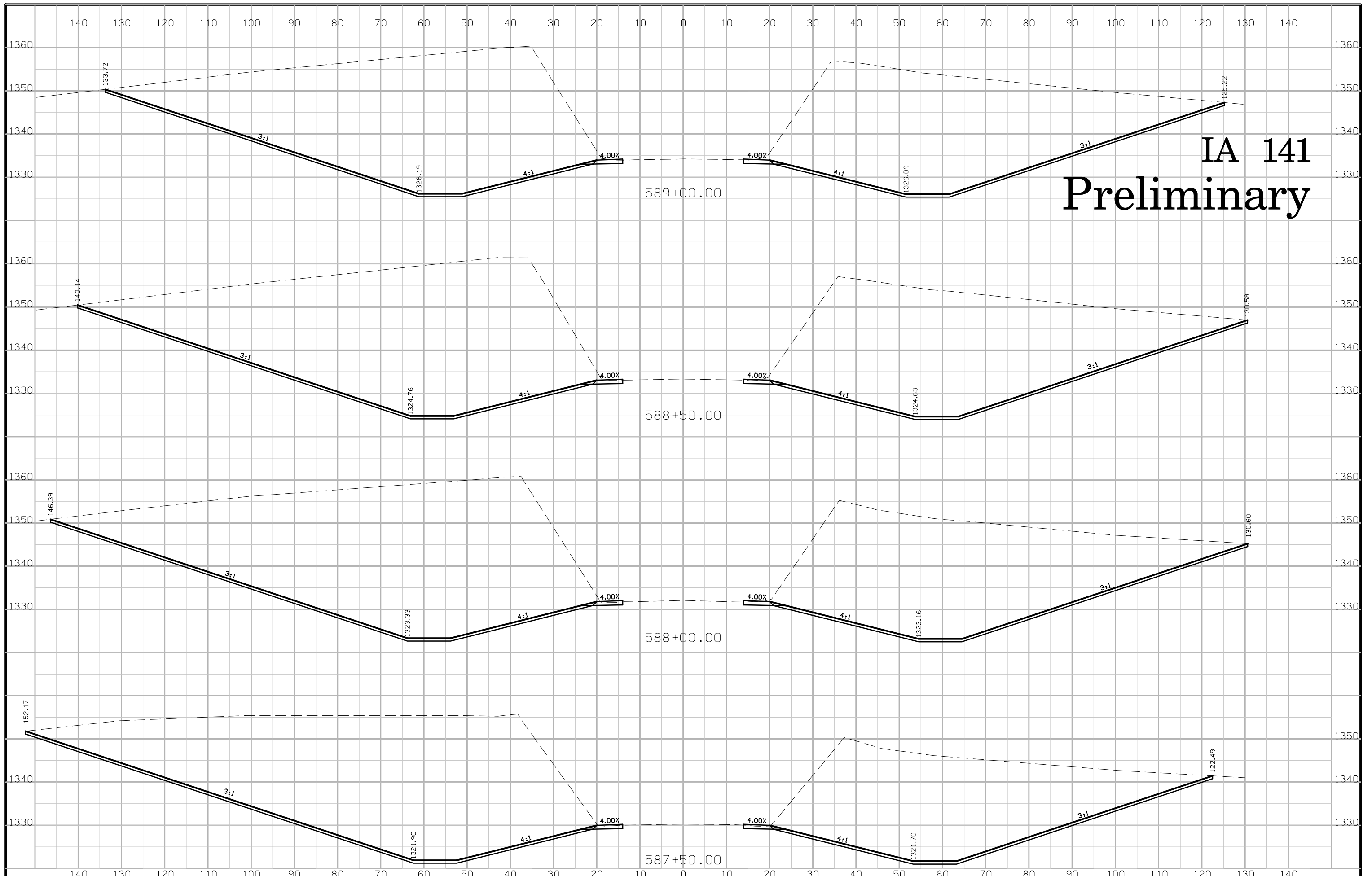

# IA 141 Preliminary



# IA 141 Preliminary

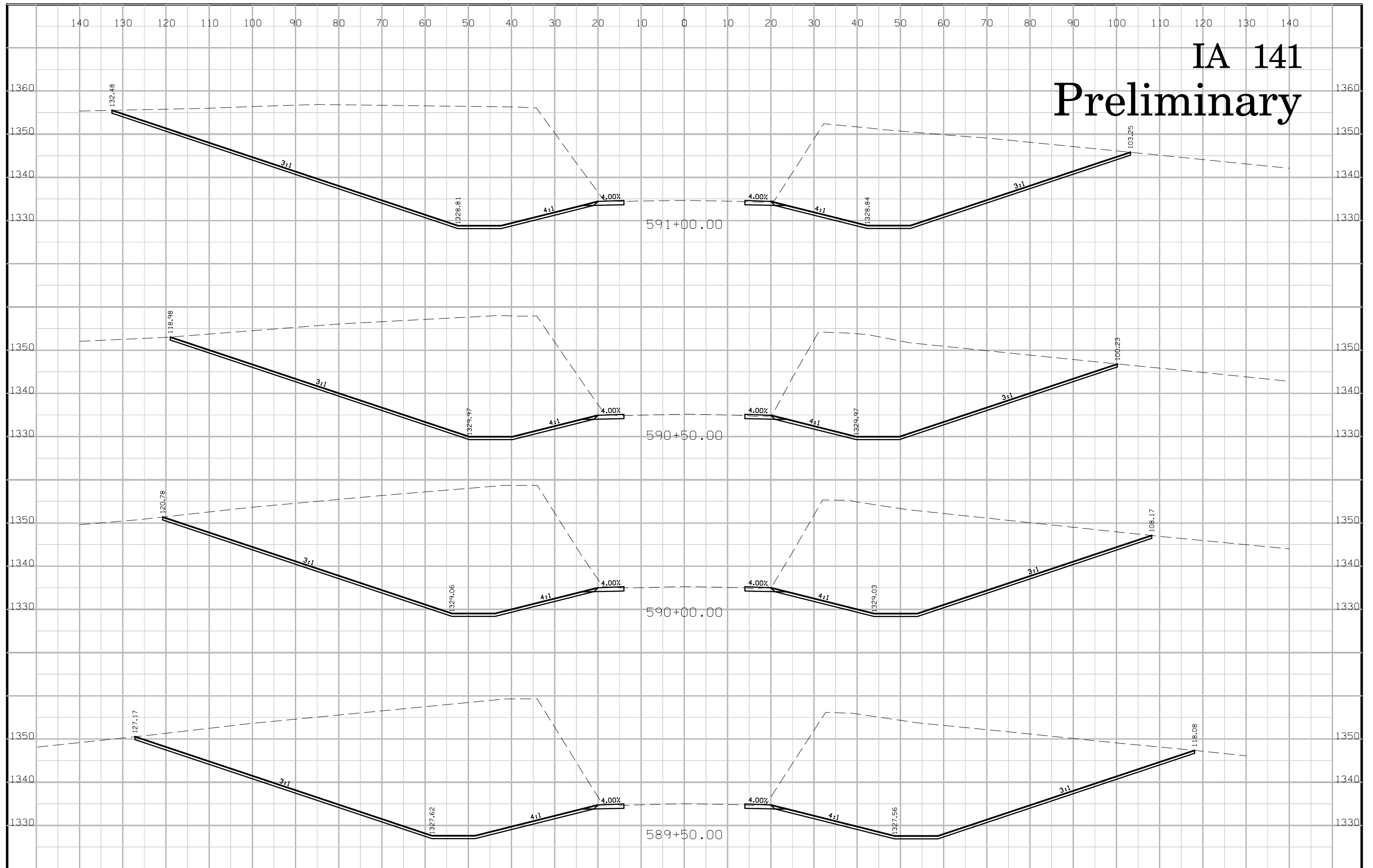

# IA 141 Preliminary

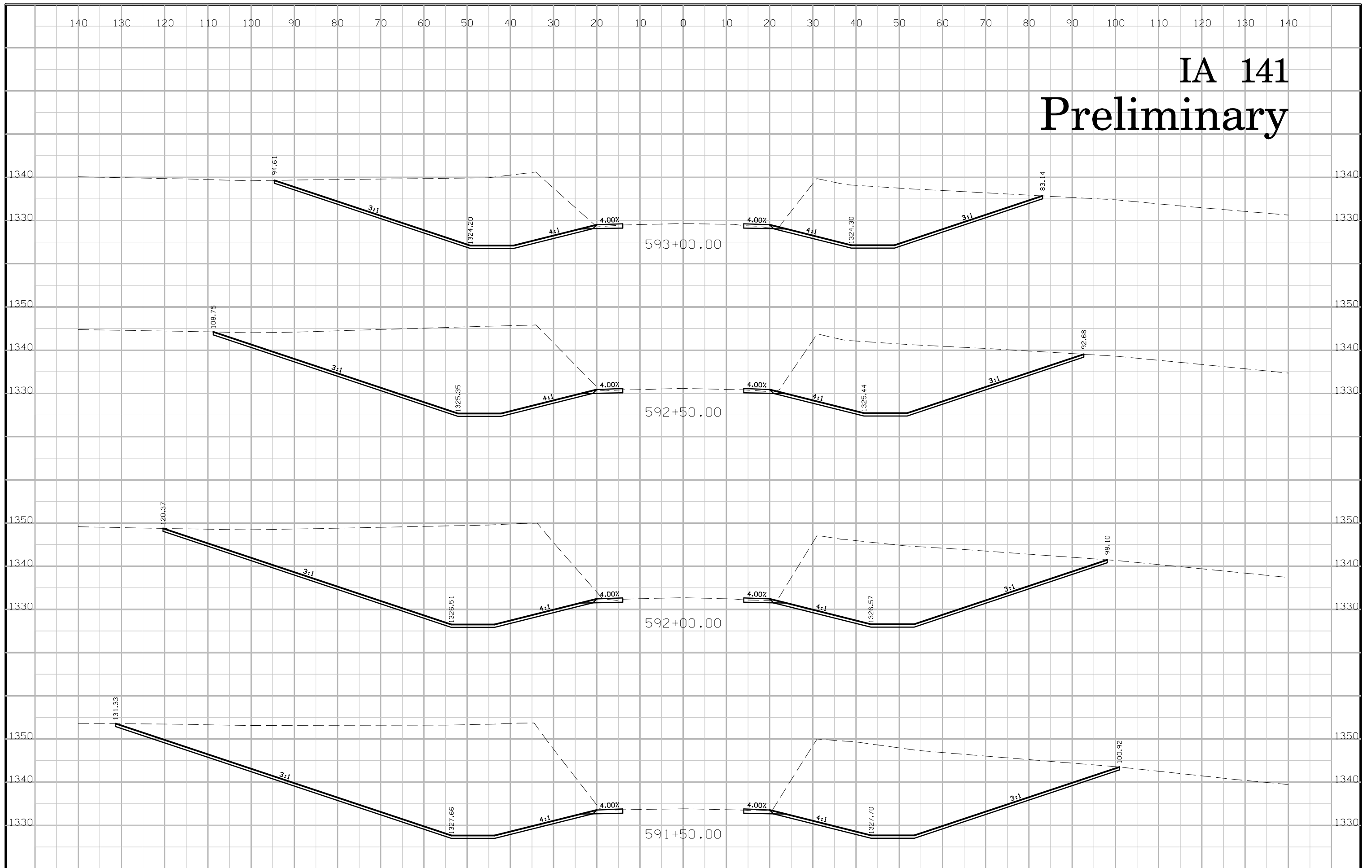

# IA 141 Preliminary

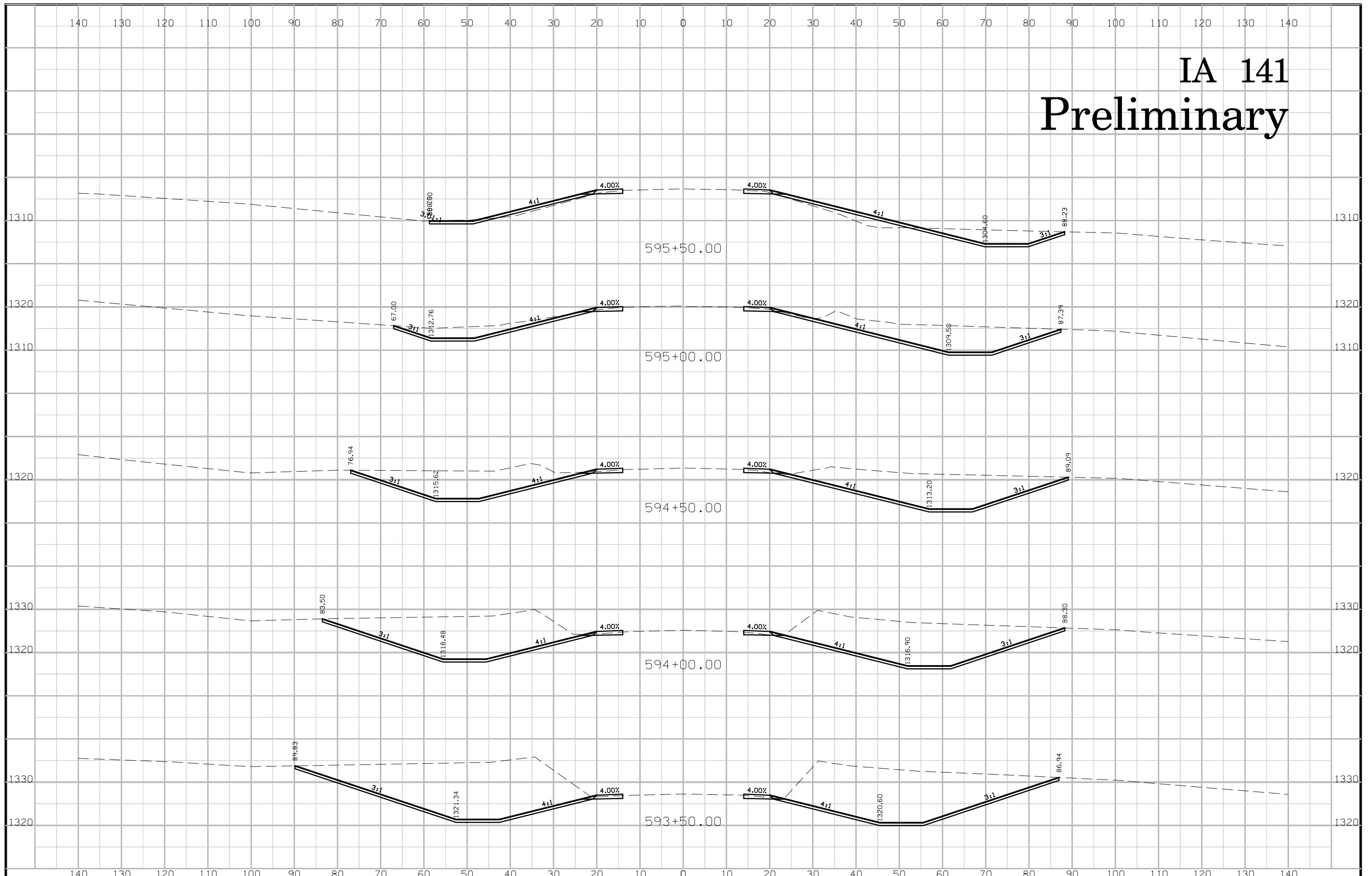

# IA 141 Preliminary

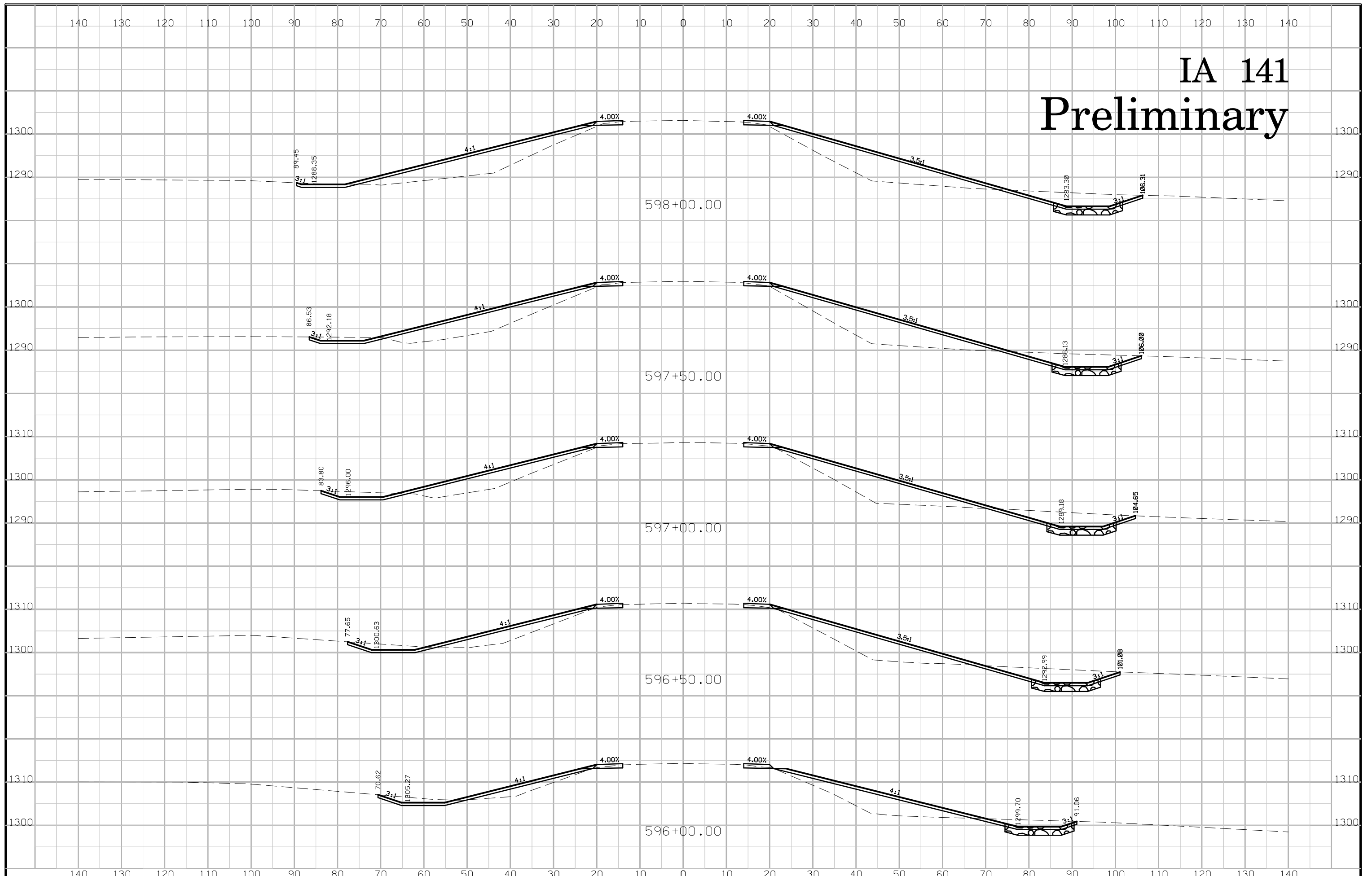

# IA 141 Preliminary

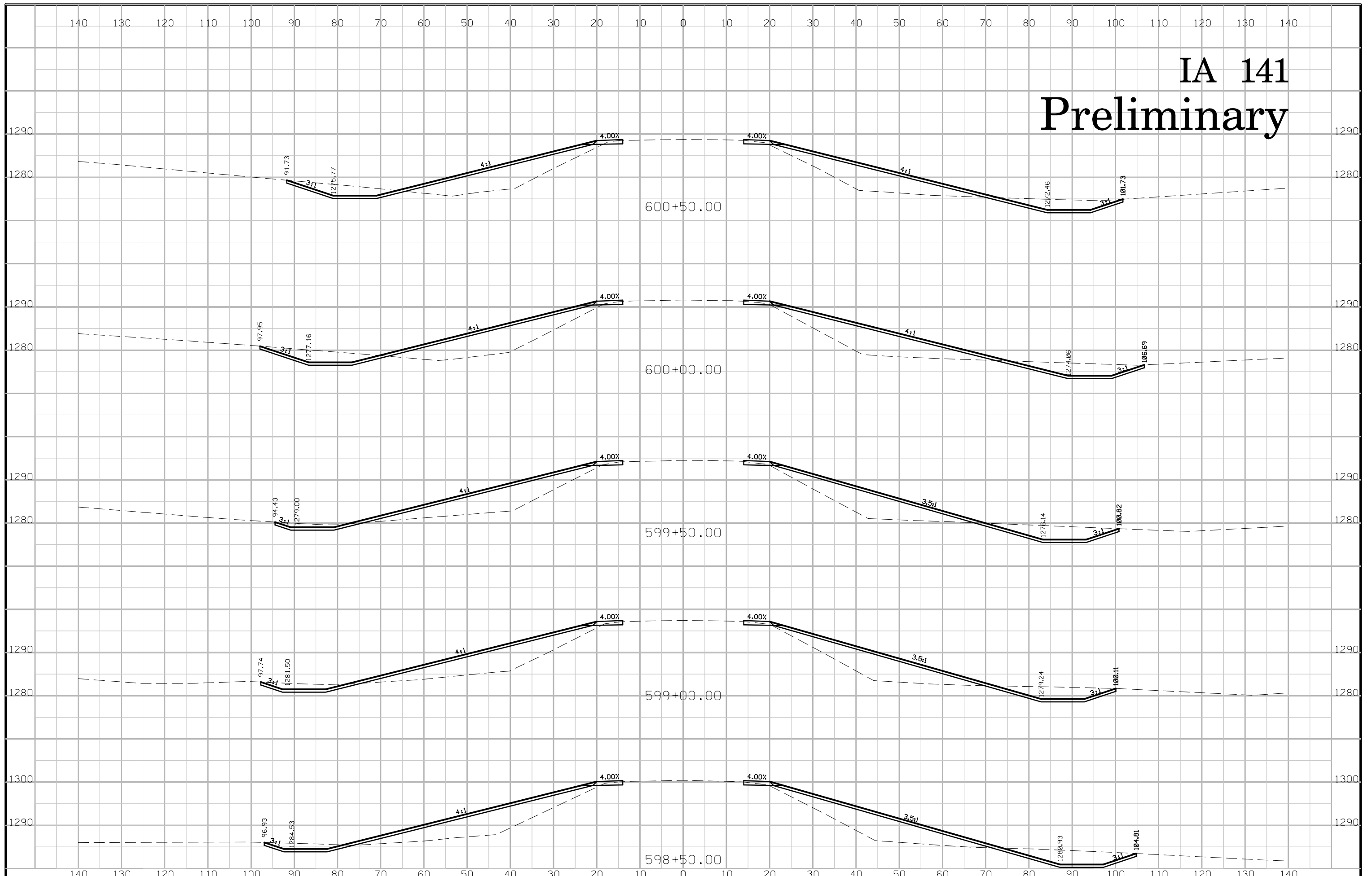

# IA 141 Preliminary

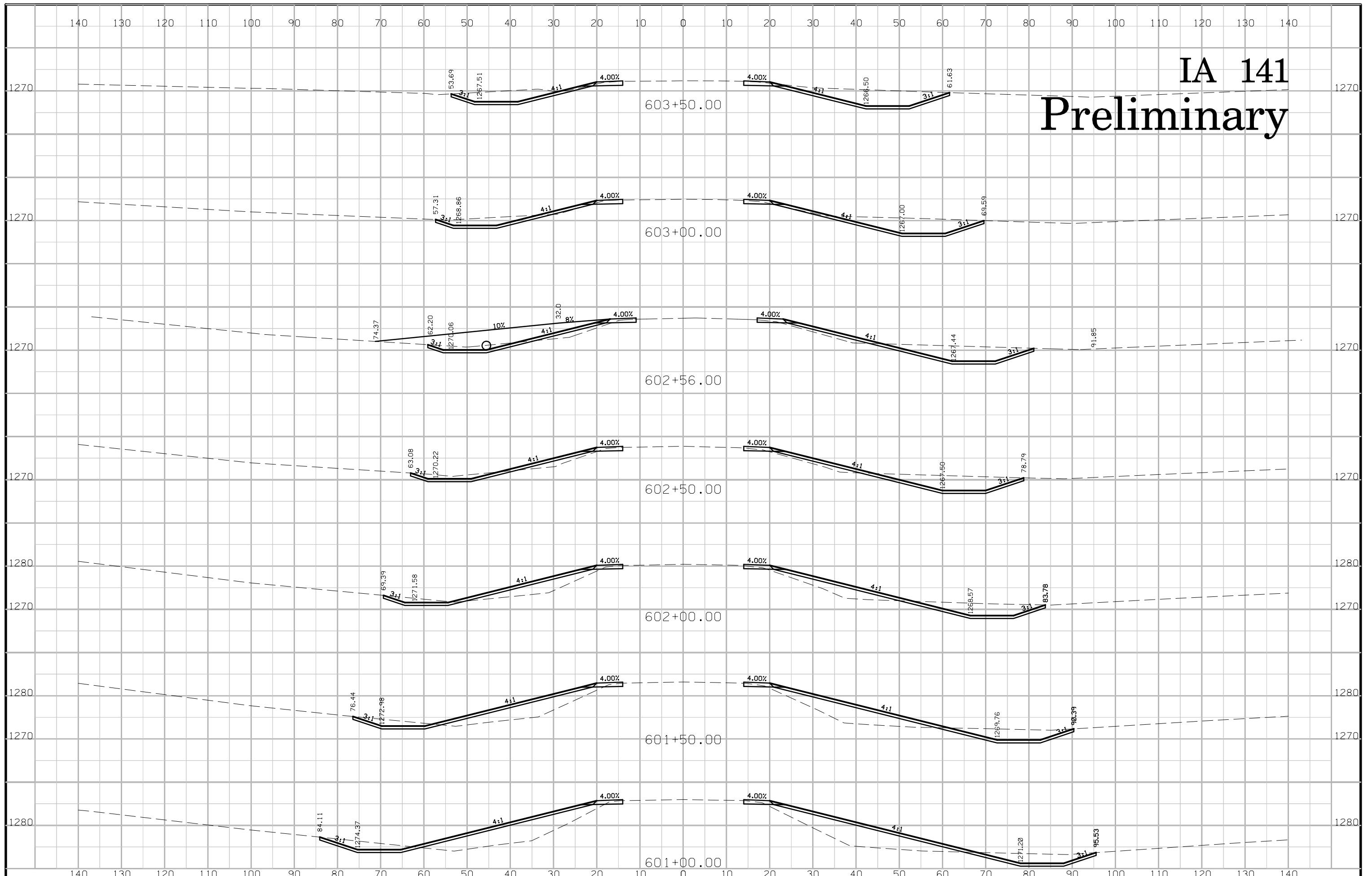



# IA 141 Preliminary

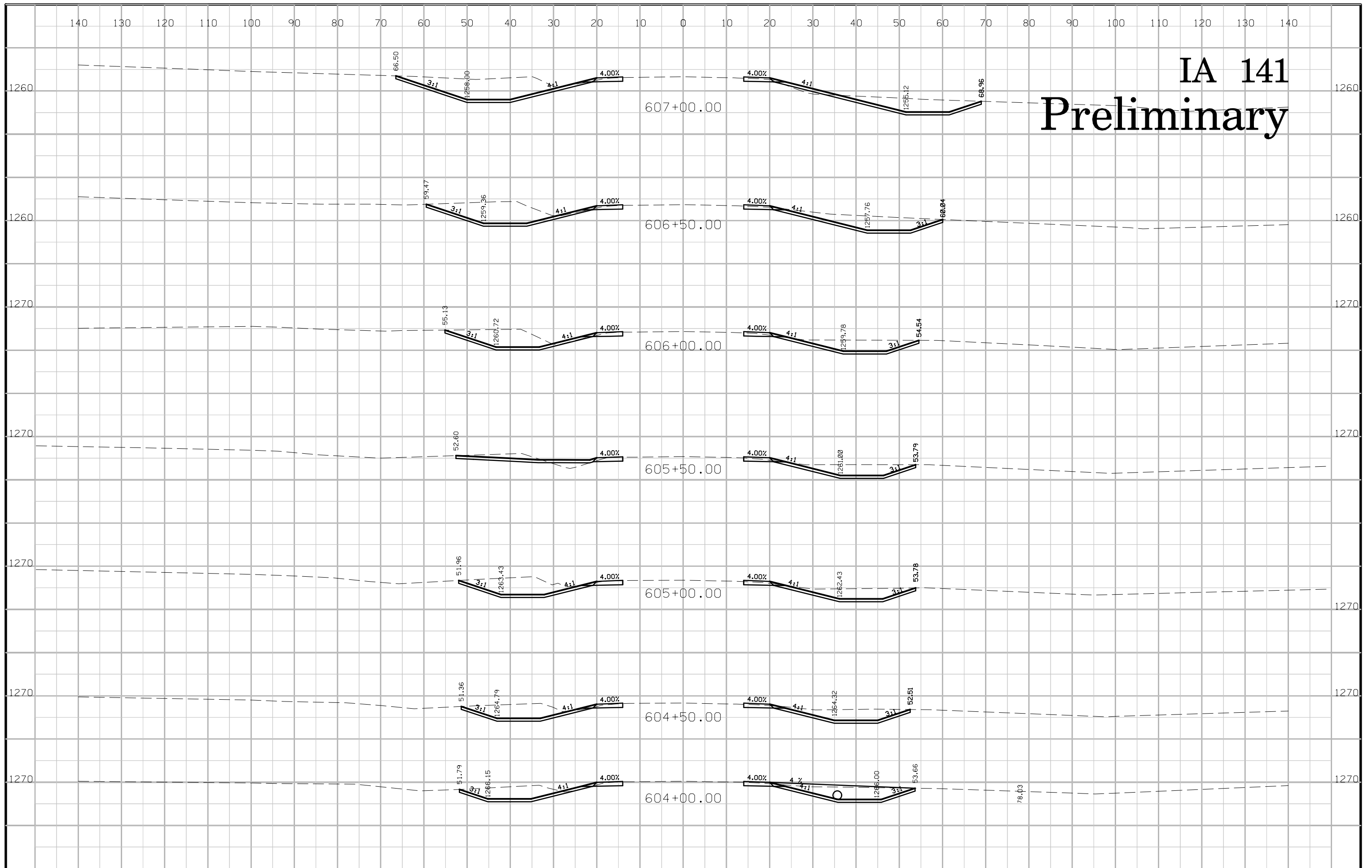

# IA 141 Preliminary

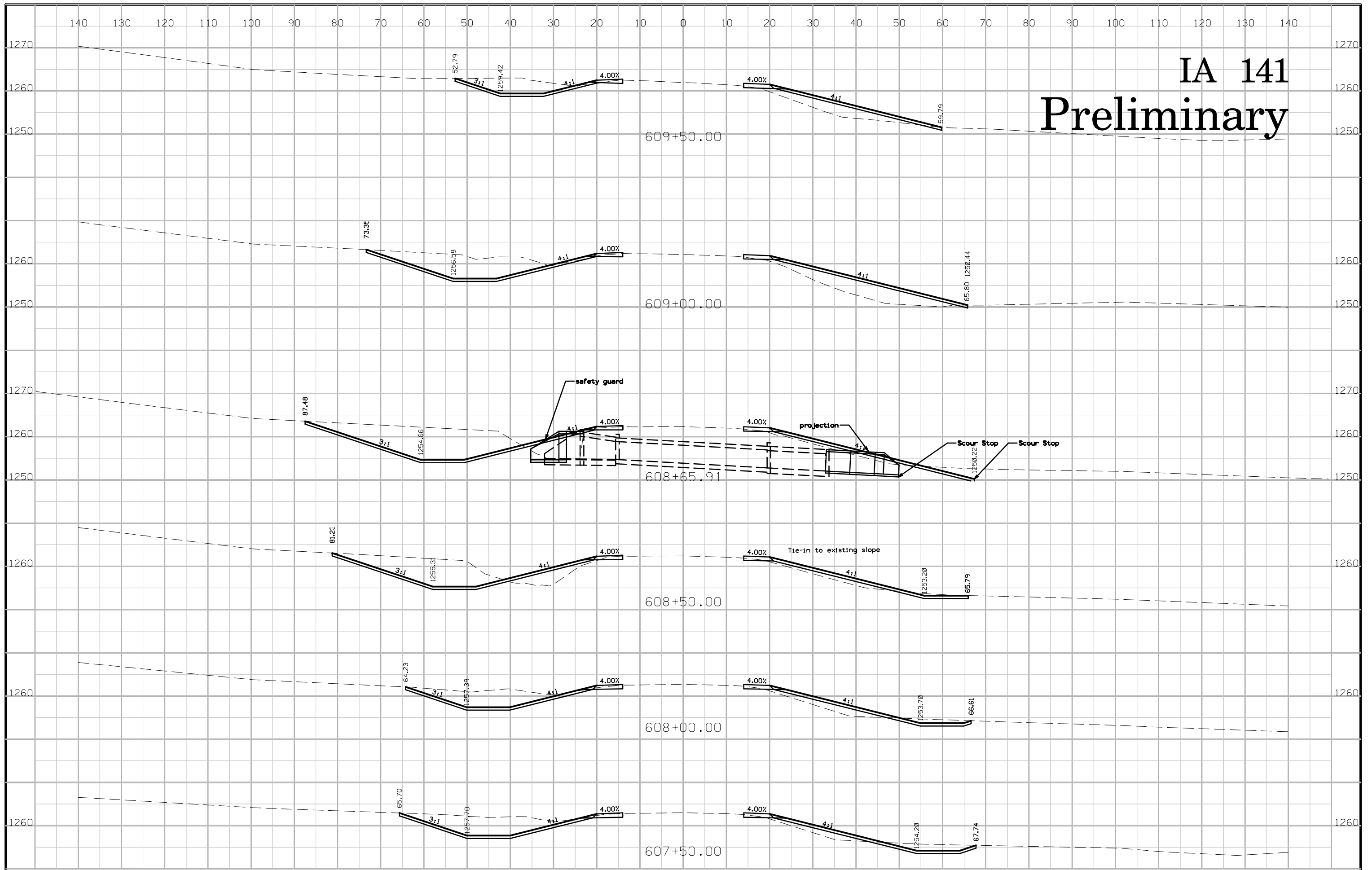

# IA 141 Preliminary

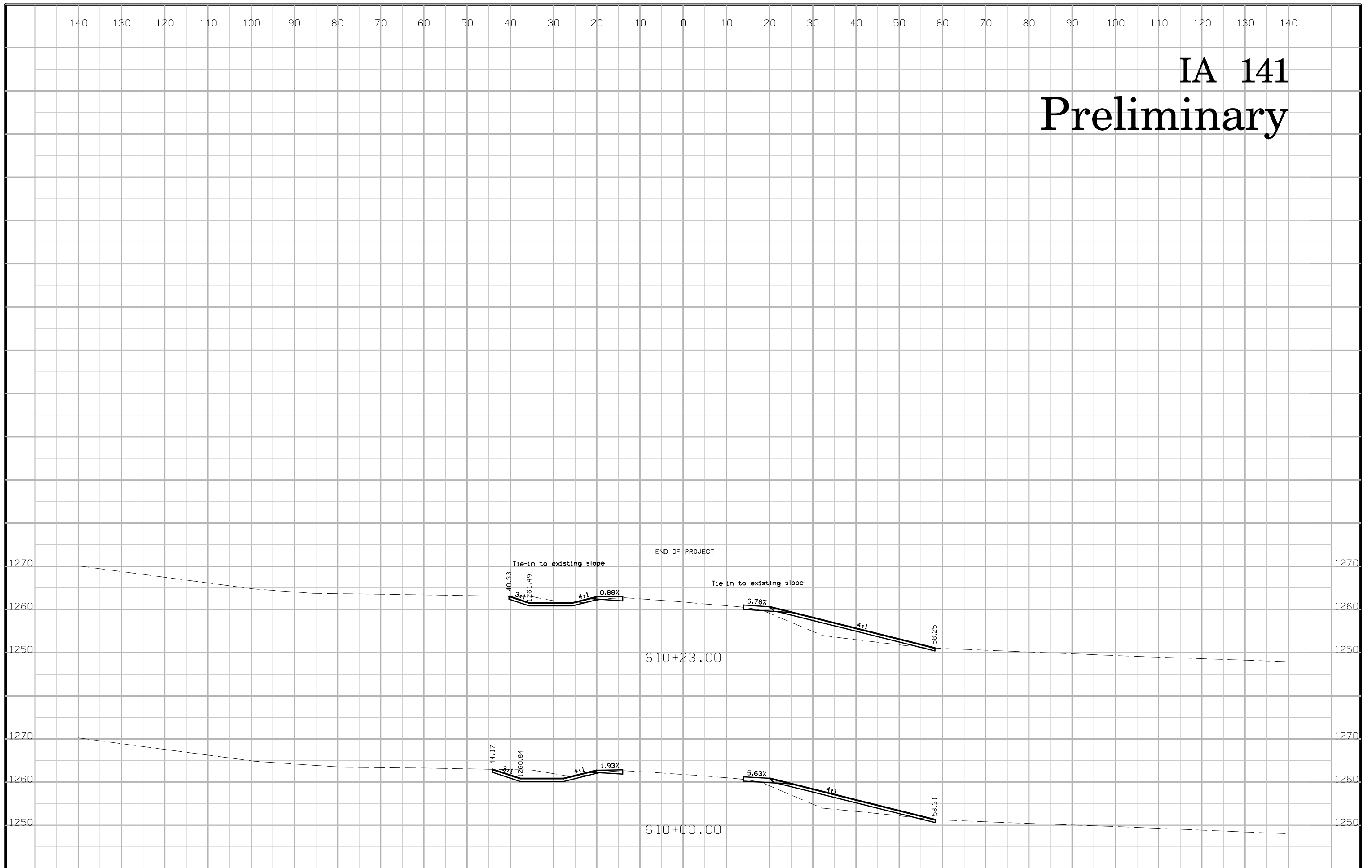

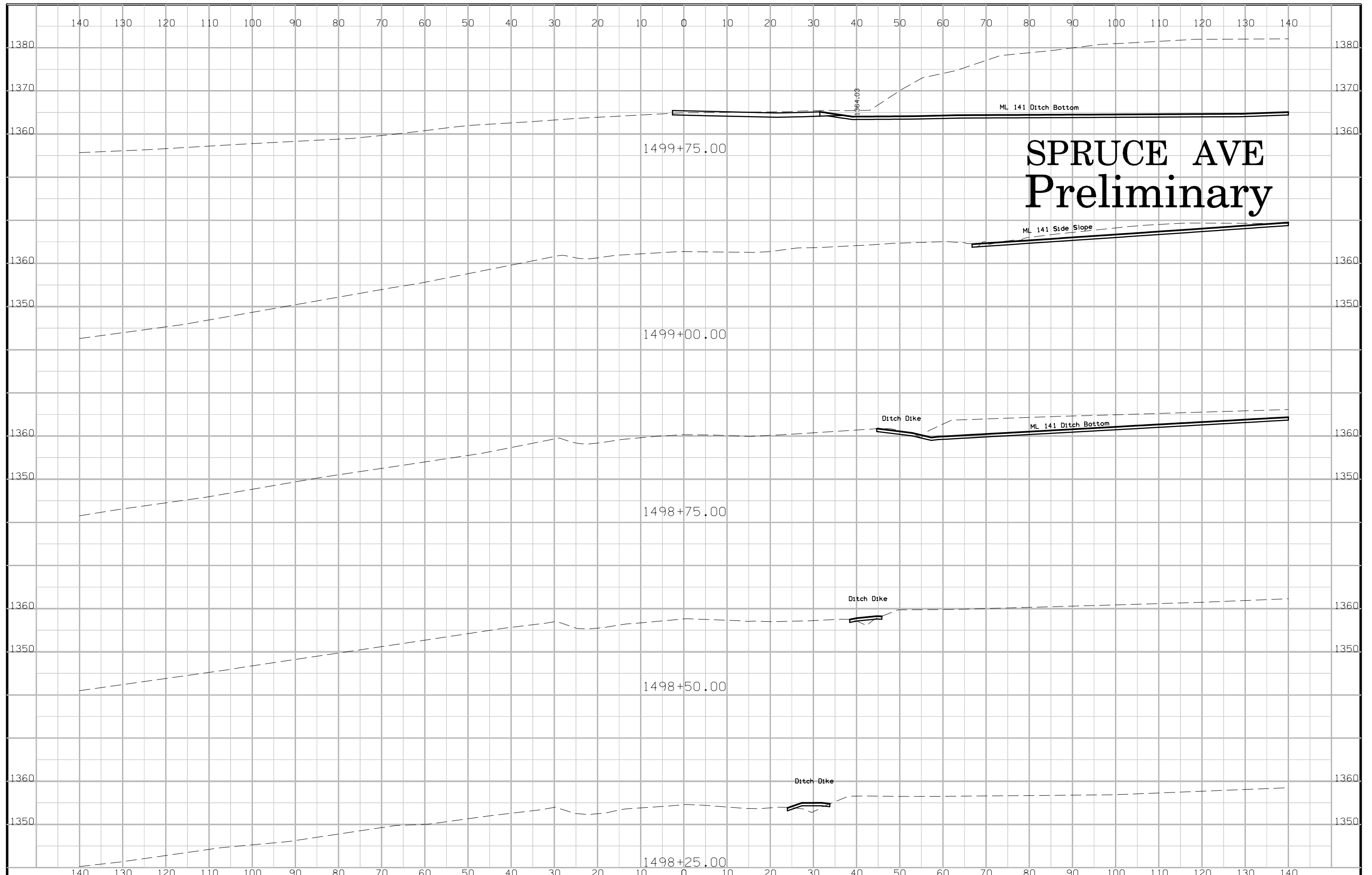

# SPRUCE AVE Preliminary

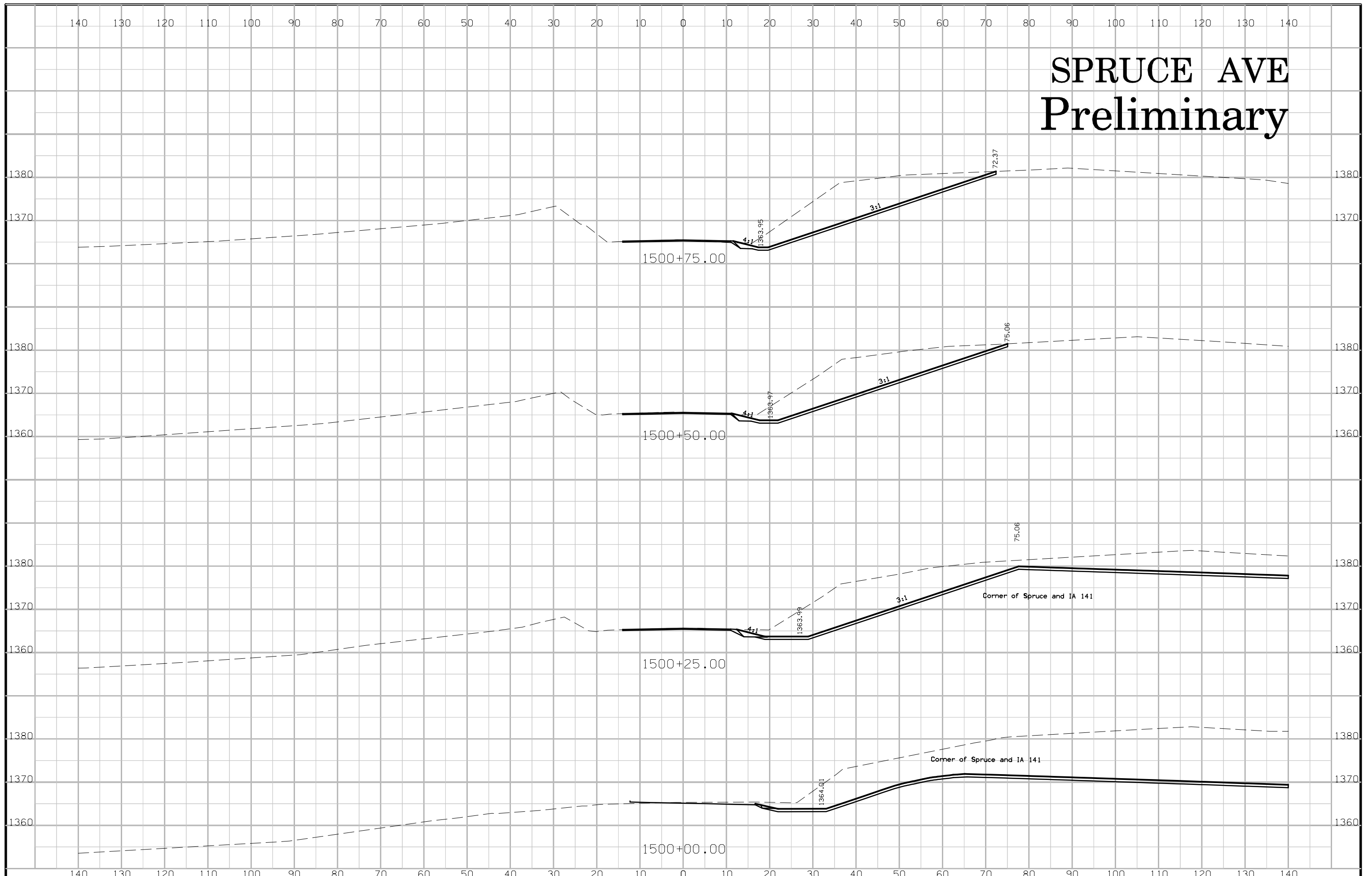

# SPRUCE AVE Preliminary

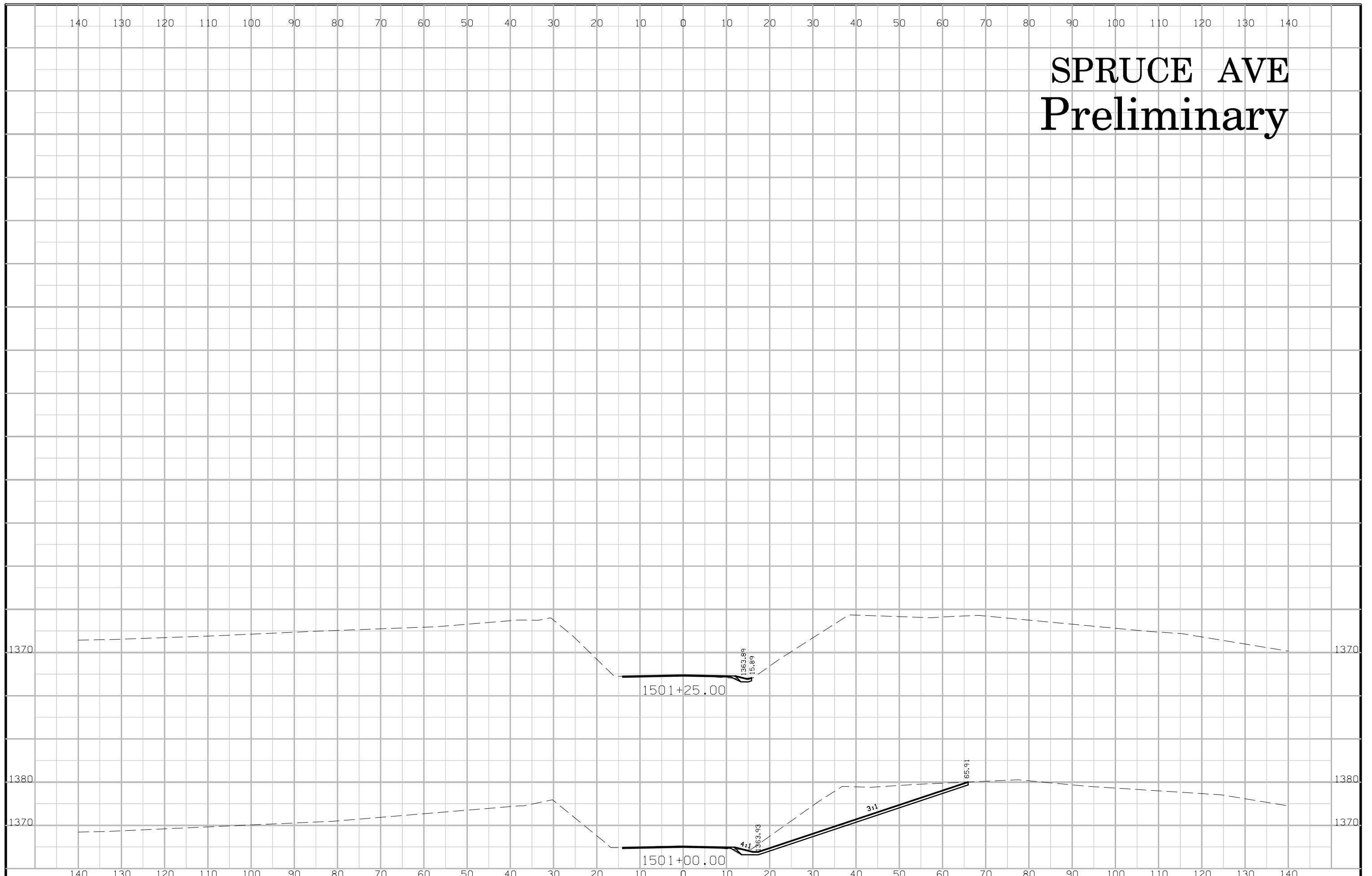



# SUMAC AVE Preliminary

