

LETTING DATE
02-16-2021

PIPE CULVERTS
STPN-202-1(5)--2J-26
DAVIS/APPANOOSE CO.



Highway Division

PLANS OF PROPOSED IMPROVEMENT ON THE

PRIMARY ROAD SYSTEM

DAVIS/APPANOOSE COUNTY
PIPE CULVERTS

Missouri State Line to IA 2

SCALES: As Noted

Refer to the Proposal Form for list of applicable specifications.

Value Engineering Saves. Refer to Article 1105.14 of the Specifications.

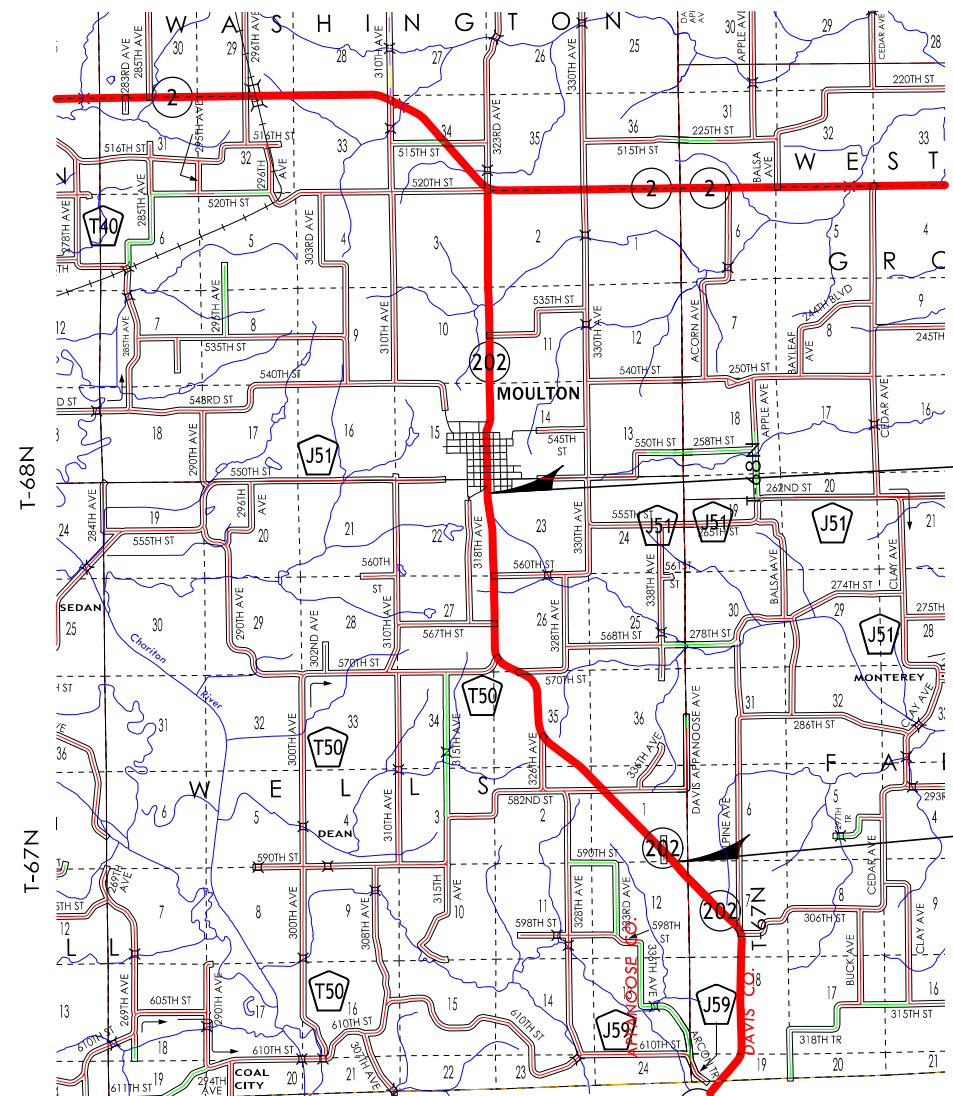

End Project
Sta. 384+83
Ref. Loc. 7.29

Begin Project
Sta. 137+60
Ref. Loc. 2.61

Project Event Dates:
DM5 10-27-2020
D09 12-01-2020

REVISIONS

TOTAL

53

PROJECT IDENTIFICATION NUMBER

20-26-202-010

PROJECT NUMBER

STPN-202-1(5)--2J-26

R.O.W. PROJECT NUMBER

STPN-202-1(6)--2J-26

INDEX OF SHEETS

No.	DESCRIPTION
A Sheets	Title Sheets
* A.1	Title Sheet and Location Map
* A.2 - 3	Strip Map
B Sheets	Typical Cross Sections and Details
B.1 - 3	Typical Cross Sections
C Sheets	Quantities and General Information
C.1	Project Description
C.1	Estimated Project Quantities
C.2	Estimate Reference Information
C.3	Standard Road Plans
C.3	Index of Tabulations
C.3	General Notes
C.4 - 6	Tabulations
CD Sheets	Drainage Tabulations
CD.1	Drainage Tabulations
D Sheets	Mainline Plan and Profile Sheets
* D.1	Plan & Profile Legend & Symbol Information Sheet
* D.2 - 13	IA 202 Plan & Profile Sheet
E Sheets	Side Road Plan and Profile Sheets
* E.1	326th Ave Plan & Profile Sheet
* E.2	560th St Plan & Profile Sheet
G Sheets	Survey Sheets
G.1	Reference Ties, Bench Marks, and Alignments
G.2	Control Point Vicinity Map
G.3	Horizontal and Vertical Project Control Coord Listing
G.4	Horizontal Control Tab. for All Alignments
J Sheets	Traffic Control and Staging Sheets
J.1	Traffic Control Plan & 511 Travel Restrictions
J.1	Coordinated Operations
* J.2	Detour Route
* J.3	Detour Signs
U Sheets	500 Series, Mod.Stds. and Detail Sheets
* U.1 - 2	Modified Detail Sheet & Standard Road Plan
W Sheets	Mainline Cross Sections
W.1 - 13	Mainline Cross Sections
X Sheets	Side Road Cross Sections
X.1 - 2	Side Road Cross Sections
	* Color Plan Sheets

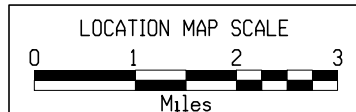
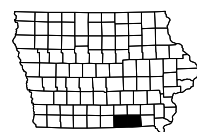

DESIGN DATA RURAL

2018 AADT	890	V.P.D.
20 -- AADT	--	V.P.D.
20 -- DHV	--	V.P.H.
TRUCKS	11.7	%
Total Design ESALs	--	

INDEX OF SEALS

SHEET NO.	NAME	TYPE
A.1	JONATHAN W. BAHR	Primary Signature Block
X	X	X

PRELIMINARY PLANS

Subject to change by final design.

In-Progress Plan
Date: 9-9-2020

FILE NO.

ENGLISH

DESIGN TEAM Holst \ Bahr \ Jackson

DAVIS/APPANOOSE COUNTY

PROJECT NUMBER

STPN-202-1(5)--2J-26

SHEET NUMBER

A.1

6:45:21 PM 9/9/2020 jbah1

pw:\nt\p\int1.dot.int.lan:P\Main\Documents\Projects\2620201020\Design\CADD.Files\Sheet.Files\SHT_26202005_A01.dgn



BEGIN PROJECT
 STA 137+60
 MP 2.61

STA 156+49
 MP 2.97

STA 163+27
 MP 3.10



582nd St

STA 198+44
 MP 3.76

STA 238+25, 74' LT
 MP 4.54

This Sheet
 For Information Only
 Do Not Scale

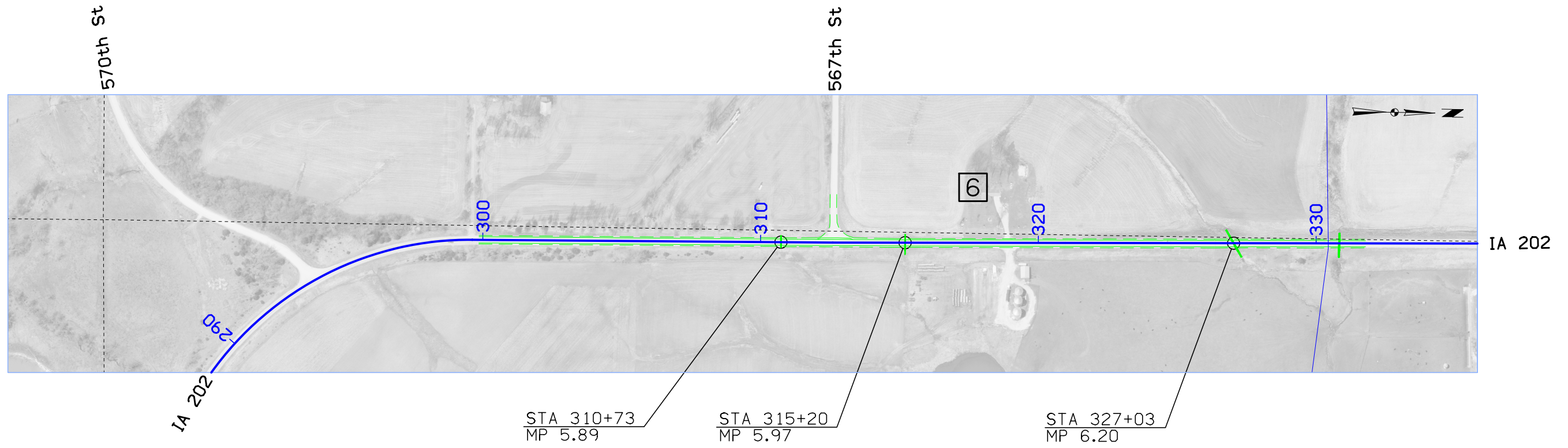

This Sheet
For Information Only
Do Not Scale

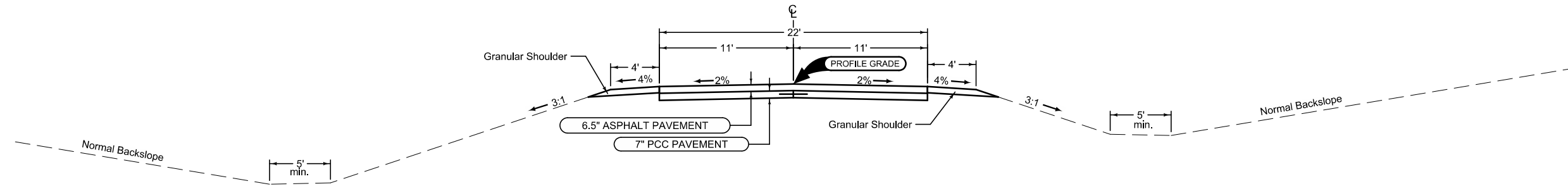

Notes:
 1) Dimensions and slopes are approximate.

**IA 202 EXISTING TYPICAL SECTION
 (For Information Only)**

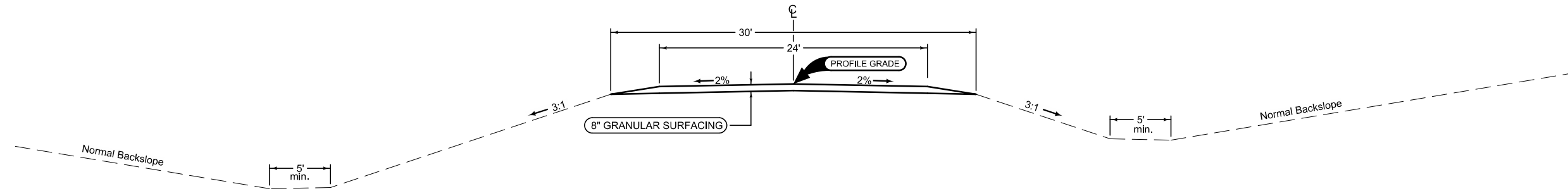

Notes:
 1) Dimensions and slopes are approximate.

**SIDE ROAD EXISTING TYPICAL SECTION
 (For Information Only)**

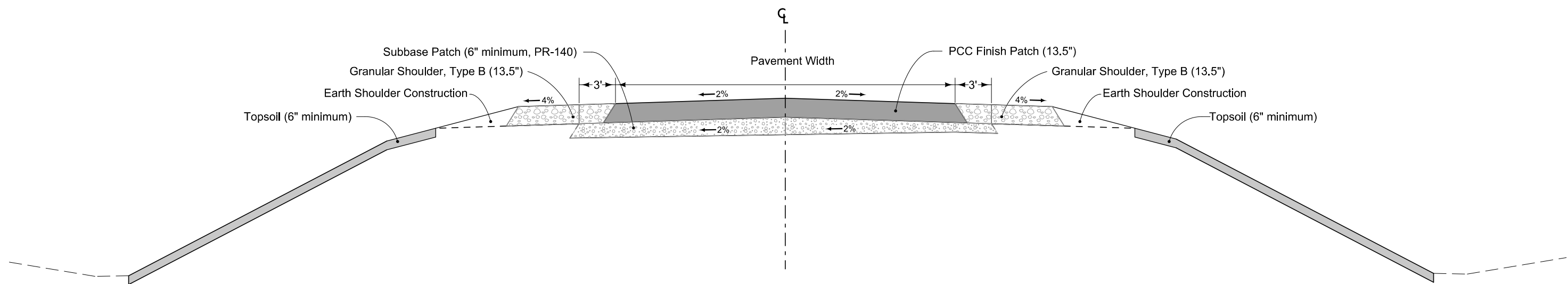

- Notes:
- 1) Refer to PR-140 for additional information.
 - 2) Slope of pavement and shoulder shall match existing at limits of patch.
 - 3) UAC existing ditches unless otherwise noted on D-Sheets.

**TYPICAL SECTION - PIPE CULVERT INSTALLATION
(IA 202, MULTIPLE LOCATIONS)**

FILE NO.	ENGLISH	DESIGN TEAM Holst \ Bahr \ Jackson	DAVIS/APPANOOSE COUNTY	PROJECT NUMBER STPN-202-1(5)--2J-26	SHEET NUMBER B.3
----------	---------	---	-------------------------------	--	-------------------------

100-1D
10-18-05

PROJECT DESCRIPTION

This project involves the Slip-Lining and Replacement of Culverts along IA 202. Patching and Erosion Control work are also included with this project. Patching is for the replacement of pavement that is removed for the culvert replacement operations.

100-1A
07-15-97

**ESTIMATED PROJECT QUANTITIES
(1 DIVISION PROJECT)**

Item No.	Item Code	Item	Unit	Total	As Built Qty.
1	2101-0850001	CLEARING AND GRUBBING	ACRE	0.5	
2	2102-2625000	EMBANKMENT-IN-PLACE	CY	175.6	
3	2105-8425015	TOPSOIL, STRIP, SALVAGE AND SPREAD	CY	166.0	
4	2121-7425020	GRANULAR SHOULDERS, TYPE B	TON	62.4	
5	2123-7450000	SHOULDER CONSTRUCTION, EARTH	STA	2.20	
6	2312-8260051	GRANULAR SURFACING ON ROAD, CLASS A CRUSHED STONE	TON	45.5	
7	2401-6745650	REMOVAL OF EXISTING STRUCTURES	LS	1.00	
8	2402-0425040	FLOODED BACKFILL	CY	330.2	
9	2402-2720100	EXCAVATION, CLASS 20, FOR ROADWAY PIPE CULVERT	CY	618.0	
10	2416-0100024	APRONS, CONCRETE, 24 IN. DIA.	EACH	8	
11	2416-0100030	APRONS, CONCRETE, 30 IN. DIA.	EACH	2	
12	2416-1180024	CULVERT, CONCRETE ROADWAY PIPE, 24 IN. DIA.	LF	219	
13	2416-1180030	CULVERT, CONCRETE ROADWAY PIPE, 30 IN. DIA.	LF	72	
14	2422-0360018	APRONS, UNCLASSIFIED, 18 IN. DIA.	EACH	14	
15	2422-0360030	APRONS, UNCLASSIFIED, 30 IN. DIA.	EACH	2	
16	2422-0360036	APRONS, UNCLASSIFIED, 36 IN. DIA.	EACH	2	
17	2422-1723018	CULVERT, UNCLASSIFIED ROADWAY PIPE, 18 IN. DIA.	LF	468	
18	2422-1723030	CULVERT, UNCLASSIFIED ROADWAY PIPE, 30 IN. DIA.	LF	87	
19	2422-1723036	CULVERT, UNCLASSIFIED ROADWAY PIPE, 36 IN. DIA.	LF	112	
20	2499-4000036	SLIPLINING EXISTING CULVERTS, LESS THAN OR EQUAL TO 36 IN. D IA. OR HEIGHT	LF	667.0	
21	2507-3250005	ENGINEERING FABRIC	SY	111.3	
22	2507-6800061	REVTMENT, CLASS E	TON	60.2	
23	2510-6745850	REMOVAL OF PAVEMENT	SY	180.9	
24	2518-6910000	SAFETY CLOSURE	EACH	12	
25	2526-8285000	CONSTRUCTION SURVEY	LS	1.00	
26	2527-9263109	PAINTED PAVEMENT MARKING, WATERBORNE OR SOLVENT-BASED	STA	2.31	
27	2528-8445110	TRAFFIC CONTROL	LS	1.00	
28	2528-8445113	FLAGGERS	EACH	See Proposal	
29	2528-9290050	PORTABLE DYNAMIC MESSAGE SIGN (PDMS)	CDAY	See Proposal	
30	2529-2242304	CD JOINT ASSEMBLY	EACH	6	
31	2529-5070110	PATCHES, FULL-DEPTH FINISH, BY AREA	SY	180.9	
32	2529-5070120	PATCHES, FULL-DEPTH FINISH, BY COUNT	EACH	6	
33	2529-8174010	SUBBASE (PATCHES)	SY	230.2	
34	2529-8174050	PATCH SUBDRAIN	EACH	3	
35	2533-4980005	MOBILIZATION	LS	1.00	
36	2602-0000320	PERIMETER AND SLOPE SEDIMENT CONTROL DEVICE, 20 IN. DIA.	LF	850.0	
37	2602-0000350	REMOVAL OF PERIMETER AND SLOPE SEDIMENT CONTROL DEVICE	LF	850.0	

ESTIMATE REFERENCE INFORMATION

Item No.	Item Code	Description
1	2101-0850001	CLEARING AND GRUBBING Refer to Tab. 110-17 on C Sheets.
2	2102-2625000	EMBANKMENT-IN-PLACE Refer to B Sheets and W Sheets for Details and Sections.
3	2105-8425015	TOPSOIL, STRIP, SALVAGE AND SPREAD Strip 8" of existing topsoil and spread to a minimum thickness of 6". Excess topsoil shall be spread uniformly over disturbed areas.
4	2121-7425020	GRANULAR SHOULDERS, TYPE B
5	2123-7450000	SHOULDER CONSTRUCTION, EARTH Refer to Tab. 112-9 on C Sheets. Refer to B sheets for Typical Sections and Details.
6	2312-8260051	GRANULAR SURFACING ON ROAD, CLASS A CRUSHED STONE Unit weight of Granular Surfacing is 140 lbs/cf. Includes 18.2 tons for culvert replacement at 326th Avenue. Includes 27.3 tons for culvert replacement at 560th Street.
7	2401-6745650	REMOVAL OF EXISTING STRUCTURES Item is for the removal of the existing culverts located at Stations: 198+42 (MP 3.76), 239+31 128' LT (MP 4.54, 326th Avenue), 310+73 (MP 5.89), 338+86.3 46' RT (MP 6.42, 560th Street), and 356+44 (MP 6.75). Refer to Tab. 104-3 on CD sheet for more information.
8	2402-0425040	FLOODED BACKFILL
9	2402-2720100	EXCAVATION, CLASS 20, FOR ROADWAY PIPE CULVERT
10	2416-0100024	APRONS, CONCRETE, 24 IN. DIA.
11	2416-0100030	APRONS, CONCRETE, 30 IN. DIA.
12	2416-1180024	CULVERT, CONCRETE ROADWAY PIPE, 24 IN. DIA.
13	2416-1180030	CULVERT, CONCRETE ROADWAY PIPE, 30 IN. DIA.
14	2422-0360018	APRONS, UNCLASSIFIED, 18 IN. DIA.
15	2422-0360030	APRONS, UNCLASSIFIED, 30 IN. DIA.
16	2422-0360036	APRONS, UNCLASSIFIED, 36 IN. DIA.
17	2422-1723018	CULVERT, UNCLASSIFIED ROADWAY PIPE, 18 IN. DIA.
18	2422-1723030	CULVERT, UNCLASSIFIED ROADWAY PIPE, 30 IN. DIA.
19	2422-1723036	CULVERT, UNCLASSIFIED ROADWAY PIPE, 36 IN. DIA.
20	2499-4000036	SLIPLINING EXISTING CULVERTS, LESS THAN OR EQUAL TO 36 IN. D IA. OR HEIGHT Refer to Tab. 104-3 on CD sheets.
21	2507-3250005	ENGINEERING FABRIC
22	2507-6800061	REVTMENT, CLASS E Refer to Tab. 100-23 on C sheets.
	2507-6800061	REVTMENT, CLASS E Granular Material Density of Class "E" Revetment is 105 lbs/cf.
23	2510-6745850	REMOVAL OF PAVEMENT Item is for the Removal of Pavement at culvert replacement locations. Refer to Tab. 102-6C on C Sheets for locations.
24	2518-6910000	SAFETY CLOSURE Refer to Tab. 108-13A on C Sheets.
25	2526-8285000	CONSTRUCTION SURVEY All monuments that are within the paved surface of the roadway (centerline, section corners, property corners) will be referenced before construction, and reestablished after construction, by the District Land Surveyor. The Contractor will be responsible for referencing and reestablishing all other monuments - including but not limited to right of way, section corners, property corners, benchmarks, etc. - that are outside of the paved highway surface. Any centerline points (PC, PI, PT, POT etc.) and their references that were found by the District Land Surveyor, may be made available to the Contractor, per their request. Roadway geometric alignments will not be provided. All other survey necessary for construction of the project, as provided by Section 2526 Construction Survey will be required by the Contractor.
26	2527-9263109	PAINTED PAVEMENT MARKING, WATERBORNE OR SOLVENT-BASED Refer to Tab. 108-22 on C Sheets.
27	2528-8445110	TRAFFIC CONTROL
28	2528-8445113	FLAGGERS
29	2528-9290050	PORTABLE DYNAMIC MESSAGE SIGN (PDMS) Refer to sheets J.2 and J.3.

ESTIMATE REFERENCE INFORMATION

Item No.	Item Code	Description
30	2529-2242304	CD JOINT ASSEMBLY
31	2529-5070110	PATCHES, FULL-DEPTH FINISH, BY AREA
32	2529-5070120	PATCHES, FULL-DEPTH FINISH, BY COUNT
33	2529-8174010	SUBBASE (PATCHES)
34	2529-8174050	PATCH SUBDRAIN Refer to Tab. 102-6C on C Sheets.
35	2533-4980005	MOBILIZATION
36	2602-0000320	PERIMETER AND SLOPE SEDIMENT CONTROL DEVICE, 20 IN. DIA.
37	2602-0000350	REMOVAL OF PERIMETER AND SLOPE SEDIMENT CONTROL DEVICE Refer to Tab. 100-19 on C Sheets and Detail 570-12 (Modified) on U Sheets.

111-25 10-18-11		
INDEX OF TABULATIONS		
Tabulation	Tabulation Title	Sheet No.
C Sheets		
100-1A	ESTIMATED PROJECT QUANTITIES (1 DIVISION PROJECT)	C.1
100-1D	PROJECT DESCRIPTION	C.1
100-4A	ESTIMATE REFERENCE INFORMATION	C.2 - C.2
100-19	PERIMETER AND SLOPE SEDIMENT CONTROL DEVICE	C.4
100-23	ROCK EROSION CONTROL	C.4
102-5	EXISTING PAVEMENT	C.4
102-6C	FULL-DEPTH PATCHES	C.5
105-4	STANDARD ROAD PLANS	C.3
108-13A	SAFETY CLOSURES	C.6
108-22	PAVEMENT MARKING LINE TYPES	C.6
110-17	CLEARING AND GRUBBING	C.4
111-25	INDEX OF TABULATIONS	C.3
112-9	SHOULDERS	C.5

105-4 10-18-11		
STANDARD ROAD PLANS		
The following Standard Road Plans apply to construction work on this project.		
Number	Date	Title
DR-102	04-21-15	Pipe Culvert (Cover and Camber)
DR-103	04-21-15	Pipe Culvert (Installation Details)
DR-104	04-19-16	Depth of Cover Tables for Concrete and Corrugated Pipe
DR-121	10-17-17	Connected Pipe Joints
DR-201	04-21-20	Concrete Aprons
DR-601	04-18-17	Reinforced Concrete Pipe Culvert
DR-651	04-18-17	Unclassified Pipe Culvert
EC-201	10-15-19	Silt Fence
EC-204	04-21-20	Perimeter and Slope Sediment Control Devices
EC-301	10-18-16	Rock Erosion Control (REC)
EW-401	10-20-15	Temporary Stream Crossing, Causeway, or Equipment Pad
PM-110	04-21-20	Line Types
PM-420	10-15-19	Two-Lane Roadway with no Turn Lanes (One-Way Stop Condition)
PR-103	04-21-20	Full Depth PCC Patch with Dowels
PR-140	04-21-15	Subbase Patches
PV-101	04-21-20	Joints
TC-1	10-15-19	Work Not Affecting Traffic (Two-Lane or Multi-Lane)
TC-202	04-21-15	Work Within 15 ft of Traveled Way
TC-213	10-15-19	Lane Closure with Flaggers
TC-252	04-21-20	Routes Closed to Traffic

262-6 10-18-05
UTILITIES (NOT A POINT 25 PROJECT)
This is NOT a POINT 25 project and is not subject to the provisions of IAC 761-115.25.

232-3A MODIFIED
EROSION CONTROL (RURAL SEEDING)
Following the completion of work in a disturbed area and according to the seeding dates in Section 2601 of the Standard Specifications, place seed, fertilizer, and mulch on the disturbed area adjacent to the shoulder:
Place seed and fertilizer according to the requirements of Article 2601.03,C,3 and Section 4169 of the Standard Specifications.
Place mulch according to the requirements of Articles 2601.03,E,2,a and 4169.07,A of the Standard Specifications.
Preparing the seedbed, furnishing and applying seed, fertilizer, and mulch are all incidental to mobilization and will not be paid for separately.

281-1 10-18-16
SECTION 404 PERMIT AND CONDITIONS
Construct this project according to the requirements of U.S. Army Corps of Engineers Nationwide, Permit No. 3. A copy of this permit is available from the Iowa DOT website (http://www.envpermits.iowadot.gov/). The U.S. Army Corps of Engineers reserves the right to visit the site without prior notice.

282-3 04-17-18
TEMPORARY STREAM CROSSING, CAUSEWAY, OR EQUIPMENT PAD
Standard Road Plan EW-401 is listed in Tabulation 105-4; however, it is included for information purposes only since it is an option. No quantities associated with constructing EW-401 are included in any bid items.

232-10 04-18-17
EMERALD ASH BORER
Any living, dead, cut or fallen material of the ash (<i>Fraxinus spp.</i>) including trees, nursery stock, logs, firewood, stumps, roots, branches, and composted or uncomposted ash chips can be freely moved within the yellow areas of the most recent Federal EAB Quarantine & Authorized Transit.
https://www.aphis.usda.gov/plant_health/plant_pest_info/emerald_ash_b/downloads/eab_quarantine_map.pdf .
Obtain appropriate Compliance Agreements from USDA APHIS PPQ prior to moving any of the above listed ash articles to areas outside the yellow zone on the map.
For questions, concerns, and general assistance, contact:
USDA APHIS PPQ, Iowa office, 515-414-3295
Or
Iowa Department of Agriculture & Land Stewardship 515-725-1470 Entomology@IowaAgriculture.gov

EXISTING PAVEMENT

No.	Location					Year	Type	Project Number	Surface		Base		Subbase		Removal		Coarse Aggregate			Reinforcement	Remarks	
	County	Route	Dir. of Travel	Begin Ref. Loc. Sign	End Ref. Loc. Sign				Type	Depth	Type	Depth	Type	Depth	Type	Depth	Source	Type	Durability Class			Type
1	4	IA 202	NB/SB	2.4	7.16	2010 2005 1979 1959		STP-202-1(2)--2C-26 MP-202-5(701)0--76-26 FN-202-1(1)--21-26 FN-644	HMA AAC BAC PCC	1.5 1.5 2 7	HMA AAC	1.5 1.5	HMA	0.5				Brown Lemley Douds Mine	C. LST. C. LST. C. LST.			

CLEARING AND GRUBBING

Location Station to Station or Ref. Loc. Sign to Ref. Loc. Sign or Description	Direction of Travel	Work and Material Type	Trees, Stumps, and Logs and Down Timber Material Diameters													All Other Materials		Estimated Quantities			Remarks		
			3"-6"	>6"-9"	>9"-12"	>12"-15"	>15"-18"	>18"-24"	>24"-30"	>30"-36"	>36"-42"	>42"-48"	>48"-60"	>60"-72"	>72"	Length	Width	Units	Area	Herbicide Application			
			FT	FT	Units	Acres	Each	FT	FT	Units	Acres	Each											
137+34 to 137+84 (MP 2.61)	NB	Trees - Clearing and Grubbing																50.0	15.0		0.14		
362+85 to 363+10 (MP 6.88)	NB	Trees - Clearing and Grubbing																25.0	18.0		0.09		
371+83 to 372+33 (MP 7.05)	NB	Trees - Clearing and Grubbing																50.0	25.0		0.24		
TOTAL																					0.46		

PERIMETER AND SLOPE SEDIMENT CONTROL DEVICE

Possible Standards: EC-204

Location		Side	Length of Installation			Remarks
Begin Station	End Station		9 inch Dia	12 inch Dia	20 inch Dia	
			LF	LF	LF	
198+27.00	198+57.00	RT			70.0	Inlet (Culvert at IA 202 198+42)
198+27.00	198+57.00	LT			100.0	Outlet (Culvert at IA 202 198+42)
2237+77.50	2238+07.50	RT			70.0	Inlet (Culvert 326th Ave. 2237+92.5, IA 202 239+31, 128' LT)
2237+77.50	2238+07.50	LT			100.0	Outlet (Culvert 326th Ave. 2237+92.5, IA 202 239+31, 128' LT)
310+58.00	310+88.00	LT			70.0	Inlet (Culvert at IA 202 310+73)
310+58.00	310+88.00	RT			100.0	Outlet (Culvert at IA 202 310+73)
6339+14.60	6339+44.60	LT			70.0	Inlet (Culvert 560th St. 6339+29.6, IA 202 338+86 46' RT)
6339+14.60	6339+44.60	RT			100.0	Outlet (Culvert 560th St. 6339+29.6, IA 202 338+86 46' RT)
356+29.00	356+59.00	LT			70.0	Inlet (Culvert at IA 202 356+44)
356+29.00	356+59.00	RT			100.0	Outlet (Culvert at IA 202 356+44)
TOTAL					850.0	

Notes:
Refer to Detail 570-12 (Modified) on U Sheets for configuration information.

ROCK EROSION CONTROL

Refer to EC-301 and Detail 570-8

Location		Side	Rock Erosion Control (REC)					Material Bid Quantities			Remarks			
Road Identification	Begin Station		End Station	(L)	(W)	Type 1	Type 2	Type 3	Type 4	Type 5		Eng. Fabric	Class E Revetment	Erosion Stone
				Lt./Rt.	FT	FT	Rock Ditch Check	Rock Ditch	Rock Flume	Rock Splash Basin		Rock Slope Protection	SY	TON
IA 202	198+42.00		LT	10.5	10.5						21.6	11.6		
IA 202	310+73.00		RT	10.5	10.5				X		21.6	11.6		
IA 202	356+44.00		RT	11.5	11.5				X		24.9	13.9		
326th Avenue	2237+92.50		LT	10.5	10.5				X		21.6	11.6		
560th Street	6339+29.60		RT	10.5	10.5				X		21.6	11.6		
TOTALS											111.3	60.2		

FULL-DEPTH PATCHES

Possible Standards: PR-101, PR-102, PR-103, PR-104, PR-105, and PR-140.

Count	Location			Dimension			PCC Patches				HMA Patches	Composite HMA	Subbase Patches	Subbase Patch w/ 'EF' Joint	Patch Subdrain	'CD' Joints	'CT' Joints	'EF' Joints	Anchor Lugs Removal	Remarks
	Station	Reference Location Sign	Lane	Length	Width	Patch Thickness	With Dowels	Without Dowels	C R C	Ramp with Dowels										
	L, R, or B	FT	FT	IN	PR-103 SY	PR-102 SY	PR-104 SY	PR-105 SY	PR-140 SY	PR-101 SY										
Full-Depth Finish Patches																				
1	198+42.00	MP 3.76	NB	22.0	11.0	13.5	26.9							34.2				1		
1	198+42.00	MP 3.76	SB	22.0	11.0	13.5	26.9							34.2		1				Place Patch Subdrain at north limit of patch.
1	310+73.00	MP 5.89	NB	16.0	11.0	13.5	19.6							24.9		1				Place Patch Subdrain at south limit of patch.
1	310+73.00	MP 5.89	SB	16.0	11.0	13.5	19.6							24.9						
1	356+44.00	MP 6.75	NB	36.0	11.0	13.5	44.0							56.0		1	2			Place Patch Subdrain at north limit of patch.
1	356+44.00	MP 6.75	SB	36.0	11.0	13.5	44.0							56.0			2			
6	TOTALS						180.9							230.2		3	6			

SHOULDERS

- ① Lane(s) to which the shoulder is adjacent.
- ② Bid Item
- ③ Applies only for Paved Shoulders constructed on project with existing granular shoulders.
- ④ Does not include shrink.

Calculations assume a HMA unit weight (lbs/cf) of 0, a Special Backfill unit weight (lbs/cf) of 140, and a Granular Shoulder unit weight (lbs/cf) of 140.

Road Identification	① Direction Of Traffic	Location		Side	P Width	G Width	L Length	Class 13 Excavation	Hot Mix Asphalt		Binder	Paved Shoulder	Reinforced Paved Shoulder	Special Backfill				Modified Subbase	Granular Shoulder		Earth Shoulder Construction Alternates			Remarks					
		Station to Station	Station to Station						TON	TON/STA				HMA Alternate		PCC Alternate			TON	TON/STA	TON	TON/STA	TON		TON/STA	STA	HMA	PCC	
		FT	FT						CY	TON				TON	TON/STA	TON	TON/STA		CY	TON	TON/STA	TON	TON/STA		TON	TON/STA	CY	CY	CY
		②	②						②	②				②	②	②	②		②	②	②	②	②		②	②	②	④	④
IA 202	NB	198+31.00	198+53.00	RT		4 to 5	22.0											7.800	35.455	0.2		1.4							
IA 202	SB	198+31.00	198+53.00	LT		4.0	22.0											7.000	31.818	0.2		1.4							
IA 202	NB	310+65.00	310+81.00	RT		4.5	16.0											5.700	35.625	0.2		1.0							
IA 202	SB	310+65.00	310+81.00	LT		4.6	16.0											5.800	36.250	0.2		1.0							
IA 202	NB	356+26.00	356+62.00	RT		4.6	36.0											13.100	36.389	0.4		2.3							
IA 202	SB	356+26.00	356+62.00	LT		5.0	36.0											14.200	39.444	0.4		2.3							
326th Avenue	NB	2237+82.50	2238+02.50	RT		3.0	20.0											2.300	11.500	0.2		0.7							
326th Avenue	SB	2237+82.50	2238+02.50	LT		3.0	20.0											2.300	11.500	0.2		0.7							
560th Street	EB	6339+20.60	6339+38.60	RT		3.0	18.0											2.100	11.667	0.2		0.7							
560th Street	WB	6339+20.60	6339+38.60	LT		3.0	18.0											2.100	11.667	0.2		0.7							
TOTALS																		62.400		2.2		12.4							

PAVEMENT MARKING LINE TYPES

See PM-110

***MNY4 - Factor of 1.00 as value includes number of 4-inch passes to cover median nose area.

*BCY4 - Place on the same side of the roadway to match existing markings near the project.

**NPY4 - For estimating purposes only. No Passing Zone Lines will be located in the field.

BCY4: Broken Centerline (Yellow) @ 0.25

DCY4: Double Centerline (Yellow) @ 2.00

NPY4: No Passing Zone Line (Yellow) @ 1.25

BLW4: Broken Lane Line (White) @ 0.25

ELW4: Edge Line Right (White) @ 1.00

ELY4: Edge Line Left (Yellow) @ 1.00

Road ID	Station to Station		Dir. of Travel	Location Marking Type	Side			Length by Line Type (Unfactored)												Remarks						
					L	C	R	BCY4*	DCY4	NPY4**	BLW4	ELW4	ELY4													
					STA	STA	STA	STA	STA	STA	STA	STA	STA	STA	STA	STA	STA	STA	STA		STA	STA	STA			
IA 202	198+31.00	198+53.00	BOTH	Waterborne/Solvent Paint		X		0.22																		
IA 202	198+31.00	198+53.00	NB	Waterborne/Solvent Paint			X						0.22													
IA 202	198+31.00	198+53.00	SB	Waterborne/Solvent Paint	X								0.22													
IA 202	310+65.00	310+81.00	BOTH	Waterborne/Solvent Paint		X		0.16																		
IA 202	310+65.00	310+81.00	NB	Waterborne/Solvent Paint			X						0.16													
IA 202	310+65.00	310+81.00	SB	Waterborne/Solvent Paint	X								0.16													
IA 202	356+26.00	356+62.00	SB	Waterborne/Solvent Paint		X		0.36																		
IA 202	356+26.00	356+62.00	NB	Waterborne/Solvent Paint			X						0.36													
IA 202	356+26.00	356+62.00	SB	Waterborne/Solvent Paint	X								0.36													
Factored Total: Waterborne/Solvent Paint								0.06	0.32	0.45	-	1.48	-	-	-	-	-	-	-	-	-	-	-	-	-	-
Bid Quantity: Painted Pavement Markings, Waterborne or Solvent-Based												2.31														

108-13A
08-01-08

SAFETY CLOSURES

Refer to Section 2518 of the Standard Specifications

Station	Closure Type		Remarks
	Road Qty.	Hazard Qty.	
197+42.00		1	
199+42.00		1	
309+73.00		1	
311+73.00		1	
355+40.00		1	
357+50.00		1	
2236+92.50		1	326th Avenue
2238+50		1	326th Avenue
6339+15.00		1	560th Street
6340+30.00		1	560th Street
See Remark	1		IA 202 @ 567th Street
See Remark	1		IA 202 @ E South Street (Moulton)
TOTALS	2	10	

DRAINAGE STRUCTURE BY ROAD CONTRACTOR

Length of unclassified pipe calculated is based on using Corrugated Metal Pipe.

- * Not a bid item
- ① Diameter or equivalent diameter
- ② UNCL = Unclassified Pipe CMP = Corrugated Metal Pipe RCP = Reinforced Concrete Pipe LCP = Arch or Elliptical Low Clearance Pipe SARC = Steel Arch Pipe
- ③ Backfill according to DR-101

Drainage Area ACRE	Location	Type	Size ① IN	Kind Of Pipe ②	Length New Const. LF	Bedding Class	Design Cover (H) FT	Camber* (DR-102) FT	Apron No.		Apron Guard* (DR-213) No.	Elbow* (DR-141) No.	Diaphragm* (DR-501) No.	Tee Section* (DR-142) No.	"D" Section* (DR-141) No.	Reducer* No.	Type 'C' Connections* (DR-122) Type No.	Connected Pipe Joint* (DR-121) Type	4" Perforated Subdrain* FT	Flow Line Elevations				Dimensions Lin. Ft.				Skew Ahead Degrees		Dike				Class 20 CY	Flowable Mortar CY	Floodable* Backfill CY (A)	Porous* Backfill CY (B)	Flooded Backfill CY (A+B)	Remarks						
									IN	OUT										Lt.	Rt.	Other	Other	Lt.	Rt.	Lt.	Rt.	Lt.	Rt.	Lt.	Rt.	Rt.	Location Station							Top Elevation	Type	CY	CY	CY	CY
									Total											Extensions		Total		Extensions		Total		Extensions		Total		Extensions								Total		Extensions		Total	
1 A/R	137+60.00	SLIP	24	UNCL	90				1	1										971.75	973.77																		(1)						
13 A/F	156+49.00	SLIP	24	UNCL	67				1	1										973.99	977.13																			(2)					
22 A/F	163+27.00	DR-601	30	RCP	52	B			1	1								Type 3		975.64	976.54																		(3)						
4 A/F	198+44.00	DR-601	24	RCP	54	B			1	1								Type 3		986.58	988.57																			(4)					
4 A/F	310+73.00	DR-601	24	RCP	38	B			1	1								Type 3		986.00	985.84																			(5)					
2 A/R	315+20.00	REMARK	24	UNCL	76				1	1										982.90	977.39	977.89																	(6)						
58 A/R	327+03.00	DR-601	54	RCP	110	B			1	1								Type 3		944.61	942.61				30														(7)						
28 A/R	356+42.00	DR-601	36	RCP	68	B			1	1								Type 3		971.03	968.00																		(8)						
13 A/R	363+10.00	DR-601	30	RCP	74	B			1	1								Type 3		970.75	969.44																		(9)						
55 A/R	372+08.00	SLIP	42	UNCL	90				1	1										962.91	956.40																		(10)						
18 A/R	378+03.00	DR-601	30	RCP	56	B			1	1								Type 3		969.71	966.23																		(11)						
5 A/R	384+83.00	SLIP	24	UNCL	52				1	1										982.04	980.26																		(12)						
33 A/R	2237+92.00	DR-601	42	RCP	36	B			1	1								Type 3		980.06	980.30																		(13)						
7 A/R	6339+30.00	DR-601	24	RCP	62	B			1	1								Type 3		962.23	961.76																		(14)						
TOTALS			18	UNCL	76					2																																			
			24	UNCL	285					8																																			
			42	UNCL	90					2																																			
			24	RCP	142					6																																			
			30	RCP	225					6																																			
			36	RCP	68					2																																			
			42	RCP	36					2																																			
			54	RCP	110					2																																			

- NOTES:**
- (1) REMOVE 6' RT AND 12' LT THEN SLIPLINE WITH 24" + 2 CMP APRONS
 - (2) REMOVE 6' RT AND 6' LT THEN SLIPLINE WITH 24" + 2 CMP APRONS
 - (3) REMOVE EXISTING 2'X2' WOOD BOX + RCP EXTENSIONS AND REPLACE WITH 30" RCP
 - (4) REMOVE EXIST 2'X2' WOOD BOX + RCP EXTENSIONS AND REPLACE WITH 24" RCP + APRONS
 - (5) REMOVE EXIST 2'X2' WOOD BOX + RCP EXTENSIONS AND REPLACE WITH 24" RCP + APRONS
 - (6) REMOVE 6' LT AND 12' RT THEN SLIPLINE WITH 60' OF 24". THEN ON RT (DOWNSTREAM) LAY 16' USING ONE 3 DEGREE ELBOW. SEE CROSS SECTION
 - (7) REMOVE EXISTING 4'X4' WOOD BOX + RCP EXTENSIONS AND REPLACE WITH 54" RCP + APRONS
 - (8) REMOVE EXIST 2.5' X 2.5' WOOD BOX PLUS RCP EXT. REPLACW WITH 36" RCP AT NEW STATION 356+58.09. DITCH INLET AND OUTLET TO DRAIN.
 - (9) REMOVE EXIST 2'X2' WOOD BOX, REPLACE WITH 30" RCP + APRONS
 - (10) SLIPLINE EXIST WOOD BOX AND RCP WITH 42" + APRONS. DITCH INLET AND OUTLET TO DRAIN
 - (11) REMOVE EXIST 2.5' X 2.0 WOOD BOX + RCP EXT AND REPLACE WITH 56' OF 30" RCP+ APRONS
 - (12) SLIPLINE WITH 24' + 2 CMP APRONS
 - (13) 326TH AVE. REMOVE EXISTING 2'X2' WOOD BOX + RCP EXTENSIONS AND REPLACE WITH 42" RCP + APRONS.
 - (14) 560TH ST. REMOVE EXISTING 2'X2' WOOD BOX + RCP EXT. INSTALL 62' OF 24" RCP + 2 APRONS. DITCH INLET AND OUTLET TO DRAIN.

HYDRAULIC DESIGN













I hereby certify that this engineering document was prepared by me or under my direct personal supervision and that I am a duly licensed Professional Engineer under the laws of the State of Iowa.

Signature _____ Date _____



Printed or Typed Name _____
My license renewal date is December 31, 20 ____

Pages or sheets covered by this seal: CD.1













SURVEY SYMBOLS

-  SIGN Sign
-  Deciduous Tree
-  Timber
-  Wire Fence
-  Telephone Pedestal
-  Power Pole
-  Existing Water Line
-  Existing Fiber Optics Telephone Line
-  Water Valve
-  Revetment (Rip Rap)
-  Existing Drainage
-  Existing Ditch Line







UTILITY LEGEND









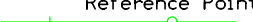

-  Tammy Wheeler
General Manager
Farmers Mutual Cooperatives Telephone Company
101 North Main Street
Moulton, IA 52572
(641) 642-3249 Cell: (641) 895-2510
twheeler@netins.net
-  Greg Proctor
CEO/Manager
Southern Iowa Electric Cooperative, Inc.
800 E Franklin Street
Bloomfield, IA 52537
(641) 864-2277
gproctor@sle.coop
-  Kelly Carol
West Distribution Superintendent
Rathbun Regional Water Association
16166 Hwy J-29
Centerville, IA 52544
(641) 647-2416 Cell: (641) 777-0925
kellycarel1962@gmail.com

PLAN VIEW COLOR LEGEND OF PLAN AND PROFILE SHEETS



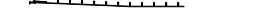
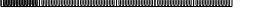



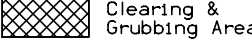

LINEWORK	Design Color No.	
Green	(2)	 Existing Topographic Features and Labels
Blue	(1)	 Proposed Alignment, Stationing, Tic Marks, and Alignment Annotation
Magenta	(5)	 Existing Utilities
SHADING	Design Color No.	
Yellow	(4)	 Highlight for Critical Notes or Features
Red	(3)	 Delineates Restricted Areas
Lavender	(9)	 Temporary Pavement Shading
Gray, Light	(48)	 Proposed Pavement Shading
Gray, Med	(80)	 Proposed Granular Shading
Gray, Dark	(112)	 Proposed Grade and Pave Shading "In conjunction with a paving project"
Brown, Light	(236)	 Grading Shading
Tan	(8)	 Proposed Sidewalk Shading
Blue, Light	(230)	 Proposed Sidewalk Landing Shading
Pink	(11)	 Proposed Sidewalk Ramp Shading

PROFILE VIEW COLOR LEGEND OF PLAN AND PROFILE SHEETS

LINEWORK	Design Color No.	
Green	(2)	 Existing Ground Line Profile
Blue	(1)	 Proposed Profile and Annotation
Magenta	(5)	 Existing Utilities
Blue, Light	(230)	 Proposed Ditch Grades, Left
Black	(0)	 Proposed Ditch Grades, Median
Rust	(14)	 Proposed Ditch Grades, Right

-  Reference Point
-  Station
-  Survey Line
-  Section Corner
-  Ground Line Intercept
-  Saw Cut
-  Guardrail
-  Trench Drain
-  HighTension Cable Guardrail
-  Sheet Pile
-  Pavement Removal
-  Clearing & Grubbing Area

RIGHT-OF-WAY LEGEND

-  Proposed Right-of-Way
-  Existing Right of Way
-  Existing and Proposed Right-of-Way
-  Easement and Existing Right-of-Way
-  Easement (Temporary)
-  Easement
-  Access Control
-  Property Line

PLAN AND PROFILE LEGEND AND SYMBOL INFORMATION SHEET

(COVERS SHEET SERIES D, E, F, & K)

WELLS TWP.
T67N R16W
SEC. 12

135

136

137

138

139

140

141

IA 202

Sta. 137+60
Skew 0.00
24" X 24" X 37.5' Wood Box Culvert
30" X 29' RCP Extension LT.
30" X 21' RCP Extension RT.
D.A. = 1 AC - R (From Plan)
(Partial Removal)

Slipline
With 90 LF 24" Dia. Culvert
Lt. 971.75
Rt. 973.77

Work Area

U.A.C. Culvert under
old Railroad bed

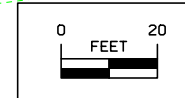

WELLS TWP.
T67N R16W
SEC. 1

STA 137+60
MP 2.61

986

986

984

984

982

982

980

980

978

978

976

976

974

974

972

972

970

970

Lt

Lt

Rt

Rt

U.A.C.
U.A.C.

135

136

137

138

139

140

141

FILE NO.

ENGLISH

DESIGN TEAM

Holst \ Bahr \ Jackson

DAVIS/APPANOOSE COUNTY

COUNTY

PROJECT NUMBER

STPN-202-1(5)--2J-26

SHEET NUMBER

D.2

WELLS TWP.
T67N R16W
SEC. 1

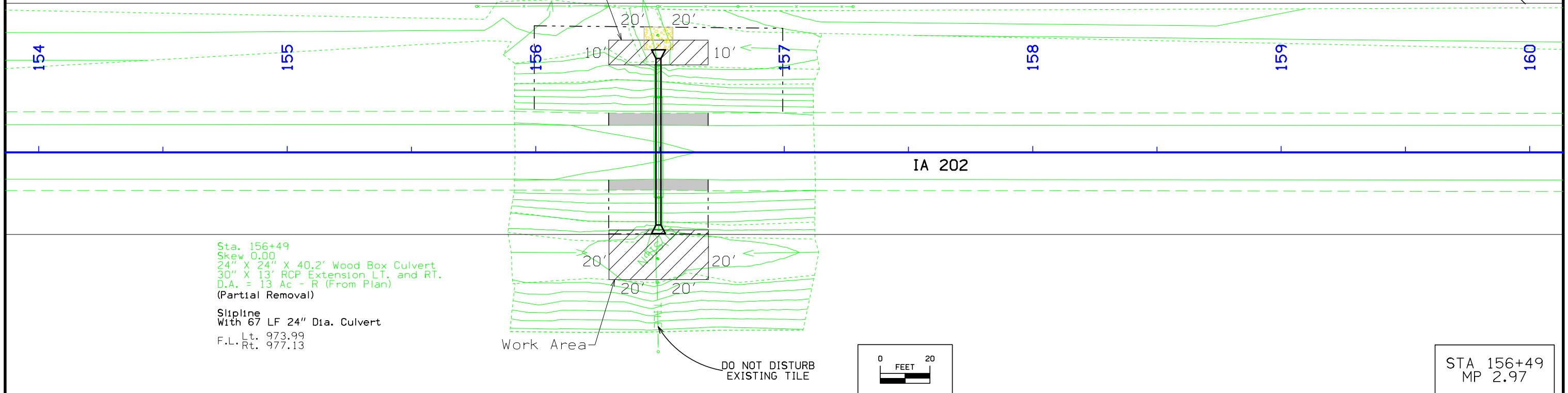
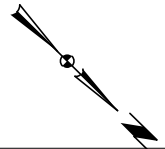

Sta. 156+49
 Skew 0.00
 24" x 24" x 40.2' Wood Box Culvert
 30" x 13' RCP Extension LT. and RT.
 D.A. = 13 Ac - R (From Plan)
 (Partial Removal)
 Slipline
 With 67 LF 24" Dia. Culvert
 Lt. 973.99
 Rt. 977.13

STA 156+49
 MP 2.97

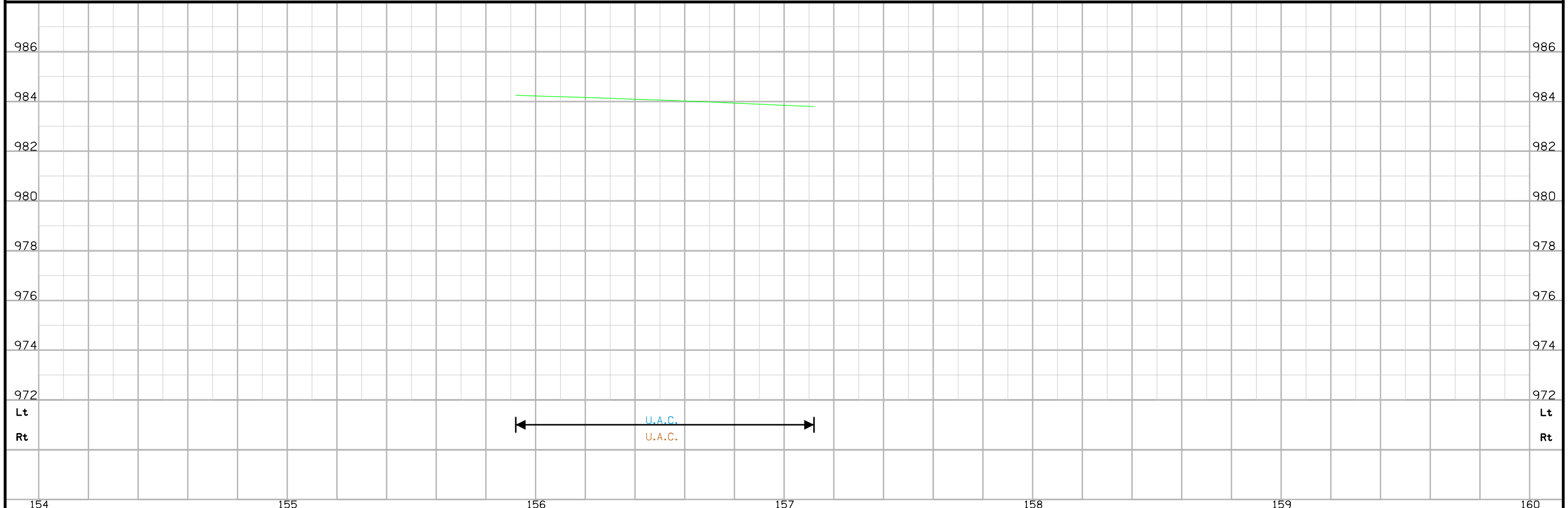

WELLS TWP.
T67N R16W
SEC. 1

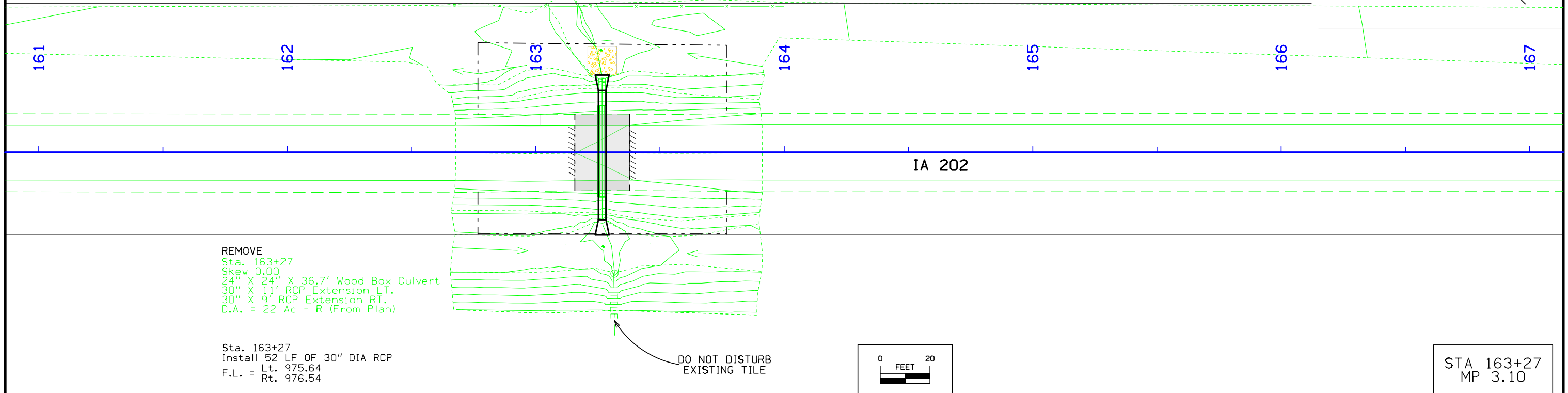
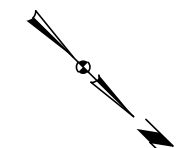

REMOVE
 Sta. 163+27
 Skew 0.00
 24" X 24" X 36.7' Wood Box Culvert
 30" X 11' RCP Extension LT.
 30" X 9' RCP Extension RT.
 D.A. = 22 Ac - R (From Plan)

Sta. 163+27
 Install 52 LF OF 30" DIA RCP
 Lt. 975.64
 Rt. 976.54

DO NOT DISTURB
 EXISTING TILE

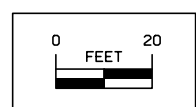

STA 163+27
 MP 3.10

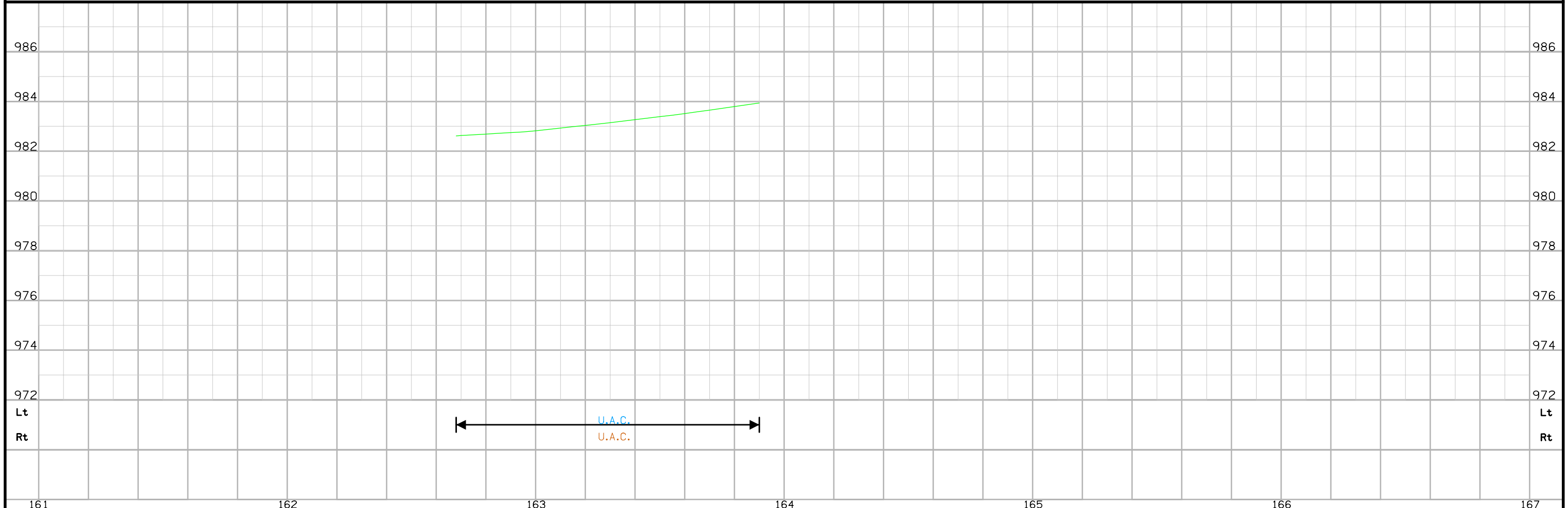

WELLS TWP.
T67N R16W
SEC. 1

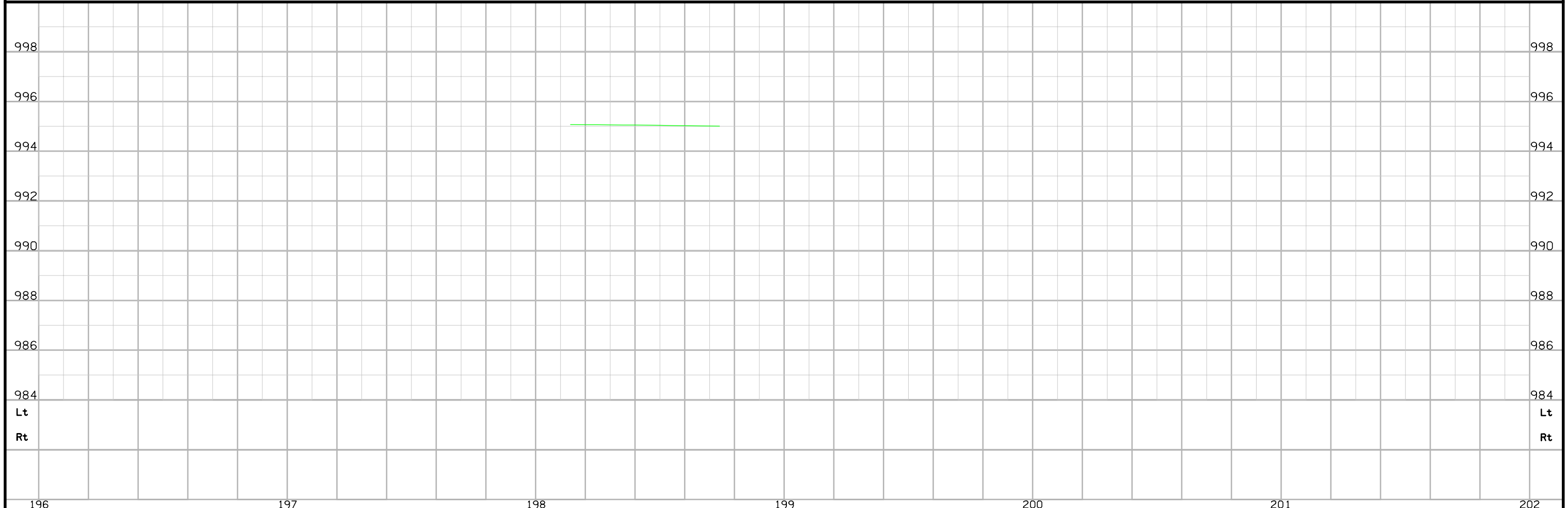
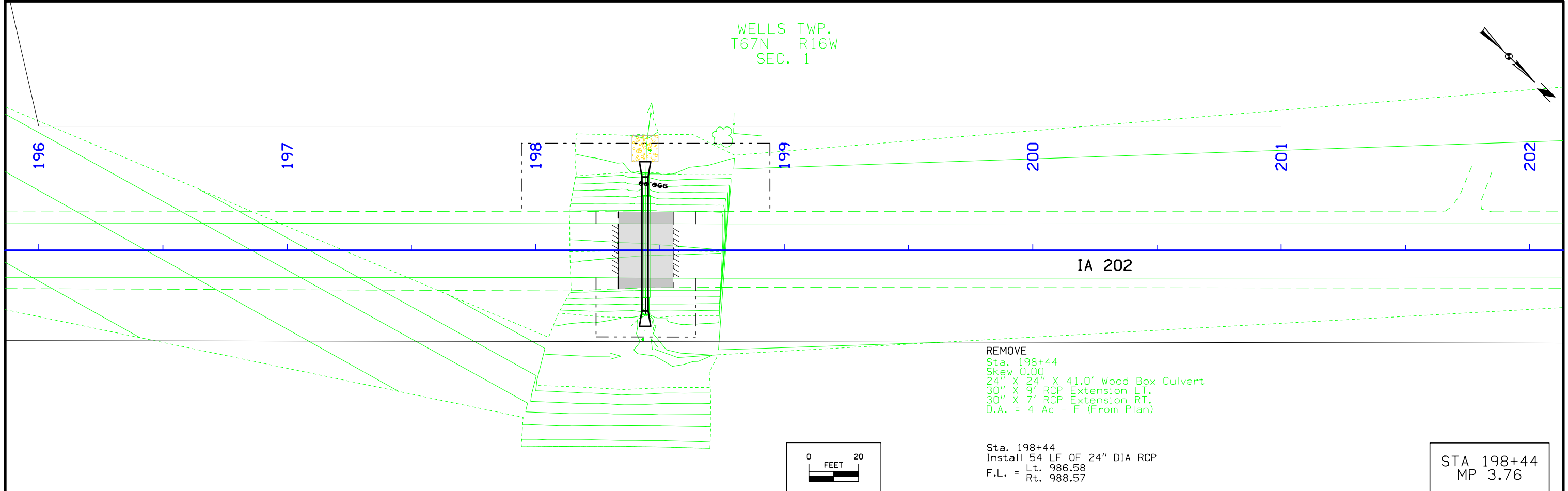
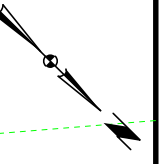

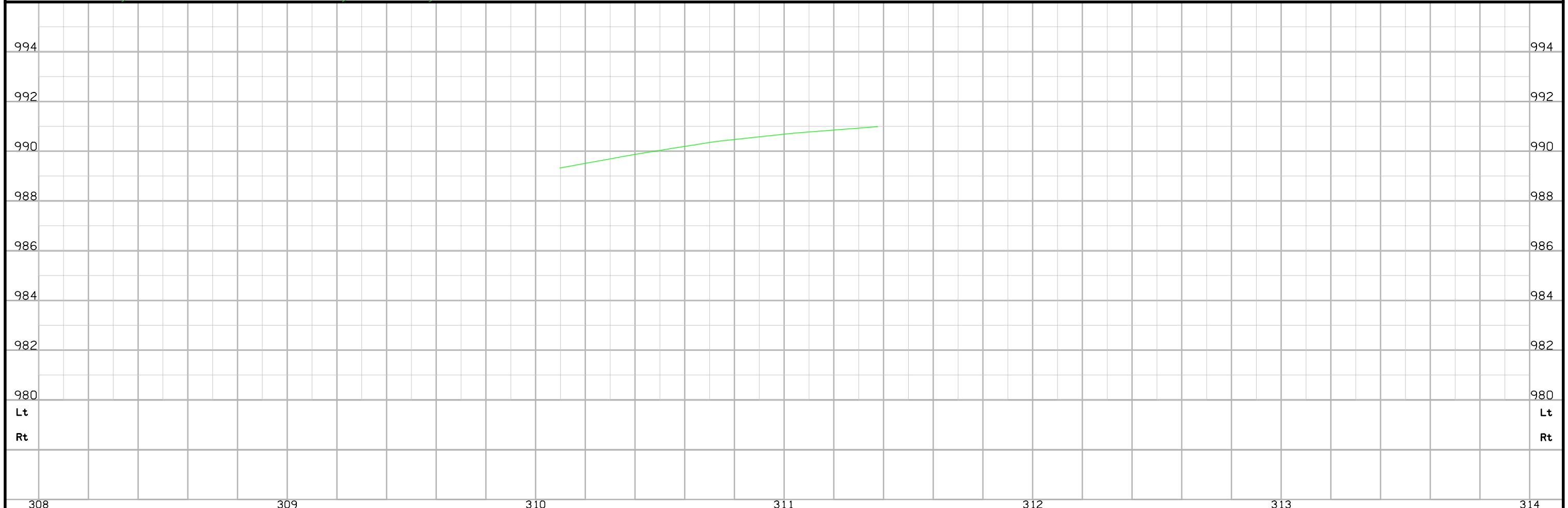
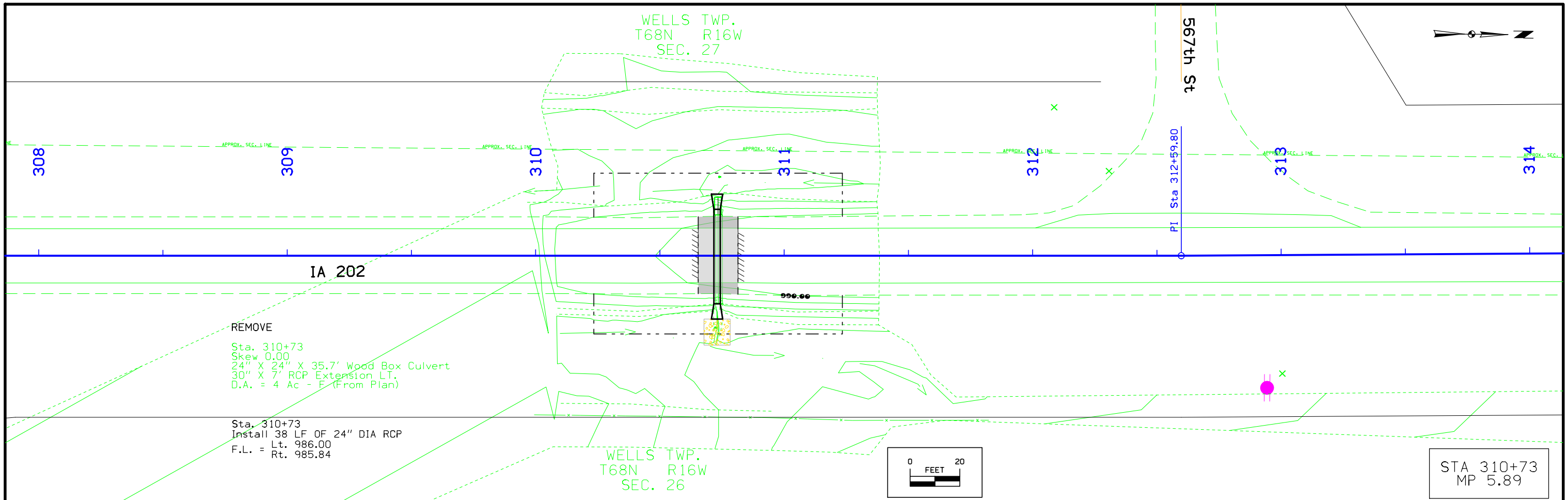

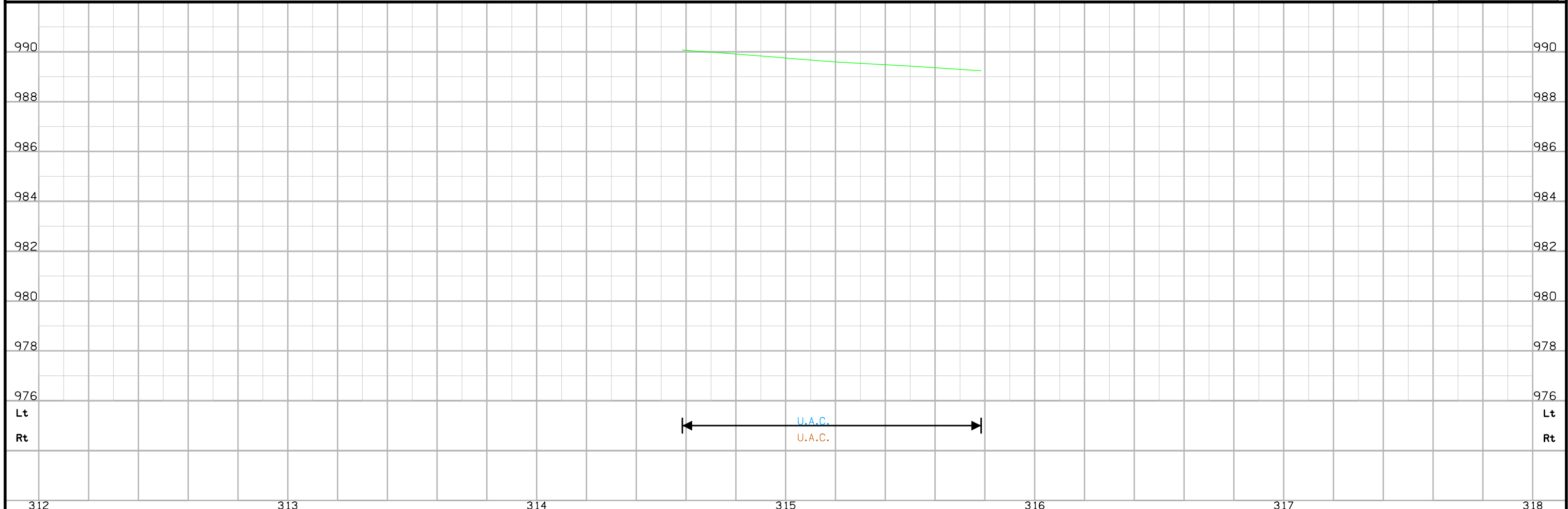
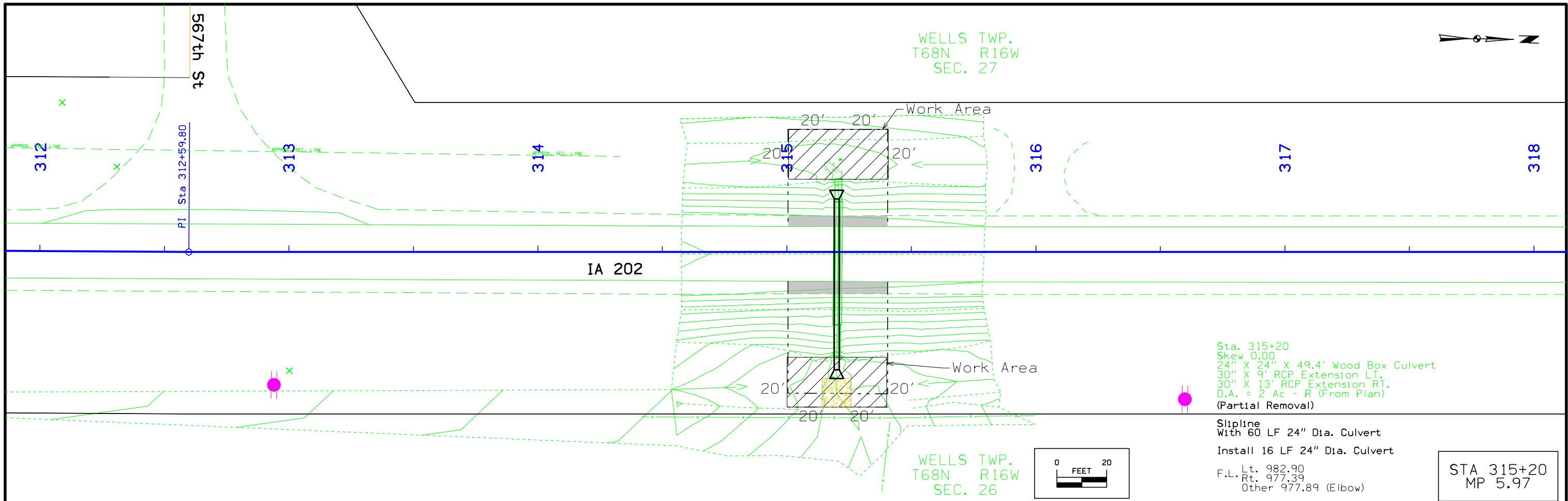

Refer to sheet D.08B
For West side.

REMOVE
Sta. 327+03
Skew 30.00
48" X 48" X 63.5' Wood Box Culvert
54" X 24' RCP Extension LT.
54" X 24' RCP Extension RT.
D.A. = 58 Ac - H (Per Plan FN 644)

Sta. 327+03
Install 110 LF OF 54" DIA RCP
F.L. = Lt. 944.61
Rt. 942.61

WELLS TWP.
T68N R16W
SEC. 27

IA 202

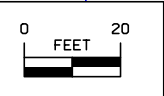

STA 327+03
MP 6.20

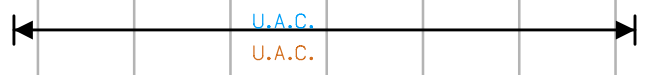
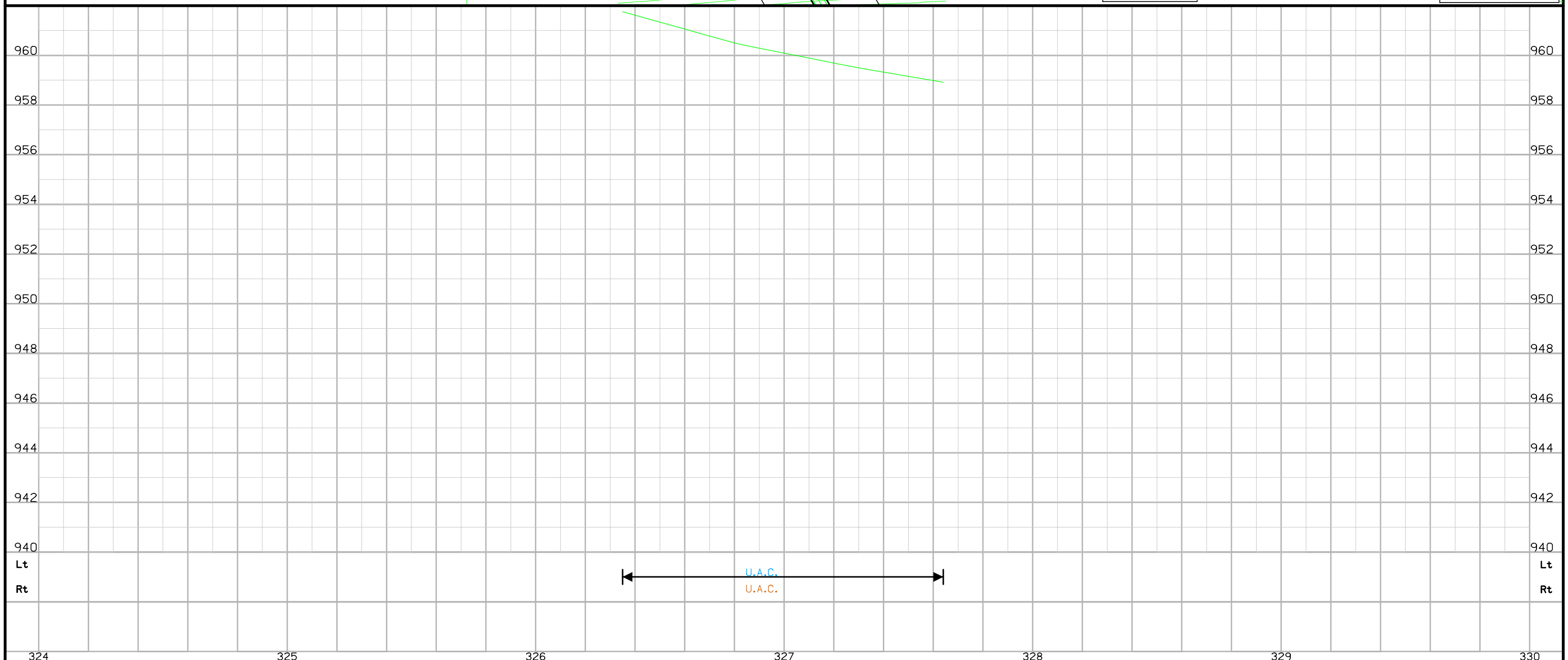

IA 202

Refer to sheet D.08A
For East side.

REMOVE

Sta. 327+03
Skew 30.00
48" X 48" X 63.5' Wood Box Culvert
54" X 24' RCP Extension LT.
54" X 24' RCP Extension RT.
D.A. = 58 Ac - H (Per Plan FN 644)

Sta. 327+03
Install 110 LF OF 54" DIA RCP
F.L. = Lt. 944.61
Rt. 942.61

WELLS TWP.
T68N R16W
SEC. 26

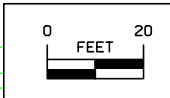

STA 327+03
MP 6.20

960

960

958

958

956

956

954

954

952

952

950

950

948

948

946

946

944

944

942

942

940

940

Lt

Lt

Rt

Rt

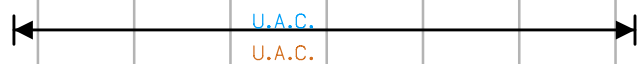

324

325

326

327

328

329

330

FILE NO.

ENGLISH

DESIGN TEAM **Holst \ Bahr \ Jackson**

DAVIS/APPANOOSE COUNTY

PROJECT NUMBER

STPN-202-1(5)--2J-26

SHEET NUMBER

D.8B

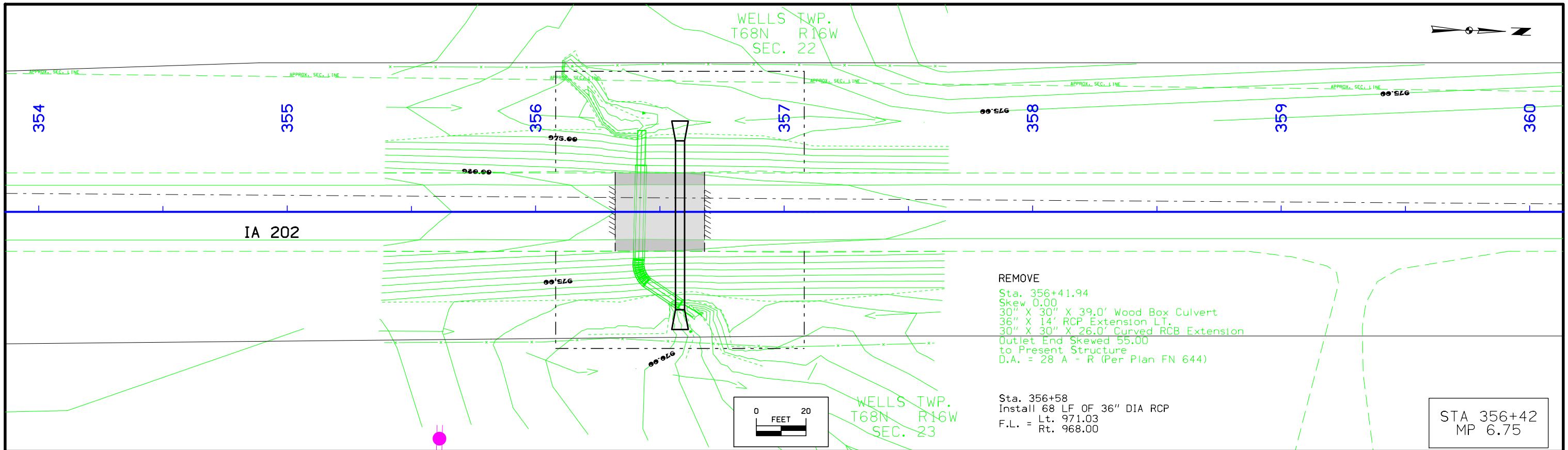

REMOVE
 Sta. 356+41.94
 Skew 0.00
 30" X 30" X 39.0' Wood Box Culvert
 36" X 14' RCP Extension LT.
 30" X 30" X 26.0' Curved RCB Extension
 Outlet End Skewed 55.00
 to Present Structure
 D.A. = 28 A - R (Per Plan FN 644)

Sta. 356+58
 Install 68 LF OF 36" DIA RCP
 Lt. 971.03
 Rt. 968.00

STA 356+42
 MP 6.75

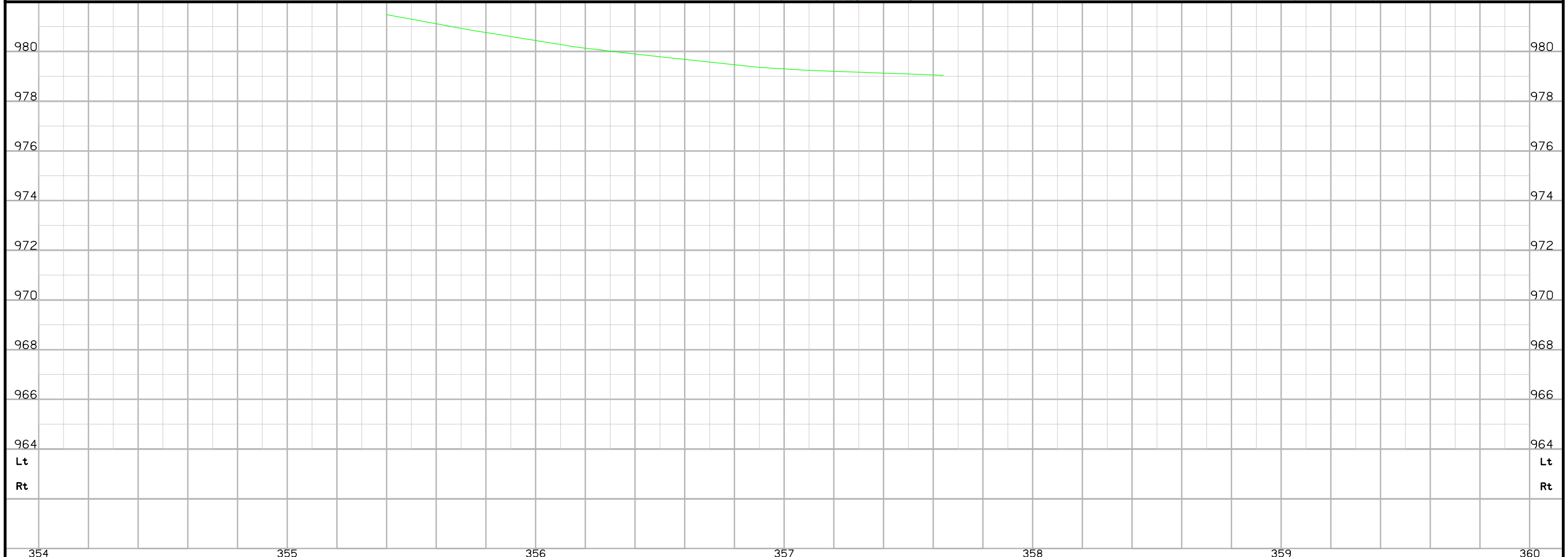
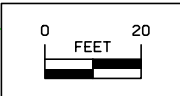

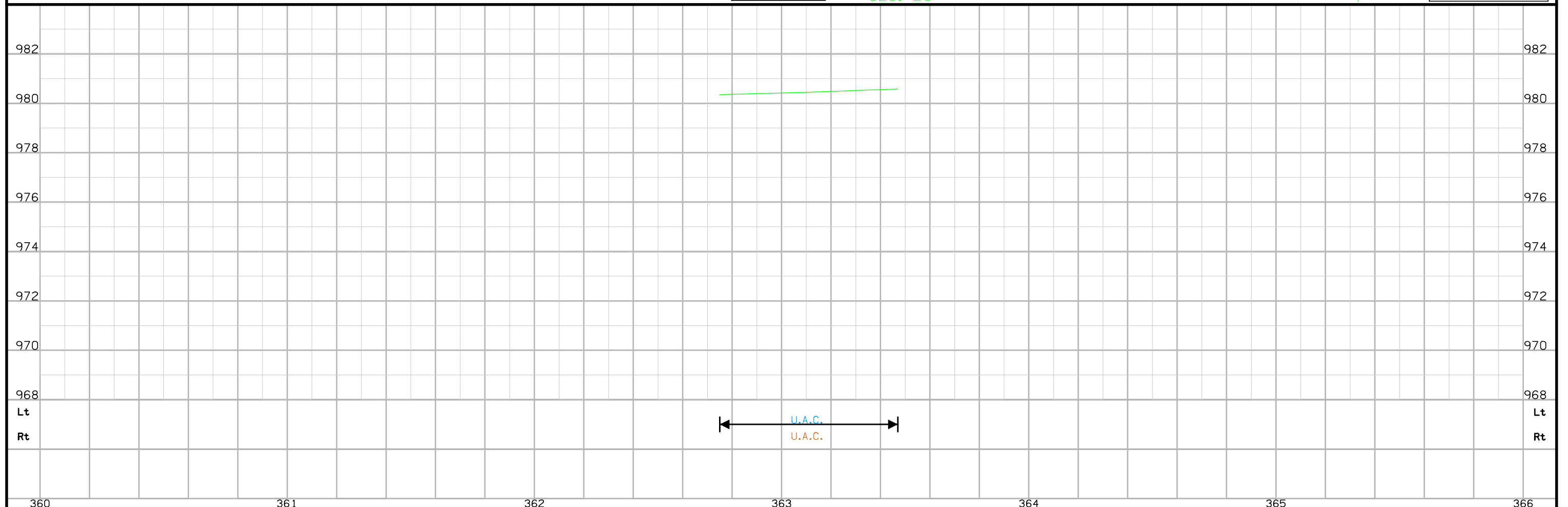
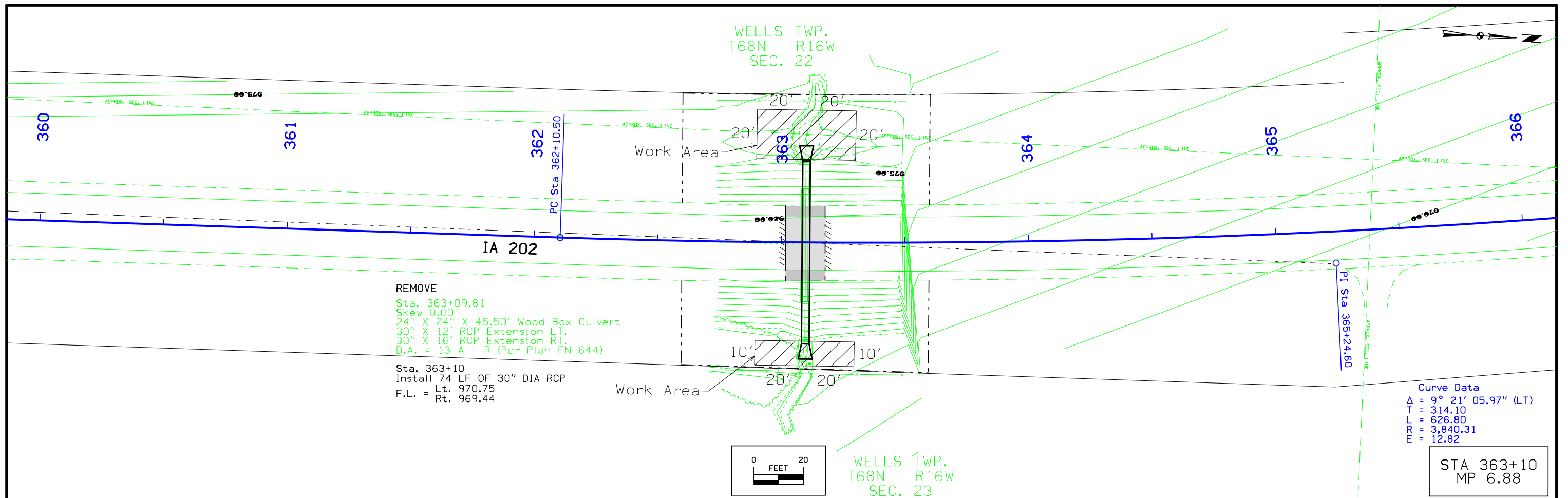

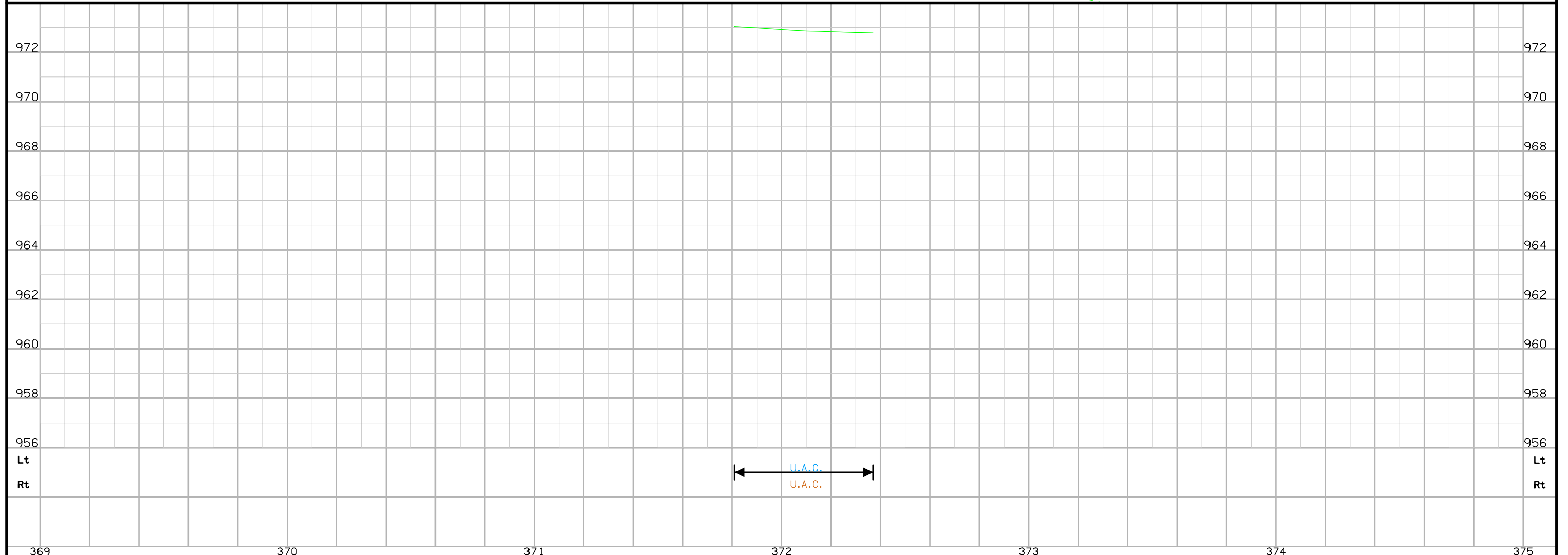
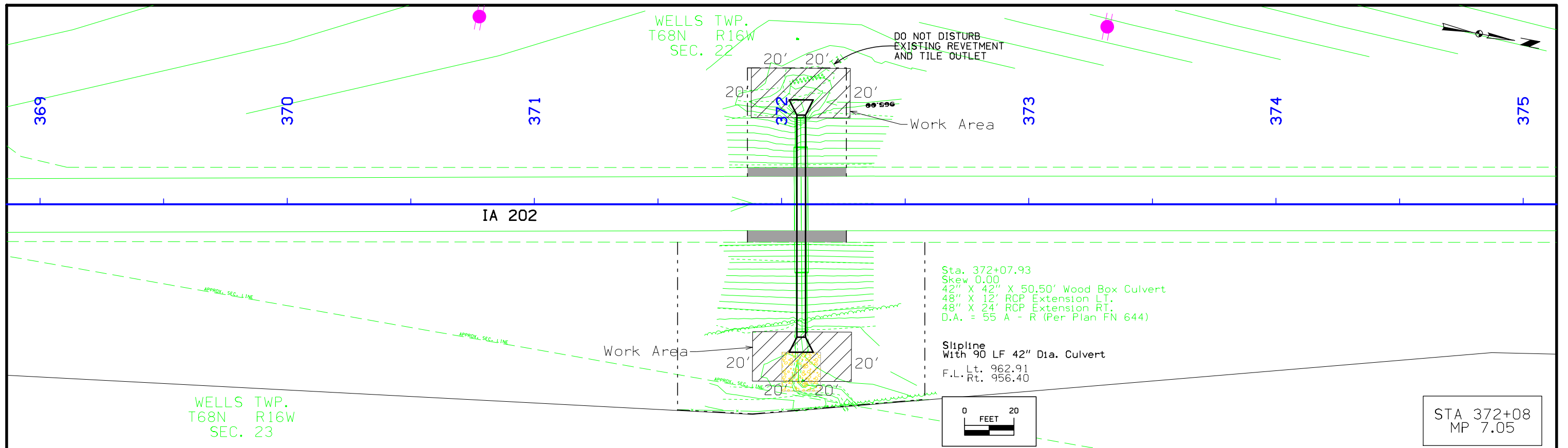

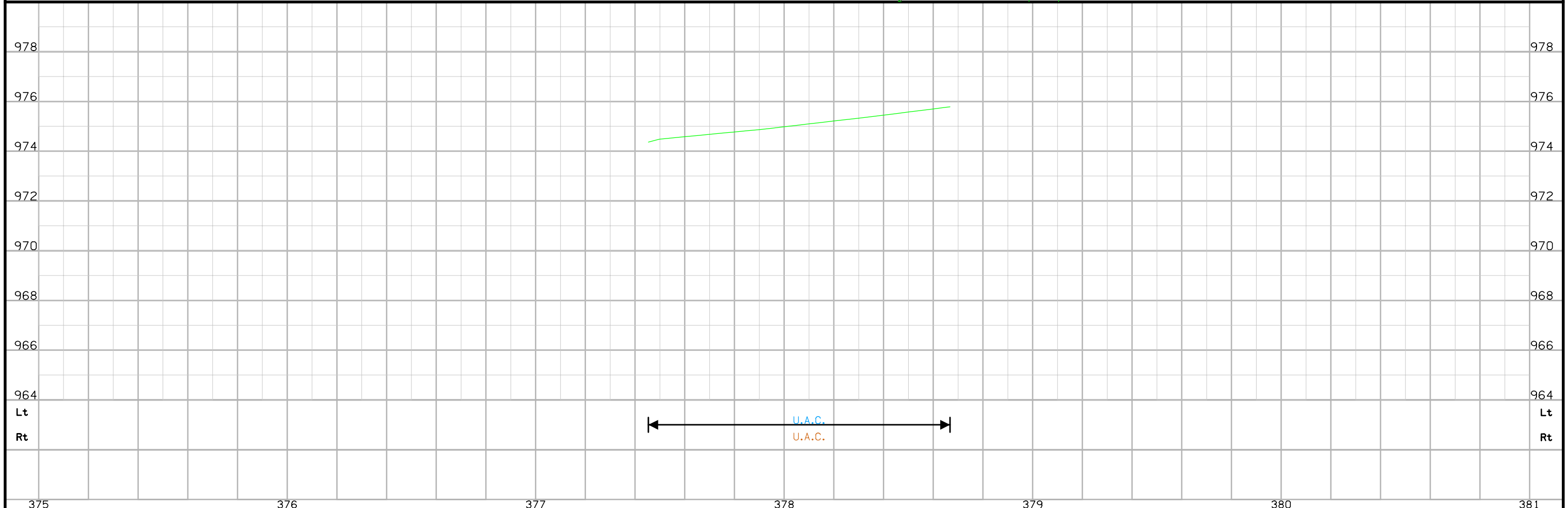
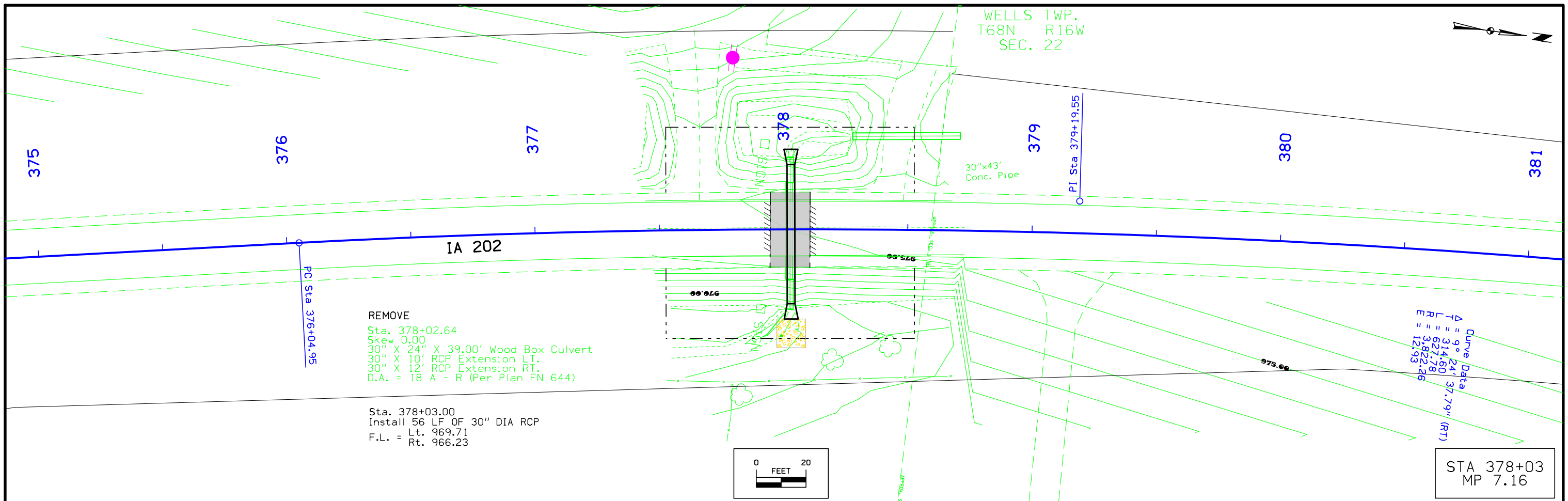

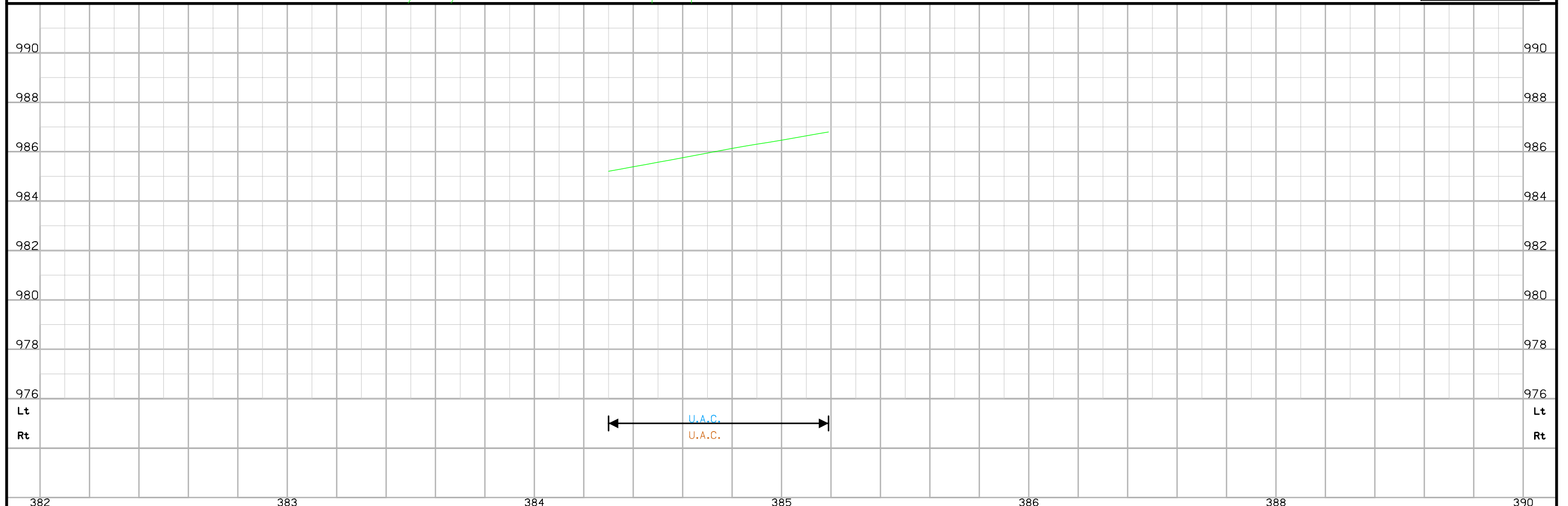
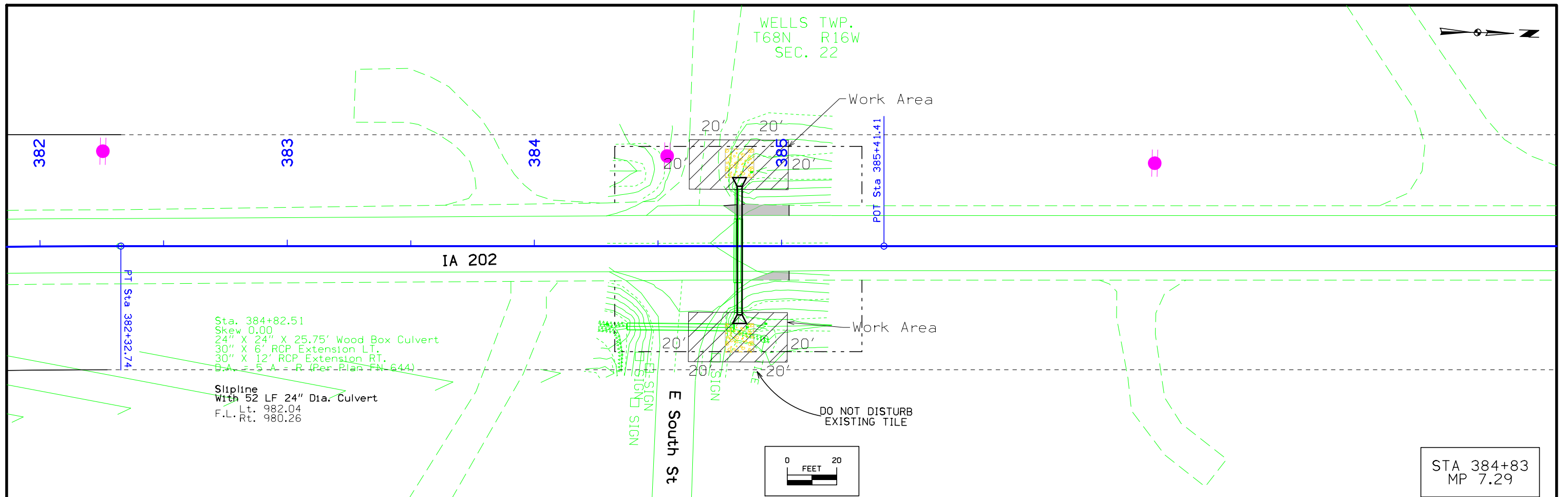

WELLS TWP.
T68N R16W
SEC. 35

Line Data
Start= 2236+31.00, N:6,101,949.44, E:22,800,656.99
End= 2239+31.00, N:6,102,249.40, E:22,800,661.60
Bearing= N 0°52'52.94" E
Distance= 300.00

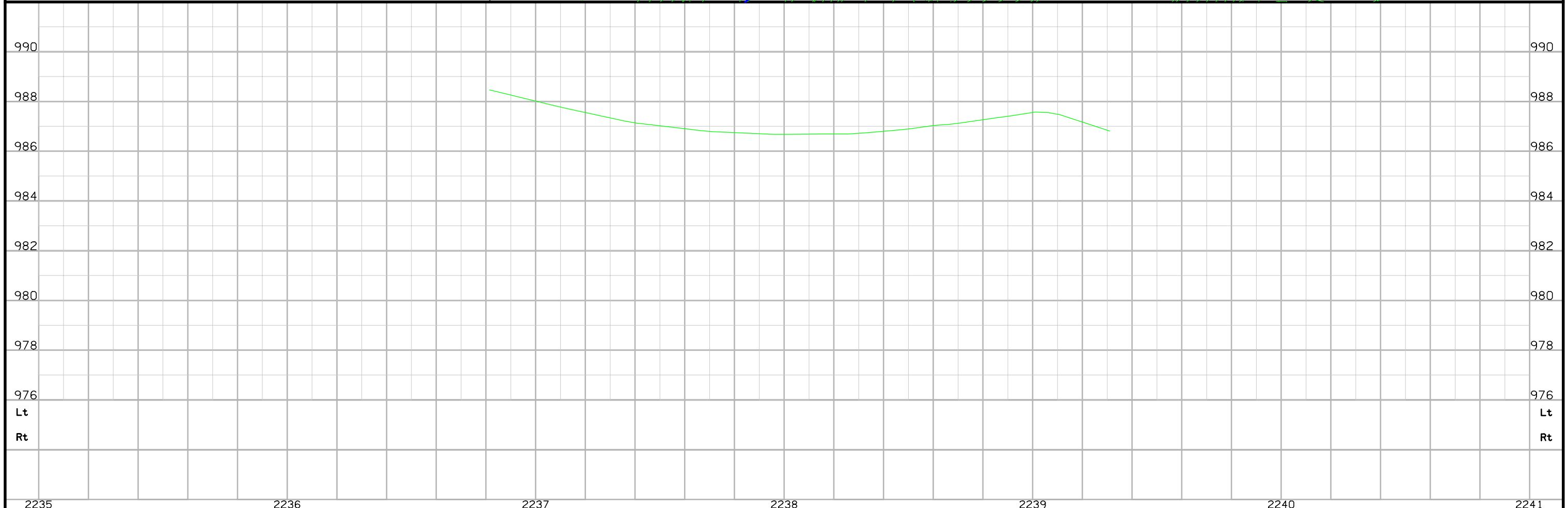
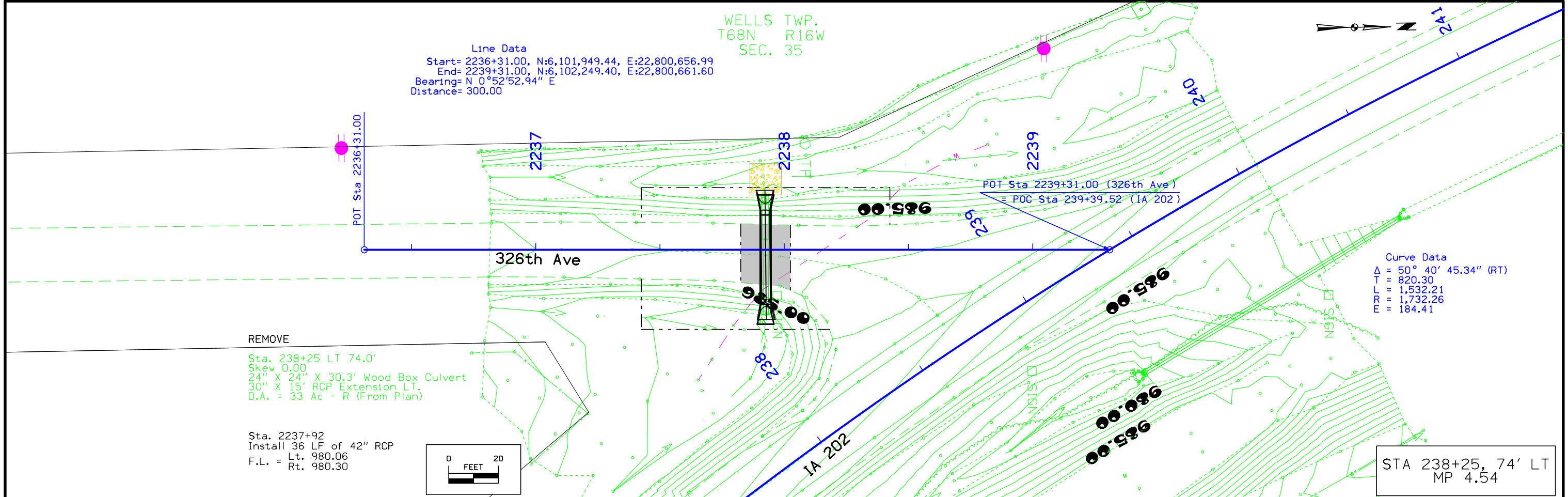

WELLS TWP.
T68N R16W
SEC. 22

WELLS TWP.
T68N R16W
SEC. 23

Line Data
Start= 6338+86.30, N:6,110,984.78, E:22,797,960.74
End= 6340+86.30, N:6,110,992.00, E:22,798,160.61
Bearing= N 87°55'55.24" E
Distance= 200.00

Sta. 338+41.49
Skew 0.00
24" X 24" X 33.5' Wood Box Culvert
30" X 13' RCP Extension LT.
30" X 16' RCP Extension RT.
D.A. = 8 A - R (Per Plan FN 644)

REMOVE
Sta. 338+86 RT 43'
Skew 0.00
24" X 24" X 29.5' Wood Box Culvert
30" X 24' RCP Extension LT.
30" X 20' RCP Extension RT.
D.A. = 7 A - R (Per Plan FN 644)

Sta. 6339+30
Install 62 LF of 24" DIA RCP
Lt. 962.23
Rt. 961.76

WELLS TWP.
T68N R16W
SEC. 26

STA 338+86, 43' RT
MP 6.42

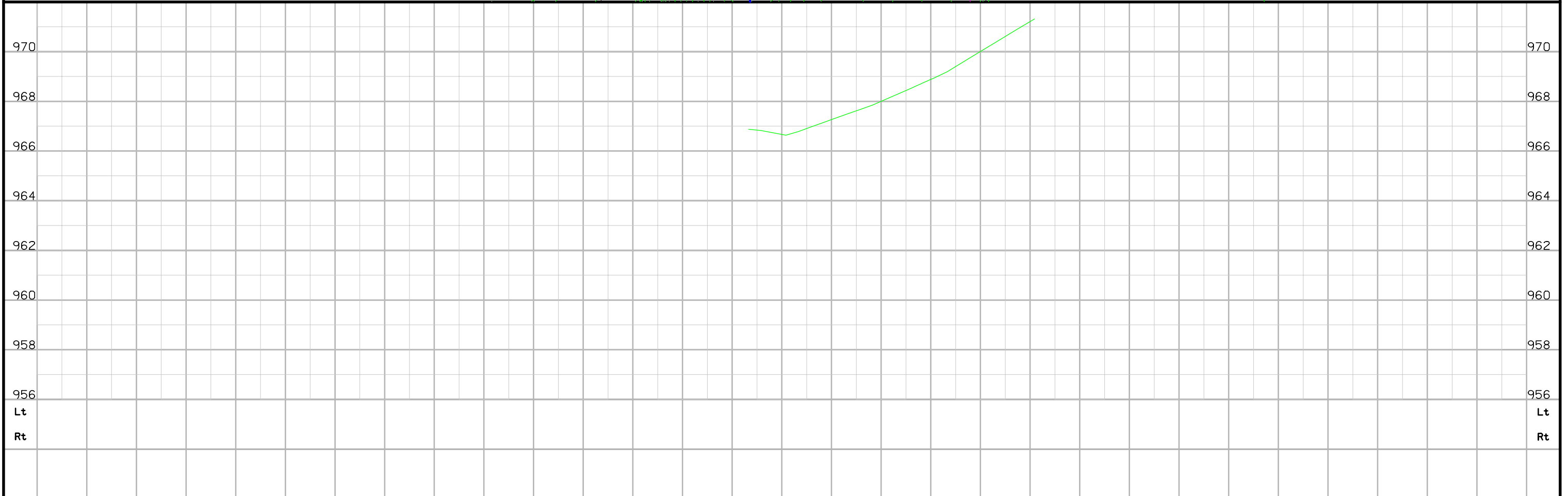
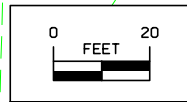

6336	6337	6338	6339	6340	6341	6342
FILE NO.	ENGLISH	DESIGN TEAM Holst \ Bahr \ Jackson	DAVIS/APPANOOSE COUNTY	PROJECT NUMBER STPN-202-1(5)--2J-26	SHEET NUMBER E.2	

Survey Information

Appanoose County
ER-202-2(7)--28-04
15 Locations 4.7 miles S. of Moulton
To the S. edge of Moulton along IA Hwy 202
20-04-202-010
Sap-741.1

Point Name	Northing	Easting	Elevation	Description
CP 1	6110913.126	22798035.204	965.935	Feno Monument
CP 2	6106470.593	22798096.656	973.366	Feno Monument
CP 3	6102263.548	22800565.113	981.864	Feno Monument
CP 4	6099267.570	22804165.472	992.709	Feno Monument
AppCo-801	6116274.496	22792529.258	970.685	CoCP-GPSmon
AppCo-8005	6116439.851	22805719.599	947.918	CoCP-GPSmon
DavisCo-305	6096043.934	22807339.024	994.165	NGSbm J120

Party Personnel

Myron Fox
 Nels Sutherland
 Geoff Tinker
 Paul Harry
 Jeff Duncan
 Mike Rummelhart

Date(s) of Survey

Begin Date 11/18/2019
 End Date 11/27/2019

General Information

Measurement units for this survey are US survey feet. This survey is for 15 Culvert locations along IA Hwy 202, 4.7 miles south of Moulton to the south edge of Moulton. Project datum and control information is provided by Design Survey Office. This project is a full field survey.

Vertical Control

Vertical Control was established on this project by 6 hour GPS static sessions. Vertical datum for this survey is relative to NAVD88. Geoid 12B was used in processing. GRS80 Ellipsoidal Height was computed at project Pts. CP 1, CP 2, Cp 3, CP 4, AppCo-8010, AppCo-8005, and DavisCo-305 (=NGS BM J120). Vertical control was verified with IARTN checks.

Horizontal Control

The project coordinate system for this survey is Iowa RCS Zone 12 (U.S. Survey Feet). This survey control is relative to IARTN reference stations (IAC1 and IABL), and MODOT RTN reference stations (MOED and MOML). IARTN Reference Station coordinates are relative to the National Reference Station network datum: NAD83 (2011). Coordinates were determined by conducting six-hour static observations. Control was verified with IARTN checks.

Alignments Information

2 alignments were generated for these projects.

SURMLA202

The alignment for this survey is a retrace of As-built Plans Project # FN 644. Survey stationing was equated to the plan at PI Sta.141+49.5, was run back and ahead with no equation throughout the survey.

Survey stationing relates to as built plan stationing as follows:

CP Sta. 130+59.0 This Survey
 = PI Sta. 130+58.0 As-built Plans Project # FN 644

PI Sta. 141+49.5 This Survey
 = PI Sta. 141+49.5 As-built Plans Project # FN 644

PI Sta. 212+55.50 This Survey
 = PI Sta. 212+53.30 As-built Plans Project # FN 644

PI Sta. 240+67.33 This Survey
 = PI Sta. 240+74.2 As-built Plans Project # FN 644

SURMLB202

The alignment for this survey is a retrace of As-built Plans Project # FN 644. Survey stationing was equated to the plan at PI Sta.312+59.80, was run back and ahead with no equation throughout the survey.

Survey stationing relates to as built plan stationing as follows:

CP Sta. 299+62.11 This Survey
 = PT Sta. 299+61.8 As-built Plans Project # FN 644

PI Sta. 312+59.80 This Survey
 = PI Sta. 312+59.8 As-built Plans Project # FN 644

PI Sta. 338+87.98 This Survey
 = PI Sta. 338+99.1 As-built Plans Project # FN 644

PI Sta. 348+33.90 This Survey
 = PI Sta. 348+45.2 As-built Plans Project # FN 644

PI Sta. 365+24.60 This Survey
 = PI Sta. 365+36.5 As-built Plans Project # FN 644

PI Sta. 379+19.55 This Survey
 = PI Sta. 379+32.3 As-built Plans Project # FN 644

CONTROL POINT VICINITY MAP

This map is a guide to the vicinity of the primary project control points
 Primary control is for use with RTK base stations and for RTN validation.
 Future surveys will use primary project control to establish temporary control as needed for construction or other surveying applications.

SURVEY SYMBOLS

- = Existing C.P. Monument
- = Set 1M. L. FENO C.P. Monument

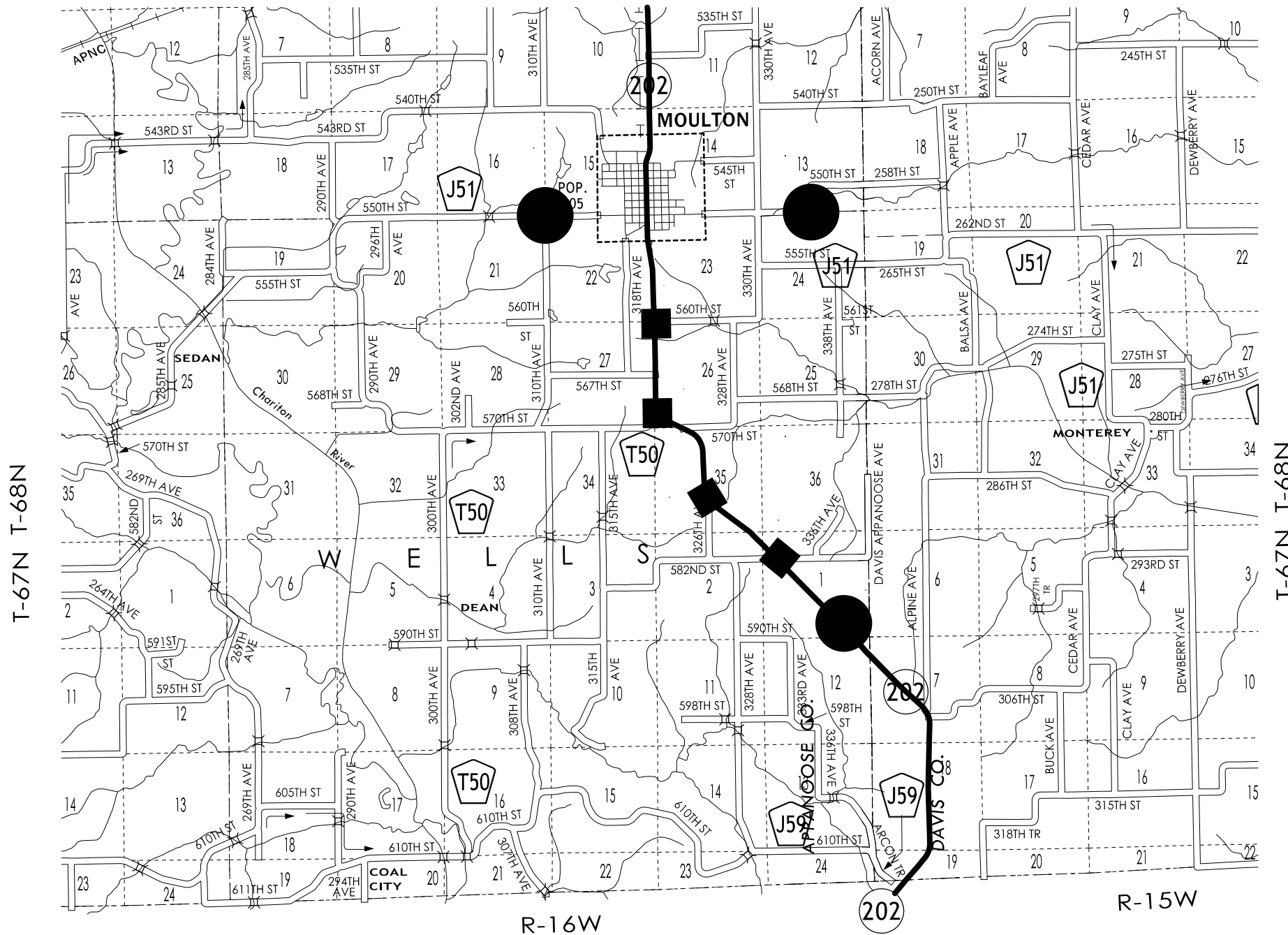

HORIZ. DATUM: NAD83(2011) EPOCH 2010.00

VERT. DATUM: NAVD88

Ia. Regional Coordinate System Zone 12

Coordinate listing from next sheet will be used with IaRTN for monument recovery. No other reference ties are given.

HORIZONTAL AND VERTICAL PROJECT CONTROL COORDINATE LISTING

HORIZ. DATUM: NAD83(2011) EPOCH 2010.00

VERT. DATUM: NAVD88

Ia. Regional Coordinate System Zone 12 (UsFt)

POINT NAME	NORTHING	EASTING	ELEVATION	FEATURE DEFINITION / DESCRIPTION
CP1	6110913.13	22798035.20	965.94	CP Set 1M. L. FENO Monument with 2in. Bronze Cap at 5in. deep. Situated at Southeast intersection of Ia. Hwy. 202 and 560th St. (to East), being located 1.8ft. South of Guy Anchor; at 28.3ft. N.E. of PVC Fence Corner Post; and 23ft. West of East R/W Fence.
CP2	6106470.59	22798096.66	973.37	CP Set 1M. L. FENO Monument with 2in. Bronze Cap at 10in. deep. Situated at Northwest intersection of Ia. Hwy. 202 and 570th St. (to Southwest) at top foreslope embankment, being located 12ft perpendicular to edge gravel (570th St.); at 58ft. West of ACC Fillet (Hwy. 202); and aligned West of Road Sign (dir. Arrow) sign post at East side of Hwy. 202.
CP3	6102263.55	22800565.11	981.86	CP Set 1M. L. FENO Monument with 2in. Bronze Cap at 8in. deep. Situated at Northwest intersection of Ia. Hwy. 202 and 326th Ave. (to South) in Curve at West R/W Fence near Station Post 240, being located 66ft West of Hwy. 202 pavement edge; and 1.7ft East of Station Post 240.
CP4	6099267.57	22804165.47	992.71	CP Set 1M. L. FENO Monument with 2in. Bronze Cap at 7in. deep. Situated at Northeast intersection of Ia. Hwy. 202 and 582nd St. (to East) near West end of North R/W Fence between 1st and 2nd Power Poles from Hwy. 202, being located 2ft South of North R/W end post (fence to East); and 15.6ft. North of North edge gravel.
AppCo-8010	6116274.50	22792529.26	970.69	Apponoose Co. GPS Mon. 8010 3-1/4in. Aluminum Disk set in 10in Diam. Poured-in-Place Concrete Monument (no depth denoted), at 3in Deep. Situated near Southeast Corner of Oakland Cemetery near intersection of 550th St. and 310th Ave., being located 50ft North of C.L. 550th St.; at 14ft West of C.L. East Cemetery entrance; at 21.5ft West of extended C.L. 310th Ave., and 16ft directly South of Cemetery Notice sign.
AppCo-8005	6116439.85	22805719.60	947.92	Apponoose Co. GPS Mon. 8005 3-1/4in. Aluminum Disk set in 10in Diam. Poured-in-Place Concrete Monument (no depth denoted), at 0.5in Deep. Situated at 35ft Southeast of C.L. curve for intersection of 550th St. and 335th Ave. (Level-B roads), being located 15.5ft North-Northeast of South R/W corner post (fence to South and West); and 23.1 East to East R/W corner post.
DavisCo-305	6096043.93	22807339.02	994.16	Davis Co. GPS Mon. 305 = NGS BM J120 1935 extends 15in Height at Residential Entrance #28876 North of Ia. Hwy. 202, and located 4ft SE. of Corner Post with NE. ROW Fence and East Fence of residential access near Dead End sign.

ALIGNMENT COORDINATES

Name	Location	Point on Tangent			Begin Spiral			Begin Curve			Simple Curve PI or Master PI of SCS			End Curve			End Spiral		
		Station	Coordinates		Station	Coordinates		Station	Coordinates		Station	Coordinates		Station	Coordinates		Station	Coordinates	
			Y (Northing)	X (Easting)		Y (Northing)	X (Easting)		Y (Northing)	X (Easting)		Y (Northing)	X (Easting)		Y (Northing)	X (Easting)		Y (Northing)	X (Easting)
1	SURMLA202	13+059.00 R1	6094657.31	22808414.89															
2	SURMLA202							14+023.70 R1	6095391.47	22807789.06	14+149.50 R1	6095487.21	22807707.46	14+275.19 R1	6095576.82	22807619.16			
4	SURMLA202							21+098.40 R1	6100436.84	22802829.97	21+255.50 R1	6100548.74	22802719.70	21+411.98 R1	6100642.49	22802593.63			
6	SURMLA202							23+247.03 R1	6101737.50	22801121.11	24+067.33 R1	6102226.99	22800462.86	24+779.24 R1	6103046.39	22800424.43			
1	SURMLB202	29+962.11 R1	6107060.97	22798011.16															
2	SURMLB202	31+259.80 R1	6108358.62	22798000.99															
3	SURMLB202							33+494.08 R1	6110592.68	22797969.94	33+887.98 R1	6110986.56	22797965.35	34+281.73 R1	6111379.77	22797942.10			
5	SURMLB202							34+523.85 R1	6111621.47	22797927.80	34+833.90 R1	6111930.98	22797909.50	35+143.89 R1	6112240.94	22797902.19			
7	SURMLB202							36+210.50 R1	6113307.26	22797877.06	36+524.60 R1	6113621.27	22797869.65	36+837.31 R1	6113929.91	22797811.32			
9	SURMLB202							37+604.95 R1	6114684.20	22797668.77	37+919.55 R1	6114993.33	22797610.34	38+232.74 R1	6115307.85	22797603.25			
10	SURMLB202	38+541.41 R1	6115616.45	22797596.29															

SPIRAL OR CIRCULAR CURVE DATA

Name	Location	ΔSCS	Horizontal Alignment Data												Remarks				
			Spiral Data						Curve Data										
			BS	Ls	Ts	Es	Xc	Yc	L.T.	S.T.	ΔC	T	L	R		E			
C1	SURMLA202														4°08'02.7"	125.800	251.491	3486	2.269
C2	SURMLA202														8°47'06.4"	157.100	313.584	2045	6.025
C3	SURMLA202														50°40'45.3"	820.300	1532.215	1732	184.409
C1	SURMLB202														2°42'54.9"	393.900	787.653	16621	4.667
C2	SURMLB202														2°02'00.2"	310.050	620.035	17471	2.751
C3	SURMLB202														9°21'06.0"	314.100	626.805	3840	12.824
C4	SURMLB202														9°24'37.8"	314.600	627.785	3822	12.925

Appanoose	ROW: STPN-202-2(9)--2J-04				PIN	20-26-202-010															
	Missouri to IA 2																				
		STATE		COUNTY		CITY				TEMP EASE	BORROW										
PARCEL NO	OWNER NAME	FEE	EASE	FEE	EASE	FEE	EASE	EXCESS			FEE	T.E.	MITIGATION	OTHER	HOUSE	BUILDING(S)	A/C ONLY	TOTAL ACQ.			
1	JDA Farm, LLP - Fee									1079 SF											
2	Luke A Brown - Fee	.02 AC								1310 SF											
3	John E Ballinger Jr. - Fee	.04 AC								1330 SF											
4	Larry G Lynch and Nancy L Revocable Trust - Fee									1278 SF											
4 Parcels	"TOTALS	0.06 AC	0 AC	0 AC	0 AC	0 AC	0 AC	0 AC	0 AC	0 AC	0 AC	0 AC	0 AC	0 AC							
		0 SF	0 SF	0 SF	0 SF	0 SF	0 SF	0 SF	0 SF	0 SF	0 SF	0 SF	0 SF	0 SF							

NO ACCESS RIGHTS ARE TO BE ACQUIRED ON THIS PROJECT.

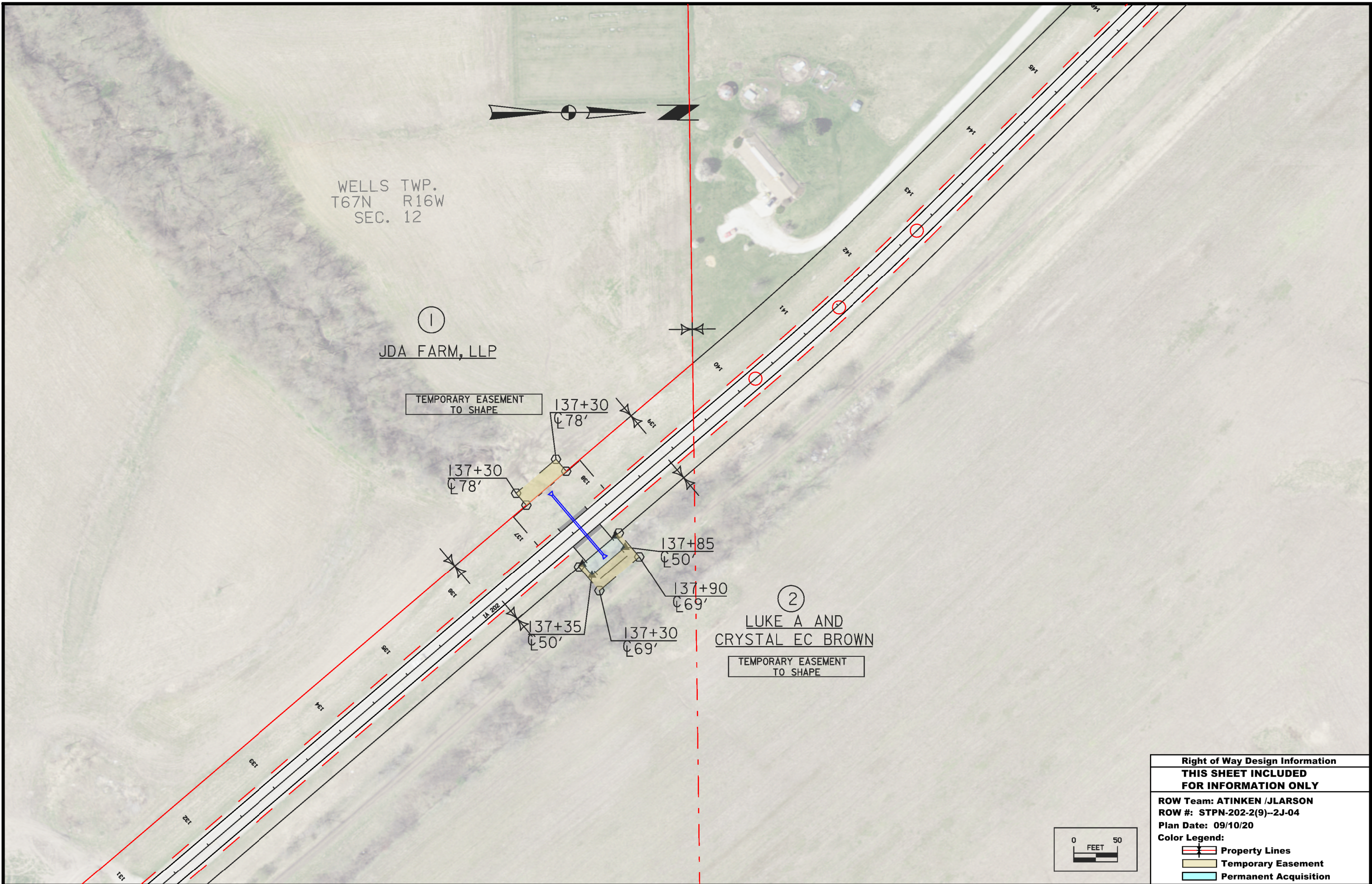

WELLS TWP.
T67N R16W
SEC. 12

①
JDA FARM, LLP

TEMPORARY EASEMENT
TO SHAPE

137+30
±78'

137+30
±78'

137+85
±50'

137+90
±69'

137+35
±50'

137+30
±69'

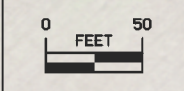

②
LUKE A AND
CRYSTAL EC BROWN

TEMPORARY EASEMENT
TO SHAPE

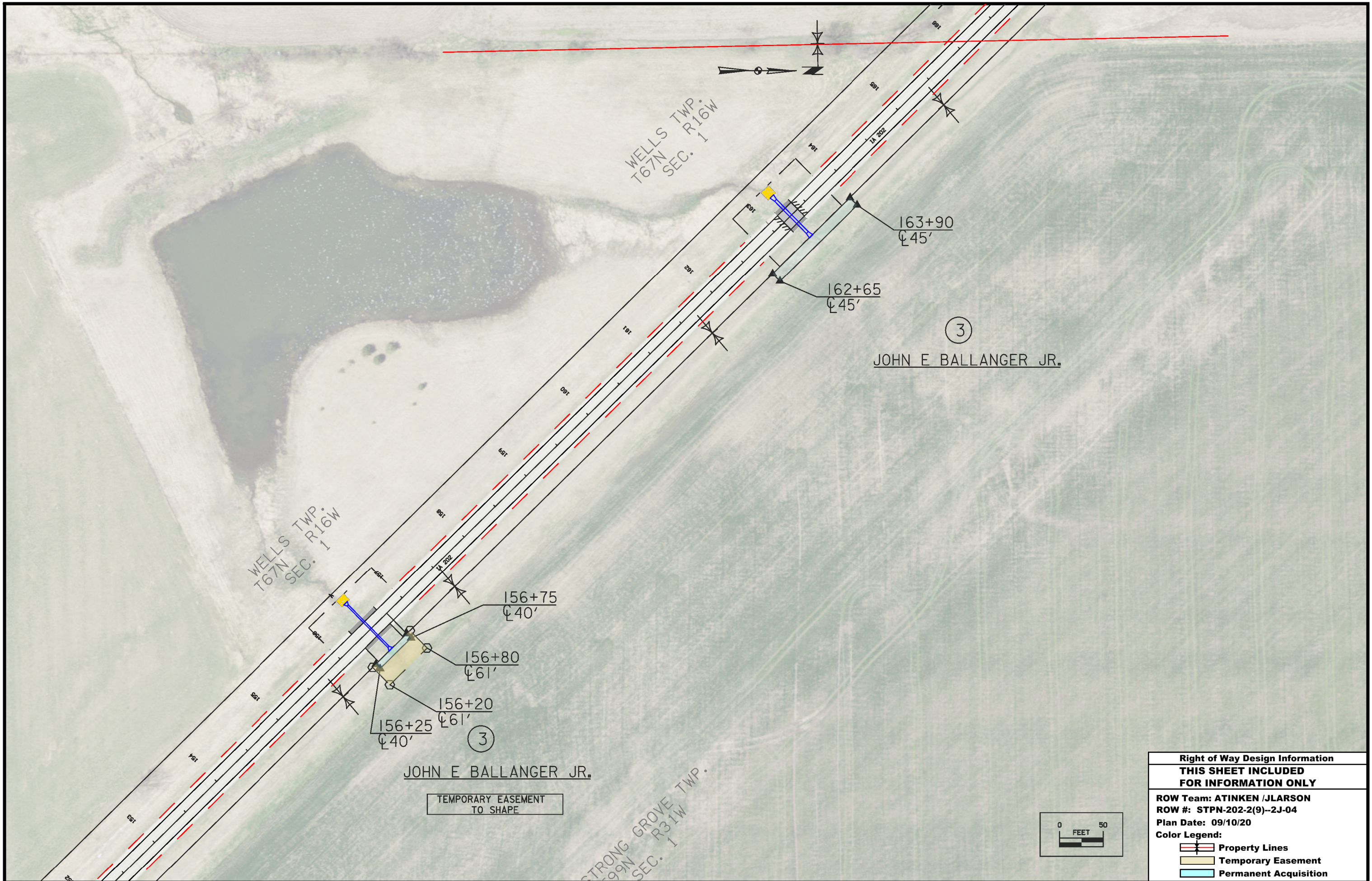

Right of Way Design Information	
THIS SHEET INCLUDED FOR INFORMATION ONLY	
ROW Team: ATINKEN /JLARSON	
ROW #: STPN-202-2(9)--2J-04	
Plan Date: 09/10/20	
Color Legend:	
	Property Lines
	Temporary Easement
	Permanent Acquisition



Right of Way Design Information	
THIS SHEET INCLUDED FOR INFORMATION ONLY	
ROW Team: ATINKEN /JLARSON	
ROW #: STPN-202-2(9)--2J-04	
Plan Date: 09/10/20	
Color Legend:	
	Property Lines
	Temporary Easement
	Permanent Acquisition



WELLS TWP.
T68N R16W
SEC. 22

WELLS TWP.
T68N R16W
SEC. 23

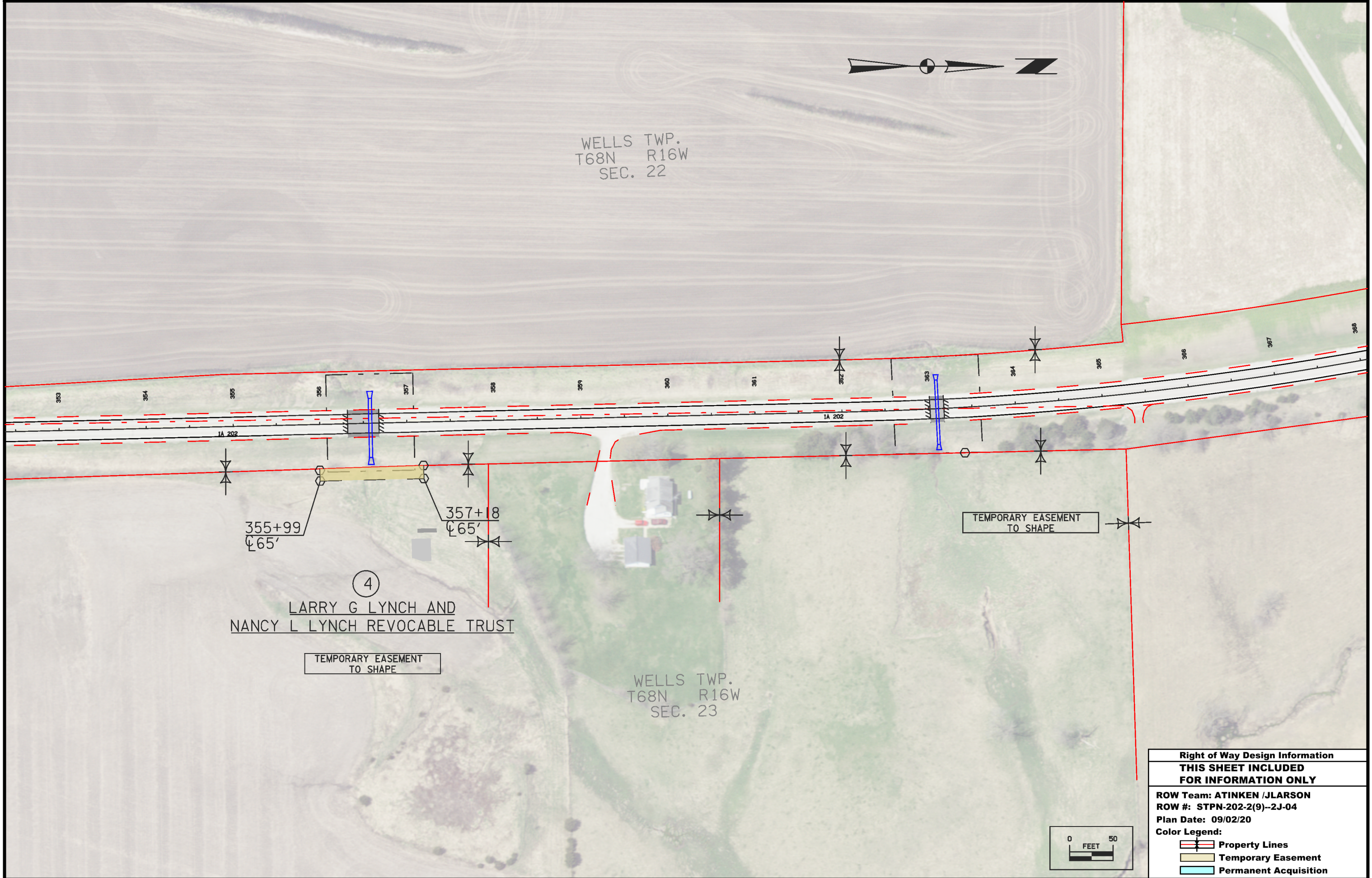

④
LARRY G LYNCH AND
NANCY L LYNCH REVOCABLE TRUST

TEMPORARY EASEMENT
TO SHAPE

TEMPORARY EASEMENT
TO SHAPE

Right of Way Design Information	
THIS SHEET INCLUDED FOR INFORMATION ONLY	
ROW Team: ATINKEN /JLARSON	
ROW #: STPN-202-2(9)--2J-04	
Plan Date: 09/02/20	
Color Legend:	
	Property Lines
	Temporary Easement
	Permanent Acquisition



108-23A
08-01-08

TRAFFIC CONTROL PLAN

1. Access to all properties shall be maintained at all times.
2. Traffic on IA 202 shall be maintained via off-site detour for construction of culverts at Stations 198.42 (MP 3.76), 239+31 128' LT (MP 4.54), 310+73 (MP 5.89), 338+86.3 46' RT (MP 6.42), and 356+44 (MP 6.75).
3. Use Standard Road Plan TC-202 and TC-213 for slipline of culverts at Stations 137+59 (MP 2.61), 156+48 (MP 2.97), 163+25 (MP 3.10), 315+19 (MP 5.97), 327+03 (MP 6.20), 363+10 (MP 6.88), 372+00 (MP 7.05), 378+03 (MP 7.16), and 384+83 (MP 7.29)
4. Side Road closure (326th Ave and 560th St) shall be closed via TC-252.
5. Installation, maintenance, and removal of the detour signs are the responsibility of the contractor. Refer to sheets J.2-J.3.
6. The Contractor shall supply two PDMS 10 days prior to closure per sheet J.3. The message shall be coordinated with the Engineer.
7. The Detour Route Marker signs labeled #1-#7 and #10-#14 and signs #15-#16 will be provided by the DOT and can be picked up at the Bloomfield Maintenance Garage. All other Road Closure Devices shall be provided by the Contractor per MUTCD and Standard Road Plan TC-252.
8. The Contractor shall return these signs to the Bloomfield Shop upon completion in good condition. If not returned in good condition, the Contractor shall replace signs that have been provided at no additional cost to the contracting authority.

Contact information:
Iowa DOT Maintenance Garage
20836 IA 2
Bloomfield, IA 52537
Phone: 641-664-2231

111-01
04-17-12

COORDINATED OPERATIONS

Other work in progress during the same period of time will include the construction of the projects listed. Coordinate operations with those of other contractors working within the same area.

Project	Type of Work
None Anticipated	

108-25
10-21-14

511 TRAVEL RESTRICTIONS

Route	Direction	County	Location Description	Feature Crossed	Object Type	Maint. Bridge No., Structure ID, or FHWA No.	Type of Restriction	Existing Measurement	Construction Measurement	Construction Measurement as Signed	Projected As Built Measurement	Remarks
IA 202	Both	Appanoose	MP 3.76	Road Closure								
IA 202	Both	Appanoose	MP 5.89	Road Closure								
IA 202	Both	Appanoose	MP 6.75	Road Closure								

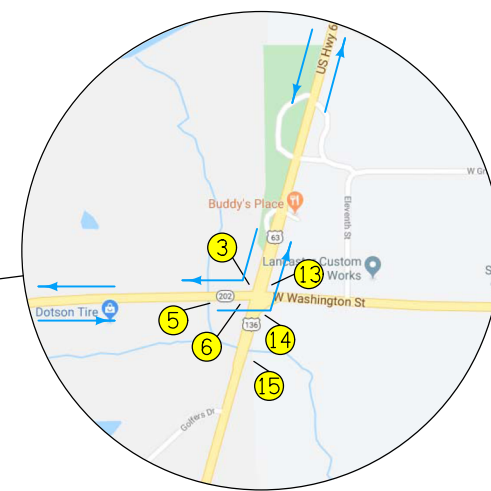
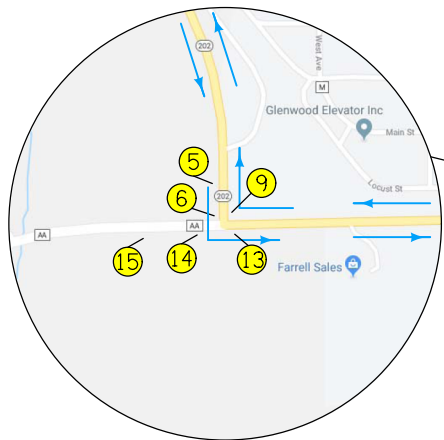
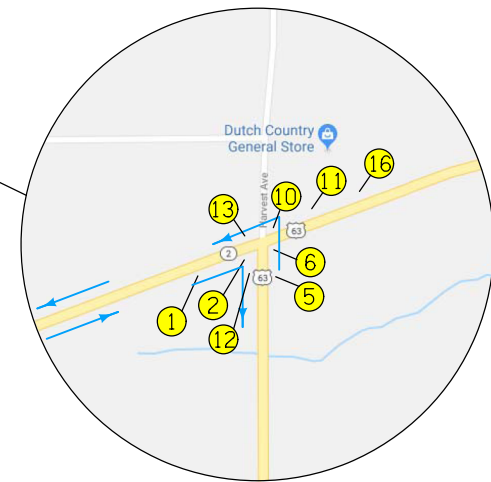

PROJECT LOCATIONS

PROJECT LOCATIONS

PROJECT LOCATIONS

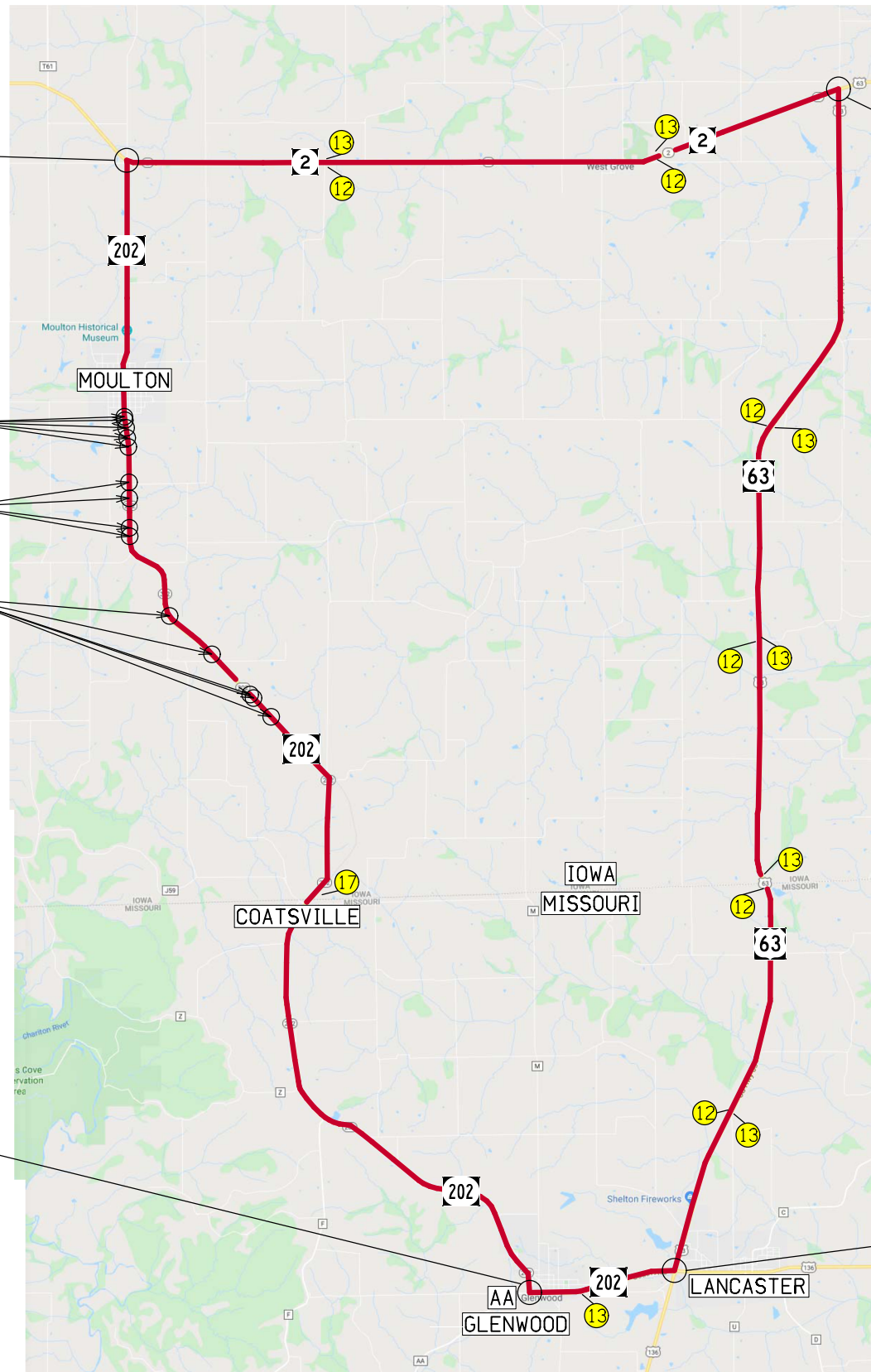

This Sheet
For Information Only

Detour

QUANTITY = 2

① **DETOUR** M4-8, 24"x12"
SOUTH M3-3, 24"x12"
202 M1-6, 30"x24"
 M5-1R, 21"x15"

QUANTITY = 3

⑤ **DETOUR** M4-8, 24"x12"
NORTH M3-1, 24"x12"
202 M1-6, 30"x24"
 M5-1L, 21"x15"

QUANTITY = 1

⑩ **DETOUR** M4-8, 24"x12"
SOUTH M3-1, 24"x12"
202 M1-6, 30"x24"
 M6-1L, 21"x15"

QUANTITY = 2

⑮

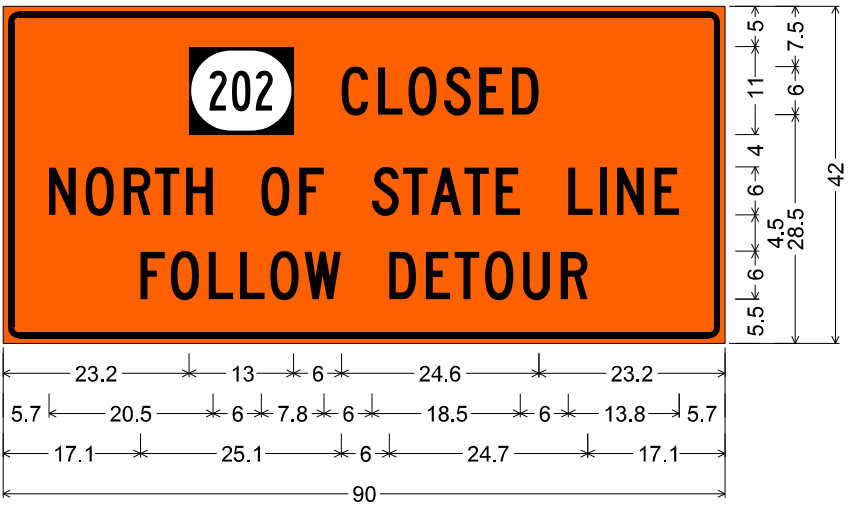

2.0" Radius, 0.8" Border, 0.6" Indent, Black on, Fluorescent orange; "CLOSED", C 2K; "NORTH OF STATE LINE", C 2K; "FOLLOW DETOUR", C 2K;

QUANTITY = 2

② **DETOUR** M4-8, 24"x12"
SOUTH M3-3, 24"x12"
202 M1-6, 30"x24"
 M6-1R, 21"x15"

QUANTITY = 3

⑥ **DETOUR** M4-8, 24"x12"
NORTH M3-1, 24"x12"
202 M1-6, 30"x24"
 M6-1L, 21"x15"

QUANTITY = 1

⑪ **DETOUR** M4-8, 24"x12"
SOUTH M3-1, 24"x12"
202 M1-6, 30"x24"
 M5-1L, 21"x15"

QUANTITY = 2

⑯

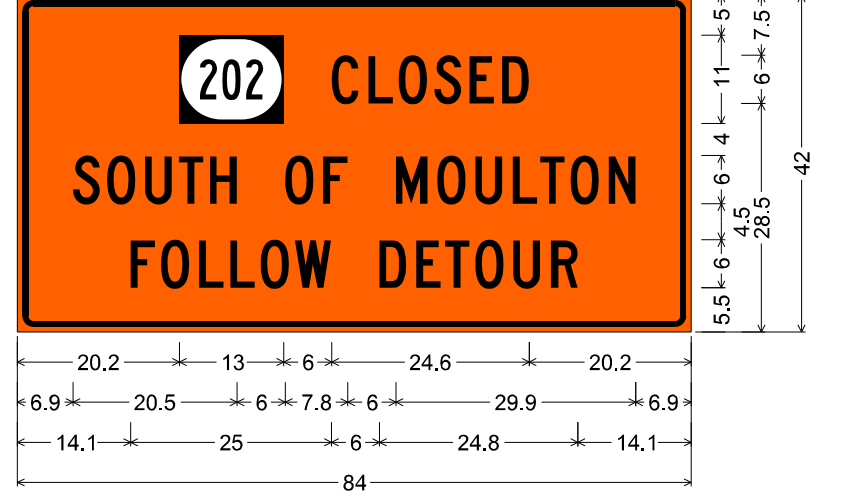

2.0" Radius, 0.8" Border, 0.6" Indent, Black on, Fluorescent orange; "CLOSED", C 2K; "SOUTH OF MOULTON", C 2K; "FOLLOW DETOUR", C 2K;

QUANTITY = 1

③ **END**
DETOUR M4-8A, 24"x18"
SOUTH M3-3, 24"x12"
202 M1-6, 30"x24"

QUANTITY = 1

⑦ **END**
DETOUR M4-8A, 24"x18"
NORTH M3-1, 24"x12"
202 M1-6, 30"x24"

QUANTITY = 8

⑫ **DETOUR** M4-8, 24"x12"
SOUTH M3-3, 24"x12"
202 M1-6, 30"x24"

QUANTITY = 1

④ **DETOUR** M4-8, 24"x12"
SOUTH M3-3, 24"x12"
202 M1-6, 30"x24"
 M6-3, 21"x15"

QUANTITY = 1

⑧ **ROAD CLOSED**
5 MILES AHEAD
LOCAL TRAFFIC ONLY R11-3A; 60"x30"

QUANTITY = 1

⑨ **ROAD CLOSED**
11 MILES AHEAD
LOCAL TRAFFIC ONLY R11-3A; 60"x30"

QUANTITY = 10

⑬ **DETOUR** M4-8, 24"x12"
NORTH M3-1, 24"x12"
202 M1-6, 30"x24"

QUANTITY = 2

⑭ **DETOUR** M4-8, 24"x12"
NORTH M3-3, 24"x12"
202 M1-6, 30"x24"
 M6-3, 21"x15"

⑰ PDMS 10 Days Prior to Closure then use static signs as shown

See Standard Road Plans EC-201, EC-204, and EC-301 for installation details.

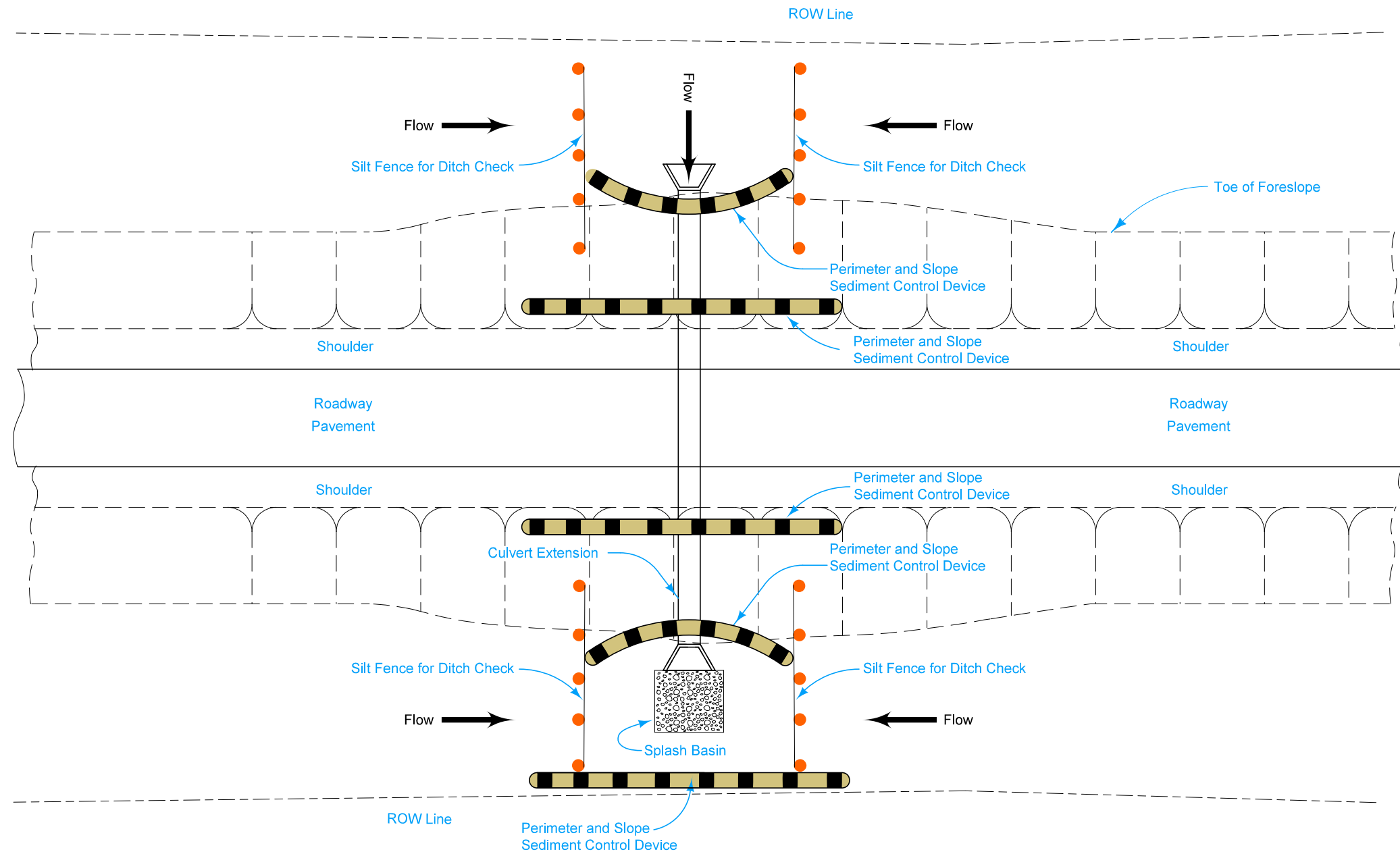

Contract Items:
 Silt Fence for Ditch Check
 Perimeter and Slope Sediment Control Device
 Class E Revetment
 Engineering Fabric

Tabulations:
 100-17
 100-19
 100-23

MODIFIED	REVISION	
	NEW	10-15-19
ROAD DESIGN DETAIL	570-11	
	SHEET 1 of 1	
<small>MODIFICATIONS: Specified the use of Silt Fence for Ditch Check at four locations in lieu of Perimeter and Slope Sediment Control Devices. Added Perimeter and Slope Sediment Control Device just above inlet apron. Specified culvert replacement in lieu of culvert extension. Revised notes referring to applicable contract items and tabulations.</small>		
TEMPORARY SEDIMENT CONTROL FOR CULVERT EXTENSION WITH EXPOSED SOIL		

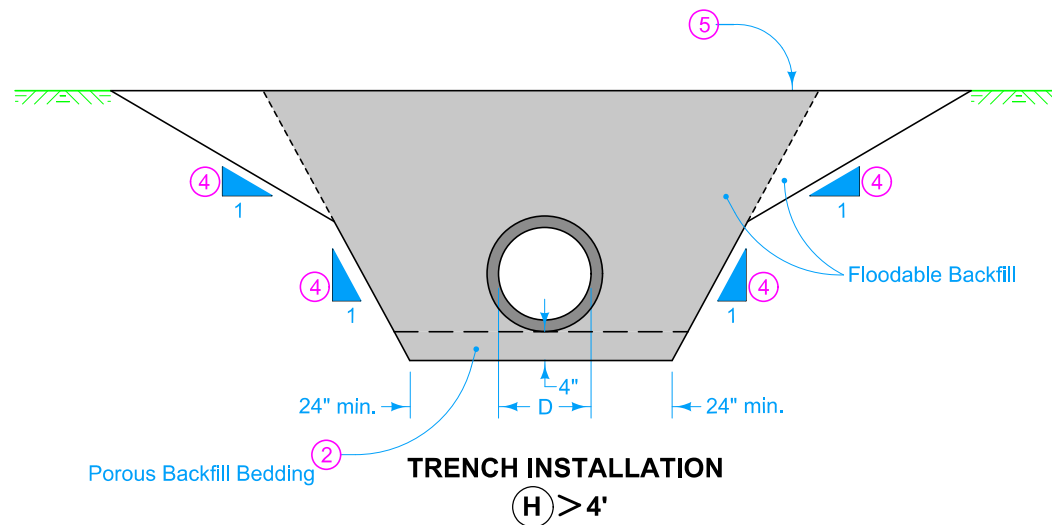
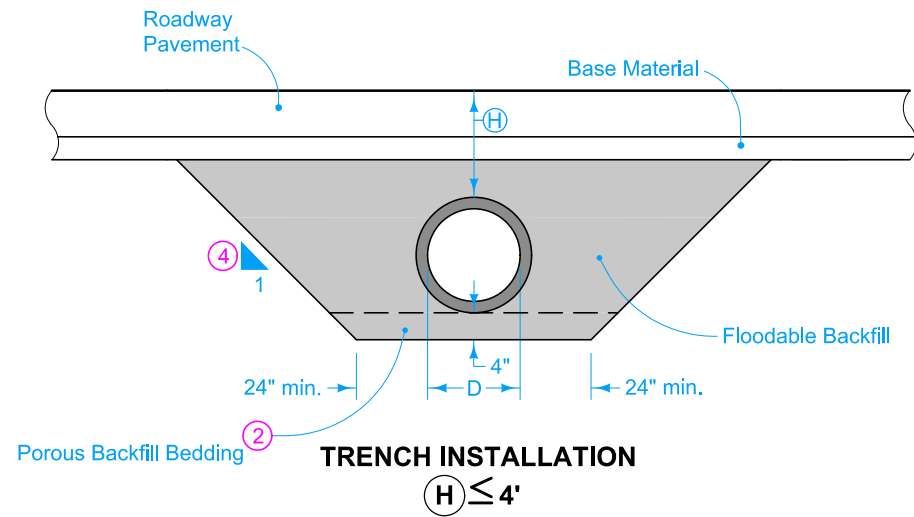

Denotes pay limits for flooded backfill

CLASS 'B' BEDDING & BACKFILL

Refer to **DR-104** for minimum and maximum allowable cover (H) for the particular kind of pipe culvert.

- 1 For culverts backfilled by flooding, place a cohesive soil plug at the inlet, outlet, and, when necessary, sides, prior to flooding.
- 2 4-inch Porous Backfill bedding. 2-inch Floodable Backfill bedding may be used under unsealed rigid pipe.
- 3 Extend Porous Backfill through the outlet end soil plug when used for bedding.
- 4 Quantity calculations are based upon a 1:1 slope and minimum trench dimension. Actual slope of trench may vary based upon Contractor's operations.
- 5 Ground Line at time of pipe installation. When existing ground exceeds 5 feet depth over pipe, backfill and compaction by flooding is not required more than 5 feet above the pipe.

Contract Items:
 Flooded Backfill
 Excavation, Class 20
 Embankment-In-Place

Tabulations:
 104-3

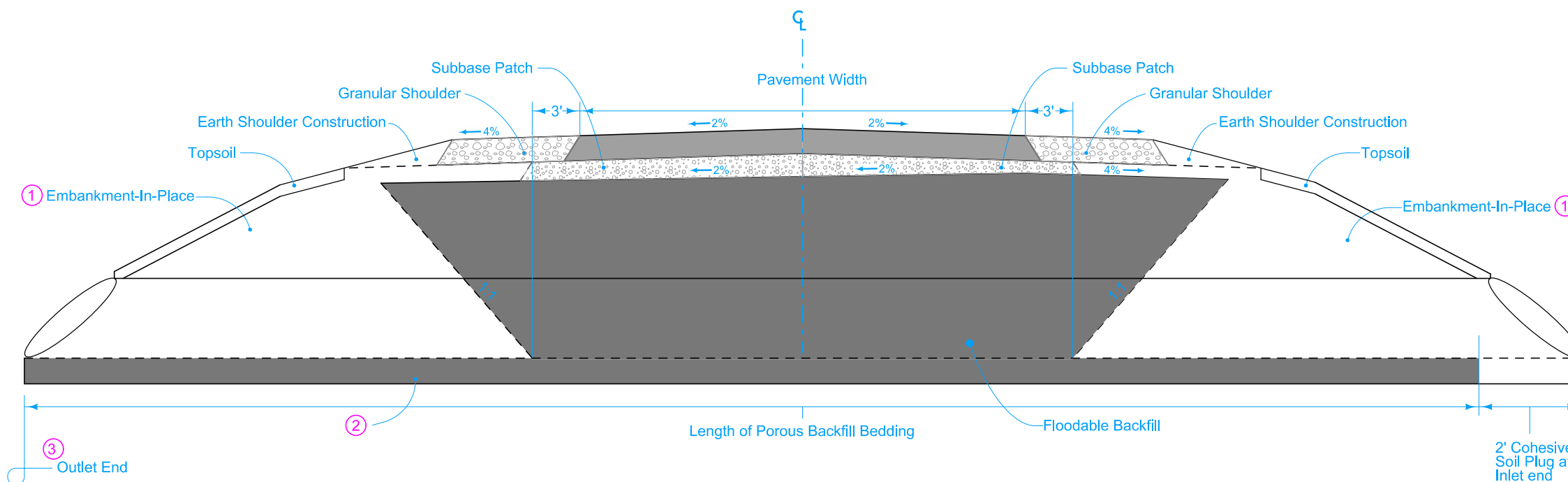

**TYPICAL SECTION - PIPE CULVERT INSTALLATION
 (IA 202, MULTIPLE LOCATIONS)**

MODIFIED	REVISION	
	2	04-18-17
	DR-101	
STANDARD ROAD PLAN	SHEET 1 of 1	

MODIFICATIONS: Removed reference to flowable mortar for trench installation. Removed detail of Fill Installation. Removed detail of Class 'C' Bedding and Backfill. Removed detail of elongated pipe. Added additional notes to the Typical Section. Removed notes 1, 2, 3, and 9 and renumbered all notes accordingly. Revised notes referring to applicable contract items and tabulations.

**PIPE CULVERT
 (BEDDING AND BACKFILL)**

IA 202 Preliminary

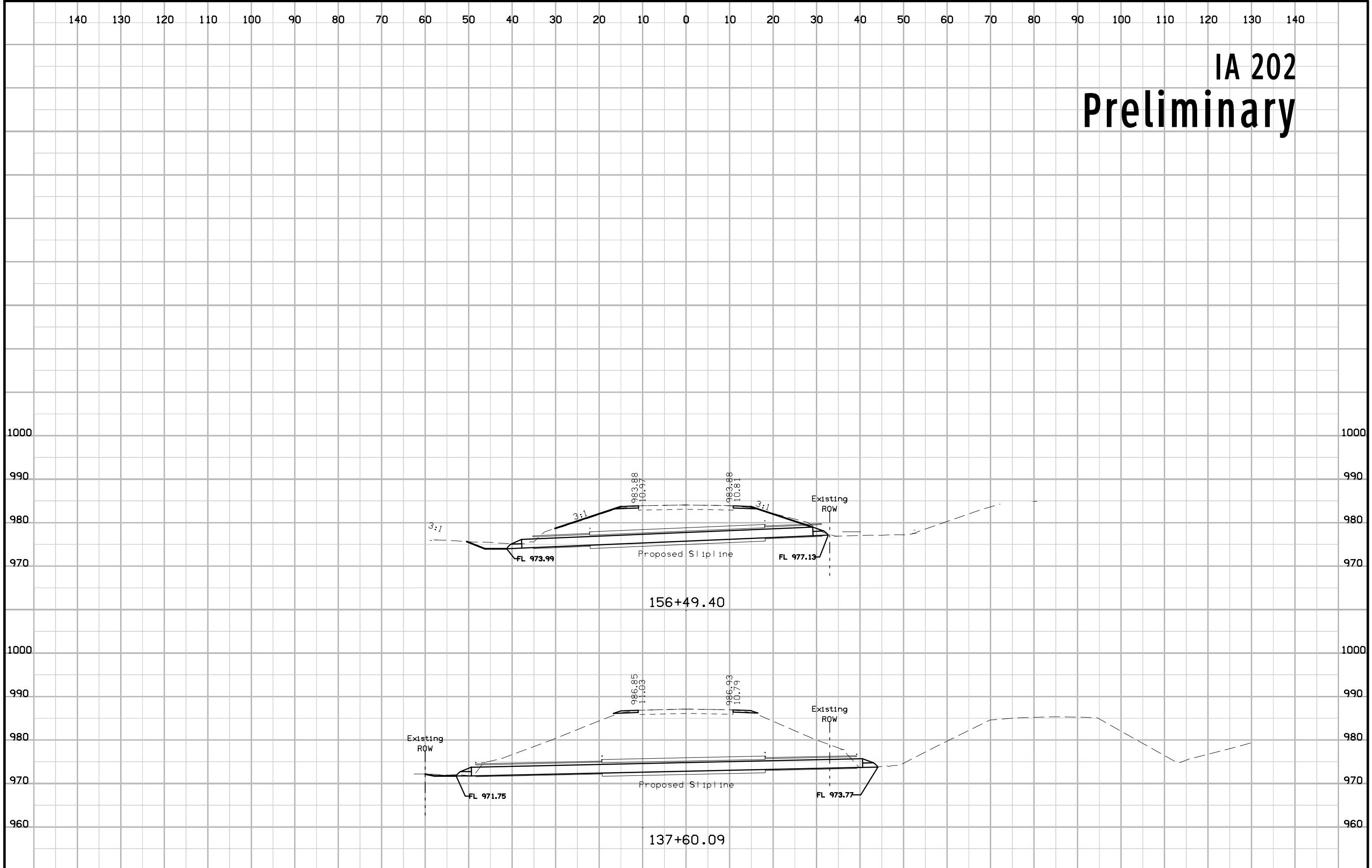

IA 202 Preliminary

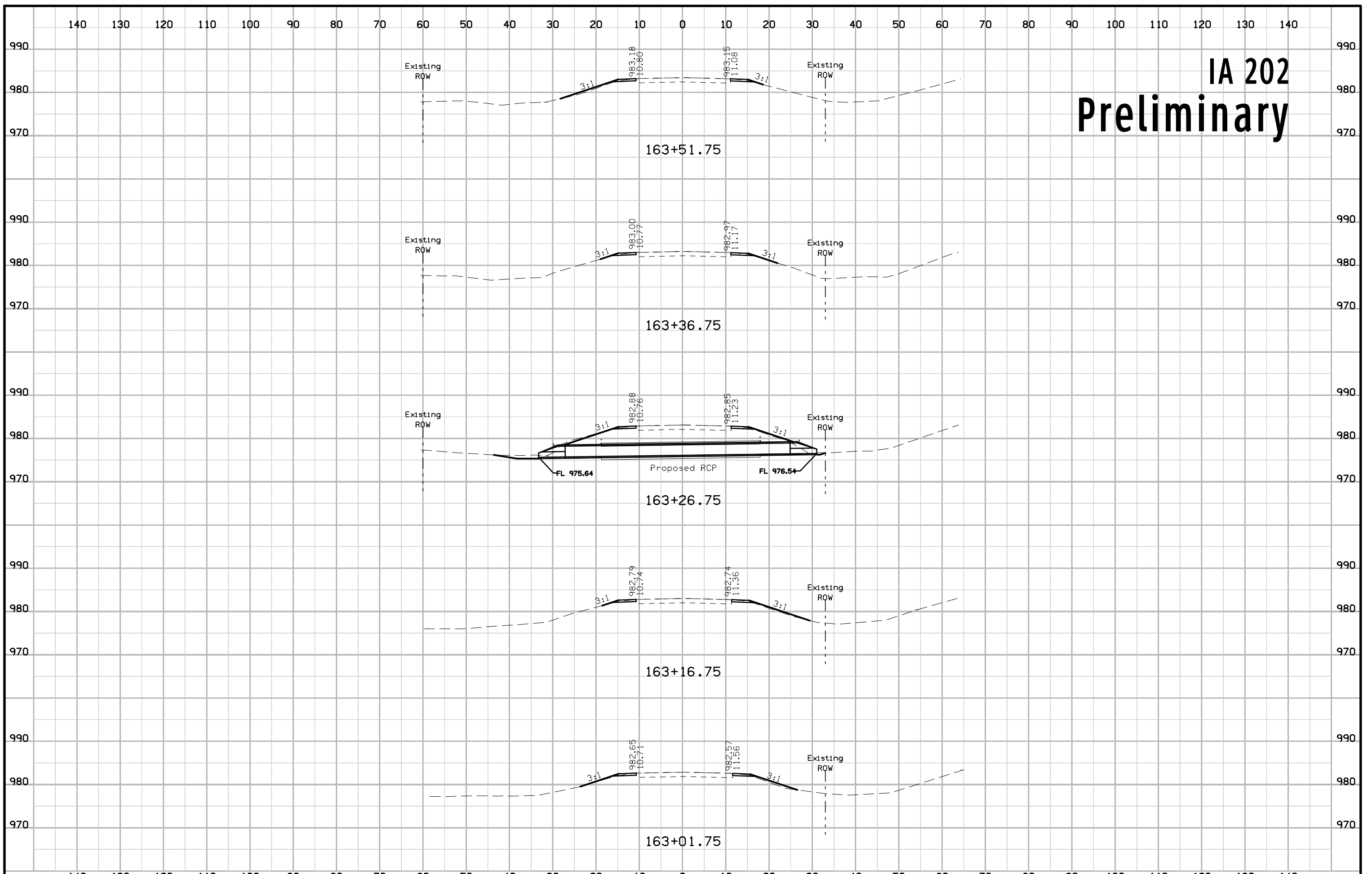

IA 202 Preliminary

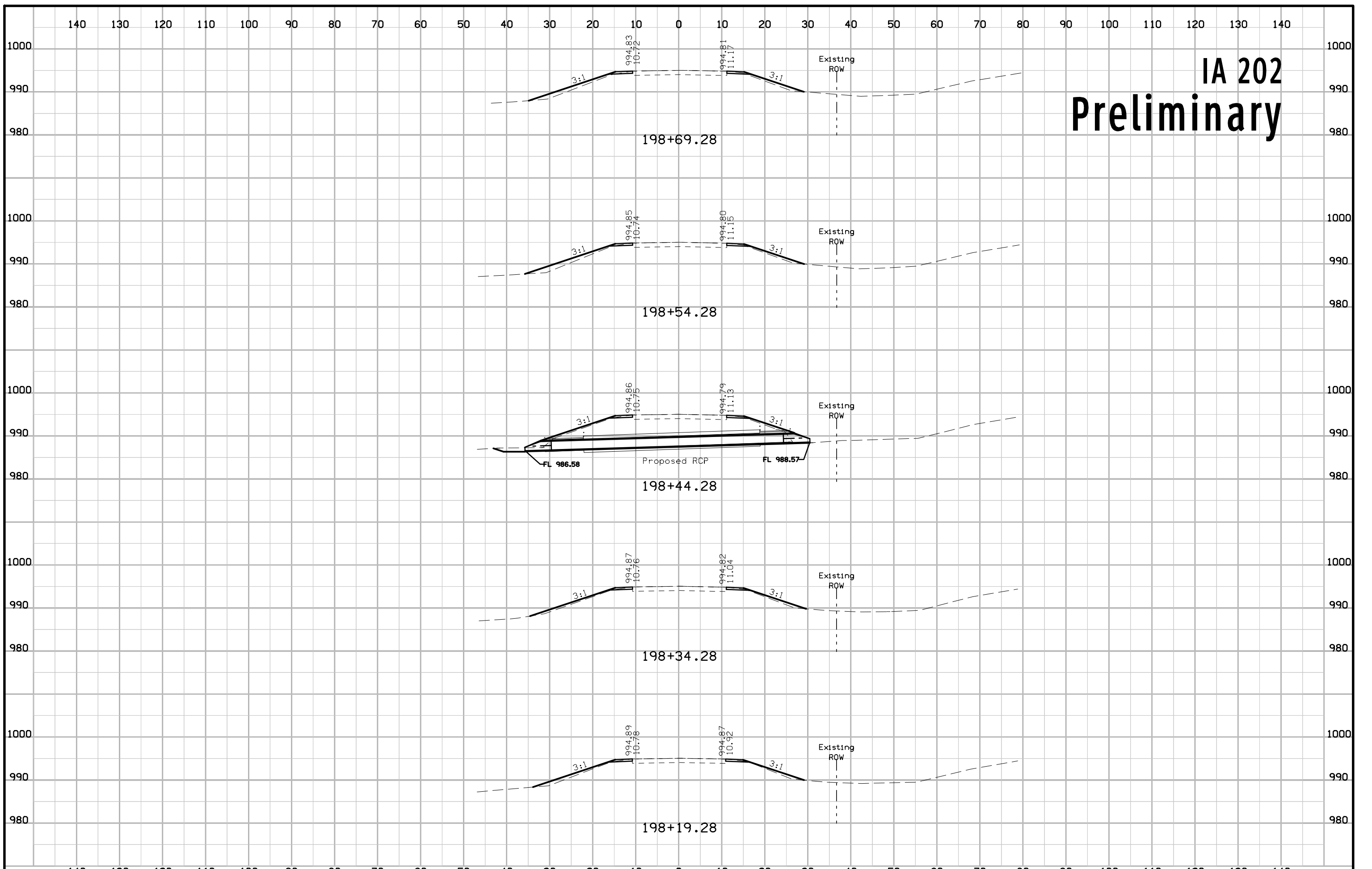

IA 202 Preliminary

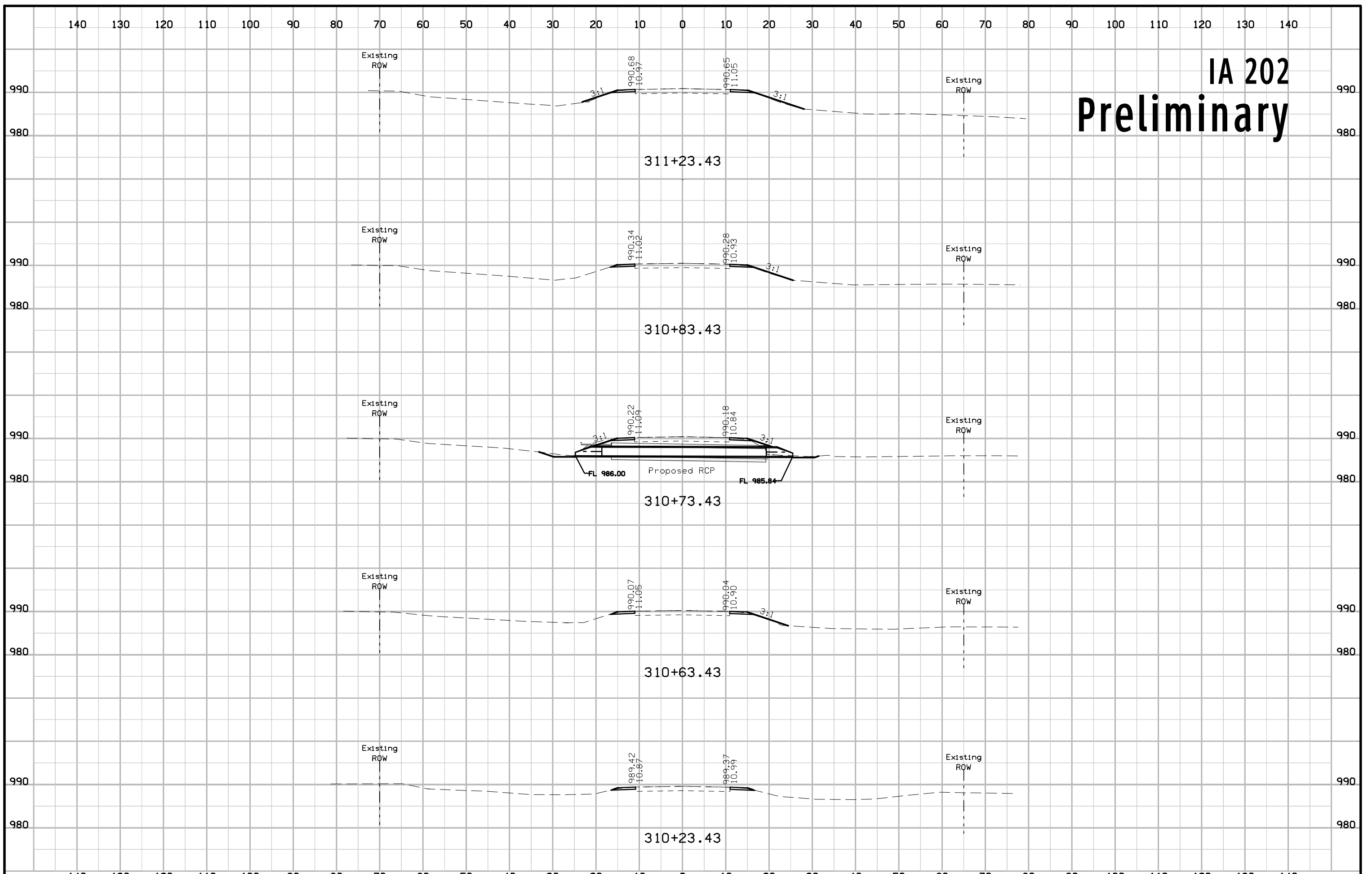

IA 202 Preliminary

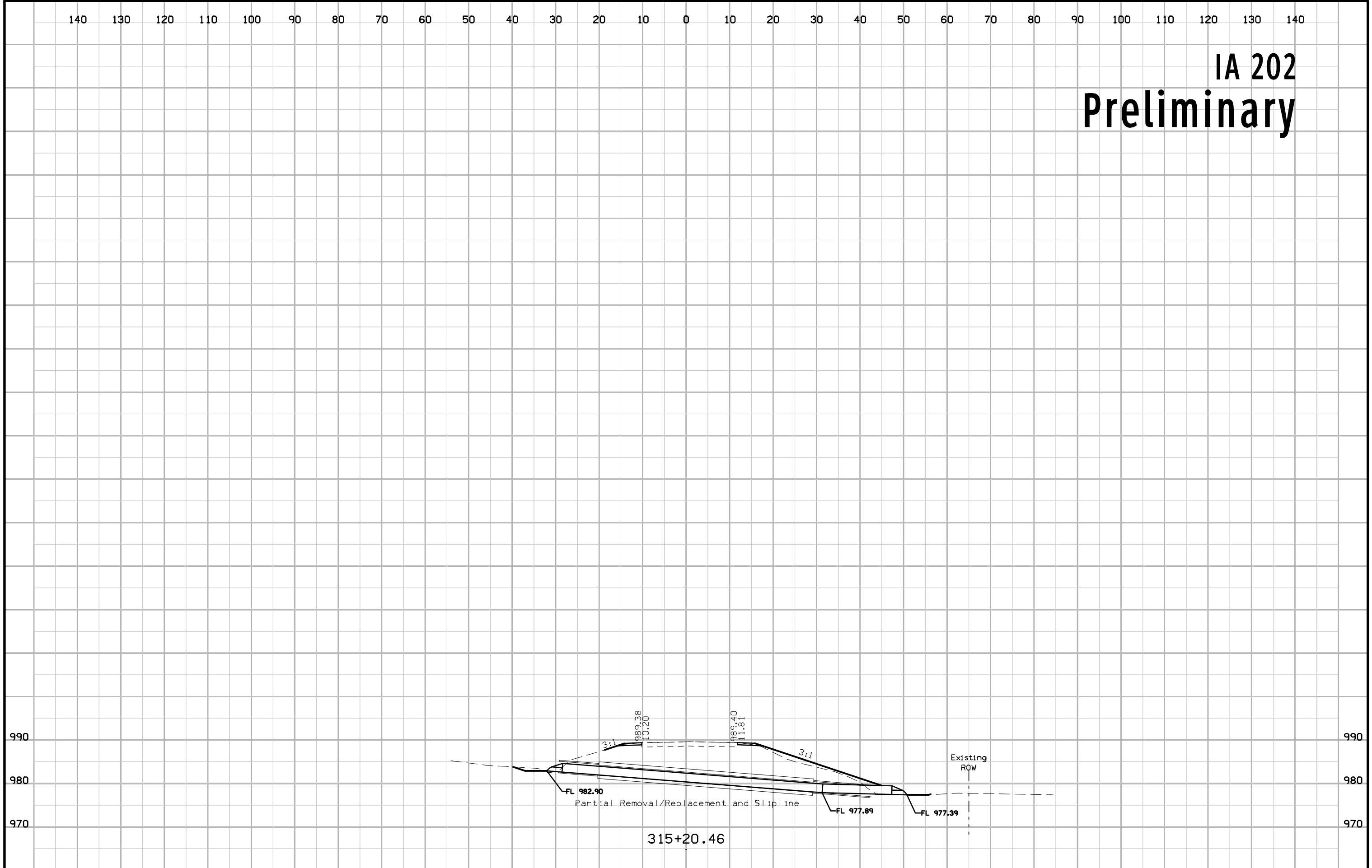

IA 202 Preliminary

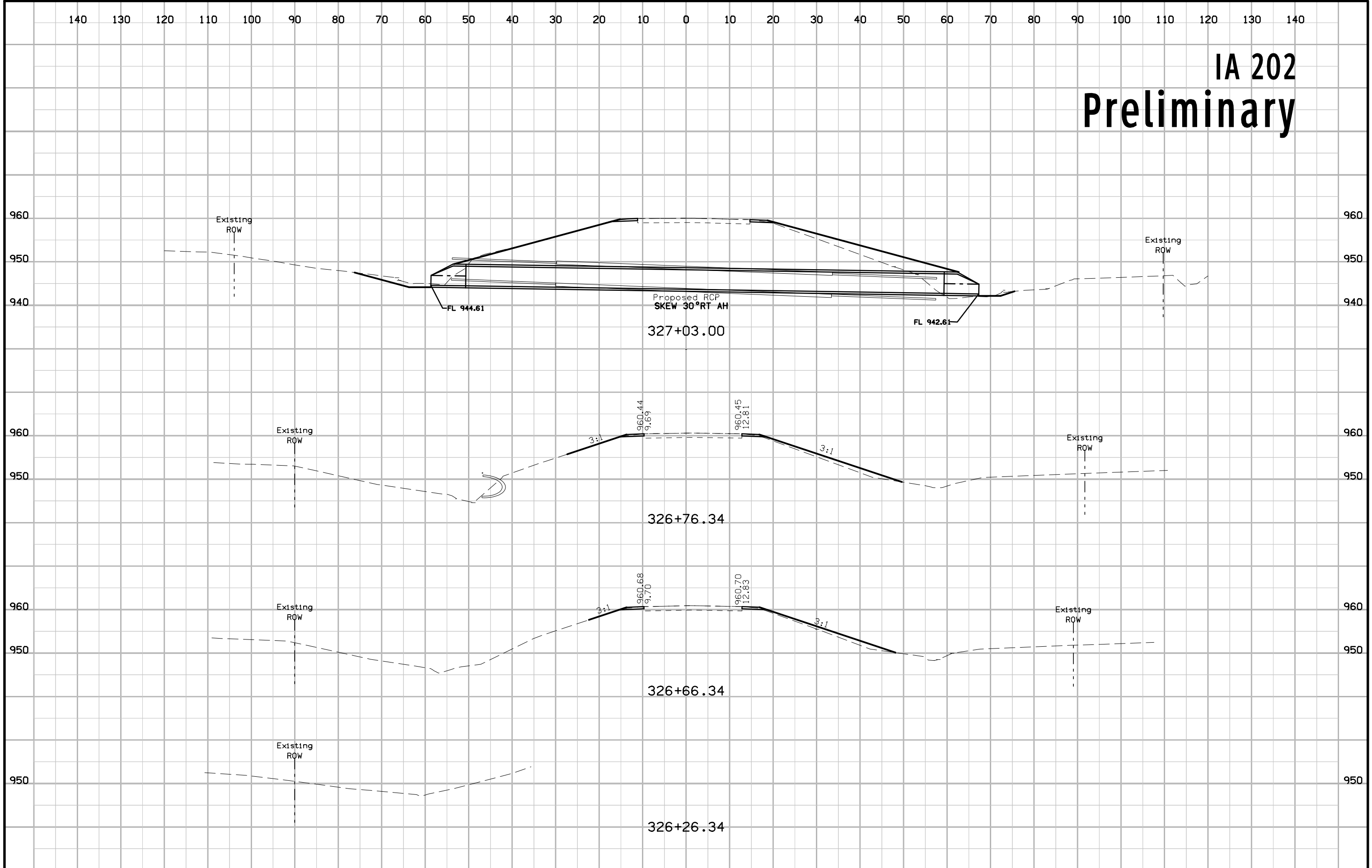

IA 202 Preliminary

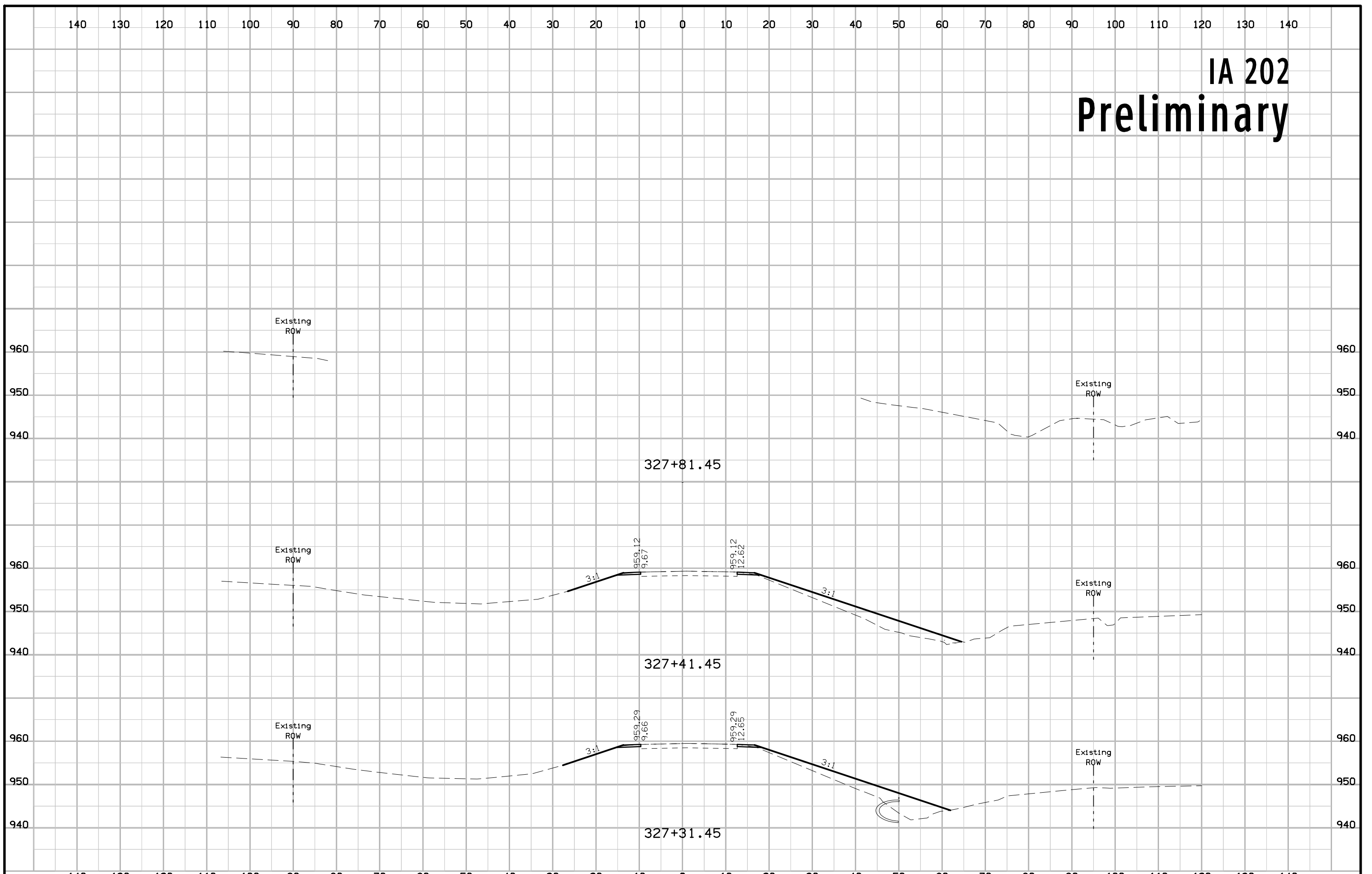

IA 202 Preliminary

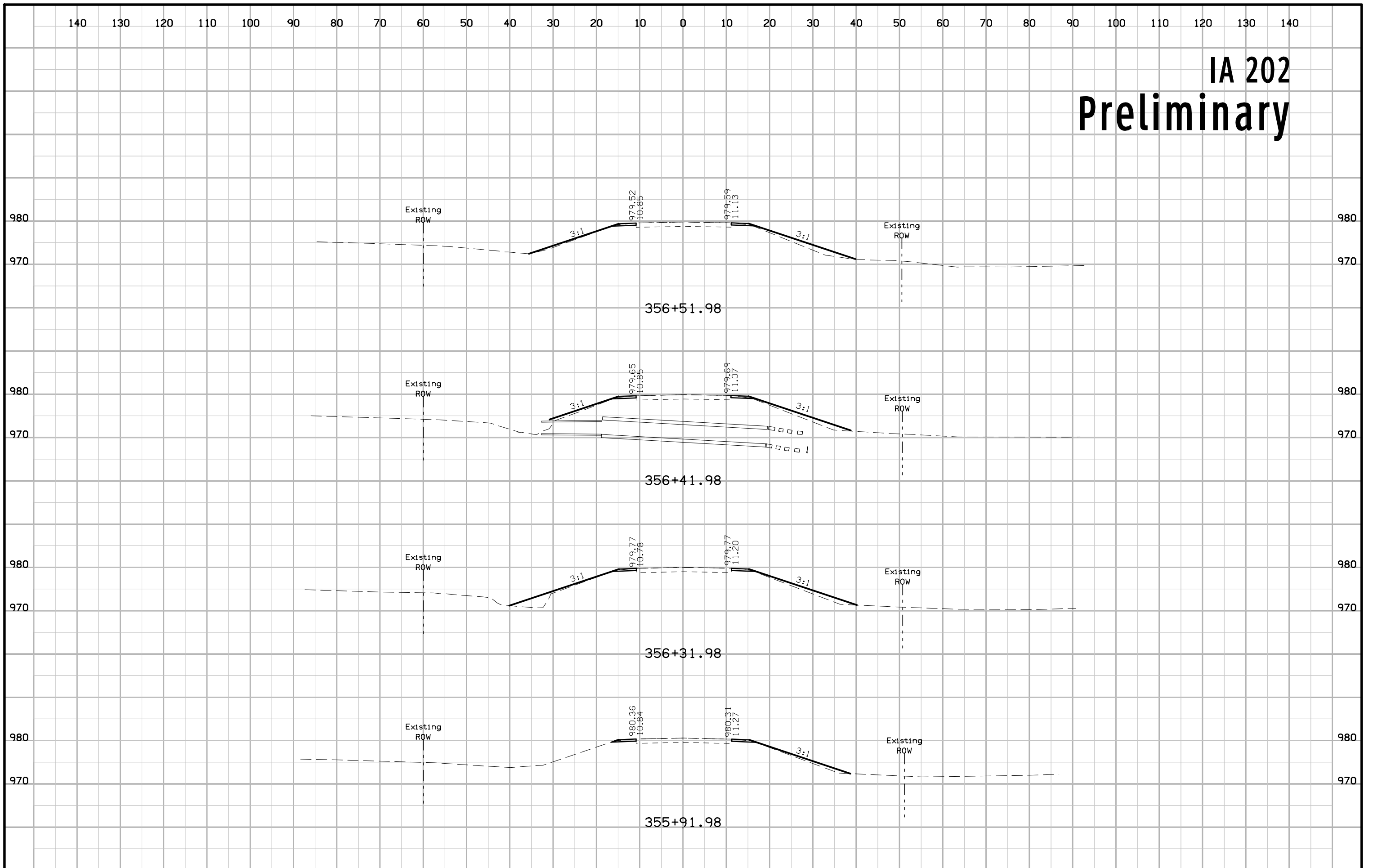

IA 202 Preliminary

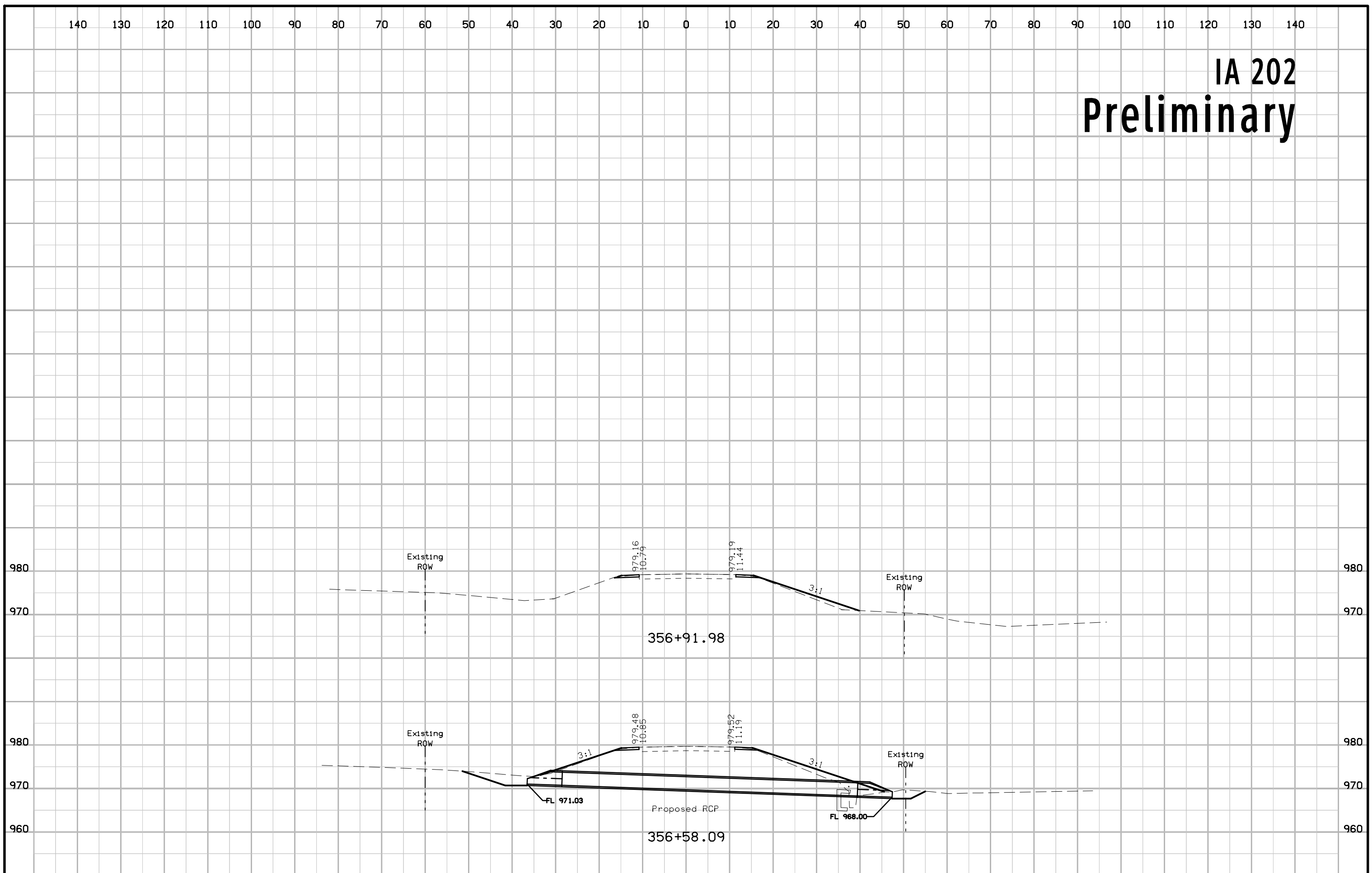

IA 202 Preliminary

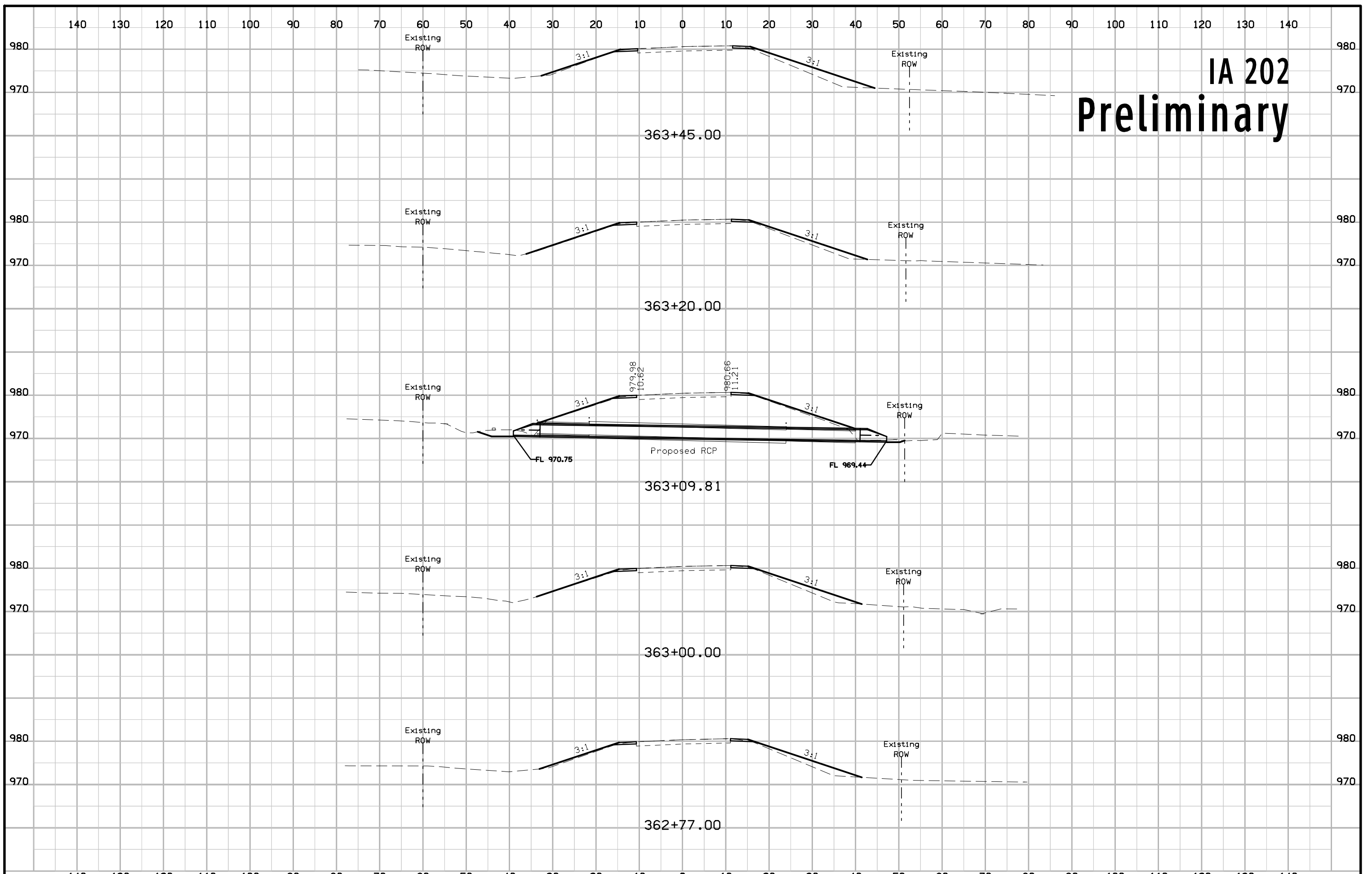

IA 202 Preliminary

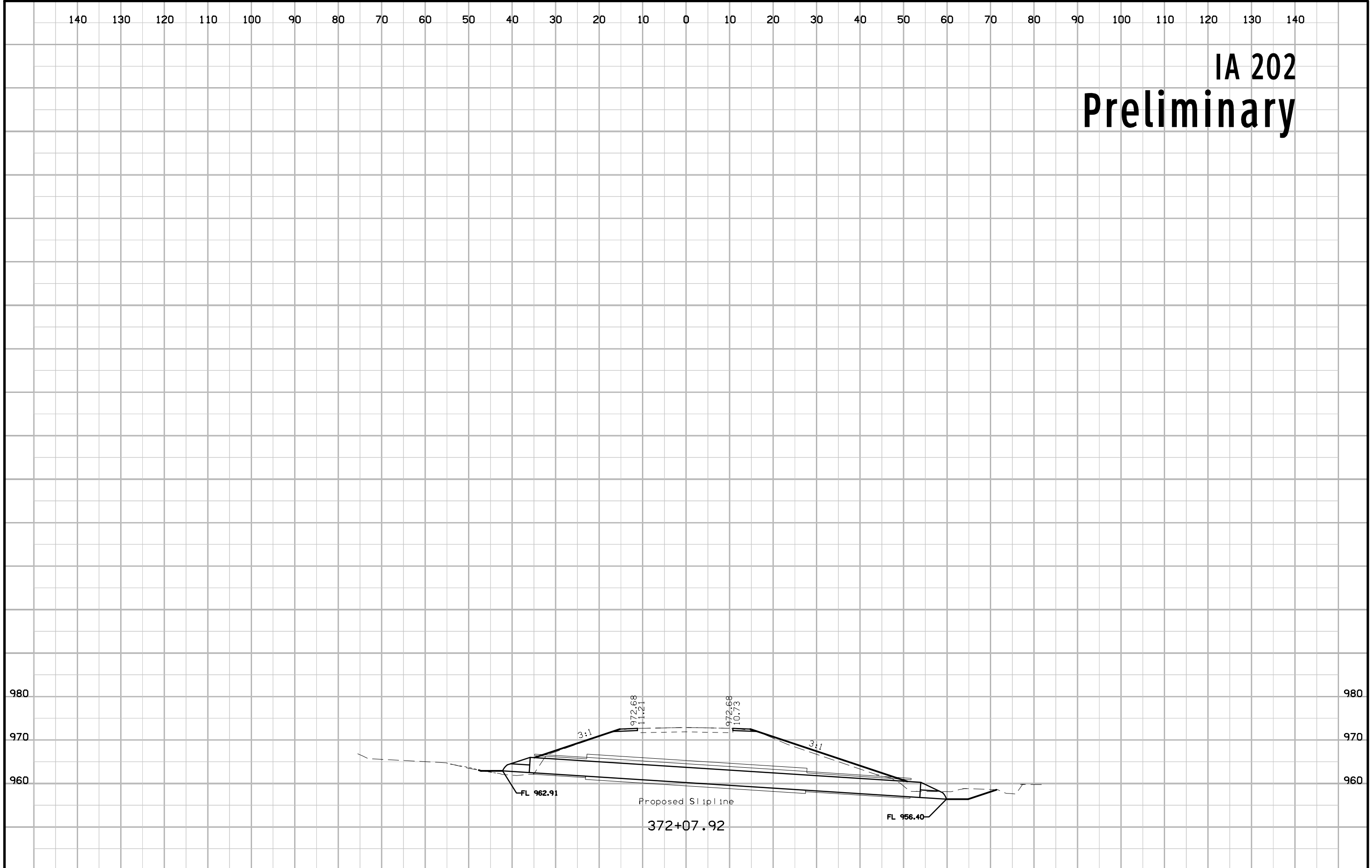

IA 202 Preliminary

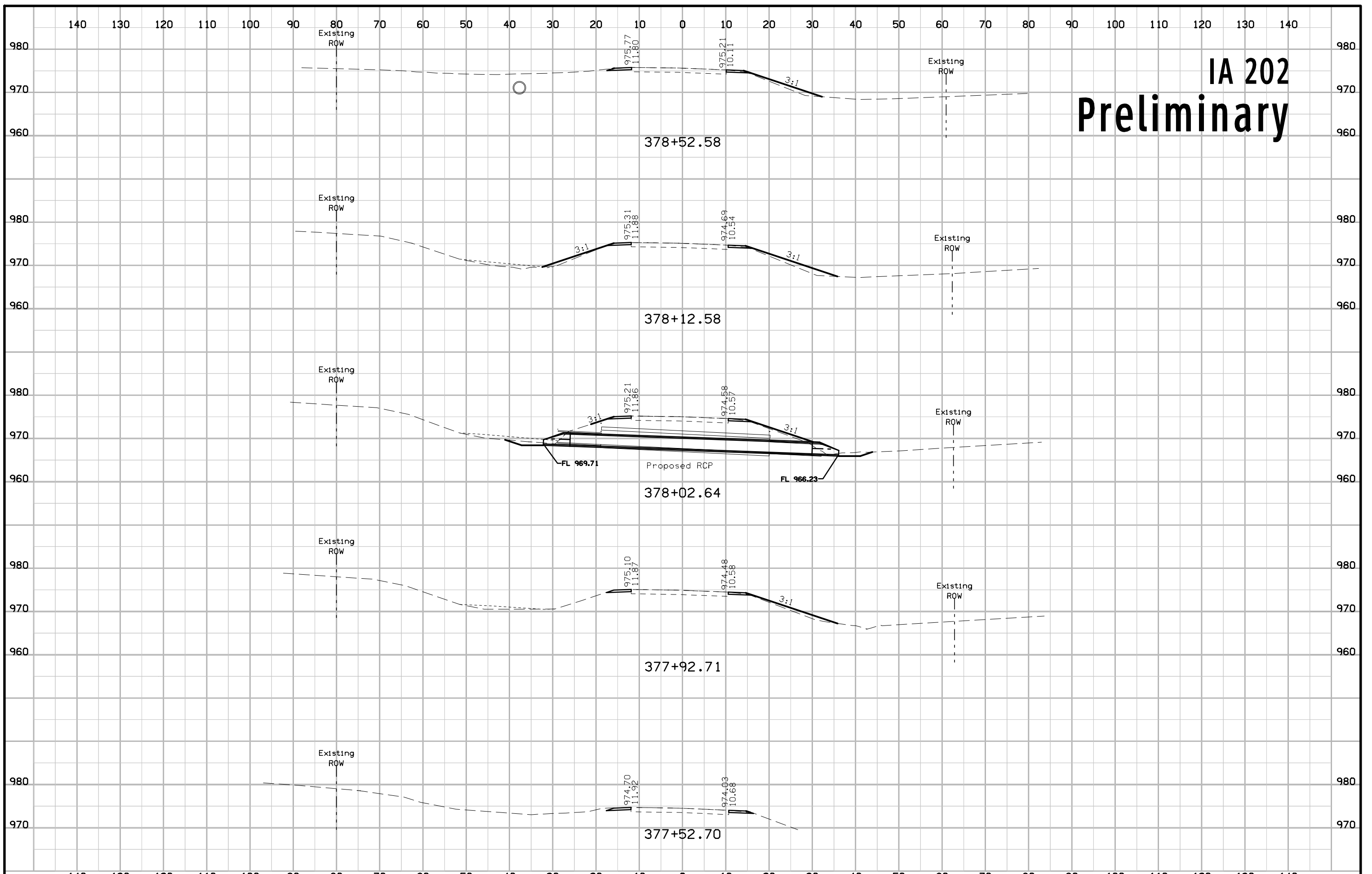

IA 202 Preliminary

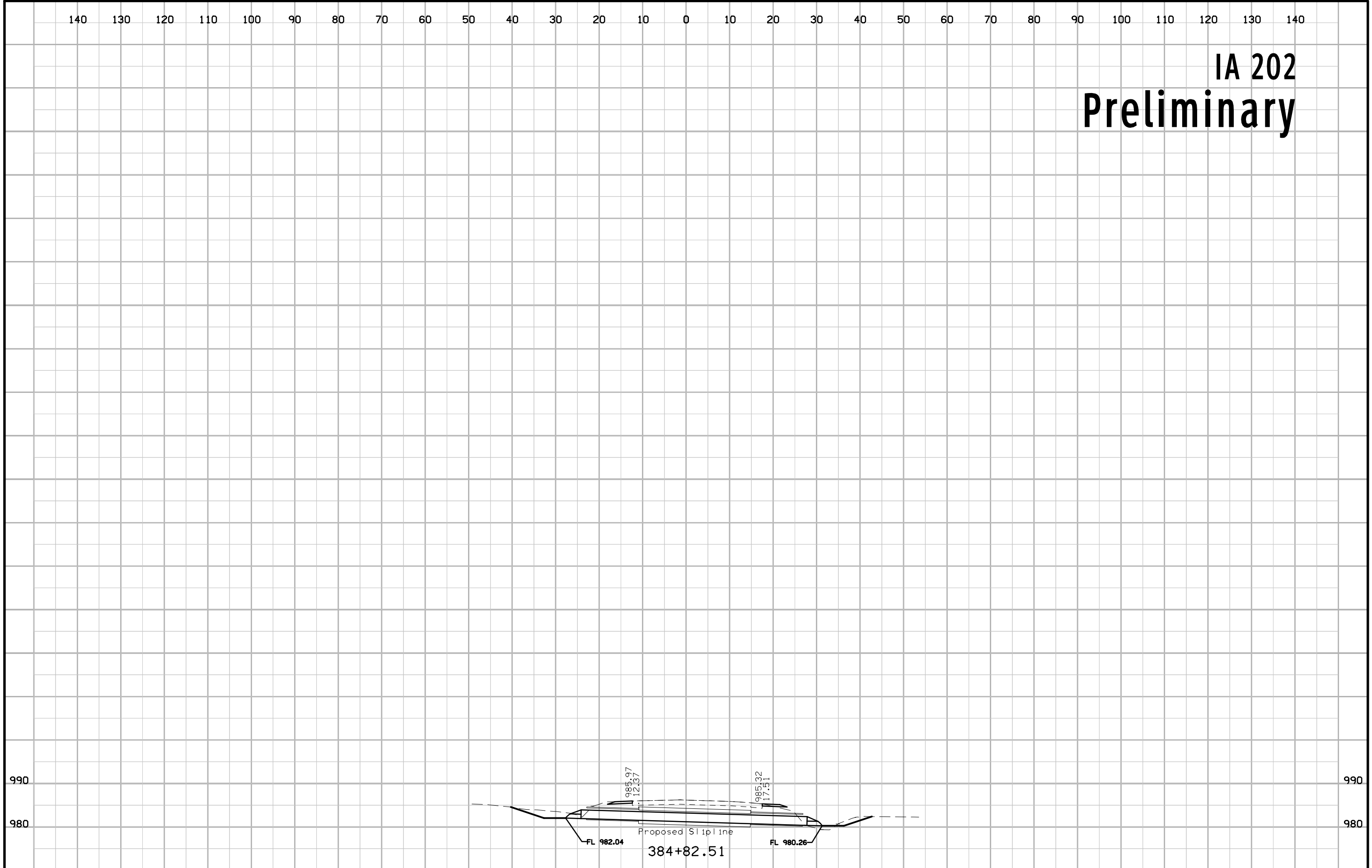

326TH AVE Preliminary

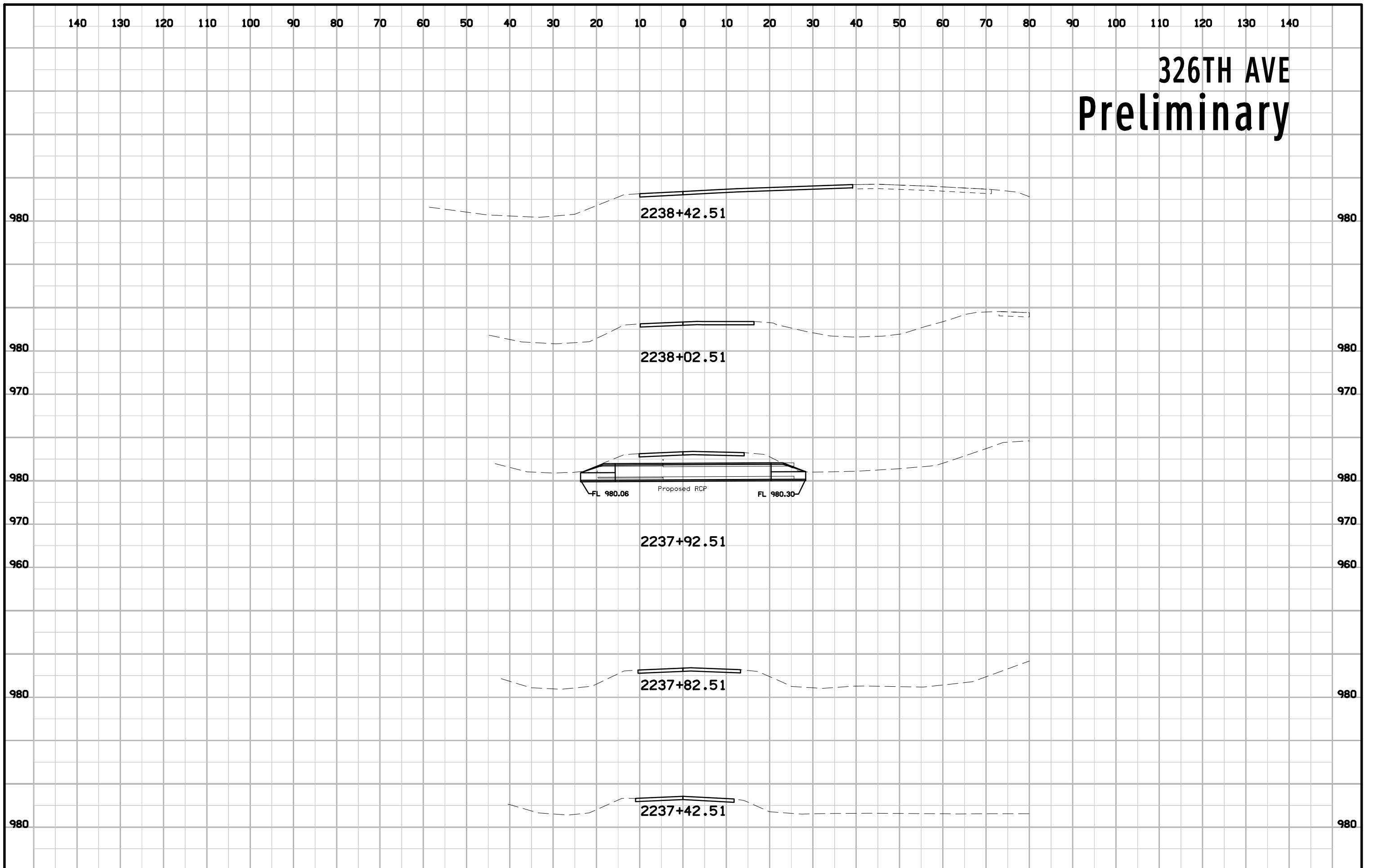

560TH ST Preliminary

