

# U.S. HIGHWAY 20 AND POPLAR AVENUE RCUT INTERSECTION IMPROVEMENTS

## WEBSTER COUNTY, IOWA

**McCLURE™**  
 705 First Avenue North  
 Fort Dodge, Iowa 50501  
 P 515-576-7155  
 F 515-576-4235

Ankeny, IA | Carroll, IA | Clive, IA  
 Cedar Rapids, IA | Fort Dodge, IA  
 North Liberty, IA | Sioux City, IA  
 Macon, MO | Columbia, MO  
 North Kansas City, MO  
 Lenexa, KS

**NOTICE:**  
 McClure Engineering Co. is not responsible or liable for any issues, claims, damages, or losses (collectively, "Losses") which arise from failure to follow these Plans, Specifications, and the engineering intent they convey, or for Losses which arise from failure to obtain and/or follow the engineers' or surveyors' guidance with respect to any alleged errors, omissions, inconsistencies, ambiguities, or conflicts contained within the Plans and Specifications.

IOWA CERTIFICATE OF AUTHORITY NO. 26887

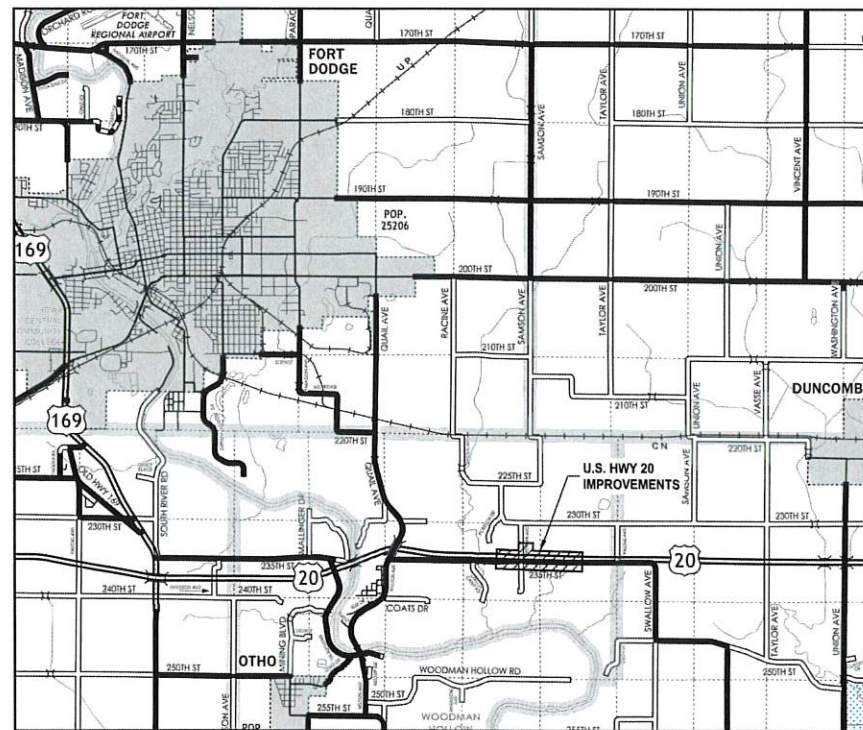

VICINITY MAP  
 WEBSTER COUNTY, IOWA

The most recent edition of the Iowa Department of Transportation Standard Specifications for Highway and Bridge Construction shall apply to all work on this project except as modified herein.

This project is covered by the Iowa Department of Natural Resources NPDES General Permit No. 2. The contractor shall carry out the terms and conditions of General Permit No. 2.

MILEAGE SUMMARY			
DIV.	LOCATION	LIN. FT.	MILES
1	U.S. HIGHWAY 20 - STA 870+80.14 TO STA 896+00.14	2520.00	0.48
1	POPLAR AVENUE - STA 1874+94.70 TO STA 1884+71.93	977.23	0.18
TOTAL		3497.23	0.66

INDEX OF SHEETS	
No.	Description
A.01	TITLE SHEET
A.02	OVERALL PROJECT LAYOUT
A.03	GENERAL LEGEND
A.04 - A.06	REMOVAL PLANS
B.01 - B.05	TYPICAL SECTIONS AND DETAILS
C.01 - C.05	QUANTITIES AND REFERENCE NOTES
C.06 - C.07	QUANTITIES AND REFERENCE NOTES
D.01 - D.03	U.S. HIGHWAY 20 PLAN AND PROFILE
E.01 - E.02	POPLAR AVENUE PLAN AND PROFILE
G.01	REFERENCE TIES, BENCHMARKS AND ALIGNMENT INFORMATION
J.01 - J.02	TEMPORARY TRAFFIC CONTROL PLAN AND DETAILS
L.01 - L.09	INTERSECTION GEOMETRIC STAKING AND JOINTING
N.01 - N.03	PAVEMENT MARKING PLANS
N.04 - N.07	SIGNING PLAN AND DETAILS
W.01 - W.05	U.S. HIGHWAY 20 CROSS SECTIONS
X.01 - X.02	POPLAR AVENUE CROSS SECTIONS

REVISIONS

PROJECT INFO  
 210178-004

ENGINEER: CFF  
 DRAWN BY: BAV  
 CHECKED BY: JSS

**IOWA ONE CALL™**  
 1-800-292-8989  
 www.iowaonecall.com

811  
 Know what's below.  
 Call before you dig.

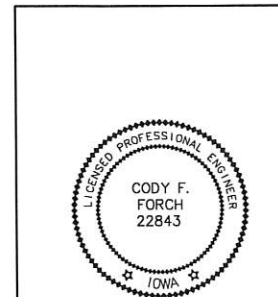
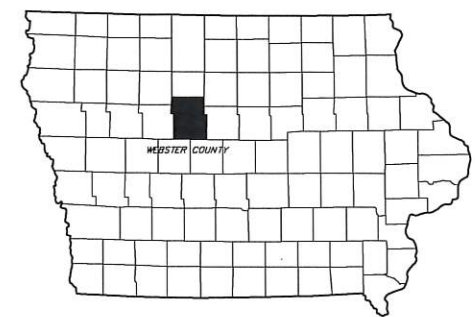

I HEREBY CERTIFY THAT THIS ENGINEERING DOCUMENT WAS PREPARED BY ME OR UNDER MY DIRECT PERSONAL SUPERVISION AND THAT I AM A DULY LICENSED PROFESSIONAL ENGINEER UNDER THE LAWS OF THE STATE OF IOWA.

*Cody Forch*  
 CODY F. FORCH, PE NO. 22843  
 DATE: 2/23/22

MY LICENSE RENEWAL DATE IS DECEMBER 31, 2022  
 PAGES OR SHEETS COVERED BY THIS SEAL:

A.01 - A.06; B.01 - B.05; C.01 - C.07; D.01 - D.03; E.01 - E.02; G.01; J.01 - J.02; L.01 - L.09; N.01 - N.07; W.01 - W.05; X.01 - X.02

US HIGHWAY 20 AND POPLAR AVENUE  
 RCUT INTERSECTION IMPROVEMENTS  
 WEBSTER COUNTY, IOWA

TITLE SHEET

R:\210178-004\06-DRAWING\CIVIL\PLANS\A.01.DWG

DRAWING NO.  
**A.01**



**McCLURE™**  
 705 First Avenue North  
 Fort Dodge, Iowa 50501  
 P 515-576-7155  
 F 515-576-4235

Ankeny, IA | Carroll, IA | Clive, IA  
 Cedar Rapids, IA | Fort Dodge, IA  
 North Liberty, IA | Sioux City, IA  
 Macon, MO | Columbia, MO  
 North Kansas City, MO  
 Lenexa, KS

**NOTICE:**  
 McClure Engineering Co. is not responsible or liable for any issues, claims, damages, or losses (collectively, "Losses") which arise from failure to follow these Plans, Specifications, and the engineering intent they convey, or for Losses which arise from failure to obtain and/or follow the engineers' or surveyors' guidance with respect to any alleged errors, omissions, inconsistencies, ambiguities, or conflicts contained within the Plans and Specifications.

IOWA CERTIFICATE OF AUTHORITY NO. 26887

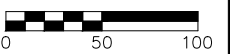

REVISIONS

PROJECT INFO  
 210178-004

ENGINEER: CFF  
 DRAWN BY: BAV  
 CHECKED BY: JSS

**US HIGHWAY 20 AND POPLAR AVENUE  
 RCUT INTERSECTION IMPROVEMENTS  
 WEBSTER COUNTY, IOWA**

**OVERALL PROJECT LOCATION**

R:210178-004-006-DRAWINGS\CIVIL\PLANS\A.02.DWG

DRAWING NO.  
**A.02**

**NOTICE:**  
 McClure Engineering Co. is not responsible or liable for any issues, claims, damages, or losses (collectively, "Losses") which arise from failure to follow these Plans, Specifications, and the engineering intent they convey, or for Losses which arise from failure to obtain and/or follow the engineers' or surveyors' guidance with respect to any alleged errors, omissions, inconsistencies, ambiguities, or conflicts contained within the Plans and Specifications.

IOWA CERTIFICATE OF AUTHORITY NO. 26887

REVISIONS

PROJECT INFO  
 210178-004

ENGINEER: CFF DRAWN BY: BAV CHECKED BY: JSS

US HIGHWAY 20 AND POPLAR AVENUE  
 RCUT INTERSECTION IMPROVEMENTS  
 WEBSTER COUNTY, IOWA

GENERAL LEGEND

DRAWING NO.  
**A.03**

# GENERAL LEGEND

EXISTING	PROPOSED	
8"SS	SS	SANITARY SEWER MAIN
SS	SS	SANITARY SEWER SERVICE
6"FM	6"FM	SANITARY SEWER FORCE MAIN
ST	ST	STORM SEWER MAIN OR CULVERT
ST	ST	SECONDARY STORM SEWER MAIN
ST	ST	SECONDARY STORM SEWER SERVICE
→	→	SUBDRAIN/TILE
W	W	WATER MAIN
UE	UE	WATER SERVICE
OHE	OHE	UNDERGROUND ELECTRIC
T	T	OVERHEAD ELECTRIC
FO	FO	UNDERGROUND TELEPHONE
TV	TV	UNDERGROUND FIBER OPTIC
G	G	UNDERGROUND CABLE TV
949	949	GAS MAIN OR SERVICE
950	950	CONTOUR LINES INTERMEDIATE
950	950	CONTOUR LINES INDEX
R/W	ROW	PROPERTY LINE / LOT LINE
		RIGHT OF WAY LINE
		SECTION LINE
		EASEMENT
X	X	GUARD RAIL
O	O	FIELD FENCE
□	□	CHAIN LINK FENCE
		WOODEN FENCE
		ROAD CENTERLINE
		GRADING LIMITS
		CONSTRUCTION LIMITS
AG	AG	AG LINE
		WATERWAY FLOWLINE
		TOP OF SLOPE
		BOTTOM OF SLOPE
		SILT FENCE

EXISTING	PROPOSED	
⊙	⊙	SANITARY SEWER MANHOLE
⊙	⊙	SANITARY SEWER CLEANOUT
⊙	⊙	AIR RELEASE MANHOLE/DRAIN MANHOLE
⊙	⊙	STORM SEWER MANHOLE
⊙	⊙	STORM SEWER CLEANOUT
⊙	⊙	STORM SEWER INTAKE
⊙	⊙	STORM SEWER BEEHIVE INTAKE
⊙	⊙	FLARED END SECTION
⊙	⊙	FIRE HYDRANT
⊙	⊙	WATER VALVE
⊙	⊙	WATER VALVE MANHOLE
⊙	⊙	CURB STOP
⊙	⊙	WATER METER MANHOLE
⊙	⊙	YARD HYDRANT
⊙	⊙	ELECTRIC MANHOLE / VAULT
⊙	⊙	ELECTRIC PEDESTAL / TRANSFORMER
⊙	⊙	OUTDOOR ELECTRIC POWER OUTLET
⊙	⊙	POWER POLE
⊙	⊙	POWER POLE w/ STREET LIGHT
⊙	⊙	STREET LIGHT POLE
⊙	⊙	GUY WIRE
⊙	⊙	FLOODLIGHT
⊙	⊙	FIBER OPTIC MARKER
⊙	⊙	TRAFFIC SIGNAL
⊙	⊙	TRAFFIC SIGNAL BOX
⊙	⊙	TRAFFIC SIGNAL MANHOLE / VAULT
⊙	⊙	RAILROAD CROSSING SIGNAL
⊙	⊙	TELEPHONE MANHOLE / VAULT
⊙	⊙	TELEPHONE PEDESTAL
⊙	⊙	CABLE TV MANHOLE / VAULT
⊙	⊙	CABLE TV PEDESTAL
⊙	⊙	GAS VALVE
⊙	⊙	IRRIGATION HANDHOLE
⊙	⊙	BOLLARD (BUMPER POST)
⊙	⊙	ROADWAY SIGN
⊙	⊙	MAILBOX
⊙	⊙	WELL
⊙	⊙	DECIDUOUS TREE
⊙	⊙	EVERGREEN TREE
⊙	⊙	SHRUB OR BUSH
⊙	⊙	TREE OR SHRUB LINE
⊙	⊙	STUMP
⊙	⊙	MONITORING WELL
⊙	⊙	SOIL BORINGS
⊙	⊙	FLAG POLE
⊙	⊙	SATELLITE DISH
⊙	⊙	SLOPE INDICATORS
⊙	⊙	CONTROL POINT
⊙	⊙	BENCH MARK
⊙	⊙	SECTION CORNER
⊙	⊙	IRON PIN SET
⊙	⊙	IRON PIN FOUND

ABBREVIATIONS			
T/S	TOP OF SLAB	TOP	TOP OF SLOPE
BC	BACK OF CURB	BOT	BOTTOM OF SLOPE
TC	TOP OF CURB	EP	EDGE OF PAVING
FG	FORM GRADE	BOP	BEGINNING OF PROJECT
FL	FLOWLINE	EOP	END OF PROJECT
CL	CENTERLINE	UAC	USE AS CONSTRUCTED
C	CUT		
F	FILL		

UTILITY CONTACT INFORMATION

IOWA ONE CALL	Ph: 811
<b>FRONTIER COMMUNICATIONS</b>	515-573-1268
Contact: Trent Flockhart	
Email: trent.flockhart@ftr.com	
<b>IOWA COMMUNICATIONS NETWORK</b>	800-572-3940
Contact: Shannon Marlow	
Email: icnoutsideplantowaonecall@iowa.gov	
<b>LEHIGH VALLEY COOP TELEPHONE</b>	515-359-2211
Contact: Jim Suchan	
Email: jsmgr@lvcta.com	
<b>MIDAMERICAN (ELECTRIC)</b>	515-574-5042
Contact: Brian Sewell	
Email: bjsewell@midamerican.com	
<b>MIDAMERICAN (GAS)</b>	515-574-5040
Contact: Jim Blocker	
Email: jhblocker@midamerican.com	
<b>MIDAMERICAN (FIBER)</b>	515-281-2313
Contact: Telecom On Call	
Email: telecomoncall@midamerican.com	
<b>NORTHERN NATURAL GAS COMPANY</b>	515-202-5067
Contact: Keith Good	
Email: keith.good@nngco.com	
<b>XENIA RURAL WATER DISTRICT</b>	515-676-2117
Contact: Laird Van Dee	
Email: lvandee@xenialwater.org	

UTILITY QUALITY SERVICE LEVELS:

UTILITY QUALITY LEVELS ARE BASED ON THE C/ASCE 38-02 STANDARD.

**UTILITY QUALITY LEVEL A:**  
 PRECISE HORIZONTAL AND VERTICAL LOCATION OF UTILITIES OBTAINED BY THE ACTUAL EXPOSURE (OR VERIFICATION OF PREVIOUSLY EXPOSED AND SURVEYED UTILITIES) AND SUBSEQUENT MEASUREMENT OF SUBSURFACE UTILITIES.

**UTILITY QUALITY LEVEL B:**  
 INFORMATION OBTAINED THROUGH THE APPLICATION OF APPROPRIATE SURFACE GEOPHYSICAL METHODS TO DETERMINE THE EXISTENCE AND APPROXIMATE HORIZONTAL POSITION OF SUBSURFACE UTILITIES.

**UTILITY QUALITY LEVEL C:**  
 INFORMATION OBTAINED BY SURVEYING AND PLOTTING VISIBLE ABOVE-GROUND UTILITY FEATURES AND BY USING PROFESSIONAL JUDGMENT IN CORRELATING THIS INFORMATION TO QUALITY LEVEL D INFORMATION.

**UTILITY QUALITY LEVEL D:**  
 INFORMATION DERIVED FROM EXISTING RECORDS OR ORAL RECOLLECTIONS.

EXAMPLES:

8"SS(A)	SANITARY SEWER MAIN - QUALITY SERVICE LEVEL A
8"SS(B)	SANITARY SEWER MAIN - QUALITY SERVICE LEVEL B
8"SS(C)	SANITARY SEWER MAIN - QUALITY SERVICE LEVEL C
8"SS(D)	SANITARY SEWER MAIN - QUALITY SERVICE LEVEL D

NOTICE:  
 McClure Engineering Co. is not responsible or liable for any issues, claims, damages, or losses (collectively, "Losses") which arise from failure to follow these Plans, Specifications, and the engineering intent they convey, or for Losses which arise from failure to obtain and/or follow the engineers' or surveyors' guidance with respect to any alleged errors, omissions, inconsistencies, ambiguities, or conflicts contained within the Plans and Specifications.

IOWA CERTIFICATE OF AUTHORITY NO. 26887

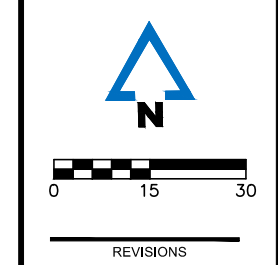

PROJECT INFO  
 210178-004

ENGINEER: CFF DRAWN BY: BAV CHECKED BY: JSS

**US HIGHWAY 20 AND POPLAR AVENUE  
 RCUT INTERSECTION IMPROVEMENTS  
 WEBSTER COUNTY, IOWA**

**U.S. HIGHWAY 20 REMOVAL PLAN**

DRAWING NO.  
**A.04**

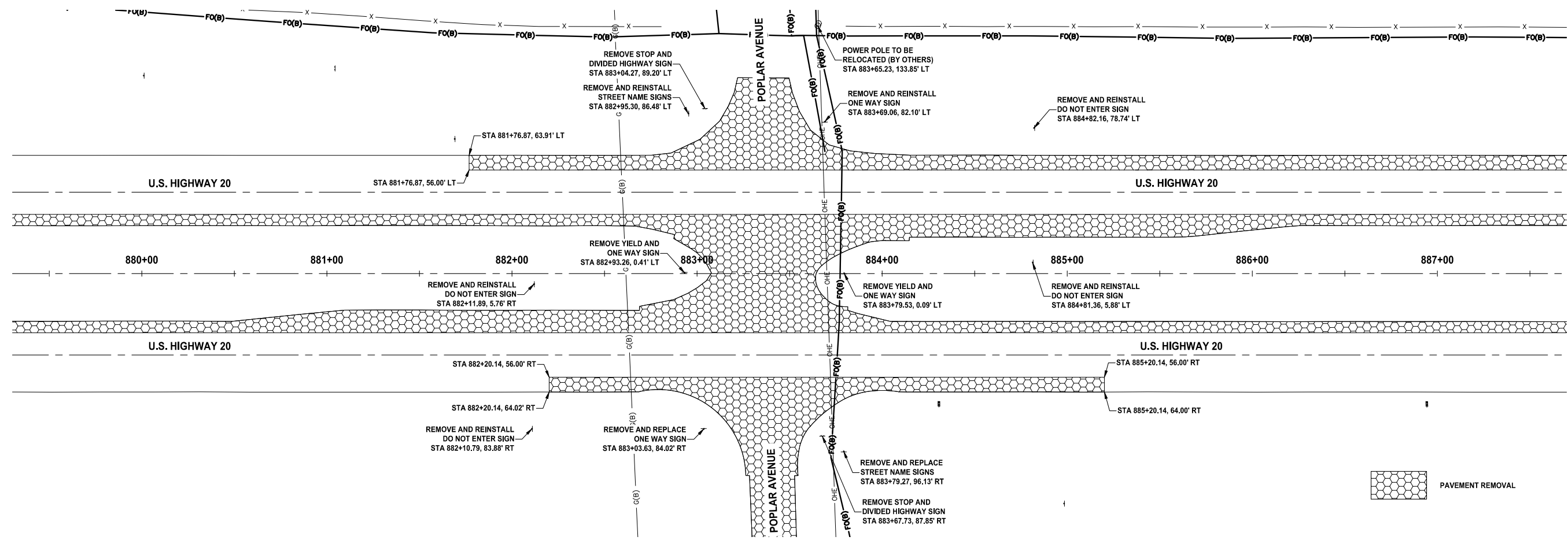
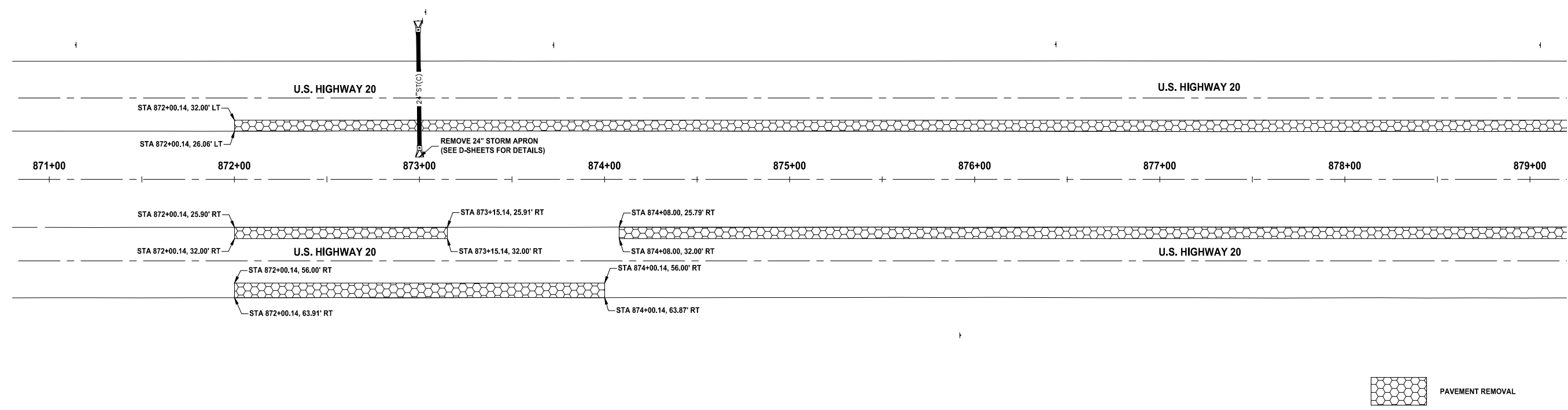

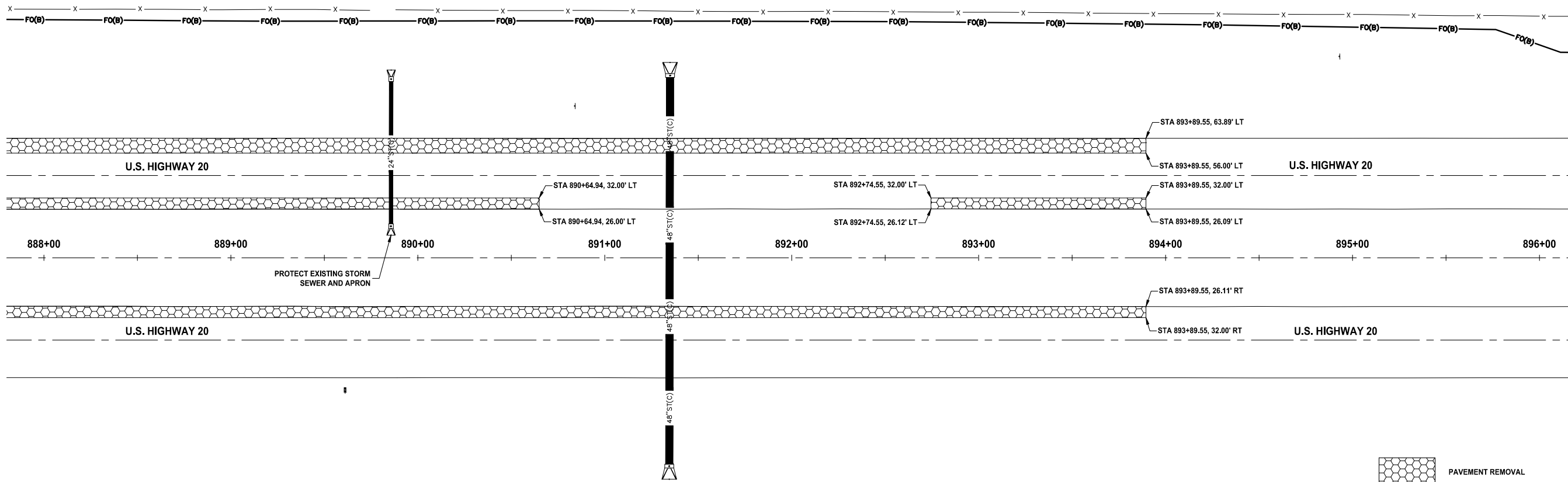

 PAVEMENT REMOVAL



705 First Avenue North  
Fort Dodge, Iowa 50501  
P 515-576-7155  
F 515-576-4235

Ankeny, IA | Carroll, IA | Clive, IA  
Cedar Rapids, IA | Fort Dodge, IA  
North Liberty, IA | Sioux City, IA  
Macon, MO | Columbia, MO  
North Kansas City, MO  
Lenexa, KS

NOTICE:  
McClure Engineering Co. is not responsible or liable for any issues, claims, damages, or losses (collectively, "Losses") which arise from failure to follow these Plans, Specifications, and the engineering intent they convey, or for Losses which arise from failure to obtain and/or follow the engineers' or surveyors' guidance with respect to any alleged errors, omissions, inconsistencies, ambiguities, or conflicts contained within the Plans and Specifications.

IOWA CERTIFICATE OF AUTHORITY NO. 26887



REVISIONS

PROJECT INFO  
210178-004

ENGINEER	DRAWN BY	CHECKED BY
CFF	BAV	JSS

US HIGHWAY 20 AND POPLAR AVENUE  
RCUT INTERSECTION IMPROVEMENTS  
WEBSTER COUNTY, IOWA

---

U.S. HIGHWAY 20 REMOVAL PLAN

DRAWING NO.  
**A.05**

R:210178-004-06-DRAWINGS\CIVIL\PLANS\A.04.DWG

**NOTICE:**  
 McClure Engineering Co. is not responsible or liable for any issues, claims, damages, or losses (collectively, "Losses") which arise from failure to follow these Plans, Specifications, and the engineering intent they convey, or for Losses which arise from failure to obtain and/or follow the engineers' or surveyors' guidance with respect to any alleged errors, omissions, inconsistencies, ambiguities, or conflicts contained within the Plans and Specifications.

IOWA CERTIFICATE OF AUTHORITY NO. 26887

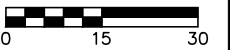

REVISIONS

PROJECT INFO  
 210178-004

ENGINEER	DRAWN BY	CHECKED BY
CFF	BAV	JSS

**US HIGHWAY 20 AND POPLAR AVENUE  
 RCUT INTERSECTION IMPROVEMENTS  
 WEBSTER COUNTY, IOWA**

**POPLAR AVENUE REMOVAL PLAN**

DRAWING NO.

**A.06**

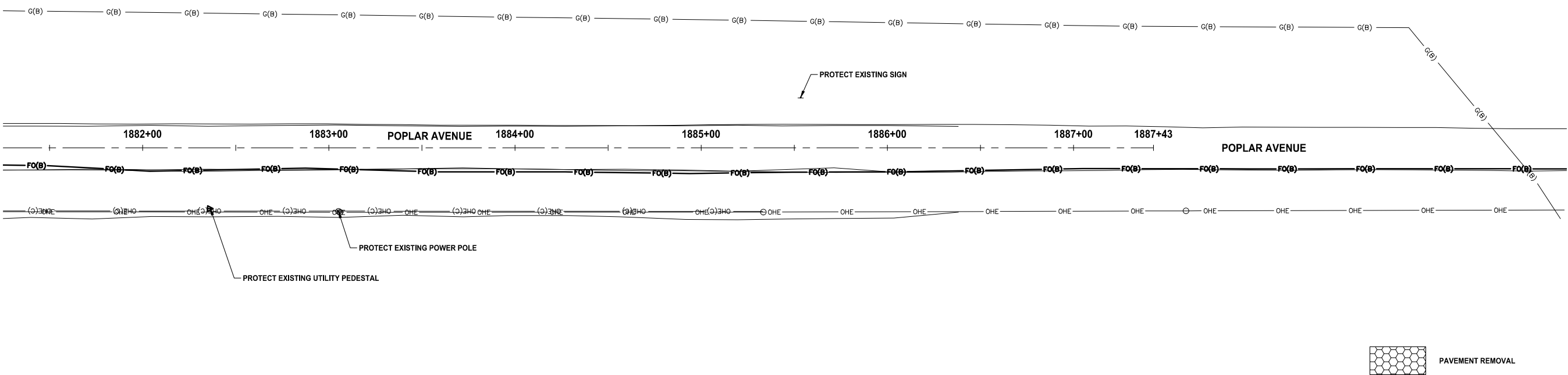
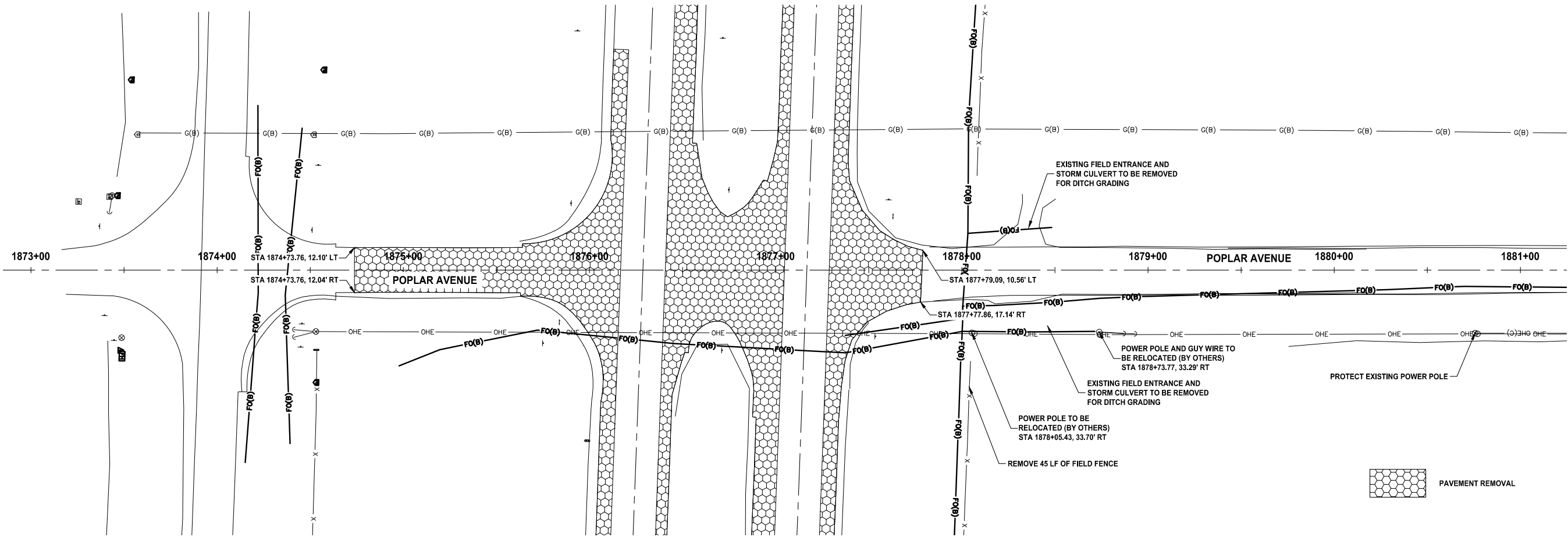

R:210178-004-06-DRAWINGS\CIVIL\PLANS\A.06.DWG

NOTICE:  
 McClure Engineering Co. is not responsible or liable for any issues, claims, damages, or losses (collectively, "Losses") which arise from failure to follow these Plans, Specifications, and the engineering intent they convey, or for Losses which arise from failure to obtain and/or follow the engineers' or surveyors' guidance with respect to any alleged errors, omissions, inconsistencies, ambiguities, or conflicts contained within the Plans and Specifications.

IOWA CERTIFICATE OF AUTHORITY NO. 26887

REVISIONS

PROJECT INFO  
 210178-004  
 ENGINEER: CFF DRAWN BY: BAV CHECKED BY: JSS

US HIGHWAY 20 AND POPLAR AVENUE  
 RCUT INTERSECTION IMPROVEMENTS  
 WEBSTER COUNTY, IOWA  
 TYPICAL SECTIONS  
 R:210178-004-006-DRAWINGS\CIVIL\PLANS\B.01.DWG

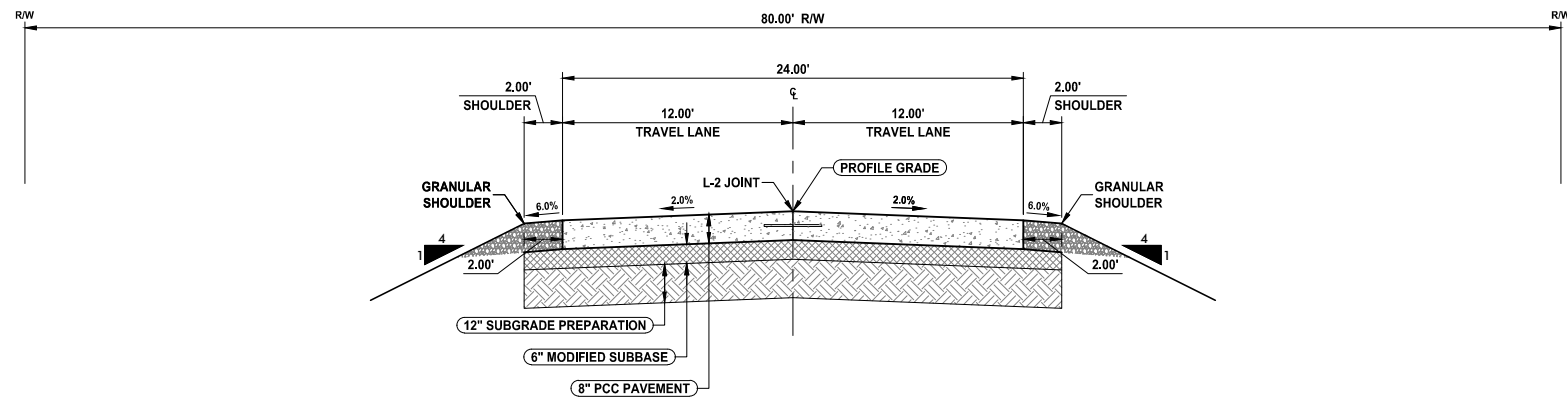

**24' PCC PAVEMENT TYPICAL SECTION  
 2 LANE - POPLAR AVENUE**  
 NOT TO SCALE

STATION TO STATION
1878+87.50 TO 1884+71.93

NOTE:  
 1. NORMAL SECTIONS SHOWN MAY BE APPROPRIATELY MODIFIED FOR AREAS SPECIFICALLY DESIGNATED BY THE ENGINEER SUCH AS INTERSECTIONS. REFER TO OTHER DRAWINGS FOR DETAILS.  
 2. SEE L-SHEETS FOR JOINT SPACING

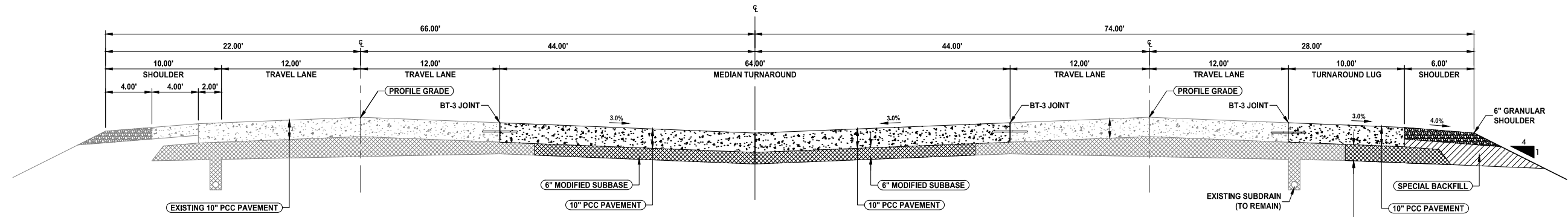

**EAST AND WESTBOUND TYPICAL SECTION  
 4 LANE - U.S. HIGHWAY 20**  
 NOT TO SCALE

STATION TO STATION
872+00.14 TO 873+00.14

NOTE:  
 1. NORMAL SECTIONS SHOWN MAY BE APPROPRIATELY MODIFIED FOR AREAS SPECIFICALLY DESIGNATED BY THE ENGINEER SUCH AS INTERSECTIONS. REFER TO OTHER DRAWINGS FOR DETAILS.  
 2. SEE L-SHEETS FOR JOINT SPACING

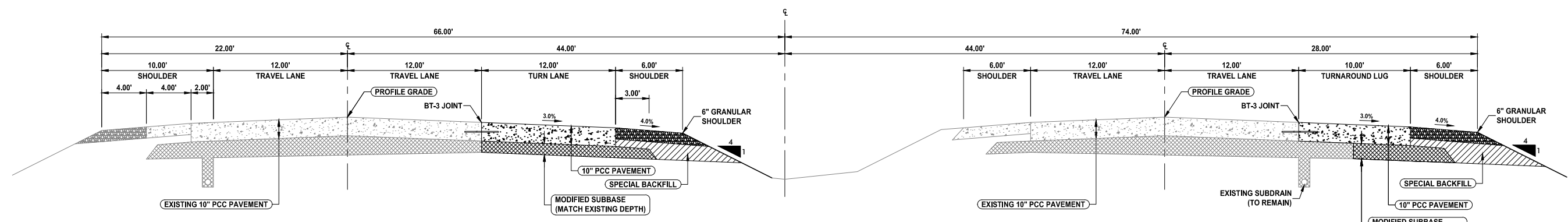

**EAST AND WESTBOUND TYPICAL SECTION  
 4 LANE - U.S. HIGHWAY 20**  
 NOT TO SCALE

STATION TO STATION
873+00.14 TO 874+00.14

NOTE:  
 1. NORMAL SECTIONS SHOWN MAY BE APPROPRIATELY MODIFIED FOR AREAS SPECIFICALLY DESIGNATED BY THE ENGINEER SUCH AS INTERSECTIONS. REFER TO OTHER DRAWINGS FOR DETAILS.  
 2. SEE L-SHEETS FOR JOINT SPACING

NOTICE:  
 McClure Engineering Co. is not responsible or liable for any issues, claims, damages, or losses (collectively, "Losses") which arise from failure to follow these Plans, Specifications, and the engineering intent they convey, or for Losses which arise from failure to obtain and/or follow the engineers' or surveyors' guidance with respect to any alleged errors, omissions, inconsistencies, ambiguities, or conflicts contained within the Plans and Specifications.

IOWA CERTIFICATE OF AUTHORITY NO. 26887

REVISIONS

PROJECT INFO  
 210178-004

ENGINEER: CFF    DRAWN BY: BAV    CHECKED BY: JSS

US HIGHWAY 20 AND POPLAR AVENUE  
 RCUT INTERSECTION IMPROVEMENTS  
 WEBSTER COUNTY, IOWA

TYPICAL SECTIONS

R:1210178-004106-DRAWINGS\CIVIL\PLANS\B.01.DWG

DRAWING NO.  
**B.02**

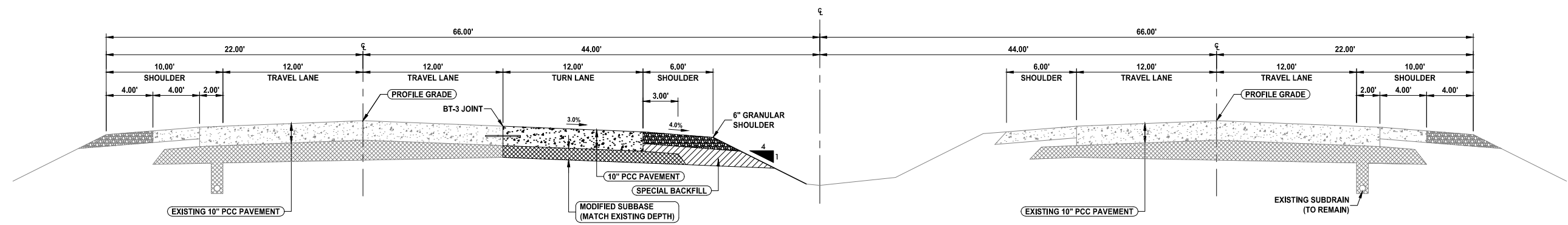

**EAST AND WESTBOUND TYPICAL SECTION  
 4 LANE - U.S. HIGHWAY 20**  
 NOT TO SCALE

STATION TO STATION
874+00.14 TO 874+08.00

NOTE:  
 1. NORMAL SECTIONS SHOWN MAY BE APPROPRIATELY MODIFIED FOR AREAS SPECIFICALLY DESIGNATED BY THE ENGINEER SUCH AS INTERSECTIONS. REFER TO OTHER DRAWINGS FOR DETAILS.  
 2. SEE L-SHEETS FOR JOINT SPACING

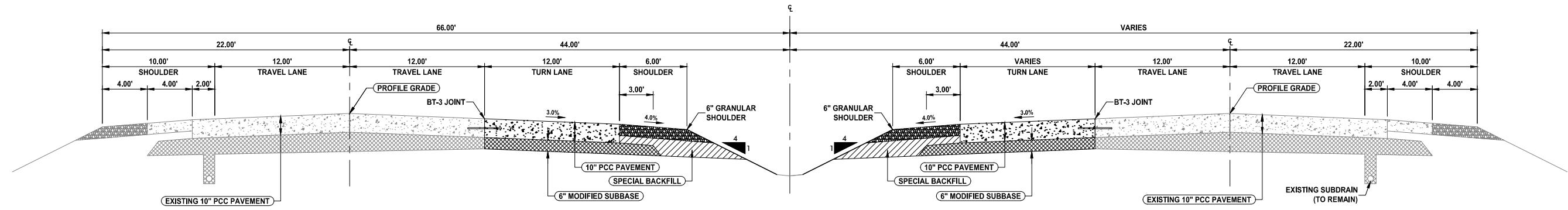

**EAST AND WESTBOUND TYPICAL SECTION  
 4 LANE - U.S. HIGHWAY 20**  
 NOT TO SCALE

STATION TO STATION
874+08.00 TO 875+43.00

NOTE:  
 1. NORMAL SECTIONS SHOWN MAY BE APPROPRIATELY MODIFIED FOR AREAS SPECIFICALLY DESIGNATED BY THE ENGINEER SUCH AS INTERSECTIONS. REFER TO OTHER DRAWINGS FOR DETAILS.  
 2. SEE L-SHEETS FOR JOINT SPACING

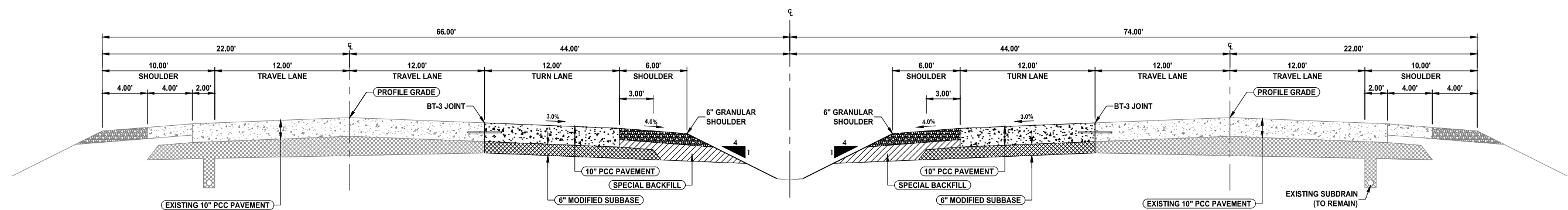

**EAST AND WESTBOUND TYPICAL SECTION  
 4 LANE - U.S. HIGHWAY 20**  
 NOT TO SCALE

STATION TO STATION
875+43.00 TO 881+00.14

NOTE:  
 1. NORMAL SECTIONS SHOWN MAY BE APPROPRIATELY MODIFIED FOR AREAS SPECIFICALLY DESIGNATED BY THE ENGINEER SUCH AS INTERSECTIONS. REFER TO OTHER DRAWINGS FOR DETAILS.  
 2. SEE L-SHEETS FOR JOINT SPACING



NOTICE:  
 McClure Engineering Co. is not responsible or liable for any issues, claims, damages, or losses (collectively, "Losses") which arise from failure to follow these Plans, Specifications, and the engineering intent they convey, or for Losses which arise from failure to obtain and/or follow the engineers' or surveyors' guidance with respect to any alleged errors, omissions, inconsistencies, ambiguities, or conflicts contained within the Plans and Specifications.

IOWA CERTIFICATE OF AUTHORITY NO. 26887

REVISIONS

PROJECT INFO  
 210178-004  
 ENGINEER: CFF DRAWN BY: BAV CHECKED BY: JSS

US HIGHWAY 20 AND POPLAR AVENUE  
 RCUT INTERSECTION IMPROVEMENTS  
 WEBSTER COUNTY, IOWA  
 TYPICAL SECTIONS  
 R:1210178-004106-DRAWINGS\CIVIL\PLANS\B.01.DWG

DRAWING NO.  
**B.03**

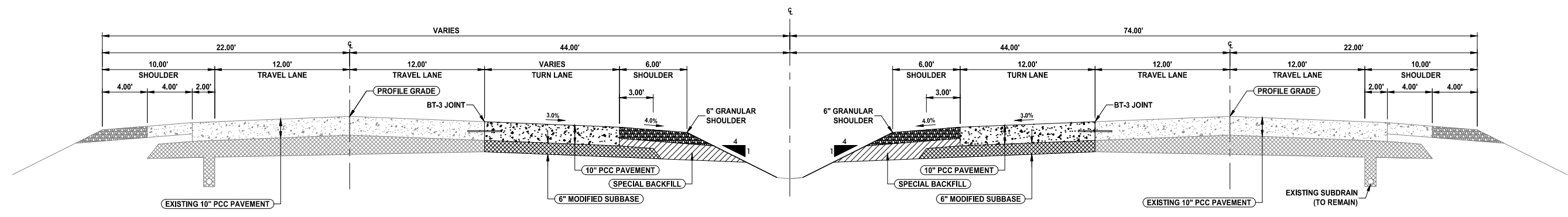

NOTE:  
 1. NORMAL SECTIONS SHOWN MAY BE APPROPRIATELY MODIFIED FOR AREAS SPECIFICALLY DESIGNATED BY THE ENGINEER SUCH AS INTERSECTIONS. REFER TO OTHER DRAWINGS FOR DETAILS.  
 2. SEE L-SHEETS FOR JOINT SPACING

**EAST AND WESTBOUND TYPICAL SECTION  
 4 LANE - U.S. HIGHWAY 20**  
 NOT TO SCALE

STATION TO STATION
881+00.14 TO 881+76.87

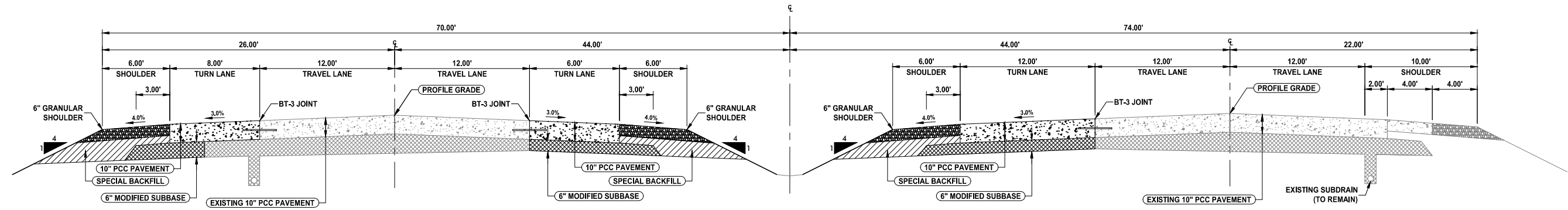

NOTE:  
 1. NORMAL SECTIONS SHOWN MAY BE APPROPRIATELY MODIFIED FOR AREAS SPECIFICALLY DESIGNATED BY THE ENGINEER SUCH AS INTERSECTIONS. REFER TO OTHER DRAWINGS FOR DETAILS.  
 2. SEE L-SHEETS FOR JOINT SPACING

**EAST AND WESTBOUND TYPICAL SECTION  
 4 LANE - U.S. HIGHWAY 20**  
 NOT TO SCALE

STATION TO STATION
881+76.87 TO 882+37.81

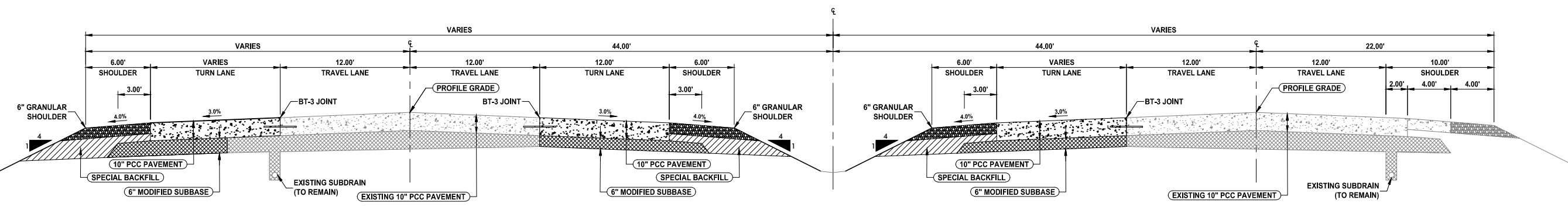

NOTE:  
 1. NORMAL SECTIONS SHOWN MAY BE APPROPRIATELY MODIFIED FOR AREAS SPECIFICALLY DESIGNATED BY THE ENGINEER SUCH AS INTERSECTIONS. REFER TO OTHER DRAWINGS FOR DETAILS.  
 2. SEE L-SHEETS FOR JOINT SPACING

**EAST AND WESTBOUND TYPICAL SECTION  
 4 LANE - U.S. HIGHWAY 20**  
 NOT TO SCALE

STATION TO STATION
884+35.13 TO 885+89.55

NOTICE:  
 McClure Engineering Co. is not responsible or liable for any issues, claims, damages, or losses (collectively, "Losses") which arise from failure to follow these Plans, Specifications, and the engineering intent they convey, or for Losses which arise from failure to obtain and/or follow the engineers' or surveyors' guidance with respect to any alleged errors, omissions, inconsistencies, ambiguities, or conflicts contained within the Plans and Specifications.

IOWA CERTIFICATE OF AUTHORITY NO. 26887

REVISIONS

PROJECT INFO  
 210178-004  
 ENGINEER: CFF DRAWN BY: BAV CHECKED BY: JSS

US HIGHWAY 20 AND POPLAR AVENUE  
 RCUT INTERSECTION IMPROVEMENTS  
 WEBSTER COUNTY, IOWA

TYPICAL SECTIONS  
 R:1210178-004106-DRAWINGS\CIVIL\PLANS\B.01.DWG

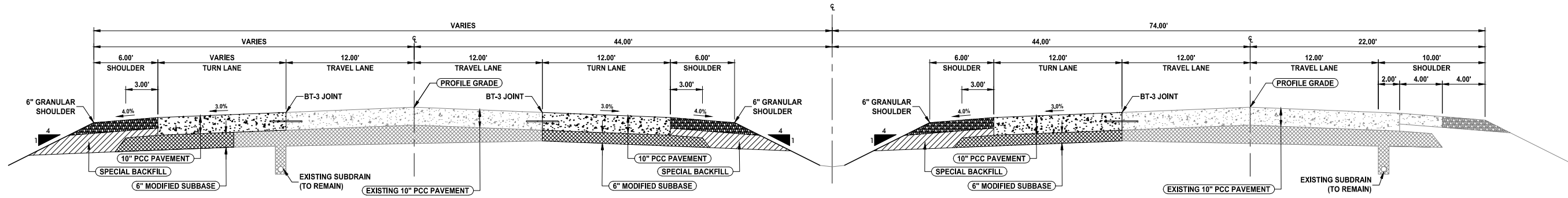

NOTE:  
 1. NORMAL SECTIONS SHOWN MAY BE APPROPRIATELY MODIFIED FOR AREAS SPECIFICALLY DESIGNATED BY THE ENGINEER SUCH AS INTERSECTIONS. REFER TO OTHER DRAWINGS FOR DETAILS.  
 2. SEE L-SHEETS FOR JOINT SPACING

**EAST AND WESTBOUND TYPICAL SECTION**  
**4 LANE - U.S. HIGHWAY 20**  
 NOT TO SCALE

STATION TO STATION
885+89.55 TO 889+29.94

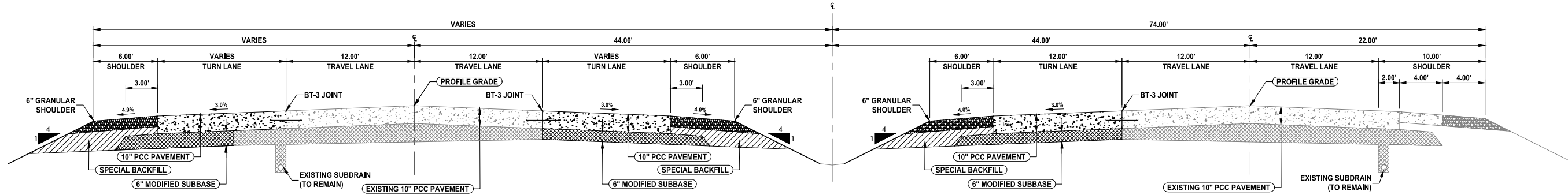

NOTE:  
 1. NORMAL SECTIONS SHOWN MAY BE APPROPRIATELY MODIFIED FOR AREAS SPECIFICALLY DESIGNATED BY THE ENGINEER SUCH AS INTERSECTIONS. REFER TO OTHER DRAWINGS FOR DETAILS.  
 2. SEE L-SHEETS FOR JOINT SPACING

**EAST AND WESTBOUND TYPICAL SECTION**  
**4 LANE - U.S. HIGHWAY 20**  
 NOT TO SCALE

STATION TO STATION
889+29.94 TO 890+64.94

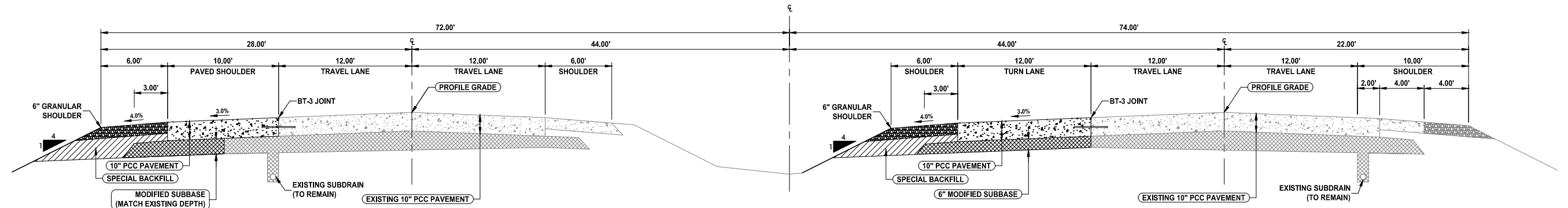

NOTE:  
 1. NORMAL SECTIONS SHOWN MAY BE APPROPRIATELY MODIFIED FOR AREAS SPECIFICALLY DESIGNATED BY THE ENGINEER SUCH AS INTERSECTIONS. REFER TO OTHER DRAWINGS FOR DETAILS.  
 2. SEE L-SHEETS FOR JOINT SPACING

**EAST AND WESTBOUND TYPICAL SECTION**  
**4 LANE - U.S. HIGHWAY 20**  
 NOT TO SCALE

STATION TO STATION
890+64.94 TO 892+74.55

NOTICE:  
McClure Engineering Co. is not responsible or liable for any issues, claims, damages, or losses (collectively, "Losses") which arise from failure to follow these Plans, Specifications, and the engineering intent they convey, or for Losses which arise from failure to obtain and/or follow the engineers' or surveyors' guidance with respect to any alleged errors, omissions, inconsistencies, ambiguities, or conflicts contained within the Plans and Specifications.

IOWA CERTIFICATE OF AUTHORITY NO. 26887

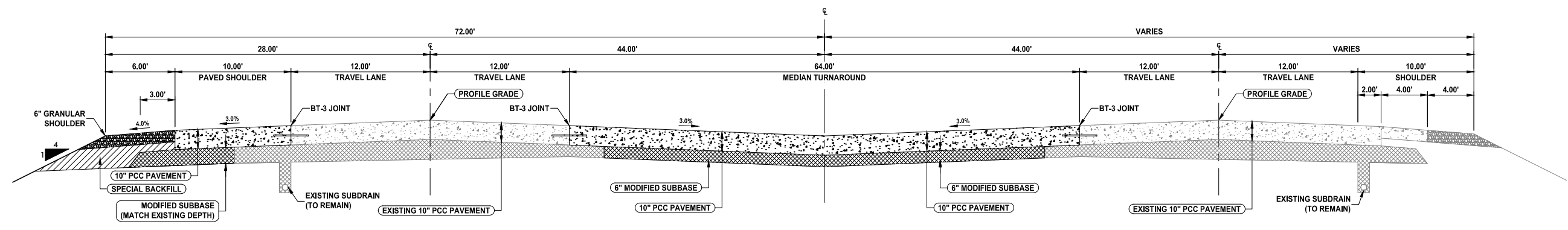

- NOTE:
1. NORMAL SECTIONS SHOWN MAY BE APPROPRIATELY MODIFIED FOR AREAS SPECIFICALLY DESIGNATED BY THE ENGINEER SUCH AS INTERSECTIONS. REFER TO OTHER DRAWINGS FOR DETAILS.
  2. SEE L-SHEETS FOR JOINT SPACING

**EAST AND WESTBOUND TYPICAL SECTION**  
**4 LANE - U.S. HIGHWAY 20**  
NOT TO SCALE

STATION TO STATION
892+74.55 TO 893+89.55

REVISIONS

PROJECT INFO  
210178-004

ENGINEER CFF    DRAWN BY BAV    CHECKED BY JSS

US HIGHWAY 20 AND POPLAR AVENUE  
RCUT INTERSECTION IMPROVEMENTS  
WEBSTER COUNTY, IOWA

TYPICAL SECTIONS

R:\210178-004\06-DRAWINGS\CIVIL\PLANS\B.01.DWG

**ESTIMATED PROJECT QUANTITIES**

This Data Entry Sheet fills Tab 100-1A effective 07-15-97

Item No.	Item Code	Item	Unit	Total	As Built Qty.
1	2102-0425071	SPECIAL BACKFILL	CY	1,466	
2	2102-2625000	EMBANKMENT-IN-PLACE	CY	700	
3	2102-2710070	EXCAVATION, CLASS 10, ROADWAY AND BORROW	CY	1,365	
4	2105-8425015	TOPSOIL, STRIP, SALVAGE AND SPREAD	CY	1,730	
5	2115-0100000	MODIFIED SUBBASE	CY	2,305	
6	2121-7425010	GRANULAR SHOULDERS, TYPE A	TON	1,470	
7	2125-2225050	RESHAPING DITCHES	STA	5	
8	2301-1034100	STANDARD OR SLIP FORM PORTLAND CEMENT CONCRETE PAVEMENT, CLASS C, CLASS 3I DURABILITY, 10 IN.	SY	11,681	
9	2301-4875006	MEDIAN, P.C. CONCRETE, 6 IN.	SY	82	
10	2301-9091000	RUMBLE STRIP PANEL (PCC SURFACE)	EA	2	
11	2416-0101036	REMOVE AND REINSTALL CONCRETE PIPE APRONS LESS THAN OR EQUAL TO 36 IN.	EA	1	
12	2416-1180024	CULVERT, CONCRETE ROADWAY PIPE, 24 IN. DIA.	LF	8	
13	2510-6745850	REMOVAL OF PAVEMENT	SY	5,735	
14	2512-1725206	CURB AND GUTTER, P.C. CONCRETE, 2.0 FT.	LF	248	
15	2518-6910000	SAFETY CLOSURE	EA	2	
16	2523-0000100	LIGHTING POLES	EA	6	
17	2524-6765010	REMOVE AND REINSTALL SIGN AS PER PLAN	EA	15	
18	2524-9276010	PERFORATED SQUARE STEEL TUBE POSTS	LF	1154	
19	2524-9276021	PERFORATED SQUARE STEEL TUBE POST ANCHOR, BREAK-AWAY SOIL INSTALLATION	EA	66	
20	2524-9325001	TYPE A SIGNS, SHEET ALUMINUM	SF	545	
21	2524-9325150	INSTALL TYPE A SIGN	EA	74	
22	2524-9380001	TYPE B SIGNS, EXTRUDED ALUMINUM STRUCTURAL PANEL	SF	957	
23	2524-9680250	INSTALL TYPE B SIGN	EA	6	
24	2526-8285000	CONSTRUCTION SURVEY	LS	1	
25	2527-9263109	PAINTED PAVEMENT MARKING, WATERBORNE OR SOLVENT-BASED	STA	170.5	
26	2527-9263137	PAINTED SYMBOLS AND LEGENDS, WATERBORNE OR SOLVENT-BASED	EA	25	
27	2528-8445110	TRAFFIC CONTROL	LS	1	
28	2533-4980005	MOBILIZATION	LS	1	
29	2548-0000200	MILLED SHOULDER RUMBLE STRIPS, PCC SURFACE	STA	4.9	
30	2555-0000010	DELIVER AND STOCKPILE SLAVAGE MATERIALS	LS	1	
31	2599-9999010	SWPPP MANAGEMENT	LS	1	
32	2601-2634100	MULCHING	ACRE	1.6	
33	2601-2636043	SEEDING AND FERTILIZING (RURAL)	ACRE	1.6	
34	2602-0000020	SILT FENCE	LF	1,672	
35	2602-0000030	SILT FENCE FOR DITCH CHECKS	LF	855	
36	2602-0000071	REMOVAL OF SILT FENCE OR SILT FENCE FOR DITCH CHECKS	LF	2,527	
37	2602-0000101	MAINTENANCE OF SILT FENCE OR SILT FENCE FOR DITCH CHECK	LF	2,527	
38	2602-0000312	PERIMETER AND SLOPE SEDIMENT CONTROL DEVICE, 12 IN. DIA.	LF	85	
39	2602-0000350	REMOVAL OF PERIMETER AND SLOPE SEDIMENT CONTROL DEVICE	LF	85	
40	2602-0010010	MOBILIZATIONS, EROSION CONTROL	EACH	3	
41	2602-0010020	MOBILIZATIONS, EMERGENCY EROSION CONTROL	EACH	1	

**ESTIMATE REFERENCE INFORMATION**

100-4A  
10-29-02

Item No.	Item Code	Description
1	2102-0425071	<b>SPECIAL BACKFILL</b> A. REFER TO B SHEETS FOR LOCATIONS AND DETAILS. B. EXISTING HMA AND PCC FROM PAVEMENT REMOVAL MAY BE USED ON THE PROJECT AS SPECIAL BACKFILL.
2	2102-2625000	<b>EMBANKMENT-IN-PLACE</b> A. SHRINKAGE FOR EMBANKMENT-IN-PLACE IS ASSUMED TO BE 30%.
3	2102-2710070	<b>EXCAVATION, CLASS 10, ROADWAY AND BORROW</b> A. EXCAVATION INCLUDES ALL WORK NECESSARY TO ACHIEVE THE GRADES AS SHOWN IN THE PLANS. B. ANY MATERIAL NOT REPURPOSED WITHIN THE PROJECT LIMITS SHALL BE WASTED AS PER ARTICLE 1106.07 OF THE CURRENT SPECIFICATIONS. C. QUANTITIES: CUT 1,365 CY FILL + SHRINK 2,065 CY TOTAL -700 CY
4	2105-8425015	<b>TOPSOIL, STRIP, SALVAGE AND SPREAD</b> A. IF TOPSOIL STRIPPED DOES NOT SUPPLY SUFFICIENT TOPSOIL TO ENSURE 6" DEPTH, CONTRACTOR WILL BE REQUIRED TO PROVIDE ADDITIONAL TOPSOIL. HALLING, STOCKPILING AND PLACEMENT IS CONSIDERED INCIDENTAL TO THIS ITEM.
5	2115-0100000	<b>MODIFIED SUBBASE</b> A. REFER TO B SHEETS FOR LOCATIONS AND DETAILS.
6	2121-7425010	<b>GRANULAR SHOULDERS, TYPE A</b> A. REFER TO B AND D SHEETS FOR LOCATIONS AND DETAILS.
7	2125-2225050	<b>RESHAPING DITCHES</b> A. RESHAPE DITCHES AT THE POPLAR AVENUE INTERSECTION TO ALLOW FOR PROPER DRAINAGE.
8	2301-1034100	<b>STANDARD OR SLIP FORM PORTLAND CEMENT CONCRETE PAVEMENT, CLASS C, CLASS 3I DURABILITY, 10 IN.</b> A. REFER TO STANDARD ROAD PLAN PV-101 FOR JOINT DETAILS. B. REFER TO STANDARD ROAD PLAN PV-102 FOR PCC CURB DETAILS. C. REFER TO L SHEETS FOR GEOMETRICS AND SPOT ELEVATIONS.
9	2301-4875006	<b>MEDIAN, P.C. CONCRETE, 6 IN.</b> A. REFER TO C AND L SHEETS FOR TABULATIONS AND LOCATIONS.
10	2301-9091000	<b>RUMBLE STRIP PANEL (PCC SURFACE)</b> A. REFER TO C SHEETS FOR TABULATIONS. B. REFER TO N SHEETS FOR LOCATIONS.
11	2416-0101036	<b>REMOVE AND REINSTALL CONCRETE PIPE APRONS LESS THAN OR EQUAL TO 36 IN.</b> A. REFER TO REMOVAL PLAN SHEETS FOR LOCATION. B. REFER TO SHEET D.01 FOR NEW FLOWLINE ELEVATION.
12	2416-1180024	<b>CULVERT, CONCRETE ROADWAY PIPE, 24 IN. DIA.</b> A. REFER TO SHEET D.01 FOR INFORMATION.

**ESTIMATE REFERENCE INFORMATION**

100-4A  
10-29-02

Item No.	Item Code	Description
13	2510-6745850	<b>REMOVAL OF PAVEMENT</b> A. REFER TO REMOVAL PLAN SHEETS FOR LOCATION. B. THE CONTRACTOR SHALL MAINTAIN ADEQUATE AND POSITIVE DRAINAGE DURING THE PROJECT. THIS MAY REQUIRE WORK AND MATERIAL TO CREATE ADEQUATE DRAINAGE OUTLETS. EXTRA PAYMENT FOR THIS WORK TO MAINTAIN ADEQUATE DRAINAGE WILL NOT BE ALLOWED.
14	2512-1725206	<b>CURB AND GUTTER, P.C. CONCRETE, 2.0 FT.</b> A. REFER TO SHEET L.09 FOR ADDITIONAL INFORMATION. B. REFER TO C SHEETS FOR TABULATION.
15	2518-6910000	<b>SAFETY CLOSURE</b> A. REFER TO J SHEETS FOR PLACEMENT LOCATION. B. WORK INCLUDES INSTALLATION AND REMOVAL OF ORANGE MESH SAFETY FENCE AND BARRICADES AS REQUIRED IN IOWA DOT STANDARD SPECIFICATIONS SECTION 2518.
16	2523-0000100	<b>LIGHTING POLES</b> A. REFER TO C SHEETS FOR TABULATIONS. B. REFER TO STANDARD ROAD PLAN LI-101 FOR ADDITIONAL INFORMATION. C. REFER TO STANDARD ROAD PLAN LI-201 FOR ADDITIONAL INFORMATION. D. LIGHTING POLES SHALL BE INSTALLED PER IOWA STANDARD SPECIFICATIONS SECTIONS 2523 AND 4185 E. LED LUMINAIRES ARE REQUIRED FOR THIS ITEM. ALL LUMINAIRES SHALL BE OF THE SAME TYPE AND MUST BE CHOSEN FROM ONE OF THE FOLLOWING: COOPER LIGHTING (NMV NAVION 'NAV-AF-04-D-UNV-T2R-800') AMERICAN ELECTRIC LIGHTING (AUTOBAHN 'ATB2 60BLEDE85 MVOLT RS DM') PHILIPS LUMEC (ROADFOCUS 'RFL 145W64LED4K-R2M-UNV').
17	2524-6765010	<b>REMOVE AND REINSTALL SIGN AS PER PLAN</b> A. REFER TO C SHEETS FOR TABULATIONS. B. REFER TO N SHEETS FOR LOCATIONS.
18	2524-9276010	<b>PERFORATED SQUARE STEEL TUBE POSTS</b> A. REFER TO C SHEETS FOR TABULATION. B. REFER TO N SHEETS FOR LOCATIONS.
19	2524-9276021	<b>PERFORATED SQUARE STEEL TUBE POST ANCHOR, BREAK-AWAY SOIL INSTALLATION</b> A. REFER TO C SHEETS FOR TABULATIONS AND PLACEMENT OF SIGNS. B. REFER TO N SHEETS FOR LOCATIONS.
20	2524-9325001	<b>TYPE A SIGNS, SHEET ALUMINUM</b> A. REFER TO C SHEETS FOR TABULATIONS AND PLACEMENT OF SIGNS. B. REFER TO N SHEETS FOR LOCATIONS.
21	2524-9325150	<b>INSTALL TYPE A SIGN</b> A. ALL MATERIALS NEEDED FOR MOUNTING ON POSTS CONSIDERED INCIDENTAL. B. REFER TO C SHEETS FOR TABULATION AND PLACEMENT OF SIGNS. C. REFER TO N SHEETS FOR LOCATIONS.
22	2524-9380001	<b>TYPE B SIGNS, EXTRUDED ALUMINUM STRUCTURAL PANEL</b> A. REFER TO C SHEETS FOR TABULATIONS AND PLACEMENT OF SIGNS. B. REFER TO N SHEETS FOR LOCATIONS.
23	2524-9680250	<b>INSTALL TYPE B SIGN</b> A. ALL MATERIALS NEEDED FOR MOUNTING ON POSTS CONSIDERED INCIDENTAL. B. REFER TO C SHEETS FOR TABULATION AND PLACEMENT OF SIGNS. C. REFER TO N SHEETS FOR LOCATIONS.
24	2526-8285000	<b>CONSTRUCTION SURVEY</b> --
25	2527-9263109	<b>PAINTED PAVEMENT MARKING, WATERBORNE OR SOLVENT-BASED</b> A. REFER TO C SHEETS FOR TABULATIONS AND PLACEMENT OF MARKINGS. B. REFER TO N SHEETS FOR ADDITIONAL INFORMATION.
26	2527-9263137	<b>PAINTED SYMBOLS AND LEGENDS, WATERBORNE OR SOLVENT-BASED</b> A. REFER TO C SHEETS FOR TABULATIONS AND PLACEMENT OF SYMBOLS B. REFER TO N SHEETS FOR ADDITIONAL INFORMATION.
27	2528-8445110	<b>TRAFFIC CONTROL</b> A. REFER TO J SHEETS FOR TRAFFIC CONTROL AND STAGING NOTES. B. ALL INSTALLATION AND MATERIALS FOR JERSEY BARRIER AND CRASH CUSHIONS FOR JERSEY BARRIER CONSIDERED INCIDENTAL. C. ALL PROPOSED CHANGES TO THE TRAFFIC CONTROL PLAN AS PRESENTED IN THE PLANS MUST BE REVIEWED AND APPROVED BY THE ENGINEER.
28	2533-4980005	<b>MOBILIZATION</b> --
29	2548-0000200	<b>MILLED SHOULDER RUMBLE STRIPS, PCC SURFACE</b> A. REFER TO C SHEETS FOR TABULATIONS.
30	2555-0000010	<b>DELIVER AND STOCKPILE SLAVAGE MATERIALS</b> A. CONTRACTOR SHALL COORDINATE THE STOCKPILING AND DELIVERY OF EXISTING SIGNS THAT ARE NOT TO BE REINSTALLED WITH THE IOWA DOT. B. REFER TO C SHEETS FOR TABULATION OF SIGNS TO BE REMOVED.
31	2599-9999010	<b>SWPPP MANAGEMENT</b> A. LUMP SUM PRICE INCLUDES ALL WORK REQUIRED TO COMPLY WITH THE ADMINISTRATIVE PROVISIONS OF THE IOWA DNR GENERAL PERMIT NO. 2; INCLUDING RECORD KEEPING, DOCUMENTATION, UPDATING THE SWPPP, FILING THE NOTICE OF DISCONTINUATION, ETC. ITEM ALSO INCLUDES WEEKLY INSPECTIONS REQUIRED TO SATISFY THE PROVISIONS OF GENERAL PERMIT NO. 2, UNLESS OTHERWISE SPECIFIED IN THE CONTRACT DOCUMENTS. B. FINAL PAYMENT WILL BE MADE WHEN THE SITE REACHES FINAL STABILIZATION AND THE NOTICE OF DISCONTINUATION IS FILED.
32	2601-2634100	<b>MULCHING</b> A. THIS ITEM INCLUDES STRAW MULCH AND HYDROMULCH AS NEEDED FOR SEEDING AND EROSION CONTROL FOR COLD WEATHER PROTECTION.
33	2601-2636043	<b>SEEDING AND FERTILIZING (RURAL)</b> A. SEED AND FERTILIZE ACCORDING TO ARTICLE 2601.03, C, 3, OF THE STANDARD SPECIFICATIONS
34	2602-0000020	<b>SILT FENCE</b> A. CONTRACTOR SHALL VERIFY THE SPECIFIC LOCATIONS WITH THE ENGINEER PRIOR TO BEGINNING PLACEMENT.
35	2602-0000030	<b>SILT FENCE FOR DITCH CHECKS</b> A. CONTRACTOR SHALL VERIFY THE SPECIFIC LOCATIONS WITH THE ENGINEER PRIOR TO BEGINNING PLACEMENT.
36	2602-0000071	<b>REMOVAL OF SILT FENCE OR SILT FENCE FOR DITCH CHECKS</b> --
37	2602-0000101	<b>MAINTENANCE OF SILT FENCE OR SILT FENCE FOR DITCH CHECK</b> --
38	2602-0000312	<b>PERIMETER AND SLOPE SEDIMENT CONTROL DEVICE, 12 IN. DIA.</b> A. LOCATION IDENTIFIED IS THE REINSTALLED APRON NEAR THE WEST MEDIAN CROSSOVER. OTHER LOCATIONS MAY BE DETERMINED BY THE ENGINEER DURING CONSTRUCTION. MATERIAL USED MUST SHALL BE COMPOST FROM AN APPROVED SOURCE MEETING THE REQUIREMENTS OF SECTION 4169 OF THE STANDARD SPECIFICATIONS. B. REFER TO STANDARD ROAD PLAN EC-204 FOR INSTALLATION DETAILS.
39	2602-0000350	<b>REMOVAL OF PERIMETER AND SLOPE SEDIMENT CONTROL DEVICE</b> A. WORK INCLUDES REMOVAL OF ALL PERIMETER AND SLOPE SEDIMENT CONTROL DEVICES AND STAKES. B. REFER TO STANDARD ROAD PLAN EC-204 FOR INSTALLATION DETAILS.
40	2602-0010010	<b>MOBILIZATIONS, EROSION CONTROL</b> A. ASSUME 3 MOBILIZATIONS FOR THIS ITEM.
41	2602-0010020	<b>MOBILIZATIONS, EMERGENCY EROSION CONTROL</b> A. ASSUME 1 MOBILIZATION FOR THIS ITEM.



**McCLURE™**

705 First Avenue North  
Fort Dodge, Iowa 50501  
P 515-576-7155  
F 515-576-4235

Ankeny, IA | Carroll, IA | Clive, IA  
Cedar Rapids, IA | Fort Dodge, IA  
North Liberty, IA | Sioux City, IA  
Macon, MO | Columbia, MO  
North Kansas City, MO  
Lenexa, KS

**NOTICE:**  
McClure Engineering Co. is not responsible or liable for any issues, claims, damages, or losses (collectively, "Losses") which arise from failure to follow these Plans, Specifications, and the engineering intent they convey, or for Losses which arise from failure to obtain and/or follow the engineers' or surveyors' guidance with respect to any alleged errors, omissions, inconsistencies, ambiguities, or conflicts contained within the Plans and Specifications.

IOWA CERTIFICATE OF AUTHORITY NO. 26887

**REVISIONS**

PROJECT INFO  
210178-004

ENGINEER CFF DRAWN BY BAV CHECKED BY JSS

**US HIGHWAY 20 AND POPLAR AVENUE RCUT INTERSECTION IMPROVEMENTS WEBSTER COUNTY, IOWA**

**QUANTITIES AND REFERENCE NOTES**

R:1210178-004-006-DRAWINGS CIVIL PLAN.C01.DWG

DRAWING NO.

**C.01**

**NOTICE:**  
 McClure Engineering Co. is not responsible or liable for any issues, claims, damages, or losses (collectively, "Losses") which arise from failure to follow these Plans, Specifications, and the engineering intent they convey, or for Losses which arise from failure to obtain and/or follow the engineers' or surveyors' guidance with respect to any alleged errors, omissions, inconsistencies, ambiguities, or conflicts contained within the Plans and Specifications.

IOWA CERTIFICATE OF AUTHORITY NO. 26887

### PCC PAVEMENT

This Data Entry Sheet fills Tab 100-24 effective 04-21-15

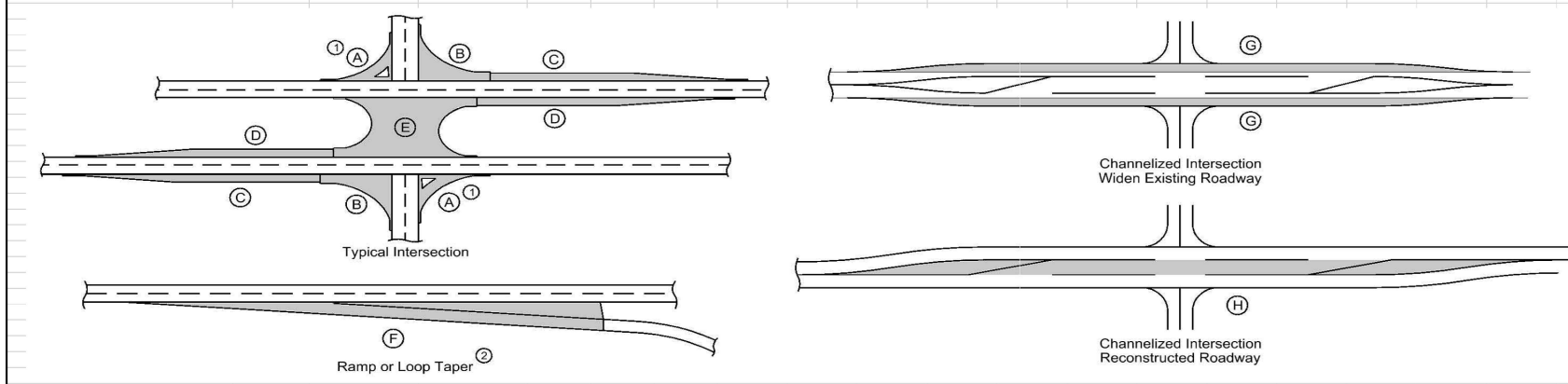

- ① Does not include raised island area or curb. Refer to tabulation 112-4 for quantities.
- ② Refer to PV-410, PV-411, PV-412, and PV-414.
- ③ Quantity includes Pavement Header.

Road Identification	Location Direction of Travel	Station to Station		Mainline			Area ③								Total Area By Pavement Thickness		Special Backfill TONS	Modified Subbase CY	Granular Subbase SY	Remarks
				Width	Length	Area	A ①	B	C	D	E	F ②	G	H	10 IN	10 1/2 IN				
				FT	FT	SY	SY	SY	SY	SY	SY	SY	SY	SY	SY	SY				
Highway 20	East	872+00.14	874+00.14		200.0															
Highway 20	East	872+00.14	873+15.14		115.0															
Highway 20	West	873+15.14	882+37.81		922.7															
Highway 20	East	874+08.00	882+37.81		829.8															
Highway 20	East	882+37.81	884+35.13		197.3															Does not include raised median
Highway 20	West	884+35.13	890+64.94		629.8															
Highway 20	East	884+35.13	892+74.55		839.4															
Highway 20	West	884+71.42	893+89.55		918.1															
Highway 20	West	892+74.55	893+89.55		115.0															
Poplar Avenue	North	1874+73.76	1876+16.70	24.0	142.9	381.2														
Poplar Avenue	North	1874+73.76	1876+21.09		147.3															
Poplar Avenue	North	1874+73.76	1876+09.97		136.2															
Poplar Avenue	North	1877+28.78	1884+71.93	24.0	743.1	1981.7														
Poplar Avenue	North	1877+34.61	1878+25.51		90.9															
Poplar Avenue	North	1877+28.33	1879+05.44		177.1															

### CURBS AND RAISED ISLANDS

Refer to PV-20, PV-102, and 6000s Detail Series.

This Data Entry Sheet fills Tab 112-4 effective 10-21-14

Island No.	Station	Offset	Island Interior Area* SY	Curb and Gutter		Remarks
				Curb Type	Length* LF	
1	1875+94.29	7.00' RT	14.0	6" Sloped PCC	50.0	
2	1876+72.74	0.00' RT	54.0	6" Sloped PCC	148.0	
3	1877+51.04	7.00' LT	14.0	6" Sloped PCC	50.0	

### REMOVAL OF FENCE

This Data Entry Sheet fills Tab 100-08 effective 04-17-18

Location				Type	Length LF	Remarks
From Station	Offset	To Station	Offset			
883+80.45	133.67' LT	884+25.45	133.64' LT	Field	45.0	

### TABULATION OF SILT FENCES

Refer to EC-201

This Data Entry Sheet fills Tab 100-17 effective 04-20-10

Location			Length LF	Remarks
Begin Station	End Station	Side		
871+81.18	874+26.18	RT	245.0	
881+58.50	882+08.50	LT	50.0	
884+88.75	894+15.75	LT	927.0	
1874+60.50	1876+03.50	LT	200.0	
1874+65.00	1875+93.00	RT	250.0	

### PERIMETER, SLOPE AND DITCH CHECK SEDIMENT CONTROL DEVICES

Possible Standards: EC-204

This Data Entry Sheet fills Tab 100-19 effective 10-19-21

Location			Perimeter and Slope Length of Installation			Ditch Check Length of Installation		Remarks
Begin Station	End Station	Side	9 inch Dia	12 inch Dia	20 inch Dia	12 inch Dia	20 inch Dia	
			LF	LF	LF	LF	LF	
873+00.00	873+00.00	Left		25				Install around 24" Storm Apron
889+85.67	889+85.67	Left		25				Install around 24" Storm Apron
891+34.97	891+34.97	Left		35				Install around 48" Storm Apron

### REVISIONS

PROJECT INFO  
210178-004

ENGINEER: CFF DRAWN BY: BAV CHECKED BY: JSS

US HIGHWAY 20 AND POPLAR AVENUE  
 RCUT INTERSECTION IMPROVEMENTS  
 WEBSTER COUNTY, IOWA  
 QUANTITIES AND REFERENCE NOTES  
 R:1210178-004-06-DRAWINGS\CIVIL\PLANS\C.01.DWG

### SILT FENCES FOR DITCH CHECKS

Possible Standard: EC-201

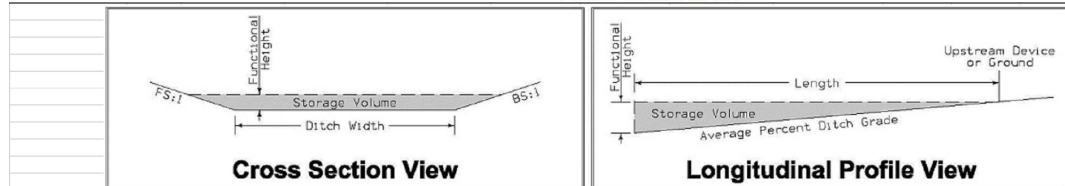

\* The functional height used in the volume equation is 85% of effective height. Effective height is 1.58 feet as shown on EC-201.

\* Volume equation:  $[0.5 \times \text{Spacing} \times (0.5 \times H^2 \times FS + DW \times H + 0.5 \times H^2 \times BS)]$

This Data Entry Sheet fills Tab 100-18 effective 10-16-18

Location	Bid Items			Stormwater Storage Volume Summary								Remarks
	Station	Side	Installation	Maintenance	Removal	Foreslope	Backslope	Ditch Width	Avg. % Slope Ditch Grade	Spacing	Down Stream	
871+75.00	CTR	LF	LF	LF	FS:1	BS:1	FT	6.0	2.0%	75.0	17.5	857.9
874+00.00	CTR	25.0	25.0	25.0	4.0	4.0	1.0	2.0%	75.0	8.6	433.7	
874+75.00	CTR	25.0	25.0	25.0	4.0	4.0	1.0	2.0%	75.0	8.6	433.7	
875+50.00	CTR	25.0	25.0	25.0	4.0	4.0	1.0	2.0%	75.0	8.6	433.7	
876+25.00	CTR	25.0	25.0	25.0	4.0	4.0	1.0	2.0%	75.0	8.6	433.7	
877+00.00	CTR	25.0	25.0	25.0	4.0	4.0	1.0	2.0%	75.0	8.6	433.7	
877+75.00	CTR	25.0	25.0	25.0	4.0	4.0	1.0	2.0%	75.0	8.6	433.7	
878+50.00	CTR	25.0	25.0	25.0	4.0	4.0	1.0	2.0%	75.0	8.6	433.7	
879+25.00	CTR	25.0	25.0	25.0	4.0	4.0	1.0	2.0%	75.0	8.6	433.7	
880+00.00	CTR	25.0	25.0	25.0	4.0	4.0	1.0	2.0%	75.0	8.6	433.7	
880+75.00	CTR	25.0	25.0	25.0	4.0	4.0	1.0	2.0%	75.0	8.6	433.7	
881+50.00	CTR	25.0	25.0	25.0	4.0	4.0	1.0	2.0%	75.0	8.6	433.7	
882+05.00	LEFT	25.0	25.0	25.0	4.0	4.0	5.0	1.0%	155.0	13.9	1386.1	
882+25.00	CTR	25.0	25.0	25.0	4.0	4.0	1.0	2.0%	75.0	8.6	433.7	
884+50.00	LEFT	35.0	35.0	35.0	4.0	4.0	5.0	1.0%	155.0	13.9	1386.1	
885+25.00	CTR	25.0	25.0	25.0	4.0	4.0	5.0	1.0%	155.0	13.9	1386.1	
886+75.00	CTR	25.0	25.0	25.0	4.0	4.0	5.0	1.0%	155.0	13.9	1386.1	
888+25.00	CTR	25.0	25.0	25.0	4.0	4.0	5.0	1.0%	155.0	13.9	1386.1	
889+75.00	CTR	25.0	25.0	25.0	4.0	4.0	5.0	1.0%	155.0	13.9	1386.1	
891+25.00	CTR	25.0	25.0	25.0	4.0	4.0	5.0	1.0%	155.0	13.9	1386.1	
892+75.00	CTR	25.0	25.0	25.0	4.0	4.0	5.0	1.0%	155.0	13.9	1386.1	
894+25.00	CTR	40.0	40.0	40.0	6.0	6.0	1.0	1.0%	155.0	12.2	1283.3	
895+25.00	CTR	40.0	40.0	40.0	6.0	6.0	1.0	1.0%	155.0	12.2	1283.3	
896+25.00	CTR	40.0	40.0	40.0	6.0	6.0	1.0	1.0%	155.0	12.2	1283.3	
1877+83.00	LEFT	25.0	25.0	25.0	4.0	4.0	5.0	1.0%	155.0	13.9	1386.1	
1878+65.50	LEFT	25.0	25.0	25.0	4.0	4.0	5.0	1.0%	155.0	13.9	1386.1	
1878+65.50	RIGHT	25.0	25.0	25.0	4.0	4.0	5.0	1.0%	155.0	13.9	1386.1	
1880+25.00	LEFT	25.0	25.0	25.0	4.0	4.0	5.0	1.0%	155.0	13.9	1386.1	
1880+25.00	RIGHT	25.0	25.0	25.0	4.0	4.0	5.0	1.0%	155.0	13.9	1386.1	
1881+75.00	RIGHT	25.0	25.0	25.0	4.0	4.0	5.0	1.0%	155.0	13.9	1386.1	
1882+25.00	LEFT	25.0	25.0	25.0	4.0	4.0	5.0	1.0%	155.0	13.9	1386.1	
1883+25.00	RIGHT	25.0	25.0	25.0	4.0	4.0	5.0	1.0%	155.0	13.9	1386.1	

### MATERIALS FOR TYPE 'B' SIGNS

This Data Entry Sheet fills Tab 190-50 effective 10-15-13

NUMBER	SIGN NUMBER					DIR OF TRAVEL	SIGN LOCATION	SIGN WIDTH	SIGN HEIGHT	NEW AREA	PERFORATED SQUARE STEEL TUBE					INSTALLATION			REMARKS		
	ROUTE	COUNTY	EXIT NUMBER	Road M,R,S	SEQ. NO.						STATION	L	M	R	ANCHOR			TYPE		DIM 'X'	DIM 'Y'
															CONC	SOIL	SLIP				
1	20 East					WB	873+26.10	14.5	11.5	166.75	22	20	18				1	12	8	See N-sheets for details.	
2	20 West					EB	876+00.00	14.5	10	145	18	20	22				1	12	8	See N-sheets for details.	
3	20 East					WB	878+50.00	14.5	11.5	166.75	22	20	18				1	12	8	See N-sheets for details.	
4	20 West					EB	888+50.00	14.5	11.5	166.75	22	20	18				1	12	8	See N-sheets for details.	
5	20 East					WB	891+00.00	14.5	10	145	18	20	22				1	12	8	See N-sheets for details.	
6	20 West					EB	892+64.55	14.5	11.5	166.75	22	20	18				1	12	8	See N-sheets for details.	

### STANDARD ROAD PLANS

The following Standard Road Plans apply to construction work on this project.

Number	Date	Title
DR-305	04-19-22	Subdrain Outlets (Standard Subdrain, Pressure Release and Special)
EC-201	04-20-21	Silt Fence
EC-204	10-19-21	Perimeter, Slope and Ditch Check Sediment Control Devices
EC-502	04-21-15	Seeding in Rural Areas
EW-105	04-21-15	Reshaping Slopes and Ditches
EW-503	10-20-15	Side Road Grading
LI-101	10-21-14	Light Pole Location
LI-201	04-18-17	Light Pole foundation
LI-211	10-20-15	Slip-Base for Light Poles
PM-110	04-21-20	Line Types
PM-111	04-21-20	Symbols and Legends
PM-120	10-21-14	Stop Lines and Islands
PM-561	10-15-19	Divided Multi-Lane Roadway with Right Turn Lanes
PM-562	10-15-19	Divided Multi-Lane Roadway with Left Turn Lanes
PV-10	04-21-20	Rumble Strip Panel for Intersection Approach
PV-12	10-20-20	Milled Shoulder Rumble Strips
PV-20	10-21-14	Raised Islands
PV-101	04-19-22	Joints
PV-102	04-21-20	PCC Curb Details
SI-101	04-19-16	Locations — Type 'A' Signs
SI-102	04-19-16	Locations — Type 'B' Signs
SI-119	10-17-17	Support Structures — Mounting Brackets
SI-131	10-18-16	Installation — Type 'A' Signs
SI-132	04-17-18	Installation — Type 'B' Signs
TC-418	04-19-22	Lane Closure on Divided Highway

### REMOVAL OF PAVEMENT

Refer to Tabulation 102-5

\* Not a Bid Item

This Data Entry Sheet fills Tab 110-1 effective 04-16-13

Begin Station	End Station	Side	Pavement Type	Length	Width	Area	Area	Saw Cut*	Remarks
872+00.14	873+15.14	Right	PCC	115	6	690	76.7	115.0	
872+00.14	874+00.14	Right	PCC	200	8	1600	177.8	200.0	
872+00.14	882+66.69	Left	PCC	1066.55	6	6399.3	711.0	1067.0	
874+08.00	882+68.90	Right	PCC	860.9	Varies	6464.3	718.3	861.0	
881+76.87	882+75.46	Left	PCC	98.59	8	788.72	87.6	99.0	
882+20.14	882+68.77	Right	PCC	48.63	8	389.04	43.2	49.0	
882+66.69	884+14.82	Both	PCC	148.13	Varies	6408.2	712.0	300.0	
883+96.15	893+89.55	Left	PCC	993.4	8	7947.2	883.0	994.0	
884+04.44	893+89.55	Right	PCC	985.11	6	5910.66	656.7	985.0	
884+08.80	885+20.14	Right	PCC	111.34	8	890.72	99.0	112.0	
884+14.82	890+64.94	Left	PCC	650.12	Varies	5034.9	559.4	650.0	
892+74.55	893+89.55	Left	PCC	115	6	690	76.7	115.0	
1874+73.76	1876+16.70	Both	PCC	142.94	Varies	5323	591.4	165.0	
1877+28.78	1877+79.09	Both	PCC	50.31	Varies	3072.9	341.4	121.0	

### MILLED RUMBLE STRIPS

\* Calculated at 18" width for Shoulder

This Data Entry Sheet fills Tab 112-10 effective 10-20-20

Road Identification	Station to Station		Installation Length		Shoulder Pavement Type	Rumble Strip Type (Centerline, Rt or Lt Shoulder)	L	Installation Length		Area	Area	Remarks
			FT	STA				PCC	HMA			
U.S. Highway 20	872+00.14	872+37.40	37.3	0.37	PCC	Left Shoulder	12"	0.37		56	6.2	
U.S. Highway 20	872+00.14	872+11.79	11.6	0.12	PCC	Left Shoulder	12"	0.12		17	1.9	
U.S. Highway 20	872+83.53	873+15.14	31.6	0.32	PCC	Left Shoulder	12"	0.32		47	5.3	
U.S. Highway 20	874+08.00	874+23.00	15.0	0.15	PCC	Left Shoulder	12"	0.15		23	2.5	
U.S. Highway 20	882+20.14	882+45.04	24.9	0.25	PCC	Right Shoulder	12"	0.25		37	4.1	
U.S. Highway 20	882+20.14	883+16.32	96.2	0.96	PCC	Left Shoulder	12"	0.96		144	16.0	
U.S. Highway 20	883+56.62	884+69.55	112.9	1.13	PCC	Left Shoulder	12"	1.13		169	18.8	
U.S. Highway 20	884+59.62	885+20.14	60.5	0.61	PCC	Right Shoulder	12"	0.61		91	10.1	
U.S. Highway 20	890+49.94	890+64.94	15.0	0.15	PCC	Left Shoulder	12"	0.15		23	2.5	
U.S. Highway 20	892+74.55	893+06.17	31.6	0.32	PCC	Left Shoulder	12"	0.32		47	5.3	
U.S. Highway 20	893+52.30	893+89.55	37.3	0.37	PCC	Left Shoulder	12"	0.37		56	6.2	
U.S. Highway 20	893+77.91	893+89.55	11.6	0.12	PCC	Left Shoulder	12"	0.12		17	1.9	

### RUMBLE STRIP PANELS

Refer to Standard Road Plan PV-10.

This Data Entry Sheet fills Tab 112-7 effective 10-19-10

Road Ident.	Station	Side	Pavement		Remarks
			New	Existing	
Poplar Avenue	1879+56.80	Left	X		
Poplar Avenue	1882+82.78	Left	X		



705 First Avenue North  
Fort Dodge, Iowa 50501  
P 515-576-7155  
F 515-576-4235

Ankeny, IA | Carroll, IA | Clive, IA  
Cedar Rapids, IA | Fort Dodge, IA  
North Liberty, IA | Sioux City, IA  
Macon, MO | Columbia, MO  
North Kansas City, MO  
Lenexa, KS

NOTICE: McClure Engineering Co. is not responsible or liable for any issues, claims, damages, or losses (collectively, "Losses") which arise from failure to follow these Plans. Specifications, and the engineering intent they convey, or for Losses which arise from failure to obtain and/or follow the engineers' or surveyors' guidance with respect to any alleged errors, omissions, inconsistencies, ambiguities, or conflicts contained within the Plans and Specifications.

IOWA CERTIFICATE OF AUTHORITY NO. 26887

### REVISIONS

PROJECT INFO  
210178-004

ENGINEER: CFF DRAWN BY: BAV CHECKED BY: JSS

US HIGHWAY 20 AND POPLAR AVENUE RCUT INTERSECTION IMPROVEMENTS WEBSTER COUNTY, IOWA

QUANTITIES AND REFERENCE NOTES

DRAWING NO.

C.03

R:210178-004-06-DRAWINGS/CIVIL/PLANS/C.01.DWG

**MATERIALS FOR TYPE 'A' SIGNS**

Refer to SI-101, SI-111, SI-119 and N Sheets  
This Data Entry Sheet fills Tab 190-51 effective 10-15-13

SIGN DESCRIPTION	SIGN NUMBER	DIR OF TRAVEL	SIGN LOCATION STATION	PERFORATED SQUARE STEEL TUBE						TYPE A SIGN MOUNTING BRACKETS					REMARKS	
				LEG 1	LEG 2	LEG 3	ANCHOR			ONE POST BRACKET	TWO POST	AUXILIARY	H	F		F1
				FT	FT	FT	CONC	SOIL	SLIPBASE							
Do Not Enter	R5-1	EB	871+12.19	17				1		1						
No U-Turn	R3-4	EB	871+12.19													
Do Not Enter	R5-1	EB	871+12.19	17				1		1						
No U-Turn	R3-4	EB	871+12.19													
Yield Sign	R1-2	EB	872+05.97	17				1		1		1				
One Way	R6-1 (Left)	EB	872+05.97													
One Way	R6-1 (Left)	EB	872+19.79	17				1		1						
Do Not Enter	R5-1	WB	873+26.10													To be mounted on back of guide sign
West	M3-4	WB	873+26.10	17				1		1		1				
US Route 20	M1-4	WB	873+26.10													
Arrow	M6-3	WB	873+26.10													
East	M3-2	EB	874+83.95	17				1		1		1				
US Route 20	M1-4	EB	874+83.95													
Speed Limit	R2-1	WB	875+50.00	17				1		1						
Must Turn Left	R3-7	WB	875+50.00	17				1		1						
West	M3-4	WB	878+50.00	17				1		1		1				
US Route 20	M1-4	WB	878+50.00													
Arrow	M6-3	WB	878+50.00													
Do Not Enter	R5-1	EB	882+03.58	17				1		1						Existing sign to be installed on new post
Do Not Enter	R5-1	EB	882+03.58	17				1		1						Existing sign to be installed on new post
Object Marker	OM1-2	EB	882+97.76	6				1		1						
Object Marker	OM1-2	WB	883+74.89	6				1		1						
Do Not Enter	R5-1	WB	884+82.23	17				1		1						Existing sign to be installed on new post
Do Not Enter	R5-1	WB	884+82.23	17				1		1						Existing sign to be installed on new post
East	M3-2	EB	888+50.00	17				1		1		1				
US Route 20	M1-4	EB	888+50.00													
Arrow	M6-3	EB	888+50.00													
Must Turn Left	R3-7	EB	890+50.00	17				1		1						
West	M3-4	WB	892+00.00	17				1		1		1				
US Route 20	M1-4	WB	892+00.00													
East	M3-2	EB	892+64.55	17				1		1		1				
US Route 20	M1-4	EB	892+64.55													
Arrow	M6-3	EB	892+64.55													
Do Not Enter	R5-1	EB	892+64.55							1						To be mounted on back of guide sign
One Way	R6-1 (Left)	WB	893+69.91	17				1		1						
Yield Sign	R1-2	WB	893+83.73	17				1		1		1				
One Way	R6-1 (Left)	WB	893+83.73													
Do Not Enter	R5-1	WB	894+50.00	17				1		1						
No U-Turn	R3-4	WB	894+50.00													
Do Not Enter	R5-1	WB	894+50.00	17				1		1						
No U-Turn	R3-4	WB	894+50.00													
Speed Limit	R2-1	EB	894+77.51	17				1		1						
To	M4-5	NB	1874+63.72	17				1		1		1				
West	M3-4	NB	1874+63.72													
US Route 20	M1-4	NB	1874+63.72													
Poplar Ave	Street	NB	1874+63.72													
Arrow	M6-1	NB	1874+63.72													
East	M3-2	NB	1874+63.72	17				1		1		1				
US Route 20	M1-4	NB	1874+63.72													
Arrow	M6-1	NB	1874+63.72													
Right Turn Only	R3-5R	NB	1875+20.95	17				1		1						
Stop Sign	R1-1	NB	1875+87.16	17	17			2								Existing sign to be installed on new post
One Way	R6-1 (Left)	NB	1875+87.16													Existing sign to be installed on new post
One Way	R6-1 (Right)	NB	1875+87.16													Existing sign to be installed on new post
Stop Sign	R1-1	NB	1875+99.18	17	17			2			1	1				
One Way	R6-1 (Left)	NB	1875+99.18													Existing sign to be installed on new post
One Way	R6-1 (Right)	NB	1875+99.18													Existing sign to be installed on new post
Keep Right	R4-7	SB	1875+99.18													
No Left Turn	R3-2	NB	1876+46.91	17				1		1						
One Way	R6-1 (Left)	SB	1876+46.91													
Yield Sign	R1-2	SB	1876+55.05	17	17			2			1					
One Way	R6-1 (Left)	SB	1876+55.05													
One Way	R6-1 (Right)	SB	1876+55.05													
Yield Sign	R1-2	NB	1876+90.42	17	17			2			1					
One Way	R6-1 (Left)	NB	1876+90.42													
One Way	R6-1 (Right)	NB	1876+90.42													
No Left Turn	R3-2	SB	1876+98.77	17				1		1						
One Way	R6-1 (Left)	NB	1876+98.77													
Stop Sign	R1-1	SB	1877+46.30	17	17			2			1	1				
One Way	R6-1 (Left)	SB	1877+46.30													Existing sign to be installed on new post
One Way	R6-1 (Right)	SB	1877+46.30													Existing sign to be installed on new post
Keep Right	R4-7	NB	1877+46.30													
Stop Sign	R1-1	SB	1877+59.01	17	17			2			1					Existing sign to be installed on new post
One Way	R6-1 (Left)	SB	1877+59.01													Existing sign to be installed on new post
One Way	R6-1 (Right)	SB	1877+59.01													Existing sign to be installed on new post
To	M4-5	SB	1878+28.78	17				1		1		1				
East	M3-2	SB	1878+28.78													
US Route 20	M1-4	SB	1878+28.78													
Poplar Ave	Street	SB	1878+28.78													
Arrow	M6-1	SB	1878+28.78													
West	M3-4	SB	1878+28.78	17				1		1		1				
US Route 20	M1-4	SB	1878+28.78													
Arrow	M6-1	SB	1878+28.78													
Right Turn Only	R3-5R	SB	1879+28.78	17				1		1						
No Parking	R8-3	NB	1879+28.78	17				1		1						
Stop Ahead	W3-1	SB	1880+28.78	17				1		1						
No Parking	R8-3	NB	1882+24.72	17				1		1						
No Parking	R8-3	SB	1882+24.72	17				1		1						

**PAVEMENT MARKING SYMBOLS AND LEGENDS**

108-29  
04-21-15

Refer to PM-111

Road Identification	Location		RTAW	LTAW	ONLY ONLW	Groove Cuts EACH	Remarks
	Station	Side					
Highway 20	873+25.00	LT		1			
Highway 20	874+25.00	LT			1		
Highway 20	875+25.00	LT		1			
Highway 20	876+25.00	LT			1		
Highway 20	877+25.00	LT		1			
Highway 20	877+95.00	RT		1			
Highway 20	878+95.00	RT			1		
Highway 20	879+95.00	RT		1			
Highway 20	880+95.00	RT			1		
Highway 20	881+95.00	RT		1			
Highway 20	884+55.00	LT		1			
Highway 20	884+75.00	LT	1				
Highway 20	885+55.00	LT			1		
Highway 20	885+75.00	LT			1		
Highway 20	886+55.00	LT		1			
Highway 20	886+75.00	LT	1				
Highway 20	887+55.00	LT			1		
Highway 20	887+75.00	LT			1		
Highway 20	888+40.00	RT		1			
Highway 20	888+55.00	LT		1			
Highway 20	888+75.00	LT	1				
Highway 20	889+40.00	LT			1		
Highway 20	890+40.00	LT		1			
Highway 20	891+40.00	LT			1		
Highway 20	892+40.00	LT		1			
<b>Total</b>			<b>3</b>	<b>12</b>	<b>10</b>		

**SUMMARY OF TYPE 'A' SIGNS**

This Data Entry Sheet fills Tab 190-66 effective 10-21-14

Sign Number	Quantity EACH	Size IN	Total Sign Area SF
M1-4	10	36 X 24	60.0
M3-2	5	30 X 15	15.6
M3-4	5	30 X 15	15.6
M4-5	2	24 X 12	4.0
M6-1	4	24 X 15	10.0
M6-3	4	24 X 24	16.0
OM1-2	2	12 X 12	2.0
R1-1	4	36 X 36	36.0
R1-2	4	36 X 36 X 36	36.0
R2-1	2	30 X 36	15.0
R3-2	2	36 X 36	18.0
R3-4	4	36 X 36	36.0
R3-5	2	30 X 36	15.0
R3-7	2	36 X 36	18.0
R4-7	2	24 X 30	10.0
R5-1	10	36 X 36	90.0
R6-1	18	54 X 18	121.5
R8-3	3	24 X 30	15.0
W3-1	1	30 X 30	6.3
Poplar Ave.	2	30 x 12	5.0

**LIGHTING INSTALLATIONS**

108-1  
10-21-14

No.	Station	Type	LI-101		LI-201	Remarks
			A	E FT		
1	872+83.56	1	4	6	A	
2	882+84.24	1	4	6	A	
3	882+86.96	1	4	6	A	
4	883+88.70	1	4	6	A	
5	883					





## POLLUTION PREVENTION PLAN

This Data Entry Sheet fills Tab 110-12L effective 10-20-20

This project is regulated by the requirements of the Iowa Department of Natural Resources (DNR) National Pollutant Discharge Elimination System (NPDES) General Permit No. 2 OR an Iowa Department of Natural Resources (DNR) National Pollutant Discharge Elimination System (NPDES) individual storm water permit. The Contractor shall carry out the terms and conditions of this permit and the Pollution Prevention Plan (PPP).

This Base PPP includes information on Roles and Responsibilities, Project Site Description, Controls, Maintenance Procedures, Inspection Requirements, Non-Storm Water Controls, Potential Sources of Off Right-of-Way Pollution, and Definitions. This plan references other documents rather than repeating the information contained in the documents. A copy of this Base Pollution Prevention Plan, amended as needed during construction, will be readily available for review.

All contractors shall conduct their operations in a manner that controls pollutants, minimizes erosion, and prevents sediments from entering waters of the state and leaving the highway right-of-way. The Contractor shall be responsible for compliance and implementation of the PPP for their entire contract. This responsibility shall be further shared with subcontractors whose work is a source of potential pollution as defined in this PPP.

### I. ROLES AND RESPONSIBILITIES

#### A. Designer:

1. Prepares Base PPP included in the project plan.
2. Prepares Notice of Intent (NOI) submitted to Iowa DNR.
3. Is signature authority on the Base PPP. If consultant designed, signature from Contracting Authority is also required.

#### B. Contractor:

1. Signs a co-permittee certification statement adhering to the requirements of the NPDES permit and this PPP. All co-permittees are legally required under the Clean Water Act and the Iowa Administrative Code to ensure compliance with the terms and conditions of this PPP.
2. Designates a Water Pollution Control Manager (WPCM), who has the duties and responsibilities as defined in Section 2602 of the Standard Specifications.
3. Submits an Erosion Control Implementation Plan (ECIP) and ECIP updates according to Section 2602 of the Standard Specifications.
4. Installs and maintains appropriate controls. This work may be subcontracted as documented through Subcontractor Request Forms (Form 830231).
5. Supervises and implements good housekeeping practices according to Paragraph III, C, 2.
6. Conducts joint required inspections of the site with inspection staff. When Contractor is not mobilized on site, Contractor may delegate this responsibility to a trained or certified subcontractor. Contracting Authority also may waive joint inspection requirement during winter shutdown. In both circumstances, WPCM (or trained or certified delegate from the Contractor) is still responsible to review and sign inspection reports.
7. Complies with training and certification requirements of Section 2602 of the Standard Specifications.
8. Submits amended PPP site map according to Section 2602 of the Standard Specifications.

#### C. Subcontractors:

1. Sign a co-permittee certification statement adhering to the requirements of the NPDES permit and this PPP if: responsible for sediment or erosion controls; involved in land disturbing activities; or performing work that is a source of potential pollution as defined in this PPP. Subcontracted work items are identified in Subcontractor Request Forms (Form 830231). All co-permittees are legally required under the Clean Water Act and the Iowa Administrative Code to ensure compliance with the terms and conditions of this PPP.
2. Implement good housekeeping practices according to Paragraph III, C, 2.

#### D. RCE/Project Engineer:

1. Is Project Storm Water Manager.
2. Takes actions necessary to ensure compliance with storm water requirements including, where appropriate, issuing stop work orders, and directing additional inspections at construction project sites that are experiencing problems with achieving permit compliance.
3. Orders the taking of measures to cease, correct, prevent, or minimize the consequences of non-compliance with the storm water requirements of the Applicable Permit.
4. Supervises all work necessary to meet storm water requirements at the Project, including work performed by contractors and subcontractors.
5. Requires employees, contractors, and subcontractors to take appropriate responsive action to comply with storm water requirements, including requiring any such person to cease or correct a violation of storm water requirements, and to order or recommend such other actions as necessary to meet storm water requirements.
6. Is familiar with the Project PPP and storm water site map.
7. Is the point of contact for the Project for regulatory officials, Inspector, contractors, and subcontractors regarding storm water requirements.
8. Is signature authority on Notice of Discontinuation.
9. Maintains an up-to-date record of contractors, subcontractors, and subcontracted work items through Subcontractor Request Forms (Form 830231).
10. Makes information to determine permit compliance available to the DNR upon their request.

#### E. Inspector:

1. Updates PPP through fieldbook entries and storm water site inspection reports if there is a change in design, construction, operation, or maintenance which has a significant effect on the discharge of pollutants from the project.
2. Makes information to determine permit compliance available to the DNR upon their request.
3. Conducts joint required inspections of the site with the contractor/subcontractor.
4. Completes an inspection report after each inspection.
5. Is signature authority on storm water inspection reports.

### II. PROJECT SITE DESCRIPTION

1. This Pollution Prevention Plan (PPP) is for the construction of a Restricted Crossing U-turn Intersection at US 20 and Poplar Avenue.
2. This PPP covers approximately 15.6 acres with an estimated 1.6 acres being disturbed. The portion of the PPP covered by this contract has 1.6 acres disturbed.
3. The PPP is located in an area of one (1) soil association (Clarion - Nicollet - Webster). The estimated weighted average runoff coefficient number for this PPP after completion will be 0.39.
4. Storm Water Site Map - Multiple sources of information comprise the base storm water site map including:
  1. Drainage Patterns - Plan and Profile sheets and Situation plans.
  2. Proposed Slopes - Cross Sections.
  3. Areas of Soil Disturbance - Construction limits shown on Plan and Profile sheets.
  4. Location of Structural Controls - Tabulations in C sheets.
  5. Locations of Non-structural Controls - Tabulations in C sheets.
  6. Locations of Stabilization Practices - Generally within construction limits shown on Plan and Profile sheets.
  7. Surface Waters (including wetlands) - Project Location Map and Plan and Profile sheets.
  8. Locations where Storm Water is Discharged - Plan and Profile sheets.
5. The base storm water site map is amended by contract modifications and progress payments (fieldbook entries) of completed erosion control work. Also, due to project phasing, erosion and sediment controls shown on project plans may not be installed until needed, based on site conditions. For example, silt fence ditch checks will typically not be installed until the ditch has been installed. Installed locations may also be modified from tabulation locations by field staff. Installed locations will be documented by fieldbook entries and amended PPP site map.
6. Runoff from this work will flow into Holliday Creek.

## POLLUTION PREVENTION PLAN

This Data Entry Sheet fills Tab 110-12L effective 10-20-20

### III. CONTROLS

A. The Contractor's ECIP specified in Article 2602.03 of the Standard Specifications for accomplishment of storm water controls should clearly describe the intended sequence of major activities, and for each activity define the control measure and the timing during the construction process that the measure will be implemented.

B. Preserve vegetation in areas not needed for construction.

C. Sections 2601 and 2602 of the Standard Specifications define requirements to implement erosion and sediment control measures. Actual quantities used and installed locations may vary from the Base PPP and amendment of the plan will be documented via fieldbook entries, amended PPP site map, or by contract modification. Additional erosion and sediment control items may be required as determined by the inspector and/or contractor during storm water site inspections. If the work involved is not applicable to any contract items, the work will be paid for according to Article 1109.03 paragraph B of the Standard Specifications.

#### 1. EROSION AND SEDIMENT CONTROLS

##### a. Stabilization Practices

- 1) Site plans will ensure that existing vegetation or natural buffers are preserved where attainable and disturbed portions of the site will be stabilized.
- 2) Initialize stabilization of disturbed areas immediately after clearing, grading, excavating, or other earth disturbing activities have:
  - a) Permanently ceased on any portion of the site, or
  - b) Temporarily ceased on any portion of the site and will not resume for a period exceeding 14 calendar days.
- 3) Staged permanent and/or temporary stabilizing seeding and mulching shall be completed as the disturbed areas are completed. Incomplete areas shall be stabilized according to paragraph III, C, 1, a, 2, b above.
- 4) Permanent and Temporary Stabilization practices to be used for this project are located in the Estimated Project Quantities (100-0A, 100-1A, or 100-1C) and Estimate Reference Information (100-4A) located in the C sheets. Typical drawings detailing construction of the practices to be used on this project are referenced in the Standard Road Plans Tabulation (105-4) in the C sheets.
- 5) Preservation of existing vegetation within right-of-way or easements will act as vegetative buffer strips.
- 6) Preservation of topsoil: Bid items to be used for this project are located in the Estimated Project Quantities (100-0A, 100-1A, or 100-1C) and Estimate Reference Information (100-4A) located in the C sheets. Additional information may be found in Tabulations in the C or T sheets or is referenced in Section 2105 of Standard Specifications.

##### b. Structural Practices

- 1) Structural practices will be implemented to divert flows from exposed soils and detain or otherwise limit runoff and the discharge of pollutants from exposed areas of the site. Additionally, structural practices may include: silt basins that provide 3600 cubic feet of storage per acre drained or equivalent sediment controls, outlet structures that withdraw water from surface when discharging basins, and controls to direct storm water to vegetated areas.
- 2) Structural practices to be used for this project are located in the Estimated Project Quantities (100-0A, 100-1A, or 100-1C) and Estimate Reference Information (100-4A) located in the C sheets, as well as all other item specific Tabulations. Typical drawings detailing construction of the devices to be used on this project can be found in the B sheets or are referenced in the Standard Road Plans Tabulation (105-4) located in the C sheets.

##### c. Storm Water Management

Measures shall be installed during the construction process to control pollutants in storm water discharges that will occur after construction operations have been completed. This may include velocity dissipation devices at discharge locations and along length of outfall channel as necessary to provide a non-erosion velocity flow from structure to water course. If included with this project, these items are located in the Estimated Project Quantities (100-0A, 100-1A, or 100-1C) and Estimate Reference Information (100-4A) located in the C sheets, as well as all other item specific Tabulations. Typical drawings detailing construction of the practices to be used on this project are referenced in the Standard Road Plans Tabulation (105-4) in the C sheets. The installation of these devices may be subject to Section 404 of the Clean Water Act.

#### 2. OTHER CONTROLS

Contractor disposal of unused construction materials and construction material wastes shall comply with applicable state and local waste disposal, sanitary sewer, or septic system regulations. In the event of a conflict with other governmental laws, rules and regulations, the more restrictive applicable laws, rules or regulations shall apply.

1. Vehicle Entrances and Exits - Construct and maintain entrances and exits to prevent tracking of sediments onto roadways.
2. Material Delivery, Storage and Use - Implement practices to prevent discharge of construction materials during delivery, storage, and use.
3. Stockpile Management - Install controls to reduce or eliminate pollution of storm water from stockpiles of soil and paving.
4. Waste Disposal - Do not discharge any materials, including building materials, into waters of the state, except as authorized by a Section 404 permit.
5. Spill Prevention and Control - Implement chemical spill and leak prevention and response procedures to contain and clean up spills and prevent material discharges to the storm drain system and waters of the state.
6. Concrete Residuals and Washout Wastes - Waste shall not be discharged to a surface water and is not allowed to adversely affect a water of the state. Designate temporary concrete washout facilities for rinsing out concrete trucks. Provide directions to truck drivers where designated washout facilities are located. Designated washout areas should be located at least 500 feet away from storm drains, streams or other water bodies. Care should be taken to ensure these facilities do not overflow during storm events.
7. Concrete Grooving/Grinding Slurry - Do not discharge slurry to a waterbody or storm drain. Slurry may be applied on foreslopes or removed from the project.
8. Vehicle and Equipment Storage and Maintenance Areas - Perform on site fueling and maintenance in accordance with all environment laws such as proper storage of onsite fuels and proper disposal of used engine oil or other fluids on site. Employ washing practices that prevent contamination of surface and ground water from wash water. Wash waters must be treated in a sediment basin or alternative control that provides equivalent or better treatment prior to discharge.
9. Litter Management - Ensure employees properly dispose of litter. Minimize exposure of trash if exposure to precipitation or storm water would result in a discharge of pollutants.
10. Dewatering - Properly treat water to remove suspended sediment before it re-enters a waterbody or discharges off-site. Measures are also to be taken to prevent scour erosion at dewatering discharge point.

#### 3. APPROVED STATE OR LOCAL PLANS

During the course of this construction, it is possible that situations will arise where unknown materials will be encountered. When such situations are encountered, they will be handled according to all federal, state, and local regulations in effect at the time.

### IV. MAINTENANCE PROCEDURES

The Contractor is required to maintain all temporary erosion and sediment control measures in proper working order, including cleaning, repairing, or replacing them throughout the contract period. This shall begin when the features have lost 50% of their capacity.

### V. INSPECTION REQUIREMENTS

1. Inspections shall be made jointly by the Contractor and the Contracting Authority's inspector at least once every seven calendar days. Storm water site inspections will include:
  1. Date of the inspection.
  2. Summary of the scope of the inspection.
  3. Name and qualifications of the personnel making the inspection.
  4. Review of erosion and sediment control measures within disturbed areas for the effectiveness in preventing impacts to receiving waters.
  5. Major observations related to the implementation of the PPP.
  6. Identification of corrective actions required to maintain or modify erosion and sediment control measures.
2. Include storm water site inspection reports in the amended PPP. Incorporate any additional erosion and sediment control measures determined as a result of the inspection. Immediately begin corrective actions on all deficiencies found within 3 calendar days of the inspection and complete within 7 calendar days following the inspection. If it is determined that making the corrections less than 72 hours after the inspection is impracticable, it should be documented why it is impracticable and indicate an estimated date by which the corrections will be made.



705 First Avenue North  
Fort Dodge, Iowa 50501  
P 515-576-7155  
F 515-576-4235

Ankeny, IA | Carroll, IA | Clive, IA  
Cedar Rapids, IA | Fort Dodge, IA  
North Liberty, IA | Sioux City, IA  
Macon, MO | Columbia, MO  
North Kansas City, MO  
Lenexa, KS

NOTICE:  
McClure Engineering Co. is not responsible or liable for any issues, claims, damages, or losses (collectively, "Losses") which arise from failure to follow these Plans, Specifications, and the engineering intent they convey, or for Losses which arise from failure to obtain and/or follow the engineers' or surveyors' guidance with respect to any alleged errors, omissions, inconsistencies, ambiguities, or conflicts contained within the Plans and Specifications.

IOWA CERTIFICATE OF  
AUTHORITY NO. 26887

### REVISIONS

PROJECT INFO  
210178-004

ENGINEER DRAWN BY CHECKED BY  
CFF BAV JSS

US HIGHWAY 20 AND POPLAR AVENUE  
RCUT INTERSECTION IMPROVEMENTS  
WEBSTER COUNTY, IOWA

SWPPP

R:1210178-004106-DRAWINGS\CIVIL\PLANS\C1.DWG

DRAWING NO.

C.06

**POLLUTION PREVENTION PLAN**

This Data Entry Sheet fills Tab 110-12L effective 10-20-20

**VI. NON-STORM WATER DISCHARGES**

This includes subsurface drains (i.e. longitudinal and standard subdrains) and slope drains. The velocity of the discharge from these features may be controlled by the use of headwalls or blocks, Class A stone, erosion stone or other appropriate materials. This also includes uncontaminated groundwater from dewatering operations, which will be controlled as discussed in Section III of the PPP.

**VII. POTENTIAL SOURCES OF OFF RIGHT-OF-WAY (ROW) POLLUTION**

Silts, sediment, and other forms of pollution may be transported onto highway right-of-way (ROW) as a result of a storm event. Potential sources of pollution located outside highway ROW are beyond the control of this PPP. Pollution within highway ROW will be conveyed and controlled per this PPP.

**VIII. DEFINITIONS**

- A. Base PPP - Initial Pollution Prevention Plan.
- B. Amended PPP - Base PPP amended during construction. May include Plan Revisions or Contract Modifications for new items, storm water site inspection reports, fieldbook entries made by the inspector, amended PPP site map by the Contractor, ECIP, NOI, co-permittee certifications, and Subcontractor Request Forms. Items amending the PPP are stored electronically and are readily available upon request.
- C. Fieldbook Entries - This contains the inspector's daily diary and bid item postings.
- D. Controls - Methods, practices, or measures to minimize or prevent erosion, control sedimentation, control storm water, or minimize contaminants from other types of waste or materials. Also called Best Management Practices (BMPs).
- E. Signature Authority - Representative authorized to sign various storm water documents.

**CERTIFICATION STATEMENT**

I certify under penalty of law that this document and all attachments were prepared under my direction or supervision in accordance with a system designed to assure that qualified personnel properly gathered and evaluated the information submitted. Based on my inquiry of the person or persons who manage the system, or those persons directly responsible for gathering the information, the information submitted is, to the best of my knowledge and belief, true, accurate, and complete. I am aware that there are significant penalties for submitting false information, including the possibility of fine and imprisonment for knowing violations.

Signature \_\_\_\_\_

Printed or Typed Name \_\_\_\_\_

Signature \_\_\_\_\_

Printed or Typed Name \_\_\_\_\_



705 First Avenue North  
Fort Dodge, Iowa 50501  
P 515-576-7155  
F 515-576-4235  
  
Ankeny, IA | Carroll, IA | Clive, IA  
Cedar Rapids, IA | Fort Dodge, IA  
North Liberty, IA | Sioux City, IA  
Macon, MO | Columbia, MO  
North Kansas City, MO  
Lenexa, KS

**NOTICE:**  
McClure Engineering Co. is not responsible or liable for any issues, claims, damages, or losses (collectively, "Losses") which arise from failure to follow these Plans, Specifications, and the engineering intent they convey, or for Losses which arise from failure to obtain and/or follow the engineers' or surveyors' guidance with respect to any alleged errors, omissions, inconsistencies, ambiguities, or conflicts contained within the Plans and Specifications.

IOWA CERTIFICATE OF AUTHORITY NO. 26887

**REVISIONS**

PROJECT INFO  
210178-004

ENGINEER    DRAWN BY    CHECKED BY  
CFF            BAV            JSS

**US HIGHWAY 20 AND POPLAR AVENUE  
RCUT INTERSECTION IMPROVEMENTS  
WEBSTER COUNTY, IOWA**

**SWPPP**

R:\210178-004\06-DRAWINGS\CIVIL\PLANS\C.01.DWG

DRAWING NO.  
**C.07**

NOTICE:  
 McClure Engineering Co. is not responsible or liable for any issues, claims, damages, or losses (collectively, "Losses") which arise from failure to follow these Plans, Specifications, and the engineering intent they convey, or for Losses which arise from failure to obtain and/or follow the engineers' or surveyors' guidance with respect to any alleged errors, omissions, inconsistencies, ambiguities, or conflicts contained within the Plans and Specifications.

IOWA CERTIFICATE OF AUTHORITY NO. 26887

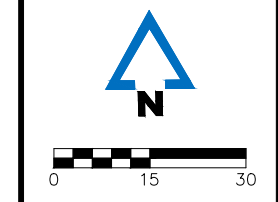

REVISIONS

PROJECT INFO  
 210178-004  
 ENGINEER: CFF    DRAWN BY: BAV    CHECKED BY: JSS

**US HIGHWAY 20 AND POPLAR AVENUE  
 RCUT INTERSECTION IMPROVEMENTS  
 WEBSTER COUNTY, IOWA**  
**U.S. HIGHWAY 20 PLAN AND PROFILE**

DRAWING NO.  
**D.01**

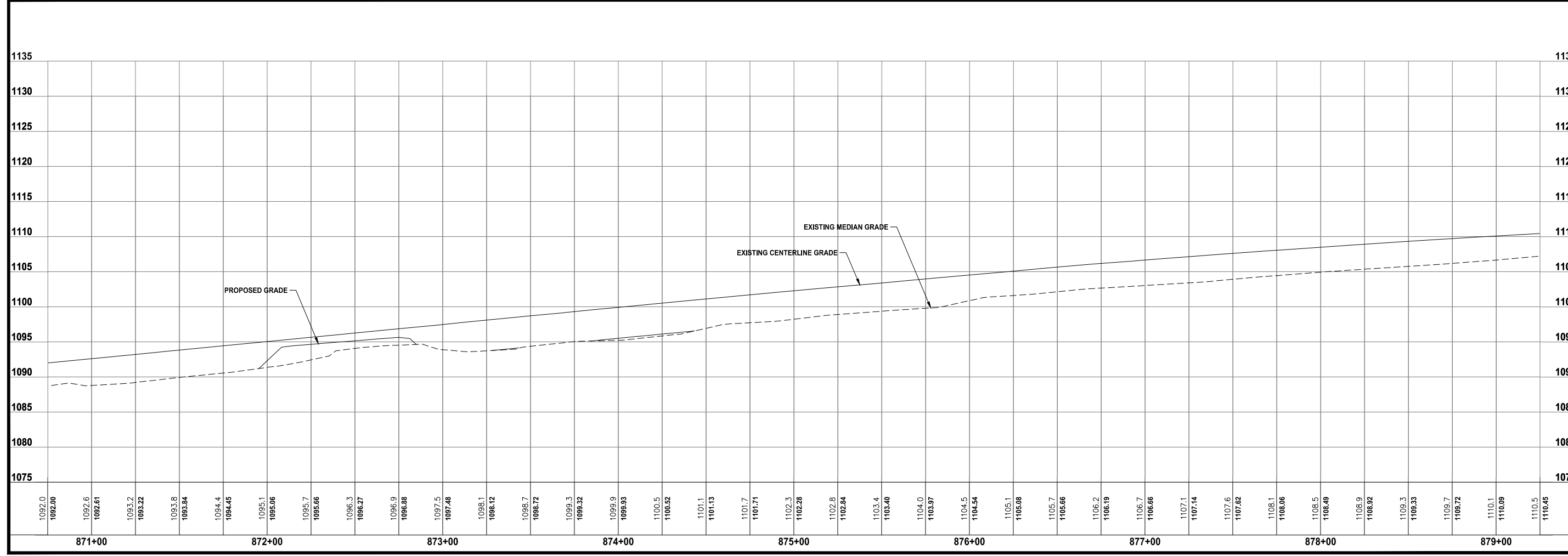
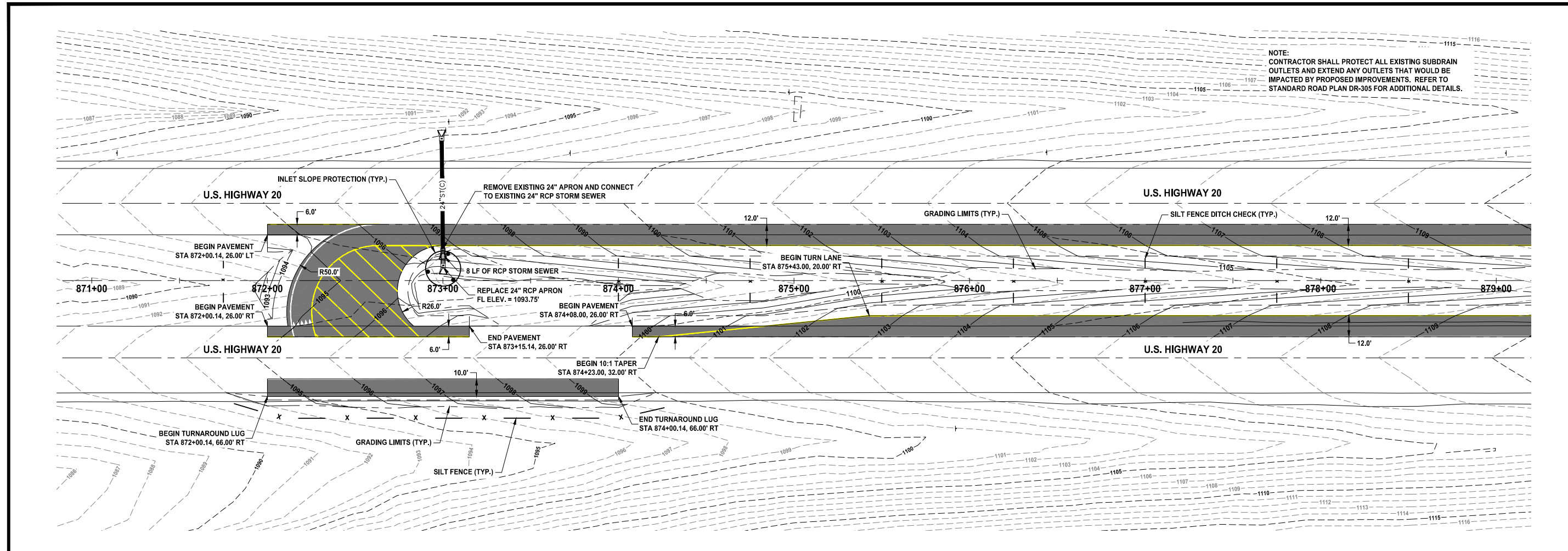

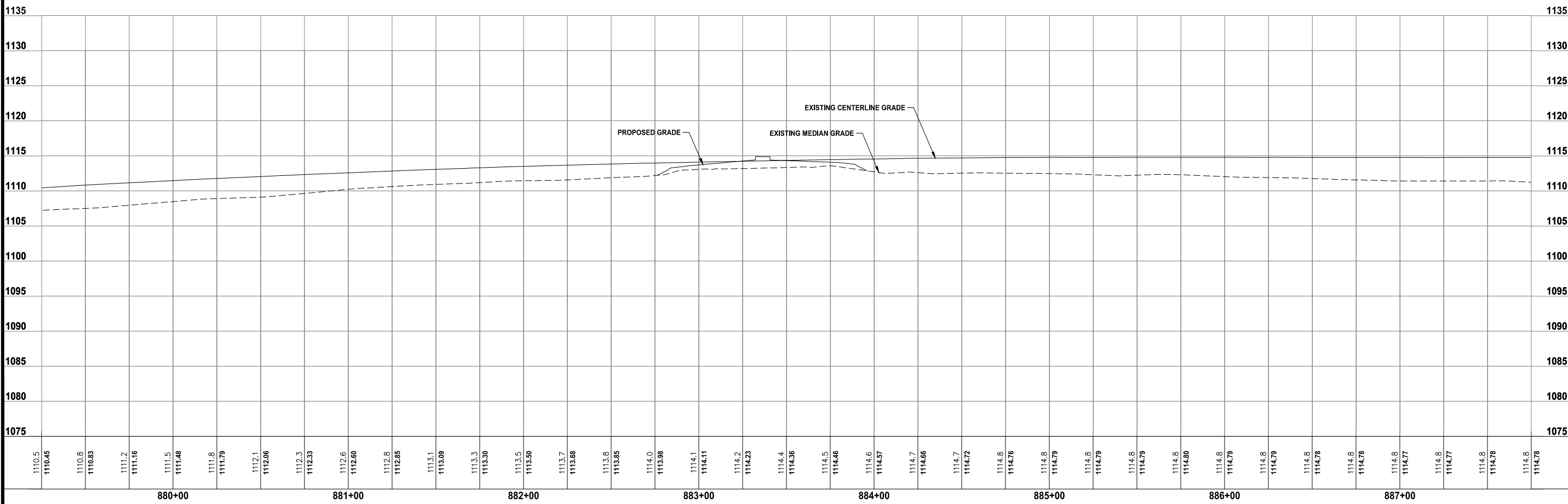
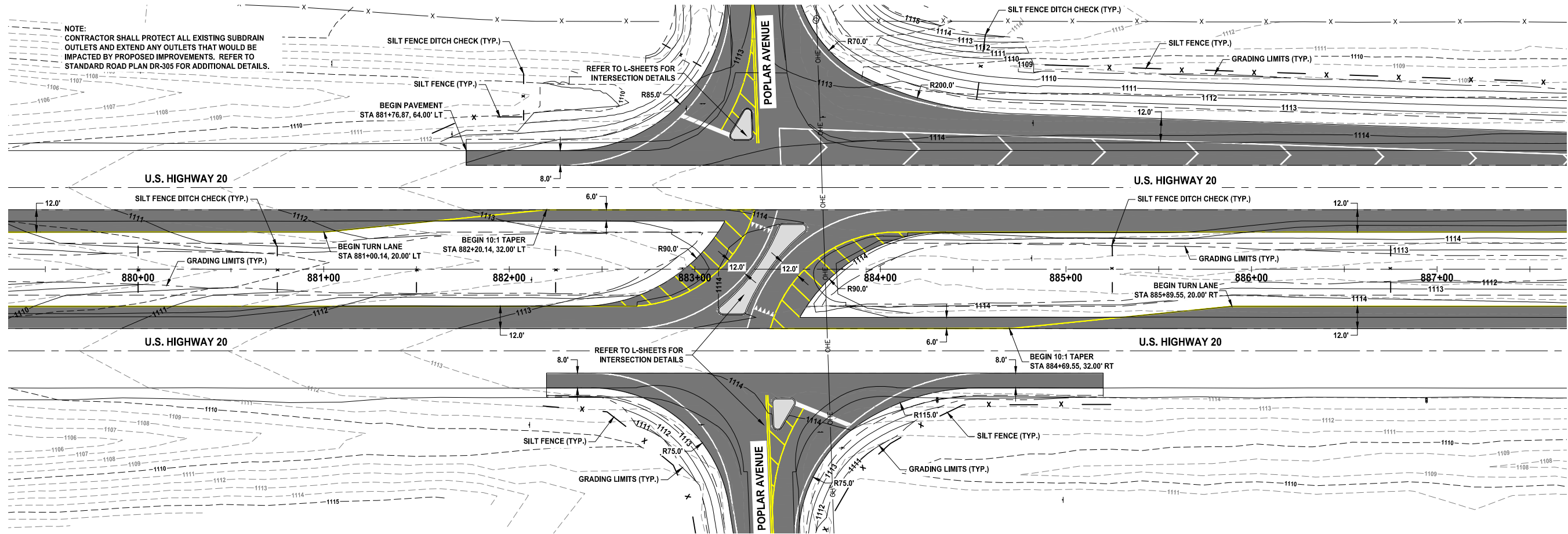

NOTE: CONTRACTOR SHALL PROTECT ALL EXISTING SUBDRAIN OUTLETS AND EXTEND ANY OUTLETS THAT WOULD BE IMPACTED BY PROPOSED IMPROVEMENTS. REFER TO STANDARD ROAD PLAN DR-305 FOR ADDITIONAL DETAILS.

**McCLURE™**  
 705 First Avenue North  
 Fort Dodge, Iowa 50501  
 P 515-576-7155  
 F 515-576-4235

Ankeny, IA | Carroll, IA | Clive, IA  
 Cedar Rapids, IA | Fort Dodge, IA  
 North Liberty, IA | Sioux City, IA  
 Macon, MO | Columbia, MO  
 North Kansas City, MO  
 Lenexa, KS

NOTICE: McClure Engineering Co. is not responsible or liable for any issues, claims, damages, or losses (collectively, "Losses") which arise from failure to follow these Plans, Specifications, and the engineering intent they convey, or for Losses which arise from failure to obtain and/or follow the engineers' or surveyors' guidance with respect to any alleged errors, omissions, inconsistencies, ambiguities, or conflicts contained within the Plans and Specifications.

IOWA CERTIFICATE OF AUTHORITY NO. 26887

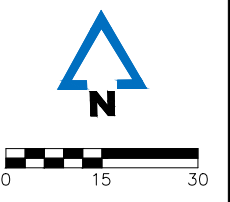

REVISIONS

PROJECT INFO  
 210178-004

ENGINEER: CFF    DRAWN BY: BAV    CHECKED BY: JSS

**U.S. HIGHWAY 20 AND POPLAR AVENUE  
 RCUT INTERSECTION IMPROVEMENTS  
 WEBSTER COUNTY, IOWA**

**U.S. HIGHWAY 20 PLAN AND PROFILE**

R:210178-004-06-DRAWINGS/CIVIL/PLANS/D.01.DWG

DRAWING NO.  
**D.02**

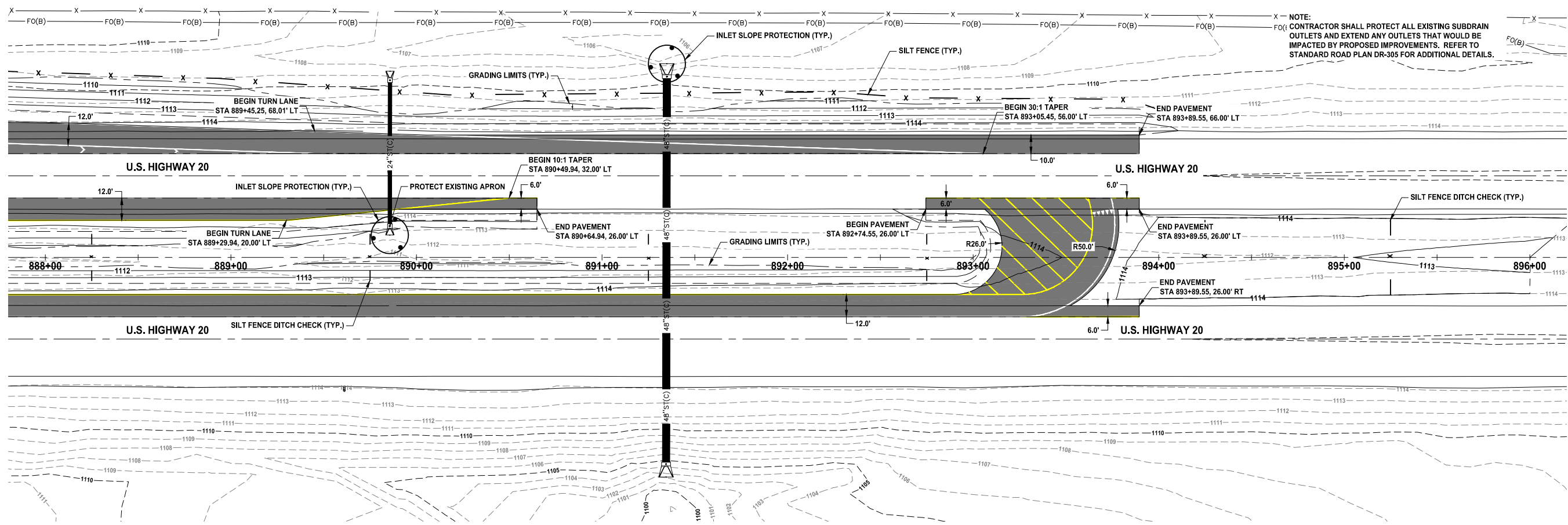

NOTE: CONTRACTOR SHALL PROTECT ALL EXISTING SUBDRAIN OUTLETS AND EXTEND ANY OUTLETS THAT WOULD BE IMPACTED BY PROPOSED IMPROVEMENTS. REFER TO STANDARD ROAD PLAN DR-305 FOR ADDITIONAL DETAILS.

**McCLURE™**  
 705 First Avenue North  
 Fort Dodge, Iowa 50501  
 P 515-576-7155  
 F 515-576-4235

Ankeny, IA | Carroll, IA | Clive, IA  
 Cedar Rapids, IA | Fort Dodge, IA  
 North Liberty, IA | Sioux City, IA  
 Macon, MO | Columbia, MO  
 North Kansas City, MO  
 Lenexa, KS

NOTICE: McClure Engineering Co. is not responsible or liable for any issues, claims, damages, or losses (collectively, "Losses") which arise from failure to follow these Plans, Specifications, and the engineering intent they convey, or for Losses which arise from failure to obtain and/or follow the engineers' or surveyors' guidance with respect to any alleged errors, omissions, inconsistencies, ambiguities, or conflicts contained within the Plans and Specifications.

IOWA CERTIFICATE OF AUTHORITY NO. 26887

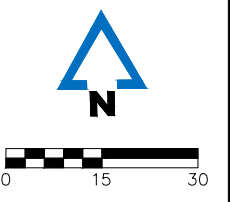

REVISIONS

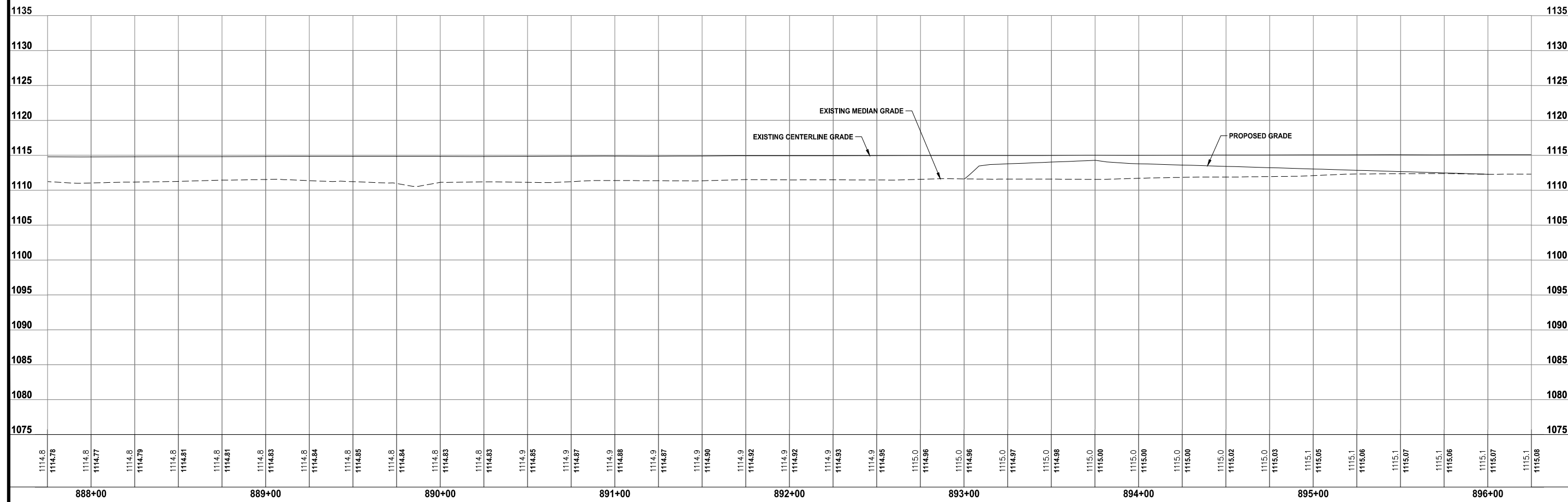

PROJECT INFO  
 210178-004

ENGINEER: CFF    DRAWN BY: BAV    CHECKED BY: JSS

**US HIGHWAY 20 AND POPLAR AVENUE  
 RCUT INTERSECTION IMPROVEMENTS  
 WEBSTER COUNTY, IOWA**

**U.S. HIGHWAY 20 PLAN AND PROFILE**

R:121078-004106-DRAWINGS\CIVIL\PLANS\01.DWG

DRAWING NO.  
**D.03**



REVISIONS

PROJECT INFO  
210178-004

ENGINEER: CFF    DRAWN BY: BAV    CHECKED BY: JSS

**US HIGHWAY 20 AND POPLAR AVENUE  
RCUT INTERSECTION IMPROVEMENTS  
WEBSTER COUNTY, IOWA**

**POPLAR AVENUE PLAN AND PROFILE**

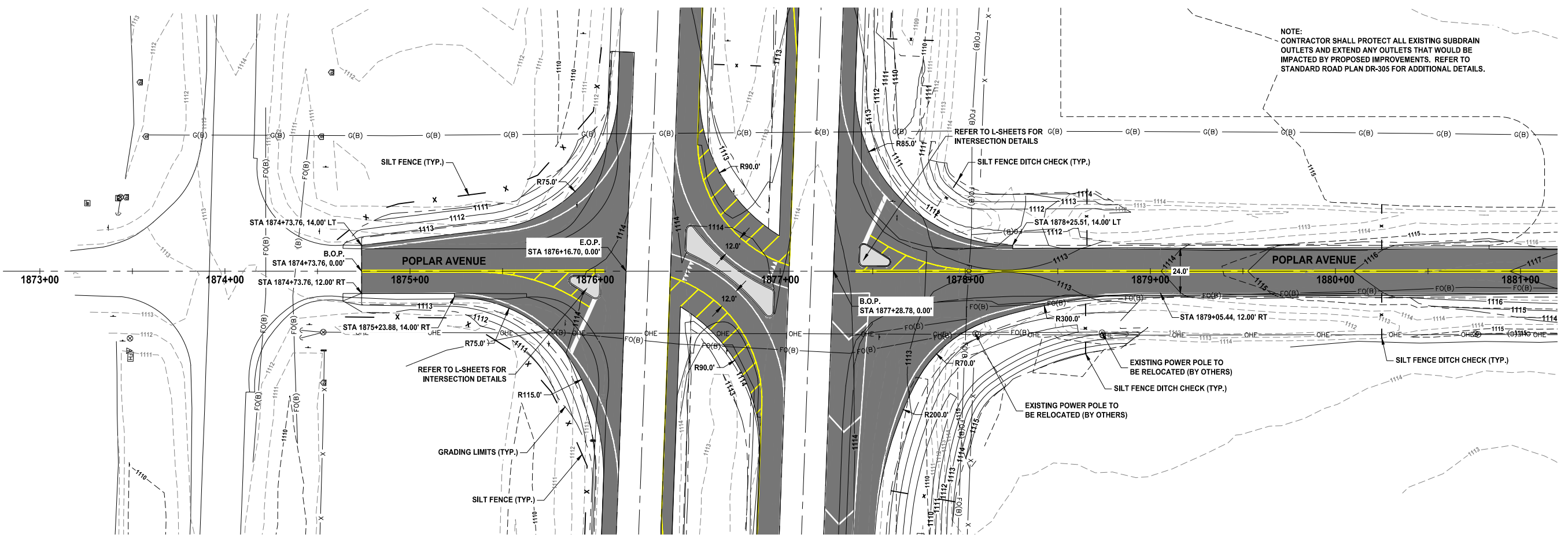

NOTE:  
CONTRACTOR SHALL PROTECT ALL EXISTING SUBDRAIN  
OUTLETS AND EXTEND ANY OUTLETS THAT WOULD BE  
IMPACTED BY PROPOSED IMPROVEMENTS. REFER TO  
STANDARD ROAD PLAN DR-305 FOR ADDITIONAL DETAILS.

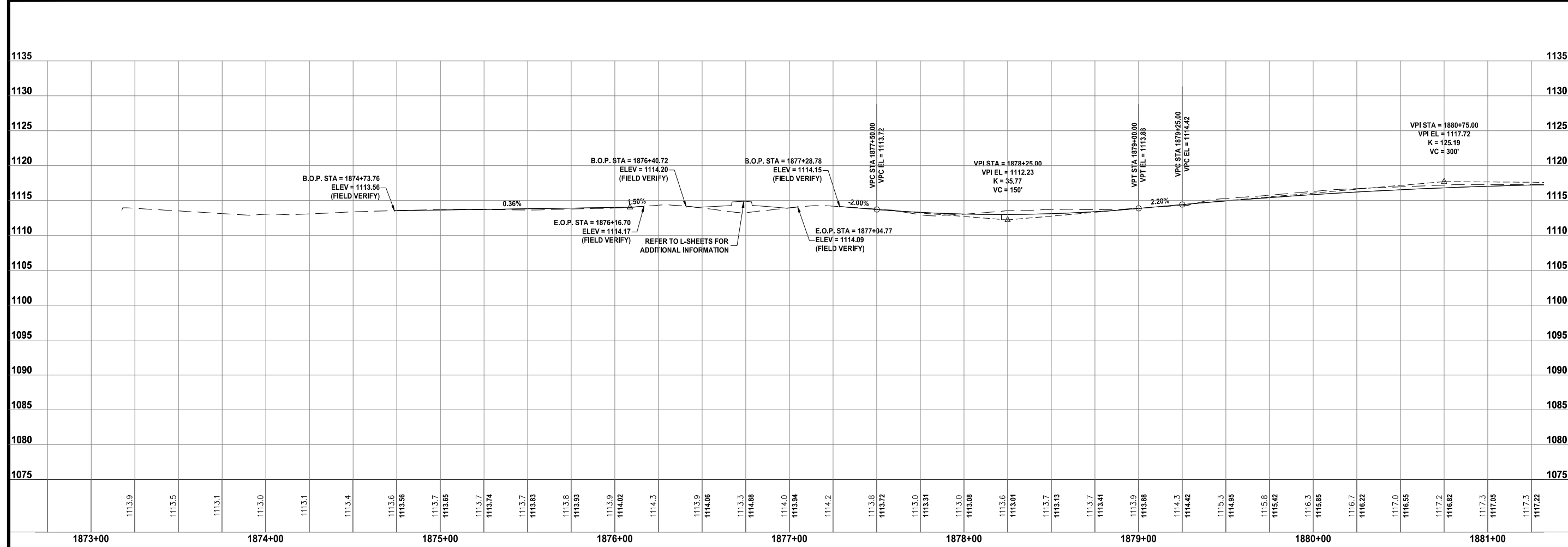

R:210178-004-06-DRAWINGS\CIVIL\PLANS\E.01.DWG

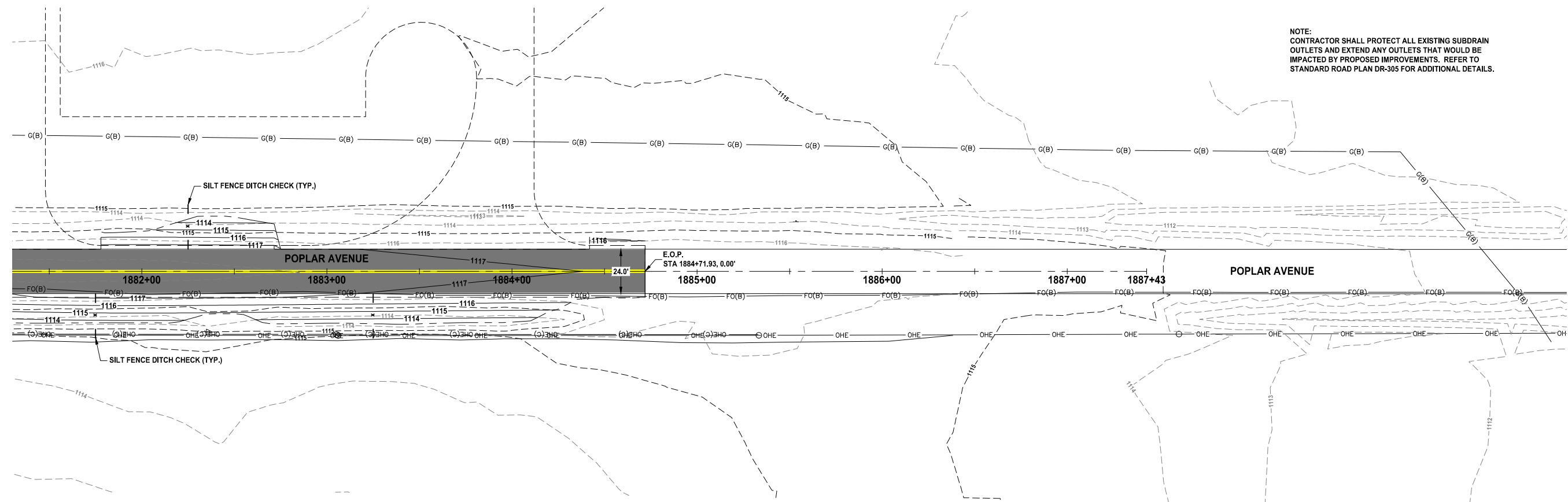

**McCLURE™**  
 705 First Avenue North  
 Fort Dodge, Iowa 50501  
 P 515-576-7155  
 F 515-576-4235

Ankeny, IA | Carroll, IA | Clive, IA  
 Cedar Rapids, IA | Fort Dodge, IA  
 North Liberty, IA | Sioux City, IA  
 Macon, MO | Columbia, MO  
 North Kansas City, MO  
 Lenexa, KS

NOTICE:  
 McClure Engineering Co. is not responsible or liable for any issues, claims, damages, or losses (collectively, "Losses") which arise from failure to follow these Plans, Specifications, and the engineering intent they convey, or for Losses which arise from failure to obtain and/or follow the engineers' or surveyors' guidance with respect to any alleged errors, omissions, inconsistencies, ambiguities, or conflicts contained within the Plans and Specifications.

IOWA CERTIFICATE OF AUTHORITY NO. 26887

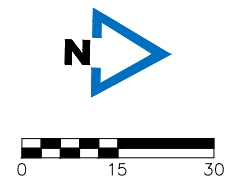

REVISIONS

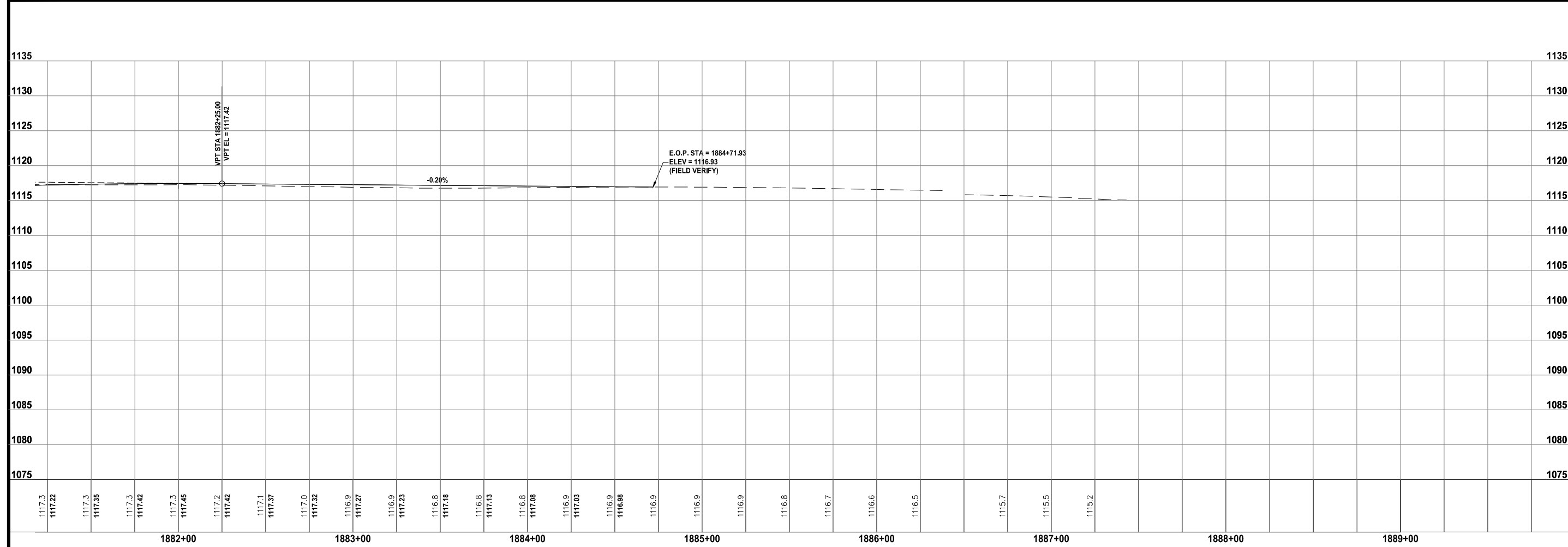

PROJECT INFO  
 210178-004

ENGINEER: CFF    DRAWN BY: BAV    CHECKED BY: JSS

US HIGHWAY 20 AND POPLAR AVENUE  
 RCUT INTERSECTION IMPROVEMENTS  
 WEBSTER COUNTY, IOWA

POPLAR AVENUE PLAN AND PROFILE

R:210178-004-06-DRAWINGS\CIVIL\PLANS\E.01.DWG

DRAWING NO.  
**E.02**

**NOTICE:**  
 McClure Engineering Co. is not responsible or liable for any issues, claims, damages, or losses (collectively, "Losses") which arise from failure to follow these Plans, Specifications, and the engineering intent they convey, or for Losses which arise from failure to obtain and/or follow the engineers' or surveyors' guidance with respect to any alleged errors, omissions, inconsistencies, ambiguities, or conflicts contained within the Plans and Specifications.

IOWA CERTIFICATE OF AUTHORITY NO. 26887

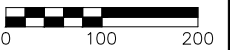

REVISIONS

PROJECT INFO  
 210178-004

ENGINEER: CFF    DRAWN BY: BAV    CHECKED BY: JSS

**US HIGHWAY 20 AND POPLAR AVENUE  
 RCUT INTERSECTION IMPROVEMENTS  
 WEBSTER COUNTY, IOWA**

**REFERENCE TIES & BENCHMARKS**

R:1210178-004-006-DRAWINGS\CIVIL\PLANS\IG.01.DWG

ALIGNMENT COORDINATES										
Name	Location	Point on Tangent			Begin Curve			End Curve		
		Station	Coordinates		Station	Coordinates		Station	Coordinates	
			Y (Northing)	X (Easting)		Y (Northing)	X (Easting)		Y (Northing)	X (Easting)
<b>U.S. Highway 20</b>										
L1		869+44.04	8,570,350.92	14,698,733.89						
		898+44.03	8,570,309.96	14,701,633.59						
<b>Poplar Avenue</b>										
L1		1870+53.86	8,569,712.54	14,700,140.39						
		1887+42.94	8,571,401.18	14,700,101.62						

CONTROL POINT COORDINATES				
Point	Northing	Easting	Elevation	Description
101	8570446.06	14700106.67	1112.44	1/2" REBAR WITH BPC
200	8570537.68	14699205.23	1117.66	1/2" REBAR WITH BPC
201	8570521.78	14699393.93	1116.87	1/2" REBAR WITH BPC
202	8571184.02	14699411.75	1111.57	1/2" REBAR WITH BPC
250	8570429.16	14701987.51	1109.11	1/2" REBAR WITH BPC
251	8570435.63	14701394.66	1112.85	1/2" REBAR WITH BPC
252	8570414.17	14700780.76	1110.24	1/2" REBAR WITH BPC
253	8570492.82	14699487.67	1117.10	1/2" REBAR WITH BPC
254	8570542.16	14698889.65	1113.46	1/2" REBAR WITH BPC
255	8570559.70	14698299.70	1102.10	1/2" REBAR WITH BPC
256	8570492.86	14697635.16	1057.53	1/2" REBAR WITH BPC
257	8570454.47	14697138.03	1054.06	1/2" REBAR WITH BPC
258	8570169.37	14701986.84	1107.98	1/2" REBAR WITH BPC
259	8570178.79	14701387.34	1108.55	1/2" REBAR WITH BPC
260	8570235.23	14700787.35	1112.34	1/2" REBAR WITH BPC
261	8570203.07	14700187.84	1111.91	1/2" REBAR WITH BPC
262	8570295.14	14697127.95	1054.56	1/2" REBAR WITH BPC
263	8570287.08	14697619.55	1059.19	1/2" REBAR WITH BPC
264	8570269.69	14698304.28	1075.09	1/2" REBAR WITH BPC
265	8570262.74	14698884.29	1089.34	1/2" REBAR WITH BPC
266	8570253.84	14699484.70	1103.00	1/2" REBAR WITH BPC
7102	8571295.89	14700088.93	1115.79	1/2" REBAR WITH BPC

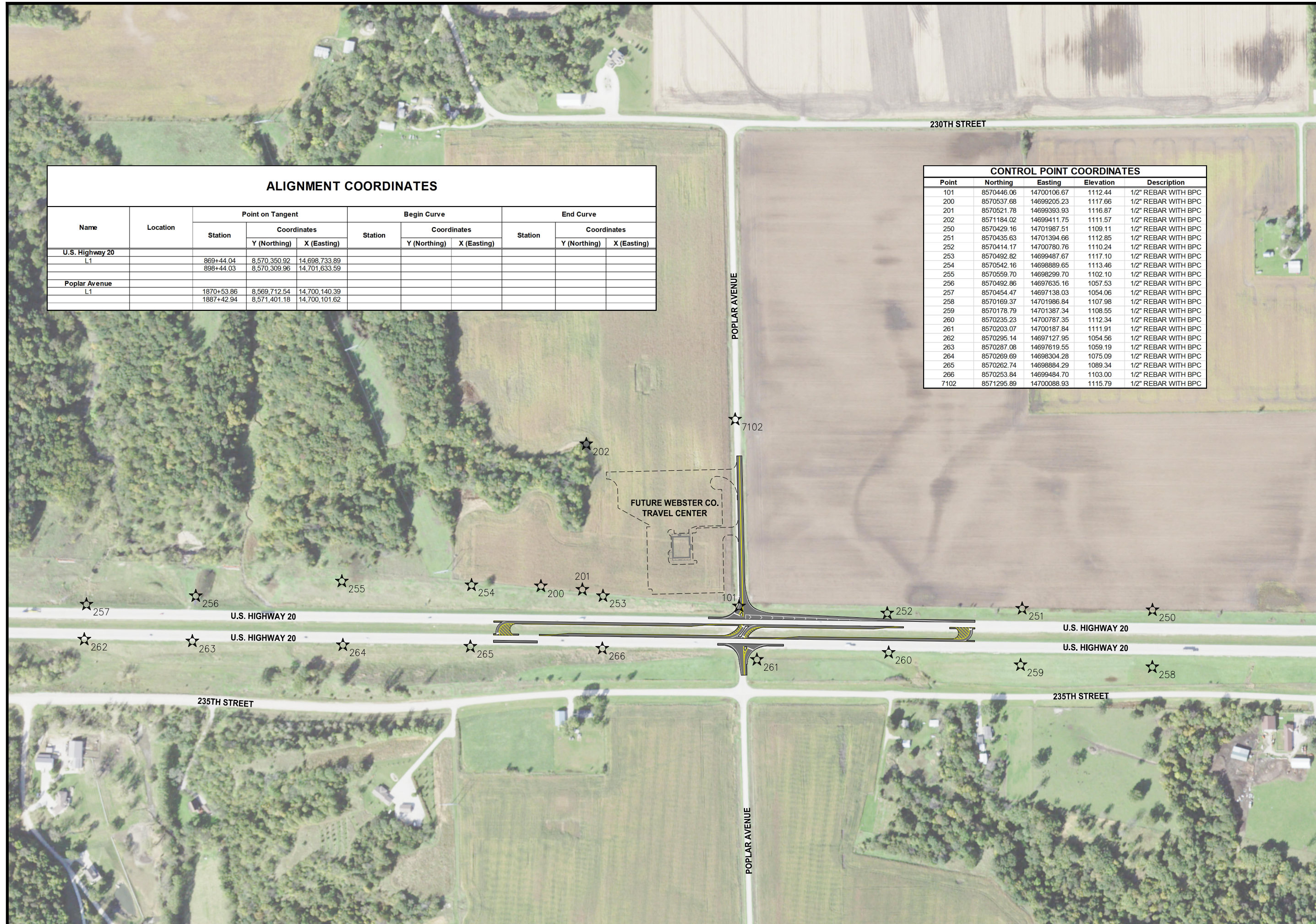



**TRAFFIC CONTROL NOTES**

THE CONTRACTOR SHALL EMPLOY SOUND PRACTICES OF SAFETY AND TRAFFIC CONTROL. THESE METHODS AND PRACTICES SHALL INCLUDE, BUT NOT BE LIMITED TO, THE FOLLOWING:

1. THE CONTRACTOR SHALL COORDINATE TRAFFIC CONTROL WITH OTHER PROJECTS IN THE AREA.
2. TRAFFIC CONTROL ON THIS PROJECT SHALL BE IN ACCORDANCE WITH SPECIFIC LAYOUTS SHOWN ON THESE PLANS AND STANDARD ROAD PLANS. TRAFFIC CONTROL DEVICES, PROCEDURES, AND LAYOUTS SHALL CONFORM TO THE MANUAL ON UNIFORM TRAFFIC CONTROL DEVICES.
3. ALL TRAFFIC CONTROL DEVICES SHALL BE FURNISHED, ERECTED, MAINTAINED AND REMOVED BY THE CONTRACTOR.
4. ALL TRAFFIC CONTROL SIGNS SHALL BE PLACED A MINIMUM OF TWO FEET CLEAR OF THE OUTSIDE EDGE OF SHOULDER WHERE POSSIBLE.
5. CONTRACTOR SHALL ERECT ALL WARNING SIGNS ON FIXED POSTS. PORTABLE MOUNTINGS FOR WARNING SIGNS MAY BE USED FOR TEMPORARY INSTALLATIONS OF 3 DAYS OR LESS.
6. THE PROPOSED SIGNING MAY BE MODIFIED TO MEET FIELD CONDITIONS, PREVENT OBSTRUCTIONS AND TO ACCOMMODATE CONSTRUCTION SCHEDULING UPON APPROVAL OF THE ENGINEER.
7. ORANGE SAFETY FENCE SHALL BE PLACED ENTIRELY ACROSS THE TRAVELED PORTION OF THE ROADWAY AND SHOULDERS AT ALL LOCATIONS WHERE TYPE III BARRICADES WITH ROAD CLOSED SIGNS ARE USED.
8. THE BACK SIDE OF THE TYPE III BARRICADES SHALL BE REFLECTORIZED BY A MINIMUM OF SIX YELLOW REFLECTORS, ON AT EACH END OF EACH RAIL, OR AT LEAST ONE RAIL ON EACH BARRICADE SHALL HAVE REFLECTORIZED STRIPES PROPERLY SLOPED AT EACH END.
9. LONG TERM OR PERMANENT TRAFFIC CONTROL SIGNS THAT CONFLICT WITH SPECIFIC LAYOUTS SHOWN ON THESE PLANS ARE TO BE COVERED AS DIRECTED BY THE ENGINEER.
10. SIGN WASHING SHALL BE CONSIDERED INCIDENTAL TO TRAFFIC CONTROL AND REQUIRED AS DIRECTED BY THE ENGINEER.
11. REFER TO IOWA DOT STANDARD SPECIFICATIONS FOR HIGHWAY AND BRIDGE CONSTRUCTION SEC. 4186.03 FOR SIGN REQUIREMENTS.
12. THE LOCATION FOR STORAGE OF EQUIPMENT AND MATERIALS BY THE CONTRACTOR DURING NON-WORKING HOURS SHALL BE AS APPROVED BY THE ENGINEER. NO STORAGE OF MATERIALS OR EQUIPMENT WILL BE PERMITTED WITHIN THE IOWA DOT RIGHT OF WAY.
13. THE BID ITEM "TRAFFIC CONTROL" SHALL INCLUDE THE COST FOR ALL TRAFFIC CONTROL MEASURES REQUIRED OF THE CONTRACTOR EXCEPT FOR THOSE WHICH ARE SEPARATE BID ITEMS OR ARE INCIDENTAL TO OTHER BID ITEMS.
14. SHOULD A SITUATION ARISE REQUIRING AN EMERGENCY RESPONSE TO THE PROJECT SITE OR ADJACENT LOCATION, THE CONTRACTOR SHALL MAKE REASONABLE ACCOMMODATIONS TO NOT HINDER EMERGENCY VEHICLES AND/OR PERSONNEL.
15. WRITTEN NOTICE SHALL BE PROVIDED TO WEBSTER COUNTY AND THE ENGINEER 7 DAYS PRIOR TO ROADWAY CLOSURES.
16. REFER TO SHEETS J.02 - J.04 FOR SPECIFIC TRAFFIC CONTROL SITUATIONS. REFER TO THE IOWA DOT STANDARD ROAD PLANS FOR ADDITIONAL TRAFFIC CONTROL SITUATIONS THAT MAY BE REQUIRED.

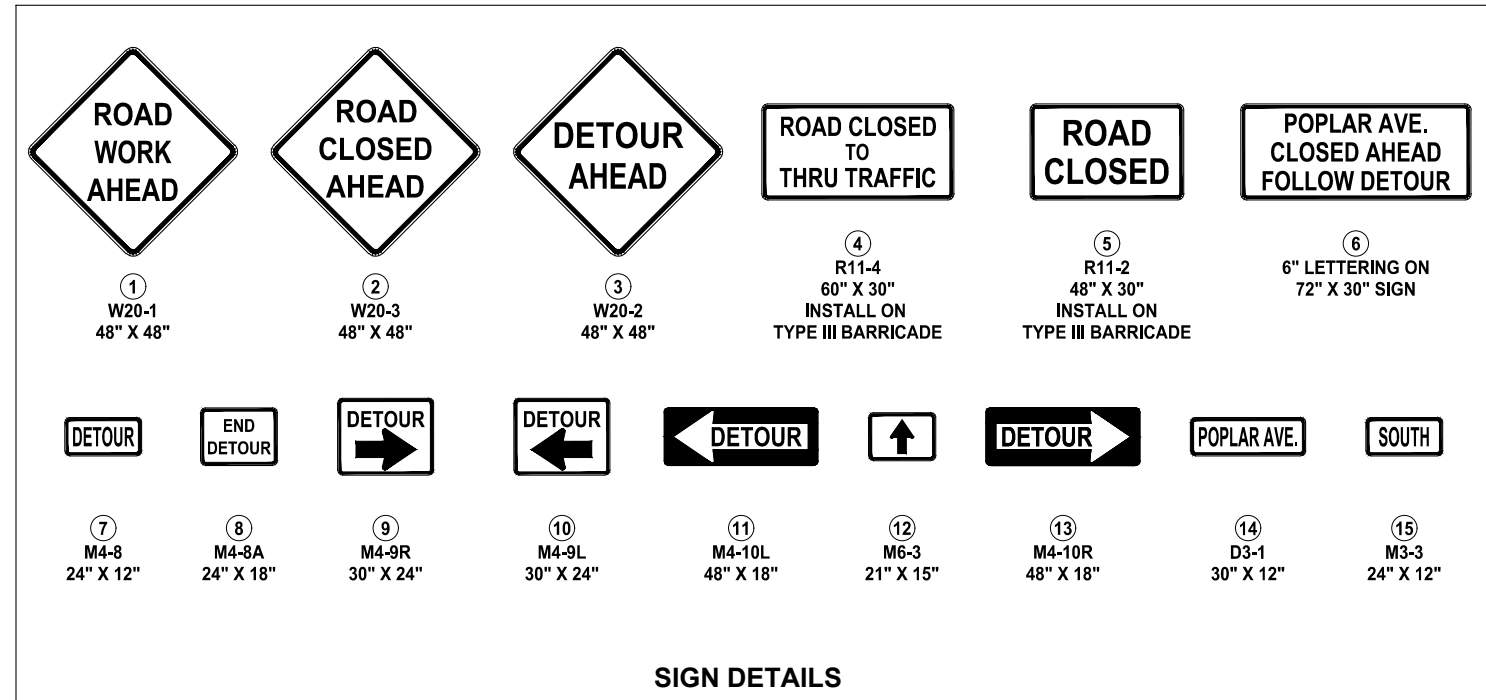

NOTICE:  
 McClure Engineering Co. is not responsible or liable for any issues, claims, damages, or losses (collectively, "Losses") which arise from failure to follow these Plans, Specifications, and the engineering intent they convey, or for Losses which arise from failure to obtain and/or follow the engineers' or surveyors' guidance with respect to any alleged errors, omissions, inconsistencies, ambiguities, or conflicts contained within the Plans and Specifications.

IOWA CERTIFICATE OF AUTHORITY NO. 26887

REVISIONS

PROJECT INFO  
 210178-004

ENGINEER: CFF    DRAWN BY: BAV    CHECKED BY: JSS

US HIGHWAY 20 AND POPLAR AVENUE  
 RCUT INTERSECTION IMPROVEMENTS  
 WEBSTER COUNTY, IOWA  
 TRAFFIC CONTROL NOTES & DETAILS  
 R:\210178-004\06-DRAWINGS\CIVIL\PLANS\J.01.DWG

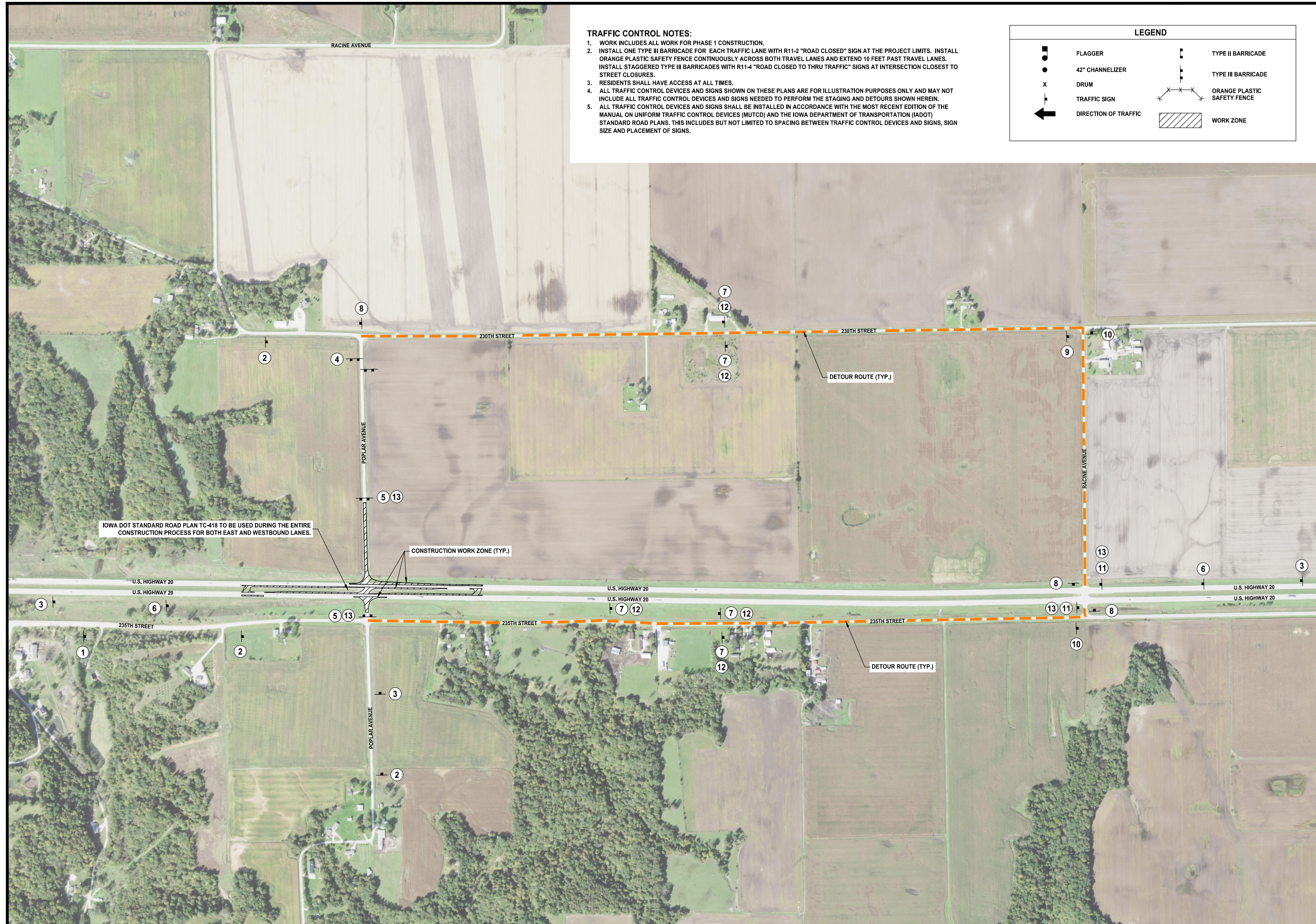

**TRAFFIC CONTROL NOTES:**

1. WORK INCLUDES ALL WORK FOR PHASE 1 CONSTRUCTION.
2. INSTALL ONE TYPE III BARRICADE FOR EACH TRAFFIC LANE WITH R11-2 "ROAD CLOSED" SIGN AT THE PROJECT LIMITS. INSTALL ORANGE PLASTIC SAFETY FENCE CONTINUOUSLY ACROSS BOTH TRAVEL LANES AND EXTEND 10 FEET PAST TRAVEL LANES. INSTALL STAGGERED TYPE III BARRICADES WITH R11-4 "ROAD CLOSED TO THRU TRAFFIC" SIGNS AT INTERSECTION CLOSEST TO STREET CLOSURES.
3. RESIDENTS SHALL HAVE ACCESS AT ALL TIMES.
4. ALL TRAFFIC CONTROL DEVICES AND SIGNS SHOWN ON THESE PLANS ARE FOR ILLUSTRATION PURPOSES ONLY AND MAY NOT INCLUDE ALL TRAFFIC CONTROL DEVICES AND SIGNS NEEDED TO PERFORM THE STAGING AND DETOURS SHOWN HEREIN.
5. ALL TRAFFIC CONTROL DEVICES AND SIGNS SHALL BE INSTALLED IN ACCORDANCE WITH THE MOST RECENT EDITION OF THE MANUAL ON UNIFORM TRAFFIC CONTROL DEVICES (MUTCD) AND THE IOWA DEPARTMENT OF TRANSPORTATION (IADOT) STANDARD ROAD PLANS. THIS INCLUDES BUT NOT LIMITED TO SPACING BETWEEN TRAFFIC CONTROL DEVICES AND SIGNS, SIGN SIZE AND PLACEMENT OF SIGNS.

LEGEND			
	FLAGGER		TYPE II BARRICADE
	42" CHANNELIZER		TYPE III BARRICADE
	DRUM		ORANGE PLASTIC SAFETY FENCE
	TRAFFIC SIGN		WORK ZONE
	DIRECTION OF TRAFFIC		

**McCLURE™**  
 705 First Avenue North  
 Fort Dodge, Iowa 50501  
 P 515-576-7155  
 F 515-576-4235

Ankeny, IA | Carroll, IA | Clive, IA  
 Cedar Rapids, IA | Fort Dodge, IA  
 North Liberty, IA | Sioux City, IA  
 Macon, MO | Columbia, MO  
 North Kansas City, MO  
 Lenexa, KS

**NOTICE:**  
 McClure Engineering Co. is not responsible or liable for any issues, claims, damages, or losses (collectively, "Losses") which arise from failure to follow these Plans, Specifications, and the engineering intent they convey, or for Losses which arise from failure to obtain and/or follow the engineers' or surveyors' guidance with respect to any alleged errors, omissions, inconsistencies, ambiguities, or conflicts contained within the Plans and Specifications.

IOWA CERTIFICATE OF AUTHORITY NO. 26887

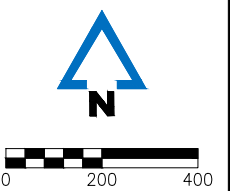

REVISIONS

PROJECT INFO  
 210178-004

ENGINEER: CFF  
 DRAWN BY: BAV  
 CHECKED BY: JSS

**US HIGHWAY 20 AND POPLAR AVENUE  
 RCUT INTERSECTION IMPROVEMENTS  
 WEBSTER COUNTY, IOWA**

**TEMPORARY TRAFFIC CONTROL PLAN**

R:1210178-004-006-DRAWINGS\CIVIL\PLANS\U.02.DWG

DRAWING NO.  
**J.02**

NOTICE:  
 McClure Engineering Co. is not responsible or liable for any issues, claims, damages, or losses (collectively, "Losses") which arise from failure to follow these Plans, Specifications, and the engineering intent they convey, or for Losses which arise from failure to obtain and/or follow the engineers' or surveyors' guidance with respect to any alleged errors, omissions, inconsistencies, ambiguities, or conflicts contained within the Plans and Specifications.

IOWA CERTIFICATE OF AUTHORITY NO. 26887



REVISIONS

PROJECT INFO  
 210178-004

ENGINEER: CFF    DRAWN BY: BAV    CHECKED BY: JSS

**US HIGHWAY 20 AND POPLAR AVENUE  
 RCUT INTERSECTION IMPROVEMENTS  
 WEBSTER COUNTY, IOWA**

**U.S. HIGHWAY 20 JOINTING PLAN**

R:1210178-004-06-DRAWINGS\CIVIL\PLANS\L01.DWG

DRAWING NO.  
**L.01**

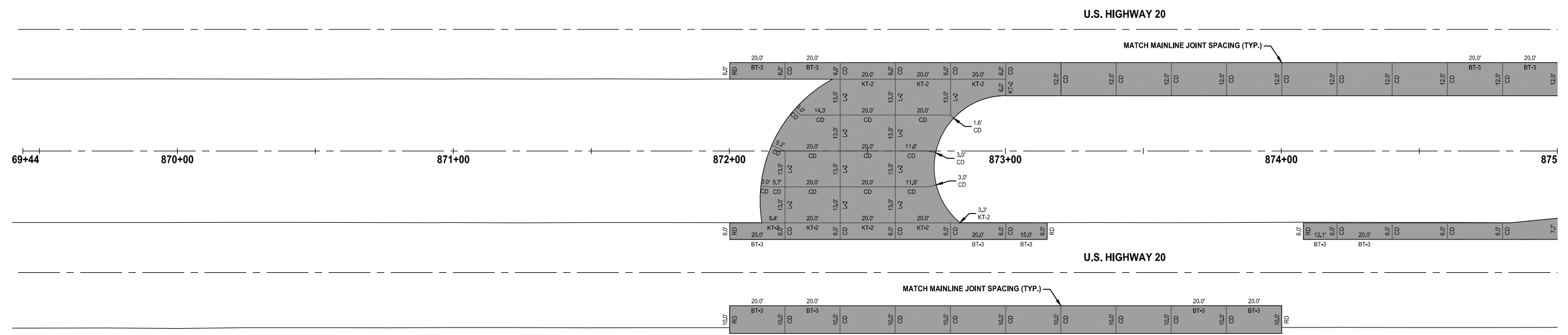

**NOTES**

1. REFER TO FIGURE 7010.101 FOR JOINT DETAILS.
2. TYPICAL CD OR C JOINT SPACING WHERE NOT SHOWN IS 20 FEET.
3. ELEVATIONS SHOWN ARE TOP OF SLAB OR FORM GRADE UNLESS NOTED OTHERWISE.
4. ELEVATIONS IN PARENTHESIS ARE EXISTING ELEVATIONS.

**U.S. HIGHWAY 20  
 (JOINTING DETAIL)**

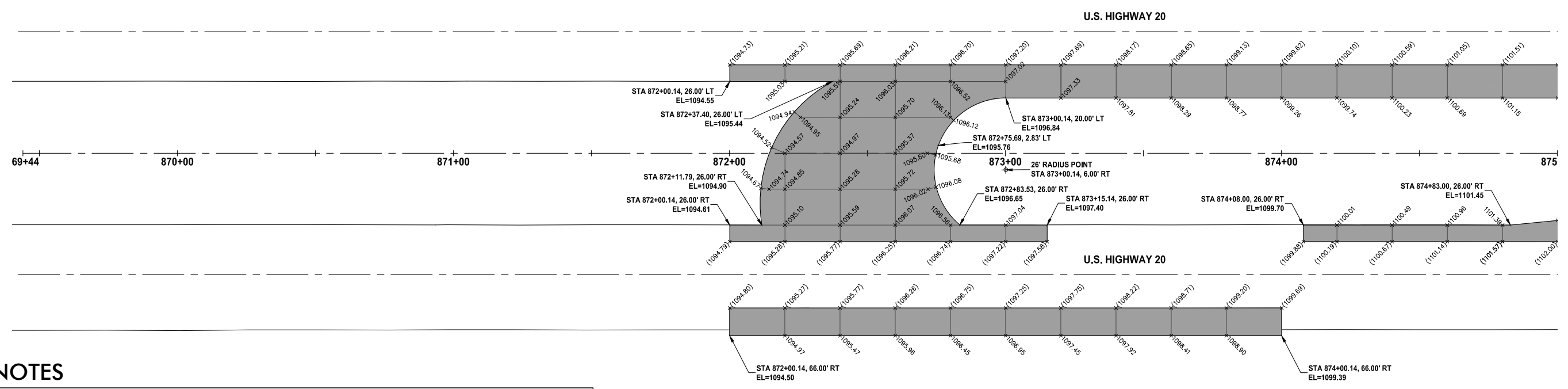

**NOTES**

1. REFER TO FIGURE 7010.101 FOR JOINT DETAILS.
2. TYPICAL CD OR C JOINT SPACING WHERE NOT SHOWN IS 20 FEET.
3. ELEVATIONS SHOWN ARE TOP OF SLAB OR FORM GRADE UNLESS NOTED OTHERWISE.
4. ELEVATIONS IN PARENTHESIS ARE EXISTING ELEVATIONS.

**U.S. HIGHWAY 20  
 (GEOMETRIC & STAKING DETAIL)**

NOTICE:  
 McClure Engineering Co. is not responsible or liable for any issues, claims, damages, or losses (collectively, "Losses") which arise from failure to follow these Plans, Specifications, and the engineering intent they convey, or for Losses which arise from failure to obtain and/or follow the engineers' or surveyors' guidance with respect to any alleged errors, omissions, inconsistencies, ambiguities, or conflicts contained within the Plans and Specifications.

IOWA CERTIFICATE OF AUTHORITY NO. 26887



REVISIONS

PROJECT INFO  
 210178-004

ENGINEER: CFF    DRAWN BY: BAV    CHECKED BY: JSS

US HIGHWAY 20 AND POPLAR AVENUE  
 RCUT INTERSECTION IMPROVEMENTS  
 WEBSTER COUNTY, IOWA  
 U.S. HIGHWAY 20 JOINTING PLAN  
R:210178-004-06-DRAWINGS\CIVIL\PLANS\L01.DWG

DRAWING NO.  
**L.02**

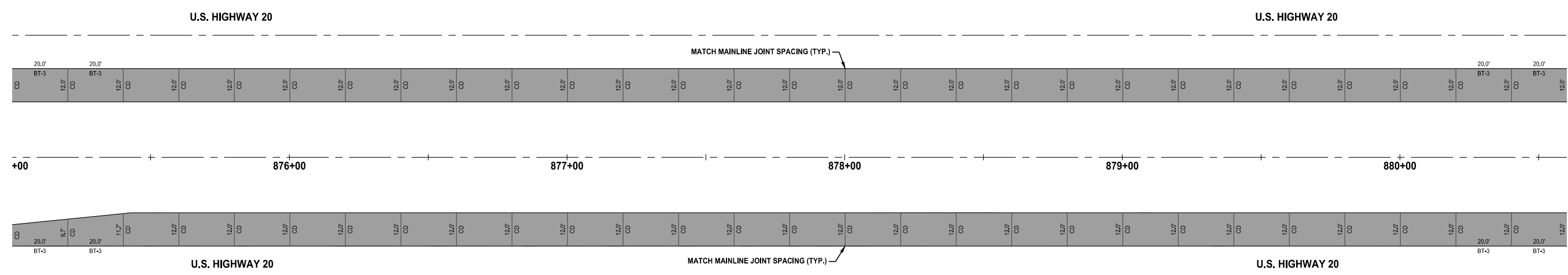

**NOTES**

1. REFER TO FIGURE 7010.101 FOR JOINT DETAILS.
2. TYPICAL CD OR C JOINT SPACING WHERE NOT SHOWN IS 20 FEET.
3. ELEVATIONS SHOWN ARE TOP OF SLAB OR FORM GRADE UNLESS NOTED OTHERWISE.
4. ELEVATIONS IN PARENTHESIS ARE EXISTING ELEVATIONS.

**U.S. HIGHWAY 20  
 (JOINTING DETAIL)**

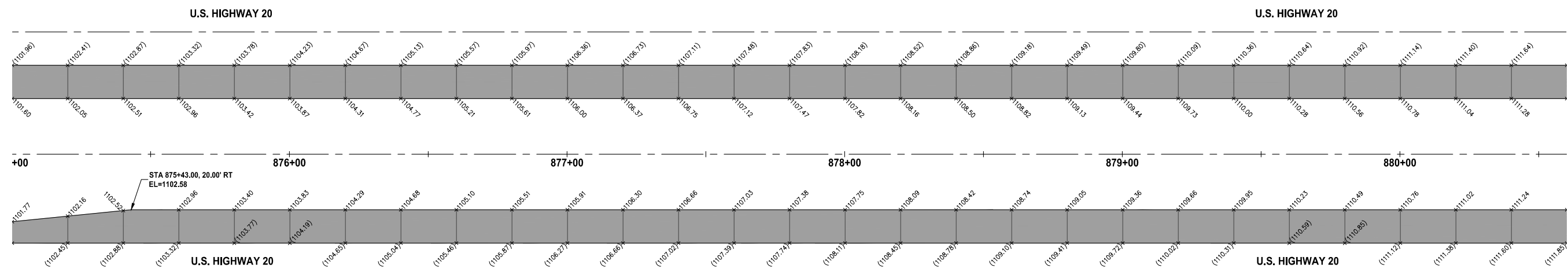

**NOTES**

1. REFER TO FIGURE 7010.101 FOR JOINT DETAILS.
2. TYPICAL CD OR C JOINT SPACING WHERE NOT SHOWN IS 20 FEET.
3. ELEVATIONS SHOWN ARE TOP OF SLAB OR FORM GRADE UNLESS NOTED OTHERWISE.
4. ELEVATIONS IN PARENTHESIS ARE EXISTING ELEVATIONS.

**U.S. HIGHWAY 20  
 (GEOMETRIC & STAKING DETAIL)**

**NOTICE:**  
 McClure Engineering Co. is not responsible or liable for any issues, claims, damages, or losses (collectively, "Losses") which arise from failure to follow these Plans, Specifications, and the engineering intent they convey, or for Losses which arise from failure to obtain and/or follow the engineers' or surveyors' guidance with respect to any alleged errors, omissions, inconsistencies, ambiguities, or conflicts contained within the Plans and Specifications.

IOWA CERTIFICATE OF AUTHORITY NO. 26887

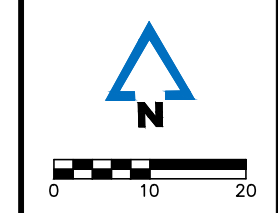

REVISIONS

PROJECT INFO  
 210178-004

ENGINEER: CFF    DRAWN BY: BAV    CHECKED BY: JSS

**US HIGHWAY 20 AND POPLAR AVENUE  
 RCUT INTERSECTION IMPROVEMENTS  
 WEBSTER COUNTY, IOWA**

**U.S. HIGHWAY 20 JOINTING PLAN**

DRAWING NO.  
**L.03**

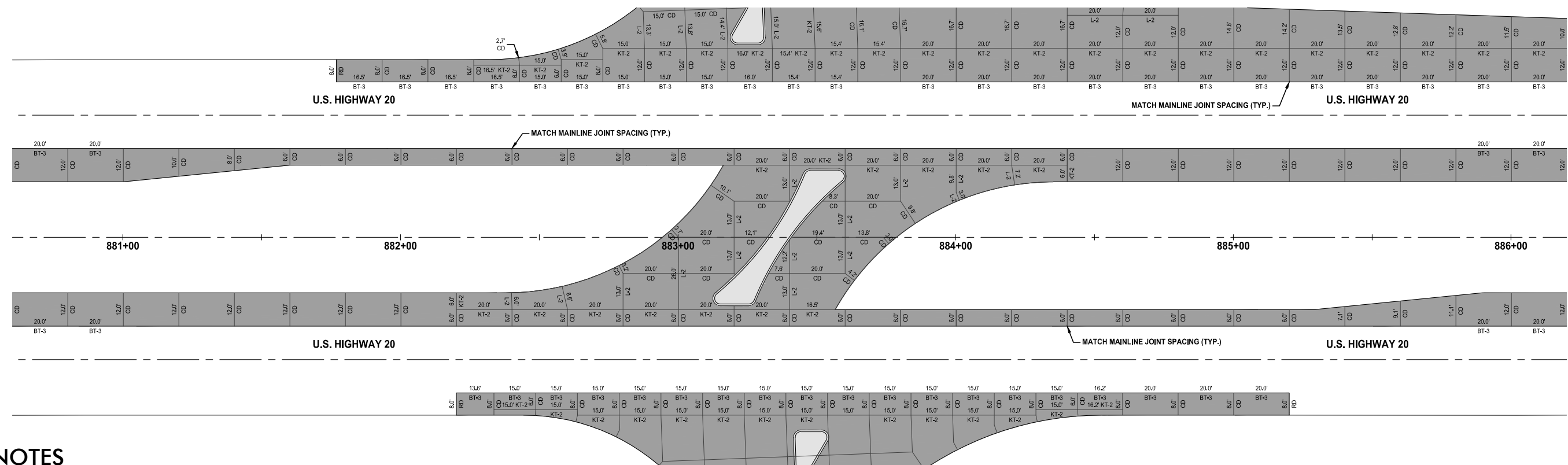

- NOTES**
1. REFER TO FIGURE 7010.101 FOR JOINT DETAILS.
  2. TYPICAL CD OR C JOINT SPACING WHERE NOT SHOWN IS 20 FEET.
  3. ELEVATIONS SHOWN ARE TOP OF SLAB OR FORM GRADE UNLESS NOTED OTHERWISE.
  4. ELEVATIONS IN PARENTHESIS ARE EXISTING ELEVATIONS.

**U.S. HIGHWAY 20  
 (JOINTING DETAIL)**

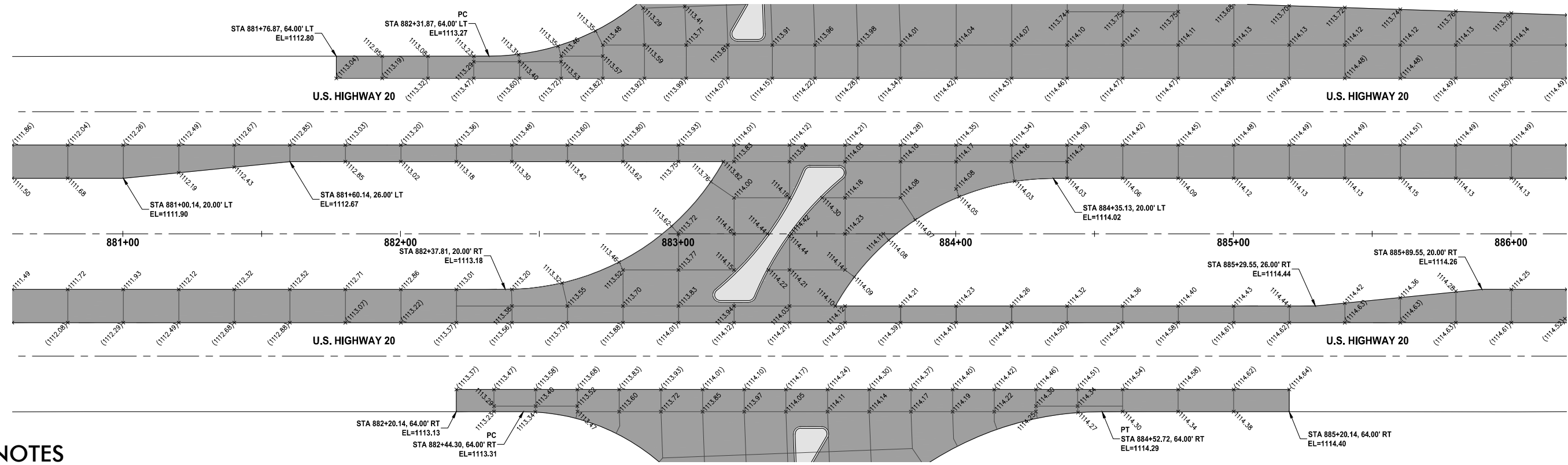

- NOTES**
1. REFER TO FIGURE 7010.101 FOR JOINT DETAILS.
  2. TYPICAL CD OR C JOINT SPACING WHERE NOT SHOWN IS 20 FEET.
  3. ELEVATIONS SHOWN ARE TOP OF SLAB OR FORM GRADE UNLESS NOTED OTHERWISE.
  4. ELEVATIONS IN PARENTHESIS ARE EXISTING ELEVATIONS.

**U.S. HIGHWAY 20  
 (GEOMETRIC & STAKING DETAIL)**

NOTICE:  
 McClure Engineering Co. is not responsible or liable for any issues, claims, damages, or losses (collectively, "Losses") which arise from failure to follow these Plans, Specifications, and the engineering intent they convey, or for Losses which arise from failure to obtain and/or follow the engineers' or surveyors' guidance with respect to any alleged errors, omissions, inconsistencies, ambiguities, or conflicts contained within the Plans and Specifications.

IOWA CERTIFICATE OF AUTHORITY NO. 26887

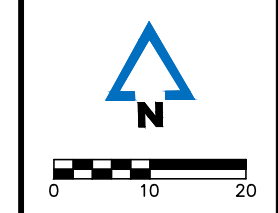

REVISIONS

PROJECT INFO  
 210178-004

ENGINEER: CFF    DRAWN BY: BAV    CHECKED BY: JSS

**US HIGHWAY 20 AND POPLAR AVENUE  
 RCUT INTERSECTION IMPROVEMENTS  
 WEBSTER COUNTY, IOWA**

**U.S. HIGHWAY 20 JOINTING PLAN**

R:210178-004-06-DRAWINGS\CIVIL\PLANS\L01.DWG

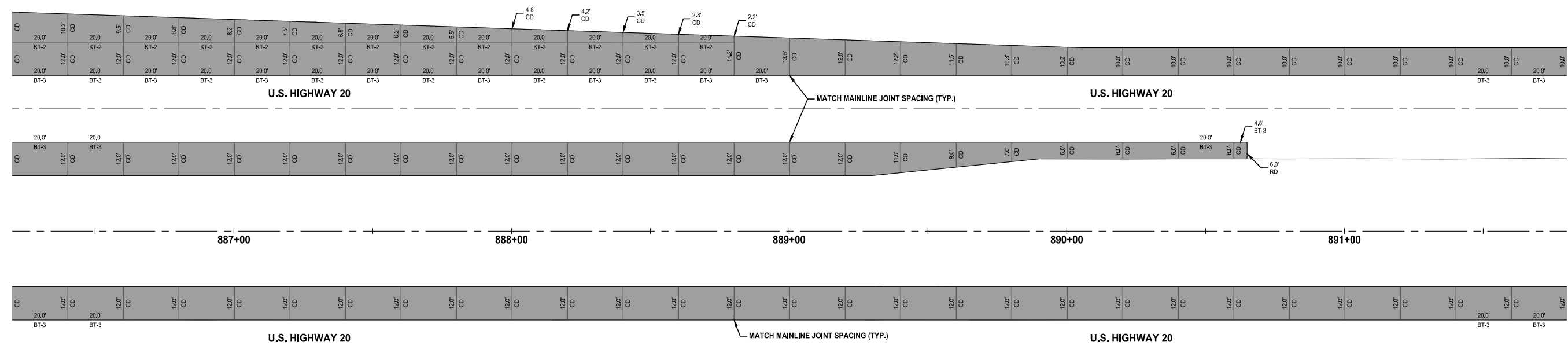

**NOTES**

1. REFER TO FIGURE 7010.101 FOR JOINT DETAILS.
2. TYPICAL CD OR C JOINT SPACING WHERE NOT SHOWN IS 20 FEET.
3. ELEVATIONS SHOWN ARE TOP OF SLAB OR FORM GRADE UNLESS NOTED OTHERWISE.
4. ELEVATIONS IN PARENTHESIS ARE EXISTING ELEVATIONS.

**U.S. HIGHWAY 20  
 (JOINTING DETAIL)**

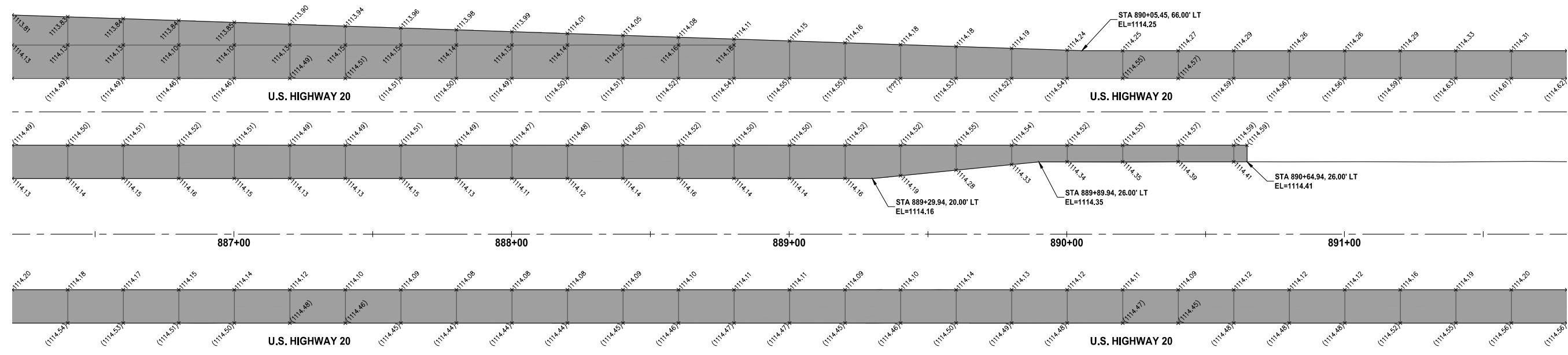

**NOTES**

1. REFER TO FIGURE 7010.101 FOR JOINT DETAILS.
2. TYPICAL CD OR C JOINT SPACING WHERE NOT SHOWN IS 20 FEET.
3. ELEVATIONS SHOWN ARE TOP OF SLAB OR FORM GRADE UNLESS NOTED OTHERWISE.
4. ELEVATIONS IN PARENTHESIS ARE EXISTING ELEVATIONS.

**U.S. HIGHWAY 20  
 (GEOMETRIC & STAKING DETAIL)**

**NOTICE:**  
McClure Engineering Co. is not responsible or liable for any issues, claims, damages, or losses (collectively, "Losses") which arise from failure to follow these Plans, Specifications, and the engineering intent they convey, or for Losses which arise from failure to obtain and/or follow the engineers' or surveyors' guidance with respect to any alleged errors, omissions, inconsistencies, ambiguities, or conflicts contained within the Plans and Specifications.

IOWA CERTIFICATE OF AUTHORITY NO. 26887



REVISIONS

PROJECT INFO  
210178-004

ENGINEER: CFF  
DRAWN BY: BAV  
CHECKED BY: JSS

**US HIGHWAY 20 AND POPLAR AVENUE  
RCUT INTERSECTION IMPROVEMENTS  
WEBSTER COUNTY, IOWA**

**U.S. HIGHWAY 20 JOINTING PLAN**

R:210178-004-06-DRAWINGS\CIVIL\PLANS\L01.DWG

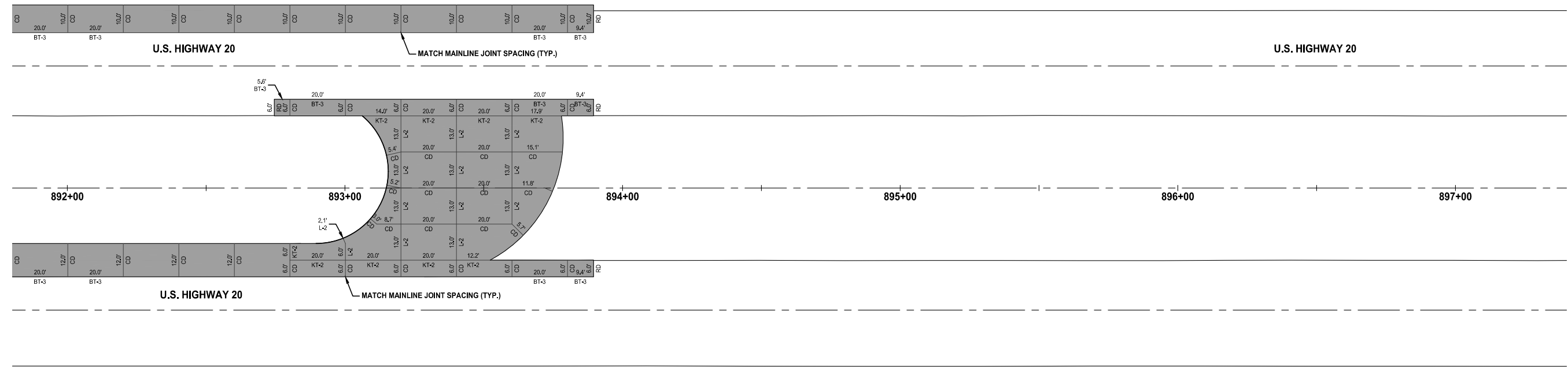

**NOTES**

1. REFER TO FIGURE 7010.101 FOR JOINT DETAILS.
2. TYPICAL CD OR C JOINT SPACING WHERE NOT SHOWN IS 20 FEET.
3. ELEVATIONS SHOWN ARE TOP OF SLAB OR FORM GRADE UNLESS NOTED OTHERWISE.
4. ELEVATIONS IN PARENTHESIS ARE EXISTING ELEVATIONS.

**U.S. HIGHWAY 20  
(JOINTING DETAIL)**

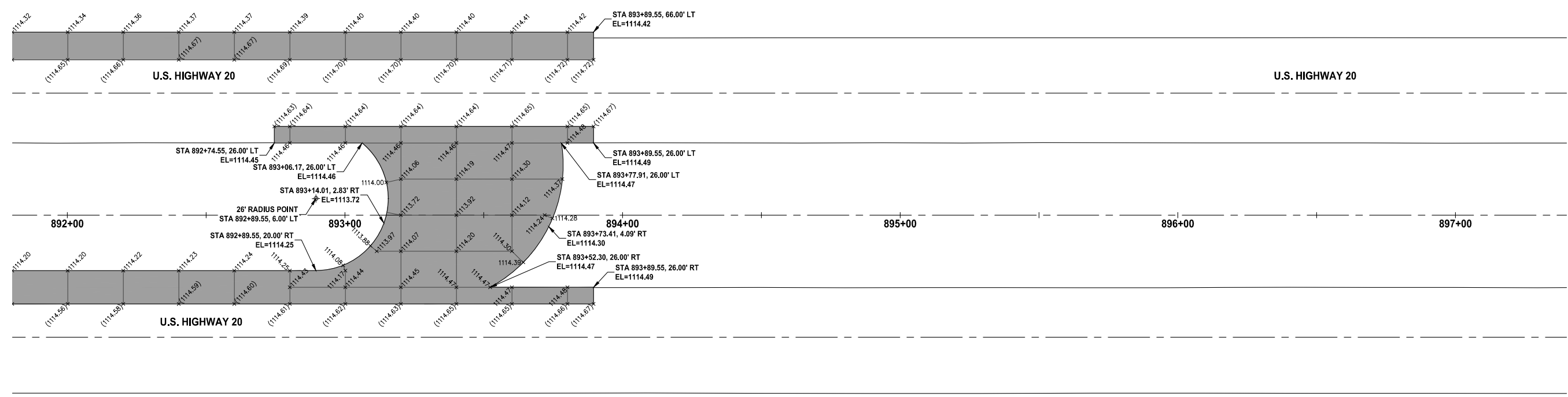

**NOTES**

1. REFER TO FIGURE 7010.101 FOR JOINT DETAILS.
2. TYPICAL CD OR C JOINT SPACING WHERE NOT SHOWN IS 20 FEET.
3. ELEVATIONS SHOWN ARE TOP OF SLAB OR FORM GRADE UNLESS NOTED OTHERWISE.
4. ELEVATIONS IN PARENTHESIS ARE EXISTING ELEVATIONS.

**U.S. HIGHWAY 20  
(GEOMETRIC & STAKING DETAIL)**

NOTICE:  
 McClure Engineering Co. is not responsible or liable for any issues, claims, damages, or losses (collectively, "Losses") which arise from failure to follow these Plans, Specifications, and the engineering intent they convey, or for Losses which arise from failure to obtain and/or follow the engineers' or surveyors' guidance with respect to any alleged errors, omissions, inconsistencies, ambiguities, or conflicts contained within the Plans and Specifications.

IOWA CERTIFICATE OF AUTHORITY NO. 26887

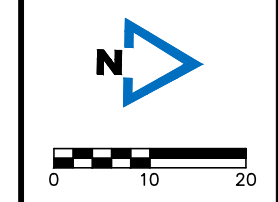

REVISIONS

PROJECT INFO  
 210178-004

ENGINEER: CFF    DRAWN BY: BAV    CHECKED BY: JSS

**US HIGHWAY 20 AND POPLAR AVENUE  
 RCUT INTERSECTION IMPROVEMENTS  
 WEBSTER COUNTY, IOWA**

**POPLAR AVENUE JOINTING PLAN**

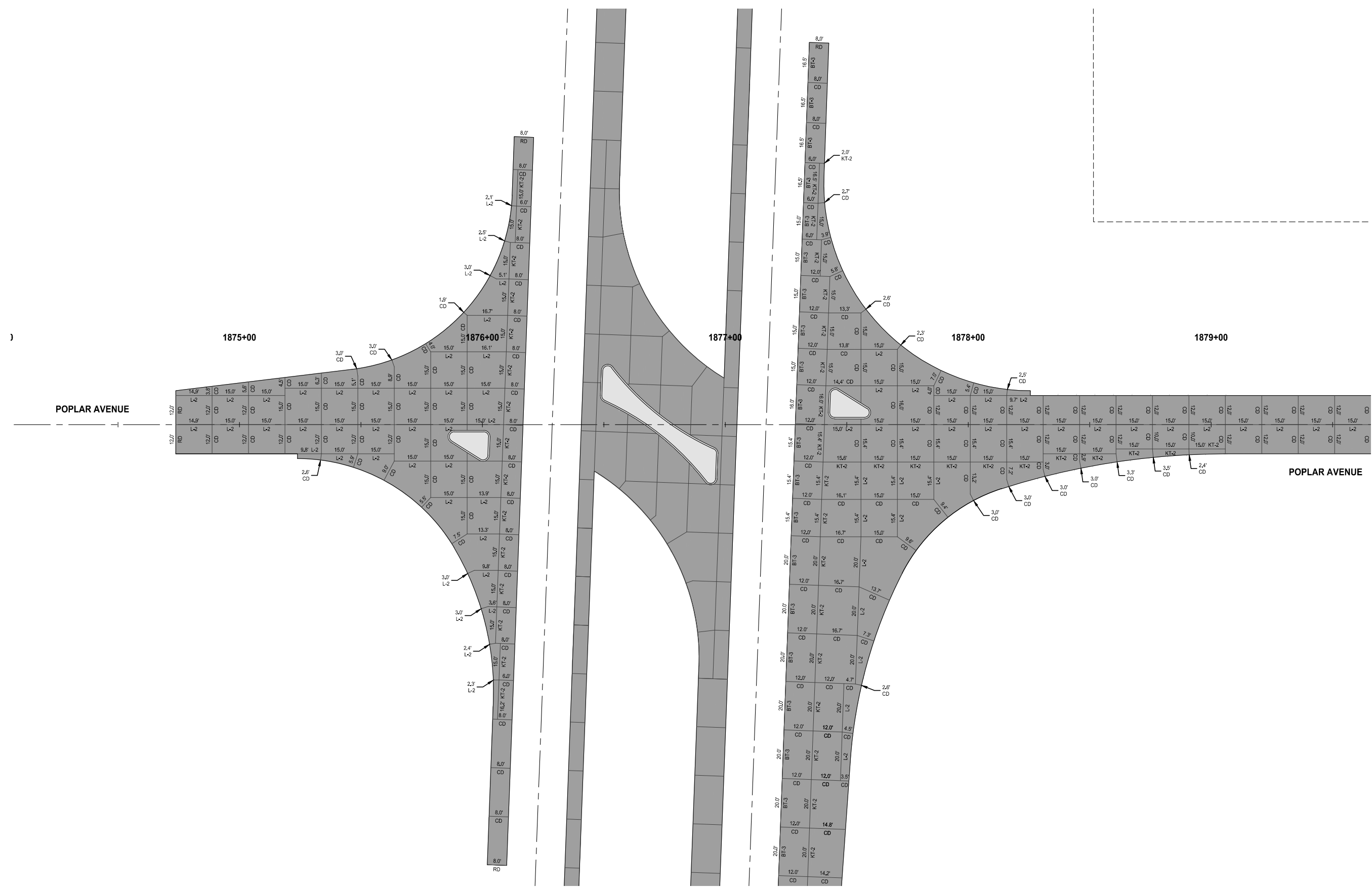

**POPLAR AVENUE  
 (JOINTING DETAIL)**

**NOTES**

1. REFER TO FIGURE 7010.101 FOR JOINT DETAILS.
2. TYPICAL CD OR C JOINT SPACING WHERE NOT SHOWN IS 15 FEET.
3. ELEVATIONS SHOWN ARE TOP OF SLAB OR FORM GRADE UNLESS NOTED OTHERWISE.
4. ELEVATIONS IN PARENTHESIS ARE EXISTING ELEVATIONS.



NOTICE:  
 McClure Engineering Co. is not responsible or liable for any issues, claims, damages, or losses (collectively, "Losses") which arise from failure to follow these Plans, Specifications, and the engineering intent they convey, or for Losses which arise from failure to obtain and/or follow the engineers' or surveyors' guidance with respect to any alleged errors, omissions, inconsistencies, ambiguities, or conflicts contained within the Plans and Specifications.

IOWA CERTIFICATE OF AUTHORITY NO. 26887

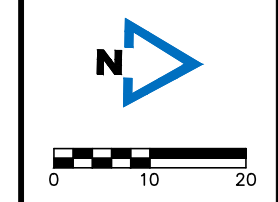

REVISIONS

PROJECT INFO  
 210178-004

ENGINEER: CFF    DRAWN BY: BAV    CHECKED BY: JSS

US HIGHWAY 20 AND POPLAR AVENUE  
 RCUT INTERSECTION IMPROVEMENTS  
 WEBSTER COUNTY, IOWA

POPLAR AVENUE JOINTING PLAN

R:210178-004-06-DRAWINGS\CIVIL\PLANS\L.06.DWG

DRAWING NO.  
**L.07**

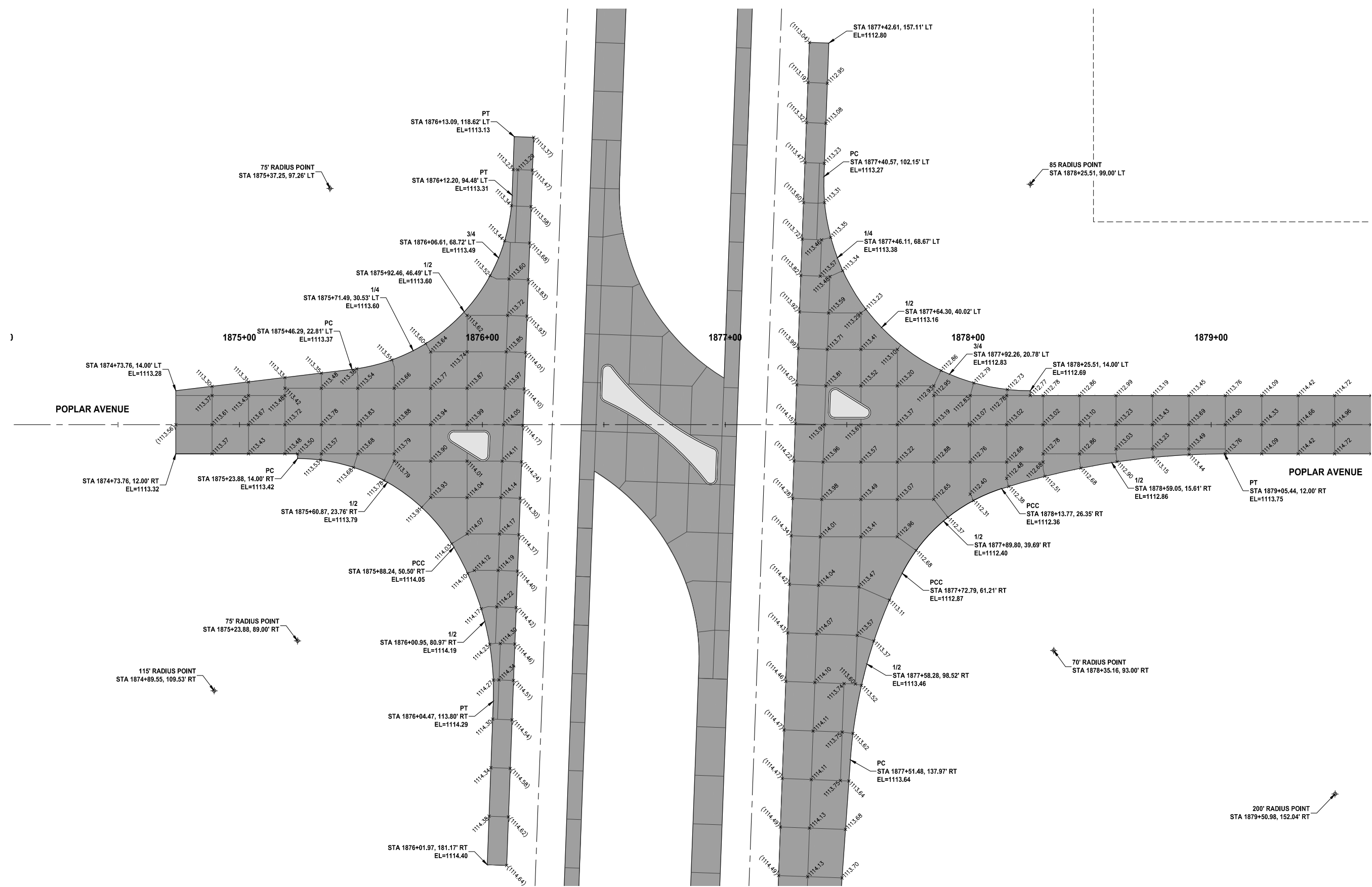

- NOTES**
1. REFER TO FIGURE 7010.101 FOR JOINT DETAILS.
  2. TYPICAL CD OR C JOINT SPACING WHERE NOT SHOWN IS 15 FEET.
  3. ELEVATIONS SHOWN ARE TOP OF SLAB OR FORM GRADE UNLESS NOTED OTHERWISE.
  4. ELEVATIONS IN PARENTHESIS ARE EXISTING ELEVATIONS.

**POPLAR AVENUE  
 (GEOMETRIC & STAKING DETAIL)**

NOTICE:  
 McClure Engineering Co. is not responsible or liable for any issues, claims, damages, or losses (collectively, "Losses") which arise from failure to follow these Plans, Specifications, and the engineering intent they convey, or for Losses which arise from failure to obtain and/or follow the engineers' or surveyors' guidance with respect to any alleged errors, omissions, inconsistencies, ambiguities, or conflicts contained within the Plans and Specifications.

IOWA CERTIFICATE OF AUTHORITY NO. 26887

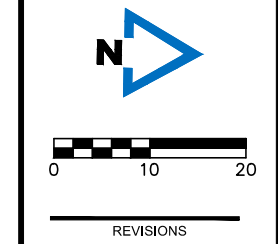

PROJECT INFO  
 210178-004

ENGINEER: CFF    DRAWN BY: BAV    CHECKED BY: JSS

US HIGHWAY 20 AND POPLAR AVENUE  
 RCUT INTERSECTION IMPROVEMENTS  
 WEBSTER COUNTY, IOWA

POPLAR AVENUE JOINTING PLAN

R:\210178-004\06-DRAWINGS\CIVIL\PLANS\L06.DWG

DRAWING NO.  
**L.08**

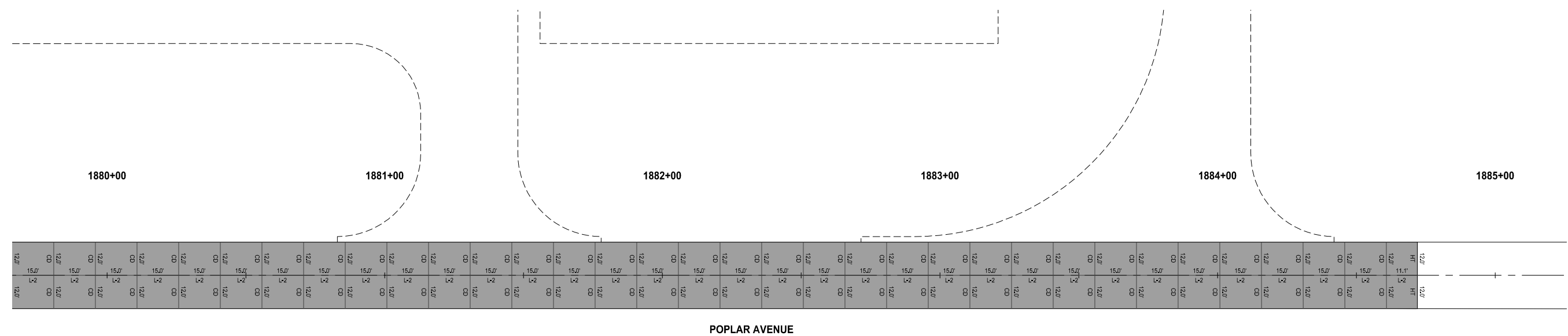

**NOTES**

1. REFER TO FIGURE 7010.101 FOR JOINT DETAILS.
2. TYPICAL CD OR C JOINT SPACING WHERE NOT SHOWN IS 20 FEET.
3. ELEVATIONS SHOWN ARE TOP OF SLAB OR FORM GRADE UNLESS NOTED OTHERWISE.
4. ELEVATIONS IN PARENTHESIS ARE EXISTING ELEVATIONS.

**POPLAR AVENUE  
 (JOINTING DETAIL)**

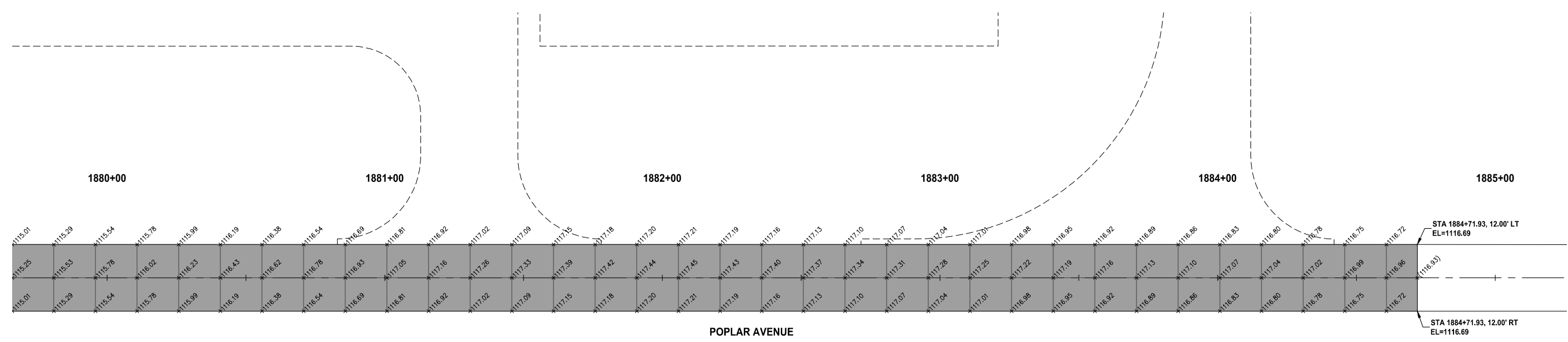

**NOTES**

1. REFER TO FIGURE 7010.101 FOR JOINT DETAILS.
2. TYPICAL CD OR C JOINT SPACING WHERE NOT SHOWN IS 15 FEET.
3. ELEVATIONS SHOWN ARE TOP OF SLAB OR FORM GRADE UNLESS NOTED OTHERWISE.
4. ELEVATIONS IN PARENTHESIS ARE EXISTING ELEVATIONS.

**POPLAR AVENUE  
 (GEOMETRIC AND STAKING DETAIL)**

NOTICE:  
 McClure Engineering Co. is not responsible or liable for any issues, claims, damages, or losses (collectively, "Losses") which arise from failure to follow these Plans, Specifications, and the engineering intent they convey, or for Losses which arise from failure to obtain and/or follow the engineers' or surveyors' guidance with respect to any alleged errors, omissions, inconsistencies, ambiguities, or conflicts contained within the Plans and Specifications.

IOWA CERTIFICATE OF AUTHORITY NO. 26887

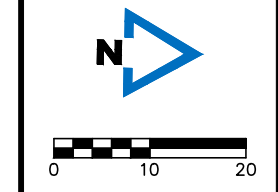

REVISIONS

PROJECT INFO  
 210178-004

ENGINEER: CFF    DRAWN BY: BAV    CHECKED BY: JSS

US HIGHWAY 20 AND POPLAR AVENUE  
 RCUT INTERSECTION IMPROVEMENTS  
 WEBSTER COUNTY, IOWA

POPLAR AVENUE JOINTING PLAN

R:\210178-004\06-DRAWINGS\CIVIL\PLANS\L.09.DWG

DRAWING NO.  
**L.09**

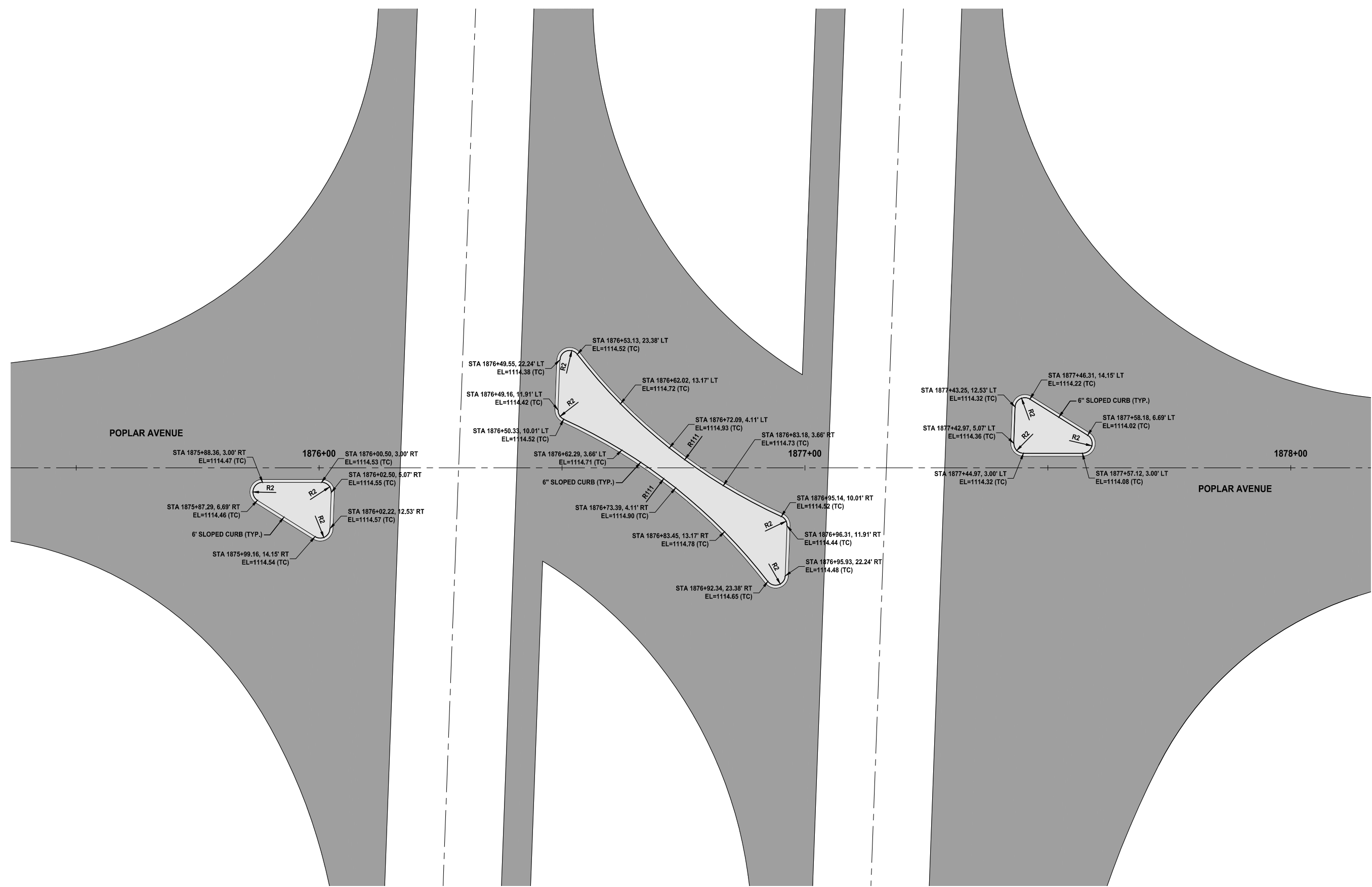

- NOTES**
1. REFER TO FIGURE 7010.101 FOR JOINT DETAILS.
  2. TYPICAL CD OR C JOINT SPACING WHERE NOT SHOWN IS 15 FEET.
  3. ELEVATIONS SHOWN ARE TOP OF SLAB OR FORM GRADE UNLESS NOTED OTHERWISE.
  4. ELEVATIONS IN PARENTHESIS ARE EXISTING ELEVATIONS.

**POPLAR AVENUE  
 (GEOMETRIC & STAKING DETAIL)**

NOTICE:  
 McClure Engineering Co. is not responsible or liable for any issues, claims, damages, or losses (collectively, "Losses") which arise from failure to follow these Plans, Specifications, and the engineering intent they convey, or for Losses which arise from failure to obtain and/or follow the engineers' or surveyors' guidance with respect to any alleged errors, omissions, inconsistencies, ambiguities, or conflicts contained within the Plans and Specifications.

IOWA CERTIFICATE OF AUTHORITY NO. 26887

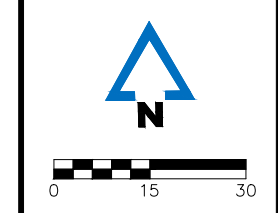

REVISIONS

PROJECT INFO  
 210178-004  
 ENGINEER: CFF DRAWN BY: BAV CHECKED BY: JSS

**U.S. HIGHWAY 20 AND POPLAR AVENUE  
 RCUT INTERSECTION IMPROVEMENTS  
 WEBSTER COUNTY, IOWA**  
**U.S. HIGHWAY 20 MARKING PLAN**

DRAWING NO.  
**N.01**

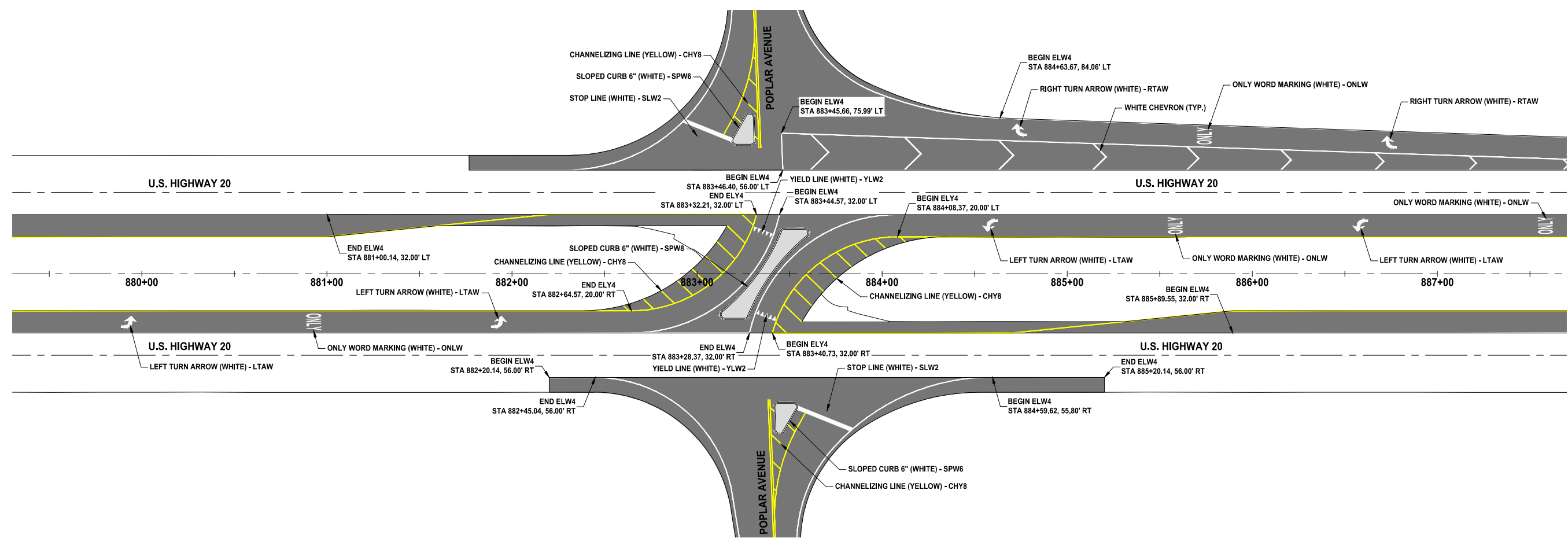
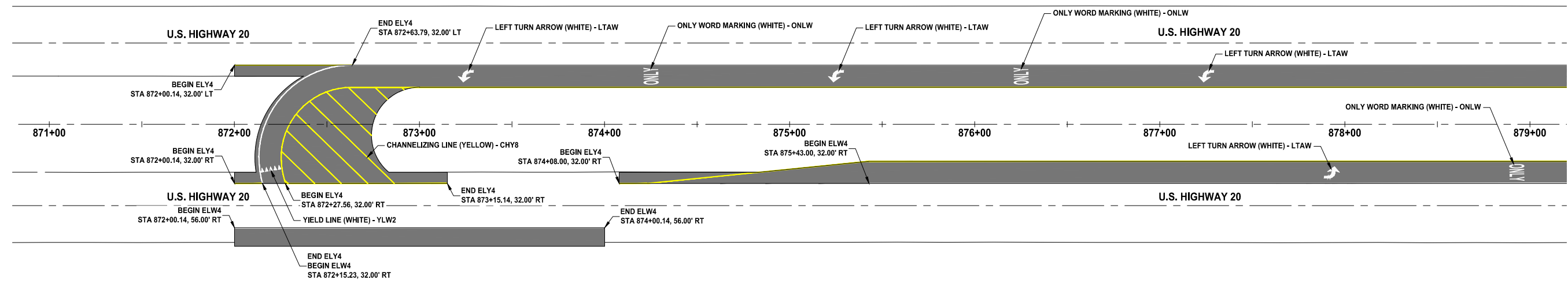

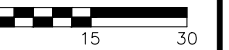

REVISIONS

PROJECT INFO  
 210178-004

ENGINEER	DRAWN BY	CHECKED BY
CFF	BAV	JSS

**U.S. HIGHWAY 20 AND POPLAR AVENUE  
 RCUT INTERSECTION IMPROVEMENTS  
 WEBSTER COUNTY, IOWA**

**U.S. HIGHWAY 20 MARKING PLAN**

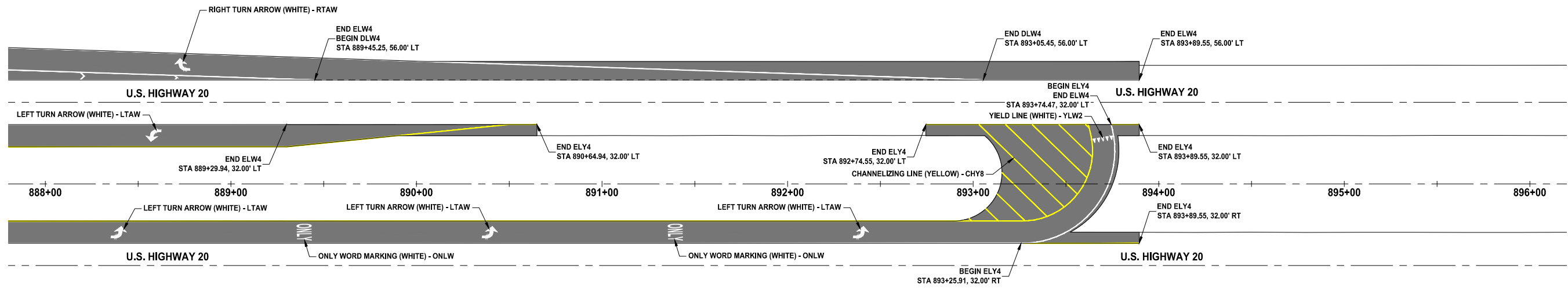

NOTICE:  
 McClure Engineering Co. is not responsible or liable for any issues, claims, damages, or losses (collectively, "Losses") which arise from failure to follow these Plans, Specifications, and the engineering intent they convey, or for Losses which arise from failure to obtain and/or follow the engineers' or surveyors' guidance with respect to any alleged errors, omissions, inconsistencies, ambiguities, or conflicts contained within the Plans and Specifications.

IOWA CERTIFICATE OF AUTHORITY NO. 26887

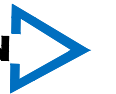

REVISIONS

PROJECT INFO  
 210178-004

ENGINEER: CFF    DRAWN BY: BAV    CHECKED BY: JSS

US HIGHWAY 20 AND POPLAR AVENUE  
 RCUT INTERSECTION IMPROVEMENTS  
 WEBSTER COUNTY, IOWA

POPLAR AVENUE MARKING PLAN  
 R:210178-004106-DRAWINGS\CIVIL\PLANS\N.01.DWG

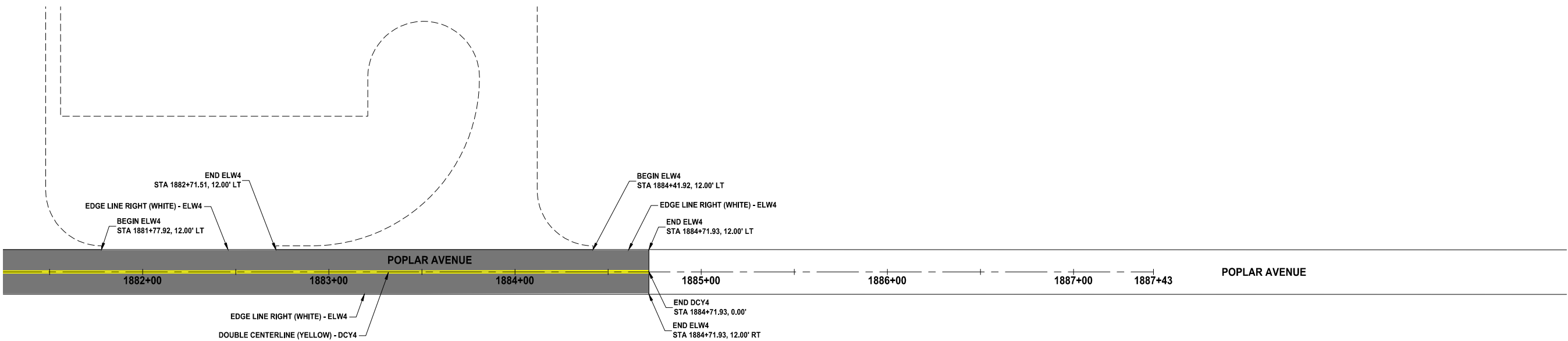
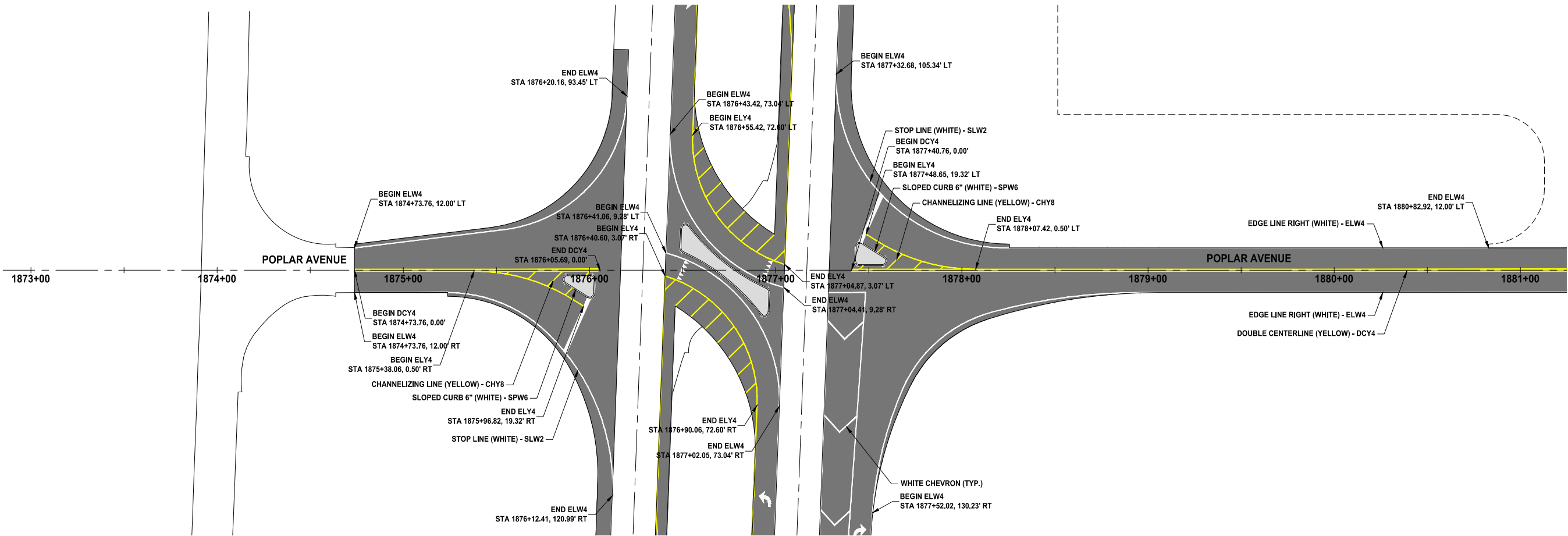



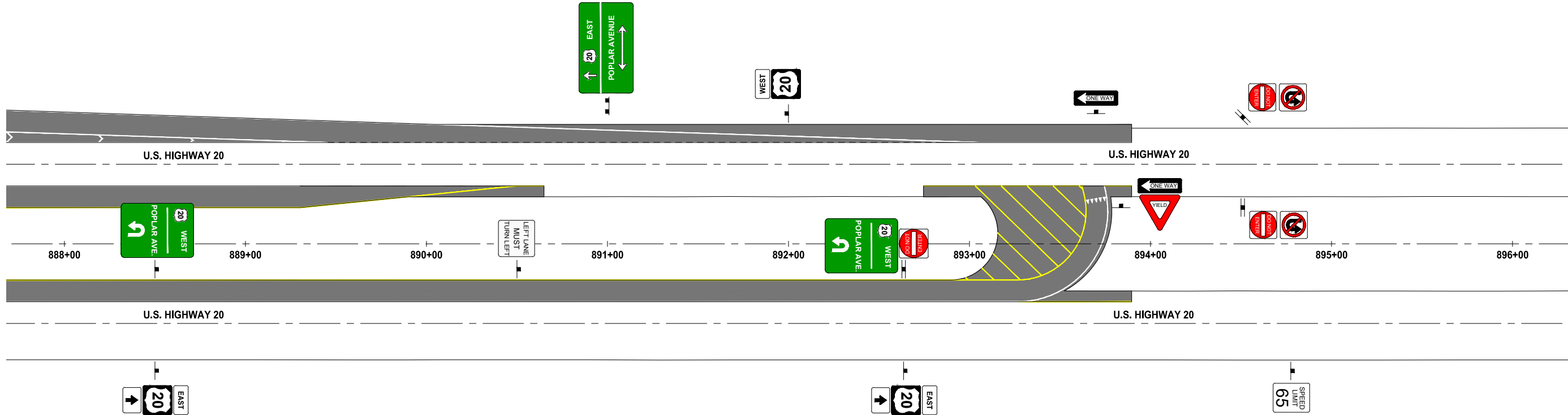

**McCLURE™**  
 705 First Avenue North  
 Fort Dodge, Iowa 50501  
 P 515-576-7155  
 F 515-576-4235

Ankeny, IA | Carroll, IA | Clive, IA  
 Cedar Rapids, IA | Fort Dodge, IA  
 North Liberty, IA | Sioux City, IA  
 Macon, MO | Columbia, MO  
 North Kansas City, MO  
 Lenexa, KS

**NOTICE:**  
 McClure Engineering Co. is not responsible or liable for any issues, claims, damages, or losses (collectively, "Losses") which arise from failure to follow these Plans, Specifications, and the engineering intent they convey, or for Losses which arise from failure to obtain and/or follow the engineers' or surveyors' guidance with respect to any alleged errors, omissions, inconsistencies, ambiguities, or conflicts contained within the Plans and Specifications.

IOWA CERTIFICATE OF AUTHORITY NO. 26887

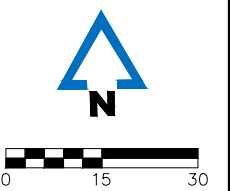

REVISIONS

PROJECT INFO  
 210178-004

ENGINEER	DRAWN BY	CHECKED BY
CFF	BAV	JSS

**US HIGHWAY 20 AND POPLAR AVENUE  
 RCUT INTERSECTION IMPROVEMENTS  
 WEBSTER COUNTY, IOWA**

**US HIGHWAY 20 SIGNING PLAN**

DRAWING NO.  
**N.05**

R:210178-004-06-DRAWINGS\CIVIL\PLANS\N.04.DWG



NOTICE:  
 McClure Engineering Co. is not responsible or liable for any issues, claims, damages, or losses (collectively, "Losses") which arise from failure to follow these Plans, Specifications, and the engineering intent they convey, or for Losses which arise from failure to obtain and/or follow the engineers' or surveyors' guidance with respect to any alleged errors, omissions, inconsistencies, ambiguities, or conflicts contained within the Plans and Specifications.

IOWA CERTIFICATE OF AUTHORITY NO. 26887

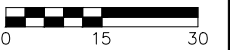
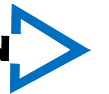

REVISIONS

PROJECT INFO  
 210178-004

ENGINEER	DRAWN BY	CHECKED BY
CFF	BAV	JSS

**US HIGHWAY 20 AND POPLAR AVENUE  
 RCUT INTERSECTION IMPROVEMENTS  
 WEBSTER COUNTY, IOWA**

**POPLAR AVENUE SIGNING PLAN**

R:210178-004-06-DRAWINGS\CIVIL\PLANS\N.04.DWG

DRAWING NO.

**N.06**

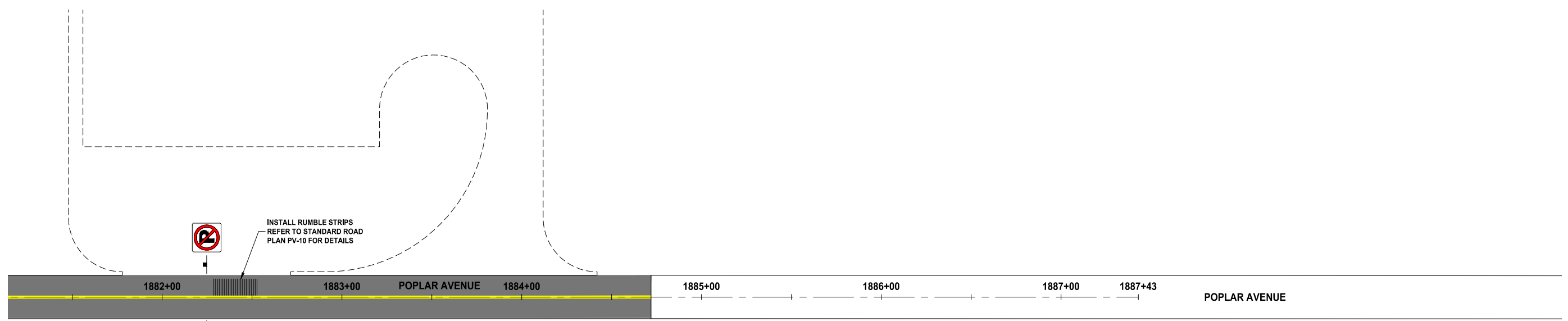
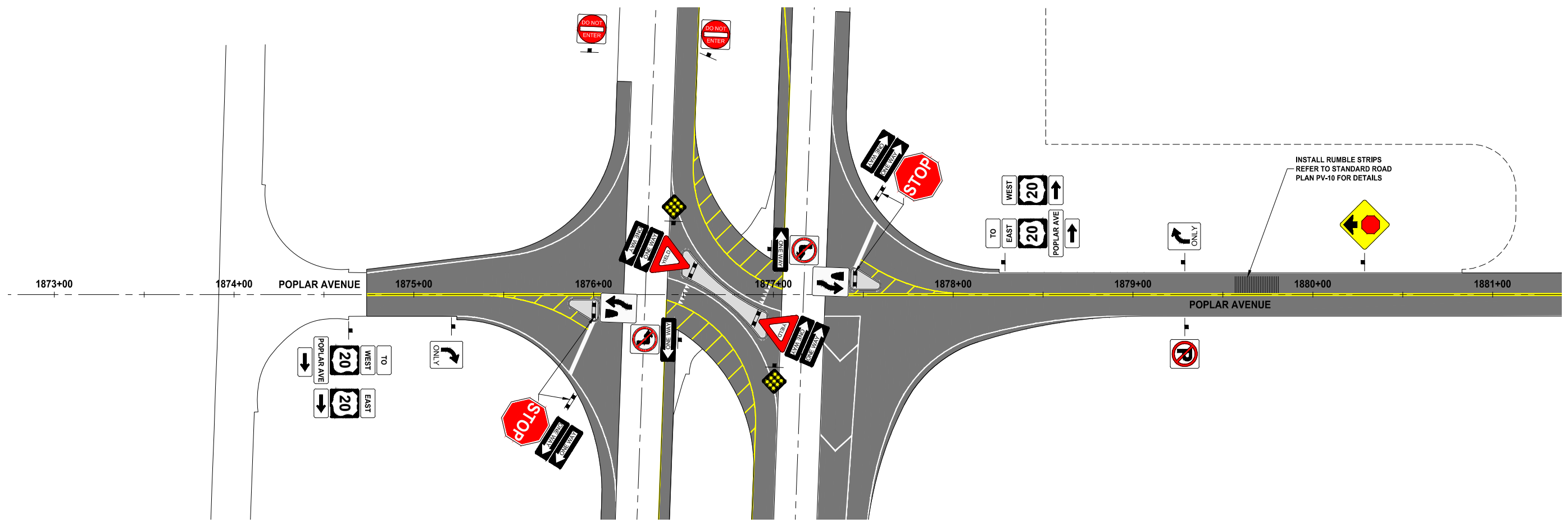

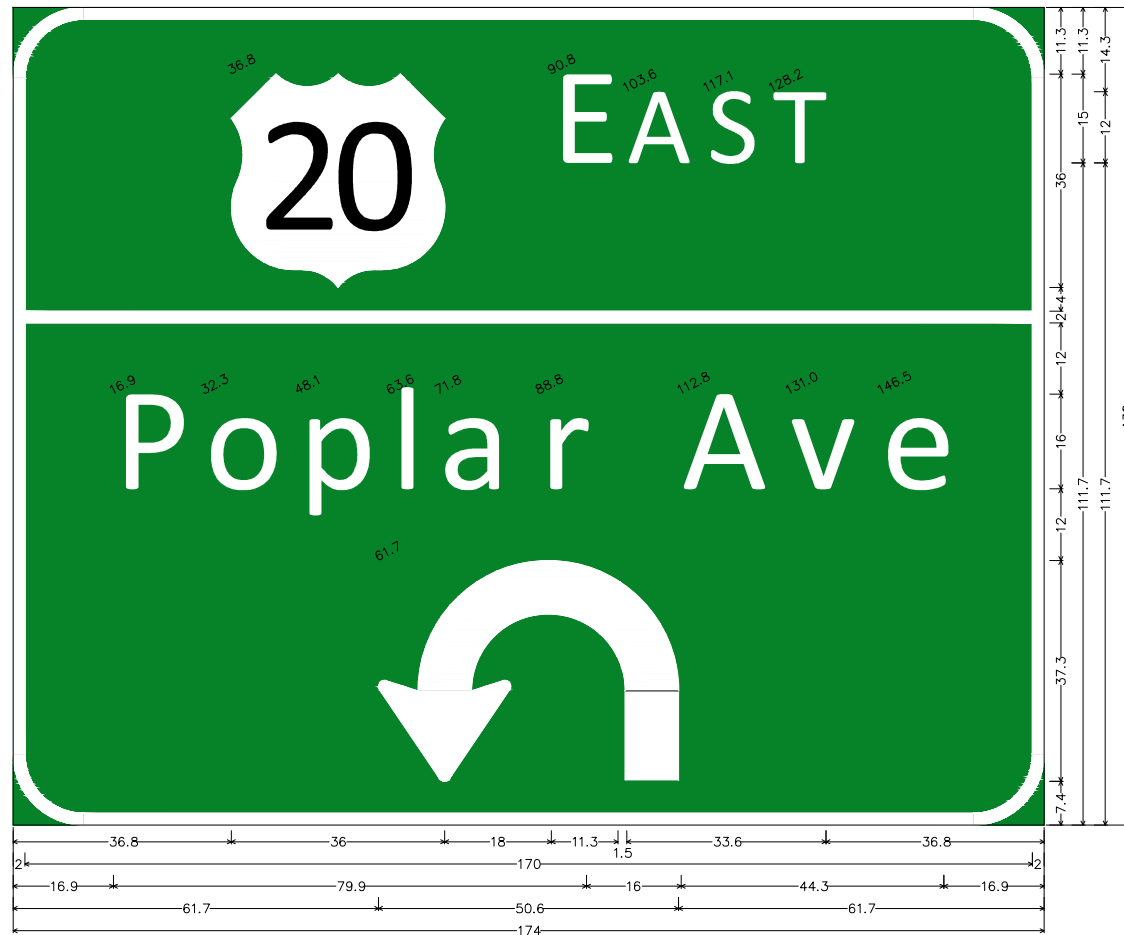

Quantity : 2;  
 12.0" Radius, 2.0" Border, White on Green;  
 "EAST", E 2K; "Poplar Ave", E Mod 2K; Turn Arrow Custom;

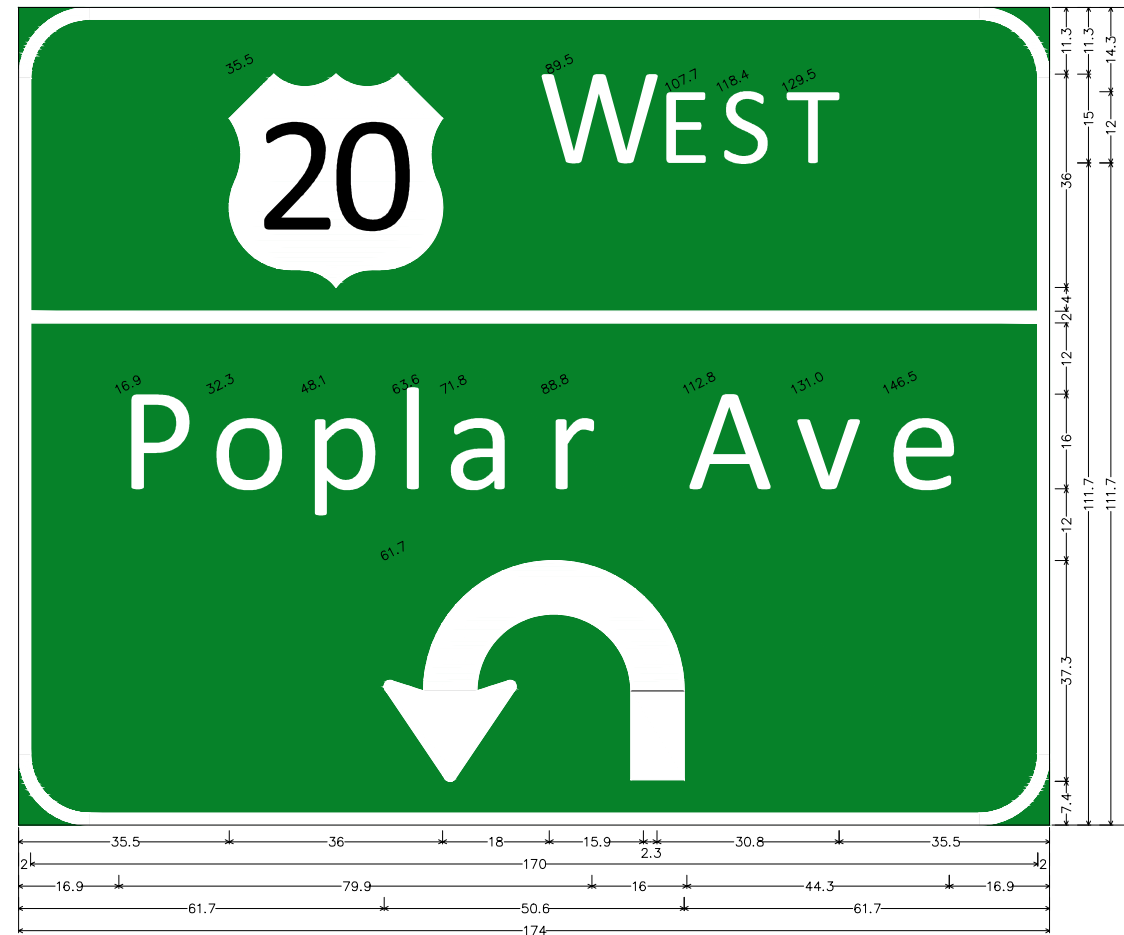

Quantity : 2;  
 12.0" Radius, 2.0" Border, White on Green;  
 "WEST", E 2K; "Poplar Ave", E Mod 2K; Turn Arrow Custom;

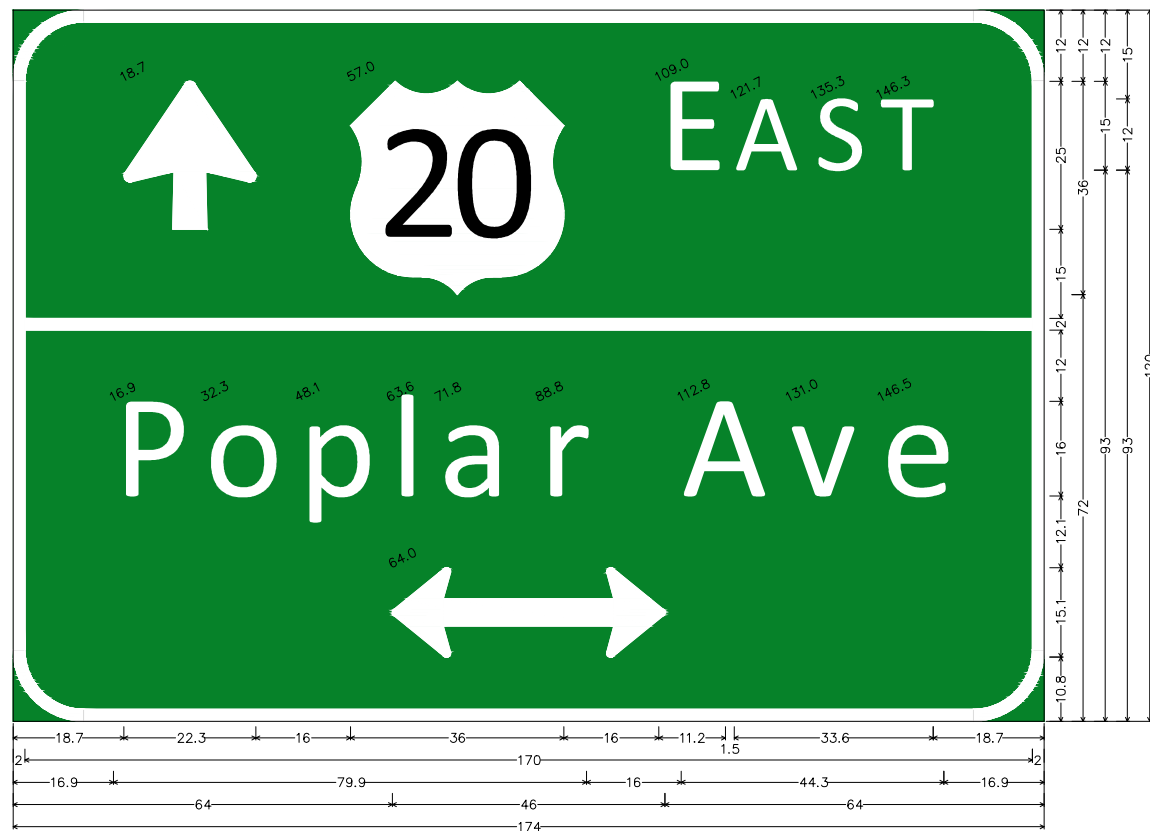

Quantity : 1;  
 12.0" Radius, 2.0" Border, White on Green;  
 Arrow I-E - 25.0" 90"; "EAST", E 2K; "Poplar Ave", E Mod 2K; Double Headed Arrow 6 - 46.0" 0;

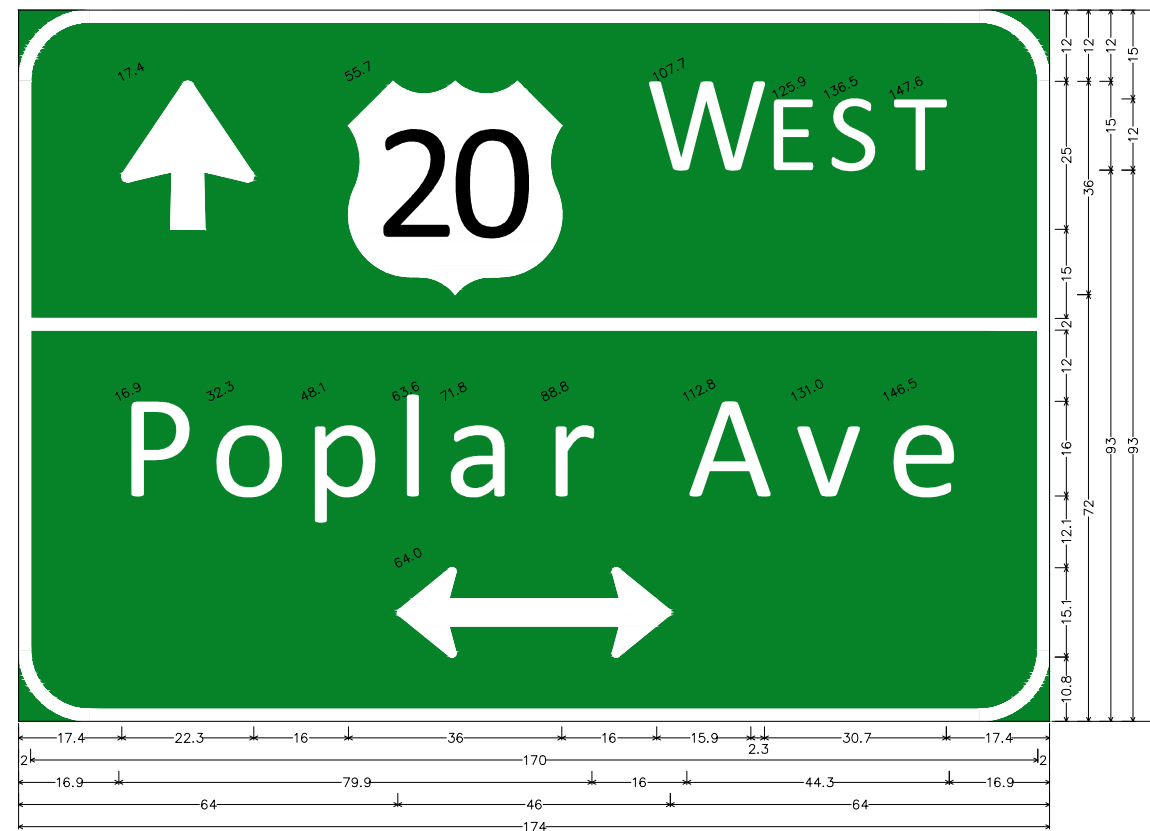

Quantity : 1;  
 12.0" Radius, 2.0" Border, White on Green;  
 Arrow I-E - 25.0" 90"; "WEST", E 2K; "Poplar Ave", E Mod 2K; Double Headed Arrow 6 - 46.0" 0;

NOTICE:  
 McClure Engineering Co. is not responsible or liable for any issues, claims, damages, or losses (collectively, "Losses") which arise from failure to follow these Plans, Specifications, and the engineering intent they convey, or for Losses which arise from failure to obtain and/or follow the engineers' or surveyors' guidance with respect to any alleged errors, omissions, inconsistencies, ambiguities, or conflicts contained within the Plans and Specifications.

IOWA CERTIFICATE OF AUTHORITY NO. 26887

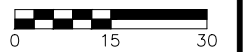

REVISIONS

PROJECT INFO  
 210178-004

ENGINEER: CFF DRAWN BY: BAV CHECKED BY: JSS

US HIGHWAY 20 AND POPLAR AVENUE  
 RCUT INTERSECTION IMPROVEMENTS  
 WEBSTER COUNTY, IOWA

GUIDE SIGN DETAILS  
 R1210178-004-06-DRAWINGS\CIVIL\PLANS\N.07.DWG

NOTICE:  
 McClure Engineering Co. is not responsible or liable for any issues, claims, damages, or losses (collectively, "Losses") which arise from failure to follow these Plans, Specifications, and the engineering intent they convey, or for Losses which arise from failure to obtain and/or follow the engineers' or surveyors' guidance with respect to any alleged errors, omissions, inconsistencies, ambiguities, or conflicts contained within the Plans and Specifications.

IOWA CERTIFICATE OF AUTHORITY NO. 26887

REVISIONS

PROJECT INFO  
 210178-004  
 ENGINEER: CFF DRAWN BY: BAV CHECKED BY: JSS

**U.S. HIGHWAY 20 AND POPLAR AVENUE  
 RCUT INTERSECTION IMPROVEMENTS  
 WEBSTER COUNTY, IOWA**

**U.S. HIGHWAY 20 CROSS SECTIONS**

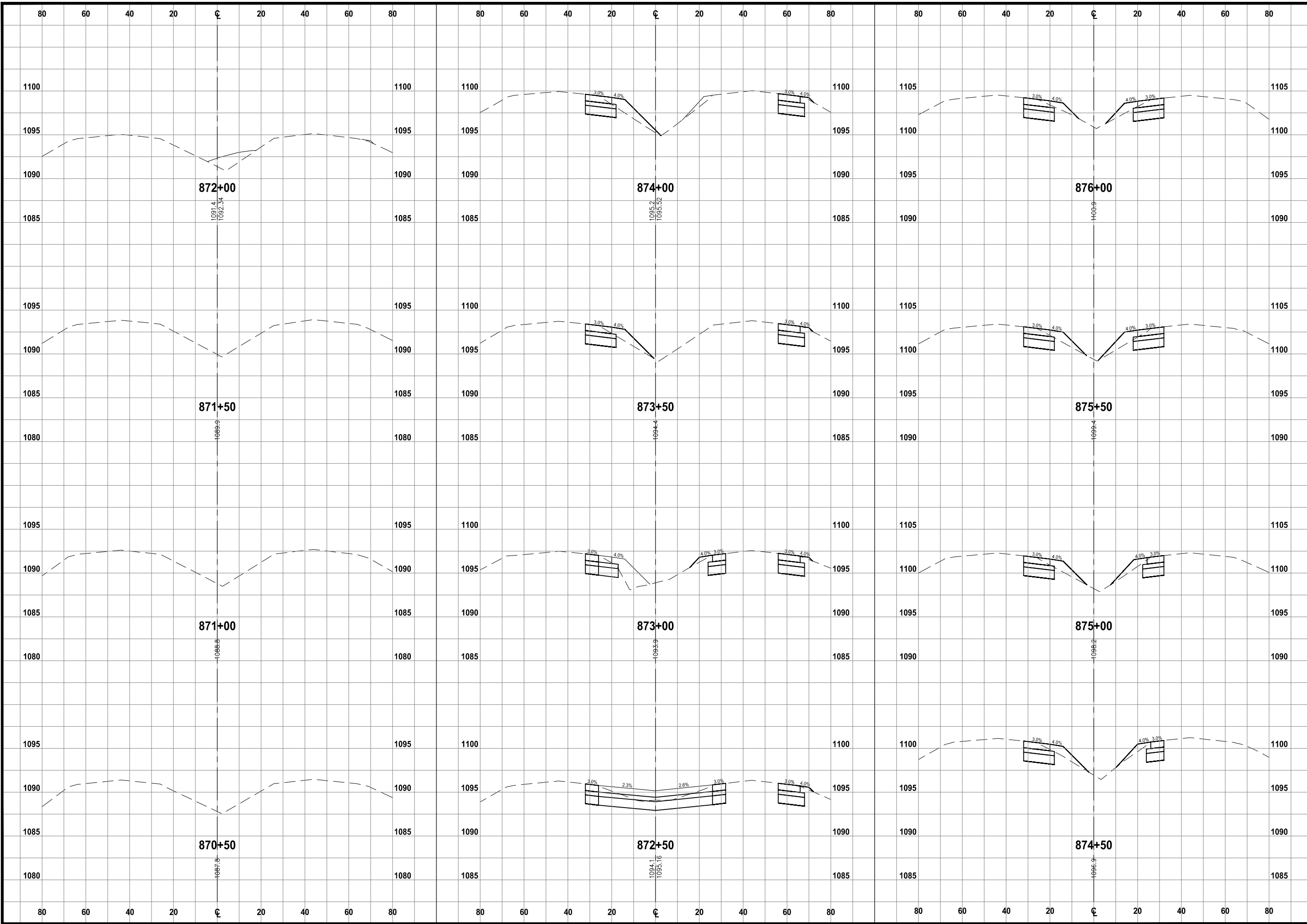

NOTICE:  
 McClure Engineering Co. is not responsible or liable for any issues, claims, damages, or losses (collectively, "Losses") which arise from failure to follow these Plans, Specifications, and the engineering intent they convey, or for Losses which arise from failure to obtain and/or follow the engineers' or surveyors' guidance with respect to any alleged errors, omissions, inconsistencies, ambiguities, or conflicts contained within the Plans and Specifications.

IOWA CERTIFICATE OF AUTHORITY NO. 26887

REVISIONS

PROJECT INFO  
 210178-004

ENGINEER: CFF    DRAWN BY: BAV    CHECKED BY: JSS

**U.S. HIGHWAY 20 AND POPLAR AVENUE  
 RCUT INTERSECTION IMPROVEMENTS  
 WEBSTER COUNTY, IOWA**

**U.S. HIGHWAY 20 CROSS SECTIONS**

DRAWING NO.  
**W.02**

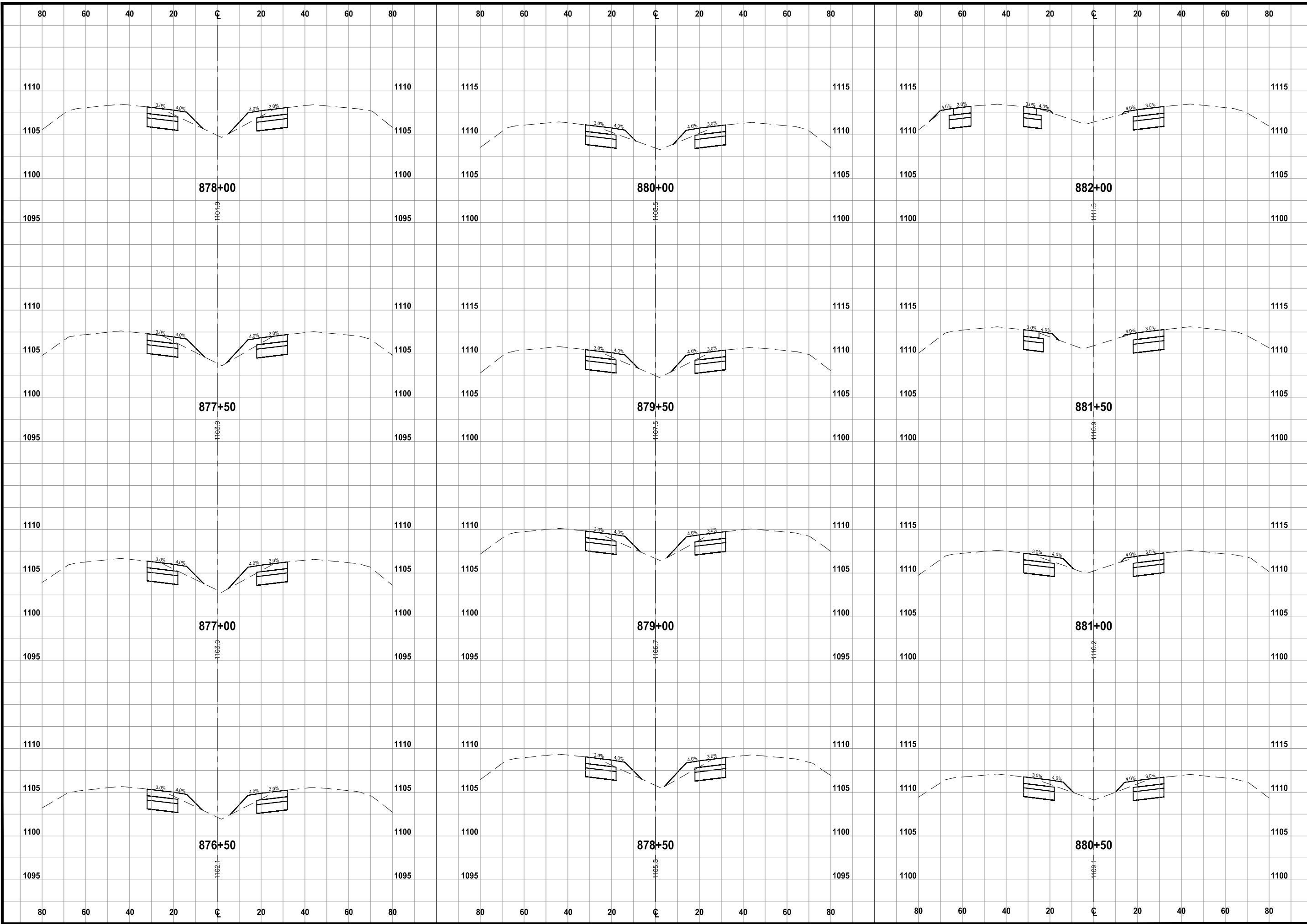

NOTICE:  
 McClure Engineering Co. is not responsible or liable for any issues, claims, damages, or losses (collectively, "Losses") which arise from failure to follow these Plans, Specifications, and the engineering intent they convey, or for Losses which arise from failure to obtain and/or follow the engineers' or surveyors' guidance with respect to any alleged errors, omissions, inconsistencies, ambiguities, or conflicts contained within the Plans and Specifications.

IOWA CERTIFICATE OF AUTHORITY NO. 26887

REVISIONS

PROJECT INFO  
 210178-004

ENGINEER: CFF    DRAWN BY: BAV    CHECKED BY: JSS

**U.S. HIGHWAY 20 AND POPLAR AVENUE  
 RCUT INTERSECTION IMPROVEMENTS  
 WEBSTER COUNTY, IOWA**

**U.S. HIGHWAY 20 CROSS SECTIONS**

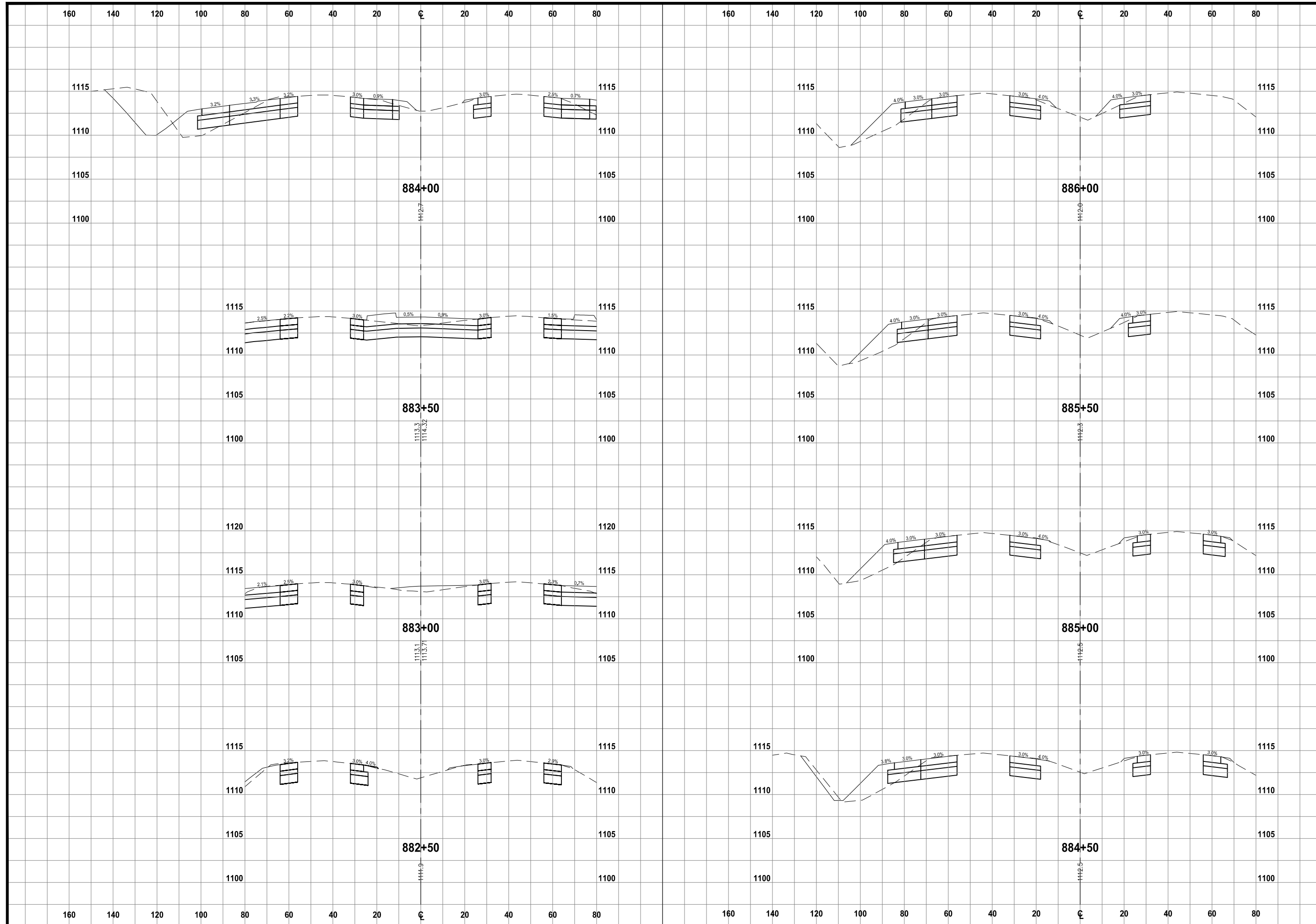

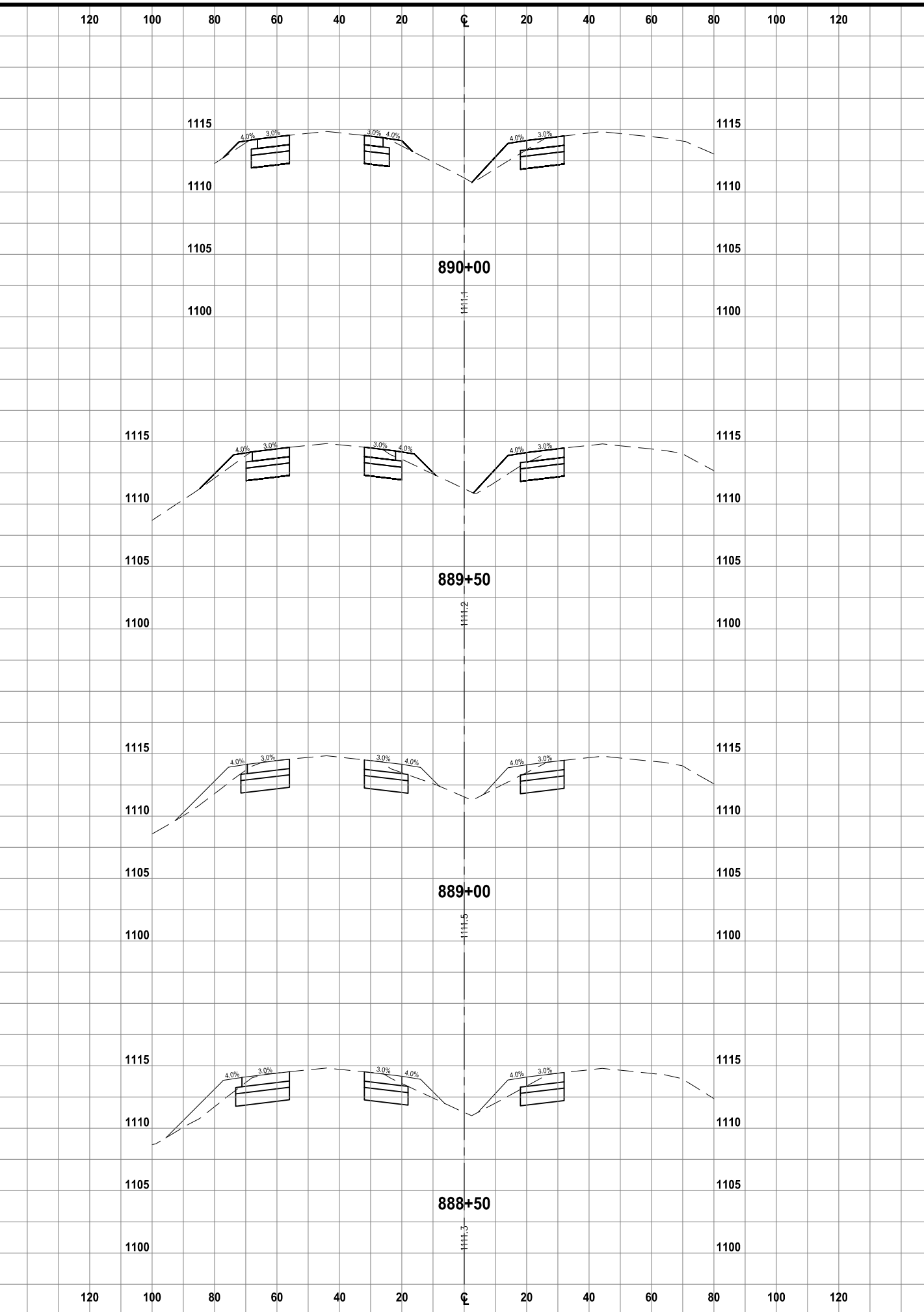
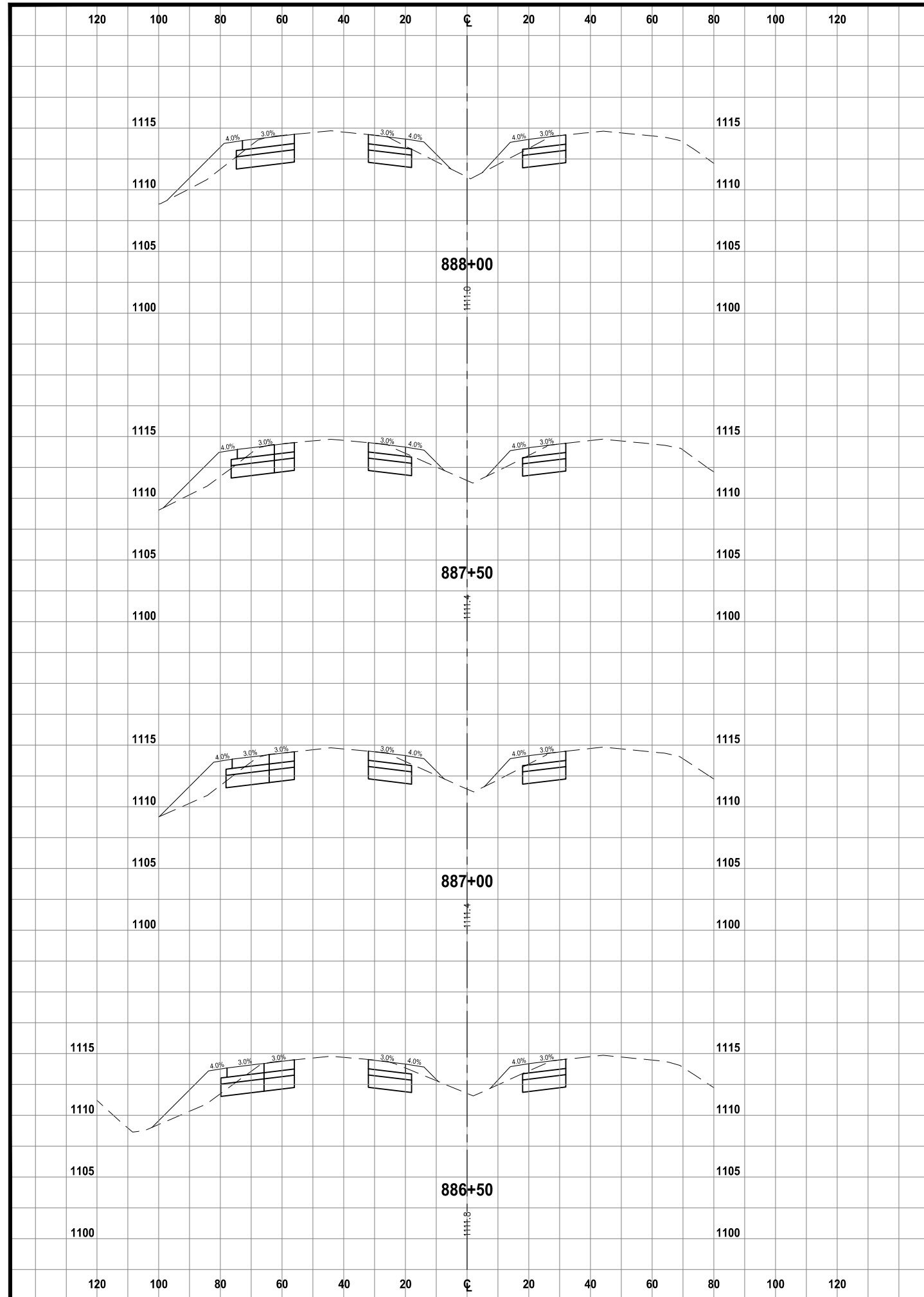



**McCLURE™**  
 705 First Avenue North  
 Fort Dodge, Iowa 50501  
 P 515-576-7155  
 F 515-576-4235

Ankeny, IA | Carroll, IA | Clive, IA  
 Cedar Rapids, IA | Fort Dodge, IA  
 North Liberty, IA | Sioux City, IA  
 Macon, MO | Columbia, MO  
 North Kansas City, MO  
 Lenexa, KS

NOTICE:  
 McClure Engineering Co. is not responsible or liable for any issues, claims, damages, or losses (collectively, "Losses") which arise from failure to follow these Plans, Specifications, and the engineering intent they convey, or for Losses which arise from failure to obtain and/or follow the engineers' or surveyors' guidance with respect to any alleged errors, omissions, inconsistencies, ambiguities, or conflicts contained within the Plans and Specifications.

IOWA CERTIFICATE OF AUTHORITY NO. 26887

---

REVISIONS

---

PROJECT INFO  
 210178-004

ENGINEER: CFF    DRAWN BY: BAV    CHECKED BY: JSS

---

**US HIGHWAY 20 AND POPLAR AVENUE  
 RCUT INTERSECTION IMPROVEMENTS  
 WEBSTER COUNTY, IOWA**

---

**U.S. HIGHWAY 20 CROSS SECTIONS**

R:210178-004-06-DRAWINGS\CIVIL\PLANS\W.01.DWG

---

DRAWING NO.  
**W.04**

NOTICE:  
 McClure Engineering Co. is not responsible or liable for any issues, claims, damages, or losses (collectively, "Losses") which arise from failure to follow these Plans, Specifications, and the engineering intent they convey, or for Losses which arise from failure to obtain and/or follow the engineers' or surveyors' guidance with respect to any alleged errors, omissions, inconsistencies, ambiguities, or conflicts contained within the Plans and Specifications.

IOWA CERTIFICATE OF AUTHORITY NO. 26887

REVISIONS

PROJECT INFO  
 210178-004

ENGINEER: CFF    DRAWN BY: BAV    CHECKED BY: JSS

**US HIGHWAY 20 AND POPLAR AVENUE  
 RCUT INTERSECTION IMPROVEMENTS  
 WEBSTER COUNTY, IOWA**

**U.S. HIGHWAY 20 CROSS SECTIONS**

DRAWING NO.

**W.05**

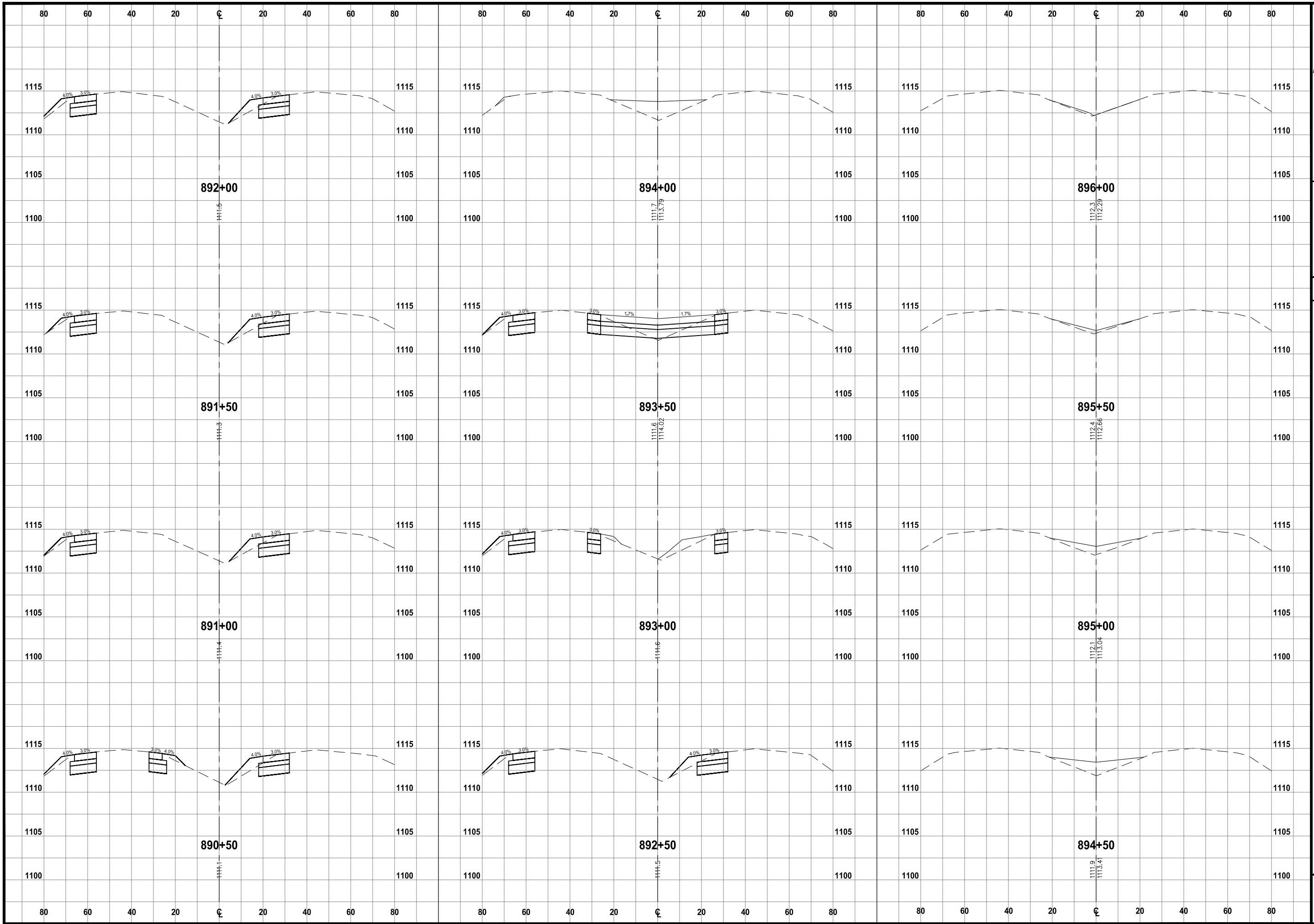

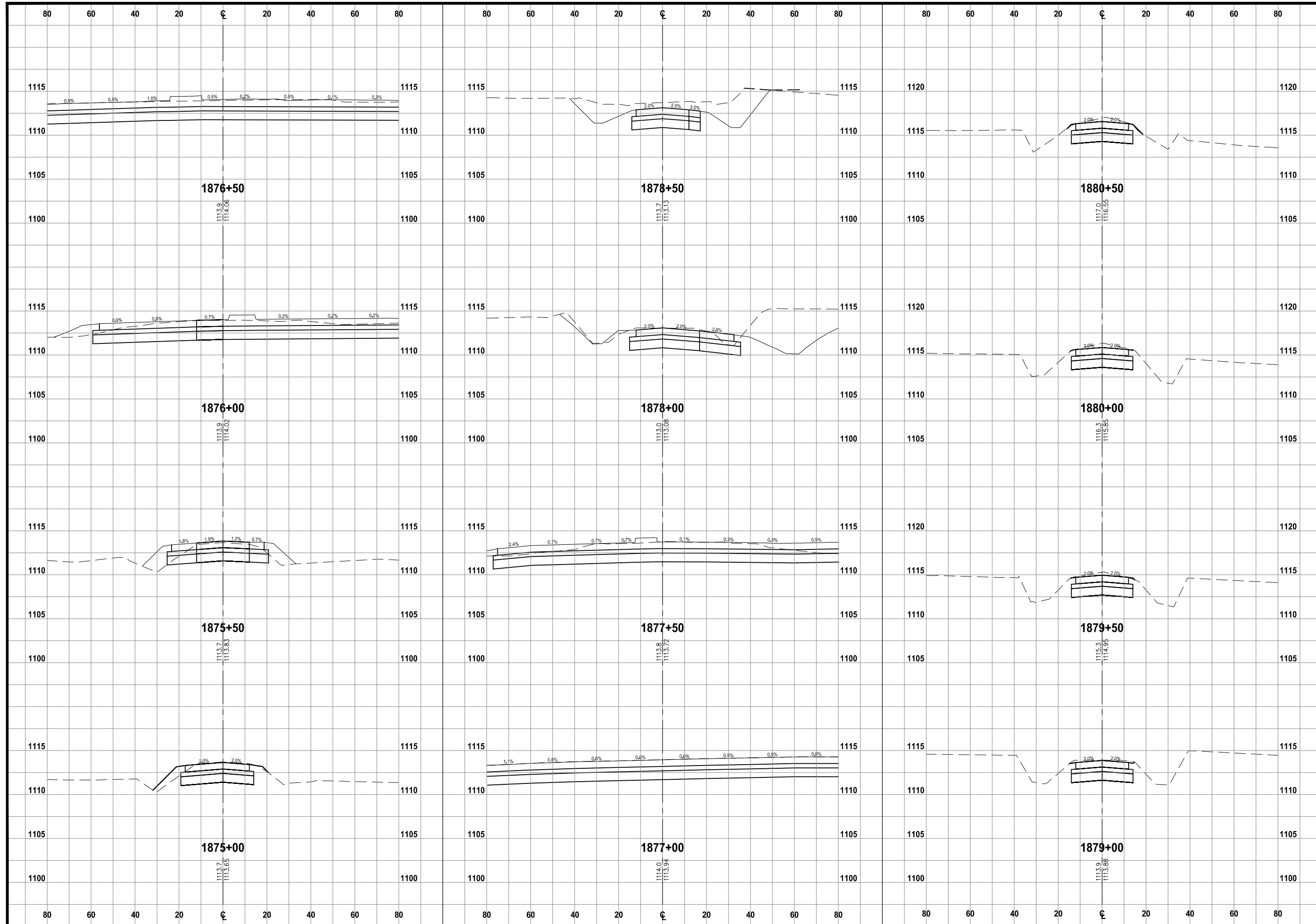

**McCLURE™**  
 705 First Avenue North  
 Fort Dodge, Iowa 50501  
 P 515-576-7155  
 F 515-576-4235  
 Ankeny, IA | Carroll, IA | Clive, IA  
 Cedar Rapids, IA | Fort Dodge, IA  
 North Liberty, IA | Sioux City, IA  
 Macon, MO | Columbia, MO  
 North Kansas City, MO  
 Lenexa, KS

**NOTICE:**  
 McClure Engineering Co. is not responsible or liable for any issues, claims, damages, or losses (collectively, "Losses") which arise from failure to follow these Plans, Specifications, and the engineering intent they convey, or for Losses which arise from failure to obtain and/or follow the engineers' or surveyors' guidance with respect to any alleged errors, omissions, inconsistencies, ambiguities, or conflicts contained within the Plans and Specifications.

IOWA CERTIFICATE OF AUTHORITY NO. 26887

REVISIONS

PROJECT INFO  
 210178-004

ENGINEER: CFF    DRAWN BY: BAV    CHECKED BY: JSS

**US HIGHWAY 20 AND POPLAR AVENUE  
 RCUT INTERSECTION IMPROVEMENTS  
 WEBSTER COUNTY, IOWA**

**POPLAR AVENUE CROSS SECTIONS**

R:210178-004-06-DRAWINGS\CIVIL\PLANS\X.01.DWG

DRAWING NO.  
**X.01**



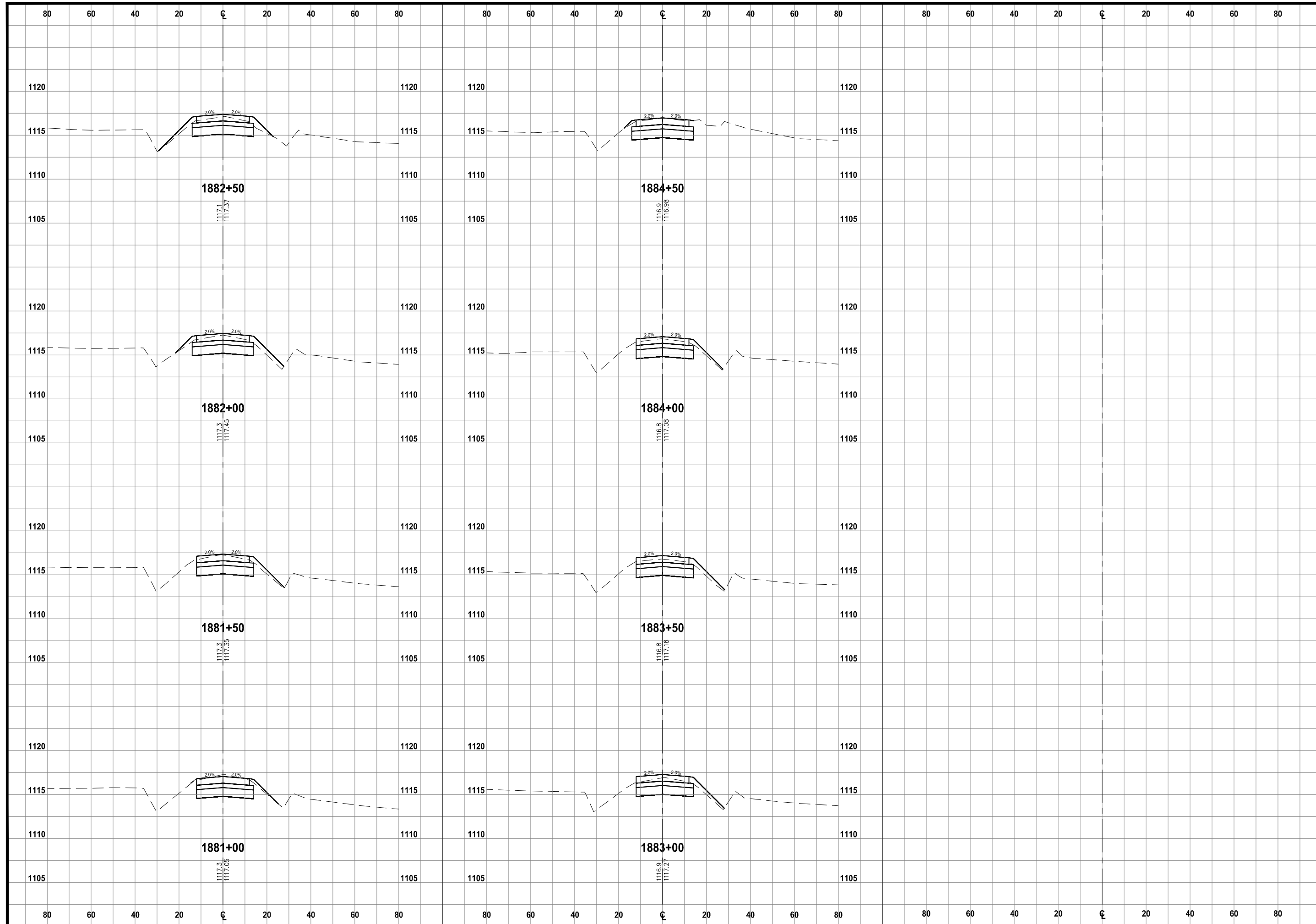

**McCLURE™**  
 705 First Avenue North  
 Fort Dodge, Iowa 50501  
 P 515-576-7155  
 F 515-576-4235  
 Ankeny, IA | Carroll, IA | Clive, IA  
 Cedar Rapids, IA | Fort Dodge, IA  
 North Liberty, IA | Sioux City, IA  
 Macon, MO | Columbia, MO  
 North Kansas City, MO  
 Lenexa, KS

**NOTICE:**  
 McClure Engineering Co. is not responsible or liable for any issues, claims, damages, or losses (collectively, "Losses") which arise from failure to follow these Plans, Specifications, and the engineering intent they convey, or for Losses which arise from failure to obtain and/or follow the engineers' or surveyors' guidance with respect to any alleged errors, omissions, inconsistencies, ambiguities, or conflicts contained within the Plans and Specifications.

IOWA CERTIFICATE OF AUTHORITY NO. 26887

REVISIONS

PROJECT INFO  
 210178-004

ENGINEER: CFF    DRAWN BY: BAV    CHECKED BY: JSS

**US HIGHWAY 20 AND POPLAR AVENUE  
 RCUT INTERSECTION IMPROVEMENTS  
 WEBSTER COUNTY, IOWA**

**POPLAR AVENUE CROSS SECTIONS**

R:210178-004-06-DRAWINGS\CIVIL\PLANS\X.01.DWG

DRAWING NO.  
**X.02**